

Service Manual

Mini Component System

DC-C70 (UK)
(XE)

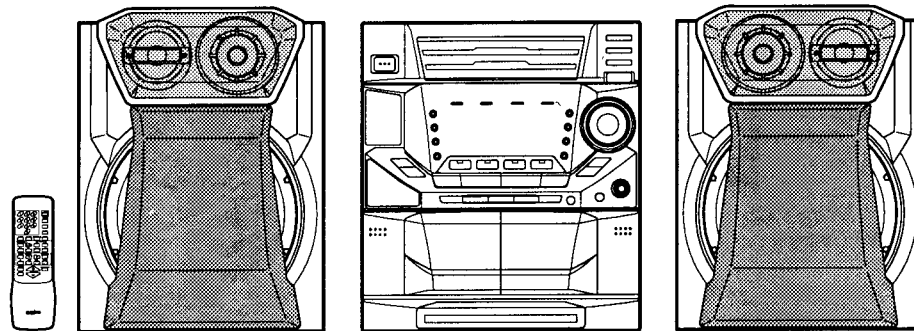

Contents

PRODUCT CODE No.

129 560 03 (UK)

129 560 04 (XE)

Specifications	1	Wiring connection	27
Laser beam safety precaution	1	Schematic diagram	
What to do if	2	(FRONT [for UK])	28
CD pick-up maintenance	2	(FRONT [for XE])	32
Service mode	2	(CD)	36
CD player adjustments	3	(DECK)	40
Tape adjustments	4	(AMPLIFIER)	42
Tuner adjustments	6	(TUNER [for UK])	44
Exploded view		(TUNER [for XE])	48
(Cabinet & Chassis)	7	Wiring diagram	
(Tape mechanism)	16	(FRONT [for UK])	30
(CD changer mechanism)	18	(FRONT [for XE])	34
(CD base mechanism)	19	(CD)	38
Parts list		(DECK)	39
(Cabinet & Chassis)	8	(TUNER & AMPLIFIER [for UK])	46
(Tape mechanism)	17	(TUNER & AMPLIFIER [for XE])	50
(CD mechanism)	19	(POWER TRANSFORMER)	52
IC block diagram & description	20	(POWER SWITCH, DISC SWITCH, and e.t.c.)	53
FL display description	25		
IC & Transistor voltages	26		

This service manual consists of "DC-C70U" (Main unit : 129 559 03 [UK], 129 559 04 [XE]), "RB-C30AR [UK] RB-C30ARD [XE]" (Remote control), "SX-C70L" (Speaker system : 133 697 02 [UK], 133 697 04 [XE]) and "SX-C70R" (Speaker system : 133 698 02 [UK], 133 698 04 [XE]).

SPECIFICATIONS

Tuner section

Reception frequency	
FM	87.5 MHz - 108.0 MHz
MW	522 kHz - 1611 kHz
LW	144 kHz - 288 kHz

Cassette deck section

Track system	4-track, 2-channel stereo
Frequency response	120 Hz - 14 kHz (Normal tape)
Signal to noise ratio	48 dB
Wow and Flutter	0.12 % (WRMS)
Fast forward / Rewind time	Approx. 110 sec. (C-60)

CD changer section

Type	Changer, 3-disc
Channels	2-channel stereo
Sampling frequency	44.1 kHz
Pick-up	Optical 3-beam semiconductor laser
Wow and Flutter	Below measurable limits

General

Output power	100 W x 2 (at 6 ohms, 10% distortion)
Inputs	
VIDEO / DVD IN	550 mV / 50k ohms
Outputs	
SPEAKERS	6 ohms
PHONES	8 - 32 ohms
OPT.(DIGITAL) OUT	Optial
Power requirements	AC 230 V, 50 Hz
Power consumption	120 W
Dimensions (W x H x D)	Approx. 270 x 300 x 321 mm
Weight	Approx. 6.8 kg

SX-C70 Speaker systems

Type	3 way bass reflex
Unit used	Woofer : 16cm cone type Mid range : 6cm cone type Tweeter : 5cm cone type
Maximum	
Power-handling capacity	180 W (peak)
Nominal impedance	6 ohms
Dimensions (W x H x D)	Approx. 240 x 315 x 282 mm
Weight	Approx. 3.9 kg (per speaker)

Specifications subject to change without notice.

LASER BEAM SAFETY PRECAUTION

- Pick-up that emits a laser beam is used in this CD player section.

CAUTION :

USE OF CONTROLS OR ADJUSTMENTS OR PERFORMANCE OF PROCEDURES OTHER THAN THOSE SPECIFIED HEREIN MAY RESULT IN HAZARDOUS RADIATION EXPOSURE

LASER OUTPUT..... 0.6 mW Max. (CW)
WAVELENGTH 790 nm

CAUTION - INVISIBLE LASER RADIATION WHEN OPEN AND INTERLOCKS DEFEATED. AVOID EXPOSURE TO BEAM.
ADVARSEL - USYNLIG LASER STRÅLING VED ÅBNING, NÅR SIKKERHEDSAFBRYDERE ER UDE AF FUNKTION, UNDGA UDSÆTTELSE FOR STRÅLING.
VARNING - OSYNLIG LASER STRÅLNING NÅR DENNA DEL ÄR ÖPPNAD OCH SPÄRR ÄR URKOPPLAD. STRÅLEN ÄR FARLIG.
VORSICHT - UNSICHTBARE LASERSTRAHLUNG TRITTS AUS, WENN DECKEL GEÖFFNET UND WENN SICHERHEITSVERRIEGELUNG ÜBERBRÜCKT IST. NICHT, DEM STRAHL AUSSETZEN.
VARO - AVATTAESSA JA SUOJALUKITUS OHITETTAESSA OLET ALTTIINA NÄKYMÄTTÖMÄLLE LASERSÄTEILYLLE. ÄLÄ KATSO SÄTEESEEN.

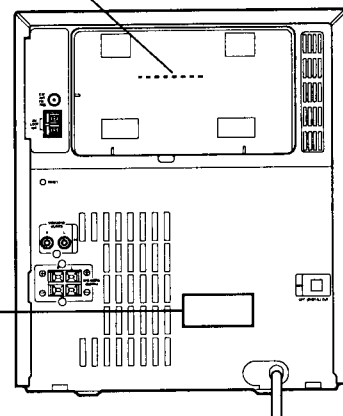
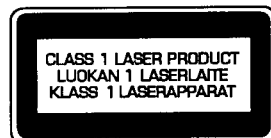

WHAT TO DO IF

- If the operation of the unit or display is not normal, or you wish to clear the contents of the memory.

1. Disconnect the power cord from AC outlet.
2. Press the **RESET** button for at least **30** seconds.
3. Connect the power cord.
4. Press the **POWER** button to turn the power on.

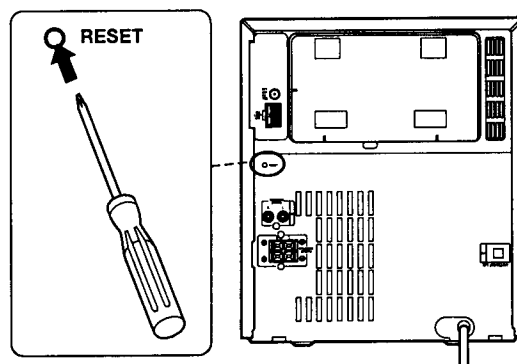

CD PICK-UP MAINTENANCE

About pick-up (Optical lens) Cleaning

Clean the lens with the specified cleaning disc or moisten a cotton swab with isopropyl alcohol and cleaning paper.

Specified cleaning disc : LC-1 (Part code : 645 026 1961 manufactured by SANYO.)

Regarding procedure of cleaning with moisten cotton swab, please refer to the attached as follows.

1. Cotton swab wrapped with Cleaning paper.
2. Add the isopropyl alcohol.
3. Gently move the tip of cotton swab just like a draw a whirlpool from inside to outside on the surface of lens.

SERVICE MODE

1. Preparation

Press the unit's STOP and FM MODE buttons at the same time. (This initiates service mode entry status.)

Next, press another button on the unit to switch to the corresponding service mode.

The unit enters a service mode only if another button is pressed during that 1 second.

2. CD Repair

1. Within 1 second of activating service mode entry status, press the CD BACK button to enter this service mode.

2. When in the CD function mode the LCD segment displays a CD operation indication that is different from its normal indication.

If a CD error occurs, a display appears as shown in below.

Also, from the point at which the error occurred onward, the CD operation display is fixed. The fixed displays is canceled by pressing the STOP button when the CD is stopped.

3. Press the POWER button to cancel this mode.

Disc No.	State of CD Error
0	Good
1	Focusing is not possible in focus serch.
2	The subcode is not input during disc startup.
3	TOC can not be read.
4	Focus was lost while the servo was on. (during playing, etc.)
5	The subcode is not input while the servo in on. (during playing, etc.)

3. Checking the FL connection

1. Within 1 second of activating service mode entry status, press the TUNING UP button to enter this service mode.
2. FL and LED turns on order when enter this mode.
3. When every indication turns on, become on and off light indication.
4. Press the POWER button to cancel this mode.

CD PLAYER ADJUSTMENTS

1. CABLE CONNECTION

- ① ASSY, CONNECTOR-S (614 303 5633)

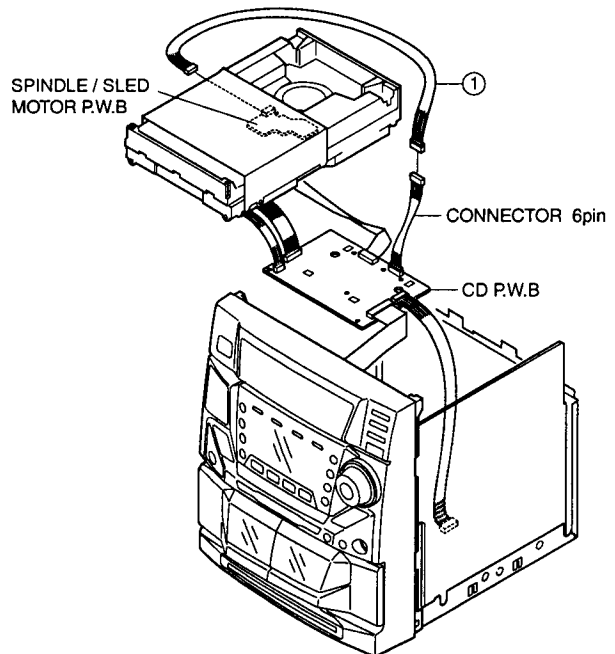
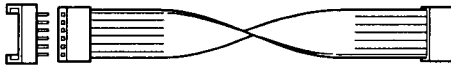

2. ADJUSTMENTS

(1) Confirm the tracking balance

1. Connect an Oscilloscope to TP2 (TE) and TP1 (VC).
2. Turn on the POWER switch.
3. Set the test disc. (DISC 1)
4. Press "STOP" button and "FM MODE" button simultaneously. Within 1 second after pressing the "PLAY/PAUSE" button. (SERVICE MODE : Tracking balance adjustment mode)
5. Confirm that the oscilloscope waveform is symmetrical on the top and bottom in relation to 0V (VC).

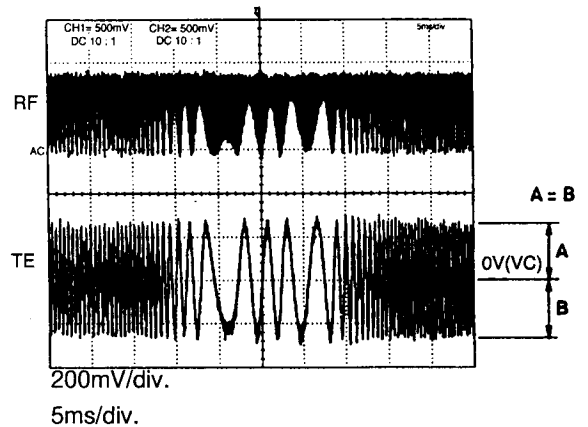

(2) Checking the "eye" pattern

1. Switch "ON" the POWER.
2. Connect an oscilloscope to TP4 (RF) and TP1 (VC).
3. Load the test disc.
4. Press the PLAY button.
5. Check to be sure that the "eye" pattern is at the center of waveform and that the diamond shape is clearly defined.
6. Press the STOP button.
7. Turn off the POWER switch.

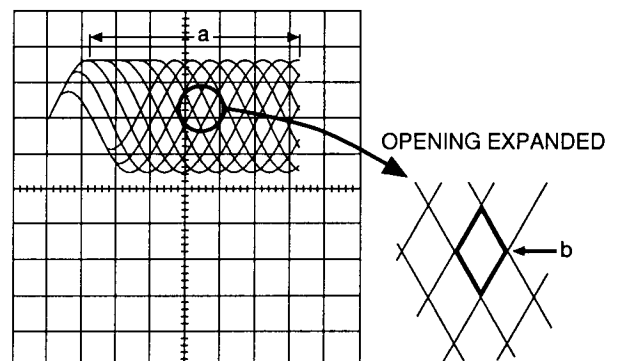
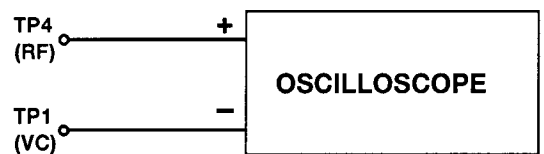

TAPE ADJUSTMENTS

Adjustment Item	Test Tape	Measuring Instrument	Output connection	Adjust location	Adjust value
(a) HEAD AZIMUTH DECK "A"	VTT738 etc. (10KHz)	AC-voltmeter	SPEAKER TERMINAL	HEAD AZIMUTH SCREW	Max.
(b) HEAD AZIMUTH DECK "B"	VTT738 etc. (10KHz)	AC-voltmeter	SPEAKER TERMINAL	HEAD AZIMUTH SCREW	Max.
(c) MOTOR SPEED (NORMAL)	MTT-111 (3,000Hz)	FREQUENCY COUNTER	SPEAKER TERMINAL	VR311	3,000Hz

1. HEAD REPLACEMENT AND AZIMUTH ADJUSTMENT

(1) Head replacement

1. After replacement, demagnetize the heads by using a degausser.
2. Be sure to clean the heads before attempting to make any adjustments.
3. Be sure both channels (1 and 2) are the same level. (Using a dual-channels oscilloscope).
4. All wiring should be returned to the original position after work is completed.

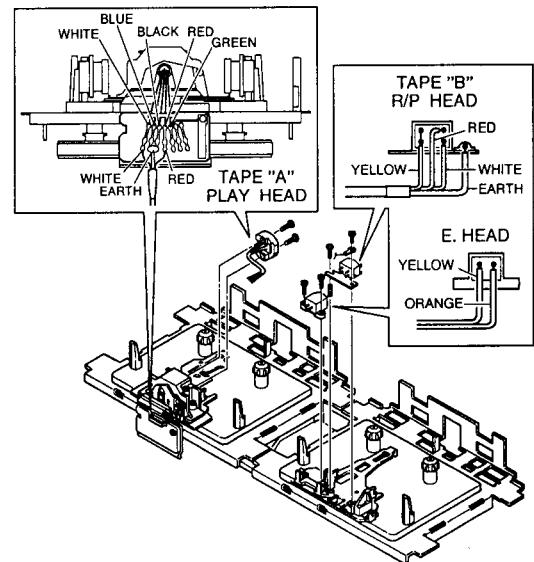

(2) Head azimuth

• DECK "A"

1. Remove the left side of CASSETTE LID.
2. Load a test tape (VTT-738, etc.: 10kHz) for azimuth adjustment.
3. Press the PLAY button.
4. Use a flat-tip (-) screwdriver to turn the screw for normal azimuth adjustment so that the left and right outputs are maximized at the same phase during normal playback.
5. Press the STOP button.

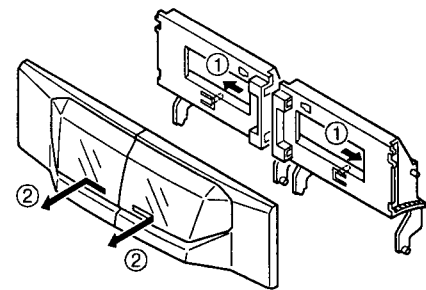

• DECK "B"

1. Remove the right side of CASSETTE LID.
2. Load a test for azimuth adjustment.
3. Press the PLAY button.
4. Azimuth screw adjustment.
5. Press the STOP button.

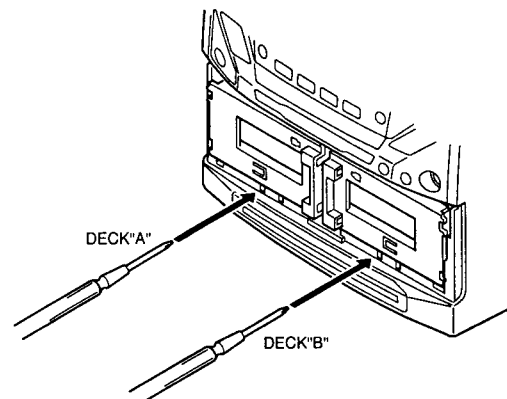

- After making the adjustment, secure the azimuth adjustment screw by applying screw lock (TB-1401B).

TAPE ADJUSTMENTS

2. MOTOR REPLACEMENT AND SPEED ADJUSTMENT

(1) Motor replacement

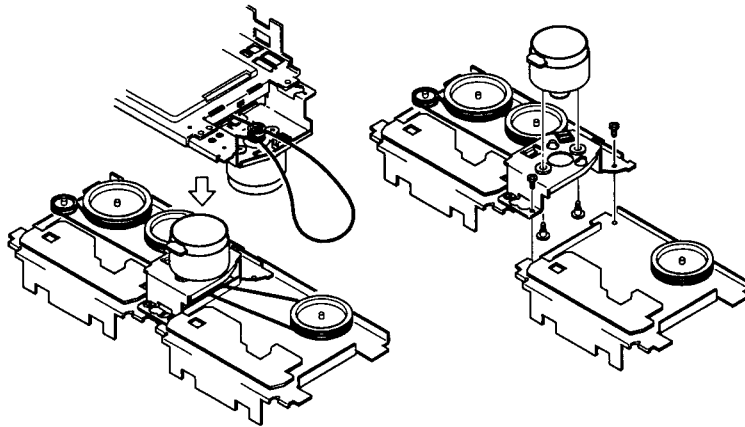

(2) Motor speed

1. Insert the test tape (MTT-111 or etc. 3,000 Hz) into DECK A.
2. Press the PLAY button.
3. Adjust VR311 so that the frequency counter show a reading of $3,020 \pm 10$ Hz.
4. Press the STOP button.

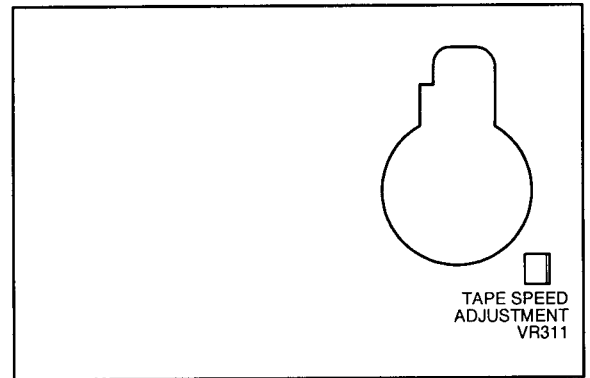

3. CHECKING THE MECHANISM TORQUES

- Clean the head, capstan and pinch roller before making any measurement.

DECK " A & B"

Measureent	Take-up torque	Back tension	Tape tension
Cassette for measurement	PLAY : TW-2111A F.FWD/REW : TW-2231	PLAY : TW-2111A	Drive-power cassette TW-2412
PLAY	25 ~ 63 gr.cm	2.0 ~ 6.0 gr.cm	70 gr or more
F.FWD/REW	60 ~ 120 gr.cm	-	-

TUNER ADJUSTMENTS

- Use a plastic screw driver for adjustments.
- MODE : STEREO
- Speaker impedance : 6 ohm
- TUNING
 - FM : 87.5 - 108.0 MHz (50 kHz step)
 - MW : 522 - 1710 kHz (9 kHz step)
 - LW : 144 - 288 kHz (9 kHz step)

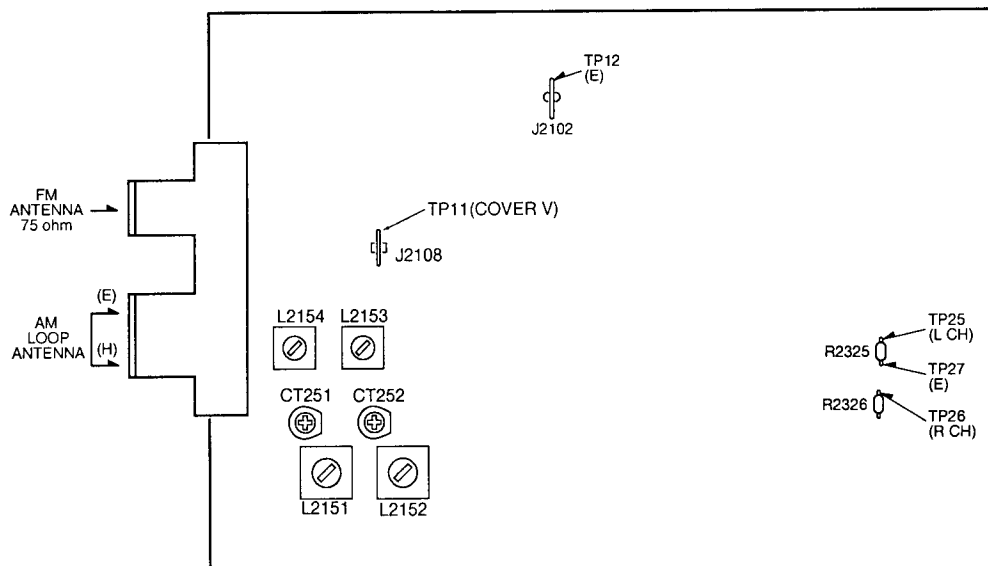

SG RF Level : 75Ω open Voltage dBμV

Antenna : 75Ω unbalanced , Modulation : 1 kHz

Dev. : ±22.5kHz(MONO) ±22.5kHz(STEREO) ±6.75kHz(PILOT)

1. FM

Step	Adjusting Circuit	Connection		SG Frequency	Set Position	Adjustment	Remark
		Input	Output				
1	Cover voltage	---	Connect Digital DC voltmeter to	87.5 MHz	Low	---	more than 0.9 V
		---	TP11(H), TP12(E).	108.0 MHz	High	---	less than 9.0 V
2	Tracking	Connect FM SG to FM Antenna	Connect to VTVM	90.0 MHz	Low	---	Max.
		(SG=8dB μV)	TP25(L) or TP26(R), TP27(E)	106.0 MHz	High	---	

SG Modulation : 1kHz, 30%

Antenna, IRE Loop, Distance: 60 cm

2. MW

Step	Adjusting Circuit	Connection		SG Frequency	Set Position	Adjustment	Remark
		Input	Output				
1	Cover voltage	---	Connect Digital DC voltmeter to	522 kHz	Low	L2153	1.0 V ± 0.05 V
		---	TP11(H), TP12(E).	1611 kHz	High	---	less than 9.0 V
2	Tracking	Connect AM SG to	Connect to VTVM	603 kHz	Low	L2152	Max.
		Test loop Ant.(SG=80dB μV)	TP25(L) or TP26(R), TP27(E).	1404 kHz	High	CT252	

3. LW

Step	Adjusting Circuit	Connection		SG Frequency	Set Position	Adjustment	Remark
		Input	Output				
1	Cover voltage	---	Connect Digital DC voltmeter to	144 kHz	Low	L2154	1.5 V ± 0.05 V
		---	TP11(H), TP12(E).	288 kHz	High	---	less than 9.0 V
2	Tracking	Connect AM SG to	Connect to VTVM	162 kHz	Low	L2151	Max.
		Test loop Ant.(SG=85dB μV)	TP25(L) or TP26(R), TP27(E).	279 kHz	High	CT251	

EXPLODED VIEW (CABINET & CHASSIS)

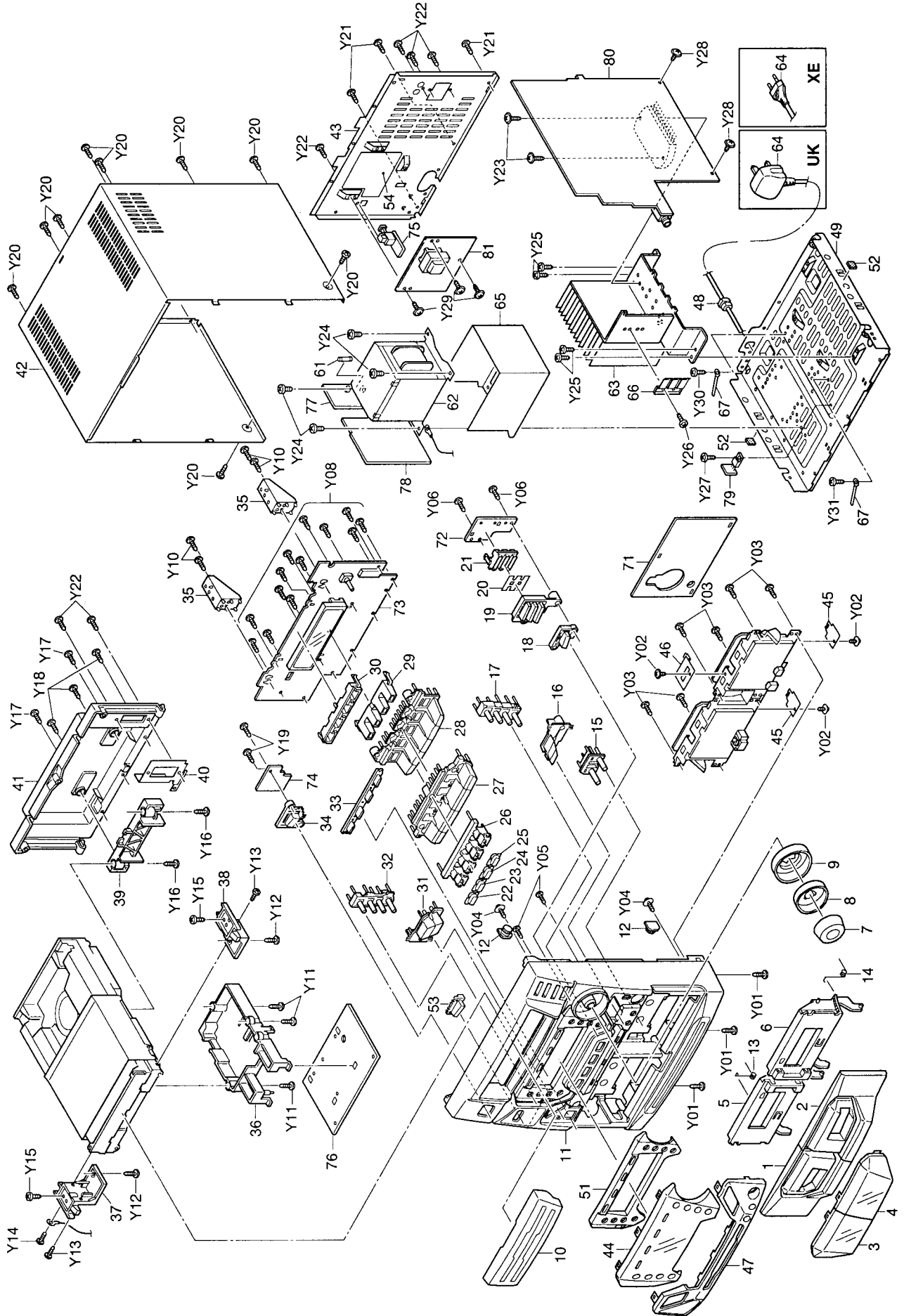

PARTS LIST

PRODUCT SAFETY NOTICE

EACH PRECAUTION IN THIS MANUAL SHOULD BE FOLLOWED DURING SERVICING. COMPONENTS IDENTIFIED WITH THE IEC SYMBOL Δ IN THE PARTS LIST AND THE SCHEMATIC DIAGRAM DESIGNATED COMPONENTS IN WHICH SAFETY CAN BE OF SPECIAL SIGNIFICANCE. WHEN REPLACING A COMPONENT IDENTIFIED BY Δ , USE ONLY THE REPLACEMENT PARTS DESIGNATED, OR PARTS WITH THE SAME RATINGS OF RESISTANCE, WATTAGE OR VOLTAGE THAT ARE DESIGNATED IN THE PARTS LIST IN THIS MANUAL. LEAKAGE-CURRENT OR RESISTANCE MEASUREMENTS MUST BE MADE TO DETERMINE THAT EXPOSED PARTS ARE ACCEPTABLY INSULATED FROM THE SUPPLY CIRCUIT BEFORE RETURNING THE PRODUCT TO THE CUSTOMER.

CAUTION : Regular type resistors and capacitors are not listed. To know those values, refer to the schematic diagram.
Regular type resistors are less than 1/4 W carbon type and 0 ohm chip resistors.
Regular type capacitors are less than 50 V and less than 1000 μ F type of Ceramic type and Electrical type.

PACKING & ACCESSORY

REF.NO.	PART NO.	DESCRIPTION	REF.NO.	PART NO.	DESCRIPTION
	614 303 6746	CARTON CASE (UK)	38	614 301 6519	MOUNTING,CD,LEFT, FRONT/CD MECHA
	614 303 6753	CARTON CASE (XE)			
	614 303 9341	CUSHION, TOP	39	614 302 1834	MOUNTING,CD,REAR, PANEL REAR/CD MECHA
	614 303 9358	CUSHION,BOTTOM			
	645 024 3745	POLY SHEET,1300X550,SET	40	614 302 1902	TERMINAL,ANT,PANEL REAR/ANT
	614 303 6937	INSTRUCTION MANUAL (UK)	41	614 302 1865	PANEL,REAR,CD MECHA
	614 303 6876	INSTRUCTION MANUAL (XE)	42	614 305 6843	ASSY,CABINET,AFTER BENDING
	614 306 7252	INSTRUCTION MANUAL,GREEK (XE)	43	614 304 1276	PANEL,REAR (UK)
	645 005 1227	ASSY,ANTENA,LOOP	43	614 304 1283	PANEL,REAR (XE)
	614 229 4635	ANT	44	614 305 2418	DEC,WINDOW,FL (UK)
	645 032 6554	REMOCON,RB-C30AR (UK)	44	614 303 6425	DEC,WINDOW,FL (XE)
	645 034 1571	REMOCON,RB-C30ARD (XE)	45	614 289 1117	MOUNTING,BRACKET, DECK MECHA BOTTOM
	645 035 8098	BATTERY COVER,REMOTE CONTROL	46	614 289 1100	MOUNTING,BRACKET, DECK MECHA TOP

CABINET & CHASSIS

REF.NO.	PART NO.	DESCRIPTION	REF.NO.	PART NO.	DESCRIPTION
1	614 304 0989	COVER,CASSETTE,LEFT	47	614 303 7897	PANEL,OPERATION
2	614 301 6373	COVER,CASSETTE,RIGHT	48	614 129 1901	FIXER,AC CORD
3	614 301 6403	DEC,WINDOW,LEFT	or	614 284 1884	FIXER,AC CORD
4	614 301 6410	DEC,WINDOW,RIGHT	49	614 290 4954	ASSY,CABINET,BOTTOM
5	614 265 7898	ASSY,LID,CASSETTE,DECK L	51	614 301 6380	COVER,FL,BASE
6	614 265 7904	ASSY,LID,CASSETTE,DECK R	52	614 250 6721	FOOT,SIDE
7	614 301 6502	KNOB,ROTARY	53	614 301 6847	BUTTON,SURROUND
8	614 301 6359	CAP,VOL	54	614 305 8656	SPACER,SHEET,SUB TRANS
9	614 301 6496	DEC,WINDOW,VOL		614 274 8190	LABEL,SAFETY,LASER
10	614 301 6427	DEC,CD,TRAY	FIXING PARTS		
11	614 303 6364	ASSY,CABINET,FRONT	REF.NO.	PART NO.	DESCRIPTION
12	614 270 8316	ASSY,GEAR	Y01	411 021 3503	SCR S-TPG BIN 3X10,BOTTOM/FRONT
13	614 302 1896	SPRING,WIRE,LID,CASSETTE,L	Y02	411 024 3708	SCR S-TPG PAN+FLG 2X6, DECK MECHA/MOUNTING PWB
14	614 302 4422	SPRING,WIRE,LID,CASSETTE,R	Y03	411 021 3503	SCR S-TPG BIN 3X10,DECK MECHA
15	614 301 6335	BUTTON,REC	Y04	411 020 9902	SCR S-TPG BRZ+FLG 3X8, GEAR CASSETTE
16	614 301 6298	BUTTON,TUNING	Y05	411 165 3803	SCR S-TPG BIN 2.3X10, FRONT/PANEL OPERATION
17	614 301 6274	BUTTON,SOUND	Y06	411 021 3503	SCR S-TPG BIN 3X10,DISC PWB
18	614 301 6250	BUTTON,CD,OPEN	Y08	411 021 3503	SCR S-TPG BIN 3X10,FRONT PWB
19	614 301 6243	BUTTON,DISC,SELECT	Y10	411 021 3503	SCR S-TPG BIN 3X10, MOUNTING CD FRONT
20	614 302 1810	DEC,SHEET,DISC,DISC,SELECT	Y11	411 021 3503	SCR S-TPG BIN 3X10, CD MECHA/COVERPICK
21	614 301 6564	REFLECTOR,DISC,SELECT	Y12	411 021 3503	SCR S-TPG BIN 3X10, MOUNING FRONT/MOUNTING L,R
22	614 302 7461	DEC,WINDOW,FUNC,CD	Y13	411 021 1806	SCR S-TPG BIN 2.6X10, CD MECHA/MOUNTING L,R
23	614 302 7478	DEC,WINDOW,FUNC,TAPE	Y14	411 027 3101	SCR S-TPG BIN 3X8,CD PWB GRAND
24	614 302 7485	DEC,WINDOW,FUNC,TUNER	Y15	411 021 3503	SCR S-TPG BIN 3X10, CD MECHA/MOUNTING L,R
25	614 302 7492	DEC,WINDOW,FUNC,VIDEO	Y16	411 021 3503	SCR S-TPG BIN 3X10, CD MECHA/MOUNTING REAR
26	614 301 6281	BUTTON,FUNCTION	Y17	411 021 3701	SCR S-TPG BIN 3X10, CD MECHA/REAR
27	614 301 6311	BUTTON,CD	Y18	411 021 3701	SCR S-TPG BIN 3X10, BOTTOM/PANEL REAR
28	614 302 3456	BUTTON,TAPE			
29	614 301 6571	REFLECTOR,FUNCTION			
30	614 300 3274	REFLECTOR SOUND,SOUND			
31	614 301 6304	BUTTON,PRESET			
32	614 301 6267	BUTTON,CLOCK			
33	614 301 6434	DEC,WINDOW,SOUND			
34	614 301 6236	BUTTON,POWER			
35	614 301 6533	MOUNTING,CD,FRONT/CD MECHA			
36	614 300 3113	COVER PICK,CD PICK COVER			
37	614 301 6526	MOUNTING,CD,RIGHT, FRONT/CD MECHA			

PARTS LIST

REF.NO.	PART NO.	DESCRIPTION	REF.NO.	PART NO.	DESCRIPTION
Y19	411 021 3503	SCR S-TPG BIN 3X10,POWER PWB	CN373	645 005 8226	PLUG,3P
Y20	411 021 3701	SCR S-TPG BIN 3X10,CABINET TOP	or	645 009 6433	PLUG,3P
Y21	411 021 3701	SCR S-TPG BIN 3X10, BOTTOM/PANEL REAR	CN374	614 305 6317	CORD,1P CONNECTOR
Y22	411 021 3701	SCR S-TPG BIN 3X10, REAR/ELECT PARTS	D3101	△ 407 148 6701	DIODE 1A3-I
Y23	411 020 9506	SCR S-TPG BRZ+FLG 3X16, POWER AMP 1,2	D3102	△ 407 148 6701	DIODE 1A3-I
Y24	411 001 3905	SCR S-TPG BIN 4X6,TRANS	D3601	407 099 5105	ZENER DIODE MTZJ4.7B
Y25	411 021 3503	SCR S-TPG BIN 3X10, HEAT SINK/BOTTOM	D3621	407 012 4406	DIODE 1SS133
Y26	411 021 3503	SCR S-TPG BIN 3X10,TR HOLDER	D3622	407 012 4406	DIODE 1SS133
Y27	411 021 6405	SCR S-TPG BIN 3X8,POWER IC	D3623	407 012 4406	DIODE 1SS133
Y28	411 020 9902	SCR S-TPG BRZ+FLG 3X8, AMP PWB/BOTTOM	D3624	407 012 4406	DIODE 1SS133
Y29	411 021 3701	SCR S-TPG BIN 3X10, REAR/SUB PWB	HS301	614 215 9347	HEAT SINK
Y30	411 001 3905	SCR S-TPG BIN 4X6,FOR LUG	HS302	614 215 9347	HEAT SINK
Y31	411 021 5705	SCR S-TPG BIN 3X6,FOR LUG	IC361	409 346 2301	IC BU2090F

ELECTRICAL PARTS

REF.NO.	PART NO.	DESCRIPTION	REF.NO.	PART NO.	DESCRIPTION
61	△ 423 016 7809	FUSE 250V 2A	Q3122	405 141 3703	TR KTA1271-Y
62	△ 645 033 8540	POWER TRANSFORMER	or	405 008 2405	TR 2SB698-F
63	△ 614 303 9471	ASSY,HEAT SINK	or	405 008 2504	TR 2SB698-G
64	△ 645 008 9732	CORD,POWER-1.8MK (UK)	or	405 006 3909	TR 2SA952-K
or	△ 645 033 7543	CORD,POWER-1.6MK (UK)	or	405 006 4005	TR 2SA952-L
or	△ 645 036 9797	CORD,POWER-1.6MK (UK)	Q3124	405 141 3703	TR KTA1271-Y
or	△ 645 036 9803	CORD,POWER-1.6MK (UK)	or	405 008 2405	TR 2SB698-F
64	△ 645 016 9939	CORD,POWER-1.74MK (XE)	or	405 008 2504	TR 2SB698-G
or	△ 614 255 2513	CORD,POWER (XE)	or	405 006 3909	TR 2SA952-K
65	614 291 6629	SHIELD,PT SHIELD	or	405 006 4005	TR 2SA952-L
66	614 291 6568	MOUNTING,PWB,TR HOLDER	or	405 141 3703	TR KTA1271-Y
67	△ 614 130 0382	LUG	Q3601	405 141 3703	TR KTA1271-Y
	△ 614 086 2164	COVER,CAPACITOR	or	405 008 2405	TR 2SB698-F
CN381	614 304 7896	ASSY,WIRE,DECK A	or	405 008 2504	TR 2SB698-G
CN382	614 303 6388	ASSY,WIRE,DECK B	or	405 006 3909	TR 2SA952-K
CN383	645 035 9460	FLEXIBLE FLAT CABLE,AMP-DECK	or	405 006 4005	TR 2SA952-L
CN384	645 028 5509	FLEXIBLE FLAT CABLE,FRONT-DECK	Q3602	405 143 8706	TR KTC3199-GR
CN681	645 033 7413	FLEXIBLE FLAT CABLE,CD	or	405 011 8609	TR 2SC1740S-S
CN682	614 302 2107	ASSY,WIRE,CD	or	405 011 8500	TR 2SC1740S-R
CN683	614 306 6545	ASSY,WIRE,CD-DIGITAL OUT	or	405 017 9600	TR 2SC3330-T
CN691	645 012 7687	FLEXIBLE FLAT CABLE,FRONT-CD	or	405 017 9709	TR 2SC3330-U

DECK P.W.BOARD ASSY

REF.NO.	PART NO.	DESCRIPTION	REF.NO.	PART NO.	DESCRIPTION
71	614 300 6053	ASSY,PWB,DECK (Only Initial)	Q3603	405 141 3307	TR KTC3198-GR
C3606	403 061 7306	POLYESTER 4700P J 50V	or	405 141 3208	TR KTC3198-Y
C3607	403 061 9607	POLYESTER 0.047U J 50V	or	405 019 3804	TR 2SC536-G-NP
CN301	645 012 5089	SOCKET,FPC 10P	or	405 019 2708	TR 2SC536-F-NP
or	645 005 4181	SOCKET,10P	Q3605	405 151 4905	TR KTC3200-GR
CN302	645 012 5096	SOCKET,FPC 12P	or	405 151 5001	TR KTC3200-BL
or	645 005 4204	SOCKET,12P	or	405 011 1907	TR 2SC1627-Y
CN311	614 035 4959	SOCKET,DIP 6P	or	405 012 8103	TR 2SC2003-L
or	645 012 7823	SOCKET,DIP 6P	or	405 137 6404	TR 2SC2003-K
CN312	614 020 6562	SOCKET,4P	Q3611	405 109 9204	TR KRC102M-A
or	614 223 9223	SOCKET	or	405 000 3103	TR DTC114ES
CN313	645 012 2729	SOCKET,DIP 7P	or	405 078 3005	TR BA1L4M
or	645 012 7830	SOCKET,DIP 7P	Q3621	405 109 9402	TR KRC111M
CN321	614 303 6647	CORD,6P CONNECTOR,A_MECHA	or	405 000 3400	TR DTC114TS
CN323	614 303 6654	CORD,7P CONNECTOR,B_MECHA	Q3622	405 109 9204	TR KRC102M-A
CN371	645 005 7373	PLUG,3P	or	405 000 3103	TR DTC114ES
or	645 007 0068	PLUG,3P	or	405 078 3005	TR BA1L4M
CN372	645 005 8127	PLUG,6P	Q3701	405 109 9402	TR KRC111M
or	645 007 0099	PLUG,6P	or	405 000 3400	TR DTC114TS
			Q3702	405 095 2708	TR 2SJ40-D
			or	405 095 2807	TR 2SJ40-E
			or	405 149 6003	TR 2SJ498
			or	405 085 9106	TR 2SJ105-GR
			or	405 095 3408	TR 2SJ105-BL

PARTS LIST

REF.NO.	PART NO.	DESCRIPTION
Q3703	405 095 2708	TR 2SJ40-D
or	405 095 2807	TR 2SJ40-E
or	405 149 6003	TR 2SJ498
or	405 085 9106	TR 2SJ105-GR
or	405 095 3408	TR 2SJ105-BL
Q3704	405 109 9204	TR KRC102M-A
or	405 000 3103	TR DTC114ES
or	405 078 3005	TR BA1L4M
Q3801	405 109 9402	TR KRC111M
or	405 000 3400	TR DTC114TS
Q3802	405 095 2708	TR 2SJ40-D
or	405 095 2807	TR 2SJ40-E
or	405 149 6003	TR 2SJ498
or	405 085 9106	TR 2SJ105-GR
or	405 095 3408	TR 2SJ105-BL
Q3803	405 095 2708	TR 2SJ40-D
or	405 095 2807	TR 2SJ40-E
or	405 149 6003	TR 2SJ498
or	405 085 9106	TR 2SJ105-GR
or	405 095 3408	TR 2SJ105-BL
Q3804	405 109 9204	TR KRC102M-A
or	405 000 3103	TR DTC114ES
or	405 078 3005	TR BA1L4M
R3608	401 011 4900	CARBON 82 JA 1/2W
VR311	645 003 5685	VR,SEMI,2.2K N

DISC SWITCH P.W.BOARD ASSY

REF.NO.	PART NO.	DESCRIPTION
72	614 301 5505	ASSY,PWB,DISC SW,(Only Initial)
CN661	614 035 4959	SOCKET,DIP 6P
or	645 012 7823	SOCKET,DIP 6P
D6621	408 037 4204	LED SLP-3118B-51HAB-T1,DISC_LED
D6622	408 037 4204	LED SLP-3118B-51HAB-T1,DISC_LED
D6623	408 037 4204	LED SLP-3118B-51HAB-T1,DISC_LED
D6624	408 037 4204	LED SLP-3118B-51HAB-T1,DISC_LED
D6625	408 037 4204	LED SLP-3118B-51HAB-T1,DISC_LED
D6626	408 037 4204	LED SLP-3118B-51HAB-T1,DISC_LED
R6609	401 038 2101	MT-GLAZE 2.7K JA 1/10W
R6610	401 038 6406	MT-GLAZE 4.7K JA 1/10W
R6611	401 039 0403	MT-GLAZE 8.2K JA 1/10W
R6624	401 038 7502	MT-GLAZE 56 JA 1/10W
R6625	401 038 7502	MT-GLAZE 56 JA 1/10W
R6626	401 038 7502	MT-GLAZE 56 JA 1/10W
S6608	614 240 1002	SWITCH,TACT
or	645 006 5958	SWITCH,PUSH 1P-1T
or	614 220 5471	SWITCH,TACT
S6609	614 240 1002	SWITCH,TACT
or	645 006 5958	SWITCH,PUSH 1P-1T
or	614 220 5471	SWITCH,TACT
S6610	614 240 1002	SWITCH,TACT
or	645 006 5958	SWITCH,PUSH 1P-1T
or	614 220 5471	SWITCH,TACT

FRONT P.W.BOARD ASSY

REF.NO.	PART NO.	DESCRIPTION
73	614 302 4125	ASSY,PWB,FRONT (UK) (Only Initial)
73	614 303 5008	ASSY,PWB,FRONT (XE) (Only Initial)
BR601	614 302 1407	HOLDER,FL,FL_MOUNT
C6095	403 291 5608	ELECT 1000U M 6.3V
CN601	645 032 5809	PLUG,22P,FRONT-PRE
CN602	614 035 4935	SOCKET,DIP 4P
or	645 012 7809	SOCKET,DIP 4P
CN603	645 012 5249	SOCKET,FPC 20P
or	645 005 4280	SOCKET,20P
CN604	645 012 5096	SOCKET,FPC 12P
or	645 005 4204	SOCKET,12P

REF.NO.	PART NO.	DESCRIPTION
CN608	614 035 4959	SOCKET,DIP 6P
or	645 012 7823	SOCKET,DIP 6P
CN612	614 303 6623	CORD,4P CONNECTOR,FRONT-PT2
D6001	407 012 4406	DIODE 1SS133
D6004	407 012 4406	DIODE 1SS133
D6007	407 099 4603	ZENER DIODE MTZJ3.9B
D6201	408 034 8700	LED SLZ-981C-13H-AB-T2,FUNC
D6202	408 034 8700	LED SLZ-981C-13H-AB-T2,FUNC
D6203	408 034 8700	LED SLZ-981C-13H-AB-T2,FUNC
D6204	408 034 8700	LED SLZ-981C-13H-AB-T2,FUNC
D6205	408 040 6806	LED SLZ-981C-06H-AB-T2, SOUND_PRESET
D6206	408 040 6806	LED SLZ-981C-06H-AB-T2, SOUND_PRESET
D6207	408 040 6806	LED SLZ-981C-06H-AB-T2, SOUND_PRESET
D6208	408 040 6806	LED SLZ-981C-06H-AB-T2, SOUND_PRESET
D6231	408 038 4104	LED SLP-3130C-81H-AB-T1,ENCODER
D6232	408 038 4104	LED SLP-3130C-81H-AB-T1,ENCODER
D6233	408 038 4104	LED SLP-3130C-81H-AB-T1,ENCODER
D6234	408 038 4104	LED SLP-3130C-81H-AB-T1,ENCODER
D6235	408 038 4104	LED SLP-3130C-81H-AB-T1,ENCODER
D6236	408 038 4104	LED SLP-3130C-81H-AB-T1,ENCODER
D6237	408 038 4104	LED SLP-3130C-81H-AB-T1,ENCODER
D6238	408 038 4104	LED SLP-3130C-81H-AB-T1,ENCODER
DS601	407 203 9203	PHOTO DIODE SPS-442-1-E,IR
FL601	645 033 3194	FLOURESCENT TUBE,FL
IC601	410 343 9804	IC LC866548A-5L39 (UK)
IC601	410 347 0500	IC LC866556B-5L85 (XE)
IC602	409 426 1903	IC KIA4558F
or	409 039 7804	IC NJM4558M
IC604	409 346 2301	IC BU2090F
IC605	409 346 2301	IC BU2090F
L6000	645 001 4550	INDUCTOR,10U K
or	645 031 7835	INDUCTOR,10U K
Q6001	405 143 8706	TR KTC3199-GR
or	405 011 8500	TR 2SC1740S-R
or	405 011 8609	TR 2SC1740S-S
or	405 017 9600	TR 2SC3330-T
or	405 017 9709	TR 2SC3330-U
Q6002	405 002 0308	TR 2SA1037K-R
or	405 005 5508	TR 2SA812-M6
Q6003	405 141 3703	TR KTA1271-Y
or	405 008 2405	TR 2SB698-F
or	405 008 2504	TR 2SB698-G
Q6005	405 143 8706	TR KTC3199-GR
or	405 011 8500	TR 2SC1740S-R
or	405 011 8609	TR 2SC1740S-S
or	405 017 9600	TR 2SC3330-T
or	405 017 9709	TR 2SC3330-U
Q6201	405 146 5306	TR KRA102S
Q6202	405 146 5306	TR KRA102S
Q6203	405 146 5306	TR KRA102S
Q6204	405 146 5306	TR KRA102S
Q6205	405 146 5306	TR KRA102S
Q6206	405 146 5306	TR KRA102S
Q6207	405 146 5306	TR KRA102S
Q6208	405 146 5306	TR KRA102S
Q6211	405 146 5306	TR KRA102S
Q6212	405 146 5306	TR KRA102S
Q6213	405 146 5306	TR KRA102S
Q6214	405 146 5306	TR KRA102S
Q6215	405 146 5306	TR KRA102S
Q6216	405 146 5306	TR KRA102S
Q6217	405 146 5306	TR KRA102S
Q6218	405 146 5306	TR KRA102S
R6044	△ 401 038 6208	MT-GLAZE 47 JA 1/10W

PARTS LIST

REF.NO.	PART NO.	DESCRIPTION
R6856	△ 401 036 9607	MT-GLAZE 56 JA 1/8W
S6001	645 033 3460	SWITCH,ROTARY(ENCODER),VOL
S6100	614 240 1002	SWITCH,TACT
or	645 006 5958	SWITCH,PUSH 1P-1T
or	614 220 5471	SWITCH,TACT
S6101	614 240 1002	SWITCH,TACT
or	645 006 5958	SWITCH,PUSH 1P-1T
or	614 220 5471	SWITCH,TACT
S6102	614 240 1002	SWITCH,TACT
or	645 006 5958	SWITCH,PUSH 1P-1T
or	614 220 5471	SWITCH,TACT
S6103	614 240 1002	SWITCH,TACT
or	645 006 5958	SWITCH,PUSH 1P-1T
or	614 220 5471	SWITCH,TACT
S6104	614 240 1002	SWITCH,TACT
or	645 006 5958	SWITCH,PUSH 1P-1T
or	614 220 5471	SWITCH,TACT
S6105	614 240 1002	SWITCH,TACT
or	645 006 5958	SWITCH,PUSH 1P-1T
or	614 220 5471	SWITCH,TACT
S6106	614 240 1002	SWITCH,TACT
or	645 006 5958	SWITCH,PUSH 1P-1T
or	614 220 5471	SWITCH,TACT
S6107	614 240 1002	SWITCH,TACT
or	645 006 5958	SWITCH,PUSH 1P-1T
or	614 220 5471	SWITCH,TACT
S6115	614 240 1002	SWITCH,TACT
or	645 006 5958	SWITCH,PUSH 1P-1T
or	614 220 5471	SWITCH,TACT
S6116	614 240 1002	SWITCH,TACT
or	645 006 5958	SWITCH,PUSH 1P-1T
or	614 220 5471	SWITCH,TACT
S6117	614 240 1002	SWITCH,TACT
or	645 006 5958	SWITCH,PUSH 1P-1T
or	614 220 5471	SWITCH,TACT
S6118	614 240 1002	SWITCH,TACT
or	645 006 5958	SWITCH,PUSH 1P-1T
or	614 220 5471	SWITCH,TACT
S6119	614 240 1002	SWITCH,TACT
or	645 006 5958	SWITCH,PUSH 1P-1T
or	614 220 5471	SWITCH,TACT
S6120	614 240 1002	SWITCH,TACT
or	645 006 5958	SWITCH,PUSH 1P-1T
or	614 220 5471	SWITCH,TACT
S6121	614 240 1002	SWITCH,TACT
or	645 006 5958	SWITCH,PUSH 1P-1T
or	614 220 5471	SWITCH,TACT
S6122	614 240 1002	SWITCH,TACT
or	645 006 5958	SWITCH,PUSH 1P-1T
or	614 220 5471	SWITCH,TACT
S6123	614 240 1002	SWITCH,TACT
or	645 006 5958	SWITCH,PUSH 1P-1T
or	614 220 5471	SWITCH,TACT
S6124	614 240 1002	SWITCH,TACT
or	645 006 5958	SWITCH,PUSH 1P-1T
or	614 220 5471	SWITCH,TACT
S6125	614 240 1002	SWITCH,TACT
or	645 006 5958	SWITCH,PUSH 1P-1T
or	614 220 5471	SWITCH,TACT
S6126	614 240 1002	SWITCH,TACT
or	645 006 5958	SWITCH,PUSH 1P-1T
or	614 220 5471	SWITCH,TACT
S6130	614 240 1002	SWITCH,TACT
or	645 006 5958	SWITCH,PUSH 1P-1T
or	614 220 5471	SWITCH,TACT
S6131	614 240 1002	SWITCH,TACT
or	645 006 5958	SWITCH,PUSH 1P-1T
or	614 220 5471	SWITCH,TACT

REF.NO.	PART NO.	DESCRIPTION
S6132	614 240 1002	SWITCH,TACT
or	645 006 5958	SWITCH,PUSH 1P-1T
or	614 220 5471	SWITCH,TACT
S6133	614 240 1002	SWITCH,TACT
or	645 006 5958	SWITCH,PUSH 1P-1T
or	614 220 5471	SWITCH,TACT
S6134	614 240 1002	SWITCH,TACT
or	645 006 5958	SWITCH,PUSH 1P-1T
or	614 220 5471	SWITCH,TACT
S6135	614 240 1002	SWITCH,TACT
or	645 006 5958	SWITCH,PUSH 1P-1T
or	614 220 5471	SWITCH,TACT
S6136	614 240 1002	SWITCH,TACT
or	645 006 5958	SWITCH,PUSH 1P-1T
or	614 220 5471	SWITCH,TACT
S6137	614 240 1002	SWITCH,TACT
or	645 006 5958	SWITCH,PUSH 1P-1T
or	614 220 5471	SWITCH,TACT
S6139	614 240 1002	SWITCH,TACT
or	645 006 5958	SWITCH,PUSH 1P-1T
or	614 220 5471	SWITCH,TACT
X6001	614 252 7627	RESONATOR,XTAL,XTAL
X6002	645 018 6103	OSC,CERAMIC,6MHZ

POWER SWITCH P.W.BOARD ASSY

REF.NO.	PART NO.	DESCRIPTION
74	614 301 5512	ASSY,PWB,POWER SW (Only Initial)
S6740	614 240 1002	SWITCH,TACT
or	645 006 5958	SWITCH,PUSH 1P-1T
or	614 220 5471	SWITCH,TACT

DIGITAL OUT P.W.BOARD ASSY

REF.NO.	PART NO.	DESCRIPTION
75	614 303 5640	ASSY,PWB,DIGITAL OUT(Only Initial)
CN168	645 005 7373	PLUG,3P
or	645 007 0068	PLUG,3P
CN169	614 240 5703	OPTO CONNECTOR

CD P.W.BPARD ASSY

REF.NO.	PART NO.	DESCRIPTION
76	614 303 5992	ASSY,PWB,CD (Only Initial)
CN101	645 005 8110	PLUG,4P,TP1-4
CN111	645 033 5525	SOCKET,FFC 16P,CD_PICKUP
CN113	645 005 8127	PLUG,6P,BASEMECHA
CN114	614 020 6562	SOCKET,4P
or	614 223 9223	SOCKET
CN115	614 020 6609	SOCKET,8P
or	614 223 9261	SOCKET
CN122	645 012 5539	SOCKET,FPC 20P
CN123	645 006 0946	PLUG,7P
CN124	614 302 2084	ASSY,WIRE,CD-CDMECHA_4P
CN125	614 302 2091	ASSY,WIRE,CD-CDMECHA_8P
CN131	645 005 7373	PLUG,3P
D1211	407 063 9108	ZENER DIODE MTZJ6.8B
D1221	407 099 5303	ZENER DIODE MTZJ5.6B
D1480	407 012 4406	DIODE 1SS133
or	407 012 5809	DIODE 1SS176
D1601	△ 407 148 6701	DIODE 1A3-I
D1602	△ 407 148 6701	DIODE 1A3-I
D1603	△ 407 148 6701	DIODE 1A3-I
D1604	△ 407 148 6701	DIODE 1A3-I
D1981	407 099 5204	ZENER DIODE MTZJ5.1B
IC101	409 378 8104	IC LA9240ML
IC102	409 435 2106	IC LC78622NE,CD_DSP

PARTS LIST

REF.NO.	PART NO.	DESCRIPTION
IC103	△ 409 372 9602	IC LA6541
IC131	△ 409 441 4507	IC TA7291S(M)
IC132	△ 409 441 4507	IC TA7291S(M)
L1451	645 031 7835	INDUCTOR,10U K
LG101	614 129 9082	LUG,CD-MECHA
PR101	△ 645 014 2482	PROTECTOR,0.315A 125V
Q1301	405 008 7202	TR 2SB810-E
or	405 008 7301	TR 2SB810-F
or	405 008 6809	TR 2SB808-F-SPA
Q1401	△ 405 141 3604	TR KTA1273-Y
or	△ 405 009 5207	TR 2SB927-S
or	△ 405 001 9302	TR 2SA1020-Y
R1211	△ 402 072 0207	RESISTOR 5.6 J- 2W
or	△ 402 082 0709	RESISTOR 5.6 J- 2W
R1221	△ 402 072 0207	RESISTOR 5.6 J- 2W
or	△ 402 082 0709	RESISTOR 5.6 J- 2W
T1001	△ 407 212 0505	THERMISTOR RXE065
X1451	645 020 9024	OSC,CRYSTAL 16.9344MHZ

POWER TRANSFORMER, PRIMARY P.W.BOARD ASSY

REF.NO.	PART NO.	DESCRIPTION
77	614 302 6785	ASSY,PWB,PT1 (Only Initial)
CN498	645 031 7903	HOLDER,FUSE
or	645 006 4760	HOLDER,FUSE
CN499	645 031 7903	HOLDER,FUSE
or	645 006 4760	HOLDER,FUSE
WR498	614 017 8203	TERMINAL BOARD
WR499	614 017 8203	TERMINAL BOARD

POWER TRANSFORMER,SECONDARY P.W.BOARD ASSY

REF.NO.	PART NO.	DESCRIPTION
78	614 302 5504	ASSY,PWB,PT2 (Only Initial)
C4936	403 329 6201	ELECT 2200U M 35V
C4937	403 329 6201	ELECT 2200U M 35V
C4938	403 062 6506	POLYESTER 0.056U J 50V
CN493	645 006 0915	PLUG,4P
or	645 009 6440	PLUG,4P
CN495	645 023 4378	SOCKET,7P
CN497	614 035 4928	SOCKET,DIP 3P
or	614 237 9769	SOCKET
D4930	△ 407 196 5800	DIODE 1N5402BD82
D4931	△ 407 196 5800	DIODE 1N5402BD82
D4932	△ 407 196 5800	DIODE 1N5402BD82
D4933	△ 407 196 5800	DIODE 1N5402BD82
D4934	△ 407 148 6701	DIODE 1A3-I
D4935	407 148 6701	DIODE 1A3-I
D4950	407 012 4406	DIODE 1SS133
D4951	407 012 4406	DIODE 1SS133
D4952	407 099 9509	ZENER DIODE MTZJ30B
D4953	407 099 6003	ZENER DIODE MTZJ9.1B
LUG49	614 051 9808	LUG
PR493	△ 645 025 5137	PROTECTOR,7A 125V
PR495	△ 645 025 5137	PROTECTOR,7A 125V
Q4950	405 141 3406	TR KTA1266-GR
or	405 141 3505	TR KTA1266-Y
or	405 005 2002	TR 2SA733-P
or	405 005 1906	TR 2SA733-K
or	405 004 4502	TR 2SA608-F-NP
or	405 004 5004	TR 2SA608-G-NP
R4954	△ 402 081 0106	FUSIBLE RES 2.2 JA 1/4W
R4955	△ 402 081 1004	FUSIBLE RES 10 JA 1/4W
R4970	△ 402 082 2802	RESISTOR 10 J- 1W
R4971	△ 402 081 0809	RESISTOR 680 J- 1W

REGULATOR P.W.BOARD ASSY

REF.NO.	PART NO.	DESCRIPTION
79	614 305 2388	ASSY,PWB,REGULATOR (Only Initial)
CN425	614 035 4928	SOCKET,DIP 3P
or	614 237 9769	SOCKET
IC425	△ 409 396 8704	IC KIA7805PI
or	△ 409 145 2809	IC NJM7805FA

AMPRIFER & TUNER P.W.BOARD ASSY

REF.NO.	PART NO.	DESCRIPTION
80	614 302 5498	ASSY,PWB,AMP-TU (UK)(Only Initial)
80	614 305 9028	ASSY,PWB,AMP-TU (XE)(Only Initial)
C2152	403 082 0201	POLYPRO 470P J 100V
C2155	403 082 2205	POLYPRO 560P J 100V
C2457	403 106 1603	NP-ELECT 1U Q 50V
C4137	403 184 9904	MT-POLYEST 0.27U J 50V
C4147	403 184 9904	MT-POLYEST 0.27U J 50V
C4440	403 262 8607	DL-ELECT 0.047F Z 5.5V
or	403 304 4802	DL-ELECT 0.047F Z 5.5V
C4446	403 291 5608	ELECT 1000U M 6.3V
C4447	403 291 5707	ELECT 2200U M 6.3V
C4705	403 057 2407	POLYESTER 0.1U J 50V
C4706	403 057 2407	POLYESTER 0.1U J 50V
C4750	403 185 0108	MT-POLYEST 0.47U J 50V
C4751	403 184 9805	MT-POLYEST 0.22U J 50V
C4805	403 057 2407	POLYESTER 0.1U J 50V
C4806	403 057 2407	POLYESTER 0.1U J 50V
C4850	403 185 0108	MT-POLYEST 0.47U J 50V
C4851	403 184 9805	MT-POLYEST 0.22U J 50V
C4902	404 079 4301	ELECT 2200U M 63V
C4903	404 079 4301	ELECT 2200U M 63V
CN201	614 255 5750	TERMINAL
or	645 032 6394	TERMINAL
CN412	645 012 2729	SOCKET,DIP 7P
or	614 249 6770	SOCKET
CN422	645 009 0042	JACK,PHONE D6.43
CN452	614 249 8613	SOCKET,VIDEO
CN454	645 012 5089	SOCKET,FPC 10P
or	645 005 4181	SOCKET,10P
CN455	645 032 5816	SOCKET,22P
CN460	614 302 6396	CORD,7P CONNECTOR
CN470	645 033 3071	TERMINAL,SPEAKER
CN489	614 303 9662	CORD,4P CONNECTOR,SUB
CN491	614 035 4935	SOCKET,DIP 4P
or	614 237 9776	SOCKET
CN492	645 023 4378	SOCKET,7P
CT251	645 032 5670	TRIMMER,27PF
CT252	645 032 5663	TRIMMER,7PF
D2151	407 091 5004	VARACTOR DI SVC321SPA-C-2
D2152	407 091 5004	VARACTOR DI SVC321SPA-C-2
D2451	407 012 4406	DIODE 1SS133
or	407 012 5809	DIODE 1SS176
or	407 153 6109	DIODE 1SS119-041
or	407 007 9904	DIODE GMA01
D2452	407 153 7502	ZENER DIODE GZS3.0B
D2454	407 012 4406	DIODE 1SS133
or	407 012 5809	DIODE 1SS176
or	407 153 6109	DIODE 1SS119-041
or	407 007 9904	DIODE GMA01
D2455	407 012 4406	DIODE 1SS133
or	407 012 5809	DIODE 1SS176
or	407 153 6109	DIODE 1SS119-041
or	407 007 9904	DIODE GMA01
D2456	407 012 4406	DIODE 1SS133
or	407 012 5809	DIODE 1SS176
or	407 153 6109	DIODE 1SS119-041
or	407 007 9904	DIODE GMA01
D2461	407 012 4406	DIODE 1SS133
or	407 012 5809	DIODE 1SS176

PARTS LIST

REF.NO.	PART NO.	DESCRIPTION	REF.NO.	PART NO.	DESCRIPTION
or	407 153 6109	DIODE 1SS119-041	or	405 020 7402	TR 2SC945A-P
or	407 007 9904	DIODE GMA01	or	405 020 7204	TR 2SC945A-K
D2464	407 012 4406	DIODE 1SS133	Q2154	405 141 3307	TR KTC3198-GR
or	407 012 5809	DIODE 1SS176	or	405 141 3208	TR KTC3198-Y
or	407 153 6109	DIODE 1SS119-041	or	405 020 7402	TR 2SC945A-P
or	407 007 9904	DIODE GMA01	or	405 020 7204	TR 2SC945A-K
D2466	407 012 4406	DIODE 1SS133 (XE)	Q2155	405 141 3307	TR KTC3198-GR
or	407 012 5809	DIODE 1SS176 (XE)	or	405 141 3208	TR KTC3198-Y
or	407 153 6109	DIODE 1SS119-041 (XE)	or	405 020 7402	TR 2SC945A-P
or	407 007 9904	DIODE GMA01(XE)	or	405 020 7204	TR 2SC945A-K
D2467	407 012 4406	DIODE 1SS133 (XE)	Q2156	405 141 3307	TR KTC3198-GR
or	407 012 5809	DIODE 1SS176 (XE)	or	405 141 3208	TR KTC3198-Y
or	407 153 6109	DIODE 1SS119-041 (XE)	or	405 020 7402	TR 2SC945A-P
or	407 007 9904	DIODE GMA01(XE)	or	405 020 7204	TR 2SC945A-K
D4110	407 012 4406	DIODE 1SS133	Q2157	405 026 9004	TR 2SK222-D
D4111	407 012 4406	DIODE 1SS133	Q2201	405 151 4103	TR KTC3193-Y
D4112	407 012 4406	DIODE 1SS133	or	405 016 0806	TR 2SC2839-E
D4114	407 012 4406	DIODE 1SS133	Q2310	405 141 3307	TR KTC3198-GR
D4150	407 099 5303	ZENER DIODE MTZJ5.6B	or	405 141 3208	TR KTC3198-Y
D4410	407 012 4406	DIODE 1SS133	or	405 020 7402	TR 2SC945A-P
D4414	407 012 4406	DIODE 1SS133	or	405 020 7204	TR 2SC945A-K
D4416	△ 407 148 6701	DIODE 1A3-I	Q2451	405 151 5209	TR KRA107M
D4501	407 099 6102	ZENER DIODE MTZJ10B	or	405 078 2404	TR BN1A4P
D4700	407 063 9108	ZENER DIODE MTZJ6.8B	or	405 000 0904	TR DTA114YS
D4701	407 063 9108	ZENER DIODE MTZJ6.8B	Q2452	405 151 5209	TR KRA107M
D4900	△ 407 196 5800	DIODE 1N5402BD82	or	405 078 2404	TR BN1A4P
D4901	△ 407 196 5800	DIODE 1N5402BD82	or	405 000 0904	TR DTA114YS
D4902	△ 407 196 5800	DIODE 1N5402BD82	Q2453	405 151 5209	TR KRA107M
D4903	△ 407 196 5800	DIODE 1N5402BD82	or	405 078 2404	TR BN1A4P
D4920	407 099 6805	ZENER DIODE MTZJ13B	or	405 000 0904	TR DTA114YS
D4921	407 099 4603	ZENER DIODE MTZJ3.9B	Q2501	405 141 3307	TR KTC3198-GR (XE)
D4940	407 099 6805	ZENER DIODE MTZJ13B	or	405 141 3208	TR KTC3198-Y (XE)
D4960	407 099 6805	ZENER DIODE MTZJ13B	or	405 020 7402	TR 2SC945A-P (XE)
IC231	409 379 2705	IC LA1832ML	or	405 020 7204	TR 2SC945A-K (XE)
IC245	409 439 4502	IC LC72121M-D	Q2502	405 151 5209	TR KRA107M (XE)
IC251	409 415 8609	IC LC72720N (XE)	or	405 078 2404	TR BN1A4P (XE)
IC411	409 426 1804	IC KIA4558S	or	405 000 0904	TR DTA114YS (XE)
IC413	409 442 1505	IC YSS247-E,SURROUND	Q4110	405 141 3307	TR KTC3198-GR
IC414	409 353 8709	IC BU4052BCF	or	405 141 3208	TR KTC3198-Y
IC458	409 431 2506	IC LC75385NE-R	or	405 020 7402	TR 2SC945A-P
IC459	409 426 1804	IC KIA4558S	or	405 020 7204	TR 2SC945A-K
IC470	△ 409 437 8007	IC STK411-200E	or	405 012 2002	TR 2SC1815-GR
L2151	614 255 5798	TRANS,RF	Q4150	405 141 3307	TR KTC3198-GR
L2152	614 255 5781	TRANS,RF	or	405 141 3208	TR KTC3198-Y
L2153	614 255 5767	TRANS,OSC	or	405 020 7402	TR 2SC945A-P
L2154	614 255 5774	TRANS,OSC	or	405 020 7204	TR 2SC945A-K
L2301	645 004 0580	INDUCTOR,1M J	or	405 012 2002	TR 2SC1815-GR
L2451	645 001 4581	INDUCTOR,100U K	Q4151	405 141 3307	TR KTC3198-GR
or	645 031 7842	INDUCTOR,100U K	or	405 141 3208	TR KTC3198-Y
L2501	645 001 4581	INDUCTOR,100U K (XE)	or	405 020 7402	TR 2SC945A-P
or	645 031 7842	INDUCTOR,100U K (XE)	or	405 020 7204	TR 2SC945A-K
L2502	645 001 4581	INDUCTOR,100U K (XE)	or	405 012 2002	TR 2SC1815-GR
or	645 031 7842	INDUCTOR,100U K (XE)	Q4401	405 141 3307	TR KTC3198-GR
L2901	645 004 0511	INDUCTOR,270U J	or	405 141 3208	TR KTC3198-Y
L4700	614 202 1712	V.H.F COIL	or	405 020 7402	TR 2SC945A-P
or	614 196 9763	V.H.F COIL	or	405 020 7204	TR 2SC945A-K
L4800	614 202 1712	V.H.F COIL	or	405 012 2002	TR 2SC1815-GR
or	614 196 9763	V.H.F COIL	Q4410	405 141 3307	TR KTC3198-GR
Q2140	405 141 3307	TR KTC3198-GR	or	405 141 3208	TR KTC3198-Y
or	405 141 3208	TR KTC3198-Y	or	405 020 7402	TR 2SC945A-P
or	405 020 7402	TR 2SC945A-P	or	405 020 7204	TR 2SC945A-K
or	405 020 7204	TR 2SC945A-K	or	405 012 2002	TR 2SC1815-GR
Q2152	405 141 3307	TR KTC3198-GR	Q4411	405 141 3307	TR KTC3198-GR
or	405 141 3208	TR KTC3198-Y	or	405 141 3208	TR KTC3198-Y
or	405 020 7402	TR 2SC945A-P	or	405 020 7402	TR 2SC945A-P
or	405 020 7204	TR 2SC945A-K	or	405 020 7204	TR 2SC945A-K
Q2153	405 141 3307	TR KTC3198-GR	or	405 012 2002	TR 2SC1815-GR
or	405 141 3208	TR KTC3198-Y	Q4431	405 141 3406	TR KTA1266-GR

PARTS LIST

REF.NO.	PART NO.	DESCRIPTION	REF.NO.	PART NO.	DESCRIPTION
or	405 141 3505	TR KTA1266-Y	or	405 021 0600	TR 2SD1012-G-SPA
or	405 005 2002	TR 2SA733-P	Q4920	405 141 3406	TR KTA1266-GR
or	405 005 1906	TR 2SA733-K	or	405 141 3505	TR KTA1266-Y
or	405 004 4502	TR 2SA608-F-NP	or	405 005 2002	TR 2SA733-P
or	405 004 5004	TR 2SA608-G-NP	or	405 005 1906	TR 2SA733-K
Q4432	405 141 3307	TR KTC3198-GR	or	405 004 4502	TR 2SA608-F-NP
or	405 141 3208	TR KTC3198-Y	or	405 004 5004	TR 2SA608-G-NP
or	405 020 7402	TR 2SC945A-P	Q4921	405 141 3406	TR KTA1266-GR
or	405 020 7204	TR 2SC945A-K	or	405 141 3505	TR KTA1266-Y
or	405 012 2002	TR 2SC1815-GR	or	405 005 2002	TR 2SA733-P
Q4433	405 141 3307	TR KTC3198-GR	or	405 005 1906	TR 2SA733-K
or	405 141 3208	TR KTC3198-Y	or	405 004 4502	TR 2SA608-F-NP
or	405 020 7402	TR 2SC945A-P	or	405 004 5004	TR 2SA608-G-NP
or	405 020 7204	TR 2SC945A-K	Q4940	△ 405 138 6403	TR KTD2058Y
or	405 012 2002	TR 2SC1815-GR	Q4941	405 141 3307	TR KTC3198-GR
Q4434	405 141 3307	TR KTC3198-GR	or	405 141 3208	TR KTC3198-Y
or	405 141 3208	TR KTC3198-Y	or	405 020 7402	TR 2SC945A-P
or	405 020 7402	TR 2SC945A-P	or	405 020 7204	TR 2SC945A-K
or	405 020 7204	TR 2SC945A-K	or	405 012 2002	TR 2SC1815-GR
or	405 012 2002	TR 2SC1815-GR	Q4960	405 141 3307	TR KTC3198-GR
Q4435	405 141 3307	TR KTC3198-GR	or	405 141 3208	TR KTC3198-Y
or	405 141 3208	TR KTC3198-Y	or	405 020 7402	TR 2SC945A-P
or	405 020 7402	TR 2SC945A-P	or	405 020 7204	TR 2SC945A-K
or	405 020 7204	TR 2SC945A-K	or	405 012 2002	TR 2SC1815-GR
or	405 012 2002	TR 2SC1815-GR	Q4961	405 141 3307	TR KTC3198-GR
Q4436	405 141 3307	TR KTC3198-GR	or	405 141 3208	TR KTC3198-Y
or	405 141 3208	TR KTC3198-Y	or	405 020 7402	TR 2SC945A-P
or	405 020 7402	TR 2SC945A-P	or	405 020 7204	TR 2SC945A-K
or	405 020 7204	TR 2SC945A-K	or	405 012 2002	TR 2SC1815-GR
or	405 012 2002	TR 2SC1815-GR	Q4962	△ 405 138 6403	TR KTD2058Y
Q4438	405 141 3307	TR KTC3198-GR	R4437	614 241 3449	RESISTOR 0.22 K- 5W
or	405 141 3208	TR KTC3198-Y	R4438	614 241 3449	RESISTOR 0.22 K- 5W
or	405 020 7402	TR 2SC945A-P	R4586	△ 402 081 9109	FUSIBLE RES 39 J- 1/4W
or	405 020 7204	TR 2SC945A-K	R4706	△ 402 081 0403	RESISTOR 4.7 J- 2W
or	405 012 2002	TR 2SC1815-GR	R4707	△ 402 081 0502	RESISTOR 330 J- 3W
Q4439	405 141 3307	TR KTC3198-GR	R4716	△ 402 081 1103	FUSIBLE RES 100 JA 1/4W
or	405 141 3208	TR KTC3198-Y	R4717	△ 402 081 1103	FUSIBLE RES 100 JA 1/4W
or	405 020 7402	TR 2SC945A-P	R4718	△ 402 081 0403	RESISTOR 4.7 J- 2W
or	405 020 7204	TR 2SC945A-K	R4750	614 241 3449	RESISTOR 0.22 K- 5W
or	405 012 2002	TR 2SC1815-GR	R4806	△ 402 081 0403	RESISTOR 4.7 J- 2W
Q4500	405 151 4400	TR KTD1303	R4807	△ 402 081 0502	RESISTOR 330 J- 3W
or	405 021 0600	TR 2SD1012-G-SPA	R4818	△ 402 081 0403	RESISTOR 4.7 J- 2W
Q4595	405 141 3307	TR KTC3198-GR	R4850	614 241 3449	RESISTOR 0.22 K- 5W
or	405 141 3208	TR KTC3198-Y	R4920	△ 402 081 1103	FUSIBLE RES 100 JA 1/4W
or	405 020 7402	TR 2SC945A-P	R4940	△ 402 081 8904	RESISTOR 1 J- 1/2W
or	405 020 7204	TR 2SC945A-K	R4963	△ 402 081 0601	RESISTOR 1K J- 2W
or	405 012 2002	TR 2SC1815-GR	R4964	△ 402 081 8904	RESISTOR 1 J- 1/2W
Q4600	405 151 4400	TR KTD1303	RY441	614 224 4531	RELAY,SPEAKER
or	405 021 0600	TR 2SD1012-G-SPA	or	645 035 6582	RELAY,SPEAKER
Q4695	405 141 3307	TR KTC3198-GR	S4900	614 215 9828	SWITCH,TACT,RESET
or	405 141 3208	TR KTC3198-Y	T2301	614 255 8119	FILTER,LC
or	405 020 7402	TR 2SC945A-P	U2101	645 033 5327	TUNER,FM
or	405 020 7204	TR 2SC945A-K	X2301	645 010 0024	OSC,CERAMIC 456KHZ
or	405 012 2002	TR 2SC1815-GR	or	614 246 0870	RESONATOR
Q4700	405 151 4400	TR KTD1303	X2451	645 023 4965	OSC,CRYSTAL 7.2MHZ
or	405 021 0600	TR 2SD1012-G-SPA	X2501	645 035 8326	OSC,CRYSTAL 4.332MHZ (XE)
Q4701	405 141 3307	TR KTC3198-GR	XF221	645 010 0079	CERAMIC FILTER 10.70MHZ
or	405 141 3208	TR KTC3198-Y	or	614 240 2917	FILTER,CERAM
or	405 020 7402	TR 2SC945A-P	or	614 254 3214	FILTER
or	405 020 7204	TR 2SC945A-K	XF222	645 010 0079	CERAMIC FILTER 10.70MHZ
or	405 012 2002	TR 2SC1815-GR	or	614 240 2917	FILTER,CERAMIC
Q4702	405 141 3406	TR KTA1266-GR	or	614 254 3214	FILTER
or	405 141 3505	TR KTA1266-Y	XF231	614 246 0849	FILTER
or	405 005 2002	TR 2SA733-P	XF233	645 018 8824	DISCR,CERAMIC
or	405 005 1906	TR 2SA733-K	or	645 018 8718	DISCR,CERAMIC
or	405 004 4502	TR 2SA608-F-NP			
or	405 004 5004	TR 2SA608-G-NP			
Q4800	405 151 4400	TR KTD1303			

PARTS LIST

SUB TRANSFORMER P.W.BOARD ASSY

REF.NO.	PART NO.	DESCRIPTION
81	614 302 6600	ASSY,PWB,SUB TRANS (Only Initial)
C4311	403 313 4602	ELECT 1000U M 16V
C4316	△ 404 033 3401	CERAMIC 0.01U Z 400V
or	△ 404 033 3302	CERAMIC 0.01U M 400V
or	△ 404 000 1607	CERAMIC 0.01U F 400V
C4320	403 313 4602	ELECT 1000U M 16V
CN335	614 017 8203	TERMINAL BOARD
CN336	614 017 8203	TERMINAL BOARD
CN337	614 017 8203	TERMINAL BOARD
CN338	614 017 8203	TERMINAL BOARD
CN432	645 005 8110	PLUG,4P
or	645 007 0075	PLUG,4P
D4300	407 012 4406	DIODE 1SS133
D4308	407 012 4406	DIODE 1SS133
D4309	△ 407 148 6701	DIODE 1A3-I
D4310	△ 407 148 6701	DIODE 1A3-I
D4311	△ 407 148 6701	DIODE 1A3-I
D4312	△ 407 148 6701	DIODE 1A3-I
D4320	△ 407 148 6701	DIODE 1A3-I
D4321	△ 407 148 6701	DIODE 1A3-I
D4322	407 099 5402	ZENER DIODE MTZJ6.2B
D4350	407 125 9008	ZENER DIODE MTZJ2.0A
D4352	407 012 4406	DIODE 1SS133
IC430	△ 409 448 9000	IC KIA78DL05PI
L4300	△ 614 234 2800	INDUCTOR,FERITE
Q4300	405 141 3307	TR KTC3198-GR
or	405 141 3208	TR KTC3198-Y
or	405 020 7402	TR 2SC945A-P
or	405 020 7204	TR 2SC945A-K
or	405 012 2002	TR 2SC1815-GR
Q4320	405 141 3307	TR KTC3198-GR
or	405 141 3208	TR KTC3198-Y
or	405 020 7402	TR 2SC945A-P
or	405 020 7204	TR 2SC945A-K
or	405 012 2002	TR 2SC1815-GR
Q4350	405 141 3406	TR KTA1266-GR
or	405 141 3505	TR KTA1266-Y
or	405 005 2002	TR 2SA733-P
or	405 005 1906	TR 2SA733-K
or	405 004 4502	TR 2SA608-F-NP
or	405 004 5004	TR 2SA608-G-NP
Q4351	405 141 3406	TR KTA1266-GR
or	405 141 3505	TR KTA1266-Y
or	405 005 2002	TR 2SA733-P
or	405 005 1906	TR 2SA733-K
or	405 004 4502	TR 2SA608-F-NP
or	405 004 5004	TR 2SA608-G-NP
RY431	△ 645 030 5597	RELAY,PRIMARY
or	△ 645 035 6575	RELAY,PRIMARY
T4301	△ 645 033 8595	TRANS,POWER

SPEAKERS(SX-C70L,R)

REF.NO.	PART NO.	DESCRIPTION
91	614 304 5168	ASSY,BOX,SPEAKER (LEFT) (UK)
91	614 304 5175	ASSY,BOX,SPEAKER (LEFT) (XE)
91	614 304 5182	ASSY,BOX,SPEAKER (RIGHT) (UK)
91	614 304 5199	ASSY,BOX,SPEAKER (RIGHT) (XE)
92	614 304 5274	ASSY,GRILLE

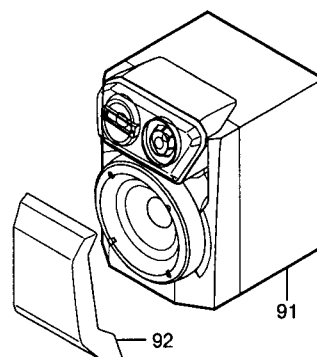

EXPLODED VIEW (TAPE MECHANISM)

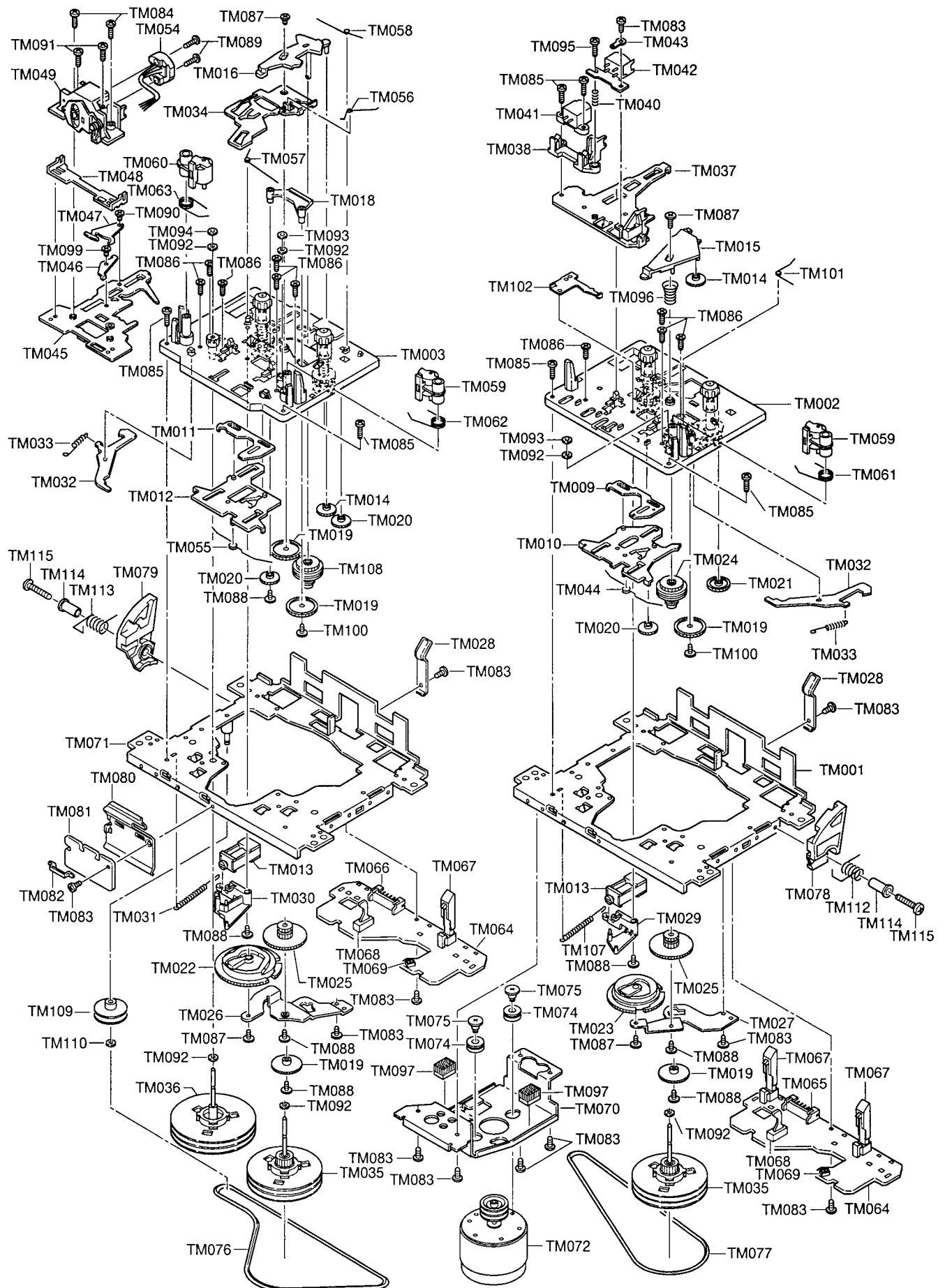

PARTS LIST

TAPE MECHANISM (TM-C50PRMEC-SH...Only Initial)

REF.NO.	PART NO.	DESCRIPTION	REF.NO.	PART NO.	DESCRIPTION
TM001	645 024 1970	MECHA-CHASSIS	TM081	645 027 9096	HEAD-PCB
TM002	645 027 9324	ASSY,MOLD-CHASSIS	TM082	645 024 3226	WIRE-CLAMP
TM003	645 027 5388	MOLD-CHASSISS-ASSY	TM083	645 025 6134	BIND SCREW
TM009	645 024 1963	SELECT-LEVER	TM084	645 024 3141	BIND-SCREW
TM010	645 027 9348	ASSY,SELECT-BASE	TM085	645 024 3158	BIND-SCREW
TM011	645 024 2007	SELECT-LEVER	TM086	645 024 3127	SCREW
TM012	645 028 0078	ASSY,SELECT-BASE	TM087	645 024 3257	SCREW
TM013	645 024 2038	SOLENOID	TM088	645 024 3103	SCREW
TM014	645 025 6301	SEND-GEAR(B)	TM089	645 024 3110	SCREW
TM015	645 027 8839	CENTER-ARM	TM090	645 024 3080	SCREW
TM016	645 027 9003	CENTER-ARM	TM091	645 024 3233	AZIMUTH SCREW
TM018	645 027 9010	FWD-ARM	TM092	645 027 8914	P-WASHER
TM019	645 024 2144	SEND-GEAR(A)	TM093	645 027 8907	L-CUT-WASHER
TM020	645 025 6295	SEND-GEAR(B)	TM094	645 028 0528	L-CUT-WASHER
TM021	645 024 2113	SEND-GEAR(C)	TM095	645 028 0535	SCREW
TM022	645 024 2120	ASSIST-GEAR	TM096	645 024 2069	PRESSURE-SP
TM023	645 027 8846	ASSIST-GEAR	TM097	645 025 5908	MAT
TM024	645 028 0559	ASSY,FF-GEAR	TM099	645 027 9041	SCREW
TM025	645 024 2229	ASSY,CENTER-GEAR	TM100	645 027 9034	HEADER SCREW
TM026	645 024 2267	PROTECT-STAY	TM101	645 027 8938	FWD-ARM-SP
TM027	645 027 8884	PROTECT-STAY	TM102	645 027 8990	F/R-LOCK-PLATE
TM028	645 024 2243	CST-HOLDER-SP	TM107	645 027 9058	TRIGGER-ARM-SP
TM029	645 024 2168	TRIGGER-ARM	TM108	645 028 0108	ASSY,FF-GEAR
TM030	645 024 2236	TRIGGER-ARM	TM109	645 029 6291	TENSION-PULLEY
TM031	645 027 8877	TRIGGER-ARM-SP	TM110	645 029 6253	P-CUT-WASHER
TM032	645 027 8860	EJECT-LOCK	TM112	614 303 2991	LOCK-CAM-SP-R
TM033	645 024 2182	EJECT-LOCK-SP	TM113	614 303 2984	LOCK-CAM-SP-L
TM034	645 027 9065	REV-PLATE	TM114	614 303 2977	COLLAR
TM035	645 025 5915	ASSY,FW-GEAR	TM115	614 303 2946	SCREW
TM036	645 029 6277	ASSY,FW			
TM037	645 027 5395	HEAD-BASE-ASSY			
TM038	645 024 2380	HEAD-SPACER			
TM040	645 024 2397	AZIMUTH-SP			
TM041	645 033 3354	HEAD,ERASE			
TM042	614 293 6634	HEAD,R/P			
TM043	645 024 2311	EARTH-LUG D2			
TM044	645 027 8853	HEAD-BASE-SP			
TM045	645 024 2458	ASSY,HEAD-BASE			
TM046	645 024 2540	REV-PLATE(B)			
TM047	645 024 2557	REV-PLATE(A)			
TM048	645 024 2465	PINCH-PLATE			
TM049	645 027 5371	HEAD-GUIDE-ASSY			
TM054	645 036 3726	HEAD,PLAY,AUDIO			
TM055	645 027 9126	HEAD-BASE-SP			
TM056	645 027 9157	REV-SP			
TM057	645 027 9072	CENTER-BASE-SP(A)			
TM058	645 027 9089	CENTER-BASE-SP(B)			
TM059	645 028 0030	ASSY,PINCH-ARM			
TM060	645 028 0542	ASSY,PINCH-ARM			
TM061	645 024 2359	PINCH-SP			
TM062	645 027 9140	PINCH-SP			
TM063	645 027 9133	PINCH-SP			
TM064	645 027 9119	SENSOR-PCB			
TM065	645 024 2762	CONNECTOR S7B-PH-K-S			
TM066	645 025 5922	CONNECTOR S6B-PH-K-S			
TM067	645 025 6141	LEAF SW MXS00821MPP0			
TM068	645 024 2335	PUSH-SW MPU10190MLB0			
TM069	645 024 2328	PHOTO-SENSOR GP2S24C			
TM070	645 024 2427	MOTOR-BKT			
TM071	645 029 6260	ASSY,MECHA-CHASSIS			
TM072	614 293 9505	ASSY,MOTOR,PLAY MECHA MOTOR			
TM074	645 024 3172	RUBBER-CUSHION			
TM075	645 024 3165	MOTOR-SCREW			
TM076	645 029 6246	MAIN-BELT			
TM077	645 025 5892	MAIN-BELT			
TM078	614 303 2953	LOCK-CAM-R			
TM079	614 303 2960	LOCK-CAM-L			
TM080	645 027 9102	SHIELD-PLATE(A)			

EXPLODED VIEW (CD CHANGER MECHANISM)

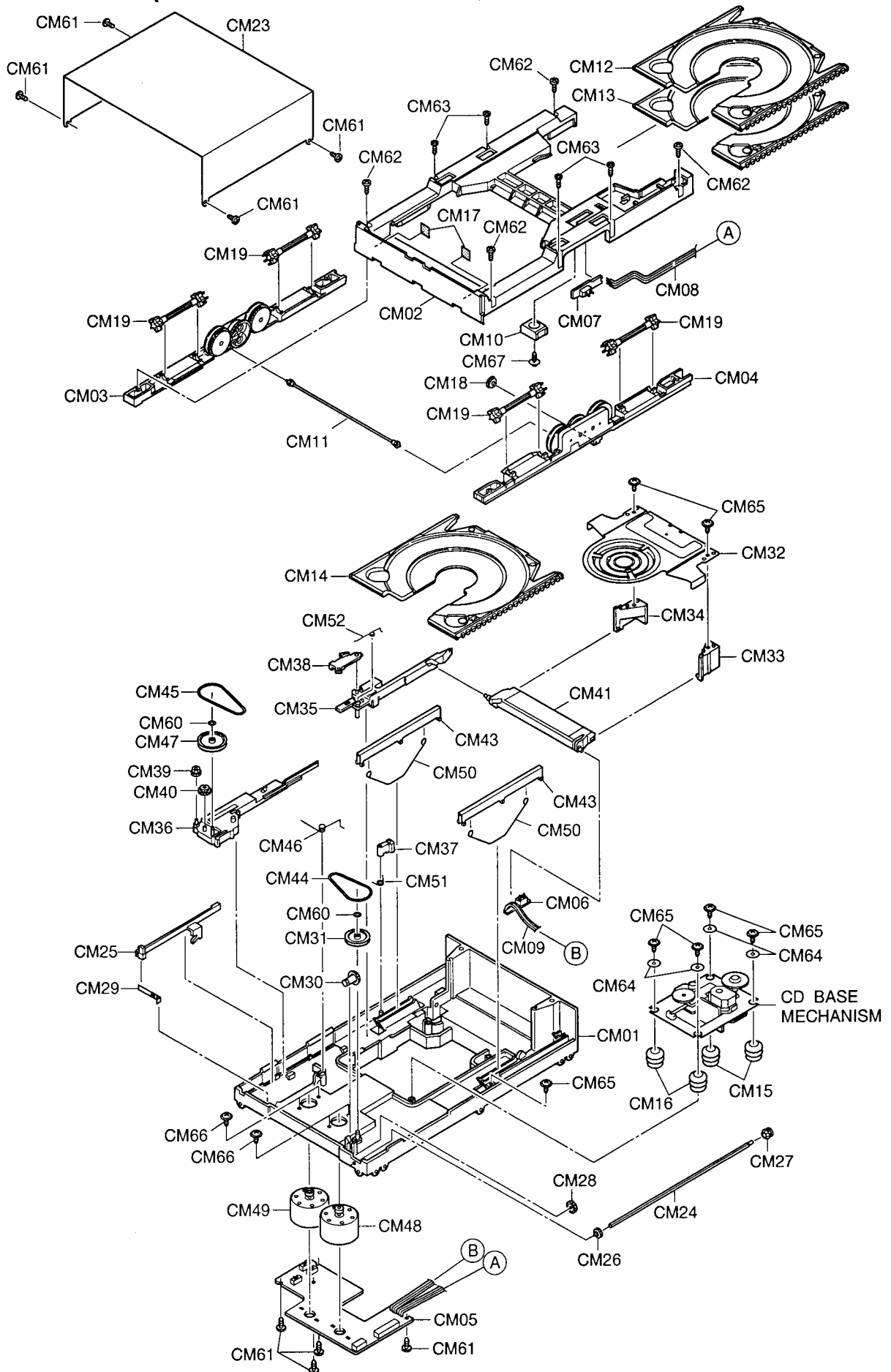

PARTS LIST

CD CHANGER MECHANISM (PM-CDC10TP-SH ... Only Initial)

REF.NO.	PART NO.	DESCRIPTION	REF.NO.	PART NO.	DESCRIPTION
CM01	645 033 6072	ASSY,CHASSIS	CM39	645 033 6263	GEAR IDLER A2
CM02	645 033 7512	DRAWER 2	CM40	645 033 6218	GEAR IDLER C
CM03	645 033 5976	ASSY,HOLDER L,DRAWER	CM41	645 033 6447	LEVER
CM04	645 033 6898	ASSY,HOLDER R3B,DRAWER	CM43	645 033 6454	LIFTER,CARRIGE LIFT UP
CM05	645 033 6041	ASSY,PC BOARD A	CM44	645 033 5778	BELT
CM06	645 033 6065	ASSY,PC BOARD B	CM45	645 033 5785	BELT
CM07	645 033 6058	ASSY,PC BOARD C	CM46	645 033 7048	SPRING
CM08	645 033 5945	LEAD WIRE	CM47	645 033 6393	PULLEY A
CM09	645 033 5952	LEAD WIRE	CM48	645 033 6003	ASSY,MOTOR CARRIGE
CM10	645 033 6713	SPACER SW	CM49	645 033 6010	ASSY,MOTOR DRAWER
CM11	645 033 6027	ASSY,GEAR DRIVE,SINCHRO	CM50	645 033 5723	SPRING
CM12	645 033 6904	ASSY,CRG 100,CARRIAGE NO.1	CM51	614 303 7545	SPRING
CM13	645 033 6911	ASSY,CRG 200	CM52	645 033 5747	SPRING
CM14	645 033 6928	ASSY,CRG 300	CM60	645 033 5648	WASHER
CM15	645 033 5877	INSULATOR	CM61	645 033 5594	SCREW
CM16	645 033 5884	INSULATOR	CM62	645 033 7031	SCREW
CM17	645 033 5907	CUSHION	CM63	645 033 5563	SCREW
CM18	645 033 6324	BEVEL GEAR 4	CM64	645 033 5631	WASHER
CM19	645 033 5990	ASSY,GEAR STAR,CARRIAGE LIFT	CM65	645 033 5570	SCREW
CM23	645 033 6089	COVER 2	CM66	645 033 5600	SCREW
CM24	645 033 6539	SHAFT	CM67	645 033 5617	SCREW
CM25	645 033 6461	SLIDER 4			
CM26	645 033 6201	GEAR SPLINE			
CM27	645 033 6232	BEVEL GEAR 1			
CM28	645 033 6270	GEAR IDLER 1			
CM29	645 033 6102	PLATE SPRING			
CM30	645 033 6287	BEVEL GEAR 3			
CM31	645 033 6225	PULLEY C			
CM32	645 033 6034	ASSY,CLAMPER			
CM33	645 033 6140	ARM SLIDER R			
CM34	645 033 6157	ARM SLIDER L			
CM35	645 033 6430	SLIDER 1			
CM36	645 033 5969	ASSY,SLIDER 2,FWD/RVS			
CM37	645 033 6980	ARM STOPPER A2			
CM38	645 033 6416	ARM STOPPER B			

CD BASE MECHANISM (CD213CCM-SNSH ... Only Initial)

REF.NO.	PART NO.	DESCRIPTION
PM01	645 033 6751	ASSY,MOTOR CHASSIS,BASE
PM01-1	645 033 6812	GEAR B RP,SLED GEAR
PM02	645 033 6744	ASSY,MOTOR GEAR,SLED
PM03	645 033 6805	SLED SHAFT,PICK RAIL
PM04	645 033 6799	GEAR A S,PICK DRIVE GEAR
PM05	645 033 6829	SCREW+P2*3,SLED MOTOR FIX
PM06	645 033 6775	LEAF SWITCH,LIMIT SWITCH
PM07	645 033 6782	MOTOR 6P S PWB
PM08	645 033 6768	CONNECTOR PIN 6P
PM09	614 303 5626	PICK UP

EXPLODED VIEW (CD BASE MECHANISM)

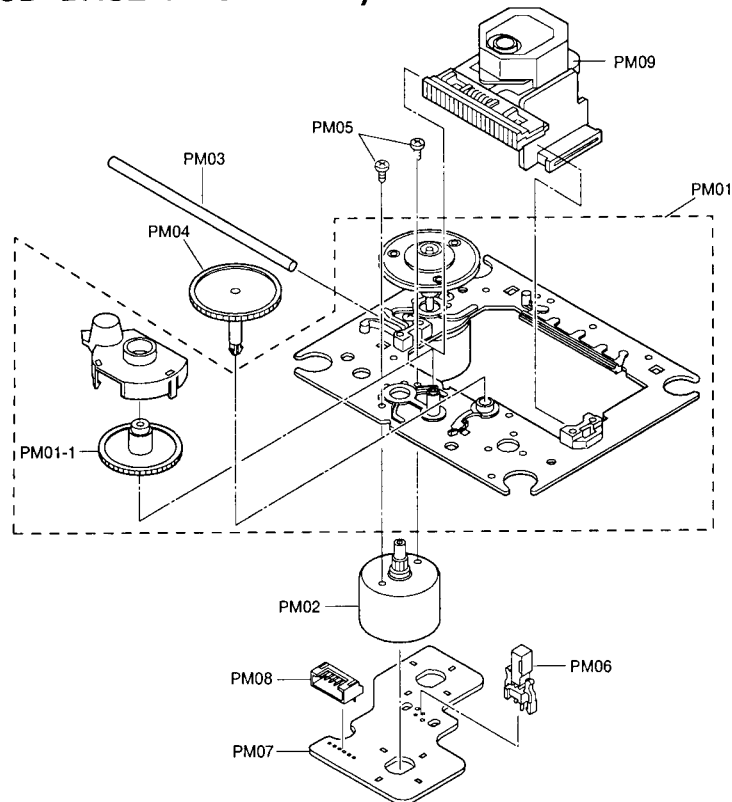

IC BLOCK DIAGRAM & DESCRIPTION

IC101 LA9240ML (Servo Signal Processor)

No.	Pin Name	I/O	Function	No.	Pin Name	I/O	Function
1	FIN2	I	Connection Pin for Photo Diode of Pickup.	34	TGL	I	Input Pin for Tracking Gain Control Signal from Digital Signal Processor. TGL = H : Gain Low
2	FIN1	I	FIN2 + FIN1 = RF, FIN2 - FIN1 = FE	35	TOFF	I	Input Pin for Tracking Off Control Signal from Digital Signal Processor. TOFF = H : OFF
3	E	I	Connection Pin for Photo Diode of Pickup.	36	TES	O	Output Pin for Track Error Sense Signal to Digital Signal Processor.
4	F	I	E - F = TE	37	HFL	I	High Frequency Level Signal Use Detection Main-Beam Position is on the pit or mirror.
5	TB	I	Input Pin for DC ingredient of TE Signal.	38	SLOF	I	Input Pin for Sled Servo Off Control.
6	TE-	I	Connection Pin for Gain Setting Resistor of TE Signal to TE Signal Pin.	39	CV-	I	Input Pin for Constant Linear Velocity Error Signal from Digital Signal Processor.
7	TE	O	Output Pin for Tracking Error Signal.	40	CV+	I	Signal from Digital Signal Processor.
8	TESI	I	Input Pin for Track Error Sense Comparator. TE Signal through Band Pass, and Inputted.	41	RFSM	O	Output Pin for RF Signal.
9	SCI	I	Input Pin for Shock Detection.	42	RFS-	I	Connection Pin for Gain Setting of RF and Constant Setting of 3T Compensation of the EFM Signal with RFSM Pin.
10	TH	I	Connection Pin for Time Constant Setting of Tracking Gain.	43	SLC	O	Slice Level Control Signal is Output Pin. It Control Level of Data-Slice by Digital Signal Processor of the RF Waveform.
11	TA	O	Output Pin for TA Amplifier.	44	SLI	I	Input Pin for Level Control of Data-Slice by Digital Signal Processor.
12	TD-	I	Connection Pin for Constant Tracking Phase Compensation, Consist of between TD and VR.	45	DGND	-	Ground for Digital Signal.
13	TD	I	Connection Pin for Constant of Tracking Phase Compensation.	46	FSC	O	Output Pin for Focus Search Smooth Condenser
14	JP	I	Connection Pin for Amplitude Setting of Tracking Jump (Kick Pulse) Signal.	47	TBC	O	Connection Pin for Variable Range Setting of EF Balance.
15	TO	O	Output Pin for Tracking Control Signal.	48	NC	-	No Connect
16	FD	O	Output Pin for Focusing Control Signal.	49	DEF	O	Output Pin for Defect Detection of Disc.
17	FD-	I	Connection Pin for Constant of Focusing Phase Compensation, Consist of between FD and FA.	50	CLK	I	Input Pin for Reference Clock Pulse. (4.23 MHz of Digital Signal Processor)
18	FA+	I	Connection Pin for Constant of Focusing Phase Compensation, Consist of between FD- and FA-.	51	CL	I	Input Pin of Clock Pulse for Command from Micro Processor.
19	FA-	I	Connection Pin for Constant of Focusing Phase Compensation, Consist of between FA and FE.	52	DAT	I	Input Pin of Data for Command from Micro Processor.
20	FE	O	Output Pin for Focusing Error Signal.	53	CE	I	Input Pin of Chip Enable for Command from Micro Processor.
21	FE-	I	Connection Pin for Gain Setting Resistor of FE Signal to FE Signal Pin.	54	DRF	O	Output Pin for Detect of RF Level.
22	AGND	-	Ground for Analog Signal.	55	FSS	I	Select Pin for Focus Search Mode
23	SP	O	Output Pin for Single End of Input Signal of the CV+, CV- Pin.	56	VCC2	-	VCC for Servo and Digital Root.
24	SPI	I	Input Pin for Spindle Amplifier.	57	REF1	I	Bus Control Connection Pin for Reference Voltage.
25	SPG	I	Connection Pin for Gain Setting Resistor, when Spindle 12 cm Mode.	58	VR	O	Output Pin for Reference Voltage.
26	SP-	I	Connection Pin for Constant of Spindle Phase Compensation with SPD Pin.	59	LF2	I	Connection Pin for Time Constant Setting of Detect Detection of the Disc.
27	SPD	O	Output Pin for Spindle Control Signal.	60	PH1	I	Capacitor Connection Pin for Peak-hold of RF Signal.
28	SLEQ	I	Connection Pin for Constant of Sled Phase Compensation.	61	BH1	I	Capacitor Connection Pin for Bottom-hold of RF Signal.
29	SLD	O	Output Pin for Sled Control Signal.	62	LDD	O	Output Pin of APC (Automatic Power Control) Circuit.
30	SL-	I	Input Pin for Sled Signal from Micro Processor.	63	LDS	I	Input Pin of APC (Automatic Power Control) Circuit.
31	SL+	I		64	VCC1	I	VCC for RF Root.
32	JP-	I	Input Pin for Tracking Jump Signal from Digital Signal Processor.				
33	JP+	I					

IC BLOCK DIAGRAM & DESCRIPTION

IC102 LC78622NE (Digital Signal Processor)

No.	Pin Name	I/O	Function
1	DEFI	I	Input terminal for detect signal of defect
2	TAI	I	Input terminal for test.
3	PDO	O	The phase comparison output terminal for external VCO control.
4	WSS	-	Ground terminal for built-in VCO
5	ISET	I	Resistance connection terminal for electric current adjustment of PDO output.
6	VVDD	-	Built-in VCO power supply terminal.
7	FR	I	VCO frequency range adjustment.
8	VSS	-	Ground for Digital
9	EFMO	O	EFM signal output terminal for slice level control.
10	EFMIN	I	EFM signal input terminal for slice level control.
11	TEST2	I	TEST pin. Normal time is non connection.
12	CLV+	O	Output terminal for Disc motor control.
13	CLV-	O	Output terminal for Disc motor control.
14	V/P	O	Change of rough servo / phase control Rough servo : "H", Phase control : "L"
15	HFL	I	Input terminal of track search signal.
16	TES	I	Input terminal of tracking error signal.
17	TOFF	O	Output terminal of tracking off.
18	TGL	O	Output terminal for change of tracking gain.
19	JP+	O	Output terminal for tracking jump control.
20	JP-	O	Output terminal for tracking jump control.
21	PCK	O	Clock monitor output terminal for EFM data playback. (4.3218 MHz)
22	FSEQ	O	Output terminal for detect of SYNC signal.
23	DVDD	-	+5V
24	CONT1	I/O	This output can control at serial control from micro processor.
25	CONT2	I/O	
26	CONT3	I/O	
27	CONT4	I/O	
28	CONT5	I/O	
29	EMPH	O	Output terminal of de-emphasis monitor . "H" : de-emphasis
30	C2F	O	Output terminal of C2 flag
31	DOUT	O	Output terminal of digital out

No.	Pin Name	I/O	Function
32	TEST3	I	Test pin.
33	TEST4	I	Test pin.
34	NC	-	Non connection.
35	MUTEL	O	Mute output terminal for L-ch
36	LVDD	-	Power supply for L-ch
37	LCHO	O	Output terminal for L-ch
38	LVSS	-	GND for L-ch
39	RVSS	-	GND for R-ch
40	RCHO	O	Output terminal for R-ch
41	RVDD	-	Power supply for R-ch
42	MUTER	O	Mute output terminal for R-ch
43	XVDD	-	Power supply of crystal oscillation
44	XOUT	O	Connection terminal of crystal oscillation (16.9344MHz)
45	XIN	I	Connection terminal of crystal oscillation (16.9344MHz)
46	XVSS	-	GND of crystal oscillation
47	SBSY	O	Output terminal for synchronizing signal of sub-cord block
48	EFLG	O	Output terminal for correction monitor of C1, C2, Single and Double
49	PW	O	Output terminal for sub-cord of P, Q, R, S, T, U and W
50	SFSY	O	Output terminal for synchronizing signal of sub-cord frame
51	SBCK	I	Input terminal for readout clock of sub-cord
52	FSX	O	Output terminal of Synchronizing signal (7.35kHz)
53	WRQ	O	Output terminal for standby of sub-cord Q output
54	RWC	I	Input terminal of read / write control
55	SQOUT	O	Output terminal of sub-cord Q
56	COIN	I	Input terminal of command from micro processor
57	CQCK	I	Clock input for reading sub-cord from SQOUT
58	RES	I	Reset (turn on : L)
59	TST11	O	Test pin
60	16M	O	16.9344MHz
61	4.2M	O	4.2336MHz
62	TEST5	I	Test pin
63	CS	I	Chip select terminal
64	TEST1	I	Test pin

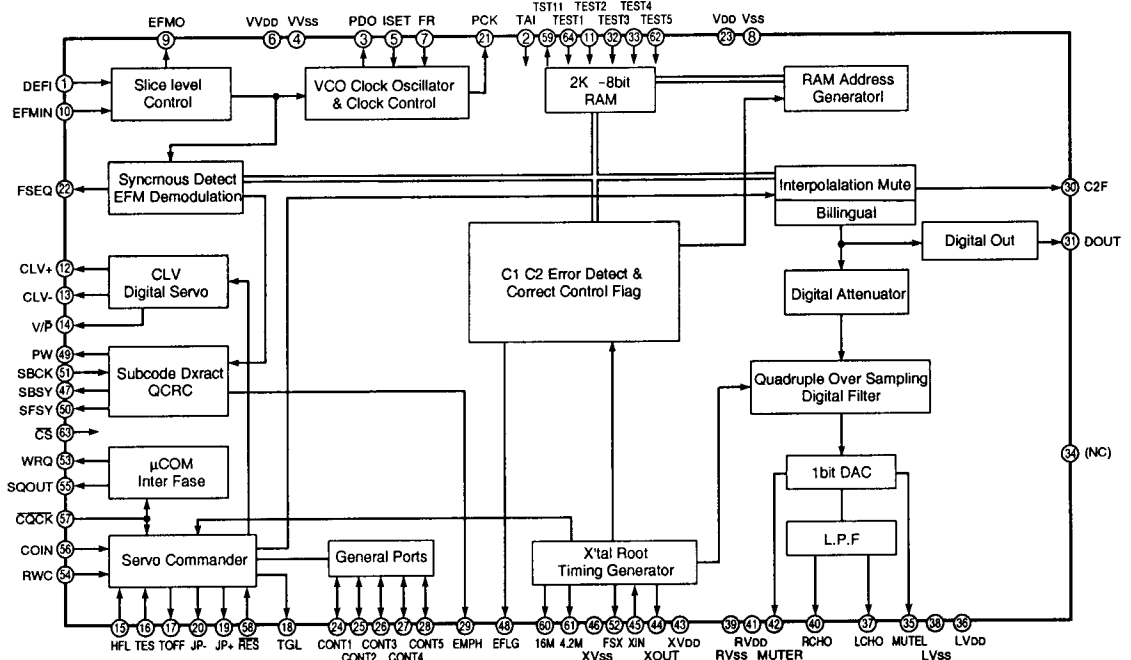

IC BLOCK DIAGRAM & DESCRIPTION

IC103 LA6541 (Pickup Actuator & CD Mechanism Motor)

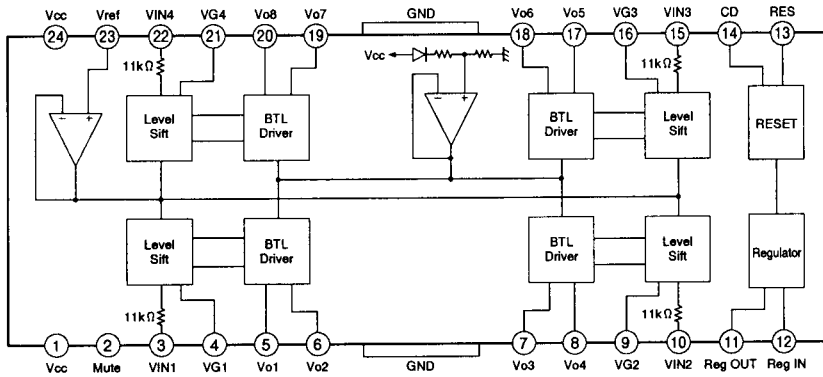

IC131, IC132 TA7291S (Bridge Driver)

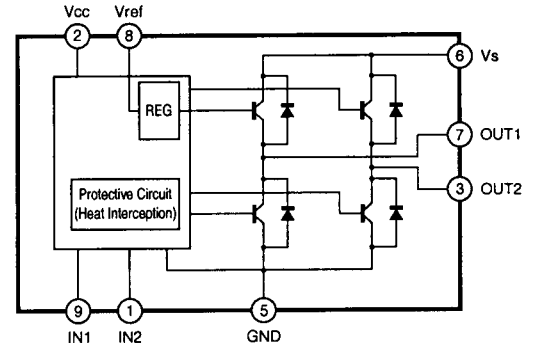

IC211 TA8176SN (FM Front End)

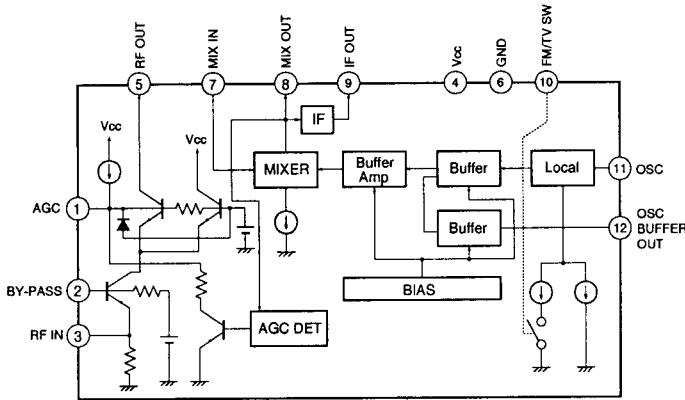

IC231 LA1832ML (AM / FM IF Amplifier & FM-MPX)

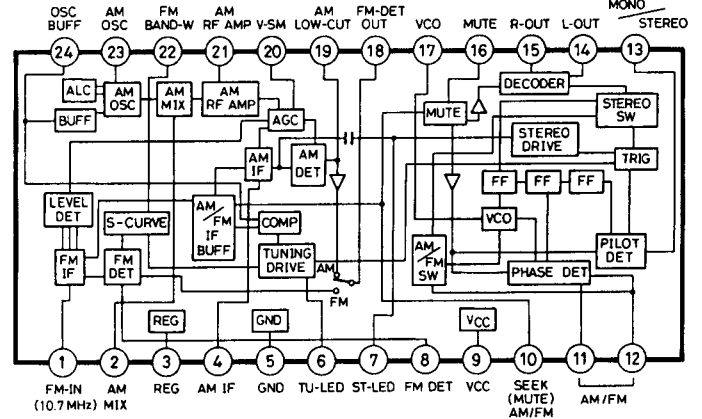

IC245 LC72121M (PLL Synthesizer)

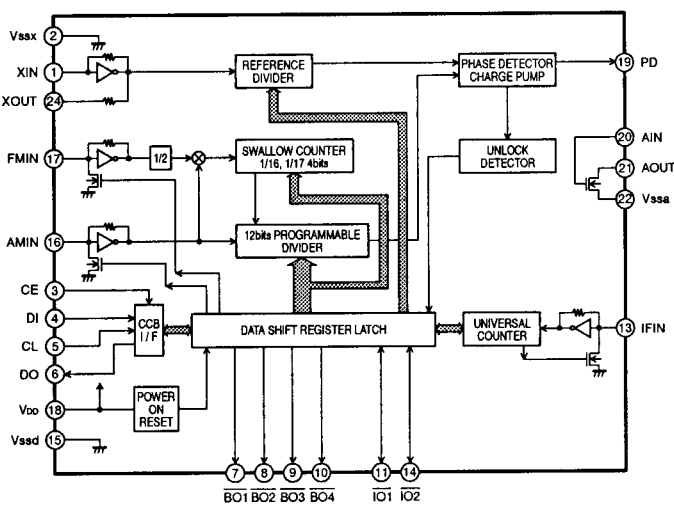

IC251 LC72720 (RDS Signal control)

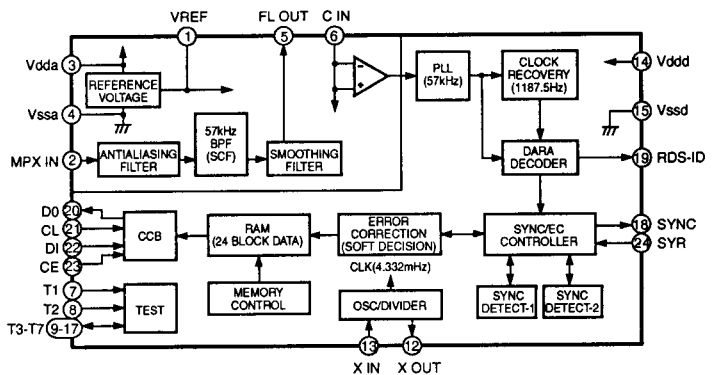

IC BLOCK DIAGRAM & DESCRIPTION

IC362 TC4011BF (NAND Gate)

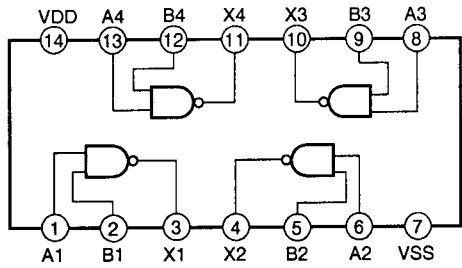

IC363 BA7755A (Head Switch)

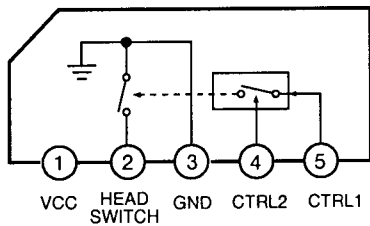

IC371 TA8189N (Pre-Amplifier for Tape Deck)

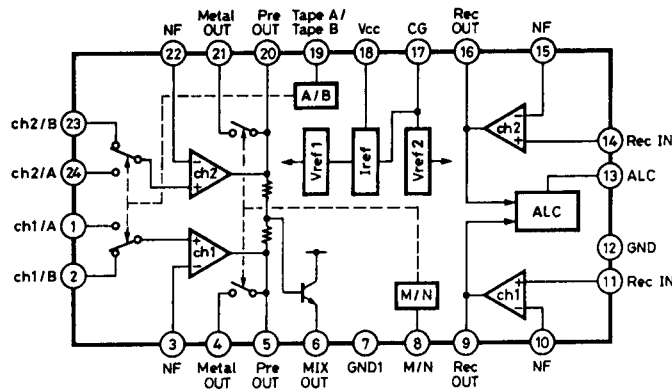

IC425 NJM7805FA (3-Terminal Voltage Regulator)

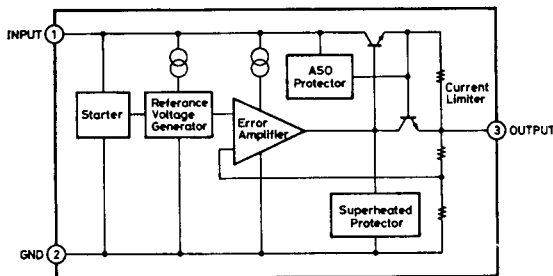

IC602, IC603 NJM4558M (Operation Amplifier)

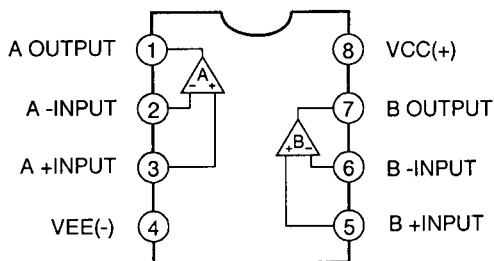

IC361 BU2090F (12bit Serial Parallel Converter)

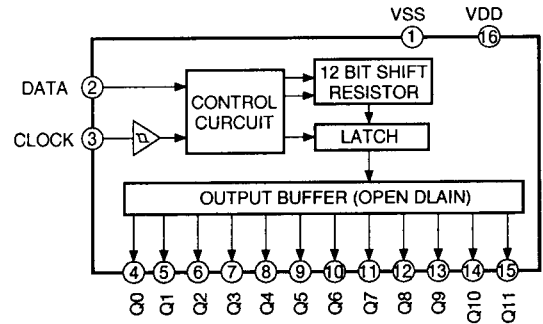

No.	Pin Name	Port Name	Function
1	VSS	VSS	Ground
2	DATA	D-OUT	Data input
3	CLOCK	EX1-CLK	Clock input
4	Q0	BEAT	Tape beat cancel output (L=Pos1, H=Pos.2)
5	Q1	OSC	Tape oscilation circuit control (L=OFF, H=ON)
6	Q2		
7	Q3	R-MUTE	Tape REC mute output (L=OFF, H=ON)
8	Q4	DECK-A/B	Deck A / B control (L=B, H=A)
9	Q5		
10	Q6	R/P	Tape Rec / Play control (L=Rec, H=Play)
11	Q7		
12	Q8	MOTOR	Tape motor output
13	Q9	A-PLY-PL	Dack A Play Plunger output
14	Q10	B-PLY-PL	Dack B Play Plunger output
15	Q11		
16	VDD	VDD	Power supply

IC604, IC605 BU2090F (12bit Serial Parallel Converter)

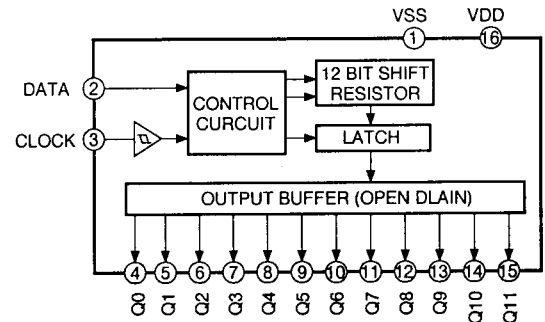

No.	Pin Name	Port Name	Function
1	VSS	VSS	Ground
2	DATA	D-OUT	Data input
3	CLOCK	EX2-CLK	Clock input
4	Q0	VF-KB	Output for Vocal fader control
5	Q1	VF-KC	Output for Vocal fader control
6	Q2	SOUND-2	Output for Surround LS1 control
7	Q3	SOUND-1	Output for Surround LS2 control
8	Q4	LED-0	POPS LED (L=ON)
9	Q5	LED-1	ROCK LED (L=ON)
10	Q6	LED-2	CLASSIC LED (L=ON)
11	Q7	LED-3	JAZZ LED (L=ON)
12	Q8	LED-4	CD Function LED (L=ON)
13	Q9	LED-5	Tape Function LED (L=ON)
14	Q10	LED-6	Tuner Function LED (L=ON)
15	Q11	LED-7	Video Function LED (L=ON)
16	VDD	VDD	Power supply

IC BLOCK DIAGRAM & DESCRIPTION

IC601 LC866548A (Micro Processor) ... for UK
LC866556B (Micro Processor) ... for XE

No.	Name	I/O	Function
1	JOG+	I	Input JogDial
2	JOG-	I	Input JogDial
3	D_CLK	O	Serial clock output for Tu/Vol_Func IC
4	D_OUT	O	Serial date output for Tu/Vol_Func/extend IC
5	EXI_CLK	O	Serial clock output for extend IC1(DECK)
6	EX2_CLK	O	Serial clock output for extend IC2(LED)
7	EX3_CLK	O	Serial clock output for extend IC3(LED)
8	VF_CE	O	Serial latch output for Vol_Func IC
9	TU_CE	O	Serial latch output for Tuner IC
10	TU_D1	I	Serial date output for Tuner IC
11	WD	I	Watchdog timer input
12	RESET	I	Reset terminal
13	XT1	I	Sub clock connection terminal
14	XT2	O	Sub clock connection terminal
15	VSS		Ground
16	CF1	I	Main clock connection terminal (6MHz)
17	CF2	O	Main clock connection terminal (6MHz)
18	VDD		Power supply (+5V)
19	KEY0	I	Key input
20	KEY1	I	Key input
21	KEY2	I	Key input
22	CD_SW0	I	SW input SW2(EXTRA) SW3(HOME)
23	CD_SW1	I	SW input SW4(C_No.) SW5(C_No.)
24	CD_SW2	I	SW input SW7(Fwd) SW8(Revs)
25	CD_SW3	I	SW input SW6(Open) Pick Limit switch
26	LEVEL	I	LEVEL input
27	WRQ	I	CD DSP interface (sub Q Request)
28	PROTECTOR	I	Set protector (Irregular:Low)
29	IR	I	Remote control input
30	Seg15	O	FL Segment output
31	Seg16	O	FL Segment output
32	Seg17	O	FL Segment output
33	Seg18	O	FL Segment output
34	Digit12	O	FL digit output
35	Digit11	O	FL digit output
36	Digit10	O	FL digit output
37	Digit9	O	FL digit output
38	Digit8	O	FL digit output
39	Digit7	O	FL digit output
40	Digit6	O	FL digit output
41	Digit5	O	FL digit output
42	Digit 4	O	FL digit output
43	Digit3	O	FL digit output
44	Digit2	O	FL digit output
45	Digit1	O	FL digit output
46	VDD		Power supply (+5V)
47	Seg19	O	FL Segment output
48	Seg20	O	FL Segment output
49	Seg21	O	FL Segment output
50	Seg22	O	FL Segment output
51	VP		FL drive output power

No.	Name	I/O	Function
52	Seg1	O	FL Segment output
53	Seg2	O	FL Segment output
54	Seg3	O	FL Segment output
55	Seg4	O	FL Segment output
56	Seg5	O	FL Segment output
57	Seg6	O	FL Segment output
58	Seg7	O	FL Segment output
59	Seg8	O	FL Segment output
60	Seg9	O	FL Segment output
61	Seg10	O	FL Segment output
62	Seg11	O	FL Segment output
63	Seg12	O	FL Segment output
64	Seg13	O	FL Segment output
65	Seg14	O	FL Segment output
66	SEL_RVS_A	I	Tape Mechanism select (Reverse=High, Normal =Low)
67	SEL_POW_RY	I	Power relay select (ON = high) ... for UK
	RDS	I	RDS input ... for XE
68	SEL_12_24	I	Timer display (24h=High 12h=Low)
69	MM_IN	I	Multimedia input input (ON = High)
70	V_CHK	I	Power suspension detection Power suspension = Low
71	C2F	I	C2Flag (DSP)
72	VDD		Power supply (+5V)
73	G_REVS	I	Failure record switch (Tape B side) (ON=Low)
74	G_FWD	I	Failure record switch (Tape A side) (ON=Low)
75	B_PACK	I	Tape set detection(B side) switch (ON=Low)
76	B_PALY	I	Play(B side) switch (ON=Low)
77	A_PACK	I	Tape set detection(A side) switch (ON=Low)
78	A_PLAY	I	Play(A side) switch (ON=Low)
79	A_REEL	I	Reel turn signal(A side)
80	B_REEL	I	Reel turn signal(B side)
81	POW_RY	O	Power relay control output (ON=High)
82	P_CON	O	Power control signal (Power on=high)
83	SP_RY	O	speaker relay control output
84	PRE_MUTE	O	PRE MUTE output (Mute on = High)
85	MAIN_MUTE	O	Main mute output (Mute on=High)
86	PULL_UP	O	pull-up power output (ON=Low)
87	DSP_RESET	O	Reset signal to DSP (CD)
88	CLK_SHIFT	O	Main clock shift
89	VSS		Ground
90	VDD		Power supply (+5V)
91	CARRIAGE+	O	CARRIAGE-MOTOR control output+
92	CARRIAGE-	O	CARRIAGE-MOTOR control output-
93	DRAWER+	O	DRAWER control output+
94	DRAWER-	O	DRAWER control output-
95	COIN	O	CD_DSP interface (command data output)
96	SQUT	I	CD_DSP interface (SubQ data input)
97	CQCK	O	CD_DSP interface (clock)
98	VD_GND	O	GND control output for micon power check
99	DRF	I	DRF signal input
100	RWC	O	CD_DSP interface (command latch)

FL DISPLAY DESCRIPTION

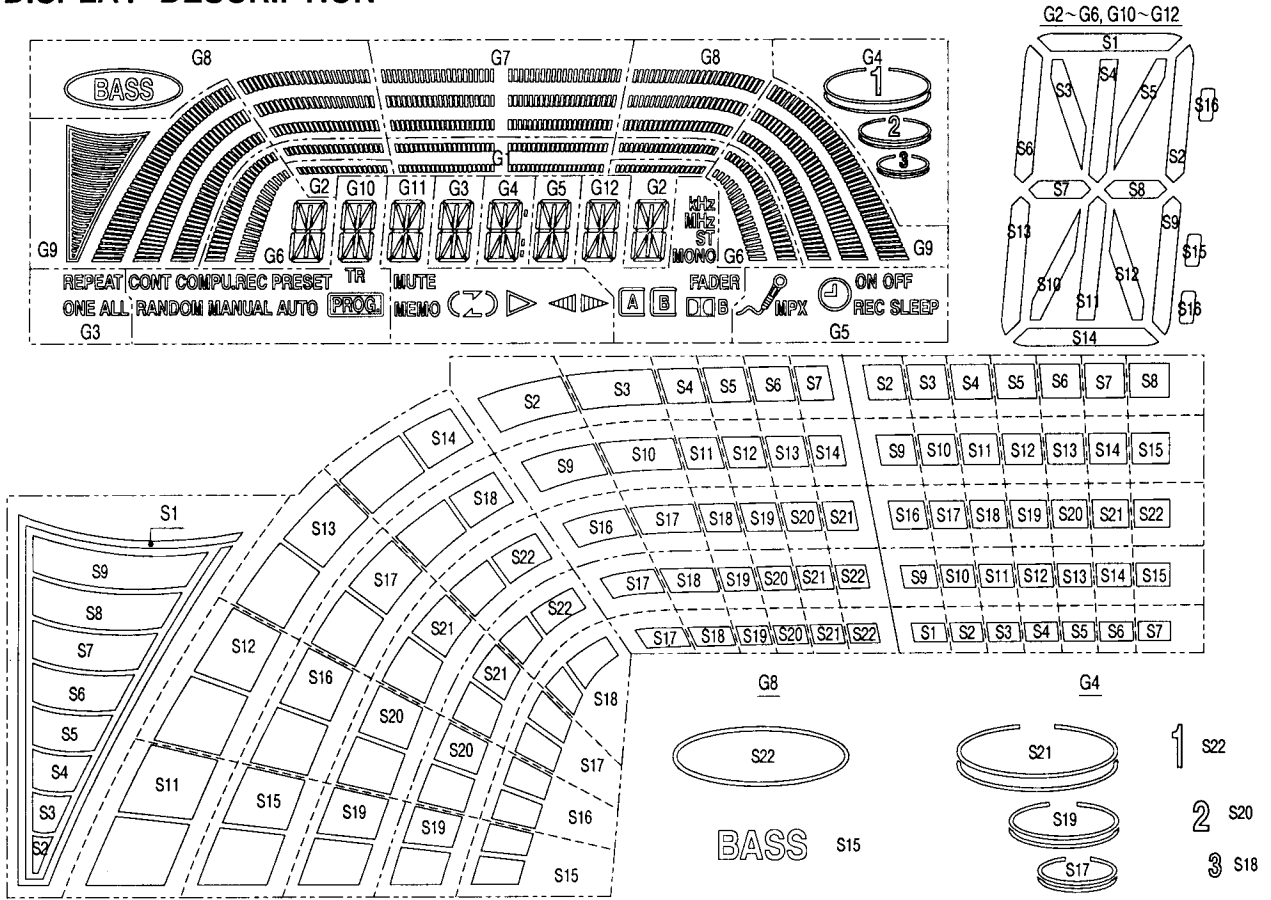

	G1	G2	G3	G4	G5	G6	G7	G8	G9	G10	G11	G12
S1	S1	S1	S1	S1	S1	S1	-	-	S1	S1	S1	S1
S2	S2	S2	S2	S2	S2	S2	S2	S2	S2	S2	S2	S2
S3	S3	S3	S3	S3	S3	S3	S3	S3	S3	S3	S3	S3
S4	S4	S4	S4	S4	S4	S4	S4	S4	S4	S4	S4	S4
S5	S5	S5	S5	S5	S5	S5	S5	S5	S5	S5	S5	S5
S6	S6	S6	S6	S6	S6	S6	S6	S6	S6	S6	S6	S6
S7	S7	S7	S7	S7	S7	S7	S7	S7	S7	S7	S7	S7
S8	-	S8	S8	S8	S8	S8	S8	-	S8	S8	S8	S8
S9	S9	S9	S9	S9	S9	S9	S9	S9	S9	S9	S9	S9
S10	S10	S10	S10	S10	S10	S10	S10	S10	-	S10	S10	S10
S11	S11	S11	S11	S11	S11	S11	S11	S11	S11	S11	S11	S11
S12	S12	S12	S12	S12	S12	S12	S12	S12	S12	S12	S12	S12
S13	S13	S13	S13	S13	S13	S13	S13	S13	S13	S13	S13	S13
S14	S14	S14	S14	S14	S14	S14	S14	S14	S14	S14	S14	S14
S15	S15	-	-	S15	-	S15	S15	BASS	S15	CONT	MUTE	kHz
S16	-	-	-	S16	OFF	S16	S16	S16	S16	COMPU.REC	MEMO	MHz
S17	S17	S17	-	S17	ON	S17	S17	S17	S17	PRESET	(ST
S18	S18	S18	-	S18	SLEEP	S18	S18	S18	S18	TR	⏏	MONO
S19	S19	S19	-	S19	REC	S19	S19	S19	S19	RANDOM)	FADER
S20	S20	S20	REPEAT	S20	⏏	S20	S20	S20	S20	MANUAL	▷	[A]
S21	S21	S21	ALL	S21	MPX	S21	S21	S21	S21	AUTO	◀	[B]
S22	S22	S22	ONE	S22	🔇	S22	S22	🔍	S22	[PROG.]	▶	[C/B]

Pin No.	1	2	3	4	5	6	7	8	9	10	11	12	13	14	15	16	17	18
Assignment	NL	NL	F1	NP	NL	G1	G2	G3	G4	G5	G6	G7	G8	G9	G10	G11	G12	H
Pin No.	19	20	21	22	23	24	25	26	27	28	29	30	31	32	33	34	35	36
Assignment	NL	NL	NL	NL	NL	NL	S22	S21	S20	S19	S18	S17	S16	S15	S1	S2	S3	S4
Pin No.	37	38	39	40	41	42	43	44	45	46	47	48	49	50	51	52		
Assignment	S5	S6	S7	S8	S9	S10	S11	S12	S13	S14	D	NL	NP	F2	NL	NL		

F1, F2 : Filament G1-G12 : Grid S1-S22 : Anode NP : No Pin NL : No Lead
 D : External connection to F2 H : Grid

IC & TRANSISTOR VOLTAGES

IC101 LA9240M

(V)

Pin No.	1	2	3	4	5	6	7	8	9	10	11	12	13	14	15
PLAY	2.5	2.5	2.5	2.5	2.5	2.5	2.5	2.5	2.5	2.5	2.5	2.5	2.5	2.5	2.6
STOP	2.5	2.5	2.5	2.5	2.5	2.5	2.5	2.5	2.5	2.5	2.5	2.5	2.5	2.5	2.5
Pin No.	16	17	18	19	20	21	22	23	24	25	26	27	28	29	30
PLAY	2.8	2.5	2.5	2.5	2.6	2.5	0	2.4	2.4	2.5	2.5	2.8	2.5	2.7	2.3
STOP	2.5	2.5	2.5	2.5	2.5	2.5	0	2.5	2.5	2.5	2.5	2.5	2.5	2.5	2.3
Pin No.	31	32	33	34	35	36	37	38	39	40	41	42	43	44	45
PLAY	2.3	0	0	4.9	0	1.5	0	0	0	0.8	2.4	2.4	2.5	2.5	0
STOP	2.3	0	0	4.9	5.0	4.8	0	4.9	0	0	1.6	2.4	2.4	2.5	0
Pin No.	46	47	48	49	50	51	52	53	54	55	56	57	58	59	60
PLAY	2.5	2.5	0	0	2.3	4.5	0	0	4.9	0	5.0	2.5	2.5	2.5	2.6
STOP	2.5	2.5	0	0	2.3	4.8	4.8	0	0	0	5.0	2.5	2.5	0.9	0.9
Pin No.	61	62	63	64											
PLAY	2.3	3.9	0	5.0											
STOP	2.2	4.3	0	5.0											

IC102 LC78622N

(V)

Pin No.	1	2	3	4	5	6	7	8	9	10	11	12	13	14	15
PLAY	0	0	1.6	0	1.6	5.0	0.3	0	2.5	2.5	0	0.9	0	0	0
STOP	0	0	0	0	1.6	5.0	0	0	2.5	2.4	0	0	0	4.9	0
Pin No.	16	17	18	19	20	21	22	23	24	25	26	27	28	29	30
PLAY	1.7	0	5.0	0	0	2.4	5.0	5.0	4.9	1.5	0	0	1.8	0	0
STOP	4.9	4.9	4.9	0	0	2.4	0	4.9	4.8	2.4	0	0	2.4	0	4.9
Pin No.	31	32	33	34	35	36	37	38	39	40	41	42	43	44	45
PLAY	2.4	0	0	0	0	5.2	2.1	0	0	2.1	5.2	0	5.0	2.0	2.0
STOP	2.4	0	0	0	4.9	5.2	2.1	0	0	2.1	5.2	4.9	4.9	2.0	2.0
Pin No.	46	47	48	49	50	51	52	53	54	55	56	57	58	59	60
PLAY	0	0.1	0	0.1	0	0.9	2.5	0.9	0	0	0	4.5	4.8	0	2.2
STOP	0	0.1	2.2	0	2.5	1.3	2.5	0	0	0	4.8	4.8	4.8	0	2.1
Pin No.	61	62	63	64											
PLAY	2.2	0	0	0											
STOP	2.2	0	0	0											

IC103 LA6541

(V)

Pin No.	1	2	3	4	5	6	7	8	9	10	11	12	13	14	15
PLAY	8.3	0	2.7	2.5	4.1	3.5	3.5	4.1	2.5	2.7	5.0	7.7	5.0	5.0	2.6
STOP	8.6	4.8	2.5	2.5	2.5	3.9	3.8	4.0	2.5	2.5	5.0	7.8	5.0	5.0	2.5
Pin No.	16	17	18	19	20	21	22	23	24						
PLAY	6.3	3.8	3.9	3.8	3.9	2.5	2.5	2.5	8.4						
STOP	2.5	3.9	3.9	3.9	3.8	2.5	2.5	2.5	8.4						

IC131 TA7291S

(V)

Pin No.	1	2	3	4	5	6	7	8	9						
DR-OPEN	4.8	11.5	7.4	0	0	11.0	0.7	6.7	0						
DR-CLOSE	0	11.5	0.7	0	0	11.0	7.4	6.7	4.8						
STOP	4.8	11.5	0.6	0	0	11.4	0.6	6.7	4.8						

IC132 TA7291S

(V)

Pin No.	1	2	3	4	5	6	7	8	9						
CA-OPEN	0	11.5	0.7	0	0	11.0	6.3	5.6	4.8						
CA-CLOSE	4.8	11.5	6.3	0	0	11.0	0.7	5.6	0						
STOP	4.8	11.5	0.6	0	0	11.4	0.6	5.6	4.8						

TRANSISTORS

PIN NAME	Q1301			Q1401		
	B	C	E	B	C	E
PLAY	4.5	1.9	3.9	8.2	5.0	5.0
STOP	4.9	1.6	4.3	8.3	5.0	7.7

WIRING CONNECTION

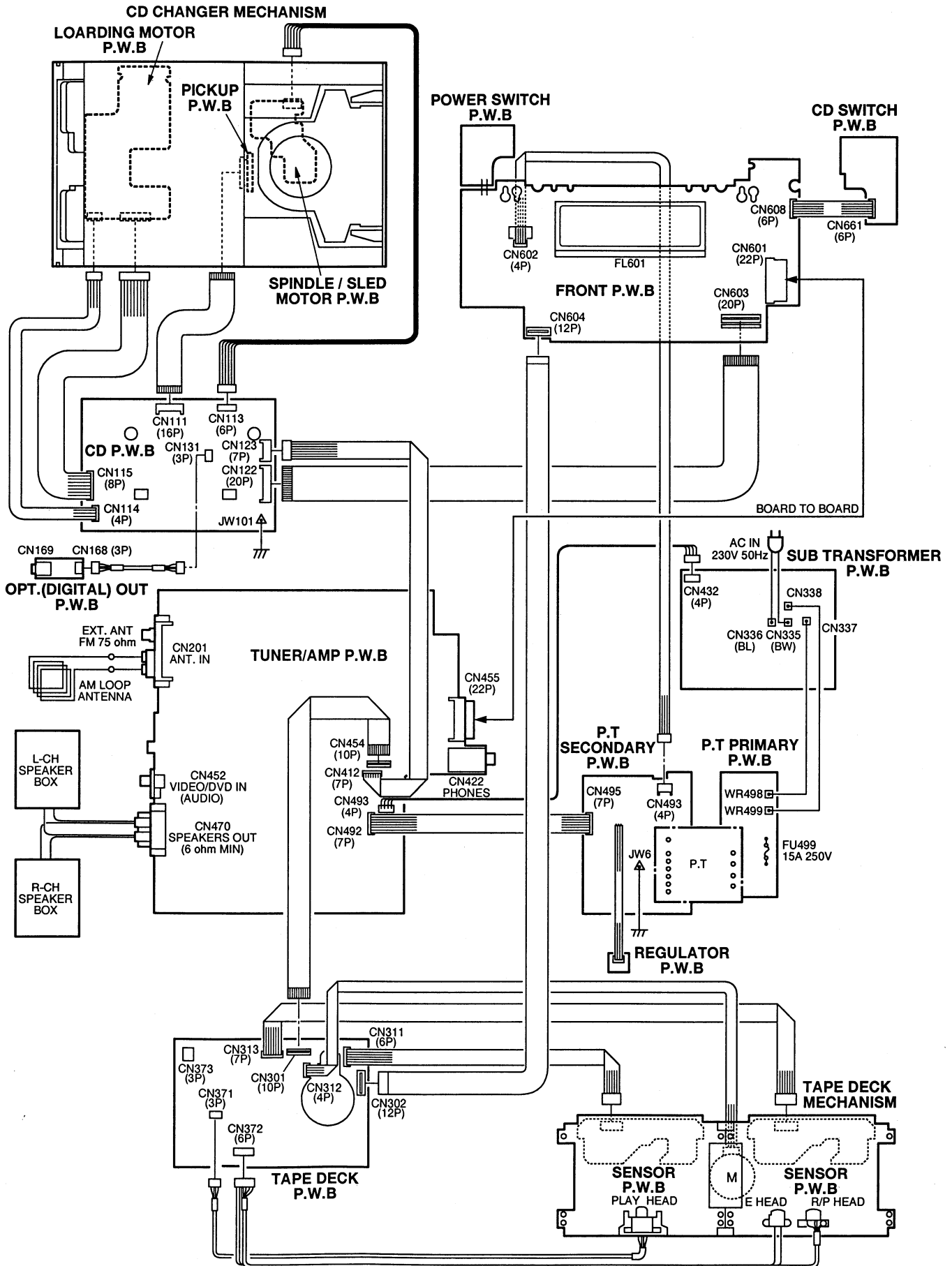

SCHEMATIC DIAGRAM (FRONT ... for UK)

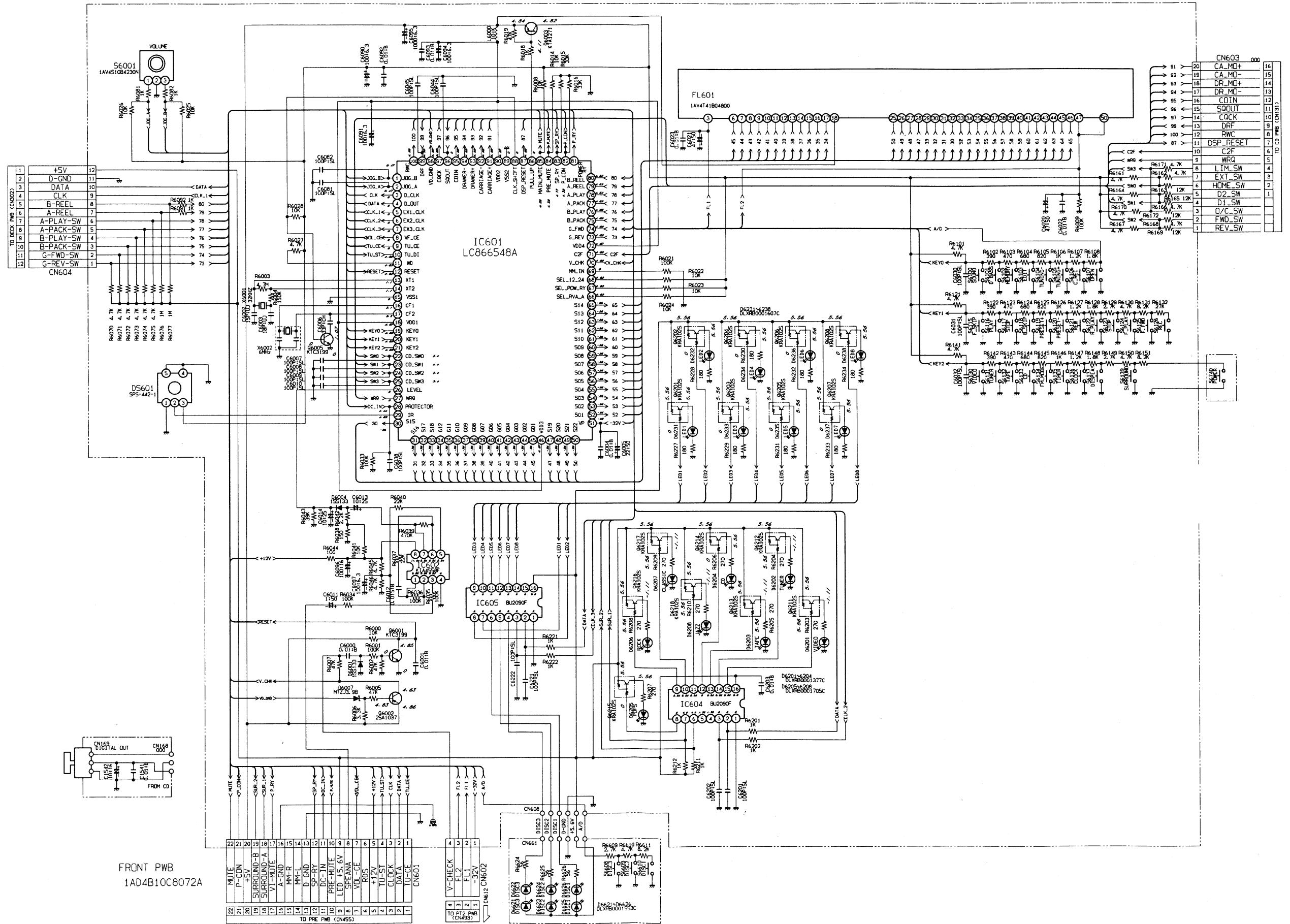

FRONT PWB
1A4B10C8072A

This is a basic schematic diagram.

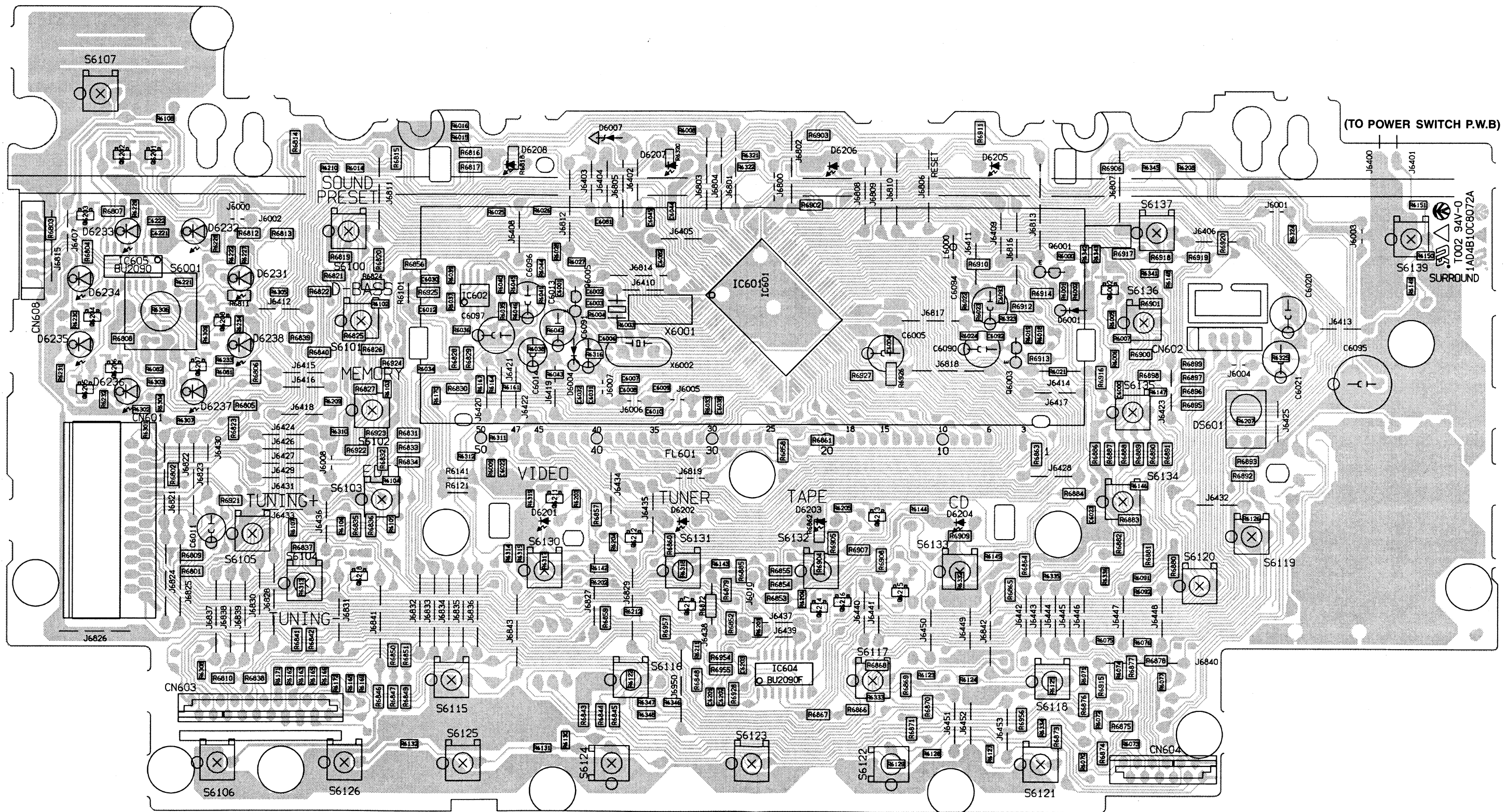

SCHEMATIC DIAGRAM (FRONT ... for XE)

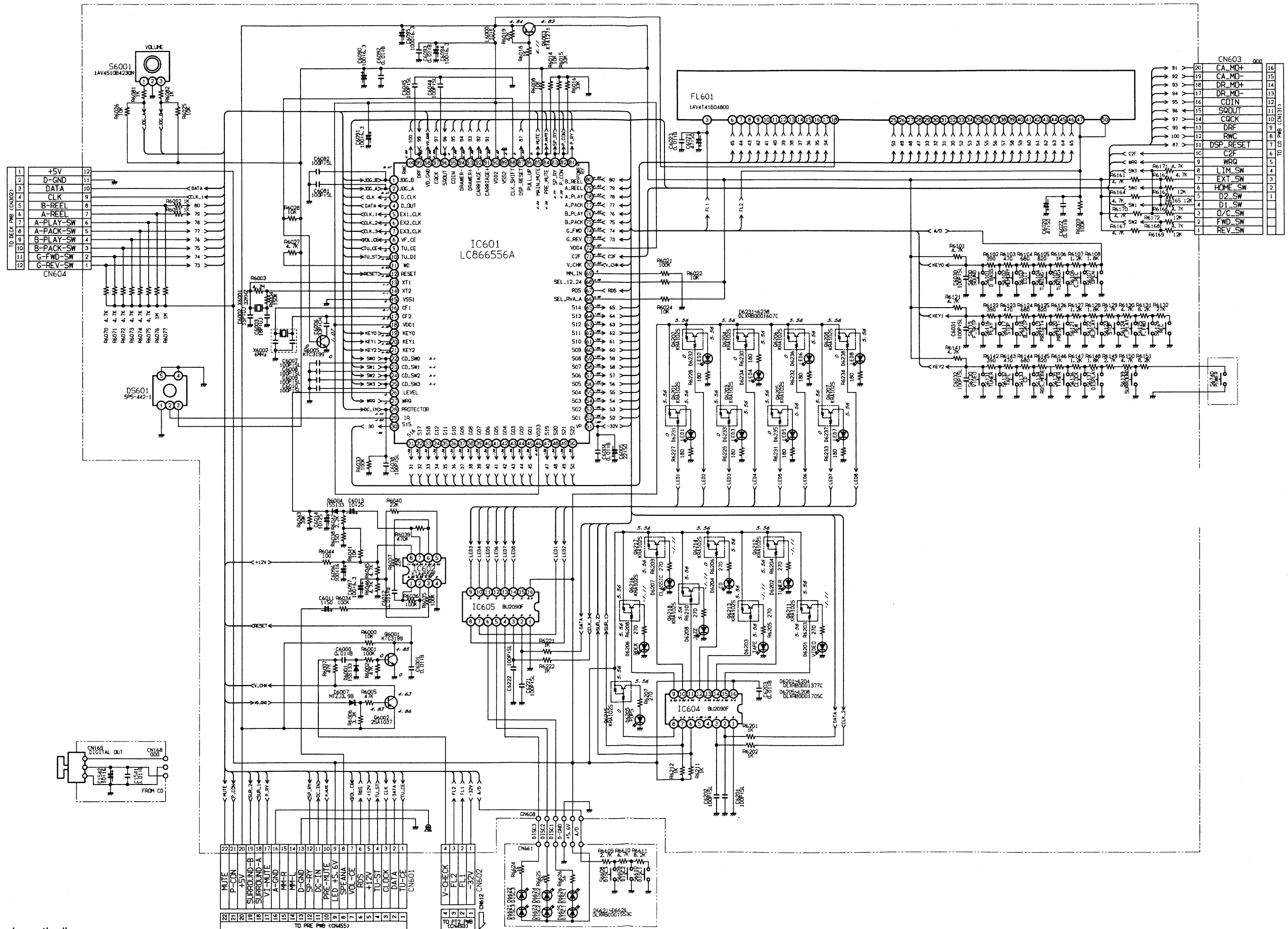

This is a basic schematic diagram.

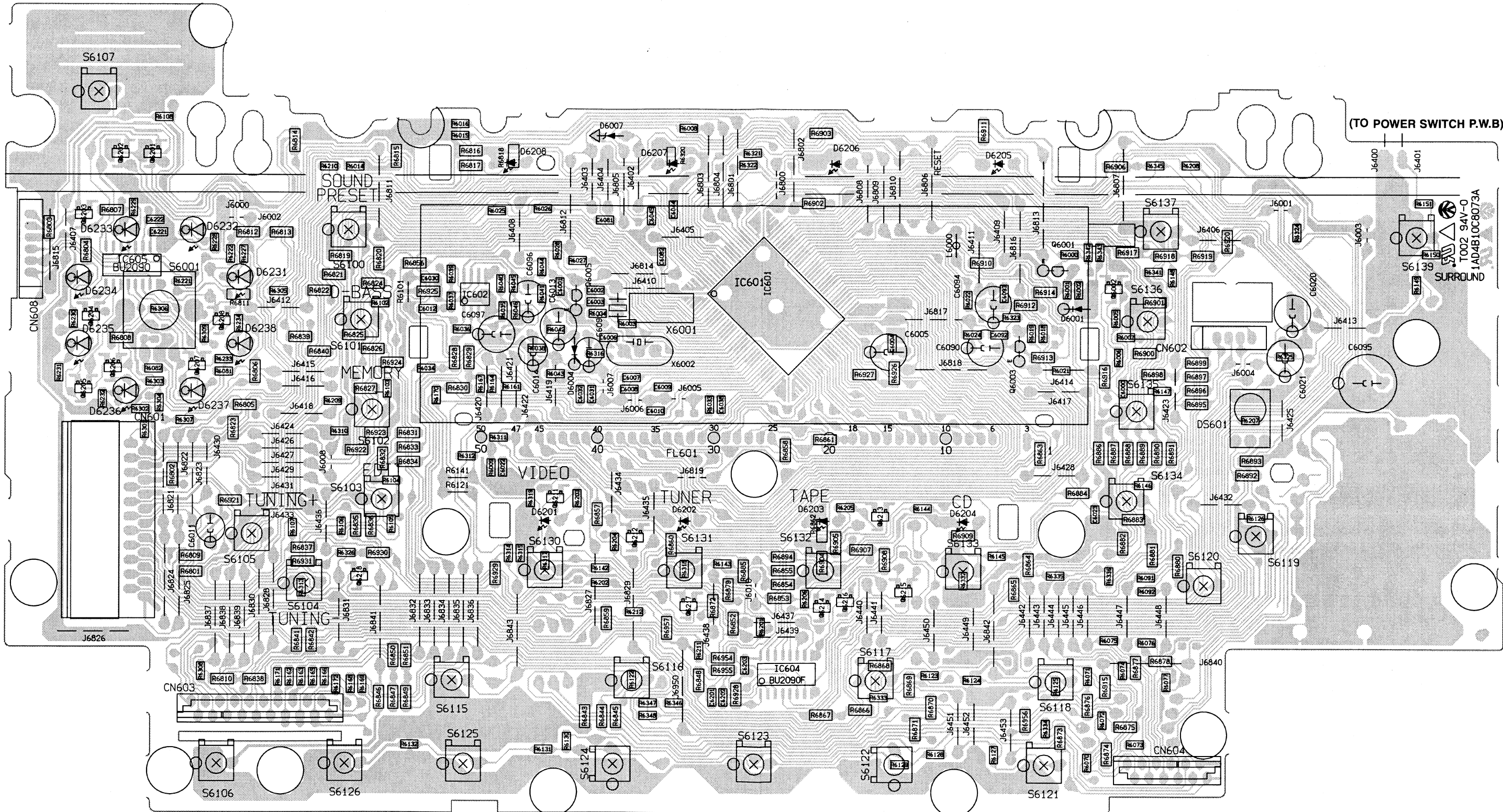

SCHEMATIC DIAGRAM (CD)

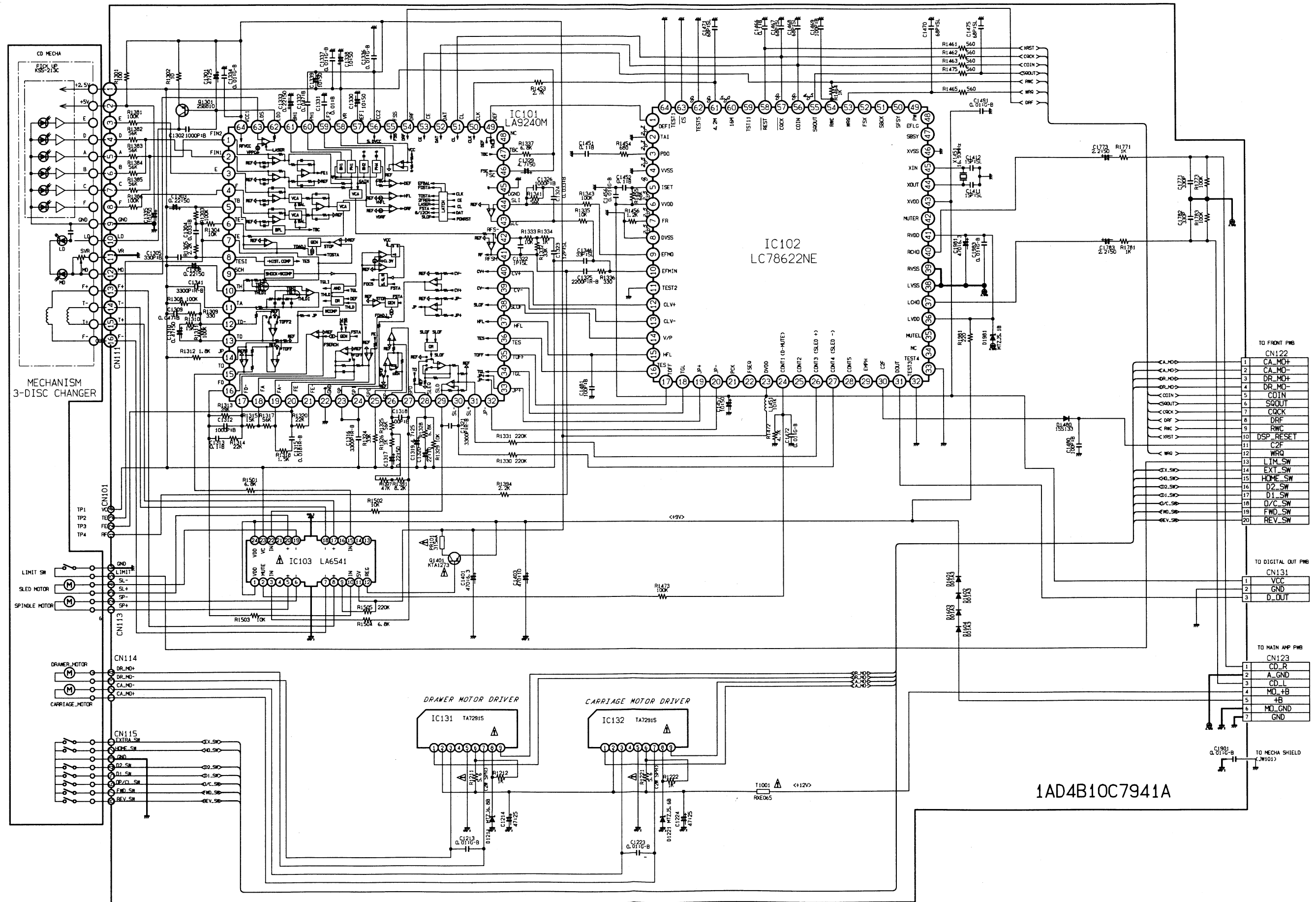

This is a basic schematic diagram.

SCHEMATIC DIAGRAM (DECK)

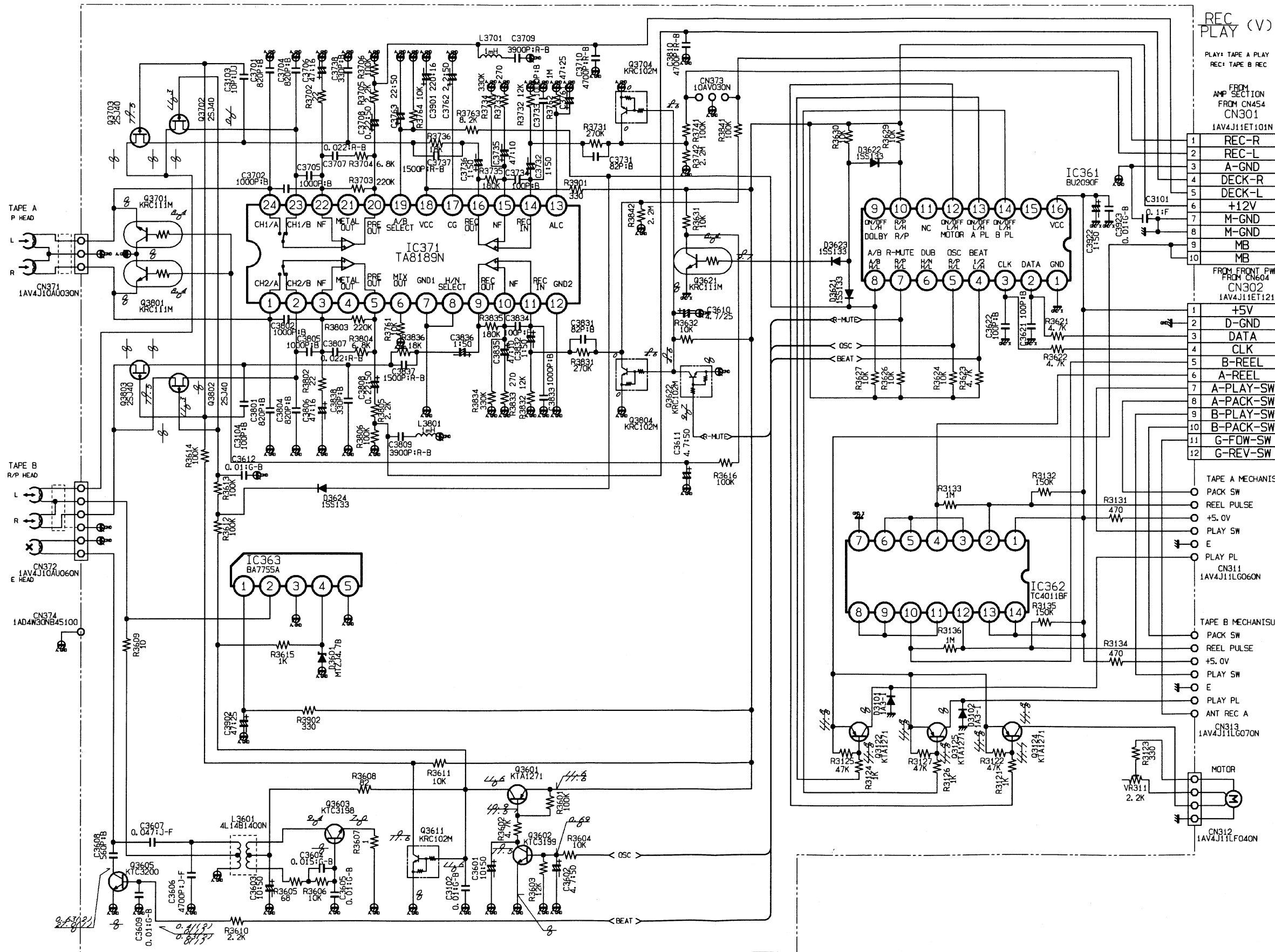

REC PLAY (V)
PLAY: TAPE A PLAY
REC: TAPE B REC

FROM AMP SECTION FROM CN454 CN301 1AV4J11ET101N

1	REC-R
2	REC-L
3	A-GND
4	DECK-R
5	DECK-L
6	+12V
7	M-GND
8	M-GND
9	MB
10	MB

FROM FRONT PWB FROM CN604 CN302 1AV4J11ET121N

1	+5V
2	D-GND
3	DATA
4	CLK
5	B-REEL
6	A-REEL
7	A-PLAY-SW
8	A-PACK-SW
9	B-PLAY-SW
10	B-PACK-SW
11	G-FOW-SW
12	G-REV-SW

TAPE A MECHANISM

1	PACK SW
2	REEL PULSE
3	+5.0V
4	PLAY SW
5	E
6	PLAY PL

TAPE B MECHANISM

1	PACK SW
2	REEL PULSE
3	+5.0V
4	PLAY SW
5	E
6	PLAY PL

ANT REC A
CN313 1AV4J11LG070N

MOTOR
CN312 1AV4J11LF040N

IC371	PLAY	REC	OTHER
1	0	0	
2	0	0	
3	1.3	1.3	
4	0	0	
5	1.3	1.3	
6	1.3	1.3	
7	0	0	
8	0	0	
9	2.0	2.0	
10	1.3	1.3	
11	0	0	
12	0	0	
13	1.0	1.0	
14	0	0	
15	1.3	1.3	
16	2.0	2.0	
17	1.4	1.4	0(B PLAY)
18	8.5	8.5	
19	1.3	1.3	
20	1.3	1.3	
21	0	0	
22	1.3	1.3	
23	0	0	
24	0	0	

IC361	PLAY	REC	OTHER
1	0	0	
2	0	0	
3	0	0	
4	0	0	
5	0	0	
6	0	0	
7	0	0	
8	0	0	
9	5.0	5.0	0(B PLAY)
10	11.5	11.4	
11	0	0	
12	0.4	0.4	11.4(STOP)
13	11.5	11.5	
14	11.5	11.5	
15	0	0	
16	5.7	5.5	

IC362	PLAY	REC	OTHER
1	5.7	5.6	
2	1.9	-	
3	0	-	
4	0.3	-	
5	0	-	
6	0	-	
7	0	0	
8	-	5.6	
9	-	5.6	
10	-	0.3	
11	-	5.6	
12	-	0.2	
13	5.7	5.6	
14	5.7	5.6	

IC363	PLAY	REC	OTHER
1	10.0	11.0	
2	0	0	
3	0	0	
4	0	4.8	
5	0	0	

This is a basic schematic diagram.

SCHEMATIC DIAGRAM (AMPLIFIER)

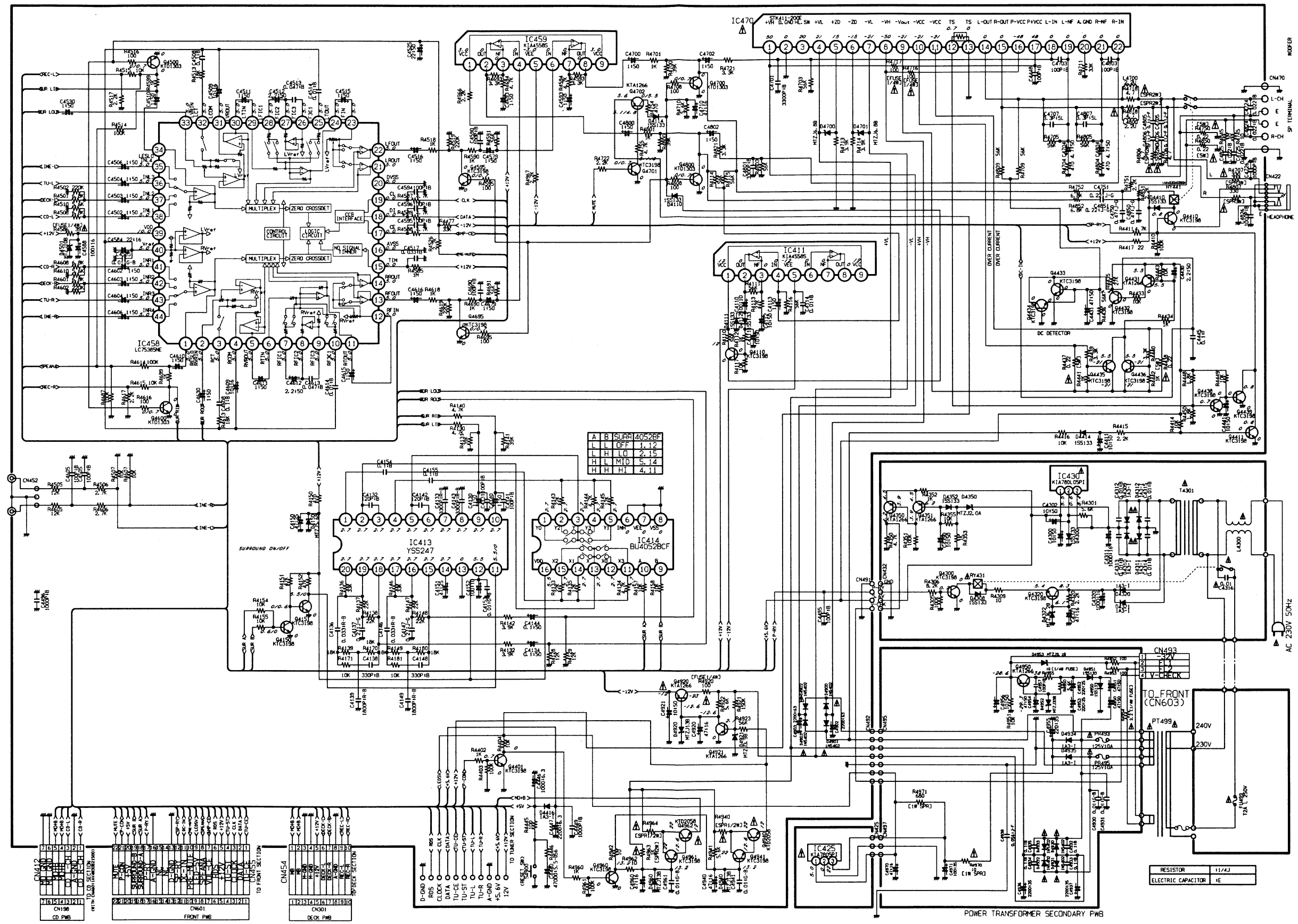

PRODUCT SAFETY NOTICE

Each precaution in this manual should be followed during servicing. Components identified with the IEC symbol Δ in the parts list and the schematic diagram designated components in which safety can be of special significance. When replacing a component identified by Δ , use only the replacement parts designated, or parts with the same ratings of resistance, wattage or voltage that are designated in the parts list in this manual. Leakage-current or resistance measurements must be made to determine that exposed parts are acceptably insulated from the supply circuit before returning the product to the customer.

This is a basic schematic diagram.

SCHEMATIC DIAGRAM (TUNER ... for UK)

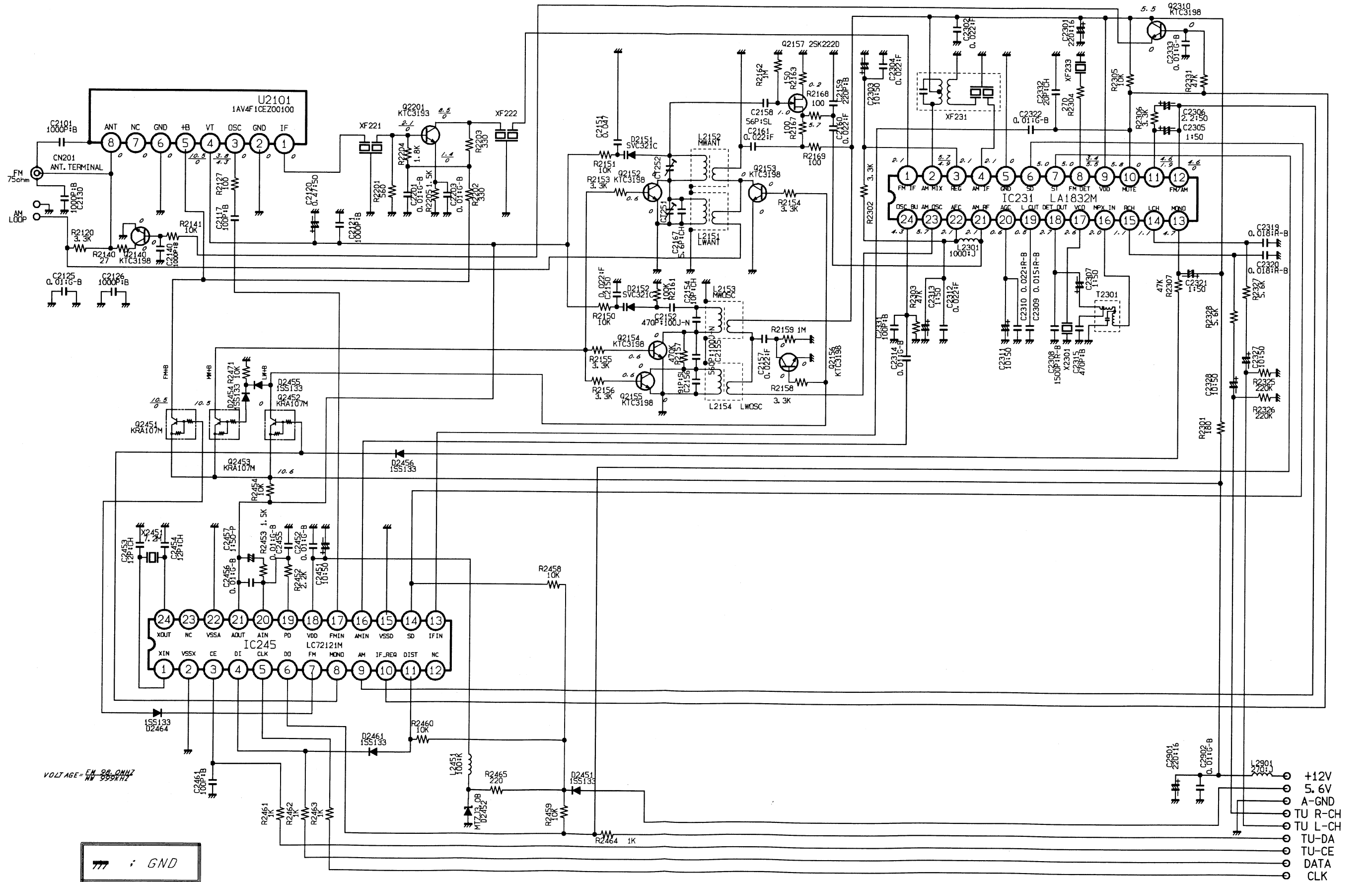

VOLTAGE = FM 98.0MHz
MW 99.9KHz

(TO PREAMP)

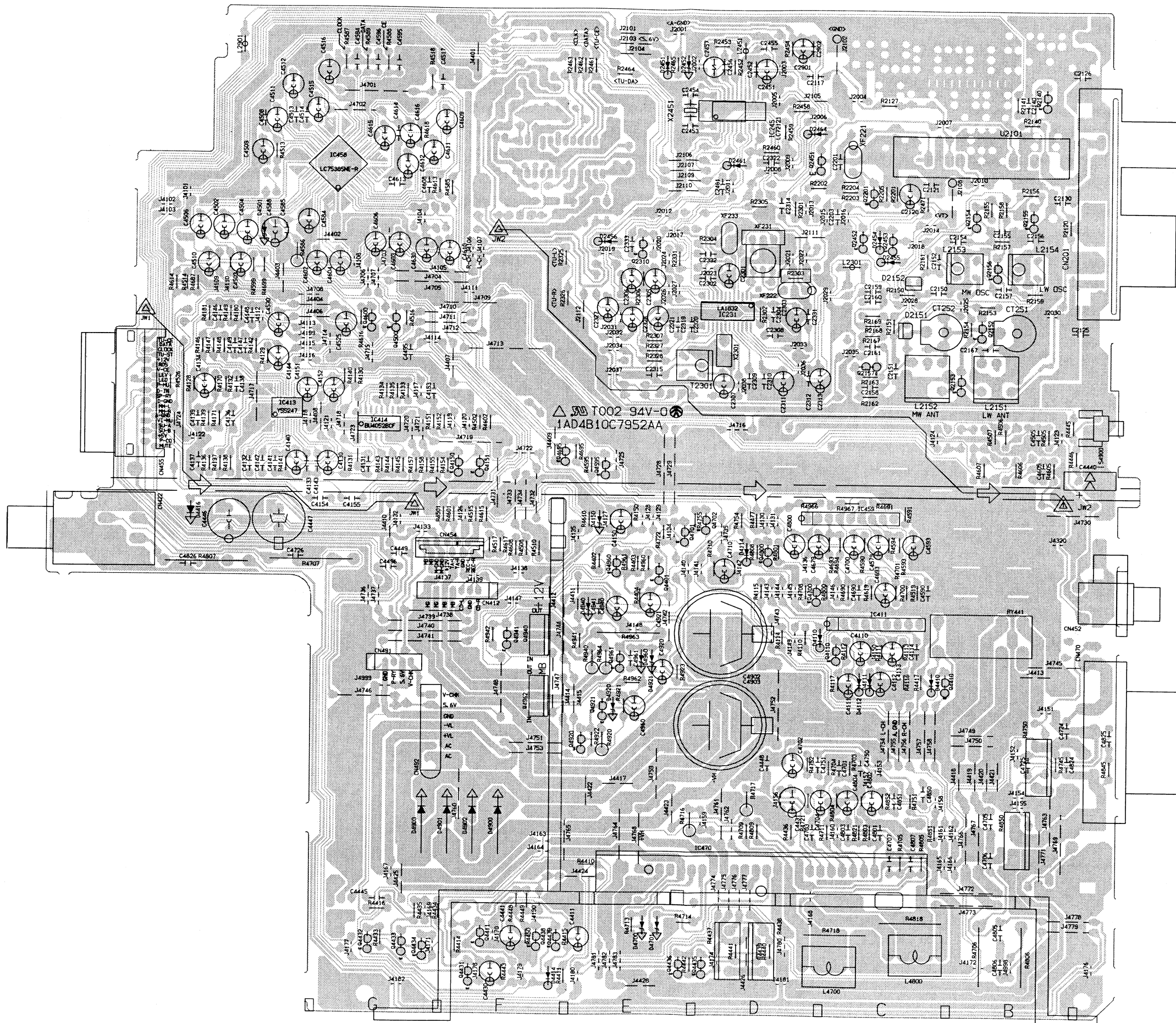

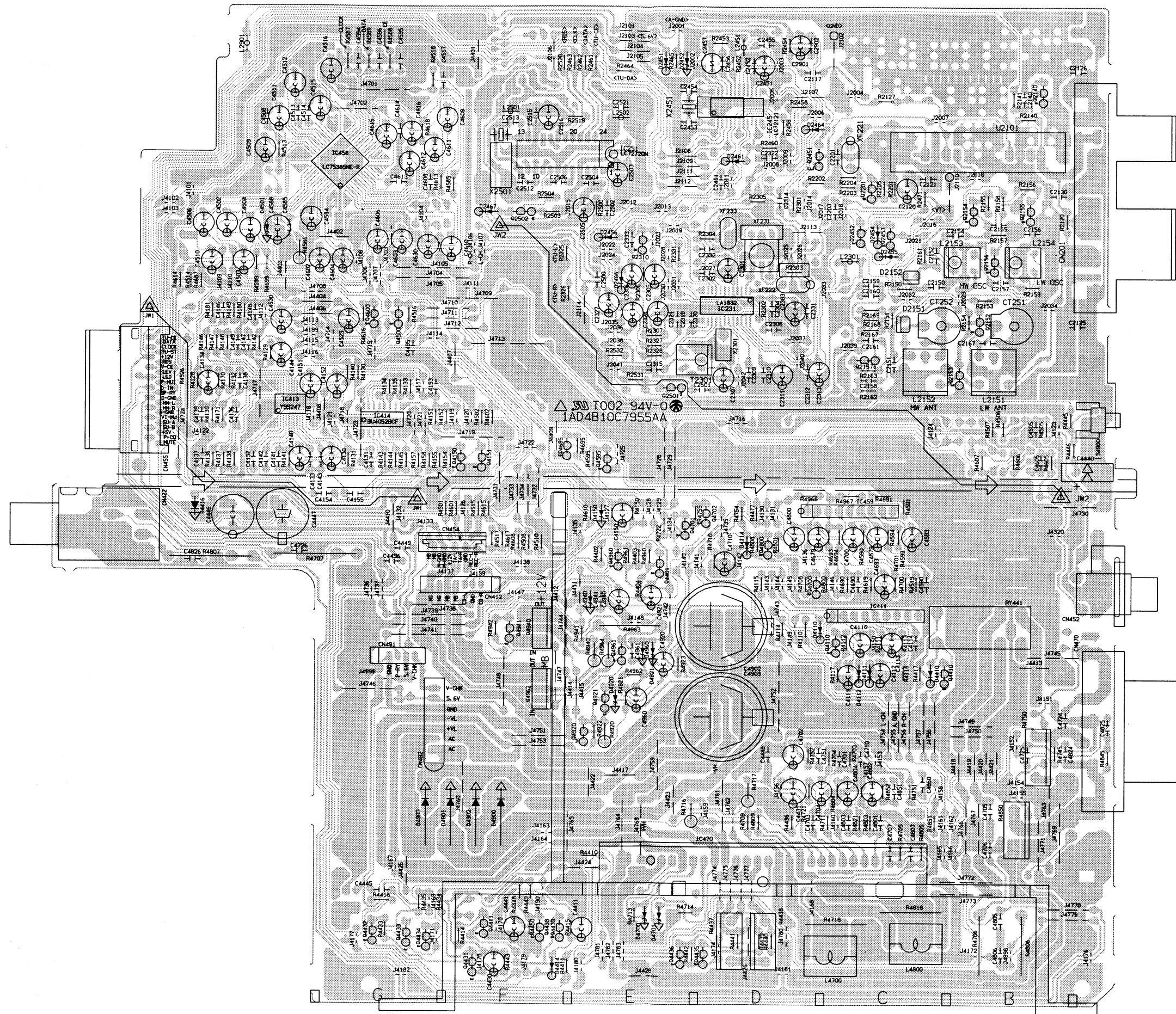

WIRING DIAGRAM (POWER TRANSFORMER)

POWER TRANSFORMER, PRIMARY P.W.B

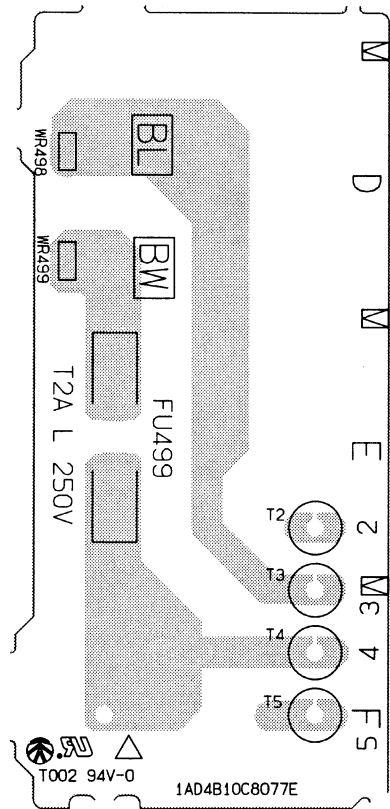

SUB TRANSFORMER P.W.B

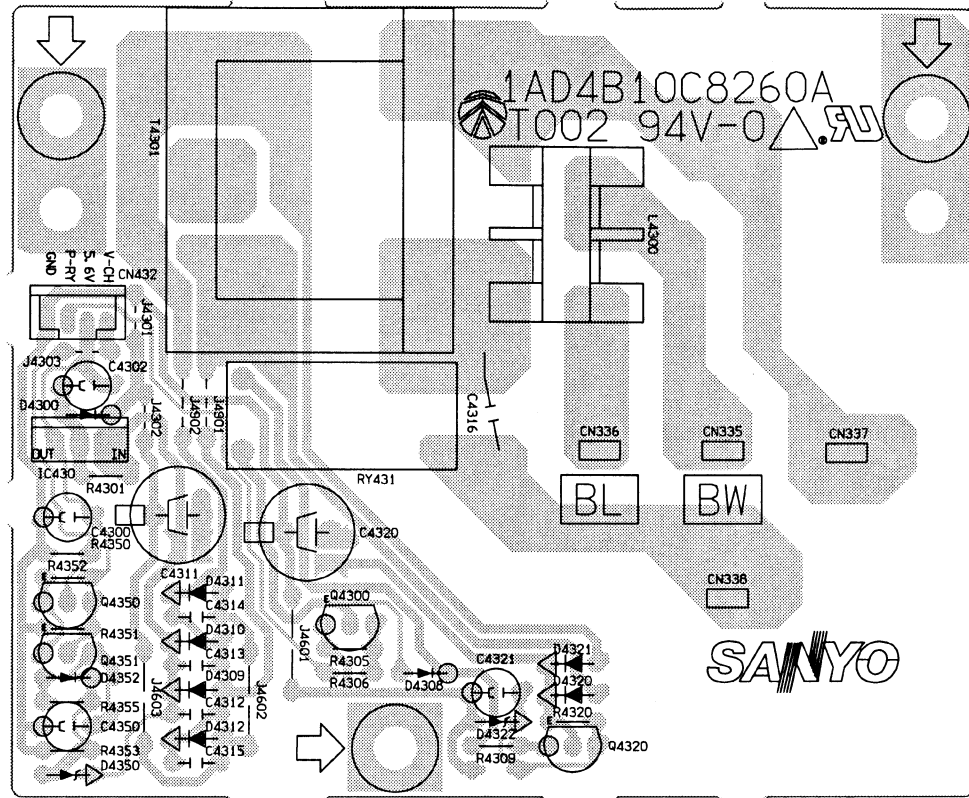

WIRING DIAGRAM (POWER SWITCH, DISC SWITCH, and e.t.c.)

DISC SWITCH P.W.B

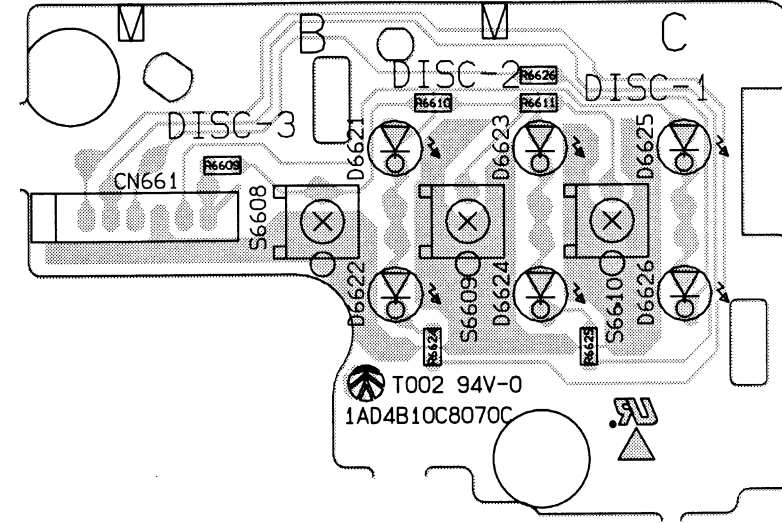

REGULATOR P.W.B

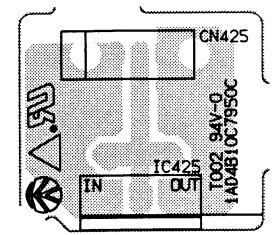

POWER TRANSFORMER, SECONDARY P.W.B

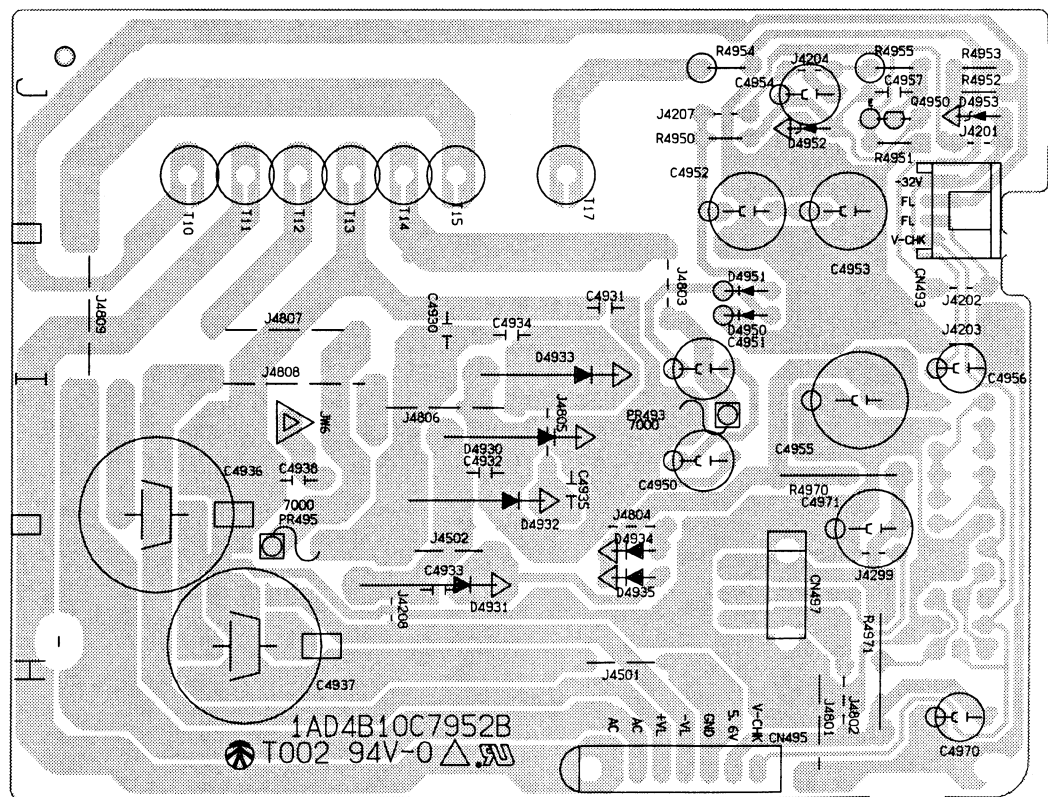

POWER SWITCH P.W.B

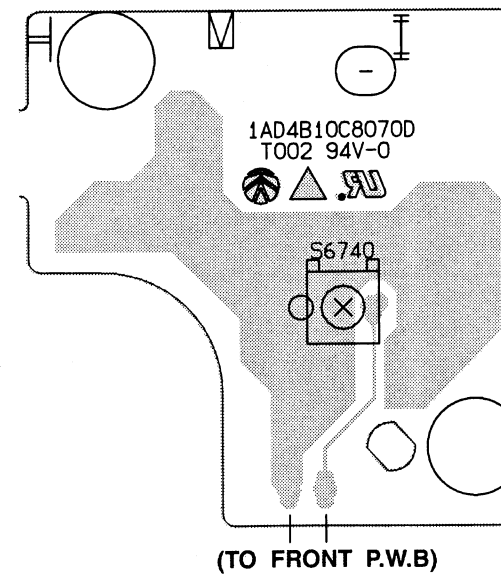

DIGITAL OUT P.W.B

