

iPECS



Hardware Description & Installation Manual

Regulatory Information

Before making connections to the telephone network, you may be required to notify your local serving telephone company of your intention to use "customer provided equipment." You may further be required to provide any or all of the following information:

PSTN Telephone numbers to be connected to the system.	
Model name:	LIK-100/300/600 IP KTS
Local regulatory agency registration number:	locally provided
Ringer equivalence:	0.7B
Registered jack:	RJ-11 w/Desk Holder/Wall Mount RJ-21X with Main Cabinet

The required regulatory agency registration number is available from your local LG-Ericsson representative.

This equipment complies with the following regulatory standards, FCC Part 15 and 68, IC (Industry Canada) CS03, TBR21, TBR03, and TBR04. Also, this equipment complies with the safety requirements of UL60950, CSA60950, EN60950, EN55022 and EN55024

iPECS has been designed to comply with the Hearing Aid Compatibility requirements as defined in Section 68.316 of Part 68 FCC Rules.

If the telephone company determines that customer provided equipment is faulty and may possibly cause harm or interruption in service to the telephone network, it should be disconnected until repair can be affected. If this is not done, the telephone company may temporarily disconnect your service.

The local telephone company may make changes in its communications facilities or procedures. If these changes could reasonably be expected to affect the use of iPECS or compatibility with the network, the telephone company is required to give advanced written notice to the user, allowing the user to take appropriate steps to maintain telephone service.

iPECS complies with rules regarding radiation and radio frequency emission as defined by local regulatory agencies. In accordance with these agencies, you may be required to provide information such as the following to the end user:

WARNING

This equipment generates and uses R.F. energy, and if not installed and used in accordance with the Instruction Manual, it may cause interference to radio communications. It has been tested and found to comply with the appropriate limits for a telecommunication device. The limits are designed to provide reasonable protection against such interference, when operated in a commercial environment.

Operation of this equipment in a residential area could cause interference, in which case the user, at their own expense, will be required to take whatever measures may be required to correct the interference.



CAUTION

This system employs a Lithium battery as back-up power for the real-time clock and memory. The battery is not replaceable in the field, refer to section 4.5.2. **RISK OF EXPLOSION IF BATTERY IS REPLACED BY AN INCORRECT TYPE.** Dispose of used batteries in accordance with the manufacturer's instructions.

Copyright© 2010 LG-Ericsson Co., Ltd. All Rights Reserved

This material is copyrighted by LG-Ericsson Co., Ltd. Any unauthorized reproductions, use or disclosure of this material, or any part thereof, is strictly prohibited and is a violation of Copyright Laws. LG-Ericsson reserves the right to make changes in specifications at any time without notice. The information furnished by LG-Ericsson in this material is believed to be accurate and reliable, but is not warranted to be true in all cases.

LG-Ericsson and iPECS are trademarks of LG-Ericsson Co.,Ltd.

All other brand and product names are trademarks or registered trademarks of their respective companies.

Update Revision History

ISSUE	DATE	DESCRIPTION OF CHANGES
1.0	28 Oct. 2002	Initial Release for standard version
1.1	08 Sep. 2003	Change the model name from LiK-100 to LiK-300
		Add Gateway Module (MFIME, VOIM, PRIM, RSGM)
1.2	09 Feb. 2004	Add a Gateway Module(VOIME)
		Add and change the description regarding safety information.
1.3	30 Aug. 2004	Update SHUB8 which supports POE
3.0	26 Jan. 2005	Update for LIP-7000 series Phones
3.1	02 Feb. 2005	Update LIK-300 figures and add a POE8 instead of SHUB8 with POE
4.0	26 Sep. 2006	Update for Phase 4, include new P4 gateways.
4.1	26 Dec. 2006	Correct some contents in issue4.0.
4.2	20 Mar. 2007	Correct the pin connection of MFIM100, MFIM300 and MFIM600
4.3	25 Apr. 2007	Update LGCM4 and BRIM2 Add SLTM4 Delete DIDM2/DIDU2 and SLTM2/SLTU2
4.4	21 Aug 2007	Add description of a option module CMU for LGCM4/LGCM8
4.5	16 Oct. 2007	Add MFIM100S
5.0	25 Jul 2008	Update for Phase 5, include MCKTE, WBRKE 1URMB, PSU, WTIM4/8 Added SLTM32 Rack mounting Added LIP-8000 series terminals Change various figures Added RSGM install in 1U-RMB Updated VSF/Capacity General edit and update through-out.
	11 Dec. 2008	Changed the Pin number of Relay contact from 1&2 to 7&8.
	04 Feb. 2009	MFIM1200 is added.
5.1	22 Jul 2009	Modification of "3.1.3.2 Module Power Requirements". SLTM32 is added in the table of "3.1.3.1 System Electrical specification".
5.2	27 May 2010	DTIM24 is added.

Table of Contents

1	INTRODUCTION	1
1.1	iPECS Overview.....	1
1.2	Hardware Components Chart	3
2	HARDWARE DESCRIPTION	5
2.1	iPECS Modules	5
2.1.1	MFIMs (Multi-Function Interface gateway Module)	5
2.1.2	VOIM8 & 24 (Voice Over IP gateway Modules)	7
2.1.3	LGCMs (Loop Start CO gateway Module)	8
2.1.3.1	LGCM4	8
2.1.3.2	LGCM8	9
2.1.4	DIDM8 (DID gateway Module)	10
2.1.5	DTIMs (Digital Terminal Interface gateway Module)	11
2.1.5.1	DTIM8	11
2.1.5.2	DTIM24	12
2.1.6	SLTMs (Single Line Telephone gateway Module)	13
2.1.6.1	SLTM4	13
2.1.6.2	SLTM8	14
2.1.6.3	SLTM32	15
2.1.7	BRIMs (BRI gateway Module)	16
2.1.7.1	BRIM2	16
2.1.7.2	BRIM4	17
2.1.8	PRIM (PRI gateway Module)	18
2.1.9	VMIM (Voice Mail Interface Module)	19
2.1.10	MCIM (Multi-Media Conference Interface gateway Module)	20
2.1.11	RSGM (Remote Services Gateway Module)	21
2.1.12	POE8 (Power Over Ethernet switching hub)	23
2.1.13	WTIM (Wireless Telephone Interface Module)	24
2.1.13.1	WTIM4	24
2.1.13.2	WTIM8	25
2.1.14	PSU (Power Supply Unit)	26
2.1.15	AD/DC adapter –G-	27
2.2	LIP Phones & Terminals	28
2.2.1	LIP-8000 Series Phones	28
2.2.2	LIP-7000 Series Phones	33
2.2.3	AC/DC Adapter –K- for LIP-Phones & Console	37
2.3	Module Mounting Hardware	37
2.3.1	DHLD (Desk Mount Holder) / DHE (Desk Mount Holder Extender)	38
2.3.2	WHLD (Wall Mount Holder)	38
2.3.3	1U-RMB (1U Rack Mount Bracket)	39

2.3.4	MCKTE (Main Cabinet Kit Enhanced)	39
2.4	Software Components	42
3	SYSTEM SPECIFICATIONS	43
3.1	System Capacity	43
3.1.1	Dimension and Weight	44
3.1.2	Environment specification	44
3.1.3	Electrical specification	45
3.1.3.1	System Electrical specification	45
3.1.3.2	Module Power Requirements	45
3.1.3.3	Maximum Station Distance from Gateway Module	46
3.1.3.4	CO loop specification	47
4	INSTALLATION	48
4.1	Overview	48
4.2	Site Preparation	48
4.2.1	General Site Considerations	48
4.2.2	Verify Equipment On-site	49
4.3	Module Mounting Hardware Installation	49
4.3.1	Enhanced Main Cabinet Installation	49
4.3.1.1	Cover Close/Open	49
4.3.1.2	Cabinet 19" Rack Installation	51
4.3.1.3	Cabinet Wall Mount Kit Installation	52
4.3.2	Main Cabinet Grounding	54
4.3.3	Module Desk Mount Holder Kit	55
4.3.4	Module Wall Mount Holder Kit	56
4.3.5	1U-Rack Mount Bracket Installation	56
4.4	PSU Installation	60
4.5	Module Installation	64
4.5.1	Module Handling and General Installation	64
4.5.1.1	Module Installation Sequence	64
4.5.1.2	Module Insertion/Removal	64
4.5.1.3	Common Module Switches	65
4.5.1.4	Module Grounding	66
4.5.1.5	Telephony Connections	66
4.5.1.6	LAN Connections	67
4.5.1.7	LAN Wiring Structures	68
4.5.1.8	RS-232 Connections	70
4.5.1.9	Module Power Adapter	71
4.5.2	MFIM Installation	71
4.5.3	VOIM8/24 Installation	74

4.5.4	LGCM4 Installation.....	75
4.5.5	LGCM8 Installation.....	77
4.5.6	DIDM8 Installation.....	79
4.5.7	DTIM8 Installation	80
4.5.8	DTIM24 Installation	81
4.5.9	SLTM4 Installation.....	83
4.5.10	SLTM8 Installation.....	84
4.5.11	SLTM32 Installation.....	85
4.5.12	BRIM2 Installation.....	87
4.5.13	BRIM4 Installation.....	88
4.5.14	PRIM Installation.....	89
4.5.15	VMIM Installation	91
4.5.16	MCIM Installation	92
4.5.17	RSGM Installation	93
4.5.18	POE8 Installation	97
4.5.19	WTIM4/8 Installation	99
4.6	MAIN CABINET WIRING.....	102
4.7	LIP Phone Installation.....	106
5	APPENDIX. USEFUL INFORMATION.....	111

List of Figures

Figure 1.1-1 iPECS Structure 2

Figure 2.1.2-1 VOIM8 & 24 Front & Rear Panels..... 7

Figure 2.1.3.1-1 LGCM4 Front & Rear Panels..... 8

Figure 2.1.3.2-1 LGCM8 Front & Rear Panels..... 9

Figure 2.1.4-1 DIDM8 Front & Rear Panels..... 10

Figure 2.1.5-1 DTIM8 Front & Rear Panels 11

Figure 2.1.5.2-1 DTIM24 Front & Rear Panels 12

Figure 2.1.6.1-1 SLTM4 Front & Rear Panels..... 13

Figure 2.1.6.2-1 SLTM8 Front & Rear Panels..... 14

Figure 2.1.6.3-1 SLTM32 Front & Rear Panels..... 15

Figure 2.1.7.1-1 BRIM2 Front & Rear Panels 16

Figure 2.1.7.2-1 BRIM4 Front & Rear Panels 17

Figure 2.1.8-1 PRIM Front & Rear Panels 18

Figure 2.1.9-1 VMIM Front & Rear Panels..... 19

Figure 2.1.10-1 MCIM Front & Rear Panels..... 20

Figure 2.1.11-1 RSGM Connection..... 21

Figure 2.1.11-2 RSGM Front & Rear Panels 22

Figure 2.1.12-1 POE8 Front & Rear Panels 23

Figure 2.1.13.1-1 WTIM4 Front & Rear Panels..... 24

Figure 2.1.13.2-1 WTIM8 Front & Rear Panels..... 25

Figure 2.1.14-1 PSU Front & Rear Panels..... 26

Figure 2.1.15-1 AD/DC adapter –G- 27

Figure 2.2.1-2 LIP-8004D 31

Figure 2.2.1-3 LIP-8012D 31

Figure 2.2.1-4 LIP-8024D 31

Figure 2.2.1-5 LIP-8040L..... 32

Figure 2.2.1-6 LIP-8012DSS..... 32

Figure 2.2.1-7 LIP-8012LSS 32

Figure 2.2.1-8 LIP-8048DSS..... 33

Figure 2.2.2-1 LIP-7004N 35

Figure 2.2.2-2 LIP-7008D	35
Figure 2.2.2-3 LIP-7016D	35
Figure 2.2.2-4 LIP-7024D	35
Figure 2.2.2-5 LIP-7024LD	35
Figure 2.2.2-6 LIP 7004WMB, Wall Mount Bracket	36
Figure 2.2.2-7 LIP 7008WMB, Wall Mount Bracket	36
Figure 2.2.2-8 LIP 7024WMB, Wall Mount Bracket	36
Figure 2.2.3-1 AC/DC Adapter –K-	37
Figure 2.3.1-1 DHLD & DHE	38
Figure 2.3.2-1 Module Wall Mount Holder	38
Figure 2.3.3-1 1U RMB	39
Figure 2.3.4-1 Main Cabinet	39
Figure 2.3.4-2 19" Rack Mount Installation	40
Figure 2.3.4-3 Desk Mount Installation	40
Figure 2.3.4-4 Wall Mount Installation	41
Figure 4.3.1.1-1 Cover installation	50
Figure 4.3.1.1-2 Cover removal	51
Figure 4.3.1.2-1 Rack (19") Installation	52
Figure 4.3.1.3-1 Cabinet Wall Mount Kit Installation	53
Figure 4.3.2-1 MCKTE Grounding	54
Figure 4.3.3-1 Module Desk Mount Holder Kit	55
Figure 4.3.4-1 Module Wall Mount Holder Kit	56
Figure 4.3.5-1 1U RMB Adapter Installation	57
Figure 4.3.5-2 1U-RMB Gateway Installation	58
Figure 4.3.5-3 1U-RMB Rack-mount Installation	59
Figure 4.4-1 Main PSU Installation	61
Figure 4.4-2 Back-up PSUs Installation	62
Figure 4.4-3 Monitoring cable Installation	63
Figure 4.5.1.2-1 Module Insertion/Removal	65
Figure 4.5.1.3-1 Common Module Switches	65
Figure 4.5.1.4-1 Module Grounding	66
Figure 4.5.1.5-1 Telephony (RJ-11 or RJ-45) Connector Pin Assignment	66

Figure 4.5.1.6-1 LAN Connector (RJ-45) Pin Assignment	67
Figure 4.5.1.7-1 iPECS LAN Wiring.....	69
Figure 4.5.1.7-2 Erroneous Loop Wiring.....	69
Figure 4.5.1.8-1 RS-232 DB-9 Pin-outs	70
Figure 4.5.2-1 MFIM100 Miscellaneous Function Connections	73
Figure 4.5.2-2 MFIM300/MFIM600/MFIM1200 Miscellaneous Function Connections...	74
Figure 4.5.4-1 Installing a CMU4 module in LGCM4	76
Figure 4.5.5-1 Installing a CMU4 module with LGCM8.....	78
Figure 4.5.8-1 DTIM24 Rack Mounting Installation.....	81
Figure 4.5.8-2 DTIM24 RJ-21X Connector Configuration	82
Figure 4.5.11-1 SLTM32 Rack Mounting Installation	85
Figure 4.5.11-2 SLTM32 RJ-21X Connector Configuration	86
Figure 4.5.12-1 BRIM2 BRI Line Connector Configuration	88
Figure 4.5.13-1 BRIM4 BRI Line Connector Configuration	89
Figure 4.5.14-1 PRI Line Connector Configuration	90
Figure 4.5.17-1 RSGM on Desk Mount Holder	93
Figure 4.5.17-2 RSGM on Wall Mount Holder	94
Figure 4.5.17-3 RSGM Connections.....	96
Figure 4.5.18-1 POE8 Installation.....	98
Figure 4.5.19-1 Cascading connections of WTIM4/8	101
Figure 4.6-1 RJ-21x Connector Backplane Wiring Diagram	102
Figure 4.6-2 Connections for LC1 & 2	103
Figure 4.6-3 Connections for LC 3 & 4	104
Figure 4.6-4 Connections for LC 5.....	105
Figure 4.7-1 LIP-8000 Wall Mount Installation.....	107
Figure 4.7-2 LIP-8000 DSS Installation	108
Figure 4.7-3 LIP-8000 DSS Installation (12DSS + 48DSS)	108
Figure 4.7-4 LIP-8000 DSS Installation (12DSS + 12LS)	109
Figure 4.7-5 LIP-8000 DSS Installation (12DSS + 12LSS+48DSS).....	109
Figure 4.7-6 LIP-7000 Wall Mount Installation.....	110
Figure 4.7-7 LIP-7000 DSS Installation	110

List of Tables

Table 1.2-1 iPECS Modules and Terminals.....	3
Table 2.1.1-1 MFIMs Comparison Chart.....	5
Table 2.2-1 LIP Phones.....	28
Table 3.1-1 System Capacities.....	43
Table 3.1.1-1 Dimensions and Weight.....	44
Table 3.1.2-1 Environmental Specifications.....	44
Table 3.1.3.1-1 System Electrical Specifications.....	45
Table 3.1.3.2-1 Module Power Requirements Chart.....	45
Table 3.1.3.3-1 Maximum Station Wiring Distance.....	46
Table 3.1.3.4-1 CO Loop Specifications.....	47
Table 4.4-1 PSU Status LED Functions.....	60
Table 4.5.2-1 MFIM100/300 Status LED Functions.....	71
Table 4.5.2-2 MFIM600 Status LED Functions.....	72
Table 4.5.2-3 MFIM Mode Switch Functions.....	72
Table 4.5.3-1 VOIM8 & VOIM24 Status LED Functions.....	74
Table 4.5.11-1 BRIM2 Status LED Function.....	87
Table 4.5.12-1 BRIM4 Status LED Function.....	88
Table 4.5.13-1 PRIM Status LED Functions.....	89
Table 4.5.14-1 VMIM Status LED Functions.....	91
Table 4.5.15-1 MCIM Status LED Functions.....	92
Table 4.5.16-1 RSGM Status LED Functions.....	94
Table 4.5.18-1 WTIM4/8 Status LED Functions.....	99
Table 4.5.18-2 WTIM4/8 Mode Switch Functions.....	99
Table 4.5.18-3 WTIM4/8 Pin assignments.....	100

1 INTRODUCTION

1.1 iPECS Overview

iPECS LIK is LG-Ericsson's Internet Protocol (IP) Enterprise Communications Solution designed to meet the telecommunication needs of the small to medium sized business. iPECS uses advanced packet voice and IP switching technology, which is combined with a rich feature content, to set a new standard in Voice over IP (VoIP) systems.

iPECS LIK consists of a family of intelligent modules, which are interconnected over a 10/100 Base-T Ethernet LAN, easing the installation process and eliminating the need for an expensive back plane. A variety of modules are available including analog and digital network access gateways, which connect to the Public Switched Telephone Network (PSTN), ISDN or public and private VoIP networks. The Ethernet switch (POE8), which provides connection to individual LIP Phones, incorporates circuitry for "power-feed" supporting Power over Ethernet LANs (PoE). LIP Phones provide the user simple access to the many features and functions of the iPECS.

The modules, which make up the iPECS, can be installed in a Main Cabinet. The cabinet can be desk, 19" rack, or wall mounted, as best fits the user needs and equipment room. Each of the system's modules is powered from a PSU, which converts 100-240 VAC to 48 VDC. In lieu of the cabinet installation, the modules can be shelf (book-end) mounted, in which case, each module is separately powered from an AC/DC adapter, which converts 100-240 VAC to 48 VDC for use by the module.

iPECS LIK supports a variety of LIP Phones; legacy digital terminals (LKD and LDP models), standard VoIP phones (SIP and H.323 V3) and analogue single line devices. With the LIP Phones, commonly used features are activated by selection of a single button. Additionally, most functions can be accessed from any telephone by dialing specific codes. For LIP and digital Phone users, these "dial codes" may be assigned to Flexible buttons for easy access. In addition to the LIP Phones, optional LIP DSS Consoles are available to expand the number of Flexible buttons available to the user.

iPECS LIK provides an environment rich in features beyond today's traditional circuit switched telephone systems. In addition to a fully featured voice intercom, the iPECS incorporates enhanced messaging, basic Auto Attendant/Voice Mail, Least Cost Routing, and Automatic Call Distribution, as well as Web based Admin, and VoIP network interface. iPECS incorporates an interface to the iPECS Applications Service Provider, a TAPI 3.1 TSP/MSP. The Application Service Provider links the iPECS to advanced Computer-Telephony applications of the iPECS Feature Server. In addition to the iPECS Auto Attendant/Voice Mail and iPECS Unified Messaging applications developed by LG-Ericsson, third party TAPI 3.1 application support is provided. Unified Communications Services (UCS) are supported through optional application software providing enhanced communications and presence. An optional Network Management Server (NMS) software package is available allowing monitoring and management of environments encompassing multiple iPECS installations.

By employing packet voice and IP switching, the iPECS infrastructure can be employed for or can share the enterprise data network. Further, since all modules and terminals have a unique IP address, they can be moved anywhere with access to a broadband network that can connect to

iPECS Release 5

Hardware Description & Installation

Issue 5.2D2

iPECS and function without the need for “re-programming”. The use of the single common infrastructure and ability to easily install or relocate modules and telephones results in significant savings at installation and over the life of the system.

The reliability, extensive feature content, the ability to support present and future applications with the iPECS Feature Server and the capability to use an array of modules and instruments, permit the iPECS to be tailored to meet the short and long term needs of the most demanding customer requirements.

Figure 1.1-1 below is a diagram of the various modules, terminals and applications available with iPECS.

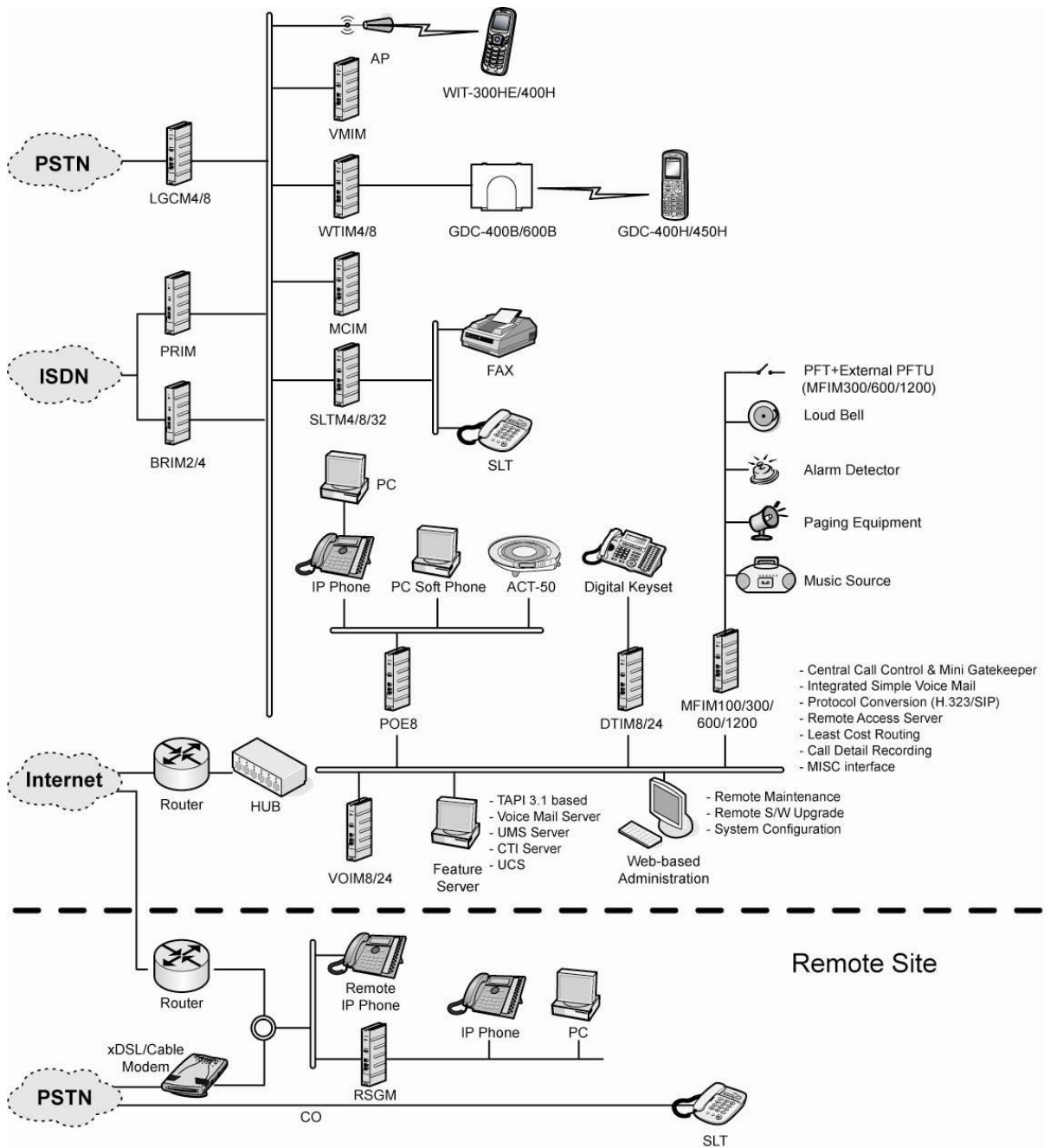

Figure 1.1-1 iPECS Structure

1.2 Hardware Components Chart

Table 1.2-1 provides a description of the hardware components that make-up iPECS. All of the iPECS Modules and terminals are connected over a 10/100 Base-T Ethernet LAN.

Table 1.2-1 iPECS Modules and Terminals

ITEM		DESCRIPTION
1	MFIM100	Multi-Function Interface gateway Module, 100 ports w/VSF ~ 210 min
	MFIM300	Multi-Function Interface gateway Module, 300 ports w/VSF ~ 210 min
	MFIM600	Multi-Function Interface gateway Module, 600 ports
	MFIM1200	Multi-Function Interface gateway Module, 1200 ports
2	PSU	Power Supply Unit for Enhanced Main Cabinet, 250W
3	VOIM8	Voice over IP Module, 8-Ch
4	VOIM24	Voice over IP Module, 24-Ch
5	LGCM4	Loop Start CO gateway Module, 4 ports
6	LGCM8	Loop Start CO gateway Module, 8 ports
7	DIDM8	DID gateway Module, 8 ports
8	DTIM8	Digital Terminal Interface gateway Module, 8 ports
9	DTIM24	Digital Terminal Interface gateway Module, 24 ports
10	SLTM4	Single Line Telephone gateway Module, 4 ports
11	SLTM8	Single Line Telephone gateway Module, 8 ports
12	SLTM32	Single Line Telephone gateway Module, 32 ports
13	BRIM2	BRI gateway Module, 2 port ISDN "T" Interface (2B+D)
14	BRIM4	BRI gateway Module, 4 port ISDN "T" Interface (2B+D)
15	PRIM	PRI gateway Module, 1 port, 30 channels
16	VMIM	Voice Mail Interface Module, 8-ch, 9 hour AA/VM module
17	MCIM	Multi-Media Conference Module (up to 32-party voice)
18	WTIM4	Wireless Terminal Interface gateway Module, 4 ports
19	WTIM8	Wireless Terminal Interface gateway Module, 8 ports
20	RSGM	Remote Services Gateway Module
21	POE8	Power over Ethernet Switching Hub, 8 ports with Uplink port
22	AC/DC Adapter –G-	AC/DC Adapter for modules, (48VDC, 0.83A)
23	AC/DC Adapter –K-	AC/DC Adapter for LIP Phones and DSS Console, (48VDC, 0.3A)
24	DHLD	Desk mount Holder for module
25	DHE	Desk mount Holder Extender, one (1) required for each Module
26	WHLD	Wall mount Holder for module
27	MCKTE	Main Cabinet Kit Enhanced
28	WBRKE	Wall mount Bracket Kit for Enhanced Main Cabinet
29	1U-RMB	1U Rack mount Bracket for gateway Modules
30	LIP-7004N	LIP Phone, Basic 4 button no display
31	LIP-7008D	LIP Phone, 8 button and basic 2-line display
32	LIP-7016D	LIP Phone, 16 button, 3-line display w/Menu, Soft & Nav. buttons
33	LIP-7024D	LIP Phone, 24 button, 3-line display w/Menu, Soft & Nav. buttons
34	LIP-7024LD	LIP Phone, 24 button, Large display w/Menu, Soft & Nav. buttons
35	LIP-7048DSS	LIP DSS Console with 48 buttons
36	LIP-8002	LIP Phone, 4 button and 1-line display, LAN 1 port

37	LIP-8004D	LIP Phone, 4 button and 1-line display, LAN 1 port
38	LIP-8012D	LIP Phone, 12 button, 3-line display w/Menu, Soft & Nav. buttons
39	LIP-8024D	LIP Phone, 24 button, 4-line display w/Menu, Soft & Nav. buttons
40	LIP-8040L	LIP Phone, 10 button, 9-line display w/Menu, Soft & Nav. buttons
41	LIP-8048DSS	LIP DSS Console with 48 buttons
42	LIP-8012DSS	LIP DSS Console with 12 buttons
43	LIP-8012LSS	LIP DSS Console with 12 buttons, w/12-line LCD button label
44	LIP-7004WMK	Wall Mount Kit for LIP-7004N
45	LIP-7008WMK	Wall Mount Kit for 7008D
46	LIP-7024WMK	Wall Mount Kit for LIP-7016D, 7024D & 7024LD
47	WIT-300HE/400H	iPECS WLAN Phone
48	GDC-400B/600B	DECT Base Station
49	GDC-400H/450H	DECT Handset
50	ACT-50	Audio Conference Terminal (Station SIP or SLT connect)

2 Hardware Description

2.1 iPECS Modules

2.1.1 MFIMs (Multi-Function Interface gateway Module)

The Multi-Function Interface gateway Modules (MFIM100, MFIM300, MFIM600 and MFIM1200), which are the main controller for iPECS and employ the iPECS protocol, extend telephony resources and call processing to the iPECS modules and terminals. Multi-Function Interface gateway Modules incorporate miscellaneous interfaces for Music-On-Hold (MOH), Background Music (BGM), contact monitors for Alarm and Doorbell inputs, Loud Bell Contacts, and Power Fail Transfer (PFT) relays. Also, Multi-Function Interface gateway Modules include battery back-up circuitry using a long-life Lithium battery to maintain the real-time clock and prevent loss of system database during power fail, refer to section 4.5.2.

There are several types of MFIMs as shown in Table 2.1.1-1.

Table 2.1.1-1 MFIMs Comparison Chart

ITEM	MFIM100	MFIM300	MFIM600	MFIM1200
System Capacity	100	300	600	1200
CO/IP Lines	42	200	600	1200
Stations	70	300	600	1200
Relay Contacts	2	4	4	4
VSF	210 min	210 min	n/a	n/a
External PFTU	No	Yes	Yes	Yes
VoIP Channels	6	6	n/a	n/a
USB Host port	1 port	1 port	1 port	1 port

Not all capacities can be simultaneously achieved, for detailed capacity specifications refer to section 3.1.

With the exception of the MFIM600 and MFIM1200, MFIMs incorporate an IP Gateway for access to standards based (SIP and H.323 v3) and iPECS protocol Voice over IP (VoIP) communications networks and a voice storage medium, the VSF. The IP gateway supports up to 6 simultaneous full duplex packet voice channels. Transcoding for major codecs (g.711, g.729a, g.723.1) is provided by on-board DSP circuitry. The VSF is used for the integrated Automated Attendant and Voice Mail services available in the iPECS software. The MFIM100 and MFIM300 have a voice storage capacity of approximately 210 minutes.

MFIMs have a 10/100 Base-T Ethernet interface, the “LAN1” RJ-45 type connector, which is the interface to the iPECS call server features and functions. Each MFIM has a second 10/100 Base-T Ethernet interface “LAN2” RJ-45 type connector. The “LAN2” port is employed for redundant processor operation. For redundant processor operation, the LAN2 ports of the main and back-up MFIM are interconnected using a standard RJ-45 cable. The Ethernet ports incorporate auto MDI, MDIX switching, therefore, both straight and cross cables can be used.

MFIMs have front panels as shown in Figure 2.1.1-1, which include:

- Power jack for the AC/DC adapter; see section 2.1.15 AD/DC adapter –G-

- Power status LED,
- RCA jack for one music (audio) source -BGM1-,
- One (1) "LAN1" RJ-45 Female LAN connector with Speed and Link/Activity LEDs,
- One (1) "LAN2" RJ-45 Female LAN connector with Speed and Link/Activity LEDs,
- Four (4)-position DIP-switch for mode selections,
- Ten (10) LEDs,
- Five (5) red LEDs display the operating status of the main processor,
- Five (5) green LEDs display the operating status of MISC functions,
- One (1) DB-9 RS-232 connector and one (1) USB host port,
- Reset Switch.

On the rear panel, each MFIM has:

- Eight (8) RJ-45 female connectors; for Alarm, BGM/MOH and Control Relay inputs, External Page outputs and Power Fail Transfer circuits,
- Ground Lug,
- Fifty (50)-pin back plane connector.

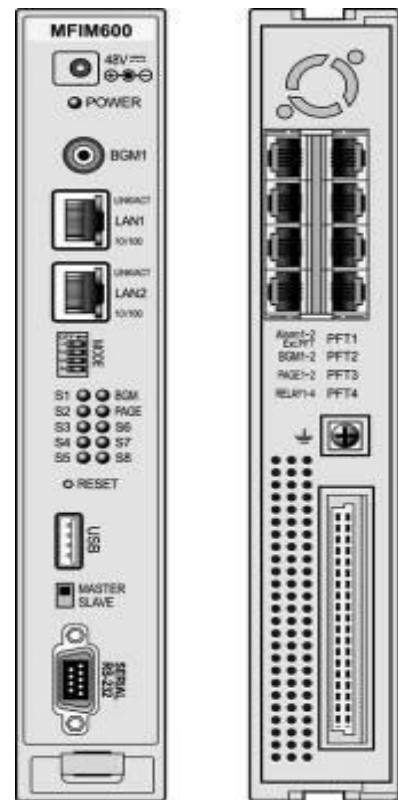

Figure 2.1.1-1 MFIM Front & Rear Panel Example

2.1.2 VOIM8 & 24 (Voice Over IP gateway Modules)

The eight (8) and twenty-four (24) channel Voice over IP gateway Module (VOIM8 and VOIM24) perform packet translation between standard H.323 or SIP protocol and the iPECS proprietary protocol. The VOIM8 contains a single processor to support eight (8) VoIP calls. The VOIM24 contains 2 processors to support maximum twenty-four (24) VoIP calls. The main processor manages packet switching and signaling for all VoIP calls. DSPs are employed to support in-band DTMF detection and transcoding between various codec types for each IP channel. The transcoding feature enables users to communicate with each other, when the codec between iPECS and other terminal is different.

The VOIM8 and VOIM24 include a 10/100 Base-T Ethernet interface using an RJ-45 type connector. (Labelled WAN) A second “LAN” RJ-45 type connector is provided for **future use** (LAN – U). Both Ethernet ports incorporate auto MDI and MDIX switching feature allowing use of either straight cable and cross cable.

As shown in Figure 2.1.2-1, the front panels of the VOIM8 and 24 have:

- Power jack for the AC/DC adapter; see section 2.1.15 AD/DC adapter –G-,
- Power status LED,
- Normal/Service switch,
- One (1) RJ-45 Female LAN connector for master processor with Speed and Link/Act LEDs,
- One (1) RJ-45 Female LAN connector with Speed and Link/Act LEDs
- Five (5) status LEDs,
- One (1) DB-9 RS-232 connector,
- Reset Switch.

On the rear panel, the VOIM8 and 24 have:

- Ground Lug,
- Fifty (50)-pin back plane connector.

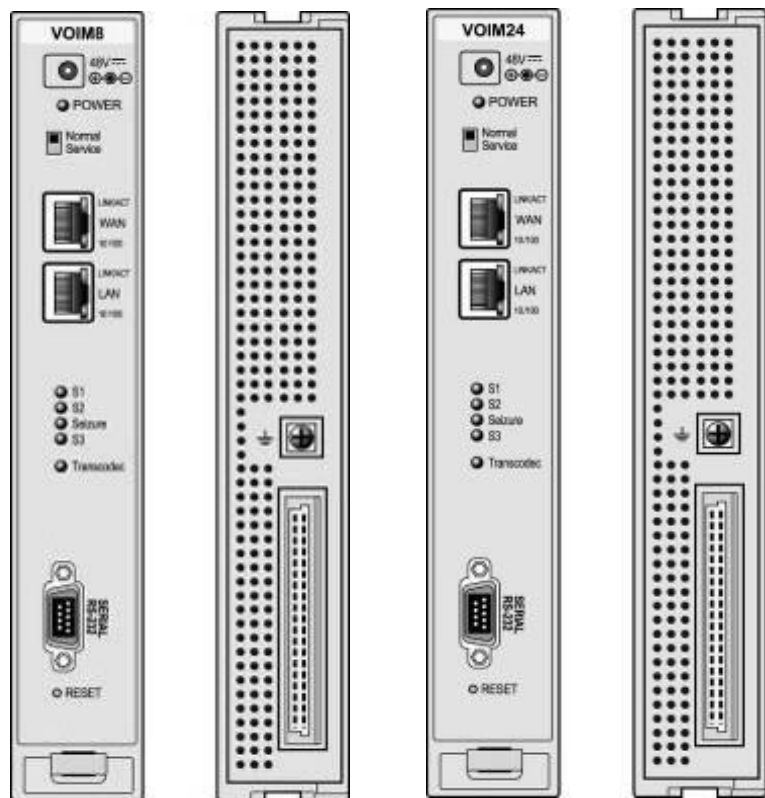

Figure 2.1.2-1 VOIM8 & 24 Front & Rear Panels

2.1.3 LGCMs (Loop Start CO gateway Module)

2.1.3.1 LGCM4

The four (4)-port Loop Start CO gateway Module (LGCM4) provides four (4) CO/PBX Loop Start Line interfaces. These interfaces support pulse or DTMF dial signals. Each Interface contains ring and loop current detection circuits, speech codec and compression functions and loop signaling circuits. The circuitry and software support tone detection. A Call Metering Unit (CMU4) optional module is needed to use the call metering function. Each CMU4 supports 4 ports and there are three versions, based on protocol CMU4-12PR, CMU4-16, CMU4-50PR. Each version is for different regions as shown below.

- 12PR – Australia, Denmark, Italy, Spain, Sweden
- 16 – Belgium, India, Israel, Norway, South Africa
- 50PR – Australia(NA), India, South Africa, South Korea, United Kingdom

The LGCM4 includes a 10/100 Base-T Ethernet interface as well as packet voice processing functions. The Ethernet port incorporates auto MDI, MDIX switching, therefore, both straight and cross cables can be used.

As shown in Figure 2.1.3.1-1, the front panel of the LGCM4 has:

- Power jack for the AC/DC adapter; see section 2.1.15 AD/DC adapter –G-,
- Power status LED,
- Normal/Service switch – In Service mode, circuits in use are busied as they return to idle,
- RJ-45 Female LAN connector with Speed and Link/Activity LEDs,
- Four (4) LEDs, one for status of each CO line,
- One (1) LED to indicate if a CMU is installed,
- DB-9 RS-232 connector,
- Reset Switch.

On the rear panel, the LGCM4 has:

- Four (4) RJ-45 female connectors
- Ground Lug,
- Fifty (50)-pin back plane connector.

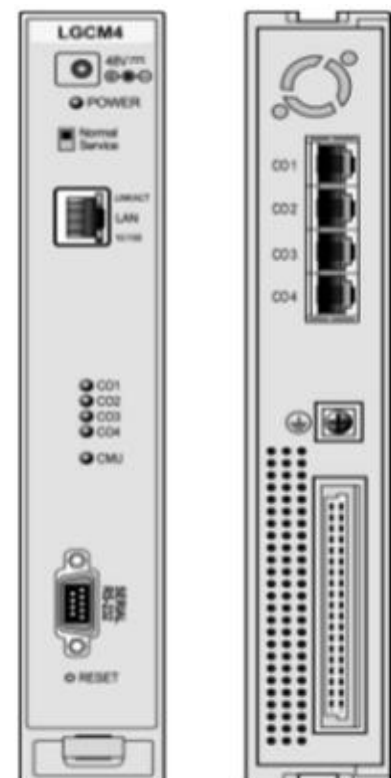

Figure 2.1.3.1-1 LGCM4 Front & Rear Panels

2.1.3.2 LGCM8

The eight (8)-port Loop Start CO gateway Module (LGCM8) provides eight (8) CO/PBX Loop Start Line interfaces. These interfaces support pulse or DTMF dial signals. Each Interface contains ring and loop current detection circuits, speech codec and compression functions, and loop signaling circuits. The circuitry and software support tone detection. Two Call Metering Unit (CMU4) optional modules are needed to use the call metering function. Each CMU4 supports four (4) ports and there are three versions based on protocol CMU4-12PR, CMU4-16, CMU4-50PR. Each version is for different regions as shown below.

- 12PR – Australia, Denmark, Italy, Spain, Sweden
- 16 – Belgium, India, Israel, Norway, South Africa
- 50PR – Australia, India, South Africa, South Korea, United Kingdom

The LGCM8 includes a 10/100 Base-T Ethernet interface as well as packet voice processing functions. The Ethernet port incorporates auto MDI, MDIX switching, therefore, both straight and cross cables can be used.

As shown in Figure 2.1.3.2-1, the front panel of the LGCM8 has:

- Power jack for the AC/DC adapter; see section 2.1.15 AD/DC adapter –G-,
- Power status LED,
- Normal/Service switch – In Service mode, circuits in use are busied as they return to idle,
- RJ-45 Female LAN connector with Speed and Link/Activity LEDs,
- Eight (8) LEDs, one for status of each CO line,
- Two (2) LEDs, one to indicate installation of each CMU4,
- DB-9 RS-232 connector,
- Reset Switch.

On the rear panel, the LGCM8 has:

- Eight (8) RJ-45 female connectors,
- Ground Lug,
- Fifty (50)-pin back plane connector.

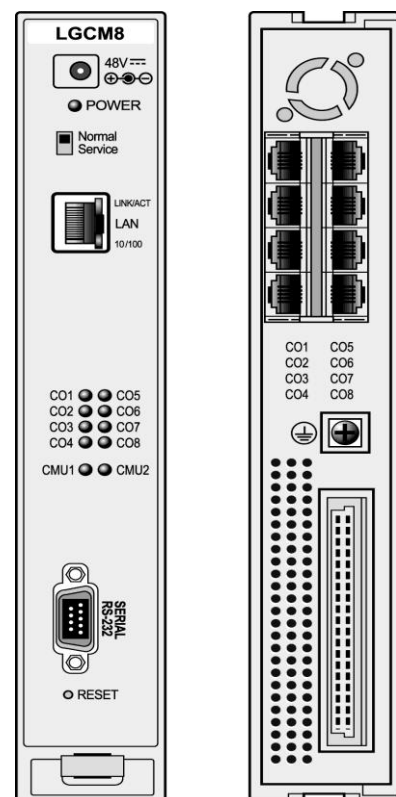

Figure 2.1.3.2-1 LGCM8 Front & Rear Panels

2.1.4 DIDM8 (DID gateway Module) (Not for Australian Use)

The eight (8)-port Direct-In-Dial gateway Module (DIDM8) provides interfaces to Direct-In-Dial Lines, supporting wink or immediate start signaling. These special PSTN lines are incoming only and send the last few digits of the dialed number to the DIDM8 identifying a particular extension/user in the system.

The DIDM8 provides interface circuitry for eight (8) DID Lines. Each interface is equipped with appropriate speech codec and compression functions, pulse and DTMF dial signal detection.

The DIDM8 includes a 10/100 Base-T Ethernet interface as well as packet voice processing functions. The Ethernet port incorporates auto MDI, MDIX switching, therefore, both straight and cross cables can be used.

As shown in Figure 2.1.4-1, the front panel of the DIDM8 has:

- Power jack for the AC/DC adapter ;see section 2.1.15 AD/DC adapter –G-,
- Power status LED,
- Normal/Service switch – In Service mode, circuits in use are busied as they return to idle - ,
- RJ-45 Female LAN connector with Speed and Link/Activity LEDs,
- Eight (8) DID LEDs, one for status of each DID Line,
- DB-9 RS-232 connector,
- Reset Switch.

On the rear panel, the DIDM8 has:

- Eight (8) RJ-45 female connectors,
- Ground Lug,
- Fifty (50)-pin back plane connector.

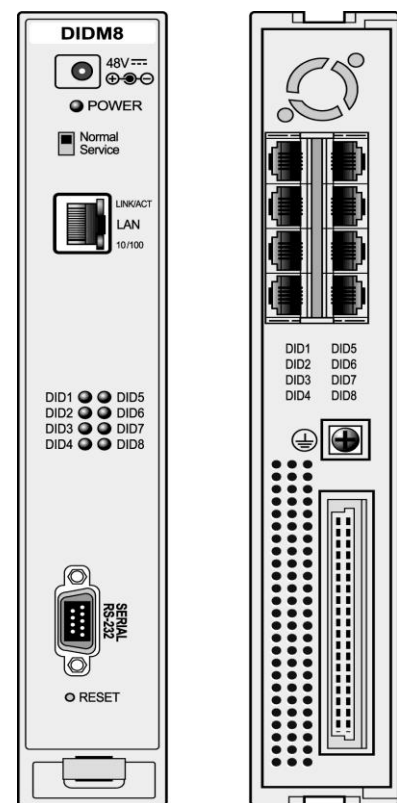

Figure 2.1.4-1 DIDM8 Front & Rear Panels

2.1.5 DTIMs (Digital Terminal Interface gateway Module)

2.1.5.1 DTIM8

The eight (8)-channel Digital Terminal Interface gateway Module supports 8 digital keysets (LKD and LDP models). Keysets have access to all the resources of the iPECS as well as keyset functionality and simple one-button feature access. The DTIM8 contains a processor for IP to TDM and signaling conversion as well as DSP circuitry to provide transcoding for each channel.

Digital keysets can be connected up to 300 meters from the DTIM8 gateway using 24 AWG twisted pair cabling.

The DTIM8 includes a 10/100 Base-T Ethernet interface as well as packet voice processing functions. The Ethernet port incorporates auto MDI, MDIX switching, therefore, both straight and cross cables can be used.

As shown in Figure 2.1.5-1, the front panel of the DTIM8 has:

- Power jack for the AC/DC adapter; see section 2.1.15 AD/DC adapter –G-,
- Power status LED,
- Normal/Service switch – In Service mode, circuits in use are busied as they return to idle,
- RJ-45 Female LAN connector with Speed and Link/Activity LEDs,
- Eight (8) DKTU status LEDs, one for status of each DTIM channel,
- DB-9 RS-232 connector,
- Reset Switch.

On the rear panel, the DTIM8 has:

- Eight (8) RJ-45 female connectors,
- Ground Lug,
- Fifty (50)-pin back plane connector.

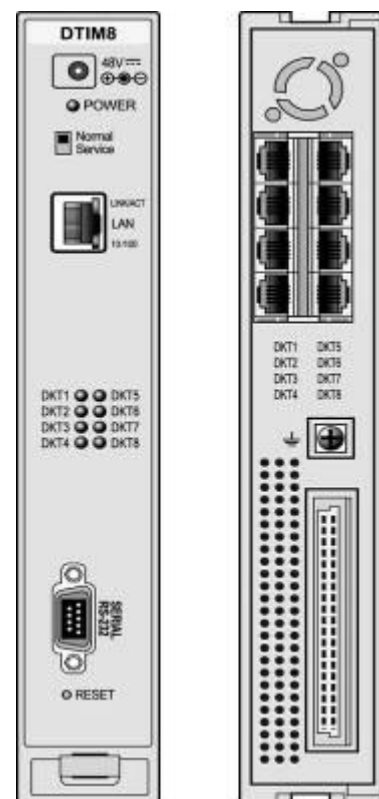

Figure 2.1.5-1 DTIM8 Front & Rear Panels

2.1.5.2 DTIM24

The twenty-four (24)-channel Digital Terminal Interface gateway Module supports 24 digital keysets (LKD and LDP models). Keysets have access to all the resources of the iPECS as well as keyset functionality and simple one-button feature access. The DTIM24 contains a processor for IP to TDM and signaling conversion as well as DSP circuitry to provide transcoding for each channel.

Digital keysets can be connected up to 300 meters from the DTIM24 gateway using 24 AWG twisted pair cabling.

The DTIM24 includes a 10/100 Base-T Ethernet interface as well as packet voice processing functions. The Ethernet port incorporates auto MDI, MDIX switching, therefore, both straight and cross cables can be used.

As shown in Figure 2.1.6.3-1, the front panel of the DTIM24 has:

- Power status LED,
- DTIM24 status LED,
- Normal/Service switch – In Service mode, circuits in use are busied as they return to idle,
- RJ-45 Female LAN connector with Speed and Link/Activity LEDs,
- Twenty-four (24) SLT LEDs, one for status of each SLT,
- DB-9 RS-232 connector,
- Reset Switch.

On the rear panel, the DTIM24 has:

- One(1) 25-pair RJ-21x connectors,
- Ground Lug,
- AC input connector.

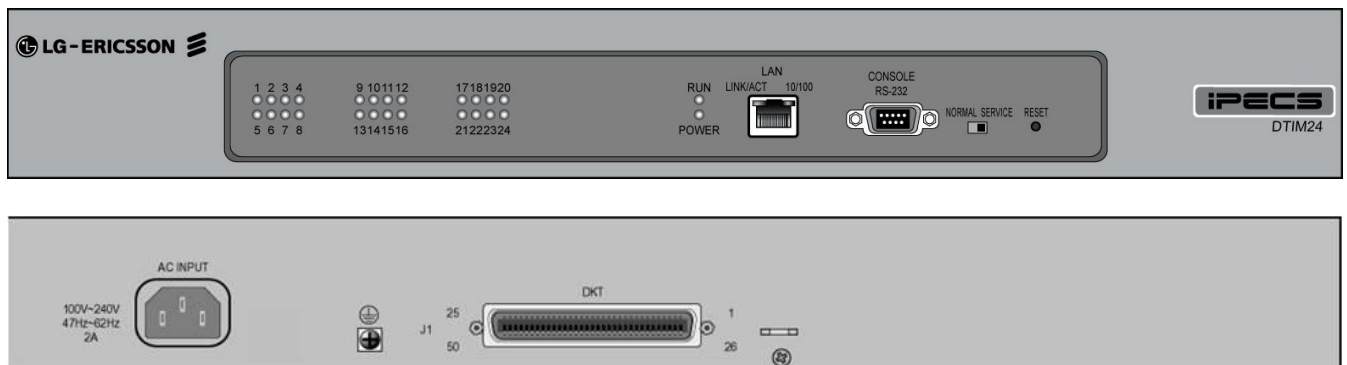

Figure 2.1.5.2-1 DTIM24 Front & Rear Panels

2.1.6 SLTMs (Single Line Telephone gateway Module)

2.1.6.1 SLTM4

The four (4)-port Single Line Telephone Module (SLTM4) allows standard analog Single Line Telephone (SLT) devices access to CO Lines, other stations, and most features of the system through the use of “dial codes”. The SLTM4 provides interface circuitry for four (4) SLTs. Each interface is equipped with appropriate speech codec and compression functions, 48 volt DC feed circuit, pulse and DTMF dial signal detection. A ring generator and message wait source are integrated in the SLTM4. The SLTM4 supports T.38 protocol for Fax over IP.

The SLTM4 allows Single Line Telephones to be connected up to 4 Kilometers (13,000 feet) from the gateway using 24 AWG wire.

The SLTM4 includes a 10/100 Base-T Ethernet interface as well as packet voice processing functions. The Ethernet port incorporates auto MDI, MDIX switching, therefore, both straight and cross cables can be used.

As shown in Figure 2.1.6.1-1, the front panel of the SLTM4 has:

- Power jack for the AC/DC adapter; see section 2.1.15 AD/DC adapter –G-,
- Power status LED,
- Normal/Service switch – In Service mode, circuits in use are busied as they return to idle,
- RJ-45 Female LAN connector with Speed and Link/Activity LEDs,
- Four (4) SLT LEDs, one for status of each SLT,
- DB-9 RS-232 connector,
- Reset Switch.

On the rear panel, the SLTM4 has:

- Four (4) RJ-45 female connectors,
- Ground Lug,
- Fifty (50)-pin back plane connector.

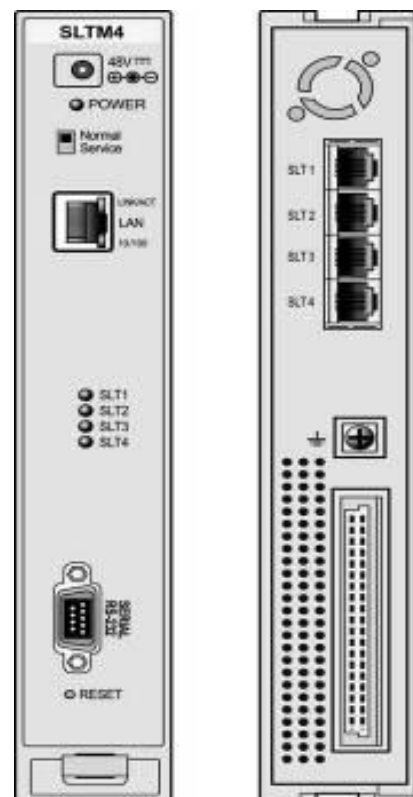

Figure 2.1.6.1-1 SLTM4 Front & Rear Panels

2.1.6.2 SLTM8

The eight (8)-port Single Line Telephone Module (SLTM8) allows standard analog Single Line Telephone (SLT) devices access to CO Lines, other stations, and most features of the system through the use of “dial codes”. The SLTM8 provides interface circuitry for eight (8) SLTs. Each interface is equipped with appropriate speech codec and compression functions, 48 volt DC feed circuit, pulse and DTMF dial signal detection. A ring generator and message wait source are integrated in the SLTM8. The SLTM8 supports T.38 protocol for Fax over IP.

The SLTM8 allows Single Line Telephones to be connected up to 4 Kilometers (13,000 feet) from the gateway using 24 AWG wire.

The SLTM8 includes a 10/100 Base-T Ethernet interface as well as packet voice processing functions. The Ethernet port incorporates auto MDI, MDIX switching, therefore, both straight and cross cables can be used.

As shown in Figure 2.1.6.2-1, the front panel of the SLTM8 has:

- Power jack for the AC/DC adapter; see section 2.1.15 AD/DC adapter –G-,
- Power status LED,
- Normal/Service switch – In Service mode, circuits in use are busied as they return to idle,
- RJ-45 Female LAN connector with Speed and Link/Activity LEDs,
- Eight (8) SLT LEDs, one for status of each SLT,
- DB-9 RS-232 connector,
- Reset Switch.

On the rear panel, the SLTM8 has:

- Eight (8) RJ-45 female connectors,
- Ground Lug,
- Fifty (50)-pin back plane connector.

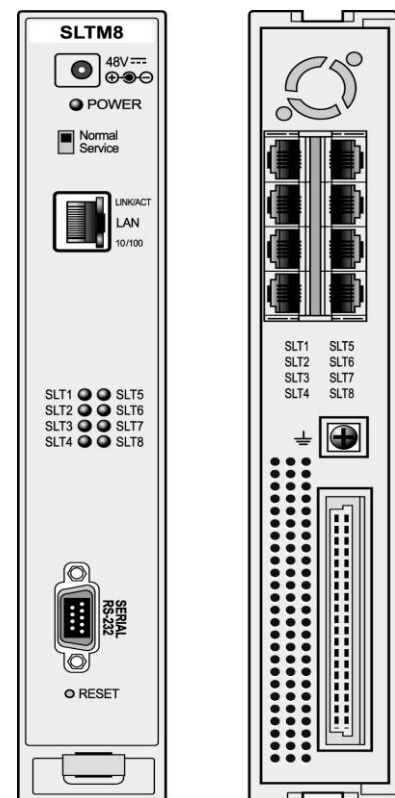

Figure 2.1.6.2-1 SLTM8 Front & Rear Panels

2.1.6.3 SLTM32

The thirty-two (32)-port Single Line Telephone Module (SLTM32) allows standard analog Single Line Telephone (SLT) devices access to CO Lines, other stations, and most features of the system through the use of “dial codes”. The SLTM32 provides interface circuitry for thirty-two (32) SLTs. Each interface supports appropriate speech codec and compression functions, 36 volt DC feed circuit; pulse and DTMF dial signal detection. A ring generator and message wait circuitry are integrated in the SLTM32. The SLTM32 supports T.38 protocol for Fax over IP.

The SLTM32 allows Single Line Telephones to be connected up to 3 Kilometers (9,800 feet) from the gateway using 24 AWG wire.

The SLTM32 includes a 10/100 Base-T Ethernet interface as well as packet voice processing functions. The Ethernet port incorporates auto MDI, MDIX switching, therefore, both straight and cross cables can be used.

As shown in Figure 2.1.6.3-1, the front panel of the SLTM32 has:

- Power status LED,
- Fan status LED,
- Normal/Service switch – In Service mode, circuits in use are busied as they return to idle,
- RJ-45 Female LAN connector with Speed and Link/Activity LEDs,
- Thirty-two (32) SLT LEDs, one for status of each SLT,
- DB-9 RS-232 connector,
- Reset Switch.

On the rear panel, the SLTM32 has:

- Two (2) 25-pair RJ-21x connectors,
- Ground Lug,
- AC input connector.

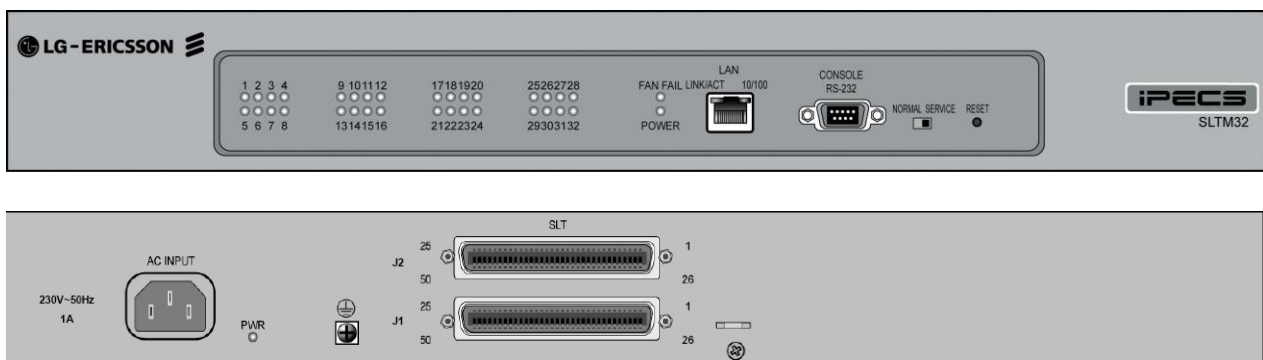

Figure 2.1.6.3-1 SLTM32 Front & Rear Panels

2.1.7 BRIMs (BRI gateway Module)

2.1.7.1 BRIM2

The Basic Rate Interface gateway Module (BRIM2) has two (2) ISDN Basic Rate Interface ports (2B+D). This Module supports the 'T' interface as described by ETSI 300.012 based on the ITU-T Recommendations I.430, and can be installed in the TE (Terminal Equipment) mode.

The BRIM2 includes a 10/100 Base-T Ethernet interface as well as packet voice processing functions. The Ethernet port incorporates auto MDI, MDIX switching, therefore, both straight and cross cables can be used.

As shown in Figure 2.1.7.1-1, the front panel of the BRIM2 has:

- Power jack for the AC/DC adapter; see section 2.1.15 AD/DC adapter –G-,
- Power status LED,
- Normal/Service switch – In Service mode, circuits in use are busied as they return to idle,
- RJ-45 Female LAN connector with Speed and Link/Activity LEDs,
- Four (4) status LEDs -two (2) for each BRI Line,
- DB-9 RS-232 connector,
- Reset Switch.

On the rear panel, the BRIM2 has:

- Two (2) RJ-45 female connectors, one for each BRI Line,
- Ground Lug,
- Fifty (50) pin-back plane connector.

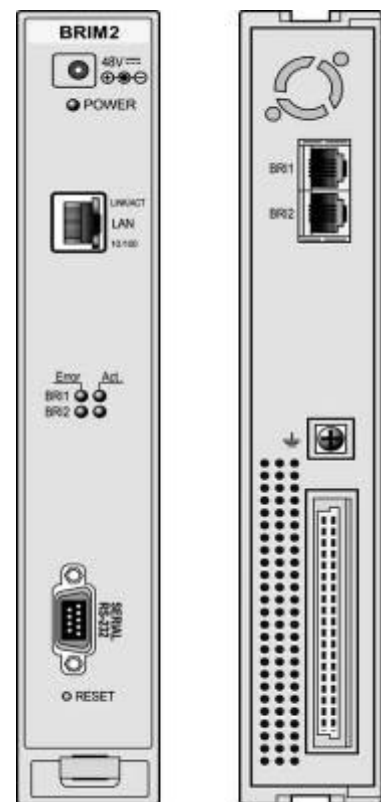

Figure 2.1.7.1-1 BRIM2 Front & Rear Panels

2.1.7.2 BRIM4

The Basic Rate Interface gateway Module (BRIM4) has four (4) ISDN Basic Rate Interface ports (2B+D). The BRIM4 supports the 'T interface' as described by ETSI 300.012 based on the ITU-T Recommendations I.430, and can be installed in the TE (Terminal Equipment) mode. The BRIM4 includes DSP circuitry for transcoding between various audio codecs.

The BRIM4 includes a 10/100 Base-T Ethernet interface as well as packet voice processing functions. The Ethernet port incorporates auto MDI, MDIX switching, therefore, both straight and cross cables can be used.

As shown in Figure 2.1.7.2-1, the front panel of the BRIM4 has:

- Power jack for the AC/DC adapter; see section 2.1.15 AD/DC adapter –G-,
- Power status LED,
- Normal/Service switch – In Service mode, circuits in use are busied as they return to idle,
- One (1) RJ-45 Female LAN connector with Speed and Link/Activity LEDs,
- Eight (8) LEDs, two (2) for each BRI Line,
- DB-9 RS-232 connector,
- Reset Switch.

On the rear panel, the BRIM4 has:

- Four (4) RJ-45 female connectors,
- Ground Lug,
- Fifty (50)-pin back plane connector.

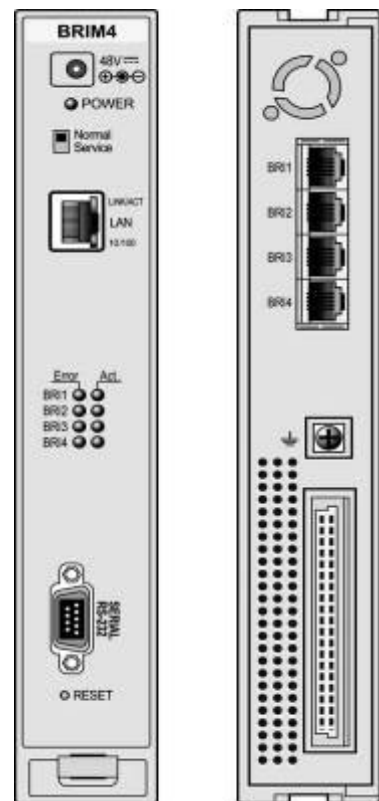

Figure 2.1.7.2-1 BRIM4 Front & Rear Panels

2.1.8 PRIM (PRI gateway Module)

The PRIM module provides one (1) PRI interface. This interface supports 30 PCM bearer and 2 signaling channels for ISDN PRI.

The PRIM includes a 10/100 Base-T Ethernet interface as well as packet voice processing functions. The Ethernet port incorporates auto MDI, MDIX switching, therefore, both straight and cross cables can be used.

As shown in Figure 2.1.8-1, the front panel of the PRIM has:

- Power jack for the AC/DC adapter; see section 2.1.15 AD/DC adapter –G-,
- Power status LED,
- Normal/Service switch – In Service mode, circuits in use are busy as they return to idle,
- RJ-45 Female LAN connector with Speed and Link/Activity LEDs,
- Five (5) LEDs,
- DB-9 RS-232 connector,
- Reset Switch.

On the rear panel, the PRIM has:

- One (1) RJ-45 female connector,
- Ground Lug,
- Fifty (50)-pin back plane connector.

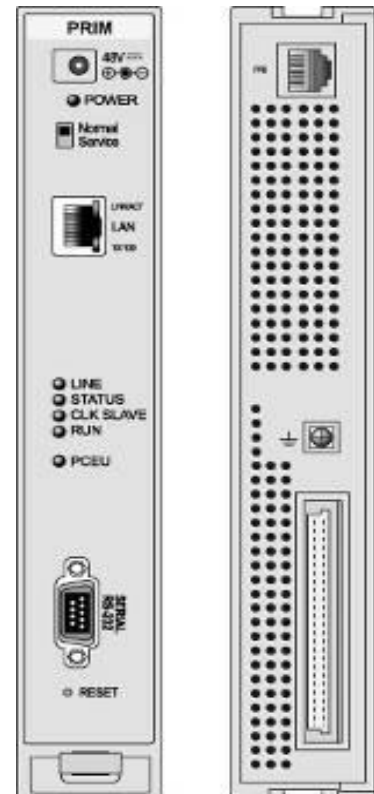

Figure 2.1.8-1 PRIM Front & Rear Panels

2.1.9 VMIM (Voice Mail Interface Module)

The VMIM (Voice Mail Interface Module) provides mid-range Auto Attendant/Voice Mail services for the iPECS, primarily intended to support the MFIM600/1200 but can be employed with any MFIM. The VMIM contains a processor and DSP circuitry to support 8 simultaneous channels and memory to support 9 hours of voice storage capacity. To provide additional channels and/or storage capacity, up to thirty (30) VMIMs may be installed in systems with an MFIM1200 for a maximum capacity of 240 channels and 270 hours of storage. In case of MFIM600, up to six (6) VMIMs may be installed in systems for a maximum capacity of 48 channels and 54 hours of storage. For MFIM100/300, a maximum of two (2) VMIMs can be supported for a maximum capacity of 16 channels and 18 hours of storage. In addition to Auto Attendant and Voice Mail functions, the VMIM also provides ACD announcements as well as Pre-defined and Custom Message Voice announcements. The VMIM can support various codecs including g.711, g.729a, and g.723.1.

The VMIM includes a 10/100 Base-T Ethernet interface as well as packet voice processing functions. The Ethernet port incorporates auto MDI, MDIX switching, therefore, both straight and cross cables can be used.

As shown in Figure 2.1.9-1, the front panel of the VMIM has:

- Power jack for the AC/DC adapter; see section 2.1.15 AD/DC adapter –G-,
- Power status LED,
- Normal/Service switch – In Service mode, circuits in use are busy as they return to idle,
- RJ-45 Female LAN connector with Speed and Link/Activity LEDs,
- Four (4) Status LEDs,
- One (1) USB Host port connector,
- DB-9 RS-232 connector,
- Reset Switch.

On the rear panel, the VMIM has:

- Ground Lug,
- Fifty (50)-pin back plane connector.

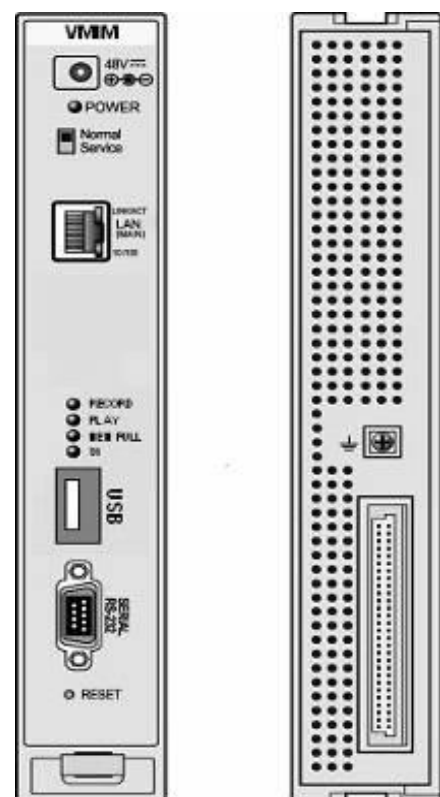

Figure 2.1.9-1 VMIM Front & Rear Panels

2.1.10 MCIM (Multi-Media Conference Interface gateway Module)

The Multi-Media Conference Interface gateway Module (MCIM) permits users to establish multi-party voice conferences with up to 32 simultaneous parties using the g.711 or g.729 codec and 24 parties with the g.723 codec. The MCIM contains a control processor as well as DSP circuitry to support conferences.

The MCIM includes a 10/100 Base-T Ethernet interface as well as packet voice processing functions. The Ethernet port incorporates auto MDI, MDIX switching, therefore, both straight and cross cables can be used.

As shown in Figure 2.1.10-1, the front panel of the MCIM has:

- Power jack for the AC/DC adapter; see section 2.1.15 AD/DC adapter –G-,
- Power status LED,
- Normal/Service switch – In Service mode, circuits in use are busy as they return to idle,
- RJ-45 Female LAN connector with Speed and Link/Activity LEDs,
- Four (4) Status LEDs,
- DB-9 RS-232 connector,
- Reset Switch.

On the rear panel, the MCIM has:

- Ground Lug,
- Fifty (50)-pin back plane connector.

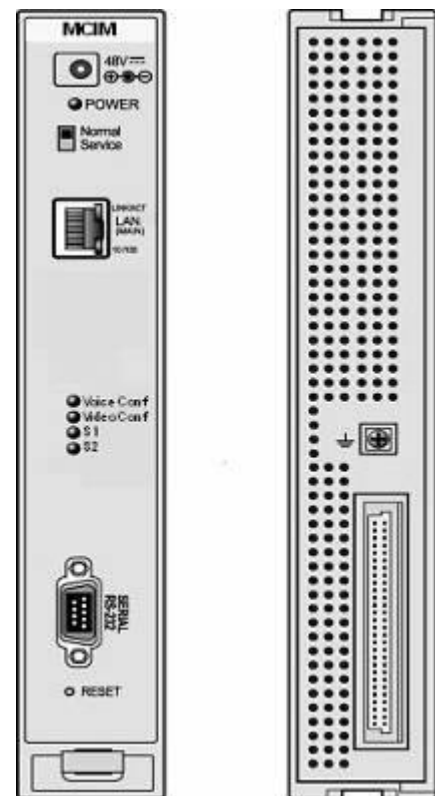

Figure 2.1.10-1 MCIM Front & Rear Panels

2.1.11 RSGM (Remote Services Gateway Module)

The Remote Services Gateway Module (RSGM) transparently extends iPECS services to users and interfaces over broadband IP networks. Remote Services are implemented with the iPECS Remote Services Application Server employing the system's VoIP channels to communicate with remote LIP Phones and RSGMs. Typical remote configurations are shown in Figure 2.1.11-1. Note that the Remote Application can service multiple LIP Phones and RSGMs separately and simultaneously.

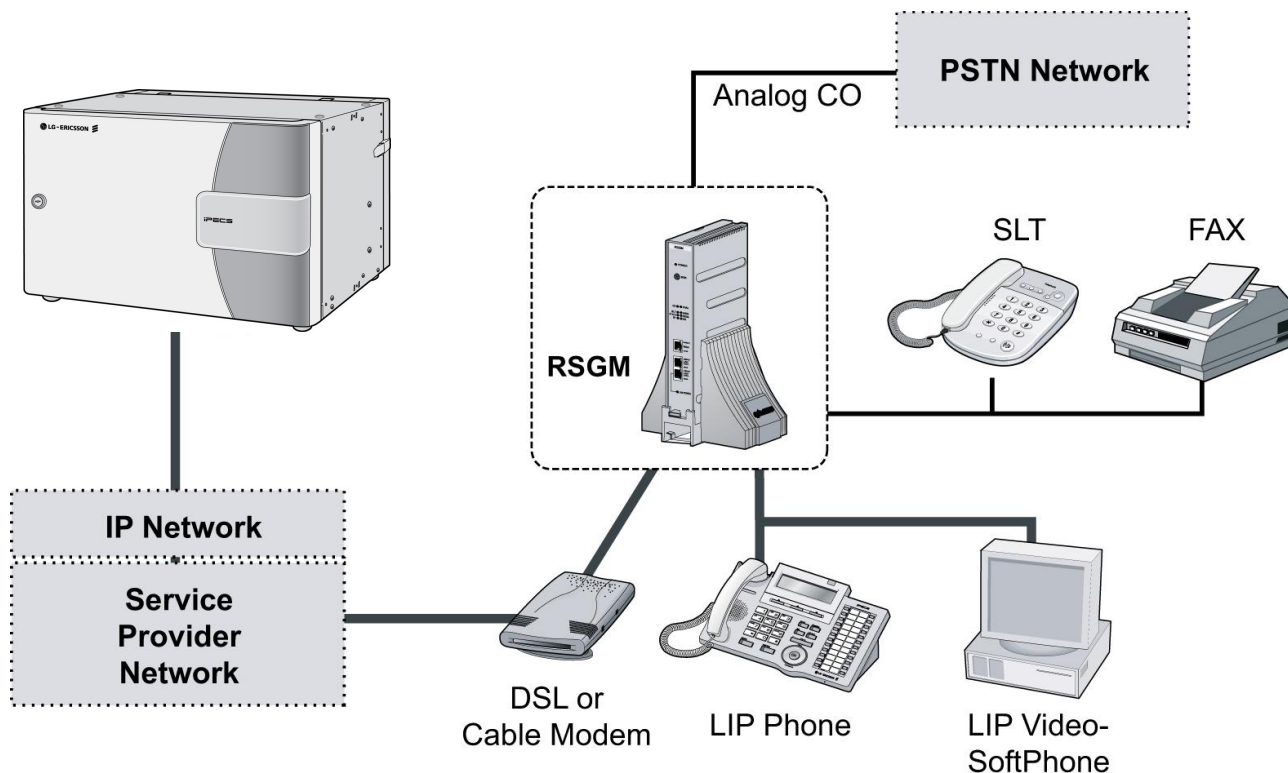

Figure 2.1.11-1 RSGM Connection

The RSGM provides following resources.

- One (1) WAN connection port (RJ-45: 10/100 Ethernet port) – Auto MDI, MDIX switching feature,
- One (1) PC port (RJ-45: 10/100 Ethernet port),
- One (1) LIP Phone port (RJ-45: 10/100 Ethernet port) w/PoE support,
- One (1) analog CO port (RJ-11),
- One (1) analog SLT port (RJ-11),
- One (1) BGM port,
- One (1) Alarm/Doorbell contact monitor,
- Two (2) dry relay contacts.

The RSGM includes 10/100 Base-T Ethernet interfaces as well as packet voice processing functions. The WAN connection Ethernet port has auto MDI, MDIX switching, therefore, both straight and cross cables can be used.

As shown in Figure 2.1.11-2, the front panel of the RSGM has:

- Power status LED,
- RCA jack for external music (audio) source -BGM-,
- Eight (8) LEDs,
- RJ-45 Female LAN connector with Speed and Link/Activity LEDs for WAN connection,
- RJ-45 Female LAN connector with Speed and Link/Activity LEDs for PC connection,
- RJ-45 Female LAN connector with Speed and Link/Activity LEDs for IP phone connection,
- LED indicator to display IP phone power feeding status.

On the rear panel, the RSGM has:

- One (1) RJ-11 female connector for analog CO Line,
- One (1) RJ-11 female connector for analog SLT,
- One (1) RJ-11 female connector for alarm/door bell input and dry relay contact #2,
- One (1) RJ-11 female connector for external BGM and dry relay contact #1,
- Four (4)-position DIP-switch for mode selections,
- One (1) position DIP-switch for IP phone power feeding selection,
- DB-9 RS-232 connector,
- Reset Switch,
- Power jack for the AC/DC adapter supplied; see section 2.1.15 AD/DC adapter –G-,
- Ground Lug.

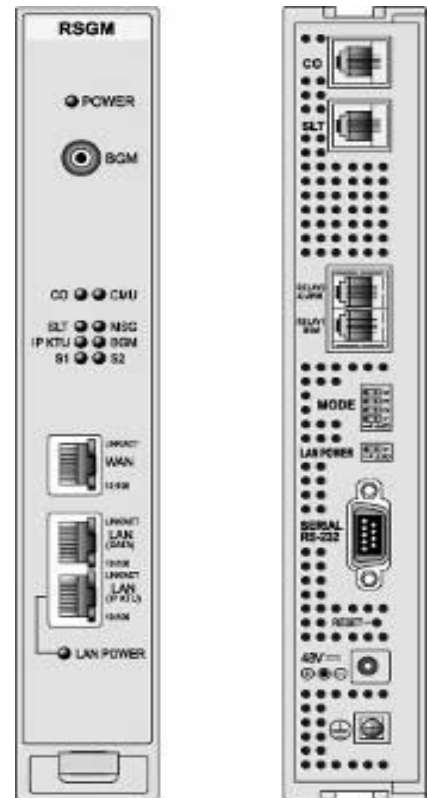

Figure 2.1.11-2 RSGM Front & Rear Panels

2.1.12 POE8 (Power Over Ethernet switching hub)

The Power over Ethernet Switching Module (POE8) has eight (8) LAN ports and an UPLINK LAN port, all of which employ Ethernet switching. All ports support Auto-sense 10/100Mbps, half/full duplex mode and auto MDI/MDIX function. Therefore a straight or cross RJ-45 cable can be used for connection between two Ethernet ports. The POE8 is a standard nine (9) port Ethernet switch, which switches packets between two specified ports. Unlike a repeater that repeats each packet to all ports, using the POE8 minimizes traffic over each port as well as the overall LAN environment.

The eight (8) LAN ports of the POE8 are equipped with circuitry to provide power (48 VDC) to the LIP Phone or LIP-7000 series console through the LAN cable. The POE8 supplies power automatically to terminals in accordance with the IEEE 802.3af PD (Powered Device) specification. LEDs are provided on the front panel to display the power feed status of each port. Note the UPLINK LAN port is not equipped with the power feed circuitry.

As shown in Figure 2.1.12-1, the front panel of the POE8 has:

- Power jack for the AC/DC adapter; see section 2.1.15 AD/DC adapter –G-,
- Power status LED,
- Eight (8)-port “PORT PWR STATUS” LEDs,
- One (1) RJ-45 Female “UPLINK” LAN connector with Speed and Link/Activity LEDs,
- Eight (8) RJ-45 Female LAN connectors with Speed and Link/Activity LEDs, one per port.

On the rear panel, the POE8 has:

- DB-9 RS-232 Serial port connector,
- Ground Lug,
- Fifty (50)-pin back plane connector.

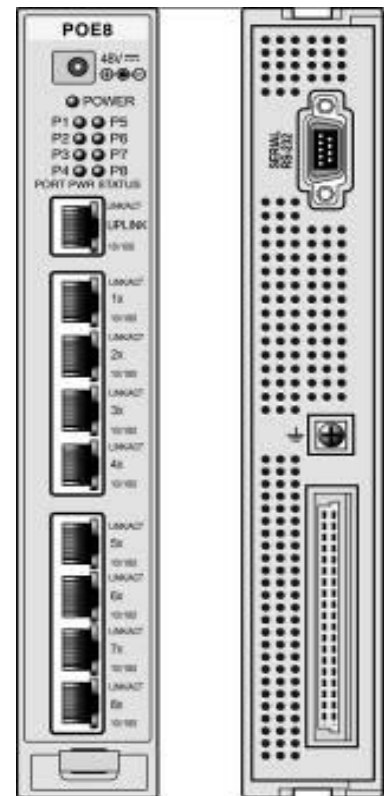

Figure 2.1.12-1 POE8 Front & Rear Panels

2.1.13 WTIM (Wireless Telephone Interface Module)

2.1.13.1 WTIM4

The four (4)-channel Wireless Terminal Interface gateway Module (WTIM4) provides four (4) interfaces for GDC-400B, which is a DECT base station classified as the Remote Fixed Part (RFP) in the DECT specification. DECT handsets can be used if the GDC-400B is connected to a WTIM4 and the proper attendant programming is completed. The WTIM4 contains a processor for IP to TDM voice and signaling conversion and DSP circuitry to provide transcoding for each channel. The GDC-400B can be connected to the WTIM4 up to 600 meters from the gateway using 24 AWG twisted pair cabling.

The WTIM4 includes a 10/100 Base-T Ethernet interface as well as packet voice processing functions. The Ethernet port incorporates auto MDI, MDIX switching, therefore, both straight and cross cables can be used.

As shown in Figure 2.1.13.1-1, the front panel of the WTIM4 has:

- Power jack for the AC/DC adapter; see section 2.1.15 AD/DC adapter –G-,
- Power status LED,
- Normal/Service switch – In Service mode, circuits in use are busied as they return to idle,
- RJ-45 Female LAN connector with Speed and Link/Activity LEDs,
- Four position Mode switch,
- Eight (8) WTIM4 status LEDs,
- Two RJ-45 Sync connectors to link WTIMs
- DB-9 RS-232 connector,
- Reset Switch.

On the rear panel, the WTIM4 has:

- Eight (4) RJ-45 female connectors,
- Ground Lug,
- Fifty (50)-pin back plane connector,

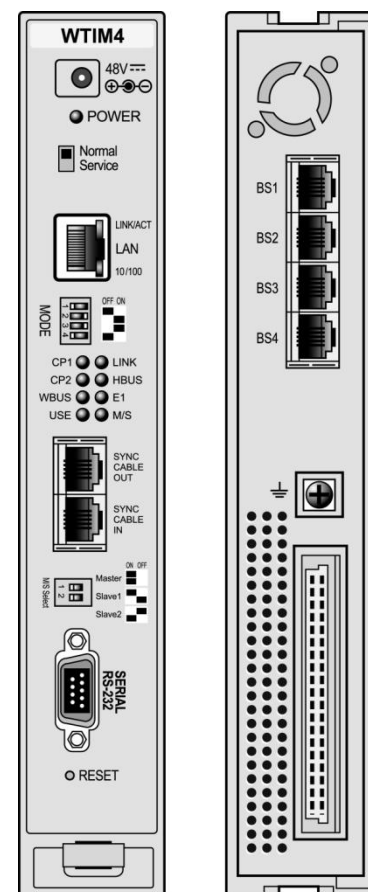

Figure 2.1.13.1-1 WTIM4 Front & Rear Panels

2.1.13.2 WTIM8

The eight (8)-channel Wireless Terminal Interface gateway Module (WTIM8) provides eight (8) interfaces for the GDC-400B, which is a DECT base station classified as the Remote Fixed Part (RFP) in the DECT specification. DECT handsets can be used if the GDC-400B is connected to the WTIM8 and the proper attendant programming is completed. The WTIM8 contains a processor for IP to TDM and signaling conversion and DSP circuitry to provide trans-coding for each channel. The GDC-400B can be connected to the WTIM8 up to 600 meters from the gateway using 24 AWG twisted pair cabling.

The WTIM8 includes a 10/100 Base-T Ethernet interface as well as packet voice processing functions. The Ethernet port incorporates auto MDI, MDIX switching, therefore, both straight and cross cables can be used.

As shown in Figure 2.1.13.2-1, the front panel of the WTIM8 has:

- Power jack for the AC/DC adapter; see section 2.1.15 AD/DC adapter –G-,
- Power status LED,
- Normal/Service switch – In Service mode, circuits in use are busied as they return to idle,
- RJ-45 Female LAN connector with Speed and Link/Activity LEDs,
- Four position Mode switch,
- Eight (8) WTIM8 status LEDs,
- Two RJ-45 Sync connectors to link WTIMs
- DB-9 RS-232 connector,
- Reset Switch.

On the rear panel, the WTIM8 has:

- Eight (8) RJ-45 female connectors,
- Ground Lug,
- Fifty (50)-pin back plane connector,

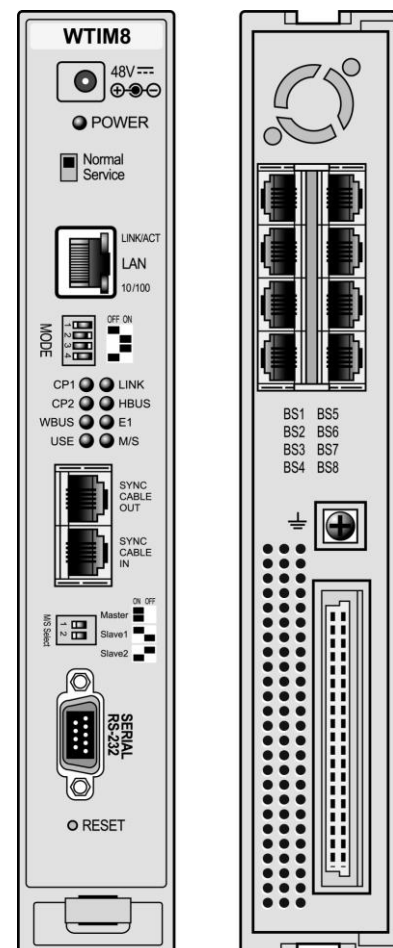

Figure 2.1.13.2-1 WTIM8 Front & Rear Panels

2.1.14 PSU (Power Supply Unit)

The Power Supply Unit (PSU) converts 100-240 VAC @ 50/60 Hz to -48V and 5V DC. The DC voltages are connected to the back plane for distribution to modules installed in the Enhanced Main Cabinet. Power is connected via the back plane connector on the PSU and individual modules.

In most configurations, the PSU is capable of supplying power to a full cabinet of nine (9) modules. However, current draw for the different modules varies greatly; PSTN, ISDN and some other modules require about 5 watts each while a POE8 driving power to 8 phones requires 40 watts. Designing a power source to deliver the maximum power to nine POE8 modules would create cost penalty for most configurations. A simple rule of thumb is to limit the number of WTIM8, WTIM8 and POE8 modules to 5 per cabinet. To calculate the precise current draw of any cabinet configuration, use the Power draw chart in section 3.1.3.2. The total current required must be less than the PSU capacity, 5.3 amps. If more than the PSU capacity, reconfigure the cabinet modules or install some of the modules in a second cabinet with a separate PSU.

The PSU includes a DB9 connector for RS-232 communication with gateway modules for alarm notifications.

As shown in Figure 2.1.14-1, the front panel of the PSU has:

- Six (6) Status LEDs,
- Alarm Switch – to activate local audio alarm via the buzzer,
- Buzzer for local audio indication of alarm condition,
- DB-9 RS-232 connector,
- Power Switch,
- AC Power Input,
- Fuse.

On the rear panel, the PSU has:

- a thirty-two (32)-pin back plane connector.

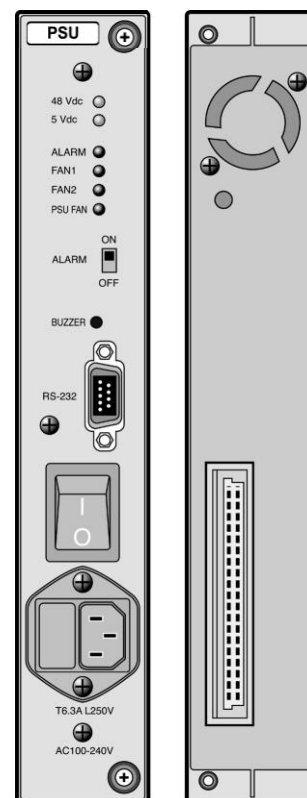

Figure 2.1.14-1 PSU Front & Rear Panels

2.1.15 AD/DC adapter –G-

An optional AC/DC adapter is available to power a module when the PSU is not employed. The adapter is supplied with a two (2) meter, six (6) foot, AC cord terminated with the nationally relevant AC blade type. The adapter supports AC input power systems with rated voltage range of 100-240 VAC @ 50/60 Hz. The adapter provides 48 VDC, 0.8 amps. The DC output connector is cabled to the adapter with a two (2) meter, six (6) foot, cable.

Figure 2.1.15-1 shows the AC/DC Adapter for the iPECS Modules.

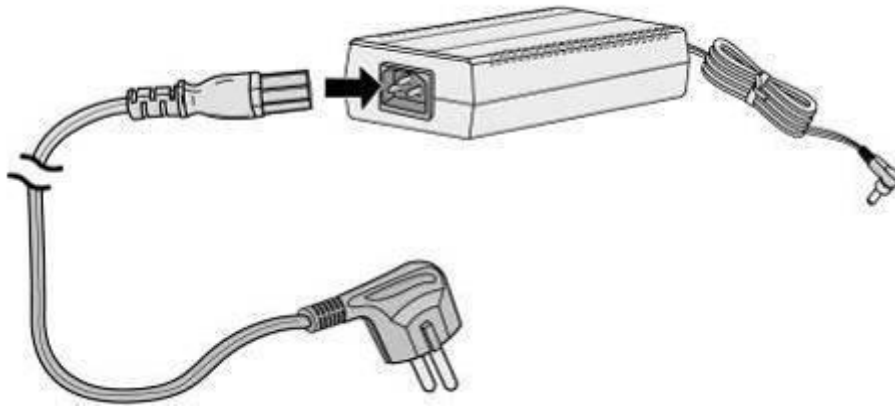

Figure 2.1.15-1 AD/DC adapter –G-

2.2 LIP Phones & Terminals

iPECS will work with a number of telephone types including standard SLTs, VoIP phones (SIP or H.323 v3), the LIP Phones. The LIP Phones are available in several configurations as shown in the Table 2.2-1.

Table 2.2-1 LIP Phones

MODEL	DESCRIPTION
LIP-7004N	Basic LIP Phone, 4 Flex buttons, no display
LIP-7008D	LIP Phone w/8 Flex buttons and 2 line display
LIP-7016D	LIP Phone w/16 Flex buttons, 3-line display, Navigation and soft-keys
LIP-7024D	LIP Phone w/24 Flex buttons, 3-line display, Navigation and soft-keys
LIP-7024LD	LIP Phone w/24 Flex buttons, Multi-line large display, Navigation and soft-keys
LIP-7048DSS	LIP DSS Console with 48 Flex buttons,
WIT300HE/400H	iPECS WLAN Wireless Phone
LIP-8002	LIP Phone, 4 button and 1-line display, LAN 1 port
LIP-8004D	LIP Phone, 4 button and 1-line display, LAN 1 port
LIP-8012D	LIP Phone, 12 button, 3-line display w/Menu, Soft & Nav. buttons
LIP-8024D	LIP Phone, 24 button, 4-line display w/Menu, Soft & Nav. buttons
LIP-8040L	LIP Phone, 10 button, 9-line display w/Menu, Soft & Nav. buttons
LIP-8048DSS	LIP DSS Console with 48 buttons
LIP-8012DSS	LIP DSS Console with 12 buttons
LIP-8012LSS	LIP DSS Console with 12 buttons, 12-line display

- Note: All LIP Phones are compliant to IEEE 802.3af standards.

2.2.1 LIP-8000 Series Phones

The LIP-8000 series phones are available in four models as well as three models of matching DSS/BLF Consoles. The models include:

- LIP-8002, 4-button 1 line display
- LIP-8004D, 4-button 1 line display
- LIP-8012D, 12-button 3 line display
- LIP-8024D, 24-button 4 line display
- LIP-8040L, 10-button large display
- LIP-8048DSS, 48-button DSS/BLF Console
- LIP-8012DSS, 12-button DSS/BLF Console
- LIP-8012LSS, 12-button 12 line LCD DSS/BLF Console

Each of the above models is shown in Figure 2.2.1- to Figure 2.2.1-. The LIP-8004D has a single LAN port for connection to the external 10/100 Base-T LAN. The other phones in the LIP-8000 series have two (2) LAN ports and thus two (2) RJ-45 connectors. One port is for connection to the LAN, the other can be connected to the desktop data device (PC) or other LAN interface terminal. The ports are connected to an intelligent 10/100Base-T switch, which gives LAN access to the data device while giving priority to voice packets.

The LIP-8000 series DSS Consoles are used to expand the number of flexible buttons available to

a user by 12 or 48 buttons and are connected to the LIP-8000 phone via a flat cable. A maximum of two (2) 12 button consoles (LED or LCD version) may be connected to an LIP-8000 phone. The LIP8012DSS and LIP-8012LSS are connected in a daisy chain and receive power from the associated LIP-8000 phone. Up to three (3) 48 button consoles may be connected in a daisy chain to one LIP-8000 phone. The LIP8048DSS is powered from an AC/DC adapter only.

Each LIP-8000 series IP phone has a standard 12-button dial-pad, color coordinated handset, an array of 4 (four) to twenty-four (24) "Flexible buttons", and fixed feature access buttons. All of the Flexible and most Fixed buttons, incorporate a long-life, super-bright LED to indicate the circuit or feature status.

The fixed feature buttons for each model include the following:

LIP-8002

- Menu
- Trans/PGM
- Conference
- Redial
- Volume Control
- Mute
- Speaker

LIP-8004D

- DND
- Speed
- Volume Control
- Trans/PGM
- Hold/Save
- Call Back
- OHD (On-Hook Dial)

LIP-8012D, LIP-8024D & LIP-8040L

- Navigation
- Menu
- DND
- Headset
- Volume Control
- Message
- Trans/PGM
- Hold/Save
- Mute
- Speaker

In addition, the LIP-8012D, 8024D and 8040L include 3 soft buttons. The function of these buttons is interactive and shown in the lower line of the LCD. These models also incorporate a full duplex speakerphone.

The LIP-8000 series phones include a Liquid Crystal Display (LCD). The LIP-8004 has a single line 24-character display; the LIP-8012 and LIP8024D have graphic displays that show three (3)

lines with up to 24-characters per line. The lower line is used to display the interactive function of the three soft buttons. The LIP-8040L has a large graphic display that displays the function of the ten flexible buttons and a line to display the function of the three interactive soft buttons.

The LIP-8000 series phone circuitry includes Digital Signal Processing to implement packet voice encoding and decoding, and echo cancellation as well as tone generation and speakerphone operation. Note the LIP-8804D does not include speakerphone operation. The Volume controls, which consist of separate volume up/down buttons, adjusts the level of the handset receiver and speaker as well as the headset receiver, when used.

The LIP-8000 series phone may be powered locally with the AC/DC Adapter, reference section 2.2.3, or powered over the LAN with the POE8 or other 802.3af compliant Ethernet switch. If both the AC/DC Adapter and powered LAN port are connected to the LIP-8000 terminal, the Adapter will provide the required power.

The LIP-8000 series phones incorporate wall mounting in the base of the phone, no additional hardware is required. Note; the matching DSS Console is also wall-mountable.

The DSS Consoles are provided in three models. The LIP-8048DSS has 48 flexible buttons with LED status indicators. The LIP-8012DSS has 12 flexible buttons with LED status indicators. The LIP-8012LSS has 12 flexible buttons and an LCD. The LCD displays the designation and status for each button with up to 20 characters.

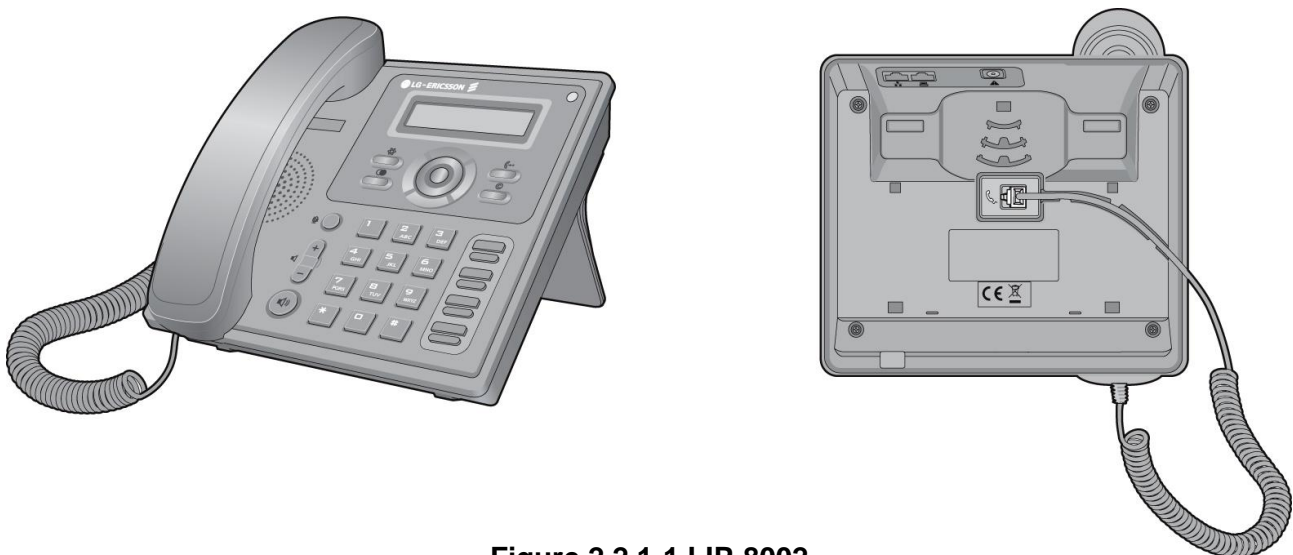

Figure 2.2.1-1 LIP-8002

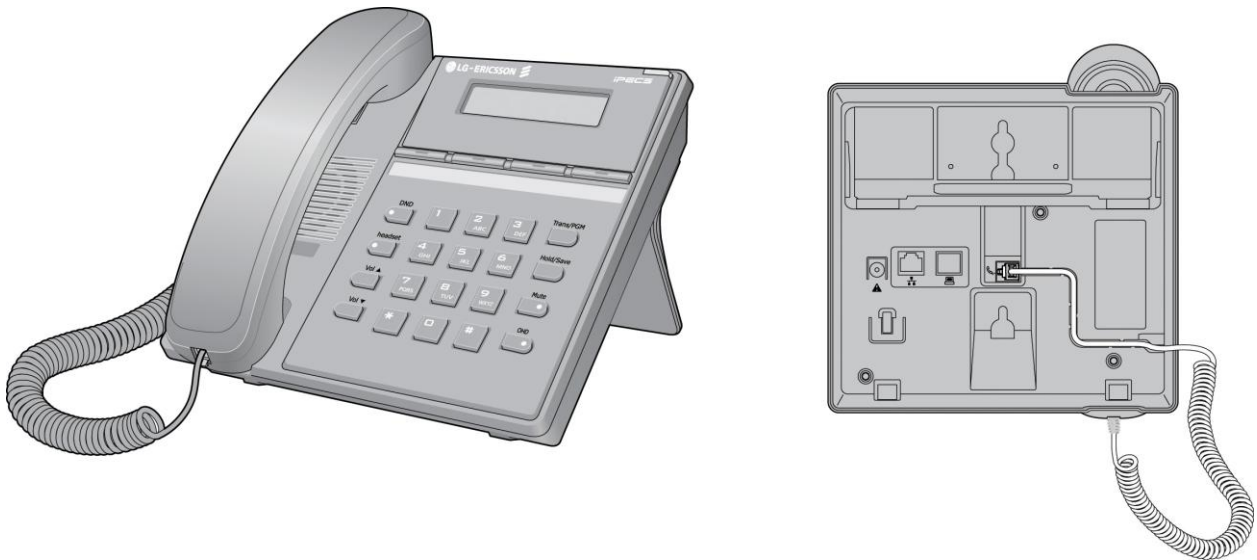

Figure 2.2.1-2 LIP-8004D

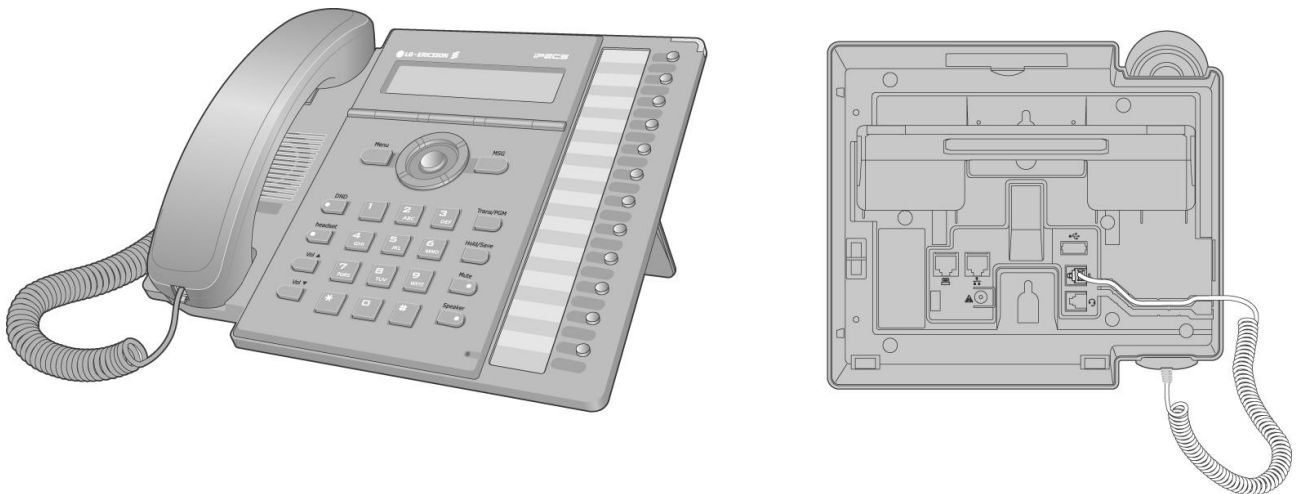

Figure 2.2.1-3 LIP-8012D

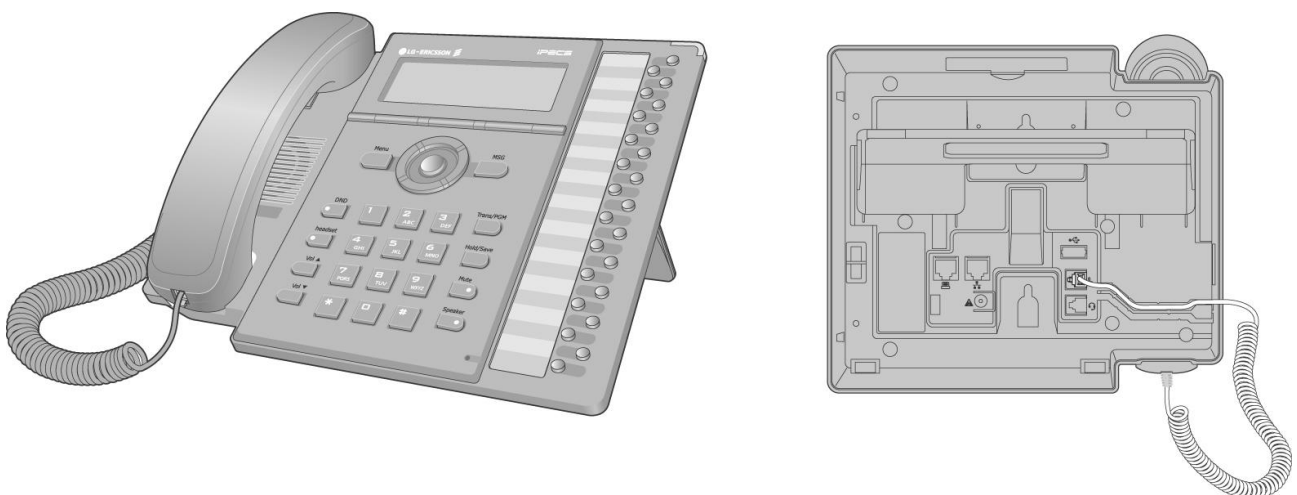

Figure 2.2.1-4 LIP-8024D

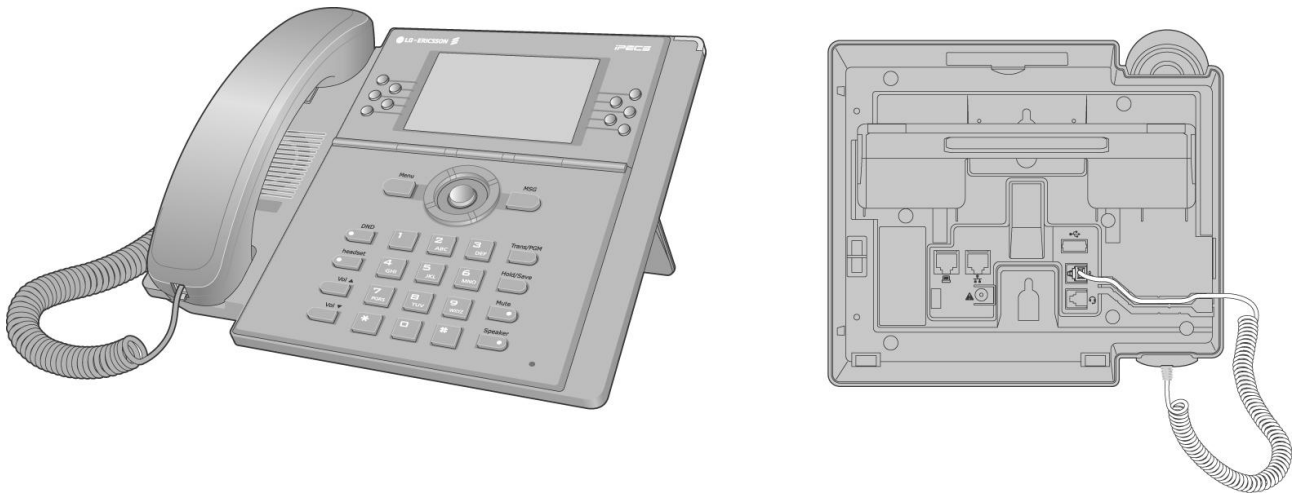

Figure 2.2.1-5 LIP-8040L

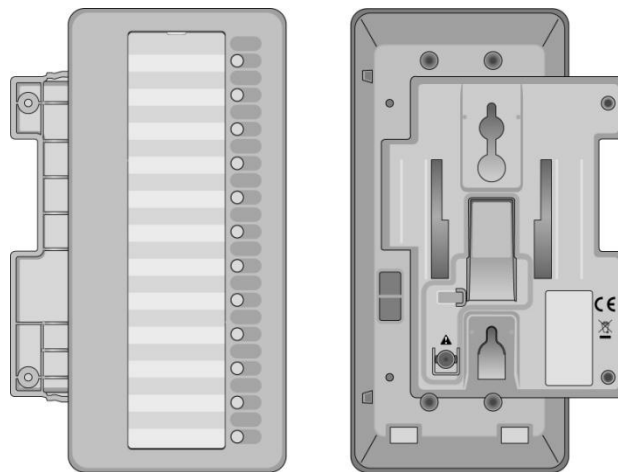

Figure 2.2.1-6 LIP-8012DSS

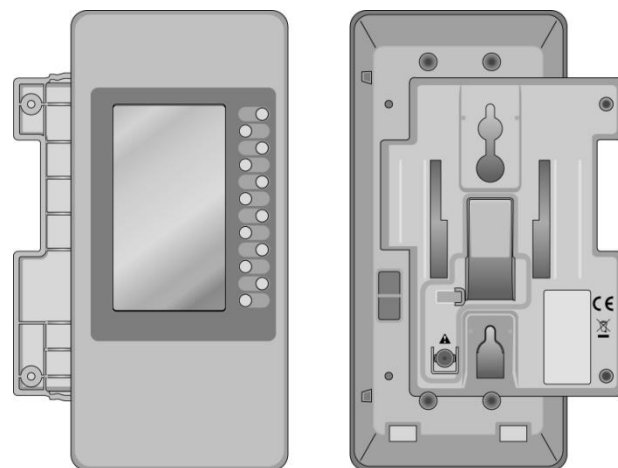

Figure 2.2.1-7 LIP-8012LSS

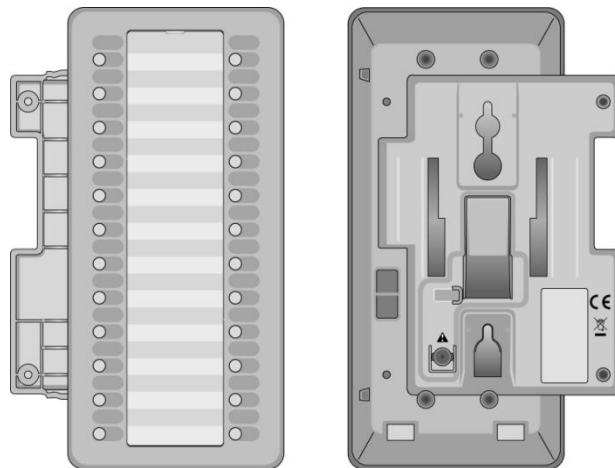

Figure 2.2.1-8 LIP-8048DSS

2.2.2 LIP-7000 Series Phones

The LIP-7000 series IP phones are available in 5 models as well as a matching DSS/BLF Console. Models available include:

- LIP-7004N, 4-button non-display
- LIP-7008D, 8-button 2-line display
- LIP-7016D, 16-button 3-line display
- LIP-7024D, 24-button 3-line display
- LIP-7024LD, 24-button large display
- LIP-7048DSS, 48-button DSS/BLF Console.

Each of the above models and Wall Mount kits are shown in Figure 2.2.2-1 to Figure 2.2.2-6. The LIP-7004N and 7008D have a single LAN port for connection to the external 10/100 Base-T LAN. The LIP-7016D, 7024D and 7024LD models have two (2) LAN ports and thus two (2) RJ-45 connectors. One port is for connection to the LAN, the other can be connected to the desktop data device (PC) or other LAN interface terminal. The ports are connected to an intelligent 10/100Base-T switch, which gives LAN access to the data device while giving priority to voice packets.

The LIP-7048DSS Console, which is used to expand the number of Flexible buttons available to a user by 48 buttons, has two (2) LAN ports. When the console is locally powered with the AC/DC Adapter, the LIP-7048DSS Console can be connected to the PC LAN port of the LIP-7016D, 7024D or 7024LD.

Each LIP-7000 series phone has a standard 12-button dial-pad, color coordinated handset, an array of 4 (four) to twenty-four (24) “Flexible buttons”, and fixed feature access buttons. All of the Flexible and most Fixed buttons, incorporate a long-life, super-bright LED to indicate the circuit or feature status.

The fixed feature buttons for each model include the following:

LIP-7004N

OHD (Off-Hook Dial)

- Hold/Save
- Volume Control
- Speed (preprogrammed Flex button)
- Trans/gm (preprogrammed Flex button)

LIP-7008D

- Speaker (Speakerphone)
- Hold/Save
- Volume Control
- Speed
- Trans/Pgm
- Dnd (preprogrammed Flex button)
- Call Back (preprogrammed Flex button)

LIP-7016D, 7024D, & 7024LD

- Hold/Save
- Volume Control
- Speed
- Trans/Pgm
- Dnd
- Call Back
- Navigation buttons

In addition, the LIP-7016, 7024D and 7024LD include 3 Soft buttons. The function of these buttons is interactive and shown in the lower line of the LCD.

The LIP-7008D includes a 2-line, 48-character (24 characters per line) Liquid Crystal Display (LCD). The LCD provides an alphanumeric display to assist the user in operation of features. In the idle mode, the display will show the station name or number on the top line and the time and date on the 2nd line. The LCD is employed to support features such as Dial-By-Name (Directory Dial) using the Volume control to scroll through name displays to find a telephone number in the directory.

The LIP-7000 series IP phone circuitry includes Digital Signal Processing to implement packet voice encoding and decoding, and echo cancellation as well as tone generation and speakerphone operation. The Volume control, which consists of a single volume up/down rocker button, adjusts the level of the handset receiver, speaker as well as the headset receiver, when used.

The LIP-7000 series IP phone may be powered locally with the AC/DC Adapter, reference section 2.2.3, or powered over the LAN with the POE8 or other 802.3af compliant Ethernet switch. If both the AC/DC Adapter and powered LAN port are connected to the LIP-7000 terminal, the Adapter will provide the required power.

Using the appropriate Wall Mount Kit, the LIP-7000 terminal can be mounted on a wall. Two handset hooks, which are used to keep the handset in-place, are molded as part of the Wall Mount bracket. One hook must be removed from the bracket and inserted in the slot just below the hook-switch to hold the handset when wall mounted. Note; the matching Console is not wall-mountable.



Figure 2.2.2-1 LIP-7004N



Figure 2.2.2-2 LIP-7008D



Figure 2.2.2-3 LIP-7016D



Figure 2.2.2-4 LIP-7024D



Figure 2.2.2-3 LIP-7024LD



Figure 2.2.2-4 LIP 7004WMB, Wall Mount Bracket



Figure 2.2.2-5 LIP 7008WMB, Wall Mount Bracket

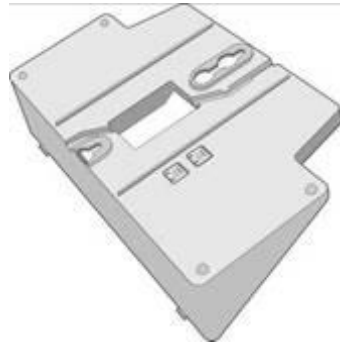

Figure 2.2.2-6 LIP 7024WMB, Wall Mount Bracket

2.2.3 AC/DC Adapter –K- for LIP-Phones & Console

When an LIP-7000 or LIP-8000 series terminal is to be powered from local AC (not provided power over the LAN), a separate AC/DC adapter must be used for power. The adapter is supplied with a two (2) meter, six (6) foot, AC cord terminated with the nationally relevant AC blade type. The adapter supports AC input power systems with rated voltage range of 100-240 VAC @ 50/60 Hz. The adapter provides 48 VDC at 0.3 amps. The DC output connector is cabled to the adapter with a two (2) meter, six (6) foot, cable.

Figure 2.2.3-1 shows the AC/DC Adapter-K.

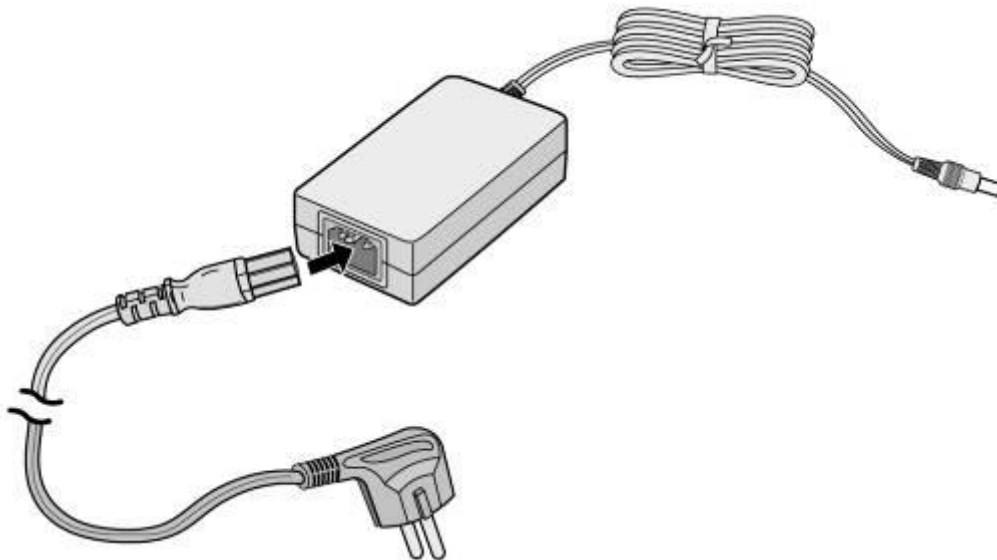

Figure 2.2.3-1 AC/DC Adapter –K-

2.3 Module Mounting Hardware

Most iPECS modules except for the SLTM32 and PSU can be installed in several different manners:

- Desk mounted using the **Desk Mount Holder**,
- Wall mounted individually using the **Wall Mount Holder**,
- 19" rack mounted individually using the **1U-Rack Mount Bracket**, or
- Cabinet installed using the **Enhanced Main Cabinet**, which can be 19" rack, Desk or Wall mounted.

The SLTM32 is intended for 19" rack mount only and the PSU is intended for cabinet installation only.

The following paragraphs describe the mounting hardware for each of the modules and cabinet mounting options.

2.3.1 DHLD (Desk Mount Holder) / DHE (Desk Mount Holder Extender)

The DHLD (Module Desk Mount Holder) consists of a pair of “book-ends” and DHE (Desk Mount Holder Extender). One Extender is installed between the bookends for each module, and the modules mounted between the bookends. The DHLD and DHE are shown in Figure 2.3.1-1.

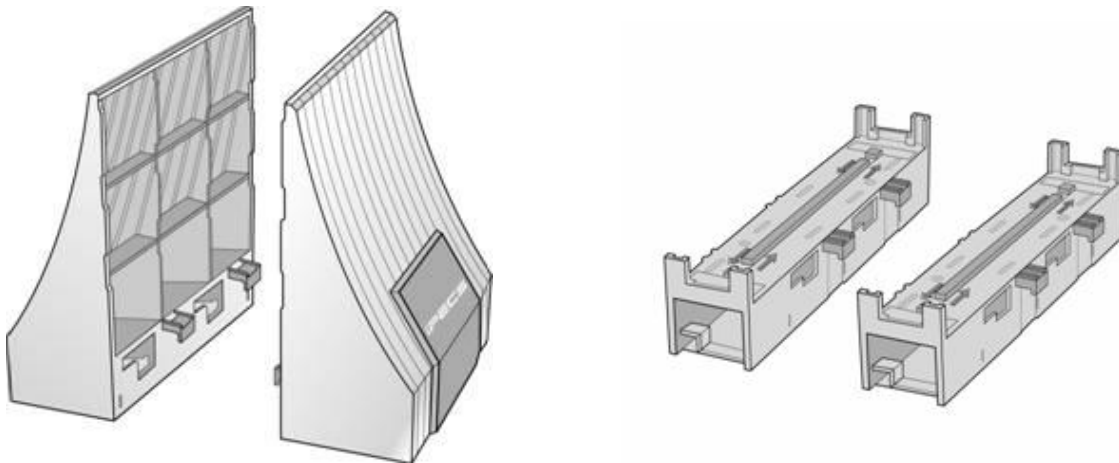

Figure 2.3.1-1 DHLD & DHE

2.3.2 WHLD (Wall Mount Holder)

iPECS modules can be individually wall mounted in the WHLD (module Wall Mount Holder), shown in Figure 2.3.2-1. The WHLD provides wall mounting for a single module.

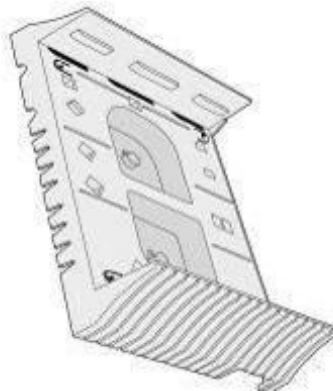

Figure 2.3.2-1 Module Wall Mount Holder

2.3.3 1U-RMB (1U Rack Mount Bracket)

iPECS modules can be individually 19" rack mounted in the 1U-RMB (Rack Mount Bracket), shown in Figure 2.3.3-1. The 1U-RMB provides 19" rack mounting for a single module.

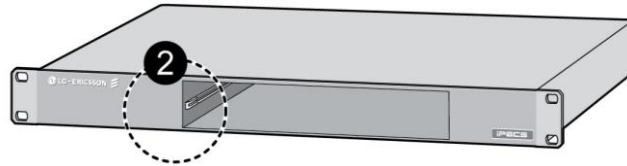

Figure 2.3.3-1 1U RMB

2.3.4 MCKTE (Main Cabinet Kit Enhanced)

The Enhanced Main Cabinet Kit has 10 slots for iPECS modules and PSU. Slot 10 is only for the PSU; slot 9 is for iPECS modules or a PSU when redundant power is required. The remaining slots may be used for any combination of iPECS modules. On the left side, the front cover of the cabinet has a push button for installing and removing the cover and incorporates a key lock, which can be locked to minimize unauthorized access. The main cabinet requires proper earthing. The cabinet is shown in Figure 2.3.4-1.

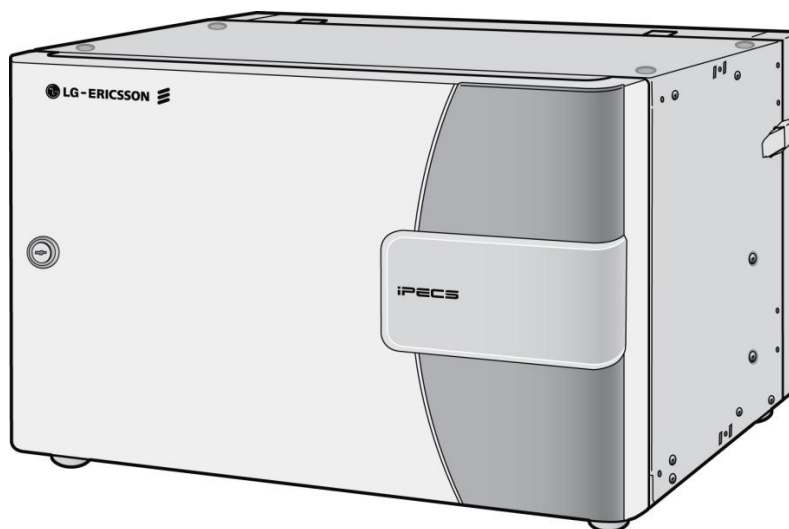

Figure 2.3.4-1 Main Cabinet

Available mounting hardware allows the cabinet to be 19" rack mounted, desk mounted, or wall mounted. In the Wall mount installation, the cabinet is connected to the Wall Mount using a hinge wall bracket allowing access to the back plane connectors.

For information on previous versions of the Main Cabinet, please refer to the appropriate previous issue of this manual.

The 19" Rack, Desk and Wall Mount hardware are shown in Figure 2.3.4-2, Figure 2.3.4-3, and

Figure 2.3.4-4 below respectively.

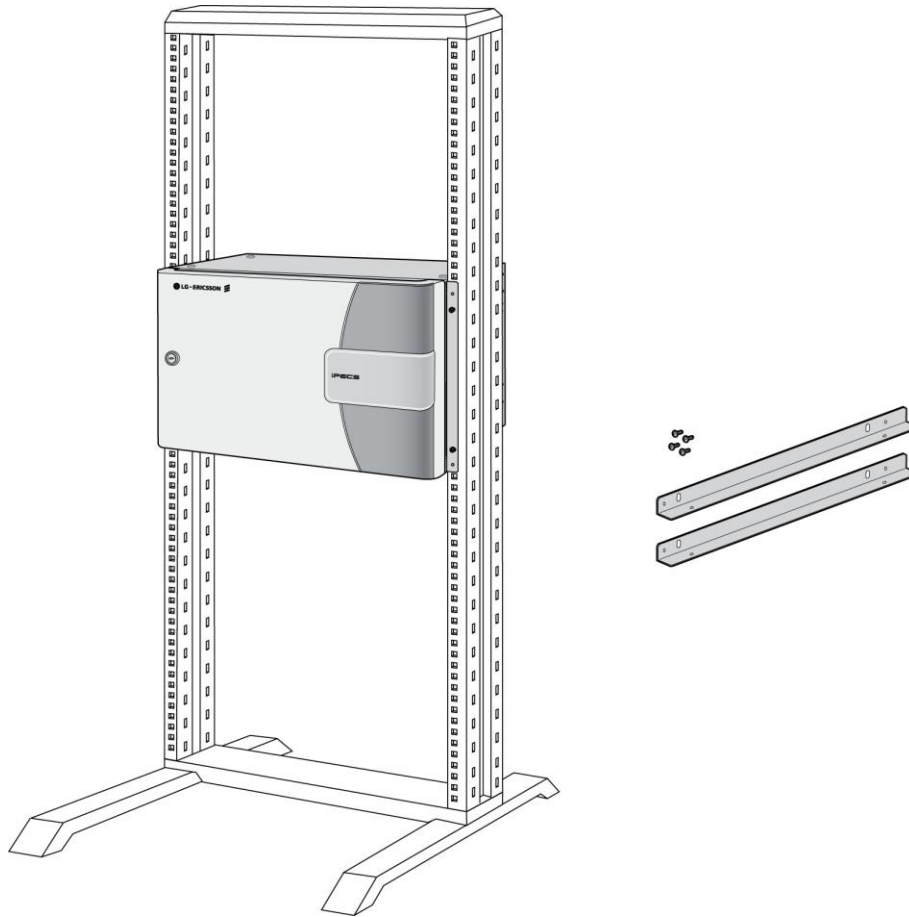

Figure 2.3.4-2 19" Rack Mount Installation

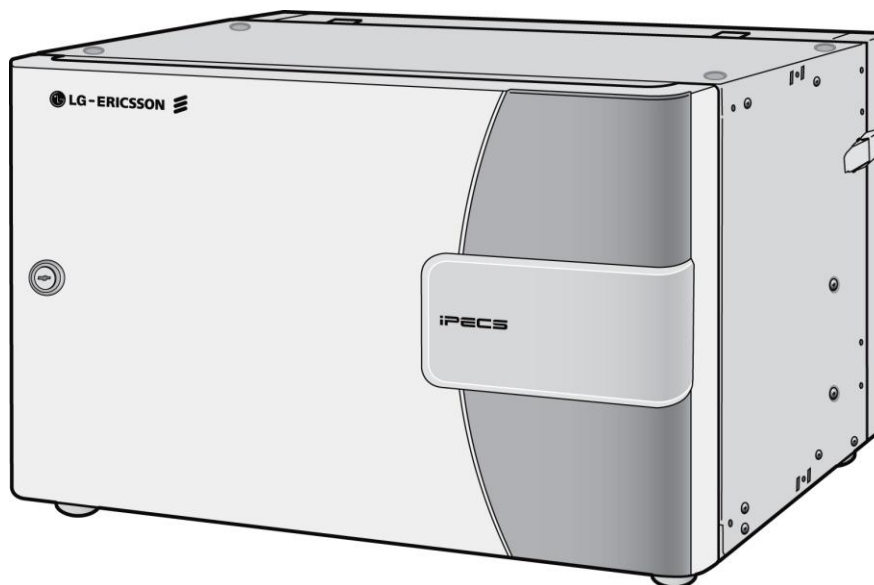

Figure 2.3.4-3 Desk Mount Installation

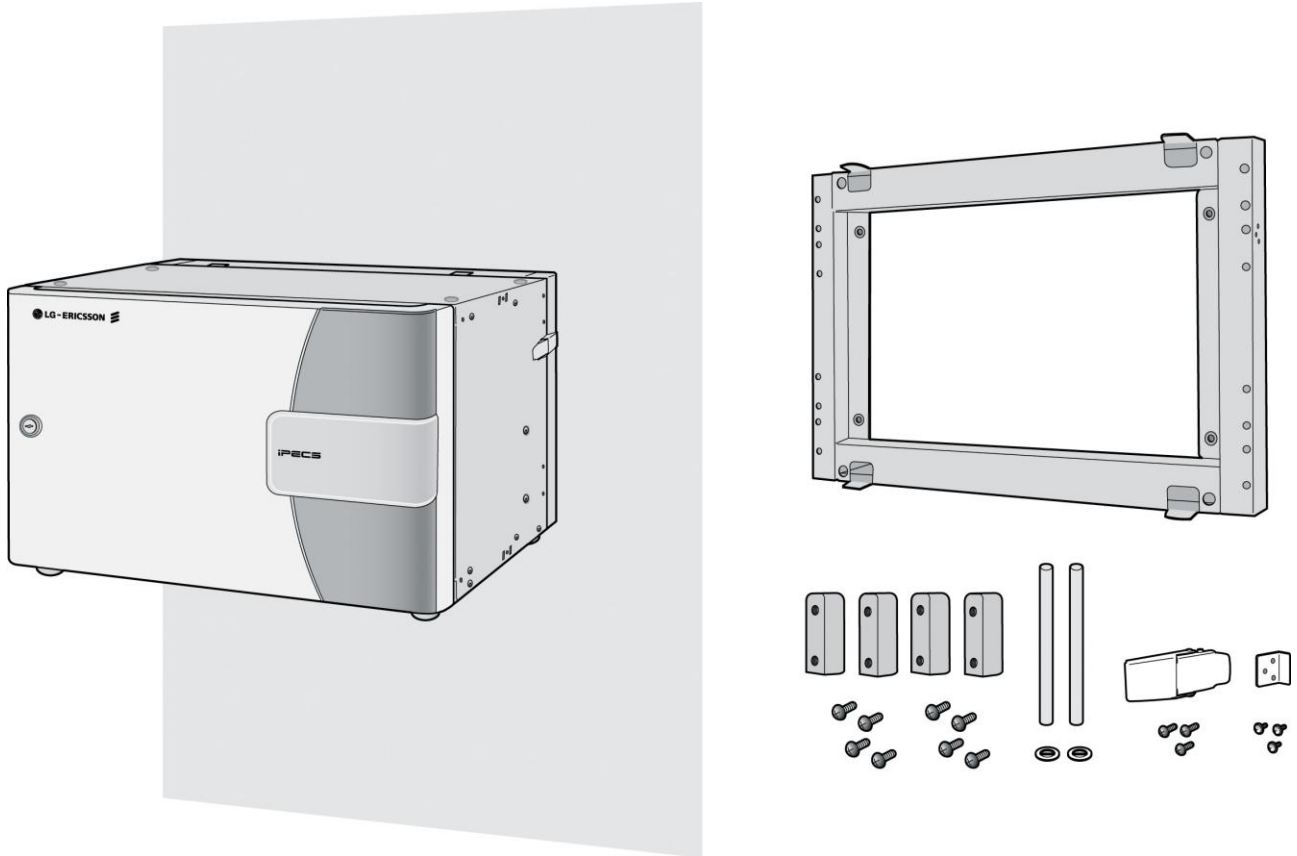

Figure 2.3.4-4 Wall Mount Installation

2.4 Software Components

iPECS software comes pre-loaded in the various system modules. In addition, application and services software have been developed to expand and enhance iPECS functionality. Applications and Services offered include:

- **iPECS Phontage PC SoftPhone**
- **iPECS Phontage PDA SoftPhone**
- **iPECS TSP/MSP - TAPI 3.1**
- **iPECS Auto Attendant, Voice Mail**
- **iPECS Unified Messaging Services (NA for Australia any longer)**
- **iPECS ez-Attendant**
- **iPECS Networking**
- **iPECS UCS (Unified Communications Services)**
- **iPECS NMS (Network Management Services)**
- **iPECS AIM (Advanced Integration Messaging)**

These software packages are documented in other manuals. Contact your local LG-Ericsson representative for a list of other documents available for iPECS.

3 SYSTEM SPECIFICATIONS

3.1 System Capacity

Table 3.1-1 System Capacities

Item	Capacity			
	iPECS-100 (MFIM100)	iPECS- 300 (MFIM300)	iPECS-600 (MFIM600)	iPECS-1200 (MFIM1200)
Main Cabinet	10 slots	10 slots	10 slots	10 slot
System Ports	100 ports	300 ports	600 ports	1200 ports
Stations*1	70	300	600	1200
PSTN circuits*1	42	200	400	600
Max. RSGMs*2	35	150	300	600
Attendants	4	5	5	5
Serial Port (RS-232C)	1	1	1	1
USB Host port	1	1	1 port	1
Alarm/Door bell input	2	2	2	2
External Control Relays	2	4	4	4
Music Source Inputs	2	2	2	2
Power Fail Circuit	4	4 + Ext. PFTU (6 optional)	4 + Ext. PFTU (6 optional)	4 + Ext. PFTU (6 optional)
External Page zones	2	2	2	2
Internal Page Zones	10	35	35	100
System Speed Dial	800 (48 digits)	3000 (48 digits)	6000 (48 digits)	12000 (48 digits)
System Speed Dial Zones (Groups)	10	10	20	50
Station Speed Dial	20 (48 digits)	100 (48 digits)	100 (48 digits)	100 (48 digits)
Last Number Redial	10 (48 digits)	10 (48 digits)	10 (48 digits)	10 (48 digits)
Save Number Redial	1 (48 digits)	1 (48 digits)	1 (48 digits)	1 (48 digits)
DSS Consoles/Station	3	9	9	9
SMDR buffer	5000	10000	15000	30000
CO Line Groups	20	72	72	200
Station & Hunt Groups	40	48	48	100
Station & Hunt Group Members	70	70	70	200
Conf. Grps - System Station	20	40	80	160
	35	150	300	600
Executive/Secretary pairs	10	36	36	100

Item	Capacity			
	iPECS-100 (MFIM100)	iPECS- 300 (MFIM300)	iPECS-600 (MFIM600)	iPECS-1200 (MFIM1200)
Authorization Codes				
Station	70	300	600	1200
System	430	700	1400	2800
Total	500	1000	2000	4000
VSF ^{*3}	210(175) minutes (6 channels)	210(175) minutes (6 channels)	n/a	n/a
VMIM	2	2	6	30
MCIM	2	4	8	30
WTIM	16	32	32	32
DECT Handsets	70	254	254	254
VoIP channels ^{*4}	6 std.	6 std	n/a	n/a
Redundancy	Yes	Yes	Yes	Yes

- Note 1 The station and CO Line maximums are not simultaneously; total ports cannot exceed the specified System Port capacity.
- Note 2 For maximum RSGM connection ports, calculation formula is ports = available system station ports/2, there must be sufficient VoIP channels to support packet relay for RSGM rtp packets.
- Note 3 Approximately 35 minutes (16 Mbytes) of the VSF memory are used to provide basic system prompts, the remaining memory can be used for announcements and voice message storage. Values in parenthesis are the announcement and storage time available.
- Note 4 Using G.711 codecs, 8 VoIP channels are available. Due to additional processing needs, complex codecs reduce the available channels; four (4) channels are available using G.723 or G.729.

3.1.1 Dimension and Weight

Table 3.1.1-1 Dimensions and Weight

ITEM	HEIGHT (mm/in)	WIDTH (mm/in)	DEPTH (mm/in)	WEIGHT (kg/lbs)
Gateway Module	230/9.1.	38.8/1.5.	194.5/7.7	1.5/3.3
Main Cabinet, Enhanced	265.6/10.5	440/17.3	318.2/12.5	7.78/17.2
PSU	230/9.1	38.3/1.5	179.4/7.1	1.4/3.1
1U RMB	38.3/1.5	482.6/19	183.2/7.2	2/4.4
DHLD ^{*1}	146/5.7	111.5/4.4 ^{*1}	128/5	0.4/0.9
WHLD	280/11.0	60/2.4	188.3/7.4	0.2/0.4

- Note 1 The width of the Desk mount does not include approximately 40mm/3.2 inches for each installed module.

3.1.2 Environment specification

Table 3.1.2-1 Environmental Specifications

	DEGREES (°C)	DEGREES (°F)
Operation Temperature	0~50	32~122
Optimum Operation Temperature	20~26	68~78
Storage Temperature	-20~60	-4~140
Relative Humidity	0~80% non-condensing	

3.1.3 Electrical specification

3.1.3.1 System Electrical specification

Table 3.1.3.1-1 System Electrical Specifications

	SPECIFICATIONS
Module AC/DC Adapter	
- AC Voltage Input	100-240 VAC, +/-10% @ 50/60 Hz
- AC Power	1.0 amps
- DC Output Power	48 VDC, 0.8 amps
Keyset AC/DC Adapter	
- AC Voltage Input	100-240 VAC, +/-10% @ 50/60 Hz
- AC Power	0.2 amps
- DC Output Power	48 VDC, 0.3 amps
PSU	
- AC Voltage Input	100-240 VAC, +/-10% @ 50/60 Hz
- Fuse	T6.3, AC250V
- DC Output Power	48VDC, 5.3 amps 5VDC, 1 amps
PSU of SLTM32	
- AC Voltage Input	187~265 VAC @ 47~63 Hz
- Fuse	T1, AC250V
- DC Output Power	36VDC, 1.2 amps 5VDC, 2.5 amps -5VDC, 0.1 amps
External Relay Contact	2 amp @ 30 VDC
Music Source Input	0 dBm @ 600 ohm
External Paging Port	0 dBm @ 600 ohm
LAN Power Feed	0.3 amps max

3.1.3.2 Module Power Requirements

Table 3.1.3.2-1 Module Power Requirements Chart

Module	Maximum current (mA)	Maximum Power (Watts)
MFIM100/300/600	150	7.2
VOIM8/24	100	4.8
VMIM	100	4.8
MCIM	100	4.8
SLTM4	280	13.4
SLTM8	440	21.1
LGCM4/8	100	4.8
BRIM2/4	100	4.8
PRIM	100	4.8
WTIM4	440	20.7
WTIM8	740	34.9
DTIM8	640	30.7

POE8 without connecting PD *	100	4.8
------------------------------	-----	-----

* Note: the power consumption of POE8 with connecting PD

Powered Device: IP Phone including another SIP Phone, Web Camera, wireless AP and so on.

1. maximum power of POE8 in above table is only the power consumption of POE8 itself without connecting any powered devices to LAN connectors.
2. When a POE8 supplies the power to powered devices, e.g. LIP Phones and so on, keep in mind that the total power taken by all ports must not exceed the power supply connected to POE8.
 - ACDC adapter : max. 800 mA including the power consumption of POE8 itself.
 - iPECS P5 cabinet with PSU : max. 5300 mA including the power consumption of other gateways in the cabinet.

* If PD is powered from the external power supply (adapter), POE8 does not supply the power to the device.

3. If you connect any powered devices to POE8, you should check the maximum power consumption of each powered device.

For example, maximum current and classification signature of each LIP-Phone is as following table.

	Model	Maximum current at PSE (mA)	Classification Signature of each device
LIP-24D/24DH	LIP-24D	70	Class 1
	LIP-24DH	70	Class 1
LIP-7000	LIP-7024LD	100	Class 2
	LIP-7024D	92	Class 2
	LIP-7016D	85	Class 2
	LIP-7008D	73	Class 2
	LIP-7004N	70	Class 2
	LIP-7048DSS	96	Class 2
LIP-8000	LIP-8040L	105	Class 2
	LIP-8024D	103	Class 2
	LIP-8012D	96	Class 2
	LIP-8004D	91	Class 2
	LIP-8040L with 1 LSS	114	Class 2
	LIP-8040L with 2 LSS	123	Class 2
	LIP-8024D with 1 LSS	112	Class 2
	LIP-8024D with 2 LSS	121	Class 2
	LIP-8012D with 1 LSS	105	Class 2
	LIP-8012D with 2 LSS	114	Class 2

* Note:

1. LIP-8012DSS and LIP-8012LSS are powered from LIP-8040L/8024D/8012D Phones.
2. Power consumption of LIP-8012LSS is a little more than that of LIP-8012DSS.
So, the power consumption of LIP Phones only with LIP-8012LSS is counted in above table.

3.1.3.3 Maximum Station Distance from Gateway Module

Table 3.1.3.3-1 Maximum Station Wiring Distance

ITEM	AWG 22 (m/Kft)	AWG 24 (m/Kft)
LIP Phone	100/0.328	100/0.328
SIP or H.323 VoIP phone	100/0.328	100/0.328
Digital Terminal	500/1.64	300/1
Single Line Telephone (SLTM4/8)	6,000/20	4,000/13
Single Line Telephone (SLTM32)	4,500/15.4	3,000/10

Note 1 All the LIP Phones are compliant to IEEE 802.3af POE standards.

3.1.3.4 CO loop specification

Table 3.1.3.4-1 CO Loop Specifications

ITEM	SPECIFICATION
Ring Detect Sensitivity	40 Vrms @ 16~30 Hz
	30 Vrms @ 30~37 Hz
DTMF Dialing	
- Frequency Deviation	Less than +/-1.8%
- Signal Rise Time	Max. 5ms
- Tone Duration, on time	Min. 50ms
- Inter-digit Time	Min. 30ms
Pulse Dialing	
- Pulse Rate	10 pps
- Break/Make Ratio	60/40% or 67/33%

Note 1 Ring sensitivity on Analogue CO lines will vary from one regulatory region to another.

4 INSTALLATION

4.1 Overview

As with any sophisticated communications device, installation of iPECS requires the care and forethought of a competent technician. Recommended installation proceeds in 6 major steps:

- ✓ Site Preparation
- ✓ Equipment verification
- ✓ Cabinet/Desk/Wall Mount Holder installation, as required
- ✓ Module installation and wiring
- ✓ LIP Phone and other terminal installation
- ✓ System Programming and Verification

By utilizing the instructions that follow, the installation is quick and efficient. Directions for system programming and verification are given in the **iPECS Admin & Program Manual**.

4.2 Site Preparation

4.2.1 General Site Considerations

The first step is to locate an acceptable site for the Module mounting hardware (Desk Mount Holder, Wall Mount Holder or Main Cabinet). When locating the mounting site, the following points must be considered:

- The Main Cabinet can be Desk, 19" Rack or Wall mounted. When desk mounting, assure that the desk has ample strength to support the Main Cabinet and other hardware to be installed.
- When wall mounting is desired, the cabinet **MUST NOT** be mounted directly to a masonry or plasterboard wall. A ½-inch plywood backboard should be firmly attached to the wall, and the cabinet and the MDFs should be mounted to the backboard.
- The location must have access to an appropriate 100~240 VAC @ 50-60 Hz power source with a circuit breaker or fuse rated at 10 amps and must be surge protected. An appropriate grounded outlet should be within approximately 2 meters (6 feet) of the equipment location. When employing the Module Desk Mount Holder, an outlet will be required for each Module; a multi-outlet extension cord can be used.
- The location must have access to a good protective earth ground, such as a metallic cold water pipe with no non-metallic joints. The ground source should be located as close as possible to the equipment.
- The system should be located in a well-ventilated area with a temperature of around 20°C (68°F) and a relative humidity of 0-80% (non-condensing).
- The equipment should be located within 8 meters (25 feet) of the telephone company's termination point. If the system is to share the LAN with data devices or be connected to an external VoIP network the system must be within 100 meters (330 feet) of the WAN connection. Also, the location should be within the prescribed station loop lengths for all phones and terminals refer to section 3.1.3.3. If existing cabling is employed, the location of existing cabling and conduits should be considered.
- The location should have adequate accessibility, space and lighting for future servicing and should consider the need for future expansion.
- The site should be away from radio transmitting equipment, arc-welding devices, copy

machines, and other electrical equipment capable of generating high levels of electrical interference. The system should be protected from flooding and heavy machinery as well as excessive dust and vibration.

4.2.2 Verify Equipment On-site

Once the equipment installation site has been identified and a dedicated AC outlet, protective earth ground, lighting and ventilation are available, verify that all equipment and tools required are on-site and the equipment has not been damaged during shipment. Assure there is no shipping damage. Check that the type and quantity of Modules and terminals received are correct. Also, assure optional equipment and Power Line Surge Protector are on-site. The individual Modules and terminals need not be unpacked at this time.

If any equipment appears damaged or is missing, notify appropriate personnel to correct the situation.

4.3 Module Mounting Hardware Installation

4.3.1 Enhanced Main Cabinet Installation

The Enhanced Main Cabinet can be desk, 19" rack or wall mounted. The following paragraphs provide directions for each of the mounting options as well as installation and removal of the front cover.

4.3.1.1 Cover Close/Open

The front cover is provided as standard equipment with the Main Cabinet. The cover hooks and snaps on to the cabinet as follows:

1. Align the notched tab on the right side of the cover with the slot in the right side of the cabinet. See Figure 4.3.1.1-1.
2. Push the tab into the corresponding slot in the cabinet.
3. Slide the cover to the right to engage the notched tabs.
4. Swing the left side of the cover closed over the cabinet engaging the cover latch.

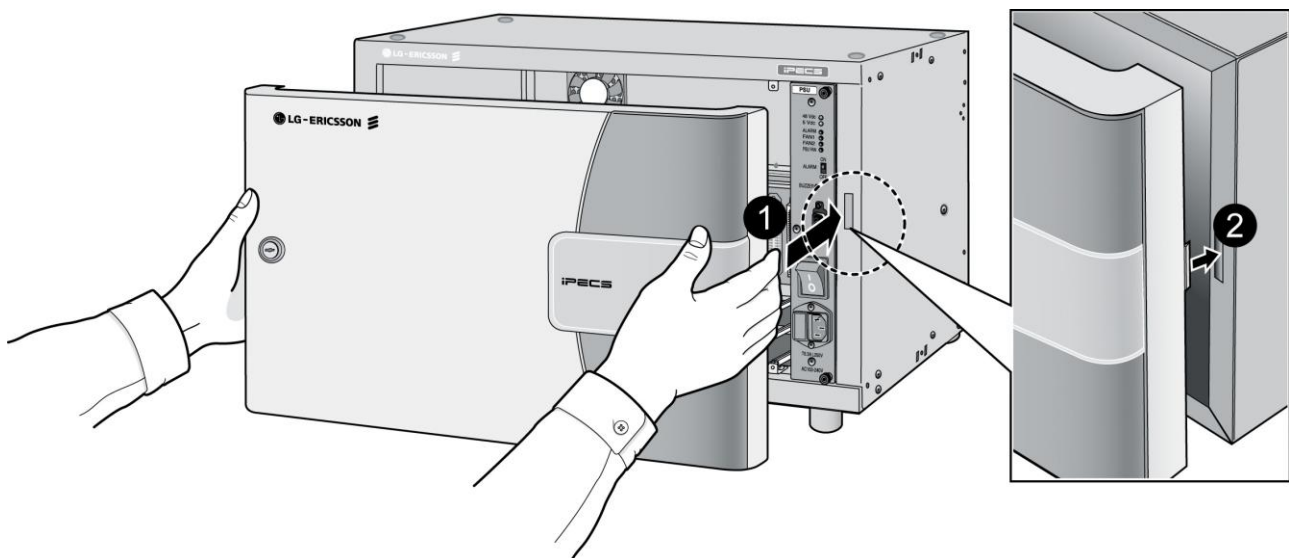

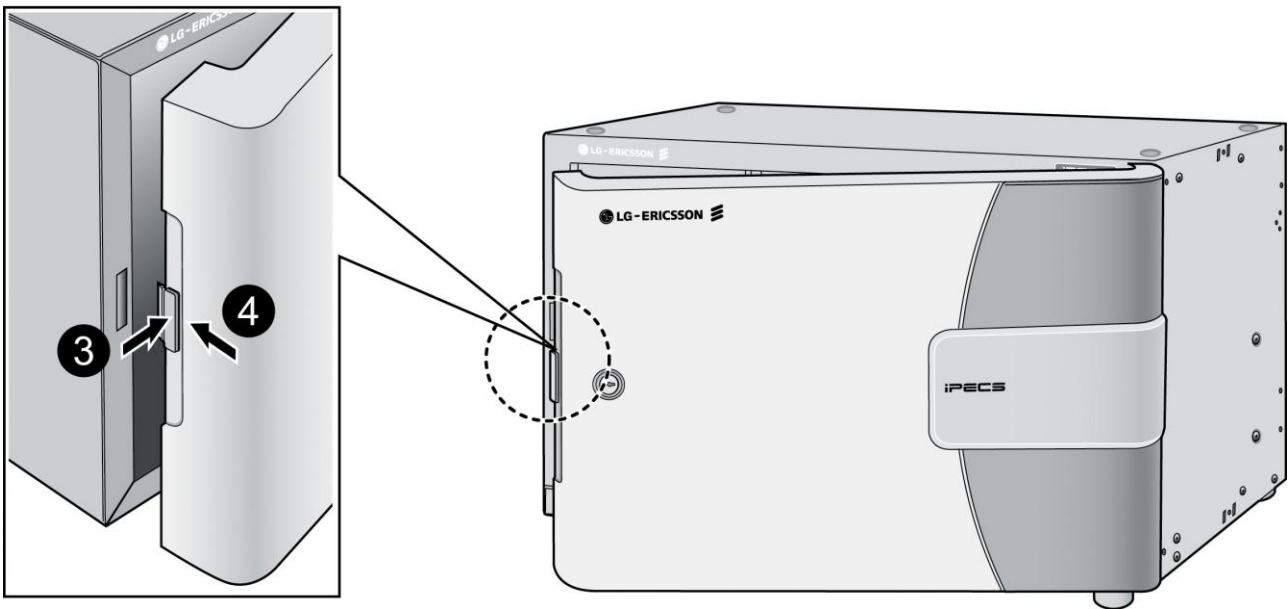
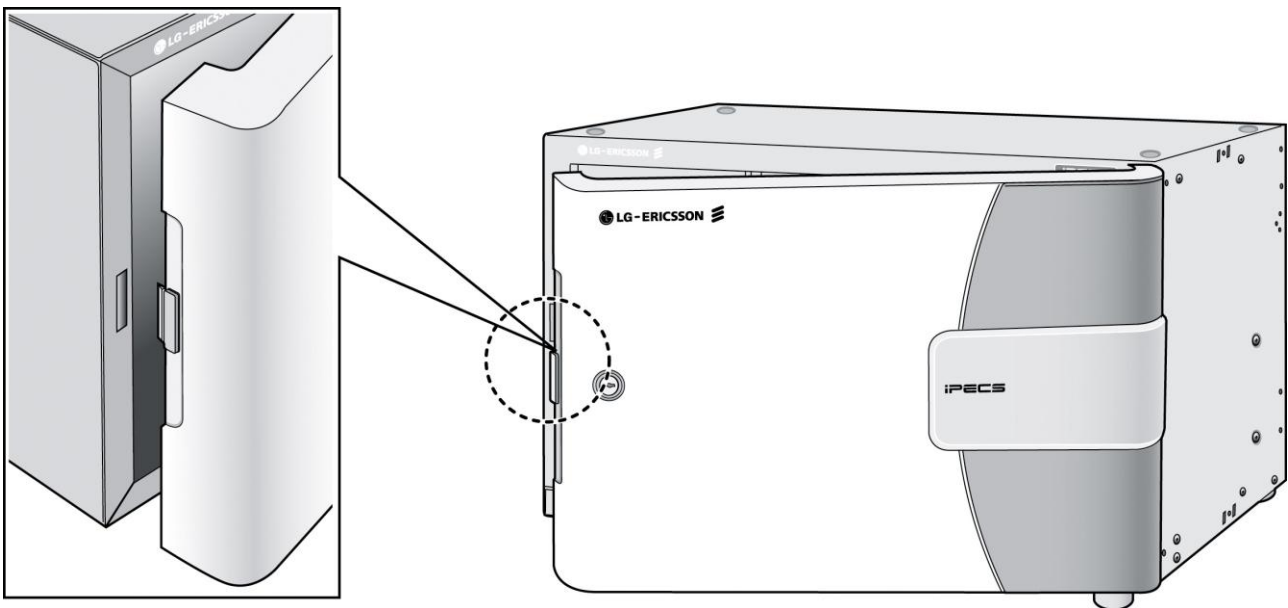

Figure 4.3.1.1-1 Cover installation

To remove:

1. Push the button on the left side of cover to disengage the latch. Refer to Figure 4.3.1.1-2.
2. Swing the left side of the cover open slightly.
3. Slide the cover to the left to disengage the notched tab.
4. Pull the cover away from the cabinet.



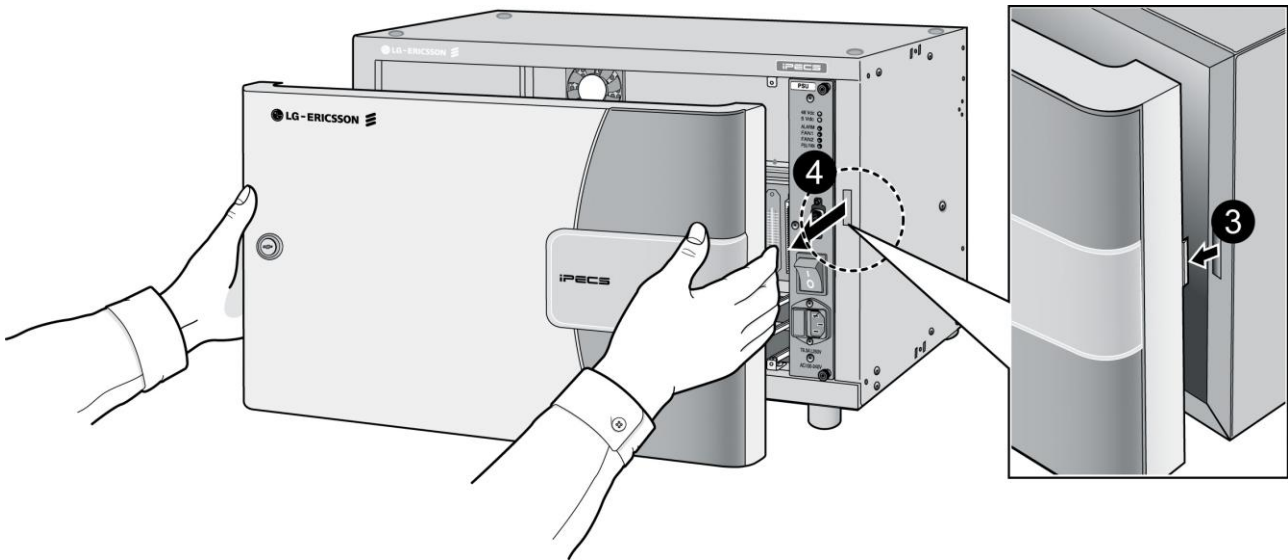

Figure 4.3.1.1-2 Cover removal

4.3.1.2 Cabinet 19" Rack Installation

Rack mount brackets are provided as standard equipment with the cabinet. These brackets attach to the front sides of the cabinet. To rack mount the cabinet:

- Bolt the Rack mount brackets securely onto the sides of the cabinet with the supplied four (4) M4 x 6 mm machine screws, refer to Figure 4.3.1.2-1.
- Connect the brackets to a standard 19" rack securely with four (4) appropriate machine screws, nuts and lock-washers.

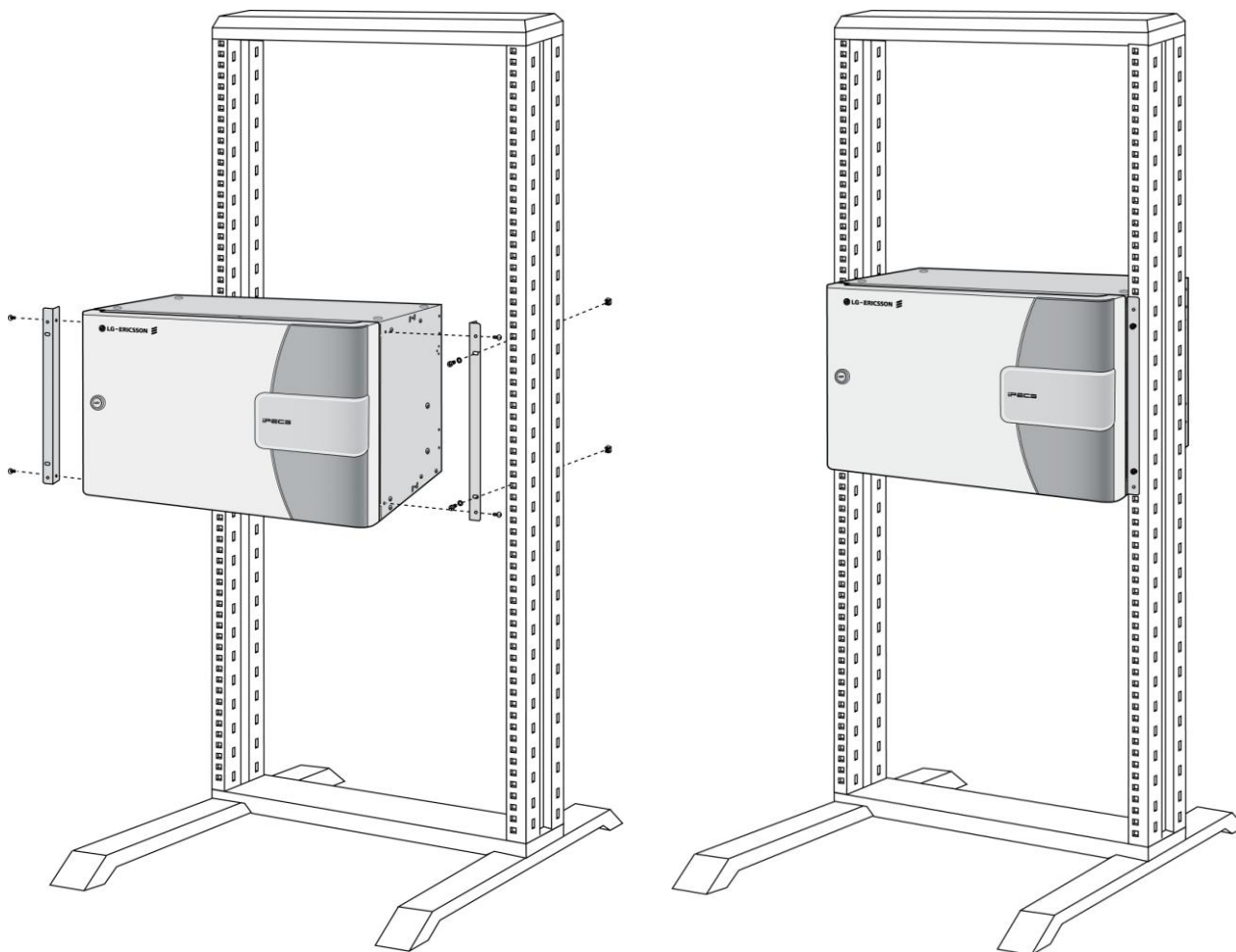

Figure 4.3.1.2-1 Rack (19”) Installation

4.3.1.3 Cabinet Wall Mount Kit Installation

If the cabinet is to be wall mounted, a wooden backboard **MUST** be installed when the location has masonry or plasterboard walls. This backboard is recommended for all Wall Mount installations. A ½-inch plywood material is sufficient for most installations. The backboard should be mounted at a convenient height, about one (1) meter above the floor, and be bolted to wall-studs in a number of places to distribute the weight of the system.

Space should be available on the backboard for separate Telephone and LAN wiring distribution frames (MDF) and for optional equipment such as music sources, etc.

The optional Cabinet Wall Mount kit mounts to the wall then the cabinet is attached to the Wall Mount kit. The Wall Mount kit permits the cabinet to swing on hinges for access to the back plane telephony cabling. The hinges may be placed on either side of the cabinet prior to installation. Select the hinged side so as to obtain maximum clearance and lighting. Also, to keep the cabinet from swinging open, a latch is provided. Follow the steps below and Figure 4.3.1.3-1 for installation.

- Disassemble the hinges by separating the hinge body and removing the hinge pin.

- Mount the separated hinge bodies, two to the Wall Mount bracket and two to the cabinet using the M6 x 8 mm machine screws two (2) for each hinge body provided.
- Use the Wall Mount kit to mark the location of four (4) mounting holes for the Wall Mount kit as shown in Figure 4.3.1.3-1. Assure the Wall Mount holes are level and plum.
- Drill four (4) 7 mm holes for the plastic wall anchors provided.
- Fully Insert a wall anchor into the each of the four (4) holes, insert and tighten screws leaving about 6 mm (¼-inch) exposed.
- Place the Wall Mount kit on the four (4) screws and tighten the screws securely.
- Insert the hinge pins and mount the cabinet to the Wall Mount kit by aligning the hinge bodies with the hinge pins and lower into place.
- Finally, mount the Cabinet Latch to the Wall Mount bracket and cabinet using the six M3 x 6 mm screws provided. The latch must be installed on the side opposite of the hinges.

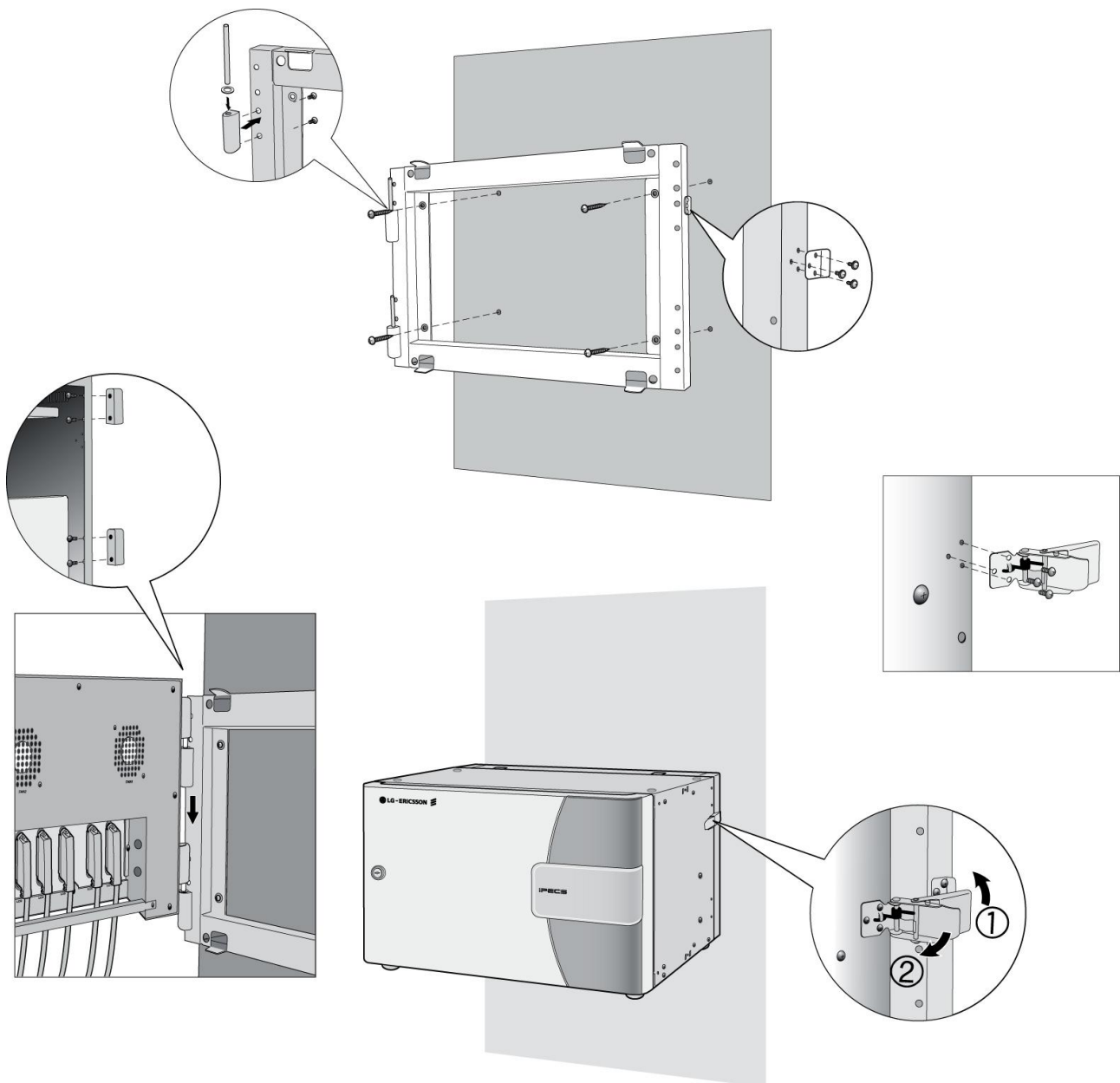

Figure 4.3.1.3-1 Cabinet Wall Mount Kit Installation

4.3.2 Main Cabinet Grounding



CAUTION

Before connection to AC power, the cabinet must be connected to a protective earth ground in conformance with the appropriate IEEE recommendations. A protective earth ground is required for user safety and to minimize EMC interference.

To ensure proper system operation and for safety purposes, a good protective earth ground is required. A metallic COLD water pipe usually provides a reliable ground. Carefully check that the pipe does not contain insulated joints that could isolate the ground path. If insulated joints exist, another protective earth ground source must be used or, if codes allowed, the joints may be bridged.

A 12 AWG UL type 1015 or larger copper wire is recommended as the protective earth ground connection wire. However, check the appropriate national and local codes for proper conductor type and size. The wire should be kept as short as possible; it is recommended that the wire be no longer than 1 meter (about 3.3 feet).

The permanent protective earth ground “” must be connected to the backplane of the Cabinet using #12 AWG or larger UL-1015 type copper wire. The protective earth ground terminal of the cabinet is located on rear bottom left side of the cabinet as shown in Figure 4.3.2-1.

- The permanent protective earth ground “60417-1-IEC-5019” must be connected to the backplane of the cabinet using #12 AWG or larger UL-1015 type copper wire. The protective earth ground terminal of the cabinet is located on rear bottom left side of the cabinet.

Loosen the “” terminal sufficiently to insert the Ground wire and re-tighten the terminal securely.

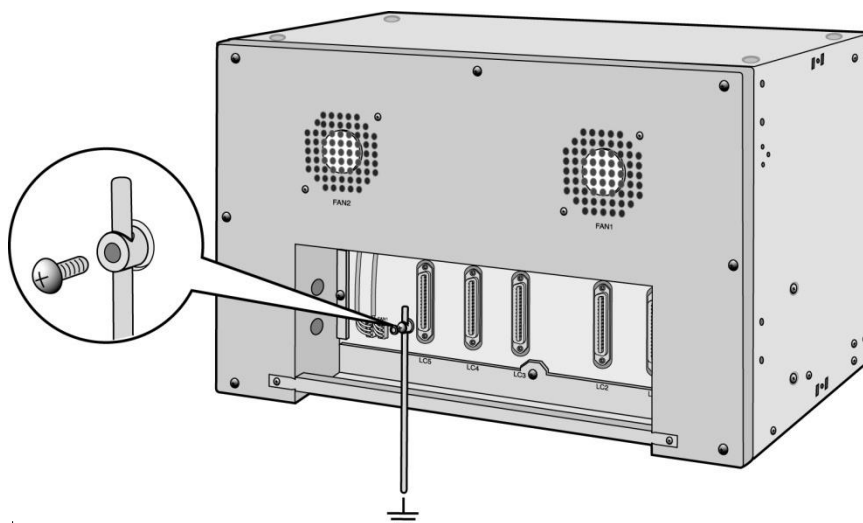

Figure 4.3.2-1 MCKTE Grounding

4.3.3 Module Desk Mount Holder Kit

To assemble the Desk Mount Holder, refer to the instructions below and Figure 4.3.3-1. Note a Desk Holder Extender is required for each Module.

- Place the key-hole slots on the side of the Extender over the keys on the side of the bookend.
- Slide the Extender and bookend in opposite directions to the locked position.
- Repeat for additional Extenders and the other bookend.

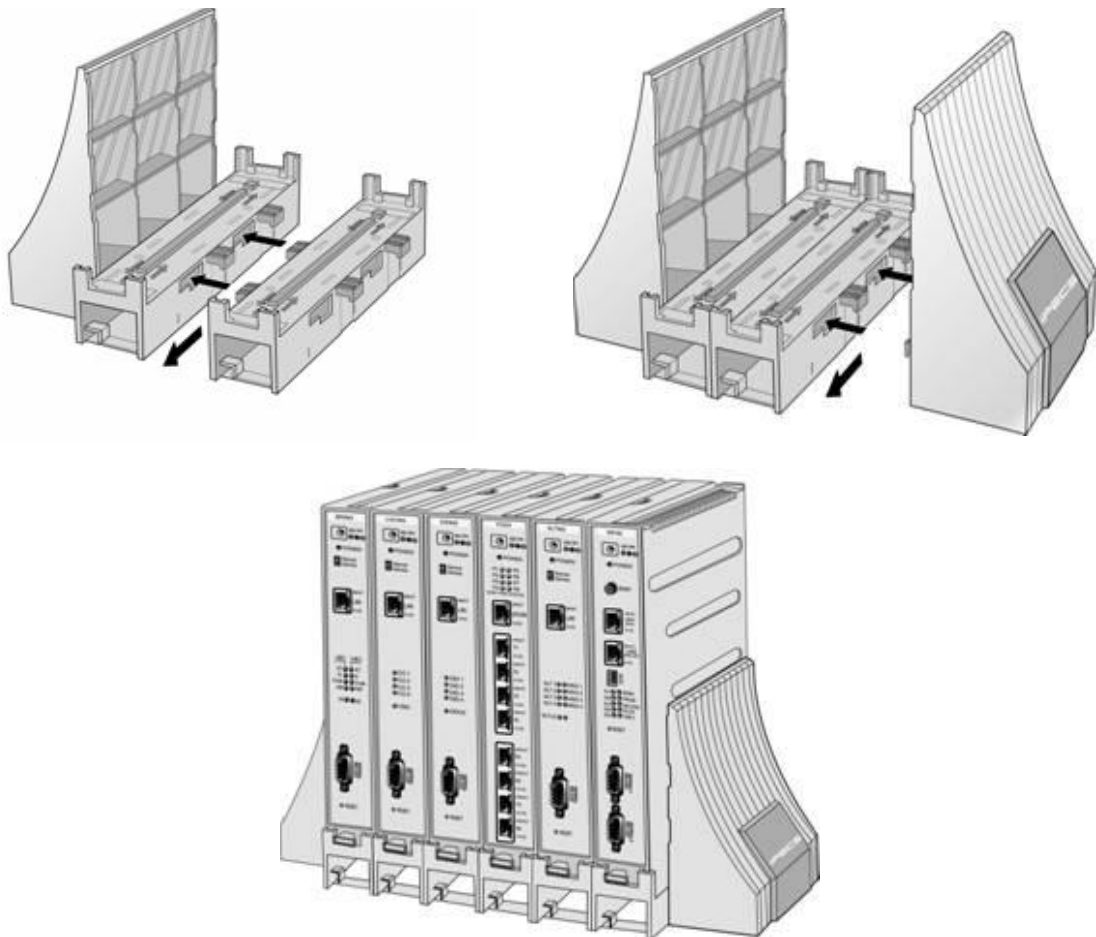

Figure 4.3.3-1 Module Desk Mount Holder Kit

Once assembled, Modules are simply placed in the Desk Holder “slots”. The front of all Modules should be placed on the same side of the Desk Holder.

4.3.4 Module Wall Mount Holder Kit

The Module Wall Mount Holder will house a single Module. To install, refer to Figure 4.3.4-1 and instructions below:

- Place the Wall Mount Holder in position and mark two (2) holes over a wall stud.
- Drill two (2) 7 mm holes for the plastic wall anchors provided.
- Insert the two (2) anchors into the holes, then insert and tighten the 2 screws leaving about 6 mm (¼-inch) exposed.
- Arrange wiring on the back of the Wall Mount Holder.
- Place (hang) the Wall Mount Holder on the screws and tighten securely.
- Slide the Module into the Wall Mount Holder until it locks.
- Connect all wiring to the Module as appropriate, refer to section 4.5.

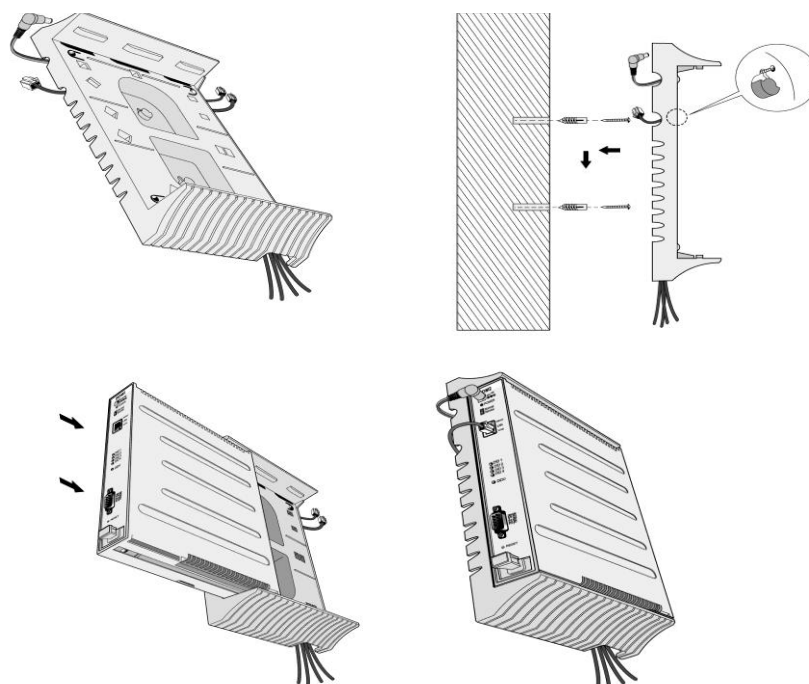

Figure 4.3.4-1 Module Wall Mount Holder Kit

4.3.5 1U-Rack Mount Bracket Installation

The Module 1U-Rack Mount Bracket will house a single Module and an AC/DC adapter to power the Module. To install, refer to figures and instructions below:

1. Install the AC/DC adapter in the 1U-RMB. Refer to Figure 4.3.5-1.
 - Remove the two (2) screws on the rear of 1U-RMB to release the upper housing.
 - Lift up and remove the upper housing.
 - Remove the two (2) screws holding the adapter bracket.
 - Lift up and remove the adapter bracket.
 - Install an adapter (The label side of the adapter should be placed on the inner surface of 1U-RMB), place the adapter bracket over the adapter and fasten the two (2) screws.
 - Insert the adapter DC plug through the hole in the front of 1U-RMB. Note for the RSGM, the DC cable should exit through the hole in the rear of the 1U-RMB.

- Insert the rubber grommet over the DC adapter cable and insert the grommet in the hole in the front of the housing.
- Replace the upper housing and fasten the two (2) screws.

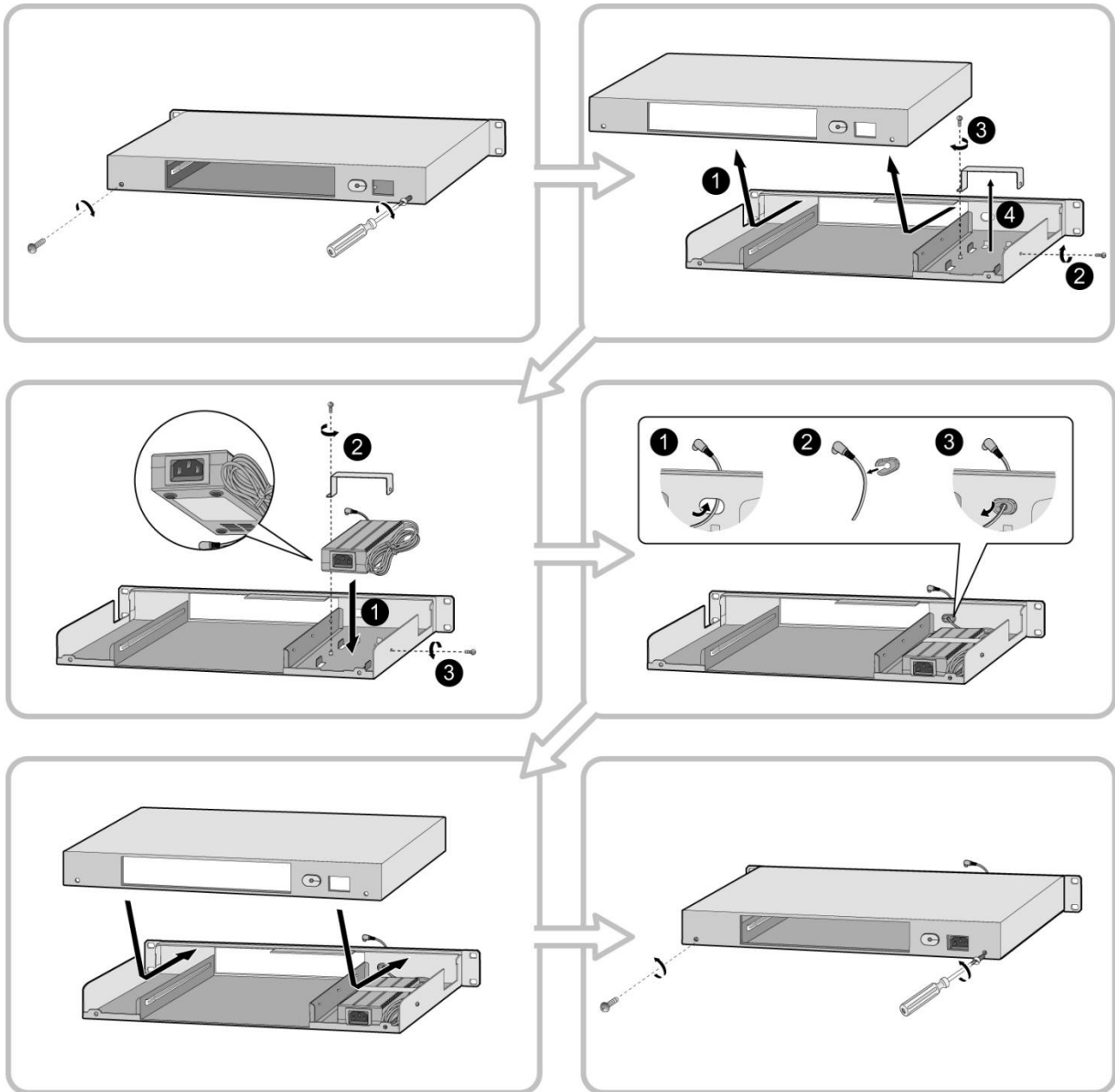

Figure 4.3.5-1 1U RMB Adapter Installation

2. Install the gateway Module into the 1U-RMB and connect the adapter plug. Refer to Figure 4.3.5-2.
 - Slide the Module into the 1U-RMB.
 - Place the Ferrite core over the DC cable and close the core over the cable. For the RSGM, the DC cable must exit the rear of the 1U-RMB. For all other modules, the DC cable must exit the front of the 1U-RMB.
 - Connect the adapter DC plug to the gateway Module.

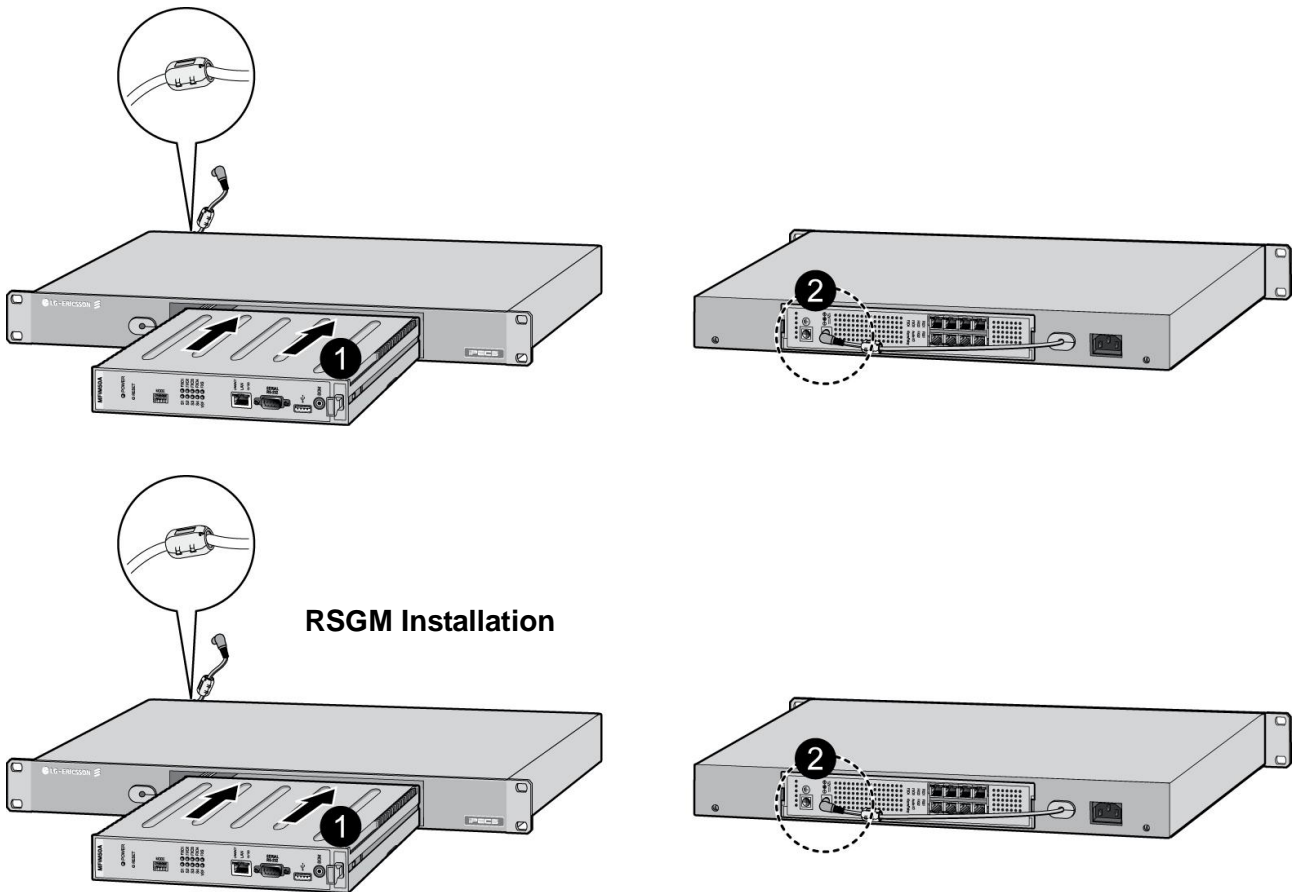

Figure 4.3.5-2 1U-RMB Gateway Installation

3. Install the 1U-RMB in a standard 19" rack securely with four (4) appropriate machine screws, nuts and lock-washers. Refer to Figure 4.3.5-3.
 - Wire the Module as described in section 4.5.
 - Connect the AC cable to the adapter and wall outlet to power the Module.

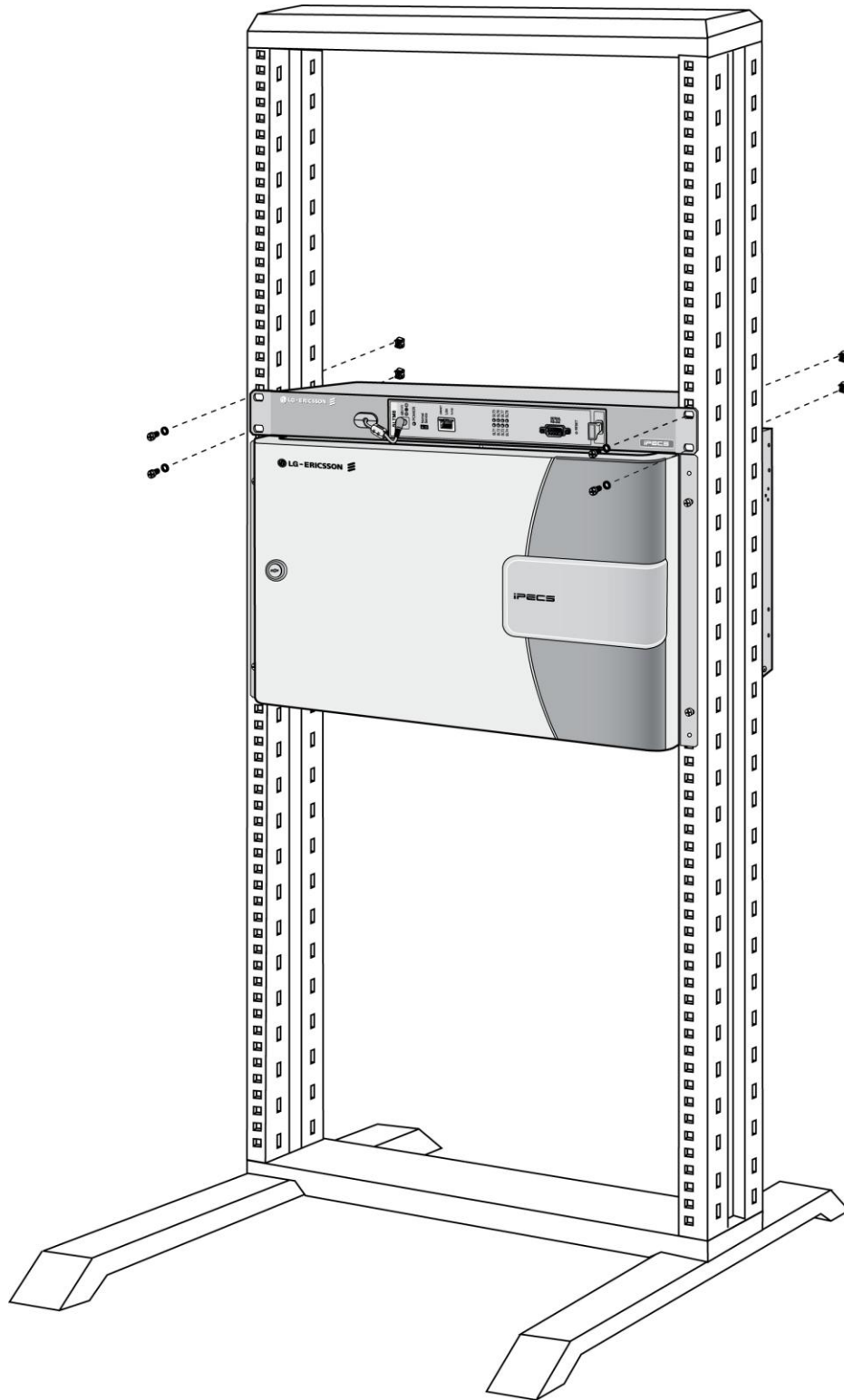

Figure 4.3.5-3 1U-RMB Rack-mount Installation

4.4 PSU Installation

The Power Supply Unit (PSU) is installed in slot 10 of the Enhanced Main Cabinet only. A back-up power supply may be installed in slot 9 to provide redundant power operation. When a back-up PSU is installed, should the main PSU fail, the back-up PSU immediately provides power to all of the Modules in the Main Cabinet.

LEDs

The PSU has six LEDs on the front panel to display the status of PSU and fans in the Main Cabinet. The function of each LED is shown in Table 4.4-1.

Table 4.4-1 PSU Status LED Functions

LED	LED FUNCTION
48Vdc	On when -48Vdc is OK.
5Vdc	On when 5Vdc is OK.
ALARM	On when -48Vdc or 5Vdc fails.
FAN1	On when FAN1 fails.
FAN2	On when FAN2 fails.
PSU FAN	On when PSU FAN fails.

Alarm Switch

The PSU has a slide switch on the front panel. This switch activates/deactivates the local audio alarm indication from the buzzer. If a local audio alarm indication is desired, the switch should be in the On (up) position. If no local audio alarm indication is desired, the Alarm switch should be in the Off (down) position.

RS-232 Connector

The PSU outputs status and alarm information over the RS-232 DB9 connector. Use the serial cable provided with the cabinet to interconnect the PSU and the monitoring gateway Module. The monitoring gateway Module is defined in the Cabinet Attributes Web Admin page (PGM 197). When a back-up PSU is installed, the serial cable should be connected to the back-up PSU only. Note that when employing a WTIM as the notifying gateway Module, Dip switch 3 of the WTIM, the Serial Mode switch, must be set to OFF, the Main CPU Serial mode.

Power Switch and AC Power Input

The PSU has a fused AC Power Input and switch which turns AC power to the PSU On and Off.

Fuse.

A T6.3A L250V fuse is installed in the fuse holder below the AC input connector. Should the fuse fail replace only with a T6.3 A L250V fuse.

The main PSU is installed as described below and shown in Figure 4.4-1.

- Slide the PSU into slot 10 of cabinet.
- Fasten the PSU by tightening the upper and lower thumb-screws on the front of PSU.
- Plug the power cord into AC power input on the front of PSU.
- To activate monitoring of the PSU and cabinet fans, connect the supplied serial cable from the DB9 connector of the PSU to the gateway Module defined in admin PGM 197. Refer to

Figure 4.4-3. Note when a back-up PSU is installed, the serial cable is connected to the back-up PSU only. Note that when employing a WTIM as the notifying gateway Module, Dip switch 3 of the WTIM, the Serial Mode switch, must be set to OFF, the Main CPU Serial mode.

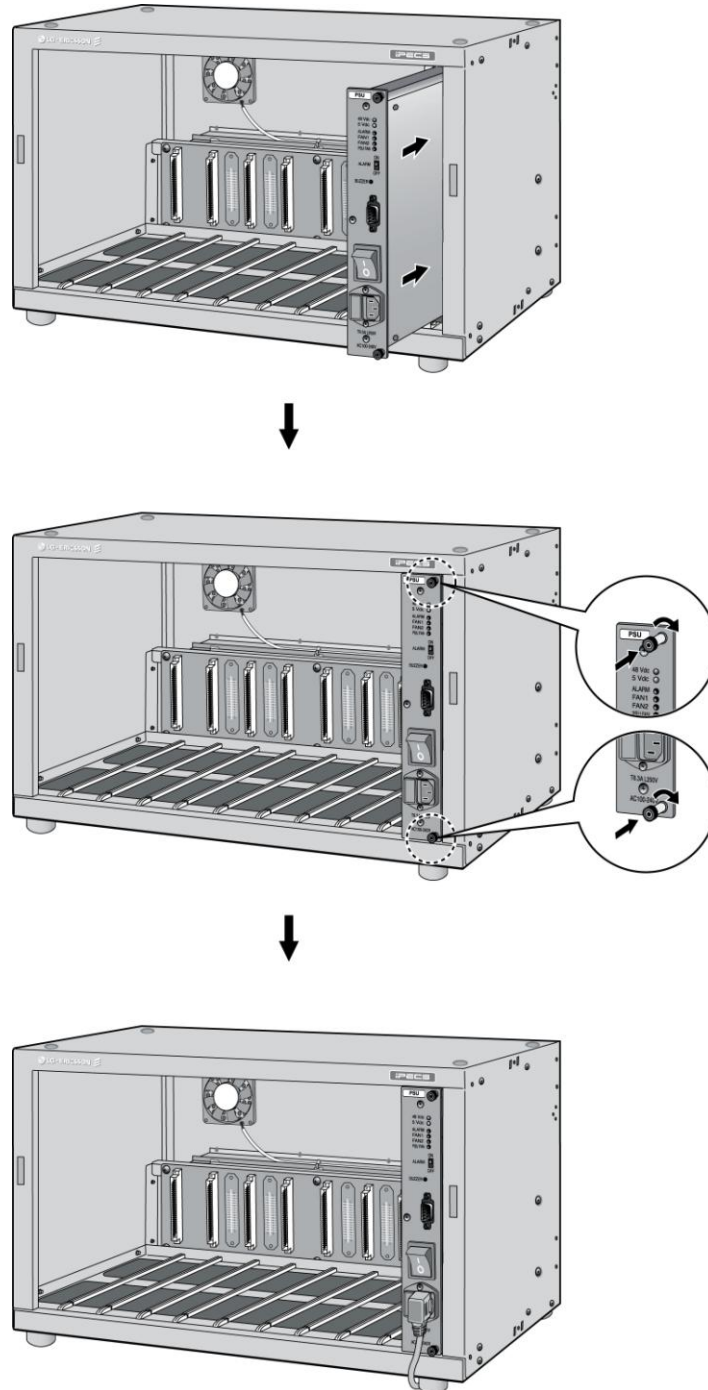

Figure 4.4-1 Main PSU Installation

The back-up PSU for power redundancy is installed as described below and shown in Figure 4.4-2.

- Install the main PSU as described above and shown in Figure 4.4-1.
- Install upper and lower PSU thumb-screw brackets to the right of slot 9 slides of the cabinet

as shown in Figure 4.4-2 using the screws provided.

- Slide the back-up PSU into slot 9 of cabinet.
- Fasten the PSU by tightening the upper and lower thumb-screws on the front of PSU into the installed brackets.
- Plug the power cord into AC power input on the front of PSU.
- To activate monitoring of the PSU and Main Cabinet fans, connect the supplied serial cable from the DB9 connector of the PSU to the monitoring gateway Module defined in admin PGM 197. Refer to Figure 4.4-3. When a back-up PSU is installed, the serial cable is connected to the back-up PSU only. Note that when employing a WTIM as the notifying gateway Module, Dip switch 3 of the WTIM, the Serial Mode switch, must be set to OFF, the Main CPU Serial mode.

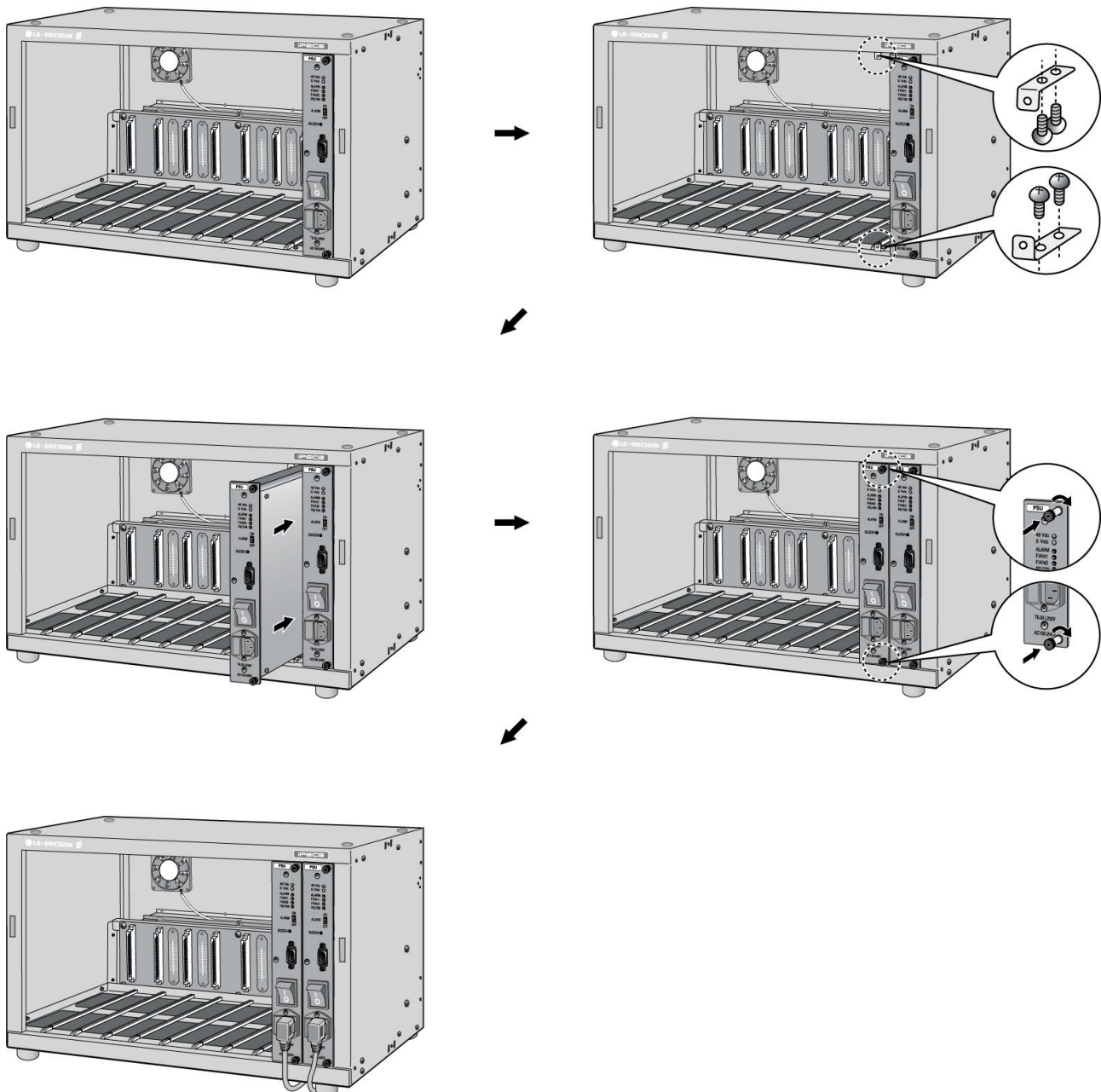

Figure 4.4-2 Back-up PSUs Installation

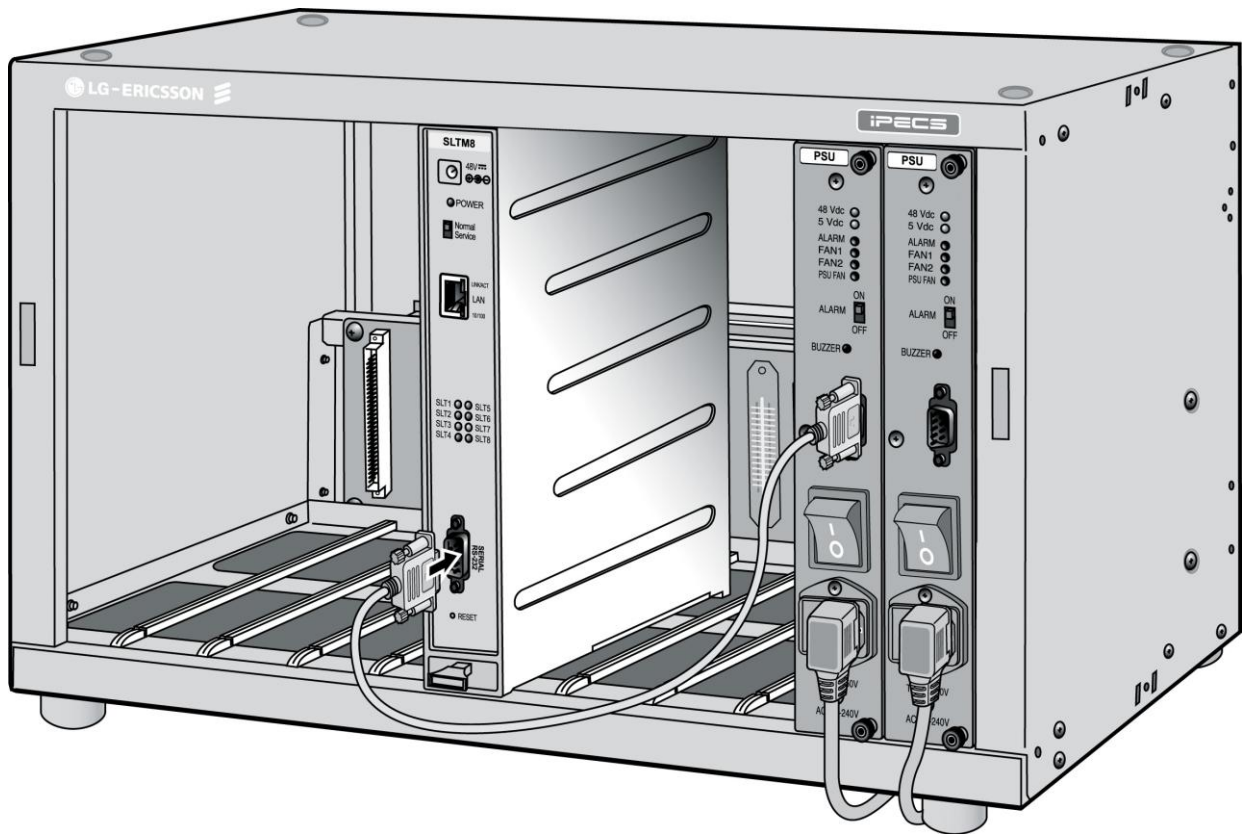

Figure 4.4-3 Monitoring cable Installation

4.5 Module Installation

4.5.1 Module Handling and General Installation

The following paragraphs provide general and common installation and wiring practices and procedures for all Modules. Procedures such as LAN wiring are common for all Module LAN ports and are discussed here. Prior to installation of any Module, it is recommended the installer be thoroughly familiar with the information in this section.

**CAUTION**

Modules must be installed in a Wall Mount Holder, Desk Holder or the cabinet for proper ventilation. Do not stack Modules or limit airflow as this may cause overheating, leading to pre-mature failure and/or faulty operation of the equipment.

4.5.1.1 Module Installation Sequence

A **SEQUENCE NUMBER** is assigned to all gateway Modules based on the order of registration with the system, refer to the **iPECS Admin & Program Manual** for further details. This **SEQUENCE NUMBER** determines the logical CO Line and station numbers assigned in the system database.

The system does not differentiate between the types of PSTN Module during initialization. Thus, an LGCM4 installed 1st is assigned **SEQUENCE NUMBER** 01 with CO Line ports 1~4, a DIDM8 installed 2nd is assigned CO Line ports 5~12 and another LGCM4 installed 3rd is assigned CO Line ports 13~16.

Although the **SEQUENCE NUMBER** in the database can be changed, connecting the gateway Modules to the iPECS in the desired sequence based on type of Module is recommended. The Module **SEQUENCE NUMBER** can be easily established at installation by controlling the order of connection of the Module's LAN port to the system (LAN switch connected to the MFIM's LAN 1 port).

Station numbers are also assigned consecutively based on the order of connection to the system. Since the first phone installed is assigned as the Admin Station (station number 100), it is recommended an LIP Phone be connected to the system prior to installing any SLT gateway Module.

4.5.1.2 Module Insertion/Removal

Modules are easily inserted into the cabinet; place the Module with front panel forward in the desired slot in the cabinet and slide the Module into the cabinet, engaging the connectors of the back plane and Module.

To remove a Module from the cabinet, pull on the Release knob while sliding the Module out of the cabinet. Refer to Figure 4.5.1.2-1.

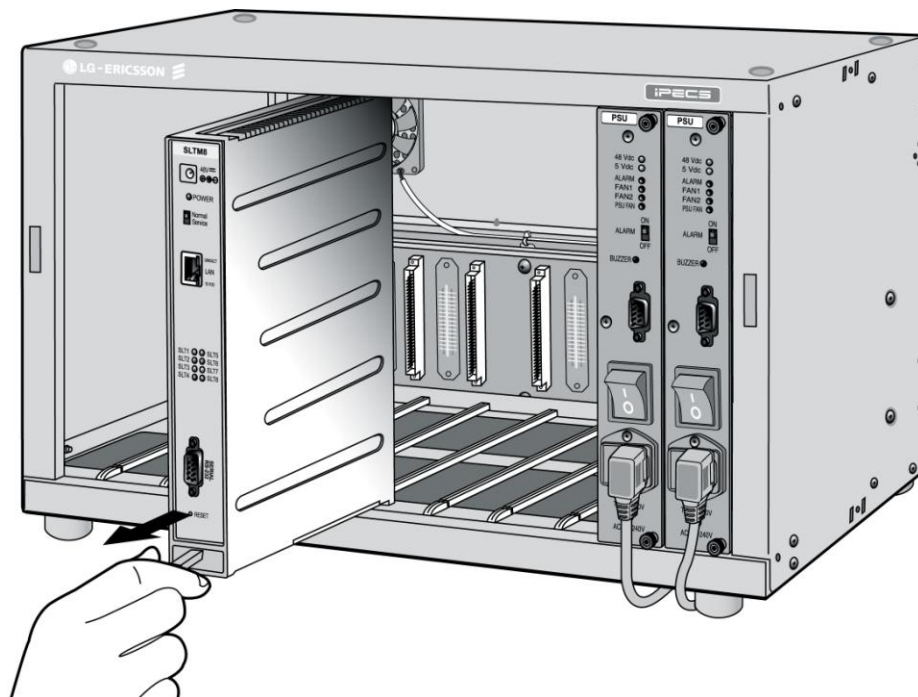

Figure 4.5.1.2-1 Module Insertion/Removal

4.5.1.3 Common Module Switches

With the exception of the POE8, all Modules have a recessed Reset and a Normal/Service switch, refer to Figure 4.5.1.3-1. These switches are employed for maintenance purposes. The Reset switch will restart the Module firmware, resetting only the scratch-pad memory. The Normal/Service switch activates a graceful shutdown of the Module, as busy circuits go idle they are marked as Out-of-Service.

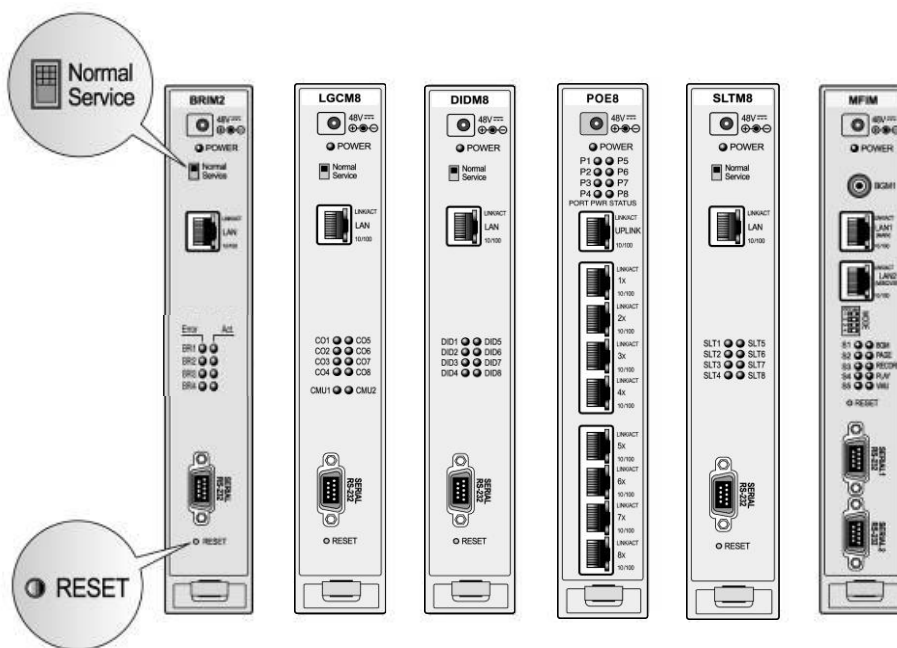

Figure 4.5.1.3-1 Common Module Switches

4.5.1.4 Module Grounding

As shown in Figure 4.5.1.4-1, a “ \perp ” or “ \oplus ” screw is located on the rear panel of each Module. For proper operation and code compliance, the grounding screw **MUST** be connected to a known protective earth ground using a #12 AWG or larger UL-1015 type copper wire. The wire should be located between the toothed lock washer and the plain washer. Note that when using the cabinet, a separate ground connection to the individual Modules is not required.

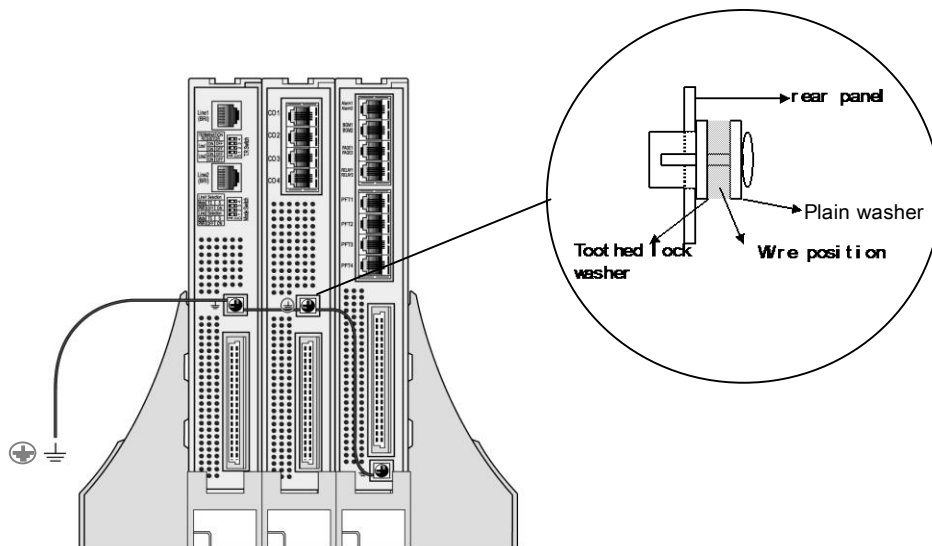

Figure 4.5.1.4-1 Module Grounding



CAUTION

When a module is installed in a Desk Mount Holder (DHL) Wall Mount Holder (WHL) or 1U-Rack Mount Bracket (1U-RMB), the protective earth ground must be connected to the earth ground terminal in rear of the module using #12 AWG or larger UL-1015 type copper wire.

4.5.1.5 Telephony Connections

In general, PSTN and SLT (telephony) connections are available on the rear of each Module, while LAN, power and RS-232 connections are on the front of each Module. Telephony connections via RJ-11 or RJ-45 type jacks are wired as in Figure 4.5.1.5-1. All telephone wiring should use standard two (2)-pair twisted 24 or 26 AWG wiring.

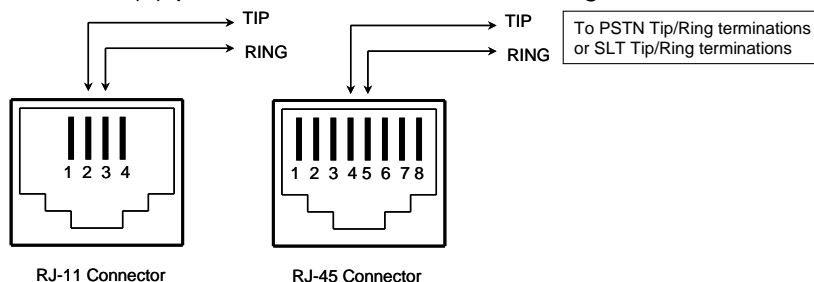

Figure 4.5.1.5-1 Telephony (RJ-11 or RJ-45) Connector Pin Assignment



CAUTION

To reduce the risk of fire, use only 26 AWG or larger UL List or CSA Certified Telecommunication Line Cord.

4.5.1.6 LAN Connections

LAN connections are made by way of RJ-45 connectors on the front panel of each Module. These connectors are shown in Figure 4.5.1.6-1. Each connector has a green Link/Activity LED and a yellow LAN speed LED, On for 100 Base-T.

The gateway Module “LAN” ports and the POE8 “UPLINK” ports as well as the LIP Phone LAN port are terminated in the standard Media Dependent Interface (MDI) configuration shown in Figure 4.5.1.6-1. The POE8 “X” LAN ports are terminated in the mating MDIX (crossover) configuration as shown in the figure. The POE8 can provide power over the LAN with 48 VDC across pin pairs 4&5 and 7&8. This configuration mates with the LIP Phone as shown in the figure. Finally, the LIP-7016D/7024D/7024LD and LIP-8012D/8024D/8040L Phones are equipped with a second LAN port, designated “PC” to connect a PC or similar device allowing a shared LAN infrastructure. This connector is terminated in the MDIX configuration mating to a typical PC with a straight cable.

All LAN wiring should use Category 5 Unshielded Twisted Pair (CAT 5 UTP) cable. No single run of LAN cable should exceed 100 meters (about 330 feet).

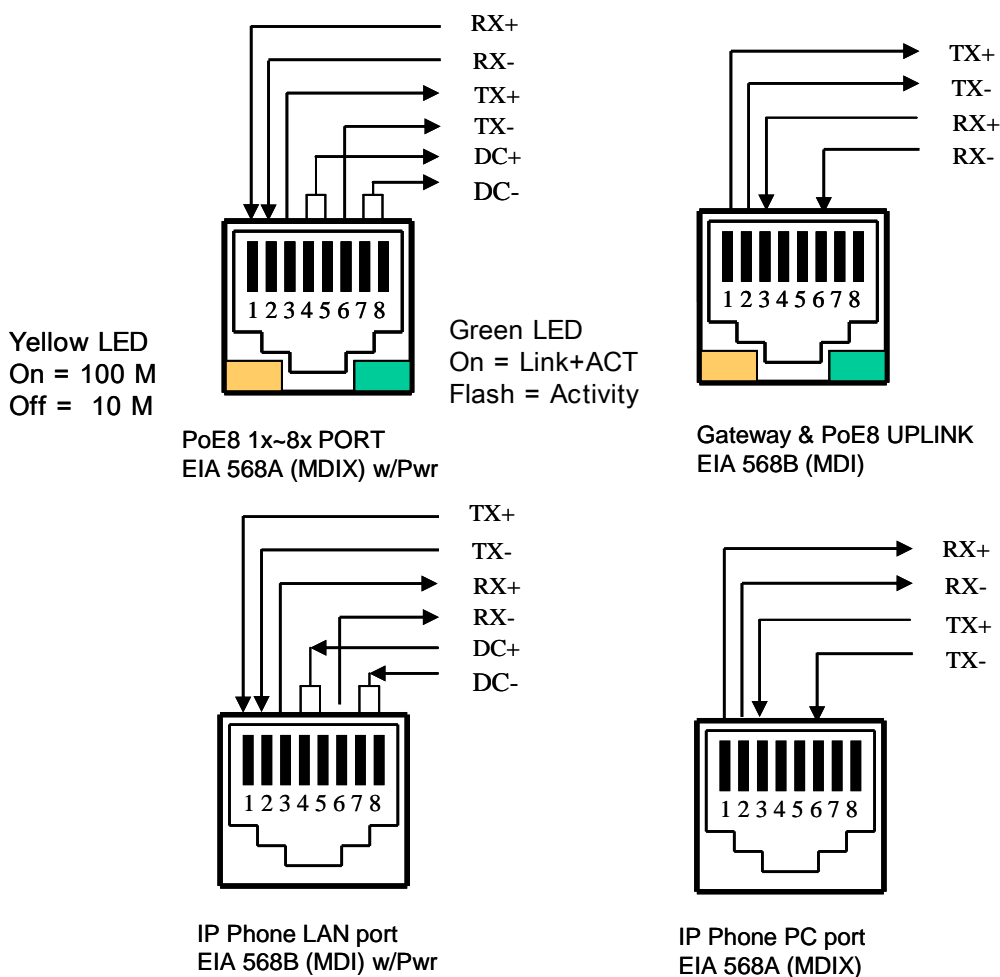

Figure 4.5.1.6-1 LAN Connector (RJ-45) Pin Assignment

4.5.1.7 LAN Wiring Structures

The LAN wiring architecture used for connecting iPECS Modules to the LAN is dependent upon several factors including:

- Shared or iPECS only LAN infrastructure
- External VoIP calling requirements
- New or existing voice and/or data installation
- Remote LAN power or local AC power for iPECS Phones

The “PC” LAN port of equipped LIP Phones can be connected to the user’s desk-top using a standard LAN cable terminated with RJ-45 LAN jacks. The LAN jack is wired to an Ethernet switch, which has access to the MFIM, other iPECS Modules and LIP Phones. This connection can be through a connection to the same switch or by an indirect connection through multiple switches.

For a new installation or, where LAN power to the LIP Phone is desired, the POE8 can be employed for the corporate LAN. For existing installations, it may be necessary to replace existing switches in a shared environment in order to provide remote power to the LIP Phones.

In the shared environment, both data and voice will have access to the WAN, which also permits external VoIP calling. In the non-shared LAN environments, the system must be connected to the WAN to support external VoIP connections.

Due to the advantages of the shared environment, support for remote LAN power, and external VoIP calling, the POE8, which is a standard Ethernet switch, should be employed. The recommended structure, called here “hierarchical” wiring, employs all “straight” LAN cables (MDI to MDIX) and is shown in Figure 4.5.1.7-1. Additional POE8 Modules are connected using the UPLINK port to the switched ports of the primary POE8. A sufficient number of POE8 modules are connected to provide the total number of ports required. Each Module, LIP Phone, and LIP-7000 series Console requires a single port and the MFIM will require two (2) ports. Thus, an 8 CO Line, 24 station system would require a total of 28 ports (MFIM = 2 ports, two LGCM4 = 2 ports, and 24 LIP Phones = 24 ports), and would be structured as in the Figure 4.5.1.7-1.

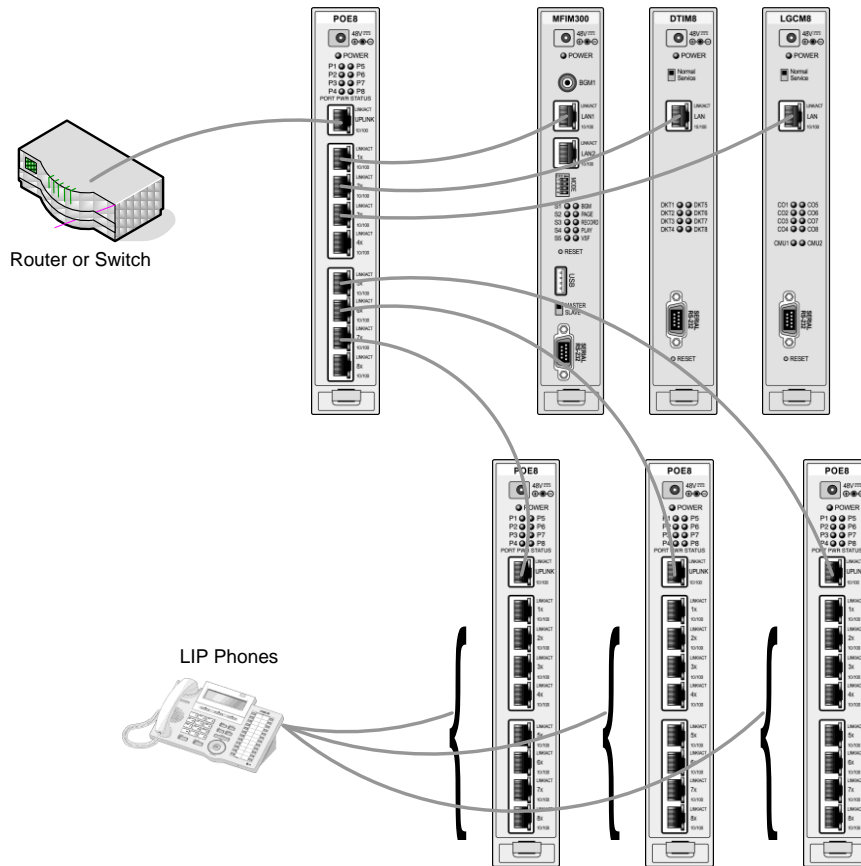

Figure 4.5.1.7-1 iPECS LAN Wiring

Cascading

When the station loop limit is beyond the 100-meter (330 feet) limit, switches may be cascaded to extend the range. For the POE8, simply connect the extension switches with their UPLINK port to a LAN 1X~8X port of the previous POE8 in the cascade.

CAUTION *The POE8 does not support spanning tree. Do not create a loop when connecting these switches to each other or other network components.*

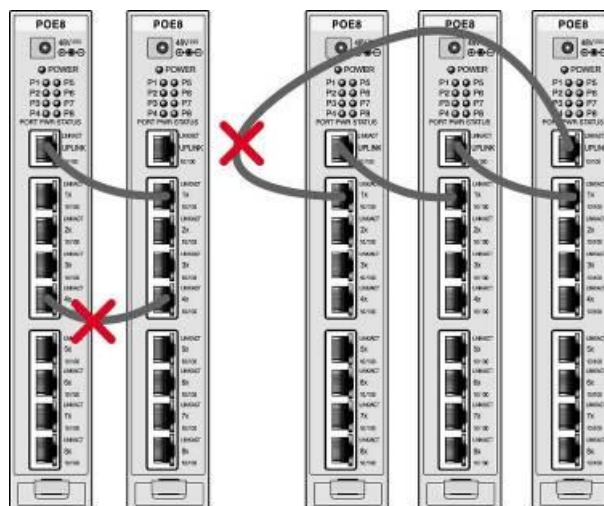

Figure 4.5.1.7-2 Erroneous Loop Wiring

4.5.1.8 RS-232 Connections

The DB-9 connector located on the front panel of each gateway Module is an RS-232 serial port. The connector is employed to provide system trace and diagnostic routines for the individual Modules. The MFIMs have one such port, which may be assigned for the desired function (SMDR, ACD, etc.). Refer to the **iPECS Admin & Program Manual**.

The Phase 4 and higher Modules and PSU are set-up for 8-bits, no parity, and one (1) stop bit running at 115,200 bps. To modify the speed and other settings, refer to the **iPECS Admin & Program Manual**.

The RS-232 connectors for gateway Modules, POE8 and MFIM are terminated in a Data Communications Equipment (DCE) configuration as displayed in Figure 4.5.1.8-1. The RS-232 connector in the PSU is terminated in a Data Terminal Equipment (DTE) configuration. Use a cable pre-terminated with DB-9 connectors to connect an appropriate device (terminal, printer, etc.) to the Module.

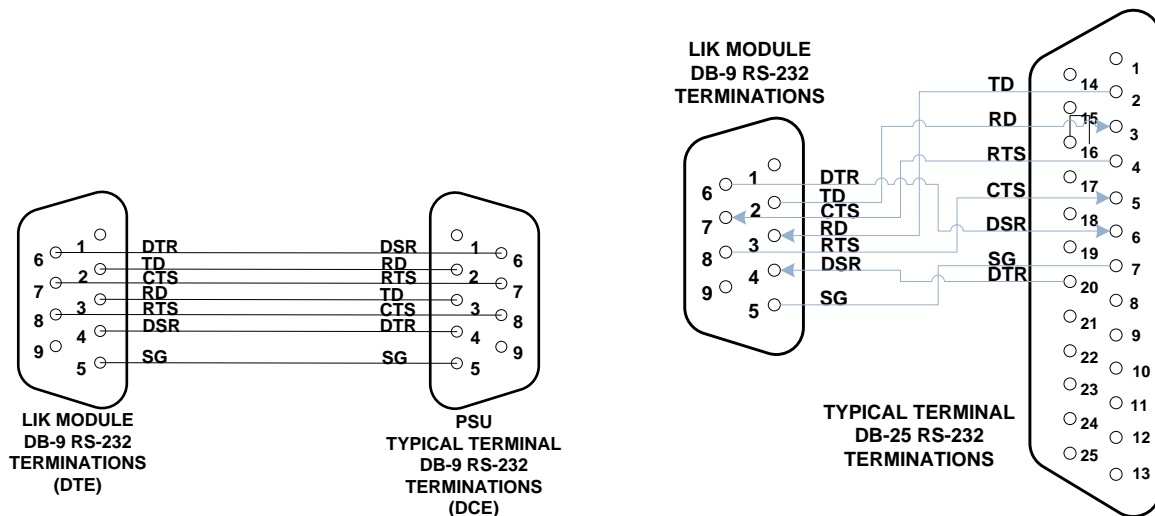

Designation	Function
TD	Transmitted Data
RD	Received Data
RTS	Request To Send
CTS	Clear To Send
DTR	Data Terminal Ready
DSR	Data Set Ready
SG	Signal Ground

Figure 4.5.1.8-1 RS-232 DB-9 Pin-outs

4.5.1.9 Module Power Adapter

Modules are shipped without AC/DC Adapters. Therefore if an adapter is required, it must be ordered separately. The AC/DC Adapter converts local AC to 48 VDC for Module power. One side of the adapter has a three (3) prong parallel blade male termination and mates with the power cord supplied. The AC power cord supplied is plugged into the adapter and into the local AC power source. See section 4.3.3 for installing the module in a DHLD, section 4.3.4 for WHLD or section 4.3.5 for 1U-RMB.

The other end of the adapter is terminated in a DC power cord with a plug at the end. This DC power plug is inserted into the power input jack on the upper front panel area of each Module. The Power LED on the Module front panel will illuminate when power is applied.

4.5.2 MFIM Installation

There are several models of the MFIM, which are all installed in the same manner. In this section the reference to MFIMs encompasses the various models of MFIMs. The MFIM may be installed anywhere except for slot 10 of the cabinet, or may be installed anywhere in the Desk Mount Holder.

Each MFIM contains a long life Lithium battery, which protects the memory and real-time clock in the event of a power failure. Minimum battery life is 10 years and the battery is not field-replaceable.

LEDs

In addition to the Power and LAN LEDs, MFIMs have ten LEDs for status and diagnostic information as in Table 4.5.2-1 & Table 4.5.2-2.

Table 4.5.2-1 MFIM100/300 Status LED Functions

LED DESIGNATION	LED STATUS FUNCTION - ON -
S1	Serial/TCP debug active
S2	Call Processing active
S3	Active data communication with Modules and IP Phones
S4	LCD control active
S5	CPU active (100ms flashing)
BGM	BGM or internal MOH active
PAGE	Ext. Page1 or Ext. Page2 in use
RECORD	VSF Record active
PLAY	VSF Play-back active
VSF	VSF Active (Flashing)

Table 4.5.2-2 MFIM600/MFIM1200 Status LED Functions

LED DESIGNATION	LED STATUS FUNCTION - ON -
S1	Serial/TCP debug active
S2	Call Processing active
S3	Active data communication with Modules and IP Phones
S4	LCD control active
S5	CPU active (100ms flashing)
BGM	BGM or internal MOH is active
PAGE	Ext. Page1 or Ext. Page2 is active
S6	Reserved
S7	Redundancy active (flashing during DB download)
S8	MISC Active (Flashing)

MODE Switch & Settings

MFIMs have a four (4) position DIP-switch identified as the “**MODE**” switch. The function of each switch position is given in Table 4.5.2-3 below.

Table 4.5.2-3 MFIM Mode Switch Functions

SWITCH	FUNCTION	ON	OFF
1	Database write protect	Protect	Unprotect
2	Boot mode protect	Enable	Disable
3	Registration	Allow registration	Registration denied
4	Initialization	Initialize on Reset	Read stored Db on Reset

To enter data in the system’s database, the Write Protect switch must be in the OFF position. In the ON position, the database cannot be modified. Thus, placing the switch in the ON position eliminates the potential for remote database modification. If remote data entry is not desired, after all installation and database entries are complete place the switch in the ON position.

When new gateway Modules and/or terminals are connected to a LAN, they will automatically attempt to register with an MFIM. With the Registration switch (switch 3) in the ON position, the system will recognize and respond to the registration request. With the switch in the OFF position, the system will not respond to the request. During initial installation, the switch should be placed in the ON position to permit the system to recognize and respond to registration requests. If it is desired to deny future registrations, the switch should be placed in the OFF position. This is useful when multiple systems may be connected to the same LAN. For details on gateway Module and terminal registration refer to the **iPECS Admin & Program Manual**.

The system database is initialized based on switch position 4. In the ON position the system will load default values in the system database when power is applied to the MFIM or the Reset button is pressed. Note if the system loses power for any reason with the switch in the ON position, the database will be initialized. Place the switch in the ON position then, after completing the system wiring and prior to any database entries, place the switch in the OFF position. For a description of the initialization process refer to the **iPECS Admin & Program Manual**.

Wiring Connectors

Before wiring any of the Modules, first connect the “ \perp ” screw on the back of the Module to a known ground, refer to section 4.5.1.4.

On the front of the MFIM are the “LAN 1” and “LAN2” RJ-45 type connectors. These connectors should be wired to the appropriate LAN points as discussed in section 4.5.1.6 and 4.5.1.7.

- Wire “LAN 1” to a 10/100 Base-T switch, a POE8 can be used to connect to the LAN.
- For redundant processor operation, wire “LAN 2” of main and back-up MFIM.
- Tag or number wiring for maintenance.

The eight (8) RJ-45 connectors on the rear panel of the MFIMs are terminated for miscellaneous functions. The connectors are wired as Figure 4.5.2-1 and Figure 4.5.2-2. Note the MFIM300 and MFIM600 include terminations for additional relay contacts and connection for the external PFTU box, GDK-100.

- Wire Miscellaneous function connectors as depicted in the sketches of Figure 4.5.2-1 and Figure 4.5.2-2. These connections are not available from the Main Cabinet back plane.

CAUTION Note the BGM1 connections on the front and rear panels of the MFIMs are the same and only one should be wired.

- Tag or number wiring for maintenance.

AC/DC Adapter

If a PSU is not employed, assure the AC/DC Adapter is plugged into a live AC outlet and the MFIM Power jack.

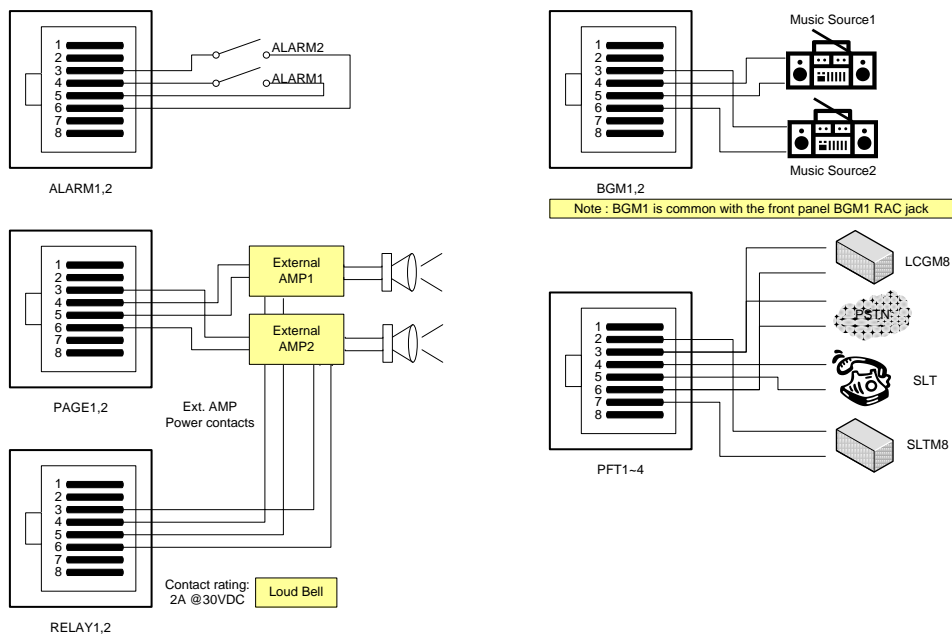

Figure 4.5.2-1 MFIM100 Miscellaneous Function Connections

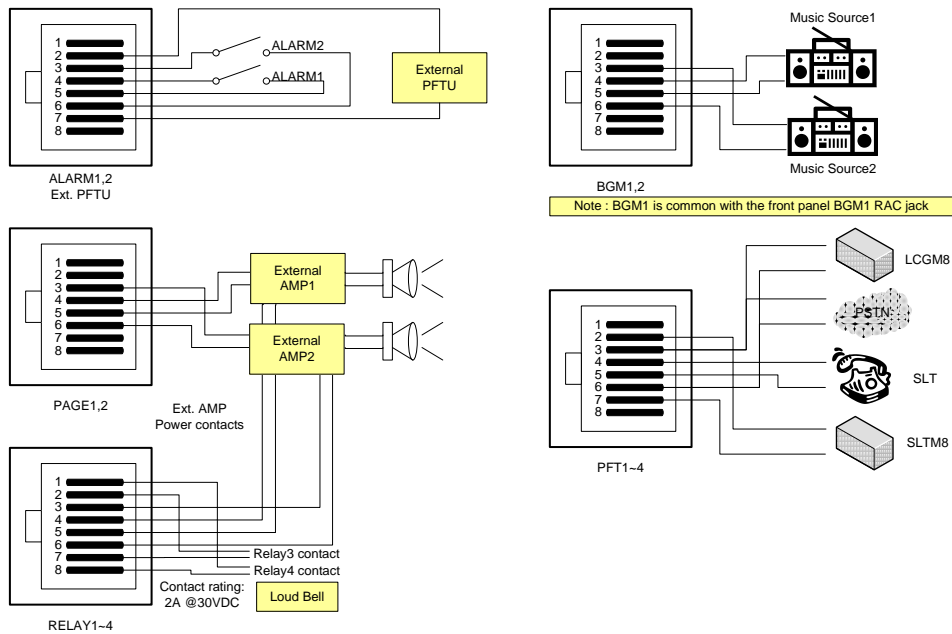

Figure 4.5.2-2 MFIM300/MFIM600/MFIM1200 Miscellaneous Function Connections

4.5.3 VOIM8/24 Installation

The VOIM8/24 may be installed anywhere except for slot 10 of the cabinet, or may be installed anywhere in the Desk Mount Holder. The VOIM8/24 is used to provide packet relay for remote devices to communicate with the host and translation between the iPECS proprietary protocols and other standard protocols (H323, SIP).

LEDs

The VOIM8 and VOIM24 have five (5) LEDs for status and diagnostic information as in Table 4.5.3-1.

Table 4.5.3-1 VOIM8 & VOIM24 Status LED Functions

LED	LED FUNCTION -
S1	Trace Task active
S2	VOIM Task active
Seizure	VoIP call active
S3	Registered to MFIM
Transcodec	Transcoding in use

Wiring Connectors

Before wiring any of the Modules, first connect the “ \perp ” screw on the back of the Module to a known ground, refer to section 4.5.1.4.

A “WAN” RJ45 type connector is located on the front of the VOIM8/24. This connector should be wired to the appropriate LAN points as discussed in section 4.5.1.6 and 4.5.1.7. In addition, the

VOIM8/24 includes an unused “LAN” RJ-45 type connector. Currently the “LAN” port is not used and no connection should be made to this port.

- Wire the “WAN” connector to a 10/100 Base-T switch, a POE8 can be used to connect to the LAN.
- Tag or number wiring for maintenance.

AC/DC Adapter

If a PSU is not employed, assure the AC/DC Adapter is plugged into a live AC outlet and the Module Power jack.

4.5.4 LGCM4 Installation

The LGCM4 may be installed anywhere except for slot 10 of the cabinet, or may be installed anywhere in the Desk Mount Holder. The LGCM4 provides a gateway between standard PSTN Loop Start Lines and other iPECS appliances. The LGCM4 can support four (4) PSTN Lines.

LEDs

In addition to the Power and LAN LEDs, the LGCM4 has four (4) green status LEDs and one (1) red status LED. The four (4) green LEDs indicate that the individual PSTN Lines are busy (LED On), idle (LED Off) or ringing (LED flashing). One (1) red LED indicates whether the CMU4 option module is installed. If installed, the LED is On.

CMU (Call Metering Unit)

The LGCM4 supports call metering with installation of an optional CMU4 module. Three types of module, based on protocol, are available CMU4-12PR, CMU4-16 and CMU4-50PR; see section 2.1.3.1. Each of the CU4 modules is for different regions as shown in the chart of section 2.1.3.1.

Before installing the CMU4 module, make sure that power is turned Off. Figure 4.5.4-1 shows the procedure for installing a CMU4 module on the LGCM4. Check the connector numbers of the CMU4 module prior to installation. Note that the connector numbers for the CMU4-12PR and 16 are the same while for the CMU4-50PR, the connector numbers are reversed.

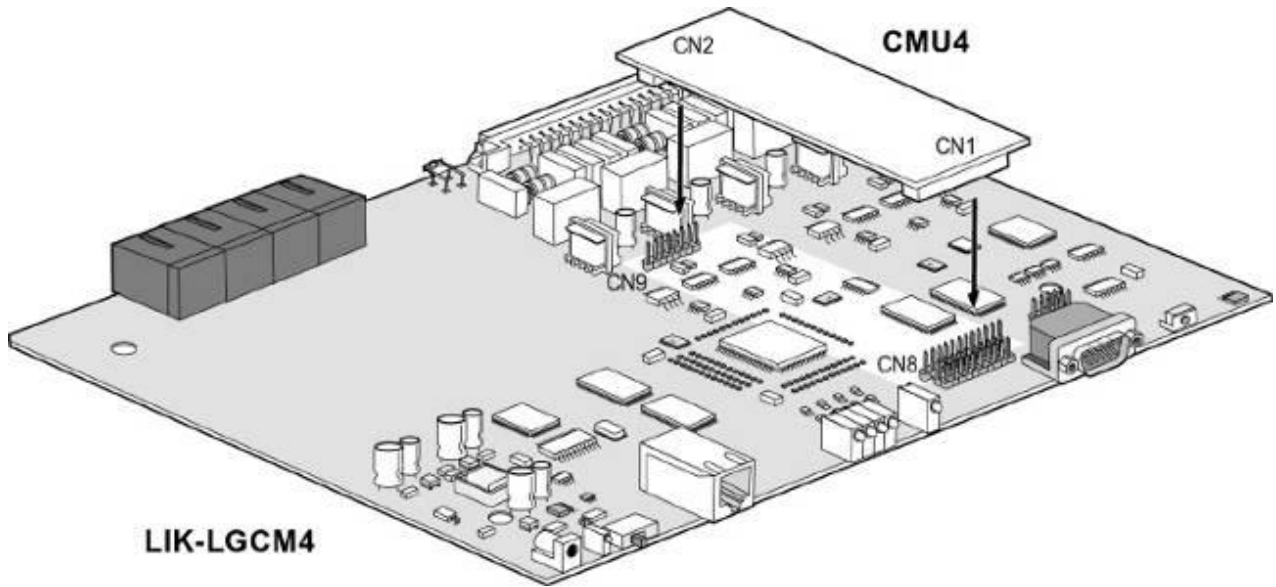

CMU4-12PR & CMU4-16

LGCM4 Connector	CMU4-12PR or 16 Connector
CN8	CN1
CN9	CN2

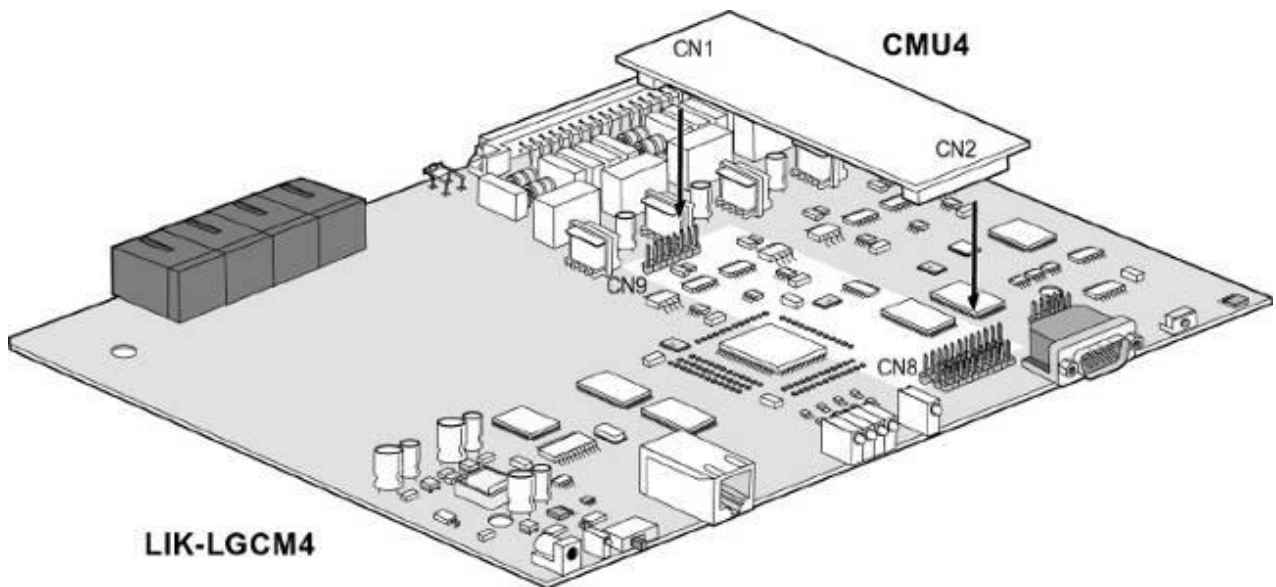

CMU4-50PR

LGCM4 Connector	CMU4-50PR Connector
CN8	CN2
CN9	CN1

Figure 4.5.4-1 Installing a CMU4 module in LGCM4

Wiring Connectors

Before wiring any of the Modules, connect the “⊥” screw on the back of the Module to a known protective earth ground, refer to section 4.5.1.4.

On the front of the LGCM4 is the RJ-45 type “LAN” connector. This connector should be wired to the appropriate LAN points as discussed in section 4.5.1.6 and 4.5.1.7.

- Wire “LAN” to a 10/100 Base-T switch, a POE8 can be used to connect to the LAN.
- Tag or number wiring for maintenance.

On the rear are four (4) RJ-45 connectors, terminated as described in section 4.5.1.5. These connectors should be cabled to the telephone company termination point.

- Wire each RJ-45 to a CO Line at the PSTN termination point/MDF.
- Tag or number wiring for maintenance.

AC/DC Adapter

If a PSU is not employed, assure the AC/DC Adapter is plugged into a live AC outlet and the Module Power jack.

4.5.5 LGCM8 Installation

The LGCM8 may be installed anywhere except for slot 10 of the cabinet, or may be installed anywhere in the Desk Mount Holder. The LGCM8 provides a gateway between standard PSTN Loop Start Lines and other iPECS appliances. The LGCM8 can support eight (8) PSTN Lines.

LEDs

In addition to the Power and LAN LEDs, the LGCM8 has eight (8) green status LEDs and two (2) red LEDs. The eight (8) LEDs indicate that the individual PSTN Lines are busy (LED On), idle (LED Off) or ringing (LED flashing). One (1) red LED on left side indicates whether the CMU4 option module for the 1st~4th port is installed. If installed, the LED is On. One (1) red LED on right side indicates whether the CMU4 option module for the 5th~8th port is installed. If installed, the LED is On.

CMU (Call Metering Unit)

The LGCM4 supports the call metering function with installation of an optional CMU4 module. Three types of module, based on protocol, are available CMU4-12PR, CMU4-16 and CMU4-50PR; see section 2.1.3.2. Before installing the CMU4 module, make sure that power is turned off. Figure 4.5.5-1 shows the procedure for installing a CMU4 module on the LGCM8. Check the connector numbers of the CMU4 module prior to installation. Note that the connector numbers for the CMU4-12PR and 16 are the same while for the CMU4-50PR, the connector numbers are reversed.

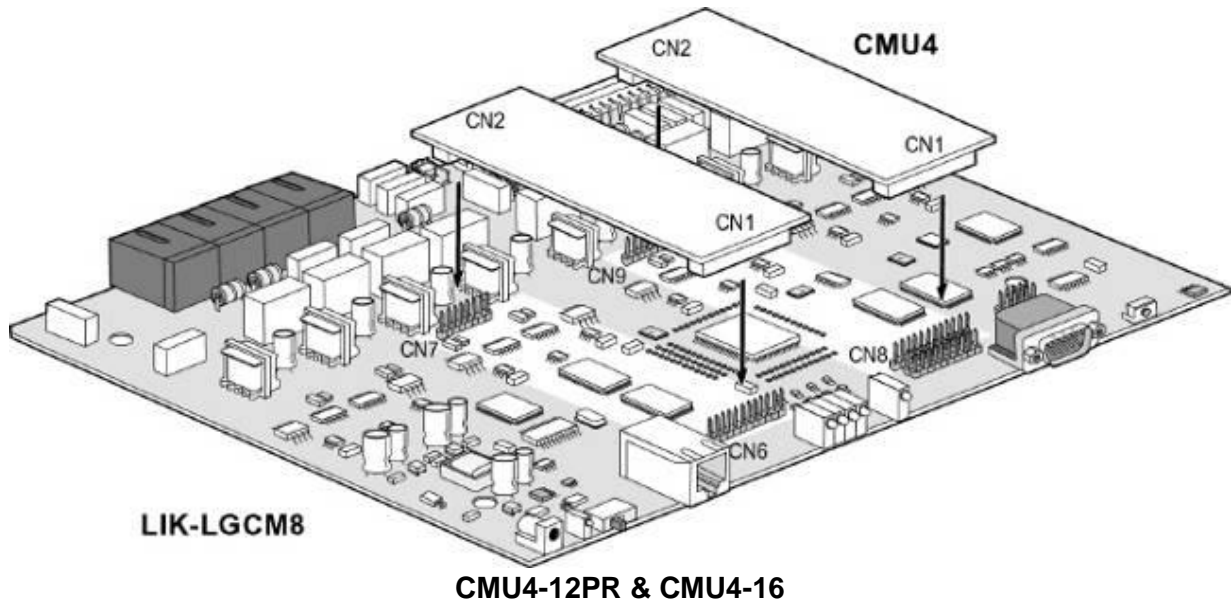

Port No	LGCM4	CMU4-12PR & 16
1st ~ 4th port	CN6	CN1
	CN7	CN2
5th ~ 8th port	CN8	CN1
	CN9	CN2

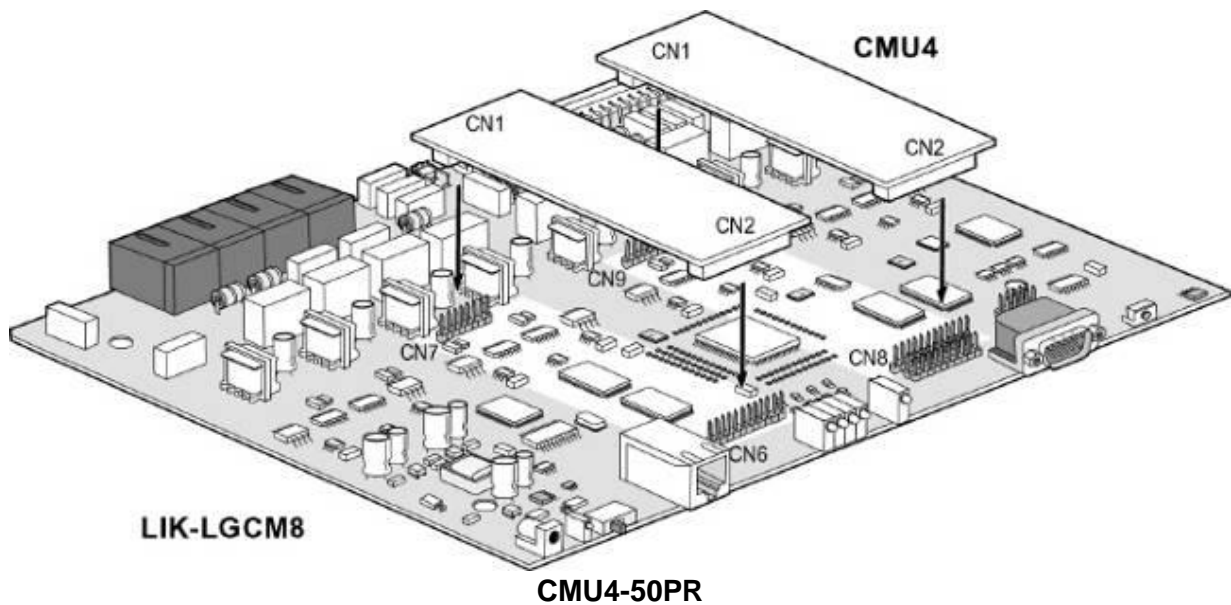

Port No	LGCM4	CMU4-50PR
1st ~ 4th port	CN6	CN2
	CN7	CN1
5th ~ 8th port	CN8	CN2
	CN9	CN1

Figure 4.5.5-1 Installing a CMU4 module with LGCM8

Wiring Connectors

Before wiring any of the Modules, connect the “” screw on the back of the Module to a known protective earth ground, refer to section 4.5.1.4.

On the front of the LGCM8 is the RJ-45 type “LAN” connector. This connector should be wired to the appropriate LAN points as discussed in section 4.5.1.6 and 4.5.1.7.

- Wire “LAN” to a 10/100 Base-T switch, a POE8 can be used to connect to the LAN.
- Tag or number wiring for maintenance.

On the rear panel are eight (8) RJ-45 female connectors terminated as described in section 4.5.1.5. These connectors should be cabled to the telephone company termination point.

- Wire each RJ-45 to a CO Line at the PSTN termination point/MDF.
- Tag or number wiring for maintenance.

AC/DC Adapter

If a PSU is not employed, assure the AC/DC Adapter is plugged into a live AC outlet and the Module Power jack.

4.5.6 DIDM8 Installation (Not for Australian Use)

The DIDM8 may be installed anywhere except for slot 10 of the cabinet, or may be installed anywhere in the Desk Mount Holder. The DIDM8 provides a gateway between standard telephone company DID Lines and other iPECS appliances.

The DIDM8 can support eight (8) DID Lines.

LEDs

In addition to the Power and LAN LEDs, the DIDM8 has eight (8) status LEDs, one for each DID Line. These LEDs indicate that the DID Line is in-use (LED On), signaling (LED flashing) or idle (LED Off).

Wiring Connectors

Before wiring any of the Modules, first connect the “” screw on the back of the Module to a known ground, refer to Section 4.5.1.4.

On the front of the DIDM8 is the RJ 45 type “LAN” connector. This connector should be wired to the appropriate LAN points as discussed in Section 4.5.1.6 and 4.5.1.7.

- Wire “LAN” to a 10/100 Base-T switch, a POE8 can be used to connect to the LAN.
- Tag or number wiring for maintenance.

On the rear are eight (8) RJ-45 connectors terminated as described in Section 4.5.1.5. These should be wired to the telephone company termination point.

- Wire each RJ-45 to a DID Line at the PSTN termination point/MDF.
- Tag or number wiring for maintenance.

AC/DC Adapter

If a PSU is not employed, assure the AC/DC Adapter is plugged into a live AC outlet and the Module Power jack.

4.5.7 DTIM8 Installation

The DTIM8 may be installed anywhere except for slot 10 of the cabinet, or may be installed anywhere in the Desk Mount Holder. The DTIM8 provides a gateway between LG-Ericsson's Digital terminals (LKD and LDP models) and other iPECS appliances. The DTIM8 can support eight (8) Digital terminals.

LEDs

In addition to the Power and LAN LEDs, the DTIM8 has eight (8) status LEDs. These LEDs indicate that the individual Digital terminals are busy (LED On), idle (LED Off) or ringing (LED flashing).

Wiring Connectors

Before wiring any of the Modules, connect the “” screw on the back of the Module to a known protective earth ground, refer to section 4.5.1.4.

On the front of the DTIM8 is the RJ-45 type “LAN” connector. This connector should be wired to the appropriate LAN points as discussed in section 4.5.1.6 and 4.5.1.7.

- Wire “LAN” to a 10/100 Base-T switch, a POE8 can be used to connect to the LAN.
- Tag or number wiring for maintenance.

On the rear are eight (8) RJ-45 connectors terminated as described in Section 4.5.1.5. These should be wired to the digital terminal termination point.

- Wire the RJ-45 connectors to a Digital terminal termination point/MDF.
- Tag or number wiring for maintenance.

AC/DC Adapter

If a PSU is not employed, assure the AC/DC Adapter is plugged into a live AC outlet and the Module Power jack.

4.5.8 DTIM24 Installation

The DTIM24 is intended for installation in a 19" rack, it is NOT intended for installation in the cabinet. The DTIM24 provides a gateway between LG-Ericsson's Digital terminals (LKD and LDP models) and other iPECS appliances.

To mount the DTIM24 in a 19" rack,

- Mount the left and right mounting brackets to the DTIM24 module using the eight (8) machine screws provided as shown in Figure 4.5.8-1.
- Mount the Module with the four (4) machine screws, nuts and washers as shown in Figure 4.5.8-1.
- Complete the installation using the instructions for wiring given below.

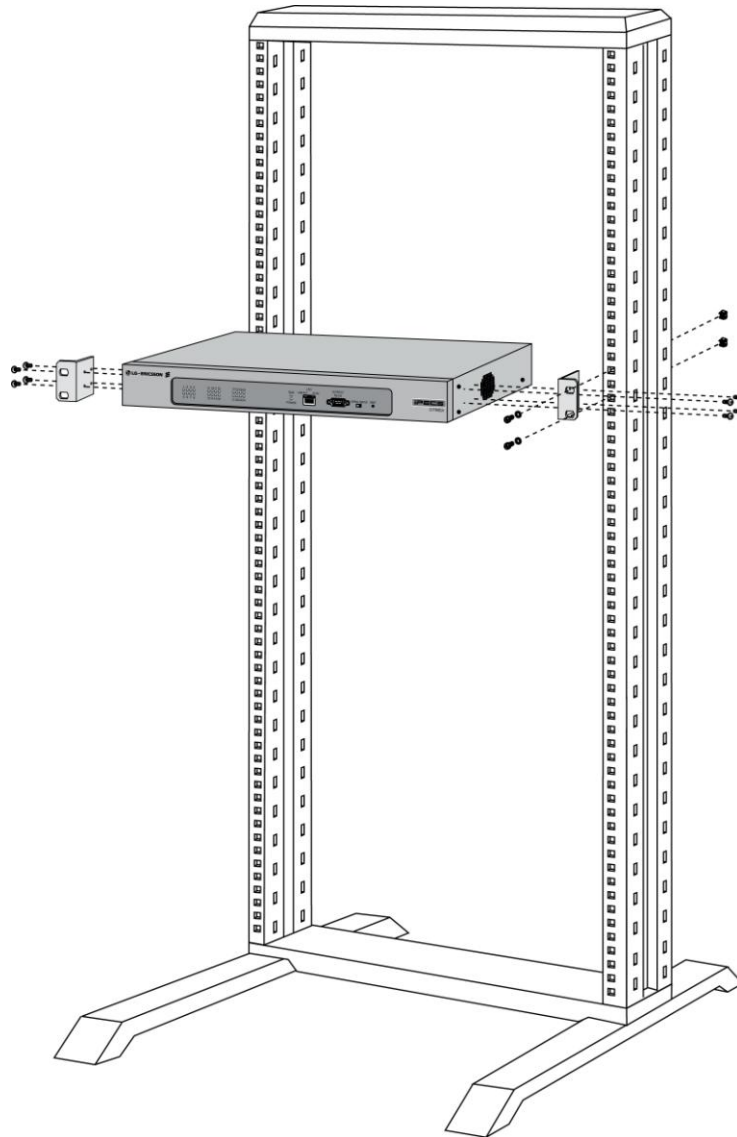

Figure 4.5.8-1 DTIM24 Rack Mounting Installation

LEDs

In addition to the Power and LAN LEDs, the DTIM24 has twenty-four (24) LEDs, which indicate that the individual Digital terminals are busy: in-use (LED On), ringing (LED flashing) or idle (LED Off).

Wiring Connectors

Before wiring any of the Modules, first connect the “⏏” screw on the back of the Module to a known ground, refer to section 4.5.1.4.

On the front of the DTIM24 is the RJ 45 type “LAN” connector. This connector should be wired to the appropriate LAN points as discussed in section 4.5.1.6 and 4.5.1.7.

- Wire “LAN” to a 10/100 Base-T switch, a POE8 can be used to connect to the LAN.
- Tag or number wiring for maintenance.

On the rear are one (1) 25-pair RJ-21x style connectors terminated as shown in Figure 4.5.8-2. These connectors should be wired to the Digital terminal termination point as shown in the figure.

- Wire each RJ-21x to a Digital terminal termination point/MDF.
- Tag or number wiring for maintenance.

AC Power Cord

Assure the AC power cord is plugged into the power input of the DTIM24 and a live AC outlet.

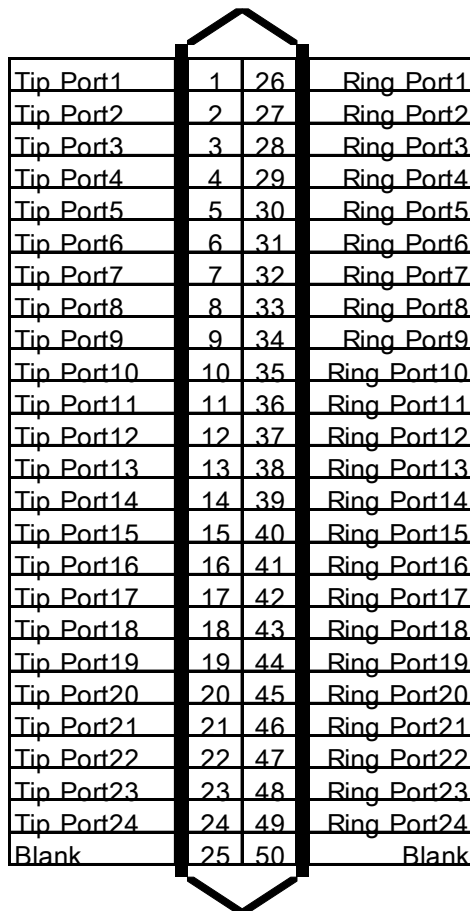

Figure 4.5.8-2 DTIM24 RJ-21X Connector Configuration

4.5.9 SLTM4 Installation

The SLTM4 may be installed anywhere except for slot 10 of the cabinet, or may be installed anywhere in the Desk Mount Holder. The SLTM4 provides a gateway between four (4) standard Single Line Telephone devices and other iPECS appliances.

LEDs

In addition to the Power and LAN LEDs, the SLTM4 has four (4) status LEDs, one (1) for each SLT port 1~4. The LEDs indicate the status of the associated SLT port: in-use (LED On), ringing (LED flashing) or idle (LED Off).

Wiring Connectors

Before wiring any of the Modules, first connect the “” screw on the back of the Module to a known ground, refer to section 4.5.1.4.

On the front of the SLTM4 is the RJ 45 type “LAN” connector. This connector should be wired to the appropriate LAN points as discussed in section 4.5.1.6 and 4.5.1.7.

- Wire “LAN” to a 10/100 Base-T switch, a POE8 can be used to connect to the LAN.
- Tag or number wiring for maintenance.

On the rear are four (4) RJ-45 connectors terminated as described in section 4.5.1.5, which should be wired to the SLT termination point.

- Wire each RJ-45 to an SLT device/MDF.
- Tag or number wiring for maintenance.

AC/DC Adapter

If a PSU is not employed, assure the AC/DC Adapter is plugged into a live AC outlet and the Module Power jack.

4.5.10 SLTM8 Installation

The SLTM8 may be installed anywhere except for slot 10 of the cabinet, or may be installed anywhere in the Desk Mount Holder. The SLTM8 provides a gateway between eight (8) standard Single Line Telephone devices and other iPECS appliances.

LEDs

In addition to the Power and LAN LEDs, the SLTM8 has eight (8) status LEDs, one (1) for each SLT port 1~8. The LEDs indicate the status of the associated SLT port: in-use (LED On), ringing (LED flashing) or idle (LED Off).

Wiring Connectors

Before wiring any of the Modules, first connect the “” screw on the back of the Module to a known ground, refer to section 4.5.1.4.

On the front of the SLTM8 is the RJ 45 type “LAN” connector. This connector should be wired to the appropriate LAN points as discussed in section 4.5.1.6 and 4.5.1.7.

- Wire “LAN” to a 10/100 Base-T switch, a POE8 can be used to connect to the LAN.
- Tag or number wiring for maintenance.

On the rear are eight (8) RJ-45 connectors terminated as described in section 4.5.1.5, which should be wired to the SLT termination point.

- Wire each RJ-45 to an SLT device/MDF.
- Tag or number wiring for maintenance.

AC/DC Adapter

If a PSU is not employed, assure the AC/DC Adapter is plugged into a live AC outlet and the Module Power jack.

4.5.11 SLTM32 Installation

The SLTM32 is intended for installation in a 19" rack, it is NOT intended for installation in the cabinet. The SLTM32 provides a gateway between thirty-two (32) standard Single Line Telephone devices and other iPECS appliances.

To mount the SLTM32 in a 19" rack,

- Mount the left and right mounting brackets to the SLTM32 module using the eight (8) machine screws provided as shown in Figure 4.5.11-1.
- Mount the Module with the four (4) machine screws, nuts and washers as shown in Figure 4.5.11-1.
- Complete the installation using the instructions for wiring given below.

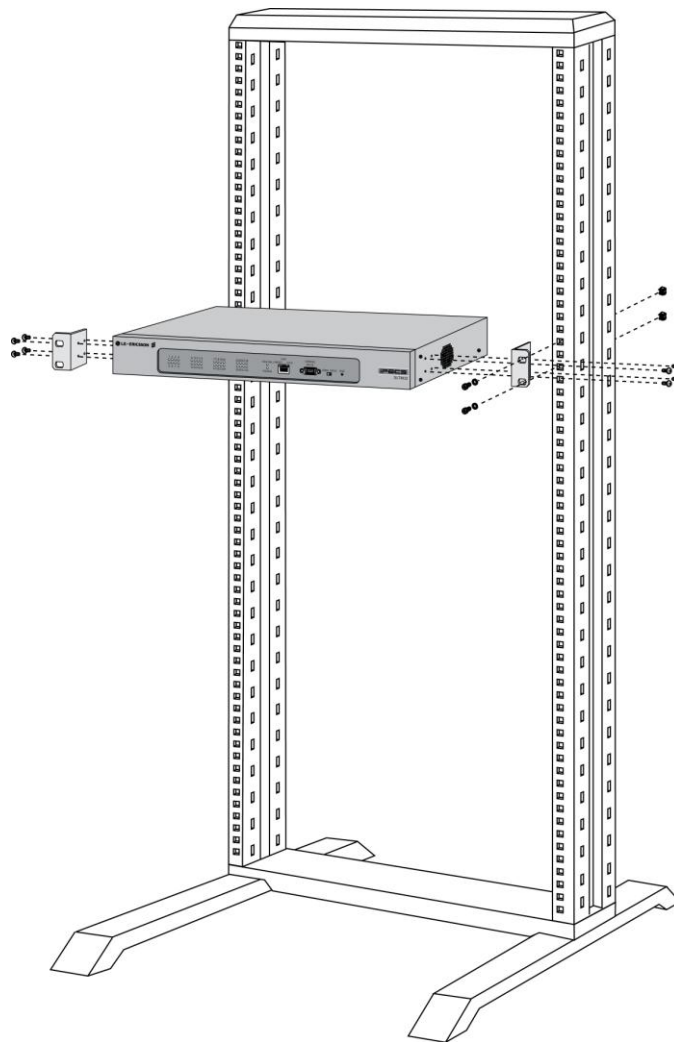

Figure 4.5.11-1 SLTM32 Rack Mounting Installation

LEDs

In addition to the Power and LAN LEDs, the SLTM32 has thirty-two (32) LEDs, which indicate the status of the associated SLT port: in-use (LED On), ringing (LED flashing) or idle (LED Off).

Wiring Connectors

Before wiring any of the Modules, first connect the “ \perp ” screw on the back of the Module to a known ground, refer to section 4.5.1.4.

On the front of the SLTM32 is the RJ 45 type “LAN” connector. This connector should be wired to the appropriate LAN points as discussed in section 4.5.1.6 and 4.5.1.7.

- Wire “LAN” to a 10/100 Base-T switch, a POE8 can be used to connect to the LAN.
- Tag or number wiring for maintenance.

On the rear are two (2) 25-pair RJ-21x style connectors terminated as shown in Figure 4.5.11-2. These connectors should be wired to the SLT termination point as shown in the figure.

- Wire each RJ-21x to an SLT device/MDF.
- Tag or number wiring for maintenance.

AC Power Cord

Assure the AC power cord is plugged into the power input of the SLTM32 and a live AC outlet.



Figure 4.5.11-2 SLTM32 RJ-21X Connector Configuration

4.5.12 BRIM2 Installation

The BRIM2 may be installed anywhere except for slot 10 of the cabinet, or may be installed anywhere in the Desk Mount Holder. The BRIM2 provides a gateway between ISDN Basic Rate Interface (BRI) lines and other iPECS appliances.

The BRIM2 can support two (2) BRI lines as a “T” interface.

LEDs

In addition to the Power and LAN LEDs, there are four LEDs, two for each BRI circuit, which provide the status information as described in Table 4.5.12-1 .

Table 4.5.12-1 BRIM2 Status LED Function

LED DESIGNATION	ON	OFF
ACT	In Use	Idle
ERR	Line Error	Normal

Wiring Connectors

Before wiring any of the Modules, first connect the “” screw on the back of the Module to a known ground, refer to section 4.5.1.4.

On the front of the BRIM2 is the RJ 45 type “LAN” connector. This connector should be wired to the appropriate LAN points as discussed in section 4.5.1.6 and 4.5.1.7.

- Wire “LAN” to a 10/100 Base-T switch, a POE8 can be used to connect to the LAN.
- Tag or number wiring for maintenance.

On the rear are two (2) RJ-45 connectors terminated to the BRI Line interface circuits. These connectors should be wired to the telephone company termination point (‘T’ Mode). The connector pin assignments for the RJ-45 type jacks on the BRIM2 are shown in Figure 4.5.12-1.

- Wire each RJ-45 to a BRI line at the ISDN termination point/MDF.
- Tag or number wiring for maintenance.

AC/DC Adapter

If a PSU is not employed, assure the AC/DC Adapter is plugged into a live AC outlet and the Module Power jack.

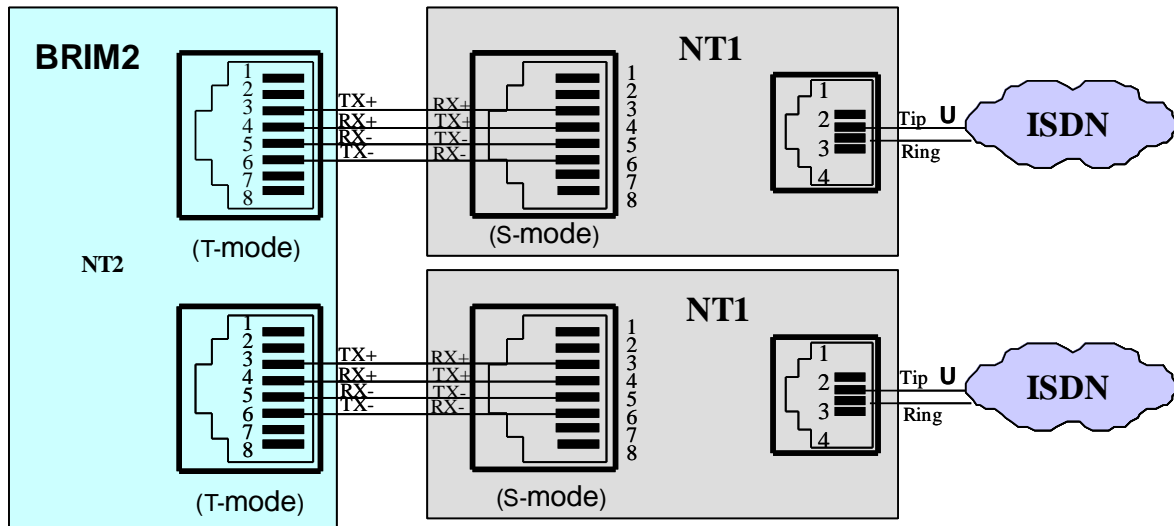

Figure 4.5.12-1 BRIM2 BRI Line Connector Configuration

4.5.13 BRIM4 Installation

The BRIM4 may be installed anywhere except for slot 10 of the cabinet, or may be installed anywhere in the Desk Mount Holder. The BRIM4 provides a gateway between ISDN Basic Rate Interface (BRI) lines and other iPECS appliances.

The BRIM4 can support four (4) BRI lines as a “T” interface.

LEDs

In addition to the Power and LAN LEDs, there are eight LEDs, two for each BRI circuit, which provide the status information as described in Table 4.5.13-1.

Table 4.5.13-1 BRIM4 Status LED Function

LED DESIGNATION	ON	OFF
ACT	In Use	Idle
ERR	Line Error	Normal

Wiring Connectors

Before wiring any of the Modules, first connect the “ \perp ” screw on the back of the Module to a known ground, refer to section 4.5.1.4.

On the front of the BRIM4 is the RJ 45 type “LAN” connector. This connector should be wired to the appropriate LAN points as discussed in section 4.5.1.6 and 4.5.1.7.

- Wire “LAN” to a 10/100 Base-T switch, a POE8 can be used to connect to the LAN.
- Tag or number wiring for maintenance.

On the rear are four (4) RJ-45 connectors terminated to the BRI Line interface circuits. These connectors should be wired to the telephone company termination point (“T” Mode). The connector pin assignments for the RJ-45 type jacks on the BRIM4 are shown in Figure 4.5.13-1.

- Wire each RJ-45 to a BRI line at the ISDN termination point/MDF.
- Tag or number wiring for maintenance.

AC/DC Adapter

If a PSU is not employed, assure the AC/DC Adapter is plugged into a live AC outlet and the Module Power jack.

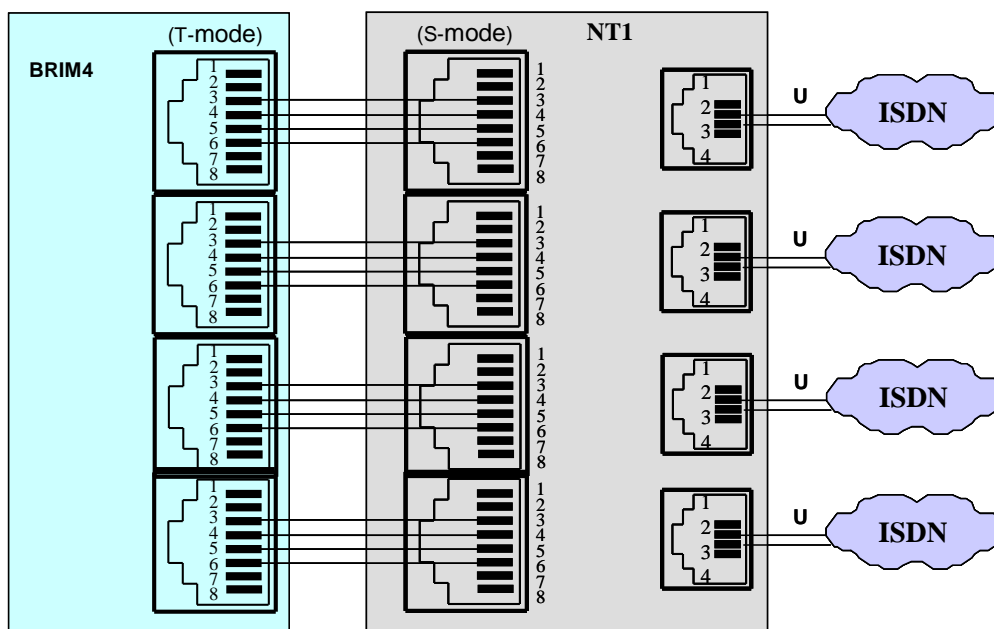

Figure 4.5.13-1 BRIM4 BRI Line Connector Configuration

4.5.14 PRIM Installation

The PRIM Module may be installed anywhere except for slot 10 of the cabinet, or may be installed anywhere in the Desk Mount Holder. The PRIM module provides a gateway for PRI line connections to other iPECS appliances.

The PRIM module can support up to 30 PCM bearer channels for European ISDN Primary Rate Interfaces.

LEDs

In addition to the Power and LAN LEDs, the T1/PRI has four (4) LEDs for status and diagnostic information as in Table 4.5.14-1.

Table 4.5.14-1 PRIM Status LED Functions

LED	LED FUNCTION
LINE	Line Signal Detected
STATUS	Channels in-use
CLK SLAVE	PRIM module clock is synchronized with PRI Line
RUN	Flashing when running

Wiring Connectors

Before wiring any of the Modules, first connect the “ \perp ” screw on the back of the Module to a known ground, refer to section 4.5.1.4.

On the front of the PRIM is the RJ 45 type “LAN” connector. This connector should be wired to the appropriate LAN points as discussed in section 4.5.1.6 and 4.5.1.7.

- Wire “LAN” to a 10/100 Base-T switch, a POE8 can be used to connect to the LAN.
- Tag or number wiring for maintenance

On the rear panel is a RJ-45 connector terminated to the PRI Line interface circuits. This connector, refer to Figure 4.5.14-1, should be wired to the Telephone Company termination point.

- Wire each RJ-45 to a PRI line at the ISDN termination point.
- Tag or number wiring for maintenance.

AC/DC Adapter

If a PSU is not employed, assure the AC/DC Adapter is plugged into a live AC outlet and the Module Power jack.

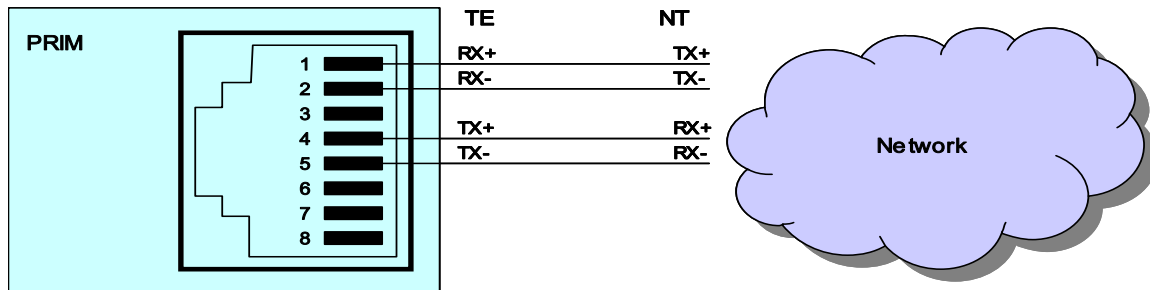

Figure 4.5.14-1 PRI Line Connector Configuration

4.5.15 VMIM Installation

The VMIM may be installed anywhere except for slot 10 of the cabinet, or may be installed anywhere in the Desk Mount Holder. The VMIM module provides voice storage and processing for Automated Attendant and Voice Mail capabilities as well as other Voice Processing features.

The VMIM module can support up to 8 channels with up to 9 hours of storage.

LEDs

In addition to the Power and LAN LEDs, the VMIM has four (4) LEDs for status and diagnostics information as shown in Table 4.5.15-1.

Table 4.5.15-1 VMIM Status LED Functions

LED	LED Function
RECORD	Voice mail Record active
PLAY	Voice mail Play back active
MEM FULL	Memory full
S1	Reversed

Wiring Connectors

Before wiring any of the Modules, first connect the “” screw on the back of the Module to a known ground, refer to section 4.5.1.4.

On the front of the VMIM is the RJ 45 type “LAN” connector. This connector should be wired to the appropriate LAN points as discussed in section 4.5.1.6 and 4.5.1.7.

- Wire “LAN” to a 10/100 Base-T switch, a POE8 can be used to connect to the LAN.
- Tag or number wiring for maintenance.

AC/DC Adapter

If a PSU is not employed, assure the AC/DC Adapter is plugged into a live AC outlet and the Module Power jack.

4.5.16 MCIM Installation

The MCIM may be installed anywhere except for slot 10 of the cabinet, or may be installed anywhere in the Desk Mount Holder. The MCIM performs the various conference functions for multi-party voice conferences. With the MCIM iPECS terminals can establish voice conferences with up to 32 parties using the g.711 or g.729 codecs or 24 parties with the g.723 codec.

LEDs

In addition to the Power and LAN LEDs, the MCIM has four (4) LEDs for status information as shown in Table 4.5.16-1.

Table 4.5.16-1 MCIM Status LED Functions

LED	LED Function
Voice Conf	Voice Conference Active
Video Conf	Video Conference Active
S1	Reversed
S2	Reversed

Wiring Connectors

Before wiring any of the Modules, first connect the “” screw on the back of the Module to a known ground, refer to section 4.5.1.4.

On the front of the MCIM is the RJ 45 type “LAN” connector. This connector should be wired to the appropriate LAN points as discussed in section 4.5.1.6 and 4.5.1.7.

- Wire “LAN” to a 10/100 Base-T switch, a POE8 can be used to connect to the LAN.
- Tag or number wiring for maintenance.

AC/DC Adapter

If a PSU is not employed, assure the AC/DC Adapter is plugged into a live AC outlet and the Module Power jack.

4.5.17 RSGM Installation

The RSGM is intended for installation in the module Desk Mount or Wall Mount Holder at the remote location. See Figure 4.5.17-1 and Figure 4.5.17-2. The RSGM should not be installed in the Main Cabinet. The RSGM provides a gateway for remote site access to/from iPECS.

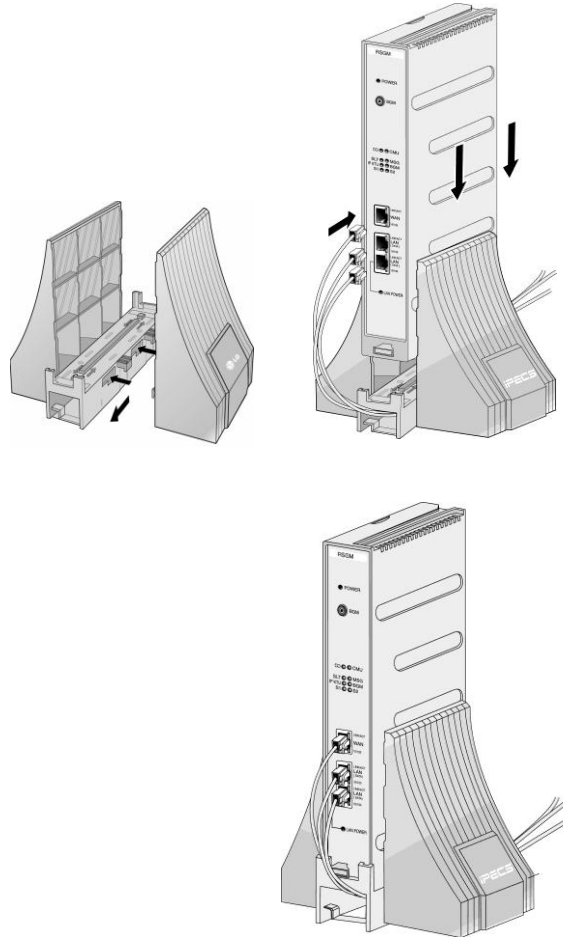

Figure 4.5.17-1 RSGM on Desk Mount Holder

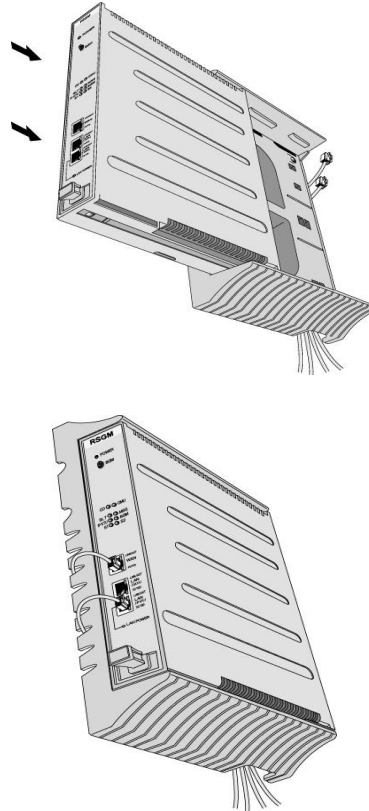

Figure 4.5.17-2 RSGM on Wall Mount Holder

The RSGM provides the following resources.

- One (1) WAN connection port (RJ-45: 10/100 Ethernet port) – Auto MDI, MDIX switching feature.
- One (1) PC connection port (RJ-45: 10/100 Ethernet port).
- One (1) LIP phone connection port (RJ-45: 10/100 Ethernet port) – Power feed capable.
- One (1) analog CO port (RJ-11).
- One (1) analog SLT port (RJ-11).
- One (1) BGM port.
- One (1) External alarm/door bell input.
- Two (2) dry relay contacts.

LEDs

In addition to the Power and LAN LEDs, the RSGM has eight (8) LEDs for status and diagnostic information, as in Table 4.5.17-1.

Table 4.5.17-1 RSGM Status LED Functions

LED	LED FUNCTION	REMARK
CO	Analog CO line is busy (Flashing when incoming ringing)	
CMU	Optional CMU installed	Note 1
SLT	Analog SLT port is in-use (Flashing when ringing)	
MSG	Message Waiting	
IP KTU	IP phone in-use	

BGM	External BGM or Internal MOH is active	
S1	Reserved	
S2	Steady On: WAN disconnected Flashing: WAN connected	

Note 1: An optional CMU (Call Metering Unit) can be installed according to the relevant national regulations, refer to the RSGM install guide and section 4.5.4.

Wiring Connectors

Before wiring any of the Modules, first connect the “” screw on the back of the Module to a known ground, refer to section 4.5.1.4.

On the front of the RSGM, there are three (3) LAN RJ-45 type connectors. These connectors should be wired to the appropriate LAN point.

- Wire the “WAN” port to a 10/100 Base-T switch, broadband modem or router.
- Tag or number wiring for maintenance.

- Wire “LAN” port to an external PC.
- Tag or number wiring for maintenance.

- Wire “IPKTS” port to an external LIP Phone.
- Tag or number wiring for maintenance.



CAUTION

Before connecting an iPECS Phone to the RSGM IPKTS port, check the LAN POWER switch on the rear panel of the RSGM.

On the rear panel, there are four (4) RJ-11 connectors. The upper most connector is for an analog CO line, which should be wired to the telephone company termination point. For detailed connection, see Figure 4.5.17-3.

- Wire the RJ-11 to a CO Line at the PSTN termination point.
- Tag or number wiring for maintenance.

The 2nd RJ-11 connector is for an SLT, which should be wired to the SLT termination point as detailed in Figure 4.5.17-3.

- Wire the RJ-11 to a SLT device.
- Tag or number wiring for maintenance.

The 3rd and 4th RJ-11 connectors are used for external alarm/door bell input, external BGM input and two (2) dry relay contacts. For detailed connection, see Figure 4.5.17-3.

- Wire each RJ-11 for miscellaneous connections as shown in Figure 4.5.17-3.
- Tag or number wiring for maintenance.

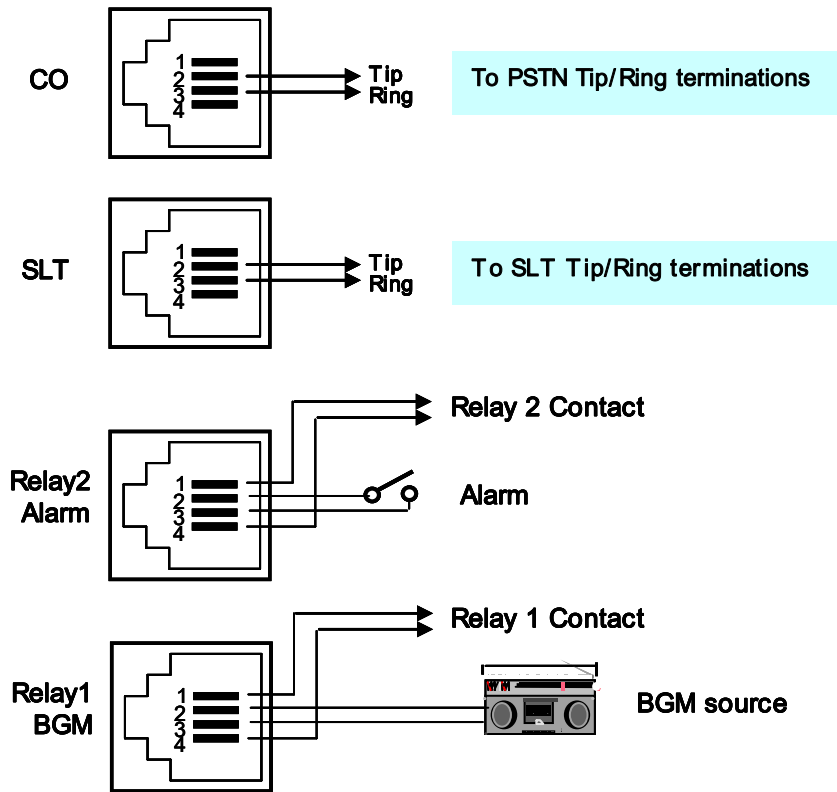

Figure 4.5.17-3 RSGM Connections

AC/DC Adapter

Assure the AC/DC Adapter is plugged into a live AC outlet and the Module Power jack.

4.5.18 POE8 Installation

The POE8 may be installed anywhere except for slot 10 of the cabinet, or may be installed anywhere in the Desk Mount Holder. The POE8 is employed to connect LIP Phones, standard VoIP phones and other iPECS Modules to the LAN.

The POE8 has eight (8) switched 10/100 Base-T Ethernet ports and an “UPLINK” port for a total of nine (9) switched ports. When DC power is supplied in accordance with IEEE 802.3af by a POE8, the associated “PORT PWR STATUS” LED is On.

LEDs

The POE8 has a Power LED and LAN connector LEDs. Each LAN connector has a green LED indicating Link and activity and a yellow LED indicating Link speed (ON for 100Mbps, OFF for 10Mbps).

Remote Power Switch & “PORT PWR STATUS” LEDs

Each switch port of the POE8, except the “UPLINK” port can provide 48VDC feed over the LAN employing pin pairs 4 & 5 (+) and 7 & 8 (-) of the RJ-45 connector. For the POE8, detection and power feed are done automatically and the power feed status of each port is displayed through the “PORT PWR STATUS” LEDs.

Wiring Connectors

Before wiring any of the Modules, first connect the “ \perp ” screw on the back of the Module to a known ground, refer to section 4.5.1.4.

On the front of the POE8 are the “UPLINK” and eight (8) switched “1X~8X” connectors, each an RJ 45 type. These connectors should be wired to the appropriate LAN points as discussed in section 4.5.1.6 and 4.5.1.7. If cascading is necessary, refer to section 4.5.1.7.

- Wire the “UPLINK” port to the corporate LAN router or switch, a POE8 can be used to connect to the LAN.
- Wire each “X” port to an RJ-45 wall/floor jack for an LIP Phone or VoIP terminal location, or to the “LAN” port of another iPECS device.
- Tag or number wiring for maintenance.

AC/DC Adapter

If a PSU is not employed, assure the AC/DC Adapter is plugged into a live AC outlet and the Module Power jack.

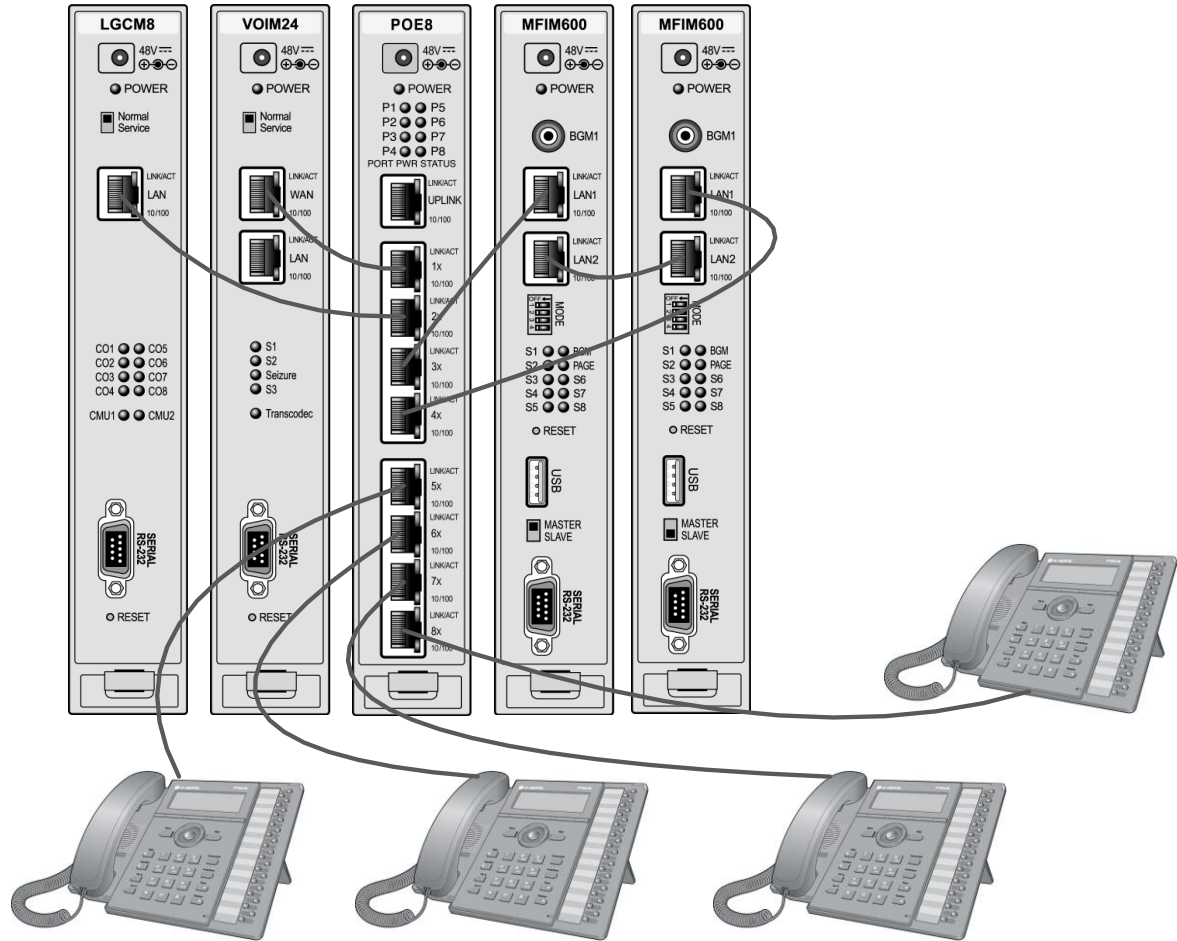

Figure 4.5.18-1 POE8 Installation with MFIM600 Redundancy

4.5.19 WTIM4/8 Installation

A WTIM4 or WTIM8 may be installed anywhere except for slot 10 of the cabinet, or may be installed anywhere in the Desk Mount Holder. The WTIM4/8 is connected to the GDC-400B System DECT Base Station, which provides the RF link between DECT handsets such as GDC-400H and other iPECS appliances.

The WTIM4 can provide up to four (4) GDC-400B interfaces. The WTIM8 can provide up to eight (8) GDC-400B interfaces. Detailed instructions on configuration and installation of WTIMs and Base Stations (GDC-400B) are provided in the IP System DECT Installation Manual. The following information is provided for reference only.

LEDs

In addition to the Power and LAN LEDs, the WTIM4/8 has eight (8) status LEDs. The definition of LEDs is shown in Table 4.5.19-1 below.

Table 4.5.19-1 WTIM4/8 Status LED Functions

LED	LED FUNCTION	REMARK
CP1	Main CPU is normal, LED flashes.	
CP2	Sub CPU is normal, LED flashes.	
WBUS	WTIM communicating with another WTIM, LED flashes.	
USE	Two or more DECT channel in use, LED On.	
LINK	WTIM connected to MFIM via LAN, LED On.	
HBUS	WTIM communicating with MFIM, LED flashes.	
E1	WTIM communicating with Base Station (GDC-400B), LED flashes.	
M/S	Main WTIM, LED is turned On. Sub-WTIM, LED is turned Off.	

MODE Switch & Settings

Each WTIM has a four (4) position DIP-switch. The function of each switch position is given in Table 4.5.19-2 below.

Table 4.5.19-2 WTIM4/8 Mode Switch Functions

SWITCH	FUNCTION	ON	OFF	DEFAULT
1	Reserved	TBR6 test mode	Normal	OFF
2	Echo-canceller control when CRC error at 400B	Enable (Enable mute Function)	Disable (Disable mute Function)	ON
3	Serial selection	Sub CPU Serial mode	Main CPU Serial mode	ON
4	S/W debugging	All base reset	One base reset	OFF

Wiring Connectors

Before wiring any of the Modules, first connect the “ \perp ” screw on the back of the Module to a known ground, refer to section 4.5.1.4.

On the front of the WTIM is the RJ 45 type “LAN” connector. This connector should be wired to the appropriate LAN points as discussed in section 4.5.1.6 and 4.5.1.7.

- Wire “LAN” to a 10/100 Base-T switch, a POE8 can be used to connect to the LAN.
- Tag or number wiring for maintenance.

Pin assignments

The RJ-45 connectors on the rear of the WTIM are used to connect to the GDC-400B Base Stations. This wiring is detailed in the System DECT Installation Manual. The pin assignments given in Table 4.5.19-3 below are provided for reference only.

Table 4.5.19-3 WTIM4/8 Pin assignments

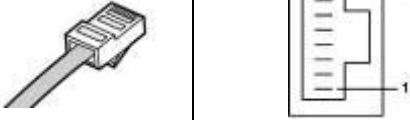
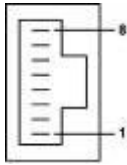
Connector	Pin Number	NO	SIGNAL NAME	FUNCTION
		1, 2, 7, 8	RESERVED	
		3	RX+	Receive Data
		4	TX-	Transmit Data
		5	TX+	Transmit Data
		6	RX-	Receive Data

AC/DC Adapter

If a PSU is not employed, assure the AC/DC Adapter is plugged into a live AC outlet and the Module Power jack.

Multiple WTIM connection

When multiple WTIMs are installed and handover between Base Stations (GDC-400Bs) is required, the WTIMs must be interconnected. Up to three (3) WTIMs may be interconnected to allow handover between the connected Base Stations. Wiring for this connection is shown in Figure 4.5.19-1 below. The WTIM interconnection is a separate connection not provided by the back plane, thus, even when the WTIMs are installed in a cabinet the interconnection of the WTIMs is required.

On the front of the WTIM are the RJ 45 type Sync Cable In and Out connectors. This connector should be wired to the appropriate Sync Cable In or Out connector of the next WTIM as discussed above.

- Wire “Sync Cable Out” directly to the “Sync Cable In” of the next WTIM.
- Tag or number wiring for maintenance.

Note that power must be removed prior to connecting the link cable between WTIMs.

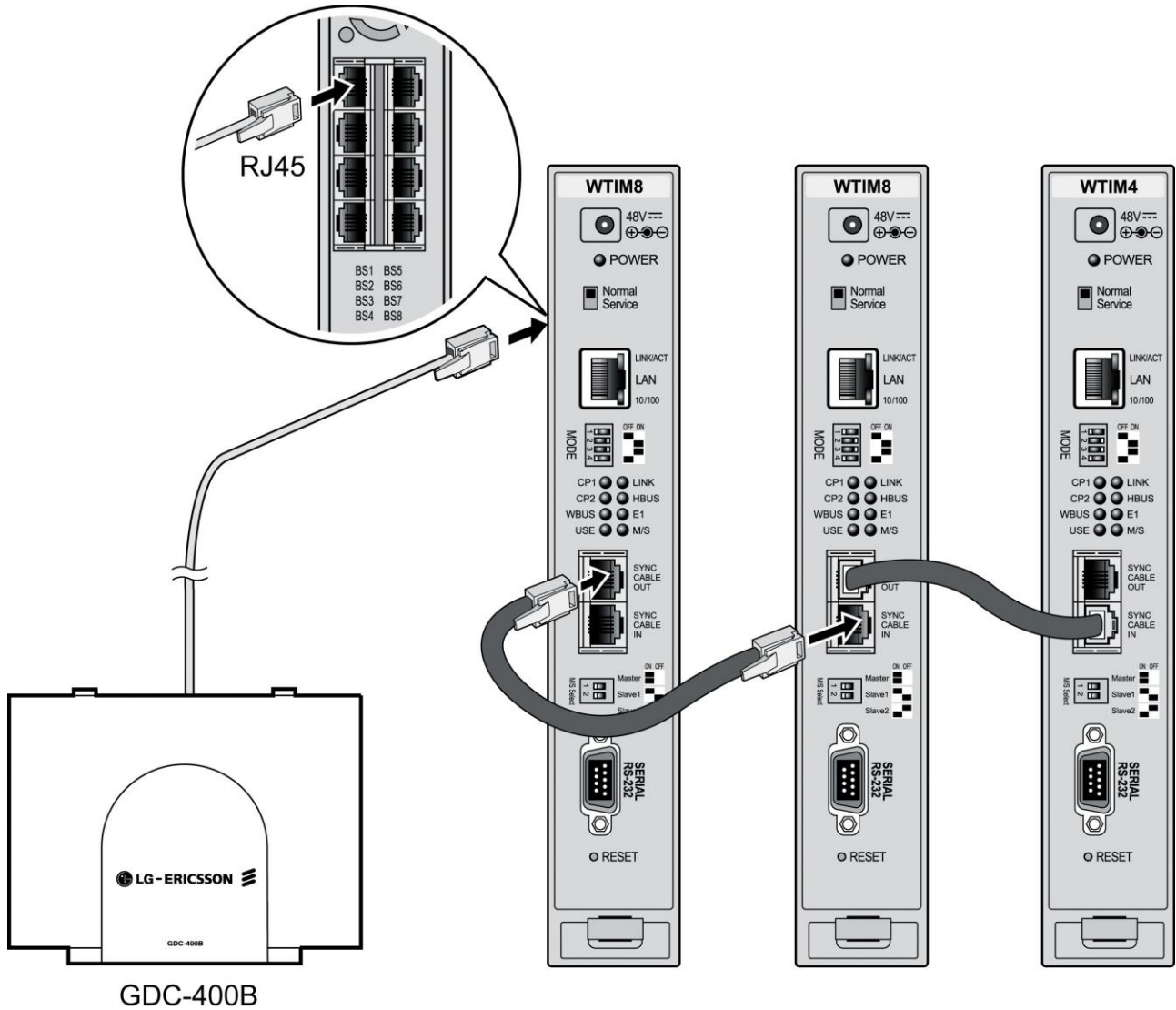

Figure 4.5.19-1 Cascading connections of WTIM4/8

4.6 MAIN CABINET WIRING

With the Enhanced Main Cabinet, telephony connections (PSTN, ISDN, SLT, and DTIM) are made through male RJ-21X 25-pair connectors mounted on the back plane. Modules terminate the telephony interfaces at the appropriate connector on the back plane, using connector pairs (circuit locations) based on the Module location in the cabinet. Each slot is terminated on the appropriate male RJ-21X connectors. The relationship between slots and RJ-21X connectors is shown in Figure 4.6-1.

But, WTIM4 and WTIM8 Do Not support the connection of male RJ-21X connectors.

Complete all the telephony wiring for the Module prior to installing and applying power to the Module. Note also consider the slot and sequence assignments when installing Modules, refer to section 4.5.1.1.

Complete all telephony wiring by making cross-connects between the RJ-21X and the appropriate telephone company termination point. For details, see the following figures. Note the Yellow boxes indicate wiring for the PRIM.

- Slot 1, 2, 3, and 4 connections, LC 1 & LC2 - Figure 4.6-2
- Slot 5, 6, 7, and 8 connections, LC3 & LC4 - Figure 4.6-3
- Slot 9 connections, LC5 – Figure 4.6-4

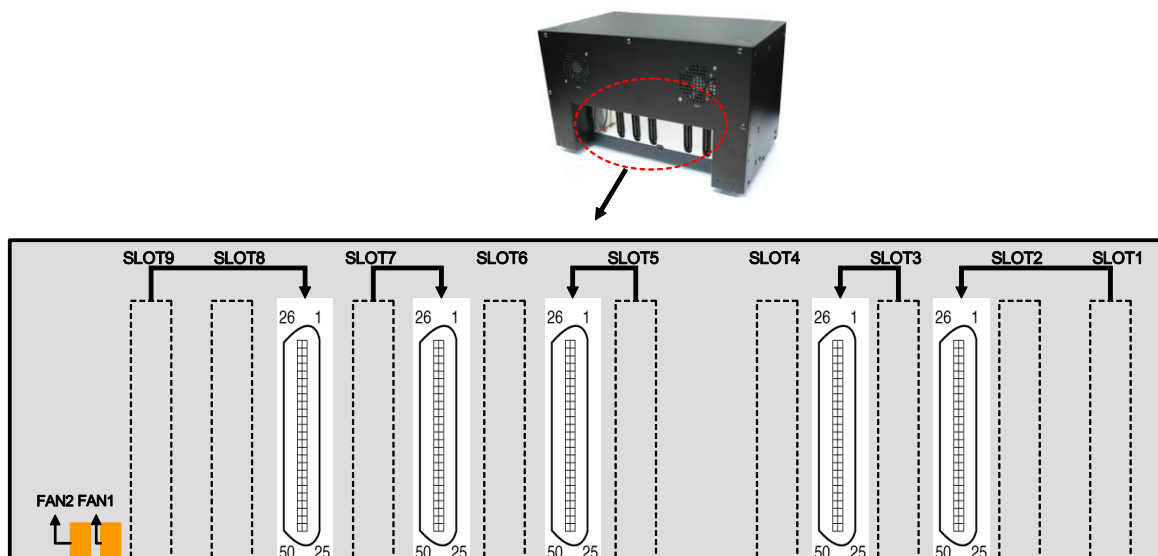
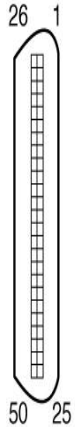

Figure 4.6-1 RJ-21x Connector Backplane Wiring Diagram

RJ-21 pin Assignment



LC1

RJ-21		LGCM8 SLTM8 DTIM8	LGCM4 SLTM4	BRIM PRIM	S L O T No.												
Pairs	Pin																
1	1	Port 1 Tip	Blank	Port 1: TX+	1												
	26	Port 1 Ring	Blank	Port 1: TX-													
2	2	Port 2 Tip	Blank	Port 1: RX+		1											
	27	Port 2 Ring	Blank	Port 1: RX-													
3	3	Port 3 Tip	Blank	Port 2: TX+			1										
	28	Port 3 Ring	Blank	Port 2: TX-													
4	4	Port 4 Tip	Blank	Port 2: RX+				1									
	29	Port 4 Ring	Blank	Port 2: RX-													
5	5	Blank	Blank	Blank					1								
	30	Blank	Blank	Blank													
6	6	Blank	Blank	Blank						1							
	31	Blank	Blank	Blank													
7	7	Port 5 Tip	Port 1 Tip	Port 3: TX+							1						
	32	Port 5 Ring	Port 1 Ring	Port 3: TX-													
8	8	Port 6 Tip	Port 2 Tip	Port 3: RX+								1					
	33	Port 6 Ring	Port 2 Ring	Port 3: RX-													
9	9	Port 7 Tip	Port 3 Tip	Port 4: TX+									1				
	34	Port 7 Ring	Port 3 Ring	Port 4: TX-													
10	10	Port 8 Tip	Port 4 Tip	Port 4: RX+										1			
	35	Port 8 Ring	Port 4 Ring	Port 4: RX-													
11	11	Blank	Blank	Blank											1		
	36	Blank	Blank	Blank													
12	12	Blank	Blank	Blank												1	
	37	Blank	Blank	Blank													
13	13	Port 1 Tip	Blank	Port 1: TX+													2
	38	Port 1 Ring	Blank	Port 1: TX-													
14	14	Port 2 Tip	Blank	Port 1: RX+	2												
	39	Port 2 Ring	Blank	Port 1: RX-													
15	15	Port 3 Tip	Blank	Port 2: TX+		2											
	40	Port 3 Ring	Blank	Port 2: TX-													
16	16	Port 4 Tip	Blank	Port 2: RX+			2										
	41	Port 4 Ring	Blank	Port 2: RX-													
17	17	Blank	Blank	Blank				2									
	42	Blank	Blank	Blank													
18	18	Blank	Blank	Blank					2								
	43	Blank	Blank	Blank													
19	19	Port 5 Tip	Port 1 Tip	Port 3: TX+						2							
	44	Port 5 Ring	Port 1 Ring	Port 3: TX-													
20	20	Port 6 Tip	Port 2 Tip	Port 3: RX+							2						
	45	Port 6 Ring	Port 2 Ring	Port 3: RX-													
21	21	Port 7 Tip	Port 3 Tip	Port 4: TX+								2					
	46	Port 7 Ring	Port 3 Ring	Port 4: TX-													
22	22	Port 8 Tip	Port 4 Tip	Port 4: RX+									2				
	47	Port 8 Ring	Port 4 Ring	Port 4: RX-													
23	23	Blank	Blank	Blank										2			
	48	Blank	Blank	Blank													
24	24	Blank	Blank	Blank											2		
	49	Blank	Blank	Blank													
25	25	Tel Ground		TEGND												2	
	50	Tel Ground		TEGND													

LC2

RJ-21		LGCM8 SLTM8 DTIM8	LGCM4 SLTM4	BRIM PRIM	S L O T No.												
Pairs	Pin																
1	1	Port 1 Tip	Blank	Port 1: TX+	3												
	26	Port 1 Ring	Blank	Port 1: TX-													
2	2	Port 2 Tip	Blank	Port 1: RX+		3											
	27	Port 2 Ring	Blank	Port 1: RX-													
3	3	Port 3 Tip	Blank	Port 2: TX+			3										
	28	Port 3 Ring	Blank	Port 2: TX-													
4	4	Port 4 Tip	Blank	Port 2: RX+				3									
	29	Port 4 Ring	Blank	Port 2: RX-													
5	5	Blank	Blank	Blank					3								
	30	Blank	Blank	Blank													
6	6	Blank	Blank	Blank						3							
	31	Blank	Blank	Blank													
7	7	Port 5 Tip	Port 1 Tip	Port 3: TX+							3						
	32	Port 5 Ring	Port 1 Ring	Port 3: TX-													
8	8	Port 6 Tip	Port 2 Tip	Port 3: RX+								3					
	33	Port 6 Ring	Port 2 Ring	Port 3: RX-													
9	9	Port 7 Tip	Port 3 Tip	Port 4: TX+									3				
	34	Port 7 Ring	Port 3 Ring	Port 4: TX-													
10	10	Port 8 Tip	Port 4 Tip	Port 4: RX+										3			
	35	Port 8 Ring	Port 4 Ring	Port 4: RX-													
11	11	Blank	Blank	Blank											3		
	36	Blank	Blank	Blank													
12	12	Blank	Blank	Blank												3	
	37	Blank	Blank	Blank													
13	13	Port 1 Tip	Blank	Port 1: TX+													4
	38	Port 1 Ring	Blank	Port 1: TX-													
14	14	Port 2 Tip	Blank	Port 1: RX+	4												
	39	Port 2 Ring	Blank	Port 1: RX-													
15	15	Port 3 Tip	Blank	Port 2: TX+		4											
	40	Port 3 Ring	Blank	Port 2: TX-													
16	16	Port 4 Tip	Blank	Port 2: RX+			4										
	41	Port 4 Ring	Blank	Port 2: RX-													
17	17	Blank	Blank	Blank				4									
	42	Blank	Blank	Blank													
18	18	Blank	Blank	Blank					4								
	43	Blank	Blank	Blank													
19	19	Port 5 Tip	Port 1 Tip	Port 3: TX+						4							
	44	Port 5 Ring	Port 1 Ring	Port 3: TX-													
20	20	Port 6 Tip	Port 2 Tip	Port 3: RX+							4						
	45	Port 6 Ring	Port 2 Ring	Port 3: RX-													
21	21	Port 7 Tip	Port 3 Tip	Port 4: TX+								4					
	46	Port 7 Ring	Port 3 Ring	Port 4: TX-													
22	22	Port 8 Tip	Port 4 Tip	Port 4: RX+									4				
	47	Port 8 Ring	Port 4 Ring	Port 4: RX-													
23	23	Blank	Blank	Blank										4			
	48	Blank	Blank	Blank													
24	24	Blank	Blank	Blank											4		
	49	Blank	Blank	Blank													
25	25	Tel Ground		TEGND												4	
	50	Tel Ground		TEGND													

Figure 4.6-2 Connections for LC1 & 2

RJ-21 pin Assignment

LC3

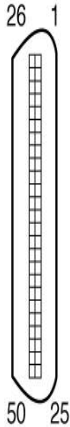

RJ-21		LGCM8 SLTM8 DTIM8	LGCM4 SLTM4	BRIM PRIM	S L O T No.
Pairs	Pin				
1	1	Port 1 Tip	Blank	Port 1: TX+	5
	26	Port 1 Ring	Blank	Port 1: TX-	
2	2	Port 2 Tip	Blank	Port 1: RX+	
	27	Port 2 Ring	Blank	Port 1: RX-	
3	3	Port 3 Tip	Blank	Port 2: TX+	
	28	Port 3 Ring	Blank	Port 2: TX-	
4	4	Port 4 Tip	Blank	Port 2: RX+	
	29	Port 4 Ring	Blank	Port 2: RX-	
5	5	Blank	Blank	Blank	
	30	Blank	Blank	Blank	
6	6	Blank	Blank	Blank	
	31	Blank	Blank	Blank	
7	7	Port 5 Tip	Port 1 Tip	Port 3: TX+	6
	32	Port 5 Ring	Port 1 Ring	Port 3: TX-	
8	8	Port 6 Tip	Port 2 Tip	Port 3: RX+	
	33	Port 6 Ring	Port 2 Ring	Port 3: RX-	
9	9	Port 7 Tip	Port 3 Tip	Port 4: TX+	
	34	Port 7 Ring	Port 3 Ring	Port 4: TX-	
10	10	Port 8 Tip	Port 4 Tip	Port 4: RX+	
	35	Port 8 Ring	Port 4 Ring	Port 4: RX-	
11	11	Blank	Blank	Blank	
	36	Blank	Blank	Blank	
12	12	Blank	Blank	Blank	
	37	Blank	Blank	Blank	
13	13	Port 1 Tip	Blank	Port 1: TX+	8
	38	Port 1 Ring	Blank	Port 1: TX-	
14	14	Port 2 Tip	Blank	Port 1: RX+	
	39	Port 2 Ring	Blank	Port 1: RX-	
15	15	Port 3 Tip	Blank	Port 2: TX+	
	40	Port 3 Ring	Blank	Port 2: TX-	
16	16	Port 4 Tip	Blank	Port 2: RX+	
	41	Port 4 Ring	Blank	Port 2: RX-	
17	17	Blank	Blank	Blank	
	42	Blank	Blank	Blank	
18	18	Blank	Blank	Blank	
	43	Blank	Blank	Blank	
19	19	Port 5 Tip	Port 1 Tip	Port 3: TX+	8
	44	Port 5 Ring	Port 1 Ring	Port 3: TX-	
20	20	Port 6 Tip	Port 2 Tip	Port 3: RX+	
	45	Port 6 Ring	Port 2 Ring	Port 3: RX-	
21	21	Port 7 Tip	Port 3 Tip	Port 4: TX+	
	46	Port 7 Ring	Port 3 Ring	Port 4: TX-	
22	22	Port 8 Tip	Port 4 Tip	Port 4: RX+	
	47	Port 8 Ring	Port 4 Ring	Port 4: RX-	
23	23	Blank	Blank	Blank	
	48	Blank	Blank	Blank	
24	24	Blank	Blank	Blank	
	49	Blank	Blank	Blank	
25	25	Tel Ground		TEGND	
	50	Tel Ground		TEGND	

LC4

RJ-21		LGCM8 SLTM8 DTIM8	LGCM4 SLTM4	BRIM PRIM	S L O T No.
Pairs	Pin				
1	1	Port 1 Tip	Blank	Port 1: TX+	7
	26	Port 1 Ring	Blank	Port 1: TX-	
2	2	Port 2 Tip	Blank	Port 1: RX+	
	27	Port 2 Ring	Blank	Port 1: RX-	
3	3	Port 3 Tip	Blank	Port 2: TX+	
	28	Port 3 Ring	Blank	Port 2: TX-	
4	4	Port 4 Tip	Blank	Port 2: RX+	
	29	Port 4 Ring	Blank	Port 2: RX-	
5	5	Blank	Blank	Blank	
	30	Blank	Blank	Blank	
6	6	Blank	Blank	Blank	
	31	Blank	Blank	Blank	
7	7	Port 5 Tip	Port 1 Tip	Port 3: TX+	8
	32	Port 5 Ring	Port 1 Ring	Port 3: TX-	
8	8	Port 6 Tip	Port 2 Tip	Port 3: RX+	
	33	Port 6 Ring	Port 2 Ring	Port 3: RX-	
9	9	Port 7 Tip	Port 3 Tip	Port 4: TX+	
	34	Port 7 Ring	Port 3 Ring	Port 4: TX-	
10	10	Port 8 Tip	Port 4 Tip	Port 4: RX+	
	35	Port 8 Ring	Port 4 Ring	Port 4: RX-	
11	11	Blank	Blank	Blank	
	36	Blank	Blank	Blank	
12	12	Blank	Blank	Blank	
	37	Blank	Blank	Blank	
13	13	Port 1 Tip	Blank	Port 1: TX+	8
	38	Port 1 Ring	Blank	Port 1: TX-	
14	14	Port 2 Tip	Blank	Port 1: RX+	
	39	Port 2 Ring	Blank	Port 1: RX-	
15	15	Port 3 Tip	Blank	Port 2: TX+	
	40	Port 3 Ring	Blank	Port 2: TX-	
16	16	Port 4 Tip	Blank	Port 2: RX+	
	41	Port 4 Ring	Blank	Port 2: RX-	
17	17	Blank	Blank	Blank	
	42	Blank	Blank	Blank	
18	18	Blank	Blank	Blank	
	43	Blank	Blank	Blank	
19	19	Port 5 Tip	Port 1 Tip	Port 3: TX+	8
	44	Port 5 Ring	Port 1 Ring	Port 3: TX-	
20	20	Port 6 Tip	Port 2 Tip	Port 3: RX+	
	45	Port 6 Ring	Port 2 Ring	Port 3: RX-	
21	21	Port 7 Tip	Port 3 Tip	Port 4: TX+	
	46	Port 7 Ring	Port 3 Ring	Port 4: TX-	
22	22	Port 8 Tip	Port 4 Tip	Port 4: RX+	
	47	Port 8 Ring	Port 4 Ring	Port 4: RX-	
23	23	Blank	Blank	Blank	
	48	Blank	Blank	Blank	
24	24	Blank	Blank	Blank	
	49	Blank	Blank	Blank	
25	25	Tel Ground		TEGND	
	50	Tel Ground		TEGND	

Figure 4.6-3 Connections for LC 3 & 4

RJ- 21 pin Assignment

LC5

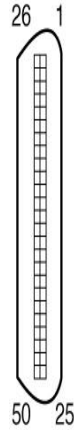

RJ- 21		LGCM8 SLTM8 DTIM8	LGCM4 SLTM4	BRIM PRIM	S L O T No.
Pairs	Pin				
1	1	Port 1 Tip	Blank	Port 1: TX+	9
	26	Port 1 Ring	Blank	Port 1: TX-	
2	2	Port 2 Tip	Blank	Port 1: RX+	
	27	Port 2 Ring	Blank	Port 1: RX-	
3	3	Port 3 Tip	Blank	Port 2: TX+	
	28	Port 3 Ring	Blank	Port 2: TX-	
4	4	Port 4 Tip	Blank	Port 2: RX+	
	29	Port 4 Ring	Blank	Port 2: RX-	
5	5	Blank	Blank	Blank	
	30	Blank	Blank	Blank	
6	6	Blank	Blank	Blank	
	31	Blank	Blank	Blank	
7	7	Port 5 Tip	Port 1 Tip	Port 3: TX+	
	32	Port 5 Ring	Port 1 Ring	Port 3: TX-	
8	8	Port 6 Tip	Port 2 Tip	Port 3: RX+	
	33	Port 6 Ring	Port 2 Ring	Port 3: RX-	
9	9	Port 7 Tip	Port 3 Tip	Port 4: TX+	
	34	Port 7 Ring	Port 3 Ring	Port 4: TX-	
10	10	Port 8 Tip	Port 4 Tip	Port 4: RX+	
	35	Port 8 Ring	Port 4 Ring	Port 4: RX-	
11	11	Blank	Blank	Blank	
	36	Blank	Blank	Blank	
12	12	Blank	Blank	Blank	
	37	Blank	Blank	Blank	
13	13	Blank	Blank	Blank	
	38	Blank	Blank	Blank	
14	14	Blank	Blank	Blank	
	39	Blank	Blank	Blank	
15	15	Blank	Blank	Blank	
	40	Blank	Blank	Blank	
16	16	Blank	Blank	Blank	
	41	Blank	Blank	Blank	
17	17	Blank	Blank	Blank	
	42	Blank	Blank	Blank	
18	18	Blank	Blank	Blank	
	43	Blank	Blank	Blank	
19	19	Blank	Blank	Blank	
	44	Blank	Blank	Blank	
20	20	Blank	Blank	Blank	
	45	Blank	Blank	Blank	
21	21	Blank	Blank	Blank	
	46	Blank	Blank	Blank	
22	22	Blank	Blank	Blank	
	47	Blank	Blank	Blank	
23	23	Blank	Blank	Blank	
	48	Blank	Blank	Blank	
24	24	Blank	Blank	Blank	
	49	Blank	Blank	Blank	
25	25	Tel Ground		TEGND	
	50	Tel Ground		TEGND	

Figure 4.6-4 Connections for LC 5

4.7 LIP Phone Installation

LIP Phones and Consoles can be connected to any standard 10/100 Base-T Ethernet switch port. When connected to an 802.3af compliant switch port, such as the POE8, the LIP Phone and LIP-7000 series consoles can derive power from the Ethernet port. When LAN power is not available, the optional AC/DC adaptor must be used.

Wiring Connectors

The LIP 7004N, 7008D, 8004D and LIP-7000 series consoles all have a single Ethernet port that is connected to the LAN using an RJ-45 plug terminated category 5 cable supplied with the Phone. A 3 meter (9 foot) cable is provided for desk mount installation. Using the cable, one RJ-45 plug is inserted into the "LAN" jack in the bottom of the Phone. The other RJ-45 plug is inserted into the RJ-45 jack previously wired to an Ethernet switch port accessible by the MFIM. To power the LIP Phone over the LAN, the switch port must support POE (Power over Ethernet) standard 802.3af.

The LIP 7016D and 7024L 8012D, 8024D, 8040L phones have two (2) 10/100 Base-T Ethernet ports, a "LAN" port and a "PC" port. An intelligent switch, which implements voice packet priority, connects the two (2) ports. This permits the LAN to be shared between the LIP Phone and the desktop PC or other Ethernet terminal without significant affect on the voice or data traffic. The "LAN" port is connected to the LAN as described above for the single port Phones. The "PC" port is connected to a desktop device using any standard straight through category 5 cable.

The LIP-8000 series consoles connect to the LIP-8000 phone using a flat serial cable. Multiple consoles, maximum 3, are supported by chaining the consoles. One console is connected to the phone, the second console is connected to the first and the final console is connected to the second using the flat serial cable provided.

Power

All LIP Phones and LIP-7000 consoles can be powered by the AC/DC Adapter-K- (48 VDC @0.1A) or over the LAN cable using the POE8 or other 802.3af compliant switch. Note the LIP-8000 series 12 button consoles, maximum 2, are powered by the associated LIP-8000 series IP phone while the 48 button must be powered by an AC/DC Adapter-K.

Using the AC/DC Adapter, after connecting the Phone to the LAN, the Adapter's DC voltage plug is inserted into the power-input jack in the base of the Phone. One end of the AC power cord is inserted into the mating receptacle of the AC Adapter; the other end is inserted into the AC power outlet.

Wall Mount

The LIP-8000 series phones incorporate wall mount into the base of the phone housing. Using the instructions below and Figure 4.7-1, wall mount the LIP-8000 phone.

- Mark and drill two (2) 7mm holes for plastic wall anchors.
- Insert the two (2) anchors into the holes and insert and tighten the 2 screws leaving about 2.5 mm (1/8-inch) exposed. Refer to Figure 4.7-1.
- Slide the LIP-8000 phone over the screws and assure the phone is secure. Note it may be necessary to remove the phone and tighten or loosen the screws for a secure mounting.

- Remove the Handset hook from the phone as shown in the figures below. Reverse the hook and re-install in the LIP-8000 phone so that the hook catches the groove in the handset receiver.

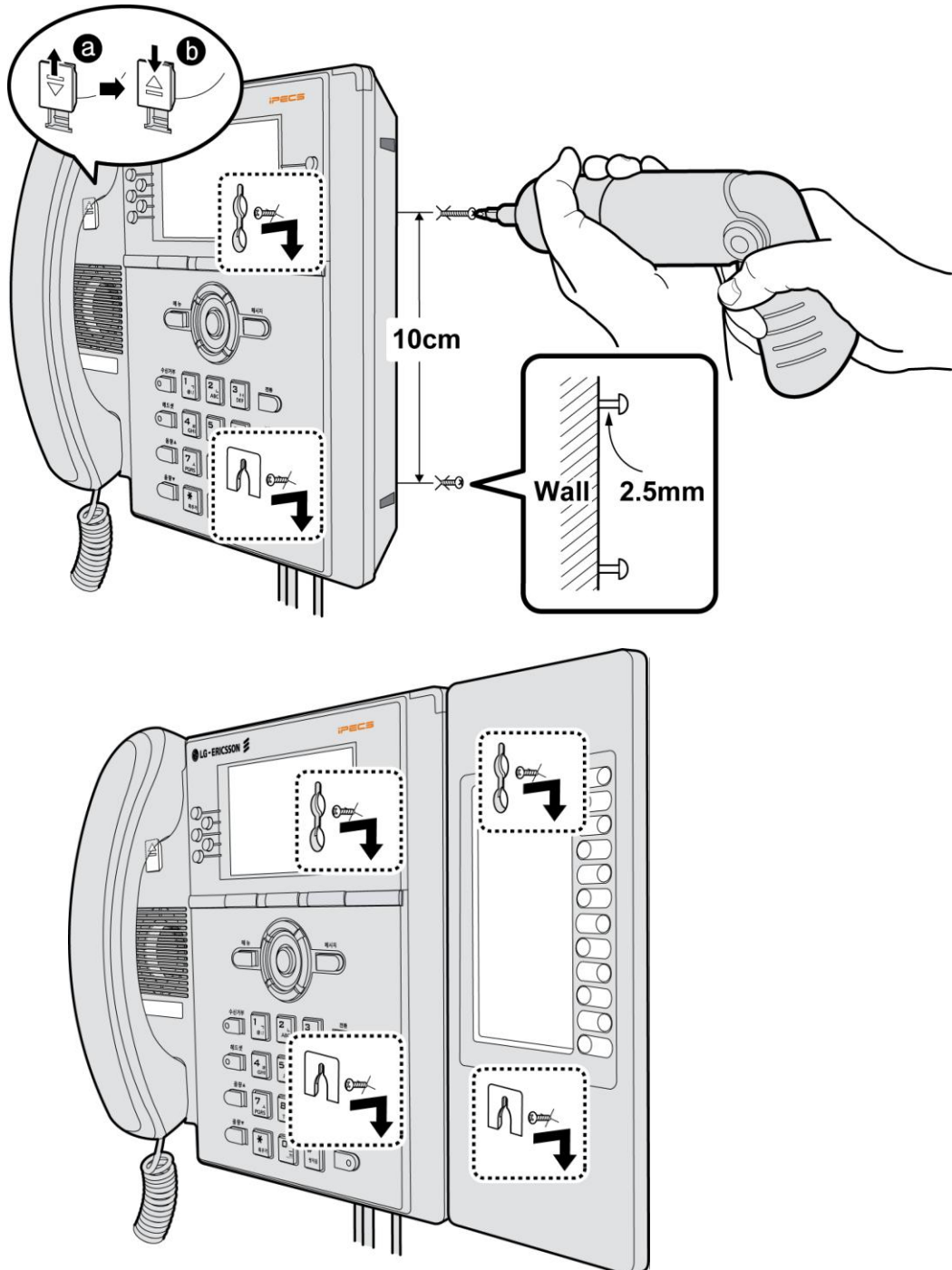

Figure 4.7-1 LIP-8000 Wall Mount Installation

A DSS console can be installed with the LIP-8000 series phone as shown in Figure 4.7-2 to Figure 4.7-5. Up to 3 consoles may be daisy chained as shown using the flat cable provided.

Keep in mind the following conditions when installing LIP-8000 DSS consoles.

- 1) The AC/DC adapter must be used for LIP-8048DSS.
- 2) Up to two (2) LIP-8012LSS and/or LIP-8012DSS can be installed with LIP-8000 Phone.
- 3) The LIP-8048DSS must be separately powered.

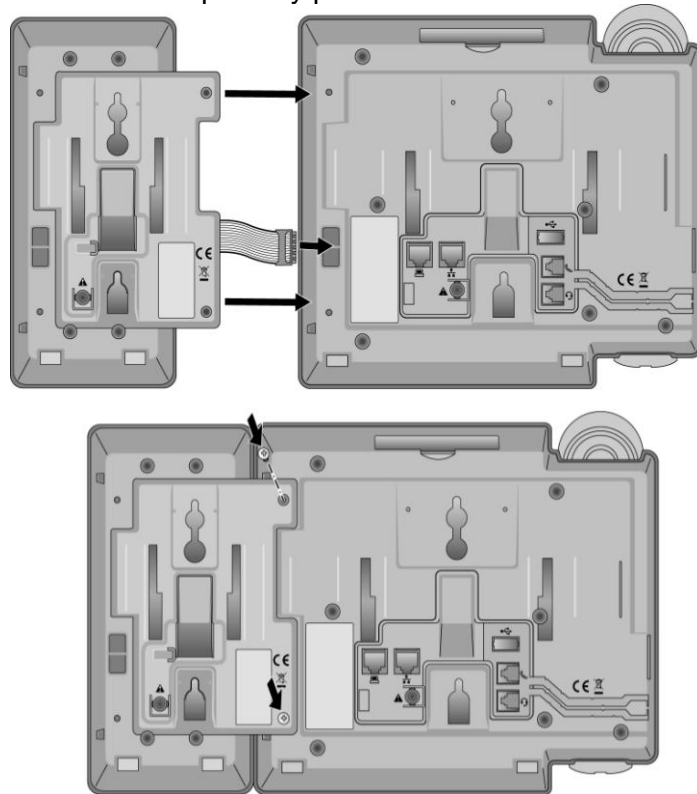

Figure 4.7-2 LIP-8000 DSS Installation

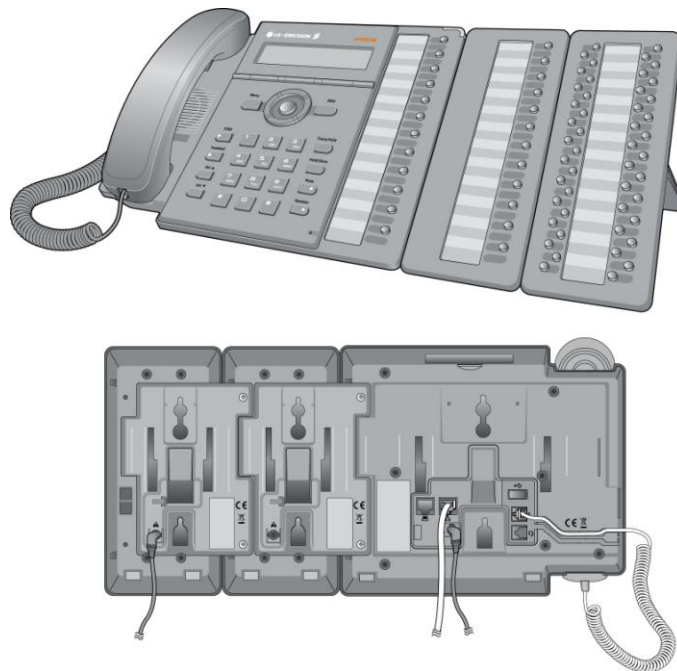

Figure 4.7-3 LIP-8000 DSS Installation (12DSS + 48DSS)

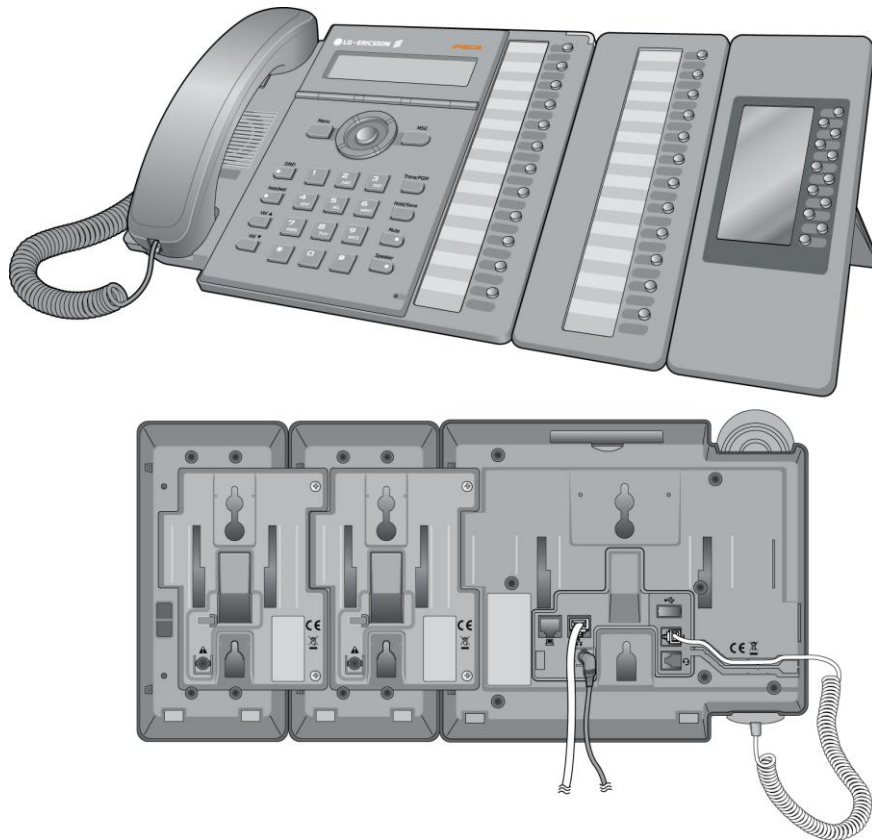

Figure 4.7-4 LIP-8000 DSS Installation (12DSS + 12LS)

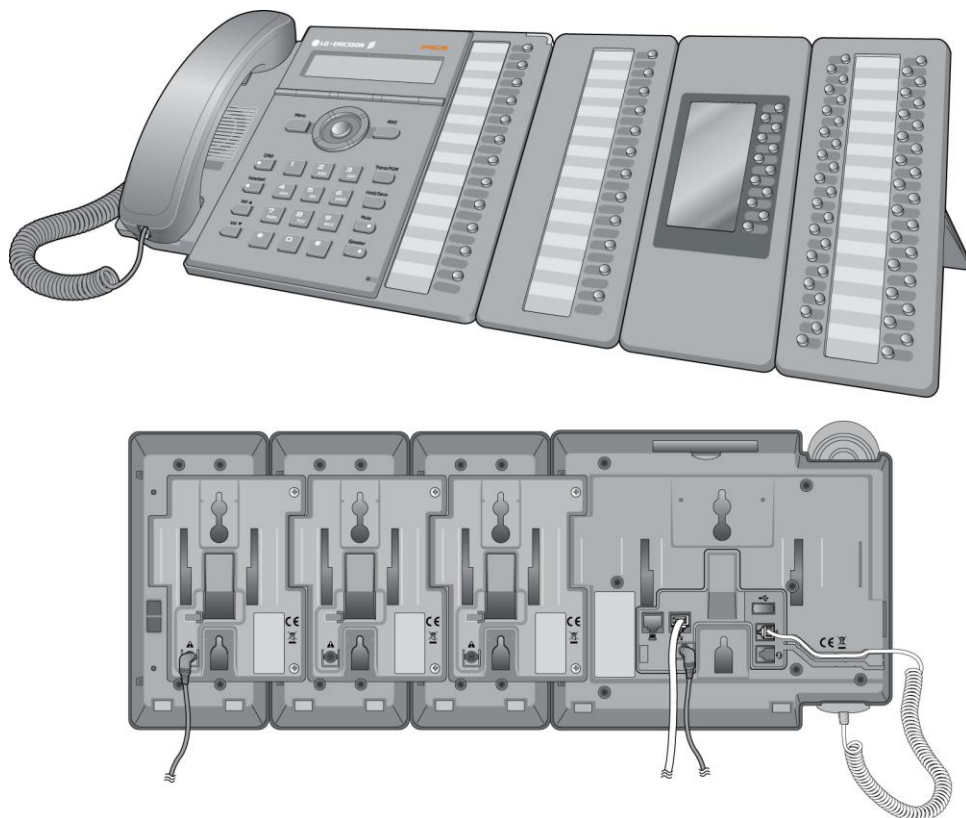

Figure 4.7-5 LIP-8000 DSS Installation (12DSS + 12LSS+48DSS)

The LIP-24D/DH or LIP 7000 Phones can be mounted on the wall using the appropriate Wall Mount Kit. The Wall Mount Kit is installed as described below and shown in Figure 4.7-6.

- Using the Wall Bracket, mark and drill two (2) 7 mm holes for the plastic wall anchors provided.
- Insert the two (2) anchors into the holes and insert and tighten the 2 screws leaving about 6 mm (¼-inch) exposed. Refer to Figure 4.7-6.
- Slide the Wall Mount bracket over the screws and tighten securely.
- Connect a short Cat 5 cable, to the LIP-24D/DH or LIP 7000 series Phone and the wall jack.
- Mount the LIP-24D/DH or LIP 7000 series Phone onto the Wall Mount bracket.
- Insert the Wall Mount handset hook to prevent the handset from slipping when wall mounted. For the LIP-7000 series, the Handset hook is molded as part of the Wall Mount bracket as shown in Figure 4.7-6.

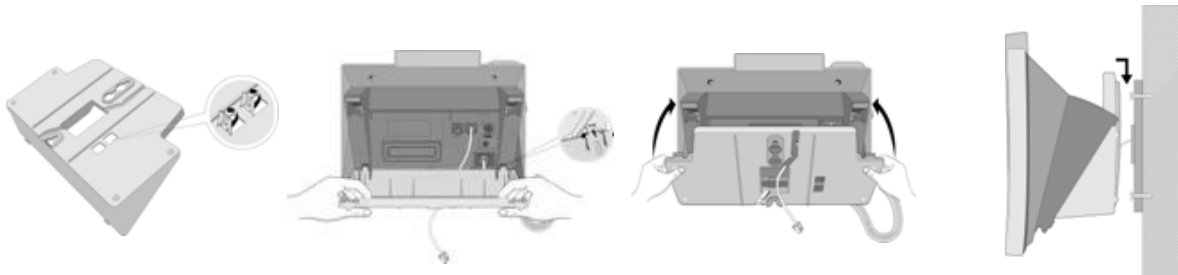

Figure 4.7-6 LIP-7000 Wall Mount Installation

The DSS Console installation with the LIP-7000 series phone is shown in Figure 4.7-7.

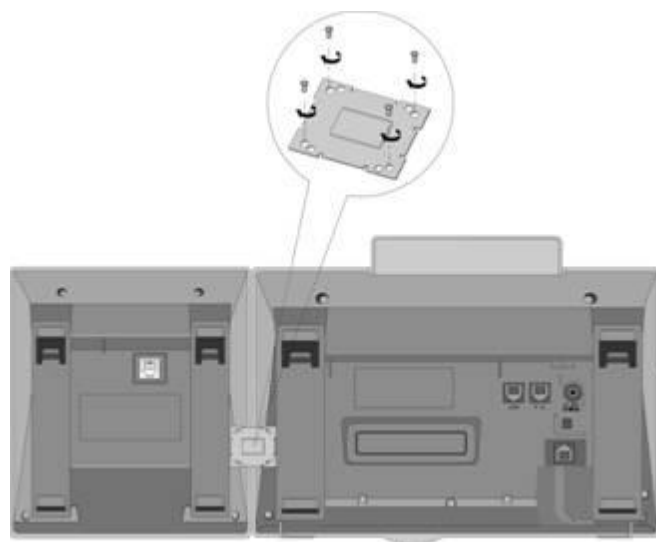

Figure 4.7-7 LIP-7000 DSS Installation

5 Appendix. Useful Information

Open Source Software Notice

This following GPL (General Public License) software used in this product are subject to the GPL License Agreements.

You can obtain a copy of the GPL licenses from LG-Ericsson Web Site (<http://www.lgericsson.com>).

GPL License:

- 1. armboot**
- 2. linux**
- 3. busybox**
- 4. dhcpcd**
- 5. pptp**
- 6. u-boot**

LG-Ericsson offers to provide source code to you on CD-ROM for a charge covering the cost of performing such distribution, such as the cost of media, shipping and handling upon e-mail request to LG-Ericsson at. : opensource@lgericsson.com.

This offer is valid for a period of three (3) years from the date of the distribution of this product by LG-Ericsson.

iPECS

Hardware Description & Installation Manual

