



**7774 Sashabaw Road
Clarkston, Michigan 48348**

2015 Tech Pack



Contents

Contacts	3
Backstage / Catering	4
Load in & Load out / Sound / Lawn Delay	5
Clear-com / Standard Mic / Lighting / Staging	6
Rigging / Power / Video/ Special Considerations	7
Map of DTE Energy Music Theatre	8
Dressing Room & Backstage Maps	9
DTE Rigging Grid	10
Arena Map	11
Maps & Directions	12
Area Hotels	13



DTE Energy Music Theatre
7774 Sashabaw Road
Clarkston, Michigan 48348

Vice President Booking / Marketing: Adam Schneider
 248.377-8215 / Aschneider@palacenet.com

Production: Mike St. Peter (O) 248.377-8239 (C) 248.640-6982 MstPeter@palacenet.com	Sr. Event Manager: Derek Boczkowski (O) 248.377-8255 (C) 248.640-6986 Dboczkowski@palacenet.com
Public Relations: Bryant Fillmore (O) 248.377-0107 (C) 248.709-3240 Bfillmore@palacenet.com	Event Coordinator: Erin Freese (O) 248.377-8229 (C) 248.568-3010 Efreesee@palacenet.com
Contract info./Booking: Bryan Szlaga (O) 248.377-8256 (C) 248.431-1555 Bszlaga@palacenet.com	Director of Box Office: Bruce Trout (O) 248.377-0167 (C) 248.640-6979 Btrout@palacenet.com
Security: Mike Keylon (O) 248.375-4071 (C) 248.496-5194 Mkeylon@palacenet.com	Catering: Ashley McGee (O) 248.377-8207 (C) 248.830-1276 Amgee@palacenet.com

Backstage Production & Dressing Rooms

Total of 8 backstage dressing rooms



Backstage Accommodations

- Two (2) star dressing rooms, 6 small dressing rooms, furnished
 - Stage Right Dressing Area Map (pg.9)
 - Stage Left Dressing Area Map (pg.9)
- All fully carpeted with private shower and restroom facilities
- TV monitors in all dressing rooms
- Visiting production office with telephone and fax hook ups
- Washer & Dryer available upon request
- Backstage deck available for meet & greets, etc

<p>DTE Event Lines Dressing Room Lines DTE Event Lines- (Appear in all Dressing Rooms, All Dial '9')</p> <p>248-371-2020 248-371-2021 248-371-2022 248-371-2023 248-371-2035 248-371-2049 248-371-2055 248-371-2062 248-371-2064 248-371-2065 248-371-2066 248-371-2067 248-371-2068 248-371-2069 248-371-2071 248-371-2079 248-371-2091</p>	
--	--

Catering / Hospitality

- Quality backstage catering provided on site by Levy Premium Group
- Standard and specialty menu selections available
- Catering/hospitality room located backstage, stage left
- Full buffet service/seating available for approximately 50 people at a time
- Fully air-conditioned



Load In & Load Out / Sound

Loading Dock

- Four (4) docks - 44" high (stage level) for unloading and two (2) 12' x 8' loading doors at back of stage
- Doors at dock level and equipment unloads directly onto stage. Space is provided in rear of theatre for truck and trailer parking

Sound

- 28 – Meyer Milo - Flown
- 20 – Meyer HP700 Subs - Flown
- 2 – Meyer Galileo 616 Processors
- 8 - KF88EAW Front Fills
- Mac computer with SMAART Interface
- 12 – TA-12 Active 2 way monitor wedges
- 2- Nexo Eline 3 way side fills with extended 18" subs
- All monitors Crown power
- Yamaha PM5DRH FOH
- Yamaha PM5DRH Monitor (or V16, Profile, Pro6)
- 2 x Microphone packages
- 4 x Shure UHFR Receiver System. (4 channel)
- 4 x Shure Hand Held Transmitters Beta58/SM58
- 1 x Active Antenna System
- 2 x Active Paddle Antenna
- 1 x 300' Audio Snake System
- 1 x 56 channel 2 way passive split with ground lifts with W1/W2 Patch
- 1 x 56 channel 25' mass monitor console fan out W4 to Fan
- 1 x 200amp 3 phase Motion lab AC Distro system
- 2 x 50' C-Form to (2) Bud Box (stage Power)
- 12 x 25' L5-30 to Quad Box (stage Power)



Lawn Delay System

- Sixteen (14) TMS3 Turbosound cabinets in eight (8) clusters mounted in the fascia around front of theatre for lawn seating coverage

Clear-Com

- System is a Clear-Com one-channel with 12 remote stations which are located stage right, stage left, house light position and spot positions

Standard Mic Compliment

- SM91, Beta 52, Sen604, Sen901, SM57, SM58, Beta 98's, ATW35, Sen421, SM81, AT451, PCDI, Active DI's, Passive DI's
- 1 x Complete mic stand case (Upright)
- 1 x Complete Work box (Mics, Adapters, Etc)

Standard Lighting System

- 2 Thomas trusses with 120k total lighting
- 2 Mole 8 lights
- 4 Racks ACL
- 8 LEKO
- LP3000/96 console
- LD2400 dimmers
- 2 Smoke machines
- All rigging, curtaining and fall protection equipment
- 1 30ft. Truss with (8) VL 3000 Spots Center Hung
- 4 VL 3000 Spots for floor

Spotlights / Platforms

- Six (6) Xenon 2K spotlights

Staging

- Stage size is 60'W x 42'D x 3.5'H
- MOJO Style - 56'W x 4'H, available upon request - first 1 row of seating must be removed to accommodate barricade



Mix Position

- Area reserved for mixing consoles measures 30'W x 15'D and is located approximately 100' center from stage

Rigging

- Rigging grid is 80'W x 48' D with a 3,000 lb cap per mid panel point
- Distance from grid to stage floor is 40'
- See Rig Plot on page 10

Show Power

- Stage Right - two (2) 600 AMP/3 Phase
- Stage Left - one (1) 400 AMP/3 Phase
- Bus power - three (3) 50 AMP/Single Phase

Backline

Yamaha 5'6" Baby Grand Piano (Black)

Video (Coming in Summer 2015)

Video Amplification

- Two (2) LED Video walls mounted stage left and stage right in the pavilion. They are approximately 10.8' x 19.2, 8mm physical pixel
- Three (3) roof mounted, rear projection screens 8.4'x 15.6' 10mm physical pixel resolution

Video Equipment (NTSC Analog Only)

- Two (2) Ikegami HL-55 hand-held cameras for stage (w/ 18 x lenses)
- Two (2) Ikegami HK366 hard cameras on platforms (w/50 x lenses)
- Grass Valley 100 production switcher (8 Inputs)
- Equipped with 2 frame syncs for feeds from touring systems



Special Considerations

- One (1) 5,000 lb. forklift
- Doors open 1 ½ hours prior to show time
- Pyrotechnics: Please contact house production manager; arrangements must be made between Fire Marshal and tour for permits and demo if necessary



DTE Energy[®]

music theatre

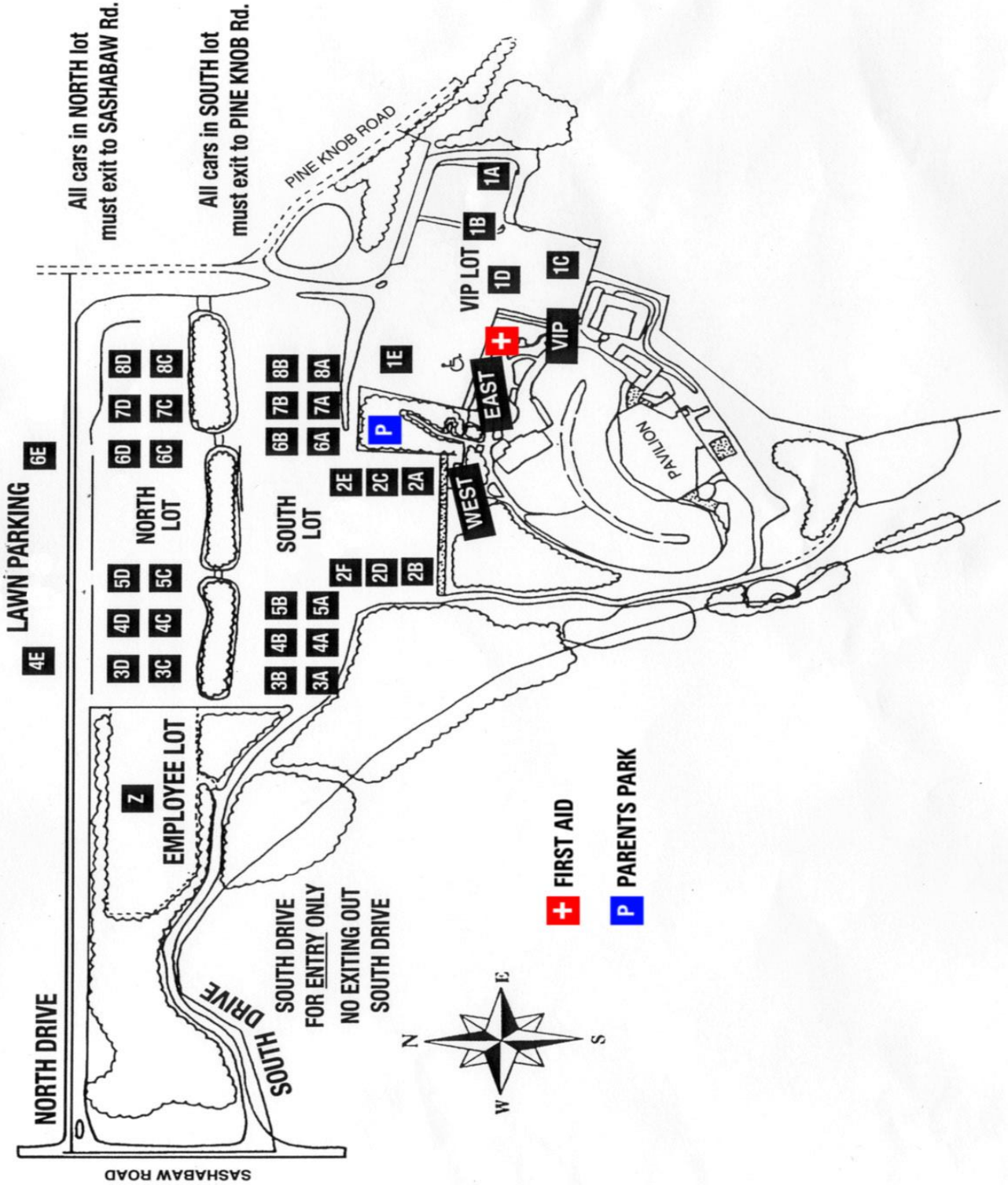

All cars in NORTH lot must exit to SASHABAW Rd.

All cars in SOUTH lot must exit to PINE KNOB ROAD.

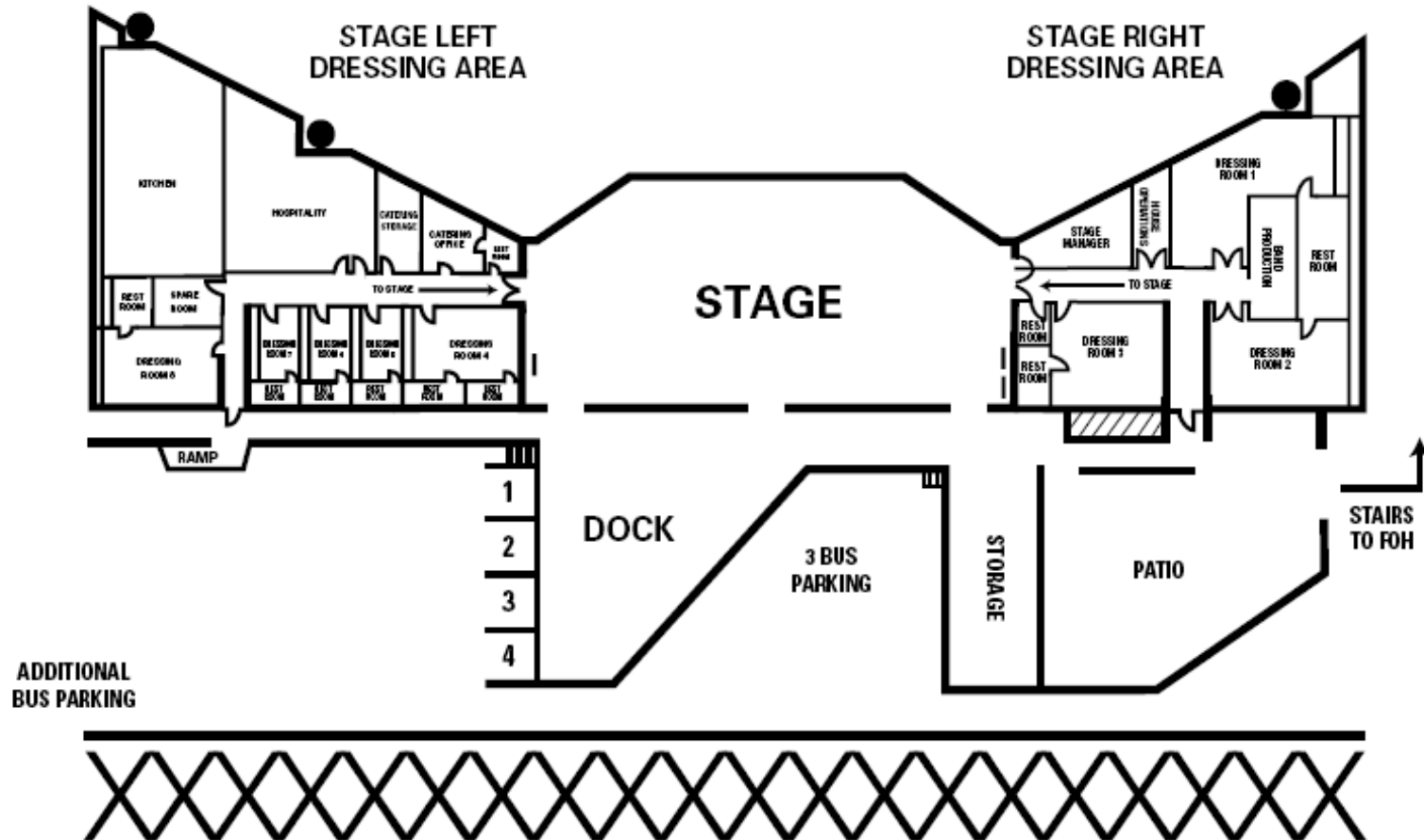

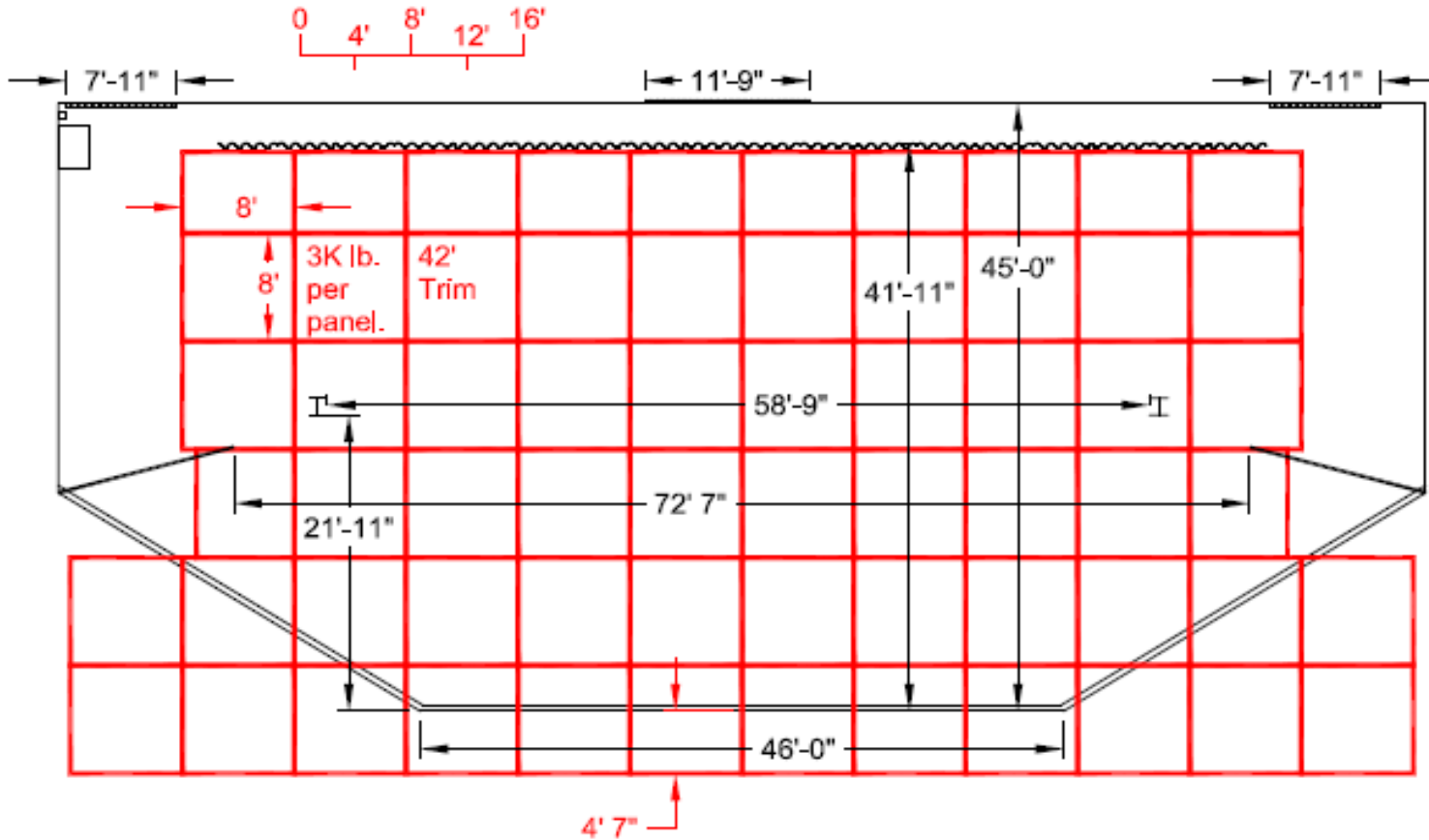

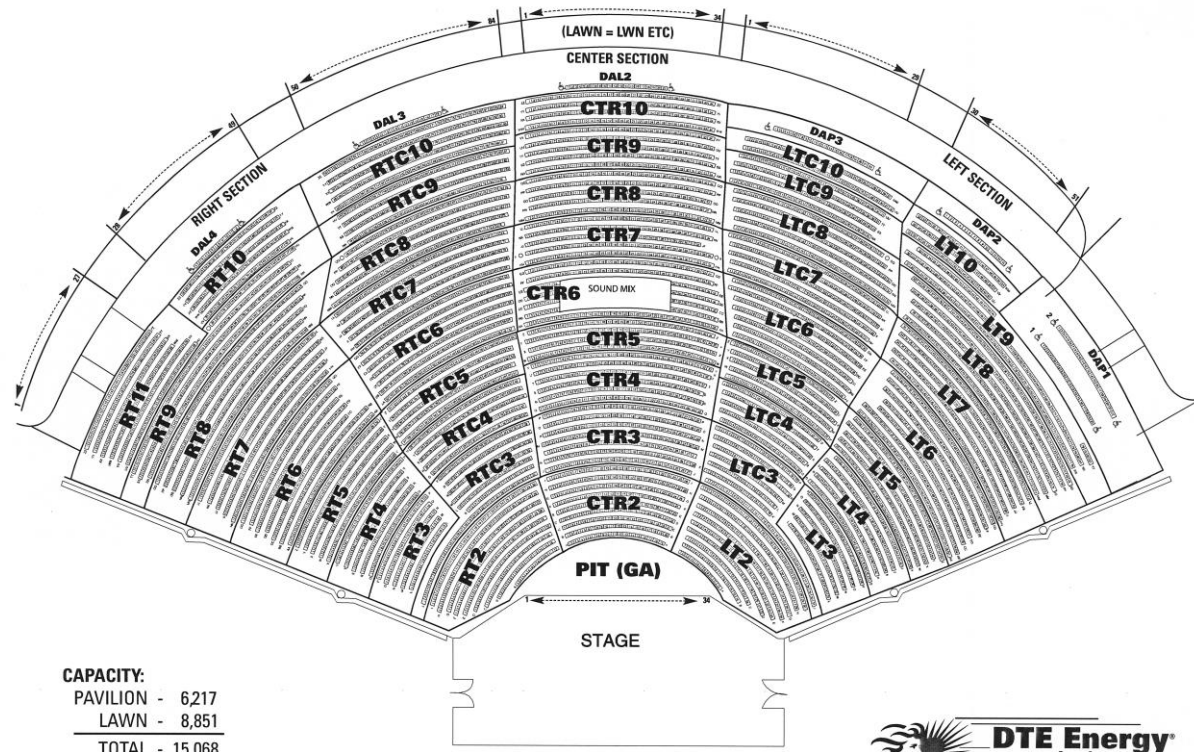

CAPACITY:
 PAVILION - 6,217
 LAWN - 8,851
 TOTAL - 15,068

* FIRST 52 ROWS UNDER COVER (AAA-SS)
 ** DAP 1-3 COVERED





Driving Directions

DTE Energy Music Theatre

7774 Sashabaw Rd
Clarkston, MI 48348

DTE Energy Music Theatre Location: Easily accessible off I-75 at Sashabaw Road, in Clarkston, Michigan (Exit 89).

Entrances:

There are two entrances off of Sashabaw Road just north of I-75. The north drive is located at the base of our large “DTE Energy” marquee sign.

The entrance just south of the marquee sign is our South Drive and is primarily for VIP & Disabled parking.

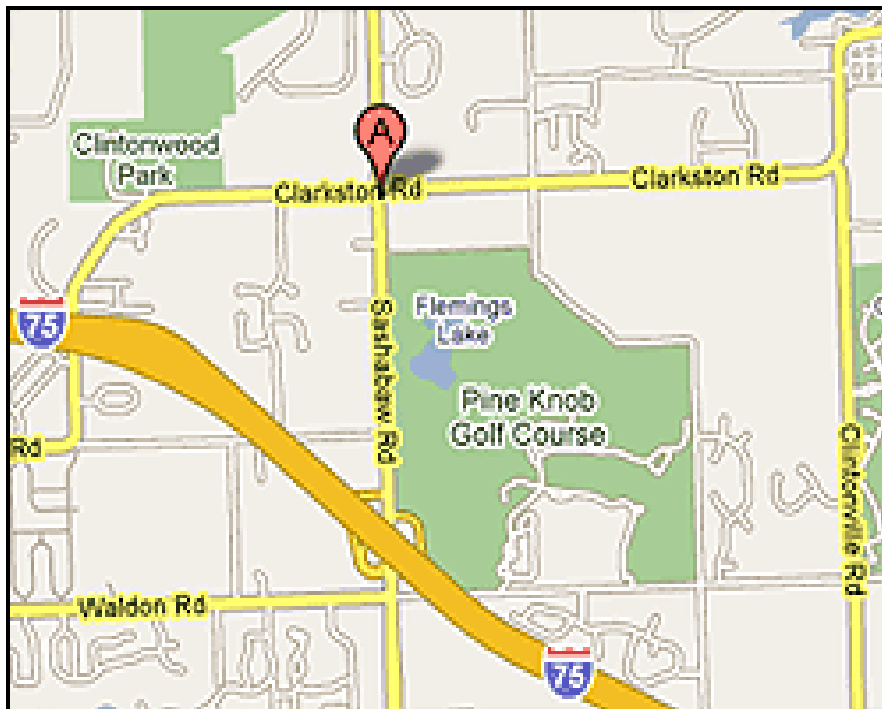



HOTELS

NAME	PHONE	FAX	CONTACT (S)	WEBSITE	DISTANCE
Holiday Inn Express 3990 Baldwin Auburn Hills, MI 48326	248-322-7000	248-322-7001		hiexpress.com	5 minutes from The Palace 15 minutes from DTE
Hyatt Place 1545 Opdyke Rd. Auburn Hills, MI 48326	248-475-9393	248-475-9399		Detroitauburnhills. place.hyatt.com	6 minutes from The Palace 16 minutes from DTE
Hilton Suites- Auburn Hills 2300 Featherstone Rd. Auburn Hills, MI 48326 Near Venue	248-322-2303	248-322-2321		Hilton.com	7 minutes from The Palace 17 minutes from DTE
Crowne Plaza – Auburn Hills Hotel 1500 Opdyke Auburn Hills, MI 48326	248-373-4550	248-323-8220	Kimberly Dasher kimberly.dasher @bfsaulco.com	cpauburnhills.com	5 minutes from The Palace 15 minutes from DTE
The Townsend Hotel 100 Townsend St. Birmingham, MI 48009	248-642-5096	248-645-9061	Kelly Clement	Townsend.com	30 minutes from The Palace 40 minutes from DTE
The Royal Park Hotel 600 East University Dr. Rochester, MI 48307	248-652-2600 office 248-633-6522 cell	248-453-8600	Lenny Williams lwilliams@royalparkhotel.net	Royalparkhotel.net	16 minutes from The Palace 25 minutes from DTE
Courtyard-Auburn Hills 2550 Aimee Lane Auburn Hills, MI	248-373-4100	248-373-1885			