

SPRING 1999

# GE APPLIANCES



AMERICA'S #1 PREFERRED APPLIANCE BRAND



*We bring good things to life.*

---

ALL THE STYLE YOU CAN IMAGINE.  
ALL THE PERFORMANCE YOU DESERVE.



GE has continued to expand the exciting GE Profile Performance™ Series. This year, the big news is the introduction of an exciting new line of GE Profile Performance™ CustomStyle™ refrigerators. Available in both top-freezer and side-by-side models, the exclusive CustomStyle design makes it easier than ever to achieve the custom, built-in look that today's discriminating consumer desires. The small news is the addition of a unique warming drawer to the GE Profile Performance Series. Small news because it fits in the space of an ordinary kitchen drawer (which is very good news to people who want all the latest conveniences for their dream kitchen). Of course, every appliance in this series, whether built-in or free-standing, has to measure up to the highest standards for both design and performance.

Cabinets: *Decora* from Aristokraft Inc., Jasper, Indiana (812) 634-2288;  
Continental Maple in Eggshell and Chestnut  
Countertops and Laminate Flooring: Wilsonart International, Inc.,  
Temple, Texas (800) 433-3222.  
Flooring: Frontier Pine  
Countertops: Graphite Mirage



*Profile Performance™*  
We bring good things to life.

# THE FASTEST GROWING BRAND OF APPLIANCES IN AMERICA TODAY.

GE Profile™ appliances were introduced in 1992 and immediately captured the consumer's imagination. And no wonder, Profile's innovative design and advanced convenience features clearly set them apart from the competition. It was Profile that introduced the first built-in-style refrigerator and now offers Water by Culligan.™ Profile introduced the quietest dishwasher in America among leading brands, and the Profile free-standing range has TrueTemp,™ the most accurate oven in America among leading manufacturers. When the consumer steps up to Profile, they never look back.



**Profile™**  
*We bring good things to life.*

# NO APPLIANCE BRAND IS RATED HIGHER BY AMERICAN CONSUMERS.

GE Quality and dependability are legendary. Year after year, the Louis Harris Poll reports that consumers rate GE products and services among the best in America. In fact, no manufacturer of appliances rates higher than GE in this distinguished poll. Experts seem to agree with consumers. According to Professional Builder magazine, America's new home builders have made GE brand appliances their number one choice in every major appliance category. GE's quality and dependability also make a winning combination for kitchen renovations and replacement appliances.



**GE Appliances**  
*We bring good things to life.*



# AMERICA'S <sup>#1</sup> PREFERRED APPLIANCE BRAND

GE is the appliance brand most often mentioned among the brands rated as offering the best products and services in America.

Source: 1998 Louis Harris Poll

VISIT GE APPLIANCES AT [WWW.GE.COM/APPLIANCES](http://WWW.GE.COM/APPLIANCES)

Discover the advantages of the GE brand family with great areas like the "Design Center," "What's New" and even "Current Promotions." You can locate nearby stores that carry our appliances, download dimension and installation information, contact Customer Service, design your own kitchen—and more!



**GE Appliances**

*GE news*

*GE business finder*

*GE products & services*



 **Monogram**

**GE Profile**

 **GE Appliances**

**HOTPOINT**



# TABLE OF CONTENTS

PRODUCT	PAGE	SPECIFICATIONS/INSTALLATION
<b>Refrigerators</b>		
CustomStyle™ Refrigerators .....	6-15.....	138-142
Side-by-Side Refrigerators .....	16-20.....	143-144
Bottom-Freezer Refrigerators.....	21 .....	145
Top-Freezer No-Frost Refrigerators.....	22-27.....	146-147
Cycle and Manual Defrost Refrigerators.....	28 .....	148
Compact Refrigerators.....	29 .....	148
Freezers.....	30-31 .....	149
Refrigeration Trim Kits.....		150-151
<b>Water Systems</b>		
Filtration Systems .....	32-39.....	152-153
Softening Systems.....	40-43 .....	154
<b>Laundry</b>		
Laundry Pairs.....	44-51 .....	155-157, 159
Front Loading Washer & Dryer.....	52-53.....	158
Spacemaker® Washers & Dryers .....	54-55.....	160-161
<b>Built-In Cooking Products</b>		
Wall Ovens.....	56-68.....	162-170
Warming Drawers .....	69 .....	171
Cooktops.....	70-75.....	172-178
Slide-In/Drop-In Ranges .....	76-79.....	178, 182-186
Ventilation Options .....	80-81.....	179-181
<b>Free-Standing Cooking Products</b>		
Electric Ranges .....	82-95.....	186-188
40" Electric Ranges .....	95 .....	189
Gas Ranges .....	96-103 .....	190-191
<b>Microwave Ovens</b>		
Over-The-Range .....	104-109 .....	192-193
Built-In .....	110.....	194
Countertop.....	111-116 .....	195-196
Spacemaker II™ .....	117.....	196
Countertop Microwave Oven Built-In Trim Kits.....	117.....	197
<b>Dishwashers</b>		
Built-In .....	118-122 .....	198-199
Convertible .....	123.....	200
Spacemaker® Undersink and Built-In.....	124.....	200-201
Disposers & Compactors.....	125 .....	202
<b>Room Air Conditioners</b>		
"J" Series Built-Ins.....	126-129 .....	204-205
Deluxe, Value and Heat/Cool Series .....	130-131.....	203
Split System .....	132.....	206
Slide-Aire .....	132.....	203
Dehumidifiers.....	132.....	206
<b>Warranty Information</b> .....	134-137	
<b>Nomenclatures</b> .....	207-210	

# ONLY GE OFFERS CUSTOMSTYLE™ REFRIGERATORS, AND THEY'RE AVAILABLE IN SIDE-BY-SIDE AND TOP-FREEZER MODELS



A GE CustomStyle side-by-side refrigerator is the perfect solution for today's open-living kitchen designs.



GE's new CustomStyle top-freezer refrigerator looks built-in on the outside, has more accessibility and convenience on the inside.

## AMERICA'S #1 MANUFACTURER OF REFRIGERATORS HAS DONE IT AGAIN!

### HOW DID GE DO IT?

Innovative engineering, that's how! GE redesigned the refrigerators from the inside out. The goal was to offer consumers a stylish refrigerator that wouldn't take up as much floor space and at the same time, offer full-capacity storage. We did it! As a result, we are now offering a whole new category of refrigerators: CustomStyle.™ This new line is available in a full color selection including stainless steel, as well as with custom panel options.

"Because they install nearly flush with the cabinets, these refrigerators save floor space. They don't stick out into the kitchen!"

#### Side-By-Side Refrigerators



#### Top-Freezer Refrigerators



# GE PROFILE PERFORMANCE SERIES™ CUSTOMSTYLE™ STAINLESS STEEL MODELS

## SLEEKER, BEAUTIFULLY-CRAFTED NEW MODELS NOW AVAILABLE

GE has kept pace with America's growing appetite for stainless steel appliances by introducing new CustomStyle refrigerators in the prestigious GE Profile Performance™ Series. With these new models, no trim or slide-in panels are required. The result is a finely-crafted, sleeker, cleaner CustomStyle appearance. Lately, more and more design-conscious home owners are discovering that incorporating stainless steel into their kitchen decor doesn't have to be an "all or nothing" decision. GE's new Profile Performance stainless steel refrigerators can be "mixed" with either black or white appliances. The effect is stunning. It's amazing how one major appliance can literally upgrade an entire kitchen. As for cabinetry, stainless steel compliments natural wood tones; and it also looks sensational with both traditional and designer colors. New stainless steel models feature sleek black handles and dispenser.

Water Systems

Laundry

Cooking Products

Microwave Ovens

Dishwashers

Room Air



**GE Profile Performance Series™**  
Side-By-Side Stainless Steel Trimless Model  
**TPS24BPC**  
• Exclusive Water by Culligan™ • Squared doors



**GE Profile Performance Series™**  
Top-Freezer Stainless Steel Trimless Model  
**TNS22PRC**  
• LightTouch! dispenser delivers cubes, crushed ice and chilled water • Rounded doors

Not all features available on all models.  
For additional features, specifications and color availability, refer to pages 138 and 141.



# CUSTOMSTYLE™ SIDE-BY-SIDE REFRIGERATORS: CHOOSE A TRIMLESS OR INSTALLED TRIM MODEL



**GE Profile Performance Series™**  
Trimless Model  
**TPX24PBB**

## TRIMLESS MODELS: INSTALLATION MADE EASY, SIMPLY SLIDE IN

The trimless CustomStyle units install by simply sliding into—way into—the space between cabinets. Because they align with counters, CustomStyle refrigerators instantly look built-in. And there's nothing to attach or custom build. Available in white, black, stainless steel and almond.

Trimless models shown on pages 12 and 13.



**GE Profile™**  
Installed Trim Model  
**TPX24BPP**  
shown with a custom wood panels and optional collar trim TRMBISWW.

## INSTALLED-TRIM MODELS: ANOTHER WAY TO CUSTOMIZE

Whether you're building a brand new kitchen or planning for a renovation, GE opens a world of design possibilities. CustomStyle™ refrigerators accept a variety of door panels: acrylic white, black or almond, and stainless steel panels. The choices are simple.

## INSTALLED TRIM MODELS

### Optional door panels: another way to customize.

When you choose GE CustomStyle™ refrigerators with installed trim the choices of design are practically endless. Order acrylic panels in white, black, almond or stainless steel panels from GE, or make and install your own custom wood panels to accent the cabinetry in your kitchen.

### Optional collar trim: available for all models listed below.

The optional collar trim is just another way GE lets you integrate our CustomStyle™ refrigerators into your kitchen decor. Available in white, black, almond and stainless steel, this trim frames the refrigerator facade, adding to the finished look of a built-in, custom kitchen. Collar trim: TRMBISWW, TRMBISBB, TRMBISAA, TRMBISSS.

### Panels available:

Models TPX24BRB is available with white, black, almond, stainless steel or custom wood panel options.

Models TPX24BPB, TPX24BIB and TPX21BRB are available with white, black, stainless steel or custom wood panel options.

## DISPENSER MODELS



**TPX24BPBBB**  
Shown with optional black acrylic panels. Water by Culligan™, LightTouch! dispenser.



**TPX24BPBBB**  
Shown with custom wood panels. Water by Culligan™, LightTouch! dispenser.



**TPX24BRBWW**  
Shown with optional white acrylic panels. LightTouch! dispenser.



**TPX24BRBAA**  
Shown with custom wood panels. LightTouch! dispenser.

## NON-DISPENSER MODELS



**TPX21BRBBB**  
Shown with custom wood panels. LightTouch! dispenser.



**TPX21BRBWW**  
Shown with optional white acrylic panels. LightTouch! dispenser.



**TPX24BIBBB**  
Shown with optional black acrylic panels. Non-dispenser.



**TPX24BIBWW**  
Shown with optional white acrylic panels. Non-dispenser.

Not all features available on all models. For additional features, specifications and color availability, refer to page 138.

# THE ONLY CUSTOMSTYLE™ TOP-FREEZER REFRIGERATOR: CHOOSE A TRIMLESS OR INSTALLED TRIM MODEL

This is the first top-freezer refrigerator designed to align with countertops and not stick out or take up valuable floor space, evoking the “premium impression” of a custom built-in kitchen. Best of all, it has full-capacity storage and saves nearly 5" of floor space.



**GE Profile Performance Series™**  
Trimless Model  
**TNX22PACWW**



**GE Profile Performance Series™**  
Installed-Trim Model  
**TNX22BACBB**  
shown with a custom wood panels.

## TRIMLESS MODELS: INSTALLATION MADE EASY, SIMPLY SLIDE IN

The trimless CustomStyle units install by simply sliding into—way into—the space between cabinets. Because they align with counters, CustomStyle refrigerators instantly look built-in. And there's nothing to attach or custom build. Available in white, black, almond and stainless steel.

Trimless models shown on pages 14 and 15.

## INSTALLED-TRIM MODELS: ANOTHER WAY TO CUSTOMIZE

Whether you're building a brand new kitchen or planning for a renovation, GE opens a world of design possibilities. CustomStyle™ refrigerators accept a variety of door panels: acrylic white or black and stainless steel panels. The choices are simple.

Not all features available on all models.  
For additional features, specifications and color availability, refer to page 141.



## INSTALLED TRIM MODELS

### Optional door panels: another way to customize.

When you choose GE CustomStyle™ refrigerators with installed trim the choices of design are practically endless. Order acrylic panels in white, black or stainless steel panels from GE, or make and install your own custom wood panels to accent the cabinetry in your kitchen.

### Optional collar trim: available for all models listed below.

The optional collar trim is just another way GE lets you integrate our CustomStyle™ refrigerators into your kitchen decor. Available in white, black and stainless steel, this trim frames the refrigerator facade, adding to the finished look of a built-in, custom kitchen. Collar trim: TRMBISWW, TRMBISBB, TRMBISS.

### Panels available:

Models TNX22BRC and TNX22BAC are available with white, black, stainless steel or custom wood panel options. Model TNS22BRC is only available with stainless steel panels.

## DISPENSER MODELS



**TNX22BRCWW**  
Shown with optional white acrylic panels. LightTouch! dispenser.

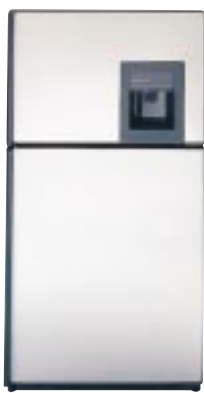

**TNX22BRCBB**  
Shown with optional stainless steel panels. LightTouch! dispenser.



**TNX22BRCBB**  
Shown with custom wood panels. LightTouch! dispenser.



**TNS22BRCBS**  
Shown with installed stainless steel panels. LightTouch! dispenser.

## NON-DISPENSER MODELS



**TNX22BACBB**  
Shown with optional black acrylic panels. Non-dispenser.



**TNX22BACBB**  
Shown with optional stainless steel panels. Non-dispenser.



**TNX22BACBB**  
Shown with custom wood panels. Non-dispenser.

Not all features available on all models. For additional features, specifications and color availability, refer to page 141.

# SIDE-BY-SIDE CUSTOMSTYLE™ MODELS: 24 CU. FT.

ALL MODELS INCLUDE • Quiet Package • Quick Space™ shelf • Spacemaker™ adjustable gallon door bins • Two slide-out, spill-proof glass shelves • Wire Everwhite slide-out freezer baskets • Smart Storage System • Beverage rack



Quiet Package significantly reduces noise.



Refreshment Center provides easy access to frequently-used items.



Water by Culligan™ provides cleaner, better tasting water and ice instantly from your LightTouch! dispenser.



Slide-Out, Spill-Proof Shelves help contain spills for ease of cleaning.



## GE Profile Performance Series™

**TPS24BPC** Trimless Stainless Steel Dispenser Model  
 • 23.5 cu. ft. capacity • Exclusive Water by Culligan™  
 • LightTouch! dispenser • Factory-installed stainless steel trimless squared doors • Full-length handles with stainless steel appearance

**TPX24BPB** Installed Trim Dispenser Model (not shown)  
 • Optional panels available  
 • Full-length color-matched handles

## GE Profile™

**TPS24BIC** Trimless Stainless Steel

Non-Dispenser Model (not shown)  
 • 23.7 cu. ft. capacity • Factory-installed stainless steel trimless squared doors • Full-length handles with stainless steel appearance

**TPS24PIB** Trimless Stainless Steel

Non-Dispenser Model (not shown)  
 • 23.7 cu. ft. capacity • Equipped with factory-installed NiceCubes™ icemaker • Rounded doors • Premium Deluxe black door handles



## GE Profile Performance Series™

**TPX24PBB** Trimless Dispenser Model  
 • 23.5 cu. ft. capacity • Exclusive Water by Culligan™  
 • Electronic Monitor and Diagnostic System  
 • Refreshment Center • Rounded doors  
 • Premium Deluxe handles

**TPS24PBB** Trimless Stainless Steel Dispenser Model (not shown)  
 • Rounded doors

## GE Profile Performance Series™

**TPX24PPB** Trimless Dispenser Model  
 • Exclusive Water by Culligan™ • LightTouch! dispenser • Premium Deluxe handles

**TPS24PPB** Trimless Stainless Steel Dispenser Model (not shown)  
 • Rounded doors

Not all features available on all models. For additional features, specifications and color availability, refer to page 138.

# SIDE-BY-SIDE CUSTOMSTYLE™ MODELS: 24 TO 21 CU. FT.

ALL MODELS INCLUDE • Quick Space™ shelf • Spacemaker™ adjustable gallon door bins • Two slide-out, spill-proof glass shelves • Wire Everwhite slide-out freezer baskets • Smart Storage System • Beverage rack



QuickSpace™ Shelf slides back for storage of tall containers.



Slide-Out Freezer Baskets allow for quick and easy loading and unloading.



Beverage Rack offers flexible tall bottle storage.



Smart Storage System offers maximum storage flexibility.



## GE Profile™

**TPX24PRB** Trimless Dispenser Model  
 • 23.5 cu. ft. capacity • LightTouch! dispenser  
 • Rounded doors • Premium Deluxe handles

**TPX24BRB** Installed Trim Dispenser Model (not shown)  
 • Optional panels available • Full-length color-matched handles



## GE Profile™

**TPX24BIB** Installed Trim Non-Dispenser Model  
 • 23.7 cu. ft. capacity • Equipped with factory-installed Nice Cubes™ icemaker • Optional panels available • Full-length color-matched handles



## GE Profile™

**TPX21BRB** Installed Trim Dispenser Model  
 • 20.7 cu. ft. capacity • LightTouch! dispenser  
 • Optional panels available • Full-length color-matched handles

**TPX21PRB** Trimless Dispenser Model (not shown)  
 • Premium Deluxe handles

**YOUR WATER BY CULLIGAN™ REPLACEMENT FILTER (FXRC1)** can be ordered through the GE Answer Center® (1-800-626-2000), Customer Service Parts Center (1-800-626-2002) or through your Authorized GE Dealer.

Not all features available on all models. For additional features, specifications and color availability, refer to page 138.



# TOP-FREEZER CUSTOMSTYLE™ MODELS: 22 CU. FT.

ALL MODELS INCLUDE • Beverage Rack • Adjustable spill-proof glass shelves • Adjustable humidity vegetable/fruit crispers • Adjustable modular gallon door bins • Dual up-front temperature control (back-lit) • QuickSpace™ shelf • Slide-out, spill-proof crisper cover • Quick Store™ bin • Adjustable temperature meat pan • Adjustable dairy compartment



Slide-Out, Spill-Proof Crisper Cover pulls out for easy access and quick cleanup.



QuickSpace™ Shelf slides back to store tall items.



Modular Door Bins store gallon containers with ease.



LightTouch! Dispenser delivers cubes, crushed ice and chilled water.



## GE Profile Performance Series™

### TNX22PRC Trimless Dispenser Model

- 21.7 cu. ft. capacity • LightTouch! dispenser delivers cubes, crushed ice and chilled water
- Rounded doors • Color-matched Premium Deluxe handles

### TNX22PAC Trimless Non-Dispenser Model (not shown)

- 21.9 cu. ft. capacity • Equipped for optional automatic icemaker



## GE Profile Performance Series™

### TNS22BRC Installed Trim Stainless Steel Dispenser Model

- 21.7 cu. ft. capacity • Factory-installed stainless steel panels, trim and full-length handles

### TNX22BAC Installed Trim Non-Dispenser Model (not shown)

- 21.9 cu. ft. capacity • Equipped for optional automatic icemaker • Factory-installed trim with optional panels and full-length color-matched handles



**GE Profile Performance Series™**  
**TNS22PRC** Trimless Stainless Steel  
 Dispenser Model  
 • 21.7 cu. ft. capacity • LightTouch!  
 dispenser delivers cubes, crushed ice and  
 chilled water • Premium Deluxe black  
 handles • Rounded doors



**GE Profile Performance Series™**  
**TNX22BRC** Installed Trim Dispenser Model  
 • 21.7 cu. ft. capacity • LightTouch!  
 dispenser delivers cubes, crushed ice and chilled water  
 • Factory-installed trim with optional panels  
 and full-length handles

Not all features available on all models.  
 For additional features, specifications and color availability, refer to page 141.

## SIDE-BY-SIDE MODELS: 30 TO 28 CU. FT.

THESE MODELS INCLUDE • Quiet Package • LightTouch! dispenser delivers cubes, crushed ice and chilled water  
 • Quick Space™ shelf • Two slide-out, spill-proof glass shelves • Wire Everwhite slide-out freezer baskets  
 • Smart Storage System • Beverage rack • Premium Deluxe handles



Quiet Package significantly reduces noise.



Water by Culligan™ provides cleaner, better-tasting water and ice instantly from your LightTouch! dispenser.



Refreshment Center provides easy access to frequently-used items.



Electronic Monitoring System is so smart, it knows when the door is ajar.



### GE Profile Performance Series™ TFX30PBB

• 29.8 cu. ft. capacity • Exclusive Water by Culligan™ • Electronic Monitor and Diagnostic System • Refreshment Center • 4 Spacemaker™ extra-deep door bins (3 with gallon storage, 1 adjustable)  
 • Rounded doors • Slide-out cantilevered freezer basket



### GE Profile Performance Series™ TFX30PPB

• 29.8 cu. ft. capacity • Exclusive Water by Culligan™ • 4 Spacemaker™ extra-deep door bins with gallon storage (3 adjustable) • Rounded doors • Slide-out cantilevered freezer basket

#### TFX28PBB (not shown)

• 28.2 cu. ft. capacity • Stainless steel model with trimless rounded door • 4 modular door bins, 2 adjustable with gallon storage



### GE Profile Performance Series™ TFS28PBB

• 28.2 cu. ft. capacity • Stainless steel model with trimless rounded door • Exclusive Water by Culligan™ • Electronic Monitor and Diagnostic System • Refreshment Center • 4 door bins, 3 with gallon storage, 1 adjustable

#### TFX28PBB (not shown)

• White on white, Black on black or Almond on almond model

Not all features available on all models. For additional features, specifications and color availability, refer to page 143.



# SIDE-BY-SIDE MODELS: 28 TO 22 CU. FT.

- THESE MODELS INCLUDE • Quiet Package • LightTouch! dispenser delivers cubes, crushed ice and chilled water
- Quick Space™ shelf
  - Two slide-out, spill-proof glass shelves
  - Wire Everwhite slide-out freezer baskets
  - Smart Storage System
  - Beverage rack
  - Premium Deluxe handles



Adjustable Modular Gallon Door Bins store gallons with ease and flexibility.



LightTouch! dispenser delivers crushed ice, cubes and chilled water through the door.



Smart Storage System offers maximum storage flexibility.



QuickSpace™ Shelf slides back for storage of tall containers.



## GE Profile Performance Series™ TFX28PPC

- 28.2 cu. ft. capacity
- Exclusive Water by Culligan™
- 4 door bins, 2 adjustable with gallon storage
- Slide-out cantilevered freezer baskets



## GE Profile Performance Series™ TFS25PPB

- 25.2 cu. ft. capacity
- Stainless steel model with trimless door
- Exclusive Water by Culligan™
- 4 door shelves, 2 adjustable with gallon storage

- TFX25PPB (not shown)
- White on white, Black on black or Almond on almond model

- TFX22PPB (not shown)
- 21.6 cu. ft. capacity

- TFS22PPB (not shown)
- Stainless steel model with trimless door



## GE Profile™ TFX25PRB

- 25.2 cu. ft. capacity
- 4 door shelves, 2 adjustable with gallon storage

- TFX27PRB (not shown)
- 26.6 cu. ft. capacity
- 5 Spacemaker™ door bins (4 adjustable with gallon storage)

- TFX25PAB Non-Dispenser Model (not shown)
- 25.3 cu. ft. capacity

- TFX22PRB (not shown)
- 21.6 cu. ft. capacity

Not all features available on all models. For additional features, specifications and color availability, refer to page 143.

## SIDE-BY-SIDE "Z" SERIES MODELS: 27 TO 22 CU. FT.

ALL MODELS INCLUDE • Quiet Package • Fresh food gallon door storage • Snack pan • Adjustable humidity vegetable/fruit crisper • Adjustable temperature meat pan • Adjustable spill-proof glass shelves • Deluxe handles



Quiet Package significantly reduces noise.



Water by Culligan™ provides cleaner, better tasting water and ice instantly from your LightTouch! dispenser



**GE**

**TFX25ZPB**

- 25.2 cu. ft. capacity
- Exclusive Water by Culligan™ • LightTouch! dispenser delivers cubes, crushed ice and chilled water
- 4 door bins, 2 adjustable with gallon storage

**TFX22ZPB** (not shown)

- 21.7 cu. ft. capacity

**TFX27ZPB** (not shown)

- 26.6 cu. ft. capacity • 4 door bins, 3 adjustable with gallon storage

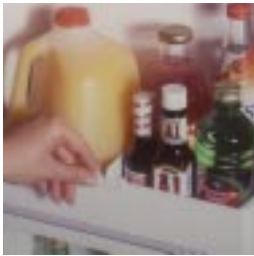

Modular Door Storage provides maximum door flexibility.



Adjustable Humidity Crisper and Adjustable Temperature Meat Pan keep vegetable/ fruits fresher longer.

## SIDE-BY-SIDE "K" SERIES MODELS: 25 TO 22 CU. FT.

ALL MODELS INCLUDE • Quiet Package • LightTouch! dispenser • Adjustable spill-proof shelves • Adjustable humidity vegetable/fruit crispers • Adjustable modular door bins with gallon storage • Adjustable temperature meat pan • Sliding freezer storage bins • Deluxe handles



Quiet Package significantly reduces noise.



Spill-proof shelves contain spills for ease of cleaning.



**GE**

**TFX25KRC**

- 25.2 cu. ft. capacity

**TFX22KRC** (not shown)

- 21.7 cu. ft. capacity

Not all features available on all models.

For additional features, specifications and color availability, refer to page 144.

# SIDE-BY-SIDE "J" SERIES MODELS: 22 TO 20 CU. FT.

ALL MODELS INCLUDE • Quiet Package • Adjustable temperature meat pan • Adjustable glass shelves • Deluxe handles



Quiet Package significantly reduces noise.



LightTouch! dispenser delivers cubes, crushed ice and chilled water through the door.



Adjustable Humidity Vegetable/Fruit Crisper keeps vegetables/fruits fresher longer.



Adjustable Fresh Food Gallon Door Storage provides maximum door storage.



**GE**

**TFX20JRB**

- 19.7 cu. ft. capacity • LightTouch! dispenser delivers cubes, crushed ice and chilled water
- Sealed vegetable/fruit crisper • 4 fixed door bins, 2 with gallon storage



**GE**

**TFX22JAB**

- 21.8 cu. ft. capacity • Equipped for optional automatic icemaker • Adjustable humidity vegetable/fruit crisper • 4 door shelves, 2 adjustable door bins with gallon storage

**TFX20JAB** (not shown)

- 19.7 cu. ft. capacity

Water Systems

Laundry

Cooking Products

Microwave Ovens

Dishwashers

Room Air

Not all features available on all models. For additional features, specifications and color availability, refer to page 144.



## SIDE-BY-SIDE "S" SERIES MODEL: 20 CU. FT.



Quiet Package significantly reduces noise.

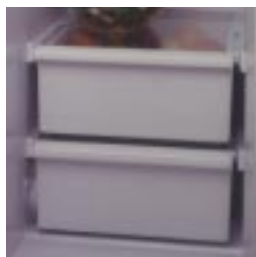

Classic White Crispers provide easy storage of vegetable and fruits.



Fixed Fresh Food Gallon Door Storage provides maximum storage flexibility.



Wire Everwhite Shelves minimize shuffling and restacking of fresh food items.



**GE**

**TFX20SAB**

• 19.7 cu. ft. capacity • Quiet Package • Equipped for optional automatic icemaker • Classic white crispers, 1 adjustable and 1 sealed • 4 fixed fresh food door bins, 2 with gallon storage • Wire Everwhite shelves • Deluxe handles

Not all features available on all models.

For additional features, specifications and color availability, refer to page 144.

# BOTTOM-FREEZER MODELS: 22 TO 18 CU. FT.

ALL MODELS INCLUDE • Adjustable humidity vegetable/fruit crispers • Snack pan • Wire Everwhite sliding freezer basket  
 • 4 modular door bins • Equipped for optional automatic icemaker



Modular Fresh Food Gallon Door Storage provides maximum storage flexibility.



Spill-Proof Shelves help contain spills for ease of cleaning. (Not available on TCX181AC)



Wire Slide-Out Can Dispenser for easy dispensing of your favorite beverage. (Not available on TCX181AC)



Clear Crispers with Limited Lifetime Warranty. See page 134 for details.



**GE Profile™**  
**TCX22PAC**  
 • 21.7 cu. ft. capacity  
 • Wire slide-out can dispenser  
 • Adjustable spill proof shelves



**GE Profile™**  
**TCX18PAC**  
 • 17.6 cu. ft. capacity  
 • Wire slide-out can dispenser  
 • Adjustable spill proof shelves  
**GE**  
**TCX181AC** (not shown)  
 • 17.6 cu. ft. capacity

Water Systems

Laundry

Cooking Products

Microwave Ovens

Dishwashers

Room Air

Not all features available on all models. For additional features, specifications and color availability, refer to page 145.

# TOP-FREEZER MODELS: 25 TO 19 CU. FT.

ALL MODELS INCLUDE • Quiet Package • Wire slide-out can dispenser • Condiment caddy • Quick Store™ bin (not on TBX19PAB) • Quick Serve™ storage dishes (not on TBX19PAB) • Slide-out, spill-proof adjustable glass shelves • Adjustable humidity vegetable/fruit crispers • Adjustable temperature meat pan • Premium Deluxe handles



Quiet Package significantly reduces noise.



Slide-Out, Spill-Proof Cantilevered Shelf help contain spills for ease of cleaning.



Wire Slide-Out Can Dispenser for easy dispensing of your favorite beverage.



Condiment Caddy offers portable storage from your refrigerator to the table. Keeps condiments organized and easy to access.



## **GE Profile™ TBX25PRB**

- 24.7 cu. ft. capacity • LightTouch! dispenser delivers cubes, crushed ice and water • 4 modular gallon door bins, 3 adjustable

**TBX22PRB** (not shown)  
• 21.5 cu. ft. capacity



## **GE Profile™ TBX25PAB**

- 24.7 cu. ft. capacity • Equipped for optional automatic icemaker • 4 modular gallon door bins, 3 adjustable

**TBX22PAB** (not shown)  
• 21.6 cu. ft. capacity • Equipped for optional automatic icemaker

**TBX22PIB** (not shown)  
• 21.6 cu. ft. capacity • Equipped with factory-installed Nice Cubes™ icemaker

**TBX19PAB** (not shown)  
• 19.0 cu. ft. capacity • 5 modular gallon door bins, 4 adjustable



## TOP-FREEZER "Z" SERIES MODELS: 22 TO 19 CU. FT.

ALL MODELS INCLUDE • Adjustable humidity vegetable/fruit crispers • Adjustable spill-proof glass shelves  
 • Snack pan • Freezer light • Baking soda holder • Modular gallon door storage • Deluxe handles



Bright Freezer Interior with new light for easy locating of food.

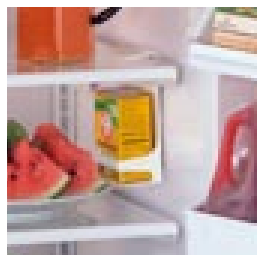

Baking Soda Holder provides added flexibility and convenience.



Adjustable Humidity Window Vegetable/Fruit Crisper keeps vegetables/ fruits fresher longer.

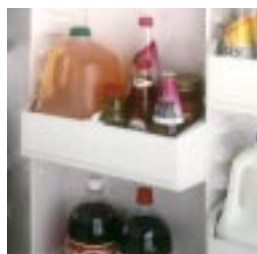

Adjustable Modular Gallon Door Bins store gallons with ease and flexibility.



**GE TBX22ZAB**  
 • 21.6 cu. ft. capacity  
 • Equipped for optional automatic icemaker  
 • 5 modular gallon storage door bins, 4 adjustable

**TBX19ZAB** (not shown)  
 • 19.0 cu. ft. capacity  
 • Equipped for optional automatic icemaker  
 • 4 modular gallon storage door bins, 3 adjustable

Water Systems

Laundry

Cooking Products

## TOP-FREEZER "M" SERIES MODEL: 22 CU. FT.

MODEL INCLUDES • Modular gallon door bins • Spill-proof shelves • Clear vegetable/fruit crispers  
 • Snack pan • Modular freezer door bins • Deluxe handles



Snack Pan conveniently stores rewrapped meats, cheeses and snacks.

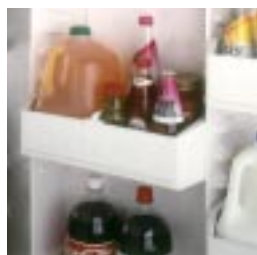

Adjustable Modular Gallon Door Bins store gallons with ease and flexibility.



**GE TBX22MAC**  
 • 21.6 cu. ft. capacity

Microwave Ovens

Dishwashers

Room Air

Not all features available on all models.  
 For additional features, specifications and color availability, refer to page 146.

# TOP-FREEZER "J" SERIES MODELS: 24 TO 16 CU. FT.

ALL MODELS INCLUDE • Adjustable split spill-proof glass shelves • Sealed Snack Pan • Clear vegetable/fruit crispers  
 • Fixed gallon door storage • Deluxe handles



Adjustable Spill-Proof Glass Shelves contain spills for ease of cleaning.



Enclosed Fresh Food Door Shelves provide extra storage protection, keeping small items secure on the door shelf.



Adjustable Humidity Vegetable/Fruit Crispers keep vegetables/fruits fresher longer.

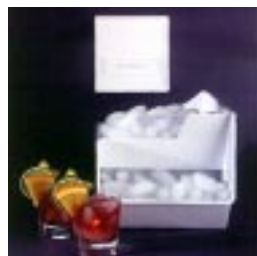

Nice Cubes™ icemaker provides rounded shaped ice for better fit into a glass.



**GE TBX24JAB**  
 • 23.6 cu. ft. capacity • Equipped for optional automatic icemaker  
 • 3 enclosed door shelves, 2 with gallon storage • Adjustable humidity vegetable/fruit crispers

**TBX21JAB** (not shown)  
 • 20.6 cu. ft. capacity • Equipped for optional automatic icemaker

**TBX21JIB** (not shown)  
 • Equipped with factory-installed Nice Cubes™ icemaker



**GE TBX18JAB**  
 • 18.2 cu. ft. capacity • Equipped for optional automatic icemaker • Tall adjustable humidity vegetable/fruit crispers  
 • 2 enclosed gallon door shelves

**TBX18JIB** (not shown)  
 • Equipped with factory-installed Nice Cubes™ icemaker



**GE TBX16JAB**  
 • 15.6 cu. ft. capacity • Fixed fresh food gallon door storage • Equipped for optional automatic icemaker • Sealed vegetable/fruit crispers • Only 28" wide

Not all features available on all models.  
 For additional features, specifications and color availability, refer to page 146.



# TOP-FREEZER "I" SERIES MODELS: 21 TO 18 CU. FT.

ALL MODELS INCLUDE • Snack pan • Clear vegetable/fruit crispers • Adjustable glass shelves • New Deluxe handles



Fixed Gallon Door Storage offers gallon and tall bottle storage.



Clear Crispers with Limited Lifetime Warranty. See page 134 for details.



Nice Cubes™ Icemaker provides rounded shaped ice for better fit into a glass.



Snack Pan conveniently stores rewrapped meats, cheeses and snacks.



## GE

### TBX21IAB

- 20.6 cu. ft. capacity • Equipped for optional automatic icemaker • 2 split, 1 full-width glass cabinet shelves • 3 door shelves, 2 with gallon storage • Tall vegetable/fruit crispers • Full-width freezer shelf



## GE

### TBX18IIB

- 18.2 cu. ft. capacity • Equipped with factory-installed Nice Cubes™ icemaker • 2 split, 1 full-width glass cabinet shelves • 2 door shelves with gallon storage • Full-width freezer shelf

### TBX18IAB (not shown)

- 18.2 cu. ft. capacity • Equipped for optional automatic icemaker

Not all features available on all models.  
For additional features, specifications and color availability, refer to page 147.

## TOP-FREEZER "D" SERIES MODELS: 16 TO 14 CU. FT.

BOTH MODELS INCLUDE • Snack pan • Clear vegetable/fruit crispers • 2 fixed gallon door storage shelves  
• Adjustable wire Everwhite shelves • Deluxe handles



Fixed Gallon Door Storage offers gallon and tall bottle storage.



Wire Everwhite Shelves minimize shuffling and restacking of food.



Clear Crispers with Limited Lifetime Warranty.



Nice Cubes™ Icemaker provides rounded shaped ice for better fit into a glass.



- GE**  
**TBX16DAB**
- 15.6 cu. ft. capacity
  - Equipped for optional automatic icemaker
  - Only 28" wide
- TBX14DAB** (not shown)
- 14.4 cu. ft. capacity

## TOP-FREEZER "T" SERIES MODEL: 18 CU. FT.



The largest capacity refrigerator that is only 28" wide.



Gallon and Tall Bottle Storage provides flexible storage for oversized containers.



- GE**  
**TBX18TAB**
- 17.6 cu. ft. capacity
  - Snack pan • Equipped for optional automatic icemaker • Clear vegetable/fruit crispers
  - Deluxe handles



# TOP-FREEZER "S" SERIES MODELS: 18 TO 10 CU. FT.

ALL MODELS INCLUDE • Wire Everwhite shelves • Classic white vegetable/fruit crispers • Tall bottle storage • Deluxe handles



Wire Everwhite Shelves minimize shuffling and restacking of food.



Classic White Crispers provide easy storage for vegetables and fruits.



Tall Bottle Storage provides flexible storage for oversized containers.



**GE TBX18SAB**  
 • 18.2 cu. ft. capacity • Snack pan • Equipped for optional automatic icemaker • Fixed gallon door storage • 2 split, 1 full-width fresh food shelves

**TBX18SIB** (not shown)  
 • Equipped with factory-installed Nice Cubes™ icemaker



**GE TBX16SIB**  
 • 16.4 cu. ft. capacity • Equipped with factory-installed Nice Cubes™ icemaker

**TBX16SAB** (not shown)  
 • Equipped for optional automatic icemaker

**TBX16SYB** (not shown)  
 • Equipped for optional automatic icemaker  
 • Recessed handles



**GE TBX14SYB**  
 • 14.4 cu. ft. capacity • Equipped for optional automatic icemaker • Recessed handles

**TBX14SIB** (not shown)  
 • Equipped with factory-installed Nice Cubes™ icemaker • Color-matched handles

**TBX14SAB** (not shown)  
 • Equipped for optional automatic icemaker  
 • Color-matched handles



**GE TBX12SAX**  
 • 12.1 cu. ft. capacity • 2 Ice 'N Easy trays  
 • 2 full-width wire Everwhite cabinet shelves  
 • Equipped for optional automatic icemaker

**TBX10SNB** (not shown)  
 • 9.8 cu. ft. capacity • Rounded doors

Not all features available on all models. For additional features, specifications and color availability, refer to page 147.

# TOP-FREEZER CYCLE DEFROST REFRIGERATORS

BOTH MODELS INCLUDE • Adjustable Wire Everwhite cabinet shelves • Full-width freezer shelf • Tall bottle storage



Wire Everwhite Shelves minimize shuffling and restacking of food.



Full-Width Freezer Shelves for maximum storage flexibility.



**GE**

**TDX11SNY**

- 11.0 cu. ft. capacity • Full-width vegetable/fruit crisper
- 2 modular door bins, 2 stationary shelves
- 3 adjustable cabinet shelves

**TDX9SNY** (not shown)

- 9.0 cu. ft. capacity • 2 mini Ice 'N Easy trays • 4 modular door bins, 1 stationary shelf
- 2 adjustable cabinet shelves

# TOP-FREEZER MANUAL DEFROST REFRIGERATOR



Wire Everwhite Shelves minimize shuffling and restacking of food.



Full-Width Crisper provides easy access to fruits and vegetables.



**GE**

**TAX10SNX**

- 9.6 cu. ft. capacity
- 2 adjustable wire Everwhite shelves • Full-width vegetable/fruit crisper • Tall bottle storage



Not all features available on all models.

For additional features, specifications and color availability, refer to page 148.

# COMPACT 6.0 TO 1.7 CU. FT. SPACEMAKER™ REFRIGERATORS



**GE  
TAX6SNXWH/WN**  
 • 6.0 cu. ft. capacity • 2 adjustable cabinet shelves • Reversible door  
 • Optional black panel or custom wood panel available with TK6 trim kit • Available in White (WH) or Woodgrain (WN)



**GE  
TAX4SNYWH**  
 • 3.7 cu. ft. capacity • 2 cabinet shelves  
 • 1 full-width vegetable/fruit pan  
 • Rounded door • Reversible door  
 • Available in White only



**GE  
TAX4ANXWN**  
 • 3.7 cu. ft. capacity • 3 cabinet shelves  
 • 2 door shelves • Available in Woodgrain only



**GE  
TAX2SNBWH**  
 • 1.7 cu. ft. capacity • 1 cabinet shelf • 1-1/2 door shelves with retaining rod • Available in White only  
**TAX2SNYWN** (not shown)  
 • Available in Woodgrain only

Not all features available on all models.  
 For additional features, specifications and color availability, refer to page 148.



# UPRIGHT FREEZERS

## ALL MODELS INCLUDE

- Cabinet shelves
- Adjustable temperature control
- Limited food loss warranty



Refrigerated Cabinet Shelves keep items extra cool.



Temperature Monitor with Audible Alarm ensures temperature control.



Slide-Out Bulk Storage Basket for maximum freezer capacity.



Safety Lock provides security.



### GE Deluxe Upright Models

- FUM17DA** Manual Defrost
- 17.1 cu. ft. capacity
  - Audible temperature alarm
  - Lock
  - Power "ON" light
  - Slide-out bulk storage basket
  - 4 cabinet shelves, 1 adjustable
  - 5 door shelves

- FUM21DA** Manual Defrost (not shown)
- 20.6 cu. ft. capacity
  - 6 door shelves

- FUM14DA** Manual Defrost (not shown)
- 14.1 cu. ft. capacity
  - 3 cabinet shelves, 1 adjustable



### GE Standard Upright Models

- FUM12SA** Manual Defrost
- 11.6 cu. ft. capacity
  - 3 cabinet shelves
  - 4 door shelves

- FUM14SA** Manual Defrost (not shown)
- 14.1 cu. ft. capacity
  - 3 cabinet shelves
  - 5 door shelves

- FUM17SA** Manual Defrost (not shown)
- 17.1 cu. ft. capacity
  - 3 cabinet shelves
  - 5 door shelves

- FUM21SA** Manual Defrost (not shown)
- 20.6 cu. ft. capacity
  - 4 cabinet shelves
  - 6 door shelves



### GE Standard Upright Models

- FUM9SA** Manual Defrost
- 8.7 cu. ft. capacity
  - 4 cabinet shelves
  - 5 door shelves

- FUM5SA** Manual Defrost (not shown)
- 5.0 cu. ft. capacity
  - Rounded doors
  - 2 cabinet shelves
  - 3 door shelves



### GE Deluxe Upright Models

- FUF20DA** Frost-Free
- 20.3 cu. ft. capacity
  - Audible temperature alarm
  - Lock
  - Power "ON" light
  - Slide-out bulk storage basket
  - 5 cabinet shelves, 3 adjustable
  - 6 door shelves

- FUF17DA** Frost-Free (not shown)
- 16.7 cu. ft. capacity
  - 4 cabinet shelves, 3 adjustable
  - 5 door shelves

- FUF14DA** Frost-Free (not shown)
- 13.7 cu. ft. capacity
  - 3 cabinet shelves, 2 adjustable

Not all features available on all models. For additional features, specifications and color availability, refer to page 149.



# CHEST FREEZERS

## ALL MODELS INCLUDE

- Adjustable temperature control
- Upfront defrost drain (not on FCM5SA)



Lift-Out and Sliding Wire Baskets for easy loading and unloading.



Interior Light brightens for easy access.



- GE FCM20DA**
- 19.7 cu. ft. capacity
  - 2 lift-out and sliding bulk storage baskets
  - Temperature Monitor with audible alarm
  - Interior light
  - Built-in lock
  - Power "ON" light

- FCM25DA** (not shown)
- 24.9 cu. ft. capacity
  - 3 lift-out and sliding bulk storage baskets

- FCM15DA** (not shown)
- 14.8 cu. ft. capacity
  - 2 lift-out and sliding bulk storage baskets



- GE FCM15SA**
- 14.8 cu. ft. capacity
  - 1 lift-out and sliding bulk storage basket



- GE FCM9SA**
- 8.8 cu. ft. capacity
  - Adjustable temperature control

- FCM9DA** (not shown)
- 8.8 cu. ft. capacity
  - 1 lift-out and sliding bulk storage basket
  - Temperature Monitor with audible alarm
  - Interior light
  - Built-in lock

- FCM7DA** (not shown)
- 7.2 cu. ft. capacity



- GE FCM5SA**
- 5.0 cu. ft. capacity
  - Adjustable temperature control

Not all features available on all models. For additional features, specifications and color availability, refer to page 149.

IMPROVE THE MOST IMPORTANT ELEMENT IN YOUR HOME



—WATER!



## INTRODUCING GE'S SMARTWATER™ IMPROVEMENT SYSTEMS

If you're among the 75% of Americans concerned about the quality of their water,\* here's some refreshing news. GE now offers a selection of water filtration and water softening systems. The advantage of a GE SmartWater™ Filtration System is healthy drinking water. It's ideal for drinking and cooking, and you will eliminate expensive bottled water costs. GE also recommends you install a GE SmartWater Softening System at the point the water enters your home. The softener alone offers tremendous benefits: sinks, tubs and showers are easier to clean; laundered clothes are cleaner, softer and brighter; dishes will have fewer spots; and after a shower or bath, soft water will feel noticeably smoother to your skin. To top it off, GE SmartWater Softening Systems increase the efficiency of your water heater, saving you money!

\*Source: Water Quality Association



# GE SMARTWATER™ FILTRATION BENEFITS—HEALTHY WATER

75% of all Americans are concerned about the quality of their water.<sup>††</sup> Homeowners are looking for water solutions from a name they can trust—GE.

## GE SMARTWATER™ FILTRATION SYSTEMS

### Dual Carbon Filtration<sup>†††</sup>

Reduces unpleasant tastes and odors, such as chlorine from your drinking water.

#### THIS SYSTEM REDUCES:

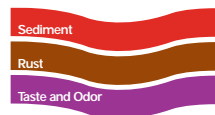

### Reverse Osmosis Filtration

This is GE's best filtration process. It combines dual carbon filtration with reverse osmosis technology.

#### THIS SYSTEM REDUCES:

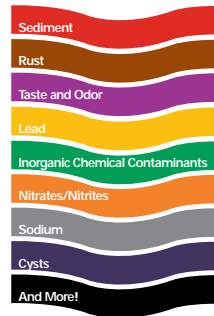

## GE SMARTWATER™ FILTRATION SYSTEMS VS. BOTTLED WATER—A COST COMPARISON

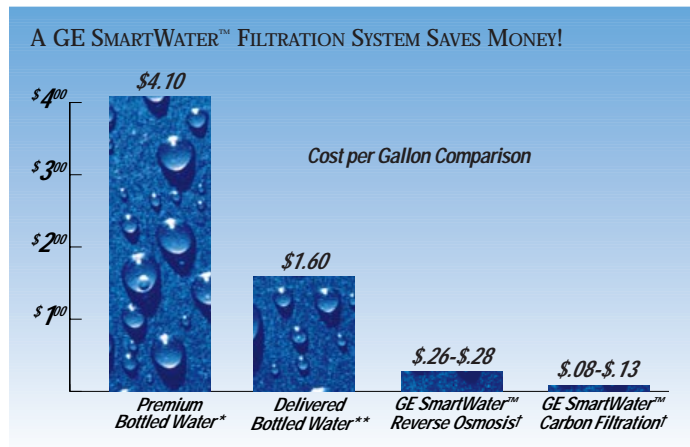

### Saves you money!

Eliminates the expense and inconvenience of purchasing bottled water at a store or scheduling home delivery of bottled water.

## GE SMARTWATER™ FILTRATION SYSTEMS—QUALITY WATER FOR DRINKING AND COOKING



**Healthy water—**  
Provides added assurance of healthy drinking water.



**Better tasting water—**  
Healthy water for drinking and making beverages such as coffee, tea, juice and baby formula.



**Great for cooking—**  
Cooking with filtered water provides great tasting foods.



**NSF certified—**  
GE is certified by NSF, the most highly recognized independent testing institution for water treatment products.

\*National average price of "Premium" bottled water.

\*\*Average cost per gallon for delivered bottled water.

†GE SmartWater™ estimate is calculated by dividing the number of gallons by consumer cost of product, installation and replacement filters.

††Source: Water Quality Association

†††Dual carbon filtration will reduce lead and cysts on certain models.

# MONITORED REVERSE OSMOSIS FILTRATION: GE PROFILE PERFORMANCE™ SYSTEM

## THESE MODELS INCLUDE

**All-In-One System** Space-saving design installs in less space than conventional models.

**Reverse Osmosis (RO) Process**  
GE's best filtration process, which combines dual carbon filtration with reverse osmosis technology, reducing up to 99%\* of the following undesirable elements: Taste and odor, Sediment, Lead, Inorganic chemical contaminants, Nitrates/Nitrites, Sodium and Cysts (such as cryptosporidium/giardia). See page 37 for a complete list of undesirable elements reduced.

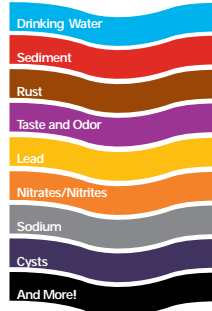

**Super Capacity** provides up to 18 gallons\*\* of high-quality filtered water per day.

### SmartWater™ Faucet with Electronic Monitor

Conveniently indicates the performance of the unit and when to replace filters and membrane. Separate faucet is used only when filtered water is needed, extending filter life.

Note: Batteries are included.

**Amber "Filter" Light:**  
The pre-filter and post-filter cartridges need replacement. This occurs after 6 months, or 900 gallons of product water use, whichever occurs first.



**Green "OK" Light:**

The RO system is providing high-quality drinking water.

**Amber "RO" Light:** The RO membrane needs replacement.

**Designer-Style Faucet** Allows you to customize the faucet color to complement the kitchen (see right for model/color selections).

**Installation Flexibility** Can be installed vertically or horizontally undercounter, in basement or other convenient location.

**Optional Accessories** See page 152 for optional accessories available.

**NSF Approved** NSF is the most highly recognized independent testing institution in the water treatment industry. NSF inspects, tests and certifies our product performance. See page 152 for details.



**GE Profile Performance Series™ PNRV18ZWW**  
Reverse Osmosis Filtration System with White on white Faucet and Monitor



**GE Profile Performance Series™ PNRV18ZBB**  
Reverse Osmosis Filtration System with Black on black Faucet and Monitor



**GE Profile Performance Series™ PNRV18ZWH**  
Reverse Osmosis Filtration System with Chrome on white Faucet and Monitor



**GE Profile Performance Series™ PNRV18ZBL**  
Reverse Osmosis Filtration System with Chrome on black Faucet and Monitor

\*Elements removed are not necessarily present in your water. See product specification sheet, packed with product, for specific elements reduced by model, or call the GE Answer Center® toll-free, 800.626.2000.

\*\*As tested and validated by the Water Quality Association using Standard S-300.

Note: Depends on water pressure, temperature and total dissolved solids.

Not all features available on all models.

For additional features, specifications and color availability, refer to page 152.

# MONITORED REVERSE OSMOSIS FILTRATION: GE PROFILE™ SYSTEM

## THIS MODEL INCLUDES

### Reverse Osmosis (RO) Process

GE's best filtration process, which combines dual carbon filtration with reverse osmosis technology, reducing up to 99%\* of the following undesirable elements: Taste and odor, Sediment, Lead, Inorganic chemical contaminants, Nitrates/Nitrites, Sodium and Cysts (such as cryptosporidium/ giardia). See page 37 for a complete list of undesirable elements reduced.

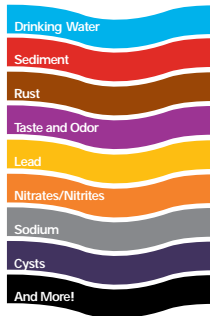

**Extra-Large Capacity** provides up to 12 gallons\*\* of high-quality filtered water per day.

### SmartWater™ Faucet with Electronic Monitor

Conveniently indicates the performance of the unit and when to replace filters and membrane. Separate faucet is used only when filtered water is needed, extending filter life.

Note: Batteries are included.



Amber "Filter" Light: The pre-filter and post-filter cartridges need replacement. This occurs after 6 months, or 900 gallons of product water use, whichever occurs first.

Green "OK" Light: The RO system is providing high-quality drinking water.

Amber "RO" Light: The RO membrane needs replacement.

**Simple Installation** Can be installed easily undercounter, in basement or other convenient location.

### Optional Accessories

See page 152 for optional accessories available.

**NSF Approved** NSF is the most highly recognized independent testing institution in the water treatment industry. NSF inspects, tests and certifies our product performance. See page 152 for details.



\*Elements removed are not necessarily present in your water. See product specification sheet, packed with product, for specific elements reduced by model, or call the GE Answer Center™ toll-free, 800.626.2000.

\*\*As tested and validated by the Water Quality Association using Standard S-300. Note: Depends on water pressure, temperature and total dissolved solids.

Not all features available on all models.

For additional features, specifications and color availability, refer to page 152.



### GE Profile™ PNRV12ZBL

Reverse Osmosis Filtration System (includes tank) with Chrome on black Faucet and Monitor



# REVERSE OSMOSIS FILTRATION: GE SYSTEM

## THIS MODEL INCLUDES

### Reverse Osmosis (RO) Process

GE's best filtration process, which combines dual carbon filtration with reverse osmosis technology, reducing up to 99%\* of the following undesirable elements: Taste and odor, Sediment, Lead, Inorganic chemical contaminants, Nitrates/Nitrites, Sodium and Cysts (such as cryptosporidium/giardia). See below for a complete list of undesirable elements reduced.

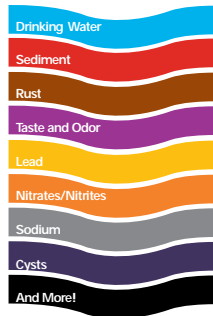

**Large Capacity** provides up to 10 gallons\*\* of high-quality filtered water per day.

### SmartWater™ Faucet

Separate short-reach faucet is used only when filtered water is needed, extending filter life.

**Simple Installation** Can be installed easily undercounter, in basement or other convenient location.

**Optional Accessories** See page 152 for optional accessories available.

**NSF Approved** NSF is the most highly recognized independent testing institution in the water treatment industry. NSF inspects, tests and certifies our product performance. See page 152 for details.



## GE GXRV10ABL

Reverse Osmosis Filtration System (includes tank) with Chrome on black Faucet

**Reverse Osmosis Technology** combines dual carbon filtration with reverse osmosis.

Dual Carbon Filtration absorbs many common organic contaminants that contribute to an unpleasant taste and odor as well as sediments and dirt.

Reverse Osmosis is a process in which water passes through a semipermeable membrane and automatically screens out and filters undesirable elements out of the system. Models PNRV18Z, PNRV12Z and GXRV10ABL reduce the following undesirable elements:\*

Ammonia	Cysts	Selenium
Barium	Fluoride	Sodium
Bicarbonate	Lead	Sulfate
Bromide	Magnesium	Tannin
Cadmium	Mercury	Zinc
Chlorine (residual)	Nickel	Chloride
Chromium	Nitrate	TDS
Copper	Sediment	Nitrite

\*Product water produced and percent rejection will vary with changes in pressure, temperature and TDS. Feed water over 10 grains of hardness may effect performance of RO membrane.

\*Elements removed are not necessarily present in your water.

See product specification sheet, packed with product, for specific elements reduced by model, or call the GE Answer Center™ toll-free, 800.626.2000.

\*\*As tested and validated by the Water Quality Association using Standard S-300. Note: Depends on water pressure, temperature and total dissolved solids.

Not all features available on all models.

For additional features, specifications and color availability, refer to page 152.

# DUAL CARBON FILTRATION SYSTEMS: GE SYSTEMS

## CarbonBlock System

Superior Carbon Block Technology—Cleaner Performance

INTRODUCING THE NEW CARBONBLOCK SYSTEM.  
ENGINEERED TO PROVIDE SUPERIOR TECHNOLOGY AND CLEANER PERFORMANCE.

THESE MODELS  
INCLUDE

### SmartWater™ Faucet with Electronic Monitor

Indicator light on the faucet  
base shows when filters  
need replacement.



Amber "Filter" Light:  
Indicates when to replace  
filters for the highest  
quality water.

**SmartWater™ Faucet** Separate faucet is used only when  
filtered water is needed, extending filter life.

**Simple Installation** Can be easily installed undercounter,  
in basement or another convenient location.

Note: Batteries are included.  
Filter Cartridges should be changed  
every six months, when monitor  
indicates replacement, or if faucet  
water pressure drops.

**Filter Options** Model  
specific filters are included with  
filtration system selected  
(see options shown); or model  
is available without filters  
(Model GXEM01B).

**NSF Approved**  
NSF is the most highly  
recognized independent testing  
institution in the water  
treatment industry. NSF  
inspects, tests and certifies our  
product performance.  
See page 153 for details.



**GE**  
**GNUL30B** (filters included)  
**Lead/Cysts Reduction Model**  
• System rated for 1250 gallons of water  
• Long-reach faucet with electronic monitor

**GE**  
**GNUT05B** (filters included)  
**Taste and Odor Reduction Model**  
• System rated for 6000 gallons of water  
• Long-reach faucet with electronic monitor

### CarbonBlock System

### CarbonBlock System

**Filter I**  
• Reduces dirt, rust and sediments  
**Filter II**  
• **Absolute 1 micron** • Reduces unpleasant tastes and odors • Removes 95.7% lead • Removes 99.98% filterable cysts (such as cryptosporidium and giardia) • Removes 99.5% chlorine

**Filter I**  
• Reduces dirt, rust and sediments  
**Filter II**  
• Reduces unpleasant tastes and odors  
• Removes 99.5% chlorine



- GE**  
**GNUT03B/GXUT03B** (filters included)  
**Taste and Odor Reduction Model**
- System rated for 6000 gallons of water
  - Short-reach faucet without electronic monitor

#### **CarbonBlock System**

##### **Filter I**

- Reduces dirt, rust and sediments

##### **Filter II**

- Reduces unpleasant tastes and odors
- Removes 99.5% chlorine



- GE**  
**GXEM01B** (filters sold separately)
- Model is customized based on water quality needs
  - Filters must be purchased separately
  - Long-reach faucet with electronic monitor

## REFRIGERATOR/ICEMAKER WATER FILTER

Provides healthy, great tasting water and ice through your refrigerator dispenser.

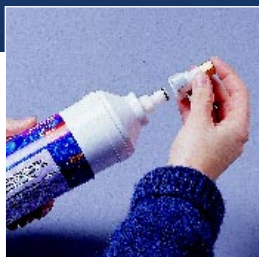

##### **GE**

##### **GXITQ**

##### **Taste and Odor Reduction Model**

- System rated for 2000 gallons of water • Quick connect fittings allow for easy installation • Filter reduces dirt, rust, sediments and chlorine
- Auto shut-off valve

##### **GXIT** (not shown)

##### **Taste and Odor Reduction Model**

- System rated for 750 gallons of water • Filter reduces dirt, rust, sediments and chlorine

##### **GXILQ** (not shown)

##### **Lead/Cysts Reduction Model**

- System rated for 1000 gallons of water • CarbonBlock Filter for cleaner performance • Quick connect fittings allow for easy installation • Filter reduces dirt, rust, sediments, chlorine, lead and cysts • Auto shut-off valve

#### **CarbonBlock System**



# GE SMARTWATER™ SOFTENING BENEFITS

85% of the U.S. has hard water.† Homeowners are looking for water solutions from a name they can trust—GE.

## GE SMARTWATER™ SOFTENING SYSTEMS—QUALITY WATER THROUGHOUT THE HOME.



### Easier to Clean

Reduces hard water build-up (less soap residue) in tub, shower and sink.

**Turn a Smart Purchase Into a Smart Investment!**

**Reduces Energy Costs**  
When used with a new water heater.\*

**Improves Water Heater Efficiency**  
Helps reduce scale build-up in water heater; increases efficiency by as much as 29% (gas) or 22% (electric).\*\*

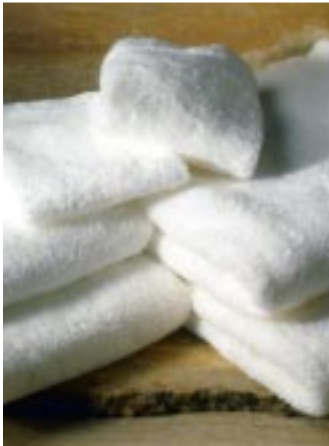

### Whiter Towels

Clothes are softer, cleaner, brighter and last longer. Towels are 45% whiter while using 1/3 less detergent. Eliminates hard water-related washer service issues.



### Reduces Spotting

Provides cleaner dishes, glassware and china by reduced spotting. Reduces detergent use and eliminates hard water-related dishwasher service issues.



### Soft Water

Will feel noticeably smoother to your skin.



### Reduces Energy Costs

Helps reduce build-up in pipes and water-using appliances, providing cost savings. Water heater efficiency on systems using softened water may be increased up to 22% if heating with electricity, up to 29% if heating with gas.\*\*

†Source: Water Quality Association

\*Assuming a typical energy bill over the life of a new electric water heater.

\*\*Based on a study done by New Mexico State University.

# WATER SOFTENING SYSTEM: GE PROFILE PERFORMANCE™ SYSTEM

## THIS MODEL INCLUDES

### **Super Capacity Means Less Maintenance**

A 38,500 grain capacity helps assure an ample supply of soft water and provides for lifestyle changes.

**300 lb. Salt Storage** Reduces the need for frequent salt replacement.

**High-Efficiency** Super capacity combined with the salt-efficiency of the unit provides cost savings and convenience. Reduces the need for frequent salt replacement.

**Demand-Initiated Regeneration** Softening system monitors water usage to determine proper amount of salt needed using demand-initiated regeneration (system will use only as much salt as needed).

**Easy Reading Backlit LCD Display** Eliminates the need for a flashlight to see display in difficult or dark locations.

**Program and Time Memory** Permanent memory maintains hardness and regeneration time settings even if power is off or unit is unplugged for extended periods. Maintains time for up to 72 hours in case of power failure. No batteries needed, unit recharges itself when power is restored.

**24-Volt Electronic System** Simplifies installation and maintenance.

**Installation Kit Included** For installing convenience, a complete installation kit with bypass valve, drain tubing and use & care video is included with product.



**GE Profile Performance Series™  
PNSF39Z**



**Easy-to-Set Electronic Controls** No calculations or complicated programming. Simply turn it on, set time of day and set the hardness level of your water supply.

**Regenerates Only When Needed** Memory maintains water usage pattern reducing salt usage and assuring an ample supply of soft water.

**Systems Monitor** Advanced electronic water management features:

- **Capacity Remaining**—The data button will indicate how much capacity is remaining and whether or not to command an extra regeneration.
- **Gallons Used**—Indicates how many gallons of water have been used per day.
- **Average Gallons Used**—Indicates the average gallons used over the past seven days.
- **Flow Rate**—Shows how much water is flowing through the softener.

# WATER SOFTENING SYSTEM: GE PROFILE™ SYSTEM

## THIS MODEL INCLUDES

### **Extra-Large Capacity Means Less Maintenance**

A 30,800 grain capacity helps assure an ample supply of soft water and provides for lifestyle changes.

**300 lb. Salt Storage** Reduces the need for frequent salt replacement.

**High-Efficiency** Extra-large capacity combined with the salt-efficiency of the unit provides cost savings and convenience. Reduces the need for frequent salt replacement.

**Demand-Initiated Regeneration** Softening system monitors water usage to determine proper amount of salt needed using demand-initiated regeneration (system will use only as much salt as needed).

**Program and Time Memory** Permanent memory maintains hardness and regeneration time settings even if power is off or unit is unplugged for extended periods. Maintains time for up to 6 hours in case of power failure. No batteries needed, unit recharges itself when power is restored.

**24-Volt Electronic System** Simplifies installation and maintenance.

**Installation Kit Included** For installing convenience, a complete installation kit with bypass valve, drain tubing and use & care video is included with product.



**GE Profile™  
PNSF31Z**



**Easy-to-Set Electronic Controls** No calculations or complicated programming. Simply turn it on, set time of day and set the hardness level of your water supply.

**Regenerates Only When Needed** Memory maintains water usage pattern reducing salt usage and assuring an ample supply of soft water.



# WATER SOFTENING SYSTEMS: GE SYSTEMS

## THIS MODEL INCLUDES

### **Large Capacity Means Less Maintenance**

A 23,100 grain capacity helps assure an ample supply of soft water and provides for lifestyle changes.

**200 lb. Salt Storage** Reduces the need for frequent salt replacement.

**High-Efficiency** Large capacity combined with the salt-efficiency of the unit provides cost savings and convenience. Reduces the need for frequent salt replacement.

**Demand-Initiated Regeneration** Softening system monitors water usage to determine proper amount of salt needed using demand-initiated regeneration (system will use only as much salt as needed).

**Program and Time Memory** Permanent memory maintains hardness and regeneration time settings even if power is off or unit is unplugged for extended periods. Maintains time for up to 6 hours in case of power failure. No batteries needed, unit recharges itself when power is restored.

**24-Volt Electronic System** Simplifies installation and maintenance.



**Installation Kit Included** For installing convenience, a complete installation kit with bypass valve, drain tubing and use & care video is included with product.

**Easy-to-Set Electronic Controls** No calculations or complicated programming. Simply turn it on, set time of day and set the hardness level of your water supply.

**Regenerates Only When Needed** Memory maintains water usage pattern reducing salt usage and assuring an ample supply of soft water.



**GE  
GNSF23Z**

## THIS MODEL INCLUDES

**18,000 Grain Capacity** Assures an ample supply of soft water.

**140 lb. Salt Storage** Combined with the compact size means easier salt loading.

**High Efficiency** The salt-efficiency of the unit provides cost savings and convenience. Reduces the need for frequent salt replacement.

**Compact Size Means Installation Flexibility** The compact housing provides installation flexibility; installs in many areas other softeners may not.

**Demand-Initiated Regeneration** Softening system monitors water usage to determine proper amount of salt needed using demand-initiated regeneration (system will use only as much salt as needed).

**Program and Time Memory** Permanent memory maintains hardness and regeneration time settings even if power is off or unit is unplugged for extended periods. Maintains time for up to 6 hours in case of power failure. No batteries needed, unit recharges itself when power is restored.



**24-Volt Electronic System** Simplifies installation and maintenance.

**Installation Kit Included** For installing convenience, a complete installation kit with bypass valve, drain tubing and use & care video is included with product.

**Easy-to-Set Electronic Controls** No calculations or complicated programming. Simply turn it on, set time of day and set the hardness level of your water supply.

**Regenerates Only When Needed** Memory maintains water usage pattern reducing salt usage and assuring an ample supply of soft water.



**GE  
GNSF18Z**

Not all features available on all models. For additional features, specifications and color availability, refer to page 154.

GE'S ULTRA FABRIC CARE SYSTEM GIVES YOUR WASH  
THE PERFORMANCE YOU DESERVE.



WPSF4170W/DPSF495EW





You expect a great deal from the GE brand. Dependability. Flexibility. Efficiency. But the number one reason that households across the country choose GE, is performance. So it should come as no surprise that these laundry pairs offer those performance features that you demand. Like SensorWash,<sup>™</sup> that regulates water temperatures exactly the way you want them for just right clothing care. Like matched color-codings on cycle and timer selections that make it easy for anyone to do the laundry. And the SpotSoak<sup>™</sup> feature makes pre-treating stains a simple matter. It's like having a faucet right at your washer. GE's Front-Loading models can be placed side-by-side, stacked, built-in, or under the counter for added space savings. And they typically use 22 to 25 gallons of water vs. 35 to 40 gallons in a standard washer. Finally, the tumble action of front-loaders provides less wear and tear on clothes. But washers are only half the story. SensorDry shuts off the dryer the minute clothes are dry, preventing fading from over drying. And the sturdy Dryer Rack is designed to dry items such as washable sneakers and stuffed animals without all the clanging! Both GE Washers and Dryers have wide openings and super capacities that welcome family-size laundry loads. And on top of all this, they're ultra quiet and impeccably styled. So if you're inclined to choose performance, along with flexibility and style—your search is over. You've just chosen GE.



# GE PROFILE PERFORMANCE SERIES™ LAUNDRY

**BOTH MODELS INCLUDE • GentlePower™ Agitator • PermaTuf II™ Basket • Self-cleaning filter • Bleach dispenser • Fabric Softener dispenser • Steel drive transmission • Auto Balance Suspension System • 100% front serviceable**



SensorWash™ senses and adjusts incoming water temperature for wash cycles to maximize detergent's potential.



UltraCare handles ultra fine fabrics with exquisite care.



SpotSoak™ provides a 7-second spray of water to assist in stain pre-treatment. It's like having a sink right at your washer.



## GE Profile Performance Series™ WPSF5170W (Shown with DPSF505EW/DPSF505GW)

- Super capacity • SensorWash™
- 5 automatic fabric care selections
- Variable water levels • 17 wash cycles
- SpotSoak™ • Ultra Care • Quick Wash cycle • Stain Removal Guide
- QuickClean controls



## GE Profile Performance Series™ WPSF4170W

- Super capacity • SensorWash™ • 5 automatic fabric care selections • Variable water levels • 17 wash cycles
- SpotSoak™ • GentleWash™ • Stain Removal Guide
- QuickClean controls



Not all features available on all models. For additional features, specifications and color availability, refer to page 155.

**BOTH DRYERS INCLUDE • DuraDrum™ interior • ColorLogic™ • Removable up-front lint filter**  
**• Reverse-A-Door • Dryer interior light • 100% front serviceable**



Sensor Dry System dries clothes quickly and efficiently. No more over-drying or under-drying of clothes.



**GE Profile Performance Series™**  
**DPSF505EW/DPSF505GW**  
 • Super 7.0 cu. ft. capacity • 10 drying cycles • 5 heat selections • Sensor Dry • QuietDrum™ • QuickClean controls • Quick Dry • Deluxe dryer rack • Drying center • Hush Insulation Package



QuietDrum™ is wrapped with additional sound-deadening material that muffles buckles and button noises.

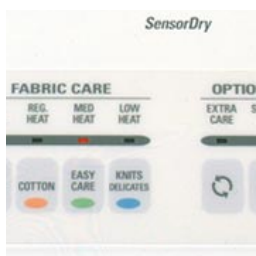

ColorLogic™ color-coded cycle buttons coordinate with timer selections to simplify usability for consumers of all ages.



**GE Profile Performance Series™**  
**DPSF495EW/DPSF495GW**  
 • Super 7.0 cu. ft. capacity • 9 drying cycles • 4 heat selections • Sensor Dry • QuietDrum™ • QuickClean controls • Deluxe dryer rack • Drying center • Hush Insulation Package



The **Exclusive** adjustable Drying Center provides a convenient place to dry garments or hang clothes straight from the dryer, minimizing wrinkling.



Not all features available on all models. For additional features, specifications and color availability, refer to pages 156, 157 and 159.

# GE PROFILE™ LAUNDRY

ALL WASHERS INCLUDE • GentlePower™ Agitator • PermaTuf II™ Basket • ColorLogic™ • Self-cleaning filter • Bleach dispenser • Fabric Softener dispenser • Steel drive transmission • Auto Balance Suspension System • 100% front serviceable



Super Capacity with a 3.2 cu. ft. basket is one of the largest capacity washers in the world!



The GentlePower™ Agitator adapts to the clothes load providing gentle and effective washing action.



**GE Profile™  
WPSR4130WWW  
(Shown with DPSR475EWWW)**

- Super capacity • SensorWash™
- 4 wash/spin speed combinations
- 4 wash/rinse temperatures
- Variable water levels • 13 wash cycles
- Spot Soak™ • HandWash®
- Deluxe Insulation Package



100% Front Serviceable for easy access to operational parts without moving the unit.



**GE Profile™  
WPSR3120W**

- Super capacity • SensorWash™ • 3 wash/spin speed combinations • 4 wash/rinse temperatures
- 4 water levels • 12 wash cycles • HandWash® • Deluxe Insulation Package

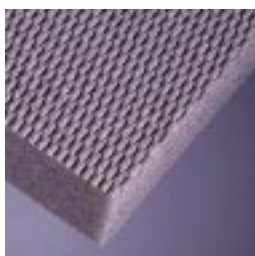

GE Profile™ Insulation dramatically reduces noise and vibration.



**GE Profile™  
WPSR3100W**

- Super capacity • 3 wash/spin speed combinations • 3 wash/rinse temperatures • 4 water levels
- 10 wash cycles

Not all features available on all models. For additional features, specifications and color availability, refer to page 155.



ALL DRYERS INCLUDE • DuraDrum™ interior • ColorLogic™ • Removable up-front lint filter • Reverse-A-Door  
 • Dryer interior light • 100% front serviceable



An extra-wide opening provides easy access to our 7.0 cu. ft. of total dryer capacity.



**GE Profile™**  
**DPSR475EW/DPSR475GW**

• Super 7.0 cu. ft. capacity • 7 drying cycles • 4 heat selections • Sensor Dry • Deluxe Insulation Package



Sensor Dry dries clothes more evenly and efficiently.



**GE Profile™**  
**DPXR475EW/DPXR475GW**

• Extra-large 6.0 cu. ft. capacity • Sensor Dry • 7 drying cycles • 4 heat selections  
 • Deluxe Insulation Package

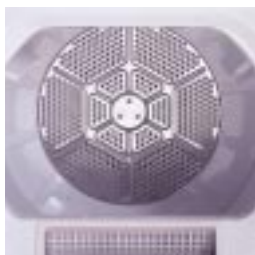

DuraDrum™ interiors provide long-lasting dependability and durability.



**GE Profile™**  
**DPSR473EW/DPSR473GW**

• Super 7.0 cu. ft. capacity • Automatic Dry Control • 7 drying cycles • 4 heat selections  
 • Deluxe Insulation Package



GE Profile™ Insulation dramatically reduces noise and vibration.



**GE Profile™**  
**DPXR473EW/DPXR473GW**

• Extra-large 6.0 cu. ft. capacity • Automatic Dry Control • 7 drying cycles • 4 heat selections

Not all features available on all models.  
 For additional features, specifications and color availability, refer to pages 156, 157 and 159.

# GE LAUNDRY

ALL WASHERS INCLUDE • Auto Balance Suspension System • PermaTuf II™ Basket • Self-cleaning filter  
 • Quiet-By-Design™ • 100% front serviceable



Super Capacity with a 3.2 cu. ft. basket is one of the largest capacity washers in the world!



**GE**  
**WJSR2080V**

- Super capacity • 2 wash/spin speed combinations • 8 wash cycles • 3 water levels
- 3 wash/rinse temperatures



100% Front Serviceable for easy access to operational parts without moving the unit.



**GE**  
**WBSR1060T**

- Super capacity • 1 wash/spin speed combination • 6 wash cycles • 3 water levels
- 3 wash/rinse temperatures

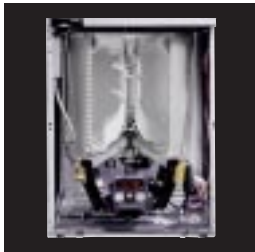

The Auto Balance Suspension System is designed to virtually eliminate off-balanced loads.



**GE**  
**WBXR2060V**

- Extra-large capacity • 2 wash/spin speed combinations • 6 wash cycles • 3 water levels
- 3 wash/rinse temperatures



PermaTuf II™ Basket resists peeling, rusting or flaking for long-term durability.



**GE**  
**WBXR1060T**

- Extra-large capacity • 1 wash/spin speed combination • 6 wash cycles • 3 water levels
- 3 wash/rinse temperatures



**GE**  
**WWLR3100V**

- 24" wide • Large capacity • 3 wash/spin speed combinations • 10 wash cycles • 4 water levels
- 4 wash/rinse temperatures

Not all features available on all models. For additional features, specifications and color availability, refer to page 155.

ALL DRYERS INCLUDE • Removable up-front lint filter • Reverse-A-Door • Quiet-By-Design™ • 100% front serviceable



An extra-wide opening provides easy access to our 7.0 cu. ft. of total dryer capacity.



**GE**  
**DWSR473EV/DWSR473GV**  
 • Super capacity • Automatic Dry Control • 7 cycles • 4 heat selections  
 • Variable End-Of-Cycle Signal



Reverse-A-Door dryers have doors that can reverse from right-hand to left-hand swing.



**GE**  
**DJXR473EV/DJXR473GV**  
 • Extra-large capacity • 7 cycles • 4 heat selections • Interior light • End-Of-Cycle Signal

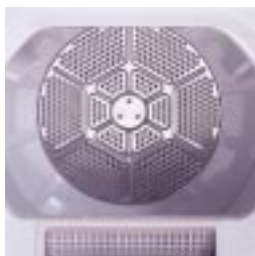

DuraDrum™ interiors provide long-lasting dependability and durability.



**GE**  
**DBXR453EV/DBXR453GV**  
 • Extra-large capacity • Automatic Dry Control • 5 cycles • 4 heat selections



Up-Front Lint Filter is close at hand for cleaning, optimizing dryer performance.



**GE**  
**DVLR223EV/DVLR223GV**  
 • Large capacity • Automatic Dry Control • 2 cycles • 2 heat selections

Not all features available on all models. For additional features, specifications and color availability, refer to pages 156, 157 and 159.



# FRONT LOADING LAUNDRY MODELS

The GE Front Loading Laundry Pair offers more than just clean clothes. They offer **Efficiency**—typically 22 to 25 gallons of water vs. 35 to 40 gallons in a standard washer. That's a 40% water savings! And the water they do use is efficiently removed, with a longer spin time for better water extraction. They provide **Flexibility**—both in installation and use. They can be placed side-by-side to create an excellent work space for folding clothes and other laundry items. They were designed to be installed under your counter, or even stacked for added space savings. And they're easy to install!

## WASHER FEATURES



Automatic Water Fill eliminates guesswork and water waste. Automatically adjusts water level to size and type of load. Water fill level remains below the door.



Automatic Dispenser automatically dispenses detergent, bleach and fabric softener at just the right time in the wash cycle.



Stacking kit included with dryer.

## DRYER FEATURE



The sturdy Dryer Rack is designed to dry items such as washable sneakers and stuffed animals, and is easy to insert and remove.



Undercounter installation requires mounting kits for washer and dryer.

Not all features available on all models. For additional features, specifications and color availability, refer to page 158.



**GE**

**WSXH208V** 120V Washer

- Front loading • High efficiency washer • 8 cycles: Regular (Heavy Soil, Medium Soil), Permanent Press (Medium Soil, Light Soil), Knits/Delicates, Pre-Wash, Extra-Rinse Cycle/Auto Option, 3 standard rinse cycles • 4 wash/rinse temperatures • Automatic water level adjustment • Fabric Softener dispenser
- Bleach dispenser • Available in White on white



**GE**

**DSXH43EV/GV** 240V Dryer

- Tumble drying • 4 Time Dry cycles (Regular, Permanent Press, Knits/Delicates, Air Fluff)
- 3 Auto Dry cycles (Regular, Permanent Press, Knits/Delicates) • 3 temperature options • Air Fluff (No Heat) • End-of-cycle signal • Reverse-A-Door • Drum light • Available in White on white



Not all features available on all models. For additional features, specifications and color availability, refer to page 158.

# SPACEMAKER®: PORTABLE/STATIONARY MODELS



- GE**  
**WSKP2060T** 120V Washer
- Portable model • 2 wash/spin speeds
  - 6 cycles: Regular (Heavy Soil, Medium Soil), Permanent Press (Medium Soil, Light Soil) Delicates and Spin Only
  - 3 wash/rinse temperatures • 4 water levels • Automatic cool down • Lint filter
  - Easy-roll rollers • Unicouple connector quickly attaches to a faucet adaptor
  - Available in white and almond with black control panel

- WSKS2060T**  
120V Washer (not shown)
- Stationary model



- GE**  
**DSKP233ET** 120V Dryer
- Portable/Stationary model • 3 drying cycles: Automatic Regular-Permanent Press, Timed Dry up to 105 minutes and Air Fluff • 2 Heat selections: Normal and No-Heat Air Fluff (in timer) • 15-amp dryer cord attached • Available in white and almond with black control panel

- DSKS433ET**  
240V Dryer (not shown)
- Stationary model • 3 drying cycles: Auto Regular-Permanent Press, Auto Delicates and Timed Dry up to 140 minutes • 4 Heat selections: Regular (High Heat), Permanent Press (Medium Heat), Delicates (Low Heat) and Air Fluff (No-Heat) • Available in white and almond with black control panel

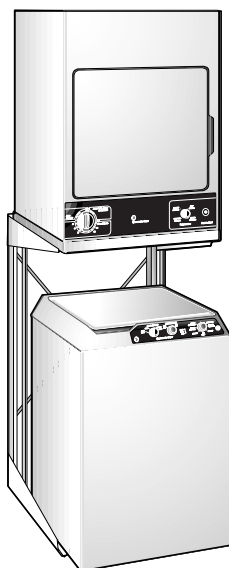

- DSR24RT Stack Rack**  
(Available at additional Cost)
- For use with Portable or Stationary Washers and Stationary Dryer

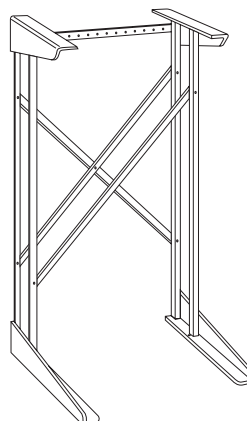

Not all features available on all models.  
For additional features, specifications and color availability, refer to page 160.

DSR24RT shown with  
WSKS2060T Washer and  
DSKS433ET Dryer



# UNITIZED WASHER/DRYER MODELS



**GE**  
**WSM2700T** Electric

- WSM2780T** Gas
- Full size 27" wide • Extra-large capacity
  - Washer features 3 cycles (Regular, Permanent Press and Delicate), 3 wash temperature options, 3 water level selections
  - Dryer features Automatic Dry Control, 4 cycles: Automatic Dry (Medium Heat), Timed Dry (High Heat), Delicate (Low Heat), Air Fluff (No-Heat) • Available in white and almond with black control panel



**GE**  
**WSM2420T** Electric

- WSM2480T** Gas
- 24" wide • Washer features 3 cycles (Regular, Permanent Press and Delicates), 3 wash/rinse temperatures, 3 water levels
  - Dryer features Automatic Dry Control, 4 cycles: Automatic Regular, Automatic Permanent Press, Timed Dry, and Air Fluff
  - Available in White on white • Electric model also available in Almond on almond

Not all features available on all models.  
For additional features, specifications and color availability, refer to page 161.

## TRUE PERFORMANCE & FLEXIBILITY



GE Wall Ovens feature the TrueTemp™ System, providing exceptional cooking performance through advanced technology and innovative design. TrueTemp™ offers SmartLogic Electronic Controls that monitor and maintain oven temperature; a Platinum Oven Sensor senses sudden heat loss, and responds with more power; and a powerful bake element (our most powerful ever!), that delivers 3410 watts of even heat distribution. But delivering consistently even oven temperatures is only the beginning.

*JT950SA Double Oven*

# THE MOST VERSATILE OVEN IN AMERICA IS ALSO THE MOST ACCURATE OVEN IN AMERICA!\*



These ovens can be installed in a wall or cabinet, or under a counter with a gas or electric cooktop. All GE 30" built-in ovens fit into common cut-out spaces making it easy to replace an installed oven with an upgrade. And the flush installation appearance is the final touch!

But there's still more to tell! Profile Performance Series™ offers professional touches like the Gourmet Shelf, that features "baking stones" as part of the rack. Dough rises more quickly and efficiently with our innovative "proofing" feature. Consistent cooking. Versatile placement. Professional features. GE Wall Ovens deliver in both cooking performance and flexibility.

\*Includes all 30" and 27" ovens.



## A GE WALL OVEN CAN BE FOUR OVENS IN ONE.



1. Conventional Baking

2. Conventional Broil  
(variable temp)

3. Convection Bake

4. Convection Roast

The addition of a convection oven gives you a whole new range of possibilities. Especially since it requires no additional space. With convection cooking, you'll find roasts turn out beautifully brown on the outside, yet tender and juicy on the inside. If you enjoy baking, you'll delight in the way your baked goods maintain their delicate texture while turning a delicious golden brown. On a practical level, convection cooking saves time and allows you to cook at lower temperatures.



GE convection ranges use the European or "true" convection system. The difference between "us and them" is a third dual loop heating element that surrounds the convection fan in the back wall of the oven. This extra fan at the rear of the oven gently circulates heated air evenly throughout the entire oven cavity—under and around the food. The moving air penetrates foods faster than stationary air.

## AND ALL OF THEM ARE EASY TO CLEAN.



The joy is in the cooking. Not in cleaning-up afterwards! That's why GE pays so much attention to "Cleanability." GE's remarkable CleanDesign wall oven is a superb example of this. CleanDesign starts with a *clean design*, meaning there are no hard to clean protrusions, corners and crevices. Instead, the surface is smooth. Virtually seamless. There are no endcaps on the control panel or on the handles. Further, the continuous surface design has no hard edges or overlaps where dirt and grease can "catch" and accumulate. Consequently, clean-up is a snap. And of course, the oven itself is self-cleaning.

Not all features available on all models.

# AMAZINGLY EASY TO OPERATE, TOO.



GE's SmartSet Electronic controls are simple to understand, simple to operate. Just read and touch.



Setting the time and temperature is easy. Digipads are numbered 1 through 0. For example, if you want to bake at 350°, you press 3...5...0... then press Bake.



Centigrade or Fahrenheit, it's your choice.

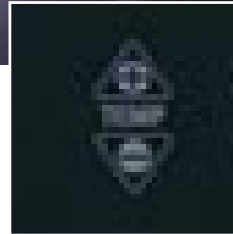

GE Slew Pads make time and temperature adjustment easy. Increase or decrease temperature or time with a touch of the finger.



It's easy to convert from conventional oven to convection, and vice versa. Convection cooking generally requires less time and lower temperatures. But don't worry about it. GE's SmartSet Controls will automatically make the corrections for you.



## SEVEN RACK BAKING. A GE EXCLUSIVE!

The oven comes equipped with three racks. But with the convection oven, you should consider buying up to four additional racks. You can get superb results with as many as seven racks. This means you can bake several sheets of cookies at the same time, with all of them turning out evenly cooked and browned. If you have a big crowd coming over, you can actually bake 14 nine-inch pizzas at once.

# BUILT-IN DOUBLE OVENS: 30" ELECTRIC

## ALL MODELS INCLUDE

- Flush appearance installation • Fits most 30" cabinets • TrueTemp™ System • SmartSet Electronic Controls
- Control lock capability
- Frameless glass oven doors
- Exclusive Big View windows • Upfront interior oven lights

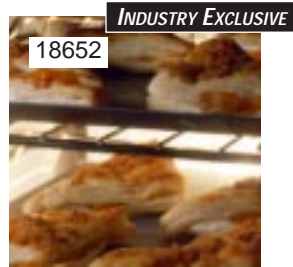

TrueTemp™ System  
"The Most Accurate Oven in America"

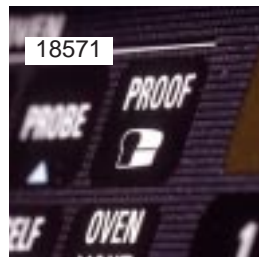

Dough rises more quickly and efficiently with our new Proofing option.



Exclusive Gourmet Shelf features "baking stones" as part of the rack.

## CONVECTION UPPER/SELF-CLEAN LOWER



### GE Profile Performance Series™ JT950SA

- Stainless steel • CleanDesign oven interior • Integrated designer handles
- #### CONVECTION UPPER OVEN
- Extra-large self-cleaning oven with Delay Clean option • Convection Bake • Convection Roast • Three oven racks, one with gourmet shelf • Exclusive 7 embossed rack positions • Roasting rack • Variable broil • Automatic meat thermometer • Proofing option
- #### THERMAL LOWER OVEN
- Extra-large self-cleaning oven with Delay Clean option • Two oven racks • 6 embossed rack positions



### GE Profile Performance Series™ JT950WA

- White on white • CleanDesign oven interior • Integrated designer handles
- #### CONVECTION UPPER OVEN
- Extra-large self-cleaning oven with Delay Clean option • Convection Bake • Convection Roast • Three oven racks, one with gourmet shelf • Exclusive 7 embossed rack positions • Roasting rack • Variable broil • Automatic meat thermometer • Proofing option
- #### THERMAL LOWER OVEN
- Extra-large self-cleaning oven with Delay Clean option • Two oven racks • 6 embossed rack positions



### GE Profile Performance Series™ JT950BA

- Black on black • CleanDesign oven interior • Integrated designer handles
- #### CONVECTION UPPER OVEN
- Extra-large self-cleaning oven with Delay Clean option • Convection Bake • Convection Roast • Three oven racks, one with gourmet shelf • Exclusive 7 embossed rack positions • Roasting rack • Variable broil • Automatic meat thermometer • Proofing option
- #### THERMAL LOWER OVEN
- Extra-large self-cleaning oven with Delay Clean option • Two oven racks • 6 embossed rack positions

- JT950AA** (not shown)
- Almond on almond

Not all features available on all models. For additional features, specifications and color availability, refer to pages 162-163.



## CONVECTION UPPER/SELF-CLEAN LOWER



True convection ovens provide even cooking and superior baking.

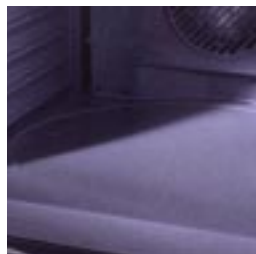

Fast and easy cleanup is made possible through our new CleanDesign oven interior.



CleanDesign wall ovens have a smooth seamless surface, making cleanup easier than ever.



**INDUSTRY EXCLUSIVE**

Exclusive Seven Rack Baking provides more usable shelf capacity.

**GE Profile™****JTP56WA**

- White on white • CleanDesign oven interior
- Integrated designer handles • Control lock capability

**CONVECTION UPPER OVEN**

- Extra-large self-cleaning oven with Delay Clean option • Convection Bake • Convection Roast
- Three oven racks • Exclusive 7 embossed rack positions • Roasting rack • Variable broil
- Automatic meat thermometer

**THERMAL LOWER OVEN**

- Extra-large self-cleaning oven with Delay Clean option • Two oven racks • 6 embossed rack positions

**JTP56BA** (not shown)

- Black on black

**JTP56AA** (not shown)

- Almond on almond

## SELF-CLEAN (BOTH OVENS)

**GE****JTP45WA**

- White on white • Extra-large self-cleaning ovens with Delay Clean option • Sure Grip designer-style handles • Variable broil • Two oven racks (each oven) • Six embossed rack positions • Control lock capability

**JTP45BA** (not shown)

- Black on black

## SELF-CLEAN UPPER/STANDARD LOWER

**GE****JTP27BA**

- Black on black • Sure Grip designer-style handles
- Six embossed rack positions (both ovens)

**UPPER OVEN**

- Extra-large self-cleaning oven with Delay Clean option • SmartSet Electronic Controls • Control lock capability • Variable broil • Two oven racks

**LOWER OVEN**

- Extra-large standard clean oven • Rotary controls
- Two oven racks

**JTP27WA** (not shown)

- White on white

Not all features available on all models.  
For additional features, specifications and color availability, refer to pages 162-163.

# BUILT-IN DOUBLE OVENS: 30" AND 27" ELECTRIC

## ALL MODELS INCLUDE

- Flush appearance installation
- Frameless glass oven doors



Sensor Microwave Cooking Controls take the guesswork out of cooking your favorite foods.



True convection ovens provide even cooking and superior baking.



SmartSet Electronic Controls are simple to understand and easy to use.

## MICROWAVE UPPER/CONVECTION LOWER



### GE Profile™

#### JTP95WA

- White on white • Fits most 30" cabinets • SmartSet Electronic Controls • Exclusive Big View window
- Upfront interior oven lights

#### MICROWAVE UPPER OVEN

- 1.6 cu. ft. cavity • Sensor Cooking Controls for Auto Cook and Reheat • Auto Defrost • Turntable
- 1000 watts

#### CONVECTION LOWER OVEN

- Self-cleaning oven with Delay Clean option
- Convection Bake • Convection Roast • Three oven racks • Exclusive 7 embossed rack positions
- Roasting rack • Variable broil • Automatic meat thermometer • Integrated designer handle
- Control lock capability

#### JTP95BA (not shown)

- Black on black

## MICROWAVE UPPER/SELF-CLEAN LOWER



### GE

#### JTP85WA

- White on white • Fits most 30" cabinets • SmartSet Electronic Controls • Exclusive Big View window
- Designer-style handle • Upfront interior oven lights

#### MICROWAVE UPPER OVEN

- 1.6 cu. ft. cavity • Sensor Cooking Controls for Auto Cook and Reheat • Auto Defrost • Turntable
- 1000 watts

#### LOWER OVEN

- Self-cleaning oven with Delay Clean option
- Variable broil • Two oven racks • Six embossed rack positions • Control lock capability

#### JTP85BA (not shown)

- Black on black

### GE

#### JKP85BA

- Black on black • Fits most 27" cabinets

#### MICROWAVE UPPER OVEN

- 1.6 cu. ft. cavity • Auto Roast • Auto Cook
- Auto Defrost • Double Duty™ shelf

#### LOWER OVEN

- Self-cleaning oven with automatic oven door lock • Two oven racks • Designer-style handle
- Electronic oven control • Variable broil
- Audible preheat signal • Electronic clock and kitchen timer • Delay Bake option

#### JKP85WA (not shown)

- White on white

Not all features available on all models. For additional features, specifications and color availability, refer to pages 162-163 and 166-167.

# BUILT-IN DOUBLE OVENS: 27" ELECTRIC

## ALL MODELS INCLUDE

- Flush appearance installation • Fits most 27" cabinets • TrueTemp™ System • SmartSet Electronic Controls
- Control lock capability
- Frameless glass oven doors • Exclusive Big View windows



True convection ovens provide even cooking and superior baking.

## CONVECTION UPPER/SELF-CLEAN LOWER



### GE Profile Performance Series™ JK950WA

- White on white • CleanDesign oven interior
- Integrated designer-style handles

#### CONVECTION UPPER OVEN

- Large self-cleaning oven with Delay Clean option
- Convection Bake • Convection Roast • Three oven racks, one with gourmet shelf • Roasting rack
- Variable broil • Automatic meat thermometer
- Proofing option

#### THERMAL LOWER OVEN

- Large self-cleaning oven with Delay Clean option
- Two oven racks



**INDUSTRY EXCLUSIVE**

TrueTemp™ System "The Most Accurate Oven in America"



### GE Profile Performance Series™ JK950AA

- Almond on almond • CleanDesign oven interior
- Integrated designer-style handles

#### CONVECTION UPPER OVEN

- Large self-cleaning oven with Delay Clean option
- Convection Bake • Convection Roast • Three oven racks, one with gourmet shelf • Roasting rack
- Variable broil • Automatic meat thermometer
- Proofing option

#### THERMAL LOWER OVEN

- Large self-cleaning oven with Delay Clean option
- Two oven racks



**INDUSTRY EXCLUSIVE**

Exclusive Gourmet Shelf features "baking stones" as part of the rack.



### GE Profile Performance Series™ JK950BA

- Black on black • CleanDesign oven interior
- Integrated designer-style handles

#### CONVECTION UPPER OVEN

- Large self-cleaning oven with Delay Clean option
- Convection Bake • Convection Roast • Three oven racks, one with gourmet shelf • Roasting rack
- Variable broil • Automatic meat thermometer
- Proofing option

#### THERMAL LOWER OVEN

- Large self-cleaning oven with Delay Clean option
- Two oven racks

Not all features available on all models. For additional features, specifications and color availability, refer to pages 166-167.



# BUILT-IN DOUBLE OVENS: 27" ELECTRIC

ALL MODELS INCLUDE • Flush appearance installation • Fits most 27" cabinets • TrueTemp™ System • Frameless glass oven doors  
• Exclusive Big View windows



**INDUSTRY EXCLUSIVE**

TrueTemp™ System  
"The Most Accurate Oven  
in America"



True convection ovens  
provide even cooking and  
superior baking.

## CONVECTION UPPER/SELF-CLEAN LOWER



**GE Profile™**

**JKP56BA**

- Black on black • CleanDesign oven interior
- SmartSet Electronic Controls • Integrated designer handles

**CONVECTION UPPER OVEN**

- Large self-cleaning oven with Delay Clean option
- Convection Bake • Convection Roast • Three oven racks • Variable broil • Automatic meat thermometer

**THERMAL LOWER OVEN**

- Large self-cleaning oven with Delay Clean option
- Two oven racks

**JKP56AA** (not shown)

- Almond on almond

**JKP56WA** (not shown)

- White on white

## SELF-CLEAN (BOTH OVENS)



Flush Installation Appearance  
integrates into cabinetry and  
makes cleanup easy.



SmartSet Electronic Controls  
are simple to understand and  
easy to use.

## SELF-CLEAN UPPER/STANDARD LOWER



**GE**

**JKP45WA**

- White on white • Two large self-cleaning ovens with Delay Clean option • SmartSet Electronic Controls • Sure Grip designer-style handles • Two oven racks (each oven)

**JKP45BA** (not shown)

- Black on black

**GE**

**JKP27WA**

- White on white • Sure Grip designer-style handles

**UPPER OVEN**

- Large self-cleaning oven with Delay Clean option
- SmartSet Electronic Controls • Control lock capability • Variable broil • Two oven racks

**LOWER OVEN**

- Large standard clean oven • Rotary control
- Two oven racks

**JKP27BA** (not shown)

- Black on black

Not all features available on all models.  
For additional features, specifications and  
color availability, refer to pages 166-167.

# BUILT-IN SINGLE OVENS: 30" ELECTRIC

ALL MODELS INCLUDE • Flush appearance installation • Fits most 27" cabinets • TrueTemp™ System • CleanDesign oven interior  
 • SmartSet Electronic Controls • Control lock capability • Frameless glass oven door • Exclusive Big View window • Upfront interior oven light

**INDUSTRY EXCLUSIVE**



TrueTemp™ System  
 "The Most Accurate Oven in America"

## SELF-CLEAN CONVECTION



### GE Profile Performance Series™ JT910SA

- Stainless steel • Integrated designer handle
- Extra-large self-cleaning oven with Delay Clean option • Convection Bake • Convection Roast • Three oven racks, one with gourmet shelf • Exclusive 7 embossed rack positions
- Roasting rack • Variable broil • Automatic meat thermometer



True convection ovens provide even cooking and superior baking.

**INDUSTRY EXCLUSIVE**



Exclusive Seven Rack Baking provides more usable shelf capacity.

## INSTALLATION FLEXIBILITY

30" wall ovens can be installed in a wall or most 30" cabinets, or under-counter installation with either a gas or electric cooktop above. See pages 164 and 165 for approved cooktop use.



### GE Profile Performance Series™ JT910WA

- White on white



### GE Profile Performance Series™ JT910BA

- Black on black
- JT910AA (not shown)
- Almond on almond

Not all features available on all models. For additional features, specifications and color availability, refer to pages 164-165.

Refrigeration

Water Systems

Laundry

Built-In  
 Cooking Products

Microwave Ovens

Dishwashers

Room Air

# BUILT-IN SINGLE OVENS: 30" ELECTRIC

ALL MODELS INCLUDE • Flush appearance installation • Fits most 30" cabinets • TrueTemp™ System • SmartSet Electronic Controls  
• Frameless glass oven door • Exclusive Big View window • Upfront interior oven light • Control lock capability



True convection ovens provide even cooking and superior baking.



Exclusive Seven Rack Baking provides more usable shelf capacity.



Fast and easy cleanup is made possible through our new CleanDesign oven interior.

## INSTALLATION FLEXIBILITY

30" wall ovens can be installed in a wall or most 30" cabinets, or under-counter installation with either a gas or electric cooktop above. See pages 164 and 165 for approved cooktop use.

## SELF-CLEAN CONVECTION



### GE Profile™

#### JTP18BA

- Black on black • Integrated designer handle • Extra-large self-cleaning oven with Delay Clean option • Convection Bake • Convection Roast • Three oven racks • Exclusive 7 embossed rack positions • Roasting rack • Variable broil • Automatic meat thermometer

JTP18WA (not shown)

- White on white

JTP18AA (not shown)

- Almond on almond

## SELF-CLEAN



### GE

#### JTP15WA

- White on white • Sure Grip designer-style handle • Extra-large self-cleaning oven with Delay Clean option • Two oven racks • Six embossed rack positions

JTP15BA (not shown)

- Black on black

JTP15AA (not shown)

- Almond on almond



# BUILT-IN SINGLE OVENS: 27" ELECTRIC

ALL MODELS INCLUDE • Flush appearance installation • Fits 27" cabinets • SmartSet Electronic Controls • Frameless glass oven door  
• Big View window • Control lock capability (except model JKS05BA)



True convection ovens provide even cooking and superior baking.



Flush Installation Appearance integrates into cabinetry and makes cleanup easy.



**INDUSTRY EXCLUSIVE**

Exclusive Gourmet Shelf features "baking stones" as part of the rack.

## INSTALLATION FLEXIBILITY

27" wall ovens can be installed in a wall or 27" cabinet, or undercounter installation with either a gas or electric cooktop above. See pages 168 and 169 for approved cooktop use.

Not all features available on all models. For additional features, specifications and color availability, refer to pages 168-169.

## SELF-CLEAN CONVECTION



### GE Profile Performance Series™ JK910WA

- White on white • Integrated designer handle
- TrueTemp™ System • Large self-cleaning oven with Delay Clean option • CleanDesign oven interior • Convection Bake • Convection Roast
- Three oven racks, one with gourmet shelf
- Roasting rack • Variable broil • Automatic meat thermometer • Proofing option

**JK910AA** (not shown) • Almond on almond  
**JK910BA** (not shown) • Black on black

## SELF-CLEAN



### GE JKP15WA

- White on white • TrueTemp™ System • Sure Grip designer-style handle • Large self-cleaning oven with Delay Clean option • Two oven racks

**JKP15BA** (not shown) • Black on black  
**JKP15AA** (not shown) • Almond on almond



### GE Profile™ JKP18WA

- White on white • TrueTemp™ System
- Large self-cleaning oven with Delay Clean option
- Convection Bake • Convection Roast • Three oven racks • Variable broil • Automatic meat thermometer • Sure Grip designer-style handle

**JKP18BA** (not shown) • Black on black  
**JKP18AA** (not shown) • Almond on almond

## STANDARD CLEAN



### GE JKS05BA

- Black on black • Sure Grip designer-style handle
- Large standard clean oven • Two oven racks

Refrigeration

Water Systems

Laundry

Built-In  
Cooking Products

Microwave Ovens

Dishwashers

Room Air

## BUILT-IN DOUBLE AND SINGLE OVENS: 24" ELECTRIC

### ALL MODELS INCLUDE

- Fits most 24" cabinets
- SmartSet Electronic Controls
- Frameless glass oven doors
- Designer-style handles
- Two oven racks (each oven)



SmartSet Electronic Controls are simple to understand and easy to use.



Self-Clean Ovens provide easy clean convenience. Simply set the controls and the oven cleans itself.



### GE JRP24BW

- Black on black

#### UPPER OVEN

- Self-cleaning oven with Delay Clean option
- SmartSet Electronic Controls
- Control lock capability
- Start pad
- Delay Bake option with Cook & Hold
- Variable broil

#### LOWER OVEN

- Standard clean oven
- Rotary controls



### GE JRP15WW

- White on white
- Self-cleaning oven with Delay Clean option
- Variable broil
- Control lock capability
- Start pad
- Delay Bake option with Cook & Hold

#### JRP15BW (not shown)

- Black on black

#### JRS04BW (not shown)

- Black on black
- Standard clean oven
- Variable broil
- Start pad
- Delay Bake option with Cook & Hold

## BUILT-IN SINGLE OVENS: 24" GAS

### ALL MODELS INCLUDE

- Fits most 24" cabinets
- SmartSet Electronic Controls
- Electronic pilotless ignition
- Frameless glass oven door
- Designer-style handle



### GE JGRP17WEW

- White on white
- Self-cleaning oven with Delay Clean option
- Control lock capability
- In-oven broiling
- Storage drawer

#### JGRP17BEW (not shown)

- Black on black



### GE JGRS14BEW

- Black on black
- Standard clean oven
- Separate broiler drawer

Not all features available on all models. For additional features, specifications and color availability, refer to pages 166-170.

# BUILT-IN WARMING DRAWERS: 30" AND 27" ELECTRIC

- ALL MODELS INCLUDE • Flush appearance installation • Frameless drawer front • Integrated designer-style handle
- Removable stainless steel drawer pan



Half Rack provides even heat distribution and allows extra space to keep food warm and tasty before serving.



Warming Drawer keeps plates warm, ready and waiting to serve that special meal.



Hidden Temperature Control has Proof, Low, Medium and High settings for warming flexibility.



## GE Profile Performance Series™ JTD910SB

- Stainless steel • 30" warming drawer
- Temperature control with Proof, Low, Medium and High settings • Crisp/Moist humidity control • ON/OFF switch
- "ON" indicator light • One-half rack

## JKD910SB (not shown)

- Stainless steel • 27" warming drawer



## GE Profile Performance Series™ JTD910WB

- White on white • 30" warming drawer
- Temperature control with Proof, Low, Medium and High settings • Crisp/Moist humidity control • ON/OFF switch
- "ON" indicator light • One-half rack

## JTD910AB (not shown)

- Almond on almond • 30" warming drawer

## JTD910BB (not shown)

- Black on black • 30" warming drawer

## JKD910WB (not shown)

- White on white • 27" warming drawer

## JKD910AB (not shown)

- Almond on almond • 27" warming drawer

## JKD910BB (not shown)

- Black on black • 27" warming drawer

Not all features available on all models. For additional features, specifications and color availability, refer to page 171.



# BUILT-IN COOKTOPS: 36" AND 30" ELECTRIC CLEANDESIGN

ALL MODELS INCLUDE • Smooth-surface glass-ceramic CleanDesign cooktop

• Fingerprint and scratch resistant patterned glass cooktop



Flush Mount Installation creates a stunning visual effect.

(Not available on stainless steel models)



Bridge Element for total cooking flexibility.

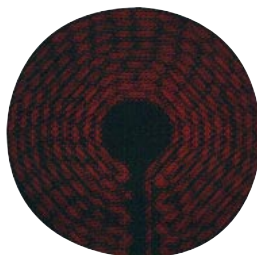

Ribbon Heating Elements direct heat straight up to the pan, providing even heat for uniform cooking.



## GE Profile Performance Series™

### JP960SA

- Stainless steel • 36" frameless cooktop
- Five ribbon heating elements, one 6", one 7", one dual (6"/9") and two 7" with connecting bridge burner • Five hot surface indicator lights

### JP960WA (not shown)

- White on white • Flush mount installation capability

### JP960AA (not shown)

- Almond on almond • Flush mount installation capability

### JP960BA (not shown)

- Black on black • Flush mount installation capability



## GE Profile Performance Series™

### JP930BA

- Black on black • 30" frameless cooktop
- Four ribbon heating elements, one 6", one dual (6"/9") and two 7" with connecting bridge burner • Four hot surface indicator lights • Flush mount installation capability

### JP930WA (not shown)

- White on white • Flush mount installation capability

### JP930AA (not shown)

- Almond on almond • Flush mount installation capability

### JP930SA (not shown)

- Stainless steel



## GE Profile™

### JP350WA

- White on white • 30" cooktop • Four ribbon heating elements: One dual (6"/9"), two 8" and one 6" • Four hot surface indicator lights • Flush mount installation capability

### JP350BA (not shown)

- Black on black

### JP350AA (not shown)

- Almond on almond



## GE

### JP340BA

- Black on black • 30" cooktop • Four ribbon heating elements: Two 6" and two 8"
- Surface "ON" light • Flush mount installation capability

### JP340WA (not shown)

- White on white

Not all features available on all models. For additional features, specifications and color availability, refer to page 172.

# BUILT-IN COOKTOPS: 36" AND 30" ELECTRIC COIL

ALL MODELS INCLUDE • Porcelain-enameled lift-up cooktop • Two 8" and two 6" plug-in Calrod® heating elements  
• Infinite heat rotary controls



**GE**

**JP626WV**

• White on white • 36" cooktop • One-piece chrome drip bowls • Upfront white glass control panel

**JP626AV** (not shown)

• Almond on almond



**GE**

**JP326BV**

• Black on black • 30" cooktop • One-piece porcelain-enameled drip bowls • Black glass control panel

**JP326WV** (not shown)

• White on white

**JP326AV** (not shown)

• Almond on almond

**JP326CV** (not shown)

• Brushed-chrome

# BUILT-IN COOKTOPS: 21" COMPACT



**GE**

**JP201CV**

• Stainless steel • 21-1/4" cooktop  
• One 8" and one 6" plug-in heating elements  
• Infinite heat rotary controls • Removable one-piece chrome drip bowls • Heating element "ON" indicator light

**JP200V** (not shown)

• White porcelain-enameled

(Available in White only)

# BUILT-IN COOKTOPS: 36" AND 30" GAS

ALL MODELS INCLUDE • Sealed burners (except JGP320EV) • Electronic pilotless ignition



Sealed Burners help contain spills from dripping beneath cooktop for easy cleanup.



Precise Simmer Burner provides more temperature control with low 700 BTU setting.



Maximum Output Burners have high power performance making cooking convenient.



## GE Profile Performance Series™

### JGP960SEA

- Stainless steel • 36" cooktop • Tempered glass cooktop • Deluxe cast grates • Five sealed burners • Two Precise Simmer burners • Maximum Output burner

Shown with JVB96SA telescopic downdraft vent.



## GE Profile™

### JGP636BEV

- Black on black • 36" cooktop • Tempered glass cooktop • Deluxe cast grates
- Five sealed burners • 2 Precise Simmer burners • Maximum Output burner

### JGP636WEV (not shown)

- White on white

### JGP636AEV (not shown)

- Almond on almond



## GE

### JGP626WEV

- White on white • 36" cooktop • Porcelain-enameled cooktop • Precise Simmer burner
- Standard cast grates

### JGP626BEV (not shown)

- Black on black

### JGP626AEV (not shown)

- Almond on almond



## GE Profile™

### JGP645BEX

- Black on black • 36" downdraft cooktop • Tempered glass cooktop • Deluxe cast grates • Automatic re-ignition • 500 CFM retractable downdraft venting system
- Upfront variable speed fan • Use optional GE accessory cover (JXBC55) for outdoor installation of blower • Detached blower for installation flexibility • **JXBA55 Downdraft Venting Kit required for installation**

### JGP645WEX (not shown)

- White on white

Not all features available on all models. For additional features, specifications and color availability, refer to pages 174-175.





**GE Profile Performance Series™**

**JGP930SEA**

- Stainless steel • 30" cooktop • Tempered glass cooktop • Deluxe cast grates
- Precise Simmer burner • Maximum Output burner



**GE Profile™**

**JGP336AEV**

- Almond on almond • 30" cooktop
- Tempered glass cooktop • Precise Simmer burner • Maximum Output burner

**JGP336WEV** (not shown)

- White on white

**JGP336BEV** (not shown)

- Black on black



**GE**

**JGP326BEV**

- Black on black • 30" cooktop • Sealed burners • Precise Simmer burner
- Standard cast grates

**JGP326WEV** (not shown)

- White on white

**JGP326AEV** (not shown)

- Almond on almond



**GE**

**JGP320EV**

- 30" lift-up cooktop • Glass control panel
- Standard porcelain steel grates
- Available in white or black

Not all features available on all models. For additional features, specifications and color availability, refer to page 174.

Refrigeration

Water Systems

Laundry

Built-In  
Cooking Products

Microwave Ovens

Dishwashers

Room Air

# BUILT-IN COOKTOPS: DOWNDRAFT GAS MODULAR

## ALL MODELS INCLUDE

- Powerful downdraft venting
- Electronic pilotless ignition
- Up-front controls

## OPTIONAL MODULES (available at additional cost)

### TWO-BURNER GAS MODULE FOR

### STANDARD BURNERS

- JXGB89W—White on white
- JXGB89B—Black on black

### GAS GRILL MODULE

JXGG89

### GRIDDLE FOR USE

### WITH OPTIONAL

### GRILL MODULE

JXGL89

### GRILL COVER

- JXGC89W—White on white
- JXGC89B—Black on black



## GE Profile™

### JGP389WEV

- White on white • 30" single modular gas cooktop • Fixed standard gas burners (right side) • Left side accepts optional cooking modules

Shown with optional Grill module JXGG89.

### JGP389BEV (not shown)

- Black on black



## GE Profile™

### JGP18BEV

- Black on black • 18" single modular gas cooktop • Accepts optional cooking modules

Shown with optional Grill module JXGG89.

# BUILT-IN COOKTOPS: PATIO GRILL



## GE

### JP380BV

- 30" patio grill • Fixed grill elements each side • Infinite heat rotary controls
- Powerful downdraft venting system
- Heating element "ON" indicator light
- Black porcelain-enameled cooktop
- Optional grill covers (JXDM4) available at additional cost.

U.L. approved for outdoor use only.

# COMMON COOKTOP CUTOUTS

## Common Cutouts—30" Cooktops

Dimensions (W x D)	Model #	Description
28-1/2" x 19-5/8"	JP930	CleanDesign
	JP350	CleanDesign
	JP340	CleanDesign
	JP326	Calrod™
	JGP930—Gas	Sealed Burner
	JGP336—Gas	Sealed Burner
	JGP326—Gas	Sealed Burner
	28-7/8" x 20-5/8"	JP389
JP387		Modular Downdraft
JP385		Modular Downdraft
JP380		Patio Grill

## Common Cutouts—36" Cooktops

Dimensions (W x D)	Model #	Description
33-7/8" x 19-1/16"	JP960	CleanDesign
	JP626	Calrod™
	JGP960	Sealed Burner
	JGP636—Gas	Sealed Burner
	JGP626—Gas	Sealed Burner
34-9/16" x 21-1/2"	JGP641—Gas	Sealed Burner Downdraft
	JGP640—Gas	Sealed Burner Downdraft

Not all features available on all models.  
For additional features, specifications and color availability, refer to pages 176-178.



# BUILT-IN COOKTOPS: DOWNDRAFT ELECTRIC SELECT-TOP™ MODULAR

ALL MODELS INCLUDE • Infinite heat rotary controls • Powerful downdraft venting system • Heating element "ON" indicator light

## OPTIONAL SELECT-TOP™ MODULES (AVAILABLE AT ADDITIONAL COST)



**GRILL MODULE**  
Front and rear controlled heating element for more cooking flexibility and energy savings. One-piece grill grate and porcelain-enameled reflector pan can be removed for cleaning in sink or dishwasher.



**GRIDDLE ACCESSORY**  
(For use with optional grill module) Place over heating element and reflector pan from optional grill module. Griddle accessory has a non-stick coating and is self-draining.



**RIBBON MODULE**  
Patterned glass top with one 8" and one 6" ribbon heating element.



**CALROD® MODULE**  
One 8" and one 6" plug-in Calrod® heating element with removable one-piece drip bowls.

**GRILL COVER** (not shown)  
Covers grill area when not in use. Available in Black on black and White on white.



**GE Profile™ JP389WV**  
• White on white • 30" dual modular cooktop  
• 3-speed fan • Porcelain-enameled cooktop  
Shown with optional Ribbon module JXDR50WV and Grill module JXDL44N.



**GE Profile™ JP389BV**  
• Black on black • 30" dual modular cooktop  
• 3-speed fan • Porcelain-enameled cooktop  
Shown with optional Ribbon modules JXDR50VB.



**GE JP385WV**  
• 30" single modular cooktop • White porcelain-enameled cooktop • Fixed 6" and 8" plug-in Calrod® heating elements • Left side accepts optional cooking modules  
Shown with optional Grill module JXDL44N.

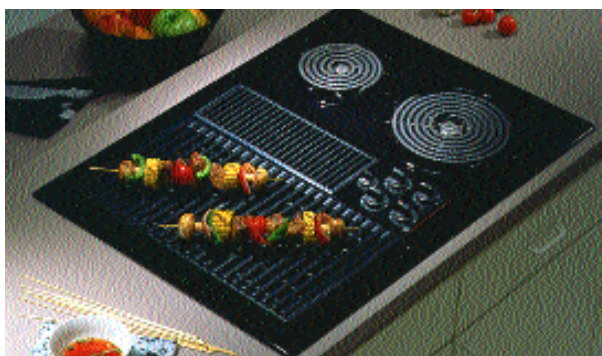

**GE JP385BV**  
• 30" single modular cooktop • Black porcelain-enameled cooktop • Fixed 6" and 8" plug-in Calrod® heating elements • Left side accepts optional cooking modules  
Shown with optional Grill module JXDL44N.

**JP385CV** (not shown)  
• Brushed-chrome cooktop

Optional Modules (available at additional cost)	Models				
Calrod® Module	JXDC44RWH	JXDC43RBL	JXDC44RWH	JXDC43RBL	JXDC41NBC
Ribbon Module	JXDR50WV	JXDR50VB	JXDR50WV	JXDR50VB	JXDR50VC
Grill Module	JXDL44N	JXDL44N	JXDL44N	JXDL44N	JXDL44N
Griddle Accessory	JXDD44R	JXDD44R	JXDD44R	JXDD44R	JXDD44R
Grill Cover	JXDM3	JXDM2	JXDM3	JXDM2	JXDM2

Not all features available on all models. For additional features, specifications and color availability, refer to pages 176-177.



# SLIDE-IN RANGES: 30" ELECTRIC

## THESE MODELS INCLUDE

- Custom built-in look with simple slide-in installation. Note: All models have black painted side panels.



Ribbon Heating Elements provide efficient cooking response.

## CLEANDESIGN



### GE Profile™

#### JSP40BW

- Black on black • SmartSet Electronic Controls • Two 8", one 6" and one dual (6"/9") ribbon heating element • 4 hot surface indicator lights • Fingerprint and scratch resistant patterned glass-ceramic CleanDesign cooktop • Self-cleaning oven with Delay Clean option • Frameless glass oven door with window • Sure Grip designer-style handle • Control lock capability

#### JSP40WW (not shown)

- White on white

#### JSP40AW (not shown)

- Almond on almond

Model shown with required filler strip provided.

- THESE MODELS INCLUDE • Lift-up overhanging porcelain-enameled cooktop • Two 8" and two 6" plug-in Calrod® heating elements • Electronic clock and kitchen timer • Custom built-in look with simple slide-in installation. Note: All models have black painted side panels.

## COIL



### GE

#### JSP34AW

- Almond on almond • SmartSet Electronic Controls • Self-cleaning oven with Delay Clean option • Frameless glass oven door with designer-style handle • Control lock capability

#### JSP34WW (not shown)

- White on white

#### JSP34BW (not shown)

- Black on black



### GE

#### JSP26BW

- SmartSet Electronic Controls • Self-cleaning oven with Delay Clean option • Frameless glass oven door with designer-style handle • Control lock capability • Available in white or almond



### GE

#### JSS26BW

- Black on black • Standard clean oven • Frameless glass oven door with designer-style handle

#### JSS16PW (not shown)

- Standard clean oven • Color-matched oven door • Visor handle • Available in white or almond

Models shown with required filler strip provided.

Not all features available on all models. For additional features, specifications and color availability, refer to page 184.

# SLIDE-IN RANGES: 30" GAS

## THESE MODELS

INCLUDE • Electronic pilotless ignition • Self-cleaning oven with Delay Clean option • Sure Grip designer-style handle • Glass cooktop • Storage drawer • Control lock capability



## GE Profile™

### JGSP44WEY

- White on white • SmartSet Electronic Controls
- Sealed burners • Standard simmer burner
- Maximum output burner • Deluxe cast grates

### JGSP44BEY (not shown)

- Black on black

### JGSP44AEY (not shown)

- Almond on almond

Model shown with required filler strip provided.

THESE MODELS INCLUDE • Electronic pilotless ignition • Frameless glass oven door

- Designer-style handle • Interior oven light • Broiler pan with grid

## OPTIONAL ACCESSORY TRIM KITS

Enhance the built-in look of these Slide-In Gas ranges with optional accessory trim kits (all models except JGSS05BEA), see page 182.



## GE

### JGSP23WEY

- White on white • SmartSet Electronic Controls • Sealed burners • Standard Simmer burner • Self-cleaning oven with Delay Clean option • Control lock capability
- White porcelain-enameled cooktop
- Standard cast grates • Storage drawer

### JGSP23BEY (not shown)

- Black on black



## GE

### JGSS05BEA

- Black on black • Extra-large standard clean oven • Black porcelain-enameled lift-up cooktop • Twin rod supports
- Separate broiler drawer with extra-large broiler pan and grid • Standard porcelain steel grates

Models shown with required filler strip provided.

Not all features available on all models. For additional features, specifications and color availability, refer to pages 182-183.

## SLIDE-IN RANGES: 30" DOWNDRAFT ELECTRIC

### BOTH MODELS

INCLUDE • Powerful downdraft venting system • Two-speed fan • Self-cleaning oven • Glass oven door with window • Designer-style handle • Electronic clock and minute timer • Delay Bake option • Dual modular porcelain-enameled cooktop • Storage drawer (half depth)



**GE**  
**JSP69WV**  
• White on white  
**JSP69BV** (not shown)  
• Black on black

The modular cooktop on these models allows you to customize the range to suit your convenience and food preparation needs. Downdraft venting allows you to fry, griddle or even grill without an overhead vent hood. These ranges are equipped with a grill module, other modules shown are available at additional cost.



**RADIANT MODULE**  
**JXGR63B**—Frameless module has patterned glass top with two 7" radiant heating elements.



**GRIDDLE ACCESSORY**  
**JXGL90**—(For use with grill module) Place over heating element from grill module. Griddle accessory has a non-stick coating.



**COIL MODULES**  
**JXGC53W**—White on white, **JXGC53B**—Black on black. One 8" and one 6" plug-in heating element with removable one-piece drip bowls.



**GRILL MODULE**  
**JXGG50**—Has two-piece, non-stick coated grates for cooking and cleaning convenience. (One included with each range.)

## DROP-IN RANGES: 30" ELECTRIC

### ALL MODELS INCLUDE

• SmartSet Electronic Controls • Lift-up overhanging porcelain-enameled cooktop • Two 8" and two 6" plug-in heating elements • Removable one-piece drip bowls • Lift-off oven door • Frameless glass oven door • Designer-style handle



**GE**  
**JDP39BW**  
• Black on black • Self-cleaning oven with Delay Clean option • Control lock capability  
**JDP39WW** (not shown)  
• White on white



**GE**  
**JDP36BW**  
• Self-cleaning oven with Delay Clean option • Control lock capability • Available with white or almond cooktop  
**JDS26BW** (not shown)  
• Standard clean oven • Available with white or almond cooktop

Not all features available on all models. For additional features, specifications and color availability, refer to pages 178 and 185.



# DROP-IN SPACEMAKER™ RANGES: 27" ELECTRIC

ALL MODELS INCLUDE • Lift-up overhanging porcelain-enameled cooktop • One 8" and three 6" plug-in Calrod® heating elements • Frameless glass oven door • Big View window • Chrome drip bowls



Electronic Oven Control provides convenient cooking functions.



Lift-Up Cooktop stays up for easy access to clean the subtop quickly.



Calrod® Heating Elements unplug for easy removal of one-piece drip bowls for cleaning and access to the subtop.

## OPTIONAL BACKGUARDS

White, black or almond painted finish is available at additional cost for all models.

JX27RWH – White,  
JX27RBK – Black,  
JX27RAD – Almond



## GE Profile™ JMP31WA

- White on white • Self-cleaning oven with automatic oven door lock • Electronic clock and kitchen timer • Auto oven shut-off • Sure Grip designer-style handle



## GE JMP28BA

- Self-cleaning oven with automatic oven door lock • White or almond cooktop • Electronic clock and minute timer • Auto oven shut-off



## GE JMS08BA

- Standard clean oven • White or almond cooktop • Rotary oven controls

Not all features available on all models. For additional features, specifications and color availability, refer to page 186.

# VENTING OPTIONS

## SLIDE-OUT HOODS

### THESE MODELS

INCLUDE • See-through glass visor slides in and out • 300 CFM performance with variable speed fan control • Auto heat sensor • Compact housing leaves ample shelf space behind cabinet doors • Vertical exhaust with 3-1/4" x 10" rectangular duct



### GE Profile Performance Series™ JV960SA

• Stainless steel • 36" vented hood with cooktop light

### JV930SA (not shown)

• Stainless steel • 30" vented hood with cooktop light

### GE Profile™

### JV695S (not shown)

• White on white • 36" vented hood with cooktop light

### JV694S (not shown)

• Black on black

### JV394S (not shown)

• Black on black • 30" vented hood with cooktop light

### JV395S (not shown)

• White on white

## HOODS

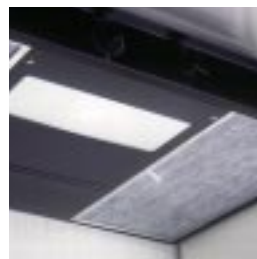

GE High Performance and Performance Hoods are designed with an easy-to-clean continuous surface and two large filters that can be cleaned at the sink or dishwasher.

The High Performance hoods are recommended for use with gas cooktops and grill/griddle cooktops. Powerful CFM performance draws smoke and odors up and out of the kitchen.



### GE

### JV376V High Performance

• 30" vented hood • Available in White on white or Black on black • Rotary controls • 2 cooktop lights • Night Light setting • Variable speed fan control • Vertical or rear exhaust (410/380 CFM) • 3-1/4" x 10" rectangular duct



### GE

### JV347X Deluxe

• 30" width • Available in White on white, Black on black or Almond on almond • Rotary control • Three-speed fan • Cooktop light with Night Light setting • Light cover • Convertible exhaust (Shipped in non-vented configuration, convertible to round or rectangular exhaust.) • Rectangular damper included

JXDA22 round damper accessory, available at additional cost.



### GE

### JV356V Performance

• 30" width • Available in White on white, Black on black or Almond on almond • Rotary controls • Variable speed fan control • 250 CFM (max.) • 2 cooktop lights • Night Light setting • Convertible exhaust options (rectangular or non-vented) • Rectangular damper included

### JV656V (not shown)

• 36" width



### GE

### JV327X Standard

• 30" width • 7" round duct • Easy-to-use rocker switches • Two-speed fan • Cooktop light • Available in white or almond

JXDA22 round damper accessory, available at additional cost.

### JV337X (not shown)

• 3-1/4" x 10" rectangular duct • Rectangular damper included

### JN327X (not shown)

• Non-vented

Not all features available on all models. For additional features, specifications and color availability, refer to pages 179-180.

## TELESCOPIC DOWNDRAFT SYSTEMS

THESE MODELS INCLUDE • 500 CFM performance • Upfront variable speed fan with slide control • Raises to 8-3/4" over cooktop surface • Retracts when not in use • Ideal for island or peninsula installations • Use optional GE accessory cover (JXBC57) for outdoor installation of blower or the indoor blower mounting kit (JXR57) for indoor remote mounting of the blower.

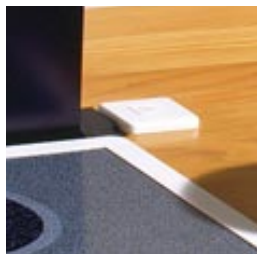

Separate remote switch to raise/lower vent provides installation flexibility and convenience of operation. (only available on JVB67)



**GE Profile™  
JVB67AWW**  
• 36" White on white telescopic downdraft system  
• Separate remote switch to raise/lower vent

**JVB67ABB** (not shown)  
• Black on black

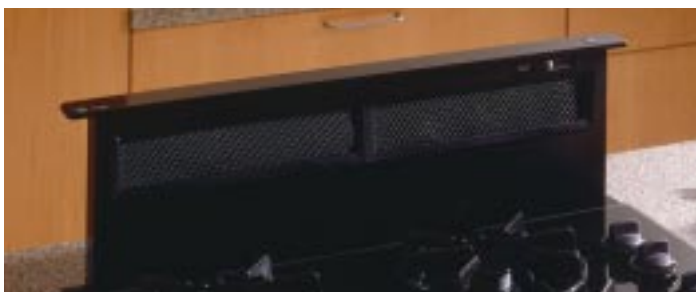

**GE Profile™  
JVB37ABB**  
• 30" Black on black telescopic downdraft system

**JVB37AWW** (not shown)  
• White on white

Note: Approved for use with all GE Profile Performance™, GE Profile™ and GE electric and sealed burner gas cooktops. Not approved for use with standard burner gas cooktops.

THESE MODELS INCLUDE • 500 CFM performance • Variable speed fan control • Raises to 7" over cooktop surface • Retracts when not in use • Ideal for island or peninsula installations • 3-1/4" x 10" rectangular duct



Raise/lower vent switch provides convenience of operation.



**GE Profile Performance Series™  
JVB96SA**  
• 36" stainless steel telescopic downdraft system

**JVB93SA** (not shown)  
• 30" stainless steel

Note: Approved for use with all GE Profile Performance™, GE Profile™ and GE electric and sealed burner gas cooktops. Not approved for use with standard burner gas cooktops.

Not all features available on all models. For additional features, specifications and color availability, refer to pages 180-181.

**Cooktop Sold Separately**



## THE NEW SPECTRA™ OVEN IS THE LARGEST,\* MOST ACCURATE OVEN IN AMERICA!



**YOU WON'T FIND A LARGER OVEN IN AMERICA! JUST IMAGINE, A FULL 5.0 CUBIC FEET!** This 5.0 cubic foot oven is big enough to handle a large quantity of food for those special occasions. It has 26% more usable space than Whirlpool's largest oven, 28% more than Maytag's and 36% more than Frigidaire's. It also features GE's exclusive six rack positions to accommodate a variety of cookware.

\*among leading manufacturers' brands

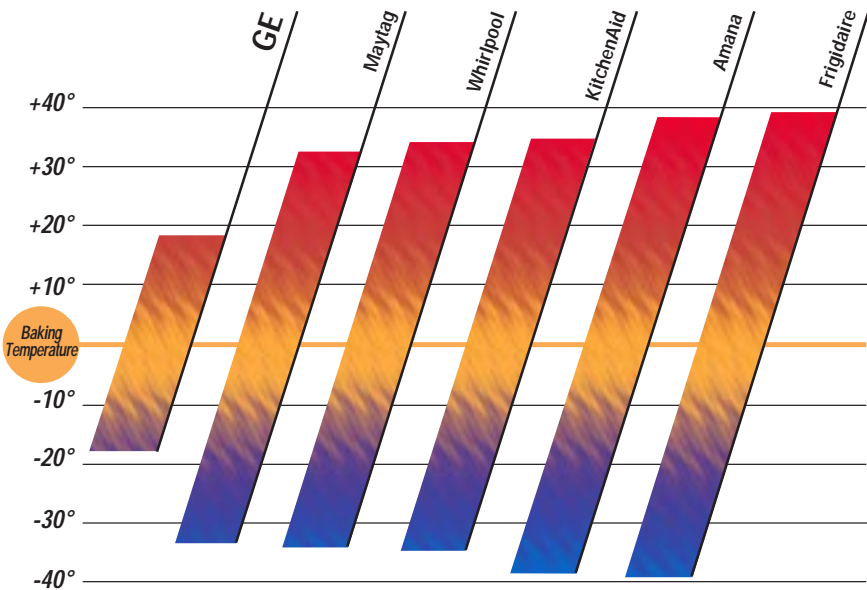

**TRUETEMP™ IS STILL THE MOST ACCURATE OVEN IN AMERICA**

TrueTemp™ electric ranges have the most advanced temperature management system in the industry. The new broiler design distributes heat evenly, so foods are cooked evenly. Less temperature variance from the unique broil element design as well as the lower bake element, means better oven accuracy for even baking and broiling performance.



# THE NEW SPECTRA™ COOKTOP GIVES YOU MORE WAYS TO COOK GREAT FOOD!



## **New!** Warming Option

Use the new warming element to keep soups, sauces, breads and pancakes warm or to melt butter and chocolate. You can also use this new burner as you would any other cooktop element.



## **GE Exclusive!**

### **Bridge Burner**

GE's remarkable bridge burner, when used with either one or both single elements, allows you to create larger cooking zones for any size cookware.



## **Flexible!**

### **6"/9" Dual Element**

The dual ring element is a small and a large element all in one. It lets you heat the element area that's needed for either a six- or nine-inch pan.



# THE NEW SPECTRA™ RANGE IS EASIER TO CLEAN THAN EVER BEFORE!



## Seamless Design

The seamless backguard provides a sleek appearance and makes cleaning fast and easy. The easy-to-use glass touch controls bring elegance and style to your range.

## Exclusive CleanDesign

As for cleanability, the CleanDesign oven interior conceals the lower oven element under a porcelain-coated steel surface. All you see and clean is a flat, smooth oven surface.



## GE SPECTRA™ RANGES ARE EASY TO USE.



*The oven is self-cleaning, of course. But for most families, 80 percent of the cooking is done on the cooktop. You can see in a glance just how easy it is to wipe the smooth ceramic glass cooktop clean.*

**STYLISH.** Please note the designer handle, frameless, full-width glass oven door, sleek control panel and overall appearance.

**ATTRACTIVE.** The decorator pattern won't wear off under normal use and also helps camouflage any smudges that might occur.

**RESPONSIVE.** GE's Prompt Response System makes the heating elements come on fast, and then direct the heat straight up to the pan or cookware.

**UNIFORM HEAT.** Elements are designed to distribute heat uniformly, pulsing on and off to maintain the selected heat level.

**PROTECTIVE.** Heating elements have a "hot surface" indicator light to let you know when the element is too hot to touch (it continues to work even if the element has been turned off).

**DURABLE.** The cooktop is made with a specially engineered ceramic glass that has an amazing resistance to both stains and impact.

## DON'T SETTLE FOR LESS THAN TRUE CONVECTION.



GE convection ranges use the European or "true" convection system. The difference between "us and them" is a third dual loop heating element that surrounds the convection fan in the back wall of the oven. This extra fan at the rear of the oven gently circulates heated air evenly throughout the entire oven cavity—under and around the food. The moving air penetrates foods faster than stationary air.

GE convection ranges use the European or "true" convection system. The difference between "us and them" is a third dual loop heating element that surrounds the convection fan in the back wall of the oven. This extra fan at the rear of the oven gently circulates heated air evenly throughout the entire oven cavity—under and around the food. The moving air penetrates foods faster than stationary air.



Convection cooking has long been acclaimed as superior by professional chefs and bakers. And no wonder. Roasting time is reduced with more "even" results. Roasts are beautifully browned on the outside, tender and juicy inside.



GE convection ovens deliver exceptional baking results with reduced temperatures (up to 25° less than a conventional oven). Expect your baked goods to maintain their delicate texture while turning a golden brown.

## AND EASY TO CLEAN.



*The porcelain-enameled subtop is designed with special containment wells for easy clean-up. Wires have all been thoughtfully positioned under the edge of the cooktop so they never interfere with cleaning*

**EXCLUSIVE DESIGN.** Only GE has the Clean-Well™ Cooktop. This closer look shows you why clean-up is so simple. First, the high spill rims around the Calrod® elements help contain the spills on top. Second, the plug-in Calrod® elements and the simple one-piece drip bowls are easily removed.

**STURDY.** Don't worry about the cooktop falling. The torsion bar and dual support rods make it easy to lift-up and lock. It's just as easy to reverse the procedure.

**LIFT-UP.** Just lift-up and lock the cooktop into place for easy access to the recessed spill containment subtop.

**CONTAINMENT.** GE's Clean-Well™ cooktops are designed to contain most spills before they reach the subtop.

## A SIMPLE GUIDE TO GE'S QUICKSET OVEN CONTROLS



### QUICKSET I

- Auto self-clean • 2-Step self-clean • Preheated oven light • Dual element bake • Quick turn oven control • Platinum-tipped electronic oven sensor



### QUICKSET II

Same as QuickSet I, plus:

- Digital temperature display with recall • Electronic digital clock • Electronic reminder timer, up to 12 hours • Audible Preheat signal • 12-Hour automatic oven shut-off • Self-clean countdown digital display, includes cool down



### QUICKSET III

Same as QuickSet II, plus:

- Automatic oven control • Delay Bake • Delay Self-Clean • Adjustable self-clean cycle time



### QUICKSET IV

Same as QuickSet III, plus:

- Auto self-clean • All touchpad control • Large digital temperature display • Variable broil



### QUICKSET V

Same as QuickSet IV, plus:

- Convection bake/roast • Temperature probe • Extra-large graphics and extra-large touchpads • Digital glass touchpad control (0-9) entry • Oven function icons



# CLEANDESIGN: CONVECTION

ALL MODELS INCLUDE • TrueTemp™ System • Warming option • Dual element bake • Six-pass power bake element • SmartLogic™ electronic control • Patterned glass-ceramic cooktop • One-piece upswept cooktop • Storage drawer • Electronic digital clock and oven controls • Four leveling legs with Easy Level System

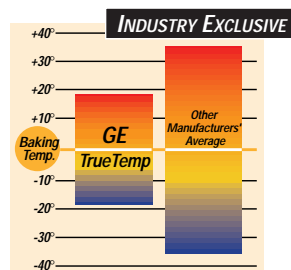

SmartLogic™ Electronic Control delivers more consistent oven temperatures for exceptional cooking results.



Bridge Element for total cooking flexibility.



Convection Ovens provide even cooking and superior baking.



CleanDesign oven interiors have a smooth seamless surface, making cleanup easier than ever.



## GE Profile Performance Series™ JB970SB

- Stainless steel • Self-cleaning convection oven with dedicated third, dual-loop heating element
- Large 3.7 cu. ft. capacity oven • Warming Zone
- QuickSet V oven controls (refer to page 87) • Two 7" ribbon heating elements with connecting bridge element • One dual 6"/9" and one 6" ribbon heating element • Hot lights • Stainless steel oven door with stainless tubular handle • Fluorescent night light • Three oven shelves • Automatic meat thermometer



## GE Profile Performance Series™ JB960AB

- Almond on almond • Largest oven in America\*
- Self-cleaning convection oven with dedicated third, dual-loop heating element • Super large 4.5 cu. ft. capacity oven • CleanDesign oven interior
- Right rear 6" burner with warming function
- QuickSet V oven controls (refer to page 87) • Two 7" ribbon heating elements with connecting bridge element • One dual 6"/9" and one 6" ribbon heating element • Easy-view hot lights • One-piece upswept cooktop • Frameless glass oven door with Sure Grip handle • Automatic self-clean oven latch
- Big View window • Fluorescent night light
- Three oven shelves, one off-set • Automatic meat thermometer

\* Among leading manufacturers

Not all features available on all models. For additional features, specifications and color availability, refer to pages 186-187.



**GE Profile Performance Series™**

**JB960WB**

- White on white • Largest oven in America\*
- Self-cleaning convection oven with dedicated third, dual-loop heating element • Super large 4.5 cu. ft. capacity oven • CleanDesign oven interior
- Right rear 6" burner with warming function
- QuickSet V oven controls (refer to page 87) • Two 7" ribbon heating elements with connecting bridge element • One dual 6"/9" and one 6" ribbon heating element • Easy-view hot lights • One-piece upswept cooktop • Frameless glass oven door with Sure Grip handle • Automatic self-clean oven latch
- Big View window • Fluorescent night light
- Three oven shelves, one off-set • Automatic meat thermometer

**JB960BB** (not shown)

- Black on black



**GE Profile Performance Series™**

**JB940BB**

- Black on black • Largest oven in America\*
- Self-cleaning convection oven with dedicated third, dual-loop heating element • Super large 4.5 cu. ft. capacity oven • CleanDesign oven interior
- Right rear 6" burner with warming function
- QuickSet V oven controls (refer to page 87)
- One dual 6"/9", one 8", and two 6" ribbon heating elements • Easy-view hot lights • One-piece upswept cooktop • Frameless glass oven door with Sure Grip handle • Automatic self-clean oven latch • Big View window • Fluorescent night light • Three oven shelves, one off-set • Automatic meat thermometer

**JB940WB** (not shown)

- White on white

**JB940AB** (not shown)

- Almond on almond

Not all features available on all models.  
For additional features, specifications and color availability, refer to pages 186-187.

# CLEANDESIGN

ALL MODELS INCLUDE • Largest oven in America\* • Super large 5.0 cu. ft. capacity oven • TrueTemp™ System • Self-cleaning oven • Dual element bake • Six-pass power bake element • SmartLogic™ electronic control • Easy-view hot lights • Patterned glass-ceramic cooktop • One-piece upswept cooktop • Storage drawer • Electronic digital clock and oven controls • Four leveling legs with Easy Level System



Six-Pass Power Bake provides more power, total coverage and even cooking.



Dual Element Bake for even baking and roasting.



6 1/8" Dual Element saves energy and provides more efficient cooking.



Largest Usable Oven Capacity\* has room enough for cooking an entire meal.



## GE Profile™

### JBP79AB

- Almond on almond • QuickSet IV oven controls (refer to page 87) • Glass backguard • One 8", two 6" and one dual 6"/9" ribbon heating elements
- Right rear 6" burner with warming option
- Frameless glass oven door with Sure Grip handle
- Fluorescent night light • Automatic self-clean oven latch • Big View window

### JBP79WB (not shown)

- White on white

### JBP79BB (not shown)

- Black on black



## GE

### JBP78WB

- White on white • QuickSet III oven controls (refer to page 87) • One 8" and two 6", and one dual 6"/9" ribbon heating elements
- Right rear 6" burner with warming option
- Frameless glass oven door with designer-style handle • Big View window

### JBP78AB (not shown)

- Almond on almond

### JBP78BB (not shown)

- Black on black



## GE

### JBP66WB

- White on white • Standard window
- QuickSet III oven control (refer to page 87)

### JBP66AB (not shown)

- Almond on almond

### JBP66BB (not shown)

- Available in white or almond with black glass door

\*Among leading manufacturers

Not all features available on all models. For additional features, specifications and color availability, refer to pages 186-187.



# CLEANDESIGN

ALL MODELS INCLUDE • Self-cleaning oven • Dual element bake • Frameless glass oven door  
 • Designer-style handle • Two 8" and two 6" ribbon heating elements • Four leveling legs with Easy Level System

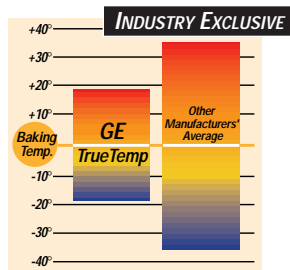

SmartLogic™ Electronic Control delivers more consistent oven temperatures for exceptional cooking results.



Six-Pass Power Bake provides more power, total coverage and even cooking.



Largest Usable Oven Capacity\* has room enough for cooking an entire meal.



Ribbon Elements direct heat directly to the pan and provide even heat for uniform cooking.



**GE JBP64BB**  
 • White or Almond • Largest oven in America\* • Super large 5.0 cu. ft. capacity oven • QuickSet II oven controls (refer to page 87) • Easy-view hot lights



**GE JBP63BB**  
 • White or Almond • QuickSet II oven controls (refer to page 87) • Easy-view hot lights



**GE JBP60BB**  
 • White • QuickSet I oven controls with auto self-clean (refer to page 87) • Easy-view hot lights

## ACCESSORY INFORMATION

For easy cleaning of the cooktop, GE provides one scraper and one 2.5-oz. bottle of cleaning creme with each range. For additional supply, call toll-free 1-800-626-2002.

\* Among leading manufacturers

Not all features available on all models. For additional features, specifications and color availability, refer to pages 186-187.

# QUICKCLEAN™ SELF-CLEAN

ALL MODELS INCLUDE • Self-cleaning oven • Dual Element Bake • Frameless glass oven door • Designer-style handle  
 • CleanWell™ cooktop system • Lift-up Cooktop • Plug-in Calrod® heating elements, two 8" and two 6" • Heating element "ON" indicator lights • Removable full-width storage drawer • Four leveling legs with Easy Level System • Removable one-piece drip bowls

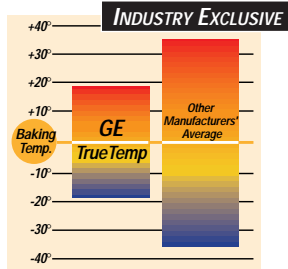

SmartLogic™ Electronic Control delivers more consistent oven temperatures for exceptional cooking results.



Six Pass Power Bake provides more power, total coverage and even cooking.



Largest Usable Oven Capacity\* has room enough for cooking an entire meal.



Lift-up cooktop locks into place for easy cleaning. Clean-Well™ Cooktop System contains spills so clean-up is simple.



## GE Profile™

### JBP48AB

- Almond on almond • Largest oven in America\*
- Super 5.0 cu. ft. capacity oven • TrueTemp™ System • SmartLogic™ electronic controls • Six-pass power bake element • Right rear 6" burner with warming option • Big View window • QuickSet IV oven controls (refer to page 87) • Sure Grip handle • Deluxe Calrod® heating elements • Automatic self-clean oven latch

### JBP48WB (not shown)

- White on white

### JBP48BB (not shown)

- Black on black



## GE

### JBP35BB

- White or Almond • Largest oven in America\*
- Super 5.0 cu. ft. capacity oven • TrueTemp™ System • SmartLogic™ electronic controls
- Six-pass power bake element • Big View window • QuickSet III oven controls (refer to page 87) • Deluxe Calrod® heating elements

\*Among leading manufacturers

Not all features available on all models. For additional features, specifications and color availability, refer to page 188.



**GE**

**JBP30WB**

- White on white • Largest oven in America\*
- Super 5.0 cu. ft. capacity oven • TrueTemp™ System
- SmartLogic™ electronic controls • Six-pass power bake element • QuickSet III oven controls (refer to page 87) • Standard window • Deluxe Calrod® heating elements

**JBP30AB** (not shown)

- Almond on almond

**JBP30BB** (not shown)

- Available in white or almond with black glass door



**GE**

**JBP24BB**

- White or Almond • Largest oven in America\*
- Super 5.0 cu. ft. capacity oven • Standard window
- QuickSet II oven controls (refer to page 87)



**GE**

**JBP19BB**

- White • QuickSet I oven controls with auto self-clean (refer to page 87)

Not all features available on all models.  
For additional features, specifications and color availability, refer to page 188.



# QUICKCLEAN™ STANDARD CLEAN

ALL MODELS INCLUDE • Clean-Well™ Cooktop System • Heating element "ON" indicator light • Removable full-width storage drawer • Four leveling legs with Easy Level System • Removable one-piece chrome drip bowls



Lift-up cooktop locks into place for easy cleaning.



Clean-Well™ Cooktop System contains spills so clean-up is simple.



Calrod® Heating Elements provide even heat distribution for better cooking performance.



- GE**  
**JBS27BY**
- White or almond • Standard clean oven
  - Lift-up cooktop • Plug-in Calrod® heating elements, two 8" and two 6" • Electronic clock and minute timer • Frameless black glass oven door with window • Designer-style handle

- JBS27WY** (not shown)  
• White on white

- JBS27AY** (not shown)  
• Almond on almond



- GE**  
**JBS26W**
- White or almond • Standard clean oven
  - Plug-in Calrod® heating elements, one 8" and three 6" • Electronic clock and minute timer • Color-matched oven door with window • Chrome visor handle



- GE**  
**JBS23BB**
- White or almond • Standard clean oven
  - Plug-in Calrod® heating elements, two 8" and two 6" • Electronic clock and minute timer • Frameless black glass oven door with window • Chrome visor handle



- GE**  
**JBS07V**
- White on white • Standard clean oven
  - Plug-in Calrod® heating elements, one 8" and three 6" • Oven door with window
  - Chrome visor handle

Not all features available on all models. For additional features, specifications and color availability, refer to page 189.



- GE**  
**JBS05Y** (Does not have Clean-Well™ Cooktop System)
- White or almond • Standard clean oven
  - Up-front controls • Plug-in heating elements, one 8" and three 6" • Color-matched oven door with window • Chrome visor handle
  - Storage drawer



- GE**  
**JBS03GV**
- White or almond • Standard clean oven
  - Plug-in Calrod® heating elements, one 8" and three 6" • Frameless solid black glass oven door • Designer-style handle
- JBS03V** (not shown)
- Solid color-matched oven door
  - Chrome visor handle



- GE**  
**JBS02BB**
- White • Standard clean oven • Plug-in Calrod® heating elements, one 8" and three 6" • Frameless solid black glass oven door • Chrome visor handle

## 40" SELF-CLEANING & STANDARD CLEAN

**BOTH MODELS INCLUDE** • Storage drawer • Lift-off oven door with window • Interior oven light • Two 6" and two 8" heating elements



Easy-to-use Electronic Controls provide cooking convenience.



- GE**  
**JCP67Y**
- White on white • Self-cleaning master oven • Standard clean companion oven
  - Electronic clock and automatic master oven timer

- JCS57Y** (not shown)
- White on white • Standard clean oven
  - Companion storage compartment with shelf • Electronic clock and timer

Not all features available on all models.  
For additional features, specifications and color availability, refer to page 189.

# WHEN IT COMES TO ACCURACY, GE TRUETEMP™ IS RIGHT ON THE MARK



## GE TRUETEMP™ THE MOST ACCURATE OVEN IN AMERICA!

The guesswork is gone. The temperamental oven is a thing of the past. GE's exclusive TrueTemp™ system manages and maintains the oven temperature you select. It's more accurate than any other leading brand. The SmartLogic™ electronic control, with a platinum sensor, constantly monitors the oven's performance to ensure more precise temperature management. (Even if you open the door when the oven is on, SmartLogic™ senses variations in temperature and responds to regain the selected setting.) The TrueTemp™ system also includes a new enhanced broil system, which distributes heat broadly and evenly for improved cooking performance. QuickSet electronic controls make it easy for you to set the oven temperature and the time for baking or broiling. And the extra-large oven, broiler pan and grid provide the capacity you need when cooking for a crowd.

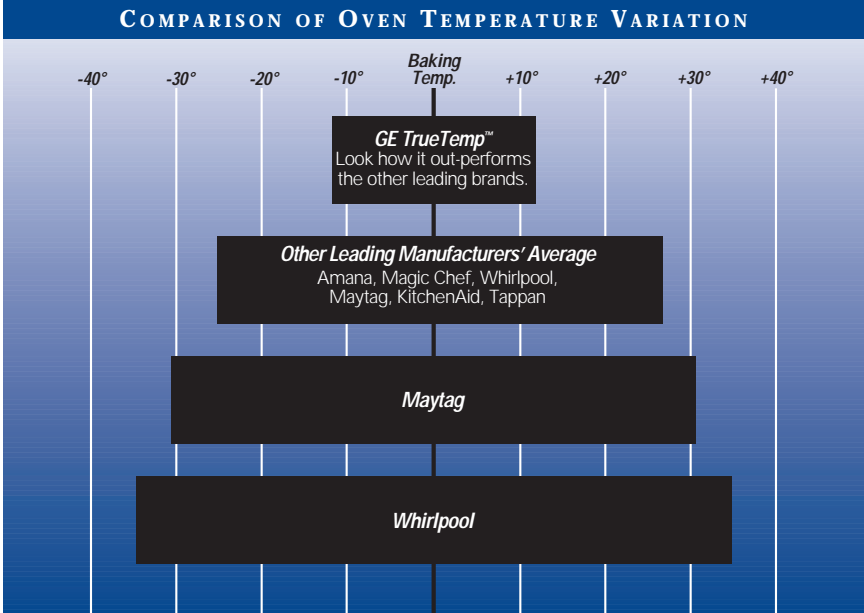





## COMPLETING THE RECIPE FOR QUALITY COOKING

Advanced temperature control is only one of the features that GE gas ranges offer. They also have an amazingly versatile cooktop—you can choose the burner that best suits the job: the Maximum Output burner for fast heating and rapid boiling; the Precise Simmer burner for gentle heating; or any of the burners for cooking over medium heat. The cooktop's seamless design and porcelain-enameled surface help make clean-up smooth and swift. Meanwhile, your TrueTemp™ oven is super-sized with the largest usable oven capacity\* available in 30" free-standing ranges.

*\*Among leading manufacturers' brands.*

# XL44™ SELF-CLEANING: SEALED BURNERS

THESE MODELS INCLUDE • TrueTemp™ System • SmartLogic™ electronic control • Extra-large self-cleaning oven • Electronic clock and automatic oven timer • Sealed burners • Precise Simmer burner • Maximum Output burners • Three oven racks • Six embossed rack positions • In-oven broiling • Extra-large broiler pan with grid • Interior oven light • Electronic pilotless ignition

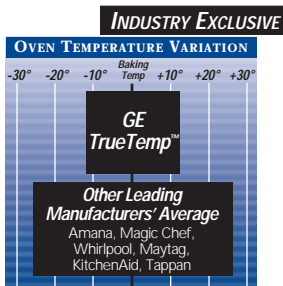

TrueTemp™ System.  
"The Most Accurate Oven in America."



Enhanced Broil System provides improved broil performance.



Largest Usable Oven Capacity\* has room enough for cooking an entire meal.



Digipad Entry provides digital precision with easy-to-set controls.



## GE Profile™

### JGBP90MEA Commercial-Style Gas Range

- Brushed chrome styling • Mirrored glass backguard • QuickSet V oven controls with digipad entry; auto oven shut-off with override; start pad; delay clean option and self-clean cool down time display
- Fluorescent cooktop night light
- Mirrored glass oven door with Big View window • Professional-style handle and control knobs • One-piece upswept brushed-chrome cooktop • Professional cooktop grates with rubber feet
- Continuous grate surface



## GE Profile™

### JGBP86WEA

- White on white • Scratch resistant glass backguard • QuickSet V oven controls with digipad entry; auto oven shut-off with override; start pad; delay clean option and self-clean cool down time display
- Fluorescent cooktop night light
- Frameless glass oven door with Big View window • Sure Grip handle • Designer-style control knobs • One-piece upswept porcelain-enameled cooktop • Professional extra-large cast iron grates • Continuous grate surface • One-piece drip pans

### JGBP86AEA (not shown)

- Almond on almond

### JGBP86BEA (not shown)

- Black on black

Not all features available on all models. For additional features, specifications and color availability, refer to page 190.

\*Among leading manufacturers' brands.



Sealed Burner Design helps contain spills from dripping beneath cooktop for easy clean-up.



Precise Simmer Burner with 600 BTUs allows for low, even heat distribution for delicate foods and sauces.



Maximum Output Burners, with 12,000 BTUs, provide maximum output for fast heat-up and boiling.



**GE Profile™  
JGBP85BEA**

- Black on black • Scratch resistant glass backguard • QuickSet V oven controls with digipad entry; auto oven shut-off with override; start pad; delay clean option and self-clean cool down time display
- Fluorescent cooktop night light
- Frameless glass oven door with Big View window • Sure Grip handle • Designer-style control knobs • One-piece upswept porcelain-enameled cooktop • Square deluxe cast grates with rubber feet
- One-piece drip pans

- JGBP85AEA** (not shown)  
• Almond on almond

- JGBP85WEA** (not shown)  
• White on white



**GE Profile™  
JGBP79AEA**

- Almond on almond • QuickSet IV oven controls with digital temperature display; auto oven shut-off with override; start pad; delay clean option; self-clean cool down time display and control lock capability
- Scratch-resistant porcelain-enameled backguard • Glass oven door with Big View window • Sure Grip handle
- Designer-style control knobs • One-piece upswept porcelain-enameled cooktop
- Square deluxe cast grates with rubber feet • One-piece drip pans

- JGBP79WEA** (not shown)  
• White on white

- JGBP79BEA** (not shown)  
• Black on black

Not all features available on all models. For additional features, specifications and color availability, refer to page 190.



# XL44™ SELF-CLEANING: SEALED BURNERS

ALL MODELS INCLUDE • Extra-large self-cleaning oven • Six embossed rack positions • QuickSet oven controls • Sealed burners • Electronic pilotless ignition • One-piece, upswept porcelain-enameled cooktop • Frameless glass oven door • Designer-style handle • In-oven broiling • Extra-large broiler pan • Two oven racks • Interior oven light



**GE**

**JGBP35BEA**

- Black on black • TrueTemp™ System
- SmartLogic™ electronic control
- QuickSet IV oven controls with digital temperature display; auto oven shut-off with override; start pad; delay clean option; self-clean cool down time display; and control lock capability • Precise Simmer burner • Maximum Output burner • Big View window • Storage drawer • Black standard cast square grates
- Black porcelain-enameled drip pans

**JGBP35AEA** (not shown)

- Almond on almond

**JGBP35WEA** (not shown)

- White on white



**GE**

**JGBP30BEA**

- TrueTemp™ System • SmartLogic™ electronic control • QuickSet III oven controls with digital temperature display; auto oven shut-off and audible preheat signal • Precise Simmer burner • Maximum Output burner • Big View window • Storage drawer • Black deluxe porcelain steel square grates • Black porcelain-enameled drip pans

**JGBP30AEA** (not shown)

- Almond on almond

**JGBP30WEA** (not shown)

- White on white



**GE**

**JGBP28BEA**

- QuickSet II oven controls with digital temperature display; auto oven shut-off and audible preheat signal • Storage drawer • Black standard porcelain steel square grates



**GE**

**JGBP27BEA**

- QuickSet II oven controls with digital temperature display; auto oven shut-off and audible preheat signal • Black standard porcelain steel square grates

# XL44™ SELF-CLEANING: STANDARD BURNERS

- ALL MODELS INCLUDE • Extra-large self-cleaning oven • Six embossed rack positions • Electronic pilotless ignition • QuickSet oven controls • Frameless glass oven door with designer-style handle • Lift-up cooktop • Square, standard porcelain steel grates • One-piece, porcelain-enameled cooktop and subtop • In-oven broiling • Extra-large broiler pan with grid • Two oven racks • Interior oven light



**INDUSTRY EXCLUSIVE**

Largest Usable Oven Capacity\* has room enough for cooking an entire meal.



Sixth Embossed Rack Position increases cooking flexibility.



- GE JGBP26BEA**
- TrueTemp™ System • SmartLogic™ electronic control • QuickSet III oven controls with digital temperature display; delay bake option; auto oven shut-off and audible preheat signal
  - Black porcelain-enameled drip pans
  - Storage drawer

- JGBP26AEA** (not shown)
- Almond on almond

- JGBP26WEA** (not shown)
- White on white



- GE JGBP24BEA**
- QuickSet II oven controls with digital temperature display; auto oven shut-off and audible preheat signal

\*Among leading manufacturers' brands.

Not all features available on all models. For additional features, specifications and color availability, refer to page 190.

# XL44™ STANDARD CLEAN: SEALED BURNERS

- ALL MODELS INCLUDE • Extra-large standard clean oven • Six embossed rack positions • Electronic clock and timer
- Sealed burners • Porcelain steel square grates • Electronic pilotless ignition • One-piece, upswept porcelain-enameled cooktop
  - Slide-out broiler drawer • Extra-large broiler pan with grid

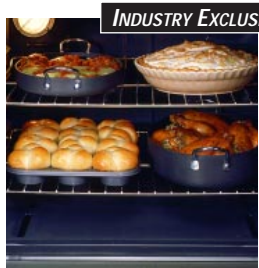

**INDUSTRY EXCLUSIVE**

Largest Usable Oven Capacity\* has room enough for cooking an entire meal.



Sealed Burner Design helps contain spills from dripping beneath cooktop for easy clean-up.



Sixth Embossed Rack Position increases cooking flexibility.



**GE**

**JGBS23AEA**

- Almond on almond • Frameless almond glass oven door with Big View window
- Designer-style handle • Precise Simmer burner • Maximum Output burner
- Taupe porcelain-enameled drip pans
- Interior oven light

**JGBS23WEA** (not shown)

- White on white
- Grey porcelain-enameled drip pans

**JGBS23BEA** (not shown)

- Black glass door
- Black porcelain-enameled drip pans



**GE**

**JGBS22BEA**

- Frameless black glass oven door with window • Interior oven light



**GE**

**JGBS21PEA**

- Solid porcelain-enameled oven door
- Chrome visor handle

\*Among manufacturers' brands.

Not all features available on all models. For additional features, specifications and color availability, refer to page 191.



# XL44™ CONTINUOUS & STANDARD CLEAN: STANDARD BURNERS

ALL MODELS INCLUDE • Six embossed rack positions • Electronic pilotless ignition • Lift-up cooktop • Square, standard porcelain steel grates • Porcelain-enameled cooktop • Easy-clean porcelain-enameled subtop • Slide-out broiler drawer • Extra-large broiler pan with grid • Two oven racks • Interior oven light



**GE**  
**JGBC20BEA**  
• Extra-large continuous clean oven  
• Electronic clock and timer • Frameless black glass oven door with designer-style handle • One-piece upswept cooktop

**JGBC20WEA** (not shown)  
• White on white

**JGBS20BEA** (not shown)  
• Extra-large standard clean oven

**JGBS20WEA** (not shown)  
• White on white



**GE**  
**JGBC17PEA**  
• Extra-large continuous clean oven  
• Electronic clock and timer  
• Color-matched porcelain-enameled oven door with designer-style handle  
• One-piece upswept cooktop

**JGBS17PEA** (not shown)  
• Extra-large standard clean oven



**GE**  
**JGBS15PEA**  
• Extra-large standard clean oven  
• Color-matched porcelain-enameled oven door with window • Chrome visor handle  
• Electronic pilotless ignition • Square standard porcelain steel grates • Interior oven light • Drop-down broiler drawer



**GE**  
**JGBS07PEA**  
• White on white • Extra-large standard clean oven • White porcelain-enameled oven door with designer-style handle  
• Interior oven light



**GE**  
**JGBS04BEA**  
• Frameless solid black glass oven door with designer-style handle • Extra-large standard clean oven

**JGBS04BPA** (not shown)  
• Standing pilot ignition

**JGBS04PEA** (not shown)  
• Solid porcelain-enameled oven door with chrome visor handle

**JGBS04PPA** (not shown)  
• Standing pilot ignition



**GE**  
**JGBS03PPA**  
• Solid porcelain-enameled oven door with chrome visor handle • Standing pilot ignition

Not all features available on all models. For additional features, specifications and color availability, refer to page 191.

Refrigeration

Water Systems

Laundry

Free-Standing Cooking Products

Microwave Ovens

Dishwashers

Room Air

## COMBINING STYLE, FLEXIBILITY



### GE — THE ORIGINAL SPACEMAKER™

In 1979, GE invented the Spacemaker™ over-the-range microwave. With so many features and the 20 years that go behind the GE Spacemaker™ it is easy to see why many people are making this their microwave of choice. When combined with a GE range, you now have a cooking center that gives even more flexibility. The GE Spacemaker™ 1600 still reigns as the largest over-the-range microwave ever! A powerful, two-speed exhaust fan, with 300 CFM, and cooktop light are integrated into the base of the microwave oven eliminating the need for a range hood. The Easy Mount system makes GE over-the-range microwave ovens simple to install. When installed above a GE range, you've increased valuable countertop space in the kitchen. Experience combined with space-saving design, exactly what you've come to expect from GE.

# AND GREAT FEATURES!



**AFTER**

*JVM1660WB*

Refrigeration

Water Systems

Laundry

Cooking Products

Microwave Ovens

Dishwashers

Room Air



# SPACEMAKERPLUS™: COMBINATION MICROWAVE/CONVECTION

ALL MODELS INCLUDE • 1.1 cu. ft. oven cavity • 825 watts\* • Sensor Cooking Controls for Popcorn, Beverage, Canned Vegetables, Fresh Vegetables and Frozen Vegetables and Reheat Pads • Combination Microwave/Convection Oven • Sensor Combination (Chicken, Fish, Potato) • Combination Roast (probe) • Combination Bake Hi/Lo • Convection Bake • Auto Defrost/Time Defrost • SmartControl System with Interactive Display • Convection Rack/Broil Pan • Temp Cook (probe) • Programmable Nite Light



The Sensor Combination pads take the guesswork out of cooking.



Convection Cooking provides a browned crisp exterior and moist interior.



The Combination Bake/Hi uses 30% microwave power, combined with convection cooking for faster cooking results.



## **GE Profile Performance Series™**

### **JVM1190SY**

- Stainless steel

### **JVM1190WY** (not shown)

- White on white

### **JVM1190BY** (not shown)

- Black on black

### **JVM1190AY** (not shown)

- Almond on almond

\*IEC-705 Test Procedure

Not all features available on all models.  
For additional features, specifications and color availability, refer to page 192.

# SPACEMAKER: SENSOR COOKING CONTROLS

ALL MODELS INCLUDE • 1.6 cu. ft. oven cavity • 1000 watts\* • Sensor Cooking Controls for Popcorn, Beverage, Reheat, Ground Meats, Fish Fillets, Chicken Pieces, Potatoes and Vegetable Pads • Audio Message Center • Appointment Scheduler • Two Custom Pads • CircuWave™ 1000 Cooking System • Turntable On/Off • SmartControl System with Interactive Display • Help Pad • Timer On/Off • Full-View Cooktop Lighting • Programmable Nite Light • Time Cook I & II • Temp Cook/Roast (probe) • Auto Defrost/Time Defrost • Add 30 Seconds • Instant On Controls • Beeper Volume Control • Child Lock-Out • Powerful 300 CFM Two-Speed, High-Capacity Exhaust Fan • Easy Mount Installation • Clock Saver • Cookbook



Sensor controls automatically eliminates guesswork.



Message Center allows you to leave audio messages for your family.



Appointment Scheduler pad allows you to schedule and input future appointments and will remind you as well.



This powerful 300 CFM venting system will remove smoke and steam from your cooktop.

\*IEC-705 Test Procedure



**GE Profile™**  
**JVM1660SB**  
• Stainless steel



**GE Profile™**  
**JVM1660WB**  
• White on white  
**JVM1660BB** (not shown)  
• Black on black  
**JVM1660AB** (not shown)  
• Almond on almond

Not all features available on all models.  
For additional features, specifications and color availability, refer to page 193.

Refrigeration

Water Systems

Laundry

Cooking Products

Microwave Ovens

Dishwashers

Room Air

# SPACEMAKER: SENSOR/CONVENIENCE COOKING CONTROLS

THESE MODELS INCLUDE • 1.6 cu. ft. oven cavity • 1000 watts\* • Sensor Cooking Controls for Beverage, Potato, Vegetables, Popcorn and Reheat pads • Convenience Controls for Cook and Snack pads • CircuWave™ 1000 Cooking System • Turntable On/Off • Time Cook I & II • Delay Start • Reminder • Auto/Time Defrost • Express Cook • Add 30 Seconds • 10 power levels • Instant On Controls • Timer On/Off • Child Lock-Out • Cooking Complete Reminder • Removable Dual Rack • Programmable Nite Light • Beeper Volume Control



Sensor controls automatically eliminates guesswork.



Auto Defrost/Time Defrost automatically sets defrosting time and power level.



Convenience Cooking Controls allow you to defrost, cook or reheat at the touch of a pad.



This powerful 300 CFM venting system will remove smoke and steam from your cooktop.

\*IEC-705 Test Procedure

Not all features available on all models. For additional features, specifications and color availability, refer to page 193.



**GE**  
**JVM1650BB**  
 • Black on black  
**JVM1651BB**  
 (not shown)  
 • Non-vented model



**GE**  
**JVM1650AB**  
 • Almond on almond  
**JVM1651AB**  
 (not shown)  
 • Non-vented model  
**JVM1650WB**  
 (not shown)  
 • White on white  
**JVM1651WB**  
 (not shown)  
 • Non-vented model



# SPACEMAKER: CONVENIENCE COOKING CONTROLS

JVM1640 AND JVM1630 INCLUDE • 1.6 cu. ft. oven cavity • 1000 watts\* • Convenience Cooking Controls for Beverage Pad • Time Cook I & II • Delay Start • Reminder • Auto/Time Defrost • Express Cook • Add 30 Seconds • 10 power levels • Instant On Controls • Timer On/Off • Child Lock-Out • Cooking Complete Reminder



**GE**

## JVM1640WB

- White on white • Convenience Cooking Controls for Popcorn, Reheat and Cook pads
- CircuWave™ 1000 Cooking System • Turntable On/Off • Beeper Volume Control
- Removable Dual Rack



## JVM1640BB

(not shown)

- Black on black

## JVM1640AB

(not shown)

- Almond on almond



**GE**

## JVM1630BB

- Black on black • Convenience Cooking Controls for Popcorn, Beverage and Reheat pads • CircuWave™ 1000 Cooking System • Turntable



## JVM1631BB

(not shown)

- Non-vented model

## JVM1630WB

(not shown)

- White on white

## JVM1631WB

(not shown)

- Non-vented model



**GE**

## JVM1420WB

- 1.4 cu. ft. oven capacity • 950 watts • White on white
- Convenience cooking controls for Popcorn, Beverage and Reheat pads • Turntable



## JVM1420BB

(not shown)

- Black on black

Not all features available on all models.

For additional features, specifications and color availability, refer to page 193.

Refrigeration

Water Systems

Laundry

Cooking Products

Microwave Ovens

Dishwashers

Room Air

# BUILT-IN MICROWAVE OVENS

ALL MODELS INCLUDE • 1.0 cu. ft. oven cavity • 800 watts\* • Sensor Cooking Controls for Popcorn, Cook, Reheat and Beverage pads • Express Cook

The new built-in microwave oven (JEB1095 and JEB1055) now fits a 27" or 30" configuration over a wall oven. A trim kit (included with all models) enables the unit to be adapted to a 30" width. The models are available in classic white and black. There is also a new stainless steel model available for the GE Profile Performance Series™.

## MICROWAVE/CONVECTION



Sensor Controls take the guesswork out of cooking.



The Built-In Microwave/Convection Oven provides a true built-in appearance.



Convection cooking produces brown exteriors and moist interiors.



Shown in 30" size

### GE Profile Performance Series™

#### JEB1095SB

- Stainless steel • Combination Roast (probe) • Combination Cooking

#### JEB1095BB (not shown)

- Black on black • Convection Cooking
- Combination Roast (probe)
- Combination Cooking

#### JEB1095WB (not shown)

- White on white

## MICROWAVE ONLY



Shown in 27" size

### GE Profile™

#### JEB1055WB

- White on white • Auto Roast (probe)

#### JEB1055BB (not shown)

- Black on black



JEB1055WB control panel

\*IEC-705 Test Procedure

Not all features available on all models. For additional features, specifications and color availability, refer to page 194.

## GE COUNTERTOP MICROWAVES



### OFFER SOMETHING FOR EVERYONE.

Size and power are typical of the choices available from GE. From .5 to 1.8 cu. ft. and from 600 to 1100 watts. GE has a countertop microwave oven for every need imaginable. The choices continue with features such as sensor pads that cook your food to perfection, convenience pads, and pre-programmed timing. GE even offers a microwave/convection model for microwave cooking with browning and broiling capabilities. And when it comes to installation, GE offers great flexibility. You can set your countertop microwave oven on a counter, hang it underneath your cabinet or build it into your wall. The choice is yours with a GE countertop microwave.



# COUNTERTOP: MICROWAVE/CONVECTION

**BOTH MODELS INCLUDE** • 1.3 cu. ft. oven cavity • 850 watts\* • Sensor Cooking Controls for Beverage, Popcorn, Cook and Reheat pads • Turntable • Time Cook I & II • Convection Cook • Combination Cook • Combination Roast • 10 power levels • SmartRack • Auto Defrost • Kitchen Timer • Delay Start • Express Cook • Deluxe Cookbook • Built-in kit (available at additional cost)



Convection Cooking produces golden brown exteriors and moist interiors.



Combination Cooking combines microwave and convection cooking.



The SmartRack provides two levels of convection cooking.



**GE Profile Performance Series™**

**JE1390GA**

• Black with greystone case



**GE Profile Performance Series™**

**JE1390WA**

• White on white



## BUILT-IN ACCESSORY TRIM KITS

Built-in accessory trim kits allow installation in a wall or cabinet alone, or over a GE 30" or 27" single electric wall oven. Use a convection wall oven under these convection microwave ovens for a complete convection cooking center. (See page 197 for dimensional data. Kit available at additional cost.)

\*IEC-705 Test Procedure

Not all features available on all models. For additional features, specifications and color availability, refer to page 195.

# COUNTERTOP: SENSOR CONTROLS

ALL MODELS INCLUDE • Scrolling Display • Sensor Cooking Controls for Beverage, Popcorn, Potato, Vegetable, Chicken/Fish and Reheat pads • Time Cook I & II • Auto Defrost/Time Defrost • Express Cook • Add 30 Seconds • 10 power levels • Instant On Controls • Timer On/Off • Child Lock-Out • Delay Start • Reminder • Cooking Complete Reminder • Variable Beeper Volume



Sensor Controls take the guesswork out of cooking.

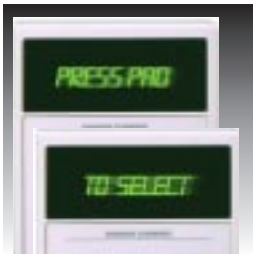

The Scrolling Display is easy to read and a helpful cooking guide.



**GE Profile™**  
**JE1860SB**

- Stainless steel • Extra-large 1.8 cu. ft. oven cavity • 1100 watts\*
- Turntable On/Off • Built-in kit available at additional cost



**JE1860GB**

(not shown)  
• Black with greystone case

**JE1860WB**

(not shown)  
• White on white



**GE Profile™**  
**JE1660WB**

- White on white • Full-size 1.6 cu. ft. oven cavity • 1100 watts\*
- Turntable • Built-in kit available at additional cost



**JE1660GB**

(not shown)  
• Black with greystone case



**GE Profile™**  
**JE1360GB**

- Black with greystone case • Family-size 1.3 cu. ft. oven cavity
- 1100 watts\* • Turntable



**JE1360WB**

(not shown)  
• White on white

\*IEC-705 Test Procedure

Not all features available on all models. For additional features, specifications and color availability, refer to page 195.

# COUNTERTOP: SENSOR CONTROLS (CONTINUED)

ALL MODELS INCLUDE • Scrolling Display • Sensor Cooking Controls for Beverage, Popcorn, Potato, Vegetable, Chicken/Fish and Reheat pads • Time Cook I & II • Auto Defrost/Time Defrost • Express Cook • Add 30 Seconds • 10 power levels • Instant On Controls • Timer On/Off • Child Lock-Out • Delay Start • Reminder • Cooking Complete Reminder • Variable Beeper Volume



Sensor Controls take the guesswork out of cooking.

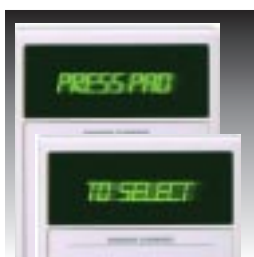

The Scrolling Display is easy to read and a helpful cooking guide.



The versatility of a GE countertop microwave fits any consumer's needs. The ability to build into a wall frees up valuable counter space.



## GE Profile™

### JE1060GB

- Black with greystone case • Family-size 1.0 cu. ft. oven cavity
- 1100 watts\* • Turntable

### JE1060WB

(not shown)

- White on white



## GE Profile™

### JEM31GA

- Black with greystone case • Mid-size .9 cu. ft. oven cavity
- 800 watts\*

### JEM31WA

(not shown)

- White on white

### JEM31SA

(not shown)

- Stainless steel



\*IEC-705 Test Procedure

Not all features available on all models. For additional features, specifications and color availability, refer to page 195.



# COUNTERTOP: CONVENIENCE CONTROLS

THESE MODELS INCLUDE • Convenience Cooking Controls for Popcorn, Reheat, Snacks, Cook and Beverage Pads  
 • Time Cook I & II • Auto Defrost • Time Defrost • Express Cook • Kitchen Timer • Child Lock-Out



**GE**  
**JE1840WB**  
 • White on white • Extra-large 1.8 cu. ft. oven cavity • 1100 watts\* • Turntable  
 • Built-in kit available at additional cost  
**JE1840GB** (not shown)  
 • Black with greystone case



**GE**  
**JE1640GB**  
 • Black with greystone case • Full-size 1.6 cu. ft. oven cavity  
 • 1100 watts\* • Built-in kit available at additional cost  
**JE1640WB** (not shown) • White on white  
**JE1640AB** (not shown) • Almond on almond



**GE**  
**JE1340WB** (not shown) • White on white  
**JE1340GB**  
 • Black with greystone case • Family-size 1.3 cu. ft. oven cavity  
 • 1100 watts\*



**GE**  
**JE1040WB**  
 • White on white • Mid-size 1.0 cu. ft. oven cavity • 1100 watts\*  
**JE1040GB** (not shown)  
 • Black with greystone case



**GE**  
**JE740WY**  
 • White on white • Compact .7 cu. ft. oven cavity • 700 watts\*  
 • Undercabinet hanging kit available at additional cost  
**JE740GY** (not shown)  
 • Black with greystone case

\*IEC-705 Test Procedure

Not all features available on all models.  
 For additional features, specifications and color availability, refer to page 195.

# COUNTERTOP



**GE**  
**JE835WW**

- White on white • Mid-size .8 cu. ft. oven cavity • 800 watts\*
- Convenience Controls for Beverage, Popcorn, Frozen Pizza, Dinner Plate, Baked Potato, Vegetables and Soup Pads • Time Preference



**GE**  
**JE520BW**

- Black with greystone case • Subcompact .5 cu. ft. oven cavity • 600 watts\* • Turntable • Electronic touch controls with electronic digital display and clock • Time Cook • Time Defrost • Cooking Complete Reminder • 10 power levels • Undercabinet hanging kit (at additional cost)



**GE**  
**JE710BA**

- Black with greystone case • Compact .7 cu. ft. oven cavity • 600 watts\* • Turntable • Mechanical dial • Undercabinet hanging kit (at additional cost)



**GE**  
**JE510BW**

- Black with greystone case • Subcompact .5 cu. ft. oven cavity • 600 watts\* • Turntable • 15-minute timer



**GE**  
**JE635WW**

- White on white • Compact .6 cu. ft. oven cavity • 600 watts\*
- Convenience Cooking Controls for Beverage, Popcorn, Frozen Pizza, Dinner Plate, Baked Potato and Vegetables Pads • Instant On controls • Auto Defrost • Auto Start • Electronic Digital Display with Clock • Child Lock-Out

\*IEC-705 Test Procedure

Not all features available on all models.  
For additional features, specifications and color availability, refer to page 196.

# SPACEMAKER II™



Easy Under Cabinet Installation leaves counter space free for food preparation.



**GE**

**JEM25WY**

- White on white • Mid-size .9 cu. ft. oven cavity • 800 watts\*
- Convenience Cooking Controls for Popcorn, Beverage, Reheat, Snacks and Cook Pads • Delay Start/Reminder • Time Defrost
- Auto Defrost • Time Cook I & II
- Express Cook • Instant On Controls • Sound On/Off • Built-in or Undercabinet Hanging Kit (available at additional cost)

**JEM25GY** (not shown)

- Black with greystone case

Not all features available on all models. For additional features, specifications and color availability, refer to page 196.

## COUNTERTOP MICROWAVE OVEN TRIM KITS



### BUILT-IN ACCESSORY TRIM KIT FOR 1.8 CU. FT. MICROWAVE OVENS

This trim kit allows for built-in installation of the 1.8 countertop microwave oven in a wall or cabinet alone, or over a GE 30" single electric wall oven as shown. In addition, this deluxe trim kit is designed to integrate handsomely for a built-in one-piece appearance.

#### 30" Deluxe Accessory Trim Kits

For models JE1860 and JE1840: JX1830SB —Stainless Steel, JX1830BB —Black, JX1830WB —White

#### 27" DELUXE ACCESSORY TRIM KIT FOR 1.8 CU. FT. MICROWAVE OVENS (not shown)

The 27" deluxe trim kit allows a 1.8 countertop microwave oven to be built into a wall or cabinet alone, or over a GE 27" single electric wall oven for a complete one-piece built-in integrated appearance.

#### 27" Deluxe Accessory Trim Kits

For models JE1860 and JE1840: JX1827SB —Stainless Steel, JX1827BB —Black, JX1827WB —White



### BUILT-IN ACCESSORY TRIM KIT FOR 1.6 CU. FT. MICROWAVE OVENS

This trim kit allows for built-in installation of the 1.6 countertop microwave oven in a wall or cabinet alone, or over a GE 30" single electric wall oven as shown. In addition, this deluxe trim kit has smooth rounded corners and is designed to integrate handsomely for a built-in one-piece appearance.

#### 30" Deluxe Accessory Trim Kits

For models JE1660 and JE1640: JX1530MAW —Almond, JX1530MBW —Black, JX1530MWW —White

#### 27" DELUXE ACCESSORY TRIM KIT FOR 1.6 CU. FT. MICROWAVE OVENS (not shown)

The 27" deluxe trim kit allows a 1.6 countertop microwave oven to be built into a wall or cabinet alone, or over a GE 27" single electric wall oven for a complete one-piece built-in integrated appearance.

#### 27" Deluxe Accessory Trim Kits

For models JE1660 and JE1640: JX1527MAW —Almond, JX1527MBW —Black, JX1527MWW —White



### GE PROFILE PERFORMANCE™ BUILT-IN ACCESSORY TRIM KITS

#### FOR 1.3 CU. FT. MICROWAVE OVENS

Built-in accessory trim kits allow installation in a wall or cabinet alone, or over a GE 30" single electric wall oven. Use a convection wall oven under these convection microwave ovens for a complete convection cooking center.

#### 30" Deluxe Accessory Trim Kits

For model JE1390: JX1330BV —Black, JX1330WV —White

#### 27" Deluxe Accessory Trim Kits

For JE1390: JX1327BV —Black, JX1327WV —White



### BUILT-IN ACCESSORY TRIM KIT FOR .9 CU. FT. MICROWAVE OVENS

For a custom built-in appearance, this kit allows built-in installation of the Spacemaker II™ microwave oven into a wall or cabinet alone.

#### Accessory Trim Kits

For models JEM31 and JEM25:  
 JX827BN —Black Trim Kits  
 JX827WN —White Trim Kits  
 JX827SS —Stainless Steel Trim Kits



### HANGING KIT FOR .5, .7 AND .9 CU. FT. MICROWAVE OVENS

This hanging kit allows installation under a cabinet.

#### Hanging Kit

4-A019 —JE510, JE520, JE710, JEM25, JEM31

Refrigeration

Water Systems

Laundry

Cooking Products

Microwave Ovens

Dishwashers

Room Air





*GSD4940CSS*

# WASHES AWAY FOOD WITHOUT DROWNING CONVERSATION



It used to be that the last place you would think of holding a conversation was in the kitchen while the dishwasher was running. However, with a GE Profile Performance™ dishwasher, it is easy to forget that the dishwasher is even on. How did we make it so quiet? *In fact, how did we make it the quietest dishwasher among leading brands?* We started with the QuietMotor – induction motor that has been designed to operate quieter and more efficiently than other industry motors. Then we added thicker insulation, an ActiveVent which closes during fill, wash, and drain cycles, and a Quiet Water Valve. All these features made the GE Profile™ and Profile Performance dishwashers consumer-rated as the quietest among leading brands.\* Besides quiet, GE Profile Performance dishwashers are powerful. Our 3 level SureClean™ Wash System provides a high pressure “Wall of Water” that effectively cleans the dirtiest of loads. With rustproof stainless steel blades that are self-sharpening, the Piranha™ Anti-Jamming Hard Food Disposer pulverizes food waste, eliminating the need for pre-rinsing. The Triple Filtration system prevents food soils from redepositing on your dishes. All these features combine to provide a powerful and thorough dishwashing system.

\*In Main Wash Cycle

# GE PROFILE PERFORMANCE SERIES™

BOTH MODELS INCLUDE • CleanSensor II • Electronic Controls • SureClean™ Wash System • Piranha™ Anti-Jamming Hard Food Disposer • Glasses Cycle • China/Crystal Cycle\* • 8-Hour Delay Start • Triple Filtration • SmartBasket • SmartBasket Plus • GE Profile Performance™ Quiet Package • GE Profile™ QuietMotor • ActiveVent • Quiet Water Valve • Trimless appearance • Child lock

**INDUSTRY EXCLUSIVE**



SureClean™ Wash System cleans dishes completely.

**INDUSTRY EXCLUSIVE**



Piranha™ Anti-Jamming Hard Food Disposer eliminates the need to pre-rinse dishes.

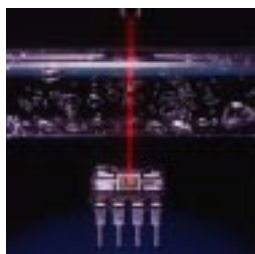

CleanSensor II adjusts water usage preventing under washing or over washing of dishes.

**INDUSTRY EXCLUSIVE**



StemSafe system eliminates handwashing by safely holding stemware securely without fear of breaking.

\*Developed in consultation with Lenox,® the leading manufacturer of fine china.

Not all features available on all models. For additional features, specifications and color availability, refer to page 198.



## GE Profile Performance Series™ GSD4940CSS

- Variable cycles/options • Power Pre-Soak option • Super (nylon) upper rack • SmartShelf with StemSafe • Super12 (nylon) lower rack with 4 rows of fold-down tines

**GSD4930ZWWW** (not shown)  
• White on white

**GSD4920ZBB** (not shown)  
• Black on black

**GSD4910ZAA** (not shown)  
• Almond on almond



## GE Profile Performance Series™ GSD4620ZBB

- Variable cycles/options • Super upper rack • SmartShelf • Super12 lower rack with 2 rows of fold-down tines

**GSD4630ZWWW** (not shown)  
• White on white

**GSD4610ZAA** (not shown)  
• Almond on almond





# BUILT-IN: GE PROFILE™ QUIETPOWER™ SERIES

BOTH MODELS INCLUDE • SureClean™ Wash System • Electronic Controls • SmartShelf • Piranha™ Anti-Jamming Hard Food Disposer • POTSCRUBBER Cycle • Hi-Temp Rinse option • Hi-Temp Wash option • Delay Start • GE Profile™ QuietMotor • Trimless appearance

**INDUSTRY EXCLUSIVE**



SureClean™ Wash System cleans dishes completely.

**INDUSTRY EXCLUSIVE**



Piranha™ Anti-Jamming Hard Food Disposer eliminates the need to pre-rinse dishes.



GE Profile™ QuietMotor is quieter and more energy efficient.



Electronic Controls provide reliability and cleanability.



## GE Profile™ GSD4330ZWW

- 5 cycles/34 options • China/Crystal cycle\*
- Dual filtration • Super12 racks • SmartBasket
- SmartBasket Plus • 8-hour Delay Start option
- QuietPower™ III package • ActiveVent

**GSD4320ZBB** (not shown)  
• Black on black

**GSD4310ZAA** (not shown)  
• Almond on almond



## GE Profile™ GSD4010ZAA

- 4 cycles/26 options • Dual filtration
- Super upper rack • Deluxe lower rack
- Super silverware basket • QuietPower™ II package • 6-hour Delay Start option

**GSD4030ZWW** (not shown)  
• White on white

**GSD4020ZBB** (not shown)  
• Black on black



\*Developed in consultation with Lenox,™ the leading manufacturer of fine china.

Not all features available on all models. For additional features, specifications and color availability, refer to page 198.

# GE BUILT-IN

- ALL MODELS INCLUDE • SureClean™ Wash System • Normal Wash cycle
- Short Wash cycle (on dial) • Heated Dry On/Off option • Trimless appearance
  - Rinse Only/Hold (on dial)

**INDUSTRY EXCLUSIVE**



SureClean™ Wash System cleans dishes completely.



**GSD3430ZWW** (not shown)  
• White on white

**GSD3410ZAA** (not shown)  
• Almond on almond

**GE**

**GSD3420ZBB**

- 6 cycles/19 options
- POTSCRUBBER Cycle
- Plate Warmer cycle (on dial) • Hi-Temp Wash option
- 6-hour Delay Start option (on dial) • Dual Filtration
- Deluxe rack system • Light Wash cycle • Energy Saver
- Super silverware basket
- Rinse Aid dispenser with indicator

**INDUSTRY EXCLUSIVE**



Piranha™ Anti-Jamming Hard Food Disposer eliminates the need to pre-rinse dishes.



**GSD33330CWW** (not shown)  
• White on white

**GSD3310CAA** (not shown)  
• Almond on almond

**GE**

**GSD3320CBB**

- 5 cycles/15 options
- POTSCRUBBER Cycle
- Plate Warmer cycle (on dial) • Hi-Temp Wash option
- Deluxe rack system • Deluxe silverware basket • Rinse Aid dispenser with indicator



Dual Filtration System eliminates the need to pre-rinse dishes.



**GSD2130CWW** (not shown)  
• White on white

**GSD2110CAA** (not shown)  
• Almond on almond

**GE**

**GSD2120CBB**

- 5 cycles/14 options
- POTSCRUBBER Cycle
- Plate Warmer cycle (on dial) • Hi-Temp Wash option
- Deluxe lower rack
- Deluxe silverware basket
- Rinse Aid dispenser
- PermaTuf® Tub



PermaTuf® Tub won't chip, peel, crack or rust under normal use.



**GSD2020ZBB** (not shown)  
• Black on black

**GSD2000ZWH** (not shown)  
• White front panels/  
black control panel

**GSD2000ZAD** (not shown)  
• Almond front panels/  
black control panel

**GE**

**GSD2030ZWW**

- 4 cycles/7 options
- Heavy Wash cycle (on dial) • Standard upper rack
- Deluxe lower rack
- Deluxe silverware basket
- Rinse Aid dispenser
- PermaTuf® Tub

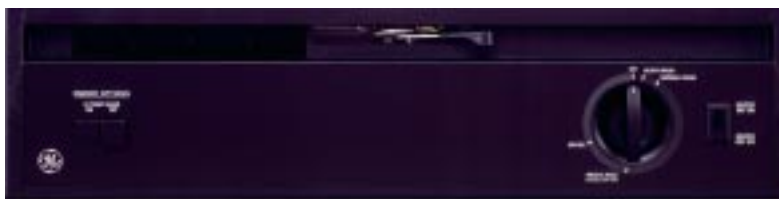

**GE**

**GSD1920CBB**

- 3 cycles/9 options
- Plate Warmer cycle (on dial) • Hi-Temp Wash Option • Heated Dry On/Off • Deluxe silverware basket • Deluxe lower rack

Not all features available on all models.

For additional features, specifications and color availability, refer to page 199.

# GE CONVERTIBLE

ALL MODELS INCLUDE • SureClean™ Wash System • POTSCRUBBER Cycle • Normal Wash cycle • Short Wash cycle (on dial)  
 • Plate Warmer cycle (on dial) • Rinse Only/Hold cycle (on dial) • Heated Dry On/Off option • Hi-Temp Wash option  
 • 3 wash levels • Deluxe rack system • Trimless appearance

**INDUSTRY EXCLUSIVE**



SureClean™ Wash System cleans dishes completely.

**INDUSTRY EXCLUSIVE**



Piranha™ Anti-Jamming Hard Food Disposer eliminates the need to pre-rinse dishes. (GSC3400 Series only)



PORTABLE NOW



BUILT-IN LATER



POTSCRUBBER Cycle



**GE**  
**GSC3430ZWW/GSC3400ZBL**  
 • 6 cycles/19 options • Light Wash cycle • Dual Filtration • 6-hour Delay Start Option (on dial) • Piranha™ Anti-Jamming Hard Food Disposer • GE QuietMotor • Super silverware basket • QuietPower™ I Package • Rinse Aid dispenser with indicator

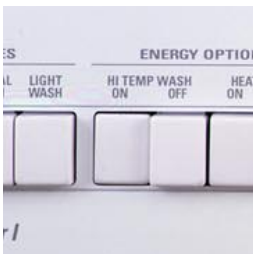

Hi-Temp Wash Option



**GE**  
**GSC3200ZBL/GSC3230ZWW**  
 • 5 cycles/14 options • Deluxe silverware basket • Standard Quiet Package  
 • Rinse Aid dispenser

Not all features available on all models.  
 For additional features, specifications and color availability, refer to page 200.



## GE SPACEMAKER®: UNDERSINK



SINGLE SINK BOWL



OFFSET INSTALLATION FOR USE WITH DISPOSER



**GE**

**GSM2100ZAD/WH**

- 5 cycles/8 options • POTSCRUBBER Cycle • Normal Wash cycle • Short Wash cycle (on dial) • Plate Warmer cycle (on dial) • Rinse Only/Hold cycle (on dial)
- 2 wash levels • Spacemaker® upper rack • Deluxe lower rack • Deluxe silverware basket • PermaTuf® Tub

Note: Undersink dishwashers can be installed under GE cooktop models JP200V and JP201CV. Refer to cooktop installation instructions.

## GE SPACEMAKER®: 18" BUILT-IN

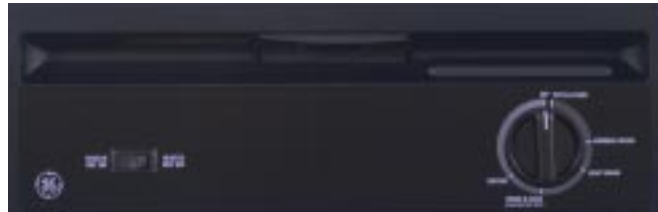

**GE**

**GSS1800Z**

- 4 cycles/6 options • 2 wash levels • Pots & Pans cycle • Normal Wash cycle (on dial) • Light Wash cycle (on dial) • Standard silverware basket • Heated Dry On/Off option • Reversible color panels Black/Harvest, Almond/White

Not all features available on all models.

For additional features, specifications and color availability, refer to pages 200-201.

# DISPOSERS

ALL MODELS INCLUDE • Dishwasher drain connector • Polyester drain housing • Stainless steel flange • Sink stopper • Manual reset protector • Dual swivel impellers • Precutter



**GFC1000Y**



**GFC800Y**



**GFC700Y/GFC705Y**



**GFC300Y/GFC305Y**



**GFC290Y/GFC295Y**



**GFB1050V**

## GE Continuous Feed Models

### GFC1000Y

- Rugged 3/4-horsepower motor • 8000 RPM grinding action
- Super Deluxe sound insulation • Power Boost feature for heavy loads • Fast Mount installation • Removable splash guard

### GFC800Y

- 1/2-horsepower motor • 8000 RPM grinding action
- Deluxe sound insulation • Fast Mount installation
- Removable splash guard

### GFC700Y

- 1/2-horsepower motor • 8000 RPM grinding action • Standard sound insulation • Fast Mount installation • Removable splash guard

### GFC705Y

Similar to GFC700Y but has attached line cord.

### GFC300Y

- 1/2-horsepower motor • 8000 RPM grinding action
- Fast Mount installation • Removable splash guard

### GFC305Y

Similar to GFC300Y but has attached line cord.

### GFC290Y

- 1/3-horsepower motor • 8000 RPM grinding action
- Fast Mount installation • Removable splash guard

### GFC295Y

Similar to GFC290Y but has attached line cord.

## GE Batch Feed Model

### GFB1050V

- Rugged 3/4-horsepower motor • 2700 RPM grinding action
- Super Deluxe sound insulation • Twist Mount installation

Where local codes permit, any GE Dishwasher and any GE Disposer may be connected to a single 20-amp circuit.

White and Almond flanges are available: GPF71 (White) and GPF72 (Almond).

# COMPACTORS

ALL MODELS INCLUDE • 1/3-horsepower • Removable key lock

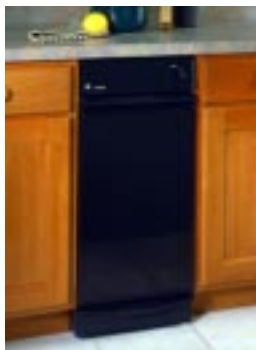

## GE GCG1530ZWW

- White on white • Optional toe pedal opener kit • Rear wheels allow easy movement and installation • Heavy-gauge steel construction

## GCG1520ZBB

- Black on black



## GE GCG950T

- Lock/start control with removable key • Bag storage compartment above compactor drawer
- Replaces standard 12-inch base cabinet

Not all features available on all models. For additional features, specifications and color availability, refer to page 202.

GE OFFERS THE MOST COMPLETE LINE OF AIR ENHANCEMENT PRODUCTS DELIVERING MAXIMUM QUALITY AND EFFICIENCY.





# THE GE LINE OF AIR COMFORT PRODUCTS FOR 1999

## WINDOW AIR



In both deluxe and value series, the window air conditioners offer efficient cooling combined with popular convenience features.

## HEAT/COOL



New for 1999, the heat/cool series offers high btu's for cooling, along with an electric heating system to provide supplemental heat during the winter months.

## SLIDE-AIRE



Only 14½" wide, these units are specially designed for use in casement or sliding windows and narrow double-hung windows.

## J-SERIES



Designed for special installation needs, these units are unique and attractive while providing both heating and cooling.

## DEHUMIDIFIERS



GE Profile™ and GE Dehumidifiers reduce moisture and humidity to provide personal comfort and protection for the home.

## QUIET-AIRE™ - SPLIT SYSTEM



For more information please refer to Pub. No. 20-S008

## WHEN SEEKING INTERIOR AIR COMFORT, LOOK FOR THE NAME YOU TRUST MOST—GE.

As shown above, GE offers a broad range of environment enhancing products, from multiple Room Air Conditioners that offer BTU's that will meet your specific needs, unique window J-series units, our new Heat/Cool series, dehumidifiers and, the next best thing to central air, the Split System Air Conditioner. Whether looking for relief from heat, cold, humidity or meeting special installation requirements, we have the product you need. GE: our name means quality, efficiency and comfort.

# BUILT-IN "J" SERIES: SLOPE-TOP CHASSIS ONLY MODELS

ALL MODELS INCLUDE • Variable setting thermostat  
 • Fan Cycle switch • Four-way air direction • Up-front, washable air filter • "Fan Only" setting for air circulation

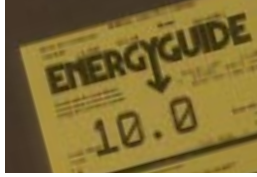

E.E.R. (Energy Efficiency Ratio) shown on the tag of each new unit, compares the air conditioner's cooling output with the electricity it requires for power. The higher the E.E.R. number, the more efficient the unit, and the less costly to operate.

Fan Cycle Switch helps reduce power consumption and operating costs.



## COOL ONLY UNITS

Offer a variety of capacities to cool many applications.

## HEAT/COOL UNITS

Provide a variety of capacities for summer cooling, plus supplemental heat for cold weather—units combine air conditioning with electric resistance heat.

## HEAT PUMP UNITS

Heat pump units offer efficient summer cooling with reverse cycle heating and back-up resistance heat for cold weather.

Units include attractive room-side grille of high-impact polystyrene.

These units are chassis-only models and require a separately purchased solid-sided wall case (RAB46, RAB47 or RAB48) and exterior grille (RAG13 or RAG14) for installation.

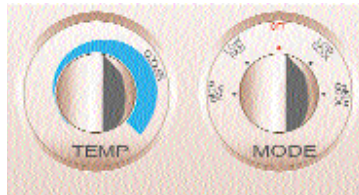

## COOL ONLY UNITS

Models	BTUH Cooling	Volts	EER	BTUH Electric Resistance Heating	Wall Case
AJCS06LC	6000	115	9.5	—	RAB46/47/48
AJCS08AC	8000	115	9.2	—	RAB46/47/48
AJCS10AC	9900	115	9.2	—	RAB46/47/48
AJCS09DC	8900/8700	230/208	9.5/9.5	—	RAB46/47/48
AJCS10DC	9900/9700	230/208	9.2/9.2	—	RAB46/47/48
AJCS12DC	11,600/11,400	230/208	9.0/9.0	—	RAB46/47/48

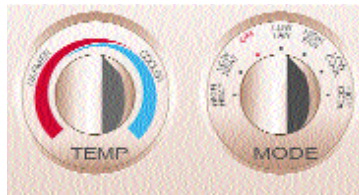

## HEAT/COOL UNITS

Models	BTUH Cooling	Volts	EER	BTUH Electric Resistance Heating	Wall Case
AJES09DC	8900/8700	230/208	9.5	11,600/9480	RAB46/47/48
AJES10DC	9900/9700	230/208	9.2/9.2	11,600/9480	RAB46/47/48
AJES12DC	11,600/11,400	230/208	9.0/9.0	11,600/9480	RAB46/47/48

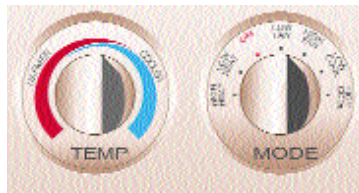

## HEAT PUMP UNITS

Models	BTUH Cooling	Volts	EER	BTUH Electric Resistance Heating	BTUH Reverse Cycle Heating†	Wall Case
AJHS08DC*	8000/7800	230/208	9.2/9.2	11,600/9480	7700/7500	RAB46/47/48
AJHS10DC*	9800/9600	230/208	9.2/9.2	11,600/9480	9700/9500	RAB46/47/48

\*Model includes two-stage heating thermostat.

†At 47°F.

Note: If any "J" Series unit is a replacement unit the existing rear grille should be replaced for better performance with either stamped aluminum (RAG13) grille or architectural louvered extruded aluminum (RAG14).

Not all features available on all models. For additional features, specifications and color availability, refer to page 204.

## BUILT-IN "J" SERIES: HI-MOUNT CHASSIS ONLY MODELS

ALL MODELS INCLUDE • Variable setting thermostat  
• Fan Cycle switch • Four-way air direction • Up-front,  
washable air filter • Multiple fan speeds



For high-mount installations where control accessibility is difficult, GE offers five "J" Series models with controls located in the lower corner of the room-side cabinet. There are two 115V and two 230V cooling only models, and one 230V model with electric heat.

Units include attractive room-side grille of high-impact polystyrene.

Each unit requires a solid-sided wall case (RAB46, RAB47 or RAB48) and exterior grille (RAG13 or RAG14) for installation.

### COOL ONLY UNITS

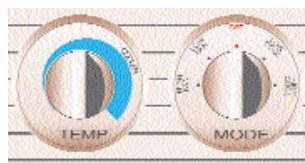

Models	BTUH Cooling	Volts	EER	BTUH Electric Resistance Heating	Wall Case
AJCH08AC	8000	115	9.2	-	RAB46/47/48
AJCH10AC	9900	115	9.2	-	RAB46/47/48
AJCH10DC	9900/9700	230/208	9.2/9.2	-	RAB46/47/48
AJCH12DC	11,600/11,400	230/208	9.0/9.0	-	RAB46/47/48

### HEAT/COOL UNIT

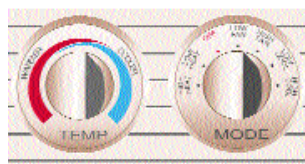

Model	BTUH Cooling	Volts	EER	BTUH Electric Resistance Heating	Wall Case
AJEH12DC	11,600/11,400	230/208	9.0/9.0	11,600/9480	RAB46/47/48

## BUILT-IN "J" SERIES: WINDOW/WALL MOUNT MODELS

ALL MODELS INCLUDE • Multiple Cooling/Heating speeds • Vent/Exhaust • Multi-position thermostat  
• Fan Cycle switch • Easy access filter • Slide-out chassis • EZ Mount window kit (for Cooling Only models)



### HEAT/COOL UNITS

Model	BTU	EER	Volts	Cools (sq. ft.)	Heater Wattage
AJES10DS	9,900/9,700	9.2/9.2	230/208	425-525	3.4/2.8 (kw)
AJES08AS	8,000	9.2	115	250-350	1.2 (kw)
AJES06LS	6,000	9.5	115	170-210	1.2 (kw)

### HEAT PUMP UNIT

Model	BTU	EER	Volts	Cools (sq. ft.)	Heater Wattage
AJHS08AS	8,000	9.2	115	250-350	1.2 (kw)

### COOLING ONLY UNITS

Model	BTU	EER	Volts	Cools (sq. ft.)
AJCS10AZ	9,900	9.2	115	425-525
AJCS08AZ	8,000	9.2	115	250-350
AJCS06LZ	6,000	9.5	115	170-210

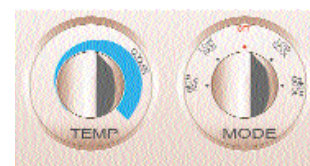

Cooling Only

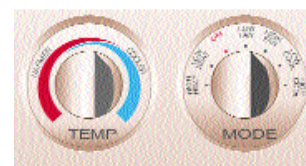

Heat/Cool, Heat Pump

For convenience and efficiency, GE offers a unique line of units that provide cooling only, cooling with electric heat, and cooling with heat pumps, for use in window or through-the-wall application.

All units include solid-sided sleeve with a slide-out chassis.

Not all features available on all models.

For additional features, specifications and color availability, refer to pages 204-205.



# ROOM AIR CONDITIONERS: DELUXE SERIES

- ALL MODELS INCLUDE • Energy Saver feature • Multiple cooling speeds • Vent/Exhaust • Adjustable thermostat  
 • Four-way adjustable air discharge • Easy access filter • Slide-out chassis • EZ Mount window kit

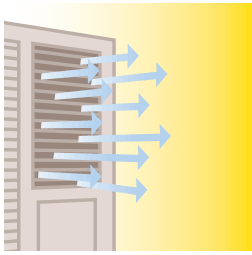

High CFMs (Cubic Feet per Minute) for more air circulation speed in a room. A high CFM means faster air flow and more comfort.



Model	BTU	EER	Volts	Cools (sq. ft.)
AVM24DD	23,500/23,000	8.7/8.7	230/208	1480-1620
AVM22DB	22,000/21,300	8.2/8.2	230/208	1330-1450
AVM18DC	18,000/17,500	9.5/9.5	230/208	1050-1150
AVM15DC	15,000/14,500	9.0/9.0	230/208	850-950
AVM14AB	14,000	10.0	115	750-850



Model	BTU	EER	Volts	Cools (sq. ft.)
AMD12DB	12,000/11,800	9.1/9.1	230/208	575-650

- Electronic controls • 12 hour timer • Circulaire oscillating air flow • Concealed controls



Energy Saver feature allows the cooling fan to continue to run while the compressor shuts down. This feature allows cool air to continue to circulate but at a lower energy level therefore reducing your energy cost.

- Concealed controls

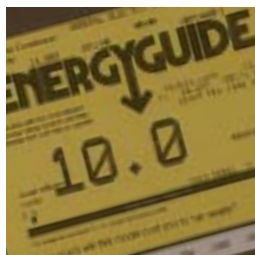

Energy Efficiency Ratio (E.E.R.) - Higher E.E.R. numbers indicate greater efficiency and lower operating costs. An E.E.R. of 10.0 (AGH08FA) compared to an E.E.R. of 9.0 (ASV08AC) can provide an annual energy savings of more than 10% while still providing the same amount of cooling BTU's.



Model	BTU	EER	Volts	Cools (sq. ft.)
AGH08FA	7,800	10.0	115	250-350

Energy Star compliant



Model	BTU	EER	Volts	Cools (sq. ft.)
AMH12AC	11,500	10.0	115	550-625
AMH10AA	10,000	10.0	115	425-525



Model	BTU	EER	Volts	Cools (sq. ft.)
AMH06LA	5,800	10.0	115	170-210

Energy Star compliant

Not all features available on all models. For additional features, specifications and color availability, refer to page 203.

# VALUE SERIES

- ALL MODELS INCLUDE • Multiple cooling speeds • 8-Position thermostat  
 • Easy access filter • EZ Mount window kit



Quick Clean Filters keep unit running efficiently and save money. Simply slide out the filter, wash and replace.



Model	BTU	EER	Volts	Cools (sq. ft.)
AGV18DB	17,800/17,400	8.8/8.8	230/208	1,000-1,100
AGV12DA	12,000	9.0/9.0	230/208	575-650

- Circulaire oscillating air flow



Model	BTU	EER	Volts	Cools (sq. ft.)
AGV12AA	12,000	9.0	115	575-650
AGV10AA	10,000	9.2	115	425-525



Easy Mount Installation—Designed for ease of placement, this unit can be installed by anyone and requires no prior experience or special tools.



Model	BTU	EER	Volts	Cools (sq. ft.)
ASV08AC	8,000	9.0	115	250-350



Model	BTU	EER	Volts	Cools (sq. ft.)
AQV06LA	6,000	9.0	115	170-210
AQV05LA	5,000	9.0	115	100-150

# HEAT/COOL SERIES

- ALL MODELS INCLUDE • Multiple cooling/heating speeds • Vent/Exhaust • 10-Position thermostat  
 • Four-way adjustable air discharge • Easy access filter • Slide-out chassis • Rigid panel window kit

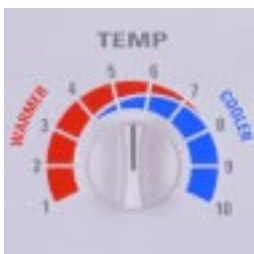

Cooling and Electric Heat—Along with comfortable cooling capabilities, our new series also provides supplemental heat during winter months and can even be used as the primary heat source in temperate zones.



Concealed Controls are hidden from view to provide a clean, contemporary appearance.



Model	BTU	EER	Volts	Cools (sq. ft.)	Heater Wattage
AVE22DA	22,000/21,300	8.2/8.2	230/208	1,330-1,450	4.7/3.9 (kw)
AVE18DA	18,000/17,500	9.5/9.5	230/208	1,050-1,150	3.0/2.6 (kw)
AVE15DA	15,000/14,500	9.0/9.0	230/208	850-950	3.0/2.6 (kw)



Not all features available on all models. For additional features, specifications and color availability, refer to pages 203 and 205.

# ROOM AIR CONDITIONERS: QUIET-AIRE™ – SPLIT SYSTEM

The GE Quiet-Aire™ – Split System Air Conditioner provides virtually silent cooling comfort. With a design that includes outside compressor placement, disturbing sounds are kept out of doors and out of earshot. This design also eliminates annoyances like rattling windows. So rest easily and peacefully. Available in heat pump and cooling only models in 9,000, 12,000 and 18,000 BTU sizes.



INDOOR UNIT



OUTDOOR UNIT

For more information, see Pub. No. 20-S008, or call the GE Answer Center® at 800.626.2000.

# ROOM AIR CONDITIONERS: SLIDE-AIRE

ALL MODELS INCLUDE • 10-Position thermostat  
• Vertical Slider Kit Panel • Multiple Cooling and Fan speeds • Two-way adjustable air discharge



Slide-Aire models accommodate the special installation needs of sliding and casement windows (those with side hinges that open in or out).



Sleek New Contemporary Styling blends quietly with most decor.



Model	BTU	EER	Volts	Cools (sq. ft.)
AVX10AC	10,000	9.0	115	425-525
AVX07FB	7,000	8.5	115	210-280

# DEHUMIDIFIERS



Model	Pints Per Day
AHG20LA	19

- Electronic Micro Computer Control
- Overflow protection
- Water Full indicator
- Automatic defrost • 6-Pint bucket capacity • External drain connector



Model	Pints Per Day
AHG50LA	50
AHG40LA	40
AHG25LA	25

- Compact and contemporary design
- Automatic Humidistat control
- Automatic Shut-Off system with Bucket Full indicator
- Easy roll casters
- External drain connector
- Automatic defrost control
- Removable condensate container
- Washable air filter

Not all features available on all models. For additional features, specifications and color availability, refer to pages 203 and 206.



# INSTANT DIMENSIONAL & INSTALLATION INFORMATION

FROM THE SPEED OF A TOUCHTONE PHONE, ORDER INSTALLATION INFORMATION TO BE DELIVERED THROUGH YOUR FAX MACHINE.



## 1-800-432-3729

THIS AUTOMATED FAX-ON-DEMAND SYSTEM PROVIDES A QUICK REFERENCE TO PRODUCT DIMENSIONS FOR MONOGRAM,<sup>®</sup> GE PROFILE PERFORMANCE SERIES,<sup>™</sup> GE PROFILE,<sup>™</sup> GE AND HOTPOINT APPLIANCES.

- **TOUCHTONE ACTIVATED**  
Simply follow the voice prompts to make your selection from any touchtone phone.
- **MODEL SPECIFIC INSTALLATION DIMENSIONS**  
Select accurate installation dimensions by individual model numbers for virtually every model. Make your selection from the List of Available Documents (available by fax from GE QuickSpecs). Select up to fifteen documents per call.
- **FEATURE AND APPEARANCES**  
Feature information and product illustrations are included for most models.
- **FAX INFORMATION TO ANY FAX TELEPHONE NUMBER**  
Once you make your selection, you will be asked to enter the fax telephone number where you wish your request to be faxed (your office, job site, customer). It will be faxed to the specified fax number within 15 minutes.
- **AVAILABLE 24 HOURS A DAY, 7 DAYS A WEEK**

# SPECIFICATIONS AND INSTALLATION INFORMATION

## CONTENTS

Warranty Information.....	134-137
CustomStyle <sup>™</sup> Refrigerators .....	138-142
Side-By-Side Refrigerators .....	143-144
Bottom-Freezer Refrigerators .....	145
Top-Freezer No-Frost Refrigerators.....	146-147
Cycle and Manual Defrost Refrigerators.....	148
Spacemaker <sup>™</sup> Refrigerators.....	148
Upright and Chest Freezers.....	149
Optional Refrigerator Panels and Trim Kits.....	150-151
Water Systems.....	152-154
Washers.....	155
Dryers.....	156-157, 159
Front Loading Washer and Dryer.....	158
Spacemaker <sup>®</sup> Washers and Dryers .....	160
Unitized Spacemaker <sup>®</sup> Washers and Dryers.....	161
30" Built-In Double Ovens.....	162-163
30" Built-In Single Ovens .....	164-165
27" and 24" Built-In Double Ovens .....	166-167
27" and 24" Built-In Single Ovens .....	168-169
24" Built-In Gas Ovens .....	170
30" and 27" Warming Drawers .....	171
Built-In CleanDesign Cooktops.....	172
Built-In Electric Cooktops .....	173
Built-in Gas Cooktops.....	174
Downdraft Gas Cooktops .....	175
Select-Top <sup>™</sup> Modular Downdraft Cooktops and Patio Grill .....	176-177
Built-In Downdraft Gas Modular Cooktops .....	178
30" Slide-In Downdraft Ranges.....	178
High Performance, Performance, Deluxe and Standard Hoods.....	179
Slide-Out Hoods .....	180
Telescopic Downdraft System.....	180-181
30" Slide-In Gas Ranges.....	182-183
30" Slide-In Electric Ranges .....	184
30" Drop-In Electric Ranges.....	185
Spacemaker <sup>™</sup> 27" Drop-In Electric Ranges .....	186
30" Free-Standing CleanDesign Electric Ranges.....	186-187
30" Free-Standing QuickClean <sup>™</sup> Electric Ranges .....	188
40" Free-Standing Electric Ranges .....	189
30" Free-Standing Gas Ranges.....	190-191
SpacemakerPlus <sup>™</sup> Microwave/Convection Ovens.....	192
Spacemaker Over-The-Range Microwave Ovens.....	193
Built-In Microwave Ovens.....	194
Countertop Microwave Ovens.....	195
Spacemaker II <sup>™</sup> Microwave Ovens .....	196
Countertop/Compact/Subcompact Microwave Ovens.....	196
Accessory Trim Kits.....	197
Built-In Dishwashers.....	198-199
Convertible/Portable Dishwashers .....	200
Spacemaker <sup>®</sup> Built-In and Undersink Dishwashers.....	200-201
Disposers and Compactors.....	202
Room Air Conditioners (Deluxe/Value/Slide-Aire) .....	203
Built-In "J" Series Units and Heat Pumps.....	204
Heat/Cool and "J" Series Window Built-In Units and Heat Pumps .....	205
Split System Room Air Conditioners/Heat Pumps .....	206
Dehumidifiers.....	206
Nomenclatures .....	207-210

Refrigeration

Water Systems

Laundry

Cooking Products

Microwave Ovens

Dishwashers

Room Air

# WARRANTY INFORMATION

The condensed list below is a convenient overview of the written warranties offered on various GE appliances described in this catalog. For complete warranty details on a specific GE appliance model, contact your nearest GE supplier, or call GE Factory Service, toll-free, 800-GE-CARES (800-432-2737).

## Refrigerators (All models *except* TAX2SNYWN, TAX2SNBWH, TAX4ANXWN, TAX4SNYWH)

For The Period Of	GE Will Replace
<b>One Year</b> From the date of the original purchase	<b>Any part</b> in the refrigerator which fails due to a defect in materials or workmanship. During this <b>full one-year warranty</b> , GE will provide all labor and in-home service costs to replace the defective part <b>free of charge</b> .
<b>Five Years</b> From the date of the original purchase	<b>Sealed Refrigeration System or Compressor</b> , if either of these parts should fail due to a defect in materials or workmanship. During this <b>full five-year warranty</b> , GE will also provide all labor and in-home service costs to replace the defective part <b>free of charge</b> .
<b>Lifetime</b> From the date of the original purchase	<b>See-Thru Vegetable/Fruit Pans</b> , if any of these parts should fail due to a defect in materials or workmanship. During this <b>lifetime limited warranty</b> , you will be responsible for service trip and labor charges.

## Refrigerators (Models TAX2SNYWN, TAX2SNBWH, TAX4ANXWN, TAX4SNYWH)

For The Period Of	GE Will Replace
<b>One Year</b> From the date of the original purchase	<b>Any part</b> in the refrigerator which fails due to a defect in materials or workmanship. During this <b>limited one-year warranty</b> , you will be responsible for service trip charges.
<b>Five Years</b> From the date of the original purchase	<b>Compressor</b> , if this part should fail due to a defect in materials or workmanship. During this <b>limited five-year warranty</b> , you will be responsible for service trip and labor charges.

## Freezers

For The Period Of	GE Will Replace
<b>One Year</b> From the date of the original purchase	<b>Any part</b> in the freezer which fails due to a defect in materials or workmanship. During this <b>full one-year warranty</b> , GE will also provide all labor and in-home service to replace the defective part <b>free of charge</b> .
<b>Five Years</b> From the date of the original purchase	<b>Sealed Refrigeration System</b> , if this part should fail due to a defect in materials or workmanship. During this <b>full five-year warranty</b> , GE will also provide all labor and in-home service to replace the defective part <b>free of charge</b> .
<b>One Year/Five Years</b> From the date of the original purchase	<b>Food Spoilage</b> , Cumulative limits: \$100—14.9 and smaller, \$150—15.0 and larger. <b>One-year</b> on spoilage from any part failure. <b>Five-year</b> on spoilage from sealed refrigeration system failure.

## Icemakers

For The Period Of	GE Will Replace
<b>One Year</b> From the date of the original purchase	<b>Any part</b> in the icemaker which fails due to a defect in materials or workmanship. During this <b>full one-year warranty</b> , GE will also provide all labor and in-home service to replace the defective part <b>free of charge</b> .

## GE SmartWater™ Filtration Systems (Models PNRV18ZWW, PNRV18ZBB, PNRV18ZWH, PNRV18ZBL, PNRV12ZBL)

For The Period Of	GE Will Replace
<b>One Year</b> From the date of the original purchase	<b>Any part</b> in the unit which fails due to a defect in materials or workmanship ( <b>excludes membrane and/or filters</b> ). During this <b>full one-year warranty</b> , GE will provide, <b>free of charge</b> , all labor and in-home service to replace the defective part.

## GE SmartWater™ Filtration Systems (Model GXRV10ABL)

For The Period Of	GE Will Replace
<b>One Year</b> From the date of the original purchase	<b>Any part</b> in the unit which fails due to a defect in materials or workmanship ( <b>excludes membrane and/or filters</b> ). During this <b>limited one-year warranty</b> , GE will provide, <b>free of charge</b> , all labor and in-home service to replace the defective part. You will be responsible for service trip costs.

## GE SmartWater™ Filtration Systems (Models GNUL30Z, GNUV10Z, GNUT05Z, GNUT03A)

For The Period Of	GE Will Replace
<b>One Year</b> From the date of the original purchase	<b>Any part</b> in the unit which fails due to a defect in materials or workmanship ( <b>excludes filters</b> ). During this <b>full one-year warranty</b> , GE will provide, <b>free of charge</b> , all labor and in-home service to replace the defective part.

## GE SmartWater™ Filtration Systems (Models GXUT03A, GXEM01Z)

For The Period Of	GE Will Replace
<b>One Year</b> From the date of the original purchase	<b>Any part</b> in the unit which fails due to a defect in materials or workmanship ( <b>excludes filters</b> ). During this <b>one-year limited warranty</b> , GE will provide, <b>free of charge</b> , all labor and in-home service to replace the defective part. You will be responsible for the service trip costs.

## GE SmartWater™ Softening Systems (Models PNSF39Z, PNSF31Z, GNSF23Z, GNSF18Z)

For The Period Of	GE Will Replace
<b>One Year</b> From the date of the original purchase	<b>Any part</b> in the unit which fails due to a defect in materials or workmanship. During this <b>full one-year warranty</b> , GE will provide, <b>free of charge</b> , all labor and in-home service to replace the defective part.
<b>Three Years</b> From the date of the original purchase	<b>Electronic Monitor</b> , if this part should fail due to a defect in materials or workmanship. During this <b>three-year limited warranty</b> , GE will provide the part and you will be responsible for labor and service trip charges.
<b>Ten Years</b> From the date of the original purchase	<b>A replacement cabinet (brine tank) and resin tank</b> , if either of these parts should fail due to a defect in materials or workmanship. During this <b>ten-year limited warranty</b> , GE will repair or replace the defective part <b>free of charge</b> ; you will be responsible for the service trip and labor charges.

**Note:** See written warranty for details.

These warranties are extended to the original purchaser and any succeeding owner for products purchased for home use within the USA. In Alaska, the One Year Warranty excludes the cost of shipping, or service calls to your home. Some states do not allow the exclusion or limitation of incidental or consequential damages. This warranty gives you specific legal rights, and you may also have other rights which vary from state to state. To know what your legal rights are, consult your local or state consumer affairs office or your state's Attorney General.

### GE Profile Performance Series™ and GE Profile™ Washers

For The Period Of	GE Will Replace
<b>One Year</b> From the date of the original purchase	<b>Any part</b> in the washer which fails due to a defect in materials or workmanship. During this <b>full one-year warranty</b> , GE will provide all labor and in-home service to replace the defective part <b>free of charge</b> .
<b>Two Years</b> From the date of the original purchase	<b>Any part</b> in the washer which fails due to a defect in materials or workmanship. During this <b>limited two-year warranty</b> , you will be responsible for service trip and labor charges.
<b>Five Years</b> From the date of the original purchase	<b>ArmorGuard Lid &amp; Cover Protection and Auto Balance Suspension System</b> , if any of these parts should fail due to a defect in materials or workmanship. During this <b>five-year limited warranty</b> , you will be responsible for service trip and labor charges.
<b>Ten Years</b> From the date of the original purchase	<b>Steel Drive Transmission, Outer Tub</b> , if either of these parts should fail due to a defect in materials or workmanship. During this <b>ten-year limited warranty</b> , you will be responsible for service trip and labor charges.
<b>Lifetime</b> From the date of the original purchase	<b>PermaTuf II™ Basket</b> , if this part should fail due defect in materials or workmanship. During this <b>lifetime limited warranty</b> , you will be responsible for service trip and labor charges.

### GE Washers

For The Period Of	GE Will Replace
<b>One Year</b> From the date of the original purchase	<b>Any part</b> in the washer which fails due to a defect in materials or workmanship. During this <b>full one-year warranty</b> , GE will provide all labor and in-home service to replace the defective part <b>free of charge</b> .
<b>Five Years</b> From the date of the original purchase	<b>Auto Balance Suspension System, ArmorGuard Lid &amp; Cover Protection and Steel Drive Transmission</b> , if any of these parts should fail due to a defect in materials or workmanship. During this <b>five-year limited warranty</b> , you will be responsible for service trip and labor charges.
<b>Ten Years</b> From the date of the original purchase	<b>Outer Tub</b> , if this part should fail due to a defect in materials or workmanship. During this <b>ten-year limited warranty</b> , you will be responsible for service trip and labor charges.
<b>Twenty Years</b> From the date of the original purchase	<b>PermaTuf II™ Basket</b> , if this part should fail due to a defect in materials or workmanship. During this <b>twenty-year limited warranty</b> , you will be responsible for service trip and labor charges.

### GE Spacemaker® Washers

For The Period Of	GE Will Replace
<b>One Year</b> From the date of the original purchase	<b>Any part</b> in the washer which fails due to a defect in materials or workmanship. During this <b>full one-year warranty</b> , GE will provide all labor and in-home service to replace the defective part <b>free of charge</b> .
<b>Five Years</b> From the date of the original purchase	<b>Transmission</b> , if this part should fail due to a defect in materials or workmanship. During this <b>five-year limited warranty</b> , you will be responsible for service trip and labor charges.

### GE Front Loading Washer

For The Period Of	GE Will Replace
<b>One Year</b> From the date of the original purchase	<b>Any part</b> in the washer which fails due to a defect in materials or workmanship. During this <b>full one-year warranty</b> , GE will provide all labor and in-home service to replace the defective part <b>free of charge</b> .
<b>Five Years</b> From the second year to fifth year from the original purchase	<b>Replacement parts for the motor, driven pulley or motor controller</b> , which prove to be defective in materials or workmanship. During this <b>five-year limited warranty</b> , you will be responsible for service trip and labor charges.
<b>Twenty Years</b> From the date of the original purchase	<b>The inner wash basket</b> , that breaks due to defective materials or workmanship. During this <b>twenty-year limited warranty</b> , you will be responsible for service trip and labor charges.

### GE Profile Performance Series™, GE Profile™ and GE Super Capacity and Extra-Large Capacity Dryers

For The Period Of	GE Will Replace
<b>One Year</b> From the date of the original purchase	<b>Any part</b> in the dryer which fails due to a defect in materials or workmanship. During this <b>full one-year warranty</b> , GE will provide all labor and in-home service to replace the defective part <b>free of charge</b> .
<b>Five Years</b> From the date of the original purchase	<b>Dryer Drum</b> , if this should fail due to a defect in materials or workmanship. During this <b>five-year limited warranty</b> , you will be responsible for service trip and labor charges.

### GE Large Capacity, Spacemaker® and Front Loading Dryers

For The Period Of	GE Will Replace
<b>One Year</b> From the date of the original purchase	<b>Any part</b> in the dryer which fails due to a defect in materials or workmanship. During this <b>full one-year warranty</b> , GE will provide all labor and in-home service to replace the defective part <b>free of charge</b> .



# WARRANTY INFORMATION (CONTINUED)

## Ranges/Cooktops/Built-In Ovens/Warming Drawers/Hoods (Excluding CleanDesign Ranges and Cooktops)

For The Period Of	GE Will Replace
<b>One Year</b> From the date of the original purchase	<b>Any part</b> in the cooking product which fails due to a defect in materials or workmanship. During this <b>full one-year warranty</b> , GE will provide all labor and in-home service to replace the defective part <b>free of charge</b> .

### Ranges (CleanDesign)

For The Period Of	GE Will Replace
<b>One Year</b> From the date of the original purchase	<b>Any part</b> in the cooking product which fails due to a defect in materials or workmanship. During this <b>full one-year warranty</b> , GE will provide all labor and in-home service to replace the defective part <b>free of charge</b> .
<b>Five Years</b> From the date of the original purchase	<b>Glass-Ceramic Cooktop, Ribbon Heating Elements and Rubber Seal</b> , if any of these parts should fail due to a defect in materials or workmanship. During this <b>five-year limited warranty</b> , GE will replace the defective part <b>free of charge</b> , you will be responsible for service trips and labor charges.

### Cooktops (CleanDesign)

For The Period Of	GE Will Replace
<b>One Year</b> From the date of the original purchase	<b>Any part</b> in the cooking product which fails due to a defect in materials or workmanship. During this <b>full one-year warranty</b> , GE will provide all labor and in-home service to replace the defective part <b>free of charge</b> .
<b>Five Years</b> From the date of the original purchase	<b>Glass-Ceramic Cooktop, Ribbon Heating Elements and Rubber Seal</b> , if any of these parts should fail due to a defect in materials or workmanship. During this <b>five-year limited warranty</b> , GE will replace the defective part <b>free of charge</b> , you will be responsible for service trips and labor charges.

### Hoods

For The Period Of	GE Will Replace
<b>One Year</b> From the date of the original purchase	<b>Any part</b> in the hood which fails due to a defect in materials or workmanship. During this <b>full one-year warranty</b> , GE will provide all labor and in-home service to replace the defective part <b>free of charge</b> .

## Microwave Ovens (Over-The-Range models, Built-In models, JEM31SA/GA/WA, JE1860SB/GB/WB, JE1840GB/WB, JE1660SA/GA/WA, JE1640GA/WA, JE1390GA/WA)

For The Period Of	GE Will Replace
<b>One Year</b> From the date of the original purchase	<b>Any part</b> in the microwave which fails due to a defect in materials or workmanship. During this <b>full one-year warranty</b> , GE will provide all labor and in-home service to replace the defective part <b>free of charge</b> .
<b>Ten Years</b> From the date of the original purchase	<b>Magnetron Tube</b> , if this part should fail due to a defect in materials or workmanship. During this <b>nine-year limited warranty</b> , you will be responsible for any labor or in-home service costs.

## Microwave Ovens (Models JE1360GA/WA, JE1340GA/WA, JEM25GY/WY, JE740GY/WY)

For The Period Of	GE Will Replace
<b>One Year</b> From the date of the original purchase	<b>Any part</b> in the microwave which fails due to a defect in materials or workmanship. During this <b>limited one-year warranty</b> , GE will provide labor and you will be responsible for service trip charges.
<b>Ten Years</b> From the date of the original purchase	<b>Magnetron Tube</b> , if this part should fail due to a defect in materials or workmanship. During this <b>nine-year limited warranty</b> , you will be responsible for any labor or in-home service costs.

## Microwave Ovens (Models JE835WW, JE710BA, JE635WW, JE520BW, JE510BW)

For The Period Of	GE Will Replace
<b>One Year</b> From the date of the original purchase	<b>Any part</b> in the microwave which fails due to a defect in materials or workmanship. During this <b>limited one-year warranty</b> , GE will provide labor and you will be responsible for service trip charges.
<b>Five Years</b> From the date of the original purchase	<b>Magnetron Tube</b> , if this part should fail due to a defect in materials or workmanship. During this <b>four-year limited warranty</b> , you will be responsible for any labor or in-home service costs.

## Dishwashers (Models GSD4010Z, GSD4020Z, GSD4030Z, GSD4310Z, GSD4320Z, GSD4330Z, GSD4610Z, GSD4620Z, GSD4630Z, GSD4910Z, GSD4920Z, GSD4930Z, GSD4940C)

For The Period Of	GE Will Replace
<b>One Year</b> From the date of the original purchase	<b>Any part</b> in the dishwasher which fails due to a defect in materials or workmanship. During this <b>full one-year warranty</b> , GE will provide, <b>free of charge</b> , all labor and in-home service to replace the defective part.
<b>Two Years</b> From the date of the original purchase	<b>Any part</b> in the dishwasher which fails due to a defect in materials or workmanship. During this <b>two-year limited warranty</b> , you will be responsible for service trip and labor charges.
<b>Five Years</b> From the date of the original purchase	<b>Racks or Electronic Control Board</b> , if either of these part should fail due to a defect in materials or workmanship. During this <b>five-year limited warranty</b> , you will be responsible for service trip and labor charges.
<b>Twenty Years</b> From the date of the original purchase	<b>PermaTuf® Tub or Door Liner</b> , if either of these parts should fail due to a defect in materials or workmanship. During this <b>full twenty-year warranty</b> , GE will provide, <b>free of charge</b> , all labor and in-home service to repair or replace the defective part.

### What GE Will Not Cover:

- Service trips to your home to teach you how to use the product.
- Improper installation.
- Replacement of house fuses or resetting of circuit breakers.
- Failure of the product if it is abused, misused, or used for other than the intended purpose or used commercially.
- Damage to product caused by accident, fire, floods or acts of God.
- Incidental or consequential damage to personal property caused by possible defects with this appliance.

**Dishwashers** (Models GSM2100Z, GSC3200Z, GSC3230Z, GSC3400Z, GSC3430Z, GSD2110C, GSD2120C, GSD2130C, GSD3310C, GSD3320C, GSD3330C, GSD3410Z, GSD3420Z, GSD3430Z)

For The Period Of	GE Will Replace
<b>One Year</b> From the date of the original purchase	<b>Any part</b> in the dishwasher which fails due to a defect in materials or workmanship. During this <b>full one-year warranty</b> , GE will provide, <b>free of charge</b> , all labor and in-home service to replace the defective part.
<b>Two Years</b> From the date of the original purchase	<b>Any part of the Water Distribution System</b> , which fails due to a defect in materials or workmanship. Associated inlet & drain plumbing parts are not covered by this warranty. During this <b>second-year limited warranty</b> , you will be responsible for any labor or in-home service costs.
<b>Ten Years</b> From the date of the original purchase	<b>PermaTuf® Tub or Door Liner</b> , if either of these parts should fail due to a defect in materials or workmanship. During this <b>full ten-year warranty</b> , GE will provide, <b>free of charge</b> , all labor and in-home service to replace the defective part.

**Dishwashers** (Models GSD1920C, GSD2000Z, GSD2020Z, GSD2030Z, GSS1800Z)

For The Period Of	GE Will Replace
<b>One Year</b> From the date of the original purchase	<b>Any part</b> in the dishwasher which fails due to a defect in materials or workmanship. During this <b>full one-year warranty</b> , GE will provide, <b>free of charge</b> , all labor and in-home service to replace the defective part.
<b>Ten Years</b> From the date of the original purchase	<b>PermaTuf® Tub or Door Liner</b> , if either of these parts should fail due to a defect in materials or workmanship. During this <b>full ten-year warranty</b> , GE will provide, <b>free of charge</b> , all labor and in-home service to replace the defective part.

### Compactors

For The Period Of	GE Will Replace
<b>One Year</b> From the date of the original purchase	<b>Any part</b> in the compactor which fails due to a defect in materials or workmanship. During this <b>full one-year warranty</b> , GE will provide, <b>free of charge</b> , all labor and in-home service to replace the defective part.

**Disposers** (Models GFC305Y, GFC300Y, GFC295Y, GFC290Y)

For The Period Of	GE Will Replace
<b>One Year</b> From the date of the original purchase	<b>Any part</b> in the disposer which fails due to a defect in materials or workmanship. During this <b>full one-year warranty</b> , GE will provide, <b>free of charge</b> , all labor and in-home service to replace the defective part.

**Disposers** (Models GFC705Y, GFC700Y)

For The Period Of	GE Will Replace
<b>Two Years</b> From the date of the original purchase	<b>Any part</b> in the disposer which fails due to a defect in materials or workmanship. During this <b>full two-year warranty</b> , GE will provide, <b>free of charge</b> , all labor and in-home service to replace the defective part.

**Disposers** (Model GFC800Y)

For The Period Of	GE Will Replace
<b>Four Years</b> From the date of the original purchase	<b>Any part</b> in the disposer which fails due to a defect in materials or workmanship. During this <b>full four-year warranty</b> , GE will provide, <b>free of charge</b> , all labor and in-home service to replace the defective part.

**Disposers** (Models GFB1050V, GFC1000Y)

For The Period Of	GE Will Replace
<b>Five Years</b> From the date of the original purchase	<b>Any part</b> in the disposer which fails due to a defect in materials or workmanship. During this <b>full five-year warranty</b> , GE will provide, <b>free of charge</b> , all labor and in-home service to replace the defective part.

**Room Air Conditioners** (Window, Window Built-In, Built-In Units and Split System Units)

For The Period Of	GE Will Replace
<b>One Year</b> From the date of the original purchase	<b>Any part</b> in the unit which fails due to a defect in materials or workmanship. During this <b>full one-year warranty</b> , GE will provide all labor and in-home service to replace the defective part <b>free of charge</b> .
<b>Five Years</b> From the date of the original purchase	<b>Sealed Refrigeration System</b> , if any of these parts should fail due to a defect in materials or workmanship. During this <b>full five-year warranty</b> , GE will provide all labor and in-home service to replace the defective part <b>free of charge</b> .

### Dehumidifiers

For The Period Of	GE Will Replace
<b>One Year</b> From the date of the original purchase	<b>Any part</b> in the dehumidifier which fails due to a defect in materials or workmanship. During this <b>full one-year warranty</b> , GE will provide, <b>free of charge</b> , all labor and in-home service to replace the defective part.*
<b>Five Years</b> From the date of the original purchase	<b>Sealed Refrigeration System (compressor, condenser, dehumidifying coil and all connecting tubing)</b> , if this should fail due to a defect in materials or workmanship. During this <b>full five-year warranty</b> , GE will provide all labor and in-home service to replace the defective part.* *Full one- and five-year warranty for model AHG20 and GE will provide labor and you will be responsible for service trip charges.

# CUSTOMSTYLE™ NO-FROST SIDE-BY-SIDE REFRIGERATORS

	GE Profile Performance Series™					GE Profile™					
	TPS24PBB TPS24PPB	TPS24BPC	TPX24PBB	TPX24PPB	TPX24BPB	TPS24PIB	TPS24BIC	TPX24PRB	TPX24BRB	TPX24BIB	TPX21PRB TPX21BRB
Stainless steel model	●	●				●	●				
<b>Capacity</b>											
Total (cu. ft.)	23.5	23.5	23.5	23.5	23.5	23.7	23.7	23.5	23.5	23.7	20.7
Fresh food (cu. ft.)	14.48	14.48	14.48	14.48	14.48	14.48	14.48	14.48	14.48	14.48	13.00
Freezer (cu. ft.)	9.05	9.05	9.05	9.05	9.05	9.25	9.25	9.05	9.05	9.25	7.65
Shelf area (sq. ft.)	23.2	23.2	23.2	23.2	23.2	24.0	24.0	23.2	23.2	24.0	23.0
<b>Features</b>											
Refreshment Center	●/-		●								
Electronic Monitor System	●/-		●								
Exclusive Water by Culligan™	●	●	●	●	●						
LightTouch dispenser											
Auto. factory-installed icemaker & ice bin	●	●	●	●	●	●	●	●	●	●	●
Cabinet shelves	3 Glass	3 Glass	3 Glass	3 Glass	3 Glass	3 Glass	3 Glass	3 Glass	3 Glass	3 Glass	3 Glass
(adjustable)	3	3	3	3	3	3	3	3	3	3	3
(slide-out, spill-proof)	2 Glass	2 Glass	2 Glass	2 Glass	2 Glass	2 Glass	2 Glass	2 Glass	2 Glass	2 Glass	2 Glass
Quick Space™ shelf	●	●	●	●	●	●	●	●	●	●	●
Smart Storage System (w/spill-proof cover)											
Snack pan (top)	Adj. Humidity	Adj. Humidity	Adj. Humidity	Adj. Humidity	Adj. Humidity	Adj. Humidity	Adj. Humidity	Adj. Humidity	Adj. Humidity	Adj. Humidity	Adj. Humidity
Vegetable/fruit crisper (middle)	Adj. Humidity	Adj. Humidity	Adj. Humidity	Adj. Humidity	Adj. Humidity	Adj. Humidity	Adj. Humidity	Adj. Humidity	Adj. Humidity	Adj. Humidity	Adj. Humidity
Meat pan (lower)	Adj. Temp.	Adj. Temp.	Adj. Temp.	Adj. Temp.	Adj. Temp.	Adj. Temp.	Adj. Temp.	Adj. Temp.	Adj. Temp.	Adj. Temp.	Adj. Temp.
Spacemaker™ door bins w/gallon storage	2 2 Adj.	2 Adj.	2	2 Adj.	2 Adj.	2 Adj.	2 Adj.	2 Adj.	2 Adj.	2 Adj.	2 Adj.
Modular door bins	4	4	4	4	4	4	4	4	4	4	4
Snuggler™ Clip(s)	2	2	2	2	2	2	2	2	2	2	2
Dairy compartment w/glass butter dish	●	●	●	●	●	●	●	●	●	●	●
Beverage rack	●	●	●	●	●	●	●	●	●	●	●
Egg bin	●	●	●	●	●	●	●	●	●	●	●
Interior light(s)	2	2	2	2	2	2	2	2	2	2	2
Freezer slide-out basket(s)	1 Wire Everwhite	1 Wire Everwhite	1 Wire Everwhite	1 Wire Everwhite	1 Wire Everwhite	1 Wire Everwhite	1 Wire Everwhite	1 Wire Everwhite	2 Wire Everwhite	1 Wire Everwhite	3 Wire Everwhite
Freezer storage bin(s) (wire Everwhite)	1 Sliding	1 Sliding	1 Sliding	1 Sliding	1 Sliding	1 Sliding	1 Sliding	1 Sliding	1 Sliding	1 Sliding	1 Sliding
Cantilevered freezer shelf	3 (2 Adj.)	3 (2 Adj.)	3 (2 Adj.)	3 (2 Adj.)	3 (2 Adj.)	3 (2 Adj.)	3 (2 Adj.)	3 (2 Adj.)	1	3 (2 Adj.)	
Freezer door shelves	4 (2 Adj.)	4 (2 Adj.)	4 (2 Adj.)	4 (2 Adj.)	4 (2 Adj.)	5 (2 Adj.)	4 (2 Adj.)	4 (2 Adj.)	4 (2 Adj.)	5 (2 Adj.)	4
Adjustable rollers	●	●	●	●	●	●	●	●	●	●	●
<b>Economical/Quiet</b>											
Quiet Package	●	●	●	●	●	●	●	●	●	●	●
Auto Energy Saver (condenser loop)	●	●	●	●	●	●	●	●	●	●	●
Insulation (cabinet and door)	Foam	Foam	Foam	Foam	Foam	Foam	Foam	Foam	Foam	Foam	Foam
Cabinet liner—Baked Enamel-on-Steel	●	●	●	●	●	●	●	●	●	●	●
Door liner—ABS	●	●	●	●	●	●	●	●	●	●	●
<b>Appearance</b>											
Color(s) available*	BS	BS	WW, AA, BB	WW, AA, BB	WW, BB	BS	BS	WW, AA, BB	WW, AA, BB	WW, BB	WW, AA, BB
CustomStyle™ configuration	Trimless	Trimless	Trimless	Trimless	Installed Trim	Trimless	Trimless	Trimless	Installed Trim	Installed Trim	Trimless Installed Trim
Premium Deluxe door handle(s)	Black	N/A	Color-Matched	Color-Matched	N/A	Black	N/A	Color-Matched	N/A	N/A	Color-Matched
Full-length handles	N/A	Stainless Steel Appearance	N/A	N/A	Color-Matched	N/A	Stainless Steel Appearance		Color-Matched	Color-Matched	Color-Matched
Exterior design	Rounded Doors	Squared Doors	Rounded Doors	Rounded Doors	Squared Doors	Rounded Doors	Squared Doors	Rounded Doors	Squared Doors	Squared Doors	Squared Doors
Textured steel			●	●	●			●	●	●	●
<b>Weights &amp; Dimensions</b>											
Height to top of hinge (in.)	69-3/4	69-3/4	69-3/4	69-3/4	69-3/4	69-3/4	69-3/4	69-3/4	69-3/4	69-3/4	69-3/4
Height to top of case (in.)	68-3/4	68-3/4	68-3/4	68-3/4	68-3/4	68-3/4	68-3/4	68-3/4	68-3/4	68-3/4	68-3/4
Case depth without door (in.)	23-7/8	23-7/8	23-7/8	23-7/8	23-7/8	23-7/8	23-7/8	23-7/8	23-7/8	23-7/8	23-3/4
Case depth less door handle (in.)	26-3/8	26-3/8	26-3/8	26-3/8	26-3/8	26-3/8	26-3/8	26-3/8	26-3/8	26-3/8	26
Case depth with door handle (in.)	28-7/16 28-15/16	28-7/16	28-15/16	28-7/16	28-7/16	28-7/16	28-7/16	28-15/16	28-7/16	28-7/16	28-1/2 27-5/8
Depth w/fresh food door open 90° (in.)	45-5/8	45-5/8	45-1/4	45-5/8	45-5/8	45-5/8	45-5/8	45-5/8	45-5/8	45-5/8	45-5/8
Width (in.)	35-3/4	35-3/4	35-3/4	35-3/4	35-3/4	35-3/4	35-3/4	35-3/4	35-3/4	35-3/4	35-3/4
Width w/door open 90° w/door handle (in.)	40-7/8	40-7/8	40-7/8	40-7/8	40-7/8	40-7/8	40-7/8	40-7/8	40-7/8	40-7/8	40
Air clearances	Each side (in.)	1/8**	1/8**	1/8**	1/8**	1/8**	1/8**	1/8**	1/8**	1/8**	1/8**
Top (in.)	1	1	1	1	1	1	1	1	1	1	1
Back (in.)	1/2	1/2	1/2	1/2	1/2	1/2	1/2	1/2	1/2	1/2	1/2
Approx. shipping weight (lbs.)	376	350	350	350	350	376	350	350	350	350	336
<b>Accessories</b>											
Factory trim kit attached	N/A	N/A	N/A	N/A	●	N/A	N/A	N/A	●	●	N/A/●
Black acrylic panels (optional)	N/A	N/A	N/A	N/A	TKP24RBBB	N/A	N/A	N/A	TKP24RBBB	TKP24IBBB	N/A/TKP21LS
White acrylic panels (optional)	N/A	N/A	N/A	N/A	TKP24RBWW	N/A	N/A	N/A	TKP24RBWW	TKP24IBWW	N/A/TKP21LS
Almond acrylic panels (optional)	N/A	N/A	N/A	N/A	N/A	N/A	N/A	N/A	TKP24RBAA	N/A	N/A
Stainless steel panels (optional)	N/A	N/A	N/A	N/A	TKP24RBSS	N/A	N/A	N/A	TKP24IBSS	TKP24IBSS	N/A/TKP21RXSS
Black collar trim (optional)	N/A	N/A	N/A	N/A	TRMBISBB	N/A	N/A	N/A	TRMBISBB	TRMBISBB	N/A/TRMBISBB
White collar trim (optional)	N/A	N/A	N/A	N/A	TRMBISWW	N/A	N/A	N/A	TRMBISWW	TRMBISWW	N/A/TRMBISWW
Almond collar trim (optional)	N/A	N/A	N/A	N/A	N/A	N/A	N/A	N/A	TRMBISAA	N/A	N/A
Stainless steel collar trim (optional)	N/A	TRMBISSS	N/A	N/A	N/A	N/A	TRMBISSS	N/A	N/A	N/A	N/A

\*Color(s) available: WW = White on white, AA = Almond on almond, BB = Black on black, BS = Black case with stainless steel doors.

\*\*If installed against a wall, allow clearance of 11-1/4" on freezer side to remove bin.

Clearance required to remove fresh food full size pan without disassembling is 14".

ALL MODELS AVAILABLE IN U.S. AND CANADA.



# GE PROFILE PERFORMANCE™ AND GE PROFILE™ SIDE-BY-SIDE CUSTOMSTYLE™ INSTALLATION INFORMATION AND SPECIFICATIONS

## Rough-In Dimensions

### Standard, New Construction and Replacement Installation

#### Installation Tips to Maximize the Built-In Look

- All wall/floor moulding should be removed prior to installation.
- Water recess on rear wall recommended to prevent water line damage. 48" minimum length 1/4" diameter water line tubing recommended.
- When possible, recess both copper water line and electrical outlet. (See local codes)
- Front and rear leveling legs are adjustable for the built-in look. (See owner's manual)
- If optional collar trim kit is to be used or anticipated, see collar trim installation on next page for different rough-in dimensions.

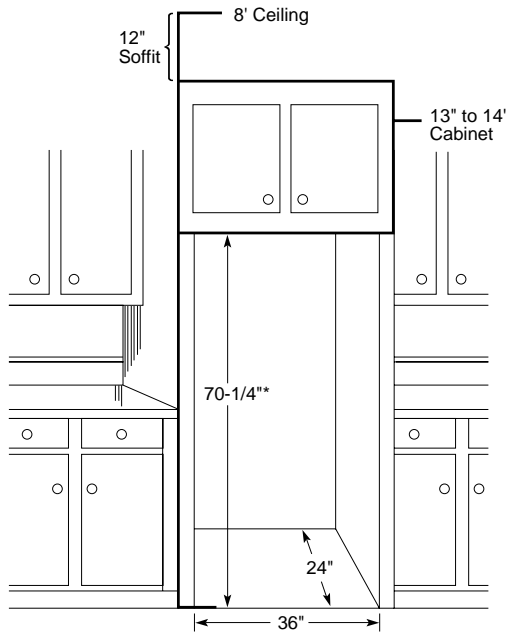

\*The rough-in dimension of 70-1/4" is minimum and is measured from the finished floor to top of opening (or the underside of the overhead cabinets). For Models with Trim Kit: If frameless style cabinets are planned for above the refrigerator, you may need to consider adding a maximum of 1/4" (70-1/2") to height of opening to allow additional clearance between cabinet doors and top of refrigerator trim when cabinet doors are in open position.

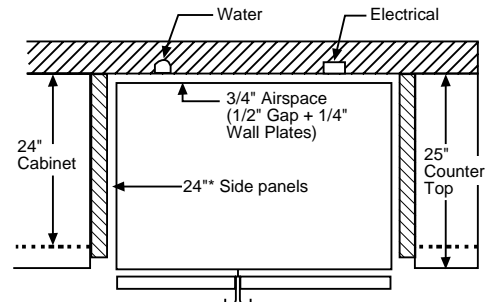

For 24 cu. ft. models only.

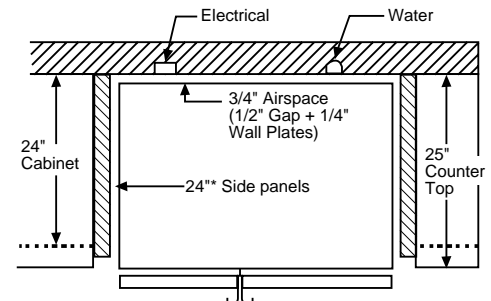

For 21 cu. ft. models only.

\*24" depth applies to the refrigerator opening, not the actual cabinet depth.

## Door Panel Dimensions

Order your own custom wood panels to match cabinetry or other decor.

	Fresh Food Panels	Freezer Panel With Dispenser	Freezer Panel Without Dispenser	Weight Limits*
<b>21 cu. ft.</b>	G-65-3/16" H-20-1/16"	C-18-3/4" D-14-5/16"	E-32-3/8" F-14-5/16"	Fresh Food = 38 lbs. Freezer = 28 lbs.
<b>24 cu. ft.</b>	G-67-1/8" H-19-5/16"	C-18-13/16" D-14-1/2"	E-34-5/16" F-14-1/2"	A-67-1/8" B-14-1/2"

Panels up to 1/4" thick will fit door frame with no special preparation. Add filler behind material thinner than 1/4" for proper fit.

Note: Panels up to 3/4" will require special routing area around handles. Dimensions may vary depending on depth of panel.

\*Total weight of panels (ie: both freezer panels)

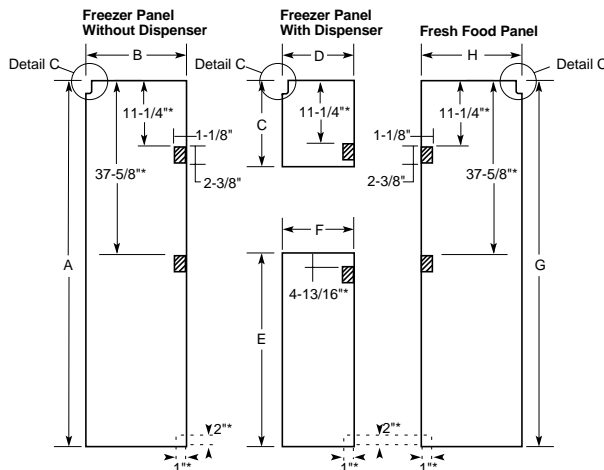

\*For 24 cu. ft. models only

### Detail C

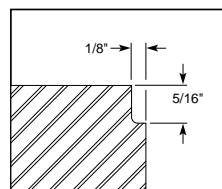

(Fresh Food panel shown)  
Notch required at top corner as noted.  
For 21 and 24 cu. ft. models

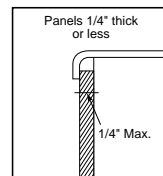

For 24 cu. ft. models only.

All other dotted lines indicate areas that must be routed out about 5/32" (4 mm) on the back side of panels 1/4" (6 mm) thick or more. For panels less than 1/4" (6 mm) thick, these areas can be cut out of the filler panel.

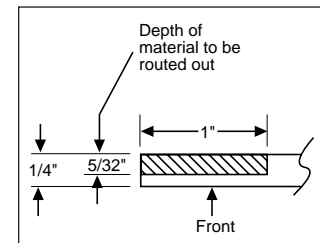

**IMPORTANT:** Before finalizing specifications for your GE Profile Performance™ and GE Profile™ CustomStyle™ Refrigerator, Please NOTE:  
• A minimum of 36" is required for refrigerator installation  
• Be sure to allow for 1/2" or 3/4" side panels in addition to the 36" minimum

# GE PROFILE PERFORMANCE™ AND GE PROFILE™ SIDE-BY-SIDE CUSTOMSTYLE™ INSTALLATION INFORMATION AND SPECIFICATIONS

## Installation of Water and Electrical Outlets

For 21 cu. ft. models only.

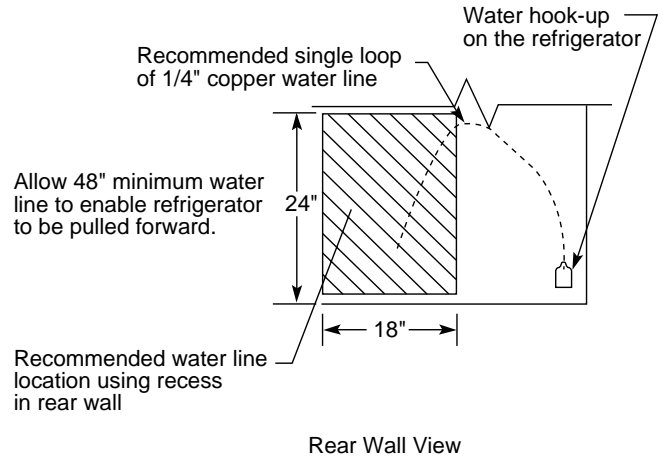
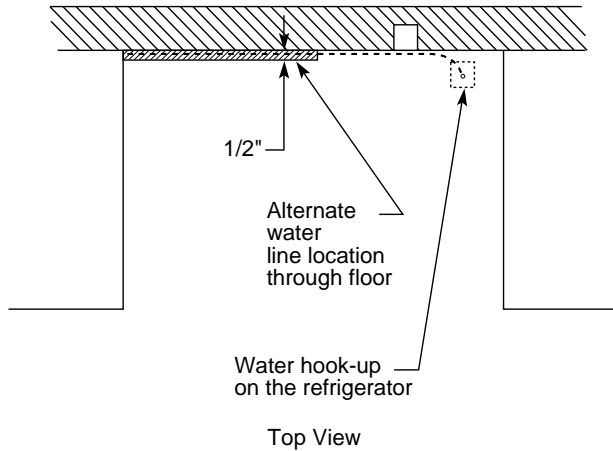

## Collar Trim Installation

An enclosure is **required** to match up to the trim, see Typical Installation. To obtain the most integrated look, the cabinet or soffit above the refrigerator should extend out to the same depth as the side panels. The refrigerator opening must have minimum dimensions of 70-1/4" high x 36-1/8" wide x 24-1/2" deep as shown at right. If there is an overhead cabinet, allow 1" for cabinet door clearance with the top trim piece so the cabinet doors can be opened without hitting the top trim. If 1/2" side panels are used, then side trim and panel will be even. If 3/4" side panels are used, then some of the side panel will extend beyond the trim and must be finished.

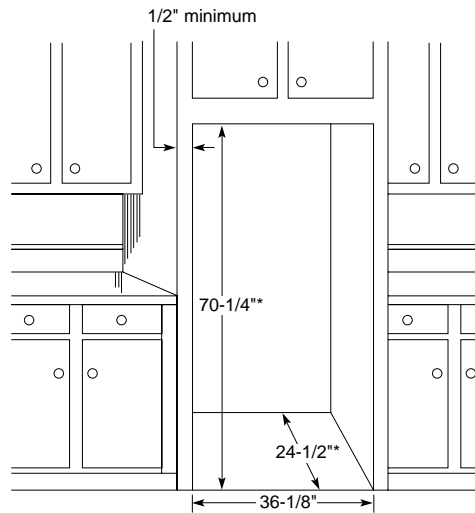

\*The rough-in dimension of 70-1/4" is minimum and is measured from the finished floor to top of opening (or the underside of the overhead cabinets). For Models with Trim Kit: If frameless style cabinets are planned for above the refrigerator, you may need to consider adding a maximum of 1/4" (70-1/2") to height of opening to allow additional clearance between cabinet doors and top of refrigerator trim when cabinet doors are in open position.

For 24 cu. ft. models only.

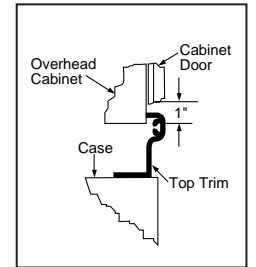
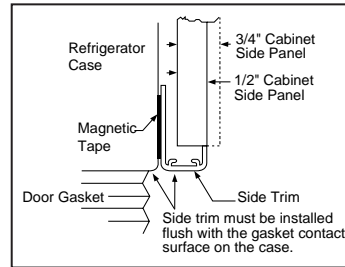

For 21 cu. ft. models only.

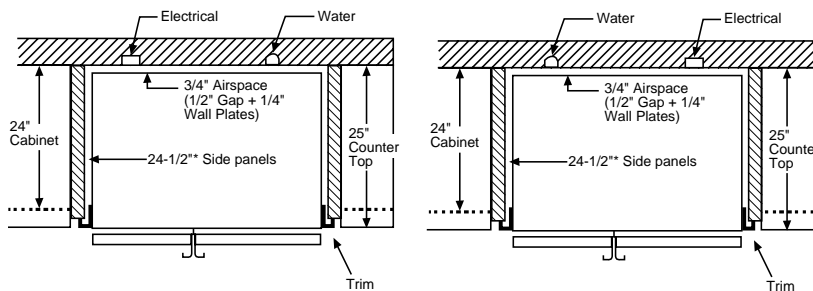
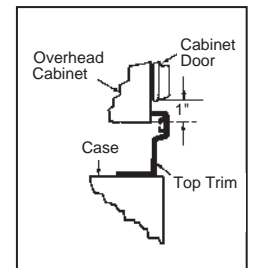
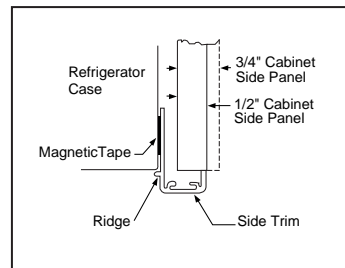

For 21 cu. ft. models only.

For 24 cu. ft. models only.

\*24-1/2" depth applies only to the refrigerator opening, not the actual cabinet depth.

**IMPORTANT:** Before finalizing specifications for your GE Profile Performance™ and GE Profile™ CustomStyle™ Refrigerator, Please NOTE:

- A minimum of 36-1/8" is required for refrigerator installation with collar
- Be sure to allow for 1/2" or 3/4" side panels in addition to the 36-1/8" minimum

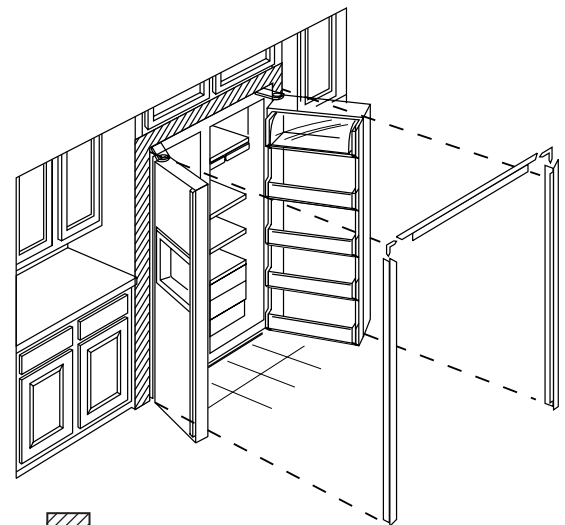

# CUSTOMSTYLE™ NO-FROST TOP-FREEZER REFRIGERATORS

	GE Profile Performance Series™					
	TNX22PRC	TNX22PAC	TNS22PRC	TNX22BRC	TNX22BAC	TNS22BRC
Stainless steel model			●			●
<b>Capacity</b>						
Total (cu. ft.)	21.7	21.9	21.7	21.7	21.9	21.7
Fresh food (cu. ft.)	15.4	15.4	15.4	15.4	15.4	15.4
Freezer (cu. ft.)	6.3	6.5	6.3	6.3	6.5	6.3
Shelf area (sq. ft.)	20.0	22.4	20.0	20.0	22.4	20.0
<b>Features</b>						
LightTouch! dispenser	Cubes, Crushed Ice & Chilled Water		Cubes, Crushed Ice & Chilled Water	Cubes, Crushed Ice & Chilled Water		Cubes, Crushed Ice & Chilled Water
Automatic icemaker & ice bin	Factory-Installed	Opt. (IM3)	Factory-Installed	Factory-Installed	Opt. (IM3)	Factory-Installed
Ice™N Easy trays		4			4	
Ice storage bin		●			●	
Cabinet shelves	4 Glass	4 Glass	4 Glass	4 Glass	4 Glass	4 Glass
(adjustable)	4	4	4	4	4	4
(slide-out)	3	3	3	3	3	3
(spill-proof)	3	3	3	3	3	3
Quick Space™ shelf	●	●	●	●	●	●
Quick Store™ bin	●	●	●	●	●	●
Beverage rack	●	●	●	●	●	●
Window vegetable/fruit crisper	2 Adj. Humidity	2 Adj. Humidity	2 Adj. Humidity	2 Adj. Humidity	2 Adj. Humidity	2 Adj. Humidity
Slide-out, spill-proof crisper cover	●	●	●	●	●	●
Meat pan	Adj. Temperature	Adj. Temperature	Adj. Temperature	Adj. Temperature	Adj. Temperature	Adj. Temperature
Modular door bins	3 Adj. w/Gallon Storage	3 Adj. w/Gallon Storage	3 Adj. w/Gallon Storage	3 Adj. w/Gallon Storage	3 Adj. w/Gallon Storage	3 Adj. w/Gallon Storage
Door shelf	1 Fixed	1 Fixed	1 Fixed	1 Fixed	1 Fixed	1 Fixed
Slide-out, slide-over pans	●	●	●	●	●	●
Snuggler™ Clip(s)	2	2	2	2	2	2
Modular dairy compartment	1	1	1	1	1	1
Glass butter dish	●	●	●	●	●	●
Dual upfront temperature control (backlit)	●	●	●	●	●	●
Fresh food upfront lighting	●	●	●	●	●	●
Freezer interior light	●	●	●	●	●	●
Freezer compartment shelf(s) (wire Everwhite)	1 Adj.	2 Adj.	1 Adj.	1 Adj.	2 Adj.	1 Adj.
Freezer door bins	2 Fixed	3 (2 Adj./ 1 Fixed w/Gallon Storage)	2 Fixed	2 Fixed	3 (2 Adj./ 1 Fixed w/Gallon Storage)	2 Fixed
Adjustable rollers	●	●	●	●	●	●
<b>Economical/Quiet</b>						
Cabinet/door insulation	Foam	Foam	Foam	Foam	Foam	Foam
Cabinet/door liner	ABS	ABS	ABS	ABS	ABS	ABS
<b>Appearance</b>						
Color(s) available*	WW, AA, BB	WW, AA, BB	BS	WW, BB	WW, BB	BS
Door handle(s)	Color-Matched Premium Deluxe	Color-Matched Premium Deluxe	Black Premium Deluxe	Color-Matched Full-Length	Color-Matched Full-Length	Stainless Steel Full-Length
Textured steel doors & case	●	●		●	●	●
Built-in configuration	Trimless	Trimless	Trimless	Installed Trim	Installed Trim	Factory-Installed Trim & Stainless Steel Panels
Exterior design	Rounded Doors	Rounded Doors	Rounded Doors			
Choose right or left door opening	●	●	●	●	●	●
Reversible doors	●	●				
<b>Weights &amp; Dimensions</b>						
Height to top of hinge (in.) A	69-7/8	69-7/8	69-7/8	69-7/8	69-7/8	69-7/8
Height to top of case (in.) B	68-3/4	68-3/4	68-3/4	70-7/16	70-7/16	70-7/16
Case depth without door (in.) C	23-3/4	23-3/4	23-3/4	23-3/4	23-3/4	23-3/4
Case depth less door handle (in.) D	26-3/4	26-3/4	26-3/4	26-3/4	26-3/4	26-3/4
Case depth with door handle (in.) E	28-5/8	28-3/8	28-5/8	28-3/8	28-3/8	28-5/8
Depth w/fresh food door open 90° (in.) F	61	61	61	61	61	61
Width (in.) G	35-3/4	35-3/4	35-3/4	35-3/4	35-3/4	35-3/4
Width w/door open 90° w/door handle (in.) H	36-1/4	36-1/4	36-1/4	36-5/8	36-5/8	36-5/8
Air clearances Each side (in.)	1/8	1/8	1/8	1/8	1/8	1/8
Top (in.)	1	1	1	1	1	1
Back (in.)	1/2	1/2	1/2	1/2	1/2	1/2
Approx. shipping weight (lbs.)	325	300	325	325	300	325
<b>Accessories</b>						
Black acrylic panels (optional)	N/A	N/A	N/A	TKP22RCBB	TKP22ACBB	N/A
White acrylic panels (optional)	N/A	N/A	N/A	TKP22RCWW	TKP22ACWW	N/A
Stainless steel panels (optional)	N/A	N/A	N/A	TKP22RCSS	TKP22ACSS	N/A
Black collar trim (optional)	N/A	N/A	N/A	TRMBISBB	TRMBISBB	N/A
White collar trim (optional)	N/A	N/A	N/A	TRMBISWW	TRMBISWW	N/A
Stainless steel collar trim (optional)	N/A	N/A	N/A	TRMBISSS	TRMBISSS	TRMBISSS

\*Color(s) available: WW = White on white, AA = Almond on almond, BB = Black on black, BS = Black case with stainless steel doors.  
**ALL MODELS AVAILABLE IN U.S. AND CANADA.**

## Top-Freezer No-Frost Refrigerator

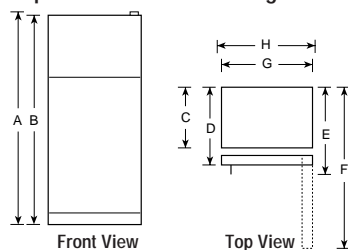

See page 134 for warranty information.

Refrigeration

Water Systems

Laundry

Cooking Products

Microwave Ovens

Dishwashers

Room Air



# GE PROFILE PERFORMANCE™ TOP-FREEZER CUSTOMSTYLE™ INSTALLATION INFORMATION AND SPECIFICATIONS

## Rough-In Dimensions

### Standard, New Construction and Replacement Installation

#### Installation Tips to Maximize the Built-In Look

- All wall/floor moulding should be removed prior to installation.
- Water recess on rear wall recommended to prevent water line damage. 48" minimum length 1/4" diameter water line tubing recommended.
- When possible, recess both copper water line and electrical outlet. (See local codes)
- Front and rear leveling legs are adjustable for the built-in look. (See owner's manual)

## Collar Trim Installation

An enclosure is **required** to match up to the trim, see Typical Installation. To obtain the most integrated look, the cabinet or soffit above the refrigerator should extend out to the same depth as the side panels. The refrigerator opening must have minimum dimensions of 70-1/4" high x 36-1/8" wide x 24-1/2" deep as shown at right. If there is an overhead cabinet, allow 1" for cabinet door clearance with the top trim piece so the cabinet doors can be opened without hitting the top trim. If 1/2" side panels are used, then side trim and panel will be even. If 3/4" side panels are used, then some of the side panel will extend beyond the trim and must be finished.

## Rough-In Dimensions

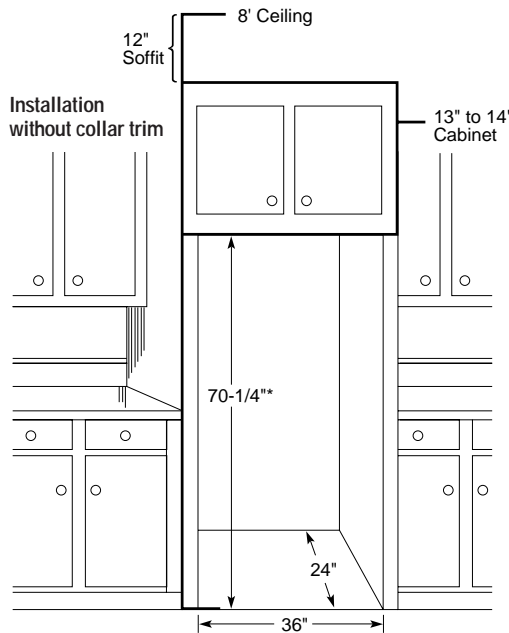

## Collar Trim Installation

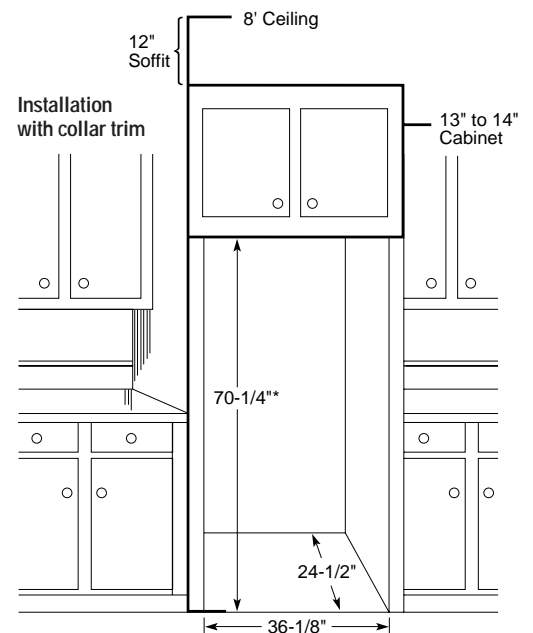

\*The rough-in dimension of 70-1/4" is minimum and is measured from the finished floor to top of opening (or the underside of the overhead cabinets). For Models with Trim Kit: If frameless style cabinets are planned for above the refrigerator, you may need to consider adding a maximum of 1/4" (70-1/2") to height of opening to allow additional clearance between cabinet doors and top of refrigerator trim when cabinet doors are in open position.

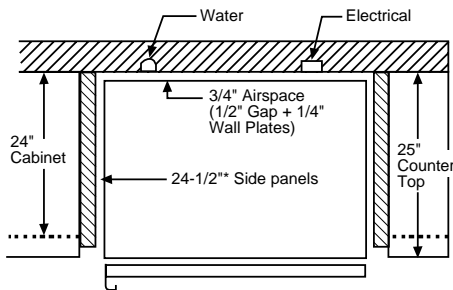

For 22 cu. ft. models only.

\*22" depth applies to the refrigerator opening, not the actual cabinet depth.

## Door Panel Dimensions

Order your own custom wood panels to match cabinetry or other decor.

	Fresh Food Panels	Freezer Panel Without Dispenser	Freezer Panel With Dispenser
22 cu. ft.	B-42-1/4"	A-24-1/16"	D-24-1/16"
	C-35-3/4"	C-35-3/4"	C-35-3/4"

Panels up to 1/4" thick will fit door frame with no special preparation. Add filler behind material thinner than 1/4" for proper fit.

Note: Panels up to 3/4" will require special routing area around handles. Dimensions may vary depending on depth of panel.

### Handle Side Clearance

-At least 2" (51 mm) on the handle side for fingertip clearances.

### Top and Bottom Clearance

-At least 3/16" (4.75 mm) at the top and bottom edges to allow for trim flange.

### Hinge Side Clearance

- A 3/4" (19 mm) thick door panel may strike the adjacent countertops when the door is fully opened. Therefore, the hinge side clearance to raised panel will vary according to the installation situation.
- Allow 1-3/4" (44 mm) clearance when installation does not include side panels.
- The installation of 3/4" (19 mm) thick side panels requires less clearance because the space between the door and adjacent countertop is wider.
- To avoid door contact to countertop consider:
  - Miter the corner of the adjacent countertops 45°, or
  - pull the refrigerator forward enough to avoid contact.

### Stability Leg

- The top-freezer refrigerator is the first cabinet depth top-freezer. This means depth is more shallow than conventional models and the width is larger. The stability leg gives the unit extra support.

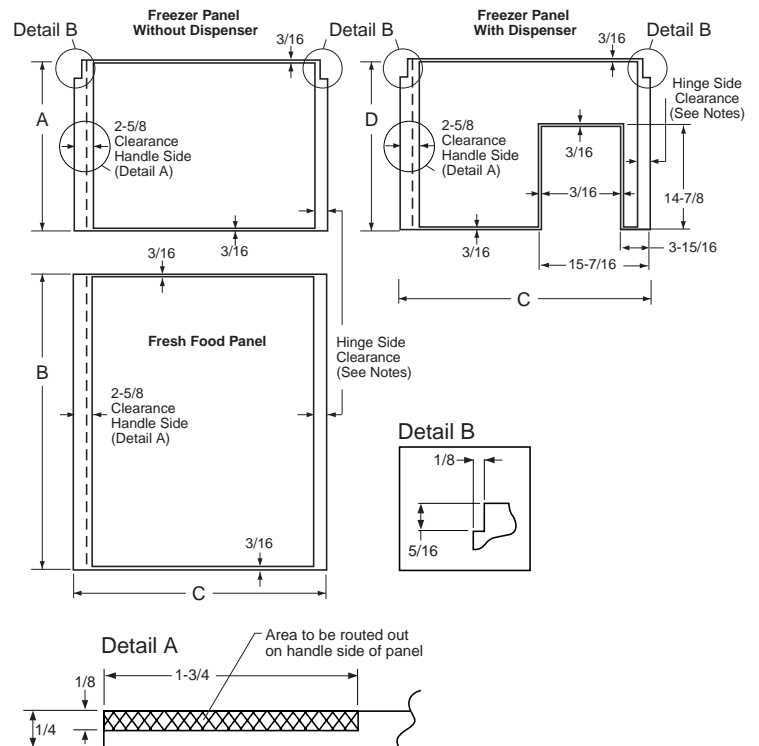

**IMPORTANT:** Before finalizing specifications for your GE Profile Performance™ CustomStyle™ Refrigerator, Please NOTE:

- A minimum of 36" is required for refrigerator installation
- Be sure to allow for 1/2" or 3/4" side panels in addition to the 36" minimum

# SIDE-BY-SIDE REFRIGERATORS

	GE Profile Performance Series™								GE Profile™		
	TFS28PBB TFS28PPB	TFS25PPB	TFS22PPB	TFX30PBB TFX30PPB	TFX28PBB	TFX28PPC	TFX25PPB	TFX22PPB	TFX27PRB	TFX25PRB TFX25PAB	TFX22PRB
Stainless steel model	●	●	●	●	●	●	●	●	●	●	●
<b>Capacity</b>											
Total (cu. ft.)	28.2	25.2	21.6	29.8	28.2	28.2	25.2	21.6	26.6	25.2/25.3	21.6
Fresh food (cu. ft.)	17.23	15.92	14.85	18.15	17.23	17.23	15.92	14.85	16.83	15.92	14.85
Freezer (cu. ft.)	10.94	9.32	6.75	11.65	10.94	10.94	9.32	6.75	9.72	9.32/9.41	6.75
Shelf area (sq. ft.)	27.5/27.7	25.2	23.4	29.8	27.5	27.7	25.2	23.4	27.6	25.2/25.6	23.4
<b>Features</b>											
Refreshment Center	●/-			●/-	●						
Electronic Monitor/Diagnostic System	●/-			●/-	●						
Exclusive Water by Culligan™	●	●	●	●	●	●	●	●			
LightTouch™ dispenser	●	●	●	●	●	●	●	●	●	●	●
Automatic icemaker and ice bin	●	●	●	●	●	●	●	●	●	●/Opt. (IM3)	●
Cabinet shelves	3 Glass	3 Glass	3 Glass	3 Glass	3 Glass	3 Glass	3 Glass	3 Glass	3 Glass	3 Glass	3 Glass
(adjustable)	3	3	3	3	3	3	3	3	3	3	3
(slide-out)	2 Glass	2 Glass	2 Glass	2 Glass	2 Glass	2 Glass	2 Glass	2 Glass	2 Glass	2 Glass	2 Glass
(spill-proof)	●	●	●	●	●	●	●	●	●	●	●
Quick Space™ shelf(s)	●	●	●	●	●	●	●	●	●	●	●
Smart Storage System (w/spill-proof cover)											
Snack pan (top)	Adj. Humid.	Adj. Humid.	Adj. Humid.	Adj. Humid.	Adj. Humid.	Adj. Humid.	Adj. Humid.	Adj. Humid.	Adj. Humid.	Adj. Humid.	Adj. Humid.
Vegetable/fruit crispers (middle)	Adj. Humid.	Adj. Humid.	Adj. Humid.	Adj. Humid.	Adj. Humid.	Adj. Humid.	Adj. Humid.	Adj. Humid.	Adj. Humid.	Adj. Humid.	Adj. Humid.
Meat pan (lower)	Adj. Temp.	Adj. Temp.	Adj. Temp.	Adj. Temp.	Adj. Temp.	Adj. Temp.	Adj. Temp.	Adj. Temp.	Adj. Temp.	Adj. Temp.	Adj. Temp.
Spacemaker™ door bins	●	●	●	●	●	●	●	●	●	●	●
Modular door bins	4 (3 w/gal. storage, 1 Adj.)	4 (2 Adj. w/gal. storage)	4 (2 Adj. w/gal. storage)	4 (3 w/gal. storage, 1 Adj.)	4 (3 w/gal. storage, 1 Adj.)	4 (2 Adj. w/gal. storage, 1 Adj.)	4 (2 Adj. w/gal. storage)	4 (2 Adj. w/gal. storage)	5 (4 Adj. w/gal. storage)	4 (2 Adj. w/gal. storage)	4 (2 Adj. w/gal. storage)
Snuggler™ Clip(s)	2	2	2	2	2	2	2	2	2	2	2
Dairy compartment w/glass butter dish	●	●	●	●	●	●	●	●	●	●	●
Beverage rack	●	●	●	●	●	●	●	●	●	●	●
Egg bin (clear)	●	●	●	●	●	●	●	●	●	●	●
Interior light(s)	2	2	2	2	2	2	2	2	2	2	2
Freezer compartment shelves (Wire Everwhite)	3 (2 Adj.)			3 (2 Adj.)	3 (2 Adj.)	3 (2 Adj.)				1 Adj.	
Freezer slide-out baskets (wire Everwhite)	1 Adj.	3	3	1 Adj.	1 Adj.	1 Adj.	3	3	3	3	3
Freezer storage bin(s) (wire Everwhite)	1 Sliding	1 Clear Sliding	1 Clear Sliding	1 Sliding	1 Sliding	1 Clear Sliding	1 Clear Sliding	1 Clear Sliding	1 Clear Sliding	1 Clear Sliding	1 Clear Sliding
Freezer door shelves	4 (2 Adj.)	5	5	4 Extra-Deep (2 Adj.)	4 (2 Adj.)	4 (2 Adj.)	5	5	5	6	5
Adjustable rollers	●	●	●	●	●	●	●	●	●	●	●
<b>Economical/Quiet</b>											
Quiet Package	●	●	●	●	●	●	●	●	●	●	●
Automatic Energy Saver (condenser loop)	●	●	●	●	●	●	●	●	●	●	●
Cabinet and door insulation	Foam	Foam	Foam	Foam	Foam	Foam	Foam	Foam	Foam	Foam	Foam
Cabinet liner-Baked enamel-on-steel	●	●	●	●	●	●	●	●	●	●	●
Door liner-ABS	●	●	●	●	●	●	●	●	●	●	●
<b>Appearance</b>											
Color(s) available*	BS	BS	BS	WW, AA, BB	WW, AA, BB	WW, AA, BB	WW, AA, BB	WW, AA, BB	WW, AA, BB	WW, AA, BB	WW, AA, BB
Premium deluxe door handle(s)	Black	Black	Black	Color-Matched	Color-Matched	Color-Matched	Color-Matched	Color-Matched	Color-Matched	Color-Matched	Color-Matched
Exterior design	Rounded Doors			Rounded Doors	Rounded Doors						
Textured steel doors and case	●	●	●	●	●	●	●	●	●	●	●
<b>Weights &amp; Dimensions</b>											
Height to top of hinge (in.) A	69-3/4	69-3/4	67-5/8	69-3/4	69-3/4	69-3/4	69-3/4	67-5/8	69-3/4	69-3/4	67-5/8
Height to top of case (in.) B	68-3/4	68-3/4	66-5/8	68-3/4	68-3/4	68-3/4	68-3/4	66-5/8	68-3/4	68-3/4	66-5/8
Case depth without door (in.) C	28	28	28	28**	28	28	28	28	28	28	28
Case depth less door handle (in.) D	30-1/2	30-1/4	30-1/4	32-1/4**	30-1/2	30-1/2	30-1/4	30-1/4	31-5/8	30-1/4	30-1/4
Case depth with door handle (in.) E	32-5/8	32-1/2	32-1/2	34-1/2**	32-5/8	32-5/8	32-1/2	32-1/2	33-7/8	32-1/2	32-1/2
Depth with door open 90° (in.) F	49-3/8	49-3/4	49-3/4	49-1/4**	49-3/8	49-3/8	49-3/4	49-3/8	50-1/4	49-3/4	49-3/8
Width (in.) G	35-3/4	35-3/4	33-1/2	35-3/4	35-3/4	35-3/4	35-3/4	33-1/2	35-3/4	35-3/4	33-1/2
Width with door open 90° less door handle (in.) H	38	36-1/8	34-1/4	40	38	38	36-1/8	34-1/4	38-1/4	36-1/8	34-1/4
Air clearances											
Each side (in.)	1/8†	3/4†	3/4†	1/8†	1/8†	1/8†	3/4†	3/4†	3/4†	3/4†	3/4†
Top (in.)	1	1	1	1	1	1	1	1	1	1	1
Back (in.)	1/2	1	1	1/2	1/2	1/2	1	1	1	1	1
Approx. shipping weight (lbs.)	421	361	332	395	395	395	335	310	386	335	310
<b>Accessories</b>											
Aluminum trim kit	N/A	N/A	N/A	TK30FBAL TK30RBAL	TK28FBAL	N/A	TK25RBAL	N/A	TK27RBAL	TK25RBAL N/A	N/A
LEXAN™ black panels	N/A	N/A	N/A	N/A	TKP28FB	N/A	TKP25RB	N/A	TKP27EB	TKP25RB/N/A	N/A
Black acrylic panels and trim kit	N/A	N/A	N/A	N/A	N/A	N/A	TFP25RB	TFP22RB	N/A	TFP25RB/N/A	TFP22RB
Stainless steel panels	N/A	N/A	N/A	TKP30FBSS TKP30RBSS	N/A	N/A	N/A	N/A	TKP27RBSS	N/A	N/A

\*Color(s) available: WW = White on white, AA = Almond on almond, BB = Black on black, BS = Black case with stainless steel doors.  
 \*\*Add 9/16" for water hook-up. Hook-up fits in 5/8" back air clearance when calculating installation depth.  
 †† Installed against a wall, allow clearance of 11-1/4" on freezer side to remove ice bin.  
 To remove fresh food pans, remove door bins.  
 Clearances required to remove fresh food full-size pan without disassembling:  
 10-1/2" on 22 cu. ft.; 13-5/8" on 25 cu. ft.; 14" on 27 cu. ft.; 13" on 30 cu. ft.  
 For Built-In Appearance allow height space of 69-3/4" on 25, 27 and 28 cu. ft.  
 Plus, allow additional space for any necessary leveling adjustments.

ALL MODELS AVAILABLE IN U.S. AND CANADA.

Note: If the doors cannot be fully opened because of an obstruction or a wall on either side, a door stop should be installed to prevent door or wall damage. If the doors cannot be opened at least 90 degrees, access to the drawers is limited.

## Side-By-Side Refrigerator

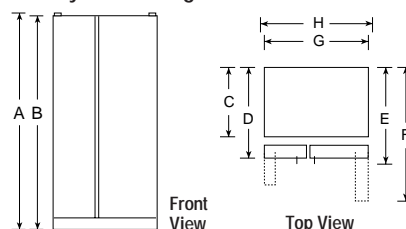

Total volume and shelf area are calculated by the Association of Home Appliance Manufacturers' standards.



Refrigeration

Water Systems

Laundry

Cooking Products

Microwave Ovens

Dishwashers

Room Air

# SIDE-BY-SIDE REFRIGERATORS

	GE "Z" Series			GE "K" Series		GE "J" Series			GE "S" Series
	TFX27ZPB	TFX25ZPB	TFX22ZPB	TFX25KRC	TFX22KRC	TFX22JAB	TFX20JRB	TFX20JAB	TFX20SAB
<b>Capacity</b>									
Total (cu. ft.)	26.6	25.2	21.7	25.2	21.7	21.8	19.7	19.7	19.7
Fresh food (cu. ft.)	16.88	15.92	14.92	15.92	14.92	14.92	12.90	12.90	12.90
Freezer (cu. ft.)	9.72	9.32	6.75	9.32	6.79	6.89	6.75	6.79	6.79
Shelf area (sq. ft.)	28.3	25.8	24.1	24.2	22.8	22.8	20.1	20.4	20.4
<b>Features</b>									
Exclusive Water by Culligan™	●	●	●						
LightTouch! dispenser	Cubes, Crushed Ice & Chilled Water	Cubes, Crushed Ice & Chilled Water	Cubes, Crushed Ice & Chilled Water	Cubes, Crushed Ice & Chilled Water	Cubes, Crushed Ice & Chilled Water		Cubes, Crushed Ice & Chilled Water		
Automatic icemaker and ice bin	●	●	●	●	●	Opt. (IM3)	●	Opt. (IM3)	Opt. (IM3)
Ice 'N Easy trays						2		2	2
Ice storage bin						●		●	●
Cabinet shelves	3 Glass	3 Glass	3 Glass	3 Glass	3 Glass	3 Glass	3 Glass	3 Glass	3 Wire Everwhite
(adjustable)	3	3	3	3	3	3	3	3	3
(spill-proof)	●	●	●	●	●				
Snack pan	●	●	●						
Vegetable/fruit crisper (upper)	1 Adj. Humid.	1 Adj. Humid.	1 Adj. Humid.	1 Adj. Humid.	1 Adj. Humid.	1 Adj. Humid.	1 Adj. Humid, 1 Sealed	1 Sealed	1 Sealed
Meat pan (lower)	1 Adj. Temp.	1 Adj. Temp.	1 Adj. Temp.	1 Adj. Temp.	1 Adj. Temp.	1 Adj. Temp.	1 Adj. Temp.	1 Adj. Temp.	
Modular door bins	4 (3 Adj. w/ gal. storage)	4 (2 Adj. w/ gal. storage)	4 (2 Adj. w/ gal. storage)	4 (2 Adj. w/ gal. storage)	4 (2 Adj. w/ gal. storage)	4 (2 Adj. w/ gal. storage)	4 (2 w/ gal. storage)	4 (2 w/ gal. storage)	4 (2 w/ gal. storage)
Snuggler™ Clip(s)	2	2	2	2	2	2	2	2	2
Dairy compartment with butter dish	●	●	●	●	●	●	●	●	●
Utility bin (clear)	●	●	●	●	●	●	●	●	●
Interior light(s)	2	2	1	1	1	1	1	1	1
Freezer cabinet shelves (wire Everwhite)	3 Adj.	3 Adj.	3 Adj.	3 Adj.	3 Adj.	4 Adj.	3 Adj.	4 Adj.	4 Adj.
Freezer storage bin(s)	1 Clear Sliding	1 Clear Sliding	1 Clear Sliding	1 Clear Sliding	1 Clear Sliding	1 Clear Sliding	1 Clear Sliding	1 Clear Sliding	1 White Sliding
Freezer door shelves	5	5	5	5	5	6	5	6	6
Metal door gasket retainers	●	●	●	●	●	●	●	●	●
Removable door gasket	●	●	●	●	●	●	●	●	●
<b>Economical/Quiet</b>									
Quiet Package	●	●	●	●	●	●	●	●	●
Automatic Energy Saver (condenser loop)	●	●	●	●	●	●	●	●	●
Cabinet and door insulation	Foam	Foam	Foam	Foam	Foam	Foam	Foam	Foam	Foam
Cabinet liner-Baked enamel-on-steel	●	●	●	●	●	●	●	●	●
Door liner-ABS	●	●	●	●	●	●	●	●	●
<b>Appearance</b>									
Color(s) available*	WW, AA, BB	WW, AA, BB	WW, AA, BB	WW, AA	WW, AA	WW, AA	WW, AA/WH	WW, AA	WW, AA
Deluxe door handle(s)	Color-Matched	Color-Matched	Color-Matched	Color-Matched	Color-Matched	Color-Matched	CM/Black	Color-Matched	Color-Matched
Textured steel doors and case	●	●	●	●	●	●	●	●	●
<b>Weights &amp; Dimensions</b>									
Height to top of hinge (in.) A	69-3/4	69-3/4	67-5/8	69-3/4	67-5/8	67-5/8	67-5/8	67-5/8	67-5/8
Height to top of case (in.) B	68-3/4	68-3/4	66-5/8	68-3/4	66-5/8	66-5/8	66-5/8	66-5/8	66-5/8
Case depth without door (in.) C	28	28	28	28	28	28	28	28	28
Case depth less door handle (in.) D	31-5/8	30-1/4	30-1/4	30-1/4	30-1/4	30-1/4	30-1/4	30-1/4	30-1/4
Case depth with door handle (in.) E	33-7/8	32-1/2	32-1/2	32-1/2	32-1/2	32-1/2	32-1/2	32-1/2	32-1/2
Depth with door open 90° (in.) F	50-1/4	49-3/4	49-3/8	49-3/4	49-3/8	49-3/8	47-3/8	47-3/8	47-3/8
Width (in.) G	35-3/4	35-3/4	33-1/2	35-3/4	33-1/2	33-1/2	31-1/2	31-1/2	31-1/2
Width with door open 90° less door handle (in.) H	38-1/4	36-1/8	34-3/8	36-1/8	34-3/8	34-3/8	32-1/4	32-1/4	32-1/4
Air clearances	Each side (in.)	Each side (in.)	Each side (in.)	Each side (in.)	Each side (in.)	Each side (in.)	Each side (in.)	Each side (in.)	Each side (in.)
Top (in.)	3/4†	3/4†	3/4†	3/4†	3/4†	3/4†	3/4†	3/4†	3/4†
Back (in.)	1	1	1	1	1	1	1	1	1
Approx. shipping weight (lbs.)	355	335	310	335	327	345	327	327	296
<b>Accessories</b>									
Aluminum trim kit	N/A	N/A	N/A	N/A	N/A	N/A	N/A	N/A	N/A
Black panels	N/A	N/A	N/A	N/A	N/A	N/A	N/A	N/A	N/A
Black acrylic panels and trim kits	N/A	TFP25RB	TFP25RB	TFP25RB	TFP22RB	N/A	TFP20RB	N/A	N/A
Stainless steel panels	N/A	N/A	N/A	N/A	N/A	N/A	N/A	N/A	N/A

\*Color(s) available: WW = White on white, BB = Black on black, AA = Almond on almond, WH = White with black handles and dispenser.

CM = Color-Matched indicates color of handle(s) matches exterior.

†If installed against a wall, allow clearance of 11-1/4" on freezer side to remove ice bin.

To remove fresh food pans, remove door bins.

Clearances required to remove fresh food full-size pan without disassembling is 10-1/2" on 20/22 cu. ft.;

13-5/8" on 25 cu. ft., and 14" on 27 cu. ft. For Built-In appearance, allow height space of 69-3/4" on 25 and 27 cu. ft.

Plus, allow additional space for any necessary leveling adjustments.

ALL MODELS AVAILABLE IN U.S. AND CANADA.



Listed by Underwriters Laboratories

## Side-By-Side Refrigerator

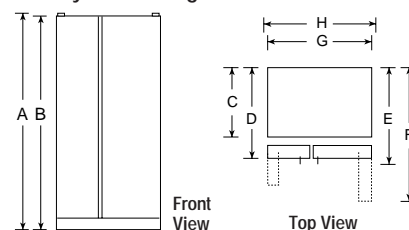



# BOTTOM-FREEZER REFRIGERATORS

	GE Profile™		GE
	TCX22PAC	TCX18PAC	TCX18IAC
<b>Capacity</b>			
Total (cu. ft.)	21.7	17.6	17.6
Fresh food (cu. ft.)	15.20	12.90	12.90
Freezer (cu. ft.)	6.51	4.7	4.7
Shelf area (sq. ft.)	30.11	23.0	23.0
<b>Features</b>			
Automatic icemaker	Opt. (UK-3S)	Opt. (IM3)	Opt. (IM3)
Ice 'N Easy trays	4	2	2
Ice tray shelf	●	●	●
Ice storage bin	●	●	●
Cabinet shelves	4 Glass	4 Glass	4 Glass
(adjustable)	4 Split	4 Split	4 Split
(spill-proof)	4	4	-
Snack pan	●	●	●
Vegetable/fruit crisper(s)	2 Adj. Humid.	2 Adj. Humid.	2 Adj. Humid.
Utility egg bin	●	●	●
Modular door bins	4 Adj.	4 Adj.	4 Adj.
Door shelf (full-width)	1 Fixed w/ gallon storage	1 Fixed w/ gallon storage	1 Fixed w/ gallon storage
Wire slide-out can dispenser	●	●	●
Dairy compartments	2 Adj. w/ butter dish	1 Clear w/ butter dish	1 Clear
Interior light	●	●	●
Wire Everwhite freezer storage basket	1 Full-Width Sliding	1 Full-Width	1 Full-Width
Freezer compartment shelf	1 Full-Width	-	1 Full-Width
Freezer door shelves	2 Full-Width 2 Half-Width	2 Full-Width, 1 w/gal. stor.	2 Full-Width
Freezer interior light	●	●	-
Upfront freezer control	●	-	-
<b>Economical/Quiet</b>			
Cabinet/door insulation	Foam	Foam	Foam
Cabinet liner	ABS	Steel	Steel
Door liner	HIPS	ABS	ABS
<b>Appearance</b>			
Color(s) available*	WW, AA, BB	WW, AA, BB	WW
Door handle(s)	Color-Matched	Color-Matched	CM Full-Length
Textured steel doors and case	●	●	●
Door stops	●	●	●
Reversible doors	●	●	●
Adjustable front rollers	●	●	●
Coil-free back	●	●	●
<b>Weights &amp; Dimensions</b>			
Height to top of hinge (in.) A	68-3/8	66-1/4	66-1/4
Height to top of case (in.) B	67-5/8	65-3/4	65-3/4
Case depth without door (in.) C	28-3/4	26-1/4	26-1/4
Case depth less door handle (in.) D	32-3/4	28	28
Case depth with door handle (in.) E	35-1/8	29-1/8	29-1/8
Depth with door open 90° (in.) F	64-1/2	57-1/4	57-1/4
Width (in.) G	32-5/8	30-1/2	30-1/2
Side clearance for 90° door open	2-1/8	1-3/4	1-3/4
Air clearances Each side (in.)	0	1/2	1/2
Top (in.)	1	1	1
Back (in.)	1	0**	0**
Approx. shipping weight (lbs.)	329	247	247

\*Color(s) available: WW = White on white, AA = Almond on almond, BB = Black on black.  
\*\*Metal cover on back, when touching wall, gives 1-1/4" clearance.

## Bottom-Freezer Refrigerators

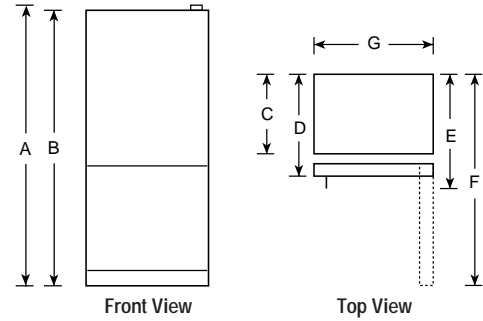

Refrigeration

Water Systems

Laundry

Cooking Products

Microwave Ovens

Dishwashers

Room Air

# TOP-FREEZER NO-FROST REFRIGERATORS

	GE Profile™					GE "Z" Series		GE "M" Series	GE "J" Series			
	TBX25PRB	TBX25PAB	TBX22PRB	TBX22PAB TBX22PIB	TBX19PAB	TBX22ZAB	TBX19ZAB	TBX22MAC	TBX24JAB	TBX21JAB TBX21JIB	TBX18JAB TBX18JIB	TBX16JAB
<b>Capacity</b>												
Total (cu. ft.)	24.7	24.7	21.5	21.6	19.0	21.6	19.0	21.6	23.6	20.6	18.2	15.6
Fresh food (cu. ft.)	17.12	17.12	14.96	14.96	13.61	14.96	13.61	14.96	16.35	14.25	13.04	11.69
Freezer (cu. ft.)	7.50	7.60	6.55	6.65	5.40	6.65	5.40	6.65	7.20	6.30	5.13	3.86
Shelf area (sq. ft.)	27.0	31.5	23.9	28.3 27.5	24.8	26.0	24.8	26.9	29.2	26.0 25.2	24.4 23.5	19.6
<b>Features</b>												
LightTouch! dispenser	Cubes, Crushed Ice & Water		Cubes, Crushed Ice & Water									
Automatic factory-installed icemaker	●	Opt. (IM3)	●	Opt. (IM3)	Opt. (IM3)	Opt. (IM3)	Opt. (IM3)	Opt. (IM3)	Opt. (IM3)	Opt. (IM3)	●	Opt. (IM3)
Ice 'N Easy trays		4		4	4	2	2	2	2	2	2	2
Ice storage bin	Dispenser	Pan w/handle	Dispenser	Pan w/handle Ice Bucket	Pan w/handle	Utility- Opaque	Utility- Opaque	Utility- Clear	Utility- Opaque	Utility-Opaque Ice Bucket	Utility-Opaque Ice Bucket	Utility- Opaque
High ice shelf	●		●	●		●	●	●	●	●	●	
Cabinet shelves (adjustable) (slide-out) (spill-proof)	4 Glass 4 Split 3 4	4 Glass 4 Split 3 4	4 Glass 4 Split 3 4	4 Glass 4 Split 3 4	4 Glass 4 Split 3 4	4 Glass 4 Split 4	4 Glass 4 Split 4	3 Glass 2 Split, 1 F/W	4 Glass 4 Split	4 Glass 4 Split	4 Glass 4 Split	4 Glass 4 Split
Quick Store™ bin	●	●	●	●								
Quick Serve™ storage dishes	On Door	On Door	On Door	On Door								
Snack pan						●	●	●	●	●	●	●
Vegetable/fruit crisper(s)	2 Adj. Humid.	2 Adj. Humid.	2 Adj. Humid.	2 Adj. Humid.	2 Adj. Humid.	2 Adj. Humid.	2 Adj. Humid.	2 Clear	2 Adj. Humid.	2 Adj. Humid.	2 Adj. Humid.	2 Clear
Meat pan	Adj. Temp.	Adj. Temp.	Adj. Temp.	Adj. Temp.	Adj. Temp.							
Modular gallon door bins	4 (3 Adj. w/ gal. storage)	4 (3 Adj. w/ gal. storage)	4 (3 Adj. w/ gal. storage)	4 (3 Adj. w/ gal. storage)	5 (4 Adj. w/ gal. storage)	5 (4 Adj.)	4 (3 Adj.)	4 (3 Adj. w/ gal. storage)				
Door shelves									3 (2 w/gal. storage)	3 (2 w/gal. storage)	2 w/gal. storage	2 w/gal. storage
Slide-out, slide-over pans	●	●	●	●	●	●	●	●	●	●	●	●
Snuggler™ Clip(s)	2	2	2	2	2	2	2	2	2	2	2	
Dairy compartment	●	●	●	●	●	●	●	●	●	●	●	●
Butter dish	●	●	●	●	●	●	●	●	●	●	●	●
Beverage rack	●	●	●	●	●							
Utility (egg) bin	●	●	●	●	●	●	●	●	●			
Interior light(s)	●	●	●	●	●							
Freezer compartment shelf(s) (wire Everwhite)	1 Adj.	1 F/W (2-Pos.)	1 Adj.	1 F/W (2-Pos.)	1 F/W (2-Pos.)	1 F/W (2-Pos.)	1 F/W (2-Pos.)	1 F/W (2-Pos.)	1 F/W (2-Pos.)	1 F/W (2-Pos.)*	1 F/W (2-Pos.)*	1
Freezer door shelves	2 (1 Adj.) Bins	3 (1 Adj.) Bins	2 (1 Adj.) Bins	3 (1 Adj.) Bins	3 (1 Adj.) Bins	3	3	3 (1 Adj.) Bins	2	2	2	2
Freezer adjustable trivet	●	●	●	●	●							
Cross-brace retainer	●	●	●	●	●	●	●	●	●	●	●	●
<b>Economical/Quiet</b>												
Quiet Package	●	●	●	●	●	●	●	●	●	●	●	●
Energy Saver Switch	●	●	●	●	●	●	●	●	●	●	●	●
Cabinet/door insulation	Foam	Foam	Foam	Foam	Foam	Foam	Foam	Foam	Foam	Foam	Foam	Foam
Cabinet/door liner	ABS	ABS	ABS	ABS	ABS	ABS	ABS	ABS	ABS	ABS	ABS	ABS
<b>Appearance</b>												
Color(s) available**	WW, AA, BB	WW, AA, BB	WW, AA, BB	WW, AA, BB	WW, AA, BB	WW, AA	WW, AA	WW, AA	WW, AA	WW, AA, BB	WW, AA, BB	WW, AA
Sure Grip (soft) door handles	CM	CM	CM	CM	CM							
Deluxe door handle(s)						CM	CM	CM	CM	CM	CM	CM
Customer installed handles						●	●	●	●	●	●	●
Textured steel doors & case	●	●	●	●	●	●	●	●	●	●	●	●
Reversible doors		●		●	●	●	●	●	●	●	●	●
Right or left door opening	●		●					●				
<b>Weights &amp; Dimensions</b>												
Height to top of hinge (in.) A	68	67-3/4	67-1/4	67	64-3/4	67	64-3/4	67	67-3/4	67	64-3/4	64-1/2
Height to top of case (in.) B	67	67	66	66	64	66	64	66	67	66-1/4	64	64
Case depth without door (in.) C	27-1/2	27-1/2	27-1/2	27-1/2	27-1/2	27-1/2	27-1/2	27-1/2	27-1/2	27-1/2	27-1/2	26
Case depth less door handle (in.) D	31	31	31	31	31	31	31	31	29-13/16	29-13/16	29-13/16	28
Case depth with door handle (in.) E	32-3/4	32-3/4	32-3/4	32-3/4	32-3/4	32-3/4	32-3/4	32-3/4	31-1/2	31-1/2	31-1/2	29-9/16
Depth with door open 90° (in.) F	62-7/8	62-7/8	59-7/8	59-7/8	58	59-7/8	58	59-7/8	62-7/8	59-7/8	58	54-1/2
Width (in.) G	34-1/2	34-1/2	31-1/4	31-1/4	29-3/8	31-1/8	29-3/8	31-1/8	34-1/2	31-1/8	29-3/8	28
Width with door open 90° less door handle (in.) H	35-5/8	35-5/8	32-5/8	32-5/8	30-3/4	32-5/8	30-3/4	32-5/8	34-1/2	31-1/4	29-3/8	29-3/4
Air clearances	Each side (in.)	3/4	3/4	3/4	3/4	3/4	3/4	3/4	3/4	3/4	3/4	3/4
	Top (in.)	1	1	1	1	1	1	1	1	1	1	1
	Back (in.)	1	1	1	1	1	1	1	1	1	1	1
Approx. shipping weight (lbs.)	320	298	293	270	250	270	250	270	266	240	230	192
<b>Accessories</b>												
Aluminum trim	TMK25LL†	TMK25K1†	N/A	N/A	N/A	N/A	N/A	N/A	N/A	N/A	N/A	N/A
Black LEXAN® panel	TMP25K	N/A	N/A	N/A	N/A	TBP21XB	TBP18XB	N/A	N/A	TBP21XB	TBP18XB	N/A

\*Shelf needs to stay in lower position to support ice bucket and icemaker.

\*\*Color(s) available: WW = White on white, AA = Almond on almond, BB = Black on black, CM = Color-Matched.

†For use on left-hand door swing.

‡For use on right-hand door swing.

Note: Clearance dimensions for any 19 cu. ft., 22 cu. ft., and 25 cu. ft. refrigerators with extra-deep doors, need an additional 3-5/8" for 90° door opening.

	GE "I" Series			GE "D" Series		GE "T" Series	GE "S" Series						
	TBX21IAB	TBX18IAB	TBX18IIB	TBX16DAB	TBX14DAB	TBX18TAB	TBX18SAB TBX18SIB	TBX16SAB TBX16SIB	TBX16SYB	TBX14SAB TBX14SIB	TBX14SYB	TBX12SAX	TBX10NSB
<b>Capacity</b>													
Total (cu. ft.)	20.6	18.2	18.2	15.6	14.4	17.6	18.2	16.4	16.4	14.4	14.4	12.1	9.8
Fresh food (cu. ft.)	14.25	13.04	13.04	11.69	10.58	13.6	13.04	12.58	12.58	10.58	10.58	9.1	7.5
Freezer (cu. ft.)	6.30	5.13	5.13	3.86	3.86	4.00	5.13	3.86	3.86	3.86	3.86	3.00	2.33
Shelf area (sq. ft.)	26.0	23.1	23.1	19.6	19.6	20.3	23.1	17.5 16.9	17.5	17.2 16.4	17.2	13.6	12.1
<b>Features</b>													
Automatic factory-installed icemaker	Opt. (IM3)	Opt. (IM3)	●	Opt. (IM3)	Opt. (IM3)	Opt. (IM3)	Opt. (IM3) ●	Opt. (IM3) ●	Opt. (IM3)	Opt. (IM3) ●	Opt. (IM3)	Opt. (IM3)	
Ice 'N Easy trays	2	2	-	2	2	2	2 2	2 2	2	2 2	2	2	2
Ice storage bin	Utility- Opaque	Utility- Opaque	Ice Bucket				Utility-WH Bucket-WH	-		-			
High ice shelf	●	●							●		●		
Cabinet shelves	3 Glass	3 Glass	3 Glass	3 Wire Everwhite	3 Wire Everwhite	3 Wire Everwhite	3 Wire Everwhite	2 Wire Everwhite	2 Wire Everwhite	2 Wire Everwhite	2 Wire Everwhite	2 Wire Everwhite	2 Wire Everwhite
(adjustable)	2 Split, 1 F/W	2 Split, 1 F/W	2 Split, 1 F/W	2 Split, 1 F/W	2 Split, 1 F/W	2 Split, 1 F/W	2 Split, 1 F/W	2 F/W	2 F/W	2 F/W	2 F/W	2 F/W	2 F/W
Snack pan	●	●	●	●	●	●	●	●	●	●	●	●	●
Vegetable/fruit crisper(s)	2 Clear	2 Clear	2 Clear	2	2	2 Clear	2	2	2	2	2	Divided	1 F/W
Fixed door shelves	3 (2 w/gal. storage)	2 w/gal. storage	2 w/gal. storage	2 w/gal. storage	2 w/gal. storage	2 w/gal. storage	2 w/gal. storage	2-tall bottle storage	2-tall bottle storage	2-tall bottle storage	2-tall bottle storage	2-1/2	4
Dairy compartment	●	●	●	●	●	1	●	●	●	●	●	●	●
Utility bin				●	●								
Freezer compartment shelf(s) (wire Everwhite)	1 F/W	1 F/W	1 F/W	1 Step Shelf	1 Step Shelf	1 Step Shelf	1 F/W (2-Pos.)						1 F/W
Freezer door shelves	2	2	2	2	2	2	2	2	2	2	2	2	1
Cross-brace retainer	●	●	●	●	●	●	●	●	●	●	●	●	●
<b>Economical/Quiet</b>													
Cabinet/door insulation	Foam	Foam	Foam	Foam	Foam	Foam	Foam	Foam	Foam	Foam	Foam	Foam	Foam
Cabinet liner	ABS	ABS	ABS	ABS	ABS	ABS	ABS	ABS	ABS	ABS	ABS	ABS	Plastic
Door liner	ABS	ABS	ABS	ABS	ABS	ABS	ABS	ABS	ABS	ABS	ABS	ABS	ABS
<b>Appearance</b>													
Color(s) available*	WW, AA	WW, AA	WW, AA	WW, AA	WW, AA	WW, AA	WW, AA	WW, AA	WW, AA	WW, AA	WW, AA	WW, AA	WH, AD
Deluxe door handle(s)	Color- Matched	Color- Matched	Color- Matched	Color- Matched	Color- Matched	Color- Matched	Color- Matched	Color- Matched	Color- Matched Recessed	Color- Matched	Color- Matched Recessed	Black	White
Customer installed handles	●	●	●				●						
Textured steel doors & case	●	●	●	●	●	●	●	●	●	●	●	●	●
Rounded doors													●
Reversible doors	●	●	●	●	●	●	●	●	●	●	●	●	●
Right or left door opening available	●	●	●				●	●	●	●	●	●	●
<b>Weights &amp; Dimensions</b>													
Height to top of hinge (in.) A	67	64-3/4	64-3/4	64-1/2	61-1/2	67-1/4	64-3/4	67-1/4	67-1/4	61-1/2	61-1/2	60-5/8	59-1/8
Height to top of case (in.) B	66-1/4	64	64	64	61	66-3/4	64	66-3/4	66-3/4	61	61	60-1/4	58-5/8
Case depth without door (in.) C	27-1/2	27-1/2	27-1/2	26	26	26-1/2	27-1/2	26-1/2	26-1/2	26	26	27-7/16	25
Case depth less door handle (in.) D	29-13/16	29-13/16	29-13/16	28	28	30	29-13/16	29-1/8	29-1/8	28	28	29-11/16	26-3/8
Case depth with door handle (in.) E	31-1/2	31-1/2	31-1/2	29-9/16	29-9/16	31-1/4	31-1/2	30-7/8	29-1/8	29-9/16	28	31-7/16	28
Depth with door open 90° (in.) F	58	58	58	54-1/2	54-1/2	55-7/8	58	54-3/4	54-3/4	54-1/2	54-1/2	51-9/16	48-3/4
Width (in.) G	31-1/4	29-3/8	29-3/8	28	28	28	29-3/8	28	28	28	28	23-3/8	23-5/8
Width with door open 90° (in.) H	31-1/4	29-3/8	29-3/8	29-3/4	29-3/4	30-1/2	29-3/8	30-1/8	29-3/4	29-9/16	28-3/4	23-9/16	24-1/8
Air clearances													
Each side (in.)	3/4	3/4	3/4	3/4	3/4	3/4	3/4	3/4	3/4	3/4	3/4	3/4	3/4
Top (in.)	1	1	1	1	1	1	1	1	1	1	1	2	1
Back (in.)	1	1	1	1	1	1	1	1	1	1	1	3/4	1
Approx. ship. wt. (lbs.)	240	230	230	187	185	196	230	190 195	188	174	168	152	157
<b>Accessories</b>													
Black Acrylic panel	TBP21XB	TBP18XB	TBP18XB	N/A	N/A	N/A	TBP18XB	N/A	N/A	N/A	N/A	N/A	N/A

\*Color(s) available: WW = White on white, AA = Almond on almond, WH = White, AD = Almond.

**Top-Freezer No-Frost Refrigerator**

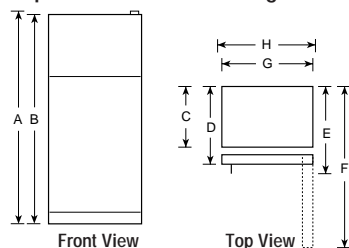

Note: All Top-Freezer No-Frost Right-Hand Refrigerator Doors: As you face the front of the refrigerator, the handle is on your left and the hinges are on your right.  
All Top-Freezer No-Frost Left-Hand Refrigerator Doors: As you face the front of the refrigerator, the handle is on your right and the hinges are on your left.



# CYCLE AND MANUAL DEFROST REFRIGERATORS

	GE		
	Cycle Defrost		Manual Defrost
	TDX11SNY	TDX9SNY	TAX10SNX
<b>Capacity</b>			
Total (cu. ft.)	11.0	9.0	9.6
Fresh food (cu. ft.)	8.6	6.6	8.64
Freezer (cu. ft.)	2.4	2.4	.94*
Shelf area (sq. ft.)	15.5	15.2	9.88
<b>Features</b>			
Ice 'N Easy trays	2 Mini	2 Mini	2
Freezer chiller tray with baffle			●
Cabinet shelves Wire Everwhite	3 Adj.	2 Adj.	2 Adj.
Vegetable/fruit crisper	1 full-width	1 full-width	1 full-width
Door shelves	2 Modules, 2 Stationary Shelves	4 Modules, 1 Stationary Shelf	3 F/W
Tall bottle storage on door	●	●	●
Dairy compartment(s)	2	2	1
Egg storage bin			Pockets
Freezer compartment shelf(s)	1 full-width	1 full-width	
<b>Economical/Quiet</b>			
Cabinet/door insulation	Foam	Foam	Foam
Cabinet/door liner	Plastic	Plastic	Plastic
<b>Appearance</b>			
Color(s) available	White	White	White
Door handle(s)	White	White	Black
Reversible doors	●	●	●
Right or left door opening			●
<b>Weights &amp; Dimensions</b>			
Height to top of hinge (in.) A	63-1/2	55	58
Height to top of case (in.) B	63	54-1/2	57-9/16
Case depth without door (in.) C	20-1/2	20-1/2	21-3/8
Case depth with door less handle (in.) D	23-1/4	23-1/4	23-1/2
Case depth with door handle (in.) E	24-1/2	24-3/4	24-13/16
Depth with door open 90° less door handle (in.) F	46	46	44-13/16
Width (in.) G	23-1/4	23-1/2	23
Width w/door open 90° less door handle (in.) H	23-3/4	23-3/4	23-1/2
Air clearances Each side (in.)	1/2	1/2	5/8
Top (in.)	2	2	2
Back (in.)	2	2	1
Approx. shipping weight (lbs.)	139	126	135

\*Compartment for short-term storage of frozen food. The frozen food compartment of this refrigerator will make ice, and pre-frozen foods can be stored for about **two weeks**. It will not effectively freeze fresh foods or provide long-term storage for meats, poultry, or fish.

## Cycle Defrost Two Door Refrigerator

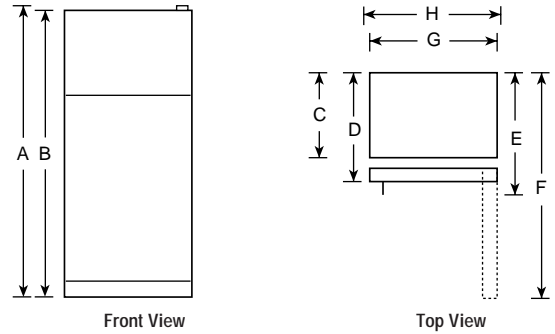

## Manual Defrost Single Door Refrigerator

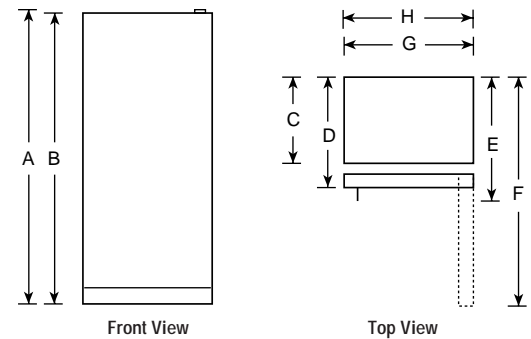

# SPACEMAKER™ COMPACT REFRIGERATORS

	GE			
	TAX6SNXWH/WN	TAX4SNYWH	TAX4ANXWN	TAX2SNYWN TAX2SNBWH
<b>Capacity</b>				
Total (cu. ft.)	6.0	3.7	3.7	1.7
Fresh food (cu. ft.)	5.51	3.26	3.42	1.51
Freezer (cu. ft.)	.49*	.42*	.34*	.21*
Shelf area (sq. ft.)	8.8	6.0	6.5	2.9
<b>Features</b>				
Ice 'N Easy Trays	2 Mini	1 Mini	1 Mini	2 Mini
Manual defrost	●	●	●	●
Cabinet shelves	2 (Adj.)	2 full-width wire	3 full-width wire (1 w/retaining rod)	1
Vegetable/fruit pan		1 full-width White		
Door shelves	3 full-width	2 full-width	2 full-width	1-1/2
Utility bin				Tray
<b>Economical/Quiet</b>				
Cabinet/door insulation	Foam	Foam	Foam	Foam
Cabinet/door liner	Polystyrene	Polystyrene	Polystyrene	Polystyrene
<b>Appearance</b>				
Color(s) available	White, Woodgrain	White	Woodgrain	Woodgrain White
Door handles	White Visor Black Visor	Color-Matched Recessed	Color-Matched Recessed	Color-Matched Recessed
Rounded doors		●		
Reversible door(s)	●	●		
Right or left door opening			Right Hand	Right Hand
<b>Weights &amp; Dimensions</b>				
Height (in.) A	34-1/4	34-1/2	34-1/2	18-7/8**
Width (in.) B	23-5/8	18-7/8	18-7/8	18-5/8
Depth with handle (in.) C	25-7/8	20-3/4	20-3/4	19-1/2
Depth with door open 90° (in.) D	47-1/2	39-1/4	39-1/4	37
Air clearances Each side (in.)	0†	1/2	1/2	1/2
Top (in.)	1-1/2	12	12	12
Back (in.)	3/4	5	5	5
Approx. shipping weight (lbs.)	88	68	71	40
<b>Accessories</b>				
Custom trim and panel	TK6 Optional			

\*Compartment for short-term storage of frozen food. The frozen food compartment of this refrigerator will make ice, and pre-frozen foods can be stored for about **two weeks**. It will not effectively freeze fresh foods or provide long-term storage for meats, poultry, or fish.

\*\*Height does not include hinge.

† If installed against a wall, allow 1-1/4" on hinge side to allow for proper door opening.

## Spacemaker™ Refrigerator

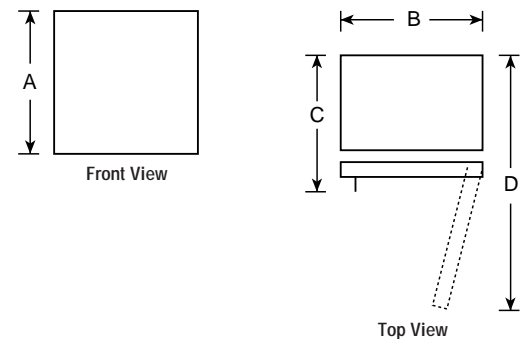

**Note: Right-Hand Refrigerator Door:** As you face the front of the refrigerator, the handle is on your left and the hinges are on your right.  
**Left-Hand Refrigerator Door:** As you face the front of the refrigerator, the handle is on your right and the hinges are on your left.

Today's GE refrigerators use about 50% as much energy as refrigerator models made in 1980.

# UPRIGHT FREEZERS

	GE											
	Frost-Free			Manual Defrost								
	FUF20DA	FUF17DA	FUF14DA	FUM21DA	FUM21SA	FUM17DA	FUM17SA	FUM14DA	FUM14SA	FUM12SA	FUM9SA	FUM5SA
<b>Capacity</b>												
Total volume (cu. ft.)	20.3	16.7	13.7	20.6	20.6	17.1	17.1	14.1	14.1	11.6	8.7	5.0
Shelf area (sq. ft.)	23.9	18.4	14.3	25.3	21.9	19.1	16.2	17.9	15.0	13.0	10.1	6.0
<b>Features</b>												
Audible temperature alarm	●	●	●	●	●	●	●	●	●	●	●	●
Temperature control	Adjustable	Adjustable	Adjustable	Adjustable	Adjustable	Adjustable	Adjustable	Adjustable	Adjustable	Adjustable	Adjustable	Adjustable
Limited food loss warranty	●	●	●	●	●	●	●	●	●	●	●	●
Door shelves (total)	6	5	5	6	6	5	5	5	5	4	5	3
Defrost water drain	●	●	●	●	●	●	●	●	●	●	●	●
Power "ON" light	●	●	●	●	●	●	●	●	●	●	●	●
Interior light	●	●	●	●	●	●	●	●	●	●	●	●
Lock	●	●	●	●	●	●	●	●	●	●	●	●
Cabinet shelves (total)	5 (3 Adj.)	4 (3 Adj.)	3 (2 Adj.)	4 (1 Adj.)	4	4 (1 Adj.)	3	4 (1 Adj.)	3	3	4	2
Refrigerated shelves				3	4	3	3	3	3	3	4	2
Bulk storage basket	Slide-Out	Slide-Out	Slide-Out	Slide-Out		Slide-Out		Slide-Out				
Drop-front storage					●		●		●	●		
<b>Economical/Quiet</b>												
Defrost	Frost-Free	Frost-Free	Frost-Free	Manual	Manual	Manual	Manual	Manual	Manual	Manual	Manual	Manual
Magnetic door gasket	●	●	●	●	●	●	●	●	●	●	●	●
Cabinet liner	Baked enamel-on-steel	Baked enamel-on-steel	Baked enamel-on-steel	Baked enamel-on-steel	Baked enamel-on-steel	Baked enamel-on-steel	Baked enamel-on-steel	Baked enamel-on-steel	Baked enamel-on-steel	Baked enamel-on-steel	Polystyrene	Polystyrene
Wrap-around condenser	●	●	●	●	●	●	●	●	●	●	●	●
<b>Appearance</b>												
Color available	White	White	White	White	White	White	White	White	White	White	White	White
Door handle	●	●	●	●	Recessed	●	Recessed	●	Recessed	Recessed	●	Recessed
Textured steel case and door	●	●	●	●	●	●	●	●	●	●	●	●
Rounded door												●
<b>Weights &amp; Dimensions</b>												
Height (in.) A	70	64-1/2	59	70	70	64-1/2	64-1/2	59	59	54-1/2	53-3/8	33-1/2
Width (in.) B	32	32	28	32	32	32	32	28	28	28	21-1/2	21-3/8
Depth (in.) C	28-1/2	26-1/2	28-1/2	28-1/2	28-1/2	26-1/2	26-1/2	28-1/2	28-1/2	26-1/2	26-3/8	26-1/8
Depth with door open 90° (in.) D	59-1/8	57-1/8	55-1/8	59-1/8	59-1/8	57-1/8	57-1/8	55-1/8	55-1/8	53-1/8	49-1/8	45-3/4
Air clearances Each side (in.)	3	3	3	3	3	3	3	3	3	3	1	1
Top (in.)	3	3	3	3	3	3	3	3	3	3	4	4
Back (in.)	3	3	3	3	3	3	3	3	3	3	4	4
Approx. shipping weight (lbs.)	231	213	173	231	231	211	211	173	173	168	120	80

NOTE: For proper installation of Upright Freezers (except FUM9SA and FUM5SA), allow clearance of 3" on each side; 3" or 4" on top; and 3" on back.

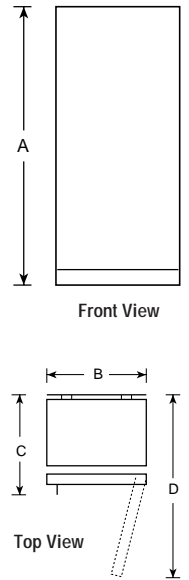

Refrigeration

Water Systems

Laundry

Cooking Products

# CHEST FREEZERS

	GE								
	FCM25DA	FCM20DA	FCM15DA	FCM15SA	FCM9DA	FCM9SA	FCM7DA	FCM5SA	
<b>Capacity</b>									
Total volume (cu. ft.)	24.9	19.7	14.8	14.8	8.8	8.8	7.2	5.0	
<b>Features</b>									
Manual defrost	●	●	●	●	●	●	●	●	
Audible temperature alarm	●	●	●	●	●	●	●	●	
Temperature control	Adjustable	Adjustable	Adjustable	Adjustable	Adjustable	Adjustable	Adjustable	Adjustable	
Wrap-around condenser	●	●	●	●	●	●	●	●	
Wrap-around evaporator	●	●	●	●	●	●	●	●	
Limited food loss warranty	●	●	●	●	●	●	●	●	
Defrost water drain	●	●	●	●	●	●	●	●	
Power "ON" light	●	●	●	●	●	●	●	●	
Interior light	●	●	●	●	●	●	●	●	
Lock	●	●	●	●	●	●	●	●	
Lift-out and sliding bulk storage basket(s)	3	2	2	1	1		1		
<b>Economical/Quiet</b>									
Insulation (cabinet and lid)-Foam	●	●	●	●	●	●	●	●	
Cabinet liner	Steel Epoxy-Coated	Steel Epoxy-Coated	Steel Epoxy-Coated	Steel Epoxy-Coated	Steel Epoxy-Coated	Steel Epoxy-Coated	Steel Epoxy-Coated	Steel Epoxy-Coated	
<b>Appearance</b>									
Color available	White	White	White	White	White	White	White	White	
Handle	●	●	●	Recessed	●	Recessed	●	Recessed	
Textured steel case and lid	●	●	●	●	●	●	●	●	
<b>Weights &amp; Dimensions</b>									
Height (in.) A	35	35	35	35	34-1/4	34-1/4	34-1/4	34-1/4	
Width (in.) B	73-1/4	61-1/4	48	48	41	41	35	27	
Depth (in.) C	29-1/2	29-1/2	29-1/2	29-1/2	23-1/4	23-1/4	23-1/4	23-1/2	
Height with lid open (in.) D	60-3/4	59-1/2	60-3/4	60-3/4	55-1/4	55-1/4	55-1/4	55-1/4	
Air clearances Each side (in.)	3	3	3	3	3	3	3	3	
Back (in.)	3	3	3	3	3	3	3	3	
Approx. shipping weight (lbs.)	229	201	160	160	137	137	120	105	

NOTE: For proper installation of Chest Freezers, allow clearance of 3" on each side and 3" on back.

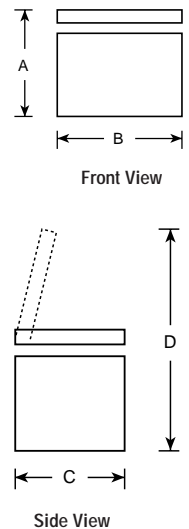

Microwave Ovens

Dishwashers

Room Air

See page 134 for warranty information.

# CREATE A CUSTOM LOOK FOR YOUR GE REFRIGERATOR

Decide from a choice of GE optional Panels and Trim to create a distinctive appearance for your new refrigerator. Pre-cut panels in Black, White, Almond or Stainless Steel provide an exciting way to express your individual taste and preference while complementing your kitchen.

## GE PROFILE PERFORMANCE SERIES™ AND GE PROFILE™ CUSTOMSTYLE™ REFRIGERATORS

Acrylic and Stainless Steel Panels

Model No.	Black Acrylic Panels	White Acrylic Panels	Almond Acrylic Panels	Stainless Steel Panels
TPX21BRB	TKP21LS	TKPW21LS		TKP21RXSS
TPX24BRB	TKP24RBBB	TKP24RBWW	TKP24RBAA	TKP24RBSS
TPX24BPB	TKP24RBBB	TKP24RBWW		TKP24RBSS
TPX24BIB	TKP24IBBB	TKP24IBWW		TKP24IBSS

Note: For custom panel cut-out dimensions refer to Installation Instructions, Pub. No. 49-6477-1.

### Collar Trim

Model No.	Black Collar Trim	White Collar Trim	Almond Collar Trim	Stainless Steel Collar Trim
TPX21BRB	TRMBISBB	TRMBISWW		
TPX24BRB	TRMBISBB	TRMBISWW	TRMBISAA	
TPX24BPB	TRMBISBB	TRMBISWW		
TPX24BIB	TRMBISBB	TRMBISWW		
TPX24BPC				TRMBISS
TPX24BIC				TRMBISS

Note: Refer to Installation Instructions, Pub. No. 31-45227-1, for kitchen cabinet dimensions before ordering cabinets or collar trim.

## GE PROFILE™ PERFORMANCE CUSTOMSTYLE™ TOP-FREEZER NO-FROST REFRIGERATORS

Acrylic Panels and Trim

Model No.	Black Acrylic Panels	White Acrylic Panels	Stainless Steel Panels	Black Collar Trim	White Collar Trim	Stainless Steel Trim
TNX22BAC	TKP22ACBB	TKP22ACWW	TKP22ACSS	TRMBISBB	TRMBISWW	TRMBISS
TNX22BRC	TKP22RCBB	TKP22RCWW	TKP22RCSS	TRMBISBB	TRMBISWW	TRMBISS

## GE PROFILE™ TOP-FREEZER NO-FROST REFRIGERATORS (NON-DISPENSER MODEL)

Lexan® Panels and Aluminum Trim

Model No.	Black Panels	Aluminum Trim	Custom Panel Dimensions (Inches)			Panel Depth
			A	B	C	
TBX25PAB	TMP25K	TMK25LL*	21-27/32	40-3/32	33-21/32	1/4
TBX25PAB	TMP25K	TMK25K**	21-27/32	40-3/32	33-21/32	1/4

Note: Black handles included with Aluminum trim kit.

\*For use on left-hand door opening.

\*\*For use on right-hand door opening.

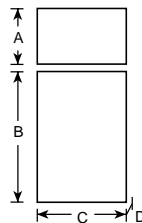

GE Profile™ Model:  
TBX25PAB

## QUALITY GE SIDE-BY-SIDE REFRIGERATORS

Acrylic Panels with Trim

Model No.	Black Acrylic Panels
TFX20JRB	TFP20RB
TFX22ZPB	TFP22RB
TFX25ZPB	TFP25RB
TFX25KRC	TFP25RB
TFX22KRC	TFP22RB

Note: Handles not included with trim kit.

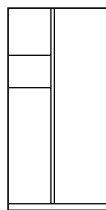

GE Models:  
TFX20JRB, FTX22ZPB, FTX25ZPB,  
TFX25KRC, FTX22KRC

## QUALITY GE TOP-FREEZER NO-FROST REFRIGERATORS

Lexan® Panels with Trim

Model No.	Black Panels
TBX21JAB/JIB/IAB	TBP21XB
TBX18SAB/SIB/JAB/JIB/IAB/IIB	TBP18XB

Note: Black handle inserts included with trim kit.

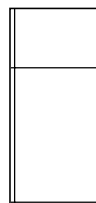

GE Models:  
TBX21JAB/JIB/IAB,  
TBX18SAB/SIB/JAB/  
JIB/IAB/IIB

## GE PROFILE PERFORMANCE SERIES™ AND GE PROFILE™ FREE-STANDING SIDE-BY-SIDE REFRIGERATORS

Lexan® Panels and Aluminum Trim

Model No.	Black Panels	Stainless Steel Panels	Aluminum Trim	Custom Panel Insert Cut-Out Dimensions (Inches)				
				A	B	C	D	E
TFX30PBB		TKP30FBSS	TK30FBAL	33-21/32	16-29/32	13-5/32	17-31/32	
TFX30PPB		TKP30RBSS	TK30RBAL	65-1/8	16-29/32	33-21/32	13-5/32	17-31/32
TFX28PBB	TKP28FB		TK28FBAL	33-21/32	16-29/32	13-5/32	17-31/32	
TFX27PRB	TKP27EB	TKP27RBSS	TK27RBAL	63-1/4	16-7/8	31-25/32	12-5/8	18-5/16
TFX25PRB	TKP25RB		TK25RBAL	63-1/4	16-7/8	31-25/32	12-15/32	18-5/32
TFX25PPB	TKP25RB		TK25RBAL	63-1/4	16-7/8	31-25/32	12-15/32	18-5/32

Note: Handles not included with trim kit.

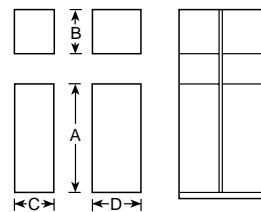

GE Profile Performance™ and  
GE Profile™ Models: TFX30PBB, TFX28PBB

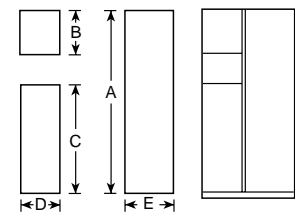

GE Profile Performance™ and  
GE Profile™ Models: TFX30PPB, TFX27PRB,  
TFX25PRB, TFX25PPB

Acrylic Panels with Trim

Model No.	Black Acrylic Panels
TFX25PPB	TFP25RB
TFX25PRB	TFP25RB
TFX22PPB	TFP22RB
TFX22PRB	TFP22RB

Note: Handles not included with trim kit.

## QUALITY GE COMPACT REFRIGERATOR

TK6 Trim

- Panel is black painted aluminum
- Trim is black plastic that covers entire side of door
- 1/4" wood can also be used with the trim

Order your own custom door panel to match cabinetry or other decor.

—Maximum panel thickness 1/4"

—Minimum panel thickness 1/8"

Notch all four corners of panel

Custom Trim

Model No.	Black Trim No.	Custom Panel Insert Cut-Out Dimensions (Inches)	
		A	B
TAX6SNX	TK6	29	22-3/4

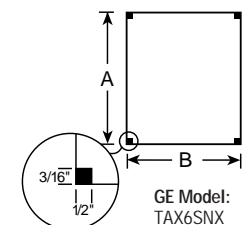

GE Model:  
TAX6SNX



## SIDE-BY-SIDE TRIM KIT SUMMARY

### Aluminum Trim Kits and Optional Panels

Current Trim Models: TK30FBAL, TK30RBAL, TK28FBAL, TK28RBAL, TK27RBAL and TK25RBAL.

Current Panel Models: TKP30FBSS, TKP30RBSS, TK28FB, TKP27EB, TKP27RBSS and TKP25RB.

#### Aluminum Trim Description:

- Requires screwing trim to doors
- Finish is brushed aluminum—no black or white accent stripe
- Each kit comes with black and white plastic parts to match units with black or white handles
- Trim can take optional panels or 1/4" wood panels
- Trim covers entire sides of doors

#### Optional Panel Description:

- Can be used with above aluminum kits
- All panels are black except ones which end in "SS" (Stainless Steel)
- Black panel material is LEXAN®

### Plastic Trim with Acrylic Panel Kits

Current Kit Models: TFP20RB

#### Plastic Trim Description:

- All panels are black and all trim is chrome
- Panels attach with magnetic tape. Each door uses 3 pieces of chrome trim that attach with double-sided tape. The trim does not cover entire side of door and bottom of door.

## TOP-FREEZER NO-FROST TRIM KIT SUMMARY

### Aluminum Trim Kits and Optional Panels

Current Trim Models: TMK25LL (left door swing), TMK25K (right door swing).

Current Panel Model: TMP25K

#### Aluminum Trim Description:

- Requires screwing trim to doors
- Finish is brushed aluminum with black accent paint stripe around front lip of trim
- Trim comes with black aluminum handle that is full length for each door.
- Trim can take optional black LEXAN® panel (TMP25K) or 1/4" wood
- Trim covers entire sides of doors

### Plastic Trim with LEXAN® Panel Kits

Current Kit Models: TBP18XB and TBP21XB

#### Plastic Trim Description:

- All panels are black and all trim is chrome
- For use with GE core line models only—no soft touch or bow handles
- Comes with standard black handle inserts
- Panels attach with magnetic tape. Fresh food door has 3 pieces of trim (2 side and 1 top). Freezer door has 2 pieces of trim (2 sides). Trim attaches with double-sided tape. Trim does not cover entire side door and bottom of doors.

## CUSTOMSTYLE™ REFRIGERATOR PANEL INSTALLATION



### GE Profile™ TPX24BRB

#### Panel installation on a GE Profile™ TPX24BRB

Optional black panels (shown above) require cardboard inserts (come with panels), which slide into top and bottom trim first to give extra support to panel. Both cardboard and panel slide across textured steel door in towards the handle. The outside door trim is then applied on side of doors to complete the built-in look.

Refrigeration

Water Systems

Laundry

Cooking Products

Microwave Ovens

Dishwashers

Room Air

# GE SMARTWATER™ REVERSE OSMOSIS FILTRATION SYSTEMS

	GE Profile Performance Series™		GE Profile™	GE
	PNRV18ZWW PNRV18ZBB	PNRV18ZWH PNRV18ZBL	PNRV12ZBL	GXRV10ABL
<b>Capacity</b>				
Storage Tank Capacity (gals.)	1.9	1.9	2.1	1.3
<b>Features</b>				
SmartWater™ Faucet	Electronic Monitor	Electronic Monitor	Electronic Monitor	Short-Reach
Faucet Color	White on white Black on black	Chrome with white Chrome with black	Chrome with black	Chrome with black
Output Per Day (gals.) – Production Rate (gpd) as tested by WQA Standard S-300	18*	18*	12	10
Process Water Used (per gal.)	4	4	4	4
Working Pressure (psi)	40 min. - 125 max.	40 min. - 125 max.	40 min. - 125 max.	40 min. - 125 max.
Max. TDS Removal (ppm)	2000	2000	2000	2000
Percent TDS Removal** (ppm)	75-92	75-92	75-92	75-92
Percent Cysts Reduction	99.95 effective	99.95 effective	99.95 effective	99.95 effective
Max. Hardness	10 grains	10 grains	10 grains	10 grains
Feed Water pH limits	4-10	4-10	4-10	4-10
Operation and Storage Water Temperature	40-100° F	40-100° F	40-100° F	40-100° F
Auto Shut-Off	●	●	●	●
<b>Filters &amp; Membrane</b>				
RO Membrane	FX18M Thin Film Polyamid (TFP)	FX18M Thin Film Polyamid (TFP)	FX12M Thin Film Polyamid (TFP)	FX12M Thin Film Polyamid (TFP)
Pre-Filter (Sediment)	FX18P-Act. Carbon Block	FX18P-Act. Carbon Block	FX12P-Carbon Composite	FX12PA-Carbon Block
Post-Filter (Taste/Odor)	FX18P-Gran. Act. Carbon	FX18P-Gran. Act. Carbon	FX12P-Carbon Composite	FX12PA-Carbon Block
RO Filtration Indicator	Electronic	Electronic	Electronic	
Filter Change Indicator	Electronic	Electronic	Electronic	
Undercounter Installation (kit included)	●	●	●	●
Optional Basement Installation (hardware not included)	●	●	●	●
<b>Appearance</b>				
Style	All-In-One	All-In-One	Bracket	Bracket
Unit Color	Grey	Grey	Grey	Grey
Filter Housing	Opaque	Opaque	Opaque	Opaque
<b>Weights &amp; Dimensions</b>				
Approximate Shipping Weight (lbs.)	16	16	23	20
Overall W x H x D (in.)	10 x 21 x 10	10 x 21 x 10	17 x 16 x 5-3/4 (unit) 11 x 17 x 11 (tank)	17 x 16 x 5-3/4 (unit) 9 x 15 x 9 (tank)
<b>Power/Ratings</b>				
Faucet Monitor Power Requirement	4 AA batteries (included)	4 AA batteries (included)	4 AA batteries (included)	
<b>Accessories (available at additional cost)</b>				
Supplemental Tank	RVTNK1	RVTNK1	RVTNK1	RVTNK1
Storage Cabinet	RV18CBNT	RV18CBNT		
Icemaker Connection Kit	RVKIT	RVKIT	RVKIT	RVKIT

\*Output according to ANSI/NSF Standard 58 as tested by Spectrum Labs, Inc. is 14 gals. per day. Feed water over 10 grains of hardness may affect performance of the filtration system.

\*\*Feed water = 50 psig, 77°F, pH = 7.5 ± 5 and 750 ppm TDS as sodium chloride. Product water produced, amount of waste and percent rejection will vary with changes in pressure, temperature and total dissolved solids. Feed water over 10 grains of hardness may affect performance of the filtration system.



GE Reverse Osmosis Models PNRV18Z, PNRV12Z and GXRV10ABL Series are tested and certified to ANSI/NSF Standard 58 for TDS and cyst reduction.

### NSF Approved

NSF is the most highly recognized independent testing institution in the water treatment industry. NSF inspects our manufacturing facilities, structurally tests our product, tests our product to make sure nothing harmful is added to the water and certifies our product performance as specified on the performance data sheet (inside the product box).

### SPECTRUM LABS INC

The GE Reverse Osmosis models PNRV18Z, PNRV12Z and GXRV10ABL Series have been quality tested by an independent laboratory, Spectrum Labs, Inc.

**Caution:** Do not use with water that is microbiologically unsafe or of unknown quality, without adequate disinfection before or after the system. Systems certified for cyst reduction may be used on disinfected water that may contain filterable cysts. This reverse osmosis unit contains a replaceable membrane cartridge treatment component critical for effective removal of Total Dissolved Solids. The water should be tested periodically to verify that the system is performing satisfactorily.

## Models PNRV18ZWW/18ZBB/18ZWH/18ZBL Installation Information (in inches)

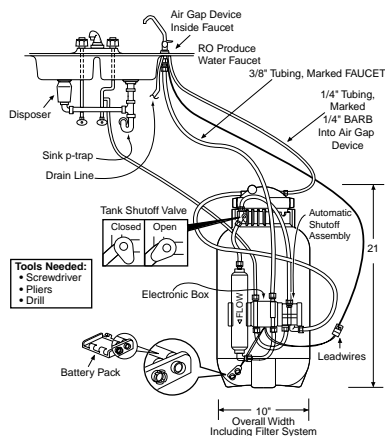

## Model PNRV12ZBL Installation Information (in inches)

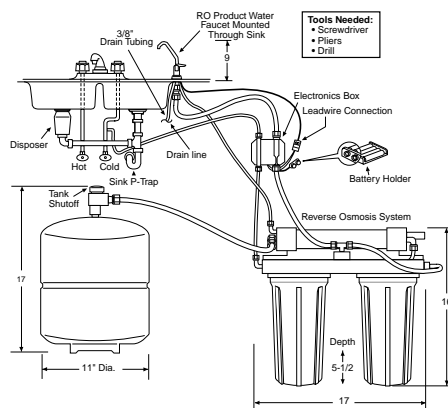

## Model GXRV10ABL Installation Information (in inches)

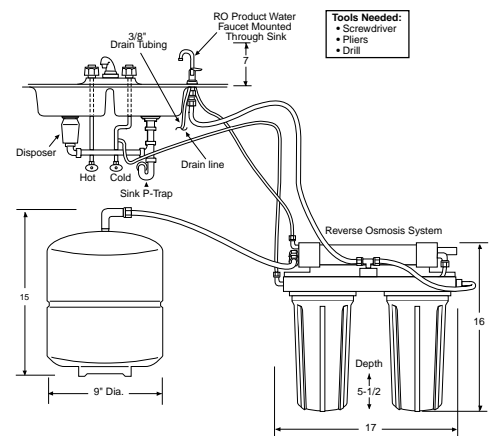

### Installation, Parts and Warranty Information

**Note:** R.O. System can be installed up to 30 feet from point-of-use/faucet.

**Note:** Can be installed undercounter (as shown), in basement, or other convenient location. Before installing, see installation instructions packed with product for complete details.

### Replacement Membranes, Pre- and Post-Filters

Call GE SmartWater Services, toll-free 800.952.5039 for convenient ordering.

### Water Test Kit

To order a water test kit, call 800.626.2000.

### Warranty Information

Models PNRV18Z and PNRV12ZBL:

**Full One-Year Warranty** – (parts and labor at no additional charge) applies to entire unit, excluding membrane and filters.

Model GXRV10ABL:

**Limited One-Year Warranty** – parts and labor at no additional charge (does not include service trip) applies to entire unit, excluding membrane and filters.

# GE SMARTWATER™ DUAL CARBON FILTRATION SYSTEMS

	GE							
	GNUL30B	GNUT05B	GNUT03B GXUT03B*	GXEM01B*	Refrigerator/Icemaker Water Filters			
					GXIT**	GXITQ**	GXILQ**	
<b>Features</b>								
SmartWater™ Faucet	Electronic Monitor	Electronic Monitor	Short-Reach	Electronic Monitor	N/A	N/A	N/A	N/A
Faucet Color	Chrome w/black	Chrome w/black	Chrome w/black	Chrome w/black	N/A	N/A	N/A	N/A
Feed Water Pressure (psi)	40 min.-125 max.	40 min.-125 max.	40 min.-125 max.	40 min.-125 max.	20 min.-125 max.	20 min.-125 max.	20 min.-125 max.	20 min.-125 max.
Feed Water Temperature	40-100°F	40-100°F	40-100°F	40-100°F	40-100°F	40-100°F	40-100°F	40-100°F
Filtered Water Flow (gpm)	0.6	0.6	0.6	0.6				
<b>Filter I (Sediment)</b>	FXUSB	FXUSB	FXUSB					
Filter Cartridge	Polyspun Depth Filter	Polyspun Depth Filter	Polyspun Depth Filter					
<b>Filter II (Carbon block)</b>	FXULB (Lead,Cysts)	FXUTB (Taste/Odor)	FXUTB (Taste/Odor)					
Filter Cartridge	Block Act. Carbon	Block Act. Carbon	Block Act. Carbon		Act. Carbon	Act. Carbon	Block Act. Carbon	
Particulate Removal	Absolute 1 micron	Nominal 1 micron	Nominal 1 micron		Nominal 5 micron	Nominal 5 micron	Absolute 1 micron	
Chlorine Reduction (percent / gals.)	99.5/1250	99.5/6000	99.5/6000		750 gal.	750 gal.	1000 gal.	
Lead Reduction (percent / gals.)	95.7/1250						>90/1000	
Cysts Reduction (percent / gals.)	99.98/1250						>99.98/1000	
Turbidity Reduction (percent / gals.)	99.7/1250							
Filter Change Indicator	Electronic	Electronic		Electronic	Sticker	Sticker	Sticker	
Undercounter Installation (kit included)	●	●	●	●	N/A	N/A	N/A	
Installation Kit					●	●	●	
Fittings					Brass	Quick Connect	Quick Connect	
Auto Shut-Off Valve						●	●	
Optional Basement Installation (hardware not included)	●	●	●	●				
<b>Appearance</b>								
Style	Bracket	Bracket	Bracket	Bracket				
Unit Color	White	White	White	White	White	White	White	
Filter Housing	White	White	White	White				
<b>Weights &amp; Dimensions</b>								
Approximate Shipping Weight (lbs.)	7	7	7	6	2	2	2	
Overall W x H x D (in.)	12 x 13 x 4-5/8	12 x 13 x 4-5/8	12 x 13 x 4-5/8	12 x 13 x 4-5/8	14 x 2 x 2	14 x 2 x 2	15 x 2-1/2 x 2-1/2	
<b>Power/Ratings</b>								
Faucet Monitor	2 AA batteries (included)	2 AA batteries (included)		2 AA batteries (included)	N/A	N/A	N/A	
Power Requirement								
<b>Accessories (available at additional cost)</b>								
Icemaker Connection Kit	UCKIT	UCKIT	UCKIT	UCKIT	N/A	N/A	N/A	

**Caution:** Do not use with water that is microbiologically unsafe or of unknown quality, without adequate disinfection before or after the system. Systems certified for cysts reduction may be used on disinfected water that may contain filterable cysts.

\*Models GXUT03B and GXEM01B have retail packaging  
\*\*All Refrigerator/Icemaker Water Filters subject to change

## Models GNUL30B/GNUT05B/GXEM01B Installation Information (in inches)

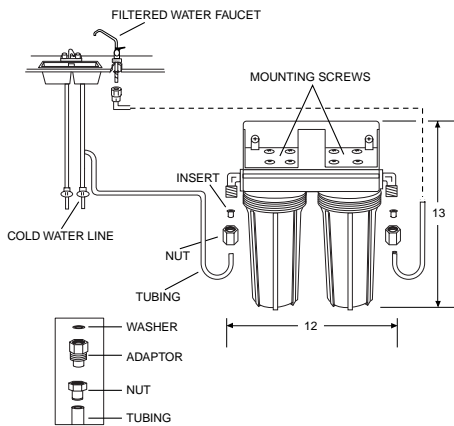

## Models GNUT03B/GXUT03B Installation Information (in inches)

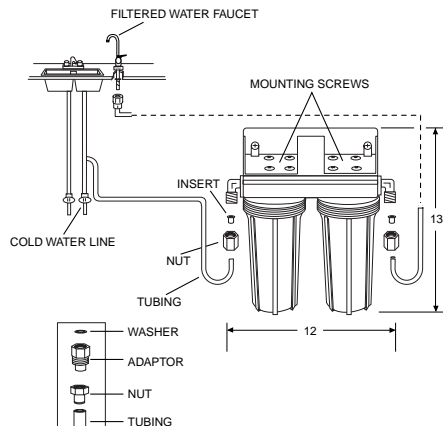

GXUT03B, GNUT03B, GNUT05B and GNUL30B are Tested and Certified by NSF International against ANSI/NSF Standard 42 for Particulate Reduction Class I, Chlorine Reduction Class I and Taste and Odor Reduction.

GNUL30B is Tested and Certified by NSF International against ANSI/NSF Standard 53 for Cyst, Turbidity and Lead Reduction.

GXEM01B is Tested and Certified by NSF International against ANSI/NSF Standard 42 for Material and Structural Integrity only.

### NSF Approved

NSF is the most highly recognized independent testing institution in the water treatment industry. NSF inspects our manufacturing facilities, structurally tests our product, tests our product to make sure nothing harmful is added to the water and certifies our product performance as specified on the performance data sheet (inside the product box).



The GE SmartWater™ Filtration System (GNUL30B) have been quality tested by an independent laboratory, Spectrum Labs, Inc.

## Installation, Parts and Warranty Information

**Note:** Can be installed undercounter (as shown), in basement, or other convenient location. Before installing, see installation instructions packed with product for complete details.

### Replacement Filters

Call GE SmartWater Services toll-free 800.952.5039 to order replacement filters.

### Water Test Kit

To order a water test kit, call 800.626.2000.

### Warranty Information

Models GNUL30B, GNUT05B:

**Full One-Year Warranty** – (parts and labor at no additional charge) applies to entire unit, excludes filters.

Models GXUT03B, GXEM01B, GNUT03B:

**Limited One-Year Warranty** – parts and labor at no additional charge, (does not include service trip) applies to entire unit, excludes filters.

See page 134 for warranty information.



# GE SMARTWATER™ SOFTENING SYSTEMS

	GE Profile Performance Series™			
	PNSF39Z	PNSF31Z	GNSF23Z	GNSF18Z
<b>Capacity</b>				
Capacity (grains)	Super-38,500*	Extra-Large-30,800*	Large-23,100*	Compact-18,000*
<b>Features</b>				
Efficiency (grains per lb.-salt)	5200**	5200**	5200**	5000**
Max. Hardness Removal (gpg)	110	95	50	25
Max. Clear Water Iron Reduction (ppm)	8	5	3	3
Resin Filter Type	Std. mesh	Std. mesh	Std. mesh	Std. mesh
Resin Weight (lbs.)	52.00	41.60	31.20	38
Resin Quantity (cu. ft.)	1.00	.80	.60	.73
Resin Tank Size (in inches)	10 x 35	10 x 35	8 x 40	10 x 21
Salt Capacity (lbs.)	300	300	200	140
Water Used for Regeneration (gals.)	43-52	40-45	23-30	25-30
Regeneration Time (min.)	Approx. 118	Approx. 118	Approx. 118	Approx. 120
Service Flow Rate (at 15 psi drop)	10	10	8	7
Systems Monitor	●	●	●	●
Electronic Controls	Backlit LCD	●	●	●
Permanent Settings Memory	●	●	●	●
Plumbing Connection	1"-NPT	1"-NPT	1"-NPT	1"-NPT
<b>Appearance</b>				
Spacesaver Design				●
Style	Cabinet	Cabinet	Round	Round
Unit Color	Grey	Grey	Grey	Grey
Electronic-Demand Driven	●	●	●	●
<b>Weights &amp; Dimensions</b>				
Approximate Shipping Wt. (lbs.)	108	95	88	66
Overall W x H x D (in.)	14 x 45-1/4 x 24	14 x 45-1/4 x 24	18-1/4 x 48-3/4 x 18-1/4	18-5/8 x 29-1/2 x 18-5/8
<b>Power/Ratings</b>				
Electronic Rating	24V, 60Hz	24V, 60Hz	24V, 60Hz	24V, 60Hz

\*PNSF39-Test protocol @ 16.0 lbs. of salt.  
 PNSF31-Test protocol @ 12.8 lbs. of salt.  
 GNSF23-Test protocol @ 9.6 lbs. of salt.  
 GNSF18Z-Test protocol @ 6.3 lbs. of salt.  
 \*\*PNSF39-Test protocol @ 2.9 lbs. of salt.  
 PNSF31-Test protocol @ 2.3 lbs. of salt.  
 GNSF23-Test protocol @ 1.8 lbs. of salt.  
 GNSF18Z-Test protocol @ 1.6 lbs. of salt.

## Models PNSF39Z and PNSF31Z Installation Information (in inches)

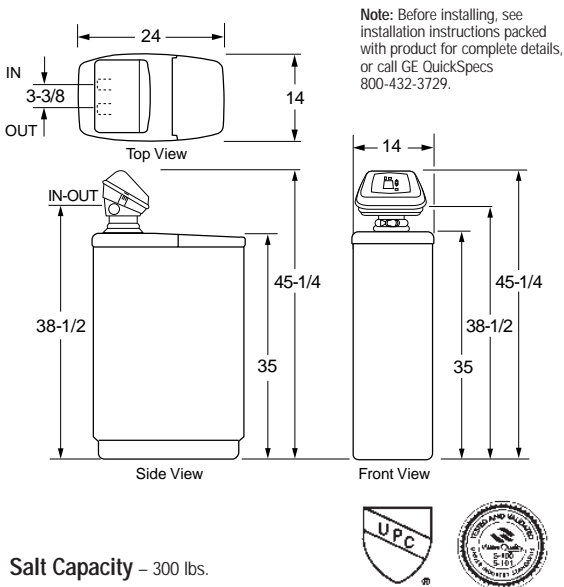

**Salt Capacity** – 300 lbs.

### Warranty Information

**Full One-Year Warranty** – (parts and labor at no additional charge) applies to entire unit.

**Limited Three-Year Warranty** – (parts only) applies to electronic monitor.

**Limited Ten-Year Warranty** – (parts only) applies to replacement cabinet (brine tank) and resin tank.

See written warranty, packed with product, for details.

**Important:** All units must be installed according to local codes.

See page 134 for warranty information.



### Installation Kit Included

For installing convenience, a complete installation kit with bypass valve, drain tubing and use & care video is included with product.

### Water Test Kit

To order a water test kit, call 800.626.2000.

## Model GNSF23Z Installation Information (in inches)

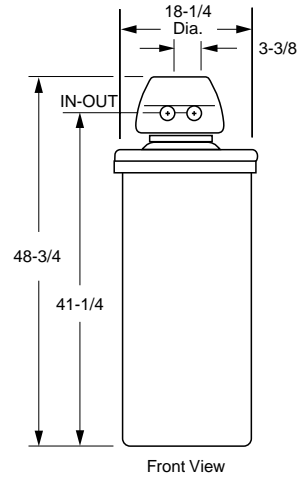

**Salt Capacity** – 200 lbs.

### Warranty Information

**Full One-Year Warranty** – (parts and labor at no additional charge) applies to entire unit.

**Limited Three-Year Warranty** – (parts only) applies to electronic monitor.

**Limited Ten-Year Warranty** – (parts only) applies to replacement cabinet (brine tank) and resin tank.

See written warranty, packed with product, for details.

**Important:** All units must be installed according to local codes.

## Model GNSF18Z Installation Information (in inches)

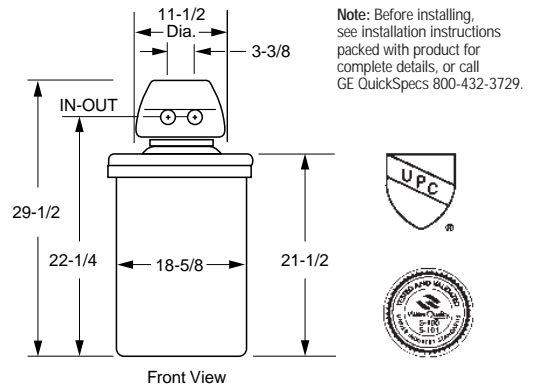

**Salt Capacity** – 140 lbs.

### Warranty Information

**Full One-Year Warranty** – (parts and labor at no additional charge) applies to entire unit.

**Limited Three-Year Warranty** – (parts only) applies to electronic monitor.

**Limited Ten-Year Warranty** – (parts only) applies to replacement cabinet (brine tank) and resin tank.

See written warranty, packed with product, for details.

**Important:** All units must be installed according to local codes.

# WASHERS

	GE Profile Performance Series™		GE Profile™			GE				
	WPSF5170W	WPSF4170W	WPSR4130W	WPSR3120W	WPSR3100W	WJSR2080V	WWLR3100V	WBSR1060T	WBXR2060V	WBXR1060T
<b>Capacity</b>										
Capacity	Super	Super	Super	Super	Super	Super	Large	Super	Extra-Large	Extra-Large
Cubic feet	3.2	3.2	3.2	3.2	3.2	3.2	2.4	3.2	2.7	2.7
<b>Features</b>										
QuickClean Controls	●	●								
Rotary Controls			●	●	●	●	●	●	●	●
Wash/rinse temperatures	5 Automatic Fabric Care Selections		4	4	3	3	4	3	3	3
Wash/spin speed combinations			4	3	3	2	3	1	2	1
Water levels	Variable	Variable	Variable	4	4	3	4	3	3	3
SensorWash™	●	●	●	●						
SpotSoak™	●	●	●	●						
Fabric softener dispenser	●	●	●	●	●	●	●			
Bleach dispenser	●	●	●	●	●	●	●			
Self-cleaning filter	●	●	●	●	●	●	●	●	●	●
GentlePower™ Agitator	●	●	●	●	●	●	●	●		
FlexCare™ Agitator									●	●
Deluxe end-of-cycle signal	●	●								
Number of wash cycles	17	17	13	12	10	8	10	6	6	6
<b>Cottons Regular</b>										
Extra Heavy	●	●	●	●	●	●				
Heavy Soil	●	●	●	●	●	●	●	●	●	●
Power Wash							●			
Medium Soil	●	●	●	●	●	●	●	●	●	●
Light Soil	●	●	●	●	●	●	●	●	●	●
Soak Cycle						●				
Auto Soak (60 min.)		●								
Auto Soak (30 min.)	●	●	●	●	●		●			
Auto Soak (15 min.)			●	●	●		●			
Optional Extra Rinse	●	●	●	●	●		●			
<b>Easy Care</b>										
Permanent Press	●	●	●	●	●		●			
Cottons	●	●	●	●	●					
Knits	●	●	●	●	●		●			
Optional Extra Rinse		●	●	●						
<b>Permanent Press</b>										
Permanent Press Cycle						●		●	●	●
Knits Cycle						●		●	●	●
Delicates Cycle								●	●	●
Quick Wash	●									
GentleWash™		●								
<b>Ultra Care</b>										
Delicates	●									
Wool/Linen	●									
Rayon/Silk	●									
<b>Delicates</b>										
Delicate Cycle					●	●	●			
HandWash™ Cycle			●	●						
Auto Soak/Prewash										
Prewash		●	●							
<b>Extended Spin</b>										
Cottons Regular	●	●								
Permanent Press/Easy Care	●	●								
GentleWash™ Cycle/Ultra	●	●								
Prewash/Quick Wash	●	●								
<b>ColorLogic™</b>										
Color Lid Instructions	●	●	●	●	●	●	●	●	●	●
Color Stain Guide/Instructions	●	●	●	●	●	●	●	●	●	●
100% Front Serviceable	●	●	●	●	●	●	●	●	●	●
PermaTuf II™/Snow-White Basket	●	●	●	●	●	●	●	●	●	●
Steel Drive Transmission	●	●	●	●	●	●	●	●	●	●
ArmorGuard Protection	●	●	●	●	●	●	●	●	●	●
<b>Quiet</b>										
Insulation Package	Hush	Hush	Deluxe	Deluxe						
Quiet-By-Design™	●	●	●	●	●	●	●	●	●	●
<b>Appearance</b>										
Colors available*	WW, AA	WW, AA	WW, AA	WW, AA	WW, AA	WW, AA	WW	WW, AA	WW, AA	WW, AA
<b>Weight &amp; Dimensions</b>										
Approx. shipping weight (lbs.)	160	160	160	160	160	160	147	160	160	160

\*Colors available: WW = White on white, AA = Almond on almond.

## Washer Dimensions (in inches)

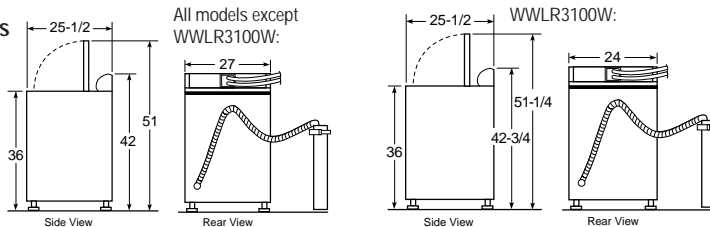

## Washer Specifications

**Circuit Requirements:** An individual, properly-grounded branch circuit, with a three-prong grounding-type receptacle, protected by a 15 or 20 amp circuit breaker or time-delay fuse is required.

**Electrical Rating:** 115V, 60Hz, 10A

**Washer Note:** Washer wall outlet must be located within 36" of service cord entry. Wall outlet must not be located behind dryer.

See page 135 for warranty information.

Refrigeration

Laundry

Cooking Products

Microwave Ovens

Dishwashers

Water Systems

Room Air

# DRYERS

	GE Profile Performance Series™		GE Profile™				GE					
	Electric	Gas	DPSF505EW	DPSF495EW	DPSR475EW	DPXR475EW	DPSR473EW	DPXR473EW	DWSR473EV	DJXR473EV	DBXR453EV	DVLR223EV
	Electric	Gas	DPSF505GW	DPSF495GW	DPSR475GW	DPXR475GW	DPSR473GW	DPXR473GW	DWSR473GV	DJXR473GV	DBXR453GV	DVLR223GV
<b>Capacity</b>												
Capacity			Super	Super	Super	Extra-Large	Super	Extra-Large	Super	Extra-Large	Extra-Large	Large
Cubic feet			7.0	7.0	7.0	6.0	7.0	6.0	7.0	6.0	6.0	5.4
<b>Features</b>												
QuickClean controls			•	•								
Rotary Controls					•	•	•	•	•	•	•	•
Sensor Dry			•	•	•	•						
Automatic Dry control							•	•	•	•	•	•
Heat selections			5	4	4	4	4	4	4	4	4	2
Number of cycles			10	9	7	7	7	7	7	7	5	2
<b>Automatic Cottons</b>												
Cottons Cycle			•	•	•	•	•	•	•	•	•	•
Optional Extra Care			•	•	•	•	•	•	•	•		
<b>Easy Care/Permanent Press</b>												
Permanent Press Cycle			•	•	•	•	•	•	•	•	•	
Optional Extra Care			•	•	•	•	•	•	•	•		
<b>Automatic Delicates</b>												
Delicates Cycle				•								
Optional Extra Care				•								
<b>Timed Dry</b>												
Actual minutes on timer			80	80	80	80	80	80	80	80	80	80
Damp Dry			•	•	•	•	•	•	•	•	•	•
De-Wrinkle			•	•	•	•	•	•	•	•	•	•
Quick Dry			•									
<b>Ultra Care</b>												
Delicates Cycle			•									
Optional Extra Care			•									
ColorLogic™			•	•	•	•	•	•				
Deluxe end-of-cycle signal			•	•								
Variable end-of-cycle signal					•	•	•		•			
Fixed end-of-cycle signal								•		•		
Dryer Rack			•	•								
Drying Center			•	•								
Removable up-front lint filter			•	•	•	•	•	•	•	•	•	•
Reverse-A-Door			•	•	•	•	•	•	•	•	•	•
Dryer interior light			•	•	•	•	•	•	•	•	•	•
DuraDrum™ interior			•	•	•	•	•	•	•	•	•	•
Porcelain drum interior												•
100% Front Serviceable			•	•	•	•	•	•	•	•	•	•
<b>Quiet</b>												
Insulation Package			Hush	Hush	Deluxe	Deluxe	Deluxe					
Quiet-By-Design™			•	•	•	•	•	•	•	•	•	•
QuietDrum™			•	•								
<b>Appearance</b>												
Colors available*			WW, AA	WW, AA	WW, AA	WW, AA	WW, AA	WW, AA	WW, AA	WW, AA	WW, AA	WW, AA
<b>Weights &amp; Dimensions</b>												
Approx. shipping weight (lbs.)	Electric	Gas	117	117	117	112	112	107	112	107	107	107
			125	125	125	120	120	115	120	115	115	124

\*Colors available: WW = White on white, AA = Almond on almond.  
GE electric dryers are available with long-ducting capability.

## Dryer Dimensions (in inches)

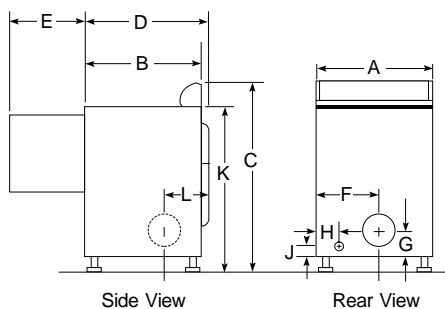

	Large Capacity	Extra-Large Capacity	Super Capacity
A	27	27	27
B	25-1/2*	25-1/2*	25-1/2*
C	42	42	42
D	25-3/4	25-3/4	28-1/4
E	23-1/2	23-1/2	23-1/2
F	11-3/4	11-1/2	11-1/2
G	5-1/2	3-1/2	3-1/2
H	2	2	2
J	2-1/2	2-1/2	2-1/2
K	36	36	36
L	4-3/4	5-1/4	8-1/2

\*24-1/2" from the edge of the side panel to the front. 25-1/2" from front to edge of end caps.

## Dryer Specifications

### Exhaust options:

**Electric:** 4-way via rear, right, left and bottom.

**Gas:** 3-way via rear, left and bottom. Dryer is shipped exhausted to the rear. Alternate exhausting knockouts are supplied.

### Circuit Requirements:

**Electric:** An individual, properly-grounded branch circuit, protected by a 30 amp circuit breaker or a time-delay fuse is required.

### Electric Dryer Rating:

120/240V, 5600W, 24A  
120/208V, 4400W, 22A

**Gas:** An individual, properly-grounded branch circuit, with a three-prong grounding-type receptacle, protected by a 15 or 20 amp circuit breaker or a time-delay fuse is required.

### Gas Dryer Electric Rating:

120V, 60Hz, 6A

**Gas (BTU/HR):** 22,000. Factory-equipped for natural gas. Tested for LP gas. LP gas supply requires an optional conversion kit, WE25M35. Check installation instructions for correct kit and have a qualified gas technician install a conversion kit. See dryer ducting information for proper installation.

**Dryer Note:** Dryer wall outlet must be located within 36" of service cord entry and accessible when dryer is mounted in position.



## Dryer Exhausting Information

For complete information see installation instructions packed with dryer.

**Important Note:** GE Kit Number WE14X70 needed when converting rear exhaust to bottom or side. (On large capacity models.)

### Ducting Materials

For best performance, this dryer should be vented with 4" diameter all rigid metal exhaust duct. If "all rigid metal" duct cannot be used, then "flexible all metal" venting can be used, but it will reduce the maximum recommended duct length.

The following kit or parts are available from your local service organization.

Kit WX8X75—7" aluminum duct and 4" hood, short tail.

(OR individual parts):

WX8X65 7" aluminum flex duct only

WX8X58 4" clamps (2)

WX8X67 4" exhaust hood

See installation instructions for complete information.

### Exhaust length calculation:

1. Determine the number of 90° turns needed for your installation. If you exhaust to the side or bottom of dryer, add one turn.

2. The maximum length of 4" rigid (aluminum or galvanized) duct which can be tolerated is shown in the table.

The maximum lengths for flexible ducts are less than for rigid duct.

See table in installation instructions. A turn of 45° or less may be ignored.

Two 45° turns within the duct length should be treated as a 90° elbow.

A turn over 45° should be treated as a 90° elbow.

**Exhausting the dryer to the outside is strongly recommended** to prevent large amounts of moisture and lint from being blown into the room. Gas dryers or any dryer located in a closet **must** be exhausted to the outside.

**Caution:** For personal safety do not terminate exhaust into a chimney, under any enclosed house floor (crawl space), or into an attic, since the accumulated lint could create a fire hazard or moisture could cause damage. Never terminate the exhaust into a common duct or plenum with a kitchen exhaust, since the combination of lint and grease could create a fire hazard.

Exhaust ducts should be terminated in a dampered wall cap to prevent back drafts, bird nesting, etc. The wall cap must also be located at least 12" above the ground or any other obstruction with the opening pointed down. Other terminations, such as louvered wall boxes, are acceptable provided they are equivalent to a 4" opening dampered wall cap.

## Special Installation Requirements

### Alcove or Closet Installation

• If your dryer is approved for installation in an alcove or closet, it will be stated on a label on the dryer back.

• The dryer **MUST** be exhausted to the outdoors.

See installation instructions for details.

• Minimum clearances between dryer cabinet and adjacent walls or other surfaces are:

0" either side

3" front and rear

• Minimum vertical space from floor to overhead cabinets, ceilings, etc. is 52".

• Closet doors must be louvered or otherwise ventilated and must contain a minimum of 60 sq. in. of open area equally distributed. If this closet contains both a washer and a dryer, doors must contain a minimum of 120 sq. in. of open area equally distributed.

• The closet should be vented to the outdoors to prevent gas pocketing in case of a gas leak in the supply line.

• No other fuel-burning appliance shall be installed in the same closet with the dryer.

### Bathroom or Bedroom Installation

• The dryer **MUST** be exhausted to the outdoors.

See installation instructions for details.

• The installation must conform with the local codes, or in the absence of local codes, with the National Fuel Gas Code, ANSI Z223.

### Minimum Clearances other than Alcove or Closet Installations

• Minimum clearances to combustible surfaces:

0" both sides

3" rear

For more information on venting kits and accessories, please call 1-800-GE-CARES.

### Dryer Exhausting Information—Use Metal Duct Only

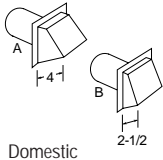

		Best Performance			
		Maximum Length of 4" Dia. Rigid Metal Duct		Maximum Length of 4" Dia. Flexible Metal Duct	
		Exhaust Hood Type		Exhaust Hood Type	
Number of 90° Turns	Cat. No. WX8X59 (Preferred)	Cat. No. WX8X59 (Preferred)		Cat. No. WX8X59 (Preferred)	
		A 4" Opening	B 2-1/2" Opening	A 4" Opening	B 2-1/2" Opening
Domestic Dryer Models	0	90 ft.	60 ft.	55 ft.	45 ft.
	1	60 ft.	45 ft.	40 ft.	30 ft.
	2	45 ft.	35 ft.	30 ft.	20 ft.
	3	35 ft.	25 ft.	20 ft.	15 ft.
Full Size All Electric Dryers	4	25 ft.	15 ft.	15 ft.	10 ft.
	0	45 ft.	30 ft.	30 ft.	15 ft.
	1	35 ft.	20 ft.	20 ft.	10 ft.
	2	25 ft.	10 ft.	10 ft.	—
Full Size All Gas Dryers	3	15 ft.	—	—	—
	0	46 ft.	37 ft.	30 ft.	24 ft.
	1	38 ft.	30 ft.	25 ft.	20 ft.
Spacemaker® Models DSKS433ET WSM2780T	2	31 ft.	22 ft.	20 ft.	14 ft.
	3	24 ft.	15 ft.	16 ft.	10 ft.
	0	43 ft.	36 ft.	30 ft.	24 ft.
Spacemaker® Model DSKP233ET	1	33 ft.	26 ft.	24 ft.	18 ft.
	3	23 ft.	16 ft.	16 ft.	10 ft.
	0	56 ft.	42 ft.	30 ft.	22 ft.
Spacemaker® Model WSM2700T	1	46 ft.	36 ft.	22 ft.	14 ft.
	2	34 ft.	28 ft.	16 ft.	10 ft.
	3	32 ft.	18 ft.	10 ft.	5 ft.
Spacemaker® Models WSM2420T WSM2480T	0	43 ft.	36 ft.	30 ft.	24 ft.
	1	33 ft.	26 ft.	24 ft.	18 ft.
	2	23 ft.	16 ft.	16 ft.	10 ft.



Listed by  
Underwriters  
Laboratories

# FRONT LOADING WASHER

## Special Installation Requirements

### Undercounter Installation

- Accessory mounting kits are required for undercounter installation. To order, call 1-800-848-7722.  
Washer—Order Pub. No. 14-A037  
Dryer—Order Pub. No. 14-A008

### Stacked Installation

- Brackets for stacking dryer over washer are included with the dryer.

### Alcove or Closet Installation

- If your dryer is approved for installation in an alcove or closet, it will be stated on a label on the dryer back.
- The dryer **MUST** be exhausted to the outdoors. See EXHAUST INFORMATION on previous page.
- Minimum clearances between dryer cabinet and adjacent walls or other surfaces are:  
0" either side  
3" front and rear
- Minimum vertical space from floor to overhead cabinets, ceilings, etc. is 52".
- Closet doors must be louvered or otherwise ventilated and must contain a minimum of 60 sq. in. of open area equally distributed. If this closet contains both a washer and a dryer, doors must contain a minimum of 120 sq. in. of open area equally distributed.
- The closet should be vented to the outdoors to prevent gas pocketing in case of a gas leak in the supply line.
- No other fuel-burning appliance shall be installed in the same closet with the dryer.

### Bathroom or Bedroom Installation

- The dryer **MUST** be exhausted to the outdoors. See EXHAUST INFORMATION on previous page.
- The installation must conform with the local codes, or in the absence of local codes, with the National Fuel Gas Code, ANSI Z223.

### Minimum Clearances other than Alcove or Closet Installations

- Minimum clearances to combustible surfaces:  
0" both sides  
3" rear

For more information on venting kits and accessories, please call 1-800-GE-CARES.

## Dryer Specifications

### Exhaust options:

**Electric:** 4-way via rear, right, left and bottom.

**Gas:** 3-way via rear, right and bottom. Dryer is shipped exhausted to the rear.

Exhaust Elbow Kit: Order Pub. No. 14-A018.

### Dryer Exhausting Information—

#### Use Metal Duct Only

		Best Performance	
		Maximum Length of 4" Dia. Rigid Metal Duct	
Number of 90° Turns	Exhaust Hood Type	A	B
		4" Opening	2-1/2" Opening
0		60 ft.	48 ft.
1		52 ft.	40 ft.
2		44 ft.	32 ft.
3		32 ft.	24 ft.
4		28 ft.	16 ft.

		Maximum Length of 4" Dia. Flexible Metal Duct	
Number of 90° Turns	Exhaust Hood Type	A	B
		4" Opening	2-1/2" Opening
0		30 ft.	18 ft.
1		22 ft.	14 ft.
2		14 ft.	10 ft.

Front Loading Dryers

See page 135 for warranty information.

GE	
WSXH208V	
<b>Capacity</b>	
Capacity	Extra-Large
Cubic Feet	2.7
<b>Features</b>	
Wash/rinse temperatures	4
Water levels	Automatic Adjustment
Standard Rinse Cycles	3
Motor Speeds	Agitation 1, Spin 2
Combinations*	HC, WW, WC, CC
Detergent dispenser (Liquid/Powder)	●
Bleach dispenser	●
Fabric softener dispenser	●
End-of-cycle signal	Adjustable
Number of wash cycles	8
Regular	
Heavy Soil	●
Medium Soil	●
Perm. Press	
Medium Soil	●
Light Soil	●
Knits/Delicates	●
Pre-Wash	●
Extra-Rinse Cycle/Auto Option	●
Leveling legs	●
Rear rollers	●
Stainless steel wash drum	●
<b>Appearance</b>	
Color available	White on white
<b>Weights &amp; Dimensions</b>	
Approx. shipping wt. (lbs.)	217
Flexible installation	Undercounter, stacked, side-by-side
Electrical requirements	120V, 60 Hertz, 12.0 Amps

\*HC = Hot-Cold, WW = Warm-Warm, WC = Warm-Cold, CC = Cold-Cold.

## Washer Dimensions (in inches)

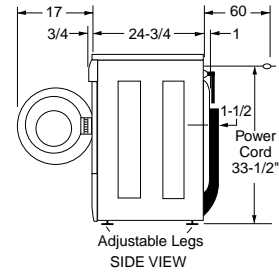
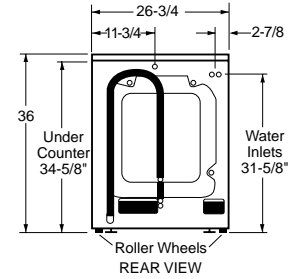

## Washer Specifications

**Circuit Requirements:** An individual, properly-grounded branch circuit, with a three-prong grounding-type receptacle, protected by a 15 or 20 amp circuit breaker or time-delay fuse is required.

See Pub. No. 31-2819 for installation information.

# FRONT LOADING MATCHING DRYER

GE	
DSXH43EV/GV	
<b>Capacity</b>	
Capacity	Extra-Large
Cubic Feet	6.0
<b>Features</b>	
Tumble Drying	●
Time Dry Cycles	4
Auto Dry Cycles	3
Temperature Options	4
High	●
Medium	●
Low	●
Air Fluff/No Heat (Cool Down)	●
Timed Dry Cycles	4
Regular	●
Permanent Press	●
Knits/Delicate	●
Air Fluff	●
Auto Dry Cycles	
Regular	●
Permanent Press	●
Knits/Delicate	●
Cool Down	●
Quick Clean Lint Screen	●
End-of-Cycle Signal	Adjustable
Drum Light	●
Dura Finish Top and Drum	●
Spill-Saver Top	●
Poly Tumbling Vanes	●
Leveling Legs	●
Total Front Serviceability	●
Exhaust Options (Electric/Gas)	4/3
Heavy-Duty Suspension System	●
<b>Appearance</b>	
Color available	White on white
<b>Weights &amp; Dimensions</b>	
Approx. Shipping Weight (Elec/Gas)	116
Flexible installation	Undercounter, stacked, side-by-side
Electrical requirements	120/240V, 3 wire, 5600, 24A 120/208V, 3 wire, 4400W, 22A
Gas requirements	120V, 60Hz, 6A
LP conversion kit	14-A038

## Dryer Dimensions (in inches)

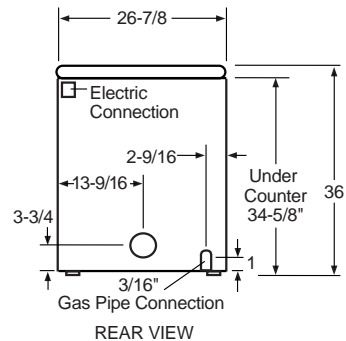
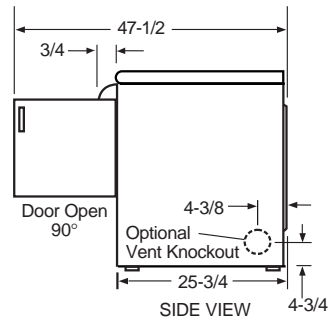

See Pub. No. 49-9963-2 for installation information.

# GENERAL INFORMATION FOR DRYER EXHAUSTING

Minimizing the length of ductwork and the number of turns in an exhaust system minimizes the potential for lint to settle and accumulate in the exhaust duct and in the interior cabinet of the dryer. Refer to your specific dryer installation instructions for recommended duct length.

## 1. WALL CAPS AND OTHER TERMINATIONS

All exhaust systems must be terminated in a manner that will prevent backdrafts from outside as well as prevent birds or other wildlife from building nests or taking refuge in the ductwork. The wall cap should present minimal resistance to the flow of exhaust air and should require little maintenance to prevent clogging. **The preferred termination is either a dampered wall cap with a 4" wide opening or a movable louvered wall cap.** A 2-1/2" wall cap restricts airflow and increases drying time. It must be installed with the opening down, and installed at a minimum of 12" above ground level or any other obstruction. Special consideration should be given in areas where heavy snow drifts are likely to occur to ensure the wall cap does not become obstructed. Other types of terminations, such as roof vents or louvered plenum chambers, are acceptable providing they are equivalent to the 4" dampered wall cap. They must contain at least 14 square inches of ventilation area and afford adequate protection against backdrafts.

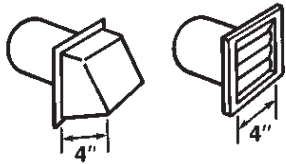

Exhaust ducts must not contain screens or other filtering devices which may become clogged with lint. The dryer exhaust must not terminate in an ordinary chimney, under an enclosed house floor or crawl space, or into an attic, since any accumulated lint could create a fire hazard and the moisture could cause damage. **Never terminate the exhaust into a common duct or plenum with a kitchen hood exhaust since the combination of grease and lint could create a fire hazard.**

## 2. SEPARATION OF TURNS IN THE DUCTWORK

All turns in the exhaust system, external to the dryer itself, including the distance from the last turn to the dampered wall cap, should be separated by at least 4' of straight metal duct. This will reduce the added resistance which results from rapid changes in airflow direction inside the ducting. If two turns must be closer than 4', deduct 10' from the maximum lengths shown in chart on page 157.

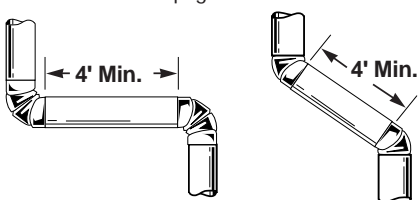

## 3. TREATMENT OF TURNS OTHER THAN 90°

One turn of 45° or less may be ignored. Two such turns should be treated as one 90°. Each turn over 45° should be treated as one 90°. Refer to specific dryer installation for maximum duct lengths and for allowable number of 90° bend. In determining the number of turns for an exhaust system, one 90° turn must be added for the bend made inside the cabinet whenever the dryer is exhausted through the right, left or bottom. NOTE: Some dryers are limited to only rear exhausting. Consult the installation instruction for the type of dryer being used.

## 4. USE OF FLEXIBLE METAL DUCTING

We recommend the use of 4" diameter rigid metal ducting for permanent and transition venting. Permanent venting is from the wall, floor or ceiling to the outside. Transition venting is from the dryer to the wall, floor or ceiling. If all rigid ducting cannot be used then flexible all metal ducting may be used, if the following precautions are adhered to:

- Use only 4" diameter all metal ducting.
- Never use foil or other ducting that can be easily punctured with a screwdriver or nail.
- It must not be allowed to collapse, kink or sag when the dryer is in its final installed position. Required turns in the exhaust system should be made with rigid elbows.
- Use the shortest duct length possible. Don't exceed the maximum allowable duct length specified in the installation instructions.
- Stretch the duct to its maximum length.
- To reduce the risk of fire, **NEVER USE PLASTIC OR OTHER COMBUSTIBLE DUCTWORK.**

NOTE: In special installations where it is impossible to use all metal rigid or all metal flexible duct for transition venting, UL Listed clothes dryer transition duct may be used. The following additional precautions should be followed if this type of ducting is used.

- Never use transition duct beyond the wall, ceiling or floor inside the dryer.
- Avoid resting the duct on sharp objects.

Please refer to the installation instructions for additional exhaust information.

## 5. SEALING OF JOINTS

All duct joints should avoid leaks. Duct joints should be made air and moisture tight by wrapping the overlapped joints with duct tape. The male ends of each section of duct should point away from the dryer.

**Do not assemble the ductwork with screws or other fasteners that extend into the duct. They will serve as a collection point for lint.**

## 6. WATER CONDENSATION

Condensation in a dryer exhaust system is caused by the moisture in the exhausted air contacting the cold inner surfaces of the ductwork. Condensation, which forms at the beginning of the drying cycle, will dissipate quickly after the ductwork becomes heated. If the ductwork passes through an area which keeps it cool throughout the drying cycle, considerable condensation within the duct can be expected. This can result in rapid accumulation of lint in the ductwork.

Ductwork which runs through an unheated area or is situated adjacent to an air conditioning duct should be insulated to avoid such condensation problems. Joints should be tight to avoid leaks and, where feasible, the duct should be dropped 1/16" per foot toward the termination.

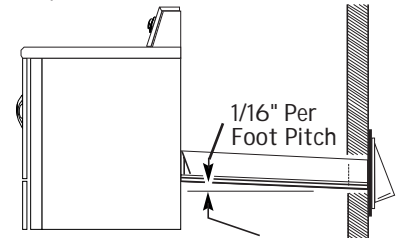

## 7. ACCESSIBILITY FOR CLEANING

Since it may be necessary from time to time to remove lint from the inside of the ductwork, it is important that the exhaust system be installed with a provision for periodic inspection and cleaning. Some provision should be made for access to turns and straight runs of duct installed in an enclosed area, such as above plastered ceilings. Special consideration should be given to the amount of maintenance required for roof caps on vertical installations, since the user cannot be expected to make frequent inspections or cleanings.

## 8. IN LINE EXHAUST (BOOSTER) FANS

Use of In Line exhaust (booster) fan for single unit installation is not recommended:

- Operator may forget to turn it on.
- It may block
- It may fail without Operator noticing it.

### Single Family-Type Dwellings

For more detailed information, refer to the installation instructions for the specific dryer model selected.

### Mobile or Manufactured Home Installation

Gas Dryer installation must conform with local Gas Codes and with CGA B149.1 or B149.2 (Installation code for Gas Burning Appliances and Equipments).

All Dryer Installations must conform to Manufactured Home Construction and Safety Standard, Title 24 CFR, Part 32-80. The dryer MUST be exhausted to the outdoors with the termination securely fastened to the mobile home structure. The exhaust MUST NOT be directed underneath the mobile home.



# SPACEMAKER® WASHERS AND DRYERS

Individual Spacemaker® Washers	GE	
	Stationary WSKS2060T	Portable WSKP2060T
<b>Capacity</b>		
Capacity	Compact	Compact
<b>Features</b>		
Wash/spin speed combinations	2	2
Wash/rinse temperatures	3	3
Water levels	4	4
Number of cycles	6	6
Regular		
Heavy Soil	●	●
Medium Soil	●	●
Perm. Press		
Medium Soil	●	●
Light Soil	●	●
Delicates	●	●
Spin Only	●	●
Automatic cool down	●	●
Bleach dispenser	●	●
Fabric softener dispenser	●	●
Lint filter	●	●
Easy-roll rollers		●
<b>Appearance</b>		
Colors available	White and Almond with Black backsplash	White and Almond with Black backsplash
<b>Weights &amp; Dimensions</b>		
Circuit requirements	120V, 60 Hertz, 15 or 20 Amps	
Dimensions (HxWxD in inches)*	34-1/4 x 22-1/4 x 24	34 x 22-1/4 x 24
Approx. shipping wt. (lbs.)	109	

\*Depth measured from front of control knob.

To Install These Washers With Matching Dryers, Use Accessory Kit: DSR24RT—Metal rack for stationary dryer with washer rolled beneath.

Note: To obtain matching appearance between the washers and dryers, the dryers must be "T" model year. For example, DSKS433ET.

## Accessories

### Stack Rack DSR24RT

For use with stationary dryers and storage of washer WSKP2060T/WSKS2060T underneath.

### Stack Rack DSR24RT with DSKP233ET and Portable Washer WSKP2060T or Stationary Washer WSKS2060T Dimensions (in inches)

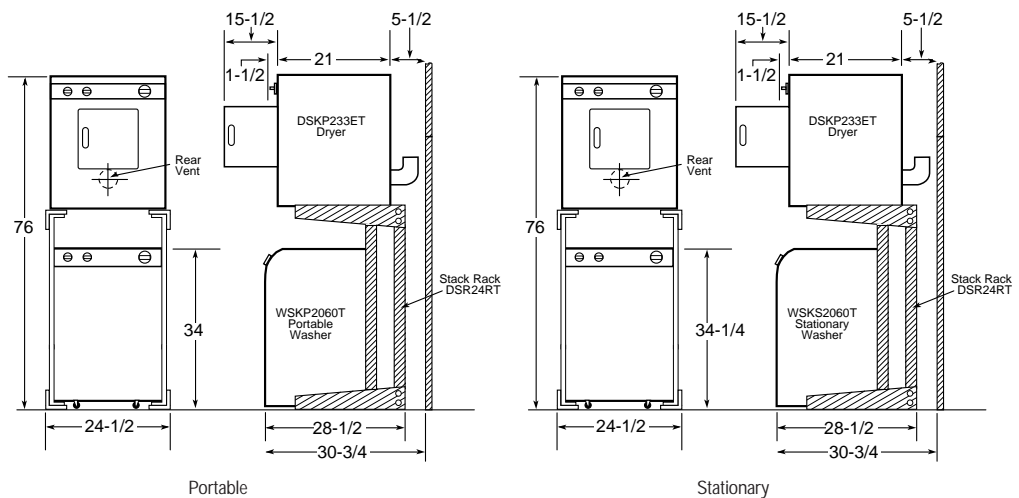

### Stack Rack DSR24RT with DSKS433ET and Portable Washer WSKP2060T or Stationary Washer WSKS2060T Dimensions (in inches)

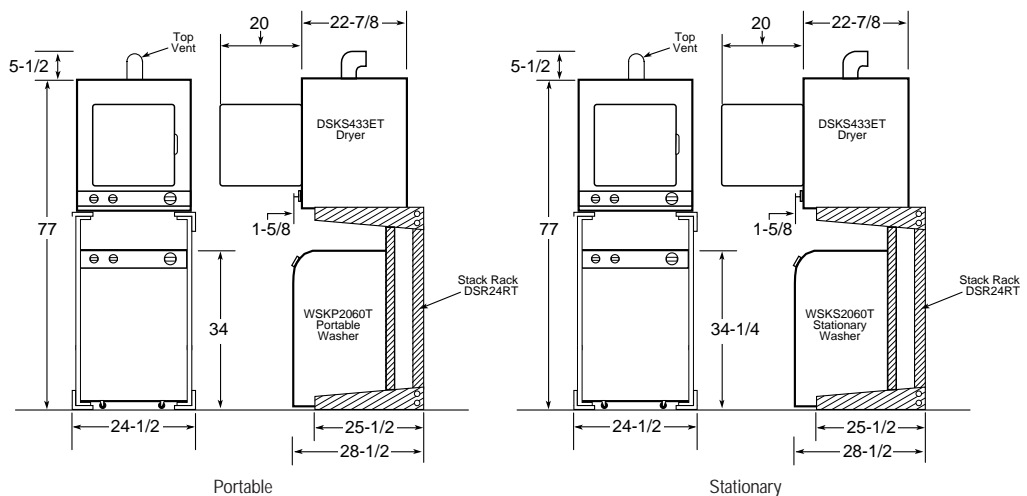

See page 135 for warranty information.

Individual Spacemaker® Dryers	GE	
	Stationary DSKS433ET	Portable/Stationary* DSKP233ET
<b>Capacity</b>		
Capacity	Compact	Compact
<b>Features</b>		
Dry control	Automatic	Automatic
Heat selections	4	2 (timer)
Number of dry cycles	3	3
Auto. Reg.—Perm. Press		●
Auto. Perm. Press & Delicate	●	
Auto. Reg.	●	
Timed Regular (min.)	140	105
Air Fluff (min.)	(Heat Selection)	10
Separate start switch	●	●
Control location	Mid-Band	Top
End-of-cycle signal		●
Lint filter	Up-Front	Back of Drum
<b>Appearance</b>		
Colors available	White and Almond with Black backsplash	White and Almond with Black backsplash
<b>Weight &amp; Dimensions</b>		
Exhaust options**	4-Way	Rear
Circuit requirements	240/208V†, 60 Hertz, 30 Amp	120V, 60 Hertz, 15 Amp
Power cord	6 feet	
Dimensions (HxWxD in inches)	33-1/4 x 23-7/8 x 24-1/2	32 x 23-7/8 x 23-5/8
Approx. shipping wt. (lbs.)	108	

\*Dryer comes equipped with casters and stationary leveling legs.

\*\*DSKS433ET shipped exhausted through the top. DSKP233ET exhausted to rear only.

†120 volt outlet: Rear-mounted outlet on DSKS433ET approved for use only with Washer/Dryer Stack Rack DSR24RT.

Circuit Requirements: An individual, properly-grounded branch circuit of the proper voltage and frequency as specified on the rating plate, with no other appliances or fixtures in circuit, is required.

# UNFITTED SPACEMAKER® WASHERS AND DRYERS

	GE			
	Electric		Gas	
Washer	Washer	Dryer	Washer	Dryer
Capacity	X-Large	X-Large	Compact	Compact
Features				
Wash/spin speed combinations	1		2	
Wash/rinse temperatures	3		3	
Water levels	3		3	
Number of wash cycles	3		3	
Regular	•		•	
Perm. Press	•		•	
Delicates	•		•	
Unbalanced load control	•		•	
Lint filter	•		•	

## Dryer

Features			
Automatic dry control		•	•
Number of dry cycles		4	4
Auto Regular		•	•
Auto Perm Press			•
Delicates		•	
Timed			•
Air Fluff		•	•
Control location		Mid-Band	Mid-Band
Exhaust options		Rear	Rear/Sides
Appearance			
Colors available	White/Almond	White on white**	
Weight & Dimensions			
Dimensions (HxWxD in inches)	75-1/2 x 27 x 30-13/16*	71-3/4 x 23-7/8 x 27-1/4*	
Approx. shipping wt. (lbs.)	300	238	

\*Depth dimension assumes water hook-up is recessed in the wall.

\*\*Electric model is also available in Almond on almond.

Note: The third prong on the WSM2780T plug configuration is a flat spade type rather than a typical round probe. It requires a matching wall outlet.

## Electrical Requirements

**WSM2700T: Electric Dryer**—This appliance should be connected to an individual, properly-grounded branch circuit with 120/240V or 120/208V single-phase 60 Hz electrical service and should be protected by 30-amp time-delay fuses or circuit breakers. This appliance is manufactured with neutral connected to the frame. Power cord should be purchased separately.

**WSM2420T: Electric Dryer**—This appliance should be connected to an individual, properly-grounded branch circuit with 120/240V or 120/208V single-phase 60 Hz electrical service and should be protected by 30-amp time-delay fuses or circuit breakers. This appliance is manufactured with the neutral connected to the frame. Power cord should be purchased separately.

**NOTE:** THESE APPLIANCES ARE NOT APPROVED FOR 120-VOLT OPERATION.

**WSM2480T: Gas Dryer**—This appliance should be connected to an individual, properly-grounded branch circuit with a three-prong grounding-type receptacle and 120-volt single-phase 60 Hz electrical service and should be protected by 15 or 20-amp time-delay fuses or circuit breakers. This appliance is equipped with a 6-foot long flexible U.L. listed 20-amp power cord to match a 15-amp receptacle.

**Gas Rated** input 10,500 BTU/HR. Factory equipped for natural gas. Tested for LP gas.

**WSM2780T: Gas Dryer**—This appliance should be connected to an individual branch circuit with 120-volt single-phase 60 Hz electrical service and should be protected by 20-amp time-delay fuses or circuit breakers. This appliance is equipped with a 4-foot long flexible U.L. listed 20-amp power cord to match a 20-amp receptacle.

**Gas Rated** input 20,000 BTU/HR. Factory equipped for natural gas.

**LP gas supply requires a conversion kit.**

Have a qualified gas technician install a conversion kit before use.

## Exhaust Information

See "Dryer Exhausting Information" on page 141.

For complete information see installation instructions packed with the product.

## Models WSM2700T and WSM2780T Dimensions (in inches)

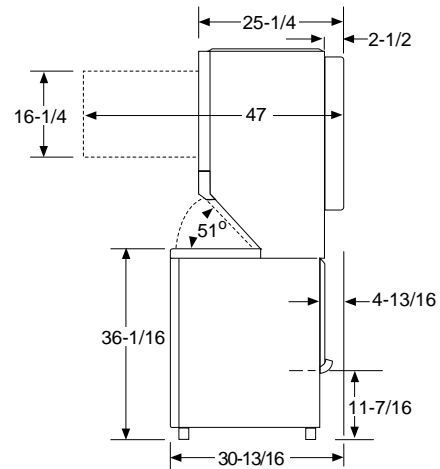
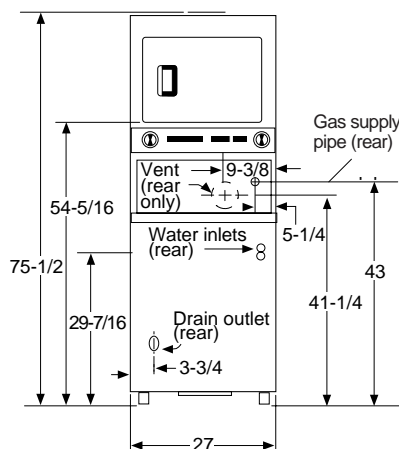

## Models WSM2420T and WSM2480T Dimensions (in inches)

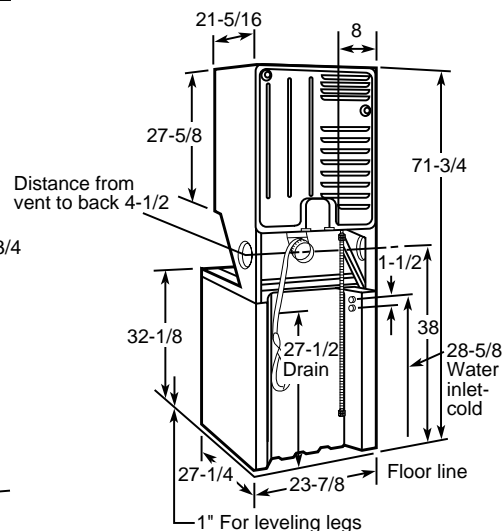
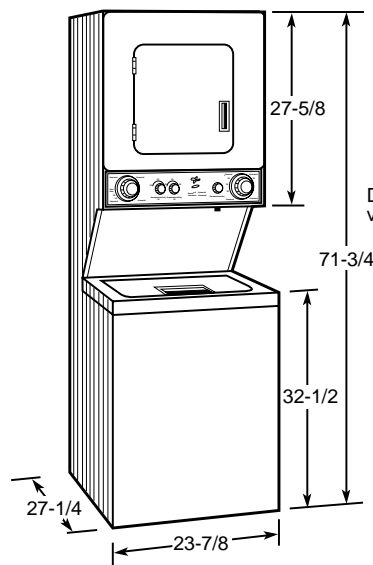

Refrigeration

Laundry

Cooking Products

Microwave Ovens

Dishwashers

Water Systems

Room Air

# 30" BUILT-IN DOUBLE OVENS

	GE Profile Performance Series™	GE Profile™	GE		GE Profile™	GE	
	Convection Double Ovens		Double Ovens		Microwave Double Ovens		
	JT950SA JT950WA JT950AA JT950BA	JTP56WA JTP56AA JTP56BA	JTP45WA JTP45BA	JTP27WA JTP27BA	JTP95WA JTP95BA	JTP85WA JTP85BA	
<b>Features</b>							
Oven interior	Upper Lower	Convection/Self-Clean Thermal/Self-Clean	Convection/Self-Clean Thermal/Self-Clean	Self-Clean Self-Clean	Self-Clean Standard	Microwave Convection/Self-Clean	
Cleaning time		Variable	Variable	Variable	Variable (upper)	Variable (lower) Variable (lower)	
Automatic self-clean oven door lock		●	●	●	Upper	Lower Lower	
Self-clean oven w/Delay Clean option		●	●	●	Upper	Lower Lower	
TrueTemp™ System		●	●	●	Upper	Lower Lower	
CleanDesign oven interior		Upper	Upper				
Variable broil/Six-pass broil element		●	●	●	●	Lower Lower	
SmartSet Controls		●	●	●	Upper	● ●	
Proofing		●					
Convection conversion		Upper	Upper			Lower	
Convection Bake		Upper	Upper			Lower	
Convection Roast		Upper	Upper			Lower	
Automatic meat thermometer		Upper	Upper			Lower	
Temperature display		●	●	●	Upper	● ●	
Start pad		●	●	●	Upper	● ●	
Delay Bake option with Cook & Hold C° or F° programmable		●	●	●	Upper	Lower Lower	
Audible preheat signal		●	●	●	Upper	Lower Lower	
Auto oven shut-off w/override		●	●	●	Upper	Lower Lower	
Electronic clock and kitchen timer		●	●	●	●	● ●	
Control lock capability		●	●	●	Upper	Lower Lower	
Oven light pad		●	●	●	●	Lower Lower	
Microwave Oven Features:							
Microwave cooking timer						99-Min./99-Sec. 99-Min./99-Sec.	
Microwave power levels						10 10	
Sensor functions						6 3	
Electronic MWO touch controls						● ●	
Microwave oven cavity (cu. ft.)						1.6 1.6	
MWO power output watts						1000 1000	
Turntable						● ●	
Embossed rack positions		7 Upper/6 Lower	7 Upper/6 Lower	6 Upper/Lower	6 Upper/Lower	7 Lower 6 Lower	
Roasting rack		Upper	Upper			Lower	
Oven racks*	Upper Lower	3 2	3 2	2 2	2 2	3 2	
Gourmet Shelf		●	●	●	●	●	
Broiler pan with grid		●	●	●	●	Lower Lower	
<b>Appearance</b>							
Color appearance**		SS WW AA BB	WW AA BB	WW BB	WW BB	WW BB	
Frameless glass oven doors		Stainless White Almond Black	White Almond Black	White Black	White Black	White Black	
Big View windows		●	●	●	●	Lower Lower	
Lift-off oven doors		●	●	●	●	Lower Lower	
Designer-style handles		Integrated	Integrated	Sure Grip	Sure Grip	Integrated Sure Grip	
Flush appearance installation		●	●	●	●	● ●	
<b>Weights &amp; Dimensions</b>							
Approx. shipping wt. (lbs.)		260	260	260	260	177 177	
Oven cabinet width required (in.)		30	30	30	30	30	
Overall dimensions (WxHxD in inches)		← 30 x 52-15/16 x 23-1/2 →				← 29-3/4 x 43-1/2 x 23-1/2 →	
Overall oven interior dimensions (WxHxD in inches)	Upper Lower	← 24 x 17-3/8 x 15-3/4 →		← 24 x 17-3/8 x 17-19/32 →		← 17-1/4 x 11-1/2 x 16-1/4 →	
		← 24 x 17-3/8 x 17-19/32 →				24 x 17-3/8 x 15-3/4 24 x 17-3/8 x 17-19/32	
<b>Power/Ratings</b>							
KW rating @ 240V		7.2	7.2	7.2	8.0	6.4 6.4	
208V		5.4	5.4	5.4	6.0	4.8 4.8	
Amps @ 240V		40	40	40	40	30 30	
208V		30	30	30	35	30 30	
Convection wattage		2500	2500			2500	
Broiler/bake wattage		3400/3410	3400/3410	3400/3410	3400/3410	3600/3410 3600/3410	

\*Additional rack kit available at additional cost. (Pub. No. 3-A014).

\*\*SS = Stainless Steel, WW = White on white, BB = Black on black, AA = Almond on almond.

# 30" BUILT-IN DOUBLE OVENS (CONTINUED)

30" Built-In Double Oven Dimensions (in inches)  
Models JT950, JTP56, 45, 27

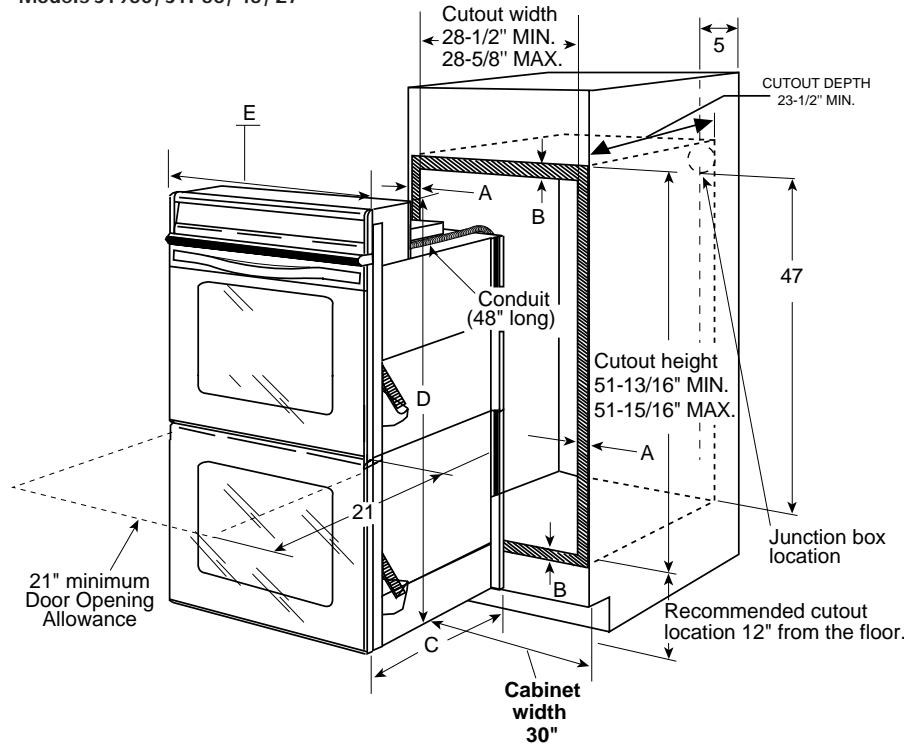

MOST 30" WALL CABINETS CAN BE USED WITH THIS UNIT  
THE OPENING BETWEEN THE INSIDE WALLS MUST BE AT LEAST 28-1/2" WIDE

30" Built-In Microwave Double Oven Dimensions (in inches)  
Models JTP95, 85

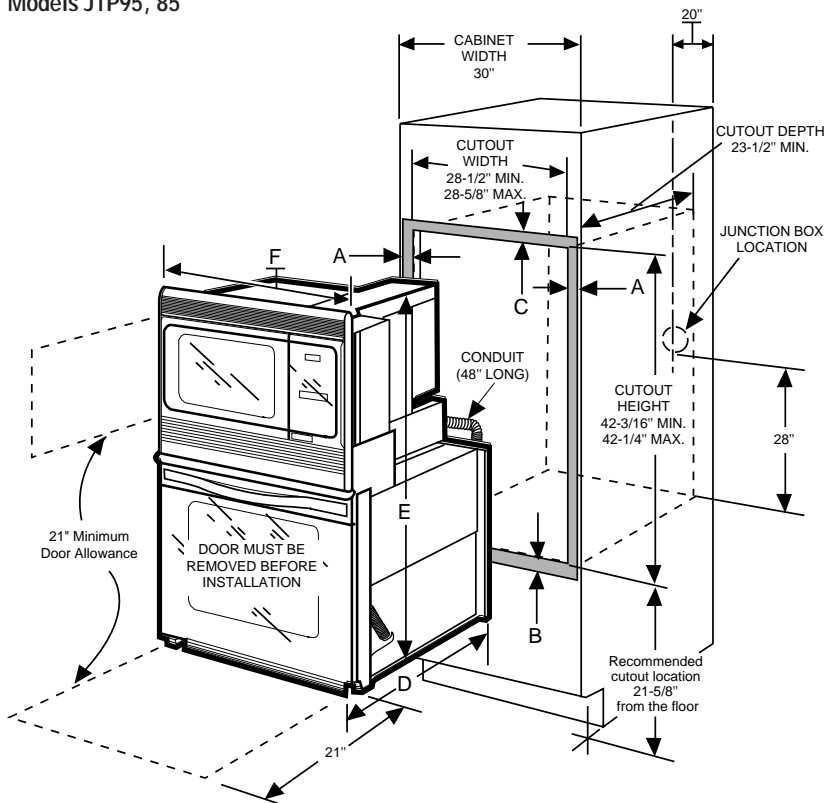

MOST 30" WALL CABINETS CAN BE USED WITH THIS UNIT  
THE OPENING BETWEEN THE INSIDE WALLS MUST BE AT LEAST 28-1/2" WIDE

Recommended for solid bottom installation

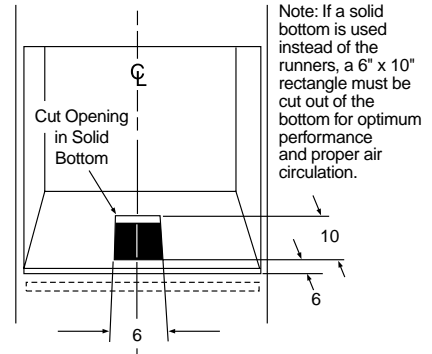

(Must support 275 LBS.)

Cabinet	30"
A - Overlap of Oven Over Side Edges of Cutout	11/16" - 3/4"
B - Overlap of Oven at Top and Bottom of Cutout	1"
Oven	
C - Overall Depth	23-1/2"
D - Overall Height	52-15/16"
E - Overall Width	30"

Note: Cabinets installed adjacent to wall ovens must have an adhesion spec of at least 194° F temperature rating.

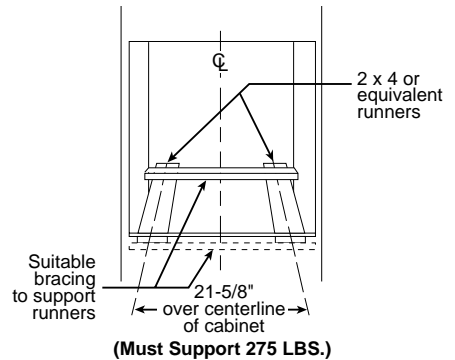

Cabinet	30"
A - Overlap of Oven Over Side Edges of Cutout	11/16"
B - Overlap of Oven at Bottom of Cutout	1"
C - Overlap of Oven at Top of Cutout	1/2"
Oven	
D - Overall Depth	23-1/2"
E - Overall Height	43-1/2"
F - Overall Width	29-3/4"

Note: Cabinets installed adjacent to wall ovens must have an adhesion spec of at least 194° F temperature rating.



Installation Information: Before installing, consult installation instructions [Pub. No. 31-10198 (JTP95/85); Pub. No. 31-10125 (JT950, JTP56/45/27)] packed with product for current dimensional data.

See page 136 for warranty information.



# 30" BUILT-IN SINGLE OVENS

	GE Profile Performance Series™	GE Profile™	GE
	Convection Single Ovens		Single Ovens
	JT910SA JT910WA JT910AA JT910BA	JTP18WA JTP18AA JTP18BA	JTP15WA JTP15AA JTP15BA
Features			
Oven interior	Convection/Self-Clean	Convection/Self-Clean	Self-Clean
Cleaning time	Variable	Variable	Variable
Automatic self-clean oven door lock	●	●	●
Self-clean oven w/Delay Clean option	●	●	●
TrueTemp™ System	●	●	●
CleanDesign oven interior	●	●	●
Variable broil/Six-pass broil element	●	●	●
SmartSet Controls			
Proofing	●	●	●
Convection conversion	●	●	●
Convection Bake	●	●	●
Convection Roast	●	●	●
Automatic meat thermometer	●	●	●
Temperature display	●	●	●
Start pad	●	●	●
Delay Bake option with Cook & Hold	●	●	●
C° or F° programmable	●	●	●
Audible preheat signal	●	●	●
Auto oven shut-off w/override	●	●	●
Electronic clock and kitchen timer	●	●	●
Control lock capability	●	●	●
Oven light pad	●	●	●
Oven racks*	3	3	2
Gourmet Shelf	●	●	●
Embossed rack positions	7	7	6
Roasting rack	●	●	●
Broiler pan with grid	●	●	●
Appearance			
	SS WW AA BB	WW AA BB	WW AA BB
Color appearance**	Stainless White Almond Black	White Almond Black	White Almond Black
Frameless glass oven door	●	●	●
Big View window	●	●	●
Lift-off oven door	●	●	●
Designer-style handle	Integrated	Integrated	●
Flush appearance installation	●	●	●
Undercounter installation	●	●	●
Weight & Dimensions			
Approx. shipping weight (lbs.)	135	135	130
Oven cabinet width required (in.)	30	30	30
Overall dimensions (WxHxD in inches)	30 x 28-1/4 x 23-1/2		
Overall oven interior (WxHxD in inches)	24 x 17-3/8 x 15-3/4		24 x 17-3/8 x 17-19/32
Power/Ratings			
KW rating @ 240V	3.6	3.6	3.6
208V	2.7	2.7	2.7
Amps @ 240V	20	20	20
208V	20	20	20
Convection wattage	2500	2500	
Broiler/bake wattage	3400/3410	3400/3410	3400/3410

\*Additional rack kit available at additional cost. (Pub. No. 3-A014)  
 \*\*SS = Stainless Steel, AA = Almond on almond, WW = White on white, BB = Black on black.

## Recommended for solid bottom installation

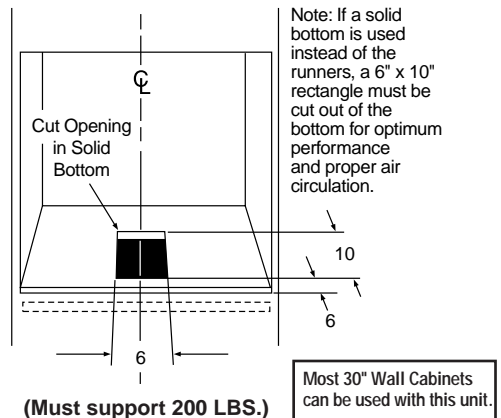

## 30" Built-In Single Oven Dimensions (in inches) Single Oven Wall-Mount or Cabinet Installation (in inches)

Note: These ovens are *not* approved for stackable or side-by-side installations.

Note: Cabinets installed adjacent to wall ovens must have an adhesion spec of at least 194° F temperature rating.

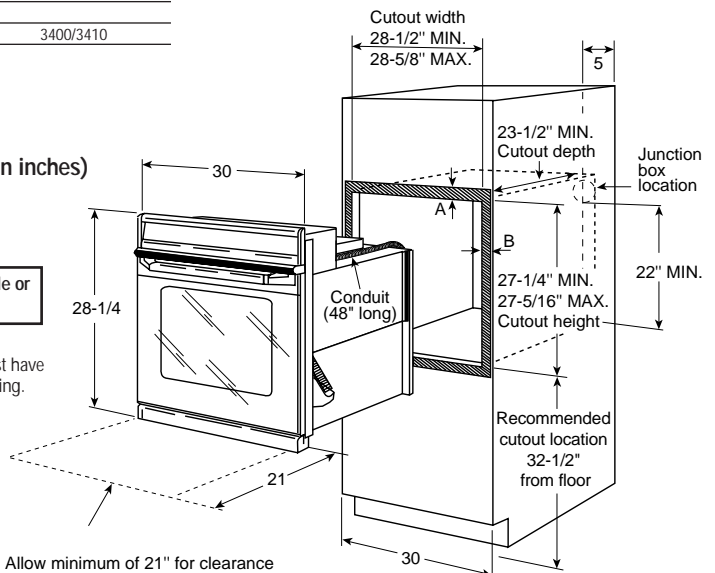

Allow minimum of 21" for clearance to adjacent corners, drawers, walls, or etc.  
 A=Allow 1" overlap of oven over top and bottom edges of cutout.  
 B=Allow 11/16"-3/4" for overlap of oven over side edges of cutout.

# 30" BUILT-IN SINGLE OVENS (CONTINUED)

## Optional Undercounter Installation With 36" Gas Cooktop (in inches)

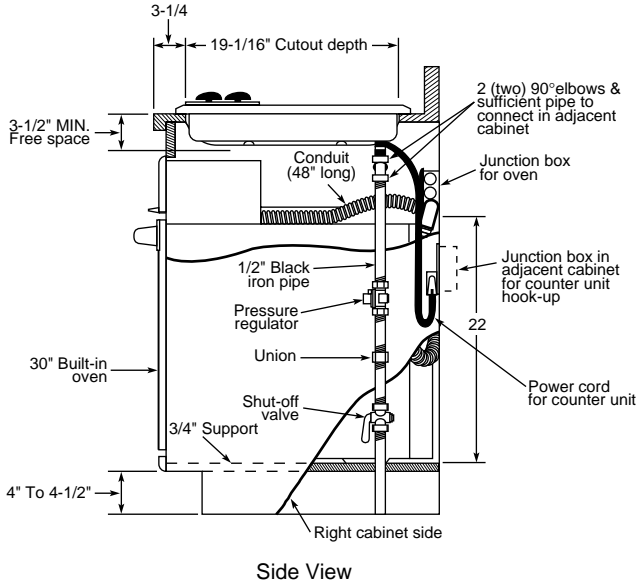

Side View

**Note:** For standard or sealed burner cooktop installation information over the 30" wall oven, refer to 27" wall oven installation, page 169.

## Optional Undercounter Installation With 30" CleanDesign or Sealed Burner Gas Cooktop (in inches)

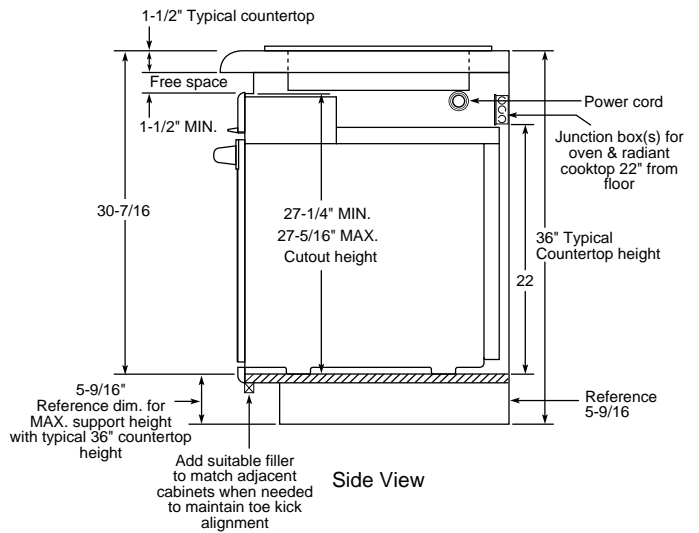

Side View

This installation is to achieve minimum gap between bottom of countertop and control panel.

**Note:** For this installation, the bottom trim **will not** be flush with a typical 4" toe kick.

**Note:** Cabinets installed adjacent to wall ovens must have an adhesion spec of at least 194° F temperature rating.

## Undercounter Installation (in inches)

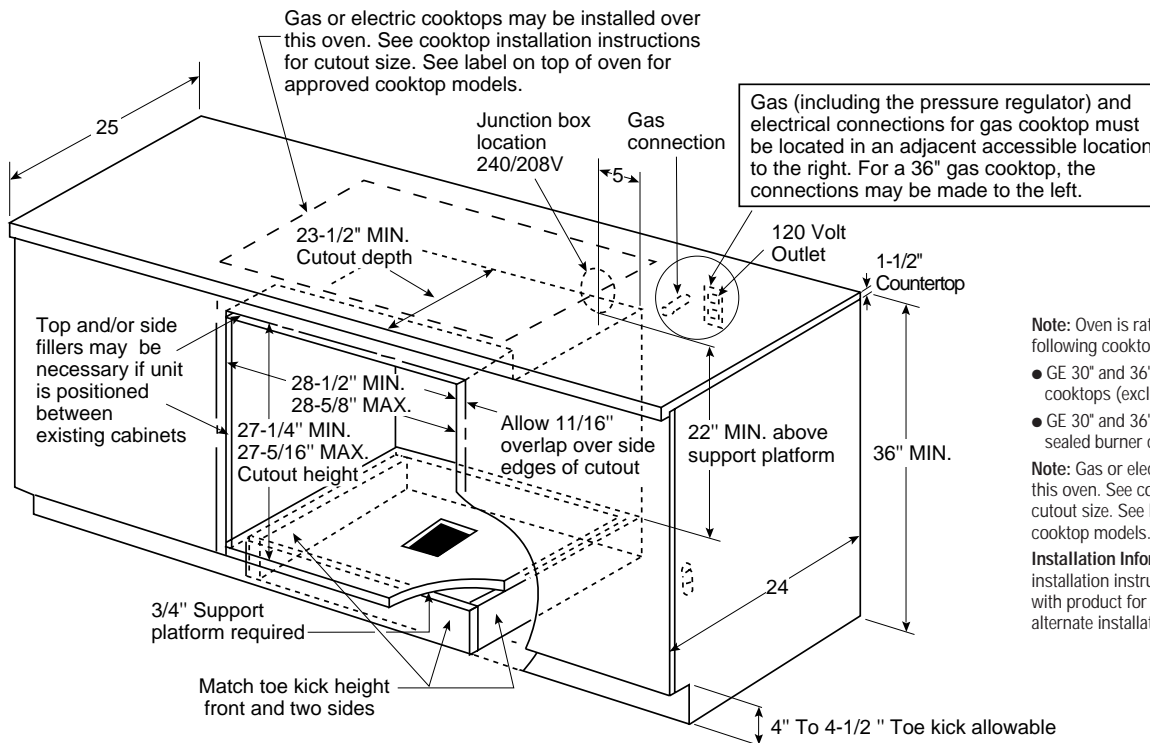

**Note:** Oven is rated for use only under the following cooktops:

- GE 30" and 36" electric coil and CleanDesign cooktops (excludes Induction cooktops)
- GE 30" and 36" gas standard and sealed burner cooktops

**Note:** Gas or electric cooktops may be installed over this oven. See cooktop installation instructions for cutout size. See label on back of oven for approved cooktop models.

**Installation Information:** Before installing, consult installation instructions (Pub. No. 31-10125) packed with product for current dimensional data and for alternate installation options.

Refrigeration

Water Systems

Laundry

Cooking Products

Microwave Ovens

Dishwashers

Room Air

# 27" AND 24" BUILT-IN DOUBLE OVENS

	GE	GE Profile Performance Series™	GE Profile™	GE		
	27" Microwave Double Ovens	27" Convection Double Ovens		27" Double Ovens		24" Double Oven
Oven Features	JKP85WA JKP85BA	JK950WA JK950AA JK950BA	JKP56WA JKP56AA JKP56BA	JKP45WA JKP45BA	JKP27WA JKP27BA	JRP24BW
<b>Features</b>						
Oven interior	Upper Oven Lower Oven	Microwave Self-Clean	Convection/Self-Clean Self-Clean	Convection/Self-Clean Self-Clean	Self-Clean Self-Clean	Self-Clean Standard
Variable cleaning time	Lower	●	●	●	Upper	Upper
Self-clean oven	Lower	●	●	●	Upper	Upper
Automatic self-clean oven door lock	Lower	●	●	●	Upper	Upper
Delay Clean option	Lower	●	●	●	Upper	Upper
TrueTemp™ System	Lower	●	●	●	Upper	
CleanDesign oven interior		●	●			
Variable broil	Lower	●	●	●	Upper	Upper
SmartSet Controls	Lower		●	●	Upper	Upper
Proofing		Upper				
Convection conversion		●	●			
Convection Bake		●	●			
Convection Roast		●	●			
Auto. meat thermometer		Upper	Upper			
Temperature display	●	●	●	●	Upper	Upper
Start pad	●	●	●	●	Upper	Upper
Cook & Hold	●	●	●	●	Upper	Upper
Delay Bake option	Lower	●	●	●	Upper	Upper
C° or F° programmable	Lower	●	●	●	Upper	Upper
Audible preheat signal	Lower	●	●	●	●	●
Auto oven shut-off w/override	Lower	●	●	●	Upper	Upper
Electronic clock and kitchen timer	●	●	●	●	●	●
Control lock capability	Lower	●	●	●	Upper	Upper
Oven light pad	●	●	●	●	●	●
<b>Microwave Oven Features:</b>						
Microwave cooking timer	99-Min./99-Sec.					
Microwave power levels	10					
Sensor functions	3					
Electronic MWO touch controls	●					
Microwave oven cavity (cu. ft.)	1.6					
MWO power output watts	1000					
Turntable	●					
Oven racks	2-Lower	3-Upper 2-Lower	3-Upper 2-Lower	2-Each	2-Each	2-Each
Gourmet Shelf		●				
Roasting rack		●	●			
Broiler pan with grid	●	●	●	●	●	●
<b>Appearance</b>						
Color appearance*	WW BB	WW AA BB	WW AA BB	WW BB	WW BB	BB
Frameless glass oven doors	White Black	White Almond Black	White Almond Black	White Black	White Black	Black
Oven doors with windows	●	Big View	Big View	Big View	Big View	●
Lift-off oven door	Lower	●	●	●	●	●
Designer-style handles	Sure Grip	Integrated	Integrated	Sure Grip	Sure Grip	●
Flush appearance installation	●	●	●	●	●	
<b>Weight &amp; Dimensions</b>						
Approx. ship. weight (lbs.)	155	162	162	157	157	135
Oven cabinet width required (in inches)	27	27	27	27	27	24
Overall dimensions (WxHxD in inches)	26-3/4 x 43 x 23-1/2	← 26-5/8 x 51-1/8 x 23-5/8 →				23-3/4 x 48-5/8 x 23-1/8
Overall oven interior dimensions (WxHxD in inches)	Upper Lower	← 19 x 15 x 16 →		← 19 x 15 x 18 →		17 x 15 x 18-1/2
		← 19 x 15 x 18 →				17 x 15 x 18-1/2
<b>Power/Ratings</b>						
KW rating @ 240V	6.5	6.8	6.8	6.8	7.1	7.1
208V	4.9	5.1	5.1	5.1	5.3	5.3
Amps @ 240V	30	30	30	30	30	30
208V	30	30	30	30	30	30
Convection wattage		2500	2500			
Broiler/bake wattage	3600/3410	3400/2650	3400/2650	3400/2650	3400/2650	3400/2650

\*WW = White on white, BB = Black on black, AA = Almond on almond.

# 27" AND 24" BUILT-IN DOUBLE OVENS (CONTINUED)

## 27" Built-In Microwave Double Oven Dimensions (in inches) Models JKP69

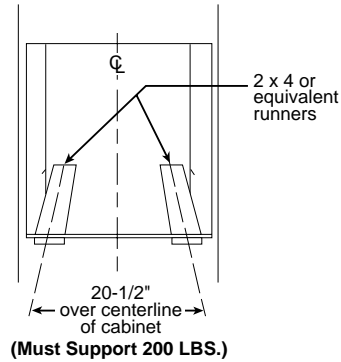
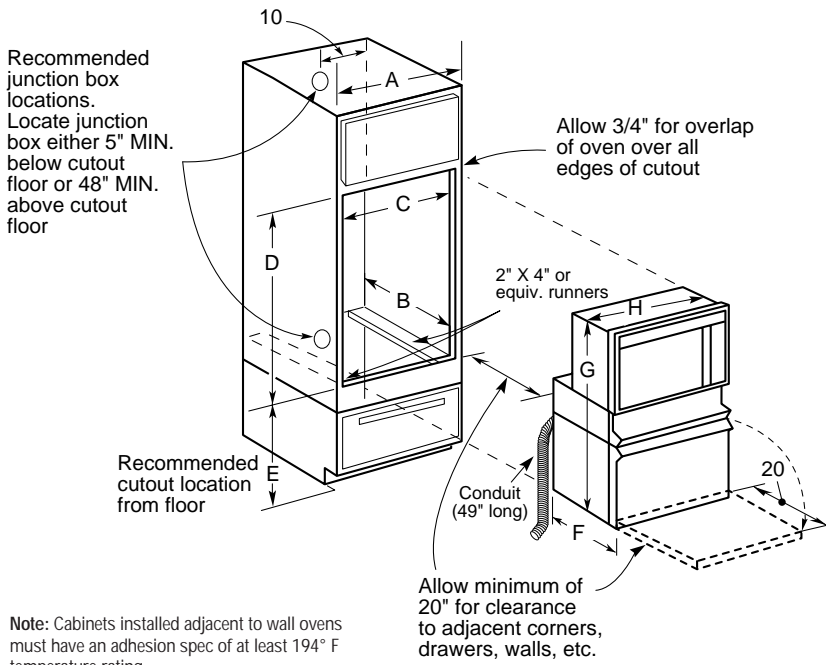

Cabinet	27"
A - Cabinet Width Required	27" min.
B - Minimum Cabinet Depth	23-5/8"
C - Minimum Opening Width	25"
D - Opening Height	41-1/4" max.
E - Recommended Cutout Location from Floor	22"
Oven	
F - Overall Depth	23-1/2"
G - Overall Height	43"
H - Overall Width	26-3/4"

## 27"/24" Built-In Double Oven Dimensions (in inches)

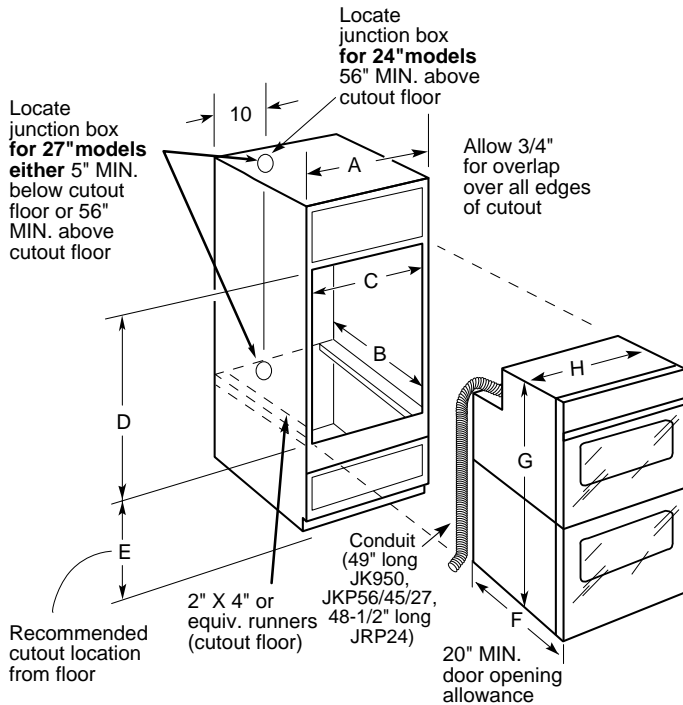

### Recommended for solid bottom installation

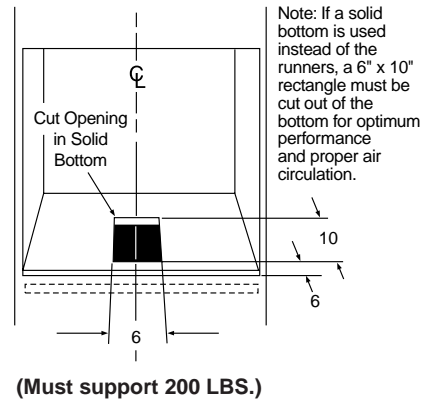

Cabinet	JK950, JKP56/45/27	JRP24
A - Cabinet Width Required	27" min.	24" min.
B - Minimum Cabinet Depth	23-5/8"	23-1/2"
C - Minimum Opening Width	25"	22-1/2"
D - Opening Height	49-1/2" min.	48-1/8" min.
E - Recommended Cutout Location from Floor	13-1/4"	14"
Oven		
F - Overall Depth	23-5/8"	23-1/8"
G - Overall Height	51-1/8"	48-5/8"
H - Overall Width	26-5/8"	23-3/4"

**Installation Information:** Before installing, consult installation instructions [Pub. No. 31-10117 (JKP69); [Pub. No. 31-10200 (JK950, JKP56/45/27); Pub. No. 31-10118 (JRP24)] packed with product for current dimensional data.



See page 136 for warranty information.



# 27" AND 24" BUILT-IN SINGLE OVENS

Features	GE Profile Performance Series™	GE Profile™	GE			
	27" Convection Single Ovens		27" Single Ovens		24" Single Ovens	
	JK910WA JK910AA JK910BA	JKP18WA JKP18AA JKP18BA	JKP15WA JKP15AA JKP15BA	JKS05BA	JRP15WW JRP15BW	JRS04BW
Oven interior	Convection/Self-Clean	Convection/Self-Clean	Self-Clean	Standard	Self-Clean	Standard
Variable cleaning time	●	●	●		●	
Automatic self-clean oven door lock	●	●	●		●	
Self-clean oven w/Delay Clean option	●	●	●		●	
TrueTemp™ System	●	●	●			
CleanDesign oven interior	●	●	●			
Variable broil	●	●	●	●	●	●
SmartSet Controls	●	●	●	●	●	●
Proofing	●					
Convection conversion	●	●				
Conv. Bake/Conv. Roast	●	●				
Automatic meat thermometer	●	●				
Temperature display	●	●	●	●	●	●
Start pad	●	●	●	●	●	●
Delay Bake option w/Cook & Hold	●	●	●	●	●	●
C° or F° programmable	●	●	●	●	●	●
Audible preheat signal	●	●	●	●	●	●
Auto oven shut-off w/override	●	●	●	●	●	●
Electronic clock and kitchen timer	●	●	●	●	●	●
Control lock capability	●	●	●	●	●	●
Oven light pad	●	●	●	●	●	●
Oven racks	3	3	2	2	2	2
Gourmet Shelf	●					
Roasting rack	●	●				
Broiler pan with grid	●	●	●	●	●	●
<b>Appearance</b>						
Color appearance*	WW AA BB	WW AA BB	WW AA BB	BB	WW BB	BB
Frameless glass oven door	White Almond Black	White Almond Black	White Almond Black	Black	White Black	Black
Oven door with window	●	●	●	●	●	●
Lift-off oven door	●	●	●	●	●	●
Designer-style handle	Integrated	Integrated	Sure Grip	●	●	●
Flush appearance installation	●	●	●	●		
Undercounter installation	●	●	●	●		
<b>Weight &amp; Dimensions</b>						
Approx. shipping weight (lbs.)	98	98	93	91	114	82
Oven cabinet width required (in.)	27	27	27	27	24	24
Overall dimensions (WxHxD in inches)	← 26-5/8 x 29-1/8 x 23-5/8 →			← 23-3/4 x 28-3/16 x 23-1/8 →		
Overall oven interior dimensions (WxHxD in inches)	← 19 x 15 x 16 →		← 19 x 15 x 18 →		← 17 x 15 x 18-1/2 →	
<b>Power/Ratings</b>						
KW rating @ 240V	3.4	3.4	3.4	3.4	3.4	3.4
208V	2.6	2.6	2.6	2.6	2.6	2.6
Amps @ 240V	20	20	20	20	20	20
208V	20	20	20	20	20	20
Convection wattage	2500	2500				
Broiler/bake wattage	3400/2650	3400/2650	3400/2650	3400/2000	3400/2650	3400/2000

\*WW = White on white, BB = Black on black, AA = Almond on almond.

### 27"/24" Built-In Single Oven Dimensions (in inches)

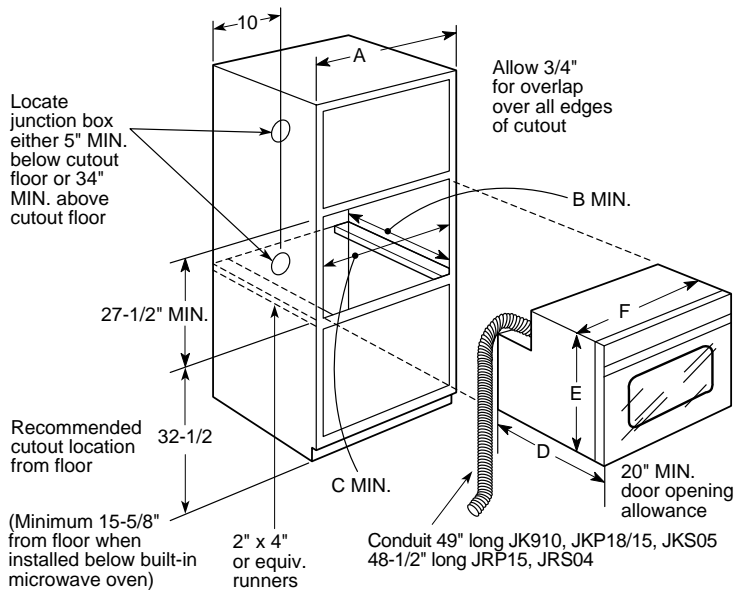

Note: These ovens are *not* approved for stackable or side-by-side installations.

Note: Cabinets installed adjacent to wall ovens must have an adhesion spec of at least 194° F temperature rating.

### Recommended for solid bottom installation

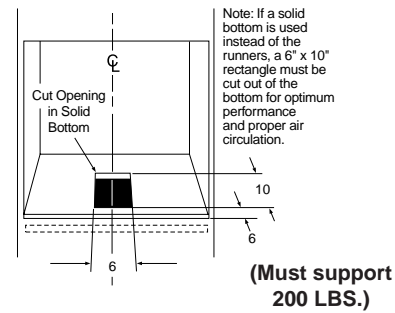

Cabinet	JK910, JKP18/15, JKS05	JRP15, JRS04
A – Cabinet Width Required	27" min.	24" min.
B – Minimum Cabinet Depth	23-5/8"	23-1/2"
C – Minimum Opening Width	25"	22-1/2"
Oven		
D – Overall Depth	23-5/8"	23-1/8"
E – Overall Height	29-1/8"	28-3/16"
F – Overall Width	26-5/8"	23-3/4"

Installation Information: Before installing, consult installation instructions [Pub. No. 31-10200 (JK910, JKP18/15, JKS05); Pub. No. 31-10118 (JRP15, JRS04)] packed with product for current dimensional data.

### Undercounter Installation Dimensions (in inches) Models JK910, JKP18, 15 and JKS05

Gas or electric cooktops may be installed over this oven. See cooktop installation instructions for cutout size. See label on top of oven for approved cooktop models

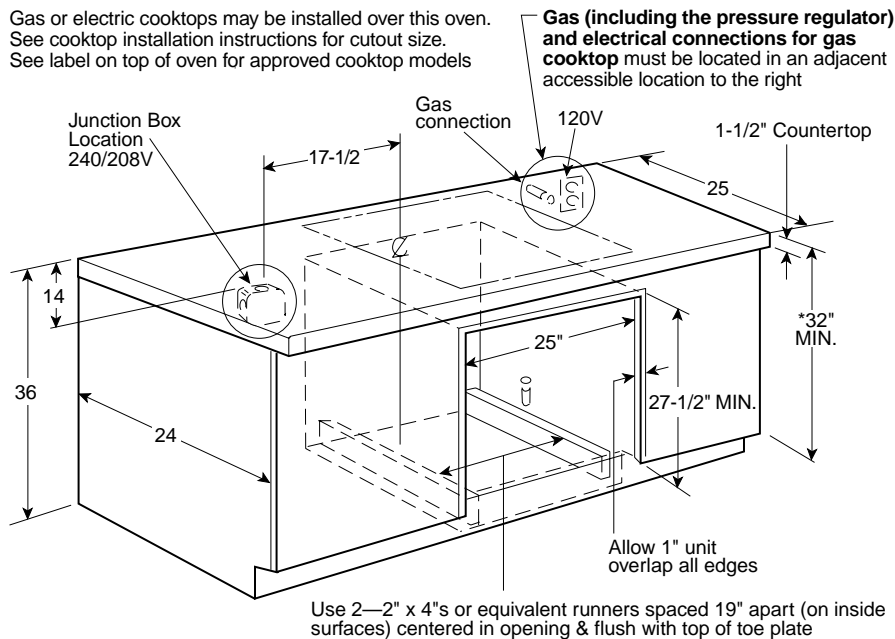

### Sealed Burner Gas Cooktop Installation Dimensions (in inches)

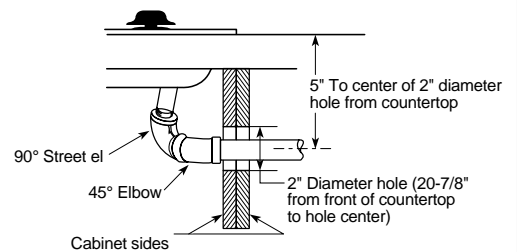

### Standard Burner Gas Cooktop Installation Dimensions (in inches)

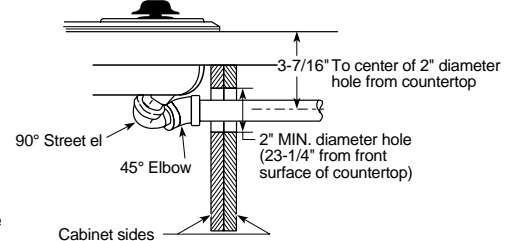

Note: Cabinets installed adjacent to wall ovens must have an adhesion spec of at least 194° F temperature rating.

Note: Oven is rated for use only under 30" standard or sealed burner gas and 30" CleanDesign and Calrod® electric cooktops (excludes Induction cooktops).

Installation Information: Before installing, consult installation instructions [Pub. No. 31-10200 (JK910, JKP18/15, JKS05)] packed with product for current dimensional data.

# 24" BUILT-IN GAS OVENS

	GE	
	JGRP17WEW JGRP17BEW	JGRS14BEW
<b>Features</b>		
Oven interior	Self-Clean	Standard
Automatic self-clean oven door lock	●	
Delay Clean option	●	
In-oven broiling	●	
Separate broiler drawer		●
Storage drawer	●	
SmartSet Controls	●	●
Temperature display	●	●
Start pad	●	●
Delay Bake option with Cook & Hold	●	●
C° or F° programmable	●	●
Audible preheat signal	●	●
Auto oven shut-off w/override	●	●
Electronic clock and kitchen timer	●	●
Control lock capability	●	
Oven light pad	●	●
Oven shelves	2	2
Broiler pan with grid	●	●
Electronic pilotless ignition	●	●
<b>Appearance</b>		
Color appearance*	WW BB	BB
Frameless oven door	White Glass Black Glass	Black Glass
Oven door with window	●	●
Designer-style handle	●	●
<b>Weights &amp; Dimensions</b>		
Approximate shipping weight (lbs.)	144	139
Oven cabinet width required (in inches)	24	24
Overall dimensions (WxHxD in inches)	← 23-3/4 x 38-3/8 x 23 →	
Overall oven interior dimensions (WxHxD in inches)	← 17 x 15 x 18-7/8 →	
<b>Power/Ratings</b>		
Gas oven electrical rating	← 120V, 60Hz, 5A →	
Oven /broiler burners (000's BTU's)	14.5 - Oven 13.0 - Broil	14.5

\*WW = White on white, BB = Black on black.  
Factory set for Natural Gas.

## Built-In Gas Oven Dimensions (in inches)

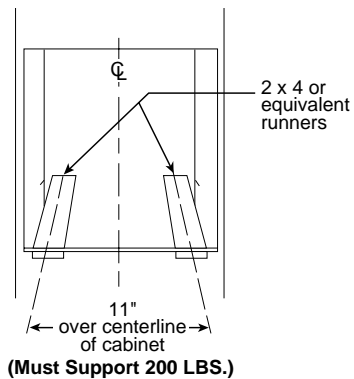
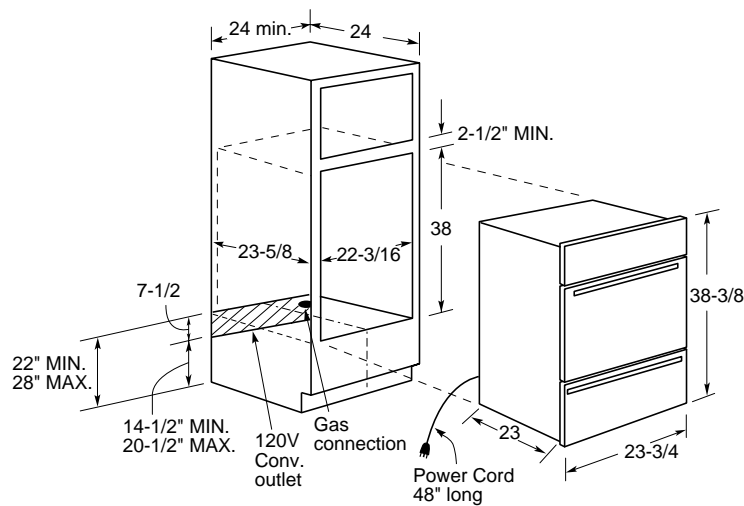

**Installation Information:**  
Before installing, consult installation instructions [Pub. No. 31-10155 (JGRP17); Pub. No. 31-10156 (JGRS14)] packed with product for current dimensional data.

**Note:** Cabinets installed adjacent to wall ovens must have an adhesion spec of at least 194° F temperature rating.

# 30" AND 27" WARMING DRAWERS

GE Profile Performance Series™		
	30" Warming Drawers	27" Warming Drawers
	JTD910SB JTD910WB JTD910AB JTD910BB	JKD910SB JKD910WB JKD910AB JKD910BB
<b>Features</b>		
Temperature control	•	•
Proof (80°F.)	•	•
Low (140°F.)	•	•
Medium (170°F.)	•	•
High (210°F.)	•	•
Humidity control	Crisp/Moist	Crisp/Moist
Hidden control	•	•
ON/OFF switch	•	•
*ON* indicator light	•	•
Half rack	•	•
Full extension drawer glide	•	•
Removable stainless steel pan	•	•
<b>Appearance</b>		
	SS WW AA BB	SS WW AA BB
Color appearance*	•	•
Frameless drawer front	•	•
Handle style	Integrated Designer-Style	Integrated Designer-Style
<b>Weights &amp; Dimensions</b>		
Interior dimensions (WxHxD in inches)	23-7/8 x 6-1/4 x 22-1/16	20-7/8 x 6-1/4 x 22-1/16
Cutout dimensions (WxHxD in inches)	28-1/2 x 9-1/4 x 23	25-1/2 x 9-1/4 x 23
Approx. shipping weight (lbs.)	65	59
<b>Power/Ratings</b>		
KW rating @ 120V	.45	.45
Amps @ 120V	15	15
Element wattage	450	450
<b>Accessories</b>		
1/4" panel kit capability	ZXD30B	ZXD27B
Pan set (5 pans with lids)	JXPN1	JXPN1

\*SS = Stainless Steel, WW = White on white, AA = Almond on almond, BB = Black on black.

## Warming Drawer Dimensions (in inches)

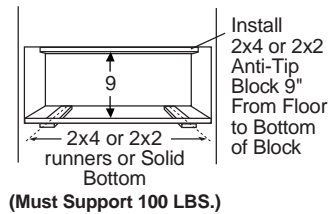
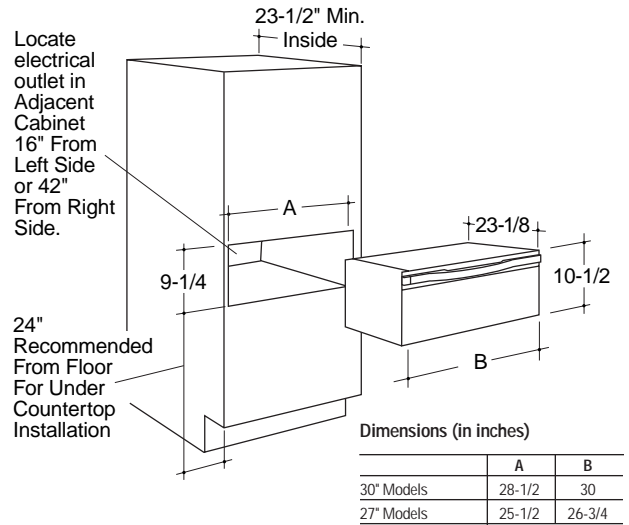

## Under Oven Installation (in inches)

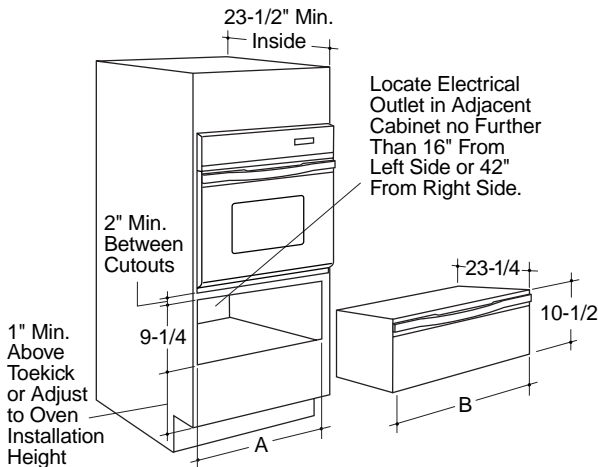

## Undercounter Installation (in inches)

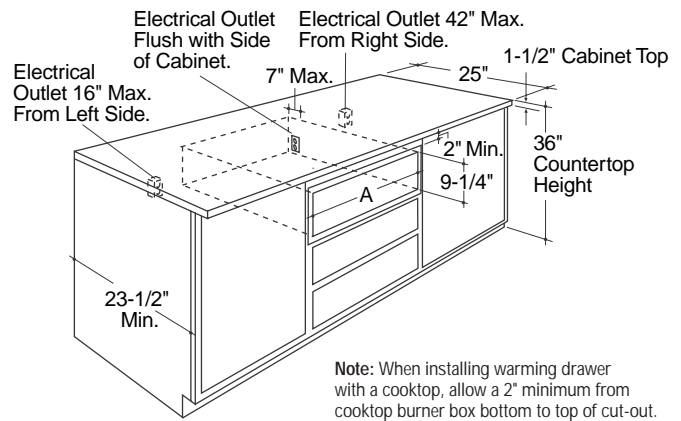

## PAN SET ACCESSORY FOR WARMING DRAWER – JXPN1

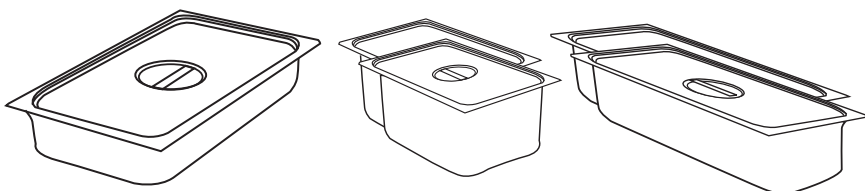

- Five commercial pans with lids (4" deep)
- One large pan (14 quarts)
  - Two medium pans (6 quarts each)
  - Two small pans (3 quarts each)



# BUILT-IN CLEANDESIGN COOKTOPS

Features	GE Profile Performance Series™		GE Profile™	GE
	Ribbon		Ribbon	Ribbon
	JP960SA JP960WA JP960AA JP960BA	JP930SA JP930WA JP930AA JP930BA	JP350WA JP350AA JP350BA	JP340BA JP340WA
Glass-ceramic surface	Patterned Black Patterned White Patterned Almond Patterned Black	Patterned Black Patterned White Patterned Almond Patterned Black	Patterned White Patterned Almond Patterned Black	Patterned Black Patterned White
Number of elements	5 Ribbon	4 Ribbon	4 Ribbon	4 Ribbon
Dual 6"/9" heating elements	1 Ribbon (2500W)	1 Ribbon (2500W)	1 Ribbon (2500W)	
8" heating elements			2 Ribbon (2000W)	2 Ribbon (2000W)
7" heating element	1 Ribbon (1500W)			
7" heating elements	2 Ribbon (1800W)	2 Ribbon (1800W)		
Bridge element	1 Ribbon (800W)	1 Ribbon (800W)		
Total wattage	4400W	4400W		
6" heating elements	1 Ribbon (1200W)	1 Ribbon (1200W)	1 Ribbon (1200W)	2 Ribbon (1200W)
Hot surface indicator lights	5	4	4	1
Appearance				
	SS WW AA BB	SS WW AA BB	WW AA BB	BB WW
Color appearance*				
Frameless	●	●	●	●
Weights & Dimensions				
Cooktop width (in inches)	36	30	30	30
Approx. shipping weight (lbs.)	44	38	38	35
Power/Ratings				
KW rating @ 240V	9.6	8.1	7.7	6.4
208V	7.2	6.1	5.8	4.8
Amps @ 240V	40	40	40	30
208V	40	30	30	30

\*SS = Stainless Steel, WW = White on white, AA = Almond on almond, BB = Black on black.

## Installation Information:

Requires a 5" free area between the bottom of the cooktop to any combustible material, i.e., shelving. Free area not required when installing wall oven underneath cooktop. Refer to installation instructions. Requires an 18" minimum from cooktop to adjacent overhead cabinets. Units are furnished with a 48" flexible armored cable.

Before installing, consult installation instructions [Pub. No. 31-10150 (JP960); Pub. No. 31-10153 (JP930); Pub. No. 31-10147 (JP350/340)] packed with product for current dimensional data.

36" Ribbon cooktops are approved for use over GE 30" Single Wall Ovens only. 30" Ribbon cooktops are approved for use over select GE 27" or 30" Single Wall Ovens. Refer to cooktop and wall oven installation instructions packed with product for current dimensional data.

Note: If installing with a GE Profile Performance™, GE Profile™ or GE Telescopic Downdraft System, consult both cooktop and downdraft installation instructions packed with product before installing. Cooktop gas/electric supply may need to be re-routed to install downdraft.

Note: The countertop must be at least 26" deep with a flat surface area of 23-1/2" or more, front to back. In addition, other clearances to the front edge of the countertop must be considered.

## Counter Installation

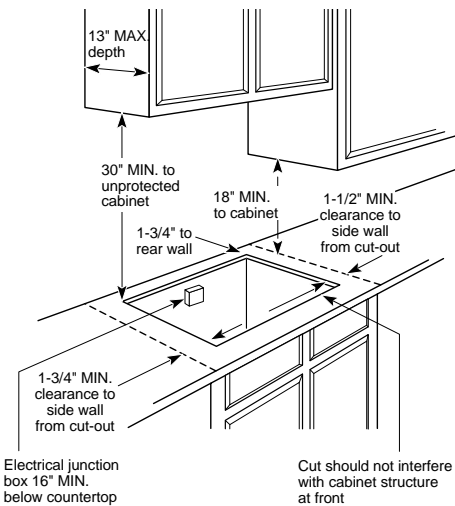

Electrical junction box 16" MIN. below countertop

Cut should not interfere with cabinet structure at front

## Cooktop Dimensions (in inches)

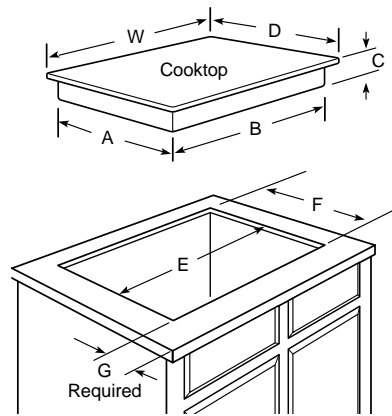

## Filler Trim Kit

When replacing an old GE 30" cooktop (with larger opening) with Models JP930/350/340, use the following one-piece trim kit to fill in the over-size hole. Available at additional cost.

- JXTR30A (Almond)
- JXTR30B (Black)
- JXTR30W (White)

## Flush Mount Installation Kit

Accommodates both 30" and 36" installations.

- JXFMAA (Almond on almond)
- JXFMWW (White on white)
- JXFMBB (Black on black)

## Dimensions (in inches)

Model	Overall				Cutout			To Edge of Front Counter (Min.)
	W	D	A	B	C	E	F	
JP960SA/WA/AA/BA	35	20	19-1/32	33-13/16	3-3/8*	33-7/8	19-1/16	2-1/2
JP930SA/WA/AA/BA	29-3/8	20-1/2	19-3/8	28-1/8	3-3/8*	28-1/2	19-5/8	2-1/2
JP350WA/AA/BA	29-3/8	20-1/2	19-3/8	28-1/8	3-3/8*	28-1/2	19-5/8	2-1/2
JP340BA/WA	29-3/8	20-1/2	19-3/8	28-1/8	3-3/8*	28-1/2	19-5/8	2-1/2

\*Depth of unit at conduit connection location (rear) is 4-3/4".

# BUILT-IN ELECTRIC COOKTOPS

GE				
	JP626WW JP626AV	JP326WV JP326AV JP326BV JP326CV	JP201CV	JP200V
<b>Features</b>				
Cooktop surface	Porcelain-Enameled	Porcelain-Enameled Porcelain-Enameled Brushed-Chrome	Stainless Steel	Porcelain-Enameled
Lift-up cooktop with support rod	●	●		
8" heating elements	2 Plug-In Calrod*	2 Plug-In Calrod*	1 Plug-In	1 Plug-In
6" heating elements	2 Plug-In Calrod*	2 Plug-In Calrod*	1 Plug-In	1 Plug-In
One-piece removable drip bowls	Chrome	Chrome Chrome Black Porc.-Enam. Chrome	Chrome	Chrome
Infinite heat rotary controls	●	●	●	●
Control panel location	Upfront	Right Side	Upfront	Upfront
Control panel	White Glass Almond Glass	White Glass Almond Glass Black Glass Black Glass		
Surface element "ON" indicator light	●	●	●	●
<b>Appearance</b>				
Color appearance*	WW AA	WW AA BB BC	SS	WH
<b>Weights &amp; Dimensions</b>				
Cooktop width (in inches)	36	30	21-1/4	21-1/4
Approx. shipping weight (lbs.)	38	29	18	18
<b>Power/Ratings</b>				
KW rating @ 240V	7.4	7.4	3.4	3.4
208V	5.6	5.6	2.5	2.5
Amps @ 240V	40	40	20	20
208V	30	30	20	20

\*SS = Stainless Steel, WW = White on white, AA = Almond on almond, BB = Black on black, BC = Brushed-Chrome, WH = White.

## Built-In Electric Cooktops

Required 5" free area between the bottom of the cooktop and any combustible material, i.e., shelving. Free area not required when installing wall oven underneath. Requires an 18" minimum from cooktop to adjacent overhead cabinets. Units are furnished with a 48" flexible armored cable.

## Installation Information:

Before installing, consult installation instructions [Pub. No. 31-10035 (JP626); Pub. No. 31-10114 (30" electric cooktops); Pub. No. 49-8204 (JP201/200)], packed with product for current dimensional data.

Cooktop models JP326WV/326AV/326BV/326CV are approved for use over select GE 27" or 30" Single Wall Ovens. JP626WV/626AV are approved for use over GE 30" Single Wall Ovens only. Refer to cooktop and wall oven installation instructions packed with product for current dimensional data.

Cooktop models JP200V and JP201CV are approved for use over GE undersink dishwasher model GSM2100. Refer to cooktop installation instructions packed with product for current dimensional data.

**Note:** If installing with a GE Profile Performance™ GE Profile™ or GE Telescopic Downdraft System, consult both cooktop and downdraft installation instructions packed with product before installing. Cooktop gas/electric supply may need to be re-routed to install downdraft.

**Note:** The countertop must be at least 26" deep with a flat surface area of 23-1/2" or more, front to back. In addition, other clearances to the front edge of the countertop must be considered.

## Counter Installation Dimensions (in inches)

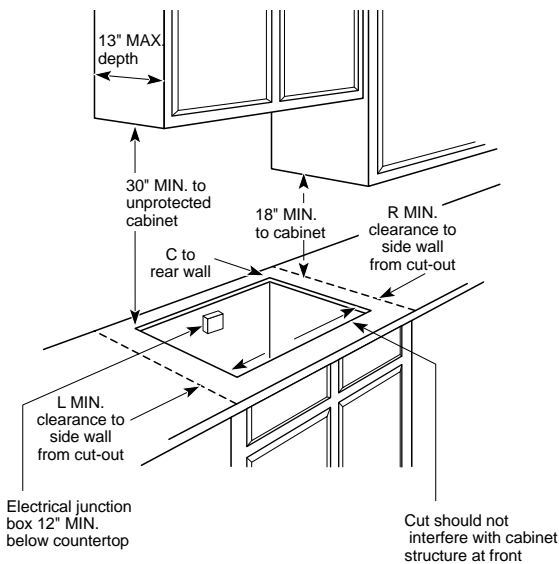

## Built-In Cooktop Dimensions (in inches)

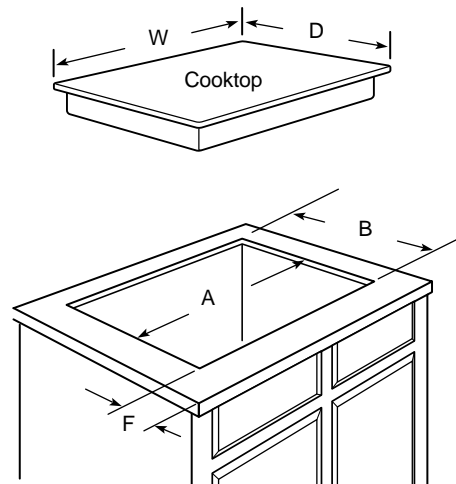

## Dimensions (in inches)

Model	Overall		Cutout			Minimum Spacing To Nearest Combustible Wall			To Edge of Front Counter (Min.)
	W	D	A	B	C	R	L	F	
JP626WV	35-1/2	21	33-7/8	19-1/16	1-3/4	6	6	2-1/2	
JP626AV	35-1/2	21	33-7/8	19-1/16	1-3/4	6	6	2-1/2	
JP326WV	30-1/4	21-1/4	28-1/2	19-5/8	1-3/4	2	5-1/2	2-1/2	
JP326AV	30-1/4	21-1/4	28-1/2	19-5/8	1-3/4	2	5-1/2	2-1/2	
JP326BV	30-1/4	21-1/4	28-1/2	19-5/8	1-3/4	2	5-1/2	2-1/2	
JP326CV	30-1/4	21-1/4	28-1/2	19-5/8	1-3/4	2	5-1/2	2-1/2	
JP201CV	21-1/4	16-5/8	20-1/8	16-1/8	2	2	2	2-1/2	
JP200V	21-1/4	16-5/8	20-1/8	16-1/8	2	2	2	2-1/2	

**Filler Trim Kit**—When replacing an old GE 30" cooktop (with larger opening) with Model JP326WV, JP326AV, JP326BV or JP326CV, use the following one-piece trim kit to fill in the over-size hole. Available at additional cost.  
 JXTR30A (Almond)  
 JXTR30B (Black)  
 JXTR30W (White)

# BUILT-IN GAS COOKTOPS

Features	GE Profile Performance Series™		GE Profile™		GE		
	JGP960SEA	JGP930SEA	JGP636WEV JGP636AEV JGP636BEV	JGP336WEV JGP336AEV JGP336BEV	JGP626WEV JGP626AEV JGP626BEV	JGP326WEV JGP326AEV JGP326BEV	JGP320EV
Cooktop burners	5 Sealed	4 Sealed	5 Sealed	4 Sealed	4 Sealed	4 Sealed	4 Standard
Maximum Output burner	●	●	●	●			
Precise Simmer burner(s)	2		2				
Valves (degree of turn)	270	210	270	210	270	210	170
Electronic pilotless ignition	●	●	●	●	●	●	●
Glass cooktop	●	●	●	●	Porc.-Enam.	Porc.-Enam.	Porc.-Enam.
Removable round burner grates	Deluxe Cast	Deluxe Cast	Deluxe Cast	Deluxe Cast	Std.Cast	Std.Cast	Standard Steel
One-piece drip pans	Porc.-Enam.	Porc.-Enam.	Porc.-Enam.	Porc.-Enam.	Porc.-Enam.	Porc.-Enam.	Chrome
Glass control panel	Black	Black	White Almond Black	White Almond Black	White Almond Black	White Almond Black	White/Black
Controls	Upfront	Right Side	Upfront	Right Side	Upfront	Right Side	Right Side
Appearance							
Color appearance*	SS	SS	WW AA BB	WW AA BB	WW AA BB	WW AA BB	WH/BL
Weight & Dimensions							
Cooktop width (in inches)	36	30	36	30	36	30	30
Approx. shipping weight (lbs.)	38	30	38	30	41	31	31
Power/Ratings							
Gas cooktop electrical rating	← 120V, 60Hz, 5A →						
Burners	Nat. Gas/ (000's/BTU's): LP Gas †	(1) 12.0/9.4 (2) 9.5/7.0 (2) 5.0/4.0	(1) 12.0/9.4 (2) 9.5/7.0 (2) 5.0/4.0	(1) 12.0/9.4 (2) 9.5/7.0 (2) 5.0/4.0	(1) 12.0/9.4 (2) 9.5/7.0 (1) 5.0/4.0	(3) 9.5/7.0 (1) 5.0/4.0	(4) 9.1/8.0

\*SS = Stainless Steel, WW = White on white, BB = Black on black, AA = Almond on almond, WH = White, BL = Black.  
†A set of LP orifices is included with each cooktop for LP conversion. Factory set for Natural Gas.

## Cooktop Dimensions (in inches)

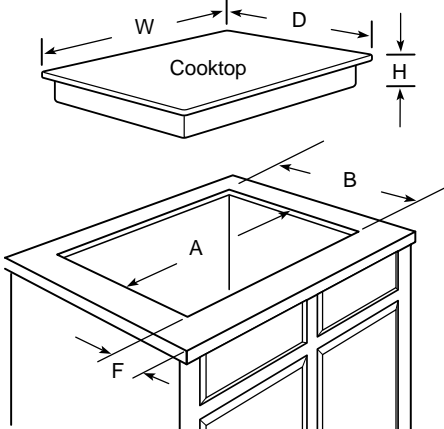

## Dimensions (in inches)

Model	Overall			Cutout			Minimum Spacing To Nearest Combustible Wall			To Edge of Front Counter
	W	D	H	A	B	C	L	R	F	
JGP960SA	36	21	3-1/16	33-7/8	19-1/16	2-1/4	3-3/4	3-3/4	3-1/4	
JGP636WEV/AEV	36	21	3-1/16	33-7/8	19-1/16	2-1/4	3-3/4	3-3/4	3-1/4	
JGP636BEV	36	21	3-1/16	33-7/8	19-1/16	2-1/4	3-3/4	3-3/4	3-1/4	
JGP626WEV/AEV	35-1/2	21	3-5/16	33-7/8	19-1/16	2-1/4	3-3/4	3-3/4	3-1/4	
JGP626BEV	35-1/2	21	3-5/16	33-7/8	19-1/16	2-1/4	3-3/4	3-3/4	3-1/4	
JGP930SA	30	21	2-1/2	28-1/2	19-1/2	2-1/4	3-3/4	3-3/4	3-1/4	
JGP336WEV/AEV	30	21	2-1/2	28-1/2	19-1/2	2-1/4	3-3/4	3-3/4	3-1/4	
JGP336BEV	30	21	2-1/2	28-1/2	19-1/2	2-1/4	3-3/4	3-3/4	3-1/4	
JGP326WEV/AEV	30-1/4	21-1/4	3-9/32	28-1/2	19-1/2	2-1/4	3-3/4	3-3/4	3-1/4	
JGP326BEV	30-1/4	21-1/4	3-9/32	28-1/2	19-1/2	2-1/4	3-3/4	3-3/4	3-1/4	
JGP320EV*	30-1/4	21-1/4	3-9/32	28-1/2	19-1/2	1-3/4	3	3	3-1/4	

\*Allow 5-3/4" depth at rear for electrical and gas connections.

**Note:** All gas cooktop models require 7/16" free area below cooktop height to combustible material. 0" clearance is required between left and right sides of cooktop below countertop. Requires 18" minimum from countertop to adjacent overhead cabinets.\*

\*AGA requirement.

**Note:** If installing with a GE Profile Performance™ GE Profile™ or GE Telescopic Downdraft System, consult both cooktop and downdraft installation instructions packed with product before installing. Cooktop gas/electric supply may need to be re-routed to install downdraft.

**Note:** The countertop must be at least 26" deep with a flat surface area of 23-1/2" or more, front to back. In addition, other clearances to the front edge of the countertop must be considered.

## Counter Installation Dimensions (in inches)

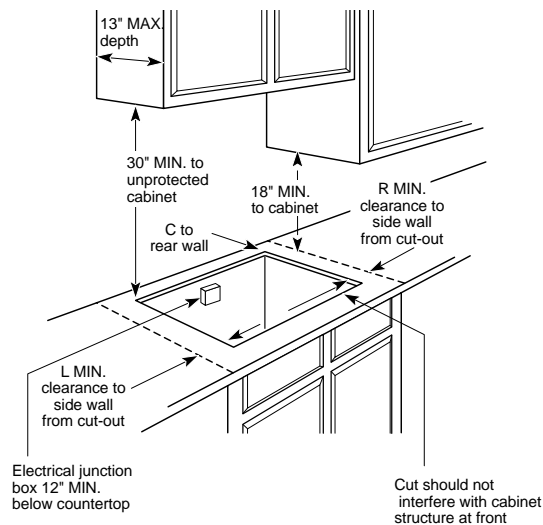

Cut should not interfere with cabinet structure at front

## Gas Connection Models JGP960, 636 and 626

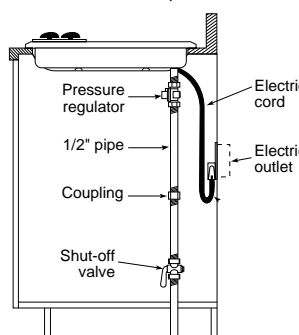

## Gas Connection Models JGP930, 336, 326 and 320

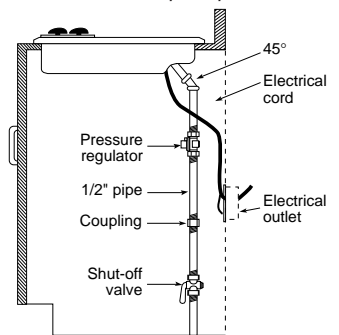

**Installation Information:** Before installing, consult installation instructions [Pub. No. 31-10169 (JGP636/626), Pub. No. 31-10172 (JGP336/326), Pub. No. 31-10004 (JGP320)] packed with product for current dimensional data.

## Installation With Single Wall Oven Information:

30" Gas Cooktops are approved for use over select GE 27" Wall Ovens. 30" and 36" Gas Cooktops are approved for use over 30" Wall Ovens. Refer to cooktop and wall oven installation instructions packed with product for current dimensional data.

## Optional Gas Range Wok Accessory (Available at additional cost)

JXWK = Wok accessory holder sits on top of maximum burner grate to hold a round-bottom wok.





# SELECT-TOP™ MODULAR DOWNDRAFT COOKTOPS AND PATIO GRILL

	GE Profile™		GE
	Dual Modular	Single Modular	Patio Grill
	JP389WV JP389BV	JP385WV JP385BV JP385CV	JP380BV
<b>Features</b>			
Configuration	Dual Modular	Single Modular	Outdoor Grill
Cooktop finish	White Porc.-Enam. Black Porc.-Enam.	White Porc.-Enam. Black Porc.-Enam. Black Brushed-Chrome	Black Porcelain-Enameled
Infinite heat controls	Rotary	Rotary	Rotary
Heating element "ON" indicator light	●	●	●
Downdraft exhaust (CFM)	400	400	375
Single speed downdraft vent fan	●	●	●
Three-speed downdraft vent fan	●		
Fixed plug-in Calrod® elements		One 6", One 8" Chrome	Fixed Grill (each side)
Removable one-piece drip bowls/trim rings		Black Porc.-Enam. Chrome	Chrome
<b>Appearance</b>			
Color appearance*	WW BB	WW BB BC	BB
<b>Weights &amp; Dimensions</b>			
Cooktop width (in inches)	30	30	30
Approx. ship. wt. (lbs.)	72	75	68
<b>Power/Ratings</b>			
Amps @ 240V	40	40	40
KW rating @ 240V	8.0	8.0	5.6
<b>Accessories</b>			
Ribbon heating elements (one 8" and one 6")	JXDR50WV JXDR50VB	JXDR50WV JXDR50VB JXDR50VC	
Calrod® heating elements (one 6", one 8" element with removable one-piece bowls)	JXDC44RWH JXDC43RBL	JXDC44RWH JXDC43RBL JXDC41NBC	
Grill Module†	JXDL44N	JXDL44N	JXDL44N
Griddle Accessory	JXDD44R	JXDD44R	JXDD44R
Grill Cover	JXDM3 JXDM2	JXDM3 JXDM2	JXDM4

\*WW = White on white, BB = Black on black, BC = Brushed-Chrome.

†Grill Module includes Calrod® heating element, one-piece Grill Grate, and porcelain reflector pan.

## Cutout Dimensions (in inches)

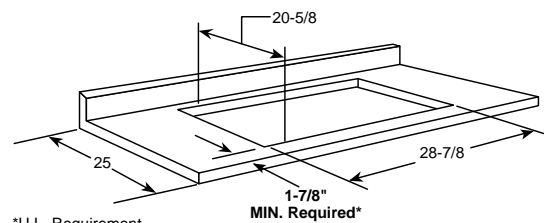

\*U.L. Requirement.

**Note:** A 6" minimum spacing to adjacent side wall is required

## Wall Installation

Wall installations require 25" countertop depth. When cabinet is flush against the wall, the fan housing can be rotated to the horizontal position for direct venting through rear wall. Make a countertop cutout that is centered in the range cabinet according to unit dimensions and installation type. Duct hole is positioned in back of cabinet for through-the-wall ducting.

## Peninsula or Island Installation

For peninsula/islands a minimum 26" countertop depth is suggested. Blower should be in vertical position. Island or peninsula cabinets may require adjustment in cutout depth and/or location within the width dimensions. Duct hole is positioned in bottom of cabinet for island or peninsula installation.

## Slab Installation

For peninsula or island installation and rear wall ducting, **PVC duct or locally approved piping should be used if installing under a poured concrete slab.**

**Note:** These cooktops are U.L. approved for indoor use only.  
Model JP380BV is U.L. approved for outdoor use only.

### Grill Module JXDL44N

Includes front/rear controlled heating element, one-piece grill grate, and porcelain-enameled reflector pan.

### Calrod® Modules

One 8" and one 6" plug-in heating element with one-piece bowls

JXDC41NBC—Brushed-chrome

JXDC43RBL—Black porcelain-enameled

JXDC44RWH—White porcelain-enameled

### Griddle Accessory JXDD44R (Use with optional Grill Module.)

Place over heating element and reflector pan from optional grill module. Griddle accessory has a non-stick coating and is self-draining.

### Ribbon Modules

Patterned glass top with one 8" and one 6" ribbon heating element

JXDR50WV—White on white

JXDR50VB—Black on black

JXDR50VC—Patterned black top with brushed-chrome trim

### Grill Cover

Covers grill area when not in use

JXDM3—White on white

JXDM2—Black on black

JXDM4—Black on black

(For model JP380 patio grill only.)

### Cooktop Options

GE lets you customize your cooktop with flexible modules to suit your taste. These optional versatile modules—*Grill, Calrod®, Ribbon, Griddle Accessory and Grill Cover*—are available at additional cost. Simply plug the modules you want into either side of the cooktop (single modular cooktops accept modules on left side only) and unplug them for easy cleaning and storage.

**Note:** See next page for dimensions and installation information.

# INSTALLATION/SPECIFICATIONS FOR SELECT-TOP™ MODULAR COOKTOPS AND PATIO GRILL

## Built-In Downdraft Cooktops

### Cooktop Dimensions (in inches)

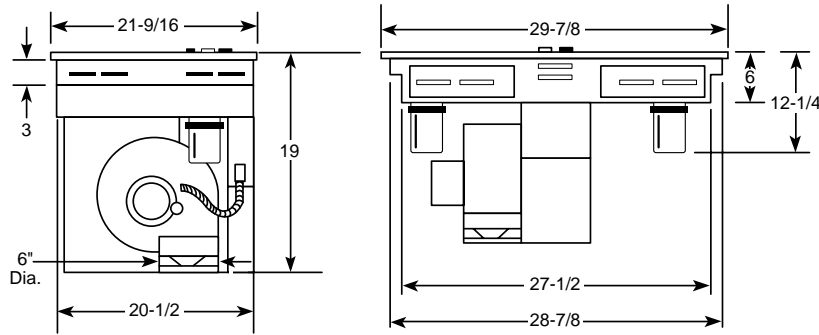

### Cabinet Dimensions (in inches)

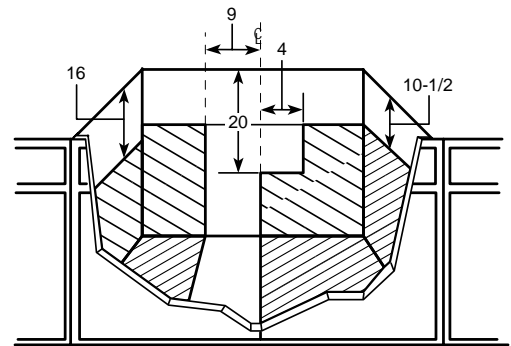

### Venting Options

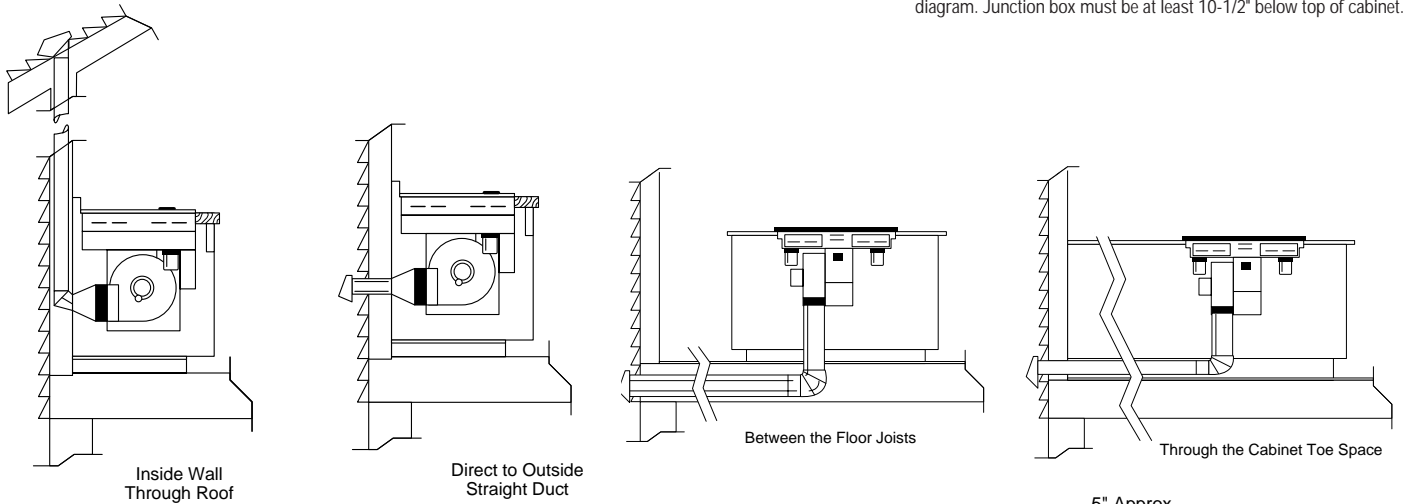

**Note:** Ductwork must be vented to outside. Do not vent into a wall, ceiling, crawlspace, attic or any concealed space. Always use an appropriate roof or wall cap with damper. **Laundry-type wall caps should never be used.** For maximum efficiency use the shortest and straightest duct run possible, with as few fittings as possible. For satisfactory performance the duct run should not exceed 100 feet equivalent length. Refer to the table of equivalent lengths (shown in Pub. No. 49-8552) for various duct configurations.

### Downward Venting (in inches)

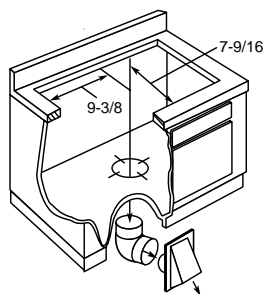

### Rear Wall Venting (in inches)

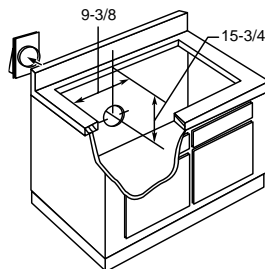

### Receptacle Location

Install an approved junction box within shaded area shown in diagram. Junction box must be at least 10-1/2" below top of cabinet.

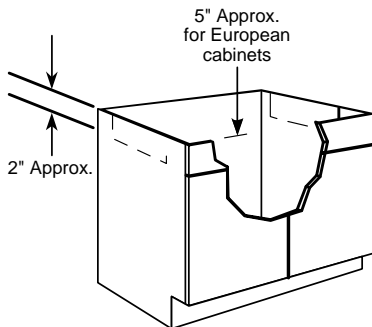

### Preparing the Cabinet for Installation

In some cabinets, the sides may need to be scooped or cut down 2" as shown (right) and the corner braces removed in order to accommodate the cooktop.

**Installation Information:** Before installing, consult installation instructions [Pub. No. 49-8672 (JP389/385); Pub. No. 49-8670 (JP380)] packed with product for current dimensional data.

### Installing the Ductwork

Use minimum 26-gauge galvanized or 24-gauge aluminum duct in 6" round or 3-1/4" x 10" size, or combination of both. **PVC duct or locally approved piping should be used if installing under a poured concrete slab.**

Refrigeration

Water Systems

Laundry

Cooking Products

Microwave Ovens

Dishwashers

Room Air

# BUILT-IN DOWNDRAFT GAS MODULAR COOKTOPS

Features	GE Profile™	
	JGP389WEV* JGP389BEV*	JGP18BEV**
Configuration	Single Modular	Single Modular
Accepts modules	Left Side	•
Fixed gas cooktop burners (right side)	Standard	•
Electronic pilotless ignition	•	•
Downdraft vent fan	•	•
Downdraft exhaust (CFM)	375	375
Appearance		
Color appearance	White on white Black on black	Black on black
Up-front controls	•	•
Weight & Dimensions		
Cooktop width (in inches)	30	18
Overall dimensions (W x D in inches)	29-7/8 x 21-1/2	18-1/16 x 21-1/2
Approximate shipping wt. (lbs.)	58	45
Power/Ratings		
Gas cooktop electrical rating	120V, 60Hz, 15A	
BTU's (000's)	Right side (burners)	10.0/9.0
Nat/LP	Grill Unit	8.0/8.0

\*Models JGP389WEV and JGP389BEV are shipped with fixed standard gas burners, right side. Left side accepts optional modules that must be ordered and are available at additional cost.  
\*\*Model JGP18BEV is shipped without modules. Optional modules must be ordered and are available at additional cost.

## Optional Modules (Available at additional cost)

Two-Burner Gas Module (standard burners)—	Gas Grill Module—JXGG89	Grill Cover—
JXGB89W—White on white	Griddle—JXGL89	JXGC89W—White on white
JXGB89B—Black on black	Grill module)	JXGC89B—Black on black



## Installation Information:

Before installing, consult installation instructions (Pub. No. 49-8585) packed with product for current dimensional data.

## Slab Installation

For peninsula or island installation and rear wall ducting, PVC duct or locally approved piping should be used if installing under a poured concrete slab.

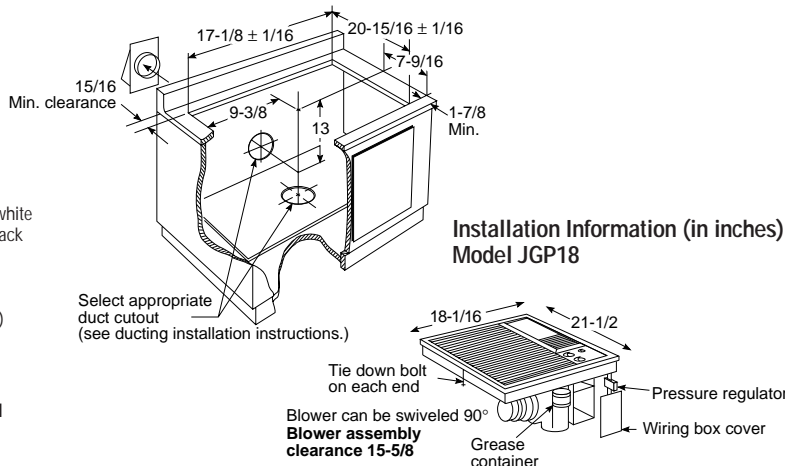
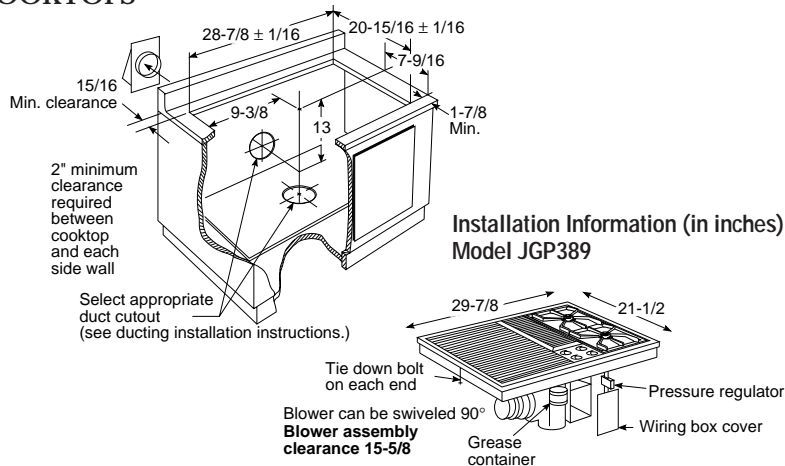

# 30" SLIDE-IN DOWNDRAFT RANGES

Features	GE	
	JSP69WV JSP69BV	
Self-cleaning oven	•	
Automatic self-clean oven door lock	•	
Oven racks	2	
Porcelain-enameled modular cooktop	•	
Electronic digital clock and timer	•	
Delay Bake option	•	
Preheat signal	•	
Electronic oven control	•	
Downdraft venting	•	
Two-speed exhaust fan	•	
Interior oven light	•	
Storage drawer (1/2 depth)	•	
Broiler pan with grid	•	
Appearance		
Color appearance*	WW BB	
Glass oven door	•	
Oven door with window	•	
Designer-style handle	•	
Weight & Dimensions		
Overall oven interior dimensions (WxHxD in inches)	23 x 16 x 17	
Approximate shipping wt. (lbs.)	171	
Power/Ratings		
KW rating @ 240V	14.0	
208V	Not Available	
Amps @ 240V	40	
208V	—	

\*WW = White on white, BB = Black on black.  
Note: (Shipped with grill module) Optional plug-in modules available.

## Range Dimensions (in inches)

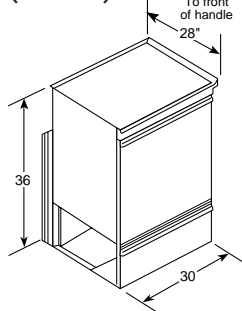

## Downdraft Installation Dimensions (in inches)

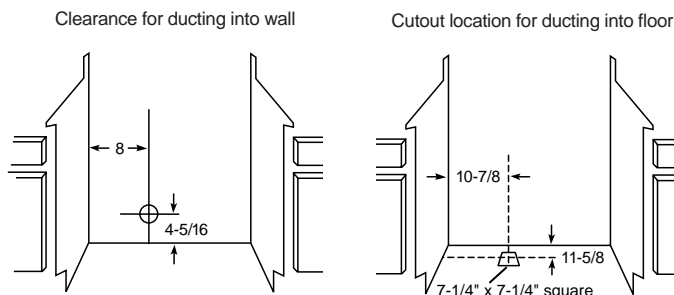

## Receptacle Location (in inches)

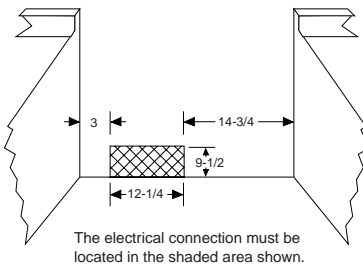

**Receptacle Locations:**  
For all 30" Slide-In Ranges locally approved flexible service cord or conduit must be used because terminals are not accessible after range installation. See shaded area in drawing for location of electrical outlet box. Recommended outlet locations allow range to be installed directly against rear wall.

## Counter Cutout Dimensions (in inches)

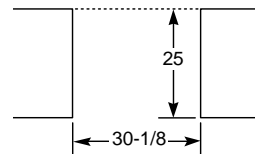

**Note:** 30" ranges conform to U.L. requirements for 0" spacing from walls below countertops. However some kitchen cabinet finishes can be damaged by heat from the heating elements. It is recommended that a clearance of at least 1-1/4" be maintained to adjacent walls. Where varnished wood or plastic film finishes are used, a minimum clearance of 6" should be maintained.

## Optional Modules (Available at additional cost)

Radiant Module—JXGR63B	Coil Modules
Griddle Accessory—JXGL90	JXGC53W—White on white
Grill Module—JXGG50	JXGC53B—Black on black

**Installation Information:** Before installing, consult installation instructions [Pub. No. 49-8643 (JSP69WV/69BV)] packed with product for current dimensional data.

# HOODS

Dimensions (in inches)

Model	A	B	C	D
JV376V	7	29-7/8	19-3/4	12
JV356V	7	29-7/8	19-3/4	12
JV656V	7	35-7/8	19-3/4	12
JV347X	5-1/2	29-7/8	17-1/2	12
JV337X	5-1/2	29-7/8	17-1/2	12
JV327X	5-1/2	29-7/8	17-1/2	12
JN327X	5-1/2	29-7/8	17-1/2	12

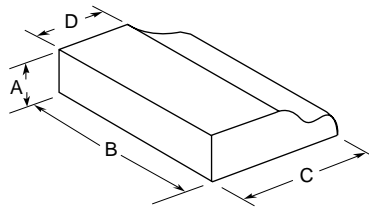

Width	GE					
	High Performance	Performance	Deluxe	Standard		
30"	JV376V	JV356V	JV347X	JV327X	JV337X	JN327X
36"		JV656V				
Features						
Variable speed fan control	•	•				
Two-speed fan control				•	•	•
Three-speed fan control			•			
Vertical exhaust (CFM)	410	250	180	160	160	
Rear exhaust (CFM)	380	230	160		150	
Damper included (rectangular)	•	•	•		•	
Optional damper accessory (round)			JXDA22	JXDA22		
Sones rating:						
Top exhaust	5.5	5.5	8.0	8.0	8.0	
Rear exhaust	5.5	5.5	8.0		8.0	
Removable grease filters	2	2*	Disposable 1-Pc. Filter	1	1	Disposable 1-Pc. Filter
Filter size (sq. in.)	162	162/256	90	90	90	90
Cooktop light(s)**	2	2	1	1	1	1
Night light position on light switch	•	•	•			
3-1/4" x 10" rectangular duct	•	Option	Option		•	
7" round duct			Option	•		
Non-vented		Option	Option			•
Appearance						
Color appearance†	WW/BB	WW/BB/AA	WW/BB/AA	Almond or White	Almond or White	Almond or White
Weights & Dimensions						
Approximate shipping weight (lbs.)	43	35	20	14	17	19
Power/Ratings						
Current rating amps @ 120V	2.5	1.4	2.5	2.5	2.5	2.5

\*WB13X5008 removable charcoal filter (for non-vented use) is available at additional cost. Call toll-free 800-626-2002.  
 \*\*Light bulbs not furnished.  
 †WW = White on white, BB = Black on black, AA = Almond on almond.

## Hood Dimensions (in inches)

### 1 Models: JV656V, JV376V and JV356V

Exhaust outlet connects to 3-1/4" x 10" rectangular duct. Vent top or rear. Includes rectangular damper.

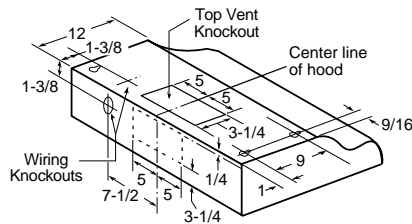

### 2 Models: JV347X\* and JV337X

\*JV347X—Refer to this drawing for rectangular exhaust option. Refer to drawing 3 for round exhaust option. Exhaust outlet connects to 3-1/4" x 10" rectangular duct. Vent top or rear. Includes rectangular damper.

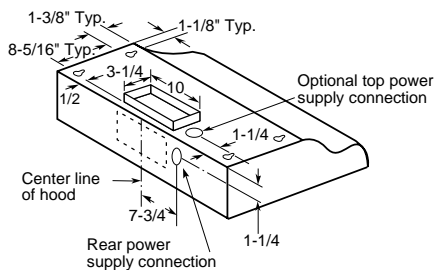

### 3 Models: JV347X\* and JV327X

\*JV347X—Refer to this drawing for round exhaust option. Refer to drawing 2 for rectangular exhaust option. Exhaust outlet connects to 7" diameter duct. Vent top only. Round damper accessory, JXDA22, available at additional cost.

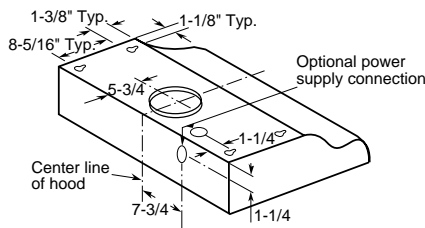

### 4 Model: JN327X

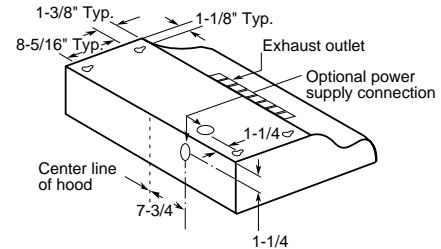

Note: Before installing, consult installation instructions [Pub. No. 49-8646 (JV376); Pub. No. 49-8809 (JV337/327/347/JN327); Pub. No. 49-8645 (JV356/656)] packed with product for current dimensional data.

See page 136 for warranty information.



# SLIDE-OUT HOODS

Features	GE Profile Performance Series™		GE Profile™			
	JV960SA	JV930SA	JV695S	JV694S	JV395S	JV394S
Variable speed fan control	●	●	●	●	●	●
Auto heat sensor	●	●	●	●	●	●
Vertical exhaust (CFM)	300	300	300	300	300	300
Sones rating: Top exhaust	4.5	4.5	4.5	4.5	4.5	4.5
Removable grease filter*	●	●	●	●	●	●
Filter size (sq. in.)	147	147	147	147	147	147
Cooktop light	●	●	●	●	●	●
3-1/4" x 10" rectangular duct	●	●	●	●	●	●
<b>Appearance</b>						
Color appearance**	SS	SS	WW	BB	WW	BB
<b>Weights &amp; Dimensions</b>						
Width (in inches)	36	30	36	36	30	30
Approximate shipping weight (lbs.)	43	40	43	43	40	40
<b>Power/Ratings</b>						
Current rating Amps @ 120V	3.7	3.7	3.7	3.7	3.7	3.7

\*Has washable one-piece smoke/grease filter.  
 \*\*SS = Stainless Steel, WW = White on white, BB = Black on black.  
**Note:** These vented hoods include an installed damper.  
**Note:** The unit is ducted vertically. Horizontal ducting can be accomplished as shown.  
**Note:** Remove glass visor from unit before installing hood in cabinet to protect visor from damage.  
**Note:** Before installing, consult Use & Care/Installation instructions [Pub. No. 49-8464 (JV694/695); Pub. No. 49-8463 (JV394/395)] packed with product for current dimensional data.

## Installation Information (in inches)

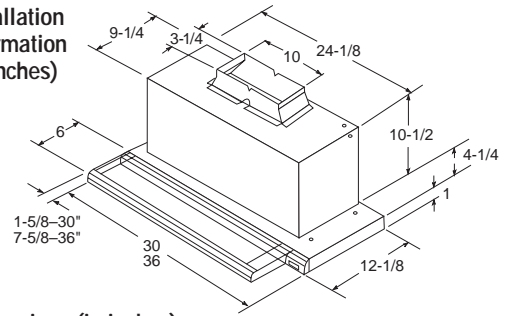

## Dimensions (in inches)

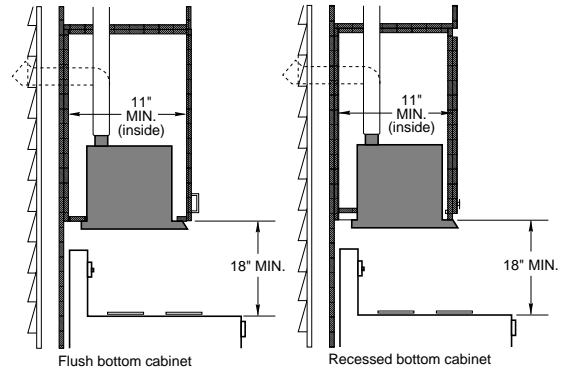

# TELESCOPIC DOWNDRAFT SYSTEMS

Features	GE Profile Performance Series™	
	JVB96SA	JVB93SA
Variable speed fan control	●	●
Downdraft exhaust (CFM)	500	500
3-1/4" x 10" rectangular duct	●	●
Removable grease filters	●	●
<b>Appearance</b>		
Color appearance	Stainless	Stainless
<b>Weights &amp; Dimensions</b>		
Width (in inches)	36	30
Approx. shipping weight (lbs.)	62	60
<b>Power/Ratings</b>		
Current rating Amps @ 120V	4.0	4.0

**Note:** Approved for use with GE Profile Performance™ GE Profile™ and GE electric and sealed burner gas cooktops.

### Accessories:

- JXB3WW—30" white trim strip for use with 30" induction cooktop JP393R
- JXB6WW—36" white trim strip for use with 36" induction cooktop JP693R

**Note:** Telescopic downdraft vents are not recommended to be installed with cooktops that are flush mounted.

**Note:** The countertop must be at least 26" deep with a flat surface area of 23-1/2" or more, front to back. In addition, other clearances to the front edge of the countertop must be considered.

**Installation Information:** Before installing, consult installation instructions (Pub. No. 49-8446, 36" and 30" Telescopic Hoods) packed with product for current dimensional data.

## Overall Dimensions (in inches) Model: JVB96SA

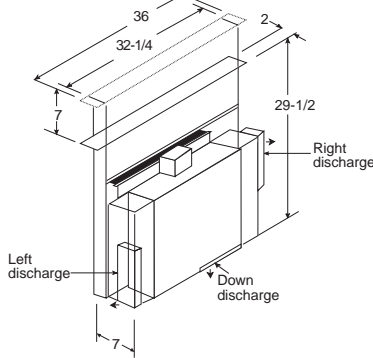

## Model: JVB93SA

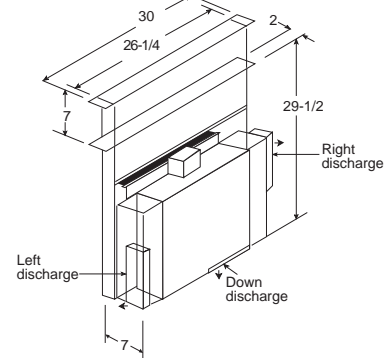

## Venting Island to Outside Wall (in inches)

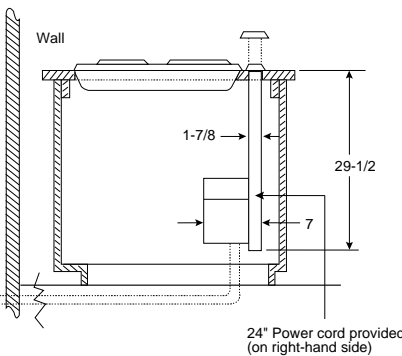

**Note:** Dimensions shown are for reference only. Before cutting out countertop, refer to instructions packed with downdraft and cooktop.

**Note:** Duct run not to exceed 100 equivalent feet.

**Note:** Installation in cabinets/countertops against the wall will not be possible in most applications.

## Counter Cutout Information

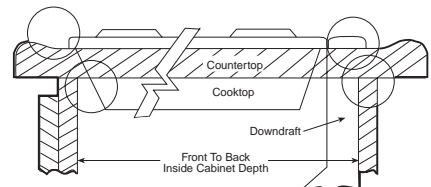

Pay special attention to the 4 areas of potential interference circled above. 2" of FLAT countertop is needed behind rear edge of cooktop to accommodate downdraft vent cover.

Approved for use with the following GE cooktops—36" and 30" Calrod® models, 36" and 30" radiant models, 30" solid disk models, 36" and 30" gas sealed burner models and 36" and 30" induction models. **Not approved for use with standard burner gas cooktops.**

# TELESCOPIC DOWNDRAFT SYSTEMS

	GE Profile™	
	JVB67AWW JVB67ABB	JVB37AWW JVB37ABB
<b>Features</b>		
Upfront variable speed fan w/slide control	●	●
Separate remote raise/lower switch	●	●
Downdraft exhaust (CFM)	500	500
Optional blower mount capabilities	●	●
3-1/4" x 10" rectangular duct	●	●
Minimum 6" round duct capability	●	●
Removable grease filters	●	●
<b>Appearance</b>		
Color appearance*	WW BB	WW BB
Cover plate	White Black	White Black
Telescopic snorkel assembly	Black	Black
<b>Weights &amp; Dimensions</b>		
Width (in inches)	36	30
Approximate shipping weight (lbs.)	76	72
<b>Power/Ratings</b>		
Current rating Amps @ 120V	4.0	4.0

\*WW = White on white, BB = Black on black.

**Note:** Approved for use with GE Profile Performance Series™ GE Profile™ and GE electric and sealed burner gas cooktops.

## Blower Position

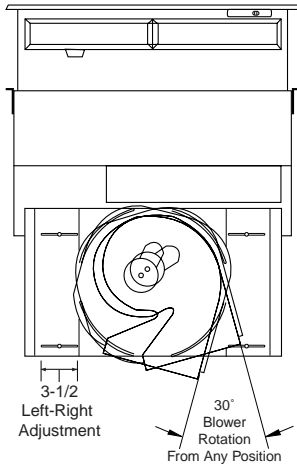

**Note:** Telescopic downdraft vents are not recommended to be installed with cooktops that are flush mounted.

Approved for use with the following GE Profile Performance Series™ GE Profile™ and GE cooktops—36" and 30" electric models, 36" and 30" gas sealed burner models and 36" and 30" induction models.

**Not approved for use with standard burner gas cooktops.**

**Note:** The countertop must be at least 26" deep with a flat surface area of 23-1/2" or more, front to back. In addition, other clearances to the front edge of the countertop must be considered.

**Note:** Dimensions shown are for reference only. Before cutting out countertop, refer to instructions packed with **downdraft and cooktop**.

**Note:** Installation in cabinets/countertops against the wall will not be possible in most applications. Against the wall installations are limited to dimension requirements. Refer to installation instructions packed with product for further details.

**JXBC57 Outdoor Cover.** Optional accessory may be ordered for installation of motor and blower assembly on outside wall.

**JXRB57 Indoor Remote Accessory.** Optional accessory may be ordered for installation of motor and blower assembly in an indoor remote location.

**Installation Information:** Before installing, consult installation instructions (49-8931) packed with product for current dimensional data.

## Overall Dimensions (in inches) Model JVB67

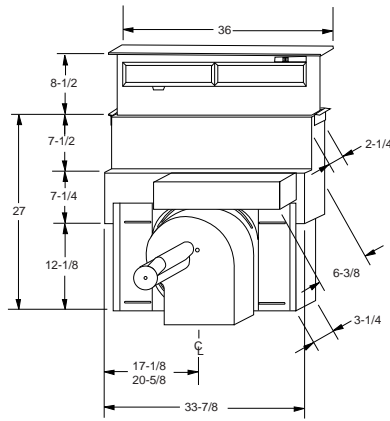

## Model JVB37

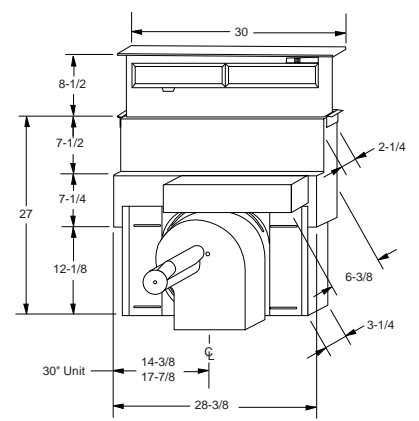

## Venting Options (Through the Floor)

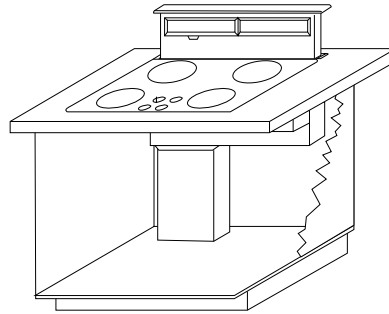

## In Cabinet Discharge (Down)

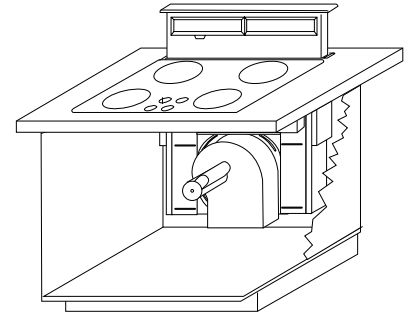

## In Cabinet Discharge (Right)

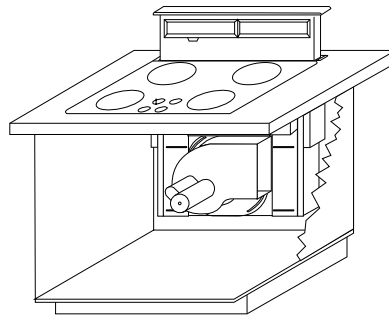

## In Cabinet Discharge (Left)

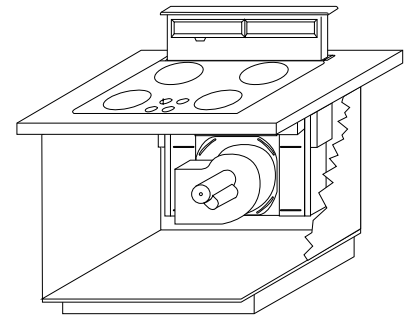

# 30" SLIDE-IN GAS RANGES

Features	GE Profile™		GE	
	JGSP44WEY	JGSP44AEY	JGSP23WEY	JGSS05BEA
	JGSP44BEY	JGSP23BEY		
Self-Clean oven with Delay Clean option	●	●	Extra-Large Standard Clean	
Variable cleaning time	●	●		
Automatic self-clean oven door lock	●	●		
Cooktop burners	Sealed	Sealed	Standard	
Maximum output burner	●	●		
Standard simmer burner	●	●		
SmartSet Controls	●	●		
Temperature display	●	●		
Start pad	●	●		
Delay Bake option with Cook & Hold	●	●		
C° or F° programmable	●	●		
Audible preheat signal	●	●		
Auto oven shut-off with override	●	●		
Electronic clock and kitchen timer	●	●		
Control lock capability	●	●		
Cooktop	White Glass Almond Glass Black Glass	White Porcelain-Enameled Black Porcelain-Enameled	Black Porcelain-Enameled	
Lift-up cooktop			●	
One-piece drip pans	Porcelain-Enameled	Porcelain-Enameled		
Removable cooktop grates	Deluxe Cast	Standard Cast	Standard Porcelain Steel	
Ignition system	Electronic	Electronic	Electronic	
Oven racks	2	2	2	
Broiler pan and grid	●	●	Extra-large	
Interior oven light	●	●	●	
Storage drawer	●	●	●	
In-oven broiling	●	●	●	
Slide-out broiler drawer			●	
Appearance				
Color appearance*	WW AA BB	WW BB	BB	
Frameless glass oven door	White Almond Black	White Black	Black	
Oven door with window	●	●	●	
Lift-off oven door	●	●	●	
Designer-style handle	Sure Grip	●	●	
Weights & Dimensions				
Overall oven interior dimensions (WxHxD in inches)	← 22-3/4 x 13 x 17 →		24 x 17 x 19	
Approx. shipping wt. (lbs.)	197	192	165	
Power/Ratings				
Gas range electrical rating	← 120V, 60Hz, 5A →			
Top burners (000's BTU's) Nat/LP	(1) 12.0/9.4 (2) 9.5/7.0 (1) 5.0/4.0	(3) 9.5/7.0 (1) 5.0/4.0	(4) 9.0/8.0	
Oven/broiler burners (000's BTU's) Nat/LP	16.0/16.0	16.0/16.0	16.0/16.0	
Accessories				
Optional backguard (available at additional cost)	JXS31 JXS33 JXS34	JXS31 JXS34		

\*WW = White on white, BB = Black on black, AA = Almond on almond.  
 Universal Orifices for Natural or LP Gas. Factory set for Natural Gas. A set of LP orifices is included with each range for LP conversion.

**Optional Kits for Slide-In Gas Ranges:**  
 (Available at additional cost on all models except JGSS05BEA)

**Rear Filler Strip Kits**  
 Models JGSP44 and JGSP23 are shipped with required "vented" rear filler strip

**Lower/Side Trim Kits**  
 JXS2BB—Lower Trim Kit (Black)  
 JXS3WW—Lower Trim Kit (White)  
 JXS4AA—Lower Trim Kit (Almond)  
 Pub. No. 3-A040 Vertical Side Trim Kit (Brushed-Chrome)

**Accessory Backguards**  
 JXS31—White Accessory Backguard  
 JXS32—Brushed-Chrome Accessory Backguard  
 JXS33—Almond Accessory Backguard  
 JXS34—Black Accessory Backguard

**Endcap Kit**  
 JXS40—Endcap kit to accommodate replacement where countertop may already be notched.

**Optional Gas Range Wok Accessory** (Available at additional cost)  
 JXWK = Wok accessory holder sits on top of maximum burner grate to hold a **round-bottom** wok.

## Counter Cutout Dimensions for Models JGSP44 and JGSP23 (in inches)

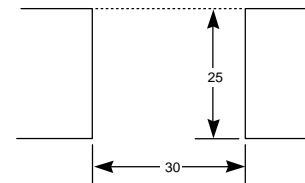

**You must use the rear filler strip kit shipped with the range or the optional accessory backguard (JXS31, JXS32, JXS33, JXS34) when installing these ranges.**

**Note:** Cabinets installed adjacent to slide-in ranges must have an adhesion spec of at least 194° F temperature rating.

**30" Slide-In Gas Ranges Dimensions (in inches)**  
**Models JGSP44 and JGSP23**

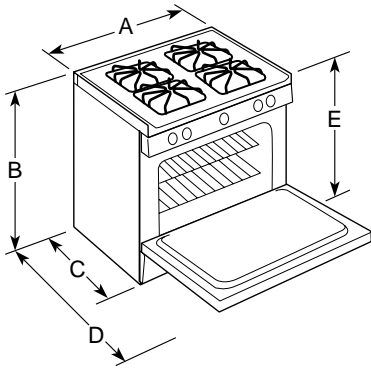

Dimensions (in inches)

Model	A	B	C*	D	E
JGSP44AEY	30	36-1/4	29-1/2	45-13/16	35-7/8 to 38
JGSP44WEY	30	36-1/4	29-1/2	45-13/16	35-7/8 to 38
JGSP44BEY	30	36-1/4	29-1/2	45-13/16	35-7/8 to 38
JGSP23WEY	30	36-1/4	28-7/8	45-1/8	35-7/8 to 38
JGSP23BEY	30	36-1/4	28-7/8	45-1/8	35-7/8 to 38

\*Depth including handle:  
 26-7/8"—Wall to front of closed oven door  
 26-1/2"—Depth to front top edge of cooktop

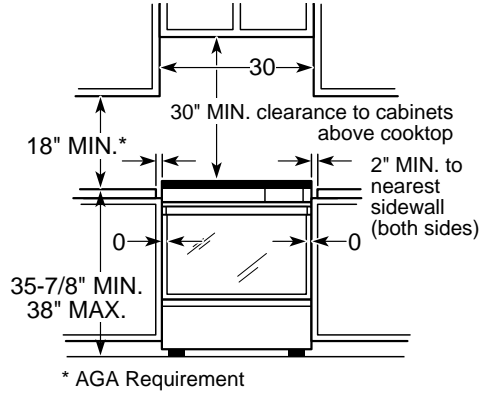

Note: Models JGSP44AEY, JGSP44WEY, JGSP44BEY, JGSP23WEY and JGSP23BEY are shipped with special "vented" rear filler strip. Post form countertops may not be used when installing this range. The filler strip (provided) or optional backguard kit is required for installation.

**Installation Information (in inches)**  
**Models JGSP44 and JGSP23**

Recommended area for 120V outlet on rear wall and area for through the wall connection of pipe stub and shut-off valve

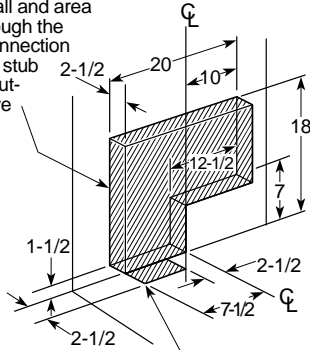

Recommended area for through the floor connection of pipe stub and shut-off valve

**Installation Information:** Before installing, consult installation instructions [Pub. No. 31-10181 (JGSP44AEY, JGSP44WEY, JGSP44BEY, JGSP23WEY and JGSP23BEY) packed with product for current dimensional data.

**30" Slide-In Gas Range Dimensions (in inches)**  
**Model JGSS05**

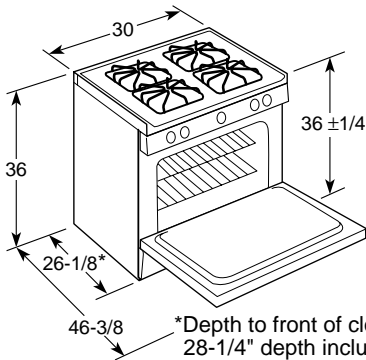

\*Depth to front of closed oven door  
 28-1/4" depth including handle  
 25-1/4" depth to front top edge of cooktop

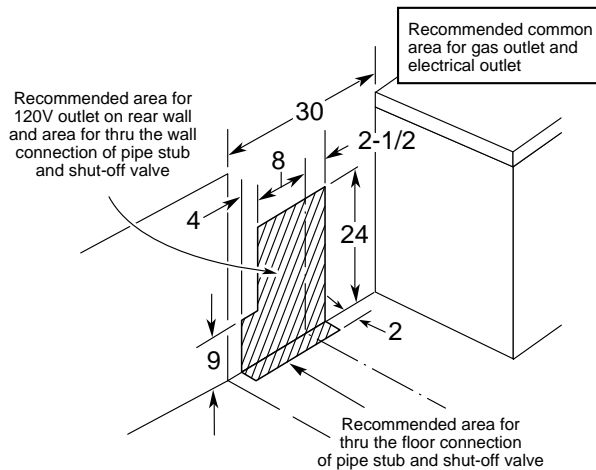

**Installation Information:** Before installing, consult installation instructions [Pub. No. 49-8751 (JGSS05)] packed with product for current dimensional data.



# 30" SLIDE-IN ELECTRIC RANGES

Features	GE Profile™		GE		
	JSP40WW JSP40AW JSP40BW	JSP34WW JSP34AW JSP34BW	JSP26BW	JSS26BW	JSS16PW
	Self-clean oven with Delay Clean option	●	●	●	Standard Clean
Variable cleaning time	●	●	●		
Automatic self-clean oven door lock	●	●	●		
Oven shelves	2	2	2	2	2
Glass-ceramic cooktop	Patterned White Patterned Almond Patterned Black				
Lift-up porcelain-enameled cooktop		White Almond Black	CM* Porc.-Enam.	Black Porc.-Enam.	CM* Porc.-Enam.
Overhanging cooktop	●	●	●	●	●
Removable one-piece drip bowls		Chrome Porc.-Enam.	Porc.-Enam.	Chrome	Chrome
Plug-in Calrod™ heating elements		●	●	●	●
8" heating elements	Ribbon**	2	2	2	2
6" heating elements	Ribbon**	2	2	2	2
Infinite heat controls	●	●	●	●	●
SmartSet Controls	●	●	●		
Temperature display	●	●	●		
Start pad	●	●	●		
Delay Bake option w/Cook & Hold	●	●	●		
C° or F° programmable	●	●	●		
Audible preheat signal	●	●	●		
Auto oven shut-off w/override	●	●	●		
Control lock capability	●	●	●		
Electronic clock and kitchen timer	●	●	●	●	●
Hot surface indicator lights	4				
Heating element "ON" indicator light		●	●	●	●
Interior oven light	●		●	●	●
Storage drawer	White Almond Black	White Almond Black	CM*	Black	CM*
Broiler pan with grid	●	●	●	●	●
<b>Appearance</b>					
Color appearance*	WW AA BB	WW AA BB	WH/AD	BB	WH/AD
Frameless glass oven door	White Almond Black	White Almond Black	CM*	Black	Painted
Oven door with window	●	●	●	●	●
Lift-off oven door	●	●	●	●	●
Designer-style handle	Sure Grip	●	●	●	Visor
<b>Weights &amp; Dimensions</b>					
Overall oven interior dimensions (WxHxD in inches)	← 22-3/4 x 15-3/4 x 17 →				
Approx. shipping weight (lbs.)	182	175	175	160	160
<b>Power/Ratings</b>					
KW rating @ 240V	11.4	10.8	10.8	11.6	11.6
208V	8.6	8.1	8.1	8.7	8.7
Amps @ 240V	40	40	40	40	40
208V	40	40	40	40	40
<b>Accessories</b>					
Optional backguard (available at additional cost)	JXS31 JXS33 JXS34	JXS31 JXS33 JXS34	JXS33/31	JXS34	JXS33/31

\*WW = White on white, BB = Black on black, AA = Almond on almond, WH = White, AD = Almond, CM = Color-Matched indicates color of the oven door matches range cooktop and drawer face (either white or almond).  
\*\*Two 8", one 6" and one dual 6"/9" ribbon heating elements.



All GE ranges are equipped with an Anti-Tip device. The installation of this device is an important, required step in the installation of the range.

See page 136 for warranty information.

## 30" Slide-In Range Dimensions (in inches)

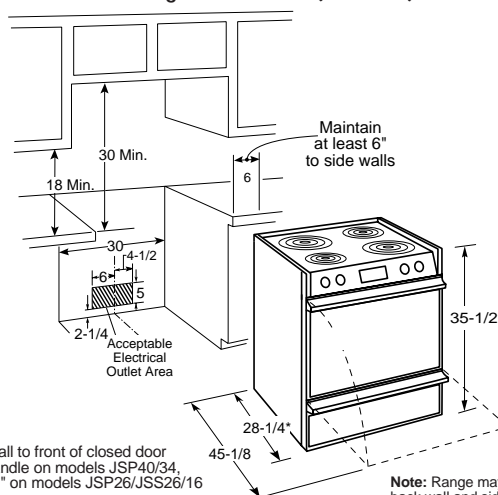

\*Wall to front of closed door handle on models JSP40/34, 28" on models JSP26/JSS26/16

**Note:** Range may be placed with 0" clearance (flush) at the back wall and side walls if the range side trims extend beyond the cabinet fronts at least 1/4". (Self-clean models only)

If you are NOT using the optional Filler or Backguard:

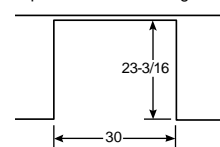

If you are using the optional Filler or Backguard:

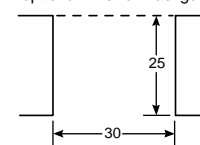

**Note:** Cabinets installed adjacent to slide-in electric ranges must have an adhesion spec of at least 194° F temperature rating.

### Optional Kits for Slide-In Electric Ranges (Available At Additional Cost)

#### Rear Filler Strip Kits

- JXS28—Rear Filler Strip Kit (Brushed-chrome)
- JXS62BB—Rear Filler Strip Kit (Black)
- JXS63WW—Rear Filler Strip Kit (White)
- JXS64AA—Rear Filler Strip Kit (Almond)

Models shown above are shipped with rear filler strip kit.

#### Accessory Backguards

- JXS31—White Accessory Backguard
- JXS32—Brushed-Chrome Accessory Backguard
- JXS33—Almond Accessory Backguard
- JXS34—Black Accessory Backguard

#### Endcap Kit

JXS40—Endcap kit to accommodate replacement where countertop may already be notched.

#### Lower/Side Trim Kits

- JXS52BB—Lower Trim Kit (Black)\*
- JXS53WW—Lower Trim Kit (White)\*
- JXS54AA—Lower Trim Kit (Almond)\*
- Pub. No. 3-A040—Vertical Side Trim Kit (Brushed-Chrome)

\*For countertop height greater than 37", it is recommended to use a lower trim kit.

**Note:** All 30" Slide-In Ranges conform to U.L. requirements for 0" spacing from range to adjacent walls below countertop. To reduce possibility of scorching of the side wall adjacent to the heating elements, it is recommended a minimum 6" spacing from adjacent side walls be allowed for possible extended high-heat, no-load heating element operation.

**Receptacle Locations:** For all 30" Slide-In Ranges locally approved flexible service cord or conduit must be used because terminals are not accessible after range installation. See shaded area in drawing for location of electrical outlet box. Recommended outlet locations allow range to be installed directly against rear wall.

**Installation Information:** Before installing, consult installation instructions (Pub. No. 31-10070) packed with product for current dimensional data.

# 30" DROP-IN ELECTRIC RANGES

	GE		
	JDP39WW JDP39BW	JDP36BW	JDS26BW
<b>Features</b>			
Self-clean oven w/Delay Clean option	●	●	Standard Clean
Variable cleaning time	●	●	
Automatic self-clean oven door lock	●	●	
Oven shelves	2	2	2
Lift-up overhanging cooktop	White Porc.-Enam. Black Porc.-Enam.	White or Almond Porc.-Enam.	White or Almond Porc.-Enam.
8" heating elements	2 Plug-in	2 Plug-in	2 Plug-in
6" heating elements	2 Plug-in	2 Plug-in	2 Plug-in
Infinite heat controls	●	●	●
Removable one-piece drip bowls	Chrome Black Porc.-Enam.	Chrome	Chrome
SmartSet Controls	●	●	●
Temperature display	●	●	●
Start pad	●	●	●
Delay Bake option w/Cook & Hold	●	●	●
C° or F° programmable	●	●	●
Audible preheat signal	●	●	●
Auto oven shut-off w/override	●	●	●
Electronic clock and kitchen timer	●	●	●
Control lock capability	●	●	●
Heating element "ON" indicator light	●	●	●
Broiler pan with grid	●	●	●
<b>Appearance</b>			
Color appearance*	WW BB	WH/AD	WH/AD
Frameless oven door	White Glass Black Glass	Black Glass	Black Glass
Oven door with window	●	●	●
Lift-off oven door	●	●	●
Designer-style handle	●	●	●
<b>Weights &amp; Dimensions</b>			
Overall oven interior dimensions (WxHxD in inches)	← 22-3/4 x 15-3/4 x 17 →		
Approx. shipping weight (lbs.)	144	144	128
<b>Power/Ratings</b>			
12KW rating @ 240V	11.6	11.6	11.6
208V	8.7	8.7	8.7
Amps @ 240V	40	40	40
208V	40	40	40

\*WW = White on white, BB = Black on black, WH = White, AD = Almond.

## 30" Drop-In Range Dimensions (in inches)

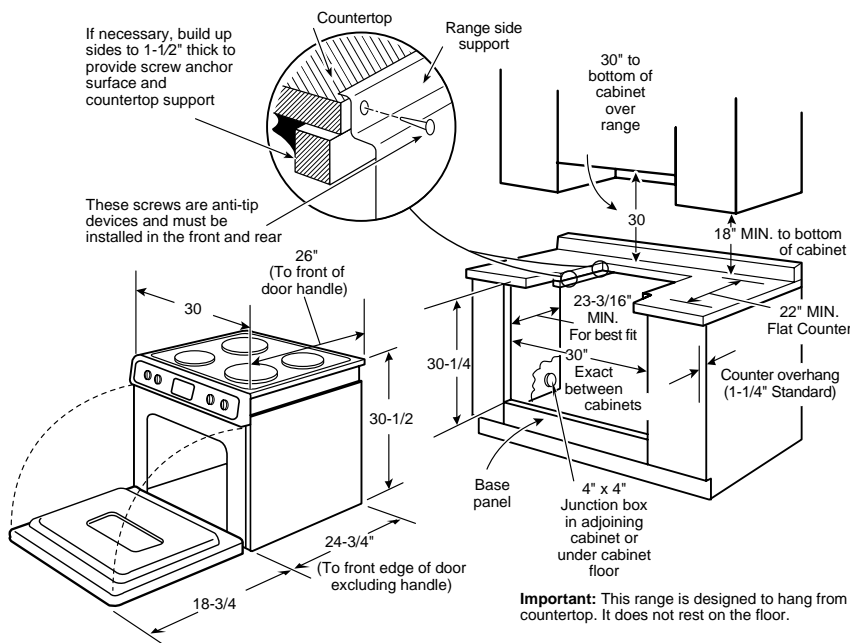

**Note:** Cabinets installed adjacent to drop-in electric ranges must have an adhesion spec of at least 194° F temperature rating.

**Installation Information:** Before installing, consult installation instructions (Pub. No. 31-10129) packed with product for current dimensional data.

**Note:** 30" Drop-In Ranges conform to requirements for 3" minimum spacing between range and adjacent side walls below countertop.

**IMPORTANT:** 30" DROP-IN RANGES ARE DESIGNED TO HANG FROM THE COUNTERTOP. IT DOES NOT REST ON THE FLOOR. FOR INSTALLATION ALTERNATIVES, REFER TO INSTALLATION INSTRUCTIONS PACKED WITH PRODUCT.

### Countertop Cutout—Top View

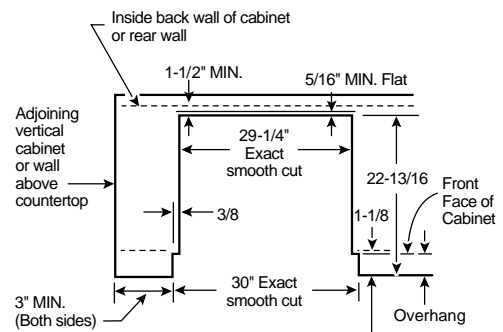

All GE ranges are equipped with an Anti-Tip device. The installation of this device is an important, required step in the installation of the range.

See page 136 for warranty information.

# SPACEMAKER™ 27" DROP-IN ELECTRIC RANGES

Features	GE Profile™	GE	
	JMP31WA	JMP28BA	JMS08BA
Oven cleaning	Self-Clean	Self-Clean	Standard Clean
Variable cleaning time	●	●	
Automatic self-clean oven door lock	●	●	
Oven shelves	2	2	2
Lift-up overhanging cooktop	White Porcelain-Enameled	White or Almond Porcelain-Enameled	White or Almond Porcelain-Enameled
8" heating elements	1	1	1
6" heating elements	3	3	3
Plug-in Calrod® heating elements	●	●	●
Infinite heat controls	●	●	●
Removable one-piece drip bowls	Chrome	Chrome	Chrome
Electronic clock and kitchen timer	●	●	●
Delay Bake option	●	●	●
Auto oven shut-off	●	●	●
Electronic oven control	●	●	●
Heating element "ON" indicator light	●	●	●
Interior oven light	●	●	●
Broiler pan with grid	●	●	●
<b>Appearance</b>			
Color appearance*	WW	WH/AD	WH/AD
Frameless oven door	White Glass	Black Glass	Black Glass
Oven door with window	Big View	Big View	Big View
Lift-off oven door	●	●	●
Designer-style handle	Sure Grip	●	●
<b>Weights &amp; Dimensions</b>			
Overall oven interior dimensions (WxHxD in inches)	19 x 15 x 18		
Approx. shipping weight (lbs.)	119	119	119
<b>Power/Ratings</b>			
KW rating @ 240V	9.8	9.8	10.1
208V	7.3	7.3	7.6
Amps @ 240V	40	40	40
208V	40	40	40

\*WW = White on white, WH = White, AD = Almond.  
Optional backguard in white, black or almond is available at additional cost for all models. JX27RWH = White, JX27RBK = Black or JX27RAD = Almond.

## Optional Backguard

(Available at additional cost)  
JX27RBK = Black  
JX27RWH = White  
JX27RAD = Almond

## 27" Drop-In Range Dimensions (in inches)

**Important:** This range is designed to hang from the countertop. It does not rest on the floor.

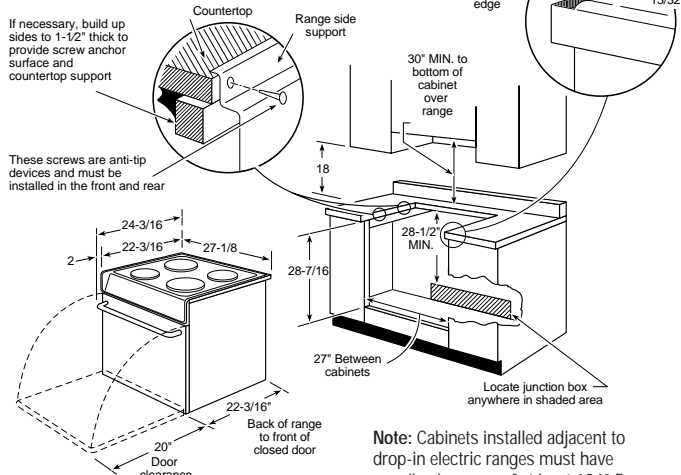

## Countertop Cutout—Top View

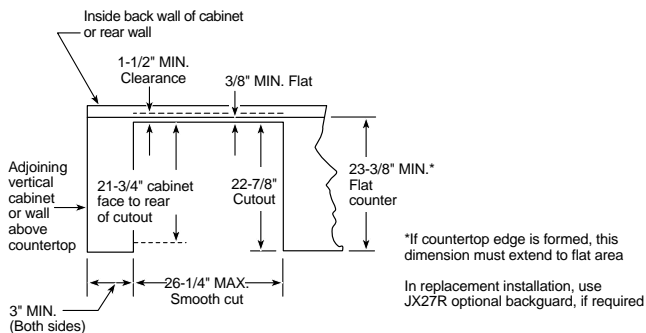

**Note:** All 27" Drop-In Electric Ranges conform to U.L. requirements for minimum spacing between range and side wall below countertop.

**Installation Information:** Before installing, consult installation instructions (Pub. No. 31-10116) packed with product for current dimensional data.

# INSTALLATION/SPECIFICATIONS FOR 30" FREE-STANDING CLEANDESIGN ELECTRIC RANGES

## Cabinet Dimensions (in inches)

Model	A	B	C*	D
JB970SB	30	48-1/4	26-5/8	45-1/8
JB960WB/AB/BB	29-7/8	46-1/2	25-3/8	47-5/8
JB940WB/AB/BB	29-7/8	46-1/2	25-3/8	47-5/8
JBP79WB/AB/BB	29-7/8	46-1/2	25-3/8	47-5/8
JBP78WB/AB/BB	29-7/8	44-7/16	25-3/8	47-5/8
JBP66WB/AB/BB	29-7/8	44-7/16	25-3/8	47-5/8
JBP64BB	29-7/8	44-7/16	25-3/8	47-5/8
JBP63BB	29-7/8	44-1/2	25-7/16	46-1/8
JBP60BB	29-7/8	44-1/2	25-7/16	46-1/8

\*Dimension from wall to front of closed oven door handle is 28-7/8" on model JB970; 27-3/8" on models JB960/940, JBP79; 27-3/4" on models JBP78/66/64; and 27-1/2" on model JBP63/60.

## Dimensions and Installation Information (in inches)

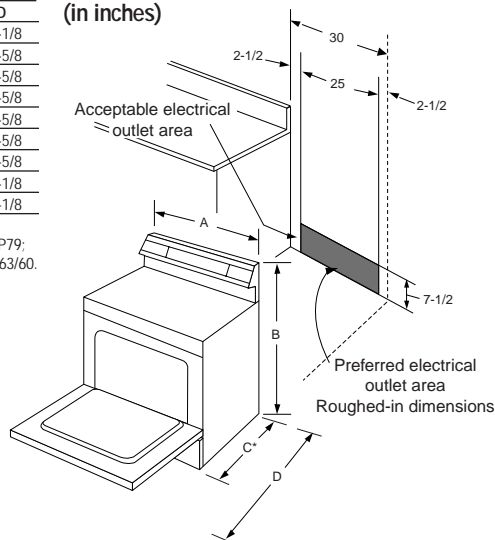

**Note:** Conforms to U.L. requirements for 0" spacing for adjacent walls below countertops. To reduce possibility of scorching of walls, it is recommended a minimum of 1-1/2" spacing be allowed from adjacent side walls to allow for possible extended, high-heat, no-load heating element operation.

**Installation Information:** Before installing, consult installation instructions packed with range for current dimensional data.

**Receptacle Locations:** For 30" Free-Standing Ranges locally approved flexible service cord or conduit must be used because terminals are not accessible after range installation. See shaded area drawing for location of electrical outlet box. Recommended outlet locations allow range to be installed directly against wall.



All GE ranges are equipped with an Anti-Tip device. The installation of this device is an important, required step in the installation of the range.

# 30" FREE-STANDING CLEANDESIGN ELECTRIC RANGES

Features	GE Profile Performance Series™			GE Profile™	GE				
	JB970SB	JB960WB JB960AB JB960BB	JB940WB JB940AB JB940BB	JBP79WB JBP79AB JBP79BB	JBP78WB JBP78AB JBP78BB	JBP66WB JBP66AB JBP66BB	JBP64BB	JBP63BB	JBP60BB
Self-cleaning oven	Convection	Convection	Convection	●	●	●	●	●	●
Self-clean latch	●	Auto	Auto	Auto	●	●	●	●	●
Oven capacity (cu. ft.)	3.7	4.5	4.5	5.0	5.0	5.0	5.0	3.7	3.7
CleanDesign Oven Interior		●	●						
Oven shelves	3 (1 off-set)	3 (1 off-set)	3 (1 off-set)	2	2	2	2	2	1
Patterned glass-ceramic cooktop	Black	White Almond Black	White Almond Black	White Almond Black	White Almond Black	White Almond Black	Black	Black	Black
One-piece upswept cooktop		●	●	●	●	●	●	●	●
Dual 6/9" heating element	1 Ribbon (1000/2500 watt)	1 Ribbon (1000/2500 watt)	1 Ribbon (1000/2500 watt)	1 Ribbon (1000/2500 watt)	1 Ribbon (1000/2500 watt)				
8" heating elements			1 Ribbon (2000 watt)	1 Ribbon (2000 watt)	1 Ribbon (2000 watt)	2 Ribbon (2000 watt)	2 Ribbon (2000 watt)	2 Ribbon (2000 watt)	2 Ribbon (2000 watt)
7" heating element	2 Ribbon (1800 watt)	2 Ribbon (1800 watt)							
Bridge element	1 (800 watt)	1 (800 watt)							
Total wattage	4400	4400							
6" heating elements	1 Ribbon (1500 watt)	1 Ribbon (1500 watt)	2 Ribbon (1500 watt)	2 Ribbon (1500 watt)	2 Ribbon (1500 watt)	2 Ribbon (1500 watt)	2 Ribbon (1500 watt)	2 Ribbon (1500 watt)	2 Ribbon (1500 watt)
Warming option									
Warming zone	1 (120 watt)								
Infinite heat controls	●	●	●	●	●	●	●	●	●
TrueTemp™ System	●	●	●	●	●	●	●	●	●
SmartLogic™ controls	●	●	●	●	●	●	●	●	●
Six-pass power bake element	●	●	●	●	●	●	●	●	●
Convection Bake	●	●	●	●	●	●	●	●	●
Convection Roast	●	●	●	●	●	●	●	●	●
Convenience Controls		●	●	●	●	●	●	●	●
QuickSet oven controls	QuickSet V	QuickSet V	QuickSet V	QuickSet IV	QuickSet III	QuickSet III	QuickSet II	QuickSet II	QuickSet I
Digital temperature display	●	●	●	●	●	●	●	●	●
Oven function icons	●	●	●	●	●	●	●	●	●
Glass touch controls	●	●	●	●	●	●	●	●	●
Digipad numeric entry	●	●	●	●	●	●	●	●	●
Convection conversion	●	●	●	●	●	●	●	●	●
Delay bake	●	●	●	●	●	●	●	●	●
Oven light pad	●	●	●	●	●	●	●	●	●
Control lock capability	●	●	●	●	●	●	●	●	●
Start pad	●	●	●	●	●	●	●	●	●
Self-clean cool-down time display	●	●	●	●	●	●	●	●	●
Auto self-clean	●	●	●	●	●	●	●	●	●
Delay clean option	●	●	●	●	●	●	●	●	●
Auto oven shut-off	w/override	w/override	w/override	w/override	w/override	w/override	w/override	w/override	w/override
Audible preheat signal	●	●	●	●	●	●	●	●	●
Dual element bake	●	●	●	●	●	●	●	●	●
Automatic meat thermometer	●	●	●	●	●	●	●	●	●
Hot surface lights	●	●	●	●	●	●	●	●	●
Oven "ON" light	●	●	●	●	●	●	●	●	●
Self-clean cycle light	●	●	●	●	●	●	●	●	●
Interior oven light	Auto/Pad	Auto/Pad	Auto/Pad	Auto/Pad	Switch	Switch	Switch	Switch	Switch
Full-width fluorescent cooktop night light	●	●	●	●	●	●	●	●	●
Storage drawer	Stainless steel	White Almond Black	White Almond Black	White Almond Black	White Almond Black	White Almond CM*	CM*	CM*	CM*
Broiler pan/grid	●	●	●	●	●	●	●	●	●
Roasting rack	●	●	●	●	●	●	●	●	●
<b>Appearance</b>									
Color appearance*	SS	WW AA BB	WW AA BB	WW AA BB	WW AA BB	WW AA BB WH/AD	WH/AD	WH/AD	WH
Frameless glass oven door	Stainless steel	White Almond Black	White Almond Black	White Almond Black	White Almond Black	White Almond Black	Black	Black	Black
Oven door with window	●	Big View	Big View	Big View	Big View	●	●	●	●
Designer-style handle	Tubular	Sure Grip	Sure Grip	Sure Grip	Sure Grip	●	●	●	●
Easy Level System	●	●	●	●	●	●	●	●	●
<b>Weights &amp; Dimensions</b>									
Overall oven interior dimensions (WxHxD in inches)	22-3/4 x 15-7/8 x 15-7/8	← 24-1/4 x 19 x 17 →		← 24-1/4 x 19 x 19 →			← 23 x 16 x 17-3/4 →		
Approx. ship. wt. (lbs.)	194	206	206	198	198	175	174	165	165
<b>Power/Ratings</b>									
KW rating @ 240V	11.9	12.4	11.5	11.0	11.0	10.5	10.5	10.5	10.5
208V	8.9	9.3	8.6	8.3	8.3	7.9	7.9	7.9	7.9
<b>Accessories</b>									
Cooktop cleaning creme and scraper	●	●	●	●	●	●	●	●	●

\*SS = Stainless steel, BB = Black on black, WW = White on white, AA = Almond on almond, WH = White, AD = Almond, CM = Color-Matched indicates color of drawer matches range cooktop (either white or almond).

## Warranty Information

Full one-year warranty (parts and labor at no additional charge) applies to the entire range. Additional limited four-year warranty on glass-ceramic cooktop (parts only). See written warranty for complete details.

See page 136 for warranty information.

Refrigeration

Water Systems

Laundry

Cooking Products

Microwave Ovens

Dishwashers

Room Air



# 30" FREE-STANDING QUICKCLEAN™ ELECTRIC RANGES

Features	GE Profile™ GE											
	JBP48WB JBP48AB JBP48BB	JBP35BB	JBP30WB JBP30AB JBP30BB	JBP26WB JBP26AB JBP26BB	JBP24BB	JBP21WB JBP21BB	JBP19BB	JBS27WY JBS27AY JBS27BY	JBS26W	JBS07V	JBS05Y	JBS03GV JBS03V
Oven cleaning	Self-Clean	Self-Clean	Self-Clean	Self-Clean	Self-Clean	Self-Clean	Self-Clean	Standard	Standard	Standard	Standard	Standard
Oven capacity (cu. ft.)	5.0	5.0	5.0	5.0	5.0	3.7	3.7	3.7	3.7	3.7	3.5	3.7
Oven shelves	2	2	2	2	2	2	1	2	2	2	2	2
Upswept porcelain-enameled cooktop	•	•	•	•	•	•	•	•	•	•	•	•
Clean-Well™ Cooktop System	•	•	•	•	•	•	•	•	•	•	•	•
Lift-up cooktop w/dual support rods	•	•	•	•	•	•	•	•	•	•	•	•
8" heating elements	2 (6 turns)	2 (6 turns)	2 (6 turns)	2 (5 turns)	2 (5 turns)	2 (5 turns)	1 (5 Turns)	2 (6 turns)	1 (6 turns)	1 (6 turns)	1 (5 turns)	1 (5 turns)
6" heating elements	2 (5 turns)	2 (5 turns)	2 (5 turns)	2 (4 turns)	2 (4 turns)	2 (4 turns)	3 (4 Turns)	2 (5 turns)	3 (5 turns)	3 (5 turns)	3 (4 turns)	3 (4 turns)
Warming option	•	•	•	•	•	•	•	•	•	•	•	•
Infinite heat controls	•	•	•	•	•	•	•	•	•	•	•	•
Plug-in Calrod™ heating elements	•	•	•	•	•	•	•	•	•	•	•	•
Removable 1-piece drip bowls	Grey Black Black	Black	Grey Black Black	Chrome	Chrome	Chrome	Chrome	Chrome	Chrome	Chrome	Chrome	Chrome
TrueTemp™ System	•	•	•	•	•	•	•	•	•	•	•	•
SmartLogic™ controls	•	•	•	•	•	•	•	•	•	•	•	•
Six-pass power bake element	•	•	•	•	•	•	•	•	•	•	•	•
Convenience controls	•	•	•	•	•	•	•	•	•	•	•	•
QuickSet oven controls	QuickSet IV	QuickSet III	QuickSet III	QuickSet III	QuickSet II	QuickSet II	QuickSet I					
Digital temperature display	•	•	•	•	•	•	•	•	•	•	•	•
Electronic oven controls	•	•	•	•	•	•	•	•	•	•	•	•
Auto oven shut-off	w/override	w/override	w/override	w/override	w/override	w/override	w/override					
Control lock capability	•	•	•	•	•	•	•	•	•	•	•	•
Start pad	•	•	•	•	•	•	•	•	•	•	•	•
Delay clean option	•	•	•	•	•	•	•	•	•	•	•	•
Auto self-clean	•	•	•	•	•	•	•	•	•	•	•	•
Self-clean cool down display	•	•	•	•	•	•	•	•	•	•	•	•
Audible preheat signal	•	•	•	•	•	•	•	•	•	•	•	•
Clock and minute timer	•	•	•	•	•	•	•	•	•	•	•	•
Dual element bake	•	•	•	•	•	•	•	•	•	•	•	•
Heating element "ON" indicator light	•	•	•	•	•	•	•	•	•	•	•	•
Interior oven light	Auto/Switch	Switch	Switch	Switch	Switch	Switch	Switch	Switch	Switch	Switch	Auto/Switch	Auto/Switch
Preheated oven light	in display	•	•	•	•	•	•	•	•	•	•	•
Removable full-width storage drawer	White Almond Black	CM*	White Almond CM*	White Almond CM*	CM*	White CM*	White CM*	White Almond CM*	CM*	White	CM*	CM*
Broiler pan with grid	•	•	•	•	•	•	•	•	•	•	•	•

Appearance	GE Profile™ GE											
	JBP48WB JBP48AB JBP48BB	JBP35BB	JBP30WB JBP30AB JBP30BB	JBP26WB JBP26AB JBP26BB	JBP24BB	JBP21WB JBP21BB	JBP19BB	JBS27WY JBS27AY JBS27BY	JBS26W	JBS07V	JBS05Y	JBS03GV JBS03V
Color appearance*	WW AA BB	WH/AD	WW AA WH/AD	WW AA WH/AD	WH/AD	WW WH/AD	WH	WW WH/AD	WH/AD	WW	WH/AD	WH/AD
Frameless oven door*	WG AG BG	BG	WG AG BG	WG AG BG	BG	WG BG	WG BG	WG AG BG	CM	White	CM	CM
Oven door with window	Big View	Big View	•	•	•	•	•	•	•	•	•	•
Removable oven door	•	•	•	•	•	•	•	•	•	•	•	•
Designer-style handle	Sure Grip	•	•	•	•	•	•	•	•	•	•	•
Easy Level System	•	•	•	•	•	•	•	•	•	•	•	•
Textured steel side panels	•	•	•	•	•	•	•	•	•	•	•	•

Weights & Dimensions	
Overall oven interior dimensions (WxHxD in inches)	24-1/4 x 19 x 19      23 x 16 x 17-3/4      23 x 16 x 17-7/8      22-3/4 x 15-3/4 x 17      23 x 16 x 17-7/8
Approx. shipping weight (lbs.)	176      173      170      172      170      144      141      141      144      141      153      141      139

Power/Ratings	
KW rating @ 240V	11.7      11.7      11.7      11.7      11.7      11.7      10.5      10.9      9.8      9.8      9.3      9.8
208V	8.8      8.8      8.8      8.8      8.8      8.8      7.9      8.4      7.4      7.4      6.9      7.4

\* WW = White on white, AA = Almond on almond, BB = Black on black, WH = White, AD = Almond, CM = Color-Matched indicates color of oven door or storage drawer matches range cooktop (either white or almond), WG = White Glass, AG = Almond Glass, BG = Black Glass.

## Cabinet Dimensions (in inches)

Model	A	B	C*	D
JBP48WB/AB/BB	29-7/8	44-7/16	25-3/8	47-5/8
JBP35BB	29-7/8	44-7/16	25-3/8	47-5/8
JBP30WB/AB/BB	29-7/8	44-7/16	25-3/8	47-5/8
JBS26WB/AB/BB	29-7/8	45-1/8	25-5/16	46-3/8
JBP24BB	29-7/8	44-7/16	25-3/8	47-5/8
JBP21WB/BB	29-7/8	44-7/16	25-3/8	47-5/8
JBP19BB	29-7/8	45-1/8	25-7/16	46-1/8
JBS27WY/AY/BY	29-7/8	45-1/8	25-7/16	46-1/8
JBS26W	29-7/8	45-1/8	25-5/16	46-3/8
JBS07V	29-7/8	45-1/8	25-5/16	46-3/8
JBS05Y	29-7/8	44-5/8	25-5/16	45-1/2
JBS03GV	29-7/8	45-1/8	25-5/16	46-1/8
JBS03V	29-7/8	45-1/8	25-5/16	46-3/8

\* Dimension from wall to front of closed oven door handle is 27-3/8" on model JBP48; 27-3/4" on models JBP35/30/26/24; 27-1/2" on models JBP21/19, JBS27 and JBS03V; and 27-1/8" on models JBS26/07/05/03GV.

## Dimensions and Installation Information (in inches)

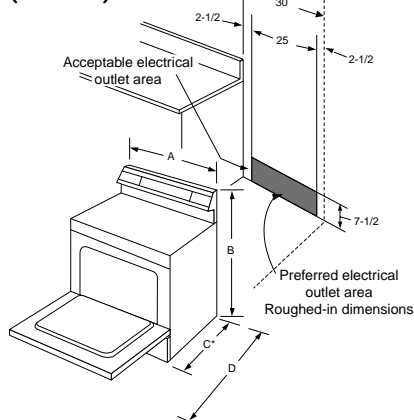

## Warranty Information

Full one-year warranty (parts and labor at no additional charge) applies to the entire range.

**Note:** 30" ranges conform to U.L. requirements for 0" spacing from adjacent walls below countertops. To reduce possible scorching of walls, engineering recommends a minimum of 1-1/2" spacing to allow for possible extended, high heat, no-load heating element operation.

### Receptacle Locations:

Locally approved flexible service cord or conduit must be used because terminals are not accessible after range installation. See shaded area in drawing for location of electrical outlet box. Recommended outlet locations allow range to be installed directly against wall.

**Installation Information:** Before installing, consult installation instructions packed with product for current dimensional data.



All GE ranges are equipped with an Anti-Tip device. The installation of this device is an important, required step in the installation of the range.

# 40" ELECTRIC RANGES

	GE	
	JCP67Y	JCS57Y
<b>Features</b>		
Oven cleaning	Master Oven—Self-Clean Companion Oven—Standard	Standard
Oven shelves	Master Oven—2 Companion Oven—1	Master Oven—2
8" heating elements	2	2
6" heating elements	2	2
Removable drip bowls	One-Piece Chrome	One-Piece Chrome
Clock and minute timer	Electronic	Electronic
Automatic oven timer	Master	
Heating element "ON" indicator light	●	●
Interior oven light	●	●
Full-width fluorescent cooktop night light	●	●
Oven cycling light	2	●
Storage drawer	●	●
Broiler pan with grid	Master Oven—1 Companion Oven—1	Master Oven—1
<b>Appearance</b>		
Color appearance*	WW	WW
Oven door with window	Master Oven	●
Lift-off oven door	Master	●
<b>Weights &amp; Dimensions</b>		
Overall oven interior dimensions (WxHxD in inches)	Master Oven— 22-5/8 x 15-7/8 x 18-1/8 Companion Oven— 9-9/16 x 16 x 19-1/2	22-5/8 x 15-7/8 x 18-1/8
Approx. shipping weight (lbs.)	224	197
<b>Power/Ratings</b>		
KW rating @ 240V	14.2	12.6
208V	10.7	9.5

\*WW = White on white.

## Warranty Information

Full one-year warranty (parts and labor at no additional charge) applies to the entire range. See written warranty for complete details.

## 40" Range Dimensions and Installation Information (in inches)

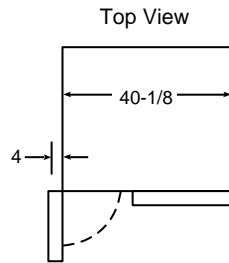
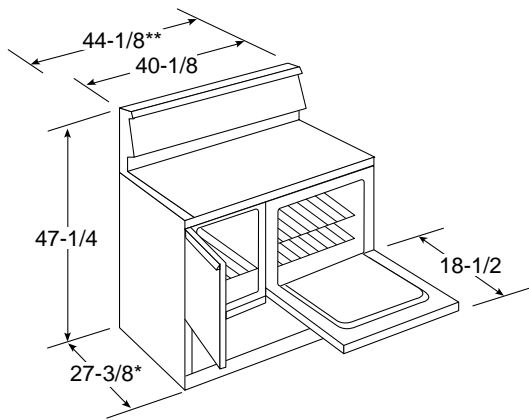

\*Dimension from wall to front of closed oven door handle.  
\*\*Includes required 4" door swing allowance for side-hinged oven or storage compartment door.

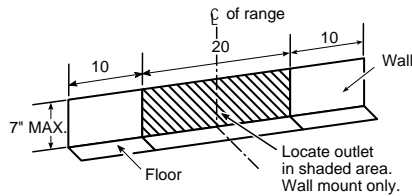

**Receptacle Locations:** For all 40" Free-Standing Ranges locally approved flexible service cord or conduit must be used because terminals are not accessible after range installation. See shaded area in drawing for location of electrical outlet box. Recommended outlet locations allow range to be installed directly against rear wall.

Refrigeration

Water Systems

Laundry

Cooking Products

Microwave Ovens

Dishwashers

Room Air

# 30" XL44™ SELF-CLEAN GAS RANGES

	GE Profile™				GE					
	Sealed Burner Models				Sealed Burner Models				Standard Burner Models	
	JGBP90MEA	JGBP86WEA JGBP86AEA JGBP86BEA	JGBP85WEA JGBP85AEA JGBP85BEA	JGBP79WEA JGBP79AEA JGBP79BEA	JGBP35WEA JGBP35AEA JGBP35BEA	JGBP30WEA JGBP30AEA JGBP30BEA	JGBP28BEA	JGBP27BEA	JGBP26WEA JGBP26AEA JGBP26BEA	JGBP24BEA
<b>Capacity</b>										
Extra-large oven	•	•	•	•	•	•	•	•	•	•
<b>Features</b>										
Oven cleaning	Self-Clean	Self-Clean	Self-Clean	Self-Clean	Self-Clean	Self-Clean	Self-Clean	Self-Clean	Self-Clean	Self-Clean
Cooktop burners	Sealed	Sealed	Sealed	Sealed	Sealed	Sealed	Sealed	Sealed	Standard/Twin	Standard/Twin
Maximum Output burner (Nat.)	(2) 12,000/ 1,000 BTU	(2) 12,000/ 1,000 BTU	(2) 12,000/ 1,000 BTU	(2) 12,000/ 1,000 BTU	(1) 12,000/ 1,000 BTU	(1) 12,000/ 1,000 BTU				
Precise Simmer burner (Nat.)	(1) 5,000/ 600 BTU	(1) 5,000/ 600 BTU	(1) 5,000/ 600 BTU	(1) 5,000/ 600 BTU	(1) 5,000/ 600 BTU	(1) 5,000/ 600 BTU				
All-purpose burners (Nat.)	(1) 9,500/ 850 BTU	(1) 9,500/ 850 BTU	(1) 9,500/ 850 BTU	(1) 9,500/ 850 BTU	(2) 9,500/ 850 BTU	(2) 9,500/ 850 BTU	(4) 9,500/ 850 BTU	(4) 9,500/ 850 BTU		
Valves (degree of turn)	270	270	270	270	270	270	140	140	270	270
TrueTemp™ System	•	•	•	•	•	•			•	
SmartLogic™ controls	•	•	•	•	•	•			•	
QuickSet oven controls	QuickSet V	QuickSet V	QuickSet V	QuickSet IV	QuickSet IV	QuickSet III	QuickSet II	QuickSet II	QuickSet III	QuickSet II
Auto Self-Clean	•	•	•	•	•	•	•	•	•	•
Electronic oven control	•	•	•	•	•	•			•	
Hi/Low broil	•	•	•	•	•	•			•	
Electronic clock and timer	•	•	•	•	•	•	•	•	•	•
Automatic oven timer	•	•	•	•	•	•			•	
Audible preheat signal	•	•	•	•	•	•	•	•	•	•
Auto oven shut-off	•	•	•	•	•	•	•	•	•	•
One-piece upswept cooktop	BC	Porc.-Enam.	Porc.-Enam.	Porc.-Enam.	Porc.-Enam.	Porc.-Enam.	Porc.-Enam.	Porc.-Enam.	Porc.-Enam.	Porc.-Enam.
Lift-up cooktop									•	•
Easy-clean porcelain-enameled subtop									•	•
Porcelain-enameled one-piece drip pans	Black	Grey Taupe Black	Grey Taupe Black	Grey Taupe Black	Grey Taupe Black	Grey Taupe Black	Opt. Access.	Opt. Access.	Chrome Chrome Black	Opt. Access.
Removable square grates	Profes. Grates	Profes. Grates Grey Taupe Black	Grey Heavy Cast Taupe Heavy Cast Black Hvy. Cast	Grey Heavy Cast Taupe Heavy Cast Black Hvy. Cast	Grey Medium Cast Taupe Medium Cast Black Med. Cast	Grey Deluxe Porc. Steel Taupe Deluxe Porc. Steel Black Deluxe Porc. Steel	Black Std. Porc. Steel	Black Std. Porc. Steel	Grey Std. Porc. Steel Taupe Std. Porc. Steel Black Std. Porc. Steel	Black Std. Porc. Steel
Ignition system	Electronic	Electronic	Electronic	Electronic	Electronic	Electronic	Electronic	Electronic	Electronic	Electronic
Oven racks	3	3	3	3	2	2	2	2	2	2
Six embossed rack positions	•	•	•	•	•	•	•	•	•	•
Extra-large broiler pan/grid	•	•	•	•	•	•	•	•	•	•
Scratch-resistant backguard	Mirrored Glass	Glass	Glass	Porc.-Enam.	Porc.-Enam.	Porc.-Enam.	Porc.-Enam.	Porc.-Enam.	Porc.-Enam.	Porc.-Enam.
Fluorescent backguard light	•	•	•	•	•	•	•	•	•	•
Interior oven light	•	•	•	•	•	•	•	•	•	•
Storage drawer	Easy Glide	Easy Glide	Easy Glide	Easy Glide	•	•	•	•	•	•
In-oven broiling	•	•	•	•	•	•	•	•	•	•
<b>Appearance</b>										
Color appearance*	BC	WW AA BB	WW AA BB	WW AA BB	WW AA BB	WW AA BB	WH/AD	WH/AD	WW AA WH/AD	WH/AD
Frameless removable oven door	Mirrored Glass	White Glass Almond Glass Black Glass	White Glass Almond Glass Black Glass	White Glass Almond Glass Black Glass	White Glass Almond Glass Black Glass	White Glass Almond Glass Black Glass	Black Glass	Solid Black Glass	White Glass Almond Glass Black Glass	Solid Black Glass
Oven door with window	Big View	Big View	Big View	Big View	Big View	Big View	•	•	•	•
Designer-style handle	Professional-Style	Sure Grip	Sure Grip	Sure Grip	•	•	•	•	•	•
Designer-style control knobs	Professional-Style	•	•	•	•	•	•	•	•	•
Four leveling legs	•	•	•	•	•	•	•	•	•	•
<b>Weights &amp; Dimensions</b>										
Overall oven interior dimensions (WxHxD in inches)	← 24 x 17 x 19 →									
Approx. shipping weight (lbs.)	230	220	220	210	210	210	210	210	200	200
<b>Power/Ratings</b>										
Top burners (000's BTU's) Nat/LP	← (2) 12.0/11.0 (1) 5.0/5.0 (1) 9.5/9.5 →				← (1) 12.0/11.0 (1) 5.0/5.0 (2) 9.5/9.5 →		← (4) 9.5/9.5 →		← (4) 9.0/8.0 →	
Oven/broiler burners (000's BTU's) Nat/LP	← 16.0/16.0 Oven 13.5/12.0 Broil →									
Gas range electrical rating	← 120V, 60Hz, 5A →									
LP conversion kit (included)	•	•	•	•	•	•	•	•	•	•

\*BB = Black on black, WW = White on white, AA = Almond on almond, WH = White, AD = Almond, BC = Brushed-Chrome.  
Factory set for Natural Gas. A set of LP orifices is included with each XL44™ range for LP conversion.

**Optional Gas Range Accessory Drip Pans for Sealed and Standard Burner Models** (Available at additional cost)  
To order these accessory drip pans, call toll-free 800-626-2002.



**Optional Gas Range Wok Accessory** (Available at additional cost)  
JXWK = Wok holder accessory sits on top of maximum burner grate to hold a round-bottom wok.



All GE ranges are equipped with an Anti-Tip device. The installation of this device is an important, required step in the installation of the range.

See page 136 for warranty information.

Model	A	B	C*	D	E
JGBP90MEA	30	47-3/4	26-1/4	46-3/8	36 ± 1/4
JGBP86BEA/WEA/AEA	30	47-3/4	26-1/4	46-3/8	36 ± 1/4
JGBP85BEA/WEA/AEA	30	47-3/4	26-1/4	46-3/8	36 ± 1/4
JGBP79BEA/WEA/AEA	30	46-1/2	26-1/4	46-3/8	36 ± 1/4
JGBP35BEA/WEA/AEA	30	46-1/2	26-1/4	46-3/8	36 ± 1/4
JGBP30BEA/WEA/AEA	30	46-1/2	26-1/4	46-3/8	36 ± 1/4
JGBP28BEA	30	46-1/2	26-1/4	46-3/8	36 ± 1/4
JGBP27BEA	30	46-1/2	26-1/4	46-3/8	36 ± 1/4
JGBP26WEA/AEA	30	46-1/2	26-1/4	46-3/8	36 ± 1/4
JGBP26BEA	30	46-1/2	26-1/4	46-3/8	36 ± 1/4
JGBP24BEA	30	46-1/2	26-1/4	46-3/8	36 ± 1/4

\*Dimension from wall to front of closed door handle is 29" on models JGBP86/85/79 and 28-1/4" on models JGBP90/35/30/28/27/26/24.  
25-1/4"—Depth to front edge of cooktop.

# 30" XL44™ CONTINUOUS AND STANDARD CLEAN GAS RANGES

	GE											
	Sealed Burner Models			Standard Burner Models								
	JGBS23WEA JGBS23AEA JGBS23BEA	JGBS22BEA	JGBS21PEA	JGBC20BEA JGBS20BEA	JGBC20WEA JGBS20WEA	JGBC17PEA JGBS17PEA	JGBS15PEA	JGBS07PEA	JGBS04BEA JGBS04BPA	JGBS04PEA JGBS04PPA	JGBS03PPA	
<b>Capacity</b>												
Extra-large oven	•	•	•	•	•	•	•	•	•	•	•	•
<b>Features</b>												
Oven cleaning	Standard Clean	Standard Clean	Standard Clean	Cont. Clean Standard Clean	Cont. Clean Standard Clean	Cont. Clean Standard Clean	Standard Clean	Standard Clean	Standard Clean	Standard Clean	Standard Clean	Standard Clean
Cooktop burners	Sealed	Sealed	Sealed	Std./Twin	Std./Twin	Std./Twin	Std./Twin	Std./Twin	Std./Twin	Std./Twin	Std./Twin	Std./Twin
Maximum Output burner (Nat.)	(1) 12,000/ 1,000 BTU											
Precise Simmer burner (Nat.)	(1) 5,000/ 600 BTU											
All-purpose burners (Nat.)	(2) 9,500/ 850 BTU	(4) 9,500/ 850 BTU	(4) 9,500/ 850 BTU									
Valves (degree of turn)	270	140	140	140	140	140	140	140	140	140	140	140
Electronic clock and timer	•	•	•	•	•	•	•	•	•	•	•	•
Porcelain-enameled cooktop	One-Piece Upswept	One-Piece Upswept	One-Piece Upswept	One-Piece Upswept	One-Piece Upswept	One-Piece Upswept	One-Piece Upswept	•	•	•	•	•
Lift-up cooktop				•	•	•	•	•	•	•	•	•
Easy-clean porcelain-enameled subtop				•	•	•	•	•	•	•	•	•
One-piece drip pans	Grey Taupe Black	Opt. Access.	Opt. Access.	Opt. Access.	Opt. Access.	Opt. Access.	Opt. Access.	Opt. Access.	Opt. Access.	Opt. Access.	Opt. Access.	Opt. Access.
Removable square grates	Deluxe Porcelain Steel	Black Standard Porcelain Steel	Black Standard Porcelain Steel	Black Standard Porcelain Steel	Grey Standard Porcelain Steel	Black Standard Porcelain Steel	Black Standard Porcelain Steel	Grey Standard Porcelain Steel	Black Standard Porcelain Steel	Black Standard Porcelain Steel	Black Standard Porcelain Steel	1-Piece Wire
Ignition system	Electronic	Electronic	Electronic	Electronic	Electronic	Electronic	Electronic	Electronic	Electronic Pilot †	Electronic Pilot †	Pilot †	Pilot †
Oven racks	2	2	1	2	2	2	2	2	2	2	2	2
Six embossed rack positions	•	•	•	•	•	•	•	•	•	•	•	•
Extra-large broiler pan/grid	•	•	•	•	•	•	•	•	•	•	•	•
Porcelain-enameled backguard	•	•	•	•	•	•	•	•	•	•	•	•
Interior oven light	•	•	•	•	•	•	•	•	•	•	•	•
Slide-out broiler drawer	•	•	•	•	•	•	Drop-Down	•	•	•	•	Drop-Down
<b>Appearance</b>												
Color appearance*	WW AA WH/AD	WH/AD	WH/AD	WH/AD	WW	WH/AD	WH/AD	WW	WH/AD	WH/AD	WH/AD	WH/AD
Frameless removable oven door	White Glass Almond Glass Black Glass	Black Glass	CM* Porc.-Enam.	Black Glass	White Glass	CM* Porcelain- Enameled	CM* Porcelain- Enameled	White Porcelain- Enameled	Solid Black Glass	CM* Porcelain- Enameled	CM* Porcelain- Enameled	CM* Porcelain- Enameled
Oven door with window	Big View	•	•	•	•	•	•	•	•	•	•	•
Designer-style handle	•	•	Chrome Visor	•	•	•	Chrome Visor	•	•	Chrome Visor	Chrome Visor	Chrome Visor
Four leveling legs	•	•	•	•	•	•	•	•	•	•	•	•
<b>Weights &amp; Dimensions</b>												
Overall oven interior dimensions (WxHxD in inches)	24 x 17 x 19											
Approx. shipping weight (lbs.)	180	170	170	175	175	175	175	165	165	165	160	160
<b>Power/Ratings</b>												
Top burners (000's BTU's) Nat/LP	(1) 12.0/11.0 (1) 5.0/5.0 (2) 9.5/9.5	(4) 9.5/9.5			(4) 9.0/8.0							
Oven/broiler burners (000's BTU's) Nat/LP	18.0/16.5											
Gas range electrical rating**	120V, 60Hz., 5A											
LP conversion kit (included)	•	•	•	•	•	•	•	•	•	•	•	•

\*WW= White on white, AA = Almond on almond, WH = White, AD = Almond, CM = Color-Matched indicates color of oven door matches cooktop (either white or almond).

\*\*Electrical rating not applicable to standing pilot models.

†JGBS04BPA, JGBS04PPA and JGBS03PPA have standing pilot ignition.

Factory set for Natural Gas. A set of LP orifices is included with each XL44™ range for LP conversion.

Note: Model JGBS03PPA does not have a flamespreader in broiler compartment.

Model	A	B	C*	D	E
JGBS23BEA/WEA/AEA	30	46-1/2	26-1/4	46-3/8	36 ± 1/4
JGBS22BEA	30	46-1/2	26-1/4	46-3/8	36 ± 1/4
JGBS21PEA	30	46-1/2	26-1/4	46-3/8	36 ± 1/4
JGBC20BEA	30	46-1/2	26-1/4	46-3/8	36 ± 1/4
JGBC20WEA	30	46-1/2	26-1/4	46-3/8	36 ± 1/4
JGBC20WEA	30	46-1/2	26-1/4	46-3/8	36 ± 1/4
JGBC17PEA	30	46-1/2	26-1/4	46-1/4	36 ± 1/4
JGBS17PEA	30	46-1/2	26-1/4	46-1/4	36 ± 1/4
JGBS15PEA	30	46-1/2	26-1/4	46-1/4	36 ± 1/4
JGBS07PEA	30	45-1/2	26-1/4	46-1/4	36 ± 1/4
JGBS04BEA/BPA	30	45-1/2	26-1/4	46-3/8	36 ± 1/4
JGBS04PEA/PPA	30	45-1/2	25-5/16	46-1/4	36 ± 1/4
JGBS03PPA	30	40	25-5/16	46-1/4	36 ± 1/4

\*Dimension from wall to front of closed door handle is 29". On models JGBS04 and JGBS03 the dimension is 27-7/16". 25-1/4"—Depth to front top edge of cooktop

## Installation Information (Dimensions in inches)

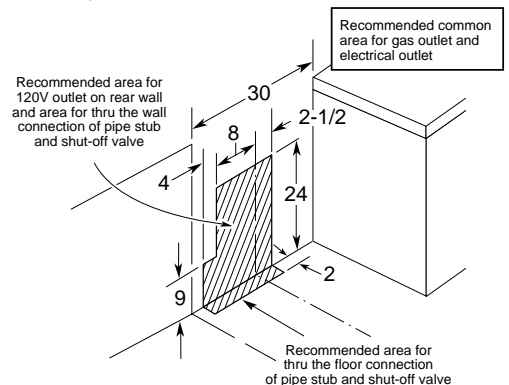
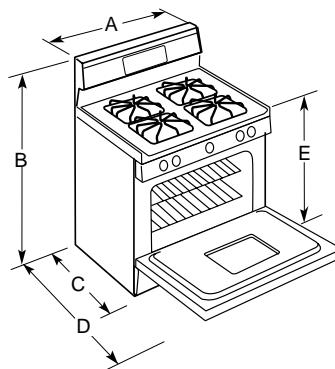

See page 136 for warranty information.



# SPACEMAKERPLUS™ MICROWAVE/CONVECTION OVENS

	GE Profile Performance Series™	
	JVM1190SY	JVM1190WY JVM1190AY JVM1190BY
<b>Capacity</b>		
Oven cavity (cu. ft.)	1.1	1.1
<b>Features</b>		
Watts (IEC-705 Test Procedure)	825	825
Electronic Touch Controls	●	●
SmartControl System w/Interactive Display	●	●
Electronic scrolling digital display w/Clock and AM/PM Pad	●	●
Variable Scroll Speed	●	●
Help Pad	●	●
Concurrent programming	●	●
Display On/Off	●	●
<b>Sensor Controls</b>		
Beverage	●	●
Popcorn	●	●
Reheat	●	●
Vegetables (Canned/Fresh/Frozen)	●	●
<b>Convection Controls</b>		
Convection Broil	Hi/Lo	Hi/Lo
Convection Bake	●	●
Combination Roast	●	●
<b>Sensor Combination</b>	Chicken, Fish, Potato	Chicken, Fish, Potato
Combination Bake	Hi/Lo	Hi/Lo
Express Cook (1-6 minutes)	●	●
Instant On Controls	●	●
Time Cook	I & II	I & II
Add 30 Seconds	●	●
Temp Cook	●	●
Auto Defrost/Time Defrost	●	●
Power levels	10	10
Delay Start	●	●
Surface light	●	●
Night Light	●	●
Programmable Night Light	●	●
Timer On/Off	●	●
Reminder	●	●
Variable Beeper Volume Control	●	●
Cooking Complete Reminder	●	●
Child Lock Out	●	●
Two-speed high-capacity exhaust fan	●	●
<b>Appearance</b>		
Color appearance*	SS	WW AA BB
Case color	Stainless Steel	White on white Almond on almond Black on black
Door Color	Stainless Steel	White on white Almond on almond Black on black
Designer-style handle	●	●
<b>Weights &amp; Dimensions</b>		
Approx. shipping weight (lbs.)	98	98
WxHxD (inches)	Cavity Exterior	18 x 8-1/16 x 12-1/2 29-15/16 x 15-1/2 x 14-1/4
<b>Power/Ratings</b>		
2450 Frequency (MHz)	●	●
Electrical input @ 120V	Watts Amperage	1300 12.5
<b>Accessories</b>		
Convection/Rack broil pan	●	●
<b>Warranty</b>		
Full One-Year In Home Warranty**	●	●
Limited Nine-Year Magnetron Warranty** (10 years total)	●	●

\*SS = Stainless steel, BB = Black on black, WW = White on white, AA = Almond on almond

\*\*See written warranty for details.

## Dimensions (in inches)

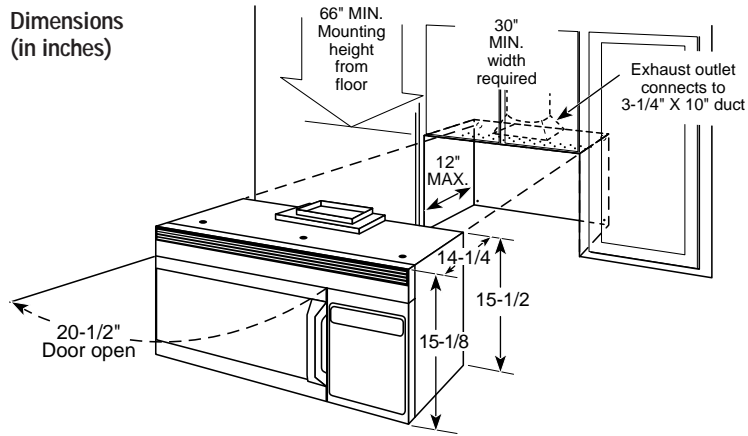

## Ventilation Options

The SpacemakerPlus™ microwave/convection and Spacemaker microwave ovens are designed for adaptation to the following three types of ventilation:

**Outside Exhaust (Vertical—**as shown above)

**Outside Exhaust (Horizontal)**

**Recirculating (Non-vented ductless—**see Filter Kit Drawing)

Requires 120V grounded outlet. Electrical receptacle must be located in cabinet above SpacemakerPlus™ microwave/convection and Spacemaker microwave ovens. No additional wiring, venting or cabinet rebuilding necessary in many cases. Complete detailed, easy-to-follow installation instructions and convenient full-size templates are packed with product.

**Important:** When installing these ovens over a range, allow minimum of 2" from bottom of microwave oven to top of range backguard to allow for removal of light covers.

## Optional Accessories (Available at additional cost)

**12" Filler Panel Kits**  
JX40AL—Almond  
JX41—Black  
JX40WH—White

**15" Filler Panel Kits**  
JX46BL—Black  
JX46AL—Almond  
JX46WH—White

When replacing a 36" or 42" range hood, this kit fills in the additional width to provide a custom built-in appearance. For installation between cabinets only; not for end-of-cabinet installation. Each kit contains two 3"-wide filler panels. Two kits are needed for a 42" opening.

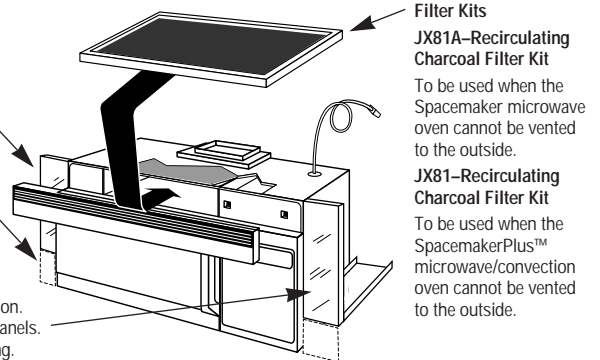

**Filter Kits**  
JX81A—Recirculating Charcoal Filter Kit  
To be used when the Spacemaker microwave oven cannot be vented to the outside.  
JX81—Recirculating Charcoal Filter Kit  
To be used when the SpacemakerPlus™ microwave/convection oven cannot be vented to the outside.

Model	Recirculating Charcoal Filter Kit	Filler Panel Kit	Decorative Panel Kit
JVM1190AY	JX81	JX40AL	JX22SS
JVM1190BY	JX81	JX41	JX22SS
JVM1190WY	JX81	JX40WH	JX22SS
JVM1190SY	JX81	—	JX22SS
JVM1660AB	JX81A	JX40AL	JX22SS
JVM1660SB	JX81A	—	JX22SS
JVM1660BB	JX81A	JX41/JX46BL	JX22SS
JVM1660WB	JX81A	JX40WH/JX46WH	JX22SS
JVM1650AB	JX81A	JX40AL/JX46AL	JX22SS
JVM1650BB	JX81A	JX41/JX46BL	JX22SS
JVM1650WB	JX81A	JX40WH/JX46WH	JX22SS
JVM1640BB	JX81A	JX41/JX46BL	JX22SS
JVM1640WB	JX81A	JX40WH/JX46WH	JX22SS
JVM1630BB	JX81A	JX41/JX46BL	JX22SS
JVM1630WB	JX81A	JX40WH/JX46WH	JX22SS

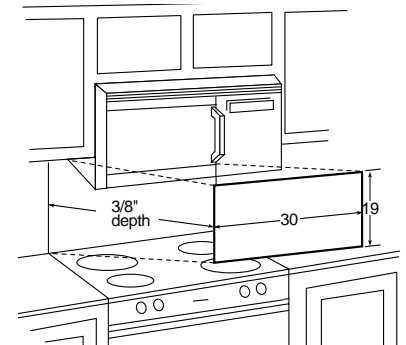

**JX22SS—Stainless Steel Decorative Panel Kit**  
When replacing a Hi/Low range with a SpacemakerPlus™ microwave/convection oven or Spacemaker over a range model, this panel kit fills in the area between the microwave and range left by the Hi/Low model.



Listed by Underwriters Laboratories

This information is not intended to be used for installing unit described. Before installing, consult installation instructions packed with product/kit for current dimensional data.

# SPACEMAKER OVER-THE-RANGE MICROWAVE OVENS

	GE Profile™		GE						
	JVM1660SB JVM1660AB	JVM1660BB JVM1660WB	JVM1651AB* JVM1650AB	JVM1651BB* JVM1650BB	JVM1651WB* JVM1650WB	JVM1640BB JVM1640WB/AB	JVM1631BB* JVM1630BB	JVM1631WB* JVM1630WB	JVM1420WB JVM1420BB
<b>Capacity</b>									
Oven cavity (cu. ft.)	1.6	1.6	1.6	1.6	1.6	1.6	1.6	1.6	1.4
<b>Features</b>									
Watts (IEC-705 Test Procedure)	1000	1000	1000	1000	1000	1000	1000	1000	950
Electronic touch controls	•	•	•	•	•	•	•	•	•
SmartControl System w/Interactive Display	•	•	•	•	•	•	•	•	•
Electronic scrolling digital display	•	•	•	•	•	•	•	•	•
Demo Mode	•	•	•	•	•	•	•	•	•
Clock and AM/PM Pad	•	•	•	•	•	•	•	•	•
Clock Saver	•	•	•	•	•	•	•	•	•
Variable Scroll Speed	•	•	•	•	•	•	•	•	•
Help Pad	•	•	•	•	•	•	•	•	•
Concurrent programming	•	•	•	•	•	•	•	•	•
Display On/Off	•	•	•	•	•	•	•	•	•
Sensor Controls									
Beverage	•	•	•	•	•	•	•	•	•
Chicken	•	•	•	•	•	•	•	•	•
Fish	•	•	•	•	•	•	•	•	•
Meats	•	•	•	•	•	•	•	•	•
Popcorn	•	•	•	•	•	•	•	•	•
Potatoes	•	•	•	•	•	•	•	•	•
Reheat	•	•	•	•	•	•	•	•	•
Vegetables	•	•	•	•	•	•	•	•	•
Appointment Scheduler Pad	•	•	•	•	•	•	•	•	•
Custom Pads (2)	•	•	•	•	•	•	•	•	•
Message Center	•	•	•	•	•	•	•	•	•
Convenience Controls									
Beverage Pad	•	•	•	•	•	•	•	•	•
Cook Pad	•	•	•	•	•	•	•	•	•
Popcorn Pad	•	•	•	•	•	•	•	•	•
Reheat Pad	•	•	•	•	•	•	•	•	•
Snacks Pad	•	•	•	•	•	•	•	•	•
Express Cook (1-6 min.)	•	•	•	•	•	•	•	•	•
Instant On Controls	•	•	•	•	•	•	•	•	•
Time Cook	I & II	I & II	I & II	I & II	I & II	I & II	I & II	I & II	I & II
Add 30 Seconds	•	•	•	•	•	•	•	•	•
Temp. Cook/Roast (Probe)	•	•	•	•	•	•	•	•	•
Auto Defrost/Time Defrost	•	•	•	•	•	•	•	•	•
Power levels	10	10	10	10	10	10	10	10	10
Delay Start	•	•	•	•	•	•	•	•	•
Reminder	•	•	•	•	•	•	•	•	•
CircuWave™ 1000 Cooking System	•	•	•	•	•	•	•	•	•
Two Cooking Racks	•	•	•	•	•	•	•	•	•
Dual Rack	•	•	•	•	•	•	•	•	•
Turntable	•	•	•	•	•	•	•	•	•
Turntable On/Off	•	•	•	•	•	•	•	•	•
Full-View cooktop lighting	•	•	•	•	•	•	•	•	•
Night light	•	•	•	•	•	•	•	•	•
Programmable nite light	•	•	•	•	•	•	•	•	•
Timer On/Off	•	•	•	•	•	•	•	•	•
Beeper sound level control	•	•	•	•	•	•	•	•	•
Cooking Complete Reminder	•	•	•	•	•	•	•	•	•
Child lock out	•	•	•	•	•	•	•	•	•
Two-speed high-capacity exhaust fan	300 CFM	300 CFM	300 CFM	300 CFM	300 CFM	300 CFM	300 CFM	300 CFM	300 CFM
Easy Mount Installation	•	•	•	•	•	•	•	•	•
<b>Appearance</b>									
Color appearance**	SS/AA	BB/WW	AA	BB	WW	BB/WW/AA	BB	WW	WW/BB
Case color	Black/Almond	Black/White	Almond	Black	White	Black/White/Almond	Black	White	White/Black
Designer-style handle	•	•	•	•	•	•	•	•	•
Big View window	•	•	•	•	•	•	•	•	•
<b>Weights &amp; Dimensions</b>									
Approx. shipping weight (lbs.)	67	67	67	67	67	67	67	67	67
WxHxD	Cavity ††		20-1/4 x 9-9/32 x 14-13/32						
(in inches)	Exterior ††		29-7/8 x 16-15/32 (rear) x 15-1/16						
<b>Power/Ratings</b>									
2450 Frequency (MHz)	•	•	•	•	•	•	•	•	•
Electrical input	1480	1480	1480	1480	1480	1480	1480	1480	1480
@ 120V	Amperage	15	15	15	15	15	15	15	15
<b>Accessories</b>									
Cookbook	•	•	•	•	•	•	•	•	•
<b>Warranty</b>									
Full One-Year In-Home Warranty†	•	•	•	•	•	•	•	•	•
Limited Nine-Year Magnetron Warranty† (10 years total)	•	•	•	•	•	•	•	•	•

\*Non-vented model.

\*\*SS = Stainless steel, AA = Almond on almond, BB = Black on black, WW = White on white.

†Exterior dimensions: depth excludes handle.

††Cavity: 19-5/16 x 9-5/16 x 13-3/16. Exterior: 29-7/8 x 16-1/2 (rear) x 14-5/16.

‡See warranty for details.

**NOTE:** Popcorn Pad designed for use with 3 packages sizes—3.5, 3.0 and 1.75 oz.

This information is not intended to be used for installing unit described. Before installing, consult installation instructions packed with product/kit for current dimensional data.

## Dimensions (in inches)

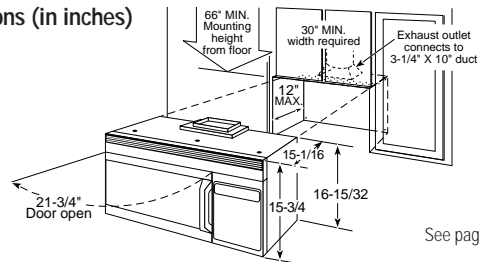

See page 136 for warranty information.

# BUILT-IN MICROWAVE OVENS

	GE Profile Performance Series™			GE Profile™	
	Microwave/Convection Oven			Microwave Oven	
	JEB1095SB	JEB1095WB	JEB1095BB	JEB1055WB	JEB1055BB
<b>Capacity</b>					
Oven cavity (cu. ft.)	1.0	1.0	1.0	1.0	1.0
<b>Features</b>					
Watts (IEC-705 Test Procedure)	800	800	800	800	800
Electronic Touch Controls	●	●	●	●	●
Electronic digital display w/clock	●	●	●	●	●
Beverage	Sensor	Sensor	Sensor	Sensor	Sensor
Cook	Sensor	Sensor	Sensor	Sensor	Sensor
Popcorn	Sensor	Sensor	Sensor	Sensor	Sensor
Reheat	Sensor	Sensor	Sensor	Sensor	Sensor
Convection Cook	●	●	●		
Combination Cook	●	●	●		
Combination Roast (Probe)	●	●	●		
Express Cook	●	●	●	●	●
Instant On Controls	●	●	●	●	●
Time Cook	I & II	I & II	I & II	I & II	I & II
Add 30 Seconds	●	●	●	●	●
Temp Cook/Hold (Probe)	●	●	●	●	●
Auto Roast (Probe)	●	●	●	●	●
Auto Defrost/Time Defrost	●	●	●	●	●
Power levels	10	10	10	10	10
Delay/Start Reminder	●	●	●	●	●
Minute Pad	●	●	●	●	●
Program cooking	5 Stage	5 Stage	5 Stage	5 Stage	5 Stage
Kitchen timer	99-M./99-S. Digital	99-M./99-S. Digital	99-M./99-S. Digital	99-M./99-S. Digital	99-M./99-S. Digital
Variable Beeper Volume	●	●	●	●	●
Cooking Complete Reminder	●	●	●	●	●
<b>Appearance</b>					
Color appearance*	SS	WW	BB	WW	BB
Designer-style handle	●	●	●	●	●
<b>Weights &amp; Dimensions</b>					
Approx. shipping wt. (lbs.)	84	84	84	75	75
WXxD Cavity	18x8-3/16x11-1/2				
(in inches) Exterior†	26-3/4x18-5/8x16-3/8				
<b>Power/Ratings</b>					
2450 Frequency (MHz)	●	●	●	●	●
Electrical input Watts	1450	1450	1450	1450	1450
@ 120V Amperage	13.0	13.0	13.0	13.0	13.0
<b>Accessory</b>					
Deluxe cookbook	●	●	●	●	●
Wire oven rack	●	●	●	●	●
30" trim kit (included)	●	●	●	●	●
<b>Warranty</b>					
Full One-Year In-Home Warranty**	●	●	●	●	●
Limited Nine-Year Magnetron Warranty** (10 years total)	●	●	●	●	●

\*WB = White on white, BB = Black on black.  
 \*\*See written warranty for details.  
 †Exterior dimensions: depth excludes handle.



## Cut-Out and Dimensional Information (in inches)

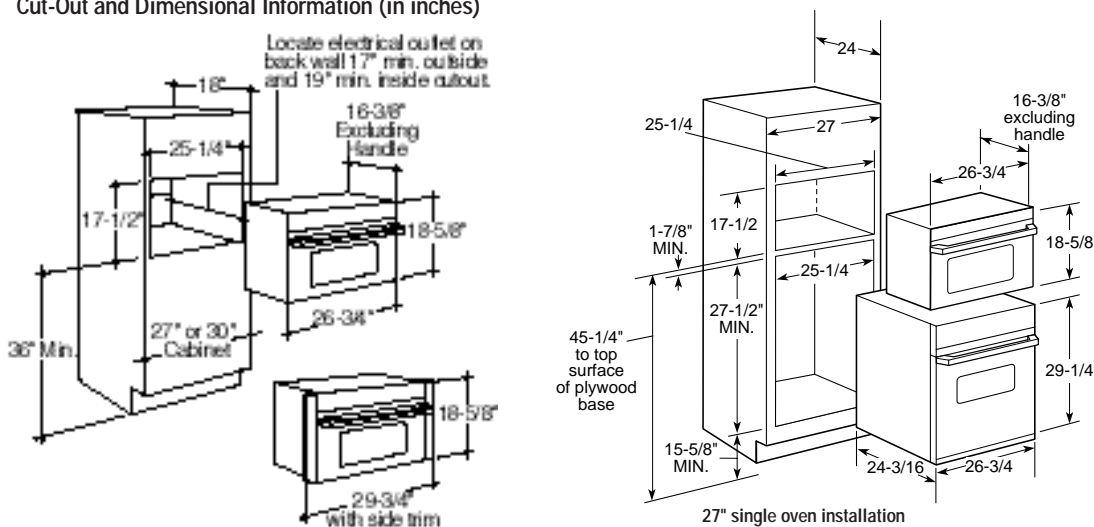

This information is not intended to be used for installing unit described.  
 Before installing, consult installation instructions packed with product/kit for current dimensional data.

**Note:** Refer to page 197 for information on Accessory Trim Kits (Available at additional cost)

See page 136 for warranty information.

# COUNTERTOP MICROWAVE OVENS

	GE Profile Performance Series™	GE Profile™	GE	GE Profile™	GE	GE Profile™	GE	GE Profile™	GE	
	Microwave/Convection	Extra-large		Full-size		Family-size		Mid-size		Compact
	JE1390WA JE1390GA	JE1860SB JE1860WB JE1860GB	JE1840WB JE1840GB	JE1660WB JE1660GB	JE1640AB JE1640WB JE1640GB	JE1360WB JE1360GB	JE1340WB JE1340GB	JE1060WB JE1060GB	JE1040WB JE1040GB	JE740WY JE740GY
<b>Capacity</b>										
Oven cavity (cu. ft.)	1.3	1.8	1.8	1.6	1.6	1.3	1.3	1.0	1.0	.7
<b>Features</b>										
Watts (IEC-705 Test Procedure)	850	1100	1100	1100	1100	1100	1100	1100	1100	700
Electronic Touch Controls	●	●	●	●	●	●	●	●	●	●
Scrolling Display with Help Pad		●		●		●		●		
Demo Mode		●		●		●		●		
Electronic digital display w/clock	●	●	●	●	●	●	●	●	●	●
Display On/Off	●	●		●		●		●		
Beverage Pad	Sensor	Sensor	●	Sensor	●	Sensor	●	Sensor	●	●
Cook Pad	Sensor		●		●		●		●	●
Chicken/Fish Pad		Sensor		Sensor		Sensor		Sensor		
Potato Pad		Sensor		Sensor		Sensor		Sensor		
Vegetable Pad		Sensor		Sensor		Sensor		Sensor		
Popcorn Pad	Sensor	Sensor	●	Sensor	●	Sensor	●	Sensor	●	●
Reheat Pad	Sensor	Sensor	●	Sensor	●	Sensor	●	Sensor	●	●
Snacks Pad			●		●		●		●	●
Convection Cook	●									
Combination Cook	●									
Combination Roast	●									
Express Cook	●	●	●	●	●	●	●	●	●	●
Instant On Controls	●	●	●	●	●	●	●	●	●	●
Time Cook	I & II	I & II	I & II	I & II	I & II	I & II	I & II	I & II	I & II	I & II
Add 30 Seconds	●	●	●	●	●	●	●	●	●	●
Temp Cook/Hold (probe)	●									
Auto Defrost	●	●	●	●	●	●	●	●	●	●
Time Defrost	●	●	●	●	●	●	●	●	●	●
Power levels	10	10	10	10	10	10	10	10	10	10
SmartRack	●									
Turntable	●	●	●	●	●	●	●	●	●	●
Turntable On/Off		●		●		●		●		●
Kitchen timer	99-M./99-S.	Timer On/Off	99-M./99-S.	Timer On/Off	99-M./99-S.	Timer On/Off	99-M./99-S.	Timer On/Off	99-M./99-S.	99-M./99-S.
Delay Start/Reminder	●	●	●	●	●	●	●	●	●	●
Sound On/Off	●		●		●		●		●	●
Variable Beeper Control		●		●		●		●		●
Cooking Complete Reminder	●	●	●	●	●	●	●	●	●	●
Child lock out	●	●	●	●	●	●	●	●	●	●
<b>Appearance</b>										
Color appearance*	WW BB	SS WW BB	WW BB	WW BB	AA WW BB	WW BB	WW BB	WW BB	WW BB	WW BB
Case color	White Greystone	Stainless Steel White Greystone	White Greystone	White Greystone	Almond White Greystone	White Greystone	White Greystone	White Greystone	White Greystone	White Greystone
Door color	White Black	Stainless Steel White Black	White Black	White Black	Almond White Black	White Black	White Black	White Black	White Black	White Black
<b>Weights &amp; Dimensions</b>										
Approx. shipping wt. (lbs.)	64	48	48	50	50	42	42	43	39	33
Cavity	14-1/2 x 10-1/8 x 14-1/2	17-1/16 x 9-3/4 x 18-5/16		16-1/2 x 9-23/32 x 16-27/32		14-3/4 x 9-1/4 x 16		13-11/16 x 8-1/2 x 14-15/16		12-1/16 x 7-11/16 x 12-1/16
WxHxD (in inches)	Exterior † 22-1/4 x 14-7/8 x 19-7/8	23-7/8 x 13-9/16 x 18-13/16		23-21/32 x 13-5/16 x 18-5/16		21-7/8 x 12-5/8 x 17-1/4		20-1/2 x 11-7/8 x 15-7/8		19-1/4 x 10-13/16 x 13-9/16
<b>Power/Ratings</b>										
2450 Frequency (MHz)	●	●	●	●	●	●	●	●	●	●
Electric Watts input @ 120V	1500 Amperage	1550 13.6	1550 13.6	1500 13.0	1500 13.0	1550 13.3	1550 13.3	1500 13.0	1500 13.0	1150 10.5
<b>Accessories</b>										
Optional built-in kit	JX1330WV/ 1327WV JX1330BV/ 1327BV	JX1830SB/ JX1827SB JX1830WB/ JX1827WB JX1830BB/ JX1827BB	JX1830SB/ JX1827SB JX1830WB/ JX1827WB JX1830BB/ JX1827BB	JX1530MWW/ 1527MWW/ JX1530MBW/ 1527MBW	JX1530MAW/ JX1527MAW/ JX1530MWW/ 1527MWW/ JX1530MBW/ 1527MBW					
Optional hanging kit										Pub. No. 4-A019
<b>Warranty</b>										
Full One-Year Warranty**	In-Home	In-Home	In-Home	In-Home	In-Home	Carry-In	Carry-In	Carry-In	Carry-In	Carry-In
Limited Nine-Year Magnetron Warranty** (10 years total)	●	●	●	●	●	●	●	●	●	●

\*SS = Stainless Steel, BB = Black on black, WW = White on white, AA = Almond on almond.

\*\*See written warranty for details.

†Exterior dimensions: height includes feet.

**Note:** Refer to page 197 for information on Accessory Trim Kits (Available at additional cost)

Refrigeration

Water Systems

Laundry

Cooking Products

Microwave Ovens

Dishwashers

Room Air



# SPACEMAKER II™ MICROWAVE OVENS

	GE Profile™		GE	
	JEM31WA	JEM31SA JEM31GA	JEM25WY	JEM25GY
<b>Capacity</b>				
Oven cavity (cu. ft.)	.9	.9	.9	.9
<b>Features</b>				
Watts (IEC-705 Test Procedure)	800	800	800	800
Electronic Touch Controls	●	●	●	●
Scrolling Display with Help	●	●		
Electronic digital display w/clock	●	●	●	●
Beverage	Sensor	Sensor	●	●
Cook	Chicken/Fish Potato Vegetable Sensor	Chicken/Fish Potato Vegetable Sensor	●	●
Popcorn	Sensor	Sensor	●	●
Reheat	Sensor	Sensor	●	●
Snacks			●	●
Express Cook	●	●	●	●
Instant On Controls	●	●	●	●
Time Cook I & II	●	●	●	●
Add 30 Seconds	●	●	●	●
Auto Defrost/Time Defrost	●	●	●	●
Power levels	10	10	10	10
Kitchen timer	Timer On/Off	Timer On/Off	99-M./99-S.	99-M./99-S.
Beeper Volume	●	●		
Sound On/Off			●	●
Cooking Complete Reminder	●	●	●	●
Delay Start/Reminder	●	●	●	●
Child Lock Out	●	●	●	●
<b>Appearance</b>				
Color appearance*	WW	SS BB	WW	BB
Door color	White	Stainless Steel Black	White	Black
Case color	White	Stainless Steel Greystone	White	Greystone
<b>Weights &amp; Dimensions</b>				
Approx. shipping wt. (lbs.)	41	41	41	41
WxHxD (in inches)	← 16-1/2 x 7-7/16 x 11-1/4 →		← 16-1/2 x 7-7/16 x 11-1/4 →	
Exterior †	← 23-25/32 x 11-3/16 x 12-9/32 →		← 23-25/32 x 11-3/16 x 12-9/32 →	
<b>Power/Ratings</b>				
2450 Frequency (MHz)	●	●	●	●
Electrical input @ 120V	Watts 1300	Watts 1300	Watts 1300	Watts 1300
Amperage	11.5	11.5	11.5	11.5
<b>Accessories</b>				
Hanging kit (Pub. No. 4-A019)**	Optional	Optional	Optional	Optional
Optional built-in kit	JX827WN	JX827BN/ JX827SS	JX827WN	JX827BN/ JX827SS
<b>Warranty</b>				
Full One-Year Warranty†	In-Home	In-Home	Carry-In	Carry-In
Nine-Year Magnetron Warranty† (10 years total)	Limited	Limited	Limited	Limited

\*BB = Black on black, WW = White on white, SS = Stainless Steel

\*\*Pub. No. 4-A019 is available at additional cost.

†See written warranty for details.

††Exterior dimensions: height includes feet.

## Cut-Out Dimensions (in inches)

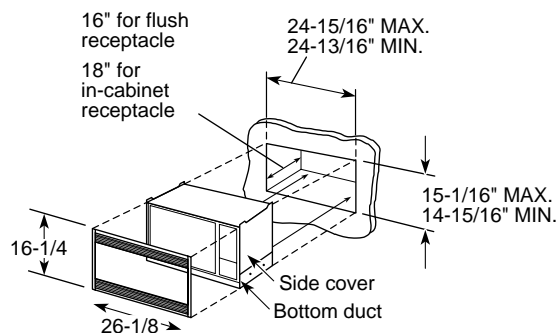

## Accessory Trim Kits for .9 Microwave Ovens (Available at additional cost)

For a custom built-in appearance, this kit allows built-in installation of the Spacemaker II™ microwave oven into a wall or cabinet alone, and is U.L.-approved for installation over a GE single electric wall oven. This kit should not be installed over a gas wall oven.

JX827BN—JEM31GA/JEM25GY, JX827WN—JEM31WA/JEM25WY  
JX827SS—JEM31SA/JEM31GA/JEM25GY

See page 136 for warranty information.

# COUNTERTOP/COMPACT/SUBCOMPACT MICROWAVE OVENS

	GE			
	JE710BA	JE835WW JE635WW	JE520BW	JE510BW
<b>Capacity</b>				
Oven cavity (cu. ft.)	.7	.8 .6	.5	.5
<b>Features</b>				
Watts (IEC-705 Test Procedure)	600	800 600	600	600
Electronic Touch Controls		●		
Electronic digital display w/clock (LED)		●	●	
Mechanical Dial	●			●
Beverage Pad		●		
Popcorn Pad		●		
Frozen Pizza Pad		●		
Dinner Plate Pad		●		
Baked Potato Pad		●		
Vegetables Pad		●		
Soup Pad		-		
Instant On Controls		●		
Time Cook	15 Min.		●	15 Min.
Auto Defrost		●		
Time Defrost			●	
Power levels	1	10	10	1
Turntable	●	●	●	●
Quick Set		●		
Auto Start		●		
Child Lock Out		●		
<b>Appearance</b>				
Door color	Black	White	Black	Black
Case color	Black	White	Black	Black
<b>Weights &amp; Dimensions</b>				
Approx. shipping wt. (lbs.)	29	33	29	29
WxHxD (in inches)	← 11-7/8 x 7-5/8 x 12-1/2 →		← 11-3/32 x 6-11/16 x 11-7/32 →	
Cavity	11-7/8 x 7-5/8 x 12-1/2		11-3/32 x 6-11/16 x 11-7/32	
WxHxD (in inches)	Exterior † 19 x 11 x 12-7/8		19-1/2 x 11-3/8 x 15-1/8 18-5/16 x 10-13/16	
<b>Power/Ratings</b>				
2450 Frequency (MHz)	●	●	●	●
Electrical input @ 120V	Watts 910	Watts 1200/920	Watts 950	Watts 950
Amperage	8.5	10.5/8.0	8.5	8.5
<b>Accessory</b>				
Hanging kit (Pub. No. 4-A019)*	Optional		Optional	Optional
<b>Warranty</b>				
Full One-Year warranty**	Carry-In	Carry-In	Carry-In	Carry-In
Four-year Magnetron warranty** (Five years total)	●	●	●	●

\*Pub. No. 4-A019 is available at additional cost.

\*\*See written warranty for details.

†Exterior dimensions: height includes feet.

## Undercabinet Mounting Kit Pub. No. 4-A019 For Spacemaker II™ Compact and Subcompact Microwave Oven Models (Available at additional cost)

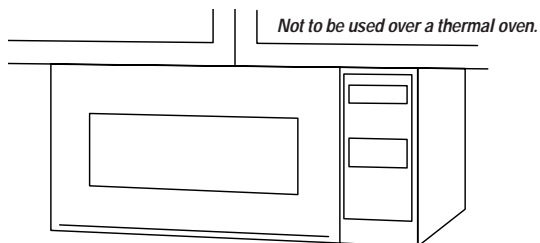

### Undercabinet Installation

Install Spacemaker II™, Compact and Subcompact microwave ovens in just a few easy steps with the mounting template, which provides all the necessary measurements.\* These microwave ovens can be installed on practically any wood or metal cabinets.

\*Installation may vary depending on cabinets.

**Note:** 120V, 60-cycle, grounded power receptacle location optional on back within cabinet opening.

This information is not intended to be used for installing unit described. Before installing, consult installation instructions packed with product/kit for current dimensional data.

# ACCESSORY TRIM KITS

## Optional Accessory Trim Kits for 1.3 GE Profile Performance™ Microwave Ovens (Available at additional cost)

For a custom built-in appearance, these kits allow built-in installation of the 1.3 countertop microwave oven into a wall or cabinet alone and are U.L.-approved for installation over a GE single electric wall oven. These kits should not be installed over a gas wall oven.

**Note:** 120V, 60-cycle, grounded power receptacle location optional on back within cabinet opening.

### 30" Deluxe Accessory Trim Kits

JX1330BV—Black  
JX1330WV—White

Model	"A"	30" Deluxe Accessory Trim Kit
JE1390GA	29-3/4"	JX1330BV
JE1390WA	29-3/4"	JX1330WV

### 27" Deluxe Accessory Trim Kits

JX1327BV—Black  
JX1327WV—White

Model	"A"	27" Deluxe Accessory Trim Kit
JE1390GA	26-3/4"	JX1327BV
JE1390WA	26-3/4"	JX1327WV

## Optional Accessory Trim Kits for 1.6 GE Profile™ and GE Microwave Ovens (Available at additional cost)

For a custom built-in appearance, these kits allow built-in installation of the 1.6 countertop microwave oven into a wall or cabinet alone and are U.L.-approved for installation over a GE single electric wall oven. These kits should not be installed over a gas wall oven.

### 30" Deluxe Accessory Trim Kits

JX1530MBW—30" Black  
JX1530MWW—30" White  
JX1530MAW—30" Almond

Model	"A"	30" Deluxe Accessory Trim Kit
JE1660WB	29-3/4"	JX1530MWW
JE1660GB	29-3/4"	JX1530MBW
JE1640WB	29-3/4"	JX1530MWW
JE1640GB	29-3/4"	JX1530MBW
JE1640AB	29-3/4"	JX1530MAW

### 27" Deluxe Accessory Trim Kits

JX1527MBW—27" Black  
JX1527MWW—27" White  
JX1527MAW—27" Almond

Model	"A"	27" Deluxe Accessory Trim Kit
JE1660WB	26-3/4"	JX1527MWW
JE1660GB	26-3/4"	JX1527MBW
JE1640WB	26-3/4"	JX1527MWW
JE1640GB	26-3/4"	JX1527MBW
JE1640AB	26-3/4"	JX1527MAW

## Optional Accessory Trim Kits for 1.8 GE Profile™ and GE Microwave Ovens (Available at additional cost)

For a custom built-in appearance, these kits allow built-in installation of the 1.8 countertop microwave oven into a wall or cabinet alone and are U.L.-approved for installation over a GE single electric wall oven. These kits should not be installed over a gas wall oven.

### 30" Deluxe Accessory Trim Kits

JX1830SB—30" Stainless Steel  
JX1830GB—30" Black  
JX1830WB—30" White

Model	"A"	30" Deluxe Accessory Trim Kit
JE1860SB	29-3/4"	JX1830SB
JE1860GB	29-3/4"	JX1830GB
JE1860WB	29-3/4"	JX1830WB
JE1840WB	29-3/4"	JX1830WB
JE1840GB	29-3/4"	JX1830GB

### 27" Deluxe Accessory Trim Kits

JX1827SB—27" Stainless Steel  
JX1827GB—27" Black  
JX1827WB—27" White

Model	"A"	27" Deluxe Accessory Trim Kit
JE1860SB	26-3/4"	JX1827SB
JE1860GB	26-3/4"	JX1827GB
JE1860WB	26-3/4"	JX1827WB
JE1840WB	26-3/4"	JX1827WB
JE1840GB	26-3/4"	JX1827GB

### Cut-Out Dimensions (in inches)

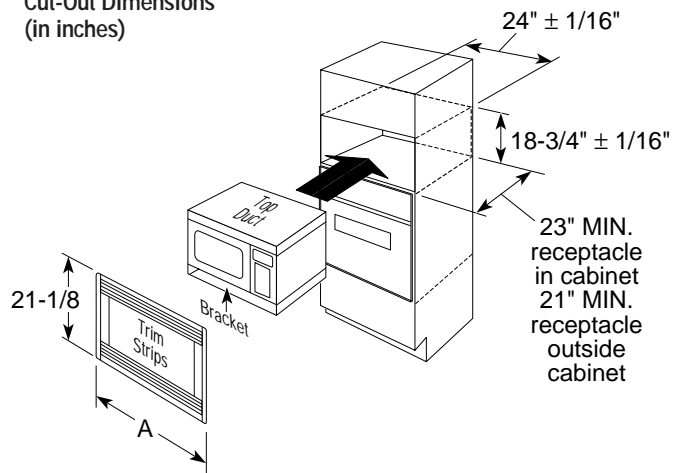

### Cut-Out Dimensions (in inches)

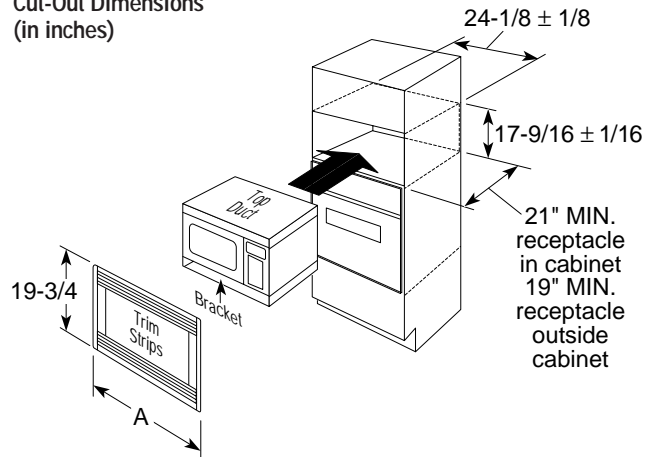

Refrigeration

Water Systems

Laundry

Cooking Products

Microwave Ovens

Dishwashers

Room Air

# BUILT-IN DISHWASHERS

Features	GE Profile Performance Series™			GE Profile™	
	GSD4940CSS	GSD4930ZWW GSD4920ZBB GSD4910ZAA	GSD4630ZWW GSD4620ZBB GSD4610ZAA	GSD4330ZWW GSD4320ZBB GSD4310ZAA	GSD4030ZWW GSD4020ZBB GSD4010ZAA
<b>Wash System</b>					
SureClean™ Wash System	●	●	●	●	●
CleanSensor II	●	●	●	●	●
CircuClean Pump	●	●	●	●	●
Wash levels	3	3	3	3	3
Filtration system	Triple	Triple	Triple	Dual	Dual
Piranha™ Hard Food Disposer	●	●	●	●	●
<b>Cycles</b>	Variable	Variable	Variable	5	4
POTSCRUBBER				●	●
Pots and Pans	●	●	●	●	●
Normal Wash	●	●	●	●	●
Light Wash	●	●	●	●	●
China/Crystal	●	●	●	●	●
Glasses	●	●	●	●	●
Rinse Only/Hold	●	●	●	●	●
<b>Options</b>	Variable	Variable	Variable	34	26
Child Lock Option	●	●	●	●	●
Delay Start	2-4-8-Hour	2-4-8-Hour	2-4-8-Hour	2-4-8-Hour	2-4-6-Hour
Heated Dry On/Off	●	●	●	●	●
Hi-Temp Wash	Automatic	Automatic	Automatic	●	●
Hi-Temp Rinse	●	●	●	●	●
Power pre-soak	●	●	●	●	●
<b>Racks, shelf &amp; basket</b>					
Upper Rack	Super Nylon	Super Nylon	Super	Super	Super
Lower Rack	Super12 w/4 Rows of Fold-Down Tines	Super12 w/4 Rows of Fold-Down Tines	Super12 w/2 Rows of Fold-Down Tines	Super12	Deluxe
SmartShelf	with Stemsafe	with Stemsafe	●	●	●
Silverware Basket	SmartBasket	SmartBasket	SmartBasket	SmartBasket	Super
SmartBasket Plus	●	●	●	●	●
<b>Control type</b>	Electronic	Electronic	Electronic	Electronic	Electronic
<b>Cycle progress indicators</b>	5 LEDs	5 LEDs	5 LEDs	1 "Clean"	1 "Clean"
<b>Touchpads</b>	11	11	10	11	10
<b>Rinse Aid dispenser</b>	with Indicator	with Indicator	with Indicator	with Indicator	with Indicator
<b>Center throw door latch</b>	●	●	●	●	●
<b>Economical &amp; Quiet</b>					
<b>Quiet</b>					
Sound insulation package	Profile Performance™	Profile Performance™	Profile Performance™	QuietPower™ III	QuietPower™ II
PermaTuf™ tub and door liner	●	●	●	●	●
GE Profile™ QuietMotor	●	●	●	●	●
ActiveVent	●	●	●	●	●
Quiet Water Valve	●	●	●	●	●
Tub collar trim	●	●	●	●	●
<b>Appearance</b>					
Colors available*	Stainless Steel	WW, BB, AA	WW, BB, AA	WW, BB, AA	WW, BB, AA
Color panels—Door & Access	Trimless	Trimless	Trimless	Trimless	Trimless
<b>Weights &amp; Dimensions</b>					
Approx. shipping weight (lbs.)	100	100	100	100	100
Height w/legs retracted (in.)	34	34	34	34	34
Overall width (in.)	24	24	24	24	24
Overall depth (in.)	24-3/4	24-3/4	24-3/4	24-3/4	24-3/4
<b>Accessories</b>					
Requires kit for 1/4" panel capability with trim	N/A	GPF425A/B/W	GPF425A/B/W	GPF425A/B/W	GPF425A/B/W
Requires kit for trimless 3/4" panel capability	N/A	GPF475	GPF475	GPF475	GPF475

All GE Profile Performance™ and GE Profile™ Dishwashers are equipped with the following: 120°F inlet water capability, Easy-Glide roller system, convection drying, horizontal mechanism, leveling screws.  
\*Colors available: SS = Stainless Steel, WW = White on white, BB = Black on black, AA = Almond on almond.

## Built-In Dishwasher Dimensions (in inches)

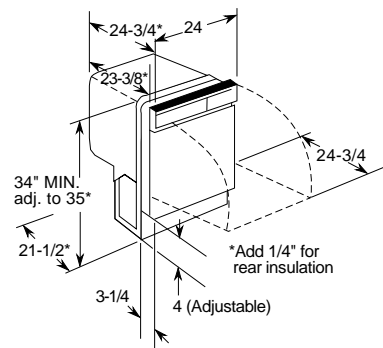

## Built-In Dishwasher Installation Information (in inches)

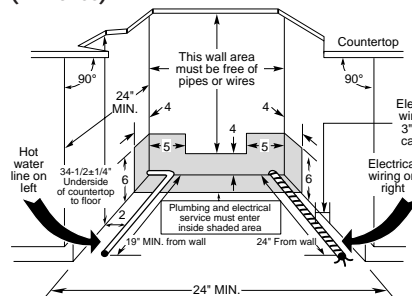

**Note:** Dishwasher must not be installed more than 10 feet from sink for proper drainage. All plumbing and electrical work must be in accordance with local codes.

**Note:** If a flush look is needed, a 25" base cabinet needs to be used.



Listed by Underwriters Laboratories

## Electrical Rating

Voltage AC .....120  
Hertz.....60  
Total connected load amperage.....8.6  
Calrod® heater watts.....500  
For use on adequately wired 120-volt, 15-amp circuit having 2-wire service with a separate ground wire. This appliance must be grounded for safe operation.

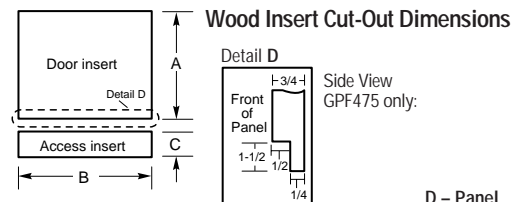

Models/Kit	A	B	C	D - Panel Thickness
GE Profile Performance™ and GE Profile™ models/GPF425	19-3/4"	23-9/16"	3-11/16"	1/4"
GE Profile Performance™ and GE Profile™ models/GPF475	19-7/8"	23-5/8**	4-1/4" to 3-11/16***	3/4"

\*Bottom of panel must be notched 1-1/2" x 1/2" to clear access panel. (See illustration above)

\*\*Adjustment required to match adjacent cabinet fronts due to leveling adjustment, 4" nominal.





# GE CONVERTIBLE/PORTABLE DISHWASHERS

Features	GE	
	GSC3430ZWW GSC3400ZBL	GSC3230ZWW GSC3200ZBL
<b>Wash System</b>		
SureClean™ Wash System	●	●
Wash levels	3	3
<b>Filtration System</b>	Dual	
Piranha™ Hard Food Disposer	●	
<b>Cycles</b>	6	5
POTSCRUBBER	●	●
Normal Wash	●	●
Light Wash	●	
Short Wash	Dial	Dial
Plate Warmer	Dial	Dial
Rinse Only/Hold	Dial	Dial
<b>Options</b>	19	14
Delay Start	1-6-Hour	
Heated Dry On/Off	●	●
Hi-Temp Wash	●	●
<b>Racks (upper/lower)</b>	Deluxe	Deluxe
Silverware basket	Super	Deluxe
Cycle progress indicator	1 "Cycle On"	Dial
Pushbuttons	7	6
Rinse Aid dispenser	with Indicator	●
<b>Economical/Quiet</b>		
<b>Quiet</b>		
Sound insulation package	QuietPower™ I	Standard
PermaTuf™ tub and door liner	●	●
GE QuietMotor	●	●
GE Motor	●	●
Sealed toekick	●	
<b>Appearance</b>		
Colors available*	WW, BL	WW, BL
Color panels—Door & Access	Trimless	Trimless
<b>Weights &amp; Dimensions</b>		
Approx. shipping wt (lbs.)	147	147
Overall height w/legs extended (in.)	36-1/8*	36-1/8*
Overall width (in.)	24-3/4	24-3/4
Overall depth (in.)	27	27

\*Colors available: WW = White on white BL = Black control panel and front panels w/almond side panels.

Dimensions (in inches)  
GSC3230ZWW, GSC3200ZBL, GSC3430ZWW and GSC3400ZBL

Portable

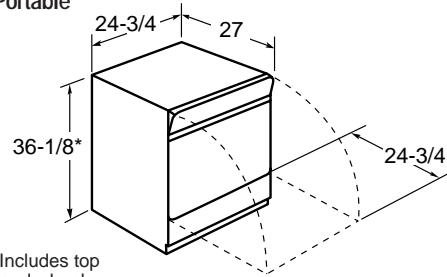

\*Includes top and wheels

Built-In

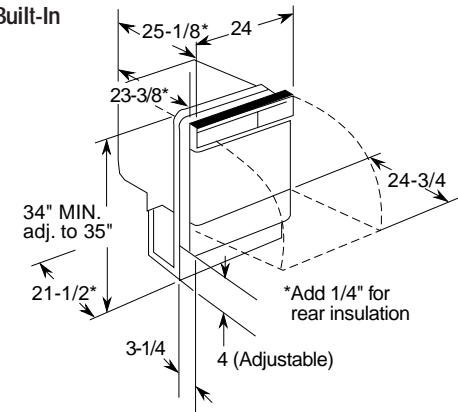

**Important Note:** GE kit number WD35M34 needed when adapting GE convertible dishwasher to a built-in installation. Contains built-in dishwasher water valve, hardware and complete instructions for changing a GE convertible dishwasher for under-the-counter installation.

# GE SPACEMAKER® BUILT-IN 18" DISHWASHER

Features	GE	
	GSS1800Z	
<b>Wash System</b>		
Wash levels	2	
<b>Cycles</b>	4	
Pots & Pans	Dial	
Normal Wash	Dial	
Light Wash	Dial	
Rinse Only/Hold	Dial	
<b>Options</b>	6	
Heated Dry On/Off	Rocker	
<b>Racks (upper/lower)</b>	Standard	
Silverware basket	Standard	
<b>Control type</b>	Turn-To-Start	
Cycle progress indicator	Dial	
Rinse Aid dispenser	●	
120°F @ inlet water capability	●	
Leveling screws	●	
<b>Economical/Quiet</b>		
<b>Tub Insulation</b>	Standard	
<b>Appearance</b>		
Colors available	Black/Almond/White	
Color panels	2 Reversible: Black/Harvest; Almond/White	
<b>Weights &amp; Dimensions</b>		
Approx. shipping weight (lbs.)	70	
Height w/legs retracted (in.)	34-1/8	
Overall width (in.)	17-13/16	
Overall depth (in.)	23-3/4	

Dimensions (in inches)

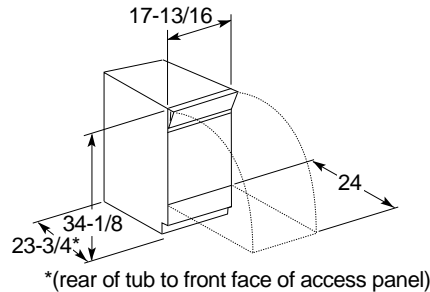

\*(rear of tub to front face of access panel)

Figure 1

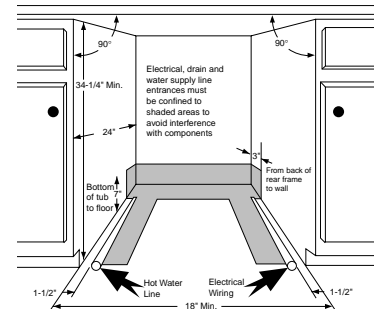

**Dishwasher Rough-In Information**

**Note:** Dishwasher must not be installed more than 10 feet from sink for proper drainage. All plumbing and electrical work must be in accordance with local codes.

Most of the installation work should be done before the dishwasher is moved into place. First, select a location as close to the sink as possible for ready access to water and drain lines. For proper operation and appearance of the dishwasher, the cabinet opening should be square and have dimensions as shown in Figure 1. If the dishwasher is to be installed in a corner, there must be sufficient clearance to open the door as shown in Figure 2. A minimum clearance of 2" is recommended.

Rough-in the water, electrical, and drain lines before proceeding with the installation. The lines should run straight to their connections on the dishwasher.

**Note:** Make sure that the lines do not cross in front of the dishwasher motor or its legs.

Figure 2

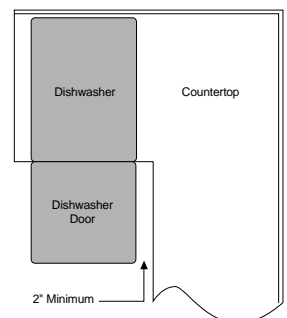

Note: For trim kit to install wood panel up to 3/16" thick on GSS1800Z model only, order Pub. No. 5-A007.

# GE SPACEMAKER® UNDERSINK DISHWASHER

GE	
GSM2100ZAD/WH	
<b>Features</b>	
Wash System	
Wash levels	2
Cycles	5
POTSCRUBBER	●
Normal Wash	●
Short Wash	Dial
Plate Warmer	Dial
Rinse Only/Hold	Dial
Options	8
Heated Dry On/Off	●
<b>Racks, shelf &amp; basket</b>	
Upper Rack	Spacemaker™
Lower Rack	Deluxe
Silverware basket	Deluxe
<b>Control type</b>	
Cycle progress indicator	Dial
Pushbuttons	4
Rinse Aid dispenser	●
<b>Economical/Quiet</b>	
PermaTuf™ tub and door liner	●
GE Motor	●
<b>Appearance</b>	
Colors available*	AD, WH
Door	Trimless
Color Panels Access	Trimless
<b>Weights &amp; Dimensions</b>	
Approx. shipping weight (lbs.)	100
Height w/legs retracted (in.)	34
Overall width (in.)	24
Overall depth (in.)	24

\*Colors available: AD = Black control panel with almond front panels.  
WH = Black control panel with white front panels.

**Note:** Undersink dishwashers can be installed under GE cooktop models JP200V and JP201CV. Refer to cooktop installation instructions.

## Cabinet Cut-Out for Sink

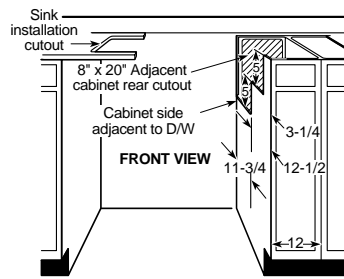

Cabinet cut-outs for offset single and double bowl sinks. Dishwasher not provided with complete enclosure. Enclosures for sides, top, bottom, and back must be provided by installer at time of installation.

## Stainless Steel Sinks Single and Double Compartment Models (Dimensions in Inches)

Model Number	Overall Size		Inside Each Compartment		
	L	W	L	W	D
GPF95 (Single Bowl, R)*	25	21-1/4	21	15-3/4	5-3/8
GPF96 (Single Bowl, L)*	25	21-1/4	21	15-3/4	5-3/8
GPF97 (Double Bowl)	33	21-1/4	14	15-3/4	5-3/8

Model Number	Cutout In Countertop 1-1/2" Radius Corners		No. Of 1-1/2" Dia. Faucet Holes	Ship. Wt. Lbs.
	L	W		
GPF95 (Single Bowl, R)*	24-3/8	20-5/8	3 or 4**	10
GPF96 (Single Bowl, L)*	24-3/8	20-5/8	3 or 4**	10
GPF97 (Double Bowl)	32-3/8	20-5/8	3 or 4**	12-1/2

**Note:** Drain opening size is 3-1/2". Above models are fully sound deadened.  
\*Suffix "L" or "R" means drain outlet is located in upper left or right corner of sink compartment.  
\*\*All have four holes, but one hole has a removable plug.

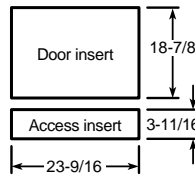

## Wood Insert Cut-Out Dimensions (in inches)

Inserts must not exceed 1/4" thickness within 5/16" of edge around full circumference. Order GPF325 kit.

## Plumbing/Electrical Rough-In

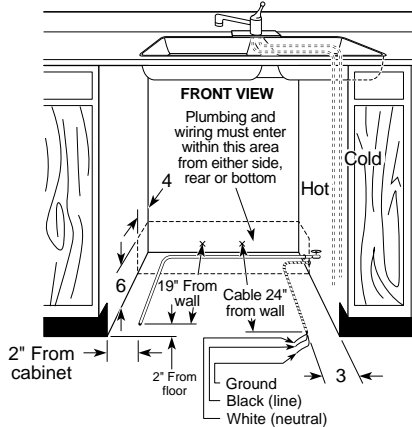

**Plumbing:** Hot Water Only: Use 3/8" O.D. copper tubing or 1/2" O.D. plastic tubing min. inlet line. Water valve has 3/8" internal threads. Hand cut-off valve is recommended.

**Electrical:** Fuse circuit with 15 amp or 20 amp standard fuse or circuit breaker. Total amp load is 8.6. Dishwasher operates on 120V, 60 Hz power. Two-wire cable (14 Ga. Min.) with ground must be installed.

**Note:** All rough-in, both plumbing and electrical, must be completed before the dishwasher is installed. All plumbing and electrical work must be in accordance with local codes.

**Specifications:** Inlet Water Temperature Recommended: Minimum 120°F. at dishwasher. Inlet Water Pressure Required: 15 to 120 lbs./sq. in.

## Cabinet Rough-In

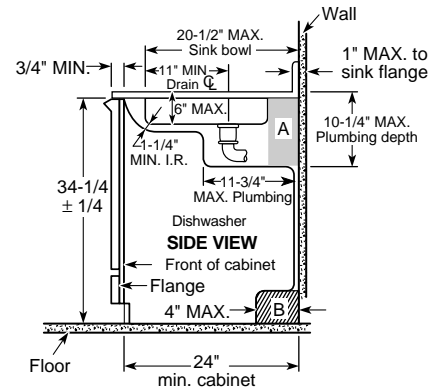
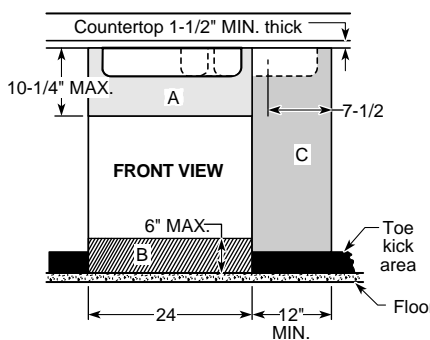

Either single- or double-bowl sink may be used, centered or offset, as shown in the front illustration above. The 20-1/2" max. dimension from wall to front of sink bowl must be accurate if dishwasher is to fit properly under sink. Water lines to sink faucet and drain from sink can be run through area "A." HOT WATER line to dishwasher is installed in area "B." Garbage disposer, water lines to faucet, trap, waste air gap and water cut-off valve are installed in 12" wide cabinet shown in area "C." Sink opening for garbage disposer must be dimensioned as shown in front view, area "C" above (7-1/2"). This will provide clearance for disposer and plumbing in cabinet "C" when using double bowl sink. If the sink bowl is more than 20-1/2" max. specified distance from the wall, or if the base cabinet is less than the 24" min. depth from the wall, a gap between the tub front flange and the front of the base cabinet may result.

## Rough-In for Installation with Disposer

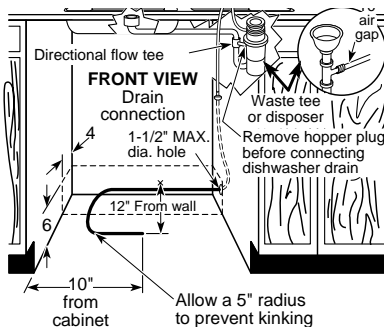

## Rear View Plumbing Arrangement

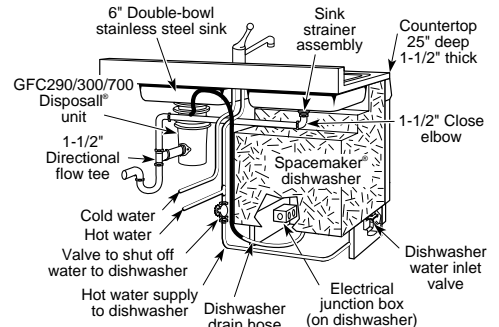

A close-fitting elbow or special shallow sink strainer is necessary to provide clearance between sink drain and dishwasher. Dishwasher furnished with 1/2" I.D. drain hose, 78" long. If using copper tubing, 2" length of 1/2" I.D. rubber hose must be provided to connect copper tubing to pump outlet. Disposer should have 7/8" I.D. dishwasher drain connector.

See page 137 for warranty information.

# DISPOSALL® FOOD WASTE DISPOSERS

Features	GE								
	Continuous Feed Models								Batch Feed Model
	GFC1000Y	GFC800Y	GFC705Y	GFC700Y	GFC305Y	GFC300Y	GFC295Y	GFC290Y	GFB1050V
Motor horsepower	3/4	1/2	1/2	1/2	1/2	1/2	1/3	1/3	3/4
Control method	Wall Switch	Wall Switch	Wall Switch	Wall Switch	Wall Switch	Wall Switch	Wall Switch	Wall Switch	Stopper
Feed type	Continuous	Continuous	Continuous	Continuous	Continuous	Continuous	Continuous	Continuous	Batch
Power connection	Direct Wire	Direct Wire	Line Cord	Direct Wire	Line Cord	Direct Wire	Line Cord	Direct Wire	Direct Wire
Power Boost	●								
Impellers									
Dual swivel	●	●	●	●	●	●	●	●	●
Jam resistant	●	●	●	●	●	●	●	●	●
Stainless steel	●	●	●	●	●	●	●	●	●
Stainless steel sink flange	●	●	●	●	●	●	●	●	●
Mounting type	Fast Mount	Fast Mount	Fast Mount	Fast Mount	Fast Mount	Fast Mount	Fast Mount	Fast Mount	Twist Top
Precutler	●	●	●	●	●	●	●	●	●
Splash guard	Removable	Removable	Removable	Removable	Removable	Removable	Removable	Removable	Non-Removable
Sink stopper	●	●	●	●	●	●	●	●	●
Dishwasher drain connector	●	●	●	●	●	●	●	●	●
Manual reset overload protector	●	●	●	●	●	●	●	●	●
Permanently lubricated bearing	●	●	●	●	●	●	●	●	●
Plastic drain elbow	●	●	●	●	●	●	●	●	●
Turntable	Stainless Steel	Galvanized	Galvanized	Galvanized	Galvanized	Galvanized	Galvanized	Galvanized	Stainless Steel
Polyester drain housing	●	●	●	●	●	●	●	●	●
Grinding speed (RPM's)	8000	8000	8000	8000	8000	8000	8000	8000	2700
Hopper	Polypropylene	Polypropylene	Polypropylene	Polypropylene	Polypropylene	Polypropylene	Polypropylene	Polypropylene	Nylon
Hopper liner and grinding ring	Stainless Steel	Stainless Steel	Stainless Steel	Stainless Steel	Galvanized	Galvanized	Galvanized	Galvanized	Stainless Steel
<b>Economical/Quiet</b>									
Sound insulation wrapper	Super Deluxe	Deluxe	Standard	Standard					Super Deluxe
<b>Weights &amp; Dimensions</b>									
Approx. shipping weight (lbs.)	12.5	10.0	9.8	9.8	8.4	8.4	8.4	8.4	14.0
Net weight (lbs.)	11	8.8	8.6	8.6	7.6	7.6	7.6	7.6	12.5
(A)	14-5/8	14-5/8	14-5/8	14-5/8	14-5/8	14-5/8	14-5/8	14-5/8	16-9/16
(B)	6-1/4	6-1/4	6-1/4	6-1/4	6-1/4	6-1/4	6-1/4	6-1/4	5-1/2
(C)	3-1/4	3-1/4	3-1/4	3-1/4	3-1/4	3-1/4	3-1/4	3-1/4	6-1/2
(D)	8-1/4	8-1/4	8-1/4	8-1/4	8-1/4	8-1/4	8-1/4	8-1/4	9-5/16
(E)	8-1/8	8-1/8	8-1/8	8-1/8	6-3/8	6-3/8	6-3/8	6-3/8	8-5/8
Dishwasher inlet diameter (in.)	7/8	7/8	7/8	7/8	7/8	7/8	7/8	7/8	1
Drain outlet diameter (in.)	1-1/2	1-1/2	1-1/2	1-1/2	1-1/2	1-1/2	1-1/2	1-1/2	1-1/2
<b>Accessories</b>									
White sink flange & stopper	GPF71	GPF71	GPF71	GPF71	GPF71	GPF71	GPF71	GPF71	GPF71
Almond sink flange & stopper	GPF72	GPF72	GPF72	GPF72	GPF72	GPF72	GPF72	GPF72	GPF72

## Disposers

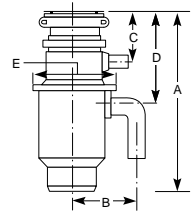

## Disposer Accessories:

GPF75 Clamp nut kit

# COMPACTORS

Features	GE	
	GCG1530ZWW GCG1520ZBB	GCG950T
	Cycle time	27 seconds max., 14 seconds min.
Motor horsepower	1/3	1/3
Compression ratio (average)	75% reduction of volume	75% reduction of volume
Ram force (lb.) (max.)	2,300	5,000
Lock/start control w/removable key	●	●
Bag storage		●
<b>Appearance</b>		
Color appearance	WW, BB	BB
Door panels included	White/Black; Black/White	Black/Almond
Heavy-gauge steel construction	●	●
1/4" panel capability	●	●
<b>Weights &amp; Dimensions</b>		
Total appliance weight (lbs.)	146	134
Overall height (in.)	34-1/4	34-1/2
Overall width (in.)	15	12
Overall depth (in.)	24-1/4	20-1/4
Clearance for drop-down drawer side	6" or more on right side	
Drawer extension for removal	23" or more in front of appliance	22" or more
Custom panel size H x W (in.)	22-15/16 x 14-5/8	20-7/8 x 11-11/16
<b>Accessories</b>		
Compactor bags	WC60X5017	WC60X5015
Optional toe pedal opener kit		GSA85

## GCG1530ZWW, GCG1520ZBB, GCG950T Convertible Compactors

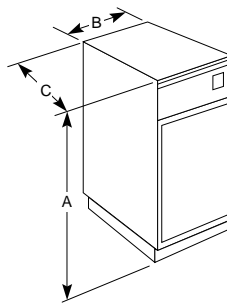

## Compactor Accessories:

GPF80 White/Black Panel  
for GCG1530  
GPF81 Black/Almond Panel  
for GCG1520

# ROOM AIR CONDITIONERS

Features	GE									
	Deluxe 230 Volt					Deluxe 115 Volt				
	AVM24DD	AVM22DB	AVM18DC	AVM15DC	AMD12DB	AVM14AB	AMH12AC	AMH10AA	AGH08FA	AMH06LA
BTUH	23,500/23,000	22,000/21,300	18,000/17,500	15,000/14,500	12,000/11,800	14,000	11,500	10,000	7,800	5,800
Voltage	230/208	230/208	230/208	230/208	230/208	115	115	115	115	115
E.E.R. (BTUH/Watt)	8.7/8.7	8.2/8.2	9.5/9.5	9.0/9.0	9.1/9.1	10.0	10.0	10.0	10.0	10.0
Amps	13.5/14.4	12.5/13.5	7.9/8.5	7.5/8.1	5.9/6.4	12.0	10.1	8.9	7.0	5.2
Watts	2,700/2,640	2,680/2,600	1,890/1,840	1,670/1,610	1,315/1,295	1,400	1,150	1,000	780	580
Plug type	Perpendicular	Perpendicular	Tandem	Tandem	Tandem	Parallel	Parallel	Parallel	Parallel	Parallel
Energy Saver Feature (speeds)	2	2	2	2	3	2	3	3	2	2
Electronic Control					●					
12-hour timer					●					
Dehumidification (pints/hr.)	8.2	8.5	5.5	4.3	3.6	4.0	3.2	3.0	2.5	0.9
Circularaire					●					
Fan Speeds (Cool/Fan Only)	2/2	2/2	2/2	2/2	3/1	2/2	3/2	3/2	2/2	2/2
CFM (High Shown)	500	450	450	420	330	400	340	325	205	220
Vent/exhaust	●	●	●	●	●	●	●	●	●	●
Control door	●	●	●	●	●	●	●	●	●	●
Thermostat	10-Position	10-Position	10-Position	10-Position	Electronic	10-Position	10-Position	10-Position	10-Position	10-Position
Filter type	Rigid Frame/Slide-Out	Rigid Frame/Slide-Out	Rigid Frame/Slide-Out	Rigid Frame/Slide-Out	Rigid Frame/Slide-Out	Rigid Frame/Slide-Out	Rigid Frame/Slide-Out	Rigid Frame/Slide-Out	Rigid Frame/Slide-Out	Rigid Frame/Slide-Out
Chassis	Slide-Out	Slide-Out	Slide-Out	Slide-Out	Slide-Out	Slide-Out	Slide-Out	Slide-Out	Slide-Out	Slide-Out
Window mounting	EZ Mount	EZ Mount	EZ Mount	EZ Mount	EZ Mount	EZ Mount	EZ Mount	EZ Mount	EZ Mount	EZ Mount/V Kit
Window opening height (min. in inches)	18-5/8	18-5/8	18-5/8	18-5/8	15-3/4	18-5/8	15-3/4	15-3/4	14	14-17/32
Window opening width (min. in inches)	30-3/4	30-3/4	30-3/4	30-3/4	26-1/2	30-3/4	25-13/16	25-13/16	25	21-5/8
Window opening width (max. in inches)	46-1/2	46-1/2	46-1/2	46-1/2	41	46-1/2	42	42	36	35
Warranty*	Full 1-Yr.	Full 1-Yr.	Full 1-Yr.	Full 1-Yr.	Full 1-Yr.	Full 1-Yr.	Full 1-Yr.	Full 1-Yr.	Full 1-Yr.	Full 1-Yr.
	Full 5-Yr.	Full 5-Yr.	Full 5-Yr.	Full 5-Yr.	Full 5-Yr.	Full 5-Yr.	Full 5-Yr.	Full 5-Yr.	Full 5-Yr.	Full 5-Yr.
<b>Case Dimensions</b>										
Height (in inches) A	17-1/4	17-1/4	17-1/4	17-1/4	14-3/4	17-1/4	14-3/4	14-3/4	13-15/16	13-5/8
Width (in inches) B	26-1/2	26-1/2	26-1/2	26-1/2	22-1/16	26-1/2	26-1/2	22	20-1/16	17-23/32
Depth (in inches) C	27-5/8	27-5/8	23-5/8	23-5/8	23-5/8	23-5/8	24	24	17-9/16	20-7/8
Depth to louvers (in inches) D	10-3/4	10-3/4	9-1/8	9-1/8	9-7/16	9-1/8	9-7/16	9-7/16	8-5/8	8-17/32
Net weight (lbs.)	174	170	121	118	93	118	77	77	71	64
Approx. shipping weight (lbs.)	187	183	128	125	100	125	88	88	77	73

\*See written warranty for details.

Features	GE									
	Value 230 Volt			Value 115 Volt				Slide-Aire		
	AGV18DB	AGV12DA	AGV12AA	AGV10AA	ASV08AC	AQV06LA	AQV05LA	AVX10AC	AVX07FB	
BTUH	17,800/17,400	12,000/11,500	12,000	10,000	8,000	6,000	5,000	10,000	7,000	
Voltage	230/208	230/208	115	115	115	115	115	115	115	
E.E.R. (BTUH/Watt)	8.8/8.8	9.0/9.0	9.0	9.2	9.0	9.0	9.0	9.0	8.5	
Amps	9.0/9.8	5.8/6.2	12.0	10.0	7.9	6.1	5.1	11.0	7.5	
Watts	2,020/1,975	1,300/1,250	1,330	1,085	890	665	555	1,110	820	
Plug type	Tandem	Tandem	Parallel	Parallel	Parallel	Parallel	Parallel	Parallel	Parallel	
Dehumidification (pints/hr.)	5.1	3.5	3.3	3.0	2.5	1.5	1.3	3.1	2.5	
Circularaire	●	●								
Fan speeds (Cool/Fan Only)	3/2	3/2	3/2	3/2	3/1	3/1	3/1	3/2	3/2	
CFM (High Shown)	425	285	285	265	220	190	190	260	210	
Vent/exhaust	Exhaust	Exhaust	Exhaust	Exhaust	Exhaust	No	No	Exhaust	Exhaust	
Thermostat	8-Position	8-Position	8-Position	8-Position	8-Position	8-Position	8-Position	10-Position	10-Position	
Filter type	Rigid Frame/Slide-Out	Rigid Frame/Slide-Out	Rigid Frame/Slide-Out	Rigid Frame/Slide-Out	Rigid Frame/Slide-Out	Rigid Frame/Slide-Out	Rigid Frame/Slide-Out	Foam	Foam	
Chassis	Slide-Out	Slide-Out	Slide-Out	Slide-Out	Slide-Out	Fixed	Fixed	Fixed	Fixed	
Window mounting	EZ Mount	EZ Mount	EZ Mount	EZ Mount	EZ Mount	EZ Mount	EZ Mount	V-Std. Mount	V-Std. Mount	
Window opening height (min. in inches)	18	16	16	16	14-3/4	14-27/32	14-27/32	21 - 40-1/2	21 - 40-1/2	
Window opening width (min. in inches)	29	27	27	27	25-1/2	23-5/8	23-5/8	15-1/2	15-1/2	
Window opening width (max. in inches)	41	39	39	39	37	35-7/16	35-7/16	—	—	
Warranty*	Full 1-Yr.	Full 1-Yr.	Full 1-Yr.	Full 1-Yr.	Full 1-Yr.	Full 1-Yr.	Full 1-Yr.	Full 1-Yr.	Full 1-Yr.	
	Full 5-Yr.	Full 5-Yr.	Full 5-Yr.	Full 5-Yr.	Full 5-Yr.	Full 5-Yr.	Full 5-Yr.	Full 5-Yr.	Full 5-Yr.	
<b>Case Dimensions</b>										
Height (in inches) A	16-7/8	15	15	15	13-3/8	14-9/16	14-9/16	20-1/2	20-1/2	
Width (in inches) B	26	23-5/8	23-5/8	23-5/8	20-1/2	19-11/16	19-11/16	14-1/2	14-1/2	
Depth (in inches) C	24-7/8	20-9/32	20-9/32	20-9/32	18-7/8	16-17/32	16-17/32	22-9/16	22-9/16	
Depth to louvers (in inches) D	10-5/16	8-5/8	8-5/8	8-5/8	8-1/4	2-3/4	2-3/4	6	6	
Net weight (lbs.)	121	95	95	90	73	44	44	102	84	
Approx. shipping weight (lbs.)	134	101	101	96	79	52	52	106	88	

\*See written warranty for details.

## Deluxe and Value Model Wall Case Dimensions

\*Distance from front of case to side louvers (excluding grille).

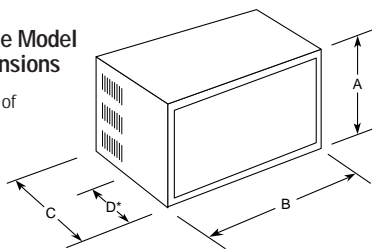

**Parallel**  
115V.  
15 Amp.



**Perpendicular**  
230/208V.  
20 Amp.



**Tandem**  
230/208V.  
15 Amp.



**Large Tandem**  
230/208V.  
30 Amp.

**Note:** When installing units in through-the-wall applications, keep louvers free. Do not restrict air flow areas. Carry-Cool units are not designed for through-the-wall applications.

**Note:** Some models may not be available in your area due to local legislation. Contact your local dealer.

## Wall Outlets

All wiring, including installation of receptacle, must be made in accordance with local electrical codes and regulations. Electrical outlet should be in reach of line cord.

**Note:** Aluminum wiring may pose special problems—consult a qualified electrician.

See page 137 for warranty information.



# BUILT-IN "J" SERIES UNITS AND HEAT PUMPS

GE										
Models	Chassis/Cool						Chassis/Cool High-Mount			
	AJCS06LC	AJCS08AC	AJCS10AC	AJCS09DC	AJCS10DC	AJCS12DC	AJCH08AC	AJCH10AC	AJCH10DC	AJCH12DC
<b>Capacity</b>										
BTUH-AHAM	6000	8000	9900	8900/8700	9900/9700	11,600/11,400	8000	9900	9900/9700	11,600/11,400
E.E.R.	9.5	9.2	9.2	9.5/9.5	9.2/9.2	9.0/9.0	9.2	9.2	9.2/9.2	9.0/9.0
Dehumidification (pints/hr.)	1.4	2.0	2.6	2.5	2.6	3.2	2.0	2.6	2.6	3.2
<b>Features</b>										
Fan speeds (Cool/Fan Only)	2/2	2/2	2/2	2/2	2/2	2/2	2/2	2/2	2/2	2/2
Airflow (cfm) roomside hi/low	210/180	250/210	250/210	250/210	250/210	265/230	250/210	250/210	250/210	265/230
Air exchange exhaust	●	●	●	●	●	●	●	●	●	●
Variable setting thermostat	●	●	●	●	●	●	●	●	●	●
Filter type	Slide-Out	Slide-Out	Slide-Out	Slide-Out	Slide-Out	Slide-Out	Slide-Out	Slide-Out	Slide-Out	Slide-Out
Rotary compressor	●	●	●	●	●	●	●	●	●	●
<b>Economical/Quiet</b>										
Fan cycle switch	●	●	●	●	●	●	●	●	●	●
<b>Appearance</b>										
Slide-out chassis	●	●	●	●	●	●	●	●	●	●
Installation	Wall	Wall	Wall	Wall	Wall	Wall	Wall	Wall	Wall	Wall
Wall case required	RAB46/47/48	RAB46/47/48	RAB46/47/48	RAB46/47/48	RAB46/47/48	RAB46/47/48	RAB46/47/48	RAB46/47/48	RAB46/47/48	RAB46/47/48
<b>Case Dimensions</b>										
Height (in inches) A	← 15-5/8 →						→			
Width (in inches) B	← 26 →									
Depth (in inches) C	← 16-7/8 →						→			
Approx. net weight (lbs.)	66	73	82	75	82	84	75	82	84	84
Approx. shipping weight (lbs.)	75	82	90	84	90	93	84	90	93	93
<b>Power/Ratings</b>										
Voltage	115	115	115	230/208	230/208	230/208	115	115	230/208	230/208
Amps-AHAM	5.7	7.9	9.7	4.2/4.6	4.9/6.3	5.8/5.3	7.9	9.7	4.9/5.3	5.8/6.3
Watts input	630	870	1075	935/915	1075/1055	1290/1265	870	1075	1075/1055	1290/1265
Line cord plug	Parallel	Parallel	Parallel	Tandem	Tandem	Tandem	Parallel	Parallel	Tandem	Tandem
Recommended circuit protection (time delay)	15 Amps	15 Amps	15 Amps	15 Amps	15 Amps	15 Amps	15 Amps	15 Amps	15 Amps	15 Amps

GE						
Models	Chassis/Heat/Cool			Chassis/Heat/Cool High-Mount	Chassis/Heat Pumps	
	AJES09DC	AJES10DC	AJES12DC	AJEH12DC	AJHS08DC	AJHS10DC
<b>Capacity</b>						
BTUH-AHAM	8900/8700	9900/9700	11,600/11,400	11,600/11,400	8000/7800	9800/9600
E.E.R.	9.5/9.5	9.2/9.2	9.0/9.0	9.0/9.0	9.2/9.2	9.2/9.2
Dehumidification (pints/hr.)	2.5	2.6	3.2	3.2	2.0	2.6
<b>Features</b>						
Fan speeds (Heating/Cooling)	2/2	2/2	2/2	2/2	2/2	2/2
Fan Only speeds	2	2	2	2	2	2
Airflow (cfm) roomside hi/low	250/210	250/210	265/230	265/230	230/190	250/210
Air exchange exhaust	●	●	●	●	●	●
Variable setting thermostat	●	●	●	●	●	●
Filter type	Slide-Out	Slide-Out	Slide-Out	Slide-Out	Slide-Out	Slide-Out
Rotary compressor	●	●	●	●	●	●
<b>Economical/Quiet</b>						
Fan cycle switch	●	●	●	●	●	●
<b>Appearance</b>						
Slide-out chassis	●	●	●	●	●	●
Wall case required	RAB46/47/48	RAB46/47/48	RAB46/47/48	RAB46/47/48	RAB46/47/48	RAB46/47/48
Installation	Wall	Wall	Wall	Wall	Wall	Wall
Window installation kit	Optional	Optional	Optional	Optional	Optional	Optional
<b>Case Dimensions</b>						
Height (in inches) A	← 15-5/8 →			→		
Width (in inches) B	← 26 →					
Depth (in inches) C	← 16-7/8 →			→		
Approx. net weight (lbs.)	77	84	84	86	75	84
Approx. shipping weight (lbs.)	86	93	93	95	84	93
<b>Power/Ratings</b>						
Voltage	230/208	230/208	230/208	230/208	230/208	230/208
Amps-AHAM	4.2/4.6	4.9/5.3	5.8/6.3	5.8/6.3	4.0/4.3	4.9/5.3
Watts input	935/915	1075/1055	1290/1265	1290/1265	870/850	1065/1045
Line cord plug	Perpendicular	Perpendicular	Perpendicular	Perpendicular	Perpendicular	Perpendicular
Recommended circuit protection (time delay)	20 Amps	20 Amps	20 Amps	20 Amps	20 Amps	20 Amps
<b>Reverse Cycle Heating</b>						
BTUH-AHAM					7700/7500	9700/9500
C.O.P. @ 47°F.					3.0	3.0
Amps-AHAM					3.4/3.7	4.3/4.7
Watts input					750/730	950/930
<b>Electric Resistance Heating</b>						
BTUH-AHAM	11,600/9480	11,600/9480	11,600/9480	11,600/9480	11,600/9480	11,600/9480
Amps (Max. connected load)	15.5/14.0	15.5/14.0	15.7/14.2	15.7/14.2	15.5/14.0	15.5/14.0
Watts output	3400/2780	3400/2780	3400/2780	3400/2780	3400/2780	3400/2780

All cooling with electric heat models and heat pumps are corrosion treated. Specifications and design subject to change without notice.

# HEAT/COOL AND WINDOW/BUILT-IN "J" SERIES UNITS AND HEAT PUMPS

Features	GE Heat/Cool			GE "J" Series							
	Heat/Cool Units			Heat/Cool Units			Heat Pump	Cooling Only Units			
	AVE22DA**	AVE18DA**	AVE15DA**	AJES10DS**	AJES08AS**	AJES06LS**	AJHS08AS**	AJCS10AZ	AJCS08AZ	AJCS06LZ	
Cooling BTUH-AHAM	22,000/21,300	18,000/17,500	15,000/14,500	9,900/9,700	8,000	6,000	8,000	9,900	8,000	6,000	
Heating BTUH-AHAM	16,000/13,400	10,200/8,700	10,200/8,700	11,600/9,480	4,100	4,100	4,100				
Voltage	230/208	230/208	230/208	230/208	115	115	115	115	115	115	
E.E.R. (BTUH/Watt)	8.2/8.2	9.5/9.5	9.0/9.0	9.2/9.2	9.2	9.5	9.2	9.2	9.2	9.5	
Rated cooling amps - AHAM	13.0/14.2	7.9/8.5	7.5/8.1	4.9/5.3	7.9	5.7	7.9	9.7	7.9	5.7	
Cooling watts	2,680/2,600	1,890/1,840	1,670/1,610	1,075/1,055	870	630	870	1,075	870	630	
Rated heating amps - AHAM	22.8/20.9	15.0/13.5	15.0/13.5	15.5/14.0	12.0	12.0	12.0				
Circuit size, amps	30	20	20	20	15	15	15	15	15	15	
Plug type (see below)	Tandem	Perpendicular	Perpendicular	Perpendicular	Parallel	Parallel	Parallel	Parallel	Parallel	Parallel	
Line cord plug recommended circuit protection (time delay)				20 Amps	15 Amps	15 Amps	15 Amps	15 Amps	15 Amps	15 Amps	
Line cord length	55" left	55" left	55" left								
Dehumidification (pints/hr.)	8.2	5.5	4.3	2.6	2.0	1.4	2.0	2.7	2.0	1.4	
CFM (high shown)	500	450	420	250	250	210	230	250	250	210	
Air exchange exhaust	●	●	●	●	●	●	●	●	●	●	
Variable air discharge	4-Way	4-Way	4-Way	4-Way	4-Way	4-Way	4-Way	4-Way	4-Way	4-Way	
Control Door	●	●	●								
Fan speeds: Cooling/Heating	2/2	2/2	2/2	2/2	2/2	2/2	2/2	2	2	2	
Fan Only position	1	1	1	2	2	2	2	2	2	2	
Fan cycle switch				●	●	●	●	●	●	●	
Thermostat	10-Position	10-Position	10-Position	Variable Setting	Variable Setting	Variable Setting	Variable Setting	Variable Setting	Variable Setting	Variable Setting	
Filter type	Rigid/Slide-Out	Rigid/Slide-Out	Rigid/Slide-Out	Slide-Out	Slide-Out	Slide-Out	Slide-Out	Slide-Out	Slide-Out	Slide-Out	
Chassis	Slide-Out	Slide-Out	Slide-Out	Slide-Out	Slide-Out	Slide-Out	Slide-Out	Slide-Out	Slide-Out	Slide-Out	
Compressor type	Recip.	Rotary	Rotary	Rotary	Rotary	Rotary	Rotary	Rotary	Rotary	Rotary	
Window mounting	Rigid Panel	Rigid Panel	Rigid Panel	Standard	Standard	Standard	Standard	EZ Mount	EZ Mount	EZ Mount	
Window opening height (min. in inches)	18-5/8	18-5/8	18-5/8	17	17	17	17	17	17	17	
Window opening width (min. in inches)	26-3/4	26-3/4	26-3/4	31	31	31	31	31	31	31	
Window opening width (max. in inches)	40	40	40	42	42	42	42	41	41	41	
<b>Case Dimensions</b>											
Height (in inches) A	17-1/4	17-1/4	17-1/4	15-5/8	15-5/8	15-5/8	15-5/8	15-5/8	15-5/8	15-5/8	
Width (in inches) B	26-1/2	26-1/2	26-1/2	26	26	26	26	26	26	26	
Depth (in inches) C	27-5/8	23-5/8	23-5/8	16-7/8	16-7/8	16-7/8	16-7/8	16-7/8	16-7/8	16-7/8	
Depth to louvers (in inches) D	10-3/4	9-1/8	9-1/8	None	None	None	None	None	None	None	
Net weight (lbs.)	172	123	120	108	96	89	98	105	93	86	
Approx. shipping weight (lbs.)	185	130	127	117	105	98	107	114	102	95	
Warranty*	Full 1-Yr. Full 5-Yr.	Full 1-Yr. Full 5-Yr.	Full 1-Yr. Full 5-Yr.	Full 1-Yr. Full 5-Yr.	Full 1-Yr. Full 5-Yr.	Full 1-Yr. Full 5-Yr.	Full 1-Yr. Full 5-Yr.	Full 1-Yr. Full 5-Yr.	Full 1-Yr. Full 5-Yr.	Full 1-Yr. Full 5-Yr.	
<b>Heating Capacity - Reverse Cycle</b>											
BTUH - AHAM - H.P.							7,700				
Rated Heating Amps - AHAM							6.8				
COP @ 47°							3.0				
<b>Heating Capacity - Electric</b>											
BTUH - AHAM - I2R	16,000/13,400	10,200/8,700	10,200/8,700	11,600/9,480	4,100	4,100	4,100				
Rating Heating Amps - AHAM	22.8/20.9	15.0/13.5	15.0/13.5	15.5/14.0	12.0	12.0	12.0				
Heating Watts***	5,200/4,280	3,320/2,690	3,320/2,690	3,400/2,780	1,200	1,200	1,200				

\*See written warranty for details.  
 \*\*These units are not intended to be the primary source of heat.  
 \*\*\*Maximum connected load.

## BUILT-IN ROOM AIR CONDITIONERS WALL OPENING FOR RAB46/47/48 CASES

A finished opening of 26-1/8" x 15-3/4", clear of intrusions, is required. Keep clearance of 4" from side walls. Brick veneer or frame walls should have wood studding surrounding case to provide firm anchoring with screws. Case can be fastened directly to brick or block walls with screws sunk in lead expansion shields.

**Note:** Units should be caulked on all four sides of case to the building exterior to assure building integrity.

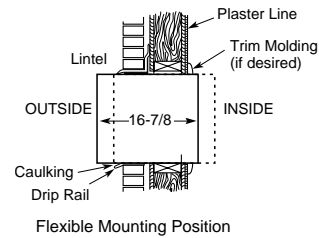
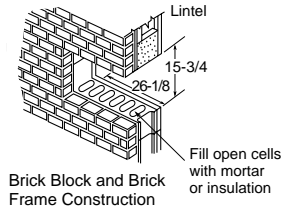
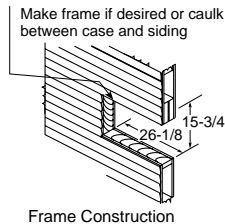

**Two Wall Cases for Tenant Option Installation**  
 When the air conditioner is offered as a tenant option, these wall cases provide protection against outside elements.

**RAB47**—includes wall case, exterior grille, weather panel and steel closure panels.

**RAB48**—includes wall case, exterior grille, steel closure panel and two layers of insulation.

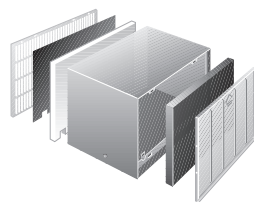

### Standard Wall Case RAB46

Solid-sided wall case fabricated of galvanized steel with baked enamel finish. Welded areas are coated with a sealing compound to help resist rust and corrosion. Polymer gasket surrounds opening to assure tight weather seal. Aluminum grille (RAG13) is included. Panels on interior and between case and grille provide weather protection prior to installation of chassis.

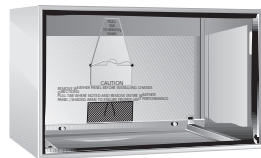

**Parallel**  
115V.  
15 Amp.



**Perpendicular**  
230/208V.  
20 Amp.



**Tandem**  
230/208V.  
15 Amp.



**Large Tandem**  
230/208V.  
30 Amp.

### Wall Outlets

All wiring, including installation of receptacle, must be made in accordance with local electrical codes and regulations. Electrical outlet should be in reach of line cord.

**Note:** Aluminum wiring may pose special problems—consult a qualified electrician.

**Note:** Some models may not be available in your area due to local legislation. Contact your local dealer.

**Note:** When installing slide out chassis units in through-the-wall applications, keep louvers free. Do not restrict air flow areas. Fixed chassis units are not suitable for through-the-wall applications.



Listed by Underwriters Laboratories



Total capacity and E.E.R. ratings are calculated based on the Association of Home Appliance Manufacturers' standards.



See page 137 for warranty information.

Refrigeration

Water Systems

Laundry

Cooking Products

Microwave Ovens

Dishwashers

Room Air

# QUIET-AIRE™ – SPLIT SYSTEM ROOM AIR CONDITIONERS/HEAT PUMPS

	GE					
	Cooling Only			Heat Pumps		
	Indoor	AS1CD09AA0	AS1CD12AA0	AS1CD18DA0	AS1RD09AA0	AS1RD12AA0
Outdoor	AS0CD09AA0	AS0CD12AA0	AS0CD18DA0	AS0RD09AA0	AS0RD12AA0	AS0RD18DA0
Cooling capacity (BTU/hr)	9,000	12,000	18,000/17,800	9,000	12,000	18,000/17,800
Heating capacity (BTU/hr)	N/A	N/A	N/A	9,000	12,000	19,000/18,700
Auto operation	●	●	●	●	●	●
Cooling fan speeds/fan only	3/3	3/3	3/3	3/3/3	3/3/3	3/3/3
LCD wireless remote	●	●	●	●	●	●
*Sleep Mode*	●	●	●	●	●	●
24 Hr. Timer (Delay Start/Pre-Set Stop)	●	●	●	●	●	●
Air flow, up & down–auto	●	●	●	●	●	●
Air flow, left/right–manual	●	●	●	●	●	●
EER, cooling	9.6	9.3	9.5/9.5	10.0	9.3	9.5/9.5
SEER, cooling	10.0	10.0	10.0/10.0	10.0	10.0	10.0/10.0
COP, heating	N/A	N/A	N/A	3.1	2.75	2.9/2.9
Watts, cooling	940	1290	1900/1870	900	1290	1900/1870
Watts, heating	N/A	N/A	N/A	860	1290	1900/1870
Voltage/Phase/Hz	115/60/1	115/60/1	230-208/60/1	115/60/1	115/60/1	230-208/60/1
Amperes, cooling	8.5	11.7	8.5/9.0	8.0	11.7	8.5/9.0
Amperes, heating	N/A	N/A	N/A	7.7	11.7	8.5/9.0
Temperature range–cool (°F)	64-86	64-86	64-86	64-86	64-86	64-86
Temperature range–heat (°F)	N/A	N/A	N/A	60-86	60-86	60-86
Temperature increments (°F)	2	2	2	2	2	2
Dehumidification (pints/hr.)	2.6	3.5	5.3	2.6	3.5	5.3
CFM (Indoor/Outdoor)	280/882	330/882	460/1835	280/882	330/882	460/1835
Washable air filter	●	●	●	●	●	●
Tube kit	Optional	Optional	Optional	Optional	Optional	Optional
<b>Weights &amp; Dimensions</b>						
Indoor (H x W x D inches)	11.4 x 35.4 x 7.2	11.4 x 35.4 x 7.2	11.4 x 42.6 x 7.2	11.4 x 35.4 x 7.2	11.4 x 35.4 x 7.2	11.4 x 42.6 x 7.2
Weight (lbs.) shipping/net	28.7/19.8	28.7/19.8	33.0/24.2	28.7/19.8	28.7/19.8	33.0/24.2
Color	Dove White	Dove White	Dove White	Dove White	Dove White	Dove White
Carton (H x W x D inches)	14.6 x 38.2 x 9.9	14.6 x 38.2 x 9.9	14.6 x 45.6 x 9.9	14.6 x 38.2 x 9.9	14.6 x 38.2 x 9.9	14.6 x 45.6 x 9.9
Outdoor (H x W x D inches)	21.9 x 31.6 x 10.3	21.9 x 31.6 x 10.3	25.8 x 34.3 x 12.6	21.9 x 31.6 x 10.3	21.9 x 31.6 x 10.3	25.8 x 34.3 x 12.6
Weight (lbs.) shipping/net	83.8/77.2	83.8/77.2	130/121	83.8/77.2	83.8/77.2	130/121
Color	Pigeon Grey	Pigeon Grey	Pigeon Grey	Pigeon Grey	Pigeon Grey	Pigeon Grey
Carton (H x W x D inches)	23.9 x 37.8 x 15.1	23.9 x 37.8 x 15.1	28.1 x 40.3 x 17.4	23.9 x 37.8 x 15.1	23.9 x 37.8 x 15.1	28.1 x 40.3 x 17.4

## Optional Tube Kits

	9,000 BTU/Hr. Models	
	TUS1542	TUS2542
Insulated Tubing	15'	25'
Wiring	30'	30'
Wall Hole Sleeve	Standard	Standard
Suction Line	0.5"	0.5"
Liquid Line	0.25"	0.25"

	12,000 BTU/Hr. Models	
	TUS1542	TUS2542
Insulated Tubing	15'	25'
Wiring	30'	30'
Wall Hole Sleeve	Standard	Standard
Suction Line	0.5"	0.5"
Liquid Line	0.25"	0.25"

	18,000 BTU/Hr. Models	
	TUS1553	TUS2553
Insulated Tubing	15'	25'
Wiring	30'	30'
Wall Hole Sleeve	Standard	Standard
Suction Line	0.625"	0.625"
Liquid Line	0.375"	0.375"

## DEHUMIDIFIERS

	GE Profile™			
	AHG20LA	AHG50LA	AHG40LA	AHG25LA
<b>Features</b>				
Dehumidification (pints/day)	19	50	40	25
Dry Airflow (CFM)	63	113	131	134
Color	Gray	Cameo White	Cameo White	Cameo White
Electronic Control	●			
Auto Shut Off	●	●	●	●
Automatic Defrost	●	●	●	●
Water Full indicator	●	●	●	●
Fan speeds	1	2	2	2
Removable bucket with handle	●	●	●	●
Bucket capacity (pints)	6	21	21	21
External drain connector	●	●	●	●
Casters - 4 movable	●	●	●	●
Voltage	115	115	115	115
Watts	450	580	550	450
Amps	5.3	5.3	5.1	5.3
Circuit size (Amps)	15	15	15	15
Plug type	Parallel	Parallel	Parallel	Parallel
<b>Case Dimensions</b>				
Height (in inches)	22-5/8	20-7/8	20-7/8	20-7/8
Width (in inches)	12-1/4	12-5/8	12-5/8	12-5/8
Depth (in inches)	10-5/8	17-1/8	17-1/8	17-1/8
Shipping weight (lbs.)	42	48	48	54
Net weight (lbs.)	38	43	43	50
Warranty*	Full 1-Yr. Full 5-Yr.	Full 1-Yr. Full 5-Yr.	Full 1-Yr. Full 5-Yr.	Full 1-Yr. Full 5-Yr.

\*See written warranty for details.

## READING SIDE-BY-SIDE REFRIGERATOR NOMENCLATURE

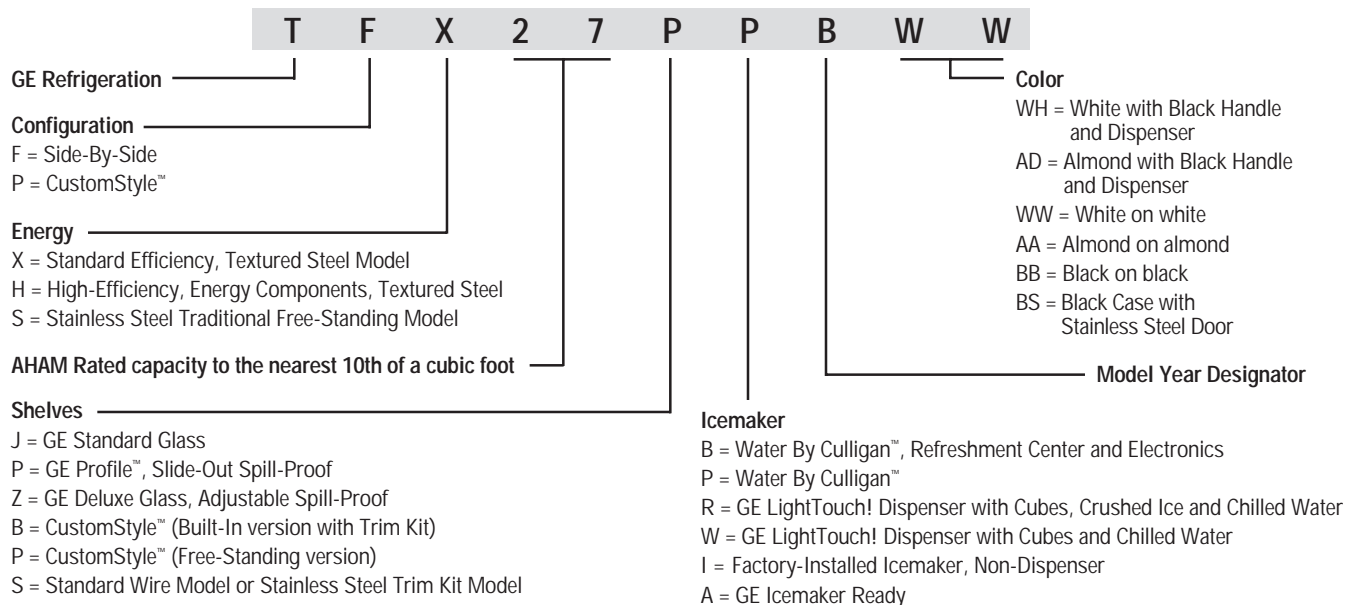

## READING TOP-FREEZER REFRIGERATOR NOMENCLATURE

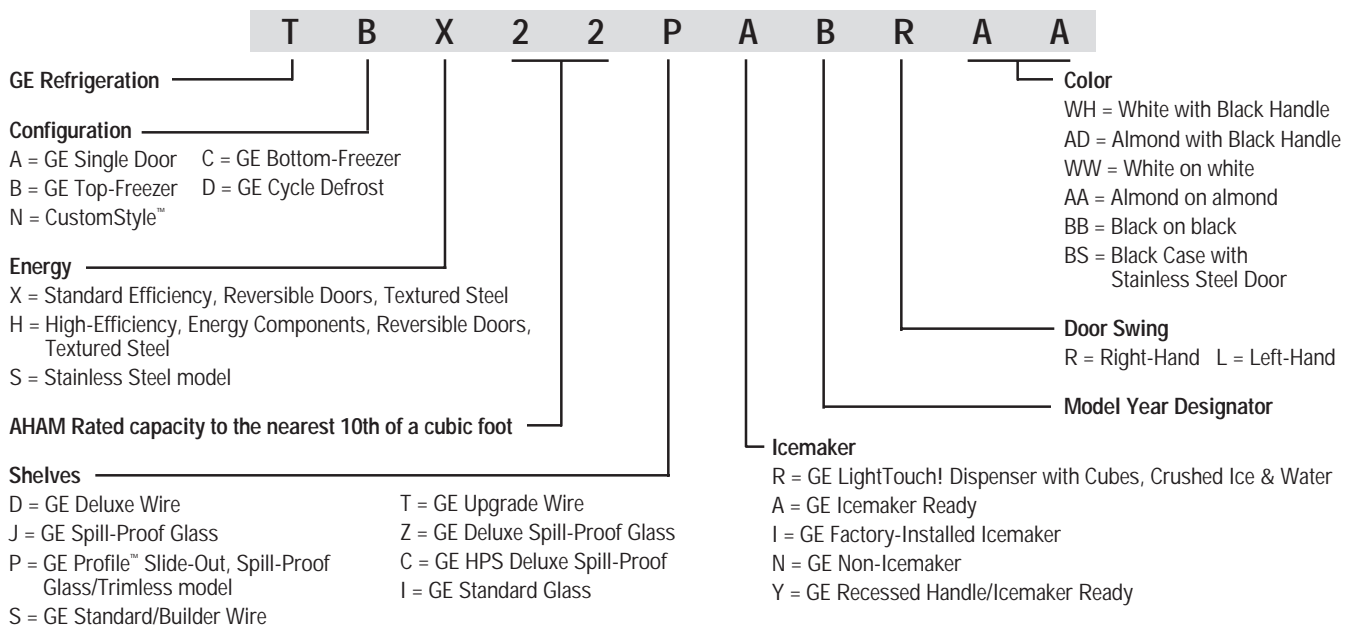

## READING FREEZER NOMENCLATURE

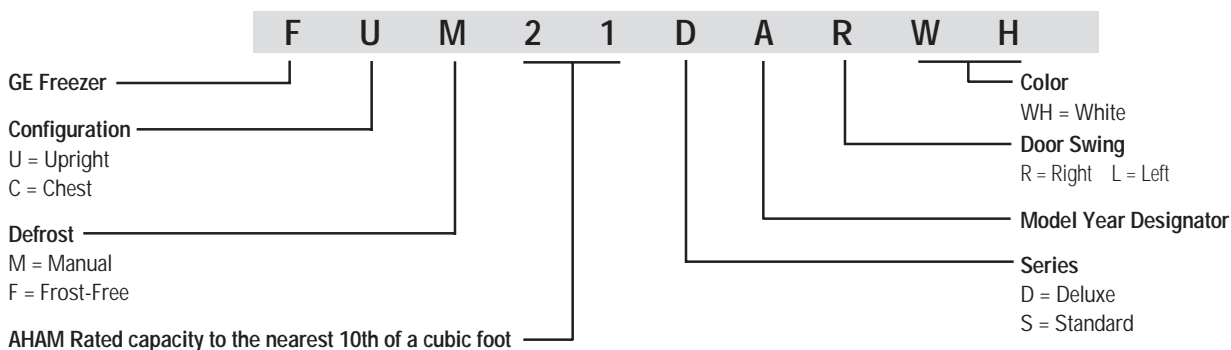



## READING WATER FILTRATION SYSTEM NOMENCLATURE

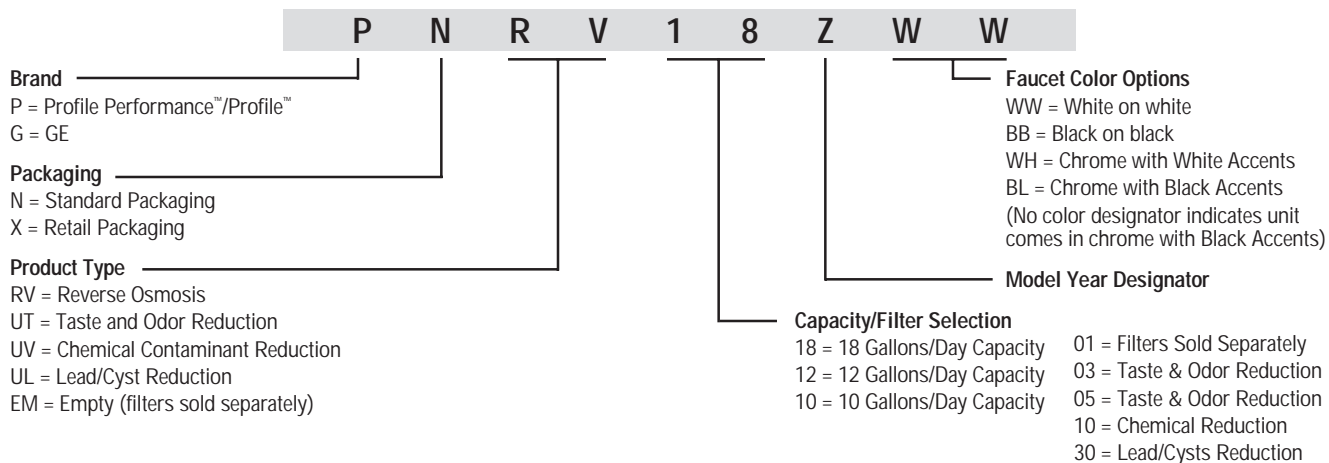

## READING WATER SOFTENING SYSTEM NOMENCLATURE

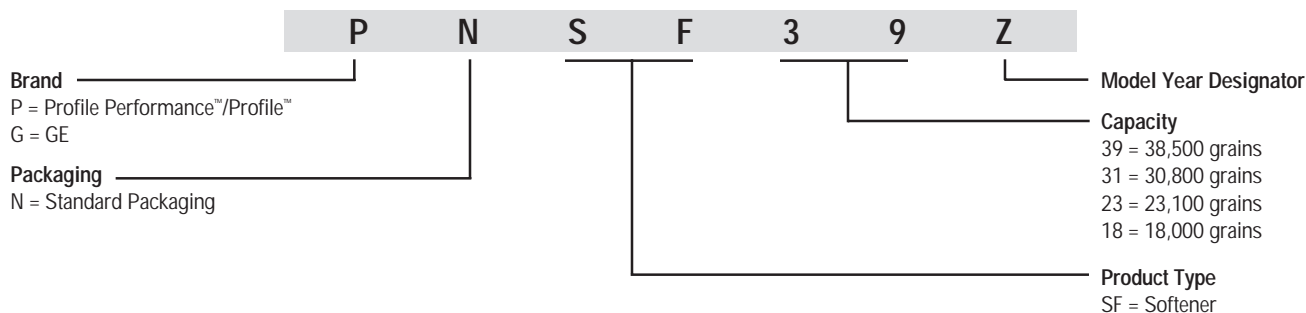

## READING WASHER NOMENCLATURE

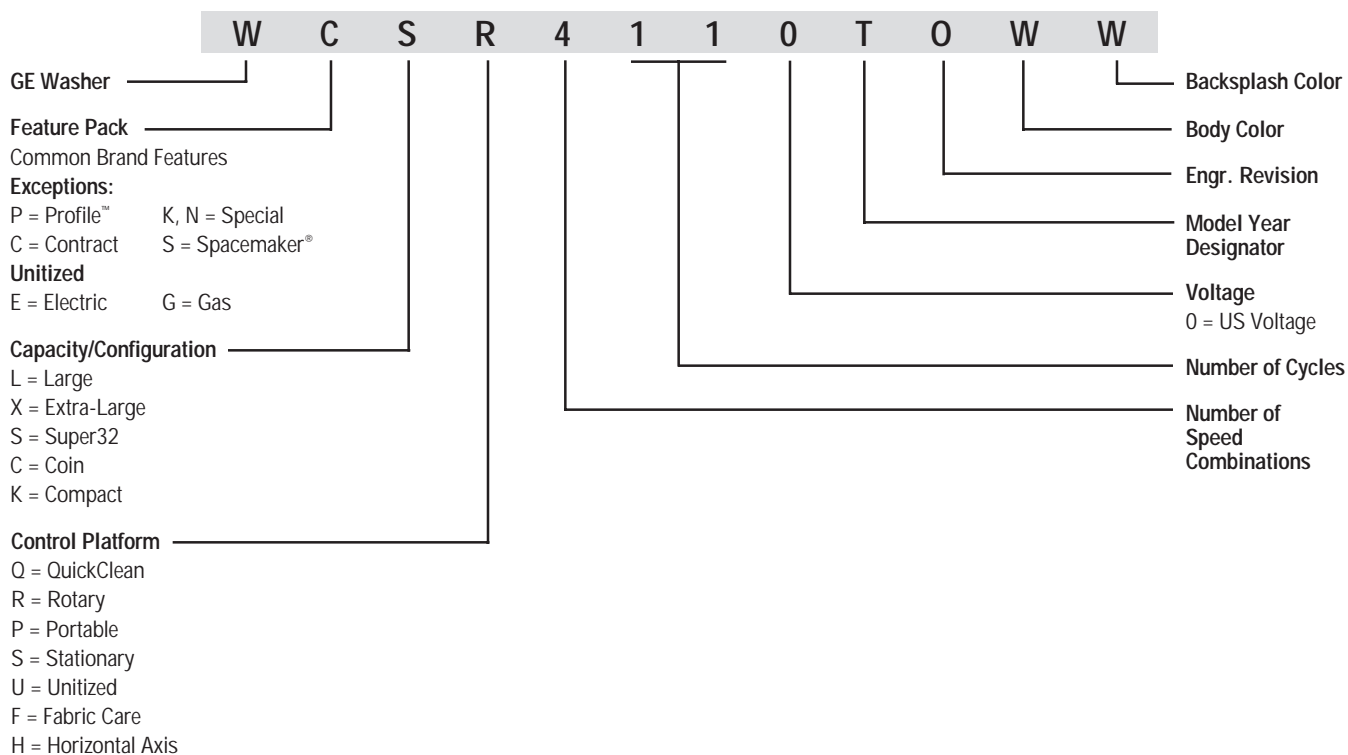



## READING DISHWASHER NOMENCLATURE

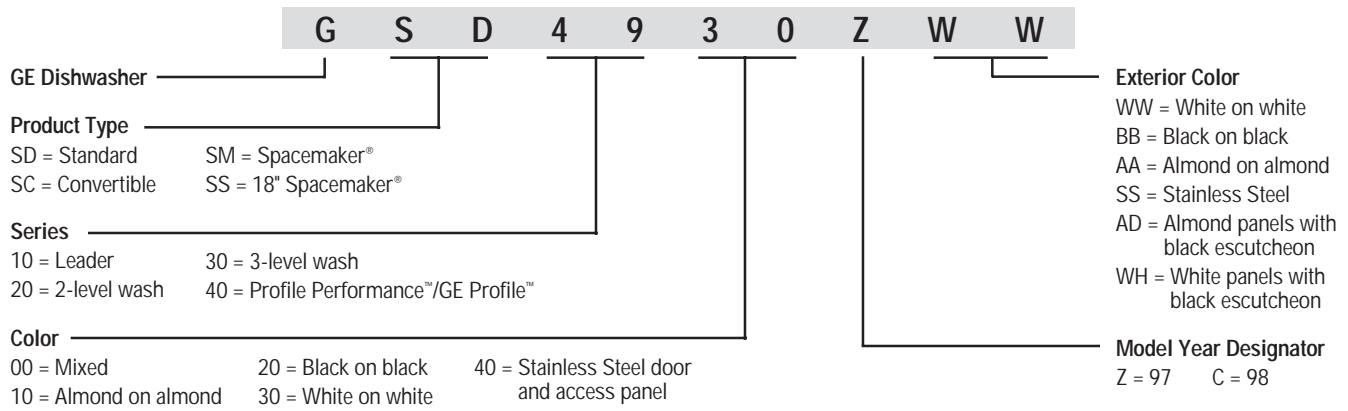

## READING WINDOW ROOM AIR NOMENCLATURE

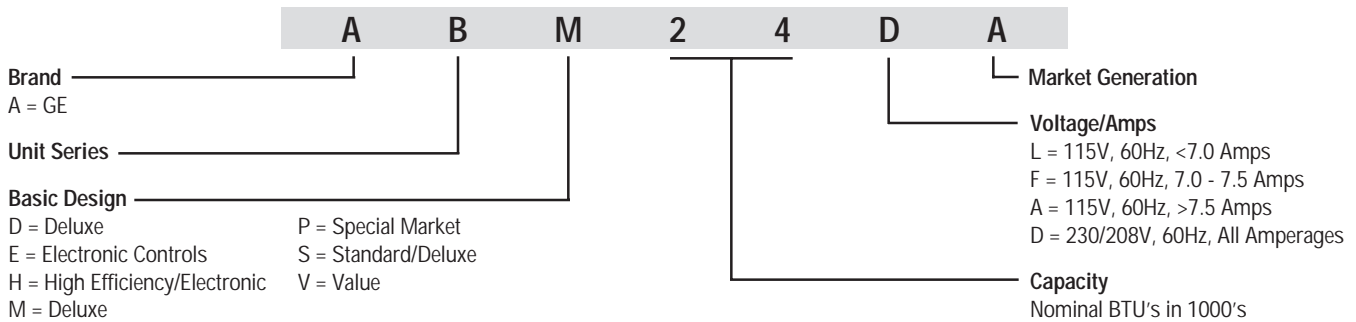

## READING BUILT-IN ROOM AIR NOMENCLATURE

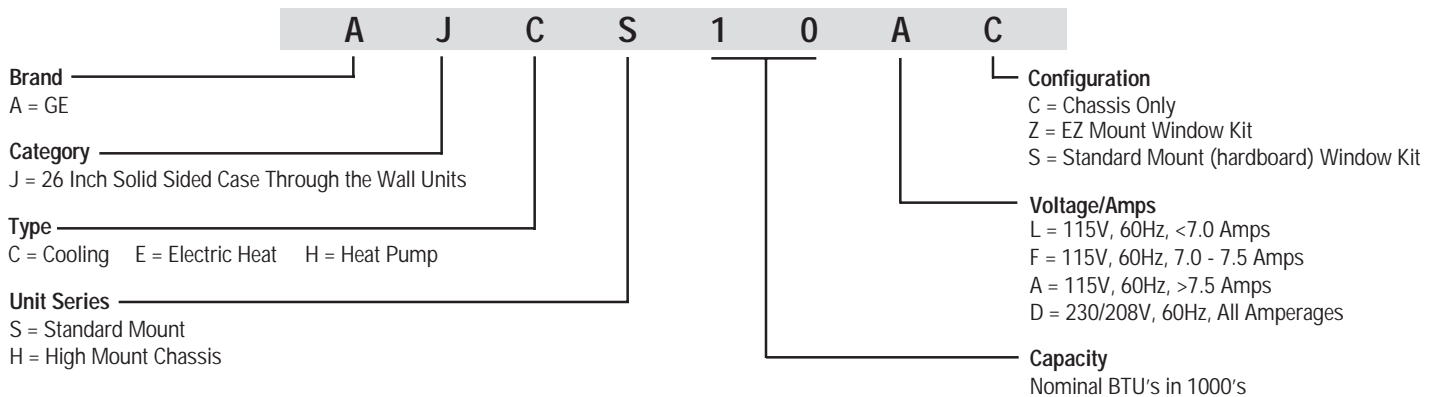

## READING SPLIT SYSTEMS ROOM AIR NOMENCLATURE

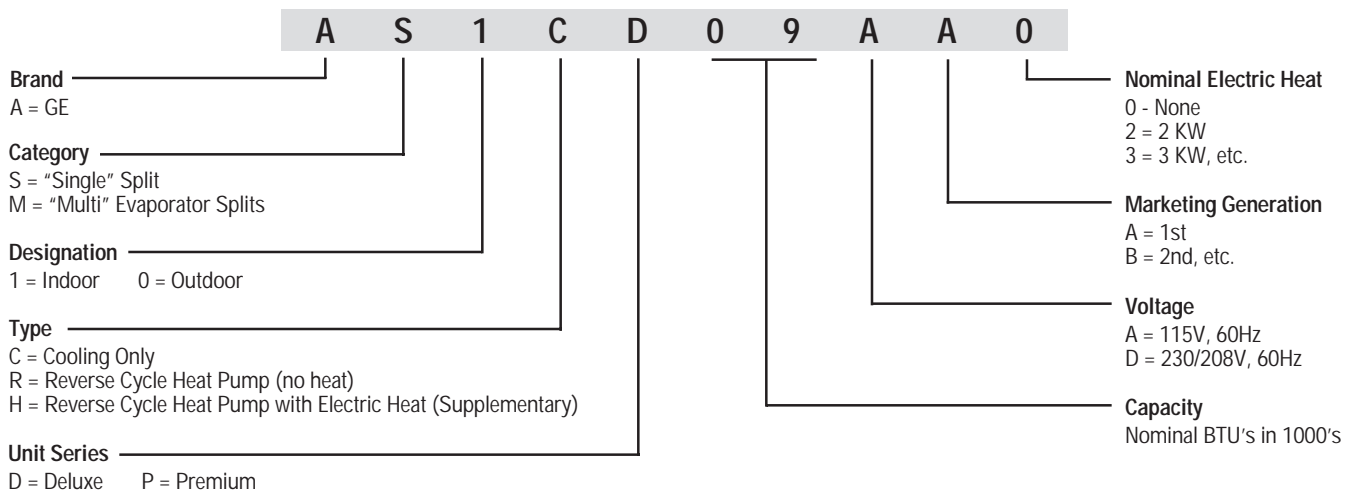

# GE CONSUMER SERVICE, WE'LL BE THERE!

HERE ARE FOUR REASONS TO CHOOSE MONOGRAM,<sup>®</sup>  
GE PROFILE PERFORMANCE SERIES,<sup>™</sup> GE PROFILE,<sup>™</sup>  
GE AND HOTPOINT APPLIANCES:



## GE APPLIANCE SERVICE

**800-GE-CARES (800-432-2737)**

EXPERT SERVICE WHEN YOU NEED IT!

- Easy to reach; prompt handling of calls.
- Same day/Next day service.
- Among the best one-call repair completion rates in the industry!
- Excellent parts availability; full five-year warranty on parts when installed by GE.

## GE ANSWER CENTER<sup>®</sup>

**800.626.2000**

WE NEVER CLOSE!

- Any hour of the day or night—even on weekends and holidays—the GE Answer Center<sup>®</sup> service is available to answer questions about Monogram<sup>®</sup>, GE Profile Performance Series,<sup>™</sup> GE Profile,<sup>™</sup> GE and Hotpoint features and installations.
- You and your customers can call toll-free before, during and after the sale.



## GE GENUINE PARTS

**800-626-2002**

WHEN YOU WANT PARTS  
TO FIX IT YOURSELF!

- We offer a complete line of parts, accessories and appliance care products for GE appliances and most other major brands too!
- Fast, convenient delivery direct to you.

## GE WARRANTY MANAGEMENT, INC.

**800-626-2224**

SERVICE PROTECTION PLUS<sup>™</sup>  
Backed By GE • Covers all brands!

ASSURE THE PERFORMANCE  
YOU PAID FOR—YEAR AFTER YEAR.

- All parts and labor costs included.
- No hidden costs/no deductibles.





## GE PROFILE PERFORMANCE™ LAUNDRY & WATER SOFTENER



*GE Appliances*

General Electric Company  
Louisville, Kentucky 40225  
[www.ge.com/appliances](http://www.ge.com/appliances)

Pub. No. 1-G019 PC12543  
4/99