

Dolphin[®] 7900 Series
Microsoft[®] Windows Mobile[™] 2003
Second Edition Software for Pocket PCs



 powered by
Adaptus[™]
imaging technology 5.0

User's Guide

Disclaimer

Hand Held Products, Inc. ("Hand Held Products") reserves the right to make changes in specifications and other information contained in this document without prior notice, and the reader should in all cases consult Hand Held Products to determine whether any such changes have been made. The information in this publication does not represent a commitment on the part of Hand Held Products.

Hand Held Products shall not be liable for technical or editorial errors or omissions contained herein; nor for incidental or consequential damages resulting from the furnishing, performance, or use of this material.

This document contains proprietary information that is protected by copyright. All rights are reserved. No part of this document may be photocopied, reproduced, or translated into another language without the prior written consent of Hand Held Products.

© 2006 Hand Held Products, Inc. All rights reserved.

Web Address: www.handheld.com

Trademarks

Dolphin, HomeBase, Mobile Base, and QuadCharger are trademarks or registered trademarks of Hand Held Products, Inc.

Windows Mobile, Windows, Windows NT, Windows 2000, Windows ME, Windows XP, ActiveSync, Outlook, and the Windows logo are trademarks or registered trademarks of Microsoft Corporation.

Intel is a registered trademark of Intel Corporation.

Chapter 9 (pages 9-1–9-11) contains copyrighted information from SyChip, Inc.

Chapter 9 (pages 9-12–9-39) contains copyrighted information from Meetinghouse Corporation. Meetinghouse, the Meetinghouse logo, and all other Meetinghouse trademarks/service marks contained herein are trademarks or registered trademarks of Meetinghouse.

Chapter 10 is copyrighted information used by permission from Bluetooth SIG, Inc.

The Bluetooth trademarks are owned by Bluetooth SIG, Inc., U.S.A. and licensed to Hand Held Products.

Chapter 11 contains information with permission from Intrinsic Software, Inc.

Other product names mentioned in this manual may be trademarks or registered trademarks of their respective companies and are hereby acknowledged.



Table of Contents

Chapter 1 - Introduction

Required Safety Labels	1-2
Laser Safety Label	1-2
Regulatory and Safety Approvals for all Dolphin 7900 Series Terminals	1-3
FCC Compliance	1-5

Chapter 2 - Getting Started

Overview	2-1
Dolphin 7900 Radio Configuration Options	2-2
Standard Configurations	2-2
Custom Configurations	2-2
Dolphin 7900 Series Peripherals	2-3
Dolphin 7900 Accessories	2-4
Using the Dolphin 7900 for the First Time	2-5
Resetting the Terminal	2-9
Soft Reset (Warm Boot)	2-9
Hard Reset (Cold Boot)	2-9
Suspend Mode	2-9

Chapter 3 - Hardware Overview

System Features	3-1
Front Panel Features	3-2
Back Panel Features	3-4
Side Panel Features	3-6
Opening the Access Door	3-6
Replacing the Access Door	3-8
Bottom Panel Features	3-9
Mechanical Connector	3-9
Battery Power	3-10
Main Battery Pack	3-10
Internal Backup Battery	3-10
Managing Battery Power	3-11
Dolphin 7900 Technical Specifications	3-13

Chapter 4 - Using Dolphin Mobile Computers

Overview	4-1
Today Screen	4-1
Navigation Bar and Start Menu	4-1
Selecting Programs	4-2
Pop-Up Menus	4-2
Adjusting the Backlight	4-3
Communication Options	4-4
Radio Options	4-5
Radio Combinations	4-5
Radio Manager	4-5

Using the Soft Input Panel (SIP)	4-6
Input Panel Options	4-7
Drawing on the Screen	4-8
Status Icons	4-9
Notifications	4-9
Using Find	4-10
Using File Explorer	4-10

Chapter 5 - Using the Image Engine

Overview	5-1
Image Engine Options	5-1
Bar Code Symbologies Supported	5-2
Activating the Engine	5-3
Decoding	5-3
Omni-Directional Scanning	5-4
Capturing Images	5-5

Chapter 6 - Using the Keyboards

Overview	6-1
Using the Function Keys	6-2
Using the Navigation Keys	6-2
Using the Modifier Keys	6-3
25-Key Numeric Keyboard	6-4
Alpha Mode	6-4
Caps Lock Key in Alpha Mode	6-4
Blue Key Combinations	6-5
Red Key Combinations	6-5
36-Key Alpha Keyboard	6-7
NUM Lock Key	6-7
Caps Lock Functionality	6-7
Blue Key Combinations	6-8
Red Key Combinations	6-8
NUM Key Combinations	6-8
Numeric Shift in Numeric Mode	6-9

Chapter 7 - Settings

Overview	7-1
Personal Tab	7-2
Buttons	7-3
Headset Control	7-4
Menus - Adding a Program to the Start Menu	7-5

System Tab	7-7
About	7-7
Backlight	7-7
Certificates	7-7
ClearType Tuner	7-7
Clock & Alarms	7-7
CPU Speed	7-8
Memory	7-8
Power	7-10
Regional Settings	7-11
Remove Programs	7-12
Screen	7-12
Connections Tab	7-15
Server-Assigned IP Addresses	7-15
Zero-Config Wi-Fi	7-15
Com Port Assignment Table	7-15
Opening the Connections Manager	7-16
Creating an External Modem Connection to an ISP	7-16
Creating an External Modem Connection to Your Work	7-19
Establishing Dialing Rules	7-23
Creating a Wireless Network Connection	7-24
Network Cards	7-24

Chapter 8 - Communications

Overview	8-1
General Help on Connecting	8-1
Installing Additional Software	8-1
Using ActiveSync	8-2
Synchronizing from Your Desktop Computer	8-2
Synchronizing from the Terminal	8-2
Exploring the Terminal from the Desktop Computer	8-3
Adding Programs to the Terminal Using ActiveSync	8-4
Using Infrared	8-5
Verify That the IrDA Port is Enabled	8-5
IrDA Port Location on the Terminal	8-5
Troubleshooting	8-7
Using an ISP	8-8

Chapter 9 - Wireless LAN (WLAN) Communications with 802.11b

Overview	9-1
Enabling the 802.11b Radio Driver	9-1
Configuration Utilities	9-1

802.11b Settings	9-2
Status Icons	9-2
Status Tab.....	9-3
Config Tab	9-4
Advanced Tab	9-8
About Tab	9-9
Using the Status Icon	9-9
802.11b Wireless Security Supplement.....	9-10
Required Network Configuration Information Worksheets.....	9-10
Opening the Client	9-14
Main Screen	9-15
Configuring the Client	9-18
Logging	9-28
Installing Certificates with CertAdd	9-29
Advice and Workarounds.....	9-29

Chapter 10 - Wireless PAN (WPAN) Communications with Bluetooth

Overview	10-1
Enabling the Bluetooth Radio	10-1
Setting Up Your Bluetooth Card.....	10-1
Assign COM Ports.....	10-1
Discover Bluetooth Device(s)	10-2
Bond With Discovered Device(s)	10-3
Set Up Your Favorite Device.....	10-5
Turn Radio Transmitter ON/OFF	10-7
Bluetooth ActiveSync.....	10-7
Bluetooth LAN Access.....	10-9
OBEX	10-11
Enable File Sharing.....	10-18
Using the Dialer.....	10-18
Get Connected Wizard.....	10-20
Dial Up Connection	10-22

Chapter 11 - Wireless WAN (WWAN) Communications with GSM/GPRS

Overview	11-1
GSM Radio types	11-1
SIM Card	11-2
Audio Modes	11-2
Keyboard Combinations for Calls	11-2
Using uPhone.....	11-3
Icons and Bubble Messages	11-3

Using the Dialler.....	11-5
Making a Call.....	11-5
Receiving a Call.....	11-6
Ending a Call.....	11-7
Call Waiting.....	11-7
Making Conference Calls.....	11-7
Touchtones.....	11-8
Tools Menu.....	11-8
Settings Menu.....	11-9
Phonebook.....	11-9
Ringtone Configuration.....	11-10
Charging.....	11-11
USSD.....	11-12
Call Log.....	11-13
uPhone Configuration.....	11-14
SMS Manager.....	11-19
Inbox.....	11-19
Sending an SMS Message.....	11-20
GPRS Settings.....	11-22

Chapter 12 - Applications

Calendar.....	12-1
Contacts.....	12-3
Tasks.....	12-5
Notes.....	12-7
Messaging.....	12-7
Pocket Internet Explorer.....	12-11
Pocket Word.....	12-14
Pocket Excel.....	12-15
Windows Media Player for Pocket PC.....	12-17
MSN Messenger.....	12-18
Pictures.....	12-19

Chapter 13 - Dolphin HomeBase

Overview.....	13-1
Front Panel.....	13-2
Back Panel.....	13-3
RS-232 Serial Connector.....	13-4
Powering the Dolphin HomeBase.....	13-4
Charging the Main Battery.....	13-5
ActiveSync Communications with the HomeBase.....	13-6
Communicating with the Dolphin Terminal.....	13-9
Mounting the HomeBase.....	13-10
Desk Mounting.....	13-10
Wall Mounting.....	13-10

Chapter 14 - Dolphin Mobile Base

Overview.....	14-1
---------------	------

Dolphin Mobile Base Hardware Overview	14-2
Front Panel	14-2
Bottom Panel.....	14-3
Back Panel.....	14-5
Mounting the Dolphin Mobile Base.....	14-6
Powering the Dolphin Terminal	14-7
Charging the Dolphin Terminal.....	14-7
Setting Up the Mobile Base for Communications	14-7

Chapter 15 - Dolphin ChargeBase

Overview	15-1
Dolphin ChargeBase Parts and Functions	15-1
Front Panel	15-1
Back Panel.....	15-2
Power Supply	15-2
Supplying Power to the ChargeBase	15-2
Inserting and Removing Terminals	15-3
Charging Terminals in the ChargeBase.....	15-3
Mounting the Dolphin ChargeBase	15-3
Using the Mounting Brackets	15-4

Chapter 16 - Dolphin QuadCharger

Overview	16-1
Dolphin QuadCharger Parts and Functions	16-1
Front Panel	16-1
Rear Panel	16-2
Supplying Power to the QuadCharger	16-3
Inserting and Removing Battery Packs	16-3
Recommendations for Storing Batteries.....	16-3
Charging Batteries in the QuadCharger.....	16-3
Using the Battery Analyzer	16-4
Mounting the QuadCharger.....	16-5
Troubleshooting.....	16-6

Chapter 17 - Customer Support

Product Service and Repair	17-1
Online Product Service and Repair Assistance.....	17-1
Technical Assistance	17-2
Online Technical Assistance	17-2
Limited Warranty	17-3

Overview

Congratulations on the purchase of the Dolphin 7900 mobile computer! You have made a wise choice in selecting the Dolphin, a device known worldwide for its ergonomic form factor, light-weight, rugged design and single-handed data collection capabilities.

Ergonomics

The patented shape of the Dolphin 7900 fits into either hand comfortably with major function keys that are easy to access. The adjustable hand strap on the back panel ensures a secure grip on the terminal for solid one-handed operation in mobile environments.

Rugged Design

Dolphin 7900 terminals are the most durable mobile computers on the market. Their rugged design can withstand repeated five-foot drops onto a concrete floor, extreme temperatures, as well as high humidity, moisture, and dust conditions. The terminals are independently tested to meet IP64 specifications.

Mobile Computing Features

- A low-power, high-resolution digital image engine for omni-directional and auto-discrimination decoding of most bar code symbologies
- An Intel® X-Scale 400MHz RISC microprocessor for fast processing
- Optional Wireless Full Area Networking™ (WFAN) configuration for real-time data and voice communications anytime, anywhere
- Microsoft Windows Mobile 2003 Second Edition Software for Pocket PCs
- 64MB RAM (optional 128MB) and 64MB synchronous Flash memory configuration for ample and secure data storage
- A mini-Secure Digital (SD) memory interface that enables memory expansion
- Adaptus Imaging Technology for advanced point-and-shoot bar code decoding and image capture

Additional Features

- Long-lasting Lithium Ion (Li-ion) batteries
- 3.8", easy-to-read 1/4 VGA (240 x 320) backlit TFT color display with industrial touch screen
- Two keyboard options: 25-key numeric and 36-key alpha
- Industrial-grade mechanical connector that supports serial and USB communications, as well as power in and out
- Full suite of compatible peripheral devices
- Decoding of stacked linear and matrix codes with Optical Character Recognition (OCR) functionality
- Buttons on both side panels that can activate the image engine for easy one-hand scanning with either hand
- Digital picture capability
- Audio jack for headset use
- Speaker and microphone on the front panel

Application Development Tools

- Dolphin SDK Add-on for Pocket PC 2003 - supports Embedded Visual C++ 4.0
- Dolphin .NET SDK for Pocket PC 2002 and 2003 - supports Visual Studio.NET 2003 (VB.NET and C#.NET)
- Dolphin GSM/GPRS SDK Add-on for Pocket PC 2003 - supports Embedded Visual C++ 4.0 and Visual Studio.NET 2003

This User's Guide

The Dolphin 7900 Series Mobile Computer User's Guide provides you with the information you need to make the most of your Dolphin terminal.

Required Safety Labels

Dolphin 7900 mobile computers meet or exceed the requirements of all applicable standards organizations for safe operation. However, as with any electrical equipment, the best way to ensure safe operation is to operate them according to the agency guidelines that follow. Please read these guidelines carefully before using your Dolphin mobile computer.

Location

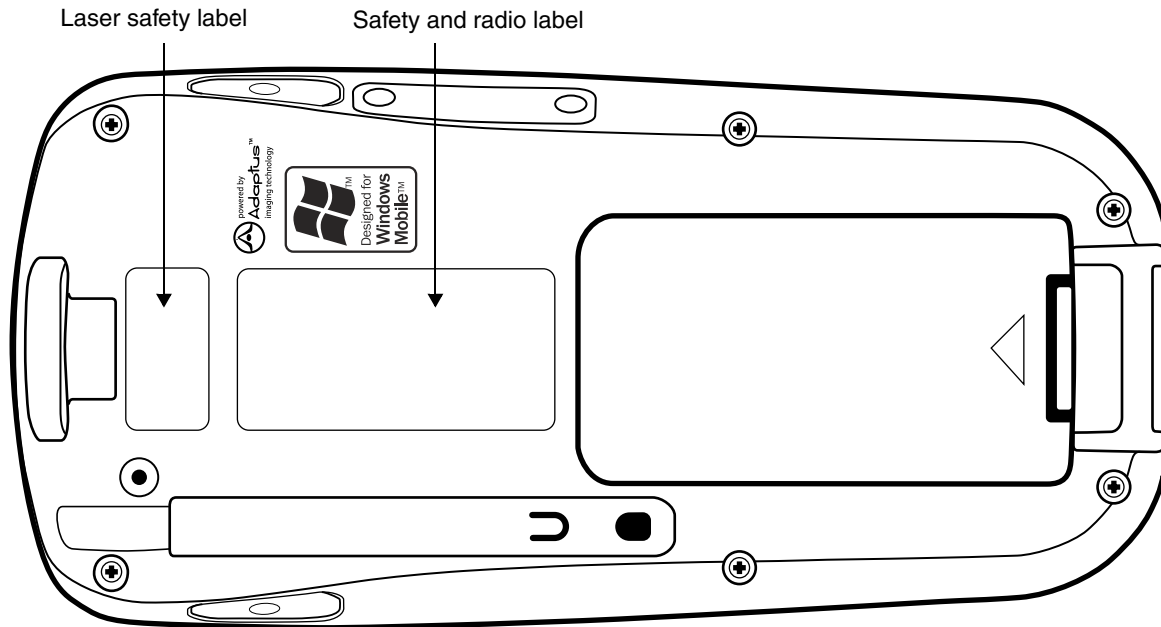

Laser Safety Label

Dolphin 7900 terminals with the 5300 image engine contain a laser aimer that projects from the imager and therefore have the following label on the back panel:

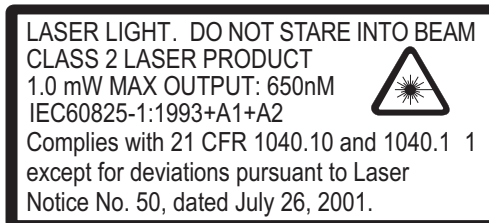

Note: The actual label is much smaller than the above graphic.



Use of controls or adjustment or performance of procedures other than those specified herein may result in hazardous radiation exposure.

Regulatory and Safety Approvals for all Dolphin 7900 Series Terminals

Parameter	Specification
U.S.A	FCC Part 15, Class B
Canada	ICES-003
European Community	EN 55022 (CISPR 22) Class B EN60950 EN60825-1 EN55024:1998

 The CE Mark on the product indicates that the system has been tested to and conforms with the provisions noted within the 89/336/EEC Electromagnetic Compatibility Directive and the 73/23/EEC Low Voltage Directive.

For further information, please contact:

Hand Held Products, Inc.
Nijverheidsweg 9
5627 BT Eindhoven
The Netherlands

Hand Held Products, Inc. shall not be liable for use of our product with equipment (i.e., power supplies, personal computers, etc.) that is not CE marked and does not comply with the Low Voltage Directive.

Dolphin 7900 Series WLAN (802.11b) or WPAN (Bluetooth) Radio

Dolphin 7900 RF terminals are designed to comply with the most current applicable standards on safe levels of RF energy developed by the Institute of Electrical and Electronics Engineers (IEEE) and the American National Standards Institute (ANSI) and has been recommended for adoption by the Federal Communications Commission (FCC).

802.11b

The required safety label that appears on the back of Dolphin 7900 terminals equipped with an 802.11b radio is as follows:



Bluetooth

The required safety label that appears on the back of Dolphin 7900 terminals equipped with a Bluetooth radio is as follows:



802.11b and Bluetooth

The required safety label that appears on the back of Dolphin 7900 terminals equipped with an 802.11b and a Bluetooth radio combination is as follows:



Dolphin 7900 Series WWAN Radio - GSM MC-45 & MC-46

Dolphin 7900 Series RF terminals are designed to comply with the most current applicable standards on safe levels of RF energy developed by the Institute of Electrical and Electronics Engineers (IEEE) and the American National Standards Institute (ANSI) and has been recommended for adoption by the Federal Communications Commission (FCC).

GSM MC-45

GSM



GSM MC-46

GSM



GSM and 802.11b



GSM and 802.11b



GSM and Bluetooth



GSM and Bluetooth



GSM, 802.11b, and Bluetooth



GSM, 802.11b, and Bluetooth



FCC Compliance

Dolphin mobile computers meet or exceed all applicable standards and have been manufactured to the highest level of quality.

Dolphin 7900 Series Batch Terminal

Dolphin 7900 Series Batch terminals comply with part 15 of the FCC rules. Operation is subject to the following two conditions: (1) this device may not cause harmful interference, and (2) this device must accept any interference received, including interference that may cause undesired operation.

Dolphin 7900 Series RF Terminal with an 802.11b, Bluetooth, and/or GSM MC-45 or MC-46 Radio

This device complies with Part 15 of the FCC Rules. Operation is subject to the following two conditions: (1) this device may not cause harmful interference, and (2) this device must accept any interference received, including interference that may cause undesired operation.

This equipment has been tested and found to comply with the limits for a Class B digital device pursuant to Part 15 of the FCC Rules. These limits are designed to provide reasonable protection against harmful interference in a residential installation. This equipment generates, uses, and can radiate radio frequency energy and, if not installed and used in accordance with the instructions, may cause harmful interference to radio communications. If this equipment does cause harmful interference to radio or television reception, which can be determined by turning the equipment off and on, the user is encouraged to try to correct the interference by one or more of the following measures:

- Reorient or relocate the receiving antenna.
- Increase the separation between the equipment and receiver.
- Connect the equipment into an outlet on a circuit different from that to which the receiver is connected.
- Consult the dealer or an experienced radio/TV technician for help.

If necessary, the user should consult the dealer or an experienced radio/television technician for additional suggestions. The user may find the following booklet helpful: "Something About Interference." This is available at FCC local regional offices. Our company is not responsible for any radio or television interference caused by unauthorized modifications of this equipment or the substitution or attachment of connecting cables and equipment other than those specified by our company. The correction is the responsibility of the user. Use only shielded data cables with this system.

In accordance with FCC 15.21, changes or modifications not expressly approved by the party responsible for compliance could void the user's authority to operate the equipment.



This device and its antenna must not be co-located or operating in conjunction with any other antenna or transmitter. To maintain compliance with FCC RF exposure guidelines for body-worn operation, do not use accessories that contain metallic components other than specified by the manufacturer.

Canadian Compliance for Dolphin 7900 Series RF Terminals with an 802.11b, Bluetooth, and/or GSM MC-45 or MC-46 Radio

This Class B digital apparatus complies with Canadian ICES-003. Operation is subject to the following two conditions: (1) this device may not cause harmful interference, and (2) this device must accept any interference received, including interference that may cause undesired operation.

To prevent radio interference to the licensed service, this device is intended to be operated indoors and away from windows to provide maximum shielding. Equipment (or its transmit antenna) that is installed outdoors is subject to licensing.

Cet appareil numérique de la Classe B est conforme à la norme NMB-003 du Canada.

RF, Regulatory, and Safety Agency Approvals for 802.11b and Bluetooth

Parameter	Specification
RF Approvals U.S.A Canada	FCC Part 15.247 RSS 210

RF, Regulatory, and Safety Agency Approvals for GSM MC-45

Parameter	Specification
RF Approvals U.S.A Canada	FCC Part 24 RSS 133

RF, Regulatory, and Safety Agency Approvals for GSM MC-46

Parameter	Specification
RF Approvals U.S.A	FCC Part 24

Dolphin 7900 Series 802.11b, Bluetooth, and/or GSM MC-45 or MC-46 R&TTE Compliance Statement

Dolphin 7900 RF terminals are in conformity with all essential requirements of the R&TTE Directive (1999/5/EC). This equipment has been assessed to the following standards:

Parameter	Specification
R&TTE	EN 300 328-2:2000 EN 301 489-1 (2002-08) EN 301 489-17 (2002-08) EN 60950: 2000 EN 50361: 2001

This product is marked with **CE0682** in accordance with the Class II product requirements specified in the R&TTE Directive, 1999/5/EC.

The equipment is intended for use throughout the European Community. Its authorization for use in France is restricted as follows:

PAN European Frequency Range: 2.402 - 2.480 GHz

Restrictions in France are as follows:

- Indoor use - Maximum power (EIRP*) of 100 mW for the entire 2400-2483.5 MHz
- Outdoor use - Maximum power (EIRP*) of 100 mW for the 2400-2454 MHz band and maximum power (EIRP*) of 10 mW for the 2454-2483 MHz band

Pacemakers, Hearing Aids and Other Electrically Powered Devices

Most manufacturers of medical devices adhere to the IEC 601-1-2 standard. This standard requires devices to operate properly in an EM Field with a strength of 3V/m over a frequency range of 26 to 1000MHz.

The maximum allowable field strength emitted by the Dolphin is 0.3V/m according to Subpart B of Part 1 of the FCC rules. Therefore, the Dolphin RF has no effect on medical devices that meet the IEC specification.

Microwaves

The radio in the Dolphin RF terminal operates on the same frequency band as a microwave oven. Therefore, if you use a microwave within range of the Dolphin RF terminal you may notice performance degradation in your wireless network. However, both your microwave and your wireless network will continue to function.

The Dolphin Batch terminal does not contain a radio, and therefore, is not affected by microwave ovens.

Care and Cleaning of the Dolphin Terminal

When needed, clean the image engine window and the LCD display with a clean, non-abrasive, lint-free cloth. The terminal can be cleaned with a damp cloth.

For European Community Users

Hand Held Products complies with Directive 2002/69/EC OF THE EUROPEAN PARLIAMENT AND OF THE COUNCIL of 27 January 2003 on waste electrical and electronic equipment (WEEE).

Waste Electrical and Electronic Equipment Information

This product has required the extraction and use of natural resources for its production. It may contain hazardous substances that could impact health and the environment, if not properly disposed.

In order to avoid the dissemination of those substances in our environment and to diminish the pressure on the natural resources, we encourage you to use the appropriate take-back systems for product disposal. Those systems will reuse or recycle most of the materials of the product you are disposing in a sound way.



The crossed out wheeled bin symbol informs you that the product should not be disposed of along with municipal waste and invites you to use the appropriate separate take-back systems for product disposal.

If you need more information on the collection, reuse, and recycling systems, please contact your local or regional waste administration.

You may also contact your supplier for more information on the environmental performances of this product.



Getting Started

Overview

The Dolphin 7900 terminal comprises one element of an enterprise data collection system that includes various models, peripherals, and accessories that you can combine to suit your exact needs. The Dolphin 7900 terminal itself combines the latest in multi-functional wireless data and voice communications technology with a unique, compact form factor, which makes it an ideal solution for today's in-transit applications.

Data Input

The Dolphin 7900 mobile computer features a PDA design with a larger display and smaller recessed keyboards. The display area is 3.8 inches with a 240 X 320 VGA display in TFT color that is backlit for maximum viewability, then covered with an industrial touch screen for maximum durability. There are two keyboard options: 25-key numeric-alpha and 36-key alpha-numeric.

Imaging

The Dolphin 7900 contains an integrated imager that can take digital images of damaged packages and recipient signatures in addition to decoding standard 1D and 2D symbologies. For the greatest ease-of-use when operating the imager, **both** side panels feature a scan button that initiates a scan with the touch of a thumb or forefinger.

Memory

The Dolphin 7900 is a Windows Mobile computer with 64 MB RAM and 64 MB non-volatile synchronous Flash memory.

Communications

Communications via the industrial, mechanical connector supports 115 Kbps using serial RS-232 and 12 Mbps using USB.

Dolphin 7900 Radio Configuration Options

Standard Configurations

Dolphin 7900 WLAN and WPAN (802.11b and Bluetooth)

This terminal features co-located 802.11b and Bluetooth radios, which means that your terminal contains the capabilities of both radios. You can operate the radios simultaneously or switch between them.

Dolphin 7900 WWAN and WLAN (GSM/GPRS and 802.11b)

This terminal features the functionality of both GSM/GPRS and 802.11b radio and network technologies.

Dolphin 7900 WWAN and WPAN (GSM/GPRS and Bluetooth)

This terminal features the functionality of both GSM/GPRS and Bluetooth radio and network technologies.

Dolphin 7900 WWAN, WLAN, and WPAN (GSM/GPRS, 802.11b, and Bluetooth)

This terminal features the functionality of GSM/GPRS, 802.11b, and Bluetooth radio and network technologies.

Custom Configurations

Please refer to the Dolphin 7900 pricing configuration guide or contact your Customer Account Representative (CAR) for details.

Dolphin 7900 WLAN (802.11b)

These terminals integrate the basic functionality of the Batch terminals with an integrated, IEEE 802.11b direct sequence radio that enable communication with a host computer through a wireless local area network (WLAN).

Dolphin 7900 WPAN (Bluetooth)

This terminal allows Bluetooth communications to Bluetooth enabled devices such as printers, mobile phones, Access Points (APs), Bluetooth-enabled PCs, etc.

Dolphin 7900 WWAN (GSM/GPRS)

This terminal features all the benefits of the Dolphin 7900 with the additional capabilities of GSM/GPRS technology.

Dolphin 7900 Series Peripherals

Each of the following items is sold separately to enhance your Dolphin 7900 terminal's capabilities.

Dolphin HomeBase™

The Dolphin HomeBase charging and communication cradle supports both RS-232 and USB communications, which enable it to interface with the majority of PC-based enterprise systems. When a terminal is seated in the HomeBase, its main battery pack charges in less than four hours. In addition, the HomeBase contains an auxiliary battery well that charges a spare Li-ion battery.

For more information, see [Dolphin HomeBase](#) on page 13-1.

Dolphin Mobile Base™

The Dolphin Mobile Base charging and communication cradle is designed specifically for in-premise and in-transit data collection applications. It features a flexible mounting bracket, a cigarette lighter adapter or power cable to adapt it to your environment.

When a terminal is seated in the Mobile Base, its main battery pack charges in less than four hours. The serial connector supports RS-232 communication and power out to peripheral devices, such as hand held scanners.

For more information, see [Dolphin Mobile Base](#) on page 14-1.

Dolphin QuadCharger™

The Dolphin QuadCharger is a four-slot charging station for Dolphin Li-ion battery packs that can charge each battery in less than four hours. The fourth slot features a battery analyzer that completely resets and re-calibrates a battery, then displays remaining capacity.

For more information, see [Dolphin QuadCharger](#) on page 16-1.

Dolphin ChargeBase

The Dolphin ChargeBase is a four-slot charging cradle that holds, powers, and charges a terminal in each slot.

For more information, see [Dolphin ChargeBase](#) on page 15-1.

Dolphin Net Base

The Dolphin Net Base is a four-slot charging/communication cradle that holds, powers, charges, and communicates with the terminal in each slot. Ethernet communication occurs via statically and dynamically-assigned IP addresses.

For more information about the Dolphin Net Base, please consult the Dolphin 7900 Net Base Quick Start Guide.

Dolphin 7900 Accessories

Each of the following items is sold separately to enhance your Dolphin 7900 terminal's capabilities.

Dolphin Cable Kits

USB and serial cables connect the Dolphin 7900 terminal directly to both a peripheral device for communication and a power source for charging.

Dolphin Mobile Charger

This charging cable plugs the terminal directly into a vehicle cigarette lighter/power port to power the terminal and charge the battery pack. This accessory converts the 12 Volts from the vehicle outlet to the 9 Volts required by the terminal.

Protective Enclosure

This enclosure wraps around the terminal to protect it from wear and tear.

Protective Holster

The protective holster holds the terminal for mobile use.

Dolphin Mobile Mount

The Dolphin Mobile Mount solution secures Dolphin 7900 in the cab of any vehicle. Used in conjunction with the Mobile Charger, Dolphin terminals can be adapted to almost any in-transit environment.

Li-ion Battery Pack

The 7.4v, 14.8 watt hour Li-ion rechargeable battery pack provides the main power supply for Dolphin 7900 terminals.

Using the Dolphin 7900 for the First Time

1. [Unpack the Carton and Verify its Contents](#), page 2-5.
2. [Install the Main Battery Pack](#), page 2-5.
3. [Charge the Main and Backup Batteries](#), page 2-6.
4. [Initialize the Mobile Computer](#), page 2-6.
5. [Let Autoinstall Run](#), page 2-7.
6. [Verify Operations with Demos](#), page 2-8.

Step 1. Unpack the Carton and Verify its Contents

Verify that the carton contains the following items:

- Dolphin 7900 mobile computer (the terminal)
- Main battery pack (7.4v Li-ion)
- Microsoft Companion CD
- Dolphin 7900 Quick Start Guide

Note: If you ordered peripherals or accessories, verify that they are included with the order.

Be sure to keep the original packaging in the event that the Dolphin terminal should need to be returned for service. For details, see [Product Service and Repair](#) on page 17-1.

Step 2. Install the Main Battery Pack

The Dolphin 7900 ships with the handstrap installed and fastened with a clip on the top panel. To install the battery pack, you must detach the hand strap.

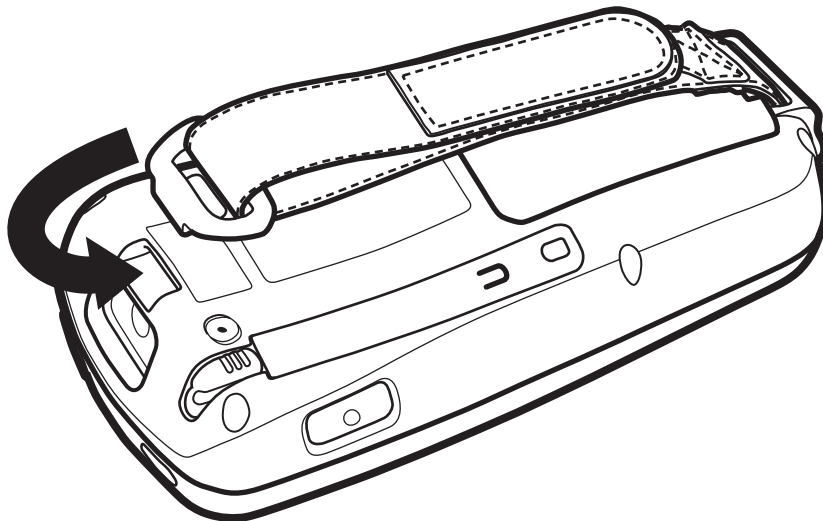

To detach the hand strap, push the clip up and away from the terminal.

To re-attach the hand strap, slide the clip back into place.

Installing the Main Battery Pack



Use only the Li-ion battery packs provided by Hand Held Products. The use of any battery pack not sold/manufactured by Hand Held Products in a Dolphin terminal will void your warranty and may result in damage to the Dolphin terminal or battery.

1. Unpack the Li-ion battery pack.
2. Hold the terminal with the front panel (keyboard) facing down and detach the handstrap.

-
3. Take the battery and insert the end without the locking tab into the top of the battery well and push down with a hinging motion until the locking tab snaps.

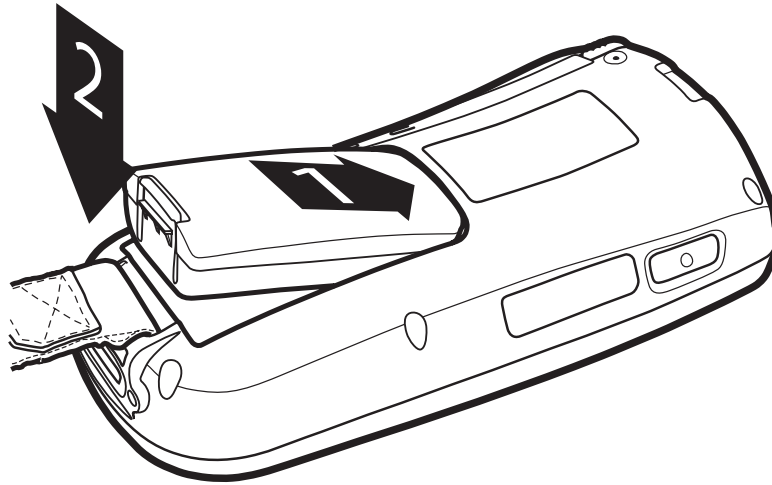

4. Re-attach the handstrap.

To Remove the Main Battery Pack

Put the terminal in Suspend mode **before** removing the battery; [Suspend Mode](#), page 2-9.

1. Detach the handstrap.
2. Press the locking tab on the battery pack and pull it away from the bottom panel.
3. Pull the battery pack up with a hinging motion.

Step 3. Charge the Main and Backup Batteries

The power supply consists of two types of battery power: the main battery pack and the backup battery located inside the terminal. The main battery powers the terminal and charges the internal backup battery. The internal backup battery maintains the application data stored in RAM and the system clock for up to 30 minutes when the main battery pack is completely discharged or removed.

Before initial use - Because the terminals are shipped with both batteries discharged of all power, charge the main battery pack for a **minimum of four hours** before initial use. When installed in the terminal, the battery pack can be charged in the HomeBase, Mobile Base, or with the appropriate charging cable. When not installed in the terminal, battery packs can be charged in the QuadCharger or the auxiliary well of the HomeBase.

Time to Charge - Four hours for the main battery pack, eight hours for the internal backup battery the first time. For more information, see [Battery Power](#) on page 3-10.

 *Use only Dolphin 7900 Series peripherals, power cables, and power adapters. Use of peripherals, cables, or power adapters not sold/manufactured by Hand Held Products will void the warranty and may damage the terminal.*

Charging with Dolphin Peripherals

When the battery is installed in the terminal, you can insert the terminal into any one of the following peripherals to charge the main battery pack:

- [Dolphin HomeBase](#) (see page 13-1)
- [Dolphin Mobile Base](#) (see page 14-1)
- [Dolphin ChargeBase](#) (see page 15-1) or the Dolphin 7900 Net Base

To fully charge the Li-ion battery before installing it in the terminal, use the

- [Dolphin QuadCharger](#) (see page 16-1)
- [Auxiliary Battery Well](#) of the Dolphin HomeBase (see page 13-5)

Step 4. Initialize the Mobile Computer

1. Power on the terminal. The decode LED lights and the scan LED blinks for approximately three seconds. Do **NOT** press any keys while the terminal is booting up.

2. The terminal initializes and the splash screen appears for a few seconds. The Build numbers indicate the software versions.

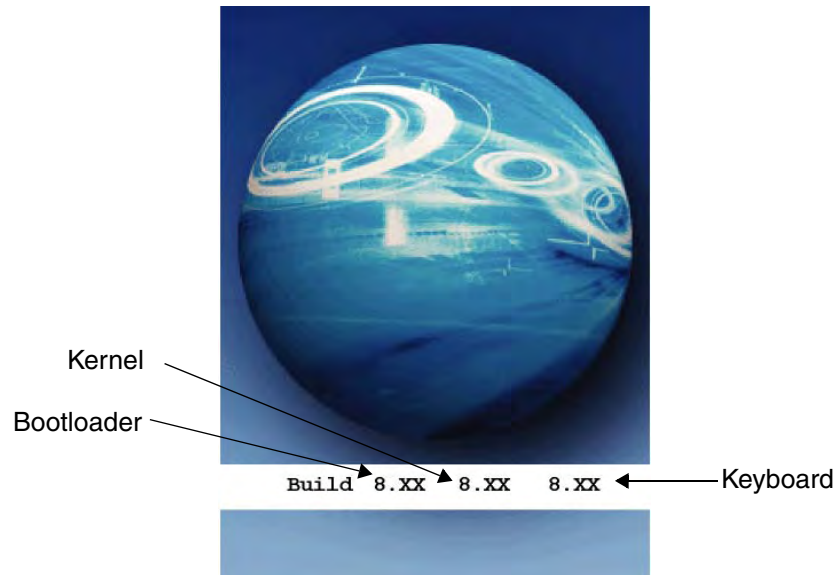

3. The system performs a hard reset. When the display activates again, follow the instructions that appear.

Step 5. Align the Screen

You are prompted to align the screen by tapping the target five times. Use the stylus provided by Hand Held Products.

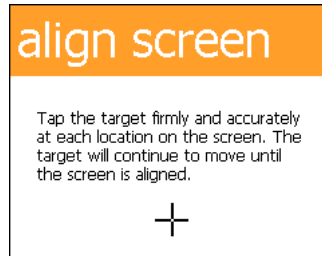

- Alignment should always be performed with a stylus designed for touch screen applications. The small point is required for accurate calibration.
- Press the stylus firmly into the center of the cross-hair target once and release. Do not “double-tap” the target.
- You can re-align the screen at any time by going to **Start > Settings > System tab > Screen**.

Step 6. Let Autoinstall Run

For each program that loads, a status bar indicates that the program is loading. Autoinstall occurs after each hard reset. Do NOT touch the keyboard or the screen while programs are loading!

All configurations of the Dolphin 7900 terminal install Demos and Power Tools. If the terminal is configured with a wireless radio, the appropriate radio drivers and utilities for each radio install.

After Autoinstall is complete, the terminal performs a soft reset automatically. When it finishes booting up after the soft reset, the Today screen appears; see [Today Screen](#) on page 4-1.

Step 7. Setting the Time and Date

The time and date need to be reset after every hard reset of the terminal. It is a good idea to set the time and date before you begin using the device, so that the system clock is accurate.

On the Today screen, tap the line that displays the time and date,



The Clock Settings screen appears.

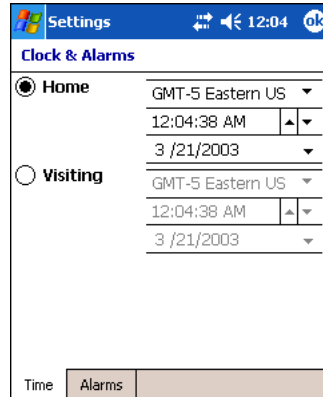

Step 8. Verify Operations with Demos

For details, see [Using the Image Engine](#) on page 5-1.

Resetting the Terminal

There are two ways to reset the Dolphin terminal: a soft and a hard reset.

Soft Reset (Warm Boot)

A soft reset re-boots the device without losing RAM data. You would perform a soft reset when

- The terminal fails to respond
- After installing some software applications
- After making changes to certain system settings, such as network cards

1. Press and hold the Red + ESC keys for approximately five seconds.
2. The decode and scan LEDs flash for approximately three seconds as the terminal resets.
3. When the reset is complete, the Today screen displays.

Hard Reset (Cold Boot)

A hard reset resets the operating system, restores the terminal back to factory defaults, and resets the terminal after a bootloader, keyboard, and kernel upgrade.



A hard reset erases all of the data stored in RAM memory and all RAM installed applications.

1. Press and hold the Red + TAB keys for approximately five seconds.
2. The decode and scan LEDs light for approximately three seconds.
3. The terminal re-initializes; see [Initialize the Mobile Computer](#) on page -6.

Suspend Mode

To put the Dolphin terminal into suspend mode manually, press and hold Blue + Backlight keys. The terminal also goes into suspend mode automatically when the terminal is inactive for a programmed period of time. For more information, see [Power](#) on page 7-10.

To wake the Dolphin terminal from suspend mode, press the SCAN key.



System Features

Processor

The Dolphin 7900 terminal is equipped with an Intel X-Scale 400MHz RISC microprocessor that runs on a 100 MHz RAM BUS, making it one of the most powerful mobile computers on the market.

Operating System

Windows Mobile 2003 Second Edition software provides a compact, highly efficient, scalable operating system. The open architecture facilitates the development of applications for energy-efficient data collection devices such as the Dolphin terminal.

Memory

Main Board/IPSM

The standard memory configuration is 64 MB RAM (optional 128 MB) and 64 MB non-volatile synchronous Flash. For more information about each kind of memory, see [Memory](#) on page 7-8.

Mini SD Card

Dolphin 7900 terminals contain a mini SD memory interface on the left side panel to support memory expansion. The memory interface is covered by an access door that can be opened to insert a memory card. For more information about the access door, see [Access Door](#) on page 3-6.

Wireless Radio Options

For more information, see [Radio Options](#) on page 4-5.

Front Panel Features

This section describes features on the front panel of the Dolphin 7900 terminal. The following graphic shows a Dolphin 7900 with a 25-key keyboard.

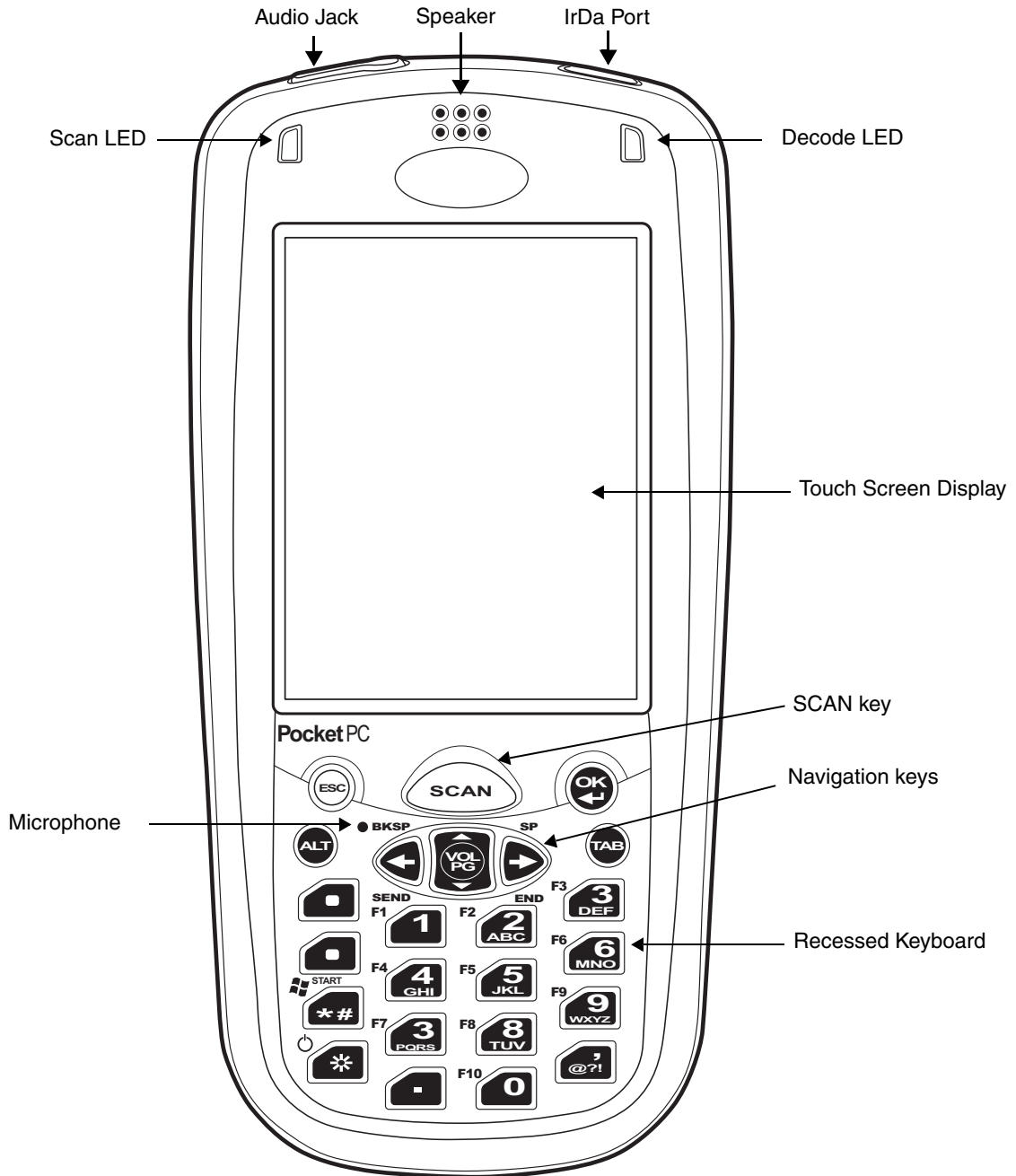

Audio Jack

Dolphin 7900 terminals contain a 2.5mm audio jack that supports both speaker (stereo) and microphone (mono) headsets. Both microphone and speaker are located on the front panel for voice communication that is fully integrated with terminal operation.

Speaker

The Dolphin 7900 terminal has an integrated speaker that sounds audio signals as you scan bar code labels and enter data. The operating frequency range is 500Hz at 71 dB up to 80 dB. The speaker can also be used for playing sounds (e.g., WAV or MP3 files).

When used in conjunction with the microphone on the keyboard, the speaker can also be used for two-way voice communications. Both speaker and microphone are located on the front panel for voice communication that is fully integrated with terminal operation.

IrDA Port

The IrDA (Infrared Data Association) port communicates with IrDA-enabled devices such as PCs, printers, modems, or other Dolphin terminals. The maximum speed is 115kbps. For more information, see [Using Infrared](#) on page 8-5.

Scan LED

The scan LED lights red when you press the SCAN key in scanning applications.

Decode LED

The decode LED lights green when a scanned bar code is successfully decoded.

Note: Both LEDs can be programmed by various software applications.

Touch Screen Display

The 3.8" liquid crystal display (LCD) is covered with an industrial, protective touch screen lens. The video graphic array (VGA) resolution is 1/4 (240 X 320 pixel). The color LCD is 16 bits/pixel and uses active display or thin film transistor (TFT) technology.

Activate the touch screen with the stylus provided or a finger. See [Using the Touch Screen](#) on page 4-2.

By default, the display backlight illuminates when the screen is touched. See [Adjusting the Backlight](#) on page 4-3.

SCAN Key

The SCAN key is centrally located for easy access with the right or left hand. When pressed, the SCAN key activates the scanner/imager. The SCAN key also functions as an on or system wakeup control for the terminal.

Navigation Keys

The centrally-located navigation keys enable you to move and position the cursor through software programs. The up and down arrows are programmed to perform specific functions when pressed in combination with the Blue and Red modifier keys.

Recessed Keyboard

The Dolphin 7900 Series features two keyboard options: 25-key numeric and 36-key alpha keyboard. Both keyboards are recessed under the overlay for maximum durability and backlit for easy viewing in various lighting conditions. For a complete overview of each keyboard, see [Using the Keyboards](#) on page 6-1.

Microphone

Dolphin 7900 terminals feature an integrated microphone that provides audio input to the terminal when a headset is not plugged into the audio jack. When a headset is plugged in, the terminal defaults to the microphone on the headset. For more information, see [Headset Control](#) on page 7-4.

Back Panel Features

The following graphic describes features on the back panel of the Dolphin 7900 terminal.

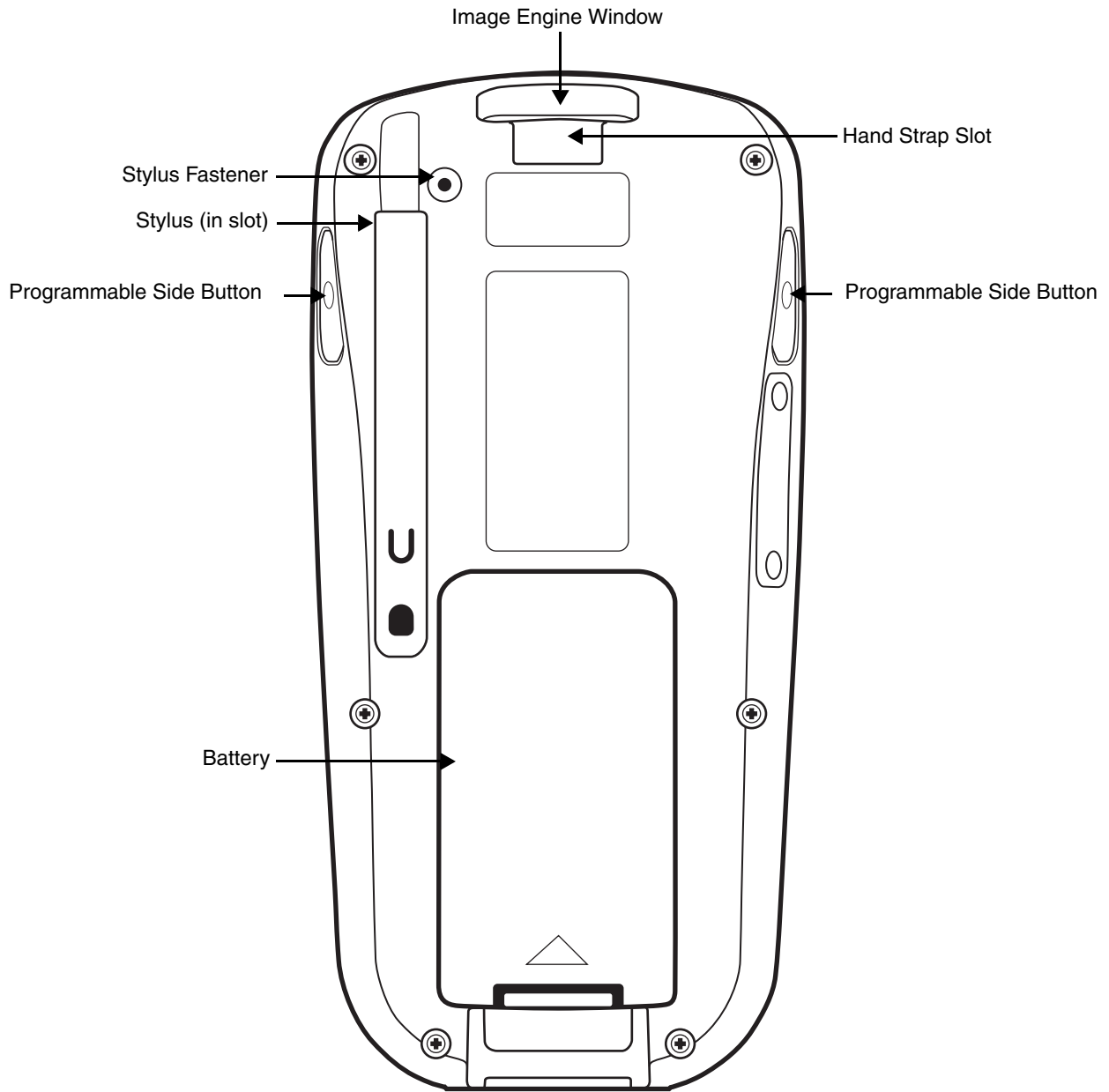

Image Engine Window

Dolphin 7900 terminals have an optional image engine that reads and decodes linear, stacked linear (PDF417), and 2D matrix bar code symbologies. With the latest CMOS-based technology, the engine works like a digital camera and enables digital image capture, signature capture, and reading of OCR characters.

The engine points out the top panel at a slight downward angle so that the terminal needs to be positioned slightly above the image or bar code when using the engine.

For more information about imaging, see [Using the Image Engine](#) on page 5-1.

Hand Strap Slot

The Dolphin 7900 has an adjustable, elastic hand strap attached to the terminal with a slot on the top of the back panel. You can detach the handstrap from this clip when you need access to the battery or other item on the back panel.

Battery

The Battery well is a recessed area on the back of the Dolphin terminal that holds the Li-Ion battery pack. For more information, see [Battery Power](#) on page 3-10.

Stylus and Fastener

The stylus is used to operate the touch screen. The back panel features this storage slot to hold the stylus when not in use. There is also a fastener on the back panel to which you can attach stylus tethers. A stylus tether is a coiled elastic cord with one end to attach to the stylus and another to attach fasten to the back panel.

Side Panel Features

The following graphic shows the left, side panel:

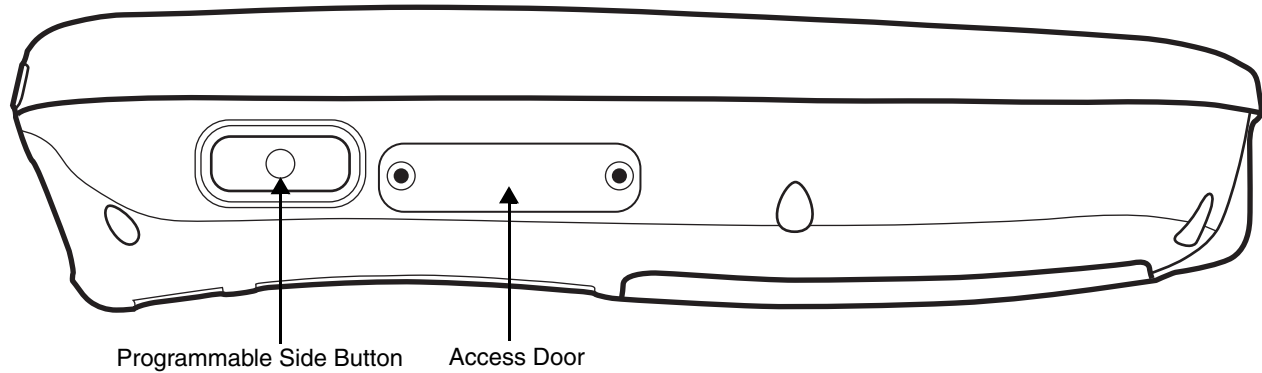

Programmable Side Button

Programmable buttons are located on both side panels. By default, these buttons activate the image/scan engine as a more ergonomic alternative to pressing the SCAN key on the keyboard. These buttons can be programmed to perform specific functions in the Buttons setting. For details, see [Buttons](#) on page 7-3.

Access Door

When the access door is open, the mini-SD memory interface and SIM card slot are available. The following graphic displays both slots as they appear when the Dolphin terminal is placed flat with the keyboard facing down.

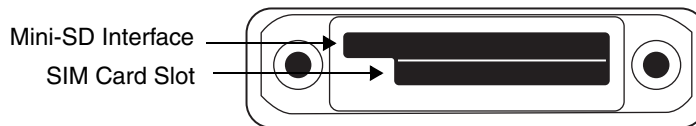

Mini-SD Interface You can install a mini-SD card to expand the capacity of the terminal's storage memory. 256 MB cards are currently available from Hand Held Products. (The mini-SD memory interface does not support SDIO.)

SIM Card SIM cards are used with a GSM/GPRS radio.

Opening the Access Door

Note: Access door removal **requires** a special tool from Hand Held Products, part number 100001024.

1. Press Blue + Backlight key to put the terminal in suspend mode; see [Suspend Mode](#) on page 2-9.
2. Remove the battery; see page 2-5.
3. Place the terminal on a flat, secure surface with the keyboard face-down.

-
- Using the special tool from Hand Held Products, unscrew both screws.

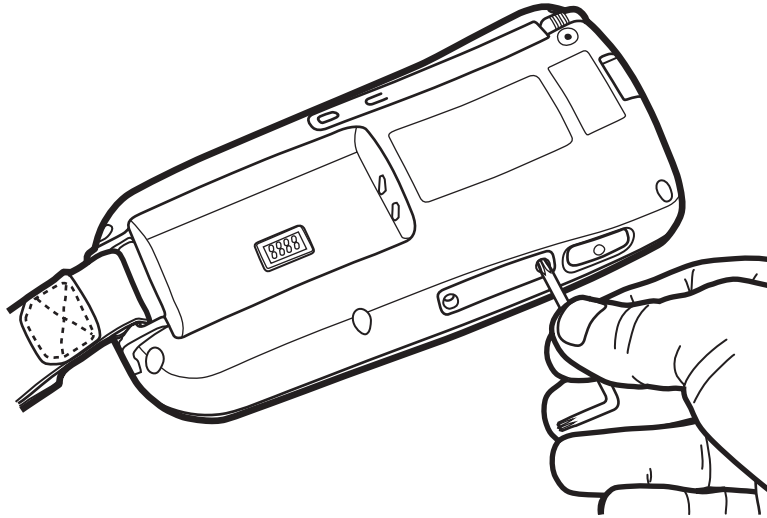

Installing a Mini-SD Card

- When the access door is open, slide the mini-SD card into the appropriate slot until it clicks into place.

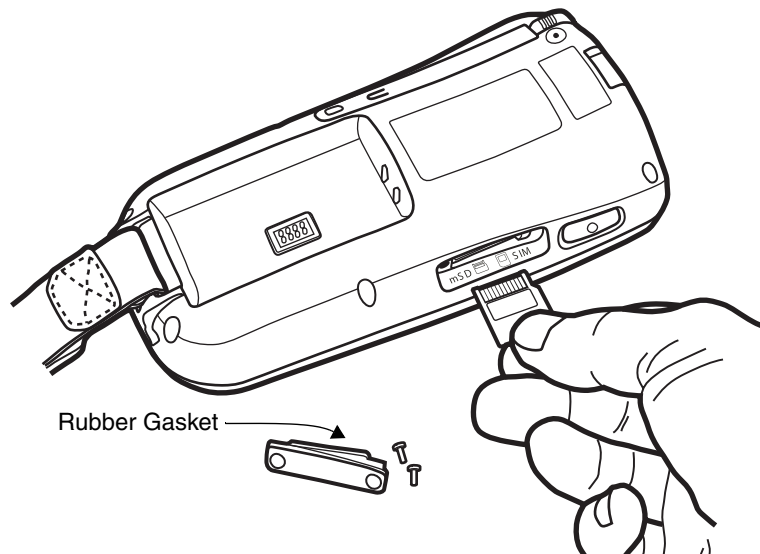

- The bottom panel inside the opening displays the following guide to help you insert the mini-SD card correctly:

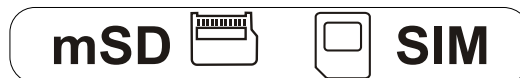

To remove an installed mini-SD card, tap on the edge lightly to unlock the card; the card will pop out just enough for you to grab its edge and pull it out.

- Replace the access door and tighten the screws. There is a rubber gasket on the inside of access door that **must** be in place when you seal the door. This gasket performs the sealing action for the door.

Installing a SIM Card

*Note: The SIM card **must** be activated by the service provider prior to installation.*

1. When the access door is open, slide the SIM card into the appropriate slot. The guide on the bottom panel inside the opening illustrates the correct position; see page [3-7](#).
2. Replace the access door and tighten the screws.
There is a rubber gasket on the inside of access door that **must** be in place when you seal the door. This gasket performs the sealing action for the door.
3. Power on the terminal.



Do NOT power on the device with the SIM card installed and the access door still open. You must secure the access door before you can resume terminal operation.

4. Tap **Start > Programs > uPhone > Dialler**. If the SIM card is not installed properly, the uPhone Dialler indicates that no SIM card is installed.

For more information about SIM cards and the GSM/GPRS radio, see [SIM Card](#) on page [11-2](#).

Replacing the Access Door

The access door must be replaced before resuming terminal operation. Replace the door and use the special tool from Hand Held Products (part number 100001024) to tighten the screws.



When closed, the access door seals the memory interface from moisture and particle intrusion thus preserving the terminal's environmental rating. The access door must be properly sealed before resuming terminal operation. Failure to seal the access door will void the warranty.

Bottom Panel Features

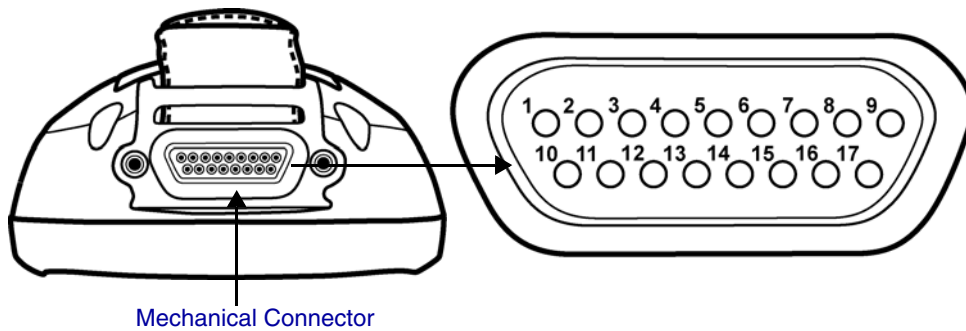

Pin #	Description
1	+USB
2	PWR
3	N/C
4	N/C
5	N/C
6	N/C
7	GND
8	5V OUT
9	DTR
10	-USB
11	USB DET
12	RI
13	DSR
14	RXD
15	RTS
16	TXD
17	CTS

Note: Signals referenced are for a DTE device.

Mechanical Connector

The bottom panel features a custom, industrial-grade connector with 17 pins. When seated in a Dolphin 7900 Series peripheral, the terminal is powered, the main battery charged, and communication occurs via this connector. All Dolphin 7900 Series peripherals are designed to work exclusively with this connector.

The 17-pin connector communicates with Dolphin peripherals via RS-232 or USB. For RS-232, the maximum communication speed is 115 Kbps with seven baud rate settings. For USB, the communication speed is up to 12 Mbps. If the peripheral unit is connected to a PC, this connector also transmits data.

Powering Out

The mechanical connector also provides power out 5V at 500mA. This means that, with the proper Hand Held Products cable, the terminal can power another device.

By default, power out is disabled. To enable power out, alter the registry as follows:

```
[HKEY_LOCAL_MACHINE\Drivers\BuiltIn\Serial4]
```

```
Conn5Venable=1
```

Battery Power

The Dolphin 7900 features intelligent battery technology with two types of battery power:

- The main battery pack installed in the back panel
- The backup battery located inside the terminal

Both batteries work together to prevent data loss when the terminal is used over long periods of time. Both batteries must also be charged to full capacity before using the Dolphin 7900 for the first time.

Main Battery Pack



Use only the Li-ion battery packs provided by Hand Held Products. The use of any battery pack not sold/manufactured by Hand Held Products in a Dolphin terminal will void your warranty and may result in damage to the Dolphin terminal or battery.

The 7.4V, 14.8 watt hour Li-Ion battery pack is the primary power source for the Dolphin. The Li-Ion battery is designed to operate in a temperature range of -10 to 50° C (14 to 122° F). For the location of the Li-Ion battery on the terminal, see [Battery](#) on page 3-5.

Charging Options

When the Li-ion battery is installed in the terminal:

- Place the terminal in a HomeBase (page 13-5), Mobile Base (page 14-7), ChargeBase (page 15-3), or Net Base that is connected to an appropriate power supply.
- Connect a charging/communication cable to the mechanical connector, plug the cable into the AC adapter, and plug the adapter cable into a power outlet.
- Connect the terminal to the Mobile Charger and vehicle power port.

When the Li-ion battery is not installed in the terminal:

- Place the battery pack in the Dolphin QuadCharger - see [Charging Batteries in the QuadCharger](#) on page 16-3.
- Place the battery pack in the auxiliary battery well of the HomeBase - see page 13-5.

Charging Time The Li-ion battery pack requires four hours to charge to full capacity.

Internal Backup Battery

Located inside the terminal, the backup battery is a 3.6 Volt nickel metal hydride (NiMH) battery.

Purpose

The internal backup battery prevents the terminal from being reset if you need to remove and replace the main battery pack. It retains RAM data and allows the real-time clock to remain operational for up to 30 minutes when the main battery pack is removed. If the terminal is left without the main battery pack for more than 30 minutes, the internal backup battery needs to be recharged to function according to its specifications.

Note: Data and programs stored in Flash memory are not lost even if the internal backup battery fails. However, you must reset the real-time clock; see [Setting the Time and Date](#) on page 2-7.

Charging

The internal backup battery is powered by the main battery pack. Therefore, charging the internal backup battery requires that the main battery pack be installed in the terminal and the terminal be connected to a charging device.

The internal backup battery must be fully charged before using the terminal for the first time. The initial charge cycle takes approximately eight hours. After that, if the internal backup battery becomes fully discharged of power, it requires a minimum of 10 hours of charging time to function normally.

Guidelines

Follow these guidelines to maximize the life of the Dolphin's internal backup battery:

- Keep a charged Li-Ion battery pack in the Dolphin terminal. The internal battery prematurely discharges if there is not at least a partially charged battery in the terminal.
- Keep the Dolphin terminal connected to power when the terminal is not in use.

Managing Battery Power

Data and files saved on the Dolphin terminal may be stored in RAM; therefore, maintain a continuous power supply to the terminal to help prevent data loss. Letting the backup battery become fully discharged causes the terminal to lose all data in RAM. The internal battery discharges prematurely if there is not at least a partially charged battery in the terminal. When you remove a battery pack, insert another charged battery pack in the Dolphin.

If the main battery is low and the terminal is in suspend mode, pressing the SCAN key will not wake the Dolphin terminal; you must replace the discharged battery with a fully charged battery.

Default Low and Critical Battery Points

The navigation bar at the top of the screen displays battery warning icons when the main battery reaches a low and critical battery points. For details about these warning icons, see [Status Icons](#) on page 4-9. If the navigation bar does not contain a warning icon, then the battery is adequately charged.

The Dolphin terminal ships with default low and critical battery points already programmed in the registry. The registry contains two DWORD settings in the [HKEY_LOCAL_MACHINE\System\CurrentControlSet\Control\Power] entry:

“**LowBatt**”=19 (25%) This sets the Low battery point to 25 percent (19 hex=25 decimal). The low battery setting is the point at which the user is notified that the battery is low. The user is notified only once for a low battery.

“**CriticalBatt**”=a (10%) This sets the Critical Battery point to 10 percent (a hex=10 decimal). The critical battery setting is the point at which the customer is warned that the battery charge is very low. This warning is posted every 3 minutes until the situation is corrected.

Note: Warnings do not appear when the terminal is on external power.

Setting Critical and Low Battery Points

Developers can re-reset the default battery points in the RegEdit Power Tool.

1. Tap **Start > Power Tools > RegEdit**.
2. Drill-down to **HKEY_LOCAL_MACHINE > System > CurrentControlSet > Control > Power**. The Battery Points appear in the list.

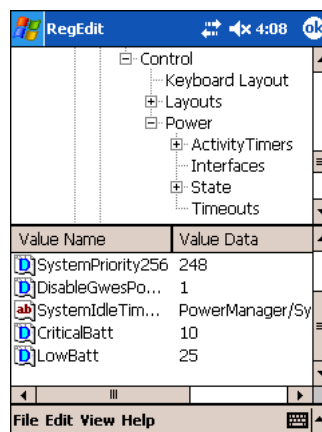

3. Tap the **Value Name** to change the Value Data. You can reset the Value Data from 0 (no warning) to 99 (would nearly always warn).
4. Tap **OK** to save changes.

For more information about the RegEdit Power Tool, refer to the Dolphin Power Tools User’s Guide available for download at www.handheld.com.

Checking Battery Power

Tap **Start** > **Settings** > **System** tab > **Power**. The Battery tab opens displaying the charge status of both the installed Li-ion battery pack and the NiMH backup battery inside the terminal.

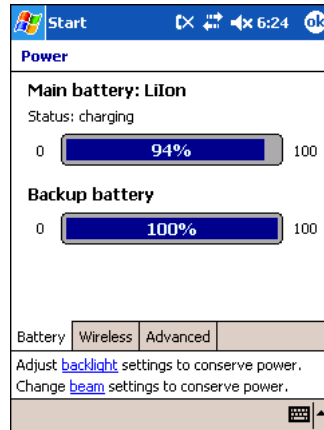

For more information, see [Power](#) on page 7-10.

Storing Batteries

To maintain optimal battery performance, follow these storage guidelines:

- Avoid storing batteries outside the specified range of -4 to 104° F (-20 to 40°C) or in extremely high humidity.
- For prolonged storage, do not keep batteries stored in a charger that is connected to a power source.

Guidelines for Battery Use and Disposal

The following are general guidelines for the safe use and disposal of batteries:

- Use only the battery supplied, recommended, or approved by Hand Held Products.
- Replace defective batteries immediately; using a defective battery could damage the Dolphin terminal.
- Never throw a used battery in the trash. It contains heavy metals and should be recycled according to local guidelines.
- Don't short-circuit a battery or throw it into a fire. It can explode and cause severe personal injury.
- Excessive discharge damages a battery. Recharge the battery when your terminal indicates low battery power.
- Although your battery can be recharged many times, it will eventually be depleted. Replace it after the battery is unable to hold an adequate charge.
- If you are not sure the battery or charger is working properly, please send it to Hand Held Products or an authorized Hand Held Products service center for inspection.

Dolphin 7900 Technical Specifications

System Architecture	
Processor:	Intel X-Scale PXA255 400MHz
Software Development Kits:	<ul style="list-style-type: none"> Dolphin SDK Add-on for Windows Mobile 2003 Second Edition (Supports Embedded Visual C++ 4.0) Dolphin .NET SDK for Windows Mobile 2003 Second Edition (Supports Visual Studio.NET 2003 (VB.NET and C#.NET)) Dolphin GSM/GPRS SDK Add-on for Pocket PC 2003 (Supports Embedded Visual C++ 4.0 and Visual Studio.NET 2003)
Operating Platform:	Windows Mobile 2003 Second Edition Software for Pocket PCs
Third-Party Software:	Support for Connect Terminal Emulation software (TNVT, 3270, 5250) and Java Virtual Machine (JVM) runtime, ITScriptNet Batch and Omni, MCL, and App Forge
Memory:	64MB RAM x 64MB non-volatile synchronous Flash standard; 128MB RAM high memory optional
Data Inputs	
Imager/Scanner:	See Image Engine Options on page 5-1.
1D Symbologies:	See 1D Symbologies on page 5-2.
2D Symbologies:	See 2D Symbologies on page 5-2.
Composite Codes	See Composite Codes on page 5-2.
OCR Fonts:	See OCR Codes on page 5-2.
Three Keyboard Options:	Two backlit keyboard options: 25-key numeric alpha, 36-key alpha numeric See Using the Keyboards on page 6-1.
Data Outputs	
Display:	See Touch Screen Display on page 3-3.
I/O Ports:	Industrial-grade mechanical connector supports communications (USB 1.1, serial RS-232 up to 115Kbps) and charging via cradles or AC adapter cables, Integrated IrDA port, Integrated Speaker, Integrated Microphone, Integrated Headset jack
Mass Storage:	User-accessible Mini Secure Digital (Mini-SD) memory interface
Wireless Radio Options	
WWAN:	GSM/GPRS Tri-band: 850/1800/ 1900 MHz in US, Latin America, and Canada or 900/1800/1900 MHz in Europe, Asia, and Australia
WLAN:	IEEE 802.11b DSSS Authentication Methodologies: LEAP, MD5, TLS, TTLS, PEAP, and WEP
WPAN:	Bluetooth radio (Class 2)
Physical	
Dimensions:	7.3"L x 3. 5"W x 1.7"D max (185 x 89 x 43 mm), 3.2"W x 1.5"D at grip (81 x 38 mm)
Weight:	Batch: 17 oz. (482 gm) WLAN: 17.3 oz. (490 gm) WPAN: 17.1 oz. (484 gm), WLAN/WPAN: 18.9 oz. (536 gm)

Dolphin 7900 Technical Specifications

Operating Temperature:	14 to 122°F (-10°C to 55°C) The terminal can operate in temperatures lower than -20°C with potential degradation in performance depending on the application.
Storage Temperature:	-22 to 176°F (-30°C to 80°C)
Humidity:	95% humidity, non-condensing
ESD:	15 KVA on all surfaces
Impact Resistance:	Withstands multiple 5ft (1.5m) drops onto concrete
Environmental Resistance:	Independently certified to meet IP64 standards for moisture and particle resistance
Power:	Lithium-Ion battery technology, 7.4V, 14.8 watt-hour main battery with hot-swappable design for fast replacement in the field
Other:	Integrated stylus with optional tether and adjustable, removable hand strap
Peripherals/Accessories	
Dolphin HomeBase	Charging/communications cradle with auxiliary battery well. Data transfer via RS-232 serial or USB ports.
Dolphin Mobile Base	Mobile charging/communication cradle. Data transfer via RS-232 serial. Power out 5 volts for peripheral devices.
Dolphin QuadCharger	Four-slot battery charger that charges four batteries in under four hours. One slot doubles as a battery analyzer.
Dolphin Mobile Charger	Charges a Dolphin terminal by plugging into a vehicle cigarette lighter/power port.
Dolphin Net Base	Four-slot charging/communication cradle designed for Ethernet-based communications.
Dolphin ChargeBase	Four-slot charging cradle that holds, powers, and charges a terminal in each slot.
Dolphin Cable Kits	USB or serial cables that charge and communicate with the terminal directly, without a cradle.
Li-Ion Battery Pack	7.4V, 14.8 watt hour Li-ion rechargeable main battery for the Dolphin.
Regulatory Approvals	
FCC-CE-Radio Country:	US/Canada, R&TTE

Overview

This chapter provides the basic instructions you need to operate the Dolphin 7900 terminal.

Today Screen

When the terminal powers one for the first time, you see the Today screen. You can also display it by tapping **Start** and then **Today**. On the Today screen, you can see at a glance important information for the day.

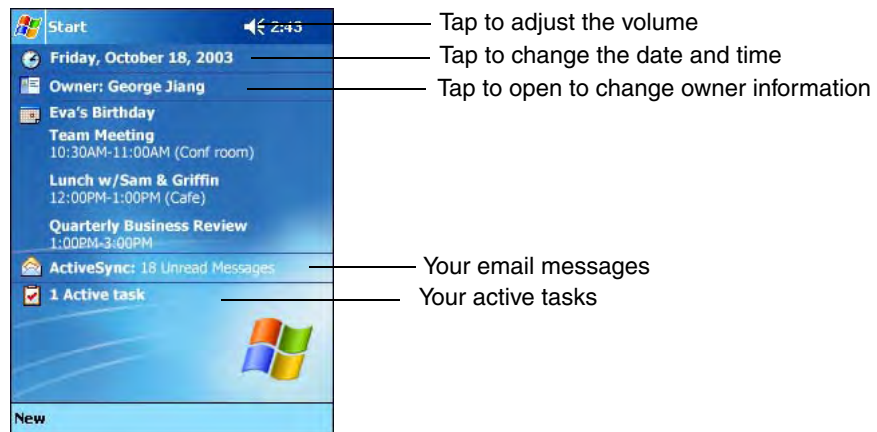

Navigation Bar and Start Menu

The navigation bar is located at the top of the screen and displays the active program and current time, and allows you to switch to programs and close screens.

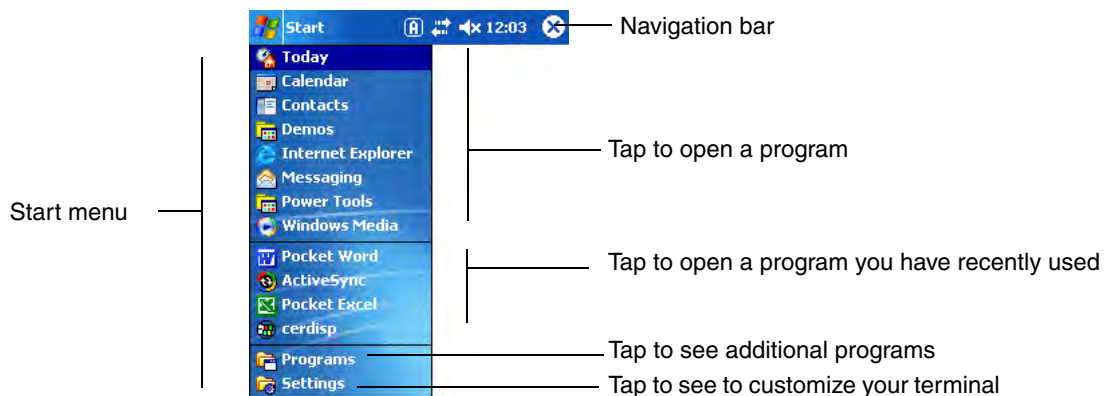

Command Bar

Use the Command bar at the bottom of the screen to perform tasks in programs. The Command bar includes menu names, buttons, and the Input Panel button.

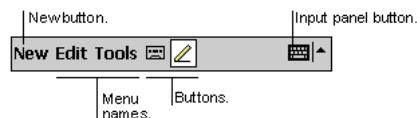

Using the Touch Screen

Hand Held Products recommends using screen protectors to protect the touch screen; especially when used with applications that require high-volume interfacing with the touch screen. Screen protectors help prevent damage to the touch screen display and are easily installed. Screen protectors can be purchased at any major computer retail store or directly from Hand Held Products; contact Hand Held Products directly for part numbers and pricing.



For touch screen input, use the included stylus or your finger. The method you choose depends on which one is appropriate for your application. While there is a great deal of variation in different applications, for buttons or icons that are close together, you generally achieve greater accuracy with the stylus. Use of other objects, such as paper clips, pencils, or ink pens can damage the input panel and will void the warranty.

Selecting Programs

To see additional programs loaded on your terminal, tap **Start > Programs**. The Programs screen displays the programs that are not listed on the Start menu. To open a program, tap once on the icon.



Some programs have abbreviated labels underneath the icon. To see the full spelling of an abbreviated label, tap and hold the stylus on the label. Drag the stylus off the label so that the command is not carried out.

Pop-Up Menus

With pop-up menus, you can quickly choose an action for an item. For example, you can use the pop-up menu in the contact list to quickly delete a contact, make a copy of a contact, or send an e-mail message to a contact. The actions in the pop-up menus vary from program to program.

1. Tap and hold the stylus on the item name. The pop-up menu appears.
2. Lift the stylus, and tap the action you want to perform.

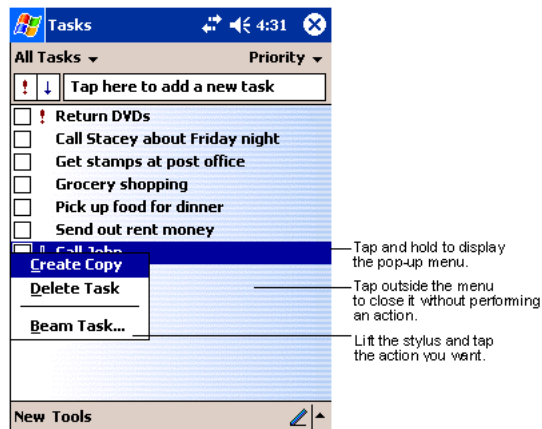

Note: To close the menu without performing an action, tap the screen anywhere outside the menu.

Adjusting the Backlight

The backlight for the color display is user-defined. There are two tabs - one for Battery and the other for External power. The options on each tab are the same. Go to **Start > Settings > System tab > Backlight**. Backlight settings open displaying the Battery tab.

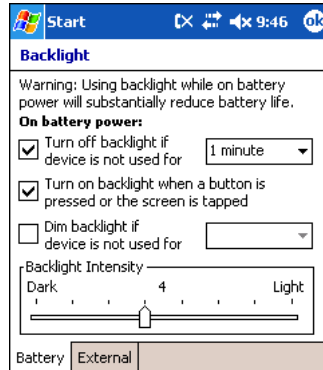

There are two tabs: **Battery** and **External**; the options on each tab are the same. The Battery tab determines display backlight settings when the terminal is running on battery power. The External tab determines display backlight settings when the terminal is powered by an external source, such as a Hand Held Products cable.

Field	Description
Turn off backlight	Select how many minutes you want to elapse before the backlight automatically turns off.
Turn on backlight	Select this option if you want the backlight to turn on when the a button is pressed or the touch screen is tapped.
Dim backlight if	Select how many minutes you want to elapse before the backlight dims.
Backlight Intensity	Move the slider to set the intensity of the backlight.
OK	Tap OK to save settings. The display backlight functions according to the settings saved on each tab.

Communication Options

Mechanical Connector

The 17-pin, industrial-grade, mechanical connector on the bottom panel is designed to work only with communication and charging peripherals sold/manufactured by Hand Held Products. For more information about the connector, see [Mechanical Connector](#) on page 3-9.

IrDA Port

The IrDA port enables the Dolphin 7900 to transmit data via pulses of light to and from other IrDA-compliant devices, such as printers and PCs or to other Dolphin terminals. For more information, see [Using Infrared](#) on page 8-5.

Wireless Radios

For more information, see [Radio Options](#) on page 4-5.

Software Communication Programs

Microsoft ActiveSync v3.7 or Higher

Microsoft ActiveSync is a tool that enables mobile computing devices, such as the Dolphin 7900, to exchange and synchronize application data with a desktop computer. For more information, see [Using ActiveSync](#) on page 8-2.

RAS

Short for Remote Access Services, RAS is a feature built into Windows NT that enables users to log into an NT-based LAN using a modem, X.25 connection or WAN link. RAS is fully supported and allows the use of PPP or SLIP connections for network connectivity.

Radio Options

Dolphin 7900 terminals can be configured with a combination of the following radios:

- 802.11b - [Wireless LAN \(WLAN\) Communications with 802.11b](#) (see page 9-1)
- Bluetooth - [Wireless PAN \(WPAN\) Communications with Bluetooth](#) (see page 10-1)
- GSM/GPRS - [Wireless WAN \(WWAN\) Communications with GSM/GPRS](#) (see page 11-1)

Radio Combinations

Note: Configuration of simultaneous radio operation is done during the manufacturing process according to FCC regulations. All radios and radio drivers are co-located inside the terminal.

802.11b and GSM radios cannot be enabled at the same time. Bluetooth radios can be enabled and operating with either the 802.11b or GSM radio or both.

Radio Driver Installation

Radio drivers install during the autoinstall process after a hard reset (see [Let Autoinstall Run](#) on page -7). Only the appropriate drivers for the terminal's radio configuration install.

Radio Manager

The Radio Manager allows you to enable and disable radios installed in the terminal after initial bootup. If the Dolphin terminal is configured with an 802.11b radio, the Radio Manager defaults to the 802.11b radio after initial bootup. However, if the Dolphin terminal is configured with a GSM radio, the Radio Manager defaults to the GSM radio after the initial bootup.

Accessing the Radio Manager

Tap **Start > Settings > Connections** tab > **Radio Manager**. The Radio Manager appears identifying which radio drivers are installed. The highlighted entry is the radio mode that is currently enabled; its Status should be Ready.

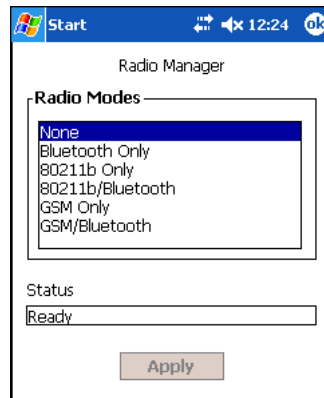

Radio Modes

The Radio Modes section lists the radio drivers currently installed on the terminal.

Status field

The Status field displays the status of the radio driver selected in the Radio Modes box.

Ready - The selected radio is enabled.

Success - The selected radio has been successfully enabled.

Error message - The radio cannot be enabled. You cannot successfully enable the radio if the radio's driver is not installed. An error will appear telling you that the radio driver is not installed.

Enabling Radios and Radio Combinations

Note: To successfully enable a radio, both the hardware module and the software driver must be installed on the terminal.

If multiple radios are installed in your terminal, you must enable the radio combination and not each individual radio. To enable a radio or radio combination, select the radio in the Radio Modes list and tap **Apply**.

The radio drivers are enabled and disabled (if necessary) in the proper sequence. For example, if the radio enabled is Bluetooth Only and you try to switch to 802.11b Only, after **Apply** is tapped, the Radio Manager disables the Bluetooth radio first, then enables the 802.11b radio.

Disabling Radios

To disable all radios, select **None** and tap **Apply**.

Using the Soft Input Panel (SIP)

Use the SIP to enter information in any program on the Dolphin terminal. You can either type on the soft keyboard or write on the touch screen using Letter Recognizer or Block Recognizer. In either case, the characters appear as typed text on the screen.

To show or hide the SIP, tap the **Input Panel** button. Tap the arrow next to the Input Panel button to see your choices.

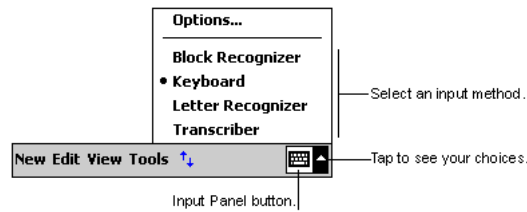

When you use the SIP, your terminal anticipates the word you are typing or writing and displays it above the input panel. When you tap the displayed word, it is inserted into your text at the insertion point. The more you use your Dolphin terminal, the more words it learns to anticipate.

To change word suggestion options, such as the number of words suggested at one time, tap **Start > Settings > Personal tab > Input > Word Completion** tab.

Using the SIP Keyboard

Tap the arrow next to the Input Panel button and select **Keyboard**. On the soft keyboard that displays, tap the keys with your stylus.

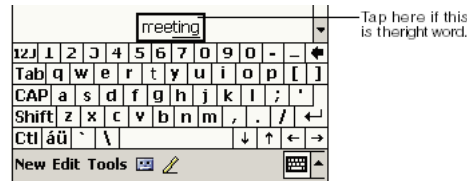

Using the Letter Recognizer

With Letter Recognizer you can write letters using the stylus just as you would on paper.

Tap the arrow next to the Input Panel button and then **Letter Recognizer** and write a letter in the box.

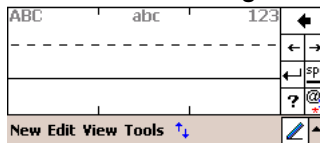

When you write a letter, it is converted to typed text that appears on the screen.

Using the Block Recognizer

With Block Recognizer you can input character strokes using the stylus.

Tap the arrow next to the Input Panel button and then **Block Recognizer** and write a letter in the box.

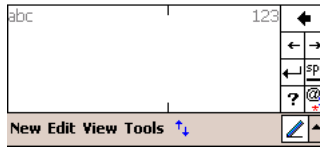

When you write a letter, it is converted to typed text that appears on the screen.

Selecting Text

To edit or format typed text, select it by dragging the stylus across the text. Then, use the commands on the pop-up menu to cut, copy, and paste the selected text.

Input Panel Options

You can set input options by going to **Start > Settings > Personal tab > Input**. The following graphics are the tab windows where you can customize the input panel to your preferences:

Input tab

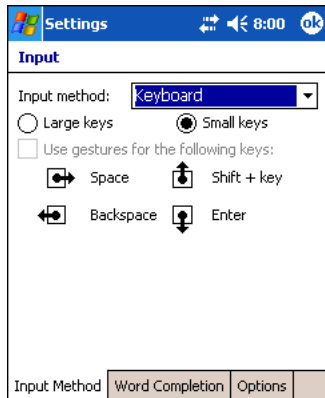

Word Completion tab

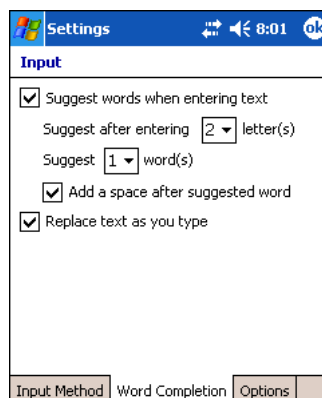

Options tab

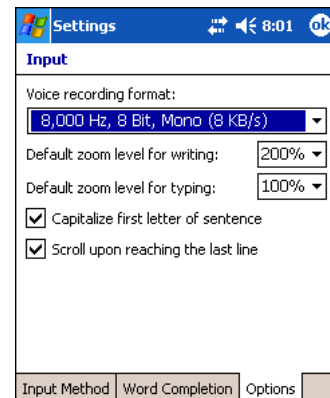

Writing on the Screen

You can use your stylus to write directly on the screen as you would on paper. To write on the screen, tap the **Pen** button to switch to writing mode. This action displays lines on the screen to help you write.

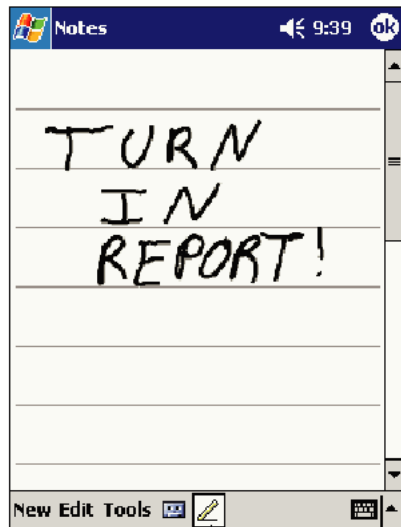

Tap the Pen button and use your stylus like a pen.

Note: Some programs that accept writing may not have the Pen button. See the documentation for that program to find out how to switch to writing mode.

To Select Writing

If you want to edit or format writing, you must select it first.

1. Tap and hold the stylus next to the text you want to select until the insertion point appears.
2. Without lifting, drag the stylus across the text you want to select.

If you accidentally write on the screen, tap **Tools**, then **Undo** and try again. You can also select text by tapping the **Pen** button to deselect it and then dragging the stylus across the screen. You can cut, copy, and paste written text in the same way you work with typed text: tap and hold the selected words and then tap an editing command on the pop-up menu, or tap the command on the **Edit** menu.

Drawing on the Screen

Drawing on the screen is similar to writing on the screen. The difference between writing and drawing on the screen is how you select items and how they can be edited. To create a drawing, cross three ruled lines on your first stroke. A drawing box appears. Subsequent strokes in or touching the drawing box become part of the drawing. Drawings that do not cross three ruled lines will be treated as writing.

For example, selected drawings can be resized, while writing cannot.

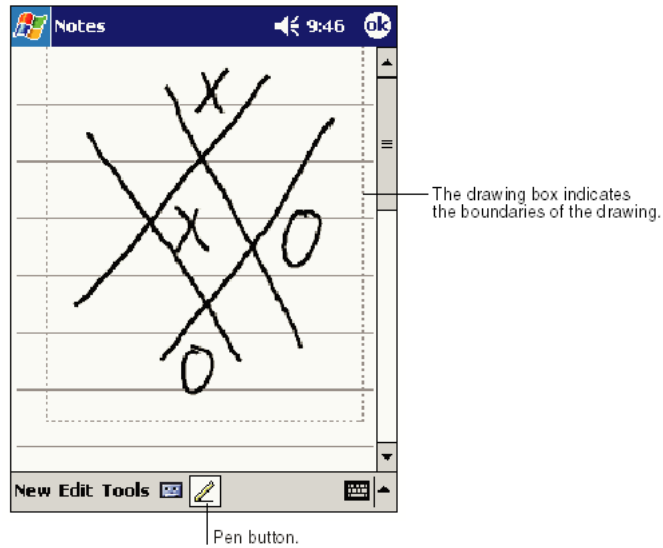

Status Icons

Status Icon	Meaning
	Opens the sound and volume drop-down that turn the sound on and off and adjust the volume
	Backup battery is low
	Main batteries are charging
	Main batteries are low
	Main batteries are very low
	Main batteries are full
	Synchronization is beginning or ending
	Notification that one or more e-mail messages were received

Note: The Notification icon displays if more notification icons need to be displayed than there is room to display them. Tap the icon to view all notification icons that cannot be displayed.

Notifications

Notifications remind you when you have something to do. For example, if you've set up an appointment in Calendar, a task with a due date in Tasks, or an alarm in Clock, you'll be notified by a message box appearing on the screen or a sound is played. To choose reminder types and sounds, tap **Start > Settings > Personal tab > Sounds & Notifications; Personal Tab**, page 7-2.

Using Find

The Find feature helps you quickly locate information. Tap **Start > Programs > Find**. Enter the text you want to find, select a data type, and then tap **Go** to start the search.

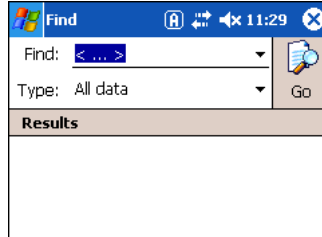

Using File Explorer

You can also use the File Explorer to find files and organize these files into folders. Tap **Start > Programs > File Explorer**.

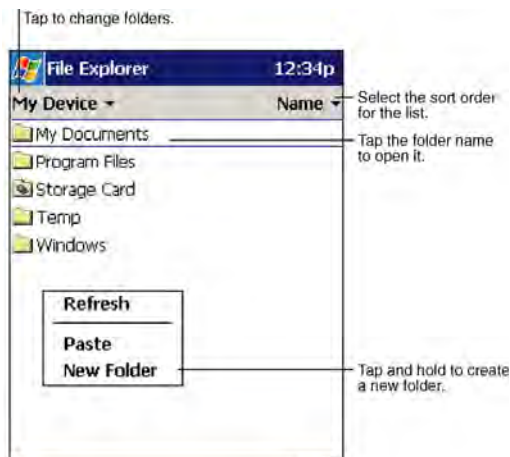

You can move files in File Explorer by tapping and holding the item you want to move, and then tapping **Cut** or **Copy** and **Paste** on the pop-up menu.

Overview

The Dolphin 7900 terminal houses a compact image engine that instantly reads all popular 1D and 2D bar codes and supports omni-directional aiming and decoding for greater flexibility in real-world settings. The image engine can also capture digital images, such as signatures and pictures of damaged inventory. Images are saved in industry-standard file formats.

Image Engine Options

Dolphin 7900 terminals may be equipped with one of the following image engines.

5300 Standard Range (5300SR)

Code	8 mil Linear	10 mil PDF417	13 mil UPC	15 mil QR	15 mil Data Matrix	35 mil MaxiCode
Working Range	(.020 cm)	(.025 cm)	(.033 cm)	(.038 cm)	(.038 cm)	(.089 cm)
Near	3.4 in. (8.6 cm)	3 in. (7.6 cm)	2 in. (5.1cm)	3 in. (7.6 cm)	2.2 in. (5.6 cm)	1.9 in. (4.8 cm)
Far	7.5 in. (19 cm)	8.9 in. (22.6 cm)	13.1 in. (33.3 cm)	8.7 in. (22 cm)	10.1 in. (25.6 cm)	12.9 in. (32.7 cm)

The 5300SR image engine contains a high-visibility aimer that projects aiming brackets around the bar code or image preview for maximum viewability. For details, see [Omni-Directional Scanning](#) on page 5-4.

Bar Code Symbologies Supported

The Dolphin 7900 supports the following bar code symbologies:

Symbology Type	Symbology Name
1D Symbologies	Codabar Code 3 of 9 Code 11 Code 32 Pharmaceutical (PARAF) Code 93 Code 128 EAN with Add-On EAN with Extended Coupon Code EAN-13 Interleaved 2 or 5 Matrix 2 of 5 Plessey PosiCode RSS Straight 2 of 5 IATA Straight 2 of 5 Industrial Telepen Trioptic Code UCC/EAN-128 UPC and UPC-A
2D Symbologies	Aztec Code 16K Composite Data Matrix MaxiCode OCR PDF417 QR Code RSS
Composite Codes	Aztec Mesa Codablock F EAN-UCC RSS-14
OCR Codes	OCR-A OCR-B
Postal Codes	Postnet and most international 4 state codes Australian Post British Post Canadian Post China Post Japanese Post KIX (Netherlands) Post Korea Post Planet Code

Activating the Engine

The Dolphin 7900 terminal offers the following options to activate the engine:

- The SCAN key located in the center of both keyboards for easy access from either hand; see [SCAN key](#) on page 3-2.
- The buttons located on each side panel; see [Side Panel Features](#) on page 3-6.

Programmable Side Buttons

By default, the buttons on each side panel activate the imager; for exact location, see [Side Panel Features](#) on page 3-6.

These buttons can be programmed to perform specific functions as well as open software applications; see [Buttons](#) on page 7-3.

Demos

Dolphin terminals contain demo programs that operate the image engine.

To access demos, tap **Start > Demos >**

- **> Scan Demo** to verify decoding; see [Decoding](#) on page 5-3.
- **> Image Demo** to verify imaging; see [Capturing Images](#) on page 5-5.

Use the Scan and Image Demos to test and verify image engine performance.

Decoding

The Dolphin terminal supports two types of image decoding for use in various bar code reading and imaging applications: full-area imaging and Advanced Linear Decoding (ALD).

Full-area Imaging

Full-area imaging provides omni-directional reading of linear and non-linear 1D and 2D bar codes, OCR, signature capture, and picture taking. When reading all bar code types using full-area imaging, a positive read can be obtained from many positions; see [Omni-Directional Scanning](#) on page 5-4. To achieve the best read, the aiming beam should be centered horizontally across the bar code.

ALD

ALD provides fast reading of linear and stacked linear bar codes. To achieve a positive read when reading linear 1D and PDF417 bar codes, the green aiming beam should be centered horizontally across the bar code. When ALD is enabled, the reader does not read matrix or postal codes.

To Decode a Bar Code

1. Tap **Start > Demos > Scan Demo**.
2. Position the Dolphin 7900 terminal over the bar code. A range of 4-10 inches (10-25 cm) from the bar code is recommended.
3. Project the aiming pattern by pressing and holding the SCAN key or one of the side buttons; [Programmable Side Buttons](#) (see page 5-3). The Scan LED lights.
4. Center the aiming pattern over the bar code. For optimal decoding, make sure the aiming beam is in line with the bar code.
5. Release the SCAN key or side button.
6. When the bar code is successfully decoded, the decode LED lights and the terminal beeps; [Decode LED](#) (see page 3-2).

Sample Bar Codes

Use the following bar codes to verify decoding. Each bar code displays a text message on the screen when scanned.

Sample 128 Bar Code



Text message: Code 128

Sample PDF417 Bar Code



Text message: PDF417 Test Message

Omni-Directional Scanning

Dolphin terminals support omni-directional scanning. The red high-vis aiming pattern frames the bar code to provide you with the best scanning performance.

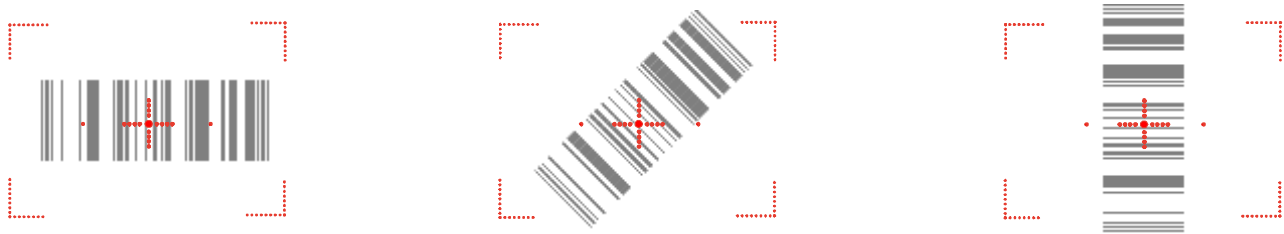

The aiming pattern is smaller when the terminal is held closer to the bar code and larger when farther from the bar code. Symbologies with smaller bars or elements (mil size) should be read closer to the terminal whereas larger bars or elements (mil size) should be read farther from the terminal.

Capturing Images

The image-capture process is an intuitive, split-second operation for experienced users. By following the basic guidelines, new users can easily develop their own technique and, with practice, quickly learn to adapt it to different application environments.

Image Preview

When the imaging process is initiated, the Dolphin 7900 touch screen displays a preview of the object. This is a live video image of what the imager is currently viewing and has a slightly degraded appearance compared to the captured image. This is normal.

File Formats

The terminal is capable of saving images in a number of industry-standard file formats such as *.bmp, *.jpg and *.png. The default file format for images is a grayscale *.jpg. To obtain the highest quality images, take grayscale images.

File Size

Digital images have a maximum image size of 640 x 480 pixels and may have up to a 256 grayscale image definition. The image quality and related file size are determined by the data compression method used by the software application used to take images. The average size of the image file is approximately 4-8K. However, the size of the image depends on the content of the image - the more complex the content, the larger the file size.

Taking an Image

1. Tap **Start > Demos > Image Demo**.
2. Point the Dolphin 7900 terminal at the object.
3. Activate the engine. The touch screen displays a preview of the object.
4. Adjust the terminal's position until the object appears on the screen the way you want it to appear in the image.
5. Hold the terminal still and release the SCAN key or side button. The touch screen flashes, and the captured image appears on the screen.



6. By default, the image is saved to the My Device folder (Start > Programs > File Explorer > My Device). To save the image to another location, tap **File > Save As**.

High-Vis Aiming Pattern

You can enable the red, high-vis aiming pattern for imaging in the Image Demo application.

Tap **Start > Demos > Imaging Demo > Options** menu > **Aimer**. The aiming pattern is now enabled for imaging.

Uploading Images

Image files can be transmitted to a host PC via

- Microsoft ActiveSync and a Dolphin communication peripheral, or
- Over your wireless radio network.



Using the Keyboards

Overview

The Dolphin 7900 Series features two keyboard options:

25-key Numeric Keyboard

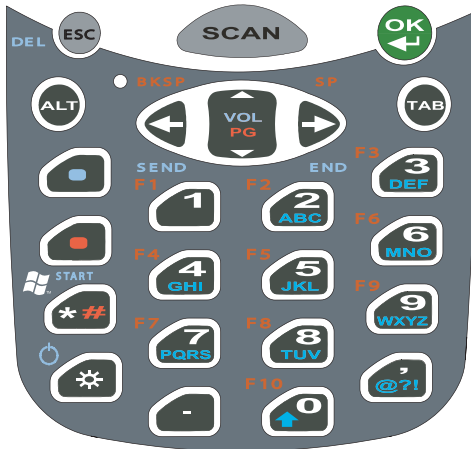

36-key Alpha Keyboard

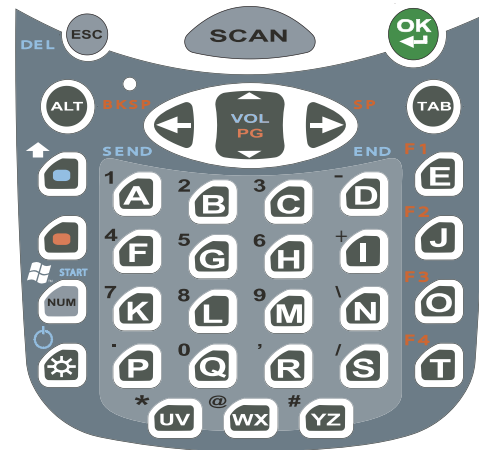









Both keyboards are recessed under the overlay for maximum durability and backlit for maximum visibility in various lighting conditions. Keyboard overlays are color-coded to indicate the functions performed or characters typed when the color-coded key is pressed immediately after the Red or Blue Modifier key.

In addition to the standard number and letter keys, both keyboards contains three types of keys:

1. Function Keys
2. Navigation Keys
3. Modifier Keys

Using the Function Keys



Function keys are those keys that perform specific functions and usually have the name of the function they perform.



Name	Key	Function
Backlight		The Backlight key turns the keyboard backlight on and off.
Backspace (BKSP)		The Backspace function is performed by pressing the Red modifier key + the left arrow. Backspace moves the cursor back one space and deletes each time the key combination is pressed. If you are typing text, a character is deleted each time you backspace.
Delete (DEL)		The delete function is performed by tapping the Blue + ESC keys. This function deletes the next character forward each time the key combination is pressed.
Escape		The Escape key performs a cancel action.
OK		The OK key functions as an Enter key.
Power		The suspend/resume function is performed by pressing the Blue + Backlight keys. Pressing this key combination puts the terminal in suspend mode and wakes it from suspend mode.
SCAN		The SCAN key activates the scan and wakes the terminals from suspend mode. Its position allows convenient one-handed image-taking and/or bar code decoding.
Space (SP)		The Space function is performed by pressing the Red modifier key + right arrow. The Space key moves the cursor one space forward. If you are typing text, it moves the text one space forward as well.
Tab		The Tab key moves the cursor to the next tab stop or the next field (on a form). Blue + Tab acts as a backtab that allows you to move back one field.

Using the Navigation Keys

Located in the center of each keyboard for easy access with either hand, the navigation keys enable you to navigate the cursor through an application screen.



Press	To ...
	Move the cursor up one row or line.
	Move the cursor down one row or line.

Press	To ...
	Move the cursor one character to the right.
	Move the cursor one character to the left.



The up and down arrows can be used for

- Volume up and down commands when pressed in combination with the blue modifier key, or
- Page up and page down commands when pressed in combination with the red modifier key.

Other functionality varies according to the application in use.

Using the Modifier Keys

Modifier keys are those keys that modify the next key pressed. They are used on combination with the keys that follow to perform functions or type special characters. In addition to the standard ALT key, the Dolphin 7900 terminal has Blue and Red modifier keys and a color-coded overlay.

Name	Key	Function
ALT		The functions performed by the ALT key depends on the software application in use and the key combination pressed.
Blue Red	 	<p>The blue and red keys are used in combination with other keys to type special characters and perform system functions. Each key modifies only the next key pressed.</p> <p>The overlay of each keyboard is color-coded to indicate the character typed or function performed when specific keys are pressed immediately after the blue or red modifier key.</p>

25-Key Numeric Keyboard

The following graphic displays the 25-key numeric keyboard.

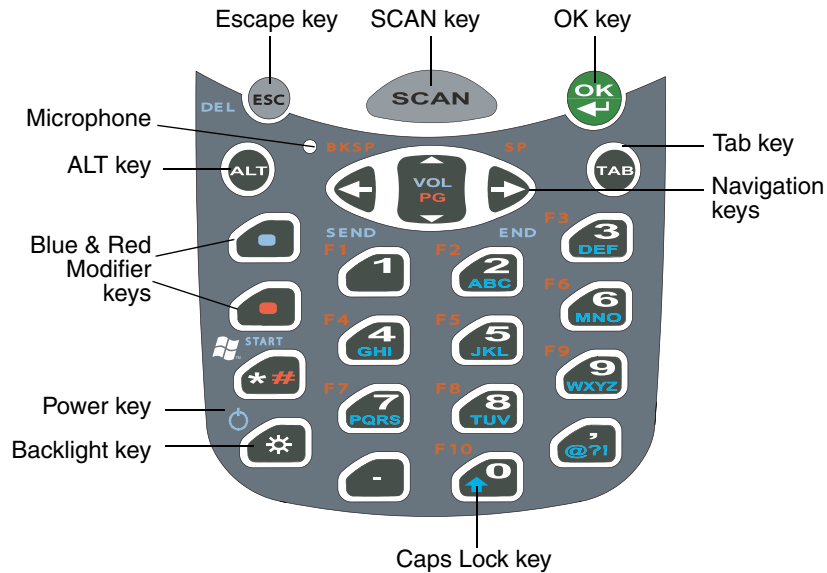

Alpha Mode

The 25-key keyboard defaults to numeric mode. Numeric mode is when you type numbers with the number keys. Alpha mode is when you type letters or characters with the number keys.

To toggle between numeric and alpha modes, double-tap the Blue modifier key. There are alpha indicators on the number buttons that specify the letters or characters that will be typed when you press that key in alpha mode.

Please note that when typing in alpha mode, you must use the same multi-press method you would use when typing letters on a phone keypad. Each key press will type the next letter in the sequence as displayed by the alpha indicator.

You can still use the Blue modifier key for regular Blue key combinations; just press and hold Blue modifier key with the next key in the combination. For details, see [Blue Key Combinations](#) on page 6-8.

Caps Lock Key in Alpha Mode

After you double-tap the Blue modifier key to switch the alpha mode and begin typing, letters appear in upper case by default. To toggle between upper and lower cases in alpha mode, tap the Caps Lock key once.

Blue Key Combinations

Alpha Mode - Double-tap the Blue modifier key

Key	Character (lower case)	Character (upper case)	
1	_ = / \	_ = / \	
2	abc	ABC	
3	def	DEF	
4	ghi	GHI	
5	jkl	JKL	
6	mno	MNO	
7	pqrs	PQRS	
8	tuv	TUV	
9	wxyz	WXYZ	
*	*	*	
.	: ; - +	: ; - +	
,	@ ? !	@ ? !	

Functions - Press the Blue key once in combination with the next key.

Key Combination	Function
Blue + Backlight	Suspend/Resume
Blue + *	Start menu
Blue + Left Arrow	Send
Blue + Tab	Backtab
Blue + Right Arrow	End
Blue + Up Arrow	Volume up
Blue + Down Arrow	Volume down

Red Key Combinations

Key Combination	Function/Special Character
Red + Left Arrow	Backspace
Red + Right Arrow	Space
Red + Up Arrow	Page up
Red + Down Arrow	Page Down
Red + ESC (hold)	Soft reset (warm boot)
Red + TAB (hold)	Hard reset (cold boot)
Red + 1	F1
Red + 2	F2
Red + 3	F3
Red + 4	F4
Red + 5	F5

Key Combination	Function/Special Character
Red + 6	F6
Red + 7	F7
Red + 8	F8
Red + 9	F9
Red + 0	F10
Red + *	#

36-Key Alpha Keyboard

The following graphic displays the 36-key alpha keyboard.



NUM Lock Key

The 36-key keyboard defaults to alpha mode. Alpha mode is when you type letters with the letter keys. Numeric mode is when you type numbers or characters with the letter keys.

To toggle between alpha and numeric modes, tap the NUM key once. There are numeric indicators above and to the left of the alpha keys that specify the number or character that will be typed when that key is pressed in numeric mode.



Caps Lock Functionality

In alpha mode, the 36-key keyboard defaults to upper case. To toggle between upper and lower case, tap the Blue modifier key twice. You can still use the Blue modifier key for regular blue key combinations; just press and hold the Blue modifier key with the next key in the combination.

Blue Key Combinations

Key Combination	Function
Blue + Backlight	Power
Blue + Left Arrow	Send
Blue + Right Arrow	End
Blue + Up Arrow	Volume up
Blue + Down Arrow	Volume down

Red Key Combinations

Key Combination	Function
Red + Left Arrow	Backspace
Red + Right Arrow	Space
Red + ESC (hold)	Soft reset (warm boot)
Red + TAB (hold)	Hard reset (cold boot)
Red + E	F1
Red + J	F2
Red + O	F3
Red + T	F4

NUM Key Combinations

Pressing the Num key **once** switches the keyboard to numeric mode.

Key	Character
A	1
B	2
C	3
D	-
F	4
G	5
H	6
I	+
K	7
L	8
M	9
N	\
P	.
Q	0
R	,
S	/
UV	*

Key	Character
WX	@
YZ	#

Note: You do NOT need to press and hold the NUM key when pressing the next key.

Numeric Shift in Numeric Mode

When typing in numeric mode, tapping the Blue modifier key acts like a Shift key that enables you to type special characters in addition to those indicated on the overlay.

Key	Character
A	!
B	@
C	#
F	\$
G	%
H	^
K	&
L	*
M	(
P	>
Q)
R	<



Overview

Customized settings are available on the Start menu. Go to **Start > Settings** and settings screen opens displaying the Personal tab. Settings consists of three tabs: Personal, System, and Connections.

Personal Tab



System Tab



Connections Tab

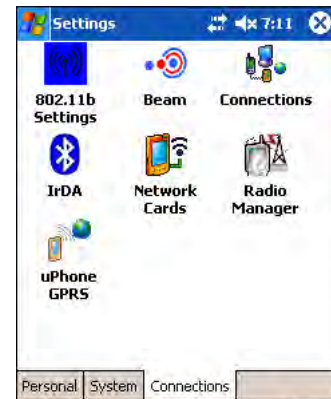

Tab

Personal

Description

Customizes buttons, set SIP options, and adjust headset settings; see [Personal Tab](#) on page 7-2..

System

Adjusts system settings; see [System Tab](#) on page 7-7..

Connections

Establishes network connections settings; see [Connections Tab](#) on page 7-15..

Personal Tab

To access the Personal tab, go to **Start > Settings**. The screen opens displaying the Personal tab.

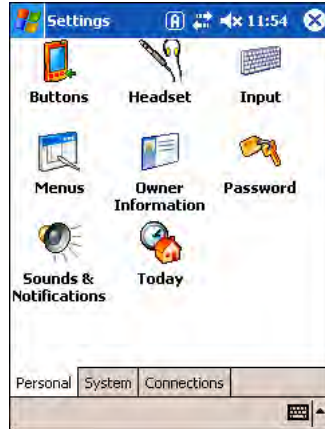

Icon	Description
Buttons	Program the side buttons to perform specific tasks. For more information, see Buttons on page 7-3..
Headset	Adjust audio settings for headset use; see Headset Control on page 7-4..
Input	Customizes the SIP. For details, see Input Panel Options on page 4-7.
Menus	Customizes what appears on the Start and New menus; see Menus - Adding a Program to the Start Menu on page 7-5..
Owner Information	Enter your contact information. This information will appear on the Today screen.
Password	Password protect the terminal to limit access to your device.
Sounds & Notifications	Set the sound volume, enable and disable sounds for specific actions, and set sound parameters for system notifications.
Today	Customize the look and the information that is displayed on the Today screen.

Note: Personal settings are stored in RAM memory. They are replaced by system defaults after each hard reset. For more information about resets, see [Soft Reset \(Warm Boot\)](#) on page 2-9..

Buttons

Buttons programs both keyboard buttons and the side buttons to launch applications or execute commands. The default button assignments that appear on the Buttons window are inactive until you enable the HotKeys Power Tool.

To Enable HotKeys



1. Tap **Start > Power Tools** and tap the HotKeys icon **once** HotKeys. HotKeys is enabled and the button assignments in the Buttons setting are active.
2. Verify the assignment by tapping the button on the keyboard.

For more information about the HotKeys Power Tool, refer to the Dolphin Power Tools User's Guide, which is available for download from the web at www.handheld.com.

Button Assignments

By default, the side buttons (for locations, see page 3-6) activate the image engine but can be programmed to launch applications or execute commands in the Buttons setting.

1. After HotKeys is enabled, tap **Start > Settings > Personal tab > Buttons**.

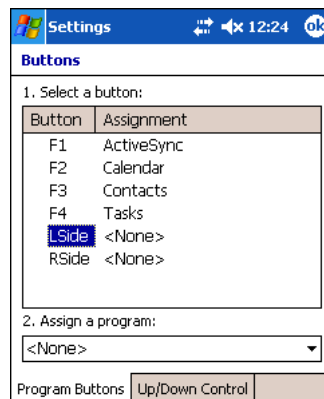

Note: The buttons that appear on this window are the only buttons that can be programmed via the Buttons setting. You cannot add buttons to this window.

2. To change button assignment, tap on the name of the application in the **Assignment** column and select a program or command in the **Assign a program** drop down list.
3. Tap **OK** to save.

Available Applications

The **Assign a program** list contains the applications installed on the terminal. If there is a program installed that you would like to see in this list, paste a Shortcut to the program in the **\\Windows\Start Menu\Programs** folder. For instructions about creating shortcuts, see [Using File Explorer](#) on page 7-5..

Additional Functions

The **Assign a program** list also contains the following commands:

Command	Description
<Input Panel>	Opens the soft input panel.

Command	Description
<None>	Nothing happens when the button is pressed. This is the default setting for the LSide and RSide buttons and means that pressing either button activates the image engine.
<OK/Close>	Performs the same function as tapping OK on the screen.
<Scroll Down>	Scrolls down in the open application.
<Scroll Left>	Scrolls left in the open application.
<Scroll Right>	Scrolls right in the open application.
<Scroll Up>	Scrolls up in the open application.
<Start Menu>	Opens the Start menu.
<Today>	Opens the Today screen.

Headset Control

The Headset Control setting adjusts headset audio settings.

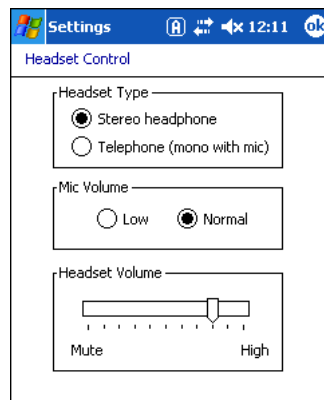

Stereo headphone

Select this option if you are using a headset for audio output only. If so, you need to use the microphone on the terminal ([Microphone](#), page 3-3) for audio input; i.e., listen via the headset and speak into the microphone. These types of headsets usually contain two earpieces for stereo sound. Tap **OK** to save your selection.

Telephone (mono with mic)

Select this option if you are using a headset that also contains a microphone. When this option is selected, you speak into the microphone on the headset and not the microphone on the terminal. These types of headsets usually have one earpiece for mono audio. Tap **OK** to save your selection.

Mic Volume

These options enable you to adjust the audio level of the microphone; Normal is the default setting. These settings apply to the selected Headset Type:

Stereo headphone Adjusts the volume on the terminal's microphone ([Microphone](#), page 3-3).
Telephone (mono with mic) Adjusts the volume on the headset's microphone.

Tap **OK** to save your selection. This setting does **not** work if you are using a GSM radio for two-way voice communication; see [Audio Modes](#) on page 11-2.

Headset Volume

The slider enables you to adjust the speaker volume (audio output) of the headset. Move the slider from Mute to High depending on your preference. The volume adjusts automatically as you move the slider. These headset volume settings apply to both Headset Types.

Menus - Adding a Program to the Start Menu

You can add existing programs you use often, such as File Explorer, to the Start menu for faster access. You are not installing the program, just allowing access to it from the Start menu.

Note: The Start menu can hold only seven applications total.

Using System Settings

1. Tap **Start > Settings > Personal tab > Menus > Start Menu** tab.



2. Tap the check box for the program you want to add and tap **OK** to save.
3. Tap the **Start** menu to verify that the program appears on it.

Using File Explorer

If you do not see the program listed, you can either use File Explorer to move the program or ActiveSync on the desktop computer to create a shortcut to the program and place the shortcut in the Start Menu folder.

Note: We recommend that you Copy and Paste Shortcut so that you do not alter your program configurations by accident. Using Copy and Paste Shortcut (as opposed to Cut and Paste) ensures that the program files remain where they need to be for the system to find them to perform system functions.

1. Tap **Start > Programs > File Explorer**, and navigate to the program. File Explorer opens to My Documents by default; to see a list of all folders, tap the folder name and then **My Device**.

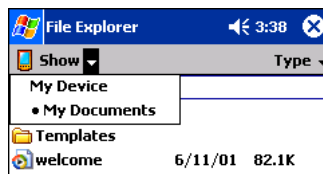

2. Tap and hold on the program, then tap **Copy** on the pop-up menu.

-
3. Navigate to the Windows folder and open the Start Menu (My Device > Windows > Start Menu), tap and hold a blank area of the window, and tap **Paste Shortcut** on the pop-up menu.

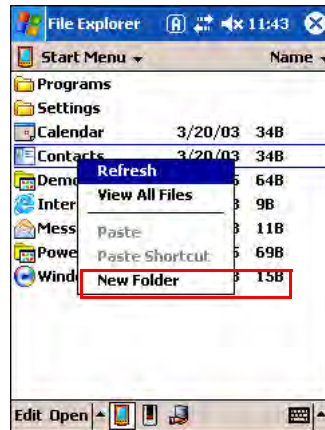

4. Tap the **Start** menu to verify that the program now appears on it.

Using ActiveSync on the Desktop Computer

Here, you are performing the same basic process as on the terminal, except that you are using the Explore utility (Windows Explorer) to copy and paste the shortcut.

1. Open **ActiveSync > Explore** and navigate to the program.
2. Right-click on the program and select **Create Shortcut**.
3. Select the shortcut, right-click, and select **Cut**.
4. Navigate to the **Start Menu** folder (Windows > Start Menu).
5. Right-click on an empty area and select **Paste Shortcut**.
6. On the terminal, tap the **Start** menu.
7. Verify that program appears.

System Tab

The System tab enables you to verify and sometimes alter system parameters. To access the System tab, go to **Start > Settings > System** tab. Tap the appropriate icon to open that system setting.



About

The About system setting displays specific information about what is loaded on the terminal. It contains three tabs:

- Version** tab Displays the information about the software, operating system, and processor of the terminal.
- Device ID** tab Displays the information the terminal uses to identify itself to other devices. It can be important to know this information if the Dolphin terminal is going to be part of a networked system of devices.
- Device name:** Displays the system's default name. This is the name used by ActiveSync.
- Description:** Displays the description of the device ID.
- Copyrights** tab Displays important copyright information.

Backlight

The Backlight system setting enables you to customize backlight functionality for the display. For more information, see [Adjusting the Backlight](#) on page 4-3.

Certificates

This system setting is designed to manage certificates for 802.11b networks. However, on Dolphin terminals, you manage certificates through Meetinghouse; see [Installing Certificates with CertAdd](#) on page 9-29..

ClearType Tuner

This system setting enables you to adjust the level ClearType font rendering by moving a slider. The sample text displays the setting results immediately. Of course, you must first enable ClearType font rendering to change the appearance of fonts on the screen; see [ClearType Tab](#) on page 7-13..

Clock & Alarms

This setting sets the system clock. Appointments, scheduled events, and any function on a schedule runs off this setting. You need to set the time zone and time after each hard reset; see [Setting the Time and Date](#) on page -7.

CPU Speed

This system setting enables you to see and change the current speed of the Central Processing Unit (CPU).

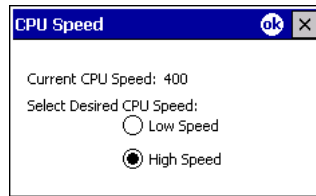

The default is **High Speed** at 400MHz. **Low Speed** is 200MHz.

To change the default, select Low Speed and tap **OK**. A message appears confirming the new CPU speed.

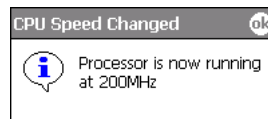

Tap **OK** to save the change.

Memory

The Memory system setting enables you to review and manage both RAM (volatile) and IPSM/Storage Card (non-volatile) memory. Access this system setting whenever you receive system messages about memory.

There are three tabs: Main, Storage Card, and Running Programs.

Main tab This tab displays current capacity and usage of the 64MB of on-board, volatile RAM memory. This is the memory used for running and storing programs as well as storing program data.

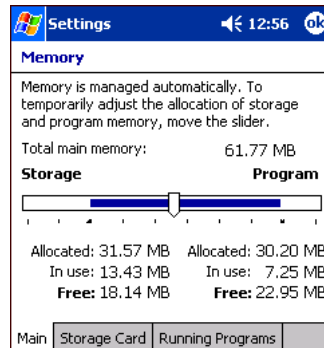

Field	Description
Total main memory	The total memory capacity of current RAM memory.
Storage	The part of RAM memory used for storing programs and program data.
Program	The part of RAM memory used to run programs.
Fields Under Storage and Program	
Allocated	Displays the current MB of memory allocated for Storage and Program use.
In use	Displays the total MB of that allocated memory being used in Storage and Program memory functions.
Free	Displays the total MB of memory available for Storage and Programs use.

To Increase/Decrease RAM Memory

To increase Program or Storage memory, tap, hold, and drag the slider away the kind of memory you want to increase. The three fields adjust automatically; Program memory decrease when you increase Storage memory and vice versa.

Storage Card Tab

This tab displays the current capacity and usage statistics of the selected memory type; IPSM or Storage Card. Select the memory type from the drop-down list. IPSM is selected by default.

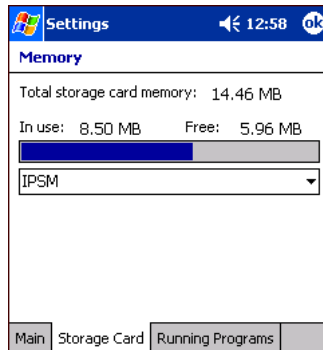

Total storage card memory The total MB of memory capacity of the selected memory.

In use The MB currently being used.

Free The MB that is still available for use.

IPSM

Short for Intel Persistent Storage Manager, this is 14MB of on-board Flash memory that is non-volatile. Because this memory is non-volatile, data or programs stored in IPSM are not affected when power is removed. Autoinstall programs, for example, are stored in IPSM so that they are always installed at cold-boot startup.

When IPSM is selected in the drop-down list, the Storage Card tab displays the IPSM memory capacity and usage statistics.

Storage Card

You can install additional memory in Dolphin terminals - see [Access Door](#) on page 3-6. If a storage card is installed in the terminal, a Storage Card entry appears in the drop-down list.

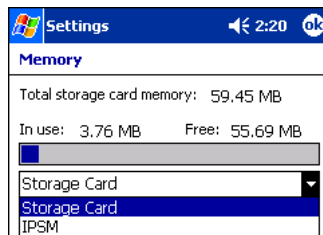

Select **Storage Card** and the Storage Card tab displays the current capacity and usage statistics of the installed storage card.

Running Programs Tab Displays the software programs currently using Storage memory.

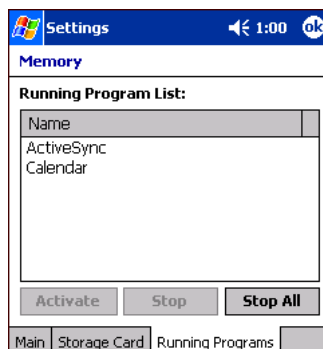

Check this tab when you are receiving out of memory errors or when the mobile computer is running slowly. You can

- Select a program in the list and tap **Stop** to stop it from running (and therefore from using memory), or

- Tap **Stop All** to automatically stop all running programs.



Anytime you stop a running program, it frees up RAM memory. Be advised that, when you stop a program here, any unsaved data in that program is lost. To free up memory without risking data loss, return to the running program, save your data, and close the application.

Find Link

Underneath the three Memory tabs is a link to the Find window that enables you to search for large files using storage memory. Clicking this link opens the Find screen with **Larger than 64KB** already selected in the **Type** field.

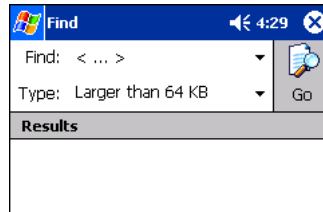

Enter the search criteria in the **Find** field and tap **Go** to perform the search.

Power

Power system settings contains three tabs: Battery, Wireless, and Advanced.

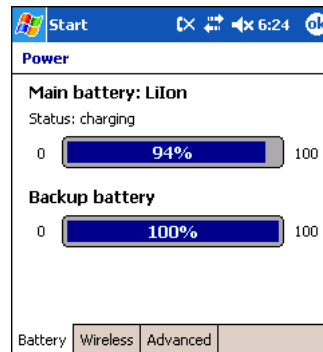

Tab	Description
Battery Tab	Checks the remaining charge of both the main and backup batteries. For more information about the terminal's batteries, see Battery Power on page 3-10.
Wireless Tab	<p>Determines the power settings for your wireless connection.</p> <p>Select Wireless signals off... when you don't want to use system power to power up the radio(s).</p> <p>Select Wireless signals on when you want the radio to use system power to transmit. This is the default settings.</p> <p>The list contains the radio firmware installed in the terminal. The items in the list with a check in the checkbox are the items using system power.</p>

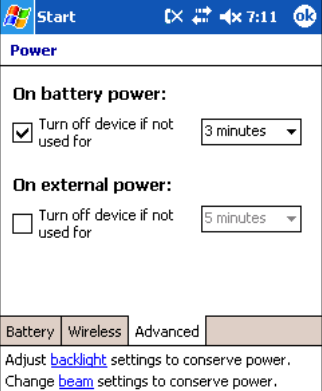
Tab	Description
Advanced Tab	<p>Determines power time-outs.</p>  <p>For On battery power, select from the drop-down list, the number of minutes of inactivity you want to pass before the terminal powers off when running on battery power.</p> <p>For On external power, select from the drop-down list, the number of minutes of inactivity you want to pass before the terminal powers off when running on external power.</p> <p>Options below the tabs Adjust backlight... opens the Backlight settings so that you can make adjustments to conserve power usage; see Backlight on page 7-7.. Change beam... opens beam settings so that you can make adjustments to conserve power usage; see Using Infrared on page 8-5.. (You would turn off receiving capabilities to conserve power.)</p>

Note: You can also set automatic turn-off times for the terminal to conserve power. When the device is “turned off,” that means that it goes into suspend mode. For more information on suspend mode, see [Suspend Mode](#) on page -9.

Regional Settings

Regional Settings enables you to customize the appearance and formatting to your geographic region. Specifically, you can customize numbers (i.e., number of decimal places allowed), currency (i.e., using the \$ or € symbol), time, and date. These specifications apply to all screens, including the Today screen. The Region tab displays an overview of the region selected in the drop-down list at the top.

The terminal is loaded with a number of pre-programmed regional settings. Select one from the list.

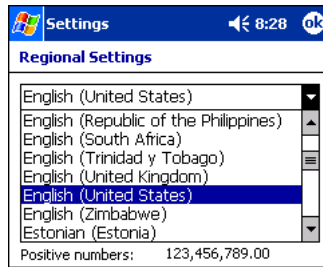

The results appear on the screen.

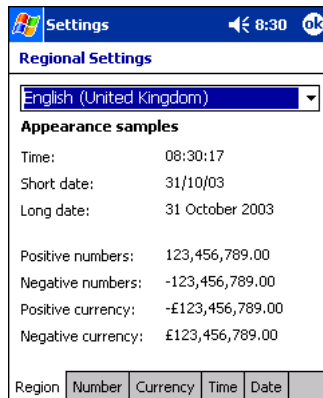

To see specific settings or change a specific setting, tap on one of the tabs, make the change and tap **OK** to save it.

Remove Programs

The Remove Programs settings enables you to remove programs installed on the terminal. Use this setting to troubleshoot when you receive messages that the device is out of memory. The programs removed are removed from RAM memory. Any program (usually *.cab or *.dll files) stored in the Autoinstall folder (My Device > IPSM > Autoinstall) will re-install after the next hard reset.

For information about the Autoinstall process, see [Let Autoinstall Run](#) on page -7.

For information about the hard reset process, see [Hard Reset \(Cold Boot\)](#) on page -9.

To Remove Programs

1. Tap **Remove Programs**. In the list, select the program you want to remove.

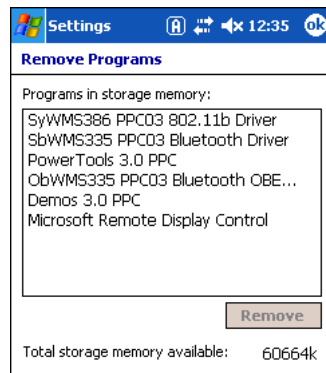

2. Tap **Remove**. The following message appears:

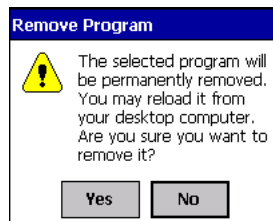

3. Tap **Yes**. Wait while the program is removed.
4. Verify that the program no longer appears in the list.

Memory

The Remove Programs screen displays the total storage memory available. It adjusts automatically when a program is removed for quick reference. For more detailed memory information, tap **memory** of “Adjust **memory** allocation” along the bottom margin. It opens the Memory system setting. For information about memory settings, see [Memory](#) on page 7-8.

Screen

Note: By default, dynamic screen rotation (i.e., the ability to switch between landscape and portrait orientation) is disabled on Dolphin 7900 terminals.

The Screen system setting contains three tabs: Alignment, Clear Type, and Text Size.

Alignment tab

The Screen system setting opens to the Alignment tab.

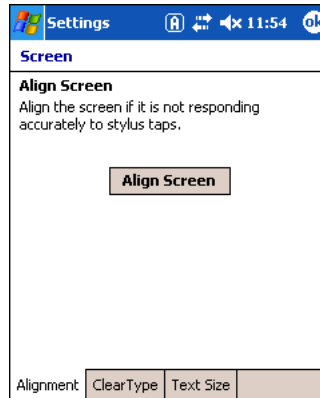

On this tab, you can re-align the screen. Remember, you first align the screen at bootup. You would need to re-align the screen again if tapping buttons or icons with the stylus no longer seems to work appropriately. For more information, see [Align the Screen](#) on page 2-7..

ClearType Tab

The Dolphin 7900 displays support ClearType font rendering. ClearType is a Microsoft technology that dramatically increases the readability of text on LCD displays.

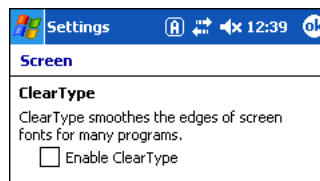

To enable ClearType font rendering, select **Enable ClearType** and tap **OK**.

To adjust the level of ClearType font rendering, use the ClearType Tuner; see [ClearType Tuner](#) on page 7-7..

For more information about ClearType font rendering, visit: www.microsoft.com/typography/cleartype/what.htm?fname=%20&fsize=

Text Size Tab

The Text Size tab enables you to perform font scaling within certain views of the Today screen, Contacts, Calendar, Messaging, and Tasks. This means that you can increase or decrease the point size of the font on application windows.

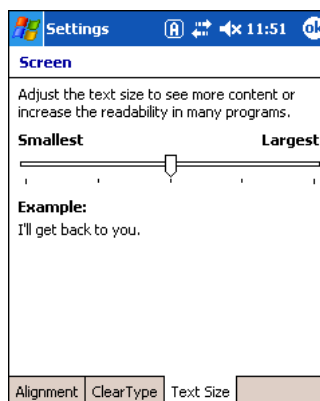

This is the default font size setting. To change the font size, move the slider toward Smallest or Largest. The Example text changes to reflect the font change. Tap **OK** to save the new font size setting.

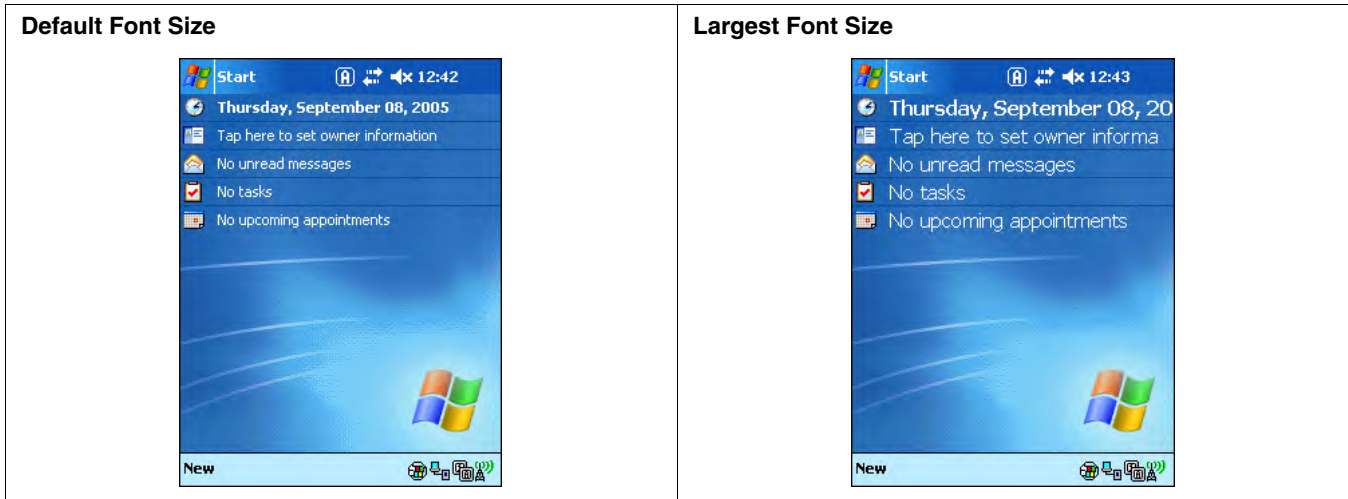

Connections Tab

The Connections tab enables you to manage your network connections.



Icon	Tapping this icon...
Beam	Enables you to verify and adjust the infrared settings of the IrDA port; see Using Infrared on page 8-5..
Connections	Enables you to configure network connections. This is the connections manager; see Connections Tab on page 7-15..
Network Cards	Enables you to access the Wireless and Network Adapters tabs; see Network Cards on page 7-24..
Radio Manager	Enables you to power up and power down the radios installed on the terminal; see Radio Manager on page 4-5.

Other Icons on the Connections Tab

Other icons appear on this window if your terminal is configured with specific network software, protocols, and/or radios.

802.11b Settings	This icon appears only if an 802.11b radio and driver is installed on the terminal. Tapping this icon enables you to configure your 802.11b radio; see Wireless LAN (WLAN) Communications with 802.11b on page 9-1.
IrDA	This icon appears only if a Bluetooth radio and driver is installed on the terminal. Tapping this icon enables you to disable or enable the IrDA port; see Verify That the IrDA Port is Enabled on page 8-5..
uPhone GPRS	This icon appears only if a GSM/GPRS radio and driver are installed on the terminal. Tapping this icon opens the GPRS settings; see GPRS Settings on page 11-22..

Server-Assigned IP Addresses

Please note that all server-assigned IP addresses use Dynamic Host Configuration Protocol (DHCP).

Zero-Config Wi-Fi

Please note that the zero-config Wi-Fi feature of Windows Mobile is **disabled** on Dolphin 7900 terminals.

Com Port Assignment Table

The Dolphin 7900 terminal ships with the com ports assigned as follows:

Com Port	Assignment
1	Serial port; this is the 17-pin connector on the bottom panel. See Mechanical Connector on page 3-9.
2	Bluetooth Module If there is no Bluetooth hardware installed on the terminal, this com port is unassigned.

Com Port	Assignment
3	Raw Infrared
4	Unassigned
5	USB virtual serial port
6	IrDA, if IrDA is enabled. If IrDA is disabled, this com port becomes available. See Verify That the IrDA Port is Enabled on page 8-5.
7, 8, 9	Unassigned; these are virtual com ports that are available for selection only when connecting to devices that use virtual com ports, such as Bluetooth.

Opening the Connections Manager

To open the connections manager, tap **Connections**. The connection manager opens displaying the Tasks tab.

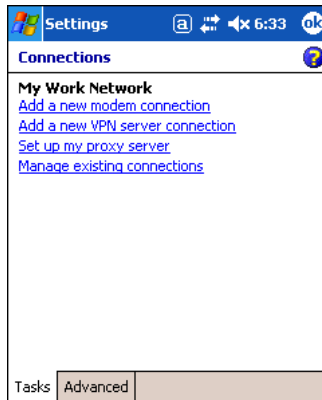

The connections manager consists of two tabs: Tasks and Advanced.

Task Tab

The Task tab enables you to configure and manage your My Work Network settings. Click on the link to setup or manage existing network accounts.

Advanced Tab

The Advanced tab enables you to configure and manage network parameters and network cards.

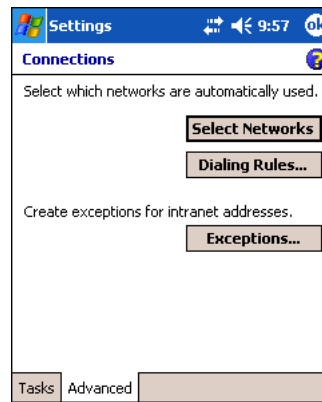

Creating an External Modem Connection to an ISP

1. Obtain the following information from your ISP:

- ISP dial-up access telephone number,
- user name,
- password, and

- TCP/IP settings.
2. Use a NULL modem cable to connect to an external modem.
 3. Tap **Start > Settings > Connections** tab > **Connections > Task** tab.
 4. Tap **Add a new modem connection**. The Make New Connection screen appears.

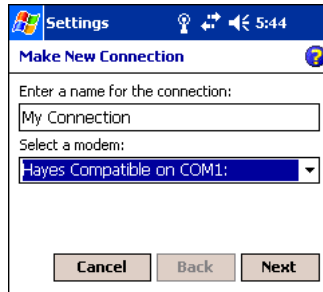

5. **Enter a name for the connection**, such as "My Connection."
6. In the **Select a modem** list, select the external modem by selecting **Hayes Compatible on COM1**.
7. Tap **Next**. The My Connection screen appears.

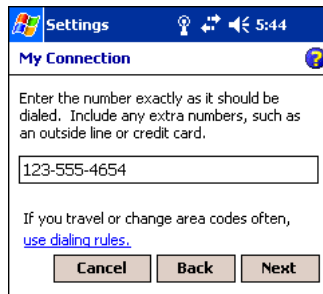

8. Enter the number that should be dialed when connecting to your ISP. Include any special digits such as "*" or "#" (see [Establishing Dialing Rules](#) on page 7-23.). Tap **Next**.

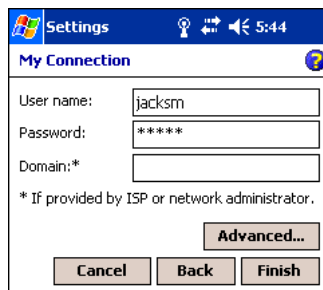

9. Now enter any authentication information your ISP requests.
10. You should not need to change any settings in **Advanced** because most ISPs now use a dynamically-assigned addresses.
11. Tap **Finish**.

Advanced Settings

Tap the Advanced button to open the Advanced settings.

General Tab

Use the General tab to change the connection speed. Wait for dial tone, dial, then wait for credit card, add dial-string modem commands, or cancel call after a set number of seconds.

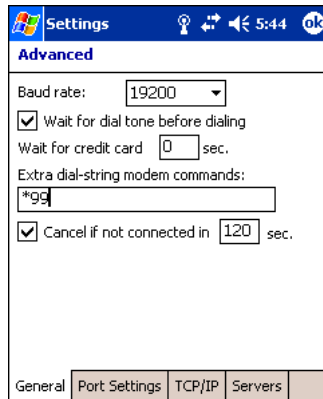
**Port Settings Tab**

The Port Settings tab has options that should be left alone unless indicated otherwise by your ISP.

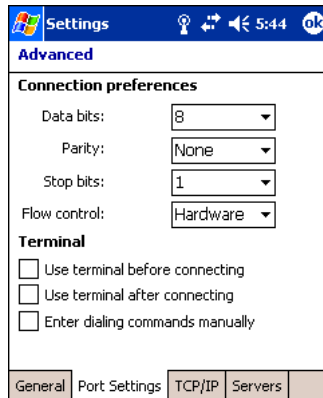
**TCP/IP Tab**

If your ISP does not use a dynamically-assigned address, enter that information into the TCP/IP tab.

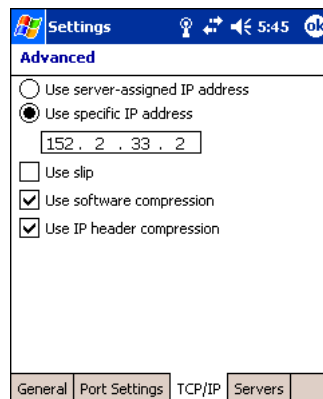

Servers Tab

Finally, if your ISP requires special DNS or WINS information, enter it into the Servers tab.

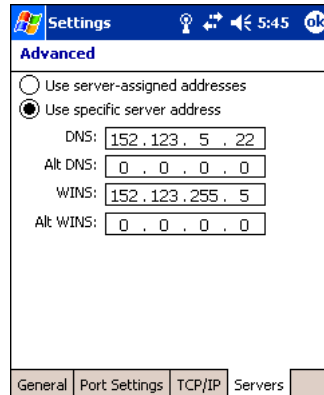

Connecting to Your ISP

1. Tap **Start** > **Settings** > **Connections** tab > **Connections** to open the connections manager.
2. Tap **Manage existing connections**.

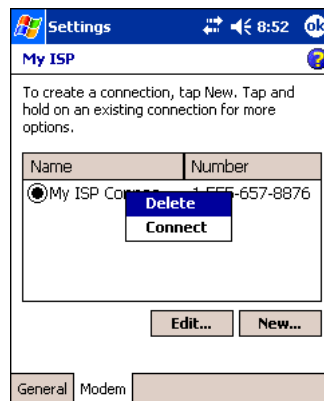

3. Tap and hold on the applicable dial-up settings and select **Connect**. (You can delete the connection by selecting Delete.)
4. Your modem will dial-out and attempt to create the connection.

Creating an External Modem Connection to Your Work

Follow the instructions for [Connecting to Your ISP](#), but select **Add a new modem connection** under **My Work Network**.

Establishing Exceptions for Work URLs

Some companies use periods in their intranet URLs (for example, intranet.companyname.com). If you attempt to connect to one of these URLs, Pocket Internet Explorer will search for the website on the Internet rather than the company's intranet.

To connect to such intranet URLs, they need to be entered as Work URL exceptions in the connections manager.

1. Go to **Start** > **Settings** > **Connections** tab > **Connections** > **Advanced** tab (see page 7-16).
2. Tap **Select Networks**.

3. Tap **Exceptions**. The Work URL Exceptions screen opens.

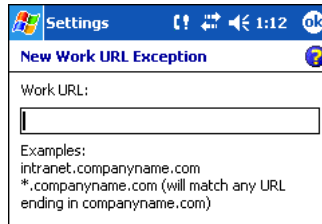

4. Enter the **Work URL** and tap **OK**.

Setting up a Proxy Server Connection for Work Connections

If you are connected to your ISP or private network during synchronization, the terminal should download proper proxy settings during synchronization from your PC. If these settings are not on your PC or need to be changed, ask your ISP or network administrator for the proxy sever name, server type, port, type of Socks protocol used, and your user name and password.

1. Go to **Start > Settings > Connections** tab > **Connections**.
2. Under the My Work Network heading, tap **Set up my proxy server**.

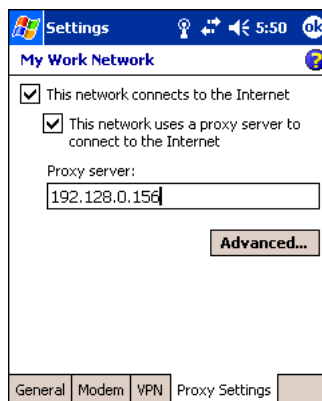

3. Select **This network connects to the Internet** and **This network uses a proxy server...**
4. In the **Proxy server** field, enter the proxy server name.
 - Tap **Advanced** for advanced settings. This information can be provided only by your network administrator.

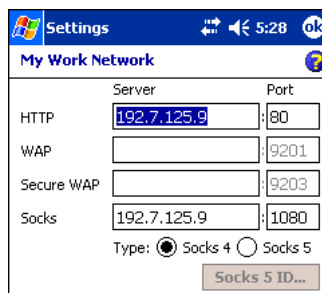

5. To change existing settings, under My Work Network, tap **Manage existing connections** and tap the **Proxy** tab.

Setting Up a VPN Connection for Work Connections

A VPN connection helps you securely connect to servers, such as a corporate network, via the Internet. Ask your network administrator for your user name, password, domain name, TCP/IP settings, and host name or IP address of the VPN server.

1. Go to **Start > Settings > Connections** tab > **Connections**.

- Under the My Work Network heading, tap **Add a new VPN server connection**.

Settings 5:48

Make New Connection

Name: My VPN

Host name/ IP: corp.software.corp

VPN type: IPSec/L2TP complete PPTP

Cancel Back Next

- Enter the requested information including VPN type and tap **Next**.

Settings 5:48

My VPN

Authenticate IPSec/L2TP connections using:

A certificate on this device

A pre-shared key

Cancel Back Next

- Indicate whether a pre-installed certificate should be used or rather a pre-shared key and tap **Next**.

Settings 5:48

My VPN

User name: jacksm

Password: *****

Domain:*

* If provided by ISP or network administrator.

Advanced...

Cancel Back Finish

- Enter your login details. If finished, tap **Finish** to complete VPN setup.
- Otherwise, tap **Advanced** to access more options.
 - Enter **TCP/IP** settings in the TCP/IP tab; server-assigned IP addresses use DHCP.

Settings 5:49

Advanced

Use server-assigned IP address

Use specific IP address

Use slip

Use software compression

Use IP header compression

TCP/IP Servers

- Enter Server DNS/WINS information in the **Servers** tab.

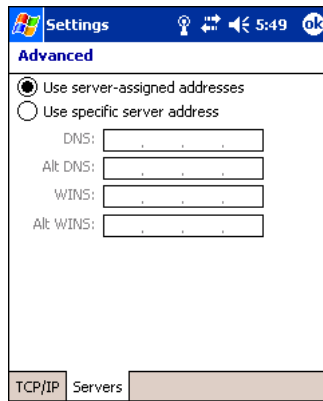



Connecting to a VPN Server

1. Go to **Start > Settings > Connections** tab > **Connections**.
2. Select **Edit my VPN servers**.

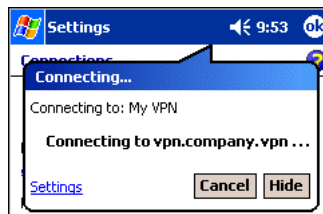

3. Tap and hold on the server, then select **Connect** on the popup menu.
(Note that through this screen you can delete your VPN server connection.)



4. Your VPN Server is accessed. When connected, tapping on the  icon displays the following bubble:

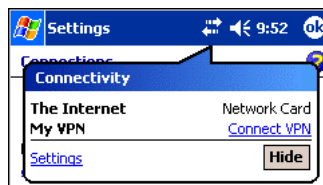

Establishing Dialing Rules

1. Tap **Start** > **System** > **Connections** tab > **Connections** > **Advanced** tab (see page 7-16).
2. Tap **Select Location**.

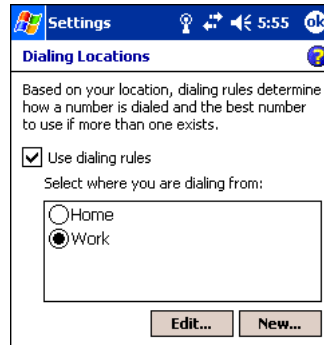

3. Select **Use dialing rules**. By default two dialing rules profiles exist: Home and Work.
4. Tap **Edit** to configure either profile.
(You can define your own dialing profile by tapping **New**. A warning appears that your existing modem connections must include the correct country and region area code settings.)



5. Tap **OK** to confirm. Enter the appropriate information on the next screen.

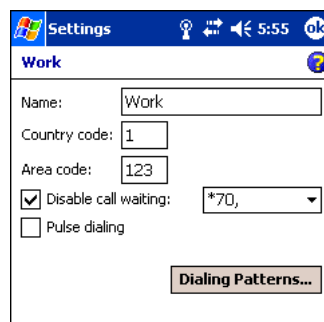

6. Tap **Dialing Patterns** to change how dialing occurs.

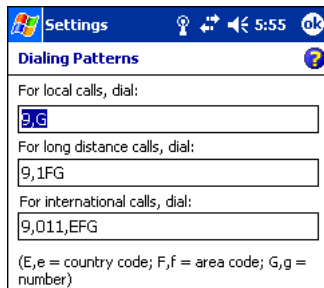

7. Following the format of "e" represents country code, "f" represents area code, and "g" represents the number, enter how local, long distance, and international calls should be dialed. Tap **OK** to save your changes.

Creating a Wireless Network Connection

In the Connections Manager, you can access the Wireless tab from **Start > Settings > Connections** tab > **Network Cards > Wireless** tab. However, on the Dolphin 7900 terminal, wireless networks need to be configured according to the radio installed in the terminal.

For more information about 802.11b radios, see [Wireless LAN \(WLAN\) Communications with 802.11b](#) on page 9-1..

For more information about Bluetooth radios, see [Wireless PAN \(WPAN\) Communications with Bluetooth](#) on page 10-1..

Network Cards

To see the network cards installed on the terminal,

1. Tap **Start > Settings > Connections > Network Cards > Network Adapters** tab.

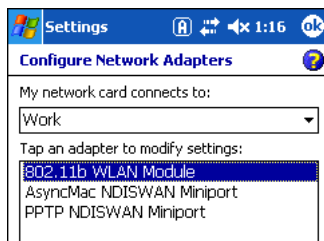

2. In the list, tap on an adapter to review its settings. (Server-assigned IP addresses use DHCP.)

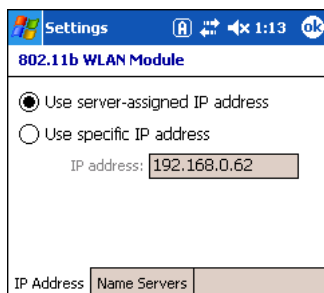

-
3. If you make a change on one of these tabs, tap **OK**. The following message appears:

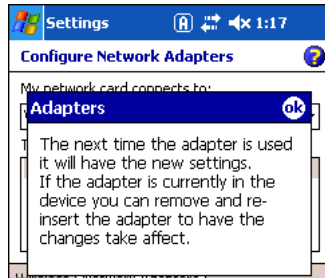

4. You must perform a soft reset to update the registry; see [Soft Reset \(Warm Boot\)](#) on page 2-9.. During the soft reset, the new registry entries created by the changes can be read by the applications that need them.



Do NOT perform a hard reset (see [Hard Reset \(Cold Boot\)](#) on page 2-9) after modifying an adapter here. Hard resets return the terminal to factory defaults, which means that any network adapter modifications are lost.



Overview

You can exchange information between your Dolphin terminal and other mobile devices, a desktop computer, a network, or the Internet using the following connection options:

- Connect to a desktop computer and synchronize via Microsoft ActiveSync v3.7 or higher; see page 8-4.
- Use the infrared (IrDA) port to send and receive files between two devices; - see page 8-4.
- Connect to an ISP via wireless radio; see page 8-8.

General Help on Connecting

More information on the procedures described here, as well as information on additional procedures, can be found in the following locations:

- ActiveSync Help on the desktop computer. In ActiveSync, click **Help** > **Microsoft ActiveSync Help**.
- Online Help. Tap **Start** > **Help** > **View** menu > **All Installed Help** > **Inbox** or **Connections**.

For more information, go to the Windows Mobile software website at: www.microsoft.com/windowsmobile/products/pocketpc/

Installing Additional Software

In addition to the default programs installed on your terminal when it is first booted up, you can install any program (created for a Windows Mobile device), as long as the terminal has enough memory to store the program and the program has an *.exe, *.cab, or *.dll extension.

The most popular place to find software on the Windows Mobile website: www.microsoft.com/windowsmobile/products/pocketpc/



When selecting programs, verify that the program and version of the program are designed for the Windows Mobile 2003 Second Edition and the terminal's processor. You can verify your processor by tapping Start > Settings > System tab > About > Version tab. Make a note of the information in the Processor field.

You can install additional software via:

- ActiveSync - see page 8-4.
- Infrared - see page 8-5.
- Internet (via wireless radio) - see page 8-8.

Using ActiveSync

Using Microsoft ActiveSync, you can synchronize and transfer information between your desktop computer and Dolphin terminal. The most current version of ActiveSync can be downloaded from www.microsoft.com.

Additional Capabilities

With ActiveSync, you can also:

- Back up and restore your device data.
- Copy (rather than synchronize) files between your device and desktop computer.
- Control when synchronization occurs by selecting a synchronization mode. For example, you can synchronize continually while connected to your desktop computer or only when you choose the synchronize command.
- Select which information types are synchronized and control how much data is synchronized. For example, you can choose how many weeks of past appointments you want synchronized.

Requirements

To synchronize, ActiveSync version 3.7 or higher *must* be installed on both your desktop computer and the Dolphin terminal. Dolphin 7900 terminals ship with ActiveSync 3.7 already installed. Therefore, you must install ActiveSync 3.7 on your desktop computer from the Microsoft Companion CD that came with your terminal.

To install ActiveSync on your desktop computer, insert the Microsoft Companion CD into the CD-ROM drive of your desktop computer. Click the **yellow arrow**, then **Start Here**, and follow the directions on your screen.



When communicating via ActiveSync, your terminal must be connected to the host PC with a peripheral device sold/manufactured by Hand Held Products, such as the Dolphin HomeBase, Dolphin Mobile Base, Dolphin Net Base, Dolphin Mobile Charger or other Dolphin 7900 Series charging/communication cable. Use of any peripheral not sold/manufactured by Hand Held Products may damage your terminal and will void the warranty.

For more information about communication peripherals, see [Dolphin HomeBase](#), page 13-1, [Dolphin Mobile Base](#), page 14-1, or [Dolphin ChargeBase](#), page 15-1.

Setting Up Your Desktop Computer

When installation of ActiveSync is complete on your desktop computer, the ActiveSync Setup Wizard helps you

- connect your terminal to your desktop computer,
- set up a partnership so you can synchronize information, and
- customize your synchronization settings.

Synchronizing from Your Desktop Computer

Because ActiveSync is already installed on the Dolphin terminal, your first synchronization process begins automatically when you finish setting up your desktop computer in the wizard and your terminal is connected to the host PC.

After your first synchronization, look at Calendar, Contacts, and Tasks on the terminal. Notice that the same information from Microsoft Outlook on your desktop computer is now on the terminal. Simply remove the Dolphin from the communication peripheral and you're ready to use it.

By default, ActiveSync does **not** automatically synchronize all types of information. Use **ActiveSync Options** to specify the types of information you want to synchronize. The synchronization process makes the data (in the information types you select) identical on both your desktop computer and your device.

For more information about using ActiveSync on your desktop computer, open **ActiveSync**, then open **ActiveSync Help**.

Synchronizing from the Terminal

ActiveSync **must** be setup on your desktop computer and the first synchronization process completed *before* you initiate synchronization from the terminal for the first time.

To initiate synchronization the first time, tap **Start > Programs > ActiveSync**. The synchronization process begins.

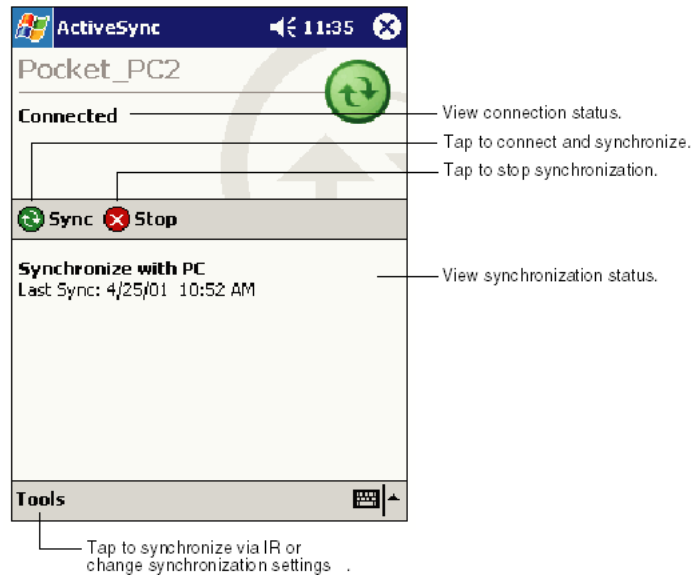

Note: If you have a wireless LAN card, you can synchronize remotely.

After the first synchronization, when using Dolphin peripherals such as the HomeBase or Mobile Base, synchronization begins automatically whenever a terminal is properly seated in the terminal well. For more information, see [Dolphin HomeBase](#) on page 13-1 or [Dolphin Mobile Base](#) on page 14-1.

Exploring the Terminal from the Desktop Computer

When the terminal and desktop computer are connected, open the main ActiveSync window (on the desktop), and click **Explore**.

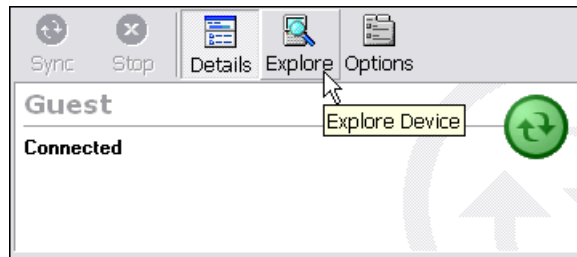

The Mobile Device folder opens in Windows Explorer.

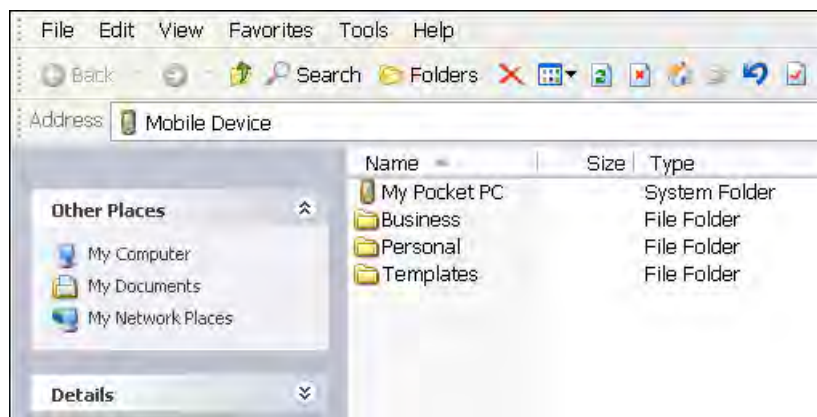

The terminal is now treated as a mass storage device, and transferring files is as simple as dragging and dropping or copying and pasting as you would for moving files between folders on your hard drive.

Adding Programs to the Terminal Using ActiveSync



When selecting programs, verify that the program and version of the program are designed for Windows Mobile 2003 Second Edition and your processor. You can verify your processor by tapping Start > Settings > System tab > About > Version tab. Make a note of the information in the Processor field.

Depending on the application, the software must be stored or installed on the host PC.

1. Download the program to your desktop computer from either the Internet or the CD or disk that contains the program. You may see a single *.exe or setup.exe file, a *.cab file, or *.dll. There may also be several versions of files for different device types and processors.
2. Read any installation instructions, Read Me files, or documentation that comes with the program. Many programs provide special installation instructions.
3. Connect the terminal to the desktop computer via a Hand Held Products communication peripheral.

If the File is an Installer:

An installer program is one that installs on the PC and the terminal simultaneously; one process installs to both devices.

1. On the PC, double-click the *.exe or *.setup.exe file. The installation wizard begins.
2. Follow the directions on the PC screen. The installation process includes transferring the software to the terminal.

If the File is Not an Installer:

Some programs cannot be installed on PCs because they are designed for terminals. In these cases, the appropriate files must be stored on the host PC, transferred via ActiveSync, and installed on the terminal. You will know the program cannot be installed on the PC if an error message appears when you try to install it stating that the program is valid but designed for a different type of computer.

1. If you cannot find any installation instructions for the program in the Read Me file or documentation, open **ActiveSync** and click **Explore**.*
2. Navigate to the **My Pocket PC** folder and copy the program file or files to the **Program Files** folder on the terminal.

If you want the program to be part of the Autoinstall that occurs after every hard reset, place the program file in the **Autoinstall** folder (\\IPSM\AutoInstall).

3. Depending on the program, you may need to open **File Explorer** on the terminal, navigate to the folder where the program is located, and tap on the program file to install it.

If you copied the file to the **Autoinstall** folder, you can either tap on the program inside the Autoinstall folder or perform a hard reset and the program will install as part of the Autoinstall process (page 2-7). Remember! A hard reset erases RAM data (page 2-9).

4. After installation on the terminal is complete, tap **Start > Programs** and the program and its icon appears on the Programs screen. Tap it to open the program.

Using Infrared

Dolphin 7900 terminals contain an IrDA port on the top panel (see [IrDa Port](#) on page 3-2). Using the IrDA port, you can send and receive data between the terminal and other devices equipped with infrared. This can include, but is not limited to, Windows Mobile information such as Contacts and Tasks, as well as software upgrades.

Verify That the IrDA Port is Enabled

The IrDA port must be enabled to transmit data. By default, the IrDA port is assigned to Com port 6 and is enabled. When a Bluetooth radio is installed, the IrDA port can be disabled to free up a Com port for Bluetooth devices.

To verify that the IrDA port is enabled, tap **Start > Settings > Connections tab > IrDA**  **IrDA**.

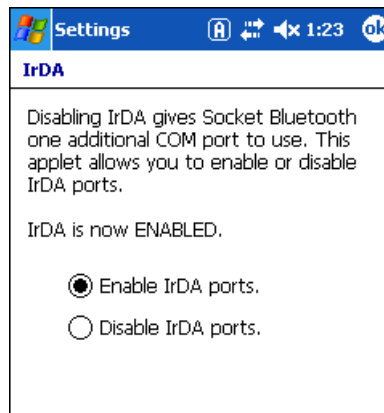

If **Enable IrDA ports** is selected, then the IrDA port is active.

*Note: The IrDA icon appears on the Connections tab **only** if there is a Bluetooth radio installed on the terminal.*

IrDA Port Location on the Terminal

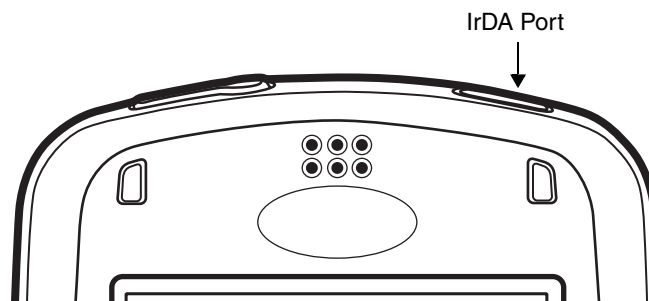

For more information, see [IrDA Port](#) on page 3-3.

Verify That Beam Settings Are Set to Receive

The Beam Settings must be set to receive for the terminal to receive data from other infrared devices. To verify, tap **Start > Settings > Connections** tab > **Beam**. The Beam Settings window should appear as follows:

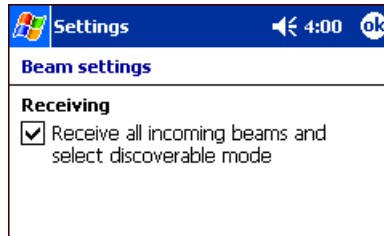

Sending and Receiving

To send or receive, the IrDA ports of both devices - whether it's two terminals, or a terminal and a host device - must be aligned with each other and within a close range. The maximum data-transfer speed is 115 Kbps.

Sending

1. Align the IrDA ports.
2. Open the program where you created the item you want to send and locate the item in the list. You can also beam files, but not folders, from File Explorer.
3. Tap and hold the item. A pop-up menu appears.

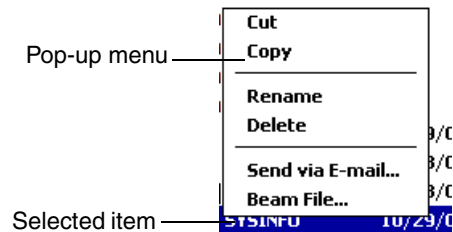

4. Select **Beam File**. The information begins transmitting to the other device.

Receiving

1. Align the IrDA ports.
2. Have the owner of the other device send the information to you.
3. Your terminal automatically begins receiving it.

To initiate a receive manually, tap the **Receive an incoming beam** link.

Troubleshooting

If the Beam Settings are not set to receive or you've aligned two IrDA ports and the terminal is still not receiving, go to **Start > Programs > Infrared Receive**. The terminal searches for the sending device.



If the terminal cannot find the sending device, the following message appears:



Using an ISP

The communication software for creating an ISP connection is already installed on your device. Your service provider should provide the software needed to install other services, such as paging and fax services.

After you are connected, you can send and receive e-mail messages by using Inbox and view web pages using Pocket Internet Explorer. For more information, see [Messaging](#) on page 12-7. You can also download software applications from the web.

Adding Programs Directly from the Internet



When selecting programs, verify that the program and version of the program are designed for the Windows Mobile 2003 Second Edition and your processor. You can verify your processor by tapping Start > Settings > System tab > About > Version tab. Make a note of the information in the Processor field.

1. Determine your device and processor type so that you know which version of the software to install. Go to **Start > Settings > System tab > About**. On the **Version** tab, make a note of the information in the **Processor** field.
2. Download the program to your device straight from the Internet using Pocket Internet Explorer. You may see a single *.exe or setup.exe file, or several versions of files for different device types and processors.
3. Read any installation instructions, Read Me files, or documentation that comes with the program. Many programs provide special installation instructions.
4. Tap the file, such as an *.exe file. The installation wizard begins. Follow the directions on the screen.

For more information about working with Pocket Internet Explorer, see [Pocket Internet Explorer](#) on page 12-11.

Overview

Dolphin terminals are available with an on-board 2.4 GHz 802.11b WLAN (Wireless Local Area Network) radio that uses Direct Sequence Spread Spectrum (DSSS) technology to spread the signal continuously over a wide frequency band at a data rate of up to 11 Mbps. In addition, the open software architecture makes the Dolphin terminal a complete solution for a variety of wireless mobile data collection applications.

Dolphin terminals are interoperable with other 802.11b Wi-Fi-compliant products including Access Points (APs), printers, PCs via PC card adapters and other wireless portable terminals.

Enabling the 802.11b Radio Driver

When the Dolphin terminal initializes, the radio driver for 802.11b is installed. The terminal defaults to the 802.11b radio during initialization unless a GSM radio is installed, in which case, the terminal defaults to the GSM radio. The 802.11b radio must be enabled before you can configure the radio on a network. Verify the radio's status before configuring.

Note: Radios are enabled manually in the Radio Manager; tap Start > Settings > Connections tab > Radio Manager.

Configuration Utilities

There are two configuration utilities for the 802.11b radio:

802.11b Settings Use this configuration utility to configure the radio without Wired Equivalent Privacy (WEP) or with standard WEP (64/128 bit) and no authentication. For more details, see [802.11b Settings](#) later in this chapter.

802.11b Wireless Security Supplement Use this configuration utility to configure the radio using WEP (beyond the standard), Wi-Fi Protected Access (WPA), and authentication. For details, see [802.11b Wireless Security Supplement](#) later in this chapter.

802.11b Settings









You can access the configuration utility two ways:

1. Tap **Start > Settings > System tab > 802.11b Settings**.
The icon appears on the System tab only if there is an 802.11b radio installed on the terminal.
2. Tap the **Status** icon  in the system tray - see [Using the Status Icon](#) on page 9-9.

The 802.11b Settings utility consists of four tabs: Status, Config, Advanced, and About. Each tab is described in its own section in this chapter.

Status Icons

This configuration utility contains icons that indicate the status of the network.

Icon	This icon means...
	Excellent signal strength. Excellent connection.
	Poor signal strength. Poor connection.
	Radio disabled. No radio connection.
	(Access Point) AP Mode.
	Peer Station, Peer-to-Peer Mode.
	WEP enabled. Network needs a WEP Key to connect.
	WEP disabled. Network does not need a WEP Key to connect.
	Mismatched WEP Key configuration with your network.
	Online help button.

Status Tab

802.11b Settings always opens to the Status tab.

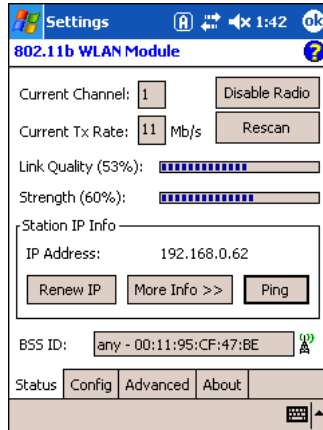

Field	Description
Current Channel	Shows the RF channel currently used by the radio.
Current TX Rate	Shows the current transmit rate. This can be 1 Mbps, 2 Mbps, 5.5 Mbps, or 11 Mbps.
Disable/Enable Radio	Tap this button to disable/enable the radio.
Rescan	Tap this button to start a rescan process to search for an AP with a stronger signal in the network.
Link Quality	Displays the signal to noise ratio.
Strength	Displays the signal strength at the receiver.
IP Address	Displays the IP address of the radio. Verify configuration information with your network administrator.
Renew IP	Tap this button to reapply the IP address from the DHCP server when automatic DHCP is enabled.
State	Displays the Network Name and the MAC address of the: AP the radio is associated with in AP mode, or Creator of IBSS into which the radio is joined in peer-to-peer (Ad-Hoc) mode. After an SSID is chosen, this field name changes to "IBSS ID."
More Info	Tap this button to display detailed TCP/IP information as shown in the following screen: <div data-bbox="771 1451 1096 1843" data-label="Image"> </div>
Ping	Tap this button to open the Ping Utility window where you can ping IP addresses.

Ping Utility Window

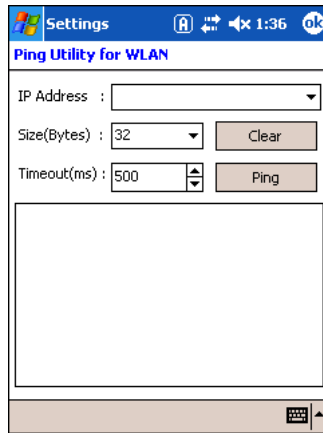

Field	Description
IP Address	Displays the current IP address. Enter another IP address to ping.
Size (Bytes)	Displays the current data packet size in bytes; 32 is the default. You can select up to 8192 from the drop-down list.
Timeout (ms)	Displays the current timeout; 500 is the default. Increase or decrease it by tapping the up and down arrow buttons.
Clear	Tap this button to clear IP Address input and the ping statistics field.
Ping	Tap this button to ping the IP address entered in the input field.
Ping Statistics	This section lists the pinging IP address and the pinging results.

Config Tab



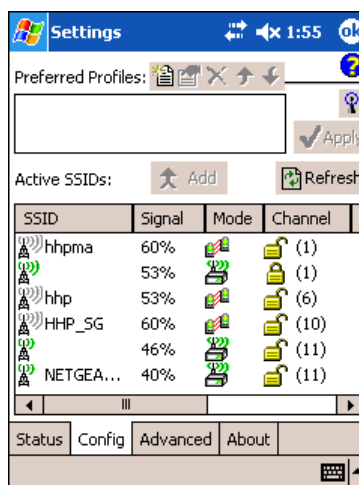

The Config tab provides a list of all APs and peer stations in range. Use the list to create and edit SSID profiles for APs that you want the terminal to associate with.



Preferred Profiles

The Preferred Profiles section displays a list of your preferred profiles, the profiles you create or add from the list of Active SSIDs below. When applied, the 802.11b radio searches for the APs in the exact order shown in the list of profiles. This section is blank after the initial installation and each hard reset. This section remains blank if there no automatic association preference selected.





This section contains several icons that enable you to add and configure APs.

Icon	Name	Description
	New	Always active, tap this button to create a new profile.
The following buttons activate only when an Active SSID in the Preferred Profile list is selected.		
	Edit	Opens the configuration screens for a selected SSID in the Preferred Profiles list.
	Delete	Deletes the selected SSID from the Preferred Profile list.
	Up	Moves the selected SSID up one place in the Preferred Profile list so that the terminal hits it prior to the next SSID.
	Down	Move the selected SSID down one place in the Preferred Profile list so that the terminal hits it after the prior SSID.
<i>Note: Remember that the terminal accesses the SSIDs in this list in the exact order that they appear; moving an SSID up or down in the list determines the order of contact.</i>		

Active SSIDs

This table shows all APs or peer stations (creator of IBSS) in the vicinity of the terminal that accept broadcast associations.

Each record displays information in the following six columns (Scroll right to see all the columns.):

Column	This column displays...
SSID	The Network Name of the AP or peer station and shows the signal strength icon  .
Signal	Strength in percentage for the selected SSID.
Mode	The mode of operation  =AP  =Peer station
Channel	The channel and applied WEP method, if any.  =WEP Key-On  =WEP Key-Off
SupRate	Supported data rate of the AP or the peer station.
BSSID (MAC Addr)	BSSID or MAC Address of the AP or the peer station.

Add



Tap this button to add an Active SSID to the Preferred Profiles list. Select and active SSID in the list, tap **Add**, and the profile moves to the Preferred Profiles list.

Apply

Tap **Apply** to associate your station with a selected SSID. The SSID selected can be in the Preferred Profile or Active SSIDs lists. When applied, the Status tab opens displaying the status of the wireless connection. If the association fails, a search for another AP in the Preferred Profile list automatically takes place, and the radio attempts to associate with the station, in order of preference.

Refresh

Tap **Refresh** to start a new search for all available APs or peer stations in the vicinity.

To Add an Active SSID to the Preferred Profile Table

An SSID needs to be in the Preferred Profile list to be edited.

1. Select an SSID in the Active SSID list and tap **Add**. The SSID moves to the Preferred Profile list. If the SSID has the WEP Key turned on, the Settings window displays and prompts you to enter the WEP Method, Encryption Key, and Key ID.

2. In the Preferred Profile list, select the SSID and tap **Edit** .
3. Follow the same process for creating a profile.
4. When configuration is complete, tap **OK**.
5. The SSID and its profile are added into the Preferred Profiles list.
If you're adding an SSID with the WEP Key turned off, the Settings window does not display and the SSID is added directly to the Preferred Profile table.

To Create a New Profile

In the Preferred Profiles section, tap the **New** button . Complete the Network Profile and Authentication tab windows.

Network Profile Tab

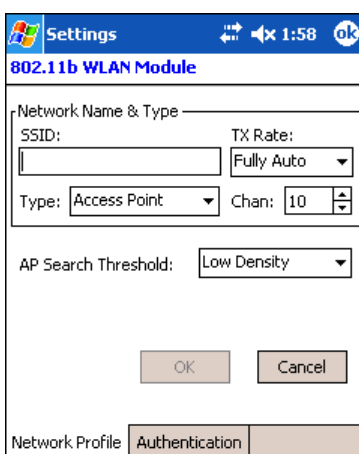

Field	Description
Network Name & Type	
SSID	Enter an SSID, which is the Network Name. Check with your network administrator for Network Name (SSID).
TX Rate	Choose the transmit rate from the drop-down list - 1 MB, 2 MB, Auto 1/2 MB, 5.5 MB, 11 MB, or Fully Auto. The transmit rate is set to Fully Auto by default.
Type	From the drop-down list, select Peer-to-Peer – This mode used for communication between two (or more) radio stations (cards) without an AP. Access Point (AP) – This mode is also called “Infrastructure” mode.
Chan	Scroll to select a channel for communication.
AP Search Threshold	Select Low Density (default), Medium Density , or High Density from the drop-down list and tap OK . AP search thresholds are used for wireless client roaming between APs. In general, the higher the density selected here, the easier your WLAN card roams between APs with the same SSID in the same network. Roaming also depends on the relative signal strength of the AP.
OK	Tap this button to save the profile or changes to the profile.
Cancel	Tap this button to close the window without saving or modifying the profile.
<i>Note: The SSID, Type, TX Rate, and Channel fields are unchangeable in AP mode, whereas TX Rate and Channel fields can be changed in Peer-to-Peer mode.</i>	

Authentication Tab

On the Authentication tab, you configure the WEP encryption key for secure wireless communication.

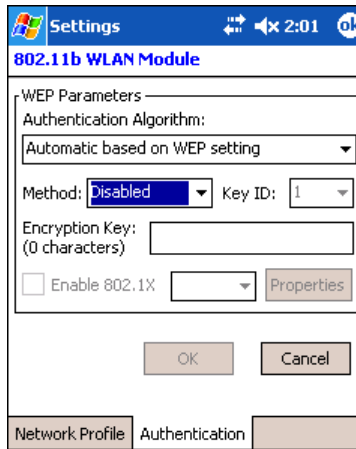

To use WEP, the encryption key **must** be configured as part of the profile before connecting. For more information about configuring a profile, see [To Create a New Profile](#) on page 9-6.

Field	Description
*Authentication Algorithm	This drop-down list is active and configurable only when the WEP Key is enabled for the selected SSID profile. If this drop-down list is active, select one of the following options: Automatic based on WEP setting – The algorithm automatically matches the AP's setting. This is the default selection. WECA Compliant (always use Open) – The algorithm should match the AP's setting for "Open." Must use Shared with WEP – The algorithm should match the AP's setting for "Shared."
Method	The options in this drop-down list determine what characters can be used to create the WEP encryption key in the Encryption Key field. Select one of the following five: Disabled – WEP Key is off 64 bit (HEX) uses 10 characters in Hexadecimal 64 bit (ASCII) uses 5 characters in ASCII 128 bit (HEX) uses 26 characters in Hexadecimal 128 bit (ASCII) uses 13 characters in ASCII HEX – Hexadecimal is a set of 16 characters from 0-9 and from A(a)-F(f). ASCII – Any printable ASCII character can be typed.
Key ID	Choose from the available Key IDs: 1 (Default), 2 , 3 , or 4 . Check with your network administrator for the WEP Key and Key ID you need to use for your network.
Encryption Key	Type in the encryption key for your wireless connection. The format allowed in this field depends on the character set and format selected in the Method field.
*Enable 802.1X	This option and drop-down list is active only when the WEP Key is enabled. Select this option if access to the network needs group authentication, then select the 802.1X security standard - PEAP or TLS - from the drop-down list.
*Properties	Tap the Properties button to choose the certificate that applies. Accessing 802.1x networks require personal certificates for authentication.
*Please note that 802.11b Settings does not support authentication; therefore, these fields are not active. If you are using authentication in your wireless 802.11b connection, you must configure that connection in the 802.11b Wireless Security Supplement. For more information, see 802.11b Wireless Security Supplement on page 9-10.	
OK	Tap this button to save the profile or changes to the profile.
Cancel	Tap this button to close the window without saving or modifying the profile.

To Delete a Profile

Profiles may be deleted either from the Preferred List or from the Preferred List and Registry. To delete a profile, select (highlight) a profile and tap the **Delete** button and the following screen displays:

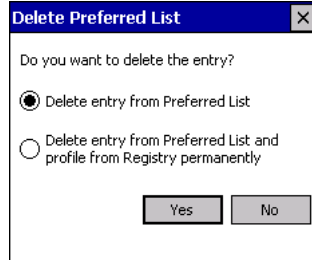

From the pop-up window select the option of your choice and tap **Yes** to confirm or **No** to cancel.

Advanced Tab

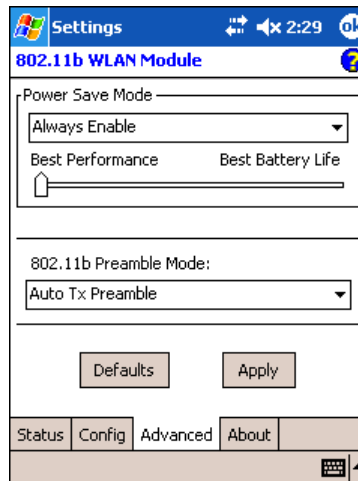

Field	Description
Power Save Mode	This drop-down list determines the settings for Power Save Mode. Disable – Disables the Power Save mode. Always Enable – Enables Power Save mode. This is the default setting. Auto Enable – Automatically enables the Power Save mode when the terminal is running on battery power and automatically disables Power Save mode when the terminal is running on external power.
Slider	The slider is active only if Power Save Mode is enabled. Move the slider between Best Performance and Best Battery Life. The setting here modulates Power Save Mode to achieve maximum performance and maximum battery life.
Preamble Mode	A preamble consists of a Synchronization (Sync) field and a 16-bit Start Frame Delimiter (SFD) field. Long TX Preamble – Where Sync field consists of 128 bits. Short TX Preamble – Where Sync field consists of 56 bits. Auto TX Preamble – Automatically changes between long and short preamble mode transmission based on AP configurations. This is the default Preamble Mode.

Field	Description
Defaults	Resets all the settings to default values <ul style="list-style-type: none"> • Always Enable for Power Save Mode, • Automatic based on WEP setting for Authentication Algorithm, and • Auto TX Preamble (for Preamble Mode).
Apply	Applies changes. This button is active only when a change has been made on the tab.

About Tab

The About tab displays Version Number and time of build for Network Driver, Configuration Utility, and NIC Firmware.

Using the Status Icon

You access the 801.11b Settings by tapping the **Status** icon once on the Today screen . The following menu pops up:

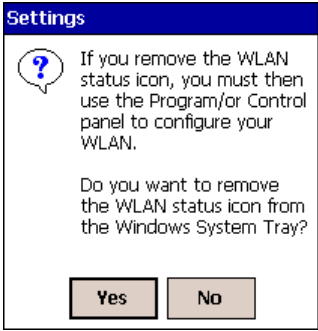

Menu Option	Selecting This Option...
Wireless Radio On	Turns on the radio. LED is on and the Link Icon displays with signal strength.
Wireless Radio Off	Turns off the radio. A pop-up window will ask for your confirmation. If confirmed, the LED will be off and the Status icon will change color from green to red on the top without signal strength displayed. The WLAN card/module will stop functioning.
Remove Status Icon	<div style="display: flex; align-items: flex-start;"> <div style="flex: 1;">  </div> <div style="flex: 1; padding-left: 10px;"> <p>Removes the Status Icon from the bottom tray. A pop-up window asks you to confirm. Click Yes to confirm, or No to cancel.</p> <p>If confirmed, the Status icon does not display in the task tray, and you will need to go to Start > Programs > 802.11b Settings in the future.</p> </div> </div>
Wireless Network Status	Opens the Status tab; Status Tab , page 9-3.
Configuration	Opens the Config tab; Config Tab , page 9-4.
Advanced Configuration	Opens the Advanced tab; Advanced Tab , page 9-8.
Version Information	Opens the About tab; About Tab , page 9-9.

Note: The Status Icon changes to a crossed lock  as a warning that you may have entered a wrong key (WEP Key mismatch) for the WEP-On AP or a station.

802.11b Wireless Security Supplement

AEGIS Client® offers the most comprehensive IEEE 802.1X supplicant for securing wired and wireless networks. The Client is a standards-based implementation of IEEE 802.1X and can be configured to work with almost any network equipment - wired or wireless - that supports the 802.1X authentication standard. The Client is interoperable with 802.1X-capable wireless APs and authentication servers including Microsoft's IAS and Cisco's ACS.

The Client solves the problem of key distribution in wireless LANs by using public key authentication and encryption between Wireless APs (WAP) and roaming stations to exchange dynamic Wired Equivalent Privacy (WEP) keys. In addition, network managers can control 802.1X user profiles from a centralized RADIUS server or, in the case of TTLS, from a RADIUS Diameter or other AAA servers. The Client supports both wireless (802.11a/b/g) and Ethernet interfaces.

Platforms Supported

There are several versions of AEGIS Client software for computers using a wide variety of operating systems. Specific capabilities of a particular version of AEGIS Client may vary according to the operating system. This is due to varying levels of support for different EAP types by manufacturers. Drivers for some types of network hardware and operating system combinations don't support as many EAP types as others combinations.

The following platforms are supported:

- Microsoft Windows Mobile Software 2003 [OS version "Pocket PC Version 4.20.1081 (Build 13100)" or later]
- Microsoft Windows Mobile Second Edition Software
- Pocket PC 2002 [OS version "Pocket PC Version 3.0.11171 (Build 11178)" or later]
- CE.NET 4.1 [OS version "CE .NET Version 4.10 (Build 908)" or later]
- CE.NET 4.2 [OS version "CE .NET Version 4.20 (Build 1088)" or later]

Note: Verify the operating system version by tapping **Start > Settings > System tab > About**.

802.1X Supplicant Protocol Support

Support for the Extensible Authentication Protocol (EAP) - RFC 2284

Supported authentication methods:

- CHAP/MD5 - RFC 1994
- EAP TLS Authentication Protocol - RFC 2716
- EAP Tunneled TLS (TTLS) - Internet Draft February 2002
- Cisco LEAP and PEAP
- Microsoft PEAP

Tested against the following servers:

- Funk Odyssey 3.2 using TLS, LEAP and TTLS
- AEGIS Server 1.1.4 using MD5, TLS, TTLS, LEAP and PEAP
- Cisco ACS 3.2 using MD5, TLS, LEAP and PEAP

AP Search Threshold



If you are using one of these authentication methodologies, you need to configure your 802.11b connection here, NOT through 802.11b Settings. However, if you want to set the AP Search Threshold above the default setting of Low Density, you do need to change that setting in 802.11b Settings; for details, see [Network Profile Tab](#) on page 9-6.

Required Network Configuration Information Worksheets

Because AEGIS Client enables your terminal to access a network that is protected by the IEEE 802.1X protocol, you must configure EAP data communication to match your network server parameters. If the EAP configuration doesn't match your network configuration, you can't access the network.

Installing and configuring the Client usually takes less than 15 minutes, provided you have the required equipment, software, and configuration information. You need clear information from the network administrator about how the network's authentication works.

The client software supports the following EAP authentication methods:

- MD5
- LEAP

-
- TLS/SmartCard
 - TTLS
 - PEAP

There is a worksheet for each method. The worksheets provide space to record the required Client configuration information to set up the Client to match specific Extensible Authentication Protocols (EAP). The forms are designed so that hard copies can be filled out, copied, and distributed.

Complete a worksheet for the authentication method you choose.

MD5 Worksheet

To configure AEGIS Client to use MD5 authentication, you need to know:

1. Will you use your Windows user name and password for network authentication? (Applies only to Windows clients.)
2. If not, what is your unique user name/password combination?

If a second set of credentials is required, you need to know the exact user name and password. These are typically case-sensitive.

User name: _____

Password: _____

LEAP Worksheet

To configure AEGIS Client to use LEAP authentication, you need to know:

1. Will you use your Windows user name and password for network authentication? (Applies only to Windows clients.)
2. If not, what is your unique user name/password combination?

If a second set of credentials is required, you need to know the exact user name and password. These are typically case-sensitive.

User name: _____

Password: _____

TLS/SmartCard Worksheet

To configure AEGIS Client to use TLS/SmartCard authentication, you need to know:

1. Is a client certificate required?

___ No.

___ Yes. This file needs to be installed on your machine by your network administrator.

2. Should the AEGIS Client validate the server certificate chain?

___ No. Skip Questions 3-4.

___ Yes.

3. Will the server accept any trusted Certificate Authority (CA), or is a particular CA required?

___ Any trusted CA is acceptable.

___ A particular CA is required: _____

4. Are intermediate certificates allowed?

No.
 Yes.

5. What is the name of the server? _____
This usually includes the server's domain, for example: server.big_school.edu.

TTLS Worksheet

To configure with TTLS authentication, you need to know:

1. Use Windows user name and password for authentication? (Applies only to Windows clients.)
2. If not, what is your unique user name? If a second set of credentials is required, you need to know the exact user name. This is usually case-sensitive.

User name: _____

3. Is a client certificate required?

No.
 Yes. This file needs to be installed on your machine by your network administrator.

4. What is the user name (identity) and password for the tunnel authentication?

User name: _____

Password: _____

5. What is the tunnel authentication protocol?

- CHAP (Challenge Handshake Authentication Protocol)
 MS-CHAP (Microsoft CHAP Extensions)
 MS-CHAP v2 (Microsoft CHAP Extensions v. 2)
 PAP
 EAP-MD5

6. Is a server certificate is required?

No.
 Yes.

7. Should the Aegis Client validate the server certificate chain?

No. Skip Questions 8-9.
 Yes.

8. Will the server accept any trusted Certificate Authority (CA), or is a particular CA required?

Any trusted CA is acceptable.
 A particular CA is required: _____

9. Are intermediate certificates allowed?

No.
 Yes.

10. What is the name of the server?

This usually includes the server's domain, for example: server.big_school.edu. _____

PEAP Worksheet

To configure AEGIS Client with PEAP Authentication, you need to know:

1. Use Windows user name and password for authentication? (Applies only to Windows clients.)
2. If not, what is your unique user name? If a second set of credentials is required, you need to know the exact user name. This is usually case-sensitive.

User name: _____

3. Is a client certificate required?

___ No.

___ Yes. If it is, this file needs to be installed on your machine by your network administrator.

4. What is the user name (identity) and password for the tunnel authentication?

User name: _____

Password: _____

5. What is the tunnel authentication protocol?

___ MS-CHAP v2 (Microsoft CHAP Extensions v. 2)

___ EAP TLS/SmartCard

___ Generic Token Card

6. Is a server certificate is required?

___ No.

___ Yes.

7. Should the Aegis Client validate the server certificate chain?

___ No. Skip Questions 8-9.

___ Yes.

8. Will the server accept any trusted Certificate Authority (CA), or is a particular CA required?

___ Any trusted CA is acceptable.

___ A particular CA is required: _____

9. Are intermediate certificates allowed?

___ No.

___ Yes.

10. What is the name of the server?

This usually includes the server's domain, for example: server.big_school.edu. _____

Opening the Client







To access the client the first time, tap **Start > Programs > Meetinghouse AEGIS Client**.

After the Client has been activated, you can tap the icon in the lower left corner of the command bar.



Icon Indicators

The color of the icon indicates the status of the controlled ports.

Icon	Color	This color icon indicates that ...
	Green	Authentication succeeded.
	Yellow	Authentication is in process.
	Red	Authentication failed.
If there is no yellow, red or green in the icon then either the ports are not being controlled by 802.1X, or there is no authentication activity on the controlled ports. The absence of yellow, red or green may also indicate that the network access server is not an 802.1X aware device.		
	Gray	The port is not in use or is disabled. Either the Client isn't running, or the port is not bound to the 802.1X protocol.
	Orange	The port is associated, but there is no response to 802.11b packets. If using WEP without 802.1x authentication, this will be the final state when the connection is complete. If using 802.1x authentication, it is either a transient condition or can indicate that attempts to authenticate have timed out as there was no response to 802.1X packets.
	Blue	There is no 802.11b activity. The port may not be connected to an 802.1X-aware entity.

Main Screen

On the terminal, open the Client. The main screen opens displaying a list of ports on the system's network interface cards. You manage ports on this screen.

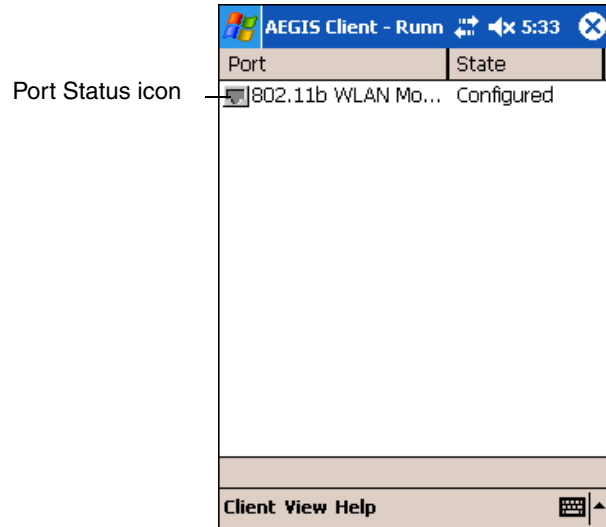

Port Status Icon

The main screen contains a port status icon to the left of each port listed. The color of this icon indicates the status of the port. The color of the icon changes as the port starts authentication, negotiates with the AP and/or authentication server, and then joins the network. As the network interface starts or stops, the color of the port icon and the status field in the Interface List updates to reflect the current state of the interface. For details about what each color means, see [Icon Indicators](#) on page 9-14.

Client Menu

To open the client menu, tap **Client** in the command bar along the bottom of the window.

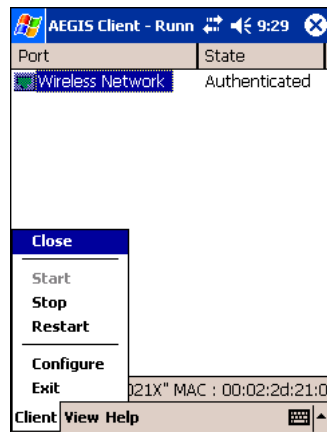

Menu Item	Tapping this item...
Close	Closes the Client's interface, while leaving the client running.

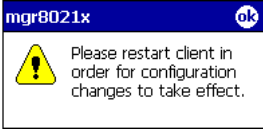
Menu Item	Tapping this item...
Start/Stop	Starts or stops 802.1X authentication. After you finish the initial configuration, tap the network interface and tap Start . If the port is already active, tap Stop first, then Start to force the program to read the new configuration file.
Restart	Same as a Stop followed by Start. Tap this when you receive a notice such as the following: 
Configure	Opens the Configuration screen displaying the User tab.
Install Protocol	Selecting this option binds the 802.1X protocol to the WLAN adapter currently installed on the device. The WLAN adapter then appears in the port list. For more information about network adapters, see Network Cards on page 7-24.
Exit	Terminates the client, which stops the 802.1X protocol.

View Menu

To access the View menu, tap **View**.

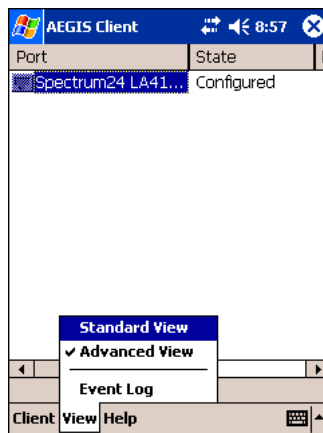

The Standard and Advanced Views control the number of columns displayed in the main menu.

Menu Item	Tapping this item...
Standard View	Displays the Port (adapter name) and State columns. This is the default view.
Advanced View	Displays the Port (adapter name), State , Primary Wireless Network , Wireless Network , and MAC Address of AP columns. Scroll right to see all columns.
Event Log	The Event Log is a text file that contains status information from the logging function.

Menu Item	Tapping this item...
	<p>Each entry is listed sequentially with a time stamp and a text message.</p>  <p>Tap Refresh to query the log again. Tap Close to return to the main screen.</p>

Help Menu

Tapping Help opens the help menu. Select **Online Help** to access online help. Select **About** to review software version information.

Status Bar

The status bar at the bottom of the main screen indicates the connection status between the network card and the AP.

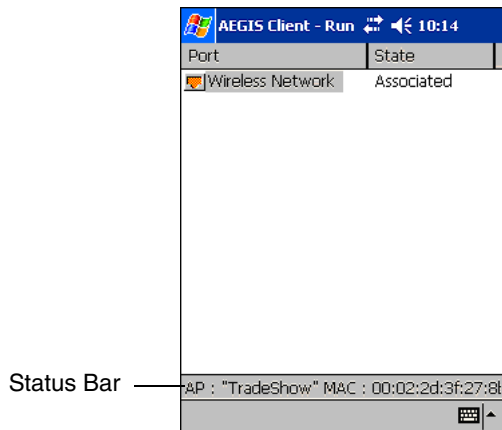

The status bar displays one of the following depending on the status of connectivity:

- "Not Associated"
- "AP : [Name of the SSID] MAC : [MAC address]."

Port Menu

On the main screen, tapping on a port opens a popup menu that allows the port to be enabled or disabled, configured, or deleted.

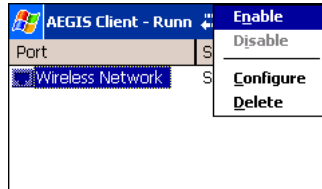

Port Menu Options

The port menu enables you to use 802.1X authentication, change the port configuration, or remove it from the port list. If there are no entries in the Port list, follow the advice in the troubleshooting section to resolve the problem.

Menu Item	Description
Enable and Disable	These commands enable or disable 802.1X authentication on the port. The port should be enabled before the protocol is started. Enabling a port is not the same as starting it (see Client Menu on page 9-15); however, both actions are required for the Client to work.
Configure	Opens the port configuration screen; see Accessing the Client Configuration Area on page 9-19.
Delete	Removes an adapter from the port list. An unused port may be deleted from the port list. The radio card must not be in the device or the radio must be turned off. Ports appear in the list only when the 802.1X protocol binds to the adapter. The protocol binds to the adapter when the adapter is in the device and the Client software is installed, or Install Protocol is selected from the Client menu (see Client Menu on page 9-15).

Configuring the Client

The Client is configured in two separate areas:

1. **Client Configuration** area - enables you to configure user settings and is accessed from the Client menu.
2. **Port Settings** area - enables you to configure Network Properties settings for individual wireless networks and is accessed from the Port menu.

Configuration Screens

Both Client Configuration and Port Settings areas lead you through a series of setup screens. The following diagram displays the different screens and how they are related:

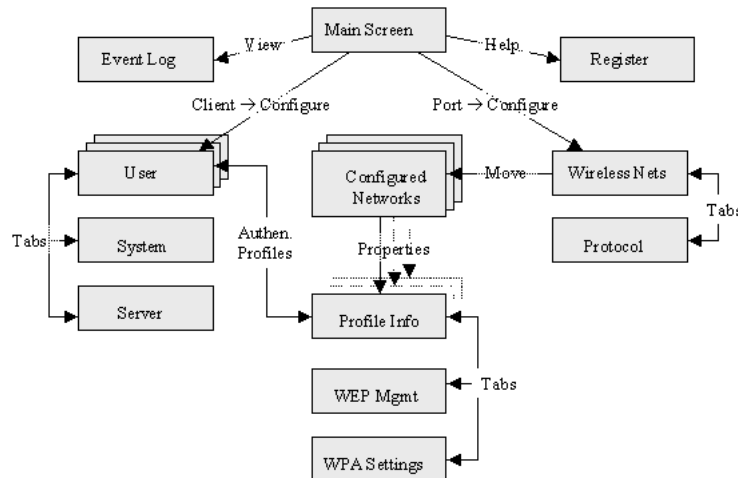

Client Configuration Area

Each user account needs to define the protocol and the credentials used to authenticate a user. Because Windows Mobile devices are usually small devices with a single NIC and, usually, a single user, the initial configuration is usually the only time the software needs to be set up. The Client will need to be reconfigured if the device is used on multiple networks, or if different users share the computer.

Note: Fields are grayed out if not relevant to the selected protocol.

Accessing the Client Configuration Area

On the main screen, tap **Client > Configure** (see [Client Menu](#) on page 9-15). The Client Configuration screen opens displaying the User tab.

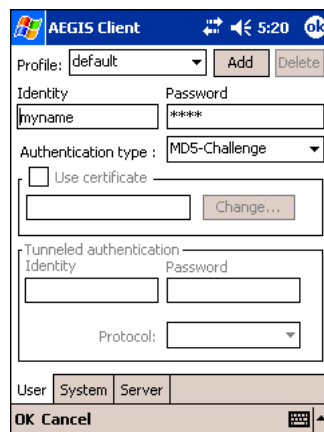

On this tab,

User Settings Tab

System Settings Tab

Server Identity Tab

You...

Configure authentication credentials and profiles.

Set the level of detail that the Client will provide in the system log and zero-config options.

Control how the Client authenticates the server that handles the 802.1X protocol on the network side. This applies only to the TLS, TTLS, and PEAP authentication methods and is used to tell the Client what server credentials to accept from the authentication server to verify the server.

User Tab

The User settings tab defines the protocol and the credentials used to authenticate a user.

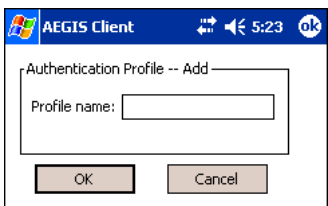
Field	Description
Profile	<p>Multiple user credential profiles can be created for use when the user roams from one network to another. The drop-down list contains existing authentication credential profiles. Select a profile from the list to edit it in the fields that follow.</p>  <p>Tapping Add permits new profiles to be added to the list. A screen appears where you can enter a name for the new profile. Enter a Profile name and tap OK. The name entered appears in the Profile drop-down list.</p> <p>Tapping Delete deletes authentication profiles. To be deleted, a profile cannot be assigned to a configured network.</p>
Identity	<p>This is the 802.1X identity supplied to the authenticator. The identity value can be up to 63 ASCII characters and is case-sensitive.</p> <p>For tunneled authentication protocols such as TTLS and PEAP, this identity (called the Phase 1 identity) is sent outside the protection of the encrypted tunnel. Therefore, it is recommended that this field not contain a true identity, but instead the identity “anonymous” and any desired realm (e.g. anonymous@myrealm.com). For TTLS and PEAP, true user credentials (Phase 2 identity) are entered in the Tunneled authentication section.</p> <p>When used with PEAP and the .NET Enterprise Server Version 5.2, this field must contain the identity used in both Phase I and Phase II. The Phase II identity field is ignored.</p>
Password	<p>This is the password used for MD5-Challenge or LEAP authentication. It may contain up to 63 ASCII characters and is case-sensitive. Asterisks appear instead of characters for enhanced security.</p>
Authentication type	<p>This is the authentication method to be used - MD5-Challenge, LEAP, PEAP, TLS, or TTLS. Your network administrator should let you know the protocols supported by the RADIUS server. The RADIUS server sits on the network and acts as a central credential repository for Access Servers that receive the radio signals and ultimately block or allow users to attach to the network.</p>

Field	Description
Use certificate	<p>This is the certificate to be used during authentication. A certificate is required for TLS, optional for TTLS and PEAP, and unused by MD5 and LEAP. Therefore, this option becomes active only when TLS, TTLS, or PEAP is selected as the Authentication type.</p> <p>If Use certificate is enabled, the client certificate displayed in the field is the one that is passed to the server for verification. To select a client certificate, tap Change and select the certificate from the list that appears.</p>  <p>To appear in this list, certificates must be installed in the system. The Issued to column should match the Identity field and the user ID on the authentication server used by the authenticator. Your certificate must be valid with respect to the authentication server. This generally means that the authentication server must accept the issuer of your certificate as a Certificate Authority. When obtaining a client certificate, do not enable strong private key protection. If you enable strong private key protection for a certificate, you will need to enter an access password for the certificate each time this certificate is used.</p>
<p>Tunneled authentication area</p> <p>Tunneled authentication parameters are used by only by TLS, TTLS and PEAP protocols, in Phase 2 of authentication, and after the secure tunnel has been established. The fields in this section are active only if the TLS, TTLS, or PEAP is selected as the Authentication type.</p>	
Identity	<p>The user identity used in Phase 2 authentication. The identity specified may contain up to 63 ASCII characters, is case-sensitive and takes the form of a Network Access Identifier, consisting of <name of the user>@<user's home realm>. The user's home realm is optional and indicates the domain to which the tunneled transaction is to be routed.</p> <p>Because Microsoft .NET Enterprise Server Version 5.2 does not use this parameter for PEAP, This field will have no effect for PEAP at this time. Phase 1 identity is used instead.</p>
Password	<p>The password used for the tunneled authentication protocol specified. It may contain up to 63 ASCII characters and is case-sensitive. Asterisks appear instead of characters for enhanced security.</p>
Protocol	<p>This parameter specifies the authentication protocol operating within the secure tunnel.</p> <p>The following protocols are currently supported for TTLS: EAP-MD5, CHAP, PAP, MS-CHAP and MS-CHAP-V2.</p> <p>The following protocols are currently supported for PEAP: EAP-MS-CHAP-V2, TLS/SmartCard, and Generic Token Card (EAP-GTC).</p>

System Tab

The System Settings tab controls logging and the port manager timeout period.

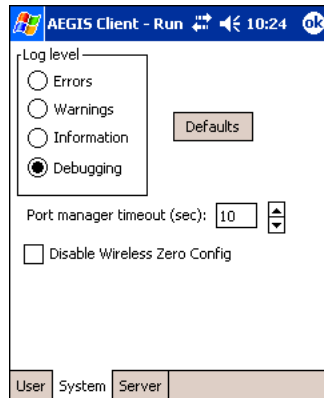

Field	Description
Log Level	<p>These settings control the detail of the log messages generated by the Client. Each level is cumulative. By default, all errors, warnings, and information events are logged. Each entry records a severity code (of one [debug message] to four [error] asterisks), a time stamp, and a message.</p> <ul style="list-style-type: none"> • Errors - only the most severe conditions are logged. • Warnings - less severe conditions are logged. • Information - all errors, warnings, and information events are logged. This is the default setting. • Debugging - creates a log message each time the Client detects or reacts to an event. Be advised that log entries fill memory quickly if the Debugging level is chosen. Do not use the Debugging option for a significant length of time because most internal operations generate messages.
Defaults	Tap this button to return log settings to the default settings.
Disable Wireless Zero Config	Use this option only as directed by technical support. Selecting this option disables other wireless utilities whether the Client is running or not. If not selected, other wireless utilities cannot apply their settings to the wireless card while the Client is running (although their status displays are usually unaffected). You will need to perform a soft reset whenever this setting is changed.
Port Manager Timeout	The interval at which the client polls the ports. This is used under different circumstances, for instance after physical changes such as card removal or insertion have been detected. This value should not be changed from the 10-second default unless so advised by technical support.

Server Tab

The Server identity tab defines the credentials the client uses to authenticate the server during TLS/TTLS/PEAP authentication message exchange. The Client uses this information to verify that the Client is communicating with a trusted server.



Field	Description
Do not validate server certificate chain	If this option is selected, the server certificate received during the TLS/TTLS/PEAP message exchange is not validated.
Certificate issuer must be	This is the certificate authority used during TLS/TTLS/PEAP message exchange. Any Trusted CA is the default selection and means that any certificate authority can be used during authentication. Both trusted intermediate certificate authorities and root authorities whose certificates exist in the system store are available for selection in the drop-down list.
Allow intermediate certificates	This option is selected by default and enables unspecified certificates to be in the server certificate chain between the server certificate and the certificate authority selected in the Certificate issuer must be field. When selected, this option allows the server certificate received during negotiation to be issued directly by the certificate authority or by one of its intermediate certificate authorities. If disabled, then the selected Certificate issuer must have directly issued the server certificate.
Server name must be	This is either the server name or the domain the server belongs to, depending on which option is selected below the text field. During authentication, this name will be compared to the server certificate's Subject: CN field.
Must match exactly	When selected, the server name entered must match the server name found on the certificate exactly.
Must contain domain name	When selected, the server name field identifies a domain and the certificate must have a server name belonging to this domain or to one of its sub-domains (e.g., zeelans.com, where the server is blueberry.zeelans.com).

Port Settings Area

In the Port Settings area, you configure network parameters for each port listed on the main screen.

1. On the main screen, tap and hold on a port. The Port popup menu appears.
2. Tap **Configure**. The Port Settings Configuration screen opens displaying the Wireless Networks tab.

Wireless Networks Tab

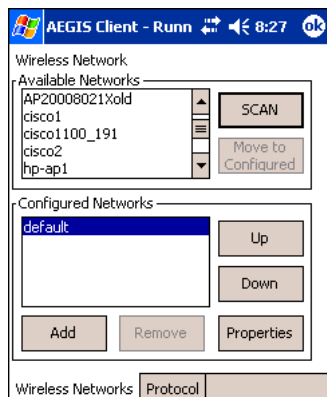

Field	Description
Available Networks	Displays the networks the terminal recognizes as available to connect to. When the Client is first installed, there are no entries in the Available Networks list.
Scan	Displays a list of networks broadcasting their availability. You can also attach to networks who are not broadcasting.
Move to Configured	Activates after Scan has been tapped and the available networks have been retrieved. In the list of networks retrieved, select the network you wish to connect to, and tap Move to Configured . This selects the network.
Configured Networks	Displays the networks your terminal is connected to. This section adds and removes networks as well as reviews and edits the properties of existing configured networks.
Default	When the Client is first installed, there is a Configured Network named "default" in the list. This profile has Associate with any network selected in its Properties selection screen. If you are going to be in a location with only one AP (or more than one AP that attaches to the same network), the default profile may be sufficient for you needs, without necessitating the selection of a specific network or networks. If default is last in the list, it can act as a wildcard should you be out of the range of your primary networks (which are listed first). Do not place default at the top or middle of the list because, if it is, connection to the other list entries will never be attempted.
Up	Moves a selected network up one place in the list.
Down	Moves a selected network down one place in the list.
<i>Note: The order of the networks in this list is the exact order that connections will be attempted. The network listed first will be attempted first and so on. Place your primary networks first.</i>	
Add	Manually adds a network to the Configured Networks list if the AP does not broadcast its SSID or you are pre-configuring the client for an AP that is not currently in range.
Remove	Removes a selected network in the list.
Properties	Displays the properties of the network selected in the list. This button opens the same network configuration screen as the Add button does; use it to edit network configuration properties.

Protocol Tab

The Protocol tab configures parameters that apply to all the networks the selected port connects to.

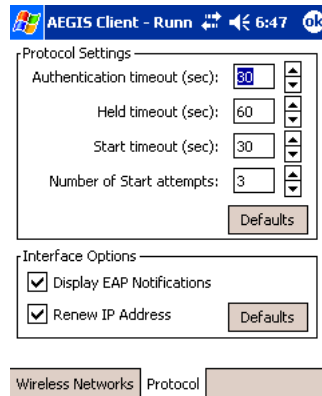

Field	Description
Protocol Settings	<p>These are the timer intervals and retry settings defined in the 802.1X standard. They determine how long the supplicant state machine will wait in a given state. These parameters shouldn't be modified without an understanding of the supplicant state machine. For more information about the supplicant state machine, obtain its 802.1X protocol specification.</p> <p>The parameters are:</p> <ul style="list-style-type: none"> • Authentication Timeout - The period of time the Client remains in the authenticating or acquired state without receiving a response from the AP or switch. • Held Timeout - The period of time the Client remains in the held state after failing authentication. • Start Timeout - The period of time the Client remains in the connecting state before restarting when there is no response. • Number of Start Attempts - The number of times the Client restarts before giving up. At that point, the Client then defaults to the authenticated state, but there will be no network connectivity because the protocol exchange was never completed.
Display EAP notifications	<p>Specifies that the EAPOL notification message will be displayed to the user. An authenticator may use such notification to inform you, for example, about a near password expiration. However, some authenticators send chatty and annoying notifications that may, for the convenience of the user, be suppressed. Note that all notifications are written to the event log even if they are not displayed.</p>
Renew IP address	<p>Initiates a DHCP request to obtain a dynamic IP address after a successful authentication, but only if the client detects that the connected network (the SSID) has changed. The result is that renewal should not occur upon re-authentication, but does occur at boot or when connecting to a different network.</p> <p>If you have a slow authenticator, you may wish to enable this option when configuring the service because a slow authenticator may prevent you from getting a DHCP-assigned IP address upon boot-up. This option is ignored if the given adapter has a static IP address.</p>

Adding a Wireless Network Configuration

To add a wireless network configuration, on the main screen, tap and hold on the port, tap **Configure** on the Port popup menu, then tap **Add** in the Network Configurations section of the Wireless Networks tab. The Network Profile screen opens displaying the Profile Info tab.

Note: The settings on these tab windows are interrelated. This means that selecting one may disable access to others.

Profile Info Tab

Field	Description
Network Profile	Enter the name of this record. This is the name that appears in the Configured Networks list and, by default, is the same as the broadcast SSID. Note that there is nothing special about the name "default". You could configure any other record similarly and it would behave the same way.
Network Name	This is the SSID of the AP. If the AP broadcasts its SSID, then this value may be derived from the Available Networks list. If the SSID does not broadcast, then you must manually enter the value here.
Peer-to-Peer Group	Select this option to have two or more client workstations communicate with each other without the benefit of an AP. You should also select Do Active Scan and, in the WEP Management page, enable Use key for data encryption while entering a common key for both sides. WPA is not supported in this mode.
Do active scan	Select this option whenever the AP (or client, for ad hoc mode) is not broadcasting its SSID.
Authentication Profile	Select the Client Configuration (user) profile associated with this network. The drop-down list contains client profile names created in the User tab of the Client Configuration Area; see User Tab on page 9-20. To open the selected profile, select it in the drop-down list and tap View . The User tab opens displaying the profile details. If you tap OK (to save changes) or Cancel , you are returned to the Profile Info tab.

WEP Mgmt Tab

The WEP Mgmt tab enables you to set WEP parameters for each port.

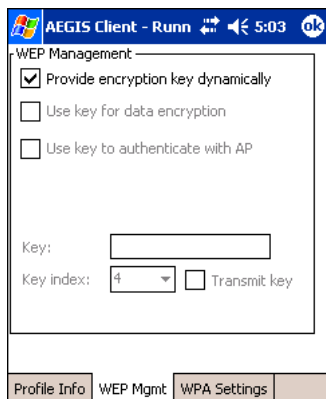

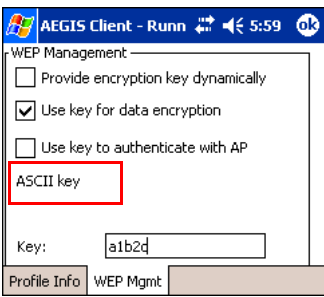
Field	Description
Provide encryption key dynamically	This option is selected by default. If this option is selected, the other WEP settings on this page are disabled. To enter a custom WEP, de-select this option. The other fields become active.
Use key for data encryption	Select this option to manually enter a WEP key to encrypt your data to the AP. You enter that key in the Key field below.
Use key to authenticate with AP	Select this option if your network does not support 802.1x authentication and you need to connect to the AP without username and password authentication. The key entered below is used to authenticate instead.
Key	<p>In this field, enter the WEP key:</p>  <p>ASCII - 5 or 13 characters Hexadecimal - 10 or 26 characters. When the key entered is in the correct format, the screen changes to display the type - ASCII or Hexadecimal.</p>
Key Index/Transmit Key	<p>The Key Index drop-down list contains the available keys. You may enter up to four keys for reception; the Client will try all four to find one that works with the AP. From the drop-down list, select the key to be used for transmission as well. If the key selected is the transmit key, the Transmit key box is checked. To change the transmit key, select another key and check the Transmit key box. The check box of the original transmit key will be automatically de-selected.</p>

WPA Settings Tab

The WPA Settings tab enables you to configure WPA settings.

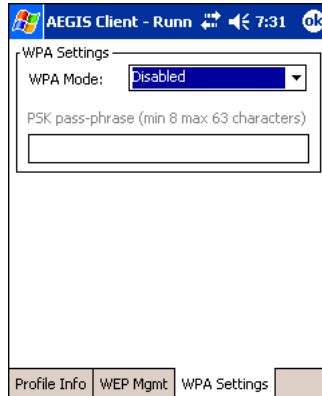

Field	Description
WPA Mode	This drop-down list contains the following options: <ul style="list-style-type: none"> • Disabled - Do not enable WPA mode. This is the default selection. • WPA 802.1x - Enable WPA and obtain key information through the 802.1x protocol. • WPA PSK - Enable WPA with Pre-Shared Key (PSK) information entered in the field below. This mode is used if the 802.1x protocol is not being used for authentication.
PSK pass-phrase	This field activates if you select WPA PSK in the WPA Mode drop-down list. Enter between 8 and 63 characters for your pass phrase. Asterisks appear as you type for increased security.

Logging

The event log is an ASCII text file named “LOG8021X.TXT” located in the directory defined by the WINDIR environment variable (usually the Windows directory). The information the log records is determined by the log settings on the System tab of the Client Configuration Area; see [System Tab](#) on page 9-22.

The format of the entries is

Time Stamp Message Text

The **Refresh** button at the bottom of the screen is used to update the log file while you are reading it. If the file gets too large, old entries are automatically deleted.

If you wish to start with a blank file, exit from the Client (so the icon no longer appears at the lower right of the screen) and delete the log file (log8021x) in File Explorer; see [Using Find](#) on page 4-10.

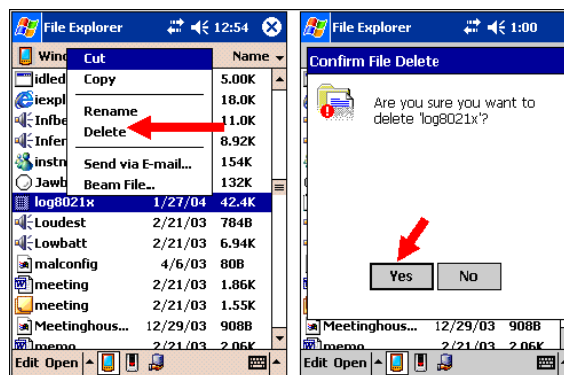

When you restart the Client, a new log file is created.

Installing Certificates with CertAdd

Certificate Requirements

During configuration, you may have specified one or two certificates to use during the authentication process. The specified identity should match the **Issued to** field in the certificate and should be registered on the authentication server (i.e., RADIUS server) that is used by the authenticator. In addition, your certificate must be valid on the authentication server. This requirement depends on the authentication server and generally means that the authentication server must know the issuer of your certificate as a trusted Certificate Authority (CA).

If the selected certificate does require a password or pass phrase to decode the private key, enter this value in the “Certificate Pass Phrase” field. This value will be encrypted when the configuration is saved. However, on some systems, there may not be a certificate. If that is the case, you can use the section below as a primer on OS X certificate management.

About CertAdd

CertAdd is a standalone utility that allows certificates to be selected and installed on a Windows Mobile device.

Installing Certificates

Client or CA certificates can be imported from *.cer (same as *.der), *.p7b, or *.pfx files.

1. Download the certificate file to the My Documents folder. The location isn't critical, although you may want to create a standard folder for consistency.
2. Go to **Start > Programs > Meetinghouse Certificate Installer**. The opening screen is displayed. All valid certificate file types located in the My Documents folder appear in the list.

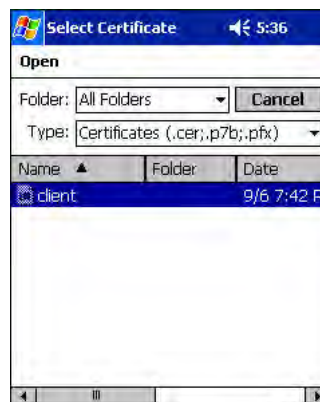

3. Tap and hold on a certificate in the list. A pop-up appears asking if you want to install the certificate.
4. Tap **OK**. The certificate is loaded into the correct certificate store.

Advice and Workarounds

Issue	Possible Causes and Solutions
The Client will not start on the device with an error message about missing files.	Perform a soft reset.
The wireless network interface (port) does not appear in the main AEGIS screen.	<ul style="list-style-type: none">• The license is not valid (If you have entered a time-limited license, is your clock on the device correct?).• Restart the client - on the main screen tap Client > Restart.• Perform a soft reset.• If the radio is turned off or the radio card is not present, this will sometimes cause the port name to not appear.• If the radio driver is very old and does not support NDIS 5.1 commands, the Client may not be able to detect it.

Advice and Workarounds

Issue	Possible Causes and Solutions
The wireless network interface appears, but when I select it and go to the "configure" menu, the Scan button is disabled.	Power up the radio; see Enabling Radios and Radio Combinations on page 4-5.
The client is not attaching to the correct AP.	The default network profile instructs the client to attach to the first available AP. You must select a network, move it to the Configured Networks list, and then move it above default in the list using the up arrow buttons. For more information, see Wireless Networks Tab on page 9-24.
The Client is failing authentication even though all my information was entered correctly.	<ol style="list-style-type: none"> Verify that the network profile for the AP corresponds to the authentication profile you created for it. <ul style="list-style-type: none"> Select the network profile in the Configured Networks list. Tap Properties. The Profile Info tab opens - see page 9-26. In the Authentication profiles drop-down list, select the profile you want to review. Tap View. The User tab appears displaying the profile's information. Verify that you have configured the identity and password into the correct fields on the User tab (page 9-26) in the authentication profile. If you are using PEAP or TTLS, the username and password are entered in the Tunneled authentication section.
My AP does not broadcast its SSID. Even though I have manually configured an AP with that name, the Client won't associate with it.	<ul style="list-style-type: none"> Make sure that the desired SSID is listed as the Network Name, not the Network Profile (which is a screen label) Verify that Do Active Scan is selected on the Profile Info tab; see Do active scan on page 9-26. Otherwise, the Client will not attempt to find the AP.
I am authenticated, but I don't get an IP address through DHCP.	On the main screen, tap and hold on your AP, tap Configure on the popup menu, and select the Protocol tab. Verify that Renew IP Address is selected; see Renew IP address on page 9-25.
I cannot attach to my old network that does not support 802.1x authentication, but is using WEP encryption.	<ul style="list-style-type: none"> Verify that you can see your SSID in the Available Networks list on the Wireless Networks tab. Move the SSID to the top of the Configured Networks list so that it is accessed first. If the SSID is not there, you can add it manually and enter the SSID as the network name - page 9-24 Select the SSID and tap Properties. On the Profile Info tab, select Do active scan if your AP does not broadcast its SSID. On the WEP Mgmt tab, select Use key for data encryption and Use key to authenticate with AP. Enter the WEP Key - see Key on page 9-27. On the Protocol tab, select Renew IP Address (unless you have entered one manually separate from the Client) Note that the port status indicator in the main screen reads "Associated," not "Authenticated" when the connection is complete; although the log file will indicate "Entered AUTHENTICATED state."
I made changes, but they do not appear to have taken effect.	Always tap OK before exiting a screen you have changed. Then restart the Client from the Client menu on the main screen.
How do I enable peer-to-peer (ad-hoc) mode to have two clients communicate without an AP?	<ul style="list-style-type: none"> On the Wireless Networks tab, add a new profile to the Configured Network list. On the Profile Info tab, give each side the same network name (SSID). Select Peer-to-Peer Group (ad hoc mode) and Do active scan. On the WEP management section, select Use key for data encryption and enter an identical key for both clients. Verify that this network profile is the first (or only) one in the Configured Network list and try to restart both clients at roughly the same time.

How 802.1X Works

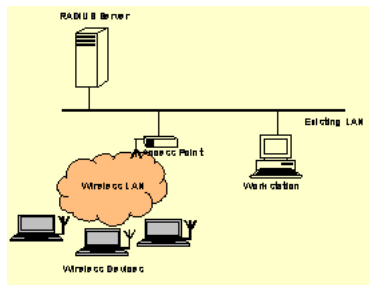

The network elements in the above graphics are those involved in a typical wireless LAN. When 802.1X is running, a wireless device must authenticate itself with the AP in order to get access to the Existing LAN. With respect to the terms used in the 802.1X standard, APs (APs) function as authenticators and wireless devices function as supplicants. The authenticator keeps a control port status for each Client it is serving. If a Client has been authenticated, its control port status is said to be Authorized, and the Client can send application data to the LAN through the AP. Otherwise, the control port status is said to be Unauthorized, and application data cannot traverse the AP.

Typical Message Exchange Using MD5 or TLS

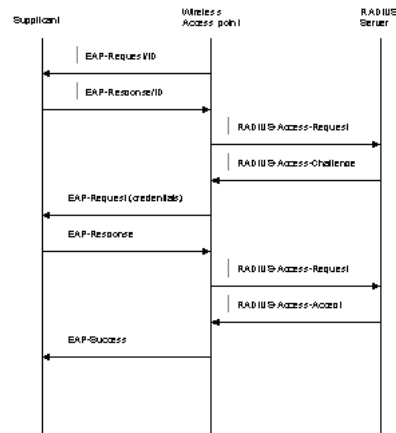

The above graphic displays the typical message exchange when the device and the AP support 802.1X. When an AP acting as an authenticator detects a wireless station on the LAN, it sends an EAP-Request for the user's identity to the terminal. In turn, the terminal responds with its identity, and the AP relays this identity to an authentication server, which is typically an external RADIUS server.

The RADIUS server can then act as a central repository of user profile information. Such use of a centralized authentication server allows the user to access wireless LANs at many different points, but still be authenticated against the same server. In response to the Access-Request, the RADIUS server sends an Access-Challenge to the AP, which is then relayed in the form of an EAP-Request to the device. The device sends its credentials to the AP, which in turn relays them to the RADIUS server. The RADIUS server determines whether access to the network is accepted or denied based on the Client's credentials.

Dynamic Session Specific Wireless Encryption Keys

There have been many published reports recently about the lack of security provided by the Wired Equivalent Privacy (WEP) protocol. One of the problems with WEP is that the shared key used by the station and the AP is inherently static. That is, this shared key will only change if it is manually reconfigured on both devices. The Client remedies this by supporting the Transport Layer Security (TLS) protocol. TLS ensures that a new shared key is generated each time a station associates itself with an AP. TLS has proven itself an excellent authentication and encryption protocol in commercial environments. The Client also supports the MD5 and TTLS security protocols.

Additional Advantages of TTLS and PEAP

The Client provides the advantage of Tunneled TLS (TTLS) and PEAP support. These protocols provide the security of TLS with greatly reduced administrative load. Security is enhanced by never passing user ID and password in the clear. No "real" user ID or password is required in Phase 1. After the secure tunnel is established, Phase 2, user credentials are passed in safe, encrypted form. To further enhance security, the WEP keys, which encrypt the data between the wireless card and the AP, may be automatically changed on a per-session basis, limiting the time available to an unauthorized sniffer to crack the keys. By limiting the session time (the reauthentication period), the keys can essentially be made uncrackable.

Administration is eased by greatly reduced certificate requirements in comparison to TLS. In TLS, each client must have a client certificate to pass to the server, and a CA certificate with which to verify a server certificate, while the server must have a client certificate from each user and CA certificates for each possible CA chain and its own server certificate. TTLS and PEAP require only that a single server certificate be created for the server to present to the client, and that the client have a CA certificate to verify the server. Because these are the same for each client on the network, they are easily managed, unlike TLS, where every client certificate is unique. TTLS and PEAP thus provide the security of a TLS channel without the need for managers to distribute and manage client certificates. Lastly, TTLS allows for the use of existing legacy authentication protocols. Administrators may continue to use established authentication databases.

Cisco LEAP

The message exchange used by Cisco LEAP is proprietary. This protocol is not a standard EAP type, but is supported by the Client through a licensing arrangement with Cisco.

Relative Merits of Authentication Protocols

MD5 is the least secure of the EAP protocols as it only does a one-way authentication, and does not support automatic distribution and rotation of WEP keys, increasing the administrative burden of manual WEP key maintenance.

TLS, while the most secure EAP protocol, requires client certificates to be installed on each wireless client. Establishing and maintaining this PKI infrastructure is normally a burden most administrators do not feel is worth the extra level of security gained.

TTLS and PEAP bypassed the certificate issue by tunneling TLS, and thus eliminating the need for a certificate on the client side. PEAP supports only EAP-compliant authentication protocols within the tunnel structure, and is rapidly becoming the most widely supported of the EAP methods. TTLS supports pre-EAP authentication protocols within the tunnel structure, and should be used in those circumstances when pre-EAP interior protocols are desirable.

LEAP is a pre-EAP, Cisco-proprietary protocol, with many of the features of EAP protocols. Cisco controls the ability of other vendors to implement this protocol, so it should be selected for use only when limited vendor choice for client, access-point, and server products is not a concern.

Differences Between Protocols

Security Feature	MD5 Challenge	TLS	TTLS	PEAP	LEAP
Client -side certificate required?	No	Yes	No	No	No
Server-side certificate required?	No	Yes	No	Yes	No
Dynamic WEP Re-keying	No	Yes	Yes	Yes	Yes
Mutual or One-way Authentication?	One-way	Mutual	Mutual	Mutual	Mutual
Support of non-EAP protocols within a secure tunnel?	N/A	N/A	Yes	No	N/A
Relative Deployment Complexity	Simple	Difficult	Moderate	Moderate	Moderate
Relative Security	Poorest	Highest	High	High	High

Wireless PAN (WPAN) Communications with Bluetooth

Overview

Dolphin terminals are available with a Bluetooth radio for WPAN (Wireless Personal Area Network) usage. When the Dolphin is first initialized, the *.cab file and module for Bluetooth are installed.

Enabling the Bluetooth Radio

Before using the radio, make sure that the Bluetooth radio is enabled. When the radio is enabled, the Bluetooth icon appears in the task tray on the Today screen.



Note: Radios are enabled in the Radio Manager; tap Start > Settings > Connections tab > Radio Manager.

Setting Up Your Bluetooth Card

Note: If you use the Get Connected! Wizard, which is recommended for normal usage, then this step is not necessary. This step would be used to change the friendly name of your device.

1. Tap the Bluetooth icon that appears in the task tray on the Today screen.
2. In the pop-up menu, select **Advanced Features**, then **My Bluetooth Device**. (If you installed OBEX, the menu also lists Transfer via Bluetooth.)

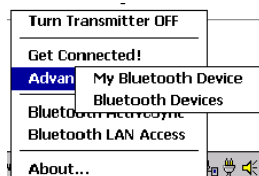

3. In the **My Bluetooth Device** screen, you can modify the **Friendly Name** and make any desired configuration changes. When done, tap **OK**.



- In normal phone connect operation, **Discoverable** mode is not needed and should be disabled.
- If you do enable **Discoverable** mode (e.g., for ActiveSync), note that it does not shut off by itself. To save power, remember to disable it when not needed.
- **Connectable**, **Use Authentication**, and **Use Encryption** are also not required for printing or dial-up networking applications.
- Check Use **Authentication** to enable the **Use Encryption** option.

Assign COM Ports

Follow these steps to view and/or modify the Bluetooth COM ports.

1. Tap on the Bluetooth icon on the Today screen. Select **Advanced Features** then **My Bluetooth Device**.

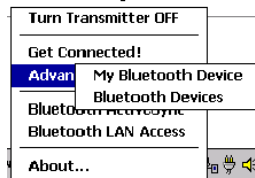

Note: If you installed OBEX, the menu also lists Transfer via Bluetooth.

2. The **My Bluetooth Device** screen appears. Tap on the **COM Ports** tab.

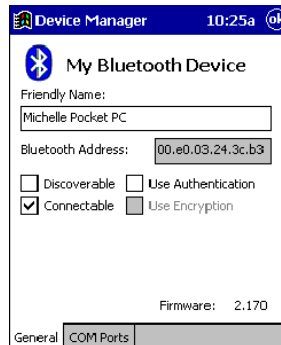

3. As needed, view and/or enable/disable the Bluetooth COM port assignments. Tap **OK**.

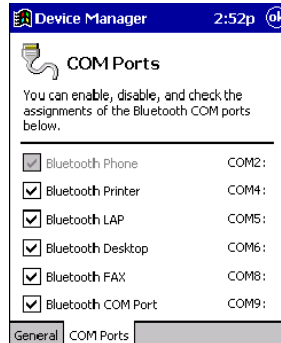

You can also disable the IrDA port to free up a port for Bluetooth devices. Tap **Start > Settings > Connections tab > IrDA** and select **Disable IrDA Port**.

Note: The Bluetooth Phone port cannot be disabled.

Discover Bluetooth Device(s)

Follow these steps to discover other Bluetooth devices nearby, including non-phone devices. The Device Discovery Wizard is a more detailed alternative to using the Bluetooth “Get Connected!” Wizard or Bluetooth ActiveSync or Bluetooth LAN Access options. The Device Discovery Wizard allows you to discover any type of Bluetooth device.

1. If not open, launch the **Bluetooth Devices** folder. Tap on the Bluetooth icon on the **Today** screen. Select **Advanced Features** then **Bluetooth Devices**.
2. In the **Bluetooth Devices Folder**, tap on the **Device Discovery** icon. Or you can tap on **Tools**. In the pop-up menu, select **Device Discovery**.

3. Follow the Bluetooth Device Discovery Wizard to search for Bluetooth devices nearby. When prompted, select the device type you seek.

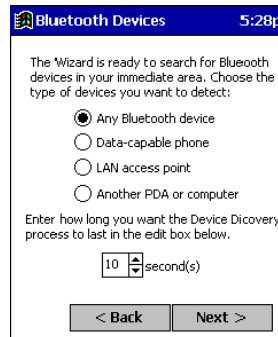

4. When the search is complete, a screen reports the discovered Bluetooth devices. Check the box next to any device you wish to save information about, (i.e., any devices you wish to connect to). Tap **Next**.

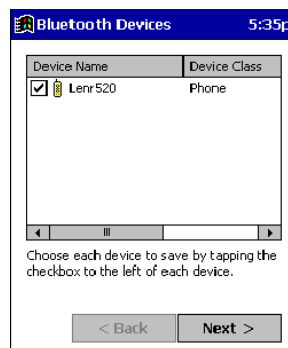

5. A service discovery phase begins, 5-10 seconds per chosen device.
6. In the next screen, tap **Finish**.

Bond With Discovered Device(s)

Follow these steps to bond with an already discovered Bluetooth device. In most cases, bonding is for establishing secure communications with a Bluetooth-enabled phone. This is a more detailed alternative to using the Bluetooth “Get Connected! Wizard.”

Important!

- Do not try to bond with a Motorola Timeport 270C or Nokia 6310!
 - Do not use this method to bond with a printer! The third-party printing software included on the installation CD also handles bonding.
1. If not open, launch the **Bluetooth Devices** folder. Tap on the Bluetooth icon in the Today screen. Select **Advanced Features**, then **Bluetooth Devices**.

-
2. Tap and hold your stylus on the Bluetooth device you want to bond with. In the pop-up menu, select **Bond**.

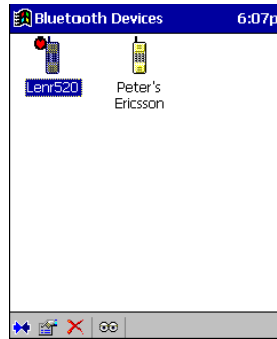

3. Alternatively, after selecting a device, tap on the **Bond** icon. Or tap on **Device**, then select **Bond**.

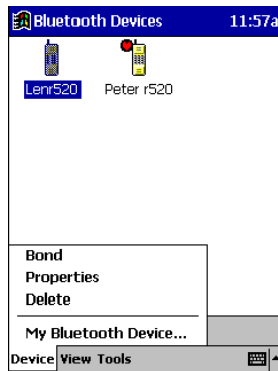

4. The **Bluetooth Device Bonding Wizard** launches. Follow the wizard to bond with your selected device.



5. As prompted, make sure the Bluetooth device that you want to bond with is in *Bondable* mode.



-
- If the remote device is set up to accept bonding, a **Bluetooth Passkey** screen appears. To continue bonding, enter the correct passkey and tap **Reply**.



- When you have successfully bonded with the other device, tap **Finish**.

View Device Properties

Follow these steps to view the properties of an already discovered device.

- If not open, launch the **Bluetooth Devices** folder. Tap on the Bluetooth icon on the Today screen. Select **Advanced Features** then **Bluetooth Devices**.
- Select a device. Tap on the **Properties** icon, or tap on **Device** then select **Properties**. Alternatively, you can tap and hold your stylus on the Bluetooth device you want to view information about. In the pop-up menu, select **Properties**.



- Use the **General** and **Services** screens to research device properties. If needed, assign a new device type icon by tapping on the arrow buttons in the **General** screen. You can also use the **Device name** field to rename the device. When done, tap **OK** for the setting to take effect.



Set Up Your Favorite Device

Follow these steps to set up default devices in the **Bluetooth Devices** folder. Please note that the Get Connected! Wizard automatically assigns the favorite phone.

- Tap **Tools > My Favorites**.

2. Tap on the tab for the type of device you would like to set a favorite for. If needed, use the arrow buttons to scroll and find the tab you need.



Note: Tabs appears only for COM ports you have enabled. To enable a port, refer to the “Assign COM Ports” section earlier in this chapter.

3. To select a favorite device, select **Use the favorite selected above**. In the drop-down list, select your device. Tap **OK**.
4. After setting a device as your favorite, its icon appears in the Bluetooth Devices folder with a heart next to it.

Change Views

You can switch between the **Large Icons** or **Details** views for the **Bluetooth Devices** folder.

1. In Bluetooth Devices, tap on **View**.
2. In the pop-up menu, choose between **Large Icons** or **Details**.

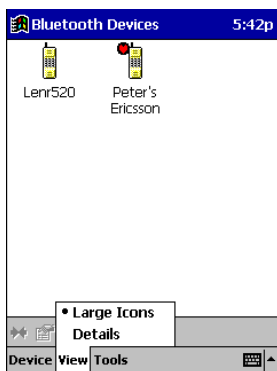

Large Icons

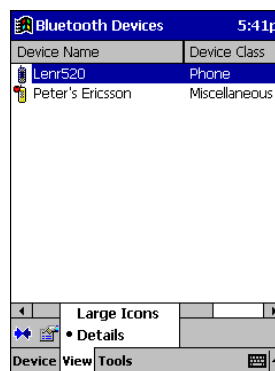

Details

Note: In Details view, you can see the Device Class and scroll right to see the current Bonded status.

Delete a Device From the Folder

If you no longer plan to connect with it, you can delete a device from the **Bluetooth Devices** folder.

1. If not open, launch the **Bluetooth Devices** folder.

-
2. Tap and hold your stylus on the device you wish to delete. In the pop-up menu, select **Delete**.



Turn Radio Transmitter ON/OFF

You may want to turn off the radio transmitter to save power or if you are entering an area with radio restrictions (e.g., an airplane).

1. Tap on the Bluetooth icon in the task tray on the **Today** screen.
2. In the pop-up menu, select **Turn Transmitter OFF**.
3. The Bluetooth Card radio transmitter shuts off. The Bluetooth icon and menu options becomes gray.
4. To turn the radio transmitter back on, tap on the gray **Bluetooth** icon. In the pop-up-menu, select **Turn Transmitter ON**.

Bluetooth ActiveSync

This section explains how to quickly and easily ActiveSync to a notebook or desktop computer with Microsoft ActiveSync.

1. Tap on the **Bluetooth** icon. In the pop-up menu, select **Bluetooth ActiveSync**.
2. The next screens varies depending on if your Bluetooth Devices folder contains any computers, and if one is chosen as your favorite. Please refer to the appropriate scenario:

SCENARIO #1: Your Bluetooth Devices folder contains a favorite desktop computer.

- (a) When you tap **Bluetooth ActiveSync**, your device automatically tries to connect to your favorite computer.
- (b) The Connect To screen appears, reporting that it is trying to connect to Wireless ActiveSync.

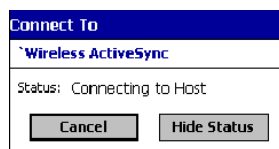

- (c) After a successful connection is made, the status screen reports Connected. Now you are ready to synchronize files, if desired.

SCENARIO #2: Your Bluetooth Devices folder contains no favorite desktop computer.

- (a) When you tap on **Bluetooth ActiveSync**, a screen appears that allows you to choose which computer to connect to in your Bluetooth Devices folder. Choose a computer from the list and tap **Select**, or tap **Find** to search for another computer.



*Note: If the computer you want to connect to is not listed, tap **Find** to begin a search. Proceed as described in Scenario #3 on page 10-8.*

- (b) Your device attempts to connect to your selected computer.

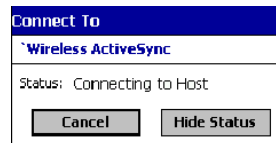

- (c) After a successful connection is made, the status screen reports **Connected**. Now you are ready to synchronize files, if desired.



SCENARIO #3: Your Bluetooth Devices folder contains no computers.

- (a) When you tap on **Bluetooth ActiveSync**, a Bluetooth Device Search automatically begins.

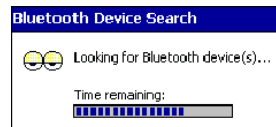

*Note: You can also start the device search by tapping **Find** in the Bluetooth Devices screen.*

- (b) After the search is complete, select the computer you wish to ActiveSync with and tap **Select**. If the computer is not listed, make sure the computer is discoverable and tap **Refresh** to search again.

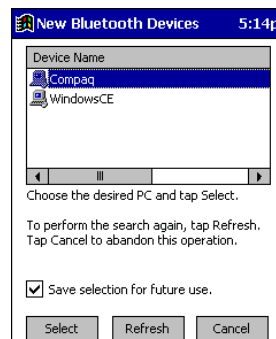

- (c) After you tap **Select**, a service discovery phase begins.

- (d) The Connect To screen appears, reporting that it is trying to connect to Wireless ActiveSync.

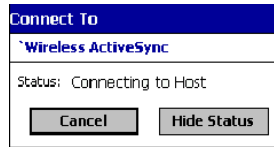

- (e) After a successful connection is made, the status screen reports Connected. Now you are ready to synchronize, if desired.

Bluetooth LAN Access

This section explains how to use the Bluetooth LAN Access feature to quickly and easily connect to a Bluetooth-enabled LAN access point.

1. Tap on the **Bluetooth** icon. In the pop-up menu, select **Bluetooth LAN Access**.
2. The next screens varies depending on if your Bluetooth Devices folder contains any access points, and if one is chosen as your favorite. Please refer to the appropriate scenario:

SCENARIO #1: Your Bluetooth Devices folder contains no favorite access point.

- (a) When you tap Bluetooth LAN Access, a screen appears that allows you to choose which access point to connect to in your Bluetooth Devices folder. Choose an access point from the list and tap **Select**.



Note: If your access point is not listed, tap Find and proceed as described in Scenario #3.

- (b) Your device tries to connect to the selected access point.

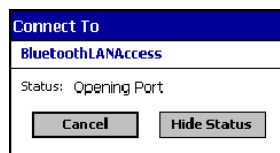

- (c) If your LAN requires a passkey, a screen appears asking for the passkey. Enter the passkey, then tap **OK**.
(d) After a successful connection is made, the status screen reports Connected.



- (e) Now you are ready to access your LAN for Internet access, files, etc.

SCENARIO #2: Your Bluetooth Devices folder contains a favorite access point.

- (a) When you tap **Bluetooth LAN Access**, the device automatically tries to connect with your favorite access point.

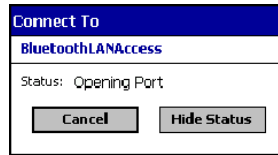

- (b) If your LAN requires a passkey, a screen appears, asking for the passkey. Enter the passkey, then tap **OK**.
(c) After a successful connection is made, the status screen reports Connected.



- (d) Now you are ready to access your LAN for Internet access, files, etc.

SCENARIO #3: Your Bluetooth Devices folder has no access points.

- (a) When you tap **Bluetooth LAN Access**, the device automatically begins to search for new Bluetooth devices.

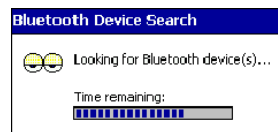

Note: You can also start the device search by tapping Find in the Bluetooth Devices screen. See Scenario #2.

- (b) After the search is complete, select the access point you wish to connect to. Tap **Select**. If the access point is not listed, tap **Refresh** to search again.



- (c) After you tap **Select**, a service discovery phase begins.

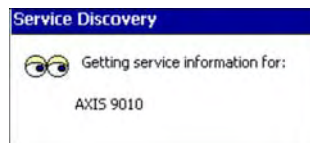

- (d) If the LAN requires a Passkey, a screen appears, asking for the Passkey. Enter the passkey, then tap **OK**.
(e) After a successful connection is made, the screen reports Connected.



- (f) Now you are ready to access your LAN for Internet access, files, etc.

OBEX

This section explains how to use the OBEX (object exchange) application to trade business cards, contacts or files with another Bluetooth device that supports OBEX.

Bluetooth OBEX application supports five operations:

- Exchange Business Cards
- Send a Contact
- Send a File
- Browse Remote Device
- Receive Contact or File
- Enable File Sharing

The first four operations - exchange business cards, send a contact, send a file, and browse remote device - are client-oriented. They involve initiating an object exchange.

The last two operations - receive contact or file and enable file sharing - are server-oriented. They involve accepting objects in an exchange initiated by another Bluetooth device.

Exchange Business Cards

1. Make sure both Bluetooth devices have a business card assigned to them.
If each device does not have a business card assigned to it, you cannot exchange business cards.

To assign a business card to your device, do the following:

- Tap on the **Bluetooth** icon. In the pop-up menu, tap **Advanced Features > My Bluetooth Device**.
- Tap on the **Object Sharing** tab. Under My business card, tap **Assign**



- In the next screen, select your business card and tap **OK**. If your business card is not listed, tap **Contacts** to create one.

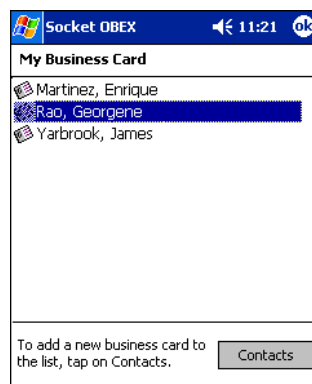

When you return to the Object Sharing screen, tap **OK**.

2. Make sure the other Bluetooth device is set up to receive a contact. The device must support the OBEX Object Push profile.

Note: If the other device is also using the Bluetooth Connection Kit, you can set it up to receive a contact by tapping the Bluetooth icon. In the pop-up menu, tap Transfer via Bluetooth > Receive Contact or File.

- Now you are ready to exchange business cards. Tap on the **Bluetooth** icon. In the pop-up menu, tap **Transfer via Bluetooth > Exchange Business Cards**.

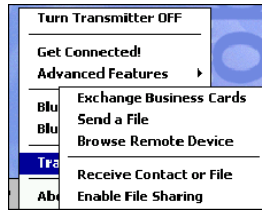

- If your device has no devices in the Bluetooth Devices Folder, then it begins to search for Bluetooth devices nearby.
- Select the Bluetooth device you wish to exchange business cards with. If the device is not listed, tap **Find**.

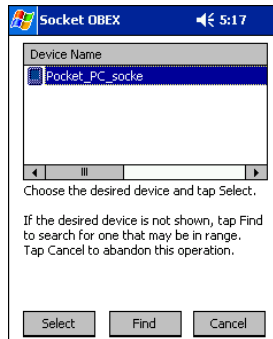

- Your device begins exchanging business cards. After the exchange, the new business card should appear in your Contacts



Send a Contact

- Make sure the other Bluetooth device is set up to receive a contact. It must support the OBEX Object Push server profile. Refer to the documentation that came with the device for instructions.

Note: If the other device is also using the Bluetooth Connection Kit, you can set it up to receive a contact by tapping the Bluetooth icon. In the pop-up menu, tap Transfer via Bluetooth > Receive Contact or File.

- Now you are ready to send a contact. Go to your Contacts folder.
- Tap and hold your stylus on the contact(s) you would like to send. In the pop-up menu, select **Send Via Bluetooth**.

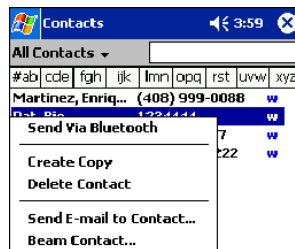

- If your device has no devices in the Bluetooth Devices Folder, then it begins to search for Bluetooth devices nearby.

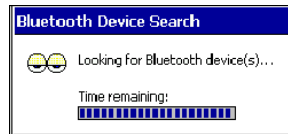

- Select the Bluetooth device you wish to send the contact(s) to. If the desired device is not listed, tap **Find**.

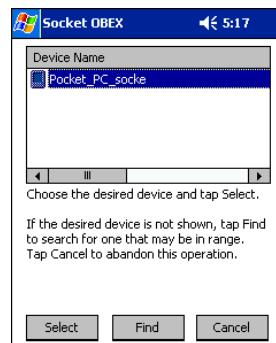

- Your device processes and sends the contact(s).

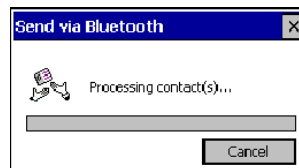

Send a File

- Make sure the other Bluetooth device can receive a file; that device must support the OBEX Object Push server profile.

Note: If the other device is also using the Bluetooth Connection Kit, you can set it up to receive a file by tapping the Bluetooth icon. In the pop-up menu, tap Transfer via Bluetooth > Receive Contact or File.

- Now you are ready to send a file. Tap the **Bluetooth** icon. In the pop-up menu, tap **Transfer via Bluetooth > Send a File**.

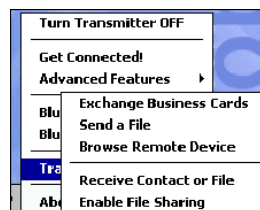

- If your device has no devices in the Bluetooth Devices Folder, then it begins to search for Bluetooth devices nearby.

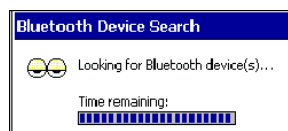

- Select the Bluetooth device you wish to send a file. If the desired device is not listed, tap **Find**.

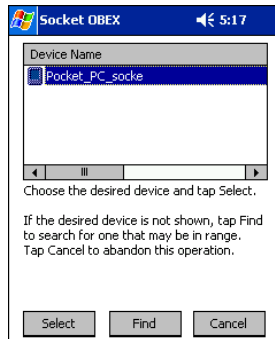

- In the next screen, tap on the file you wish to send. You can use the **Folder** and **Type** drop-down menus to search for your file. Also, you can scroll horizontally to view the folder, date, size, type, and location of each file.

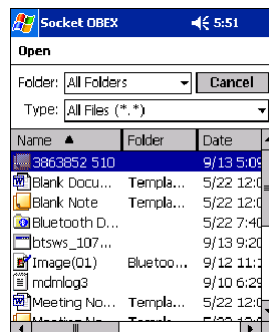

- Your device sends the file.

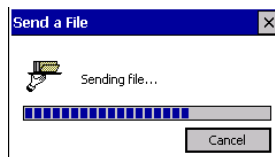

Browse Remote Device

The Bluetooth File Explorer lets your device share files with another Bluetooth device. The other device must support the OBEX File Transfer server profile.

This section covers the following file transfer operations:

- Prepare for file transfer
- Send/receive file(s) or folder(s)
- Create a folder
- Delete file(s) or folder(s)
- Refresh remote view
- Connect/disconnect
- Exit the program

Note: "Local device" refers to the device you are running the OBEX from. "Remote device" refers to the Bluetooth device you are trying to transfer files with.

Prepare for File Transfer

- Make sure the remote device has file sharing enabled. It must support the OBEX File Transfer server profile.

Note: If the other device is also using the Bluetooth Connection Kit, you can enable file sharing by tapping the Bluetooth icon. In the pop-up menu, tap Transfer via Bluetooth > Enable File Sharing.

- Now you are ready to browse the remote device. Tap on the **Bluetooth** icon. In the pop-up menu, tap **Transfer via Bluetooth > Browse Remote Device**.

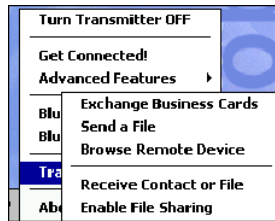

- If your device has no devices in the Bluetooth Devices Folder that supports OBEX File Transfer, then it begins to search for Bluetooth devices nearby.

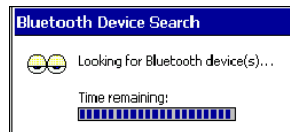

- Select the Bluetooth device you wish to browse. If the desired device is not listed, tap **Find**.

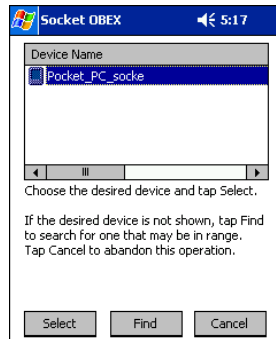

- Your device begins to establish a file sharing connection.

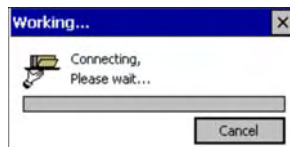

- After the devices successfully connect, the Bluetooth File Explorer appears. Half of the screen shows contents of the remote device, while the other half shows contents of your device (the local device). The very bottom of the screen reports the connection status.

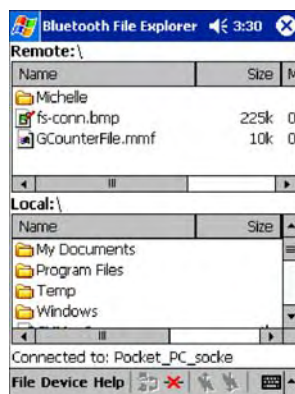

Send/Receive File(s) or Folder(s)

- Single-tap items to select them for transfer.
 - Double-tap on a folders to open it and see its contents.
1. Select the file(s) or folder(s) that you wish to transfer. You can select items from only one device per transfer session.

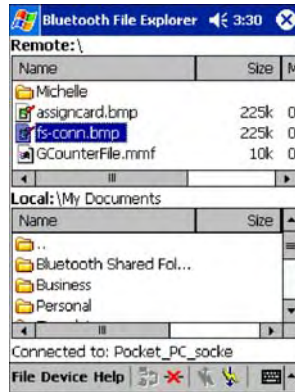

2. There are two different ways to initiate the transfer:
 - Tap **File > Send to remote** or **Get from remote**, as applicable. The inappropriate option should be gray.
 - Tap on the **Send to remote** icon or **Get from remote** icon, as applicable. The inappropriate icon should be gray.
3. A screen reports the status of the transfer.

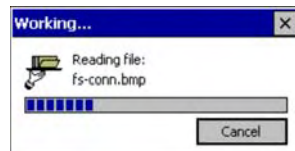

4. After the transfer, a copy of each selected item should appear in the other device.

Create a Folder

1. Tap on the **File** menu. Select **Remote device** or **Local device**, wherever you want to create a folder, then tap **Create remote folder** or **Create local folder**, as applicable.

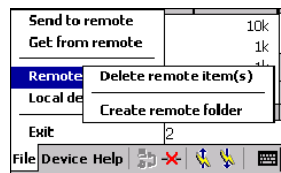

2. You can also tap and hold your stylus on an item in either the remote or local device that you wish to put in a new folder. In the pop-up menu, select **Create folder**.

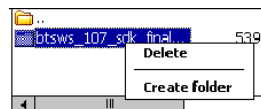

3. In the next screen, enter a name for your new folder. Tap **OK**.



4. The new folder should be listed under the appropriate device.

Delete File(s) or Folder(s)

1. Select the items you wish to delete. You can only delete items from one device at a time.
2. Tap on the **File** menu. Select **Remote device** or **Local device**, wherever the items are located, then tap **Delete remote item(s)** or **Delete local item(s)**, as applicable.

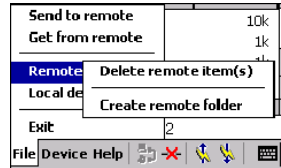

3. Tap and hold your stylus on an item in either the remote or local device that you wish to put in a new folder. In the pop-up menu, select **Delete folder**.



4. In the Confirm screen, tap **Yes**.

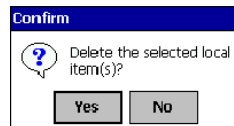

Refresh Remote View

1. Tap on the **Device** menu. Select **Refresh** remote view.



2. Your local device begins to read the contents of the remote device.
3. After a few seconds, the contents view of the remote device is refreshed.

Connect/Disconnect

To connect to the remote device, do the following:

1. Make sure the remote device has file sharing enabled.
2. Start the connection process by either of two methods:
 - Tap **Device > Connect**.
 - Tap the **Connect** icon.
3. On the next screen, select the device you wish to connect to and tap **Select**. Your device attempts to connect to the selected device.

To disconnect from the remote device, do the following:

1. Start the disconnection process by either of two methods:
 - Tap **Device > Disconnect**.
 - Tap the **Connect** icon.
2. Your device disconnects from the remote device. Afterwards, no contents are listed for the remote device.

Exit Bluetooth File Explorer

To exit the Bluetooth File Explorer, tap **File > Exit**.

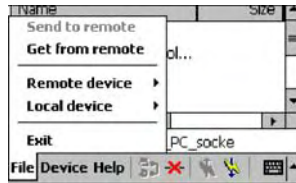

Receive Contact or File

1. Tap on the **Bluetooth** icon. In the pop-up menu, tap **Transfer via Bluetooth > Receive Contact or File**.

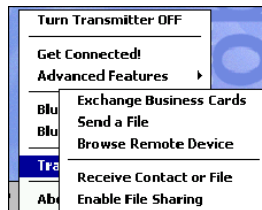

2. The Receive Contact or File status screen appears. Your device waits two minutes for the contact or file.

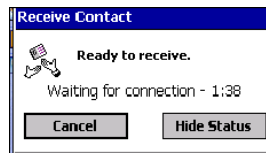

3. After successfully connecting to the remote device, the screen reports Connected then disappear. The new contact or file should now be on your device.
4. If two minutes passes before you receive the item, tap **Wait Again**.
5. After you receive the file or contact, the "Receive Contact or File" feature is automatically disabled.

Enable File Sharing

1. Tap on the **Bluetooth** icon. In the pop-up menu, tap Transfer via **Bluetooth > Enable File Sharing**.
2. The Enable File Sharing status screen appears. Your device waits two minutes for the remote device to connect.

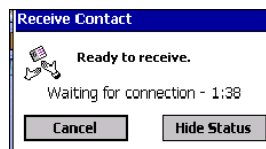

3. After successfully connecting to the remote device, the screen reports that you are connected.
4. If two minutes passes before you connect, tap **Wait Again**.
5. File sharing is enabled until you end it by tapping **Cancel**.

Using the Dialer

This section explains how to assign a dialing prefix and use the Dialer to dial a number directly from your Contacts list. The Dialer makes it quick and easy to perform dial-up networking.

Note: The Dialer has been verified to work with Nokia and Ericsson phones and is known not to work with the Motorola 270c, NTT Docomo Paldio 633S or Sony au C413S phone. Results may vary with other phones that are not listed as being supported by the Bluetooth system.

Assign a Dialing Prefix

If you have not already assigned a dialing prefix during the install process, you can do so by following these steps:

1. Tap **Start > Settings > System tab > Dialer**.
2. Select the appropriate Dialing Prefix, then tap **OK**.



Using the Dialer

1. To use the dialer, the device must already be connected to the Bluetooth phone. You can use the Get Connected! Wizard to do this. Also, the Bluetooth phone must be selected as your favorite.
2. Tap **Start > Contacts**.
3. Tap and hold your stylus on the contact you wish to dial to. In the pop-up menu, select **Dial Contact**. Alternatively, you can tap on **Tools** and select **Dial Contact**.

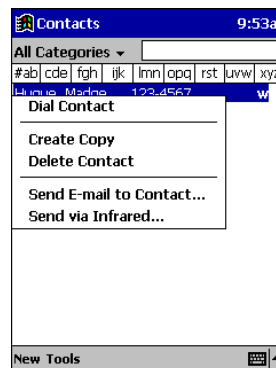

4. If you have multiple phone numbers for a contact, a screen appears listing them, including any dialing prefix you may have assigned. Select the phone number you wish to dial.

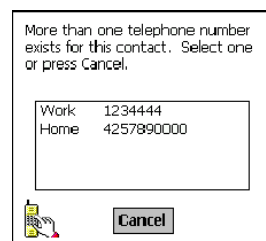

-
5. Your device connects to your phone and begins dialing.

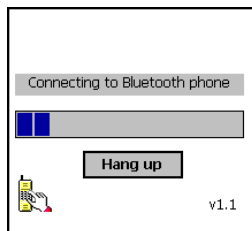

The Dialer can dial a phone number containing any of the following non-numeric characters:

* # + . / ! @ - \ space A B C D T P W

The following string can also be included in a phone number: (',')

The Dialer cannot dial a phone number containing non-numeric characters other than those listed above. HHP recommends that you follow the standard Microsoft Outlook format for phone numbers.

Get Connected Wizard

The Get Connected! Wizard guides you through a one-time setup process that prepares the device and phone for Bluetooth connections. The wizard varies depending on what phone you want to connect to.

Ericsson, Nokia 6210, NTT DoCoMo, Sony Phones

1. Tap on the **Bluetooth** task tray icon. In the pop-up menu, select **Get Connected!**
2. Follow the Bluetooth "Get Connected!" Wizard. In the second screen, use the drop-down list to select your Bluetooth phone. The wizard provides tailored instructions based on your selection.

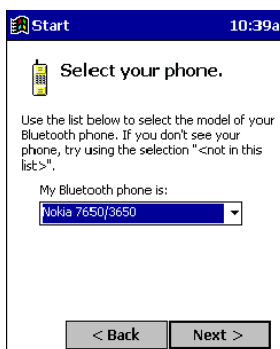

3. Follow the next screen(s) to prepare your specific phone for Bluetooth connections. You may need to do 1, 2 or all of the following steps:
 - (a) Naming your Bluetooth phone
 - (b) Setting your Bluetooth phone in Discoverable mode

(c) Preparing your Bluetooth passkey.

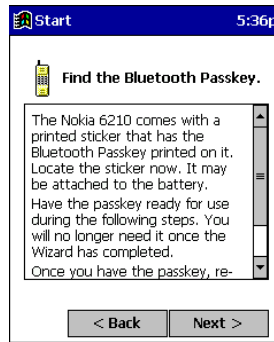

4. When the search is complete, a list of the discovered Bluetooth phones appears. Choose the phone you wish to connect to, and tap **Select**. A service discovery phase begins, about 5-10 seconds.

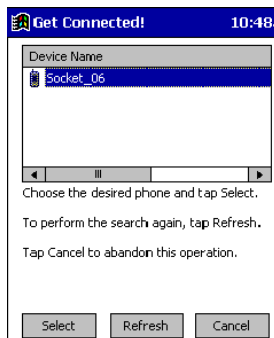

5. As prompted in the next screen, prepare your phone for bonding. For instructions on setting your phone to “Bondable” or “Pairable” mode, refer to your phone manual. Have your passkey ready, then tap **Next>**.
6. In the next screen, enter the passkey. Tap **Reply**.

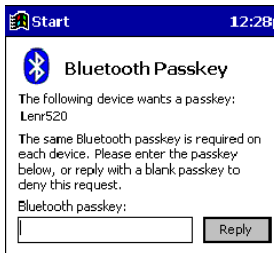

7. The mobile phone may then either automatically accept the passkey or ask you to enter one. If prompted for a passkey, use the same one you entered on the mobile computer.

Note: Ericsson T68/T68i only: When the phone asks you if you want to bond, select 2: Add to paired devices. Do not tap ACCEPT.

8. Tap **Finish**. After successfully connecting, the phone appears in the Bluetooth Devices folder. On the Today screen, the Bluetooth icon blinks. You do not need to run the Get Connected! Wizard again unless you plan to switch between different phones.

Note: You may also switch between different phones by assigning a new “favorite phone” in the Bluetooth Devices folder.

Motorola Timeport 270C, Nokia 3650/6310/7650/8910/8910i

1. Tap on the **Bluetooth** task tray icon. In the pop-up menu, select **Get Connected!**
2. Follow the Bluetooth “Get Connected!” Wizard. In the second screen, use the drop-down list to select your Bluetooth phone. The wizard provides tailored instructions for your phone.

Note: The screens below are for the Nokia 7650.

- As directed on the next two screens, assign the phone a unique name, set the phone to Discoverable mode, and tap **Next**.
- The device searches for the phone. When the search is over, a list of the discovered Bluetooth phones appears.

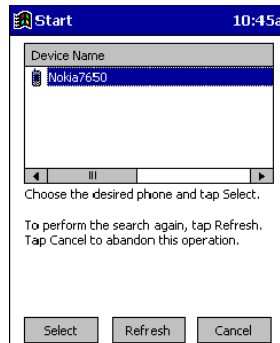

- Choose the phone you want to connect to, and tap **Select**. A service discovery phase begins, about 5-10 seconds.
- The next two screens describe procedures you complete outside of the wizard. Read through each screen but do not complete the described procedures until you exit the wizard.

Bonding with your phone - This must be completed to establish the Bluetooth connection and involves dial-up networking.

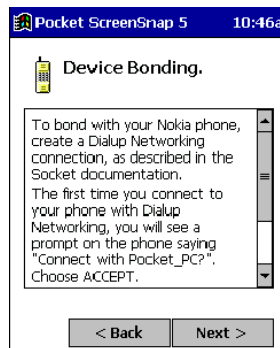

Automatic Connections - This procedure is optional but makes future Bluetooth connections more convenient.

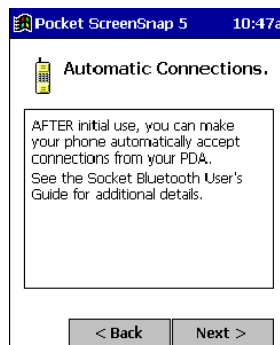

- Continue to the last screen of the wizard and tap **Finish**. Now proceed to STEP 6 to complete the bonding process and, if desired, set up automatic connections.

Dial Up Connection

Complete the following steps to create a new Bluetooth internet connection via an ISP. Before setting up dial-up networking, prepare yourself with dial-up information and other necessary settings from your office network or isp. Also, refer to Microsoft's connection manager for additional information.

1. Tap **Start** > **Settings** > **Connections** tab > **Connections**.
2. In the top field, select **Internet Settings** and tap **Modify**. Then, tap **New**.



3. Name=A name that you will remember for future connections.
Modem=**Bluetooth Phone**.
Baud Rate=**115200**.
4. Tap **Next**.
5. In the Phone number field, enter the dial-up number. Tap **Next**.
6. Uncheck **Wait for dial tone before dialing**. Tap **Finish**.



7. Now you are ready to start the connection. In the Connections screen, under Internet Settings, tap **Connect**. In Network Log On, verify the dialing settings. Tap **OK**.



Automatic Connections for Motorola Timeport 270C:

- On the phone, press MENU.
- Scroll to Settings, then press SELECT.
- Scroll to Connection, then press ON.
- On Bluetooth Link, press SELECT.
- Scroll to Devices, then press SELECT.
- Choose your mobile computer, then press EDIT.
- Scroll to Access:Ask, then press CHANGE.
- Scroll to Automatic, then press SELECT. Press DONE.

Automatic Connections for Nokia 3650/7650:

- On the phone, press MENU.
- Scroll to Connectivity, then press OPTIONS.
- The Open option should be highlighted. Press SELECT.
- The Bluetooth option should be highlighted. Press OPTIONS.
- The Open option should be highlighted. Press SELECT.

-
- Scroll to the right tab to access the Paired devices list. Highlight your mobile computer, then press OPTIONS.
 - Scroll to Set as authorized, then press SELECT.
 - In the confirmation screen, press YES.

Automatic Connections for Nokia 6310/8910/8910i:

- On the phone, press MENU.
- Scroll to 10 Bluetooth, then press SELECT.
- Scroll to 4 View Paired Devices, then press SELECT.
- Highlight the Dolphin terminal, then press OPTIONS.
- Scroll to 3 Request Connection Authorization, then press NO.

To use a different Bluetooth phone for dial-up networking, you can use the same connection setup, but you must make the new phone your favorite. Just run the Get Connected! Wizard again, select the new phone, and make it your new Favorite when prompted.

Overview

Dolphin terminals can be configured with a Siemens® GSM/GPRS tri-band radio module for Wireless WAN connectivity.

GSM GSM stands for Global System for Mobile communications. It is an open, non-proprietary wireless wide area networking system that is constantly evolving and growing. One of its great strengths is international roaming capability, which provides standardized dialing in more than 170 countries.

GPRS GPRS stands for General Packet Radio Service. It is a non-voice value added service that allows packet switched data and information to be instantly sent and received across a network.

GSM Radio types

Dolphin 7900 terminals can support either an MC-45 or MC-46 radio.

MC-45 Radio Supports 900/1800/1900 MHz frequencies for use in Europe, Middle Eastern, and Asian countries. Dolphin terminals with an MC-45 radio have two-way voice and data communication.

MC-46 Radio Supports 850/1800/ 1900 MHz frequencies for use in the U.S., Latin America, and Canada. Dolphin terminals with an MC-46 radio have two-way data communication only.

Enabling the GSM/GPRS Radio Driver

When the mobile computer is first initialized, the radio driver for the GSM module is installed. Before using the radio, make sure that the GSM radio is enabled. For more information, see [Radio Manager](#) on page 4-5.

Tri-Band Antenna

Dolphin 7900 terminals configured with an MC-45 or MC-46 radio feature an external antenna that is optimized for power output and receiver sensitivity.

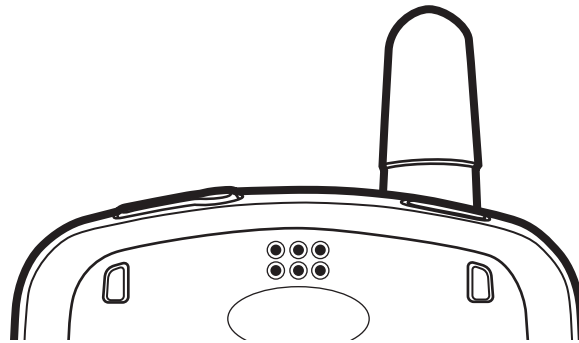

Requirements

Using GSM/GPRS on a Dolphin terminal requires a:

- Network subscription to a GSM/GPRS network (you need to know what service providers are in your geographic area), and
- SIM card installed on the terminal (see [SIM Card](#) on page 11-2).

Capabilities

Dolphin computers with integrated GSM/GPRS MC-45 radios are optimized for the following two-way voice and data communications:

- GSM voice data ("dial-up")
- Short Message Service (SMS) text messages
- GPRS Class 10 data transmissions average - 40-60 Kbps (The speed is dependent on the wireless network carrier.)

SIM Card

SIM stands for Subscriber Information Module. A SIM card stores the subscriber's personal information, GSM/GPRS radio settings, security key, contacts, etc. SIM cards can be installed and removed from compatible mobile devices, enabling you to switch devices without losing your personal information. SIM cards are obtained and activated by the network provider that supports your GSM/GPRS network.

SIM Card Requirements

Before installing the SIM card:

- The SIM card **must** be activated by the service provider.
- The terminal **must** be powered down.

Note: If no SIM card is installed, you can still make emergency phone calls such as 9-1-1, for example.

Installing a SIM Card

For detailed instructions, see [Opening the Access Door](#) on page 3-6. If the SIM card is not installed properly, the Dialler screen will indicate that no SIM card is installed.

Audio Modes

The Dolphin 7900 contains both a speaker and a microphone that you can use to send and receive audio signals over the GSM network. For details about the microphone and speaker, see [Front Panel Features](#) on page 3-2.

There are three audio modes: Handset, Headset, and Speakerphone

Handset

Handset mode is when you use the use the front panel of the terminal just as you would a cell phone, holding the speaker to your ear to receive audio information and the microphone to your mouth to send audio information. This is the default audio mode.

Headset

Headset mode is when you plug a headset into the audio jack and speak into the microphone. You must use a 2.5mm plug; no other audio plug will fit. For details see, see [Audio Jack](#) on page 3-2.

Speakerphone

The microphone on the front panel ([Microphone](#), page 3-2) can be used as a speakerphone. To switch the front panel to speakerphone, open the Dialler (**Start > Programs > uPhone > Dialler**) and tap **Settings > Speakerphone**. The audio levels adjust appropriately for speakerphone use.

Keyboard Combinations for Calls

Each keyboard option contains a Blue modifier key combination to send and end a call.

Keyboard	To Send, Press...	To End (reject), Press...
25-key keyboard	Blue + Left Arrow	Blue + Right Arrow
36-key keyboard	Blue + Left Arrow	Blue + Right Arrow

For more information about Dolphin 7900 keyboards, see [Using the Keyboards](#) on page 6-1.

Using uPhone

The uPhone Application Suite contains three programs that function together to provide a complete voice, data, and text messaging solution for a mobile device fitted with a radio modem:

- **Dialler** emulates a mobile phone and is used to make and receive telephone calls.
- **Call Log** displays a list of the most recent calls.
- **SMS Manager** is a text messaging program.

Accessing uPhone

Tap **Start > Programs > uPhone**. Tap one of the icons to launch the program.

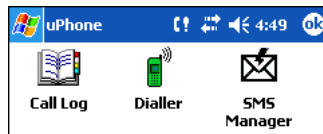

Navigation Bar Icons



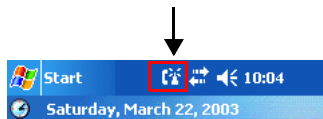





When the Dialler or SMS Manager applications are not open, the icons in the Navigation bar at the top of the screen indicates the status of the phone and messaging system. Each icon indicates a specific action and, when tapped, displays a bubble window that lets you know what is happening.

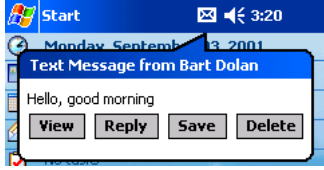

Icons and Bubble Messages

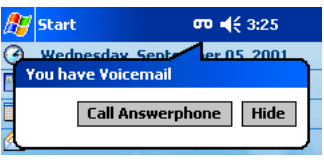
Icon	Description	Tap this icon to display:	Bubble Options
	The phone is off.		Tap Power Phone On to turn the phone on and close the bubble. Tap Hide to leave the phone off and close the bubble.
	The phone can only make emergency calls. This usually means there is no SIM card installed or PIN number established.		Tap Hide to dismiss the bubble. This icon will appear in the Navigation bar until a SIM card is installed or a PIN is entered.
	The phone is registering on the network.		Tap Hide to dismiss the bubble. This is a temporary state. This icon appears only until the phone is registered on the network.
	The phone is on and registered. To the right of the phone is a bar that indicates signal strength.		Tap Hide to dismiss the bubble. Tap Power Phone Off to turn off the phone. The icon in the Navigation bar changes to indicate the phone is now off.
	Medium signal strength.		

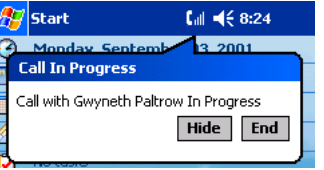
Icons and Bubble Messages

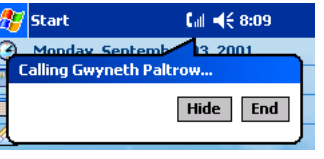
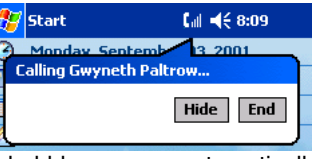
Icon	Description	Tap this icon to display:	Bubble Options
	Good signal strength.		
	Full signal strength.		
	Incoming SMS message available.	 <p>This bubble appears automatically when a new SMS message is received. It contains the sender's information and the first line of the text message.</p>	<p>Tap View to display the full message in SMS Manager.</p> <p>Tap Reply to switch to the SMS Manager Compose screen. The 'To:' field is auto-filled with the sender's address.</p> <p>Tap Save to put the message in the SMS Manager Inbox.</p> <p>Tap Delete to delete the message.</p> <p>Tapping each button closes the bubble.</p>
	A new voicemail message is available.	 <p>This bubble appears automatically when a voicemail notification is received.</p>	<p>Tap Call Answerphone to dial the Answerphone service and retrieve voicemail messages.</p> <p>Tap Hide to close the bubble.</p>
	There is a call in progress to the name or number shown in the bubble.		<p>Tap Hide to close the bubble.</p> <p>Tap End to end the call.</p>
	<p>This icon appears when there is a call coming in or going out.</p> <p>A different bubble displays for each circumstance. If the incoming call is a conference call, a different bubble displays.</p>	<p>For a call going out</p>   <p>This bubble appears automatically when a call comes in and while the ringtone sounds.</p>	<p>Tap Hide to close the bubble.</p> <p>Tap End to end the call.</p> <p>If the caller is in the Phonebook, the name displays. If not in the Phonebook, the caller's number displays; if the number can't be read, "no number" displays.</p> <p>Tap Answer to answer the call; this places any current call on hold.</p> <p>Tap Reject to reject the call.</p>

Using the Dialler

The Dialler is the program that manages your GSM/GPRS cell phone calls.

To launch the Dialler, tap **Start > Programs > uPhone > Dialler**. The program launches and the uPhone Dialler screen opens:

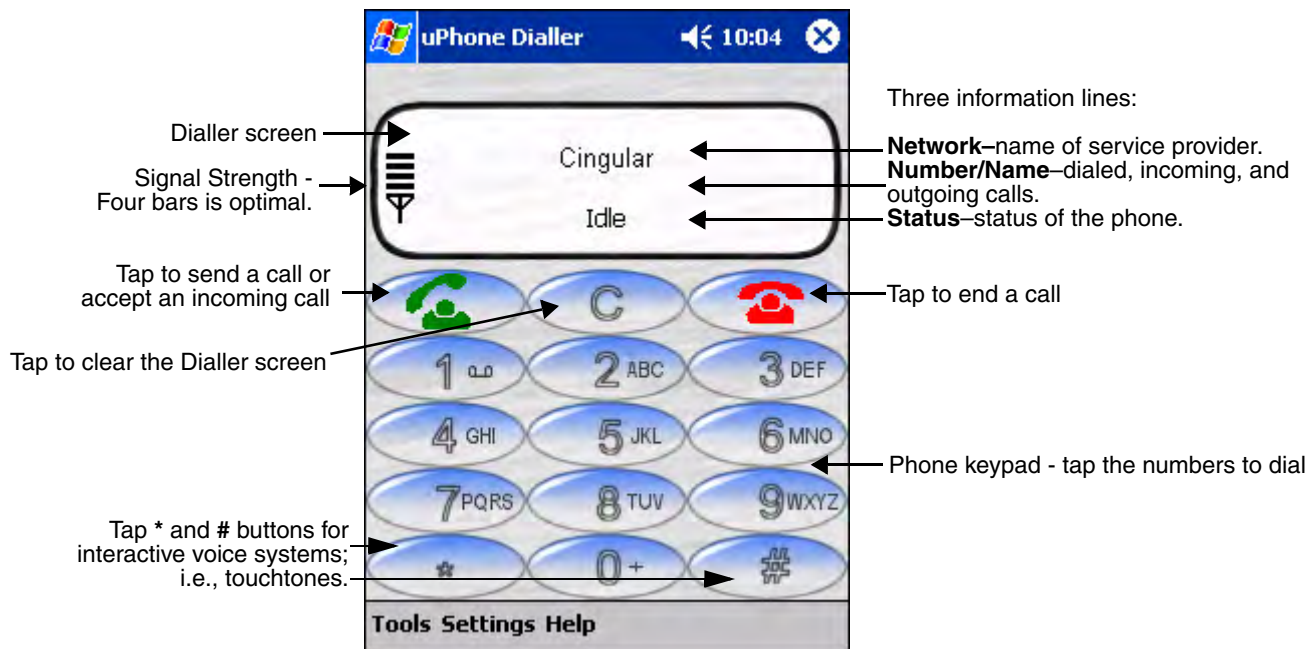

Making a Call

Entering a Phone Number



You can:

- **Enter the numbers manually** using the phone keypad on the Dialler screen, the SIP, or the Dolphin keyboard.
 - As you enter each number, the digits appears on the Dialler screen in the **Name/Number** line. If a contact matching the entered number is found in the Phonebook, the name of the contact appears in the **Name/Number** line as you type; tapping on the name enters the rest of the number automatically.
- **Use the Phonebook** to
 - Select an existing contact.
Tap **Tools > Phonebook**, select a name or number in the list, and tap **OK** (you can also tap and hold on the entry). The number is automatically entered in the Dialler and appears on the screen.
 - Use speed dial.
Tap and hold on the list to see a popup menu of speed dial numbers.
- **Use the Call Log**
 - When the phone is in Idle status, you can tap the **Send** button on the screen , press the ENTER key, or tap **Tools > Call Log** to see a list of the last 20 calls made or received. Tap and hold on an entry in the list and select **Dial**. Pressing the **Send** button or ENTER key performs this function only when the phone is in an Idle Status.

Sending a Call

You can:

- Tap the **Send** button .
- Press the ENTER key on the keyboard.
- Press the appropriate key combination on the keyboard.

When the call is connected, the three information lines display the following:

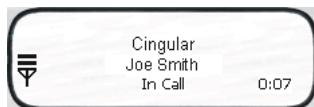

- Network Operator** Displays the name of the service provider you are using.
- Name/Number** Displays the name and/or number you called. If the number is from your Phonebook, that entry displays.
- Status** The status of the call.
Idle - means no calls are incoming or outgoing.
In Call - means a phone call is in progress.
Incoming Call - means that a call is coming in.
- 0:00** The numbers in the lower, right corner display the minutes:seconds that have elapsed.

Receiving a Call

When the Dialler screen is open and an incoming call is detected, text is displayed on the Dialler screen. If the Dialler is not visible at the time of the incoming call, a Navigation Bar notification appears.

When a call is coming in, the ringtone sounds and the three information lines on the Dialler screen display the following:

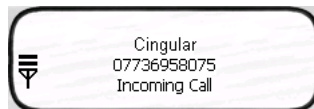

- Network Operator** Displays the name of the service provider you are using.
- Name/Number** Displays the name and/or number calling in. If the number is in your Phonebook, that entry displays.
- Status** Incoming Call.

Answering a Call

You can:

- Tap the **Send** button .
- Press the ENTER key on the keyboard.
- Press the appropriate key combination on the keyboard.

Rejecting a Call

You can:

- Tap the **End** button .
- Press the appropriate key combination on the keyboard.

Call Waiting

If call waiting is enabled, a second incoming call can be received while a first call is in progress. The second incoming call uses a different ringtone but displays the same incoming call notification.

If a second call is coming in, answering it automatically places the first call on hold. You can also reject the second call by tapping the **End** button.

Ending a Call

To end or reject a call, you can:

- Tap the **End** button .
- Press the appropriate key combination on the keyboard.

Call Waiting

If two calls are in progress, the above options end the active call and place the other on hold. To activate the call on hold, tap **Send** or press ENTER or the key combination to send calls. To end the call on hold, tap **End** or press the key combination to end calls on the keyboard.

Conference Call

If a conference call is in progress, tap **End** or the key combination to end calls.

Call Waiting

The uPhone Dialler supports call waiting functionality. This means that you can receive a second call while on a first call.

Placing the Current Call on Hold

When a second call is coming in, to place the current call on hold

- Tap the **Send** button .
- Press the ENTER key on the keyboard.
- Press the key combination for sending calls on the keyboard.

The Status line of the first call changes to **Call on Hold**. Tapping **Send**  again restores the call on hold.

Making a Second Call

To make a second call, place the current call on hold, then dial the second number. When there are two calls (one active and one held) the status line displays **In Call, Call on Hold**.

Switching Between Calls

To switch between the active and held call, tap **Send**, press ENTER, or the appropriate key combination to send calls. The display is updated to show the active call details, and that the other call is on hold.

Making Conference Calls

In addition to supporting call waiting functionality, the uPhone Dialler enables you to join two calls into a conference call. When two calls are in progress, tap the phone icon on the Navigation bar. This opens a bubble dialog that enables you to conference both calls into one.



Button	Tapping this button...
Hold Active and Accept Held	Swaps between the currently held and active calls. Tapping Send or pressing ENTER performs the same function without opening this bubble dialog.
End Active and Accept Held	Drops the current active call and connects the held call.
Join Held in Conference Call	Connects the held call and the currently active call in a three-way conference call. More than three parties can join a conference call via networking; each of the other parties can add another call to the conference, and so on.
End Held	Drops the held call, and continues with the currently active call.

Button	Tapping this button...
Hide	Closes the bubble.

Touchtones

To transmit touchtones for interactive voice systems while in a call, you can

- Tap the **0-9**, *****, and **#** buttons on the uPhone Dialler screen.
- Press 0-9 keys on the Dolphin keyboard; use the uPhone Dialler screen buttons for ***** and **#**.

Dialler Menus

There are three menus in the Dialler application:

1. **Tools** - Accesses application tools.
2. **Settings** - Opens application settings.
3. **Help** - Opens the About screen.

Tools Menu

The Tools menu provides the following options:

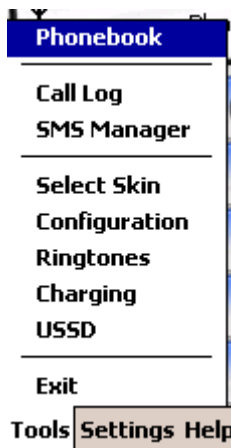

Menu Item	Description	See Page
Phonebook	Displays the Phonebook	11-9
Call Log	Opens the Call Log	11-13
SMS Manager	Opens the SMS Manager Inbox	11-19
Select Skin	Selects a new skin for the uPhone Dialler application.	N/A
Configuration	Opens the uPhone Configuration control panel.	11-14
Ringtones	Opens the ring tone selection control panel.	11-10
Charging	Displays call meter values.	11-11

Menu Item	Description	See Page
USSD	Sends text messages via USSD as opposed to SMS.	11-12
Exit	Exit the uPhone Dialler.	

Settings Menu



- Speakerphone** Toggles speakerphone mode on and off. When an audio plug (for a headset) is inserted into the audio jack (2.5mm), Speakerphone is inactive on this menu.
- Mic mute** Toggles microphone mute on and off (the other party cannot hear a private conversation when the microphone is muted). This mode is active only during a call and automatically cancelled at the end of a call.

A checkmark to the left of the menu item indicates that the mode is active. When the menu item is grayed-out, it is unavailable and cannot be selected.

Phonebook

The Phonebook contains the contacts from the SIM card and Pocket Contacts. If fixed dialing is set in the SIM, then only those numbers in the fixed dialing list are shown in the Phonebook, and only these numbers can be called from the Dialler.

You can access the Phonebook manually by opening the Dialler and going to **Tools > Phonebook**. When you tap and hold on an entry, a popup menu displays.

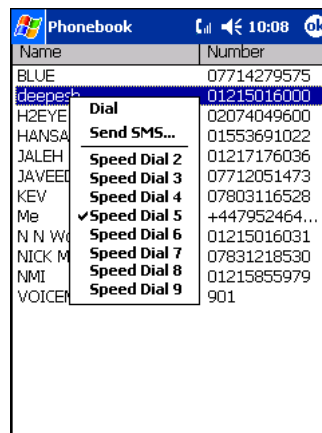

- Dial** Opens the Dialler with the number entered ready for dialing.
- Send SMS** Opens the SMS Manager in the Compose screen with the 'To:' field populated with the number.
- Speed Dial 2-9** These eight slots are used to assign the Dialler Speed Dial keys. To assign a number to a Speed Dial slot, tap on an entry to assign the number. Tapping and holding the associated button when in Dialler will automatically dial the assigned contact.

Ringtone Configuration

Different ringtones, with individual volume settings, can be set for the following:

Ring Tone	Sounds on an incoming call.
Message Tone	Sounds on an incoming SMS or Voicemail notification.
Call Waiting Tone	Sounds to indicate an incoming call while you are already on a voice call.

You can access Ringtones two ways:

1. Tap **Start > Settings > Personal** tab > **Ringtones** icon OR
2. Open the Dialler (tap **Start > Programs > uPhone > Dialler**) and tap **Tools > Ringtones**. The Ringtones screen opens displaying the current settings.

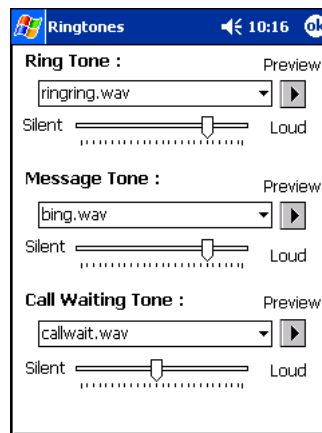

Select the desired ringtone for each type of tone in the drop-down lists. Tapping **OK** saves any changes. Opening another screen without tapping **OK** discards any changes.

WAV Files

You can customize your ringtones with *.wav files installed on your terminal. To appear here, *.wav files must be stored in the **Programs Files > uPhone > Ring Tones** folder.

Previewing Tones

You can preview each tone by selecting the *.wav file in the drop-down list and tapping the **Preview** button. Use the slider to set the volume for each tone.

While the tone is playing, the Preview button changes to a **Stop** button; tap it to stop the preview.

Charging

Accessed from the Tools menu, the Charging tool displays call meter values from the network service provider. Tap **Tools > Charging** and the Charging window opens displaying the current values for the phone.

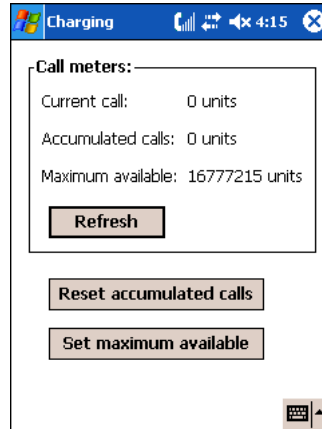

Field	Description
Call meters	
Current call	Displays the number of charge units used on the current call.
Accumulated calls	Displays the number of charge units used to date.
Maximum available	Displays the maximum number of units available from the subscriber.
Refresh	Updates the Current call and Accumulated calls fields with the number of charge units used, read from the SIM card.
Reset accumulated calls	Display a window for the subscriber to enter a PIN number—"PIN2"—from the subscriber. When the correct PIN is entered, the accumulated call units are reset to 0 on the SIM card.
Set maximum available	Display a window for the subscriber to enter a PIN number—"PIN2"—from the subscriber. When the correct PIN is entered, the maximum available charge units for the user is set on the SIM card.

USSD

Short for Unstructured Supplementary Service Data, (USSD) is a technology unique to GSM that enables session-based text-messaging as opposed to SMS, which is store-and-send text-messaging. Turnaround response times for interactive applications are generally shorter for USSD than SMS. USSD is not currently available on all carrier networks.

USSD communicates with a USSD application portal, a news portal or a chat session with a co-worker.

Tap **Tools > USSD**.

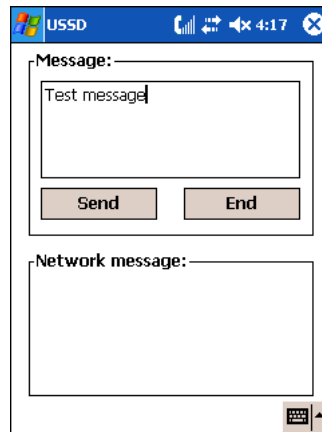

Send	Sends the text entered in the Message section and begins the USSD session.
End	Ends the USSD session.
Message	Enter text to a USSD portal.
Network message	Displays the USSD message received from the network, allowing a session-based interaction.

Call Log

The Call Log maintains a list of the last 20 calls made or received in each of the following categories:

- Voice Calls In (Default)
- Voice Calls Out
- Voice Calls Missed
- GPRS Data

You can access the Call Log two ways:

1. Tap **Start > Programs > uPhone > Call Log** OR
2. Open the Dialler and tap **Tools > Call Log**.

The Call Log opens displaying the last few Voice Calls In; the most recent call always appears at the top.

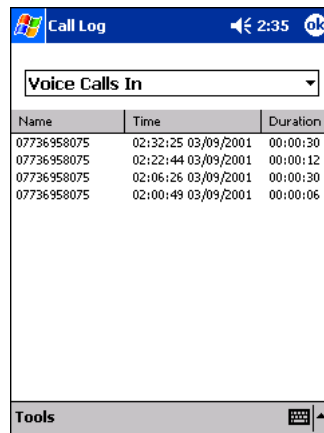

- Name** The phone number or the name if the call was from or to a matching entry in the Phonebook.
- Time** Time and date the call started. This is the local time and date.
- Duration** Duration of the call (hours:minutes:seconds). The clock starts when the call connects, not when dialed.

From the drop-down list, select the option you want to view.

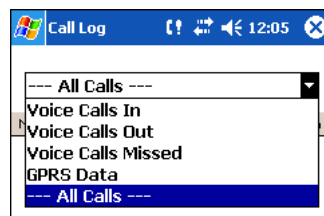

To see everything, select **All Calls**.

Tools Menu



- Clear** Deletes the entire Call Log.
- Exit** Closes the Call Log.

uPhone Configuration

uPhone Settings enable you to establish the normal operating parameters for uPhone applications.

Requirements

To open the uPhone configuration tools, the GSM radio **must** be enabled and an active SIM must be installed. The configuration tools access the network directly. If you are not connected, settings cannot be configured and you will receive an error notification when you attempt to open the configuration tools.

Accessing uPhone Configuration

You can access uPhone Settings two ways:

1. Tap **Start > Settings > System tab > uPhone icon**  **Settings**.
2. In the Dialler application, selecting **Tools > Configuration**.

An animated wait icon displays the following message while the system accesses the network.

If there is no response from the network within 60 seconds, this message times-out and the control panel closes. If the network responds, the uPhone Settings screen displays; the General tab appears first by default.

Tab Windows

uPhone Configuration consists of five tabs: General, Network, Divert, Bar, and Messaging. Tapping **OK** accepts any changes and exits the uPhone Configuration.

General Tab

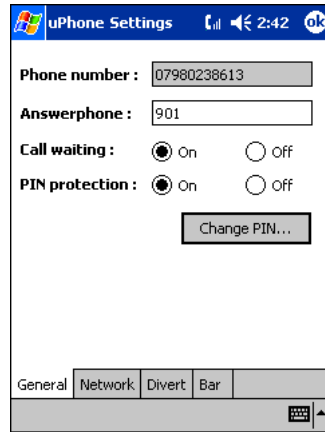

Field	Description
Phone Number	This is the phone number stored on the SIM. It is displayed here for information only.
Answerphone	This is the number to dial to retrieve voicemail messages. To enter a new number, tap on this field and enter the digits.
Call waiting	Select On or Off to enable or disable call waiting functionality. Call waiting must be set to On for conference calls.
PIN protection	Select On or Off to enable or disable PIN protection. If enabled, a PIN number is requested when the phone is switched on.
Change PIN	<p>This button is active only if PIN protection is set to On. Otherwise, the button is grayed-out. If you tap Change PIN, a dialog box appears enabling you to change the PIN.</p>  <p>Enter the PIN. Tap OK to save the change. While typing, the numbers appear as asterisks to hide the number from observation by third parties.</p>

Network Tab

The Network tab provides the ability to choose between **Automatic** and **Manual** network selection.

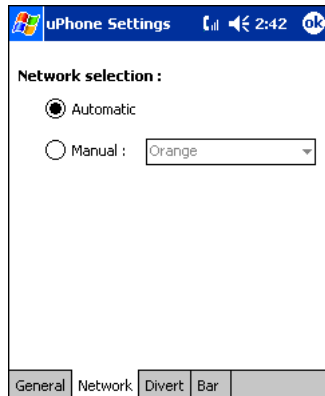

If you choose **Manual** network selection, the drop-down list of available networks activates. Choose a network from this list and tap **OK**. A wait icon appears while the system accesses the selected network.

Divert Tab

The divert tab enables you to select divert options for incoming calls when you are unavailable to answer; e.g., when the phone is off, you are out of network coverage, busy, or not able to answer.

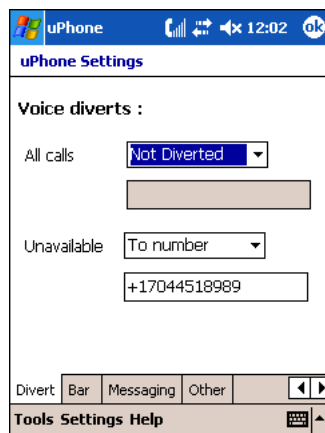

All Calls diverts all incoming calls automatically.

Unavailable diverts incoming calls when you are unavailable.

The options in both lists are as follows:

- Not Diverted** Select this option to not divert calls. This is the default setting for both All Calls and Unavailable lists.
- Answerphone** Select this option to divert calls to voicemail.
- To number** Select this option to forward incoming calls to another number.

Bar Tab

The Bar tab sets enables you to bar both incoming and outgoing calls.

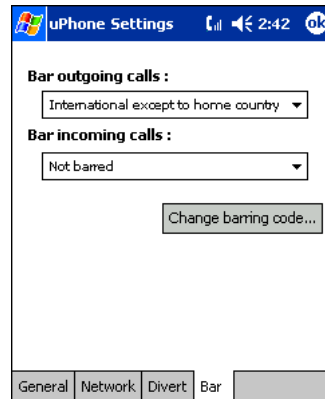

Bar outgoing calls

Select one of the following options from the drop-down list:

- | | |
|--------------------------------|--|
| Not barred | No restrictions on outgoing calls. |
| International calls | Bar international calls. |
| International except... | Only international calls to the home country designated on the SIM card can be made. |
| All outgoing calls | Bar all outgoing calls. |

Bar incoming calls

Select one of the following options from the drop-down list:

- | | |
|-------------------------------|--|
| Not barred | No restrictions on incoming calls. |
| Incoming calls when... | Bar incoming calls when the network coverage is in roaming status. |
| All incoming calls | Bar all incoming calls. |

Change barring code

Tap this button to change the barring code.

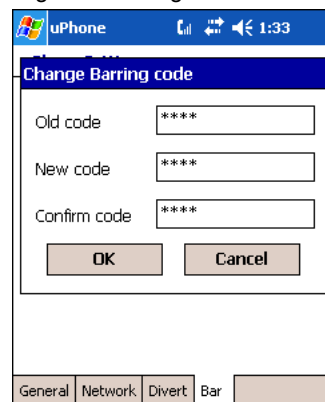

In the **Old code** field, enter the current code, and enter the new code in the **New code** and the **Confirm code** fields. While typing, the numbers appear as asterisks to hide the number from observation by third parties.

To save the barring options, tap **OK**. The system displays a dialog requesting the barring password before sending the updated settings to the network. Type in the password and tap **OK**.

Messaging Tab

The Messaging tab enables you to adjust the default SMS settings.

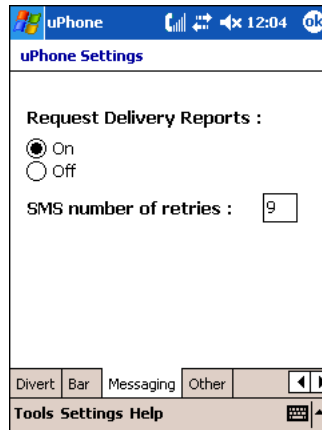

Request Delivery Reports

By default, the SMS manager receives a confirmation report that each SMS message has been sent. These confirmation reports can take up valuable space and memory. Therefore, you can cancel these reports on this tab by selecting Off and tapping **OK**.

SMS number of retries

This setting enables you to control the number of times the system will try to send an SMS message until the message is sent. Nine is the default number. To change the default, enter the number in the field and tap **OK**.

SMS Manager

Abbreviated for Short Message Service, SMS enables the transmission of short messages (140-160 characters) to and from a cell phone. SMS messages travel over the system's control channel, which is separate from the voice channel.

SMS Manager supports creation, sending, receiving, and storing of SMS text messages. Text messages sent or received can be up to 160 characters long.

Opening the SMS Manager

You can access the SMS Manager two ways:

1. Tap **Start > Programs > uPhone > SMS Manager**, OR
2. Open the Dialler (**Start > Programs > uPhone > Dialler**) and tap **Tools > SMS Manager**. The SMS Manager opens to the Inbox, which displays a list of your most recent text messages.

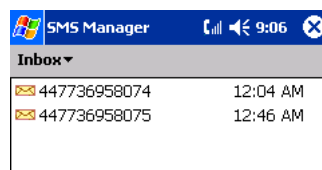

There are three folders: Inbox, Sent, and Outbox. Tap the **Inbox** folder to see all three folders. The name of the folder appears in the gray bar just under the title bar.

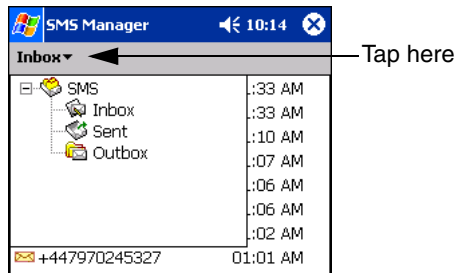

Note: Click the SMS box to expand and collapse the folders.

Inbox

The Inbox folder displays received text messages. Received messages have an envelope icon to the left. The Inbox folder also receives error messages from text messages that could not transmit successfully.

When the Inbox folder is selected, received messages appear in the list.

To	Do this...
Open a message	Tap on the message and the content of the message appears.
Delete a message	Tap and hold on the message. Tap Delete on the popup menu that appears.

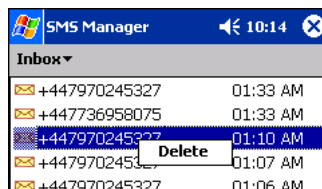

Sent Folder

The Sent folder displays sent messages.

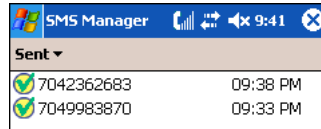

Outbox Folder

The Outbox folder displays text messages waiting to be sent.

Sending an SMS Message

1. In the task tray at the bottom of the screen, tap **New**. The new message screen opens with the cursor active in the text area.
2. Tap inside the **To:** field. To add the number, you can type it in or tap **To:** to select an entry from your Phonebook.
 - You must type a number that is in the appropriate international ISDN format for the country you are dialing. However, you can dial a local number without the country code.
 - Destination numbers *can* start with a “+” sign.
3. Tap inside the text area. To write a message, you can use the SIP or the terminal keyboard.

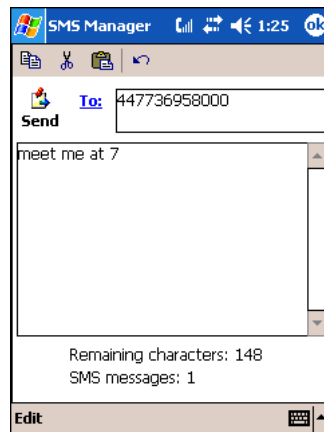







The **Remaining characters** field displays how many characters you can type in a message. Because 160 is the maximum number of characters per message, the number portion of the field counts backwards from 160 as you type.

4. When finished typing, tap the **Send** icon to transmit the message . *If you tap **OK** before tapping Send, the program requests confirmation before discarding the message.*
5. The **Sending message** box appears over the message.



6. When the message has been sent, the **Message sent** box appears.

Icons at the Top of the Message Screen

Icon	Description
At the top of the window:	
	Copy selected text.
	Cut selected text.
	Paste text.
	Undo the previous action.
	This icon appears only in a message that has been sent. Tapping this button will re-send the message.
In the task tray at the bottom of the window:	
	Send all messages in the Outbox.

Edit Menu

The Edit menu provides the same options as the icons at the top of the screen, with the following additional options:

- Select All** Selects all text in the active message section.
- Clear Selection** De-selects all text in the active message section.

GPRS Settings

uPhone includes pre-configured GPRS connection profiles to connect to a GPRS network. When the GSM driver is enabled uPhone selects the appropriate pre-configured profile based on the service provider information on the installed SIM card.

Before connecting to GPRS, you need to confirm and save the selected uPhone GPRS profile (or create one) in uPhone GPRS Settings, then enter the ISP information in Microsoft's connection manager.

The default profiles are for a modem connection. However, you can also configure GPRS for VPN or Proxy Server connections by creating a GPRS connection profile for that connection type in Microsoft's connection manager.

Requirements

No ActiveSync Make sure that you are **not** connected to a host PC via ActiveSync when configuring the connection settings!

Service Provider Information You need the **APN Number**, and **User name** and **Password** from your network service provider.

Configuring the GPRS Connection

The GSM driver installs pre-configured GPRS connection profiles. When enabled, the GSM driver reads the installed SIM card and selects the matching pre-configured connection profile.

1. Tap **Start > System > Connections** tab > **uPhone GPRS**. The GPRS Settings screen appears with the selected profile in the Current Profile drop-down list. .

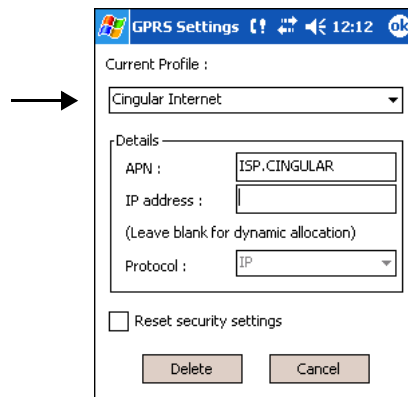

2. In the **Current Profile** drop-down list, select the profile associated with your account.

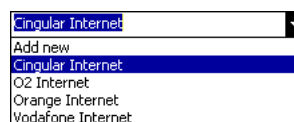

The Details section is already complete. A default GPRS profile (for a modem connection) is created in Microsoft's connection manager based on the profile selected here.

If your profile does not appear in the Current Profile list, select **Add new** and complete the Details section.

3. In the **Details** section
 - Type in the **APN** number
 - Type in the **IP address** (Leave blank to use DHCP.)
 - Select the **Protocol**
4. Tap **OK**. You return to the Connections tab.

5. Because GPRS is ISP technology, you need to complete the connection profile in Microsoft's connection manager with information from your ISP. On the **Connections** tab, tap **Connections**. The connections manager opens.

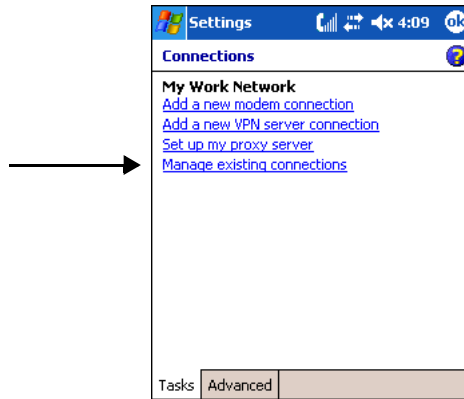

6. Tap **Manage existing connections**.

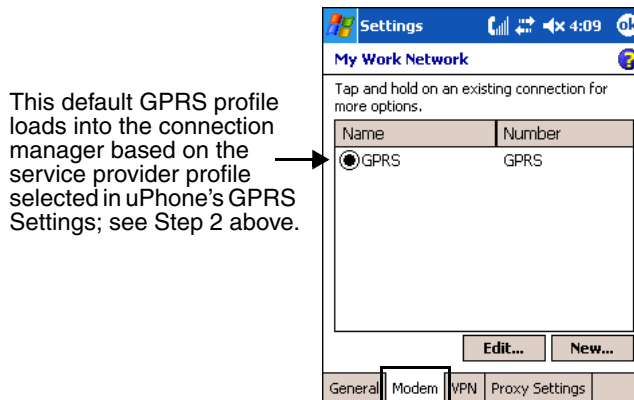

Note: A modem connection is the default connection type. If you want to create a VPN connection, for example, you need to create a GPRS profile on the VPN tab using the parameters in the following steps.

7. Make sure that **GPRS** is selected and tap **Edit**.

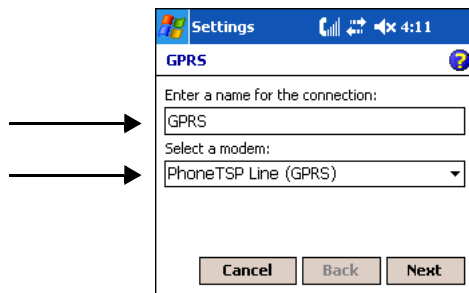

8. You can enter a custom name for the connection but leave **PhoneTSP Line (GPRS)** as the selected modem.

9. Tap **Next**.

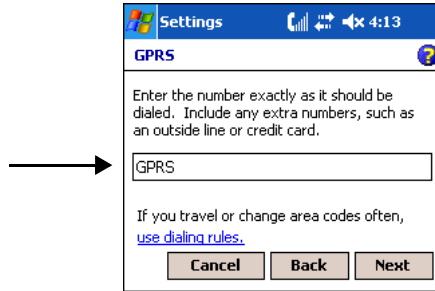

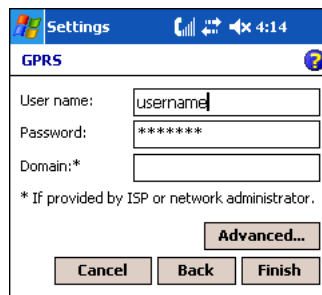

10. Enter the number provided by your ISP or leave the default “GPRS” if no number has been provided. If you leave “GPRS,” the GSM radio uses the APN Number entered in the uPhone profile (see Step 2 above). Tap **Next**.

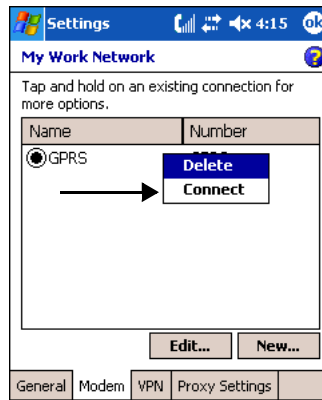

11. Enter the **User name** and **Password** provided by your ISP. Tap **Finish**.
Entering your user name and password here in the connection manager profile means that you don't have to enter them every time you try to connect via GPRS.

12. Tap and hold on the **GPRS** connection and select **Connect** on the popup menu.



13. You terminal attempts to connect to the GPRS network. When the connection is established, the double arrows appear in the Navigation bar .

14. To verify your connection, tap **Start > Programs > Internet Explorer**. Your homepage should appear.





Dolphin terminals ship with the following Microsoft applications installed:

- [Calendar](#) (page 12-1)
- [Contacts](#) (page 12-3)
- [Tasks](#) (page 12-5)
- [Notes](#) (page 12-7)
- [Messaging](#) (page 12-7)
- [Pocket Internet Explorer](#) (page 12-11)
- [Pocket Word](#) (page 12-14)
- [Pocket Excel](#) (page 12-15)
- [Windows Media Player for Pocket PC](#) (page 12-17)
- [MSN Messenger](#) (page 12-18)
- [Pictures](#) (page 12-19)

Note: Microsoft® Money, Microsoft® Reader are NOT installed on the Dolphin 7900 when shipped but may be installed from the Microsoft Companion CD.

Calendar

Use Calendar to schedule appointments, including meetings and other events. You can check your appointments in one of several views (Agenda, Day, Week, Month, and Year) and easily switch views by using the **View** menu.

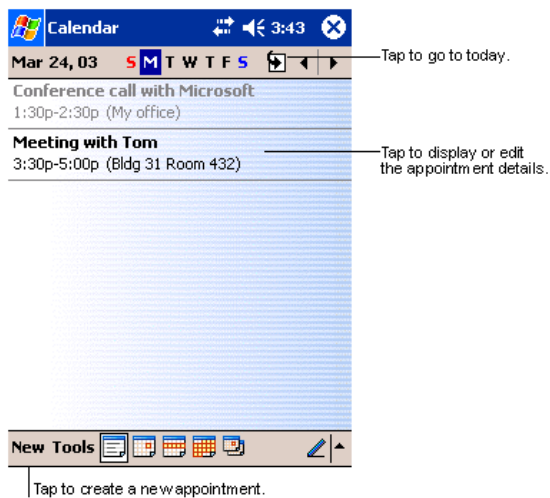

*Note: You can customize the Calendar display, such as changing the first day of the week, by tapping the **Tools** menu.*

Creating an Appointment

1. If you are in Day or Week view, tap the desired date and time for the appointment.
2. Tap **New**.

- Using the input panel, enter a description and a location. Tap first to select the field.

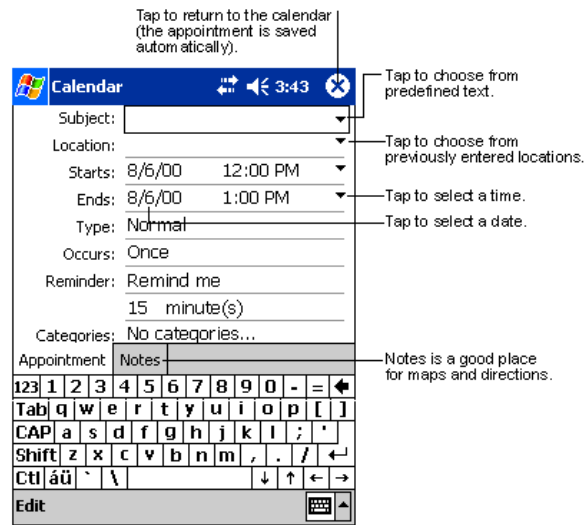

- If needed, tap the date and time to change them.
- Enter other desired information. To see all available fields, hide the input panel.
- To add notes, tap the **Notes** tab. You can enter text, draw, or create a recording. For more information on creating notes, refer to [Notes](#) on page 12-7.
- When finished, tap **OK** to return to the calendar.

*Note: If you select **Remind me** in an appointment, you will be reminded according to the options set in **Start > Settings > Personal tab > Sounds & Reminders**.*

Using the Summary Screen

When you tap an appointment in Calendar, a summary screen displays the details of the appointment.

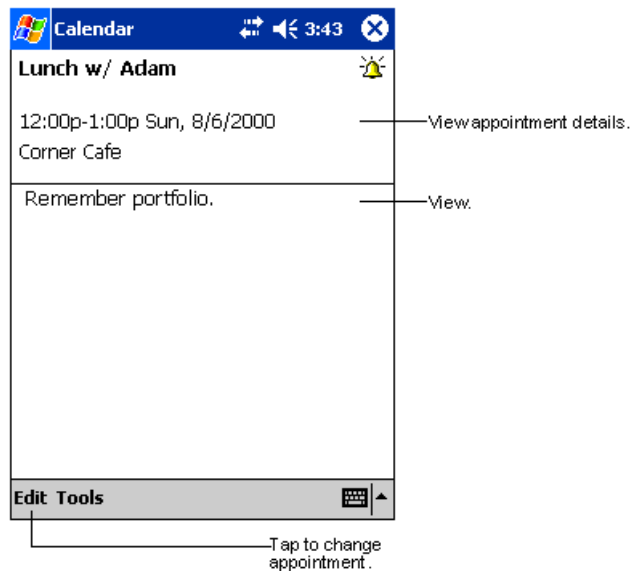

Creating Meeting Requests

You can use Calendar to set up meetings with users of Outlook or Pocket Outlook. The meeting request is created automatically and sent either when you synchronize Inbox or when you connect to your e-mail server. Indicate how you want meeting requests sent by tapping **Tools** and then **Options**. If you send and receive e-mail messages through ActiveSync, select **ActiveSync**.

Scheduling a Meeting

1. Create an appointment.
2. In the appointment details, hide the input panel, and then tap **Attendees**.
3. From the list of e-mail addresses you've entered in Contacts, select the meeting attendees. The meeting notice is created automatically and placed in the Outbox folder.

For more information on sending and receiving meeting requests, see Calendar Help and Inbox Help.

Contacts

Contacts maintains the contact information - phone numbers, e-mails, addresses, etc. - you need on your terminal.

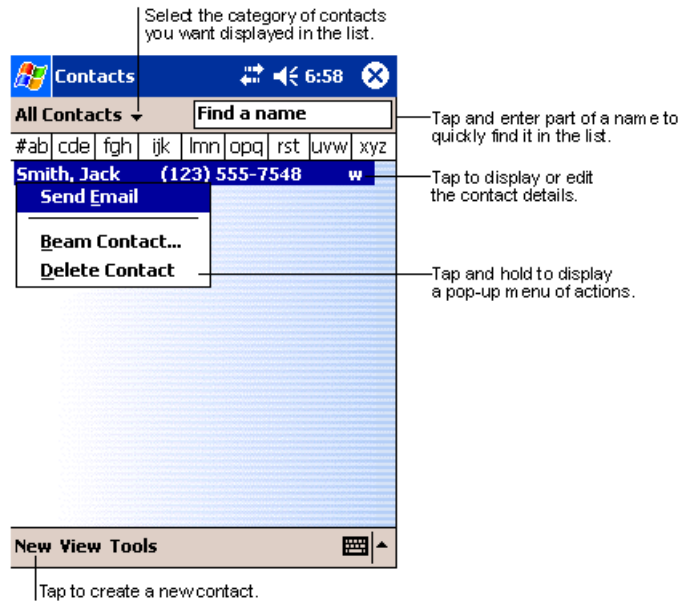

Note: To change the way information is displayed in the list, tap **Tools** > **Options**.

Creating a Contact

1. On the Contacts screen, tap **New**.

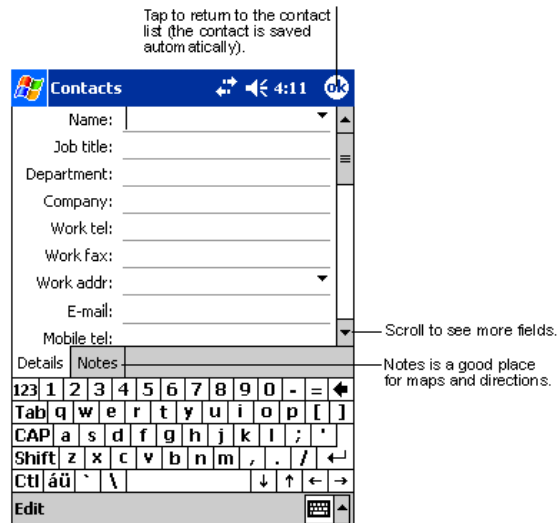

2. Using the SIP or Dolphin keyboard, enter the contact's information. Scroll down to see all available fields.
3. To assign the contact to a category, scroll to and tap **Categories**, then select a category from the list. (In the contact list, you can display contacts by category.)
4. To add notes about this contact, tap the **Notes** tab. For more information on creating notes, refer to [Notes](#) on page 12-7.
5. When finished, tap **OK** to return to the contact list.

Searching for Contacts

There are four ways to find a contact:

- In the contact list, enter a contact name in the box under the navigation bar. To show all contacts again, clear text from the box or tap the button to the right of the box.
- In the contact list, tap the category list (labeled **All Contacts** by default) and select the type of contact that you want displayed. To show all contacts again, select **All Contacts**. To view a contact not assigned to a category, select **None**.
- To view the names of companies your contacts work for, in the contact list, tap **View > By Company**. The number of contacts that work for that company are displayed to the right of the company name.
- Tap **Start > Find**, enter the contact name, select **Contacts** for the type, and then tap **Go**.

Using the Summary Screen

When you tap a contact in the contact list, a summary screen displays their information.

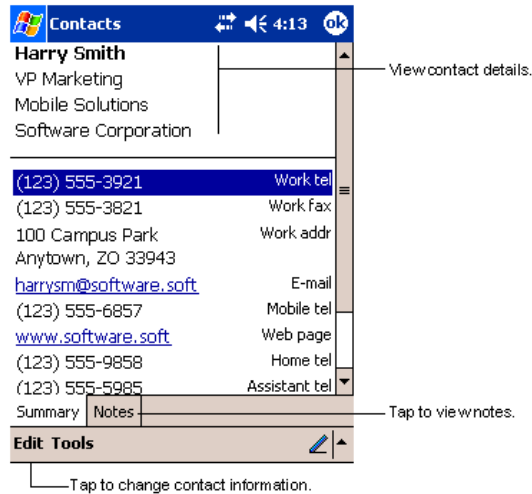

Tasks

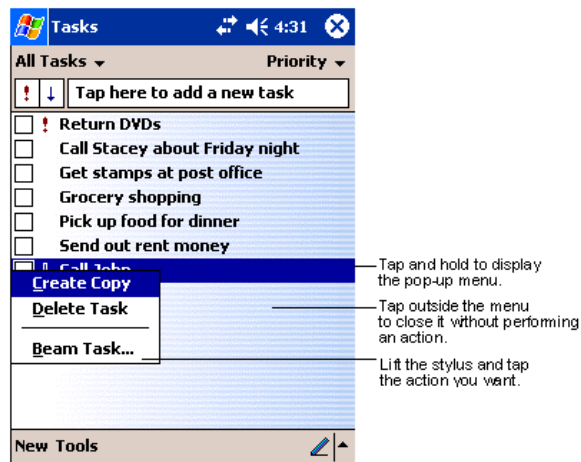

Note: To change the way information is displayed in the list, tap **Tools** > **Options**.

Creating a Task

1. Tap **New**.

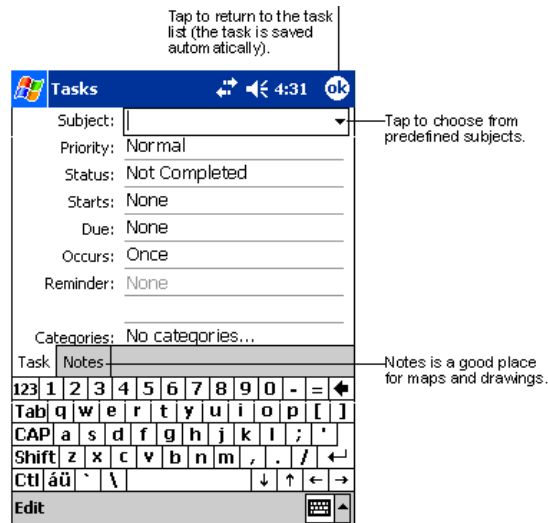

2. Using the SIP or Dolphin keyboard, enter the task information. If the input panel is open, you need to hide it to see all available fields.
3. Tap **Starts** to enter a start date and/or **Due** to enter a due date for the task.
4. To assign the task to a category, tap **Categories** and select a category from the list. In the task list, you can display tasks by category.
5. To add notes, tap the **Notes** tab. For more information on creating notes, refer to [Notes](#) on page 12-7.
6. When finished, tap **OK** to return to the task list.

Note: To quickly create a task with only a subject, tap **Entry Bar** on the **Tools** menu. Then, tap **Tap here** to add a new task and enter your task information.

Using the Summary Screen

When you tap a task in the task list, a summary screen displays the task information.

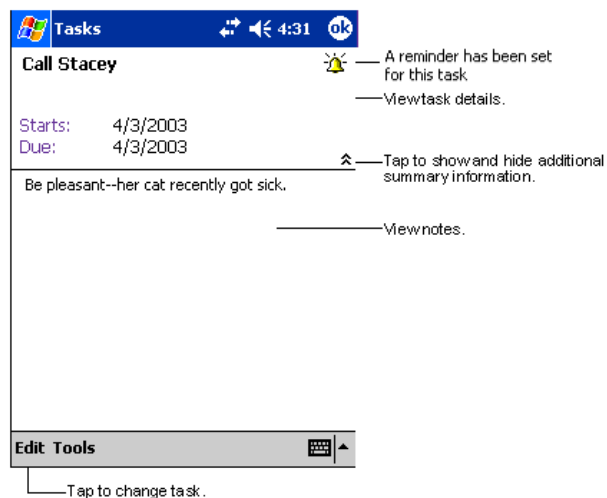

Notes

Quickly capture thoughts, reminders, ideas, drawings, and phone numbers with Notes. If a note is open when you create the recording, it will be included in the note as an icon.

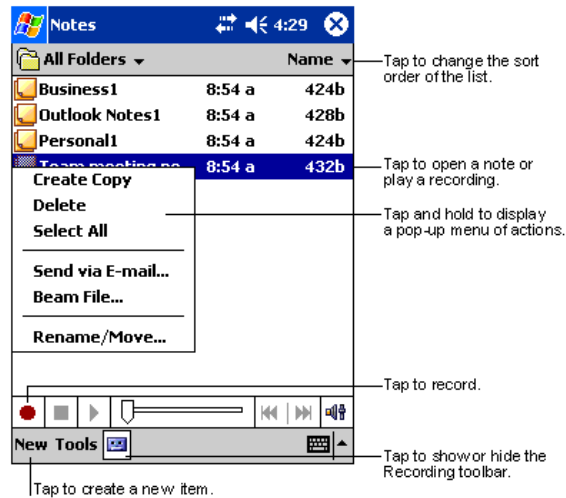

Creating a Note

1. Tap **New**.

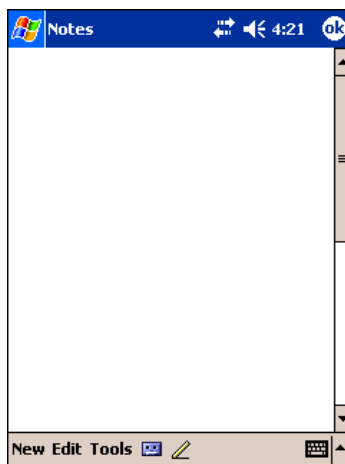

2. Type your note using the SIP or the Dolphin keyboard.

Messaging

Use Messaging to send and receive e-mail messages; this is your email Inbox. To use e-mail, you can:

- Synchronize e-mail messages with Microsoft Exchange or Microsoft Outlook on your desktop computer.
- Send and receive e-mail messages by connecting directly to an e-mail server through an ISP or a network.

Synchronizing E-mail Messages

E-mail messages can be synchronized as part of the general synchronization process. You need to enable Inbox synchronization in ActiveSync. For information on enabling Inbox synchronization, see ActiveSync Help on the desktop computer.

During synchronization:

-
- Messages are copied from the mail folders of Exchange or Outlook on your desktop computer to the ActiveSync folder in Inbox on the terminal. By default, you will receive messages from the past three days only, the first 100 lines of each message, and file attachments of less than 100 KB in size.
 - E-mail messages in subfolders must be selected in ActiveSync on your desktop computer to be transferred.
 - E-mail messages in the Outbox folder on the terminal are transferred to Exchange or Outlook, and then sent from those programs.

Note: You can also synchronize e-mail messages with your desktop computer from a remote location. For more information, see Chapter 7.

Connecting Directly to an E-mail Server

In addition to synchronizing e-mail messages with your desktop computer, you can send and receive e-mail messages by connecting to an e-mail server. When you connect the terminal to the e-mail server, new messages are downloaded to the Inbox folder, messages in the Outbox folder are sent, and messages that have been deleted on the e-mail server are removed from the Inbox folder.

Messages received directly from an e-mail server are linked to your e-mail server rather than your desktop computer. When you delete a message on the terminal, it is also deleted from the e-mail server the next time you connect the terminal to the e-mail server according to the settings selected in ActiveSync.

You can work online or offline. When working online, you read and respond to messages while connected to the e-mail server. Messages are sent as soon as you tap **Send**, which saves space on the terminal. When working offline, after you've downloaded new message headers or partial messages, you can disconnect from the e-mail server and then decide which messages to download completely. The next time you connect, Inbox downloads the complete messages you've marked for retrieval and sends the messages you've composed.

Receiving Messages

When you connect to your e-mail server or synchronize with your desktop computer, by default, you'll receive messages from the last five days only, the first 100 lines of each new message, and file attachments of less than 100 KB in size. The original messages remain on the e-mail server or your desktop computer.

You can mark the messages that you want to retrieve in full during your next synchronization or e-mail server connection. In the message list, tap and hold the message you want to retrieve. On the pop-up menu, tap **Mark for Download**. The icons in the Inbox message list give you visual indications of message status.

You specify your downloading preferences when you set up the service or select your synchronization options. You can change them at any time:

- Change options for Inbox synchronization using ActiveSync options. For more information, see ActiveSync Help.
- Change options for direct e-mail server connections in Inbox on the terminal. Tap **Tools** and then tap **Options**. On the **Service** tab, tap the service you want to change. Tap and hold the service and select **Delete** to remove a service.

Using the Message List

Messages you receive are displayed in the message list. By default, the most recently received messages are displayed first in the list and unread messages are displayed in bold type.

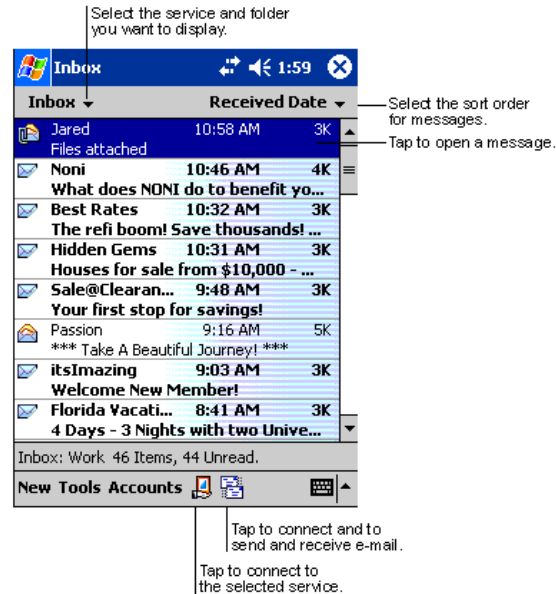

When you tap on a message to open it, the following screen appears:

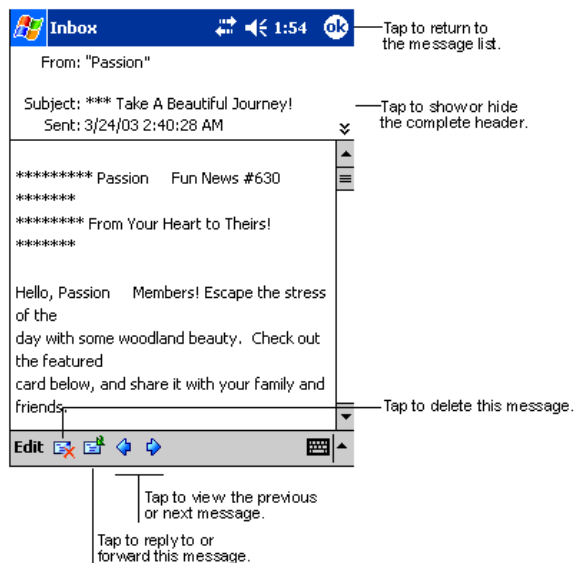

Composing Messages

1. Tap **New**.
2. In the **To** field, enter the e-mail or SMS address of one or more recipients, separating them with a semicolon (;), or select a name from the contact list by tapping the **Address Book** button. All e-mail addresses entered in the e-mail fields in Contacts appear in the Address Book.
3. Compose your message. To enter preset or frequently used messages, tap **My Text** and select a message.
4. Tap **Send** when you've finished the message. If you are working offline, the message is moved to the Outbox folder and will be sent the next time you connect.

-
5. If you are sending an SMS message and want to know if it was received, tap **Edit, Options**, and select **Request SMS text message delivery notification** before sending the message.

Managing E-mail Messages and Folders

Messages are displayed in one of five folders for each service you have created: Inbox, Deleted Items, Drafts, Outbox, and Sent Items.

The Deleted Items folder contains messages that have been deleted on the device. The behavior of the Deleted and Sent Items folders depends on the selected options. To select these options, tap **Tools > Options > Message** tab.

To move a message to another folder, in the message list, tap and hold the message, tap **Move to** on the pop-up menu, and select the desired folder.

To create additional folders, tap **Tools > Manage Folders**.

Folder Behavior with a Direct Connection to an E-mail Server

The behavior of the folders you create depends on whether you are using ActiveSync, SMS, POP3, or IMAP4.

ActiveSync

If you use ActiveSync, e-mail messages in the Inbox folder in Outlook on your desktop computer are automatically synchronized with the terminal. You can select to synchronize additional folders by designating them for ActiveSync. The folders you create and the messages you move will then be mirrored on the server.

For example, if you move two messages from the Inbox folder to a folder named Family, and you have designated Family for synchronization, the server creates a copy of the Family folder and copies the messages into that folder. You can then read the messages while away from your desktop computer.

SMS

If you use SMS, messages are stored in the Inbox folder.

POP3

If you use POP3 and you move e-mail messages to a folder you created, the link is broken between the messages on the terminal and their copies on the mail server. The next time you connect, the mail server will see that the messages are missing from the terminal Inbox and delete them from the server. This prevents you from having duplicate copies of a message, but it also means that you will no longer have access to messages that you move to folders created from anywhere except the terminal.

IMAP4

If you use IMAP4, the folders you create and the e-mail messages you move are mirrored on the server. Therefore, messages are available to you anytime you connect to your mail server, whether it is from the terminal or desktop computer. This synchronization of folders occurs whenever you connect to your mail server, create new folders, or rename/delete folders when connected.

Pocket Internet Explorer

Use Microsoft Pocket Internet Explorer to view Web or WAP pages. You can use the following methods:

- During synchronization with your desktop computer, download your favorite links and mobile favorites that are stored in the Mobile Favorites subfolder in Internet Explorer on the desktop computer.
- Connect to an ISP or network and browse the Web. When connected to an ISP or network, you can also download files and programs from the Internet or intranet.

Accessing Pocket Internet Explorer

To open Pocket Internet Explorer, tap **Start** and then Internet Explorer.

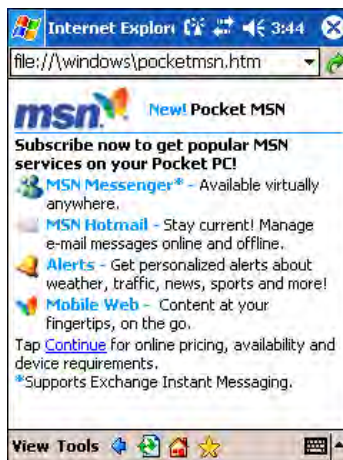

You can use Pocket Internet Explorer to browse Mobile Favorites and channels that have been downloaded without connecting to the Internet. You can also connect to the Internet through an ISP or a network connection and browse the Web.

Browse the Internet on Your Terminal

Note: You must set up a connection to your ISP or corporate network using Connections before browsing; see [Using an ISP](#) on page 8-8. If you select Pocket Internet Explorer before setting up the network connections, a screen may appear allowing you to proceed to the connection settings screen.

1. Open Internet Explorer (**Start > Internet Explorer**).
2. To connect and start browsing, tap **View** and then **Address Bar**.
3. In the address bar that appears at the top of the screen, enter the Web address you want to visit and then tap **Go**.
4. Tap the arrow to choose from previously entered addresses. If Mobile Favorites have been set up, you can tap one of them to start browsing. See [Mobile Favorites Folder](#) on page 12-12.

View Options

You can switch to a One Column view, which condenses web content into a single column so that you do not have to scroll right to see the entire page. Tap **View > Layout > One Column**.

Default View



One Column View



Mobile Favorites Folder

Purpose

The Mobile Favorites folder was created on your desktop computer when you installed ActiveSync. It enables you to create Favorite Links on your desktop computer that you can transfer to your Dolphin terminal. Those Favorite Links are then available when browsing the internet on your terminal.

Process

First, you create your Favorite Links in the Mobile Favorites folder on your desktop computer. Then, the next time you sync your desktop computer with your terminal, those Mobile Favorites are transferred to the Mobile Favorites folder on to your terminal.

Only items stored in the Mobile Favorites subfolder in the Favorites folder in Internet Explorer on your desktop computer are synchronized with the Mobile Favorites folder on your terminal.

Note: Unless you mark a Favorite Link as a mobile favorite, only the link downloads to your terminal, and you will need to connect to your ISP or network to view the content. For more information on synchronization, see [ActiveSync Help](#) on the desktop computer.

Creating and Synchronizing Mobile Favorites

If you are using Microsoft Internet Explorer 5.0 or later on your desktop computer, you can download Mobile Favorites to the terminal. Synchronizing mobile favorites downloads Web content to your device so that you can view pages while you are disconnected from your ISP and desktop computer.

Use the Internet Explorer plug-in installed with ActiveSync to create mobile favorites

1. On your desktop computer, open Internet Explorer, click **Tools > Create Mobile Favorite**.

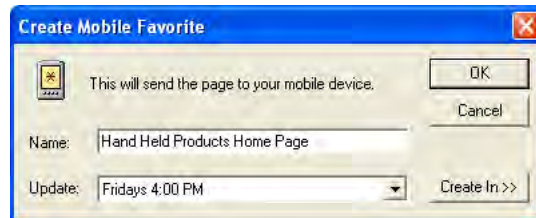

2. To change the link name, enter a new name in the **Name** box.
3. Optionally, in **Update**, select a desired update schedule.
4. Tap **OK**. Internet Explorer downloads the latest version of the page to your desktop computer.
5. If you want to download the pages that are linked to this mobile favorite, in Internet Explorer on the desktop computer, right-click the mobile favorite and then click **Properties**. On the **Download** tab, specify the number of links down that you want to download. To conserve memory, go only one level down.
6. Synchronize the terminal and desktop computer. Mobile favorites that are stored in the Mobile Favorites folder in Internet Explorer are downloaded to the terminal.

If you did not specify an update schedule in Step 3, you will need to manually download content to keep the information updated on your desktop computer and terminal. Before synchronizing, in Internet Explorer on your desktop computer, click **Tools** and then **Synchronize**. You will see the last time content was downloaded to the desktop computer, and you can manually download content if needed.

You can add a button to the Internet Explorer toolbar for creating mobile favorites. In Internet Explorer on your desktop computer, click **View, Toolbars**, and then **Customize**.

Using Mobile Favorites and Channels

1. Open Pocket Internet Explorer.
2. Tap the Favorites button to display your list of favorites .

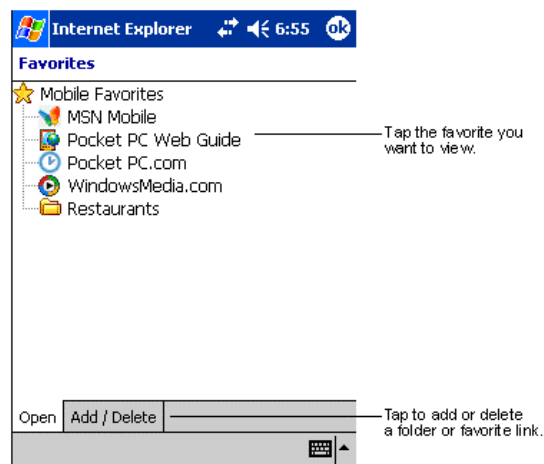

3. Tap the page you want to view.

You'll see the page that was downloaded the last time you synchronized with your desktop computer. If the page is not on the terminal, the favorite will be dimmed. You will need to synchronize with your desktop computer again to download the page to the terminal, or connect to the Internet to view the page.

Mobile favorites take up storage memory on the terminal. To minimize the amount of memory used:

- In the settings for the Favorites information type in ActiveSync options, turn off pictures and sounds, or stop specific mobile favorites from being downloaded to the terminal. For more information, see **ActiveSync Help**.
- Limit the number of downloaded linked pages. In Internet Explorer on the desktop computer, right-click the mobile favorite you want to change and then Properties. On the Download tab, specify 0 or 1 for the number of linked pages you want to download.

Using AvantGo® Channels

AvantGo is a free interactive service that provides access to personalized content and thousands of popular web sites. Subscribe to AvantGo channels directly from the terminal. For more information, visit: <http://avantgo.com/frontdoor/index.html>.

1. In ActiveSync options on the desktop computer, turn on synchronization for the AvantGo information type.
2. In Pocket Internet Explorer, tap the **Favorites** button to display your list of favorites .
3. Tap the **AvantGo Channels** link.
4. Tap **Activate** and follow the directions on the screen. Synchronize the terminal with your desktop computer and then tap the **My Channels** button to complete the AvantGo setup.
5. When synchronization is complete, tap the **AvantGo Channels** link in your list of favorites to see a few of the most popular channels. To add or remove channels, tap the **Add or Remove** link.

Pocket Word

Pocket Word works with Microsoft Word on your desktop computer to give you easy access to copies of your documents. You can create new documents on the terminal, or you can copy and paste documents from your desktop computer. Synchronize documents between your desktop computer and your device so that you have the most up-to-date content in both locations.

You can open only one document at a time; when you open a second document, you'll be asked to save the first. You can save a document you create or edit in a variety of formats, including Word (.doc), Pocket Word (.psw), Rich Text Format (.rtf), and Plain Text (.txt).

Using Pocket Word

Pocket Word contains a list of the files stored on the terminal. Tap a file in the list to open it. To delete, make copies of, and send files, tap and hold a file in the list. Then, select the appropriate action on the pop-up menu.

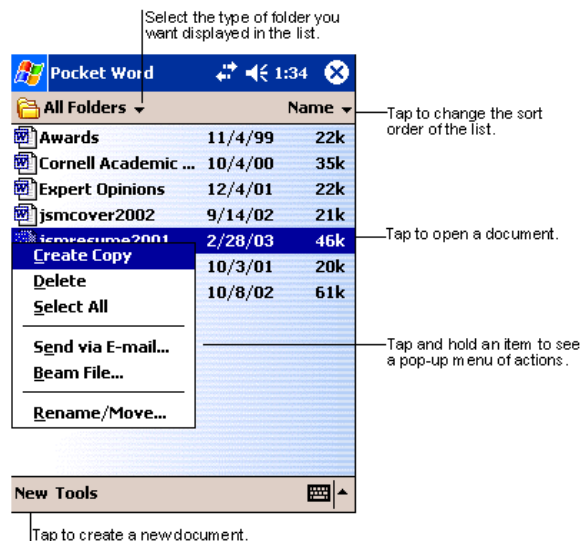

You can change the zoom magnification by tapping **View > Zoom**, and then selecting the percentage you want. Select a higher percentage to enter text and a lower one to see more of your document. If you're opening a Word document created on a desktop computer, select **Wrap to Window** on the **View** menu so that you can see the entire document.

Creating a Word File

To create a new file, tap **Start > Programs > Pocket Word > New**. A blank document appears. If you've selected a template for new documents in the Options dialog box, that template appears with appropriate text and formatting already provided.

You can enter information in Pocket Word in one of two modes (typing on the SIP or keyboard and drawing), which are displayed on the **View** menu.

Typing Mode

Using the SIP or Dolphin keypad, enter typed text into the document.

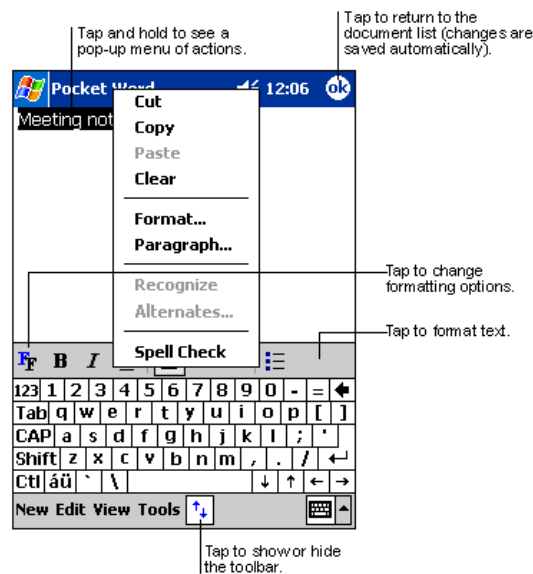

To format existing text and to edit text, first select the text. You can select text as you do in a Word document, using your stylus instead of the mouse to drag through the text you want to select. You can search a document to find text by tapping **Edit** and then **Find/Replace**.

Drawing Mode

In drawing mode, use your stylus to draw on the screen. Gridlines appear as a guide. When you lift your stylus off the screen after the first stroke, you'll see a drawing box indicating the boundaries of the drawing. Every subsequent stroke within or touching the drawing box becomes part of the drawing.

For more information on using Pocket Word, tap **Start** and then **Help**.

Pocket Excel

Pocket Excel works with Microsoft Excel on your desktop computer to give you easy access to copies of your workbooks. You can create new workbooks on the terminal, or you can copy and paste workbooks from your desktop computer. Synchronize workbooks between your desktop computer and the terminal so that you have the most up-to-date content in both locations.

You can open only one workbook at a time; when you open a second workbook, you'll be asked to save the first. You can save a workbook you create or edit in a variety of formats, including Pocket Excel (.pxl) and Excel (.xls).

Pocket Excel contains a list of the files stored on your device. Tap a file in the list to open it. To delete, make copies of, and send files, tap and hold a file in the list. Then select the appropriate action from the pop-up menu. Pocket Excel provides fundamental spreadsheet tools, such as formulas, functions, sorting, and filtering. To display the toolbar, tap **View > Toolbar**.

Creating an Excel File

To create a new file, tap **Start > Programs > Pocket Excel > New**. A blank workbook appears. If you've selected a template for new workbooks in the Options dialog box, that template appears with appropriate text and formatting already provided.

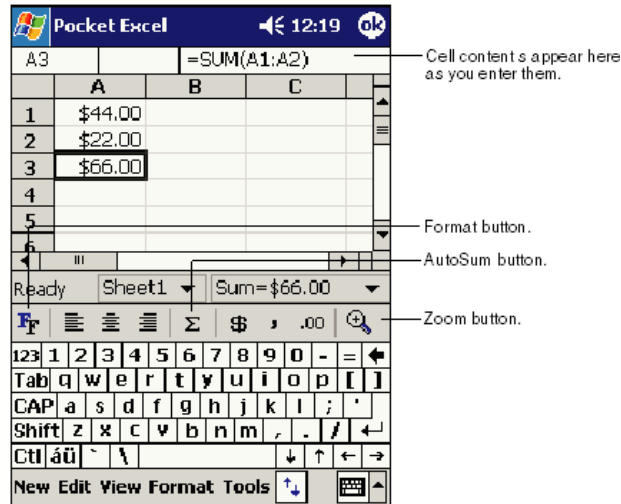

If your workbook contains sensitive information, you can protect it with a password. To do so, open the workbook, tap **Edit**, and then **Password**. Every time you open the workbook, you will need to enter the password, so choose one that is easy for you to remember but hard for others to guess.

Tips for Working in Pocket Excel

- View in full-screen mode to see as much of your worksheet as possible. Tap **View** and then **Full Screen**. To exit full-screen mode, tap **Restore**.
- Show and hide window elements. Tap **View** and then tap the elements you want to show or hide.
- Freeze panes on a worksheet. First select the cell where you want to freeze panes. Tap **View > Freeze Panes**. You might want to freeze the top and left-most panes in a worksheet to keep row and column labels visible as you scroll through a sheet.
- Split panes to view different areas of a large worksheet. Tap **View > Split**. Then drag the split bar to where you want it. To remove the split, tap **View > Remove Split**.
- Show and hide rows and columns. To hide a hidden row or column, select a cell in the row or column you want to hide. Then tap **Format > Row or Column > Hide**. To show a hidden row or column, tap **Tools > Go To**, and then type a reference that is in the hidden row or column. Then tap **Format > Row or Column > Unhide**.

For more information on using Pocket Excel, tap **Start > Help**.

Windows Media Player for Pocket PC

Use Microsoft Windows Media Player (WMP) for Pocket PC to play digital audio and video files stored on the terminal. To switch to Windows Media Player for Pocket PC, tap **Start > Windows Media**.



After a media file has been loaded, you can play, pause, stop, song advance/reverse, mute sound, or adjust volume.

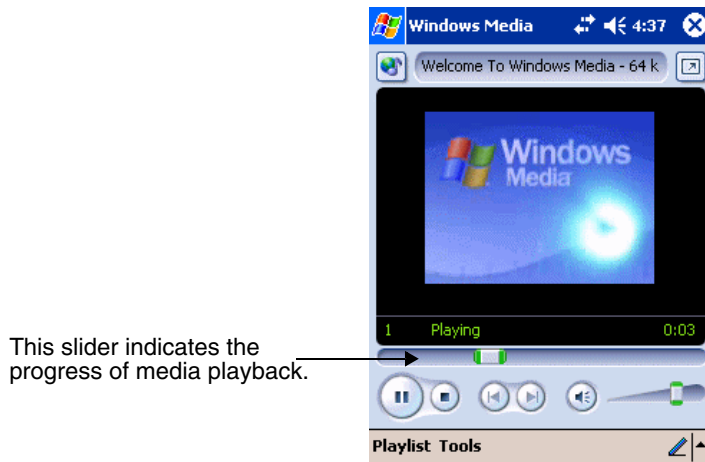

Tools Menu

The tools menu allows you to perform several important functions.

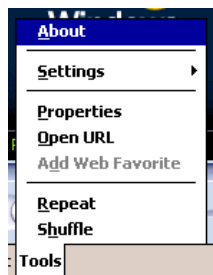

About gives you information about the codecs used in your version of WMP.

Settings allows you to configure several important aspects of WMP.

Properties gives a detailed listing of a media file's attributes.

Open URL allows you to open WMP-compliant media from a network or Internet resource.

Add Web Favorite adds a streaming media file that is currently playing to web favorites.

Repeat plays a playlist repeatedly.

Shuffle plays items in a playlist in a random order.

MSN Messenger

MSN Messenger is an instant messaging program that lets you:

- See who is online.
- Send and receive instant messages.
- Have instant message conversations with groups of contacts.

Note: To use MSN Messenger, you must have a Microsoft Passport™ account or a Microsoft Exchange e-mail account. You must have a Passport to use MSN Messenger Service. If you have a Hotmail or MSN account, you already have a Passport account. Sign up for a Microsoft Passport account at www.passport.com.

Setting Up

Before you can connect for the first time, you must enter the information from your Passport or Exchange account. After you set up your account information on the terminal for the first time, you will go directly to login when you access MSN Messenger.

Note: Ensure that you are connected to the Internet (see [Connections Tab](#) on page 7-15).

1. Tap **Start > Programs > MSN Messenger**



2. Tap **Tools > Options > Account** tab.



3. In the Accounts tab, enter your Passport or Exchange account information. Be sure to indicate the service you're using to connect - Messenger or Exchange.
4. When complete, tap **OK**. You are returned to the sign-in screen.
5. To sign in, tap the sign-in screen and enter your e-mail address and password.

Note: If you already use MSN Messenger, your contacts will show up on your device without being added again.

Pictures

Use Pictures to view JPEG pictures stored on the terminal or storage card. To begin, tap **Start > Programs > Pictures**.

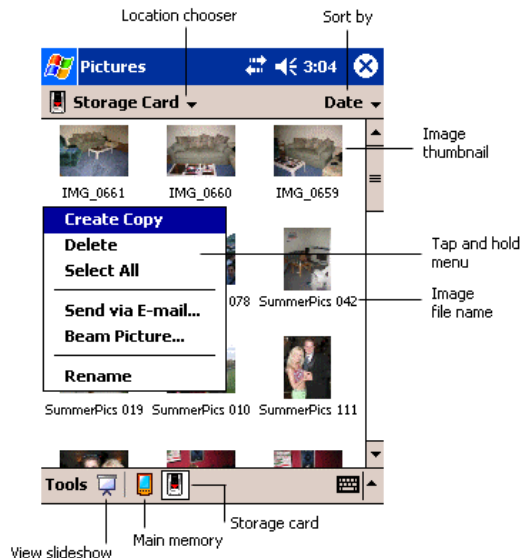

Choose to view main memory or storage card contents. By tapping and holding on an image, you can create a clone of that file, delete that file, select all files, send file via e-mail, beam picture, or rename the image.



Overview

As the hub of your Dolphin 7900 system, the Dolphin HomeBase charging and communication cradle supports both RS-232 and USB communications, enabling your terminal to interface with the majority of PC-based enterprise systems.

Communications

RS-232 transmits data at speeds of up to 115 Kbps. With USB port, the data transmission rate goes up to 12 Mbps.

Dolphin HomeBases cannot be physically connected to each other—sometimes referred to as “daisy-chaining”—but can be networked together via serial or USB hubs.

Convenient Storage

Intelligent battery charging makes the Dolphin HomeBase a safe and convenient storage receptacle for your Dolphin terminal.

Capacity

The Dolphin HomeBase can charge two battery packs: one that's installed in the terminal and another in the auxiliary battery well. While charging the battery pack in the terminal, the HomeBase also powers the Dolphin terminal. The auxiliary battery well located behind the terminal well charges a battery pack independently of the terminal well.

Intelligent Battery Charging

The Dolphin HomeBase completes a full charge of the main battery pack in less than four hours.

In addition to charging, the HomeBase powers the intelligent battery charging system in the terminal that protects the battery from being damaged by overcharging. The unit senses when a battery pack is fully charged and automatically switches to a trickle charge that maintains the battery at full capacity.

As battery packs charge, the charging circuitry follows the two-step charging process (CC-CV) that is recommended for Li-Ion batteries. The process monitors changes in temperature, current, and voltage.

As a result, Dolphin terminals may be stored in the HomeBase without damage to the terminals, battery packs, or peripherals.

Power Supply

The Dolphin HomeBase is available with US, UK, and European power supplies. Each version is designed to convert that voltage from the power sources in each geography to the 9.5 volts DC required by the Dolphin terminal.



Use only the peripherals, power cables, and power adapters from Hand Held Products. Use of peripherals, cables, or power adapters not sold/manufactured by Hand Held Products will void the warranty and may damage the terminal.



Use only the Li-ion battery packs provided by Hand Held Products. The use of any battery pack not sold/manufactured by Hand Held Products in a Dolphin terminal will void your warranty and may result in damage to the Dolphin terminal or battery.

Front Panel

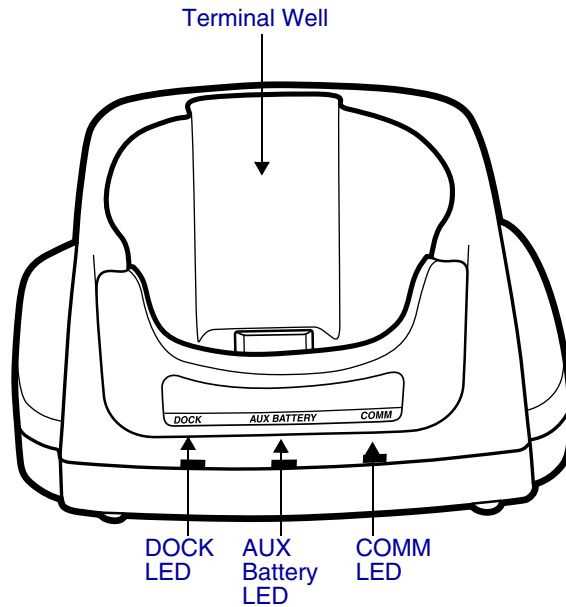

AUX Battery LED

Indicates status of the battery charging in the auxiliary battery well; see page 13-5.

This color...	means...
Orange	The auxiliary battery is charging.
Green	The auxiliary battery has completed charging and is ready for use.

COMM LED

This is the communication LED. It indicates the status of data transfer between the Dolphin terminal and the host PC. The color of this LED differs if the HomeBase is using the serial or USB port connection.

If using the serial port

This color...	means...
Red	Serial data is being sent from the host device to the Dolphin HomeBase.
Green	Serial data is being sent from the Dolphin HomeBase to the host device.
Orange	Serial data is being sent at high data rates.

If using the USB port

This color...	means...
Green LED	A USB connection is established with the host computer.

DOCK LED

Turns solid green when the Dolphin terminal is properly seated in the Dolphin HomeBase. When this light is on, the terminal is connected to the base.

Terminal Well

Place the Dolphin terminal in this well to communicate with a host device, power the terminal, and charge its battery pack. If the host device is a desktop computer that uses ActiveSync, synchronization begins immediately.

Back Panel

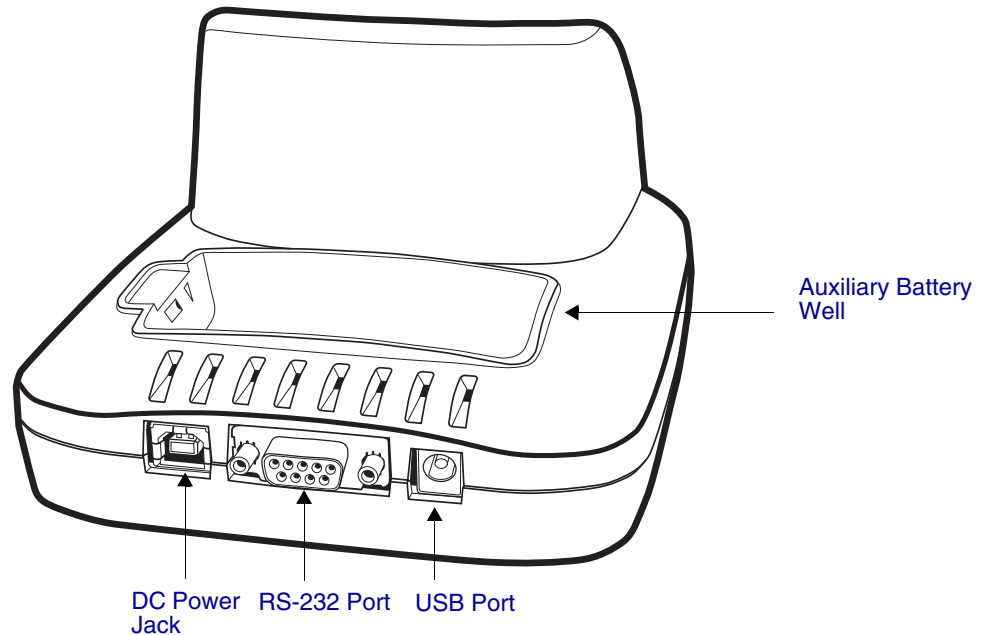

Auxiliary Battery Well

The auxiliary battery well charges an additional Li-ion battery pack independently of the terminal well. This feature ensures that you can always have a fully-charged battery for your Dolphin terminal; see [Charging a Spare Battery in the Auxiliary Battery Well](#) on page 13-5.

DC Power Jack

Use a power cable from Hand Held Products to supply power to this power jack. For more information, see [Powering the Dolphin HomeBase](#) on page 13-4.

RS-232 Port

For RS-232 data communication, use the 9-pin, RS-232 cable from Hand Held Products to connect this port to a peripheral device. For more information, see [RS-232 Serial Connector](#) on page 13-4.

USB Port

This USB Port is full-speed and 2.0 compliant and requires ActiveSync 3.7 or higher. Using a USB cable, you can connect the HomeBase to a USB-compliant device. When the HomeBase is connected to the device, the terminal is connected to the device when seated in the terminal well.

RS-232 Serial Connector

The following diagram displays the pins of the RS-232 serial connector of the [Back Panel](#) (see page 13-3).

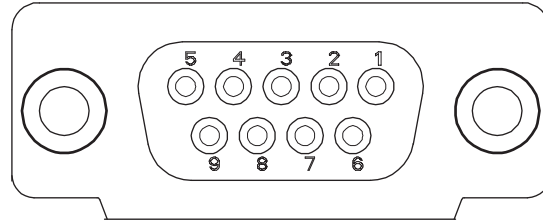

<u>Pin #</u>	<u>Description</u>
1	Internal Jumper to Pin 6
2	TXD
3	RXD
4	DSR
5	GND
6	DTR
7	CTS
8	RTS
9	RI

Note: Signals referenced are for a DTE device. The HomeBase is at a right-angle to the printed circuit board (PCB). The ninth pin has a ring indicator (RI).

Powering the Dolphin HomeBase

The terminal requires 9.5 volts DC input for communications and battery charging; the power adapter on the power cable converts the voltage from the power source to 9.5 volts DC. Only power adapter cables from Hand Held Products converts the voltage appropriately.

We recommend that you leave the Dolphin HomeBase connected to its power source at all times, so that it is always ready to use.

1. Connect the power cable to the DC jack on the rear panel of the HomeBase.
2. Connect the power cable to the power adapter.
3. Plug the power adapter into the power source.
4. The HomeBase is now powered. When a terminal is inserted into the terminal well, the HomeBase powers the terminal, charges the terminal's main battery pack, and launches ActiveSync communications (if applicable.)

Charging the Main Battery

The Dolphin HomeBase powers the terminal and fully charges its main battery pack in less than four hours. To check battery power, see [Power](#) on page 7-10.

To Power a Terminal and Charge its Main Battery

1. Install the battery pack in the terminal; see [Install the Main Battery Pack](#) on page 2-5.
2. Power the HomeBase; see [Powering the Dolphin HomeBase](#) on page 13-4.
3. Slide the terminal into the terminal well until the Dock LED lights green to indicate that the terminal is properly seated.

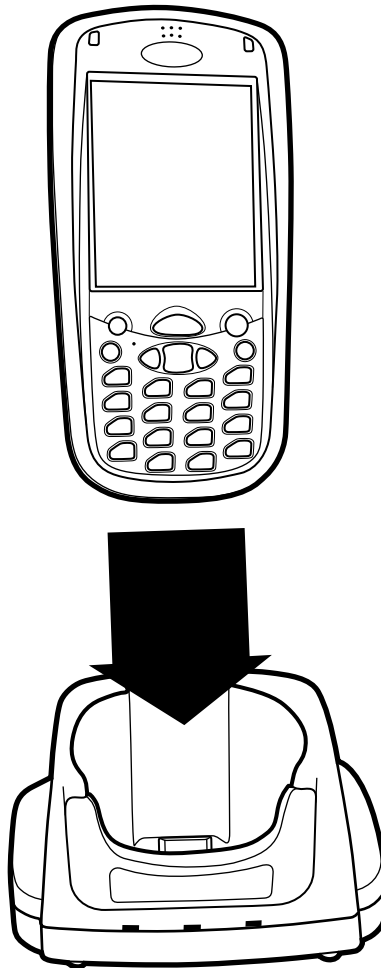

4. The battery pack begins charging.

Charging a Spare Battery in the Auxiliary Battery Well

The auxiliary battery well located on the back panel ([Auxiliary Battery Well](#), page 13-3) charges a spare battery. The [AUX Battery LED](#) (page 13-2) on the front panel indicates the charge status of the battery in this well. Charge time is less than four hours and the charge process is independent of the terminal well.

1. Insert the end of the battery without the locking tab into the bottom of the auxiliary well opening.
2. Snap the battery into place with a hinging motion. The Aux Battery LED lights orange.
3. The AUX Battery LED monitors the charge progress.

ActiveSync Communications with the HomeBase

The HomeBase can communicate via USB or RS-232 using ActiveSync 3.7 or higher. The HomeBase should have only one type of interface cable connected at a time, either USB or RS-232.

- USB** The **USB Port** (see page 13-3) on the back panel allows the Dolphin terminal to communicate with a PC or to networked through a USB hub. The HomeBase acts as a USB device by interfacing the USB signals of the Dolphin to the USB signals of the host computer.
Maximum data transfer rate is 12 Mbps.
- RS-232** The **RS-232 Port** (see page 13-3) on the back panel allows the Dolphin terminal to communicate with a PC, modem, or any RS-232 device using a standard serial cable and communications software.
Maximum data transfer rate is 115 Kbps.

Required Equipment for Setup

- HomeBase powered by a power adapter cable from Hand Held Products
- USB Cable
- Serial Cable (for RS-232)
- ActiveSync v3.7 or higher
- Windows® 98 Second Edition*, Windows® Me, Windows® 2000, or Windows® XP computer.

*Note: The HomeBase does not support Windows NT® when using a USB connection. This is because Windows NT does not support USB. *Windows® 98 second edition provides full USB support.*

USB Communications

The Dolphin terminal is defaulted to support USB communications out of the box.

To Install the HomeBase Using USB

1. Plug in the power supply and connect it to the back of the HomeBase.
2. Plug the USB cable into the back of the HomeBase and the PC.
3. At this point, the hardware is installed and operating. (You may need to reboot your PC to complete the installation process.)

Setting up the Terminal for ActiveSync Communications

1. On the terminal, tap **Start > ActiveSync > Tools > Options**. ActiveSync opens displaying the PC tab.
2. In the **Use this PC** drop-down list, select the name of the host PC.
3. Select **Sync with this PC during manual sync** to indicate that the terminal syncs with the selected host PC when synchronization is run from the terminal.

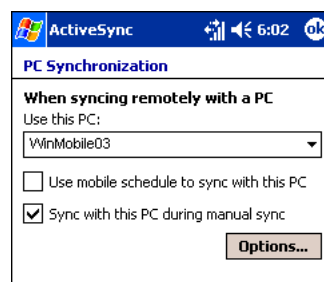

4. Tap **Options**.

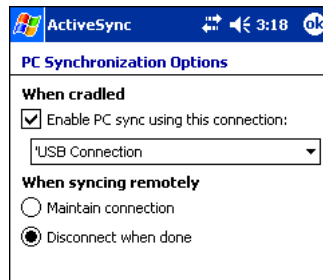

5. Select **Enable PC sync using this connection**, and select **'USB Connection'** from the drop-down list.
6. Tap **OK** and place the Dolphin in the HomeBase. The Dolphin terminal attempts to start an ActiveSync connection with the PC automatically.

Setting up the PC for ActiveSync Communications

Verify that ActiveSync on the PC has selected the appropriate communication type by clicking **File > Communication Properties**.

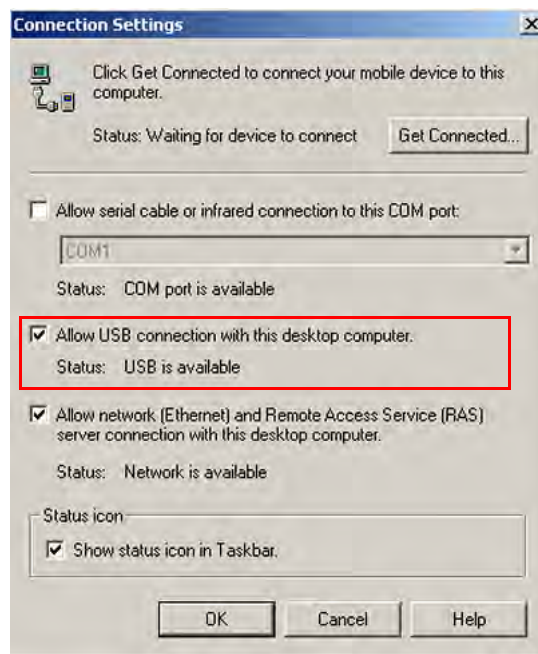

The **Allow USB connection with this desktop computer** box must be checked. Do **not** check the serial cable box.

RS-232 Communications

Connecting the Cables

Connect the HomeBase to the host computer or other device by plugging an RS-232 serial cable into the **RS-232 Port** (see page 13-3) on the back panel. The wiring of your cable depends on whether the other device is set up as a Data Communications Equipment (DCE) or Data Terminal Equipment (DTE) device.

The HomeBase communication port is configured as a DCE device. To communicate with a DCE device, use either a null modem adapter in line with a standard RS-232 cable, or a null-modem serial cable. To communicate with a DTE device such as a PC, use a standard (or straight-through) RS-232 cable.

You can make your own cables by following the pin configuration in the chart below. To do so, you must determine if your host RS-232 device is 9-pin or 25-pin, and whether it is configured as a DCE or DTE device.

RS-232 Pin Configuration

HomeBase /Host Port (DCE)	IBM AT DB9 (DTE)	IBM XT DB25 (DTE)	Modem DB25 (DCE)
Pin / Input Signal			
2 / (RD)	2	3	2
3 / (TD)	3	2	3
5 / (SG)	5	7	7
4 / (DTR)	4	20	6
6 / (DSR)	6	6	20
7 / (RTS)	7	4	5
8 / (CTS)	8	5	4

Note: The HomeBase **cannot** be daisy-chained.

Setting up the Terminal for ActiveSync Communications via RS-232

1. On the terminal, tap **Start > ActiveSync > Tools > Options**. ActiveSync opens displaying the PC tab.
2. In the **Use this PC** drop-down list, select the name of the host PC.
3. Select **Sync with this PC during manual sync** to indicate that the terminal syncs with the selected host PC when synchronization is run from the terminal.

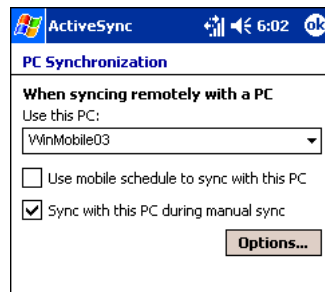

4. Tap **Options**.

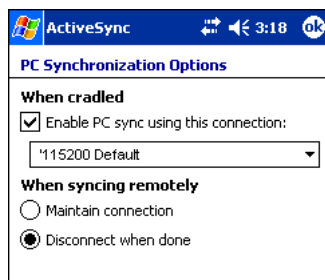

5. Under **When cradled**, select **Enable PC sync using this connection**, and select ***115200 Default** from the drop-down list. *115200 baud is recommended for RS-232 communication.
6. Tap **OK** and place the Dolphin in the HomeBase. The Dolphin terminal attempts to start an ActiveSync connection with the PC automatically.

Setting up the PC for ActiveSync Communications

ActiveSync must be installed and configured for RS-232 on the desktop computer to sync successfully with a Dolphin terminal that is configured for RS-232 communication. Verify that ActiveSync on the PC has the correct ActiveSync Connection Settings. Open ActiveSync and click **File > Communication Properties**.

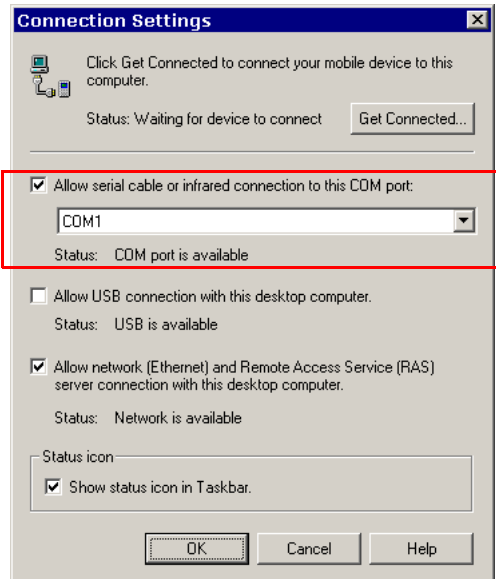

Note: You can have the USB connection box checked in addition to the serial cable box without affecting processing. However, you should use RS-232 or USB.

Communicating with the Dolphin Terminal

1. Insert the Dolphin terminal into the terminal well of the HomeBase.
 - The DOCK LED lights green. If the DOCK LED does not light, make sure that the terminal is properly seated. You may need to remove and re-insert the terminal.
 - The Dolphin terminal activates. If the terminal does not power on, verify that the Hand Held Products power supply is properly connected to the cradle and plugged into a functioning outlet.
 - The Dolphin terminal automatically opens ActiveSync to establish a connection.
2. The HomeBase can now transfer data between the terminal and the host device. If communication does not occur, check the port connections to ensure that the cradle is correctly configured.

Verifying Communication

You can verify that the USB driver is functioning by watching the COMM LED on the USB HomeBase. When the COMM LED lights solid green, the HomeBase is communicating with the PC.

Verifying Data Transfer

The COMM LED flashes when data is being transferred via the HomeBase. For an RS-232 connection, the COMM LED flashes red and green. For a USB connection, the COMM LED flashes green.

Mounting the HomeBase

Set the Dolphin HomeBase on a dry, stable surface, such as a desktop or workbench near an electrical outlet. Be sure to provide enough workspace with good lighting for the user to view and operate the Dolphin terminal while it is in the HomeBase.

When choosing a location, bear in mind that:

- The mounting location must allow users easy access to the [AUX Battery LED](#) (see page 13-2).
- The serial, USB, and power jack face straight out of the rear panel. You will most likely want easy access to them in the future.

Desk Mounting

Dolphin charging/communication cradles have a DIN rail (7.5mm high X 35mm wide) slot on the bottom to allow for secure desk attachment of the unit if desired.

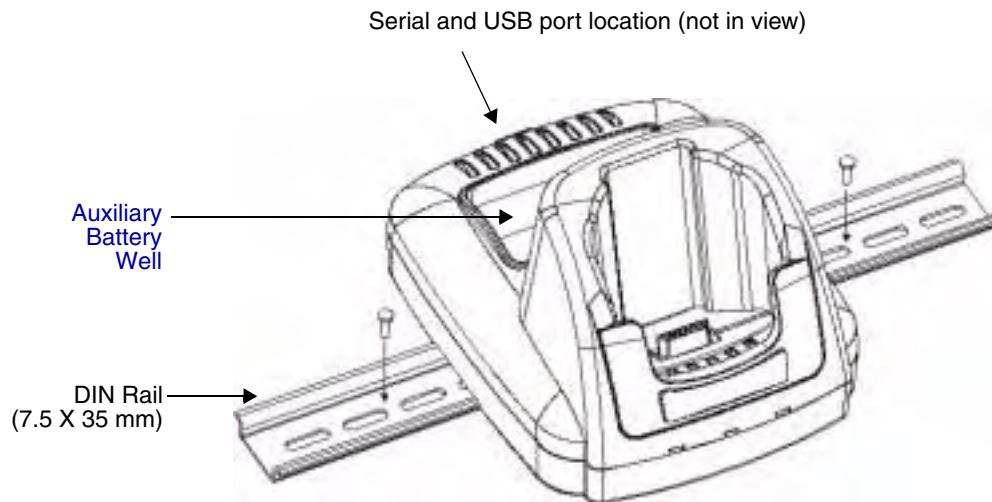

1. Slide the DIN rail slot along the bottom panel.
2. Using the appropriate nuts and bolts, secure the DIN rail to the desk or flat surface.

Wall Mounting

A wall mount kit that contains a screws and a mounting bracket can be purchased separately. The bottom panel of the HomeBase contains four rubber feet - one at each corner - that help keep it stable and secure when resting on a flat surface. Those rubber feet should be removed with pliers before wall mounting the HomeBase.

1. Secure screws to the bottom panel by sliding them into the available slots.

-
2. Attach the bottom panel to the mounting bracket - match the holes to the secured screws.

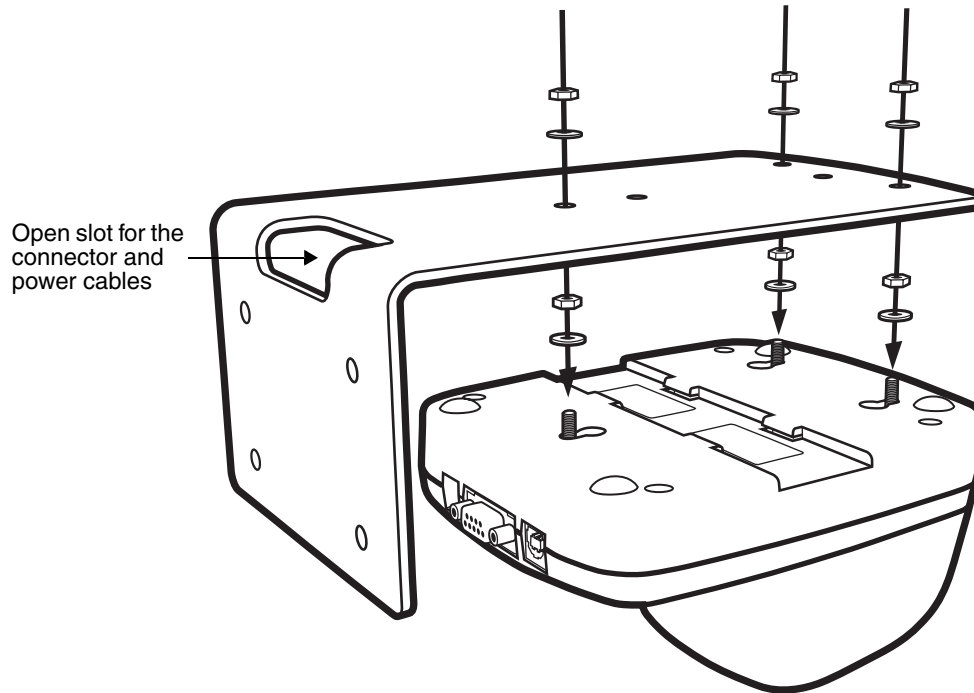

3. Fasten the screws to secure the HomeBase to the mounting bracket.

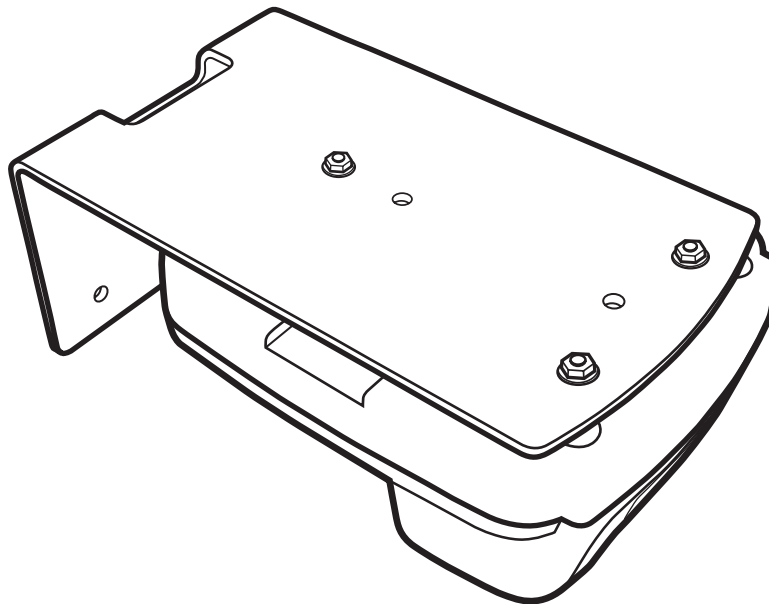

4. Turn the secured HomeBase right side up.

5. Using the appropriate screws, secure the mounting bracket to the wall or vertical surface as shown.

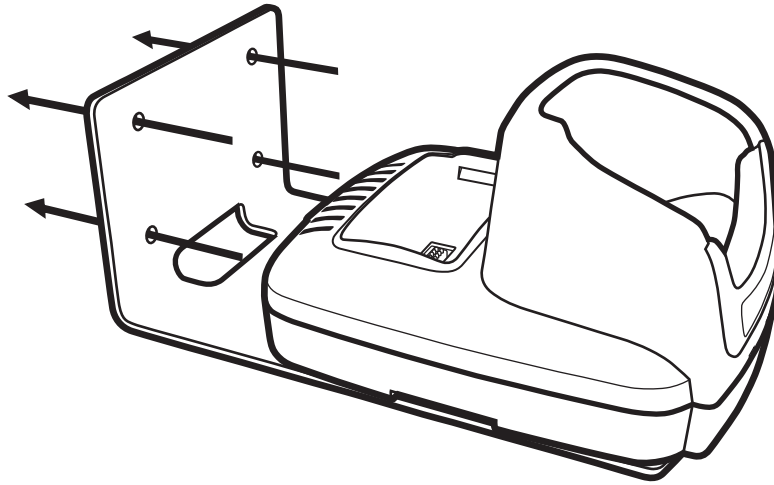

Overview

The Dolphin Mobile Base charging and communication cradle is designed specifically for in-premise and in-transit data collection applications. It features a flexible mounting bracket, a cigarette lighter adapter, and a power cable to adapt it to your environment.

When a terminal is seated in the Mobile Base, its main battery pack charges in less than four hours. The serial connector supports RS-232 communication and power out to peripheral devices, such as hand held scanners.

As the hub of your mobile data collection system, the Mobile Base performs three important functions: charging, communications, and storage.

Charging

The Mobile Base completes a full charge of the main battery pack in less than four hours. The Mobile Base also provides power to the intelligent battery charging system in all Dolphin terminals that senses when a full charge has been achieved and switches to a trickle charge to prevent over- and undercharging.

Communications

The Mobile Base transmits data at speeds of up to 115K baud via its RS-232 serial port.

Convenient Storage

Intelligent battery charging makes the Mobile Base a safe and convenient storage receptacle for your Dolphin terminal.

Capacity

The Mobile Base holds one terminal.



Use only the peripherals, power cables, and power adapters from Hand Held Products. Use of peripherals, cables, or power adapters not sold/manufactured by Hand Held Products will void the warranty and may damage the terminal.



Use only the Li-ion battery packs provided by Hand Held Products. The use of any battery pack not sold/manufactured by Hand Held Products in a Dolphin terminal will void your warranty and may result in damage to the Dolphin terminal or battery.

Dolphin Mobile Base Hardware Overview

Front Panel

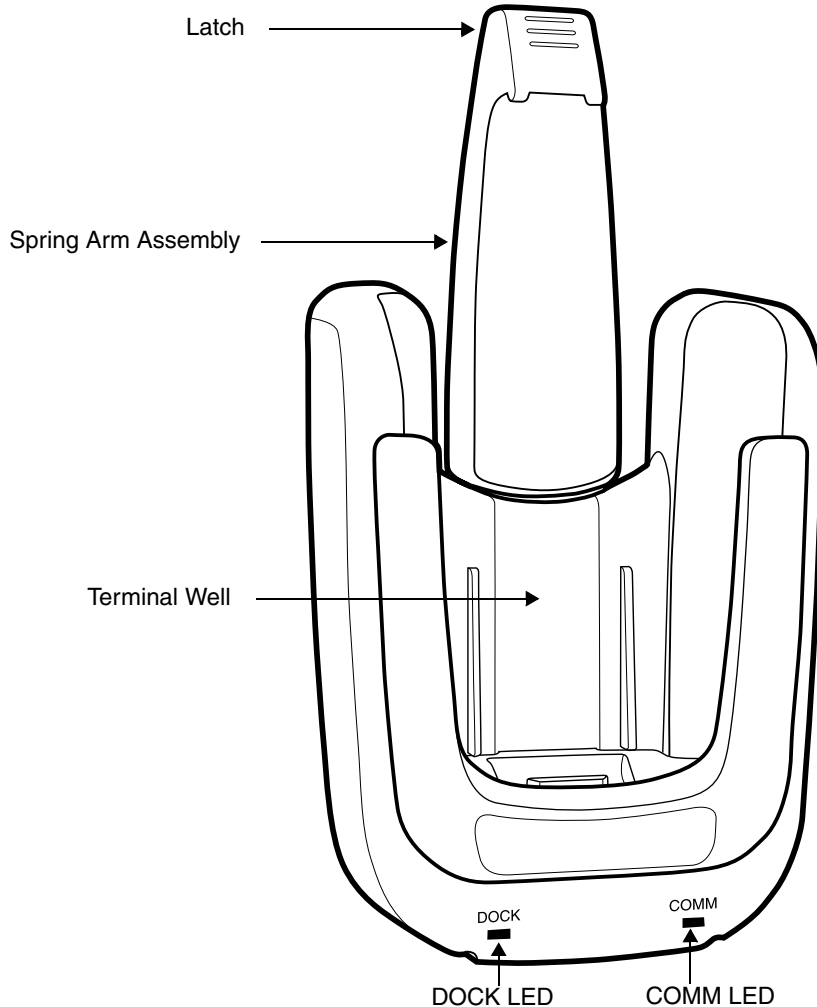

Latch

You can use the latch at the top of the spring arm assembly to snap a seated terminal into place. The latch can rest on top of the hand strap slot on the back panel of the terminal; see page 14-6.

Spring Arm Assembly

For more information, see [Spring Arm Assembly](#) on page 14-5..

Terminal Well

Place the terminal in this well to communicate with a host device and charge the main battery pack.

DOCK LED

Lights solid green when the Dolphin terminal is properly seated in the terminal well.

COMM LED

Indicates the status of data transfer between the host device and the Dolphin terminal

COMM LED Color Indicates that...

Red	Data is being sent from the host device to the Dolphin Mobile Base.
Green	Data is being sent from the Dolphin Mobile Base to the host device.
Orange	Data is being sent at high data rates.

Bottom Panel

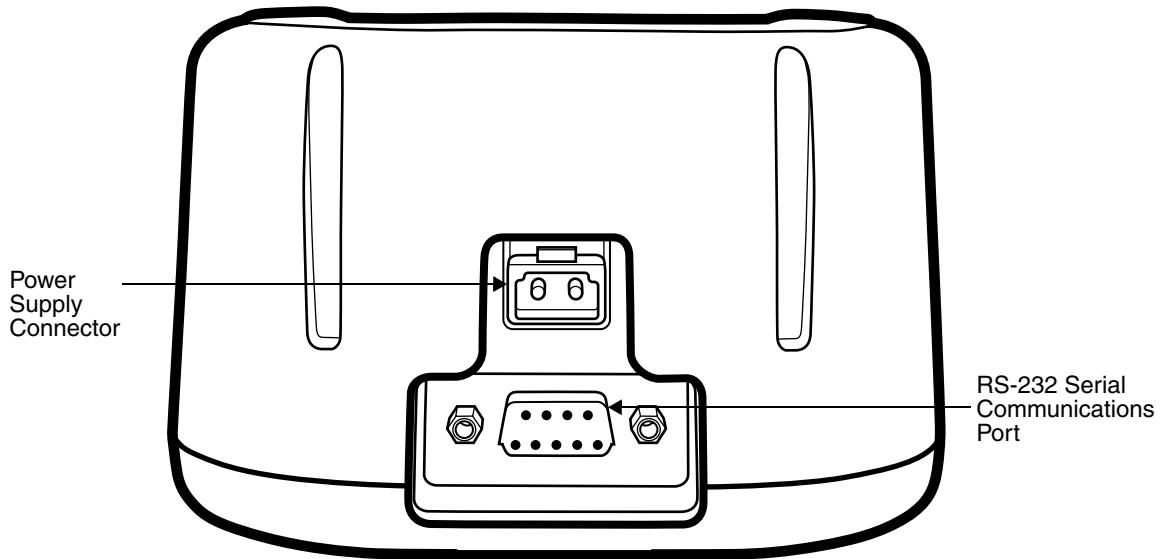

Power Supply Connector

Attach a power cable from Hand Held Products to this connector. The Mobile Base can be powered by an external DC power source between 11 VDC to 48 VDC. To run on vehicle power, you can use the 12 VDC cable or 24 VDC cable option. The appropriate cable comes with the kit you ordered. The 12 VDC cable can be used with a cigarette lighter outlet. The 24 VDC, pigtail cable can be used to "hard-wire" into the vehicle power bus.



Verify that the power source is always within the specified range and observe correct input voltage polarity. An improper input voltage range (above the 48 VDC maximum) or reverse polarity could damage the power conversion circuitry.

RS-232 Serial Communications Port

Use a standard serial cable to connect to the host device via RS-232. The following diagram displays the pin diagram of the serial connector of the bottom panel of the Mobile Base.

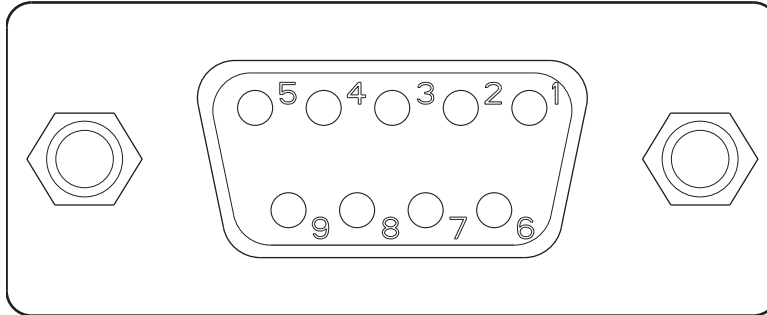

<u>Pin #</u>	<u>Description</u>
1	Internal Jumper to Pin 6
2	TXD
3	RXD
4	DSR
5	GND
6	DTR
7	CTS
8	RTS
9	5 VOLT OUT

Signals referenced are for a DTE device.

The Mobile Base connector is straight to the printed circuit board (PCB). The ninth pin sends 500mA at 5 Volts power out. This can power a peripheral device, such as a mobile printer, as long as that peripheral device can accept 500mA at 5 Volts.

Back Panel

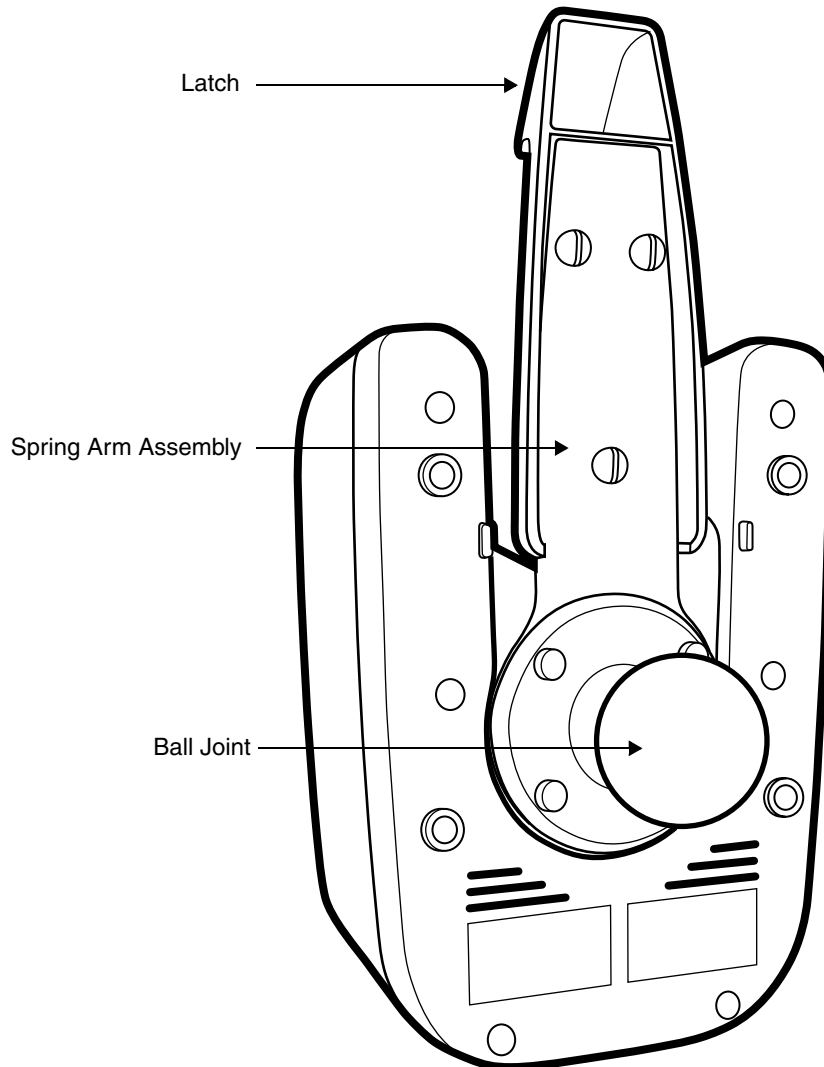

Spring Arm Assembly

The spring arm assembly holds the terminal securely in place and connects the Mobile Base to the ball joint.

Ball Joint

There are two ball joints: one on the back of the Mobile Base and one on the mounting bracket. Both ball joints are inserted into the mounting bracket and secured by the turnscrew.

Mounting the Dolphin Mobile Base

There are three items you use to mount the Dolphin Mobile Base: the ball joints on the both the back panel and the ball joint connector, the mounting bracket, and the turnscrew.

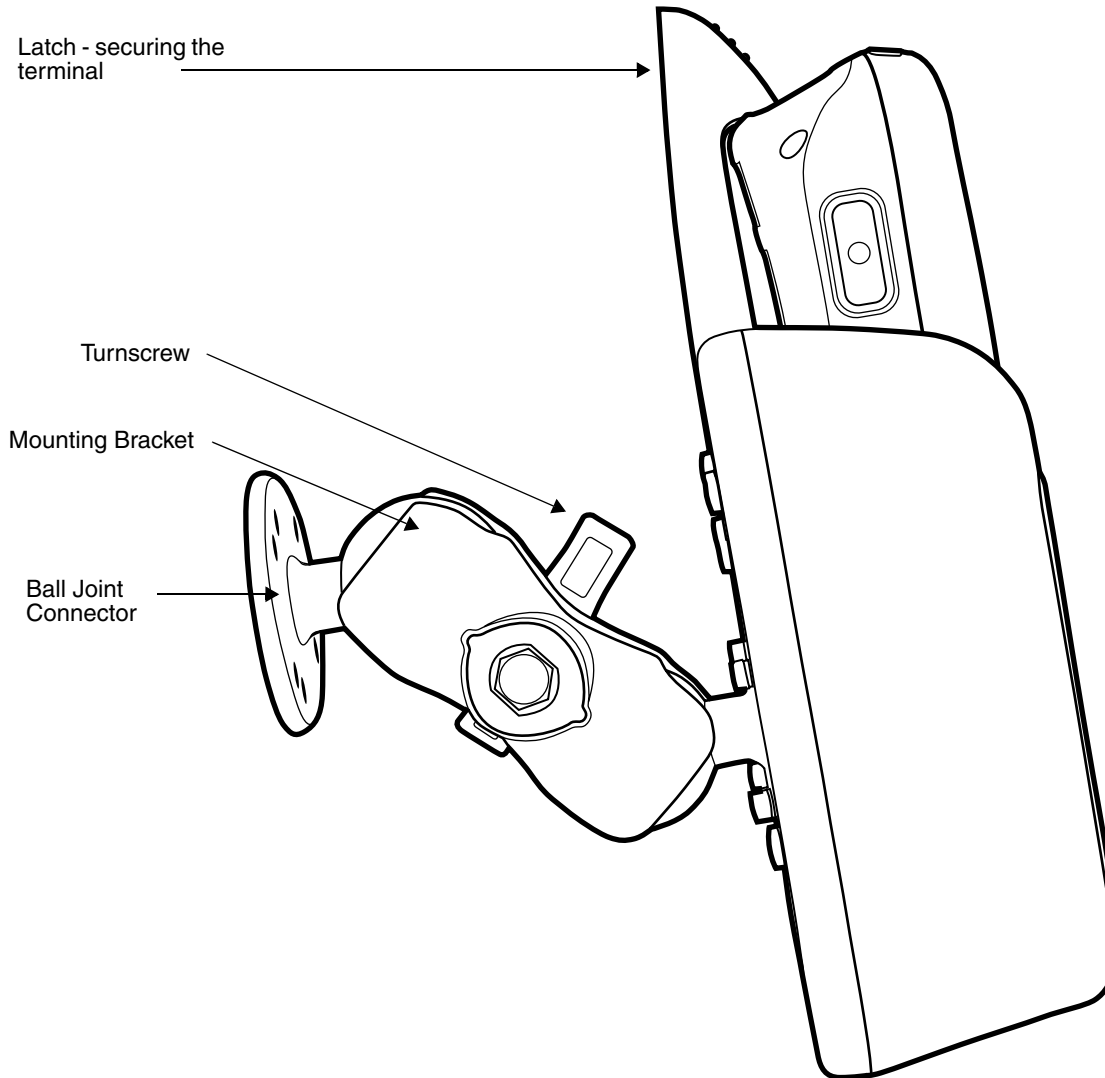

Turnscrew

The turnscrew is located on the top of the bracket. Rotate the turnscrew to secure or loosen the ball joint slots.

Mounting Bracket

The bracket contains the turnscrew and two slots - one for the ball joint on the back panel and one for the ball joint connector. Both ball joints are inserted into a slot and secured with the turnscrew.

Ball Joint Connector

The ball joint is what you attach to the mounting surface. It is comprised of a ball joint and flat disk. The disk contains drill holes you use to secure the Mobile Base to the mounting surface.

To Mount the Dolphin Mobile Base

1. Secure the ball joint connector to a stable, mounting surface.
When selecting a surface, keep in mind that the power supply and serial connectors point straight out the bottom panel.

2. On the mounting bracket, loosen the turnscrew.
3. Insert both ball joints into the mounting bracket.
4. Tighten the turnscrew to secure both ball joints.

Powering the Dolphin Terminal

When seated in a Mobile Base that is connected to the appropriate power source, the Dolphin terminal receives the power to charge its main battery and run its internal circuitry. Keep the Mobile Base plugged into the power source so that the Dolphin terminal battery pack stays fully charged.

Charging the Dolphin Terminal

Dolphin terminals contain an intelligent battery charging system that monitors the charging of the battery pack to protect the battery from damage by overcharging. Therefore, the Dolphin terminal may be stored indefinitely in the Mobile Base without damage to the terminal, the battery pack, or the Mobile Base.

1. Insert a battery pack into the Dolphin terminal.
2. Slide the terminal, imager window up and the LCD visible, into the terminal well of the Mobile Base until it stops.
3. When the Dolphin terminal is properly seated, the DOCK LED lights solid green. The terminal begins charging automatically.

Setting Up the Mobile Base for Communications

The Mobile Base RS-232 interface allows the Dolphin terminal to communicate to a personal computer, modem, or any standard RS-232 device using a standard serial cable and communications software.

Connecting the Cables

Plug an RS-232 serial cable into the RS-232 Communications Port on the bottom panel. Plug the other end of the RS-232 serial cable into the correct port on the host RS-232 device.

The wiring of your cable depends on whether the other device is set up as a Data Communications Equipment (DCE) or Data Terminal Equipment (DTE) device. The Mobile Base communication port is configured as a DCE device. To communicate with a DCE device, use either a null modem adapter in line with a standard RS-232 cable, or a null-modem serial cable. To communicate with a DTE device such as a computer, use a standard (or straight-through) RS-232 cable.

RS-232 Pin Configuration

Refer to this table if you want to make your own cables. To do so, you must determine if your host RS-232 device is 9-pin or 25-pin and configured as a DCE or DTE device.

Mobile Base /Host Port (DCE)	IBM AT DB9 (DTE)	IBM XT DB25 (DTE)	Modem DB25 (DCE)
Pin / Input Signal			
2 / (RD)	2	3	2
3 / (TD)	3	2	3
5 / (SG)	5	7	7
4 / (DTR)	4	20	6
6 / (DSR)	6	6	20
7 / (RTS)	7	4	5
8 / (CTS)	8	5	4

Configuring the Terminal for ActiveSync Communications

1. On the terminal, tap **Start > ActiveSync > Tools > Options**. ActiveSync opens displaying the PC tab.

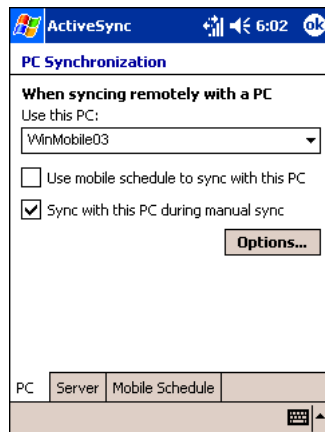

2. In the **Use this PC** drop-down list, select the name of the host PC.
3. Select **Sync with this PC during manual sync** to indicate that the terminal syncs with the selected host PC when synchronization is run from the terminal.
4. Tap **Options**.

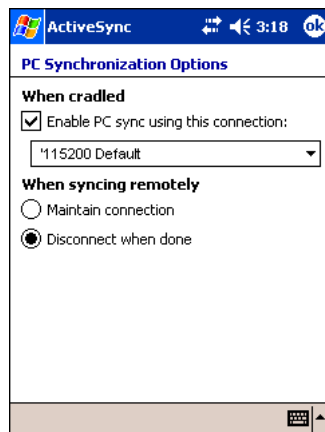

5. Under **When cradled**, select **Enable PC sync using this connection**, and select **115200 Default** from the drop-down list. '115200 baud is recommended for RS-232 communication.
6. Tap **OK**.
7. Place the Dolphin in the Mobile Base. The Dolphin attempts to start an ActiveSync connection with the desktop computer automatically.

Overview

The Dolphin ChargeBase is a four-slot charging cradle that can power four Dolphin terminals, and charge their main batteries in less than four hours. Each charging slot charges terminals independently of the other slots.

Charging

The Dolphin ChargeBase completes a full charge of the main battery pack in less than four hours. The ChargeBase also provides power to the intelligent battery charging system in all Dolphin terminals that senses when a full charge has been achieved and switches to a trickle charge to maintain the full charge.

As battery packs charge, the charging circuitry follows the two-step charging process (CC-CV) that is recommended for Li-Ion batteries. The process monitors changes in temperature, current, and voltage.

Convenient Storage

Intelligent battery charging makes the Dolphin ChargeBase a safe and convenient storage receptacle for Dolphin terminals.

Capacity

The ChargeBase can hold up to four Dolphin 7900 terminals.



Use only the peripherals, power cables, and power adapters from Hand Held Products. Use of peripherals, cables, or power adapters not sold/manufactured by Hand Held Products will void the warranty and may damage the terminal.



Use only the Li-ion battery packs provided by Hand Held Products. The use of any battery pack not sold/manufactured by Hand Held Products in a Dolphin terminal will void your warranty and may result in damage to the Dolphin terminal or battery.

Dolphin ChargeBase Parts and Functions

Front Panel

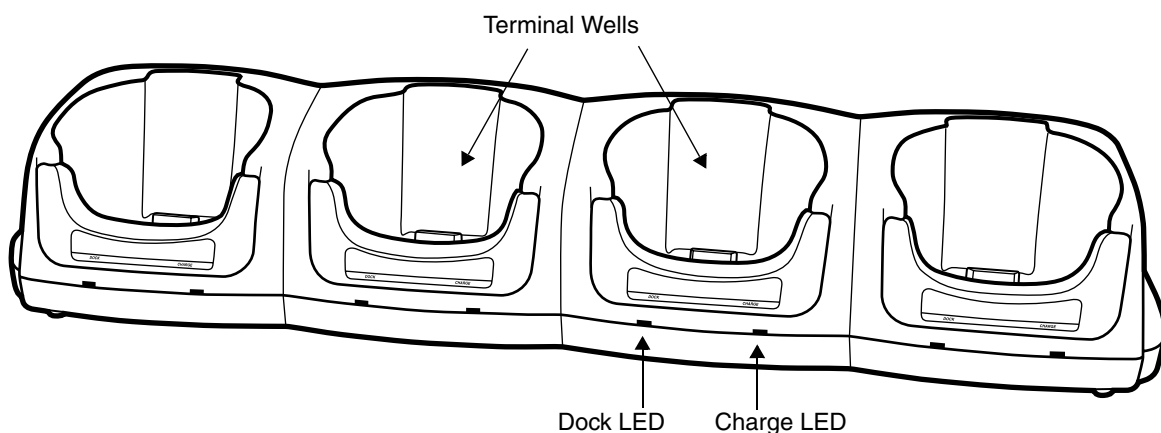

Terminal Wells

The ChargeBase contains four terminals wells. Each terminal well

- Holds and charges the main battery pack of one Dolphin terminal.
- Contains the companion to the industrial-grade, 17-pin connector on the bottom panel of Dolphin terminals.
- Has two LEDs on the front: the Dock LED and the Charge LED.

Dock LED

Each terminal well displays a Dock LED on the front that lights solid green when a terminal is properly seated, which means that the terminal and the base are connected.

Charge LEDs

Each terminal well displays a Charge LED on the front that lights green to indicate charging. For details, see [Charging Terminals in the ChargeBase](#) on page 15-3.

Back Panel

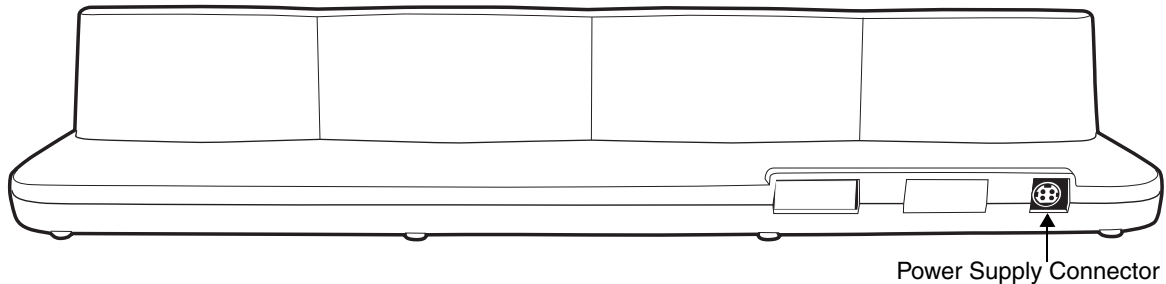

Power Supply Connector

This connector receives input from the power adapter. Plug the power connector cable from the power adapter into this connector. There is no ON/OFF switch on the back panel of the ChargeBase. The ON/OFF switch is on the power adapter.

Power Supply

The Dolphin ChargeBase includes a power supply that contains a power adapter to ensure the proper voltage. The power adapter plugs into standard AC/DC outlets.

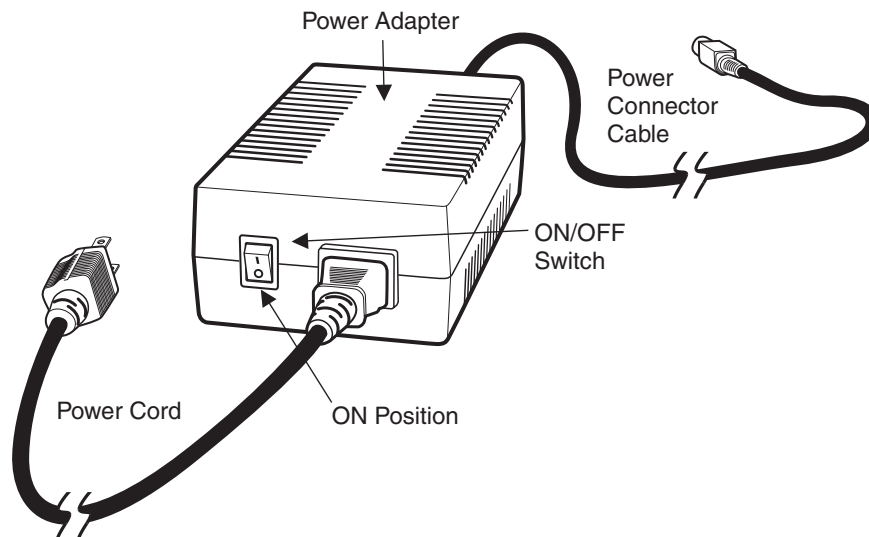

Supplying Power to the ChargeBase



You must use the power adapter provided by Hand Held Products with the Dolphin ChargeBase. Using a non-Hand Held Products power adapter voids your warranty and could result in serious damage to the circuitry of the Dolphin ChargeBase.

1. Be sure the power switch on the power adapter is in the OFF position.

-
2. Plug the power cord into the power adapter.
 3. Plug the power connector cable into the power connector on the back panel of the ChargeBase.
 4. Plug the power cord into a standard wall outlet.
 5. On the power adapter, turn the power switch to the ON position. The LEDs light as the ChargeBase powers up.
 6. The Dolphin ChargeBase is ready to begin charging terminals.

Inserting and Removing Terminals

To insert a terminal, hold the terminal with the bottom panel perpendicular to the base. Slide the terminal into the well until the Dock LED lights solid green. Charging begins immediately.

To remove a terminal, grasp it firmly in your hand and lift it up and out of the terminal well. The LEDs for the terminal well turns off.

Charging Terminals in the ChargeBase

The Dolphin ChargeBase charges the main battery of each terminal in less than four hours. The Dolphin ChargeBase works with the intelligent battery charging system incorporated in the Dolphin terminal to prevent overcharging. This means that Dolphin terminals may be stored in the ChargeBase indefinitely without damage to the terminals, battery packs, or the ChargeBase.

1. Power the ChargeBase; see [Supplying Power to the ChargeBase](#) on page 15-2.
2. Insert a terminal into a terminal well; see [Inserting and Removing Terminals](#) on page 15-3.
3. The Charge LED lights green to indicate that the terminal is powered and charging.

Mounting the Dolphin ChargeBase

The Dolphin ChargeBase should be placed on a dry, stable surface. To easily adapt the ChargeBase to your environment, it can be mounted on a flat, horizontal surface such as a desktop or workbench, or a flat, vertical surface such as a wall.

When choosing a location, always bear in mind that

- The mounting location must allow users easy access to the power connector.
- The ChargeBase should be oriented so that users can easily read the labels.

Bottom Panel

The bottom panel of the Dolphin ChargeBase offers two mounting options: insert a DIN Rail in the available slot for desk mounting or secure two mounting brackets with the available screw slots.

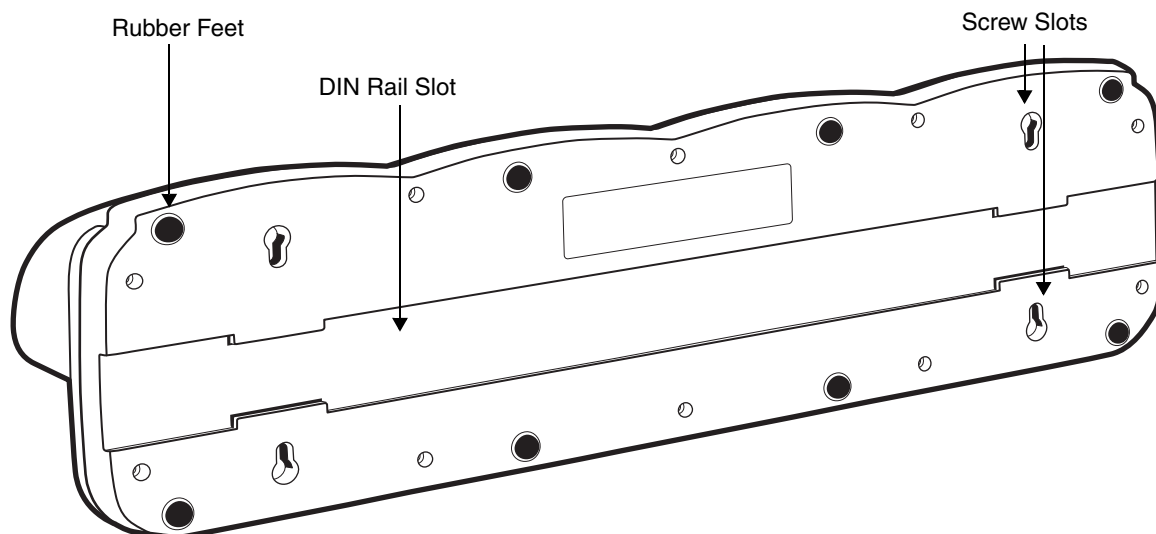

Using the DIN Rail

All Dolphin charging/communication cradles have a slot for a 7.5mm (high) X 35mm (wide) DIN rail on the bottom panel that enables you to mount to a desk or secure, flat surface.

1. Slide the DIN Rail into the DIN Rail slot on the bottom panel.

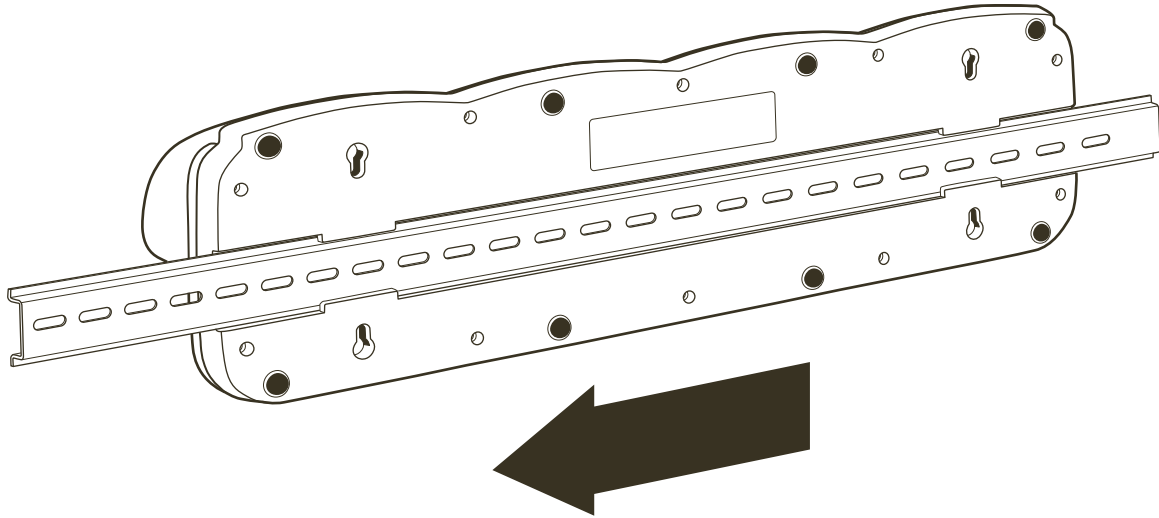

2. Turn the ChargeBase and DIN Rail right side up.
3. Secure the DIN Rail to a stable, flat horizontal surface.

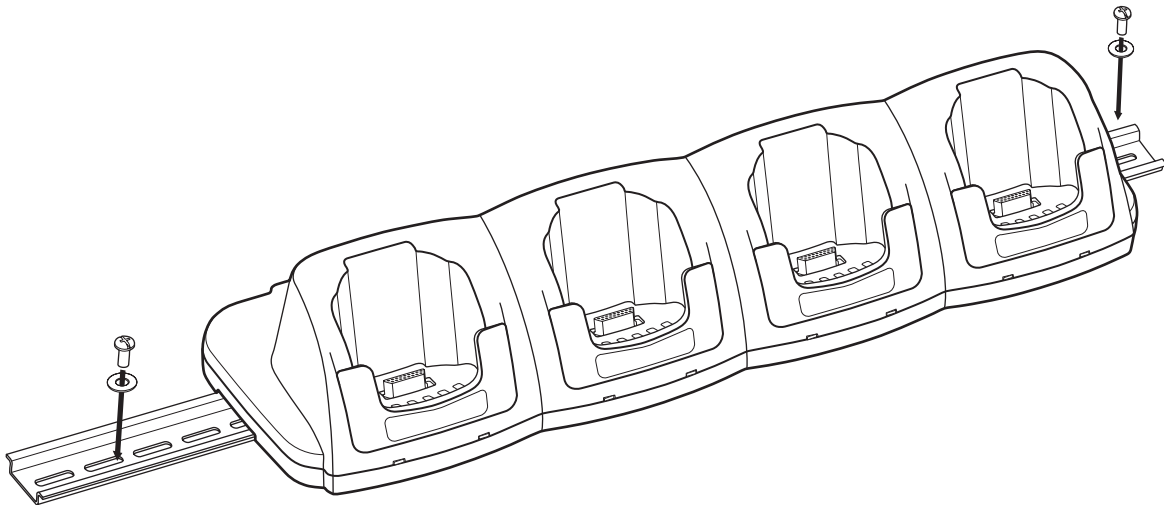

Using the Mounting Brackets

A wall mount kit can be purchased separately. It contains two mounting brackets to secure both ends of the ChargeBase. Use the screws and the mounting brackets to mount the ChargeBase to a wall or other vertical surface. Each mounting bracket contains an open slot in the back to accommodate the connector cables.

The bottom panel of the ChargeBase contains rubber feet that hold it steady on a flat surface. We recommend that those rubber feet be removed with pliers prior to applying the mounting brackets to the bottom panel.

1. Secure the screws into the four screw slots on the bottom panel. Insert the heads into the round end and slide towards the narrow end until the screw is secure.

-
2. Attach the bottom panel to the two mounting brackets.

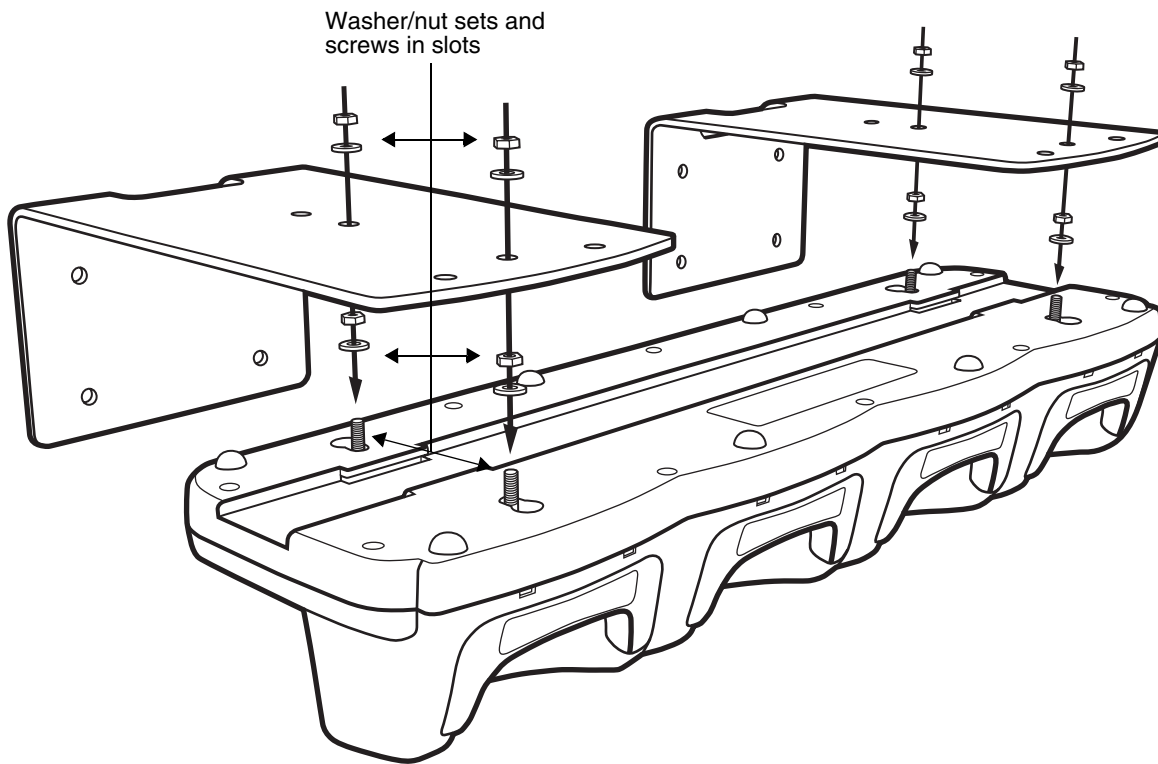

3. Using the nuts and bolts, secure the mounting brackets to the bottom panel.

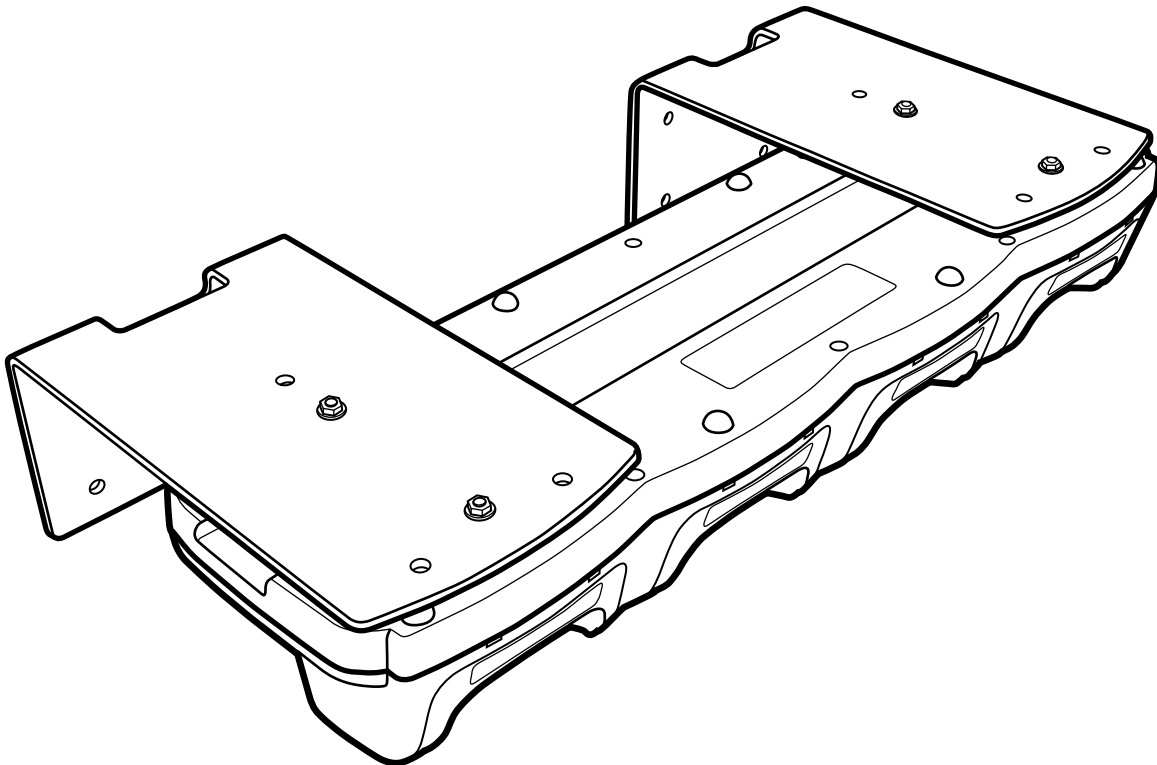

-
4. Secure the mounting brackets to an appropriate horizontal surface.

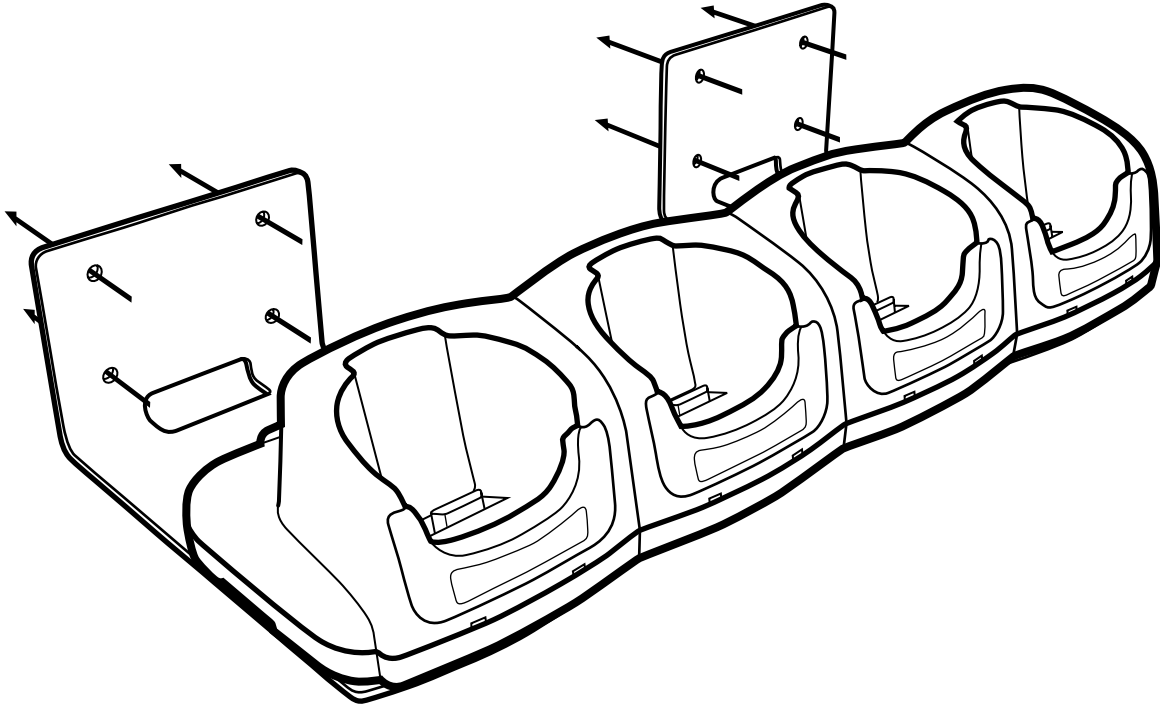

Overview

The Dolphin QuadCharger is a four-slot charging station that can charge a Li-ion battery in less than four hours. The fourth slot features a battery analyzer that completely resets and re-calibrates a battery and displays its resulting capacity.

Compatibility

The QuadCharger is compatible with the Li-ion batteries that power Dolphin 7900 Series terminals.

Charging Process

Each charging slot works independently of the other three.

As battery packs charge, the charging circuitry follows the two-step charging process (CC-CV) that is recommended for Li-Ion batteries. The process monitors changes in temperature, current, and voltage. The charger also resets and calibrates battery pack data to accurately show battery status on the Dolphin display.



Use only the peripherals, power cables, and power adapters from Hand Held Products. Use of peripherals, cables, or power adapters not sold/manufactured by Hand Held Products will void the warranty and may damage the terminal.



Use only the Li-ion battery packs provided by Hand Held Products. The use of any battery pack not sold/manufactured by Hand Held Products in a Dolphin terminal will void your warranty and may result in damage to the Dolphin terminal or battery.

Dolphin QuadCharger Parts and Functions

Front Panel

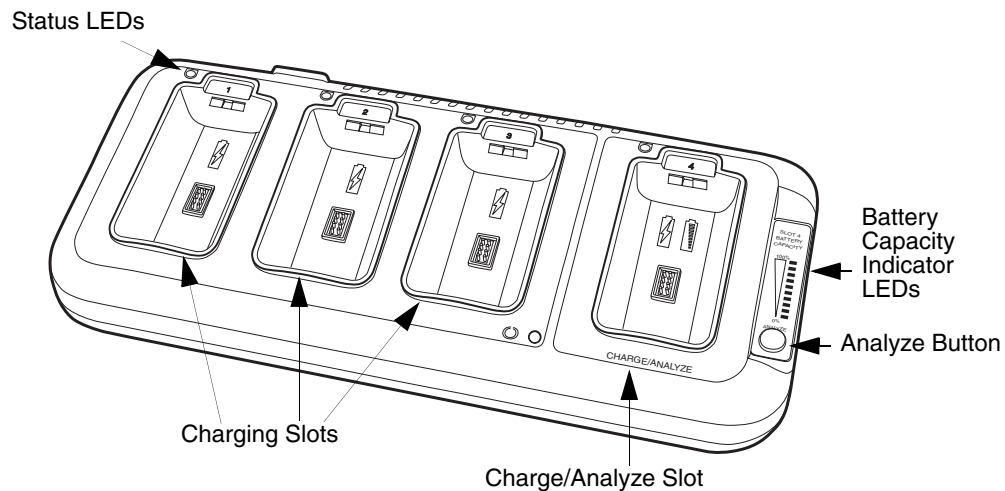

Charging Slots

The QuadCharger contains four charging slots. Each slot holds one battery. When a battery is placed in a slot, it immediately begins charging.

Charge/Analyze Slot

This is the fourth slot and the only one that can be used to analyze a battery. When a battery is placed in this slot, it begins charging just as it does in the other three slots. However, if you press the ANALYZE button, it runs the battery in this slot through the complete Analyze cycle. For more information, see [Using the Battery Analyzer](#) on page 16-4.

Battery Capacity Indicator LEDs

These LEDs give a readout of the remaining battery capacity after it has run through a complete analyze cycle. For more information, see [Battery Capacity Indicator LEDs](#) on page 16-2.

Analyze Button

Press this button to start a battery analyze cycle; see [Using the Battery Analyzer](#) on page 16-4..

Status LEDs

A status LED is located above each of the four battery slots. The color of the LED indicates the charge status of the batteries in its slot.

Status LED color	This color indicates that the battery in the slot...
Green	Has completed its charge cycle and is ready for use.
Orange	Is being charged at a maximum charge rate.
Red	Encountered an error during the most recent charge cycle.

Rear Panel

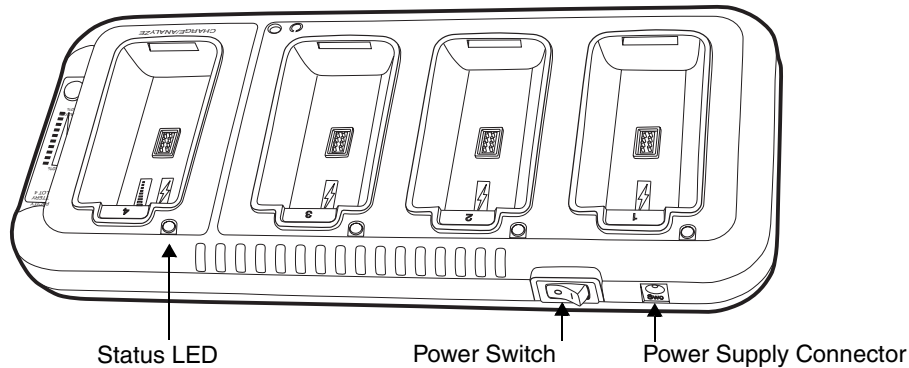

Power Switch

Toggle the power switch to turn the QuadCharger on and off.

Power Supply Connector

Use this connector to attach the power supply to the QuadCharger. The universal power supply accepts input voltages between 90-265 volts.

Supplying Power to the QuadCharger

You must use the power adapter cable from Hand Held Products so that voltage is adjusted appropriately.

1. Locate the AC power adapter cable and plug it into the power source.
2. Connect the power cable to the power adapter.
3. Connect the power cable to the supply connector on the back of the QuadCharger.
4. Press the power switch to the ON position.
The power LED illuminates green, and the charger performs a self-diagnostic test that lasts approximately five seconds.

Inserting and Removing Battery Packs

To insert a battery pack, place the end of the battery without the locking tab into the bottom of the charging pocket and snap the battery into place with a hinging motion. The Status LED for that particular slot illuminates orange when the battery has been properly inserted.

To remove a battery pack, push the locking tab down and pull the battery out from the charging slot with a hinging motion.

Recommendations for Storing Batteries

To maintain top performance from batteries, follow these storage guidelines:

- Avoid storing batteries outside of the specified temperature range of -4 to 104° F (-20 to 40°C) or in extremely high humidity.
- For prolonged storage, do not keep batteries stored in a charger that is connected to a power source.

Charging Batteries in the QuadCharger

For best results, battery packs should be at room temperature before recharging them; temperature has a marked effect on charging. The recommended temperature range is 50° to 95° F (10° to 35° C).

1. Set up the QuadCharger.
2. Supply the QuadCharger with power and turn the power switch on.
3. Insert batteries into the appropriate slots. The Status LED for each slot turns orange to indicate that the battery has begun a charge cycle.
4. When the Status LED turns green, the battery in the slot has completed charging.

Using the Battery Analyzer

Purpose

Using the Charge/Analyze slot helps you monitor the charge capacity of Li-ion batteries over time. The LEDs in this slot provides a readout of the battery's capacity after a complete discharge and full charge. They tell you the maximum charge level the battery can hold.

Location

The battery analyzer is located in the fourth slot of the ChargeBase. Only batteries in this slot can be analyzed.

Analyze Cycle

The Analyze cycle is initiated when a battery is placed in the Charge/Analyze slot and the ANALYZE button is pressed. In an Analyze cycle, batteries are completely discharged, then recharged to capacity, as well as completely reset and re-calibrated.

The length of time it takes for a battery to complete the Analyze cycle varies depends on initial state of the battery's charge. Minimum time is 8 hours, maximum time is 12 hours.

Battery Capacity Indicator LEDs

The Battery Capacity Indicator LEDs are located along the right side of the Charge/Analyze slot. These LEDs display the capacity of the battery at the end of the Analyze cycle. Battery capacity is displayed as a percentage of measured capacity/rated capacity. Each LED equates to 10% battery capacity.



Status LED

The Charge/Analyze slot also contains a standard status LED in the upper, left corner of the slot. When this slot is used for regular charging, this LED operates in the usual manner; see [Status LEDs](#) on page 16-2..

When this slot is being used to analyze a battery, the status LED functions as follows:

Status LED color	Indicates that the battery in the slot...
Solid Green	Has completed the Analyze cycle.
Flashing Orange	Is being analyzed.
Solid Red	Encountered an error during the Analyze cycle.

To Analyze a Battery

Complete these steps:

1. Insert the battery into the Charge/Analyze slot (the fourth).
2. Press the ANALYZE button. The Status LED flashes orange to indicate that the analyzing cycle has begun.
3. Upon completion of the Analyze cycle, the Status LED lights solid green, and the Battery Capacity Indicator LEDs display the battery's capacity.



The Dolphin QuadCharger is accumulating battery pack information during the entire Analyze cycle. Do NOT remove the battery until the cycle has been completed.

Mounting the QuadCharger

The Dolphin QuadCharger should be on a dry, stable surface. To easily adapt the QuadCharger to your environment, it can be mounted on a flat, horizontal surface such as a desktop or workbench, or a flat, vertical surface such as a wall.

When choosing a location, always bear in mind that

- the mounting location must allow users easy access to power switch and power connector.
- the QuadCharger should be oriented so that users can easily insert and remove battery packs and read the labels, especially for the Battery Analyzer.

Using the DIN Rail

Most Dolphin peripherals have a DIN Rail (7.5 high X 35 wide mm) slot on the bottom panel to enable secure mounting.

To mount the Dolphin QuadCharger, you slide the DIN Rail into the slot on the bottom panel. Then, using the appropriate nuts and bolts, secure the DIN rail to the desk or wall.

Desk Mounting

The following graphic displays how to mount the QuadCharger to a desk:

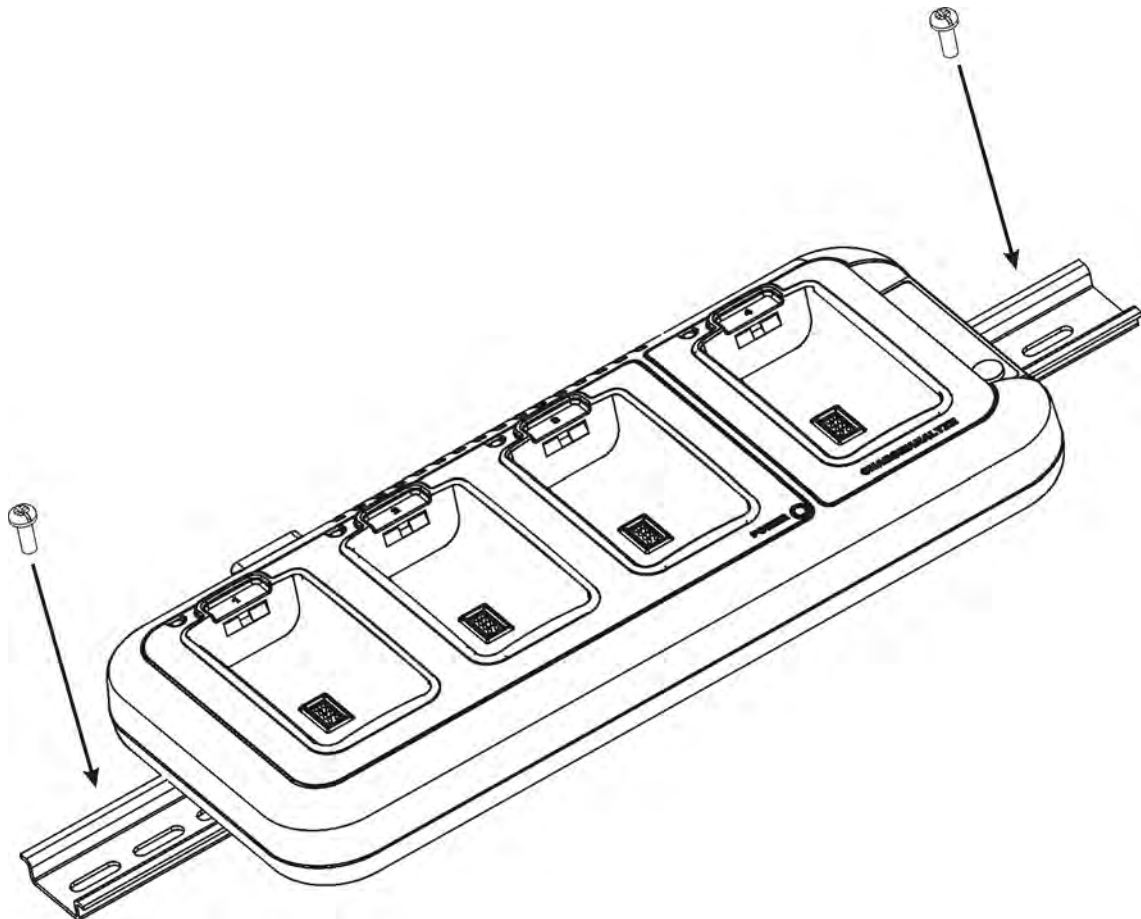

Wall Mounting

The following graphic displays how mount a QuadCharger to a wall:

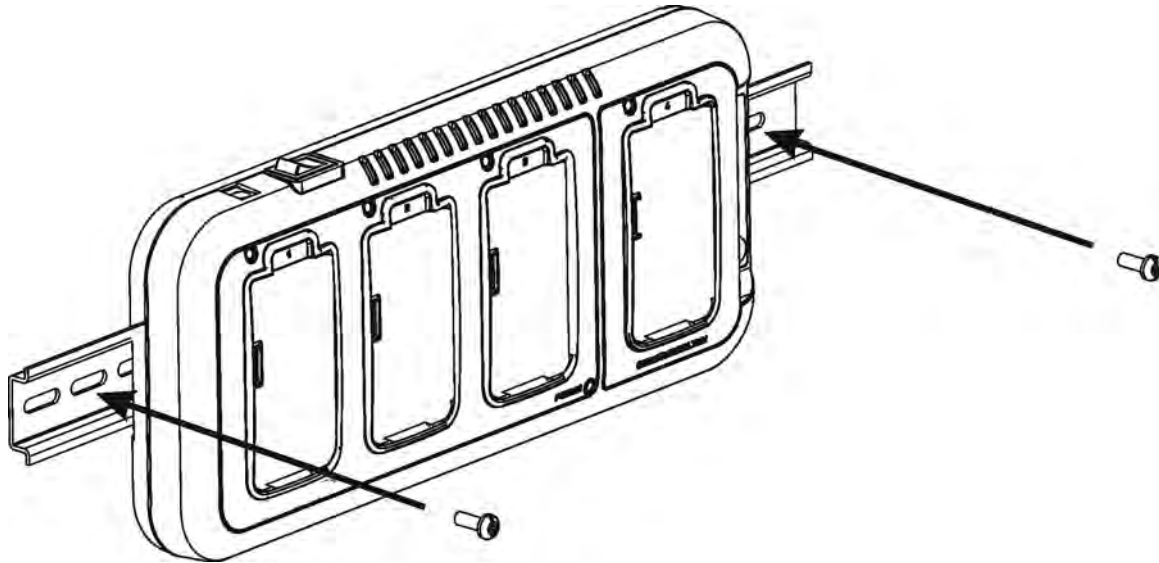

Troubleshooting

If you encounter problems with your Dolphin QuadCharger, refer to chart below for possible solutions. If problems persist, please contact Technical Support.

Problem	Issue
The Status LED does not come on when I insert a battery pack into the Dolphin QuadCharger	Check the power connections on the Dolphin QuadCharger; make sure the POWER switch is ON and the battery pack is properly seated.
The Status LED lights red during charging.	Try to charge the battery in one of the other charging slots. If the red Status LED comes on again, then the problem is associated with the battery pack. If the red status stays with the charging slot, the problem is associated with the charging circuitry.
The Status LED lights red and stays on without a battery in the charging slot.	An error occurred during the self-diagnostic test for that particular charging pocket. Call Hand Held Products Product Service and request an RMA. For additional warranty and return information, see Customer Support on page 17-1.

Product Service and Repair

Hand Held Products provides service for all its products through service centers throughout the world. To obtain warranty or non-warranty service, return the unit to Hand Held Products (postage paid) with a copy of the dated purchase record attached. Contact the appropriate location below to obtain a Return Material Authorization number (RMA #) before returning the product.

North America

Hand Held Products Corporate Offices
Telephone: (800) 782-4263, option 3
Fax: (704) 566-6015
E-mail: naservice@handheld.com

América Latina

Hand Held Products América Latina
Teléfono: (800) 782-4263, opción 8, opción 4
Teléfono: (704) 998-3998, opción 8, opción 4
Fax: (239) 263-9689
E-mail: laservice@handheld.com

Brasil

Hand Held Products São Paulo
Teléfono: Int+55 (11) 2178-0500
Fax: Int+55 (11) 2178-0502

Hand Held Products Rio de Janeiro
Teléfono: Int+55 (21) 2178-0500
Fax: Int+55 (21) 2178-0505

São Paulo and Rio de Janeiro
E-mail: brservice@handheld.com

México

Hand Held Products México
Teléfono: Intl+52 (55) 5203-2100
Fax: Intl+52 (55) 5531-3672
E-mail: mxservice@handheld.com

Europe, Middle East, and Africa

Hand Held Products Europe
Telephone: +31 (0) 40 29 01 633
Fax: +31 (0) 40 2901631
E-mail: euservice@handheld.com

Asia Pacific

Hand Held Products Asia/Pacific
Telephone: +852-2511-3050
Fax: +852-2511-3557
E-mail: apservice@handheld.com

Japan

Hand Held Products Japan
Telephone: +81-3-5770-6312
Fax: +81-3-5770-6313
E-mail: apservice@handheld.com

Online Product Service and Repair Assistance

You can also access product service and repair assistance online at www.handheld.com.

Technical Assistance

If you need assistance installing or troubleshooting, please call your Distributor or the nearest Hand Held Products technical support office:

North America/Canada:

Telephone: (800) 782-4263, option 4 (8 a.m. to 6 p.m. EST)
Fax number: (315) 685-4960
E-mail: natechsupport@handheld.com

América Latina:

Teléfono: (800) 782-4263, opción 8, opción 3
Teléfono: (704) 998-3998, opción 8, opción 3
E-mail: latechsupport@handheld.com

Brasil

São Paulo

Teléfono: Int+55 (11) 2178-0500
Fax: Int+55 (11) 2178-0502

Rio de Janeiro

Teléfono: Int+55 (21) 2178-0500
Fax: Int+55 (21) 2178-0505

São Paulo and Rio de Janeiro

E-mail: brtechsupport@handheld.com

México

Teléfono: (800) 782-4263, opción 8, opción 3
Teléfono: (704) 998-3998, opción 8, opción 3
E-mail: latechsupport@handheld.com

Europe, Middle East, and Africa:

Telephone-
European Ofc: Int+31 (0) 40 79 99 393
U.K. Ofc: Int+44 1925 240055
E-mail: eutechsupport@handheld.com

Asia Pacific:

Telephone: Int+852-3188-3485 or 2511-3050
E-mail: aptechsupport@handheld.com

Online Technical Assistance

You can also access technical assistance online at www.handheld.com.

Limited Warranty

Hand Held Products, Inc. ("Hand Held Products") warrants its products to be free from defects in materials and workmanship and to conform to Hand Held Products' published specifications applicable to the products purchased at the time of shipment. This warranty does not cover any Hand Held Products product which is (i) improperly installed or used; (ii) damaged by accident or negligence, including failure to follow the proper maintenance, service, and cleaning schedule; or (iii) damaged as a result of (A) modification or alteration by the purchaser or other party, (B) excessive voltage or current supplied to or drawn from the interface connections, (C) static electricity or electro-static discharge, (D) operation under conditions beyond the specified operating parameters, or (E) repair or service of the product by anyone other than Hand Held Products or its authorized representatives.

This warranty shall extend from the time of shipment for the duration published by Hand Held Products for the product at the time of purchase ("Warranty Period"). Any defective product must be returned (at purchaser's expense) during the Warranty Period to Hand Held Products' factory or authorized service center for inspection. No product will be accepted by Hand Held Products without a Return Materials Authorization, which may be obtained by contacting Hand Held Products. In the event that the product is returned to Hand Held Products or its authorized service center within the Warranty Period and Hand Held Products determines to its satisfaction that the product is defective due to defects in materials or workmanship, Hand Held Products, at its sole option, will either repair or replace the product without charge, except for return shipping to Hand Held Products.

EXCEPT AS MAY BE OTHERWISE PROVIDED BY APPLICABLE LAW, THE FOREGOING WARRANTY IS IN LIEU OF ALL OTHER COVENANTS OR WARRANTIES, EITHER EXPRESSED OR IMPLIED, ORAL OR WRITTEN, INCLUDING, WITHOUT LIMITATION, ANY IMPLIED WARRANTIES OF MERCHANTABILITY OR FITNESS FOR A PARTICULAR PURPOSE.

HAND HELD PRODUCTS' RESPONSIBILITY AND PURCHASER'S EXCLUSIVE REMEDY UNDER THIS WARRANTY IS LIMITED TO THE REPAIR OR REPLACEMENT OF THE DEFECTIVE PRODUCT. IN NO EVENT SHALL HAND HELD PRODUCTS BE LIABLE FOR INDIRECT, INCIDENTAL, OR CONSEQUENTIAL DAMAGES, AND, IN NO EVENT, SHALL ANY LIABILITY OF HAND HELD PRODUCTS ARISING IN CONNECTION WITH ANY PRODUCT SOLD HEREUNDER (WHETHER SUCH LIABILITY ARISES FROM A CLAIM BASED ON CONTRACT, WARRANTY, TORT, OR OTHERWISE) EXCEED THE ACTUAL AMOUNT PAID TO HAND HELD PRODUCTS FOR THE PRODUCT. THESE LIMITATIONS ON LIABILITY SHALL REMAIN IN FULL FORCE AND EFFECT EVEN WHEN HAND HELD PRODUCTS MAY HAVE BEEN ADVISED OF THE POSSIBILITY OF SUCH INJURIES, LOSSES, OR DAMAGES. SOME STATES, PROVINCES, OR COUNTRIES DO NOT ALLOW THE EXCLUSION OR LIMITATIONS OF INCIDENTAL OR CONSEQUENTIAL DAMAGES, SO THE ABOVE LIMITATION OR EXCLUSION MAY NOT APPLY TO YOU.

All provisions of this Limited Warranty are separate and severable, which means that if any provision is held invalid and unenforceable, such determination shall not affect the validity of enforceability of the other provisions hereof.

Hand Held Products extends these warranties only to the first end-users of the products. These warranties are non-transferable.

The limited duration of the warranty for the Dolphin 7900 Series is as follows:

- Terminals with an integrated imager are covered by a two-year limited warranty.
- Terminals with an integrated laser engine are covered by a one-year limited warranty.
- Touch screens are covered by a one-year limited warranty.
- HomeBase, Mobile Base, Mobile Charger, Net Base, ChargeBase, and QuadCharger are covered by a one-year limited warranty.
- Batteries are covered by a one-year limited warranty. Use of any battery not sold/manufactured by Hand Held Products may damage the terminal and/or the battery and will void the warranty. Batteries returned to Hand Held Products in a reduced state may or may not be replaced under this warranty. Battery life will be greatly increased when following the battery instructions in the Dolphin 7900 Series User's Guide.
- Use of any peripheral not manufactured/sold by Hand Held Products will void the warranty. This includes but is not limited to: cables, power supplies, cradles, and docking stations.
- Use only power adapters approved for use by Hand Held Products. Failure to do so may result in improper operation or damage to the unit and will void the warranty.

Hand Held Products extends these warranties only to the first end-users of the products. These warranties are non-transferable.

How to Extend Your Warranty

Hand Held Products offers a variety of service plans on our hardware products. These agreements offer continued coverage for your equipment after the initial warranty expires. For more information, contact your Sales Representative, Customer Account Representative, or Product Service Marketing Manager from Hand Held Products, or your Authorized Reseller.





Hand Held Products, Inc.
700 Visions Drive
P.O. Box 208
Skaneateles Falls, NY 13153-0208