

## Features

### Configurations

- Upflow / Highboy
- Basement / Lowboy
- Horizontal / Counterflow

### Heat Exchanger

- Heavy-duty 14 gauge steel with a long lasting ceramic fiber combustion chamber
- Easy access large diameter stainless steel clean out ports

### Cabinet

- Foil-faced high density fiberglass insulation reduces heat loss and noise
- Pre-painted steel for maximum durability

### Blower

- Direct drive with slide-out design (upflow only) and quick plug-in wiring
- 4 speed PSC direct drive motors with dynamically balanced blower wheel and resilient motor mounts for smooth and quiet operation

### Burner

- High quality Beckett™ Flame Retention AFG Burner for efficient combustion
- High efficiency PSC Burner motor to provide consistent operation through all operating conditions
- Solid state ignition provides a consistent 10,000 volts for smooth ignition
- Color coded wiring for easy service
- 40VA Transformer and cooling fan relay are factory wired for easy add-on cooling installation

### Venting

- Includes field installed barometric damper
- Optional sidewall vent kit available

### Warranty

- 10 year limited parts warranty / lifetime heat exchanger warranty available. See limited warranty document for details.



LUF = Upflow / Highboy  
LBF/R = Basement / Lowboy  
LHF/R = Horizontal / Counterflow  
LHR 168/196 = Horizontal only



### GeniSys™ Advanced Burner Control

(Model: 7505B1500) features the following:

- Programmable valve-on delay and motor-off delay
- Three indicator lights for system monitoring and diagnostics
- Two communication ports for adding alarm contacts, programming display, and/or future wireless communications
- Welded relay protection with redundant motor relays
- Limited reset and limited recycle
- Sleek, modern design
- Technician Pump Prime mode

## Model Number Guide

L	83	UF	1	D	84/95	E	20	- 1
L - Oil Furnace	AFUE 83 = 83% Efficiency	UF = Upflow - front flue BF = Basement - front flue BR = Basement - rear flue HF = Horizontal - front flue HR = Horizontal - rear flue	1 = 1 Stage	V = Variable Speed D = Direct Drive			CFM x 100 Cabinet Width	Revision code 08=2T 12=3T 14=3.5T 16=4T 20=5T E = 19.5" (19.5 Horiz. only) F = 22.5" (20.5 Horiz. only) Nominal Output 57 - 57,000 72 - 72,000 84 - 84,000 95 - 95,000 112 - 112,000 125 - 125,000

## Physical and Electrical Data (Continued on next page)

Configuration	Model	Nozzle Size	Input (Btuh)	Output (Btuh)	AFUE	Nom. Cooling Cap.	Flue Dia. (in.)	Filter Size (in.)	Volts/Hz/Phase	Max. Time Delay Breaker or Fuse (amp)	Trans. (V.A.)	Shipping Weight (lb.)
Upflow / Highboy	L83UF1D57/72E12-1	.50GPH-80°A	67,500	57,000	84.0	2.0 - 3.0	6	16 X 25	120/60/1	15	40	230
		.65GPH-80°B	85,500	72,000	84.0							
	L83UF1D84/95E16-1	.65GPH-80°B	101,000	84,000	83.0	2.5 - 4.0	6	16 X 25	120/60/1	15	40	250
		.75GPH-80°B	113,500	95,000								
	L83UF1D112/125F20-1	.85GPH-80°B	TBD	TBD	83.0	3.0 - 5.0	6	(2) 16 X 25 <sup>1</sup>	120/60/1	15	40	---
		1.00GPH-80°B	TBD	TBD								
Basement	L83BF/R1D57/72E12-1	.50GPH-80°A	67,500	57,000	84.0	2.0 - 3.0	6	18 X 19	120/60/1	15	40	220F
		.65GPH-80°B	85,500	72,000	84.0							225R
	L83BF/R1D84/95E16-1	.65GPH-80°B	101,000	85,000	83.0	2.5 - 4.0	6	18 X 19	120/60/1	15	40	225F
		.75GPH-80°B	113,500	95,000								230R
	L83BF/R1D112/125F20-1	.85GPH-80°B	TBD	TBD	83.0	3.0 - 5.0	6	19 X 21	120/60/1	15	40	---
		1.00GPH-80°B	TBD	TBD								

## Physical and Electrical Data (Continued from previous page)

Configuration	Model	Nozzle Size	Input (Btuh)	Output (Btuh)	AFUE	Nom. Cooling Cap.	Flue Dia. (in.)	Filter Size (in.)	Volts/Hz/Phase	Max. Time Delay Breaker or Fuse (amp)	Trans. (V.A.)	Shipping Weight (lb.)
Horizontal / Counterflow	L83HF1D84/95E12-1	.65GPH-80°B	101,000	85,000	83.0	2.0 - 3.0	6	Filters are not supplied with these models	120/60/1	15	40	250
		.75GPH-80°B	113,500	95,000								
	L83HR1D57/72E12-1	.50GPH-80°A	67,500	57,000	83.0	2.0 - 3.0	6		120/60/1	15	40	225
		.65GPH-80°B	84,000	72,000								
	L83HR1D84/95E12-1	.65GPH-80°B	101,000	85,000	83.0	2.0 - 3.0	6		120/60/1	15	40	250
		.75GPH-80°B	113,500	95,000								
	L83HF/R1D112/125F20-1	.85GPH-80°B	TBD	TBD	83.0	3.0 - 5.0	6		120/60/1	15	40	---
		1.00GPH-80°B	TBD	TBD								

<sup>1</sup> Requires return air be brought to both sides above 1600 CFM.

Note: Upflow models shipped with filter(s) for side return.  
All models are rated at 140 psi pump pressure except the LUF80C57/72 and LBF/R 57/72 which is rated 100 psi.

**Blower Performance Data** (Continued on next page)

Description	Model	Motor Size (hp)	Blower Size	Temp. Rise °F	Blower Speed	CFM @ ext. static pressure - in W.C.							
						.20	.30	.40	.50	.60	.70	.80	.90
Upflow / Highboy	L83UF1D57/72E12-1	1/3	10 x 8	50 - 80	High	1,410	1,355	1,300	1,220	1,155	1,075	990	890
					Med High	1,260	1,215	1,170	1,120	1,060	990	915	800
					Med	1,040	1,025	990	960	910	860	790	680
					Low	885	880	850	830	785	740	680	605
	L83UF1D84/95E16-1	1/2	10 x 10	50 - 80	High	1,755	1,695	1,940	1,590	1,495	1,360	1,250	1,095
					Med High	1,445	1,425	1,400	1,335	1,285	1,200	1,065	965
					Med	1,190	1,180	1,145	1,110	1,055	985	895	825
					Low	990	980	960	925	880	835	775	690
	TBD L83UF1D112/125F20-1	3/4	12 x 11	45 - 75	High	/	/	/	/	/	/	/	/
					Med High	/	/	/	/	/	/	/	/
					Med	/	/	/	/	/	/	/	/
					Low	/	/	/	/	/	/	/	/
Basement / Lowboy	L83BF/R1D57/72E12-1	1/3	10 x 8	45 - 75	High	1,400	1,350	1,305	1,250	1,185	1,105	1,025	915
					Med High	1,135	1,130	1,105	1,075	1,025	965	895	765
					Med	930	915	905	865	845	800	730	630
					Low	785	775	755	730	705	665	604	518
	L83BF/R1D84/95E16-1	1/2	10 x 9	45 - 75	High	1,760	1,670	1,600	1,550	1,410	1,315	1,170	1,000
					Med High	1,605	1,515	1,460	1,395	1,305	1,190	1,080	935
					Med	1,375	1,345	1,300	1,260	1,190	1,075	975	830
					Low	1,160	1,150	1,130	1,105	1,035	955	855	650
	TBD L83BF/R1D112/125F20-1	3/4	12 x 10	45 - 75	High	/	/	/	/	/	/	/	/
					Med High	/	/	/	/	/	/	/	/
					Med	/	/	/	/	/	/	/	/
					Low	/	/	/	/	/	/	/	/

## Blower Performance Data

(Continued from previous page)

Description	Model	Motor Size (hp)	Blower Size	Temp. Rise °F	Blower Speed	CFM @ ext. static pressure - in W.C.							
						.20	.30	.40	.50	.60	.70	.80	.90
Horizontal / Counterflow	L83HF1D84/95E-12-1	1/2	10 x 10	45 - 75	High	1,410	1,320	1,280	1,195	1,090	1,000	850	790
					Med High	1,340	1,280	1,190	1,100	1,015	900	801	680
					Med	1,235	1,175	1,090	1,015	920	845	730	600
					Low	1,090	1,035	975	900	855	770	665	545
	TBD L83HF1D112/125F20-1	3/4	12 x 9	45 - 75	High	/	/	/	/	/	/	/	/
					Med High	/	/	/	/	/	/	/	/
					Med	/	/	/	/	/	/	/	/
					Low	/	/	/	/	/	/	/	/
	L83HR1D57/72E12-1	1/3	10 x 8	45 - 75	High	1,405	1,340	1,275	1,205	1,125	1,010	915	785
					Med High	1,255	1,205	1,155	1,090	1,020	920	815	685
					Med	1,010	980	950	905	840	775	685	540
					Low	835	820	800	760	715	650	560	405
	L83HR1D84/95E12-1	1/2	10 x 10	45 - 75	High	1,485	1,400	1,305	1,210	1,105	995	870	740
					Med High	1,380	1,305	1,220	1,150	1,035	930	800	670
					Med	1,230	1,170	1,110	1,000	935	845	735	595
					Low	1,055	1,020	970	910	835	755	640	505
	TBD L83HR1D112/125F20-1	3/4	12 x 9	45 - 75	High	/	/	/	/	/	/	/	/
					Med High	/	/	/	/	/	/	/	/
					Med	/	/	/	/	/	/	/	/
					Low	/	/	/	/	/	/	/	/

## Accessories

Description	Used with	Catalog number	Kit number
Clean Out Kit	All models	1.841025	ABRSH380-3
Field Controls Side Wall Vent Kit *	All models	See Note Below	See Note Below
Evaporator Coil Mounting Kit	L83B(F/R)84/95 to EU1P (18,24,30,36,43,48) BN	1.841175	AGOILKDCC19
Evaporator Coil Mounting Kit	L83BF/R84/95 & L83B(R)140/168 to EU1P (30,43,48,49,50,60)	1.841176	AGOILKDCC22
Evaporator Coil Mounting Kit	L83BF/R112/125, L83BR140/168 & EU1P (60, 62) DN	1.841177	AGOILKDCC24
Evaporator Coil Mounting Kit	L83BF/R112/125, L83BR140/168 & L83BR196 to EU1P59DN	1.841179	AGOILKDCC27
Combustion Air Kit	All Models	1.841038	ABOOT571
Clean Out Cap Kit	All Models	1.841037	ACAP570
Combustible Floor Base	L83HF/R84/95, LHR57/72	1.841022	BASE537-1
Combustible Floor Base	L83HF/R112/125	1.841023	ABASE538-1

Note: \* This can be ordered from Field Controls, part number SWG-5-CK61.

UPFLOW

Dimensions (in.)

Model	A	B	C	D	E
L83UF1D57/72E12-1	19-1/2	18	30-5/8	19-5/8	9-3/4
L83UF1DC84/95E16-1					
L83UF1D112/125E20-1	22-1/2	21	33-1/8	22-1/8	11-1/4

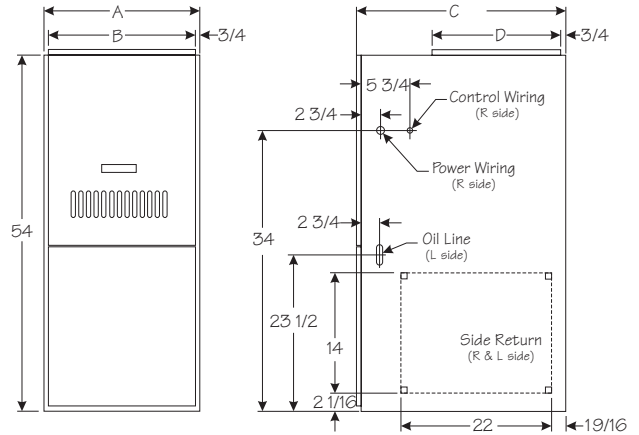
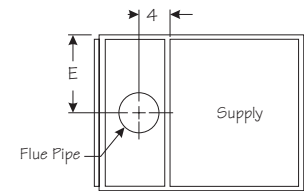

Clearances to combustibles (in.)

Model	Front	Sides	Rear	Floor	Above	Flue
L83UF1D57/72E12-1	4	0	0	Combustible	2	6
L83UF1D84/95E16-1						
L83UF1D112/125E20-1						

BASEMENT

Dimensions (in.)

Model	A	B	C	D	E	F	G	H	J	K
L83BF1D57/72E12-1	19-1/2	18	37	9-3/4	21	3-1/4	16	1-1/2	52	N/A
L83BF1D84/95E16-1										
L83BF1D112/125E20-1	22-1/2	21	37	11-1/4	21	3-1/4	16	1-1/2	52	N/A
L83BR1D57/72E12-1	19-1/2	18	37	N/A	21	3-1/4	16	1-1/2	52	27-5/8
L83BR1D84/95E16-1										
L83BR1D112/125E20-1	22-1/2	21	37	N/A	21	3-1/4	16	1-1/2	52	27-5/8

Clearances to Combustibles (in.)

Model	Front	Sides	Rear	Above	Flue	Floor
L8BF/R1D57/72E12-1	4	6	24	2	9	Combustible
L83BF/R1D84/95E16-1						
L83BF/R1D112/125E20-1						

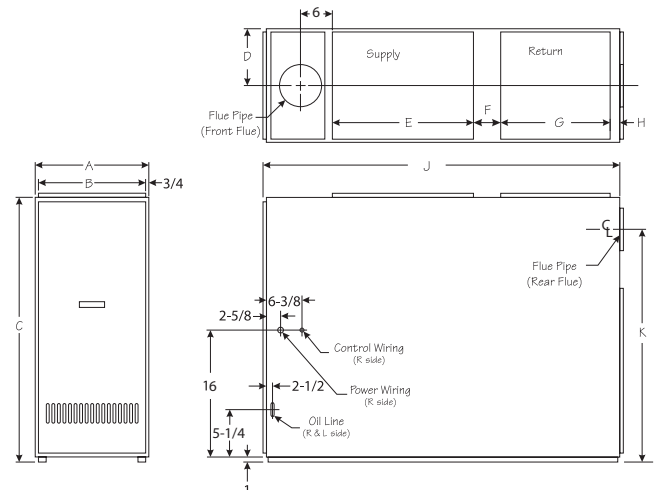

HORIZONTAL / COUNTERFLOW

Dimensions (in.)

Model	A	B	C	D	E	F	G	H	J	K	L	M	N	P	Q	R	S
L83HF1D84/95E12-1	59	20-1/2	20-1/2	18-1/4	18-1/4	1-1/4	1-1/4	18	18	1-1/4	1-1/4	32-1/2	10-1/4	3	41-1/2	3	14-1/2
L83HF1D112/125E20-1	59	23-1/2	23-1/2	21-1/4	21-1/4	1-1/4	1-1/4	21	21	1-1/4	1-1/4	32-1/2	11-3/8	3	41-1/2	3	17-1/2
L83HR1D57/72E12-1	59	20-1/2	20-1/2	18-1/4	18-1/4	1-1/4	1-1/4	18	18	1-1/4	1-1/4	32-1/2	10-1/4	3	41-1/2	3	14-1/2
L83HR1D84/95E12-1																	
L83HR1D112/125E20-1	59	23-1/2	23-1/2	21-1/4	21-1/4	1-1/4	1-1/4	21	21	1-1/4	1-1/4	32-1/2	11-3/8	3	41-1/2	3	17-1/2

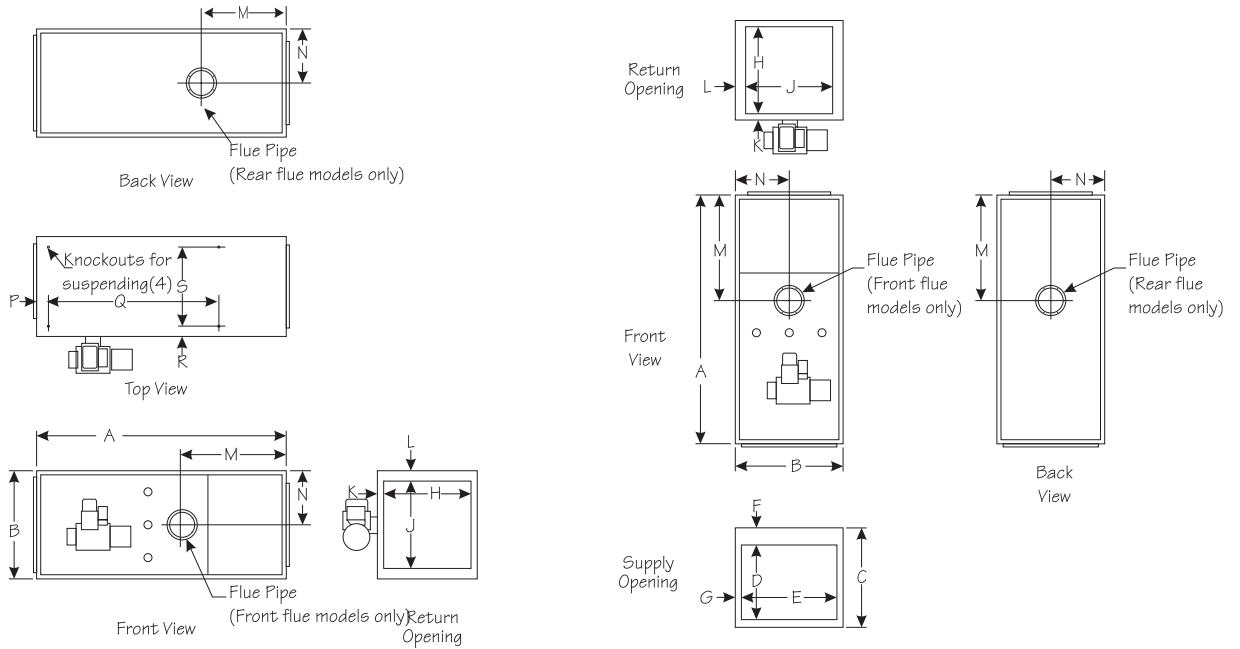

Clearances To Combustibles (in.)

Horizontal Position

Model	Front	Above	Rear	Flue	Bottom
L83HF1D84/95E12-1	24	1	1	7	1
L83HF1D112/125E20-1					
L83HR1D57/72E12-1	24	1	24	7	1
L83HR1D84/95E12-1					
L83HR1D112/125E20-1					

Counterflow Position

Model	Front	Above	Rear	Flue	Sides	Floor
L83HF1D84/95E12-1	16	0	1	7	1	Non Combustible
L83HF1D112/125E20-1						
L83HR1D57/72E12-1	16	0	1	7	1	
L83HR1D84/95E12-1						
L83HR1D112/125E20-1						

All specifications and illustrations subject to change without notice and without incurring obligations.



www.ducanevac.com  
1-800-448-5872