

BUILD THIS ELECTRONIC STOPWATCH



Simple circuit adds elapsed time measurement feature to basic calculator circuit without affecting calculator operation.

by TOMMY N. TYLER

WITHIN THE PAST YEAR SEVERAL 6-DIGIT hand-held calculators have appeared on the market, often retailing for less than \$15. These units are fairly limited in their calculating abilities. They are fine for adding up the grocery bill or balancing the check book, but they do not have a floating decimal point and operate with whole numbers only. Nevertheless, considering the functions they perform, these little calculators are a marvel of simplicity as well as a bargain source of components for digital display projects. With less than \$10 worth of additional parts you can modify one of them to provide a handy digital stopwatch as well as a calculator. This is not only a fun and useful project, but also a chance to learn more about the techniques of keyboard scanning and display multiplexing used in many current calculators.

The best calculator to use is the Minuteman-6 manufactured by Commodore Business Machines, although the National Semiconductor Model 600, or the Model 650 "Mathbox" manufactured by the Novus Division of National Semiconductor are essentially equivalent except for styling and keyboard construction. These units use a National Semiconductor type MM5736 calculator chip which features an automatic constant on all four functions. The automatic constant enables the calculator to perform as a counter by entering a "1" and then pressing the "ADD" key repetitively, each opera-

tion adding 1 to the previous total. By operating the ADD key electronically with a precision oscillator which is gated on and off, we can measure elapsed time quite effectively. The 6-digit display counts up to 9999.99 seconds, which is over 2³⁴ hours. If you would prefer to build just the stopwatch alone, the MM5736 calculator chip is being offered at under \$4 (check the advertisements in the back of this issue.)

Basic calculator operation

Figure 1 shows a schematic diagram of a typical calculator. The MM5736 calculator chip has three inputs (K1, K2, and K3) and two sets of outputs. One set of outputs (digits 1 through 6) drives the 6-digit display in multiplex fashion, using a 75492 digit driver IC. The other set of outputs (*a* through *g*) provides a 7-segment coded output of the calculator's display register. It is also multiplexed so that the segments for digit 1 appear during digit-time 1, the segments for digit 2 appear during digit-time 2, and so on. Both the digit and segment drive signals return to zero momentarily between digits to prevent ghosting or smear. This is referred to as interdigit blanking. Figure 2 shows a timing diagram of the digit and segment outputs for a display reading of "654321." Digit 1 is at the far right of the display, and the digits are scanned from right to left.

Numbers or functions are entered into the calculator by connecting one

of the strobed digit outputs to one of the three inputs. The digit outputs are therefore performing double duty by scanning the keyboard and display simultaneously. It's tricks like this that enable the chip manufacturer to put the entire calculator into a DIP package with only 18 pins.

Battery B1 is an ordinary 9 volt transistor radio battery. An alkaline battery will power the calculator for about 10 to 20 hours, depending on how it is used. Adding the stopwatch reduces this by only a few hours. Note that the artificial decimal point on these calculators is merely a single LED between the second and third digits which is driven through resistor R1. This fixed decimal point is in just the right place for our stopwatch.

Keyboard debounce

Keyboard debounce refers to an operation performed in the calculator chip to discriminate against noisy key contacts which might otherwise cause multiple entries. It is both a blessing and a curse in that it allows the calculator to operate reliably with "cheap and dirty" keyboards, but it also limits the speed of operation in a way that affects our stopwatch. Debounce is accomplished by requiring that one of the digit outputs remain connected to one of the three inputs for at least 8 consecutive keyboard scan cycles before the entry is executed in the chip. Before another entry can be made, at

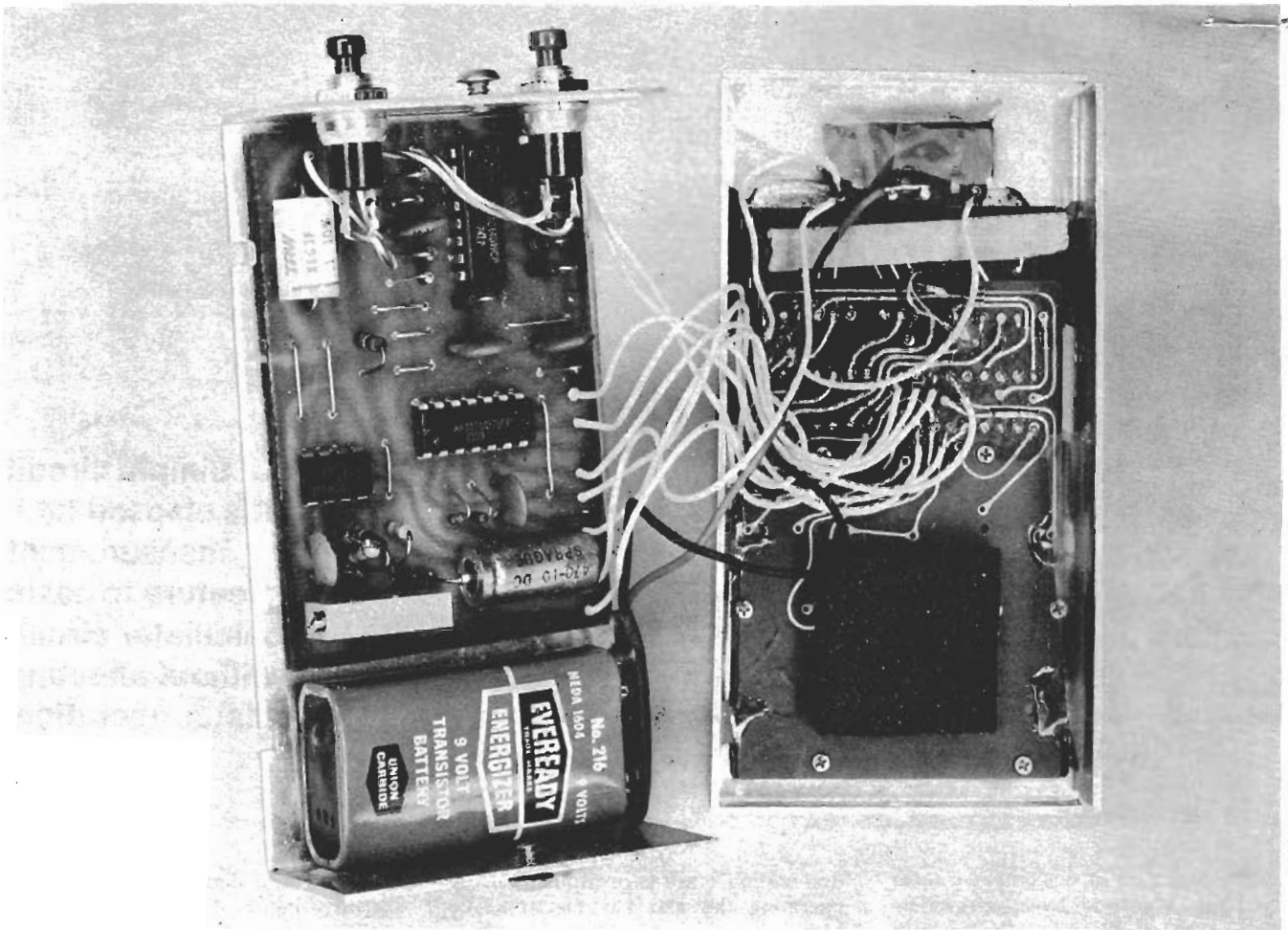

STOPWATCH printed circuit board (left) is added to basic calculator circuit (right). Both the calculator printed circuit board and display remains intact.

least 8 consecutive scan cycles must elapse during which *none* of the digit outputs are connected to any of the K inputs. When using the calculator as a counter, the counting speed is limited by this requirement for a minimum of 16 scan cycles per count.

Figure 3 shows a block diagram of the stopwatch. Pressing the RESET switch clears the calculator and then enters a "1." Pressing the START/STOP switch turns on the oscillator, which electronically "presses" the "+" key 100 times per second. The first timing pulse to the ADD circuit merely transfers the original "1" to the accumulator register. The second pulse adds another 1, giving a total of 2. The third pulse brings the total to 3, and so on. The calculator is, in effect, counting time in hundredths of a second.

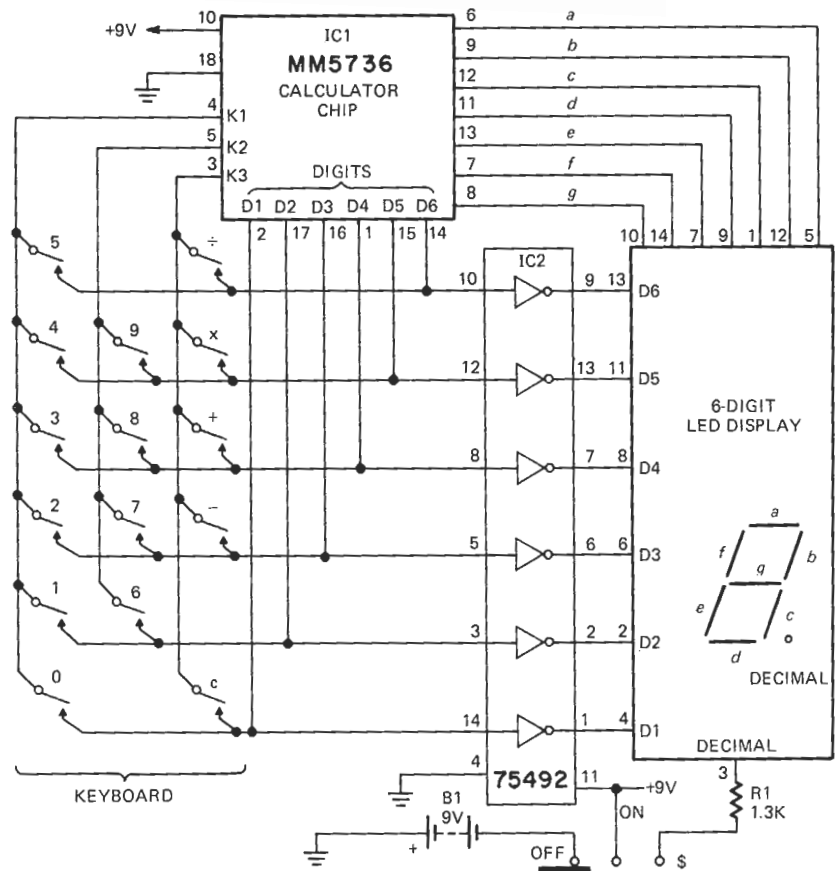

FIG. 1—BASIC CALCULATOR consists of two IC's, keyboard, display and switched DC power source. The keyboard and display are multiplexed.

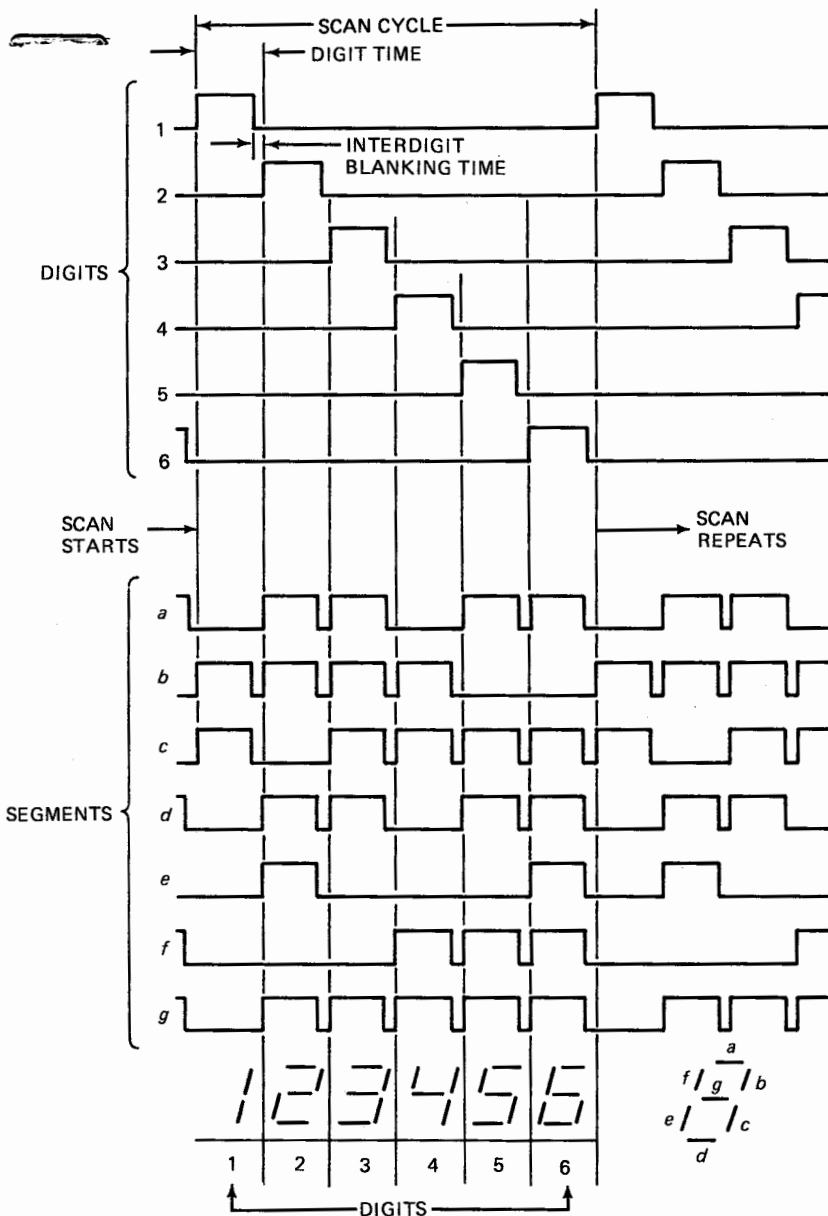

FIG. 2—TIMING DIAGRAM showing digit and segment output waveforms from the calculator chip. The display appears as "654321" because of right to left scanning provided by the calculator chip.

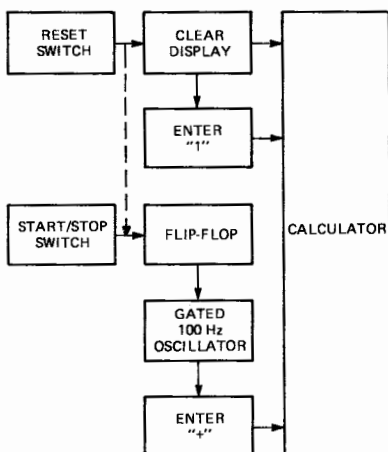

FIG. 3—STOPWATCH circuitry automatically enters a "1" when the reset button is depressed. The gated 100 Hz oscillator then enters "+" repeatedly.

Counting speed

The MM5736 calculator chip has a built-in clock oscillator which provides a typical keyboard scanning rate of 1 kHz, with some running as slow as 700 Hz and some faster than 2 kHz due to inherent variations in chip parameters during manufacture. If we satisfy the debounce requirement of 8 scans closed and 8 scans open per count, our maximum counting speed is typically 60 Hz, with some as slow as 40 Hz or as fast as 150 Hz.

Fortunately there is a way to speed up the counting rate by using the circuit shown in Figure 4. The maximum counting rate attainable with this circuit will depend on the particular chip used, but will run from about 80 Hz up to about 300 Hz. The increase in

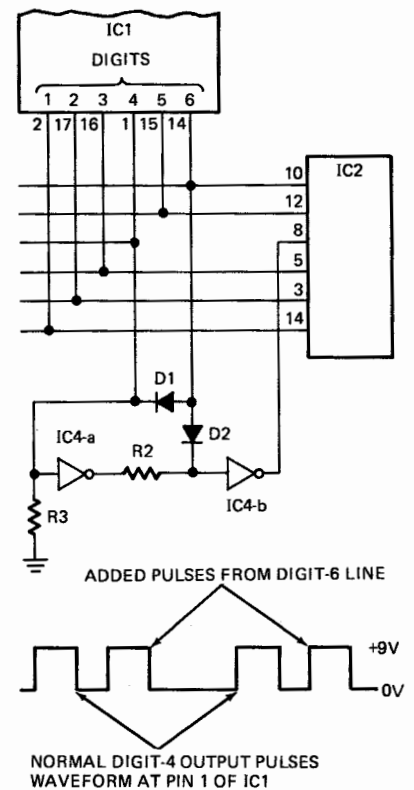

FIG. 4—ADDED COMPONENTS fool calculator into cycling at double speed. The components are only for those calculator chips that will not count at the 100-Hz speed.

counting rate is obtained by feeding the digit-6 output pulse back to the digit-4 line, through diode D1. This fools some internal logic in the chip so that the debounce requirement is satisfied whenever a key remains closed at least 4 scan-cycles, followed by at least 4 scan-cycles during which no key is closed. The other components are necessary to prevent the double pulse from appearing on the digit-4 display driver input, which would cause digit-4 to display a ghost image of digit 6. During digit-4 time, the output pulse from digit-4 line is fed through inverters IC4-a and IC4-b to the driver input, lighting digit 4. During digit-6 time, the digit-4 line is again driven high through D1, but this time D2 conducts and the digit-6 pulse holds the input of IC4-b high to prevent digit 4 from being lighted at the same time as digit 6.

Most chips will count at 100 Hz after the addition of the speedup circuit. For those that don't, the stopwatch can still be built to measure time to the nearest 1/50 second. Referring to Fig. 3, this is done by arranging the RESET switch to enter a "2" instead of a "1," and slowing the oscillator to 50 Hz.

Next month, the article will continue with the schematic and the parts list. The foil pattern, component placement, construction details and operation and calibration procedures will also appear next month.

R-E

BUILD THIS

ELECTRONIC STOPWATCH

PART II

Add elapsed time measurement feature to basic calculator circuit.

by TOMMY N. TYLER

THE FIRST PART OF THIS ARTICLE (November, 1975 issue) described the basic operation of the calculator circuitry.

This second and concluding part presents the foil pattern, construction and operation of the stopwatch.

Stopwatch operation

Figure 5 shows the complete schematic of the stopwatch circuit. For good temperature stability and accuracy throughout the allowable battery voltage range of 6.5 to 9 volts, a 555 integrated circuit timer is used for the 100 Hz oscillator. Inverters IC4-c and IC4-d form a flip-flop that alternately switches the reset (pin 4) of the 555 timer from low to high in response to successive closures of S1, turning the oscillator on and off. The flip-flop offers immunity to contact bounce and ignores contact resistance even as high as 1K ohms.

The operation of the "+," "C," and "1" keys of the calculator are simulated by AND gates IC5-b, IC5-c and IC5-d, respectively. Closing RESET switch S2 causes the output of inverter IC4-e to go high, and after a slight delay from the R7-C2 time constant, IC5-b is enabled to clear the display. When the RESET switch is released, IC5-b is disabled immediately while the input to IC5-a and IC4-f rises slowly due to the R6-C4 time constant. This provides a slight delay following the CLEAR operation, to satisfy debounce requirements. When the voltage on capacitor C4 reaches the threshold of IC5-a, its output goes high and enables IC5-d to enter a "1" into the calculator. Almost simultaneously, the output of inverter IC4-f goes low, and after a few milliseconds delay from R8-C3, IC5-a and IC5-d are disabled.

Switch S2 is also connected through diode D3 to the start/stop flip-flop so

that the timer will be automatically switched off if the RESET switch is pushed while it is running. The delay provided by R7-C2 before application of the clear signal is to satisfy the debounce requirements in case the timer output line (pin 3) happens to be high at the moment S2 was closed. Diode D4 eliminates any delay in removal of the clear signal. If the stopwatch is operated at 50 Hz, the input to IC5-d is taken from the digit-3 output instead of the digit-2 output, so that a "2" is entered instead of a "1."

Resistor R12 and capacitor C7 filters the noise on the +9V supply so that it does not cause jitter in the oscillator. The component values for R9, R10, R11, and C6 shown in Figure 5 are for 100 Hz operation. For 50 Hz operation either double the value of C6, or increase the values of R9, R10, and R11 to 120K, 22K, and 50K, respectively. The stability of the oscillator will be almost entirely dependent upon the quality of these four components. For outdoor operation under widely varying temperature conditions use metal film resistors for R9 and R10, a Cermet pot for R11, and a Mylar for the 50 Hz version.

If you choose to build just the stopwatch and omit the keyboard, tie unused input K2 to ground. The MMS736 calculator chip is capable of directly driving only the small, low current LED displays that require 1 mA or less average current per segment. Most of the .080-in. to .125-in. high common-cathode digital displays fall into this category, particularly the ones that have integral magnifying lenses. Each segment output pulse is current limited in the chip to about 6 mA. Since each digit is lighted only 1/6 of the time due to the multiplexing, the average current per segment is about 1 mA. The total

current consumption with all six digits displaying "8s" is therefore about 40 to 50 mA. When you consider that the calculator chip itself only draws about 5 mA, it's easy to see where all the power goes and why battery life is so dependent on how the calculator is used. In fact, for timing long intervals or for preserving reading over extended periods of time, you might even want to add a display blanking switch which removes the +9V supply from the digit driver.

If you use individual digits, such as the MAN-3 for your display, connect a suitable resistor from the +9V bus to the decimal point of the third digit. For multidigit arrays that have decimal points for all positions tied together on a common bus, a different technique is required to light only the digit-3 decimal point. Connect the decimal bus to the digit-3 output. This will enable the anodes of all decimal points during digit-3 time, but only the one in position 3 will have its cathode enabled at the same time by the digit driver.

Construction

The unit pictured was made from a Commodore Minuteman-6 calculator, which is the easiest to use because the "works" can be removed from the case with the keyboard and display intact. Remove the 3-position battery switch from the old case and carefully pry the display window loose from the aluminum top cover where it is cemented at each end. Using the top cover as a template, scribe the keyboard and display openings onto the chassis box and cut these out using a nibbler, jeweler's saw, file, or whatever method you favor for making chassis cutouts. Also cut a rectangular hole for the slide switch.



Cement the window into its opening, taking care not to get cement or scratches on the polished surfaces. Next, cement the keyboard into position very carefully with a blob of epoxy at each corner. Try not to overlap the circuit board on the back of the keyboard with epoxy so that it can be taken out later for servicing if necessary by removing the seven screws. Above all, do not let epoxy get into the key holes. Finally, cement the slide switch to the chassis box, again making sure the epoxy doesn't interfere with

the operation of the switch.

All of the added stopwatch components can be placed on a 2-in. \times 3-in. printed-circuit board Vector board. Figure 6 is a full-size layout of the board, and Figure 7 shows component placement and external connections. Resistors and diodes are mounted on end to conserve space. Jumpers on the board are No. 22 bus wire. Use very small gauge stranded hookup wire for the interconnections between the stopwatch board and the calculator board. All of these connections are made at

the calculator board by laying the tinned ends of the wires against the pad at the appropriate IC pins or other suitable points, and heating the solder just enough to hold them in place. Cut away a small section of the foil pattern on the calculator board between pin 1 of the calculator chip (IC1) and pin 8 of the digit driver (IC2) as indicated by the dotted line in schematic, Fig. 5.

Operation and calibration

The circuit is designed so that the stopwatch oscillator is always off when

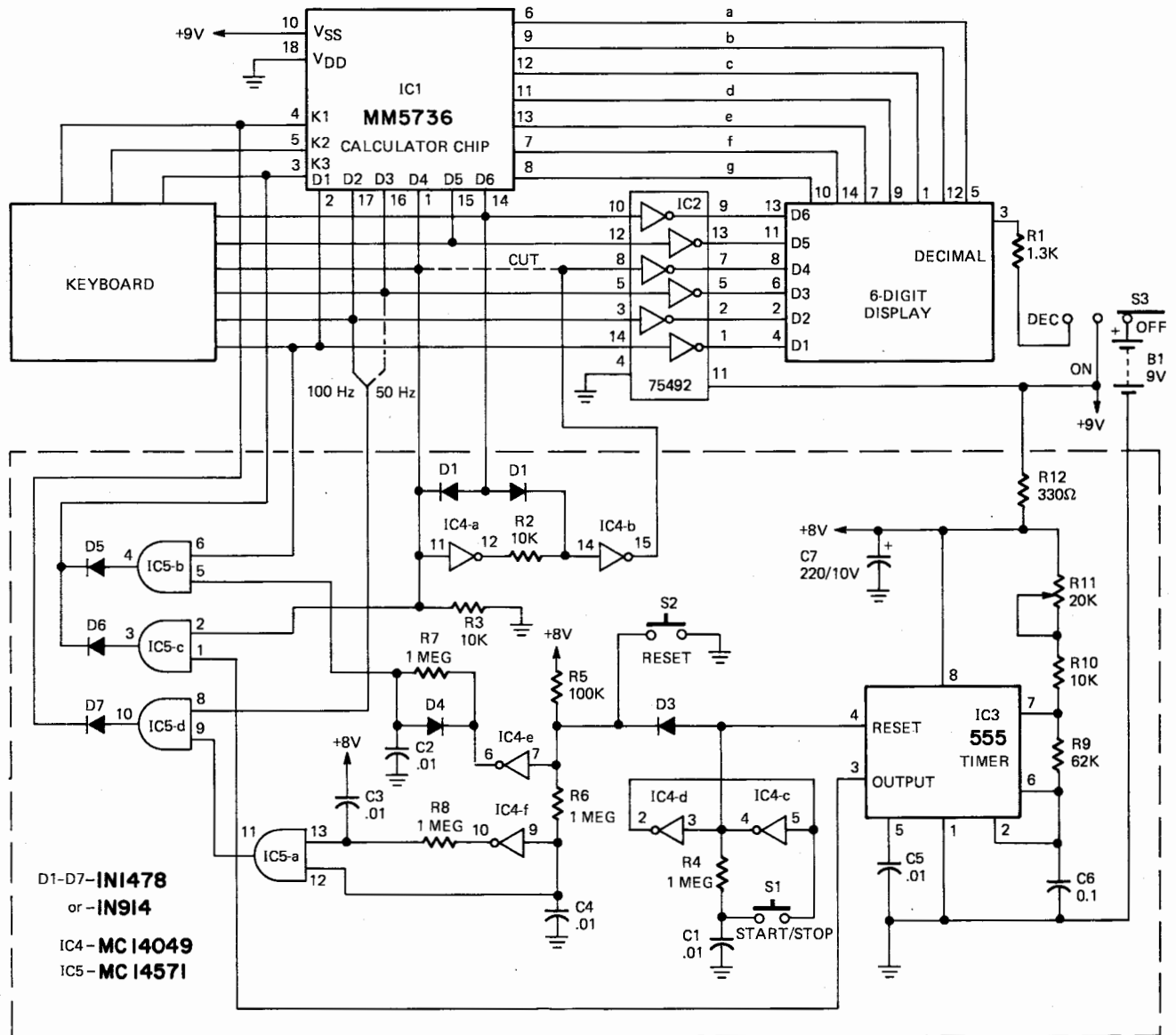

FIG. 5—STOPWATCH CIRCUITRY is shown within the dotted lines. Calculator circuit appears outside dotted lines.

Note: If a calculator is not purchased, the following additional parts will be required.

- IC1—MM5736 calculator chip
- IC2—DM75492 digit driver
- B1—9V transistor radio battery
- Battery connector
- S3—Slide switch, SPDT, miniature (Cal-electro Cat. No. E2-104, or equal.)
- R1—1,300 ohms, 1/4 W, 10%
- Display—6-digit LED, National Semiconductor, type NSN66A, dual NSN33 or NSN98A (or equal.)

- R2, R3, R10—10,000 ohms, 1/4 W, 5%
- R4, R6, R7, R8—1 megohm, 1/4 W, 10%
- R5—100,000 ohms, 1/4 W, 10%
- R9—62,000 ohms, 1/4 W, 5%
- R12—330 ohms, 1/4 W, 10%
- R11—20K Trimpot, 20-turn (Amphenol type 3805P-203, or equal.)
- C1, C2, C3, C4, C5—0.01 μ F disc ceramic
- C6—0.1 μ F Mylar
- C7—220 μ F/10V electrolytic

- D1-D7—1N4748 or 1N914, diode
- IC3—LM555 Timer
- IC4—MC14049 CMOS Hex Inverter
- IC5—MC14571 CMOS Quad 2-Input AND
- S1, S2—Pushbutton switch, SPST-NO, momentary contact (Radio Shack Cat. No. 275-1547 or equal.)
- Chassis Box—4 1/8-in. \times 2 1/8-in. \times 1 1/8-in. (Cal-electro Cat. No. J4-744)

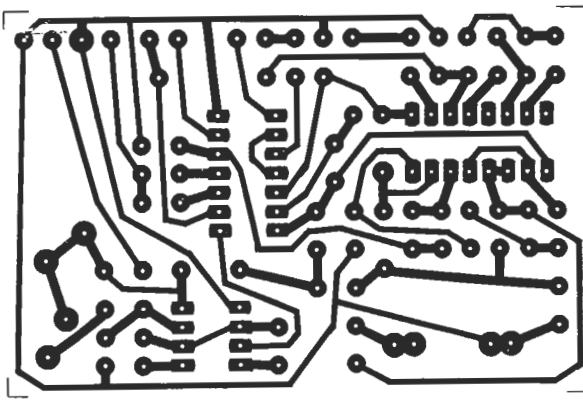

FIG. 6—FOIL PATTERN for stopwatch circuitry is shown full size.

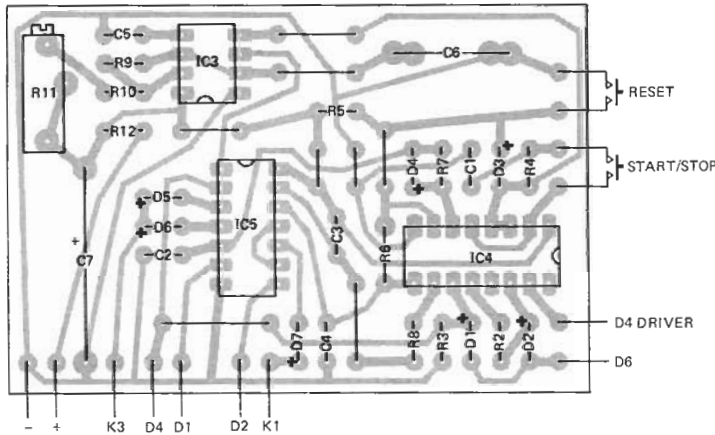

FIG. 7—COMPONENT PLACEMENT of stopwatch circuit board. Connections are made to calculator board.

the calculator is first turned on. The calculator should be cleared twice to ensure that all registers are reset to zero. The first CLEAR operation affects only the display register; the second CLEAR affects all other registers. You can also clear the calculator by pushing the RESET switch twice. When this switch is held down the display will read "0." When it is released the display will read "1." Pressing the start/stop switch once starts the stopwatch, and pressing it again stops it. The stopwatch can be restarted without resetting if desired. Pressing the RESET switch while the stopwatch is running will immediately stop the counter and reset the display to "1." The calculator can be used in the normal manner any time the stopwatch is not running.

The easiest way to calibrate the oscillator is with a precision frequency counter attached to pin 3 of IC3. If you don't have access to that kind of equipment, you can calibrate the unit pretty accurately by trial-and-error fashion using a line-operated wall clock with a sweep second hand. While watching the clock, start and stop the stopwatch at known intervals and adjust R11 to speed up or slow down the oscillator as necessary. Use short intervals at first, say 10 or 20 seconds, increasing the interval as accuracy progresses. The longer the interval, the less will be the error caused by your

reaction time in pushing the start/stop switch. With a little patience you should be able to time a period of 10 minutes on the clock with less than 1/2 second error on the stopwatch. This corresponds to an accuracy of better than 0.1%.

Troubleshooting

The MM5736 chip was designed for battery operation where the DC source is switched. If you decide to do preliminary testing with a bench power supply to save on batteries, make sure the voltage on the V_{SS} pin rises abruptly, since a slow ramp will not always initialize the calculator chip properly.

If you run out of adjustment of oscillator frequency (R11) it probably means R9 and C6 are both at one end of their allowable tolerance. Reduce R10 to about 4.7K if the oscillator can't be adjusted fast enough. Increase it to about 15K if it can't be adjusted slow enough.

A missing digit-4 (fourth from right) indicates a problem in the stopwatch circuitry since the drive pulse for this digit passes through inverters IC4-a and IC4-b. Another point to keep in mind is that when any key is pressed, the calculator will not do anything further until that key is released for the required debounce time. If the calculator seems "hung up" with the display lighted and will not respond to any key

switches, check to see if the output of IC5-b, IC5-c or IC5-d is staying high.

If the calculator operates properly, the RESET switch clears and enters a "1," the output of the oscillator appears at IC5-c, and yet the stopwatch doesn't count, it may be that the debounce requirements are preventing the calculator from cycling as fast as the 100-Hz oscillator. Test for this by starting and stopping the unit about a half dozen times to see if the display reading increases by 1 each time it is started. Another way to check is to temporarily shunt capacitor C6 with additional capacitance to slow down the oscillator and see if the stopwatch starts counting. Make sure the waveform on the digit-4 line has the characteristic double pulse shape shown in Fig. 4, which indicates the speedup circuit is working. The oscillator circuit has been designed to provide about a 40% duty cycle on, 60% off. This is about as close to the ideal square wave as we can get and still have a practical range of adjustment of frequency. To meet the debounce requirements discussed previously, at least four pairs of the double pulses on digit-4 line must occur within the shortest (40%) portion of the oscillator waveform. Verify this on a scope by comparing the waveform at pin 1 of IC5-c and pin 1 of the calculator chip. If you cannot obtain a 100-Hz waveform with the required four scan cycles minimum in both the ON and OFF portions of the signal, you will have to try another calculator chip or revert to the 50-Hz version. **R-E**

HORIZONTAL AND COLOR PROBLEMS

This Wards Airline 12448A has a horizontal sync problem, and no color. Do you have any ideas on it?—J.O., Deming, WA.

I've got one very good idea! Find out what's the matter with the horizontal sync first, and fix that. When you do, you may find out that your color problem is fixed too. This applies to any color set. If the horizontal pulses are out of phase, this can literally kill the color by upsetting the numerous gated stages.

UNLISTED TRANSISTOR

I need a horizontal driver transistor for an old Motorola 19P1. I can't find a reference on it, and the parts man says that they don't make this any more. Do you know of a substitute?—C.B., Youngstown, OH.

You could use a TO-5 transistor jammed into that heat sink. However, I would rather try mounting a TO-3 socket on the chassis. You've got room. Then you could use something like an RCA SK-3034; this one has plenty of safety factor to hold the load. (Reader says: "I did, and it worked.")

ELECTRONIC STOPWATCH

I built the Electronic Stopwatch from the article that appeared in the November, 1975 and February, 1976 issues of **Radio-Electronics**. Rather than use another case as stated in the article, I used the original calculator case but with an edge spacer that I formed from a strip of plastic ($\frac{1}{8} \times \frac{11}{16} \times 15\frac{1}{2}$ -inches) using a heat gun (actually a modified hair dryer) and soldering iron for bending, molding and joining the expander between the two



halves of the original calculator case. This worked out well for me and I am quite happy with the results.

I used a Novus Mathbox model 650. In so doing I ran into a few problems. The Mathbox has a different hook-up on the 75492 digit driver from that shown in your schematics. Except for making allowance for the modified digit driver hook-up, I followed your schematics with the result of good functioning stopwatch.

A.M. LACAVA

Tustin, CA