

F7K Block Diagram

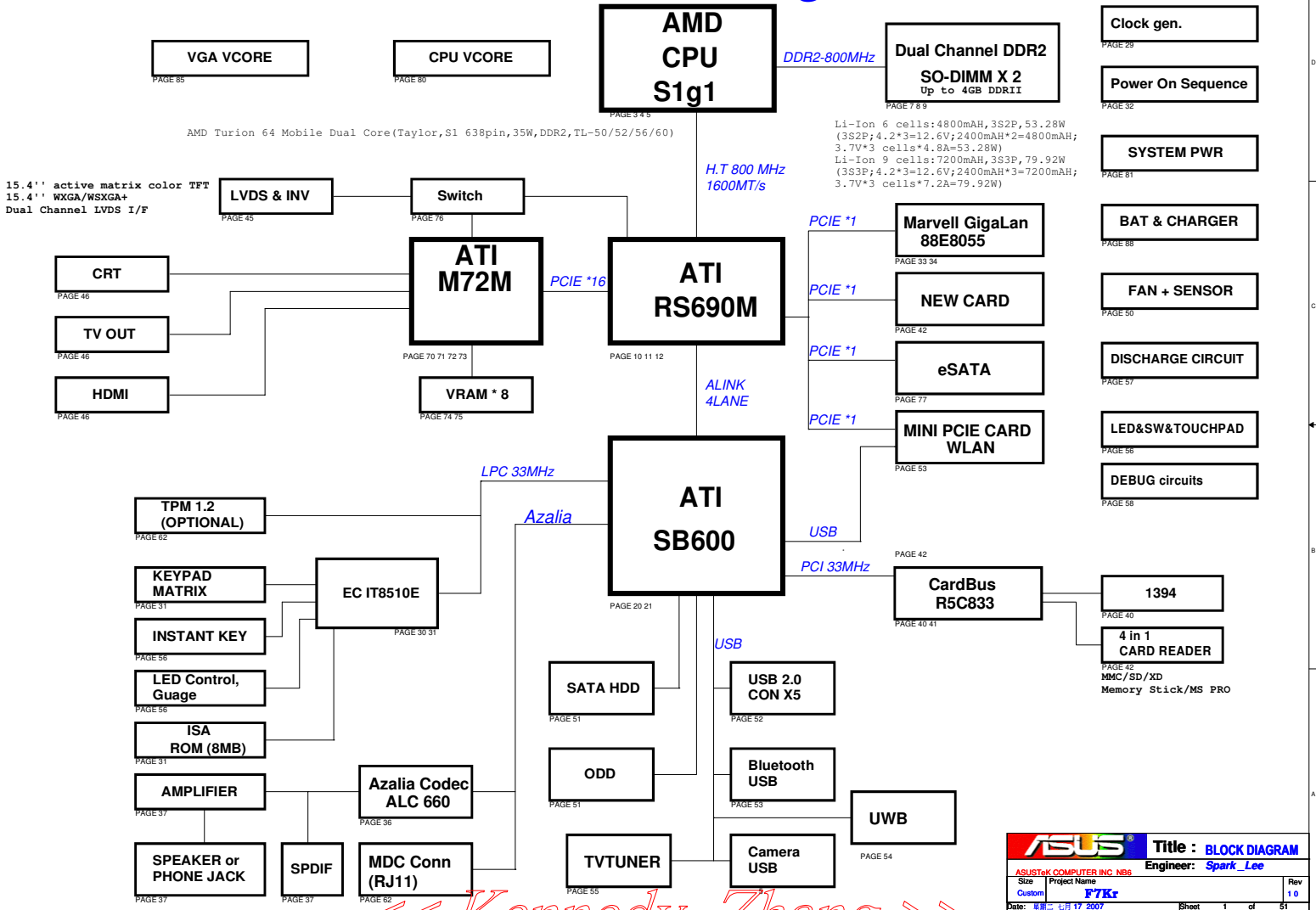

ASUS		Title : BLOCK DIAGRAM	
ASUSTeK COMPUTER INC. NBS		Engineer: Spark_Lee	
Site	Project Name		Rev
Custom	F7K		1.0
Date: 08-11-17 2007		Sheet	1 of 51

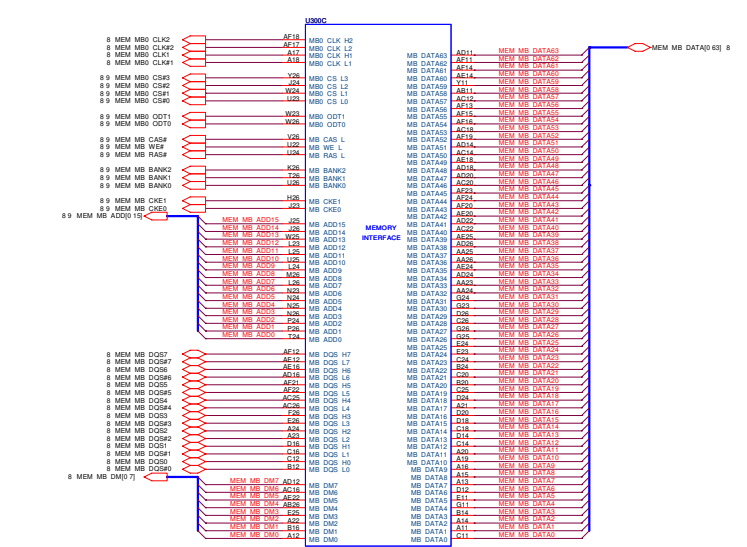
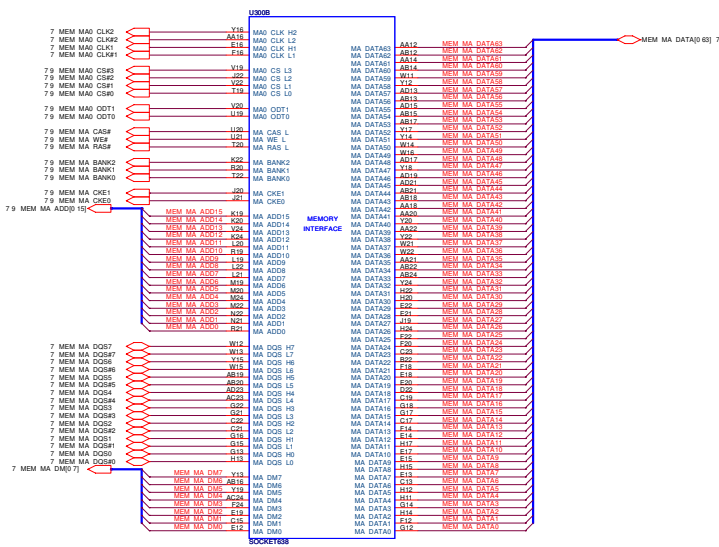

U000

7400	TPC28T	1	CPU RSVD MAO CLK#3	P20	RSVD MAO CLK H3	RSVD MA RESET L	H16	CPU RSVD MA RESET L	7401	TPC28T
7403	TPC28T	1	CPU RSVD MAO CLK#2	P22	RSVD MAO CLK L3	RSVD MA RESET L	H18	CPU RSVD MAO CLK#1	7403	TPC28T
7404	TPC28T	1	CPU RSVD MAO CLK#1	P24	RSVD MAO CLK L0	RSVD V DSTRB#	S3	CPU RSVD V DSTRB#	7405	TPC28T
7406	TPC28T	1	CPU RSVD MAO CLK#0	P26	RSVD MAO CLK L0	RSVD V DSTRB#	C1	CPU RSVD V DSTRB#	7407	TPC28T
							H6	CPU RSVD V DSTRB#	7408	TPC28T
							D5	CPU RSVD CORE TYPE	7410	TPC28T

MISC

7411	TPC28T	1	CPU RSVD MB CLK#3	P30	RSVD MB CLK H3	FREE	B24	FREE
7412	TPC28T	1	CPU RSVD MB CLK#2	P32	RSVD MB CLK L3	FREE	B22	FREE
7413	TPC28T	1	CPU RSVD MB CLK#1	P34	RSVD MB CLK L0	FREE	H16	FREE
7414	TPC28T	1	CPU RSVD MB CLK#0	P36	RSVD MB CLK L0	FREE	H14	FREE

SOCKET#88

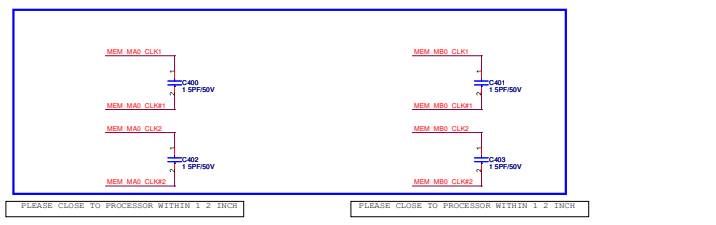

ASUS **Intel®** **AMD S1 CPU-DDR2**
 SOLVING COMPUTERS AND MORE
 828 Project Name: **Spark_Leo** Engineer:
 Date: **08-13-11** Rev: **1.0**
 Drawn: **FJK** Sheet: **4** of **51**

« Kennedy_Zhang »

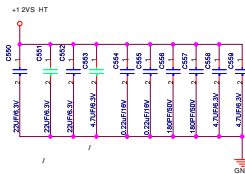
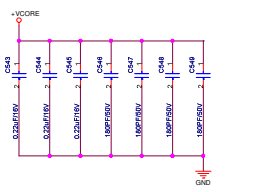
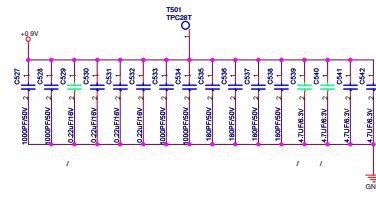
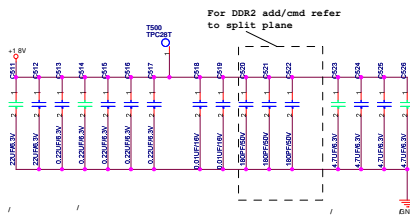
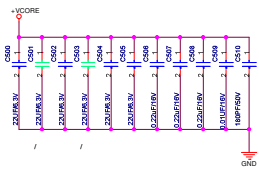
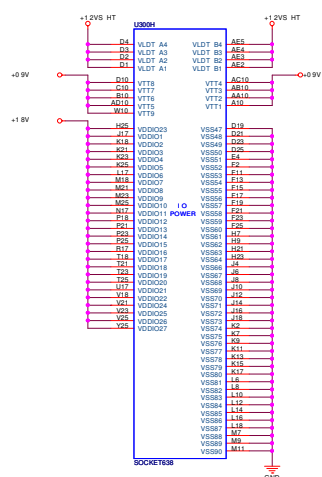
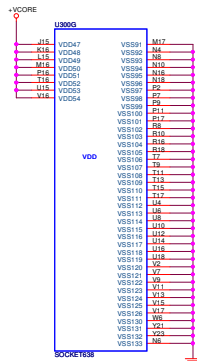
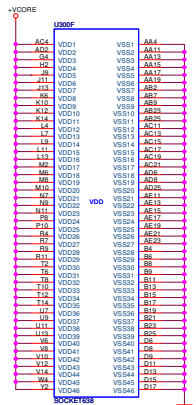

<< Kennedy_Zhang >>

REV . TYPE

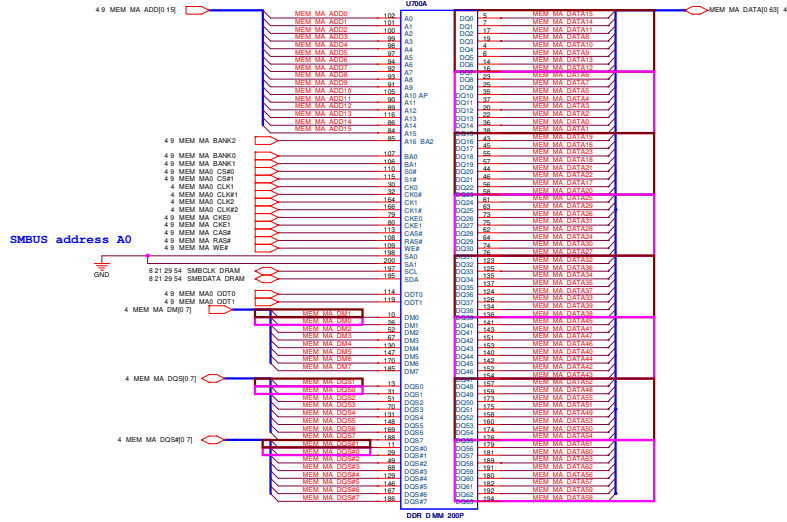

second source is 12G025332003 (FOXCONN)
main source is 12G025122006 (TYCO)

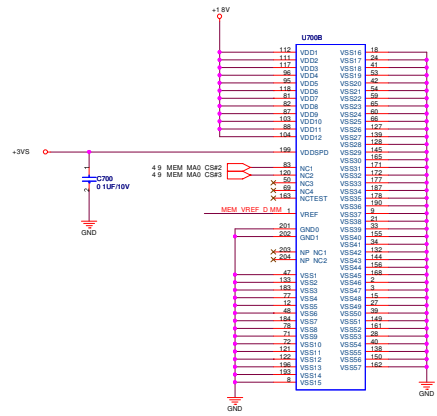
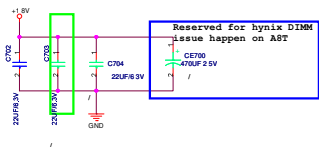

DOR DIMM 200P

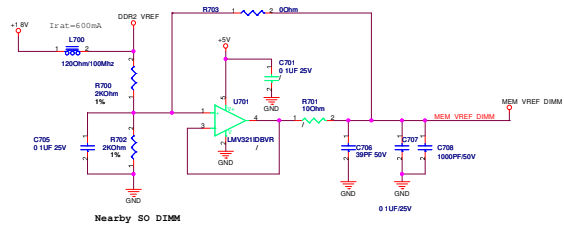

Nearby SO DIMM

« Kennedy_Zhang »

STD. TYPE

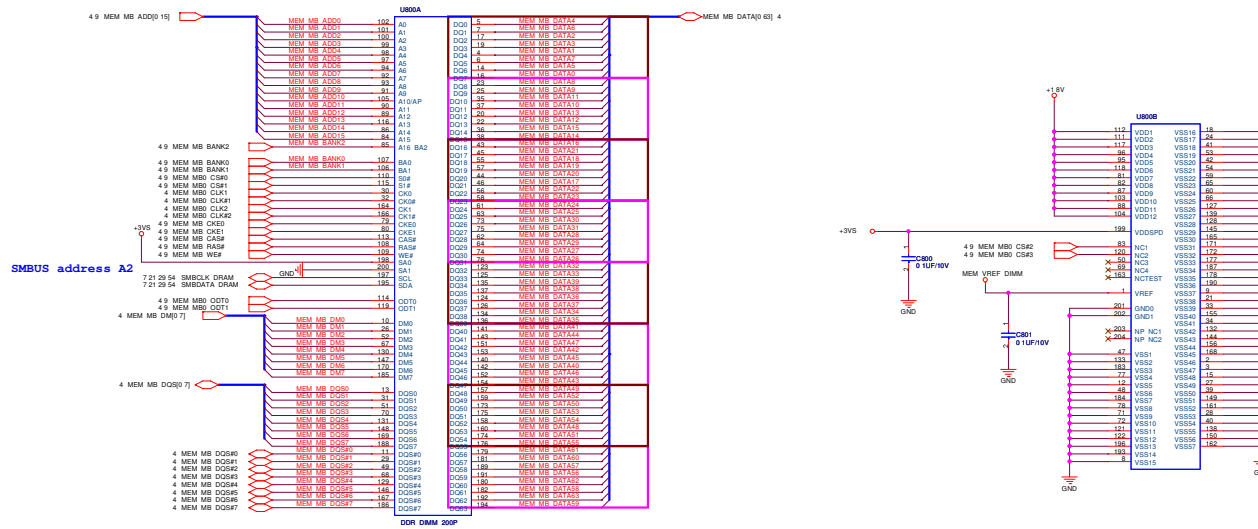

Second source is 12G025122000 (FOXCONN)
Main source is 12G025122007 (TYCO)

DDR DIMM 20P

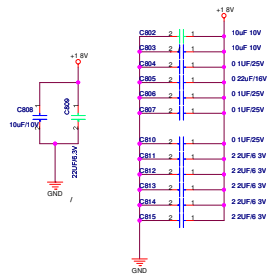

« Kennedy_Zhang »

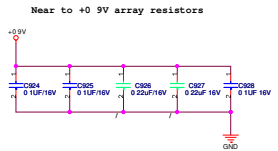
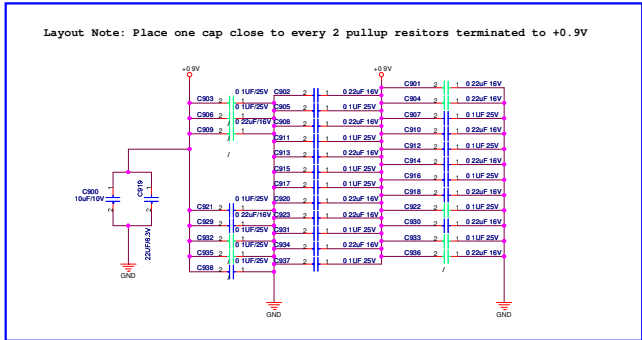
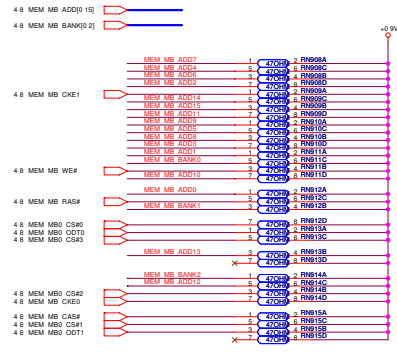
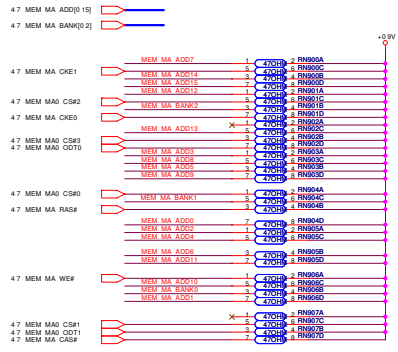

« Kennedy_Zhang »

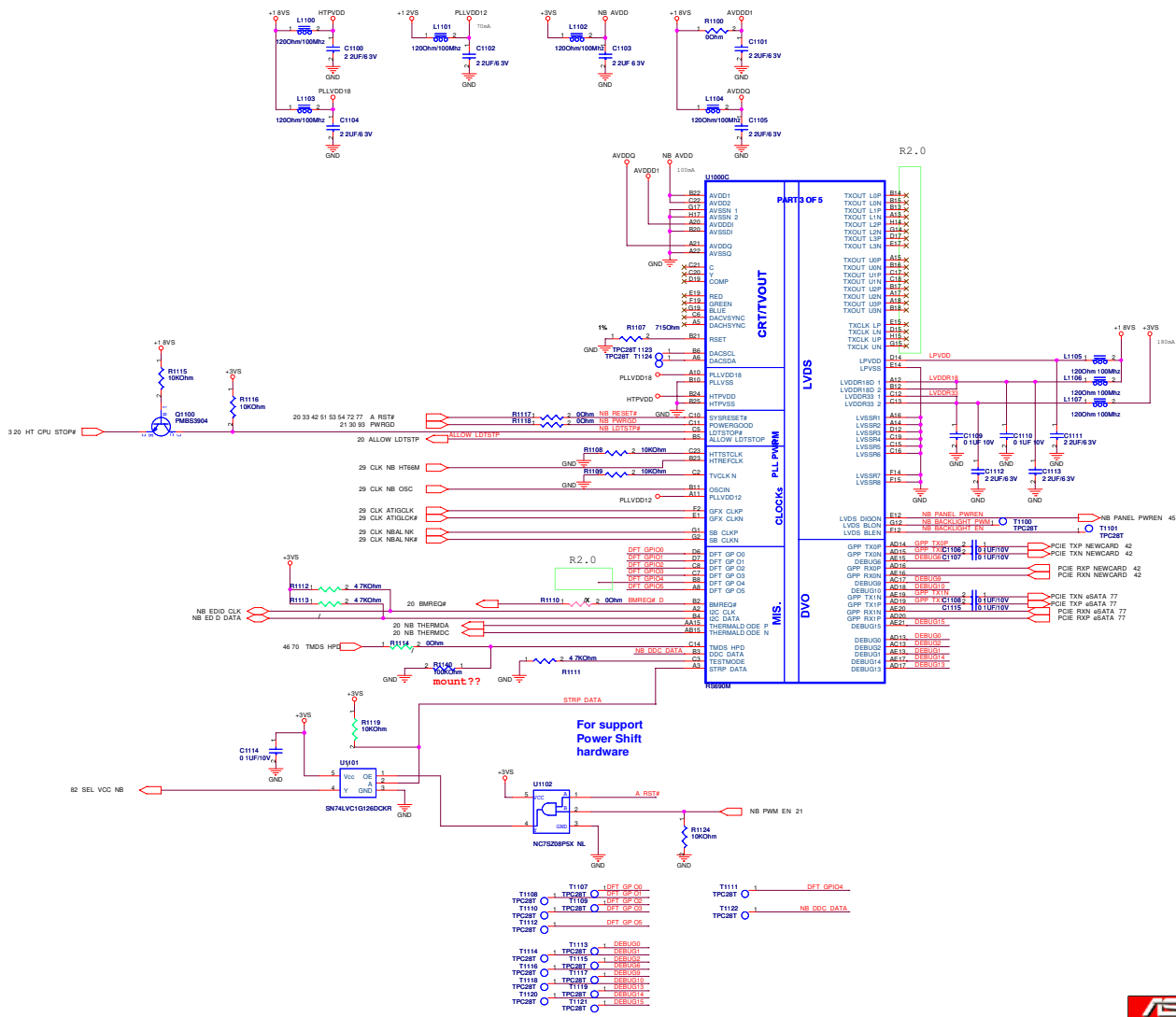

« Kennedy_Zhang »

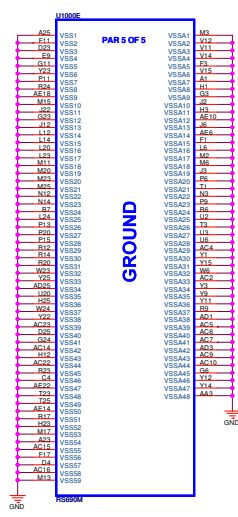
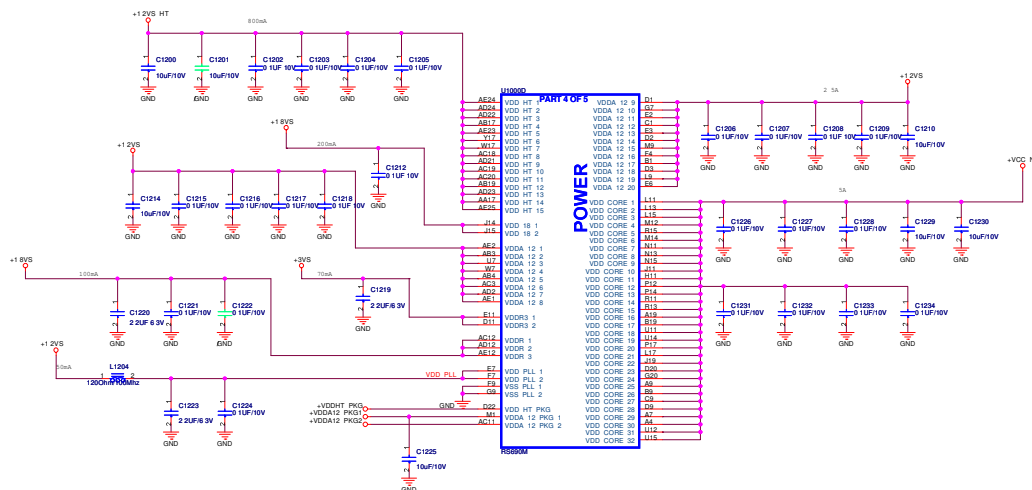

« Kennedy_Zhang »

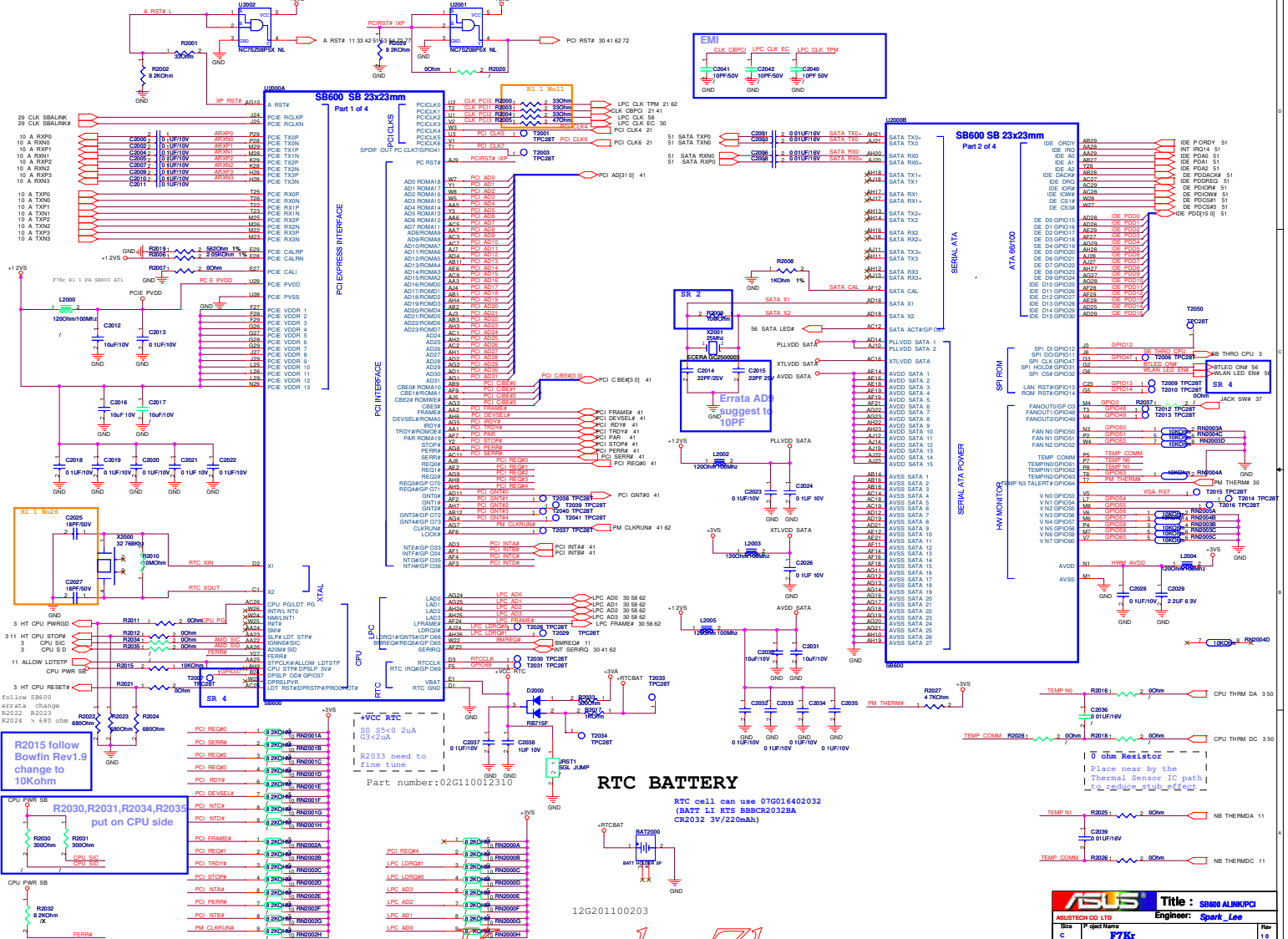

Kennedy_Zhang

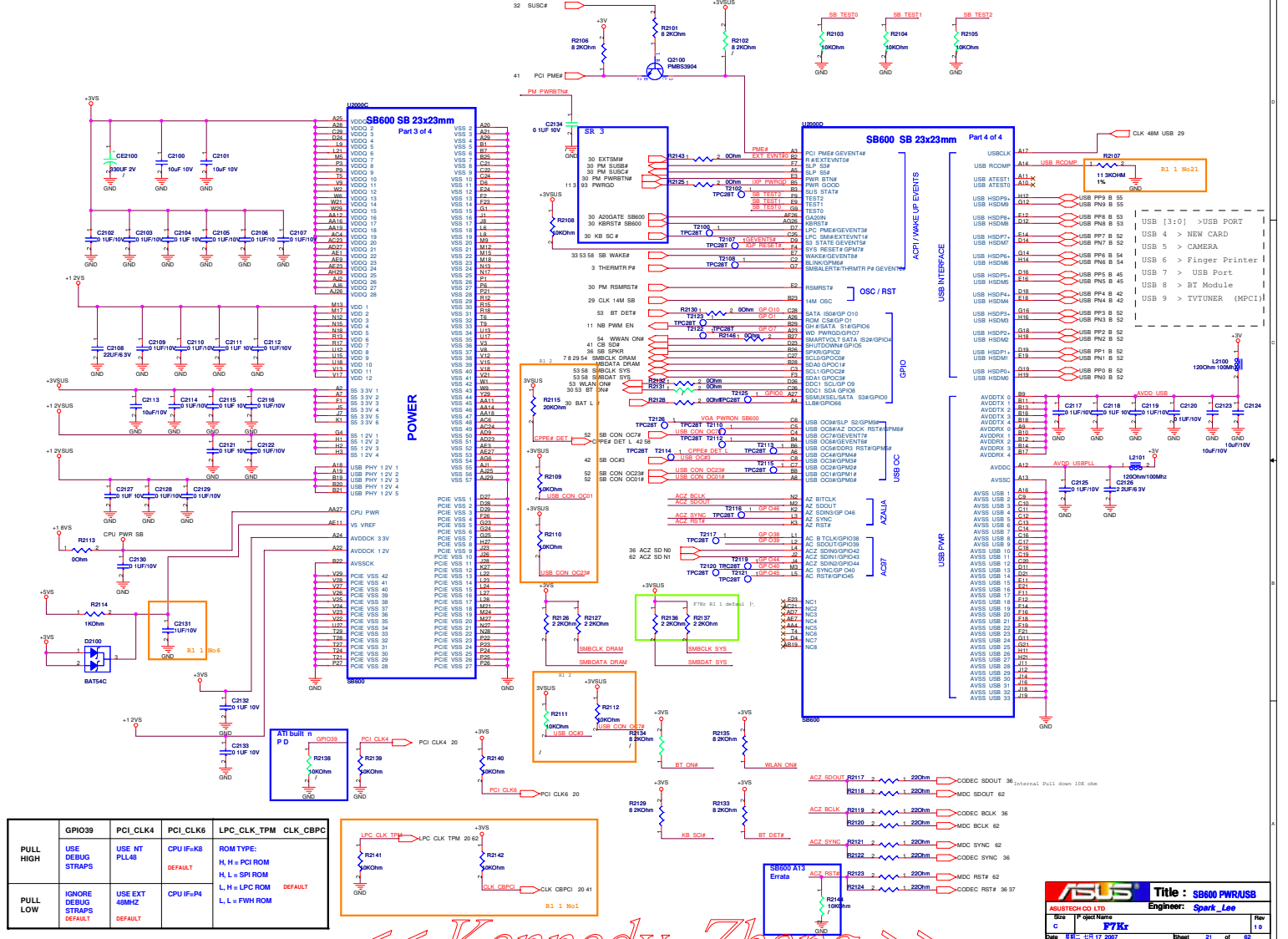

	GPIO39	PCI_CLK4	PCI_CLK6	LPC_CLK_TPM	CLK_CBPC
PULL HIGH	USE DEBUG STRAPS	USE NT PULL	CPU IF:K8 DEFAULT	ROM TYPE: H, H = PCI ROM H, L = SPI ROM L, L = LPC ROM L, L = FW ROM	DEFAULT
PULL LOW	IGNORE DEBUG STRAPS DEFAULT	USE EXT 48MHZ DEFAULT	CPU IF:P4 DEFAULT		

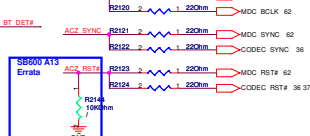
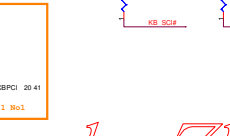
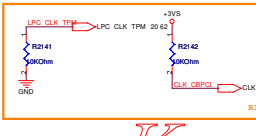

ASUSTeCH CO LTD
Title: SB600 PWR/USB
Engineer: Spark_Lee

Ver	1.0	Rev	1.0
Date	2007-07-17	Sheet	11 of 16

Kennedy_Zhang

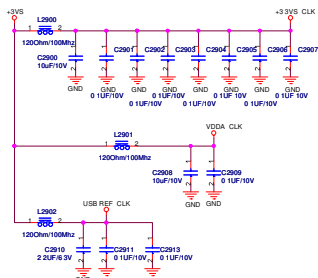

EXT CLK FREQUENCY SELECT TABLE (MHZ)

FS2	FS1	FS0	CPU	SRCCLK [2:1]	HTT	PCI	USB	COMMENT
0	0	0	HI Z	100 00	HI Z	HI Z	48 00	Reserved
0	0	1	X	100 00	X/3	X/6	48 00	Reserved
0	1	0	180 00	100 00	60 00	30 00	48 00	Reserved
0	1	1	220 00	100 00	36 56	73 12	48 00	Reserved
1	0	0	100 00	100 00	66 66	33 33	48 00	Reserved
1	0	1	133 33	100 00	66 66	33 33	48 00	Reserved
1	1	1	200 00	100 00	66 66	33 33	48 00	Normal ATHLON64 operation

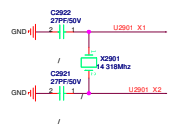
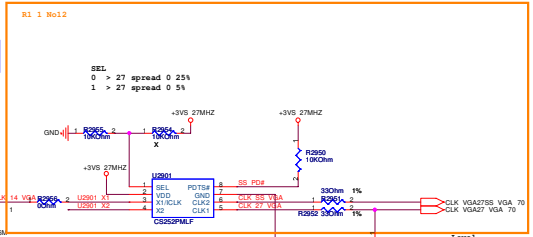
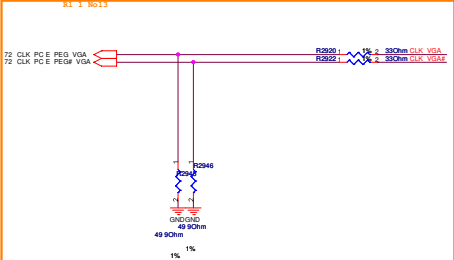
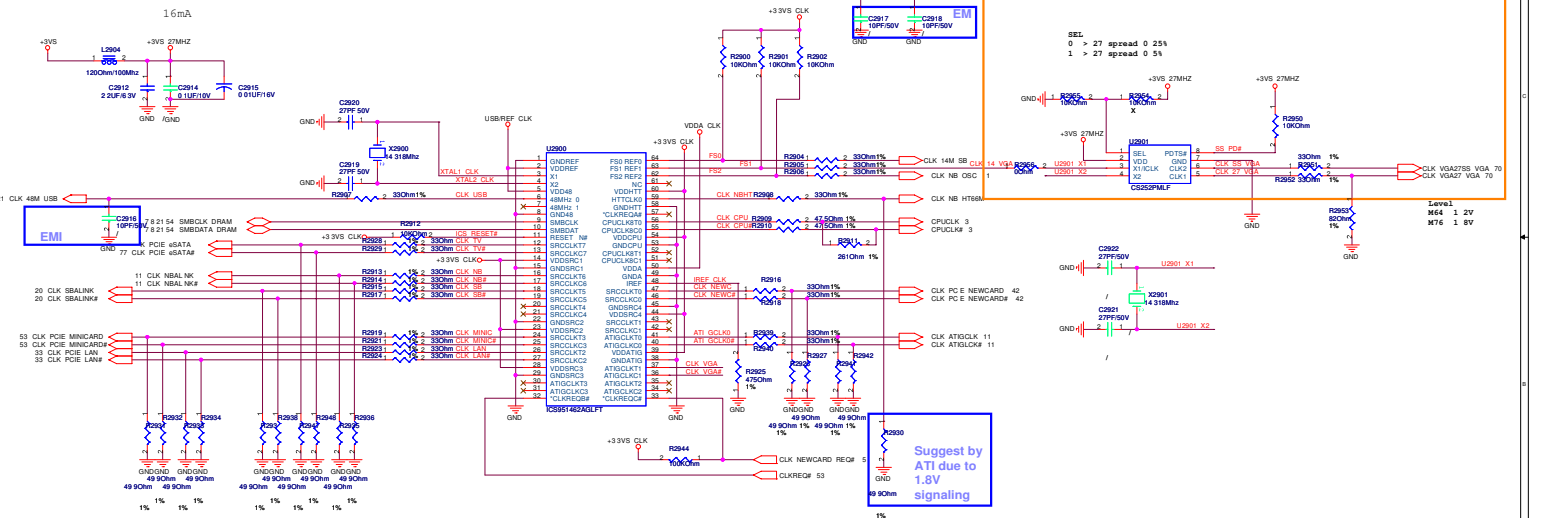

« Kennedy_Zhang »

KBC connector

Follow F7F

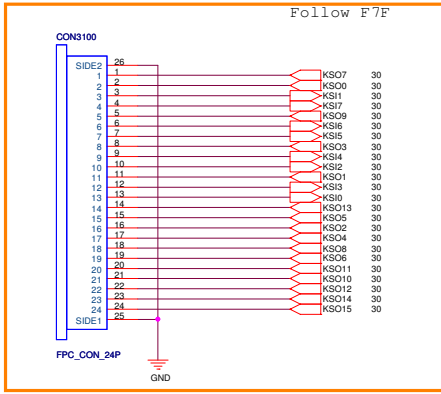

12G182402405

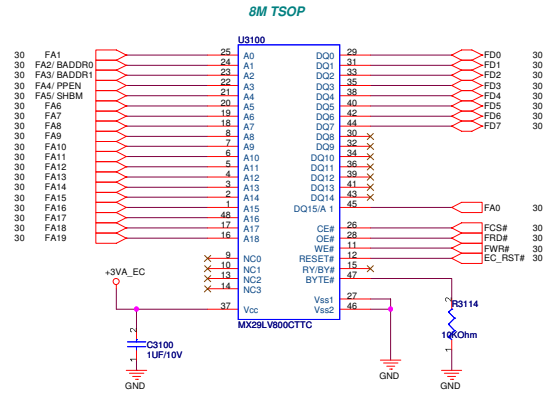

EC ADC

R2.0-S37

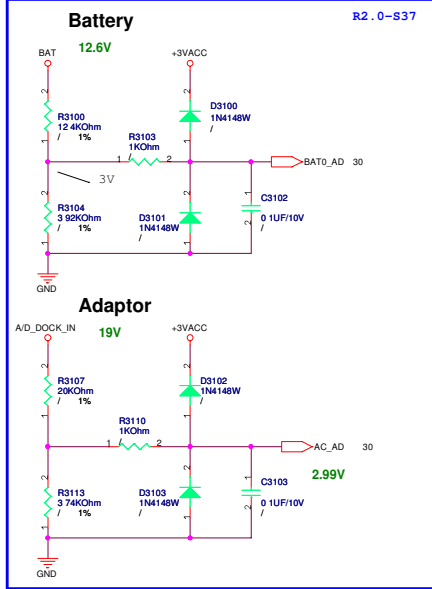

EC Hardware Strap

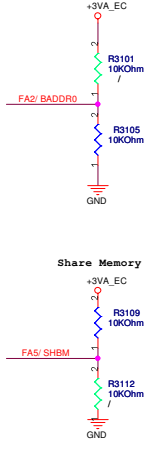

PNPCFG base address set by SWCBAR/SWCBALR

Share Memory

SHEM
No pull up:
disable shared memory with host BIOS
Ext 10K up:
enable shared memory with host BIOS

strap value sampled after VSTBY power up reset

BADDR[1:0]
No pull up:
The register pair to access PNPCFG is 002Eh and 002Fh.
Ext 10K up on BADDR0:
The register pair to access PNPCFG is 004Eh and 004Fh.
Ext 10K up on BADDR1:
The register pair to access PNPCFG is determined by EC domain registers SWCBALR and SWCBARR.

PPEN
No pull up:
Normal
Ext 10K up:
KBS interface pins are switched to parallel port interface for in-system programming.

ASUS		Title : EC I78510TC(2/2)	
ASUSTeK COMPUTER INC. NBS		Engineer: Spark_Lee	
Size	Project Name		Rev
Custom	FTK		1.0
Date: 08-11-17 2007		Sheet	31 of 62

« Kennedy_Zhang »

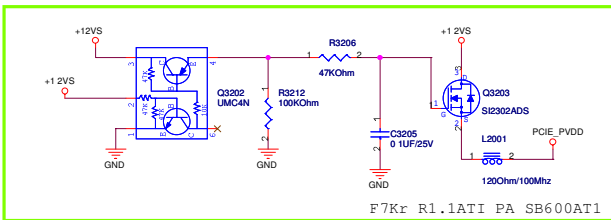
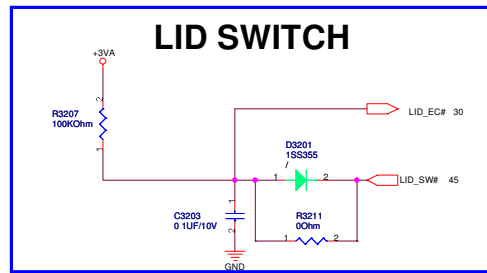
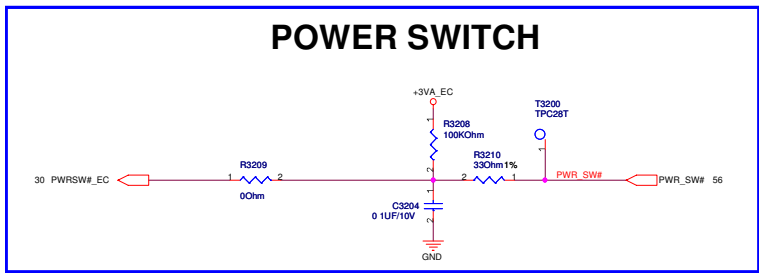
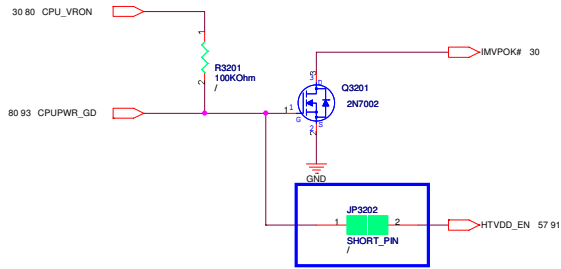
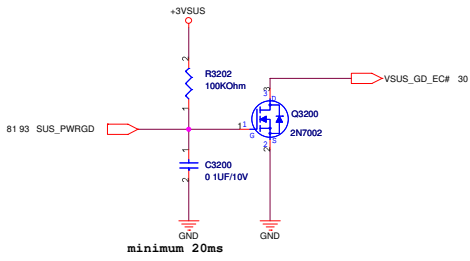
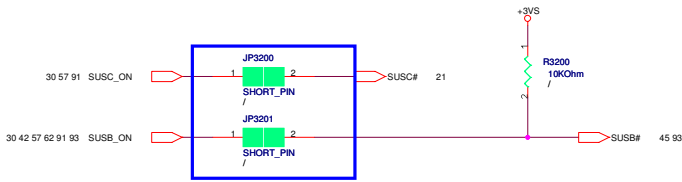

ASUS		Title : POWER-ON SEQUENCE	
ASUSTek COMPUTER INC		Engineer: <i>Spark_Lee</i>	
Site	Project Name	Rev	1.0
Custom	F7Kr		
Date: 03/11/2007		Sheet	32 of 62

« Kennedy_Zhang »

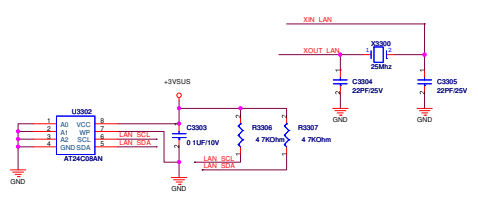
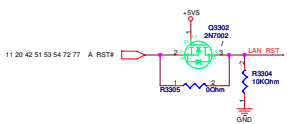
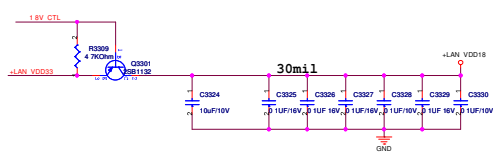
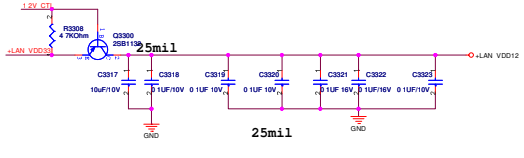
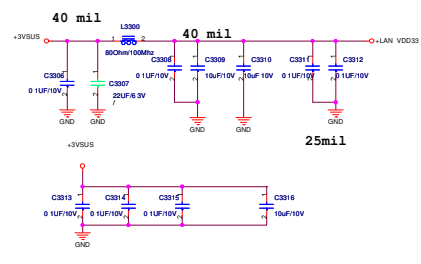
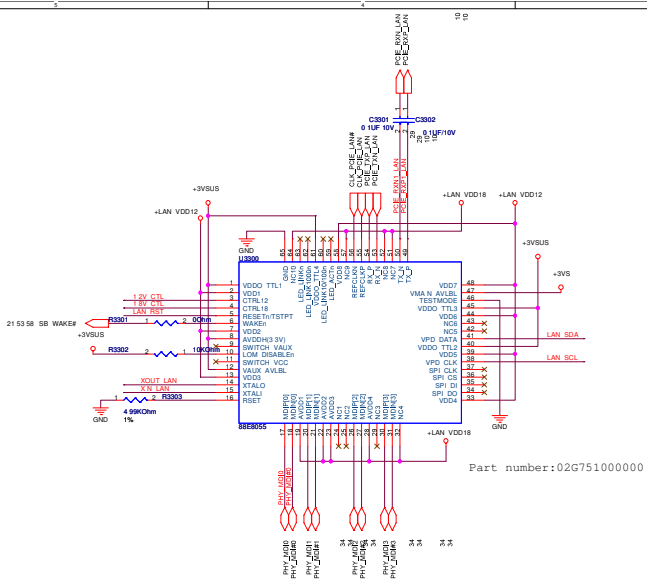

ASUS		Title : LAN RTL8111B	
ASUSTEK COMPUTER INC.		Engineer: Spark_Lee	
Doc	P: gpc/hzhs	Rev	1.0
C	P7Kc		
Doc	118 - 03-17-2007	Sheet	33 of 32

<< Kennedy_Zhang >>

LAN PORT

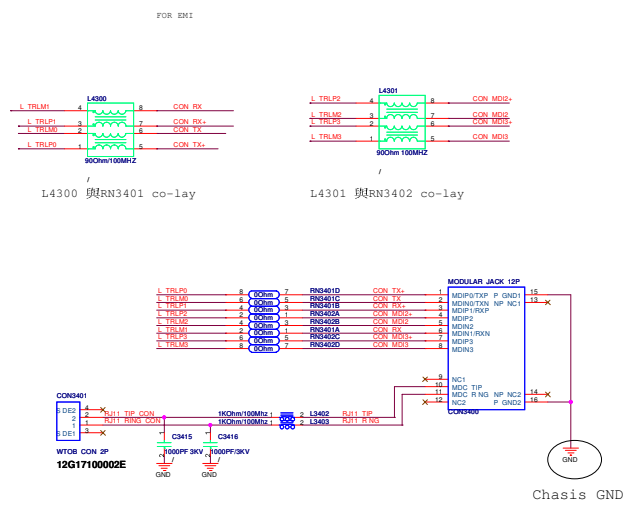
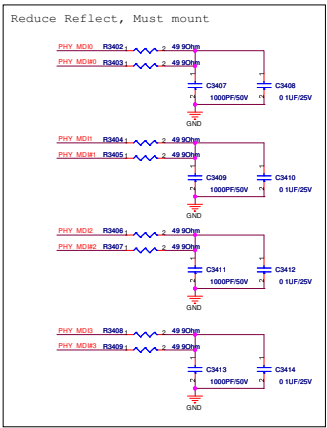
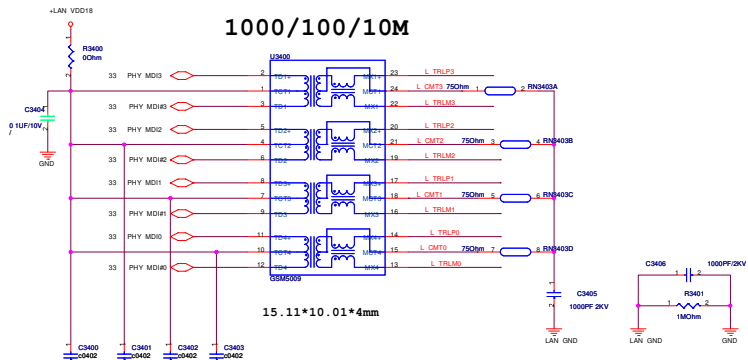

« Kennedy_Zhang »

AUDIO CODEC

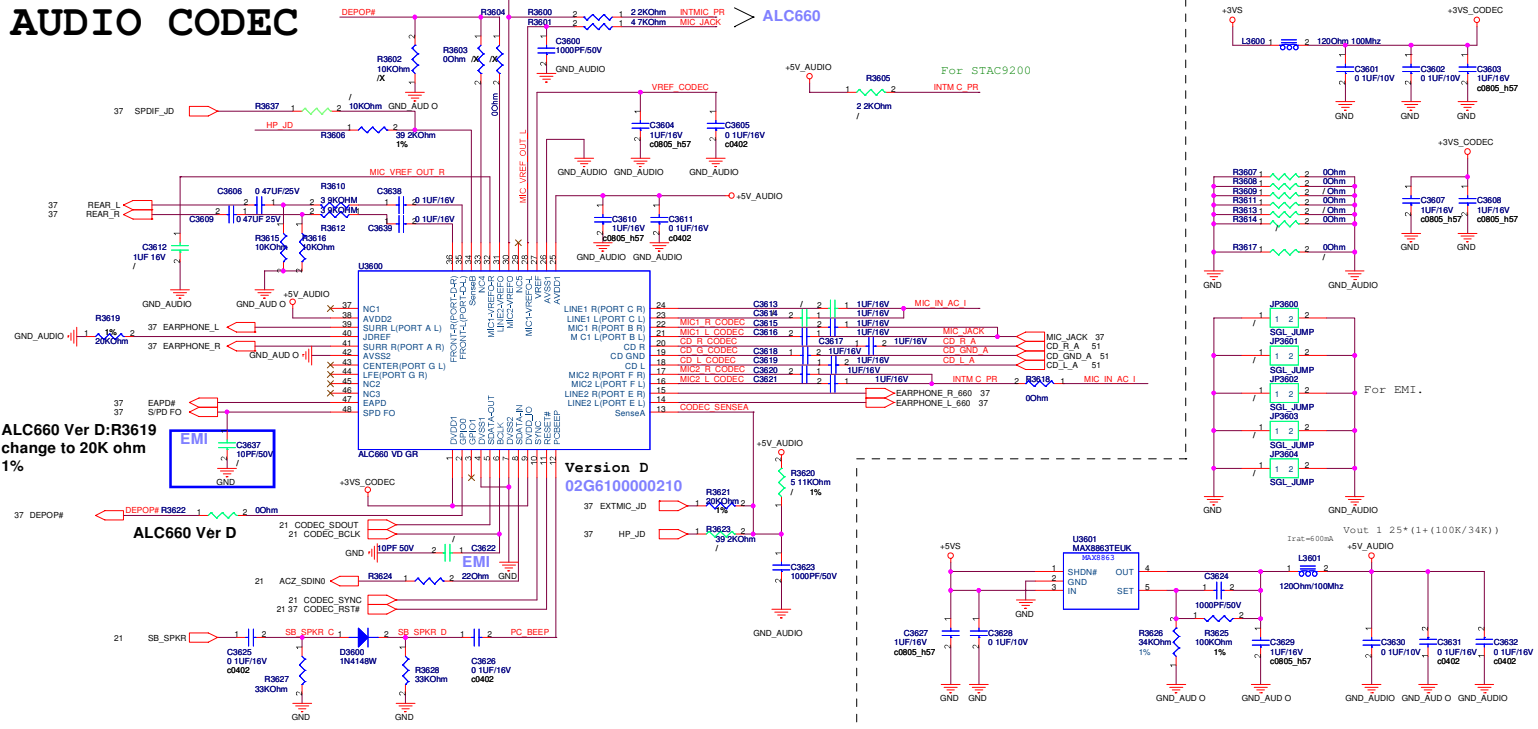

Internal MIC Pre-Amplifier

(Follow F2J R1.1)

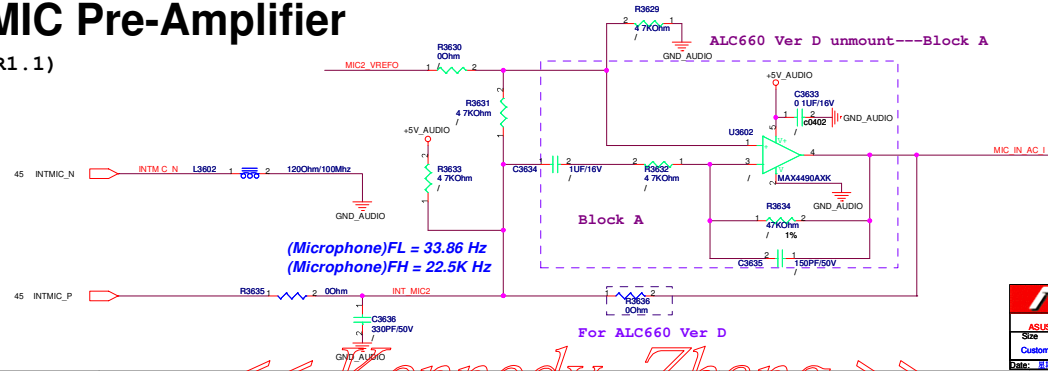

ASUS		Title : AUDIO CODEC-ALC660	
ASUSTeK COMPUTER INC		Engineer: Spark_Lee	
Size	Project Name	Date	Rev
Custom	F7Kz	8/8 14:17:2007	1.0
		Sheet	36 of 82

« Kennedy_Zhang »

AUDIO AMPLIFIER

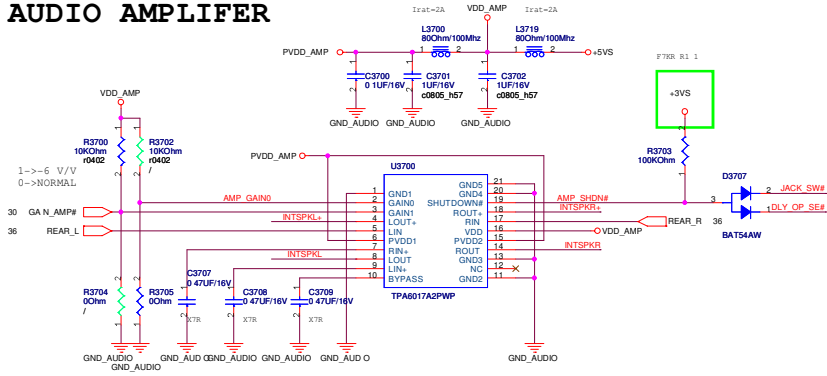

SPEAKER

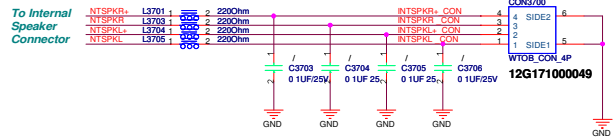

HeadPhone&SPDIF

TYPE	LINE_OUT	S/PDIF_OUT	NC
HP_JD	L	H	H
JACK_SW#	L	L	H

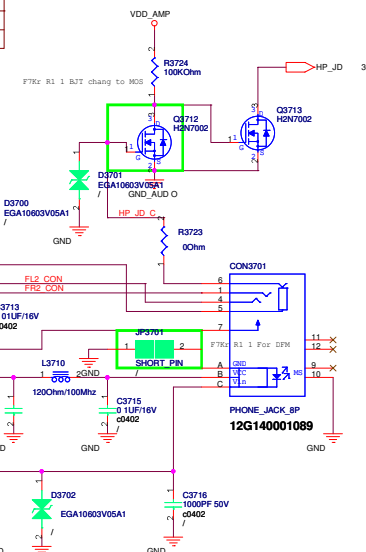

DEPOP CIRCUIT

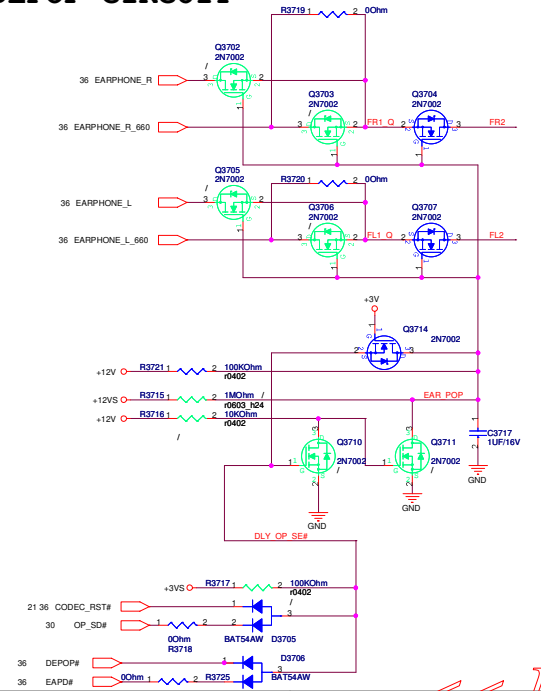

Co-Layout with CE3702/CE3703

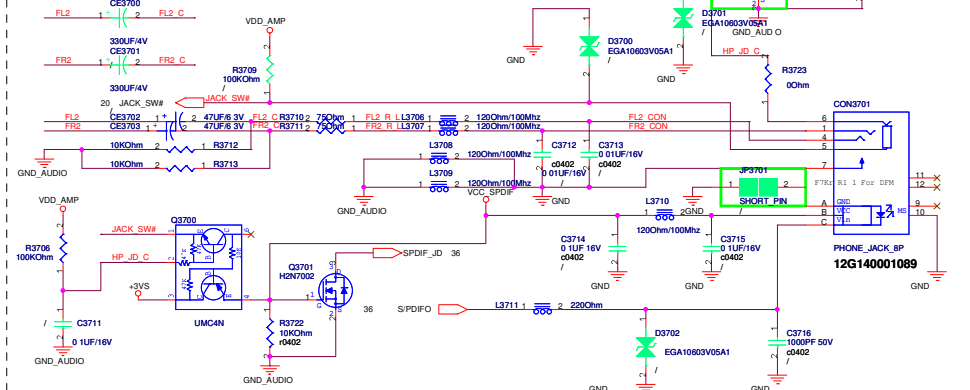

External Microphone

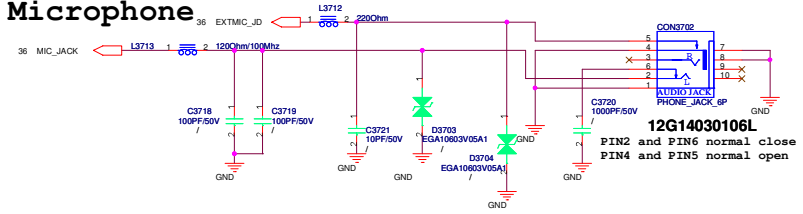

ASUS Title : AUDIO AMP & JACK
 ASUSTeK COMPUTER INC Engineer: Spark_Lee
 Site: Project Name: FTKr
 Date: 11/17/2007 Sheet: 37 of 82

« Kennedy_Zhang »

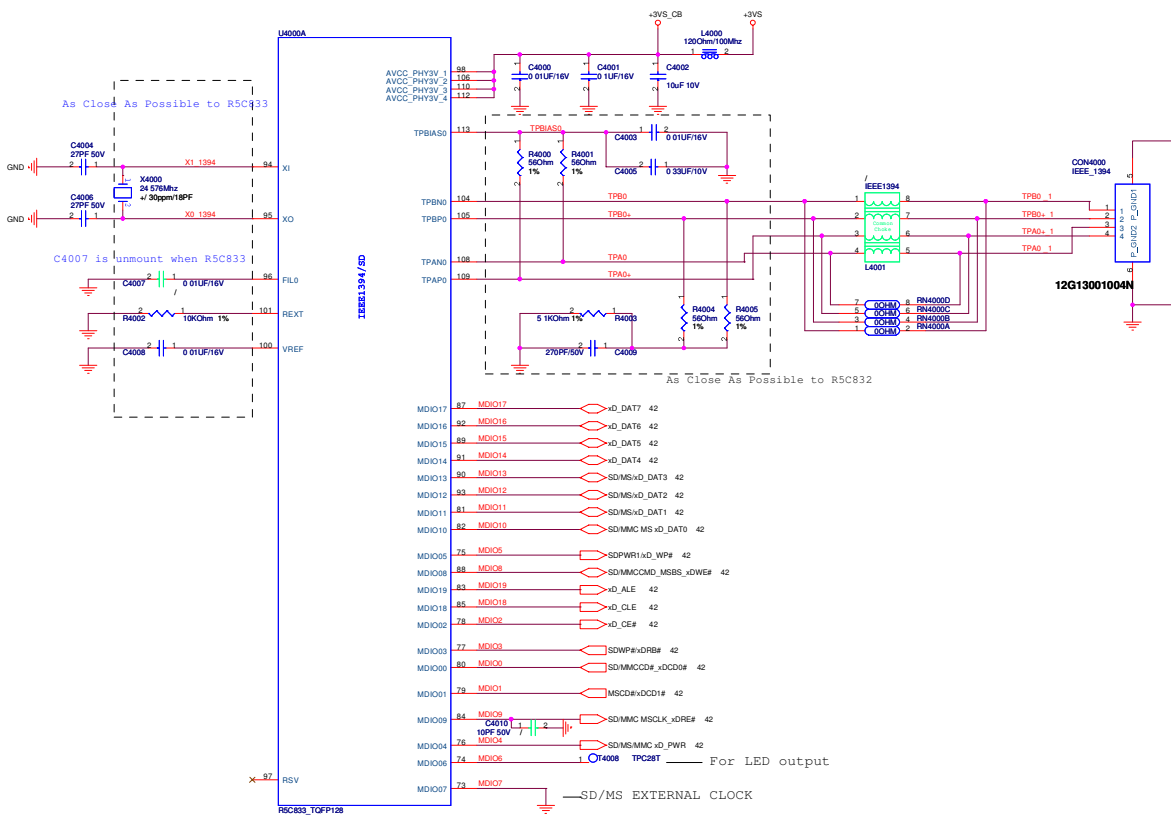

MDIO02	> xDCE#
MDIO05	> xD Power Control 1 / xDNP
MDIO04	> xD/MS/SD LED Control
MDIO14	> xD Data
MDIO15	> xD Data
MDIO16	> xD Data
MDIO17	> xD Data
MDIO18	> xD CLE
MDIO19	> xD ALE

MDIO01	> MS Card Detect
MDIO03	> SD Write Protect
MDIO04	> SD Card Power0 Control/MS Power Control
MDIO07	> SD External Clock/MS External Clock
MDIO09	> SD Command/MS Bus State
MDIO08	> SD Clock/MS Clock
MDIO10	> SD Data 0/MS Data 0
MDIO11	> SD Data 1/MS Data 1
MDIO12	> SD Data 2/MS Data 2
MDIO13	> SD Data 3/MS Data 3

MDIO00	> SD Card Detect
MDIO01	> MS Card Detect
MDIO03	> SD Write Protect
MDIO04	> SD Card Power0 Control/MS Power Control
MDIO08	> SD Command/MS Bus State
MDIO09	> SD Clock/MS Clock
MDIO10	> SD Data 0/MS Data 0
MDIO11	> SD Data 1/MS Data 1
MDIO12	> SD Data 2/MS Data 2
MDIO13	> SD Data 3/MS Data 3

ASUS Title: RICH 5C832-CARD&1394
 Engineer: Spark_Lee

Size	Project Name	Rev
Custom	F7K7	1.0
Date: 01/12/2007	Sheet	20 of 25

<< Kennedy_Zhang >>

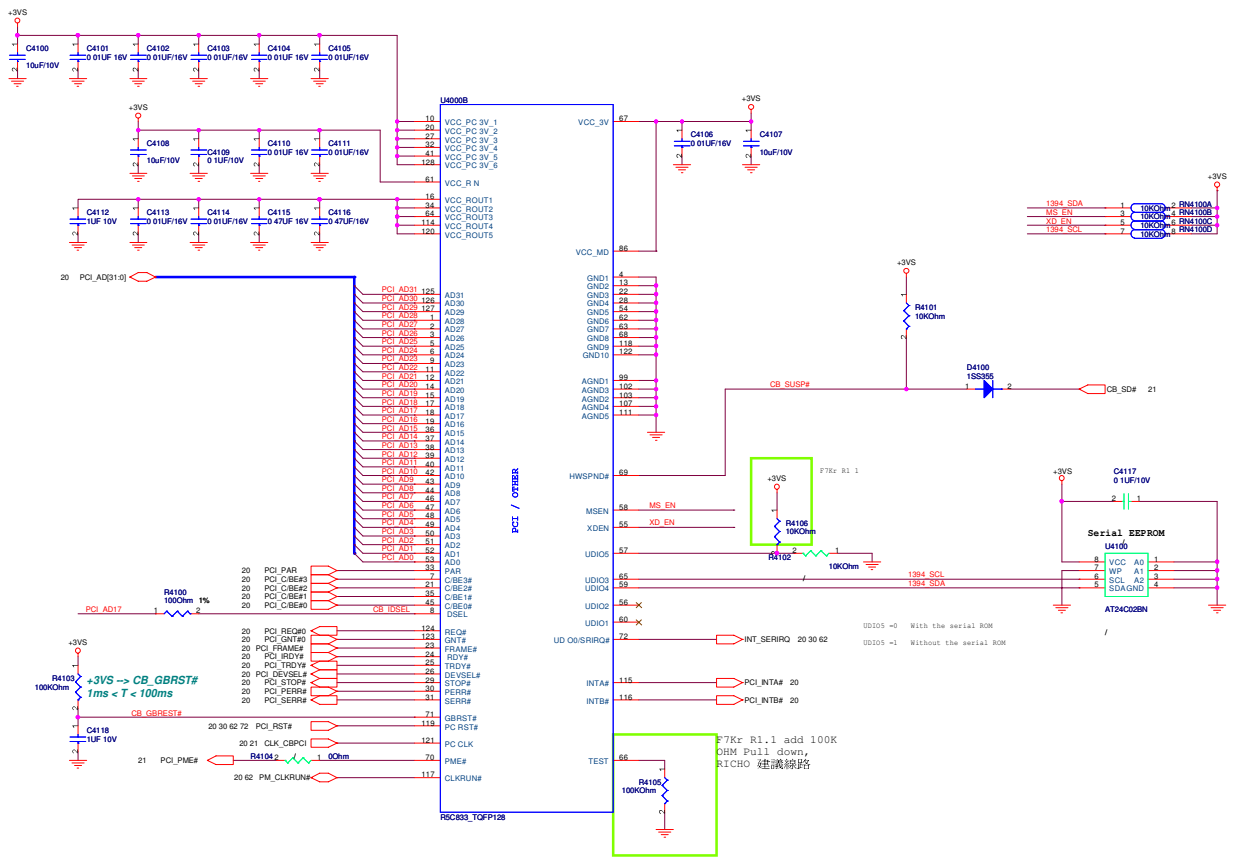

<< Kennedy_Zhang >>

NEW CARD SOCKET

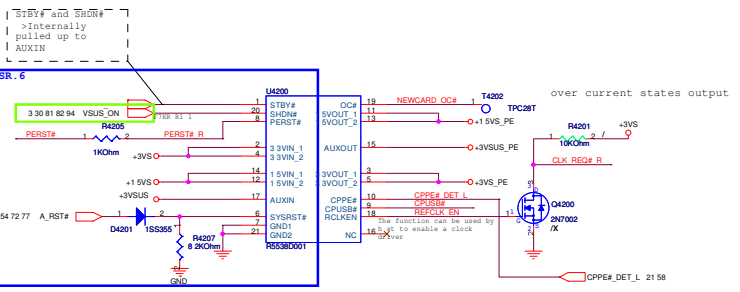

!! ExpressCard Standard 1.0:
Change Pin7 from RESERVED to SMBCLK
Change Pin8 from SMBCLK to SMBDATA
Change Pin9 from SMBDATA to +1.5V

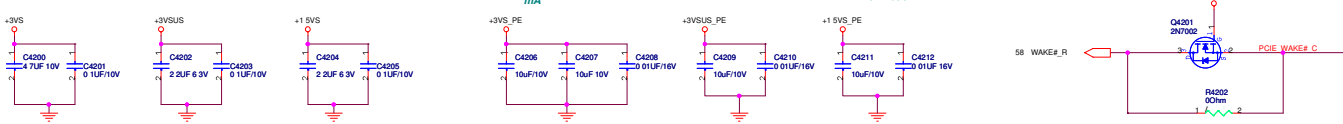
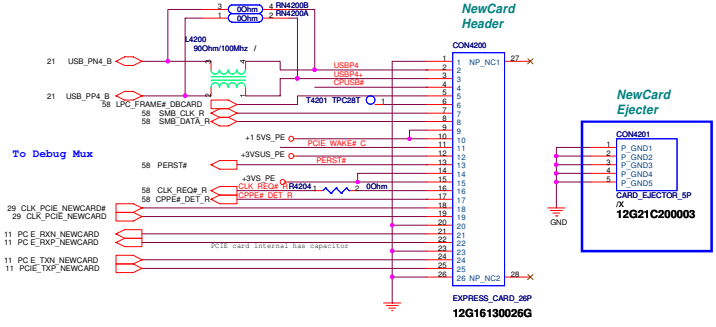

4 IN 1 CARD READER SOCKET

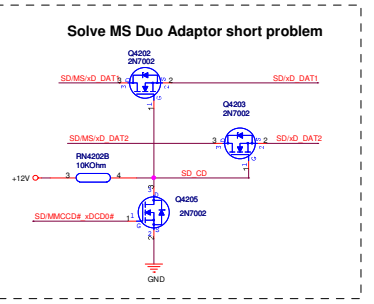
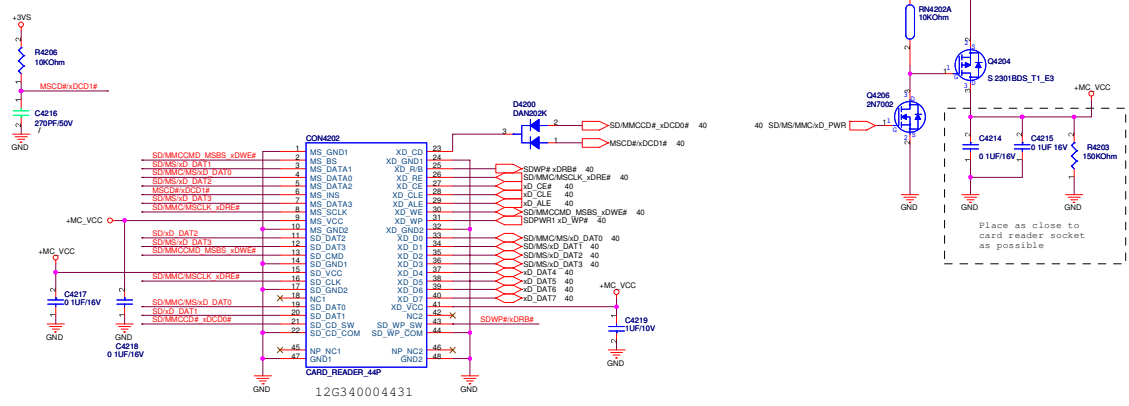

ASUS Title : Express Card & Card Reader
 ASUSTek COMPUTER INC. NBS Engineer: Spark_Lee
 Size Project Name Rev
 Custom FTK
 Date: 10/11/2007 Sheet 42 of 48

<< Kennedy_Zhang >>

LCD Power

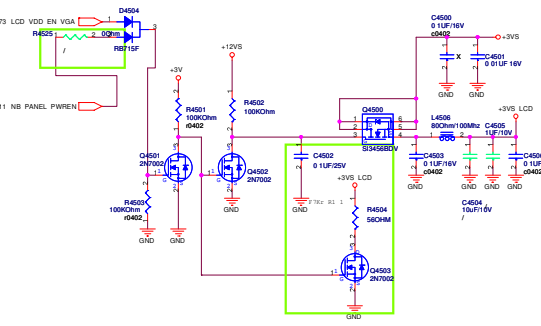

LCD LVDS Interface

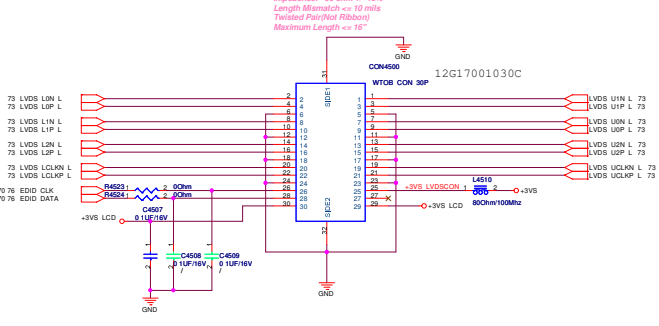

INVERTER Interface

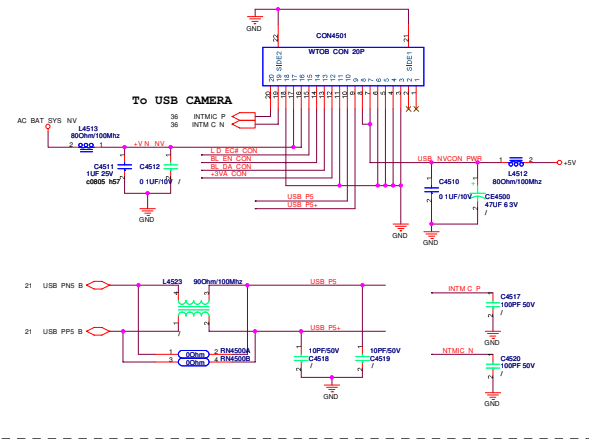

Backlight Enable

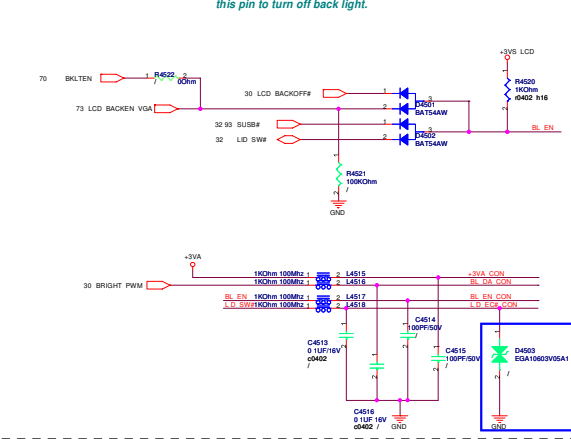

« Kennedy_Zhang »

VGA OUT

Reference Schematics L=47nH

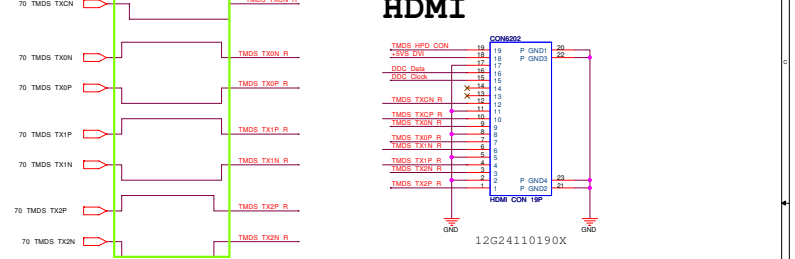
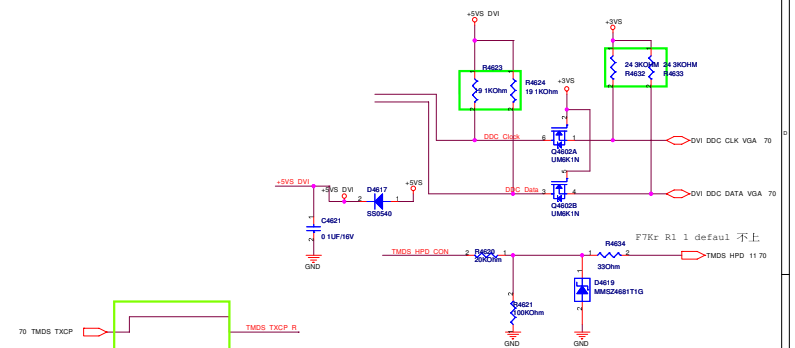
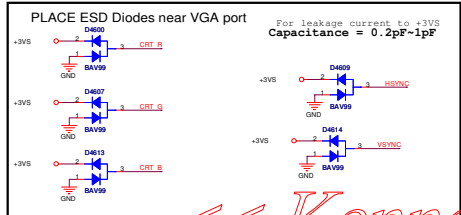
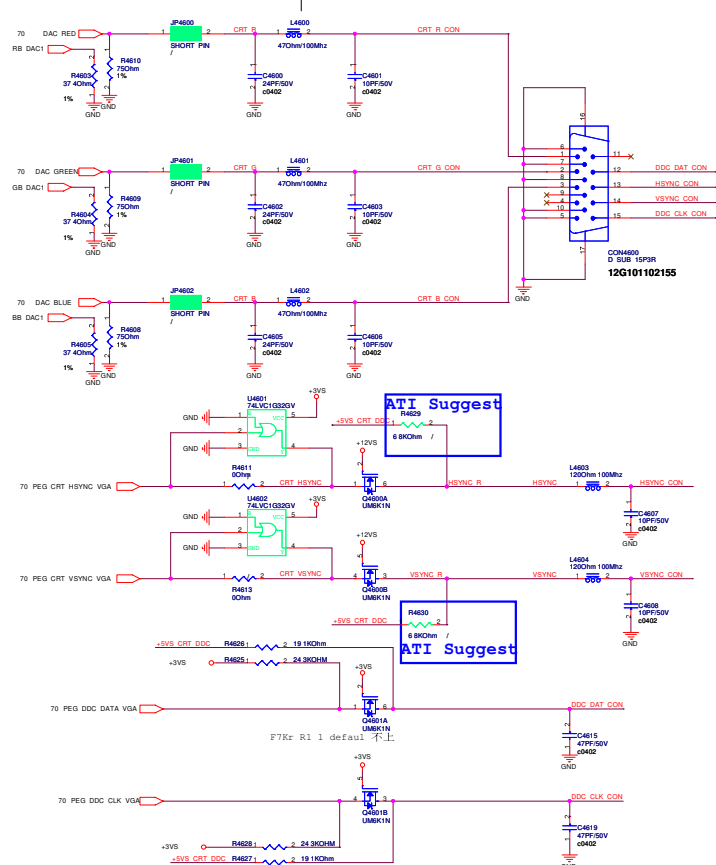

TV OUT

Reference Schematics L=470nH

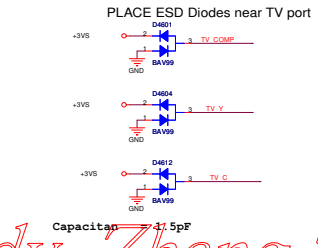
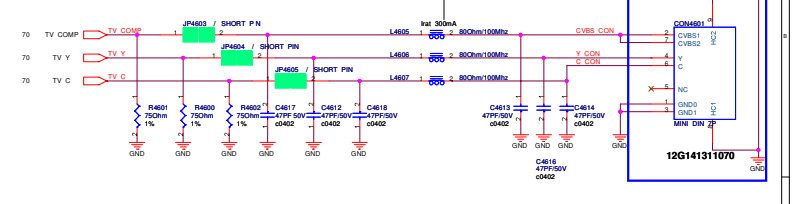

ASUS		Title : TV&CRT CONNECTOR	
Rev	0	Enginer	Spark_Lee
Date	11-17-2007	Sheet	45 of 45

« Kennedy_Zhang »

DC FAN control

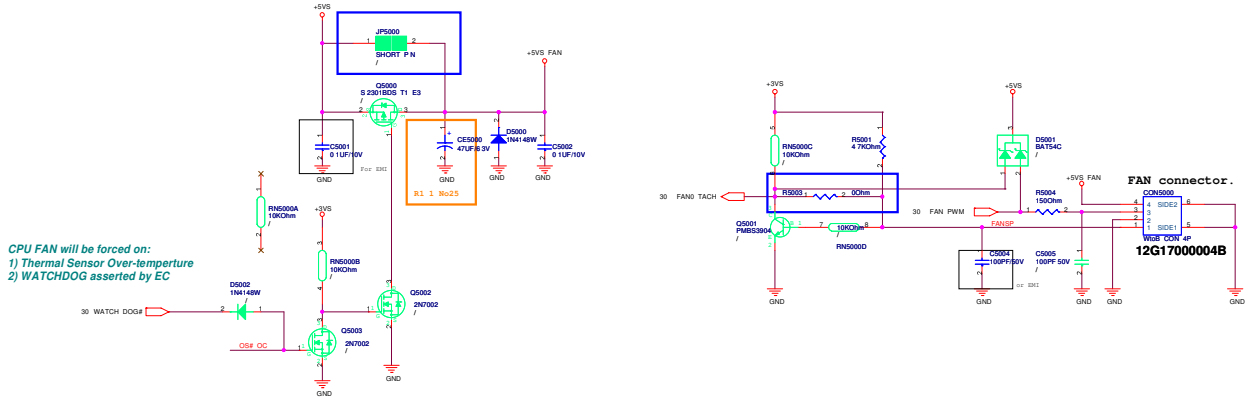

Thermal Sensor

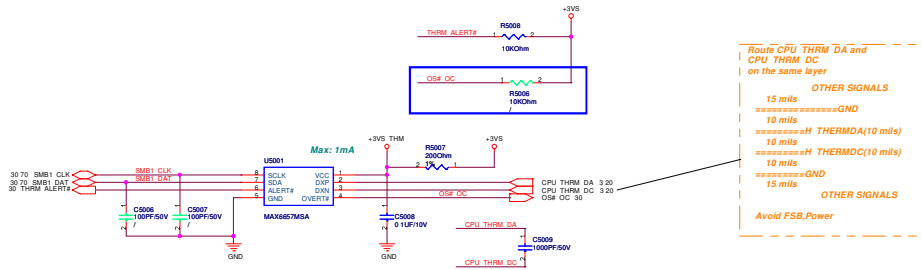

<< Kennedy_Zhang >>

		Title : THERMAL & FAN CONTROL	
ASUSTek COMPUTER INC. HKS		Engineer: Spark_Lee	
Doc No:	Doc Name:	Rev:	1.0
Date: 11-18-17 20:07		Sheet: 50 of 55	

SATA_HDD(Default)

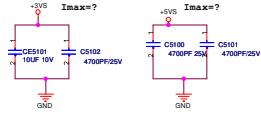
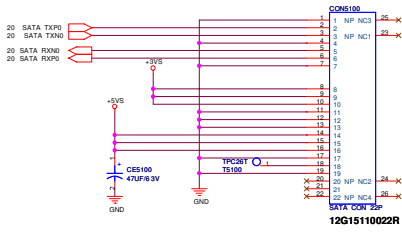

CD-ROM

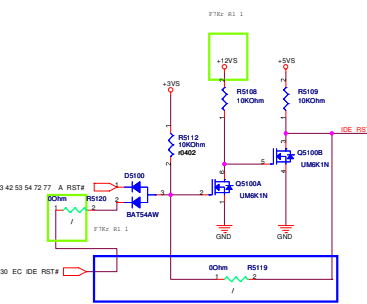
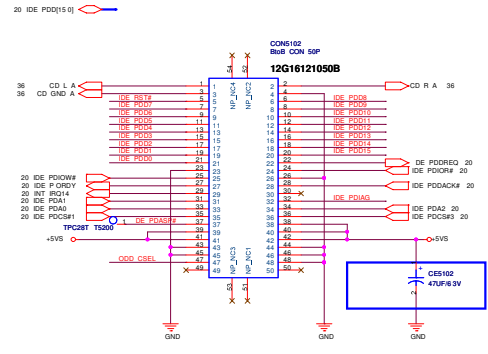
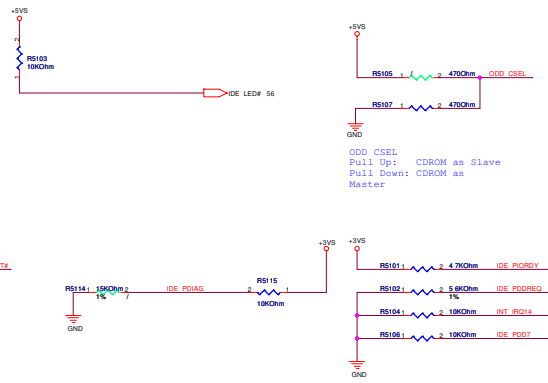

« Kennedy_Zhang »

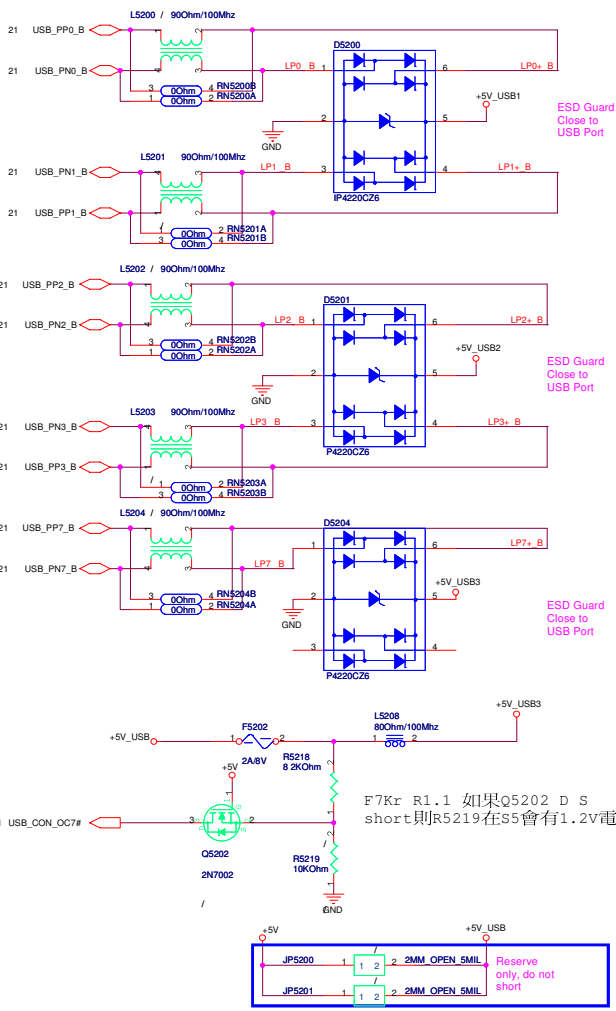

F7Kr R1.1 如果Q5202 D S short則R5219在S5會有1.2V電

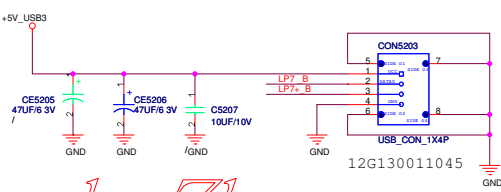
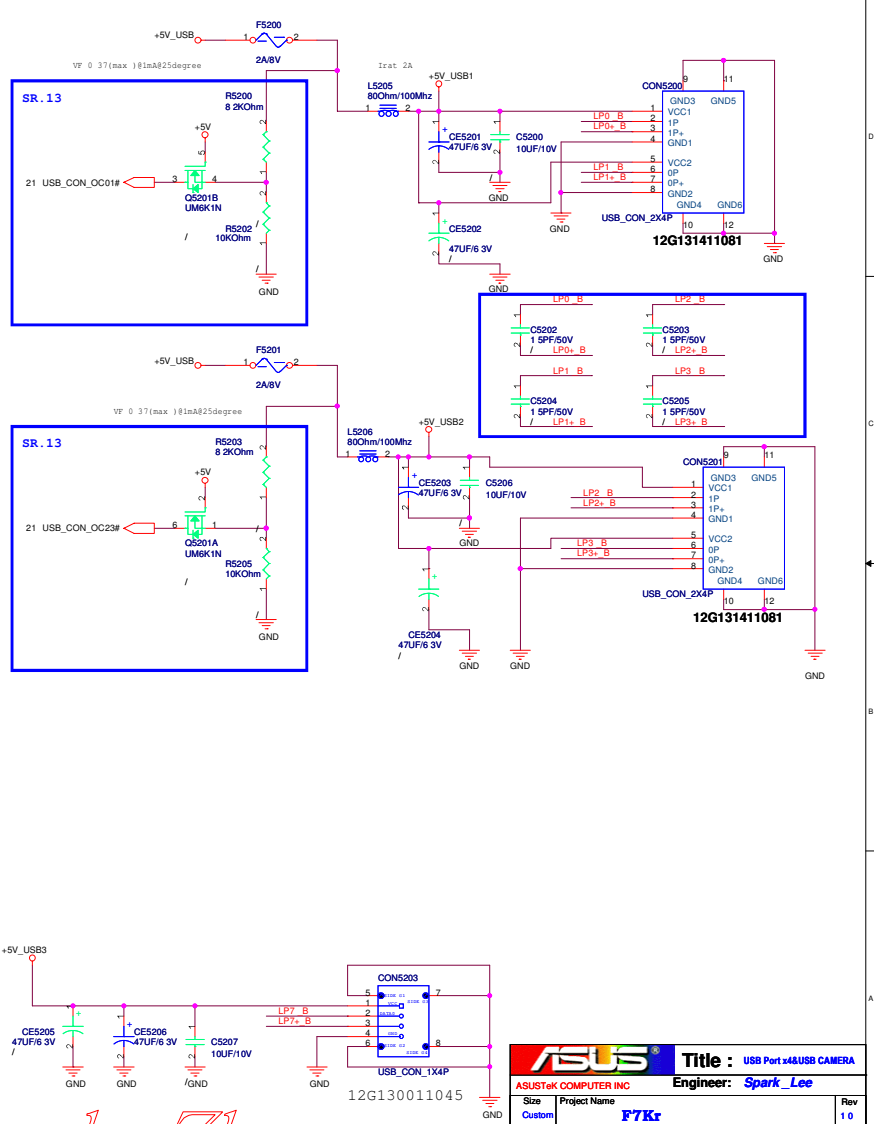

ASUS		Title : USB Port x4&USB CAMERA	
ASUSTek COMPUTER INC		Engineer: Spark_Lee	
Site	Project Name	Date	Rev
Custom	F7Kr	11/17/2007	1.0
Date: 11/17/2007		Sheet	52 of 62

<< Kennedy_Zhang >>

WLAN

MINI PCIEX CONNECTOR

Instead of Mini-PCIEX latch connector. For cost down.

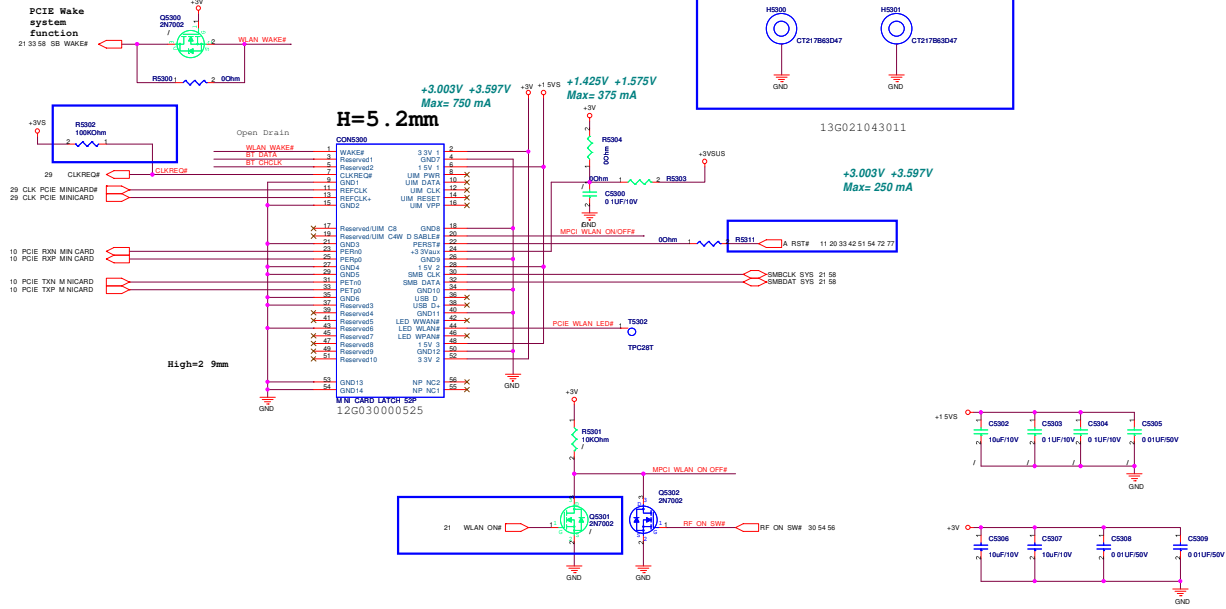

BLUETOOTH CONNECTOR

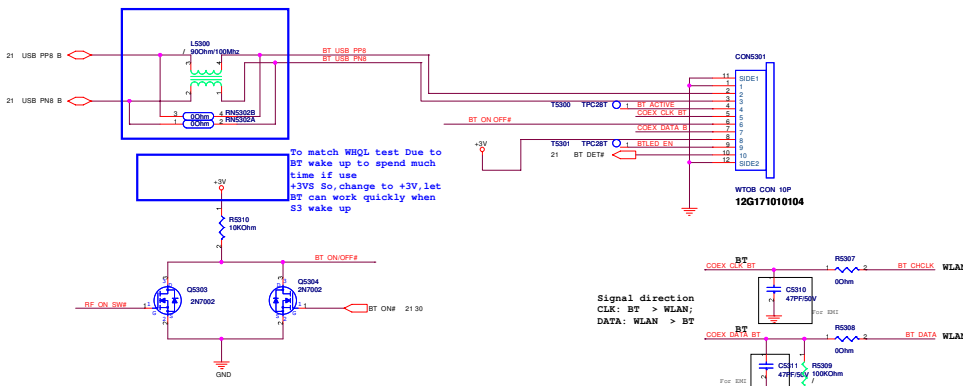

<< Kennedy_Zhang >>

UWB

H=4.0mm

+3.003V~+3.597V
Peak = 2.75A,
Notch at 2.5V-1A, 575V
Max= 375 mA

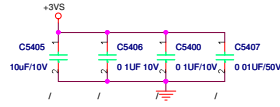
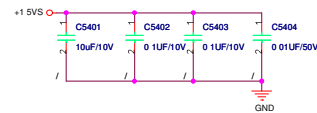

+3.003V~+3.597V
Max= 250 mA

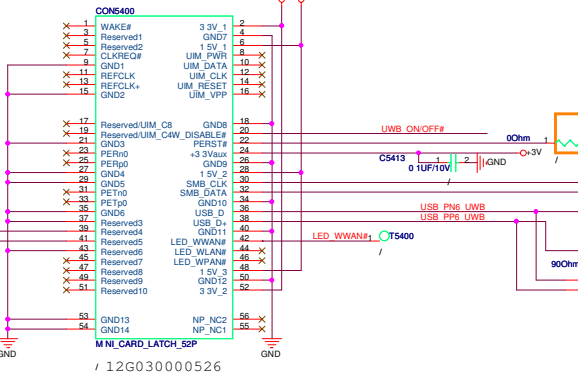
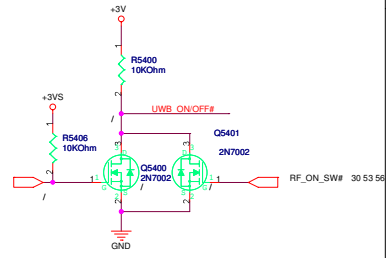

Height issue.
change to
220uF/6.3V

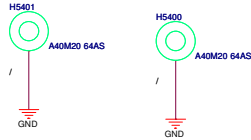

ASUS		Title : MINI Card-Windigo	
ASUSTek Computer INC		Engineer: Spark_Lee	
Size	Project Name		Rev
B	FTKr		1.0
Date: 11/17/2007		Sheet 54	of 62

<< Kennedy_Zhang >>

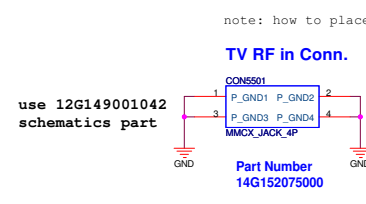
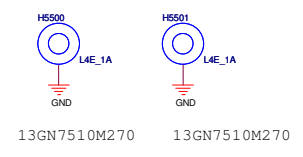
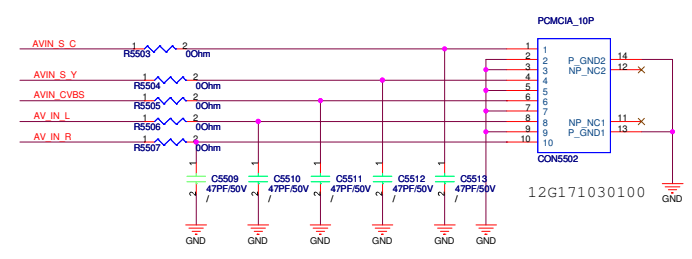
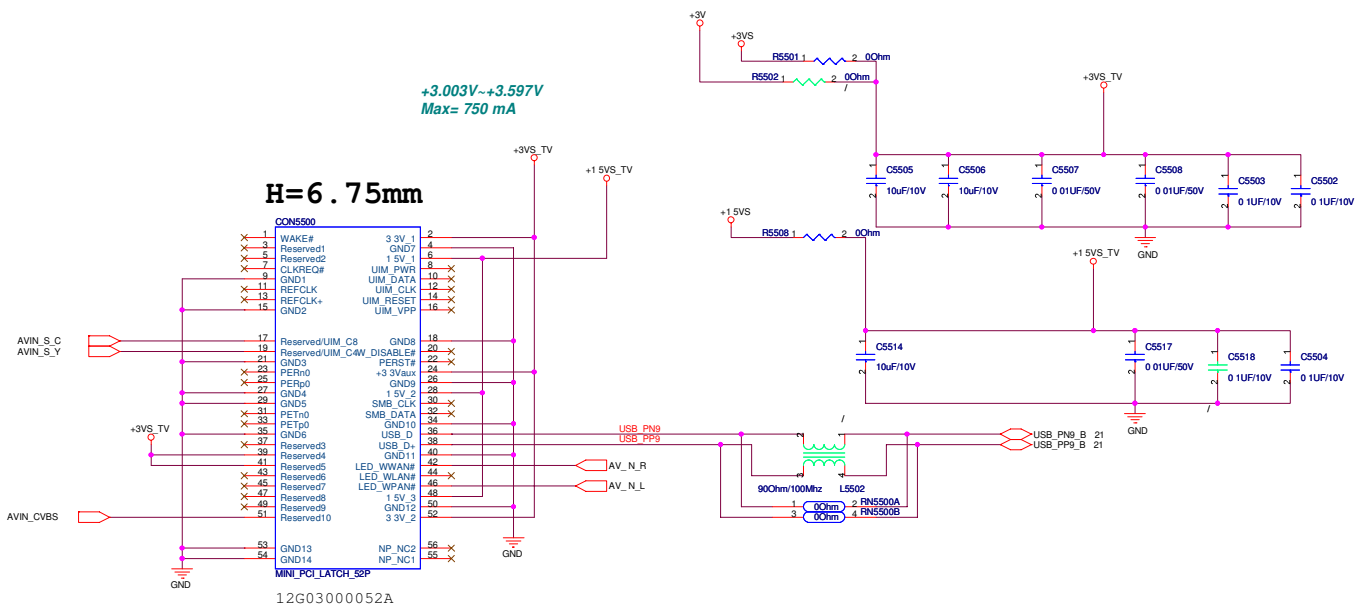

ASUS		Title: TV TUNER CONN	
ASUSTek COMPUTER INC		Engineer: Spark_Lee	
Size B	Project Name F7Kr	Rev 1.0	Rev 1.0
Date: 2007-11-17, 2007		Sheet 55	of 82

<< Kennedy_Zhang >>

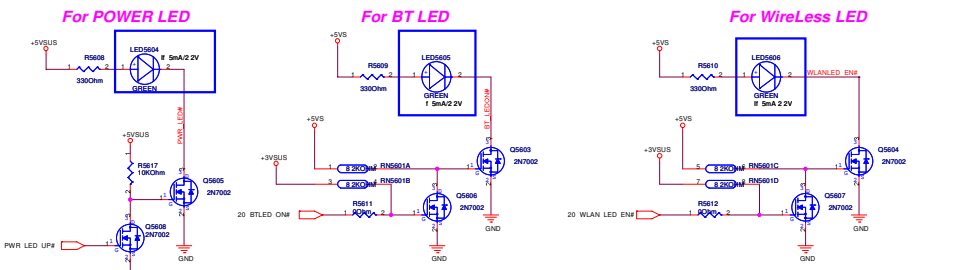
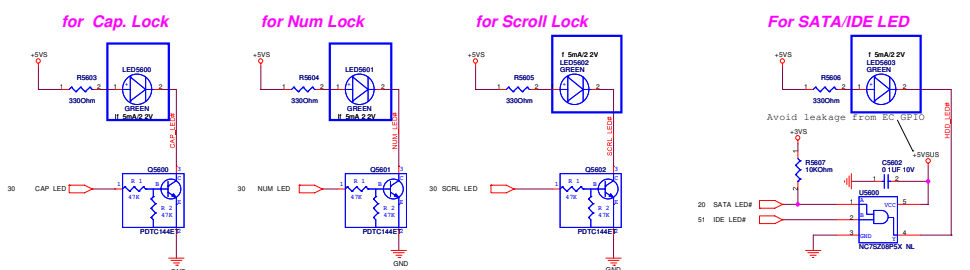
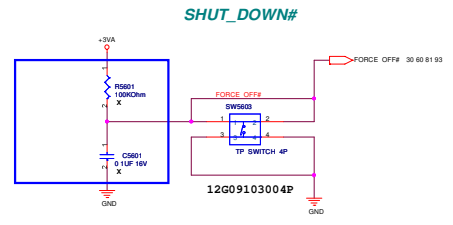
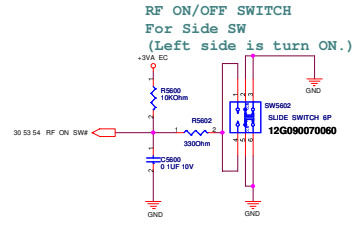
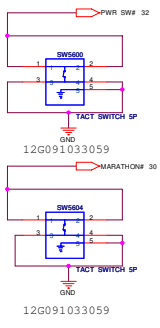

TOUCH PAD SWITCH

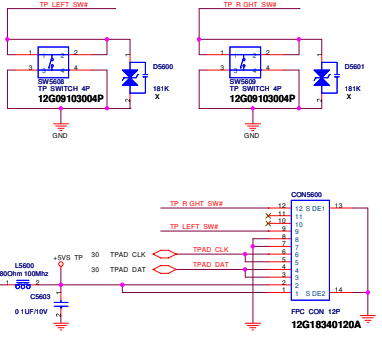

Green: 07G015700341
Orange: 07G015700064

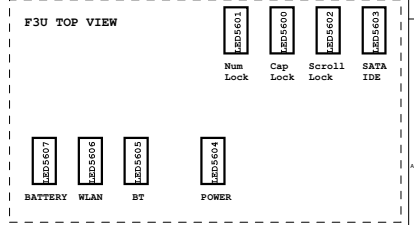
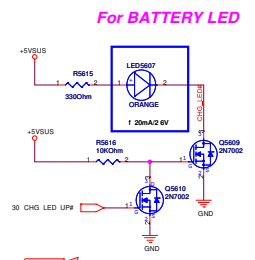

ASUS		Title: LED&SWTOUCHPAD	
ASUSTEK COMPUTER INC.		Engineer: Spark_Lee	
BSA	P: oped Name	Rev	1.0
C	FR	Sheet	56 of 66
Date: 11-18-11			

« Kennedy_Zhang »

DISCHARGE CIRCUIT

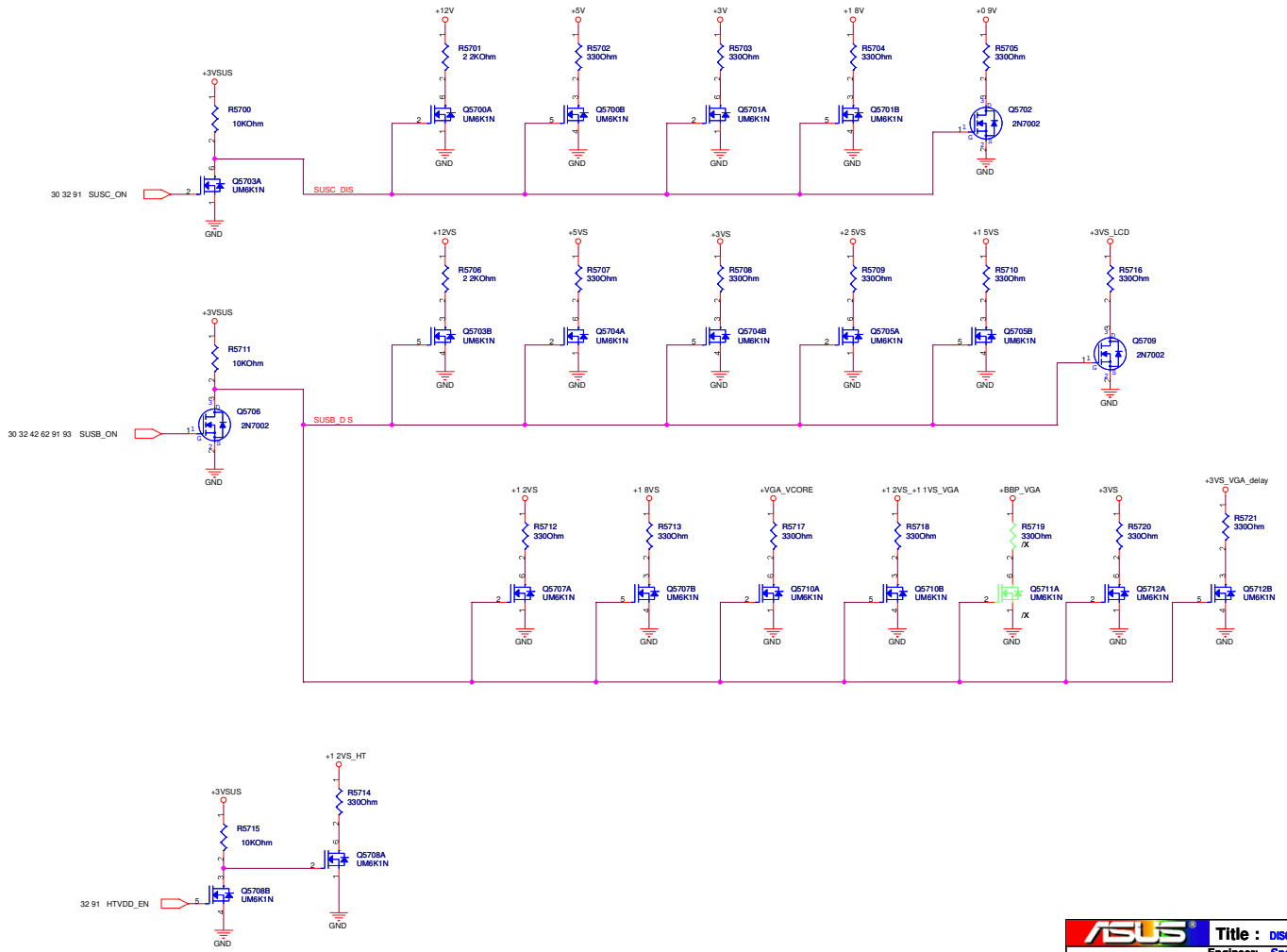

« Kennedy_Zhang »

ASUS		Title : DISCHARGE CIRCUIT	
ASUSTEK COMPUTER INC		Engineer: Spark_Lee	
Site:	Project Name:	Rev:	1.0
Cus on:	PTK	Date:	11/17/2007
Sheet 57 of 82			

Without Battery & Pull out Adapter

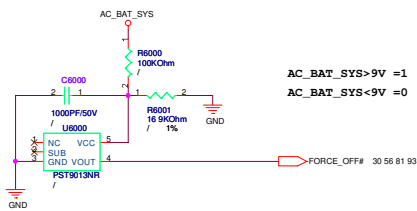

DC Power Jack

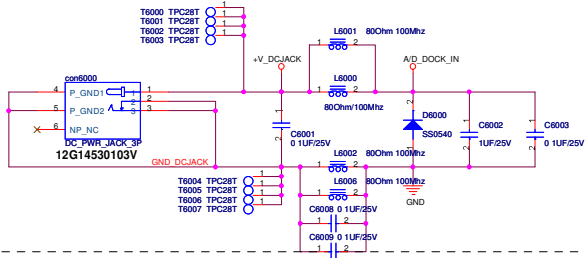

Battery Connector

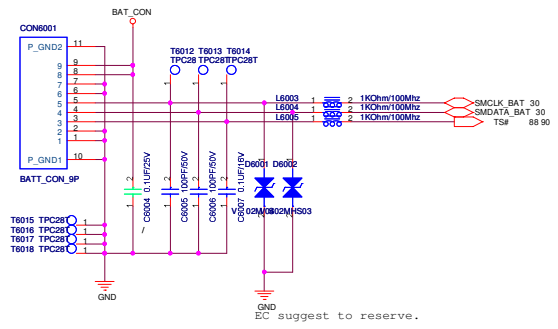

FOR LEFT UNDER

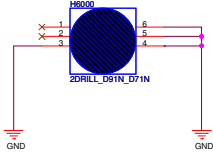

FOR RIGHT UP

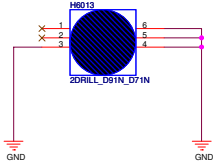

FOR VGA

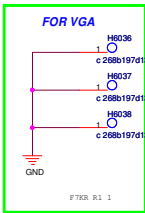

FOR CPU

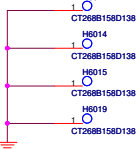

FOR FAN

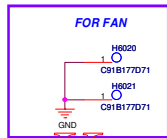
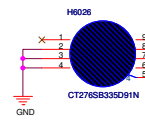
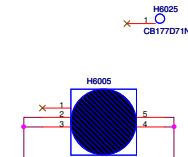
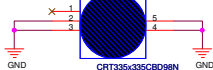
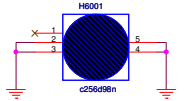

FOR SCREW HOLE

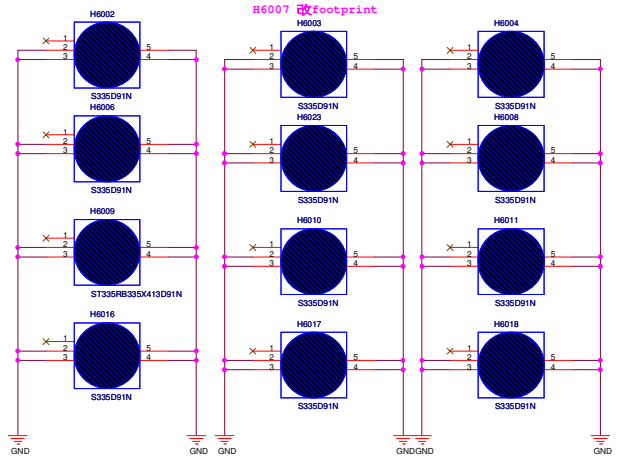

ASUS		Title : DC IN & SCREW HOLE	
ASUSTeK COMPUTER INC		Engineer: Spark_Lee	
Size	Project Name	Date:	Rev
Cus on	FTK	14/17/2007	1.0
Date: 14/17/2007		Sheet: 80 of 82	

« Kennedy_Zhang »

MDC CONN.

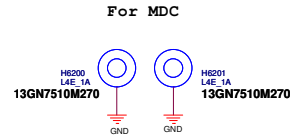
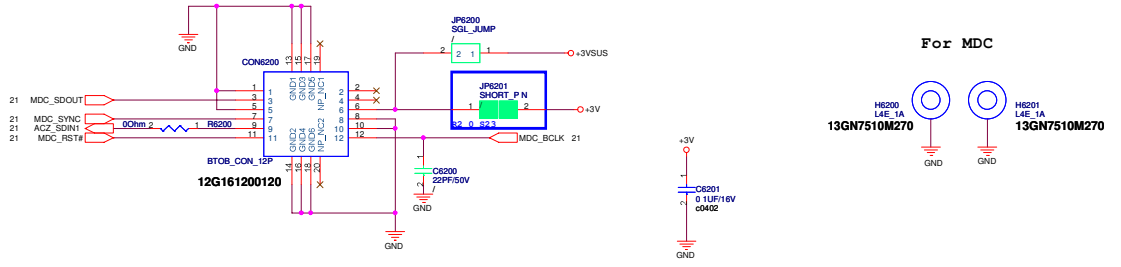

TPM CONN.

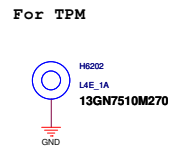
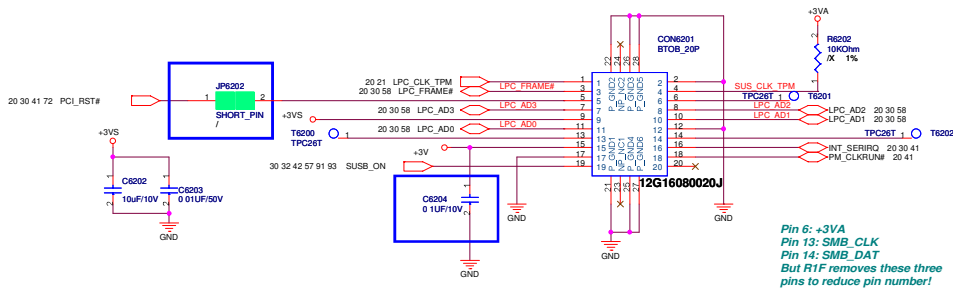

ASUS		Title : TPM&MDC CONNECTOR	
ASUSTEK COMPUTER INC		Engineer: Spark_Lee	
Site	Project Name	Rev	
Cus on	FTK	1.0	
Date: 8/8	14/17/2007	Sheet	62 of 62

« Kennedy_Zhang »

		Title : Finger Printer
ASUSTek Computer INC		Engineer: Spark_Lee
Size	Project Name	Rev
B	F7K	1.0
Date: 2007.11.17		Sheet 63 of 62

<< Kennedy_Zhang >>

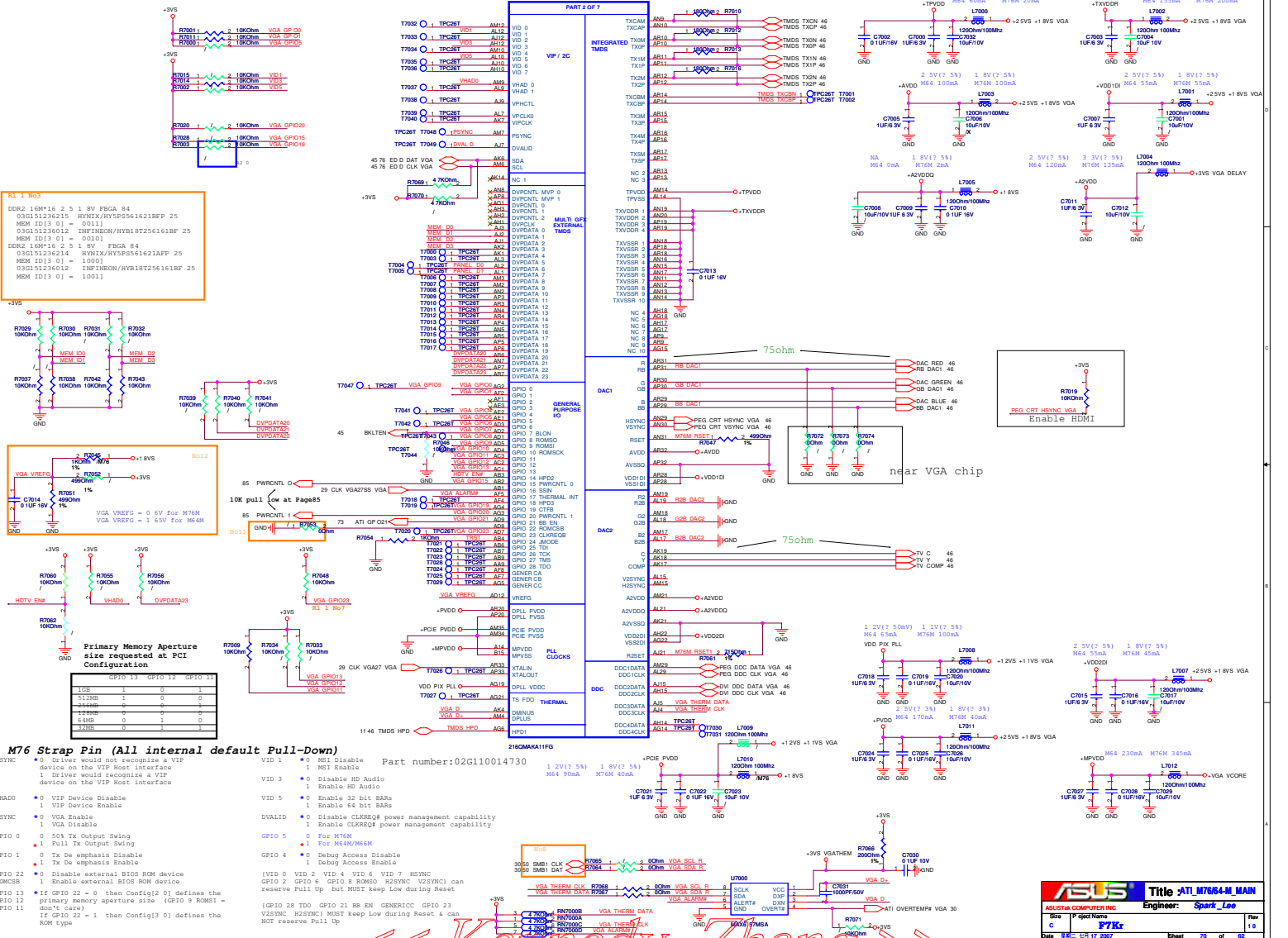

« Kennedy_Zhang »

ASUS		Title: ATI_M7684-M_MAIN	
ASUSTAR COMPUTER INC.		Engineer: Spark_Lee	
Ver:	P: Qcd Name:	Rev:	
C:	PTX:	1.0	1.0
Rev:	Rev:	Rev:	Rev:

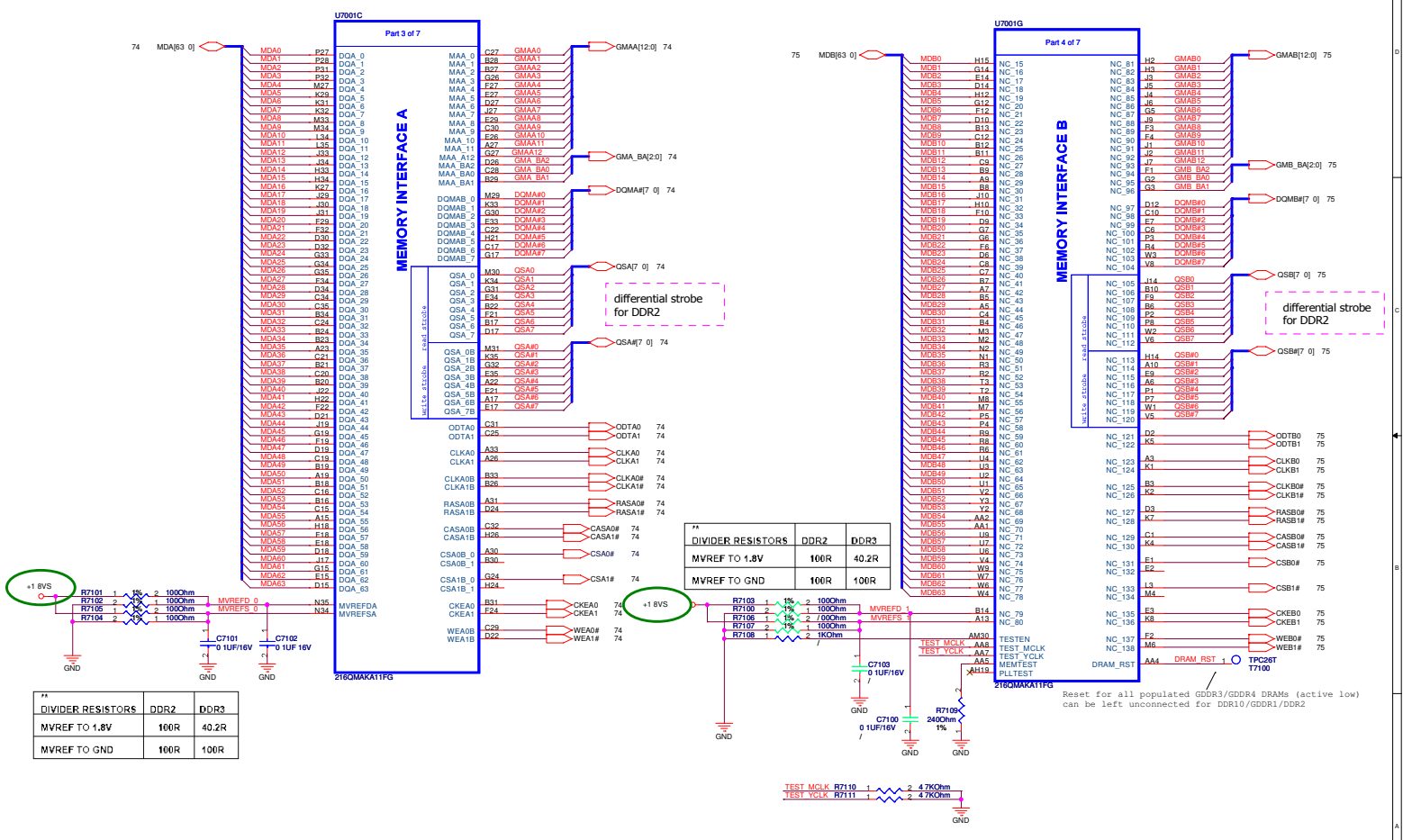

** DIVIDER RESISTORS			
	DDR2	DDR3	
MVREF TO 1.8V	100R	40.2R	
MVREF TO GND	100R	100R	

** DIVIDER RESISTORS			
	DDR2	DDR3	
MVREF TO 1.8V	100R	40.2R	
MVREF TO GND	100R	100R	

Reset for all populated GDDR3/GDDR4 DRAMs (active low) can be left unconnected for DDR10/GDDR1/DDR2

ASUS Title : AT1_M7684-M_Memory
 ASUSTek COMPUTER INC. NBE Engineer: Spark_Lee
 Size Project Name: Cus on FTKr
 Date: 8/8 14:17:2007 Sheet 71 of 82

« Kennedy_Zhang »

U7001E

Pin	Signal	Signal	Pin	Signal	Signal
P33	PCIE VSS 1	VSS 95	L33	PCIE ENB RANK0	C7261.2
P34	PCIE VSS 2	VSS 96	L34	PCIE ENB RANK1	C7262.2
P35	PCIE VSS 3	VSS 97	L35	PCIE ENB RANK2	C7263.2
P36	PCIE VSS 4	VSS 98	L36	PCIE ENB RANK3	C7264.2
P37	PCIE VSS 5	VSS 99	L37	PCIE ENB RANK4	C7265.2
P38	PCIE VSS 6	VSS 100	L38	PCIE ENB RANK5	C7266.2
P39	PCIE VSS 7	VSS 101	L39	PCIE ENB RANK6	C7267.2
P40	PCIE VSS 8	VSS 102	L40	PCIE ENB RANK7	C7268.2
P41	PCIE VSS 9	VSS 103	L41	PCIE ENB RANK8	C7269.2
P42	PCIE VSS 10	VSS 104	L42	PCIE ENB RANK9	C7270.2
P43	PCIE VSS 11	VSS 105	L43	PCIE ENB RANK10	C7271.2
P44	PCIE VSS 12	VSS 106	L44	PCIE ENB RANK11	C7272.2
P45	PCIE VSS 13	VSS 107	L45	PCIE ENB RANK12	C7273.2
P46	PCIE VSS 14	VSS 108	L46	PCIE ENB RANK13	C7274.2
P47	PCIE VSS 15	VSS 109	L47	PCIE ENB RANK14	C7275.2
P48	PCIE VSS 16	VSS 110	L48	PCIE ENB RANK15	C7276.2
P49	PCIE VSS 17	VSS 111	L49	PCIE ENB RANK16	C7277.2
P50	PCIE VSS 18	VSS 112	L50	PCIE ENB RANK17	C7278.2
P51	PCIE VSS 19	VSS 113	L51	PCIE ENB RANK18	C7279.2
P52	PCIE VSS 20	VSS 114	L52	PCIE ENB RANK19	C7280.2
P53	PCIE VSS 21	VSS 115	L53	PCIE ENB RANK20	C7281.2
P54	PCIE VSS 22	VSS 116	L54	PCIE ENB RANK21	C7282.2
P55	PCIE VSS 23	VSS 117	L55	PCIE ENB RANK22	C7283.2
P56	PCIE VSS 24	VSS 118	L56	PCIE ENB RANK23	C7284.2
P57	PCIE VSS 25	VSS 119	L57	PCIE ENB RANK24	C7285.2
P58	PCIE VSS 26	VSS 120	L58	PCIE ENB RANK25	C7286.2
P59	PCIE VSS 27	VSS 121	L59	PCIE ENB RANK26	C7287.2
P60	PCIE VSS 28	VSS 122	L60	PCIE ENB RANK27	C7288.2
P61	PCIE VSS 29	VSS 123	L61	PCIE ENB RANK28	C7289.2
P62	PCIE VSS 30	VSS 124	L62	PCIE ENB RANK29	C7290.2
P63	PCIE VSS 31	VSS 125	L63	PCIE ENB RANK30	C7291.2
P64	PCIE VSS 32	VSS 126	L64	PCIE ENB RANK31	C7292.2
P65	PCIE VSS 33	VSS 127	L65	PCIE ENB RANK32	C7293.2
P66	PCIE VSS 34	VSS 128	L66	PCIE ENB RANK33	C7294.2
P67	PCIE VSS 35	VSS 129	L67	PCIE ENB RANK34	C7295.2
P68	PCIE VSS 36	VSS 130	L68	PCIE ENB RANK35	C7296.2
P69	PCIE VSS 37	VSS 131	L69	PCIE ENB RANK36	C7297.2
P70	PCIE VSS 38	VSS 132	L70	PCIE ENB RANK37	C7298.2
P71	PCIE VSS 39	VSS 133	L71	PCIE ENB RANK38	C7299.2
P72	PCIE VSS 40	VSS 134	L72	PCIE ENB RANK39	C7300.2
P73	PCIE VSS 41	VSS 135	L73	PCIE ENB RANK40	C7301.2
P74	PCIE VSS 42	VSS 136	L74	PCIE ENB RANK41	C7302.2
P75	PCIE VSS 43	VSS 137	L75	PCIE ENB RANK42	C7303.2
P76	PCIE VSS 44	VSS 138	L76	PCIE ENB RANK43	C7304.2
P77	PCIE VSS 45	VSS 139	L77	PCIE ENB RANK44	C7305.2
P78	PCIE VSS 46	VSS 140	L78	PCIE ENB RANK45	C7306.2
P79	PCIE VSS 47	VSS 141	L79	PCIE ENB RANK46	C7307.2
P80	PCIE VSS 48	VSS 142	L80	PCIE ENB RANK47	C7308.2
P81	PCIE VSS 49	VSS 143	L81	PCIE ENB RANK48	C7309.2
P82	PCIE VSS 50	VSS 144	L82	PCIE ENB RANK49	C7310.2
P83	PCIE VSS 51	VSS 145	L83	PCIE ENB RANK50	C7311.2
P84	PCIE VSS 52	VSS 146	L84	PCIE ENB RANK51	C7312.2
P85	PCIE VSS 53	VSS 147	L85	PCIE ENB RANK52	C7313.2
P86	PCIE VSS 54	VSS 148	L86	PCIE ENB RANK53	C7314.2
P87	PCIE VSS 55	VSS 149	L87	PCIE ENB RANK54	C7315.2
P88	PCIE VSS 56	VSS 150	L88	PCIE ENB RANK55	C7316.2
P89	PCIE VSS 57	VSS 151	L89	PCIE ENB RANK56	C7317.2
P90	PCIE VSS 58	VSS 152	L90	PCIE ENB RANK57	C7318.2
P91	PCIE VSS 59	VSS 153	L91	PCIE ENB RANK58	C7319.2
P92	PCIE VSS 60	VSS 154	L92	PCIE ENB RANK59	C7320.2
P93	PCIE VSS 61	VSS 155	L93	PCIE ENB RANK60	C7321.2
P94	PCIE VSS 62	VSS 156	L94	PCIE ENB RANK61	C7322.2
P95	PCIE VSS 63	VSS 157	L95	PCIE ENB RANK62	C7323.2
P96	PCIE VSS 64	VSS 158	L96	PCIE ENB RANK63	C7324.2
P97	PCIE VSS 65	VSS 159	L97	PCIE ENB RANK64	C7325.2
P98	PCIE VSS 66	VSS 160	L98	PCIE ENB RANK65	C7326.2
P99	PCIE VSS 67	VSS 161	L99	PCIE ENB RANK66	C7327.2
P100	PCIE VSS 68	VSS 162	L100	PCIE ENB RANK67	C7328.2
P101	PCIE VSS 69	VSS 163	L101	PCIE ENB RANK68	C7329.2
P102	PCIE VSS 70	VSS 164	L102	PCIE ENB RANK69	C7330.2
P103	PCIE VSS 71	VSS 165	L103	PCIE ENB RANK70	C7331.2
P104	PCIE VSS 72	VSS 166	L104	PCIE ENB RANK71	C7332.2
P105	PCIE VSS 73	VSS 167	L105	PCIE ENB RANK72	C7333.2
P106	PCIE VSS 74	VSS 168	L106	PCIE ENB RANK73	C7334.2
P107	PCIE VSS 75	VSS 169	L107	PCIE ENB RANK74	C7335.2
P108	PCIE VSS 76	VSS 170	L108	PCIE ENB RANK75	C7336.2
P109	PCIE VSS 77	VSS 171	L109	PCIE ENB RANK76	C7337.2
P110	PCIE VSS 78	VSS 172	L110	PCIE ENB RANK77	C7338.2
P111	PCIE VSS 79	VSS 173	L111	PCIE ENB RANK78	C7339.2
P112	PCIE VSS 80	VSS 174	L112	PCIE ENB RANK79	C7340.2
P113	PCIE VSS 81	VSS 175	L113	PCIE ENB RANK80	C7341.2
P114	PCIE VSS 82	VSS 176	L114	PCIE ENB RANK81	C7342.2
P115	PCIE VSS 83	VSS 177	L115	PCIE ENB RANK82	C7343.2
P116	PCIE VSS 84	VSS 178	L116	PCIE ENB RANK83	C7344.2
P117	PCIE VSS 85	VSS 179	L117	PCIE ENB RANK84	C7345.2
P118	PCIE VSS 86	VSS 180	L118	PCIE ENB RANK85	C7346.2
P119	PCIE VSS 87	VSS 181	L119	PCIE ENB RANK86	C7347.2
P120	PCIE VSS 88	VSS 182	L120	PCIE ENB RANK87	C7348.2
P121	PCIE VSS 89	VSS 183	L121	PCIE ENB RANK88	C7349.2
P122	PCIE VSS 90	VSS 184	L122	PCIE ENB RANK89	C7350.2
P123	PCIE VSS 91	VSS 185	L123	PCIE ENB RANK90	C7351.2
P124	PCIE VSS 92	VSS 186	L124	PCIE ENB RANK91	C7352.2
P125	PCIE VSS 93	VSS 187	L125	PCIE ENB RANK92	C7353.2
P126	PCIE VSS 94	VSS 188	L126	PCIE ENB RANK93	C7354.2
P127	PCIE VSS 95	VSS 189	L127	PCIE ENB RANK94	C7355.2
P128	PCIE VSS 96	VSS 190	L128	PCIE ENB RANK95	C7356.2
P129	PCIE VSS 97	VSS 191	L129	PCIE ENB RANK96	C7357.2
P130	PCIE VSS 98	VSS 192	L130	PCIE ENB RANK97	C7358.2
P131	PCIE VSS 99	VSS 193	L131	PCIE ENB RANK98	C7359.2
P132	PCIE VSS 100	VSS 194	L132	PCIE ENB RANK99	C7360.2
P133	PCIE VSS 101	VSS 195	L133	PCIE ENB RANK100	C7361.2
P134	PCIE VSS 102	VSS 196	L134	PCIE ENB RANK101	C7362.2
P135	PCIE VSS 103	VSS 197	L135	PCIE ENB RANK102	C7363.2
P136	PCIE VSS 104	VSS 198	L136	PCIE ENB RANK103	C7364.2
P137	PCIE VSS 105	VSS 199	L137	PCIE ENB RANK104	C7365.2
P138	PCIE VSS 106	VSS 200	L138	PCIE ENB RANK105	C7366.2
P139	PCIE VSS 107	VSS 201	L139	PCIE ENB RANK106	C7367.2
P140	PCIE VSS 108	VSS 202	L140	PCIE ENB RANK107	C7368.2
P141	PCIE VSS 109	VSS 203	L141	PCIE ENB RANK108	C7369.2
P142	PCIE VSS 110	VSS 204	L142	PCIE ENB RANK109	C7370.2
P143	PCIE VSS 111	VSS 205	L143	PCIE ENB RANK110	C7371.2
P144	PCIE VSS 112	VSS 206	L144	PCIE ENB RANK111	C7372.2
P145	PCIE VSS 113	VSS 207	L145	PCIE ENB RANK112	C7373.2
P146	PCIE VSS 114	VSS 208	L146	PCIE ENB RANK113	C7374.2
P147	PCIE VSS 115	VSS 209	L147	PCIE ENB RANK114	C7375.2
P148	PCIE VSS 116	VSS 210	L148	PCIE ENB RANK115	C7376.2
P149	PCIE VSS 117	VSS 211	L149	PCIE ENB RANK116	C7377.2
P150	PCIE VSS 118	VSS 212	L150	PCIE ENB RANK117	C7378.2
P151	PCIE VSS 119	VSS 213	L151	PCIE ENB RANK118	C7379.2
P152	PCIE VSS 120	VSS 214	L152	PCIE ENB RANK119	C7380.2
P153	PCIE VSS 121	VSS 215	L153	PCIE ENB RANK120	C7381.2
P154	PCIE VSS 122	VSS 216	L154	PCIE ENB RANK121	C7382.2
P155	PCIE VSS 123	VSS 217	L155	PCIE ENB RANK122	C7383.2
P156	PCIE VSS 124	VSS 218	L156	PCIE ENB RANK123	C7384.2
P157	PCIE VSS 125	VSS 219	L157	PCIE ENB RANK124	C7385.2
P158	PCIE VSS 126	VSS 220	L158	PCIE ENB RANK125	C7386.2
P159	PCIE VSS 127	VSS 221	L159	PCIE ENB RANK126	C7387.2
P160	PCIE VSS 128	VSS 222	L160	PCIE ENB RANK127	C7388.2
P161	PCIE VSS 129	VSS 223	L161	PCIE ENB RANK128	C7389.2
P162	PCIE VSS 130	VSS 224	L162	PCIE ENB RANK129	C7390.2
P163	PCIE VSS 131	VSS 225	L163	PCIE ENB RANK130	C7391.2
P164	PCIE VSS 132	VSS 226	L164	PCIE ENB RANK131	C7392.2
P165	PCIE VSS 133	VSS 227	L165	PCIE ENB RANK132	C7393.2
P166	PCIE VSS 134	VSS 228	L166	PCIE ENB RANK133	C7394.2
P167	PCIE VSS 135	VSS 229	L167	PCIE ENB RANK134	C7395.2
P168	PCIE VSS 136	VSS 230	L168	PCIE ENB RANK135	C7396.2
P169	PCIE VSS 137	VSS 231	L169	PCIE ENB RANK136	C7397.2
P170	PCIE VSS 138	VSS 232	L170	PCIE ENB RANK137	C7398.2
P171	PCIE VSS 139	VSS 233	L171	PCIE ENB RANK138	C7399.2
P172	PCIE VSS 140	VSS 234	L172	PCIE ENB RANK139	C7400.2
P173	PCIE VSS 141	VSS 235	L173	PCIE ENB RANK140	C7401.2
P174	PCIE VSS 142	VSS 236	L174	PCIE ENB RANK141	C7402.2
P175	PCIE VSS 143	VSS 237	L175	PCIE ENB RANK142	C7403.2
P176	PCIE VSS 144	VSS 238	L176	PCIE ENB RANK143	C7404.2
P177	PCIE VSS 145	VSS 239	L177	PCIE ENB RANK144	C7405.2
P178	PCIE VSS 146	VSS 240	L178	PCIE ENB RANK145	C7406.2
P179	PCIE VSS 147	VSS 241	L179	PCIE ENB RANK146	C7407.2
P180	PCIE VSS 148	VSS 242	L180	PCIE ENB RANK147	C7408.2
P181	PCIE VSS 149	VSS 243	L181	PCIE ENB RANK148	C7409.2
P182	PCIE VSS 150	VSS 244	L182	PCIE ENB RANK149	C7410.2
P183	PCIE VSS 151	VSS 245	L183	PCIE ENB RANK150	C7411.2
P184	PCIE VSS 152	VSS 246	L184	PCIE ENB RANK151	C7412.2
P185	PCIE VSS 153	VSS 247	L185	PCIE ENB RANK152	C7413.2
P186	PCIE VSS 154	VSS 248	L186	PCIE ENB RANK153	C7414.2
P187	PCIE VSS 155	VSS 249	L187	PCIE ENB RANK154	C7415.2
P188	PCIE VSS 156	VSS 250	L188	PCIE ENB RANK155	C7416.2
P189	PCIE VSS 157	VSS 251	L189	PCIE ENB RANK156	C7417.2
P190	PCIE VSS 158	VSS 252	L190	PCIE ENB RANK157	C7418.2
P191	PCIE VSS 159	VSS 253	L191	PCIE ENB RANK158	C7419.2
P192	PCIE VSS 160	VSS 254	L192	PCIE ENB RANK159	C7420.2
P193	PCIE VSS 161	VSS 255	L193	PCIE ENB RANK160	C7421.2
P194	PCIE VSS 162	VSS 256	L194	PCIE ENB RANK161	C7422.2
P195	PCIE VSS 163	VSS 257	L195	PCIE ENB RANK162	C7423.2
P196	PCIE VSS 164	VSS 258	L196	PCIE ENB RANK163	C7424.2
P197	PCIE VSS 165	VSS 259	L197	PCIE ENB RANK164	C7425.2
P198	PCIE VSS 166	VSS 260	L198	PCIE ENB RANK165	C7426.2
P199	PCIE VSS 167	VSS 261	L199	PCIE ENB RANK166	C7427.2
P200	PCIE VSS 168	VSS 262	L200	PCIE ENB RANK167	C7428.2
P201	PCIE VSS 169	VSS 263	L201	PCIE ENB RANK168	C7429.2
P202	PCIE VSS 170	VSS 264	L202	PCIE ENB RANK169	C7430.2
P203	PCIE VSS 171	VSS 265	L203	PCIE ENB RANK170	C7431.2
P204	PCIE VSS 172	VSS 266	L204	PCIE ENB RANK171	C7432.2
P205	PCIE VSS 173	VSS 267	L205	PCIE ENB RANK172	C7433.2
P206	PCIE VSS 174	VSS 268	L206	PCIE ENB RANK173	C7434.2
P207	PCIE VSS 175	VSS 269	L207	PCIE ENB RANK174	C7435.2
P208	PCIE VSS 176	VSS 270	L208	PCIE ENB RANK175	C7436.2
P209	PCIE VSS 177	VSS 271	L209	PCIE ENB RANK176	C7437.2
P210	PCIE VSS 178	VSS 272	L210	PCIE ENB RANK177	C7438.2
P211	PCIE VSS 179	VSS 273	L211	PCIE ENB RANK178	C7439.2
P212	PCIE VSS 180	VSS 274	L212	PCIE ENB RANK179	C7440.2
P213	PCIE VSS 181	VSS 275	L213	PCIE ENB RANK180	C7441.2
P214	PCIE VSS 182	VSS 276	L214	PCIE ENB RANK181	C7442.2
P215	PCIE VSS 183	VSS 277	L215	PCIE ENB RANK182	C7443.2
P					

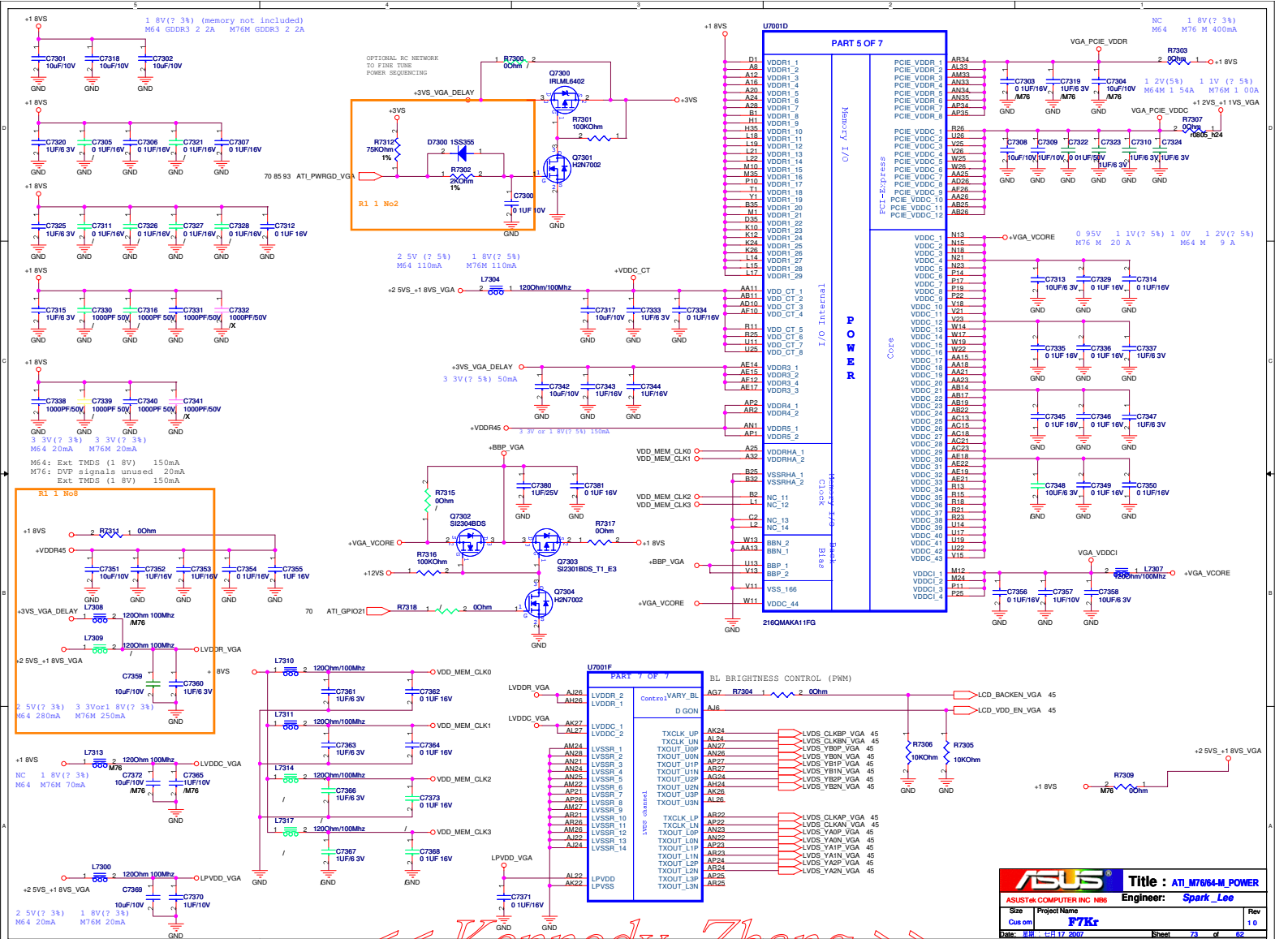

Kennedy_Zhang

ASUS		Title : ATL M76M-M POWER	
ASUSTeK COMPUTER INC. <small>NEB</small>		Engineer: Spark_Lee	
Site		Project Name	
Cut on		Date: 8/8 14:17 2007	
Rev		Sheet 73 of 82	

B0

03G15133F110

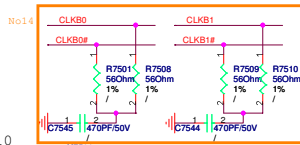

Swapable

B1

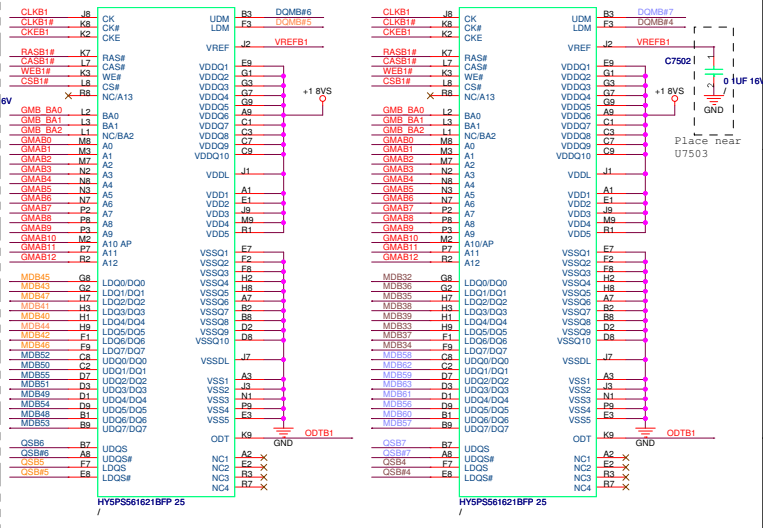
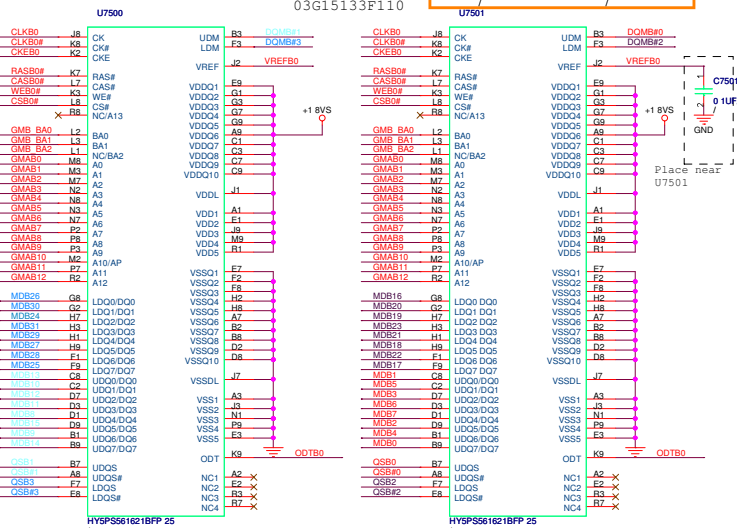

VDD/VDDQ = 1.8V

Place near right VRAM >>

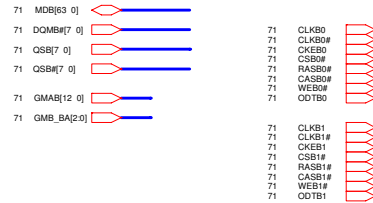
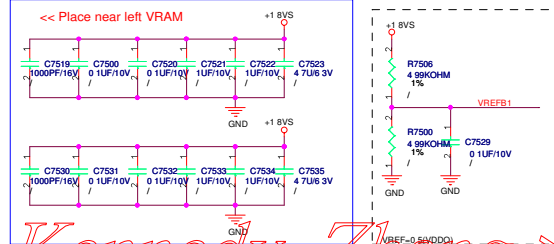
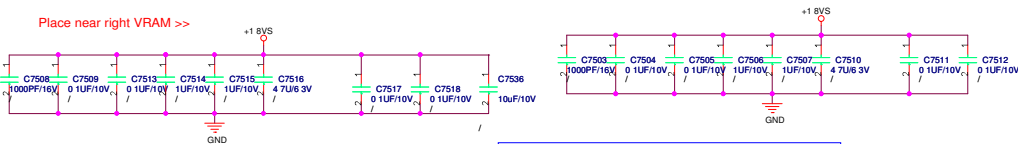

« Kennedy_Zhang »

ASUS Title: ATL_M76/G4-M_VRAM_B
 ASUSTek COMPUTER INC NBS Engineer: Spark_Lee
 Size: Custom Project Name: FTKr Rev: 1.0
 Date: 2007-11-17 12:07:00 Sheet: 75 of 82

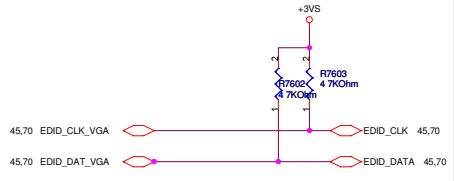
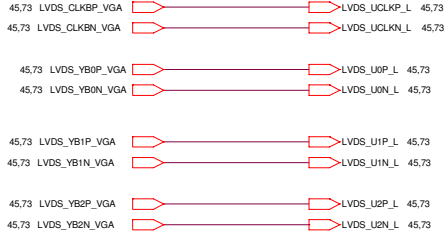
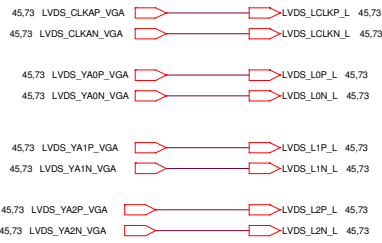

<-Variant Name>

ASUS		Title : LVDS SWITCH
ASUSTek COMPUTER INC NBS		Engineer: Sean Chou
Size B	Project Name F3Ka / F3Ke	Rev 1.1
Date: 2007-11-17		Sheet 76 of 82

<< Kennedy_Zhang >>

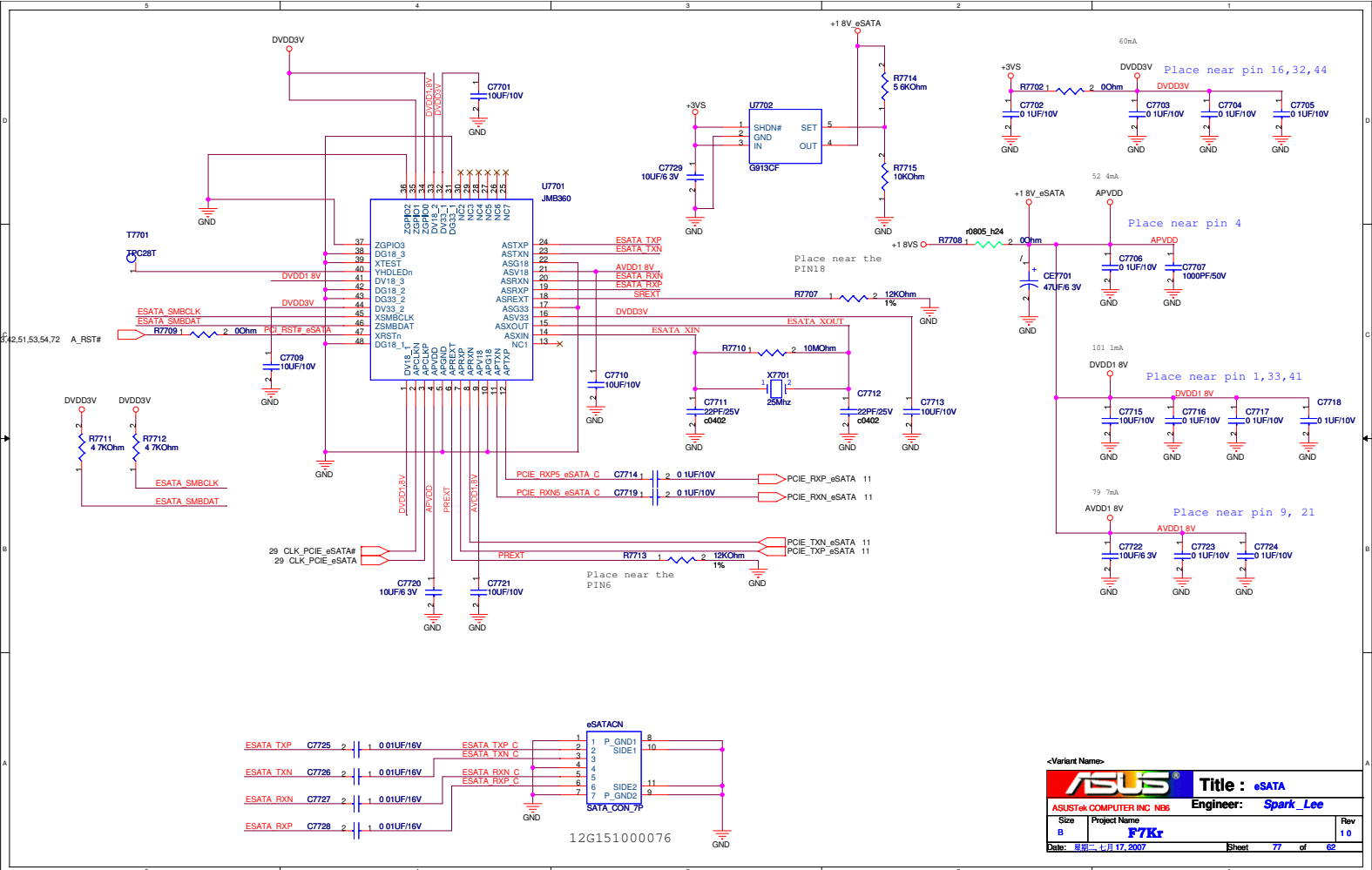

<< Kennedy_Zhang >>

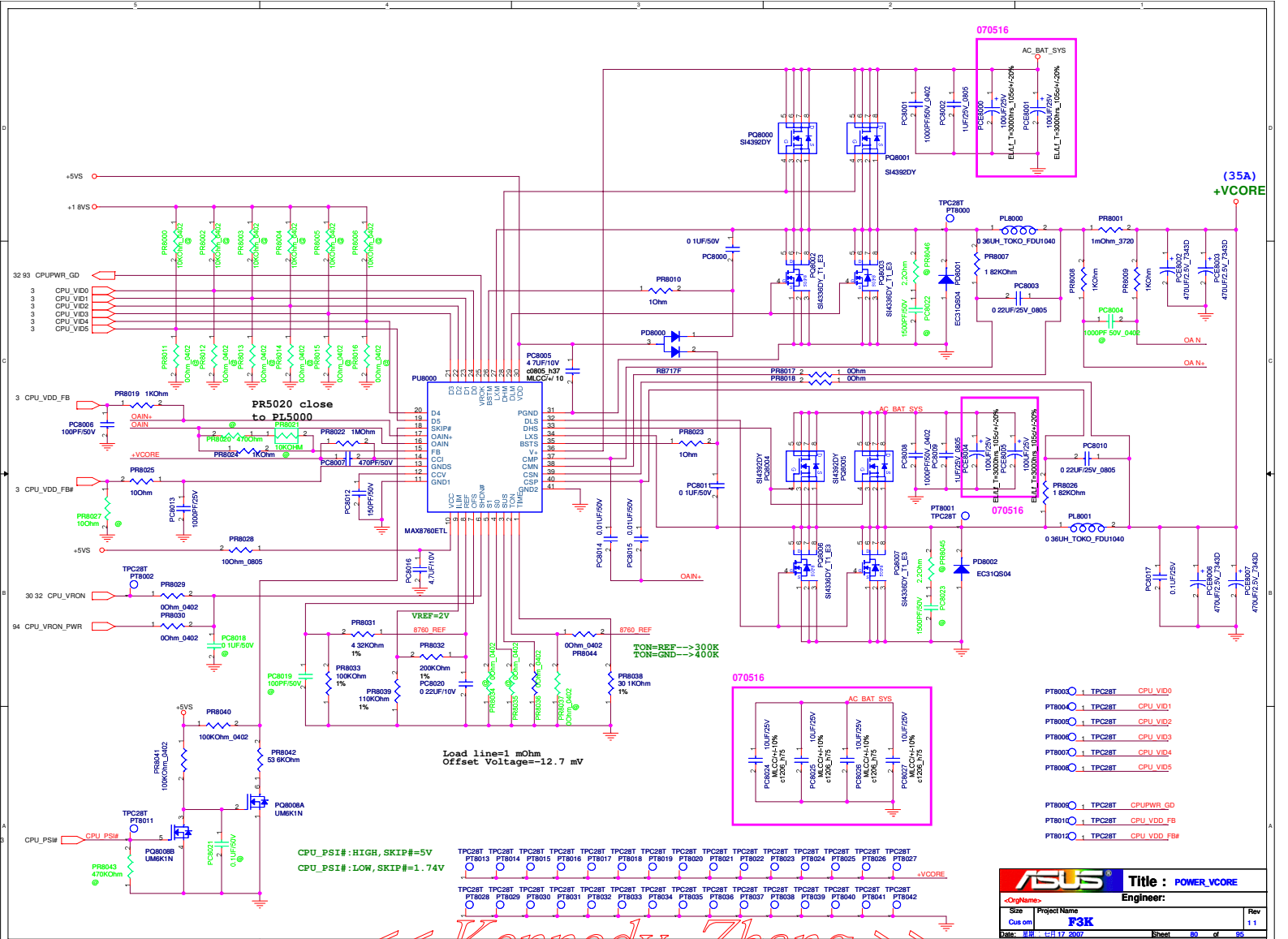

« Kennedy_Zhang »

ASUS		Title : POWER_VCORE	
-<OrigName>		Engineer:	
Site	Project Name	Rev	
China	F3K	1.1	
Date: 8/8	14/17/2007	Sheet	80 of 85

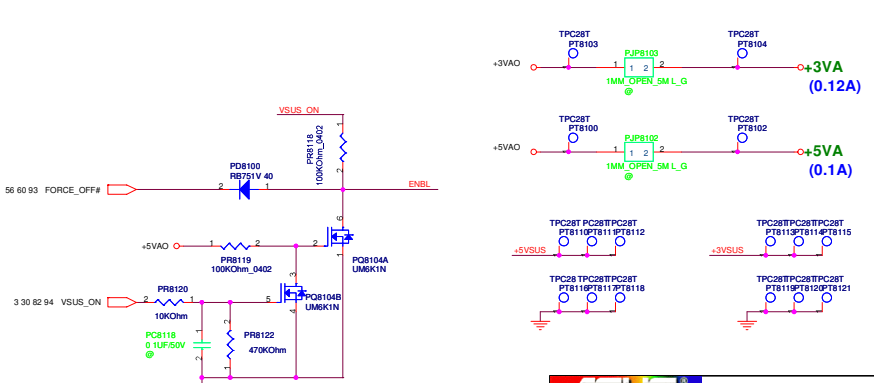
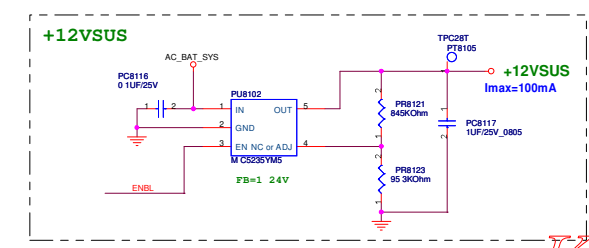
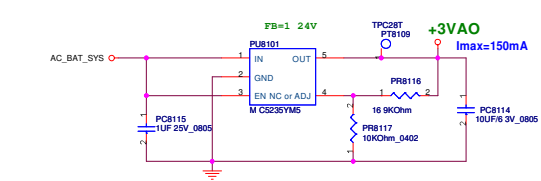
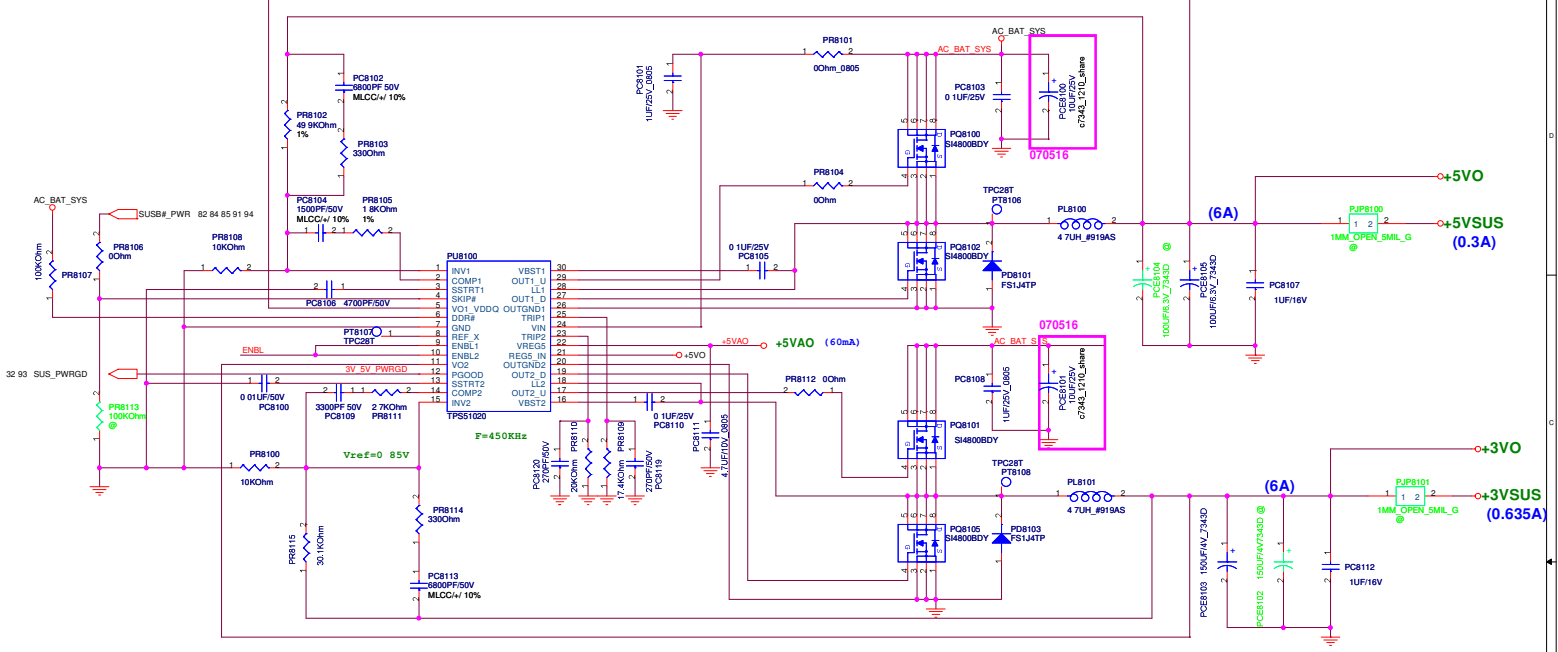

ASUS		Title : POWER_SYSTEM
Engineer:		
Site:	Project Name	
Use on:	F3K	
Date:	14-17-2007	Sheet 81 of 85

« Kennedy_Zhang »

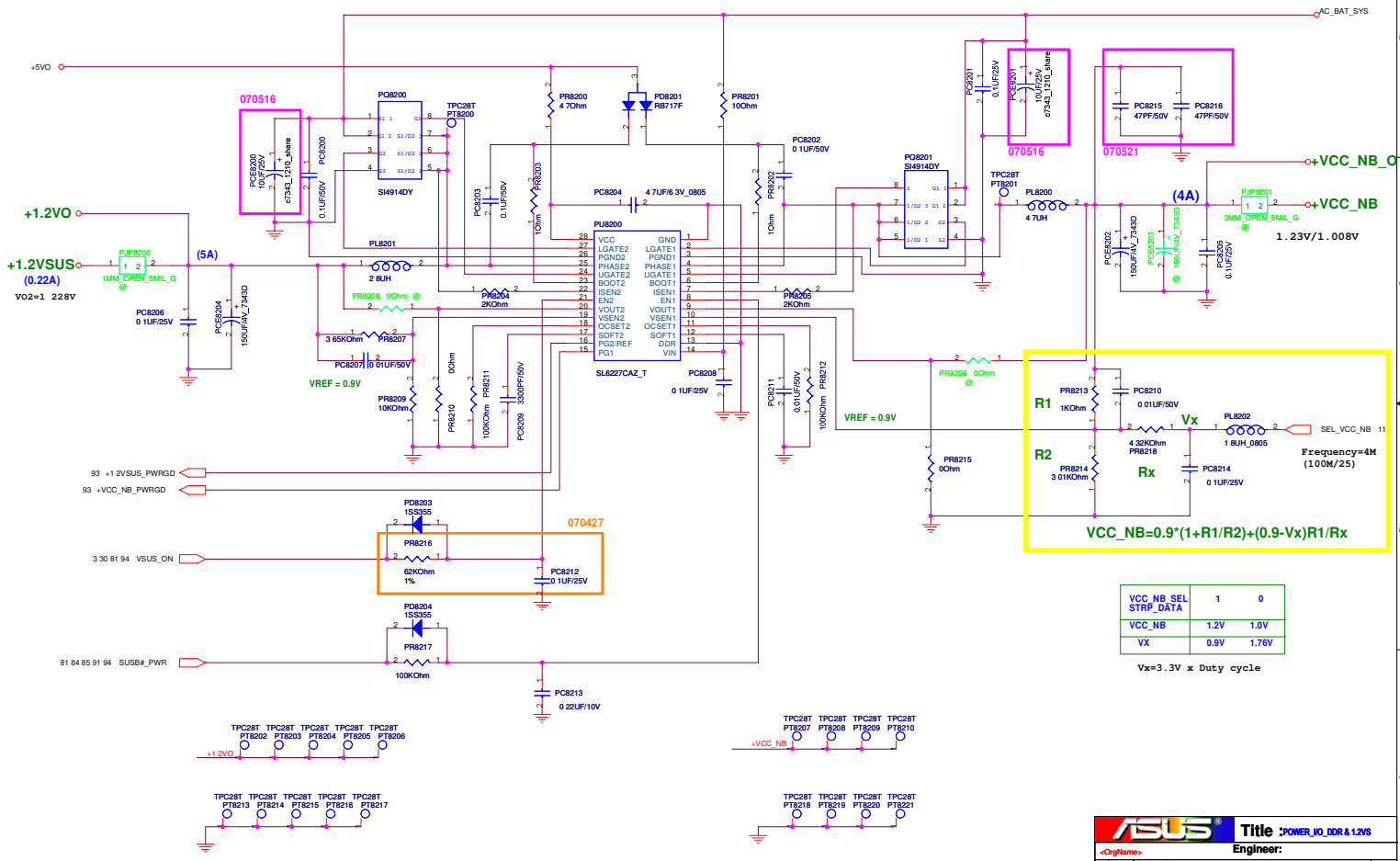

VCC_NB_SEL	1	0
VCC_NB	1.2V	1.0V
Vx	0.9V	1.76V

Vx=3.3V x Duty cycle

ASUS		Title :POWER_M0_DDR & 1.2V5	
-<OrigName>		Engineer:	
Size	Project Name	Rev	
0	STRIP_DATA	1	1
Cus om	FSK		
Date: 2007-04-17 20:07	Sheet	82	of 85

<< Kennedy_Zhang >>

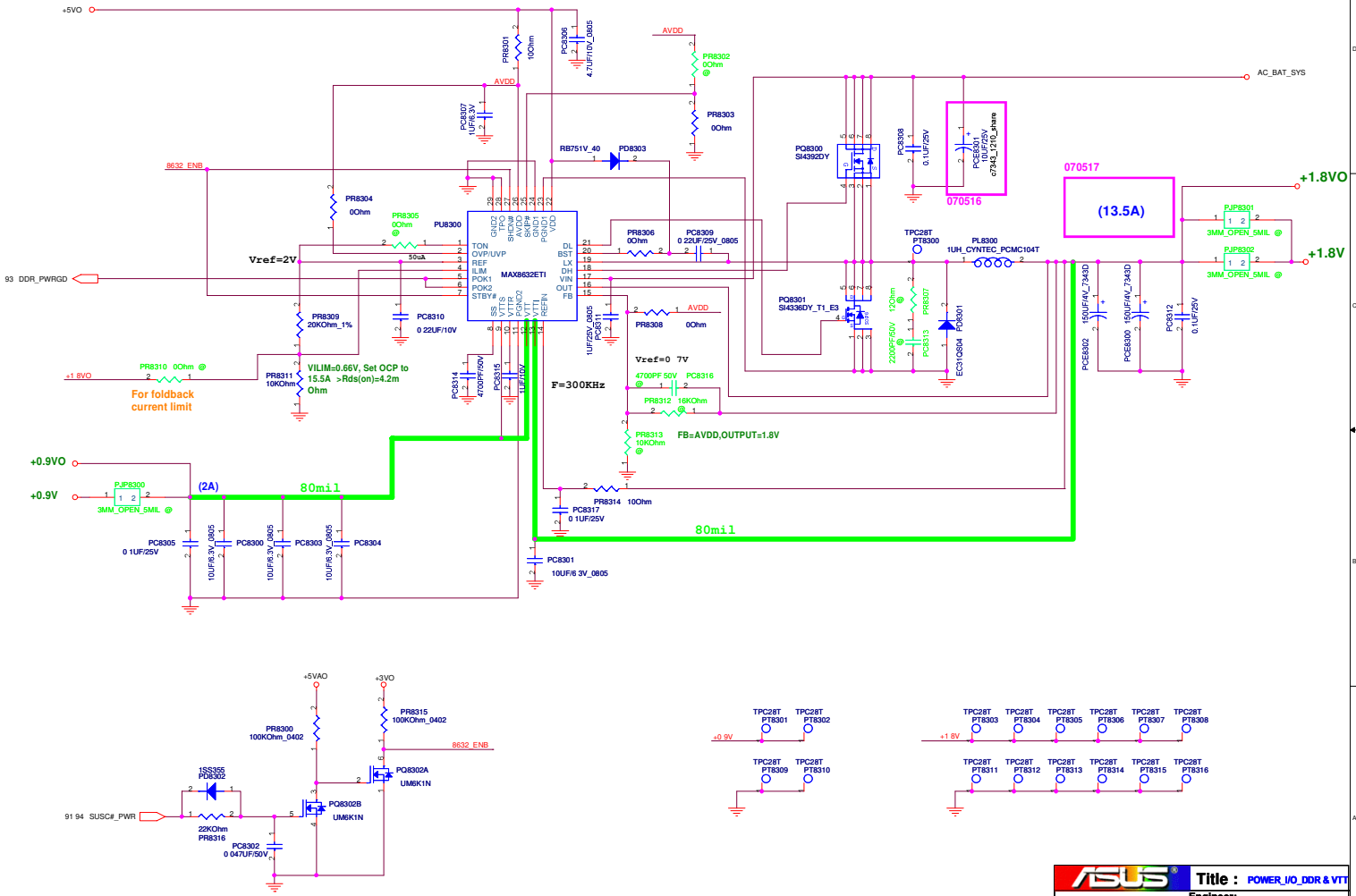

« Kennedy_Zhang »

ASUS		Title : POWER_UO_DDR & VTT	
-<OrigName>		Engineer:	
Sz	Project Name		
Custom	F3K	Rev	1.1
Date: 11/17/2007		Sheet	83 of 98

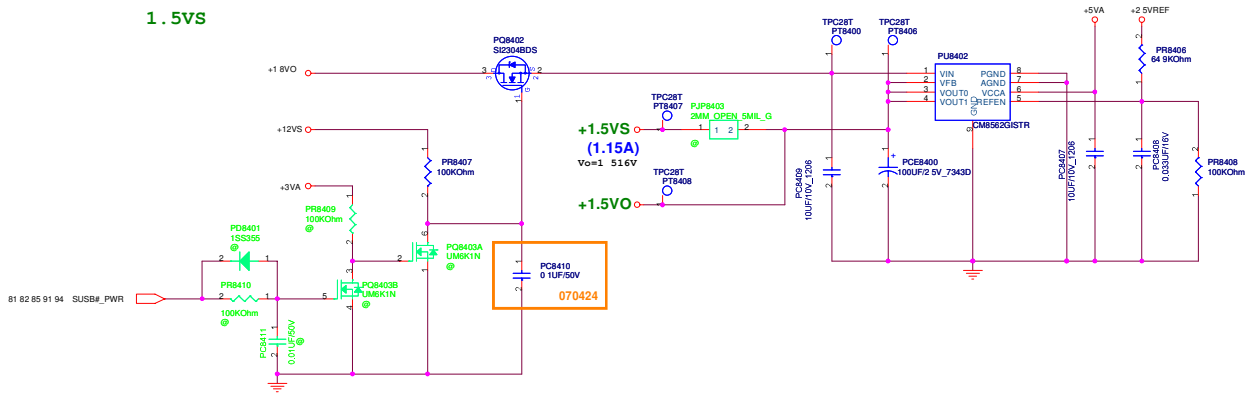
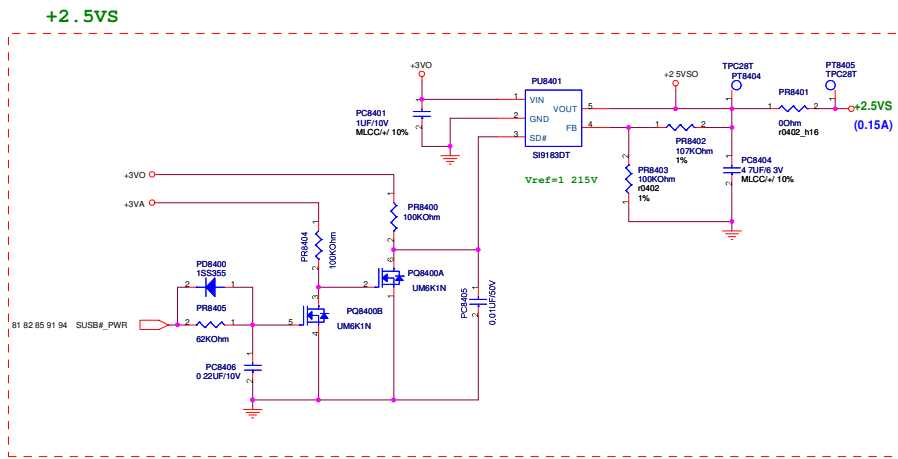

ASUS		Title POWER_2.5VS& 1.5VS & 2.5VS	
S2a		Project Name	
Custom		F3K	
Date: 11/17/2007		Sheet 84 of 95	
Engineer:		Rev 1.1	

<< Kennedy_Zhang >>

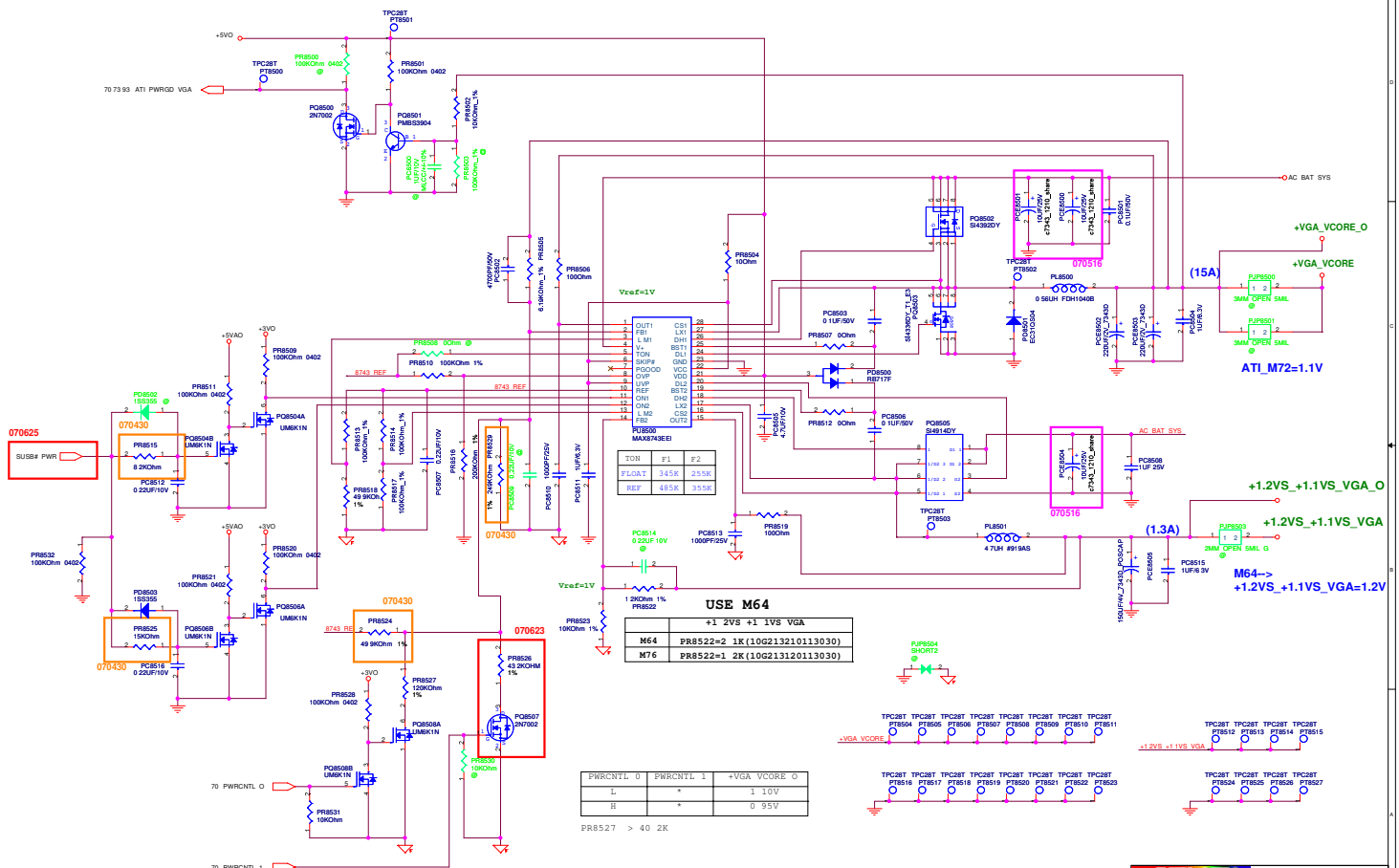

<< Kennedy_Zhang >>

		Title : POWER_VGA_+1.2VSP	
<OrgName>		Engineer:	
Size	Project Name	Rev	
B	F3K	1.1	
Date: 2007-11-17	Sheet 86		of 95

<< Kennedy_Zhang >>

		Title : POWER_SHUTDOWN#	
<OrgName>		Engineer:	
Size	Project Name	Rev	
B	F3K	1.1	
Date: 2007.11.17	Sheet 87 of 95		

<< Kennedy_Zhang >>

POWER PATH & BAT_LEARN
90W-->4.73A

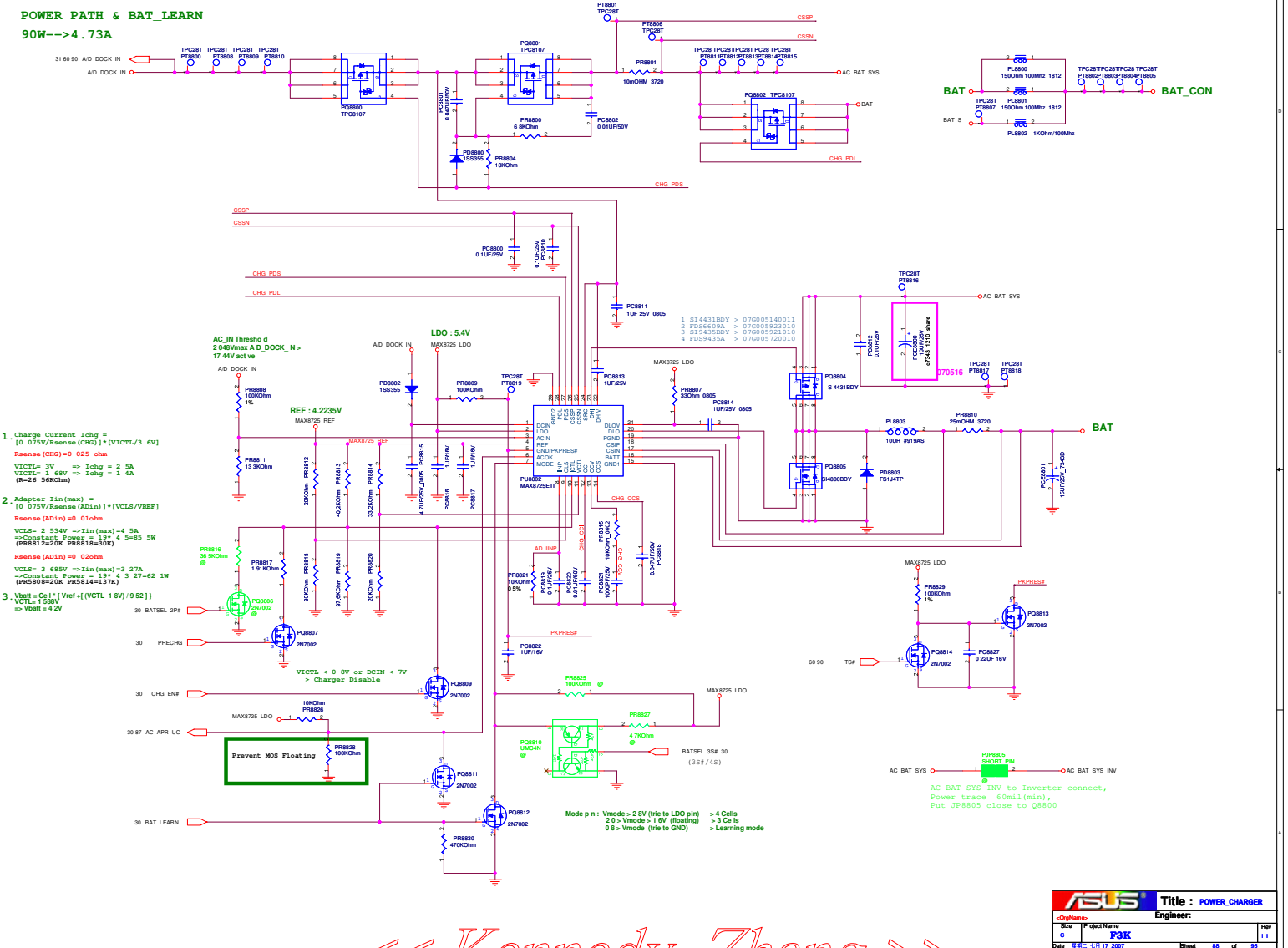

« Kennedy_Zhang »

ASUS		Title : POWER_CHARGER	
DocName:	Project Name:	Rev:	
Doc: 11-12-17-2007	Project Name: F3R	Rev: 11	
Sheet: 51	of: 51	of: 51	

D

D

C

C

B

B

A

A

		Title : POWER_PIC	
<OrgName>		Engineer:	
Size	Project Name		Rev
A	F3K		1.1
Date: 星期二, 七月 17, 2007		Sheet	89 of 95

« Kennedy_Zhang »

BATTERY IN DETECT

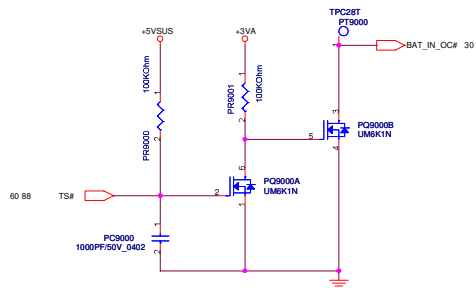

ADAPTER IN DETECT

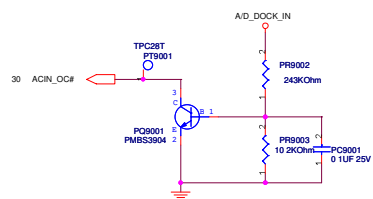

+2.5VREF

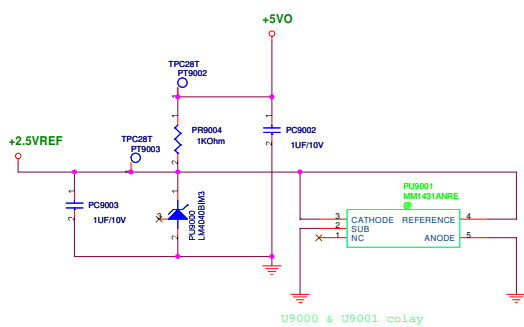

ASUS		Title : POWER_DETECT	
-<OrigName>		Engineer:	
Site	Project Name	Rev	
Bus on	F3K	1.1	
Date: 8/8	14/17/2007	Sheet	80 of 88

« Kennedy_Zhang »

SUSC#_STAGE POWER

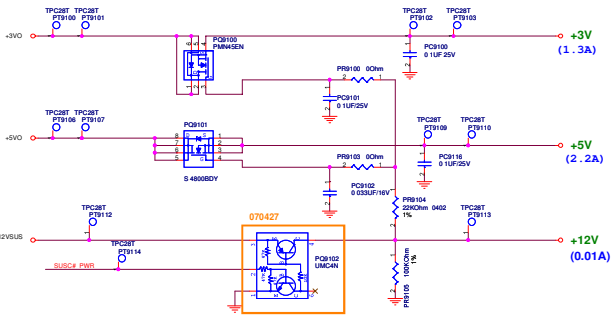

070625



SUSB#_PWR POWER

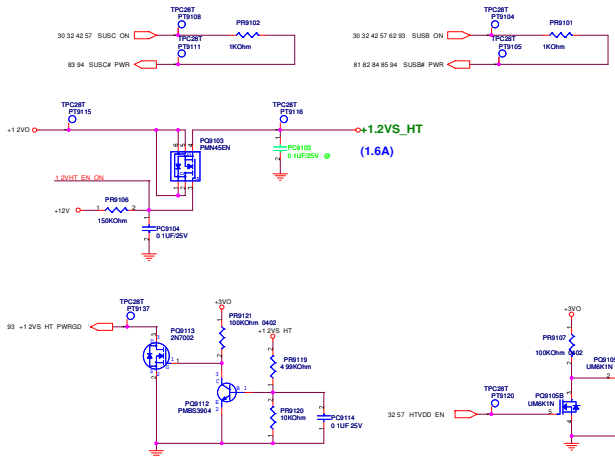
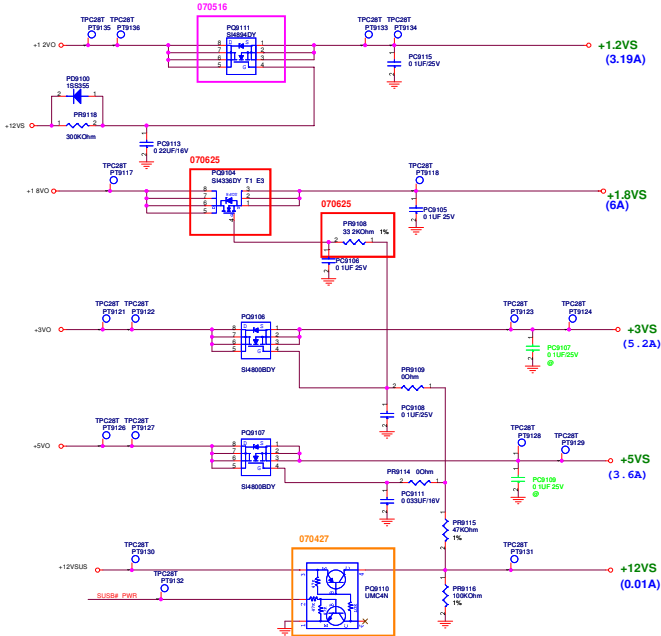

ASUS		Title : POWER_LOAD SWITCH	
Engineer:			
Task	Project Name	Rev	
Customer	FGK	11	
Date	08-17-2007	Page	11 of 25

<< Kennedy_Zhang >>

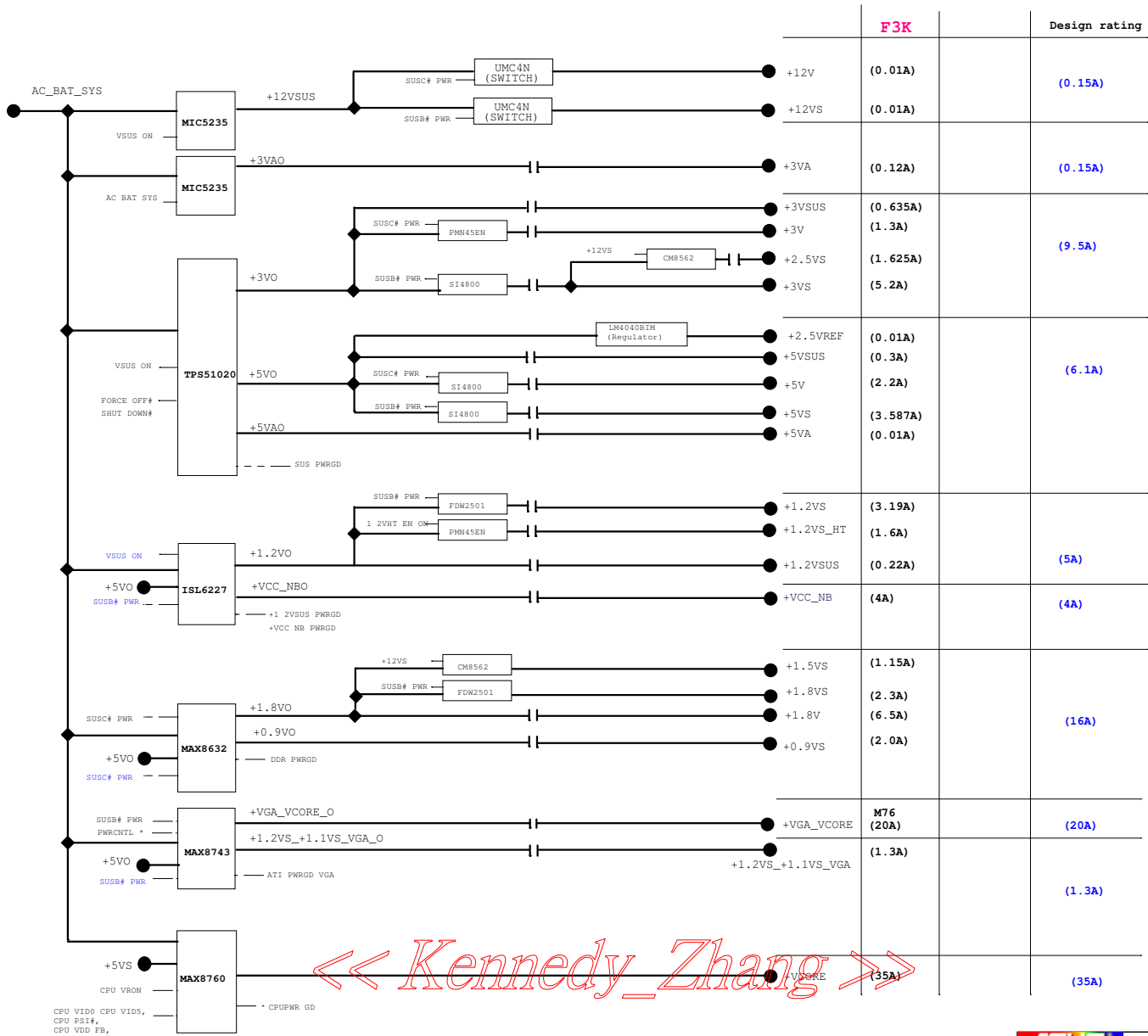

« Kennedy_Zhang »

POWER GOOD DETECTOR

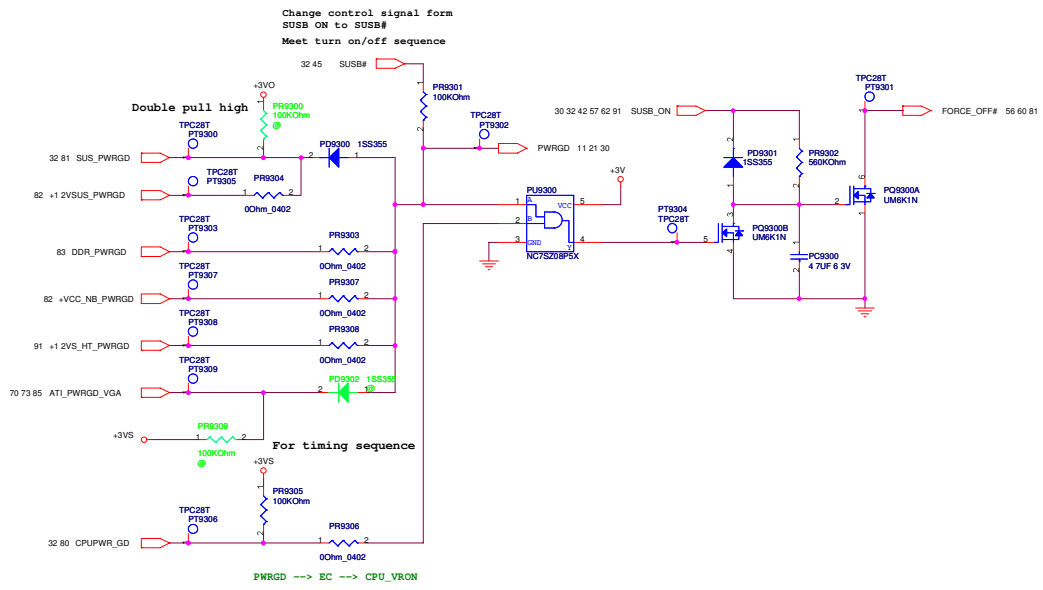

« Kennedy_Zhang »

ASUS		Title : POWER_PROTECT	
-<OrigName>		Engineer:	
Site	Project Name	Rev	
Site on	F3K	1.1	
Date:	14.11.2007	Sheet	83 of 88

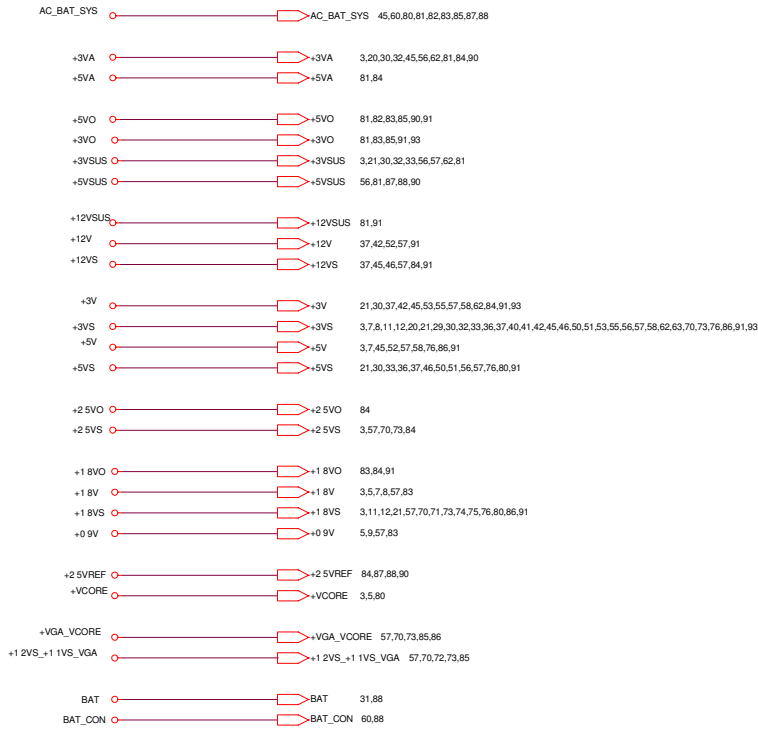

FOR POWER TEST

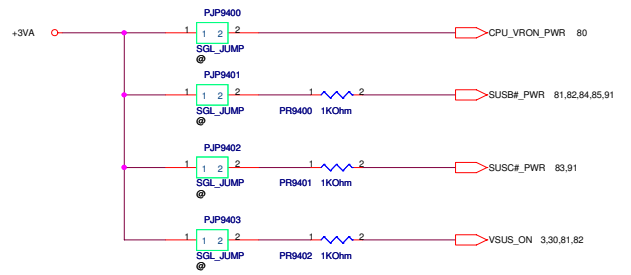

ASUS		Title : POWER_SIGNAL
<OrgName>		Engineer:
Size	Project Name	Rev
B	F3K	1.1
Date:	2007-11-17, 2007	Sheet 84 of 95

<< Kennedy_Zhang >>

3/2 Amp change to TPA6017

D

D

C

C

B

B

A

A

		Title : History
ASUSTek Computer INC. NB1		Engineer:
Size	Project Name	Rev
A	F3K	1.1
Date: 星期二 七月 07, 2007		Sheet 95 of 95

← Kennedy_Zhang →

```

12/08
13 RGB circuits modify
14 p53,54 add common choke
15 CE5200, CE5203 change package, USB add power name
16 New card change +3V PP
17 delete 0 ohm on P76 switch
18 net name USB_FAN# > test point; TVTUNER_ON# pull high to P55; VGNND change to GND
19 change P1205, C11201, L1202 and relative power name
20 unmount R2012, R2144, change AVDD_SATA# read to ZA
21 (SB) FANIN[2:0] & F56#IN2 & VGNND & VGNND & VGNND[2:7] use 10K to GND
12/12
13 power name +3VS VGATHEM
14 change R5C833 and unmount C4007
12/13
14 add add power name +3VS CB & +3VS FP, UIM FWR CON
15 swap VRAM
17/14
16 swap DDR, VRAM again
17 follow F5U; Delete R1120, R1121, R1122, R1123, D1100, Q1101, Change U1101 to 74126 to reduce cost
12/15
16 swap DDR
17 Change C2038 to mounting component to meet ATI's requirement
12/16
19 change P11 AVDD to NB AVDD to prevent short with P83
20 change package: U101, U701, P8R09, X3300, XZ011, P00300, U3602
21 delete 3 unknown line at P74: N17626888, N17631382, N17635879, and 1 power line: N62696617
22 delete another WMAW_MIC / WMAW_MIC port at P36
23 change C1100, C1100, C1100 package to C55000, C1100, C1100 for coincidence
12/20
21 change USB power plane
12/21
22 USB common choke swap (LP3, 1394) & swap USB 5,6,8
23 follow F3U, Change D5206, D5207, D5208, D5209 to mounting component to Protect the SB USB ports
12/25
26 add C4010 for EMI
12/26
27 swap LPC A03, LPC LDRQ#1 to termination, CLK CBPC1, LPC CLK, LPC CLK IFM, LPC CLK EC to RC
12/27
28 R3701, R3626, C3629 connect to GND AUDIO
12/30
31 add JP for RGB layout
1/3
2 D4200, R7200 change part
1/5
3 U4100, U5501 change part
3/4
4 C400 C403 mount
17/12
35 follow SB 600 errata, change R2022, R2023, R2024 to 680 ohm
36 C3613, C3614 unmount mistake, change to mount part
37 change power circuits

```

```

R1 1 2007/01/23
N01: Page37, Strap correction
N02: Page37, add pull high add change RC value for sequence and C7300 change X7R
N03: Page70, M64 ID from 0x1 to 0x0
N04: Page70, R7009 change to /M76 because of M76:256MB, M64:128MB
N05: Page37, KB connector inversion
N06: Page37, follow demo circuits change to 1uF
N07: Page70, VGR GPIO23 pull high
N08: Page73, follow ref131 5, delete VDDR45 3 3V path & 1VDDR 3 3V for M76M, 2 5V for M64M
N09: Page54, unmount R5405 (for RST of WMAW) for SR function
N10: Page45, C4502 change to 0 1uF for fixing white screen from CMOS setup change to 0 22uF
N11: Page20, modify PC# CLK[0] damping R
N12: Page29, SS clock gen will be changed to ICS252 R2949 3 92ohm for M64, R2953 82ohm for M76
N13: Page29, CLK for PCIe VGA is changed from SR04 to AT01
N14: Page55, unmount R5501 for not supporting TV wake function
N15: Page21, A SATA (for optional) use for WMAW & WMAW USB for TVTUNER
N16: Page33, A SATA to LAN use MOS for leakage issue
N17: Page21, A SATA (for optional) add inverter 2: USB# use for inverter 1 and inverter 2 and CE4501 change to H 1 1
N18: Page52, USB ESD diode need mount
N19: Page42, A SATA to NW C400, add diode for leakage issue
N20: Page46, change R4626 & R4627 to 2 7K ohm for CR1 detect issue, R4623 & R4624 for DVI function
N21: Page21, change R4102 to 1 1K for USB eye diagram
N22: Page55, change TV TUNER connector and mtb lower for thermal issue
N23: Page71, R5572, R4530, R4505, R4500 swap
N24: Page71, delete R4210; because R4210 does the same function, change branch to page 45
N25: Page51, R5500 change part for height issue
N26, Page20, modify RTC capacitor 18pF

```

« Kennedy_Zhang »

		Title : Modified list	
ASUSTek Computer, Inc.		Engineer: Sean1.Chou	
C	F3Ra / F3Ke	Rev	11
Date: 01-17-2007		Sheet	01 of 01