

# ***Hustler® TrimStar General Service Manual***

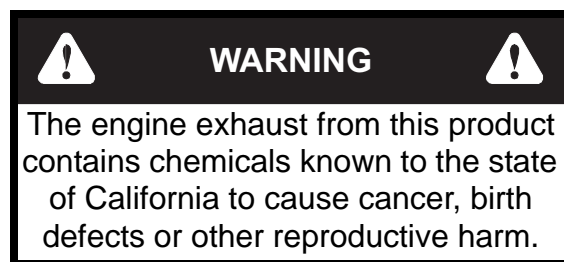

**HUSTLER®**  
TURF EQUIPMENT

.....  
P.O. Box 7000  
...  
Hesston, Kansas  
.  
67062-2097



#### NOTICE OF REQUIREMENT OF SPARK ARRESTER MUFFLER

This equipment may create sparks that can start fires around dry vegetation. California Public Resources Code Section 4442.6 provides that it is unlawful to use or operate an internal combustion engine on any forest-covered, brush-covered, or grass-covered land unless the engine is equipped with a spark arrester maintained in effective working order. A spark arrester is a device constructed of nonflammable materials specifically for the purpose of removing and retaining carbon and other flammable particles over 0.0232 of an inch in size from the exhaust flow of an internal combustion engine that uses hydrocarbon fuels or which is qualified and rated by the United States Forest Service. Other states or federal areas may have similar laws. The Operator Should Contact Local Fire Agencies For Laws or Regulations Relating to Fire Prevention Requirements. **THIS EQUIPMENT DOES NOT HAVE A SPARK ARRESTER AND YOU SHOULD CONTACT YOUR AUTHORIZED DEALER FOR THE PURCHASE OF A SPARK ARRESTER.**

Inspect spark arrester daily; replace every 500 hours or as needed.

The Engine Owner's Manual provides information regarding the U.S. Environmental Protection Agency (EPA) and the California Emission Control Regulation of emission systems, maintenance and warranty.

Keep Engine Owner's Manual with your unit. Should the Engine Owner's Manual become damaged or illegible, replace immediately. Replacements may be ordered per the information found in the Product Information section of the owner's manual.

Federal law and California State law prohibit the following acts or the causing thereof:

1. The removal or rendering inoperative by any person other than for purposes of maintenance, repair, replacement, of any device or element of design incorporated into any equipment for the purposes of emissions control prior to or after its sales or delivery to the ultimate purchaser or while it is in use, or
2. The use of the equipment after such device or element of design has been removed or rendered inoperative by any person.

## Table of Contents

General Information . . . . .	1-1
Safety . . . . .	2-1
Torque . . . . .	3-1
Power Unit Maintenance . . . . .	4-1
Engine Maintenance . . . . .	5-1
Deck Adjustments . . . . .	6-1
Electrical . . . . .	7-1
Maintenance Schedule . . . . .	8-1
Troubleshooting . . . . .	9-1



# GENERAL INFORMATION

## Hustler® TrimStar Service Program

---

This manual is part of a service package for the Hustler® TrimStar mowers. Use of this manual in conjunction with other Hustler® TrimStar mower and component manuals will provide the information necessary to service and maintain Hustler® TrimStar mowers.

This maintenance manual is a service guide for use by Service Technicians. It provides the necessary information needed to perform normal maintenance requirements on these units.

The Parts Manual provides a complete parts listing for the unit. Use this manual when ordering parts.

The Operator's Manual provides fundamental operational information and operational safety that is needed when operating the mower.

The component manuals are furnished by the various manufacturers to be used for the troubleshooting and servicing of their products.

## Maintenance Introduction

---

Regular maintenance is the best prevention for costly downtime or expensive, premature repair. The following pages contain suggested maintenance information and schedules which the operator/mechanic should follow on a routine basis.

Remain alert for unusual noises, they could be signaling a problem. Visually inspect the machine for any abnormal wear or damage. A good time to detect potential problems is while performing scheduled maintenance service. Correcting the problem as quickly as possible is the best insurance.

Clear away heavy build-up of grease, oil and dirt, especially

in the engine and hydraulic reservoir areas; minute dust particles are abrasive to close-tolerance engine and hydraulic assemblies.

**Daily inspect** mower for grass clippings and wire and string tangles. The underside of the mower deck will collect a build-up of grass clippings and dirt, especially when grass is wet or has high moisture content. This build-up will harden, restricting blade and air movement and will probably show a poorer quality of cutting. Therefore it should be removed routinely.

To do this it will be necessary to raise and block the deck, using jack stands or blocks, in the full up position and scrape the build-up from underneath.

Some repairs require the assistance of a trained service mechanic and should not be attempted by unskilled personnel. Consult your Hustler® Turf Equipment service center when assistance is needed.

Information included in this manual was current at the time of printing, but subsequent production changes may cause your machine to vary slightly in detail. Hustler® Turf Equipment reserves the right to redesign and change the machine as deemed necessary, without notification. If a change has been made to your machine which is not reflected in this service manual contact the Customer Service Department at Hustler® Turf Equipment for additional information.

## Warranty

---

Warranty repair must be performed by a Hustler® Turf Equipment Authorized Dealer before warranty credit can be allowed. Work performed by anyone other than an Authorized Dealer will invalidate the warranty claim and warranty credit will not be approved.



# SAFETY



This safety alert symbol is used to call attention to a message intended to provide a reasonable degree of PERSONAL SAFETY for operators and other persons during the normal operation and servicing of this equipment.



Denotes immediate hazards which WILL result in severe personal injury or death.



Denotes a hazard or unsafe practice which COULD result in severe personal injury or death.

## Safe Servicing Practices

This product is capable of amputating hands and feet and throwing objects. Always follow all safety instructions to avoid serious injury or death.

### Understand Correct Service

- ▲ Be sure you understand a service procedure before you work on the machine.
- ▲ Unauthorized modifications to the machine may impair the function and/or safety and affect machine life.
- ▲ If it is necessary to make checks with the engine running, always use two people - with the operator at the controls, able to see the person doing the checking.

## Pre-Operation Precautions

### Fuel Handling

- ▲ To avoid personal injury or property damage, use extreme care in handling fuel. Fuel is extremely flammable and the vapors are explosive.
- ▲ Observe usual fuel handling precautions:
  - Do not smoke while refueling. Extinguish all cigarettes, cigars, pipes and other sources of ignition.
  - **Do not remove the fuel tank cap or fill fuel tank with engine running or while the engine is hot.** Never refuel near an open flame or near devices which can create a spark. Refuel outdoors. Never refuel or drain the fuel from the machine indoors.
  - Allow engine to cool before storing machine inside a building.
  - Keep fuel away from open flame or spark and store machine away from open flame or spark or pilot light such as on a water heater or appliances.

- Use extreme care when handling gasoline and other fuels. They are extremely flammable and vapors are explosive. A fire or explosion from fuel can burn you and others and can damage property.
- Refuel outdoors. Never refuel or drain the fuel from the machine indoors.
- Never attempt to start engine when there is a strong odor of gasoline or diesel fuel fumes present. Locate and correct cause.
- Store fuel in an approved container and keep it out of the reach of children. Never buy more than a 30 day supply of fuel.
- Do not fill fuel containers inside a vehicle or on a truck or trailer bed with interior carpets or plastic truck bed liners. Always place fuel containers on the ground away from your vehicle before filling.
- When practical, remove gas or diesel fuel powered equipment from the truck or trailer and refuel the equipment with its wheels on the ground. If this is not possible, then refuel such equipment on the truck or trailer using a portable container and not a fuel dispenser nozzle. If a fuel dispenser nozzle must be used, keep the nozzle in contact with the rim of the fuel tank or container opening at all times until fueling is complete. Do not use a nozzle lock-open device.
- Never use gasoline or diesel fuel for cleaning parts.
- Read and observe safety precautions elsewhere in this manual.
- ▲ Gasoline and diesel fuel is harmful or fatal if swallowed.
  - Long-term exposure to vapors can cause serious injury and illness.
  - Avoid prolonged breathing of vapors.
  - Keep face away from nozzle and gas tank or fuel container opening.
  - Keep fuel away from eyes and skin.
  - If fuel is spilled on clothing, change clothing immediately.

### Understand Machine Operation

- ▲ Only qualified and trained personnel should operate the equipment.
- ▲ Carefully read the operator's manual and all manuals furnished with the attachments. Learn the location and purpose of all controls, instruments, indicators and labels.

### Wear Protective Clothing

- ▲ Do not operate or service the equipment while wearing sandals, tennis shoes, sneakers, shorts or any type of loose fitting clothing. Long hair, loose clothing or jewelry may get tangled in moving parts. Always wear long pants, safety glasses, ear protection and safety shoes when operating or servicing this machine.
- ▲ Always wear adequate eye protection when servicing the hydraulic system and battery (if applicable), or when grinding mower blades and removing accumulated debris.
- ▲ Prolonged exposure to loud noise can cause impairment or loss of hearing.

- Always wear adequate ear protection, such as earplugs, when operating this equipment as prolonged exposure to uncomfortable or loud noises can cause impairment or loss of hearing.
- Do not wear radios or music headphones while operating the machinery. Safe operation requires your full attention.

## Operation Precautions

---

### Avoid Fire Hazards

- ▲ **Clean flammable material from machine. Prevent fires by keeping engine compartment, exhaust area, battery (if applicable), fuel line and fuel tank clean of accumulated trash, grass clippings, and other debris. Always clean up spilled fuel and oil.**

### Start Engine Safely

- ▲ Avoid possible injury or death from machine runaway.
- ▲ Do not start engine by shorting across starter terminals.

## Operate Machine Safely

---

- ▲ Refer to the unit's operator's manual for complete safety information on safe machine operation.
- ▲ Always maintain a safe distance from people and pets when mowing
- ▲ Always be aware of what is behind the machine before backing up.
- ▲ Never leave machine unattended with ignition key in switch, especially with children present.
- ▲ Follow daily and weekly checklists, making sure hoses are tightly secured and bolts are tightened.
- ▲ Always keep engine and machine clean, removing accumulated dirt, trash and other material from machine.
- ▲ Never put hands or feet under any part of the machine while it is running.
- ▲ Never attempt to start engine when there is a strong odor of gasoline fumes present. Locate and correct cause.
- ▲ Keep all safety shields and covers in place, except for servicing.
- ▲ Do not touch hot parts of machine.

## General Maintenance Precautions

---

- ▲ **Repairs or maintenance requiring engine power should be performed by trained maintenance personnel only.**
- ▲ Never run the engine in an enclosed area unless exhaust is vented to the outside. Exhaust gases contain carbon monoxide which is odorless and deadly poison.
- ▲ Unless specifically required, **DO NOT** have engine running when servicing or making adjustments to mower. Park the machine on level ground. Always disengage deck clutch, place H-Bar steering in neutral, place neutral lock/park brake lever in park brake position, stop engine, and remove ignition key when leaving the unit. Remove the spark plug wires from the spark plugs, or, if applicable, disconnect the negative battery cable. Wait for engine and all moving parts to come to a complete stop before doing any maintenance, adjusting, cleaning or repairing. Repairs or maintenance requiring engine

power should be performed by trained maintenance personnel only. To prevent carbon monoxide poisoning, be sure proper ventilation is available when engine must be operated in an enclosed area. Read and observe safety warnings in front of manual

- ▲ Before working on or under the deck, make certain engine cannot be accidentally started. Shut engine off and disconnect spark plug wires from the spark plugs for maximum safety. If machine has a battery, disconnect negative battery cable. Repairs or maintenance requiring engine power should be performed by trained personnel only.
- ▲ Except when changing or checking belt, **always** keep belt covers on mower deck for safety as well as cleanliness.
- ▲ Use a stick or similar instrument to clean under the mower making sure that no part of the body, especially arms and hands are under mower.
- ▲ Keep your machine clean and remove any deposits of trash and clippings, which can cause engine fires and hydraulic overheating as well as excessive belt wear. Clean up oil or fuel spillage. Allow machine to cool before storing.
- ▲ Always wear adequate eye protection when servicing the hydraulic system and battery (if applicable), or when grinding mower blades and removing accumulated debris.
- ▲ Never attempt to make any adjustments or repairs to the mower drive system, mower deck or any attachment while the engine is running or deck clutch is engaged.
- ▲ Never work under the machine or attachment unless it is safely supported with jack stands. Make certain machine is secure when it is raised and placed on the jack stands. The jack stands should not allow the machine to move when the engine is running and the drive wheels are rotating. **Use only certified jack stands.** Use only appropriate jack stands, with a minimum weight rating of 2000 pounds to block the unit up. Use in pairs only. Follow the instructions supplied with the vehicle stands.
- ▲ Keep nuts and bolts tight, especially the blade attachment bolts. Keep equipment in good working condition.
- ▲ Never tamper with safety devices. Check their proper operation regularly.
- ▲ Exercise caution when working under the deck as the mower blades are extremely sharp. Wrap the blade(s) or wear gloves and use extra caution when servicing them.
- ▲ Use only genuine Hustler® Turf Equipment replacement parts to ensure that original standards are maintained

## Maintenance Precautions

---

### Avoid Fire Hazards

- ▲ Be prepared if an accident or fire should occur. Know where the first aid kit and the fire extinguishers are located and how to use them.
- ▲ Provide adequate ventilation when charging batteries.
- ▲ Do not smoke near battery.
- ▲ Never check fuel level with an open flame.
- ▲ Never use an open flame to look for leaks anywhere on the equipment.



- ▲ Never use an open flame as light anywhere on or around the equipment.
- ▲ When preparing engine for storage, remember that fuel stabilizer is volatile and therefore dangerous. Seal and tape openings after adding the inhibitor. Keep container tightly closed when not in use.
- ▲ Inspect electrical wiring for worn or frayed insulation. Install new wiring if wires are damaged.

### Prepare For Emergencies

- ▲ Be prepared if a fire starts.
- ▲ Keep a first aid kit and fire extinguishers available.
- ▲ Keep emergency numbers for doctor, ambulance service, hospital, and fire department near the telephone.

### Prevent Battery Explosions

- ▲ Battery posts, terminals, and related accessories contain lead and lead compounds, chemicals known to the State of California to cause cancer and reproductive harm. Wash hands after handling.
- ▲ Charge batteries in an open well ventilated area, away from sparks and flames. Unplug charger before connecting or disconnecting from battery. Wear protective clothing and use insulated tools.
- ▲ Avoid skin and clothing contact with battery acid.
  - Always wear eye protection when checking the battery, acid can cause serious injury to skin and eyes. If contact occurs, flush area with clean water and call physician immediately. Acid will also damage clothing.
  - Do not drink the battery electrolyte.
  - Do not allow open flame near the battery when charging.
  - Hydrogen gas forms inside the battery. This gas is both toxic and flammable and may cause an explosion if exposed to flame. Always **disconnect** the negative (black) battery cable(s) before disconnecting the positive (red) cable(s). Always **connect** the positive (red) battery cable(s) before connecting the negative (black) cable(s).
  - Do not overfill battery.

- Electrolyte may overflow and damage paint, wiring or structure. When cleaning the battery, use soap and water. Be careful not to get soap and water into the battery. Clean the battery terminals with a solution of four parts water and one part baking soda when they become corroded.

- ▲ Shorts caused by battery terminals or metal tools touching metal mower components can cause sparks. Sparks can cause a battery gas explosion which will result in personal injury.
  - Prevent the battery terminals from touching any metal mower parts when removing or installing the battery.
  - Do not allow metal tools to short between the battery terminals and metal mower parts.
- ▲ Incorrect battery cable routing could cause damage to the mower and battery cables. This can cause sparks which can cause a battery gas explosion which will result in personal injury. Always **disconnect** the negative (black) battery cable(s) before disconnecting the positive (red) cable(s). Always **connect** the positive (red) battery cable(s) before connecting the negative (black) cable(s).

### Avoid Acid Burns

- ▲ Sulfuric acid in battery electrolyte is poisonous. It is strong enough to burn skin, eat holes in clothing and cause blindness if splashed in eyes.

#### Avoid the hazard by:

- Filling batteries in a well-ventilated area.
- Wearing eye protection and rubber gloves.
- Avoiding breathing fumes when electrolyte is added.
- Avoiding spilling or dripped electrolyte.

#### If you spill acid on yourself:

- Flush your skin with water.
- Apply baking soda or lime to help neutralize the acid.
- Flush your eyes with water for 10-15 minutes. Get medical attention immediately.

#### If acid is swallowed:

- Drink large amounts of water or milk.
- Then drink milk of magnesia, beaten eggs or vegetable oil.
- Get medical attention immediately.



# TORQUE

## Standard Torques

The following chart lists the standard torque values for the threaded fasteners found in this manual. Torque all cap screws, nuts and set screws to these values unless a different torque is shown in the Special Torques section.



Size	Ft-lbs	Nm	Size	Ft-lbs	Nm
#10	32.4 IN.-LBS.	3.6	M3	12 IN.-LBS.	1.3
.250	98.4 IN.-LBS.	11.1	M4	26.4 IN.-LBS.	3
.312	204 IN.-LBS.	23	M5	54 IN.-LBS.	6.1
.375	30	40	M6	92.4 IN.-LBS.	10.4
.438	48	65	M8	222 IN.-LBS.	25
.500	73	99	M10	37	50
.562	105	143	M12	64	87
.625	145	200	M14	103	140
.750	260	350	M16	160	215
.875	420	565	M20	320	435

## Special Torques

Description	Ft-lbs.	Nm
Wheel (lug) nuts <sup>1</sup>	65 – 75	88.14 – 101.7
Blade spindle bolt top	118	160.01
Blade spindle bolt bottom	118	160.01
Electric Clutch mounting bolt <sup>3</sup>	45 – 48	61 – 65
Transaxle hub nut	250	339
Transaxle pump pulley nut	45 – 55	61 – 74.6

### NOTE:

- Lug nuts only** – It is recommended that these be checked after the first 2 hours of operation and every 50 hours and following removal for repair or replacement.
- Engine torque values** – Refer to the respective engine owner's manual.
- If clutch mounting bolt is loosened or removed, **do not re-use**. Replace with a new bolt. Use only hand tools to install this fastener.

	<b>WARNING</b>	
<p>Particular attention must be given to tightening the drive wheel lug nuts and blade spindle bolts. Failure to correctly torque these items may result in the loss of a wheel or blade, which can cause serious damage or personal injury.</p>		



# POWER UNIT MAINTENANCE

## Steering Adjustments

### Steering neutral adjustment

The mower's steering has been factory adjusted to eliminate creeping when the H-Bar steering lever is in the neutral position. However, should the mower begin to creep, the steering control linkage can be adjusted.

Before considering any adjustment, check the tire air pressure. Unequal tire pressure will cause the mower to drift to one side. Refer to tire pressure information in the *Tires* section for detailed information.

**NOTE:** Proper park brake adjustment must be completed before the steering control neutral adjustment can be done. Refer to the *Park Brake Spring Adjustment* section for detailed information.

Fine adjustment to the unit's steering is made with the transmission's control rod.

Neutral is properly adjusted when the H-Bar steering lever is in the neutral position and the mower does not creep or the transmissions do not "whine".

If this occurs, the steering control linkage may be adjusted as follows:



### WARNING



This procedure will require that the unit to be raised and blocked up off of the ground. It is necessary for the wheels to rotate without coming in contact with the floor or any object that would permit the unit to propel itself. Stay clear and exercise caution when rotating wheels to prevent injury. Use only appropriate vehicle stands, with a minimum weight rating of 2000 pounds to block the unit up. Use in pairs only. Follow the instructions supplied with the vehicle stands.



### WARNING



Keep hands, hair, clothing, etc., clear of the cooling fans on top of the transmissions. Exercise extreme caution.



### WARNING



Untrained maintenance personnel should never attempt to make any adjustments or repairs to the mower's drive system while the engine is running. **The following procedures should be performed by trained maintenance personnel only.**

1. Raise the rear of the mower and block with certified jack stands. The rear wheels need to be able to rotate freely and clear of all obstructions.
2. Check the front tires.

3. Remove brake link from lower brake bell crank. Figure 4-1

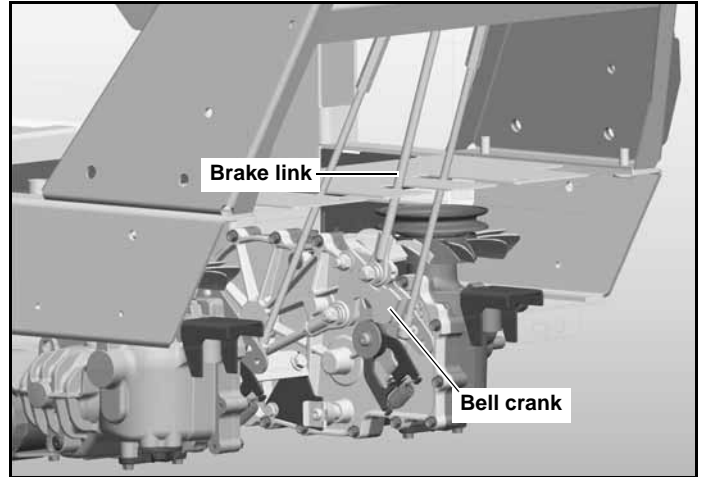

Figure 4-1

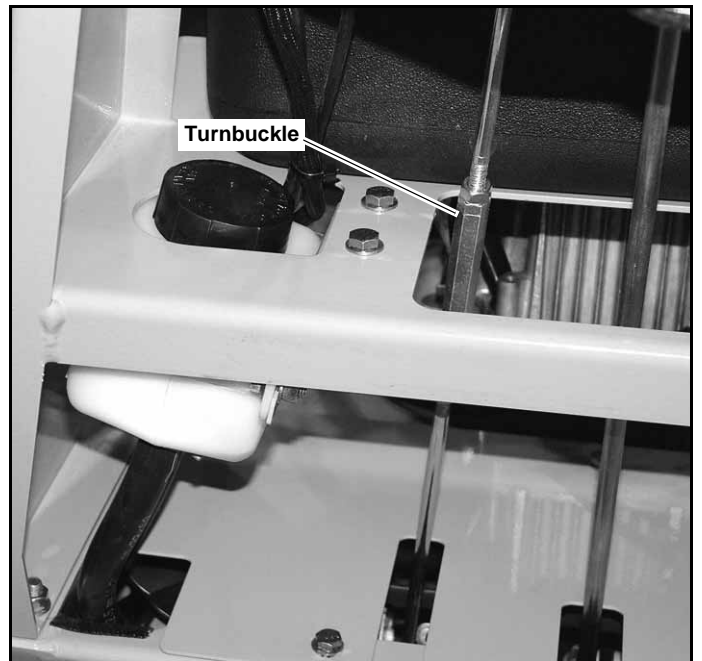
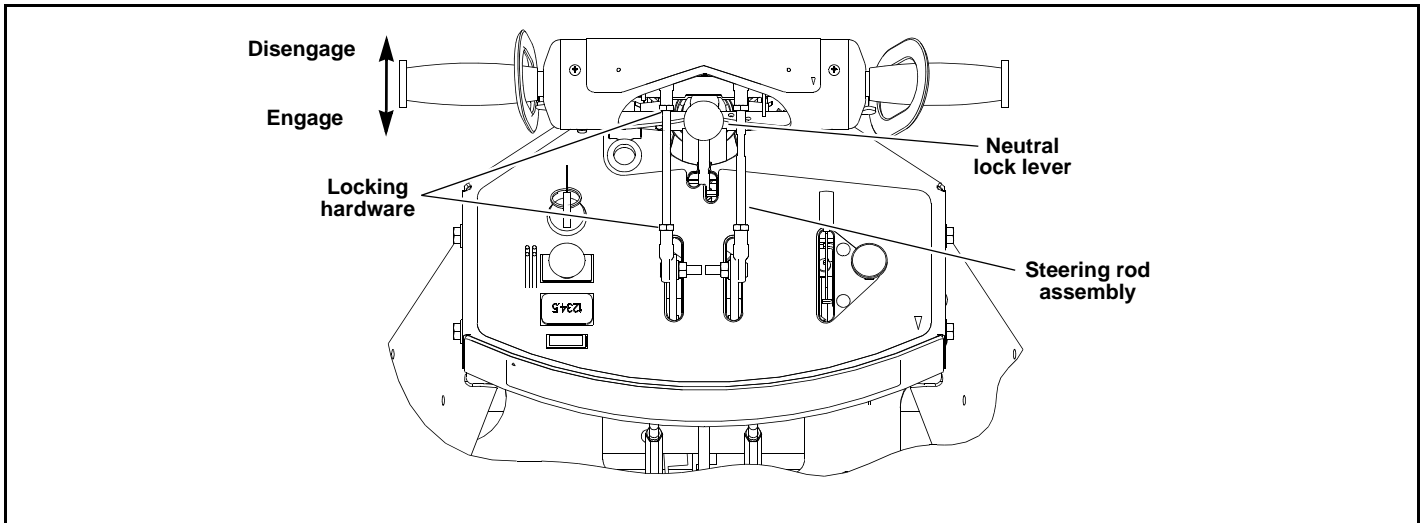

Figure 4-2

4. Place the neutral lock/park brake lever in the park brake position with the engine running. Figure 4-3
5. If rear wheels rotate forward or rearward, loosen the locking hardware on the turnbuckle assembly. Figure 4-2
6. Tighten or loosen the turnbuckle until rear wheel comes to a stop. Figure 4-2
7. Retighten locking hardware.
8. Neutral should now be set.
9. Re-attach the brake link to the lower brake bell crank. Figure 4-1
10. Place the neutral lock/park brake lever in the unlocked position.
11. With engine running, rotate the H-Bar steering lever forward, and then into reverse.



**Figure 4-3**

12. Wheels should both return to neutral when the H-Bar steering lever is pulled forward out of reverse. If not, repeat step 4-6 until they do. Return neutral lock/park brake lever to the park brake position and check to make sure wheels are not rotating.
13. If wheels rotate, repeat steps 3- 11.
14. Once both sides are properly adjusted, check them together to make sure everything is working properly.
15. Check to make sure all tools or obstructions are removed from under the mower.
16. Raise the rear of the mower and remove the jack stands. Lower the mower.

### Drive straight linkage adjustment

It may be necessary to adjust the drive linkage on the mower. If the mower tracks to the right or left when operating use the following method to adjust the drive linkage:

1. If the unit pulls to the right, loosen the lock nuts on the right hand steering rod assembly. If the unit pulls to the left, loosen the lock nuts on the left hand steering rod assembly. Figure 4-3
2. Start the engine.
3. While driving, adjust the steering rod assembly by rotating the center adjustment rod until the tractor tracks straight. Figure 4-3
4. Stop the machine and shutoff the engine.
5. Tighten the lock nuts on the steering rod assembly. Figure 4-3
6. Repeat steps 2 - 5 for the other side if necessary.

### Park Brake Spring Adjustment

Occasionally check the park brake spring adjustment using the following method:

1. Park the machine on level ground. Disengage deck clutch, place the H-Bar steering lever in neutral, place neutral lock/park brake lever in park brake (engaged) position, stop engine, and remove ignition key. Remove the spark plug wires from the spark plugs, or, if applicable, disconnect the negative battery cable.

2. Raise the rear of the mower and block with certified jack stands. The rear wheels need to be able to rotate freely and clear of all obstructions.
3. Chock the front tires.
4. Place the H-Bar steering lever in the neutral position and the neutral lock/park brake lever in the park brake (engaged) position.
5. Measure the park brake spring. It should be compressed to the 2.00". If it is not adjust the nylock nut until the proper spring compression is achieved. Figure 4-4
6. Check engagement of internal park brake pawl by manually rotating transmission axle in both directions. If pawl is engaged, the axle should not rotate.
7. Place the H-Bar steering lever in the run position and the neutral lock/park brake lever in the disengaged position.
8. The washer under the double jam nuts should still be free to rotate, and have approximately .06" clearance. If not, re-adjust jam nuts to this dimension.
9. With brakes still in the disengage/run position, verify that wheels rotate freely without brakes grabbing. If brakes are grabbing, adjust jam nuts closer to end of brake rod assembly until wheels rotate freely. Re-engage brake lever to ensure that brakes are set.
10. Repeat engagement and disengagement as required to ensure that brakes are set in the engaged position and are released in the operate (disengaged) position.
11. Brakes are now set.

### Belts

Inspect belts frequently for wear and serviceability. Replace a belt that shows signs of severe cuts, tears, separation, weather checking and cracking, or burns caused by slipping. Slight raveling of belt covering does not indicate failure, trim ravelings with a sharp knife.

Inspect the belt pulley grooves and flanges for wear. A new belt, or one in good condition, should never run against the bottom of the groove. Replace the pulley when this is the case, otherwise belt will lose power and slip excessively.

Never pry a belt to get it on a pulley as this will cut or damage the fibers of the belt covering.

Keep oil and grease away from belts, and never use belt dress-

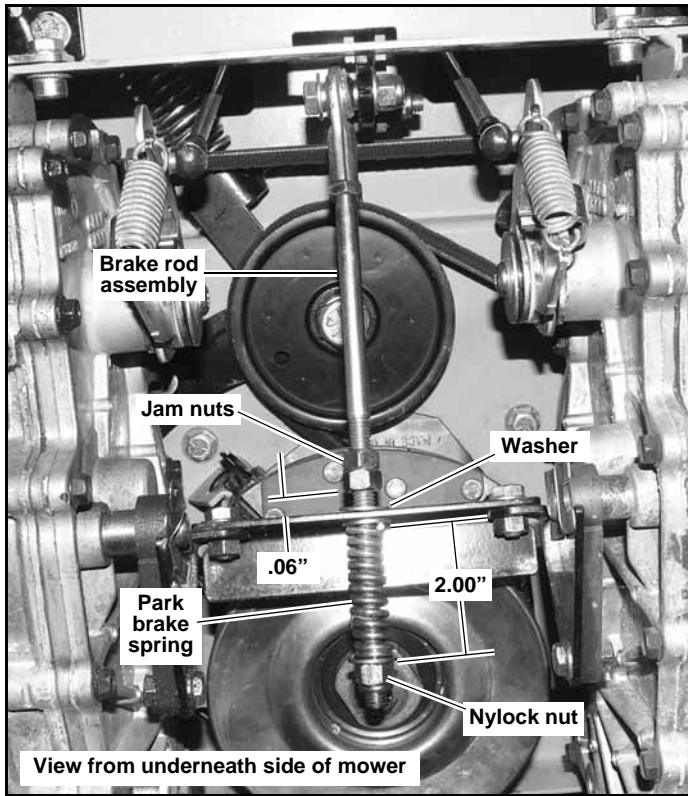

Figure 4-4

ings. Any of these will destroy the belt composition in a very short time.

### Pump Clutch Belt Adjustment

The TrimStar mower is equipped with a pump clutch that disengages the pump clutch belt. When the belt is disengaged, the engine will start easier in colder temperatures.

**To disengage** the pump clutch, **pull the chain** (Figure 4-5) until the tension is released from the pump drive belt and latch in the slot. Figure 4-5

**To engage** the pump clutch, with the H-Bar steering lever locked in neutral, release the chain from the latching slot.

**NOTE:** When engaged the spring should be extended to a dimension of 5.4" – 6.4" (13.7cm – 16.3cm). Figure 4-6

**NOTE:** Never operate the unit with the pump clutch partially engaged. Make sure the clutch is completely released and the chain has slack.

### Hydraulic system

**The TrimStar mower is equipped with two transaxles.**

**IMPORTANT:** Never use hydraulic or automatic transmission fluid in this system; use only motor oil as specified. Remember, dirt is the primary enemy of any hydraulic system.

The hydraulic expansion tank is located behind the left rear corner of the engine. Figure 4-7

Check oil level in hydraulic system after every 50 hours of operation or weekly, whichever occurs first. Check more often if system appears to be leaking or otherwise malfunctioning.

Fluid level should be at the "Full Cold" line on the expansion tank. Use only SAE 20W50 SL service motor oil.

Initial system oil and filter change **must** be after the first 75 hours of use or 1 year whichever comes first. Thereafter, replace

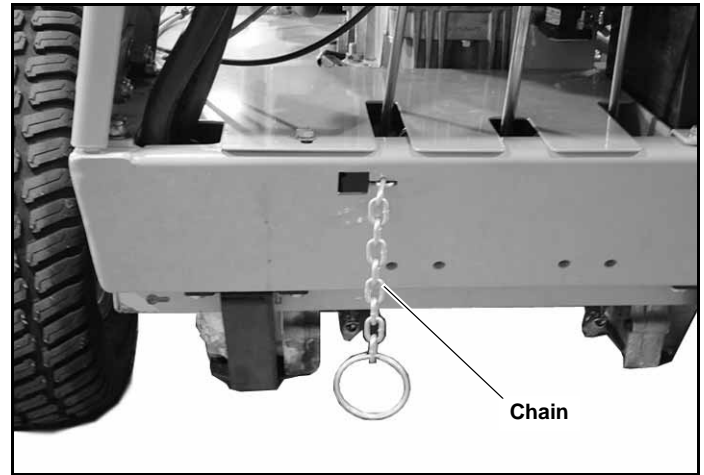

Figure 4-5

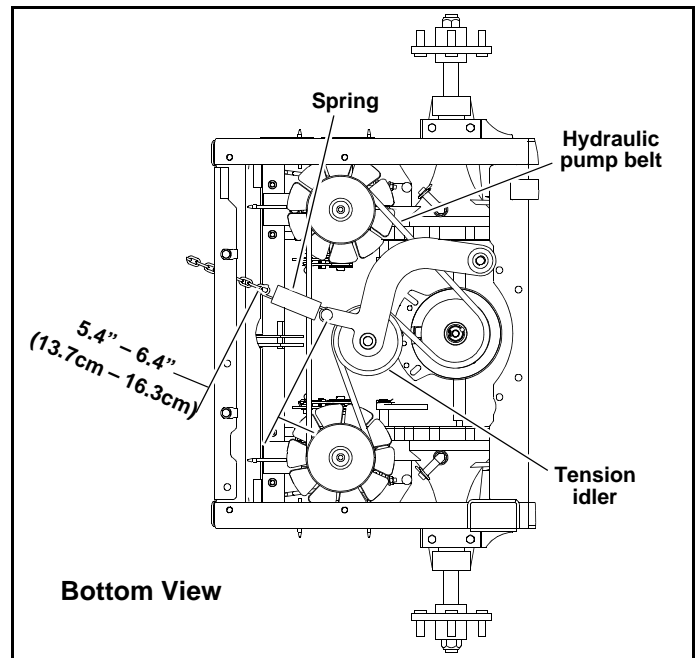

Figure 4-6

filter and oil in each transaxle every 2 years or 200 hours, whichever comes first. **NOTE:** The filter guard must be removed to access filter.

Each transaxle's filter is located per Figure 4-8. A standard oil filter wrench is used to change filter, threads are right handed. **Use a Hustler approved filter element only.**

**WARNING**

When washing the mower, direct the spray away (especially if using a power washer) from the transaxle's seals to prevent water intrusion and to ensure component performance.

### Fluid changing procedure

1. Park the machine on level ground. Disengage deck clutch, place the H-Bar steering lever in neutral, place neutral lock/park brake lever in park brake position, stop engine, and remove ignition key. Remove the spark plug

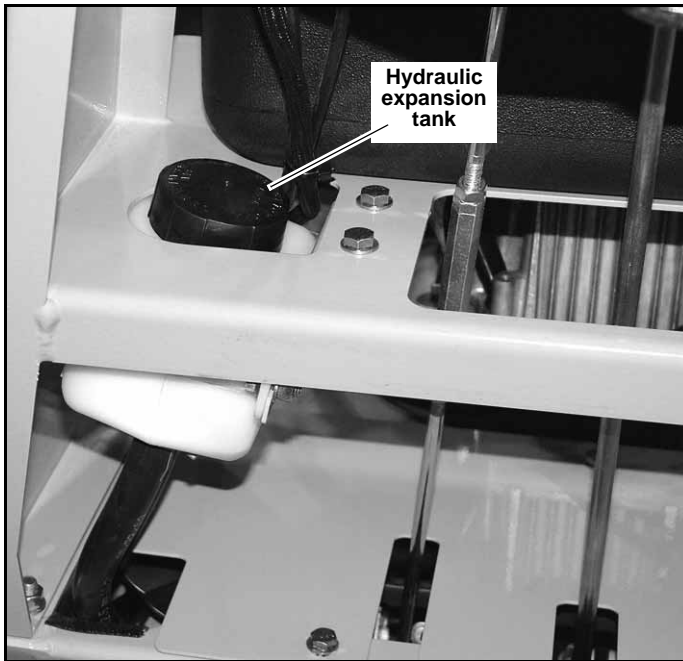

Figure 4-7

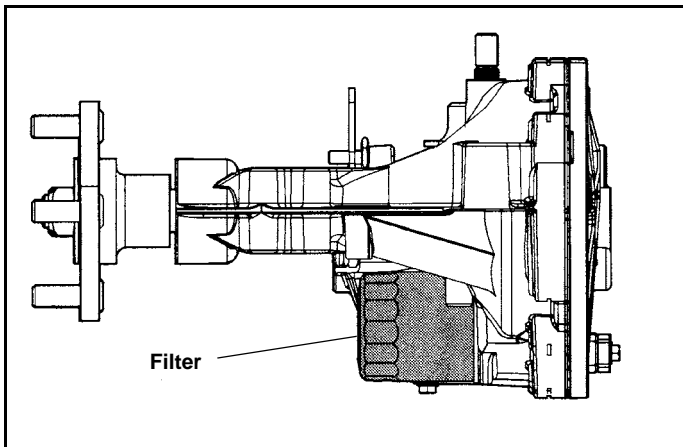

Figure 4-8

wires from the spark plugs, or, if applicable, disconnect the negative battery cable.

2. Remove the three 1/4" filter guard screws and filter guard. Clean any loose debris from around the filter Figure 4-9
3. Place an oil drain pan beneath the oil filter and remove the oil filter from the transaxle.
4. After the oil has been drained, wipe the filter base surface off and apply a film of new oil to the gasket of the new replacement filter.
5. Install the new filter by hand, turn 3/4 to one full turn after the filter gasket contacts the filter base surface.
6. Re-install the filter guard with three 1/4" screws. Torque the screws to 65 in.-lbs. each. Figure 4-9
7. Repeat steps 2 - 6 for the opposite side transaxle.
8. Drain oil filters of all free flowing oil prior to disposal. Place used oil in appropriate containers.
9. **IMPORTANT:** Remove the top port plug from both transaxles prior to filling with oil. This will allow the transaxles to vent during oil fill. Figure 4-10
10. Remove the cap from the transaxle's expansion tank.

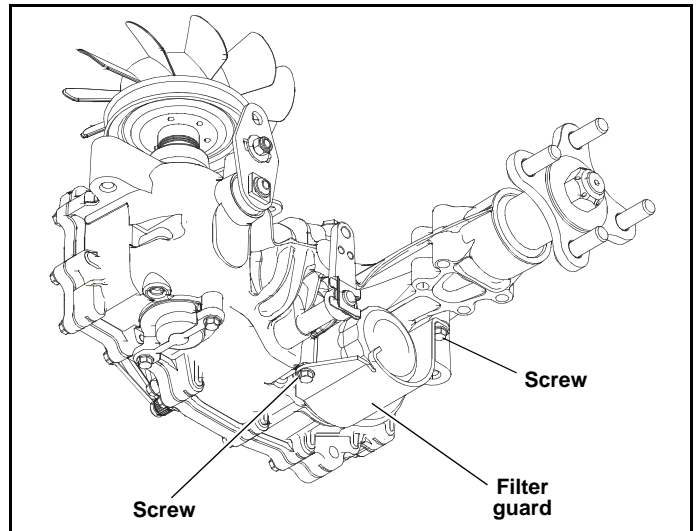

Figure 4-9

11. Fill with 20W50 motor oil until oil just appears at the bottom of each transaxle top port (approximately 2 qts. per transaxle). Install the top port plug into each transaxle as the oil level reaches this port. Torque plugs to 180 in. lbs. Clean up any oil that leaked from the ports. Figure 4-10
12. Continue to fill the transaxles through the expansion tank until the "Full Cold" line is reached on the expansion tank.
13. Re-install the expansion tank cap by hand. Be careful not to overtighten.
14. Proceed to the purge procedure.

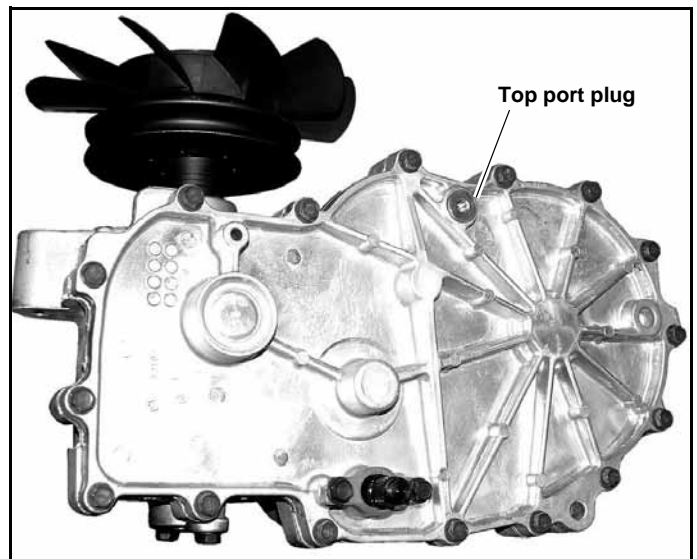

Figure 4-10

### Purging procedure

Due to the affects air has on efficiency in hydrostatic drive applications, it is critical that it is purged from the system.

Air creates inefficiency because its compression and expansion rate is higher than that of the oil approved for use in hydrostatic drive systems.

These purge procedures should be implemented any time a hydrostatic system has been opened to facilitate maintenance or the oil has been changed.





The resulting symptoms in hydrostatic systems may be:

1. Noisy operation.
2. Lack of power or drive after short term operation.
3. High operation temperature and excessive expansion of oil.

Before starting, make sure the transaxle is at the proper oil level. If it is not, fill to the specifications outlined in this manual.

The following procedures are performed with the vehicle drive wheels off the ground.

1. Raise and block the mower up so the drive wheels are off of the floor.

 **WARNING** 

Never work under the machine or attachment unless it is safely supported with jack stands. Make certain machine is secure when it is raised and placed on the jack stands. The jack stands should not allow the machine to move when the engine is running and the drive wheels are rotating. **Use only certified jack stands.** Use only appropriate jack stands, with a minimum weight rating of 2000 pounds to block the unit up. Use in pairs only. Follow the instructions supplied with the vehicle stands.

2. Chock the front tires.
3. With the bypass valve open and the engine running, slowly move the H-Bar steering lever in both forward and reverse directions (5 or 6 times). Figure 4-11
4. With the bypass valve closed and the engine running, slowly move the H-Bar steering lever in both forward and reverse directions (5 or 6 times). Check the oil level, and add oil as required after stopping the engine.

5. It may be necessary to repeat Steps 3 and 4 until all the air is completely purged from the system. When the transaxle operates at normal noise levels and moves smoothly forward and reverse at normal speeds, then the transaxle is considered purged.

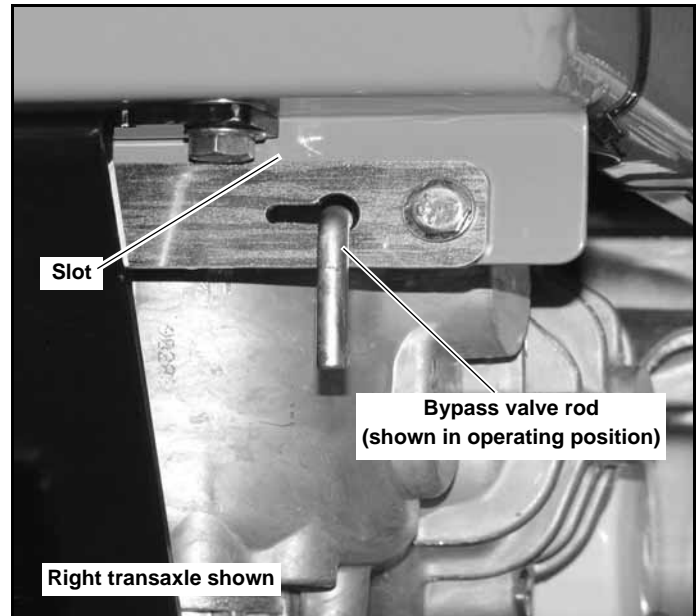

Figure 4-11

## Tires

It is important for level mowing that the tires have the same amount of air pressure. The recommended pressure are:

- Drive wheels . . . . . 8-12 psi (55-83 KPa)
- Gauge wheels. . . . . 8-12 psi (55-83 KPa)

**Solid fill tires are not recommended** for Hustler® TrimStar mowers. On any machine, with solid filled tires, the warranty claim will be denied.



# ENGINE MAINTENANCE

## General Engine Maintenance

Detailed instructions and recommendations for break-in and regular maintenance are specified in the Engine Owner's manual. Please refer to this manual for engine servicing, lubricating oil levels with quality and viscosity recommendations, bolt torques, etc. The engine warranty is backed by the manufacturer.

## Engine Oil and Filter



### WARNING



If the engine has been running and is up to operating temperature, allow the engine to cool before changing the oil. Engine and engine oil will be very hot, so be very careful when changing oil and wear the appropriate protective gear to avoid being burned or exposed to engine oil.

Check engine oil daily and after every 4 hours of operation. Mower must be on a level surface when checking oil. Refer to engine manual and maintenance schedule for oil recommendation and capacities.

Change the engine oil and filter after the first 5 hours of operation and then per the engine manufacturer's recommendations after that. If mower is being operated in extremely dirty conditions, then it is recommended oil be changed more frequently.

**IMPORTANT:** All oil drips or spills **must** be cleaned off of the exhaust system before operating the machine.

### Draining the engine oil:

1. Locate the oil drain valve on the engine. Figure 5-1
2. Locate the oil drain hose that was supplied with the machine. Be sure to clean and clear it of debris that might block the flow of the engine oil.
3. Attach one end of the hose onto the oil drain valve nipple. Make sure the hose is pushed all the way onto the valve.
4. Position the loose end of the hose out to the side of the mower so that it can drain into a suitable oil drain container.
5. With the hose in position, twist the valve counterclockwise and pull out to open the valve. Allow 10 minutes for engine oil to adequately drain.
6. After oil is drained, close the valve by pushing in on the valve body and twisting it clockwise.
7. Once the valve is closed, carefully remove the oil drain hose and clean up any spilled oil.

**IMPORTANT:** All oil drips or spills **must** be cleaned off of the exhaust system before operating the machine.

8. Re-install the dust cap on the oil drain valve nipple.
9. Clean the oil drain hose and store it appropriately. Figure 5-1

## Engine Air Filter

Perform engine air filter maintenance per the engine's

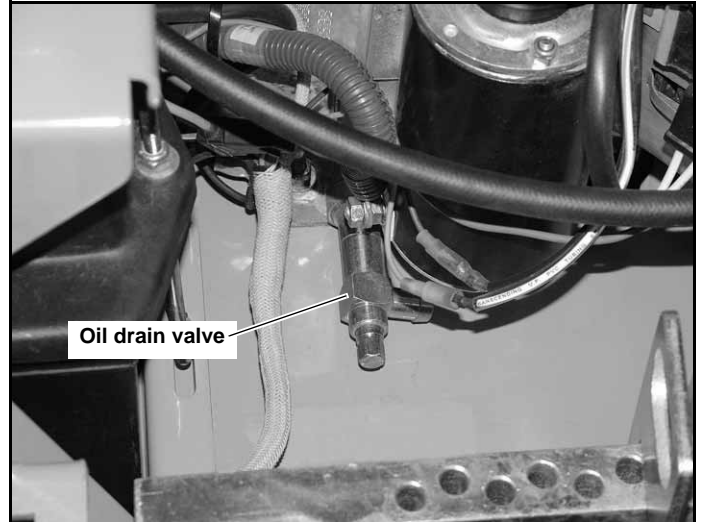

Figure 5-1

owner's manual. Figure 5-2



Figure 5-2

## Carbon canister

Some Hustler® TrimStar mowers will have a carbon canister incorporated into the fuel system. Figure 5-3

These canisters should be replaced every 5 years or if they become damaged.

## Fuel evaporation system filter

All domestic Hustler® TrimStar mowers, manufactured after January 1, 2011, have a fuel evaporation system filter. Non-domestic Hustler® TrimStar mowers (units with a CE or EX extension after the model number) manufactured between serial number 11010000 and 12010641, have a fuel evaporation system filter. Non-domestic TrimStar mowers (units with a CE or EX extension after the model number) manufactured after serial number 12010641 do not have a fuel evaporation system filter.

## Fuel & evaporative system line routings

There are two rubber hoses that are connected to the fuel tank. One is the fuel hose that is part of the fuel system. The other is the vapor line that is part of the fuel evaporative system.

The fuel hose is connected to the port on the side wall of the fuel tank. It connects the fuel tank to the fuel shutoff valve. Figure 5-5

The vapor line is connected to the port in the top of the fuel tank. It connects the fuel tank to the engine's vapor port. Figure 5-5

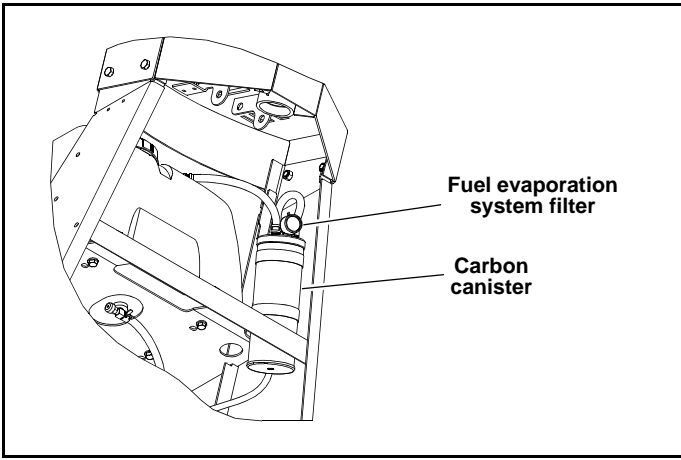

Figure 5-3

Figure 5-4

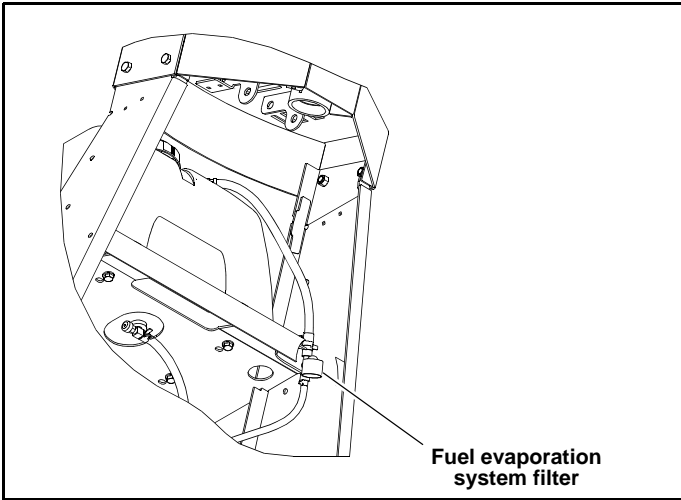

Figure 5-4

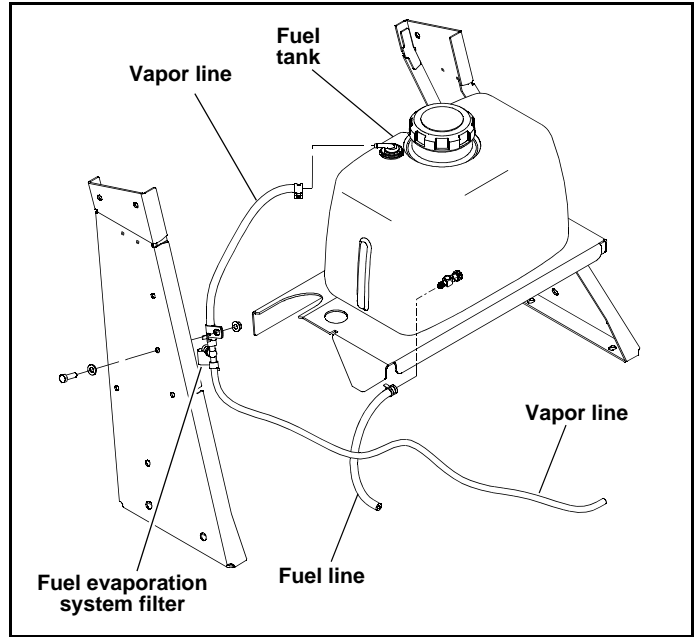

Figure 5-5

## Engine RPM Settings

---

The engine rpm's are set at the factory for maximum mowing efficiency. Occasionally it may be necessary to check and adjust the settings. The engine speeds should be set as follows:

<b>Kawasaki FS481 / FS541 / FS600</b>	
<b>ENGINE SPEED</b>	
<b>MODEL NO. ENDING WITH:</b>	<b>HIGH IDLE</b>
MODEL NO. WITHOUT EXTENSION MODEL NO. WITH <b>EX</b> EXTENSION MODEL NO. WITH <b>US</b> EXTENSION MODEL NO. WITH <b>CE</b> EXTENSION	3600 ± 50 RPM

**NOTE:** Model numbers may or may not end with an extension after the number. There are several different extensions that may be shown; i.e. EX or CE.

**Example:** 922222 (no extension)  
922222 EX  
922222 CE  
922222 US





# DECK ADJUSTMENTS

## Deck Leveling – 48”/54” Side Discharge Deck

Leveling the deck must be done in the following manner and order:

1. Check tire pressures to make certain they are properly inflated before starting to level deck. The recommended pressures are as follows:  
Drive wheels tire pressure . . . . .8 - 12 psi  
Gauge wheels tire pressure . . . . .8 - 12 psi

**WARNING**

Stop engine. Make sure deck clutch switch is **in the down (OFF) position**. Place neutral lock/park brake lever in the brake (engaged) position.

2. Park the unit on a flat surface.
3. Place 3” high deck support blocks (two stacked 2” x 4” blocks can be used to create a 3” [7.62cm] high support) at the four corners of the deck as shown. **NOTE:** Back of deck will automatically be set 1/4” (6.35mm) higher. Figure 6-1

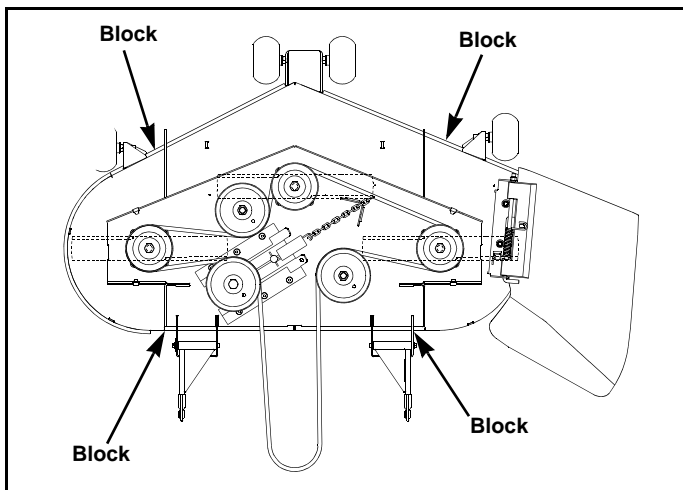

**Figure 6-1**

4. Place the height stop in the 3” (7.62cm) hole, with the flat side of the height adjusting stop against the stop handle. Clamp the height adjusting stop against the deck stop bracket. This will assure that the height will not move during the setting process. Figure 6-2
5. Loosen all nuts on the deck lift threaded rods, and the hardware on the height indicator bar (on the right front), until **all** the deck lift chains are loose, **and** the deck is sitting tightly on all four blocks. Figure 6-2
6. Loosen the two nuts on the front of height indicator bar

so that the bar has play. Figure 6-2

7. Start the leveling process on the **left front** of the mower.
8. Set the amount of threads protruding on the deck lift rod from the lift block at approximately 1” (2.54cm) (left & right side). Figure 6-2
9. Jam both nuts against the block. Push or pull on the deck lift bell crank until the chain on the left front just becomes tight, making sure that the deck stays tight against the block. Figure 6-2
10. While keeping the chain tight, tighten the nuts against the deck lift block on the height indicator rod, just enough to carry most of the deck weight on that side — the block should be able to move with only a slight drag. Figure 6-2
11. Jam nuts tightly together against the deck lift block. Figure 6-2
12. Go to the **right front** of the mower.
13. Loosen the 5/16” jam nut on the adjuster lift chain, and back the adjuster bolt out to allow the adjuster to move up and down freely. Figure 6-2
14. Tighten the adjuster bolt until the chain just becomes tight. Then tighten just enough to carry the weight of the front of the deck on that side—to check, move the blocks back and forth; they should move with a slight drag. Figure 6-2
15. Tighten the adjuster bolt jam nut to prevent the adjuster bolt from moving. Figure 6-2
16. Tighten the hardware holding the chain and adjuster onto the deck lift arm. Go to the **right rear** of the mower.
17. Make sure that there is still slack in the chain. If not, loosen the two nuts on the block holding the threaded rod until there is slack in the deck lift chain. Figure 6-2
18. Tighten the appropriate nut until the chain just becomes tight, and carries most of the deck weight. Check by moving the block—it should move with a slight drag. Figure 6-2
19. Tighten the other nut on the opposite side of the block, and jam them tightly together against the block. Go to the **left rear** of the mower. Figure 6-2
20. Make sure that there is still slack in the chain. If not, loosen the two nuts on the block holding the threaded rod until there is slack in the deck lift chain. Figure 6-2
21. Tighten the appropriate nut until the chain just becomes tight, and carries most of the deck weight. Check by moving the block—it should move with a slight drag. Figure 6-2
22. Tighten the other nut on the opposite side of the block, and jam them tightly together against the block. Figure 6-2
23. When completed, all chains will be tight, and deck cutting height will be set to the deck height indicator.

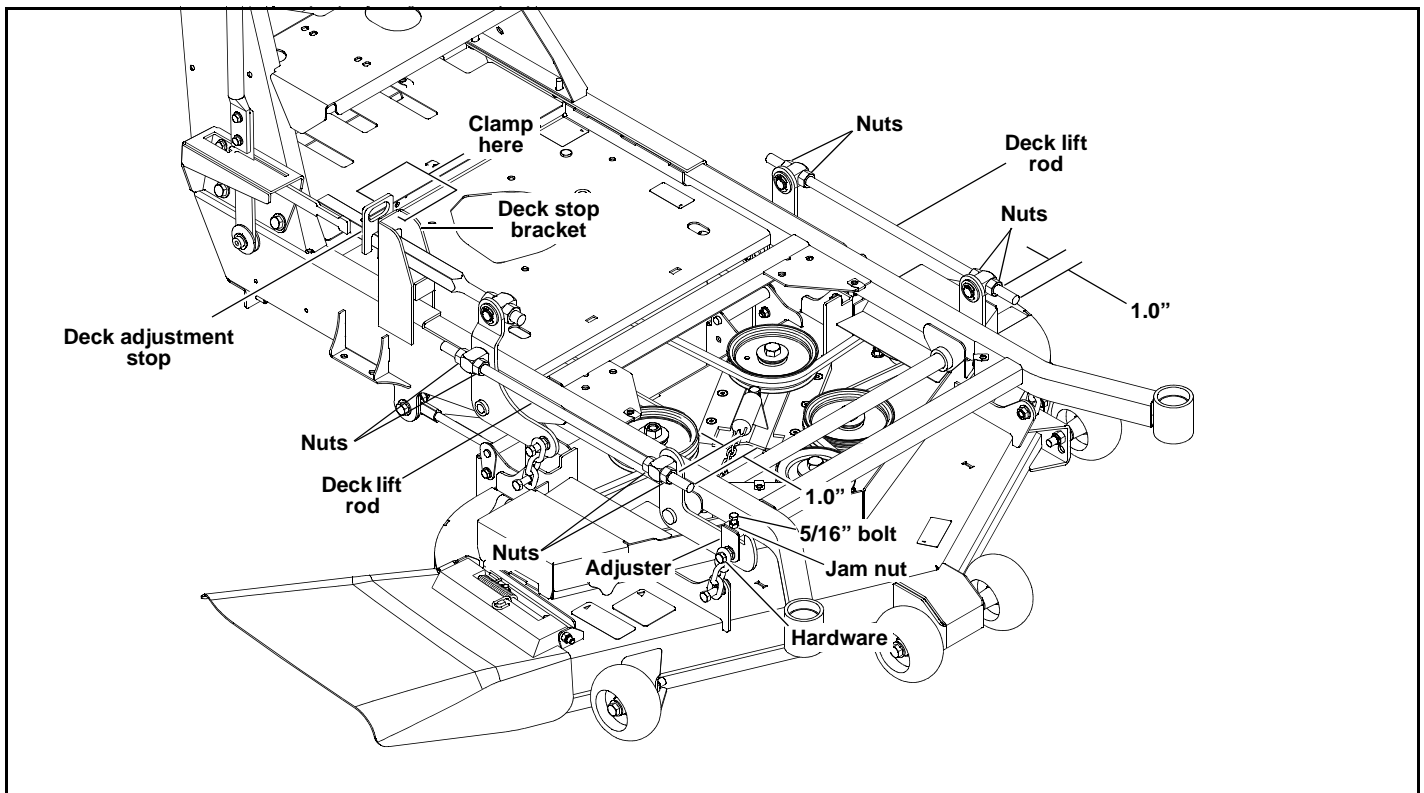

Figure 6-2

### Deck Leveling – 36” Side Discharge Deck

Leveling the deck must be done in the following manner and order:

1. Check tire pressures to make certain they are properly inflated before starting to level deck. The recommended pressures are as follows:  
 Drive wheels tire pressure . . . . . 8 - 12 psi  
 Gauge wheels tire pressure . . . . . 8 - 12 psi

⚠
WARNING
⚠

Stop engine. Make sure deck clutch switch is **in the down (OFF) position**. Place neutral lock/park brake lever in the brake (engaged) position.

2. Park the unit on a flat surface.
3. Place 3” high deck support blocks (two stacked 2” x 4” blocks can be used to create a 3” [7.62cm] high support) at the four corners of the deck as shown. **NOTE:** Back of deck will automatically be set 1/4” (6.35mm) higher. Figure 6-3
4. Place the height stop in the 3” (7.62cm) hole, with the flat side of the height adjusting stop against the stop handle. Clamp the height adjusting stop against the deck stop bracket. This will assure that the height will not move during the setting process. Figure 6-4
5. Loosen all nuts on the deck lift threaded rods and the hardware on the adjuster (on the left rear), until **all** the deck lift chains are loose, **and** the deck is sitting tightly on all four blocks. Figure 6-4

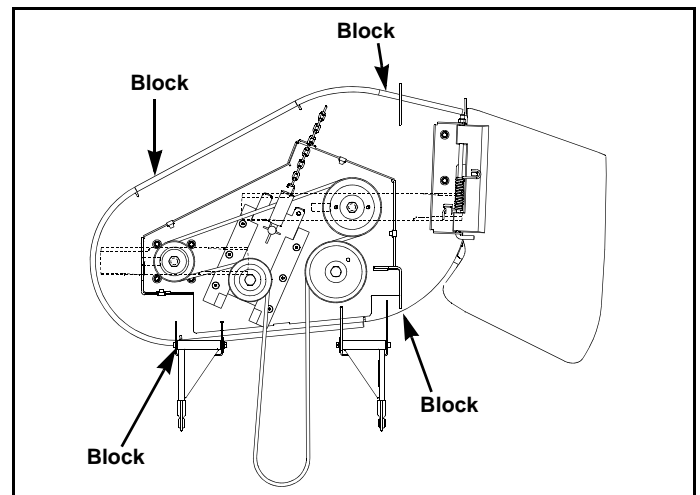
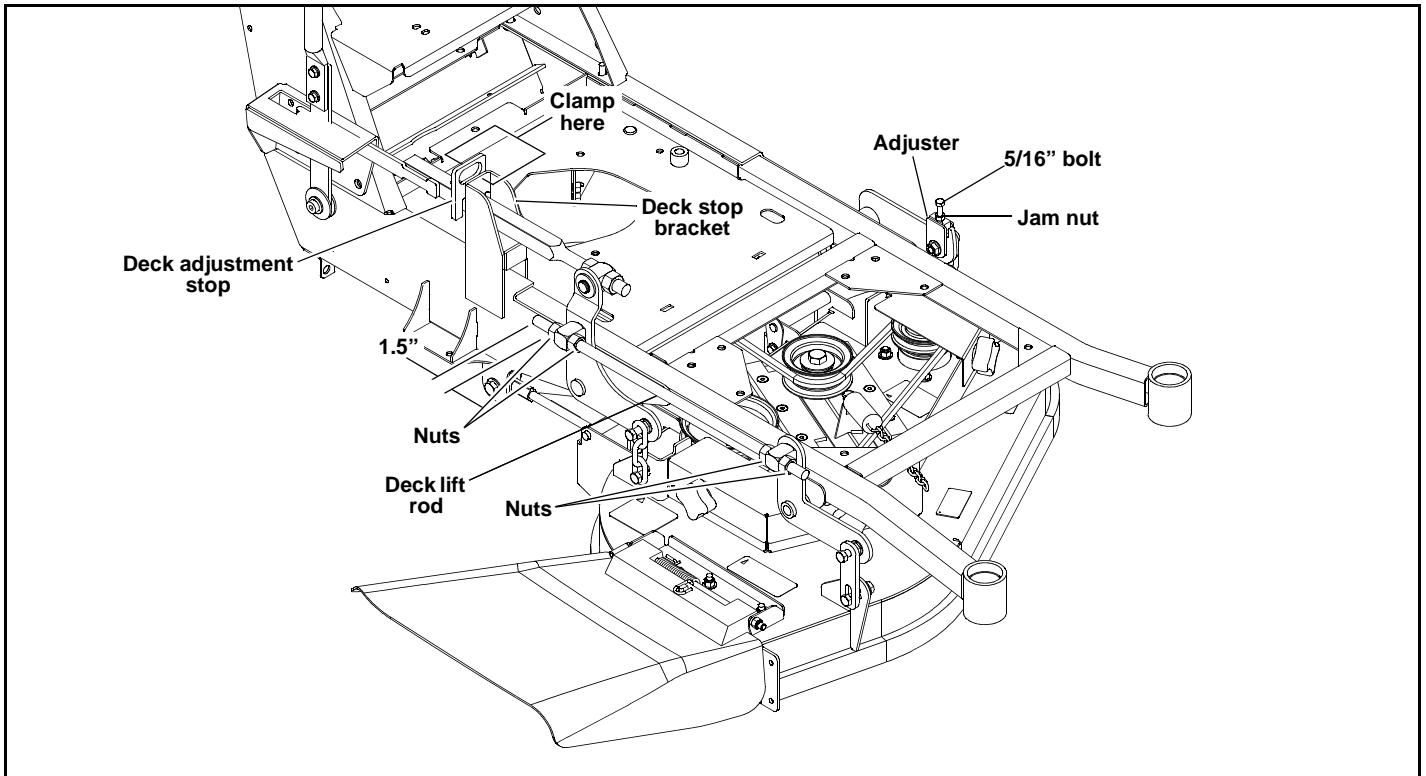

Figure 6-3

6. Loosen the two nuts on the front of height indicator bar so that the bar has some play. Figure 6-4
7. Start the leveling process on the **right rear** of the mower.
8. Set the amount of threads protruding on the deck lift rod from the lift block at approximately 1.50” (left & right side). Figure 6-4
9. Jam both nuts against the block. Figure 6-4
10. Push or pull on the deck lift bell crank until the chain on the **right rear** just becomes tight, making sure that the deck stays tight against the deck support block. Figure 6-4
11. While keeping the chain tight, tighten the nuts against the deck lift block on the height indicator. Figure 6-4
12. Go to the **left rear** of the deck.





**Figure 6-4**

13. Loosen the jam nut on the adjuster, and back the 5/16" bolt out to allow the adjuster to move up and down freely. The deck lift chain should be slack. Figure 6-4
14. Tighten the 5/16" bolt until the chain just becomes tight, making sure that the deck stays tight against the deck support block. Figure 6-4
15. Tighten the jam nut to prevent the adjuster from moving. Figure 6-4
16. Tighten the hardware holding the chain and adjuster onto the deck lift arm. Figure 6-4
17. Go to the **right front** of the deck.
18. Make sure that there is still slack in the chain. If not, loosen the two nuts on the block holding the threaded rod until there is slack in the deck lift chain. Figure 6-4
19. Tighten the appropriate nut until the chain just becomes tight, making sure that the deck stays tight against the deck support block. Figure 6-4
20. Tighten the other nut on the opposite side of the block, and jam them tightly together against the block. When completed, all chains will be tight, and deck will be resting on the blocks. Figure 6-4

### Deck Leveling – 48" Rear Discharge Deck

**NOTE:** 48" Rear discharge deck is available as a CE mower only.

Leveling the deck must be done in the following manner and order:

1. Check tire pressures to make certain they are properly inflated before starting to level deck. The recommended pressures are as follows:  
 Drive wheels tire pressure . . . . . 8 - 12 psi

Gauge wheels tire pressure. . . . . 8 - 12 psi

! **WARNING** !

Stop engine. Make sure deck clutch switch is **in the down (OFF) position**. Place neutral lock/park brake lever in the brake (engaged) position.

2. Park the unit on a flat surface.
3. Place 3" high deck support blocks (two stacked 2" x 4" blocks can be used to create a 3" [7.62cm] high support) at the four corners of the deck as shown. **NOTE:** Back of deck will automatically be set 1/4" (6.35mm) higher. Figure 6-5

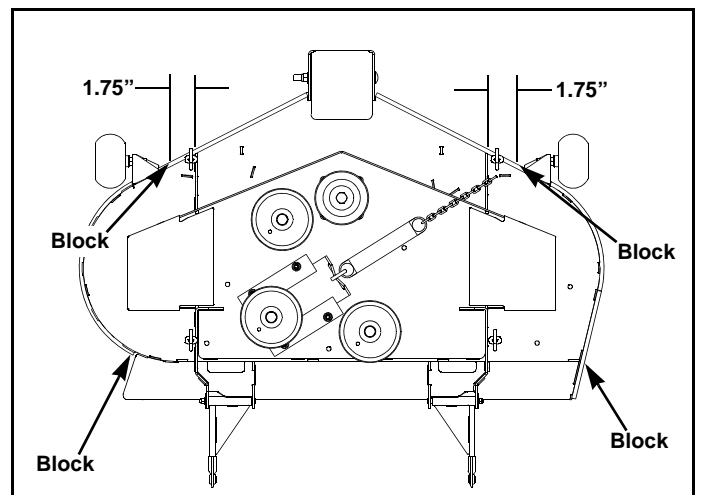

**Figure 6-5**

4. Place the height stop in the 3" (7.62cm) hole, with the flat side of the height adjusting stop against the deck stop bracket. Clamp the height adjusting stop against the deck stop bracket. This will assure that the height will not move during the setting process. Figure 6-6
5. Loosen all nuts on the deck lift threaded rods and the hardware on the adjuster (on the right front), until **all** the deck lift chains are loose, **and** the deck is sitting tightly on all four blocks. Figure 6-6
6. Loosen the two nuts on the front of height indicator bar so that the bar has some play. Figure 6-6
7. Start the leveling process on the **right rear** of the mower.
8. Set the amount of threads protruding on the deck lift rod from the lift block at approximately 1.50" (left & right side). Figure 6-6
9. Jam both nuts against the block. Figure 6-6

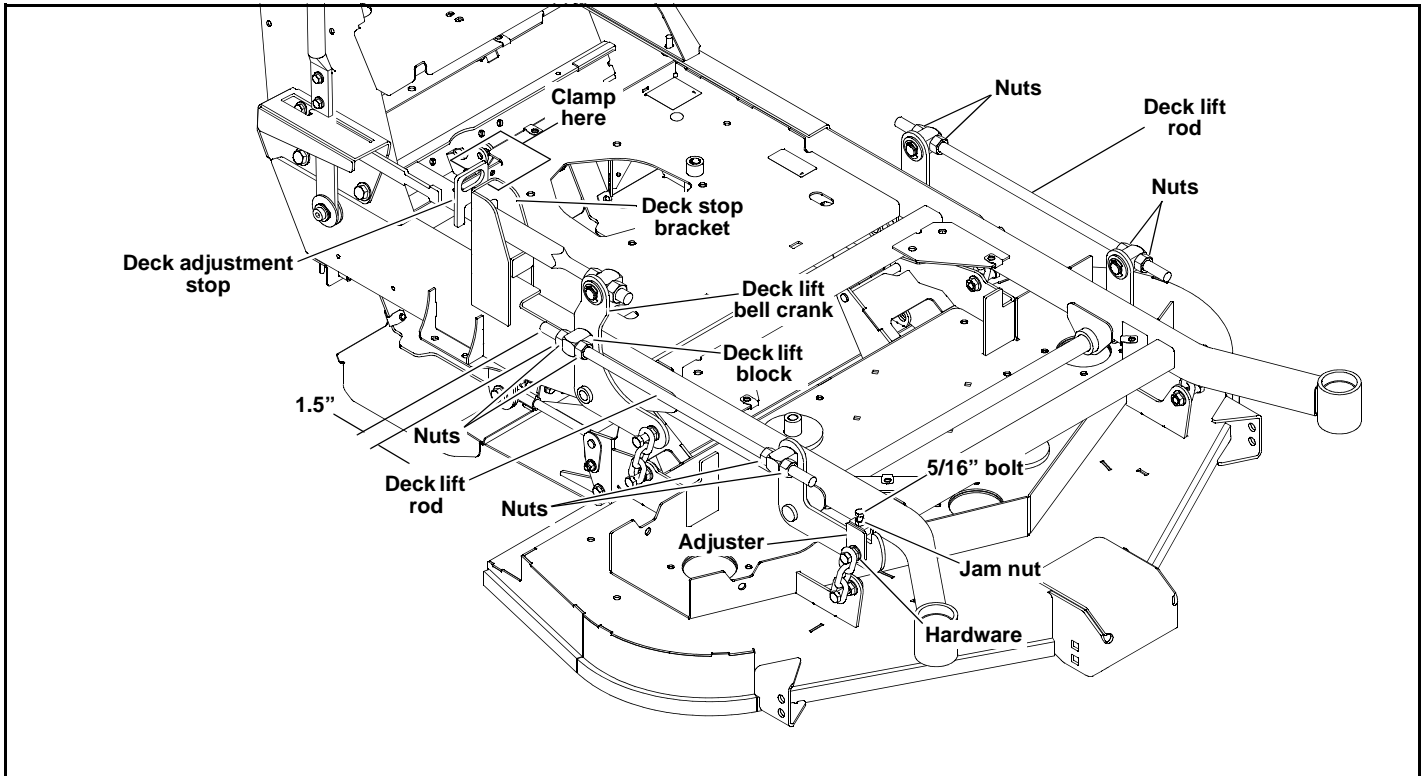

**Figure 6-6**

10. Push or pull on the deck lift until the chain on the **right rear** just becomes tight, making sure that the deck stays tight against the deck support block. Figure 6-6
11. While keeping the chain tight, tighten the nuts against the deck lift block on the height indicator. Figure 6-6
12. Jam nuts tightly together against the deck lift block. Figure 6-6
13. Go to the **left front** of the mower.
14. Make sure that there is still slack in the chain. If not, loosen the two nuts on the block holding the threaded rod until there is slack in the deck lift chain. Figure 6-6
15. Tighten the appropriate nut until the chain just becomes tight, making sure that the deck stays tight against the deck support blocks. Figure 6-6
16. Tighten the other nut on the opposite side of the block, and jam them tightly together against the block. Figure 6-6
17. Go to the **right front** of the mower.
18. Loosen the 5/16" jam nut on the deck leveler yoke, and back the 5/16" adjuster bolt out to allow the deck leveler yoke to move up and down freely. Figure 6-6
19. Be sure that the deck adjuster is free to move up and down. Figure 6-6
20. Tighten the adjuster bolt until the chain just becomes tight, making sure that the deck stays tight against the deck support blocks. Figure 6-6
21. Tighten the adjuster bolt jam nut to prevent the deck adjuster from moving. Figure 6-6
22. Tighten the hardware holding the chain and deck adjuster onto the deck lift arm. Figure 6-6
23. Go to the **left rear** of the deck.
24. Make sure that there is still slack in the chain. If not, loosen the two nuts on the block holding the threaded rod until there is slack in the deck lift chain. Figure 6-6
25. Tighten the appropriate nut until the chain just becomes tight, making sure that the deck stays tight against the deck support blocks. Figure 6-6
26. Tighten the other nut on the opposite side of the block, and jam them tightly together against the block. Figure 6-6
27. When completed, all chains should be tight and the deck should still be resting on the blocks.

## Deck Leveling – 36" Rear Discharge Deck

**NOTE:** 36" Rear discharge deck is available as a CE mower only.

Leveling the deck must be done in the following manner and order:

1. Check tire pressures to make certain they are properly

inflated before starting to level deck. The recommended pressures are as follows:

- Drive wheels tire pressure . . . . .8 - 12 psi
- Gauge wheels tire pressure . . . . .8 - 12 psi

⚠
WARNING
⚠

Stop engine. Make sure deck clutch switch is **in the down (OFF) position**. Place neutral lock/park brake lever in the brake (engaged) position.

2. Park the unit on a flat surface.
3. Place 3" high deck support blocks (two stacked 2" x 4" blocks can be used to create a 3" [7.62cm] high support) at the four corners of the deck as shown. **NOTE:** Back of deck will automatically be set 1/4" (6.35mm) higher. Figure 6-7
4. Place the height stop in the 3" (7.62cm) hole, with the flat side of the height adjusting stop against the deck stop bracket. Clamp the height adjusting stop against the deck stop bracket. This will assure that the height will not move during the setting process. Figure 6-8
5. Loosen all nuts on the deck lift threaded rods and the hardware on the adjuster (on the left rear), until **all** the deck lift chains are loose, **and** the deck is sitting tightly

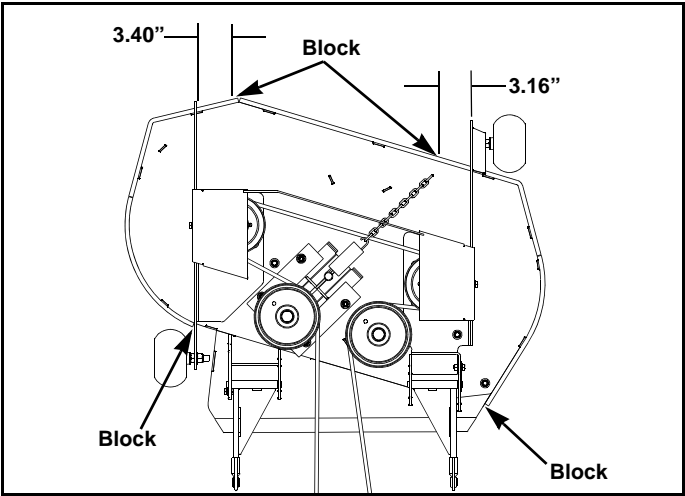

**Figure 6-7**

- on all four blocks. Figure 6-8
6. Loosen the two nuts on the front of height indicator bar so that the bar has some play. Figure 6-8
7. Start the leveling process on the **right rear** of the mower.
8. Set the amount of threads protruding on the deck lift rod from the lift block at approximately 1.50" (left & right side). Figure 6-8
9. Jam both nuts against the block. Figure 6-8

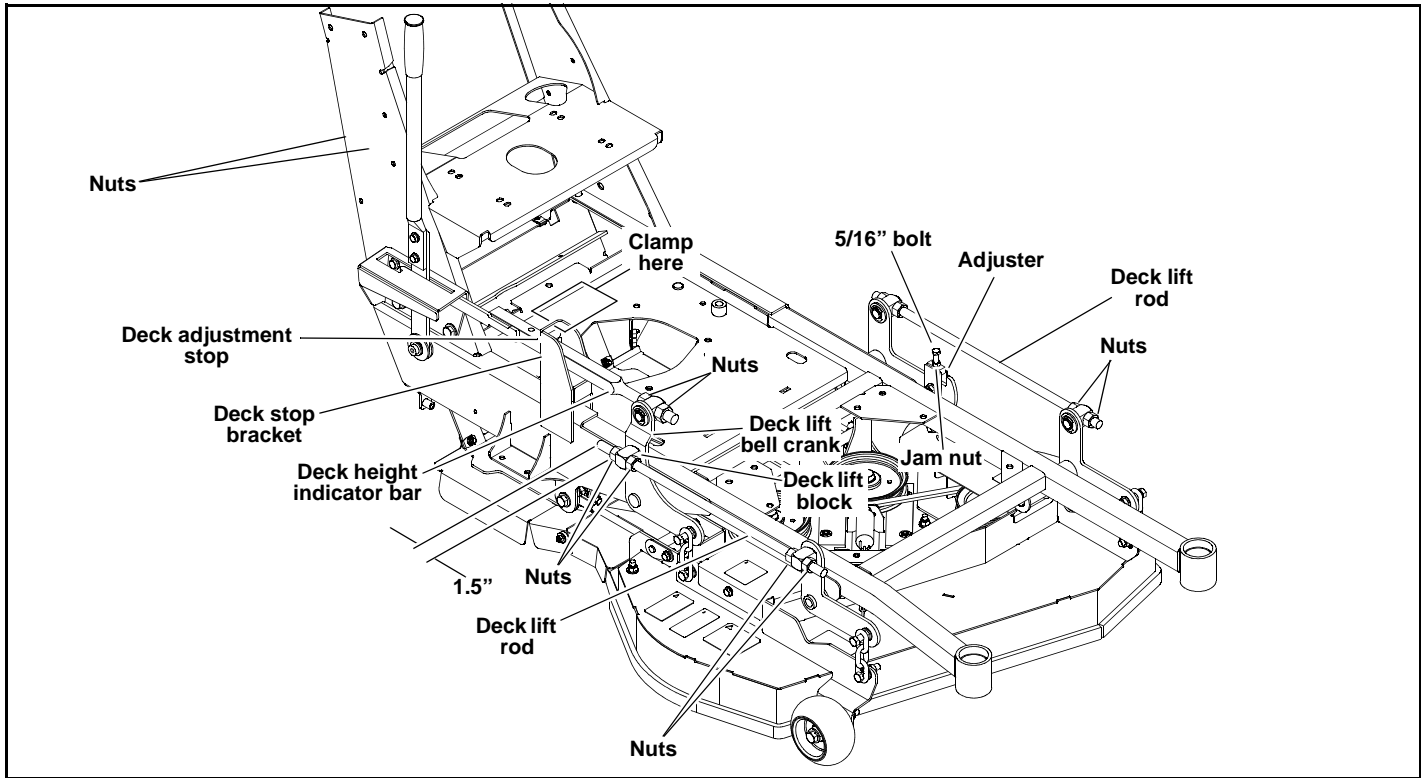

**Figure 6-8**

10. Push or pull on the deck lift bell crank until the chain on the **right rear** just becomes tight, making sure that the deck stays tight against the deck support block. Figure 6-8
11. While keeping the chain tight, tighten the nuts against the deck lift block on the height indicator. Figure 6-8
12. Go to the **right front** of the mower.
13. Make sure that there is still slack in the chain. If not, loosen the two nuts on the block holding the threaded rod until there is slack in the deck lift chain.
14. Tighten the appropriate nut until the chain just becomes tight, making sure that the deck stays tight against the



- deck support blocks.
15. Tighten the other nut on the opposite side of the block, and jam them tightly together against the block.
  16. Go to the **left front** of the mower.
  17. Make sure that there is still slack in the chain. If not, loosen the two nuts on the block holding the threaded rod until there is slack in the deck lift chain.
  18. Tighten the appropriate nut until the chain just becomes tight, making sure that the deck stays tight against the deck support blocks.
  19. Tighten the other nut on the opposite side of the block, and jam them tightly together against the block.
  20. Go to the **left rear** of the mower.
  21. Loosen the 5/16" jam nut on the deck adjuster, and back the 5/16" adjuster bolt out to allow the deck adjuster to move up and down freely, and there is slack in the deck lift chain.
  22. Tighten the adjuster bolt until the chain just becomes tight, making sure that the deck stays tight against the deck support blocks.
  23. Tighten the adjuster bolt jam nut to prevent the deck leveler yoke from moving.
  24. Tighten the hardware holding the chain and deck adjuster onto the deck lift arm.
  25. When completed, all chains should be tight, and deck should still be resting on the deck support blocks.

## Blades



### Mower blade maintenance

Check the mower blades daily, they are the key to power efficiency and well groomed turf. Keep them sharp, a dull blade will tear rather than cut the grass, leaving a brown ragged top on the grass within a few hours. A dull blade also requires more power from the engine. Figure 6-9

Replace any blade which is bent, cracked or broken. Figure 6-10 & Figure 6-11

WARNING



Never attempt to straighten a bent blade by heating, or weld a cracked or broken blade as the blade may break and cause serious injury. Replace worn or damaged blades.

WARNING

Never work with blades while engine is running or deck clutch switch is engaged (on). Always place deck clutch switch in the disengaged position, place neutral lock/park brake lever in the brake (engaged) position, turn engine off, and remove ignition key when leaving the unit. Remove the spark plug wires from the spark plugs, or, if applicable, disconnect the negative battery cable. Block up mower when you must work under it. Wear gloves when handling blades. Always check for blade damage if mower strikes a rock, branch or other foreign objects during mowing!

WARNING

Always wear adequate eye protection when grinding mower blades.

WARNING

Mower blades are sharp and can cut. Wear gloves and use extra caution when servicing them.

Always place deck clutch switch in the **disengaged position**, place neutral lock/park brake lever in the brake (engaged) position, turn engine off, and remove ignition key when leaving the unit. Remove the spark plug wires from the spark plugs, or, if applicable, disconnect the negative battery cable. Block up mower when you **must** work under it. Wear gloves when handling blades. **Always check for blade damage** if mower strikes

a rock, branch or other foreign objects during mowing!

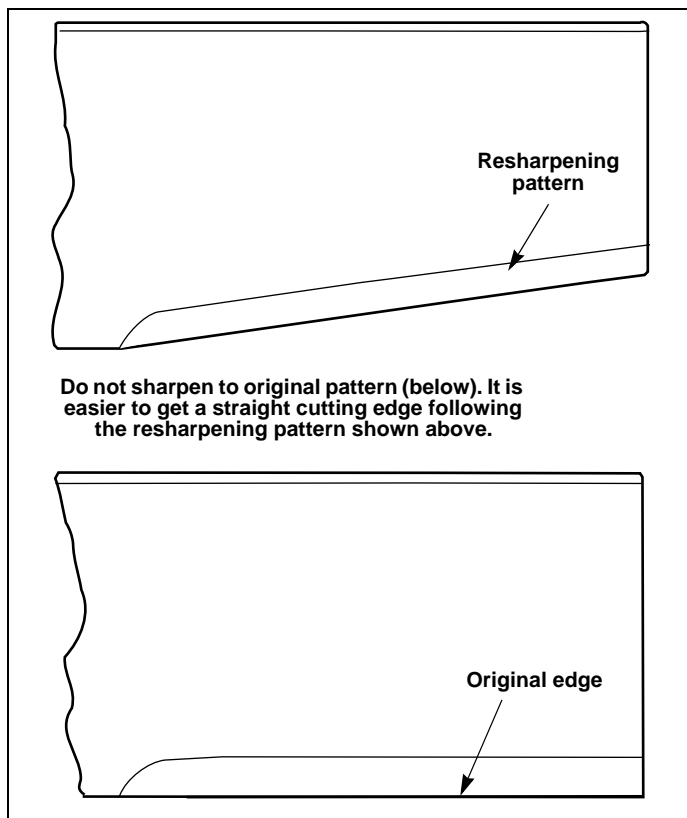

Figure 6-9

### Mower blade removal

Use a 15/16" wrench to remove the 5/8" cap screw holding the blade to the spindle shaft from underneath. **NOTE:** A blade holding tool (part number 381442) is available from Hustler® Turf Equipment. It is designed to prevent the blades from rotating when they are being removed or installed on the spindle. Contact your Hustler® Turf Equipment dealer for more information.

Sharpen the blades on a grinder following pattern as shown in Figure 6-9. Touch-up sharpening can be done with a file.

Check the blades for balance following grinding. A commercial balancing tool is available through most hardware supply stores, or balancing can be done by placing the blade on an inverted line punch or 5/8" bolt. Blade should not lean or tilt. Spin the blade slowly, blade should not wobble. If blade is out of balance, true it up before reinstalling.

Lay the blade on a flat surface and check for distortion (Figure 6-10 and Figure 6-11). Replace any distorted blade.

Do not re-use spindle bolts which have stripped, worn or undercut threads. Torque bolts on spindles to 118 foot-pounds (160.01Nm) when reinstalling blades.

**IMPORTANT:** The blade sail (curved part) must be pointing upward toward the inside of the deck to ensure proper cutting.

**IMPORTANT:** When mounting blades, rotate them after installation to ensure blade tips do not touch each other or sides of the mower.

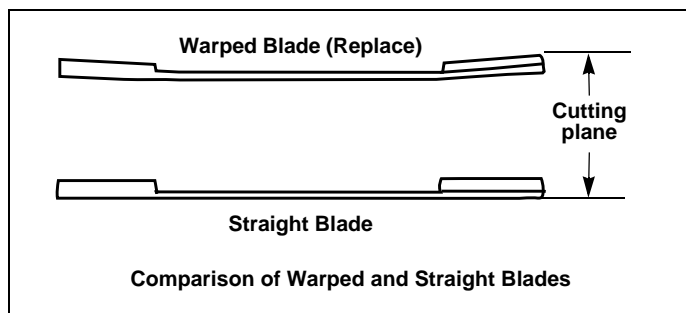

Figure 6-10

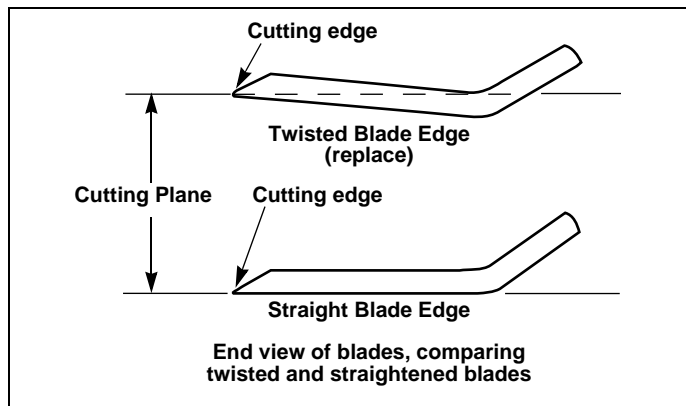

Figure 6-11

**WARNING**

Failure to correctly torque the bolt may result in the loss of the blade which can cause serious injury.

### Belts

Inspect belts frequently for wear and serviceability. Replace a belt that shows signs of severe cuts, tears, separation, weather checking and cracking, or burns caused by slipping. Slight raveling of belt covering does not indicate failure, trim ravelings with a sharp knife.

Inspect the belt pulley grooves and flanges for wear. A new belt, or one in good condition, should never run against the bottom of the groove. Replace the pulley when this is the case, otherwise belt will lose power and slip excessively.

Never pry a belt to get it on a pulley as this will cut or damage the fibers of the belt covering.

Keep oil and grease away from belts, and never use belt dressings. Any of these will destroy the belt composition in a very short time.

### Deck Belt Adjustment

The spindle belt tension remains constant by means of a tension idler and spring. The spring tension should be such that the belt does not slip under normal operating load conditions, assuming the belt is not excessively worn or damaged. As the belt stretches and wears in, adjustment may become necessary. To increase belt tension, move the spring chain one (or more) link(s) at the anchor point on the deck frame. Figure 6-12, Figure 6-13, Figure 6-14 & Figure 6-15

**IMPORTANT:** Do not over tension the spring to compensate

for a badly worn belt or pulley.

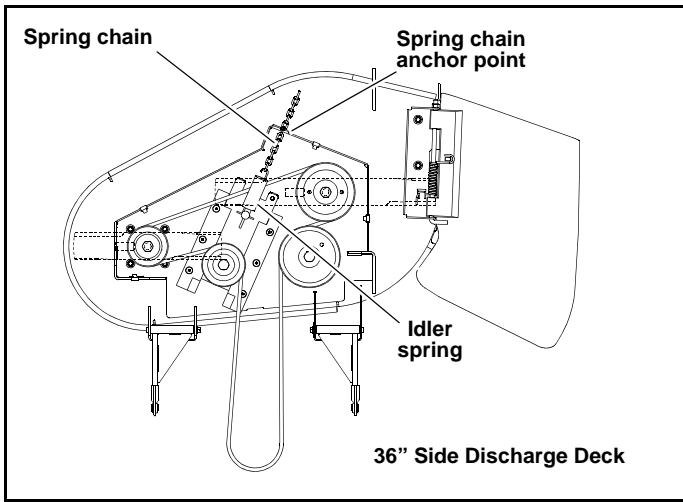

Figure 6-12

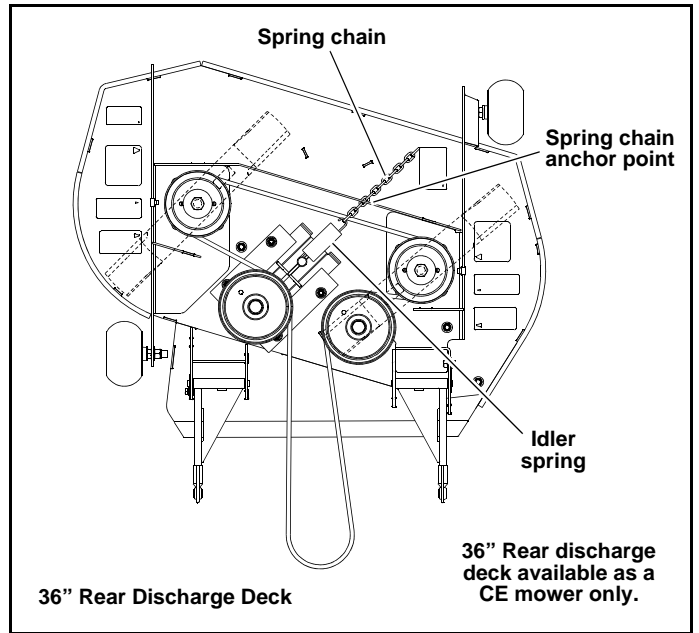

Figure 6-14

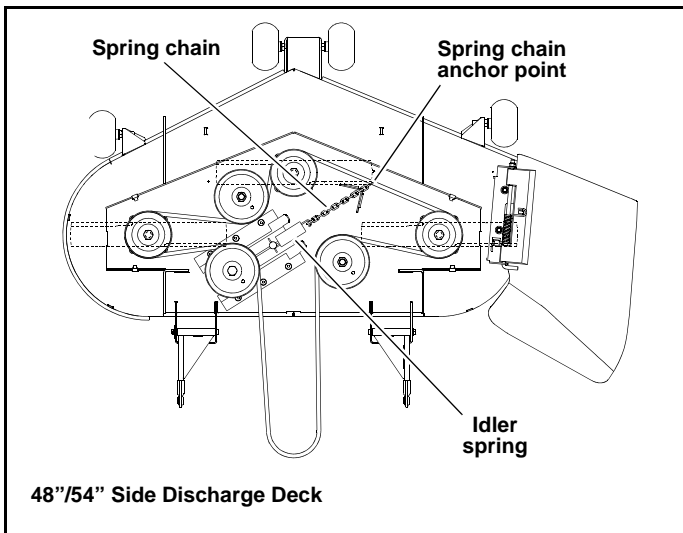

Figure 6-13

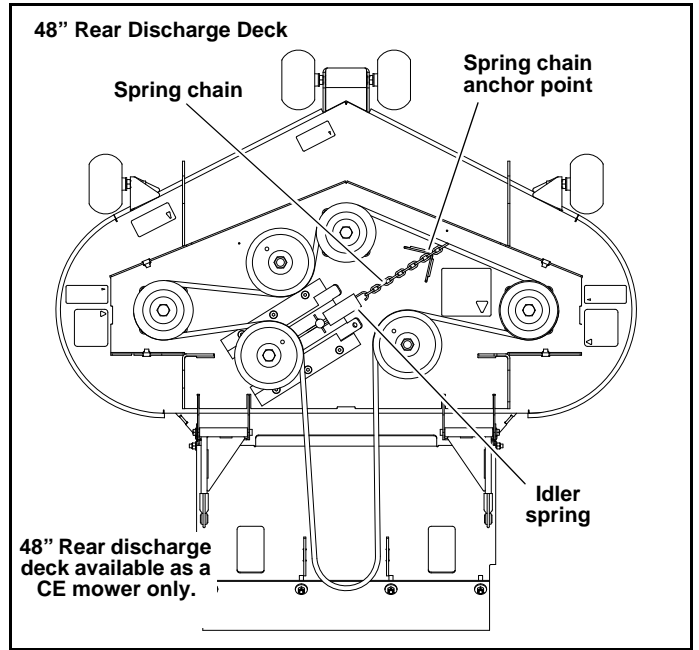

Figure 6-15

## Deck Belt Routing & Tensioning

**NOTE:** The following notes are the same for all the different decks shown.

1. Spring length after tensioning new belt. Measured from outside of hook to outside of hook with deck set at 3¼" cut height.
2. Route belt as shown.

### 36" Side Discharge Deck

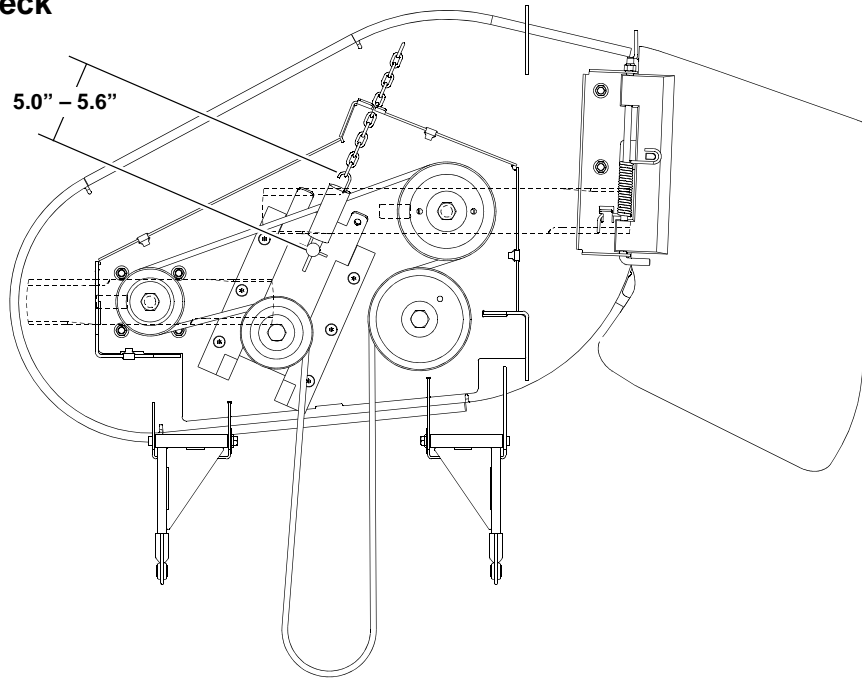

Figure 6-16

### 48" Side Discharge Deck

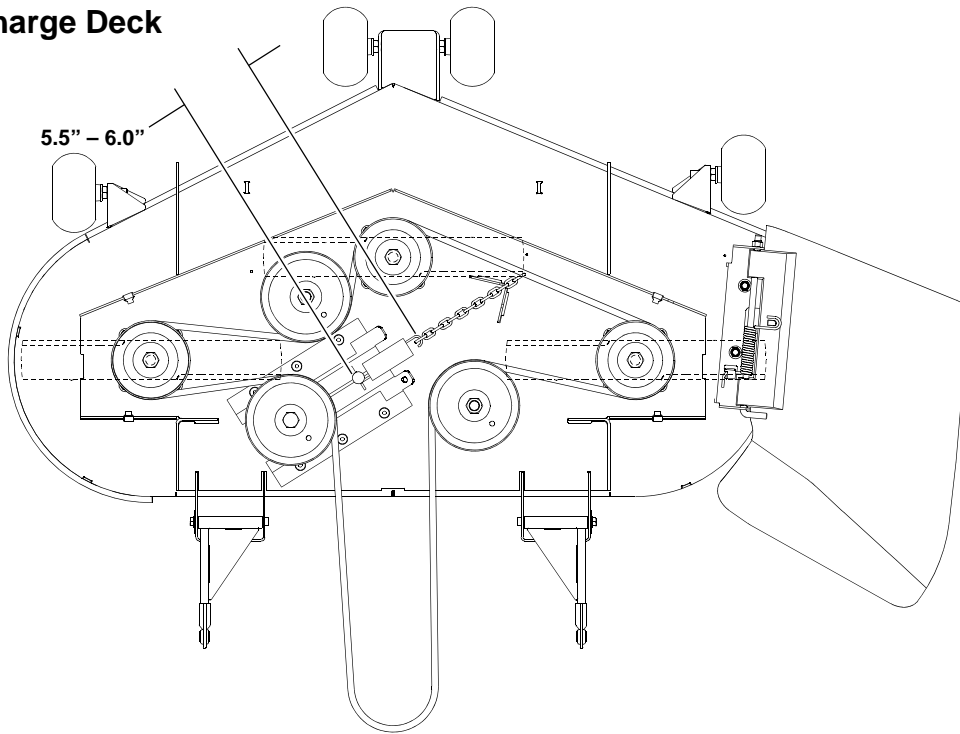

Figure 6-17

### 54" Side Discharge Deck

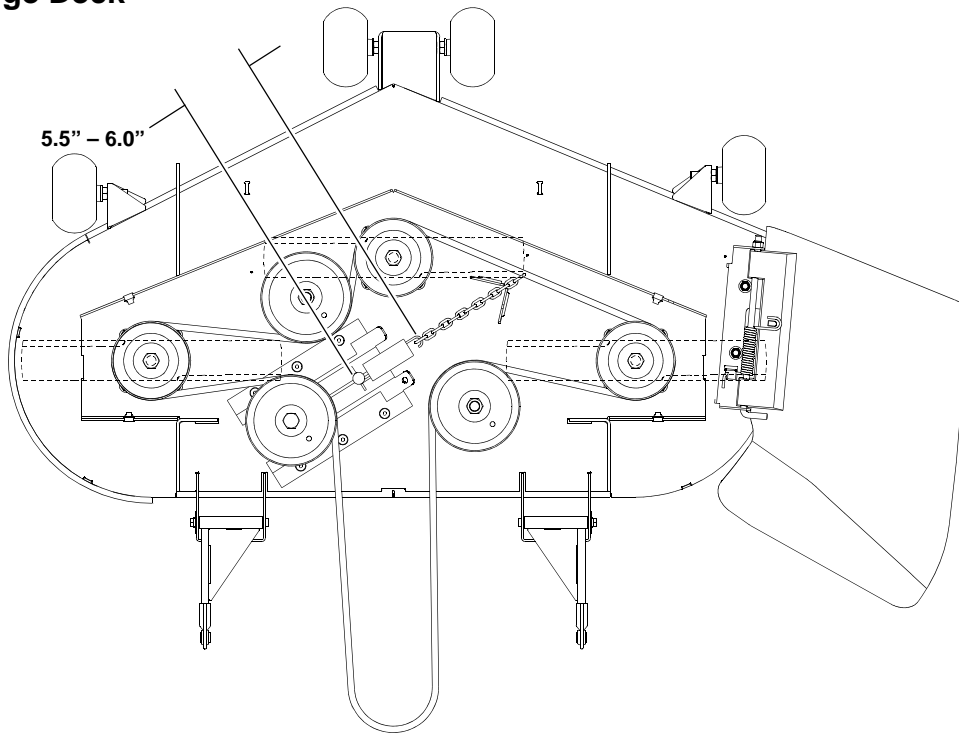
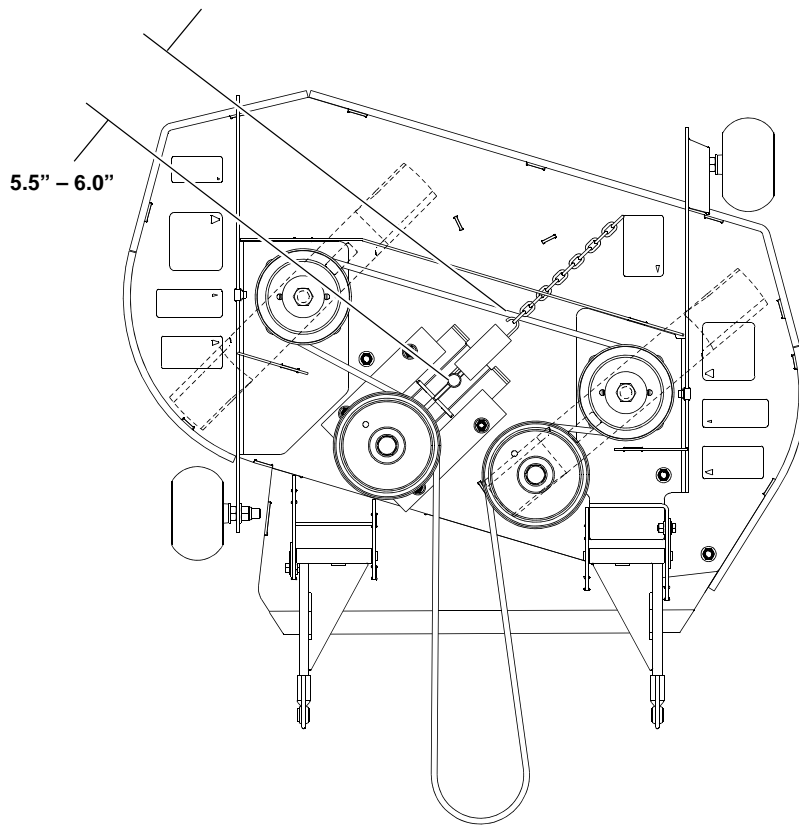

Figure 6-18

### 36" Rear Discharge Deck



36" Rear discharge deck available as a CE mower only.

Figure 6-19



# 48" Rear Discharge Deck

48" Rear discharge deck available as a CE mower only.

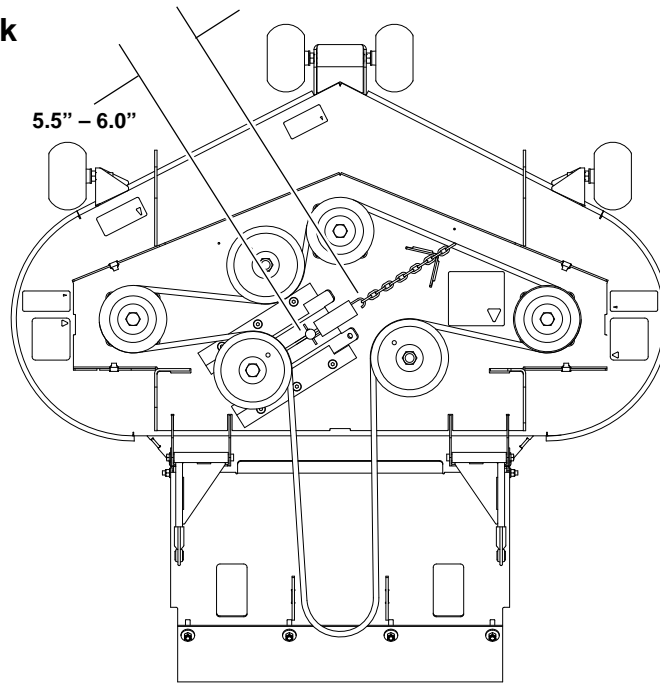
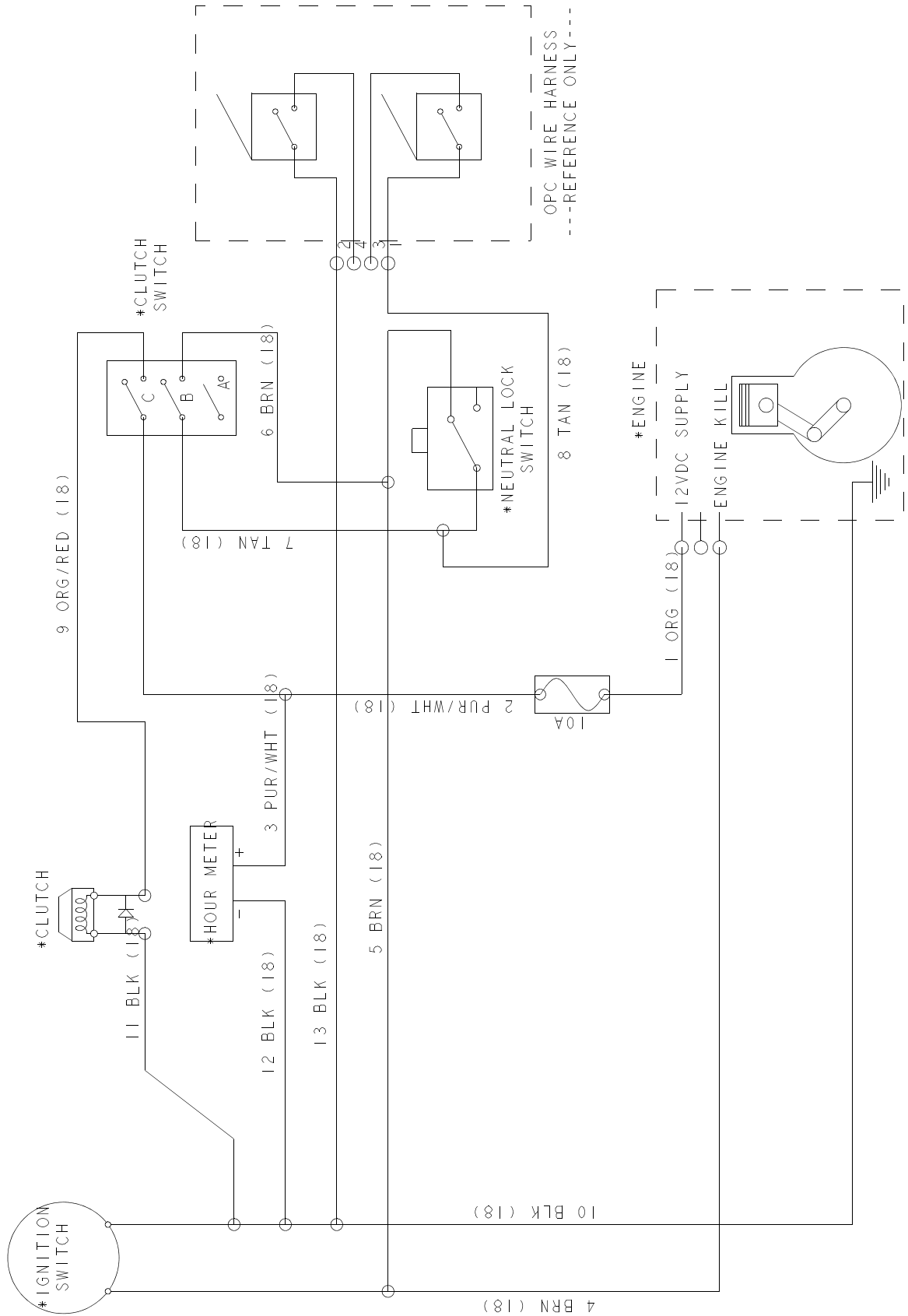

Figure 6-20



# ELECTRICAL

## Electrical Schematic – Recoil Start



# Electrical Schematic – Electric Start

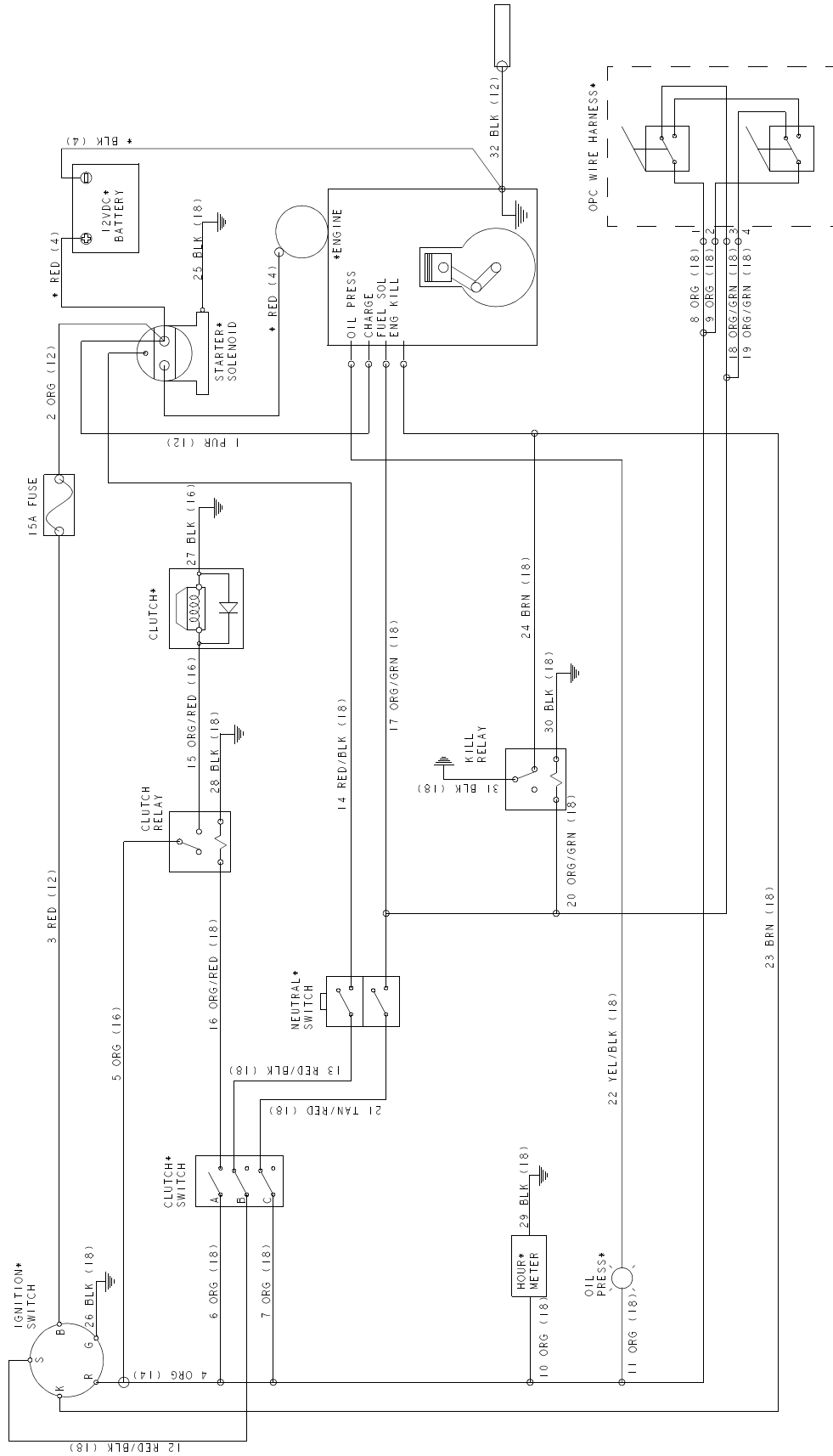

# MAINTENANCE SCHEDULE

**Hustler® TrimStar  
Maintenance Schedule**  
Refer to Figure 8-1, Figure 8-2, Figure 8-3,  
Figure 8-4, Figure 8-5, Figure 8-6 & Figure 8-7

SERVICE AT INTERVALS INDICATED	WEEKLY OR 50 HOURS	MONTHLY OR 100 HOURS	ANNUALLY OR 300 HOURS
Verify safety start interlock system	Prior to each use		
Visually inspect unit for loose hardware and/or damaged parts	Prior to each use		
Visually inspect tires	Prior to each use		
Check oil level, engine (1)	Prior to each use or every 4 hours		
Clean air intake screen (4)	Prior to each use or every 4 hours		
Check fuel level	Prior to each use		
Blades - sharpen & securely fastened	Prior to each use		
Discharge chute - securely in place & in lowest position	Prior to each use		
Replace air cleaner paper element	As needed		
Clean engine & transaxle compartment	Daily		
Change transaxle oil & filter (7)	Every 200 hours or 2 years		
Grease deck height pivots	X		
Grease front wheel bearings	X		
Change engine oil & filter (1)(3)	X		
Clean cylinder & head fins (a)	X		
Check battery connections	X		
Check tire pressure with a gauge	X		
Check hydraulic oil level	X		
Clean engine exterior (a)	X		
Clean & regap spark plugs (a)		X	
Check pump & deck belt tension and condition (5)		X	
Check fuel system (6)		X	
Check fuel tank grommet (6)		X	
Check hydraulic lines		X	
Tighten lug nuts on wheels (2)		X	
Change fuel filter			X
Replace spark plugs			X
Replace fuel evaporation system filter (8)			X

**NOTES:**

1. Initial oil change is after 5 hours of operation. Thereafter, change oil after every 50 hours operation. Change more often under dusty or dirty conditions and during hot weather periods.
2. Torque initially and after first 2 hours of operation.
3. Change engine oil filter per the engine manufacturer's recommendations. Refer to *Engine Owner's Manual* for recommendations and other maintenance items.
4. Service more often under dusty or dirty conditions.
5. **Pump drive belt only - Inspect every 6 months or 100 hours** and replace if worn or cracking is noticed. Otherwise, **replace every 200 hours or 2 years** whichever comes first. Refer to *Cold weather pump clutch* section for tensioning information.
6. Check fuel system for any crack or leaks including, but not limited to, fuel line hoses, fuel valve, vent line hoses, vent valve, vapor valve, carbon canister, and grommets.
7. Initial system oil and filter change **must** be after the first 75 hours of use or 1 year whichever comes first. Thereafter, replace filter and oil in each transaxle every 2 years or 200 hours, whichever comes first.
8. More often under dusty or dirty conditions and during hot weather.
- 9.

**REFERENCES:**

a—Refer to Engine Owner's Manual

**NOTE:** After completing maintenance cycle (300 hours), repeat cycle.

# Maintenance Locator Chart

**Figure 8-1**

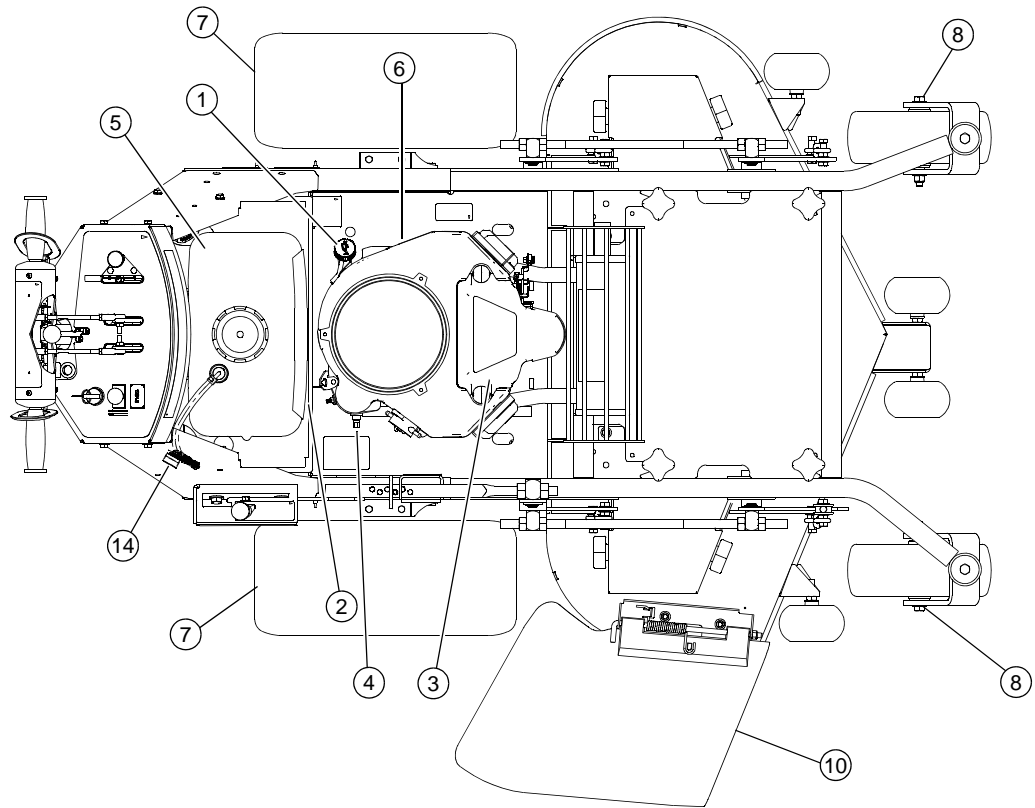

**Figure 8-2**

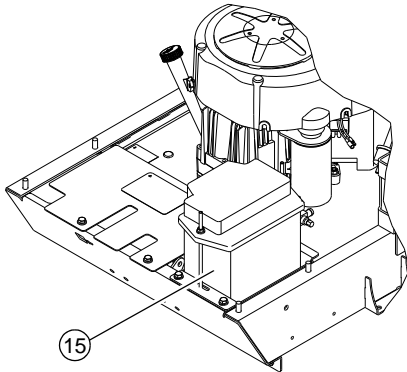

**Figure 8-3**

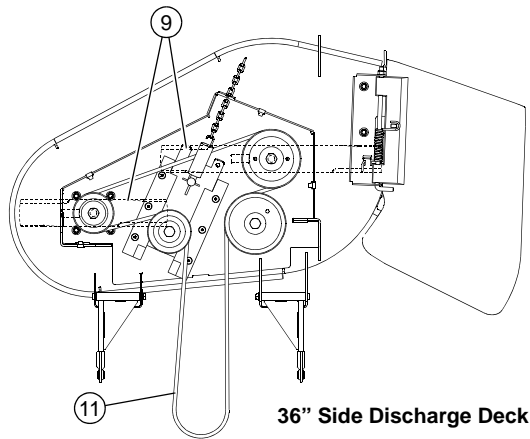

**Figure 8-4**

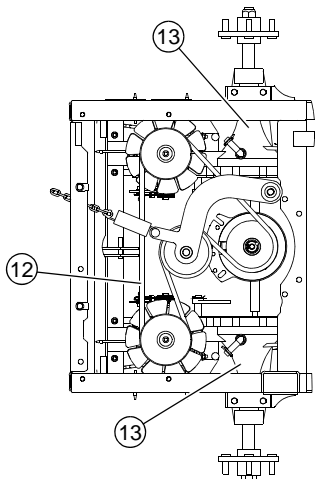

**Figure 8-5**

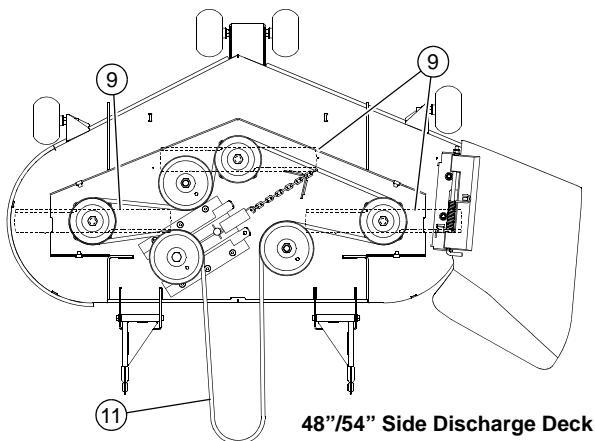

1. Engine oil fill & dipstick
2. Fuel filter
3. Engine air cleaner
4. Engine oil drain
5. Fuel tank
6. Engine oil filter
7. Drive tire
8. Gauge wheel bearings
9. Blades
10. Discharge chute
11. Deck drive belt
12. Pump belt
13. Transaxle oil filter
14. Evaporative emission system filter
15. Battery

**Figure 8-6**

**48" Rear Discharge Deck**

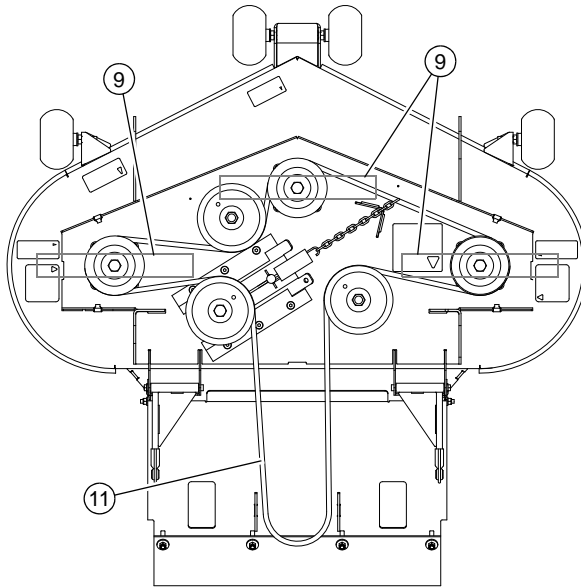

1. Engine oil fill & dipstick
2. Fuel filter
3. Engine air cleaner
4. Engine oil drain
5. Fuel tank
6. Engine oil filter
7. Drive tire
8. Gauge wheel bearings
9. Blades
10. Discharge chute
11. Deck drive belt
12. Pump belt
13. Transaxle oil filter
14. Evaporative emission system filter

**Figure 8-7**

**36" Rear Discharge Deck**

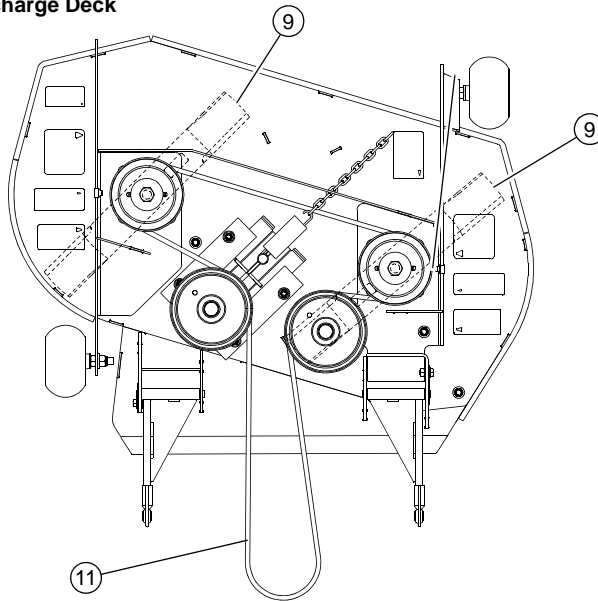

1. Engine oil fill & dipstick
2. Fuel filter
3. Engine air cleaner
4. Engine oil drain
5. Fuel tank
6. Engine oil filter
7. Drive tire
8. Gauge wheel bearings
9. Blades
10. Discharge chute
11. Deck drive belt
12. Pump belt
13. Transaxle oil filter
14. Evaporative emission system filter





# TROUBLESHOOTING

SYMPTOMS	PROBABLE CAUSES	SUGGESTED REMEDIES
The engine will not start, starts hard or fails to keep running	Deck clutch engaged	Disengage deck clutch
	No fuel or line plugged	Fill tank or replace line
	Fuel valve is turned off	Open the fuel valve
	There is incorrect fuel in the fuel system	Drain the tank and replace the fuel with the proper type
	There is dirt in the fuel filter	Replace the fuel filter
	Dirt, water or stale fuel in the fuel system	Contact your Dealer
	The choke is not on	Move the choke lever to ON
	Numerous	See engine manual
Engine: Runs with continuous misfiring or engine runs unevenly or erratically	Numerous	See engine manual
Loss of power or system will not operate in either direction	Restrictions in air cleaner	Service air cleaner
	Poor compression	Contact your Dealer
	Steering linkage needs adjustment	Adjust linkage
	Tow valve open	Close tow valve
	The traction drive belt is worn, loose or broken	Install a new traction drive belt
	The traction drive belt is off the pulley	Install the traction drive belt and check for a reason
	For additional causes	See engine manual
Overheating	Air intake screen or cleaning fins clogged	Clean screen and fins
	For additional causes	See engine manual
Low engine oil pressure	Low oil level	Add oil
	Oil diluted or too light	Change oil and check for source of contamination
High oil consumption	Numerous	Contact your Dealer
Mower jerky when starting or operates in one direction only	Steering control linkage needs adjustment	Adjust linkage
	Transaxle component faulty	Contact your Dealer

SYMPTOMS	PROBABLE CAUSES	SUGGESTED REMEDIES
Mower creeps when H-Bar steering lever is in neutral	Steering linkage needs adjustment	Adjust linkage
Mower circles or veers in one direction	Steering linkage needs adjustment	Adjust linkage
	Tires improperly inflated	Adjust air pressure to 8 - 12 psi (55 - 83 KPa)
	Transaxle component faulty	Contact your Dealer
There is abnormal vibration	The engine mounting bolts are loose	Tighten the engine mounting bolts
	The engine pulley, idler pulley or blade pulley is loose	Tighten the appropriate pulley
	The engine pulley is damaged	Contact your Dealer
	The cutting blade(s) is/are bent or unbalanced	Install new cutting blade(s)
	A blade mounting bolt is loose	Tighten the blade mounting bolt
	Spindle bearing is worn or loose	Replace or tighten spindle bearing
	A blade spindle is bent	Contact your Dealer
Uneven cutting height	The blade(s) are not sharp	Sharpen the blades
	A cutting blade(s) is/are bent	Install new cutting blade(s)
	The deck is not level	Level the deck per the Deck leveling and height adjustment section of the parts manual
	An anti-scalp wheel is not set correctly	Adjust the height of the anti-scalp wheel
	The underside of the deck is dirty	Clean the underside of the deck
	Tires improperly inflated	Adjust air pressure to 8 - 12 psi (55 - 83 KPa)
	A blade spindle is bent	Contact your Dealer
Blades do not rotate	The deck drive belt is worn, loose or broken	Install a new deck drive belt
	The deck drive belt is off the pulley	Install the deck drive belt and check for a reason
	Electric clutch is not engaging	Check and/or replace 10 amp fuse. Contact your dealer



# INDEX

	<b>PAGE</b>		<b>PAGE</b>
Belts .....	4-2, 6-7	Maintenance Precautions .....	2-2
Blades .....	6-6	Maintenance Schedule .....	8-1
Carbon canister .....	5-1	Mower blade maintenance .....	6-6
Deck Belt adjustment .....	6-7	Mower blade removal .....	6-7
Deck Belt Routing & Tensioning .....	6-9	Operate Machine Safely .....	2-2
Deck leveling .....	6-1	Operation Precautions .....	2-2
Electrical Schematic .....	7-1	Park Brake Spring Adjustment .....	4-2
Engine air filter .....	5-1	Pre-Operation Precautions .....	2-1
Engine oil and filter .....	5-1	Pump Clutch Belt Adjustment .....	4-3
Engine RPM settings .....	5-3	Safe servicing practices .....	2-1
Fuel & evaporative system line routings .....	5-2	Service Program .....	1-1
Fuel evaporation system filter .....	5-1	Special torques .....	3-1
General engine maintenance .....	5-1	Standard torques .....	3-1
General Maintenance Precautions .....	2-2	Steering adjustments .....	4-1
Hydraulic system .....	4-3	Steering neutral adjustment .....	4-1
Maintenance introduction .....	1-1	Tires .....	4-5
Maintenance Locator Chart .....	8-2	Warranty .....	1-1