

Service
Service
Service



Service Manual

TABLE OF CONTENTS

	Page
Location of PCBs & Version variations	1-2
Technical Specifications	1-3
Measurement setup	1-4
Service Aids, Safety Instruction, etc	1-5
Preparations & Controls	2-1
Disassembly Instructions & Service positions	3-1
Service Test Programs	3-3
Set Block diagram	4-1
Set Wiring diagram	5-1
Front & Combi Board	6
ECO Power Board	7
Tape Mechanism	9
3CDC-LLC-MCD1 Module	10
Set Mechanical Exploded view & parts list	11



© Copyright 2001 Philips Consumer Electronics B.V. Eindhoven, The Netherlands
All rights reserved. No part of this publication may be reproduced, stored in a retrieval system or transmitted, in any form or by any means, electronic, mechanical, photocopying, or otherwise without the prior permission of Philips.

Published by SL 0342 Service Audio Printed in The Netherlands Subject to modification



3140 785 32770

Version 1.0



PHILIPS

SPECIFICATIONS**GENERAL:**

Mains voltage : 110-127V/220-240V Switchable for /21
 230V \pm 10% for /22/25

Mains frequency : 50/60Hz /21
 50Hz /22/25

Power consumption : \leq 15W at Standby /21
 \leq 11W at Standby /22/25
 \leq 0.5W at ECO Standby /22/25
 25W Active /21
 30W Active /22/25

Clock accuracy : $<$ 4 seconds per day

Dimension centre unit : 265 x 310 x 330mm

Weight (w/o speakers) : 4.6Kg

TUNER:**FM**

Tuning range : 87.5-108MHz

Grid : 50kHz

IF frequency : 10.7MHz \pm 20kHz

Aerial input : 75 Ω coaxial

Sensitivity at 26dB S/N : $<$ 22 μ V

Selectivity at 300kHz bandwidth : $>$ 25dB

Image rejection,98MHz : $>$ 40dB /21
 $>$ 80dB /22/25

Distortion at RF=1mV, dev. 75kHz : $<$ 3%

-3dB Limiting point : $<$ 23.5 μ V

Crosstalk at RF=1mV, dev. 40kHz : $>$ 18dB

MW

Tuning range : 530-1700kHz /21
 : 531-1602kHz /22/25

Grid : 10kHz /21
 : 9kHz /22/25

IF frequency : 450kHz \pm 1kHz

Aerial input : Frame aerial, 18.1 μ H

Sensitivity at 26dB S/N : $<$ 4.4mV/M

Selectivity at 300kHz bandwidth : $>$ 18dB

IF rejection : $>$ 45dB

Image rejection : $>$ 28dB

Distortion at RF=50mV, m=80% : $<$ 5%

AMPLIFIER:

Output power ¹⁾ : 2 x 3.5W \pm 1dB

Frequency response within -3dB : 50Hz-15kHz

Dynamic Bass Boost : DBB1, DBB2, DBB3, DBB Off ²⁾

Digital Sound Control : Jazz, Techno, Optimal, Rock ²⁾

Headphone output at 32W : 900mV \pm 1dB (max Vol.)

CASSETTE RECORDER:

Frequency response : 80 - 12500Hz (8dB)

Number of track : 2 x 2 stereo

Tape speed : 4.76 cm/sec \pm 2.5/-1.5%

Wow and flutter : $<$ 0.35% DIN

Fast-wind/rewind time C60 : 130 sec

Bias system : 75kHz \pm 5kHz

Rec/Pb frequency response within 8dB : 80Hz - 10kHz

Signal to noise ratio (A-weighted) : \geq 48dBA

COMPACT DISC:

Measurement done at output conn. of the CDC module.

Frequency response within \pm 1.5dB : 20Hz - 20kHz

Output level (in Vrms) : 550mV, $Z_{out} = 100\Omega$

Signal/Noise ratio (A-weighted) : $>$ 80dBA

Distortion at 1kHz : $<$ 0.003%

Channel unbalance at 1kHz : \pm 1dB

Channel separation at 1kHz : $>$ 60dB

De-emphasis : 0 or 15/50 mS (Switched by subcode on the disc)

¹⁾ 3 Ω , 1 kHz, 10% THD

²⁾ Frequency response in each setting is software controlled.

MEASUREMENT SETUP

Tuner FM

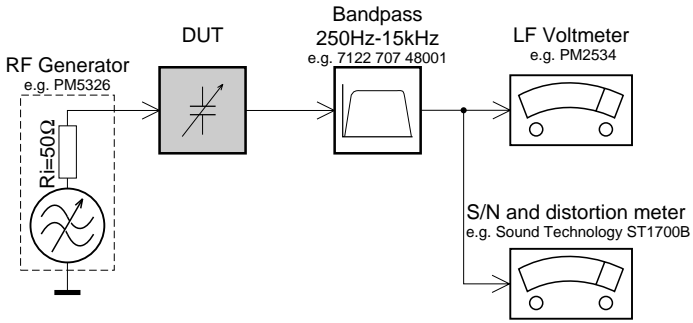

Use a bandpass filter to eliminate hum (50Hz, 100Hz) and disturbance from the pilotone (19kHz, 38kHz).

Tuner AM (MW,LW)

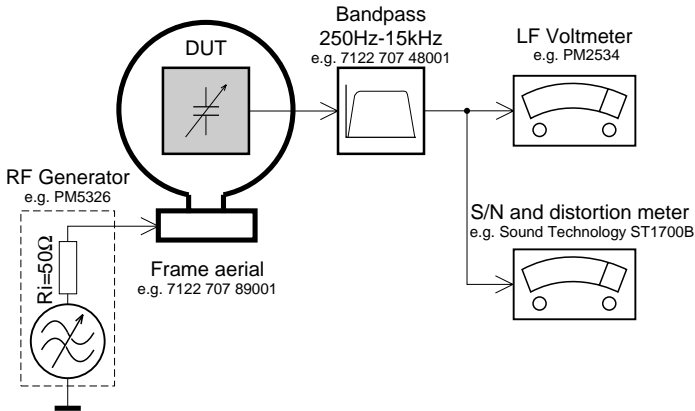

To avoid atmospheric interference all AM-measurements have to be carried out in a Faraday's cage. Use a bandpass filter (or at least a high pass filter with 250Hz) to eliminate hum (50Hz, 100Hz).

CD

Use Audio Signal Disc SBC429 4822 397 30184 (replaces test disc 3)

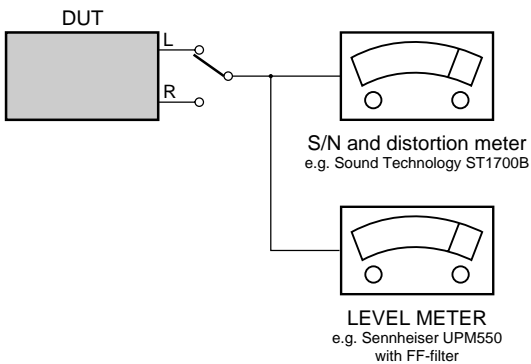

Recorder

Use Universal Test Cassette **CrO2** SBC419 4822 397 30069 or Universal Test Cassette **Fe** SBC420 4822 397 30071

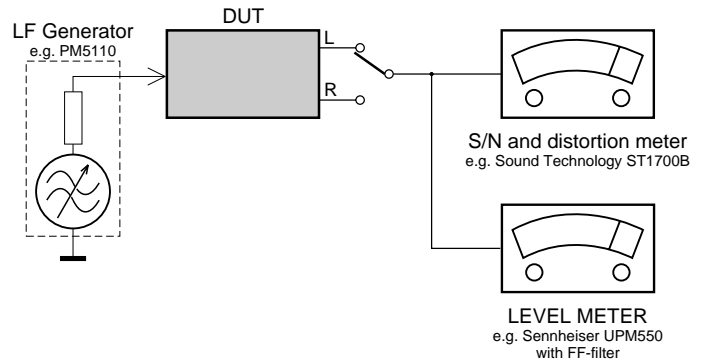

SERVICE AIDS

Service Tools:

Universal Torx driver holder	4822 395 91019
Torx bit T10 150mm	4822 395 50456
Torx driver set T6 - T20	4822 395 50145
Torx driver T10 extended	4822 395 50423

Cassette:

SBC419 Test cassette CrO2	4822 397 30069
SBC420 Test cassette Fe	4822 397 30071
MTT150 Dolby level 200nWb/M	4822 397 30271

Compact Disc:

SBC426/426A Test disc 5 + 5A	4822 397 30096
SBC442 Audio Burn-in Test disc 1kHz	4822 397 30155
SBC429 Audio Signals disc	4822 397 30184
Dolby Pro-logic Test Disc	4822 395 10216

ESD Equipment:

Anti-static table mat - large 1200x650x1.25mm ...	4822 466 10953
Anti-static table mat - small 600x650x1.25mm	4822 466 10958
Anti-static wristband	4822 395 10223
Connector box (1MΩ)	4822 320 11307
Extension cable (to connect wristband to conn. box)	4822 320 11305
Connecting cable (to connect table mat to conn. box)	4822 320 11306
Earth cable (to connect product to mat or box)	4822 320 11308
Complete kit ESD3 (combining all above products)	4822 320 10671
Wristband tester	4822 344 13999

HANDLING CHIP COMPONENTS

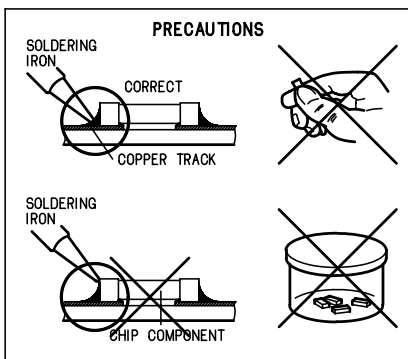
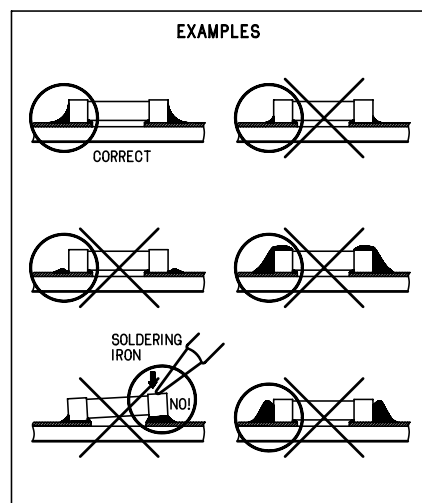
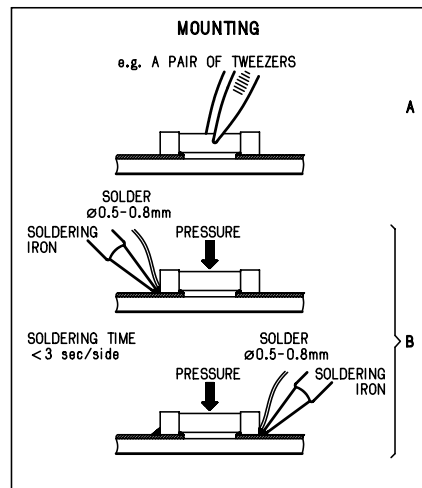
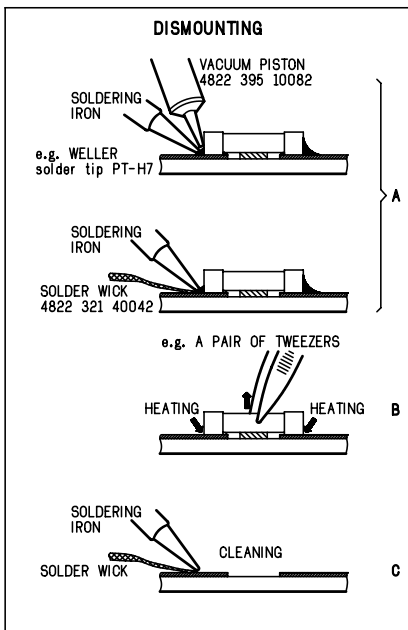
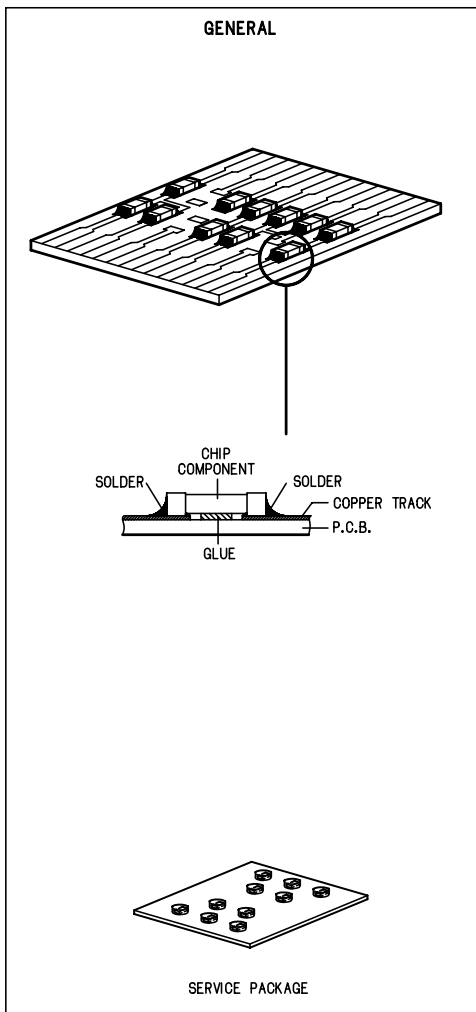

(GB) WARNING

All ICs and many other semi-conductors are susceptible to electrostatic discharges (ESD). Careless handling during repair can reduce life drastically.

When repairing, make sure that you are connected with the same potential as the mass of the set via a wrist wrap with resistance. Keep components and tools also at this potential.

ESD**(NL) WAARSCHUWING**

Alle IC's en vele andere halfgeleiders zijn gevoelig voor electrostatische ontladingen (ESD).

Onzorgvuldig behandelen tijdens reparatie kan de levensduur drastisch doen verminderen. Zorg ervoor dat u tijdens reparatie via een polsband met weerstand verbonden bent met hetzelfde potentiaal als de massa van het apparaat.

Houd componenten en hulpmiddelen ook op ditzelfde potentiaal.

(F) ATTENTION

Tous les IC et beaucoup d'autres semi-conducteurs sont sensibles aux décharges statiques (ESD).

Leur longévité pourrait être considérablement écourtée par le fait qu'aucune précaution n'est prise à leur manipulation.

Lors de réparations, s'assurer de bien être relié au même potentiel que la masse de l'appareil et enfilez le bracelet serti d'une résistance de sécurité.

Veiller à ce que les composants ainsi que les outils que l'on utilise soient également à ce potentiel.

(D) WARNUNG

Alle ICs und viele andere Halbleiter sind empfindlich gegenüber elektrostatischen Entladungen (ESD).

Unvorsorgfältige Behandlung im Reparaturfall kann die Lebensdauer drastisch reduzieren.

Veranlassen Sie, dass Sie im Reparaturfall über ein Pulsarmband mit Widerstand verbunden sind mit dem gleichen Potential wie die Masse des Gerätes.

Bauteile und Hilfsmittel auch auf dieses gleiche Potential halten.

(I) AVVERTIMENTO

Tutti IC e parecchi semi-conduttori sono sensibili alle scariche statiche (ESD).

La loro longevità potrebbe essere fortemente ridotta in caso di non osservazione della più grande cauzione alla loro manipolazione.

Durante le riparazioni occorre quindi essere collegato allo stesso potenziale che quello della massa dell'apparecchio tramite un braccialetto a resistenza.

Assicurarsi che i componenti e anche gli utensili con quali si lavora siano anche a questo potenziale.

(GB)

Safety regulations require that the set be restored to its original condition and that parts which are identical with those specified, be used.

"Pour votre sécurité, ces documents doivent être utilisés par des spécialistes agréés, seuls habilités à réparer votre appareil en panne".

(NL)

Veiligheidsbepalingen vereisen, dat het apparaat bij reparatie in zijn oorspronkelijke toestand wordt teruggebracht en dat onderdelen, identiek aan de gespecificeerde, worden toegepast.

(F)

Les normes de sécurité exigent que l'appareil soit remis à l'état d'origine et que soient utilisées les pièces de rechange identiques à celles spécifiées.

(D)

Bei jeder Reparatur sind die geltenden Sicherheitsvorschriften zu beachten. Der Originalzustand des Geräts darf nicht verändert werden; für Reparaturen sind Original-Ersatzteile zu verwenden.

(I)

Le norme di sicurezza esigono che l'apparecchio venga rimesso nelle condizioni originali e che siano utilizzati i pezzi di ricambio identici a quelli specificati.

"After servicing and before returning set to customer perform a leakage current measurement test from all exposed metal parts to earth ground to assure no shock hazard exist. The leakage current must not exceed 0.5mA."

**(GB) Warning !**

Invisible laser radiation when open. Avoid direct exposure to beam.

(S) Varning !

Osynlig laserstrålning när apparaten är öppnad och spärren är urkopplad. Betrakta ej strålen.

(SF) Varoitus !

Avatussa laitteessa ja suoalukituksen ohitettaessa olet alltiina näkymättömälle laserisäteilylle. Älä katso säteeseen!

(DK) Advarse !

Usynlig laserstråling ved åbning når sikkerhedsafbrydere er ude af funktion. Undgå udsættelse for stråling.

PREPARATIONS AND CONTROLS

Preparations

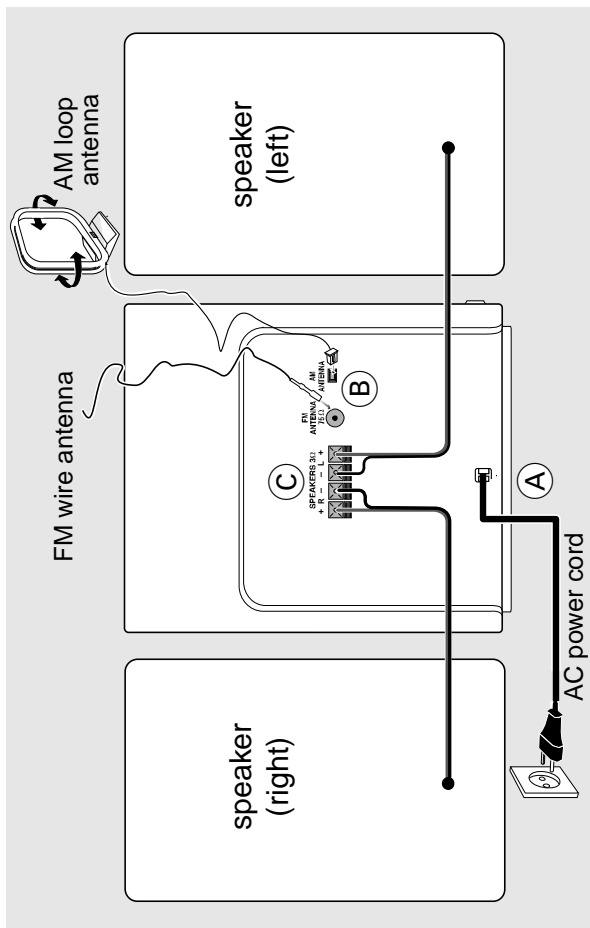

Rear connections

The type plate is located at the rear of the system.

For users in the U.K.: please follow the instructions on page 2-3.

(A) Power

Before connecting the AC power cord to the wall outlet, ensure that all other connections have been made.

WARNING!

- For optimal performance, use only the original power cable.
- Never make or change any connections with the power switched on.

(B) Antennas Connection

Connect the supplied AM loop antenna and FM antenna to the respective terminals. Adjust the position of the antenna for optimal reception.

AM Antenna

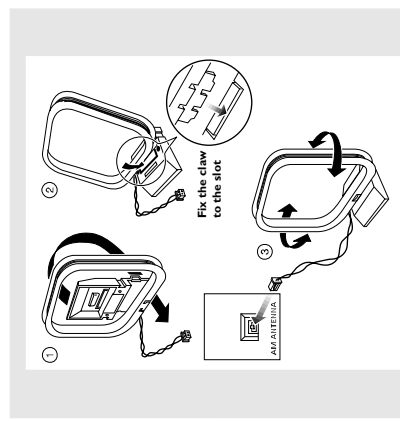

- Position the antenna as far as possible from a TV, VCR or other radiation source.

Preparations

Inserting batteries into the remote control

Insert two batteries type R03 or AAA (not supplied) into the remote control with the correct polarity as indicated by the "+" and "-" symbols inside the battery compartment.

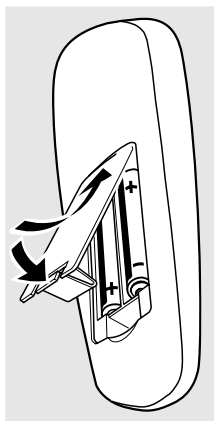

CAUTION!

- Remove batteries if they are exhausted or will not be used for a long time.
- Do not use old and new or different types of batteries in combination.
- Batteries contain chemical substances, so they should be disposed off properly.

FM Antenna



- For better FM stereo reception, connect an outdoor FM antenna to the FM ANTENNA terminal.

(C) Speakers Connection

Front Speakers

Connect the speaker wires to the SPEAKERS terminals, right speaker to "R" and left speaker to "L", coloured (marked) wire to "+" and black (unmarked) wire to "-".

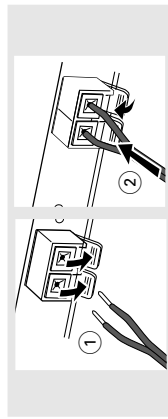

- Fully insert the stripped portion of the speaker wire into the terminal as shown.

Notes:

- For optimal sound performance, use the supplied speakers.
- Do not connect more than one speaker to any one pair of + / - speaker terminals.
- Do not connect speakers with impedance lower than the speakers supplied. Please refer to the SPECIFICATIONS section of this manual.

Controls

Controls on the system and remote control

- ① **STANDBY ON** to switch the system on or to standby mode.
- ② **TUNER (BAND)** to select waveband : FM or MW.
- ③ **TAPE (TAPE 1-2)** to select tape mode.
- ④ **ECO POWER** to switch the system on or to Eco Power standby mode.

- ⑤ **CD 1/ CD 2/ CD 3 (CD 1/2/3)** to select disc tray 1, 2, or 3.
- ⑥ **DSC (DIGITAL SOUND CONTROL)** to select the desired sound effect : JAZZ, ROCK, TECHNO or OPTIMAL.
- ⑦ **OPEN/CLOSE** to open or close the disc tray.
- ⑧ **DISC CHANGE** to change disc(s).
- ⑨ **DBB (DYNAMIC BASS BOOST)** to select the desired bass boost level.
- ⑩ **PROGRAM** for CD to programme disc tracks.
for Tuner to programme preset radio stations.
for Clock to select 12- or 24-hour clock mode.
for Timer to select CD programme mode as the wake up source.

- ⑪ **Tape deck 1 operation**
 - to start recording.
 - to start playback.
 - to rewind or fast forward.
 - to stop playback/recording or to open the tape door.
 - to interrupt playback or recording.
- ⑫ **Tape deck 2 operation**
 - to start playback.
 - to rewind or fast forward.
 - to stop playback or to open the tape door.
 - to interrupt playback.
- ⑬ **CLOCK-TIMER** to view the clock, set the clock or set the timer.
- ⑭ **DIM MODE (DIM)** to select different brightness for the display screen : DIM 1, DIM 2, DIM 3 or DIM OFF.
- ⑮ **MASTER VOLUME (VOL +/-)** to increase or decrease the volume.
- ⑯ **Mode Selection**
 - PLAY-PAUSE** to start or interrupt playback for CD (on the system only) to initiate for Plug & Play... (on the system only) to initiate and start plug & play mode.
 - SEARCH-TUNING** to search backward/forward for CD to tune to a lower or higher radio frequency.
for Clock (on the system only) to set the hour.
 - STOP-CLEAR / DEMO STOP** for CD to stop playback or to clear a programme.
for Tuner (on the system only) to stop programming or to erase a selected preset.
for Demo (on the system only) to activate / deactivate the demonstration.
for Clock (on the system only) to exit clock setting or cancel timer.
for Plug & Play... (on the system only) to exit plug & play mode.

PREPARATIONS AND CONTROLS

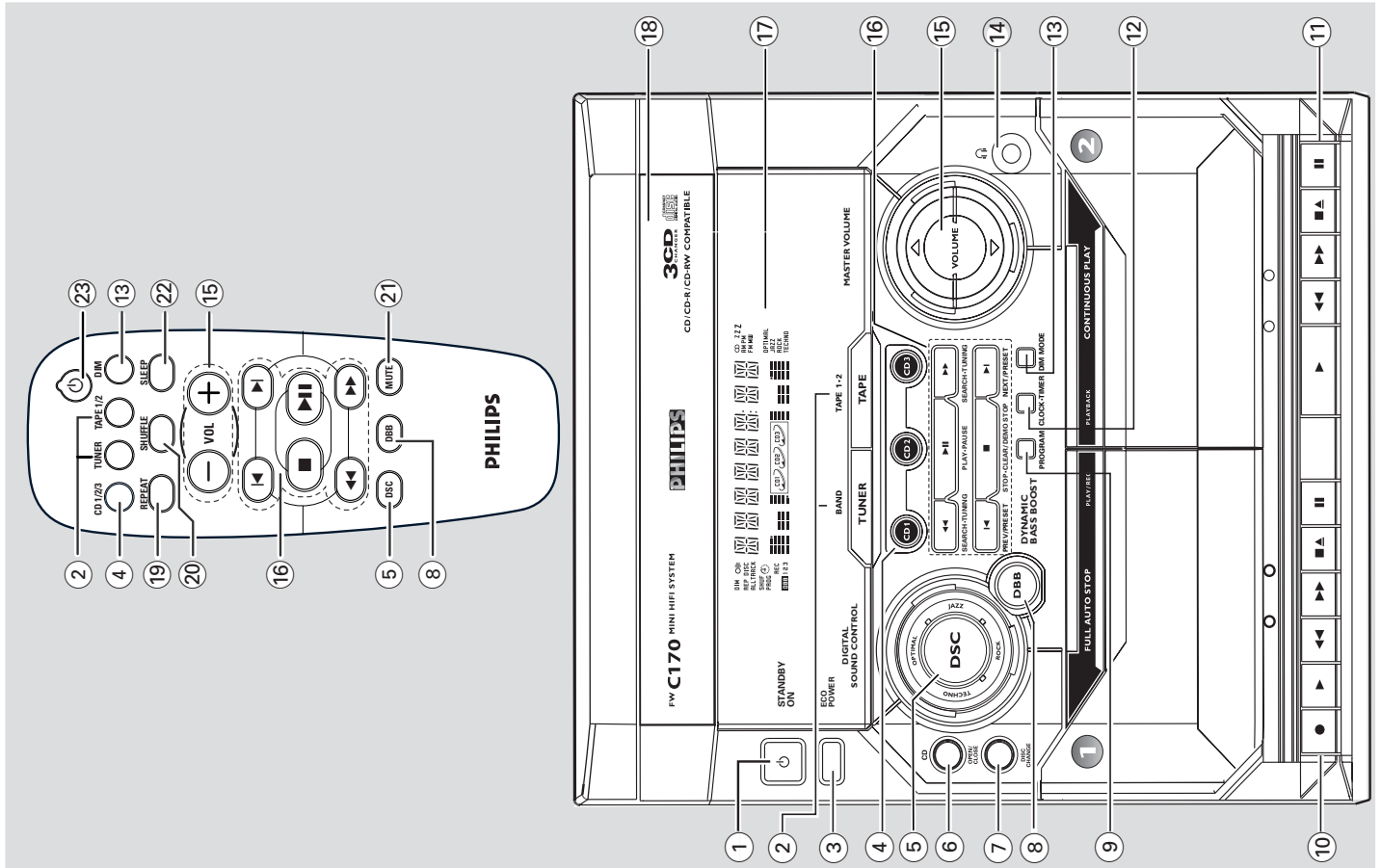

Controls

PREV ◀ / PRESET ▼ NEXT ▶ / PRESET ▲

- for CDto skip to the beginning of the current, previous, or next track.
- for Tunerto select a preset radio station.
- for Clock(on the system only) to set the minute.

17 Display screen

- to view the current status of the system.

18 Disc tray

- **REPEAT** to playback track(s)/disc(s)/programme repeatedly.

20 SHUFFLE

- to playback all available discs and their tracks/programme in random order.

21 MUTE

- to interrupt or resume sound reproduction.

22 SLEEP

- to activate/deactivate or set the sleep timer.

23 ⏻

- to switch the system to standby mode.
- to switch the system to Eco Power standby mode.

Notes for remote control:

- First, select the source you wish to control by pressing one of the source select keys on the remote control (CD 1/2/3 or TUNER, for example).
- Then select the desired function (▶, ◀, ▶, ◀, for example).

Important notes for users in the U.K.

Mains plug

This apparatus is fitted with an approved 13 Amp plug. To change a fuse in this type of plug proceed as follows:

- 1 Remove fuse cover and fuse.
- 2 Fix new fuse which should be a BS1362 5 Amp, A.S.T.A. or BSI approved type.
- 3 Refit the fuse cover.

If the fitted plug is not suitable for your socket outlets, it should be cut off and an appropriate plug fitted in its place.

If the mains plug contains a fuse, this should have a value of 5 Amp. If a plug without a fuse is used, the fuse at the distribution board should not be greater than 5 Amp.

Note: These vered plug must be disposed of to avoid a possible shock hazard should it be inserted into a 13 Amp socket else where.

How to connect a plug

The wires in the mains lead are coloured with the following code: blue = neutral (N), brown = live (L).

- As these colours may not correspond with the colour markings identifying the terminals in your plug, proceed as follows:
 - Connect the blue wire to the terminal marked N or coloured black.
 - Connect the brown wire to the terminal marked L or coloured red.
 - Do not connect either wire to the earth terminal in the plug, marked E (or ⚡) or coloured green (or green and yellow).

Before replacing the plug cover, make certain that the cord grip is clamped over the sheath of the lead - not simply over the two wires.

Copyright in the U.K.

Recording and playback of material may require consent. See Copyright Act 1956 and The Performer's Protection Acts 1958 to 1972.

Italia

DICHIARAZIONE DI CONFORMITA'

Si dichiara che l'apparecchio FWC717 Philips risponde alle prescrizioni dell'art. 2 comma 1 del D.M. 28 Agosto 1995 n. 548.

Fatto a Eindhoven

Philips Consumer Electronics
Philips, Glaslaan 2
5616 JB Eindhoven, The Netherlands

Norge

Typeskilt finnes på apparatens underside.

Observer: Nettbyteren er sekundært innkoplet. Den innebygde nettdelen er derfor ikke frakoplet nettet så lenge apparatet er tilsluttet nettkontaktene.

For å redusere faren for brann eller elektrisk støt, skal apparatet ikke utsettes for regn eller fuktighet.

CAUTION

Use of controls or adjustments or performance of procedures other than herein may result in hazardous radiation exposure or other unsafe operation.

Cleaning the Cabinet

- Use a soft cloth slightly moistened with a mild detergent solution. Do not use a solution containing alcohol, spirits, ammonia or abrasives.

Cleaning Discs

- When a disc becomes dirty, clean it with a cleaning cloth.
- Wipe the disc from the centre out. Do not wipe in a circular motion.
- Do not use solvents such as benzene, thinner, or antistatic spray intended for analogue records.

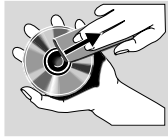

Cleaning the Heads and the Tape Paths

- To ensure good recording and playback quality, clean the heads (A), the capstan(s) (B), and pressure roller(s) (C) after every 50 hours of tape operation.
- Use a cotton swab slightly moistened with cleaning fluid or alcohol.
- You also can clean the heads by playing a cleaning tape once.

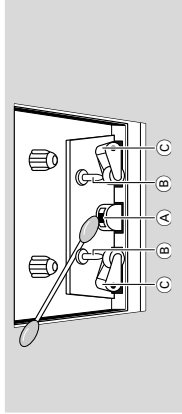

Cleaning the disc lens

- After prolonged use, dirt or dust may accumulate at the disc lens. To ensure good playback quality, clean the disc lens with Philips CD Lens Cleaner or any commercially available cleaner. Follow the instructions supplied with the cleaner.

Demagnetising the heads

- Use a demagnetising tape available at your dealer.

RADIO RECEPTION

Radio reception is poor

- If the signal is too weak, adjust the antenna or connect an external antenna for better reception.
- Increase the distance between the Mini HiFi System and your TV or VCR.

TAPE OPERATION/RECORDING

Recording or playback cannot be made.

- Clean deck parts, see "Maintenance".
- Use only NORMAL (IEC) tape.
- Apply a piece of adhesive tape over the missing tab space.

The tape deck door cannot open.

- Remove and reconnect the AC power plug and switch on the system again.

GENERAL

The system does not react when buttons are pressed.

- Remove and reconnect the AC power plug and switch on the system again.

Sound cannot be heard or is of poor quality.

- Adjust the volume.
- Disconnect the headphones.
- Check that the speakers are connected correctly.
- Check if the stripped speaker wire is clamped.

The left and right sound outputs are reversed.

- Check the speaker connections and location.

The remote control does not function properly.

- Select the source (CD or TUNER, for example) before pressing the function button (▶, ◀, ◀▶).
- Reduce the distance between the remote control and the system.
- Insert the batteries with their polarities (+/- signs) aligned as indicated.
- Replace the batteries.
- Point the remote control in the direction of the system's IR sensor.

The timer is not working.

- Set the clock correctly.
- Press TIMER ON/OFF to switch on the timer.
- If recording is in progress, stop recording.

Not all lighted buttons are showing light.

- Press DISPLAY to select NORMAL or MODE 1 display mode.

The Clock/Timer setting is erased.

- Power has been interrupted or the power cord has been disconnected. Reset the clock/timer.

The system displays features automatically and buttons start flashing.

- Press and hold DEMO STOP ■ on the system to switch off the demonstration.

Cleaning the Cabinet

- Use a soft cloth slightly moistened with a mild detergent solution. Do not use a solution containing alcohol, spirits, ammonia or abrasives.

Cleaning Discs

- When a disc becomes dirty, clean it with a cleaning cloth.
- Wipe the disc from the centre out. Do not wipe in a circular motion.
- Do not use solvents such as benzene, thinner, or antistatic spray intended for analogue records.

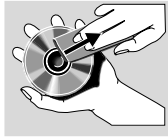

Cleaning the Heads and the Tape Paths

- To ensure good recording and playback quality, clean the heads (A), the capstan(s) (B), and pressure roller(s) (C) after every 50 hours of tape operation.
- Use a cotton swab slightly moistened with cleaning fluid or alcohol.
- You also can clean the heads by playing a cleaning tape once.

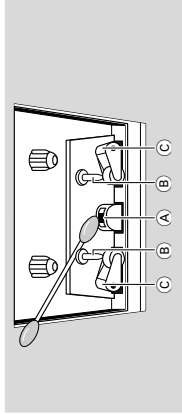

Cleaning the disc lens

- After prolonged use, dirt or dust may accumulate at the disc lens. To ensure good playback quality, clean the disc lens with Philips CD Lens Cleaner or any commercially available cleaner. Follow the instructions supplied with the cleaner.

Demagnetising the heads

- Use a demagnetising tape available at your dealer.

WARNING

Under no circumstances should you try to repair the system yourself, as this will invalidate the warranty. Do not open the system as there is a risk of electric shock.

If a fault occurs, first check the points listed below before taking the system for repair. If you are unable to remedy a problem by following these hints, consult your dealer or service centre.

Problem

Solution

CD OPERATION

"NO DISC" is displayed.

- Insert a disc.
- Check if the disc is inserted upside down.
- Wait until the moisture condensation at the lens has cleared.
- Replace or clean the disc, see "Maintenance".
- Use a finalised CD-R(W) or CD-R.

"DISC NOT FINALIZED" is displayed.

- Use a finalised CD-R(W) or CD-R.

DISMANTLING INSTRUCTIONS

Dismantling of the Lens Cassette

- 1) Uncatch 4 catches along the edge of the Cassette door (pos 5) as shown in figure 1 and 2 to remove the Lens cassette (pos 2).

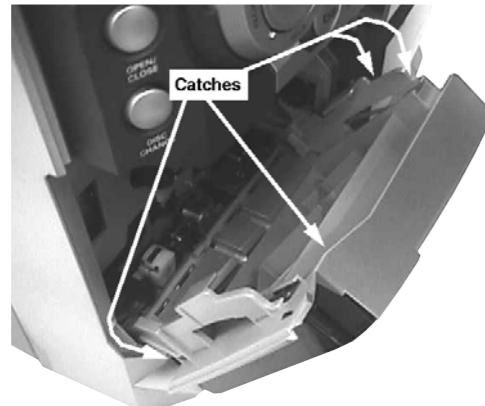

Figure 1

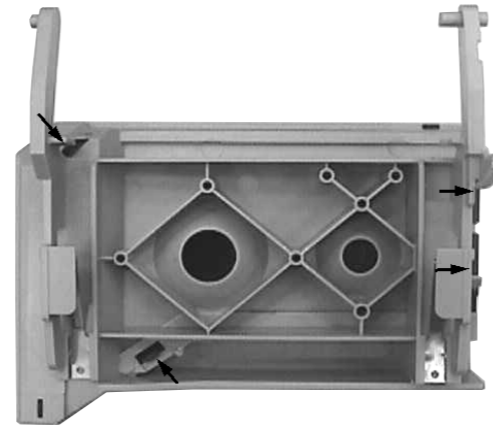

Figure 2: Left Cassette door

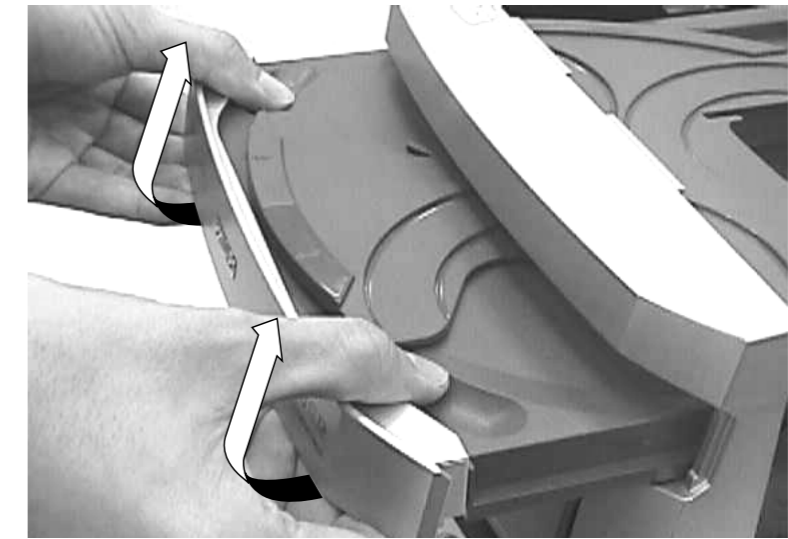

Figure 4

Dismantling the 3CDC Module

- 1) Loosen the 4 screws, slide Cover top (pos 30) towards the rear and remove it upwards.
- 2) Loosen 3 screws slide the Panel right (pos 26) towards the rear and remove it outwards. Do likewise for the Panel left (pos 27).
- 3) Push the gear slowly towards the front as shown in figure 3 until the CDC tray starts to move out of the Front Cabinet (pos 8). The CDC tray is now disengage and can be pulled out completely.
- 4) Remove the Cover Tray (pos 29) as shown in figure 4.
- 5) Loosen 4 screws A to remove the CDC Module (pos 28) as shown in figure 3.

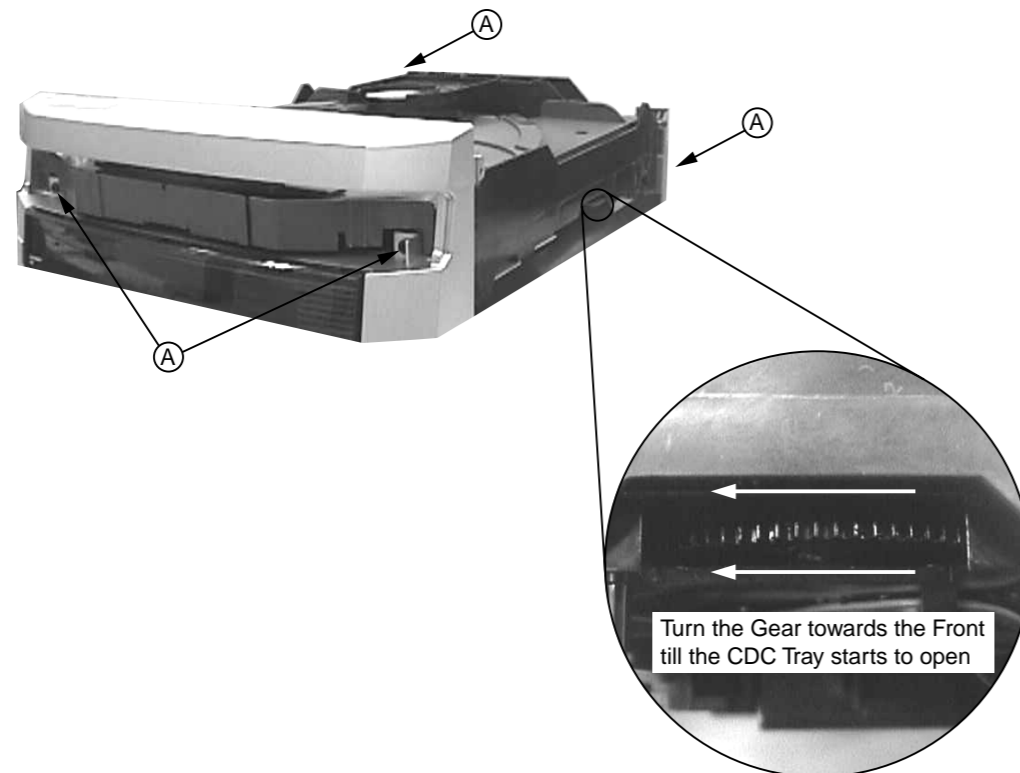

Figure 3

Dismantling of the Panel Rear

- 1) Loosen 6 screws C on the Panel rear (pos 24).
- 2) Press the 2 catches C1 inwards and dismantle the Panel rear by pulling it towards the rear.

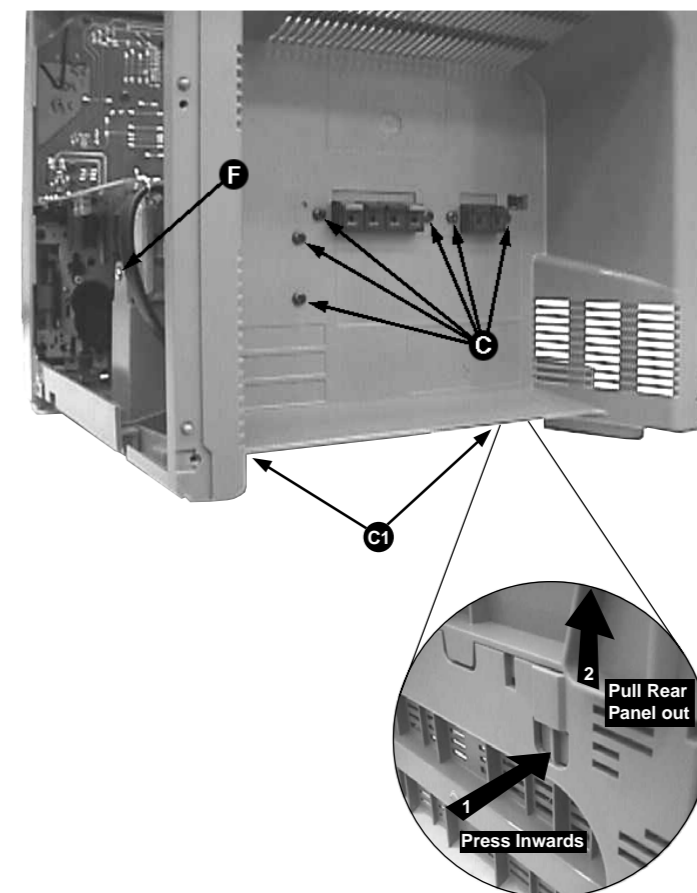

Figure 5

Dismantling of the Front Panel and Bottom Panel assembly

- 1) Remove 8 screws D mounting the Front board.
- 2) Remove 1 screw E supporting the bracket, Combi board (pos 33) to the Panel front (pos 8).
- 3) Remove 1 screw F (see figure 5) mounting the Mains transformer body to the Panel Bottom (pos 25).

Note: Care must be taken not to damage the board because of the heavy Mains transformer.

- 4) The Front and Combi boards together with the Mains transformer can now be remove.
- 5) Loosen 6 screws G and eject both cassette doors to remove the Tape mechanism (pos 12).

Note: During re-assembly of the Tape mechanism and Front board care must be taken to ensure the wires are properly dressed and not touching any moving parts on the Tape mechanism.

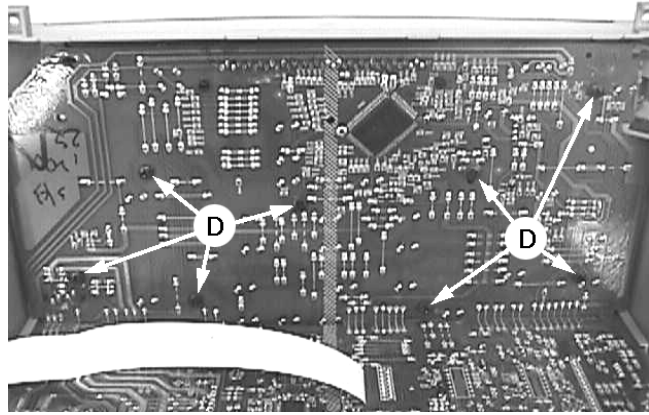

Figure 6

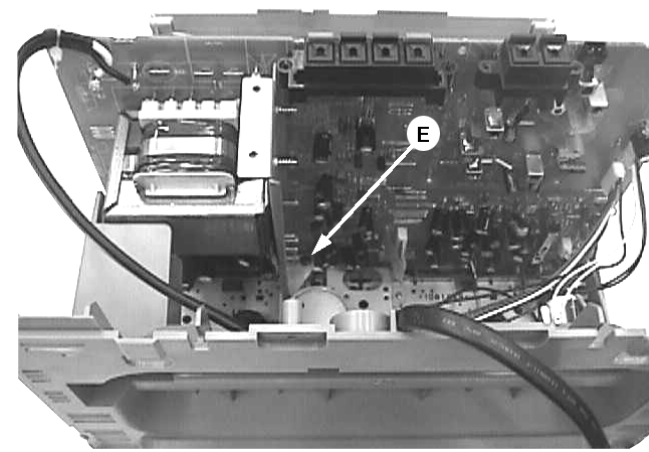

Figure 7

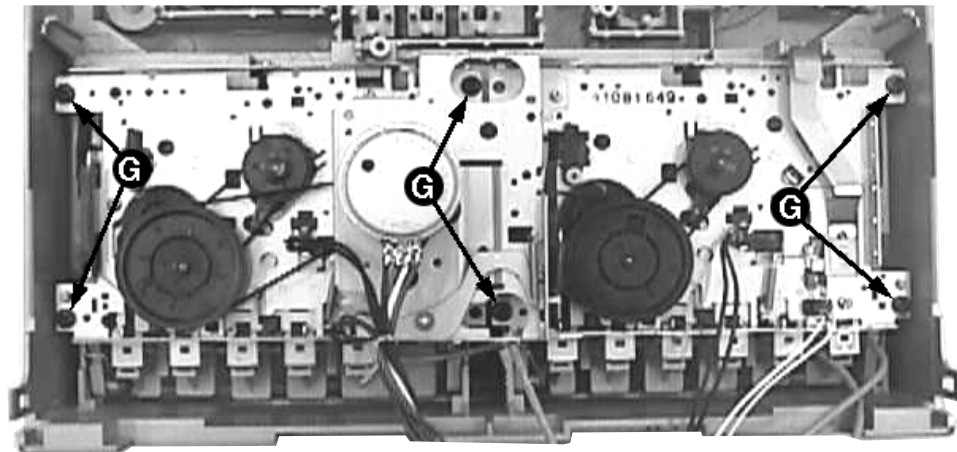
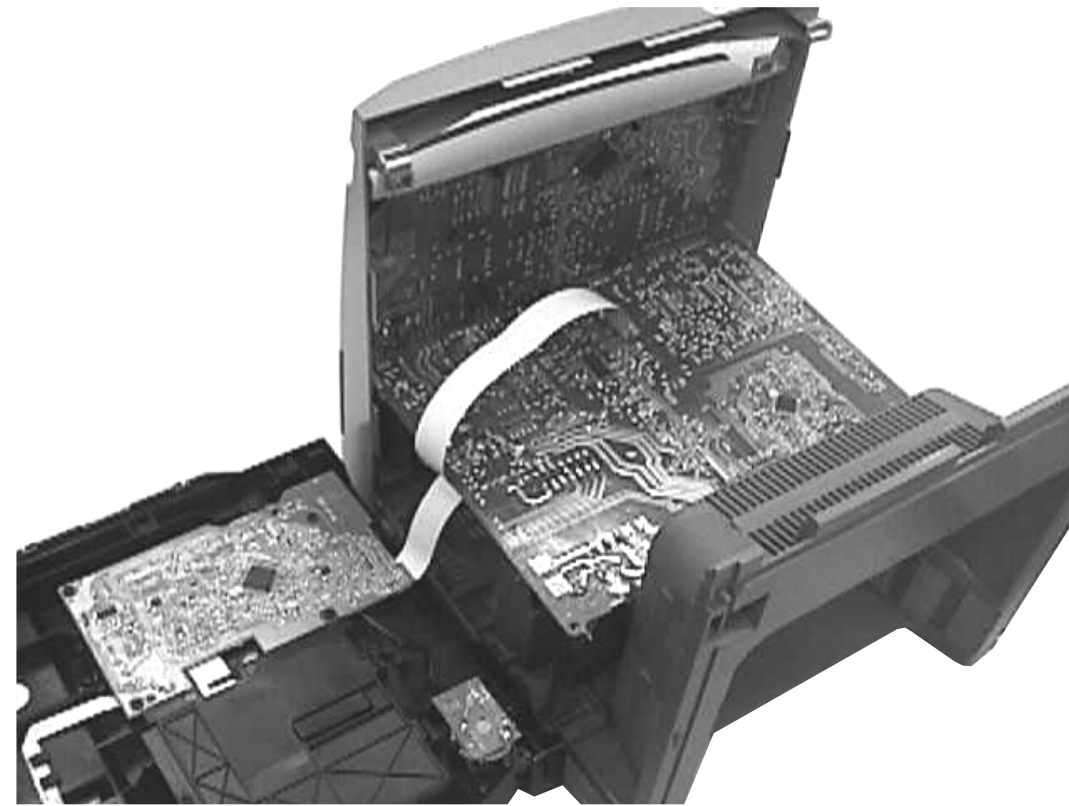

Figure 8

Service pos A



Note: After re-assembly, it is very important to ensure the wires from the Tape mechanism are routed properly to ensure that they do not touch/obstruct all moving parts.

Service pos B



SERVICE TEST PROGRAM

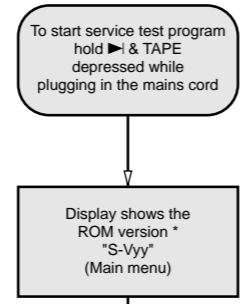

S refers to Service Mode.
 V refers to Version.
 yy refers to Software version number of Processor.
 (Counting up from 01 to 99)

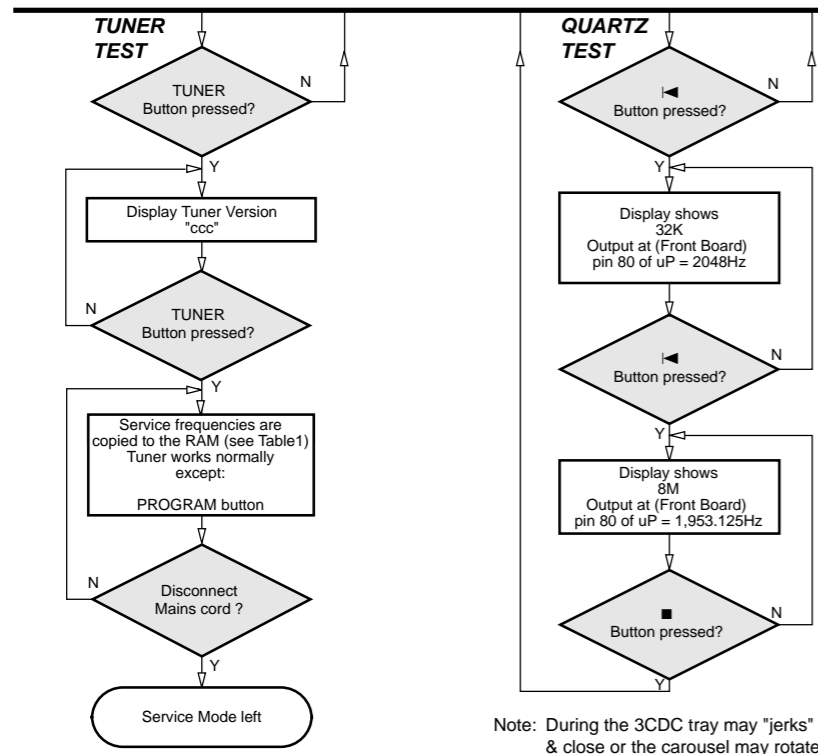

Note: During the 3CDC tray may "jerk" open & close or the carousel may rotate slightly. This is due to sharing of control lines during the Service test program.

PRESET	Europe "EUR"	East Eur. Extended-band "EAS"	East Eur. "EAS"	USA "USA"	Oversea "OSE"
1	87.5MHz	65.81MHz	87.5MHz	87.5MHz	87.5MHz
2	108MHz	108MHz	108MHz	108MHz	108MHz
3	531kHz	74MHz	531kHz	530kHz	530/531kHz*
4	1602kHz	87.5MHz	1602kHz	1700kHz	1700/1602kHz*
5	558kHz	531kHz	558kHz	560kHz	560/558kHz*
6	1494kHz	1602kHz	1494kHz	1500kHz	1500/1494kHz*
7	87.5MHz	558kHz	87.5MHz	98MHz	98/87.5MHz*
8	87.5MHz	1494kHz	87.5MHz	87.5MHz	87.5MHz
9	87.5MHz	98MHz	87.5MHz	87.5MHz	87.5MHz
10	87.5MHz	70.01MHz	87.5MHz	87.5MHz	87.5MHz
11	98MHz	65.81MHz	98MHz	87.5MHz	87.5/98MHz*

Table 1

Note: * Depending on the selected grid frequency (9 or 10kHz)
 By holding the TUNER and ►► buttons depressed while switching on the Mains supply, one of the undermentioned features will be activated:
 - the tuning grid frequency is toggled between 9kHz and 10kHz for the Oversea (/21) version.
 - the extended FM1 (65.81MHz - 74MHz) is toggled on and off for East Eur. (/34) version.

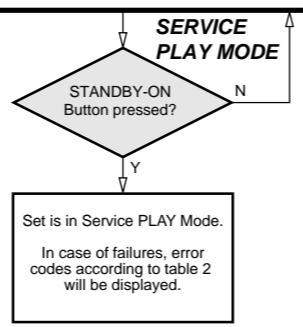
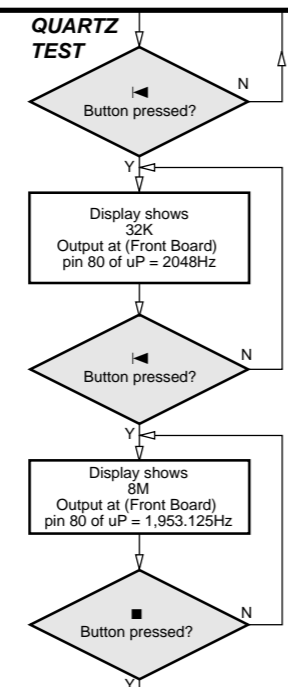

The Service Play Mode is intended to detect and identify the failures in the CD Mode.
 In this mode the electronics will still function even when an error is detected so that repair activities can be carried out.

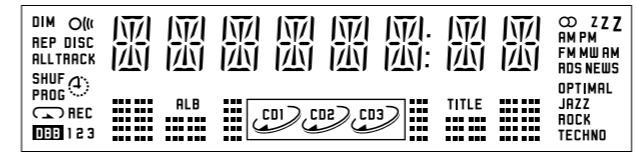

note 1: JAZZ & TECHNO are on while OPTIMAL is off, other LEDs status are not important (applicable only for sets with LEDs)
 Figure 1

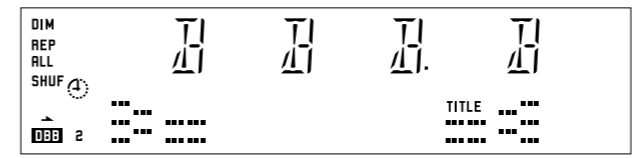

note 2: OPTIMAL is on while JAZZ & TECHNO are off, other LEDs status are not important (applicable only for sets with LEDs)
 Figure 2

Error code	Error Description
E1000	Focus Error Triggered when the focus could not be found within a certain time when starting up the CD or when the focus is lost for a certain time during play.
E1001	Radial Error Triggered when the radial servo is off-track for a certain time during play.
E1002	Sledge In Error The sledge did not reach its inner position (inner-switch is still close) before approximately 6 Sec. have passed by. Inner-switch or sledge motor problem.
E1003	Sledge Out Error The sledge did not come out of its inner position (inner-switch is still open) before approximately 250 mSec. have passed by. Inner-switch or sledge motor problem.
E1005	Jump-offtrack error Triggered in normal play when the jump destination could not be found within a certain time. When this error occurred, software will try to recover by initiating the jump command again. If it is recoverable, the disc will continue to play.
E1006	Subcode Error Triggered when a new subcode was missing for a certain time during play.
E1007	PLL Error The Phase Lock Loop could not lock within a certain time.
E1008	Turntable Motor Error Generated when the CD could not reached 75% of speed during startup within a certain time. Discmotor problem.
E1020	Focus Search Error The focus point has not been found within a certain time.
E1070	This happens when the carousel switch is defective and closed all the time, or when the carousel is blocked when it is located exactly at a disc position.
E1071	This happens when the carousel switch is defective and does not closed electrically, or when the carousel is blocked in between two disc positions. The time-out is approximately 5 Sec.
E1079	The drawer could not open or enter the inside position and is opening again. This happen when the drawer is blocked and cannot go fully inside or when the drawer switch is defective and does not close.

Table 2

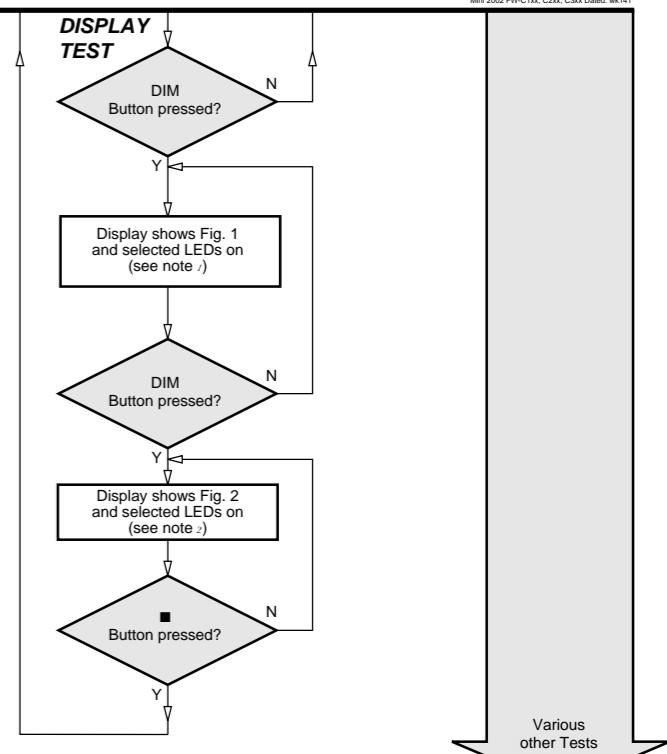

TEST	Activated with	ACTION
EEPROM TEST	►►	A test pattern will be sent to the EEPROM. "PASS" is displayed if the uProcessor read back the test pattern correctly, otherwise "FAIL" will be displayed.
EEPROM FORMAT	◄◄	Load default data. Display shows "NEW" for 1 second. Caution! All presets from the customer will be lost!!
ROTARY ENCODER TEST	Volume Knob or Jog Shuttle knob	Display shows value for 2 seconds. Values increases or decreases in steps of 1 until 0 (Min.) or 40 (Max.) is reached.
DEMO	DBB	DEMO will toggle on or off. The message: "DEMO ON" or "DEMO OFF" will scroll across the display to show the new status of the set.
LEAVE SERVICE TESTPROGRAM	Disconnect mains cord	

Various other Tests

BLOCK DIAGRAM

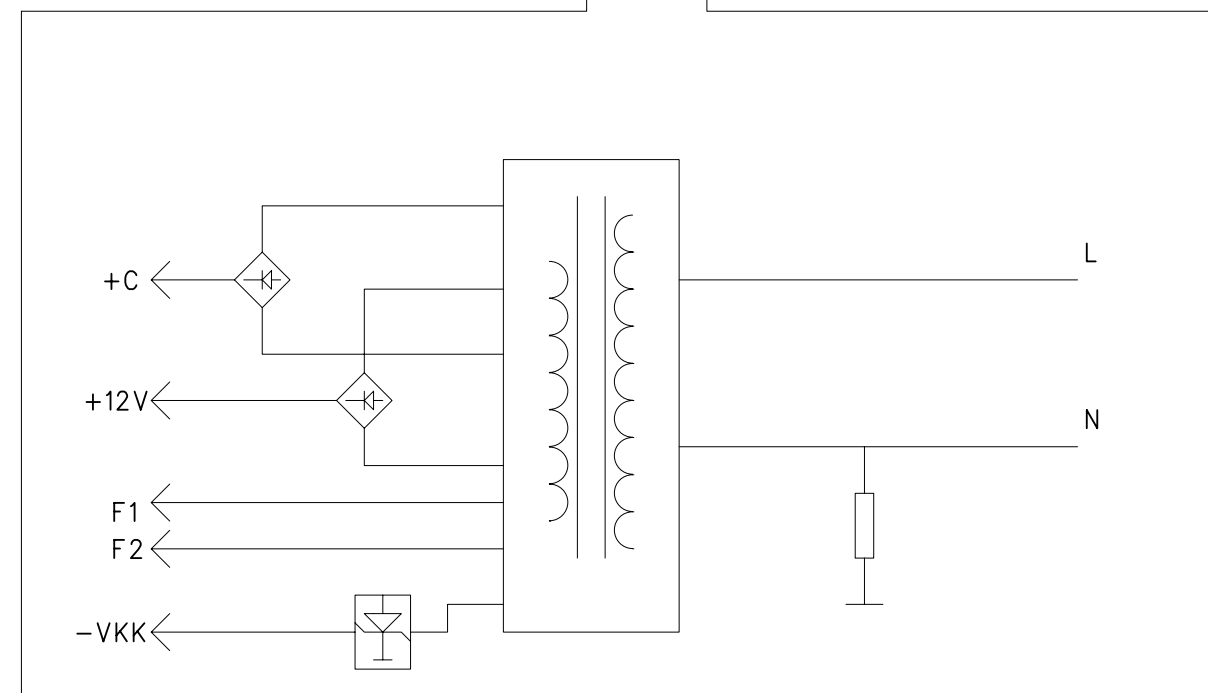
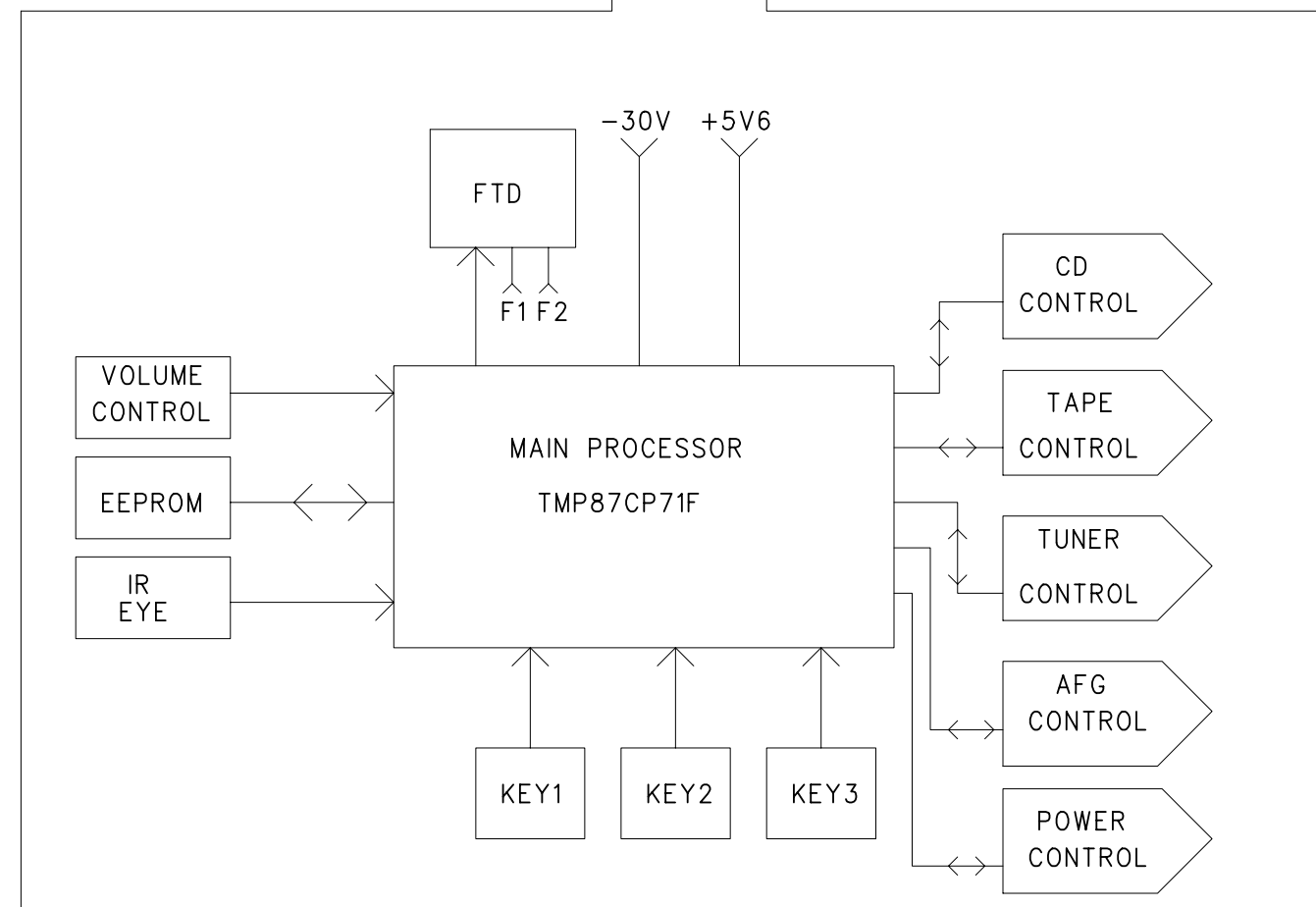
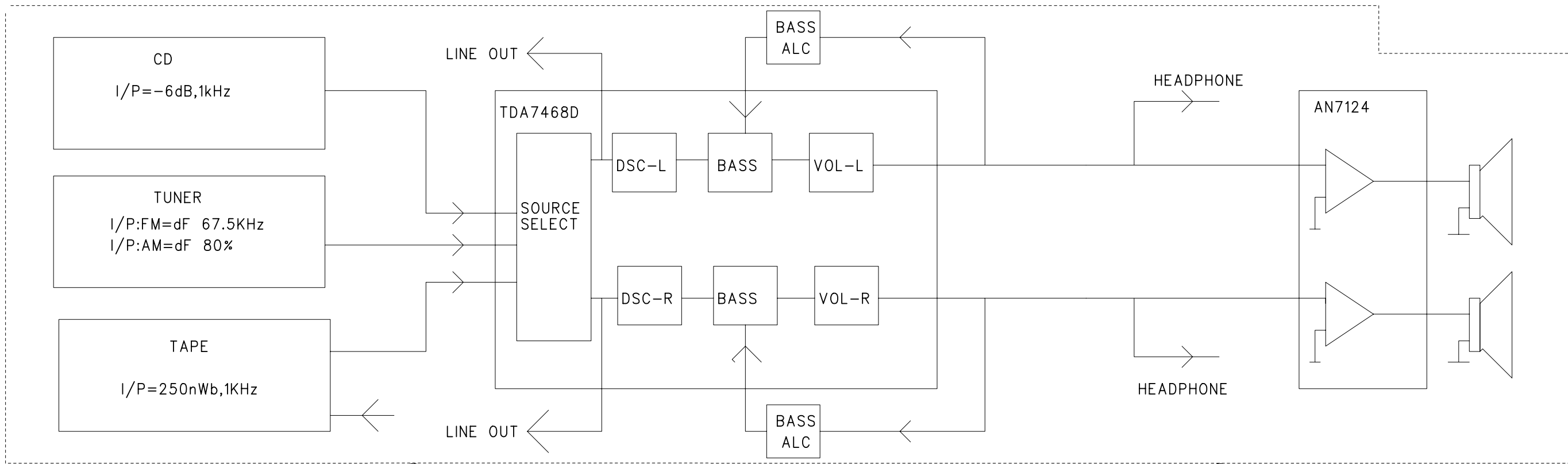

SET WIRING DIAGRAM

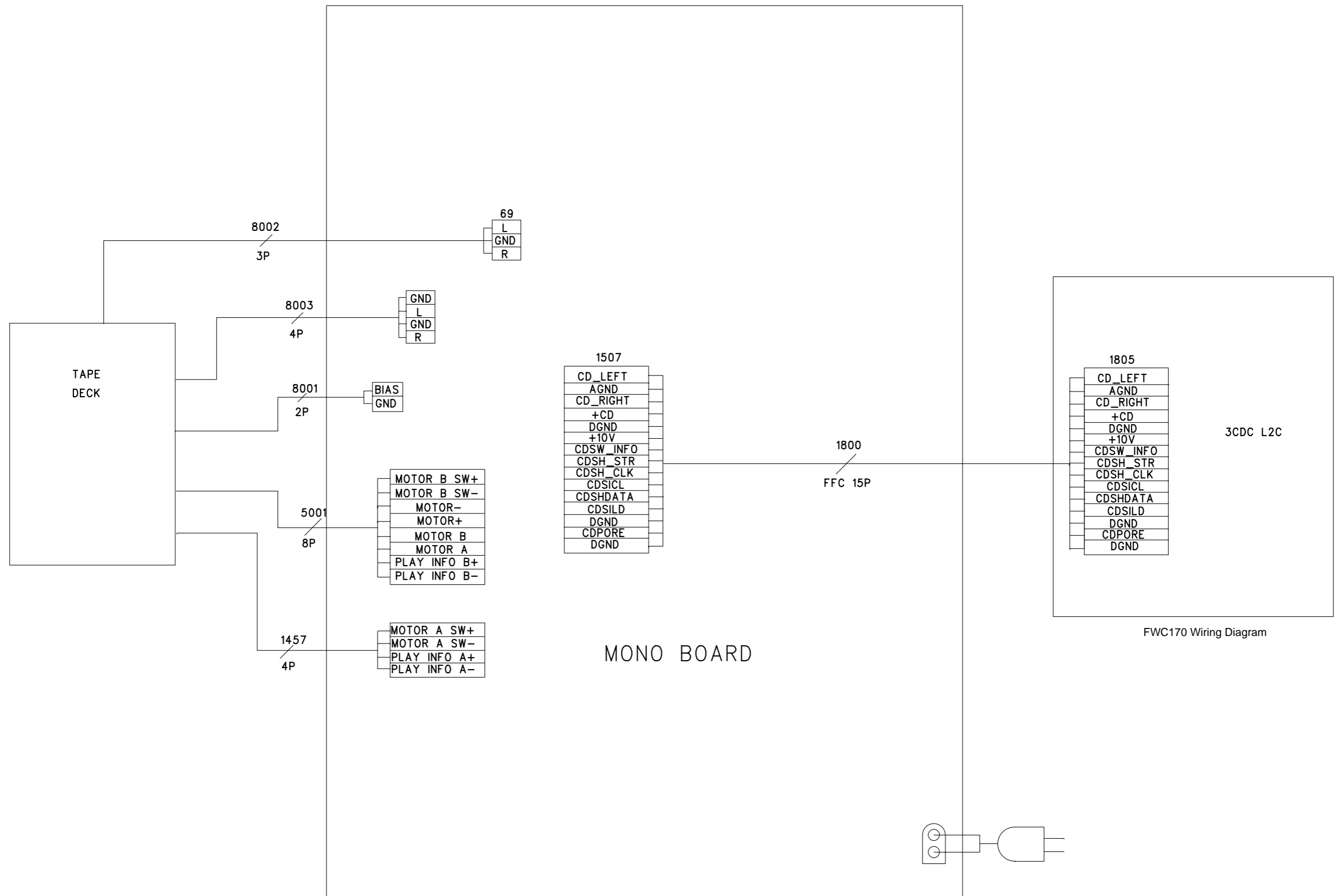

FWC170 Wiring Diagram

FTD DISPLAY PIN CONNECTIONS

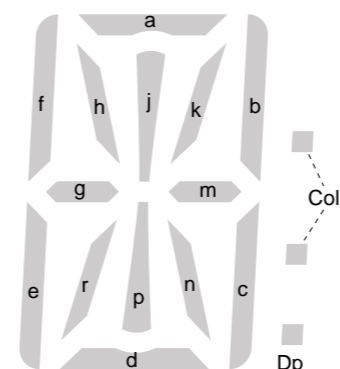
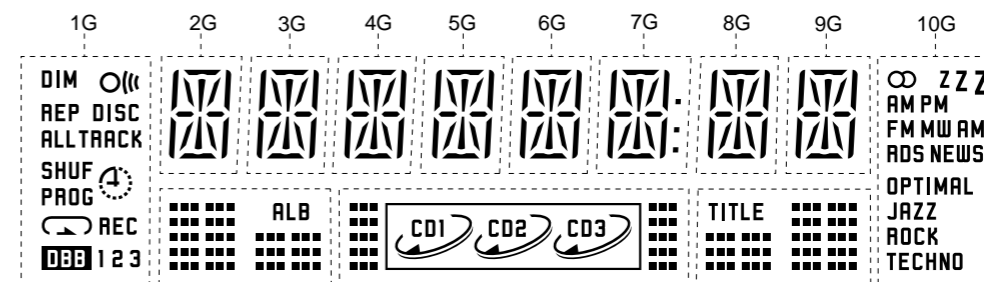

(2G - 9G)

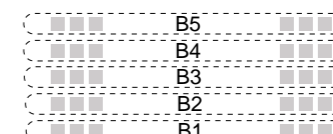

(12G)

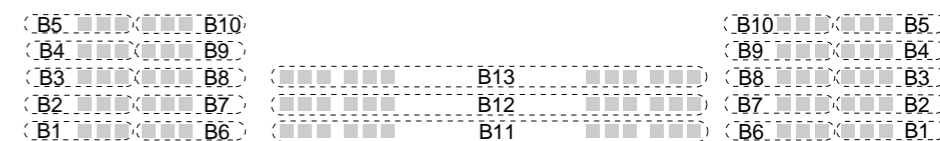

(11G)

COMBI & FRONT BOARDS

TABLE OF CONTENTS

- FTD Display pin connection 6-1
- Tape Adjustment & Mesurement 6-2
- Tuner Adjustment Table 6-2
- Combi part Component Layout 6-3
- Combi part SMD Layout 6-4
- Tuner Circuit 6-5
- Supply & Power Amplifier Circuit 6-6
- Tape Circuit 6-7
- Front Circuit 6-8
- Front part SMD Layout 6-9
- Front part Component Layout 6-10
- TDA7468 & TMP87CN71 Internal Block diagram 6-11
- Electrical parts list 6-11

	12G	11G	10G	9G	8G	7G	6G	5G	4G	3G	2G	1G
P1	B1	B1	∞	a	a	a	a	a	a	a	a	DIM
P2	B2	B2	Z (Left)	h	h	h	h	h	h	h	h	⊞
P3	B3	B3	Z (Middle)	j, p	j, p	j, p	j, p	j, p	j, p	j, p	j, p	REP
P4	B4	B4	Z (Right)	k	k	k	k	k	k	k	k	DISC
P5	B5	B5	AM (Up)	b	b	b	b	b	b	b	b	ALL
P6	CD1	B6	PM	f	f	f	f	f	f	f	f	TRACK
P7	CD2	B7	FM	m	m	m	m	m	m	m	m	SHUF
P8	CD3	B8	MW	g	g	g	g	g	g	g	g	PROG
P9	(1)	B9	AM (Low)	c	c	c	c	c	c	c	c	⌚
P10	(2)	B10	RDS	e	e	e	e	e	e	e	e	↶
P11	(3)	B11	NEWS	r	r	r	r	r	r	r	r	▶
P12	□	B12	OPTIMAL	n	n	n	n	n	n	n	n	REC
P13	-	B13	JAZZ	d	d	d	d	d	d	d	d	DBB
P14	-	ALB	ROCK	-	-	Col	-	-	-	-	-	1
P15	-	TITLE	TECHNO	-	-	Dp	-	-	-	-	-	2
P16	-	-	-	-	-	-	-	-	-	-	-	3

FTD DISPLAY PIN NO.	3	3	3	3	3	3	3	3	3	2	2	2	2	2	2	2	2	1	1	1	1	1	1	1	1	1	9	8	7	6	5	4	3	2	1		
FUNCTION	F	-	-	-	1	2	3	4	5	6	7	8	9	10	11	12	-	-	P	P	P	P	P	P	P	P	P	P	P	P	P	P	-	-	-	F	
	2				G	G	G	G	G	G	G	G	G	G	G	G			1	2	3	4	5	6	7	8	9	10	11	12	13	14	15	16			1

TAPE ADJUSTMENTS & MEASUREMENTS

TUNER ADJUSTMENT TABLE (ECO6 FM/MW- and FM/MW/LW - versions with AM-frame aerial)

	TEST CASSETTE	RECORDER MODE	MEASURE ON	READ ON	ADJUST	
					with	to
General						
ADJUST MOTOR SPEED	SBC420 (4822 397 30071) 3150Hz	PLAY deck A or B	◊11 or ◊12 LEFT or RIGHT or headphone socket	frequency counter	3758	3150Hz ±1%
CHECK WOW & FLUTTER	SBC420 (4822 397 30071) 3150Hz	PLAY deck A or B	◊11 or ◊12 LEFT or RIGHT or headphone socket	W&F-meter	check only	≤0.4 % DIN or ≤0.35 % CCIR
ADJUST AZIMUTH	SBC420 (4822 397 30071) 10kHz	PLAY deck A PLAY deck B	◊11 ◊12 LEFT RIGHT or headphone socket	mV-meter or oscilloscope	left hand screw	max. output level & left=right
Playback						
CHECK PLAYBACK FREQUENCY RESPONSE	SBC420 (4822 397 30071)	PLAY deck A PLAY deck B	◊11 or ◊12 LEFT RIGHT	mV-meter	Check	limits see fig.1
Recording						
PRE-ADJUST BIAS	FERRO	RECORD	◊15	mV-meter	5701	14V _{rms} (40V _{pp})
CHECK OVERALL FREQUENCY RESPONSE	FERRO	RECORD				
Input signal: 3mV 100Hz, 250Hz, 1kHz, 10kHz via ◊13 or ◊14	RECORDED CASSETTE	PLAY	◊11 or ◊12 LEFT RIGHT	mV-meter	check only	limits see fig.2
CHECK DISTORTION	FERRO	RECORD				
Input signal: 300mV 1kHz via ◊13 or ◊14	RECORDED CASSETTE	PLAY	◊11 or ◊12 LEFT RIGHT	THD-meter	check only	≤5%
Remark: If high frequencies are not within lower limit, decrease bias and re-measure. If distortion is too high increase bias and re-measure.						

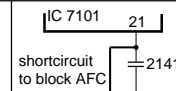
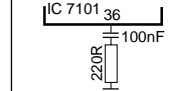
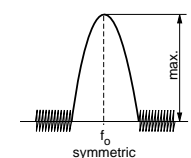
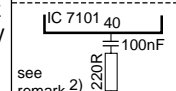
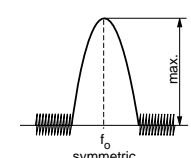
Waverange	Input frequency	Input	Tuned to	Adjust	Output	Scope/Voltmeter
VARICAP ALIGNMENT						
FM 87.5 - 108MHz (65.81 - 74, 87.5 - 108MHz)			108MHz	5130		8V ±0.2V
			87.5MHz (65.81MHz)	check		4.3V ±0.5V (1.2V ±0.5V)
MW FM/AM-version, 10kHz grid 530 - 1700kHz			1700kHz	5123		8V ±0.2V
			530kHz	check		1.1V ±0.4V
FM/MW-version, 9kHz grid 531 - 1602kHz			1602kHz	5123	◊1	6.9V ±0.2V
			531kHz	check		1.1V ±0.4V
LW 153 - 279kHz			279kHz	5122		8V ±0.2V
			153kHz	check		1.1V ±0.4V
MW FM/MW/LW- version, 9kHz grid 531 - 1602kHz			1602kHz	5123		8V ±0.2V
			531kHz	check		1.1V ±0.4V
FM IF						
FM	10.7MHz, 45mV continuous wave	◊D		5119	◊2	0 ± 3 mV DC
FM RF						
FM 87.5 - 108MHz (65.81 - 74, 87.5 - 108MHz)	108MHz	◊A mod=1kHz Δf=±22.5kHz	108MHz	2155	◊4	MAX
	87.5MHz (65.81MHz)		87.5MHz (65.81MHz)	5131		
VCO						
FM	98MHz, 1mV continuous wave	◊A	98MHz	3142	◊3	152kHz ±1kHz ¹⁾
AM IF						
MW	450kHz connect pin 6 of IC 7101 (AM Osc.) with 3.3kΩ to Vcc	◊C Δf=±10kHz V _{RF} = 0.5mV (as low as possible) see remark 2)		5111	◊5	
				5112		
AM AFC		◊C		5114	◊2	0 ± 2 mV DC
AM RF³⁾						
MW⁴⁾ FM/MW/LW- and FM/MW-version (9kHz grid) 531 - 1602kHz	1494kHz	◊B	1494kHz	2106	◊5	
	558kHz		558kHz	5102		
LW	198kHz		198kHz	5103		
MW FM/AM-version, 10kHz grid 530 - 1700kHz	1500kHz	◊B Δf = ±30kHz V _{RF} as low as possible	1500kHz	2106	◊5	
	560kHz		560kHz	5102		

Use Service Testprogram. By selecting the TUNER TEST test frequencies will be stored as preset frequencies automatically.

1) If sensitivity of frequency counter is too low adjust to max. channel separation (input signal: stereo left 90% + 9%, adjust output on right channel to minimum)

2) RC network serves for damping the IF-filter while adjusting the other one.

3) For AM RF adjustments the original frame antenna has to be used !

4) MW has to be aligned before LW.

↑ Repeat

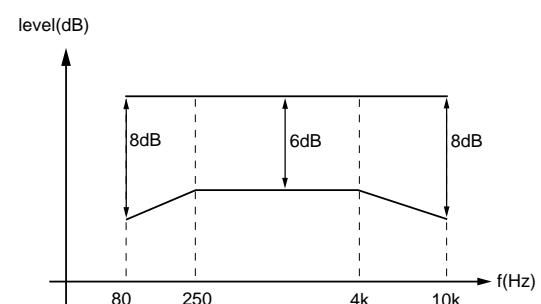

figure. 1

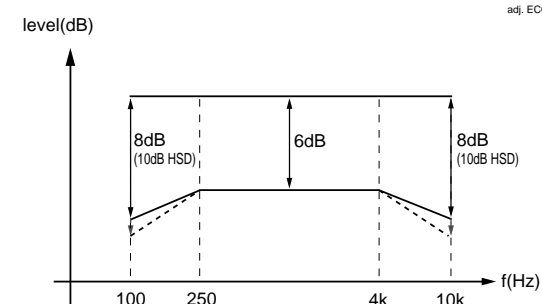
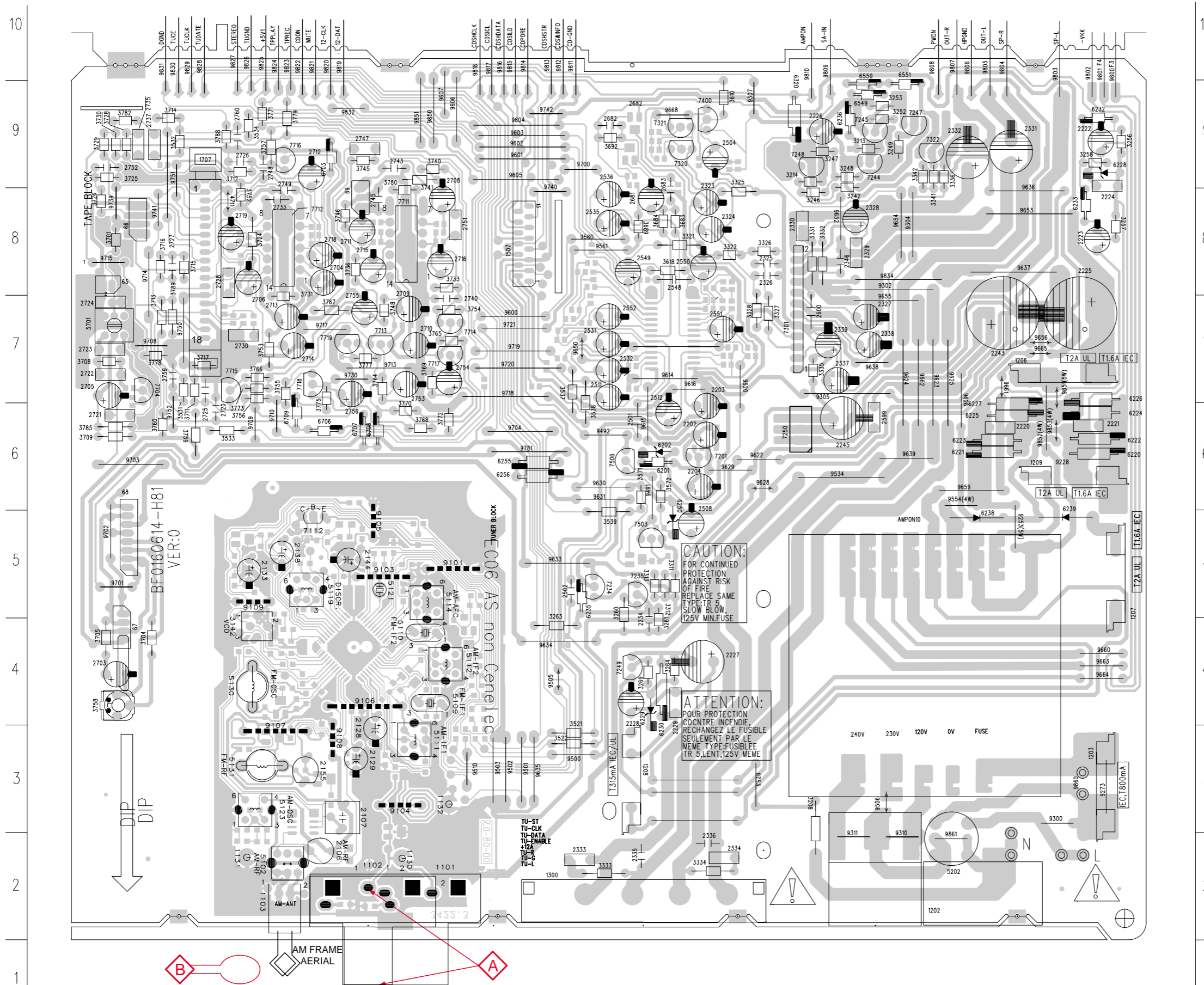

figure. 2

adj. ECO MTF DD AS. 110399

ECO6. Sys + PA with frame aerial. 070799

COMBI PART - COMPONENT LAYOUT(ONLY FOR /21)



65	B8	2531	F7	3249	I9	3754	E7	7716	C9	9815	F9
66	B8	2532	G7	3252	I9	3755	C7	7717	E7	9816	F9
67	B8	2535	F8	3253	I9	3756	C7	7718	E7	9817	F9
68	B5	2548	F8	3256	K9	3757	C9	7719	D7	9818	E9
69	D5	2547	G8	3257	K8	3758	B4	9101	E5	9819	D9
1101	E2	2548	G8	3258	K9	3759	C6	9103	D5	9820	D9
1102	D2	2549	G8	3259	G5	3760	B6	9104	E3	9821	D9
1103	C2	2550	G8	3260	G5	3761	D7	9105	D5	9822	D9
1202	J2	2551	H7	3261	G4	3765	F7	9106	D4	9823	D9
1203	K3	2552	G7	3263	F4	3766	C7	9107	C3	9824	D9
1206	K7	2560	H7	3264	G4	3767	D7	9108	D3	9825	C9
1207	K5	2561	G7	3269	G4	3768	E6	9109	C5	9826	C9
1208	G3	2565	F7	3272	I9	3769	E7	9228	K6	9827	C9
1209	K6	2566	H7	3271	G5	3770	E6	9253	J5	9828	C9
1300	F2	2570	I7	3312	G5	3771	C9	9273	K3	9829	C9
1507	F8	2589	F8	3313	G5	3772	E6	9300	K3	9830	C9
1707	C9	2590	H7	3318	G5	3773	C7	9302	I8	9831	B9
2101	D3	2591	F7	3321	G8	3774	D6	9304	I8	9832	D9
2102	D2	2592	H8	3322	H8	3775	D7	9305	I7	9834	I8
2103	C3	2593	F8	3325	H8	3776	D7	9307	H9	9850	E9
2104	E3	2594	H7	3326	H8	3777	D7	9310	I2	9851	K7
2105	D2	2597	G9	3327	H7	3778	B7	9311	I2	9851	E9
2106	D2	2598	H9	3328	H7	3779	D9	9491	G6	9852	K6
2107	D3	2599	I6	3329	G9	3780	E8	9492	F6	9852	C9
2112	E4	2600	H7	3330	H9	3781	C7	9500	F3	9853	C9
2119	C3	2641	F8	3331	H8	3782	B9	9501	F3	9854	C9
2120	C3	2642	G7	3332	H8	3785	B6	9502	F3	9855	C9
2124	C2	2643	G7	3333	F2	3787	B7	9503	E3	9856	C9
2125	C2	2681	G8	3334	G2	3788	C9	9505	F4	9857	C9
2126	C5	2682	G9	3335	H7	3789	B7	9506	I3	9858	C9
2127	D4	2683	G8	3336	J9	4103	E4	9510	E3	9859	C9
2128	D3	2703	B4	3337	I7	4106	D3	9534	I6	9860	C9
2129	D3	2704	D8	3341	J9	4107	D4	9554	J6	9861	C9
2130	C4	2705	B7	3342	I9	4108	D4	9560	F8	9862	C9
2131	D4	2706	C8	3507	F8	5102	C2	9561	F8	9863	C9
2132	C5	2708	E8	3509	H9	5109	E4	9600	F7	9864	C9
2133	C5	2709	E7	3511	F7	5110	E4	9601	F9	9865	C9
2134	C5	2710	E7	3512	F7	5111	E3	9602	F9	9866	C9
2135	C5	2711	D8	3513	G6	5112	E4	9603	F9	9867	C9
2136	E4	2712	D9	3514	F7	5114	E5	9604	F9	9868	C9
2137	E4	2713	C7	3517	F3	5119	D5	9605	F9	9869	C9
2138	C5	2714	D7	3522	F3	5121	D5	9606	E9	9870	C9
2139	D5	2715	D8	3523	F4	5123	C3	9607	E9	9871	C9
2140	D5	2716	E8	3524	F4	5130	C4	9614	G7	9872	C9
2141	D5	2718	D8	3531	C7	5131	C3	9615	G6	9873	C9
2142	D5	2719	C8	3532	B9	5202	J2	9616	G7	9874	C9
2143	D5	2721	B6	3533	C6	5403	F13	9620	H7	9875	C9
2144	D5	2722	B7	3534	C9	5701	B7	9622	H6	9876	C9
2145	E4	2723	B7	3537	F7	6103	D3	9623	J7	9877	C9
2146	E5	2723	B7	3537	F7	6103	D3	9623	J7	9878	C9
2147	E4	2724	B7	3538	F7	6105	D3	9624	I7	9879	C9
2148	E5	2725	C6	3539	F5	6106	D2	9625	J7	9880	C9
2149	C5	2726	C9	3539	G5	6107	D5	9626	J7	9881	C9
2150	E4	2727	B8	3545	F7	6120	E4	9628	H6	9882	C9
2151	D4	2728	C8	3546	E7	6130	C4	9629	H6	9883	C9
2152	D4	2730	C7	3562	F7	6131	D3	9630	F6	9884	C9
2153	D3	2731	C8	3563	H7	6201	G6	9631	F6	9885	C9
2154	D3	2732	C7	3568	G5	6202	G6	9633	F5	9886	C9
2155	D3	2733	C8	3569	G5	6220	K6	9634	F4	9887	C9
2161	E5	2735	B9	3570	G5	6221	J6	9635	F3	9888	C9
2163	E5	2737	B9	3571	G6	6222	K6	9636	J8	9889	C9
2164	D5	2738	D8	3572	G6	6223	J6	9637	J8	9890	C9
2165	D4	2740	E7	3591	F7	6224	K6	9638	I7	9891	C9
2166	D5	2741	E7	3592	H8	6225	J6	9639	I6	9892	C9
2167	D5	2743	E9	3593	F8	6226	K7	9650	F7	9893	C9
2169	E3	2744	E7	3594	G8	6227	J6	9652	I8	9894	C9
2202	G6	2745	D8	3610	H9	6228	K9	9653	J8	9895	C9
2203	G6	2747	D9	3618	G8	6229	G4	9654	I8	9896	C9
2204	G6	2748	D9	3683	G8	6230	G4	9655	I7	9897	C9
2205	G6	2749	C8	3684	G8	6232	K9	9656	K7	9898	C9
2206	G6	2751	E9	3686	G6	6233	K8	9659	J6	9899	C9
2220	J6	2752	B9	3687	G9	6235	F9	9660	K4	9900	C9
2221	K6	2753	E7	3688	G9	6236	I9	9661	J7	9901	C9
2222	K9	2754	E7	3689	G8	6238	J5	9662	I7	9902	C9
2223	K8	2755	D7	3692	G9	6239	K5	9663	K4	9903	C9
2224	K9	2756	D7	3701	B8	6250	G6	9664	K4	9904	C9
2225	K7	2759	B7	3704	B4	6255	F6	9665	K7	9905	C9
2226	H9	2760	C9	3705	B4	6256	F6	9700	F9	9906	C9
2227	G4	2761	C8	3706	D8	6320	H9	9701	B5	9907	C9
2228	G4	2762	D8	3707	B7	6549	I9	9702	B5	9908	C9
2229	G4	3101	C4	3708	B7	6550	I9	9703	B6	9909	C9
2234	G5	3102	D3	3709	B6	6551	I9	9704	F6	9910	C9
2243	J7	3103	D3	3711	C6	6703	D9	9708	B7	9911	C9
2245	I6	3104	E3	3712	C9	6706	D6	9709	C6	9912	C9
2321	G9	3105	D3	3713	B7	6707	D6	9710	C6	9913	C9
2322	G9	3113	E4	3714	B9	6708	D6	9711	C8	9914	C9
2323	G8	3119	E4	3715	C8	6709	D6	9713	D7	9915	C9
2324	G8	3132	C4	3716	B8	7101	D4	9714	B8	9916	C9
2325	H8	3134	C3	3717	C7	7102	C3	9715	B8	9917	C9
2326	H8	3141	D4	3718	C8	7103	C5	9717	D7	9918	C9
2327	I7	3142	C4	3719	C7	7111	E4	9718	F7	9919	C9
2328	I8	3144	E5	3720	C7	7112	D5	9719	F7	9920	C9
2329	I8	3145	D4	3721	C8	7119	E4	9720	F7	9921	C9
2330	H8	3146	D5	3722	C8	7201	G6	9721	F7	9922	C9
2331	J9	3152	E3	3724	C8	7234	F5	9730	D7	9923	C9
2332	J9	3153	E3	3725	B9	7235	G5	9739	B8	9924	C9
2333	F2	3154	D5	3726	B8	7244	I9	9740	F8	9925	C9
2334	H2	3155	D5	3727	B9	7245	I9	9741	B8	9926	C9
2335	G2	3156	E5	3728	B9	7247	I9	9742	F9	9927	C9
2336	G2	3157	E5	3729	B9	7248	H9	9750	C7	9928	C9
2337	I7	3158	E3	3730	B9	7249	G4	9751	B9	9929	C9
2338	I7	3159	E4	3731	D7	7250	H6	9752	B6	9930	C9
2339	I7	3160	E4	3733	E8	7301	H7	9753	H3	9931	C9
2346	I8	3161	E4	3734	E8	7320	G9	9781	F6	9932	C9
2501	G6	3167	E5	3736	D8	7321	G9	9800	K9	9933	C9
2502	F5	3168	D6	3737	E8	7322	J9	9801	K9	9934	C9
2504	H9	3169	D5	3738	E8	7400	G9	9802	K9	9935	C9
2507	G7	3170	E5	3740	E9	7503	G5	9803	K9	9936	C9
2508	G5	3172	D5	3741	E9	7504	G5	9804	J9	9937	C9
2511	F7	3176	C5	3742	D8	7506	G6	9805	J9	9938	C9
2512	G6	3181	C4	3743	D8	7511	G7	9806	J9	9939	C9
2513	G6	3202	G6	3745	D9	7681	G9	9807	J9	9940	C9
2514	F7	3208	H3	3746	D8	7682	G9	9808	J9	9941	C9
2517	G7	3213	I9	3747	D8	7704	B7	9809	I9	9942	C9
2518	H7	3214	H9	3748	H9	7711	E9	9810	I9	9943	C9
2519	F7	3249	I9	3749	D8	7712	D8	9811	F9	9944	C9
2520	H7	3246	H8	3750	D8	7713	D7	9812	F9	9945	C9
2521	F7	3247	I9	3752	C8	7714	E7	9813	F9	9946	C9
2522	H7	3248	I9	3753	C7	7715	C7	9814	F9	9947	C9

This assembly drawing shows a summary of all possible versions. For components used in a specific version see schematic diagram and respective parts list.

A	B	C	D	E	F	G	H	I	J	K	L
---	---	---	---	---	---	---	---	---	---	---	---

COMBI PART - SMD LAYOUT(ONLY FOR /21)

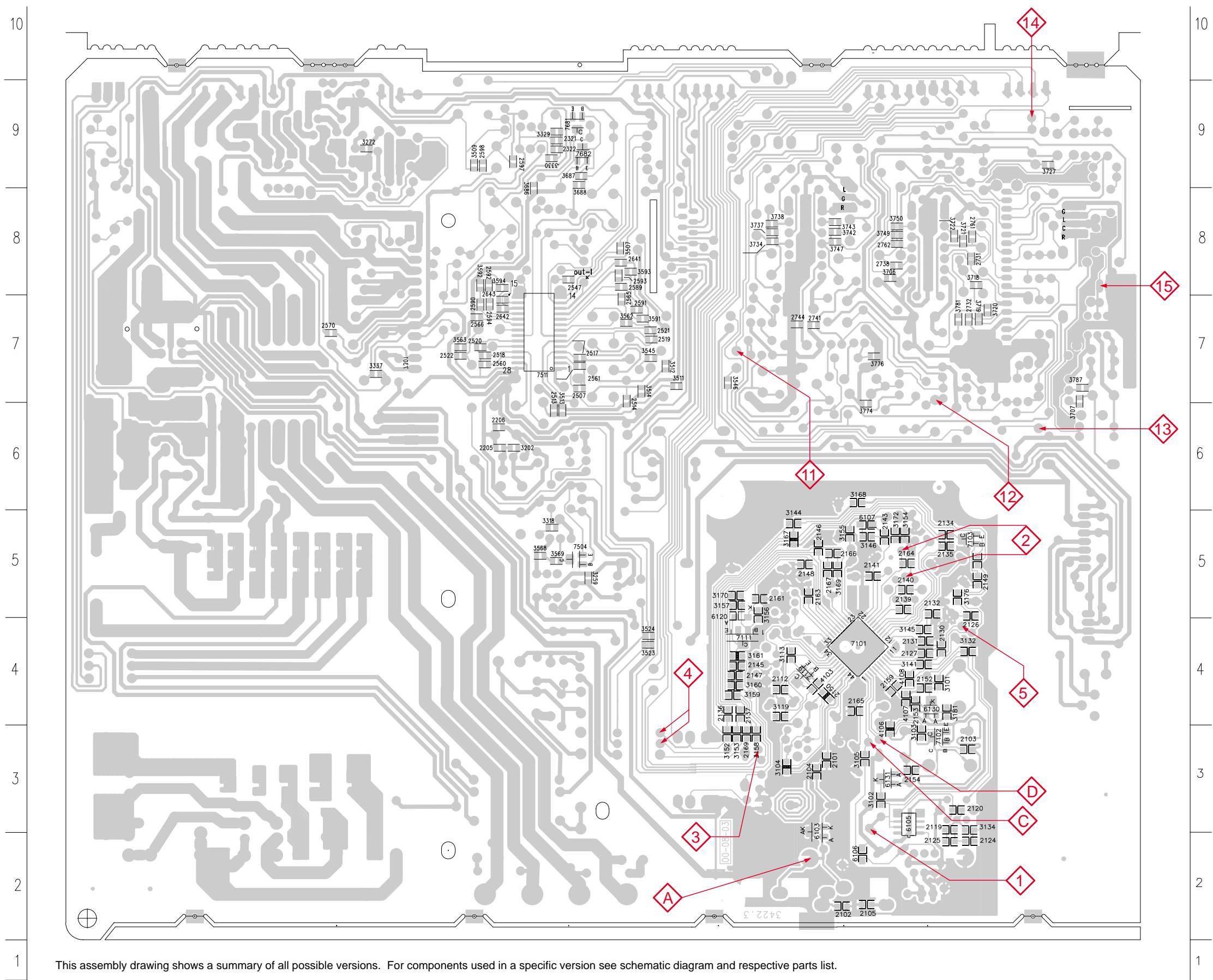

This assembly drawing shows a summary of all possible versions. For components used in a specific version see schematic diagram and respective parts list.

65	B8	2531	F7	3249	I9	3754	E7	7716	C9	9815	F9
66	B8	2532	G7	3252	I9	3755	C7	7717	E7	9816	F9
67	B4	2535	F8	3253	I9	3756	C7	7718	D7	9817	E9
68	B5	2536	F8	3256	K9	3757	C9	7719	D7	9818	E9
69	D8	2547	G8	3257	K8	3758	B4	9101	E5	9819	D9
1101	E2	2548	G8	3258	K9	3759	C6	9103	D5	9820	D9
1102	D2	2549	G8	3259	G5	3760	B6	9104	E3	9821	D9
1103	C2	2550	G8	3260	G5	3764	D7	9105	D5	9822	D9
1202	J2	2551	H7	3261	G4	3765	E7	9106	D4	9823	D9
1203	K3	2552	G7	3263	F4	3766	C7	9107	C3	9824	D9
1206	K7	2560	H7	3264	G4	3767	D7	9108	D3	9825	C9
1207	K5	2561	G7	3269	G4	3768	E6	9109	C5	9826	C9
1208	G3	2565	F7	3272	I9	3769	E7	9228	K6	9827	C9
1209	K6	2566	H7	3311	G5	3770	E6	9253	J5	9828	C9
1300	F2	2570	I7	3312	G5	3771	C9	9273	K3	9829	C9
1507	F8	2589	F8	3313	G5	3772	E6	9300	K3	9830	C9
1707	C9	2590	H7	3318	G5	3773	C7	9302	I8	9831	B9
2101	D3	2591	F7	3321	G8	3774	D6	9304	I8	9832	D9
2102	D2	2592	H8	3322	H8	3775	D7	9305	I7	9834	I8
2103	C3	2593	F8	3325	H8	3776	D7	9307	H9	9850	E9
2104	E3	2594	H7	3326	H8	3777	D7	9310	I2	9851	K7
2105	D2	2597	G9	3327	H7	3778	B7	9311	I2	9851	E9
2106	D2	2598	H9	3328	H7	3779	D9	9491	G6	9852	K6
2107	D3	2599	I6	3329	G9	3780	E8	9492	F6	9853	K6
2112	E4	2600	H7	3330	G9	3781	C7	9500	F3	9850	F3
2119	C3	2641	F8	3331	H8	3782	B9	9501	F3	9501	F3
2120	C3	2642	G7	3332	H8	3785	B6	9502	F3	9502	F3
2124	C2	2643	G7	3333	F2	3787	B7	9503	E3	9503	E3
2125	C2	2681	G8	3334	G2	3788	C9	9505	F4	9505	F4
2126	C5	2682	G9	3335	H7	3789	B7	9506	I3	9506	I3
2127	D4	2683	G8	3336	J9	4103	E4	9510	E3	9510	E3
2128	D3	2703	B4	3337	I7	4106	D3	9534	I6	9534	I6
2129	D3	2704	D8	3341	J9	4107	D4	9554	J6	9554	J6
2130	C4	2705	B7	3342	I9	4108	D4	9560	F8	9560	F8
2131	D4	2706	C8	3507	F8	5102	C2	9561	F8	9561	F8
2132	C5	2708	E8	3509	H9	5109	E4	9600	F7	9600	F7
2133	C5	2709	E7	3511	F7	5110	E4	9601	F9	9601	F9
2134	C5	2710	E7	3512	F7	5111	E3	9602	F9	9602	F9
2135	C5	2711	D8	3513	G6	5112	E4	9603	F9	9603	F9
2136	E4	2712	D9	3514	F7	5114	E5	9604	F9	9604	F9
2137	E4	2713	C7	3521	F3	5119	D5	9605	F9	9605	F9
2138	C8	2714	D7	3522	F3	5121	D4	9606	E9	9606	E9
2139	D5	2715	D8	3523	F4	5123	C3	9607	E9	9607	E9
2140	D5	2716	E8	3524	F4	5130	C4	9614	G7	9614	G7
2141	D5	2718	D8	3531	C7	5131	C3	9615	G6	9615	G6
2143	D5	2719	C8	3532	B9	5202	J2	9616	G7	9616	G7
2144	D5	2721	B6	3533	C6	5403	F13	9620	H7	9620	H7
2145	E4	2722	B7	3534	C9	5701	B7	9622	H6	9622	H6
2146	E5	2723	B7	3537	F7	6103	D3	9623	J7	9623	J7
2147	E4	2724	B7	3538	F7	6105	D3	9624	I7	9624	I7
2148	E5	2725	C6	3539	F5	6106	D2	9625	J7	9625	J7
2149	C5	2726	C9	3539	G5	6107	D5	9626	J7	9626	J7
2150	E4	2727	B8	3545	F7	6120	E4	9628	H6	9628	H6
2152	D4	2728	C8	3546	E7	6130	C4	9629	H6	9629	H6
2153	D4	2730	C7	3562	F7	6131	D3	9630	F6	9630	F6
2154	D3	2731	C8	3563	H7	6201	G6	9631	F6	9631	F6
2155	D3	2732	C7	3568	G5	6202	G6	9633	F5	9633	F5
2159	D4	2733	C8	3569	G5	6220	K6	9634	F4	9634	F4
2161	E5	2735	B9	3571	G6	6221	J6	9635	F3	9635	F3
2163	E5	2737	B9	3571	G6	6222	K6	9636	J8	9636	J8
2164	D5	2738	D8	3572	G6	6223	J6	9637	J8	9637	J8
2165	D4	2740	E7	3591	F7	6224	K6	9638	I7	9638	I7
2166	D5	2741	E7	3592	H8	6225	J6	9639	I6	9639	I6
2167	D5	2743	E9	3593	F8	6226	K7	9650	F7	9650	F7
2169	E3	2744	E7	3594	G8	6227	J6	9652	I8	9652	I8
2202	G6	2745	D6	3610	H9	6228	K9	9653	J8	9653	J8
2203	G6	2747	D9	3618	G8	6229	G4	9654	I8	9654	I8
2204	G6	2748	C9	3683	G8	6230	G4	9655	I7	9655	I7
2205	G6	2749	C8	3684	G8	6232	K9	9656	K7	9656	K7
2206	G6	2751	E8	3686	G9	6233	K8	9659	J6	9659	J6
2220	J6	2752	B9	3687	G9	6235	F5	9660	K4	9660	K4
2221	K6	2753	E7	3688	G9	6236	I9	9661	J7	9661	J7
2222	K9	2754	E7	3689	G8	6238	J5	9662	I7	9662	I7
2223	K8	2755	D7	3692	G9	6239	K5	9663	K4	9663	K4
2224	K9	2756	D7	3701	B8	6250	G6	9664	K4	9664	K4
2225	K7	2759	B7	3704	C7	6255	F6	9665	K7	9665	K7
2226	H9	2760	C9	3705	B4	6256	F6	9700	F9	9700	F9
2227	G4	2761	C8	3706	D8	6320	H9	9701	B5	9701	B5
2228	G4	2762	D8	3707	B7	6549	I9	9702	B5	9702	B5
2229	G4	3101	C4	3708	B7	6550	I9	9703	B6	9703	B6
2234	G5	3102	D3	3709	B6	6551	I9	9704	F6	9704	F6
2243	J7	3103	D3	3711	C6	6703	D9	9708	B7	9708	B7
2245	I6	3104	E3	3712	C9	6706	D6	9709	C6	9709	C6
2321	G9	3105	D3	3713	B7	6707	D6	9710	C6	9710	C6
2322	G9	3113	E4	3714	B9	6708	D6	9711	C8	9711	C8
2323	G8	3119	E4	3715	C8	6709	D6	9713	D7	9713	D7
2324	G8	3132	C4	3716	B8	7101	D4	9714	B8	9714	B8
2325	H8	3134	C3	3717	C7	7102	C3	9715	B8	9715	B8
2326	H8	3141	D4	3718	C8	7103	C5	9717	D7	9717	D7
2327	I7	3142	C4	3719	C7	7111	E4	9718	F7	9718	F7
2328	I8	3144	E5	3720	C7	7112	D5	9719	F7	9719	F7
2329	I8	3145	D4	3721	C8	7119	E4	9720	F7	9720	F7
2330	H8	3146	D5	3722	C8	7201	G6	9721	F7	9721	F7
2331	J9	3152	E3	3724	C8	7234	F5	9730	D7	9730	D7
2332	J9	3153	E3	3725	B9	7235	G5	9739	B8	9739	B8
2333	F2	3154	D5	3726	B8	7244	I9	9740	F8	9740	F8
2334	H2	3155	D5	3727	B9	7245	I9	9741	B8	9741	B8
2335	G2	3156	E5	3728	B9	7247	I9	9742	F9	9742	F9
2336	G2	3157	E5	3729	B9	7248	H9	9750	C7	9750	C7
2337	I7	3158	E3	3730	B9	7249	G4	9751	B9	9751	B9
2338	I7	3159	E4	3731	D7	7250	H6	9752	B6	9752	B6
2339	I7	3160	E4	3733	E8	7301	H7	9753	H3	9753	H3
2346	I8	3161	E4	3734	E8	7320	G9	9781	F6	9781	F6
2501	G6	3167	E5	3736	D8	7321	G9	9800	K9	9800	K9
2502	F5	3168	D6	3737	E8	7322	J9	9801	K9	9801	K9
2504	H9	3169	D5	3738	E8	7400	G9	9802	K9	9802	K9
2507	G7	3170	E5	3740	E9	7503	G5	9803	K9	9803	K9
2508	G5	3172	D5	3741	E9	7504	G5	9804	J9	9804	J9
2511	F7	3176	C5	3742	D8	7506	G6	9805	J9	9805	J9
2512	G6	3181	C4	3743	D8	7511	G7	9806	J9	9806	J9
2513	G6	3202	G6	3745	D9	7681	G9	9807	J9	9807	J9
2514	F7	3208	H3	3746	D8	7682	G9	9808	J9	9808	J9
2517	G7	3213	I9	3747	D8	7704	B7	9809	I9	9809	I9
2518	H7	3214	H9	3748	D7	7711	E8	9810	H9	9810	H9
2519	F7	3242	I9	3749	D8	7712	D8	9811	F9	9811	F9
2520	H7	3246	H8	3750	D8	7713	D7	9812	F9	9812	F9
2521	F7	3247	I9	3752	C8	7714	E7	9813	F9	9813	F9
2522	H7	3248	I9	3753	C7	7715	C7	9814	F9	9814	F9

L K J I H G F E D C B A

COMBI PART - SMD LAYOUT(ONLY FOR I22/25)

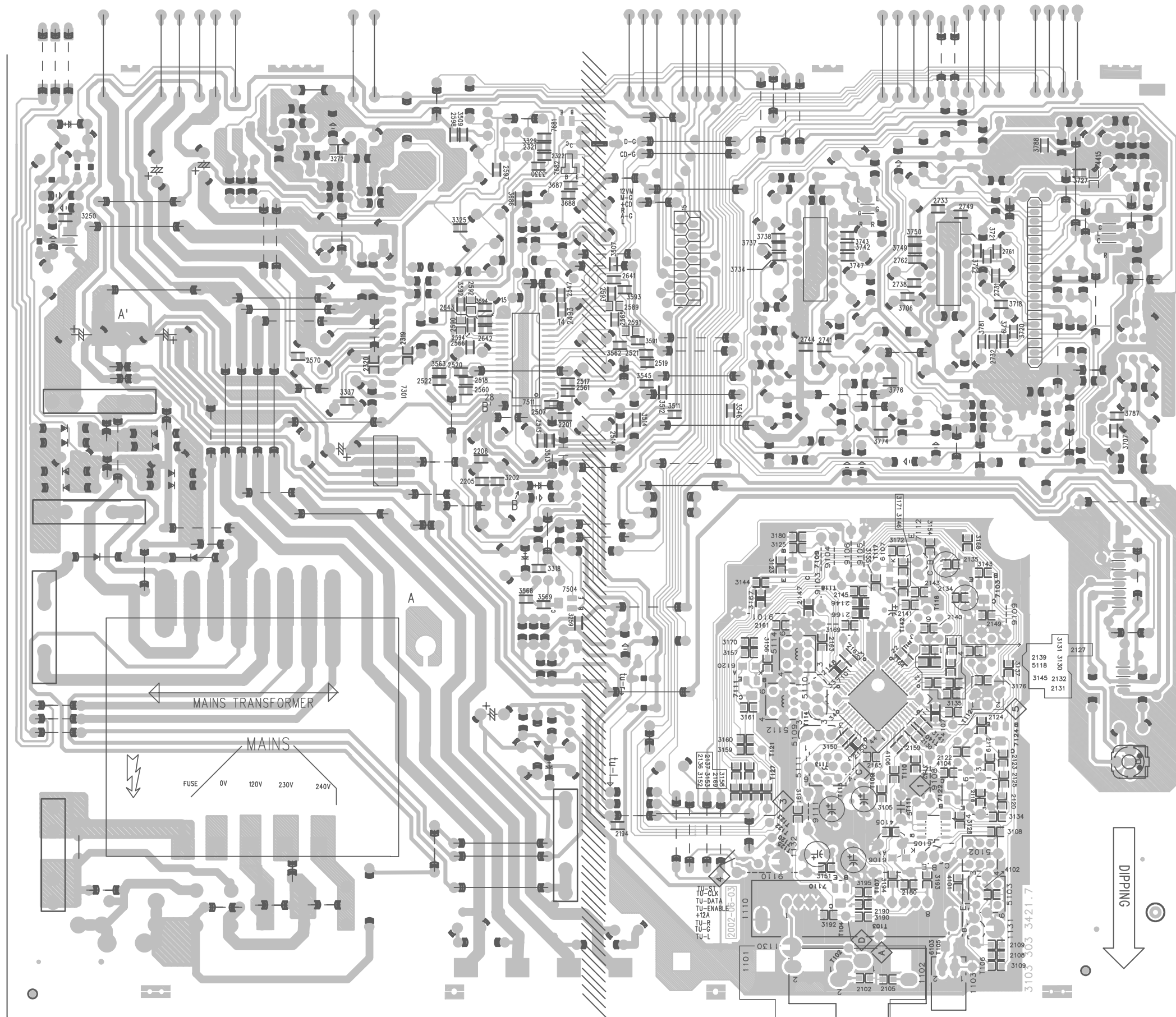

NON CENELEC TUNER CIRCUIT

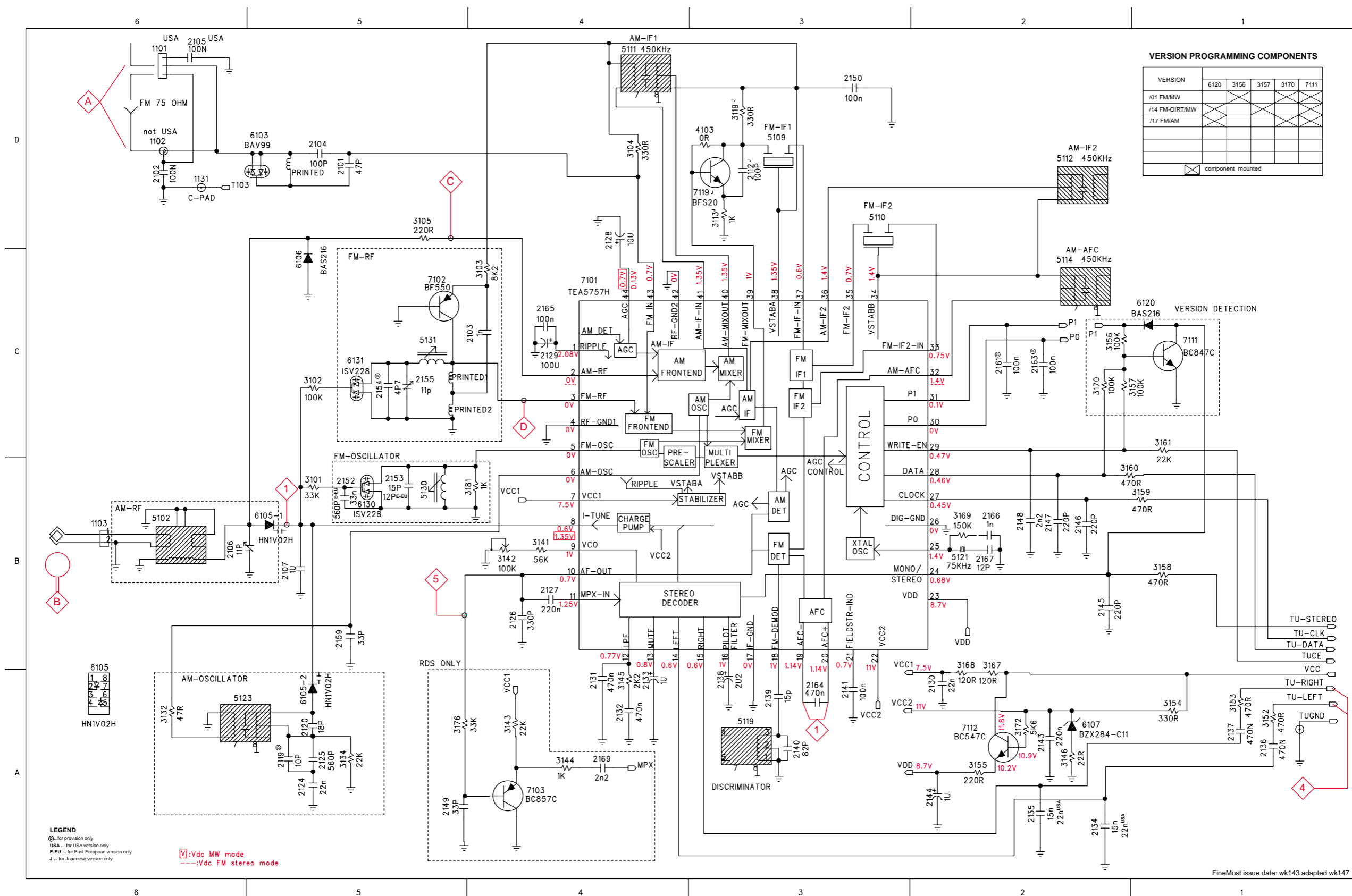

VERSION PROGRAMMING COMPONENTS

VERSION	6120	3156	3157	3170	7111
/01 FM/MW					
/14 FM-OIRT/MW					
/17 FM/AM					

☒ component mounted

- 1101 D6 6105-2 A5
- 1102 D6 6106 C5
- 1103 B6 6107 A2
- 1131 D6 6120 C1
- 2101 D5 6130 B5
- 2102 D6 6131 C5
- 2103 C4 7101 C4
- 2104 D5 7102 C5
- 2105 D6 7103 A4
- 2106 B6 7111 C1
- 2107 B5 7112 A2
- 2112 D3 7119 D3
- 2119 A5
- 2120 A5
- 2124 A5
- 2125 A5
- 2126 B4
- 2127 B4
- 2128 D4
- 2129 C4
- 2130 A2
- 2131 A4
- 2132 A4
- 2133 A4
- 2134 A2
- 2135 A2
- 2136 A1
- 2137 A1
- 2138 A3
- 2139 A3
- 2140 A3
- 2141 A3
- 2143 A2
- 2144 A2
- 2145 B2
- 2146 B2
- 2147 B2
- 2148 B2
- 2149 A5
- 2150 D3
- 2152 B5
- 2153 B5
- 2154 C5
- 2155 C5
- 2159 B5
- 2161 C2
- 2163 C2
- 2164 A3
- 2165 C4
- 2166 B2
- 2167 B2
- 2169 A4
- 3101 B5
- 3102 C5
- 3103 C4
- 3104 D4
- 3105 D5
- 3113 D3
- 3119 D3
- 3132 A6
- 3134 A5
- 3141 B4
- 3142 B4
- 3143 A4
- 3144 A4
- 3145 A4
- 3146 A2
- 3152 A1
- 3153 A1
- 3154 A1
- 3155 A2
- 3156 C2
- 3157 C1
- 3158 B1
- 3159 B1
- 3160 B1
- 3161 C1
- 3167 A2
- 3168 A2
- 3169 B2
- 3170 C2
- 3172 A2
- 3176 A5
- 3181 B4
- 4103 D3
- 5102 B6
- 5109 D3
- 5110 D3
- 5111 D4
- 5112 D2
- 5114 C2
- 5119 A3
- 5121 B2
- 5123 A5
- 5130 B5
- 5131 C5
- 6103 D5
- 6105-1 B5

LEGEND
 @... for provision only
 USA ... for USA version only
 E-EU ... for East European version only
 J ... for Japanese version only

☒: Vdc MW mode
 ---: Vdc FM stereo mode

CENELEC TUNER CIRCUIT

TUNER BOARD ECO6 / SYSTEMS-CENELEC

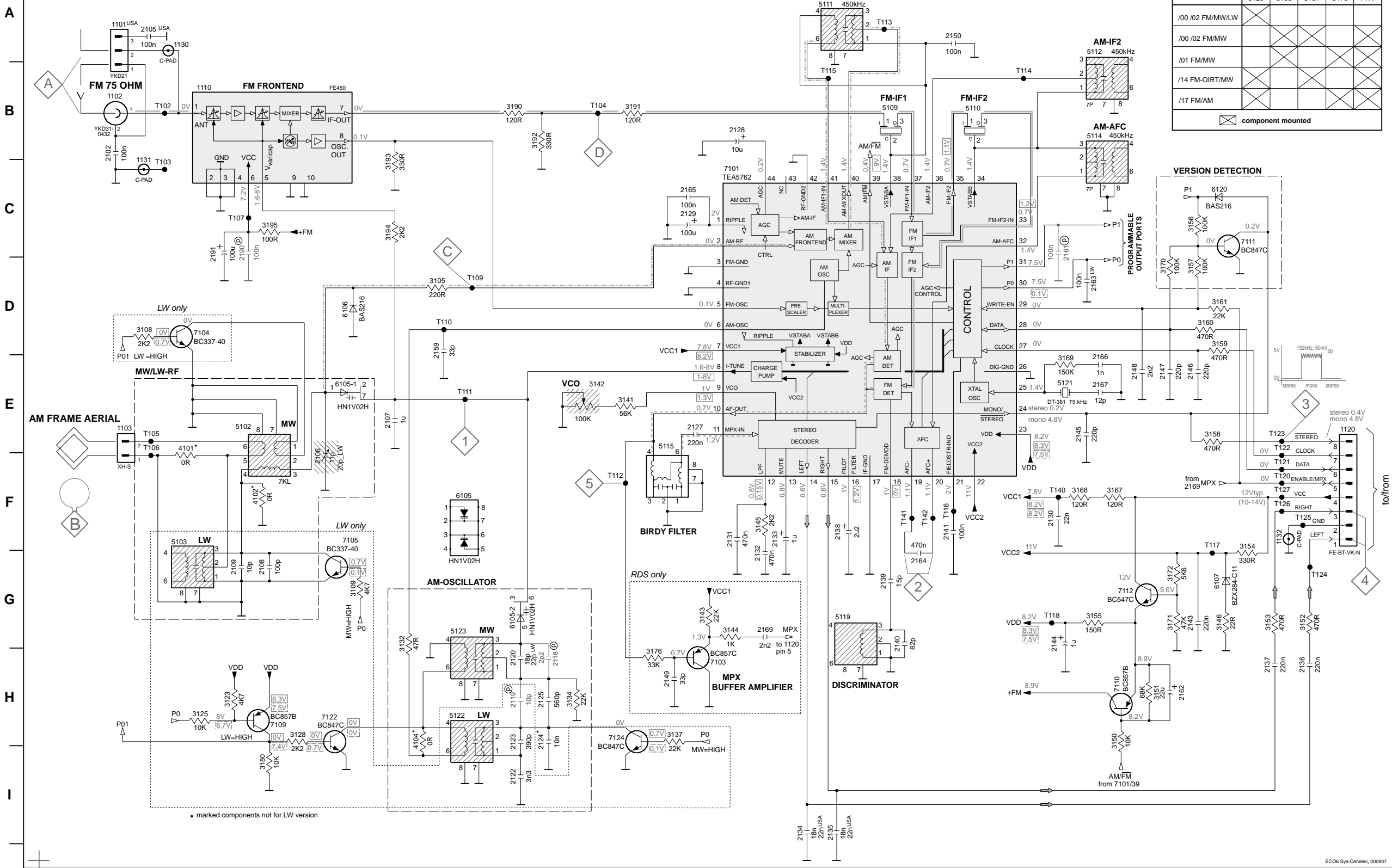

VERSION PROGRAMMING COMPONENTS

VERSION	6120	3156	3157	3170	7111
/00 /02 FM/MW/LW					
/00 /02 FM/MW					
/01 FM/MW					
/14 FM-OIRT/MW					
/17 FM/AM					

☒ component mounted

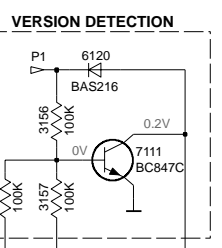

- A 1102 A2
- A 1102 B1
- A 1103 E2
- A 1110 B2
- A 1120 E14
- A 1130 A2
- A 1131 C2
- A 1132 F13
- A 2102 B1
- A 2105 A2
- A 2106 E3
- A 2107 E4
- A 2108 G3
- A 2109 G3
- A 2118 H6
- A 2119 H6
- A 2120 H6
- A 2122 I6
- A 2123 H6
- A 2124 H6
- A 2125 H6
- A 2127 E7
- A 2128 B8
- A 2129 C7
- A 2130 F11
- A 2131 F8
- A 2132 F8
- A 2133 F8
- A 2134 I8
- A 2135 I9
- A 2136 H14
- A 2137 H13
- A 2138 F9
- A 2139 G9
- A 2140 G9
- A 2141 F10
- A 2143 G12
- A 2144 G11
- A 2145 E11
- A 2146 E12
- A 2147 E12
- A 2148 E2
- A 2149 H7
- A 2150 A10
- A 2159 D5
- A 2161 C11
- A 2162 H12
- A 2163 D11
- A 2164 G10
- A 2165 C7
- A 2166 E11
- A 2167 E11
- A 2169 G8
- A 2180 C3
- A 2191 C3
- A 3105 D5
- A 3108 D2
- A 3109 G4
- A 3123 H3
- A 3125 H2
- A 3128 H3
- A 3132 G4
- A 3134 H6
- A 3137 H7
- A 3141 E7
- A 3142 E6
- A 3143 G7
- A 3144 G8
- A 3145 F8
- A 3146 G13
- A 3150 H12
- A 3151 H12
- A 3152 G14
- A 3153 G13
- A 3154 F13
- A 3155 G12
- A 3156 C12
- A 3157 D12
- A 3158 E13
- A 3159 D13
- A 3160 D13
- A 3161 D13
- A 3167 F12
- A 3168 F11
- A 3169 E11
- A 3170 D12
- A 3171 G12
- A 3172 G12
- A 3176 H7
- A 3180 I3
- A 3191 B7
- A 3192 B6
- A 3193 C4
- A 3194 C4
- A 3195 C3
- A 4101 E2
- A 4102 F3
- A 4104 H5
- A 5102 E3
- A 5103 F2
- A 5109 B9
- A 5110 B10
- A 5111 A9
- A 5112 A11
- A 5114 B11
- A 5115 E7
- A 5119 G9
- A 5121 E11
- A 5122 H5
- A 5123 G5
- A 6105-1 E4
- A 6105-2 G6
- B 6106 D4
- B 6107 G13
- B 6120 C13
- B 7101 C8
- B 7103 H8
- B 7104 D2
- B 7105 F4
- B 7109 H3
- B 7110 H12
- B 7111 C13
- B 7112 G12
- B 7122 H4
- B 7124 H7
- B 7102 B2
- B 7103 B2
- B 7104 B6
- B 7105 E2
- B 7106 E2
- B 7107 C3
- B 7109 D5
- B 7110 D5
- B 7111 E5
- B 7112 F7
- B 7113 A9
- B 7114 B11
- B 7116 F10
- B 7117 F13
- B 7118 G11
- B 7120 F13
- B 7121 F13
- B 7122 E13
- B 7123 F13
- B 7124 G14
- B 7125 F14
- B 7126 F13
- B 7127 F13
- B 7140 F11
- B 7141 F10
- B 7142 F10
- C 2122 H6
- C 2123 H6
- C 2124 H6
- C 2125 H6
- C 2126 H6
- C 2127 E7
- C 2128 B8
- C 2129 C7
- C 2130 F11
- C 2131 F8
- C 2132 F8
- C 2133 F8
- C 2134 I8
- C 2135 I9
- C 2136 H14
- C 2137 H13
- C 2138 F9
- C 2139 G9
- C 2140 G9
- C 2141 F10
- C 2143 G12
- C 2144 G11
- C 2145 E11
- C 2146 E12
- C 2147 E12
- C 2148 E2
- C 2149 H7
- C 2150 A10
- C 2159 D5
- C 2161 C11
- C 2162 H12
- C 2163 D11
- C 2164 G10
- C 2165 C7
- C 2166 E11
- C 2167 E11
- C 2169 G8
- C 2180 C3
- C 2191 C3
- C 3105 D5
- C 3108 D2
- C 3109 G4
- C 3123 H3
- C 3125 H2
- C 3128 H3
- C 3132 G4
- C 3134 H6
- C 3137 H7
- C 3141 E7
- C 3142 E6
- C 3143 G7
- C 3144 G8
- C 3145 F8
- C 3146 G13
- C 3150 H12
- C 3151 H12
- C 3152 G14
- C 3153 G13
- C 3154 F13
- C 3155 G12
- C 3156 C12
- C 3157 D12
- C 3158 E13
- C 3159 D13
- C 3160 D13
- C 3161 D13
- C 3167 F12
- C 3168 F11
- C 3169 E11
- C 3170 D12
- C 3171 G12
- C 3172 G12
- C 3176 H7
- C 3180 I3
- C 3191 B7
- C 3192 B6
- C 3193 C4
- C 3194 C4
- C 3195 C3
- C 4101 E2
- C 4102 F3
- C 4104 H5
- C 5102 E3
- C 5103 F2
- C 5109 B9
- C 5110 B10
- C 5111 A9
- C 5112 A11
- C 5114 B11
- C 5115 E7
- C 5119 G9
- C 5121 E11
- C 5122 H5
- C 5123 G5
- C 6105-1 E4
- C 6105-2 G6
- D 2159 D5
- D 2161 C11
- D 2162 H12
- D 2163 D11
- D 2164 G10
- D 2165 C7
- D 2166 E11
- D 2167 E11
- D 2169 G8
- D 2180 C3
- D 2191 C3
- D 3105 D5
- D 3108 D2
- D 3109 G4
- D 3123 H3
- D 3125 H2
- D 3128 H3
- D 3132 G4
- D 3134 H6
- D 3137 H7
- D 3141 E7
- D 3142 E6
- D 3143 G7
- D 3144 G8
- D 3145 F8
- D 3146 G13
- D 3150 H12
- D 3151 H12
- D 3152 G14
- D 3153 G13
- D 3154 F13
- D 3155 G12
- D 3156 C12
- D 3157 D12
- D 3158 E13
- D 3159 D13
- D 3160 D13
- D 3161 D13
- D 3167 F12
- D 3168 F11
- D 3169 E11
- D 3170 D12
- D 3171 G12
- D 3172 G12
- D 3176 H7
- D 3180 I3
- D 3191 B7
- D 3192 B6
- D 3193 C4
- D 3194 C4
- D 3195 C3
- D 4101 E2
- D 4102 F3
- D 4104 H5
- D 5102 E3
- D 5103 F2
- D 5109 B9
- D 5110 B10
- D 5111 A9
- D 5112 A11
- D 5114 B11
- D 5115 E7
- D 5119 G9
- D 5121 E11
- D 5122 H5
- D 5123 G5
- D 6105-1 E4
- D 6105-2 G6
- E 3108 D2
- E 3109 G4
- E 3123 H3
- E 3125 H2
- E 3128 H3
- E 3132 G4
- E 3134 H6
- E 3137 H7
- E 3141 E7
- E 3142 E6
- E 3143 G7
- E 3144 G8
- E 3145 F8
- E 3146 G13
- E 3150 H12
- E 3151 H12
- E 3152 G14
- E 3153 G13
- E 3154 F13
- E 3155 G12
- E 3156 C12
- E 3157 D12
- E 3158 E13
- E 3159 D13
- E 3160 D13
- E 3161 D13
- E 3167 F12
- E 3168 F11
- E 3169 E11
- E 3170 D12
- E 3171 G12
- E 3172 G12
- E 3176 H7
- E 3180 I3
- E 3191 B7
- E 3192 B6
- E 3193 C4
- E 3194 C4
- E 3195 C3
- E 4101 E2
- E 4102 F3
- E 4104 H5
- E 5102 E3
- E 5103 F2
- E 5109 B9
- E 5110 B10
- E 5111 A9
- E 5112 A11
- E 5114 B11
- E 5115 E7
- E 5119 G9
- E 5121 E11
- E 5122 H5
- E 5123 G5
- E 6105-1 E4
- E 6105-2 G6
- F 3108 D2
- F 3109 G4
- F 3123 H3
- F 3125 H2
- F 3128 H3
- F 3132 G4
- F 3134 H6
- F 3137 H7
- F 3141 E7
- F 3142 E6
- F 3143 G7
- F 3144 G8
- F 3145 F8
- F 3146 G13
- F 3150 H12
- F 3151 H12
- F 3152 G14
- F 3153 G13
- F 3154 F13
- F 3155 G12
- F 3156 C12
- F 3157 D12
- F 3158 E13
- F 3159 D13
- F 3160 D13
- F 3161 D13
- F 3167 F12
- F 3168 F11
- F 3169 E11
- F 3170 D12
- F 3171 G12
- F 3172 G12
- F 3176 H7
- F 3180 I3
- F 3191 B7
- F 3192 B6
- F 3193 C4
- F 3194 C4
- F 3195 C3
- F 4101 E2
- F 4102 F3
- F 4104 H5
- F 5102 E3
- F 5103 F2
- F 5109 B9
- F 5110 B10
- F 5111 A9
- F 5112 A11
- F 5114 B11
- F 5115 E7
- F 5119 G9
- F 5121 E11
- F 5122 H5
- F 5123 G5
- F 6105-1 E4
- F 6105-2 G6
- G 3108 D2
- G 3109 G4
- G 3123 H3
- G 3125 H2
- G 3128 H3
- G 3132 G4
- G 3134 H6
- G 3137 H7
- G 3141 E7
- G 3142 E6
- G 3143 G7
- G 3144 G8
- G 3145 F8
- G 3146 G13
- G 3150 H12
- G 3151 H12
- G 3152 G14
- G 3153 G13
- G 3154 F13
- G 3155 G12
- G 3156 C12
- G 3157 D12
- G 3158 E13
- G 3159 D13
- G 3160 D13
- G 3161 D13
- G 3167 F12
- G 3168 F11
- G 3169 E11
- G 3170 D12
- G 3171 G12
- G 3172 G12
- G 3176 H7
- G 3180 I3
- G 3191 B7
- G 3192 B6
- G 3193 C4
- G 3194 C4
- G 3195 C3
- G 4101 E2
- G 4102 F3
- G 4104 H5
- G 5102 E3
- G 5103 F2
- G 5109 B9
- G 5110 B10
- G 5111 A9
- G 5112 A11
- G 5114 B11
- G 5115 E7
- G 5119 G9
- G 5121 E11
- G 5122 H5
- G 5123 G5
- G 6105-1 E4
- G 6105-2 G6
- H 3108 D2
- H 3109 G4
- H 3123 H3
- H 3125 H2
- H 3128 H3
- H 3132 G4
- H 3134 H6
- H 3137 H7
- H 3141 E7
- H 3142 E6
- H 3143 G7
- H 3144 G8
- H 3145 F8
- H 3146 G13
- H 3150 H12
- H 3151 H12
- H 3152 G14
- H 3153 G13
- H 3154 F13
- H 3155 G12
- H 3156 C12
- H 3157 D12
- H 3158 E13
- H 3159 D13
- H 3160 D13
- H 3161 D13
- H 3167 F12
- H 3168 F11
- H 3169 E11
- H 3170 D12
- H 3171 G12
- H 3172 G12
- H 3176 H7
- H 3180 I3
- H 3191 B7
- H 3192 B6
- H 3193 C4
- H 3194 C4
- H 3195 C3
- H 4101 E2
- H 4102 F3
- H 4104 H5
- H 5102 E3
- H 5103 F2
- H 5109 B9
- H 5110 B10
- H 5111 A9
- H 5112 A11
- H 5114 B11
- H 5115 E7
- H 5119 G9
- H 5121 E11
- H 5122 H5
- H 5123 G5
- H 6105-1 E4
- H 6105-2 G6
- I 3108 D2
- I 3109 G4
- I 3123 H3
- I 3125 H2
- I 3128 H3
- I 3132 G4
- I 3134 H6
- I 3137 H7
- I 3141 E7
- I 3142 E6
- I 3143 G7
- I 3144 G8
- I 3145 F8
- I 3146 G13
- I 3150 H12
- I 3151 H12
- I 3152 G14
- I 3153 G13
- I 3154 F13
- I 3155 G12
- I 3156 C12
- I 3157 D12
- I 3158 E13
- I 3159 D13
- I 3160 D13
- I 3161 D13
- I 3167 F12
- I 3168 F11
- I 3169 E11
- I 3170 D12
- I 3171 G12
- I 3172 G12
- I 3176 H7
- I 3180 I3
- I 3191 B7
- I 3192 B6
- I 3193 C4
- I 3194 C4
- I 3195 C3
- I 4101 E2
- I 4102 F3
- I 4104 H5
- I 5102 E3
- I 5103 F2
- I 5109 B9
- I 5110 B10
- I 5111 A9
- I 5112 A11
- I 5114 B11
- I 5115 E7
- I 5119 G9
- I 5121 E11
- I 5122 H5
- I 5123 G5
- I 6105-1 E4
- I 6105-2 G6

LEGEND

- * ... only assembled in FM/AM-version
- Ⓢ ... for provision only
- USA ... for USA version only
- LW ... for LW version only

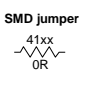

- ...V FM mode stereo
- ...V MW mode
- ...V LW mode
- voltages measured while set is tuned to a strong transmitter

Signal path

- FM
- - - AM
- - - MPX (Audio Frequency)
- ⇒ AF - left/right

SUPPLY CIRCUIT

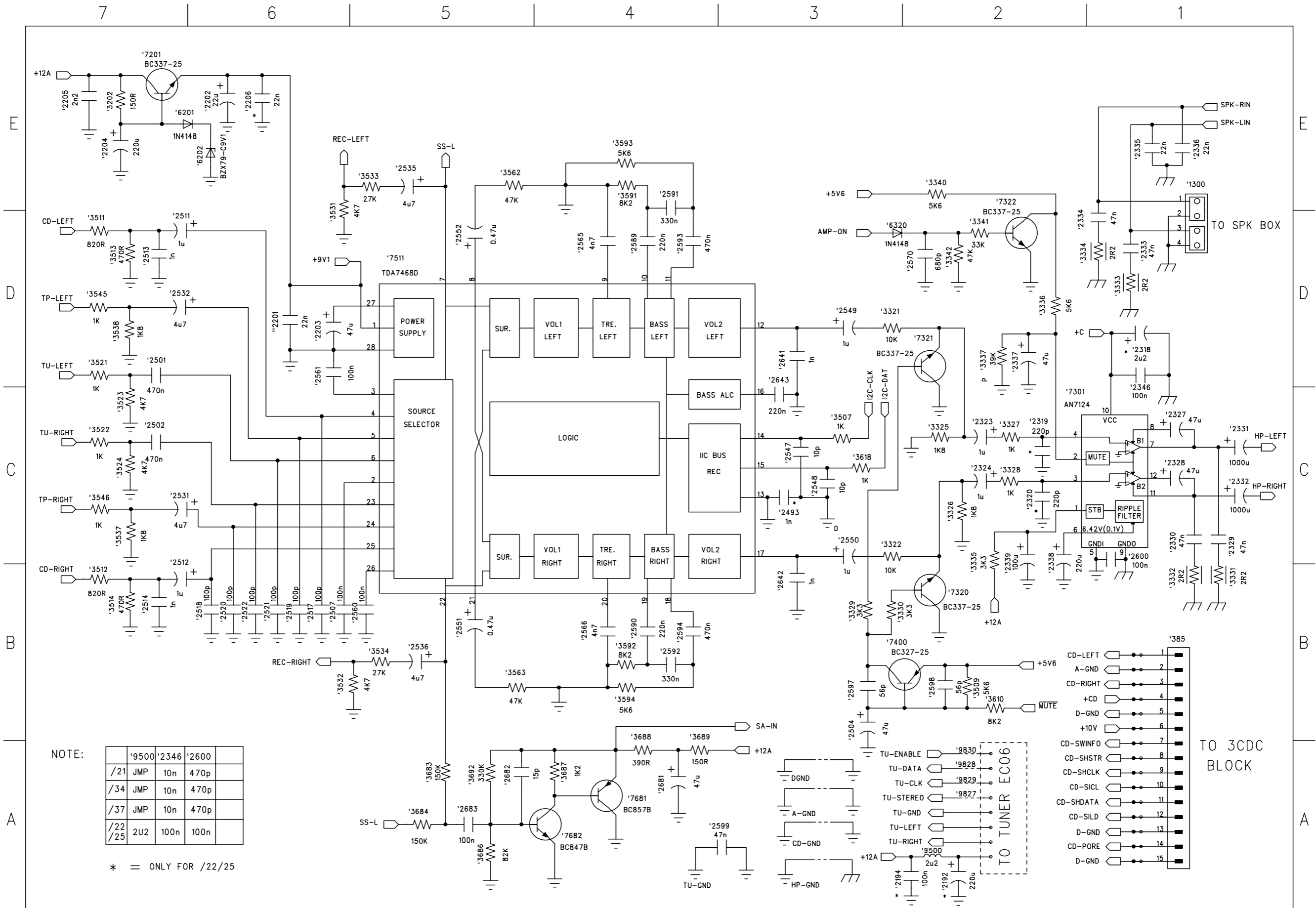

TAPE CIRCUIT

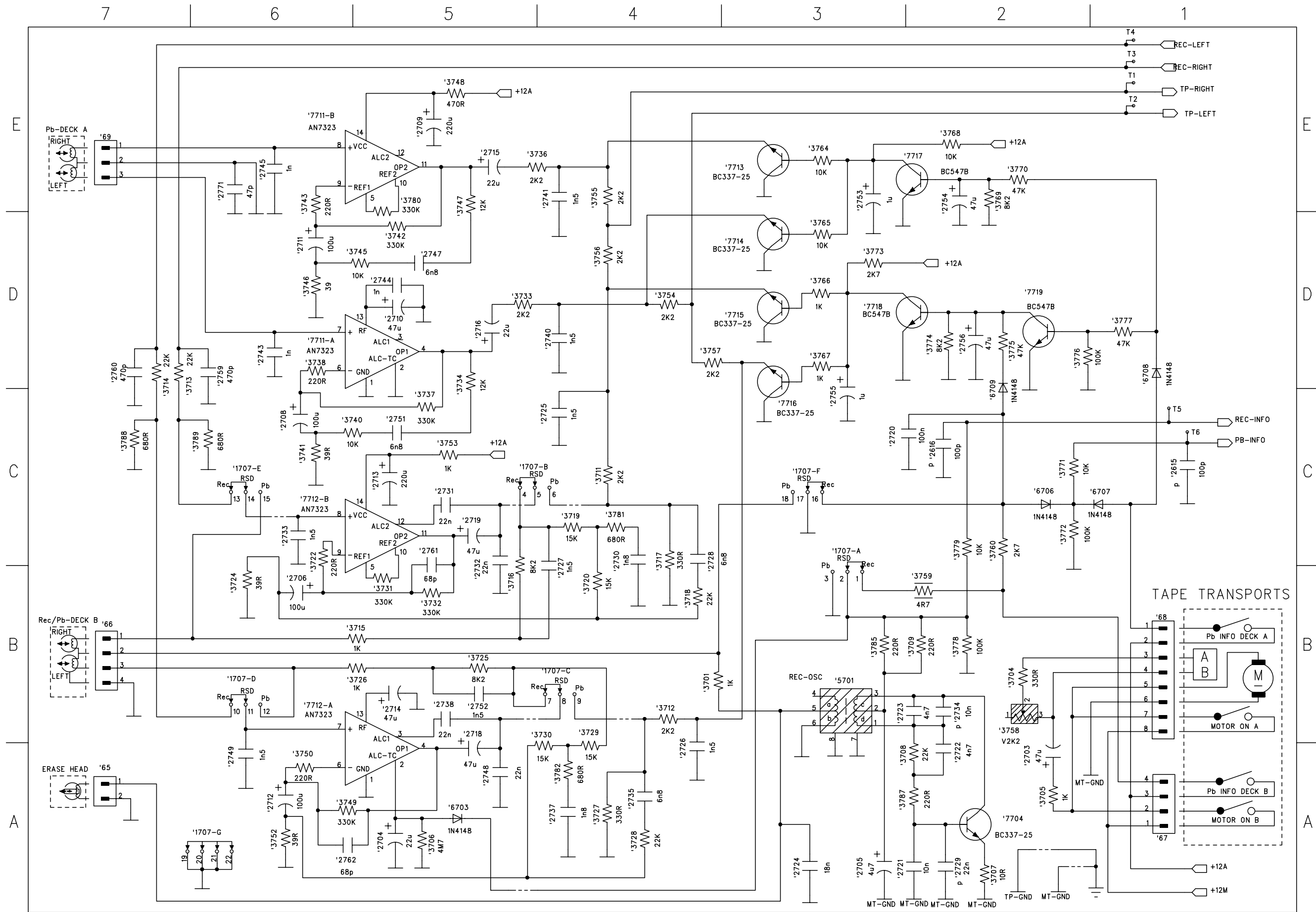

POWER AMPLIFIER & ECO CIRCUIT

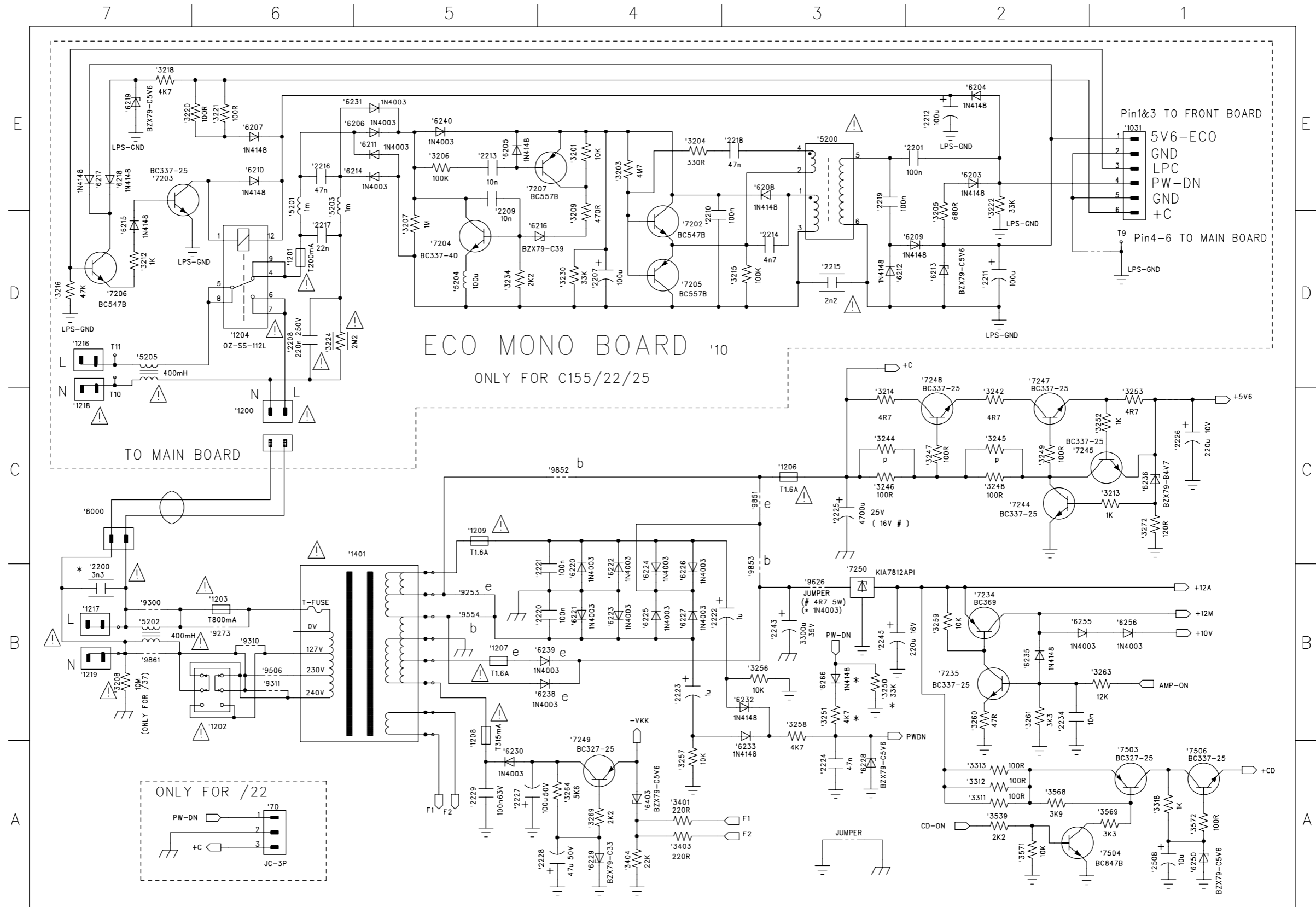

NOTE:

	'10	'8000	'5202	'9300	'9626	'1203	'9273	'1202	'9310	'9311	'9506	'3208
/21			×		JMP	×		×				
/22	×	×	×		1N		×				×	
/25					4003							
/34			×		JMP		×				×	
/37			×		4R7		×		×			×
					5W							

e = ONLY FOR /21
 * = ONLY FOR /22/25
 # = ONLY FOR /37
 b = BOTH FOR /22/25/34/37

FRONT PART - COMPONENT LAYOUT

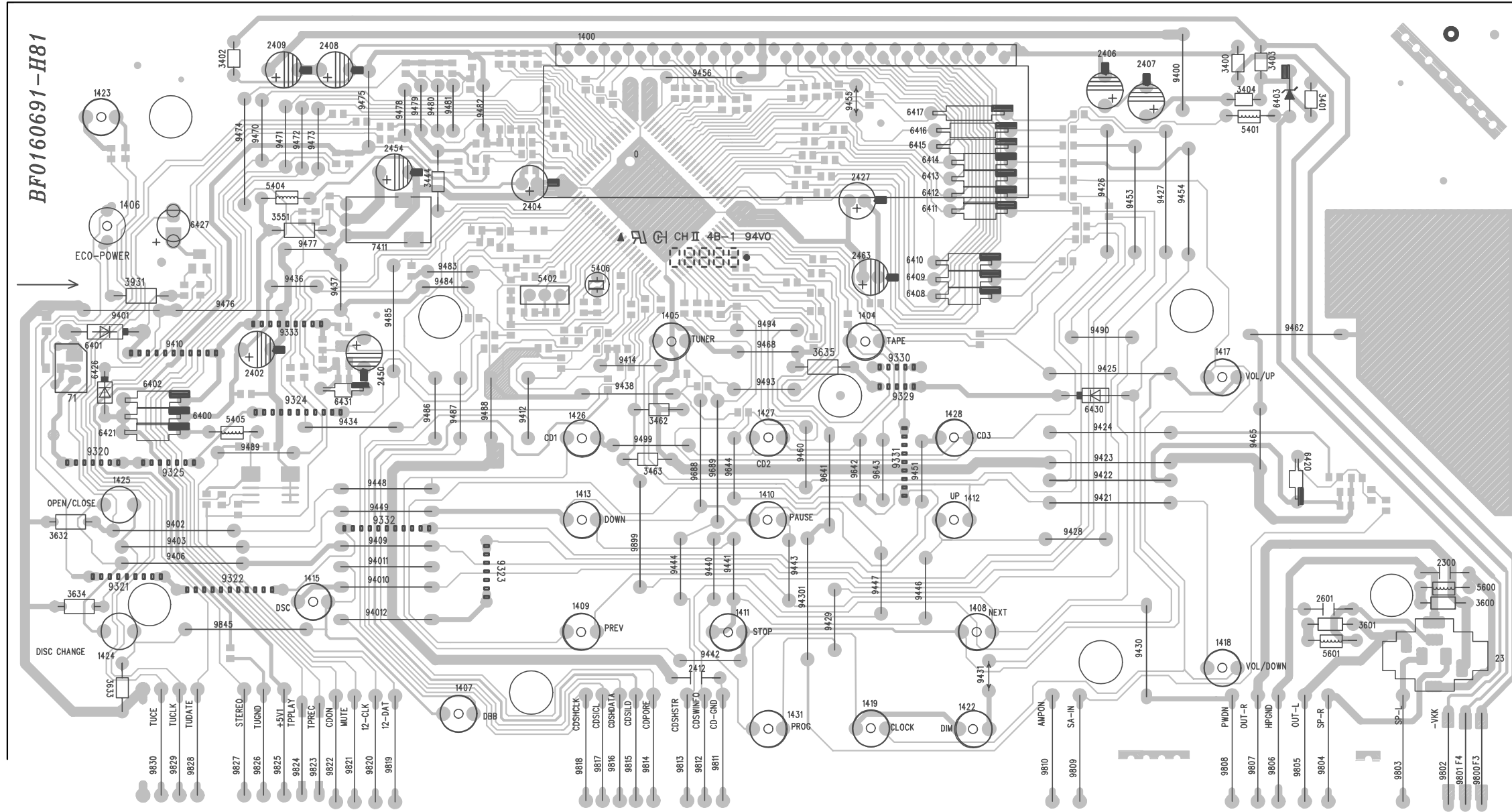

FRONT PART - SMD LAYOUT

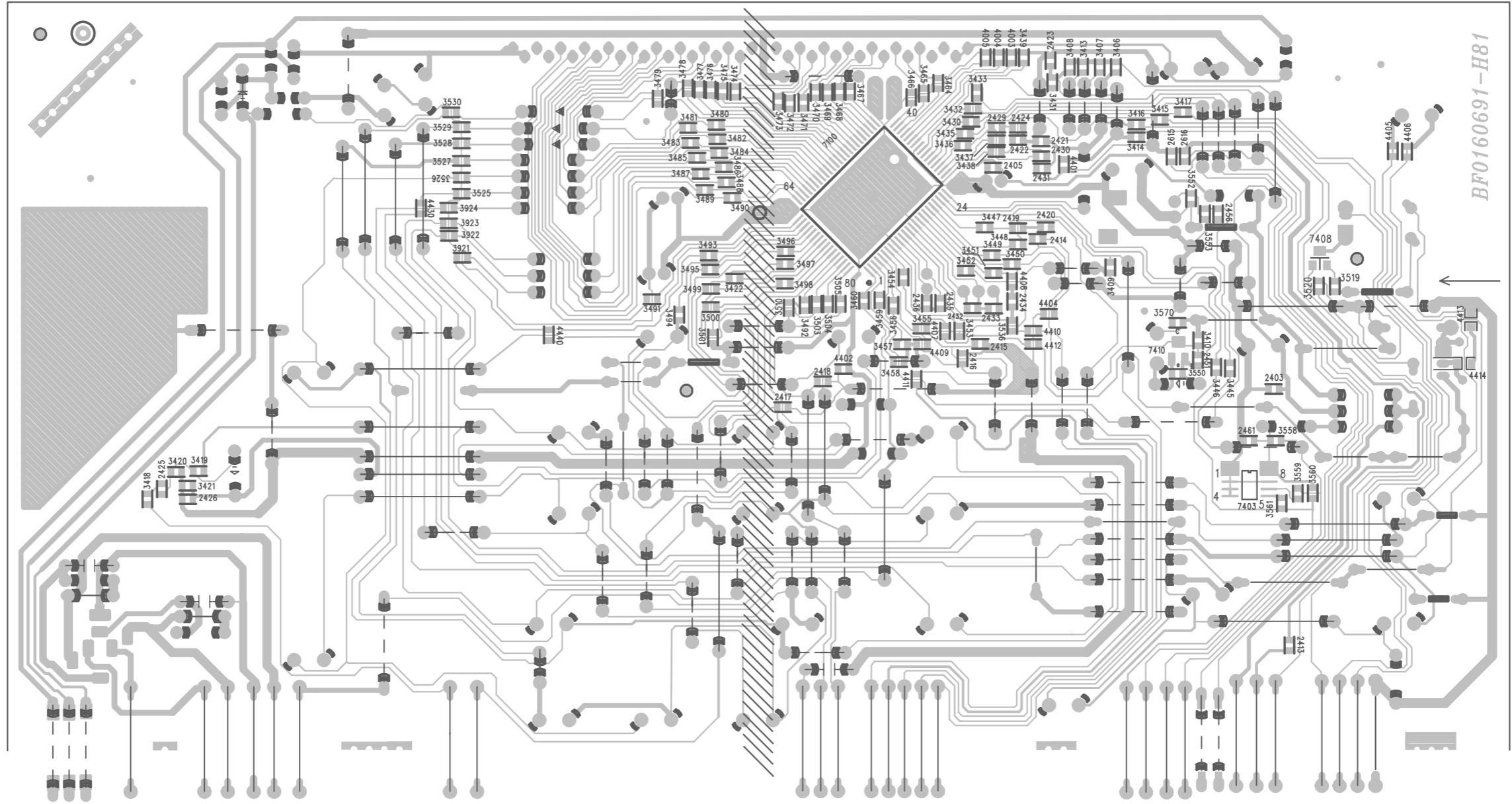

FRONT CIRCUIT

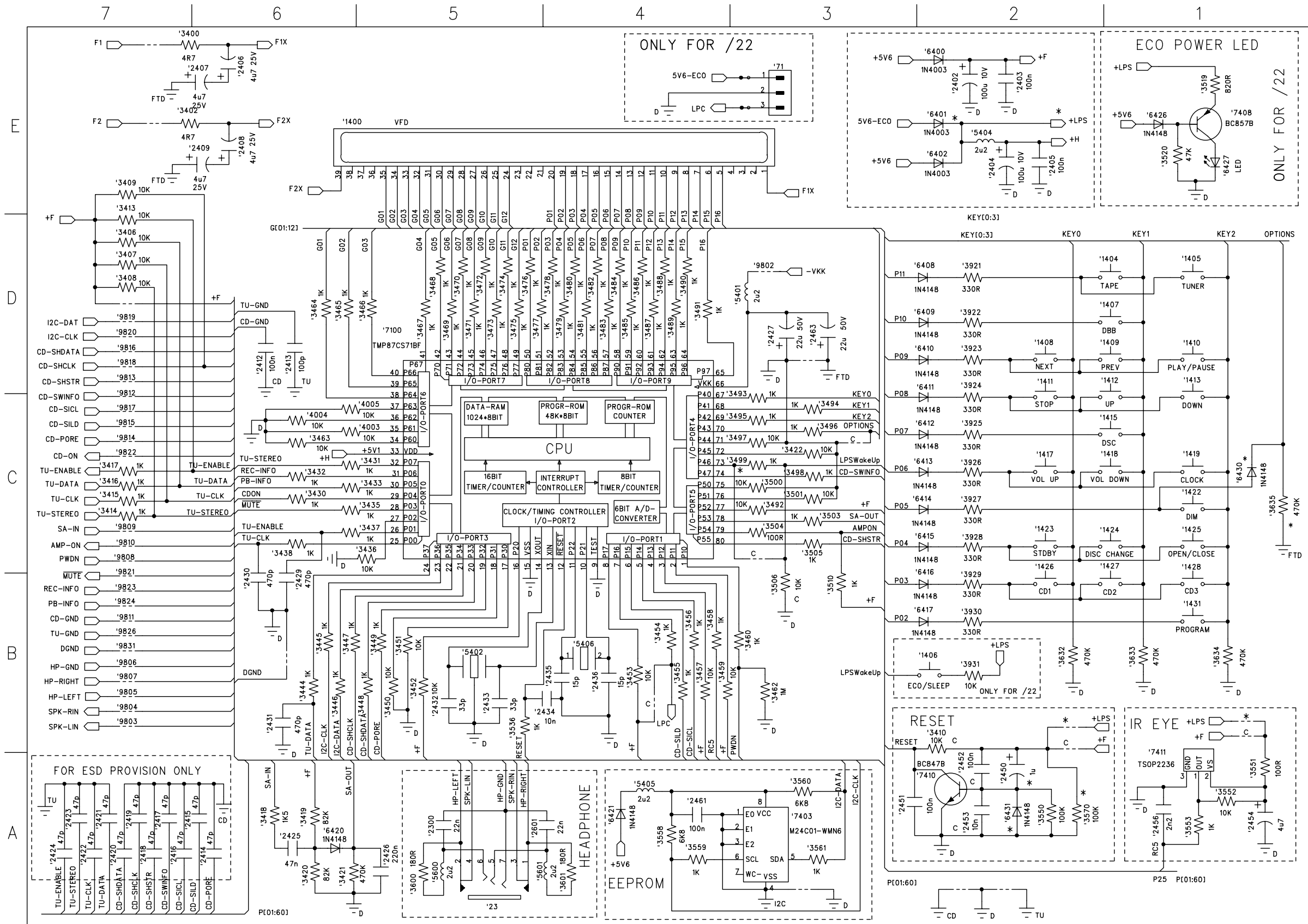

NOTE:

	'3454	'3496
/21	10K	10K
/22	1K	1K
/34	10K	10K
/37	10K	10K

- e = ONLY FOR /21
- * = ONLY FOR /22/25
- # = ONLY FOR /37
- C = BOTH FOR /21/34/37

TDA7468 INTERNAL BLOCK DIAGRAM

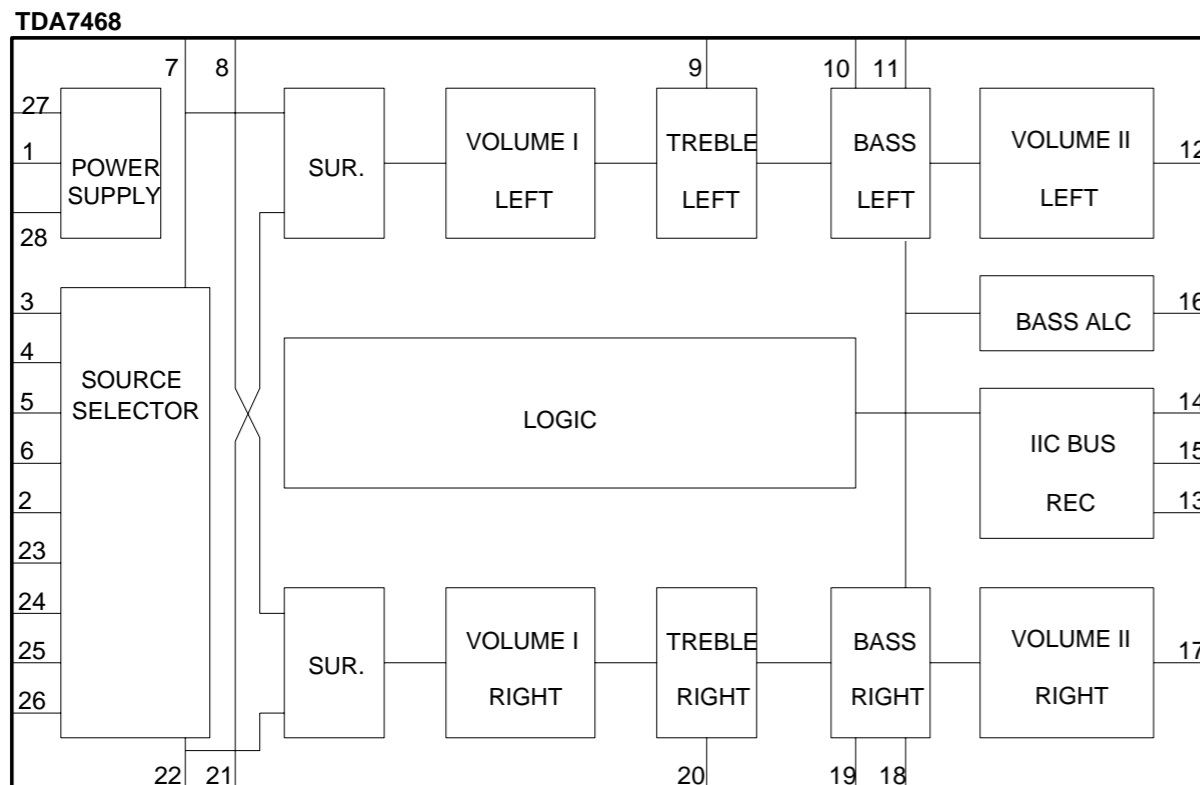

ELECTRICAL PARTS LIST - FRONT PART & COMBI PART

- MISCELLANEOUS -

23	9965 000 11366	HEADPHONE SOCKET D3,5
1101	4822 267 10283	YKD31-0432
1102	9965 000 11365	FM ANTENNA SOCKET /21
1110	2422 542 90071	FM FRONTEND FE450-G01
1202	△9965 000 11348	VOLTAGE SELECTOR 2P /21

1206	△9965 000 11349	FUSE 1,6A 250V T218
1207	△9965 000 11349	FUSE 1,6A 250V T218 /21
1208	△9965 000 11350	FUSE 315MA 250V T 218
1209	△9965 000 11349	FUSE 1,6A 250V T218
1300	9965 000 16263	SPEAKER TERMINAL 4P

1400	9965 000 11374	FTD DISPLAY HNA-12SS09T
1404	9965 000 11259	TACT SWITCH
1405	9965 000 11259	TACT SWITCH
1406	9965 000 11259	TACT SWITCH /22/25
1407	9965 000 11259	TACT SWITCH

1408	9965 000 11259	TACT SWITCH
1409	9965 000 11259	TACT SWITCH
1410	9965 000 11259	TACT SWITCH
1411	9965 000 11259	TACT SWITCH
1412	9965 000 11259	TACT SWITCH

1413	9965 000 11259	TACT SWITCH
1415	9965 000 11259	TACT SWITCH
1417	9965 000 11259	TACT SWITCH
1418	9965 000 11259	TACT SWITCH
1419	9965 000 11259	TACT SWITCH

1422	9965 000 11259	TACT SWITCH
1423	9965 000 11259	TACT SWITCH
1424	9965 000 11259	TACT SWITCH
1425	9965 000 11259	TACT SWITCH
1426	9965 000 11259	TACT SWITCH

1427	9965 000 11259	TACT SWITCH
1428	9965 000 11259	TACT SWITCH
1431	9965 000 11259	TACT SWITCH
1507	9965 000 11353	SOCKET, FLEX CABLE 15PIN
1707	9965 000 11378	SWITCH SLIDE 6P2T

- RESISTORS -

3331	△9965 000 11219	FUSE RES 1/4W(J) 2,2Ω
3332	△9965 000 11219	FUSE RES 1/4W(J) 2,2Ω
3333	△9965 000 11219	FUSE RES 1/4W(J) 2,2Ω
3334	△9965 000 11219	FUSE RES 1/4W(J) 2,2Ω
3462	9965 000 16265	S CARBON 1MΩ 1/4W /22/25

3758	9965 000 11362	POTENTIAL METER 2,2KΩ
3759	△9965 000 11286	RES FUSE 4Ω7 1/4W

- COILS & FILTERS -

5102	4822 157 71634	MW AERIAL
5109	9965 000 11355	CER. FIL SFE10,7MS3AZ /21
5109	9965 000 16266	CER FIL SFE10,7MJ A1 /22/25
5110	9965 000 11355	CER FILTER SFE10,7MS3AZ
5111	9965 000 11355	IND VAR 7MM 7PY 450KHZ

5112	9965 000 11357	IND VAR 7MM 7P 450KHZ
5114	9965 000 11357	IND VAR 7MM 7P 450KHZ
5115	9965 000 16267	BIRDIE COIL /22/25
5118	9965 000 16268	IND FXD SM 0μ10 /22/25
5119	4822 157 11443	2μ4 10M7

5121	4822 242 10261	T6252F00 (75KHZ)
5123	2422 549 44108	IND VAR 7MM 7PY 796KHZ
5130	4822 157 11843	MD7B-01F /21
5131	4822 157 11843	MD7B-01F /21
5202	9965 000 11379	FILTER MAINS 400μH

5401	9965 000 11361	FIXED IND 2,2μH K TP=52MM
5402	9965 000 11372	X'TAL 8MHZ
5404	9965 000 11361	FIXED IND 2,2μH K TP=52MM
5405	9965 000 11361	FIXED IND 2,2μH K TP=52MM
5406	9965 000 11373	X'TAL 32,768KHZ

5600	9965 000 11361	FIXED IND 2,2μH K TP=52MM
5601	9965 000 11361	FIXED IND 2,2μH K TP=52MM
5701	4822 157 10371	COIL

- DIODES -

6103	5322 130 34337	BAV99
6105	4822 130 83075	HN1V02H-B
6106	9340 255 30135	BAS216
6107	9340 386 90115	BZX284-C11
6130	4822 130 82833	1SV228 /21

6131	4822 130 82833	1SV228 /21
6201	4822 130 30621	1N4148
6202	4822 130 30862	BZX79-B9V1
6220	4822 130 31878	1N4003G
6221	4822 130 31878	1N4003G

- CAPACITORS -

2106	9965 000 11368	CER TRIMMER 3P-11P 100V /21
2106	9965 000 16264	CER TRIMMER 20P /22/25
2155	9965 000 11368	CER TRIMMER 3P-11P /21
2200	9965 000 17110	CER.CAP Y2 250V 3.3NF /22/25
2453	4822 130 30621	1N4148 /22/25

- RESISTORS -

3142	4822 100 12159	100KΩ 30%
------	----------------	-----------

MICROPROCESSOR TMP87CS71 INTERNAL BLOCK DIAGRAM

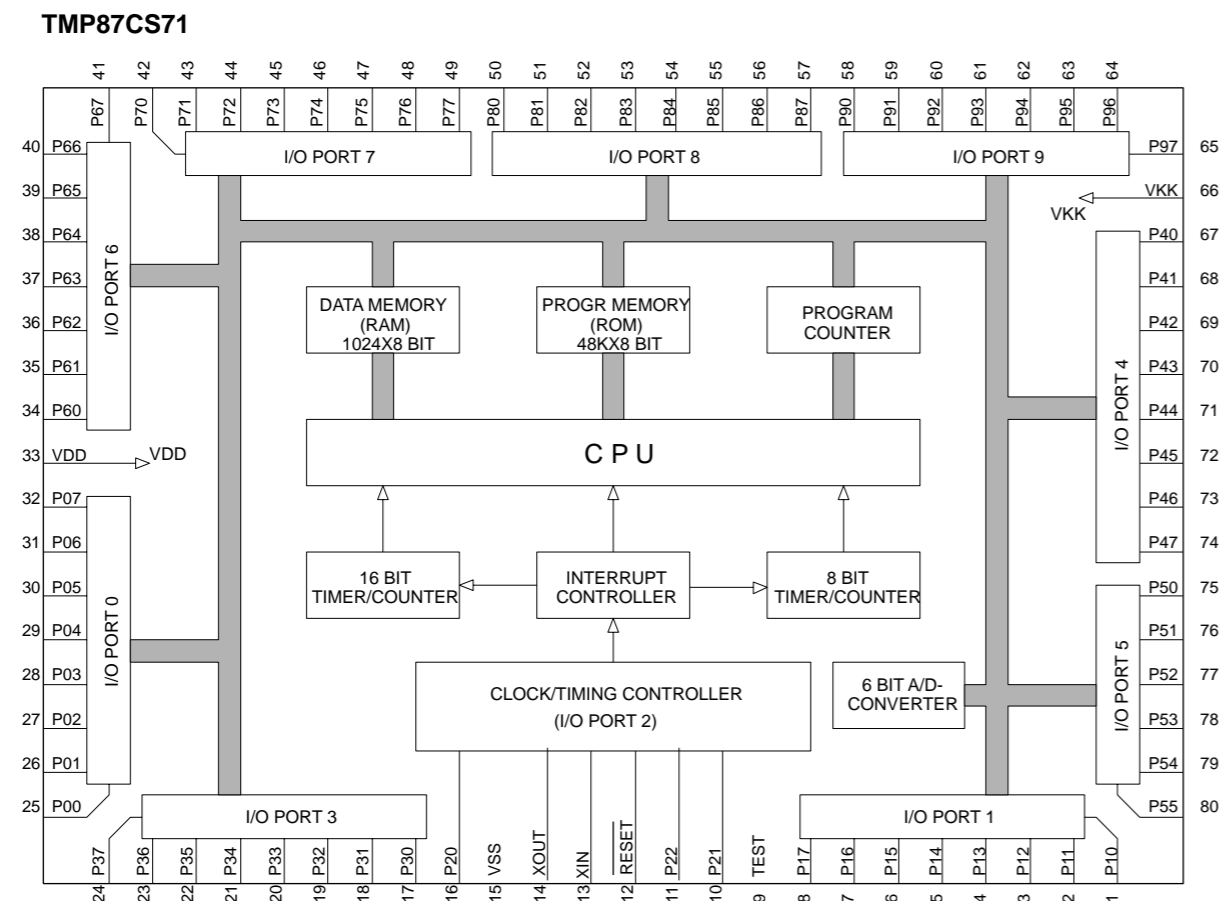

ELECTRICAL PARTS LIST - FRONT PART & COMBI PART**- DIODES -**

6222	4822 130 31878	1N4003G
6223	4822 130 31878	1N4003G
6224	4822 130 31878	1N4003G
6225	4822 130 31878	1N4003G
6226	4822 130 31878	1N4003G
6227	4822 130 31878	1N4003G
6228	4822 130 34173	BZX79-C5V6
6229	4822 130 34142	BZX79-B33
6230	4822 130 31878	1N4003G
6232	4822 130 30621	1N4148
6233	4822 130 30621	1N4148
6235	4822 130 30621	1N4148
6236	4822 130 34174	BZX79-B4V7
6238	4822 130 31878	1N4003G /21
6239	4822 130 31878	1N4003G /21
6250	4822 130 34173	BZX79-C5V6
6255	4822 130 31878	1N4003G
6256	4822 130 31878	1N4003G
6266	4822 130 30621	1N4148 /22/25
6320	4822 130 30621	1N4148
6400	4822 130 31878	1N4003G
6401	4822 130 31878	1N4003G /22/25
6402	4822 130 31878	1N4003G
6403	4822 130 34173	BZX79-C5V6
6408	4822 130 30621	1N4148
6409	4822 130 30621	1N4148
6410	4822 130 30621	1N4148
6411	4822 130 30621	1N4148
6412	4822 130 30621	1N4148
6413	4822 130 30621	1N4148
6414	4822 130 30621	1N4148
6415	4822 130 30621	1N4148
6416	4822 130 30621	1N4148
6417	4822 130 30621	1N4148
6420	4822 130 30621	1N4148
6421	4822 130 30621	1N4148
6426	4822 130 30621	1N4148 /22/25
6427	9322 179 76676	LED VS LTL-816EELC /22/25
6430	4822 130 30621	1N4148 /22/25
6703	4822 130 30621	1N4148
6706	4822 130 30621	1N4148
6707	4822 130 30621	1N4148
6708	4822 130 30621	1N4148
6709	4822 130 30621	1N4148

- IC & TRANSISTORS -

7100	3139 110 53481	TMP87CS71BF-4N94
7101	9351 772 20557	IC SM TEA5762H/V1
7102	4822 130 42131	BF550 /21
7110	4822 130 60373	BC856B
7111	5322 130 42755	BC847C
7112	4822 130 40959	BC547B
7201	4822 130 40981	BC337-25
7234	5322 130 44593	BC369
7235	4822 130 40981	BC337-25
7244	4822 130 40981	BC337-25
7245	4822 130 40981	BC337-25
7247	4822 130 40981	BC337-25
7248	4822 130 40981	BC337-25
7249	4822 130 41246	BC327-25
7250	9965 000 16574	KIA7812API TO220 ST 3P 12V
7301	4822 209 12925	AN7124
7320	4822 130 40981	BC337-25
7321	4822 130 40981	BC337-25
7322	4822 130 40981	BC337-25
7400	4822 130 41246	BC327-25
7403	9322 131 04668	IC SM M24C01-WMN6 (ST00)
7408	4822 130 60373	BC856B /22/25
7410	5322 130 60159	BC846B
7411	9965 000 11375	SENSOR RECEIVER
7503	4822 130 41246	BC327-25 /21
7504	5322 130 60159	BC846B
7506	4822 130 40981	BC337-25
7511	9322 150 74668	IC SM TDA7468D (ST00) R
7681	4822 130 60373	BC856B
7682	5322 130 60159	BC846B
7704	4822 130 40981	BC337-25
7711	4822 209 17498	AN7323
7712	4822 209 17498	AN7323
7713	4822 130 40981	BC337-25
7714	4822 130 40981	BC337-25
7715	4822 130 40981	BC337-25
7716	4822 130 40981	BC337-25
7717	4822 130 40959	BC547B
7718	4822 130 40959	BC547B
7719	4822 130 40959	BC547B

ECO POWER BOARD

TABLE OF CONTENTS

ECO Power Circuit	11-2
ECO Power Layout	11-3
Electrical Parts List	11-4

ECO POWER & AMPLIFIER CIRCUIT

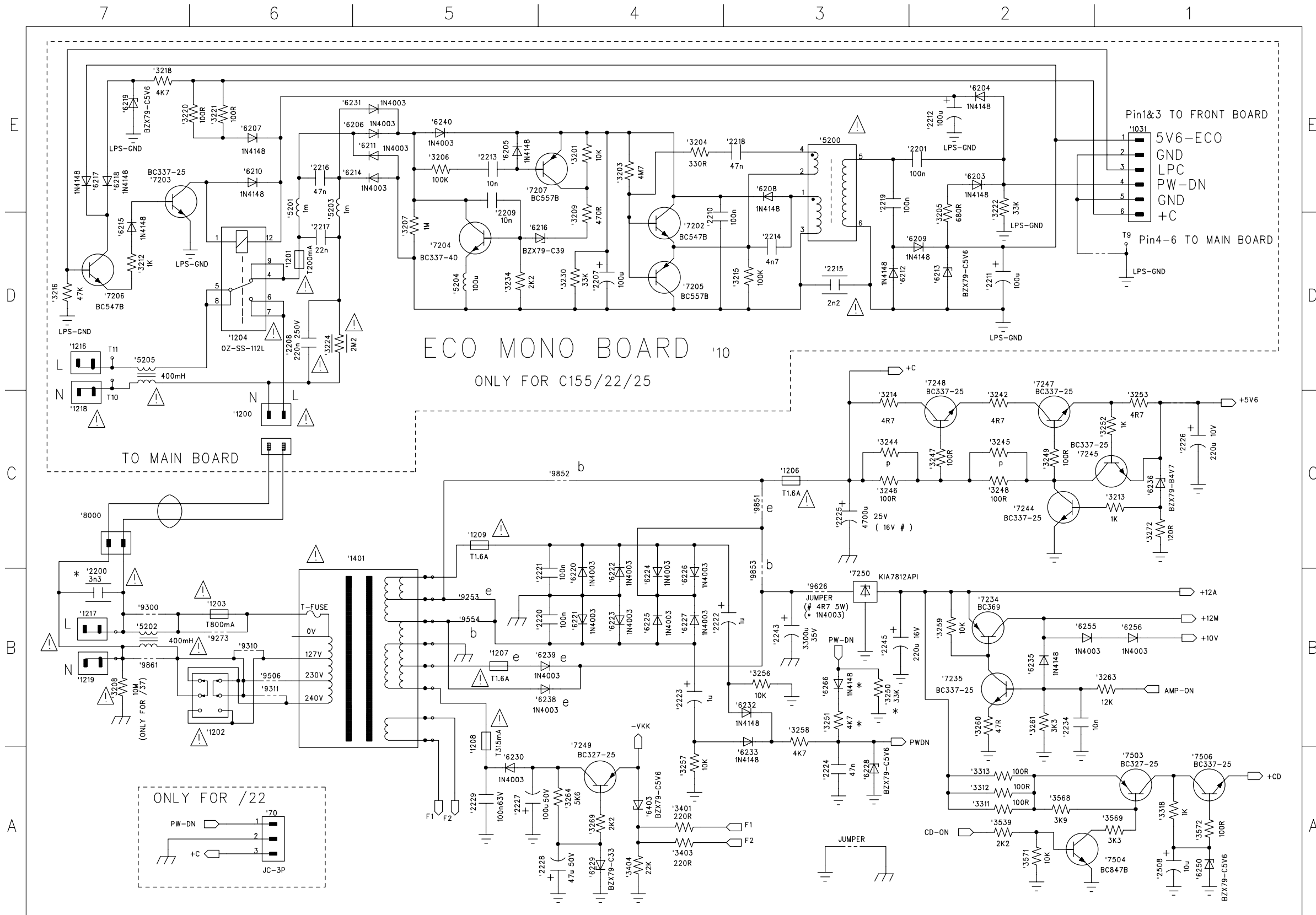

NOTE:

	'10	'8000	'5202	'9300	'9626	'1203	'9273	'1202	'9310	'9311	'9506	'3208
/21			×		JMP	×		×				
/22	×	×	×		1N		×				×	
/25					4003							
/34			×		JMP		×				×	
/37			×		4R7		×		×			×
					5W							

e = ONLY FOR /21

* = ONLY FOR /22/25

= ONLY FOR /37

b = BOTH FOR /22/25/34/37

ECO POWER BOARD LAYOUT

'1031	C1	'2208	B4	'2216	A4	'3206	B2	'3221	C2	'5204	B3	'6209	B1	'6217	C3	7205	A2
'1200	C5	'2209	B3	'2217	A4	'3207	B3	'3222	C1	'5205	A5	'6210	C4	6218	C3	7206	C3
'1201	A5	'2210	A2	'2218	B2	'3209	B2	'3224	B4	'6203	C1	'6211	A3	6219	C1	7207	B2
'1204	B4	'2211	C2	'2219	B1	'3212	C3	'3230	B3	'6204	C2	'6212	B1	6231	A3	9001	C1
'1216	B5	'2212	B2	'3201	B2	'3215	A2	'3234	B3	'6205	B2	'6213	C1	6240	A3	9002	A5
'1218	B5	'2213	B2	'3203	A2	'3216	C3	'5200	B1	'6206	A3	'6214	A3	7202	A2	9003	A2
'2201	B1	'2214	A1	'3204	A2	'3218	C2	'5201	A4	'6207	C3	'6215	C3	7203	C4	9004	B1
'2207	A2	'2215	A1	'3205	C1	'3220	C3	'5203	A4	'6208	A2	'6216	B3	7204	B3		

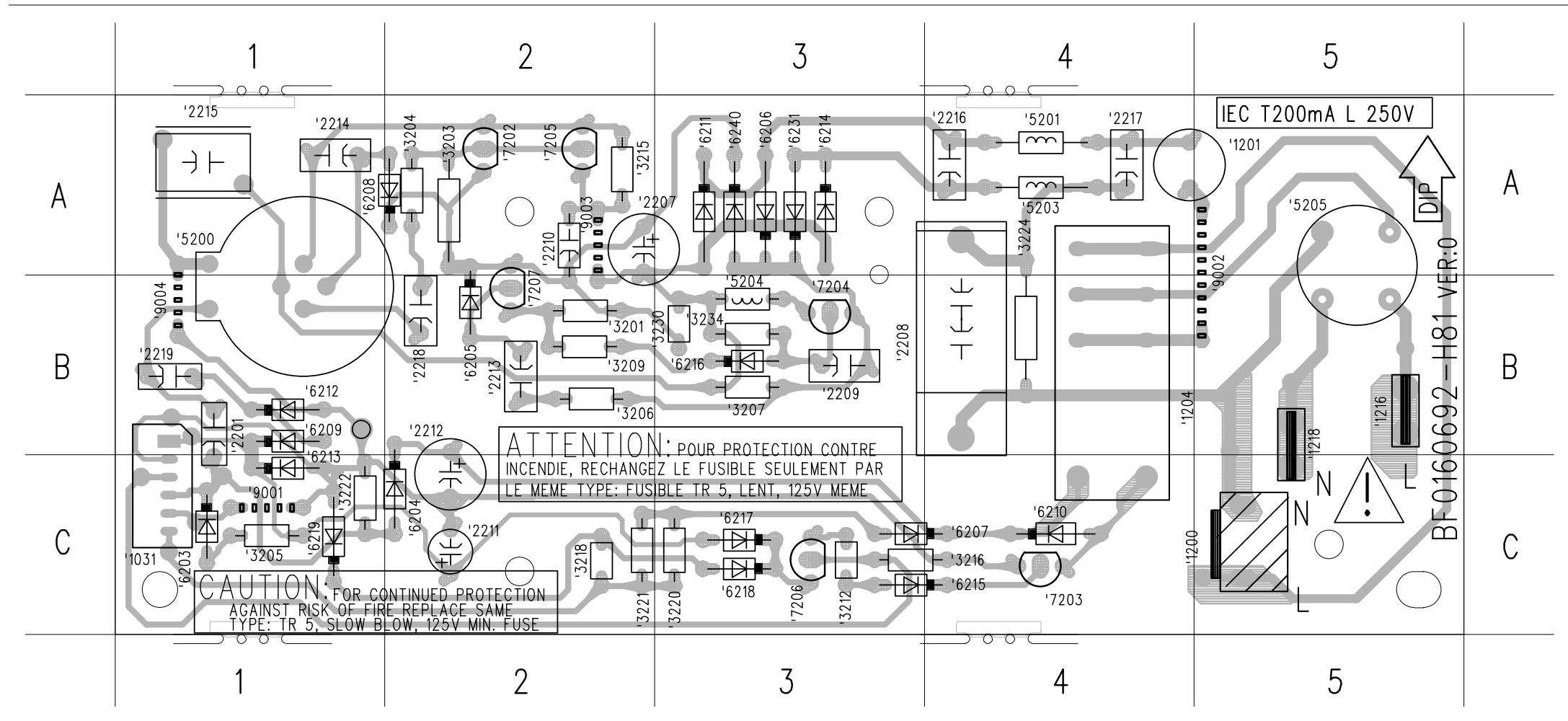

ELECTRICAL PARTS LIST - ECO POWER PART**- MISCELLANEOUS -**

1201	△	4822 071 52001	FUSE 19372(200MA)
1204	△	9965 000 16270	RELAY DC 12V 5A
5200		9965 000 16272	ST.BY TRANSFORMER

- CAPACITORS -

2208		9965 000 16271	CAP MPP 275V 220NF
2215		4822 126 14088	2,2NF 20% 250V

- RESISTORS -

3203		4822 050 24705	4M70 1% 0,6W
3224		4822 053 21225	2M20 5% 0,5W

- COILS & FILTERS -

5201		9965 000 16273	FIX 1MH TP=52MM
5203		9965 000 16273	FIX 1MH TP=52MM
5204		9965 000 16274	FIXED IND 100UH TP=52MM
5205	△	9965 000 11379	FILTER MAINS 400UH

- DIODES -

6203		4822 130 30621	1N4148
6204		4822 130 30621	1N4148
6205		4822 130 30621	1N4148
6206		4822 130 31878	1N4003G
6207		4822 130 30621	1N4148
6208		4822 130 30621	1N4148
6209		4822 130 30621	1N4148
6210		4822 130 30621	1N4148
6211		4822 130 31878	1N4003G
6212		4822 130 30621	1N4148
6213		4822 130 34173	BZX79-C5V6
6214		4822 130 31878	1N4003G
6215		4822 130 30621	1N4148
6216		4822 130 34145	BZX79-B39
6217		4822 130 30621	1N4148
6218		4822 130 30621	1N4148
6219		4822 130 34173	BZX79-C5V6
6231		4822 130 31878	1N4003G
6240		4822 130 31878	1N4003G

- IC & TRANSISTORS -

7203		4822 130 40981	BC337-25
7204		4822 130 41344	BC337-40
7205		4822 130 44568	BC557B
7206		4822 130 40959	BC547B
7207		4822 130 44568	BC557B

Note : Only these parts mentioned in the list are normal service parts.

- IC & TRANSISTORS -

7202		4822 130 40959	BC547B
------	--	----------------	--------

TAPE MECHANISM

TAPE MECHANISM WIRING

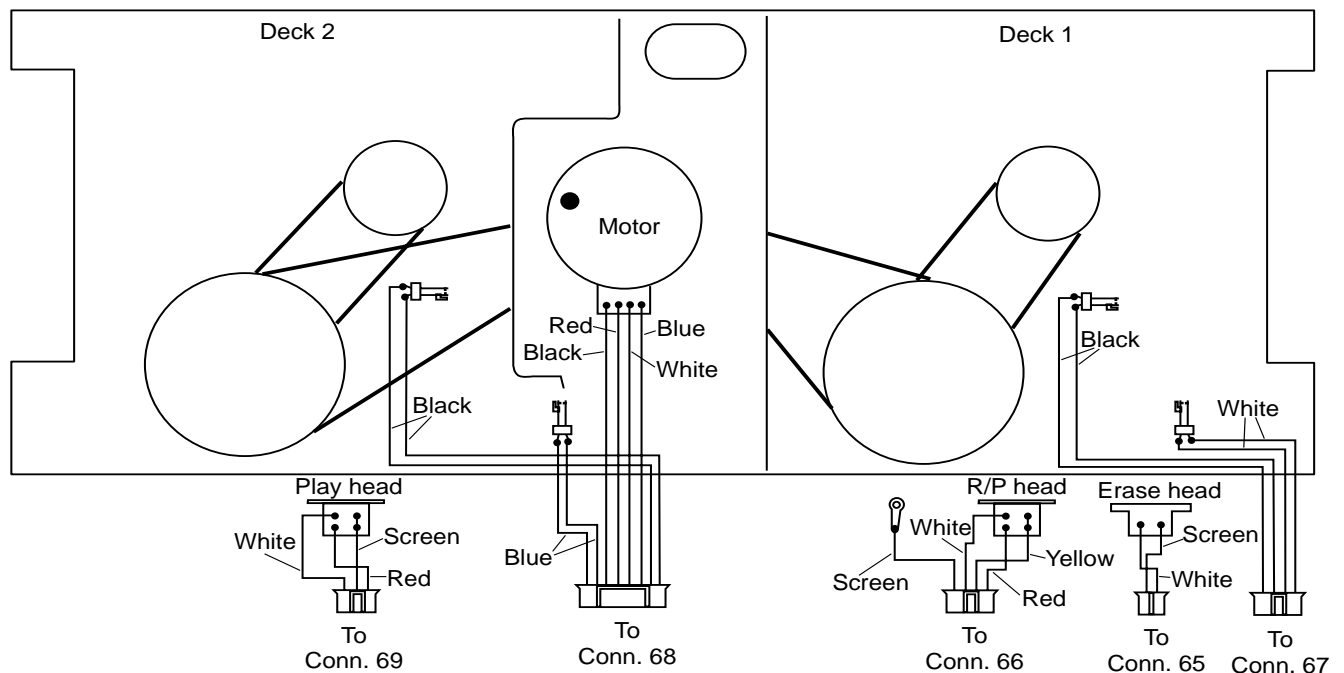

MECHANICAL PARTS LIST - TAPE MECHANISM

23	4822 278 90596	LEAF SWITCH	67	9965 000 11412	ERASE HEAD
35	4822 403 40513	PINCH ROLLER ARM ASSEMBLY	68	9965 000 11413	MOTOR M9T12U20-T
40	4822 358 30921	RF BELT (SMALL)			
41	4822 278 90744	LEAF SWITCH MSW-17820MVD			
					Note: Only the parts mentioned in this list are normal service spare parts.
58	4822 528 81415	MOTOR PULLEY			
59	9965 000 11410	MAIN BELT (BIG)			
65	9965 000 11411	PLAY HEAD AP-4211L(S3)			
66	9965 000 11411	REC/PB HEAD AP-4211L(S3)			

EXPLODED VIEW

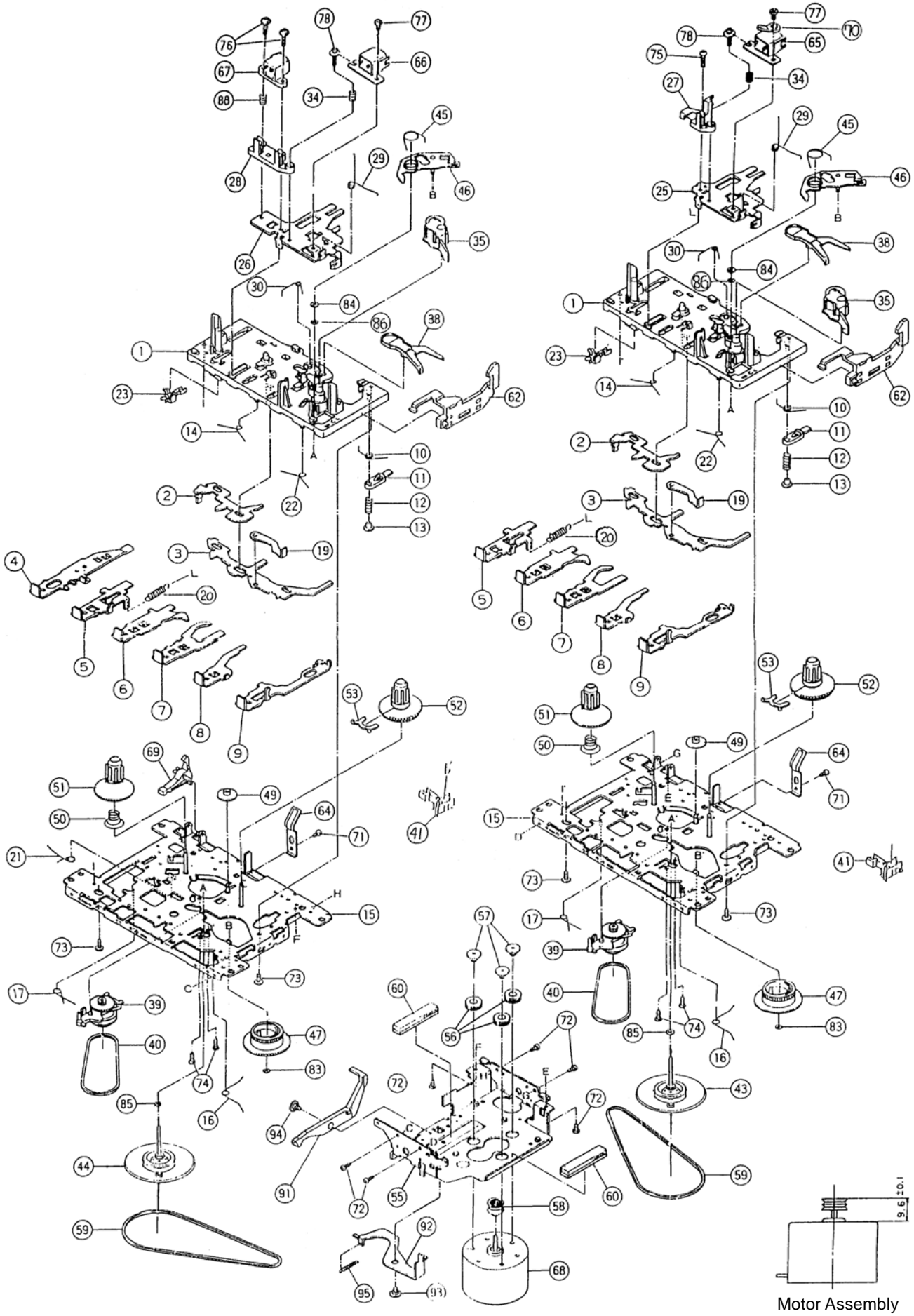

Motor Assembly



3CDC-LLC-MCD1

(3 Disc Carousel Changer)

Layout stage .3

TABLE OF CONTENTS

Service Hints	10-2
Blockdiagram	10-5
Component Layout Main Board	10-6
Circuit Diagram part1	10-7
Component Layout Main Board	10-8
Circuit Diagram part2	10-9
Exploded View	10-10
Partslist	10-12



Service hints

CAUTION

CHARGED CAPACITORS ON THE SERVO BOARD MAY DAMAGE THE CD DRIVE ELECTRONICS WHEN CONNECTING A NEW CD MECHANISM. THAT'S WHY, BESIDES THE SAFETY MEASURES LIKE

- **SWITCH OFF POWER SUPPLY**
- **ESD PROTECTION**

ADDITIONAL ACTIONS MUST BE TAKEN BY THE REPAIR TECHNICIAN.

The following steps have to be done when replacing the CD mechanism:

1. Disconnect flexfoil cable from the old CD drive
2. Put a paperclip on the flexfoil to short-circuit the contacts (fig.1)
3. Remove the old CD drive
4. Remove paperclip from the flexfoil and connect it to the new drive
5. Position the new CD drive in its studs
6. Remove solder joint from the Laserunit

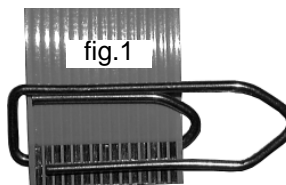

Attention: The laser diode of this CD drive is protected against ESD by a solder joint which shortcircuits the laserdiode to ground.

For proper functionality of the CD drive this solder joint must be removed **after** connection the drive to the set.

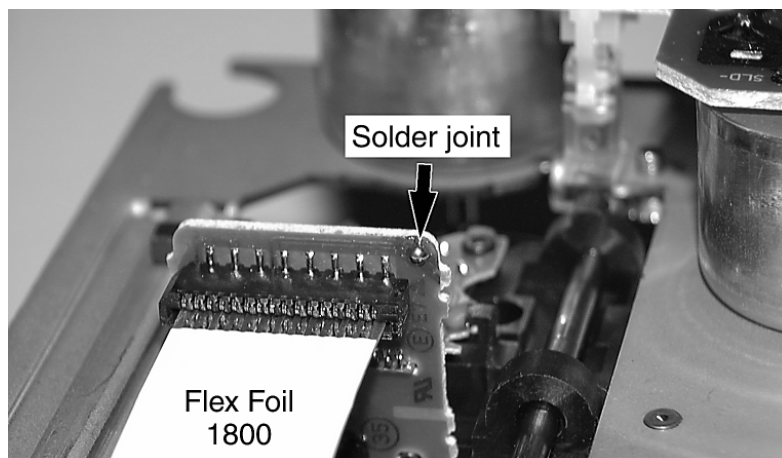

Emergency open

In case of a Supply fault, the tray can be opened manually.

1. Remove the top cover of the set to get access to the Changer Module.
2. Turn gearwheel clockwise (as shown in picture below).

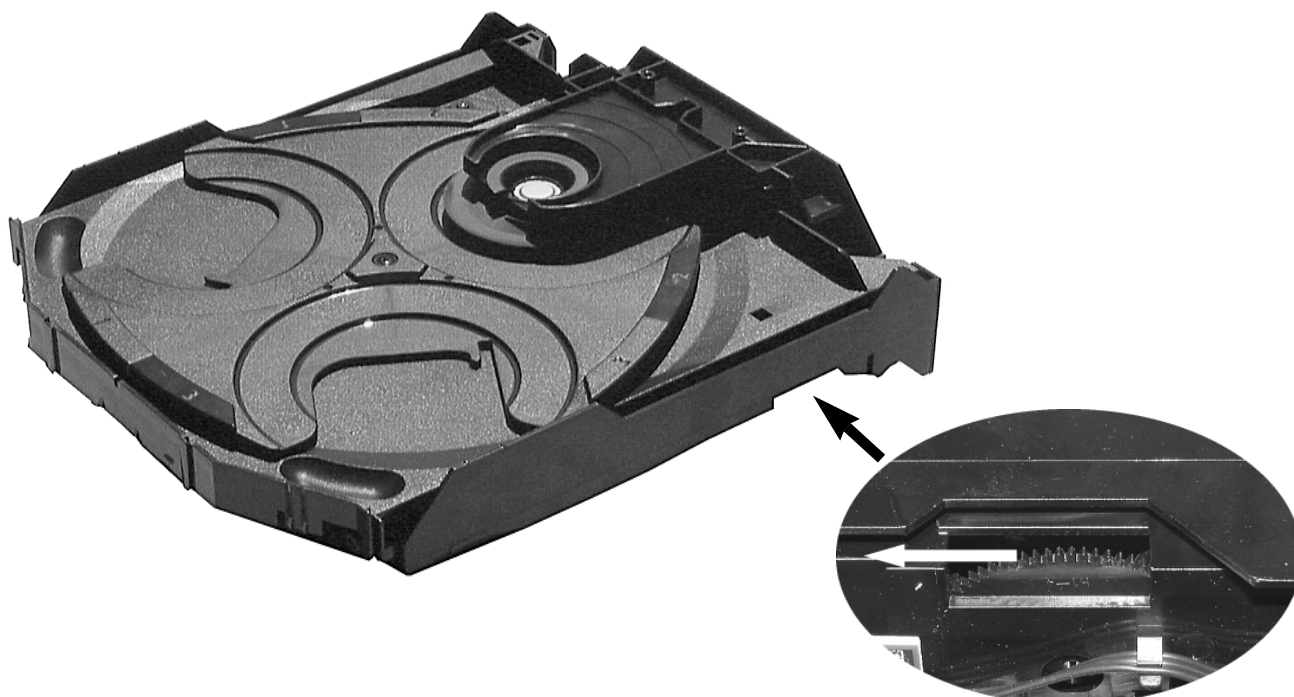

Service hints

Dismantling of Tray

1. Open the tray.
2. Release 2x catch as shown in fig. 2 and Detail A
3. Pull tray out.

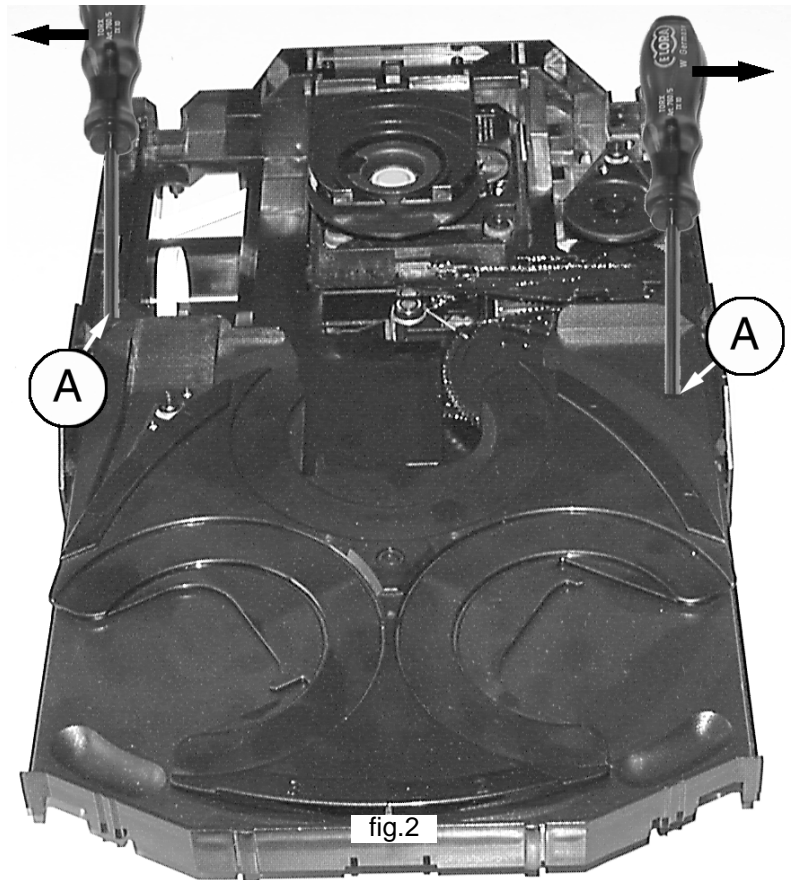
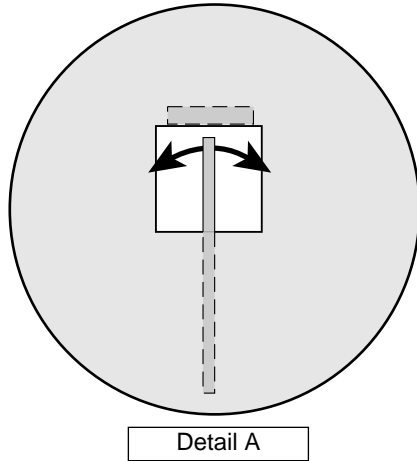

Assembling of Tray

1. Turn Cam (pos. 48) clockwise to end position.
2. If necessary - move Guiding (pos. 49) to the right end position.
3. Insert the Tray.

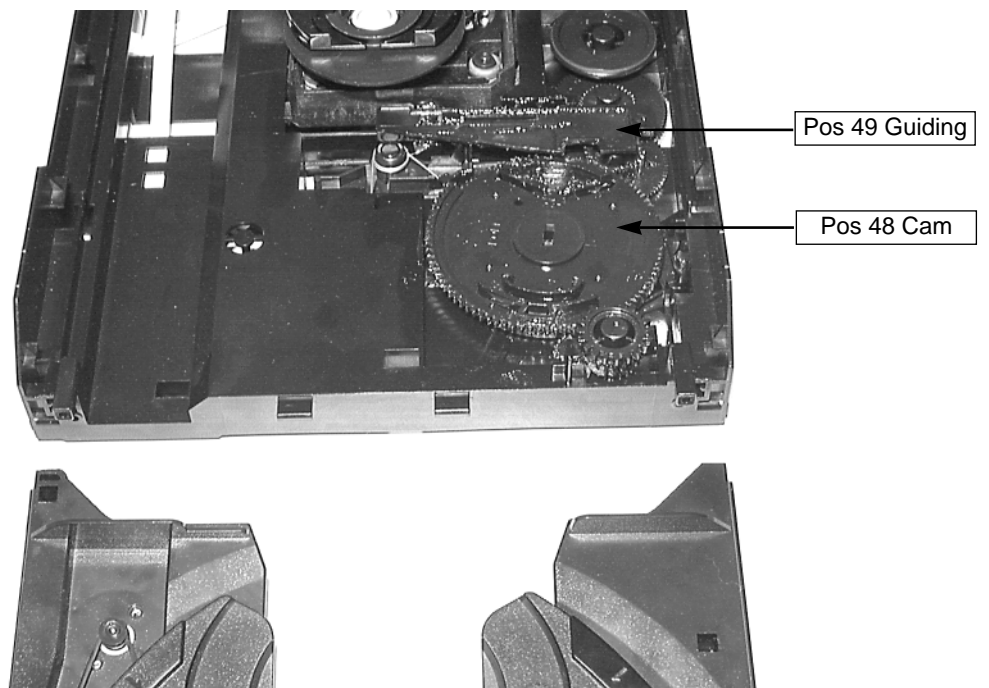

Service Position

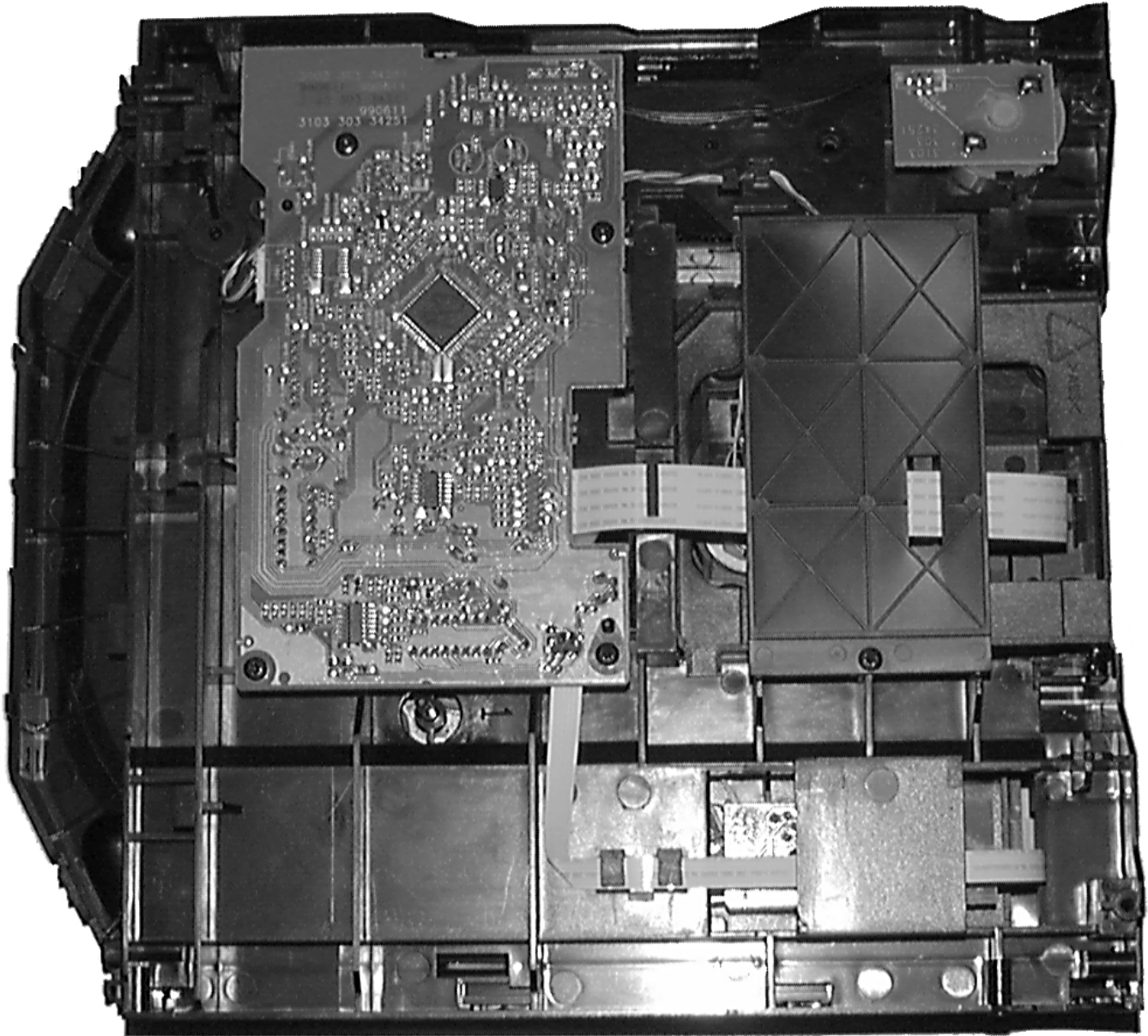

BLOCK DIAGRAM 3CDC-LLC-MCD1

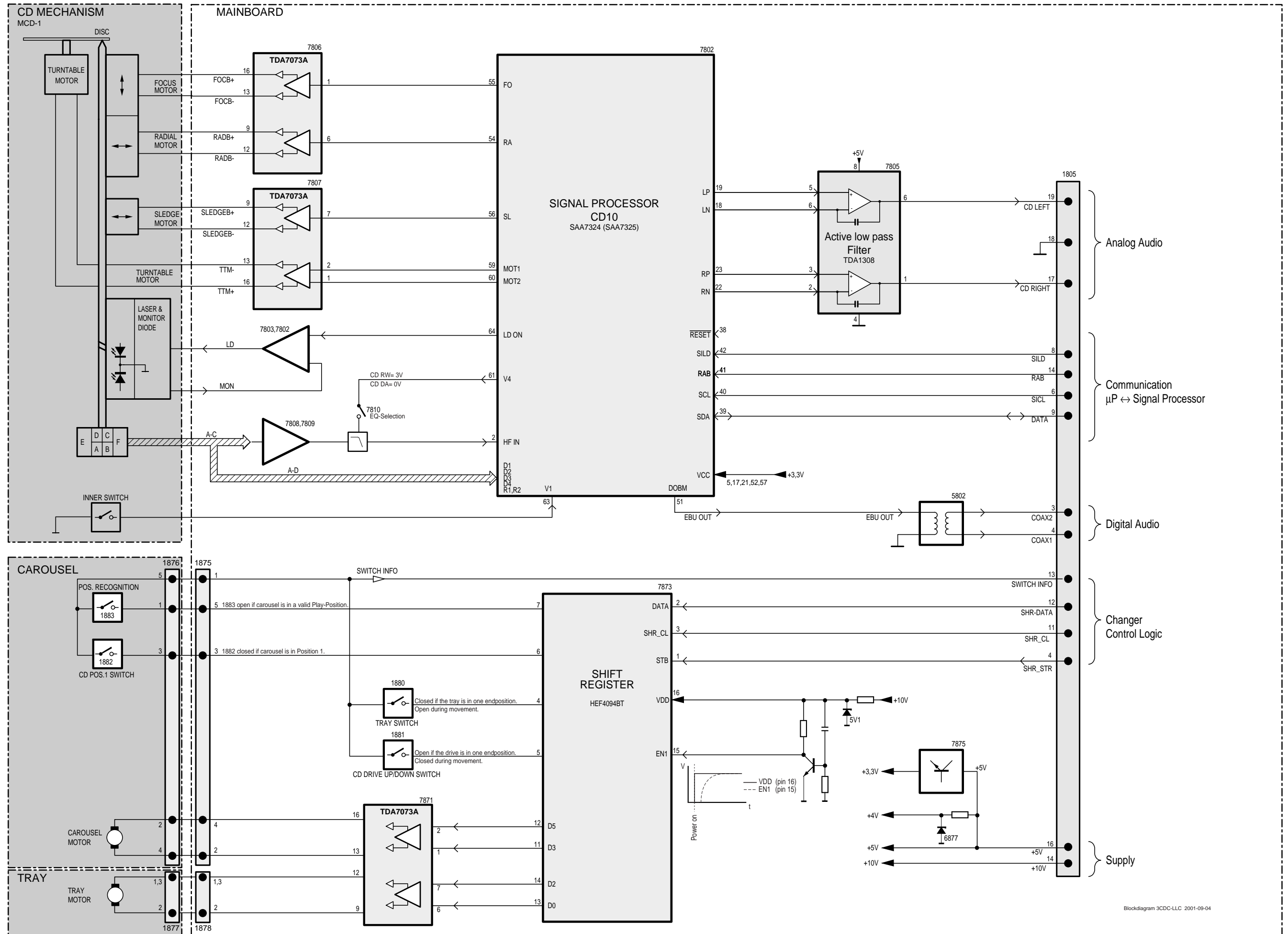

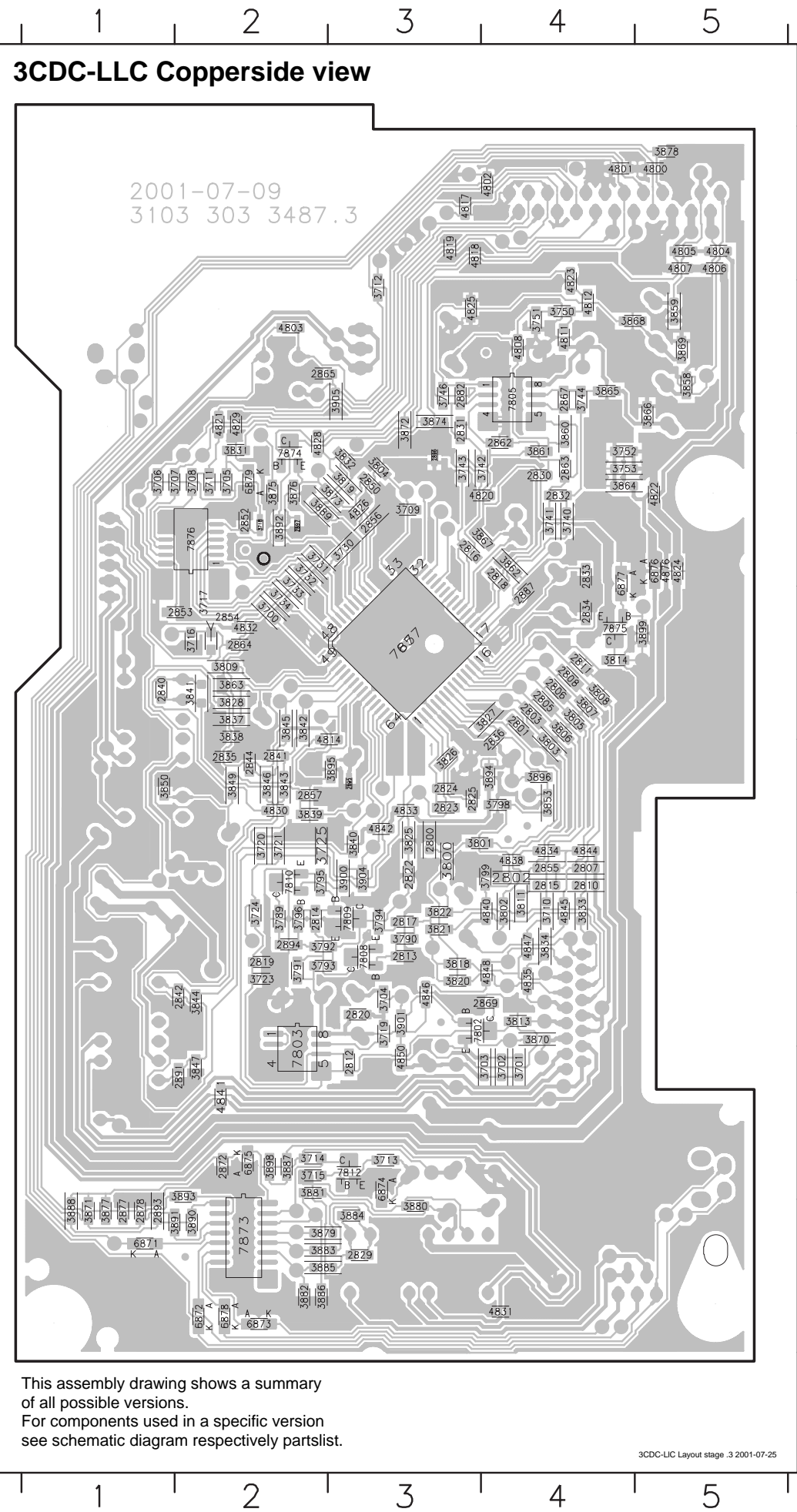

Mapping

Copperside		Componentside	
2800 E3	3741 C4	3889 C2	1800 F2
2801 D4	3742 C4	3890 H2	1801 C5
2802 E4	3743 C3	3891 H2	1805 A2
2803 D4	3744 B4	3892 C2	1810 C2
2805 D4	3746 B3	3893 G2	1875 H1
2806 D4	3750 B4	3894 E4	1878 B3
2807 E4	3751 B4	3895 E3	1880 B5
2808 D4	3752 C4	3896 E4	1881 G1
2810 E4	3753 C4	3898 G2	2804 F3
2811 D4	3789 F2	3899 D5	2809 E4
2812 G3	3790 F3	3900 E3	2826 D3
2813 F3	3791 F2	3901 F3	2828 D4
2814 F2	3792 F3	3904 E3	2837 E5
2815 E4	3793 F3	3905 B3	2838 F2
2816 C3	3794 F3	4800 A5	2839 E5
2817 F3	3795 E2	4801 A4	2851 C2
2818 C4	3796 F2	4802 A4	2858 B2
2819 F2	3798 E4	4803 B2	2860 B1
2820 F3	3799 E4	4804 A5	2861 B1
2822 E3	3800 E3	4805 A5	2873 H2
2823 E3	3801 E4	4806 A5	2875 G3
2824 E3	3802 F4	4807 A5	2876 B2
2825 E3	3803 D4	4808 B4	2881 G3
2829 H3	3804 C3	4811 B4	2885 D2
2830 C4	3805 D4	4812 B4	2888 F4
2831 B3	3806 D4	4814 D3	3812 F4
2832 C4	3807 D4	4817 A3	3815 G3
2833 C4	3808 D4	4818 A3	3835 F5
2834 D4	3809 D2	4819 A3	3851 G2
2835 E2	3811 F4	4820 C4	3852 E5
2836 D4	3813 F4	4821 B2	5802 B4
2840 D1	3814 D4	4822 C5	7806 F5
2841 E2	3818 F3	4823 A4	7807 D5
2842 F2	3819 C3	4824 C5	7871 H3
2844 E2	3820 F3	4825 B3	
2850 C3	3821 F3	4826 C3	
2852 C2	3822 F3	4828 C2	
2853 D2	3825 E3	4829 B2	
2854 D2	3826 E3	4830 E2	
2855 E4	3827 D4	4831 H4	
2856 C3	3828 D2	4832 D2	
2857 E2	3831 C2	4833 E3	
2862 C4	3832 C3	4834 E4	
2863 C4	3833 F4	4835 F4	
2864 D2	3834 F4	4838 E4	
2865 B3	3837 D2	4840 F4	
2867 B4	3838 D2	4841 G2	
2869 F4	3839 E2	4842 E3	
2872 G2	3840 E3	4844 E4	
2877 H1	3841 D2	4845 F4	
2878 H1	3842 D2	4846 F3	
2882 B3	3843 E2	4847 F4	
2887 C4	3844 F2	4848 F4	
2891 G2	3845 D2	4850 G3	
2893 H1	3846 E2	4876 C5	
2894 F2	3847 G2	6871 H1	
2895 E3	3849 E2	6872 H2	
2896 C3	3850 E1	6873 H2	
2897 C2	3853 E4	6874 G3	
3700 D2	3858 B5	6875 G2	
3701 G4	3859 B5	6876 C5	
3702 G4	3860 B4	6877 C4	
3703 G4	3861 C4	6878 H2	
3704 F3	3862 C4	6879 C2	
3705 C2	3863 D2	7802 F4	
3706 C1	3864 C4	7803 F2	
3707 C2	3865 B4	7805 B4	
3708 C2	3866 B5	7808 F3	
3709 C3	3867 C4	7809 F3	
3710 F4	3868 B5	7810 E2	
3711 C2	3869 B5	7812 G3	
3712 A3	3870 F4	7873 H2	
3713 G3	3871 H1	7874 C2	
3714 G2	3872 B3	7875 D4	
3715 G2	3873 C3	7876 C2	
3716 D2	3874 B3	7877 D3	
3717 D2	3875 C2		
3718 C2	3876 C2		
3719 F3	3877 H1		
3720 E2	3878 A5		
3721 E2	3879 H3		
3723 F2	3880 G3		
3724 F2	3881 G2		
3725 E2	3882 H2		
3730 C3	3883 H3		
3731 C2	3884 H3		
3732 C2	3885 H3		
3733 C2	3886 H2		
3734 D2	3887 G2		
3740 C4	3888 H1		

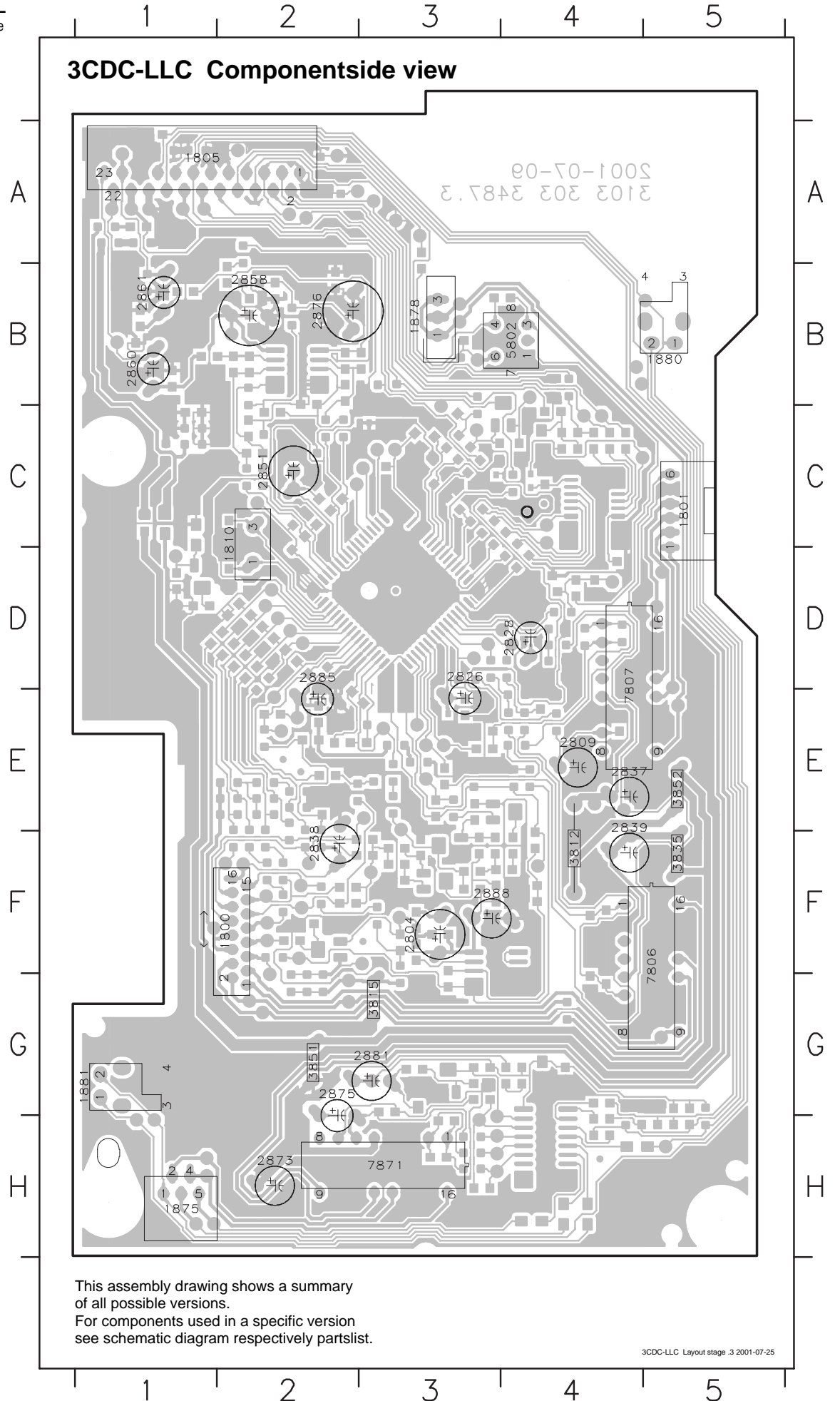

1800 F1	2804 D4	2811 A9	2818 B11	2826 G12	2838 D8	2851 B11	2888 C4	3702 D3	3721 D6	3792 F8	3800 D8	3807 B9	3819 D14	3828 G11	3839 H6	3846 F5	3863 G13	3895 G12	7803-B D5	MP713 C9	MP743 D2	MP813 B3	MP820 F8	MP837 D4	MP844 E9	MP851 E2	MP873 H4	MP884 C5
1801 G1	2805 C8	2812 D5	2819 E5	2828 G13	2839 F4	2855 C8	2891 F4	3703 D3	3723 E6	3793 E8	3801 D8	3808 A9	3820 C3	3832 C15	3840 G5	3847 F5	3867 A11	3896 E9	7806 G3	MP715 D9	MP744 C2	MP814 G2	MP821 C15	MP838 G6	MP845 F4	MP852 G2	MP875 F13	MP893 F10
1810 B10	2806 B8	2813 F7	2820 D4	2833 B10	2840 G4	2856 D15	2894 F8	3704 D4	3724 D6	3794 F7	3802 C8	3811 C8	3821 B3	3833 A8	3841 G5	3849 H5	3870 E2	3900 F9	7807 H3	MP716 B9	MP745 E2	MP815 B3	MP827 B10	MP839 G6	MP846 H2	MP853 G2	MP876 E2	
2800 D8	2807 B8	2814 F7	2822 F9	2834 B10	2841 F5	2857 H5	2895 G12	3709 C14	3725 D6	3795 F8	3803 C8	3812 H4	3822 B3	3834 B8	3842 E6	3850 H5	3873 D14	3901 D4	7808 F7	MP717 A9	MP800 E2	MP816 A3	MP828 G11	MP840 E6	MP847 H2	MP858 G8	MP877 E3	
2801 D8	2808 B9	2815 B8	2823 F10	2835 H7	2842 E5	2869 D3	2896 H12	3710 B8	3789 F8	3796 F8	3804 C14	3813 E2	3825 F9	3835 F5	3843 E5	3852 H5	3889 D15	3904 G10	7809 G8	MP729 B9	MP802 B15	MP817 A3	MP829 A3	MP841 F6	MP848 E2	MP859 E10	MP878 B13	
2802 C8	2809 H4	2816 B12	2824 F10	2836 E10	2844 F5	2885 E9	2897 H12	3719 D4	3790 F7	3798 D8	3805 B8	3815 C4	3826 F9	3837 G7	3844 E5	3853 E9	3892 E15	7802 D3	7810 F9	MP730 C9	MP809 D10	MP818 C4	MP831 A4	MP842 H6	MP849 E2	MP860 C2	MP879 B11	
2803 C8	2810 A8	2817 F7	2825 E9	2837 H4	2850 C14	2887 B10	3701 D3	3720 D5	3791 E7	3799 D8	3806 C8	3818 B3	3827 E10	3838 H7	3845 F6	3862 A10	3894 E9	7803-A B5	7877 D12	MP731 B13	MP812 G2	MP819 F10	MP836 D3	MP843 G7	MP850 E2	MP872 C15	MP883 C4	

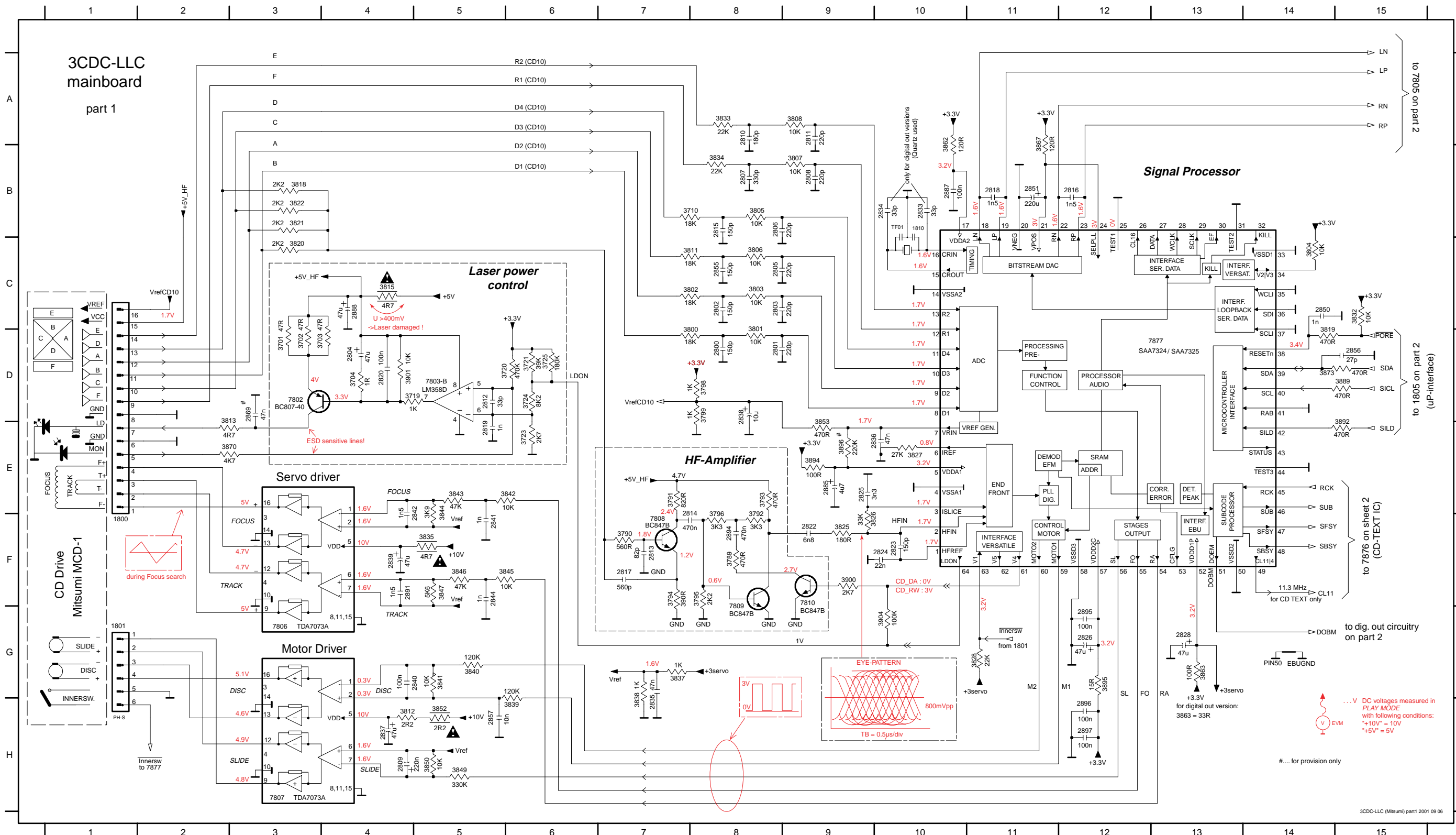

Mapping

3CDC-LLC Copperside view

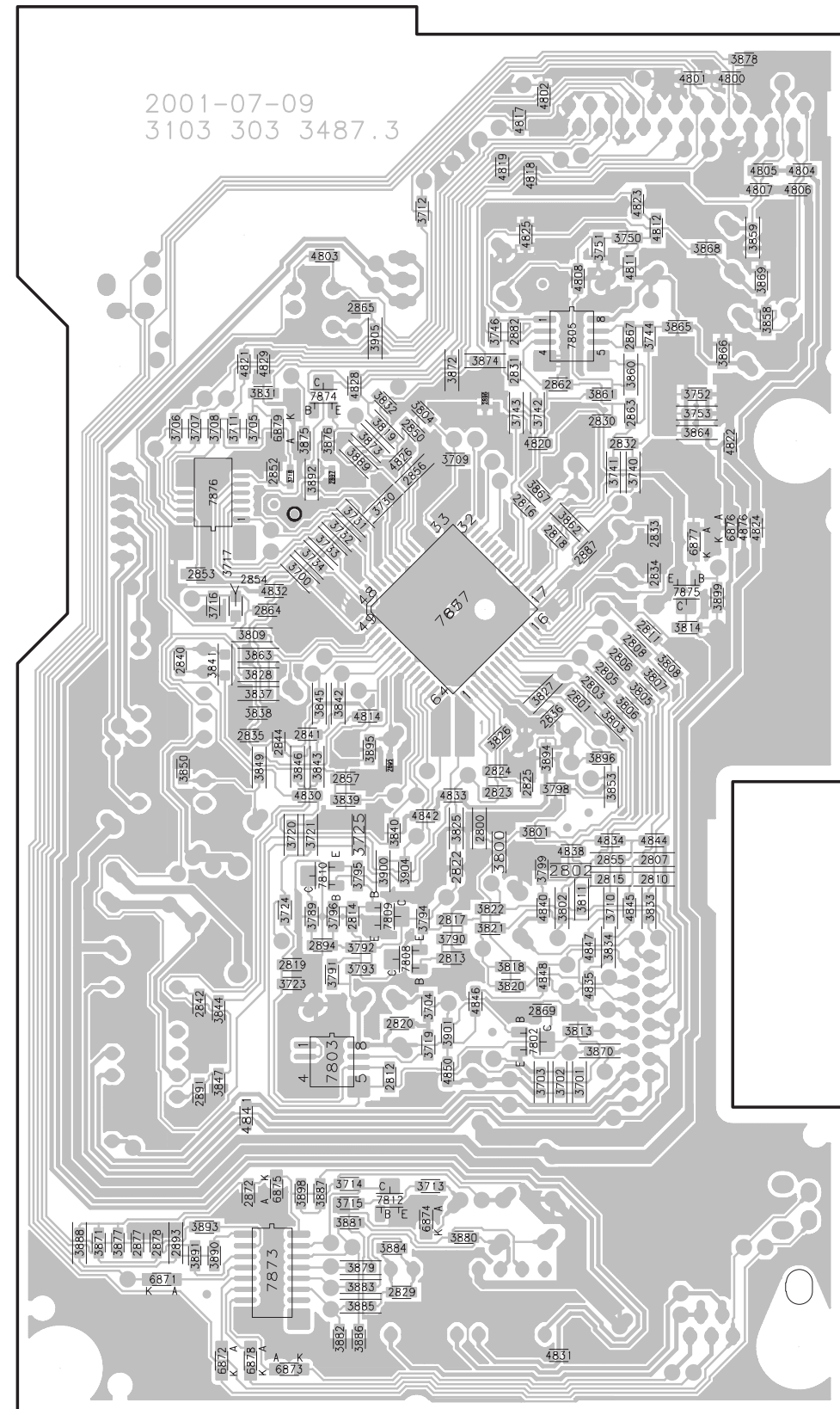

This assembly drawing shows a summary of all possible versions. For components used in a specific version see schematic diagram respectively partlist.

Copperside		Componentside	
2800 E3	3741 C4	3889 C2	1800 F2
2801 D4	3742 C4	3890 H2	1801 C5
2802 E4	3743 C3	3891 H2	1805 A2
2803 D4	3744 B4	3892 C2	1810 C2
2805 D4	3746 B3	3893 G2	1875 H1
2806 D4	3750 B4	3894 E4	1878 B3
2807 E4	3751 B4	3895 E3	1880 B5
2808 D4	3752 C4	3896 E4	1881 G1
2810 E4	3753 C4	3898 G2	2804 F3
2811 D4	3789 F2	3899 D5	2809 E4
2812 G3	3790 F3	3900 E3	2826 D3
2813 F3	3791 F2	3901 F3	2828 D4
2814 F2	3792 F3	3904 E3	2837 E5
2815 E4	3793 F3	3905 B3	2838 F2
2816 C3	3794 F3	4800 A5	2839 E5
2817 F3	3795 E2	4801 A4	2851 C2
2818 C4	3796 F2	4802 A4	2858 B2
2819 F2	3798 E4	4803 B2	2860 B1
2820 F3	3799 E4	4804 A5	2861 B1
2822 E3	3800 E3	4805 A5	2873 H2
2823 E3	3801 E4	4806 A5	2875 G3
2824 E3	3802 F4	4807 A5	2876 B2
2825 E3	3803 D4	4808 B4	2881 G3
2829 H3	3804 C3	4811 B4	2885 D2
2830 C4	3805 D4	4812 B4	2888 F4
2831 B3	3806 D4	4814 D3	3812 F4
2832 C4	3807 D4	4817 A3	3815 G3
2833 C4	3808 D4	4818 A3	3835 F5
2834 D4	3809 D2	4819 A3	3851 G2
2835 E2	3811 F4	4820 C4	3852 E5
2836 D4	3813 F4	4821 B2	5802 B4
2840 D1	3814 D4	4822 C5	7806 F5
2841 E2	3818 F3	4823 A4	7807 D5
2842 F2	3819 C3	4824 C5	7871 H3
2844 E2	3820 F3	4825 B3	
2850 C3	3821 F3	4826 C3	
2852 C2	3822 F3	4828 C2	
2853 D2	3825 E3	4829 B2	
2854 D2	3826 E3	4830 E2	
2855 E4	3827 D4	4831 H4	
2856 C3	3828 D2	4832 D2	
2857 E2	3831 C2	4833 E3	
2862 C4	3832 C3	4834 E4	
2863 C4	3833 F4	4835 F4	
2864 D2	3834 F4	4838 E4	
2865 B3	3837 D2	4840 F4	
2867 B4	3838 D2	4841 G2	
2869 F4	3839 E2	4842 E3	
2872 G2	3840 E3	4844 E4	
2877 H1	3841 D2	4845 F4	
2878 H1	3842 D2	4846 F3	
2882 B3	3843 E2	4847 F4	
2887 C4	3844 F2	4848 F4	
2891 G2	3845 D2	4850 G3	
2893 H1	3846 E2	4876 C5	
2894 F2	3847 G2	6871 H1	
2895 E3	3849 E2	6872 H2	
2896 C3	3850 E1	6873 H2	
2897 C2	3853 E4	6874 G3	
3700 D2	3858 B5	6875 G2	
3701 G4	3859 B5	6876 C5	
3702 G4	3860 B4	6877 C4	
3703 G4	3861 C4	6878 H2	
3704 F3	3862 C4	6879 C2	
3705 C2	3863 D2	7802 F4	
3706 C1	3864 C4	7803 F2	
3707 C2	3865 B4	7805 B4	
3708 C2	3866 B5	7808 F3	
3709 C3	3867 C4	7809 F3	
3710 F4	3868 B5	7810 E2	
3711 C2	3869 B5	7812 G3	
3712 A3	3870 F4	7873 H2	
3713 G3	3871 H1	7874 C2	
3714 G2	3872 B3	7875 D4	
3715 G2	3873 C3	7876 C2	
3716 D2	3874 B3	7877 D3	
3717 D2	3875 C2		
3718 C2	3876 C2		
3719 F3	3877 H1		
3720 E2	3878 A5		
3721 E2	3879 H3		
3723 F2	3880 G3		
3724 F2	3881 G2		
3725 E2	3882 H2		
3730 C3	3883 H3		
3731 C2	3884 H3		
3732 C2	3885 H3		
3733 C2	3886 H2		
3734 D2	3887 G2		
3740 C4	3888 H1		

3CDC-LLC Componentside view

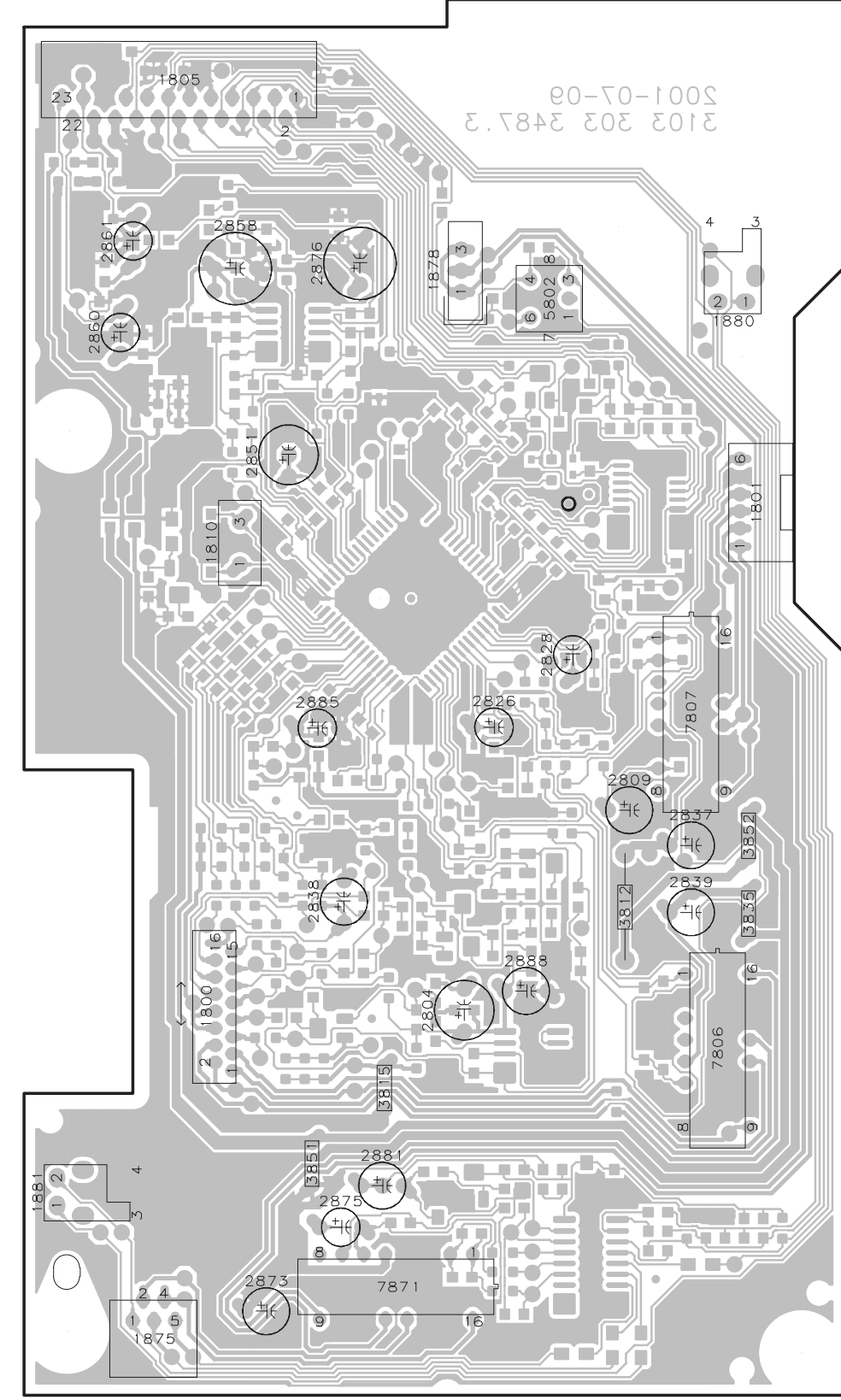

This assembly drawing shows a summary of all possible versions. For components used in a specific version see schematic diagram respectively partlist.

1805 E15	2830 C9	2858 A9	2865 C4	2877 F11	3705 G4	3713 G8	3730 G2	3741 A7	3751 C7	3851 D7	3865 A10	3874 C13	3880 E6	3886 E7	3898 F7	4876 D13	6875 F7	7805-B A8	7876 G3	MP726 D8	MP804 G14	MP811 F14	MP832 G9	MP863 C11	MP871 D6	MP888 G5	MP898 E13
1875 D2	2831 B9	2860 A11	2867 A8	2878 F11	3706 G4	3714 F8	3731 G2	3742 B7	3752 A6	3858 A11	3866 A10	3875 C12	3881 E7	3887 D6	3899 D12	5802 B4	6876 D13	7812 G8	7812 G8	MP721 C8	MP740 H14	MP805 F13	MP822 E3	MP865 D11	MP874 D12	MP889 G5	MP899 E14
1878 E2	2832 A8	2861 B11	2872 G10	2881 F8	3707 G4	3715 G8	3732 G2	3743 B7	3753 A6	3859 B11	3868 B10	3876 C11	3882 D7	3888 F12	3905 C5	6871 F8	6877 D12	7871 C5	7871 C5	MP722 E8	MP742 G14	MP806 F13	MP823 E3	MP835 F14	MP866 E8	MP881 G2	MP890 B3
1880 F8	2852 H2	2862 B8	2873 D6	2882 B10	3708 H4	3716 B3	3733 G2	3744 A9	3809 B2	3860 B7	3869 B10	3877 F12	3883 D6	3890 F11	4803 B4	6872 E8	6878 E8	7873 D10	7873 D10	MP723 D8	MP742 G14	MP807 F14	MP824 D4	MP854 A13	MP867 E8	MP882 G2	MP891 B5
1881 E8	2853 G4	2863 B8	2875 E6	2883 F12	3711 G5	3717 B3	3734 H2	3746 B10	3814 D12	3861 B8	3871 F12	3878 E12	3884 D6	3891 F11	4811 A7	6873 E8	6879 G4	7874 C12	7874 C12	MP724 D8	MP801 E12	MP808 F13	MP825 D4	MP856 E14	MP868 F8	MP886 G3	MP892 B5
2829 D6	2854 B3	2864 B3	2876 C7	3700 H2	3712 B4	3718 G3	3740 A7	3750 B7	3831 G4	3864 A7	3872 C13	3879 D7	3885 D6	3893 F11	4812 B7	6874 G7	7805-A B9	7875 D12	7875 D12	MP725 D8	MP803 F10	MP810 F13	MP830 A7	MP857 B13	MP869 C12	MP887 H5	MP897 E13

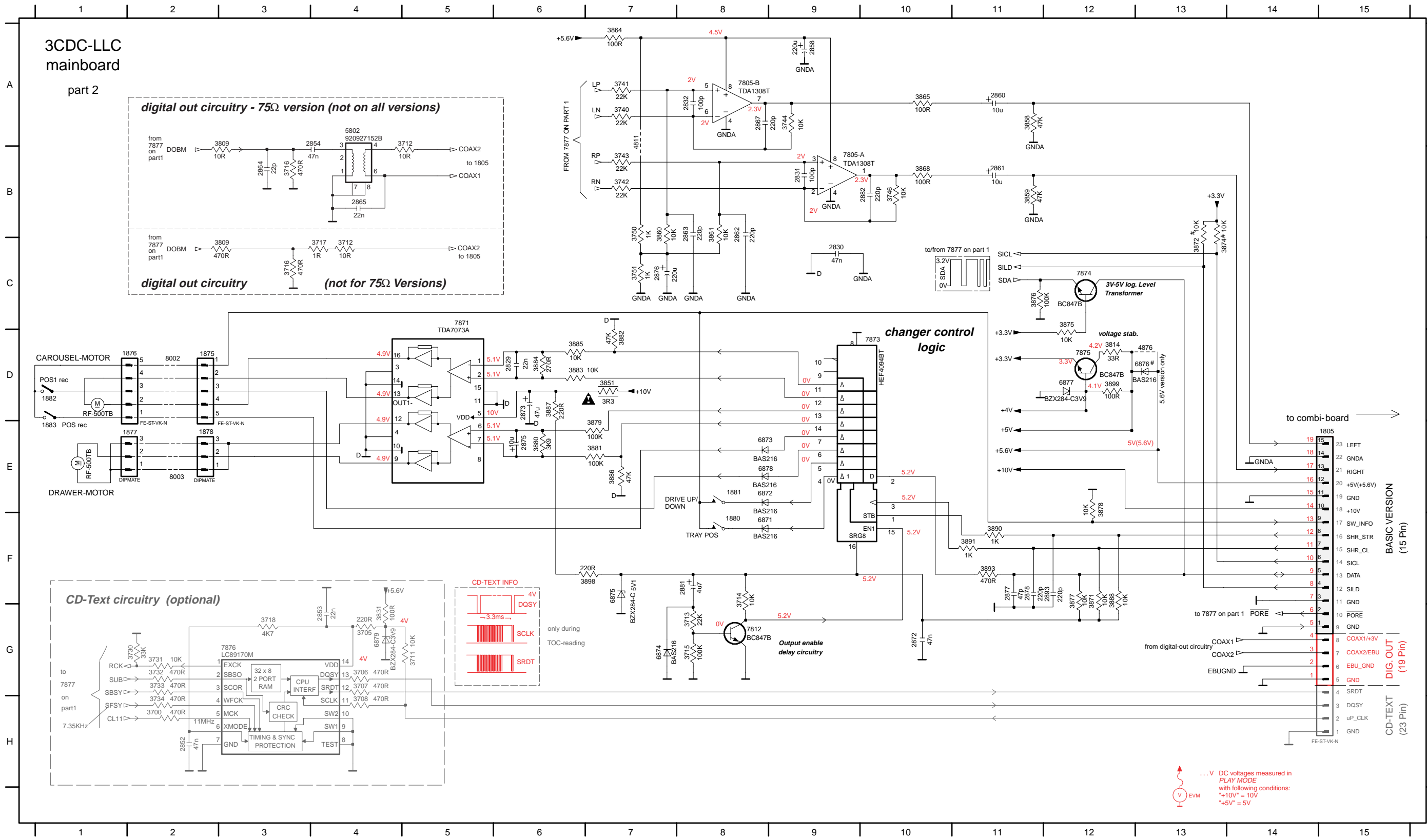

EXPLODED VIEW (3CDC-LC MODULE)

MECHANICAL PARTS Loader → this page

20	3103 304 66500	DRAWER
21	3140 114 29070	PRESSURE RING-MCD1
23	3140 111 21270	METAL RING-MCD1
30	3103 304 66560	SUPPORT
31	4822 529 10386	RUBBER DAMPER CD DRIVE, REAR
32	4822 529 10387	RUBBER DAMPER CD DRIVE, FRONT
33	3103 304 06970	WASHER
35	3103 309 05350	CD DRIVE MCD1B
41	3103 304 66480	FRAME
42	3103 304 66540	BRACKET-GUIDING
43	3103 301 06460	SPRING-GUIDING
44	3103 304 06890	GEAR-3
45	3103 304 06980	NAIL FIXATION
46	3103 304 06880	GEAR-2
47	3103 304 66530	BRACKET-LOAD
48	3103 304 06910	CAM
49	3103 304 66510	GUIDING
51	3103 304 06900	GEAR-4
52	3103 304 06870	GEAR-1
53	3103 304 06960	PULLEY-FRAME
54	3103 304 66910	DRIVING-BELT-DRAWER
55	4822 361 10753	TRAY MOTOR
56	4822 502 12548	SCREW M2,6X3,5
57	3103 304 69880	COVER-MCD1
59	4822 466 12146	RUBBER

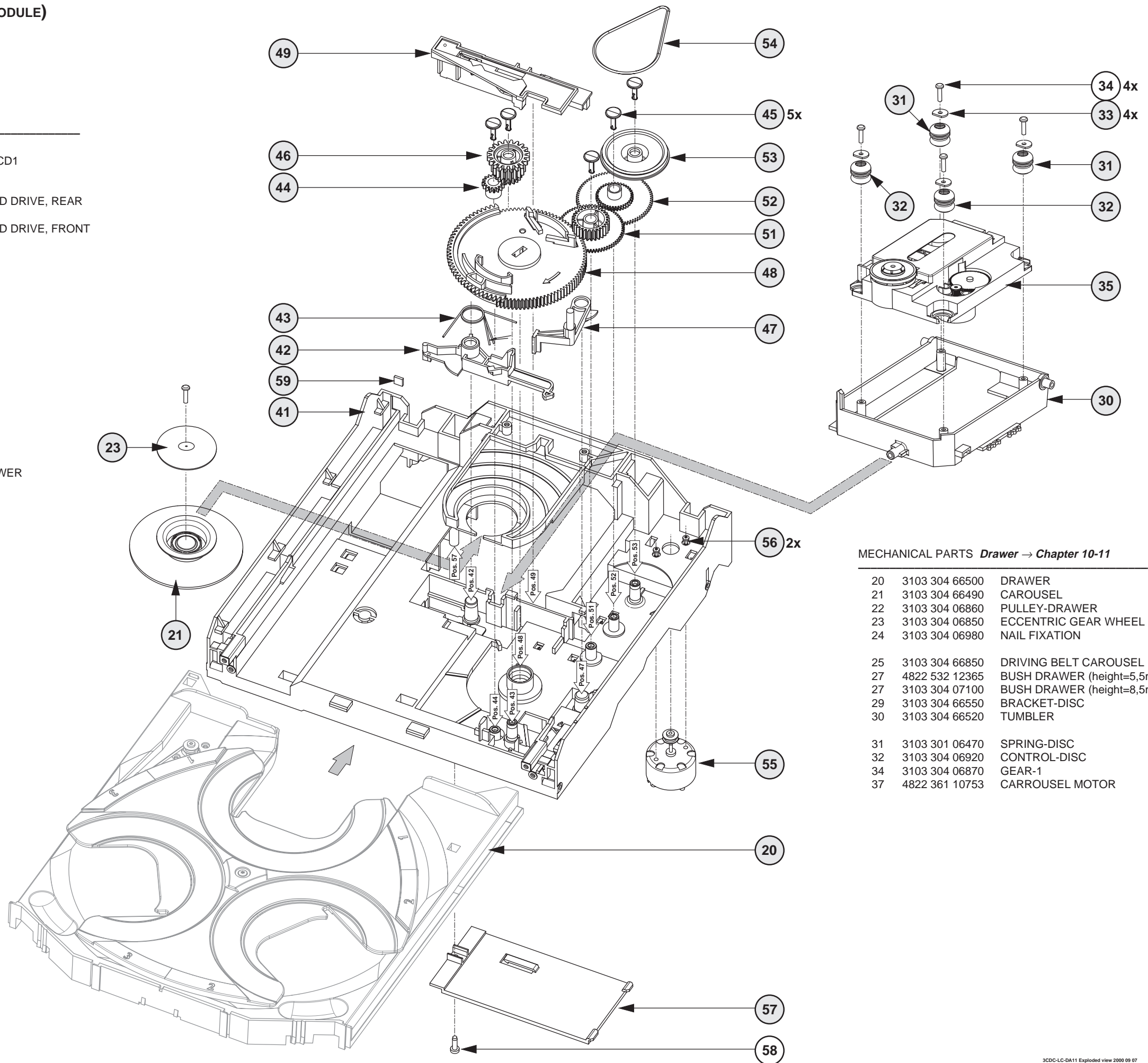

MECHANICAL PARTS Drawer → Chapter 10-11

20	3103 304 66500	DRAWER
21	3103 304 66490	CAROUSEL
22	3103 304 06860	PULLEY-DRAWER
23	3103 304 06850	ECCENTRIC GEAR WHEEL
24	3103 304 06980	NAIL FIXATION
25	3103 304 66850	DRIVING BELT CAROUSEL
27	4822 532 12365	BUSH DRAWER (height=5,5mm,d=9,4mm)
27	3103 304 07100	BUSH DRAWER (height=8,5mm,d=16mm)
29	3103 304 66550	BRACKET-DISC
30	3103 304 66520	TUMBLER
31	3103 301 06470	SPRING-DISC
32	3103 304 06920	CONTROL-DISC
34	3103 304 06870	GEAR-1
37	4822 361 10753	CARROUSEL MOTOR

- X** spare part
- Y** non spare part

Drawer bottom view

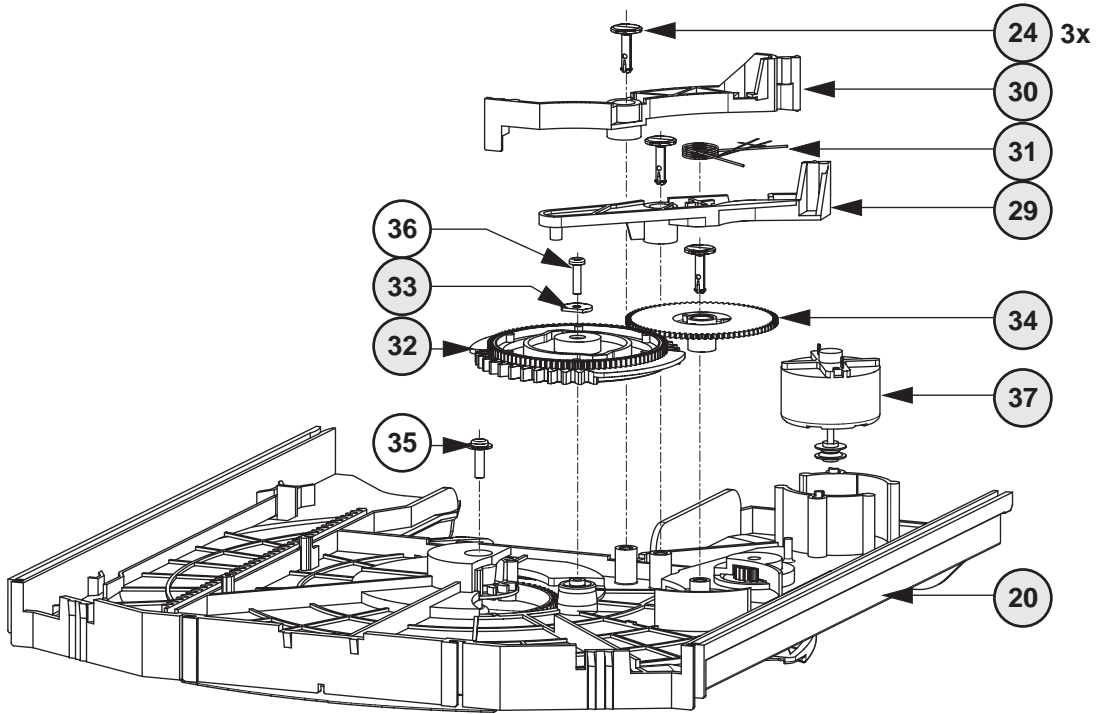

Drawer top view

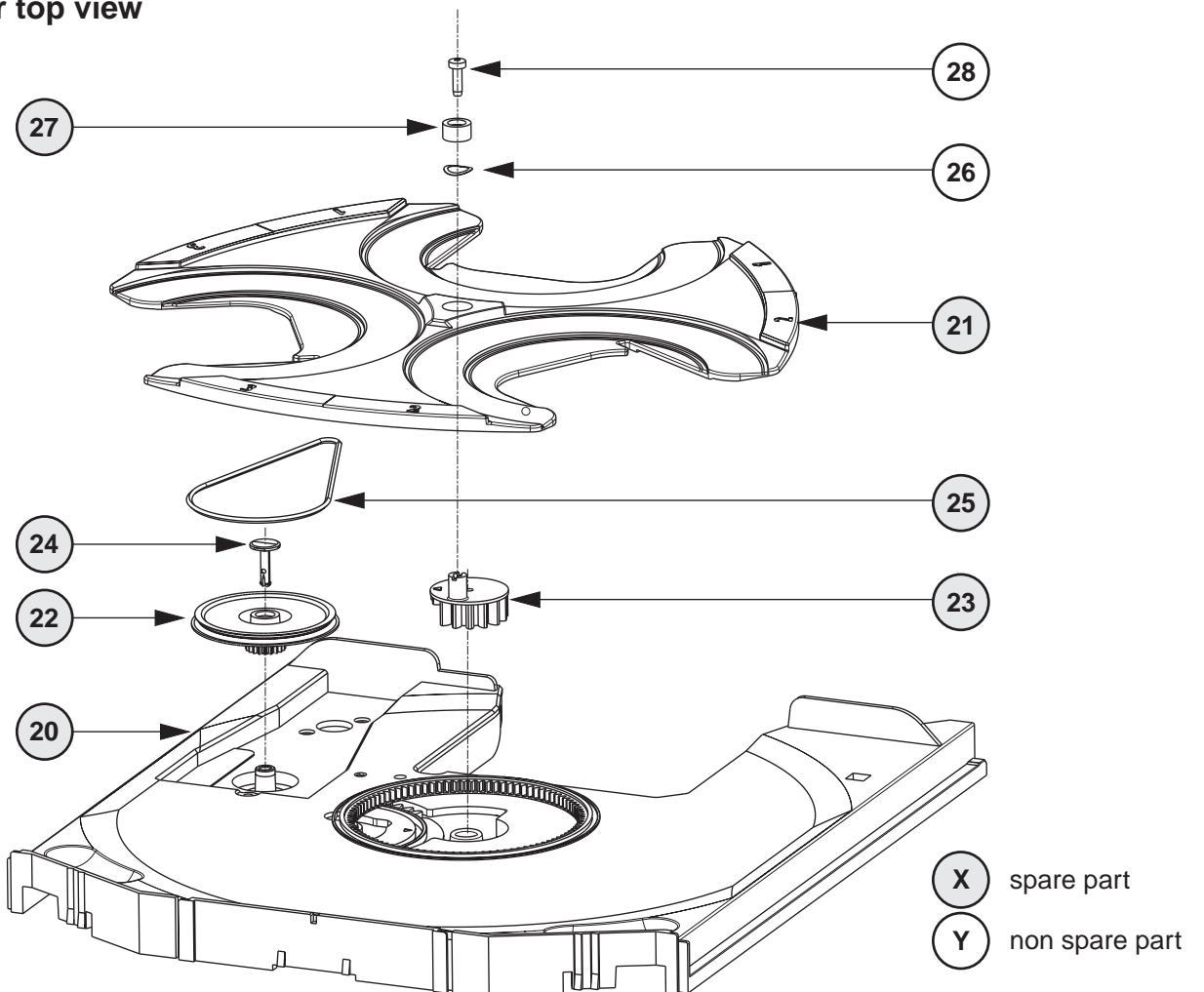

ELECTRICAL PARTSLIST 3CDC-LLC-MCD1 MODULE**MISCELLANEOUS**

35	3103 309 05350	CD DRIVE MCD1B
37	4822 361 10753	CAROUSEL MOTOR
55	4822 361 10753	TRAY MOTOR
1800	2422 025 17389	FLEX FOIL CONNECTOR 16Pin
1805	4822 265 10979	FLEX FOIL CONNECTOR 15Pin
1805	4822 265 11545	FLEX FOIL CONNECTOR 19Pin
1875	4822 267 10958	FLEX FOIL CONNECTOR 5Pin
1876	2422 025 08332	FLEX FOIL CONNECTOR 5Pin
1880	4822 276 13503	SWITCH, Tray switch
1881	4822 276 13503	SWITCH, Drive UP/DOWN
1882	4822 276 13503	SWITCH, CD Pos.1 recognized
1883	4822 276 13503	SWITCH, valid CD Play position
8002	3103 308 91990	FLEX FOIL CABLE 5P, 200mm 1:n
8005	3103 308 92930	FLEX FOIL CABLE 16P 170mm 1:n

CAPACITORS

2800	4822 122 33172	390pF	5%	50V
2801	4822 126 13883	220pF	5%	50V
2802	4822 122 33172	390pF	5%	50V
2803	4822 126 13883	220pF	5%	50V
2804	4822 124 41751	47μF	20%	16V
2805	4822 126 13883	220pF	5%	50V
2806	4822 126 13883	220pF	5%	50V
2807	5322 122 31863	330pF	5%	50V
2808	4822 126 13883	220pF	5%	50V
2809	4822 124 40746	0,22μF	20%	63V
2810	4822 126 10326	180pF	5%	
2811	4822 126 13883	220pF	5%	50V
2812	2222 867 15339	33pF	5%	50V
2813	4822 126 14226	82pF		50V
2814	2238 246 59858	450nF	20%	10V
2815	4822 122 33172	390pF	5%	50V
2816	4822 126 14247	1,5nF	10%	50V
2817	4822 126 14249	560pF	10%	50V
2818	4822 126 13344	1,5nF	5%	63V
2819	5322 126 11578	1nF	10%	63V
2820	4822 126 14305	100nF	10%	16V
2822	5322 122 31866	6,8nF	10%	63V
2823	3198 016 31510	150pF	10%	50V
2824	5322 122 32654	22nF	10%	63V
2825	4822 122 33891	3,3nF	10%	63V
2826	4822 124 12362	47μF	20%	4V
2828	4822 124 12362	47μF	20%	4V
2829	3198 017 42230	22nF	10%	50V
2830	4822 126 13751	47nF	10%	50V
2831	4822 122 31765	100pF	5%	50V
2832	4822 122 31765	100pF	5%	50V
2835	3198 024 44730	47nF	5%	50V
2836	3198 024 44730	47nF	5%	50V
2837	4822 124 40433	47μF	20%	25V
2838	4822 124 40248	10μF	20%	63V
2839	4822 124 40433	47μF	20%	25V
2840	4822 126 14585	100nF	10%	50V
2841	5322 126 10511	1nF	5%	50V
2842	4822 126 14247	1,5nF	10%	50V
2844	3198 016 31020	1nF	5%	25V
2850	5322 126 11578	1nF	10%	63V
2851	4822 124 42383	220μF	20%	4V
2855	4822 122 33172	390pF	5%	50V
2856	4822 126 13691	27pF	1%	63V
2857	5322 126 11583	10nF	10%	63V
2858	4822 124 12245	220μF	20%	16V

CAPACITORS

2860	4822 124 11947	10μF	20%	16V
2861	4822 124 11947	10μF	20%	16V
2862	4822 126 13883	220pF	5%	50V
2863	4822 126 13883	220pF	5%	50V
2865	4822 126 14494	22nF	10%	25V
2867	4822 126 13883	220pF	5%	50V
2872	3198 024 44730	47nF	5%	50V
2873	4822 124 80231	47μF	20%	16V
2875	4822 124 11947	10μF	20%	16V
2876	4822 124 12245	220μF	20%	16V
2877	4822 122 33777	47pF	5%	63V
2878	4822 126 13883	220pF	5%	50V
2881	4822 124 40769	4,7μF	20%	100V
2882	4822 126 13883	220pF	5%	50V
2885	4822 124 40769	4,7μF	20%	100V
2887	4822 126 14585	100nF	10%	50V
2888	4822 124 80231	47μF	20%	16V
2891	4822 126 14247	1,5nF	10%	50V
2893	4822 122 33575	220pF	5%	50V
2894	3198 017 44740	470nF	20%	10V
2895	4822 126 14305	100nF	10%	16V
2896	4822 126 14305	100nF	10%	16V
2897	4822 126 14305	100nF	10%	16V

RESISTORS

3701	4822 051 20479	47Ω	5%	0,1W
3702	4822 051 20479	47Ω	5%	0,1W
3703	4822 051 20479	47Ω	5%	0,1W
3704	4822 117 12917	1Ω	5%	0,06W
3710	4822 051 51831	18kΩ	5%	0,1W
3712	4822 051 30109	10Ω	5%	0,06W
3713	4822 051 30223	22kΩ	5%	0,06W
3714	4822 051 30103	10kΩ	5%	0,06W
3715	4822 117 13632	100kΩ	1%	0,06W
3716	4822 051 30471	470Ω	5%	0,06W
3717	4822 117 12917	1Ω	5%	0,06W
3719	4822 051 30102	1kΩ	5%	0,06W
3720	4822 051 20474	470kΩ	5%	0,1W
3721	4822 051 20393	39kΩ	5%	0,1W
3723	4822 051 30272	2,7kΩ	5%	0,06W
3724	4822 117 12902	8,2kΩ	1%	0,06W
3725	4822 051 30184	180kΩ	5%	0,06W
3730	4822 051 20333	33kΩ	5%	0,1W
3740	4822 051 20223	22kΩ	5%	0,1W
3741	4822 051 20223	22kΩ	5%	0,1W
3742	4822 051 20223	22kΩ	5%	0,1W
3743	4822 051 20223	22kΩ	5%	0,1W
3744	4822 051 30103	10kΩ	5%	0,06W
3746	4822 051 30103	10kΩ	5%	0,06W
3750	4822 051 30102	1kΩ	5%	0,06W
3751	4822 051 30102	1kΩ	5%	0,06W
3789	4822 051 30471	470Ω	5%	0,06W
3790	4822 051 30561	560Ω	5%	0,06W
3791	4822 117 12968	820Ω	5%	0,06W
3792	4822 051 30332	3,3kΩ	5%	0,06W
3793	4822 051 20471	470Ω	5%	0,1W
3794	4822 051 30391	390Ω	5%	0,06W
3795	4822 051 30222	2,2kΩ	5%	0,06W
3796	4822 051 30332	3,3kΩ	5%	0,06W
3798	4822 051 30102	1kΩ	5%	0,06W
3799	4822 051 30102	1kΩ	5%	0,06W
3800	4822 051 51831	18kΩ	5%	0,1W

ELECTRICAL PARTSLIST 3CDC-LLC-MCD1 MODULE

RESISTORS

3801	© 4822 051 30103	10kΩ	5%	0,06W
3802	© 4822 051 51831	18kΩ	5%	0,1W
3803	© 4822 117 10833	10kΩ	1%	0,1W
3804	© 4822 051 30103	10kΩ	5%	0,06W
3805	© 4822 051 30103	10kΩ	5%	0,06W
3806	© 4822 051 30103	10kΩ	5%	0,06W
3807	© 4822 051 30103	10kΩ	5%	0,06W
3808	© 4822 051 30103	10kΩ	5%	0,06W
3809	© 4822 051 20471	470Ω	5%	0,1W
3811	© 4822 051 51831	18kΩ	5%	0,1W
3812	4822 053 10228	2,2Ω	5%	1W
3813	© 4822 117 13608	4,7Ω	5%	0,06W
3814	© 4822 051 30339	33Ω	5%	0,06W
3815	4822 052 10478	4,7Ω	5%	NFR
3818	© 4822 051 30222	2,2kΩ	5%	0,06W
3819	© 4822 051 20471	470Ω	5%	0,1W
3820	© 4822 051 30222	2,2kΩ	5%	0,06W
3821	© 4822 051 30222	2,2kΩ	5%	0,06W
3822	© 4822 051 30222	2,2kΩ	5%	0,06W
3825	© 4822 051 20181	180Ω	5%	0,1W
3826	© 4822 051 30333	33kΩ	5%	0,06W
3827	© 4822 051 20273	27kΩ	5%	0,1W
3828	© 4822 051 20223	22kΩ	5%	0,1W
3831	© 4822 051 30101	100Ω	5%	0,06W
3832	© 4822 051 30103	10kΩ	5%	0,06W
3833	© 4822 051 30223	22kΩ	5%	0,06W
3834	© 4822 051 20223	22kΩ	5%	0,1W
3835	4822 052 10478	4,7Ω	5%	NFR
3837	© 4822 051 10102	1kΩ	2%	0,25W
3838	© 4822 051 30102	1kΩ	5%	0,06W
3839	© 4822 051 20124	120kΩ	5%	0,1W
3840	© 4822 051 30124	120kΩ	5%	0,06W
3841	© 4822 117 10833	10kΩ	1%	0,1W
3842	© 4822 117 10833	10kΩ	1%	0,1W
3843	© 4822 117 10834	47kΩ	1%	0,1W
3844	© 4822 051 20392	3,9kΩ	5%	0,1W
3845	© 4822 117 10833	10kΩ	1%	0,1W
3846	© 4822 117 10834	47kΩ	1%	0,1W
3847	© 4822 051 20562	5,6kΩ	5%	0,1W
3849	© 4822 051 20334	330kΩ	5%	0,1W
3850	© 4822 051 30103	10kΩ	5%	0,06W
3851	4822 052 10338	3,3Ω		NFR25
3852	4822 052 10228	2,2Ω	5%	0,33W
3853	© 4822 051 20471	470Ω	5%	0,1W
3858	© 4822 117 12925	47kΩ	1%	0,06W
3859	© 4822 117 10834	47kΩ	1%	0,1W
3860	© 4822 117 10833	10kΩ	1%	0,1W
3861	© 4822 051 30103	10kΩ	5%	0,06W
3862	© 4822 051 20121	120Ω	5%	0,1W
3863	© 4822 117 11373	100Ω	1%	0,1W
3864	© 4822 117 11373	100Ω	1%	0,1W
3865	© 4822 051 30101	100Ω	5%	0,06W
3867	© 4822 051 30121	120Ω	5%	0,06W
3868	© 4822 051 30101	100Ω	5%	0,06W
3870	© 4822 051 20472	4,7kΩ	5%	0,1W
3871	© 4822 051 30103	10kΩ	5%	0,06W
3873	© 4822 051 20471	470Ω	5%	0,1W
3875	© 4822 051 30103	10kΩ	5%	0,06W
3876	© 4822 117 13632	100kΩ	1%	0,06W
3877	© 4822 051 30103	10kΩ	5%	0,06W
3878	© 4822 051 30103	10kΩ	5%	0,06W
3879	© 4822 117 10837	100kΩ	1%	0,1W

RESISTORS

3880	© 4822 051 30392	3,9kΩ	5%	0,06W
3881	© 4822 117 13632	100kΩ	1%	0,06W
3882	© 4822 117 12925	47kΩ	1%	0,06W
3883	© 4822 117 10833	10kΩ	1%	0,1W
3884	© 4822 051 30271	270Ω	5%	0,06W
3885	© 4822 117 10833	10kΩ	1%	0,1W
3886	© 4822 117 12925	47kΩ	1%	0,06W
3887	© 4822 051 30221	220Ω	5%	0,06W
3888	© 4822 117 10833	10kΩ	1%	0,1W
3889	© 4822 051 20471	470Ω	5%	0,1W
3890	© 4822 051 30102	1kΩ	5%	0,06W
3891	© 4822 051 30102	1kΩ	5%	0,06W
3892	© 4822 051 20471	470Ω	5%	0,1W
3893	© 4822 051 30471	470Ω	5%	0,06W
3894	© 4822 051 30101	100Ω	5%	0,06W
3895	© 4822 117 12971	15Ω	5%	0,06W
3898	© 4822 051 30221	220Ω	5%	0,06W
3899	© 4822 051 30101	100Ω	5%	0,06W
3900	© 4822 117 12955	2,7kΩ	1%	0,1W
3901	© 4822 117 10833	10kΩ	1%	0,1W
3904	© 4822 117 13632	100kΩ	1%	0,06W
4800	© 4822 051 20008			CHIP JUMPER 0805
4801	© 4822 051 20008			CHIP JUMPER 0805
4802	© 4822 051 20008			CHIP JUMPER 0805
4803	© 4822 051 30008			CHIP JUMPER 0603
4804	© 4822 051 20008			CHIP JUMPER 0805
4805	© 4822 051 30008			CHIP JUMPER 0603
4806	© 4822 051 20008			CHIP JUMPER 0805
4807	© 4822 051 20008			CHIP JUMPER 0805
4808	© 4822 051 20008			CHIP JUMPER 0805
4811	© 4822 051 20008			CHIP JUMPER 0805
4814	© 4822 051 20008			CHIP JUMPER 0805
4817	© 4822 051 20008			CHIP JUMPER 0805
4818	© 4822 051 20008			CHIP JUMPER 0805
4819	© 4822 051 20008			CHIP JUMPER 0805
4820	© 4822 051 20008			CHIP JUMPER 0805
4821	© 4822 051 20008			CHIP JUMPER 0805
4822	© 4822 051 20008			CHIP JUMPER 0805
4823	© 4822 051 20008			CHIP JUMPER 0805
4824	© 4822 051 30008			CHIP JUMPER 0603
4825	© 4822 051 30008			CHIP JUMPER 0603
4826	© 4822 051 20008			CHIP JUMPER 0805
4828	© 4822 051 20008			CHIP JUMPER 0805
4829	© 4822 051 20008			CHIP JUMPER 0805
4830	© 4822 051 20008			CHIP JUMPER 0805
4831	© 4822 051 20008			CHIP JUMPER 0805
4832	© 4822 051 30008			CHIP JUMPER 0603
4833	© 4822 051 20008			CHIP JUMPER 0805
4834	© 4822 051 20008			CHIP JUMPER 0805
4835	© 4822 051 20008			CHIP JUMPER 0805
4838	© 4822 051 30008			CHIP JUMPER 0603
4840	© 4822 051 20008			CHIP JUMPER 0805
4841	© 4822 051 30008			CHIP JUMPER 0603
4842	© 4822 051 20008			CHIP JUMPER 0805
4844	© 4822 051 20008			CHIP JUMPER 0805
4845	© 4822 051 20008			CHIP JUMPER 0805
4846	© 4822 051 20008			CHIP JUMPER 0805
4847	© 4822 051 20008			CHIP JUMPER 0805
4848	© 4822 051 20008			CHIP JUMPER 0805
4850	© 4822 051 20008			CHIP JUMPER 0805
4876	© 4822 051 20008			CHIP JUMPER 0805

ELECTRICAL PARTSLIST 3CDC-LLC-MCD1 MODULE**COILS**

 1810 4822 242 73557 CERAMIC RES. 8,46MHz

DIODES

 6871 © 4822 130 11397 BAS316
 6872 © 4822 130 11397 BAS316
 6873 © 4822 130 11397 BAS316
 6874 © 4822 130 11397 BAS316
 6875 © 9340 548 52115 BZX284-C5V1

 6877 © 9322 129 34685 BZX284-C3V9
 6878 © 4822 130 11397 BAS316
 6879 © 9322 129 34685 BZX284-C3V9
TRANSISTORS

 7802 © 5322 130 60123 BC807-40
 7808 © 4822 130 60511 BC847B
 7809 © 4822 130 60511 BC847B
 7810 © 4822 130 60511 BC847B
 7812 © 4822 130 60511 BC847B

 7874 © 4822 130 60511 BC847B
 7875 © 4822 130 60511 BC847B
INTEGRATED CIRCUITS

 7803 © 5322 209 82941 LM358D, Dual Opamp
 7805 © 4822 209 33165 TDA1308T/N1
 7806 4822 209 32852 TDA7073A/N2
 7807 4822 209 32852 TDA7073A/N2
 7871 4822 209 32852 TDA7073A/N2

 7873 © 5322 209 11306 HEF4094BT, SHIFT REGISTER
 7877 © 9352 641 80557 SAA7324H/M2B,"CD10" SIGN.PROC.

SET MECHANICAL EXPLODED VIEW

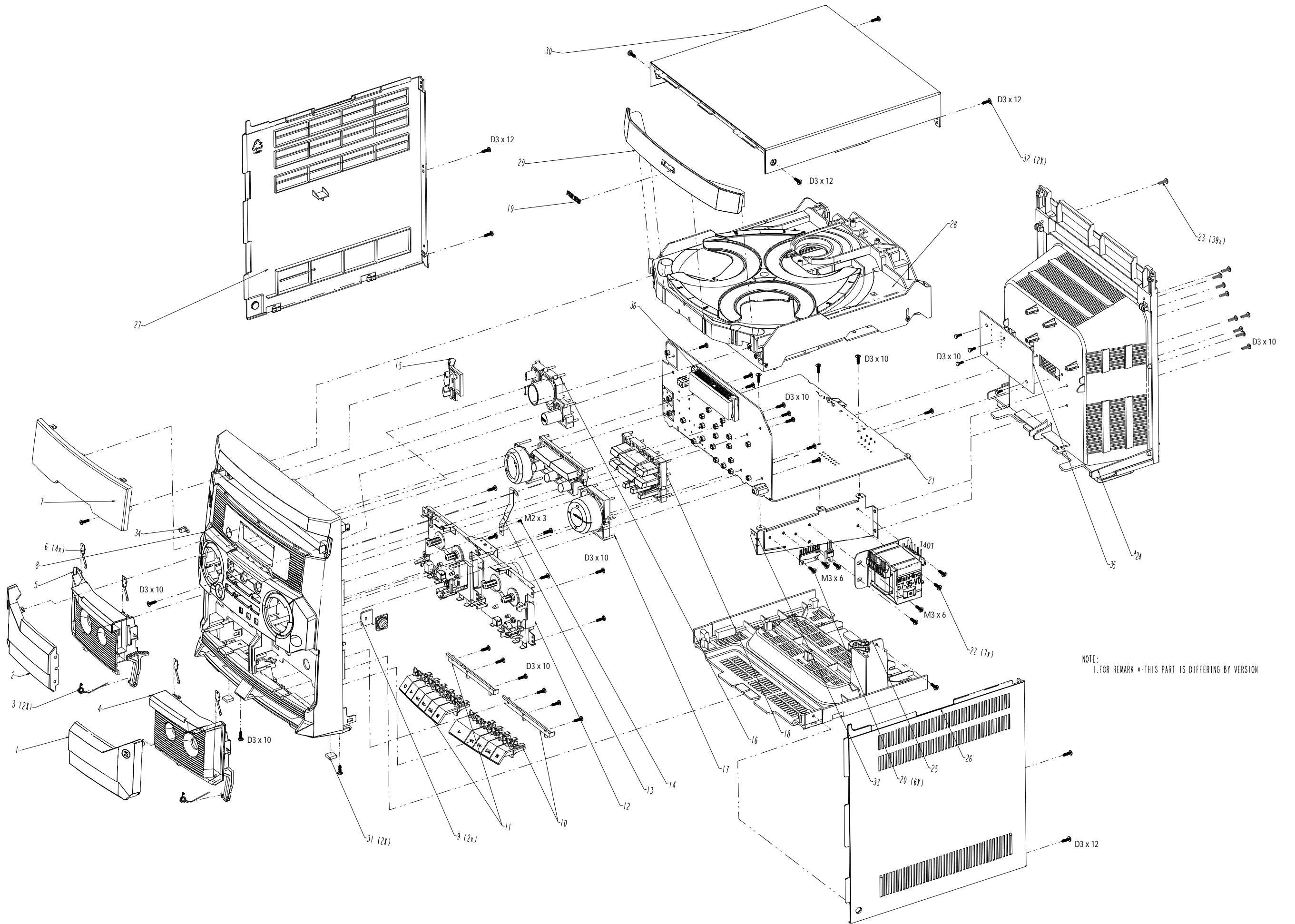

NOTE:
1. FOR REMARK * THIS PART IS DIFFERING BY VERSION

MECHANICAL & ACCESSORIES PARTSLIST

1	9965 000 22390	LENS CASS RIGHT
2	9965 000 22389	LENS CASS LEFT
3	9965 000 11170	CASSETTE DOOR SPRING
4	9965 000 22378	DOOR CASS RIGHT
5	9965 000 22377	DOOR CASS LEFT
6	9965 000 11173	SPRING LEAF
7	9965 000 22399	WINDOW DISPLAY
8	9965 000 22398	FRONT CABINET
9	4822 529 10322	DAMPER ASSY
10	9965 000 11177	CASSETTE KEY SET RIGHT
11	9965 000 11178	CASSETTE KEY SET LEFT
12	9965 000 13617	CASS DECK
13	9965 000 22393	SPRING RECORD
15	9965 000 22400	KEY POWER ECO /22/25
15	9965 000 22392	BUTTON SET POWER /21
16	9965 000 22386	BUTTON SET DBB
17	9965 000 22387	BUTTON SET MODE
18	9965 000 22388	BUTTON SET CONTROL
19	4822 454 13408	BADGE PHILIPS
24	9965 000 22379	PANEL REAR /21
24	9965 000 22397	PANEL REAR /22/25
26	9965 000 22383	PANEL RIGHT
27	9965 000 22382	PANEL LEFT
28	3103 308 54360	3CDC ASSY
29	9965 000 22385	DOOR-CDC
30	9965 000 22384	COVER-TOP
31	9965 000 16259	FOOT RUBBER-2
	9965 000 22394	IFU FWC170/21
	9965 000 16257	IFU FWC170/22
△	9965 000 22395	ADAPTOR CONVERSION /21
	9965 000 11157	FM ANTENNA WIRE
	4822 303 50082	AM LOOP ANTENNA
△	9965 000 11187	MAINS TRANSFO 120V/240V /21
△	9965 000 11190	MAINS TRANSFO 230V /22/25
	9965 000 11159	REMOTE CONTROL
△	9965 000 17244	AC CORD UK 2M /25
△	9965 000 11189	AC CORD BLACK /21/22
	9965 000 11188	FLEX CABLE 15PIN 1,25MM 35CM
	9965 000 22403	SPK BOX FWC170/22/25
	9965 000 22396	SPK BOX FWC170/21

Note: Only these parts mentioned in the list are normal service parts.