

Fire Arson Investigation Manual

Chemistry and Physics of Fire Behaviour

INTRODUCTION

Fire is a complex chemical process, and fire investigators must understand the basic chemistry and physics involved to enable them to formulate opinions based on these scientific principles rather than on "old fire investigators' tales."

Not being able to explain the technical aspects of fire behavior may prevent an investigator from qualifying as an expert witness. Opposing attorneys easily can use questions about the chemistry and physics of fire to effectively discredit a fire investigator.

The **diffusion flame process** (fire) consists of three basic elements: fuel, oxygen, and heat. These basic components have been recognized in the science of fire protection for over 100 years. The diffusion flame process is defined by Richard Tuve in the *Principles of Fire Protection Chemistry* as "a rapid self-sustaining oxidation process accompanied by the evolution of heat and light of varying intensities."

LIFE CYCLE OF FIRE

The six elements of the life cycle of fire are described by Dawson Powell in *The Mechanics of Fire*. These elements are input heat, fuel, oxygen, proportioning, mixing, and ignition continuity. All of these elements are essential for both the initiation and continuation of the diffusion flame combustion process. The first three elements—input heat, fuel, and oxygen—are represented by the fire triangle which is familiar to all firefighters. The combustion reaction can be depicted more accurately by a four-sided solid geometric form called a tetrahedron. The four sides represent heat, fuel, oxygen, and uninhibited chain reactions.

Elemental: Input Heat

Solid or liquid materials do not burn. For combustion to take place, these materials must be heated sufficiently to produce vapors. It is these vapors which actually burn. The lowest temperature at which a solid or liquid material produces sufficient vapors to burn under laboratory conditions is known as the **flashpoint**. A few degrees above the flashpoint is the **flame point**, the temperature at which the fuel will continue to produce sufficient vapors to sustain a continuous flame.

The temperature at which the vapors will ignite is the **ignition temperature**, sometimes referred to as the auto-ignition temperature. If the source of the heat is an open flame or spark, it is referred to as **piloted ignition**.

For example, gasoline has a flashpoint of -45°F (-42.5°C) and an ignition temperature of 536°F (280°C). This means that at any temperature at or above -45°F (-42.8°C), the gasoline will be producing sufficient vapors to be ignited if exposed to an open flame, spark, or any heat source of 536°F (280°C) or greater.

Element 2: Fuel Initially the fuel may be in the form of a gas, liquid, or solid & the ambient temperature. As discussed previously, liquid and solid fuels must be heated sufficiently to produce vapors.

In general terms, **combustible** means capable of burning, generally in air under normal conditions of ambient temperature and pressure, while **flammable** is defined as capable of burning with a flame. This should not be confused with the terms flammable and combustible liquids.

Flammable liquids are those which have a flashpoint below 100°F (37.8°C), such as gasoline, acetone, and ethyl alcohol. **Combustible liquids** are those which have a flashpoint at or above 100°F (37.8°C), such as kerosene and fuel oil.

The **specific gravity** of a liquid is the ratio of the weight of the substance to that of water which is assigned a value of 1. A substance with a specific gravity greater than 1 will tend to sink, while one whose specific gravity is less than 1 will tend to float.

Element M: Oxygen

Normally, the primary source of oxygen is the atmosphere, which contains approximately 20.8 percent oxygen. A concentration of at least 15 to 16 percent is needed for the continuation of flaming combustion, while charring or smoldering (pyrolysis) can occur with as little as 8 percent. Pyrolysis is defined as the transformation of a compound into one or more other substances by heat alone. While the atmosphere typically is the primary source of oxygen, certain chemicals, called "oxidizers," can be either the primary or secondary source. Examples are chlorine and ammonium nitrate.

Elements #4 and #5: Mixing and Proportioning

Mixing and proportioning are reactions which must be continuous in order for fire to continue to propagate. The fuel vapors and oxygen must be mixed in the correct proportions. Such mixture of fuel vapors and oxygen is said to be within the **explosive limits or flammable limits**. Explosive or flammable limits are expressed in the concentration (percentage) of fuel vapors in air. A mixture which contains fuel vapors in an amount less than necessary for ignition to occur is too

lean, while a mixture which has too high a concentration of fuel vapors is too rich. The lowest concentration that will burn is known as the **Lower Explosive Limit (LEL)**, while the highest level is known as the **Upper Explosive Limit (UEL)**.

For example, the explosive or flammable limits for propane are 2.15 (LEL) to 9.6 (UEL). This means that any mixture of propane and air between 2.15 percent and 9.6 percent will ignite if exposed to an open flame, spark, or other heat source equal to or greater than its ignition temperature, which is between 920°F (493.3°C) and 1,120°F (604.4°C).

Another important characteristic of gases is vapor density—the weight of a volume of a given gas to an equal volume of dry air, where air is given a value of 1.0. A vapor density of less than 1.0 means that the gas is lighter than air and will tend to rise in a relatively calm atmosphere, while a vapor density of more than 1.0 means that the gas is heavier than air and will tend to sink to ground/floor level.

The following chart shows the flashpoints, ignition temperatures, flammable limits, vapor densities, and specific gravities of various materials. NFPA 325M, *Guide to Fire Hazard Properties of Flammable Liquids, Gases, and Volatile Solids*, contains a more extensive listing of this type of information.

Element M: Ignition Continuity

Ignition continuity is the thermal feedback from the fire to the fuel. Heat is transferred by conduction, convection, radiation, and direct flame contact. **Conduction** is the transfer of heat by direct contact. **Convection** is the transfer of heat caused by changes in density of liquids and gases. It is the most common method of heat transfer; when liquids or gases are heated they become less dense and will expand and rise. Transfer of heat by **radiation** is less commonly understood or appreciated than conduction or convection. Radiation is the transfer of heat by infrared radiation (heat waves, e.g., the sun) which generally is not visible to the naked eye. (See the graphic examples of conduction, convection, and radiation below.)

Direct flame contact is a combination of two of the basic methods of heat transfer. As hot gases from the flame rise into contact with additional fuel, the heat is transferred to the fuel by convection and radiation until the additional fuel begins to vaporize. These additional vapors then will be ignited by the flames.

The amount of heat generated is measured in **British thermal units** or Btu's. One Btu is the amount of heat required to raise the temperature of 1 pound of water 1°F (when the measurement is performed at 60°F (15.5°C)).

Fires are classified by the types of materials that are burning. **Class A fires** involve ordinary combustible materials, such as wood, cloth, paper, rubber) and many plastics. **Class B fires** involve flammable/combustible liquids, greases, and

gases. **Class C fires** involve energized electrical equipment **Class D fires** involve combustible metals, such as magnesium, titanium, zirconium, sodium, and potassium.

All fires produce **combustion products**. Combustion products fall into four categories: heat, gases, flame, and smoke. **Heat** is defined as a form of energy characterized by vibration of molecules and capable of initiating and supporting chemical changes and changes of state. **Gases** are substances which have no shape or volume of their own and will expand to take the shape and volume of the space they occupy. Fire gases include carbon *monoxide*, hydrogen cyanide, ammonia, hydrogen chloride, and acrolein. (See **box** below for the effects of several typical fire gases.) **Flame** is the luminous portion of burning gases or vapors. **Smoke** is the airborne particulate products of incomplete combustion, suspended in gases, vapors, or solid or liquid aerosols. Soot, black particles of carbon, is contained in smoke.

EFFECTS OF VARIOUS FIRE GASES

Ammonia (NH ₃)	1,000 ppm fatal within 10 minutes
Hydrogen Chloride (HCl)	1,500 ppm fatal within several minutes
Phosgene (00012)	25 ppm fatal within 30 minutes
Acrolein (CH ₂ CHCHO)	30-100 ppm fatal within 10 minutes
Oxides of Nitrogen (NO _x)	200 ppm fatal within 10 minutes
Carbon Monoxide (CO)	10,000 ppm exposure fatal within 1 minute
Carbon Dioxide (002)	70% concentration fatal within several minutes
Hydrogen Cyanide (HCN)	450 ppm causes death in 9 to 13 minutes
Hydrogen Sulfide (H ₂ S)	400-700 ppm dangerous in 30 minutes
Sulfur Dioxide (802)	500 ppm fatal within 10 minutes

ROOM FIRE SEQUENCE

A fire in a room or defined space generally will progress through three predictable **developmental stages**. In order to determine the origin and cause of a fire properly, the investigator must be able to interpret the effects of these stages correctly during the examination of the fire scene.

The first stage of fire development is the incipient stage (growth). This begins at the moment of ignition, and at this time the flames are localized. At this stage the fire is **fuel** regulated. That is, the fire propagation is regulated not by the available oxygen but by the configuration, mass, and geometry of the fuel itself. The oxygen content is within the normal range and normal ambient temperatures still exist. A plume of hot fire gases will begin to rise to the upper portions of the room. As convection causes the plume to rise it will draw additional oxygen into the bottom of the flames. Fire gases such as sulfur dioxide, carbon monoxide, and others will begin to accumulate in the room. If there is any solid fuel above the flame, both

convection and direct flame contact will cause upward and outward fire spread, producing the characteristic "V" pattern charring.

Second is the **free-burning stage** (development). In this stage more fuel is being consumed, and the fire is intensifying. Flames have spread upward and outward from the initial point of origin by convection, conduction, and direct flame impingement. A hot, dense layer of smoke and fire gases is collecting at the upper levels of the room and is beginning to radiate heat downward. This upper layer of smoke and fire gases contains not only soot, but also toxic gases such as carbon monoxide, hydrogen cyanide, hydrogen chloride, acrolein, and others. Unless the room of origin is sealed tightly, the smoke and fire gases will be spread throughout the building. The temperature at the ceiling level has begun to rise rapidly while the floor temperature is still relatively cool. It is still possible to survive in the room at the cooler lower level.

The fire continues to grow in intensity and the layer of soot and fire gases drops lower and lower. The soot and combustible gases continue to accumulate until one (or more) of the fuels reaches its ignition temperature. **Rollover** occurs when ignition of the upper layer results in fire extending across the room at the ceiling level. This rollover causes the ceiling temperature to increase at an even greater rate and also increases the heat being radiated downward into the room. Secondary fires can and do result from the heat being generated. The fire is still fuel regulated at this time.

When the upper layer reaches a temperature of approximately 1,100°F (593.3°C), sufficient heat is generated to cause simultaneous ignition of all fuels in the room. This is called **flashover**. Once flashover has occurred, survival for more than a few seconds is impossible. Temperatures in the space will reach 2,000°F (1,093.3°C) or more at the ceiling level down to over 1,000°F (537.8°C) at the floor. At the point of flashover the fire is still fuel regulated; however, if the fire stays confined to the room of origin it quickly becomes oxygen regulated. The rapid temperature rise associated with flashover generally results in windows breaking, which then produces an unlimited supply of oxygen causing the fire to transfer back to the fuel-regulated phase. As a general rule, once flashover has occurred, full involvement of the structure follows quickly.

Flashover results in intense burning of the entire room and its contents. Flashover will produce heavy floor-level burning and can even result in burning on the underside of objects in the room. The length of time necessary for a fire to go from the incipient stage to flashover depends on the fuel package, the room geometry, and ventilation. In the typical residential accidental fire setting, this time may be as short as 2 to 3 minutes.

Eventually, the fuel is consumed and open burning becomes increasingly less prevalent. If the fire has been contained to a room or space, and the oxygen level drops below 15 to 16 percent, open flaming combustion will stop even if unburned fuel is still present. At this point glowing combustion will take place; this is known as the **smoldering stage** (decay). High temperatures and considerable quantities of soot and combustible fire gases have accumulated, and

at this point the fire is oxygen regulated. The temperatures may exceed the ignition temperatures of the accumulated gases. If a source of oxygen is introduced in the area, the accumulated soot and fire gases may ignite with explosive force. This smoke explosion is known as a **backdraft**. The pressures generated by a backdraft are enough to cause significant structural damage and endanger the lives of firefighting personnel and bystanders.

Backdrafts can take place in any enclosed space; they are not limited to rooms. Attics, basements, and concealed ceiling spaces also are susceptible. There also is a danger of backdraft during overhaul.

The behavior of a fire in a **corridor** is affected by the same conditions as a room fire. The physical configuration of a corridor can cause the fire to spread rapidly, since the corridor will function as a horizontal chimney or flue. Rapid fire spread in a corridor can occur with normal materials providing the fuel load.

Fire Hazard Properties of Liquids and Gases

Material	Flashpoint	Ignition Temp.	C°	Flammable Limits	Vapor Density	Specific Gravity
Acetone	-4 (-20°C)	°F 869°F	465°	2.5-12.8	2.0	.8
Acetylene	Gas	581°F	305°	2.5-100	0.9	-
Anhydrous Ammonia	Gas	1,204°F	651°	15-28	0.6	0.7
Benzene	12°F (-11.1°C)	928°F	498°	1.2-7.8	2.8	0.9
Carbon Monoxide	Gas	1,128°F	608°	12.5-74	1.0	-
Ethyl Alcohol	55°F (12.7°C)	685°F	362°	3.3-19	1.6	0.8
Fuel Oil #1 (kerosene)	100-162°F (37.8-72.2°C)	410°F	210°	0.7-5	+1	+1
Fuel Oil #2 (diesel)	126-204°F (52.2-95.6°C)	494°F	256°	0.7-5	+1	+1
Gas, Natural	Gas	900-1,170°F	482-632°	3.8/6.5-13/17	0.6	-
Gasoline	-45°F (-42.8°C)	536°F	280°	1.4-7.6	3-4	0.8
Heptane	25°F (-3.9°C)	399°F	204°	1.05-6.7	3.5	0.7
Hexane	-7°F (-21.7°C)	437°F	225°	1.1-7.5	3.0	0.7
Hydrogen	Gas	932°F	500°	4.0-75	0.1	-
Mineral Spirits	104°F (40°C)	473°F	245°	0.8-	3.9	0.8
Motor Oil	300-450 (148-232°C)	500-700°F	260-371°	-	-	-
Turpentine	95°F (35°C)	488°F	253°	0.8-	-	+1
o-Xylene	81°F (27.2°C)	867°F	463°	0.9-6.7	3.7	0.9

Source: NFPA 325M, 1991 Ed.

SUMMARY

Fire is a very complex process influenced by many factors that affect its growth, spread, and development. The physical shape and state of the fuel, the available oxygen, and the transmission of heat all play vital roles in fire development. While each fire is different, all fires follow certain predictable patterns which, when

understood by the investigator, provide a scientific basis for determination of origin and cause.

BIBLIOGRAPHY

DeHaan, John D. *Kirk's Fire Investigation*, 3rd ed. New Jersey: Brady, 1991.

Drysdale, Dougal. *An Introduction to Fire Dynamics*. New York: Wiley, 1986.

Fang, J.B. *Fire Development in Residential Basement Rooms*. National Institute of Standards and Technology.

Fire Dynamics. Emmitsburg: National Fire Academy, 1984.

Fire Protection Handbook, 17th ed. Quincy: National Fire Protection Association, 1991

Fung, Francis. "The NBS Program on Corridor Fires" *Fire Journal*, May 1973.

NFPA 921, *Guide for Fire and Explosion Investigations*. 1992 ed. Quincy: National Fire Protection Association.

NFPA 325M, *Manual on Fire Hazard Properties of Flammable Liquids, Gases, and Volatile Solids*. 1991 ed. Quincy: National Fire Protection Association.

NFPA 1033, *Standard for Professional Qualifications for Fire Investigator*. Quincy: National Fire Protection Association, 1993.

Powell, Dawson. *The Mechanics of Fire*. Rhode Island: Grinnell Company Inc., 1955.

Tuve, Richard L. *Principles of Fire Protection Chemistry*. Quincy: National Fire Protection Association, 1976.

Building Construction and It's Components

INTRODUCTION

A basic understanding of the characteristics of building construction is a critical element in conducting a proper fire loss analysis. The type of construction, materials used, and any fire protection systems in place will influence fire behavior. Failure to consider the effects of construction methods, materials, and fire protection systems can result in an incorrect determination of the origin and

cause of a fire. *Building Construction/or the Fire Service* by Francis Brannigan is a useful resource in this important area.

Building Materials and Fire Spread

The amount of heat produced by burning is determined almost entirely by the chemical composition of the material. The physical form of the material determines the speed with which heat is produced. Hydrocarbon- based materials consume 50 percent more oxygen, and thus produce about 50 percent more heat than equivalent amounts of other materials. On a weight basis, pound for pound, hydrocarbons produce twice the heat. For example, some plastics produce an average of 16,000 Btu's per pound, while wood produces an average of 8,000 Btu's per pound. A gallon of gasoline will produce 115,000 Btu's in comparison to a polyurethane mattress or sofa which will produce 340,000 Btu's. The chart below identifies the Btu's per pound produced by various materials.

Fire Loading

Fire loading is the measurement of the maximum heat that would be liberated if all combustibles in the fire area burned. Fuel load is quantity (in lbs/sq. ft.) of combustibles in a given area, and is normally expressed in weight of combustibles having a value of 8,000 Btu's per pound—given as equivalent weight of wood.

Rate of Heat Release (RHR)

While the fire load determines the amount of heat that would be generated, just as important is the **Rate of Heat Release (RHR)**. The RHR indicates how fast the heat in the fuel is released. The type and form of materials affect the RHR. The higher the RHR, the more rapidly the fire will increase in severity.

Steel

The popularity of steel-frame building construction is due to its high strength, ease of fabrication, and assured uniformity of quality, but exposed structural steel is vulnerable to fire damage and structural collapse. Fire protection generally is provided by encasing the members in concrete, lath and plaster, and/or sprayed fibers, or by installing a ceiling membrane, such as tiles, in a grid system.

The intensity of stress in a steel member influences the load-carrying capacity. The higher the load stress, the more quickly a member will fail at elevated temperatures; 1,100°F (609°C) normally is considered to be the critical temperature. At this temperature, steel has lost 60 percent of its carrying capacity at room temperatures. If the ends of a structural member are restrained, expansion due to heat under load can cause rapid collapse. Fifty feet of steel heated

uniformly over its length from 721°F to 972°F (383° to 522°C) expands 3.9 inches.

Concrete

Although collapse of reinforced concrete structures is rare, loss of strength and damaging effects do occur. Factors that influence strength reduction are type of aggregate; moisture content; type of loading; and level of stress. The greatest problem of prestressed concrete is the elevated temperature of the stressed steel. Elasticity is reduced by 20 percent when the temperature of the steel reaches 600°F (316°C). Prestressed wires are permanently weakened when they reach 800°F (427°C).

Wood

Depending on its form, wood may or may not provide reasonable structural integrity in a fire. Fire-retardant treatment delays ignition and retards combustion; however, all wood will burn. Burning produces charcoal, which initially provides a protective coating that insulates the unburned wood. Thicker members provide much more structural integrity over the period of fire exposure than do thin ones. Heavy timber has proven to be an excellent form of construction. Wood-frame construction uses structural members smaller than mill construction and, when exposed to fire, it offers relatively little structural integrity.

BUILDING CONSTRUCTION CLASSIFICATIONS

Fire-Resistive Construction

In fire-resistive construction all structural members, including walls, partitions, columns, floors, and roofs, are of noncombustible materials with fire-resistive ratings. Fire-resistive ratings are established by tests under laboratory conditions. Poured-in-place concrete is a common building material.

There are usually two subtypes of fire-resistive construction, with the basic difference between them being the level of fire protection specified for the structural frame. A building in which no structural steel is exposed and all vertical openings are enclosed with approved fire doors would be fire resistive. The bearing walls may be made of steel with fire-resistive covering applied. Structural steel often is protected by encasing, sprayed on protection, or membrane ceilings. Exterior walls generally will be curtain walls and not structurally supporting. Exterior or interior nonbearing walls will have varying degrees of fire resistance. Stairwells are enclosed in fire-resistive materials. Roof construction may be similar to floor construction.

Fire spread via exterior of building is a primary concern in this type of construction. This may occur from window to window or through a gap between

the floor and an exterior curtain wall. Finally, fire-resistive buildings typically are constructed with a center-core design. This allows outside walls to be used for offices, apartments, etc.

Noncombustible Construction

In noncombustible construction walls, partitions, and structural members are of noncombustible or limited combustible materials which do not qualify as fire-resistive. Often noncombustible construction is steel, which provides a totally noncombustible building in which the structural elements are exposed to the effects of the fire. Totally noncombustible refers only to the structural materials, not to interior finish and contents. The building's structural framework is made of steel bolted, riveted, or welded together. This is susceptible to expansion, distortion, or relaxation of steel members resulting in early collapse. An example of this type of construction is the pre-engineered steel building. Fire occurring in this type of building can result in collapse in as little as 15 to 20 minutes. Wall enclosures may be masonry, steel, aluminum, glass, or other material. Concrete construction also can be considered noncombustible. The floor and roof support system often will be lightweight bar joists, trusses, or other lightweight steel. Like the pre-engineered structure, collapse of this type of roof system can occur in as little as 15 to 20 minutes.

The obvious strengths of this type of construction are the assurance that structural elements will not add to the fire load, and means of egress are enclosed in fire-resistive materials. Obvious weaknesses are that steel exposed to heat will expand approximately one inch for every 10 feet at 1,100°F (593°C). Also, steel members are subject to early distortion and relaxation.

Heavy-Timber Construction

In heavy-timber (mill-type) construction bearing walls and bearing portions of walls are noncombustible and have a minimum fire resistance rating of 2 hours. Columns, beams, and girders are heavy timbers with wood floor and roof construction.

Heavy-timber structural members (columns, beams, arches, floors, and roofs) are unprotected wood with large cross-sectional areas. These buildings consist of masonry exterior walls and structural members of substantial timber construction. The minimum dimension of structural wood supports is 8 inches for columns, beams, girders, and arches. All *exposed* wood has a minimum dimension of 2 inches. This type of construction is found commonly in older factories and mills. Wood floors will generally be a minimum thickness of 3 inches and may be oil soaked from years of supporting heavy machinery on which lubricating oils were used. Roof supports will be wood with minimum dimensions of 4 by 6 inches, and a minimum roof decking thickness of 1-1/8 inches.

The main advantage of heavy-timber construction is that the large-mass support timbers burn a long time before being destroyed. On the other hand, when fires in this type of construction get away from initial efforts they will tend to be pretty spectacular. Large, open, interior areas, unprotected vertical shafts, and laminated timbers which may weaken all provide potential for rapid fire development.

Ordinary Construction

In ordinary construction exterior bearing walls or bearing portions of exterior walls are of noncombustible materials, while floors, roofs, and interior partitions may be of combustible materials. In this type of construction, all or part of the interior structural elements may be combustible. Exterior walls are required to be of noncombustible materials, but they can have a limited fire-resistance rating. The building will have masonry exterior walls and wooden structural members and interior construction. The building generally will not exceed six stories, and will most often be two or three stories in height. This type of construction is often called "Main Street USA." Floor and roof supports usually are wood, but may contain steel joists or beams. Floor and roof rafters are inserted in wall sockets, and typically cut on an angle called a "fire cut." This allows structural members to fall out of the wall without toppling the entire wall.

Floor and roof decking will most frequently be wooden boards, tongue- and-groove boards, plywood, or composition board. Common walls between buildings may share wall sockets for floor joists and roof rafters.

The main strengths of ordinary construction are the masonry walls, full-dimension lumber, and fire cuts in roof and floors. Critical weaknesses are common walls with wall sockets, common crawl spaces or attics, renovations such as dropped ceilings, and spreader rods.

Wood-Frame Construction

In wood-frame construction, exterior walls, bearing walls and partitions, and floors and roofs and their supports are wholly or partly made of wood or other combustible materials. Usually wood frame is subdivided into two types: protected—in which structural elements have limited fire resistance ratings; and unprotected—in which structural elements have no fire resistance ratings.

Post-and-beam construction has a frame of substantial dimension wood and is sided with a lightweight covering such as wood boards. This construction commonly is used for barns, sheds, and storage buildings but also may be used in dwellings and other occupancies.

In balloon-frame construction, studs run from the foundation to the attic. This was used extensively in many parts of the country until the late 1930's for residential and light commercial. Floor joists are tied into the wall, allowing for fire extension in any direction. Firestopping was not a common practice.

In platform-frame construction the walls of each successive story are built on a platform formed by the preceding floor. The joists for the deck may be full dimension lumber or lightweight construction. Once the floor/deck is in place, walls are placed on it with a sill at the bottom of the wall and a plate on top. Platform-frame construction provides a natural fire barrier for vertical extension within walls. Openings in walls for water, sewer, ventilation, or heating/air conditioning pipes can create a void for fire extension. Multifamily dwellings frequently have extensive vertical openings and void spaces.

Lightweight Construction

Lightweight construction is not a separate classification but it presents special problems under fire conditions. Lightweight supporting members can be used to span large open areas. These lightweight structural members may be steel bar joists, wood trusses, or laminated wood beams. Lightweight "sandwich beams" or "I joists" are typically of 3/8-inch plywood sandwiched into 2- by 3-inch top and bottom chords.

While these types of structural members provide sufficient structural strength to support the building and its contents under normal (nonfire) conditions, these elements fail very easily when exposed to fire conditions. Collapse may occur after as little as 5 minutes of fire exposure. An additional problem associated with wooden trusses is that they create large, combustible concealed spaces in which rapid fire spread can be expected.

OCCUPANCY CLASSIFICATIONS

The use of a building or structure determines its occupancy or use classification. While the specific terminology may vary among the different building codes used in various parts of the country, the following designations are commonly accepted.

Assembly occupancies include, but are not limited to, all buildings or portions of buildings used for gatherings of 50 or more persons for such purposes as deliberation, worship, entertainment, eating, drinking, amusement, or awaiting transportation.

Educational occupancies include all buildings or portions of buildings used for educational purposes through the 12th grade by six or more persons for 4 or more hours per day or more than 12 hours per week. Educational occupancies also include day-care centers. Colleges generally are classified as business occupancies.

Health-care occupancies are used to provide medical or other treatment or care for persons suffering from physical or mental illness, disease, or infirmity; and/or care of infants, convalescents, or infirm aged persons. Health-care occupancies

provide sleeping facilities for four or more occupants and are occupied by persons who mostly are incapable of self-preservation because of age, physical or mental disability, or because of security measures not under the occupants' control.

Detention and correctional occupancies are those used to house occupants under some degree of restraint or security. Detention and correctional occupancies are occupied by persons who mostly are incapable of self-preservation because of security measures not under the occupants' control.

Residential occupancies

are those in which sleeping accommodations are provided for normal residential purposes such as apartments, hotels and motels, dormitories, lodging/rooming houses and one- and two-family dwellings.

Mercantile occupancies include stores, markets, and other rooms, buildings, or structures for the display and sale of merchandise.

Business occupancies are used for the transaction of business, for the keeping of accounts and records, and for other similar purposes. Doctors' and lawyers' offices are included in this category.

Industrial occupancies include factories making products of all kinds and properties devoted to operations such as processing, assembling, mixing, packaging, finishing or decorating, and repairing.

Storage occupancies include all buildings or structures used primarily for the storage or sheltering of goods, merchandise, products, vehicles, or animals.

All of the building codes and National Fire Protection Association (NFPA) 101*, *Life Safety Code*, base many of their requirements on the occupancy or use classification. Among those requirements are the type of construction permitted, the height and area of the building, interior finishes, means of egress (exits), and fire protection systems such as fire alarms, heat and smoke detection, and suppression systems such as automatic sprinklers.

STRUCTURAL LOADS

Specific terminology is used to describe the different loads that are or can be placed on a building.

Dead load is defined as the weight of the building itself and any equipment permanently attached or built in. Additional dead loads may be added to a structure during alterations without any strengthening of the structure. Additions such as roof-top air conditioning units may cause early structural failure under fire conditions.

Live loads are any other loads other than dead loads. This includes furniture and occupants.

Impact loads are those which are delivered in a short period of time. This would include such things as the overturning of a heavy object, i.e., a safe, the collapse of heavy, nonstructural, ornamental masonry onto a roof, or a firefighter jumping onto a floor or roof.

FIRE PROTECTION SYSTEMS

Fire protection systems include automatic sprinkler systems, automatic alarm and smoke detection systems, single' and multiple-station detectors, standpipe systems, and special extinguishing systems such as those used in commercial cooking operations.

The information contained in this section is very elementary and is presented merely to familiarize the fire investigator with these types of systems. In order to properly conduct an analysis of a fire that occurs in a building containing one or more of these types of systems, the investigator must use individuals who have indepth knowledge of the systems if he or she does not have adequate personal expertise in this area. Additional information on the principles of operation of automatic sprinkler systems can be found in *Automatic Sprinkler and Standpipe Systems* (Bryan, John L., 2nd ed., NFPA, 1990). Additional information on fire alarm and detection systems can be found in the *Fire Alarm Signaling Systems Handbook*, (NFPA, 1987).

Automatic Sprinkler Systems

An automatic sprinkler system is a network of pipes suspended throughout a building and ready to deliver water through regularly spaced nozzles (sprinklers) shortly after a fire starts. Water is released automatically when a sprinkler' s fusible element—usually a metal link or glass bulb—is heated to, or above, its temperature rating. The link melts or the bulb bursts, releasing the water under pressure, which hits the sprinkler' s deflector to fonn an umbrella-like spray pattern over the fire. Each sprinkler operates individually.

Automatic sprinkler systems are the most commonly installed automatic fire suppression system. Sprinkler systems have two main purposes: 1)to extinguish unwanted fires; and 2) to control the size of the fire until trained fire suppression crews arrive to extinguish the fire. Either of these activities results in increased property protection and life safety. When connected to an approved fire alaim system, sprinkler systems provide the added benefit of acting as initiating devices to activate the fire alarm system.

Types of Systems

Of the two basic types of automatic sprinkler systems, wet pipe sprinkler systems are the most common and generally are used unless there is danger of the water in the pipes freezing or when other special conditions require one of the other types of systems. Wet pipe systems use closed automatic sprinklers attached to piping containing water under pressure at all times. When individually fused sprinklers operate, the water immediately discharges and continues to flow until the system is shut off.

Dry pipe sprinkler systems are used in unheated areas where water in piping would be susceptible to freezing. Instead of water, the piping contains pressurized air. The air holds back the water behind a dry pipe valve, which must be located in a heated area. When a sprinkler operates, the drop in air pressure causes the dry pipe valve to open, letting the water flow into the pipes. The water then is discharged through the individually fused sprinklers as with a wet system. The water will continue to be discharged until the system is shut off. A dry pipe system is slightly less efficient than a wet pipe system, because it takes more time to deliver the water to the sprinklers.

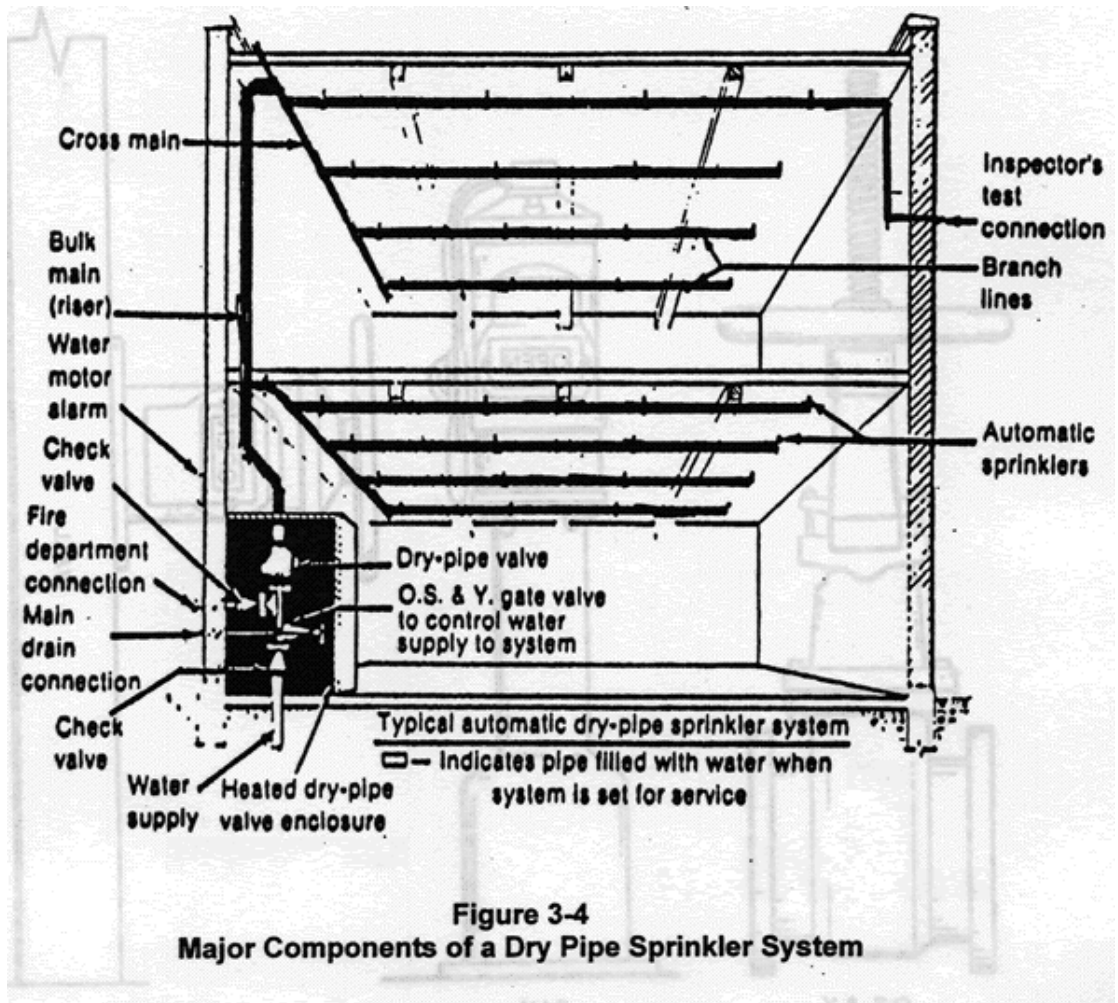

Basic System Components

Post-indicator valve (PIV) is one type of control valve which is found in the yard. The valve has a window which shows its position as open or closed.

Fire department connection (FDC) is a thread connection located either on the exterior of a wall of the building or in the yard. During a fire situation, hoselines from a pumper are connected to the FDC to boost the water flow and pressure to the sprinkler system.

Fire pumps are used to maintain adequate pressure for wet systems in highrise structures.

Outside stem (or screw) and yoke (OS&Y) is a control valve and is designed so that the stem of the valve is exposed. The amount of valve stem exposed depends upon the position of the valve.

A water motor gong is an alarm device used on automatic sprinkler systems. Its bell is actually operated by water flowing through it.

Wall-indicator valve (WIV) is the same as a PIV, but it's mounted on the wall.

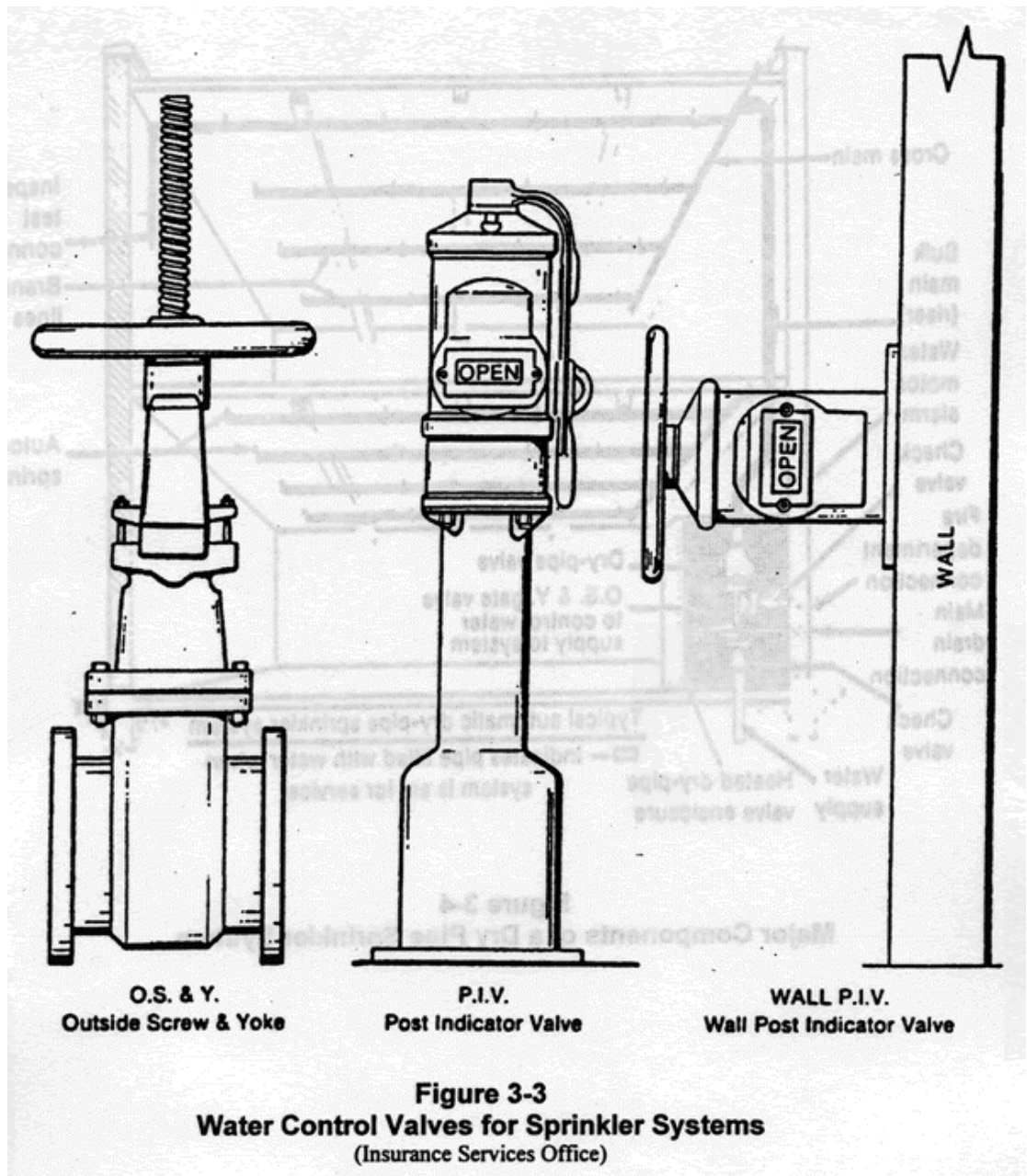

Alarm valves or alarm check valves are used on wet pipe sprinkler systems. Their function is to provide a method of initiating an alarm when the system activates.

Butterfly valves are a type of indicating valve (visually showing open or closed) which control the flow of water with a metal valve plate that opens and closes like butterfly wings.

Control valves are any type of valve used to control the water supply in an automatic sprinkler system. All control valves must visually indicate their position—open or closed.

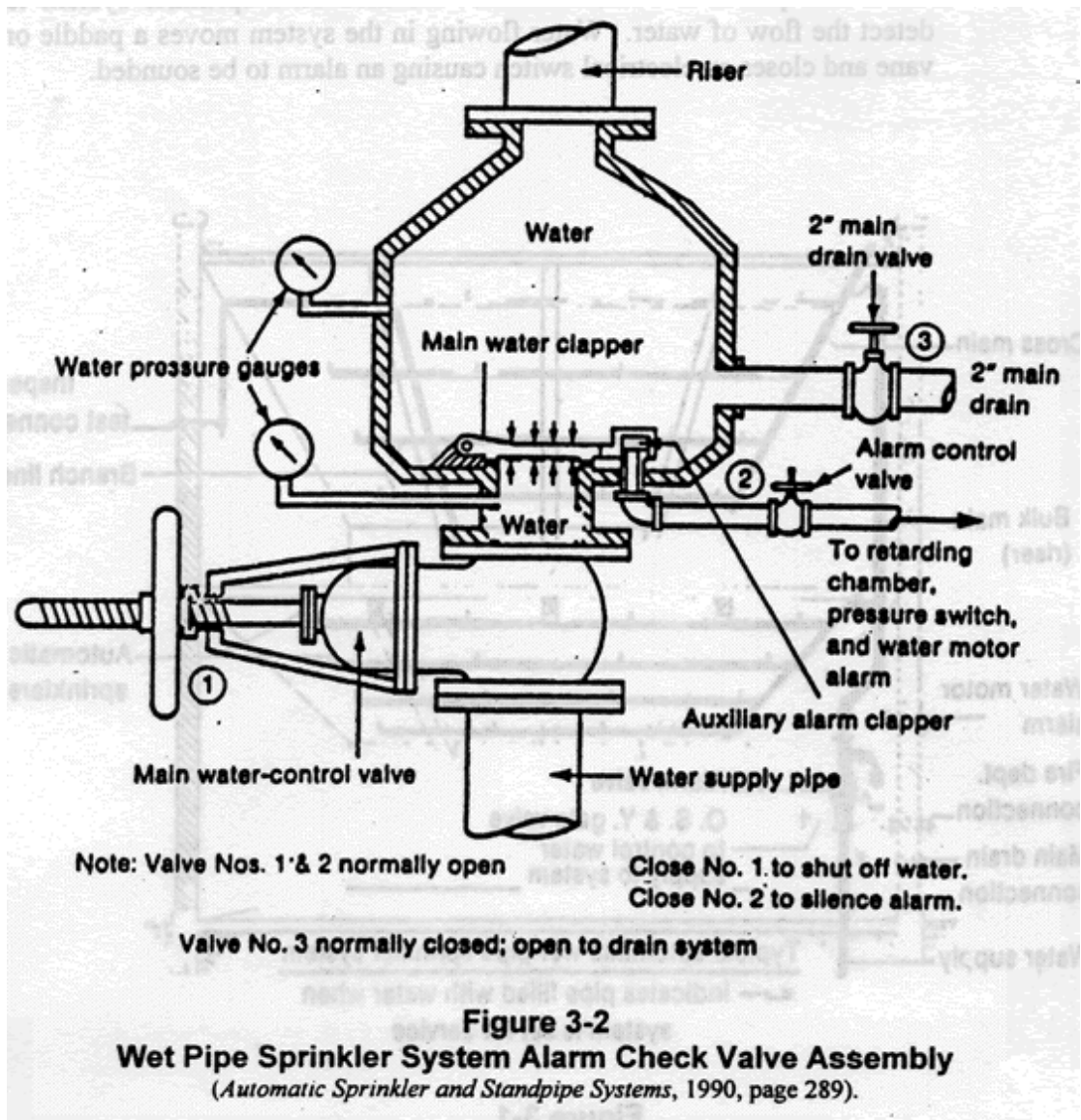

Diy pipe valves or differential dry pipe valves are used on dry pipe sprinkler systems. These types of valves are held closed by air pressure and prevent the water from entering the overhead sprinkler piping except when a sprinkler head opens or the air pressure otherwise drops. These valves use the differential principle to hold back the water. They are designed so that for every pound of air pressure on the top of the valve, the valve will hold back 6 pounds of water pressure.

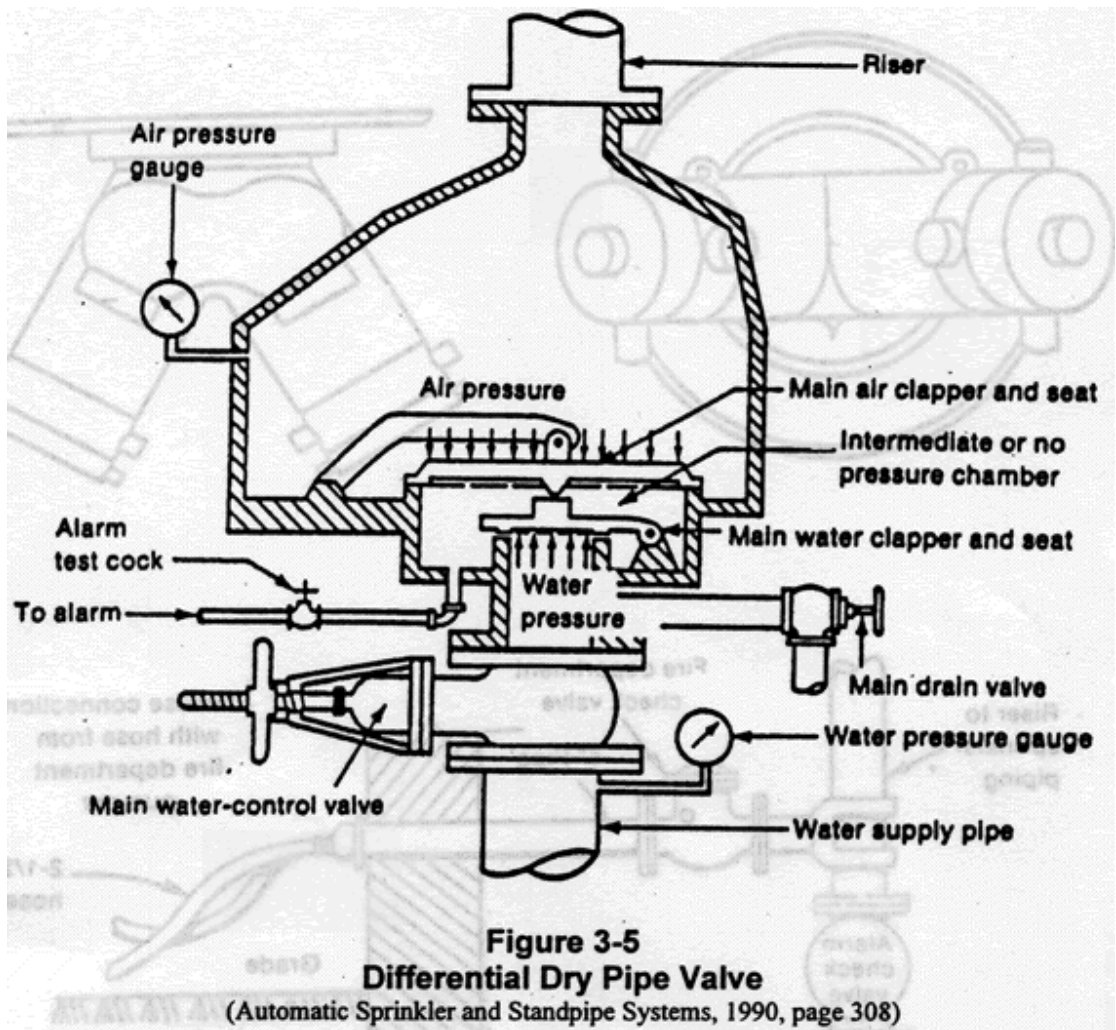

A vane or paddle switch is a device installed on a sprinkler system to detect the flow of water. Water flowing in the system moves a paddle or vane and closes an electrical switch causing an alarm to be sounded.

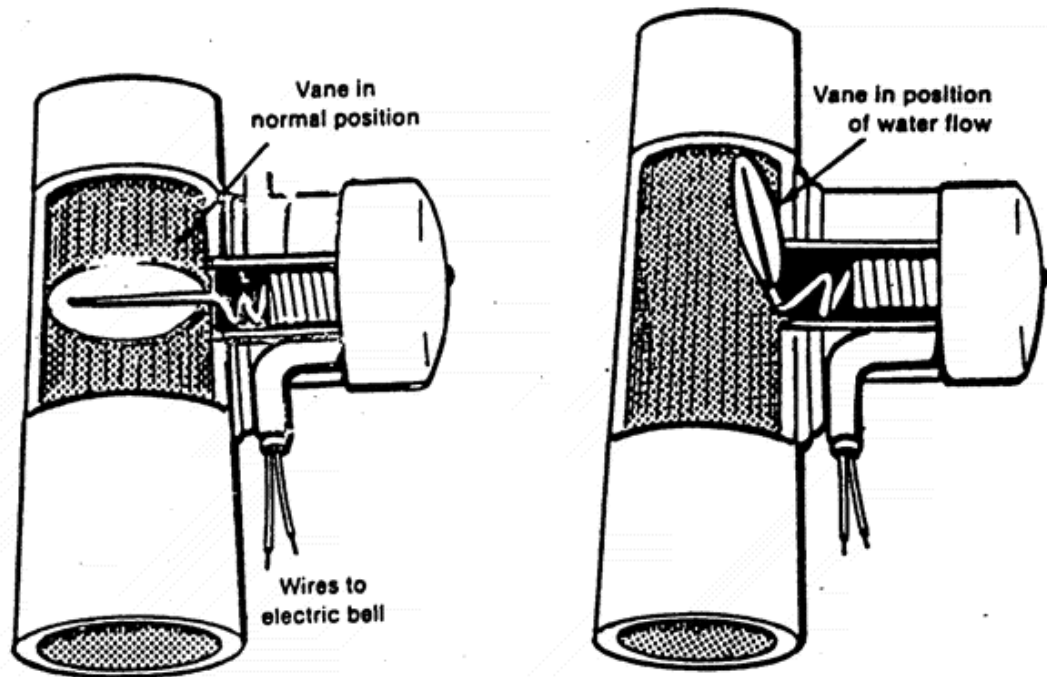

Figure 3-7
Vane or Paddle Switch
 (Insurance Services Office)

How Systems Are Disabled

Automatic sprinkler systems are highly reliable, and have a success rate of more than 90 percent in controlling or extinguishing fires. Sprinkler system failures generally can be traced to one of three major causes:

1. A design deficiency in the sprinkler system. This can happen when the quantity or volume of water available is not adequate to control the fire. The water supply itself may be inadequate, or the sprinkler system may be designed improperly for the building and/or its contents. Each automatic system is designed for a specific occupancy. The original design may have been adequate, but a change to more hazardous contents, for instance from metal parts storage to plastics, can render a system inadequate. Even seemingly minor changes within a warehouse can compromise existing sprinkler protection.

Generally, automatic sprinkler systems are designed to protect a structure against one fire at a time. The experiences in the Los Angeles area during the civil disturbances in 1992 clearly demonstrated that properly operating sprinkler systems can protect a building during multiple simultaneous fires.

2. An impairment to the sprinkler system before the fire. This generally occurs when a sprinkler system is shut off during new construction or building renovations, or when an obstruction such as a rock works its way into sprinkler piping and blocks the flow of water. Another scenario is becoming increasingly

common: an intentional firesetter will purposely close sprinkler control valves and set fire to the building, knowing the sprinklers won't work. Another way to impair the water supply is for someone to pack the sprinkler riser with dry ice in order to freeze it.

3. An impairment to the sprinkler system during a fire. This is perhaps the most serious threat to a fully sprinklered building. The system is impaired when control valves are shut off too soon during fire suppression operations. Well-meaning facility employees or fire suppression personnel may shut off the valve in order to reduce smoke or to control water damage. This action only prevents the sprinklers from gaining control of the fire during the critical development stage. Even if the valve is opened again, the fire might have grown beyond the point where the sprinkler system can control it.

Standpipe Systems

Standpipe and hose systems are installed in buildings to assist in manual fire suppression activities by building occupants and/or fire personnel. Standpipe systems are an arrangement of piping, valves, hose connections, and related equipment installed within a building. The systems may or may not have hoses permanently attached.

Standpipe systems are used primarily by fire department personnel. The fixed piping of the system allows the fire department to connect its hoselines into a pressurized water source near the fire location. The fire service consequently is relieved of the burden of extending hoses into the building from ground level to the fire location.

There are three types of standpipe systems:

- Class I systems have 2-1/2-inch hose connections and are designed to be used by the fire department and fire brigades trained in the use of heavy hose streams.
- Class II systems have only 1-1/2-inch hose connections and are designed to be used primarily by building occupants. A hose and nozzle are provided.
- Class III systems have both 1-1/2-inch and 2-1/2-inch connections and combine the features of both Class I and Class II systems.

Some standpipe systems have pressure-reducing devices built into the outlet valves. If these devices are not properly designed, installed, and maintained, adequate water may not be available from the system.

Automatic Alarm/Detection Systems

A fire alarm system is intended primarily to indicate and warn of abnormal conditions, summon appropriate aid, and control occupant facilities to enhance

property protection and life safety. The system can be either automatic or manual in the sensing of a fire and notification of the occupants and the fire department

A properly designed, installed, operated, and maintained fire alarm system can reduce the losses associated with fire in any building. These losses include both property and, more importantly, human life. The primary motivation for fire alarm system requirements in building and fire codes is to provide early warning so occupants can exit the building, and secondly, to notify the fire service so it can respond to the fire. In settings such as hospitals, the fire alarm system provides notification to staff so they can respond to the fire emergency (as opposed to evacuating the building).

Fire alarm systems commonly have **six general components**:

1. Alarm initiating device circuits are the circuits to which initiating devices such as smoke detectors, heat detectors, manual pull stations, and water flow alarms are connected.

2. Alarm indicating appliance circuits are those to which audible and visible warning devices are connected. Devices that send a signal offpremises also can be connected to these circuits.

3. Fire alarm control panels contain the electronics that supervise and monitor the fire alarm system. The initiating and indicating circuits are connected directly to this panel.

4. The primary power supply powers the entire fire alarm system. Primary power for fire alarm systems typically is provided by connecting into the local commercial power service.

5. A secondary power supply, or backup power supply, is required so that the fire alarm operation can continue if failure of the main power supply occurs. The secondary power supply should activate within 30 seconds of the primary power failure to maintain its normal operating voltage. Secondary power supplies must be capable of powering the system for at least a 24-hour period. Batteries with chargers are a common form of secondary power and engine-driven generators also are acceptable.

6. A final important feature of any fire alarm system is the trouble signal. Upon detection of an abnormal condition within the fire alarm system, the trouble signal is activated to attract attention to the system so that it can be repaired.

A manually operated system relies totally upon human intervention in order to operate. In this type of system, once an individual becomes aware of a fire condition, it is necessary to operate one of the pull stations located throughout the building. Once the pull station has been activated, an alarm will be sounded within the building and may be transmitted offsite to alert the fire department as well.

An automatic detection and alarm system is activated by water flow in a sprinkler system, smoke detectors, heat detectors, or flame detectors. These systems do not rely on human intervention to activate. If a building is equipped with an automatic sprinkler system, it is required in almost all areas of the country that activation of the sprinkler system (water flow) activates the fire alarm system. Smoke detectors and/or heat detectors and/or flame detectors may be located throughout the building and provide automatic detection of smoke, heat, or flame.

Heat detectors are used commonly for the detection of fires. Heat detectors are not as prone to false alarms and are less expensive than smoke detectors. However, the response of heat detectors may not be adequate in many instances. Heat detectors are slower to respond to fire than smoke detectors because they cannot respond to smoke. Typically, heat detectors are best suited for detecting fast-growing fires in small spaces. Also, heat detectors are a means of fire detection in locations that cannot be protected by smoke detectors due to environmental effects such as mist, normally occurring smoke, and high humidity. Many different types of heat detectors are available.

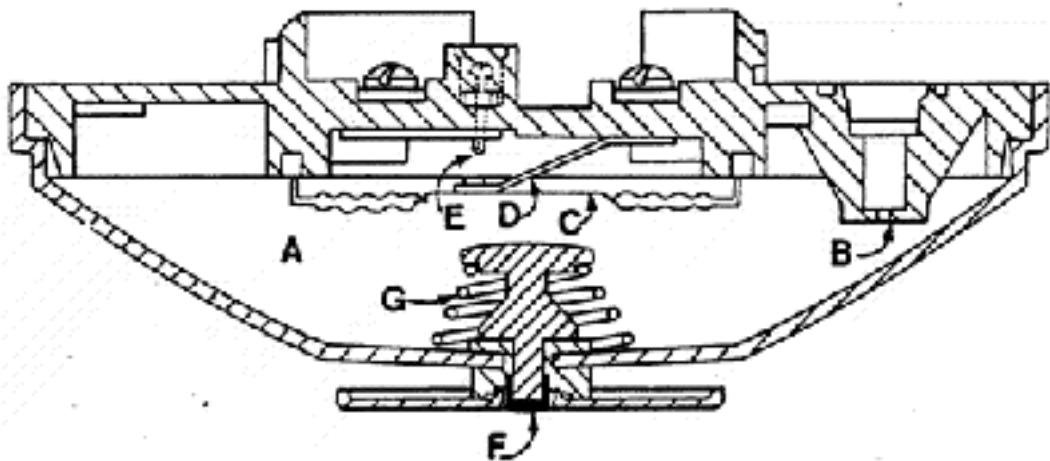

Figure 3-8 Spot Type Combination Rate of Rise, Fixed Temperature Heat Detector The air in chamber A expands more rapidly than it can escape from vent B. This causes pressure to close electrical contact D between diaphragm C and contact screw D. Fixed temperature operation occurs when fusible alloy F melts, releasing spring G which depresses the diaphragm closing points. (*Fire Alarm Signaling Systems Handbook*, 1987, page 41)

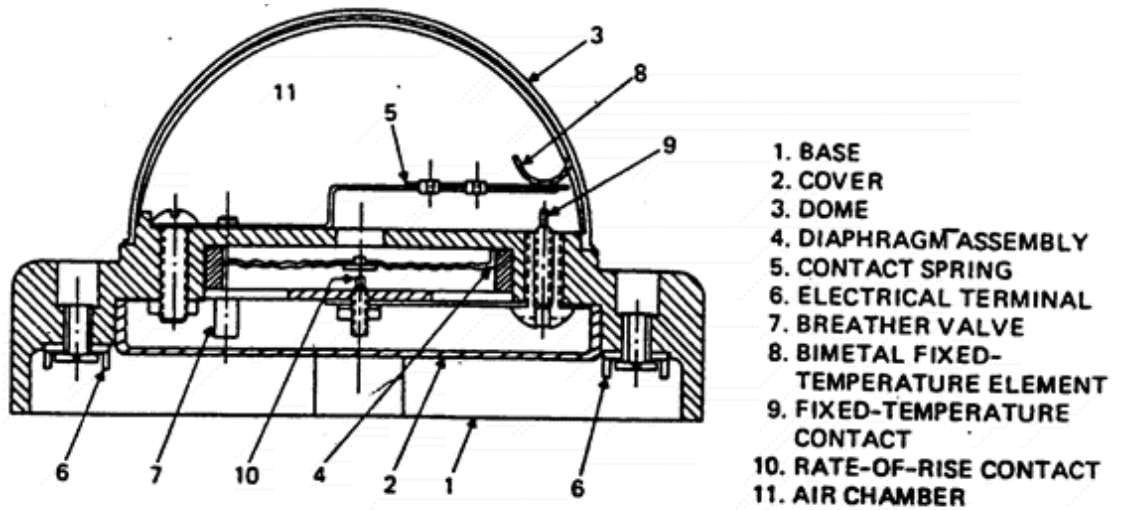

Figure 3-9
Combination Rate of Rise and Fixed Temperature Heat Detector With Resetting Fixed Temperature Element
(Fire Alarm Signaling Systems Handbook, 1987, page 44)

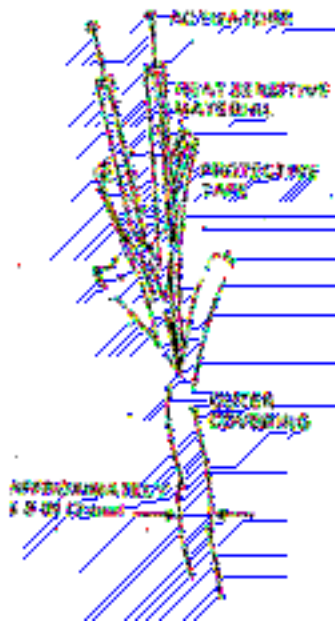

Fig 3-11

Fig 3-11 Line type Heat Detector

Heat-sensitive insulator of wires melts at a specific temperature causing the wires to touch and completing the circuit to initiate an alarm.

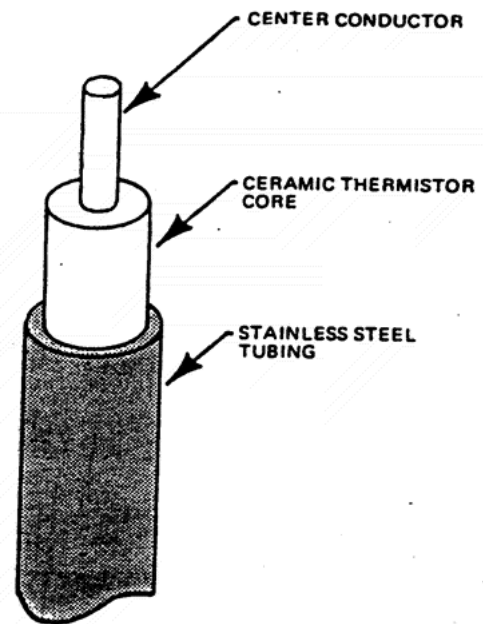

Fig 3-12

Fig 3-12 Line Type Heat Detector

A rise in temperature causes the ceramic thermistor core to allow current to flow between the center conductor and outer tubing causing an alarm to be initiated.

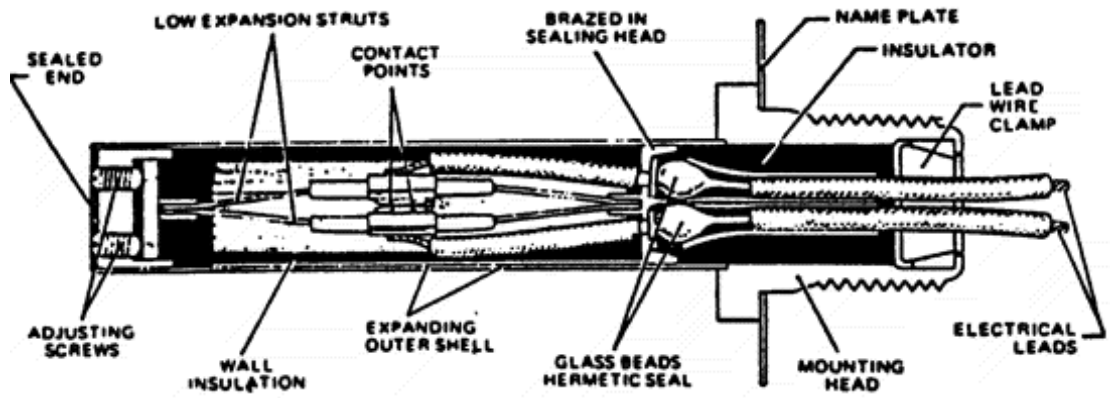

Fig. 3-13. Spot Type rate Compensation Detector

Device responds when the surrounding air reaches a predetermined level regardless of the rate of rise (Fire Alarm Signaling Systems Handbook, 1987, page 47)

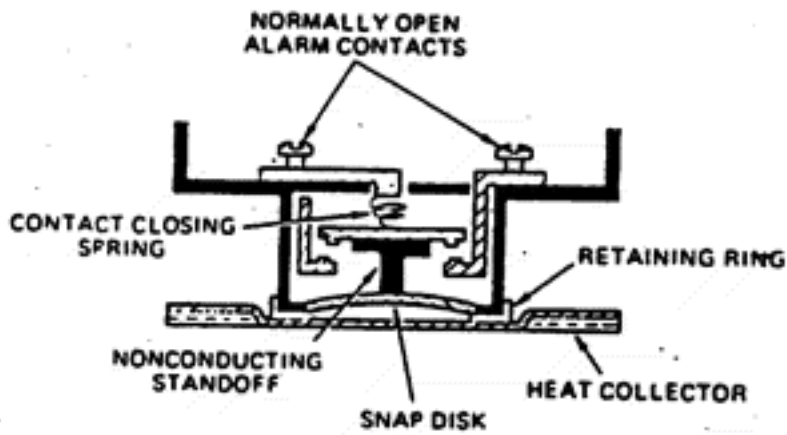
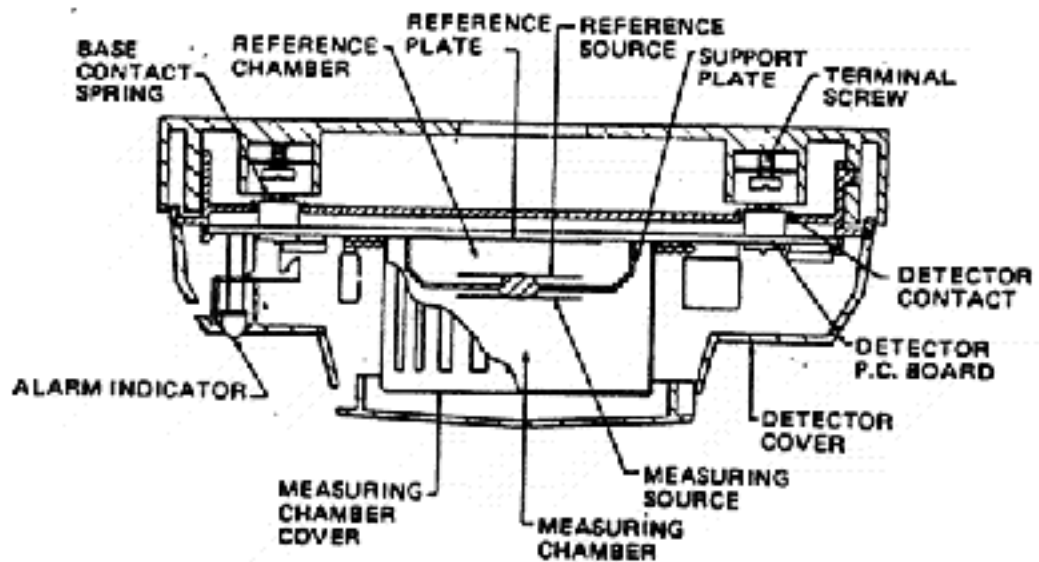
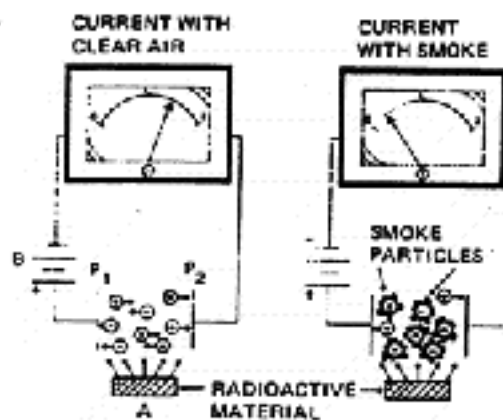

Figure 3-10
Spot Type Fixed Temperature Snap Disc
 (Fire Alarm Signaling Systems Handbook, 1987, page 44)

The benefits of **smoke detectors** cannot be overemphasized. However, smoke detectors are not usable in all environments and their effectiveness varies

depending on the fire scenario and occupant capability. Smoke detectors are available in three basic types: ionization, photoelectric, and combination ionization/photoelectric. Ionization detectors use a small amount of a radioactive material located within the detector which "ionizes" the air entering the detection chamber. Once ionized, the air particles become conductive and allow a current to flow through the detector circuits. Smoke entering the ionization chamber causes a reduction in the current flow and when a certain reduced level of current flow is detected, the detector signals an alarm. Most photoelectric detectors operate on the "light scattering" principle. A light source inside the detector is an-angled so that under normal (nonalarm conditions) it cannot be seen by a light-sensitive device also inside the detector. When smoke enters the detector, the light is scattered or reflected and is seen by the photo receiver. When a preset amount of light is seen, the detector signals an alarm.



Ionization Type Smoke Detector

Detector uses a very small amount of radioactive material ionize the air inside the measuring chamber. When ionized, a small amount of electrical current can flow through the air. If smoke enters the chamber, it interferes with the current flow and causes the detector to go into alarm. Most residential smoke detector s

are ionization type (Fire Alarm Signaling Systems Handbook, 1987, pages 52 and 53)

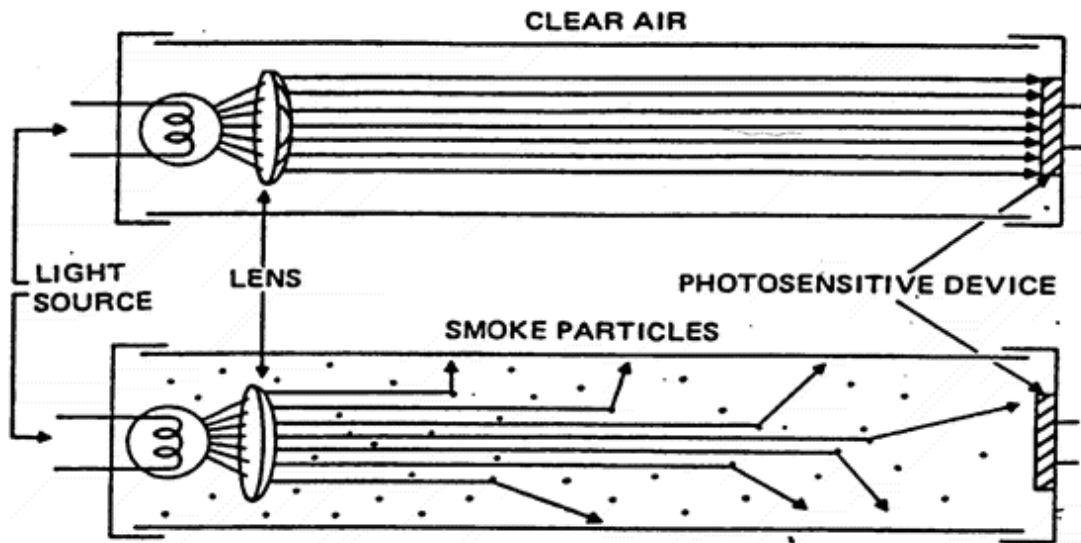

Fig 3-15 Photoelectric Smoke Detector - Light Obscuration

Inside the detector is a light source and a photosensitive device. When smoke obscures the light beam, the amount of light reaching the photosensitive device is reduced, thereby initiating the alarm (Fire Alarm Signaling Systems Handbook, 1987, page 54)

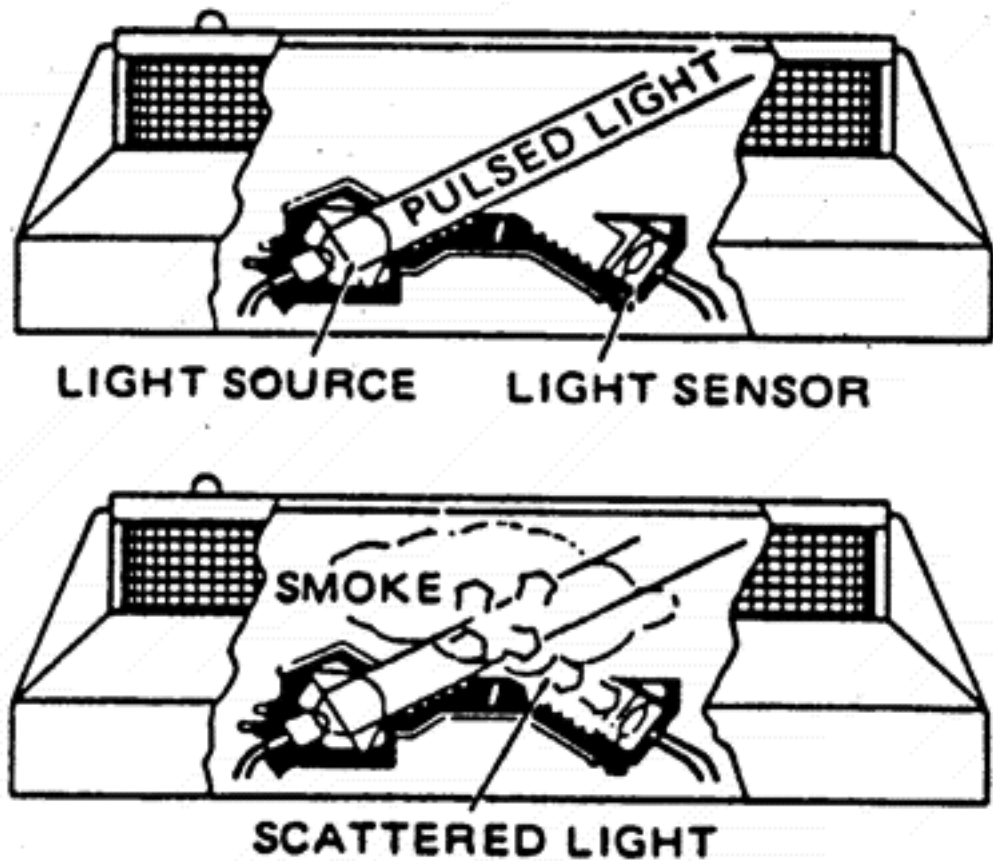
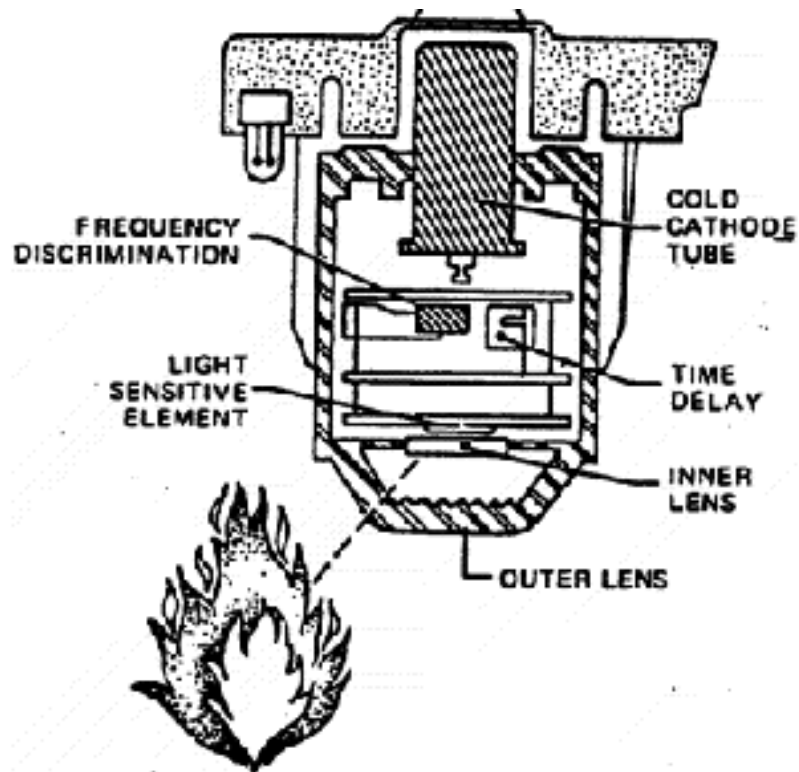

Fig 3-16. Photoelectric Smoke Detector - Light Scattering.

Detector uses a light source and a photosensitive device which are arranged so that normally the light rays cannot be seen by the photosensor. Smoke causes the light rays to scatter and reflects them so that the photosensor can see them. This causes the detector to initiate an alarm (Fire Alarm Signaling Systems Handbook, 1987, page 55)

Flame detectors are sensitive to light waves emitted by fires. These typically operate by detecting ultraviolet (UV) or infrared (IR) energy. These detectors are extremely quick to operate and typically are used only in high hazard areas such as industrial process facilities, fuel loading areas, and areas where explosions may occur, and that are protected with explosion suppression systems.



Manual fire alarm boxes usually are referred to as manual pull stations. These are simple devices which operate manually, i.e., a person must operate the mechanism. These are found in a building' s hallways, near exits, and at other strategic locations such as nurse' s stations or security centers.

If an alarm system or automatic detection system fails to properly detect a fire condition, activate the building alarm, or transmit the alarm offsite, then an indepth analysis of the system must be conducted to determine the reason(s) for the failure.

Additional information on the operation of fire alarm and detection systems can be found in *Fire Alarm Signaling Systems Handbook* published by the NFPA.

Single and Multiple Station (Innerconnected) Smoke Detectors

Smoke detectors are required in residential occupancies in almost all parts of the country. Residential occupancies include one- and two-family dwellings, apartments, hotels and motels, dormitories, and lodging and rooming houses. These detectors are required outside each separate sleeping area, in the immediate vicinity of the bedrooms, and on each additional story of the family living unit, including basements and excluding crawl spaces and unfinished attics. Each detection device should cause the operation of an alarm which is clearly audible in all bedrooms over normal ambient background noise.

Single and multiple station smoke detectors may be powered by battery, alternating current (AC), and/or AC/battery combination. Most manufacturers

recommend that detectors be tested weekly. Smoke detectors fail most often because their batteries are dead, disconnected, or missing.

Specific requirements for the selection, installation, testing and maintenance of single and multiple station smoke detectors is contained in NFPA 72, *National Fire Alarm Code*". (Prior to 1993 this information was contained in NFPA 74, *Standard for the Installation, Maintenance, and Use of Household Fire Warning Equipment*.)

Local and State codes should be consulted for specific requirements in your jurisdiction.

For a summary of smoke detector requirements for one- and two-family dwellings, see the article "State by State. ..An Update of Residential Smoke Detector Legislation," which appeared in the January/February 1990 issue of *Fire Journal*.

Commercial Cooking Equipment

Commercial cooking equipment requires special attention. The main problem with cooking equipment is the accumulation of grease in the duct, hood, and fan housing. If a fire should start in the system, burning grease can reach a temperature of 2,000°F (1,093°C).

Cooking equipment can include ranges, deep fat fryers, portable ovens, convection ovens, steamers, broilers, warmers, microwave ovens, and tilting skillets. Some of this equipment can produce grease-laden vapors that contribute to the spread of fire; installation of such equipment next to combustible materials also can contribute to fire causes.

The hood and duct work must comply with the requirements of NFPA 96, *Standard for Ventilation Control and Fire Protection of Commercial Cooking Equipment*, or other similar codes. Both must be constructed out of the proper metals, and all joints and seams must be externally welded and grease-tight. Hood and duct work must be separated at least 18 inches from combustible materials

Automatic fire extinguishing equipment must be provided to protect the cooking equipment, hood, and duct work. Most commonly provided systems are dry chemical or wet chemical, although automatic sprinkler protection is used also. Operation of the extinguishing system also must shut off all sources of fuel and heat under the hood. Routine maintenance is required every 6 months on the extinguishing system. Failure to provide the required maintenance, which includes replacement of the fusible links and checking of the agent, can lead to equipment failure under fire conditions. A properly designed, installed, and operating fire extinguishing system should control a fire occurring in the cooking equipment, hood, or duct work.

FIRE TRAVEL PREDICTIONS

The path of travel and extension of fire, heat, and smoke is influenced by the construction of the building, building design and layout, fuel load, built-in fire protection features, the heating, ventilation and air- conditioning (HVAC) system, and fire department operations.

The effects of the type of building construction, fuel loading, or built-in fire protection features on fire travel were discussed previously in this unit. The **building layout or room arrangement** can affect fire spread in several ways. Obviously, in large open areas, there are no partitions to slow the spread of fire, heat, and smoke. In smaller rooms, the construction of the rooms and protection of openings determine to what extent the compartmentation will retard fire spread. If the rooms are constructed with some degree of fire resistance, and openings are protected by properly operating fire rated self-closing doors, the spread of fire will be slowed.

Almost all buildings have some type of HVAC system. Depending on the size of the system, they may have smoke detectors and/or heat detectors installed in order to shut down the system in the event of a fire. If the system fails to shut down or is not equipped to do so, it will provide an additional supply of oxygen for the fire and also will spread fire, heat, and smoke to remote areas of the building.

Fire **department operations** also affect fire spread. The placement and use of hoselines can push the fire into other areas as well as prevent the fire from spreading to other areas. Likewise, ventilation efforts can help spread the fire. If positive-pressure ventilation (PPV) is used, then it is possible that the fire can be accelerated and extended to other parts of the building. PPV involves the use of fans to push fresh air into the fire building in order to force the heat and smoke out

PPV involves placing a high-powered fan outside the building at a door opening and using it to force air into the building, causing the heat and smoke to be forced out of other openings. In negative-pressure ventilation the fan is placed inside of the building and the heat and smoke are drawn out of the building

How Fire Extends

Fire may extend from **room-to-room** through unprotected door openings, by conduction of heat through steel beams or pipes, and/or by burning through walls. It also may extend from **floor-to-floor** through unprotected stair openings, and through windows, vertical extensions, or floors. Finally, fire may extend from **building-to-building** through combustible walls, by radiant heat, or by flying embers.

SUMMARY

This unit provided another piece of the jigsaw puzzle that must be completed in order to conduct a proper fire loss analysis. Understanding the characteristics of building construction is a critical element in conducting a proper fire loss analysis. The type of construction, materials used, and fire protection systems all influence fire behavior. Failure to consider the effects of construction methods, materials, and fire protection systems easily can result in an incorrect determination of the origin and cause of a fire. Such incorrect determination could result in someone being wrongfully charged with arson or denied his/her insurance proceeds.

Determining the Point of Origin

INTRODUCTION

In fire investigation, the place where a fire starts is referred to as the "point of origin." This may be an exact point or a general area. In almost all cases, the point of origin must be located correctly in order to determine the fire cause properly. In the past, individuals often referred to cause and origin; the correct phrase and procedure is **origin and cause**.

In general, fire will burn longer at or near the point of origin, thus the damage generally will be greater. Normally the fire cause will be found at, or very near, the point of origin, and physical evidence of the fire cause, whether accidental or incendiary, is often recovered. Once the point of origin is determined, it may confirm or contradict the statements of owners/occupants/witnesses/suspects.

One of the most important aspects of any fire investigation is the proper recognition, identification, and analysis of fire patterns. As stated in Unit 2: Chemistry and Physics of Fire Behavior, the circumstances of every fire are different, but each fire is governed by the same scientific principles involved in the chemistry and physics of fire and by building construction, as discussed in Unit 3: Building Construction and its Components.

The contents of this unit are based substantially upon the material contained in Chapter 4 of NFPA Standard 921, *Guide for Fire and Explosion Investigations*, 1992 ed. Additional detailed information is contained in the articles included at the end of the unit.

DEFINITIONS

Fire **patterns** are the actual physical effects that can be seen or measured after a fire, including charring, oxidation, distortion, melting, color changes, and structural collapse.

Lines or areas of demarcation are the borders defining the different levels of heat and smoke as they affect various items at the fire scene. The production of these lines and areas is dependent upon a combination of variables: the material itself, the Rate of Heat Release (RHR), fire suppression activities, temperature of the heat source, ventilation, and the length of time of exposure.

Surface effect is the result of the nature and material of the surface which contains the fire pattern, affecting the actual shape of the lines of demarcation displayed, or increasing or decreasing the amount of pyrolysis and combustion in different areas. For example, if both smooth and rough surfaces of the same material are equally exposed to the same level of heat, the rougher surface will sustain more damage. Surfaces such as paint, tiles, brick, wallpaper, plaster, etc., can increase or decrease the amount of damage sustained to the surface.

The **penetration of horizontal surfaces** (bum-throughs) from above or below can be the result of radiant heat, direct flame impingement, or smoldering in a localized area. Downward penetrations often are considered unusual, since the more natural direction of heat and fire spread is upward. However, once flashover has occurred, the hot fire gases may be forced downward through small preexisting openings, such as for ductwork, resulting in a penetration. Downward penetrations also can result from the intense burning of polyurethane mattresses, couches, or chairs. Dropping off flaming or smoldering materials also can lead to floor penetrations. Any downward penetration should be examined carefully and its cause determined.

The **burn direction** of a penetration can be determined by an examination of the sides of the hole. Sides that are wider at the top of the hole, and slope inward, indicate that the fire came from above. On the other hand, sides that are wider at the bottom and slope upward toward the center of the hole indicate that the fire came from below.

4 Another method that can be used to determine whether a fire spread up or down through a hole is to compare the overall extent of damage to the two levels separated by the penetrated surface. If the fire moved inward, most often the damage to the underside of the surface will be more severe. If the fire moved downward, then the opposite most likely will be true.

Given the many circumstances that can affect fire behavior, it is possible for both upward and downward fire spread to occur through the same penetration. However, it is likely that only the **last** direction of movement will still be evident.

Loss of material and mass may occur when wood or other combustible materials bum. The remains of these materials themselves can display lines of demarcation, and ultimately fire patterns that can be analyzed. Examples of this are the top of wall studs burned away at progressively lower levels, which can be used to

determine the direction of fire travel. Likewise, the extent of damage on opposite sides of a door opening can be used to determine the direction of fire travel.

PATTERNS AND SURFACE EFFECTS OF CHAR

Types of Patterns

Fire patterns fall into two general types, both of which are regulated by the chemistry and physics of fire, as well as by building construction.

Movement patterns are those which are the result of growth and extension of fire and products of combustion away from the original heat source.

Proper inspection of the fire scene will result in tracing these patterns back to the original heat source. **Intensify patterns** are produced by the effects of the various intensities of heat exposure to the structure and its contents. The varying heat levels can produce lines of demarcation which can be used to determine the characteristics and quantities, of fuel loading, as well as to indicate the direction of fire spread.

General Effects of Charring The heat produced during a fire will result in the decomposition of various surfaces. The extent and degree of the discoloration and charring that result from this decomposition are compared to other areas to find the areas of heaviest damage.

Charred wood is likely to be found in nearly every structural fire. Wood undergoes a chemical decomposition *when* exposed to elevated temperatures. During this decomposition, gases, water vapor, and various pyrolysis products such as smoke are produced. After extended or intense heat exposure, the remaining solid residue is mainly carbon. As the charring is taking place the material shrinks, and develops cracks and blisters. Char is the carbonaceous material that has been burned and has a blackened appearance.

Rate of Wood Charring

An old rule of thumb was that wood would char at a rate of 1 inch per 45 minutes of burning. This **rate of charring** is based upon one set of laboratory conditions in a test furnace using pine lumber. Since fires burn with intensities that are different from those produced during this test, this rule of thumb should not be relied upon to determine the length of time that a fire has burned. In other words, no specific time of burning can be determined based solely upon the depth of char.

Another old rule of thumb is that old wood burns faster. However, wood tends to gain or lose moisture according to the ambient conditions to which it is exposed. Because of this, old, dry wood is no more combustible than new, kiln-dried wood, under the same conditions.

Depth of Charring

The **depth of char** can be used as a reliable means of establishing fire spread. By measuring the relative depth and extent of charring, it is possible to determine what portions of a material or construction have been exposed longest to a heat source. The relative depth of char from point to point is the key to appropriate use of charring: that is, locating the places where damage was more severe due to exposure, ventilation, or fuel placement. In comparing the extent of charring, it also is important to take into consideration the type of materials involved. For example, a room in which wood paneling is the interior finish, may be charred more heavily than an adjoining room in which the interior is gypsum board, even though the fire may have originated in the gypsum board room. In comparing charring, remember not to "compare apples to oranges."

In comparing the depth of charring it also is critical to consider the **effects of ventilation**. Wood can exhibit a deeper charring when adjacent to a ventilation source or an opening where hot gases can escape. For example, the portion of a room adjacent to a sliding glass door can be charred more heavily than a point of origin across the room, if the fire ventilated through the door opening.

The depth of char can be measured using blunt-ended probes such as certain types of calipers, tire tread depth gauges, or specifically modified metal rulers. The same measuring tool should be used for any set of compared measurements. Char depth measurements should be made in the center of char blisters.

When fuel gases or oxygen are the initial fuel sources for a fire, they generally produce relatively even char patterns over the often wide area that they cover. Deeper charring may exist in close proximity to the point of gas leakage. This type of charring may be highly localized because of the pressurized gas jets that can exist at the leakage point.

Certain segments of the fire investigation community have accorded greater significance to the appearance of charring, cracks, and blisters than is substantiated by scientific experiments. One of the old rules of thumb was that the presence of large, shiny blisters (sometimes called alligator char or alligatoring) is proof that a liquid accelerant was present. This is false. These types of char can be found in many different types of fires and there is no scientific justification they are an exclusive indication of an accelerated fire.

Another old rule of thumb was that the surface appearance of the char- dull, shiny, or colored-points to the use of a hydrocarbon accelerant. Again, there is no scientific justification for this correlation. Investigators should not claim that indicators such as large, shiny blisters or dull or **SPALLING** colored char are indications of accelerant, based on the appearance of the char alone.

The depth of char **can** be used to estimate the duration of a fire. Remember that the charring of wood varies depending on such things as rate and duration of

heating; ventilation effects; surface area to mass ratio; direction, orientation, and size of wood grain; species of wood; moisture content; and nature of surface coating.

SPALLING

See the article entitled "Spalling and Determination of Origin and Cause" in the Supplementary Readings at the end of this unit for a detailed discussion of spalling.

OXIDATION

Oxidation is a very basic chemical process associated with fire. Even though some materials do not burn readily, oxidation of these materials can produce lines of demarcation and fire patterns. The effects of such oxidation can include changes of color or texture. Generally, the higher the temperature and the longer the exposure time, the more pronounced the oxidation will be.

The surface of bare galvanized steel exposed to a mild level of heating will become a dull white. When uncoated iron or steel is exposed to a fire, the surface first becomes a dull blue-gray. Further oxidation can result in thick layers of oxide that flake off. After the fire, if the metal has been wet, the usual rust-colored oxide may appear.

Since the steel surface is being oxidized by the fire, and most probably is being wetted down during suppression activities, it is not unusual to find holes in thin metal surfaces.

On stainless steel, mild oxidation has color fringes, while severe oxidation will result in a dull gray color.

When exposed to heat, copper forms a dark red or black oxide. The color of the oxide is not important. What is significant is that oxidation can form a line of demarcation.

Patterns of oxidation even can be found on rocks and soil. When heated, these materials often change to colors which range from yellowish to red.

Soot and char also are subject to the effects of oxidation. The char on paper surfaces of gypsum wallboard, soot deposits, and paint can be oxidized by continued exposure to heat. The result of this oxidation is that the carbon will turn to gases and disappear from the surfaces on which it was present. This oxidation results in what is known as a "clean burn" which will be discussed later in this unit.

MELTING OF MATERIALS

The melting of any material is a change in its physical state brought about by its exposure to heat. The border between melted and solid portions of materials can produce lines of heat and temperature demarcation which can be used to define fire patterns.

Knowing the melting points of various materials can help establish temperatures reached during the fire. **Melting temperatures** of materials may range from slightly over normal ambient, room temperatures to thousands of degrees. The following chart, taken from NFPA 921, *Guide for Fire and Explosion Investigations*, provides the melting temperatures of numerous common materials.

Material	Melting temperatures	
	F	C
Aluminium (alloys)	1,050-1,200	566-649
Aluminium	1,220	660
Brass (yellow)	1,710	932
Brass (red)	1,825	996
Bronze (aluminium)	1,800	982
Cast iron (grey)	2,460-2,550	1,349-1,399
Cast iron (white)	1,920-2,010	1,049-1,099
Chromium	3,550	1,954
Copper	1,981	1,082
Fire brick	2,980-3,000	1,638-1,649
Glass	1,100-2,600	593-1,427
Gold	1,945	1,063
Iron	2,802	1,539
Lead	621	327
Magnesium (AZ31B alloy)	1,160	627
Nickel	2,651	1,455
Paraffin	129	54
Platinum	3,224	1,773
porcelan	2,820	1,549
Pot metal	582-752	294-400
Quartz	3,060-3,090	1,682-1,699
Silver	1,760	960
Solder (tin)	275-350	135-177
Steel (stainless)	2,600	1,427
Steel (carbon)	2,760	1,516
Tin	449	232
Wax (pqriffin)	120-167	49-75
White pot metal	562-752	294-400
Zinc	707	375

Alloying of metals

Another reaction that occurs during a fire is the formation of **eutectic alloys**. Eutectic is the lowest melting point of an alloy or solution of two or more substances that is obtainable by varying the percentage of the components. This takes place when the melting temperature of one material is reached during the fire, and this melting material comes in contact with another metal. The resulting mixture (alloy) will melt at a temperature lower than the melting temperature of the higher melting temperature metal, and in many cases lower than either metal. In fire situations eutectic alloying occurs when molten aluminum or zinc comes in contact with steel or copper

Copper wiring, tubing, and piping quite often are affected by alloying. Aluminum can mix with the copper to form an alloy which ranges in color from yellow to silvery. The surface of the spot of aluminum might appear gray in color, while the surface near the aluminum-copper interface may be fairly dark. The copper wire will be very brittle. Zinc also will alloy with copper, forming a yellowing brass.

Alloying with steel does not occur readily in most fires; however, if aluminum or zinc are heated for an extended time with a steel object then alloying may result in pits or holes.

Alloying may be confirmed by metallurgical analysis, and the alloy may be identified. One theory is that if metals with high melting temperatures are found melted, this is an indication of incendiarism. Scientific fact shows that if these metals are melted due to alloying, such melting, is not an indication that accelerants or unusually high temperatures were present during the fire.

Plastics

Thermoplastics have melting temperatures ranging from around 200°F (93°C) to near 750°F (399°C). The article "Plastics and Fire Investigations" included at the end of this unit provides additional information about plastics in the fire environment.

Knowing the approximate melting temperatures of various materials enables the investigator to estimate the temperatures achieved during the fire. This assists in determining the intensity and duration of the heating, the extent of heat movement, and the relative rate of heat release from fuels.

THERMAL EXPANSION AND DEFORMATION OF MATERIALS

All common materials will expand when heated. Such expansion can adversely affect structural stability, as discussed in Unit 3. The bending of steel beams and columns will occur when the temperature reaches 1,100°F (593°C) and steel will not support its own weight at 1,500°F (816°C). The more load the steel object is carrying, the more severe the deformation will be.

Bending is not a result of melting and the thermal expansion of a beam can be a factor if the ends of the beam are restrained. Contrary to belief, the application of a hose stream will not cause heated steel to collapse. Such water application will "freeze" the steel in its current position if it has been deformed already, and if applied early in the fire may prevent the steel from being heated sufficiently to cause collapse.

Plastered surfaces also are subject to thermal expansion. Heating of plaster walls and ceilings may cause the plaster to expand and separate. The failure can result in fire patterns or lines of demarcation.

SMOKE AND SOOT

Smoke is an airborne particulate product of incomplete combustion suspended in gases, vapors, or solid and liquid aerosols. Soot consists of the black particles of carbon produced in a flame.

Any *fuel* that contains carbon will produce soot under normal fire conditions. This is especially true with petroleum products and almost all plastics. Soot can be deposited on walls and ceilings by direct flame contact or it can be deposited on surfaces by settling.

Smoke and soot can collect on cooler surfaces of the structure and/or its contents, and quite often on upper portions of walls in rooms away from the fire. Smoke, especially smoke generated by a slow, smoldering fire, has a tendency to condense on walls, windows, and other cooler surfaces.

Brown deposits are from smoke; soot deposits are black. Smoke condensates can be wet and sticky, thin or thick, or dried and resinous. After drying, such smoke deposits are not easily wiped off. Where there has been open flame, both soot and smoke are likely to be deposited. During some fires, only dry soot deposits will be produced. Such deposits are wiped easily from windows and other surfaces. When smoke deposits on a window are heated later in the fire, the brown deposits will turn black due to carbonization.

CLEAN BURN

Clean burn occurs on noncombustible surfaces when the soot and/or smoke deposits are burned off. Such clean burning is most commonly a result of direct flame contact or intense radiant heat. Although such clean burns can indicate intense heating, they do not, by themselves, necessarily indicate point of origin. Demarcation lines between the clean burn and the sooted/smoked areas may be used to determine the direction of fire spread or differences in intensity or time of burning.

CALCINATION

The numerous changes which occur in plaster or gypsum board under fire conditions are known as **calcination**. Calcination is the result of the fire driving off the naturally contained water in these materials.

When gypsum wallboard is exposed to heat, the paper surface will char. Depending on the intensity of the exposure, the paper also may burn off. The exposed side of the gypsum board will gray from the charring of the organic binder. Further heating will result in the gray color going all the way through, and charring of the paper surface on the backside. The exposed surface will become whiter as the carbon is burned away. When the gypsum board has turned completely white, there will be no paper left on either side and the remaining gypsum will be a crumbly solid.

Fire-rated gypsum board has mineral fibers or vermiculite particles added to it in order to preserve the strength of the wallboard during fire exposure. These fibers add strength to the material even after it has been thoroughly calcined.

The lines of demarcation between the calcined and noncalcined portions are fire patterns that can be used by the fire investigator.

WINDOW GLASS

Current research indicates that temperature differences of 140°F or more between the exposed and insulated portions of the glass will result in long, smooth undulating cracks radiating from the edges of the frame to the center of the pane.

Sudden flame contact with one side of the window pane, as occurs during flashover, will cause the glass to fracture. It once was thought that such rapid heating would result in a complicated pattern of small cracks (often called crazing), but this has not been confirmed by scientific research.

As a general rule, the pressures developed during a building fire alone are not sufficient to either break windows or force them from their frames. However, it should be remembered that a backdraft explosion is capable of doing both.

Crazing, small craters, or pits are caused by the application of water to the glass surface when the surface of the glass is heated to at least 600°F (316°C).

Finding glass fragments that are free of soot or smoke deposits is evidence that the glass has been subjected to rapid heating, failure early in the fire, or flame contact. The proximity of the glass to the area of origin or heat source can affect the amount of deposits.

The presence of thick, oily soot on glass was once thought to be positive proof of the presence or use of an accelerant. This has not been supported by scientific research. The presence of such deposits also can result from incomplete combustion of wood and other materials.

COLLAPSED SPRINGS

The collapse of furniture springs was thought to indicate exposure to a flaming accelerant or smoldering combustion. Scientific laboratory testing has shown that annealing of springs (loss of spring tension) is a function of the total heat treatment.

Testing has shown that short-term heating at high temperatures and long-term heating at moderate temperatures of about 750°F (399°C), both can cause annealing and collapse. The presence of any weight load upon the springs during the heating increases the loss of spring tension.

Any analysis of the condition of springs after a fire must take into consideration all materials that were placing a load on them, and a comparison of the lines of demarcation. An excellent article on this subject is included at the end of this unit.

LOCATION OF OBJECTS

The location of objects at the fire scene can be determined by the identification and use of certain patterns.

Heat shadowing occurs when the object blocks the path of radiated heat, convected heat, or direct flame contact. Conducted heat does not produce heat shadowing. Any object that absorbs or reflects heat energy can produce a heat shadow on the material that it protects.

Protected areas are caused by an object preventing the deposit of products of combustion on the material that the object protects. Any object that prevents the settling of the products of combustion may cause the production of a pattern on the material it protects.

Both heat shadowing and protected areas assist the fire investigator in reconstructing the scene. Quite often these patterns will be obscured by debris, and in order to properly use these patterns, debris removal will be necessary.

LOCATION OF PATTERNS

Patterns developed during the course of a fire may be found on any exposed surface. These include the structure itself, its contents, and outside features such as outbuildings, adjacent structures, and other features.

Patterns present on **walls** are the most observable. These patterns may appear as lines of demarcation resulting from heating to deeper burning. The patterns may extend to the underlying support members.

Patterns also can occur on **ceilings and the bottom surfaces** of such items as tables and shelves. Since heated fire gases rise, they will concentrate the heat energy on the horizontal surfaces above the heat source. Most horizontal patterns are roughly circular with portions of circular patterns often being found at the junction of walls and ceilings and at the edges of tabletops and shelves.

Patterns present on **the floor** are extremely important. To inspect the floor properly for patterns, the debris must be removed. Floor patterns can be the result of intense radiant heat, melted plastics, burning liquids, or the hot gas layer produced during and after flashover.

Seams or cracks in the flooring materials and around door thresholds can show evidence of burning from radiation or collection of liquid accelerants. Postflashover burning also can produce holes in floors and around door thresholds as a result of the hot combustible fire gases and the air gaps provided in construction. Even very small gaps can provide sufficient air for combustion of floors.

Fire-damaged vinyl floor tiles may have curled edges that expose the floor underneath. While this action has been attributed to the presence of an accelerant, it also can occur solely because of radiant heating of the floor surface. Analysis for the presence of accelerants may prove difficult due to the presence of hydrocarbons in tile adhesives.

External surfaces of structures such as roof and walls also can display fire patterns. In addition to the regular patterns that may be found, burn-throughs can be present on both vertical and horizontal surfaces. As a general rule, these burn-throughs can point to areas of intense or sustained burning.

Patterns also can be present on the **sides, tops, and bottoms of building contents**. Any pattern that can be produced on walls, ceilings, and floors also can be produced on contents. The patterns will be similar in shape but may display only a portion of the pattern due to the limited size of the items.

- **Low burn patterns** may be produced by an accelerant, but they are not in themselves proof of an accelerant fire. Postflashover conditions also can produce low burn patterns.

During the progress of any fire, burning debris quite often will fall to lower levels. This **fall down** (drop down) may result in secondary fires. It also can ignite other combustible materials resulting in low burn patterns and burn-throughs.

PATTERN GEOMETRY

The chemistry and physics of fire result in various types of patterns having distinctive geometry or shapes. Since the interpretation of all possible fire patterns cannot be traced directly by scientific research, the fire investigator is cautioned

that alternative, interpretations of a given pattern are possible. Definitive scientific research has begun in this area.

A common fire pattern shape displayed on vertical surfaces is the "**V** pattern**." The lateral spread of the sides of this pattern are caused by radiated heat from above and by the upward and outward movement of flames and hot fire gases when they encounter a horizontal surface such as a ceiling, an eave, a tabletop, or a shelf.

The angled lines that produce the "V" can often be traced back toward a point of origin. As a general rule, the wider the angle of the "V," the longer the burned material has been subjected to heating. The angle produced on a vertical combustible surface will be wider than on a noncombustible surface for a comparable heat source and burn time.

It was long believed that a narrow-angle "V" pattern, is produced by a fast-burning fire, while a wide angle "V" pattern is produced by a slow- burning fire. This is incorrect, since the angles of the lines of the "V" pattern actually are a result of the size of the fire, burning rate, ventilation, and combustibility of the walls rather than the RHR alone. These patterns are valuable because they indicate the direction of fire spread, not what caused them.

Inverted cone patterns, also called inverted "V" patterns, are triangular patterns wider at the base than at the top. Inverted cone patterns are the result of relatively short-lived fires which do not fully evolve into floor-to- ceiling flame plumes or flame plumes that are not restricted by ceilings. Since they often appear on noncombustible surfaces, it was thought that they were caused by fast-burning fires. *The* correct analysis of such patterns is that the burning was of short duration; there is no relationship to the RHR. Inverted cone patterns also have been interpreted as proof of a liquid accelerant fire, but any fuel that produces flame zones that do not become vertically restricted can produce such patterns.

Leaking natural gas can cause inverted cone patterns, especially if the leakage occurs below floor level and escapes above the intersection of the floor and wall. The resulting burning will not reach the ceiling and thus will result in the characteristic inverted cone pattern shape.

Hourglass patterns result from the combination of the plume of hot gases and the flame zone. The plume of hot fire gases is shaped like a "V," while the flame zone is shaped like an inverted "V." If the fire itself is very close to or in contact with the vertical surface, this may result in a pattern *displaying* the effects of both the hot gas plume and the flame zone. This results in a pattern with the general shape of an hourglass.

*' **U patterns** are similar to "V" patterns. "U" patterns display more gently curved lines of demarcation, as opposed to the angled lines of the "V" pattern and are the result of the effects of radiant heat on vertical surfaces more distant *from* the heat source than surfaces displaying sharp "V" patterns. "U" patterns are analyzed in the same manner as "V" patterns.

Truncated cone patterns (also called truncated plumes) are three-dimensional fire patterns, created on both horizontal and vertical surfaces. This pattern occurs at the intersection of two vertical surfaces. The cone-shaped pattern is the result of the natural expansion of the fire plume as it rises and the horizontal spread of the heat energy when the plume encounters a horizontal surface such as a ceiling.

Pointer and arrow patterns are commonly displayed on the remains of vertical wooden wall studs or furring strips when the surface sheathing has been destroyed by the fire. As a general rule, the shorter and more severely charred studs were closer to the source of the fire than the taller studs. The heights of the remaining studs increase as the distance from a source of fire increases.

Circular patterns are common at fire scenes and generally represent areas which were protected from burning by circular items such as wastebaskets or the bottoms of pieces of furniture.

Irregular, curved, or pool-shaped patterns on floors and floor coverings once were considered positive proof of the presence or use of a liquid accelerant. While such patterns can be the result of an accelerant, this cannot always be determined reliably from visual observation alone.

These types of patterns are very common in postflashover fire conditions, in fires with long extinguishing times, or in building collapse. They can be the result of radiant heat, flaming and smoldering debris, melted plastics, or ignitable liquids. If the presence of ignitable liquids is suspected, supporting evidence such as the use of a combustible gas indicator and/or chemical analysis of debris for residues, or the presence of liquid containers should be sought. Be cautious when using combustible gas indicators, since many plastic materials release hydrocarbon fumes when they pyrolyze or burn. These fumes may very well have an odor similar to petroleum products, and can be detected by a combustible gas indicator when no ignitable liquids have been used. In addition, chromatographic analysis of burned carpet made of petroleum-based materials can indicate the presence of hydrocarbons even when no accelerants were used.

In general, patterns resulting from accelerants have deeper char at the edges than in the center (doughnut patterns). However, pooled ignitable liquids that soak into flooring or floor covering materials, as well as melted plastics, can produce irregular patterns that are burned more deeply in the center than at the edges. These patterns also can be the result of localized heating after flashover or drop down. Irregular patterns on wood flooring caused by ignitable liquids will have "fingers" that follow the cracks in the flooring.

A distinct "**doughnut**" pattern, where a **roughly** ring-shaped burn surface surrounds a less burned area, may result from an ignitable liquid. This pattern is the result of the cooling effects of the liquid in the center of the pool; the edges burn, producing charring around the perimeter. When this condition is found, further examination is needed to seek supporting evidence of the presence of ignitable liquids.

In any situation where the presence of ignitable liquids is suggested, the effects of flashover, airflow, hot gases, melted plastics, drop down, and building collapse must be eliminated. The investigator must be careful to identify the initial fuel source correctly for any irregularly shaped or circular burn patterns.

Many modern plastic materials will burn. They first react to heating by liquefying (melting); when they burn as liquids they produce irregularly shaped or circular patterns. When discovered in unexpected locations, they can be identified mistakenly as flammable or combustible liquid patterns and thus associated with an incendiary fire cause.

Often the presence of an ignitable liquid is ruled out, based upon the fact that an explosion did not occur. This is not always accurate, since the expansion of the products of combustion from flammable liquids will cause explosions only if they are sufficiently confined and have the proper fuel-to-air mixture.

The burning of **common fuel** gases (natural gas and liquefied petroleum (LP)) can result in distinctive fire patterns. Localized burning between ceiling joists, between interior vertical wall studs, and in the corners of room ceilings is quite common and is a good indicator of the presence of natural gas. This is due to the fact that natural gas has a vapor density of .65 and thus will rise to the upper portions of the room or structure. On the other hand, LP gas is heavier than air and will tend to pocket in low levels of the building.

Saddle burns are found on the top edges of floor or ceiling joists. These are caused by the fire burning downward through the affected joists.

LINEAR PATTERNS

Patterns that have overall linear or elongated shapes are referred to as linear patterns. They appear most commonly on horizontal surfaces.

When fuels are intentionally "trailed" from one area to another, the elongated patterns may be visible. Such **trailers** can be found along floors, connecting separate fire sets, or up stairways to move fires from one floor or level to another. Trailers may be ignitable liquids, solids, or a combination.

Long, wide, fairly straight patterns may be a result of **protected areas** caused by furniture, counters, storage, or other items. These patterns also may be the result of normal wear to the floor and floor coverings from high traffic. Irregularly shaped objects, such as clothing or bedding, also may provide protection and produce patterns that may be interpreted inaccurately.

Linear patterns also can be produced by **ignited fuel gas jets**.

AREA PATTERNS

Some patterns may be found which appear to cover entire rooms or large areas without any readily detectable source. These patterns most often are caused by fuels that are dispersed widely prior to ignition or when the movement of the fire through an area is very rapid, as in a flash fire.

Whenever flashover occurs in a compartment, the spread of fire from one point to another in the compartment is very rapid. Flashover can produce entire areas of relatively even burning, without good physical evidence of the direction of fire travel in the affected area. Flashover may not necessarily destroy previously generated fire patterns, but the time and extent of burning, both preflashover and postflashover, is important in considering the relationship between the movement patterns and flashover area patterns.

The ignition of gases or vapors from liquids does not always result in an explosion. If the fuel/gas mixture is at or very near the lower explosive limit (LEL), and there is no explosion associated with ignition, the gases may burn as a flash fire and there will be little or no subsequent burning.

MATERIAL DISTORTION

Other fire patterns can be observed by the changes in the physical shape and distortion of objects in the fire scene.

Incandescent **light bulbs** can sometimes indicate the direction of fire travel. As the side of the bulb facing the heat source is heated and softened, the gases inside a bulb of greater than 25 watts begin to expand and can push out the softened glass in a "bubble" effect. The bulged portion of the bulb will point in the direction of the heat source. With bulbs under 25 watts, the exposed surface will pull inward, due to the interior of the bulb creating a vacuum.

When heated, metal construction elements will soften and collapse or expand.

SUMMARY

An understanding of what types of patterns are produced during a fire and the factors that influence their production, gives the fire investigator scientific factors upon which to base his/her opinions. Without this understanding and its proper application, a fire investigator's opinions will be based upon old fire investigators' tales and such opinions will not meet the challenge of reasonable examination.

BIBLIOGRAPHY

DeHaan, John D. *Kirk's Fire Investigation*, 3rd ed. New Jersey: Brady Publishing Co., 1991.

Fiire, Frank. "Plastics and Fire Investigations." *Fire Engineering*, Jan. 1985.

Lentini, John J. "Baseline Characteristics of Residential Structures Which Have Burned to Completion: The Oakland Experience." *Fire Technology*, Aug. 1992.

Munger, James G. "Spalling and Determination of Origin and Cause." *Fire Engineering*, Apr. 1991.

NFF' A 921, *Guide for Fire and Explosion Investigations*. 1992 ed. Quincy: National Fire Protection Association.

Tobin, William A. "What Collapsed Springs Really Tell Arson Investigators." *Fire Journal*, Mar./Apr., 1990.

Accidental Fire Causes

INTRODUCTION

The determination of the cause of any fire requires the clear identification of those conditions necessary for the fire to have occurred. These conditions include, but are not limited to, the device or equipment involved, the presence of a competent ignition source, the type and form of the material first ignited, and the circumstances or actions that brought all the factors together.

Scientific Method

The analysis of any fire or explosion or similar incident must be undertaken using the systematic scientific method. The scientific method is defined in NFPA 921 as "The systematic pursuit of knowledge involving the recognition and formulation of a problem, the collection of data through observation and experiment, and the formulation and testing of a hypothesis."

The use of this approach often will result in the discovery of additional data which may result in previous opinions being reevaluated. Using this approach is a vital component of forming opinions which will withstand the challenge of reasonable examination.

Classifications of Fire Cause

The cause of any fire may be classified as accidental, natural, incendiary, or undetermined.

Accidental fires are those in which the proven cause does not involve any deliberate human act to ignite or spread the fire. While in most instances, this classification is clear, some deliberately set fires can be accidental. For example, an individual using a barbecue grill on an apartment balcony unintentionally knocks the unit over, causing the fire to spread to the structure itself. The spread of the fire is accidental even though the initial fire was deliberate.

Natural fires involve events such as lightning, earthquake, wind, and the like and do not involve any direct human intervention. They sometimes are referred to as "Acts of God."

Incendiary fires are set deliberately under circumstances in which the individual knows that the fire should not be set.

An undetermined fire cause means that the cause cannot be proved. The fire still might be under investigation, and the cause might be determined at a later date.

The term **suspicious** should not be used to describe a fire cause. Mere suspicion concerning a fire' s cause is an unacceptable level of proof and should be avoided.

Source and Form of Heat of Ignition

The source of ignition will be at or very near the point of origin. Remaining physical evidence of the ignition source may be found at the point of origin, or such evidence may be damaged heavily or even destroyed by the fire. Regardless of its condition, the source of ignition should be identified for the cause to be proved. If the source can merely be inferred, then the cause will be the most probable one.

A competent source of ignition requires sufficient temperature and energy and contact with the first fuel ignited long enough to raise it to its ignition temperature. The ignition process involves generation, transmission, and heating.

Once the area or point of origin is identified, the investigator must identify the heat-producing device, substance, or circumstance that could have resulted in ignition. Heat-producing appliances can include heating equipment, appliances, and lighting equipment.

Evidence of malfunctions also should be determined in the types of devices listed above, and in the building' s electrical wiring and gas service.

Heat Sources

There are four basic heat sources.

Chemical Heat Sources

- Heat of combustion is heat released during complete oxidation. It is the heat given off by a burning object, also referred to as the caloric fuel value

- . • Spontaneous heating is an increase in temperature which does not draw heat from the surroundings. This also has several forms.

Heat of decomposition comes from the decomposition of an organic substance—wet lawn clippings in a trash can, for example.

Heat of solution occurs when a substance is dissolved in liquid. Slaked lime and water is an example.

Electrical Heat Energy

The next source of heat is electrical energy. The most common form is resistance heating. The heat is produced by the flow of electrons through a conductor that impedes the flow. This impediment (resistance) produces heat. Electric space heaters, ranges, and clothes dryers are but a few examples of this form of electrical heat.

Induction heating is another type of electrical energy producing heat. Again the heat is produced by the electrons' movement. This type of heat is produced by passing electrons through the heated object.

The microwave oven is the most common example. The electrons are in the form of an alternating magnetic field that fluctuates at such a high rate that it is no longer contained within a conductor. This is called radio frequency (RF), and is also the basis of radio and television transmission.

In a microwave oven this RF energy is contained within the oven and passes through the object to be heated. You also can get microwave burns from a powerful radio transmitter—don' t touch a 100-watt fire department radio antenna while transmitting.

Dielectric heating is a form of uncontrolled electrical heat. Have you ever seen a high-voltage transmission system on a dark night? The long insulators sometimes show a light blue/white light from the dirt, dust, and moisture, allowing a flow of electrons over the surface of the insulation. This is a ground fault leak of electrical energy.

Electrical heat also is produced by arcing. An arc is produced when the flow of electrons is interrupted by separating the conductors. This can be as simple as opening a switch or breaking a wire.

Static electricity also can produce arcs and heat. Ungrounded moving objects will produce static electricity. Moving belts, hovering helicopters or walking across a carpet all can produce a shock and arc.

Lightning also is a form of static electricity. Because of the power that is transmitted, lightning is considered a separate form of heat in this course.

Mechanical Heat Energy

Mechanical heat energy also takes three basic forms. The first is friction heat. This is the heat from direct mechanical contact between moving objects, such as rubbing sticks together to make fire. Another form of mechanical heat energy is friction sparks. The best examples of this type are a grinding wheel or the brakes on a railroad train.

The third form is the heat of compression. When a gas is compressed, the molecules are forced closer together and heat is produced. Filling SCBA air tanks is one form of this heat. A diesel engine is dependent on this form of heat to run. The spark plugs are replaced with a very high compression ratio (over 20 to 1). The compression of the air in the cylinders increases its temperature above the ignition point of the diesel fuel. When the fuel is injected into the cylinders, it ignites and the engine runs.

Nuclear Energy Heat

Nuclear energy heat is the fourth type. Since it is not a major fire cause in this country, it is simply mentioned and will not be discussed in detail.

First Material Ignited

The first material ignited (the initial fuel) is that which sustains combustion beyond the ignition source. The physical configuration of the fuel plays a critical role in its ability to be ignited. The initial fuel also can be part of the device that malfunctioned and/or may be an item that was too close to a heat producing device. The determination of the initial fuel ignited is a very important element in understanding properly the events that caused the fire.

Ignition Factor or Cause

The mere presence of an ignition source and an initial fuel, by themselves, does not create a fire. The fire is the direct result of bringing together the fuel and ignition source. The sequence of events that led to the combination of these two elements establishes the cause.

Consider a fire that originated in a deep fat fryer in a restaurant. The proper cause determination is much more than "the deep fat fryer caused the fire." It is

necessary to establish more precisely what occurred. Did the controls fail? Was the thermostat set too high? Was the unit too close to combustible materials?

Potential causes should be ruled out only if there is clear and definite evidence that they could not have caused the fire.

Certainty of Opinions

Opinions formed by the fire investigator must stand the challenge of reasonable examination. NFPA 921, *Guide for Fire and Explosion Investigations*, has defined four specific levels of confidence against which opinions can be measured. These also are based on guidelines established by the American Academy of Forensic Sciences.

1. Conclusive. At this level of confidence, all reasonable alternatives to the hypothesis are considered and eliminated, leaving only that hypothesis under consideration as true.

2. Probable. This level of confidence corresponds to being more likely true than not. At this level of confidence, the chance of the hypothesis being true is more than 50 percent.

3. Possible. At this level of confidence, the hypothesis can be

•, demonstrated to be feasible but cannot be declared probable.

4. Suspected. This level of confidence corresponds to a perception that the hypothesis may be true, but there are insufficient data to draw a conclusion to the exclusion of any other reasonable conclusion.

Quite often the report filed by the local fire department, local fire marshal, or State fire marshal will be used by a plaintiff's lawyer to file suit against the manufacturer, supplier, and/or installer of various types of equipment when that report indicates that some type of equipment was responsible for causing the fire. The investigator must remember that the mere presence of an item at the point of origin does not necessarily mean that it was the fire cause. All reports should indicate the degree of certainty of the investigator's opinion. Any time the degree of certainty is either possible or suspected, the cause should be listed as undetermined.

MAJOR ACCIDENTAL FIRE CAUSES

The accidental fire causes that are discussed in this unit are not all-inclusive. It is impossible to cover each and every fire cause that you might encounter in your career; there are simply too many possibilities. Almost anything used in our lives can become a fire cause if handled improperly. Nothing is foolproof because fools

can be very ingenious. This unit covers the most commonly encountered major accidental fire causes.

Test Standards

All types of equipment and appliances are tested and listed by various laboratories such as Underwriters Laboratories, Inc. (U/L), American Gas Association (AGA), Factory Mutual Research Corporation (FM), and many others. The purpose of these standards is to test under certain laboratory conditions and, while such testing does provide a high degree of safety, tests are not infallible. It is helpful if the test conditions are compared to those found in actual installations. Copies of the various testing standards can be obtained from the testing laboratories or the Learning Resource Center (LRC) at the National Fire Academy.

Heating Equipment

Heating equipment in various forms can present an ignition source. The equipment may be fixed or portable; it also can be either electrical or fuel fired. Fixed equipment may be wall mounted or located in closets, attics, or crawl spaces.

One of the major causes of accidental fires is defective, misused, or overheated heating equipment, or equipment installed too close to combustible materials. A fire may start if materials such as newspapers, clothing, or furniture are placed near a heating unit.

One specific problem associated with **wall-mounted radiant electric heaters** is that some of the thermostats do not have a positive "off" position. Turning these units all the way down does not ensure that they will not come on if the temperature drops sufficiently, around 40°F. Often, items of furniture are placed near the heater during the summer months and, with the first cold snap, the heater may come on, resulting in ignition of the furniture. This could happen even with heaters that do have thermostats with positive "off" positions, if the thermostat is not in the off position.

Oil- and gas-burning equipment is designed to provide safe, reliable heat; it is manufactured to current industry standards. People are the unpredictable factor. When these units are misused, installed incorrectly, or not maintained properly, they can start a fire.

If you suspect that gas or oil equipment is the source of the fire, check the firebox, pipes, and flue for excess soot. The presence of excess soot and carbon may indicate that incomplete combustion has been taking place over a period of time. Also look for signs of malfunctions and improper adjustment.

Check controls and fuel lines for prior trouble with equipment. Look for previously attempted home repairs. The presence of fresh tool marks may indicate that the owner attempted a repair.

Check for signs of fuel leakage in the area of the unit. These units use flammable gases or combustible liquids for fuel. When combustible fuels leak, they may soak into the floor and leave stains or liquid burn patterns.

All fixed heating equipment must be installed in accordance with the manufacturer's installation instructions. Such equipment is provided with **internal safety thermostats** intended to prevent the equipment from overheating. Overheating still can occur if these safety devices fail.

Valves and controls for fuel fire equipment may malfunction, allowing unburned fuel to escape. Gas valves on both liquefied petroleum (LP) and natural gas appliances and equipment may fail to operate properly for several reasons. Numerous types of these control valves have been subject to recalls. Information about recalls can be obtained from the manufacturers, the U.S. Consumer Product Safety Commission (CPSC), and from other sources such as the LRC at the National Fire Academy. A valve also may fail when debris enters the system and prevents it from closing properly.

Anytime that a gas valve is determined to have been or is suspected to be involved in the cause of a fire or explosion, it should be x-rayed prior to being disassembled.

Portable kerosene heaters can become ignition sources for several reasons. The first is flareups. The leading cause of kerosene heater flareups is the use of improper fuel—occasionally pure gasoline, but usually contaminated fuel. A very small percentage (1.2 percent) of gasoline contamination can cause the heater to overfire. Such flareups also can occur, even if the proper fuel is used, when the wick is adjusted improperly, i.e., either too high or too low. Improper mantle seating and the use of the wrong wick also have been known to cause flareups. Other flareups have occurred when an overabundance of fuel vapors are drawn out of the heater by a slight draft. What appears to occur is that the heater is producing kerosene vapors faster than it is burning them. The excess vapors collect inside the heater until forced out by a draft. In the household setting, this draft may occur when the user opens a window or door to the outside, or when a forced air heating system turns on. Finally, although kerosene heaters must be equipped with a mechanism which will shut off the heater if it is tipped over, the mechanism may not be effective in all circumstances.

Other fires involving kerosene heaters have been caused by a **fuel leak**. Heaters with inverted tanks are more susceptible to tank leaks. The leak may involve a metal seam, and might involve the sight gauge. When the integrity of an inverted tank is violated, the tank will overfill the reservoir in the bottom of the heater, causing it to overfire and allowing the fuel to spill out of the heater. Fuel spills also occur while filling the heater. While the proper method of filling the heater is

to remove it to the outside of the building, in some cases, the filling operation is conducted with the heater still operating.

Of course, portable kerosene heaters also may become an ignition source if they are placed too near to combustible materials. With any fire involving a kerosene heater it is advisable to obtain fuel samples so that they can be checked for contamination.

Portable electric heaters may become ignition sources if placed too near combustibles, if operated with extension cords, or if tipped over.

Numerous fires also have been attributed to oil-filled heaters. These portable heaters, which look like steam radiators, are filled with mineral oil. The internal heating element heats the oil. The oil circulates in the heater by convection. The problems which have occurred have been a result of the heaters having an inadequate quantity of oil or a failure of the thermostats. Even if the heater was not the ignition source it might contribute to the fire spread. Exposure to the temperature levels which exist during a structural fire may cause the heater to rupture, spraying the oil into the areas around the heater. This release can cause substantial increase in the intensity of the fire and injuries to nearby firefighting personnel.

Heat tapes, used to prevent the freezing of water lines, also can become ignition sources. There are two types of these tapes. One comes preassembled in certain lengths which are ready to be used. With other types the heat tape is cut to length, with the male attached plug placed on one end and a termination cap on the other. The first type can become an ignition source if the thermostat fails or if the tape is installed improperly. Improper installation includes wrapping the tape over itself, thus insulating the tape (unless recommended by the manufacturer). In addition to these conditions, the second type can fail if water enters the tape. This can cause the tape to bum like a fuse.

Coal, wood, or other solid-fuel heating systems have become more common in recent years. These systems, like other heating systems, are subject to misuse and abuse. If this is a suspected fire cause, check the fuel supply. Is there an oversupply of fuel, or is an improper fuel being used? Wood-burning equipment will fail rapidly if coal is used; likewise the solid-pellet units are sensitive to improper fuel use and loading.

Fire may occur in nearby combustible materials, including the fuel stored nearby. Installation too close to combustible materials is one of the leading causes of fires involving solid-fuel heating equipment. Proper installation not only of the heater, but of the flue and chimney is critical for the unit to function safely. Examine the flue where it passes through the walls or ceiling. Remember to consider the distance from the equipment and the length of exposure of the material to the heat source.

Creosote buildup on the seams of flue pipes may indicate a lack of cleaning and maintenance. Stovepipes, flues, or chimneys which appear extremely clean inside may have been involved in a chimney fire.

Creosote is a dark, tarry substance produced by the incomplete combustion of wood. It enters the chimney as a vapor and condenses on the relatively cool surfaces of the flue liner. Continued exposure to hot flue gases evaporates the more volatile components, eventually resulting in a hard coating. This coating has been found to ignite at between 1,170° and 1,300°F (632° and 704°C). As little as 1/8 to 1/4 inch of creosote can produce a chimney fire. The operation of a solid-fuel heater with slow-burning fires increases the production and accumulation of creosote. The type of wood burned has very little influence on creosote accumulation.

Once ignited, the fire inside the chimney can spread to nearby combustibles, if adequate clearance has not been provided. The fire also may spread to the structure through cracks or other defects in the chimney. During a chimney fire, temperatures of over 2,000°F (1,093°C) may be achieved. Metal prefab chimneys have been reported to fail under such conditions. Chimney or flue fires can cause roof fires, when burning soot and debris are drawn out of the flue during the fire.

Converting old solid-fuel heaters to burn fuel oil is another dangerous practice. Some older units are not suitable for conversion. They can overheat easily and allow leakage of combustion products into the building.

The **improper disposal of hot ashes and coals** is also a common accidental fire cause. Fires have occurred when ashes have been removed and placed into paper bags, cardboard boxes, and trash cans. The time element may seem extreme, as the ash may hold burning embers for several days or longer. Always consider the insulating effect of the ashes and of the storage container.

With any heating equipment—space or water—it is vital that the proper quantity of combustion air be provided. Whether the equipment is vented or unvented, improper combustion air can result in dangerous levels of carbon monoxide being produced, resulting in serious injury or death to building occupants. Dangerous levels of carbon monoxide also can be produced by failure to vent the products of combustion properly. Vent piping can become blocked, disconnected, or penetrated by rust, allowing dangerous levels of CO to accumulate inside the building. An excellent discussion of the dangers of carbon monoxide from heating equipment is contained in *Kirk's Fire Investigation*.

Cooking Equipment

Cooking equipment, like heating units, is designed to provide safe, reliable service. It is manufactured to current industry standards and must be installed in accordance with the manufacturer's instructions. Again, people are the unpredictable factor. When cooking equipment is misused, installed incorrectly, or not maintained properly, it can become an ignition source.

If cooking equipment is a suspected cause, check the positions of the controls. They usually will survive even a severe fire, and such examination can establish their position at the time of the fire. Also check the contact points of the controls, switches, and thermostats for malfunction, signs of pitting, and arcing.

Check the location of the kitchen's trash container in relation to the point of origin. It is not unusual for occupants to place a trash container between the cooking equipment and a cabinet or wall. This close proximity can result in ignition of the trash container by the conduction of heat from the cooking unit.

Use of cooking equipment for space heating can lead to overheating and ignition of nearby combustibles.

Poor housekeeping can be a factor in this type of fire. An accumulation of trash and dirt may provide a source of material to be ignited.

Occupants frequently attempt to remove burning pans from cooking equipment. The burning pan and liquid contents may be dropped or thrown. The point of origin then may appear to be at floor level, with burn patterns consistent with a liquid fuel. The point of origin also may be near the sink or exit. The owner or occupant may have burn injuries from attempts to extinguish the fire. Depending upon the quantity of grease in the pan and the temperature setting, the grease may begin to smoke in about 10 minutes and ignite within 20 minutes.

Several facts need to be determined with an accidental cooking fire. Did the fire occur during normal meal preparation times? What is normal preparation time for the occupant? What other evidence of meal preparation is present?

Automatic drip coffeemakers can be potential sources of ignition. There are two basic types of these appliances: one has a brewer element which also serves as the warmer element; the other has separate brewer and warmer elements.

The component most likely to be an ignition source is the brewer element. In order for this to occur two things must happen: the operating thermostat must fail, and the safety fuse(s) (TCO or thermal cutoff) also must fail. Tampering with the unit (or improper repairs) also can cause the unit to become an ignition source if the TCO is bypassed.

Those units which use the brewer element as the warmer element have the heating element located under where the pot normally sits. If this unit overheats, the heating area assembly will take on the shape of the top of a cupcake. There also will be severe charring under the appliance. A recent fire problem has been associated with **toasters**. Several fires have occurred when toasters were being used to heat frosted pop-up pastries. The coating on these pastries is largely sugar; if the toaster is set on high, or if the toaster fails to pop up, the sugar coating can melt and ignite, leading to the ignition of other nearby combustible materials.

Refrigeration Compressors

Refrigeration compressors often are cited as a fire cause. Compressors used on domestic refrigerators and freezers and commercial types of equipment are of either the hermetic or semihermetic type. These types of compressors are constructed so that the electric motor portion of the unit is enclosed completely within the refrigeration system. Hermetic compressors use a welded compressor shell, while semihermetic compressors are bolted together.

These types of compressors are constructed so that the temperature on the outside of the shell cannot exceed certain limits, usually around 300°F (149°C). Extensive tests have shown that these compressors will not ignite combustible materials, even if they are in direct contact with the shell. In tests, compressors have been covered completely with materials such as dust, wood shavings, or shredded newspaper, and have operated for extended periods with no ignition occurring.

It is possible, however, for an electrical failure to occur with components and wiring outside of the compressor which might serve as an ignition source.

Smoking and Related Fires

The heat generated by burning cigarettes will vary from 550°F (288°C) measured on the outside of the glowing ash to 1,3 SOT (732°C) in the center of the glowing ash. Higher temperatures have been recorded in research experiments.

In order for a discarded cigarette to ignite an item of furniture or bedding, it must be insulated. If the cigarette is dropped on the surface of the item, the most probable result will be only local surface charring and it most likely will self-extinguish.

The cigarette becomes insulated when it is located in cracks or crevices. This insulating effect allows the buildup of heat from the glowing ash, and increases the surface contact with the heat source. The greater the insulating effect, the greater the chance a fire will occur.

Smoldering fires in furniture such as sofas, chairs, or beds usually require long periods of time to produce open flame. It is difficult to identify the minimum time period needed, but laboratory tests have shown open flame as early as 20 minutes and as late as 6 to 8 hours. The typical time is from 1 to 1-1/2 hours, but this time can vary greatly in either direction.

A smoldering fire inside padded furniture eventually may produce temperatures of between 1,400° and 1,600°F (760° and 871°C) inside the furniture. This temperature is sufficient to cause the annealing and collapse of springs. As discussed in detail in Unit 4, the collapse of springs must be considered in conjunction with other indicators.

Smoldering fires also produce large quantities of heavy smoke. Heavy accumulations may be present on walls, ceiling, and windows as well as other

items or contents. Remember that if a fire vents through a nearby window a clean burn may occur.

Heavy floor damage may occur when an item of padded furniture burns, regardless of the ignition source. If the padding is foam, it will melt and produce patterns at the edge and under the furniture which can be misinterpreted as being the result of an accelerant. It is not unusual for burn through to occur as the result of the dropping down of this burning material.

A cigarette dropped into trash or other similar combustible materials also can become an ignition source. Again, it depends upon the type of materials available as to how long a delay might occur before open flame. It could range from a few minutes to several hours.

Flammable and Combustible Liquids

Units 6 and 7 contain detailed discussions about the indicators of the presence of flammable and combustible liquids as accelerates. This unit focuses on **accidental** circumstances such as spills, leaks, etc.

The **improper storage and handling** of flammable and combustible liquids is a major cause of accidental fires. These types of liquids can be found in almost any storage area in residential occupancies, such as utility rooms, kitchen cabinets, bathrooms, garages, carports, and basements.

Commercial and industrial occupancies frequently use various types of flammable and combustible liquids. These can be found in such areas as offices, work areas, storage areas, manufacturing areas, assembly rooms, and warehouses.

Improper selection and use of storage containers is a major contributing factor in fires involving flammable and combustible liquids. Plastic containers not specifically designed for such use, such as milk jugs and antifreeze containers, will become brittle with age and may develop *cracks* or leaks. They also are susceptible to being punctured by sharp objects, edges, or comers and may break upon impact if dropped. The liquid also may act as a solvent and actually dissolve the container.

Lightweight metal containers also can be dangerous, in that the lightweight construction may rust or deteriorate along the crimped seams. This will cause slow leaks to develop. Regardless of whether the can is plastic or metal, it should be listed and approved for the storage of a flammable or combustible liquid.

Another common cause of fires is the **improper use of flammable liquids** for cleaning. The most commonly misused product is gasoline. The use of this type of liquid usually results in the vapors of the product being spread over a wide area.

Because flammable and combustible liquid vapors are heavier than air, they settle at the lowest points of the building or room. These vapors may contact an ignition

source a considerable distance away and flash back to the container or source. The most readily available ignition sources are gas appliances, hot water heaters, sparking of electrical equipment, sparking of light switches, telephones, motors, static electricity, and smoking.

The presence of flammable liquid vapors can cause either a flash fire or an explosion depending upon the quantity of vapors present. The indicators of a fire involving flammable liquid vapors are rapid flame spread, very heavy charring, and low burning. Corroborating evidence would include the presence of cleaning equipment containing the residue of flammable liquids, the presence of containers, and witness statements. This type of fire also commonly involves children playing in the areas in which the liquids had been stored.

It should be remembered that when a combustible liquid is heated to its flashpoint or above, it will behave like a flammable liquid. This can occur either in an industrial process or in a residential setting. Several fires have resulted from an individual pouring a combustible liquid into a solid fuel heating device to rekindle the fire. Embers or coals in the heating equipment heated a portion of the liquid to above its flashpoint, and an explosion followed.

Fuel Gases

Fuel gases such as natural gas and LP (propane, butane) can be involved in a fire. Leaks involving equipment and piping and malfunctioning equipment can lead to explosions and/or fires. These gases, which are naturally odorless, are required to be odorized; however under certain circumstances odorization may fail, thus allowing the presence of the fuel gas to be undetected.

LP gases are heavier than air and normally will settle to the lower levels of the structure. Explosions involving LP gas usually will produce heavier damage at the lower levels. Natural gas, on the other hand, is lighter than air and will rise to the upper levels of the structure. Explosions involving this gas tend to produce heavier damage at upper levels.

The most common odorant is ethyl mercaptan—this gives natural gas the characteristic rotten egg smell. It is known that a certain small percentage of the population has a complete or partial loss of sense of smell and that some people are insensitive to the odorant. Factors such as age, colds, allergies, and certain diseases affect the ability of the human nose to detect gas odorant. It is estimated that approximately 96 percent of the population has a "normal" sense of smell.

The odorant also may be "lost" in other ways. Anytime the gas is piped underground and a leak occurs, it is possible for the odorant to be leached out by the soil. Soil that is clay rich is more likely to leach out the odorant. Because the boiling points of the odorant and LP are different, odor fade can occur when an LP tank has been out of service for some time. As gas is first drawn from the container, the level of odorant will be at its lowest level and may be undetectable.

As more gas is drawn from the tank, the liquid and odorant will begin to boil and the odorant level in the vapor will increase.

Odorant fade also can occur with new LP containers. In these new containers, the odorant can be absorbed by the steel and/or may react with any rust inside the container. The precise mechanism of odor fade has not yet been determined and further research is underway.

Open Flames or Sparks

Cutting and welding operations often are conducted in areas where combustibles are stored. A fire may smolder for a long period of time after completion of the actual welding and cutting operation. The fire may result from the effects of heat conduction or convection from the welding, when welding or cutting objects are connected to or pass through combustible construction, or by direct flame contact.

The indicators of a fire caused by cutting or welding include slag in the area of origin, spot burning, welding or cutting equipment in the area, the presence of metal objects showing evidence of recent welding/cutting, and witness statements.

Soldering of pipes also can lead to the ignition of nearby combustible materials. Quite often the piping is concealed partially in the structure and the heat is transferred by conduction from the area being soldered to other areas. This heat generally is not sufficient to ignite solid wooden members but can result in the ignition of insulation and insulation boards. These types of fires may smolder for long periods of time and may not be discovered until hours after the operation has ceased. The same results may occur when an open flame torch is used to thaw frozen pipes.

Electric welding equipment also has been used to thaw frozen metal piping; this can lead to fires with multiple points of origin and has even been known to cause fires in nearby structures.

The sparks produced by **grinding operations** also can provide an ignition source for both combustible materials and flammable and combustible vapors.

Candles are another ignition source. How long a candle will burn is dependent upon its size. Large candles can burn for more than eight hours. The open flame of the candle can become an ignition source if it is not placed on a noncombustible surface or if combustible materials are placed around or near the candle.

Friction and sparks from machinery are another cause of accidental fires. The friction from high-speed rotation of objects may result in extreme heat being generated if the machinery is lubricated improperly. This may result in the ignition of nearby combustible materials by conduction or convection.

Indicators of a fire caused by friction may include a report of trouble or noise from the equipment involved or a point of origin near or inside the suspected equipment

or machinery. Localized damage to the metal portions of the machinery may be present and, depending on the intensity of the heat, actual melting.

Sparks from machinery also may serve as an ignition source. These sparks may be from an electrical or mechanical source. Sparks from grinding will produce indicators that are similar to open-flame cutting.

Spontaneous Heating

Spontaneous heating leading to combustion sometimes is used as a catchall by investigators. Spontaneous heating does occur, but certain materials and conditions must be present. Spontaneous heating can be produced in three ways: chemical action, fermentation, or microbial thermogenesis (oxidation).

Since the most frequently encountered situation is **fermentation**, this section concentrates on this method. If a chemical reaction or oxidation is suspected, consult additional references such as NFPA 491M, *Manual of Hazardous Chemical Reactions*.

Moisture is a prime factor in the fermentation process. In grasses and hay, the drying time prior to storage is critical. Storage while wet or green is an invitation to spontaneous heating. Spontaneous heating may be accelerated by outside heat sources such as sunshine, storage near steam pipes or heaters, or drying processes.

Another critical element of spontaneous heating is air movement. Too much air or air movement can dissipate the heat and keep the mass below ignition temperature. Too little air may accelerate the heating. For example, a rag soaked in linseed oil may produce spontaneous heating if wadded up at the bottom of a trash can, but the same rag simply will dry out if spread open on the floor or ground.

The mass of the material is important also. Material usually must be several inches deep to allow for spontaneous heating. The heating may occur in a matter of hours, or may take months to reach its ignition temperature. Bacteriological preheating may initiate the mass. The bacteria may die as the mass reaches temperatures in the 175°F (79°C) range. At that point, the heating may continue or halt, depending upon the other factors present.

Indicators of fires caused by spontaneous heating include charring inside the mass, or more than one area of such charring. It is also important that the suspected material be from some living source or base, although there are some exceptions. Some of the common materials that are susceptible to spontaneous heating are linseed oil, charcoal, fish meal, wool waste, and foam rubber. A more complete listing is included in NFPA's *Fire Protection Handbook*.

Charcoal in the unused marketable form of briquettes does not appear to be susceptible to spontaneous heating. Extensive research by the Clorox Technical Center has shown that the self-ignition of a 20-pound bag of briquettes cannot

occur unless the briquettes are exposed to an ambient temperature of 250°F (121°C) or more for more than 20 continuous hours. However, past experience has shown that charcoal which has been used and extinguished and placed into a container or bag is susceptible to spontaneous heating.

Spontaneous heating also is responsible for **cloth fires** after certain fabrics have been dried in a dryer. This applies to both residential as well as commercial dryers. It has been shown that fabrics which contained vegetable oils can produce spontaneous heating after being laundered. The spontaneous heating can occur if the items are left in the dryer or even if they are removed and placed into some type of container or basket. The contributing factors include the type of fabric, the amount and type of oil absorbed by the fabric, the type of detergent used, the manner in which the clothes were washed, and the temperature level to which the washed clothes were exposed. (See article entitled "Spontaneous Combustion of Vegetable Oils on Fabrics" at the end of this unit.)

Materials such as tennis shoes and foam padding also have been known to be susceptible to spontaneous heating after being dried in a dryer.

Fires can occur if the venting system of the dryer is installed incorrectly or blocked. Accumulations of lint block proper air flow.

Low-Temperature Ignition

When wood or similar materials are subjected to temperatures as low as 250°F (121°C) for an extended period of time, pyrophoric carbon is formed. In this process, the character of the material is changed. The exposed material becomes almost pure carbon and is subject to spontaneous heating. The time required for such ignition to occur depends upon the level of heat exposure, the duration of the exposure, the mass/density of the material, and ventilation. The timeframe may be several weeks or months although there have been cases that took several years.

Although it generally is believed that 250°F (121°C) is the minimum temperature at which spontaneous heating can occur, there is some research that indicates that a temperature as low as 212°F (100°C) could initiate such combustion.

Low-temperature ignition may develop in areas where combustibles are in contact with or very near light bulbs, steam pipes, or other low-temperature, heat-producing appliances. Low mass or low density (small or thin) materials usually are not affected by low-temperature heat. Low-temperature pyrolysis usually occurs only in solid timbers. This is attributed to the insulating effect of the larger mass/density.

Watch for the presence of a large charred section accompanied by a low-temperature heat source. Generally, even though a very large charred area can be expected, the charring will appear baked and will have very few, if any, deep

cracks along the surface. A smooth surface with hairline dehydration cracks is the more common occurrence.

The following are examples of situations or equipment which can provide the necessary heat for low-temperature ignition.

- Saturated steam pipes (approximate temperatures on or near surface).

10 Ib. gauge pressure 240T (121°C)
15 Ib. gauge pressure 250°F (121°C)
20 Ib. gauge pressure 259°F (126°C)

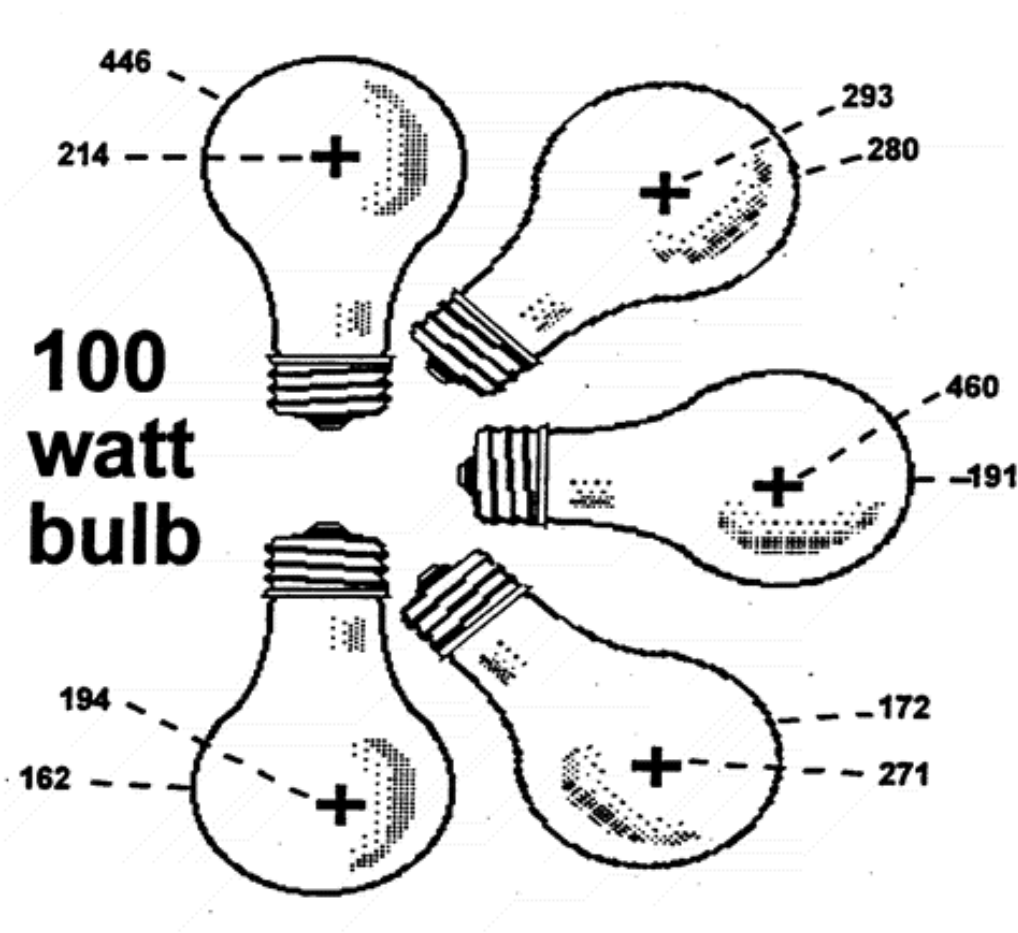

Lightning

Lightning is a tremendous discharge of electrical energy. The discharge usually consists of several strokes back and forth, each lasting a few millionths of a second. The current flow during a lightning strike can reach as much as 200,000 amperes. Lightning strikes usually are accompanied by some physical destruction of any poor electrical conductor in its path. Windows can be blown out, wood splintered, and electrical appliances and wiring can be charred heavily.

The air in the path of the main stroke is heated to a temperature of 30,000°C (54,000°F) and expands at supersonic speed. The pressure wave can damage nearby structures with near explosive force. In the flash itself, the heat being generated by the current flow can be sufficient to cause ignition.

Fire resulting from a lightning strike may appear immediately or may be a slow, smoldering one. Multiple points of origin are not uncommon. Lightning damage to electrical conductors may result in ignition months or years later

Wildland Fires

Wildland and open-land fires are not restricted to rural and remote areas. Even large cities have open wooded areas subject to wildland fires of both accidental and incendiary origin.

In some areas lightning is the major cause of wildland fires. Lightning is usually violent and causes obvious physical damage such as the splitting of trees and poles.

Often this damage is caused by the electrical charge converting the internal moisture in the object into steam. The resulting pressure buildup then causes the splitting of the object. Lightning may strike power or phone lines, causing overloading of protective devices.

Lightning also may run along fences and cause fires remote from the point of the lightning strike.

Spontaneous heating in wildland fires requires special conditions and is considered a rare occurrence. Falling rocks have caused sparks and fires, but this is extremely rare.

Sunlight can be a fire cause, but again, special conditions are required. It is possible for magnifying glasses and mirrors to concentrate rays of sunlight. This also can occur when liquid-filled containers cause a concentration of light energy. The spherically concave bottoms of aerosol cans also can produce a concentration of sunlight.

Campfires left unextinguished or unattended may smolder for long periods of time; this occurs even when they have been covered with dirt. The fire may travel through combustibles underground and then break into flames at a point somewhat remote from the original site.

Improperly discarded cigarettes or other forms of burning, smoking materials can provide an ignition source. This often is listed when no other fire cause can be determined. Burning carbon particles may be thrown from the exhaust systems of vehicles and trains; heated vehicle parts, such as broken brake shoes, broken clutches, and drive parts, have been documented as the causes of wildland fires.

Controlled burning of trash and burning or "greening" of farmlands is also a common fire cause. People have used fire in an attempt to destroy pests, even though it usually does not work.

Downed or damaged power lines can result in electrical shorts and sparks with temperatures of from 2,000 to 7,000°F. This may occur overhead or at ground level and can cause fires during conditions of high wind.

Other accidental wild land fire causes include sparks, shells, fireworks, projectiles from firearms, or animals.

A wildland fire uninfluenced by a strong wind will burn uphill in a fan-shaped pattern. On level ground, also uninfluenced by wind, the fire will spread from the center in all directions but its spread will be influenced by the wind the fire itself creates, blowing the fire in all directions. Such a fire generally will spread very slowly.

Ambient wind will modify the pattern by adding an additional spreading component, so that the fan-shaped pattern on the hill side will deflect to one side or the other, and in one predominant direction on level ground.

In the uncommon circumstance of a strong downhill wind, the fire will burn down the hill only to the degree that the ambient wind can overcome the fire's natural tendency to burn uphill.

In a fire having an extended perimeter, the direction of burning may be in almost any direction, depending upon the terrain, the air currents created by the fire itself, and the ambient wind.

Very simply, wildland fires are controlled by fuels, weather, and topography. In the investigation of wildland fires, no one item will indicate a point of origin. Flames will wrap around trees and posts. Fire will move faster uphill than when on level ground or when burning downhill. If a fire burns uphill, the bottom of the char pattern usually is steeper than the uphill ground slope. If the fire is burning downhill, the bottom of the char pattern usually is parallel to the slope.

More crown fires will occur when the fire is burning uphill, and more grass stubble will remain if the fire travel is uphill. Fire travel downhill will result in the grass being burned closer to the ground.

With either direction of travel, pine cones and other loose fuels may ignite and roll downhill, starting new fires in the unburned fuel. These new fires then will burn uphill.

To determine the direction of fire travel in a grass fire, rub your hand over the grass stubble. The grass will feel smooth in one direction and sharp-pointed in the other. The sharp points will be in the direction of fire travel.

Burned objects in the path of the fire are charred and weakened on the side that the fire came from. Unburned grass stems will fall toward the weakened side. This is toward the point of origin of the fire.

Other Accidental Fire Causes

Animals also can be involved in fire cause. They may damage equipment or wiring, knock over heating equipment, or push materials into contact with heat sources.

The sun's rays may be concentrated by various methods to produce the ignition temperatures of common combustible materials. Many items and articles have been reported to have been involved in such fires, including fish bowls, shaving mirrors, makeup mirrors, the rounded bottoms of aerosol cans, defective window glass, magnifying glasses, eyeglasses, and even decorative prisms.

Accidental chemical spills also have been reported as fire causes. Oxidizing materials in contact with reducing agents may produce heat and fire. Swimming pool chlorine contaminated with brake fluid has caused numerous garage and storage room fires. The contamination of chemicals may produce sufficient heat to cause the ignition of nearby combustible materials.

Christmas trees are one other deadly type of fire cause. They often are left in the home until almost completely dried out. When ignited they produce a very intense, very fast fire. A common ignition source is electrical lighting. Candles also have been identified as ignition sources.

BASIC ELECTRICITY

Introduction

A fire investigator must possess a basic knowledge in various fields to determine fire causes successfully. Electricity is one of those fields. The intent of this section is not to make the investigator an expert in the field of electricity, but to provide a basic understanding of electrical terminology, how electrical systems operate, and what indicators will be present to assist in determining a fire of electrical cause. When unexplainable circumstances occur, or when you have unanswered questions, seek the expertise of a professional electrician, electrical engineer, or personnel from the local power utility company for assistance.

Some experts in the electrical field claim that electricity cannot cause fires. Although this statement is incorrect, many fires have been determined improperly by fire investigators to be electrical in nature. Electrical systems have become a "catch-all" cause when no other cause can be found and there is heavy fire damage to the system. Electricity can and does create fire situations. However, specific indicators must be present to substantiate such a determination. An electrical fire cause determination never should be based on one single indicator.

Basic Terms

The following are basic electric terms with which every fire investigator should be familiar.

Electricity is the flow of electrons due to a difference in energy potential between two points on a conductor. All matter is composed of molecules that, in turn, are composed of atoms. An atom consists of a positive charged nucleus (protons and neutrons) surrounded by negative charged electrons which orbit around the nucleus. It is the electrons, and the ease with which they can move about, that determine the electrical properties of a material. Like charges (+ and + or - and -) repel each other, while unlike charges (+ and -) attract each other.

Anytime a current of electricity is flowing, a magnetic field will be generated. This is the basic operating principle of an electric motor. Conversely, whenever a conductor is moved through a magnetic field, an electric current will be produced in the conductor. This is the basic operating principle of a electric generator.

Neither heat nor magnetism can be eliminated completely from an electric circuit. However, circuits can be designed to produce mostly heat (toaster) or to produce mostly magnetism (motor).

Another byproduct of current flow is heat. The electrons passing through a conductor constantly collide with one another, generating heat. The greater the current flow, the greater the amount of heat produced. (*Kirk's Fire Investigation*, 2nd Ed., pg. 173.)

A conductor is any material that allows free flow of electricity. Some examples of better known conductors are gold, silver, copper, aluminum, , and carbon.

An insulator is a material that restricts or inhibits the flow of electricity. Rubber, plastic, glass, and porcelain are common examples of excellent insulating materials.

Units of Electricity

There are four basic units of electricity. **Voltage** is a unit of force or pressure that causes electrons to flow in a conductor (electromotive force) and is expressed in **volts**.

Current is the rate of electricity used. Current flow is determined by measuring the amount of electrons flowing past a single point in one second. This rate is expressed as amperes or amps. (*Kirk's Fire Investigation*, 2nd Ed., pg. 176.)

Resistance is the opposition of a conductor to the flow of current. Resistance is expressed in **ohm 's**. Current flowing through resistance creates heat and every

circuit offers some resistance. An excess of resistance in a circuit can create temperatures high enough to eventually cause ignition of nearby combustibles. Resistance in circuits can be caused by pinched conductors, twisted or wound conductors, severely bent wires, or loose electrical connections. Each of these conditions poses the potential for a fire.

Wattage is a quantitative measurement of work done or power consumed. This measurement usually is expressed in watts per hour. (*Kirk 'sFire Investigation*, 2nd Ed., pg. 177.)

Every electrical appliance is rated as to the amount of power or energy it consumes. This rating is expressed in watts (per hour). Heat-producing appliances, such as hair dryers, curling irons, coffee makers, toasters, electric blankets, etc., have a higher wattage rating than nonheat-producing appliances, such as radios, clocks, table lamps, etc. Larger appliances, such as refrigerators, microwave ovens, air conditioners, dish washers, clothes washers, etc., also have a higher-wattage rating. (See the chart below for common appliances and approximate wattage ratings.)

Appliance	Wattage
Lamps, incandescent	10 and upward
Lamps, fluorescent	15-60
Christmas lights	30-150
Clock	2-3
Radio	40-150
Television	200-350
Sunlamp (ultraviolet)	275-400
Heating pad	50-75
Blanket	150-200
heater, portable	500-1,500
Heater, baseboard	1,000-2,500
Fan	50-200
Air conditioner, window	800-1,500
Hair dryer	350-1,000
Projector, slide or movie	300-1,000
Sewing machine	60-90
Vacuum cleaner	500-1,500
Refrigerator	150-300
Freezer, household	300-500
Iron, hand (steam or dry)	660-1,200
Hotplate (per burner)	600-1,000
Stove (all burners and oven on)	8,000-14,000
Stove (burners separate)	4,000-6,000
Oven (separate)	4,000-5,000
Toaster	500-1,200
Coffeepot (percolator)	500-1,000
Waffle iron	600-1,000
Roaster	1,000-1,650

Rotisserie (broiler)	1,200-1,650
Deep fat fryer	1,000-1,650
Frying pan	1,000-1,200
Blender	500-1,000
Knife	100
Mixer, food	120-250
Dishwasher	1,200-1,800
Garbage disposal	500-800
Clothes washing machine	350-550
Clothes dryer (electric)	4,000-5,000
Water heaters (electric)	2,000-5,000
Motors 1/4 hp	300-400
1/2hp	450-600
over 1/2 hp (per hp)	950-1,000

A Comparison

Most firefighters are familiar with hydraulics and water flow as they relate to pumper or engine operations. Because of this, an analogy between hydraulic and electrical systems can be used to better understand the electrical system. Below is a table which lists the basic elements of a hydraulic system and the corresponding elements of an electrical system.

Hydraulic	Electrical
pump	generator
pressure	voltage
ponds per souare inch(psi)	volts
pressure gauge	voltmeter
booster pump	transformer
water	electrons
flow	current
gallons per minute (gpm)	amperes
flowmeter	ammeter
space inside pipe	conductor (wire)
valve	switch
friction	resistance (ohms)
pipe size (inside diameter)	wire size (AWG)

In a hydraulic system, a pump is used to create the hydraulic pressure necessary to force the water through pipes; in an electrical system a **generator** is used to create the necessary electrical pressure to force electrons along a wire. The electrical pressure is the **voltage**. The amount of hydraulic pressure is expressed in pounds per square inch and can be measured with a pressure gauge. The amount of electrical pressure is expressed in **volts** and is measured with a **voltmeter**.

Once the hydraulic pressure is generated, it frequently is necessary to increase it locally. To accomplish this a booster pump is used. In the electrical system, once

voltage is generated it can be varied (increased or decreased) in parts of the system with the use of a **transformer**.

With the use of the hydraulic system, it is water that flows for a purpose. In the electrical system, **electrons** are the units that flow for a purpose and this flow is called **current**. Gallons per minute refer to the amount of water flow and is measured with a flowmeter. Electric current is expressed in **amperes or amps** and is measured with an **ammeter**.

Electric current can be either direct current (DC), or alternating current (AC). **Direct current** is usually a low voltage system (i.e., 6-, 9-, or 12- volts) and supplied by a battery. **Alternating current** is usually 120-, 240-, or 440-volts and is supplied by electric utility companies. Direct current flows in only one direction, while alternating current flows back and forth with a specific frequency. The frequency of 60 Hertz, or 60 cycles per second, is used in the United States. Further explanation of the differences between DC and AC is beyond the scope of this manual.

The space inside a pipe provides a path for the flow of water; **conductors**, such as wire, provide a pathway for the flow of electrons. In a closed circulating hydraulic system, water is discharged from the pump, flows in a loop, and is returned to the pump, where it is recirculated through the loop. If the valve is in a closed position, the water flow stops. Opening the valve resumes the water flow. An electrical system operates in much the same manner. The current must flow in a loop or a completed circuit. If the **switch** is in the on position, the circuit is completed and the current flows. When the switch is turned **off**, the circuit is opened and the current flow ceases throughout the entire circuit.

It should be noted that, as in a closed water system, even though all of the outlets are in the off position, if the pump is still providing pressure, there may be "leaks" in the system. In an electrical circuit, there is still pressure or potential along the entire circuit up to the inlet side of the switch or outlet. There may be electrical "leaks" allowing unintended current flow. This is often the result of a high resistance fault to ground, and it may have the ability to generate a sufficient amount of heat to initiate a fire in ordinary combustibles.

Friction losses in pipes result in pressure drops. Electrical friction in wires and other parts is referred to as **resistance** and also results in electrical pressure (voltage) drops.

The size of the pipe basically controls the flow of water in that pipe at a given pressure. The larger *Has* pipe, the more water will flow through that pipe, or more gallons per minute. The same principle is found with electric circuits. The larger wire allows more current flow, while less current flows in a smaller diameter wire. Wire sizes are designated by American Wire Gauge (AWG) numbers. The larger the AWG number, the smaller the wire diameter. Larger wires, such as 14, 12, and 10 AWG usually are found in residential circuitry. Larger diameter wires create less resistance in the wires than smaller gauge wires. In other words, a No.

12 AWG conductor will conduct a given current with less resistance than a smaller No. 18 copper wire.

Effects of Electricity

There are four effects of electricity; three of these effects can create heat that may be involved in the ignition of a fire. The first effect produced by electricity is a **thermal action**, which is heat. Examples of this action are evident in toasters, electric space heaters, or any other heat-producing appliance. The second effect is **magnetism**. As current flows along a conductor, a magnetic field is produced and this field has the capability of creating heat. A **chemical reaction**, in the form of oxidation, is the third effect and can occur at loose or poorly made connections. This buildup of oxidation creates resistance, which, in turn, produces heat. The last effect of electricity is **lumination**, the light that can be observed with a glowing conductor.

Ohm ' s Law

Ohm' s Law is the fundamental law of electricity. It states that the voltage in a circuit is equal to the current multiplied by the resistance. The equation for Ohm' s Law is:

$$\mathbf{E \text{ (voltage)} = I \text{ (current)} \times R \text{ (resistance)}}$$

Use this equation to determine the voltage drop if the current and resistance are known. If the voltage and resistance are known, the formula can be rearranged to determine the current:

$$\mathbf{I \text{ (current)} = E \text{ (voltage)} \div R \text{ (resistance)}}$$

Or, when the voltage and current are known, the resistance can be determined by using the following equation:

$$\mathbf{R \text{ (resistance)} = E \text{ (voltage)} \div I \text{ (current)}}$$

When electrons are moved (electrical current) through a resistance, electrical energy is spent. This can be observed in the light of a lamp, rotary motion in an electric motor, or the heating of a wire. The rate at which this work is done, or the rate at which energy is used, is referred to as **power**. The amount of power is expressed in watts.

The relationships among power, current, voltage, and resistance are important to fire investigators because of the need to determine how many amps were drawn in a particular circuit in some circumstances. If, for example, several appliances were discovered to be plugged into one extension cord or several receptacles on the same circuit, the investigator should calculate the current draw to find if the ampacity was exceeded.

The chart below gives recommended ampacity for the size of the wire.

Wire Size	Ampacity
AWG14	15 amperes
AWG12	20 amperes
AWG10	30 amperes
Awn R	40 amperes

The following equation can be used to determine if a particular circuit was the victim of an overloaded condition.

$$\mathbf{W(wattage) = E(voltage) \times I (current)}$$

Now, we know the wattage (W) and the voltage (E), but need to find the current (I) draw for that circuit. Using a variation of the above equation, this can be accomplished.

$$\mathbf{I (current) = W (wattage) \div E (voltage)}$$

Because ampacities of wires and ratings of fuses and circuit breakers are given in amperes, the investigator usually needs to be concerned with amperage or current flow.

Example: Based on the information provided below, determine whether or not an overload existed

- 15-amp circuit.
- The following appliances were in use at the time of the fire.

Television 300 watts
Hair dryer 1,000 watts
Radio 100 watts
Incandescent lamp 10 watts
Air conditioner 1,000 watts
Total 2,410 watts

STRUCTURAL ELECTRICAL SYSTEMS

This section describes and explains electrical service into and throughout a building, so that the investigator can recognize, identify, and use *proper* terminology when investigating the electric system.

Electricity is initiated at a utility company power plant from a generator and can originate from coal, steam, hydro, or nuclear sources. The utility company then

dispenses this electricity, via overhead conductors, to transformers that are mounted either on utility poles or on the ground.

The overhead conductors that come from the pole to the building are called a **service drop**. They usually are owned and installed by the local power company. There normally will be three conductors: two "hot" cables that each carry 120 volts potential to ground or 240 volts potential between each other, and one "grounded" cable.

Commercial and industrial buildings often will have four wires (known as a three-phase system). The three cables may be separate, but for many years, two insulated conductors have been wrapped around a bare grounded cable. The service drop can enter a pipe (service raceway) or connect to a heavily insulated circuit (riser) through a **weatherhead**. This protects the connection from inclement weather. In newer areas, the utility service may enter the building underground and is called a service **lateral**.

The service entrance conductors connect to an **electric meter**, which is the property of the power company, and measures how much energy is used. These meters may be found either inside or outside of the building. From the meter, the service conductors may go to service equipment where they connect to a main switch, or disconnect which allows for turning off all power in the structure. This service equipment may be a fuse or circuit breaker panel called a **service distribution panel box**. (See Figure 5-1.)

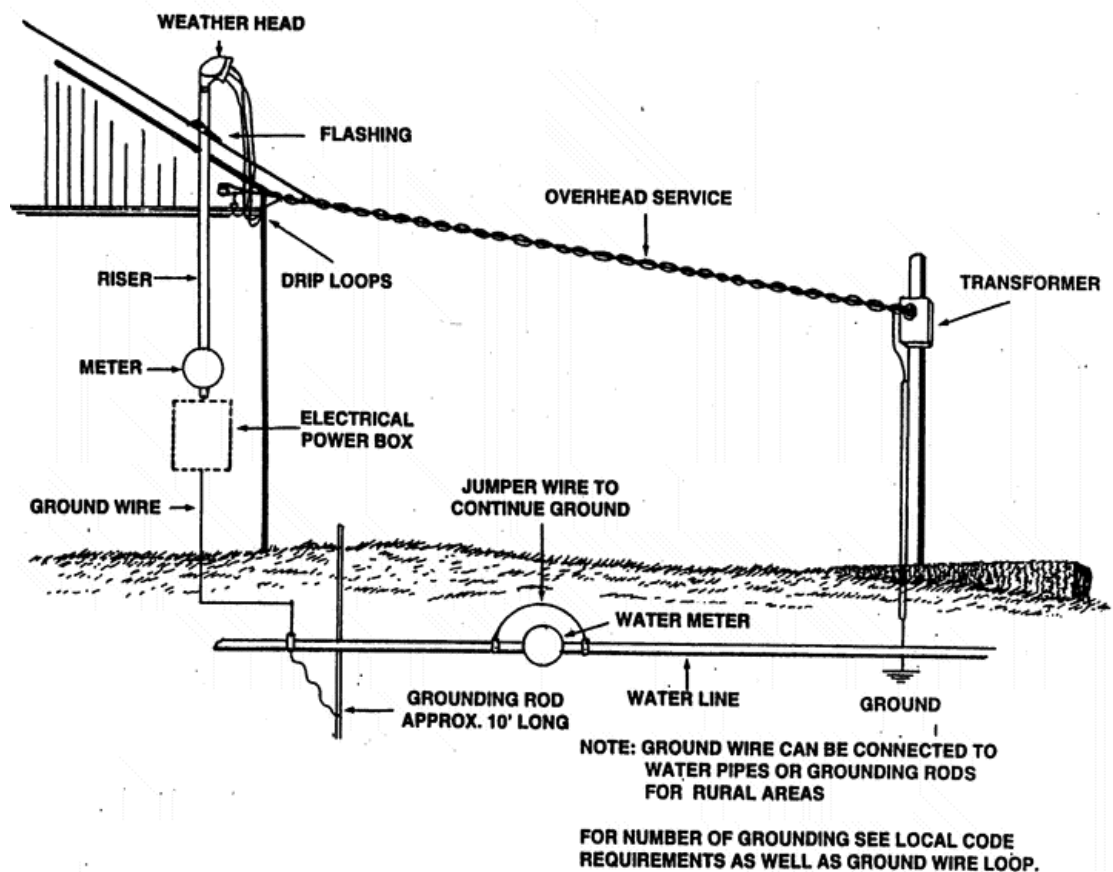

The Service Distribution Panel

The ground wire of the incoming electrical service connects to a **neutral terminal block** inside the distribution panel. The neutral terminal block is grounded to a rod or electrode driven into the earth and/or attached to a subterranean cold water pipe. It should be noted that the neutral wire terminal block and the equipment grounding terminal block are joined together only at the main service distribution panel. The neutral or **grounded** wires (white or gray) are designed to carry current routinely, whereas the **grounding** wires (green or bare copper) are designed to carry current only in the event of a fault or failure to ground. (*National Bureau of Standards Handbook 134*, pg. 100.)

The two "hot" cables, carrying 120 volts each, connect to a pair of *busses*, which are conductive bars mounted to a panel board inside the electric distribution panel. These panel boards may or may not contain **main disconnect switches**, which shut the power off to the entire building. However, the panel board will contain **overcurrent protection devices** commonly referred to as fuses or circuit breakers. These overcurrent protection devices are connected to the buss bar and protect the branch circuits from short circuit faults and overheating conditions.

Branch circuits are those circuits that feed electricity to the various switches and wall outlets throughout the building. Most branch circuits will carry 120 volts, with amperage ranging normally from 15 to 30 amps. Normal household appliances, such as lamps, radios, televisions, and small cooking appliances will operate from these circuits. Larger appliances such as electric stoves, clothes dryers, freezers, or central air conditioning units will operate with 240 volts. These circuits will be protected by the larger amperage overcurrent protection devices which connect to both buss bars.

Most newer residential or small commercial construction consists of copper, three-wire circuitry. The hot wire connects to the circuit breaker, while the neutral and ground wires connect to their respective terminals inside the box.

Electric installations in most residential structures normally are simple, consisting of 100- to 150-amp service in the structure. The amount of amperage within the service is based on the size and electric usage within the structure. Sixty-amp service still is found in many older residences. Installations in commercial buildings can become complicated with several panels and disconnects, as well as subpanels located in various areas throughout the building. In any of these situations, a wiring diagram or schematic of the building should be obtained, and the assistance of local, county, or State electrical inspectors should be requested. (See Figure 5-2.)

3 WIRE SYSTEM FROM WEATHERHEAD

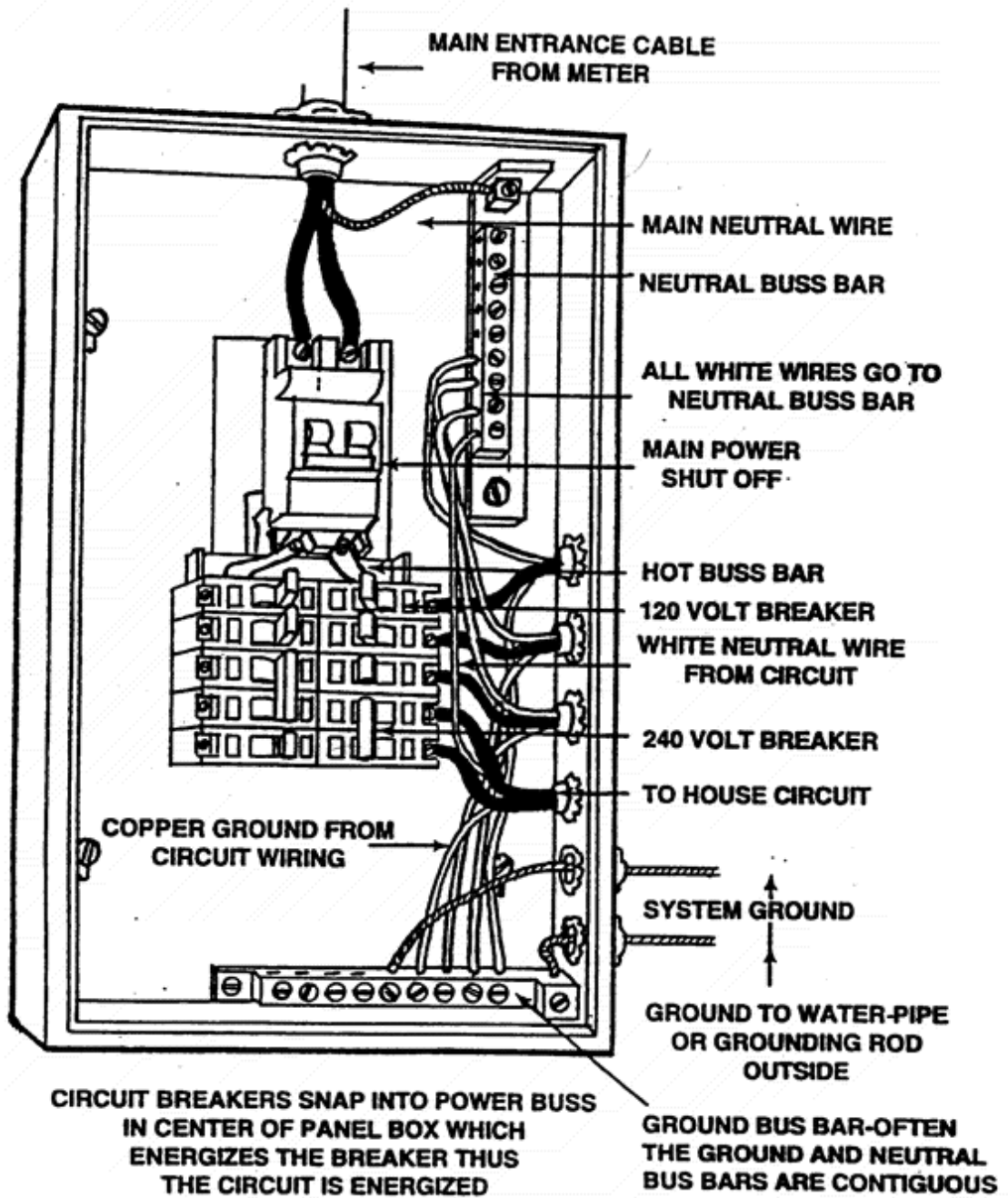

Figure 5-2

Grounding Requirements

Dangerous voltages, which can be a fire hazard and/or a personal injury hazard, may be imposed on the electrical distribution systems and equipment. Such potential hazards may be caused by lightning, inadvertent contact with a high-voltage primary system, breakdown of insulation, surface leakage due to dirt or

moisture, or an energized "hot" wire coming in contact with a conductive material such as metal, or by coming loose.

The grounding of one conductor of the electrical system and grounding all metal that comes in contact with an energized, ungrounded conductor ("hot" wire) reduces the potential hazards.

The grounding electrode usually observed in most structures consists of a pipe or rod driven into the ground, a metal plate buried below the permanent moisture level, or an underground water pipe that enters the structure. In all cases, the ground cable is connected to one of these metallic devices and will allow any excess current on the circuit to be dispersed safely into the earth, hence the term "ground."

Open Electrical Neutral Hazards

As previously stated, electricity is carried via the hot wire, the neutral wire returns the current back to the circuit breaker, and the ground wire takes any excess current and feeds it directly into the earth. (See Figure 5-3.)

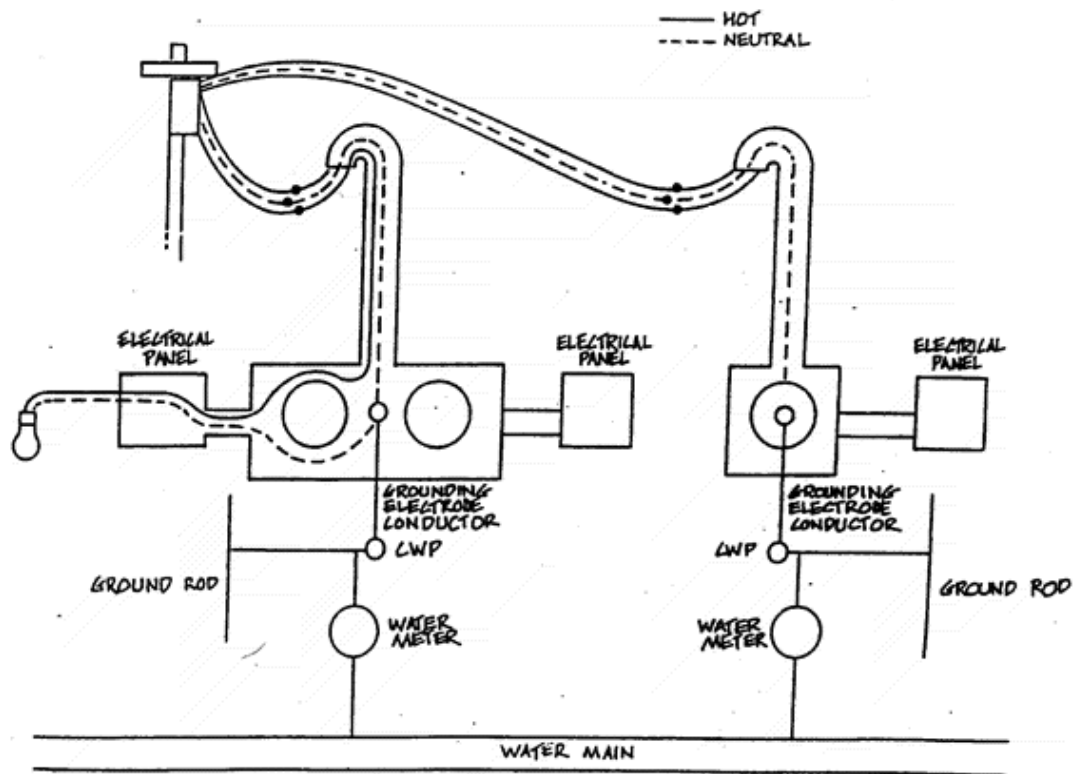

Figure 5-3

In an open electrical neutral hazard, electricity will seek an alternate abnormal circuit, energizing metal that normally would not be thought to be energized (i.e., the cold water pipe). (See Figure 5-4.)

In an open electrical neutral hazard, electricity will seek an alternate abnormal circuit, energizing metal that normally would not be thought to be energized (i.e., the cold water pipe). (See Figure 5-4.)

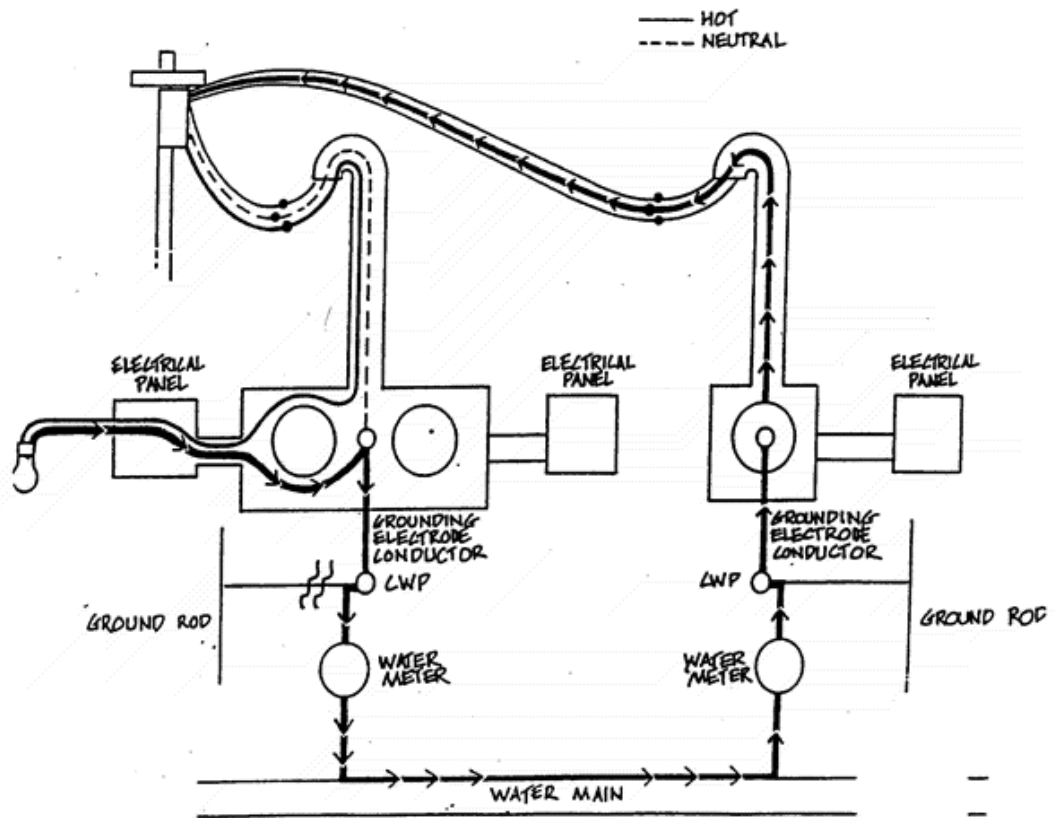

Figure 5-4

Thus, even though the fire department has pulled the meter or shut off the main electrical circuit, current still may be flowing.

Due to this open electrical neutral hazard phenomenon the following problems can exist for fire investigators.

- Fires may occur in occupancies away from the location where the open neutral hazard exists.
- Fires may give the appearance of having multiple points of origin.
- Electricity may be eliminated prematurely as the fire cause.

The following two discoveries during an investigation may indicate an open electrical neutral hazard.

I. Shock hazards.

Personnel on scene—whether firefighters, power company employees, police officers, plumbers, gas company employees, telephone technicians, cable company installers, or occupants—may describe receiving electrical shocks, may have received injuries, or may even have been electrocuted.

If this condition does exist or even if you simply suspect it exists, then treat the electrical service as energized until you can confirm that it is off by using an electrical measuring device.

2. Pyrophoric carbonization.

This condition results when a low heat source dries out the cellulose fibers of the wood over an extended period of time, lowering its ignition temperature to a point that the wood starts to smolder.

Thus, the appearance of a long-smoldering type of fire adjacent to an electrical source may be present on the wooden structural members. Some of the signs that can be noticed or described are

- Light smoke emanating from the baseboards or electrical outlets.
- Open flame seen inside the wall space around the electrical outlet.
- Heavy charring seen around points where metal (junction box, nails, staples) comes into contact with wood.

For further information on this specific subject, see the article by Larry Weintraub and Luis M. Jimenez in the Supplementary Readings section of this unit.

OVERCURRENT PROTECTION DEVICES

Current flow generates heat and the amount of heat (to some extent) is dependent on the conductor and its inherent resistance. Excessive heating can be caused by excess current demand, such as too many appliances or too great a load on a single circuit.

Short circuits develop when two elements of different potential come in contact with each other. A **ground fault** occurs when a hot wire comes in contact with a ground wire or ground potential. A **true short circuit** occurs when the hot wire comes in contact with the neutral wire. Large surges of current can be produced when either of these situations occurs.

If the circuits are installed properly and operating, excess heating or current surges should cause fuse elements to melt or circuit breakers to trip. This will produce an open circuitry and stop the flow of current.

Fuses and circuit breakers have built-in delays so they can withstand the temporary surge of current associated with equipment startup, such as compressors in refrigerators, freezers, and air conditioners.

Fuses

There are two basic types of fuses: the ordinary Edison base fuse and the S-type fuse. Both usually have a 30-amp rating or less. The most common size fuses are 15, 20, and 30 amps, and usually can be identified in 3 different ways. Fuses that are 15 amps or less have hexagonal windows; fuses that are from 15 amps to 30 amps have round windows. The color of the fuse (if not solid glass) also will help designate fuse amperage. Blue signifies a 15-amp fuse, orange or red a 20-amp fuse, and green a 30-amp fuse.

The Edison base or S-type fuses may or may not be of the time delay type, which allow for short-time current surges that occur with the starting of motors or condensers on some appliances or machines. These current surges can be up to six times greater than the usual current, but are harmless because of the short time period. If a short circuit or high ground fault problem occurs in the circuit, the time delay fuse will operate at the same speed as a non-time-delay type fuse.

The S-type *fuse* is designed so that tampering with the fuse is difficult. After installation of an S-type fuse into the Edison-based fuseholder, the base of the S-type fuse remains, and cannot be removed without damaging the fuse holder. These adapters are designed to prevent the use of Edison-based fuses, to prevent a larger fuse from being used in an adapter designed for a lower amperage rating, and to prevent fuse tampering such as placing a penny behind a fuse. The Edison-based fuse will fit any Edison-based fuseholder, despite the amperage of the fuse.

Cartridge-type fuses usually are 30 amps or larger but they are sometimes 15 or 20 amps.

Circuit breaker fuses are designed with a reset button on the face of the fuse that can be pushed, resetting the fuse once it is activated. This type of fuse is illegal in many jurisdictions.

Circuit Breakers

Circuit breakers, unlike fuses, do not have to be replaced when they are tripped. Most circuit breakers have a three-position switch: on, off, and reset. Once a circuit breaker trips, it goes to a neutral position and can be reset without having to discard the breaker. A circuit breaker cannot be placed manually into the tripped position. However, there are some breakers that have only "off" and "on" positions, and—when tripped—go to the "off" position.

Most residential circuit breakers are of the thermal-magnetic type. The thermal element, usually a thermal strip, provides for overload protection, while the

magnetic element provides protection in cases of short circuits and ground faults. It should be noted that circuit breakers and/or fuses are designed primarily to protect the wiring of the home or building, and any protection that they may offer to appliances is incidental to this basic purpose. (*Electrical Fire Analysis*, Yereance, 1987, p. 220.)

Circuit breakers are difficult to alter; however, there is a screw with a manufacturer's preset adjustment that governs the sensitivity of the breaker. This set screw normally is sealed with a hard white substance that should be present at the time of the investigator's examination. If this hard white substance is missing, it may be an indicator that the breaker was tampered with prior to the fire. An internal examination of the breaker is difficult for the investigator as most breakers are sealed with rivets that have to be drilled out before opening the breaker. It is recommended that a qualified laboratory or electrical engineer conduct these examinations.

In new installations, especially when the electric circuit is located in areas where water or elements of weather are present, a ground fault interrupter type circuit breaker will be found. This type of circuit breaker will turn off with a slight ground fault to better protect against electrical shock. In addition, the ground fault interrupter operates as a typical circuit breaker.

WIRING METHODS AND MATERIALS

Several wiring methods are recognized in electrical systems, some suitable for general use and others only for special purposes. Those that are most widely used are Romex cable, BX cable, and metal conduits.

Romex Cable

Romex cable usually contains two to four separately insulated conductors bound by a rubber or plastic shielding. This outer shielding usually is stamped with the size (gauge) of the conductors, the number of conductors, and whether or not a ground wire is present.

BX Cable

BX cable is an armored cable, twisted or wound, that contains two to four separately insulated conductors. The armored cable is usually the ground for the circuit.

Metal Conduit

A metal conduit is nothing more than a metal pipe that houses separately insulated conductors. This type of wiring usually is found in industrial or large commercial buildings.

Open Wiring (Knob and Tube)

Open wiring, more commonly referred to as knob and tube, is an exposed wiring method that uses cleats, knobs, tubes, and flexible tubing to protect and support single insulated conductors, run in or on buildings, and not concealed by the building structure.

This wiring method normally will be found in older structures, but may still be an active circuit. The newer, conventional wiring methods may be tied into an open wiring circuit.

Conductors (Wiring)

When a 240-volt circuit is present in a structure, it is normally a bare, heavy gauge, aluminum or copper conductor. This circuit connects from the overcurrent protection device to a 240-volt receptacle.

Conductors (wires) are measured by the diameter of the conductor and the terminology used is American Wire Gauge (AWG). The larger the diameter of the wire, the smaller the gauge. (Example: 12 AWG wire is thicker than 18 AWG wire.)

Most common residential branch circuitry uses a 14 AWG copper conductor that will accommodate up to 15 amperes of current and will be protected by a 15-amp fuse or breaker.

A 12 AWG copper conductor circuit will accommodate up to 20 amperes of current and generally is protected by a 20-amp fuse or breaker. This heavier gauge conductor normally will be found where large wattage appliances are in use.

Most modern construction has a three-conductor (wire) circuit. The "neutral" conductor insulation is always white or natural gray, the "equipment grounding" conductor shall be bare or covered with green insulation, and the "hot or line" conductor insulation may be of any color except white, gray, or green. (*National Electrical Code*, 1987, pp. 310- 12.) Current flows to the source, from the overcurrent protection device, on the "hot" wire and returns on the "neutral" wire. The ground wire takes any excess current and returns it directly into the earth.

EXAMINING FIRES OF ELECTRICAL ORIGIN

This section is designed to assist the fire investigator in identifying indicators of fires of electrical origin. A single indicator is not sufficient to classify a fire as electrical. This indicator must be validated by displaying that other conditions existed that caused the situation. Caution must be exercised by the investigator to

identify whether the physical electrical conditions found are a cause or a result of the fire.

Remember, safety is always the first consideration that should be taken into account by the fire investigator. Prior to beginning any type of examination of a fire scene, the investigator should first ascertain whether the electric service to the structure has been terminated. On many occasions, the electric meter has been removed, but if there is a problem with a neutral line, low voltage current can still backfeed into the structure and any metal objects that come in contact with the circuit become energized, posing a shock hazard. For your own safety, as well as the - safety of overhaul crews, check to make sure that the incoming service has been cut at the pole by the power company.

If a fire is suspected of being electrical in cause, the investigator must identify properly the equipment that was involved in the ignition. Such identification must include the manufacturer' s name, model number, serial number, voltage and current ratings, and if the equipment was laboratory certified.

There are several means of producing heat in electrical systems and equipment. These include arcs and sparks, heated connections, and overheated conductors. Careful determination of the precise form of electrical heating that initiated the fire should be made and then identification made of the material that was ignited.

The equipment involved, the form of heat, and the first material ignited are the three basic elements of an electrical fire cause, and would be considered direct evidence. It is the circumstantial evidence, however, which supports the case and ties the basic elements together.

Examine the Service Entrance

Check the exterior areas for indications of electrical short circuits. Examine connections at the weatherhead to ascertain that all connections are proper. Look for malfunctions in the power company weatherhead, meter, or disconnects. Some power company policies will dictate that their service ends at the weatherhead, while other companies will take responsibility to the meter. Know your local power company' s policy.

Examine the Distribution Panel

Examine "blown" fuses for evidence of shorting or overheating. When an overheating condition causes a fuse to open, the fuse element will melt, leaving the glass and fuse housing relatively clean. On the other hand, when the fuse element opens as the result of a short circuit, the glass on the face of the fuse often will blacken. In some cases, the glass itself may be damaged. Also, small particles of the bimetal fuse element may adhere to the inside of the fuse glass.

Tripped circuit breakers should be removed from the buss bar and examined for evidence of pitting or arcing at the metal contacts. Also, examine the breakers for evidence of arcing between breakers or across wire connections.

Inspect the connections inside the panel box. Look for evidence of tool marks that may indicate tampering or recent repairs. Is the cover plate in place and firmly secured to the panel box? If missing, why? Check for loose wire terminal connections that could have created an overheating condition.

Examine the distribution panel for evidence of previous electrical system problems. Are there blown or discarded fuses in or on the distribution panel? This may indicate problems the owner or occupant may have been experiencing with the electrical system. -

Examine the panel for indications of efforts to bypass the overcurrent protection devices. Some examples of tampering with these devices include placing a penny behind the fuse, cutting a strip off the metal screw threads and bending it down to the metal tip at the base of the fuse, wrapping the fuse in foil, replacing the fuse with a screw base plug and placing a staple or brad into the receptacle openings. A cartridge-type fuse can be bypassed by wrapping it in foil, running a nail through the length of the cartridge, or simply replacing the cartridge fuse with a metal bar or copper tubing.

Examine the interior of the panel. Conductors inside the distribution panel may display indications of arcing or other electrical activity that took place. Melted or molten beads of copper or aluminum adhered to the interior walls of the panel **box** usually indicates that arcing occurred.

Finally, if necessary, safely remove the entire distribution panel box and be observant for indications of heating to the back of the panel box or objects to which the panel box was mounted. This is a protected area and should display little or no damage. Extreme current surges or arcing can cause physical damage to the panel box, such as bulging, and lightning may actually blow out the rear of the panel box.

Remember to check the set screw on circuit breakers.

Examine Undamaged Areas

The investigator should watch for any signs of unprofessional electrical work/repairs. Check for missing cover plates on junction boxes, wall outlets, or wall switches. The electric code requires that receptacle boxes be covered. Look for loose connections or improper splices, which can create high resistance, and thus heat.

Evaluate the electrical system

Evaluate the entire electrical system and determine if any do-it-yourself repairs or additions to the system were performed by the owner, occupant, or unqualified electrician. Questions that should be answered through the investigator's observations include

- Is there an adequate number and proper placement of receptacles?
- Is there excessive or unsafe use of extension or drop cords?
- Are there cube or octopus adapters used in receptacles? And if so, are they overloaded?

Show calculations (Ohm's Law) that indicate the misuse or overloading of electrical circuits. This will assist in verifying your findings.

Although the misuse of an electrical system does not prove the fire was of electrical cause, such indications do help to reinforce the investigative efforts.

Dismantle and examine all wiring and receptacles at or near the point of origin. Look for evidence of arcing or overheating. Examine all of the involved branch circuits, including junction boxes, switches, outlets, power cords, and appliances along the entire circuit from the service panel to the termination of the branch circuit. This examination can assist with either validating the investigator's claims or eliminating electrical causes.

Common Structural Wiring

Aluminum wiring appeared in residences and commercial occupancies during the late 1950's. Literally millions of structures had aluminum wire installation before problems were identified with this type of conductor.

One problem identified with aluminum wire was the fact that aluminum expands and contracts approximately 38 percent more than copper. This expansion causes loose connections, which, in turn, creates resistance and/or oxidation and causes heat generation. Another problem is that aluminum wire oxidizes more than copper wire. The connections which oxidize create resistance heating, which causes additional oxidation.

Aluminum and copper wire may react with each other causing increased aluminum oxidation. This reaction is called **electrolysis**. The oxidation of the aluminum wire reduces the diameter of the conductor, which reduces its capacity for carrying the necessary current safely. Thus, heat is increased on the conductor and/or its connections. Proper connectors must be used when connecting aluminum wire to copper wire. The older connectors were labeled AL/CU; however, after 1972, approved connectors were labeled CU-ALR.

The major problem with aluminum wiring is the mechanical connections at the screw terminal. Again, loose connections can develop, creating "glowing

connections" that may, over time, cause ignition of wood structural members. When examining aluminum wiring and loose connections as a fire cause, check for evidence of long duration' s of heating at the point of origin.

Pure aluminum wire melts at 1,220°F (660°C), and often will melt, run, and pool in the area of origin. There may be very little, if any, evidence to corroborate the investigator' s claims of an aluminum wire malfunction. Quite frequently, with aluminum wire, the process of elimination of all other causes must be followed.

Copper wiring is the most common 120-volt conductor found in most residential and commercial structure branch circuits. Usually, residential and small commercial circuitry will be comprised of solid core, copper conductor of various gauges. Extension cords, lamp cords, and other small appliance power cords are constructed of twisted, copper strands of wire. These wires will vary in size depending on the electric draw of the appliance or designated use for the extension cord.

Generally, pure copper is considered a safe conductor of electricity, and with a melting temperature of 1,981°F (1,082°C), is capable of greater resistance heating than aluminum. Although aluminum also is considered a good conductor of electricity, copper has far fewer problems and is the most prevalent.

ELECTRIC WIRING MALFUNCTIONS

Clues and Causes

A single indicator of an electrical malfunction is not sufficient to classify a fire as electrical in cause. An indicator must be validated by proving the necessary physical cause and conditions were present. If indicators cannot be validated, the fire cause should not be determined as electrical.

The physical conditions in a fire scene which serve as clues may be created by a hostile fire of other than electrical origin. Although not absolutely necessary, there should be some circumstantial evidence to indicate that the fire occurred as a result of age or deterioration of the electrical system. Some examples of the circumstantial evidence needed are the system or component parts were misused or misapplied, the system or its components were installed improperly; an accident occurred, or a defective product was involved.

Arcs and Sparks

There are several ways that arcs and sparks are produced. Some arcs are an unavoidable result of operating electrical equipment and switches. That small spark that is observed when a wall switch is turned on is actually an arc. Breakdown, malfunction, or damage in electrical systems or equipment also can cause arcs. Static electricity, such as when a person scuffs his/her feet across a

carpet and then touches another conducting object and causes a spark, is another example of arcing. Lightning is yet another form of a natural arc

Temperatures that can be developed by arcs typically range from 2,000° to 7,000°F (1,093°C to 3,871°C). Arcing temperatures can cause metal objects, such as copper conductors, to melt and splatter hot particles over a wide area. When the hot particles come in contact with combustible materials, the potential for a fire exists.

Normal arcing occurs when a fire attacks energized electrical conductors and equipment. The presence of arc damage alone is not sufficient to determine that the fire was caused by the arcing action. A competent fire investigator must have the ability to differentiate between fire-caused arcing and fire-originating arcing.

The following conditions are necessary to determine that normal arcing caused ignition:

- • It can be proved that ignitable mixtures of air and flammable gases, vapors, or dust were in an electrical system, or that equipment was not designed for this type of atmosphere.
 - The electrical equipment was energized and operating at the time of ignition.
 - The fire scene has signs of a flash fire or explosion typical of the material ignited.
- All other sources of ignition have been ruled out.

Abnormal arcs can be produced by abnormal operations, failure, or damage to the electrical systems or equipment. Indicators of a fire caused by abnormal arcing are

- Holes melted in metal enclosures for electrical equipment or wiring.
- Holes melted into the metal conduit or armor shielding of a BX cable, usually at the point of the arcing.
- Portions of electrical insulators in equipment destroyed or damaged in areas adjacent to normally energized parts, while other insulators are not damaged in the same manner.
- Electrical equipment dislodged or deformed in a manner not consistent with damage caused by the fire. This may be an indication of heavy current flow.
- Electrical cabinets bulged or distorted from internal pressure.
- Melted or beaded wiring not consistent with temperatures developed by the fire. Conditions necessary for abnormal arcing and ignition to occur are

- Some outside influence must be present to initiate the arcing process, such as physical damage, water on live parts, or conductive objects coming in contact with live parts. The voltages present on normal residential and small commercial electrical systems will not begin to arc spontaneously.
- The suspected circuit or equipment must be energized and there must be current flow. The current flow can be the result of normally operating equipment or appliances, or it may be the result
 - of "leakage" or an unintended path to ground (ground fault) through a high-resistance medium (moisture, dirt, etc.).
 - Low level or intermittent faults may not cause a fuse or circuit breaker to open. Under these conditions, sufficient heat generated can cause ignition.
 - The arcing must occur in the area of origin of the fire with suitable combustibles present. Example: The hot particles scattered by an arc could ignite newspapers or the paper backing on wall insulation, but are less likely to ignite framing lumber or wood flooring.
 - Arcing must be of sufficient duration to ignite the suspected combustibles.
 - All other sources of ignition have been eliminated.

Overheated Connections

Any time one conductor is connected to another conductor, or to the terminal on a piece of equipment, the potential has been created for excessive heat. When a connection is made properly, the materials involved must be compatible, clean, and held with sufficient area of contact to provide a low resistance to the flow of electricity. The amount of heat generated in a proper contact will be very small. In a poorly made or deteriorated connection, normally safe and acceptable current flow over a long period of time in the circuit can cause the connection to become hot enough to ignite common combustibles, including the plastic wire insulation or twist-on connector.

NFPA 70, *National Electrical Code*, requires that all connections be enclosed in an approved junction box, cabinet, or terminal box, with covers in place, and unused openings effectively closed. The enclosure requirement serves several purposes: physical protection for the connections, separation of the connections from combustibles, limitation of oxygen and containment of overheated materials should a breakdown occur, and protection of live parts from accidental contact with other conductive materials.

An overheated connection may continue to deteriorate and become an arcing fault, or may ignite adjacent combustibles such as the plastic wire insulation, before it is noticed.

Contacting surfaces in a switch or fuse holder, when they are loose, are a potential source of heating in the same manner as an overheated connection.

Indicators of a fire caused by an overheated electrical connection are

- The suspected electrical parts display indications of localized heating.
- Surfaces of the wires, terminals, or connectors are discolored, pitted, or eroded. In a good installation, these surfaces are protected from fire damage by the enclosure. ..
- Charring is deeper where the electrical enclosure was in contact with combustible supporting surfaces. Normally, an electrical box or piece of equipment will provide a degree of protection (protected area) from an external fire to the surface on which it is mounted.
- Portions or all of a connection are deteriorated while other connections in the same enclosure are intact or display exposure damage only.
- Localized pitting, erosion, or deterioration is observed at the point of origin in normally nonenergized metal parts of the electrical system.

There are two conditions necessary for ignition from overheated electrical connections. First, current must be flowing at or through the suspected connection. This is not always obvious, as an unused receptacle may serve as a connecting point for a downstream load. The connection can be energized, but will not heat until current flows to operate an appliance/fixture, or a current flow is caused by a fault at or downstream from the suspected connector. Second, susceptible combustibles must be exposed to the suspected connections or enclosures.

Overheated Wires

Whenever electric current is flowing on a conductor, heat is generated. The allowable current capacity of a wire is based on several factors: the temperature rating and type of wiring; the type of metal, the diameter of the wire; the number of conductors; and whether they are enclosed or in open air.

If the overcurrent protective devices are not sized properly for the circuit, or are malfunctioning, or defective in some manner, the potential for excessive current exists within the branch circuit.

Indicators of a fire caused by overheated wires are

- Damage to the insulation from internal heating throughout the length of the circuit from the point of overload, or fault, all the way back to the overcurrent protective device. This will occur if the fault draws a significant amount of

current (amps) above the rated capacity of the conductor prior to operation of the overcurrent protective device.

- Indications of internal heating are loose (sleeving), sagging, swollen, or charred insulation along the entire length of the branch circuit. The legitimacy of a fault in this branch circuitry initiating the fire is enhanced greatly if other branch circuits in the immediate vicinity do not exhibit similar damage.
- Defective, tampered-with, modified, or improper fuses or circuit breakers serving the suspected circuit may contribute to the overheating and subsequent failure of the insulation.
- Multiple points of origin which occur along the suspected circuit.
- Charring inside holes where the suspected circuit passes through or comes in contact with wood structural members.

In order to have overheated wire ignition, the following conditions are necessary:

- a flow of current in the suspected conductor;
- an overload or fault condition which allowed excessive current flow; and
- a suitable combustible present at the point of origin.

Effects on *Wires* from Electrical Malfunctions

Whenever arcing occurs on wires, there will be characteristic marks left at the point of arcing. Arc marks can be distinguished from mechanical marks and fire melting. An arc mark is a distinct spot, but there may be multiple arc marks close together. The mark is an area where the metal has been melted. It may be a smooth cavity or a cavity with a projection. Sometimes, the small cavity will be rough with numerous small projections. Next to the arc mark, the surface of the wire will not be melted. However, there may be some splatter of melted metal onto the nearby surface if the wire was bare at the time of the arc. Arcs can leave cavities in wires or they can sever wires. The ends of severed wires may be melted smoothly or beaded.

Arcs are generally similar, whether in copper or aluminum wires. However, arcing in aluminum wire may leave only melted globs of aluminum rather than the characteristics found in copper wire.

Arcing in twisted, copper strand wire, found commonly in lamp cord or extension cords, usually will cause heading, rather than cavities, at the point of separation.

Arcing that occurs within a junction box or other metal enclosure frequently will leave small droplets of metal around the interior of the box.

External Heat Impingement

When external heat impingement on the wire has occurred, fire melting usually can be distinguished from arc marks because the fire affects a wider area. Fire melting of copper wire gives a graduation from light oxidation to distortion of the surface, to blistering, to flow of metal. Under some conditions, the flow of melted copper leaves a smooth surface with thin necks, beads, and a pointed end. This sometimes is referred to as "icicling."

It is characteristic of copper wire to melt on the surface and have an unmelted core. Fire melting of copper wire will be a function of the duration of the fire, the location of the wire, and the protection of the wire.

Caution must be exercised by the investigator, as fire can cause arcing of building electrical wiring. This arcing in the fire can continue to destroy electric wire from the original point of the fire-induced arc back toward the power supply. This arcing may not activate circuit-protecting devices. Again, caution must be exercised as this arcing or melting mistakenly can be taken to be the cause of the fire rather than a consequence of the fire.

Aluminum wiring will behave differently from copper wire during fire melting. Aluminum sometimes will drop off sharply because it melts throughout the entire conductor, instead of having an unmelted core.

Fire can obliterate arc marks, or any other characteristic effects that were present at the start of the fire. Failure to find characteristic marks in fire-melted wires does not necessarily mean that no arcing occurred. This is especially a problem with aluminum wiring because it melts at such a relatively low temperature.

Overheating or Overcurrent Conditions

When a wire is melted by greatly excessive current (overcurrent), it tends to melt all through and along the wire at the same time. When the wire finally separates, current stops and the wire cools. Often, there will be offsets where the wire began to fall apart when the current stopped. This effect can be found in copper, aluminum, or any other kind of wire.

When evidence of overcurrent is found (offsets, sleeving, or heated insulation on nonfire areas), *fuses* or circuit breakers need to be examined. Arc marks may indicate that the circuit was energized prior to and during the fire. Small isolated arcs are not likely to start fires unless a very easily ignitable fuel is present. Massive arcs, such as those that occur in service equipment, easily can ignite fires.

Mechanical marks or gouges in wires usually can be distinguished by shape or by lines of scraping. A wire that is gouged by a nail, saw, or some other means, but is not severed, will not create enough heat to cause a fire at allowable amperage,

assuming that a short or ground fault is not created. (See Appendix for an inspection checklist to use for fires suspected to have an electrical cause.)

Recent Development-Harmonic Imbalance

The most recent development in electrical fire cause is the discovery of an overheating situation created by an electronic phenomenon known as **harmonic imbalance**.

This situation normally will occur in office buildings where electronic office equipment such as computers, facsimile machines, copiers, etc., are used, or where electronic ballast's are used in fluorescent lighting. Another location for fires resulting from harmonic imbalance can be manufacturing plants that use variable-speed, three-phase motors.

Electrical fires seldom start in undamaged, uninterrupted runs of wire. Fires often do start in damaged wires.

What is harmonic imbalance? Most electricity that feeds power to office equipment or small motors is 120-volt service, operating at 60 cycles per second, and is alternating current (AC). Once this current enters the equipment, it passes through a converter that changes the current to direct current (DC). This is done so that the electronic components, such as capacitors, diodes, resistors, etc., within the electronic equipment can operate properly. As we learned earlier, in an AC circuit, current enters the circuit on the "hot" wire and returns on the "neutral" wire. With DC, there is no neutral wire and when the direct current is converted back to alternating current, the excess current causes overheating.

Electric circuits in North America operate on 60 cycles (or megahertz) per second. These cycles form a sine wave that can be observed on a piece of electronic equipment called an oscilloscope. (See Figure 5-5.) If this 60-cycle sine wave remains constant, the harmonics are in balance. The excess current that occurs from the use of modern office equipment gives an erratic sine wave, thus causing a harmonic imbalance. (See Figure 5- 6.)

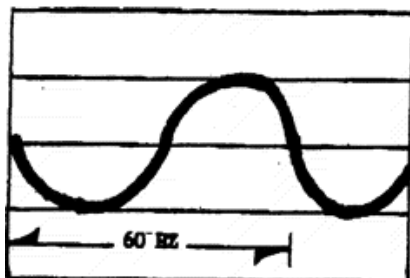

Figure 5-5
Balanced Harmonics

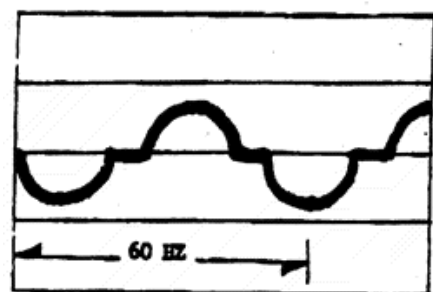

Figure 5-6
Harmonic Imbalance

This harmonic unbalance can cause transformers and/or neutral phase conductors to overheat and create a fire situation if the overcurrent protection devices do not activate.

When a harmonic imbalance occurs with the operation of three-phase, variable-speed electric motors, it can cause the motors to burn out.

If a fire resulting from harmonic imbalance is suspected, ask the following questions.

1. Have there been previous problems with unexplained tripping of circuit breakers?
2. Have there been complaints of "burning or overheating odors"?
3. Have there been recent problems with the equipment itself?

Obtain the assistance of a qualified electrician or electrical engineer to verify your determination. Tools and formulas can verify the fact that a harmonic imbalance has occurred, but it is best to seek the help of a professional to corroborate your findings.

SUMMARY

Major causes of accidental fire include heating equipment, cooking equipment, smoking, flammable/combustible liquids, fuel gases, open flames/sparks, spontaneous heating, low-temperature ignition, lightning, and electrical failure.

Fire cause determination requires identification of the device or equipment involved, the presence of a competent ignition source, the type and form of material first ignited, and the circumstances or actions that brought all factors together.

BIBLIOGRAPHY

Alternative Heater Fires: A Critical Review of Safety Issues. Emmitsburg: United States Fire Administration, 1987.

Brannigan, Francis, ed. *Fire Investigation Handbook.* Washington: National Bureau of Standards, 1980.

DeHaan, John D. *Kirk ' Fire Investigation*, 3rd ed. New Jersey: Brady, 1991

Final Report on the Portable Heater Project. Washington: U.S. Consumer Product Safety Commission, 1987.

Fire Protection Handbook. 17th ed. Quincy: National Fire Protection Association, 1991.

Hansen, Arthur H. "Lightning." Unpublished paper.

Kaufinan, John, ed. *IES Lighting Handbook*. New York: Illuminating Engineering Society, 1972.

Kerosene Heaters, Project Status Report and Recommendations. Washington: U.S. Consumer Product Safety Commission.

Lemoff, Theodore C., ed. *National Fuel Gas Code Handbook*. Quincy: National Fire Protection Association, 1987

Monroe, Gwendolyn, and John Wuepper. "Spontaneous Combustion of Vegetable Oils on Fabrics." *Appliance Engineer*, Oct. 1992

NFPA 70, *National Electrical Code**. Quincy: National Fire Protection Association, 1993.

NFP' A 491M, *Manual of Hazardous Chemical Reactions*. 1991 ed. Quincy: National Fire Protection Association

Indicators of Incendiarism

INTRODUCTION

Methods used to produce incendiary fires are limited only by the imagination of the firesetter. The investigator must understand how incendiary fires are set (started) so that an investigation will produce the necessary evidence of incendiarism. The use of flammable accelerants is common with incendiary fires, and the investigator must be aware of the various indicators available to identify the use of such materials.

INDICATORS OF INCENDIARISM

Following is a list of indicators of possible incendiarism that will be covered in this unit. This list should not be considered inclusive **of all** the indicators of incendiary fire causes. Also, there may be times when any of these indicators may be present in an accidental fire.

- absence of all accidental fire causes;
- multiple fires;
- trailers;

- presence of liquid accelerants;
- use of common equipment and/or appliances;
- structural damage prior to the fire;
- removal or substitution of contents prior to the fire;
- major appliances removed prior to fire;
- absence of personal items or important papers;
- location of the fire;
- evidence of other crimes in the structure;
- unnatural fire spread, excessive damage, and/or extreme heat;
- limited entry or view;
- injuries to occupants;
- time between exit of occupant and fire;
- previous fires in same structure;
- presence of fuel near the point of origin;
- fires on holidays or weekends at commercial/industrial complexes;
- time of day;
- convenient heat source;
- fires during renovations/remodeling;
- fires during electrical storms or bad weather;
- activities of owners/occupants; and
- statements by owners or occupants.

ELIMINATE ACCIDENTAL CAUSES (NEGATIVE *CORPUS DELICTI*)

Prior to determining any fire to be incendiary, all other causes for that fire must be eliminated. *Corpus delicti* is the "body" upon which a crime has been committed; e.g., the charred remains of a house which burned due to the criminal act of arson. Negative *corpus delicti* means burning has occurred, but as a result of an accidental cause or causes.

Even though the fire may be remote from such appliances as the electric distribution panel, water heater, or furnace, each of these appliances must be examined and eliminated as a possible fire cause. (Photographs will verify this in later court proceedings.) Very detailed notes are required indicating that all internal systems were examined and eliminated as a fire cause. This will also help to support evidence of incendiarism. Due to the lack of expertise on the part of both the judge and jury, it may be difficult to prove incendiarism to the satisfaction of the court unless you can show you have eliminated all accidental causes.

MULTIPLE FIRES

If, during the course of conducting a fire scene examination, the fire investigator discovers more than one point of origin, it must be proved that each fire is independent of the other(s) (i.e., not caused by communication of the first fire to other areas and fuels).

The investigator must establish that these multiple fires are separate and unconnected, and that no accidental or natural cause could produce separate fires. In nearly all such cases, establishing the *corpus delicti* is quite simple. The investigator should be prepared to explain why these multiple fires could not have been caused by such things as heat transfer (i.e., radiation, conduction, and/or convection), burning fuels dropping to start secondary fires, overhaul, or flashover. The investigator should check for trailers when examining a fire scene with multiple unconnected fires.

TRAILERS

The working definition of a trailer is "any combustible or flammable material used to spread fire from one point or area to another."

Trailers usually leave char or bum patterns on surfaces where used, such as floors, carpets, steps, or through doors, windows, or wall openings (may be existing openings or openings made for fire spread).

Class "A" trailers are ordinary combustible materials that will leave an ash or glowing residue. These trailers usually leave a surface burn on the overlay on which they are used.

Some of the common materials used as Class "A" trailers are newspapers (flat, rolled, or "bunched"); rope, string, twine, etc.; fuse cord, which may produce "skip" char pattern or may leave an asphalt-like residue; clothing, bedclothes, drapes, or other household materials; waxed paper or tissue paper; and fabric softener sheets. Occasionally, although rare, building contents may be arranged to form a trailer. These often are used with incendiary devices such as candles.

Class "B" trailers are flammable/combustible liquids. The liquids, when used as trailers, soak into any type of porous overlay. When they burn, they usually leave a deep-seated bum or blisters if used on tile or linoleum overlay.

Some common Class "B" hydrocarbon liquids used as trailers are gasoline, kerosene, lighter fluid, turpentine, or any other common or readily available liquid accelerant fuel.

Ketones and alcohol are the most common Class "B" nonhydrocarbon liquids used as trailers.

PRESENCE OF LIQUID ACCELERANTS

When accelerants are found in areas where they would not be in a given occupancy normally, the investigator must determine the reason for their presence. Once it can be established that the presence of these accelerants was not caused by the actions of the owner/occupant, the investigator can proceed with the

investigation using this information as an indicator that the accelerants were introduced by another person, and that this fire may be of incendiary origin.

Probable Cause

Liquid accelerants may be common in some occupancies or in certain areas within the occupancy, such as garages, basements, storerooms, or storage sheds.

When the presence of accelerants is detected in a fire, some indicators of incendiarism are

The accelerant is found throughout an area and was not spread by explosion or due to container leakage.

The accelerant is found above the floor area and was not spread by an explosion.

The accelerant is found on or in furniture, drawers, cabinets, boxes, files, desks, books, etc.

Properties of Accelerants

Almost all commonly used liquid accelerants tend to form flammable/explosive vapors at room temperature. Ignition of a given accelerant vapor requires that the vapor be within its flammable/explosive range at the point it encounters an ignition source, and at or above its ignition temperature. Hydrocarbon liquid accelerants do not ignite spontaneously.

Many commonly used hydrocarbon liquid accelerant vapors are heavier than air and tend to flow downward into stairwells, cellars, drains, crevices, and cracks. These liquids also are lighter than water, immiscible, and display a "rainbow" coloration when floating on water. The "rainbow" coloration can also be the result of other hydrocarbon residue (e.g., carpet, carpet padding, plastics, etc.). Certain other liquid accelerants (e.g., alcohol's, acetone, and polar solvents) are water soluble.

Liquid accelerants have a tendency to flow down grade and form pools or puddles in low areas. Many of these liquids are absorbed readily by structural materials and natural or synthetic substances. They are also powerful solvents that tend to dissolve or stain many floor surfaces, finishes, and adhesives.

When a liquid accelerant is poured on a floor and ignited, two things take place. First, many types of synthetic surfaces (e.g., vinyl) or surface treatments will mollify (soften) beneath the liquid. Second, at the edge of the pool, burning vapor adjacent to the liquid will cause many floor surfaces to char while certain others (such as vinyl) melt, then char. As the liquid boils off, its edge recedes. Floor surface charring (or melting and charring) follows the receding liquid edge. The

floor area under the liquid accelerant is protected from the burning until the liquid boils off that section.

Experiments indicate that the greatest temperatures in a liquid accelerant fire occur above the center of the burning liquid pool. Maximum concentrations of accelerant residues are found at the edges of the burn pattern, and minimum concentrations toward the center. Some arson investigators believe this is controversial and take samples from both the edge and the center.

Accelerants with high vapor pressure like alcohol or acetone tend to "flash and scorch" a surface, whereas accelerants with higher boiling components like gasoline tend to "wick, melt, and burn" leaving stronger patterns. The amount of ventilation available to the fire is a factor in burn pattern appearance.

Common Indicators

There are some common indicators which may assist the investigator in determining the presence (or use) of a liquid accelerant (fuel).

Charring of Floor Surfaces

Most accidental structural fires may produce very little floor charring, since temperatures at floor level usually are below ignition temperature in most fires. There may be charring to flooring which is the result of postflashover. "V" burns or grooves between floorboards may indicate the presence of a liquid fuel. Liquid accelerants may soak between floorboards, burn, and develop small, sharp "V" patterns between edges of the floorboards.

Liquid Accelerants

Liquid accelerant fires are associated with an area of origin, instead of a point of origin. This is because the liquid flows outward away from the point at which it is poured. The arsonist usually pours this liquid over a large area, splashing it or trailing it throughout the room or structure.

If the investigator finds traces of a liquid accelerant in a structure, he/she must determine if its presence is normal for that location and that occupancy. Obviously, the presence of gasoline on a mattress in a dwelling house is highly suspicious. With such evidence, the investigator will probably have little trouble establishing a *corpus delicti* of arson in court. On the other hand, evidence of gasoline found at a fire involving an automobile repair garage might pose serious problems in court. The presence of a liquid accelerant at the scene of a fire, nevertheless, is a strong indication that the fire was of incendiary origin.

Even in the absence of an incendiary device, the crime of arson can be proven in the absence of **all** logically possible accidental and natural causes at the point of

origin. This is called *negative corpus*, since a complete positive corpus for the crime of arson includes the proof of burning, proof of incendiary cause, and the proof of absence of natural and accidental causes.

If the investigator finds evidence of extensive floor damage with an irregular shape, he/she should view it with suspicion and should look further for possible evidence of an accelerant. A dramatic line of demarcation between burned and unburned flooring is an excellent sign of the use of a liquid accelerant.

Because a liquid accelerant will settle to the lowest level of a floor, its presence often can be detected in such locations as the corners of a room or along the base of a wall. Often the investigator will find the evidence he/she is looking for by removing the baseboard) quarter round, or tacked carpet strip, since the liquid accelerant may run under those items and become trapped.

Low Levels of Charring

Another indication that a liquid accelerant may have been used is evidence of very low charring at the base of a wall or at the base of furniture items. Because an accelerant will burn at floor level, the investigator may observe charring of such things as table legs and baseboards at a lower level than normally would be expected following an accidental fire. Examination of the underside of low furniture items will prove valuable. One would not expect an accidental fire to char the undersides of coffee tables or night stands. If that condition is found, it indicates that a liquid accelerant may have flowed under the piece of furniture, with flames burning it from below. The investigator should examine the bottom edge of a door for charring. During an accidental fire, charring of this area would be extremely unusual. Finding charring in this location should alert the investigator to take steps to search for evidence of an accelerant. Hydrocarbon liquids have a greater ability to penetrate than does water. They may seep into areas that water cannot

Liquid accelerants tend to soak between floorboards before burning. Where this occurs, there may be dark charring along the line of the cracks or joints of the floorboards. This can result in the burning away of some wood along the joints of the floorings. *The* burning will appear as a dark "V" or groove.

Many times, a liquid accelerant will soak into the wood flooring itself, causing holes to burn through the floor. If this occurs, the investigator may have to prove that the flooring burned from above and not from below. A fire which has burned through a piece of wood will normally leave a beveled edge around the hole. This bevel will usually be on the same side of the wood as the fire. A hole burned through wood flooring from above should reveal a slight bevel slanting downward and inward toward the hole. The underside of flooring which has burned through should appear relatively clean of any charring around the hole.

Liquid accelerants may run through the flooring and burn under it. Evidence of the liquid accelerant may be trapped between the floor and the subfloor. Soil samples

taken from that area should be examined. Often, soil will retain traces of a liquid accelerant for many days. When a liquid accelerant runs through flooring and burns, it frequently leaves an unusual burn pattern on the sides of the floor joists, similar to a "lace curtain." This unusual burn pattern on the sides of the joists is caused by the liquid accelerant burning downward. On concrete or cement floors, evidence of an accelerant may appear in the form of an irregular pattern of various shades of gray to black. Often, it will have a blotchy appearance due to the uneven soot and hydrocarbon residue remaining.

Liquid accelerates may soak into any absorbent material, such as carpet, floor-length drapes, and plaster walls.

An area may have to be cleared of debris before a liquid accelerant pattern is discovered. When sweeping or rinsing the floor, be careful not to destroy the evidence underneath. Pouring water onto the floor may indicate the direction of settling or running of the accelerant.

Spalling of Concrete or Masonry

As discussed in Unit 4: Determining the Point of Origin, the spalling of concrete or masonry floors may indicate the presence of a liquid accelerant. Spalling is the result of the concrete reaching a sufficiently high temperature and then being cooled rapidly by water. This causes the surface to crack and loosen and produce a pitted appearance. Some investigators look upon the spalling of concrete as a strong indication that a liquid accelerant has been distributed on the surface and burned. But spalling also can be produced by a fire set in ordinary combustibles.

Spalling of the concrete should be considered only as a **possible** indicator of an accelerant's presence. Spalling also may consist of larger craters in the concrete which may be mistaken for the results of explosives. Spalling also is caused by the boiling and rapid evaporation of the moisture found in most concrete.

Other actors that may cause spalling include the age of the concrete, concrete mixture, chemical reaction mechanical breaks, extreme cold or extreme heat; and fall down of heavy objects. If in doubt, take samples from the spalled area and have them analyzed for accelerant presence. (See Unit 11: Collection and Preservation of Evidence, for a detailed discussion of evidence collection related to concrete.)

Floor Coverings

A floor covered by asphalt or vinyl tiles also may reveal an irregular burn pattern and discoloration similar to that observed on cement. Tiles may be blistered. These are good indicators that a flammable liquid may have been distributed on the surface. Attempting to recover trapped accelerant residue from beneath the tiles can be frustrating because usually the adhesive used to secure the tiles also has a petroleum base. Often, the investigator will have to sweep a floor clean of

all fire debris and even rinse the floor with water before he/she can examine it properly. If floor asphalt or vinyl tiles are submitted for laboratory examination, a comparison sample also must be submitted.

Liquid accelerants will cause blistering and/or destruction of floor tiles or linoleum floor coverings. This type of floor covering may indicate flow patterns and should be examined closely.

Localized "gapping" of vinyl floor seams within *the* pour or burn pattern may be caused by a liquid accelerant burning inside the seam. "Ghost marks" also may occur between the seams of floor tiles in the pour area where an accelerant seeped, dissolving the tile adhesive and resulting in a checkerboard pattern on the subfloor.

The burning of the liquid and adhesive tends to curl the edges of the tile upward and may result in a deeper char burn between the seams on flooring or heavy discoloration of the area compared to surrounding areas. The curling of edges may be caused by normal shrinkage from loss of flexibility caused by *Hoe* nature of floor tiles and fire conditions.

Building Contents

Liquid accelerants may produce unusual burning of contents and/or building components. Charring on the bottom surface of doors often indicates of liquid accelerants at floor level. However, when a door is closed and the fire is developed fully, hot gases may extend to the floor. These gases may escape under the door and cause charring on the underside of the door. Burning of the floor surface along its edge or at contact with walls may be due to the presence of liquid accelerants. Corners and wall-to-floor edges may be dead air spaces, which suffer little, if any, fire damage unless liquid accelerants are present. The liquid accelerants may carry flame behind baseboards or molding. Moldings should be removed and the backside examined. If fire damage is observed on the protected area of the wall or on the backside of the baseboard or molding, there is a strong possibility that a liquid accelerant was present.

The charring of the undersides of furniture usually indicates that the fire burned at some level below the surface being examined (i.e., the fire was burning below the furniture). This may be due to the use of a liquid accelerant. There may be other possible causes of charring of the underside of furniture such as drop down, melting, burning foam, etc.

Flashover

As discussed in Unit 2: Chemistry and Physics of Fire Behavior, the effect of flashover is another phenomenon that the investigator must consider. Flashover is caused by hot smoke and gases from a fire rising to ceiling level and then burning rapidly upon reaching ignition temperature. The heat radiated downward from this

flashover causes horizontal surfaces such as floors, table tops, and beds to char or singe. The effect that this radiated heat has on a floor, for example, is similar to the effect of an accelerant. Two important differences exist. Flashover produces an even or uniform burn on exposed surfaces as opposed to the uneven burn associated with an accelerant. Also, an accelerant would be expected to run down a vertical surface and produce a unique burn pattern, but the damage resulting from flashover usually will be limited to horizontal planes.

Another effect of flashover is to ignite curtains, drapes, and other common combustibles, causing them to drop from their rods and hooks. Such items burning on the floor or on furniture may give the appearance of multiple set fires.

In recent years, many commercial buildings have been constructed with panelized roofs. Frequently, these roofs have insulation attached to the underside of plywood sheathing. Flashover occurring inside buildings with this type of roof can cause insulating material to ignite and drop to the floor. This also might result in the appearance of multiple points of origin. Almost always evidence of drop down will be found.

Char Pattern

The burning of combustible building components (wood) produces char in a broken pattern. As discussed in Unit 4, depth of char will depend on such factors as the rate and duration of heating, ventilation effects, surface area-to-mass ratio, size of wood grain, species of wood, moisture content, surface coating, etc.

A large rolling char pattern simply may be the result of a very fast-moving hot fire or, it may be the result of the burning of liquid accelerants. This type of char is identified by very large blisters with deep cracks between the blisters. The cracks between the blisters sometimes are referred to as dehydration cracks, and they develop as the fuel is exposed to heat.

Consider whether the material was exposed to flame in the early or late stages of the fire's growth. Materials that were involved after the fire vented itself may develop large char naturally.

Burning in a "downward" direction may be considered unnatural. Liquid accelerants may have run and carried flames downward. Liquid accelerants may soak into floors and cause holes to be burned through the flooring. Holes produced by liquid accelerants on floor surfaces often are shaped irregularly, and may even follow the direction of flooring joints.

Splash Patterns on Walls

Arsonists frequently throw or splash accelerants on a wall prior to ignition. This liquid will run downward and, when ignited, will leave a distinctive pattern often referred to as "fingering." Liquid accelerant poured at the base of the wall, and

then burned usually will leave an inverted "V" pattern on the wall after being extinguished, because of the vertical flame plume of the burning volatile fuels not reaching the ceiling. This pattern is caused by the liquid flowing outward along the base of the wall and then burning very rapidly, so that oxygen is drawn into the flames with such velocity that a chimney effect is produced.

Containers

The discovery of liquid accelerant containers in or around the fire may be a good indicator that a flammable accelerant is present. Liquid containers should be retained as evidence for laboratory analysis comparison samples. If the container is not damaged, it may help to prove that accelerant spread was not due to explosion. In addition, latent fingerprints possibly can be obtained from the container. Have qualified persons attempt to obtain the fingerprints. If plastic containers were used to carry the accelerant into the scene, they may be melted or totally consumed in the ensuing fire. They may still contain residue. Do not cut, break, or crush the container; this could result in the accelerant or vapor residue being lost.

Flashback

Firefighters are the first professional observers at a fire scene. Their observation of smoke and flame color is more valuable than that of the average person. Firefighters may have observed flashback during operations to extinguish fires, which should be considered as strong evidence of the presence of an accelerant. Flashback occurs when gas or vapor from a fuel reignites and flashes back over the fuel surface.

Odors

Liquid accelerant odors also may have been detected by firefighters. Odors often remain after extinguishment, and may have been detected during overhaul operations.

Evidence

Residue (evidence) should be collected as soon as possible. Many liquid accelerants evaporate rapidly, and any delay may result in loss of opportunity for collecting positive samples. Liquid accelerants may leave an oily surface on water or contents. Look for this and obtain samples from it. Residue of liquid accelerants may be detectable by the use of ultraviolet light, which may aid in identifying locations where samples should be obtained.

A hydrocarbon detector may assist the investigator in detecting residue of liquid accelerants. This instrument measures vapors of accelerant residue in parts per

million and is used to assist the investigator in determining the presence and/or location of an accelerant. A vapor detector will not identify the liquid accelerant, and its findings should never be testified to in a court of law. This instrument is merely a "tool of the trade."

Accelerant detection canine teams also may be used to detect accelerant residue. The investigator should confer with the handler for best results and always should advise the crime lab that a *dog* assisted in locating evidence. (See Unit 11 for a detailed discussion of evidence collection.)

COMMON EQUIPMENT OR APPLIANCES AS INCENDIARY FIRE CAUSES

Frequently common household, commercial, and/or industrial equipment or appliances are used as incendiary devices. Some examples of these are discussed below.

Heating Equipment

Space heaters, wood-burning stoves, fireplaces, furnaces, water heaters, etc., can serve as incendiary devices. Investigative examination should include checking the control settings. Make sure the appliance was turned on, plugged in, or operating at the time of the fire. Look for tool marks on the fuel lines or evidence of tampering with fuel supply lines, wiring, etc.

Cooking Equipment

Toasters, coffeemakers, toaster ovens, etc., should be examined. How many fires are caused by a pan of oil/grease left on the stove? Were they accidental? Examine appliances for evidence of tampering, such as removing the bimetal strip or the fusible link.

Lighting Equipment

Look for clothes draped over lamps, or high-intensity lamps. Check for tampering with the lamps. Be sure to examine the entire branch circuit. Look for evidence of lighting equipment in unnatural places, *sod* check for evidence of combustible fuel having been arranged nearby.

Small Appliances or Equipment

Irons, hair dryers, curling irons, etc., are all possible incendiary devices. Determine whether the appliance or equipment is being used in an unnatural

location or during an unusual time. Examine the appliance or equipment for tampering or modification.

Cigarettes

Cigarettes may be used as a time-delay device. When cigarettes are used as an ignition device, it is often difficult to prove intent.

STRUCTURAL DAMAGE PRIOR TO FIRE

Check for holes in walls, floors, or ceilings made to allow the fire to spread into other structural areas or from one area to another. Keep in mind that such damage could be accidental or simply poor upkeep of the building. Also, make sure the damage was not the result of overhaul or fire suppression activity.

REMOVAL OR SUBSTITUTION OF CONTENTS PRIOR TO FIRE

Removal of Contents

Expensive objects, antiques, or objects with sentimental value may be removed prior to an arsonist setting a fire. Some examples to look for are

- wedding or family photo albums;
- coin or stamp collections;
- jewelry;
- rifles and/or handguns;
- paintings or other art objects;
- tools;
- sports memorabilia (baseball cards, hockey sticks, etc.); and
- televisions, VCR's, CD players, etc.

An inventory of remaining contents may indicate missing items when compared to the proof-of-loss statement. Interview neighbors who may have noticed removal of contents. Neighbors also may be able to state that objects are missing.

Substitution of Contents

Prior to a fire the owner may remove usable contents or major cost items and replace them with junk furnishings. An arsonist hopes the investigator will not be able to identify quality of contents, or thinks there will be total destruction by the fire that will cover the switch. Again, neighbors may have witnessed the exchange of contents or the presence of a truck or trailer. The source of junk contents may be identified by checking used furniture stores. Goodwill stores, and Salvation Army stores.

When high-ticket items are replaced by substitute items, certain telltale signs may be present.

- Substitute appliances may not be connected to power outlets or fuel lines.
- Substitute appliances may be empty, in bad repair, or in poor condition.
- Substitute appliances may not fit area of installation.

Examine the floor or cabinet cutout area for indications that the unit does not fit. Check for indentations of leveling screws or leg buttons in the floor covering. Check and record model and serial numbers for comparison with manufacturer or with insurance proof of loss for ownership.

Contents Out of Place or Not Assembled

The owner/occupant may stack or pile combustible contents to provide fuel for the fire. Used or junk furniture may be brought into the structure, but left unassembled.

Locking plates from beds should show locking surfaces clear of smoke stains and/or heat damage if the units were assembled at the time of the fire-. Drawers in the closed position usually burn late in the fire. Evidence of empty storage containers, such as boxes, drawers, etc., are unusual and suspicious.

Again, the arsonist believes evidence will be destroyed in the fire. However, if the investigator is thorough enough, the evidence usually can be located.

ABSENCE OF PERSONAL ITEMS OR IMPORTANT PAPERS

Most homes and businesses contain personal items. Absence of personal items may indicate that only basic contents were left to burn.

Examples of personal items which frequently are removed prior to a set fire in business, commercial, or industrial occupancies include handtools, portable power tools, work clothing (uniforms), business machines (typewriter, checkwriter, calculators, etc.), guns, or petty cash.

In residential occupancies, items that may be removed include expensive clothing, jewelry, family photographs, family records (birth certificates, family Bible, etc.), hobby equipment, guns, fishing or other sports equipment, tools, or handcrafted items.

Important papers frequently removed prior to a set fire are checking and/or savings account books, titles and deeds, school records, wills, marriage and church records, and insurance policies. Some people continue to believe that it is necessary to have their copy of an insurance policy in order to collect on that policy.

ADDITIONAL INDICATORS

Location of the Fire

A fire in an unusual location should arouse the investigator' s suspicions. Unusual locations are areas with no identifiable heat source. Fires in bathrooms, closets, crawl spaces, or under porches are all considered unusual.

Evidence of Other Crimes

A fire may have been set to cover other crimes such as murder, burglary, embezzlement, tax fraud, etc. Keep in mind that another crime could have been staged to help explain the set fire. This is a situation where the owner/occupant must be investigated thoroughly.

Unnatural Fire Spread, Excessive Damage, and/or Extreme Heat

Unnatural fire spread may be due to the presence of some accelerant. What appears to be unnatural fire spread by itself proves nothing, but such situations should cause the investigator to conduct an extensive scene examination. Questions that the investigator should ask are

- Was the fire damage increased due to the presence of some accelerant?
- Was the fire damage excessive as compared to similar fires in similar occupancies?

The answer to this question will require extensive scene examination.

Evidence of extreme heat may be unnatural and may be due to an accelerant. Structural fires may produce extreme temperatures (up to or above 2,000°F (1,093.3°C)). These temperatures usually are attained during the later stages of the fire or when the structure is fully involved. During the earlier stages of the fire, and at the lower levels within the structure, temperatures may not exceed 1,500°F (815°C) to 1,600T (871.1°C).

Metals

The melting of metals within the structure may indicate an extremely hot fire. A list of metals and their approximate melting temperatures is found in Unit 4.

Consider the following:

- The discovery of an aluminum storm window frame which melted during the fire might not indicate excessive heat if the fire vented through that window opening. Additionally, since the upper portion of the window frame

extends into the upper portion of the involved room, one could expect the aluminum frame to melt.

- Finding the aluminum threshold of a doorway melted could indicate excessive heat, since the floor surface generally stays much cooler than the upper portions of an involved room.

Occasionally chromium or other shiny metal surfaces may become discolored due to exposure to extreme heat. After the fire, these surfaces may retain this discoloration as an indicator of the presence of extreme heat. Take into consideration the extent to which an object has been affected and the level (height) at which the object was located.

The following list is simply a guideline and **should not** be used as a definitive guide in attempting to determine actual temperatures.

Limited Entry or View

Firefighters have encountered attempts by the arsonist to block access to the fire scene, or to block entry to a structure. (The investigator must be able to prove that the blocking was done prior to the fire in order to slow entry or extinguishment) A few of the arsonist's tricks are

- removing door hardware (handles or knobs);
- doors and/or windows nailed, bolted, wired shut; and
- moving contents to block doors and/or windows.

Occasionally the view into the structure will be blocked or obscured to delay detection of the fire. Windows will be covered with paper or window cleaning wax, or boxes will be stacked in front of windows.

Injuries

Sometimes the flash of flammable vapors from accelerants being spread through a structure will cause burn injuries to the arsonist. The injuries may involve only the arms, hands, and/or face, and at times the injuries *may* be severe. While interviewing the owners/occupants, examine them for indications of singeing of eyebrows, facial hair, or hair on their head or arms and hands. Look for reddening of the face, arms, or hands, similar to first-degree burns. Be sure to verify their story of how they sustained the injury.

Time Between EXIT of Occupant and Fire

As part of the investigation, ascertain the time period between when the last occupant was present in the structure or at the scene and time of the fire's discovery. One question should be addressed during the examination of any fire

scene: "Are the time factors in this incident reasonable, appropriate, or believable?"

Previous Fires in Same Structure

A second fire in the same structure over a short period of time may indicate incendiarism. This is not an absolute, as people may experience more than one accidental fire in their lifetime. However, the circumstances of each previous fire should become a part of the investigation. The first fire may have been an unsuccessful arson attempt, or even may not have been reported. The second fire may involve large quantities of liquid accelerants and/or may result in injuries to the firesetter. The occupant may have obtained "junk" furnishings to fill the structure. Such furnishings may be damaged, obsolete, or even fire damaged. The occupant believes the fire will destroy such evidence.

Presence of Fuel Near the Point of Origin

Readily available kindling fuels such as newspapers may be placed at or near the point of origin. Questioning of the owner/occupant should address the reasons for such fuel placement. Interviews with other family members or neighbors may assist in confirming that these fuels were always in that location, or that this was an isolated incident.

Fires on Holidays or Weekends at Commercial/Industrial Complexes

Commercial or industrial complex fires that occur during holidays or on weekends may be an indicator of incendiarism. Holiday and/or weekend fires provide the arsonist the necessary setup time while the workers are away, also lessening the chances of injury to any employees. In addition, fires during these times help provide an alibi for the arsonist, who may claim he/she was out of town. There will be fewer witnesses in the area, which provides a delayed detection and longer burn time.

Time of Day

Determine if the fire cause and/or the occupant's explanation of the fire fits with the time of the fire.

- Kitchen fires (e.g., food on the stove) at odd times may (or may not) be an indication of incendiarism.
- Sofa fire (cigarette dropped into a sofa) during daytime hours also may be incendiarism. Sofa or furniture fires caused by cigarettes often are discovered early in fire's progress if occupants are in the area

Convenient Heat Source

Many times appliances which have a history of causing fires are used as an invented fire cause in an attempt to cover incendiarism. Remember, the possibility of an accidental fire does exist. Examine the appliance for evidence of tampering; also check for indicators of a flammable liquid introduced to the area.

Fires During Renovations/Remodeling

Accidental fires do occur due to various situations associated with renovations and/or remodeling. Causes of an accidental fire during renovation or remodeling are poor housekeeping, temporary electrical wiring, or the presence of flammable liquids. Incendiary fires may occur when the owner of the structure decides to sell the property to the insurance company because the structure was in worse condition than originally believed, the would-be renovator found the job to be too much for him/her, or money ran out before the job was completed.

Fires During Electrical Storms or Bad Weather

The arsonist may believe lightning is a convenient "cover" for the set fire. A telephone call to the local Weather Bureau either will confirm or eliminate this possibility. Talk with other residents of the area to verify that an electrical storm occurred.

Snow or ice storms will delay fire department response, allowing longer burn time for the fire and causing increased damage or total destruction.

Activities of Owners/Occupants

Witnesses or neighbors may report conditions or activities by the owner/occupant which may indicate possible incendiarism. Always canvass the neighborhood. Interviews conducted may bring forth information on fights or arguments in the neighborhood or between members of the occupant family. A truck or other vehicle may have been seen at the involved property prior to the fire, or the owner/occupant may have been observed removing items prior to the fire.

Statement by Owners or Occupants

While interviewing the owner/occupant, be aware of statements about economic conditions or the neighborhood declining. Be aware of remarks about domestic *or* marital problems or pending separation/divorce proceedings. One spouse may not want the other to gain possession of the house. Neighbor problems may be a motive for the fire if the property will not sell, but the owner/occupant feels he/she

no longer can reside by "bickering" neighbors. (Sec Unit 15: Interviews and Interrogations.)

SUMMARY

Incendiary fires are set or started with the intention of destroying. The methods used are limited only by the imagination of the firesetter.

To prove incendiarism, the fire investigator must eliminate all other fire causes. This often is used to support evidence of incendiarism with other evidence.

As we have learned, there are other indicators of incendiarism besides trailers, multiple fires, or the use of flammable accelerants. Often evidence associated with an incendiary fire is recovered at the fire scene. One indicator is not sufficient. Take all available indicators into consideration.

BIBLIOGRAPHY

Bates, Edward B. *Elements of Fire and Arson Investigation*. Santa Cruz: Davis Publishing Co., Inc.

Carroll, John R. *Physical and Technical Aspects of Fire and Arson Investigation*. Springfield: Charles C. Thomas Publisher.

Carter, Robert E. *Arson Investigation*. Encino: Glencoe Publishing Company. 1978.

DeHaan, John D. *Kirk's Fire Investigation*, 3rd ed. New Jersey: Brady, A Prentice-Hall Division, 1991.

Factory Mutual Engineering Corporation. *A Pocket Guide to Arson Investigation*, 2nd ed. Norwood: 1979.

National Fire Protection Association. NFPA 921, *Guide for Fire and Explosion Investigations*. 1992 ed. Quincy.

ACTIVITY SHEETS

Activity 6.1

Fire Cause Determination

Purpose

To determine probable fire cause based on available information.

Directions

1. Individually, read the two fire scenarios. Based on your personal experience and the material covered thus far in class, determine whether the probable fire cause was accidental, natural, incendiary, or undetermined.
2. As a group, discuss and reach an agreement on how to complete the worksheet provided for each scenario.

Scenario 1 -Hospital Fire

This modern hospital was constructed of noncombustible materials. Fire protection was provided by a partial sprinkler system in storage areas, hose standpipes, and portable fire extinguishers. A central fire alarm system was connected to the fire department.

The X-ray department had five X-ray units located in separate rooms. The electrical controls for the unit involved in the fire were located in a closet having a floor area of 8 feet by 2 feet and a ceiling height of 8 feet. The closet was constructed of 3/8-inch gypsum board on steel studs with a suspended ceiling of mineral-treated tile. The control panel, a molded case circuit breaker, two transformers, and associated wiring were located in the room.

Just after 8 a.m., an attendant brought a patient into the X-ray room. The attendant noticed smoke coming from the closet that housed the electrical equipment. The attendant removed the patient from the room and sounded the fire alarm. Hospital personnel found the area of the closet rapidly becoming involved. They attacked the fire with portable extinguishers and put it out. The fire department also responded to the alarm, but the fire was extinguished before firefighters arrived. Three 5-pound carbon dioxide extinguishers and ten 5-pound dry chemical extinguishers were used to fight the fire. Power to the electrical equipment was disconnected by hospital personnel during the fire.

Examination of the electrical controls revealed wire with a lacquered appearance and bare of insulation. There was no discoloration of the electrical fuses. Two boxes of computer paper were stacked in the closet. The uppermost box showed surface char 1 inch deep. The remaining contents of this box were scorched on the edges near the closet door, and the front surfaces of both boxes were burned.

All of the X-ray unit' s control equipment and wiring was moderately damaged; there was moderate damage to the room.

Scenario 2-Junior High School Fire

The fire occurred in a junior high school of masonry construction with steel joist framing for the floors and roof. A partial sprinkler system had been installed in the

auditorium area of the building. There were no automatic smoke detection systems.

The fire occurred at approximately 4:30 p.m. Classes were not in session, but a gymnastic field day was being held on the school grounds. A staff member discovered fire in a stack of plastic chairs in a corner of the cafeteria. He attempted to fight the fire, but it spread rapidly, moving to nearby chairs and the particle board in the plastic laminated tables. The staff member retreated to call the fire department. Flames leapt from the stacked chairs, burning through the ceiling and into the library above.

Four firefighters were injured during the fire. Loss was estimated at \$300,000. After the fire was extinguished, the fire officer examined the point of origin and found evidence of melted, napalm-like plastic. The most severe burns were on the floor where the chairs were stacked.

The principal and staff interviewed reported consistent petty vandalism by a suspect group in school over the past 6 months and an incident in which a group of students from a rival school sprayed windows of the main office with black paint. This event had occurred 3 days before and was attributed to field day rivalry.

BIBLIOGRAPHY

NFPA 907M, *Manual on the Investigation of Fires of Electrical Origin*. Quincy: National Fire Protection Association, 1983.

NFF' A 921, *Guide for Fire and Explosion Investigations*. 1992 ed. Quincy: National Fire Protection Association.

Weintraub, Lairy and Luis M. Jiminez. "Open Electrical Neutral Hazards." *Fire and Arson Investigator*, Dec. 1993.

Wolthers, F.C. *Studies of Self-Ignition in Kingsford Charcoal Briquets and Match Light Charcoal Briquets*. California: Clorox Technical Center, 1988.

Yereance, Robert A. *Electrical Fire Analysis*. Illinois: Charles C. Thomas, 1987.

Incendiary Devices, Explosions, and Explosives

INTRODUCTION

Since a fire scene investigator may come in contact with incendiary devices or explosives in day-to-day scene investigation, he/she must know what materials

commonly are used to produce incendiary devices, how they are constructed, and what evidence is likely to remain in a fire scene.

When a fire has been started by one of several incendiary devices, it may be that some of these devices could operate some hours after the others. Scene safety is important at any postfire or postblast scene investigation, since investigators may not be fully aware of the hazards to which they are subjecting themselves.

It is important for the investigator to determine which parts of the structure are safe and which are not. It is better to delay the investigation than to endanger lives by venturing into a building in imminent danger.

Protective clothing should be worn at all times to ensure the investigator's safety. This should include hardhats, overalls, gloves, footwear, and, at times, self-contained breathing apparatus (SCBA). Overalls are intended to protect clothing in a dirty environment and, if waterproof, to provide weather protection and partial protection against toxic and corrosive chemicals.

Air monitors should be used to monitor air samples to indicate when toxic vapors are present. Investigators should use SCBA's when air samples indicate they are in a toxic atmosphere.

Although the investigator's attention is concentrated on determining origin and cause, it is important always to keep all senses alert to the possibility of danger.

INCENDIARY DEVICES

An incendiary device is any mechanical, electrical, or chemical device used to initiate combustion and start a fire intentionally.

A delay mechanism consists of chemical, electrical, or mechanical elements that provide a time delay. These elements may be used singly or in combinations.

Incendiary materials are materials that burn with a hot flame for a period of time. Their usual purpose is to set fire to other materials or structures.

Construction of Incendiary Devices

Incendiary devices come in all shapes and sizes, and may be simple or elaborate in design. The type of device is limited only by the actor's imagination and ingenuity.

An incendiary device can be a simple match applied to a piece of paper, or a matchbook and cigarette arrangement, or a complicated self-igniting chemical device. Normally, an incendiary device is a material or mixture of materials, either liquid or powder, designed to produce enough heat and flame when used against

combustible material to cause it to be self-sustaining once its ignition temperature has been reached.

Each device consists of three basic components: an igniter or fuse, a container or body, and an incendiary material or filler. The container can be glass, metal, plastic, or paper, depending on its desired use. A device containing chemical materials usually will be in a metal or other nonbreakable container. An incendiary device that uses a liquid accelerant usually will be in a breakable container (e.g., glass).

TYPES OF INCENDIARY DEVICES

Generally, there are three types of incendiary devices encountered by a fire investigator: electrical, mechanical, or chemical. These elements may be used singly or in combinations.

Incendiary devices discovered before ignition should be handled only by experienced and trained personnel. Handling of such devices by inexperienced individuals can result in ignition and possible injury or death.

Electrical Incendiary Devices

Almost any electrical equipment or appliance may be used as part of an incendiary device, in order to 1) produce a spark; 2) produce heat; or 3) activate some other device such as a timer mechanism.

Electrical incendiary devices also may be classified by some other action. A dry cell battery could be used to heat a coil which would ignite nearby chemicals. This device could be classified as both an electrical device and a chemical device.

Some examples of common electrical devices:

- **Light bulbs** placed in or on combustibles. (Heat produced by light bulbs depends on design, wattage, and position of the bulb.) Evidence includes light bulbs found in unusual or unnatural locations, and charred, combustible fragments adhering to the remains of the bulb. Light bulbs may be used to contain liquid accelerants. When the bulb is energized, it may explode and spray flaming liquid accelerant over a wide area.
- **Electrical appliances** also are used for incendiarism. Heating devices commonly are used. Heating coils or soldering irons placed in or on combustibles will cause ignition. Portable heaters placed near or in combustibles also will initiate combustion. Evidence includes electrical appliances found in unusual or unnatural locations, or electrical appliances used at improper times (e.g., electric heater being used during hot weather).

- **Electric clocks, watches, and timers** can be connected to blasting caps, which may have an additional electrical power supply. These items also can act as time delay mechanisms, affording the arsonist an alibi for not being in the area at the time of the fire's inception.

Other Electrical Incendiary Devices

Radio-controlled devices are designed to operate other incendiary devices, usually from an area remote from the fire. Again, this affords the arsonist the alibi of not being in the area, and also eliminates the possibility of eyewitnesses. Common radio-controlled devices include electric garage-door openers and controllers for model airplanes.

Telephone devices can be used fairly simply, for example, by attaching an incendiary device to bell terminals. When a phone call is received, the bell system is activated, which in turn activates the incendiary device. Another method is to attach a piece of sandpaper or emery to the bells and a match head to the striker. When the phone rings, the striker rubs the sandpaper, igniting the match head. Discovery of remaining evidence may require detailed examination of the remains of the telephone by an expert or by a telephone company representative to help identify the evidence.

Mechanical Incendiary Devices

A clock is probably the most common mechanical incendiary device used by the arsonist. Depending on the type of clock, this device can cause a delay in ignition of up to 24 hours. A string attached to the wind-up key of mechanical clocks can be used to pull over flammable accelerant containers, strike matchheads against an igniter, pull insulating material from between two reactive chemicals, or trip an electric device. Remaining evidence should include the burned clock with evidence of modifications. Examine the wind-up key for traces of string or twine.

Trip-type mechanical devices are designed to activate upon some action by an individual, such as devices wired to doors, etc. A simple item such as a mousetrap can become a creative incendiary device. This can create ignition by striking, breaking, or making an electrical connection.

Chemical Incendiary Devices

The following chemical combinations frequently are used as incendiary devices:

- granulated sugar and potassium chlorate (ignited by concentrated sulfuric acid);
- granulated sugar and sodium peroxide (ignited by water or sulfuric acid)
- aluminum powder and sodium peroxide (ignited by water or sulfuric acid);
- potassium permanganate (ignited by glycerin);

- silver nitrate and magnesium powder (ignited by water or sulfuric acid);
- white phosphorous (ignited by contact with air); and
- magnesium powder and barium peroxide (ignited by fuse cord or open flame).

COMMON INCENDIARY DEVICES

Cigarette and Match Delay

This device can delay ignition times from 5 to 15 minutes. The combination of a book of paper matches and a cigarette is one of the most used and simplest incendiary devices. The delay depends on length of cigarette, tightness of tobacco, and whether or not the match is inserted fully into the cigarette. Filter-tip cigarettes limit the delay to approximately 7 minutes.

It can be assembled in several different ways. One of the most common methods is to place a cigarette horizontally, just along the tops of the heads of the matches. The distance that the end of the cigarette protrudes beyond the row of match heads measures the amount of delay time wanted by the arsonist. The cigarette is lit. As it burns, it eventually comes in contact with the matches, which, in turn, will burst into flames. This type of incendiary device can be used in conjunction with any combustible or flammable materials, solid or liquid.

Highway Flares

The ignition offlares may be delayed by the use of cigarettes, matches, or model rocket fuses, available at most hobby shops for approximately \$1. Flares may produce temperatures up to 1,200°F (648.9°C) and usually will burn for 15 to 30 minutes. They are easily obtainable (in most auto parts stores) in various colors, shapes, and sizes.

Fire Envelopes

This device consists of an envelope, calcium hypochlorite (granular dry chlorine), and a grooming gel that contains glycerin. The ignition can occur in minutes and will vary with the ambient temperature, surface contact of the chlorine and gel, and the freshness of chemicals. Burning produces white smoke with a strong chlorine odor with a hard chalk-like residue. This residue often is thought to be from plastic or drywall and removed from the scene during overhaul/cleanup operations.

Potassium Permanganate and Glycerin

Many devices have been designed to cause delayed contact of two components. Permanganate crystals are wrapped in paper towels or cloth and taped shut. The

packet then is dipped in glycerin and left at the target site. Time delay is length of time before the glycerin soaks through and contacts crystals, causing ignition. Burning is accompanied by a red- purple flame with a black crusty residue.

Brake Fluid and Calcium Hypochlorite

This device is constructed by piping dry chlorine in the bottom of a container. Several layers of cloth or paper towels are placed over the opening of the container and brake fluid is poured on the cloth or towels. Time delay is the length of time before the brake fluid soaks through and contacts chlorine. Burning is accompanied by a bright yellow flame, white smoke, and a strong chlorine odor with a hard white residue remaining. The molten residue will harden and break when cooled.

Fireworks

Class "C" fireworks may be used to ignite and spread liquid accelerants, resulting in the burning accelerant being thrown over a large area. Fireworks may be used to break a glass container upon activation, igniting the fire. They also have been used to melt and ignite plastic bags of accelerants.

Pressure Containers

This device consists of a pressurized aerosol container with a highway flare taped to the outside. It is activated by igniting the flare which will burn alongside the container, thereby raising the temperature inside the container. Once the container reaches its explosive limit, a violent explosion will take place.

INCENDIARY DEVICES DESIGNED TO BE THROWN

Usually, when the words "incendiary device" are mentioned, what comes to mind is the Molotov cocktail. "Fire bombs" are more descriptive of the variations of this incendiary device. A fire bomb is a crude incendiary hand grenade. It consists of a fragile container filled with a flammable liquid, usually gasoline. It is fitted with a wick or some other similar ignition device which ignites the contents upon impact or breakage.

Fire bombs usually are designed to be ignited in one of three ways. The most common method is with an **open flame device**, generally a match or lighter, applied to a cloth wick just prior to throwing the fire bomb at the intended target. A second method is with a **time-delay device**, often consisting of a length of safety fuse and a nonelectric blasting cap attached to the container. This type of ignition device allows the bomber to place the device exactly where he/she wants it, and allows adequate time for escape. The third, and least detectable ignition source, is the hypergolic or **self-igniting method**. Certain chemicals or

compounds, when combined, tend to burst into flames and react with explosive violence. An example is a capped frangible container filled with gasoline and a mixture of concentrated sulfuric acid. A label coated with a dried solution of potassium chlorate and sugar is attached on the outside of the container. When the container is broken, the sulfuric acid reacts with the chlorate and sugar, resulting in instant ignition of the flammable liquid.

Standard Molotov Cocktail

A standard Molotov cocktail consists of a thin-walled breakable bottle filled with gasoline and wicked with a sanitary napkin, rag, or paper towel. The arsonist (bomber) lights the wick and throws the cocktail against a hard surface, normally a wall.

Cocktails often fail to function properly because thick glass soda bottles are used which do not break on contact. If the bottle does not strike a solid target, or if the cocktail is thrown too soon and self-extinguishes in flight, it will not operate. On occasion, the wick is not secured to the bottle properly and falls away during flight. This may produce small fires over a long flight path.

Highway Flare as Cocktail Fuse

In this adaptation of the Molotov cocktail, a standard highway safety flare is taped to a bottle filled with accelerant, the flare is ignited, and the cocktail is thrown.

Tampon Molotov Cocktail

This device is constructed with a thin glass bottle containing a flammable liquid. The wick is made of a tampon with several wooden strike- anywhere-type matches wrapped around it and inserted into the neck of the bottle. The bottle neck is scraped across a rough surface and the tampon wick is ignited. This device provides easy wick ignition.

Thickened Accelerants and Cocktails

Various materials frequently are added to accelerants to limit the spread of the accelerant and to cause the accelerant to stick to the target. One device of this type is produced by mixing an accelerant with heavyweight oil (a 50/50 mixture of heavy oil and gasoline) in a thin-walled bottle. The bottle is shaken prior to wick ignition in order to produce necessary mixing. Any type of fuse or wick can be used. In addition to this mixture' s adhering capability, it produces a longer burn time also.

Chemical Molotov Cocktail

The chemical Molotov cocktail (sometimes called a British Molotov) is a bottle filled with a mixture of gasoline and concentrated sulfuric acid. The bottle then is capped, and may be stored for long periods. (The liquid darkens as it ages.) A 50/50 mixture of sugar and potassium chlorate is combined with water to form a paste and a rag is soaked in the paste. The rag is tied to the bottle and allowed to dry. (The potassium chlorate and sugar mixture does not go inside the bottle.) The bottle is thrown, and ignition occurs. However, ignition may be delayed after impact as the heat of ignition is produced. This type of cocktail may fail to operate in subfreezing temperatures.

Another design for the British Molotov can be made by attaching a mixture of dry sugar and potassium chlorate to the outside of a bottle with a label, and carrying the device in a bag or under a newspaper. Examine the target area for bottle fragments that may be covered with brown, wet, oil beads of decomposed sulfuric acid. A brown track may be left on the wall; however, if the wall is concrete, there may be a black track.

EXPLOSIONS

Identifying the cause of an explosion can be a matter of considerable difficulty. Explosions may occur as a result of fires, and fires can be caused by explosions. An explosion is not always incendiary. Some explosions are accidental. Although the detailed investigation of an explosion is a task for an explosion specialist, every fire investigator should be familiar with the basic principles of explosions and explosives.

An explosion is a sudden and rapid release of energy from a confined space, accompanied by high temperatures, violent shock, and loud noise. There are two major types of explosions with which investigators usually are involved: **mechanical and chemical**. There are several subtypes which are differentiated by the source or mechanism by which the explosive pressure is produced.

Mechanical Explosion

A mechanical explosion occurs when high pressure gas is produced by purely physical reactions and no basic chemical reaction is involved. When a container or vessel is heated, overpressure occurs; when the pressure no longer can be confined, the vessel fails and an explosion results. A steam boiler blowing or an air compressor exploding are common mechanical explosions.

The Boiling Liquid Expanding Vapor Explosion (BLEVE) is a type of mechanical explosion. A BLEVE occurs when the temperature of a liquid and vapor or compressed gas confined in a vessel or container is raised by heat, often external. When the internal pressure no longer can be contained, the vessel explodes. BLEVE's can occur in any liquid container, e.g., large, small, or vessels. It does

not require a flammable or combustible liquid. Any liquid with a boiling point has the potential to cause a BLEVE.

Chemical Explosions

Chemical explosions generate high pressure, which changes the chemical nature of the fuel, resulting in an exothermic reaction.

Combustion explosions are the most common of the chemical explosions. Combustion explosions are caused by the burning of a combustible hydrocarbon fuel when it is present with an oxidizer such as air. In combustion explosions, the burning of a fuel produces large quantities of heated gases and combustion byproducts which will raise pressures.

According to the types of fuels involved, combustion explosions may be classified into several subtypes. Some of the most common are backdraft explosions, dust, explosives, and flammable gases.

ORDERS OF EXPLOSIONS

An explosion is classified either as a low-order or high-order explosion- this should **not** be confused with low or high explosives. The terms "yield" and "order" are considered interchangeable. -Classifications are based on the type of damage incurred by the type of explosion.

Low-Order Explosions

Low-order explosions occur when the pressure rises at a slow rate inside a confined space such as a structure. When the explosion occurs, large pieces of debris usually are blown short distances from the structure. Other common damage indicators include walls bulging outward and/or roofs or ceilings being lifted slightly and replaced, etc. Glass in windows or doors usually is intact, while the frame is dislodged.

High-Order Explosions

High-order explosions occur when the pressure rises at a rapid rate. Indications of a high-order explosion include structural members located long distances from the structure in small pieces, shattered, pulverized, or destroyed.

EFFECTS OF EXPLOSIONS

Groups of Effects

Damage to a structure or surrounding area is the result of expanding heat and pressure waves. In explosion investigation, the effects of an explosion are observed in four major groups: blast pressure wave, shrapnel effect, thermal effect, and seismic effect

Blast Pressure Effect

The blast wave is the result of gases being released rapidly, resulting in a pressure wave which travels outward from the center. As the wave increases in distance, the strength decreases. This pressure wave is the primary reason for injuries and damage.

The positive-pressure phase is the result of the blast wave moving away from the seat of the blast as gases are expanding. The positive phase is responsible for the majority of damage, because of its power.

The negative-pressure phase occurs in the same way as the positive- pressure phase, except that it displaces and heats the surrounding air creating low air pressure at the seat or origin. As the positive phase moves outward, a negative phase or low-pressure region is formed behind the pressure wave. The result is air rushing back towards the explosion center. This negative wave results in additional structural damage and may conceal the origin due to debris being carried backwards.

Shrapnel (Fragmentation) Effect

Shrapnel (or fragmentation) consists of small pieces of debris from a container or structure which ruptures from containment or restricted blast pressure. Shrapnel may be thrown over a wide area and a great distance causing personal injury and other types of damage to surrounding structures or objects.

Thermal Effect

Thermal heat is energy in the form of a fireball, the result of burning combustible gases or flammable vapors and ambient air at very high temperatures. Thermal heat is present as a ball of fire during an explosion and for a limited duration after the explosive event.

Seismic Effect When a blast occurs at or near ground level, the air blast creates a ground shock or crater. As shock waves move across or underground, a seismic disturbance is formed similar to an earthquake. The distance the shock wave travels depends on the type and size of the explosion and the type of soil.

Factors Controlling Explosion Effects

A number of important factors may influence the effects of an explosion, which produces a wide range of physical damage.

The design and construction of a **containment vessel**, along with the type of fuel and volume stored, affect an explosion. A small vessel (volume) has a higher rate of pressure in relation to air/fuel mixture. This usually results in a stronger or more violent type of explosion.

The strength of an **ignition source** usually has little effect on the type of explosion which may occur. However, a larger ignition source usually increases the pressure development.

Venting of a vessel or structure usually will cause damage outside of the vessel or structure, with the most damage occurring at the vent opening. When a structure is able to allow the venting process through windows or doorways, the damage incurred is usually in direct line of the openings. However, if there is a rapid pressure buildup inside a structure and the venting effects are insufficient, depending on construction materials, usually more of a shatter effect occurs, and residue or debris is located some distance from the structure.

The shape and size of a containment vessel, along with the pressure and location of the source that introduces a fuel into a vessel, have an important effect on the severity of the explosion. Any **turbulence** with a dust/air or vapor/air mixture increases the combustion rate and pressure.

Seated Explosions

The word "seat" is defined as a crater or area of greatest damage as related to an explosion. The greatest damage is located at the point of detonation. "Seats" may range from a few inches to several feet in diameter. Evidence of a "seated" explosion is usually a crater which will show pulverizing of soil or structural members. Explosive velocities exceeding the speed of sound produce a "seat," except when damage is produced by shrapnel.

BLEVE' s which occur in small, tightly confined containers (steam boilers, explosives, and fuel gases or liquid vapors) are other types which may produce "seated" explosions.

Nonseated Explosions

Fuels which are diffused at the time of an explosion because the explosive velocities are subsonic often produce a nonseated explosion.

Certain fuel gases, such as natural gas and liquefied petroleum (LP) gases, usually produce nonseated explosions because the explosive speeds are subsonic. Backdraft or smoke explosions and the explosion of vapors from pooled

flammable or combustible liquids also produce nonseated explosions due to their subsonic explosive speed.

Usually the most violent and damaging of the nonseated explosions are dust explosions in confined areas. Some of these areas are coal mines, processing plants, and grain elevators. These large areas preclude the production of a crater or "seat."

Vapor Density and Structural Damage

Vapor density is defined as the ratio of weight of a volume of a given gas or vapor fuel to an equal volume of dry air (air == 1). Under laboratory conditions, this is used to determine if a given gas or vapor fuel will rise or sink in relation to air in a given area.

Lighter-than-air gases (vapor density less than 1.0), such as natural gas, tend to rise and collect in upper areas. Burning between ceiling joists or pocketed areas may be indicative of a lighter-than-air fuel rather than a heavier-than-air gas or vapors. Heavier-than-air gases and vapors (vapor density greater than 1.0), such as flammable liquids and LP gases, tend to settle to lower areas. Ventilation, both natural and mechanical, can change the movement of the gas and vapor and move or spread to adjacent areas or rooms.

It has been widely thought that if the walls were blown out at ceiling level, the fuel was lighter than air; if blown out at floor level, the fuel was heavier than air. However, it has been demonstrated that the level of the explosion damage within a conventional room is a function of the construction strength of the wall, headers, and bottom plates, with the least resistive giving way first.

EXPLOSIVES

An explosive is any chemical compound, mixture, or device whose primary purpose is to function by explosion.

Explosives are used commercially to do various types of work. They also are used in a clandestine manner to destroy and to kill. In the commercial field, an explosive in the form of a cup-shaped charge will, when detonated, actually drill a hole in metal or rock. Another type of charge is a linear shape charge, which is laid on metal, rock, or wood. When detonated, it cuts the metal, wood, or rock along the length of the explosion, much as one would cut something with an ax. Explosives are used most commonly in mining or quarry operations, to break up rock, or to move dirt in large amounts at one time.

Types of Explosives

Explosives (not to be confused with explosions) are classified into two main types: low explosives, and high explosives. Classifications are based on the explosive velocities of the materials when activated.

Low explosives are characterized by a deflagration which has a subsonic blast wave. Low explosives are designed to be used where a slow pushing action is required, such as weapon cartridges and rockets, or in pyrotechnics where the effects desired are heat and light, but where blast effects are to be avoided.

Some common low explosives are black powder, flash powder, smokeless gun powder, and solid rocket fuel.

High explosives are characterized by a detonation designed to produce a shattering effect by their high rate of pressure and extremely high detonation pressure. These high pressures are responsible for localized damage near the "seat" of the explosion and cratering at the epicenter.

Some common high explosives are dynamites, plastics, ammonium nitrate-fuel-oil (ANFO), pentaerythritol tetranitrate (PETN), cyclotrimethylene trinitramine (RDX), and cast types such as TNT.

Blasting Caps

Blasting caps are used as an initiator for other explosives. Blasting caps contain the most sensitive type of primary explosives and are considered to be the most dangerous item in the field of explosives.

There are two types of blasting caps: electric and nonelectric fuse. Each type contains the same type of explosives, is of the same diameter (approximately 1/4 inch), and is the same relative size. The size or lengths range in even graduations such as #2, #4, #6, #8, #10. The shell or casing is made from copper or aluminum.

The basic difference between the electric and nonelectric (fuse type) blasting cap is that the electric blasting cap will have two plastic-covered wires of various colors and lengths, depending on the brand and use. The two wires are joined inside the blasting cap with a thinner bridge wire. When electricity flows through the wires, it meets the smaller bridge wires which become overloaded and heat, which, in turn, causes instant detonation of the explosives inside the blasting cap.

The nonelectric blasting cap usually has an opening on one end, into which the time fuse is inserted and crimped, using a pair of crimpers. This creates an indentation in the metal near the top of the blasting cap and holds the fuse inside the cap. The time fuse is lit manually by using a fuse lighter or a match and is detonated by the use of nonelectric detonators Using detonating cord, shock tubes, safety fuse, or any other replacement for electric leg wires. The black powder core of the time fuse burns inside the fuse at a rate of 3 5 to 45 seconds per foot. When the fire has reached the end of the fuse inside the blasting cap, a small spit of fire exits the fuse and causes the explosive inside the blasting cap to detonate.

The most important advantage of the electric blasting cap over the nonelectric blasting cap is actual control of the detonation. The electric blasting cap is detonated instantly when electricity is applied by the blaster. On the other hand, once the time fuse on the nonelectric blasting cap is lit and burning inside a bore hole or even while covered with dirt, and even under water, the fuse cannot be stopped from burning and there is no further control of the detonation.

SCENE INVESTIGATION

Postblast scene investigation requires specialized explosives training. Investigators with this specialized training should lead an explosives investigation and those without this training should contact law enforcement or other agencies for assistance. A systematic approach to postblast investigation is the most effective.

The first responder should establish and maintain control of the structure and surrounding area and all unauthorized persons should be prevented from entering the scene before the arrival of the investigators). No blast debris or evidence should be touched or removed by anyone prior to documentation. Securing the scene also prevents injuries to personnel and unauthorized persons.

The scene should be searched from the outer perimeter inward toward the area of greatest damage.

Each scene will dictate the type of search pattern to be used. The pattern may be a grid, circular, or spiral. (See Appendix for an illustration of each type of search pattern.) The search pattern should overlap; all areas should be searched more than once so no evidence is undetected or lost.

The investigator in charge should brief all searchers on proper procedures of identifying, marking and mapping of evidence, logging, and photographing of evidence.

Special scene safety considerations always are recommended when dealing with postblast explosive investigations. Structures which have been subject to an explosion and/or fire have a greater tendency to collapse.

Investigators should be on the lookout for additional devices and undetonated explosives. A thorough search of the scene should be conducted for secondary devices, explosives, and any undetonated explosive devices prior to the postblast investigation. If any explosives are located, do not touch or move them under any condition. The structure and surrounding area should be evacuated immediately and the explosives isolated. Only qualified and trained explosive disposal personnel should be allowed to handle these explosives.

Debris is thrown from the center of the explosion by force. The greater the explosive energy, the farther the debris will be thrown. All significant evidence

should be documented properly and completely on the scene, along with the direction and distance. Different drag/lift characteristics of fragment shape will indicate the need for further investigation.

SUMMARY

A fire investigator may encounter fire scenes in which explosions or explosives may have been located or used. Each incendiary device, explosion, or explosive usually leaves certain kinds of evidence and residue.

Scene safety is a major priority for investigators and fire personnel. The scene should be rendered safe before postblast investigation and any secondary devices or explosives should be handled only by trained explosive disposal personnel.

All evidence should be documented properly prior to removal. Sketches and photographs always should be completed prior to evidence removal.

BIBLIOGRAPHY

Blasters Handbook, 175th Anniversary Edition. Wilmington: E.I.duPontdeNemours & Co. (Inc.), Explosive Products Division.

Cardoulis, John N. *The Art and Science of Fire Investigation*. St. John's, Newfoundland: Breakwater, 1990.

NFPA 921, *Guide for Fire and Explosion Investigations*. Quincy: National Fire Protection Association, 1992.

Yallop, H. J. *Explosive Investigation*. The Forensic Science Society and Scottish Academic Press, 1980.

Automobile Fires

PROBABILITY OF ACCIDENTAL VEHICLE FIRES

Vehicle fires can occur accidentally, and vehicles may be destroyed by fires of various causes:

- improper or careless use of lighted cigars or cigarettes;
- leaking flammable liquids in contact with some ignition source; or
- overheating of mechanical equipment.

Accidental vehicle fires can cause vehicle destruction. However, most accidental vehicle fires cause limited or localized damage and most total-loss vehicle fires are thought to be of incendiary origin.

When reference is made to total-loss vehicle fires, the words "total loss" relate to the physical damage and not to a total loss as would be identified by an insurance adjuster.

MODERN VEHICLE SAFETY DESIGN

Vehicle Electrical Systems

Manufacturers' designs of vehicle electrical systems provide for basic fire safety. Electrical overload protection helps limit short-circuit damage. Damage from short circuits usually is limited to the wiring between the short and the first-line fuse. Equipment and accessory short circuits usually cause localized damage only.

Materials used as electrical insulation seldom add to the overall fire damage.

Vehicle Fuel Systems

Newer fuel systems (nonvented) do pose explosion hazards; these systems will be discussed in detail later in this unit.

Older fuel systems usually do not pose explosion hazards because flammable vapors are released from the fuel storage tank. These vapors usually will burn away at or near the tank filler neck.

Metal fuel lines seldom melt if they contain liquids to help dissipate absorbed heat.

Interior Finishes

Fire safety also has been designed into the vehicle's interior. Fabrics often are manufactured to be flame-retardant. Also, foam padding often is manufactured to resist attack from fire. Without the constant impingement of flame or heat, burning will cease.

Ignition System

Vehicle designs usually provide the maximum separation between fuel and ignition sources; however, there are overall moderate ignition possibilities as fire causes. The ignition system always should be examined.

TWO VEHICLE EXAMINATIONS MAY BE NECESSARY

Two separate vehicle examinations may be necessary in order to conduct a proper vehicle fire investigation:

- incident scene examination; and
- detailed vehicle examination.

At times the investigator will be unable to complete the detailed examination of a burned vehicle at the incident scene. When this occurs, a second examination of the vehicle may be necessary after the burned vehicle has been moved from the incident scene. It is the responsibility of each investigator to determine what activities are to be completed at the incident scene.

Keep in mind that if a vehicle must be removed from the original fire site to a second location, the investigator, or some authority, must stay with the vehicle so as not to lose the chain of custody.

INCIDENT SCENE INVESTIGATION

The fire scene examination usually will provide the investigator with a first impression of the fire. The purpose of the scene examination is to obtain as much information as possible about the fire. This information will help to determine the cause of the fire.

Do not rush any part of the investigation. Focus on accomplishing these five objectives:

1. Identify the fire's point of origin. This is the exact location where the fire started. It is usually the lowest point of the fire, where the damage is the greatest.
2. Find the heat source. This is the energy that ignited the fire. An open flame is an example of a heat source.
3. Determine the fuel source. This is the material that was ignited by an ignition source.
4. Determine the event of the fire. This is the method by which the heat source and combustion combined at the point of origin to create a spark.
5. Determine the category of fire. Fires are accidental, incendiary, or undetermined. You must accomplish the other objectives before you can determine a fire's category.

Often a fire investigation begins with an examination of the fire scene. Although each fire is unique, the following paragraphs provide some basic guidelines for all investigations.

Fire scene examination is an important part of the investigation, as evidence may be discovered that will either lead the investigation in the proper direction or "seal" the case.

Shoeprints

Shoeprints or footprints can place the owner at the incident scene. Identifying the shoeprints as those of the owner/operator may contradict a story that the vehicle was stolen and then burned. Shoeprints may help to identify accomplices and may indicate direction of departure from the incident scene. This type of evidence is rarely found right around the vehicle, as most shoeprints are destroyed or obliterated by firefighters or fire apparatus.

Skid Marks

Skid marks or the absence of skid marks are indicators for the investigator. Sudden fire normally will cause panic stops, which usually produce skid marks. The lack of skid marks may contradict the driver' s story.

Gas Caps

The gas cap and filler pipe to the gas tank should be examined. Tests have shown that gasoline tanks do not ordinarily explode as a result of fire. They may fracture from other damage, or crack from the heat of an adjacent fire. Either of these occurrences releases the contents of the tank and will probably result in total destruction of the car. A missing gas cap may indicate that the cap was deliberately removed; however, one must use caution and not consider this an absolute. Some vehicles may not have a gas cap and the owner will use class "A" materials, e.g., rags, cloth, paper, etc., as a cap. The neck of the filler pipe will show striations if the cap was blown off by an explosion. Newer vehicles' plastic caps have threads and screw in. This type of cap may melt from heat and leave residue in and around the filler opening. Any time a "victim" of an auto fire says his/her gas tank *exploded*, the filler pipe should be preserved. These striations will not disappear unless the fire is so intense that the pipe melts. If the gas cap can be located, it should, of course, be checked for fingerprints.

Accelerant Residue

Accelerant residue may be recovered from the soil under or near the vehicle. The floor of the vehicle contains seams and drain plugs, and if an accelerant is poured on the floor of a vehicle, oftentimes it will leak out onto the ground. Spillage from the container also may occur as the arsonist pours or splashes the accelerant in or on the vehicle. Accelerant may be used as a trailer allowing the arsonist to start a fire some distance from the vehicle. Take soil samples from a depth of several

inches, from under the vehicle or by the doors and have these samples analyzed. The results may be surprising. However, keep in mind that liquid on soil also may be from leaking fuel from the engine or transmission.

Damage to Area

Note any damage to the surrounding area. Photograph the overall scene showing the location of the vehicle and any burn damage to vegetation, buildings or structures, and other vehicles. It may be caused by flammable accelerants on the ground or by the intense burning of the vehicle.

Accelerant Containers

Accelerant containers often are recovered at the incident area. The arsonist may throw these containers into nearby ground cover. Check each side of the road for several hundred yards in each direction from the scene. An accelerant container may be thrown from the vehicle used to transport the arsonist after the fire was set.

VEHICLE EXTERIOR EXAMINATION

Once the fire scene examination is completed, move on to inspect the exterior of the vehicle. It is best to examine the vehicle at the fire scene, so evidence is not damaged or destroyed. Also, it is a good idea to observe the vehicle in the setting where the fire occurred in case there is something significant about that location.

Vehicle Roof

At one time, a sagging vehicle roof was believed to indicate an incendiary fire. Earlier interior finishes did not produce a high enough temperature to weaken the roof.

On newer vehicles, a sagging roof can be the result of the burning of certain types of seat padding. Materials used on the interior of vehicles built after 1984 burn at higher temperatures which can cause the roof to sag even when an accelerant was not used.

The sagging of the roof should be noted and documented, but it does not prove the fire was incendiary in newer vehicles.

Underside of Vehicle

An arsonist may spray or pour an accelerant on the underside of a vehicle. Usually this is indicated by soot on the vehicle's undercarriage. However, keep in mind

that this soot may have been caused by liquid from a leaking fuel line or transmission.

Don't forget to take soil samples and photograph the area.

Collision Damage

Evidence of collision damage to the vehicle may be a strong indicator of incendiarism. The owner/operator may have been involved in a hit and run accident, or a teenager may be attempting to cover up an accident in the family car.

Check police reports for record(s) of an accident prior to the fire, which may show previous damage to the vehicle. The insured may have a policy with a high deductible and would have to pay for the repairs from the accident himself/herself.

Exterior Fire Damage

Liquid accelerants on the exterior of a vehicle may show evidence of running or dripping down the sides of the vehicle.

Examine the burn patterns on the exterior paint for signs that an accelerant was used. A normal burn pattern is a wide "V" shape starting at the fire's point of origin and moving up and out from there. Also check for blistered or peeled paint which may help identify the point of origin. In addition, the position of the windows and doors at the time of the fire will affect burn patterns.

Tires

Tires are almost never totally consumed in a vehicle fire. The portion of the tire that is resting on the ground will usually remain after the fire. This remaining portion of the tire is called the "pad." These pads should be collected as evidence.

Check tires or pads for odd treads or uneven wear, which may indicate a change of tires prior to the fire. The actual condition of the tires should be compared to the owner's proof-of-loss statement. The owner often will claim the vehicle was equipped with new, expensive tires. Original tires may be located on the owner's or accomplice's property.

Wheels (Rims)

As with tires, the wheel rims should be examined closely. Remember, most are made of steel and will not suffer extensive damage in a fire. Some of the newer rims are constructed of aluminum or a magnesium alloy and may melt or burn from the fire and add to the fire load. Frequently, the owner of a vehicle will

replace new tires with old ones just prior to the fire. Look for a jack impression in the ground around the vehicle. Check for missing lugs or lug nuts, indicating haste in the fire preparations. Also, check to see if all four rims are the same color, and *ii* they match the rim of the spare tire. If not, this may indicate changing of tires prior to the fire, and will have to be explained by the owner/operator.

VEHICLE INTERIOR EXAMINATION

Fires in the driver/passenger area usually are blamed on electrical shorts or foreign objects. The possibility of major damage caused by an electrical short is unlikely even if a fire does occur in today' s newer vehicles. There is a better chance of a foreign object causing a fire, but unless exposed to an open flame, foreign objects usually will cause only minor damage. If neither of these appears to have caused the fire, you will have to look for other clues.

Accelerant Containers and Residue

Frequently accelerant containers are left inside the vehicle. The arsonist often believes the container will be consumed, and in some instances, especially if a plastic milk container is used, this may be the case; nevertheless, a relatively unburned spot on the floor may exist to show that something was there at the time of the fire.

Most accelerant containers will leave some type of evidence.

- When glass jugs are used, the neck and/or carrying ring is made of thick glass and usually will withstand the high temperatures of a fire.
- When plastic jugs are used, melted plastic may be found.
- The accelerant may have been transported in metal cans. If the can was left in the car, it will still be present after fire extinguishment. The container may still contain some accelerant for comparison samples.

Discovery of an accelerant container may help to discredit the alibi or story of the owner/operator. Check with local gas stations in the area or near the residence of the owner/operator. He/She may have purchased gasoline just prior to the fire, and the attendant may be able to identify the purchaser or the container used.

Automobile floors have low spots where accelerant residue may be recovered. Accelerants usually may be recovered from floor carpets and padding, under floor mats, in metal floor indentations, insulation, or around rubber grommets.

The investigator' s sense of smell may not be effective in locating liquid accelerant residue. Gasoline is an integral part of a vehicle and its odor normally will be present around the burned vehicle.

Combustibles Inside Vehicle

Combustibles (paper, cloth, etc.) inside the vehicle often leave little evidence when subjected to fire. However, combustibles under seats may survive fire or fire streams and valuable evidence may be recovered.

Insurance arsonists routinely claim the loss of personal property in the fire. Pieces of this property may be noncombustible. Zippers, buttons, and hard metal items should still be in the interior.

Ashtrays

Ashtrays should be examined for possible accelerant and other evidence. Evidence of heavy smoking, heavy drinking, or drug use may be discovered.

The ashtray may contain liquid accelerants which the arsonist poured or splashed around prior to the fire. It may be a good source for comparison samples.

An examination of the ashtray may help to disprove the owner' s/operator' s story of a discarded cigarette as the fire cause. -An unused ashtray may indicate that the owner does not smoke or allow smoking in the vehicle.

Seat Cushions

Vehicle seat cushions are made of many types of foam rubber or synthetic materials and are covered with upholstery fabrics and materials which are flame resistant. These materials are difficult to ignite without an open flame.

These modern materials used in seats and upholstery can be ignited by a lit cigarette if this ignition source becomes encapsulated between seat cushions, paper, or debris. *Proper* ventilation also is required.

Certain types of foam rubber, polyfoam, or foamed plastics may be ignited readily by an open flame (age plus cleaning fluids may affect the foam). Once ignited, these materials often produce large amounts of smoke and high heat.

Spring Temper

Extreme heat is required for loss of spring temper in seats. High temperatures attained may be the result of burning of foam, synthetic cushions, or padding materials. However, these extreme temperatures also may be due to the presence of a liquid accelerant.

Loss of spring temper indicates a hot fire but does not prove that the fire was incendiary. The weight of an individual normally occupying that seat, or the

amount of usage of the seat, as in police cars or taxi cabs, can have an influence on the spring temper.

Seat springs on newer vehicles are made from a lighter gauge metal which tends to collapse during early stages of a fire.

Windows

Position and/or condition of all the vehicle' s windows may provide clues on the type of interior fire.

Open windows during very cold weather are not normal, nor are closed windows in very hot weather. However, air conditioning must be taken into consideration in hot-weather conditions.

The fire may self-extinguish if windows are left closed. Therefore, an arsonist may open vehicle windows to allow for oxygen to feed the fire.

If glass is melted, check the window mechanical lift arms to determine the position of the windows at the time of the fire. If the arm is at the bottom of the door, the window was open, and vice versa. Melted window glass indicates a hot fire but does not prove the fire was incendiary in today' s modern vehicles.

Doors

The position of the vehicle doors may be an indicator of incendiarism. Vehicle doors often are left open when the vehicle is intentionally burned to allow oxygen to feed the fire. Or, possibly, the fire progression was so rapid that the arsonist did not have time to close the door.

When interviewing firefighters, ask about the position of doors upon their arrival and determine whether or not they had to open the doors.

Steering Lock Assembly

An examination of the steering lock assembly may discredit the owner' s story of a stolen vehicle. This may require an expert examination by a locksmith to determine whether or not the assembly was damaged.

Attempts to Extinguish

Evidence of attempts to extinguish the fire should be noted. Sand, dirt, or extinguishing agents often can be found in the vehicle interior. This may help to confirm or contradict the owner' s/operator' s story.

Debris

Ignition Key

Examination of debris in the vehicle' s interior should include looking for the ignition key. If the key was in the ignition at the time of the fire, it may fall to the floor when the ignition switch melts, and remain embedded in the white metal of the ignition assembly. Even if the key melts from the ignition, a portion of the key still should remain inside the assembly.

Finding a single key usually is not normal, since most people carry more than one key. Quite often, keys are on a metal ring that normally remains after a fire

Always check the floor below the ignition assembly for the remainder of the assembly or the car keys. When interviewing the owner/operator, account for every key and ask to see them. This may refute the story of a stolen vehicle.

Personal Items

All passengers should be questioned to determine items that were in the vehicle at the time of the fire. Most items leave some evidence of their presence, such as buttons, zippers, or the soles of shoes. Mechanics' tools are never consumed in a vehicle fire and are readily identifiable.

An inventory of the remains of personal items may help to identify a fraud attempt, and evidence (remains) of incendiary devices may be recovered from the vehicle' s interior.

Removal of Accessories

When an incendiary vehicle fire occurs the owner often removes accessories for later use. The owner may wish to give or sell these accessories to accomplices, friends, or relatives at a later time.

One of the more popular accessories in vehicles is the cellular telephone. The brackets may be mounted on the floor area and wired directly to the battery to eliminate interference.

Most vehicle accessories do not burn or melt totally and will leave melted metal in mount holes or brackets. Empty mounting brackets or holes should be considered suspicious.

Serial numbers and physical descriptions of all accessories should be recorded for later comparison to the insured' s proof-of-loss statement.

EXAMINATION OF VEHICLE ' STRUNK

An empty trunk is usually considered suspicious. Most people always have something in their trunk. Standard items found in the trunk will include the following.

Spare Tire

New vehicles normally will have a new spare tire. Compare the wheel rim color with the other rims on the vehicle, or check with the local dealer to determine proper wheel color. Newer models may have a temporary tire, and the color may not match.

Jack (Tools)

This accessory should be present as most people do not want to be caught with a flat tire and no jack with which to change it. However, a missing jack is **not** conclusive evidence that a fire may have been incendiary.

EXAMINATION OF VEHICLE FUEL SYSTEM

Tank Fill Cap and Spout

The owner may claim that a fuel tank explosion blew the cap off. Examine flanges or filler tube neck to see if they are damaged. If cap was blown off as a result of an explosion within the gas tank, the flanges will be damaged. If an explosion did occur within the gas tank, the tank should be misshapen. The ends and sides should be bulged outwardly.

The fill cap often is removed to allow the siphoning of fuel from the gas tank. The cap may have been thrown away. Be sure to check nearby ground cover, alongside the road under the vehicle or inside the vehicle for the missing cap. Also, check in either direction along the road, as the arsonist may have discarded the cap while departing the scene.

Fuel Tank Drain Plug

The fuel system of the vehicle gives the arsonist an excellent supply source for his/her accelerant. Examine the fuel tank drain plug. (However, newer model cars have eliminated the use of drain plugs.) The arsonist may have removed the drain plug, if present, to allow the fuel to drain under the vehicle. The plug may not be replaced due to the presence of fuel under the vehicle. Even if the plug is replaced, it may not have been tightened completely. Fires do not cause the drain plug to unscrew itself.

The owner may claim the drain plug was blown out by an explosion of the fuel tank, but this can be investigated easily by an examination of the threads. If the plug was blown out, the threads usually show signs of damage; the collar around the plug often is blown out with the plug.

If the drain plug can be located, check for recent tool marks on the plug. This may indicate the plug was removed and then replaced after the fuel (accelerant) was obtained. Question the owner/operator about this.

Examine the fuel tank for evidence of intentional damage (puncture holes, etc.) for the purpose of obtaining fuel.

Fuel Lines

Examine the fuel line and fitting where it connects to the gas tank. Check for loosened fuel lines or evidence of tool marks. This may show recent tampering or repair work done to the fuel system.

On vehicles where this line connects near the bottom of the gas tank or about halfway down from the top, there have been cases where it was disconnected, allowing the gas to feed by gravity onto the ground under the car and then ignite.

Also, there have been cases where it was drained into a container for the purpose of throwing the gasoline into the interior of the vehicle or on the motor.

If gasoline was permitted to drain on the ground underneath the vehicle, there should be more severe damage to the rear of the vehicle such as rear tires burned off, evidence of fire on the ground, etc. It is advisable in such a case to dig down six or eight inches and get a sample of the soil. Be sure to take the slant of the ground into consideration, as the accelerant naturally will drain toward the lowest point. Usually, the pattern of burning on the ground will indicate the proper place to attempt to secure the soil sample. Naturally, the soil is more porous in some areas than others. Therefore, the length of time of contamination will vary. Weather conditions such as rain, cold, or heat also will affect this.

EXAMINATION OF VEHICLE ENGINE COMPARTMENT

A thorough examination of the engine compartment must be conducted. As most accidental vehicle fires originate in this compartment, the investigator must eliminate all possible accidental causes. A clever arsonist will attempt to disguise an incendiary fire by making it appear there was an engine malfunction, such as backfiring through the carburetor, or a fuel leak. Attempting to disguise an electrical malfunction can be difficult, but it is possible.

Radiator

Solder in radiator joints usually does not melt out during an accidental fire. An exception to this is when a fuel line leaks and creates an unusually hot fire. If a fuel leak can be eliminated, the radiator damage may indicate the presence of an accelerant. Check the level of water or antifreeze inside the radiator and the radiator hose top and bottom to see if the connection is tight. Some radiators on newer vehicles are constructed of aluminum or plastic and may melt or be distorted by heat.

Motor Supports

Motor supports seldom receive extensive fire damage during accidental fires. If the supports show evidence of damage, it may indicate the presence of an accelerant.

Broken motor supports may indicate a costly repair and show the reason for the intentional fire.

Belts

Fan, generator, or air conditioner belts seldom are destroyed in accidental vehicle fires. Damage to these belts may be localized in the area of an accidental fire, but if they are consumed totally, it may indicate use of an accelerant.

Carburetor

Accidental carburetor fires may self-extinguish without damage to the entire vehicle. Engine backfires can cause some damage to the carburetor and the surrounding area. Fuel-injected engines cannot backfire. If the fire is accidental, caused by backfire or ignition of fuel inside the carburetor, usually there will be internal damage to the carburetor, and possible meltdown of the alloy metal walls of the carburetor. Examine the air filter for damage or soot stain to the inside which may point to the carburetor as the point of origin. It may be difficult to prove an arsonist poured gasoline into and over the carburetor since this is a natural location for gasoline. Some carburetors are constructed of aluminum alloy and may melt in an accidental fire.

Fuel Pump and Fuel Line

Total-loss vehicle fires can occur if a fuel line connection disconnects and the vehicle's motor is running, causing the fuel pump to continue to operate, or if the fuel pump is operated electrically and it continues to run.

Examine the fuel pump for light connections, as well as the fuel filter, especially if it is an in-line filter. Sometimes gasoline is obtained by disconnecting the fuel

line from the fuel pump and running the starter. Check for any missing parts of the fuel pump or carburetor and evidence of tampering.

Steel fuel lines do not burn, especially if there is fuel in the lines. On the other hand, neoprene gasoline lines will burn and expel small amounts of gasoline onto the fire. Examine remaining fuel line hoses to make sure they are not rubber. Frequently, the do-it-yourself mechanic will replace these lines with improper hoses. A new, improper rubber hose replacement can begin to leak in a very short period of time.

Some manufacturers of newer vehicles have installed a safety feature that deenergizes an electric fuel pump when the engine is not running and after a vehicle collision.

Missing Accessories

Batteries, carburetors, generators or alternators, starters, etc., are not destroyed in a fire. These accessories may receive heavy damage as a result of the fire, but some portion of them will remain. If these items are missing it may indicate removal prior to the fire or extensive engine repairs that the owner/operator could not afford.

Attempts to Extinguish

Evidence of attempts to extinguish the fire in the engine compartment should be noted. Sand, dirt, or extinguishing agents often are found on the engine block, frame, or side panels. Cloth, rags, or paper often are used to extinguish a carburetor fire. Residue should be located inside the breather or carburetor itself.

EXAMINATION OF VEHICLE ENGINE AND DRIVE TRAIN

Motor and Drive Train

Check for missing or loose headbolts around the motor. Examine the engine for damage such as cracked heads or a hole in the block. Look under the vehicle for missing or loose oil pan bolts, or missing parts of the drive train; check to see if the drive train even is connected. Some of the newer engine blocks are constructed of magnesium and aluminum alloys. If any of these problems exist, it will indicate major costly engine repair, and a possible motive for an incendiary fire.

Mechanical Examination

A thorough mechanical inspection of the vehicle may show motive. The mechanical aspects of the vehicle provide important sources for both accidental

and intentional fires. Any competent mechanic can check out the vehicle for prefire damage. The presence or absence of salable accessories should be noted, as should the replacement of salable parts with non-working items.

Most engines in burned-out cars will run when rewired, since the fire seldom damages the interior of the engine. A transmission and rear end should run free also, although the drive shaft may no longer be true or may have exploded.

The usual places for an accidental fire in the engine compartment are in the areas around the fuel pump, carburetor, and wiring. Gasoline seldom is present accidentally on the engine in such quantity that it runs down the sides to the motor mounts or onto the ground. Evidence of a gasoline fire on some part of the engine remote from the fuel source is an obvious arson sign. When an accelerant is poured in the engine compartment, drops commonly splash in other places. If these burn they leave behind splotches on the paint or other material on which they fall.

EXAMINATION OF VEHICLE ELECTRICAL SYSTEM

Fuses and Fusible Links

Examine all fuses and fusible links. Modern vehicles are protected well from electrical short circuits and current overloads. The local dealership may provide assistance as to the location of fusible links and wiring diagrams.

Examine all wiring. Most electrical wiring in a vehicle is small gauge, copper strand conductor, and several circuits running through a wiring harness. It may be difficult to trace the circuit to its origin, as circuits may sever and fall to the ground. Look for evidence of direct short circuits.

Check for evidence of any tampering or any attempt to bypass any electrical circuits. Most accidental vehicle fires that result from an electrical malfunction will cause only localized damage.

Battery

The battery may drain rapidly when a short circuit occurs. Batteries which remain fully charged probably were not involved in a short circuit malfunction. Check the battery with a tester. Be extremely cautious of explosion potential. Hydrogen is present in vehicle batteries. Hydrogen gas is explosive and is ignited easily by the smallest energy source.

Extensive fire damage to a battery is not found in most accidental fires. The areas not facing the fire usually are not damaged extensively.

Always be cautious when working with or around the battery. Make sure the battery has been disconnected prior to any examination. Battery acid is extremely caustic and can burn skin or clothing.

LOCATION OF SECOND (DETAILED) VEHICLE EXAMINATION

The location of the second, or detailed, vehicle examination is very important to the case. A police impoundment lot is preferred since it helps to maintain a proper chain of evidence. If the vehicle must be taken to a public or private salvage yard, assure proper security. Attempt to have the vehicle kept in a locked garage, if at all possible; a secured, fenced lot will suffice. Take photographs of the security measures to appease the courts, and make your examination as soon as possible.

Reminder: Have somebody in authority (preferably the investigating person) stay with the vehicle from the original incident scene until it is secured properly. Log all time and do not break the chain of evidence.

OWNERSHIP AND VEHICLE IDENTIFICATION NUMBERS (VIN)

The vehicle identification number (VIN) plate attachment on the dashboard usually is made of metal and riveted to the dashboard. The round head "pop" rivet is aluminum, stainless steel, or plastic. Some imported vehicles occasionally use sheet metal screws to attach the VIN plate. Since the mid 1970's, some manufacturers have used both concealed and exposed rivets to attach the VIN plates.

Prior to 1969, VIN's were located in various places on the vehicle. They were known as hidden VIN's, and in order to locate them an investigator had to contact a police department auto theft division, the National Automobile Theft Bureau, or the local auto dealership.

Since 1970, in all domestic passenger vehicles, the VIN has been located on the left topside of the dashboard, visible from the outside of the vehicle. These numbers sometimes can be found on the door edge or door jamb on vehicles manufactured after 1969, but care must be taken so the VIN does not get confused with other manufacturer numbers or warranty numbers. There still are hidden VIN's in other locations on the vehicle, in order to identify the vehicle after someone has removed the dashboard numbers.

Prior to 1984, Corvette VIN's were displayed on the left side windshield post. There are several foreign vehicles (e.g., Volvo, Porsche, Mercedes Benz) that still display the VIN on the left side windshield post.

Vehicle identification numbers and EPA numbers should match on the vehicle. This is one way of confirming identification. Compare the VIN to the insurance policy to verify that the burned vehicle is the same as the insured vehicle.

Altered or missing VIN' s usually are indicators of tampering. During the examination look for 1) grinding, filing, or sanding marks, 2) overprints, or 3) plastic replacement numbers (check the local Division of Motor Vehicles (DMV) for regulations covering new VIN' s and how they are displayed).

For vehicles assembled through the 1980 model year, the VIN consisted of a combination of 13 characters (numbers and letters). Beginning with the 1981 model year, VIN' s have 17 characters. By tracing the number, such information as manufacturer, country of origin, body style, engine type, assembly plant, model year, and production number can be obtained.

Document the VIN number with photographs, and in field notes. Never remove the VIN plate from the vehicle.

NEW VEHICLE FUEL SYSTEMS

The Clean Air Act of 1970 required new vehicle designs. Key targets of this legislation were vehicle emission controls and fuel system vapor recovery.

Emission Control System

The vehicle emission control system uses catalytic converters to convert hydrocarbons and carbon monoxide to safer compounds. The converter usually is covered by a stainless steel shell. It has a very large interior containing clay-like compounds which are treated to react with hydrocarbon emissions in a honeycomb design.

Usually, the vehicle must have heat shields to protect from excess heat. These heat shields are located between the top of the converter and the floor of the vehicle. Some states require that the converter be covered on the bottom as well.

Fire dangers from catalytic converters include ignition of vehicle undercoating or insulation near the converter.

When operating properly, catalytic converters generate heat up to 1,600**F (871.1°C). If the engine is not operating properly, the converter could reach temperatures of up to 2,500°F (1,371.1°C), causing nearby combustibles, such as ground cover, vehicle undercoating, or combustibles inside the vehicle, to ignite.

One of the main problems which causes the catalytic converter to overheat is engine malfunction, which allows excessive unburned fuel to reach the converter. This creates higher temperatures which destroy the catalyst and, in most cases, melt the converter internally, and plug the converter.

Be cautious with investigations of vehicle fires resulting from catalytic converters. They may pose problems in determining a cause and may appear to be incendiary.

Fuel Vapor Recovery System

In some vehicles, fuel vapors escape illegally from the tank. Newer designs may use closed fuel systems which will recirculate the vapors. The vapors then are collected for later burning by the vehicle engine. With this system, the fuel tanks are no longer vented through the gas filler cap, thus having a sealed system.

This system does create fire hazards as it may allow extreme pressure buildup, which could result in an explosion of the fuel tank and propel fuel considerable distances.

MOTIVES AND VEHICLE ARSON

Motives for incendiary vehicle fires are usually the same as those for incendiary structure fires. (Motives will be discussed in detail in Unit 12: Motivation of the Firesetter.) Some specific additional motives that may be associated with vehicle arson fires follow.

Mechanical Problems

Often, mechanical problems are a reason for an owner to bum his/her car; the following is a list of common excuses:

- Major repair work is required on the vehicle, and the owner cannot afford it.
- The vehicle is a "lemon," and the owner cannot get any satisfaction from the dealer or manufacturer.
- The vehicle was near mechanical failure when purchased, possibly at an auction sale of used police, fire department, or municipal vehicles, or used fleet cars and rental cars.
- The vehicle is worn out and the insurance value is greater than the sale or trade (Blue Book) value.

Always check with manufacturers and dealers to see whether there were vehicle recalls for the type of vehicle that burned.

Owner ' s Financial Problems

Always conduct a financial background check on the owner. Friends, neighbors, and relatives often are not aware of a person' s financial problems. In some instances, even the spouse is not aware.

Unemployment causes obvious financial problems. The owner may have a second vehicle which is owned outright, so he/she burns the vehicle which has payments past due, because if the vehicle is repossessed, the owner gets nothing.

The owner may need ready cash because of a divorce, gambling, owing money to a loan shark, or simply living beyond his/her income.

The trade-in value of the burned vehicle may be below the amount still owed on the vehicle.

Witnesses

Someone, somewhere, saw something, heard something, or knows something.

Vehicle fires usually are witnessed or discovered prior to self- extinguishment. Check the neighbors closest to the fire scene. If nobody is home, return at a later time. Through interviews conducted during a neighborhood canvass, the investigator may learn, that someone may have heard two or more voices or may have noticed the period of time that elapsed between the stopping of the car and discovery of the fire.

Check with neighbors of the vehicle' s owner. They may have witnessed the vehicle being towed, or repair work being performed on the car. The neighbors may know of complaints about the vehicle made by the owner. They may have made complaints to the police about the vehicle sitting idle for a long period.

Accomplices

The owner/operator of a vehicle may not be the actual arsonist. Quite frequently, he/she will procure the services of another person. When more than one person is involved in a criminal act, they are known as accomplices. The accomplice may be more knowledgeable on how to bum a vehicle, and the two will commit the act together.

Vehicles are burned in areas which provide cover, and the arsonist must have some way back. Accomplices may help to bum the vehicle or may provide the transportation for the arsonist. Question the owner as to why he/she was in the area.

SUMMARY

It is essential to investigate motor vehicle fires due to the millions of dollars in property loss. The fire cause may present the fire investigator a greater challenge due to construction and vehicle components in new vehicles compared to older vehicles.

With newer vehicles it may be more difficult to prove an incendiary cause because of the burn characteristics of new materials.

The investigation of vehicle fires may require that you hire an expert mechanic to help with the examination. **Do not** hesitate to obtain such assistance.

BIBLIOGRAPHY

Carter, Robert E. *Arson Investigation*. Encino: Glencoe Publishing Co.

Cole, Lee S. *The Investigation of Motor Vehicle Fires*, 2nd ed. 1985.

National Insurance Crime Bureau. Palos Hills.

O' Connor, John J. *Practical Fire and Arson Investigation*. New York: Elsevier Science Publishing Company, Inc., 1987.

United States Fire Administration, Federal Emergency Management Agency. *A Guide to Investigating Motor Vehicle Fires*. 1991.

Injury and Fatal Fire Investigation

INTRODUCTION

In many localities, the fire investigator is required to determine if the police or other agencies should be notified concerning a fire injury or death. Many fire injuries or deaths are connected to other crimes and must be investigated jointly, by the fire department and other agencies. Fire investigators frequently are required to testify in civil law actions concerning fire injuries and deaths—sometimes many years after the incident. Fire scenes where victims are injured or killed require more detailed examination and investigation than other fires. The investigation of major injury or fatal fires may be subject to very detailed examination (or review) by government administrators, news media, and court officials, even years after the incident.

RESPONSIBILITIES IN THE INVESTIGATION OF FATAL FIRES

Security of Incident Scene

Fatal fires most likely will attract more spectators than other fires. Following is a discussion of the more common spectators who may be present at a fatal fire scene.

The media are in the business of reporting news. Most media personnel have scanners and listen to fire and police frequencies. Serious injuries and deaths usually are considered sensational and newsworthy. Be prepared for the media; they will be interested in this type of incident.

Community religious leaders also may show up at these scenes, especially if the victims are members of their congregations.

Local government officials also may arrive. Elected officials usually are concerned about their constituents. They can be a significant problem for the fire investigator because their presence is a distraction and they typically demand access to the fire scene.

Relatives and friends of building occupants also wish to confirm the safety of family members and friends also may appear at the fire scene. They often are scared and distraught. These people should be bandied with care and consideration. If mishandled, these individuals can cause considerable problems for the fire investigator.

Thrill seekers are attracted to many sensational types of incidents. Crowds will gather at the sight of fire trucks and flashing lights. This reaction will increase with a fire injury or death and also can cause significant problems for the fire investigator. Scene security can be overwhelmed by crowds of thrill seekers attempting to view the scene or look at the victims.

Neighbors often will be the first spectators on the scene. Their interests may be similar to those of friends and relatives; in fact they often are friends and relatives. The same care should be applied when handling these individuals. They are also a valuable source of information regarding their observations before, during, and after the fire.

Notification of Appropriate Agencies

Fire scene security may be more difficult because of the interest generated by this type of incident. The Incident Commander (IC) may have to request additional assistance from other fire companies, mutual-aid departments, volunteer firefighters, paid call firefighters, call-back personnel, police department, or other law enforcement agencies. Scene control is critical to a professional investigation. Be specific when making requests for assistance and follow formalized policies and procedures of your local jurisdiction in the notification of appropriate agencies.

Any indication of serious injury, death, or nonaccidental fire usually requires contacting other agencies and individuals such as the police department, the sheriffs department, the coroner/medical examiner, etc.

Provide Investigative Assistance

A fire investigator often will be the best qualified person to provide information as to the origin and cause of the fire. Always compare information you discover about the fire with that developed by the police and/or coroner (medical examiner). Discrepancies between fire origin and cause, and fire death must be reconciled.

FIRE SCENE EXAMINATION

A fire scene examination may be divided into two individual investigations. The fire origin and cause investigation will be separate and distinct from the fire death investigation. The fire death may or may not be related to the actual cause of the fire. Victims may die in a way that has no bearing on the fire cause.

For example, consider an early morning fire from an improperly installed furnace. The home has no smoke detector and the occupants are overcome by smoke in their sleep. The fire cause—accidental—is not what made this fire a fatal incident. The lack of smoke detectors or sprinklers and the timing of the fire (early morning) were the factors that turned a fire from a destroyer of property into a deadly encounter. Injury/Fatal fires should be examined for the origin and cause of the fire as well as the factors that caused the injury/death of the victims. Any contradiction of facts developed may indicate a need to involve other agencies in your investigation.

Three Bridges

Before moving the body of a deceased victim, keep in mind that you will cross three bridges. Once you cross each bridge, you cannot go back— "**You burn the bridge**" once you cross it.

Moving the Body

The first bridge is moving the body. Once the scene around the body is disturbed, the body **never** can be replaced exactly as it was originally found. Moving the body will displace debris, litter, and possibly even parts of the body.

Embalming the Body

The second bridge is embalming the body. Many states require that a body be embalmed prior to disposal. Certain religions strongly object to embalming and autopsies. The remains of their dead are disposed of in their natural state.

A body is embalmed by the injection of a preservative fluid (usually formaldehyde based) into the blood circulatory system. The fluid perfuses through the tissues and prevents normal decay. This process also freezes the tissue's position, making

the body very rigid. This is a permanent condition and not like the temporary stiffening of *rigor mortis*.

This process not only preserves the body, it destroys much of the evidence needed in scientific testing. Numerous tests, including many drug screens, no longer can be performed after embalming.

Final Disposal of the Body

The funeral industry had developed standard methods of disposal of remains that take common traditions into account. There are three basic ways by which human remains are disposed: burial, entombment, and cremation. Burial and entombment are similar in that the body is placed in a casket and placed at a permanent location. Burial involves placement of the remains and the container under the ground. In entombment the remains are placed in a tomb or crypt above the ground either in a special building (mausoleum) or an individual tomb. In cremation the body is reduced by heat to a light gray ash and the ashes are either scattered or placed in an urn for disposal.

Once a body is buried, any attempt to disinter or exhume the remains may result in a long, hard court struggle. Our society in general and the court system in particular take a very hard look at the reasons for opening a grave and disturbing a body. Many factors, aside from legal resistance, also affect the advisability of entering into the exhumation process.

The manner of disposal and the type of casket used will have a bearing on the information that may be learned from the remains. If the body is embalmed and entombed in a mausoleum, it will be in an excellent state of preservation for many years. Likewise, a body in a sealed casket and a burial vault also may remain in good condition. If that same body is not in a sealed casket and the soil is damp or wet, there may be nothing left but bones in just a few months. When an unembalmed body is buried, putrefaction begins and the body is decayed in a manner that makes tests difficult, if not impossible, in a very short time.

The net effect is that the disposal of a body is the last bridge you cross. It is possible to exhume a body which has been buried or entombed, but a cremation is absolutely final.

Moving the Body

Most States do not forbid moving a body prior to the coroner's arrival; however, local policies often stipulate that, generally, the body should not be moved until the coroner arrives.

Local policy will dictate options that are available. There are several factors that should be considered in your decision on whether or not to move a body.

The first consideration always is uncertainty as to the actual death of a victim. This is a situation which usually will occur during extinguishment activities and not after arrival of the fire investigator. If there is any doubt, remove the victim and transport to hospital. This may eliminate later criticism of your actions.

Another prime reason for moving a body is the likelihood of additional damage being done to the body. If the probability of further destruction exists due to the spread of fire, falling debris, or the threat of building collapse, move the body.

The ability of the coroner or medical examiner to identify the victim and to determine the cause of death decreases proportionally with extent of damage to a body.

If additional damage to the body is unlikely, leave the body as discovered for scene examination by investigators, coroner, or medical examiner. Follow local policies, and procedures, as well as instructions from the coroner's office if the coroner is not available to respond to the scene.

Photograph and Diagram Prior to Disturbing Scene

« Photographs and diagrams of the scene are among the most important records that you will make of the incident. Photography equipment (type of film and camera) is not the subject of this course; it is assumed that the evidence technician/photographer is trained in the technical aspects of evidence photography. However, the most common type of camera used by fire investigators is a 35 mm SLR (single lens reflex) using color film. Compared to the evidentiary value, the cost of film is minimal. Photograph early and often.

Photograph and diagram the area around each victim prior to disturbing the scene. (See Unit 10: Fire Scene Investigation and Unit 11: Collection and Preservation of Evidence, for a detailed discussion of photographing, sketching, and diagramming.)

Remove Debris Near Body

Remove debris near the body carefully, layering and examining the debris as it is removed. Photograph each stage of the debris removal. Be extremely careful to preserve evidence. Save the debris for later examination and sifting. Photograph each stage of this process.

Photograph Removal of Body

Photograph the body prior to removal, photograph removal of body, and photograph the area under the body after removal. Photograph and identify any objects found under the body and show the outline of where the body was discovered. Look for anything unusual or out of place.

Special Considerations in Fatal Fire Investigations

Human Behavior in a Fire Situation

People often behave in unexpected ways in a fire situation. The following paragraphs summarize some common reactions. (See "*The Effects of Smoke on Human Behavior*" in the Supplementary Readings Section of this unit for a more indepth discussion.)

Fear causes people to act. A delayed fear reaction may cause people to do unexplainable things, such as jumping from an upper floor to the street or ignoring a safe exit to run through the fire to escape. *

Panic usually does not take place in life-threatening situations, if people believe they can escape. People may become barbaric when panic occurs. It is a common experience in the military that soldiers may be brave in the company of others but may freeze or run when isolated. In a fire situation, a similar reaction may occur. Panic may cause a person to freeze in place or to run aimlessly, losing all sense of direction and logical thought.

Trained fire behavior may play a role. Humans are creatures of habit. That is why fire departments train their personnel, to build good habits. When faced with an emergency situation, humans will react as they have been trained. Therefore, how people react in a fire will be affected by their training and whether or not they have participated in fire or emergency exit drills.

Individuals who have not had training also will react in what appears to be illogical ways: moving towards the fire, trying to re-enter a burning building for various reasons. They may try to save a pet or loved one; they may think the fire is not severe. Studies indicate that if little smoke is present, people will try to re-enter the fire building.

Late effects of smoke inhalation may make people act inationally or heroically. They may appear to be carrying out normal activities when they may be in shock from injuries or the effects of smoke. The effects of smoke and carbon monoxide will be discussed in detail later in this unit.

Photograph Obstacles

Note and photograph any evidence of attempts to escape from the fire. Photograph all obstacles that may have blocked or interfered with the victim' s efforts to escape: building or room contents, locked doors, closed doors, closed windows, locked windows, or the rapid spread of fire.

Also note and photograph normal exit paths or escape routes available to the victim even if they are not blocked: doors, fire escapes, stairs, windows.

Facts Concerning Victim ' s Location, Position, and Appearance

Following are a few of the questions that should be addressed in your examination of the victim and the fire scene.

- Was the victim moved from his/her original position?
- Where was victim found?
- Was the victim' s location normal to type of occupancy?
- Was the victim' s location normal based on time of day or night?
- What was the victim' s location in reference to point of origin of the fire?
- Was there visible evidence of violence on body?
- How was the victim dressed? Does burn/heat damage to clothing match the victim' s injuries?
- Was the type and manner of dress appropriate to the time and location?

Code Violations in the Structure

The structure should be inspected thoroughly for code violations. Past code violations in the structure likewise should be researched and documented. The Fire Prevention Bureau and/or the Building Inspection Department are the most common sources for records on the fire building.

These records should be searched for information regarding outstanding violations of existing codes, notices of any pending abatement hearings or pending notices of court actions, and condemnation proceedings against the building, owner, or occupant.

The record of prior violations and abatement proceedings may become important to criminal and/or civil court actions if a link or relationship between fire cause and code violations can be established. The use of experts in the fire prevention or life safety field may be necessary.

The relationship between fire cause and fire code violations is important in criminal and civil prosecutions that may be filed. It is important to document carefully current, prior, or outstanding code violations on the property or against the owner. In today' s society it is almost a certainty that at least a civil suit will be filed in the case of serious injury or death. Code violations may be a key factor in that civil suit, citing the violations as being a contributing cause of death. Civil

suits may not come to trial until many years after the incident. Careful investigation and documentation will avoid embarrassment.

Personal Information Required

Following is a list of people about whom information must be gathered. For each, a checklist is provided to guide the collection of information. Not all items on the checklist will be required in all cases.

The Deceased

- Full name.
- Address (if different from address of fire, why was victim in burned building?).
- Date of birth, sex, and race.
- Income sources (employment).
- Marital status. - Current and prior domestic problems.
- Physical condition. - Disabilities. - Physical defects.
Mental status - current - prior- Record of problems or treatment.
- Habits. - Smoking. -Drinking. -Drugs. - Medication.
- Possible conflicts. - Employment. - Union. - Political. -Criminal. - Love affairs.

Individual(s) Discovering the Victim

If they are police or fire department personnel, the following checklist may not apply. The checklist is more appropriate for people other than police or fire department members who discover the victim.

- Full name.
- Address.
- Date of birth, sex, and race.
- Employment.
- Relationship to or association with deceased.
- Why in area?
- Activities/Actions prior to discovery.
- Actions taken after discovery.
- Circumstances of discovery.
- Mental condition. - Current. - Prior.

The Last Individual at the Point of Origin

- Full name.
- Address.
- Date of birth, sex, and race.

- Employment.
- Relationship to or association with deceased.
- Reason for being at point of origin.
- Actions while at point of origin.
- Activities/Actions prior to fire.
- Actions after the fire

Individual Discovering the Fire

- Full name.
- Address.
- Date of birth, sex, and race.
- Employment.
- Relationship to or association with deceased.
- Why in area?
- Activities/Actions while in area.
- Circumstances of discovery.
- Actions taken after discovery.

The Last Individual to See the Victim Alive

- Full name.
- Address.
- Date of birth, sex, and race.
- Employment.
- Relationship to or association with deceased.
- Circumstances of contact with deceased.
- Conversation with deceased.

Details of Insurance Coverage

Details of insurance coverage also must be obtained whenever possible. Again, these are checklists only, and not all information is appropriate for every case.

Fire Insurance

- Company/Carrier (name and address).
- Policy number.
- Names of agent and adjuster.
- Amount.
- Date issued.
- Recent changes.
- Beneficiary (payee).

Life Insurance

- Company/Carrier (name and address).
- Policy number.
- Names of agent and adjuster.
- Amount.
- Date issued.
- Recent changes.
- Beneficiary (payee).

DETERMINING CAUSE OF DEATH

Thermal (Heat) Injury

Heat injures the human body in one of two ways. The first and most common is the damage or destruction of living tissue by heat (thermal energy). The second is the overheating of the body's temperature-regulating mechanism, causing systemic hyperthermia (heat stroke).

The survivability of burn injury is dependent on several factors. The most important is the age and physical condition of the victim. The area of involvement is also a factor. Small areas of involvement (less than 20 percent) generally are not a fatal injury. A large area of involvement (more than 20 percent) is a critical burn and is more likely to be fatal. The greater the extent of burns, the greater the likelihood of systemic reactions, shock, infection, and death.

Victims of severe burns may succumb to their injuries days, weeks, or even many months after the initial injury. This is the reason that any fire where a serious burn injury occurs is a potentially fatal fire. If this fire is investigated with the same techniques as a fatal fire, you may avoid being embarrassed at a later date.

Additionally, if a burn victim is at the scene and you can interview him/her prior to or while awaiting transport to the hospital you should take advantage of this opportunity. The normal course of treatment of a burn victim often will result in intubation or a tracheotomy being performed shortly after arrival at the hospital. This treatment will render the victim unable to speak and if he/she succumbs to the injuries, the opportunity to interview will be lost forever.

The Four Categories of Burns

Burns traditionally are classified into *two* categories based on the type of damage exhibited by the victim.

First degree burns are superficial burns with damage limited to the outer layer of the skin (epidermis). The victim displays red, swollen, painful skin, but no blisters.

Second degree burns cause destruction of the upper layers of the skin, including the dermis and epidermis. Hair follicles and sweat glands are left intact, from which healing may take place, but often with some scarring. Typically the victim has blistering. These burns are a serious injury and may be extremely painful as the nerve endings are not destroyed.

Third degree burns cause destruction of the entire thickness of the skin, including both the epidermis and dermis. Pain is absent because the nerve endings are destroyed.

Fourth degree burns involve charring of the skin and underlying tissues. These are very rarely seen in a living victim, except in the case of military-type ordnance, such as white phosphorus.

Burn Classifications Used by Physicians

The classification of burns by treating physicians reflects the treatment methods used.

Partial thickness burns include first and second degree burns. This category is subdivided into **superficial partial thickness burns**, which include first and some minor second degree burns, and **deep partial thickness burns**, which include the old second degree burn category. The skin is red, swollen, painful. In deeper burns there may be considerable blistering and pain (second degree burns). The treatment of these burns usually does not require skin grafts, but infection is a serious danger. Deep partial thickness burns may exhibit waxy, white, soft elastic regions of injury which tend to be much less painful than the superficial partial thickness burns. These may require some local grafting and are a much more serious injury.

Full thickness burns destroy the entire epidermis and dermis. The victim may exhibit hard, dry, blanched white-to-tan lesions which soon become desiccated, parchment-like, and translucent with a very rigid tough eschar. This is a critical injury requiring extensive surgery and skin grafts. The damaged skin will have lost its elasticity, and full circumference burns are an extreme danger to the hands, feet, and limbs. The swelling under a full circumference burn will compromise the blood supply and the limb or appendage may be lost.

It should be noted that there are significant variations in skin thickness throughout the body; exposure to the same amount of heat will result in burns of different depths. For instance, deeper burns can occur with less heat over the malar portion of the face in contrast to the upper portion of the back.

Fire investigator's determination regarding the cause of death is preliminary to coroner's final report.

Forensic Pathologist and Autopsies

The post-mortem examination is somewhat different in forensic medicine. The basic purpose of an autopsy is to determine cause of death. Forensic pathology is specialized and differs in objectives in relation to a normal autopsy. The objectives of the forensic autopsy are

- To identify the victim through the examination and evaluation of evidence, including photographs, fingerprints, dental evaluation, etc. •
- To determine the time of death using the scientific tests of the profession: serial body temperature measurements, serial evaluation of rigidity, and other physical symptoms. • To determine the primary immediate cause or causes of death.
- To determine the secondary, contributory, or predisposing cause or causes of death. • To examine the circumstances of death.
- To find, collect, identify, and ensure the proper handling of evidence.
- If the victim was a homicide, to aid in the identification of the person responsible for death and the lethal weapons used; if an accident, to aid in the identification of the person, persons, events, or items responsible for death; if a suicide, to aid in the identification of the exact mode of suicide.

After examining these objectives, it is obvious that the forensic pathologist has obligations that are somewhat different than those of the medical pathologist. Critical differences include the need for positive identification, estimation of the post-mortem interval, reconstructing the circumstances of death, and the finding and proper handling of evidence.

To achieve many of these objectives, the forensic pathologist must examine the external portion of the body and the clothes in much closer detail than does the medical pathologist.

Forensic Autopsy Procedures

In order to achieve the aforementioned objectives, a complete forensic autopsy must be performed. The following are procedures usually followed in a forensic autopsy. It will become apparent that there is much more involved than simply a dissection of the body.

- When appropriate and/or required by local policies, the coroner or medical examiner may assist in the scene investigation.
- Obtain complete information concerning the known circumstances of death and all information possible in regard to the past history, particularly the past medical history, of the decedent and the alleged assailant.

- Supervise the removal and transport of the body, avoiding undue disturbance of the body and clothes.
- Absolutely no procedure should be carried out on the body (including embalming) prior to the pathologist' s examination.
- Locate a proper facility for conducting the medical legal examination with adequate support services. If possible, avoid "field" autopsies.
- Conduct an external examination of the body with meticulous attention to the clothes, the surface of the body, and all bodily orifices. Make a careful search for any items possibly deposited by an assailant and any items possibly deposited on the body as a result of accidental death.
- Do a complete post-mortem examination, including head and neck organs, genitalia, and microscopic examination of all important organs.
- Radiological examination is mandatory in all types of traumatic injury, particularly gunshot wounds, known or suspected assaults, accidents, bodies found in fires, sudden infant death syndrome, victims of child abuse, decomposed bodies, skeletal remains, etc.

Laboratory procedures fall into two categories: routine laboratory procedures and various special procedures performed in view of the circumstances of death.

- Routine laboratory procedures on all coroner' s cases include blood grouping and typing; blood and urine ethanol; blood carbon monoxide; drug screen; and examination of the anal, rectal, vaginal, oral, and other regions, if indicated, for seminal ejaculate.

- Special laboratory procedures frequently carried out on the basis of the circumstances of death include more sophisticated toxicological procedures which generally are sent to the state Toxicology Laboratory, microbiology examinations in case of suspected overwhelming infectious processes, certain routine chemistry tests (blood sugar and other chemical tests), etc.

Ensure proper handling of evidence with documentation of transmittal of all evidence.

Photograph and diagram.

Encourage the "team concept" with appropriate authorized personnel acting as a team in the medical-legal investigation.

Prepare an adequate, understandable report.

Cause and Manner of Death

Many so-called fire deaths actually are caused by associated illness such as heart disease, injuries from falling, or other chronic diseases. Very few individuals actually die from fire (flame). Most victims die from asphyxiation, asphyxiation in conjunction with carbon monoxide (CO) poisoning, pulmonary edema (presence of large quantities of body fluid in the lungs), shock or shock in conjunction with other illness, spasm of the epiglottis (strangling) which can be caused by the inhalation of super- heated fire gases and smoke (this is a rare occurrence), or internal injuries caused by an explosion.

Smoke. Carbon Monoxide Asphyxiation

Carbon monoxide (CO) is absorbed into the body primarily through breathing. CO is a colorless, odorless gas that bonds with the hemoglobin in the red blood cells. The hemoglobin in the red corpuscles has up to 210 times the affinity for CO than for oxygen. This interferes with the effective transfer of oxygen to cells, because the CO prevents the red corpuscles from carrying oxygen. The CO will stay with the blood cells for a considerable period of time and will accumulate in the system, reaching as high as 90 percent concentrations.

Amount of carbon monoxide saturation in the blood depends upon concentration of the gas, and the oxygen needs of the individual. If O₂ needs are great, symptoms appear with lower concentration and lower exposure time.

Twenty-percent CO concentration will produce symptoms that include mild to throbbing headaches.

Thirty- to fifty-percent CO concentration will produce symptoms that include headache, irritability, confusion, dizziness, hallucinations, with nausea and faulting possible.

Fifty- to eighty-percent CO concentration will produce symptoms that include coma, convulsions, respiratory failure, and death.

In ' healthy, young to middle-aged adults, 50- to 60-percent CO concentrations usually are fatal. Cats and dogs usually die earlier than humans because of their higher metabolic rates and smaller circulating blood volume. *The* ingestion of alcohol, barbiturates, and other drugs increase the toxic action of carbon monoxide. A CO level of 30 to 40 percent in a healthy, sober person probably will not be fatal. In presence of 0.2 percent blood alcohol, however, it may be fatal to that same individual. There are recorded deaths with CO as low as 14 percent with the presence of alcohol at .15 percent and marijuana traces present. The effect is cumulative in a geometric progression—one .plus one may not equal two, it may equal five!

Carbon Monoxide and Pathotodic Changes

Due to the action of CO the blood will appear bright red, similar to well-oxygenated blood. The action of the CO fools the red corpuscles into believing that they are oxygenated. The victim will present a cherry-red discoloration, notably in regions of lividity (look at fingernail beds and inside lips). The blood will remain fluid without post-mortem clotting for longer periods of time.

The cherry-red coloration from CO progresses through a series of changes. With onset of decomposition, the colors will turn green and brown. Decomposition of the body does not produce CO and will not increase the blood levels of CO. Carbon monoxide is one of the few elements that can be detected in the body after embalming and prolonged burial.

Other conditions that may produce this cherry-red appearance are cyanide poisoning (gas chamber) and exposure of the body to extreme cold.

Soot around nose and mouth and in nostrils may indicate the victim was alive during fire. In cases of strangling or suffocation (lack of oxygen) the victim may develop a blue tint similar to a heart attack victim.

Blistering of victim' s skin may indicate that victim was alive at the time of the fire, although **small** amounts of blistering can occur after death.

Strangling or Suffocation

A victim of strangulation may develop a blue tint similar to a heart attack victim.

Blistering

Skin blistering may indicate that the victim was alive at the time of the fire, although **small** amounts of blistering can occur after death.

Post-mortem Lividity

Post-mortem lividity (*livor mortis*) is the appearance that is caused by blood settling to low areas of the body. At death the blood stops circulating and will be pulled by gravity to the low areas of the body.

It will usually start 1 to 2 hours after death and usually is completed after 3 to 4 hours. *Livor mortis* may show as pink or red skin. The blood eventually will clot, and the lividity will "fix": that is, be permanent. This fixing of lividity may indicate that victim was moved after death. In cases with high concentrations of carbon monoxide, the blood will remain fluid without post-mortem clotting for longer periods of time.

Appearance and Condition of the Burned Body

The appearance and condition of the burned body is important to the investigator. The burns and damage should be matched with the other indicators found within the fire.

Fourth degree burns on a body usually do not occur until long after the death of the individual. This charring of the skin and underlying tissues is very rarely seen in a living victim except in the case of military-type ordnance, such as white phosphorus.

Fourth degree burns create severe disfigurement, and most likely will cause problems in identification of the body. The reaction to heating may cause the extremities to take on altered appearances due to severe constrictions of muscle (so-called "pugilistic attitude"). These contractions can cause fracturing of the long bones in the legs and arms. These fractures may be mistaken for violence on the body and require examination by a trained pathologist to reveal their true cause. These heat fractures are common; curved fractures may be present in bones exposed to high heat. These apparently occur during the cooling process.

The action of heat also may cause the tongue to protrude. This is caused by muscle contraction of neck and facial tissues.

Skulls may burst or fracture due to the effects of heat. These fractures are common in young children. The skulls often will fracture along the suture lines of the skull due to the heating of brain tissues. A similar condition may occur with the hollow organs of the abdomen, which may swell and burst through the abdominal wall. This condition also is seen in small children.

Other fractures also occur from falling debris and building collapse. Water streams from high pressure hoses easily may fracture bones made brittle by heat.

Heat will cause hair color changes; gray hair turns blonde and brown hair may take on a reddish color.

IDENTIFICATION OF THE VICTIM

Animal or Human

The amount of destruction of the remains may make impossible a gross examination to determine if the remains are animal or human. The identification will require expert examination by a trained pathologist. If there is any doubt, all remains should be considered human and handled accordingly.

Purpose of Identification

Identification of human remains is required for several reasons. First is the proper notification of the victim's family. Second, if the victim was insured, the insurance

company must confirm the death prior to paying the claim. The victim may be a murder victim disguised to fit the description of the insured, or it may be a suicide made to appear accidental to bypass the suicide clause of the policy.

Methods of Identification

At the Fire Scene

There are several methods of identification that may be used at the fire scene. Release of a field identification may cause problems if the results are made public prior to the official identification by the coroner/medical examiner. Follow your local policy.

A visual (or "gross") identification may be made by friend(s), relative(s), or neighbor' s).

Identification may be based on personal effects such as clothing, rings, watch, belt buckle, shoes, billfold, purses, papers, etc. Extreme caution is required because items belonging to others may be found in the area of the victim. There have been cases where items have been placed on the victim with the intent to cause misidentification.

Identification by elimination is sometimes possible, but extreme caution is required. A comparison of the physical description of the victim to that of individuals reported to be in a structure during the fire is used to eliminate possible victims.

Expert Examination

Expert examination and identification by the coroner, medical examiner, anthropologist, or pathologist is the preferred method of identification. In this method many factors are examined.

Weight and height of a charred body may be severely altered by fire, and are unreliable as identification. Skeletal examination can provide description of size and weight of victim.

Tightening of skin due to the heat will alter features and change appearance.

Other methods of identification include blood type (although it is not positive proof of identity), sex of the victim (used to eliminate victims of the other sex), and race of the victim (likewise used to eliminate victims of other races).

HOMICIDES AND SUICIDES

The fire investigator usually is best qualified to determine the incendiary portion of the crime of homicide. This determination is critical to the elements of the homicide/arson. After this determination is made, the fire investigator will assume a supporting role and assist the police investigators as necessary.

Arson resulting in the death of building occupants may result in a charge of murder. The arsonist is responsible for the results of his/her criminal actions (known as the "felony murder rule"). Also research your State statutes.

Sometimes a fire is set to conceal a homicide. This may be difficult to detect during scene examination of victim. Other agencies must be contacted if any questions remain or if any suspicion of murder is present.

Suicide by fire or arson to conceal murder is designed to make fire and death appear accidental and could allow a beneficiary to collect double indemnity on life insurance policies. Incendiary devices may be set with the intention of destroying the body and building after suicide. This is done in an attempt to defeat the suicide clause in a life insurance policy.

SUMMARY

You now should have an understanding of the relationship between an origin and cause investigation and an injury or death investigation. You should be able to identify the roles of the coroner, the medical examiner, and the fire investigator. You also should be able to explain the importance of the fire victim's location, condition, physiology, and position.

The fire investigator must be able to observe and document the details surrounding a fatal fire scene. The investigator also must be ready to cooperate with other agencies in investigating the cause of death or serious injury at a fire scene.

BIBLIOGRAPHY

Fire Protection Handbook, 17th ed. Quincy: National Fire Protection Association, 1991

Phillips, Anne W., M.D. "The Effects of Smoke on Human Behavior." *Fire Journal*, Vol. 72 (May 1978): 69-83.

Fire Scene Investigation

INTRODUCTION

Due to the destructive powers of fire, investigators must be aware of their surroundings. Fire scenes, as can be expected, are dangerous places. Fire investigators have a duty and a responsibility to themselves and to others to conduct a safe fire scene investigation. This includes working in pairs, wearing proper safety clothing, using proper respiratory protection, and remaining alert to fire scene hazards.

Only with proper safety precautions instituted can the investigator commence the scene investigation. The investigator must know what information is to be collected during the examination of the incident scene. He/She also must understand the necessity for proper security to protect the incident scene during fire suppression and continuing through the scene investigation. How exterior structural conditions of the burned structure may affect the examination of the incident must be understood. Finally, the investigator must understand the relationship between the physical condition of the structure and the identification of motives.

FIRE INVESTIGATOR SAFETY

Fire investigation can be more complex than fire suppression. Investigators find themselves examining more areas than those actually involved in the fire, spending more time processing the fire scene, conducting detailed scene examination, and sifting through the debris. Thus, they are exposed to a variety of hazards and usually are subject to continuous physical exertion.

Fire investigators have a tendency to ignore personal safety in their effort to determine the origin and cause of the fire. However, personal safety should be a top priority. Analysis of the exterior of the building must be done continuously while conducting exterior scene investigation. Similarly, prior to the interior examination, the occupancy must be determined safe to work in by conferring with the Incident Commander (IC) or requesting an inspector from building and safety. Prior to going inside, ensure that the atmosphere has been analyzed and is safe. Confirm that utilities are off prior to examining any electrical circuit, appliance, or wiring.

Avoid working alone. If an accident occurs, no one may be present to help. Also, if you encounter a hostile witness or a suspect, backup may be required.

Use proper personal protective equipment at all times, including approved boots with steel toe and midsole, gloves, helmet or hardhat, respiratory protection (Self-Contained Breathing Apparatus (SCBA) or particle respirators), eye protection, and a work uniform. Finally, do not eat or drink at the fire scene.

FIRE SCENE HAZARDS

Respiratory Hazards

Generally, heated air and gases rise during the fire. As the area cools, gases drop to lower levels. The atmosphere must cool before investigators spend extended periods processing the fire scene. If it is not possible to allow for cooling and to provide adequate ventilation, then respiratory protection should be used.

Common combustible materials will give **off toxic gases** when exposed or involved in fire. Some common products and the gases they produce are listed in the chart below.

TOXIC GASES CREATED BY VARIOUS (MATERIALS)

toxic gases	common materials	odor	Color
Carbon Monoxide	Wood, Cotton, Paper, plastic, petroleum products, wool, silk, rubber, PVC	practically odorless	Colorless
Carbon Dioxide	Wood, cotton, paper plastic, petroleum products, wool, silk, PVC	Odorless	Colorless
Formaldehyde	Wood, cotton, paper	Strong, pungent	Colorless
Formic Acid	Wood, cotton, paper	Penetrating	Colorless
Methyl Alcohol	Wood, cotton, paper	Slightly pungent	Colorless
Acetic Acid	Wood, cotton, paper	Pungent	Colorless
Hydrogen chloride	plastic, PVC	Suffocating	Colorless
Ammonia	Plastic, wool, silk	Sharp, intensely irritating	Colorless
Cyanides (Hydrocyanic acid)	plastic, wool, silk	Like bitter almonds	Water/White liquid
Nitrogen Oxide	Plastic	odorless	Colorless
Acrolein	Petroleum products	Disagreeable, choking odor	Colorless/ Yellowish
Hydrogen Sulfide	Wool, silk, rubber	Offensive	Colorless
Sulfur Dioxide	wool, silk, rubber	Sharp/Pungent	Colorless

Source: Hawle/s Condensed Dhemistry Dictionary (Eleventh Edition)

Structural Hazards

Investigators also must be concerned with structural hazards; *How* stability of the structure is of paramount concern. Did the fire weaken the floors, ceiling, and/or roof? Are there glass and nail hazards present? Is there a possibility of structural collapse?

Fire suppression activities can result in structural damage such as hanging beams and rafters; holes broken through floors, roof, and walls; or the possibility of the floor weakened from water loading.

Utility hazards also are possible. The electrical power still may be in service, even though the fire may have damaged wires and energized equipment. Natural or Liquefied Petroleum (LP) gas leaks or pockets of escaped gas may be present.

Electrical hazards still exist even with the meter pulled. Recent studies have shown that the neutral wire may still be energized.

Unprotected openings such as sump pump holes, old cisterns, pools, and shafts may be full of water and unnoticeable after extinguishment. Remember that ashes may be covering *up* holes and that the ashes on top may be cold while the ashes inside are still hot. This situation is referred to as a "black hole."

Hazardous Substances

Materials containing **asbestos** often are found in structures. Typical exterior locations include siding, roof felt, shingles, window putty, and undersheeting. Typical interior locations include insulation, flooring, air duct lining, electrical equipment, acoustical ceilings and tile, heat reflectors, appliances, and artificial fireplace logs.

Materials which contain asbestos deteriorate during fire, releasing asbestos fibers into the air. The primary hazard to the investigator is inhalation. Asbestos fibers can be reduced by wetting down the area. Investigators also should observe safety precautions such as wearing a respirator mask with a particle filter, and bagging uniforms and washing them separately. If breathing apparatus (SCBA) is available, use it.

PCB' s (Polychlorinated biphenyl(s)) are found in electrical equipment, coolants, roofing materials, and storage areas. The main hazards are skin exposure and ingestion. PCB' s can be spread by fire. If involved in fire, dioxin is created in the smoke. PCB' s are nonvolatile. Safety precautions include chemical-resistant gloves and shoe covers, and the use of a respirator mask.

Chemical fires present a variety of hazards, such as instability, combustibility, explosive tendencies, oxidation, corrosiveness, and water or air reactivity. Stable chemicals involved in fire may become unstable. Identification of fire-damaged chemicals often proves difficult; in addition, chemicals or explosives may have

been used to start the fire. Unburned chemicals often remain after the fire, and explosives may not have detonated completely and can be unstable. Safety precautions include identifying the chemicals involved, securing the area, getting technical assistance, and using special protective gear and breathing apparatus.

Always seek assistance from the proper authorities when dealing with chemicals, asbestos, and PCB' s. This includes hazardous materials units, or the bomb squad if you need to X-ray articles.

Insecticides and pesticides also pose respiratory, ingestion, and skin hazards. Be aware of smoke and gases present during incidents that involve them; take the required safety measures, such as using respirators, breathing apparatus, and chemical-resistive clothing. Decontamination steps will be necessary if you are exposed.

Toxic gases and smoke are present **in treated lumber**, in the form of chromium copper arsenate (CCA). Even though the fire scene is cold, with no smoke or gases, CCA still is present in the ashes. Investigators should follow previously mentioned safety precautions to minimize ingestion and respiratory hazards.

Nuclear hazards including radioactive materials, may be present in a variety of occupancies. Microwaves are common in homes, schools, and businesses. X-ray machines and radioactive waste are common in laboratories and hospitals.

When dealing with any of the aforementioned materials, be sure to notify appropriate agencies such as the U.S. Coast Guard, Occupational Safety and Health Administration (OSHA), the Health Department, and EPA.

INVESTIGATOR PRIORITIES UPON ARRIVAL AT THE SCENE

Confer With Incident Commander (IC)

Always inform the IC of your arrival. This is not only a courtesy, but he/she usually will have pertinent information to pass along, such as the safety of the involved structure and the progress of suppression efforts.

Never assume the request for an investigator is based on the IC' s belief that the fire is incendiary. The incident commander should be questioned about his/her reason for requesting a fire investigator, unless he/she is following standard operating procedures.

The IC may request an investigation for any of the following reasons:

- possible evidence of incendiarism;
- deaths or injuries;
- inability of fire suppression personnel to determine cause;
- extent of damage;
- dollar loss;

- number of fire companies on scene;
- type of occupancy;
- prior incidents;
- information gained at the scene;
- actions or statements by owners/occupants;
- presence of spectators;
- city liability; and
- celebrity involved.

The IC should be informed of special needs, such as a delay in overhaul, additional equipment (such as tractors, lighting, or analysis equipment), special staffing needs (such as the coroner, an anthropologist, the medical examiner, graphic artists, forensic photographers, etc.), canines, or scene security. Often it is easier to obtain manpower and equipment prior to the departure of fire suppression companies than it is to request companies to return to the scene.

Other agencies/personnel may need to be notified. Such agencies/personnel include police, the building department, the District Attorney, utility and gas companies, surveyors, the media, the bomb squad, the health department, the coroner, anthropologists, the Coast Guard, Fish and Game, and animal control. It may be necessary to remind these agencies of possible legal problems regarding their presence or activities. Authority over the incident must be established as soon as possible. Any need to delay or eliminate normal operations by other agencies should be explained and arranged by the investigator. Examples of activities or procedures which may be delayed during the scene investigation include salvage operations, occupants' return, property survey, repair crew inspections, and news media survey.

The investigator should solicit specific information from the IC regarding **fire suppression activities** such as placement of companies, assignments given to companies, identification of companies on scene, strategy/tactics employed, unusual odors noted, reaction observed at application of water, location of the fire upon arrival, ventilation methods, hoseline placement, etc. Obtaining information about firefighting operations during the incident may be invaluable. The actual court date may be months or even years after the fire; attempting to secure such information at that late date may prove to be impossible.

Find out if any overhaul operations were conducted prior to your arrival. Did fire suppression companies use wet water (chemical additive) or foam to suppress the fire? If objects were removed, what was removed, from where, and by whom?

Firefighters should be made aware of their responsibility to provide the investigator with accurate, complete, and timely information about the incident.

Time and method of alarms are critical information also. Times play an important part in the investigation, because the investigator may be able to show an abnormality between the time the fire was reported and the amount of fire at the time of the first arrival of fire suppression companies. The investigator should

interview the person(s) reporting the fire. Also, it is important to note the time the first fire suppression company arrived.

The investigator must observe **condition of the scene** at his/her time of arrival. Note the amount of damage as viewed from the exterior, as well as extension of the fire to the interior portions of the occupancy. Note the progress of fire suppression efforts at this time as well. Observe how the fire vented itself: natural ventilation versus fire suppression ventilation techniques. Note any removal of debris, furnishings, stock, supplies, etc. Ensure security procedures are established.

The structure may suffer extensive damage after the arrival of the investigator. Such information helps eliminate wasted time and effort in determining the origin of the fire. Remember that areas of extensive damage may not indicate the area of origin; this may have been caused by fire suppression efforts. In addition, a fire still can result in a total loss even after the fire is thought to be under control.

Other areas of burning may have required more immediate attention by fire suppression personnel because of protection of life, dangerous materials, high value areas, or preventing extension of the fire. Note areas of open burning (visible flames) which may indicate the types of fuel being consumed.

Ascertain whether there was complete or partial collapse of the structure. Was there ignition or exposure of flammable or hazardous materials? Were there reports of an explosion? Were firefighters forced to back out due to fast fire spread?

Weather conditions should be noted and recorded. Note wind direction and speed, and compare it with the direction of fire travel. Wind may account for the intensity and/or spread of the fire. Make note of clear weather conditions versus rain, snow, ice, etc. If the fire was incendiary, it may have been the arsonist's intention to set the fire in bad weather in order to delay the fire department's response.

Temperature and humidity also should be recorded. Low temperatures may cause fire hydrants to freeze, or pose other hazards that can delay fire suppression efforts. Climatic conditions and statistics can be obtained from the local office of the National Weather Service. If weather conditions were changing throughout the suppression and investigation stages, note all specific changes and times.

Occupancy records. If fire prevention records are available, look for any prior history of fires or problems.

Note fire protection systems such as alarms, sprinklers, standpipes, or smoke detectors. Ensure that someone will determine their status and effectiveness at the time of the fire. If the occupancy has a security/fire alarm, check to see the time the alarm went off; if the system is monitored, are there any printouts, tapes, or videos available? Note the fire load of the occupancy as it relates to furnishings

and appliances. Note the conditions of the utilities to the occupancy, and ascertain which companies and persons were responsible for shutting them off.

The type, size, use, and condition of the structure must be noted and recorded by the investigator. Detailed information about the structure is vital to the investigation report.

Most other crimes produce evidence which can be presented in court to help prove criminal intent. In the case of an incendiary fire, frequently the evidence is destroyed in the fire. The investigator often is asked to "paint a picture" of the burned structure, and these details often are necessary to identify motives and suspects. Include in the report relevant details about the neighborhood:

- Is it declining or changing?
- Have other fires occurred?
- Are there a lot of vacant buildings, numerous for sale signs, or other problems?

Color of Flames and Smoke

Color of smoke may indicate the type of material being burned. Complete combustion often produces little or no smoke, while dense smoke often indicates incomplete combustion. Flame color may indicate the type of materials being burned. As the amount of hydrocarbons increase, the flames will become darker or more orange in color. A lack of sufficient oxygen usually causes flames to be darker than when the same fuel is burned in a well-ventilated area.

Extreme caution is required when using color of smoke and flames as an indicator. Remember, the investigator often arrives on the fire scene during the latter stages of the fire, and may observe smoke colors that relate to materials burning in the latter stages, which will give false indications. Also, most occupancies contain fuels with hydrocarbon bases which, when burning, may produce smoke and/or flames which can mislead the investigator. Smoke and flame colors which indicate the type of material being burned are listed in the chart below.

FUEL	COLOR OF SMOKE	COLOR OF FLAME
Plastics	black	yellow, smoky
Rubber	black	yellow, smoky
Wood	gray to brown	yellow to red
Paper	gray to brown	yellow to red
Cloth	gray to brown	yellow to red
Gasoline	black	yellow to white
Naptha	black to brown	yellow to white
Benzene	white to gray	yellow to white
Lubrication oil	black	yellow to white
Lacquer	brownish to black	yellow to red
Turpentine	brown to black	yellow to white
Acetone	black	blue
Cooking oil	brown	yellow
Kerosene	black	yellow
Chlorine	green	yellow
Tar	black	yellow, smoky
Grass	gray	yellow to orange
Brush	brown	yellow to orange

Source: Kirk's *Fire Investigation*, 1991 and Factory Mutual Engineering Corporation. *A Pocket Guide to Arson Investigation*, 1979.

SCENE SECURITY

Fire or police personnel should be posted at all the occupancy' s points of entry, and they should be instructed to deny entry to all unauthorized personnel, including spectators, occupants, owners, and news media. Individuals claiming to have authority should be referred to the IC or the lead investigator. Scene security personnel should be in work or dress uniform with proper identification. Inform the officer in charge of the steps which have been taken to secure the incident scene.

Scene security is of the utmost importance both during and after firefighting operations have been completed. Ensure that arrangements are made to delay overhaul operations, so that the investigation is not hampered.

Deny entry to all unauthorized persons. Owners and/or occupants usually will attempt to re-enter the area, claiming the need to survey damage or salvage property. Spectators also like to enter these occupancies to survey and/or steal valuables. The arsonist may attempt to re-enter the structure for the purpose of destroying or recovering evidence of incendiary devices, covering up incendiarism, or attempting to mislead investigators.

The investigator should anticipate problems of scene security. Locate and inform the owners/occupants that their reentry into the structure will be delayed during the scene examination. The investigator can arrange for temporary shelter for tenants displaced due to fire. This will help remove the occupants from the immediate area and will provide for some comfort and protection during severe weather. The American Red Cross provides this service for persons displaced as a

result of a fire or other disaster. If they are not available, see if the owners/occupants have relatives, friends, or neighbors with whom they can stay temporarily. Another source of assistance can be the victim' s insurance company. Be sure to tell the owner how to get a copy of the fire investigation report, or you may want to recontact them yourself to inform them of the results of your investigation.

Scene security must be maintained without breaks in the chain of control over the occupancy. If the investigator cannot be present on the scene during the suppression efforts, the fire department or police department should be asked to provide scene security until his/her arrival. If a break in the chain of control does occur, the investigator will need to gain permission from the owner/occupant to reenter the fire scene to conduct the investigation. Follow legal precedents in scene investigation and the collection of evidence. (Refer to Unit 13: Legal Considerations.)

FIRE SCENE EXAMINATION

The "Backwards Theory"

In determining the origin and cause of a fire, the "Backwards Theory" provides a systematic investigative process that ensures that the total occupancy is investigated.

A backwards investigation is conducted from the exterior to the interior; from the least damaged areas to the most heavily damaged areas. Be sure to examine the entire occupancy, even rooms or areas where no fire damage occurred. Note the direction of heat flow, the lowest point of burning, ceiling damage, and fire patterns, including "V" patterns, glass, char, line of demarcation, spalling, and calcination.

Determining the Point of Origin

An exterior examination of the structure should be conducted. Try to view the occupancy from above, such as from an adjacent high building, aerial ladder, or helicopter. This may allow you to see various indicators. Examine the area for evidence of exterior ignition sources. Search for evidence of the fire origin and/or fire spread from the outside to the inside of the structure. Observe exterior fire, heat, fire patterns or smoke damage. Examine the area for the use of liquid accelerants. Downward burning on exterior surfaces, such as doorways and beneath window sills, may indicate the use of accelerants. Look for flammable liquid containers or containers which could have been used to transport liquid accelerants to the scene. While conducting your exterior examination also note evidence of forcible entry. Compare observed damage with that made by fire department personnel, neighbors, or occupants involved in fighting the fire. Record and photograph the condition of doors, windows, and locks. Note evidence of individuals having traveled in the area, such as shoeprints or tire

tracks. Remember, casts can be made and/or latent fingerprints can be taken from fire scenes.

Check the condition of the utilities (gas, electrical, and water). Note the overall condition and appearance of the occupancy (occupied, vacant, or for sale).

The **interior examination** also should be conducted in a "systematic backwards investigation," in order to provide a logical approach to determine the origin of the fire, and then to determine the cause.

Search for, identify, record, and photograph all evidence and note its location in a rough fire scene sketch. The investigator can never take too many photographs of a fire scene. Remember, a picture is worth a thousand words in the courtroom. Photographs and sketches of the scene make excellent visual aids.

If the cause is accidental, determine all facts concerning the incident according to formalized departmental policy.

If the cause is incendiary, continue the investigation to determine all facts concerning the incident according to formalized departmental policy, as well as State and Federal laws.

Reconstruction of the Fire Scene

Reconstruction is the act of finding the point of origin and reconstructing the fire scene. Replace doors and furnishings; match up furniture posts with marks on the floor. If necessary, seek the assistance of firefighters, owners, and occupants. When possible, examine other rooms or buildings with similar layouts and/or features.

Fire scene reconstruction can fit in anywhere during the examination process. The scene examination and reconstruction process are interwoven. Reconstruction not only involves replacing furnishings, but entails validating the fire indicators through interviews with firefighters, owners, occupants, neighbors, law enforcement, medical personnel, and witnesses.

Fire suppression personnel can provide information about the condition of windows and doors, and whether forcible entry was made prior to or by fire department personnel. They can provide information on suppression tactics, such as whether there were any unusual odors, how the fire reacted to the application of water, whether they saw, heard, or found any devices, the location of the fire at their time of arrival, etc.

The person(s) who discovered the fire must be interviewed, as must owners, occupants, witnesses, police officers, contractors, and emergency medical personnel. Each story should be compared; variations will result with respect to time of discovery. Witnesses will observe the fire in different stages and from

different locations, which will cause discrepancies in the accounts of their observations.

Interviews should focus on ascertaining the circumstances surrounding the fire, as well as information on records, inventory, valuables, keys, utility service, business history, personnel history, financial conditions, insurance, and repairs. Interviewing will be covered in depth in Unit 15: Interviews and Interrogations.

Determine the Fire Cause

Determining the cause of the fire was discussed in detail in previous units. In brief, you must be able to eliminate natural and accidental fire causes (mechanical, electrical, spontaneous heat, etc.) prior to determining the fire to be incendiary. Once you have determined the fire to be incendiary, note all evidence of incendiarism, including trailers, plants, devices, accelerants, multiple fires, crime coverup, or other preparation of the occupancy. If the cause of the fire cannot be determined definitely, then stating that the fire cause is undetermined pending the receipt of further information is appropriate.

DOCUMENTATION

Field Notes

Document all pertinent information related to the investigation in the form of **field notes** (facts, observations, questions and answers, incident information, scene information, and suppression information).

Sketching

Another step in the documentation of evidence is preparing diagrams or sketches of measurements for the location of evidence.

Sketching is a basic, but essential investigative technique that is well within the capability of the most novice investigator, and is employed conscientiously by more experienced investigators on every fire scene.

A schematic artist may assist the evidence technician in the inventory of evidence collected to ensure that all evidence is noted on the evidence sketch. He/She also may prepare a legend on the sketches and properly mark and identify the evidence sketch for court presentation.

A sketch is a graphic representation of a crime or incident scene and of the items within that scene that are of interest to the investigation. It is the investigator's responsibility to decide what must be sketched. Sketches are important for, unlike photographs, they depict only the conspicuous aspects of the scene without

showing nonessential detail; they also have the advantage of showing relative proportions, distances, and dimensions.

The primary purpose of an evidence sketch is orientation, which shows the positions of objects that were collected as evidence. This overall view of the scene usually is not available in photographs, and shows only relevant and important items that were collected and their location in a room or area.

An accurate sketch provides a clear overall illustration of the scene and shows the exact location of various items of evidence and their position in relation to each other and their surroundings. Thus, the scene will be preserved for future use in questioning witnesses or suspects; assisting the prosecutor, judge, and jury to better understand the conditions at the fire scene; and refreshing the investigator's memory when giving courtroom testimony. The investigator who can take the stand and state with confidence that a gasoline can was found on rectangular coordinates 2 feet, 7 inches from the south wall and 1 foot, 5 inches from the east wall of the kitchen makes a much greater professional impression on the jury than one who can state only, "The can was lying on the floor in the corner of the room."

Rough Sketch

The **rough sketch** is made at the scene of the investigation after the preliminary search of the scene, but before movement or removal of any evidence. When objects, such as bodies, must be removed from the scene before the sketch is complete, the object should be photographed and exact locations recorded and marked with chalk or other marking device.

The sketch must contain all appropriate information, i.e., name of person making the sketch, date, incident number, furniture placement, smoke damage, and dimensions. Usually it is not drawn to scale.

When doing a sketch, objects are not drawn as they actually appear; rather, **symbols** are used when possible. Architectural supply shops have available at very modest costs plastic templates of architectural symbols. The templates may not have a great practical application when preparing the rough sketch in the field, but they will be invaluable in the preparation of the finished drawing. Considerable time will be saved when rough sketching if some of the most commonly used symbols, such as windows, doors, and stairways are used.

The **legend** is an explanation of the signs, symbols, or characters used in a sketch or drawing. Whenever possible, conventional signs and symbols should be used. When unconventional signs and symbols are used, an explanation or description is required in the legend.

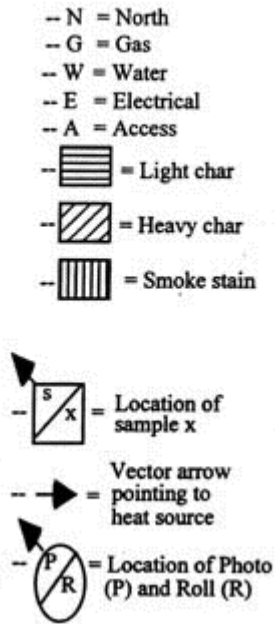

When numbers are used to differentiate objects in a sketch, they should be circled or squared to prevent confusion with the numbers used as measurements. Symbols used in a sketch must be consistent with the ones appearing in the legend. Examples:

The diagram/sketch is done by the investigator to show different objects of importance and their locations. Diagrams/Sketches will not always show the same objects, because objects of importance change with each investigation. Multiple diagrams/sketches can be done to show multiple floors, points of origin and/or

body locations if there are fatalities.

The information on a diagram/sketch must be accurate and consistent with information in the investigator' s notes and photographs. A diagram/sketch should **not** be drawn to scale: the entire diagram/sketch could be discredited by a single inaccuracy and a diagram/sketch **must** be completely accurate.

When sketching a fatal fire scene, the location(s) of the body or bodies is very important and always is included on the diagram/sketch.

The diagram/sketch can be done in connection with photographs to better illustrate the fire scene. The diagram/sketch should be retained with the case file

A magnetic North identification should be included. North should be recorded at the top right of sketch with a direction arrow indicating the direction. An inexpensive compass is required on all fire scene investigations. (See Appendix A for a sample rough sketch.)

Finished Sketch

The finished sketch usually is prepared in the investigator' s office for courtroom presentation. It is based upon the information contained in the rough sketch, and like the rough sketch, the finished drawing is not drawn to scale, and embodies all the fine points of drafting technique. This is your masterpiece; therefore, neatness is paramount and goes hand-in-hand with accuracy. Unimportant measurements, dimension lines and extraneous information should be omitted to keep the drawing uncluttered and easy to understand. The investigator has considerable latitude in regard to dramatic presentation of transparent plastic overlays; different

colored inks and heavy inking may be used to attract the viewer' s attention to certain points or objects.

The finished sketch is done under ideal conditions and often is prepared by a graphic artist, based on the investigator' s rough sketch. The finished sketch is included in the final report and may be used in court proceedings. (See Appendix B for a sample finished sketch.)

Sketehino Systems

There are two common types of sketches. A two-dimensional sketch shows the length and width of an area from above. It is sometimes called a "bird' s eye" view and is the most common type of sketch.



The three-dimensional sketch shows the entire area sketched. It looks as if the walls have been folded flat

For accurate case documentation, record basic information on each sketch: incident/case number; incident date; case name; location; "not to scale" identifier, person making sketch; date sketch was drawn

The three-dimensional sketch shows the entire area sketched. It looks as if the walls have been folded flat.

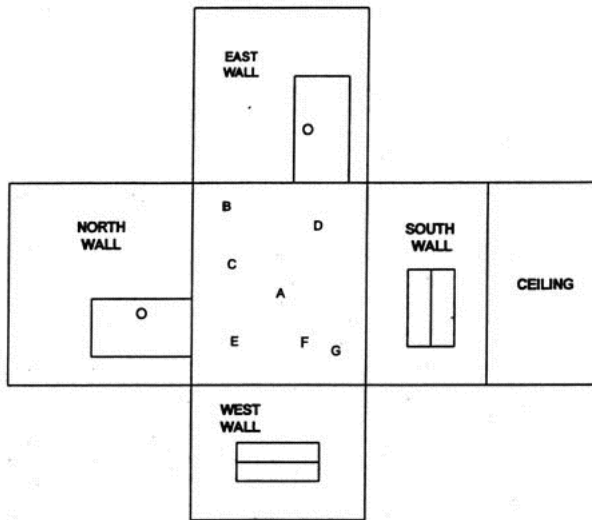

Legend:

- | | | | |
|----|-----------------|----|-------------------|
| A. | Body | E. | Chair and ottoman |
| B. | Piano and stool | F. | Cocktail table |
| C. | Television | G. | Sofa |
| D. | Cabinet | | |

Plotting Methods

Accurate measurements are a must to establish the reliability of the drawing. They eliminate any guesswork in locating objects and they permit the investigator to testify with confidence and precision. It is, therefore, essential that all measurements be taken from fixed objects that normally cannot be moved or misplaced. It is not necessary to be overly precise in taking measurements. There are certain acceptable

latitudes in measuring. To say, for example, that the bottle of alcohol was found 10' 7-3/16" from wall A is somewhat overdoing it

When measuring the inside of a room, the measurements are taken from finished wall to finished wall, and inside trim such as baseboards are disregarded. Windows, doors, and other openings are measured along the wall in which they are located, but window and floor trim also are disregarded, and only the actual openings are measured.

When critical measurements are taken, the investigator preparing the sketch should verify the readings. This will permit two investigators to testify in the event the accuracy of the measurements is challenged.

There are three basic methods of locating objects on a sketch: rectangular, triangulation, and straight line. (See Appendix C for graphic examples of each.) **Rectangular measurement** is a simple and commonly used method in which a point is located by making a measurement at right angles from two walls, thus establishing an imaginary rectangle.

The **triangulation** method is simple and accurate and is good particularly for areas lacking straight lines. A measurement is made from each of two fixed objects to the point you desire to locate so as to form an imaginary triangle. The point of intersection of the two lines is the exact location.

Straight line measurements usually are made of furniture or evidence which may be located on a wall. Two measurements are taken from fixed points to either side of the object.

Photographs

When documenting a fire scene, take as many photographs as necessary to document and record the scene adequately. It is recognized that time and expense considerations may affect the number of photographs taken.

Photographs need to be taken as soon as practical to ensure the scene is undisturbed.

If you are present during fire suppression efforts, beginning photo documentation then will prove invaluable.

When collecting evidence samples be sure to take a minimum of three photographs for each sample:

- Photograph the sample prior to collecting.
- Photograph the sample in the evidence container adjacent to collection site.
- Photograph the sample site with sample and evidence container removed.

Photographs should be organized into photograph logs that specify photograph number, roll number, subject of the photograph, direction taken, case number, incident date, and photographer. When taking photographs, do not include equipment or fire department personnel in the picture. Don't add anything to the photograph that is not part of the fire scene. This can contaminate the picture and cause the photograph to be ruled inadmissible in court. When photographing the fire scene take pictures in the same order in which you are processing the fire scene. (See Appendix D for a sample Photo Log.)

The photographer is responsible for the complete accountability of all photographs, they must be recorded, processed, and stored in a way which ensures the integrity of photographs. Do not throw away bad pictures.

Negatives should be maintained as would any other evidence. Negatives are just as important as photo prints and are considered direct evidence of scene documentation.

Do not mix fire scenes on the same roll of film. Negatives should be cataloged and stored separately from the case report. This eliminates the possibility of damage.

Chain of custody protects the integrity of each roll of film from scene investigation to processing to court.

Evidence

Use notes, photos, and sketches to document the evidence collection process. Remember to make notes and sketches pertaining to the collection, and photograph the collection of each piece of evidence. Just as in photographing the fire scene, you need to document evidence in a similar fashion. This documentation is done on an evidence log. (See Appendix E for a sample log. This will be discussed in detail in Unit 11.)

INCIDENT COMMAND SYSTEM FOR FIRE INVESTIGATION

Larger investigations, e.g., complex fires, multiagency fires, or serial arson fires, merit an organizational structure which assures that all participants can fit into the command structure. Procedures, need to be established for designating who will be in charge of the incident (IC); who will be responsible for the overall operations of the investigation, including origin and cause determination; photography; evidence; diagrams; fatalities; injuries; interviews; who will handle the planning stage, which includes the research and technical phases of the investigation; and who will be responsible for the logistics, including supplies, security, sanitation, food, communication, and finance. (See Appendix F for a detailed summary of a Fire Investigation ICS.)

Consider whether additional resources will be required, such as assistance *from* other jurisdictions; mutual-aid agreements; local task forces; or the Bureau of Alcohol, Tobacco, and Firearms (BATF) National Response Teams. Accelerant detection dogs are available. Computerized arson information systems can assist in investigative analysis.

For further information on the ICS read the article by Seidel listed in the bibliography.

Summary

Due to the destructive powers of fire, the investigator must continually *be* aware of his/her surroundings and must ensure that proper scene safety measures are instituted. This includes working in pairs, wearing proper safety clothing, using proper respiratory protection, and being alert to fire scene hazards always.

This unit has explained how fire suppression companies can assist in the investigation process by not destroying or damaging the structure and contents any more than needed during extinguishment. During overhaul, the fire suppression companies need to proceed as carefully as possible to safeguard possible evidence. In order to ensure scene safety, properly determine the origin and cause, prevent contamination, and properly conduct your investigation. Scene security must be maintained legally. The importance of securing the fire scene cannot be overemphasized.

Collection and Preservation of Evidence

INTRODUCTION

The successful presentation of evidence of incendiarism from a fire scene depends on the ability to identify such evidence properly at the scene. Evidence that is not collected, is collected or handled improperly, or is not documented properly will severely compromise any investigation.

Evidence collection and preservation is one of the most important tasks associated with fire investigation. Everything needed to confirm the origin, cause, or contributing factors associated with a particular fire must be collected and recorded.

Sketches are used in conjunction with photographs to present both selective and detailed illustration of the evidence. A photograph usually will show only a portion of the scene or evidence, but what is shown is depicted in great detail. A sketch depicting where evidence was collected will illustrate the entire area with distance and depth relationships to be selected. Presented together, sketches and photographs constitute thorough fire scene evidence reproduction. (See Unit 10: Fire Scene Investigation, for an in-depth discussion of documentation of evidence.)

Proper evidence collection and chain of custody are the responsibility of the scene investigator or a designated evidence technician who selects and assembles all evidence collection equipment and materials.

As evidence is identified, the technician may work with a photographer and/or a schematic artist. He/She is responsible for proper documentation of evidence prior to collection, maintaining an evidence log and numbering system, packaging and preserving all evidence collected, and maintaining custody at the fire scene and during transportation to a storage area. He/She also is responsible for laboratory analysis requests and transmitting evidence to the laboratory.

Contamination of Evidence

Evidence can be contaminated even before it is discovered and collected, either by fire personnel during extinguishment and overhaul or by returning occupants wanting to view the damage and to salvage belongings. Occupants who want to return to retrieve documents, medication, etc., should be accompanied by fire department personnel.

Evidence also may be contaminated and/or lost by exposure to the atmosphere; thus, it must be sealed in an airtight container. It also may be contaminated by an improper evidence container. Flammable vapors may deteriorate portions of

containers, at the seam of metal containers or the rubber seals of lids on glass containers.

Cross-Contamination

Cross-contamination is the transfer of liquid or solid accelerant residue from one fire scene or location to another evidence collection site.

There are four potential sources of cross-contamination at a fire scene: tools, turnout gear, evidence containers, and portable generators or power tools. Fire investigators should carry out certain "housekeeping" procedures to preclude possible accelerant cross-contamination from previous fire scenes.

Tools

All fire investigation units and, if possible, each fire investigator should have a special tool kit to process fire scenes (see Appendix A). These tools should be kept separate from other fire department equipment and must never be coated with any rust preventive material. After a fire scene examination is completed, tools should be rinsed clean with a strong stream of flushing water. Before taking any excavation or cutting tools into a fire scene, it is a good practice to cleanse each tool with isopropyl alcohol and clean paper wipes or cloth, then flush with fresh water in the presence of a witness. Detergents such as dishwashing soaps are also effective in dissolving residues that remain on tools. Note that accelerant liquids derived from crude oil generally are not soluble in water alone. Check with the lab on recommended cleaning procedures.

Turnout Gear

It is important to clean boots prior to entering the area where samples are to be taken. Avoid walking through accelerants en route to the collection site. Do not handle accelerant samples with fire gloves on. Carry several pairs of latex gloves in your pocket or kit Two latex "surgical type" gloves will conveniently fit into an empty 35mm film container with a snap top. Wear latex gloves to handle potential residue evidence. Follow established local procedures for glove retention/disposal.

Evidence Containers

Fire investigators should carry a supply of various evidence containers, including both one-quart and one-gallon clean, unused metal evidence cans, or the equivalent, in which to store residue samples. A good practice is to seal a one-quart evidence can and place it inside a one-gallon evidence can. Then, seal the one-gallon can before placing the cans in your vehicle. This saves space and prevents contamination. Seal the can using only hand pressure to eliminate

contamination from outside vapors. Open the cans just prior to physically collecting the sample at the collection site.

Portable Generators and Power Tools

Gasoline-powered equipment should be placed outside the scene in order to eliminate the possibility of vapor contamination. Investigators should work closely with firefighters to limit potential contamination when possible. Find out where such tools were used or fueled.

Chain of Custody

Chain of evidence problems are one of the prosecutor' s greatest areas of concern in preparing and trying a case. However, the prosecuting attorney usually is not involved in the investigative stages of the case and the chain of custody either will have been preserved or violated by the time the filing is received, with no chance to rehabilitate the integrity of the evidence so that it might become admissible. Therefore, the fewer the people who have handled the evidence, the easier the proof of the chain of custody will be.

When evidence is expected to be subject to analysis, as in an arson investigation, it is necessary to be able to establish that the item seized is the same item that was analyzed. Consider the following advice from Melville, *Manual of Criminal Evidence*, Second Edition, Denver D.A.' s office:

Whenever any piece of evidence must be passed from hand to hand to set up the chain of evidence in a case, it is essential that every person who has anything to do with the matter must be prepared to testify as to 1) when and how such piece of evidence came to him, 2) what *he* did with it while it was in his possession, and 3) when, why, how and to whom he delivered it.

Frequently, important evidence is rejected because the prosecution is unable to prove continuity of possession from collection to being offered in evidence. A police officer or investigator always should take the precaution of initialing or otherwise physically marking every piece of physical evidence coming into his/her hands in the course of a criminal investigation so that he/she can give persuasive evidence of his/her one- time possession of the item by identifying his/her initials or other marks on it.

Types of Evidence

During the course of any fire scene investigation, the fire investigator is responsible for the proper collection of scene debris or evidence suspected to contain accelerant residue. When fire scene evidence is collected, the fire investigator should collect two evidence samples: primary evidence samples and comparison samples.

Primary Evidence

Primary evidence should be obtained in an area or areas suspected to have been exposed to some type of liquid accelerant and should be analyzed to identify the accelerant.

In cases where only a small quantity of accelerant is used, the investigator should search the area of origin for an unusual pattern of localized damage. Some reliable indicators would include an odor of accelerant; intermixed light, medium, and heavy floor or other horizontal burn patterns; and wall char *from* the floor seam up.

Common Sampling Errors

When collecting evidence to be analyzed, collecting insufficient samples (too small) is one of the common errors. Ineffective sample preservation techniques and obtaining no comparison samples are other errors. Sampling from the wrong area(s) or the wrong materials can result in a negative analysis.

Evidence Collection Areas

The key evidence collection skill is knowing what to collect what not to collect. Accelerant liquids burn better than most surfaces and onto which they are poured. Expect to find better, stronger samples in protected areas and inside absorbent materials.

The most desirable areas for collecting include the lowest areas and insulated areas within a burn pattern. Porous plastic, synthetic fibers, cloth, paper, or cardboard in direct contact within the pattern will absorb any possible liquid which might have been used to expedite the fire. Inside cracks, tears, seams, or floor drains are other good collection areas for residue, since liquids will collect or pool in these areas. Liquids also will collect around load-bearing support columns or along the base area of walls.

Areas of deeply charred wood, gray ash areas, or edges of holes burnt through floors are less desirable due to the complete burn of material. The center of any burn pattern is not a desirable area due to intense burn of fuel. In general, any area exposed to the greatest heat or hose streams is a less desirable collection area.

Comparison Samples

Comparison samples are materials or objects that are believed to be nearly identical to similar accelerant debris samples, with the exception that they are not believed to contain accelerant residues. The purpose of such samples is to identify

and minimize or eliminate sources of interference in the analysis of such samples. Examples of comparison samples include the following:

- New, unused evidence containers. Most evidence containers yield no chromatographic interference. However, some types of containers, like certain types of plastic bags and specially coated containers, may give off background vapors that can obscure chromatographic analysis of evidence. New types of containers and new lots of certain container types, like plastic bags, should be submitted periodically to the laboratory for chromatographic analysis as comparison samples. Likewise, collection materials sometimes may present a source of interference. For example, some absorbent materials for controlling petroleum spills are unsuitable for evidence collection because they have been found to contain traces of contaminants.
- Comparable material samples. It is desirable to collect samples of materials identical to those found in the accelerant debris matrix, except that they contain no accelerant. These materials, such as carpet or wood trim, often may give off pyrolysis products which partially obscure accelerant patterns during analysis. A comparison sample should be collected for every questioned fire debris sample. Absorbent materials for controlling petroleum spills are unsuitable for evidence collection because they have been found to contain traces of contaminants.
- Comparable accelerant samples. Often investigators need to identify similarities between samples of known flammable and combustible liquids collected at the scene, those found in containers or obtained from other sources near the fire scene, and flammable and combustible liquid residues found in fire debris. Flammable and combustible liquid residues in debris samples may come from sources inherent to the scene, or may be brought to the scene from another source. For example, insecticides often have a petroleum-based carrier. Comparing debris samples with samples of liquids from these sources and with comparison samples of materials similar to those present in the fire debris may be a valuable method of distinguishing between what was at the scene before the fire and what was brought to the scene to start or spread the fire.

Comparisons often are requested by fire investigators when statements, evidence, or circumstances indicate that an accelerant may have come from a specific source, like a suspect's automobile or a nearby gas station. Occasionally forensic science analysts can discriminate between samples of similar materials as having clearly different sources. However, if no differences are found, the strongest statement that can be made is that the samples may have had a common source. This is due largely to the marketing practices of the petroleum industry and the near impossibility of accounting for every possible source. Another possible conclusion is that the samples belong to the same or different classes of petroleum products, identifiable using gas chromatographic pattern recognition. Liquid-to-liquid samples are the best for such comparisons. It is much more difficult to determine a common source using liquid samples and debris samples.

Comparison samples can be *very* important in making a positive identification of a material. When there is any doubt about whether a comparison sample is needed, one should be collected and submitted, or the laboratory should be contacted.

Trace Evidence

The characterization and comparison of trace evidence can provide a compelling link of a suspect to an arson scene, or of one scene or device to another.

Glass fragments, torn matches, cigarette butts, cloth wicks, tape segments, or other device components may be associated with items in a suspect' s possession through **physical matching** or torn or fractured edges, by analysis of the **composition and construction** of the materials present, or by comparison of **incidental trace evidence** such as hairs, fibers, stains, or soil.

Toolmarks present on locks, doors, windows, valves, or sprinkler or alarm system components at an arson scene may be identified as having been produced by a specific tool recovered from a suspect. **Shoe impressions** left at a fire scene may provide investigative leads regarding the number of individuals present or the type(s) of footwear represented, and may be compared with shoes recovered from a suspect.

Latent fingerprints also may survive on objects or surfaces at the scene.

Packaging Evidence

Evidence packaging is important for preserving and protecting evidence between the time it is collected and when it can be analyzed in the laboratory. In some cases, it may take several weeks to have evidence processed by a forensic science laboratory. Therefore, fire investigators should take particular care in packaging and preserving evidence to maintain the quality of the sample and prevent the release, deterioration, or contamination of such residue as flammable/combustible liquids, insecticides, cleaning liquids, etc.

Metal Containers

The best containers for liquid accelerants and contaminated materials, according to laboratory personnel, are new, unused metal cans with tight- fitting lids. Laboratory personnel cite the advantages of the large openings in relation to overall container diameter, vapor-tightness, rigid form, lightness of weight, durability, lack of appreciable background interference during analysis, availability, and range of available sizes. One-quart and one-gallon cans are recommended. The container should be loosely packed and filled to no more than two-thirds of its volume, leaving the remaining one-third as airspace between the top of sample and lid.

Whenever the sample permits, e.g., carpet, linoleum, paper, cardboard, or cloth, it should be rolled prior to placing it in an evidence container. This is what is referred to as a "chimney roll."

Evidence must be documented with a photograph and a fixed line drawing.

After placing the sample in the container, seal the container by tapping the lid firmly into the container top. **Do not** place excessive pressure on the lid; you want to avoid distorting the seams on the sides of the container. A good basic rule is to **always** place the label on the side of the container and **not** on the lid. Lids may be removed during laboratory testing and may be misplaced or mixed up.

Special Evidence Bags

Many fire investigators have found Kapak® bags to be a good substitute for metal containers. These self-sealing bags have an exterior layer of polyester and an interior layer of polyethylene. Despite their advantages these bags can tear if used for debris samples that contain sharp objects such as glass or nails. Consult your laboratory for its recommendation.

Glass Containers

For a small amount of a liquid residue or a liquid sample for comparison, glass containers may be used, e.g., glass jars, pharmacy bottles, etc.

Some fire investigators prefer Mason® jars for collecting and preserving evidence. The primary advantages are the availability of these containers at hardware, variety, and farm stores, especially in remote or rural areas away from central cities. With proper protection and packaging these containers can be excellent for collecting and preserving accelerant residue samples. The screw-top, vapor-tight lids work well, and the wide mouth makes it easy to insert and remove samples. Moreover, the sample remains visible, permitting inspection without opening the container.

The obvious major disadvantage of glass containers is the potential for breakage during transportation and/or storage. Also, some petroleum products and volatiles present in fire debris may degrade the jar's rubber lid seal, allowing vapors to escape. One proposed solution to this problem is to insert a layer of aluminum foil between the jar opening and the lid.

Other Common Containers

Other possible evidence containers include envelopes, paper bags, plastic bags, or containers designed for certain types of physical evidence. The selection of

containers depends on the size and shape of the type of physical evidence, laboratory policies and procedures, and the type of exam or test being done.

Labeling Evidence

After the container has been sealed, it is important to label it and its contents. A variety of evidence labels which have an identifying information area are available. Attach these labels to the side of the container, not to the top or bottom of the container.

Record the exact description of the evidence, location where evidence was recorded with measurements, evidence number, who recovered the evidence, date and time of recovery, and the investigator's name, rank, and agency. Other information to record includes the address of the fire scene, fire incident number, and any witnesses present when evidence was recovered.

If the sample is for comparative purposes, that fact should be noted on the evidence label.

Storage of Evidence

Proper storage of evidence is important in the chain of custody. Keeping evidence with a law enforcement agency usually is the best way to get "secured" storage, which is more readily acceptable to courts. Store evidence in a fire investigator's office only as a last resort; it is often difficult to prove that the evidence was secure. At the very least storage should be in a locked cabinet and in a locked office area.

Follow local policy for storage of evidence.

With the delays in processing evidence becoming longer in many parts of the country, proper storage is increasingly important. Some agencies may find themselves responsible for evidence samples due to delays in shipment, laboratory backlogs, or samples returned from one laboratory awaiting shipment to another laboratory. Under such circumstances, fire investigators should be prepared to store, document, and preserve the evidence in the same manner as would occur while awaiting analysis at the laboratory. The American Society for Testing and Materials Standard ASTM E1492-92, *Standard Practice for Receiving, Documenting, Storing and Retrieving Evidence in a Forensic Science Laboratory*, details the specific practices recognized throughout the forensic science community for maintaining chain of custody and preserving evidence samples before and after forensic analysis.

Transportation of Evidence

The admissibility of evidence in a court of law depends entirely on the fire investigator's efforts to maintain proper security, i.e., chain of custody from the time of discovery and collection, throughout storage, during shipping to laboratory, up to date of court appearance. Whenever possible, evidence should be handled and control maintained by the original fire investigator (evidence technician).

Personal transportation of evidence to a laboratory for testing is the best method. If possible, the same person who recovers the evidence should seal, initial, and transport it to the laboratory. This eliminates the possibility of the chain of evidence being broken and also eliminates handling by other investigators or personnel.

It may become necessary to ship (mail) evidence to a laboratory for examination or testing. When this becomes necessary, every precaution to preserve the chain of custody must be taken.

Select a durable shipping container (box) large enough to hold all of the evidence containers. Never ship evidence from more than one investigation in the same container.

All evidence containers should be sealed properly to prevent escape of vapors and identified and marked properly. Each evidence container should be protected properly from physical damage and packed securely in the shipping box. Seal the shipping box and mark "evidence" on it. Place a transmittal letter in an envelope, tape it on the box, and mark it "invoice." Wrap the sealed shipping box in outside wrapping paper and secure it with durable, resistant shipping tape.

Ship the sealed shipping **box** with any commercial courier company, (Federal Express, Airborne Express, United Parcel Service, etc.). If using the U.S. Postal Service, request registered mail with return receipts and signature.

EVIDENCE COLLECTION TECHNIQUES

Safety for the Fire Scene Investigator

Given the possible dangers at fire scenes under investigation, investigators need to keep in mind the potential for serious injury at any time and avoid taking unnecessary risks. A postfire structure can be unstable; the investigator needs to be aware of the unknown when working below or above ground level.

When a threat to personal health and safety is present, special equipment may be required for scene investigation. Rubber gloves, self-contained breathing apparatus (SCBA), and specialized filter masks are examples of this type of equipment. Always wear protective gear, boots, gloves, and helmet when on the scene. If possible, never work alone.

Accelerant Detection Canine Teams

Accelerant detection canines are specially trained to detect liquid accelerant residue at fire scenes. Dogs are used when fire investigators cannot detect accelerant vapors but see indicators of possible accelerant use.

It is important that the evidence technician collect evidence from the **exact** location indicated by the dog. This is both the best location and best opportunity to obtain a positive sample. It's also important to tell the laboratory that you had canine assistance.

Liquid Accelerant Samples

The presence of accelerant residue, particularly where such evidence normally would not be elected, may be a good indication of incendiarism. However, many other cases involve the collection and analysis of such debris samples to rule out the presence of accelerants or to *identify* possible accelerant residue from sources other than accelerants.

Because of the volatile nature of liquid accelerants, the collection of debris samples should begin as soon as possible after fire suppression activities have been completed. Fire effects, evaporation, and dilution or dispersion by fire streams diminish the chances of collecting a positive sample where one should be present.

Clean, dry, absorbent cotton, sterile gauze bandages, sanitary napkins, or tampons make good absorbent materials for skimming and collecting liquid residue. Commercial absorbent pads, such as those made of polypropylene, are unsuitable because they often contain background contamination. These products are used in hazardous material spills and are designed specifically for that purpose, **not** for evidence collation. If sanitary napkins are used, use nondeodorant, individually wrapped types. Paper towels can produce background contamination. A sample of any absorbent material should be submitted to the laboratory for comparison.

SAMPLING TECHNIQUES

The best place to collect samples when accelerants have been used is at the periphery of so-called pour patterns. These are identified by a distinct interface between the most heavily damaged area(s) and the less damaged areas.

Prior to collecting any samples, record this area by using sketches and photographs. This should be a standard practice for the collection of both the primary and comparison samples.

Photographing a suspected accelerant pattern after sampling damage has occurred may not represent a "fair and accurate representation of the evidence" and may not be admissible in a trial.

Carpet

Carpet readily absorbs accelerant and retains the residue for a longer period of time compared to other floor coverings.

Document the burn pattern with photographs before cutting the carpet. Cut the carpet in long strips along the edge of the stain or burn pattern.

A "chimney roll" is the best technique. Roll the carpet sample with the backing, nap, foam padding, or rubber to the inside to lessen the chance that it will stick to the inside of the container. The backing or padding contains background contamination. Insert the rolled sample of carpet in the vertical position in the evidence container and photograph the container with evidence visible and in the cut area. Obtain a comparison sample outside the pattern area from the same type of carpet.

Concrete and Cement

Spalling of concrete was discussed in detail in Units 4: Determining the Point of Origin, and 6: Indicators of Incendiarism. Some types of concrete actually make good samples, especially when the sample is particularly porous and collected before the potential accelerant sample can be diluted, dispersed, or evaporated.

Photograph the spalled area prior to collecting the sample. Wet down pattern area with a mist of water. Calcium carbonate, activated charcoal, or finely ground agricultural lime are used to absorb accelerant residue from concrete. Non-self-rising flour may be used as a substitute for these.

Spread absorbents approximately 1/2-inch thick over the spalled area and let stand for approximately one-half hour. Recover the absorbent material

and place it in an evidence container. Do not pack. If flour is used as a substitute, have it analyzed as soon as possible; it tends to decompose. Otherwise, refrigerate sample. Comparison sample should be collected away from the spalled area.

Floor Tiles

Floor tiles offer good residue collection because they have seams into which liquid accelerants can seep or be absorbed. Photograph all "ghost patterns." Adhesives used to adhere tiles to flooring can cause additional background contamination.

Photograph the area before you collect the sample. Cut strips along each side of seams and place the backing of one tile against the backing of another tile. This helps to eliminate the chances that the adhesive will stick to the side of the container. If the strips are too long to fit into the container, break in half and place

both pieces in the container. Lay the container on its side while placing the sample tile vertically in the container. Photograph.

Linoleum

Linoleum is manufactured from products of wood, gum, burlap, cork, canvas, etc., for linoleum flooring and thermoplastic polymers of vinyl compounds for vinyl flooring, and coated with a nonabsorbent covering which repels or inhibits liquids on the surface of the product. When the product is installed, glue or epoxy is used to attach it to flooring.

As discussed in Unit 6, a liquid accelerant on a surface such as linoleum will bum from the outer edges of the pooled liquid inward. The surface often will soften and begin to dissolve, and the edge of the pool will melt, burn, and/or char once ignited; this produces a bum pattern.

Identify the edge of the accelerant pool and document with photographs. Cut along the edge of the bum or stain area in long strips. Roll the sample with the backing to the inside to lessen the chances of the adhesive sticking to the side of the container. Insert the roll vertically into the container and photograph again. Always obtain comparison samples of both flooring and adhesive outside the bum area.

Wood/Wood Flooring

Wood is used extensively in the construction of commercial and residential structures for flooring and subflooring, moldings, framing, etc.

Liquid accelerants poured onto wood floors will seek joints or seams as collection areas. Liquids also will flow behind moldings, and under furniture, door frames, and threshold plates.

Wood sampling should be concentrated at seams and joints. Liquid accelerants seep between these seams and joints and may remain cool during a fire. Liquids are absorbed into the wood grain or fibers of the wood boards.

Collect splintered wood slivers from the edges of these seams, grooves, or joints and place them vertically in the evidence container. Lay container on its side and lay these splinters of wood in container. This helps to eliminate the chances of sharp edges puncturing the container. The container should be filled to no more than two-thirds of its volume. Always obtain a comparison sample of similar wood outside the bum area.

PROCESSING "COLD WEATHER" FIRE SCENES

Among the most difficult scene investigations are "cold weather" scenes which are covered with snow and/or ice. Such a scene has the additional danger of the increased dead-load weight of snow and ice.

Drain water from damaged area as soon as possible. Use heavy-duty heaters and floodlights with extension cords to keep the area of origin warm and prevent it from flexing. In some cold areas of the country tents have been used to cover the burn area completely, and auxiliary heating used to warm the area.

SUMMARY

For *evidence* to be accepted in court, it must be proved that it is relevant to the fire scene. It is the responsibility of the fire scene investigator to prove that the chain of custody has not been tainted from the time of recovery to the date it is presented in court.

Proper documentation through photographs, sketches, and proper evidence collection procedures are the fire investigator's responsibility. Failure to document a single step in this process usually results in the evidence being inadmissible in a court of law.

BIBLIOGRAPHY

Annual Book of ASTM Standards, Section 13, Medical Devices, 1992.

ATF Arson Investigative Guide. Department of the Treasury, Bureau of Alcohol, Tobacco and Firearms.

Basic Tools and Resources for Fire Investigators: A Handbook. Federal Emergency Management Agency, U. S. Fire Administration, Jan. 1993.

Dietz, W.E. "Physical Evidence of Arson: Its Recognition, Collection, and Packaging." *Fire and Arson Investigator*, Vol. 41, No. 4, June 1991, p. 35.

Melville. *Manual of Criminal Evidence*, 2nd ed. Denver: District Attorney's Office.

NFFA 921 *Guide to Fire and Explosion Investigations*. Quincy: National Fire Protection Association, 1992.

Phillips, Calvin C., and David A. McFadden. "Investigating the Fireground." *Fire Engineering* 1986.

Sanderson, J.L., C.A. Balliet, and M.A. Balliet "Sampling Techniques for Accelerant Residue Analysis," *Fire and Arson Investigator*, Vol. 40, No. 3, Mar. 1990, p. 36.

Whistine, William H., Jr. *Sniffing the Ashes, K-9 'in the Fire Service*. Ashland: International Society of Fire Service Instructors, 1992.

Motivation of the Firesetter

INTRODUCTION

Various types of arson fires can be identified more readily if the fire investigator is aware of possible motives. Certain motives often relate to specific types of fires. The investigator must understand why people turn to firesetting. Being able to identify a motive can assist in determining a suspect for the fire. "There is a cause and effect for everything people do, or fail to do. Although the individual may be otherwise normal, the act of destructive firesetting is not normal." (James Bromly, Cause and Origin Determination, Office of Fire Prevention and Control, Department of State, State of New York, undated).

MOTIVE VERSUS INTENT

Investigators frequently confuse "motive" and "intent." A motive is the reason for setting the fire, while intent is the deliberateness of the act. Motive is not necessary to prove the corpus delicti of the crime of arson. However, identification of the motive will assist the investigator during interviews. Frequently the prosecuting attorney may decline to file the case if the motive is not identified clearly. Or, the jurors may fail to find the accused guilty of arson, unless they understand why the crime was committed.

COMMON ARSON MOTIVES

Common basic motives frequently encountered by today's fire investigator include

- spite/revenge;
- pyromania;
- crime concealment;
- arson for profit;
- civil disorder, revolutions, and political activities;
- and
- vanity

The act of firesetting, whether committed by an individual, a gang, or even a cult, usually falls into one, or several, of the above categories. While not a motive in the strictest sense of the word, many fires are the result of the actions of juveniles. This unit, therefore, also will include a section on juvenile firesetting.

Spite/Revenge

At this time, spite or revenge is the most common motive encountered. It is found frequently in domestic disputes where fire is the preferred weapon for someone who wants to be removed from the physical act of violence. A spite fire is often the most deadly and can result in extensive loss of life. Almost every age group can be involved in this type of fire. These fires are initiated because of hatred, jealousy, or other uncontrollable emotions, and they may involve a lover' s quarrel or a bar fight; there may be racial or religious connotations.

Spite fires often result from a problem in a personal relationship and usually occur at night. They may involve the use of available combustibles, but often are set using flammable liquids as an accelerant. In such cases, articles of clothing may be gathered in a pile to be burned.

A vindictive person may target a valued possession, such as an auto, vehicle, tools, jewelry, or clothes for a spite fire. Statements made about neighborhood disputes can be a valuable tool in establishing spite as a motive for a fire. Be alert to signs of various types of emotional conflict, such as hostile work relationships, labor disputes, racial confrontations, or religious antagonisms.

Pyromania

Pyromania is defined as the uncontrollable impulse to start fires. This may or may not be connected with sexual desires or gratification. The composite characteristics/traits of a male pyromaniac may include all, some, or none of the following:

- He is a loner/loser.
- He may be extremely deceptive or cunning
- He may be suffering from some type of a setback
- He may get some type of sexual gratification from the fire.
- He usually uses available material for starting the fire.
- He may require a drink for courage to set the fire, but rarely is an alcoholic.
- He usually sets fires in areas with good access.
- His fires usually occur in buildings other than his own.
- He usually follows some type of activity pattern, i.e., setting numerous fires in the general area.
- He may not stay at the incident.
- He may travel aimlessly to avoid detection.
- He may even continue to set fires during incarceration.

Pyromania occurs in both sexes. Some of the characteristics/traits found in a female pyromaniac:

- She usually sets fires near her home.
- Her fires often are set in daylight hours.
- She usually sets small fires.
- She seldom uses an accelerant.
- She may not stay at the incident.

When apprehending and interviewing a pyromaniac, do not try to bluff the suspect. Avoid verbal abuse and scare tactics. The suspect is seldom aggressive and often there is a need to confess. A religious or moral interview approach may help. Help him/her realize the need for Professional help. Going back several years when questioning may reveal other fires. Attempt to get admission on one fire, then work on others.

Crime Concealment

In this motive arson is used to conceal other crimes. In all circumstances where a fire may have been set to cover a crime, efforts must be made to protect the scene.

When books or records are destroyed, the arsonist usually wants to cover up shortages of stocks, materials, cash, etc. Burglars may use arson to destroy evidence of forced entry, fingerprints and rifled drawers. Also, an owner may stage a burglary; this situation is difficult to investigate and requires an intensive follow-up investigation.

Sometimes fires are set some distance away from the scene of another criminal activity in order to draw attention away from the crime.

Arson may be used to conceal murder or suicide, or as a means of escape for prisoners or patients under confinement.

Recently, drug- and gang-related arsons have been increasing rapidly. Fires are set to conceal thefts of drugs or as revenge for a drug deal gone bad.

Arson For Profit

Fraud is defined as a deception deliberately practiced in order to secure unfair or unlawful gain. There are two types of arson-for-profit motive: direct and indirect.

In direct-gain fires, the fire usually is started for the collection of insurance moneys. Some of the more common reasons for direct fraud fires are:

- Economic conditions: unemployment causing the inability to meet mortgage and other payments; embarrassment among family or friends; inability to sell the property; condemnation proceedings levied against the building; estate or divorce settlement (disagreement over who gets what; money is easier to divide than property).

- Business problems: business failure or recession; completion of a season or contract; canceled orders; merchandise obsolete; a large inventory with no market; increasing business and the building is too small; a desire to redecorate; a lack of stock; partners who disagree; outstanding accounts; dissatisfaction with the location; changes in traffic patterns; desire to break a lease; a desire to retire; disappointing profits; and loss of insurance coverage.
- Vehicle profit fires: usually associated with mechanical problems; the vehicle is a lemon; trade-in value below the amount owed; or insurance value above trade or sale value.
- Earthquakes, floods, and hurricanes: insurance premiums are expensive, with high deductibles; fire may be the best alternative.

Arson for indirect profit includes those fires where the insured usually is innocent, while the firesetter benefits either directly or indirectly. These reasons include:

- Contracts: contractor seeking to make repairs; public adjuster (an independent contractor hired by the insured who works for a percentage of the claim) seeking contract; salvage dealer seeking a contract; or mortgage holder needing cash.
- Business: individual seeking employment; business competition; tenant fires; or landlord fires.

Arson for profit fires that can be associated with both direct and indirect gain include

- Organized crime: the fire may be used for extortion, intimidation, elimination of competition, or insurance fraud.
- Welfare fraud: individual desires new or different housing; victim moves to the top of waiting list or receives assistance from various agencies: Red Cross, Salvation Army, etc. Occasionally an individual receives additional money, food stamps, or clothing for the inconvenience of the fire.
- Insurance coverage: the amount of insurance is relative to the needs of the firesetter. Fraud can be used in both increased or decreased insurance coverage. An increase usually is a direct gain, whereas a decrease may remove suspicion.

Investigators must use caution when accepting property/content loss estimates from the fire department incident reports.

Civil Disorder, Revolution, and Political Activities

There has been an increase in acts of disturbance and terrorism being committed by groups of people seeking attention for their cause or beliefs. This type of arson/bombing has been found generally in urban areas. In these cases, fire often is used as a weapon. It produces destruction of property and creates an illusion that a large group of people is involved in the firesetting/bombing. These incidents are difficult to pursue, since the individuals/groups may travel from town to town. State to State, in carrying out their actions.

Fire/Bombing is often used as a show of power. These incidents may occur in labor disputes, political terrorism, or as an act of intimidation of the public and/or opponents.

Often this motive can relate to other motives, such as spite/vengeance, fraud, and crime concealment. The "credit" for the fire/bombing may not be taken by the responsible party, but by others seeking attention. Also, patterns can develop in these types of fires.

Vanity

There are basically two types of vanity fires. "Profit vanity" fires may be a form of indirect fraud. For example, a security guard or watchman may set one or more fires to secure a raise in pay, or an "on-call" firefighter may seek to secure his/her job position by setting and then extinguishing fires. Or, someone may set a fire to convince the business to hire him/her.

"Hero vanity" fires are incidents which many believe to be closely related to some form of pyromania. This would include a fire set by an individual who seeks attention by finding and extinguishing the fire.

Actions of Juveniles

Juveniles often are involved in many different types of fire setting. Between the ages of 4 and 12 both boys and girls often are naturally curious about fire. This curiosity does not have any criminal intent. If the child's intent was not to set fire to the building and/or if the act was intended as playing or experimenting with fire, then the incident should be listed as an accidental fire, not incendiary

The age of accountability in Federal law is 7 years old. Under the age of seven a child is not accountable. State laws may vary.

As noted above, the most common motive associated with fires set by 4 to 12-year-old juveniles is curiosity. However, some are motivated by revenge and others are attempts to cover up a crime. Crime cover ups usually are attempted by juveniles who are over 8 years old, and may be related to vandalism and influenced by television.

When fires are set by juveniles between the ages of 12 and 16 years, intent should be a primary consideration. Common motives for this age group include revenge (predominant in this age group, since fire may be the only weapon), profit (hired by landlords or property owners), pyromania (often confused with vandalism) and crime concealment (possible gang affiliation; usually involves vandalism).

Juvenile firesetters between the ages of 16 and 18 are most commonly motivated by revenge (often between rival gangs), profit (the "amateur torch"), pyromania, crime concealment (usually vandalism or burglary), or vanity (seeking notoriety)

Investigating fires set by juveniles requires identifying the method(s) used to set the fire, evaluating the availability of fuels and matches, and checking the youth's experience with fire. The time element may be critical—juveniles' fires often are set after school hours, on holidays or weekends, or during vacations. Typical locations include outbuildings, vacant occupancies, schools, under beds, closets, under porches, or other hidden places. Remember that firefighting operations (noise, lights, sirens, etc.) often fascinate children, especially young boys. Be aware of recurring problems in a certain geographic area.

Clues that may assist you in identifying a suspect are abnormal behavior, such as a child who shows little or no interest in the fire. If a child appears scared or shy, this can be a fear of detection, not a fear of the fire. A child who appears brave or fearless may be getting a kick out of the fire or may just be a loudmouth.

The investigator's responsibilities include following local policy regarding juveniles, proving intent (remember lack of intent removes the act of arson), and obtaining professional assistance for the juvenile and, possibly, the family.

Remember when dealing with juvenile firesetters that they have the same rights as adults. However, local statutes may vary and it is imperative that you follow established legal policies and procedures regarding juveniles.

When asking questions, use simple, understandable words. Remember that you are bigger than the child, so remain seated. In order not to cause intimidation avoid any verbal abuse or scare tactics, and gain assistance from parents if possible. It is always good to listen to the juvenile's story, then ask questions. Don't underestimate their intelligence.

Other Concerns/Motives

With the increase in gang activity across the nation, investigators must use interagency assistance or arson task force concepts. In Los Angeles alone there are approximately 600 gangs, and 70,000 registered gang members. (Gang members are registered by law enforcement agencies.) Gangs usually are territorial and are associated with certain crimes, and gang members form strong allegiances with

other gangs. Gang formation may be based on ethnic, racial, social, or geographical boundaries. Often gangs are identified by dress, tattoos, logos, graffiti, and characteristic hand signs.

Excitement, peer pressure, attention, or financial benefit are some of the reasons people join gangs. Lack of parental supervision, immaturity, or family tradition are among other reasons young adults join a gang. Gangs often are involved in rival confrontations as well as illegal crimes, including arson.

When there is gang involvement in a fire scene, witnesses may be reluctant to get involved because of intimidation, fear of retaliation, or extortion.

Business "fronts" sometimes associated with gang activity include car detail shops, car wash/body shops, and cellular telephone shops. However, there also are many reputable persons involved in such businesses.

Cults/Satanic Crimes

Cults/Satanists prey on insecure individuals who need reassurance, who are looking for answers, and who need confidence and affirmation. They masquerade their true identities with warmth and fellowship.

By "coercive persuasion" they force converts to do what they want. Cults establish rigorous standards, take away material possessions, and impose guilt. Questions are discouraged; intense group sessions and activities are used to inculcate group norms.

Crimes associated with cults/Satanism include burglary, vandalism, arson, graffiti, drugs, animal sacrifices, and even murder.

(See additional material on Satanic symbols/terminology in the Appendix.)

Serial Arsonists and Profiling

A serial arsonist is defined as an arsonist involved in three or more fires, with a characteristic cooling-off period that may last for days, weeks, or even years between fires. The targeted victims, the unpredictable gaps between incidents and the fact that a serial arsonist can start many fires during one episode make this particular form of compulsive firesetting extremely dangerous.

Characteristics of a typical serial arsonist include

- single white male;
- Twenty to 27 years old;
- raised in an unstable family environment;
- high-school educated;
- considered an underachiever by educational professionals;

- sloppy and unkempt in appearance;
- poorly adjusted socially and sexually;
- if married, usually has periods of separation;
- feels as though he is taken advantage of;
- subject to infantile behavior and fits of rage;
- feels a sense of satisfaction after the fire; and
- when arrested, shows no remorse.

The goal for investigators is to find common characteristics in serial arsons, determine the method of operation used by the arsonists, identify characteristics that differentiate motives for serial arsonists, and construct an intelligence system that will provide investigative consultation in serial arson crimes.

Arson profiling is only part of the criminal investigative analysis. A number of different factors need to be considered, including:

- a detailed study of the crime scene;
- area demographics;
- a review of maps;
- aerial photography;
- * a review of fire and police reports;
- an analysis of the time, day, week the fires are set;
- possible motives; and
- experience of the investigative staff.

Subsequently, there is a need to develop an intelligence system that will provide investigative consultation in serial arson crimes.

The Federal Bureau of Investigation (FBI) and the Bureau of Alcohol, Tobacco and Firearms (BATF) can assist local investigators in the following areas:

- interview strategies;
- case consultation;
- criminal investigative analysis;
- profiling;
- prosecutorial assistance; and
- courtroom testimony.

SUMMARY

This unit has shown that identifying motive assists the investigator throughout the investigative process. Identifying a motive can assist in developing a line of questioning during the interview process. The prosecuting attorney may not file the case without an identified motive and jurors may not find the accused guilty without knowing why the crime of arson was committed.

The common basic arson motives frequently encountered by today' s investigator have been discussed at length. Your ability to understand the reasons people set

fires will provide assistance in identifying a suspect or suspects for the fire.

The act of firesetting is not normal; however, there is a reason behind every deliberately set fire. Knowing that reason or where to turn for assistance is another tool in combating the crime of arson. Remember, even if you identify a motive, it still does not have a bearing on your origin and cause investigation.

BIBLIOGRAPHY

Baner,PaulB. Manual on Satanism. South Carolina Criminal Justice Academy, 1988.

Bates, Edward B. Elements of Fire and Arson Investigation. Santa Cruz: Davis Publishing Co., Inc., 1975.

Carter, Robert E. Arson Investigation. Encino: Glencoe Publishing Co., 1978.

DeHaan,JohnD. Kirk' s Fire Investigation, 3rded. New Jersey: Brady,1991.

Denny, James P., and Donald Lee. Gang Recognition and Tactical Response. Los Angeles: Denny Publication Inc., 1993.

Higgins, Stephen E. "Portrait of a Serial Arsonist." Firehouse, Aug. 1990.

Icove, David J., and M.H. Estep, "Motive-based Offender Profiles of Arson and Fire Related Crimes." FBI Law Enforcement Bulletin, June-Aug. 1980.

Metoyer,Pat. "Occult." Police, Feb. 1987.

Parsons Walt. Satanic/Cult Awareness. Arvada: Arvada Police Department Bulletin, 1989.

Rider, Anthony Olen. "The Firesetter: A Psychological Profile." Fire and Arson Investigator, Oct-Dec. 1980; Jan.-Mar. 1981.

USFA. Child Firesetter Handbook. (2 volumes) Emmitsburg: USFA, 1990.

USFA. Adolescent Firesetter Handbook, Ages 14-18. Emmitsburg: USFA, 1990.

MATERIAL ON SATANISM

SYMBOLS



The "upside down" cross is an inverted Christian cross.

The Inverted Cross

The early 1960' s peace symbol is now commonly thought of as the "Cross of Nero" by heavy metalheads and occultists.



Cross of Nero



The "Ankh" is an ancient magical Egyptian symbol for life. The top portion represents the female and the lower portion the male.

The Ankh

The "Cross of Confusion" is an ancient Roman symbol questioning the existence or validity of Christianity



The Cross of Confusion

666

FFF

99
6



Four different ways to refer to the "Mark of the Beast, or Satan." Note that the letter "F" is the sixth letter of the alphabet

Various Versions of the Mark of the Beast

Here, the moon goddess "Diana" and the morning star of "Lucifer" are represented. This symbol is found in nearly all types of witchcraft and Satanism. When the moon is turned to face the opposite direction, it is primarily Satanic



The pentagram, or, without the circle, the pentacle is used in most forms of occult. Magic spirit conjured within the pentagram supposedly cannot leave the circle without permission. Witches generally conjure spirits from outside the pentagram while Satanists can submit to possession by the spirit by standing within the pentagram while calling up a demon. Generally,

the top point represents the spirit, and the other points represent wind, fire, earth, and water.

The upside down pentagram, often called the "baphomet," is strictly Satanic in nature and represents the goat's head



The hexagram, also referred to as the "Seal of Solomon," is said to be one of the most powerful symbols in the occult

The Roman symbol of justice was a double-bladed ax in the upright position. The representation of "antijustice" is inverting the double-bladed ax



Triangle

The "triangle" may vary in size, but is generally inscribed or drawn on the ground and is the place where a demon would appear in conjuration rituals

The "circle" has different meanings; one symbolizes eternity. Another implies protection from evil without and power within. When used for ritual, it is 9 feet in diameter

A "talisman" or "amulet" is an object with drawing or writing inscribed in it of a god's name or image of a supernatural power



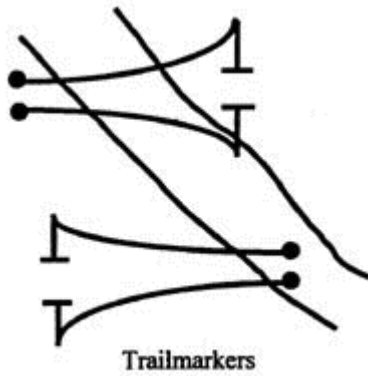

Trail Markers

There are many forms of directional trail markers used by formal and casual occult groups alike. These markers indicate locations where occult activities may take place and how to get there. The markers depicted below show a small circle or starting place, then a direction to be taken. The rise or fall of the line shows hills and valley-type terrain. Other marker types

could be a pentagram on the right or left side of a road, trail, or even on a house or a building.

The inverted cross of Satanic justice is often found carved into a traitor' s chest. It also is used as a backdrop near "baphomet" for curse and compassion rituals. The center vertical line indicates man' s presence. The horizontal line indicates eternity, past and future. The arch indicates the world. The inverted cross appearance symbolizes the defeat of Christianity.

The sexual ritual symbol is used to indicate the place and purpose. It is often carved into a stone or painted on the side of the road to show present use of the location

The blood ritual symbol represents human and animal sacrifices

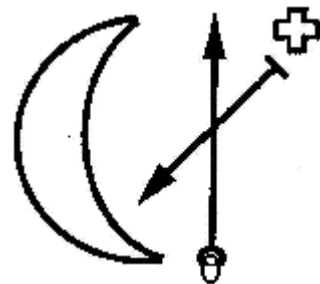

.Black mass indicators.

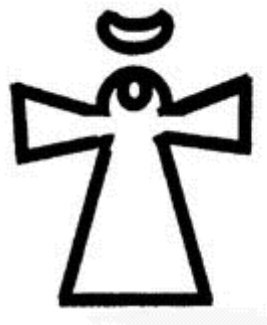

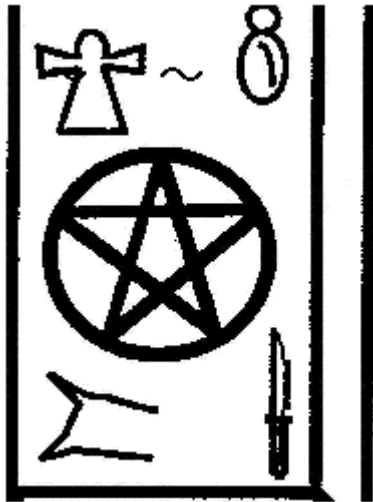

The altar may be any flat object on which the implements of the ritual are placed. The altar usually will be placed within the 9-foot circle. This diagram shows a marble or granite slab 48" x 22" x 22". The pentagram in the center is etched into the slab. Human or animal blood is then poured into the etching. Other symbols may be carved into the slab according to individual group traditions. Implements that could be placed on the altar would include athame, chalice, candles, parchment, cauldron. Book of Shadows, etc.

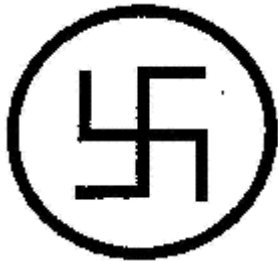

The "Swastika" or "Broken Cross" is of ancient origin. Originally, it represented the four winds, four seasons, and four points of the compass. At that time, its arms were at 90° angles turned the opposite way from that depicted here. The "Swastika" shown here shows the elements of forces turning against nature and out of harmony. Nazis and occult groups use it in this manner

The symbol of "anarchy" represents the abolition of all law. Initially, those into punk music used this symbol, but it is now widely used by heavy metal followers and Satanic dabblers.



Legal Considerations

OVERVIEW OF THE INVESTIGATIVE ROLE

Origin and cause investigation reveals information vital to improving the safety of consumer products, residential and commercial buildings, and to developing codes and other regulatory measures to protect life and property. Fire investigation also uncovers the objective facts necessary for courtroom use. When a determination is made that a fire is the result of criminal action, a competently conducted professional fire investigation provides the reliable evidence on which a successful prosecution depends.

A fire investigator's decisions and actions must meet juridical standards for admissibility and they also must be convincing to a jury. A competent professional fire investigator must understand and properly apply search and seizure law and the law of confessions, if the information developed in the course of the investigation is to reach the jury. This module of the fire investigation course familiarizes investigators with some of the key legal concepts necessary for successful criminal prosecution.

SOURCES OF AMERICAN ARSON LAW

Common Law

Modern American arson law derives, in part, from the traditions of English common law. The common law is a distillation of the legal principles relied *on* by judges over several hundreds of years. The common law of England defined arson as the willful and malicious burning of the dwelling house of another. The term "dwelling house" at common law included all the buildings in close proximity to the residence itself. These "structures appurtenant" are sometimes referred to as the "curtilage." The common law principle of special protection for dwellings is reflected in the United States Constitution's Fourth Amendment and remains a central concept in today's law of search and seizure.

Statutory Law

In most States, arson is defined by statute. Statutes are the product of legislative action. Statutes not only define the substance of the crime of arson, but also define the procedural steps in criminal prosecutions. Arson, which is proscribed by statute, generally is broader in scope than common law arson. Statutory arson typically protects business and commercial buildings, in addition to dwellings. Motor vehicles, also, generally are protected under arson statutes. Most jurisdictions statutorily prohibit insurance fraud by arson; at common law fraud generally was a form of larceny by trick. Judges make law through the process of judicial

interpretation of statutes. When the legislature's intent is expressed clearly in a statute, courts are required to apply the plain meaning of the legislature's words, but when the language of a statute is ambiguous, or when two or more statutes appear to be in conflict, courts are allowed to interpret and clarify the legislature's intentions. Only when a statute infringes on a constitutional right, can a court overrule legislative intent and declare a statute legally void.

Congress has defined Federal arson statutorily at 18 U.S.C. 844 and it applies to "whoever maliciously damages or destroys or attempts to damage or destroy, by means of fire or an explosive, any building, vehicle, or other real or personal property used in interstate or foreign commerce or in any activity affecting interstate or foreign commerce..."

In *U.S. v. Viscome* (6/18/98 No. 96-3049), the eleventh circuit found that a City of Palm Harbor Florida park department truck was in interstate commerce because it was leased from a Ford motor company dealer based in Atlanta, Georgia. In *U.S. v. Dascenzo* (8/31/98 No. 96-3621), the eleventh circuit quoted *Russell v. United States* 471 U.S. 858 (1985), finding that 18 U.S.C. 844 was "intended to protect all business property... but perhaps not every private home." *Dascenzo* upheld Federal jurisdiction because the home was a rental and rental property, in general, has an interstate effect.

California's Penal Code at Section 451 statutorily defines arson as willful and malicious setting of fire to, or causing to burn, any structure, forest land, or property.

New Jersey's arson statute defines arson as purposely starting a fire or causing an explosion that recklessly places another person, building, or structure in danger, or with the purpose of collecting insurance, or with the purpose of evading state, or local property use laws. See 2C: 1 7-1 (b).

Criminal Liability Theories Related to Arson

Attempt: An attempt occurs when a "substantial step" is taken toward the completion of a specific crime. A robbery is an attempt if there is no money in the cash drawer because there is no "taking" of property by force or fear.

Conspiracy: A conspiracy to commit a crime occurs when two or more persons "agree" to commit a crime and there is at least one "overt act in furtherance" of the planned crime. The existence of the conspiratorial agreement generally is established by circumstantial evidence. The overt act in furtherance of a conspiracy may be entirely legal in itself. An example of this would be the buying of gasoline with the intent to use it as an accelerant. Statements made by a co-conspirator during the course of and in furtherance of the conspiracy are admissible evidence as an exception to the hearsay rule of evidence. *Kruiewitch v. U.S.*, 336 U.S. 440 (1949). The rationale justifying admission of co-conspirator's statements comes from the law of agency. It is said that the participants in a conspiracy are agents for the others. *U.S. v. Perez*, 989 F.2d 157411577, (10th Cir. 1993).

Conviction of both a criminal attempt and a conspiracy can occur because there are separate elements of proof. A conspiracy requires at least two individuals and an attempt does not; because there are separate elements, there are separate crimes. On the other hand, an attempted crime "merges" into the completed crime and a conviction for both an attempt and the same completed crime is unlawful.

Criminal Intent

Arson is a "general intent" crime. Proving any crime requires evidence of both a **criminal intent** and of an act. The essence of the crime of arson is an incendiary

and, therefore willful, burning of property. A willful setting fire to or burning would be such an act consciously and intentionally, as distinguished from accidentally, involuntarily, or negligently done, and implies that the act must be done knowingly and according to a purpose. (5 Am. Jur. 2d Arson and Related Offenses section I I, p. 808.)

Defendant stole a car, drove it to a position blocking the front entrance to a church and spread motor oil as an accelerant. He then lit a fire in the car and the burning car ignited the church.

The sentencing court heard testimony from the fire chief, an emergency medicine physician, and a Bureau of Alcohol, Tobacco and Firearms (ATF) origin and cause expert concerning *tine* dangers to firefighters posed by such an occurrence. The court enhanced the sentence finding that the arson created a danger to firefighters and that the proximity of the church parsonage to the burning church also created a risk to persons justifying sentence enhancement.

The sixth circuit reversed, finding that the defendant did not "knowingly" create a substantial risk of death or great bodily injury to the firefighters. The circuit court used the model penal code definition: a person acts "knowingly" when "...he is aware that it is practically certain that his conduct will cause such a result" (MPC 2.022 (2) (b)(ii)) The enhanced sentence was allowed to stand, though, based on the proximity of the parsonage. *U.S. v. Johnson*, (8/17/98 No. 97-5323)

To prove an attempt or a conspiracy, there must be evidence of a "specific intent." This difference between general intent and specific intent crimes is important in an investigation because certain criminal defenses are allowed to specific intent crimes, but are not allowed for general intent crimes. Intoxication is an example of a defense to a specific intent crime, but intoxication is not a defense to general intent crimes.

In some jurisdictions, recklessness is a sufficient intent to sustain a conviction for arson. New Jersey' s arson statute states: "A person who knows that a fire is endangering life or a substantial amount of property of another and either fails to take reasonable measures to put out or control the fire, when he can do so without substantial risk to himself, or to give prompt-fire alarm, commits a crime of the fourth degree if ...(2) the fire was started, albeit lawfully, by him or with his assent, or on property in his custody or control." 2C: 1 7-1 (c).

A person is guilty of unlawfully causing a fire when he recklessly sets fire to or burns or causes to be burned, any structure, forest land, or property." California Penal Code 452.

"Recklessly means a person is aware of and consciously disregards a substantial and unjustifiable risk that his or her act will set fire to, burn, or cause to burn, a structure, forest land, or property." California Penal Code 450.

In a typical civil suit, an actor is held legally responsible for all the reasonably foreseeable consequences of his/her acts.

Generally, persons under the age of majority, "juveniles," are prosecuted in special courts. Most states have procedural rules, which limit the age at which a juvenile may be tried in an adult court, and there is considerable variation among the various State juvenile systems. In the Federal system, a juvenile cannot be charged if the child is under 7 years of age. The rationale given is that a child under this age cannot form the necessary criminal intent.

Burdens of Proof

In a criminal case the government, at all times, bears the burden of proof and must prove every element of each offense charged "beyond a reasonable doubt."

In a civil suit, the burden of proof is on the proponent of a fact and the standard of proof is preponderance of the evidence, which sometimes is described as more likely than not, or "51."

Legal Obligations of the Prosecutor

In *Brady v. Maryland*, 373 U.S. 83 (1963), the Supreme Court held that the U.S. Constitution requires the prosecutor to locate and disclose to the defense in any criminal case, all evidence developed by investigators which may tend to show that the defendant did not commit the crime charged (exculpatory evidence), and all evidence which might reduce the punishment of the defendant (mitigating evidence). Although not an obligation of the prosecutor, at least two State supreme courts have recognized an affirmative duty upon crime scene investigators to collect potentially exculpatory evidence. The general rule is that there is no such duty. See *Daniels v. State*, 956 P. 2d 1111 (Nev. 1998). Because the Brady decision was constitutionally based, it is law in all States.

Ignorance of the prosecutor as to the existence of exculpatory or mitigating evidence is no excuse. MRPC 3.8 (d). The model rules of professional conduct (MRPC) are adopted as substantive law in most States.

Another model rule of professional conduct, MRPC 3.6, makes it unlawful for a prosecutor to make any public disclosure about a criminal case which:

- relates to the criminal history of any suspect, defendant, or witness or the anticipated testimony of any of these persons; or
- relates to the existence or content of any confession or statement or a refusal to make any statement; or
- relates to the results of any scientific testing of any evidence; or
- relates to the description of any physical evidence.

Prosecutors also are legally required to prevent the disclosure of any of this information by others, including investigators or other public officials.

Prosecutors or investigators who knowingly conceal exculpatory or mitigating evidence lose qualified immunity under Federal civil rights laws and may incur both civil and criminal liability. Where a court finds that exculpatory evidence has been concealed, dismissal of charges against the defendant is a distinct probability.

THE FOURTH AMENDMENT

"The right of the people to be secure in their persons, houses, papers, and effects, against unreasonable searches and seizures, shall not be violated, and no Warrants shall issue, but upon probable cause, supported by Oath or affirmation, and particularly describing the place to be searched, and the things to be seized." Fourth Amendment to the U.S. Constitution.

The purpose of the Fourth Amendment is to prohibit general searches and/or seizures by law enforcement officers. The Fourth Amendment to the U.S. Constitution applies to the States by operation of the Fourteenth Amendment's "due process" clause under the U.S. Supreme Court holding in *Mapp v. Ohio*, 367 U.S. 643 (1961). The Fourth Amendment contains two key clauses. The first is sometimes described as the "reasonableness" clause; the second, as the "warrants" clause.

The Fourth Amendment protects expectations of privacy that society is prepared to recognize as "reasonable" as opposed to purely subjective expectations. *Katz v. U.S.*, 389 U.S. 347 (1967). Only individuals who have a "reasonable expectation of privacy" in the place or thing in issue have the legal right to challenge a search or seizure, i.e., "standing." *Rakas v. Illinois*, 439 U.S. 128 (1978).

After a residential fire in a house occupied by a mother and adult son, investigators determined the point of origin to be in the mother's bedroom closet where they seized an electric heater. The cause was determined to be accidental. The heater seizure was not authorized by continuous presence, consent, or warrant. Later, the son bragged about starting the fire and the heater was retrieved, examined, and found to have been packed with combustibles. At the son's trial, he moved to exclude the heater and all derivative evidence as seized unlawfully. Held: son lacks "standing." *State v. Pichard* 954 P.2d 338 (Wash. 1998).

Observations into a greenhouse where marijuana was being cultivated, from a police helicopter flying within public airspace, did not violate any reasonable expectation of privacy. *Florida v. Riley*, 488 U.S. 445 (1989).

Officers present in an apartment to conduct a protective sweep moved a piece of electronic equipment to read a serial number. This was held to be an unreasonable search. *Arizona v. Hicks*, 480 U.S. 321 (1987).

The requirements for issuance of a valid search warrant are

- oath;
- probable cause;
- particularity of places and things; and
- neutral and detached magistrate.

Probable cause is not proof beyond a reasonable doubt. It is a flexible, non-technical probability that incriminating evidence is likely to be found at a particular place or that a particularly identified person has committed a crime. Probable cause is determined by application of the "totality of the circumstances" test. *Illinois v. Gates* 103 S.Ct. 2317 (1983). Remember that the Fourth Amendment warrants clause applies both to searches of places and to seizures of persons or things.

If each of these four warrant requirements is supported by sufficient facts, to the judge' s satisfaction, in the warrant application, the judge will sign the warrant commanding officers to search the specific place and seize the items or person particularly described.

Search or Seizure

A search or seizure, which is made under the authority of a warrant, is presumed to be constitutional during any court proceedings. A search or seizure, which is made other than by search warrant, i.e., under an "exception" to the warrant clause, is presumed to be unconstitutional.

Remember that the exclusionary rule was created by the Supreme Court to punish what it perceived as abusive police practices. *Mapp v. Ohio* 367 U.S. 643 (1961). Courts will uphold searches which are marginal if the warrant process has been followed, but will find a violation of the Constitution on those same facts, if the warrant process is not followed.

One common challenge to a search warrant involves a claim that the information provided to the judge failed the probable cause test. If a trial or appellate court reweighs the evidence and does not believe the evidence used to obtain the warrant was sufficient, the search warrant, and therefore all the evidence seized under that warrant' s authority and all the evidence derived from that warrant, would, by operation of the exclusionary rule, be unavailable for use at trial. This illogical "punishment" of the officer for the issuing magistrate' s legal error concerning probable cause led to the Supreme Court' s creation of an exception to the exclusionary rule. This exception to exclusion is known as the "good faith" exception.

"Good Faith" Exception

The Supreme Court's exclusionary rule has had a major impact on the investigation of criminal cases. The Court's ruling that exclusion under the Fourth Amendment is constitutionally based means that not only is the evidence excluded which was set out in the defective warrant, but also all derivative evidence is excluded as "fruit of the poisonous tree." The rationale is that law enforcement should not be allowed to gain any investigative advantage from a violation of constitutional rights.

The practical effect of applying the exclusionary rule and excluding evidence generally is that the key evidence cannot be admitted or even discussed at trial and criminal prosecution becomes impossible. Because the Court has been criticized for this result, there has been a trend to limit the scope of the exclusionary rule.

In *U.S. v. Leon* 468 U.S. 897 (1984), the Court announced a "good faith" exception to exclusion. When the defense convinces a reviewing court of insufficient probable cause in the warrant application, the government may introduce evidence which establishes that the investigator making the application acted in "good faith" by following the warrant process. When this showing is made, the good faith exception to exclusion applies and the evidence is admissible at trial unless the defense can show that:

- The issuing judge was deliberately misled by false or recklessly indifferent information in the application. *Franks v. Delaware* ' 154 (1978); or
- The issuing magistrate abandoned his/her neutral and detached role; or
- The warrant failed to particularize the location to be searched and the items to be seized; or
- The probable cause statement was so weak that no reasonably well-trained officer could have believed it legally sufficient.

Attacks on the sufficiency of search warrants based on a claim of misleading require that the false or misleading statement be legally "material" to the finding of probable cause. "Where a defendant makes a substantial preliminary showing that a false statement knowingly and intentionally or with reckless disregard for the truth, was included by the affiant in the warrant affidavit, and if the allegedly false statement is necessary to the finding of probable cause, the Fourth Amendment requires that a hearing be held at the defendant's request".... and if the falsity is established by a preponderance of the evidence, suppression follows. *Franks* at 155-56.

Another attack on searches by warrant is based on the actual execution of the warrant. Remember, the Fourth Amendment contains both a "warrants" and a "reasonableness" clause. One example of a reasonableness clause requirement is the "knock and announce" rule. In *State v. Cohen* 957 P.2d 1014 (Ariz. App. Div. 1 1998), officers made eye contact as they approached a townhouse to serve a search warrant for drugs. The first officer knocked and announced, then paused for "maybe a second" before entering through a screen door. The front door was

open. The appellate court excluded the evidence, finding this was essentially a "no-knock" warrant execution and "unreasonable."

Stop-and-Frisk Exception to the Warrant Requirement

For Fourth Amendment purposes, a seizure of the person occurs when a government agent intentionally interferes in a substantial way with a citizen's freedom of movement. *Brower v. County of Inyo* 486 U.S. 593 (1989).

"Interference with a person need not be accomplished by means of physical force, but may result from a mere show of authority. Our cases show, moreover, that a police officer has seized a person ... if that person believes that he or she has been seized and that belief is objectively reasonable. Finally, our cases hold any examination into whether an encounter between a police officer and a citizen constitutes a seizure is necessarily a fact specific inquiry into the totality of the circumstances of the particular case." *State v. Juarez-Godinez* 942 P.2d 772 (Or. 1997).

In *Terry v. Ohio* 392 U.S. 1 (1968), the Court authorized a limited purpose and duration seizure on a "reasonable suspicion" that a crime was planned or in progress; however, "when actions by the police exceed the bounds permitted by reasonable suspicion, the stop becomes an arrest and must be supported by probable cause. *U.S. v. Robinson* 949 F.2d 851 (6th Cir. 1991). *Terry* is unique because it is both an exception to the warrant requirement and an exception to the probable cause requirement.

Conduct which may convert a stop and frisk into an arrest includes physical restraint, detention, in a police vehicle, display of weapons, or the use of handcuffs. A reviewing court balances the restrictions imposed by the officers on a detainee and the law enforcement purpose being served at the time, against the individual's liberty interest *U.S. v. Sharpe*, 470 U.S. 675,685 (1985); and *Maryland v. Wilson*, 519 U.S. 408 (1997).

"Where a police officer observes unusual conduct which leads him reasonably to conclude in light of his experience that criminal activity may be afoot and that the persons with whom he is dealing may be armed and dangerous, where in the course of investigating this behavior he identifies himself as a policeman and makes reasonable inquiries, and where nothing in the initial stages of the encounter serves to dispel his reasonable fear for his own or others' safety, he is entitled for the protection of himself and others in the area to conduct a carefully limited search of the outer clothing of such persons in an attempt to discover weapons which might be used to assault him." *Terry* at 30.

Fire Scene Control

A problem can arise on fire scenes when individuals with an interest in the property or mere bystanders attempt to enter the scene or interfere with the investigation. Most jurisdictions have statutes prohibiting "obstructing or

interfering with an officer" and "disorderly conduct." Protecting the integrity of the scene is a recognized and legitimate law enforcement duty, but there have been changes in the limits of officers' lawful use of these statutes.

The "reasonableness" clause of the Fourth Amendment requires a narrow construction for these statutes. Public criticism of officers, including fire investigators, has been held to be "protected speech" under the First Amendment. "Obstructing" law generally does not allow individuals to be arrested or removed from scenes simply for critical speech directed at officers. Physical activity, which actively interferes with an investigation, or damages the integrity of a scene is not constitutionally protected and investigators should take reasonable measures to protect themselves, bystanders and crime scenes in these circumstances. See *Bufflans v. City of Omaha* 922 F.2d 465 (8th Cir. 1990), citing *Houston v. Hill*, 482 U.S. 451(1986).

Individuals present at scenes who refuse to identify themselves are another delicate problem. If they are reasonably suspected of committing a **crime**, there is a basis for continued detention for a limited *terry* investigation, but an arrest solely for refusing to identify is constitutionally suspect. The scope of an investigative detention requires use of the "least intrusive means reasonably available to verify or dispel the officer' s suspicions in a short period of time. *Florida v. Royer* 460 U.S. 491(1983).

Plain View Exception

One of the most important exceptions to the warrant clause is the exception recognized by the Court for seizure of evidence in plain view. A constitutionally valid seizure of evidence can be made when an officer is present lawfully, observes in plain view an obviously incriminating item, and the officer also has a lawful right of access to that item. *Norton v. California* 496 U.S. 128 (1990).

If officers create circumstances which could have been avoided and attempt to rely on an exception to the warrant requirement, courts generally find a Fourth Amendment violation. *State v. Foldesi* 963 P. 2d 1215 (Idaho App. 1998). Exigent circumstances pose an immediate and substantial danger to life or property, destruction of evidence, or flight of a suspect.

***Michigan v. Tyier* 98 S. CT. 1942 (1978)**

A furniture store was discovered burning about midnight and firefighters responded. During the suppression two cans of flammable liquid were found on a showroom floor. A fire investigator responded and he, in turn, involved a police detective. Due to darkness, smoke, and steam, they left the scene and returned some five hours later. At this time, the investigators observed a pour pattern on the carpet. They left the scene a second time to obtain tools, returned, and took carpet and debris samples for testing. Three weeks later a State investigator

conducted further investigation that was important to the case. None of the entries by investigators involved search warrants or consent.

The Supreme Court stated that even if the owner had burned the property intentionally, arson does not establish abandonment of Fourth Amendment protections. "A search of private property without proper consent is unreasonable unless it has been authorized by a valid search warrant—the showing of probable cause necessary to secure a warrant may vary with the object and intrusiveness of the search, but the necessity for the warrant remains." *Tyler at 194S*.

The Supreme Court then discussed the kinds of facts necessary to justify issuance of an administrative search warrant to determine the origin and cause of a fire. It is suggested that there should be a statement concerning:

- a recent fire of undetermined cause;
- the number of entries already made at the scene;
- the scope of the search proposed to be made;
- the time of day for the search proposed;
- the time elapsed since the fire was controlled;
- whether there is a continuing use of the building; and
- whether there have been attempts to secure the building against intruders.

"Officials need no warrant to remain in a building for a reasonable time to investigate the cause of the blaze." *Tyler at 1950*.

Michigan v. Clifford 104 S. CT. 641 (1984)

A fire was reported in a residence during the early morning hours. The residents were out of town. Six hours later, a fire investigator arrived and found a construction crew boarding up the windows and doors and pumping water out of the basement. The investigator entered and located a point of origin in the basement under a staircase. There was a strong smell of flammable liquid. Two cans of Coleman™ fuel are found in the basement, and a plugged-in crockpot with a timer set for early morning hours was found under the staircase. The investigator checked upstairs and found old clothing in drawers, nails in walls without pictures, and stereo connections without the electronics in place. The entries and seizures were without consent or warrant

The Supreme Court restated that an administrative search warrant was necessary unless there was continuous presence or consent and that the requirements for an administrative search warrant were a fire of recent undetermined cause, and a proposed search, which was limited in its scope and duration so as to minimize the intrusive effect

If the primary objective of the search is to gather evidence of criminal activity, a criminal search warrant is required based on a showing of probable cause to believe that a crime has occurred and that evidence of that crime is located in a particular place. If the object of the search is an origin and cause investigation, an administrative search warrant is sufficient. When evidence of criminal activity is

discovered in the origin and cause search, the evidence may be subject to seizure under the plain view doctrine, but a criminal search warrant provides *officer* assurance that the evidence will be admissible and the search and seizure held to be constitutional. In *Clifford*, "because the cause of the fire was then known, the search of the upper portions of the house described above could only have been a search to gather evidence of the crime of arson...such a search requires a criminal warrant. After the blaze has been extinguished and the fire and police units have left the scene, we hold that a subsequent post-fire search must be conducted pursuant to a warrant, consent, or some new exigency. So long as the primary purpose is to ascertain the cause of the fire, an administrative search warrant will suffice." *Clifford at 649*.

Methods for Lawful Access at Fire Scenes

Consent is another key exception to the warrant clause by which to conduct lawful searches or seizures at fire scenes. Consent is not an exigency-based exception to the warrant requirement.

Effective consent requires

The person giving consent to search must have a present possessory interest in the place or property. *U.S. v. Matlock* 415 U.S. 164 (1974). Hotel clerks or nonresident landlords cannot give valid consent for rented or leased premises. *Stone v. California* 376 U.S. 483 (1964).

Consent must be given freely and voluntarily. *Schneckloth v. Bustamonte* 412 U.S. 483 (1973). Intimidation or coercion voids consent. *Florida v. Bostick*, III S. Ct. 2382 1991. In requesting consent, a statement that consent may be refused reduces the chance that a reviewing court will find coercion. *U.S. v. Mendenhall*, 446 U.S. 544 (1980).

The burden to prove a free and voluntary consent to search is on the government and the presumption of unconstitutionality applies because consent is an exception to the warrant requirement. Generally, written consents are of greater evidentiary weight than oral consents.

One constitutionally questionable practice is the so-called "knock and talk" encounter. In *State v. Powelson* 961 P.2d 869 (Or. App. 1998), investigators developed information of a marijuana growing operation at a residence. The investigator concluded that he had sufficient information to establish probable cause, but instead of applying for a search warrant, he and three other officers went to the defendant's home and requested consent to search. The defendant was told that if he did not consent to a full search, he would be detained until the officers could make application for a search warrant "He could sit in his house with an officer. He could ask us all to leave, which we would do. Then he would come outside, or he could sit in a holding cell." *Powelson at 571*. "Defendant believed that he was not 'free' after the officers entered the house, and under the circumstances, an objectively reasonable person would have believed the

same...unlawful police conduct may render a subsequent consent involuntary when the illegality has an effect on the state of mind of the person giving consent, affecting whether the consent is a voluntary act of that person's free will." *Powelson* at 873. The evidence was excluded.

THE FIFTH AMENDMENT

"No person...shall be compelled in any Criminal Case to be a witness against himself..." U.S. Constitution, Fifth Amendment

The chief justice of the California Supreme Court summarized confession rules recently in *People v. Peevy* 953 P.2d 1212 (Cal. 1998). "In order to protect the exercise of the privilege against self-incrimination, the United States Supreme Court has declared that persons subject to custodial interrogation must be informed of certain rights, including the right to counsel, and that once such a person invokes the right to counsel, the police must cease interrogation until counsel is provided, or the suspect initiates further contact and makes it clear that he wishes to proceed without counsel." (citations omitted)

One problem area with confession law involves ambiguous or equivocal requests for counsel. In *Davis v. United States* 512 U.S. 452, 457 (1994), the U.S. Supreme Court held that "after a knowing and voluntary waiver of the Miranda rights, law enforcement officers may continue questioning until and unless the suspect clearly requests an attorney." Four justices concurred in the result but preferred a rule which requires law enforcement officers faced with an ambiguous request for counsel to "stop their interrogation and ask him to make his choice clear." *Davis* at 460. Ambiguous statements include: "I do want an attorney before it goes much further," "I want an attorney before making a deal," "I think I might need a lawyer," "Will you supply a lawyer now so that I can ask him if I should continue with this interview at this moment?" *Davis* at footnote 7.

The U.S. Supreme Court has decided that a statement taken in violation of these rules is inadmissible at trial in the prosecution's case in chief, but is admissible to impeach the defendant's credibility as a witness, so long as the statement is otherwise voluntary.

Involuntary or Coerced Statements

"To assess whether a confession is the result of coercion, we consider the totality of the circumstances, including whether the police administered the Miranda warnings, the place of interrogation, the duration of questioning, whether the questioning was continuous, and the defendant's maturity, education, physical condition, and mental health." (citations omitted).

Interrogation over a four-hour period while the suspect was sedated in an intensive care hospital constituted coercion in *Mincey v. Arizona* 437 U.S. 385 (1978). Although the right to remain silent must be scrupulously honored once

invoked, it generally cannot be invoked "anticipatorily," which is to say, before custodial interrogation occurs or is "imminent." This is the rule in the second, seventh, ninth, and eleventh circuits and the U.S. Supreme Court has never recognized that Fifth Amendment rights can be anticipatorily invoked. *McNeily. Wisconsin* 501 U.S. 171,182(1991).

In *U.S. v. Grimes* (6/8/98 No. 96-2916), the eleventh circuit considered this issue when a bomber was incarcerated for worthless checks.

Investigators enlisted the cooperation of an acquaintance of Grimes who tape-recorded phone conversations the defendant made to him from the jail; they then asked the acquaintance to elicit incriminating statements from Grimes during the calls. The acquaintance told Grimes that he knew some "businessmen" who were interested in hiring a man with expertise in bombing. Grimes was released from jail and met with the "businessmen" where he discussed details of the fatal bombing under investigation.

Does Grimes' invocation of his right to remain silent on the worthless check charges bar his statements on the phone or to the "businessmen?" No. What Grimes told his acquaintance in the site calls was not "interrogation" and when he met with the "businessmen" after his release from jail, he was not in custody. Statements made to cellmates or officers posing as prisoners are admissible on the same rationale, i.e., Miranda was aimed at the coercive combination of custody and official interrogation.

Deception

There is a possible trend in State courts to find that some police misrepresentations to suspects during interrogation may constitute a form of coercion. Police deception, which proximately causes a confession, may be unconstitutional on State grounds. *People v. Musselwhite* 954 P.2d 475,489 (Cal. 1998).

On-the-Scene Statement

Statements made without "custody" are admissible without Miranda warnings. Information obtained in general on-the-scene questioning is admissible only with a "voluntariness" showing.

Juvenile Interrogation

A large minority of State courts consider juveniles incapable of giving a valid Miranda waiver without first consulting with a lawyer or parent. The totality of the circumstances test generally is employed and takes into account variables such as the suspect' s age, prior contact with law enforcement, education, mental and physical condition, and the circumstances of the interrogation. *Fare v. Michael C.*,

442 U.S. 707, 725, (1979); Matter of B.M.B. 955 P.2d I I I (Kan. 1 998). Rules concerning juvenile interrogation are highly variable and it is particularly important to be familiar with local and State rules in these cases.

COURTROOM PREPARATION

Preparation for the courtroom begins even before the investigation commences; thorough and convincing investigations are the product of knowing how to conduct systematic and appropriate collection of evidence. The information gathered then must be communicated clearly in written reports and face-to-face discussions with court, counsel, and the jury.

The first indication that a case is scheduled for court usually arrives in the form of a subpoena. A subpoena is an order to appear at a particular time and place in order to give testimony or produce items of evidence. A subpoena which directs the production of physical evidence, a subpoena *duces tecum*, will list or describe the items to be brought. On receipt of a subpoena, the investigator should record the date, time, and place on the calendar. Failing to honor a subpoena can result in a contempt of court action against the investigator, and/or employer sanctions.

It is important for the investigator to contact the prosecutor handling the case as early in the investigation as possible. It becomes critical to contact the prosecutor once the case is scheduled for court. Effective communication between the investigator and the prosecutor often is critical to successful prosecution.

Also, it is important for the investigator to check on the location and condition of evidence and of any testing which must be completed in advance of the court date. Court schedules typically are crowded and delays due to misplaced or untested evidence are avoidable with anticipation.

Obtain a *complete* copy of the case report and familiarize yourself with the key points. Take the report with you to court. If the investigator does not communicate a thorough understanding of all aspects of the case, it is difficult to motivate jurors or the court to work toward that goal.

Schedule adequate time to arrive before the hearing and to meet with the prosecutor. Dress appropriately; jurors and the court expect professionalism by investigators and there really is only one opportunity to make a good first impression.

Remember that nothing is more important than your credibility. Jurors and judges require investigators to be competent and credible.

Common Court Proceedings

The names for court proceedings vary. Courts hold a general hearing with counsel prior to trial to discuss a variety of issues, including the evidence which is expected to be presented. This sometimes is known as an "omnibus" hearing.

Hearings also are held before trial on specific motions filed by the defense challenging admission of physical evidence or confessions. Typically, these motions to suppress evidence raise constitutional issues. If the defense succeeds at such a hearing the case may be impossible to prosecute.

Motions *in limine* or to limit testimony may challenge the qualifications of investigators to testify as expert witnesses, or may seek to exclude evidence of prior criminal conduct or civil wrongs by defendants. The Federal rule of evidence involved is found at 404(b) and State evidence codes also contain a similar provision. "Other crimes" or "prior acts" evidence is powerful for the prosecution and is subjected to very close scrutiny by courts.

' » In *Wesfield Ins. v. Harris* (1/20/98 No. 97-1835), the fourth circuit reviewed a case where the district court struck the testimony of the Deputy State Fire Marshal on the ground that his opinion of arson was based largely on the reported observations of the insurance company's private investigator. The circuit court reversal the district court finding that an "expert" may rely on data or reports of others in reaching his conclusion. \

The government must establish the lawful basis for the use at trial of any statement given by a defendant. These *Jackson v. Denno* 378 U.S. 368 (1964), hearings require the investigator to establish the *Miranda* warning and waiver if custodial interrogation was involved or the noncustodial circumstances showed voluntariness.

In jurisdictions that use the preliminary bearing procedure, as opposed to the grand jury procedure, investigators often will testify both at the "prelim" and later, at motion hearings and at trial. Defense counsel at preliminary hearings often "test" investigators to determine the strength of the government's case. It is important for investigators to be thoroughly prepared every time they testify. Investigators should anticipate that defense counsel will attempt to discredit the conclusions reached. Be prepared to be professional.

At a jury trial, the government presents its witnesses and evidence first. The defense then may present its case or may choose not to present evidence. After these "cases in chief," rebuttal evidence may be offered.

These stages in a trial can take days to complete and investigators should be prepared for delays. Investigators frequently are given "sequestration" orders, which prohibit the discussion of testimony between witnesses until the case is concluded.

One critical stage in any criminal trial is cross-examination of the investigator. It is important for investigators to maintain a professional demeanor and to be thoroughly prepared for defense efforts to paint investigator testimony as

inconsistent or biased, or to characterize the investigator' s work as incompetent or insufficient to justify the conclusions offered.

Expert Testimony

An expert is someone who, by virtue of special training, skill, or experience, may be of help to the jury in understanding the evidence presented. The reason for the rule is the jury' s need for assistance with technical material. F.R.E. 701 and 702.

The trial court makes the determination of whether sufficient training, experience, or skill has been demonstrated by the witness to allow testimony as an expert and whether the evidence establishes a jury need for expert testimony.

If the witness is allowed to testify as an expert, he or she can testify as to his/her opinion on technical matters or interpretation of facts but is not allowed to offer an opinion on ultimate issues such as the defendant' s guilt.

In *Daubert v. Dow Pharmaceutical* 509 U.S. -579(1993), parents of children with a birth defect sued, claiming a prescription drug manufactured by Dow and prescribed during the pregnancy caused the defect. The trial court dismissed the suit based on the plaintiffs' expert' s use of non-published or peer-reviewed studies as the basis for their opinions (failure to meet the *Frye* test). *Frye* excludes evidence which is not based on "generally accepted methods" in the expert' s field. The ninth circuit upheld the dismissal and the Supreme Court granted *certiorari*.

The Supreme Court held that *Frye* had been superseded by adoption of the Federal rules of evidence and that FRE 702 did not require general acceptability. Judges continue to be gatekeepers of scientific evidence but the standard for admission is less defined.

Michigan v. Tyier

A. Facts:

1. Fire starts shortly before January 21, 1970, at 0000.
2. Chief See arrives at scene on January 21, 1970, at 0200.
3. Chief See' s responsibility: "to determine the cause and make out all reports."
 - a. Chief See is informed by Lieutenant Lawson that two plastic containers of flammable liquid were found in the building.
 - b. Chief See determines the fire "could possibly have been an arson" and calls for Detective Webb.
 - c. Chief See "looked throughout *the* rest of building to see if there was any further evidence, to determine what the cause of the fire was."

4. Detective Webb arrives at scene at 0330
5. Fire is extinguished and firefighters depart at 0400.
6. Webb takes several pictures but abandons efforts because of smoke and steam.
 - a. Webb takes containers to fire station for safekeeping.
 - b. Neither Webb nor See had consent or a warrant for entries, nor the removal of the containers.
7. See returns with Assistant Chief Somerville around 0800.
 - a. Somerville' s job is to determine the "origin of all fires that occur within the township."
 - b. Fire was extinguished and building empty when they arrived.
8. Webb returns around 0900.
 - a. Webb discovers suspicious "bum marks in the carpet which he could not see earlier because of heat, steam, and darkness."
 - b. Webb also discovers "pieces of tape, with bum marks, in the stairway."
 - c. Webb removes the carpet and sections of the stairs to preserve as evidence.
 - d. Somerville searches through rubble "looking for any other signs of evidence that showed how this fire was caused."
9. Sergeant Hofiman of Michigan State Police Arson Section arrived on February 16, 1970, to take photos at scene.
 - a. Hofiman checked circuit breakers.
 - b. Hoflman had television repairmen examine remains of television sets found in ashes.
 - c. Hofiman' s entries were without warrants or consent.
 - d. Hofiman' s purpose was "of making an investigation and seizing evidence."

B. Michigan Supreme Court holding:

1. Once firefighters leave the premises, a warrant is required to reenter and search premises, unless there is consent, or premises have been abandoned.
2. All evidence collected after fire was extinguished at 0400 was excluded in violation of Fourth and Fourteenth Amendments.

C. State of Michigan' s position:

1. Entry to investigate cause of fire is outside protection of Fourth Amendment because no individual *privacy* interests are threatened.

a. If occupant set blaze, then his "actions show he had no expectation of privacy."

b. If fire has other causes occupants are treated as victims. 2. No purpose would be served by requiring warrants to investigate cause of fire.

D. Majority opinion.

1. Recognizes people still have protected, privacy interests in burned property.

2. Courts specifically held that it is impossible to justify warrantless search on grounds of abandonment by arson.

3. Fourth Amendment applies to firefighters.

4. Both administrative searches and searches for evidence of crime are encompassed by the Fourth Amendment.

a. Probable cause for administrative searches exists if reasonable legislative or administrative standards for conducting area inspection are satisfied.

b. Such searches will not necessarily depend on specific knowledge of the conditions of the particular dwelling; rather, may be based upon passage of time, nature of building, condition of entire area, etc. *Camara v. Municipal Court*, 387 U.S. 523.

5. Major function of warrant is to provide property owner with sufficient information to reassure him of the entry's legality.

6. If authorities are seeking evidence to be used in criminal prosecution, the usual standard of probable cause will apply.

7. All entries in this case were without proper consent and were not authorized by valid search warrant—each is therefore illegal **unless** it falls within one of the carefully defined classes of cases (**exigent circumstances**).

8. Burning building is exigency to render warrantless entry reasonable.

a. Once inside, firefighters may seize evidence of arson that is in plain view.

b. Supreme Court specifically rejects position that once fire ends, the justification for being on property ends.

9. Officials need no warrant to remain for reasonable time to investigate cause of blaze after extinguished.

10. Court finds morning re-entries by Chief See, after firefighters departed at 0400, acceptable as an actual continuation of the first entry.

a. Court permits evidence collected on January 22 as admissible evidence.

b. All entries after January 22 were done without consent or valid warrant and no exigent circumstances existed to justify reentry.

Michigan v. Clifford

A. Timeline:

1. Fire truck arrives at Clifford house on October 18, 1980, at 0540.
2. Fire extinguished and all fire and police depart 0704.
3. Lieutenant Beyer told to investigate Clifford fire on October 18 at 0800.
4. Lieutenant Beyer arrives at Clifford house on October 18 at 1300.
 - a. Beyer sees work crew on scene boarding up house.
 - b. Crew pumping six inches of water out of basement.
 - c. Neighbor tells Beyer he called Clifford and has been instructed to call Clifford' s insurance agent to hire boarding crew to secure house.
5. Lieutenant Beyer begins search of house at 1330, after water is pumped out.

B. Evidence:

1. In driveway. Lieutenant Beyer sees fuel can which firefighters found in basement. He seizes the evidence.
2. Lieutenant Beyer begins search without a warrant or obtaining consent.
3. Beyer*s search quickly confirms that fire originated beneath basement stairway.
4. Beyer detects strong odor of fuel throughout basement.
5. Beyer finds two more Coleman" fuel cans beneath stairway.
6. Beyer further finds crockpot with attached wires leading to electrical timer plugged into outlet Timer set to turn on at 0345 and to turn off at 0900. Timer had *stopped* somewhere between 0400 and 0430.

7. Beyer and partner then search remainder of house going through drawers and closets. They find nails but no pictures on the walls.

C. Clifford' s position:

1. Exclude evidence in basement and upstairs searches because the searches were to gather evidence of arson and were conducted without warrant, consent, or exigent circumstance.
2. Search violated the Fourth and Fourteenth Amendments.

D. State' s position:

1. Exempt from warrant requirement all administrative investigations into cause and origin of fire.
2. Modify *Tyler* to allow warrantless searches in this case.

E. Issue the Court decided Can an arson investigator, in the absence of exigent circumstances or consent, enter a private residence without a warrant to investigate the cause of a recent -fire? «

F. Plurality opinion (Powell, Brennan, White, and Marshall).

1. Court declines to exempt administrative investigation into cause and origin of a fire from warrant requirement.
2. Constitutionality of warrantless and nonconsensual entries onto fire-damaged premises turns on several factors:
 - a. Are there legitimate privacy interests in fire-damaged property that are protected by the Fourth Amendment?
 - b. Do exigent circumstances justify governmental intrusion regardless of any reasonable expectation of privacy?
 - c. Is the object of the search to determine the cause of the fire or to gather evidence of criminal activity?
3. Legitimate privacy interests.
 - a. Objective test: whether the expectation of privacy is one that society is prepared to recognize as "reasonable" (*Katz v. United States*).
 - If yes, then warrant requirement applies.
 - If no, then there is no warrant requirement.
 - b. Court found Cliffords had personal belongings which remained after the fire and that they had taken action to secure their home against intrusion.
 - c. The Cliffords retained a reasonable privacy interest in their fire-damaged residence, and postfire investigations were subject to warrant requirement.

4. Exigency:

- a. Court followed *Tyler* and held that a burning building creates an exigency that justifies a warrantless entry to fight the blaze.
- b. Once in the building the fire officials need no warrant to remain for a "reasonable time to investigate the cause of a blaze after it has been extinguished." (*Tyler*).
- c. Determining cause and origin of fire serves as compelling public interest; warrant requirement does not apply in such cases.
- d. Additional investigation begun after fire was extinguished and firefighters and police have left the scene generally must be made pursuant to a warrant or the identification of some new exigency.

5. Object of the search (if warrant is necessary)

:

- a. If primary objective is to determine origin and cause, an administrative warrant is sufficient. Must show
 - Fire of undetermined origin has occurred on premises.
 - Scope of proposed search is reasonable and will not intrude unnecessarily on fire victim' s privacy.
 - Search will be executed at reasonable and convenient time.
 - Evidence found in plain view may be seized in administrative search.
 - Administrative search into cause of a recent fire does not give fire officials license to roam freely through fire victim' s private residence.
- b. If primary objective is to gather evidence of criminal activity, criminal search warrant may be obtained on showing of probable cause to believe relevant evidence will be found in place to be searched.

6. Court found warrantless and nonconsensual search of basement and house would be valid only if exigent circumstances justified object and scope of each.

- a. Beyer' s search was for evidence of criminal activity as to basement and house.
- b. Excludes all evidence except the gas can found on the driveway in plain view.

7. Plurality distinguishes *Clifford* from *Tyler*.

- a. Challenged search was not continuation of earlier search.
- b. The Cliffords had taken steps to secure their privacy interests that remained in their residence.
- c. • The Cliffords' privacy interests in their residence were significantly greater than those of Tyler in the fire-damaged furniture store.

8. Plurality holds: A subsequent postfire search must be conducted pursuant to a warrant, consent, or the identification of some new exigency.

G. Stevens' concurrence:

1. Unanimity exists, within the Court, regarding the scope of Fourth Amendment protection afforded to owner of fire-damaged building:

a. No one questions right of firefighters to make forceful, unannounced, nonconsensual, warrantless entry into a burning building.

b. Firefighters have the right to remain on premises, not only until the fire is extinguished and no danger of rekindling exists, but also to investigate the cause of the fire.

c. After investigators determine the cause of fire and have located the place it originated, search of other portions of premises may be conducted only pursuant to a warrant

2. Argues the presumption that once firefighters depart, fire has been extinguished and any danger of rekindling is slight

3. Stevens argues fire investigators should give the homeowner reasonable advance notice of their reentry unless they have probable cause to believe the crime of arson has occurred.

H. Dissent (Chief Justice Rehnquist, Blackmun, and O' Connor).

1. Finds the plurality's distinction from *Tyler* to be inconsequential.

2. Allows search of Clifford basement, but does not allow evidence from search of remainder of house.

The Rules Of Evidence

The study of Federal Rules of Evidence (FRE) is a study in the attempted proof of one party's case. In other words, vast collections of information exist in this world, but much of the information never will be admitted at trial. Why then, does some evidence get admitted while other evidence is excluded from trial? The FREs were originally developed to secure fairness in the administration of justice. In effect, by providing FREs, attorneys have a better handle on evaluating cases and in determining the strengths and weakness of the case.

RELEVANT EVIDENCE

In order to be admitted into evidence at trial, the piece of information or exhibit must be RELEVANT. Relevant evidence is defined in FRE 401 as being "evidence having **any** tendency to make the existence of any fact that is of consequence to the determination of the action more probable or less probable than it would be without the evidence." Therefore, all relevant evidence will be admitted in the trial UNLESS there is a specific rule that keeps the evidence out. Most juries like to know all of the facts possible before returning a verdict. For the mother who abused the children, it may be relevant to know what kind of day she

had at work. For the arsonist, it may be important to bear from the arsonist's girlfriend even though she has no direct information about the fires.

Relevant evidence is that evidence that has any tendency to make the existence of any fact of consequence more or less probable. Courts, obviously, in deciding whether to admit evidence struggle with the definition of "any tendency." Most courts agree that a scintilla of evidence meets the relevancy definition. FRE 401 deals with propositions in dispute. Questions that are helpful in determining the issue of relevancy are:

- What proposition is the evidence being offered to prove?
- Is that proposition a material issue in the case?
- Is the evidence offered, probative of that proposition?

Evidence that is relevant is generally admissible; while evidence that is irrelevant is not admissible (FRE 402). The first question, then, must be. Is the evidence that is being offered relevant? If the answer to the first question is yes, then the next question must be Does the probative value of the evidence outweigh the danger of unfair prejudice (FRE 403)? The fear in court is that if the evidence is too prejudicial (difficult to define) then a jury may reach a decision based solely on the prejudicial evidence and not by reviewing all of the other evidence offered. Evidence usually excluded can be broken into various categories:

- evidence that will be excessively emphasized by the jury;
- evidence that will unduly influence the jury;
- evidence that will only confuse the jury;
- evidence that will only waste time; and
- evidence that will only present cumulative evidence.

Evidence frequently emphasized by the jury includes the question of insurance. If the jury learned the defendant had lots of insurance and that he/she would not have to cover the judgment, might that affect the jury's decision? This does not mean, however, that the issue of insurance may not come into evidence in a different way; it simply means that if the plaintiff seeks to ask the witness, "Do you have insurance coverage for this accident?" the Court likely would sustain a relevancy objection to the question. What about the rape victim who admits on the witness stand that she was raped three separate times within the past two years? Another form of prejudice that may present problems in criminal cases is the defendant's record of prior convictions. The jury is impaneled to consider the defendant's guilt on this case. If the defendant does not testify, should his/her prior criminal record be admitted into evidence? The theory for admitting the prior record would be that the defendant is "good" for this crime because he/she committed lots of crimes before. If the jury heard such evidence, the fear is it would be unduly influenced by that information and not listen to the other evidence in the case.

Another form of evidence that may be unduly influential for the jury is the defendant's performance on a lie detector test.

Much other scientific evidence exists to offer examples of balancing the admission question. DNA testing is at the forefront of the issue of admissibility. Voice identification is another example of evidence that may confuse or mislead the jury. Admission of scientific evidence generally requires acceptance of the principle of the experiment, the method of testing done by the experiment, the manner in which the test was conducted, and the reliability of the person conducting the test and the report generated. The general standard often is referred to as the *Frye* test, based upon a Supreme Court case involving the admission of disputed scientific evidence.

EVIDENCE ALWAYS EXCLUDED

Some evidence always will be excluded because of possible prejudice. This evidence presents the clearest example of presumed prejudice in evidence.

1. Liability insurance is inadmissible to prove the person acted negligently or wrongfully (FRE 411). Liability insurance may be admissible to show some other proposition, such as ownership or control of the building when the ownership is in dispute. A possible question to show when liability insurance may be admissible is, "Mr. Smith, if you don' t own the building, why did you purchase liability insurance on this building?"
2. Repairs made after the accident are not admissible to prove negligence or culpable conduct against the person making those repairs (FRE 412). Subsequent repairs may be admissible for another proposition other than negligence, such as ownership and control; state of art; or feasibility of precautionary measures.
3. Settlement offers are inadmissible to prove liability, invalidity of the claim, or amount of damages (FRE 408). The Court wants to encourage the settlement of claims and will not punish either side for attempting to resolve disputes prior to trial.
4. Criminal negotiations cannot be used against the defendant where the plea of guilty is later withdrawn; in offers to plead guilty; or in statements made in negotiating such pleas. In addition, a plead of *nolo contendere* generally cannot be used against the defendant (FRE 410). Clearly, a valid plea of guilty, not withdrawn, can be used against the defendant if he/she testifies.
5. Payment of medical expenses is not relevant to prove liability for injury (FRE 409). Just like the inadmissibility of offers to compromise, the courts are not going to punish a defendant who pays the medical expenses before being ordered *to* make payments or before a money judgment is awarded. The plaintiff cannot ask the defendant on the stand, "Well, sir, if you dispute liability, why did you pay the medical expenses?"
6. Character evidence in civil cases is not admissible to show the defendant acted in conformity on this particular occasion. A person' s general behavior

patterns are irrelevant and inadmissible in evidence (FRE 404). The attempt is to argue, circumstantially, that because of the defendant' s prior behavior, we can infer that at the time and place in question, he/she probably acted in conformity with that earlier behavior pattern.

7. Character evidence of the accused in a criminal case is not relevant to show the defendant probably acted in conformity with that character unless the defendant presents evidence of good character (FRE 404b). Evidence of other crimes, wrongs, or acts, however, may be relevant to prove **motive, opportunity, absence of mistake, intent, identity, or common scheme or plan.**

8. Evidence of prior similar occurrences generally is not admissible to show that this act probably occurred or didn' t occur. The defense should not be able to argue that 50,000 people every 10 minutes walk across the sidewalk and never trip. Essentially, courts are reluctant to admit the absence of similar accidents must show the absence of negligence. Evidence of prior occurrences may be admissible to show a dangerous condition; to refute the defense of improbability or impossibility; to establish causation of present harm; or to prove knowledge of defect by defendant.

9. Courts will not allow opinion or reputation evidence concerning the victim' s past sexual conduct (FRE *412). In rape cases, evidence concerning the victim' s prior sexual activity is usually limited to two situations:

- prior sexual conduct between the victim and the defendant, where consent is a defense; or
- prior sexual conduct between victim and another person to show an alternative source of semen.

CHARACTER EVIDENCE

If the study of evidence were simply a determination of whether the evidence were relevant and its probative value outweighed any prejudice, the study would be childlike. Unfortunately, the rules of evidence are much more complicated. Character evidence, for example, is found in Rule 404. Generally, character evidence is not admissible in the trial to prove the defendant acted in conformity with his/her character. In criminal cases, the prosecution may not make the argument that defendant Willie "the Weasel" Criminal is *up* to his old tricks. Everyone knows he' s a criminal and by golly, folks, here he is again. However, defendants may offer their own character evidence to show that their reputation is different from what one normally would expect to find in a person who does these dastardly things. Typically, defense attorneys will put the defendant' s character in issue and claim the defendant has the reputation for being honest, law abiding, truthful, etc. The defendant' s character evidence may come in only through an opinion of his/her reputation in the community, or the person' s own knowledge of the defendant. The defense may not prove the defendant' s reputation by referring to specific instances of good character.

Evidence of a person' s character, under the Federal Rules of Evidence, may be introduced in three separate ways. Character evidence may be introduced through witnesses who know the accused' **s reputation** in the community. Character evidence also may be introduced by witnesses who have an **opinion** as to the accused' s conduct. Finally, character evidence may come in through **specific instances of past conduct**. The prosecution may not introduce evidence of the defendant' s bad character until the defendant puts his/her character in issue. The defendant, however, cannot then argue evidence of good character. Specific instances of good character are relevant only in one case described below.

Once the defendant has interjected his/her character into the case, the prosecution may reply by cross examining the defendants witnesses as to specific instances of bad conduct that the prosecution has a good-faith basis for believing. Some examples may prove the point. Let' s assume the defendant has reputation witnesses who claim he/she has a reputation for being law abiding and honest. The prosecution could ask those witnesses:

- Did you know, or had you heard, that the defendant left an 87-year-old lady stranded in the middle of the San Francisco Golden Gate bridge at rush hour?
- Did you know that the IRS subjected the defendant to a JS300 penalty for lying on his/her income tax return?
- Did you know the defendant smoked marijuana in front of his/her small children?
- Did you know the defendant pled guilty to voluntary manslaughter in 1985?

FRE 404(b) offers the most frequently debated issue in evidence, generally speaking. Evidence of other crimes committed by the defendant is not admissible to prove the defendant acted in conformity with his/her earlier character. It may be admissible, however, for other purposes such as proof of **motive, opportunity, intent, preparation, common scheme, plan, knowledge, identity, or absence of mistake or accident**. This is the side of Rule 404 which prosecutors most frequently attack. The prosecutor will argue, "Judge, the evidence of the defendant' s involvement in other crimes is not offered to prove character, rather, it' s offered to show absence of mistake, identity, common scheme, or plan, etc."

Suppose the prosecution is trying a defendant for arson of several buildings in the city. The defendant has a previous conviction for murder in the case. The prosecution has evidence through the accomplice that the reasons for the fire are to embarrass the police whom the arsonist believes are responsible for his murder conviction. Can the previous murder conviction be introduced to show **motive, absences of mistake, or intent**?

Finally, the defendant, under Rule 404(a)(2) may seek to offer character evidence of the victim. Let' s say the victim of a shooting was known in the community to be an enforcer for Louie the Loan Shark. The defendant shoots the victim because he/she is approaching him/her in a threatening manner. Here the defendant is showing exactly what is prohibited in his/her case: that the victim, in fact, acted in

conformity with his/her character. In this case, the prosecution may respond with evidence of the victim' s good character.

CATEGORIES OF EVIDENCE

There are four separate categories of evidence generally found in the Federal Rules of Evidence. Those four categories are direct evidence, circumstantial evidence, prepared evidence, and documentary evidence. Before the evidence can be admitted, there must be sufficient authentication to make the documents meet the requirements of reliability. The requirements for authentication are found in FRE 901.

The question of authentication, in some respects, comes before the issue of relevancy. In order to authenticate the evidence, the party offering the evidence must adduce sufficient testimony or evidence to support a finding by the court that the item is what the proponent claims. Once the piece of evidence has been authenticated, the court will determine if the evidence is relevant (FRE 401) and finally whether its probative value outweighs its prejudicial effect (FRE 403).

Direct evidence is evidence offered to prove the facts about the object as an end in itself. In other words, direct evidence is actual evidence about the subject of the litigation or one of the central elements to the lawsuit. Real evidence, if properly authenticated, always will be admissible, unless its prejudicial effect would outweigh the probative value. For example, a victim was held for ransom. While being held, his/her favorite diamond ring was taken from him/her. If the victim can recognize the person who kidnapped him/her, that would be direct evidence.

Circumstantial evidence is the proof of facts about the object to use as a basis for the inference that other facts are true. Fingerprints, weapons, and other items usually are circumstantial evidence. Once a chain of custody has been laid, assuming the object is . not unique, the circumstantial evidence is authenticated and the court can determine the relevancy.

Prepared evidence includes such items as sketches, models, or photographs that may be shown to the trier of fact. The authentication for this kind of evidence is the question of whether or not the exhibit fairly and accurately depicts the object it attempts to depict. The actual photographer need not testify. Anyone who says the photograph is a fair and accurate representation may get that in.

Finally, documents are the fourth kind of evidence. Special problems exist for the waiting to be authenticated. Writings can be authenticated in a variety of ways. In order to make it easier, writings may be authenticated either with direct evidence or through circumstantial evidence. Direct evidence of authentication includes an admission (Yes, that is my signature on the bottom of the document); eyewitness testimony (I saw him sign the document); proof of the handwriting; or through testimony of a handwriting expert. Anyone who recognizes the signature of another may testify that it is his/her signature. Expert opinion of handwriting may

come in criminal cases for bad checks when there is a dispute as to who actually passed or wrote the check.

Circumstantial evidence for the authentication for a writing may be in the form of the Reply Letter Doctrine. The writing is authenticated by evidence that it was written in response to a communication sent to the claimed author. If Jones writes Smith a letter stating, "I accept your offer contained in the letter to me dated August 1st" then sufficient circumstantial evidence exists to deduce Jones saw the letter. Additionally, circumstantial evidence may include the Concept of Ancient Documents rule. Here, the evidence would indicate that the condition of the document does not raise suspicion; it was found in a place where it would likely be; and it was in existence for more than 20 years.

Some documents are self-authenticating and may be admitted without any other authentication. Documents bearing the seal of the United States government may be admitted without further proof. Some documents bearing the seal of a state also can be admitted without further proof. In many states, there are self-proving wills, which are notarized.

Written documents face the additional problem of the "best evidence" objection. Simply stated, when the terms of a writing are in dispute, then any testimony about the document that is not firsthand testimony probably will be kept out. The "best evidence" objection is based upon the theory that the document speaks for itself and the jury does not need to hear testimony about the contents. If the writings are collateral to the issue being litigated, then the best evidence rule does not apply. If Norton wants to testify about the person fleeing the scene of the crime and offers a description of what the fleeing person wore, then the best evidence objection would not apply. That is true even if Norton testifies the writing on his shirt said "Ralph."

WITNESSES

In order to be competent to testify at trial, the witness must be able to do four things as found in FRE 601. The witness must have an ability to **observe, recollect, communicate,** and to **appreciate the obligation to speak the truth.** A child's ability to be a competent witness will depend on his/her capacity and intelligence. Judges may not testify as witnesses in the same trial and jurors may not testify before the same jury they serve.

Expert witnesses are required to provide additional information before they may offer an expert opinion. The expert must demonstrate sufficient training or education to be able to offer an opinion. The expert must be able to describe what facts are used to form an opinion. Additionally, the testimony must aid the trier of fact with information not readily available to the trier. If plaintiff wished to offer expert testimony on how to correctly pump gasoline into an automobile, most courts would not allow the testimony, because all of the jury knows how to properly pump gasoline. A much closer question is the use of expert testimony to challenge eyewitness accounts. The expert would testify that eyewitnesses usually

have seconds to view a situation and they cannot really recall what they saw. Experts may base their (pinions, according to FRE 703, on their knowledge in the field, facts made known to them during the trial (hypothetical questions), or to the opinions offered by other experts in the case.

Once on the witness stand, the witness may (and frequently does) forget some fact that would be beneficial. In that case, the attorney may use documents to refresh the witness' s recollection. Present recollection refreshed is any document prepared which contains the information requested. The writing does not have to be authenticated because it is not being offered in the case. The source of this writing is not in issue. However, if the document is examined, it must be produced for the other side. If the other side wants to introduce the document into evidence, then the originating party may not object (FRE 612).

Past recollections recorded, unlike present recollection refreshed, must follow a specific pattern. If the witness can' t remember the facts and becomes incompetent with respect to those facts, the witness must testify that he/she cant remember. He/She must further testify that at one time he/she had full knowledge of the facts and that he/she prepared a writing when his/her knowledge was full. Further the witness must testify that he/she believed the writing or statement was true at the time he/she made it or adopted it Once this is done and the writing is identified, then the writing may come in as an exception to the hearsay rule.

Perhaps the most difficult concept in evidence is the issue of hearsay. To the untrained observer (even to many trained observers) hearsay evidence comes into evidence at trial when it should not. Hearsay can be divided into three different categories: definition of hearsay, exceptions to the hearsay rule when the availability of the declarant is not material; and exceptions when the declarant is unavailable. While most of us think automatically that hearsay is only spoken words, a statement is defined in 801 (a) as being (1) an oral or written assertion, or (2) nonverbal conduct of a person, if it is intended by him as an assertion.

Hearsay, under FRE 801(c) is defined as: "**A statement, other than one made by the declarant while testifying at the trial or hearing, offered in evidence to prove the truth of the matter asserted.** Certain statements, however, are exempted from the definition of hearsay, according to FRE 801(d). Prior statements by witnesses are not hearsay if the declarant was subject to cross-examination concerning the statement and was either inconsistent with his/her current testimony (as long as the witness was under oath with all of the consequences) or is consistent with the current testimony and is offered to rebut a charge (express or implied) of recent fabrication or improper influence or motive.

A second category of statements which are not hearsay is admissions by party opponents. If the statement is offered against the party and was his/her own statement, either in a representative or official capacity, or was a statement that the opponent manifested his/her adoption or belief in its truth. Statements by someone authorized by the party opponent about the subject may be exceptions to the hearsay rule. Statements by the opponent' s agency or servant concerning a matter within the scope of his/her agency or employment made during the

existence of the relationship are yet another exception. Finally, statements by coconspirators of the party during and in furtherance of the conspiracy are exceptions to the hearsay rule.

Certain statements, because of an inherent trustworthiness, are exceptions to the hearsay requirement. This means that the person's statement must be reliable because, in certain situations, most people do not make statements that are lies. These statements come into evidence, whether the declarant (the person making the statement) is available or not.

Following is a listing of the most important exceptions to the hearsay rule. In recent years some states have attempted to admit statements of children which describe abuse. Many of those attempts have failed because courts are not willing to accept the claim of inherent trustworthiness.

1. PRESENT SENSE IMPRESSIONS will be admitted if the statement is describing an event or condition made while the declarant is perceiving the condition or immediately thereafter. An example of the present sense impression may be a witness to a car accident. While walking down the street, the witness tells his friend, "the yellow car ran the red light and struck the green car." This comment may be made while the incident is going on or immediately thereafter.

2. EXCITED UTTERANCES are statements relating to a startling event or condition made while the declarant is still under stress. "Bob shot Susan right before he started the fire" would be an excited utterance if the person who witnessed it just blurted out the statement, while still under stress. The time requirement for an excited utterance is more limited than the time requirement for a present sense impression.

3. THEN-EXISTING MENTAL, EMOTIONAL, OR PHYSICAL CONDITION statement made by the declarant. "My head is hurting;" "I'm feeling terrible since the death of my dog;" etc.

4. STATEMENT FOR THE PURPOSE OF A MEDICAL DIAGNOSIS.

5. BUSINESS RECORDS.

Finally, some statements may be admissible when the declarant is no longer available. This is true as long as the reason for the unavailability is not a result of the party attempting to get the statement in.

1. Former testimony of the witness as long as it is against a party who was involved in the first case when the witness gave his/her testimony.
2. Declaration against interest.
3. Belief of impending death. It is not required the declarant actually die when he/she thought he/she was going to. As long as the witness actually believed

he/she was going to die, any statement made in that condition can come into evidence.

The study of evidence is an exciting study. Cases are won or lost based on the attorney' s ability to get crucial evidence into trial. Documenting when statements were made, together with who was present, may make the difference in a successful prosecution

Rule 702. Testimony by Experts

If scientific, technical, or other specialized knowledge will assist the trier of fact to understand the evidence or to determine a fact in issue, a witness qualified as an expert by knowledge, skill, experience, training, or education, may testify thereto in the form of an opinion or otherwise.

1. Key questions:

- a. Will scientific knowledge assist the trier of fact?
- b. Is witness qualified as an expert?
- c. Is field recognized in responsible scientific community?

2. *Frye v. United States* 293 f. 1013 (D.C. Cir., 1923).

- a. Defense tried to introduce, through expert, the results of a deception test.
- b. Court refused to allow testimony because the scientific process which was involved was not sufficiently established to gain general acceptance in the particular technical field to which it belongs.

3. Current topics where the issue is litigated:

- a. DNA testing.
- b. Eyewitness experts.
- c. "Battered wife" syndrome.
- d. "Rape trauma" syndrome.
- e. Voiceprint evidence.
- f. Hypnotically enhanced testimony.

Rule 703. Bases of Opinion Testimony by Experts

The facts or data in the particular case upon which an expert bases an opinion or inference may be those perceived by or made known to him at or before the hearing. If of a type reasonably relied upon by experts in the particular field in forming opinions or inferences upon the subject, the facts or data need not be admissible. Sources of data include:

1. First hand observation.

2. Hypothetical questions.
3. Presentation of data outside court and other than by his own perception.

Suggestions for Testifying in Criminal Cases

1. Always tell the truth; your reputation for truth and honesty is more important than any case.
2. Make eye contact with the jury as early and as often as possible.
3. View your testimony as a chance to explain your profession. (Most people have, at one time, wanted to be a firefighter.)
 - Convey the danger of your profession; fires are hot and dangerous.
 - We can describe the path of a fire (up and out and follow the path of least resistance), but it is still very dangerous.
 - Don't let the defense attorney pick a fight with you about insignificant matters.
 - Impress the court with descriptions of damage (because the door paint melted off the door, we know the fire temperature had to be in excess of 700°, etc.).
 - Use terms with which you are familiar; if the State's attorney is doing his/her job, he/she will stop you when a new term comes up.
 - Diagrams and photos are always interesting.
 - Bring the fire into the courtroom with the help of your prosecutor.
 - Talk about evidence collection you did in the case.
 - Any lightbulbs of significance you can bring?
4. If cross-examined about books, pamphlets, etc., which the defense wants to introduce, accept them as authoritative if you are familiar with them and you know they are recognized in the field.
5. Dress comfortably because it will be stressful. If possible, consider wearing your uniform. (Talk with your prosecutor about this.)
6. Discuss any potential weaknesses with the prosecutor prior to testifying so that both of you can be prepared.
7. Answer only the question asked. Do not volunteer information on cross-examination.
 - Defense attorneys may want to cut you off in an embarrassing way in front of the jury.
 - As long as you don't respond with nastiness, the jury most likely will side with you in a confrontation.

8. Testifying generally is not humorous. Don't try to be funny on the witness stand. This is especially true if there are fatalities or serious injuries.

- Consider using black and white photos of persons badly charred in the fire because they may be more dramatic and less prejudicial.
- Treat evidence recovered from bodies with great respect.

BIBLIOGRAPHY

Brown, Dennis E. *Customer Service and Company Inspections: Teaching the Elephant to Dance*. Barberton: Barberton Fire Department, Aug. 1991.

Crawford, Jim. *Marketing for Survival in the 90's*. Portland: Portland Bureau of Fire, Rescue & Emergency Services, July 26, 1993.

Greenslade, Terry. *Fire Department PR: Do We Have To Sell Ourselves!?!* Jackson: City of Jackson, Michigan, Fire Department, Oct. 1992.

Marinucci, Richard, and Peter D. Baldwin. "' Survey Says...' Seeking Public Opinion of Fire Department Services.' *Fire Engineering*, Jan. 1989.

Porter, James T. *Marketing Your Services From a Small Town Perspective*. Howell: City of Howell Fire Department, Dec. 1994.

St. John, Susan. "Marketing Your Fire Department." *Firehouse*, Sept. 1994.

Stanton, William J. *Fundamentals of Marketing*. New York: McOraw-Hill Book Co., 1988.

loth, Robert K. "Promoting Your Fire Department (In Less Than Perfect Times)." *Fire Engineering*, June 19&9.

Van Benschoten, Guy J. *A Customer Service Survey for the Ithaca*. New York Fire Department, Ithaca: Ithaca Fire Department, Oct. 1991.

Report Writing

INTRODUCTION

There are a variety of reasons for collecting and documenting accurate and complete information about a fire. First, it is written documentation that the fire occurred. Second, it provides information to enable the fire department to analyze and evaluate suppression and prevention performance. Third, it produces data on fire problems, fire protection equipment, building components, and fire losses.

One of the most critical tasks in the field of fire investigation is preparing reports. Supervisors frequently evaluate investigators' performance on the basis of their reports. Documents produced by fire and police agencies usually are available to the public for review. The prosecuting attorney' s decision whether or not to prosecute an incendiary fire often is determined, in part, by investigator' s reports.

Reports and field notes must be written so that the investigator can go back and review the information at a later date. Once field notes are incorporated into a report, their disposition should be determined by department policy.

Some departments recommend that the investigator keep the notes; other departments allow the investigator to destroy the notes after incorporating them into the report. Both procedures are legal; however, be guided by department policy. Investigative reports often are read—and judged—by persons who know nothing about fire investigation. Thus, the language in the report must be adjusted for the target audience.

TYPES OF REPORTS

There are four basic reports with which an investigator will be involved. The **fire incident report** usually is prepared by the Incident Commander (IC). This report documents fire suppression methods, fire prevention systems, injuries/fatalities, and possibly origin and cause determination.

The investigator is involved in preparing the other three types of reports. The **preliminary report** contains the basic information surrounding the fire scene. It includes field notes, sketches, evidence, interviews, and a description of findings at the fire scene. The **follow-up report** provides additional details or information, usually received through interviews, link analysis, evidence analysis, records, and research. The **prosecution report** summarizes the investigator' s case reports. It includes witness statements, statutes violated, bail information, motives and, of course, information about suspect(s).

PRELIMINARY REPORTS

Investigator' s Field Notes

Field notes are one of the investigator' s most important tools. These notes are used to write the complete preliminary report surrounding the incident. Field notes are defined as a collection of pertinent or essential information related to a specific incident. (See Appendix A for a sample format.)

It is important that the investigator take complete, concise, and accurate notes at every step of the investigation. If the building is demolished, there may not be a second opportunity to look at the fire scene. Other investigative duties and

caseload priorities may delay the writing of the preliminary report. Scene documentation is very important!

Primarily, field notes help the investigator to recall incidents, situations, images, and details. They also support sketches, photographs, laboratory analysis, and evidence, and aid in formulating questions for interviews. In other words, field notes serve as an initial outline for the preliminary report.

Field notes should contain only pertinent information. Avoid personal opinions or comments. Record only facts and objective observations. Don't compile information on different cases in the same set of notes. Include times, dates, weather conditions, case name and number, description of the occupancy, and description of the fire scene.

In the fire scene description, take notes on each room, describing the fire damage and travel. Also, note fire suppression efforts, fire protection systems, forcible entry, point of origin, elimination of accidental and natural causes, and the fire cause with all supporting evidence. Document in notes, as well as photographs and sketches, the evidence discovered and collected.

Compile field notes on all persons interviewed in connection with the incident. In these notes, identify the person interviewed, other persons present during the interview, location of the interview, and questions/answers. In preparing interview questions, be sure to address the standard investigative questions: who, what, where, when, why, and how.

Be sure to document ownership of the occupancy, person discovering the fire, any injuries or deaths, and any insurance information available.

As mentioned previously, always follow department procedures regarding storage/disposition of field notes. Remember, if you do retain field notes they are subject to subpoena for court or depositions.

Preparation of the Preliminary Report

When the investigator finds the time to sit down and actually write the report, his/her recollection of the incident usually is dependent on the field notes, sketches, and diagrams. The preliminary report of the incident is an official record. This report is a reflection on you and your department, and will serve as proof of the fire and possibly as proof of a crime. It is a collection of facts, objectively taken, regarding an incident.

The preliminary report usually is written in narrative form and includes the investigator's findings. Departmental preprinted cover sheets often are used in preliminary reports.

The preliminary report may well be the proof that an incendiary fire occurred. Thus, it must contain the collection of facts used to prove the crime of arson, and

it must show how the investigator collected these facts and came to his/her conclusion.

No matter what layout is used for the report, consistency is critical. A well-designed report will produce mental pictures of the incident, occupancy, fire damage information, point of origin, fire cause, possible motives, and documentation. (See Appendix B for a suggested format for a preliminary report.)

Standard Layout

A standard layout that has proved successful includes the following sections: Provide a **description** of the time, date, incident number, address, manner of dispatch, investigative personnel dispatched, incident commander, occupancy type and construction, weather conditions, and fire suppression companies on scene. Next, include **observations** of the scene, physical evidence, indicators, point of origin, and cause determination. Next, document **statements** related to ownership of property, insurance company and policy information, if known, any information that witness(es) or reporting parties may provide, statements by firefighters or police officers, and any other person who may possess pertinent information. **Documentation** in the form of sketches, evidence, flowcharts, photographs, and analysis reports can be included or attached. The investigator is allowed to render an **opinion** of his/her findings. Here the investigator describes the suspect, motive, evidence, and statements in a final summary. **Attachments** that can be included are waivers, written or typed statements, recorded or transcribed statements, or information referred to in the report.

FOLLOWUP REPORTS

Followup reports also are written in narrative form and may include preprinted cover sheets. Again, the layout should be easy to follow. Usually these reports are not lengthy; often they include just one point or statement.

Followup reports contain information about an ongoing case or a case that is reopened due to the discovery of additional evidence. Followup reports also are written from field notes, telephone conversations, and correspondence. Usually, information that was not available to the investigator for his/her preliminary report is included in the followup investigation. Information normally found in followup reports includes insurance company and policy information, interview results, lab analysis results, financial records, and other agency reports.

Insurance

Contact the victim' s insurance company to ascertain the total amount of fire insurance in force on the property and business. Also, document the name of the insurance company, policy numbers, and dates of inception and expiration. Note any increases/decreases in the policy. Also, check the policy to see if there is a

business interruption clause. Note who is handling the policy and if there is a public adjuster involved.

Interviews

Construct a personal history on owners, operators, and employees. Ascertain whether any of them have a past history offers or firesetting, a criminal record, or employee problems. Remember to document all interviews. (See Unit 15: Interviews and Interrogations, for a detailed discussion.)

Laboratory Analysis

Be aware of the different types of tests and reports that are available through local, State, Federal, and private laboratories that deal in evidence analysis, as it relates to fire investigation. (See Unit 11: Collection and Preservation of Evidence, for a detailed discussion.)

Financial Records

The investigator needs to examine all books and records found on the premises. Be sure to consult an attorney for guidance on obtaining such documents. Look for any significant information such as large financial transactions, decline in business, large personal checks or withdrawals, unidentified "coded" entries, entries listed by nicknames or slang terms, any indication of illegal or questionable transactions, and notices of debts or legal actions.

Note utility payment records, indicating any late or delinquent payments. Did the utility company shut off the service for nonpayment? Also, obtain any records of trouble reports to or from the utility company.

Determine the general condition of the business. Identify whether or not the business is expanding, declining, or even operating. Conduct a personal history check of personnel in the business. If the business is a corporation, obtain the identity and titles of all officers and percentages of stock distribution. Inventory can be a good indicator of the status of the business. Look for evidence of invoices, receipts, and checks. Watch for evidence or indicators of stock when doing an examination of the fire scene. Items in stock usually leave a protected area when involved in a fire. Record such indications noting size, shape, and number of impressions. Compare your findings with those of the owner and/or his/her inventory sheets.

Conduct a complete financial background check. This commonly is referred to as "The Paper Chase." Examine business assets to determine the value of stock, machinery, and equipment. Review accounts receivable to determine the amount of business being conducted. Determine solvency of the business by checking loans receivable. If outstanding loans are present, ascertain the creditor' s name,

terms of payment, and the reason for the loan. Stocks, bonds, and property owned should be established, as well as the bank balance in the business account. Obtain the name of the bank, the branch where business is conducted, and the bank employee(s) usually contacted. What liabilities does the business have? Check to see if the payments are up-to-date, what the interest rate(s) is/are, and reasons for the loans.

Check on existing mortgages, including buildings, land, and equipment. Examine all local, State, and Federal tax records. Evaluate business expenses versus income. Business expenses can include salaries, rent or mortgages, commissions, and normal operating expenses. Also, check with other agencies that may have reports pertinent to the case.

Link Analysis

Link analysis can be used for a variety of purposes. It is a method of compiling, organizing, and better use of all data related to the investigation. Development of the link analysis follows a process using data collection, assembling business and organization names, constructing an association matrix, determining number of links, diagramming, clarifying the diagram, and conclusions. These data include telephone numbers, associations of persons, associations of businesses, and relationships of individuals to businesses. The process assists in case management, helps target suspects, and makes it easier to present complex facts/cases to the prosecutor.

Link analysis graphically illustrates the clarity of relationships among individuals and businesses. Often investigators rely on their memories in recalling these types of relationships; in a complex case where the investigator is dealing with numerous individuals, this technique is not very effective. When the individuals involved own or have dealings with many businesses or organizations, the use of link analysis is extremely helpful.

Link analysis is used to simplify complex investigations by showing relationships and degrees of involvement among individuals and organizations or businesses, thus enabling many investigators to understand readily the parts played by people in a conspiracy. The charts also show the sequence of events and provide a visual description of what happened.

Description of Link Analysis

First, raw data or information are gathered during the investigative phase and organized into some logical order. Key data points (names of individuals and/or organizations) are identified.

Then, a rough draft is prepared using the following guidelines:

- circles indicate individuals;

- rectangles or squares show organizations;
- triangles depict involvement with, but not membership in, organizations;
- start with individual showing the most links and add his/her associates;
- connect with solid lines if strong link;
- use broken lines for weak or unsubstantiated associations;
- check that all individuals have been accounted for; and
- assure that all associations are properly represented. Finalize the link analysis chart. Examine the final product for presentation to task force and prosecuting- authority.
- Is the analysis of associations and criminal activity complete?
- Do any areas need further clarification?
- Have you included recommendations for further investigation and dissemination?

Appendix C illustrates link analysis in a sample follow-up report.

PROSECUTION REPORTS

The prosecution report is often a summary of the case submitted to the prosecutor. Depending on the detail and number of reports in the case, the prosecutor may not have time to review the entire stack of detailed reports. In such situations, a decision on whether or not to file the case may be based on the quality of the prosecution report summary.

A well-designed summary can be the key to getting a case filed. A prosecution report usually contains the following.

- summary of the fire investigation information;
- laboratory reports and analysis;
- list of possible witnesses:
 - the information they can provide,
 - where they can be found, and
 - witnesses' personal history information;
- statements made by the witnesses;
- statements made by the accused;
- statutes violated; and
- bail information.

(See Appendix D for a sample prosecution report.)

ESSENTIALS OF A GOOD REPORT

A good report is complete and accurate. It should answer all questions concerning the incident, including ensuring that all persons and places mentioned in the report are identified in detail. The report should paint a complete picture of the incident. The overall quality of the report influences the readers' impression of the investigation.

Reports must be proofread to eliminate grammar, spelling, and punctuation errors. Readers of the report must be able to focus on the facts in the case and should not be distracted by mechanical errors. Reports should be concise. They should not be "padded" to increase their length, but they need to contain all the facts pertinent to the case. Reports should not ramble, but get to the point. Reports need to answer the basic questions about the fire and investigation: who, what, where, when, why, and how. For example

Who

- discovered the fire;
- extinguished the fire;
- provided scene security;
- has pertinent knowledge;
- was the victim;
- made the report; and
- has a motive for the crime.

What?

- happened;
- actions were taken;
- was the damage;
- was the crime;
- do witnesses know;
- evidence was found;
- was done with the evidence;
- is the chain of custody of the evidence;
- and agencies are involved.

Where?

- did the fire start;
- did the fire travel;
- was the witness;
- were the owners/occupants;
- was the evidence collected;
- is the evidence stored;
- and was the crime committed.

When?

- the fire discovered;
- was it reported;
- was the investigation conducted;
- and were the interviews conducted.

Why?

did the witnesses make statements;
were the witnesses reluctant to talk;
and was the crime committed.

How?

was the fire discovered;
did the fire start;
was the evidence collected and secured;
and did the suspect arrive/leave the scene.

WRITING THE REPORT

Preparation

In writing any report, **preparation** is the first step. All necessary information must be collected and compiled before writing the report. Next, material should be arranged in a systematic order, and any material not pertinent to the case should be discarded.

The use of an **outline** helps to ensure that the report is in chronological order. A **rough draft** is typically the next step. At this point, do not worry too much about spelling, punctuation, and grammar. The use of a rough draft usually allows for an easy transition into a final report that is in order and easy to read.

Final Report

The final report will be read by peers, supervisors, the public, and colleagues. It must take into account all items discussed in this unit. Correct grammar and spelling are essential; misspellings and improper grammar can give the entire investigation a sloppy appearance. Each document needs to be proofread for completeness and accuracy.

When writing investigative reports it is proper to use the first person: "I arrived at the scene..." or "I observed..." Avoid second and third person styles: "This investigator..." or "This officer observed..." The investigator needs to determine the target audience and write the report for that audience. Since the person reading the report may know nothing about fire investigation, avoid terminology that only fire investigators understand. If such terminology is required, provide a clear explanation. For example, explain that "V patterns" point toward the area of origin or that a "liquid accelerant pour pattern" is typical for the use of accelerants.

Avoid terminology that cannot be explained, such as "smelled like Benzene." That is a hard odor to describe.

Use a writing style that is simple, short, and to the point. Keep your paragraphs short. Long paragraphs tend to turn off most readers. Write the way you talk.

Reports should contain only material/information pertinent to the case. Personal opinions, conclusions, and suspicions need to be eliminated. However, the **expert opinion** of a qualified investigator based on the evidence found needs to be included in the report. Reports are statements of fact and observations discovered by the investigator, written in an objective, factual manner.

Forms

A variety of forms are used by today's investigators. The National Fire Protection Association (NFPA) has developed standards for fire incident and investigative reports. Whichever report your department uses, ensure that all information needed for your particular case is presented.

NFPA manuals contain forms commonly used by fire investigators, including

NFPA902M	Fire Reporting Field Incident Manual
NFPA904	Incident Follow-Up report guide 7
NFPA906-M-0	Case Supervision
NFPA906-M-1	Field Notes for All Fires
NFPA906-M-2	Structure Fires
NFPA906-M-3	Motor Vehicles
NFPA906-M-4	Wildland Fires
NFPA906-M-5	Fire Casualties
NFPA906-M-6	Witness Statements
NFPA906-M-7	Evidence
NFPA906-M-8	Photographs
NFPA906-M-8	Sketches
NFPA906-M-10	Insurance Information Records and Documents

CURRICULUM VITAE

Every investigator at some time in his or her career will have to qualify as an expert witness or make a request to obtain a search warrant. The prosecutor usually will ask for a resume, fact sheet, or curriculum vitae. This is a summary of an individual's professional history and qualifications. The prosecutor must know not only the case, but also the qualifications of the investigator. Form "fact sheets" should be developed for both the investigator and the incident. Once developed, they should be kept current.

Investigator fact sheets should include

- name;
- age;
- employer;
- title;
- duties;
- years of experience;
- estimated number of fires investigated;
- testimony in fire investigations;
- fire investigative/law enforcement training;
- formal education;
- professional memberships; and
- books/articles published.

The **incident fact sheet** is a brief summary for your use in discussing the case with the district attorney, other investigators involved, or when obtaining a search warrant.

The incident fact sheet should include

- incident name;
- incident number;
- owner of property;
- occupant;
- type of occupancy;
- extent of fire damage;
- motive (if known);
- evidence to prove the element of crime;
- evidence of nonaccidental cause;
- evidence of incendiaryism;
- names of witnesses and their statements;
- possible questions for you; and
- possible questions to be asked of the witnesses.

SOURCES OF INFORMATION

In any investigation, knowing where to look for the first, basic piece of information is crucial. Obtaining vital data requires familiarity with a variety of agencies. Information sources that are available to the investigator in the preparation of his/her case include Federal, State, local, and private resources. (Appendix E contains a detailed list of such information sources.)

SUMMARY

The accurate and understandable documentation of a fire scene is perhaps the most important aspect of fire investigation. A complete and thorough fire scene investigation means little if the report is written in a manner that confuses the reader or leads to wrong conclusions/opinions.

Often the fire scene investigation report will be the only source of information available concerning a fire incident. The report should be written so that a person reading it for the first time would have at least a general understanding of what had occurred.

The fire scene investigation report will be used in civil cases at depositions and will be scrutinized heavily for content and completeness. Prosecutors for State and Federal agencies will rely both on the individual investigator and on the report in criminal proceedings.

Additionally, the impression left by a well-prepared and complete report also will tend to establish credibility for the investigator. The fire scene investigation report will be representative of both the individual investigator and the respective department. To use the analogy of a manufacturing business, our written report is the product we turn out. This product should be legible, neat, and understandable.

BIBLIOGRAPHY

Fire Service Communication. Instructor Guide/Student Manual, Emmitsburg: National Fire Academy, 1983.

Link Analysis. "Advanced Arson for Profit." Glynco: Bureau of Alcohol, Tobacco and Firearms Course Manual, 1993.

NFPA 902, *Fire Reporting Field Incident Manual, Basic Incident Reporting*. Quincy: National Fire Protection Association, 1990.

NFPA 904, *Incident Follow-Up Report Guide 7*. Quincy: National Fire Protection Association, 1992.

NFPA 906M, *Guide for Fire Incident Field Notes*. Quincy: National Fire Protection Association, 1988.

Interviews and Interrogations

INTRODUCTION

The ability to elicit information through interpersonal communications is a critical skill for the investigator. Physical evidence at the fire scene may indicate that a crime has been committed, but the development of a valid link between the crime scene and a suspect probably will result from an effective interview or interrogation.

Physical evidence may have only limited value in court. The overwhelming majority of the testimony presented in the courtroom will involve information elicited by the investigator from those persons involved in the incident. Approximately 85 percent of the information gathered during an investigation will come from the interviews or interrogations of such persons. The preferred method for conducting both interviews and interrogations is face-to-face.

The successful investigator needs to develop effective techniques for conducting interviews and interrogations. The investigator must be able to employ basic proven methods and techniques which meet ethical and legal standards. The manner in which an interview or interrogation is conducted will determine acceptance or rejection by the judicial system.

INTERVIEWS

Definition

An interview is asking questions of individuals who may have knowledge pertaining to the investigation.

How to Approach an Interview

There are three possible approaches. The investigator may approach with trust. This approach is used with persons whose information can be assumed to be reliable, including (but not limited to) city and county government officials, representatives of financial institutions, and persons who have no specific interest in the fire.

Or, the investigator may approach with caution persons whose information may or may not be considered reliable. This includes persons who have a specific interest in the fire. The investigator must verify the validity of information received very carefully.

Finally, the investigator may approach with distrust persons whose information is assumed to be unreliable, including those who have an interest in the fire scene, persons who may gain from the fire, or suspects.

Goals for Interviews

Possible goals may be to:

- obtain usable information;
- obtain corroborative information;
- identify negative or deceptive information;
- verify information;
- identify suspects;
- eliminate suspects; and

- assist in conducting link analysis.

Human Factors

Various human factors can affect the success of the interview. One is the witness' s willingness to talk. This may be influenced by his/her fear of retaliation, resentment, or it simply may be inconvenient. The accuracy or truthfulness of the information obtained during the interview must be validated. Perception and memory are dependent on the witness' s ability to observe, recollect, and communicate the information. Thus, it is important to try to interview the witness as soon as possible to minimize time lapses.

Other factors include physical disabilities (bearing, vision, communication); language barriers may require translators (in such instances, try to use persons who have no interest in the case to ensure correct translation). Emotions (traumatic experiences, personal involvement), prejudices, and personality conflicts need to be recognized and eliminated in the interview process. Finally, cultural barriers must be recognized and cultural differences must be respected.

Witnesses Present

When planning an interview, the investigator must decide who will be present. Follow department policies, but ensure that they are within legal guidelines. Too many persons in the interview room can cause the interviewee to be reluctant to talk. Always have a witness when interviewing persons of the opposite sex or juveniles.

Persons to Interview

The reporting party is a critical interviewee. Make sure that dispatch personnel understand the importance of obtaining as much information from the reporting party as possible, including a detailed identification, in order to be able to interview him/her at a later date. Information needed from the reporting party includes why he/she was at the scene, at what stage was the fire when he/she noticed it (color of flames/smoke), his/her observations, the time he/she noticed the fire, what he/she was doing when the fire was discovered, where he/she was going, whether he/she saw anyone else, whether he/she noticed any other activities going on, how he/she reported the fire, and how long it took the fire department to arrive on scene.

Witnesses to the incident also must be interviewed. This includes taking statements from spectators, which may confirm or contradict your findings. They may report suspicious activities going on, information regarding a crime, suspect, or motives. Witnesses may volunteer this information, but, if not, an interview will be necessary. Information to seek includes time element, observations of

unusual activity around the fire scene, fire location, direction of fire spread, and any other useful information.

The owners/occupants also will need to be interviewed. They often will provide key facts surrounding the incident. This interview may take place away from the fire scene, especially if there is emotional trauma, possible involvement, or fear of retaliation. Questioning should include how they were notified about the fire, who the last person was in the occupancy, how many keys are available and who has them, what is the status of the business, any recent problems, and do they know anyone who might have set the fire.

Police officers present at the fire scene also can provide very useful information. They may have been the first persons on the scene. They are trained to notice peculiarities and may possess "street information." They may have information about activities going on around the scene prior to the fire. Questions asked of police officers are very similar to those asked of firefighters: where was the fire located, when did they arrive at the scene, what was the color of smoke and flames, did they see any vehicles leaving the scene, did they observe any suspicious actions, where were owners/occupants, and how did they act?

Personnel engaged in fire suppression operations can provide useful information to the investigator. This interview usually is conducted back at the fire station and should be done without delay. First-arriving fire suppression companies and firefighters can provide key information on the origin and cause of the fire. Was there any suspicious activity noticed en route, e.g., problems with fire hydrants or access to scene? What was the location and extent of the fire when they arrived? How did they gain entrance e.g., were forcible entry measures employed—where and by whom? What was the color of smoke and flames? Were any spectators acting suspiciously or dressed in a peculiar manner? Were there any vehicles leaving in a hurried manner? Were any possessions or equipment removed prior to the fire? Also ask if there were any unusual odors, any accelerant containers, unusual fire load, and the reaction of the fire when water was applied. What fire protection systems were in place and what was their condition? Was the occupancy prepared for burning?

Were owner(s)/occupant(s) on scene? If so, what were their attitudes, opinions, and statements regarding the fire? If they were not on scene, how soon after notification did they arrive? How were they dressed?

The investigator also needs to identify all persons allowed into the fire scene. Note any physical evidence removed and by whom. Did the fire department start overhaul procedures?

Question the condition of the utilities—were they on or off; if off, who did it? Were there any construction workers in the area prior to or during the fire, or while you were investigating the fire scene?

Ask the officer in charge why he/she called an investigator. If the reason is for suspicion of an incendiary fire, then find out what evidence of incendiarism

resulted in your notification. Was it flash fires, fires in unnatural locations, more than one fire, fires that were hard to extinguish, devices, or low-burning fires? Were there any civilian burns or fatalities? Elicit any additional information firefighters may have surrounding this incident.

Distracting Interviews

A distracting interview is any attempt to draw attention away from the facts in the investigation. An investigator often finds himself/herself interviewing persons who have no real connection with the crime, but nevertheless present information to the investigator. They may falsely claim to be witnesses, victims, or even the perpetrator. People do this because of vanity, for recognition, to falsely accuse someone, because they bear a grudge, or because they need to lie. By keeping abreast of and familiar with the evolving case you can identify these inconsistencies readily.

Preparing for the Interview

In preparing for the interview, review all the facts that surround this specific person's involvement. Obtain all possible information on the subject to help you decide the best approach and to elicit the maximum information. Use questions which allow the interviewee to tell a story regarding the fire scene rather than giving yes or no answers. This usually allows you to obtain the maximum amount of information and tests the truthfulness of the subject. Don't overestimate or underestimate the interviewee, because you can "turn off" the subject, and this may result in lost information.

Tactical Planning for the Interview

Schedule the interview as soon as possible after the incident, while the information is fresh in everyone's mind and before the subject can develop an alibi, or be intimidated.

Select a controlled environment. Limit furnishings, distractions, and items that can impair the investigators view of the subject. If possible, conduct the interview at a site where the investigator has the advantage.

The best location may depend on the type of information desired. For instance, an interview at the subject's home may make the subject feel comfortable and at ease, whereas an interview at the investigator's office may place tension on the subject. Whatever the location, the investigator should be positioned so that he/she can see the interviewee's entire body in order to observe body language. The investigator needs to make the subject open up in order to obtain the necessary information surrounding the case. Try to avoid a cold, jail-like setting.

Schedule the interview at a time convenient for all involved. Allow for enough time to conduct a thorough interview and to establish a distraction-free environment. Try to ensure that the interview does not cause problems for the interviewee. The physical surroundings should be set up to enhance the interview. Remove any barriers which might come between the investigator and the interviewee. Check on lighting, temperature, and other physical comforts, such as food, drink, or restroom facilities.

Occasionally there are special situations that arise, such as confidentiality of the case or not wanting to draw unnecessary attention to the interviewee. In these situations it may be necessary to have the interview at a "secure" location agreed upon by all parties. Remember, if the interview is at your office you can control the environment, prevent distractions, and control the interview process.

CONDUCTING THE INTERVIEW

Introductions

The investigator should begin the interview by introducing and identifying himself/herself. Then confirm the subject's identity—a driver's license usually contains all the required information. The introductions are usually oral.

Styles of introduction include the business approach, where the investigator introduces himself/herself with a business card. In a nonchalant approach the investigator is very casual with no pressure being applied. In the authoritative approach the investigator uses his/her title and exhibits an in-charge attitude. A friendly approach begins with a handshake or a pat on the back.

Opening Statement

Advise the interviewee that you wish to record the interview. You can use notes, tape recorder, or video.

The opening statement begins the actual interview process. The investigator starts by stating the date, time, location, and persons present during the interview. The investigator then will make opening statements regarding the incident. Do not disclose any specific facts regarding the case.

Investigator's Attitude

The investigator's attitude can be a deciding factor in the success of the interview. A positive and professional attitude is necessary. Maintain an objective demeanor; focus on getting the facts. Attempt to get the interviewee in a talkative mood. Allow the subject to complete his/her answers without interruptions. Note any inconsistencies. Be prepared for any spontaneous statements; the interviewee may stop talking if you appear to be caught off guard. Phrase your questions to

maintain a free flow of information. The interviewee may provide more information than you expected him/her to know. Be prepared to vary the line of questioning.

Investigator ' s Approach

The most effective approach to the interview is one that allows the interviewee to relate his/her information freely. Specific or direct questioning may not be needed until after the interviewee has told his/her story. If interrupted, the interviewee may not finish. Direct questioning usually occurs only when the interviewee shows dislike toward the investigator, is reluctant to talk, or is trying to protect someone close.

When interviewing complainants, be receptive and assure them that you' re aware of the importance of the situation and that appropriate actions will be taken. Use caution in making a decision regarding what the complainant says; he/she may be acting on a grudge. Always hear both sides before making a final judgment

When interviewing witnesses, examine relationships between the witness and others connected to the incident

Be sympathetic when interviewing owners and/or occupants. They may be suffering emotional trauma and may actually be in a state of shock. Be objective when comparing statements to physical evidence.

Statements From Subjects

There are four types of statements given by interviewees: oral, handwritten, typed, and recorded.

Oral statements usually are recorded in the investigator' s notes or reports. Keep in mind that witnesses may change their story later.

Handwritten statements, preferably written by the interviewee, need to be signed and dated on each page. If the interviewee has poor handwriting or cannot write, then someone else may write the statement for him/her. However, read it back and have him/her sign or initial each page. Mistakes also should be corrected and initialed. This type of statement is hard to deny in court

Typewritten statements also must be signed and dated. They, too, are hard to deny in court. As in the handwritten statement, the interviewee must initial mistakes and corrections. -

Recorded statements may be audio, video, or both. This is often the easiest statement to obtain. The statement must include the date, time, location, name of person making the statement, identification of all the facts pertaining to the statement, and identification of all persons involved.

When you change sides of a tape, begin a new tape, or end the interview include a statement with the date, time, and persons involved. Negative statements or denials also should be recorded and signed by the interviewee. Statements with the subject' s attorney present should be noted to prevent claims that the question was never asked.

Closing the Interview

In closing the interview ensure there are no additional questions, and that all the needed information has been checked and recorded. Then thank the interviewee and assure him/her that the information provided will remain confidential but may be used as a basis for legal action. Ask if there is anything additional he/she would like to add. If you put your notebook away early, the interviewee may think you are done, and may drop his/her guard, providing additional information necessary to the case.

Evaluating the Interview

Always conduct an evaluation when the interview is concluded. Evaluate the interviewee' s emotional state and mannerisms. Evaluate the information received, confirm all information, identify conflicting information, and review the case for gaps or missing information. Finally, objectively evaluate your own performance: Did you maintain an objective, fact-finding approach or were you subjective and emotionally involved?

Documenting the Interview

Documentation is the key to a successful interview. It demonstrates the investigator' s professionalism and it may be the key to preventing denial by the interviewee at a later time.

Proper documentation includes taking good notes: if possible, tape recording the interview; obtaining written statements; and identifying all pictures or diagrams with statements.

INTERROGATION

Interrogation is defined as a formal line of questioning used to obtain information from reluctant individuals or suspects.

An admission is a verbal acknowledgment of guilt. A confession is a signed statement of guilt. A statement is a written, oral, typed, or recorded assertion of certain facts pertaining to the investigation.

Individuals Interrogated

Individuals normally interrogated are persons with good reason to be thought guilty of the crime, those thought to be accomplices, and those persons thought to be withholding information.

Preparation

In preparing for the interrogation the investigator must have a good understanding of the facts of the case, background information on the subject, an awareness of statements made by other witnesses and/or victims, and a knowledge of the physical evidence.

The investigator must be able to reconstruct the incident mentally, to anticipate facts the subject may provide, and should have an outline of questions prepared.

Set up the interrogation room to meet your needs. Consider environment, lighting, physical factors, and furnishings. Have recording instruments and equipment available to take statements. The environment should be free from distractions.

Remember, it is very important when interrogating a suspect that witnesses be present to protect against charges of abuse, duress, or coercion, particularly when interrogating juveniles and persons of the opposite sex.

Psychological Factors

An interrogation should be done as soon as possible after the incident to prevent the use of alibis. The interrogation period should be free of distractions. Allow plenty of time. Interrogations are usually lengthy, but remember, this may be construed as duress. Allow for breaks and stay within legal bounds.

The location of the interrogation should be the investigator' s office, police station, or the district attorney' s office. Keep the environment simple: plain furnishings, no distracting objects, no telephone. But don' t go overboard—avoid a jail-like atmosphere.

Classifications of Suspects

There are two classifications of suspects: known criminals and those whose guilt is uncertain. Certain suspects cannot be classified because of the inexperience of the investigator. The wrong classification may destroy the interrogation effort.

Conducting the Interrogation

Various techniques may be employed in the interrogation. In the direct approach, the investigator is confident and stresses evidence and testimony available.

The sympathetic approach relies on an understanding attitude. Often this approach is used in spite/venge motives since the suspect is more apt to respond. Here the investigator attempts to gain the confidence of the suspect by minimizing the moral implications, and avoids mentioning the penalties of the crime. If the suspect shows signs of stress or nervous tension, point them out and urge him/her to tell the truth. * *

The logical approach is used when you are trying to convince the suspect that his/her guilt can be proved. Here you can confront the suspect with the evidence. This approach often results in an admission.

The psychological approach focuses on the moral issues. The intent is to make the suspect aware of his/her guilt and realize he/she has committed a crime. Emphasizing the suspect' s family, parents, friends, childhood, upbringing, and background may allow the suspect to save face by rationalizing the crime.

The indirect approach usually is exploratory, where the guilt of the suspect is questionable. Using known facts about the case and implying that the suspect knows more than he/she is telling may yield successful results.

Finally, the hypothetical story approach relates a fictitious crime story that is very similar to the actual incident The suspect is asked to fill in the details of this story. Often new facts regarding the investigation are revealed.

Personal Observations

The investigator must be able to interpret the reactions of suspects through their body language. These include nervous, emotional, or physical reactions. Nervous reactions can result from withholding information, lying, or simply from the interrogation environment. Indicators of anxiety include flushing, perspiration, voice fluctuations, dryness of the mouth, and restlessness. Indicators of deception include looking away when answering questions, covering the mouth, assuming a fetal position, sudden lapses in memory, bringing parents into the questioning, taking an oath, questioning the investigator, inquiring about possible punishments, and sudden physical or emotional changes.

Obviously, reading these signs accurately can be an advantage to the investigator. Sometimes an investigator will try to increase the suspect' s anxiety level; the goal is to cause the suspect to concentrate on the physical situation, and can result in his/her inability to hold back information.

Leaning towards the suspect, moving closer, and invading his/her "personal space" are ways to increase a suspect' s anxiety that can be used to the investigator' s benefit. However, be aware that the suspect' s increased anxiety could lead to violence and/or attitude changes, or the suspect might try to employ

reverse psychology on you. Such techniques also may be misinterpreted by persons of the opposite sex.

At the conclusion of the interrogation ask the suspect to repeat his/her story. Have him/her tell it forward and backward to ensure consistency.

SUMMARY

Successful investigators plan their interviews and interrogations. They analyze available information, decide what else is needed, and then formulate a game plan. During the interview/interrogation they always listen to what is being said, and observe body language and mannerisms. They are cognizant that a nonjudgmental, objective approach is most productive and professional.

If investigators use these techniques, evaluate themselves honestly, examine their strategies, and develop their expertise, then, and only then, will they succeed in a successful interview or interrogation.

BIBLIOGRAPHY

Interviewing Witnesses. Study notes, Niles: Police Science Services Inc., 1976.

Link, Fred and Glen Foster. The Kinesic Interview Technique. Riverdale: Interrotec Associates, 1989.

NFPA 921, Guide for Fire and Explosion Investigations. 1992 ed. Quincy: National Fire Protection Association.

O' Connor, John J. Practical Fire and Arson Investigation. New York: Elsevier Science Publishing Co., Inc., 1987.