

# **flexarray**

**TFA-600H/DP mid/high**  
**TFA-600HW/DP wide dispersion mid/high**  
**TFA-600L/DP low frequency**

## **Rigging User Guide**

(Please refer to [www.turbosound.com](http://www.turbosound.com) for the latest updates)

Version 1.2 December 2010

## The Flex Array Flying System

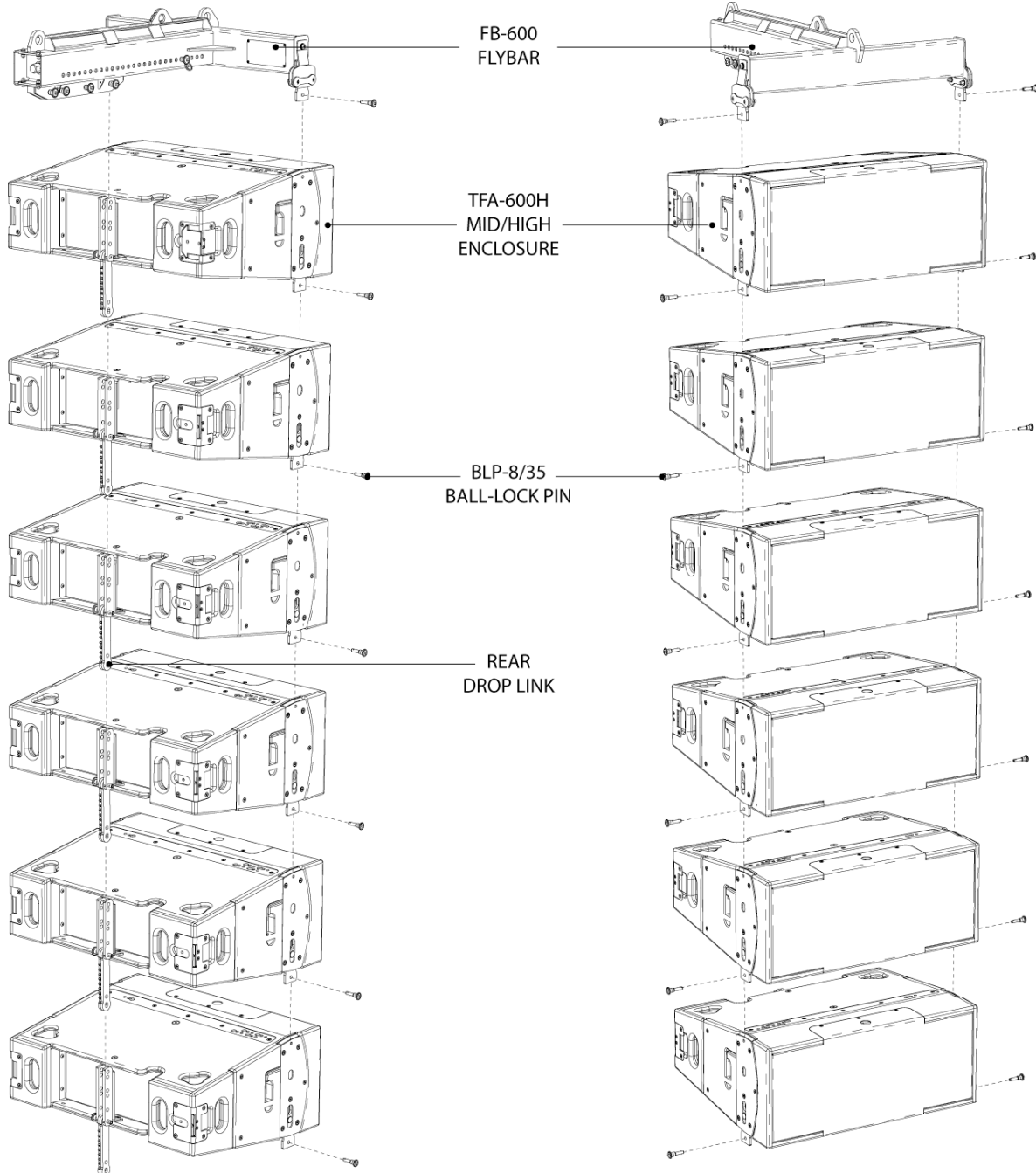

## SAFETY INFORMATION

### Safety Notes on Rigging



The Turbosound rigging system has been designed and constructed to a high standard of safety, and tested to the most demanding of specifications. In order to ensure the highest safety standards, the information following on the assembly and safe use of rigging accessories must be carefully understood and followed.

Only use Turbosound recommended rigging accessories, which are specifically designed for their intended purpose. Do not use Turbosound rigging with other types or brands of loudspeakers. This practice may compromise safety standards and Turbosound will not be responsible for damage or injury so caused. Do not modify the rigging accessories, or use them in a way other than that described in this user manual. Rigging components supplied as part of a complete assembly are non-interchangeable and must not be exchanged with the component parts of any other assembly. The component parts of a Turbosound rigging accessory must only be assembled using the fasteners and methods of assembly recommended in this guide. The use of fasteners and methods of assembly not specified or approved by Turbosound may result in an unsafe rigging assembly. Welding, or any other means of permanently fixing rigging components to each other or to cabinet fixing points is not allowed. Rigging assemblies must only be assembled using the appropriate parts and fixings as specified in this manual using the specific mounting instructions. Rigging components or assemblies must only be fixed to Turbosound loudspeaker cabinets using the cabinet fixing points, assembly methods and fasteners specified in this guide and the specific mounting instructions.

### Secondary Safeties

All loudspeakers flown in theatres, studios or other places of work and entertainment must, in addition to the principle load bearing means of suspension, be provided with an independent, properly rated and securely attached secondary safety. Only steel wire ropes or steel chains of an approved construction and load rating may be used as secondary safeties. Plastic covered steel wire ropes are not permitted for use as secondary safeties.

### Safety Inspections



Carefully inspect rigging systems components and cabinets for defects or signs of damage before proceeding to assemble a flown array. If any parts are damaged or suspect, **DO NOT USE THEM.**

Regular, more rigorous test and inspection of rigging components must also be carried out. Safety legislation and test and inspection requirements will vary from country to country. In most cases, annual independent test and inspection by a suitably approved and qualified inspector will be required. Users must ensure compliance with all applicable safety requirements. Turbosound recommends regular safety inspections and further recommends that a logbook be kept detailing the test and inspection history of each Turbosound rigging accessory. Always wear protective headwear, footwear and eye protection in accordance with local regulations. Anyone involved in flying ANY sound system should take note of the following advice:

The rigging of a flown sound system may be dangerous unless undertaken by qualified personnel with the required experience and certification to perform the necessary tasks. Fixing of hanging points in a roof should always be carried out by a professional rigger and in accordance with the local rules of the venue. The house rigger and/or building manager must always be consulted.

Flying System components have been individually tested in accordance with the following regulations:

The Health and Safety at Work Act 1974

The Supply of Machinery (Safety) Regulations 1992

The Lifting Operations and Lifting Equipment Regulations 1998

## **GENERAL DESCRIPTION**

To take full advantage of the extremely flexible properties of the Flex Array system, the rigging is fully integrated into the enclosure. The flying systems are inherently safe, flexible, self-contained and simple to use. The load is taken entirely through the flygear and not through the cabinet's woodwork.

The rigging design allows the creation of clusters and arrays that can be assembled quickly and with a minimum number of crew, and with full control of the vertical angles between enclosures and their vertical inclination.

## **RIGGING PARTS**

The rigging system consists of steel flygear rebated into the short sides of the loudspeaker enclosure, working together with integrated drop links which locate into the flygear of the cabinet directly underneath, and form the pivot point about which cabinets can be angled. The drop links are secured in position with captive ball-lock pins and retract into the flygear for transportation.

The Flex Array rigging system includes all the necessary hardware to enable vertical suspension of TFA-600 series cabinets from a single rigging point and using a single motor rated at up to and including 1 tonne.

The rigging system permits a range of inter-cabinet angle adjustment in 2° increments from 0° to 16°. A rear link locates into a clevis connection plate with multiple holes at the rear of the cabinet.

### **FB-600 Flybar**

A rigid 'T' shaped flybar with screw thread front-to-rear adjustment of the pickup point that enables the suspension of loads up to the SWL of 700kg. The frame is constructed from a rectangular box section with a unique formed rear spine that forms a channel in which the movable lift point is located.

A single hang of up to 12 mid/high cabinets, or a combination of mid/high and low frequency cabinets of equal weight, can be flown using this bar and a single one-tonne motor. The drop links at the front of the bar locate into the Flex Array cabinet's integrated flygear and are secured with ball-lock pins.

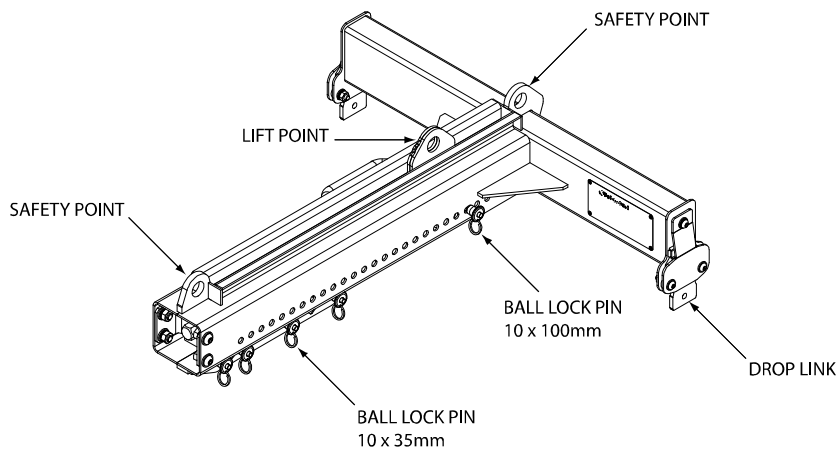

The movable lift point can be traversed along the spine by means of a screw which is turned by a 22mm (7/8") socket (available from Turbosound) fitted to a speed brace or electric drill.

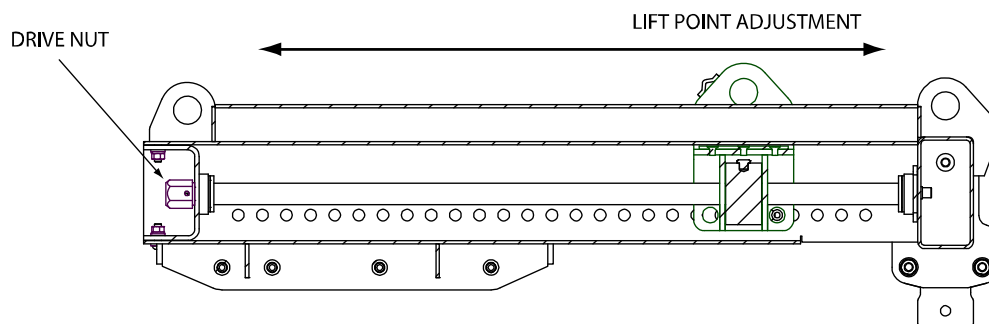

Turning the drive nut on the end of the shaft the lift point moves along the rear spine, tilting the load by varying the motor connection point relative to the centre of mass of the cluster. The screw is located in polymer sealed bearings requiring no maintenance under normal operating conditions, and is designed to last the lifetime of the product.

A 100mm / 4" ball locking pin is supplied attached to the flybar and must be fitted through the appropriate holes in both the moving lift point and the rear spine to ensure that when the TFA-600 cabinets are in use the vibration cannot cause unwanted tilt adjustment. The holes are based on a vernier scale adjustment ensuring precise alignment for tilt angles as specified in the Array Calculator. **The adjustment holes do not represent the angle of the flybar to the horizontal and are used to lock the flybar where required.**

### Connection to TFA-600 cabinets

Floating drop links are located at the ends of the box section enabling the easy connection of the FB-600 to the mid/high or low frequency cabinets, ensuring that the link will easily slide into any cabinet assembly. To link the rear of the FB-600 to the appropriate loudspeaker a pair of cabinet connection drop links is provided, each at the correct spacing to ensure easy assembly.

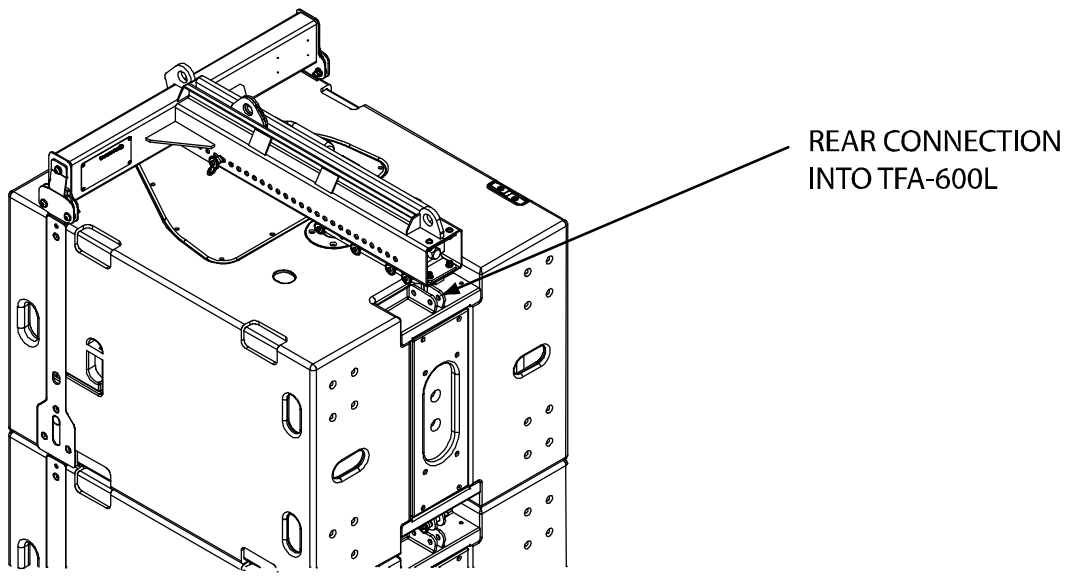
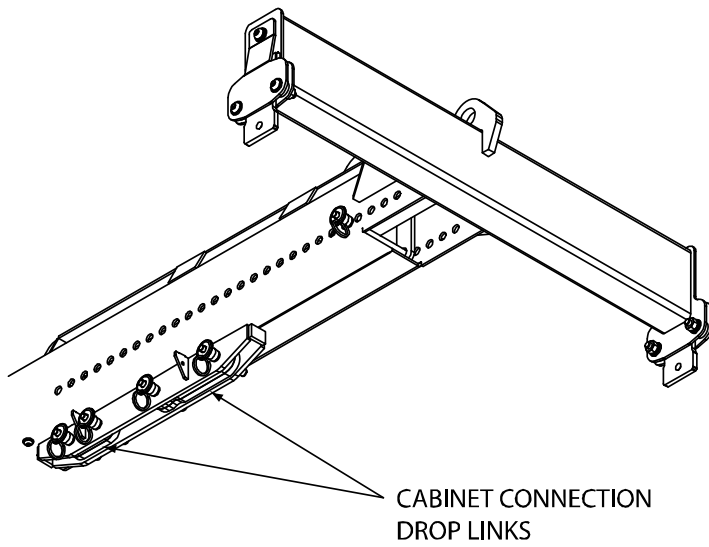

### Important Safety Notes

To ensure the continued safe operation of the FB-600 flybar the following points should be noted:

- A. The 100mm / 4" locking pin should **always** be fitted to lock the moving tilt point
- B. Four ball lock pins **must** be fitted to ensure the safe lifting of the cluster

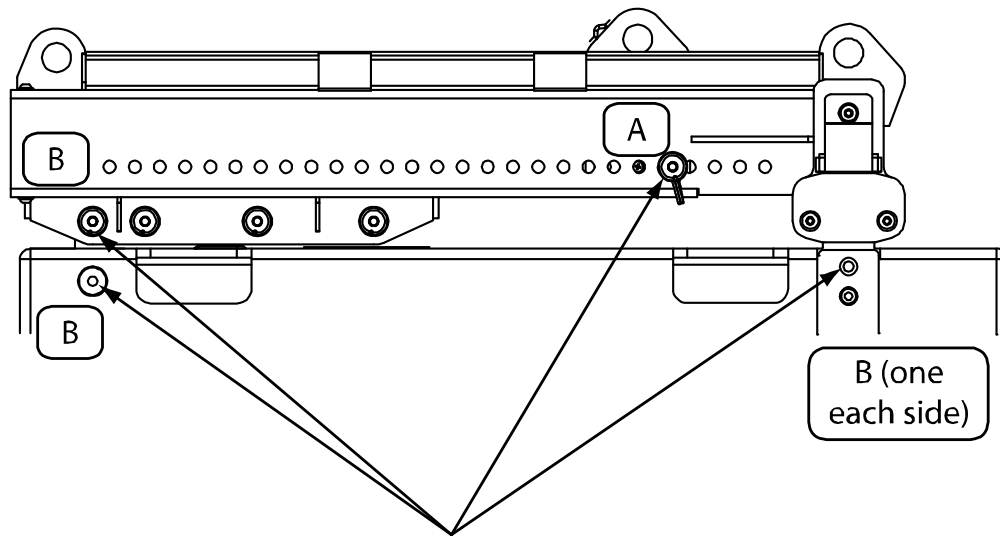

**CRITICAL CONNECTION POINTS**

C. Under no circumstances should hands be placed in the open top of the spine when the flybar is in use.

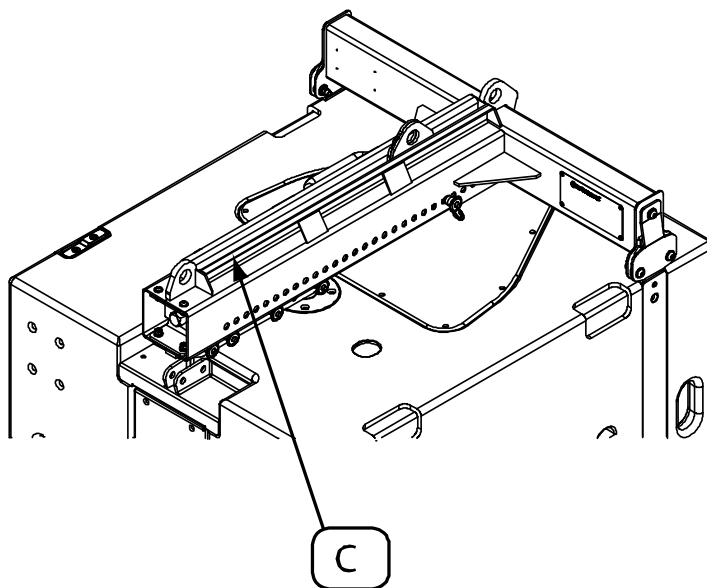

D. Two safety lifting lugs are provided for attaching wire safety rope. No other part of the flybar can be used for this purpose.

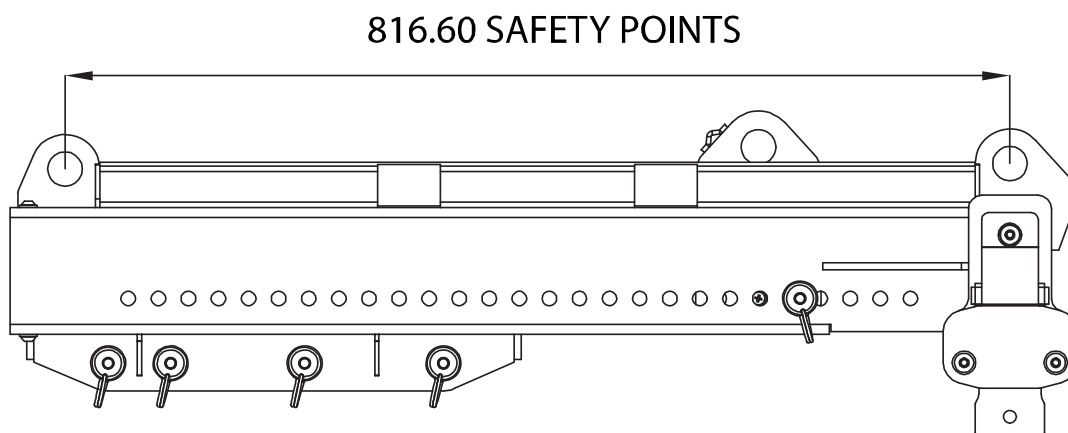

E. Any components that are damaged should be repaired / replaced by an approved service centre.

F. In the extremely unlikely event if the failure of the screw, the safety of the bar is not compromised.



### CF-600 Conversion Frame

The conversion frame is used to interface between bass cabinets and mid/high cabinets in a flown column of Flex Array loudspeakers. The conversion frame has a SWL of 520kg which enables a column of up to a maximum of 12 TFA-600H cabinets to be suspended below it.

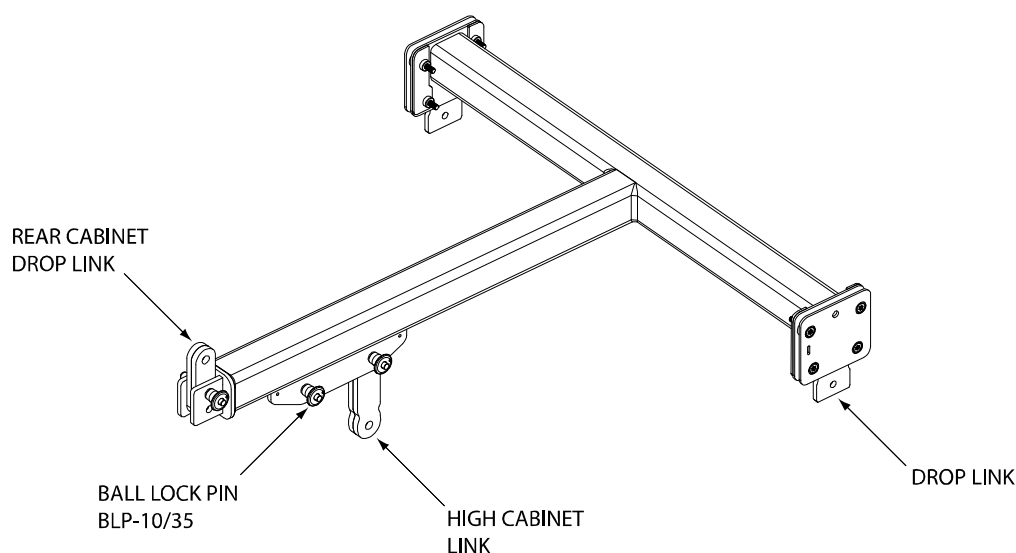

The CF-600 conversion frame also functions as a ground stacking frame, interfacing between ground stacked TFA-600L bass cabinets and the mid-high cabinets positioned on top.

The net weight of the conversion frame is 11kg (24.2lbs)

### CF-600 Conversion Frame in a Flown Column

The conversion frame is fitted underneath the lowest TFA-600L low frequency cabinet in a flown column as shown in the diagram below. TFA-600H cabinets are suspended from the conversion frame using the captive ball-lock pins

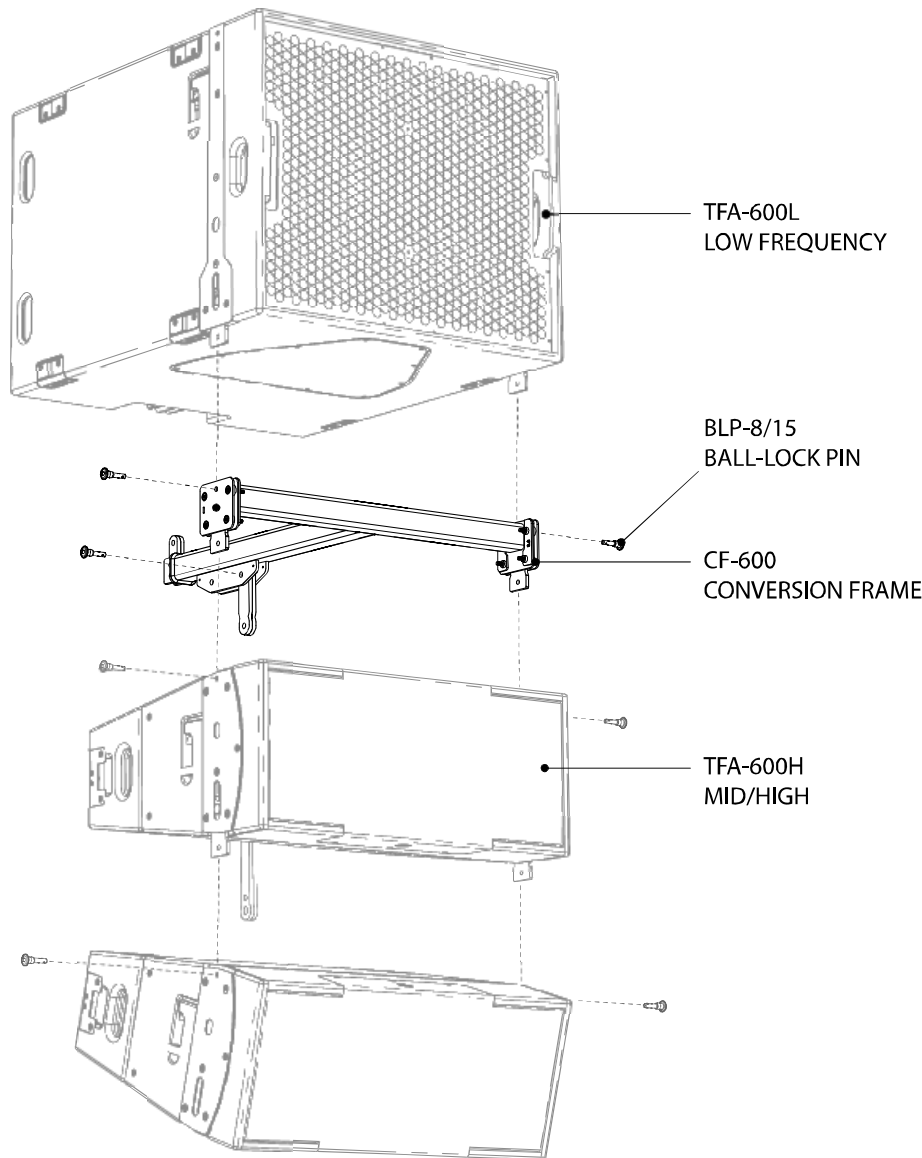

Connection to the first TFA-600H cabinet is made via two 10mm ball-lock pins which are engaged into the rear spine of the mid/high cabinet (one pin is located on the loudspeaker and one pin is located on the conversion frame).

The drop link from the TFA-600L low frequency cabinet is released by removing one of the pins and pivoting the link into the conversion frame.

The drop link from the conversion frame locates into the clevis connection plate of the top mid/high cabinet in one of several predetermined locations, which allows for a range of inter-cabinet angles.

**Ground Stacking with the CF-600 Conversion Frame**

In this application the conversion frame locates on the top of a ground stacked bass cabinet(s) and engages into the flygear of the first mid/high cabinet. The system allows for the lowest mid/high cabinet to be tilted down by approximately 8°.

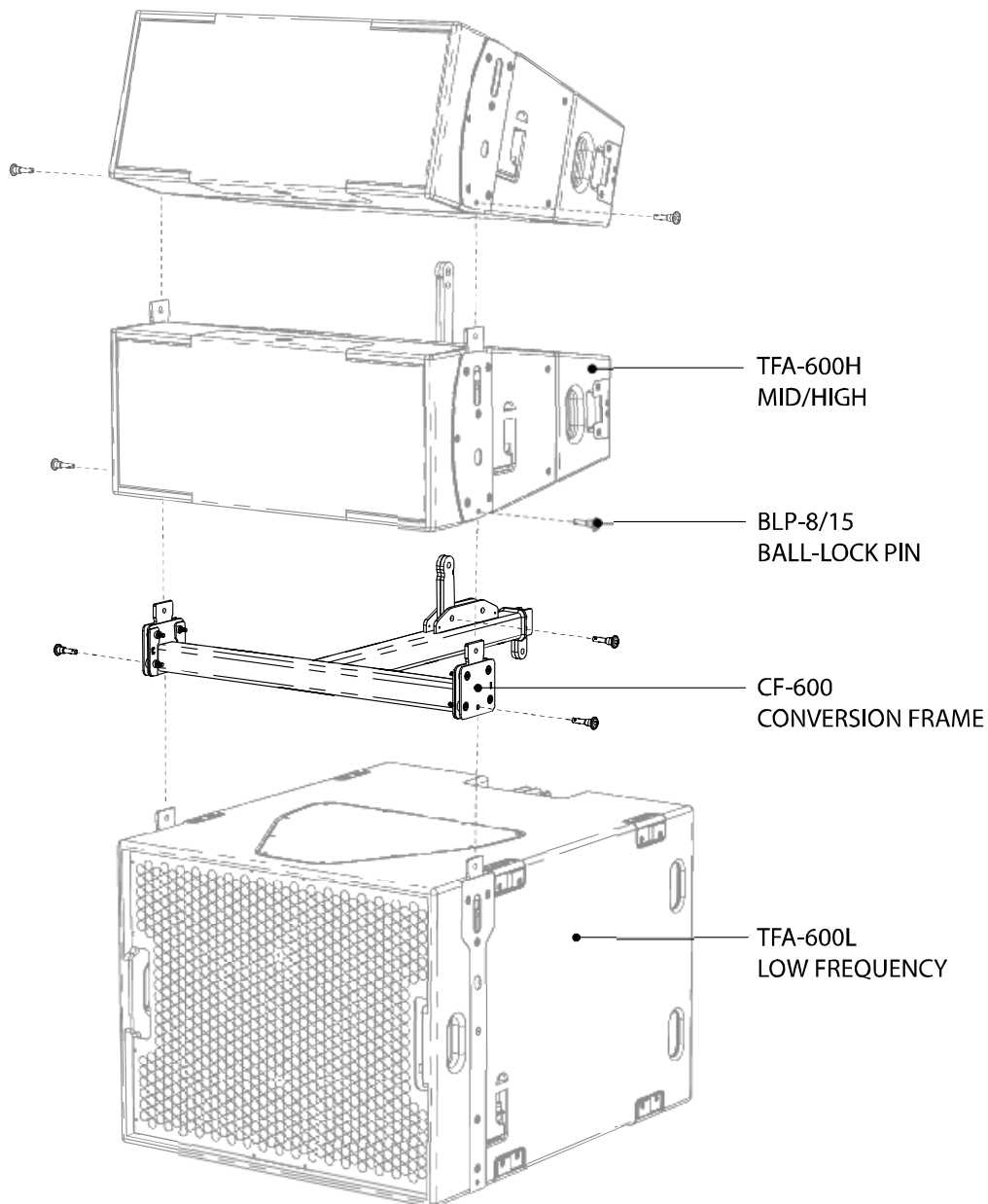

### Rigging a Single Column of Flex Array TFA-600 Cabinets

1. Choose flying points as necessary and attach a chain motor to the flybar's pickup point. Note that the pickup point is adjustable from front to rear and can be moved even when under load.
2. Wheel in a block of three pre-rigged cabinets in their transport case, position them under the flybar and secure the enclosure tabs into the top cabinet with ball-lock pins.
3. Raise the array to allow a further block of three cabinets to be positioned underneath, extend the drop links on the third cabinet and secure them to the fourth cabinet's flygear with ball-lock pins.
4. Repeat with additional cabinets as necessary.

### Setting The Angle Between Cabinets

Precise adjustment of inter-cabinet angle is achieved by selecting one of nine possible engagement positions of the rear link and the clevis, giving a maximum angle of 16° in 2° increments.

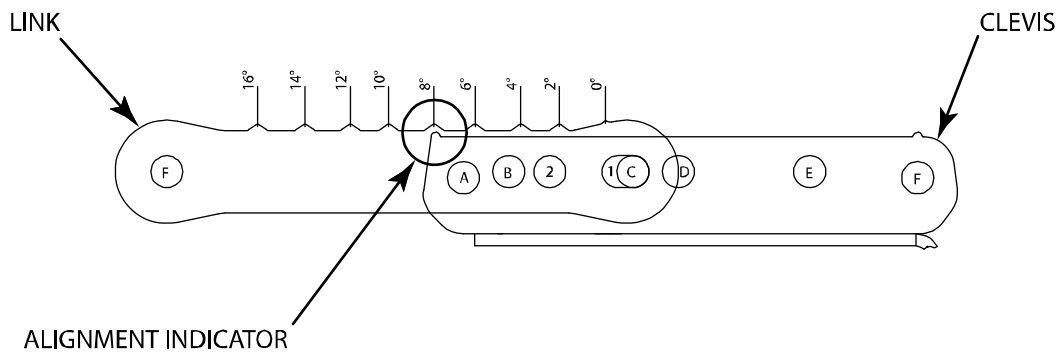

The following table shows the position of the rear link relative to the cabinet clevis to achieve the required inter-cabinet angle.

Hole No. on Link	Hole Letter on Clevis	Angle Setting
1	A	0°
1	B	2°
2	A	4°
2	B	6°
1	C	8°
1	D	10°
2	C	12°
2	D	14°
1	E	16°