

DeltaV™ Digital Automation System

System Overview



DELTA V™
DELTA V™



DELTA V DIGITAL AUTOMATION SYSTEM

With continued focus on human centered design, the DeltaV system delivers significant enhancements that help eliminate unnecessary work processes, removes the complexity of using the latest technologies and embeds specialized knowledge—improving your operations, easy.

I/O on Demand

What you want, when you want it, where you want it.



With the introduction of I/O on Demand, an unprecedented amount of field I/O adaptability, ease-of-integration and plant availability becomes possible.

Costs and concerns around single points of failure, marshalled cross-wiring, power and grounding of FOUNDATION™ fieldbus segments, and late project I/O and process design change orders can completely disappear.

wireless—you can add and begin using the information all natively and with far less engineering, design, and field work. You choose the I/O you need, we make it easy. I/O on Demand—your I/O, any type, anytime, anywhere.

Regardless of I/O type—traditionally wired I/O, FOUNDATION fieldbus, Profibus DP, DeviceNet, AS-i bus, or even redundant

Ultimate Scalability

Inherent functionality regardless of size.

Process control facilities and applications certainly come in all sizes and levels of complexity. To maximize the return on your investment, the automation system should easily scale without adding complexity.

Part of Emerson's PlantWeb™ architecture, the DeltaV™ system is built from the ground up for ultimate scalability. Regardless of your application's size, the DeltaV

system keeps the same look and feel. This reduces administration and training costs, and optimizes both initial investment and future expansions.

From bench top, to pilot plant, to full production; from 25 I/O points to over 1 million, your system adapts to meet your needs. Same operations experience. Same maintenance experience. Same system, scaled to fit. Easy.

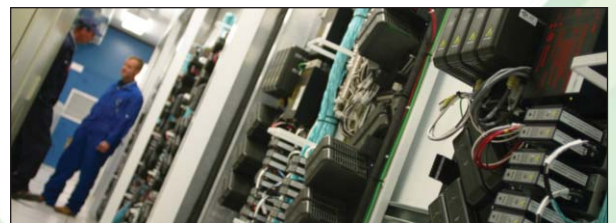

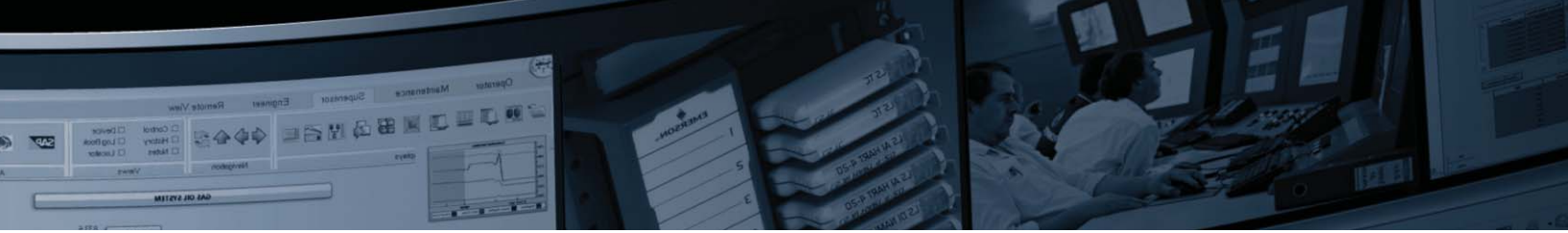

Embedded Intelligent Control

Advanced technologies that are easy to use and maintain.

Plant availability at peak performance, that's really the ultimate goal of any automation system. Keeping the facility running in a safe and secure manner, while optimizing the production, is what the DeltaV system with AMS Suite: Intelligent Device Manager is all about.

All the predictive power of smart devices is combined with the latest advanced control technologies to provide the ultimate in embedded intelligent control. Whether it's the latest in virtualization, predictive device alerts, adaptive tuning, or model predictive control—you have the power of



embedded intelligent control within an integrated system that's easy to use and maintain.

Inherently Integrated

Delivering the power of PlantWeb to every installation.

The DeltaV system has the commissioning power of AMS Device Manager included. This combination connects your operations with the predictive intelligence in smart devices—for greater availability.

The inherent integration of the DeltaV system extends to batch,

advanced control, change management, engineering tools, diagnostics, simulation, and event and continuous historian.

Emerson provides solutions that integrate with your plant systems above, below, and in parallel with the DeltaV system. And, it is tightly integrated with:

- Syncade™ suite which provides operations management
- AMS Suite which provides predictive maintenance
- DeltaV SIS™ system which provides an integrated yet separate safety system
- Integrated machinery monitoring.



Built for Purpose

Designed specifically for your process control applications.

Over the last ten years, commercial off-the-shelf technologies (COTS) have provided tremendous increases in functionality and cost advantages. The DeltaV system was the first such system on the market, and continues to provide open, proven products to its process manufacturers.

However, while COTS have given many advantages, it has also come

with expensive administration and life-cycle cost requirements. A better approach is to take advantage of the cost benefits and open standards of COTS, but to add functionality that allows the equipment to function more like other parts of the system—plug-and-play, full lifecycle support without upgrades, built-in security, etc. We call this balance “built for purpose”, and the DeltaV system is



the first automation system to address this critical need in many of the most important facets of the system.

I/O on Demand

Ultimate Scalability

Embedded
Intelligent Control

The DeltaV Architecture

Improve plant performance with PlantWeb

The proven PlantWeb digital plant architecture helps you detect operations, process, and equipment problems before they even occur, so you can move from reactive to proactive and profitable plant operations.

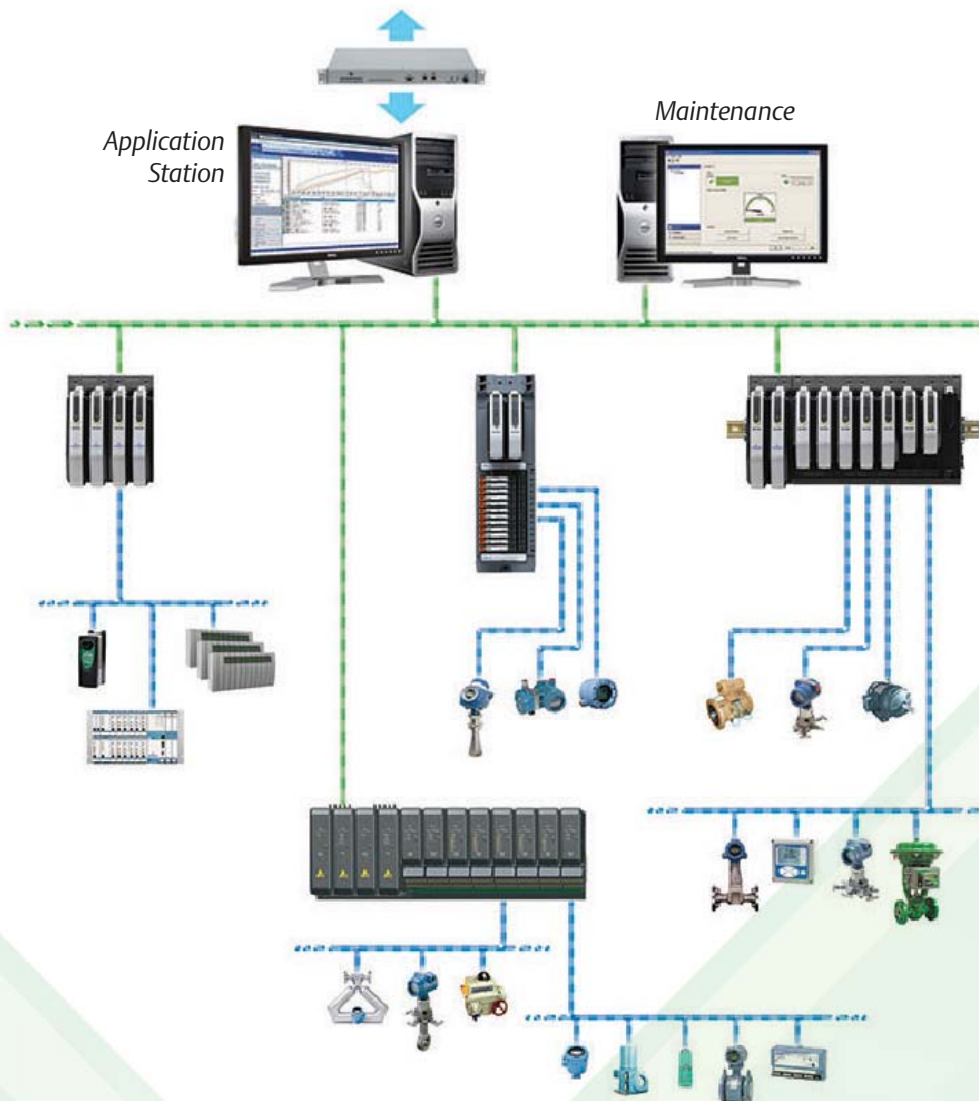

Inherently
Integrated

Built for Purpose

Services

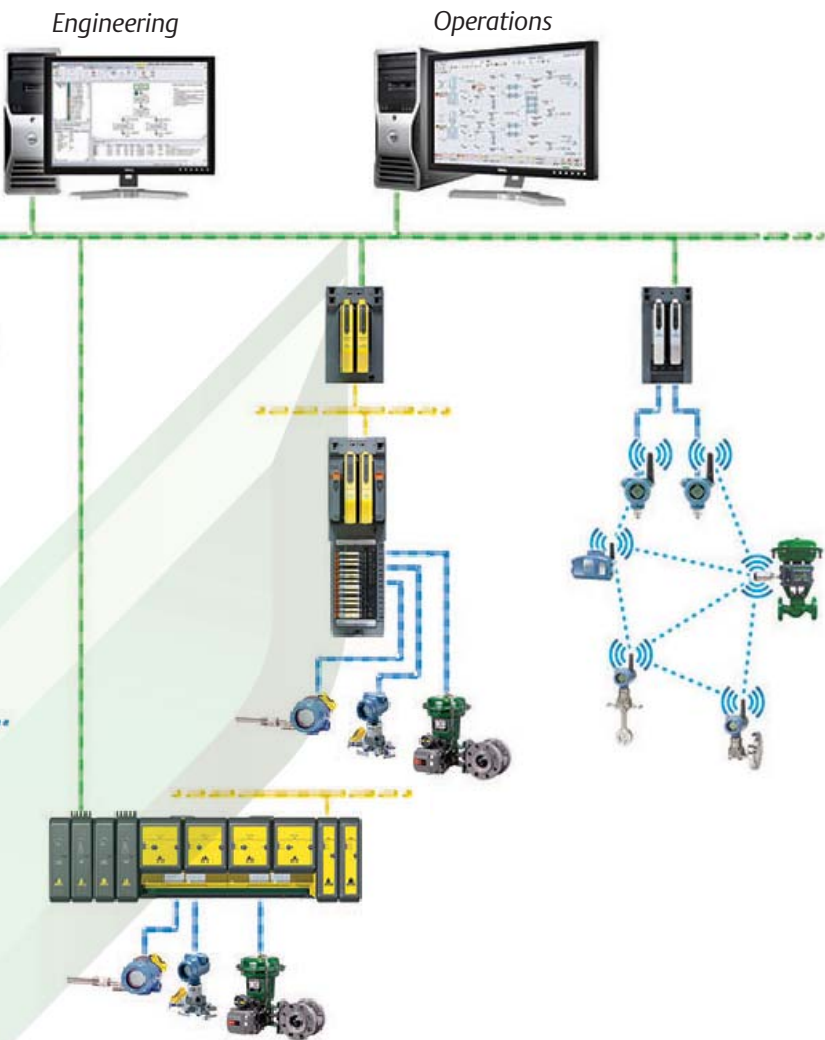

The DeltaV architecture provides reliability through redundancy:

- Ethernet network connections including Virtual I/O Modules (VIM)
- Controllers
- System power
- Field interface power supplies
- Digital HART I/O and classic field interface cards
- H1 FOUNDATION fieldbus with integrated power and diagnostics
- Profibus DP Master interface
- Modbus RTU/ASCII interface
- SIS logic solvers
- SISNet communications
- Batch Executive
- Zone servers
- OPC servers

Digital Communications

- FOUNDATION fieldbus
- HART
- WirelessHART
- Profibus DP
- DeviceNet
- AS-i bus
- Modbus RTU/ASCII/TCP
- Ethernet/IP
- OPC classic
- OPC .NET 3.0



Reduce Complexity with Electronic Marshalling

Flexibility to give you the I/O you want, when you want it, where you want it.

The DeltaV system's unique flexible field architecture delivers I/O on demand—providing the I/O you want, when you want it, where you want it. It is flexible because you can now decouple the process design from the I/O infrastructure design, to easily incorporate late process changes into the automation system.

Electronic Marshalling made easy

Electronic Marshalling makes design easier and more forgiving, because any input value can be read by any DeltaV controller regardless of where the wiring is landed.

DeltaV Electronic Marshalling eliminates the complexity associated with marshalling field wiring in a control system.

Electricians can terminate the field wires on terminal strips in the same way they have in the past, but the cross-wiring from the marshalling panel to I/O cards has been eliminated. This greatly simplifies control cabinet design, installation, and maintenance.

Installation of Electronic Marshalling is intuitive and easy, because it is similar to existing methods for terminating field wiring. No special training or expertise is needed to terminate wiring on the terminal blocks. An integrated “knife-edge”

disconnect eliminates the worry over accidentally induced faults during hot cutovers and maintenance.

Increased robustness

Troubleshooting of installation issues can be done on a channel-by-channel basis, because problems are isolated to a single channel—providing increased robustness.

Because each analog CHARM comes fully equipped with the ability to read HART v7 data, intelligent field devices can be monitored and quickly diagnosed around the clock. In addition HART data access is quicker with CHARMs than with traditional I/O cards.

Redundancy ensures reliability:

- Redundant CHARM I/O card
- Redundant communications between CHARMS and the CHARM I/O card
- Redundant power between CHARM I/O card to each CHARM
- Redundant network communications between CHARM I/O cards and controllers.

Electronic Marshalling

Tight project schedules with changing requirements during design and implementation are a way of life. DeltaV Electronic Marshalling lets you land field cabling wherever you want, regardless of signal type or control strategy.

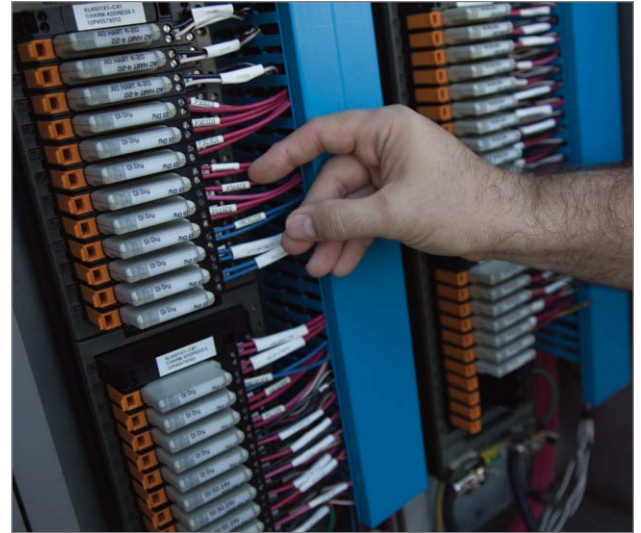

With Electronic Marshalling, each terminal block has a channel characterization module, or CHARM, which includes signal characterization for different types of I/O. Field wiring of any signal type can be terminated anywhere and characterized by the various CHARMs. A digital communication bus runs along the terminal strip to send device signal information to the top, the redundant CHARM I/O card, a redundant 96 channel based multipurpose I/O card, where I/O conditioning is completed.

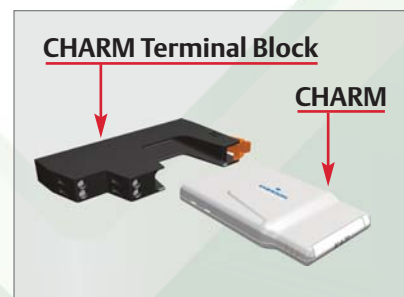

Inherently Integrated

Built for Purpose

Services

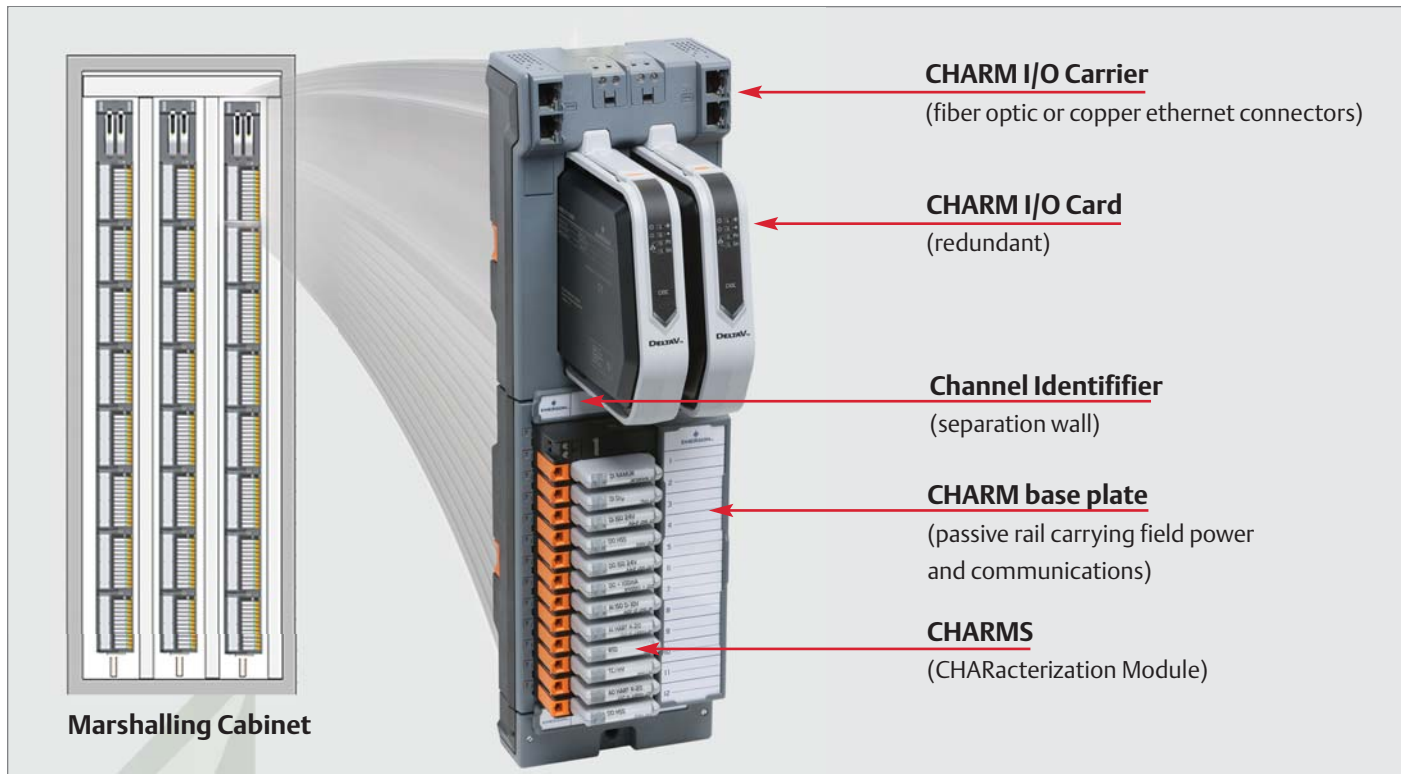

Integrated CHARMS

- CHARM base plate snaps on rail
- CHARM terminal block snaps into baseplate
- Auto keying sets terminal block when first CHARM is inserted
- CHARM secured with locking mechanism in both operating and “knife-edge” disconnect positions
- Insertable/removable under power in a Zone 2 environment
- Signal fault protection and circuit protection built in
- Single channel fault isolation built in
- Can be mixed with IS CHARMS using a separate baseplate.

Intrinsically Safe in hazardous areas

The DeltaV Intrinsically Safe I/O M-series subsystem provides the perfect solution for locating I/O in

hazardous areas. The I/O subsystem connects intrinsically safe field circuits and field devices into FM Class I, Division 1, Zone 1, and Zone 0 hazardous areas for most standard analog input, discrete input and discrete output applications.



With the addition of Intrinsically Safe CHARMS to the S-series Electronic Marshalling concept, field wiring to hazardous areas is even easier. Field devices located in FM Class I, Division 1, ATEX or IECEx Zone 1 or Zone 0 hazardous areas can now directly be connected to the flexible IS AI and IS AO CHARMS, IS DI NAMUR and IS DO as well to IS RTD and IS TC CHARMS.

Late project changes? No problem.

Every project has late changes that can have significant impact on cost and schedule. Making these late changes is now easier, because new field wiring can be added to cabinets at any time with no impact on the system architecture.

Flexibility with Traditional I/O

Proven, plug and play—a smart choice for your control system.

Traditional I/O is a modular subsystem that offers flexibility during installation. It's designed to be installed in the field near your devices. Modularity, protection keys, and plug-and-play capabilities make DeltaV traditional I/O a smart choice for your process control system.

Traditional I/O is available in two designs—the established M-series and the S-series. The S-series incorporates human-centered design concepts to improve usability and robustness with the same proven technology inside. The exterior hardware design delivers easier installation and improved robustness.

Easy snap-in installation

Installation is easy since I/O is automatically auto-sensed when added to the system. No-value engineering is eliminated.

S-series traditional I/O is equipped with a snap-in retention system for quick installation and error-free maintenance.

A guide prevents bent pins and cards easily snap in to place. Carriers snap onto the DIN Rail—no tools required. Snap-in technology makes cards easy to install with tight connections every time and easy to release with a push of a button.

I/O cards, terminal interfaces and terminal blocks have I/O function keys. This ensures the correct I/O

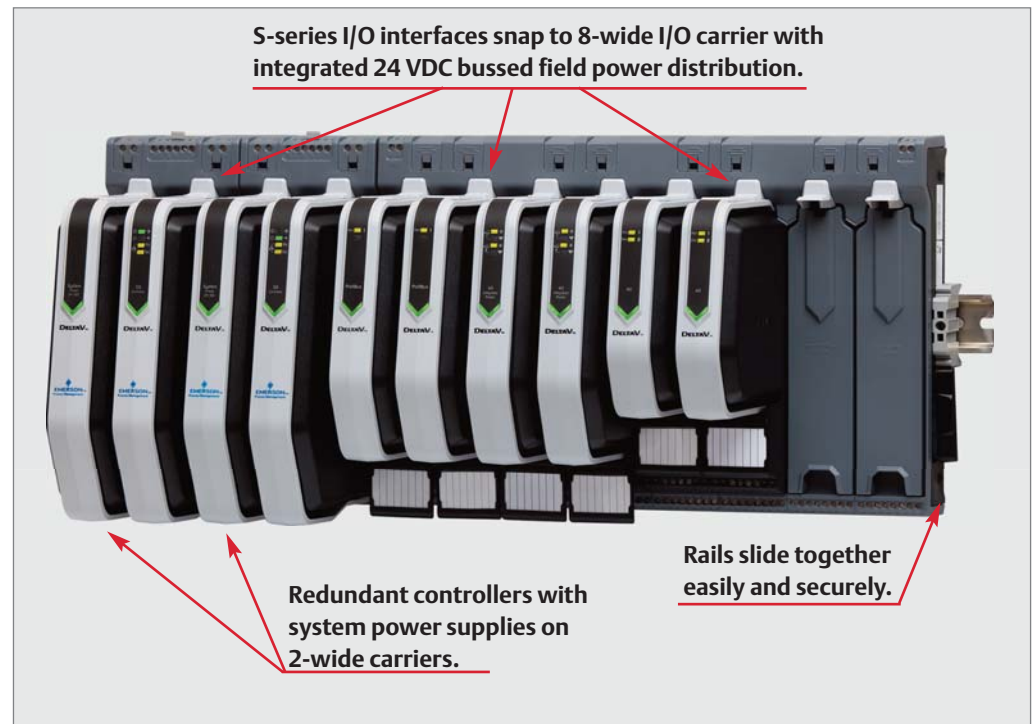

card is always plugged into its corresponding terminal block.

All wiring is through the carriers and terminal blocks so that I/O cards and system power supplies can easily be removed without disconnecting any wires.

The DeltaV system supports a full range of analog, discrete, digital bus, thermocouple, and RTD field devices.

Reliable means available

Reliability and increased system availability are built in throughout the rugged DeltaV control hardware. Redundancy options are available for:

- Controllers
- System power

- Field interface power
- Controller Ethernet communications
- Many classic field interface cards
- H1 FOUNDATION fieldbus
- Profibus DP
- Serial interface.

Online addition of new I/O cards means your process does not get interrupted. The DeltaV system enables you to add system components including controllers, I/O cards, field devices and workstations while the system is powered and running by autosensing the new component without the need of presetting an address. This enables you to expand and upgrade your system on-the-fly with no downtime.

Inherently Integrated

Built for Purpose

Services

The rugged S-series hardware includes a venting system that prevents screws, metal shavings, and other debris that could short-circuit electronic components from entering.

Modular design for added flexibility

Both the S-series and M-series traditional I/O hardware can co-exist in the same DeltaV system with no trade-offs or incompatibilities.

The modular design lets you buy the exact number of I/O cards, 8-wide carriers, power/controllers, and 2-wide carriers you need and add more DeltaV I/O as your system grows.

Rugged design for use anywhere

DeltaV control hardware is built rugged and flexible to mount

almost anywhere. It is designed for extreme field installation conditions, including:

- Class 1 Division 2 areas
- CENELEC Zone 2 areas
- ISA-71.04-1985 Airborne Contaminants Class G3.

All DeltaV traditional I/O cards are rated for extreme operating temperature ranges of -40 to 70 °C (-40 to 158 °F). You can mount the I/O interface carrier in a junction box in the field, significantly reducing your equipment footprint.

Shared remote I/O is available for Zone 2 installations. Unlike other remote I/O, DeltaV remote I/O can be shared among several controllers for a greater range of applications and installation flexibility.



Latched installation delivers tight connections every time.

Guide prevents bent pins and card snaps in place.

Screw fastening eliminated. No broken cards due to over-tightening.

With snap-clamps the correct tightness is assured. Cards remain securely in place.

Venting system prevents debris/objects from entering.



Rugged S-series hardware addresses your toughest applications.

Built for Busses

Digital communications deliver predictive diagnostics for improved operations.

The DeltaV system is the only system built from the ground up to unleash the advantages of FOUNDATION fieldbus. Not an add-on, not an afterthought, it's built to deliver the project and operational savings of a digital plant—easy!

Digital busses

The DeltaV system includes other popular digital communication busses such as Profibus DP and DeviceNet for integration of motor starters and drives. It also includes AS-i bus for low-cost, simple installation of discrete devices such as push-buttons, on/off valves, and proximity sensors.

The DeltaV system provides native support for configuring busses with no need for third-party configuration tools. Ethernet I/O devices are easily connected through a virtual I/O module (VIM).

With the DeltaV system you have a wide variety of digital busses from which to choose, as well as the world's best implementation of HART and Wireless HART to easily take advantage of the diagnostics that HART-based intelligent field devices provide.

FOUNDATION fieldbus (Ff) devices deliver predictive alerts, millisecond data capture, validated data, field-based control, diagnostics, and asset information bi-directionally with the DeltaV system. DeltaV Ff I/O communicates digitally with field devices, increases your input/output capacity, and provides access to more information about your process than conventional I/O subsystems. DeltaV Ff I/O enhances device diagnostics that affect your control strategy and alert operators to device malfunctions.

Multi-dropping up to 16 devices on one port reduces your wiring expenses substantially. The DeltaV Ff I/O's integrated design can eliminate the need for marshalling panels—saving you even more.

Easy design, installation, and commissioning

Fieldbus power conditioners are integrated in the S-series H1 interface card. This eliminates difficult segment power design, installation, and troubleshooting. The additional cabinet footprint associated with use of external Ff segment power supplies is eliminated.

FOUNDATION fieldbus devices are auto-sensed when connected to the control network and automatically added to your configuration. As a result, your engineering and commissioning efforts are dramatically reduced.

Improved plant availability

Benefits include upfront engineering, installation, and commissioning savings. Of greater significance are the ongoing savings in reducing process variability, improving quality, increasing throughput and avoiding upset conditions that can limit your production capability.

Reliability and increased system availability are built in throughout the rugged DeltaV control hardware. Card redundancy options are available for serial, FOUNDATION fieldbus, HART, Wireless Hart and Profibus DP.



Inherently
Integrated

Built for Purpose

Services

Smart Wireless

Extending predictive intelligence more economically where you need it.

Wireless Field Network

Emerson's Smart Wireless solutions provide an interoperable, adaptive, flexible approach to wireless. It has been proven in installations around the globe. At its heart, a self-organizing wireless network based on the globally accepted IEC 62591 (*WirelessHART*) standard, provides secure, robust, and reliable performance.

Reliable

Redundant DeltaV wireless I/O cards each connected to a Smart Wireless Field Link, providing a fully redundant solution for critical wireless communications that is reliable enough for control.

The wireless "mesh" continuously monitors communication paths for degradation and automatically improves itself. If an obstruction occurs, devices will find the best alternate communication path. Greater than 99% reliability is ensured.

Flexible

Many plants are missing important measurements. Typically, the measurements and associated wiring were not easy to add—given distances, hazardous areas, or path blockages. *WirelessHART* devices and easy DeltaV connectivity open the path to improved plant efficiency. AMS Device Manager with the AMS Wireless SNAP-ON™ application helps you effectively plan and monitor your wireless

network for maximum process availability. The DeltaV PID control algorithm is specifically designed to handle communications variability from *WirelessHART* instrumentation. It is ideal for control applications like level and temperature control.

Robust

Redundant DeltaV wireless I/O cards provide reliable communications with the self-organizing, adaptive wireless mesh networks.

Secure

DeltaV wireless field networks protect valuable information with multi-tiered, always-on security. Based on the highly-secure *WirelessHART* standard, the network devices implement encryption, authentication, verification, anti-jamming and key management methods to ensure that data transmissions are secure.

Wireless Plant Solutions

Smart Wireless solutions for plant-wide operations provide standards-based network infrastructure for easy integration of all the wireless applications in your plant, including video, location tracking, mobile worker productivity solutions, as well as a



field data backhaul to bring remote wireless field data to the system.

Wireless access points provide Wi-Fi coverage and can even be implemented in hazardous areas. Emerson services tie these Wi-Fi access points with the applications you need for a total solution—easy.

Monitor process in tough places.

A North Sea offshore oil and gas producer needed a better way to measure well casing pressure. Sudden pressure drops can indicate problems with a well. Twice daily, operators manually recorded these pressure readings from this Zone 1 hazardous area. Adding WirelessHART, AMS Device Manager and pressure transmitters provided continuous monitoring to spot and initiate corrective actions sooner.

Integrated Smart SIS

Flexibility provides the safety you want, when you want, where you want it.

Safety instrumented systems (SIS) perform a critical role in providing safer, more reliable process operations at your facility. They also add complexity to your automation system design, engineering and maintenance. And because a safety system is designed to perform only when an abnormal situation occurs, it's hard to know during day-to-day operations whether it will perform reliably when you need it to. With its proven, IEC 61511-compliant, separate-but-integrated architecture, the DeltaV SIS System increases visibility for better reliability. And with the addition of electronic marshalling and characterization modules (CHARMs), Emerson dramatically reduces SIS complexity.

Electronic marshalling, SIS CHARMs

Electronic marshalling simplifies the design, installation, wiring and commissioning of any SIS project while at the same time increasing capacity and reducing footprint. Based on human centered design (HCD) principles, the DeltaV SIS CHARMs logic solver architecture eliminates the need for

conventional marshalling. That simplifies both your installation and commissioning processes. The system can be implemented as a standalone SIS solution, natively integrated as part of a DeltaV installation, or connected to any DCS. This flexibility can simplify the design, implementation, and operation of any safety system.

Optimized reliability

Based on industry research, over 85% of all faults in SIS applications occur in field instruments and control elements. That's why it's critical to consider the entire safety instrumented function (SIF)—from sensor, to logic solver, to final element—as a complete entity.

The DeltaV SIS system helps you to improve your process safety by continuously monitoring and diagnosing the ability of the sensors, logic solvers, and final elements to perform on demand as required. To increase your process availability, the DeltaV SIS system detects component failures and

Integrated operations, engineering and maintenance.

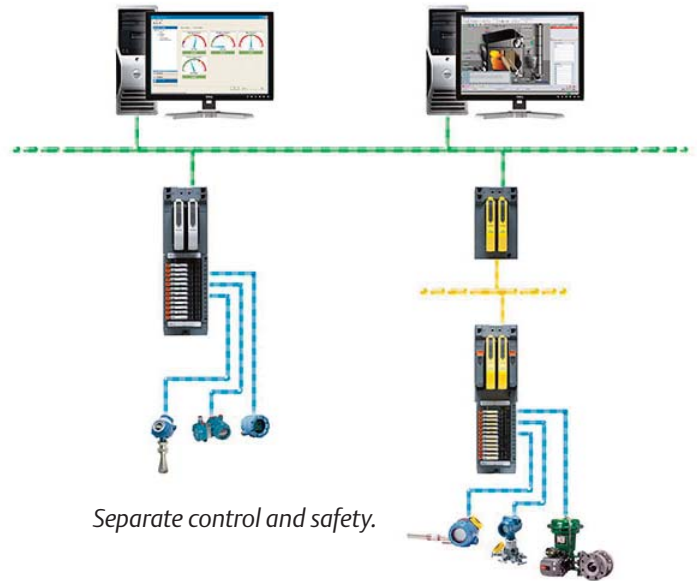

Separate control and safety.

keeps you running when other systems might shut you down.

The use of digital intelligence and predictive diagnostics increases system availability while reducing life cycle costs by providing:

- Health diagnostics to detect device failures
- Device alerts for quick action
- Automatic partial stroke testing
- Automated proof testing
- Integrated, comprehensive documentation tools.

Increased visibility into your process

The DeltaV SIS system's integrated architecture meets IEC 61511 requirements for separation of safety and control—with dedicated safety hardware, software and networks; and integrated configuration, operations, and maintenance with the DeltaV



SMART SIS



Inherently Integrated



Built for Purpose



Services

system. Yet it provides unmatched visibility into your process by enabling direct access to all SIS information across the entire safety loop.

Flexibility to meet your process needs

The DeltaV SIS system provides a unique modular, distributed architecture that is based on a safety instrumented function approach to logic solving. The modular architecture eliminates a single point of failure, while the distributed architecture enables implementation of complex logic across multiple logic solvers. This optimum architecture simplifies change management and enables the system to be custom fit for SIS applications.

The DeltaV SIS system is IEC 61508 certified for use in SIL 3 applications.

The modular logic solver hardware scales in sizes of 96 configurable I/O; therefore, memory and CPU are added with each logic solver.

For further flexibility, the I/O mix is configurable and can be located remotely. And the system can be as large as your application requires—30,000 I/O.

Physical separation and independence

The DeltaV SIS system provides key safety functionality that is independent of the DeltaV basic process control system. Separate safety hardware features include a unique logic solver, independent operating system, and diverse

advanced safety function blocks. Additionally, the power supply and communication networks are dedicated and independent for the DeltaV SIS hardware. For added protection, the DeltaV Controller acts as a firewall between the SIS logic solvers and the control network.

Integrated engineering, operations and maintenance

The DeltaV SIS platform seamlessly integrates with the DeltaV system to provide a comprehensive process safety solution that leverages your automation investment.

- Integrated engineering provides all of the capabilities that make the DeltaV system easy. It eliminates the time wasted to maintain data mapping and handshaking between the control and safety systems.
- Integrated operations ensure that personnel are quickly notified of alarms and can easily access safety information in a familiar environment.
- Integrated AMS Device Manager provides comprehensive asset capabilities for SIS components that are critical to safe operations.
- Integrated historian provides comprehensive event collection and reporting with time synchronization.

Reduced engineering and complexity

The DeltaV SIS advanced function blocks deliver powerful functionality out of the box, and simplify the implementation of

complex SIS applications. A full pallet of IEC 61508 certified function blocks is built to the IEC 61131-3 function block standard, making safety logic development intuitive and easy. Simple drag-and-drop configuration process requires no custom programming. Simplified configuration with less complexity reduces your lifecycle costs and process risks.

Simplified regulatory compliance

The DeltaV SIS system is built from the ground up to simplify regulatory compliance, eliminating your concerns related to proper implementation. The engineering tools enforce good practices, so special restrictions need not be considered when configuring the system. Simplified IEC 61511 compliance is provided by:

- Change management of safety logic and field device configuration and calibration
- Security management, including authorization of online trip point or bypass changes
- Secure write mechanism for repeat confirmation of online changes
- Automatic logging of system events and diagnostics faults
- Automated workflow for proof-testing field devices.



Ultimate Scalability

Easily fits applications of any size.

Process control applications come in many different sizes and levels of complexity. It's critical to have an architecture built to support this required scalability, or you end up with multiple, isolated, difficult-to-integrate solutions.

Scalability starts at the field device level. Technologies like *WirelessHART* and its self-organizing wireless communications help you scale your instrumentation device by device, and area by area within your plant. AMS Device Manager captures and delivers predictive diagnostics from all of these devices, as well as your HART, FOUNDATION fieldbus and Profibus DP devices—even across multiple DeltaV systems.

Scales to fit

The DeltaV architecture scales in size from as small as 25 I/O. Yet, by integrating I/O through open interfaces, scaling to more than one million I/O is possible. No matter how small or how large your application is, the DeltaV system scales to fit.

DeltaV Zones segment the systems to ensure flexible operation and expansions with enhanced system performance. Maintenance or commissioning activities can be performed in each zone without impacting other zones. Also, to more easily manage software upgrades based on process criticality, each system

can operate using different DeltaV software revisions, and still share data across zones.

To meet the challenges of your process operations, the scalable DeltaV system expands online, without redesign, and with the existing software—no upgrade required.

Application scalability

The DeltaV system scales in functionality to provide you with the tools you need for your process control application. With a common set of engineering tools and a common database, it provides a single platform and eliminates the typical headaches associated with integration. You have the flexibility to add advanced control, or batch, or safety instrumented functions as needed.



No matter your application's size, all hardware components are the same—the engineering tools are the same, operations and maintenance applications are the same. The result? Less training, fewer spares, and easier operations.

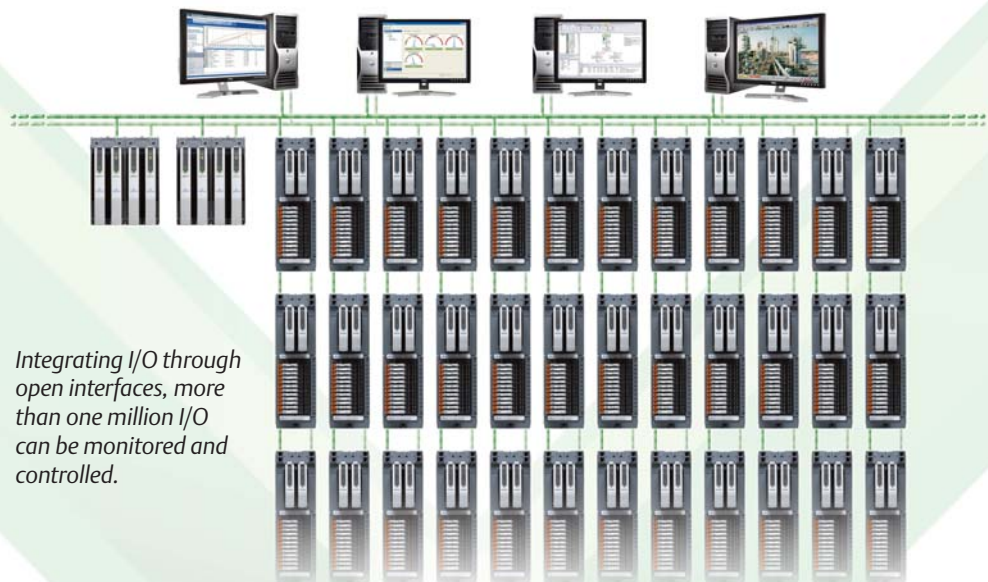

Integrating I/O through open interfaces, more than one million I/O can be monitored and controlled.

Inherently Integrated

Built for Purpose

Services

Virtualization

Reduce implementation and maintenance costs.

Virtualization lets you consolidate computer resources, reduce hardware footprint, increase availability, and reduce implementation and maintenance costs. With the DeltaV system's integrated virtualization you can confidently capture the value of virtualization with a fully tested and supported solution.

DeltaV Virtual Studio

DeltaV Virtual Studio makes it easy to create and maintain virtual DeltaV systems for development, testing, training and on-line production. Virtualization is made easy using pre-built DeltaV virtual machine templates and virtual networks which simplify system set-up and reduce the risk of configuration errors.

DeltaV Virtual Studio supports all DeltaV workstation types including AMS™ Device Manager functionality.

DeltaV Virtual control hardware

For off-line development and test systems, DeltaV Virtual control hardware simulation provides an easy, cost-effective way to implement and test control configurations and I/O assignments in a host computer without the actual controller hardware. DeltaV Virtual Control hardware simulation includes:

- Virtual CHARMs simulation
- Virtual S-series and M-series controller simulation

DeltaV obsolete server replacement

This Emerson offering lets you replace older server hardware used with legacy DeltaV v9.3 and v10.3 with new server hardware running DeltaV software in a virtual machine.

DeltaV Simulate standalone virtual machine

The DeltaV Simulate Standalone Virtual Machine (a.k.a., "simulate on a stick") makes it simple to run DeltaV simulate on your laptop or desktop computer without any software installation.

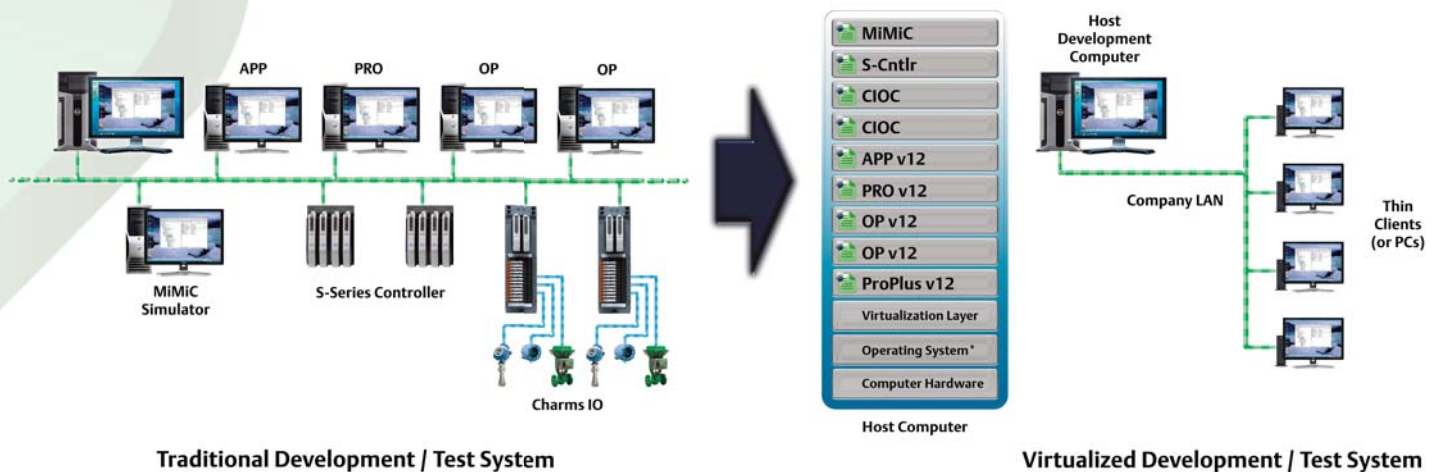

Example for Off-line Virtual Development/Test Systems

I/O on Demand

Ultimate Scalability

Embedded
Intelligent Control

Embedded Intelligent Control

Continuously adapting to changing conditions helps optimize your plant.

Emerson revolutionized the process control industry with the introduction of the PlantWeb architecture, which provides predictive intelligence through the use of intelligent field devices. Now, with embedded intelligent control, Emerson takes predictive intelligence a step further. By embedding learning algorithms directly into the DeltaV system, it can systematically apply the process knowledge it acquires to:

- Locate hidden variability and under-performing control loops
- Monitor control performance against model-based performance benchmarks
- Identify problems and diagnose causes such as faulty valves or process interactions
- Prevent downtime and increase availability
- Reduce variability, increase quality and throughput
- Sustain gains from performance improvements.

DeltaV embedded intelligent control provides you a full array of applications including enhanced PID control, automatic variability inspection, tuning, fuzzy logic control, model predictive control, and neural networks. Never before has a control system provided a full suite of embedded advanced control applications that enable you to get the most from your plant, with the least amount of effort.

Advanced control—easy

DeltaV embedded intelligent control enables you to quickly deploy state-of-the-art control technologies without the implementation and maintenance problems associated with traditional advanced control systems. Designed for the average control system engineer, advanced control has never been easier. With embedded intelligent control, advanced applications can be implemented with minimal

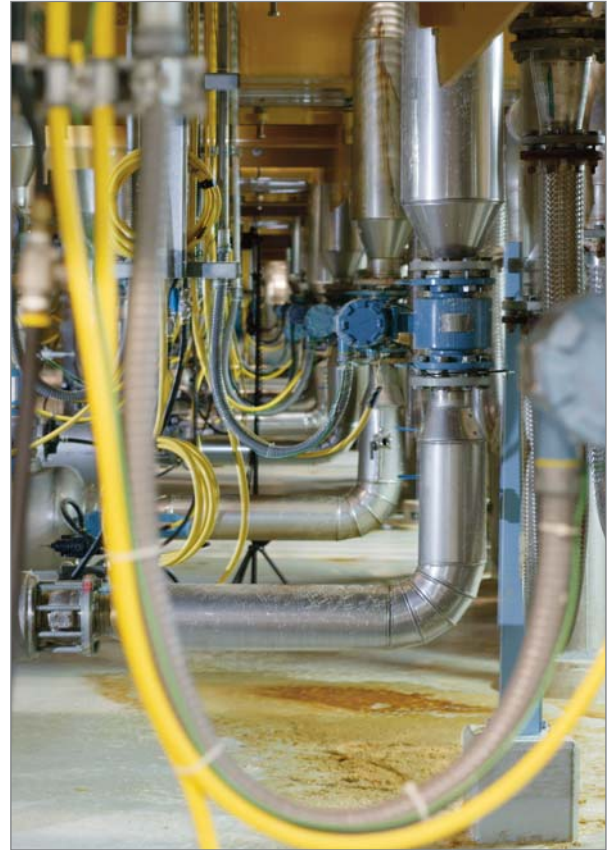

configuration and maintenance because all the technology and tools are inherently integrated with the DeltaV system. No data mapping is required. It is not an add-on, it is part of the DeltaV system.

DeltaV advanced control applications are built as part of the same, easy-to-learn and -use environment as standard regulatory control. PID, Fuzzy, Predict, and Neural function blocks are all available for you to drag and drop from the Control Studio pallet—it's that easy!

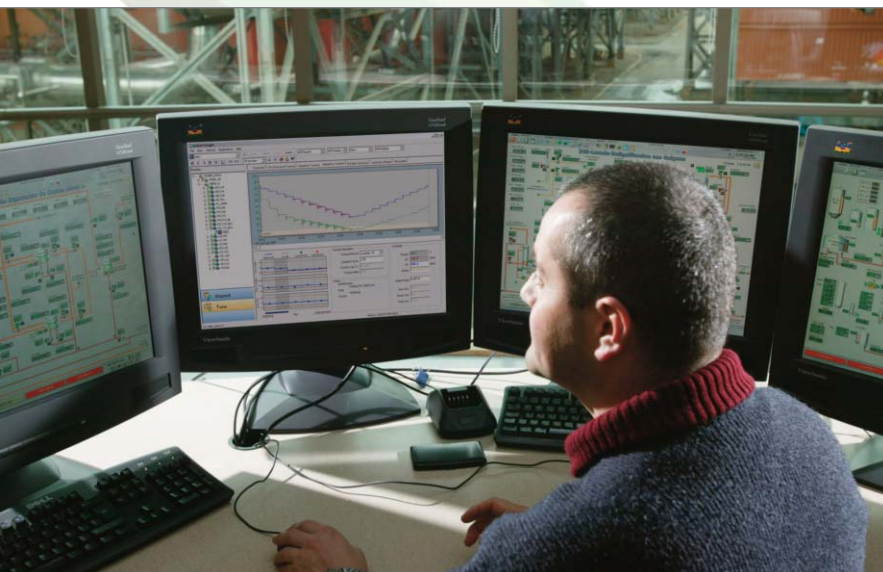

Inherently Integrated

Built for Purpose

Services

Intelligent control also makes life easier for your operators. More robust control means that your operators are less likely to operate in manual mode. Automatic control with reduced variability gives your operators less to worry about, so they can focus on other important operating activities.

Reliable information increases availability

You cannot have sustainable advanced control unless you have a strong foundation—built on healthy devices and reliable field information. The DeltaV system uses validated data and equipment health information from intelligent field assets to ensure the right control action is taken, preventing unwanted shutdowns when an asset fails.

All DeltaV intelligent control functions run in the DeltaV controller, including advanced control algorithms. This ensures that critical strategies run in a rugged, high-speed, optionally redundant environment.

Online adaptability

Changing process conditions require a control system to quickly adapt and take corrective action to prevent unsafe or sub-optimal operations. Reliable measurements and intelligent control strategies provide accurate and flexible control during changing process conditions and market demand.

Intelligent field devices that provide diagnostic information ensure the regulatory and advanced control algorithms are working with good data and that corrective action can be taken in the case of questionable or bad data.

The DeltaV system's embedded intelligent control provides the ability to quickly adapt to changing process conditions and the flexibility to confidently respond to changing market demand. Embedded learning algorithms identify control problems and provide continuous adaptive control to automatically adapt to changing process conditions. Model predictive control and optimization go one step further to continuously monitor process and economic conditions to ensure optimal plant performance within operating constraints.

The embedded DeltaV intelligent control applications are designed for you to use on a broad array of control challenges, enabling you to develop the right control strategies for your plant, at a fraction of the traditional cost—what you want, when you want it, where you want it.

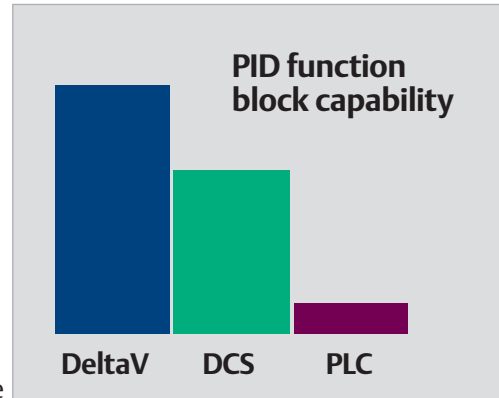

The DeltaV system outperforms all others—even for basic PID control.

Preventing hazardous consequences

By reducing process variability and adapting to changing conditions, embedded intelligent control keeps your process running smooth and within safe limits. This helps prevent unwanted shutdowns or hazardous consequences that may otherwise result from abnormal situations such as process disturbances, upsets, and unplanned events.

How do you know if your loops are under-performing?

Studies have shown that nearly 40% of all process loops are under-performing. You are responsible for hundreds of control loops and instruments and you don't have the time or the tools to monitor and maintain them. Your company is losing millions of dollars each year due to process variability and poor control performance. With embedded intelligent control, the DeltaV system provides you with a systematic way to automatically monitor, diagnose, and improve process control performance.

Embedded Intelligent Control

Optimized loops—all the time.

DeltaV PID Control

Intelligent control begins with robust regulatory control. DeltaV PID control delivers improved performance using intelligent device information and enhanced PID algorithms. Even for basic PID control, the DeltaV system has more capability than other DCSs and PLCs.

DeltaV InSight

DeltaV software provides the tools to monitor, analyze and tune control loops for peak performance. DeltaV InSight, inherently integrated into the system, instantly identifies under-performing control loops, enabling you to reduce process variability and increase the efficiency of your operation. It can be used to commission and automatically tune both PID and Fuzzy blocks. There is no setup or configuration required, because InSight automatically recognizes function blocks as they are configured.

DeltaV Adapt

DeltaV Adapt continuously adjusts PID tuning for optimal control as process conditions change. In addition to calculating new tuning, DeltaV Adapt also remembers the best tuning from the last time it was controlling in the same operating region. And best of all, DeltaV Adapt can be applied to any PID loop in the control system—without control configuration changes.

DeltaV Fuzzy

DeltaV Fuzzy offers a practical, field-proven substitute for PID control for processes that may benefit from non-linear control action. Using an embedded fuzzy logic control algorithm with automated loop tuning requires no special expertise in fuzzy logic.

DeltaV Fuzzy is robust and provides superior performance over PID control in many cases, providing faster response to set point changes or load

disturbances without overshoot. Benchmark tests have shown loop performance improvement of 30-40% over traditional PID.

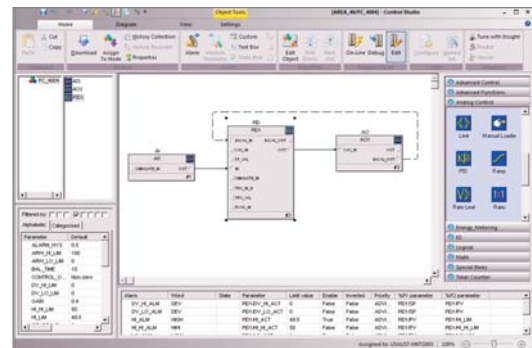

PID control in Control Studio.



InSight control performance monitoring.

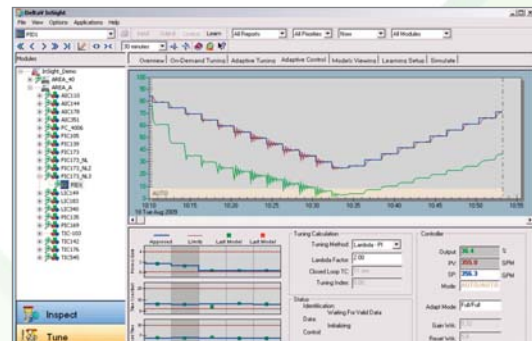

Apply DeltaV Adapt to any PID loop in the control system without control configuration changes.

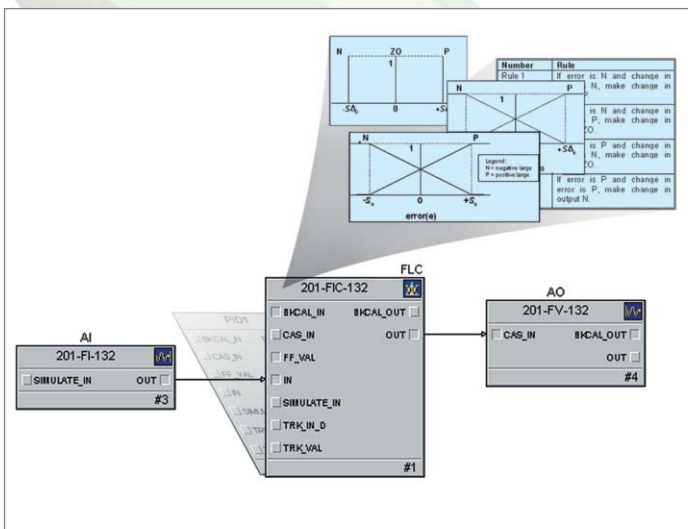

Fuzzy logic control is implemented just like PID—with drag-and-drop ease.

Inherently Integrated

Built for Purpose

Services

DeltaV Predict

Get greater throughput, reduced variability, and increased profitability by using DeltaV Predict and DeltaV PredictPro to implement multivariable model predictive control strategies. DeltaV Predict and PredictPro use the power of model predictive control to easily address process interaction and difficult dynamics. Since DeltaV Predict and PredictPro are fully embedded in the DeltaV system, you can use pre-engineered components and function blocks to quickly develop, validate, test and deploy your multivariable control strategies.

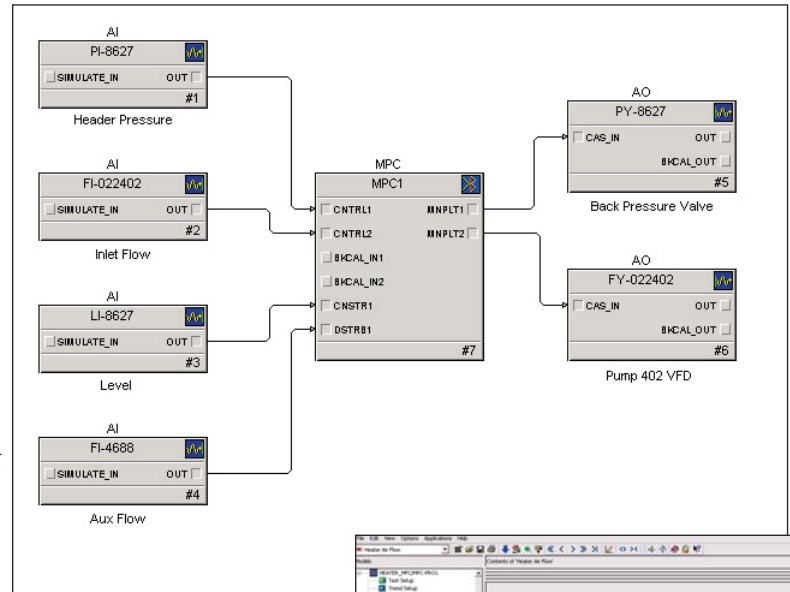

DeltaV Predict implementation with Function Blocks.

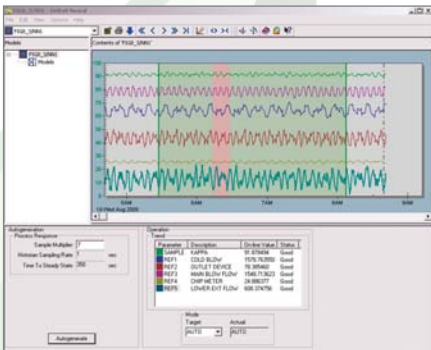

Deploy virtual sensors with DeltaV Neural.

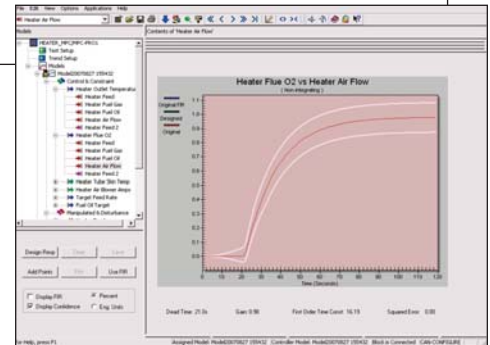

DeltaV Predict provides powerful model predictive control and optimization—available in every DeltaV system.

DeltaV Neural

DeltaV Neural provides a practical way to create virtual sensors for measurements previously available only through the use of lab analysis or online analyzers. Easy to understand and use, DeltaV Neural gives process engineers a way to produce extremely accurate results, even

Without prior knowledge of neural network theory. DeltaV Neural automatically uses the historical data provided from embedded historian, making it easy for you to quickly train the neural network and verify the accuracy of the resulting model.

I/O on Demand

Ultimate Scalability

Embedded Intelligent Control

Engineering Tools

Intuitive, fast drag-and-drop engineering.

The DeltaV suite of engineering tools handles configuration management, both locally and remotely, for all aspects of the DeltaV system and intelligent field devices. A single, global configuration database enables you to coordinate all configuration activities. Forget about data mapping between separate databases or referencing your process and engineering information by arcane registers or numbers. With DeltaV software, it's all in one dynamic tag-driven configuration database:

- Control strategies
- Batch control strategies
- Safety strategies
- Process graphics
- History
- Events
- Change management

In the DeltaV system, context-sensitive help takes you right to the documentation that's relevant for the task you are doing. There is no need to search through books and manuals. DeltaV Books Online shows you what you need to know, when you need it, where you need it.

DeltaV Explorer

DeltaV Explorer is the primary tool for system configuration. It presents the complete system in a single view and allows direct access to any item. Similar in appearance to the Windows Explorer, it lets you define system components and view the overall structure and layout of your system. The system comes PlantWeb-ready through tighter integration with AMS Device Manager. You can now commission and configure devices "out-of-the-box" from DeltaV Explorer. The DeltaV system is predominantly configured in place through interactive dialogs within DeltaV Explorer.

Easy I/O configuration

DeltaV controllers, I/O, and FOUNDATION fieldbus devices are auto-sensed when connected to the control network and automatically added to your configuration. The result is dramatically reduced engineering and commissioning time.

Native support for configuring busses with no need for third party configuration tools makes it

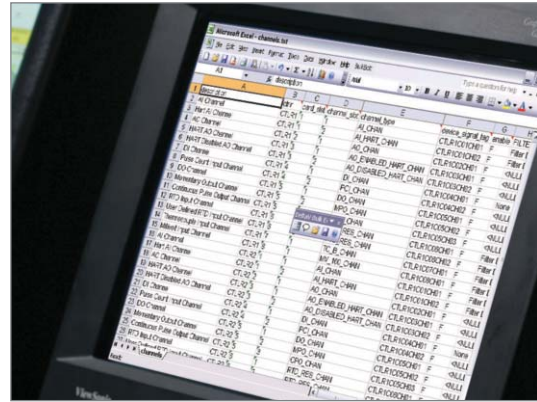

DeltaV Bulk Edit streamlines your configuration efforts.

easy to configure Profibus DP, DeviceNet, and AS-i bus I/O.

Bulk Edit can be used to speed up the configuration process and eliminate tedious tasks.

DeltaV Control Studio

Control Studio lets you graphically create and modify individual modules and templates that make up your control strategies. The DeltaV system helps you create and maintain control strategies as small, modular components (modules). These modules become reusable configurations for control of your process equipment.

Control Studio treats each module as a separate entity—allowing you to focus on a specific module without affecting other modules that may be running in the same controller. Built on IEC 61131-3 control languages, including function block diagrams, sequential function charts and structured text, Control Studio



Inherently Integrated

Built for Purpose

Services

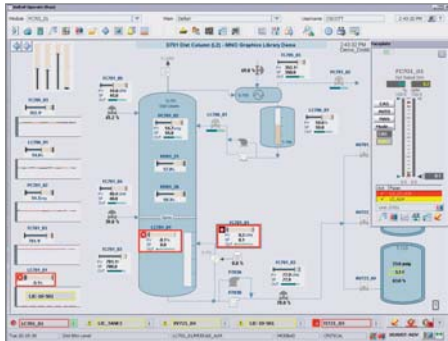

Modules include graphical display elements to simplify overall display development.

provides a drag-and-drop palette to easily design and document your control strategies.

Use DeltaV Control Studio to develop:

- Regulatory control
- Advanced process control
- Basic logic
- Sequential logic.

Display configuration is easy with pre-defined, modular graphics such as faceplates, module detail displays, trends, alarm summaries and display directories.

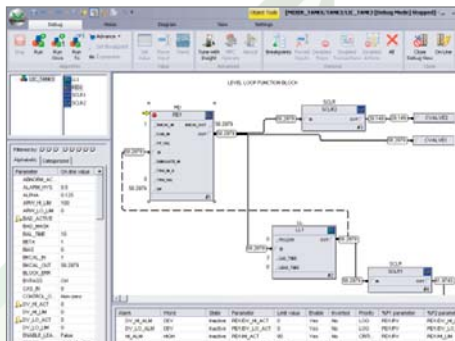

Control strategies are easily created with drag-and-drop function blocks.

Configuration made easy

With an intuitive user interface based on Microsoft's Fluent Interface, you can quickly learn to develop control strategies using drag-and-drop configuration. Self-documenting graphical modules make it easy to design and document your control strategies.

Standard product design and pre-engineered, out-of-the-box solutions make configuration inherently easy to learn, use, and customize.

Unlike hybrid and component-based automation systems, operating faceplates and history collection are built automatically as you assemble your control strategies.

DeltaV embedded history automatically collects historical continuous and event data for all modules in an assigned area.

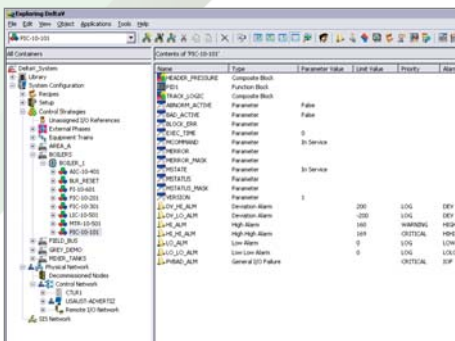

The DeltaV Explorer graphically displays your configuration and components.

Eliminate low-value engineering for quicker start-up.

With the pressure on to get up and running on schedule, it is more and more important to have a common set of engineering tools to configure, calibrate, and commission different types of equipment. This ensures that you can quickly complete your tasks in a single interface, without having to make the same change in multiple locations.

With the DeltaV Explorer, you can easily design the control system architecture, including all busses, without the need to map data between databases or to use third party configuration tools. The DeltaV Explorer enables you to configure your I/O and your field devices in a common interface.

When configuring control logic with DeltaV Control Studio, it makes no difference whether the associated I/O comes from FOUNDATION fieldbus, serial interface, DeviceNet, or traditional I/O. It simply connects to any I/O, without any special tools required for different types of I/O.

The DeltaV engineering tools are developed with ease of use as a primary design criteria. The DeltaV system is designed to eliminate low-value engineering to ensure quick configuration, testing, and commissioning of any process manufacturing plant.

I/O on Demand

Ultimate Scalability

Embedded Intelligent Control

Engineering Tools

Implement your DeltaV system any way you want.

Adaptable

The DeltaV system gives you the flexibility to implement your system how you want, when you want, where you want.

Multiple users can concurrently configure the system and access the global configuration database from DeltaV workstations. For very large or tight deadline projects, the DeltaV system's multi-client architecture provides:

- Off-line configuration
- Bulk editing in spreadsheet mode
- Bulk import from third-party software
- Bi-directional communication with Intergraph's SmartPlant Instrumentation (INtools).

The DeltaV modules help you design your system from the top down and implement as you go. With minimal effort, you can specify loops and field devices, then quickly complete the configuration.

Implement portions of the system on the fly in a modular fashion as process design and control requirements become available. You can finish what you know and leave other sections to complete later. Work-in-progress flags ensure that no items are left incomplete.

Your configuration can be built from the bottom up, starting with I/O and finishing with control strategies and displays.

With Control Studio On-line, it's easy to modify existing strategies independent of the running process and simulate them offline. When you are ready, just install the changes to the running system without affecting other control modules executing in the controller.

SmartPlant® Instrumentation integration

The SmartPlant Instrumentation (SPI) software from Intergraph Corporation is used by many

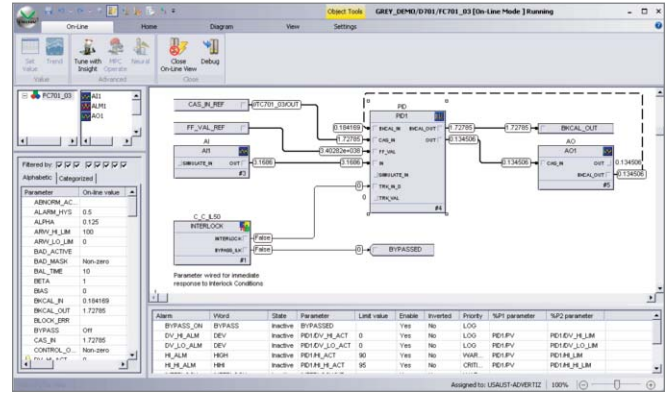

Simulate control strategies with Control Studio On-line.

engineers for instrumentation design. Projects that use SPI can benefit from the DeltaV data exchange interface.

The DeltaV system has a bi-directional interface with SPI that provides the seamless exchange of I/O and instrumentation information between the two databases. The information that can be transferred spans conventional I/O, including HART, Fieldbus I/O and CHARMS I/O systems.

The SPI product has been enhanced to allow DeltaV definitions for I/O hardware objects, DeltaV terminology, and FOUNDATION fieldbus device definitions to appear directly in SPI.

Using the DeltaV SPI integration capabilities significantly reduces DeltaV and SPI engineering hours and delivers higher quality project deliverables because shared data is entered once. Data conversion or transfer errors caused by manual processes are eliminated.

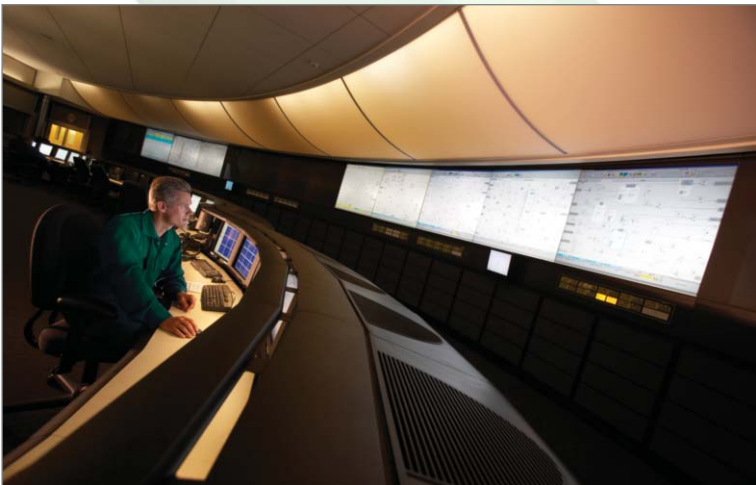

**Inherently
Integrated**

Built for Purpose

Services

DeltaV Operate

Intuitive view provides situational awareness and better decision support.

Demands on operators continue to increase as their span of control increases and as technology advances create more information to digest. It's more critical than ever to start from the operators' perspective; to streamline and focus their view into the process, especially in abnormal plant situations.

Human-centered design

Emerson founded the Human Centered Design Institute and is a key participant in the Center for Operator Performance, an operator-focused, human factors research consortium whose members include academics, engineering and automation suppliers, and process manufacturers. Improved DeltaV Operate and AMS Suite software usability emerged out of this extensive research and human centered design approach. The results include easily seen alarms at a glance, faster abnormal situation recognition, and intuitive views of loop deviations.

The operator experience begins with color-scale graphics, which provide subdued colors to make the bright colors associated with alarms and abnormal conditions stand out. Based on the ISA S18 alarm standard, operator-centric alarm help is available to provide immediate in-context access to allow response time, probable cause and operator instruction. These can include equipment protection and prediction through

integrated machinery monitoring, environmental protection, product quality and process efficiency.

Fast access

DeltaV Operate gives operators easy, one-click access to alarm summaries, faceplates, trends, display navigation, and on-line help. Unlike pieced-together automation solutions, the built-in, one-click access capability makes the DeltaV system easy to learn and use. As a result, operator training costs are typically reduced by 50% compared to other automation solutions.

DeltaV Flexlock provides the application accessibility that is appropriate for personnel's job function and skill level.

AMS Device Manager provides detailed alert information from DeltaV operator faceplates. Detailed troubleshooting information is available in the Audit Trail records and through applications such as AMS ValveLink™ SNAP-ON application.

Easy alarm analysis

DeltaV Analyze, which is based on the ISA S18 and EEMUA 191 alarm metric standards, simplifies alarm analysis. It allows you to quickly spot which areas and modules have the most alarms in a given time period by connecting embedded historical alarms and events from the DeltaV Event Chronicle or Plant Event Historian.

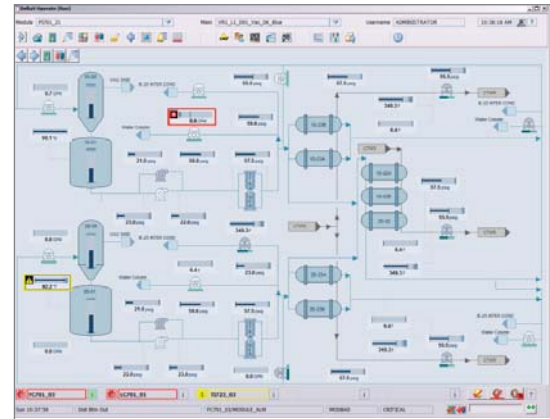

Alarms stand out helping operators address and resolve abnormal situations—easy.

You can also zero in on the types of recurring alarms and their frequency to help get to the root cause and its solution.

DeltaV diagnostics

As a key component of the PlantWeb digital plant architecture, DeltaV diagnostics extend not only to the system components, but beyond—to cyber-security and intelligent device and machinery monitoring diagnostics with AMS Suite software. Diagnostics from FOUNDATION fieldbus, Profibus DP, DeviceNet, HART, WirelessHART, and smart switches are easily incorporated into control strategies and operator graphics to reduce abnormal situations and provide rapid decision support to normalize the process.

Change Management

Inherent change management simplifies regulatory compliance.

Increasingly stringent regulations require manufacturers to provide comprehensive documentation of their process. DeltaV Configuration Audit Trail is a powerful tool that tracks changes and manages revision information for any item in the DeltaV configuration database, including Safety Instrumented System (SIS) items. This application creates and maintains a configuration change history for configuration items, such as modules, SIS modules, phases, operations, unit procedures, user accounts, and operator graphics—simplifying configuration management and regulatory compliance.

Easy to track changes

Comprehensive version control of a configuration item is automatically tracked and updated. The new version is time-stamped and a history comment can be recorded when the item is checked back in. Embedded reporting tools give users the ability to print configuration change histories for any item in the configuration database.

By keeping detailed historical information on configuration items, the system automatically maintains quality data for regulatory compliance requirements and troubleshooting. Configuration Audit Trail is tightly integrated with the DeltaV configuration tools, such as Explorer, Control Studio, Recipe

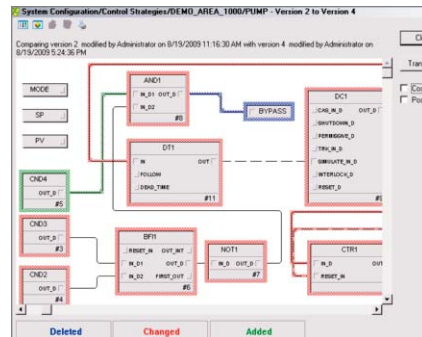

Configuration Audit Trail and Version Management automatically collects revision information—viewed in either graphical or text-based formats.

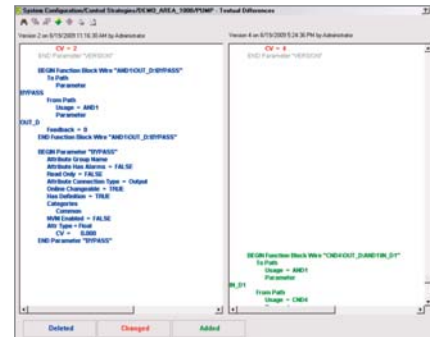

Studio and Graphics Configuration. DeltaV administrative tools allow the Configuration Audit Trail database and the DeltaV database to be backed up together in one operation. It is also possible to archive and restore versions of items in the audit trail database.

Ensure authorized configuration changes

The DeltaV security system provides the ability to grant privileges to individual users. Items may be checked out for editing only by approved users.

Ensure compliance during operation with Electronic Signatures

To support regulatory compliance requirements, including FDA 21 CFR Part 11, the DeltaV system provides comprehensive electronic signature capability during process operations. Any actions taken can be configured to require a confirmation in which

the user name and password is needed to execute, as well as an additional verifying user name and password if required.

Change management provides these key benefits:

- Tracks configuration changes
- Displays differences between different versions of a configuration item
- Rolls back an individual item or the entire database to a prior version
- Creates change management reports
- Displays version identifiers online for downloaded configuration items
- Logs recipe authorization before release to production
- Tracks SIS Module download authorization based on SIL level
- Tracks SIS Module testing approval based on SIL level.

**Inherently
Integrated**

Built for Purpose

Services

Security

Built-in, flexible, system-wide security safeguards your assets.

Security is an important element of any control system especially today when viruses and other sophisticated threats are on the rise. Following the industry standard defense-in-depth layered security strategy, the DeltaV built-in security ensures that you have the appropriate security measures installed and implemented. The DeltaV system provides easy, flexible, system-wide security management—right out of the box.

Built-in security

The DeltaV system was developed with system security as a key design criterion. To safeguard your assets and ensure controlled access, the DeltaV system delivers the security capabilities you need as part of the standard features.

■ The DeltaV control network architecture inherently creates a separate control system network completely segmented from other networks in the plant, delivering a protected system from unauthorized external access.

■ The DeltaV system automatically applies the latest

operating system hardening templates to create a more secure workstation. Hardening disables unused system services and blocks access to DVD drives and USB ports to help prevent the introduction of viruses and malware from portable media.

■ Using the integrated DeltaV User Manager and our role-based security key, it's easy to create users with the appropriate access to system functions and span of control in the process. The User Manager automatically creates the Windows user as you create the DeltaV user so coordinating Windows and DeltaV user security is never a problem. The DeltaV roles allow you to easily create users with "least privilege" to follow best practice user security management.

■ The easy-to-implement Emerson Smart Firewall creates a more secure system perimeter to help protect your system from unauthorized access by people or applications on external LANs.

■ Plug-and-play DeltaV Smart Switches provide auto port



lockdown from our Smart Switch Command Center to prevent unauthorized access to the network from switch ports.

■ The DeltaV Event Journal tracks system events, alarms and user activities to provide tracking and auditing of security-related events on the system—including attempts to connect to locked smart switches.

■ All DeltaV network devices have to authenticate as part of system configuration as they connect to the system. They must be recognized as a valid DeltaV device before they can participate in control communications on the network.

■ All routine system maintenance and troubleshooting is done from secured DeltaV workstations so physical access to equipment is not required. This reduces security risks, as no unsecured external equipment is required to service the system. No open network ports on field equipment are necessary, so risk of unauthorized access is eliminated.

Who made that change?

Starting up a large manufacturing facility can be stressful—often there is too much to do and too little time. An inherent change management system can help eliminate pressure and improve productivity. DeltaV system changes are made by authorized personnel and are automatically tracked and approved as needed. The result is up-to-date documentation that supports regulatory compliance requirements. Made a mistake? No problem. The database can be rolled back to a prior version.

Operate with Confidence

Depend on the performance and reliability of your critical production assets.

The seamless integration of AMS Suite: Intelligent Device Manager with the DeltaV system enables your operations and maintenance teams to easily monitor field device health status. Plant personnel can then work together to resolve potential issues before they become costly problems.

Only Emerson's technologies and the PlantWeb architecture are built to turn the wealth of intelligent field device diagnostic data into focused, actionable information. AMS Device Manager and DeltaV software help you move to a predictive maintenance environment by giving plant staff a window into the health of intelligent field devices.

Based on real-time diagnostics from intelligent field devices, your staff can respond quickly and make informed decisions to prevent unexpected downtime.

With AMS Device Manager, you can monitor status and alerts on drives, instruments, and valves, troubleshoot from the control room, perform advanced diagnostics, manage calibration, and automatically document activities with a single application.

Easy-to-use interface

A graphical device dashboard interface makes diagnostic information easy to understand. The interface, powered by EDDL, provides compelling visualization to aid in troubleshooting and support decision-making. These diagnostics are based on human-centered design principles for fast,

easy access. In addition, AMS Device Manager provides complete asset management capabilities for HART, FOUNDATION fieldbus, *WirelessHART*, Profibus DP and PA devices—a single user interface in an integrated operating environment. And with the addition of DTM support, you have freedom to choose the best device for an application with the confidence you are getting the best of that device's functionality.

Increase plant availability

Predictive maintenance using AMS Device Manager helps you avoid unplanned shutdowns and inefficient practices. Online access to device diagnostics allows you to continually monitor devices and to know immediately if there is a problem. SNAP-ON applications like AlertTrack can be used for email and cell phone notification of process upsets, helping you to intercept problems before they cause major plant upsets.

Proactive maintenance pre-empts unplanned downtime

AMS Device Manager provides adaptability in many ways:

- Remotely access status and diagnostic information from connected devices to identify issues and easily make configuration changes or replace a device.
- Automatically document device information including alerts, configuration changes, and calibration events using AMS Device Manager Audit Trail.



EDDL-based device dashboard screens apply a graphical indication of device condition.

- Associate electronic drawings and notes with a particular device quickly and easily.
- Speed commissioning by planning and storing your field device configurations in a single database. Perform device loop tests, interlock validations, and calibrations quickly and efficiently.

Asset management improves safety

Online access to critical asset information eliminates unnecessary trips to the field and reduces visits to hazardous locations. The DeltaV system passes status and diagnostics to AMS Device Manager, giving clear and specific descriptions of faults. When maintenance functions are performed, records are automatically produced and logged in the Audit Trail. The documentation step is done simultaneously and accurately to give a complete history of your device maintenance records, reducing maintenance costs over typical paper-based systems. Asset Management allows you to operate with confidence.

Inherently
Integrated

Built for Purpose

Services

Integrated Machinery Monitoring

Fast, easy integration delivers real-time feedback on Machinery Health.

As much as 50% of machinery malfunctions occur because of process changes or process conditions. Without real-time feedback, operators lack the visibility to see the effects of their actions or effects of the process on these critical machines. Without healthy machines, efficiency suffers, production is at risk and unplanned shutdowns occur.

When operators have visibility of the health of these high-stakes assets, they can make process adjustments and reduce process disruptions. Real-time integration of machinery information in the DeltaV system delivers actionable information to operations staff.

Eliminate complex and expensive integration

With most control systems, integration of machinery health information using MODBUS may

require as many as 2400 steps for 24 vibration channels to complete the integration process—not to mention the discovery process to determine vibration and process automation systems are implemented.

Save hundreds of man-hours and gain a more complete, error-free integration of machinery information when you use the CSI 6500 Machinery Health Monitor with your DeltaV system. You will gain integrated prediction, protection, and performance monitoring that is pre-engineered with automatic sensor health and automatic synchronization of alarm limits in the DeltaV system.

Emerson's technologies streamline integration in three easy steps: scan, configure, and import. From AMS Suite and the CSI 6500, asset parameters are scanned and then imported to the

DeltaV system. The entire process is completed in 10 minutes.

Build operator graphics fast

I/O and control modules are automatically configured in the DeltaV system. Function blocks are automatically created in control studio allowing custom rules for plant-specific abnormal situation scenarios. Machinery health faceplate templates and dynamos are pre-built and ready for operator graphics. What once required custom programming is now a drag-and-drop process to quickly build a machinery health operator interface.

Out-of-the-box machinery health warnings for operators

After the integration process, simply launch DeltaV Operate and if any machinery health alarms occur, they are automatically displayed in the alarm banner. Pre-configured instrumentation alarms provide instrumentation health feedback. If alarm limits are changed in the machinery protection system, these limits are automatically replicated in the DeltaV system.

Through easy integration of the CSI 6500 with DeltaV, real-time machinery health feedback is provided to operators. Comprehensive protection, plant-wide prediction, and performance monitoring integrated with process control gives confidence that your mechanical equipment is truly operating reliably.

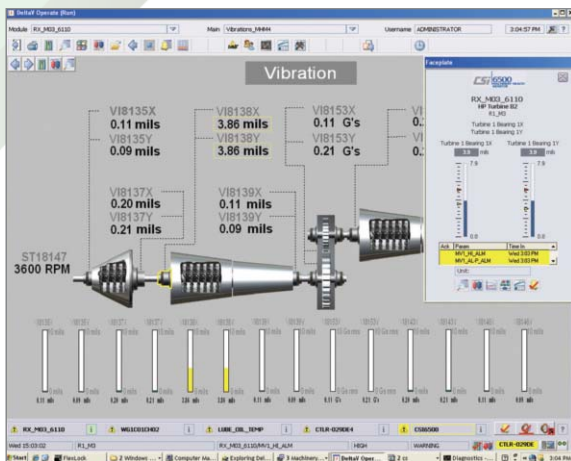

The easy integration process delivers real-time feedback so operators can see the effects of their actions on machinery health.

I/O on Demand

Ultimate Scalability

Embedded
Intelligent Control

Continuous and Event Historian

High resolution, high fidelity historical data helps optimize your process.

Ready access to continuous and event historical information from your process is critical to operating, analyzing, and optimizing your process. This collected information needs to extend beyond the control system boundaries down to the intelligent field devices, which are much closer to the process and have a higher resolution view of the process.

Continuous Historian

The Continuous Historian is a database designed for historical storage, retrieval, and integration into the DeltaV system, as well as open access from the system. It captures analog, discrete, and text data and stores it for future analysis.

As an Emerson Process Management product, the DeltaV Continuous Historian was designed to support the PlantWeb architecture and provide a data repository for the information available in intelligent field devices. The DeltaV Continuous Historian captures the value, timestamp, and status or validity of the information from these intelligent field devices. You can make better decisions with this high fidelity data.

Instead of being a layered application afterthought, the DeltaV Continuous Historian is embedded in the system and can easily scale from 250 to 30,000 historical items. Since it's fully integrated with the DeltaV system, it's easy to start collecting information and maintain it. No

data mapping or non-value engineering is required.

DeltaV regulatory and advanced control applications including model predictive control and neural networks use the historical information and its associated status. For higher availability and robustness, these applications can automatically detect when the item status is not good, alerting the operator or application that data is suspect.

Event Chronicle

The Event Chronicle captures all system events, such as operator changes, control module installations, alarms, sequence of events and changes in device status. For each event, information such as who made a change and when the change occurred is recorded.

The DeltaV system is designed to capture data values and their associated time stamps at the lowest possible level in the system, providing you with a more accurate picture of the alarms and events as they occur. The Event Chronicle receives these time stamps and events and makes them available to the operator for easy viewing and troubleshooting.

Multiple Event Chronicles can be used in the DeltaV system to collect events from different plant areas or from the same plant areas for added data availability and



**Inherently
Integrated**

Built for Purpose

Services

robustness. Since the events are time stamped in the DeltaV controller, multiple Event Chronicles will always have consistent time stamps.

Plantwide Event Historian

Beyond the boundaries of your DeltaV system, the Plantwide Event Historian captures and displays event data such as alarms, operator actions, system events, and sequences of events from DeltaV and third-party automation systems throughout the entire plant.

History View Software Suite

The DeltaV History View Software Suite is the window into your operation's continuous, event, and batch data. It provides easy access to real-time and historical trend monitoring—with seamless movement between the two. A single view integrates real-time and historical data, including continuous and event data.

Process engineers can more easily see how user changes have impacted the process through these views of real-time and historical data. Embedded historical trends are available in DeltaV Operate that enable operators to quickly scan the direction and magnitude of process changes before taking action.

History Analysis

History Analysis is a web-based historian client application that allows you to view DeltaV historical data from any computer running Microsoft Internet Explorer—from anywhere in the world. History Analysis has access to DeltaV historical batch, continuous, and event data, and it integrates the DeltaV historical data in a single, easy-to-use client application. History Analysis also provides an intuitive data search engine to make it easy for users to find just the right data. Once the data is found and evaluated, you can save the data view or export the data for further analysis.

DeltaV Reporter

The DeltaV system comes with DeltaV Reporter—an Excel-based historical data reporting and analysis tool available on any workstation. Use DeltaV Reporter to populate a spreadsheet with historical process and event data. Once in the spreadsheet, use the power of Excel to view, analyze, and create reports on the data. DeltaV Reporter also enables you to easily add historical data collected from outside the DeltaV system, such as laboratory data. This historical data includes status information, is saved in the historical database, and is available for viewing and reporting with the rest of the continuous data.



History Analysis provides an intuitive data search engine making it easy to find just the right data.

Historical data anywhere

With the DeltaV OPC History Server, OPC Event Server, OPC .NET and History Web Service, you can extend the wealth of historical data to other data historians such as OSIsoft's PI and web service-based client applications. Using these industry standard interfaces, the DeltaV system can deliver information to other systems, applications or users on the plant local area network or across the Internet. Through an intuitive web browser-based client, powerful local history clients and easy-to-use and secure historical data interfaces, the DeltaV system enables your experts to quickly identify optimization opportunities or issues to resolve.

Built for Batch

Totally integrated batch enables flexibility for agile manufacturing.

The DeltaV system architecture is based on the ISA88 Batch Standard. Whether it is the physical model, procedural model, or easy-to-use class-based configuration—the DeltaV system is “built-for-batch.”

Like the rest of the DeltaV system, DeltaV Batch fully supports compliance with the FDA’s 21 CFR Part 11 requirements with recipe and campaign management, batch history, automatic version control and change management, and electronic signature support.

DeltaV Batch is a complete suite of products supporting all components of the ISA88 Control Activity Model. All batch control logic for a unit, including phases, is executed in the DeltaV controllers. The same intuitive, drag-and-drop user interface used throughout the system makes it easy to configure your recipes. Batch data is entered once into the same common global system database—no data mapping is needed.

The Batch Executive is the batch engine which coordinates all batch processing activity, creates detailed batch history records and schedules recipes and resources.

Recipe Studio is a powerful yet simple-to-use application for graphically configuring recipes and formulas for successful batch production.

The Campaign Manager creates and manages campaigns by specifying the recipe, formula, equipment, and number of batches that are to be run within the campaign. A web service enables external applications to programmatically interact with the Campaign Manager.

The Batch Historian automatically collects and displays recipe execution data from the DeltaV Batch Executive and process management event data from the DeltaV Event Chronicle. The History Analysis application enables web-based access to recipe event and continuous historian information for anyone, anywhere.

Recipe Exchange provides an open, programmatic interface to the DeltaV recipe management system. Recipe Exchange is based on an XML schema that provides the ability to use web services to import and export DeltaV recipes.

Batch Analytics detects faults and predicts end-of-batch quality in real time using multi-variate models based on historical batch data. Operations is presented with reasons for deviations so that they can take action before a batch requires rework or lost.

Easier batch operations

From recipe scheduling to real-time fault detection and end of batch quality prediction; from simple sequencing to multi-stream formulations; from operator prompts to automatic unit selection, the DeltaV system makes your batch operations easy.

DeltaV Batch is inherently integrated with the DeltaV system. In DeltaV Operate, your operators have easy access to all batch information in a single, integrated environment. And batch records are automatically collected for easy regulatory compliance. DeltaV Batch provides batch standard compliance out of the



Inherently Integrated

Built for Purpose

Services

box because the ISA88 batch hierarchy is built into the DeltaV system.

When used with Emerson's Syncade Smart Operations Management suite, DeltaV Batch offers a comprehensive operations management solution to optimize work processes plant-wide.

Reliability is built in

Every batch is run as a separate process in the Batch Executive. As a result, batch failure is isolated from impacting other batches.

DeltaV Batch provides redundancy at all levels of execution—reducing process shutdowns and eliminating risk of lost batches. Online upgrades are supported for systems with redundancy, thus minimizing the impact on production, and making it easy to stay current with the latest technology available.

Redundancy is available for the DeltaV controller, Batch Executive, and Campaign Manager, providing robustness for unit, process, and recipe execution.

Flexibility for agile manufacturing

During recipe execution, DeltaV Batch provides flexibility for agile manufacturing to meet real-time demands and captures comprehensive records for regulatory compliance. Class-based configuration and recipe management deliver repeatability. DeltaV Batch enables recipe

changes and equipment selections on-the-fly. Support for dynamic unit selection, automatic unit selection, unit aliasing, and equipment trains delivers:

- better support for flexible manufacturing
- improved process equipment failure handling
- reduced risk of equipment selection errors.

Know when, where and why changes are made

To meet your regulatory compliance requirements, the DeltaV system integrates change management into your process automation. This Configuration Audit Trail provides a complete version-to-version comparison, including not only what changed, but who made the change, when, where and why.

DeltaV function-based security lets you control who can perform batch tasks in the system. Examples include restricting operator access to modify recipe parameter values and starting/stopping batches and recipes.

DeltaV Batch incorporates electronic signatures into your batch processing to support regulatory compliance requirements, including FDA 21 CFR Part 11. Any and all actions taken can be configured to require a confirm mechanism. A user's name and password, along with a verifying user's name and password, if required, are needed to execute the action.

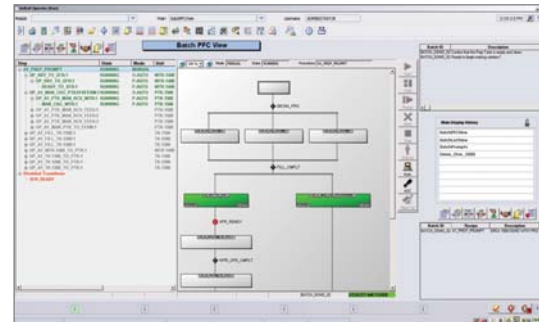

An integrated engineering and operations environment makes it easy to control your batch processes.

Facility expansion required to meet urgent product demand.

A large life science manufacturer needs to expand an existing facility to meet the urgent demand for a vaccine. By adding onto the existing DeltaV system and using the reusable, standards-based software modules of DeltaV Batch, the engineers can easily configure the added equipment—saving precious time. Additionally, complete redundancy of the system, from control to recipe level, gives the manufacturer a robust system that will not cause process shutdowns. End result: faster product to market.

I/O on Demand

Ultimate Scalability

Embedded Intelligent Control

Optimize Operations Across Your Facility

Smart Data. Smart Decisions with Syncade™ Suite.

The seamless integration of Syncade suite with the DeltaV system provides a comprehensive operations management solution that optimizes work processes and increases productivity, plant-wide.

By using the latest technology and adhering to industry standards, Syncade Smart Operations Management suite provides a modular, manufacturing IT solution to increase manufacturing performance by managing resources, optimizing operations, integrating information, simplifying regulatory compliance, and improving material logistics management.

Resource Management reduces variability

Syncade suite helps you effectively manage resources and allows you to do more with less. By scheduling and tracking equipment usage, Syncade suite can increase manufacturing capacity. It can reduce waste and rework by optimizing material usage and eliminating the use of outdated material. Syncade suite replaces paper equipment records with electronic logbooks that guide operators through manual processes and enable easy access to support documents—resulting in improved productivity. Additionally, personnel training and qualifications can be verified in real time to ensure proper authorization.

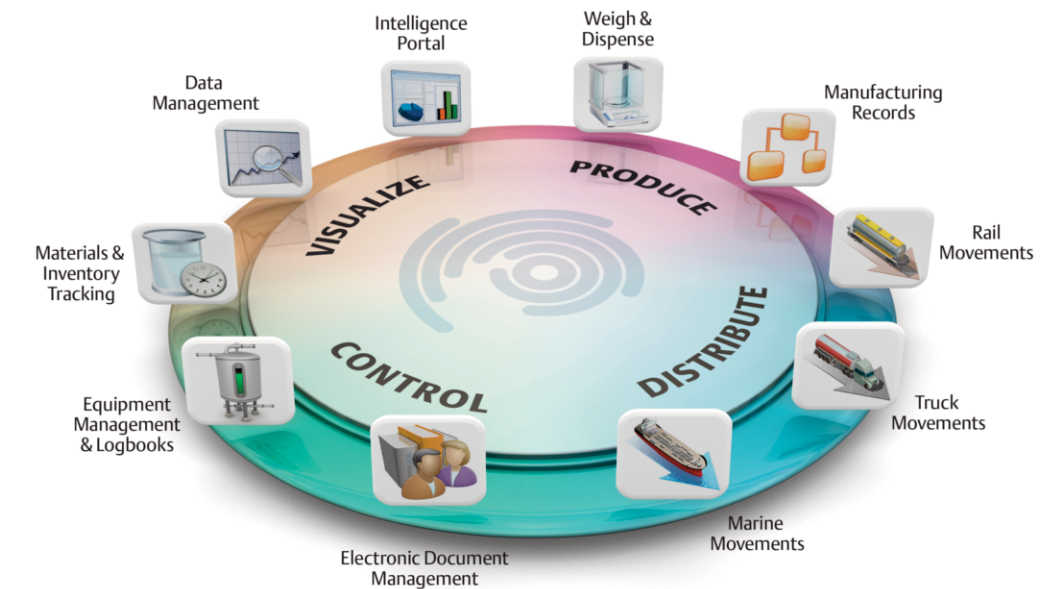

Optimized Operations improves efficiency

Syncade suite manages workflow across plant functions to assure “right-first-time” production. Coordinating manual and automated processes enables your plant personnel to make the most of their time. Syncade suite provides a single recipe / procedures that adheres to ISA88 / ISA95 standards—reducing engineering efforts by enabling modular, reusable software libraries. Forced electronic procedures or work instructions that guide the operator and provide access to reference documentation (such as SOPs and MSDS) can eliminate errors and ensure that accurate data is collected and omissions are flagged during production.

Integrated information supports better decisions

Many manufacturing facilities use numerous systems that don’t often communicate with each other, resulting in an inefficient use of time and resources.

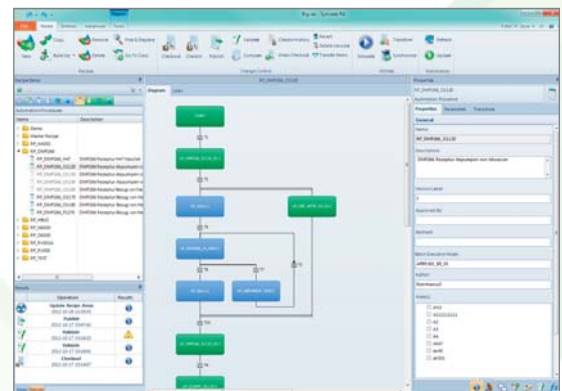

Recipe Authoring provides a quick way to create integrated orders and recipes—using standardized libraries, modular building block construction and drag-and-drop design tools.

Inherently Integrated

Built for Purpose

Services

Syncade suite enables easy communication between business and manufacturing systems. It helps improve productivity by enabling interdependent activities to be effectively synchronized while eliminating duplicate efforts or manual data entry. By validating data and putting it in relative context for consumption by users and other applications, Syncade suite creates the information for collaboration and improved decision-making. Syncade suite can automatically create manufacturing orders with automated downloads from the enterprise resource planning (ERP) system. Using Syncade suite as a single engine tool to gather all your data needs from the manufacturing process, you can streamline your process and improve productivity.

Syncade suite is easy to use, integrate and maintain because it's built on industry standard OPC and .NET-based web services. Syncade suite synchronizes your key business and plant floor systems for total knowledge management.

Quality and Compliance simplifies document management and reduces errors

Efficiently managing documents saves time and money. Documentation is a necessity of

effective operations and includes many types of documents. These documents support a wide array of audiences, such as operations, maintenance, and quality, and convey various types of information, such as production records, SOPs, order forms, and lab reports. The development, change management, and approval of documentation can be inefficient and time consuming.

Syncade suite provides comprehensive document management including online storage, change control, review and approval routing, version management, and archiving. In addition, user groups and privileges provide security to ensure proper access and authorization.

Movement management optimizes storage tank and terminal operations

Increasing tank farm and terminal agility in the face of constant customer and operational changes can significantly improve terminal and tank farm revenue and profits. Eliminating potential problems before they can contaminate refined products is key. Procedure errors like routing material through the wrong pipe or not setting a line-up correctly or even completing a proper line flush unnecessarily can all negatively impact the product and inevitably will time and money to recover.



Syncade suite provides a flexible, integrated logistics solution for marine, rail, and truck terminals. These include real-time planning and scheduling tools, route selection optimization, integrated inventory reconciliation, and comprehensive reporting / auditing of all custody transfer activity.

Missed information can result in lost or reworked batches.

The batch is complete. The records are collected. Then it becomes obvious that data is missing from the batch record. If only operations became aware of this omission before the batch progressed to the next step! Syncade suite enables comprehensive production records to be generated in real time—flagging omissions or inaccurate data during processing, as well as enabling review by exception. This functionality speeds batch release time and improves manufacturing performance.

Third Party Integration

Streamlining collaboration for greater production efficiency.



At the heart of your production process is your process automation system. Its ability to easily connect up, down, and sideways with other systems and applications is critical for providing an information-sharing, collaborative environment. The DeltaV system provides many data integration options with its open, interoperable standards-based technologies such as serial, OPC Classic, OPC .NET 3.0, high-speed Ethernet, SQL, XML and web services.

Ethernet and serial device connectivity

Simplifying integration with your plant subsystems, the DeltaV virtual I/O module (VIM) connects through Ethernet using Modbus TCP and Ethernet/IP protocols. With redundancy, this external data can be robustly integrated into your control strategies. Making integration easy, Ethernet device configuration may be bulk loaded into DeltaV control strategies to reduce engineering efforts.

Serial communications using MODBUS RTU/ASCII protocols also makes integration with other systems easy, by connecting your legacy DCSs and PLCs to the DeltaV system.

OPC and OPC .NET 3.0

Open and interoperable OPC communications have served the process industries well for over a decade as a way to connect servers of data with a multitude of valuable clients. This standard supports real-time and historical data access as well as alarm/event data access. Cyber-security concerns and increased use of firewalls around the automation system's perimeter have created problems with network distributed OPC communications—until now.

OPC .NET 3.0 (formerly known as Express Interface (Xi)) is a new data communications interface developed by diverse process automation suppliers to meet customer needs for a secure, reliable and standard way to exchange data between the automation system and the enterprise. OPC connectivity provides secure, robust, firewall-friendly data access to real-time and historical process data, as well as real-time alarm and event data. To ease migration to OPC .NET from current OPC classic systems, OPC .NET can directly interface to existing OPC Data Access, OPC Historical Data Access and OPC Alarms & Events clients and servers to deliver a secure data communication path even on legacy systems. In addition,

OPC .NET provides process manufacturers a migration path to the OPC Unified Architecture (UA) as needed. OPC .NET is based on Windows Communication Foundation (WCF), the latest communications technology from Microsoft, enabling both fast and efficient data communications between Windows-based clients

Lost changes? Enter it once and be done.

Your EPC is using Intergraph's SmartPlant Instrumentation (SPI) software to design your large projects. In the past you have been able to import the I/O configuration from the SPI tool, automatically configuring your DCS with the same I/O layout. However, without bi-directional communication, any changes made to the I/O design on the DCS side cannot be re-incorporated into the SPI database without manual effort.

Synchronizing the configuration after changes are made to the DCS configuration means that two tasks must be performed, one in each system, likely by two different people. This creates significant coordination costs and often results in quality problems when errors are made or changes are lost.

Now with DeltaV XML-based bi-directional SPI-integration, data exchange and synchronization in both directions is accomplished with only a few clicks of the mouse. You can enter it once and be done. It's that easy!

Inherently Integrated

Built for Purpose

Services

and servers, as well as secure and reliable data communications through firewalls and to non-Windows systems.

OPC .NET also facilitates the development of visually stunning client applications using Windows Presentation Foundation (WPF), Microsoft's next generation user-interface development platform.

SQL

Connecting upwards with transactional, planning-based systems often requires SQL database connectivity. DeltaV alarms, events, and batch history data are stored in an SQL-server database and available to applications like operations management systems, enterprise planning systems and other decision support systems requiring access to information from the process.

This well-known, well-proven, easily-adaptable standard supports the data requirements for your workflow processes.

Web Services

Many process manufacturers want to integrate their control and business systems to more efficiently run their organization, but existing solutions may not be flexible or secure enough to meet the demands of these systems. Service Oriented Architecture (SOA) provides a way to address these requirements. It's a standards-based design approach to create an integrated IT infrastructure and agile, loosely coupled dynamic applications capable of rapidly responding to changing business needs.

Web services use specific standards and language protocols to execute an SOA approach. The DeltaV system provides an SOA approach to ISA95 Level 3 and Level 4 data integration with DeltaV Web Services for batch recipe creation and batch execution scheduling data. The DeltaV SOA Gateway with DeltaV Web Services provides a highly-secure, authenticated means of communications between the DeltaV system and plant planning and execution applications.

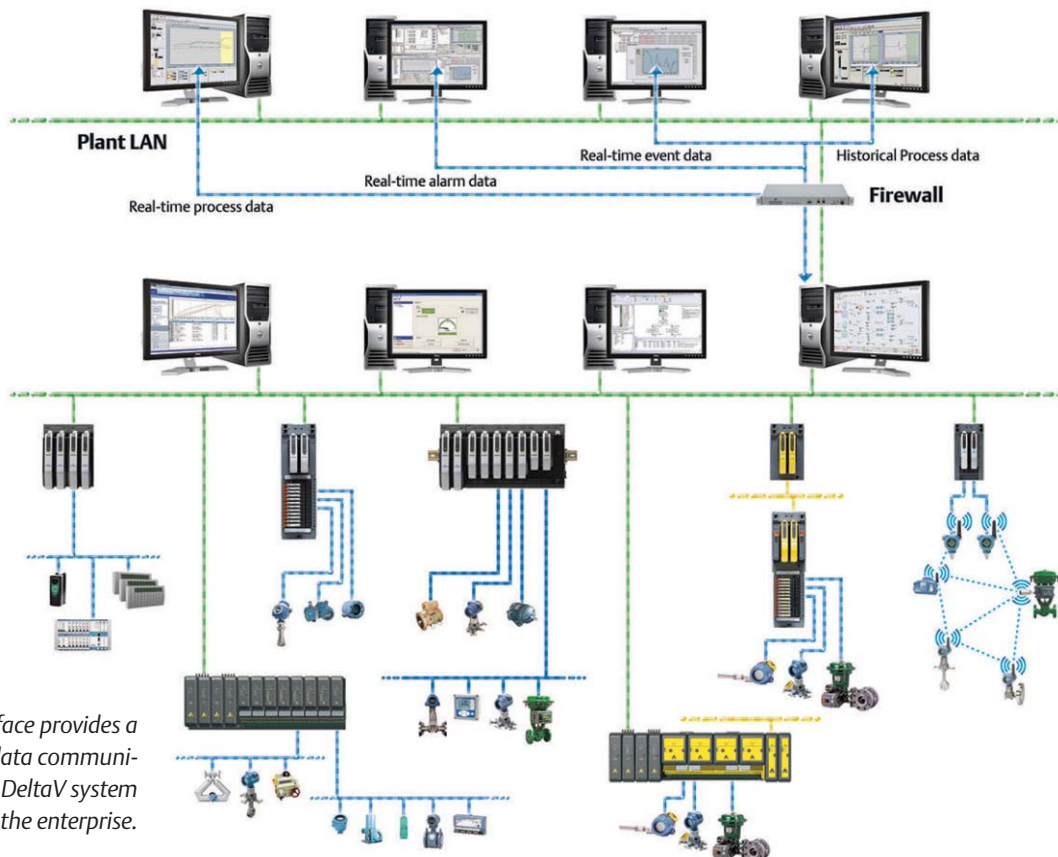

The DeltaV OPC .NET interface provides a secure, firewall-friendly data communications path between the DeltaV system and the enterprise.

Built for Purpose

Designed for ease of use in your most demanding applications.

For more than ten years, commercial off-the-shelf (COTS) technologies have provided tremendous increases in functionality and cost advantages to end-users of today's automation systems. The DeltaV system was the first of this kind and continues to provide open, proven products to its user base.

However, while COTS has provided many advantages, it has also come with a price—increased administration and life-cycle costs requirements. A better approach is to take advantage of the cost benefits and open standards of COTS, but to add functionality that allows the equipment to function much more like other parts of the system (plug-and-play capability, full life-cycle support without upgrades, security built in, etc.) We call this balance “built for purpose”, and the DeltaV system is the first automation system to address this critical need in many of the most important facets of the system.

Built for security

To help you address challenges created by using COTS, security is integrated throughout the DeltaV system architecture. DeltaV Smart Switches are treated as DeltaV switches and are fully preconfigured for purpose. Alerts and diagnostics from these devices are integrated with other maintenance alerts so your maintenance staff, not your IT

staff, can quickly address any issues. DeltaV Smart Switches come completely preconfigured to plug and play in the DeltaV network with no additional configuration or trouble-shooting required. To prevent physical intrusion on the control network, you can automatically lock down unused switch ports with a single mouse click.

A perimeter firewall is an important security element that protects your control system from security risks from outside the control network. The Emerson Smart Firewall provides a built-for-purpose, easy-to-implement firewall that allows plant operations to implement and manage their system perimeter security without the need for firewall or security expertise.

On your control network, DeltaV Controller Firewalls provide an additional layer of protection for further protection of your control hardware.

Security extends up to the enterprise applications through OPC .NET and web services providing two-way, authenticated communications for historical process data control, and advanced control data, alarms and events, and batch-based information. Unlike other automation systems, the data includes status information from the intelligent field devices.



The Emerson Smart Firewall protects the DeltaV system with an easy-to-use perimeter defense solution.

Instead of wondering if critical business decision-making information coming from the automation system is accurate—the quality of the data comes along with the data.

AMS Device Manager integrates with the DeltaV software to provide common security and confidence in the operation of your field assets.



**Inherently
Integrated**



Built for Purpose



Services

Built for you

DeltaV engineering applications organize the functions in ribbon bars, which consolidate functions by logical task and are fully customizable. Productivity enhancing tooltips and fast keys streamline your configuration efforts. Because time is precious, this technology helps focus process engineers on high-value activities like control strategy improvements instead of keyboard data entry.

The DeltaV system has led the way in easy-to-use engineering applications to simplify project execution and ongoing maintenance. Whether your application is continuous, batch, or process safety-related, this common set of engineering applications provides the simplicity and flexibility for your most demanding applications.

The DeltaV system built for process control

The DeltaV system enables you to quickly deploy state-of-the-art intelligent control to improve your process plant performance, without the aid of costly outside experts. DeltaV hardware components are plug-and-play. You plug them in and they are auto-sensed and recognized by the system. Software configuration is drag-and-drop, with automatic process control functionality delivered out of the box. With the DeltaV system, you install your system hardware, connect everything together, configure the logic and everything works—easy!

Built for busses

The DeltaV digital automation system is the only system built from the ground up to unleash the advantages of digital fieldbus communications. Not an add-on, not an afterthought, it's built to deliver the project and operational savings of a digital plant—easy!

Built for batch

The DeltaV system provides an architecture that is based on the ISA 88 batch standard. Whether it is the physical model, procedural model, or easy-to-use class-based configuration, the DeltaV system is “built for batch” —easy!



I/O on Demand

Ultimate Scalability

Embedded
Intelligent Control

DeltaV Services

Delivering global services expertise and execution capabilities.

To complement our industry-leading technology, Emerson offers services that enable you to improve your financial results by unlocking the true potential of your process operations and assets. Day after day, year after year, Emerson's industry experts have been helping companies like yours improve business performance and protect their automation investment with an array of services from opportunity assessment through design, project execution, commissioning, maintenance, performance improvement and training. This expertise is supported by more than 30 years of process industry experience and thousands of customers worldwide.

Opportunity Assessment Services

Opportunity Assessment Services help you identify potential areas of process or plant improvement; and identify and select the best solution to generate operational

benefits and high financial return. Having deep automation expertise and extensive industry experience, Emerson's consultants are committed to learning and understanding your requirements to develop the conceptual design and master automation plan that will produce lasting business results. Working with your experts, our consultants will help prepare a financial justification for the chosen solution. Engaging Emerson consultants improves the probability of obtaining project approval.

Project Execution Services

Helping you capitalize on business opportunities, Emerson's project services provide the resources, knowledge, techniques and tools to reduce project risk, lower costs and shorten your overall project schedule.



Emerson provides detailed project plans that identify all instrument, control, and system activities, with each activity assigned to the best resource – blending and coordinating on-site activities with remote engineering.

Emerson uses our Project Management Office (PMO) standards and processes to increase engineering efficiency, drive execution excellence, and enable global consistency. Emerson can be as involved as you need in delivering a project—from small instrumentation upgrades to full main automation contractor (MAC) engagements. We also have services available to transition from project implementation to operations and provide any support required after the project is complete.



**Inherently
Integrated**

Built for Purpose

Services

Lifecycle Services

Emerson helps you maximize business value and operational investment over the lifecycle of your system through availability, sustainability and performance improvement services. Through our global network of local and factory specialists, we deliver on the promise of improving your competitive advantage and bottom line business results. We recognize that lifecycle support needs vary from one customer to another in both services activity content and time commitment, and that you make investments over the system lifecycle for three basic reasons:

Essential Services keep your plant operating safely, reliably and economically each and every day. Activities are designed to help you achieve the desired level of certainty for system uptime.

Standard Services are those that are necessary for achieving ongoing, predictable, proven and measurable operational results with no surprises and an end goal of performance improvement over time.

Advanced Services are there to offer the full advantage of a trusted partner working with you to deliver a competitive advantage, innovative technologies and solutions that drive business results.

Because every customer has different support needs, we created our Lifecycle Services program to be flexible, allowing you to choose the coverage that meets your plant and staff's particular needs. Emerson will work with you to build a customized program for one year or multiple years that fits just right based on your plant's unique operating history, maintenance requirements, control system configuration, performance improvement needs, staff experience, manpower levels and budgetary constraints.

Guardian Support is the core element of our support program. The Guardian service module is designed to help you proactively achieve peak availability, sustainability and performance on your system investment through critical service and support information. Guardian consolidates and securely delivers personalized, real-time service intelligence tailored specifically to your system architecture, assets and use. Guardian provides a single-point source of critical services and system information to help you effectively manage your DeltaV system throughout its lifecycle.

Training

To ensure you maximize value from your automation investment, Emerson Process Management's Educational Services offers training programs designed for ongoing education and development of



Emerson's Virtual Classroom delivers an affordable, live, interactive, instructor-led training experience that saves time and travel.

operators, engineers, technicians, and maintenance personnel.

Courses provide vital hands-on experience and build practical skills. Training can be delivered at a regional training center, customer site, on-line Virtual Classroom, or web-based eLearning. Additionally, training for plant operators is offered through a suite of operator training options.

To address your specific learning objectives and business needs, our global network of certified training staff can assess workforce skills and knowledge with recommended training solutions.

Visit www.EmersonProcess.com/Education to view the catalog of available courses.



Emerson Process Management

1100 W. Louis Henna Blvd., Building One
Round Rock, TX 78681-7430

www.EmersonProcess.com/DeltaV

Form B-000035 /Printed in USA/18K AQ / 7K A4 / 04-13

The contents of this publication are presented for informational purposes only, and while every effort has been made to ensure their accuracy, they are not to be construed as warranties or guarantees, express or implied, regarding the products or services described herein or their use or applicability. All sales are governed by our software licensing agreement and terms and conditions, which are available upon request. We reserve the right to modify or improve the designs or specifications of our product and services at any time without notice.

© 2013 Emerson Process Management. All rights reserved. The Emerson logo is a trademark and service mark of Emerson Electric Co.

For Emerson Process Management trademarks and service marks, go to www.emersonprocess.com/home/news/resources/marks.pdf. All other marks are the property of their respective owners.

