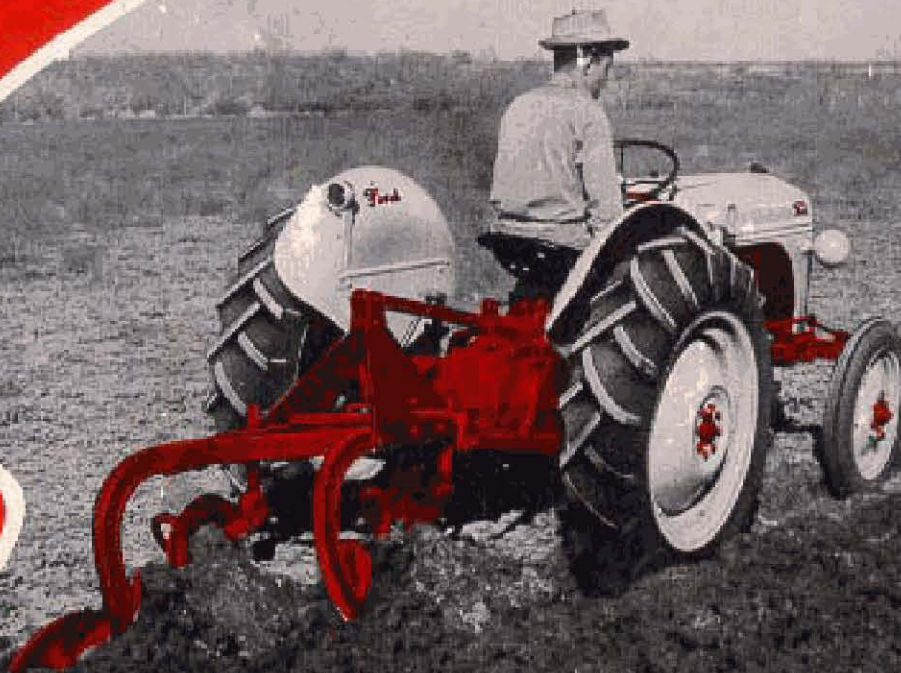


DEARBORN

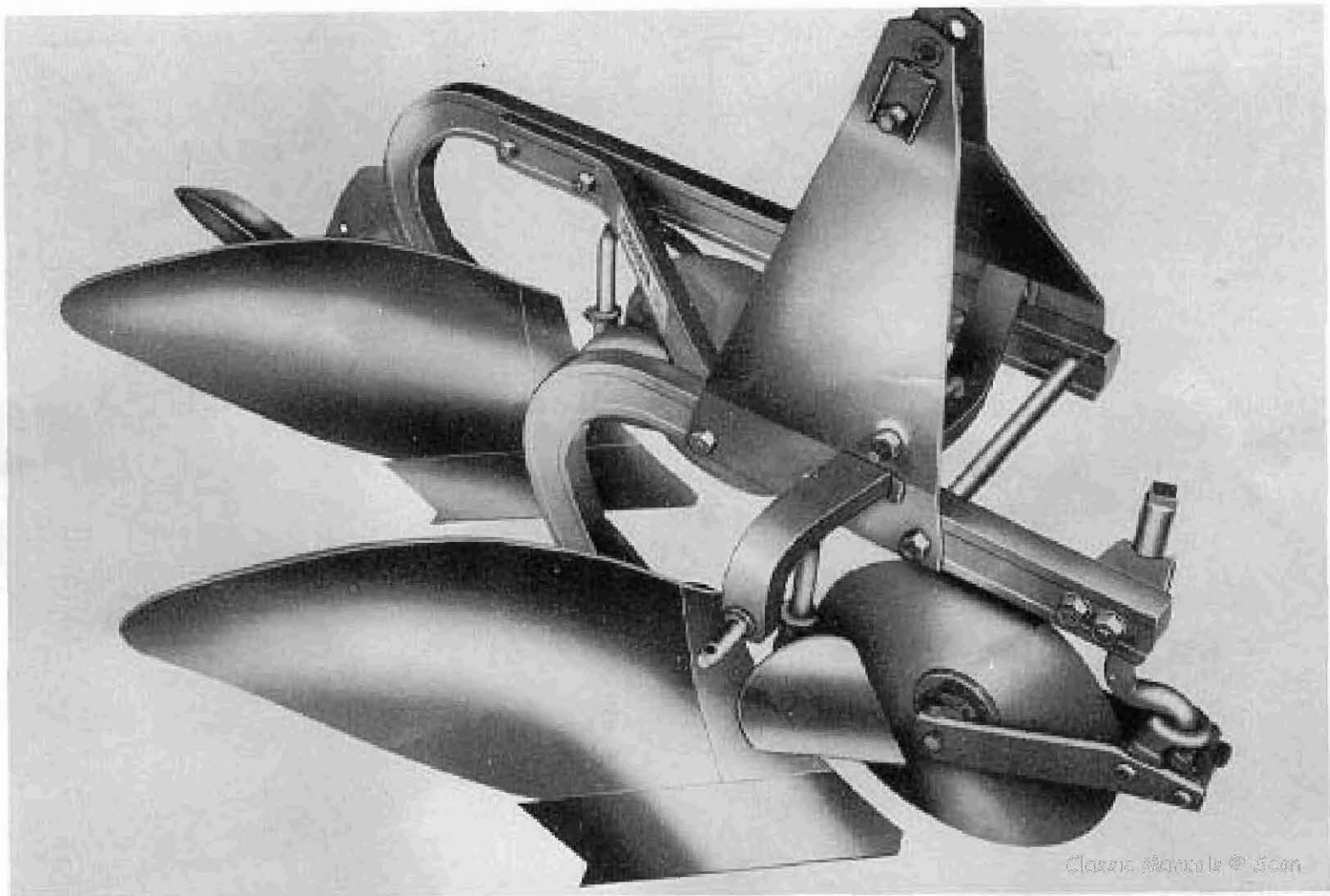
ECONOMY PLOW



ASSEMBLY and OPERATING *Instructions*

Classic Manuals © 2008

DEARBORN MOTORS CORPORATION — BIRMINGHAM, MICHIGAN



Classic Models © Scan

The Dearborn Economy Plow

Design features of the Dearborn Economy Plow are: Rugged construction, easy adjustment, interchangeability of models and a low cost replacement share.

The frame is constructed of high carbon tempered steel to withstand hard usage and provide surplus strength and rigidity for satisfactory operation. Increased weight also provides better penetration, and traction through the transfer of weight to the tractor.

In this plow conventional shares are replaced by low cost "Razor Blade" shares. This eliminates the expense and inconvenience of resharpening worn shares. The penetration properties have been increased since the new share has such

throughout its entire length. The Economy bottoms are provided with replaceable shins to prolong the life of the moldboards.

The Dearborn Economy Plow is easily attached and detached from the Ford Tractor with the standard 3-point hookup. Through the use of Constant Draft Control for rolling land and Implement Position Control for level land, a uniform furrow depth can be maintained.

In addition to the four types of Economy bottoms there are seven standard bottoms in the Dearborn line which may be used with the Economy frame. The Economy frame is easily and inexpensively converted to accommodate 10", 12", 14" or 16" bottoms.

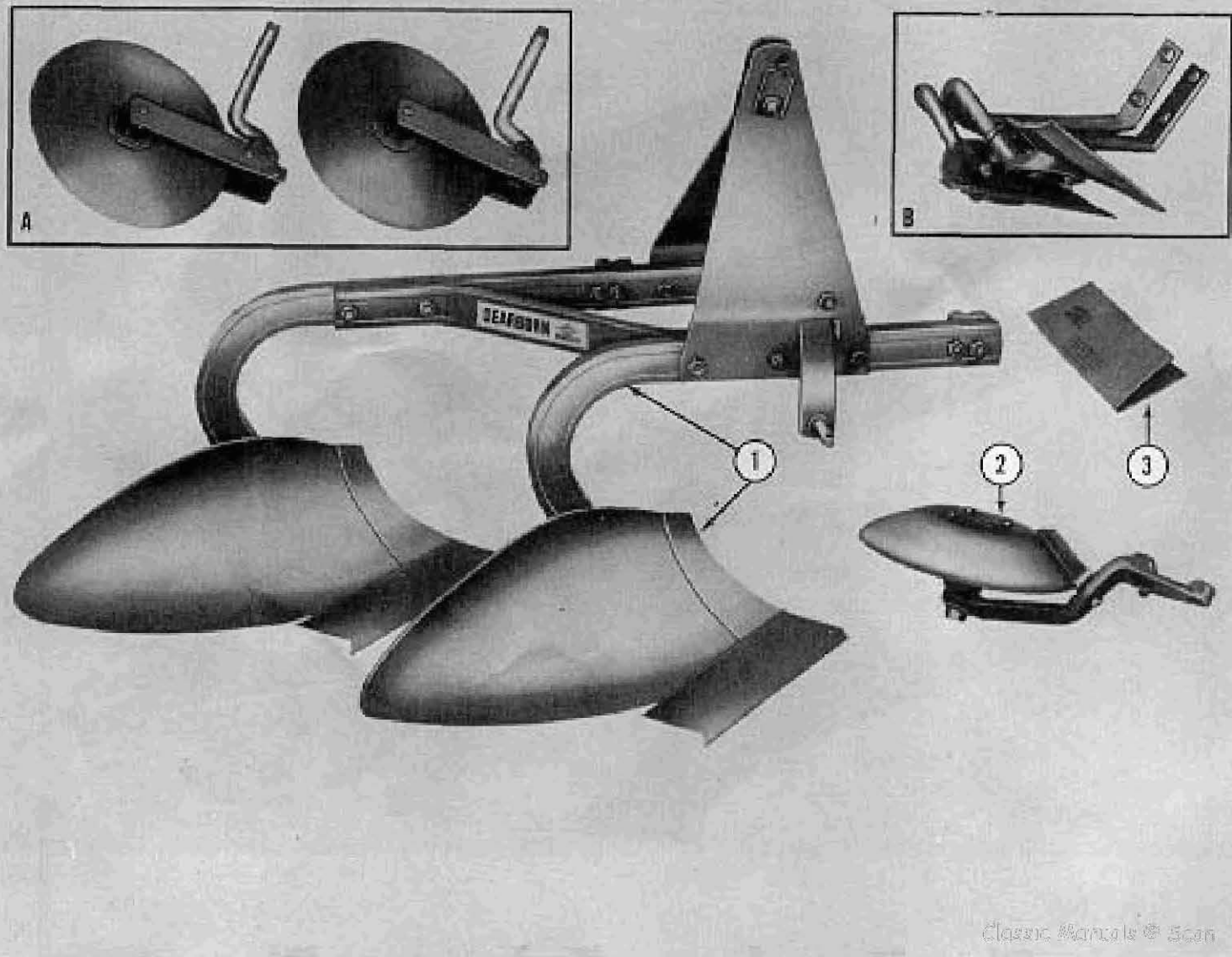


Figure 1

Implement Breakdown for Shipment

NOTE: *Assembly of the Dearborn Economy Plow is the responsibility of the Ford Tractor and Dearborn Farm Equipment dealer. The plow should be delivered completely assembled. The following instructions are provided in case of need.*

SHIPPING INFORMATION

The Dearborn Economy Plow is shipped in two bundles which contain the parts listed below. Check the shipment against this list and Figure 1 to be sure all parts are received.

KEY
NO.

DESCRIPTION

1. The Plow frame with bottoms attached.
2. One rolling landside assembly.

NOTE: *The coulters (see insert A), Figure 1, and the jointers (see insert B) are bundled for shipment as shown and are sold separately. The Assembly Manual envelope (3), Figure 1, is taped to the plow frame.*

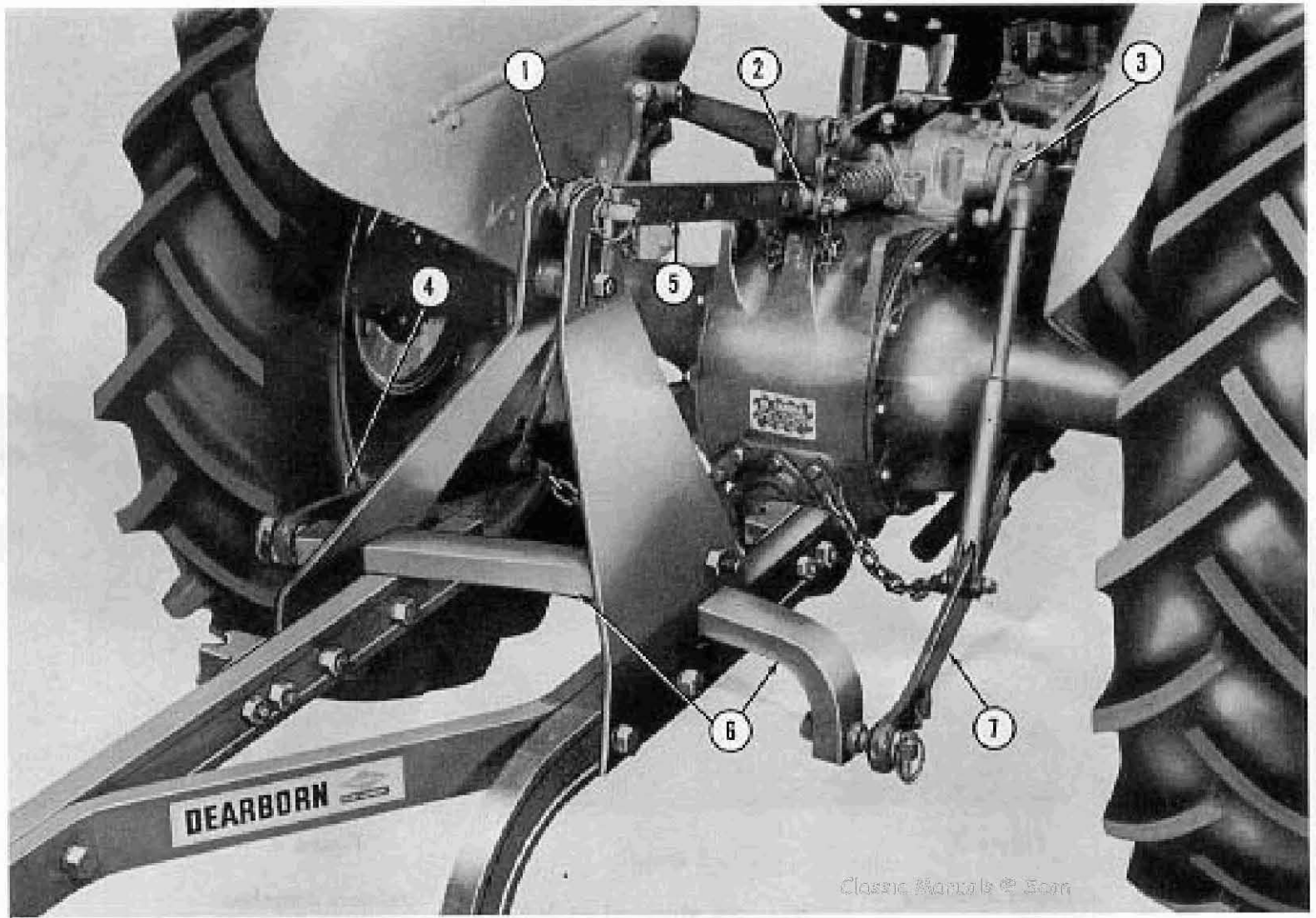


Figure 2

The Economy Plow Attached to the Ford Tractor

ASSEMBLY PROCEDURE

NOTE: For added traction it is possible to increase the weight of the tractor by the use of calcium chloride and water in the tires. See the Ford Tractor manual for tire loading procedure.

The following steps include the assembly of extra equipment as well as the basic plow.

1. Back the tractor up to the plow frame so the lower links (4) and (7), Figure 2, are aligned with the plow cross shaft (6) as shown.
 - a. Turn the adjusting crank (3), Figure 2, to

align the right tractor link (7) with the right side of the cross shaft (6).

- b. Attach the lower links (4) and (7), Figure 2, to each end of the cross shaft and secure with the linch pins provided.
- c. Attach the tractor top link (5), Figure 2, to the top of the A-frame with the pin (1) and linch pin.
- d. Attach the forward end of the top link (5), Figure 2, to the lower hole on the tractor rocker assembly with the pin (2) and secure with linch pin.

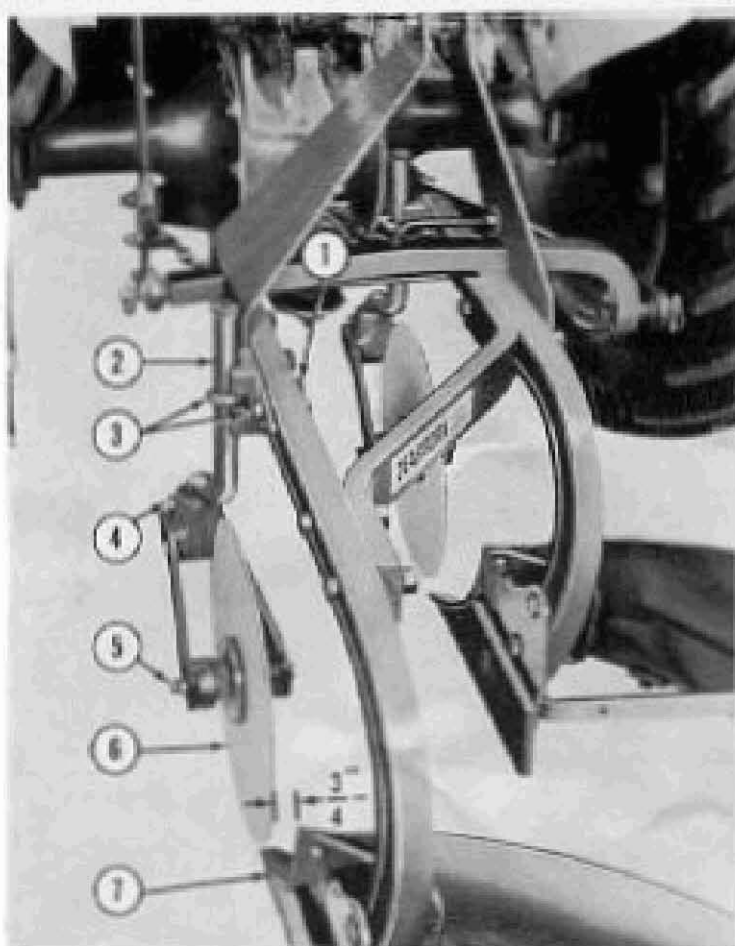


Figure 3

Coulters Attached

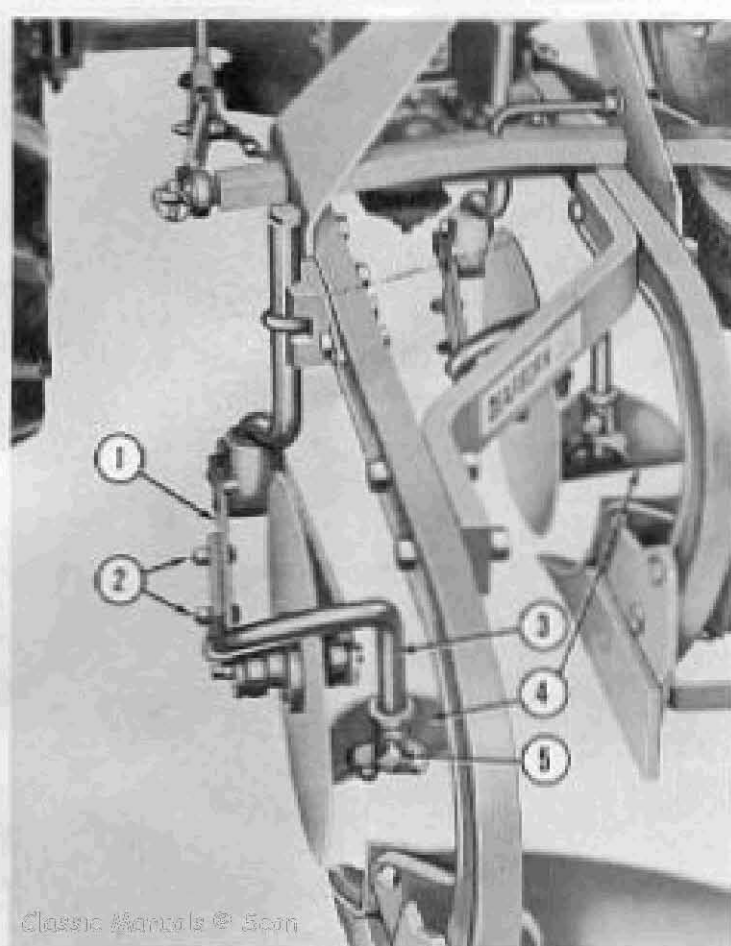


Figure 4

Jointers Attached

2. Where coulters are used, they should be attached to the forward end of each beam as follows:

- a. Attach the coulter stem (2), Figure 3, to the left side of each beam with the stem seat and eye bolt clamp (3).
- b. Adjust the coulter for depth and width of cut desired and tighten the eye bolt nut (1), Figure 3, securely.

NOTE: The eye bolt clamp (3), Figure 3, may be attached in reverse, thus providing a forward or rearward adjustment for the coulter blade. The forward position as shown is used under normal plowing conditions. The rearward position is used in hard ground or where heavy trash lies close to the ground.

- c. The swing of the coulter (6), Figure 3, may be controlled by loosening the nut (4) on the limit stop and adjusting the stop. Tighten the nut (4), Figure 3, **SECURELY**.

NOTE: This nut must be kept tight at all times.

- d. Adjust the nut on the bolt (5), Figure 3, to take up excess play in the bearings and secure with the locknut provided.

3. When jointers are used one should be attached to each coulter as follows:

- a. Attach a jointer arm (3), Figure 4, to the left side of each coulter fork (1) with the two carriage bolts (2), lock washers and nuts.

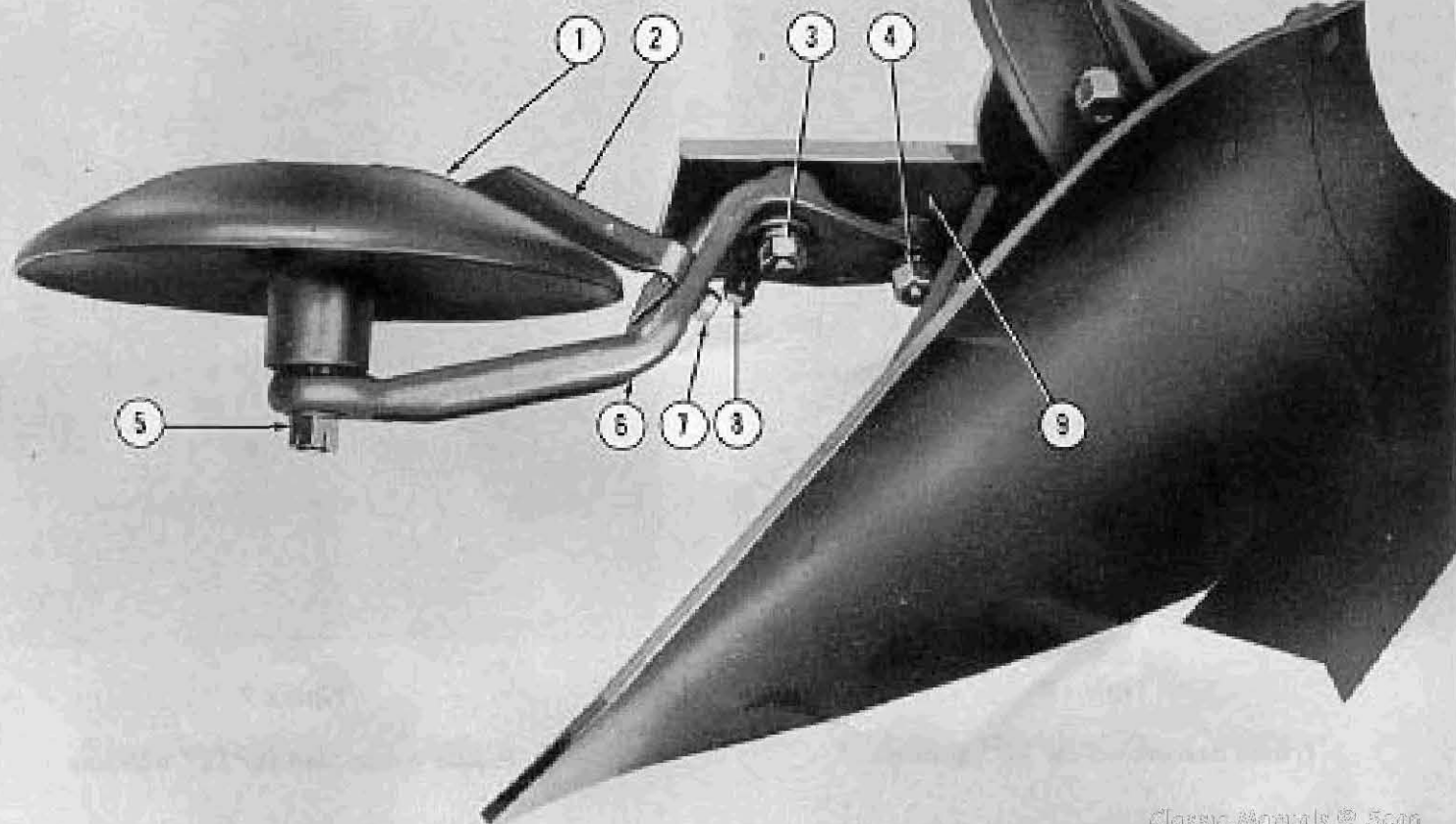


Figure 5

Rolling Landside Attached

- b. Adjust the jointers (4), Figure 4, with the point lightly touching the coulter blades (6), Figure 3.
 - c. To adjust the jointers (4), Figure 4, loosen the set screw (5) and position as desired.
4. Attach the rolling landside assembly to the rear bottom as follows:
- a. Bolt the rolling landside arm (6), Figure 5, to the rear bottom sliding landside (9) with the plow bolts (3) and (4) loosely. Do not tighten at this time.
 - b. Raise the plow with the Ford Tractor Hydraulic Touch Control lever until the rear bottom assembly is clear of the ground.
 - c. For the Economy Bottom turn the adjust-

ing bolt (8), Figure 5, until the rolling landside (1) is not more than $\frac{1}{2}$ inch below the lower edge of the sliding landside (9) and secure with the locknut.

NOTE: For the Standard Bottoms the rolling landside should be from $\frac{1}{2}$ inch to $\frac{3}{4}$ inch below the lower edge of the sliding landside.

- d. Tighten the nuts on the bolts (3) and (4), Figure 5, securely and lower the plow to the ground.
- e. Adjust the scraper (2), Figure 5, so it just touches the rolling landside (1) and secure with the carriage bolt (7), lockwasher and nut.

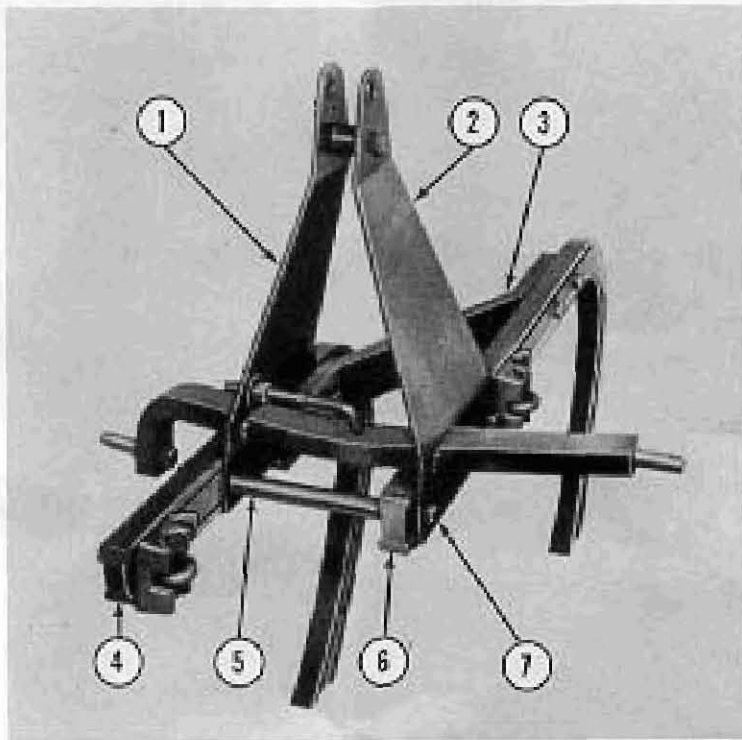


Figure 6

Frame Assembled for 10" Bottoms

PLOW FRAME

CONVERSION PROCEDURE

The Economy Plow can readily be converted to accommodate all widths and types of bottoms in the Dearborn line through the use of standard parts.

PLOW FRAME—10 INCH

To change from a 12" frame to a 10" frame, attach the right "A" frame member (1), Figure 6, to the left side of the right beam (4) and use the brace (3)*, the tie rod spacer (5)* and the tie rod bolt (7)*. Attach the left "A" frame member (2), on the left side of the beam (6).

PART NUMBERS*

- (3), Figure 6, Brace#105146
- (5), Figure 6, Spacer, Tie Rod#105144
- (7), Figure 6, Bolt, Tie Rod#105100

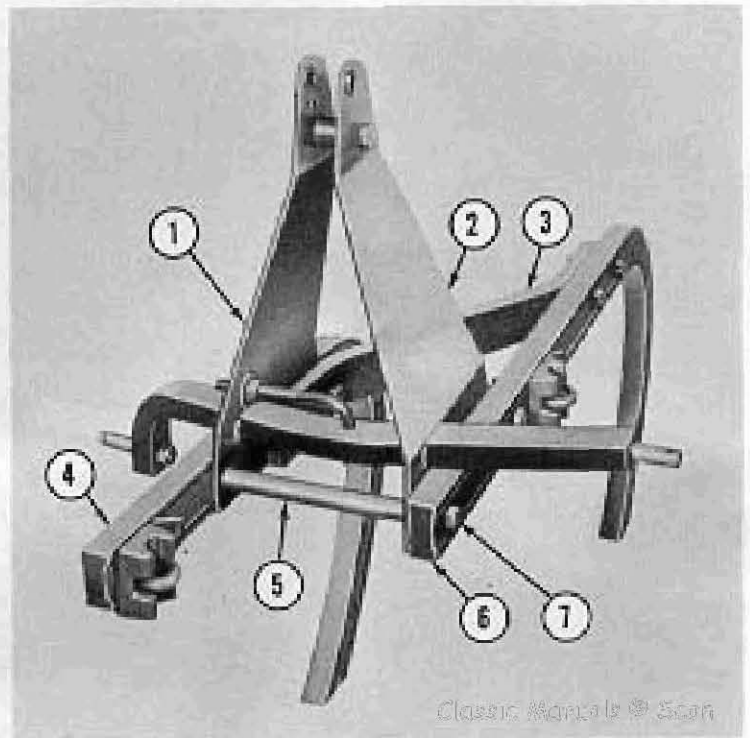


Figure 7

Frame Assembled for 12" Bottoms

PLOW FRAME—12 INCH

To change from a 10" frame to a 12" frame, attach the right "A" frame member (1), Figure 7, to the left side of the right beam (4) and use the brace (3)*, the tie rod spacer (5)*, and the tie rod bolt (7)*. Attach the left "A" frame member (2), on the right side of the beam (6).

To change from the 14" or 16" frame to a 12" frame, the left "A" frame member (2), Figure 8, will have to be replaced with (2)*, Figure 7, in addition to the above changes.

PART NUMBERS*

- (2), Figure 7, "A" Frame Assy., Left #104372
- (3), Figure 7, Brace#105147
- (5), Figure 7, Spacer, Tie Rod#105143
- (7), Figure 7, Bolt, Tie Rod#105102

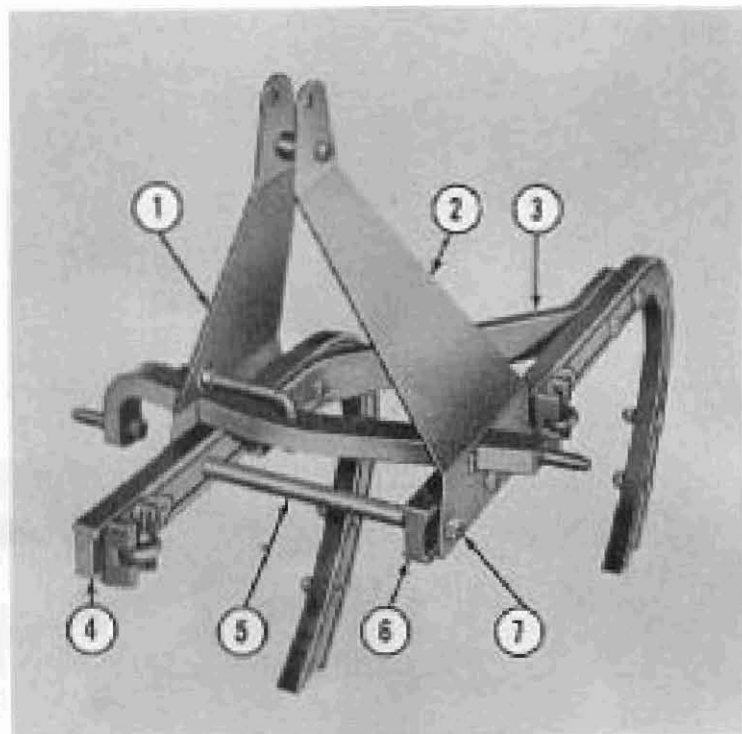


Figure 8

Frame Assembled for 14" Bottoms

PLOW FRAME—14 INCH

To change from a 16" frame to a 14" frame attach the right "A" frame member (1), Figure 8, to the right side of the right beam (4) and use the brace (3)*, the tie rod spacer (5)*, and the tie rod (7)*. Attach the left "A" frame member (2), on the left side of the beam (6).

To change from the 10" or 12" frame to a 14" frame the left "A" frame member (2), Figure 7, will have to be replaced with (2)*, Figure 8, in addition to the above changes.

PART NUMBERS*

- (2), Figure 8, "A" Frame Assy., Left #104373
- (3), Figure 8, Brace #104331
- (5), Figure 8, Spacer, Tie Rod #104304
- (7), Figure 8, Bolt, Tie Rod #105104

PLOW FRAME—16 INCH

To change from a 14" frame to a 16" frame, attach the right "A" frame member (1), Figure

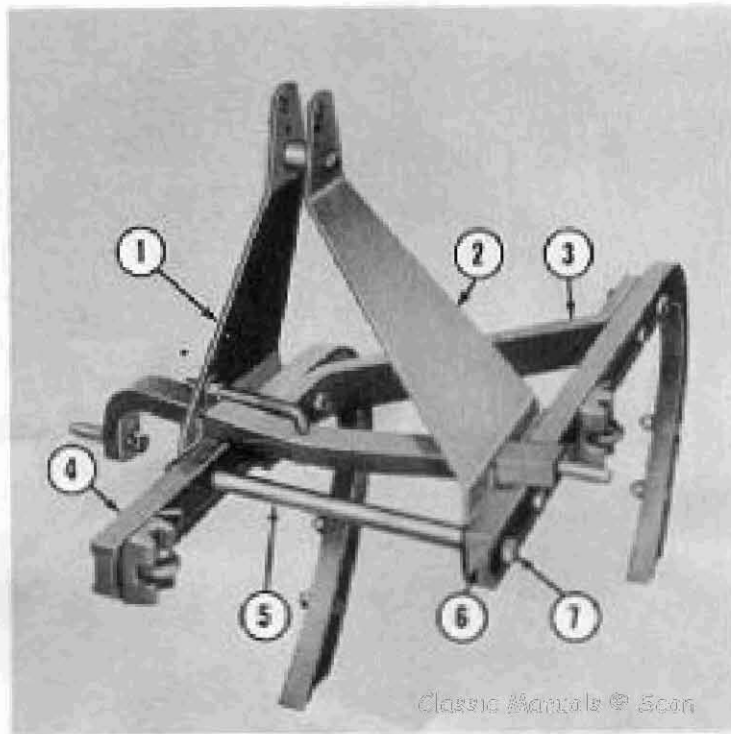


Figure 9

Frame Assembled for 16" Bottoms

9, to the right side of the right beam (4) and use the brace (3)*, the tie rod spacer (5)*, and the tie rod bolt (7)*. Attach the left "A" frame member (2), on the right side of beam (6).

To change from the 10" or 12" frame to a 16" frame the left "A" frame member (2), Figure 7, will have to be replaced with (2)*, Figure 9, in addition to the above changes.

PART NUMBERS*

- (2), Figure 9, "A" Frame Assy., Left #104373
- (3), Figure 9, Brace #104333
- (5), Figure 9, Spacer, Tie Rod #105145
- (7), Figure 9, Bolt, Tie Rod #105106

THIRD BEAM CONVERSION KIT

In some areas soil conditions permit satisfactory plowing with three bottoms. The Dearborn two-bottom plow may be readily converted to a three-bottom plow with standard plow parts as follows:

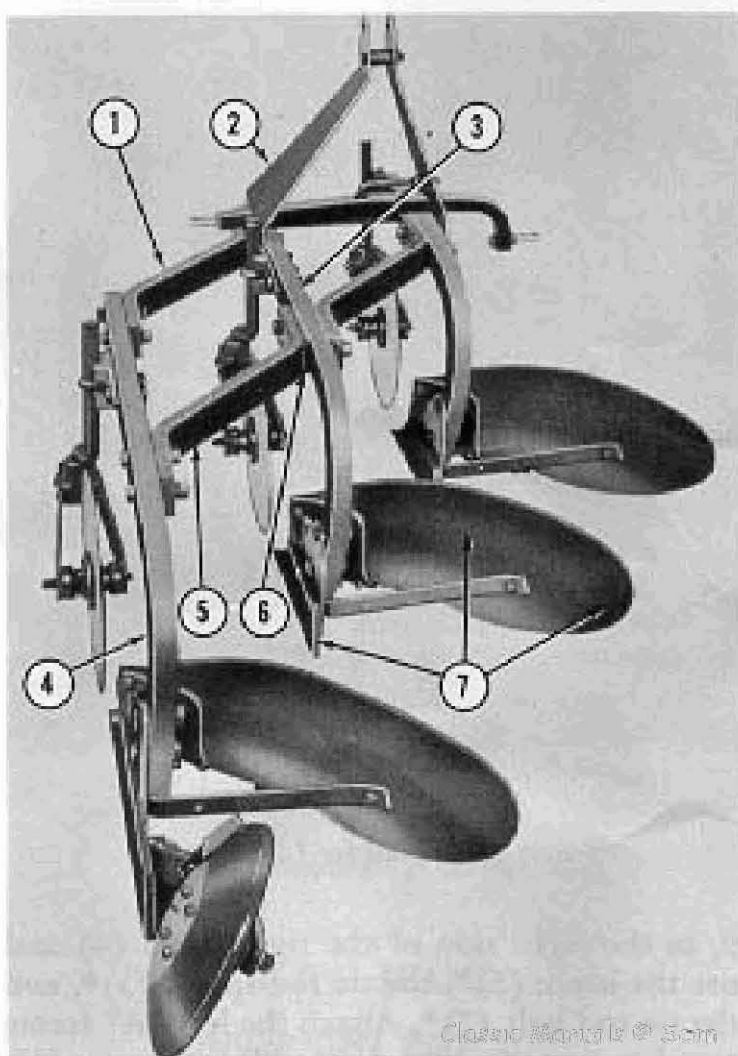


Figure 10

The Dearborn Three Bottom Plow

To add a third bottom to the 14" plow as shown in Figure 10, remove the rear bottom and rolling landside from the beam (3) and attach it to the third beam (4). Attach the third bottom (7) to the center beam (3), Figure 10. Attach the beam (4) to the beam (3) with the braces (1) and (5) as shown in Figure 10. Use a spacer (6) between the beam (3) and the brace (5).

For the conversion of the 12" two-bottom plow frame to a three-bottom frame, the spacer (6), Figure 10, is also used between the brace (1) and the beam (3).

NOTE: It is recommended that 100 lb. front wheel weights be used with the Third Beam Conversion Kit.

The model 10-61 Third Beam Conversion Kit is for the 10" frame. The model 10-62 is for the

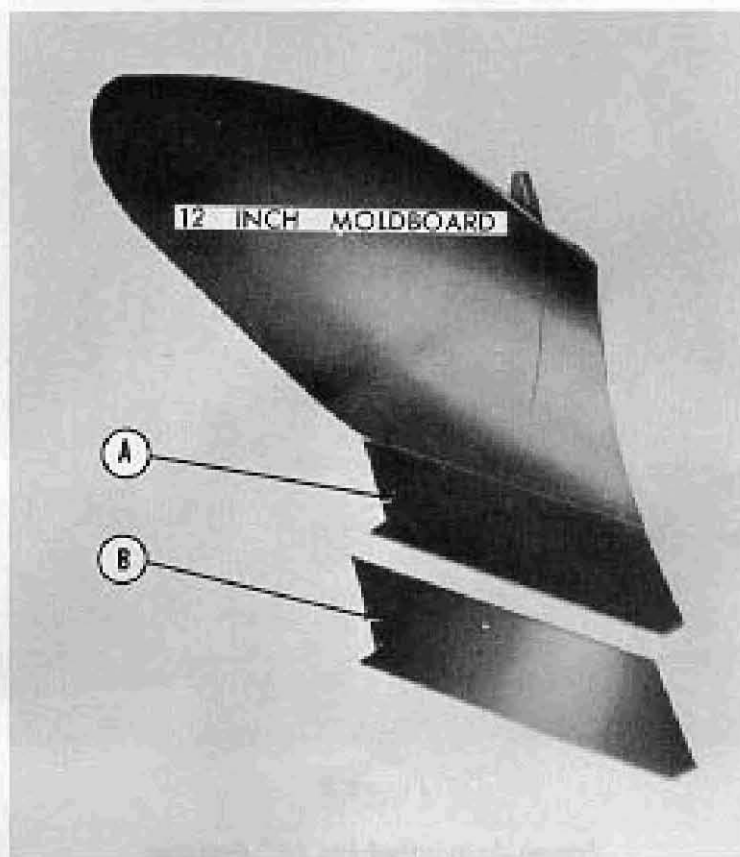


Figure 11

12" Moldboard and Share Combinations

12" frame and 10-63 for the 14" frame. The following bottom assemblies are available for the above Conversion Kits.

- Model 10-162 Scotch Bottom 10"
- Model 10-164 Economy Bottom 12"
- Model 10-41 Sod and Clay Bottom 12"
- Model 10-20 Slat Bottom 12"
- Model 10-22 General Purpose Chilled Bottom 12"
- Model 10-166 Economy Bottom 14"
- Model 10-168 Economy Combination Bottom 14"
- Model 10-36 General Purpose Bottom 14"
- Model 10-170 Stubble Bottom 14"

SHARE USAGE

It is desirable that the correct share and moldboard combination is used for the job at hand. Combinations of regular and long shares in different sizes add to the all-around utility of the Economy Plow. Study the chart on page 9 along with Figures 11, 12 and 13 for information on share usage.

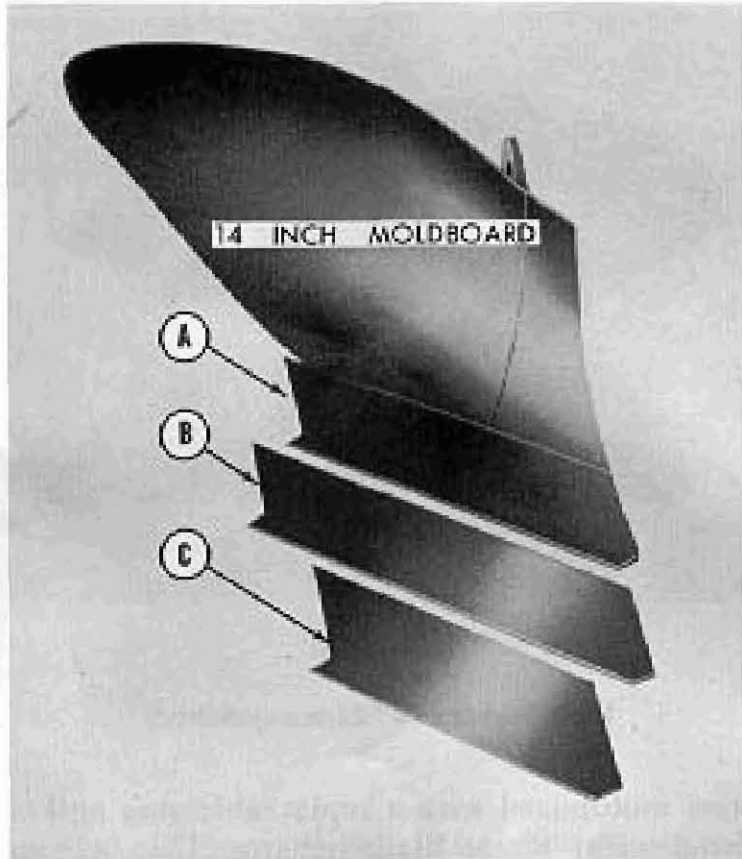


Figure 12

14" Moldboard and Share Combinations

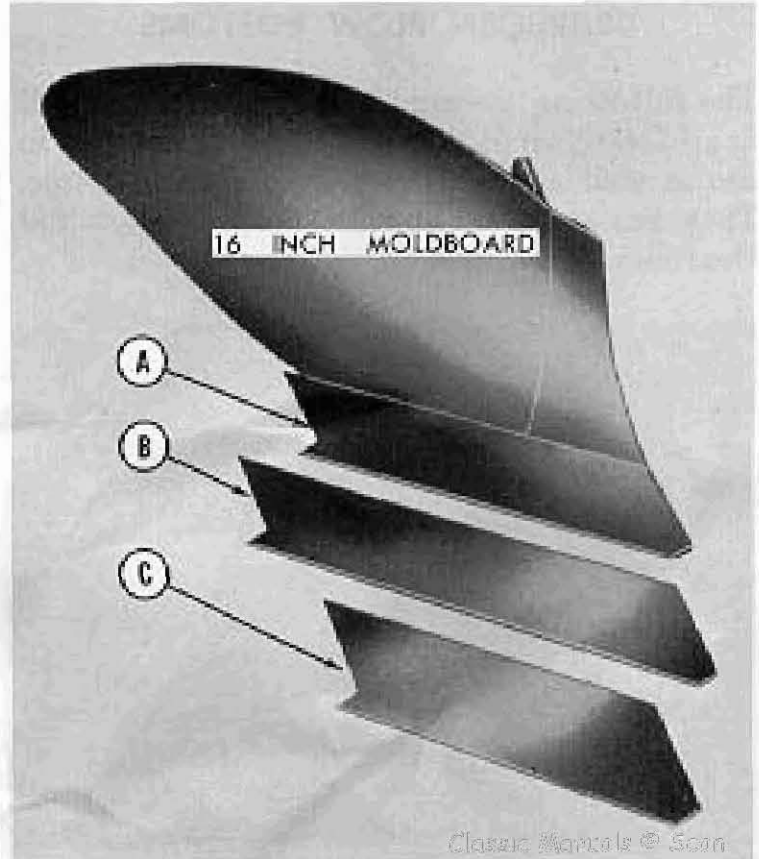


Figure 13

16" Moldboard and Share Combinations

CONDITIONS	SUGGESTED COMBINATIONS		
For Normal Plowing Conditions use a...	12 Inch Moldboard and a 12 Inch Regular Share (See A, Figure 11)	14 Inch Moldboard and a 14 Inch Regular Share (See A, Figure 12)	16 Inch Moldboard and a 16 Inch Regular Share (See A, Figure 13)
For Plowing Deep Rooted Crops such as Alfalfa or Sweet Clover use a.....	12 Inch Moldboard and a 12 Inch Long Share (See B, Figure 11)	14 Inch Moldboard and a 14 Inch Long Share (See B, Figure 12)	16 Inch Moldboard and a 16 Inch Long Share (See B, Figure 13)
For Hard or Stony Soil use a.....	12 Inch Moldboard and a 12 Inch Long Share (See B, Figure 11)	14 Inch Moldboard and a 12 Inch Regular Share (See C, Figure 12)	16 Inch Moldboard and a 14 Inch Regular Share (See C, Figure 13)

DEARBORN PLOW BOTTOMS

The following assorted bottom assemblies will fit all Dearborn Moldboard Plow frames now in use as well as the new Economy Plow frame. They are available at your Ford Tractor and Dearborn Farm Equipment dealer.

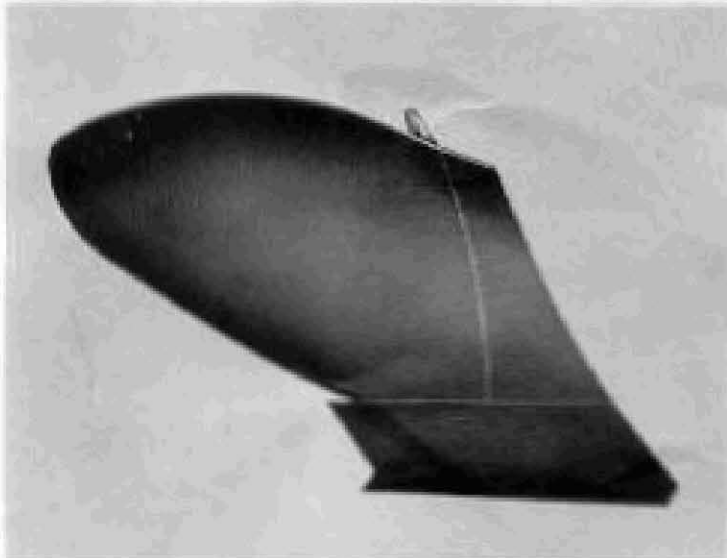


Figure 14

The Dearborn 12" Economy Bottom

The 12" Economy bottom shown in Figure 14 has a modified general purpose type moldboard. This bottom has light draft, provides good pulverization and scours exceptionally well.

It has a soft center type carburized steel moldboard with a replaceable shin and special heat treated steel "Razor Blade" shares. This bottom is for use in tough, hard-to-scour soils where light draft, good covering, pulverizing, and scouring is required.

The 14" Economy bottom shown in Figure 15 has a soft center type carburized steel moldboard with a replaceable shin and special heat treated steel "Razor Blade" shares. It is a modified general purpose type moldboard and may be used in a great majority of soils and conditions. It is an exceptionally good covering, pulverizing and scouring bottom.

The 14" Economy Combination Bottom shown in Figure 16 has a soft center type carburized

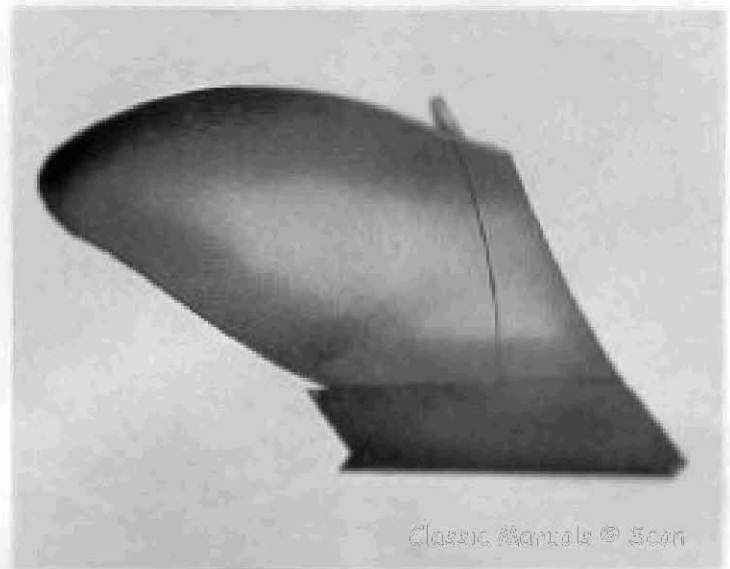


Figure 15

The Dearborn 14" Economy Bottom

steel moldboard with a replaceable shin and is fitted with "Razor Blade" shares. This bottom has light draft, pulverizes well and does an exceptionally good job in hard-to-scour soils.

The 16" Economy bottom shown in Figure 17 has a modified general purpose moldboard of soft center type carburized steel. It has replaceable shins and special heat treated steel "Razor Blade" shares. This bottom is used pri-

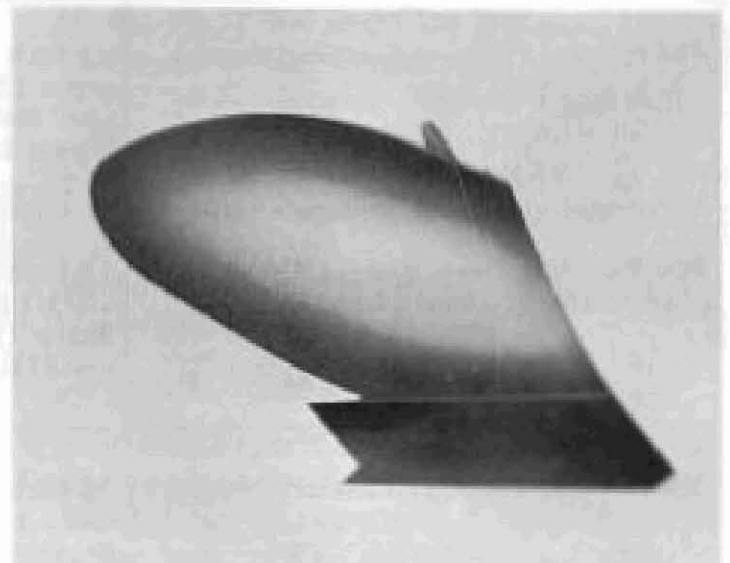


Figure 16

The Dearborn 14" Economy Combination Bottom

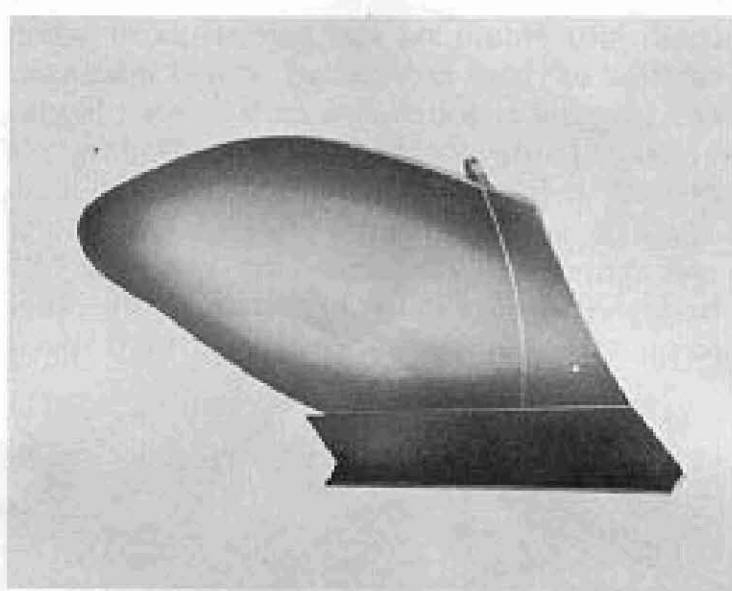


Figure 17

The Dearborn 16" Economy Bottom

marily in light to moderately light soils where exceptionally good covering and pulverizing is required.

The 10" Scotch bottom shown in Figure 18 has a soft center laminated steel moldboard and cast steel shares. This type of bottom is designed to stand the furrow slice on edge, rather than invert it. It is well adapted to fall plowing where the

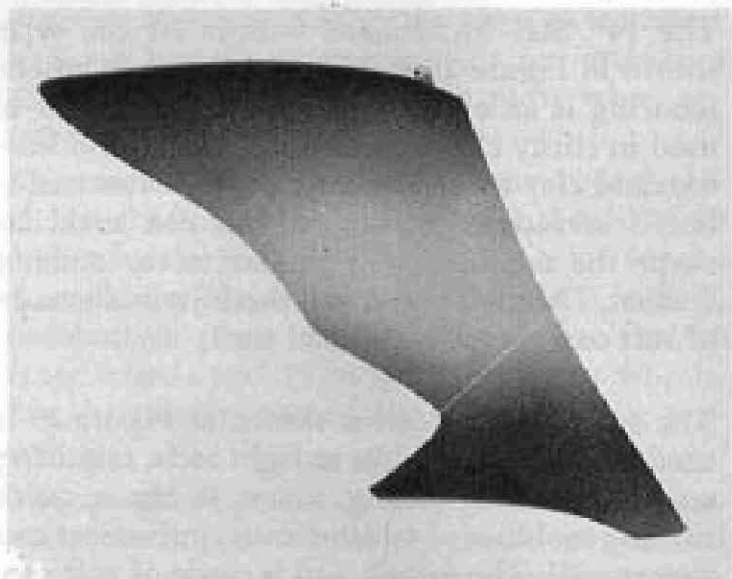


Figure 18

The Dearborn 10" Scotch Bottom

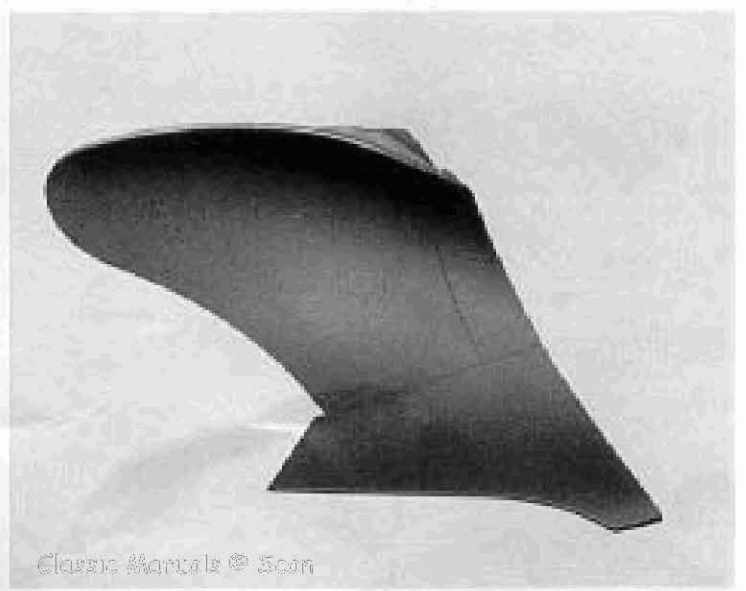


Figure 19

The Dearborn 12" General Purpose Chilled Bottom

land is to be left rough through the winter, or for control of wind and water erosion.

The 12" General Purpose chilled bottom shown in Figure 19 is made of extremely hard, chilled cast iron. It has a moderately quick turning moldboard which resists wear, gives excellent covering and pulverization. The shares are chilled iron and the moldboard has a replaceable chilled shin. This bottom is for use in highly abrasive soils where excessive wear is a problem.

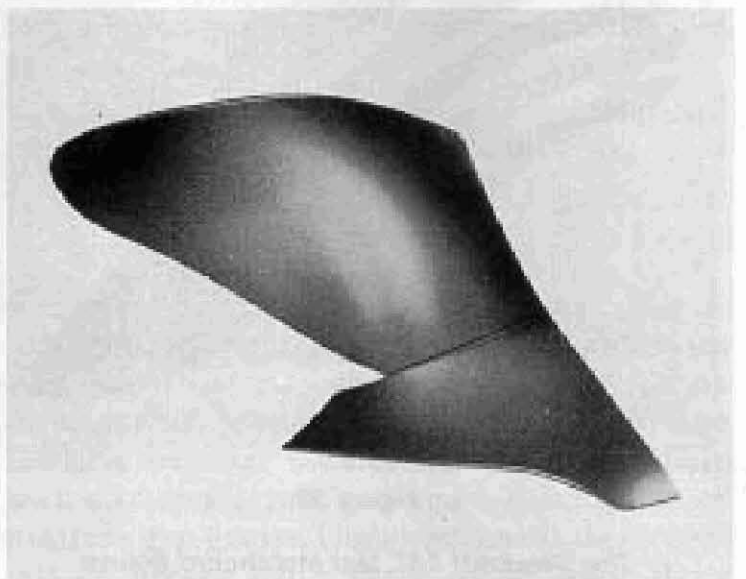


Figure 20

The Dearborn 12" Sad and Clay Bottom

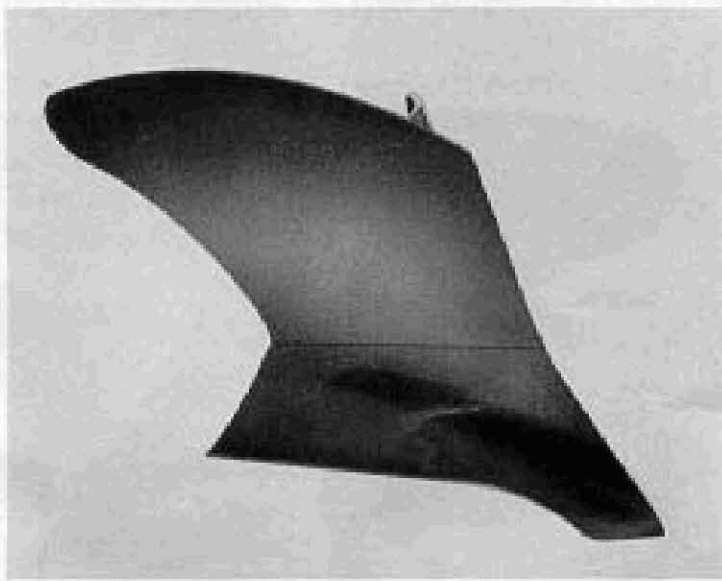
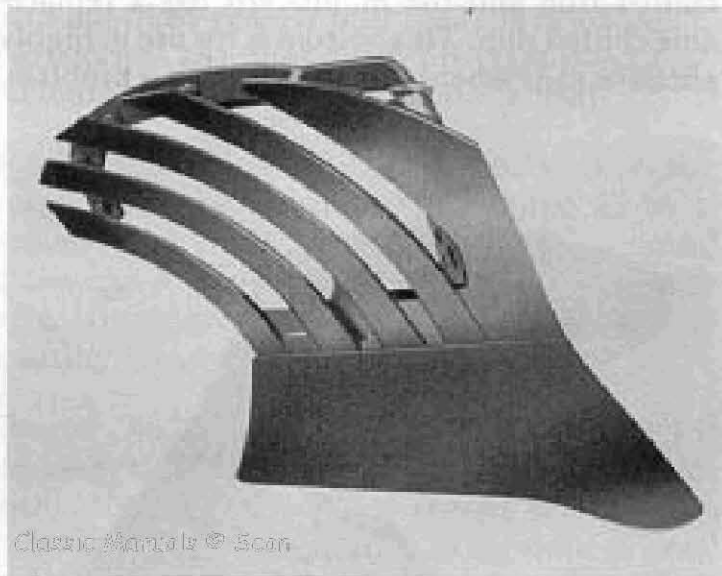


Figure 21

The Dearborn 14" General Purpose Bottom

The 12" Sod and Clay bottom shown in Figure 20 is a modified general purpose bottom with a soft center type laminated steel moldboard and a choice of chilled or soft center type carburized steel shares. This bottom is for use in sod, and such tight "clay" soils where a slow turning moldboard is required.



Classic Mantele © Scan

Figure 22

The Dearborn 14" Slat Moldboard Bottom

The 14" General Purpose bottom shown in Figure 21 is designed to do work under the varying

conditions found on the general farm where rotation of crops is practiced. It will meet average plowing requirements such as the plowing of stalk land, stubble land, tame sod or old ground. It has a slow turning moldboard made of soft center steel and a choice of chilled or soft center type carburized steel shares. This bottom is for use in heavy sod and is designed to operate at a reasonably high ground speed.

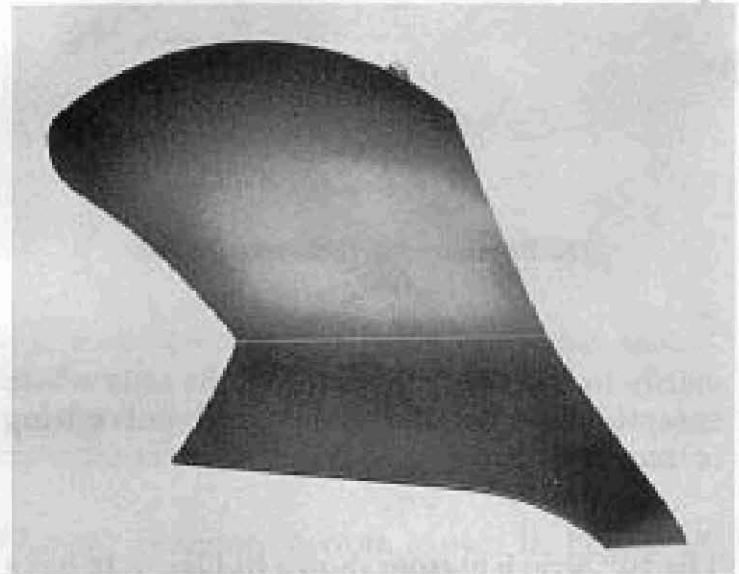


Figure 23

The Dearborn 14" Stubble Bottom

The 14" Slat Moldboard bottom of the type shown in Figure 22 is designed for areas where scouring is an extremely serious problem. It is used in sticky clay upland soils, black land bottom and clay soils. The slats provide less moldboard surface to which the soil can stick. In shape the slat bottom is similar to the stubble bottom. The moldboard and share are both made of soft center type laminated steel.

The 14" Stubble Bottom shown in Figure 23 is used in moderately light to light soils, requiring an exceptionally strong share. It has a quick turning moldboard which scours, pulverizes and covers well. The moldboard is made of soft center laminated steel and there is a choice of soft center type carburized steel or chilled shares.



Figure 24

The Dearborn Economy Plow at Work

The Dearborn Economy Plow is easily operated from the tractor seat. This means not only normal plowing operations such as changing the plowing depth or raising the plow to transport position but tilting the bottoms for making a scratch furrow or freeing the plow when obstructions are hit.

The tractor wheel spacings for the 10-inch, 12-inch and 14-inch two-bottom plow should be 48 inches for the front wheels and 52 inches for the rear wheels. The wheel spacings for the 16-inch, two-bottom plow should be 52 inches for the front wheels and 56 inches for the rear wheels. See the tractor manual for wheel spacing procedure.

The speed of operation while plowing will vary with conditions. However, the recommended engine operating speed under average conditions is 1750 r.p.m. in second gear or about 4 m.p.h. The plowing depth can be varied over

wide limits depending upon soil cover and the job to be done.

The Economy Plow is so designed that the necessary adjustments for proper operation are held to a minimum.

The following information on lubrication and adjustments should be adhered to for best results.

LUBRICATION

The three lubrication fittings on the Dearborn Economy Plow are located as follows: One on each coulter bearing, and one on the rolling landside bearing. Lubricate these fittings daily with a tractor grease gun and a good grade of pressure gun grease. Under extremely dusty conditions grease twice daily. After each day's operation cover all ground engaging parts with oil or other rust preventive.

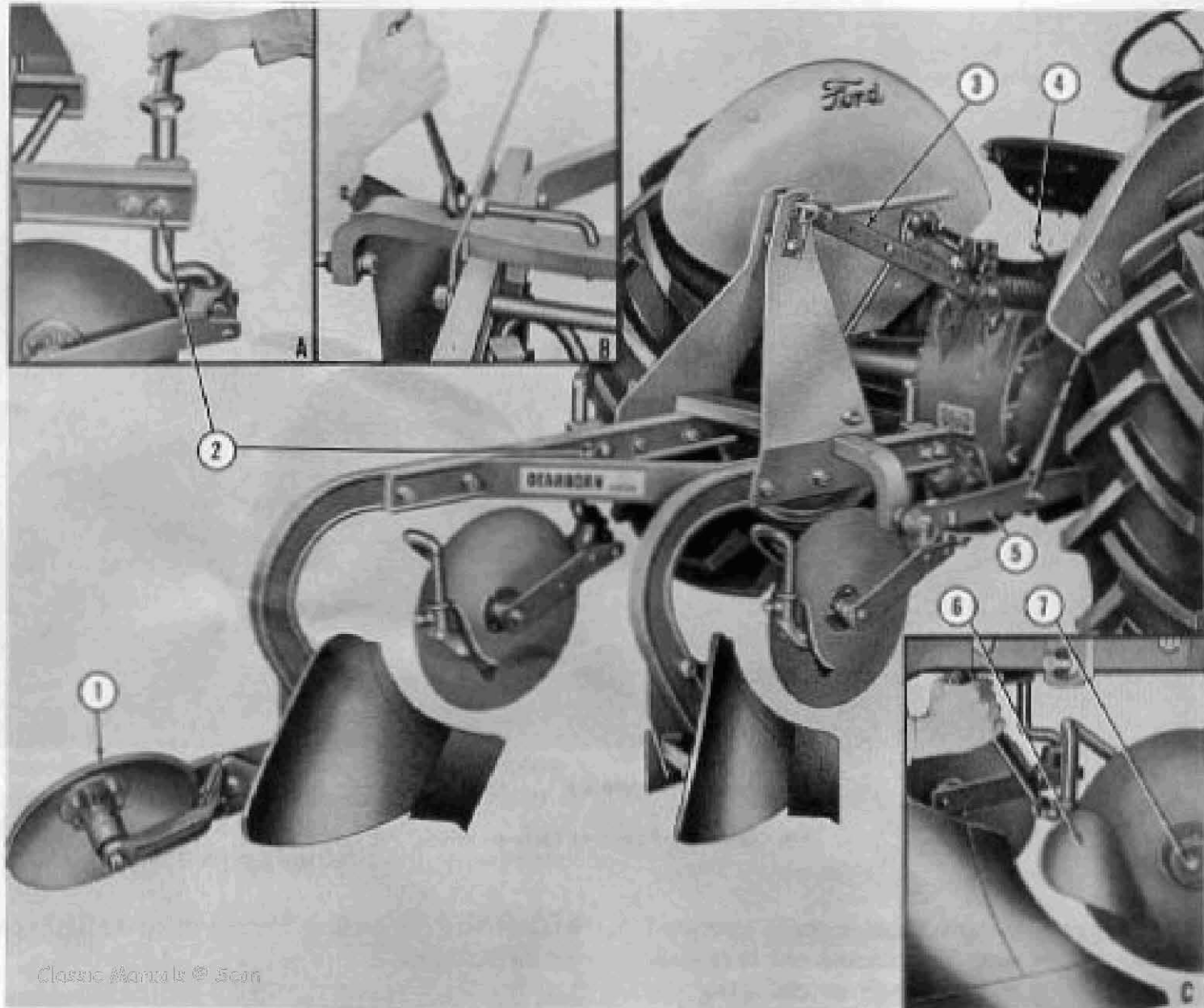


Figure 25

Plow Adjustments

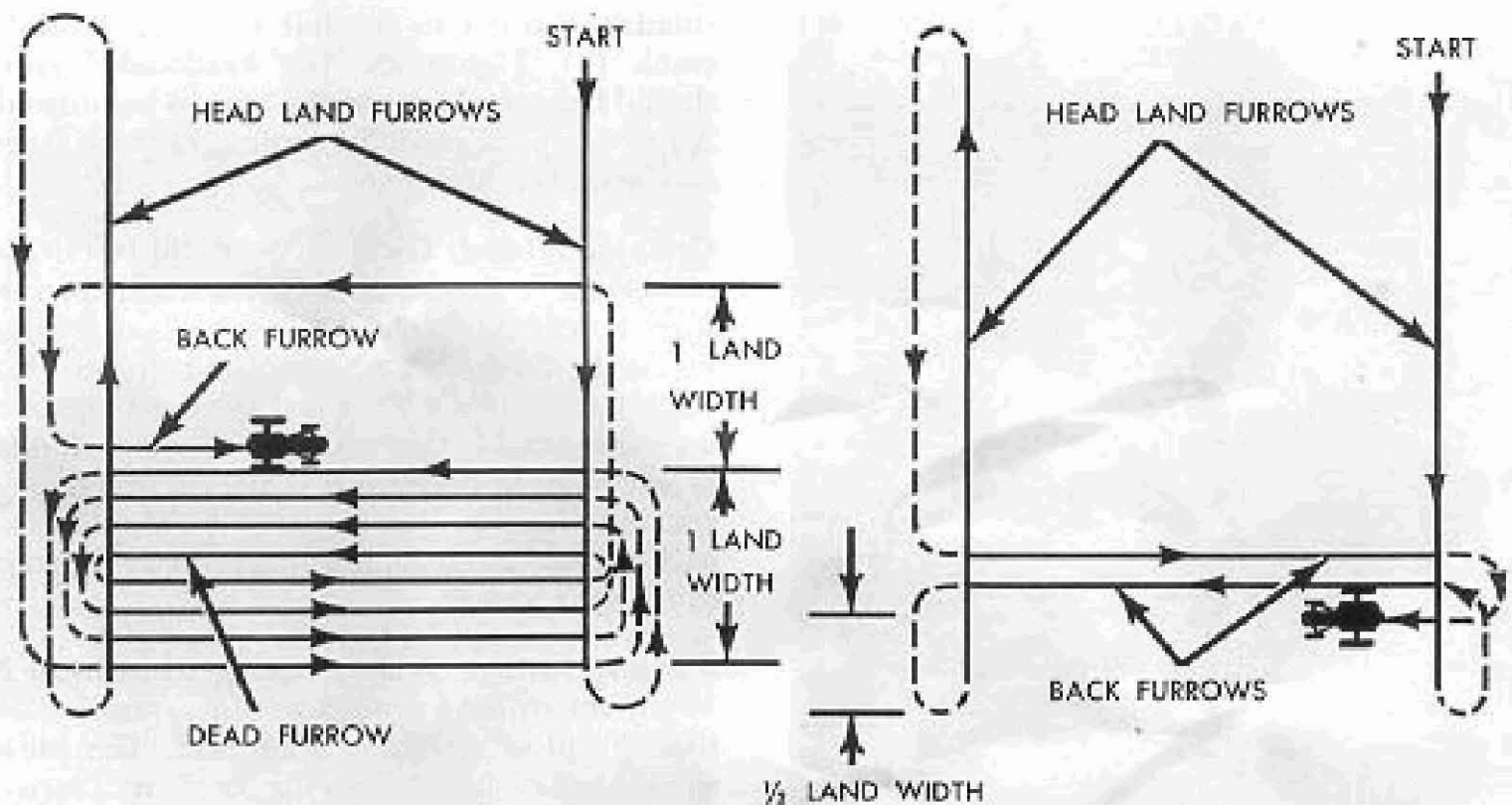
FIELD ADJUSTMENTS

Width of Cut: To adjust the plow frame for width of cut loosen and tighten the hex nuts on the adjusting arm as shown in the insert "B", Figure 25. This adjustment of the arm slides the drawbar laterally in the "A" frame.

To decrease the width of cut, loosen the outside nut and tighten the inside nut. To increase the width of cut, loosen the inside nut and tighten the outside nut.

Moving the drawbar $\frac{1}{4}$ inch laterally changes the width of cut about one inch. One rotation of the adjusting nuts changes the width of cut about $\frac{1}{4}$ inch. This adjustment does not affect the pitch of the plow.

Side Tilt: The plow side tilt is adjusted by turning the leveling crank (4), Figure 25, which raises or lowers the tractor right hand lift link (5). This adjustment is necessary to level the plow and to set the plow at an angle when finishing a land, striking out a land, making a scratch furrow, or in forming terraces. Under



Classic Manuals © Scan

Figure 26

Two Methods of Opening a Field to Be Plowed by Lands

conditions, tilting the wing of the plow up will increase penetration.

Bottom Pitch: For normal conditions the top link (3), Figure 25, should be set at its shortest length. In certain soil conditions it may be lengthened to obtain the desired pitch of the bottoms, however, the plow must be leveled.

Rolling Landside: To adjust the rolling landside (1), Figure 25, loosen the two plow bolts which attach it to the sliding landside. Turn the adjusting bolt until the rolling landside is not more than $\frac{1}{2}$ inch below the lower edge of the sliding landside and secure with the locknut. Tighten the nuts on the plow bolts securely.

Coulters: Normally, the rolling coulters should be set approximately $1\frac{1}{4}$ inches above the nearest point of the plow bottom. Set the coulters just deep enough to cut the trash. Notched coulters blades are sold separately and are recommended for plowing in trashy and stony ground. The horizontal setting of the coulters blade is usually

about $\frac{3}{4}$ inch to the left of the moldboard shin. Loosen the nut (2), Figure 25, and set the coulters stem with a plow wrench as shown in the insert "A", Figure 25. Tighten the eye bolt nut (2) securely.

Exact coulters settings vary greatly with soil conditions. The proper setting for a given field can be determined by the adjustment which produces a sharp, clean, vertical furrow wall.

Coulters Bearings: The coulters have cone type bearings with white iron male outer cones and chilled grey iron inner mating cones. Adjust the nut on the bolt (7), Figure 25, to take up excess play and secure with locknut.

Jointer: The jointer (6), Figure 25, should be set with the point lightly touching the coulters blade. Jointers should be set to cut from one to three inches deep for better trash coverage. To adjust, loosen the set screw on the jointer arm collar as shown in the insert "C", Figure 25.



Figure 27

Opening a Land

PLOWING PROCEDURES

Good plowing is an art in which most farmers take great pride. Many have developed methods to meet their own needs. The following paragraphs cover some of the common terminology used, together with an explanation of some accepted plowing methods.

PLOWING BY LANDS

Plowing by lands is a method whereby the field is plowed in sections or strips. The following operations are performed when plowing by lands. Figure 26 shows a procedure for laying out the field.

Headland Furrows: Headland furrows should be marked out when opening up a field. This is a big aid in securing a uniform plowing job.

When making headland furrows, the plow should be tilted to the left with the leveling crank (4), Figure 25. The headland furrow should be turned toward the area to be plowed. Allow adequate room for turning between fence and headland furrows.

Opening a Land: Tilt the plow to the left in the same manner as when plowing a headland furrow. Lower the plow into the soil and drive across the field. Picking two points, one at the opposite end of the field and a second between the tractor and in line with the first, and driving in line with the two points is helpful in plowing a straight furrow. (See Figure 27.) Complete the back furrow and then level the plow at the start of the next round.

Entering Furrow: When entering a furrow, it is important to have the tractor in a position so that the plow will take a full cut. The plow should be lowered by moving the Ford Tractor Hydraulic Touch Control Lever forward as the rear wheels cross the headland furrow. Drive with the right front wheel of the tractor close to the furrow wall to insure the proper width of cut.

Leaving Furrow: After finishing a furrow when the rear wheels cross the headland furrow, raise the plow by returning the Ford Tractor Hydraulic Touch Control Lever to the top of the quadrant. The turn should not be started until the plow is clear.

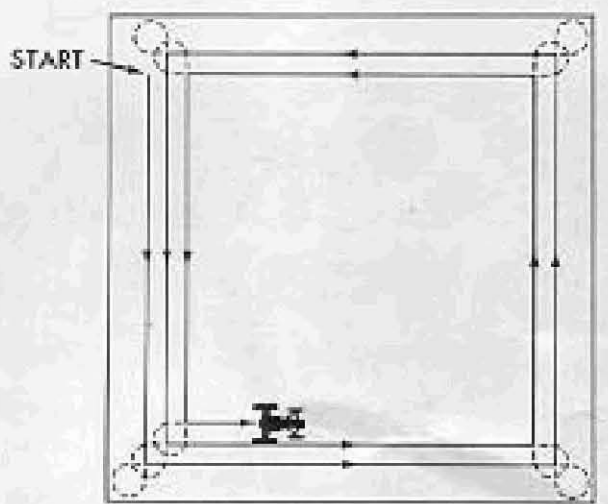
Finishing a Land: When the unfinished land is narrower than the tractor tread, level the plow with the leveling crank. The left front wheel should be driven near the furrow wall as shown in A and B, Figure 28. This will leave a narrow strip which may be neatly finished on the return trip by steering the right front wheel near the furrow wall. (See C and D, Figure 28). Re-level the plow as needed.

Finishing Out Field: Headlands are plowed after the lands have been plowed. Place the plow in working position and plow along the headland furrow, turning the soil toward the plowed ground. Repeat this operation until the headlands are plowed.

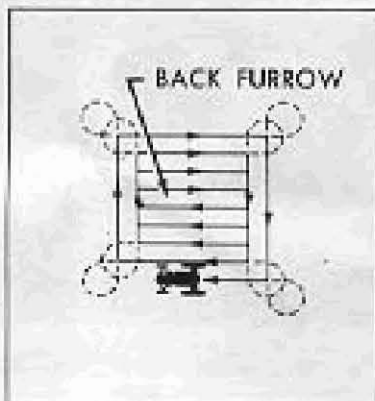


Figure 28

Finishing a Land



A—DEAD FURROW IN CENTER OF FIELD



B—BACK FURROW IN CENTER OF FIELD

Figure 29

*Rectangular Plowing***RECTANGULAR PLOWING**

To leave the dead furrow in the center of the field, an opening furrow is plowed around the field. Continue following this furrow until the area is plowed (See diagram A, Figure 29). One disadvantage of this method is that turns must be made on the plowed ground.

To plow from the center of the field, the first step is to make a short back furrow in the center of the field (see diagram B, Figure 29). Plow along this back furrow until the area is large enough to plow around the rectangle. Turns in this method are made on unplowed ground.

CONTOUR PLOWING

Many farmers prefer to plow on the contour for soil conservation reasons. When plowing ter-

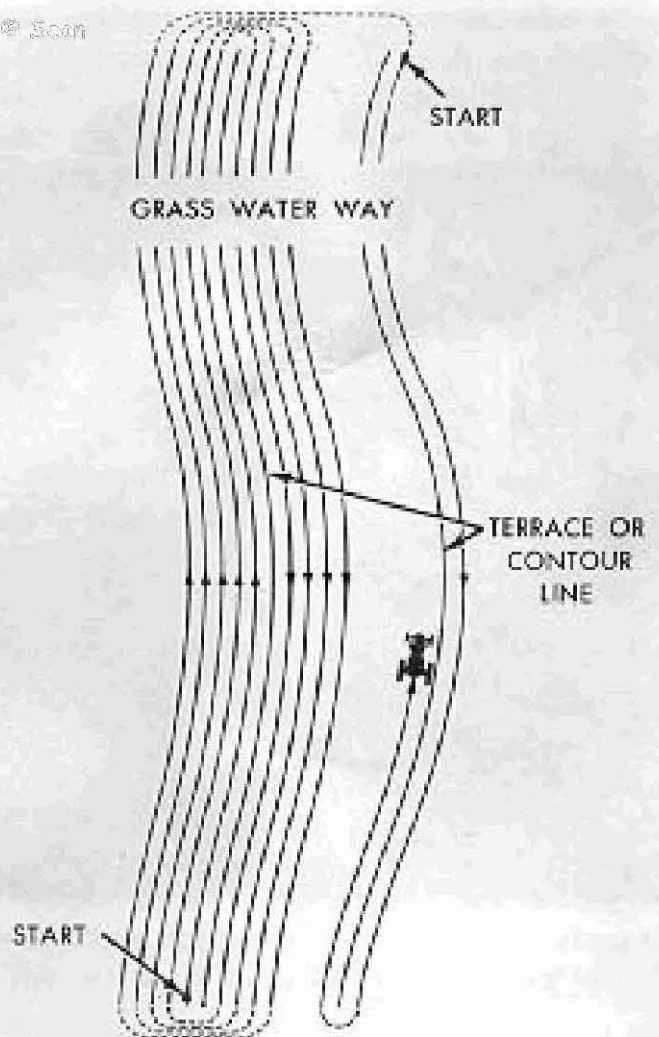


Figure 30

Contour Plowing Terraced Land

aced land, it is possible, during seedbed preparation, to turn the soil in such a manner as to build up the terrace crown (see Figures 30 and 31). The short coupled, maneuverable Ford Tractor with the Dearborn Economy plow is exceptionally well-suited for contour plowing. The Ford Tractor Hydraulic Touch Control eliminates lever tugging when crossing grassed waterways.

MAINTENANCE

1. Lubricate the two coulter bearing fittings and the rolling landside fitting daily with a good grade of pressure gun grease.
2. Keep the plow bottoms equipped with sharp shares.
3. Keep all nuts and bolts tightened securely.



Figure 31

Classic Manuals © Scam

Contour Plowing

4. Use touch-up paint where necessary on painted surfaces to prevent rust and maintain appearance of the implement.
5. After each days' operation cover all ground engaging parts with oil or other rust preventive.
6. Store the plow in a clean dry place between operating seasons and coat all ground engaging surfaces with a good rust preventive.
7. Your Ford Tractor and Dearborn Farm Equipment dealer carries genuine Ford Tractor and Dearborn Farm Equipment replacement parts. These parts are manufactured and inspected to assure high quality and accurate

fit. Insist on genuine Ford Tractor and Dearborn Farm Equipment replacement parts.

SAFETY PROCEDURE

Most farm implement accidents can be prevented by following these simple precautions:

1. Do not permit anyone to ride on the tractor with the operator.
2. Always lower the implement to the ground and turn off the engine when leaving the tractor.
3. Keep all nuts and bolts tightened securely.
4. Keep the tractor keys where they are not available to children.

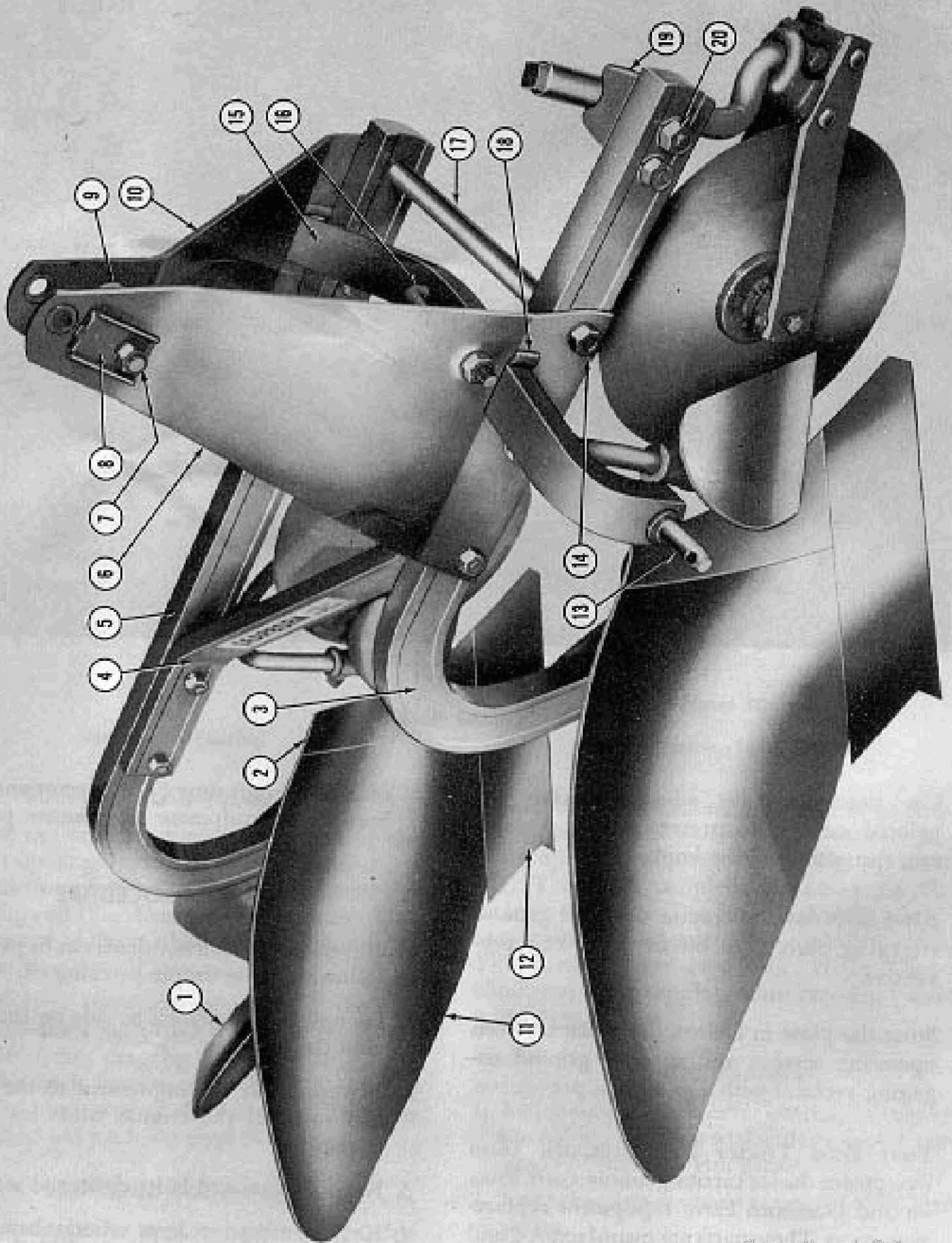
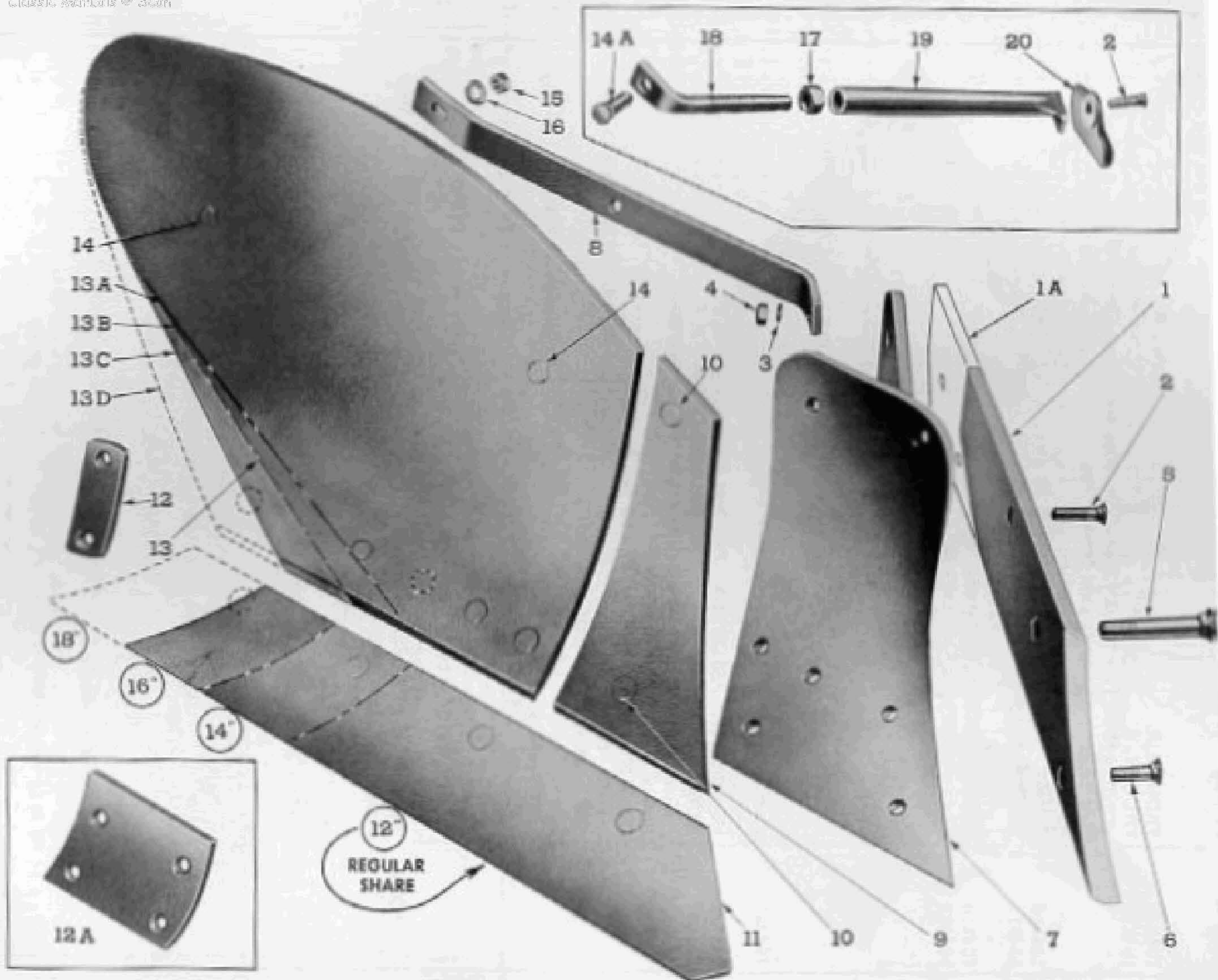
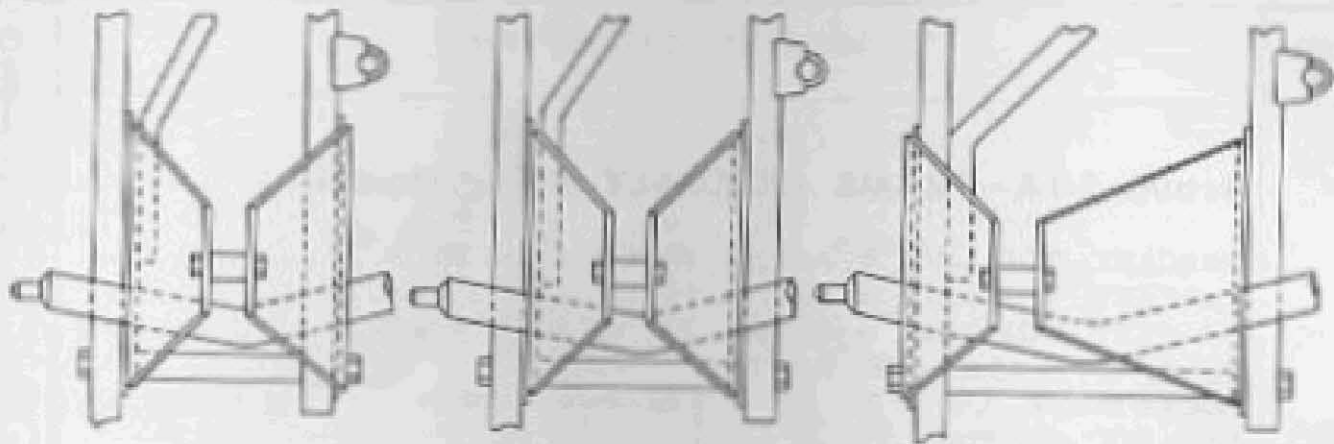


Figure 32

SERVICE PARTS

KEY	PART NO.	NAME AND DESCRIPTION	REQ.
6	104371	Bracket, Top Link, R.H. "A" Frame	1
10	104372	Bracket, Top Link, L.H. "A" Frame (for 10" or 12" frames)	1
10	104373	Bracket, Top Link, L.H. "A" Frame (for 14" or 16" frames)	1
9	104376	Spacer, Top Link Bracket	1
8	103029	Locator, Linch Pin	1
7	300624	Bolt 5/8"-18 x 3 1/4" Hex. Hd.	1
17	105144	Spacer, Tie Rod (for 10" frames)	1
17	105143	Spacer, Tie Rod (for 12" frames)	1
17	104304	Spacer, Tie Rod (for 14" frames)	1
17	105145	Spacer, Tie Rod (for 16" frames)	1
14	105100	Tie Rod (for 10" frames)	1
14	105102	Tie Rod (for 12" frames)	1
14	105104	Tie Rod (for 14" frames)	1
14	105106	Tie Rod (for 16" frames)	1
15	104375	Shaft, Cross (w/pin at left end only)	1
13	104383	Pin, Link	1
16	104310	Arm, Adjusting	1
18	104344	Snubber, Cross Shaft and Bracket	2
3	104302	Beam, Short	
5	104301	Beam, Long	
4	105091	Brace, Beam (for 10" frames)	1
4	105092	Brace, Beam (for 12" frames)	1
4	104331	Brace, Beam (for 14" frames)	1
4	104333	Brace, Beam (for 16" frames)	1
19	104313	Seat, Coultter Stem	2
20	104306	Eyebolt, Coultter Stem	2
	104356	Landside, Front Bottom (Short)	1
	104355	Landside, Rear Bottom (Long)	1
	104401	Frog	2
	104407	Brace, Moldboard to Beam	2
2	104428	Shin Assembly w/bolts and nuts	2
12	105325	Share Assembly 12" Regular	2
12	105326	Share Assembly 14" Regular or 12" Long	2
12	105327	Share Assembly 16" Regular or 14" Long	2
12	105328	Share Assembly 16" Long	2
11	104424	Moldboard Assy. 12"	2
11	104425	Moldboard Assy. 14"	2
11	104426	Moldboard Assy. 16"	2
1	103000	Landside Assy., Rolling	1
		Model 10-179 Economy Frame Assy. 10"	
		Model 10-180 Economy Frame Assy. 12"	
		Model 10-181 Economy Frame Assy. 14"	
		Model 10-182 Economy Frame Assy. 16"	
		Model 10-174 Coultter Assy. (15 1/2" Plain Disc)	
		Model 10-175 Coultter Assy. (15 1/2" Notched Disc)	
		Model 10-176 Coultter Assy. (18" Plain Disc)	
		Model 10-177 Coultter Assy. (18" Notched Disc)	
		Model 10-178 Jointer Assy. (for 15 1/2" or 18" Plain or Notched Discs)	
		Model 10-164 Economy Bottom Assy. 12" Front	
		Model 10-165 Economy Bottom Assy. 12" Rear	
		Model 10-166 Economy Bottom Assy. 14" Front	
		Model 10-167 Economy Bottom Assy. 14" Rear	
		Model 10-168 Economy Combination Bottom Assy. 14" Front	
		Model 10-169 Economy Bottom Assy. 14" Rear	
		Model 10-172 Economy Bottom Assy. 16" Front	
		Model 10-173 Economy Bottom Assy. 16" Rear	





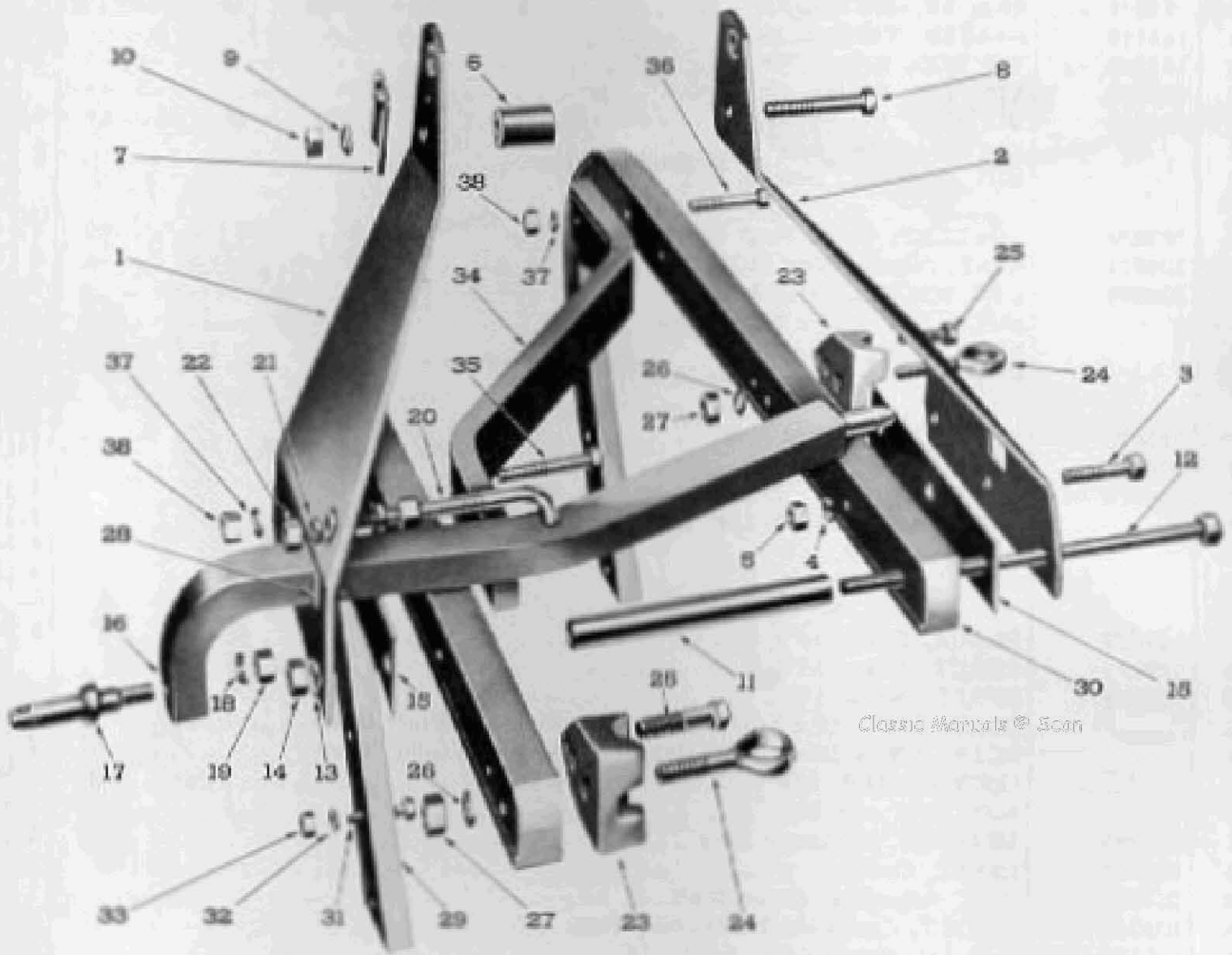
10"

12"

16"

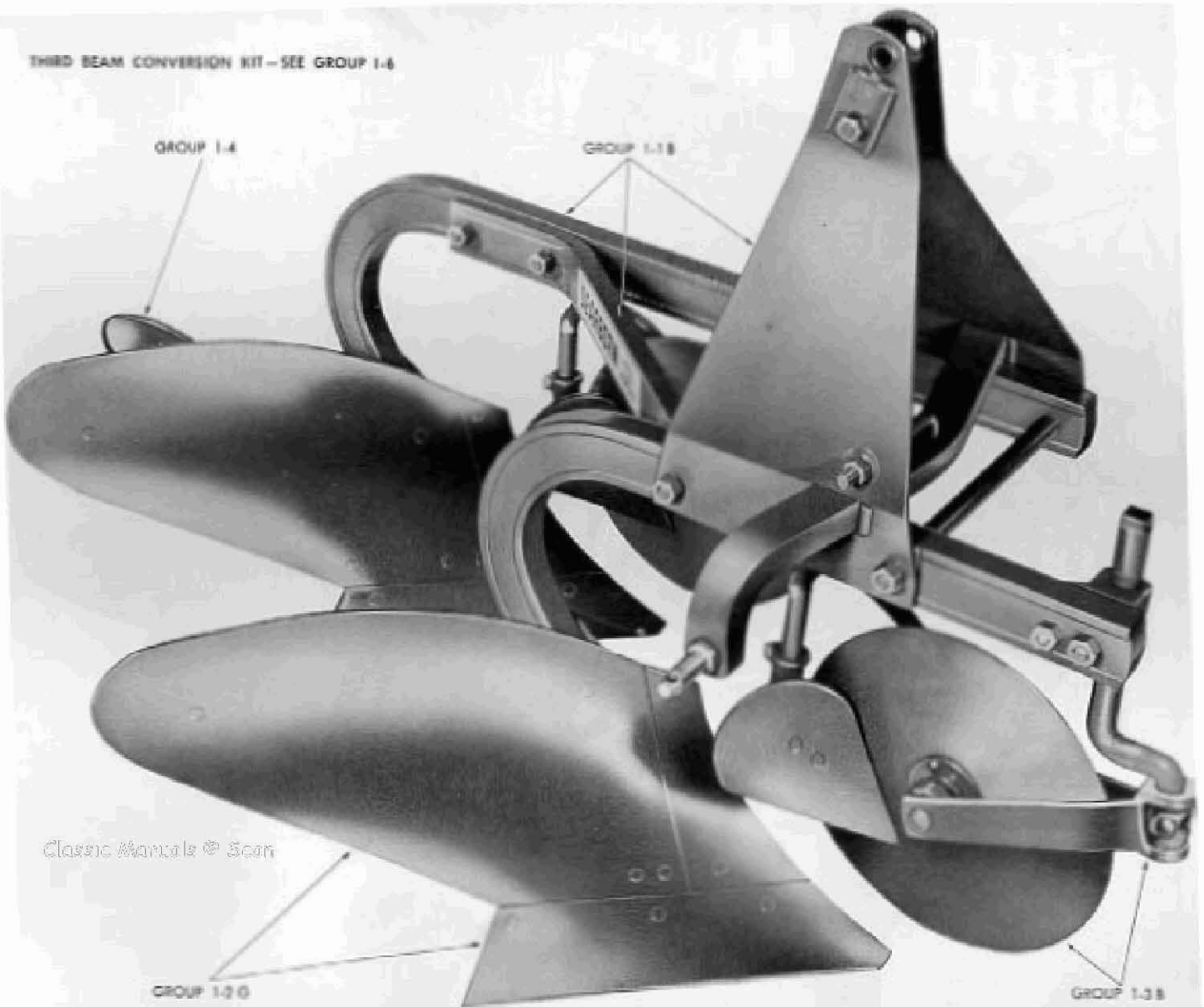


14"



Classic Manuals © Scan

THIRD BEAM CONVERSION KIT - SEE GROUP 1-4



Classic Mancolex © Scan

Figure 2 - Dearborn Economy Plow, Double Bottom

FIG. 18	PART NO.	NAME AND DESCRIPTION	QTY. REQ.										
			For Economy Plow				For Two-Way Plow						
			12"	14"	16"	18"	16"	18"	L.H.	R.H.			
		Group 1-2G—ECONOMY BOTTOM											
		Models											
		Quantity Shown Per One Bottom											
		10-164 BOTTOM ASSY., 12" Front	1										
		10-165 BOTTOM ASSY., 12" Rear	1										
		10-166 BOTTOM ASSY., 14" Front		1									
		10-167 BOTTOM ASSY., 14" Rear		1									
		10-168 BOTTOM ASSY., 14" Front (Note A)		1									
		10-169 BOTTOM ASSY., 14" Rear (Note A)		1									
		10-172 BOTTOM ASSY., 16" Front			1								
		10-173 BOTTOM ASSY., 16" Rear			1								
		10-180 BOTTOM ASSY., 18" Rear				1							
		10-194 BOTTOM ASSY., 16" L.H.					1						
		10-195 BOTTOM ASSY., 16" R.H.						1					
		10-196 BOTTOM ASSY., 18" L.H.							1				
		10-197 BOTTOM ASSY., 18" R.H.								1			
1	104356	LANDSIDE, Front Bottom (Short)	1	1	1								
1A	104355	LANDSIDE, Rear Bottom (Long)	1	1	1	1							
1A	105054	LANDSIDE, R.H. (Long)						1				1	
-	105078	LANDSIDE, L.H. (Long)						1			1		
2	104463	BOLT, 7/16" - 20 x 1-3/4" Flat Hd. Sq. Nk.											
		L'side to Frog to Br.	1	1	1	1	1	1	1	1	1	1	1
3		LOCKWASHER, 7/16" L'side to Heel to Br.								1	1	1	1
4		NUT, 7/16" - 20 Hex.											
5		BOLT, 5/8" - 18 x 3-1/4" Flat Hd. Sq. Nk.											
		L'side to Frog to Beam.	1	1	1	1	1	1	1	1	1	1	1
-		LOCKWASHER, 5/8" L'side to Rolling L'side											
-		NUT, 5/8" - 18 Hex. (Rear Bottom only)	2	2	2	2							
6		BOLT, 7/16" - 20 x 1-1/4" Flat Hd. Sq. Nk.											
		Landside to Frog	1	1	1	1	1	1	1	1	1	1	1
-		NUT, 7/16" - 20 Hex.											
7	104401	FROG	1	1	1	1		1			1		
-	105077	FROG, L.H.						1			1		
8	104407	BRACE, Moldboard	1	1	1	1		1			1		
-	105079	BRACE, Moldboard, L.H.						1			1		
9	104428	SHIN ASSEMBLY	1	1	1	1		1			1		
-	105063	SHIN ASSEMBLY, L.H. Consists of Shin which is not serviced separately plus items listed below:						1			1		
10		BOLT, 7/16" - 20 x 1-1/4" Flat Hd. Sq. Nk.											
--		NUT, 7/16" - 20 Hex. Shin to Frog	2	2	2	2	2	2	2	2	2	2	2
11		SHARE ASSEMBLY, (Includes Fixed Bolts and Nuts) (Note B)	1	1	1	1	1	1	1	1	1	1	1
12	104406	PLATE, Moldboard to Share		1	1			1	1				
12	104444	PLATE, Moldboard to Share (Used on 14" Bottom w/a 12" Moldboard).		1									
12A	104417	PLATE, Moldboard to Share				1				1	1		
13A	104424	MOLDBOARD ASSEMBLY	1										
13B	104425	MOLDBOARD ASSEMBLY, (Note A)		1									
13C	104426	MOLDBOARD ASSEMBLY			1			1					
13D	104427	MOLDBOARD ASSEMBLY				1						1	
--	105064	MOLDBOARD ASSEMBLY, L.H.						1					

FIG. 18	PART NO.	NAME AND DESCRIPTION	QTY. REQ.							
			For Economy Plow				For Two-Way Plow			
			12"	14"	16"	18"	16"		18"	
				LH	RH	LH	RH			
		Group 1-2G—ECONOMY BOTTOM (Cont'd)								
--	105065	MOLDBOARD ASSEMBLY, L.H. Consists of Moldboard which is not serviced separately plus items listed below:							1	
14		BOLT, 7/16" - 20 x 1-1/4" } Moldboard to Frog Flat Hd. Sq. Nk. } & Brace	4	4	4	4	3	3	3	
15		NUT, 7/16" - 20 Hex. } Moldboard to Plate		1	1	2	1	1	2	
14A		BOLT, 7/16" - 20 x 1-3/4" } Flat Hd. Sq. Nk. } Moldboard to Brace					1	1	1	
16		WASHER, 1/2" Flat }	1	1	1	1	1	1	1	
17	105057	BRACE, Landside (Pipe)					1	1	1	
18	105058	BRACE, Landside (Bar)					1	1	1	
19	8N-1134	NUT, 5/8" - 18 Hex. - Bar to Pipe Brace					1	1	1	
20	105059	HEEL, R.H.						1	1	
--	105060	HEEL, L.H.					1		1	
<p>NOTE: "A" Models 10-168 or 10-169 are economy <u>Combination Bottoms</u> 14", and have 12" Economy Bottom Moldboards.</p> <p>"B" Standard and additional service shares to be found on Share Reference List.</p> <p>When installing an Economy Bottom on a Moldboard Type Plow (Prior Model) Frame it is necessary to replace the bolts attaching the bottom to the Beam as follows:</p> <p>Page 40, Item 5 -- Replace with: BOLT, 5/8" - 18 x 2-1/2" Flat Hd. Sq. Nk.</p> <p>Page 27, Item 22 & 23 -- Replace with: BOLT, 5/8" - 18 x 2-5/8" Button Hd. Fl. Side</p>										



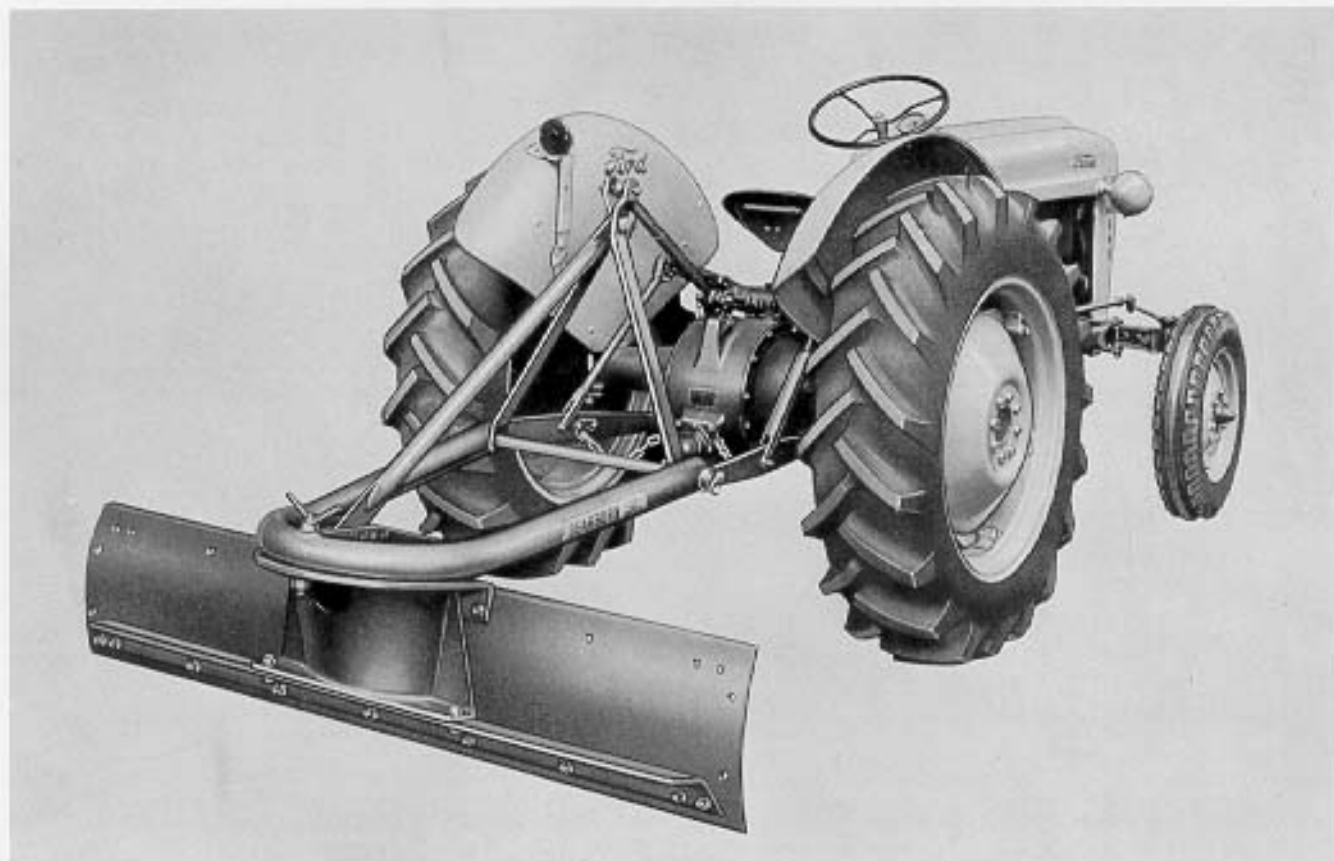
DEARBORN

ECONOMY BLADE



MODEL 19-72

ASSEMBLY AND OPERATING INSTRUCTIONS



The Dearborn Economy Blade is a sturdy, lightweight implement. It is rear mounted on the tractor three point linkage and controlled by the Ford Tractor Hydraulic System. The frame assembly is of one piece tubular steel construction, designed for long, dependable service.

The blade is well adapted to jobs that require scraping, cutting or leveling. This implement may be used for terracing, building and maintaining roads and ditches, for drainage and irrigation, for back filling work and for cleaning feeding lots or barn yards. By reversing the blade, it can be used effectively for back filling erosion gullies or ditches. Being a compact mounted implement makes it extremely well suited for

use in relatively small working areas. When equipped with end plates, the implement becomes an excellent tool for snow removal.

The moldboard of the Economy Blade may be set in five different angle positions as well as fully reversed for back filling operation. Pitch is easily controlled by a four position pitch control bar.

Side Plates, Part No. 194776, and a Ditching Point, Part No. 194775, are available at your Ford Tractor and Implement Dealer and add to the versatility of this implement.

This manual contains information on the Assembly and Operation of your Dearborn Economy Blade. Read it carefully and keep it available for ready reference.

TRACTOR AND IMPLEMENT DIVISION

Ford Motor Company

BIRMINGHAM, MICHIGAN

ECONOMY BLADE

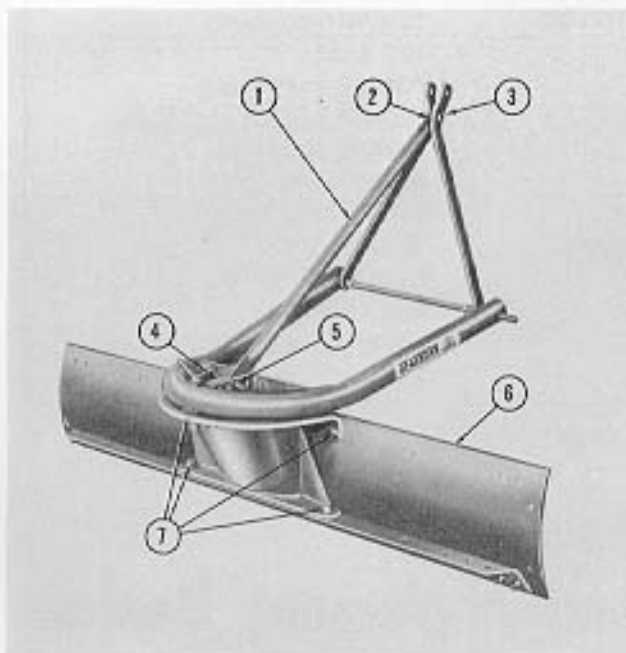


Figure 2

Dearborn Economy Blade Assembled

1. Back the tractor into position.
2. Attach the right and left lower links and secure with the linch pins.
3. Attach the tractor top link to the lower hole in the three hole rocker assembly. Secure the link to the blade "A" frame with the linch pins.
4. To detach the blade from the tractor, reverse the above procedure.

ADJUSTMENTS

Depth of Cut: The depth of cut is controlled by the Ford Tractor Hydraulic Touch Control. The hydraulic system should be operated in Implement Position Control.

Blade Pitch: The pitch of the moldboard may be changed by moving the adjusting pin (5), Figure 2, to any of the four positions (holes) in the adjustment bracket (4).

Angle of the Blade: The blade angle may be changed by removing the turntable wing bolt (1) Figure 3, and turning the blade to any one of the six desired positions.

Offsetting the Blade: The Dearborn Economy Blade is so designed that the blade may be offset in four positions. There are two positions left and two positions right of center. To offset the blade, remove the four bolts (2), Figure 3, and slide the blade to the desired position. Replace the respective bolts, nuts and lockwashers as shown.

Reversing the Blade: When the ground engaging edge of the blade becomes worn, the blade may be reversed to obtain a new cutting edge.

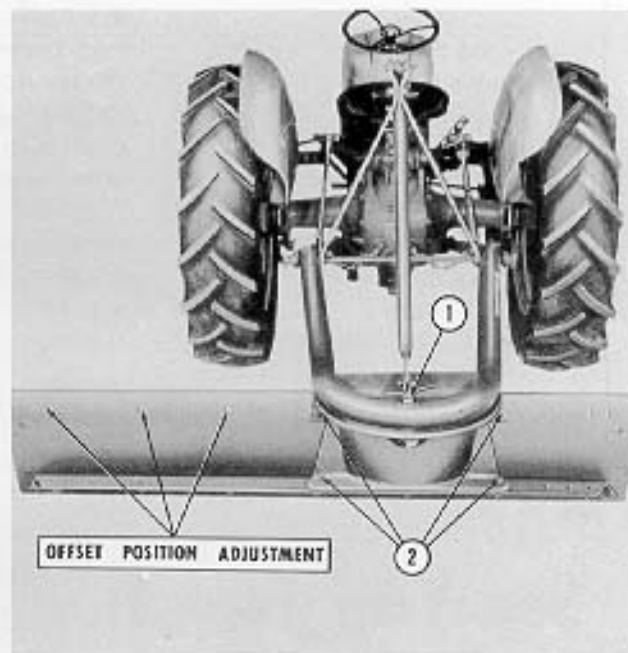


Figure 3

Dearborn Economy Blade Attached to the Tractor

ATTACHMENTS

Ditching Point: The Ditching Point, Part No. 194775, is mounted on the left end of the blade, as follows:

1. Position the point as shown in Figure 4 (See Insert).
2. Insert the plow bolt (1) and hex head bolt (2), Figure 4, and secure with the lockwashers and nuts provided.

Side Plates: The Side Plates, Part No. 194776, are attached as shown in Figure 4. Secure with the bolts, lockwashers and nuts provided.

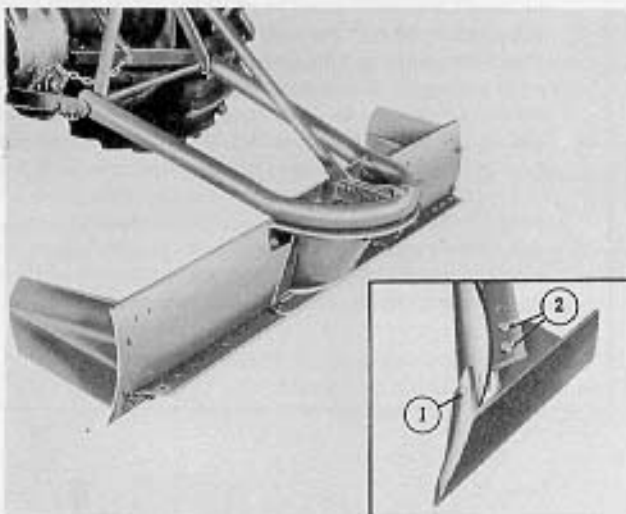


Figure 4

Dearborn Economy Blade Attachments

ECONOMY BLADE

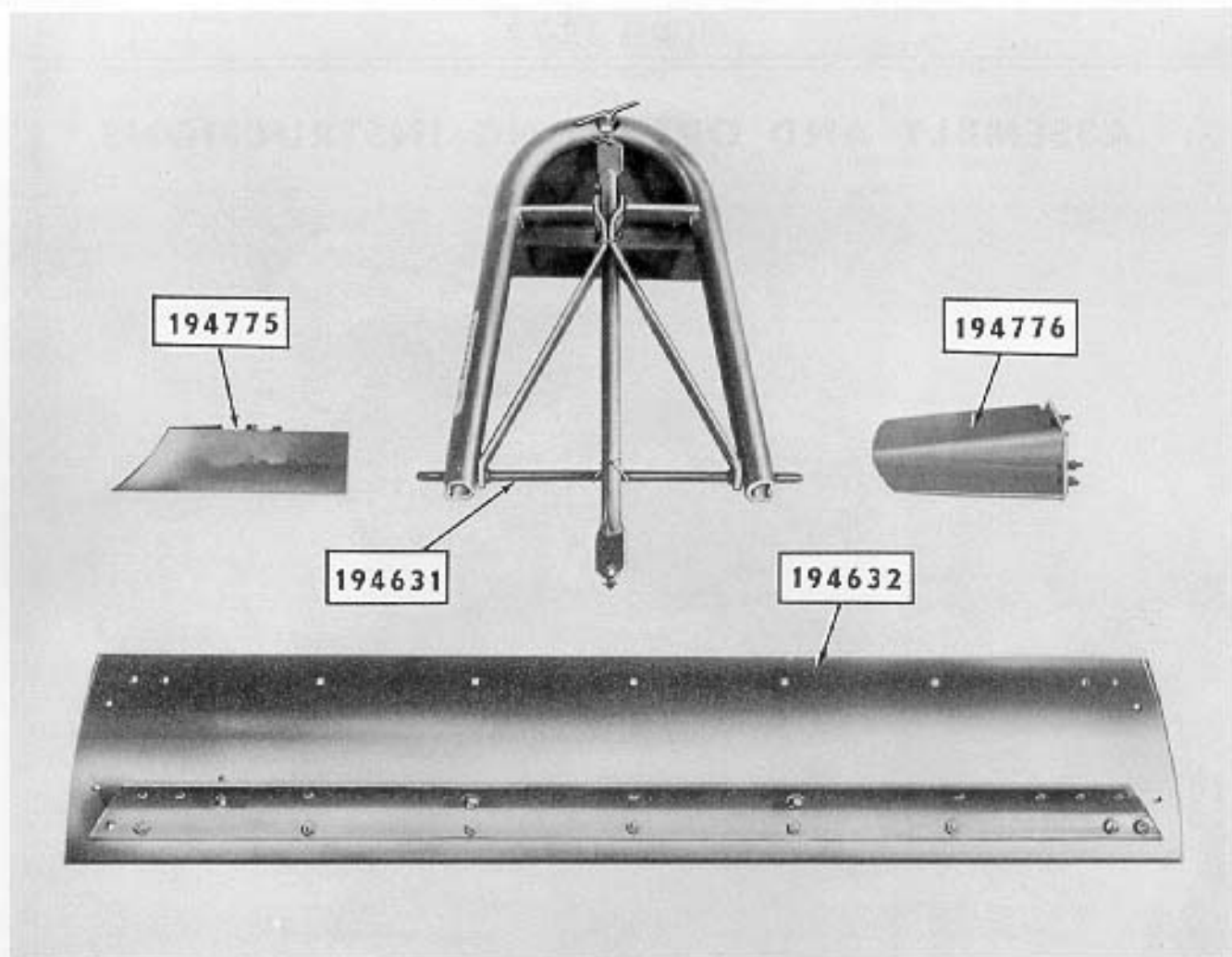


Figure 1
Dearborn Economy Blade Bundled for Shipment

SHIPPING INFORMATION

The Dearborn Economy Blade, Model 19-72, is shipped in two bundles. The attachments are bundled separately as shown in Figure 1. Check the shipment against the following list and Figure 1, to be sure all parts are received.

Bundle No.	Description	Required
194631	Frame and Turntable Assembly . . .	1
194632	Moldboard and Angle Reinforcing Assembly	1
194775	Ditching Point	1
194776	Side Plates (2)	1

NOTE: All nuts and bolts are in their respective positions when the implement is shipped to facilitate assembly.

ASSEMBLY PROCEDURE

NOTE: The assembly of the Dearborn Economy Blade is the responsibility of your Ford Tractor and Imple-

ment Dealer. The implement should be delivered completely assembled. The following instructions are provided in case of need.

1. Cut the wires from the frame and turntable assembly and remove the pitch bar. Lay out all parts.
2. Position the pitch bar (1), Figure 2 as shown, and secure it to the "A" frame (2) with the $\frac{5}{8}$ " x 2" bolt, nut and lockwasher (3) provided.
3. Connect the lower end of the pitch bar to the adjustment slot (4), Figure 2, and secure the $\frac{5}{8}$ " x $1\frac{3}{4}$ " adjustment pin (5) and cotter pin.
4. Position the moldboard assembly (6), Figure 2, as shown and secure it to the frame assembly with the two $\frac{3}{8}$ " x $1\frac{1}{2}$ " hex head bolts, and the two $1\frac{1}{2}$ " x $1\frac{1}{2}$ " plow bolts, lockwashers and nuts (7) provided.

ATTACHING

Attach the Dearborn Economy Blade to the tractor as follows: