

GOPHER FAMILY SELF ROTARY SWIVELS USER MANUAL



GO-MP9
22K (1500 bar)



GO-H9-C
40K (2800 bar)

TABLE OF CONTENTS

MANUFACTURER'S INFORMATION	3
SPECIFICATIONS FOR ALL MODELS	3
KEY FEATURES FOR ALL MODELS	3
TOOL DESCRIPTION AND INTENDED USE	3
WARNING AND SAFETY INSTRUCTIONS	4
22K (1500 bar) GO-MP9	5
HEAD AND NOZZLE CONFIGURATIONS	5
OPERATION	6
TROUBLESHOOTING	7
TOOL SERVICE INFORMATION	8
FLUID REPLACEMENT	8
HIGH PRESSURE SEAL REPLACEMENT	9
DISASSEMBLY	10
ASSEMBLY	13
PART NAMES/NUMBERS	19
SERVICE KITS	19
40K (2800 bar) GO-H9-C	20
HEAD AND NOZZLE CONFIGURATIONS	20
OPERATION	21
TROUBLESHOOTING	22
TOOL SERVICE INFORMATION	23
FLUID REPLACEMENT	23
HIGH PRESSURE SEAL REPLACEMENT	24
DISASSEMBLY	25
ASSEMBLY	28
PART NAMES/NUMBERS	33
SERVICE KITS	33
GOPHER ACCESSORIES	34
TERMS AND CONDITIONS AND WARRANTY	36

This manual must be used in accordance with all applicable national laws. The manual shall be regarded as a part of the machine and shall be kept for reference until the final dismantling of the machine, as defined by applicable national law(s). Updated manuals can be downloaded at:

<https://www.stoneagetools.com/manuals>

StoneAge Inc.
466 S. Skylane Drive
Durango, CO 81303, USA
Phone: 970-259-2869
Toll Free: 866-795-1586
www.stoneagetools.com

StoneAge Europe
Unit 2, Britannia Business Centre
Britannia Way
Malvern WR14 1GZ
United Kingdom
Phone: +44 (0) 1684 892065

Gopher Model Specifications		
Model	GO-MP9	GO-H9-C
Pressure Range	2–22k psi (140–1500 bar)	22k–40k psi (1500–2800 bar)
Flow Range	8–25 gpm (30–95 l/min)	4–10 gpm (15–40 l/min)
Flow Coefficient	0.84 Cv	0.30 Cv
Rotation Speed	600–1000 rpm	600–1000 rpm
Inlet Connection	9/16 MP	9/16 HP
Port Size	1/8 NPT (P2)	1/4-28 UNF (S4)
Nozzle Type	AP2	OS4
Port Plug	GP 025-P2SS	OS4 002
Swivel Diameter	1.6 in. (42 mm)	1.6 in. (42 mm)
Swivel Length	7.8 in. (200 mm)	7.8 in. (200 mm)
Swivel Weight	2.3 lb (1.0 kg)	2.6 lb (1.2 kg)
Head Weight	0.60–0.75 lb (0.27–0.34 kg)	0.60–0.75 lb (0.27–0.34 kg)
Maximum Water Temperature	160 °F (70 °C)	160 °F (70 °C)

DESCRIPTION OF EQUIPMENT AND INTENDED USE

- The **Gopher MP9** and **H9-C** are self-rotating swivels designed for large tube and small pipe cleaning. They both have an outside diameter of 1.62 inches (42mm).
- The **MP9** can be used at operating pressures from 2,000 to 22,000 psi (140 to 1500 bar) and flow rates from 8 to 25 gpm (30–95 l/min).
- The **H9-C** can be used at operating pressures up to 40,000 psi (2800 bar) and flow rates from 4 to 10 gpm (15–40 l/min).
- Both tools have a 9/16 pressure cone seal and threaded female inlets.
- The **MP9** can be supplied with inlet adapter fittings for 1/2 or 3/8 NPT female pipe thread.
- The **H9-C** comes with an easily replaced High Pressure Seal Cartridge assembly.

FEATURES

- The swivels are filled with 10W-40 for lubrication; it also affects rotation speed.
- Self-rotary, speed controlled - Rotary tools provide complete internal coverage while speed control provides optimum jet delivery
- Two head options - 7-port unplugging option for maximum forward hitting power and a 6-port polishing head for IRIS inspection polishing
- Multiple jetting configurations - Same tool can be re-jetted to match a wide variety of cleaning applications — great for when you need more pulling force or forward hitting power

WARNING AND SAFETY INSTRUCTIONS

⚠️ WARNING

Gopher Models can turn around in large pipes and come back at the operator at a high rate of speed. If cleaning larger pipes, a rigid “stinger” should be used between the hose and the tool. It is recommended that the rigid length of the tool including hose end is 1-1/2 times the inside diameter of the pipe being cleaned (see below).

Make sure there is an operator controlled dump in the system, operated by the person closest to the cleaning job. Flush out the high pressure hoses before connecting the Gopher. It is recommended that the hose be marked a few feet from the end with a piece of tape so the operator knows when to stop when retracting the tool. Position the tool in the pipe opening. Close the dump and slowly bring up to pressure the first time to make sure no nozzles are plugged and the jet thrust is correct. The Gopher should begin to slowly rotate. Once operating pressure is reached, feed the tool into the pipe to begin the cleaning job. Allow the jets time to do their work by feeding the hose out at a controlled rate. The StoneAge ABX-500 Hose Control Device can be used to achieve consistent feed rates for pipe cleaning. When the work is complete and the tool is disconnected from the hose, blow out all water to prolong the life of the tool. A small amount of lubricant can be blown into the tool as well as an added measure to maximize tool life.

It is strongly recommended to use a backout prevention device. Please see the “Accessories” section of this manual for a list of backout preventers available through StoneAge Tools.

⚠️ DANGER

Operations with this equipment can be potentially hazardous. Caution must be exercised prior to and during machine and water jet tool use. Please read and follow all of these instructions, in addition to the guidelines in the WJTA Recommended Practices handbook, available online at www.wjta.org.

Deviating from safety instructions and recommended practices can lead to severe injury and/or death.



IMPROPER USE:
Gopher will turn around in large diameter pipe
VERY DANGEROUS!

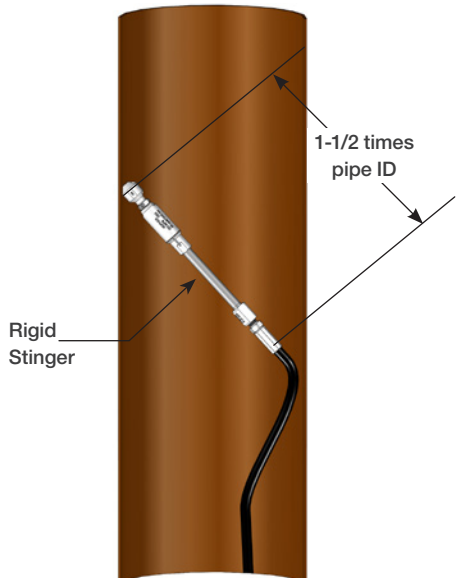

PROPER USE:
Gopher with rigid “stinger” to prevent turnaround.

22K PSI (1500 BAR) GOPHER HEAD CONFIGURATIONS

HEAD SELECTION FOR 22K PSI (1500 bar) GOPHER HEAD:

There are two standard head configurations for the MP9 Gopher tools; both have 1/8" NPT pipe threads for AP2 nozzles. The GO 042 Polisher Head is intended for removing scale. The GO 043 Unplugging Head is intended for use in plugged tubes. The head offset is what makes the head rotate and is stamped on each head. (See the chart below). If less flow is used than the range shown, the swivel will not rotate. If more flow is used than shown in the range, the tool will rotate too fast, damaging the bearings, speed control and accelerating the wear rate of the high pressure seal. Consult the table for the correct flow range for each head offset. Custom heads are available on request.

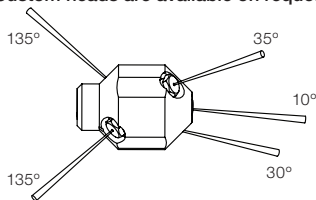

GO 043 UNPLUGGER

5 Ports:

1 @ 10°, 1 @ 30°, 1 @ 35°, 2 @ 135°

The correct head specification is based on the swivel, pressure, and flow of the pump.

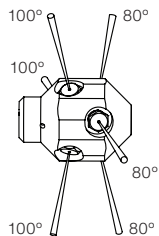

GO 042 POLISHER

6 Ports:

3 @ 80°, 3 @ 100°

Swivel	Pressure	Flow		Unplugging Head	Polisher Head
GO-MP9	15k psi (1000 bar)	9–18 gpm	34–68 l/min	GO 043-R.17	GO 042-R.14
		18–25 gpm	68–95 l/min	GO 043-R.08	GO 042-R.07
	22k psi (1500 bar)	10–15 gpm	38–57 l/min	GO 043-R.17	GO 042-R.14
		15–25 gpm	57–95 l/min	GO 043-R.08	GO 042-R.07

PLEASE NOTE: Pressures and flows in the above table are only approximations of common jetting scenarios.

JETTING

The next step is to determine where the nozzles and plugs should go in the head. The thrust of the jets can be used to pull the tool through a pipe or tube. Little or no pull is needed for cleaning vertically downward, but more pull is needed if cleaning horizontally or climbing upward. The nozzle sizes should be selected based on proportioning the total flow rate between the forward and backward jets to achieve the pulling force needed, but still applying enough power to the material being removed ahead of the tool.

For most accurate head selection, use the StoneAge Jetting App:

<http://jetting.stoneagetools.com>

NOZZLES AND PLUGS

Gopher tool heads can be jetted in different configurations depending on the application. The table below shows suitable nozzle/plug configurations for the Gopher tools:

Head Style	10° Port	30° Port	35° Port	135° Ports
Unplugging	1 x Nozzle	1 x Nozzle	1 x Nozzle	2 x Nozzle
	1 x Nozzle	1 x Plug	1 x Plug	2 x Nozzle
	1 x Plug	1 x Nozzle	1 x Nozzle	2 x Nozzle
	1 x Plug	1 x Plug	1 x Plug	2 x Nozzle

Head Style	80° Ports	100° Ports
Polisher	3 x Nozzle	3 x Nozzle
	3 x Plug	3 x Nozzle

22K (1500 bar) GO-MP9 OPERATION

OPERATION:

- Make sure there is an operator controlled dump in the system, operated by the person closest to the cleaning job.
- Flush out the high pressure hoses before connecting Gopher to hose end or stinger to eliminate debris.
- When cleaning a pipe or tube, it is recommended that the hose be marked a few feet from the end with a piece of tape so the operator knows when to stop on the way back out.
- When cleaning a pipe, a stinger is recommended; a stinger is a rigid piece of pipe or tubing used between the end of the hose and the nozzle. It is typically 2 feet in length, and is primarily a safety device for hand flex lancing. This is illustrated on the "Warning and Safety Instructions" page of this manual.
- Position the Gopher in a tube or the pipe while the pressure is being set. The high pressure seal may leak initially; it should stop when pressure is increased and rotation begins.
- Close the dump and slowly bring up to pressure the first time, to make sure no nozzles are plugged and that the jet thrust is correct. The swivel should begin to slowly rotate.
- Once operating pressure is reached, feed the tool into the tube or pipe to begin the cleaning job.
- When using rotating heads in plugged tubes, the Gopher must not be forced into the deposit, as this may stop the rotation of the tool and impede the cutting ability. When the Gopher contacts the deposit, allow it to cut away the material and advance at it's own rate. If it stops advancing, pull back slightly on the hose to pull the head slightly away from the deposit, in case it is being stopped from rotating by the deposit. This also allows the angled jets to attack the deposit at different places.
- When polishing tubes with scale, it is possible to allow the tool to pass through the tube at very fast rates; unless the deposit is very easy to remove, this will not completely remove the scale.
- The operator needs to be trained to feed the Gopher through the tube at a rate sufficient to clean the tube.
- Once the work is complete and the Gopher is disconnected from the hose, blow out all water to prolong the life of the tool. A small amount of lubricant can be blown into the inlet nut as well.

HIGH-PRESSURE WATER SEALS LEAK:

- The high pressure seal may leak initially at lower pressures, but should pop closed as pressure is increased. A continuous leak at operating pressure from the weep holes indicates the need to replace the HP Seal and Seat. HP Seals wearing out too quickly can be an indication that the shaft bore is worn, the HP Seat in the seal assembly is installed upside-down, or the tool is over spinning. Over spinning may be caused by a lack of 10W-40 lubricating fluid, water in the fluid chamber (replace shaft seals), or too much jet torque. Refilling the 10W-40 every 20-40 hours of operation is important for proper speed control. Only use StoneAge recommended lubricating fluids.

SEALS WEAR OUT TOO QUICKLY:

- The tool must be disassembled and inspected. The carbide seat should be checked for correct installation. The seat should not have any chips or erosion marks on it. The seal holder (GO 020) should be replaced if it has any groove in the bore where the seal fits.

HEAD WILL NOT ROTATE:

- First try rotating head by hand and see if it feels rough or gritty to turn. If it does, the tool must be disassembled and repaired. If the Gopher has just been repaired and the head starts to rotate but slows down and stops as pressure is increased, the RJ 007 Front Bearing is installed backwards. If the tool feels okay, check to see if any nozzles are plugged; even if a nozzle is only partially blocked it can keep the head from rotating. Nozzles must be removed from the head to properly clean them. Refer to the above description about the head offset and double check the nozzle sizes to make sure they are correct for the expected flow rate.

HEAD SPINS TOO FAST:

- A significant increase in rotation speed means that the speed control mechanism in the tool has lost functionality. This can be a result of fluid loss or fluid contamination. Operation of the tool in this state can cause damage to other components and accelerated wear of the high pressure seal. If this occurs, the first step is to flush the tool with new viscous fluid as shown in the "Lubricant Replacement" instructions in this manual.

LEAKAGE FROM HERE
INDICATES IMPROPER
INSTALLATION

LEAKAGE FROM HERE
INDICATES A WORN H.P. SEAL
OR DAMAGED SHAFT



22K (1500 bar) GO-MP9 TOOL SERVICE INFORMATION

TOOL SERVICE

***Product training and proper tools are required to service this nozzle.

If you are uncomfortable performing the service, send in or bring the tool to your authorized dealer. StoneAge provides maintenance videos for the Gopher models online.

<https://www.stoneagetools.com/gopher>

The use of a bench vice and an arbor press is recommended. Take care throughout the entire procedure to keep the internals clean and free from grit, lint, and contamination. Failure to do so could result in premature failure after service.

LIST OF TOOLS:

- Bench Vice (recommended)
- Arbor Press (recommended)
- GO 612 Kit Contains; MT 105 and RJ 105 Seal Press tools
- 18" Adjustable Wrench (such as Crescent® C718 Automatic Adjustable Pipe Wrench)
- Small size flat-head screw driver
- Medium size flat-head screw driver
- Pick
- Ball point pen
- 9/64" Hex Wrench
- Snap Ring Pliers

LIST OF MATERIALS:

- Clean lint free rags or blue shop towels
- 10W-40 lubricant
- Anti-Seize - StoneAge Part Number GP 043 Blue Goop
- Lithium Soap Grease - StoneAge Part Number GP 048 Grease
- P-80® Grip-IT Lubricant

Blue Goop® is a registered trademark of the Swagelock® Corporation.

P-80® Grip-IT Lubricant is a registered trademark of the International Products Corporation.

22K (1500 bar) GO-MP9 LUBRICANT REPLACEMENT

LUBRICANT FLUSH INSTRUCTIONS

It is recommended that a full syringe of fresh lubricant be added to the Swivel after every 20-40 hours of use.

1. Remove the FT 026 Port Plug from the Body.
2. Fill the FT 110 Syringe with 10W-40 lubricant by removing the end near the handle, pulling out the plunger, and pouring the 10W-40 lubricant in to fill the Syringe Body. With plunger re-installed, purge air out of Syringe hose.
3. Thread the syringe end into the port in the body and squeeze fresh 10W-40 lubricant in until clean lubricant comes out of the slots in the Swivel. Hold the tool so the port in the Nut is the highest point. If air bubbles come out of the port on the nut, keep flushing new fluid until air bubbles stop.
4. Remove the Syringe and install the Port Plug into the Body.

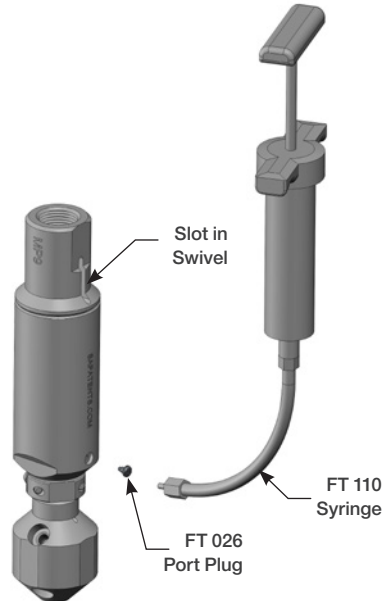

Figure 1: Lubricant Flush

22K (1500 bar) GO-MP9 HIGH PRESSURE SEAL REPLACEMENT

TO REPLACE THE HIGH PRESSURE SEAL:

1. Remove the BJ 072 O-Ring from groove in Inlet Nut. It is easiest to push it inward from the top of the slot.
2. Use two picks inserted through the slots to pry the GO 020 Seal Holder and GO 022 Inlet Seat up and out.
3. Remove the RJ 011-KC Carbide Seat and RJ 012-KTO H.P. Seal. Inspect the GO 020 Seal Holder for grooves. If it is badly grooved, it can be flipped over or replaced.
4. Inspect the Carbide Seat for chips or erosion. Replace if damaged. Inspect end of shaft for dings or erosion.
5. Check that GO 123 O-Ring is in groove of Inlet Seat. Place Seal Holder on top of Inlet Seat.
6. Apply grease to a new H.P. Seal and install in Seal Holder. Apply grease to the flat face of the Carbide Seat and install with this flat face against the H.P. Seal.
7. Stack the Inlet Seat and Seal Holder on the tip of a ballpoint pen; turn Gopher upside down and slide these parts into the Inlet Nut. Make sure that the Carbide Seat stays in bore of Seal Holder.
8. Turn the Gopher inlet end up; the Inlet Seat and Seal Holder should be far enough in to install the BJ 072 O-Ring into the groove in the Inlet Nut.

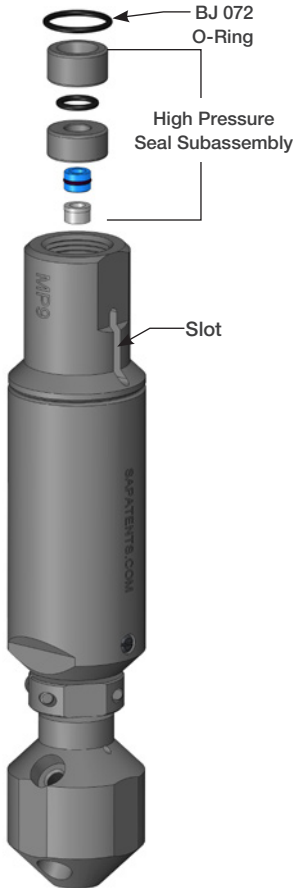

Figure 2: Remove BJ 072 O-Ring

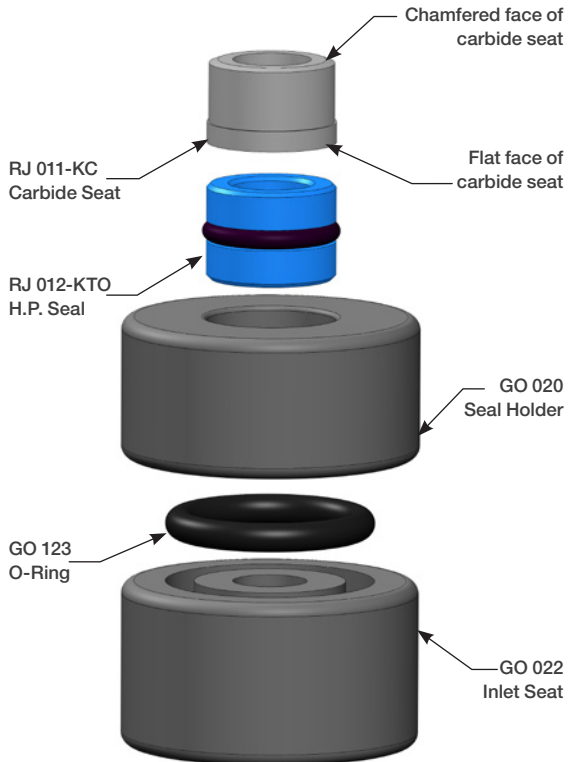

Figure 3: High Pressure Seal Subassembly

22K (1500 bar) GO-MP9 DISASSEMBLY

DISASSEMBLY

1. Locate the flats on the Head and tighten them in a vice, so that the Inlet Nut end of the Gopher is facing up.
2. Slide an adjustable wrench onto the Collar flats and loosen the Head from the Body.

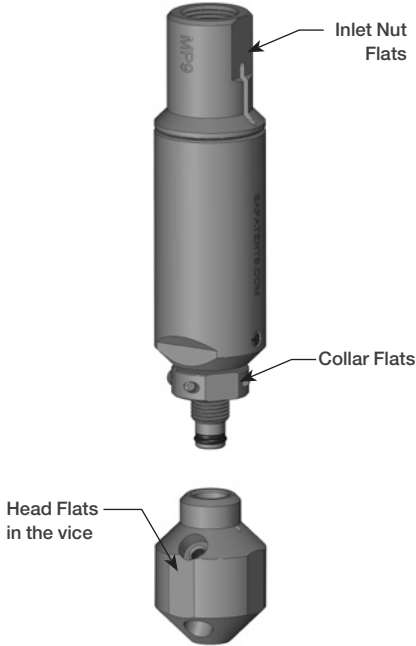

Figure 4: For Steps 1-2

3. Remove the Gopher from the vice, flip it over and secure the Inlet Nut flats in the vice.
4. Using a pick, remove the BC 040 O-Ring from the Shaft Assembly.
5. Remove the BC 031 Backup Ring.

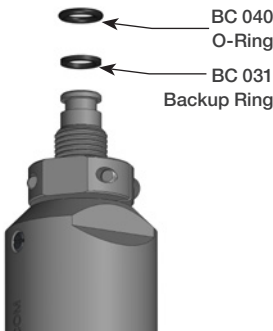

Figure 5: For Steps 3-5

6. Remove the GO 025 Collar halves with a 9/64" hex wrench and set them aside.
7. Remove the FT 026 Port Plug with a small flat-head screw driver.

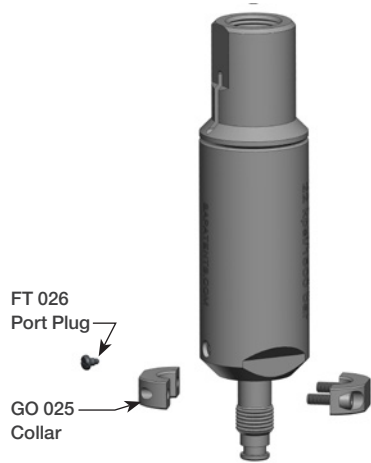

Figure 6: For Steps 6-7

8. Remove the High Pressure Seal Subassembly by first removing the BJ 072 O-Ring with a pick, then remove the body from the vice and tap it on a flat surface so the seal stack will drop out of the inlet nut.

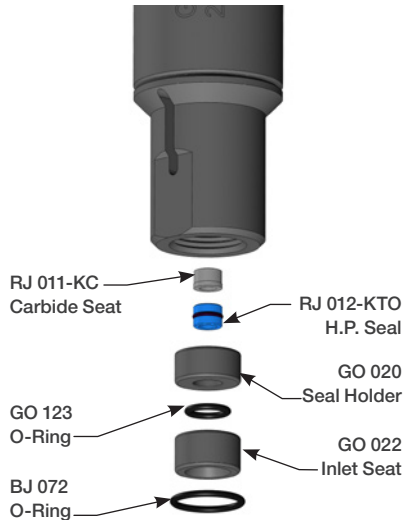

Figure 7: For Step 8

- Disassemble the seal stack using a pick to pull the GO 123 O-Ring from the Inlet Seat and the Carbide Seat and High Pressure Seal from the Seal Holder. Retain the Inlet Seat. The rest are wear items that can be replaced with the GO 610 Overhaul Kit. You will need to retain the Seal Holder in addition to the Inlet Seat if you are using the GO 600 Service Kit.

See the "GO-MP9 Maintenance Kits" section in this manual for a complete list of kit parts.

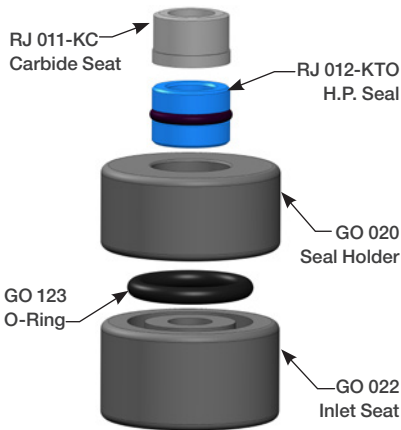

Figure 8: For Step 9

- Clamp Inlet Nut flats in the vice so the top of the Shaft Assembly is facing up. Using an adjustable wrench on the wrench flats of the Body, loosen the Body from the Inlet Nut. Remove the tool from the vice and continue to unscrew the Body from the Inlet Nut. Lubricant may drain out and this is normal.
- Slide the Shaft Seal Assembly out of the Body. Remove the BC 009 Bearing and the BC 222 Washer from the Shaft Assembly.

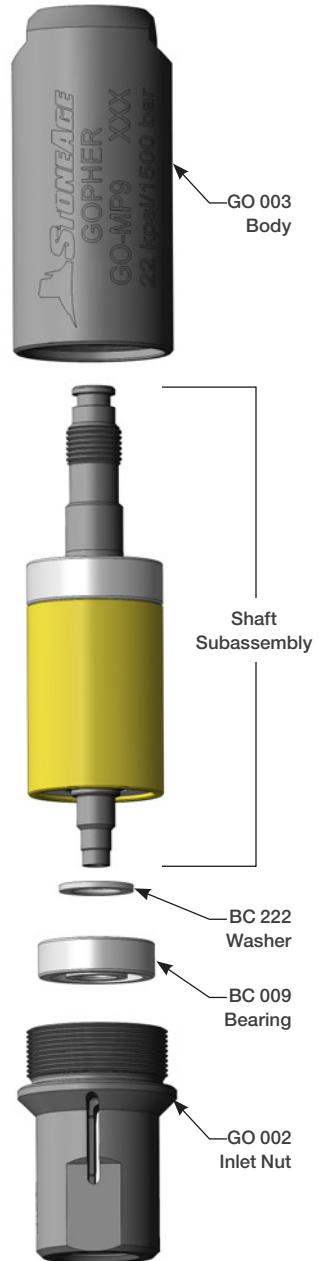

Figure 9: For Steps 10-11

22K (1500 bar) GO-MP9 DISASSEMBLY

- Slide the BC 230 Brass Sleeve off the Shaft Assembly.
- Remove the RJ 007 Bearing Ring from the Shaft.

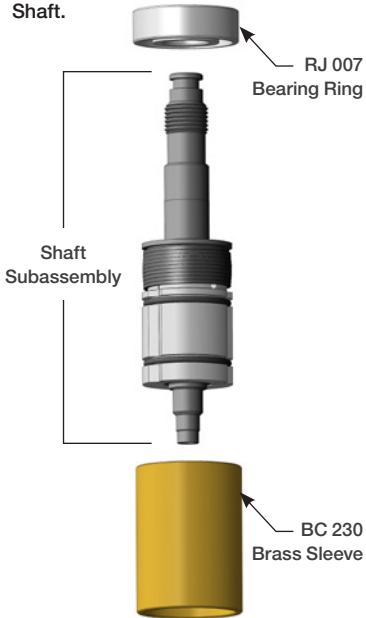

Figure 10: For Steps 12-13

- With a pick, remove the first spring end from the Weight set and set the Weight Set aside.
- Remove the second spring end from the Shaft and set the Spring and Shaft aside.

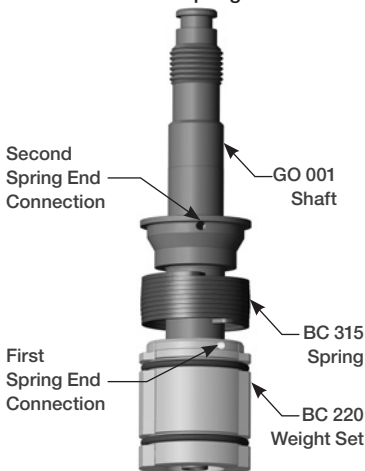

Figure 11: For Steps 14-15

- Remove the RJ 029 Shaft Seal from the GO 003 Body with a pick or Snap Ring Pliers.

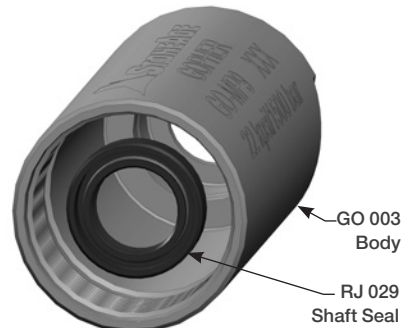

Figure 12: For Step 16

- Remove the MT 010 Shaft Seal from the GO 002 Inlet Nut with a pick or Snap Ring Pliers.
- Remove the RJ 008 O-Ring from the GO 002 Inlet Nut threads.

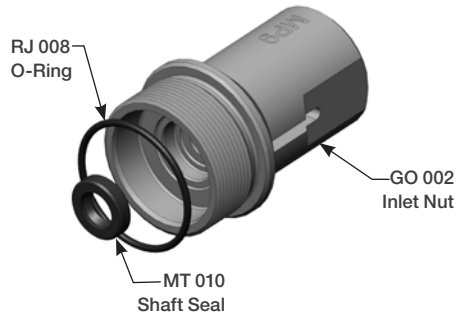

Figure 13: For Steps 17-18

NOTICE

Before reassembly of the tool
Wash all parts in solvent and blow dry
and
Inspect wear items, (High Pressure Seal
Assembly, O-Rings, and Port Screw.)

See the "Maintenance Kits" section of this manual for a complete list of Service, Overhaul, and, Tool kits.

ASSEMBLY

1. Lubricate the RJ 029 and MT 010 Shaft Seals with P-80® Grip-IT Lubricant or equivalent.
2. Put the MT 010 Shaft Seal on the MT 105 tool (LIP SIDE UP) and using an Arbor press, press the seal into the Body.
3. Put the RJ 029 Shaft Seal on the RJ 105 tool (LIP SIDE DOWN) and using an Arbor press, press the seal into the Body.

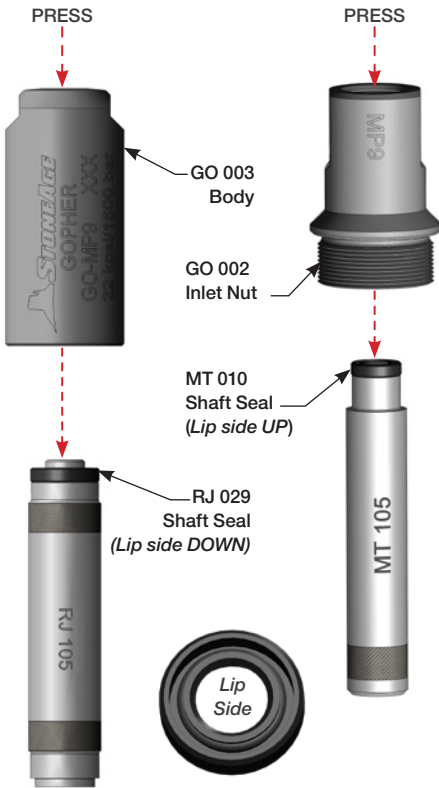

Figure 14: For Steps 1-3

4. Grease the RJ 008 O-Ring with Blue Goop and install it at the base of the threads on the GO 002 Inlet Nut.



Figure 15: For Step 4

5. Install the RJ 007 Bearing Ring onto the Shaft with the Wide Inner Race facing the Shoulder.

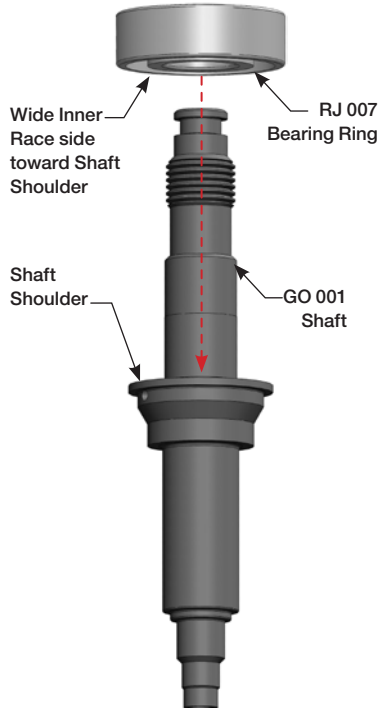

Figure 16: For Step 5

22K (1500 bar) GO-MP9 ASSEMBLY

6. Install the first Spring end into the hole in the Weight set.

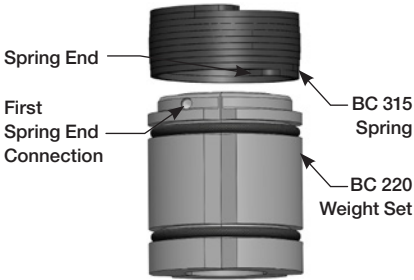

Figure 17: For Step 6

7. Slide the Spring/Weight set onto the Shaft and connect the second spring end into the hole on the Shaft.
8. Twist the Shaft and Weight assemblies to make sure the Spring is engaged at both ends.

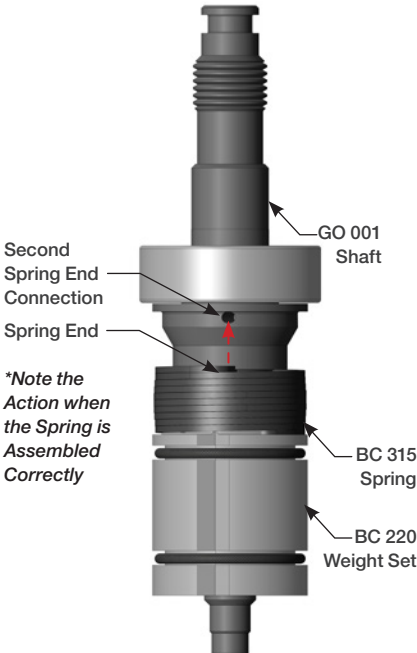

Figure 18: For Steps 7-8

9. Replace the Brass Sleeve and Shim Washer on the Shaft. *The chamfer side of the Washer faces the Weight Set

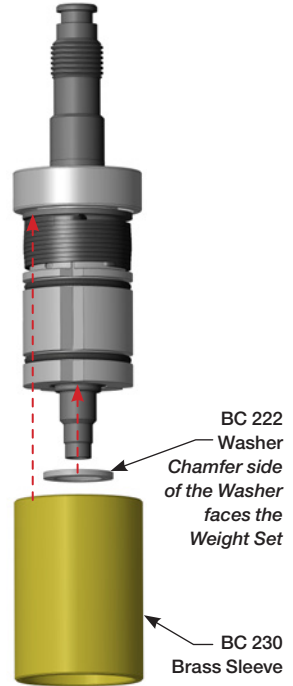

Figure 19: For Step 9

10. Replace the BC 009 Bearing Ring over the BC 222 Washer.

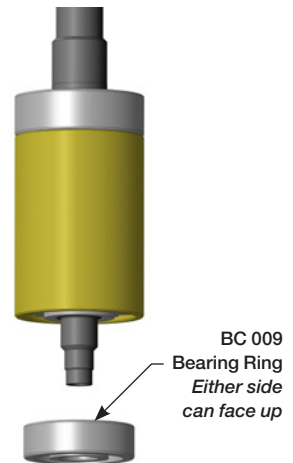

Figure 20: For Step 10

11. Prepare the Body by greasing the Shaft Seal from Both ends.
12. Slide the Shaft Assembly into the Body.

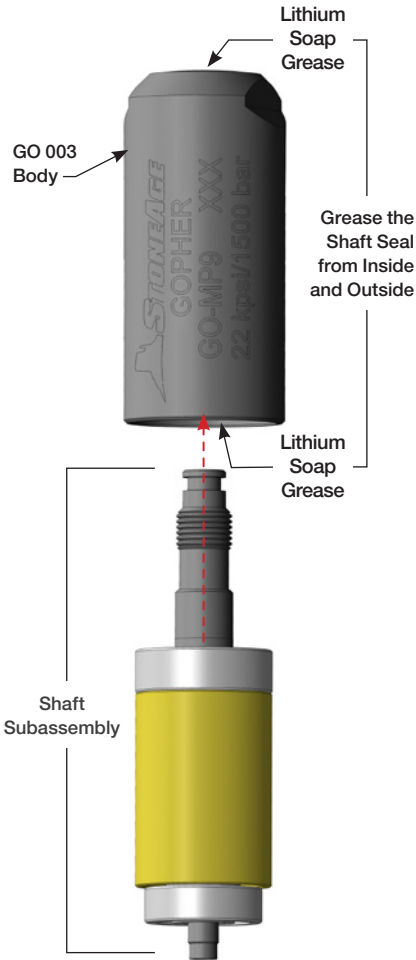

Figure 21: For Steps 11-12

13. Clamp the wrench flats on the Body toward one side of a vice, so that the Shaft can easily be rotated by hand.
14. Fill the tool with 10W-40 lubricant.
15. Remove the tool from the vice and rotate the Shaft in the Body to allow the lubricant to settle inside the tool.

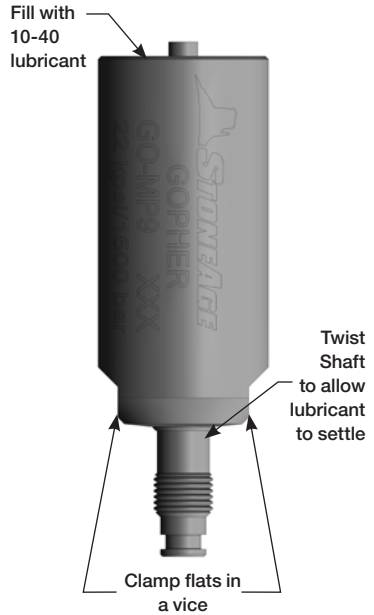

Figure 22: For Steps 13-15

16. Replace the Port Screw and continue to fill and twist until lubricant covers the top bearing

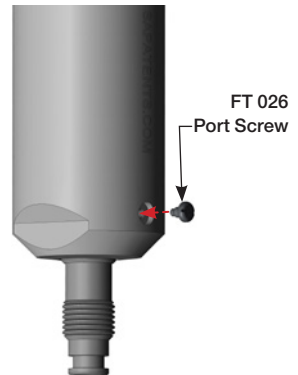

Figure 23: For Step 16

22K (1500 bar) GO-MP9 ASSEMBLY

17. Prepare the Inlet Nut by greasing the Shaft Seal and applying the Anti-seize to the threads of the Inlet Nut.
18. With the Body flats still secured in the vice, Screw in the Inlet Nut and tighten with an adjustable wrench.

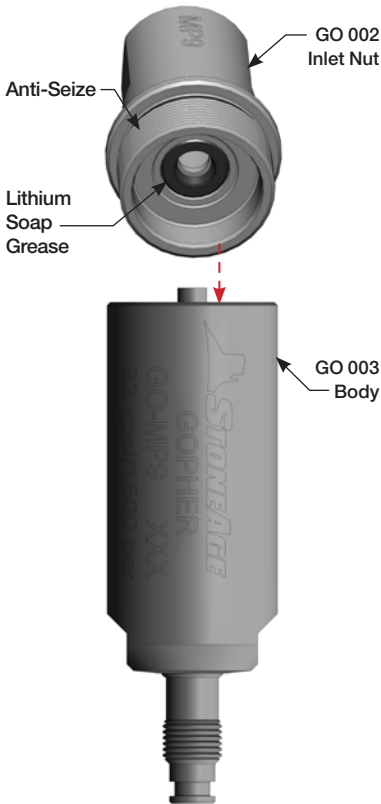

Figure 24: For Steps 17-18

19. Begin Reassembly of the High Pressure Seal by placing the GO 123 O-Ring in the groove on the GO 022 Inlet Seat.

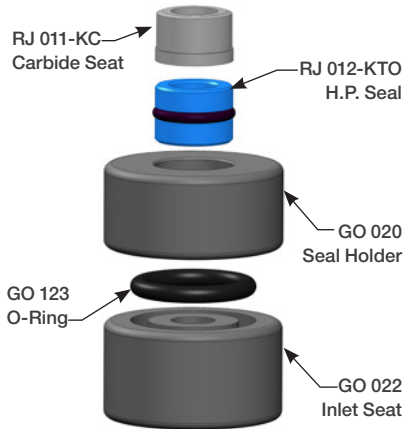

Figure 25: For Step 19

20. Grease the RJ 012-KTO H.P. Seal and place it into the GO 020 Seal Holder. Push it in enough to leave a 1/16" recess for grease.
21. Grease the Seal Holder and H.P. Seal.
22. Place the RJ 011-KC Carbide Seat chamfer side up, in the recess of the Seal Holder.

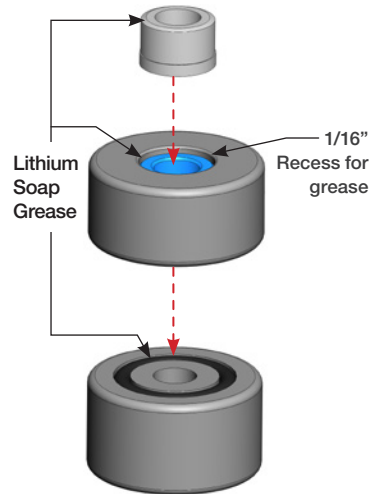

Figure 26: For Steps 20-22

23. Use a ball point pen to position the stack up in the Inlet Nut. When the Stack is in place flip the tool and insert the stack into the back of the Inlet Nut.

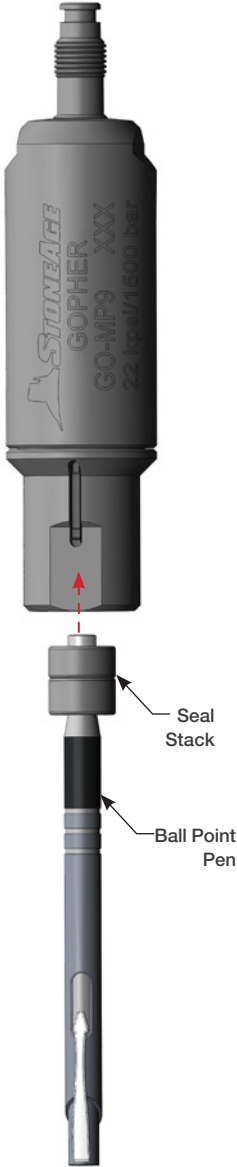

Figure 27: For Step 23

24. Place the New BJ 072 O-Ring in the Inlet Nut to hold the seal stack in place. Use a pick to make certain the O-Ring is nestle in the Groove inside the Inlet Nut.



Figure 28: For Step 24

25. Place the tool in the vice with the head end up. Loosen the Port Screw to allow the air to escape (burp) and tighten the screw.

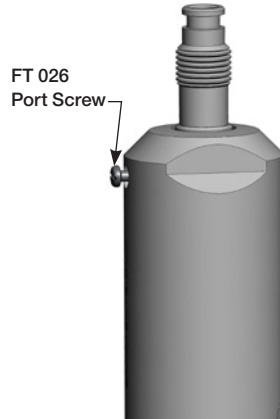

Figure 29: For Step 25

22K (1500 bar) GO-MP9 ASSEMBLY

26. Replace the Collar halves and tighten evenly with 9/64" hex wrench. Make certain the gap is the same on both sides when tight.



TECH TIP: Use a pick to measure the gap on each side.

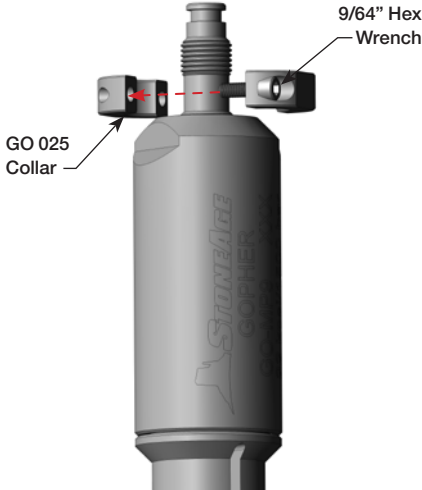

Figure 30: For Step 26

27. Slip the Backup O-Ring onto the Shaft first with the flat side down and concave side up to receive the regular O-Ring.

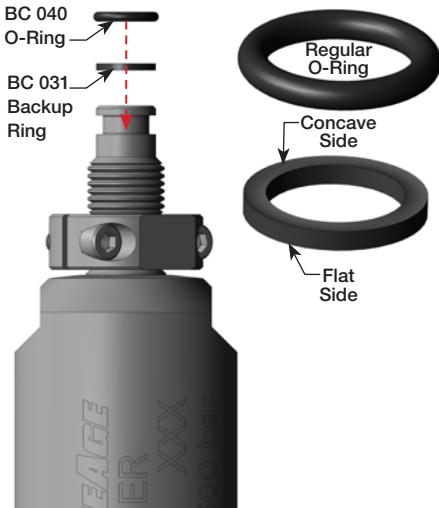

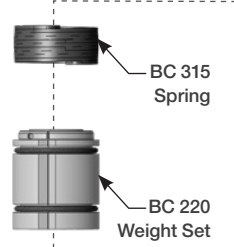
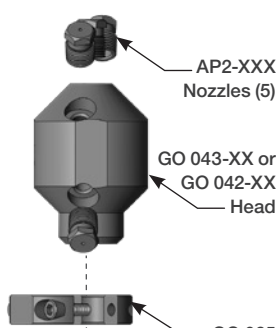
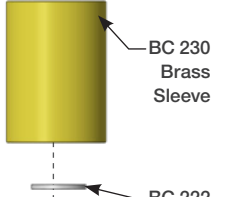

Figure 31: For Step 27

28. Grease the O-Rings.
29. Apply Anti-seize to the threads and screw the head onto the tool.
30. Place the flats on the Head in a vice and Tighten with an adjustable wrench.



Figure 32: For Step 28-30

22K (1500 bar) GO-MP9 MAINTENANCE KITS

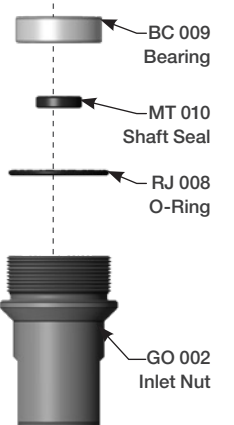
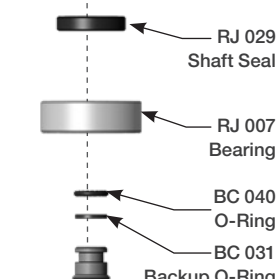
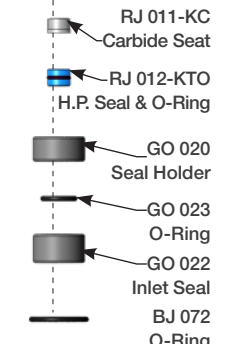
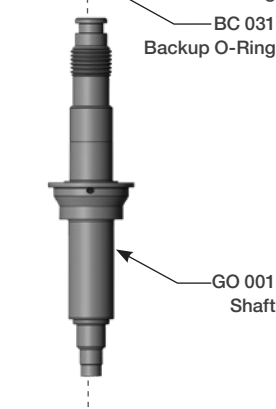
KITS	PART NUMBER OVERVIEW	
<p>GO 600 SERVICE KIT</p> <ul style="list-style-type: none"> 1 BC 031 Back-up Ring 1 BC 040 O-Ring 1 BJ 062-S Antiseize, 2g 1 BJ 072 O-Ring 1 FT 026 Port Screw w/ O-Ring 1 FT 110 Syringe Assy 1 GO 123 O-Ring 1 GP 044 10W-40 Lubricant, 32 oz 1 PL 674 Gopher Family User Manual 1 RJ 011-KC Carbide Seat 1 RJ 012-KTO H.P. Seal & O-Ring 	 <p>BC 315 Spring</p> <p>BC 220 Weight Set</p>	 <p>AP2-XXX Nozzles (5)</p> <p>GO 043-XX or GO 042-XX Head</p> <p>GO 025 Collar</p>
<p>GO 602 15K & 20K SEAL KIT</p> <ul style="list-style-type: none"> 1 BJ 072 O-Ring 1 GO 123 O-Ring 1 RJ 011-KC Carbide Seat 1 RJ 012-KTO H.P. Seal & O-Ring 	 <p>BC 230 Brass Sleeve</p> <p>BC 222 Washer</p>	 <p>FT 026 Port Plug</p> <p>GO 003 Body</p>
<p>GO 610 OVERHAUL KIT</p> <ul style="list-style-type: none"> 1 BC 009 Bearing, Ball, JEM 1 BC 031 Back-up Ring 1 BC 040 O-Ring 1 BC 222 Washer 1 BC 230 Bronze Sleeve 1 BC 315 Spring 1 BJ 072 O-Ring 1 FT 026 Port Screw w/ O-Ring 1 GO 020 Seal Holder 1 GO 123 O-Ring 1 GP 044 10W-40 Lubricant, 32 oz 1 MT 010 Seal, Shaft Small 1 PL 674 Gopher Family User Manual 1 RJ 007 Bearing, Thrust 1 RJ 008 O-Ring 1 RJ 011-KC Carbide Seat 1 RJ 012-KTO H.P. Seal & O-Ring 1 RJ 029 Seal Piston 	 <p>GO 002 Inlet Nut</p> <p>BC 009 Bearing</p> <p>MT 010 Shaft Seal</p> <p>RJ 008 O-Ring</p> <p>RJ 029 Shaft Seal</p>	 <p>RJ 007 Bearing</p> <p>BC 040 O-Ring</p> <p>BC 031 Backup O-Ring</p>
<p>GO 612 TOOL KIT</p> <ul style="list-style-type: none"> 1 MT 105 Seal Press Tool 1 RJ 105 Seal Press Tool 	 <p>RJ 011-KC Carbide Seat</p> <p>RJ 012-KTO H.P. Seal & O-Ring</p> <p>GO 020 Seal Holder</p> <p>GO 023 O-Ring</p> <p>GO 022 Inlet Seal</p> <p>BJ 072 O-Ring</p>	 <p>GO 001 Shaft</p>

40K PSI (2800 BAR) GOPHER HEAD CONFIGURATIONS

HEAD SELECTION FOR 40K PSI (2800 bar) GOPHER HEAD:

There are two standard head configurations for the H9-C Gopher tools; both have ¼-28 threads for Sapphire nozzles. The GO 342 Polisher Head is intended for removing scale. The GO 343 Unplugging Head is intended for use in plugged tubes. The head offset is what makes the head rotate and is stamped on each head. (See the chart below). If less flow is used than the range shown, the swivel will not rotate. If more flow is used than shown in the range, the tool will rotate too fast, damaging the bearings, speed control, and accelerating the wear rate of the high pressure seal. Consult the table for the correct flow range for each head offset. Custom heads are available on request.

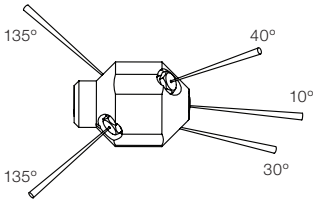

GO 343 UNPLUGGER

5 Ports:

1 @ 10°, 1 @ 30°, 1 @ 40°, 2 @ 135°

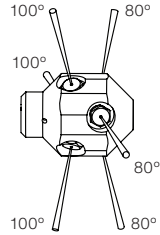

GO 342 POLISHER

6 Ports:

3 @ 80°, 3 @ 100°

The correct head specification is based on the swivel, pressure, and flow of the pump.

Swivel	Pressure	Flow		Unplugging Head	Polisher Head
GO-H9-C	30k psi (2100 bar)	4–8 gpm	15–30 l/min	GO 343-R.18	GO 342-R.14
		8–12 gpm	30–45 l/min	GO 343-R.08	GO 342-R.08
	40k psi (2800 bar)	4–8 gpm	15–30 l/min	GO 343-R.18	GO 342-R.14
		8–12 gpm	30–45 l/min	GO 343-R.08	GO 342-R.08

PLEASE NOTE: Pressures and flows in the above table are only approximations of common jetting scenarios.

JETTING

The next step is to determine where the nozzles and plugs should go in the head. The thrust of the jets can be used to pull the tool through a pipe or tube. Little or no pull is needed for cleaning vertically downward, but more pull is needed if cleaning horizontally or climbing upward. The nozzle sizes should be selected based on proportioning the total flow rate between the forward and backward jets to achieve the pulling force needed, but still applying enough power to the material being removed ahead of the tool.

For most accurate head selection, use the StoneAge Jetting App:

<http://jetting.stoneagetools.com>

NOZZLES AND PLUGS

Gopher tool heads can be jetted in different configurations depending on the application. The table below shows suitable nozzle/plug configurations for the Gopher tools:

Head Style	10° Port	30° Port	40° Port	135° Ports
Unplugging	1 x Nozzle	1 x Nozzle	1 x Nozzle	2 x Nozzle
	1 x Nozzle	1 x Plug	1 x Plug	2 x Nozzle
	1 x Plug	1 x Nozzle	1 x Nozzle	2 x Nozzle
	1 x Plug	1 x Plug	1 x Plug	2 x Nozzle

Head Style	80° Ports	100° Ports
Polisher	3 x Nozzle	3 x Nozzle
	3 x Plug	3 x Nozzle

OPERATION:

- Make sure there is an operator controlled dump in the system, operated by the person closest to the cleaning job.
- Flush out the high pressure hoses before connecting Gopher to hose end or stinger to eliminate debris.
- When cleaning a pipe or tube, it is recommended that the hose be marked a few feet from the end with a piece of tape so the operator knows when to stop on the way back out.
- When cleaning a pipe, a stinger is recommended; a stinger is a rigid piece of pipe or tubing used between the end of the hose and the nozzle. It is typically 2 feet in length, and is primarily a safety device for hand flex lancing. This is illustrated on the "Warning and Safety Instructions" page of this manual.
- Position the Gopher in a tube or the pipe while the pressure is being set. The high pressure seal may leak initially; it should stop when pressure is increased and rotation begins.
- Close the dump and slowly bring up to pressure the first time, to make sure no nozzles are plugged and that the jet thrust is correct. The swivel should begin to slowly rotate.
- Once operating pressure is reached, feed the tool into the tube or pipe to begin the cleaning job.
- When using rotating heads in plugged tubes, the Gopher must not be forced into the deposit, as this may stop the rotation of the tool and impede the cutting ability. When the Gopher contacts the deposit, allow it to cut away the material and advance at it's own rate. If it stops advancing, pull back slightly on the hose to pull the head slightly away from the deposit, in case it is being stopped from rotating by the deposit. This also allows the angled jets to attack the deposit at different places.
- When polishing tubes with scale, it is possible to allow the tool to pass through the tube at very fast rates; unless the deposit is very easy to remove, this will not completely remove the scale.
- The operator needs to be trained to feed the Gopher through the tube at a rate sufficient to clean the tube.
- Once the work is complete and the Gopher is disconnected from the hose, blow out all water to prolong the life of the tool. A small amount of lubricant can be blown into the inlet nut as well.

40K (2800 bar) GO-H9-C TROUBLESHOOTING

HIGH-PRESSURE WATER SEALS LEAK:

- The seal may leak initially up to several thousand psi, but should pop closed as pressure is increased. If operating pressure is reached and the seal is leaking continuously, the cartridge should be replaced. Refer to the “40k GO-H9-C Maintenance Kits” section of this manual for Seal Kit information. If the cartridge is replaced and the tool still leaks, inspect the shaft end face for damage such as dents, nicks or erosion. A continuous leak at operating pressure from the weep hole in the Inlet Nut could also indicate improper installation of the HP Seal Assembly and O-Ring.

SEALS WEAR OUT TOO QUICKLY:

- Remove and inspect the cartridge parts. The carbide seat should be checked for chips or erosion marks on it. When the life of the high pressure seal becomes noticeably less, the seal retainer needs to be replaced. Also replace the carbide seat if it has not been replaced with each seal change. HP Seals wearing out too quickly can be an indication that the shaft bore is worn, the HP Seal is installed upside-down, or the tool is over spinning. Over spinning may be caused by a lack of 10W-40 lubricating fluid, water in the fluid chamber (replace shaft seals), or too much jet torque. Refilling the 10W-40 every 20-40 hours of operation is important for proper speed control. Only use StoneAge recommended lubricating fluids.

HEAD WILL NOT ROTATE:

- First try rotating head by hand and see if it feels rough or gritty to turn. If it does, the tool must be disassembled and repaired. If the tool has just been repaired and the head starts to rotate but slows down and stops as pressure is increased, the RJ 007 front bearings are installed backwards. If the tool feels okay, check to see if any nozzles are plugged; even if a nozzle is only partially blocked it can keep the head from rotating. Nozzles must be removed from the head to properly clean them. Refer to the “40k Gopher Head Configurations” page for the head offset and double check the nozzle sizes to make sure they are correct for the expected flow rate.

TOOL SPINS TOO FAST:

- A significant increase in rotation speed means that the speed control mechanism in the tool has lost functionality. This can be a result of viscous fluid loss or fluid contamination. Operation of the tool in this state can cause damage to other components and accelerated wear of the high pressure seal. If this occurs, the first step is to flush the tool with new viscous fluid as shown in the “Lubricant Replacement” instructions in this manual.

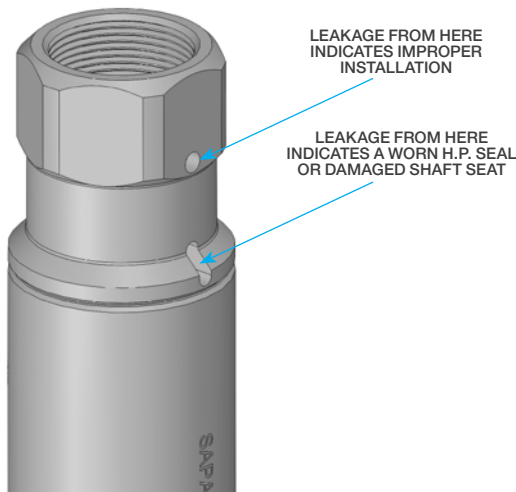

40K (2800 bar) GO-H9-C TOOL SERVICE INFORMATION

TOOL SERVICE

***Product training and proper tools are required to service this nozzle.

If you are uncomfortable performing the service, send in or bring the tool to your authorized dealer. StoneAge provides maintenance videos for the Gopher models online.

<https://www.stoneagetools.com/gopher>

The use of a bench vice and an arbor press is recommended. Take care throughout the entire procedure to keep the internals clean and free from grit, lint, and contamination. Failure to do so could result in premature failure after service.

LIST OF TOOLS:

- Bench Vice (recommended)
- Arbor Press (recommended)
- GO 612 Kit Contains; MT 105 and RJ 105 Seal Press tools
- 18" Adjustable Wrench (such as Crescent® C718 Automatic Adjustable Pipe Wrench)
- Small size flat-head screw driver
- Medium size flat-head screw driver
- Pick
- Ball point pen
- 9/64" Hex Wrench
- Snap Ring Pliers

LIST OF MATERIALS:

- Clean lint free rags or blue shop towels
- 10W-40 Lubricant
- Anti-Seize - StoneAge Part Number GP 043 Blue Goop
- Lithium Soap Grease - StoneAge Part Number GP 048 Grease
- P-80® Grip-IT Lubricant

Blue Goop® is a registered trademark of the Swagelock® Corporation.

P-80® Grip-IT Lubricant is a registered trademark of the International Products Corporation.

40K (2800 bar) GO-H9-C LUBRICANT REPLACEMENT

LUBRICANT FLUSH INSTRUCTIONS

It is recommended that a full syringe of fresh lubricant be added to the Swivel after every 20-40 hours of use.

1. Remove the FT 026 Port Plug from the Body.
2. Fill the FT 110 Syringe with 10W-40 lubricant by removing the end near the handle, pulling out the plunger, and pouring the 10W-40 lubricant in to fill the Syringe Body. With plunger re-installed, purge air out of Syringe hose.
3. Thread the syringe end into the port in the body and squeeze fresh 10W-40 lubricant in until clean lubricant comes out of the slots in the Swivel. Hold the tool so the port in the Nut is the highest point. If air bubbles come out of the port on the nut, keep flushing new fluid until air bubbles stop.
4. Remove the Syringe and install the Port Plug into the Body.

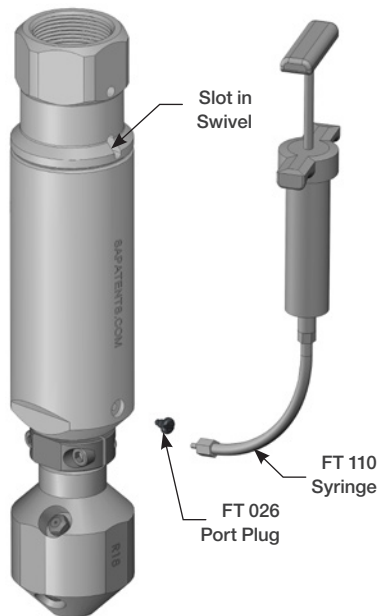

Figure 1: Lubricant Flush

40K (2800 bar) GO-H9-C HIGH PRESSURE SEAL REPLACEMENT

TO REPLACE THE HIGH PRESSURE SEAL:

1. Remove the BJ 417 O-Ring from groove in Inlet Nut. It is easiest to push it inward from the top of the slot.
2. If necessary, use two picks inserted through the slots to pry the BC 505-S Cartridge Assy up and out of the Body.
3. Turn the swivel inlet end up; insert a fresh Cartridge Assy into the inlet port and re-insert the O-ring behind the Cartridge Assy to secure it in place.



Figure 2: Remove BJ 417 O-Ring

TO ASSEMBLE THE CARTRIDGE ASSEMBLY:

You must have the BC 602-H9-C Seal Kit in order to service the High Pressure Seal Assembly. Detailed installations instructions are provided with the Seal Kit.

1. Place BC 414 Mandrel on a flat surface.
2. Stack the BC 522-001 Inlet Seat with the internal cone at the bottom onto the Mandrel.
3. Insert BC 524 Compression Spring into bore of Inlet Seat.
4. Insert BC 512-O H.P. Seal into bore of Inlet Seat making sure the end with the O-Ring and seal support goes in first. (see detail)
5. Stack the BC 511 Carbide Seat making sure the chamfered end is against the H.P. Seal. (see detail)
6. Stack the BC 520 Seal Retainer around the Carbide Seat.
7. Stack the BC 506 Seat Face.
8. Slip the BC 407 Cartridge Housing over entire stack and pick up the whole assembly with mandrel still inserted.
9. Insert BJ 072 O-Ring into slot in Cartridge Housing to capture the components. Be sure to check that the entire O-Ring is seated properly.
10. Remove the Mandrel.

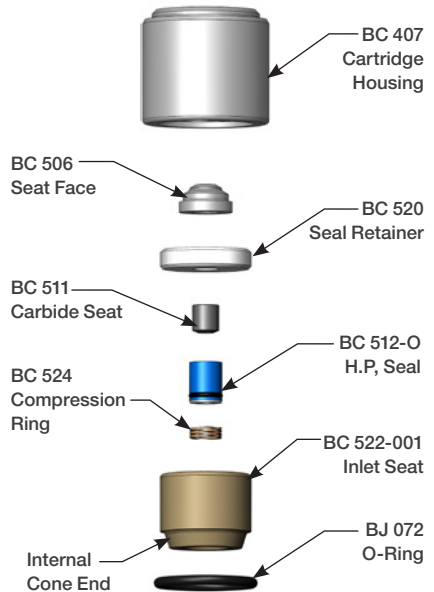

Figure 3: High Pressure Seal Subassembly

DISASSEMBLY

1. Locate the flats on the Head and tighten them in a vice, so that the nut end of the Gopher is facing up.
2. Slide an adjustable wrench onto the Collar flats and loosen the Head from the Body.
3. Remove the Gopher from the vice, flip it over and secure the inlet nut flats in the vice.

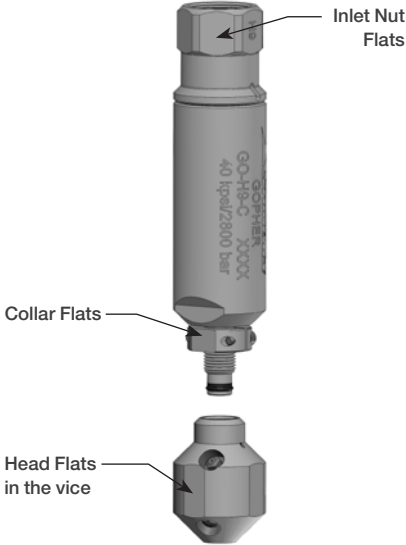

Figure 4: For Steps 1-3

4. Using a pick, remove the BC 040 O-Ring from the Shaft Assembly.
5. Remove the BC 031 Backup Ring.

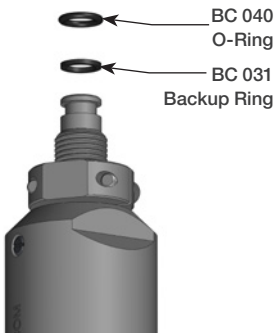

Figure 5: For Steps 4-5

6. Remove the Collar halves with a 9/64" hex wrench and set them aside.
7. Remove the FT 026 Port Plug with a small flat-head screw driver.

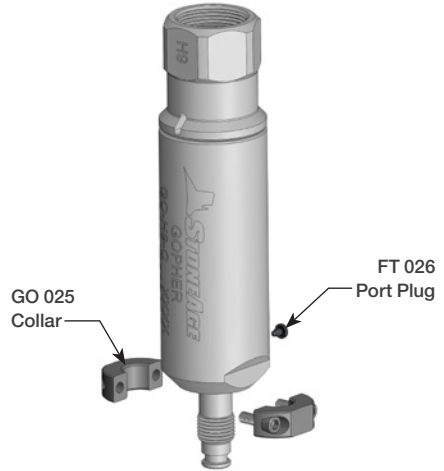

Figure 6: For Steps 6-7

8. Remove the BC 505-S High Pressure Seal Subassembly by first removing the BJ 417 O-Ring with a pick, then remove the body from the vice and tap the Inlet Nut side on a flat surface so the seal stack will drop out.

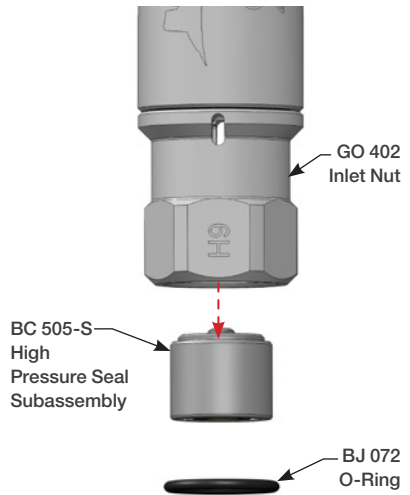

Figure 7: For Step 8

40K (2800 bar) GO-H9-C DISASSEMBLY

9. Clamp Inlet Nut flats in the vice so the top of the Shaft Assembly is facing up. Using an adjustable wrench on the wrench flats of the Body, loosen the Body from the Inlet Nut. Remove the tool from the vice and continue to unscrew the Body from the Inlet Nut. Lubricant may drain out and this is normal.
10. Slide the Shaft Seal Assembly out of the Body.

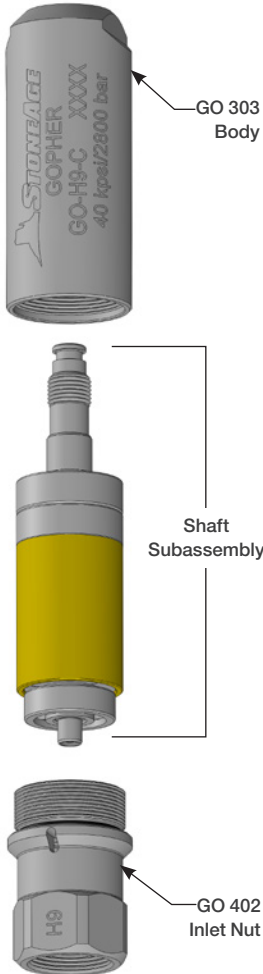

Figure 8: For Steps 9-10

11. Remove the two RJ 007 Bearings from the Shaft Assembly.
12. Slide the BC 230 Brass Sleeve off the Body.
13. Remove the RJ 009 Bearing Ring from the Shaft.

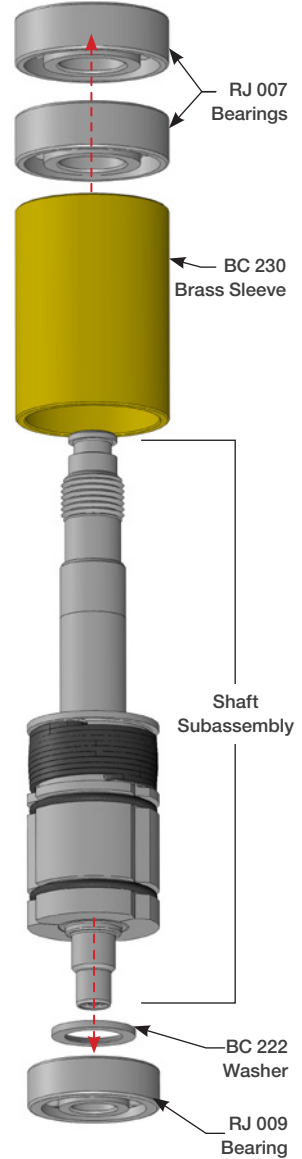

Figure 9: For Steps 11-13

14. With a pick, remove the first spring end from the Weight set and set the Weight Set aside.
15. Remove the second spring end from the Shaft and set the Spring and Shaft aside.

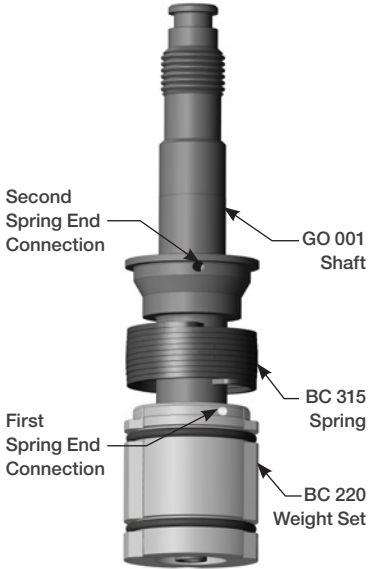

Figure 10: For Steps 14-15

16. Remove the RJ 029 Shaft Seal from the GO 303 Body with Snap Ring Pliers.



Figure 11: For Step 16

17. Remove the MT 010 Shaft Seal from the GO 002 Inlet Nut with a pick or Snap Ring Pliers.
18. Remove the RJ 008 O-Ring from the GO 002 Inlet Nut threads.



Figure 12: For Steps 17-18

NOTICE

Before reassembly of the tool
Wash all parts in solvent and blow dry
and

Inspect wear items, (High Pressure Seal
Assembly, O-Rings, and Port Screw.)

See the "Maintenance Kits" section of this
manual for a complete list of Service, Overhaul,
and, Tool kits.

40K (2800 bar) GO-H9-C GO-MP9 ASSEMBLY

ASSEMBLY

1. Lubricate the RJ 029 and MT 010 Shaft Seals with P-80® Grip-IT Lubricant or equivalent.
2. Put the MT 010 Shaft Seal on the MT 105 tool (LIP SIDE UP) and using an Arbor press, press the seal into the Body.
3. Put the RJ 029 Shaft Seal on the RJ 105 tool (LIP SIDE DOWN) and using an Arbor press, press the seal into the Body.

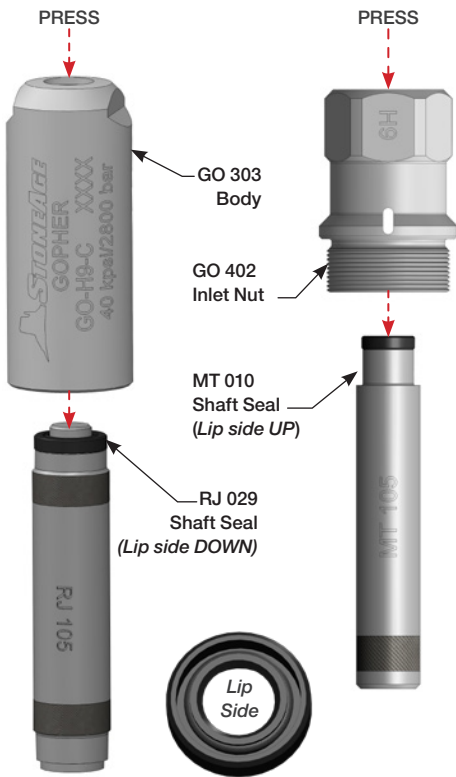

Figure 13: For Steps 1-3

4. Grease the RJ 008 O-Ring with Blue Goop and install it at the base of the threads on the GO 402 Inlet Nut.



Figure 14: For Step 4

5. Install the two RJ 007 Bearing Rings onto the Shaft with the Wide Inner Races facing the Shoulder.

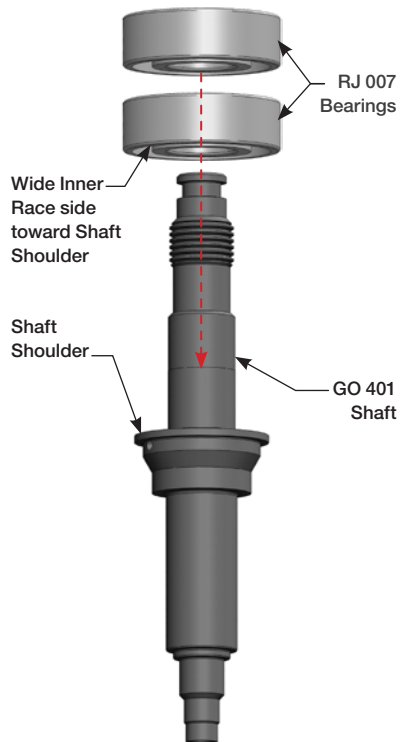

Figure 15: For Step 5

6. Install the first Spring end into the hole in the Weight set.

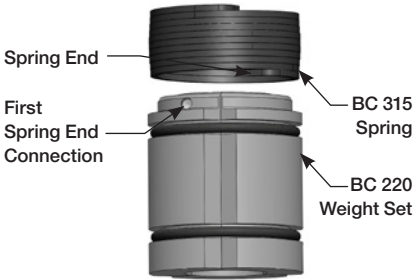

Figure 16: For Step 6

7. Slide the Spring/Weight set onto the Shaft and connect the second spring end into the hole on the Shaft.
8. Twist the Shaft and Weight assemblies to make sure the Spring is engaged in both ends.

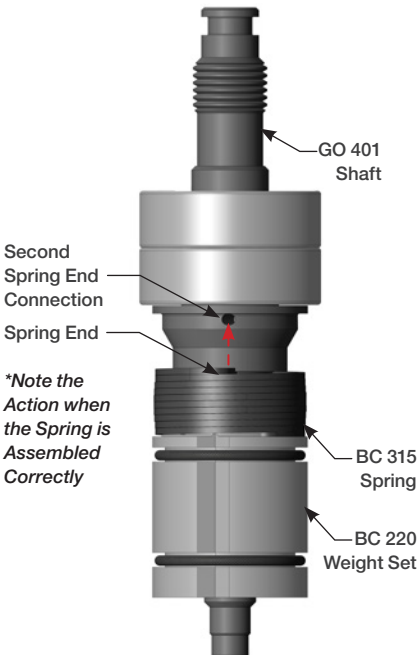

Figure 17: For Steps 7-8

9. Replace the Brass Sleeve and Shim Washer on the Shaft. **The chamfer side of the Washer faces the Weight Set*

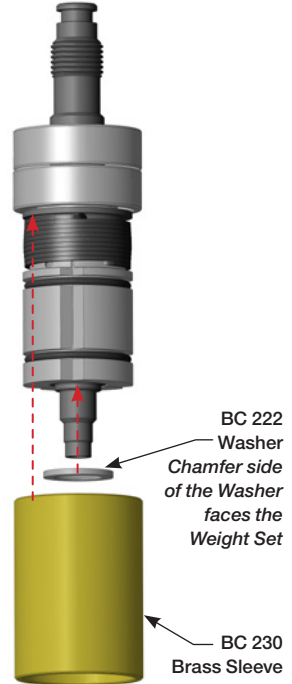

Figure 18: For Step 9

10. Replace the BC 009 Bearing Ring over the BC 222 Washer.

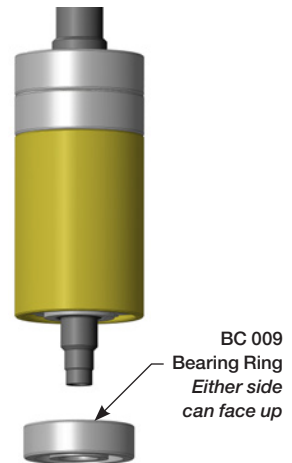

Figure 19: For Step 10

40K (2800 bar) GO-H9-C ASSEMBLY

11. Prepare the Body by greasing the Shaft Seal from Both ends.
12. Slide the Shaft Assembly into the Body.

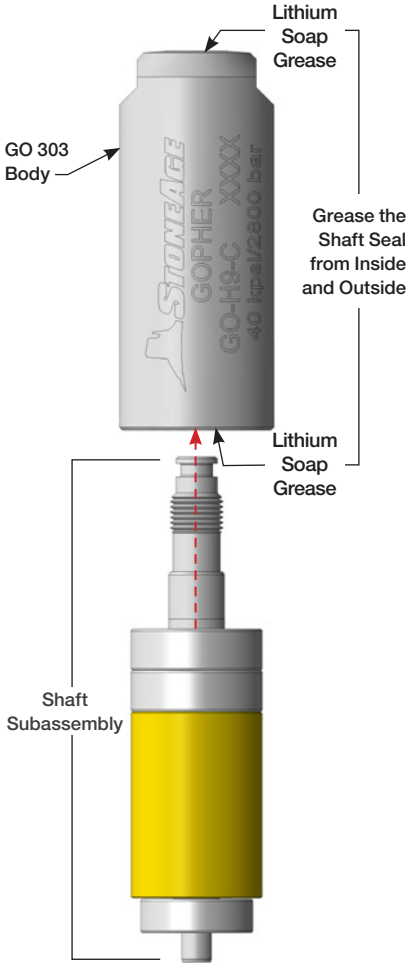

Figure 20: For Steps 11-12

13. Clamp the wrench flats on the Body toward one side of a vice, so that the Shaft can be easily rotated by hand.
14. Fill the tool with 10-40 lubricant.
15. Remove the tool from the vice and rotate the Shaft in the Body to allow the lubricant to settle inside the tool.

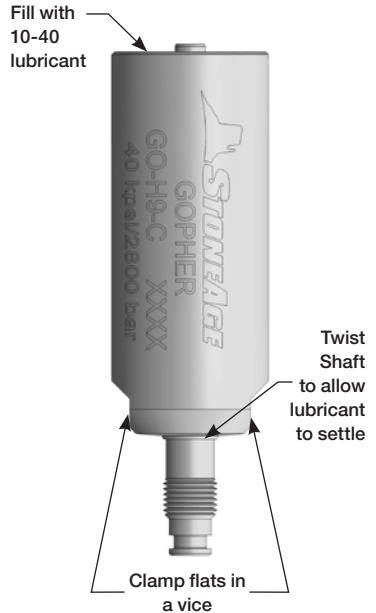

Figure 21: For Steps 13-15

16. Replace the Port Screw and continue to fill and twist until lubricant covers the top bearing

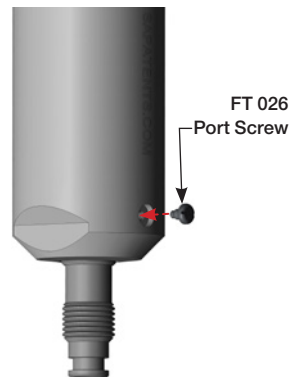

Figure 22: For Step 16

17. Prepare the Inlet Nut by greasing the Shaft Seal and applying the Anti-seize to the threads of the Inlet Nut.
18. With the Body flats still secured in the vice, Screw in the Inlet Nut and tighten with an adjustable wrench.



Figure 23: For Steps 17-18

19. Drop the BC 505-S High Pressure Seal Cartridge into the Shaft with the O-Ring end facing up.
20. Place the New BC 417 O-Ring in the Inlet Nut to hold the seal stack in place. Use a pick to make certain the O-Ring is nestle in the Groove inside the Inlet Nut.



Figure 24: For Steps 19-20

40K (2800 bar) GO-H9-C ASSEMBLY

- Place the tool in the vice with the head end up. Loosen the Port Screw to allow the air to escape (burp) and tighten the screw.



Figure 25: For Step 21

- Slip the Backup O-Ring onto the Shaft first with the flat side down and concave side up to receive the regular O-Ring.

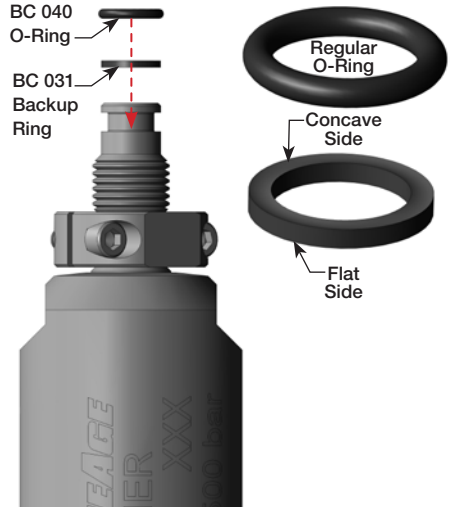

Figure 27: For Step 23

- Replace the Collar halves and tighten evenly with 9/64" hex wrench. Make certain the gap is the same on both sides when tight.



TECH TIP: Use a pick to measure the gap on each side.

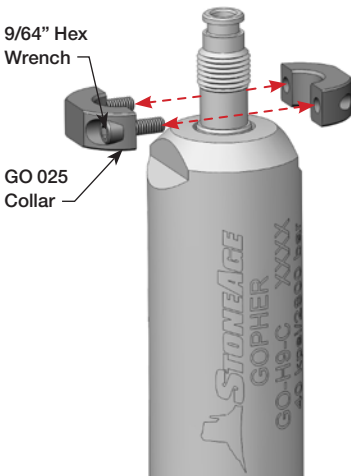

Figure 26: For Step 22

- Grease the O-Rings.
- Apply Anti-seize to the threads and screw the head onto the tool.
- Place the flats on the Head in a vice and Tighten with an adjustable wrench.

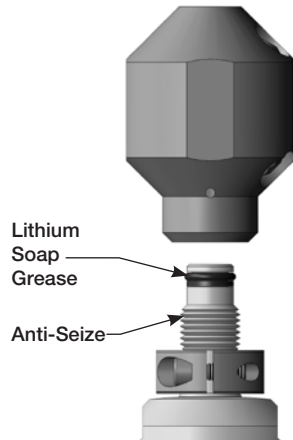

Figure 28: For Steps 24-26

40K (2800 bar) GO-H9-C MAINTENANCE KITS

KITS	PART NUMBER OVERVIEW	
<p>GO 600-H9-C SERVICE KIT</p> <ul style="list-style-type: none"> 1 BC 505-S Cartridge Assy w/ Spring 1 FT 026 Port Screw w/ O-Ring 1 FT 110 Syringe Assy 1 GP 044 10W-40 Lubricant, 32 oz 1 PL 674 Gopher Family User Manual 		
<p>BC 602-H9-C SEAL KIT</p> <ul style="list-style-type: none"> 1 BC 414 Mandrel- Cartridge Assembly 1 BC 506 Seat Face 1 BC 511 Carbide Seat- 40kpsi 1 BC 512-O HP Seal Assembly- 40kpsi 1 BC 520 Seal Retainer-40kpsi 1 BC 522-001 Grooved Inlet Spring 1 BC 524 Cmpression Spring 1 PL 512 BC 505-S Insert 1 BJ 072 O-Ring 1 BJ 417 O-Ring 1 PL 512 BC 505-S Manual Insert 		
<p>GO 610-H9-C OVERHAUL KIT</p> <ul style="list-style-type: none"> 1 BC 009 Bearing, Ball, JEM 1 BC 031 Back-up Ring 1 BC 040 O-Ring 1 BC 222 Washer 1 BC 230 Bronze Sleeve 1 BC 315 Spring 1 BC 505-S Cartridge Assy w/ Spring 1 BJ 062-S Antiseize, 2g 1 FT 026 Port Screw w/ O-Ring 1 GP 044 10W-40 Lubricant, 32 oz 1 MT 010 Seal, Shaft Small 1 PL 674 Gopher Family User Manual 1 PL 512 BC 505-S Insert 1 RJ 007 Bearing, Thrust 1 RJ 008 O-Ring 1 RJ 029 Seal Piston 		
<p>GO 612 TOOL KIT</p> <ul style="list-style-type: none"> 1 MT 105 Seal Press Tool 1 RJ 105 Seal Press Tool 		

CENTRALIZER OPTIONS

A centralizer helps to protect the tool as it passes through the pipe and balances jet standoff distance for more consistent cleaning. In cases where pipe size is more than 1.5 times the diameter of the tool, a centralizer is an important safety device, preventing the tool from turning around and thrusting backwards out of the pipe.

Two types of centralizers are available for Gopher tools

CENTRALIZER WITH SKIDS AND COLLARS				
Pipe Size	Centralizer (Complete)	Weight	Collar*	Skid**
4 in. 100 mm	GO 070-4	1.4 lb 0.6 kg	GO 070.1	RJ 070.2-4
5 in. 127 mm	GO 070-5	1.6 lb 0.7 kg	GO 070.1	RJ 070.2-5
6 in. 152 mm	GO 070-6	1.9 lb 0.9 kg	GO 070.1	RJ 070.2-6
8 in. 203 mm	GO 070-8	2.2 lb 1.0 kg	GO 070.1	RJ 070.2-8
12 in. 305 mm	GO 070-12	4.0 lb 1.8 kg	GO 070.1	RJ 070.2-12

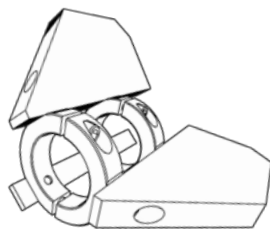

*Set of 2 collars **Set of 3 skids with 6 screws

PLASTIC CENTRALIZER WITH SET SCREWS		
Pipe Size	Centralizer (Complete)	Weight
3 in. 76 mm	GO 075-3	0.3 lb 0.1 kg
4.5 in. 114 mm	GO 075-4.5	0.4 lb 0.2 kg

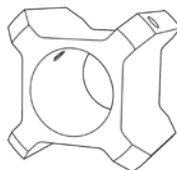

STORAGE

A Pelican™ brand protection/carrying case with custom cut foam insert is available for Gopher tool models.

CARRYING CASE			
Exterior Dimensions (L x W x D)	Interior Dimensions (L x W x D)	Color	Case Part ID
11.6 x 8.3 x 3.8 in. 29.6 x 21.2 x 9.6 cm	10.5 x 6.0 x 3.2 in. 26.8 x 15.3 x 8.0 cm	Black	BC 080

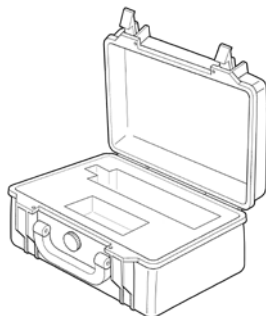

SAFETY OPTIONS

Backout preventers increase operator safety by keeping the tool from backing out of the pipe. Several options are available including fixtures for small diameter pipes, pipes with various flange bolt circle diameters, and adapters for pipes with no-flange entry.

BACKOUT PREVENTERS				
Pipe Size	Hose OD	Backout Preventer	Description	Weight
2–6 in. 51–150 mm	0.3–0.7 in. 8–18 mm	BJ 305*	Backout preventer for small pipes	5.6 lb 2.5 kg
4–8 in. 100–200 mm	0.3–1.5 in. 8–38 mm	BJ 310	Backout preventer for small to medium pipes	7.6 lb 3.4 kg
5–17 in. 130–430 mm	0.3–1.5 in. 8–38 mm	BJ 320	Backout preventer for medium to large pipes	6.3 lb 2.9 kg
15–36 in. 380–910 mm	N/A	BJ 325	Extension kit for BJ 320 backout preventer	8.5 lb 3.6 kg
8–36 in. 130–910 mm	N/A	BJ 340	No-flange kit for BJ 320 backout preventer	17 lb 7.7 kg

*Securing device not supplied

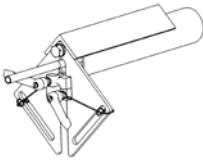

BJ 305

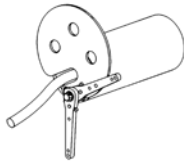

BJ 310

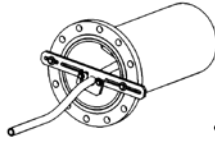

BJ 320

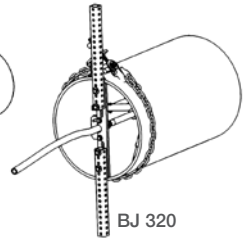

BJ 320
shown with BJ 325
extension kit and BJ 340
No-flange attachment kit

MAINTENANCE RESOURCES

Complete part breakdowns of each kit are available in the “Maintenance Kits” sections in this manual. Kit components and tool maintenance/assembly videos are also available on our website: WWW.STONEAGETOOLS.COM

For questions or help with a specific application, configuration or tool repairs, please contact StoneAge Customer Service.

KITS						
Swivel	Service Kit	Seal Kit	Overhaul Kit	Tool Kit	Lubricant	Manual
GO-MP9	GO 600	GO 602	GO 610	GO 612	GP 044	PL 674
GO-H9-C	GO 600-H9-C	BC 602-H9-C	GO 610-H9-C	GO 612	GP 044	PL 674

TERMS AND CONDITIONS AND WARRANTY INFORMATION

1. Acceptance of Terms and Conditions. Receipt of these Terms and Conditions of Sale ("Terms and Conditions") shall operate as the acceptance by StoneAge, Inc. ("Seller") of the order submitted by the purchaser ("Buyer"). Such acceptance is made expressly conditional on assent by Buyer to these Terms and Conditions. Such assent shall be deemed to have been given unless written notice of objection to any of these Terms and Conditions (including inconsistencies between Buyer's purchase order and this acceptance) is given by Buyer to Seller promptly on receipt hereof.

Seller desires to provide Buyer with prompt and efficient service. However, to individually negotiate the terms of each sales contract would substantially impair Seller's ability to provide such service. Accordingly, the product(s) furnished by Seller are sold only according to the terms and conditions stated herein and with the terms and conditions stated in any effective StoneAge Dealer Agreement or StoneAge Reseller Agreement, if applicable. Notwithstanding any terms and conditions on Buyer's order, Seller's performance of any contract is expressly made conditional on Buyer's agreement to these Terms and Conditions unless otherwise specifically agreed to in writing by Seller. In the absence of such agreement, commencement of performance, shipment and/or delivery shall be for Buyer's convenience only and shall not be deemed or construed to be an acceptance of Buyer's terms and conditions.

2. Payment/Prices. Unless other arrangements have been made in writing between Seller and Buyer, payment for the product(s) shall be made upon receipt of invoice. The prices shown on the face hereof are those currently in effect. Prices invoiced shall be per pricelist in effect at the time of shipment. Prices are subject to increase for inclusion of any and all taxes which are applicable and which arise from the sale, delivery or use of the product(s), and the collection of which Seller is or may be responsible to provide to any governmental authority, unless acceptable exemption certificates are provided by Buyer in accordance with applicable law. Buyer shall pay all charges for transportation and delivery and all excise, order, occupation, use or similar taxes, duties, levies, charges or surcharges applicable to the product(s) being purchased, whether now in effect or hereafter imposed by any governmental authority, foreign or domestic.

3. Warranty. SELLER MAKES NO WARRANTIES OR REPRESENTATIONS AS TO THE PERFORMANCE OF ANY PRODUCT EXCEPT AS SET FORTH IN THE STONEAGE LIMITED WARRANTY PROVIDED WITH THE PRODUCT.

4. Delivery. Seller is not obligated to make delivery by a specified date, but will always use its best efforts to make delivery within the time requested. The proposed shipment date is an estimate. Seller will notify Buyer promptly of any material delay and will specify the revised delivery date as soon as practicable. UNDER NO CIRCUMSTANCES SHALL SELLER HAVE ANY LIABILITY WHATSOEVER FOR LOSS OF USE OR FOR ANY DIRECT OR CONSEQUENTIAL DAMAGES RESULTING FROM DELAY REGARDLESS OF THE REASON(S).

All product(s) will be shipped F.O.B. point of origin, unless specifically agreed otherwise, and Buyer shall pay all shipping costs and insurance costs from that point. Seller, in its sole discretion, will determine and arrange the means and manner of transportation of the product(s). Buyer shall bear all risk of loss commencing with the shipment or distribution of the product(s) from Seller's warehouse. Order shortages or errors must be reported within fifteen (15) business days from receipt of shipment to secure adjustment. No product(s) may be returned without securing written approval from Seller.

5. Modification. These Terms and Conditions are intended by Seller and Buyer to constitute a final, complete and exclusive expression of agreement relating to the subject matter hereof and cannot be supplemented or amended without Seller's prior written approval.

6. Omission. Seller's waiver of any breach or Seller's failure to enforce any of these Terms and Conditions at any time, shall not in any way affect, limit or waive Seller's right thereafter to enforce and compel strict compliance with every term and condition hereof.

7. Severability. If any provision of these Terms and Conditions is held to be invalid or unenforceable, such invalidity or unenforceability shall not affect the validity or enforceability of the other portions hereof.

8. Disputes. Seller and Buyer shall attempt in good faith to promptly resolve any dispute arising under these Terms and Conditions by negotiations between representatives who have authority to settle the controversy. If unsuccessful, Seller and Buyer shall further attempt in good faith to settle the dispute by nonbinding third-party mediation, with fees and expenses of such mediation apportioned equally to each side. Any dispute not so resolved by negotiation or mediation may then be submitted to a court of competent jurisdiction in accordance with the terms hereof. These procedures are the exclusive procedures for the resolution of all such disputes between the Seller and Buyer.

9. Governing Law. All sales, agreements for sale, offers to sell, proposals, acknowledgments and contracts of sale, including, but not limited to, purchase orders accepted by Seller, shall be considered a contract under the laws of the State of Colorado and the rights and duties of all persons, and the construction and effect of all provisions hereof shall be governed by and construed according to the laws of such state.

STONEAGE TRADEMARK LIST

View the list of StoneAge's trademarks and service marks and learn how the trademarks should be used. Use of StoneAge trademarks may be prohibited, unless expressly authorized.

<http://www.StoneAgetools.com/trademark-list/>

STONEAGE PATENT DATA

View the list of StoneAge's current U.S. patent numbers and descriptions.

<http://www.sapatents.com>

STONEAGE TERMS AND WARRANTY

View StoneAge's Terms and Warranty Conditions online.

<http://www.stoneagetools.com/terms>

<http://www.stoneagetools.com/warranty>

10. Jurisdiction and Venue. Seller and Buyer agree that the state or federal courts located within the City and County of Denver, Colorado shall have sole and exclusive jurisdiction over any litigation concerning any dispute arising under these Terms and Conditions not otherwise resolved pursuant to Section 9 as well as any alleged defects of any Products or damages sustained as a result of such alleged defects. Seller and Buyer further agree that should any litigation be commenced in connection with such a dispute, it shall only be commenced in such courts. Seller and Buyer agree to the exclusive jurisdiction of such courts and neither will raise any objection to the jurisdiction and venue of such courts, including as a result of inconvenience.

11. Attorney's Fees. If any litigation is commenced between Seller and Buyer, or their personal representatives, concerning any provision hereof, the party prevailing in the litigation shall be entitled, in addition to such other relief that is granted, to a reasonable sum as and for their attorneys' fees and costs in such litigation or mediation.

WARRANTY:

Warranties set forth herein extend only to End-Users, meaning customers acquiring, or that have previously acquired, a product manufactured by StoneAge ("Product") for their own use and not for resale, either directly from StoneAge Inc. ("StoneAge") or from a StoneAge Authorized Dealer or Reseller ("Dealer"). No warranty of any kind or nature is made by StoneAge beyond those expressly stated herein.

1. LIMITED WARRANTY PERIOD. Subject to the limitations and conditions hereinafter set forth, StoneAge warrants its Product to be free from defects in workmanship and material for a period of one (1) year from the date of purchase by the End-User, provided that the end of the limited warranty period shall not be later than eighteen (18) months from the date of shipment of the Product to the Dealer or the End-User by StoneAge ("Limited Warranty Period"). All replacement parts which are furnished under this Limited Warranty and properly installed shall be warranted to the same extent as the original Product under this Limited Warranty if, and only if, the original parts were found to be defective within the original Limited Warranty Period covering the original Product. Replacement parts are warranted for the remainder of the original Limited Warranty Period. This Limited Warranty does not cover any component part of any Product not manufactured by StoneAge. Any such component part is subject exclusively to the component manufacturer's warranty terms and conditions.

2. LIMITED WARRANTY COVERAGE. StoneAge's sole obligation under this Limited Warranty shall be, at StoneAge's option and upon StoneAge's inspection, to repair, replace or issue a credit for any Product which is determined by StoneAge to be defective in material or workmanship. StoneAge reserves the right to examine the alleged defective Product to determine whether this Limited Warranty is applicable, and final determination of limited warranty coverage lies solely with StoneAge. No statement or recommendation made by a StoneAge representative, Dealer or agent to End-User shall constitute a warranty by StoneAge or a waiver or modification to any of the provisions hereof or create any liability for StoneAge.

3. WARRANTY SERVICE PROVIDERS. Service and repair of the Product is to be performed only by StoneAge authorized service representatives, including Dealers who are authorized repair centers, with StoneAge approved parts. Information about StoneAge authorized service representatives can be obtained through the StoneAge website at www.stoneagetools.com/service. Unauthorized service, repair or

modification of the Product or use of parts not approved by StoneAge will void this Limited Warranty. StoneAge reserves the right to change or improve the material and design of the Product at any time without notice to End-User, and StoneAge is not obligated to make the same improvements during warranty service to any Product previously manufactured.

4. WARRANTY EXCLUSIONS. This Limited Warranty does not cover, and StoneAge shall not be responsible for the following, or damage caused by the following: (1) any Product that has been altered or modified in any way not approved by StoneAge in advance in writing; (2) any Product that has been operated under more severe conditions or beyond the rated capacity specified for that Product; (3) depreciation or damage caused by normal wear and tear, failure to follow operation or installation instructions, misuse, negligence or lack of proper protection during storage; (4) exposure to fire, moisture, water intrusion, electrical stress, insects, explosions, extraordinary weather and/or environmental conditions including, but not limited to lightning, natural disasters, storms, windstorms, hail, earthquakes, acts of God or any other force majeure event; (5) damage to any Product caused by any attempt to repair, replace, or service the Product by persons other than StoneAge authorized service representatives; (6) costs of normal maintenance parts and services; (7) damage sustained during unloading, shipment or transit of the Product; or (8) failure to perform the recommended periodic maintenance procedures listed in the Operator's Manual accompanying the Product.

5. REQUIRED WARRANTY PROCEDURES. To be eligible for warranty service, the End-User must: (1) report the Product defect to the entity where the Product was purchased (i.e. StoneAge or the Dealer) within the Limited Warranty Period specified in this Limited Warranty; (2) submit the original invoice to establish ownership and date of purchase; and (3) make the Product available to a StoneAge authorized service representative for inspection to determine eligibility for coverage under this Limited Warranty. This Limited Warranty shall not extend to any person or entity who fails to provide proof of original purchase from StoneAge or a Dealer. No Product may be returned for credit or adjustment without prior written permission from StoneAge.

TERMS AND CONDITIONS AND WARRANTY INFORMATION

6. **DISCLAIMER OF IMPLIED WARRANTIES AND OTHER REMEDIES.** EXCEPT AS EXPRESSLY STATED HEREIN (AND TO THE FULLEST EXTENT ALLOWED UNDER APPLICABLE LAW), STONEAGE HEREBY DISCLAIMS ALL OTHER WARRANTIES, EXPRESS OR IMPLIED, INCLUDING WITHOUT LIMITATION ALL IMPLIED WARRANTIES OF MERCHANTABILITY OR FITNESS FOR A PARTICULAR PURPOSE, AND ANY AND ALL WARRANTIES, REPRESENTATIONS OR PROMISES AS TO THE QUALITY, PERFORMANCE OR FREEDOM FROM DEFECT OF THE PRODUCT COVERED BY THIS LIMITED WARRANTY. STONEAGE FURTHER DISCLAIMS ALL IMPLIED INDEMNITIES.

7. **LIMITATION OF LIABILITY.** End-User specifically acknowledges that the Product may be operated at high speeds and/or pressures, and that as such it may be inherently dangerous if not used correctly. End-User shall familiarize itself with all operation materials provided by StoneAge and shall at all times use and require its agents, employees and contractors to use all necessary and appropriate safety devices, guards and proper safe operating procedures. In no event shall StoneAge be responsible for any injuries to persons or property caused directly or indirectly by the operation of the Product if End-User or any agent, employee, or contractor of End-User: (1) fails to use all necessary and appropriate safety devices, guards and proper safe operating procedures; (2) fails to maintain in good working order such safety devices and guards; (3) alters or modifies the Product in any way not approved by StoneAge in advance in writing; (4) allows the Product to be operated under more severe conditions or beyond the rated capacity specified for the Product; or (5) otherwise negligently operates the Product. End-User shall indemnify and hold StoneAge harmless from any and all liability or obligation incurred by or against StoneAge, including costs and attorneys' fees, to or by any person so injured.

TO THE FULL EXTENT ALLOWED BY APPLICABLE LAW, STONEAGE SHALL NOT BE LIABLE FOR ANY INDIRECT, SPECIAL, INCIDENTAL, CONSEQUENTIAL, OR PUNITIVE DAMAGES (INCLUDING WITHOUT LIMITATION, LOSS OF PROFITS, LOSS OF GOODWILL, DIMINUTION OF VALUE, WORK STOPPAGE, INTERRUPTION OF BUSINESS, RENTAL OF SUBSTITUTE PRODUCT, OR OTHER COMMERCIAL LOSS EVEN TO THE EXTENT SUCH DAMAGES WOULD CONSTITUTE DIRECT DAMAGES), WITH RESPECT TO THE COVERED STONEAGE PRODUCT, OR OTHERWISE IN CONNECTION WITH THIS LIMITED WARRANTY, REGARDLESS OF WHETHER STONEAGE HAS BEEN

ADVISED OF THE POSSIBILITY OF SUCH DAMAGES.

IT IS UNDERSTOOD THAT STONEAGE'S LIABILITY, WHETHER IN CONTRACT, IN TORT, UNDER ANY WARRANTY, IN NEGLIGENCE, OR OTHERWISE SHALL NOT EXCEED THE AMOUNT OF THE PURCHASE PRICE PAID BY THE END-USER FOR THE PRODUCT. STONEAGE'S MAXIMUM LIABILITY SHALL NOT EXCEED, AND END-USER'S REMEDY IS LIMITED TO EITHER (1) REPAIR OR REPLACEMENT OF THE DEFECTIVE WORKMANSHIP OR MATERIAL OR, AT STONEAGE'S OPTION, (2) REFUND OF THE PURCHASE PRICE, OR (3) ISSUANCE OF A CREDIT FOR THE PURCHASE PRICE, AND SUCH REMEDIES SHALL BE END-USER'S ENTIRE AND EXCLUSIVE REMEDY.

YOU, THE END-USER, UNDERSTAND AND EXPRESSLY AGREE THAT THE FOREGOING LIMITATIONS ON LIABILITY ARE PART OF THE CONSIDERATION IN THE PRICE OF THE STONEAGE PRODUCT YOU PURCHASED.

Some jurisdictions do not allow the limitation or exclusion of liability for certain damages, so the above limitations and exclusions may not apply to you. This Limited Warranty gives you specific legal rights, and you may also have other rights which vary from jurisdiction to jurisdiction. If any provisions of this Limited Warranty is held to be invalid or unenforceable, such invalidity or unenforceability shall not affect the validity or enforceability of the other portions hereof.



1-866-795-1586 • www.STONEAGETOOLS.com

© 2019 StoneAge, Inc. All Rights Reserved