

# GSM DOOR INTERCOM SYSTEM



TECHNICAL MANUAL  
EDITION 1.2.1

**VIDEX**  
The Power to Secure



# CONTENTS

	<b>PAGE</b>
Manual introduction	4
System introduction	4
Precautionary advice	5
System components	6 – 13
Intercom module	6 – 7
Expansion button modules	8 - 9
VX800 Codelock	10 - 12
Door panel mounting frames	13
Power supply	13
Wiring diagrams	14
Accessories wiring guide	15
Cable guide	16
Installation overview	16
Panel care	16
Testing, power up and reset	17
Programming	18 – 27
Programming by text message	18 – 24
Programming by dial in	25 – 27
System operation	28 - 29
User commands	28
Checking the balance of a Pay As You Go SIM	29
Understanding the signal strength test	29
Dial in priority	29
Call button record keeping table	30
Dial in access control record keeping table	30 - 31
Understanding the beeps	32
Troubleshooting guide	33
Conformance information	34
Software updates	35

## MANUAL INTRODUCTION

The information in this manual is intended as an installation and commissioning guide for the GSM door intercom system. This manual should be read carefully before the installation commences. Any damage caused to the equipment due to faulty installations where the information in this manual has not been followed is not the responsibility of Videx Security Ltd.

VIDEX run free training courses for engineers who have not installed this system before. Technical help is also available on 0191 224 3174 during office hours or via e-mail [tech@videx-security.com](mailto:tech@videx-security.com).

## SYSTEM INTRODUCTION

The system is designed to work on the same technology as mobile phones. It enables a call to be made from an entry point (Door, gate etc), to any telephone number (mobile or land line). Up to ten call buttons can be connected to the door panel, each able to call two telephone numbers (If the first is busy or not answered, the call can be diverted to the second). Features of the system include a dry contact relay output, an open collector auxiliary output, push to exit input and switched 0V auxiliary input. Programming of the telephone numbers and additional features can be carried out via text messaging or dial in. An additional access control feature is also available on the system allowing a number of callers to open the gate/door simply by dialling the telephone number of the intercom panel (The intercom panel will not answer these calls but will activate the relay output).

A SIM card is required for this product but not supplied. It is recommended to choose the SIM card which has the best coverage for the area in which the intercom panel will be installed. Both contract and 'Pay as you go' SIM cards can be used but if using a 'Pay as you go' we would recommend setting up an automatic top up to avoid running short on credit and losing the use of the intercom panel. Alternatively if you already have a contract mobile phone it should be possible to get a second SIM card and telephone number on the existing account. For more information contact the SIM card providers or visit their web sites.

When registering a new SIM you may be asked for the IMEI number. This is the unique serial number of the GSM intercom and can be found on the rear of the module as shown in the picture below:-



## PRECAUTIONARY ADVICE

- When mounting the GSM antenna, choose a location which is away from human interaction and away from the intercom panel. Route the GSM antenna cable from the intercom panel so that it is separate from the power supply cables and microphone wire.
- Always ensure the power is off to the intercom panel before inserting or removing the SIM card.
- New SIM cards will need registering before they can be used. Full details of how this is done can normally be found in the SIM card pack. It will normally require that the SIM card is inserted into a mobile phone, a number dialled and instructions followed. While the SIM is in the mobile phone it would be a good time to disable any PIN codes, call diverts, ring back and disable features such as voicemail and text alerts. Details of how to do this can be found on the SIM card provider's web site or by calling their customer services. Please use one of the following SIM card providers (Vodafone, T-Mobile, O2 or Orange). We do not recommend using 3 at this present time.
- To be able to receive text messages from the intercom panel, the SIM card will require an SMS service centre number. This is normally preinstalled on new SIM cards but if you are having trouble receiving SMS messages you will need to confirm this by inserting the SIM card into a telephone and using the telephones menu options to check it. If a number is not programmed then it should be programmed while in the telephone (The number can be obtained from the service provider).
- Voicemail and text alerts must be switched off on the SIM card when using the dial in to release the door/gate feature. For Vodafone and O2 this can be done while the SIM card is in the intercom panel. For Orange and T-Mobile the SIM card must be remove and put into a mobile phone.
- When storing the intercom panel's telephone number in your own mobile phone avoid using an obvious name such as 'Front Door, or 'My Gate' as this would make it easy to decipher if your phone was lost or stolen.
- The PIN request feature must be disabled on the SIM card before using it in the Intercom panel. It is likely on a new SIM card that it will not be enabled but if it is, it will prevent the system from working at all.
- This product may not be suitable for installation in hospitals, health care facilities or in the presence of flammable gases or liquids. Seek advice and authorisation before installing this product in these locations.

### IMPORTANT NOTE ABOUT SIM CARD

When using a pay monthly SIM card you must ask the service provider to put a spend limit on the account (Vodafone call this service 'spend checker'). This is to safeguard against possible problems which could result in a large phone bill at the end of the month. All providers offer this service. You will need to either ring them or e-mail them to set this up. Automatic top ups should also have a monthly limit.

## SYSTEM COMPONENTS

A system comprises of an intercom panel, power supply, SIM card and antenna. The intercom panel is of modular design allowing it to be customised to the installation requirements by including proximity access control, coded access or bioaccess and also including the correct number of call buttons.

## INTERCOM MODULE

The intercom panel can include any of the modules from the 4000 Series range and uses the standard 4000 series surface and flush mounting frames. The GSM amplifier module is however essential and includes all the GSM communication electronics, SIM card (Supplied separately) and connections. The intercom module is available in a 0 button, 1 button, 2 button, & 4 button configuration as shown below along with their part numbers.

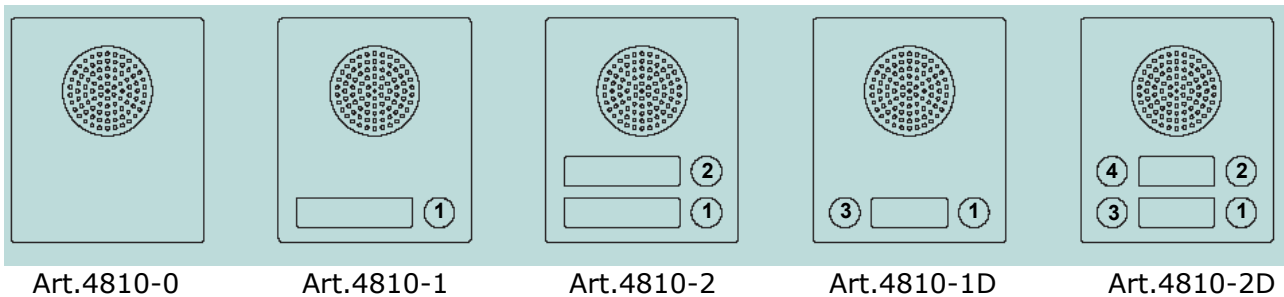

## JUMPER SETTINGS

There are 3 jumpers located on the back of the module. JP2 & JP3 can be used to alter the volume from the Door Intercom speaker. JP1 is set to indicate the type of power supply used to power the system.

### POWER SUPPLY SELECTION

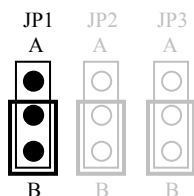

JP1	POWER SUPPLY TYPE
A	12-14.0Vdc Only
B	15-24Vdc or 13Vac Only

Note: PSU should be capable of supplying a current of 1A continuously

### SPEAKER VOLUME

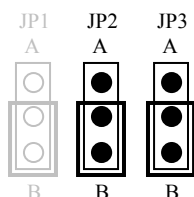

JP2	JP3	GAIN (dB)
B	B	6
A	B	12
B	A	18
A	A	23.5

CONNECTION	DESCRIPTION	
12Vout	12Vdc output to power auxiliary relay	
0V	Ground connection	
e	a – e are switched 0V inputs from the call buttons. The common side of the call buttons connects to either C1 or C2 (C1 with a-e for buttons 1-5, C2 with a-e for buttons 6-10)	
d		
c		
b		
a		
C2	Common 2 for call buttons 6-10 & AI(SMS sent)	
C1	Common 1 for call buttons 1-5 & PTE & AI(AO Output trigger)	
PTE	Exit button input (Between PTE & C1) Triggers relay for programmed time.	
AI	Auxiliary input (Between AI & C1 triggers AO, Between AI & C2 sends an SMS to the number stored in memory location 020)	
AO	0V auxiliary output (Open collector) Max. 150mA	
C	Common connection of dry contact relay	Relay contacts: 3A@24Vdc 3A@120Vac
NO	Normally open connection of dry contact relay	
NC	Normally closed connection of dry contact relay	
Vin	Power supply input (See JP1 table above for correct voltage)	
Vin	Power supply input (See JP1 table above for correct voltage)	

### ANTENNA

The GSM antenna connects to the SMA female bulkhead on the rear of the module. A GSM antenna with a SMA male connector should be used. A block style antenna is supplied along with an L mounting bracket. Other types on GSM antenna can also be used.

**Note: An antenna must always be connected.**

**Note: Always route the GSM cable away from the microphone wires and the power supply wires to avoid interference on the speech channels.**

## EXTENSION BUTTON MODULES

The GSM intercom module will accept up to ten call buttons. Any of the standard 4000 series button modules can be used as shown below (Button 1 is in the bottom right corner counting up).

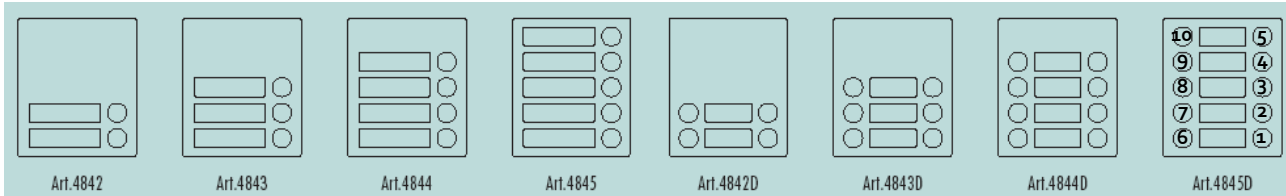

Button connections to the GSM module are shown below. Note the positions of the jumpers on the button modules (Note: For clarity power and other connections are not shown below). Also take care when using additional button modules with intercom modules which also have buttons. For example, an intercom module with one button means the extension button modules must begin from button 2, an intercom module with 2 buttons means the extension module must begin from button 3.

Up to 5 call buttons using a single row button module

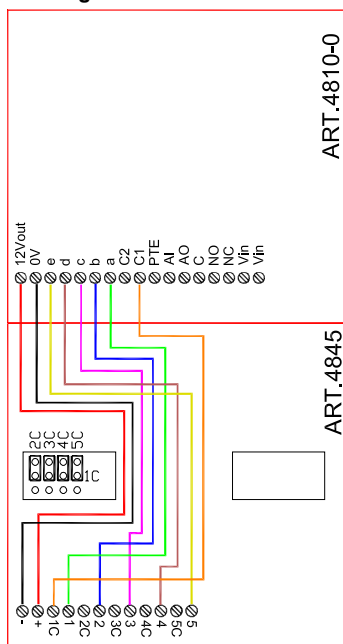

Up to 10 call buttons using a double row button module

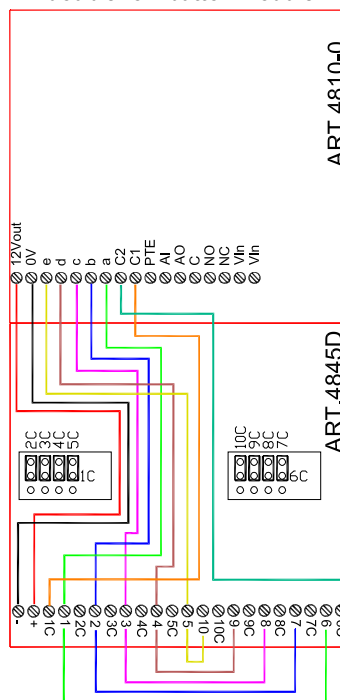

Up to 10 call buttons using the single row button modules

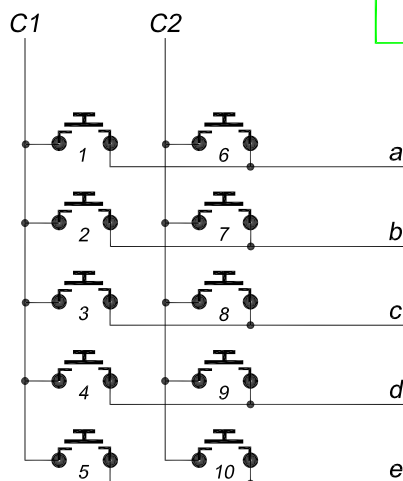
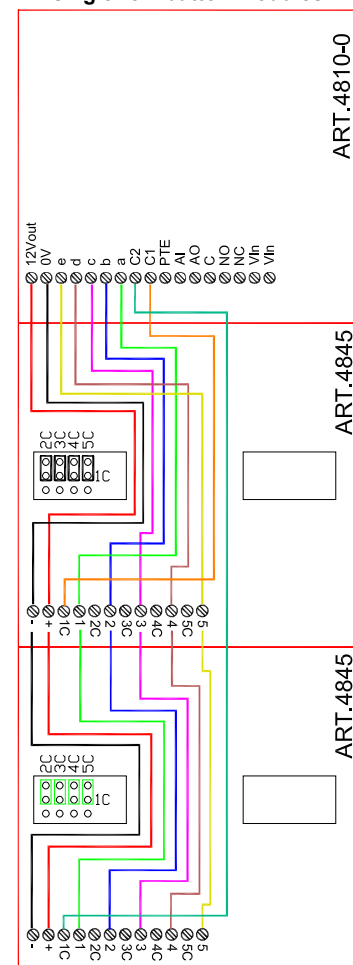



**Button module notes:**

- If the GSM module has 1 button, the additional button module buttons should be addressed beginning with 2 (i.e. The first button of the button module should be connected between C1 & b, the next between C1 & c etc)
- If the GSM module has 2 buttons, the additional button module buttons should be addressed beginning with 3 (i.e. The first button of the button module should be connected between C1 & c, the next between C1 & d etc)
- If the GSM module has 4 buttons, the additional button module buttons should be addressed beginning with 5 (i.e. The first button of the button module should be connected between C1 & e, the next between C2 & a etc)

**6 BUTTON EXAMPLE**

**An explanation of the jumpers**

When the jumper is in the top position, one side of that button is common to C1. When a jumper is in the bottom position, that button is completely isolated from the others.

In this example, button 1-4 of the module have a common side to C1 and button 5 is fully isolated.

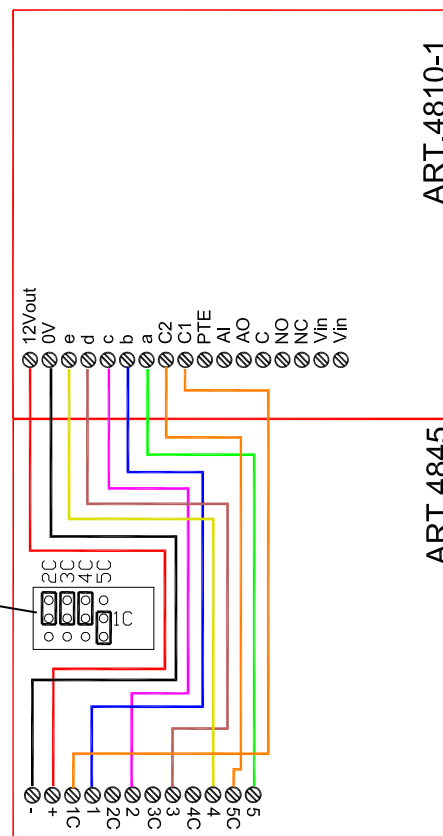

## CODELOCK MODULE (4800)

The 4800 codelock includes three relay outputs, two push to exit button inputs and operates from a 12-24V ac/dc power supply. Up to 2 unique codes can be programmed, each in the range of 4-8 digits. Relay time can be programmed from 01 – 99 seconds or set to latching mode with a relay time of 00 (To latch, type in the code followed by Enter, to unlatch, type in the code followed by clear).

Art.4800 Connections	
Connection	Function
+	12-24V ac/dc power input
-	0V power input
C1	Common connection of relay 1 (Dry contact)
NO1	Normally open connection of relay 1 (Dry contact)
NC1	Normally closed connection of relay 1 (Dry contact)
C2	Common connection of relay 2 (Dry contact)
NO2	Normally open connection of relay 2 (Dry contact)
NC2	Normally closed connection of relay 2 (Dry contact)
C3	Common connection of relay 3 (Dry contact)
NO3	Normally open connection of relay 3 (Dry contact)
NC3	Normally closed connection of relay 3 (Dry contact)
SW1	Push to exit input for relay 1 (Triggered by 0V)
SW2	Push to exit input for relay 2 (Triggered by 0V)

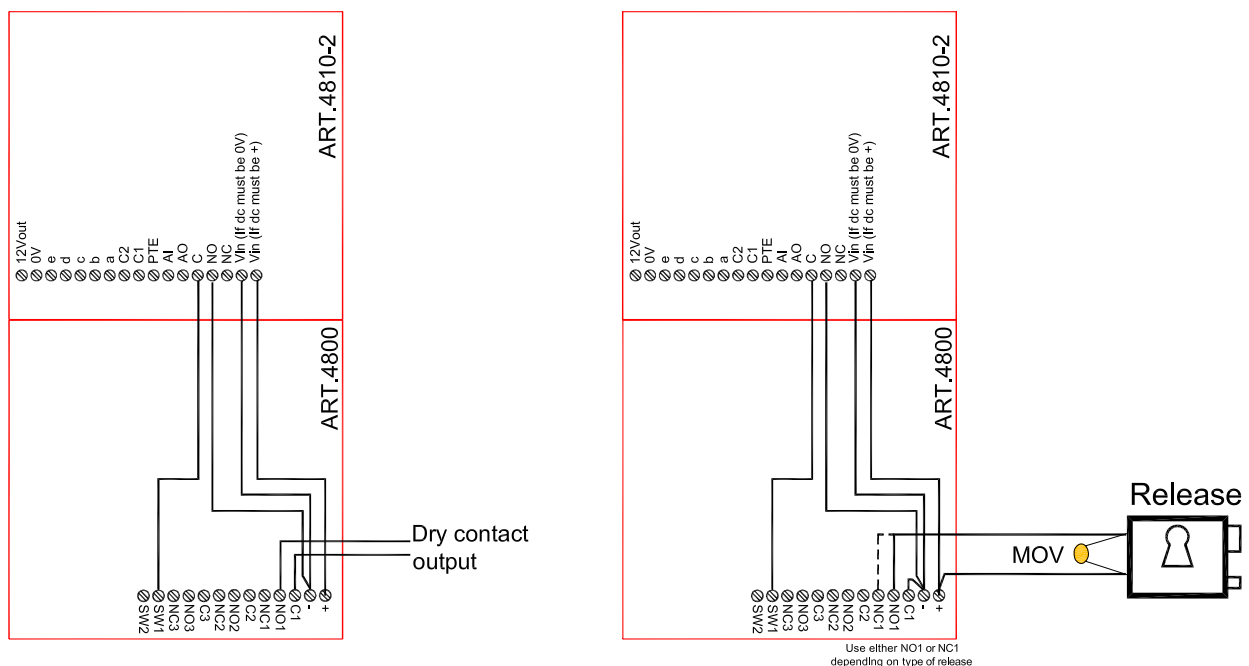

## ART.4800 CODELOCK INITIAL PROGRAMMING

All programming is carried out using the code lock keypad. The programming menu is protected by an engineer's code. The factory default engineers code is 111111 (6x1). This code can be changed to any four to eight digit code during the program but must be different to the codes used to gain entry. Follow the flow chart to setup the system:-

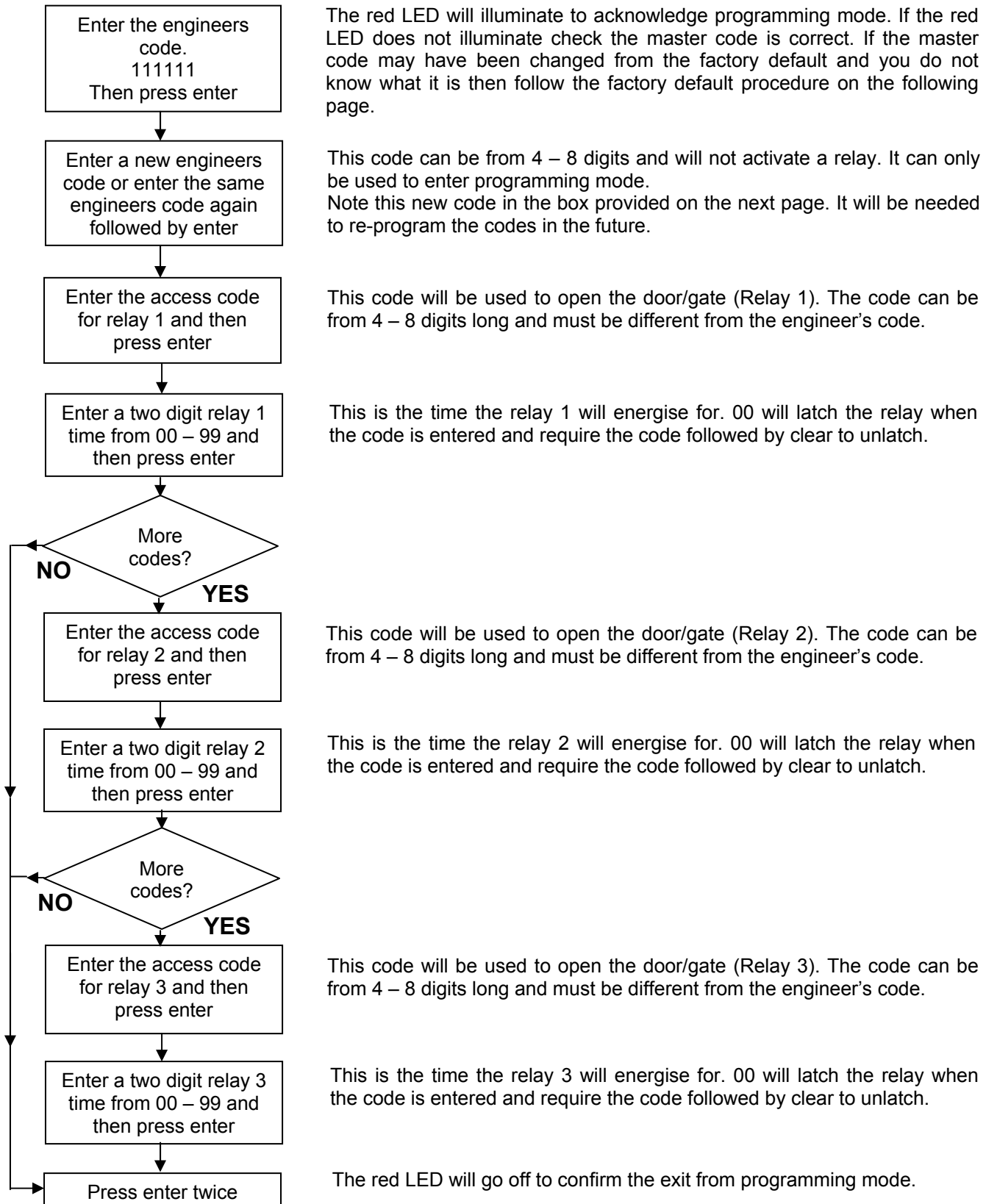

## ART.4800 CODELOCK REPROGRAMMING GUIDE

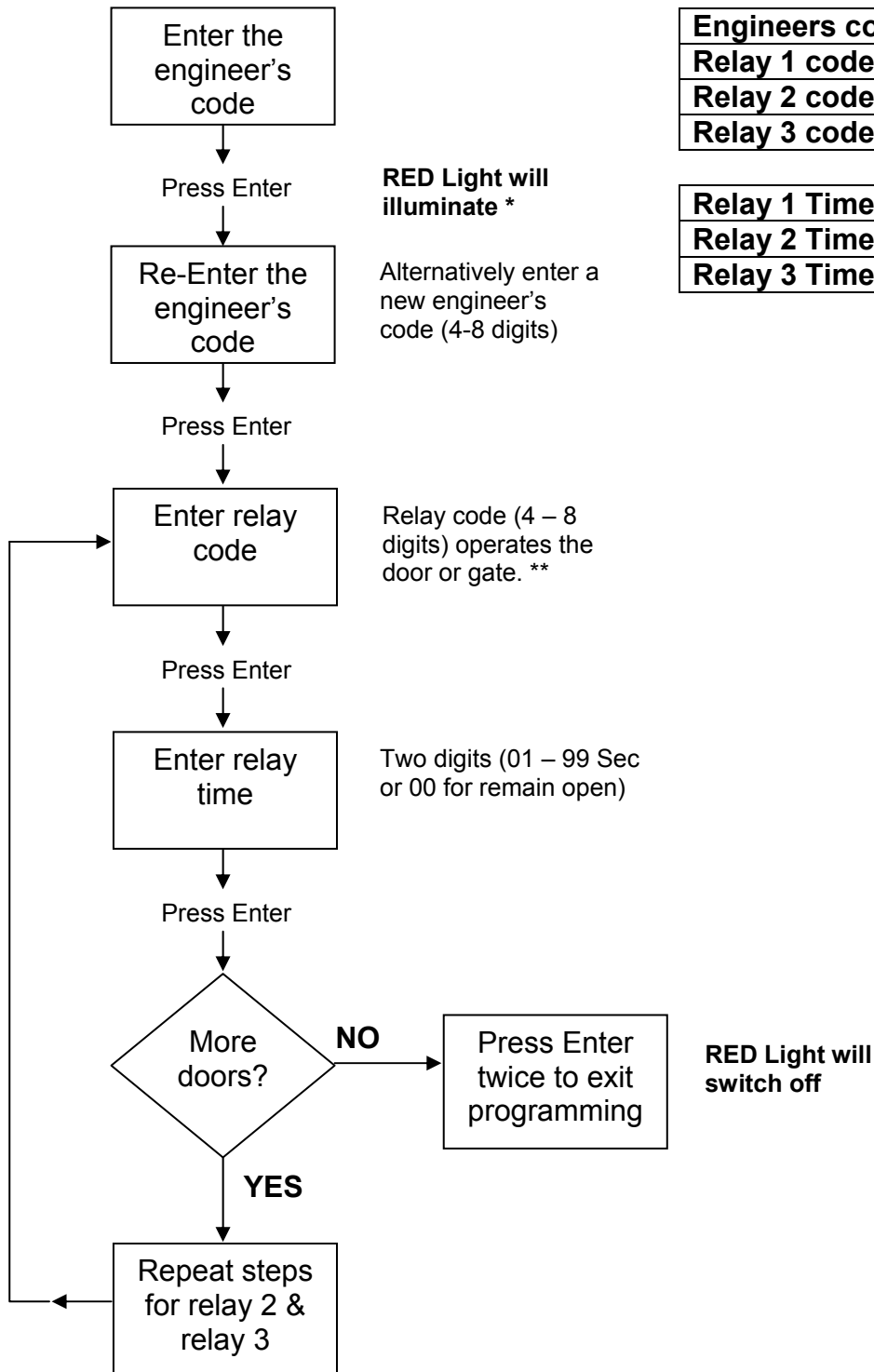

Engineers code	
Relay 1 code	
Relay 2 code	
Relay 3 code	

Relay 1 Time	
Relay 2 Time	
Relay 3 Time	

### Notes:

\* If the red light does not illuminate, the engineers code is incorrect. Follow the factory default procedure below.

\*\* On the first loop of the flow chart its relay 1, second loop is relay 2.

### FACTORY DEFAULT PROCEDURE

Step 1 Remove the power from the keypad

Step 2 Press and hold the enter button while re-powering the keypad

Step 3 Release the enter button. The factory engineer's code is restored to 111111 (6 x 1)

## DOOR PANEL MOUNTING FRAMES

Both surface and flush mounting frames are available. The size of the frame will depend on the number of modules that make up the door panel. The last digit of the frame code indicates the number of modules it will take. Frames are available in gun metal gray finish, chrome finish (Suffix \C to the frame code) or gold finish (Suffix \G to the frame code).

Flush frames:

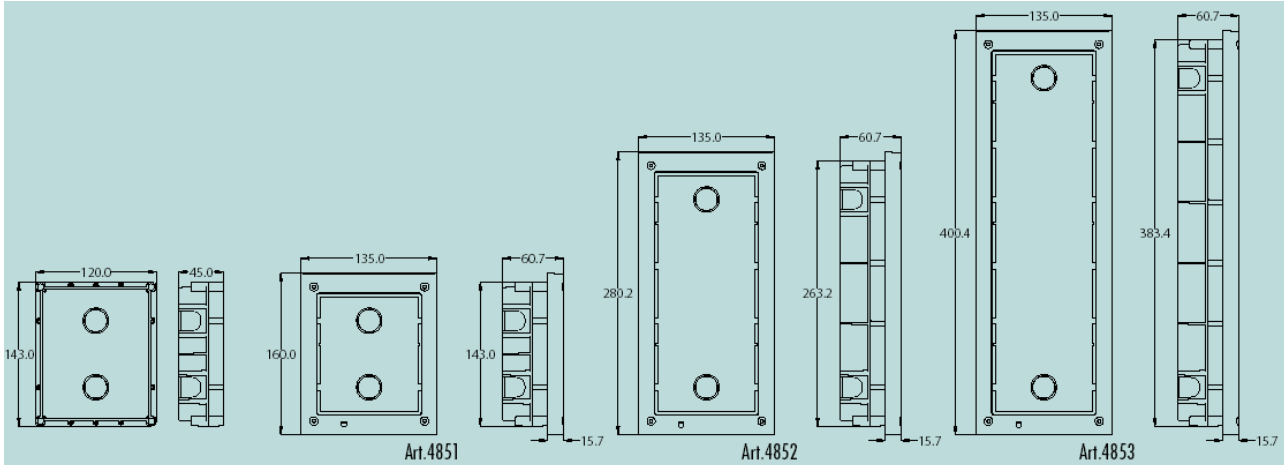

Surface frames:

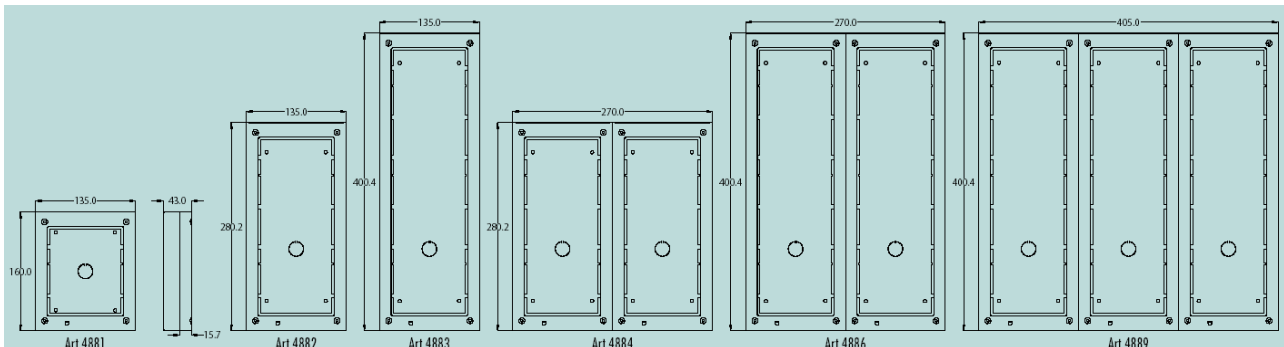

## POWER SUPPLY

The GSM intercom panel is designed to work with power supplies in the range or 12-24Vdc or 13Vac. The power supply should be capable of supplying a constant current of no less than 1 amp (If the system is to work with failsafe lock releases or magnetic locks we would recommend a minimum of 2 amps). The following Videx power supplies can be used:-

Art.521B	13.5Vdc 1A DIN box PSU
SP29	13.8Vdc 2A boxed PSU with battery back up facility
SP28	13.8Vdc 3A boxed PSU with battery back up facility

**Note: JP1 on the intercom panel must be set correctly for the type of PSU selected as shown earlier in this manual.**

# WIRING DIAGRAMS

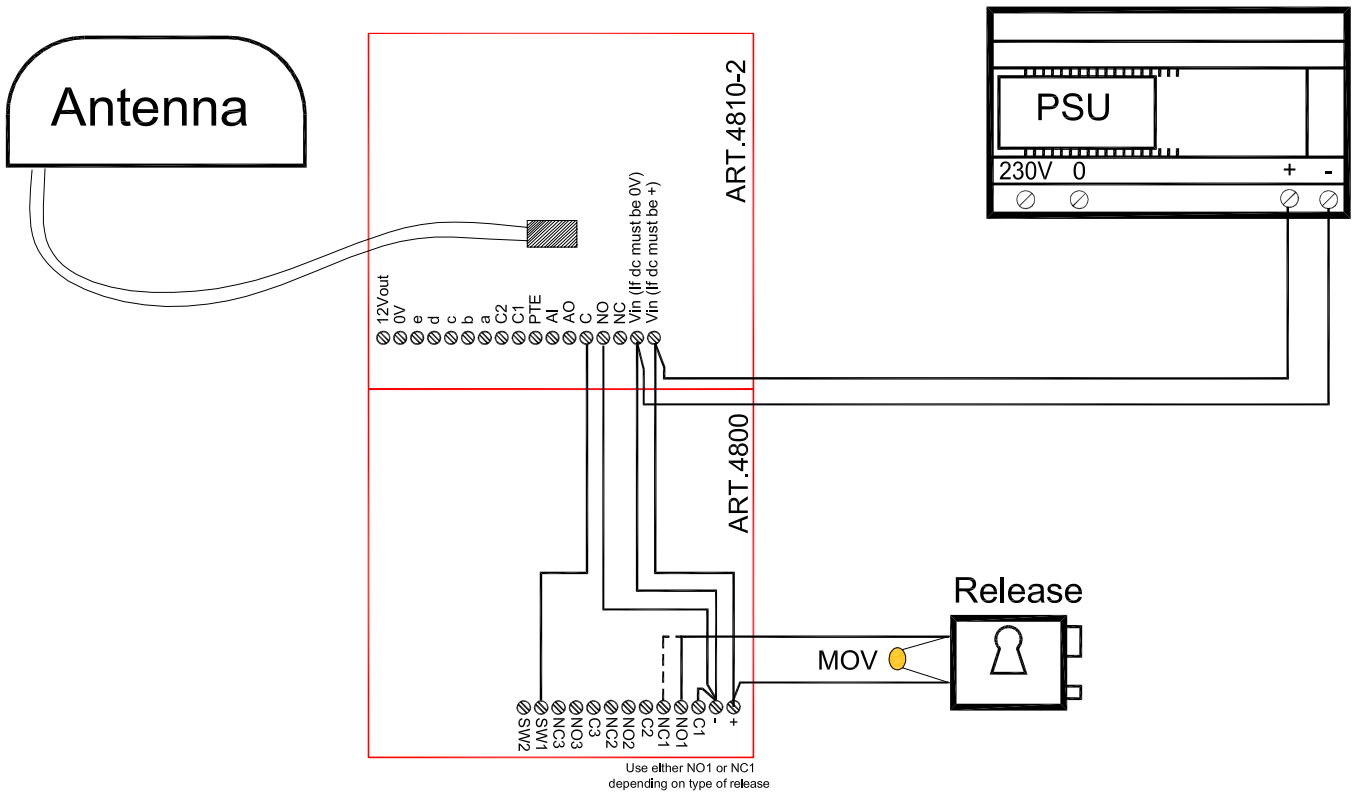
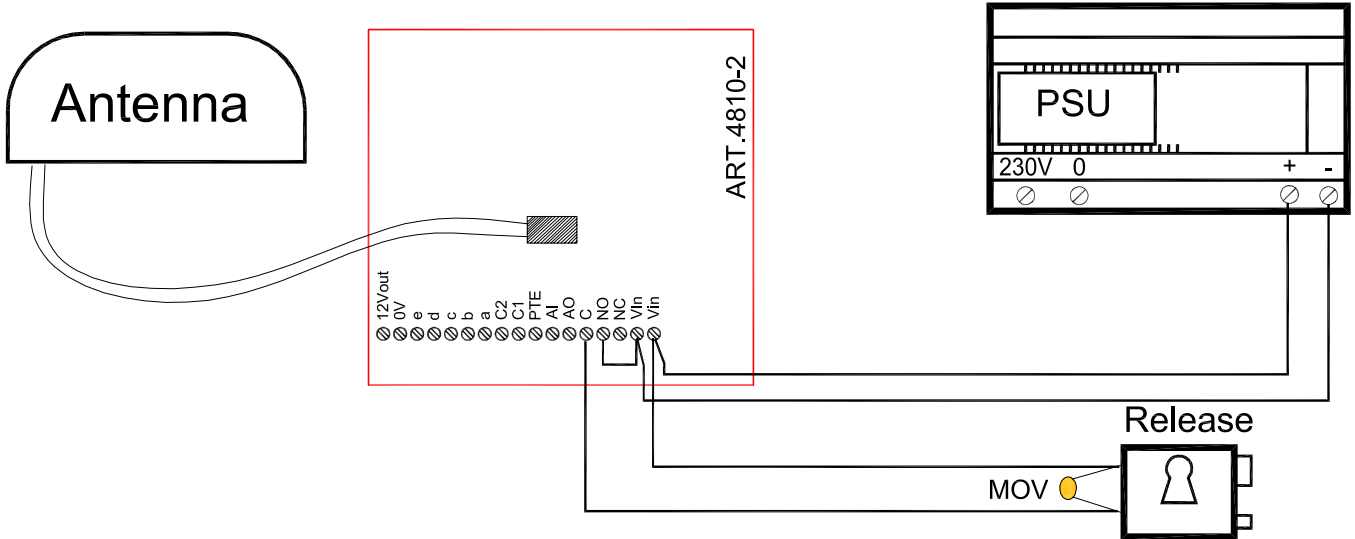

## PUSH TO EXIT BUTTON AND AUXILIARY INPUTS/OUTPUTS

**PUSH TO EXIT BUTTON, TRIGGERS RELAY FOR PROGRAMMED TIME**

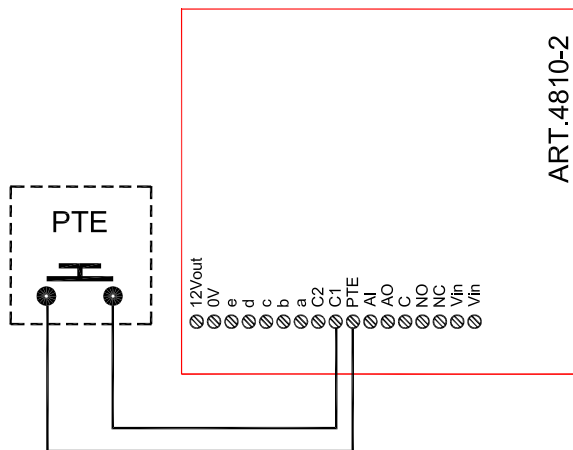

**AUXILIARY OUTPUT (OPEN COLLECTOR), TRIGGERS WHEN C1 & AI ARE SHORTED**

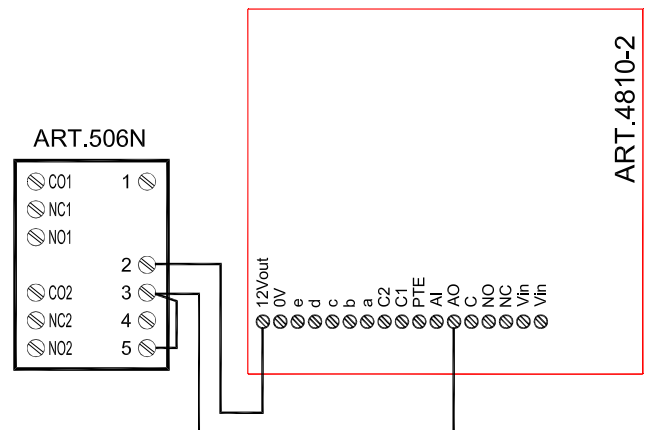

**AUXILIARY INPUT, TRIGGERS AUXILIARY OUTPUT (AO)**

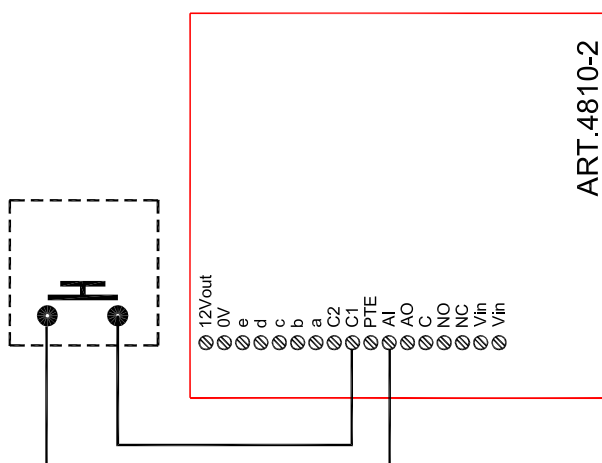

**AUXILIARY INPUT, SENDS A SMS MESSAGE TO THE TELEPHONE NUMBER STORED IN MEMORY LOCATION 020**

(NOTE: Once triggered, it can't be triggered again for 4 minutes. This avoids multiple SMS messages being sent for the same alarm)

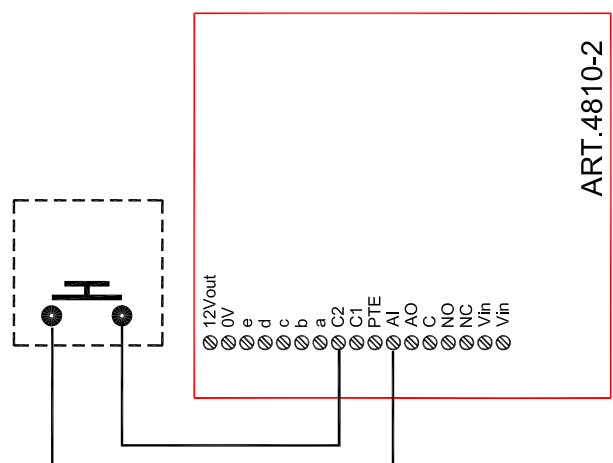

## CABLE SIZE GUIDE

Connections for power supply output to intercom panel and lock release connections.

	20m	50m	100m
<b>Connections</b>	0.5mm <sup>2</sup>	1.0mm <sup>2</sup>	1.5mm <sup>2</sup>

The power supply should be located as close to the intercom panel as possible for best performance.  
Maximum acceptable resistance for above cables = 3Ω

## INSTALLATION

- Check that all components are free from damage before installing (Do not proceed with installation in the event of damage).
- Keep all packaging away from children.
- Do not obstruct the ventilation openings or slots on any of the devices.
- All connections to mains voltages must be made to the current national standards (IEE Wiring regulations)
- Install an appropriate fused spur or isolation switch to isolate the mains.
- Isolate the mains before carrying out any maintenance work on the system.
- Avoid water ingress into the rear of the module, always seal the module frame after installation using a suitable silicon based sealant.
- All intercom and access control cables must be routed separately from the mains.

**Lock release back EMF protection :** A capacitor must be fitted across the terminals on an AC lock release and a diode must be fitted across the terminals on a DC lock release as shown in the diagrams below to suppress back EMF voltages.

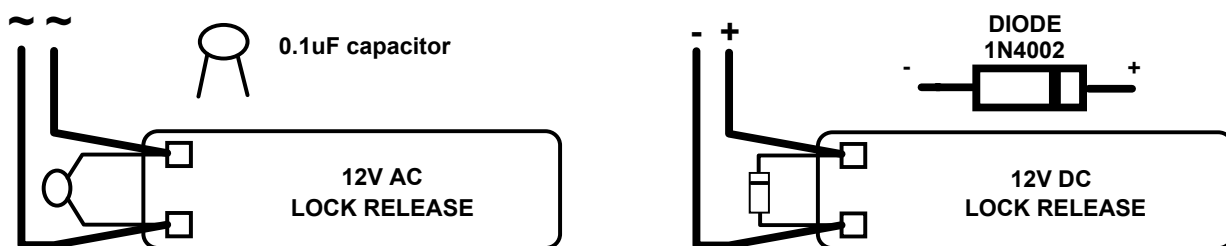

## PANEL CARE

The door panels facia is either mirror finish stainless steel or matt finish aluminium. It is important that the facia is cleaned on regular occasions to prevent dirt build up and tarnishing of the metal. A general household metal polish can be used but care should be taken to follow the grain of the metal when polishing and also avoid any polish build up around the call buttons which may prevent the buttons from operating correctly.



## TESTING, POWER UP AND RESET

After connecting the power supply, antenna, lock output and auxiliary devices as shown in this manual and before powering up a SIM card must be installed. The SIM holder can be found on the back of the module under the label 'SIM'. A SIM card from any supplier can be used. Simply push the SIM holder in the direction of 'OPEN' and then lift. Insert the SIM card (It will only fit one way) and then push back down and into the 'LOCK' position.

**IMPORTANT: Replace the label over the SIM hole.**

- Check all the connections have been made correctly and then power up the system.
- The GSM intercom requires approximately 30 seconds too initialise properly. We recommend not sending SMS messages or pressing buttons during this time.
- From power up; two short beeps will be heard and then following a short delay of approximately 15 seconds, the name plate light will illuminate and a further short beep will be heard. After approximately another 15 seconds another short beep will be heard. The module is now fully initialised (Note: If you here a different combination of beeps in place of the last short single beep then you can find the meaning of these beeps towards the back of this manual. Once initialised, you can begin programming.

### Power up initialisation sequence

- ✓ 2 short beeps
- ✓ Approx. 15 seconds delay
- ✓ 1 short beep and the 4810 name plate illuminates (Note: button module name plates will already be illuminated)
- ✓ Approx. 15 seconds delay
- ✓ One short beep
- ✓ System is ready

## RESET TO FACTORY DEFAULTS

There are two reset modes available. The first will reset the master code only and the second will reset everything and clear all stored call button telephone numbers.

### RESET THE MASTER CODE TO 1111

1. Power down the intercom panel
2. Put a short across C1 & PTE
3. Power up, 2 beeps will be heard followed by a delay and then a further beep.
4. Remove the short after the 3rd beep.
5. The master code is now reset to 1111

### FULL RESET

1. Power down the intercom panel
2. Put a short across C2 & PTE
3. Power up, 2 beeps will be heard followed by a delay and then a further 3 beeps.
4. Remove the short after the 5<sup>th</sup> beep.
5. All settings are returned to factory defaults

## PROGRAMMING

Programming can be carried out either by text message or by dialling into the intercom panel (Certain programming features can only be setup by text message).

**IMPORTANT NOTE:** When you are required to use “ in a text message it is very important to use the correct symbol and not for example ‘ (Or two ‘ single apostrophes side by side which you will see look the same but will be interoperated differently by the SMS intercom panel).

### PROGRAMMING BY TEXT MESSAGE

Programming by text message is the simplest way to customise the settings of the intercom panel and add or delete telephone numbers. Simply send texts in the format below to the telephone number of the SIM within the intercom panel:-

**<4 DIGIT CODE><3 DIGIT FUNCTION CODE><OPTIONAL DATA><OPTIONAL ?>**

**4 DIGIT CODE:** The code prevents unauthorised access to the programmable features of the system. The code must be four digits long but can be any combination using digits 0 – 9. The default code is 1111 and will be used for all examples in this manual.

**3 DIGIT FUNCTION CODE:** The 3 digit function code identifies the programmable feature to be changed. The code must be in capital letters. The table below lists the available codes.

DESCRIPTION	CODE	EXAMPLE	SETTINGS	DEFAULT	PAGE
Store a telephone no.	STN	1111STNnnn"01912243174"	nnn = 001-250	N/A	19-20
Set call time	SPT	1111SPTnn	nn = 01 - 12	02 (40s)	20
Set relay time	RLT	1111RLTnn	nn = 00 - 99	05 (5s)	21
Set auxiliary out time	AOT	1111AOTnn	nn = 00 - 99	05 (5s)	21
Set auxiliary out mode	AOM	1111AOMnn	nn = 00 or 01	01	21-22
Keep connection facility	NOD	1111NODnn	nn = 01 - 99	30 (30days)	22
Divert to second no. time	DIT	1111DITnn	nn = 01 - 99	15 (15s)	22
Enable/disable divert	DIV	1111DIVnm	n = 0-9 m = 0-1	m = 0	22-23
Check GSM signal strength	SIG	1111SIG?	N/A	N/A	28-29
Check software version	VER	1111VER?	N/A	N/A	28
Dial a number	DLE	1111DLE"123"	N/A	N/A	23
Store SMS message for C2-AI	SMS	1111SMS"HouseAlarm"	N/A	AUX TRIG	23
Change 4 digit code	CDE	1111CDE1234	Any 4 digits	1111	22
Initiate a special command	PRG	1111PRG(command)	AT commands	N/A	24
Trigger the relay	RLY	1111RLY	N/A	N/A	28
Trigger the auxiliary output	AUX	1111AUX	N/A	N/A	28
Store balance check dial string	SDL	1111SDL"*#1345#"	N/A	N/A	24
Check credit balance	BAL	1111BAL?	N/A	N/A	28-29
Latch the relay	RLA	1111RLA	N/A	N/A	28
Unlatch the relay	RUL	1111RUL	N/A	N/A	28
Latch the auxiliary output	ALA	1111ALA	N/A	N/A	28
Unlatch the auxiliary output	AUL	1111AUL	N/A	N/A	28

**OPTIONAL DATA:** The optional data will vary depending on the command used. It may be a telephone number, a time setting or may not be used at all. For more information see the command settings below.

**OPTIONAL ?:**

Most of the commands support the ? feature. When this is added to the end of the text message, a confirmation text message will be sent back to the sender indicating the new data has been received and stored.

When sending text messages there may be a delay from when you send the message to when it is received by the intercom panel depending on how congested the network is. If you are at the door panel when sending the message you will here a single beep from the intercom panel to indicate it has receive the message.

**STORING A CALL BUTTON TELEPHONE NUMBER**

Telephone numbers can be stored for the ten available call buttons. Each call button can call up to two telephone numbers (If the first is busy or not answered in a certain time it can call the second number if the divert facility is setup). The messages to store/check numbers are as follows (**See important note on page 18**):-

**111STNnnn"yyyyyyyyyy"** Store the telephone number yyyyyyyyyy in position nnn

**111STNnnn"yyyyyyyyyy"?** Store the telephone number yyyyyyyyyy in position nnn and send a confirmation text message to confirm storage of new number.

**111STNnnn?** Query the telephone number stored in location nnn. A text message will be sent to the sender with the stored number for that location.

**111STNnnn""** Delete the telephone number stored in location nnn.

**111STNnnn""?** Delete the telephone number stored in location nnn. A text message will be sent to the sender with the delete confirmation for that location.

**nnn** can be found using the following table. The telephone number y can be a maximum of 19 digits.

Call Button	Memory location (nnn) of first number called	Memory location (nnn) of divert to number to call
Button 1 (C1 & a)	001	011
Button 2 (C1 & b)	002	012
Button 3 (C1 & c)	003	013
Button 4 (C1 & d)	004	014
Button 5 (C1 & e)	005	015
Button 6 (C2 & a)	006	016
Button 7 (C2 & b)	007	017
Button 8 (C2 & c)	008	018
Button 9 (C2 & d)	009	019
Button 10 (C2 & e)	010	020

Use the chart on page 26 to record the telephone numbers stored.

## STORING A TELEPHONE NUMBER FOR DIAL IN DOOR RELEASE

Dial in door release allows users of telephones with their number stored to release the door/gate simply by dialling the telephone number of the SIM in the intercom panel. The intercom panel will check the callers ID when it receives a call and if it matches the list of stored numbers, it will clear the call down (Avoiding the caller being charged for the call) and will activate the relay for the programmed time. The number of numbers that can be stored depends on the SIM card's available memory. SIM cards are normally able to store 100 – 250 numbers. The messages to check, store or delete numbers are as follows (**See important note on page 18**):-

- 1111STNnnn"yyyyyyyyyy"** Store the telephone number yyyyyyyyyyy in position nnn where nnn = 100 - 250
- 1111STNnnn"yyyyyyyyyy"?** Store the telephone number yyyyyyyyyyy in position nnn where nnn = 100 - 250 and send a confirmation text message to confirm storage of new number.
- 1111STNnnn?** Query the telephone number stored in location nnn where nnn = 100 - 250. A text message will be sent to the sender with the stored number for that location.
- 1111STNnnn#** Delete the telephone number stored in location nnn where nnn = 100 - 250.
- 1111STNnnn#?** Delete and confirm deletion of a telephone number in location nnn where nnn = 100 - 250.

Memory location nnn can be in the range of 100 – 250. (Important note: Some SIM cards may use some of the memory locations for special features such as checking balance, retrieving voice mails etc. If you are not planning to use all memory location we would suggest storing from location 111 onwards. Use the chart on page 26-27 to record the telephone numbers stored.

**Note: It is important to switch off voicemail and automatic SMS features on the SIM card when using this feature. See the 'Forced Dial' section for more details. Also note that it will not be possible to use the dial in and program facility from a number stored to release the door/gate when dialling in.**

## SET CALL TIME

The call time is the maximum time in seconds that a call can last before the intercom panel automatically clears the call down. The time can be from 20 seconds up to 240 seconds (4 minutes) and begins from when the call button is pressed. The default time is 40 seconds. The following messages are used to set/check the maximum call time.

- 1111SPTnn** Store the time nn x 20 seconds (e.g. nn = 03, time = 60 seconds).

**1111SPTnn?** Store the time nn x 20 seconds (e.g. nn = 02, time = 40 seconds. Also send a confirmation text back to the sender.

**1111SPT?** Query the current stored time. A text message will be sent to the sender showing the stored time. (Remember to multiple the number in the received text by 20 seconds)

#### SET RELAY TIME

The relay time can be from 01 – 99 seconds or latching (Set the relay time to 00 for latched mode. In latch mode, the relay will stay energised until the command is send again).

**1111RLTnn** Store the time nn = time in seconds.

**1111RLTnn?** Store the time nn = time in seconds. Also send a confirmation text back to the sender.

**1111RLT?** Query the current stored time. A text message will be sent to the sender showing the stored time.

#### SET AO (AUXILIARY OUTPUT) TIME (FOR AOM = 01 ONLY)

The AO time can be from 01 – 99 seconds or latching (Set the AO time to 00 for latched mode).

**1111AOTnn** Store the time nn = time in seconds.

**1111AOTnn?** Store the time nn = time in seconds. Also send a confirmation text back to the sender.

**1111AOT?** Query the current stored time. A text message will be sent to the sender showing the stored time.

#### SET AO (AUXILIARY OUTPUT) MODE

There are two mode of operation for the AO terminal:-

User activated: nn = 01

To activate the AO terminal either short AI to C1 or press 6 on the telephone during a call.

Call activated: nn = 00

AO will activate when a call begins and deactivate when the call ends.

**1111AOMnn** Store the mode nn = 01 or 00.

**1111AOMnn?** Store the mode nn = 01 or 00. Also send a confirmation text back to the sender.

**1111AOM?** Query the current stored mode. A text message will be sent to the sender showing the stored mode.

#### CHANGING THE FOUR DIGIT CODE

The four digit code can be any combination of numbers 0-9 but must be 4 digits long. The code allows access to the programming menu in dial in mode and must be used when sending text messages to the intercom panel. The following message changes the code:-

**1111CDEnnnn** nnnn = new 4 digit code

#### SET DAYS TO WAIT BEFORE MAKING A CALL

In the event the intercom panel is not used for long periods of time it could be possible that the network disconnects it. To prevent this from happening it is possible to program a time period (From 01 – 99 days) to wait before the intercom panel makes a short call to refresh the connection. This time period is reset after each call made on the system and will only happen if the full time period elapses without any incoming or outgoing calls.

**1111NODnn** Store the time nn = time in days.

**1111NODnn?** Store the time nn = time in days. Also send a confirmation text back to the sender.

**1111NOD?** Query the current stored time. A text message will be sent to the sender showing the stored time.

#### DIVERT TIME

The divert time is the number of seconds to wait for a call to be answered before diverting to the second number (The divert facility must be set for this to work). The default time is 15 seconds (The count down begins from when the call button is pressed, but is refreshed when the telephone begins to ring) and can be set to 01 – 99 seconds).

**1111DITnn** Store the time nn = time in seconds.

**1111DITnn?** Store the time nn = time in seconds. Also send a confirmation text back to the sender.

**1111DIT?** Query the current stored time. A text message will be sent to the sender showing the stored time.

#### DIVERT SETUP

Divert can be set for any or all of the call buttons. When set, if a call is not answered within the divert time, the call will be forwarded to the second number and the call time will be refreshed. The following table shows the value of **nm** used in the programming messages. Default is all divers disabled (**m=0**).

CALL BUTTON	SET DIVERT	DISABLE DIVERT
Button 1 (C1 & a)	01	00
Button 2 (C1 & b)	11	10
Button 3 (C1 & c)	21	20
Button 4 (C1 & d)	31	30
Button 5 (C1 & e)	41	40
Button 6 (C2 & a)	51	50
Button 7 (C2 & b)	61	60
Button 8 (C2 & c)	71	70
Button 9 (C2 & d)	81	80
Button 10 (C2 & e)	91	90

**n** = Call Button number from 1 – 10 (0-9)

**m** = Divert set (1) or divert not set (0)

**1111DIVnm** Store the divert setting.  
**1111DIVnm?** Store the divert setting. A text message will be sent to the sender with the acknowledgment.

#### FORCED DIAL

A useful feature of the Intercom panel is its ability to call a number sent to it in a text message. This feature can be used when setting up the SIM card. For example, disabling the voicemail facility or disabling automatic SMS messages or missed calls. Any number up to 15 digits can be called and the call will last for a maximum of 40 seconds. The example below would switch off voicemail on a Vodafone SIM card. Substitute the Vodafone number for other service providers (**See important note on page 18**).

**1111DLE"1210"** Dial 1210 for the intercom panel

Other useful numbers which can be used with this feature are as follows. Please also check the service provider's web sites for other useful codes.

	Vodafone	O2
Disable voicemail	1210	1760
Disable text alerts	#148#	1760

**NOTE:** Disabling voicemail and text alerts is very important as there is no way to retrieve either of these services from an intercom panel. Disabling these features will also prevent the intercom panel switching to voicemail or sending a text when dialling in from another phone.

#### STORE SMS AUXILIARY MESSAGE

When C2 & AI are shorted on the intercom panel, a text message will be sent to the number stored in memory location 020. The text message can be customised using the following message (**See important note on page 18**) :-

**1111SMS"HouseAlarm"** Change message to HouseAlarm

**Note:** The message can be a maximum of 20 characters long and can not include spaces or ". The memory location used to store the telephone where the text will be send is also the same memory location used for the divert telephone number for button 10 (i.e. 020).

## PROGRAM BY 'AT' COMMANDS

This is an advanced feature of the system which can allow an AT format command to be sent to the OEM GSM module.

**1111PRG(command)**                      Send an AT command to the OEM module

## STORE CREDIT BALANCE CHECK STRING

Several network providers offer the facility to check available balance on their pay as you go tariffs. For example, on Vodafone the string is `*#1345#` and on O<sup>2</sup> the string is `*#10#`. Other networks may also have this feature. Because the intercom will not know the details of the network provider's SIM card which you have inserted it will be necessary to store the correct string in order to use the credit balance check features.

**1111SDL"\*#1345#"**                      Store the balance check string for a Vodafone pay as you go.

**1111SDL"\*#10#"**                        Store the balance check string for an O<sup>2</sup> pay as you go.



## PROGRAMMING BY DIAL IN

**Note: programming dial in cannot be used from telephones which are already programmed to open the door when they dial the intercom panel.**

**When dialling into the GSM intercom from a telephone number which is already stored as one of the call button telephone numbers it will be necessary be press \*\* to switch from call mode to programming mode.**

To gain access to the programming menu via dial in, follows these steps:-

1. Call the telephone number of the intercom panel.
2. Wait for the intercom panel to answer and signal by two beeps (If the number you are dialling from is already programmed as a call button number then you will need to press \*\* before proceeding to the next step).
3. Enter the four digit code listening for a confirmation beep after each digit.
4. If the code is correct, you will here two beeps to indicate programming mode. If the code is incorrect the call will end and the line will go dead.

Once in programming mode, the following options are available. Remember to listen for a beep after each digit entered. This indicates that it has been received and understood by the intercom panel. The intercom panel will stay in programming mode until the call ends or a timeout occurs. The timeout will occur after 30 seconds if no buttons are pressed. This is reset to 30 seconds each time a button is pressed.

**Note: At any point press the # key to clear and begin a programming sequence again. # is also used to confirm and store a new value. After pressing #, two beeps will be heard from the telephone to indicate successful completion of a command, four beeps will indicate an error in the command.**

The following table outlines the available programming codes. These are explained in detail on the following pages.

DESCRIPTION	CODE	EXAMPLE	SETTINGS	DEFAULT	PAGE
Store a telephone no.	01-10	nn01912243174#	nn = 01-10	N/A	26
Storing a divert telephone no.	11-29	nn01912243174#	nn = 11-20	N/A	26
Set call duration time	50	50nn#	nn = 01-12	02	26
Set relay time	51	51nn#	nn = 00 - 99	05 (5s)	26
Set auxiliary out time	52	52nn#	nn = 00 - 99	05 (5s)	26
Keep connection facility	55	55nn#	nn = 01 - 99	10 (10days)	27
Divert to second no. time	56	56nn#	nn = 01 - 99	15 (15s)	27
Set auxiliary out mode	57	57nn#	nn = 01 or 00	01	27
Enable/disable divert	58	58nm#	n = 0-9 m = 0-1	m = 0	27
Change 4 digit code	59	59nnnn#	nnnn= 4 digits	1111	26

**NOTE:** While in dial in mode it is also possible to start a call with the intercom panel which will open the speech and also allow the user functions such as triggering the relay to work. After dialling in, enter the 4 digit code and the press \*\* to start the call.

## STORING A CALL BUTTON TELEPHONE NUMBER

Telephone numbers can be stored for the ten available call buttons. Each call button can call up to two telephone numbers (If the first is busy or not answered in a certain time it can call the second number if the divert facility is setup). The following programming sequence stores telephone numbers.

**nnyyyyyyyyyyy#** Store the telephone number yyyyyyyyyyy in position nn

**nn#** Delete the telephone number yyyyyyyyyyy in position nn

**nn** can be found using the table. The telephone number y can be a maximum of 19 digits.

Call Button	Memory location (nn) of first number called	Memory location (nn) of divert to number to call
Button 1 (C1 & a)	01	11
Button 2 (C1 & b)	02	12
Button 3 (C1 & c)	03	13
Button 4 (C1 & d)	04	14
Button 5 (C1 & e)	05	15
Button 6 (C2 & a)	06	16
Button 7 (C2 & b)	07	17
Button 8 (C2 & c)	08	18
Button 9 (C2 & d)	09	19
Button 10 (C2 & e)	10	20

Use the chart on page 26 to record the telephone numbers stored.

## SET CALL TIME

The call time is the maximum time in seconds that a call can last before the intercom panel automatically clears the call down. The time can be from 20 seconds up to 240 seconds (4 minutes) and begins from when the telephone rings. The default time is 40 seconds. The following programming sequence stores a new call time.

**50nn#** Store the time nn x 20 seconds (e.g. nn = 3, time = 60 seconds.)

## SET RELAY TIME

The relay time can be from 01 – 99 seconds or latching (Set the relay time to 00 for latched mode).

**51nn#** Store the time nn = time in seconds.

## SET AO (AUXILIARY OUTPUT) TIME

The AO time can be from 01 – 99 seconds or latching (Set the AO time to 00 for latched mode).

**52nn#** Store the time nn = time in seconds.

## CHANGING THE FOUR DIGIT CODE

The four digit code can be any combination of numbers 0-9 but must be 4 digits long. The code allows access to the programming menu in dial in mode and must be used when sending text messages to the intercom panel. The following message changes the code:-

**59nnnn#** nnnn = new 4 digit code

## SET DAYS TO WAIT BEFORE MAKING A CALL

In the event the intercom panel is not used for long periods of time it could be possible that the network disconnects it. To prevent this from happening it is possible to program a time period (From 01 – 99 days) to wait before the intercom panel makes a short call to refresh the connection. This time period is reset after each call made on the system and will only happen if the full time period elapses without any incoming or outgoing calls.

**55nn#** Store the time nn = time in days.

## DIVERT TIME

The divert time is the number of seconds to wait for a call to be answered before diverting to the second number (The divert facility must be set for this to work). The default time is 15 seconds (The count down begins from when the call button is pressed) and can be set to 01 – 99 seconds).

**56nn#** Store the time nn = time in seconds.

## DIVERT SETUP

Divert can be set for any or all of the call buttons. When set, if the call is not answered within the divert time, the call will be diverted to the second number. The following table shows the value of nn used in the programming messages. Default is, all divers disabled.

CALL BUTTON	SET DIVERT	DISABLE DIVERT
Button 1 (C1 & a)	01	00
Button 2 (C1 & b)	11	10
Button 3 (C1 & c)	21	20
Button 4 (C1 & d)	31	30
Button 5 (C1 & e)	41	40
Button 6 (C2 & a)	51	50
Button 7 (C2 & b)	61	60
Button 8 (C2 & c)	71	70
Button 9 (C2 & d)	81	80
Button 10 (C2 & e)	91	90

**58nn#** Store the divert setting.

## AUXILIARY OUT MODE

There are two mode of operation for the AO terminal:-

User activated: nn = 01

To activate the AO terminal either short AI to C1 or press 6 on the telephone during a call.

Call activated: nn = 00

AO will activate when a call begins and deactivate when the call ends.

**57nn#** Store the mode nn = 01 or 00.

## SYSTEM OPERATION

### TO MAKE A CALL FROM THE INTERCOM PANEL

Press the required call button. Two beeps will be heard to indicate the call has been placed. If a mistake is made, press any other button to clear the call (A long beep followed by a short beep will be heard to confirm the call has been cleared. (Note: If the same button is pressed after five seconds of placing the call this will also clear the call down. Pressing the same button before five seconds will do nothing).

### DOOR/GATE RELEASE

This is signalled by 1 second interval beeps from the intercom panel. Pressing 3 releases the door/gate for the programmed time. Pressing 1 followed by 0 will latch the door/gate in the open position (Note: To unlatch press 3, the door/gate will unlatch after the programmed time).

### RELEASING THE GATE/DOOR BY DIALLING THE INTERCOM PANEL NUMBER

This feature is only possible if the caller's number has been stored correctly for this feature. Simply dial the number of the intercom panel. The intercom panel will drop the call and then open the gate/door for the programmed time.

## USER COMMANDS

The following commands can be carried out during a call: (Note: Successful commands are signalled by two beeps from the telephone, errors are signalled by four beeps).

FUNCTION	1 <sup>st</sup> KEY TO PRESS	2 <sup>nd</sup> KEY TO PRESS
LATCH RELAY (UNLATCH BY PRESSING 3)	1	0
RELEASE THE DOOR OR GATE	3	N/A
ACTIVATE THE AUXILIARY OUTPUT	6	N/A
END A CALL	8	N/A
ADJUST DOOR SPEECH VOLUME	4	0-9 (0=Lowest, 9 = Highest)
ADJUST PHONE SPEECH VOLUME	7	0-9 (0=Lowest, 9 = Highest)
ENTER PROGRAMMING MODE DURING A CALL	*	*

The following text messages can be sent while in standby (Examples show code as 1111):

FUNCTION	MESSAGE TO SEND
CHECK THE SIGNAL STRENGTH	1111SIG?
CHECK THE AVAILABLE BALANCE*	1111BAL?
CHECK THE SOFTWARE VERSION	1111VER?
RELEASE THE DOOR/GATE	1111RLY? (? Optional, send if a confirmation is required)
ACTIVATE THE AUXILIARY OUTPUT	1111AUX? (? Optional, send if a confirmation is required)
LATCH THE RELAY	1111RLA? (? Optional, send if a confirmation is required)
UNLATCH THE RELAY	1111RUL? (? Optional, send if a confirmation is required)
LATCH THE AUXILIARY OUTPUT	1111ALA? (? Optional, send if a confirmation is required)
UNLATCH THE AUXILIARY OUTPUT	1111AUL? (? Optional, send if a confirmation is required)

## CHECKING THE BALANCE

\*Note: The balance can only be checked if the correct balance check string has previously been stored using the SDL code explained earlier in the manual.

The intercom also has the facility to monitor the available credit and then text you to inform you when it has fell below £5.00, €5.00 or \$5.00. It will then remind you with another text after every 5 calls until the credit is either increased or it runs out. To use this feature, the following settings must first be made:-

- You must be using a Pay AS You GO SIM card from a provider that offers this service (Vodafone, O<sup>2</sup>)
- The correct balance check string must be stored using the SDL code.
- A mobile phone number in which to receive the balance low text must be stored in location 020 using the STN code.

## UNDERSTANDING THE SIGNAL STRENGTH

When a request for signal strength message is sent to the intercom panel it will reply with a two digit signal strength code. The code will be between 0 – 31 or 99. Ideally the signal strength should be as close to 31 as possible. The lower the number, the weaker the signal. Signal strengths lower than 10 may cause operational problems such as loss of speech quality (and possibly missing DTMF tones) and network loss. A signal strength of 99 indicates it could not be detected.

## DIALLING INTO THE INTERCOM FROM ANOTHER TELEPHONE

There are three possible outcomes to dialling into the GSM intercom depending on the telephone number you are dialling in from and the features setup during programming. The three possible outcomes are shown in the table below and are shown in order of priority (For example, if the number is programmed to automatically activate the relay, this will take priority over the following two options and if the telephone number is stored as a telephone number called from one of the push buttons, this will take priority over the last option.

FUNCTION	REQUIREMENT	PRIORITY
Dial in to open the door.  After dialling the number, the relay will activate and the call will be dropped.	The telephone number of the telephone dialling in must be stored in memory location 100 - 250	1st
Dial in to activate a call (Live speech, activate relay/AUXO)  After dialling the number, the call will be answered and two beeps will be heard. The speech will then be live.	The telephone number of the telephone dialling in must be stored in memory location 001 - 020	2nd
Dial in to enter programming mode.  After dialling the number, the call will be answered and two beeps will be heard. You will then be required to enter the four digit code to gain access to the programming menu.	If neither of the two requirements above are met.	3rd

### RECORD SHEET

<b>INTERCOM PANEL TELEPHONE No.</b>			
<b>IMEI NUMBER</b>			
<b>MASTER CODE</b>			
<b>BUTTON</b>	<b>MEM. LOCATION</b>	<b>USER NAME</b>	<b>TELEPHONE No.</b>
Button 1	001		
Button 1 (Divert)	011		
Button 2	002		
Button 2 (Divert)	012		
Button 3	003		
Button 3 (Divert)	013		
Button 4	004		
Button 4 (Divert)	014		
Button 5	005		
Button 5 (Divert)	015		
Button 6	006		
Button 6 (Divert)	016		
Button 7	007		
Button 7 (Divert)	017		
Button 8	008		
Button 8 (Divert)	018		
Button 9	009		
Button 9 (Divert)	019		
Button 10	010		
Button 10 (Divert)	020		

### DIAL IN ACCESS CONTROL MEMORY RECORD SHEET

Mem.	User Name	Telephone No.	Mem.	User Name	Telephone No.
100			176		
101			177		
102			178		
103			179		
104			180		
105			181		
106			182		
107			183		
108			184		
109			185		
110			186		
111			187		
112			188		
113			189		
114			190		
115			191		
116			192		
117			193		
118			194		
119			195		
120			196		
121			197		
122			198		
123			199		

124		
125		
126		
127		
128		
129		
130		
131		
132		
133		
134		
135		
136		
137		
138		
139		
140		
141		
142		
143		
144		
145		
146		
147		
148		
149		
150		
151		
152		
153		
154		
155		
156		
157		
158		
159		
160		
161		
162		
163		
164		
165		
166		
167		
168		
169		
170		
171		
172		
173		
174		
175		

200		
201		
202		
203		
204		
205		
206		
207		
208		
209		
210		
211		
212		
213		
214		
215		
216		
217		
218		
219		
220		
221		
222		
223		
224		
225		
226		
227		
228		
229		
230		
231		
232		
233		
234		
235		
236		
237		
238		
239		
240		
241		
242		
243		
244		
245		
246		
247		
248		
249		
250		

## UNDERSTANDING THE BEEPS

Functions and errors are indicated by beeps from the intercom panel. The following will help you understand the different beeps heard and what, if anything needs to be done in response to the beeps.

BEEP	REASON	SOLUTION
Short beeps at 1 second intervals	Relay or auxiliary output activated.	None, this is normal
Single short beep while the system is in standby and not being used.	A valid text message has been received and processed	None, this is normal
Two short beeps followed by a long beep	Button pressed but no number stored	Program a telephone number for the button pressed.
Long beep followed by short beep while the system is in standby.	Invalid text message received.	If this has happened when sending one of the programming text messages then check the message for errors. These beeps will also be heard if the 4 digit code in the text message is incorrect. If you are unsure of the 4 digit code, try resetting it to 1111.
Long beep followed by short beep while the system is in use.	Manually ending a call by pressing a call button	None, this confirms the call has been cancelled. Another call can be placed if required.
Four long beeps	Not registered with a network provider but still trying	Leave it a short while to see if it manages to find the network. If the beeps repeat every 30 seconds then try moving the antenna to a better location or changing the SIM to another network provider.
Six long beeps	Unknown registering problem	Try moving the antenna to a better location. Try changing the SIM card to another network provider.
Eight long beeps	Registered but roaming for a better network	This could happen if it registers to another network instead of its primary one. This may result in higher call charges. Try another SIM provider for that area.
Single short beep every 10 seconds after power up	Unable to see the SIM card	Check the SIM card is fitted correctly. Try removing the SIM card, cleaning and fitting again. Try a different SIM card.



## TROUBLE SHOOTING

SYMPTOM	TEST
Interference on the speech	Check the signal strength '1111SIG?'. If the signal strength is to low the GSM module which increase it's power to compensate causing interference with the speech circuits. Try relocating the antenna or using a more powerful or directional antenna.
	Ensure the antenna cables are not running close to the power supply cables or the microphone wires inside the intercom panel
	Try a different SIM card from a different service provider as they may have better coverage in that area.
The intercom panel repeatedly beeps twice and the name plate back light of the module (Not additional button modules) does not illuminate.	Check the power supply is of adequate voltage as show earlier in this manual and that the jumper JP1 is in the correct position.
	Try a full reset as shown earlier in the manual (Powering up with C2 & PTE shorted).
	Try a different SIM card.
A long beep is heard when I press a button.	Intercom module may have a fault.
	No telephone number setup for that button. Check the programming.
The intercom panel does not respond to SMS messages	Check the SIM card is fitted correctly.
	Check the SIM card has a SMS service centre number stored. This will require putting the SIM card into a mobile phone to check. Contact the SIM card provider if you are not sure.
	Check the number you are sending the message to is correct (The number of the SIM card in the intercom panel). After sending a SM to the intercom panel. Listen for a single short beep from the Intercom panel. This will indicate that the message was received and understood. If a long beep is heard it indicates the message was either not understood or the 4 digit code was incorrect.
The call keeps dropping out	Try resetting the 4 digit code to 1111 as shown earlier in this manual (Powering up with C1 & PTE shorted).
	Increase the call time in programming.
Speech echoes and feeds back	Check the signal strength and if necessary, move or change the antenna or try a different SIM card provider.
	Try lowering the speaker volume using jumpers JP2 & JP3
	Try adjusting the volume using the programmable settings during a call
ERROR message returned in SMS when programming or no SMS returned at all even though a ? was included at the end of the message sent.	Check the microphone is fitted correctly in the intercom panel and that the mic hole is not blocked in any way.
	Check over the message sent again and compare it with the examples in the manual. Common errors include:-
	1. Using two apostrophe marks side by side instead of “. Note that these look the same in the message. An easy way to see if this is the problem is to move the cursor along in the message and if the cursor can get between the two “ then it is not the connect character used.
	2. Lower case letters instead of upper case. For example using stn when STN should be used.

**Enfora certifies that the Enfora Enabler IIG TM MHz GSM Radio Module (FCC ID: MIVMLG0208) complies with the RF hazard requirements applicable to broadband PCS equipment operating under the authority of 47 CFR Part 22 or Part 24, Subpart E of the FCC Rules and Regulations.**

**This certificate is contingent upon installation, operation and use of the Enabler IIG module and its host product in accordance with all instructions provided to both EOM and end user. When installed and operated in a manner consistent with the instructions provided, the Enfora Enabler IIG module meets maximum permissible exposure (MPE) limits for general population/uncontrolled exposure as defined in section 1.1310 of the FCC Rules and Regulations.**

### **WARNING**

**To comply with FCC RF exposure requirements, a separation distance of 20cm (7.87”) or more must be maintained between the antenna of this product and all persons**

**Separate FCC approval for this product is not required as it will be classed as a fixed installation.**

**THIS PRODUCT IS NOT DESIGNED TO BE USED AS AN EMERGENCY CALL POINT**



*The product is CE marked demonstrating its conformity and is for distribution within all member states of the EU with no restrictions.  
This product follows the provisions of the European Directives 89/336/EEC & 92/31/EEC (EMC), 73/23/EEC (LVD) and 93/68/EEC (CE marking).*

<b>Date</b>	<b>Software Version</b>	<b>Revision</b>
30/09/2008	GSM0.3.3	Added facility to latch the relay by pressing 1 during a call.
05/11/2008	GSM0.3.4	Added facility to check credit balance on selected Pay as You Go SIM cards. Improved echo cancellation during a call. Inserted divert time refresh after dialling finishes and ringing begins. Changed latch activation facility from pressing 1 to pressing 10 to activate. Added additional refresh to SMS facility after each call.
25/11/2008	GSM0.3.5	Added additional software resets.
06/01/2009	GSM0.3.6	Re-enabled latching relay facility when relay time is 00 (Previously disabled in version 0.3.4 when new latching facility was added using keys 10 to latch)
09/02/2009	GSM0.3.7	Added facility for telephone numbers which are stored in memory locations 001 – 020 (Call button locations) to automatically open speech (Call mode) when dialling into the GSM intercom (As oppose to going into programming mode and requesting the master code). Dial in to release the door still takes priority. The following SMS codes have been added:- RLA - Latch the relay (e.g. 1111RLA?) RUL - Unlatch the relay (e.g. 1111RUL?) ALA - Latch the AUXO (e.g. 1111ALA?) AUL - Unlatch the AUXO (e.g. 1111AUL?) Added facility to switch into programming during a call by pressing ☆☆
05/05/2009	GSM0.3.8	Added facility to control the mode of operation for the auxiliary out terminal (Either user activated or call activated).



**Northern Office**

Videx Security Ltd  
Unit 4-7 Chillingham Ind. Est.  
Newcastle Upon Tyne  
NE6 2XX  
TEL 0870 300 1240  
FAX 0191 224 5678

**Southern Office**

1 Osprey  
Trinity Park  
Trinity Way  
London  
E4 8TD  
FAX 0208 523 5825

**TECHNICAL SUPPORT**

[tech@videx-security.com](mailto:tech@videx-security.com)  
TEL 0191 224 3174  
FAX 0191 224 4938  
<http://www.videx-security.com>