

Program Logic

IBM System/360 Time Sharing System

On-Line Test Control Program

Program Logic Manual

This publication describes the internal logic of the On Line Test Control Program for IBM System/360 Time Sharing System (TSS/360). It is intended for use with the appropriate program listings. Its primary purpose is to serve as a guide to those listings.

This program logic manual is directed to the IBM customer engineer who is responsible for program maintenance. It can be used to locate specific areas of the program, and it enables the reader to relate these areas to the corresponding program listings. Program logic information is not necessary for program operation and use.

PREFACE

This program logic manual is a detailed guide to the On Line Test Control program for TSS/360. It supplements the program listing by providing descriptive text and flowcharts.

Effective use of this manual requires an understanding of IBM System/360 operation and of Time Sharing System/360. Reference publications for this information are:

IBM System/360 Principles of Operation,
Form A22-6821

IBM System/360 Time Sharing System:
Concepts and Facilities, Form
C28-2003

IBM System/360 Time Sharing System; Sys-
tem Programmer's Guide, Form C28-2008

IBM System/360 Time Sharing System:
Command System User's Guide, Form
C28-2001

IBM System/360 Time Sharing System:
Manager's and Administrator's Guide,
Form C28-2024

Second Edition (January 1970)

This is a major revision of, and makes obsolete, Y28-2042-1 and Technical Newsletter Y28-3069.

This revision incorporates the changes resulting from the addition of the Remote Terminal Access Method (RTAM) to the system, and the removal of the Basic Sequential Access Method Print Option.

Changes to pages are indicated as follows:

<u>Symbol</u>	<u>Meaning</u>
• (next to a page number or caption of an illustration)	The page (or illustration) has been revised and should be reviewed in its entirety.
(in the margin left of the text)	Adjacent text contains a change. (This symbol is not used if a bullet appears next to the page number.)

This edition applies to Version 6, Modification 0, of IBM System/360 Time Sharing System, and to all subsequent releases until otherwise indicated in new editions or Technical Newsletters. Changes are periodically made to the (specifications) herein; before using this publication in connection with the operation of IBM systems, refer to the latest edition of IBM System/360 Time Sharing System: Addendum, Form C28-2043, for the editions of publications that are applicable and current.

The contents of this publication are subject to change from time to time. Any such changes will be reported in subsequent revisions or Technical Newsletters.

This publication was prepared for production using an IBM computer to update the text and to control the page and line format. Page impressions for photo-offset printing were obtained from an IBM 1403 Printer using a special print chain.

Requests for copies of IBM publications should be made to your IBM representative or to the IBM branch office serving your locality.

A form is provided at the back of this publication for reader's comments. If the form has been removed, comments may be addressed to IBM Corporation, Time Sharing System/360 Programming Publications, Department 643, Neighborhood Road, Kingston, N.Y. 12401

CONTENTS

INTRODUCTION	1	APPENDIX A: SECTION CONTROL TABLE	39
On Line Test System (OLTS)	1	APPENDIX B: OLTS PRINT FORMATS	41
On Line Test Control Program (OLTCP)	1	APPENDIX C: PRINT CONTROL TABLE	42
Functions	1	Flags in Control Bytes	42
Initiation and Job Setup	1	Subtable (Heading Parameters)	42
Test Sequencing	4	APPENDIX D: OLTS TEST EVENT CONTROL	
On Line Test Access Method (OLTAM)		BLOCK AND CHECK FIELD	43
Interface to Hardware	4	Checkfield Flags	43
Output	4	APPENDIX E: OLTS TERMINAL TABLE	44
Utilities	4	APPENDIX F: OLTS SUBSYSTEM TABLE	45
Dynamic Control	4	APPENDIX G: SYSTEM TABLE DATA	
Organization	4	REFERENCES	46
Setup Control Routine (CMATF)	5	INDEX	47
OLTS Device Allocation Routine			
(CZATG)	8		
OLTAM Execute I/O (CZATA)	11		
OLTAM Posting Routine (CZATB)	13		
OLTS Print (CMATC)	14		
OLTS Compare (CMATD)	14		
OLTS Convert (CMATE)	15		
FLOWCHARTS	16		

ILLUSTRATIONS

FIGURES

Figure 1. Overall Operation of On
Line Test System 2
Figure 2. OLTCP Interfaces to Other
Parts of TSS/360 3

TABLES

Table 1. Data Integrity Measures for
DASDs 12

CHARTS

Chart AA. Setup Control (CMATF)	16	Chart AN. Process Dashed Pair (CZATG)	29
Chart AB. Attention Processor (CMATF)	17	Chart AO. OLTAM EXIO Routine (CZATA)	30
Chart AC. Section Selection (CMATF) (Part 1 of 2)	18	Chart AP. OLTAM - Data Integrity (CZATA)	31
Chart AE. Routine Selection (CMATF)	20	Chart AQ. OLTAM Posting Routine (CZATB)	32
Chart AF. Job Option Selection (CMATF) (Part 1 of 2)	21	Chart AR. OLTS Print Routine (CMATC) (Part 1 of 3)	33
Chart AH. Sequencer (CMATF)	23	Chart AU. Compare (CMATD)	36
Chart AI. Device Allocation (CZATG) (Part 1 of 5)	24	Chart AV. Conversions (CMATE) (Part 1 of 2)	37

ON LINE TEST SYSTEM (OLTS)

The On Line Test System (OLTS) is a collection of programs designed to assist the IBM customer engineer (CE) in testing and maintaining the hardware of the System/360 Model 67. A control program and a group of device-oriented test programs make up the system. All OLTS programs run in virtual storage in conversational mode. The test programs are non-privileged; the control program is made up of several routines, three of which are privileged. OLTS shares most system resources except the element under test. OLTS needs only minimum hardware requirements.

OLTS has the following purposes and uses:

1. On known error - to exercise the failing equipment, in order to further locate the malfunction.
2. After repair - to verify the repair prior to making the item available to customers again.
3. In adjustment - to provide a tool to assist in making adjustments to the equipment.
4. For periodic check - to ascertain condition of element.

Overall operation of the On Line Test System is shown in Figure 1.

ON LINE TEST CONTROL PROGRAM (OLTCP)

The On Line Test Control Program is the major interface between OLTS, the CE, and the I/O supervisor; it is also a source of utility routines for the test programs. See Figure 2.

FUNCTIONS

The functions of OLTCP are:

- Job Setup
- Device Allocation
- Test Sequencing
- I/O Control
- Utilities

Initiation and Job Setup

The setup modules CMATF and CZATG (Figure 1) gain control as a result of the RUN command and enter direct communication with the CE at the SYSIN-SYSOUT device.

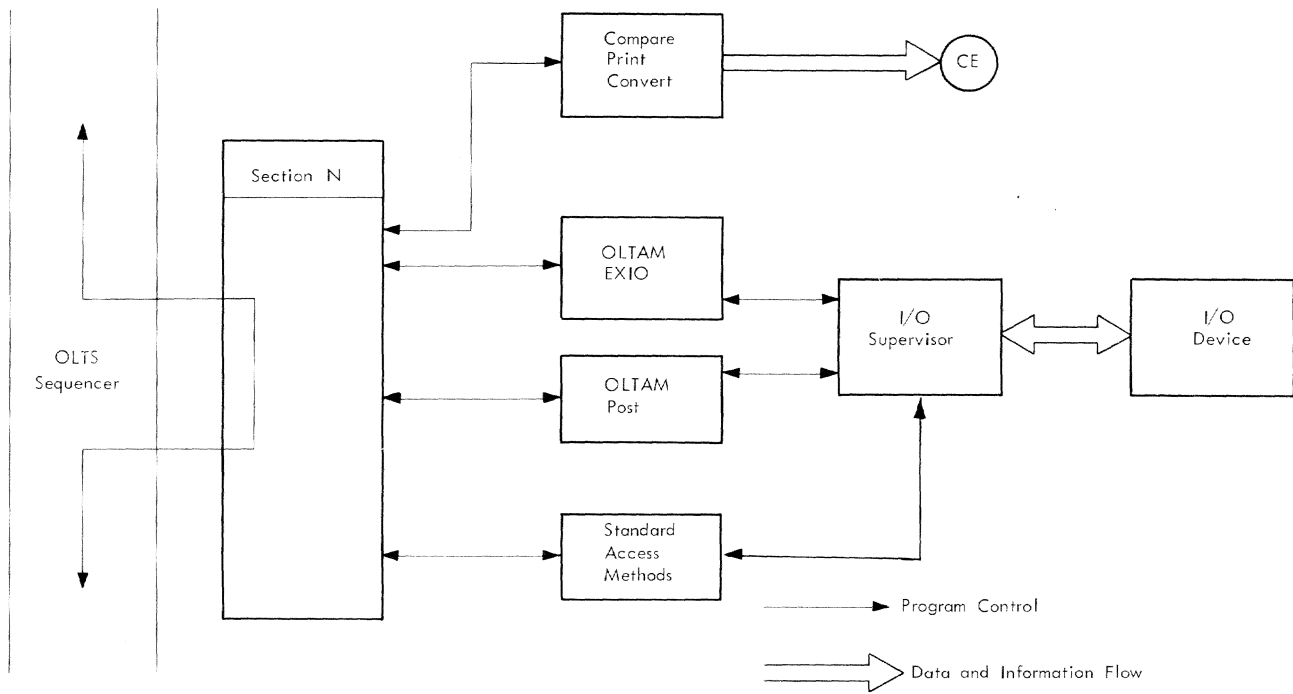
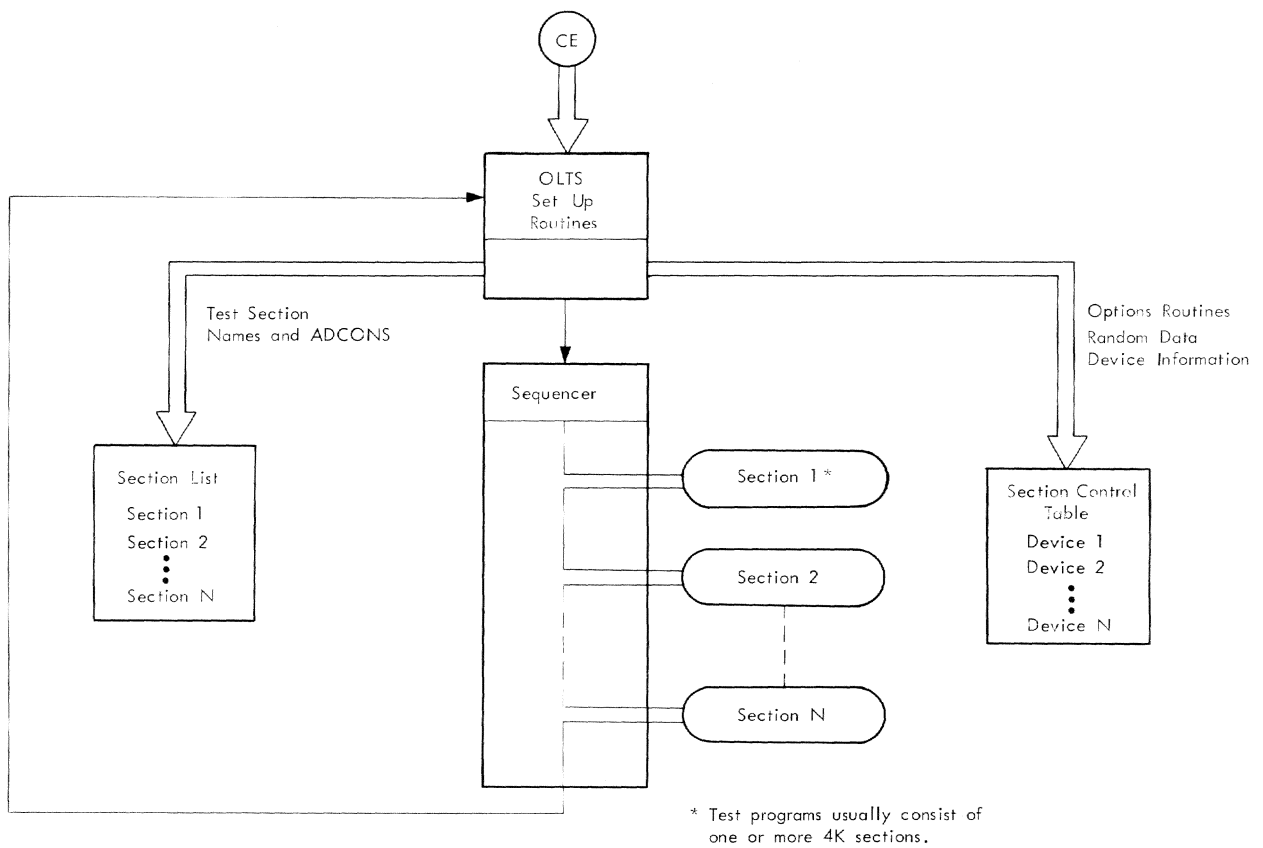
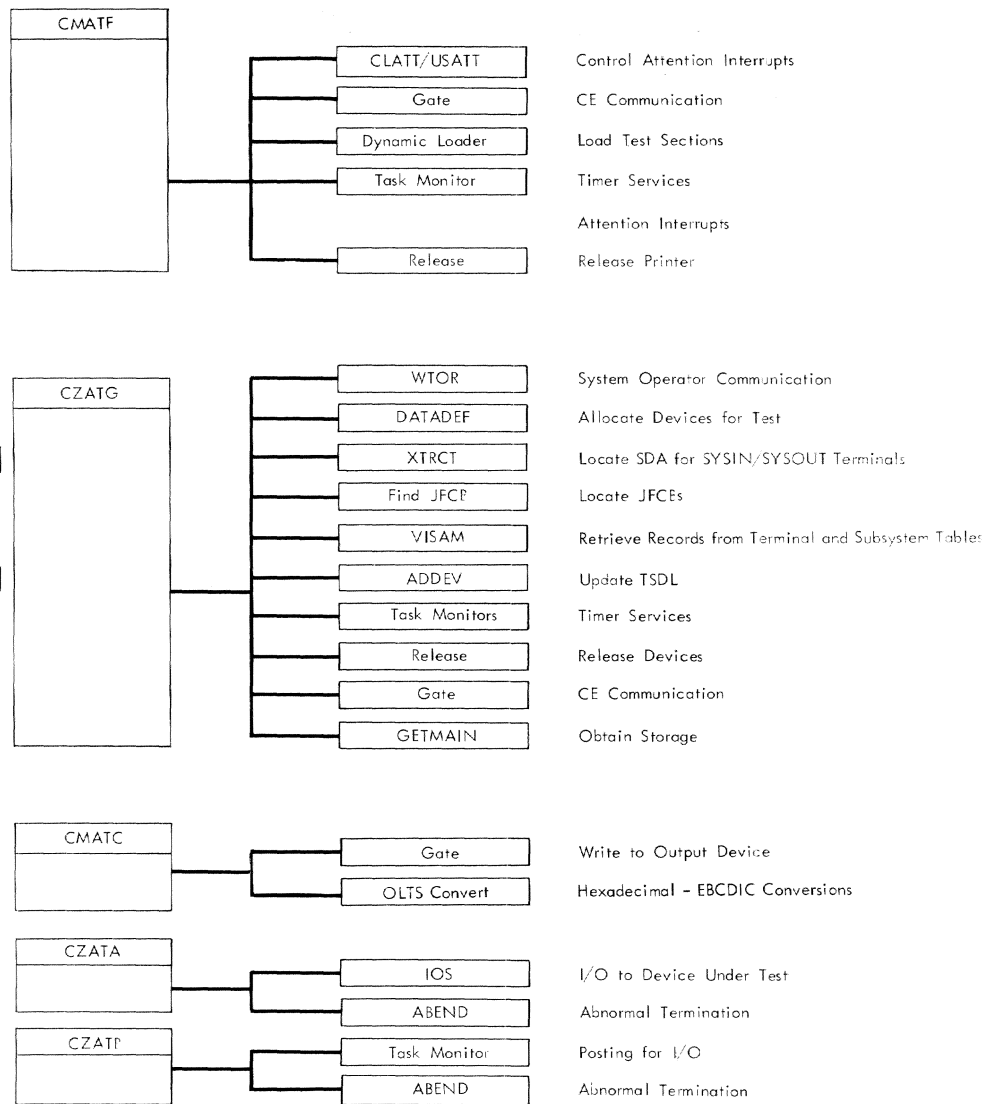

Figure 1. Overall Operation of On Line Test System



• Figure 2. OLTCP Interfaces to Other Parts of TSS/360

The CE enters:

1. The unique symbolic name assigned to the units or subsystems to be tested
2. The names of the test sections to be run
3. The routines of a selected test section
4. Run options

This information is used to get the devices allocated, call the test sections and build tables defining the job request.

The tables constructed are: the section control table (Appendix A), which describes the job to the test programs, and the section list, which lists the sections selected for sequencing. In addition, a table describing terminal attributes is constructed if terminal tests are selected.

Test Sequencing

When the job request has been defined, the sequencer subroutine is entered. This subroutine operates on the section list constructed by the setup routines. It gives control, in turn, to each section in the list, passing to each a pointer to the section control table, which describes the job to be performed. The section tests the devices described in the section control table, using the routines and options chosen by the CE.

On Line Test Access Method (OLTAM) Interface to Hardware

Test sections may access I/O hardware via the on line test access method (OLTAM), standard access methods, or a combination of these. OLTAM consists of two routines that interface test program I/O operations to the supervisor. It exists because system access methods do not, in general, provide the flexibility required by test programs.

OLTAM allows test programs to specify their own CCW lists. OLTAM permits a test program to specify an I/O path of its own choosing, rather than accepting an arbitrary path provided by other access methods. If the specified path is busy, the request will be queued in the supervisor until the path becomes free. OLTAM returns condition codes to the test program, along with CSW and sense data if applicable. It returns the final CSW and sense data on completion of the operation. This information is placed in an OLTAM-defined test event control block (TECB) for use by the test program. Test event control blocks are summarized in Appendix D. OLTAM interfaces to the supervisor via the IORCB and the IOCAL SVC.

OLTAM provides a posting routine which provides the essential services involved in marking an I/O event complete and passing status information to the test program.

Output

Test results, usually in standard formats, are displayed on a device designated by the CE. The OLTCP print routine (CMATC) provides uniform message formatting and directs results to the SYSIN-SYSOUT terminal (via the GATE routine).

Utilities

Two utility routines are provided. The Convert routine converts EBCDIC and HEX; the Compare routine compares expected and received results of I/O operation for test programs.

Dynamic Control

OLTS may be interrupted dynamically to change options, end a test section, redefine a job, or end a session. The CE presses ATTENTION at SYSIN, and a routine prompts for and processes changes.

ORGANIZATION

The following modules, all of which are parallel, reenterable, and run in virtual storage, make up the OLTCP.

<u>Module</u>	<u>Title</u>	<u>Privileged</u>
Setup	CMATF	No
Device Allocation	CZATG	Yes
OLTAM Execute I/O	CZATA	Yes
OLTAM Posting	CZATB	Yes
Print	CMATC	No
Convert	CMATE	No
Compare	CMATD	No

Setup Control Routine (CMATF)

This routine:

1. Communicates with the CE at the SYSIN device to obtain test parameters.

The format of a non-prompt-mode entry is
DEVICES/TESTS,ROUTINES/OPTIONS

For example,

10,11/2311A,5/NEP,EL

which says: test symbolic devices 10 and 11, using test section 2311A, Routine 5; loop on errors, and do no error printing.

2. Calls the device allocation routine (CZATG) to get devices allocated, and complete the device fields of the section control table. (CZATG interfaces to system device management routines.)
3. Constructs the test option and routine selection fields of the SKT.
4. Loads and sequences test programs.

Entry Point: SYSTEST, via RUN command; Type-III linkage.

Input: None.

Operation: SETUP is entered from the command system by the sequence of a LOGON and RUN command. As soon as the routine is entered, a request for input parameters is sent to SYSIN, via the GATE subroutine. At this point, if the CE desires to enter the prompting mode, the PROMPT MODE flag is set so that the routines that analyze the parameters will prompt for them.

The device allocation routine (CZATG), the section selection subroutine, the routine selection subroutine (if applicable), the test option subroutines and sequencer subroutine are run (the subroutines are within CMATF). After sequencing all selected tests, the loop-test option is tested; if set, the entire job is rerun; if off, return is made to the beginning of setup, from which the request for input parameters is repeated.

The job may be ended at any time via LOGOFF.

The major subroutines of CMATF are:

SECTION SELECTION SUBROUTINE: This subroutine analyzes the input stream to pick up test selections, determines whether the requested sections are available, and constructs a list of the available requested sections for subsequent sequencing.

The section selection subroutine is entered from the setup control routine. Upon entry, the OLTS prompt mode flag is checked. If it is on, a prompting message is sent to SYSIN. When the response arrives, or if no prompt was made, the input stream is checked for a 4-digit number.

If this number is not present, an error message is sent to SYSIN, and prompting is initiated. A series of letters, commas, and dashes will follow the 4-digit numeral. These characters are expanded into full test section names, and the modules are loaded, via the dynamic loader, to verify their availability. As each section is loaded, its name and address constants are entered into the section list, and the section counter is incremented. A slash or a decimal digit signals the end of the section field.

Error Checks: A check is made to determine that the first four characters of the section selection field are decimal digits.

The input stream is monitored for illegal or illogical character appearance.

The availability of each requested section is checked by an attempt to load it into virtual storage.

Checks are made that at least one section has been successfully loaded, and that no more than 26 sections have been selected.

If any error is detected, the CE is given the option to erase current selections and make new selections.

ROUTINE SELECTION SUBROUTINE: This subroutine sets up the routine selection halfword in the section control table. It is entered only when a single test section has been requested, and the CE desires to run specific routines within this test section.

On entry, if the prompt flag is set, a request for routines is sent to the CE at SYSIN. If the prompt flag is not on, the routine selection data will be taken from the main input stream. The input is checked for routine numbers 1 to 16, and the respective bits are set in the routine selection halfword of the section control table.

Error Checks: Permissible characters are decimal digits, commas, blanks and dashes. If an illegal character or a legal character in an illogical context is encountered, the CE is informed of the error and is given the option to retain current routine selections or to erase them and make new selections.

Routine numbers are from 1 to 16, inclusive.

OPTION SELECTION SUBROUTINE: This routine sets bits in the job option halfword of the section control table. The available options are:

- No control printouts
- No error printouts
- Loop if error detected
- Loop the test
- Scope Loop

This routine first checks to see if the prompt mode flag is set. If so, a request for options is sent to the CE. The response contains either the options desired or the character D for DEFINITION. If D, another message defining the option codes is sent to the CE. The CE enters the desired options which are checked against permitted options, and when a match is found, the respective bit in the job option halfword is set.

Error Checks: An illegal entry causes a message to the CE that defines current options and allows new selections.

SEQUENCE SUBROUTINE: This subroutine runs the test sections in the order specified by the CE.

The sequence subroutine, entered from the setup control routine, calls test sections, based on entries in the section list. Normally, a message is printed prior to entering a test section (e.g., "S2250A") and on return from a test section ("T").

On entry to the test section, register 1 points to a 4-word parameter list:

- Word 1 - Pointer to the Section Control Table
- Word 2 - Pointer to the Internal Terminal Table
- Word 3 - Pointer to the Relocated SDAT*
- Word 4 - Pointer to the nonrelocated SDAT

On return from a test section, general register 15 contains a code set by the test section that defines the termination circumstances and subsequent action to be taken for this test program. The codes are:

- Code = 0 - Normal Termination. Print "T".
- Code = 1 - Abnormal Termination. Proceed to next section of program, if any. Print "T*".
- Code > 1 - Abnormal Termination. Terminate Job Request. Print "T*". Print "JOB TERMINATED."

When all sections have run, the test-loop flag in the section control table is tested. If set, the entire section list is processed again. If it is not set, control is passed to a point where a request for a new job request will be made.

Restrictions: Used only by Class E users.

Modules/Macros:

- GATE (CZAAB) - Communication with user.
- OLT Device Allocation (CZATG) - Obtain use of devices; build device portion of section control table.
- USATT - Direct SYSIN attentions away from command system.
- SIR - Enable interrupt control block.
- CLATT - Direct SYSIN attention to command system.
- STIMER & TIMER - Establish random number.
- Dynamic Loader SVC 127 - Load test sections.
- Test Sections (C>NNNX) - Run test programs.

*If a 2250 is being tested, the SDAT table, which is fetch-protected, is moved to an area of storage that can be read by nonprivileged test sections. This makes it possible for these tests to obtain necessary information.

Exits: To exit from this routine, the user must cause an attention interrupt. A routine will prompt for and execute an exit procedure. An exit to the Command System may also be made by responding to any prompting message with E, END, or EOT. An exit to the Command System will be made if the return code from CZATG is 8.

OLTS Device Allocation Routine (CZATG)

This routine scans the device field of the CE input request line. It determines the devices to be tested and takes action to ensure that they have been disassociated from operational requirements. It constructs the device fields of the section control table.

Entry Point: CZATG1, via Type-II linkage from CMATF.

Input: On entry, general register 0 contains either zero, or a pointer to the device field of the CE input line. If zero, prompting is required.

Operation:

1. The privilege class of the user (in the Task Common table) is tested. If the user has privilege class E, the OLTS bit is set to one in the ISA to inform system device management routines that OLTS is interfacing with them. If the user does not have privilege class E, the job is terminated.
2. The SDA and SYSIN data are located via the XTRCT macro.
3. If prompting is indicated, a message defining the required input format is sent to the CE. In nonprompt mode, register 0 points to the first character of the device field on entry to the routine.
4. The device field is scanned for three types of device entry: subsystem, identified by the characters SUBDD; terminal, identified by the characters TDDD; and local device, identified by the characters HHHH. These are hexadecimal characters identical to the device's SDAT identity. D is a decimal digit. In addition, a specific path to a device may qualify a terminal or local device name. The specific path is represented by HHHH where H is a hexadecimal digit.
5. When a subsystem entry is encountered, the subsystem definition record (Appendix F) is retrieved, via VISAM, from the subsystem table. The contents of the input line scanner are saved, the scanner is pointed to the subsystem record, and control is passed to the main scan function (item 6 below). For nonsubsystem entries, the main scan function is started immediately.
6. A check is made to ensure that a legitimate combination of characters for a device or terminal is present. Then a check is made to determine whether a specific path is present. If present, the path is converted to binary and saved in the section control table, and the specific path flag is turned on.

If the device is a terminal, item 7 is followed; otherwise, item 10 is followed.
7. If the device is a terminal, a record (Appendix E) describing its characteristics is retrieved, via VISAM, from the terminal table and added to an internal table. The terminal flag is turned on in the section control table (CHASKT). If the terminal is SYSIN, item 10 is followed; otherwise, item 8 is followed.

8. If the terminal is not SYSIN, it can be reached either via a dedicated line or via any line that has an autocall adapter. The details are extracted from the terminal table record.
9. If an autocall unit (ACU) is indicated, a check is made to see whether a line with an autocall adapter that can be used to reach this terminal has been obtained. If so, it is used; if not, the SDAT is searched for a suitable entry and if one is found, the procedure in item 10 is followed. If no suitable line can be found, a message is printed, and this device entry is skipped.
10. If the device to be tested is SYSIN, whether a terminal or a local device, its SDA is obtained by using the XTRCT macro. A pointer to the SDAT is derived from the Task Common entry (TCMSIN), and the SYSIN flag in the section control table is turned on. Item 12 is then followed. If the device is not SYSIN, the procedure in item 11 is followed.
11. A local I/O device that is being tested, or that is necessary to test a terminal, must be listed in the SDAT (see Note 1, after item 15). The device's SDAT entry is found, and a check is made to determine whether it is private. If private, CZAEA is called to obtain the device's allocation and construction of its JFCB (see Note 2). If the device is not private, its SDAT CE bit is tested. The CE bit must be set before OLTS will use a nonprivate device. If the CE bit is set, CZAEA is called, via the DDEF macro, for allocation and JFCB construction.
12. The system symbolic name of the local I/O device and its characteristics word are moved from the SDAT, using the derived SDAT pointer, to the section control table.

If the device is a direct access device (DAD), with demounting capabilities or a tape drive, steps are taken to ensure that a CE volume is mounted. If correct volume mounting for a DAD cannot be verified, indicators are set in the section control table to inhibit writing via OLTAM. (Read or SEEK tests may still operate.)
13. A slash in the field being scanned signals the end of the field. If a subsystem scan is in process, the slash signals its termination; the main stream pointer is restored and scanning resumes. If a slash is encountered when no subsystem is being processed, the end of the device field has been reached.
14. When device specification is complete, a list of I/O devices to be used is printed. If any errors were encountered, the CE is given the option of erasing current selections and reentering new selections.
15. Finally, the device fields of the section control table are moved to protected storage to guard against possible alteration by a non-privileged program.

Note 1: All local I/O devices are listed in the SDAT. This includes allocable and nonallocable devices. Each 2702 line is considered a device.

Note 2: CZAEA (DDEF) is called by problem programs to obtain use of devices and for construction of job file control blocks (JFCBs). The JFCB contains information describing a data set and/or device and must be present for use by system access methods. Normally, allocation is restricted to available private devices; however, CZAEA and CZCAA take the following special actions if OLTS is the caller:

- Any private device is allocated if it is not in use.
- Private devices marked as in use (not available) are allocated if the SDACE flag is on. This flag is set by the HOLD command (see IBM System/360 Operating System: Operator's Guide, Form C28-2033).
- Nonprivate devices are allocated.
- All volume mounting is bypassed.
- A JFCB is constructed for any device.

Devices are not allocated if they are partitioned.

Error Checks: A check is made that the user has privilege class E. If not, a call is made to ABEND.

Restrictions: Restricted to Class E users.

Modules/Macros

DDEF	(CZAEA)	- Allocate devices; build JFCBs.
FINDJFCB	(CZAEB)	- Find JFCBs.
OPEN	(CZCLA)	- Open DCBs for subsystem and terminal tables.
VISAM READ	(CZCPE)	- Read terminal and subsystem tables.
GETMAIN	(CZCG2)	- Obtain read/write storage to place SDAT in.
SET TIMER		Time I/O operation.
TEST TIMER		
WTOR	(CZABQ)	- Write message to system operator.
OLTAM EXIO	(CZATA)	- Verify CE pack or bin mounted on direct access device.
RELEASE	(CZAFJ)	- Release devices and JFCBs.
GATE	(CZAAB)	- Communicate with user.
SYSERR	(SVC228)	- Report illogical occurrences.
ABEND	(CZACP)	- Force abnormal task termination.

Exit: On exit, register 0 points to the byte following the slash that ended the device field. Register 15 contains one of the following return codes:

<u>Return Code</u>	<u>Meaning</u>
0	Normal return
4	A request for initialization or an attention was received as a response to a prompting message.
8	A response of E, END, or EOT was made to a prompting message.

OLTAM Execute I/O (CZATA)

This routine constructs an IORCB from parameters provided by a calling test routine and passes the IORCB to the IOS for execution.

Entry Point: CZATA1, type-I or type-II linkage

Input: Upon entry, register 1 contains a pointer to the following parameter list which is located in the calling test program:

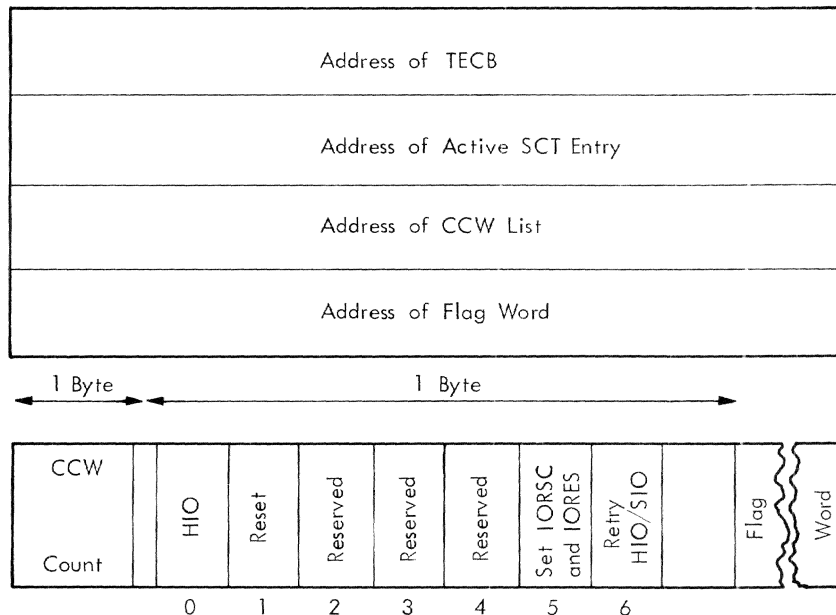

Operation: On entry, OLTAM immediately checks whether the user has privilege class E. If not, an exit is made to ABEND.

A check is made to determine whether CZATG (OLTS Device Allocation routine) is the calling program. If so, section control table (SKT) validity checks and data integrity checks are bypassed. If not, the checks are made.

First a check is made to ensure that the test program has provided a valid SKT pointer, and that the device fields of the SKT have not been altered. SKT alteration or an invalid SKT pointer results in a call to ABEND.

Next, it is determined whether a direct access device (DASD) is being tested. If so, the following restrictions are enforced:

1. For 2311, 2314, or 2301 devices, the first CCW in the chain may be any type of command except WRITE or SEARCH; for all other DASDs, the first CCW must be a control seek (op code 07).
2. For all DASDs, the second CCW must be a SET FILE MASK command.

If either condition is not met, a call is made to ABEND.

The file mask operand of the second CCW is set as indicated in Table 1. The flag field of the SKT entry for the device will have been set by CZATG to tell whether CE volume mounting was verified.

Seek sections are identified by testing a bit in their section preface.

Writing on 2321s is confined to cell 0, subcells 16 to 18 (CE bin only). Writing on 2302s is confined to cylinder 250 and above. This is

done by checking the initial seek operand and allowing head seeks only thereafter.

Table 1. Data Integrity Measures for DASDs

	1	2	3	4	5
	If CE volume mount verified	Then set file mask to allow writing	Then set file mask to allow any seek	Then set file mask to allow seek head only	Then check limits of initial seek
Any seek section	-	N	Y	N	N
2311/2314 nonseek section	Y*	Y	Y	N	N
	N	N	Y	N	N
2321 nonseek section	Y	Y	N	Y	Y
	N	N	N	Y	Y
2302 nonseek section	-	Y	N	Y	Y
2301 nonseek section	-	Y	Y	N	N
Y=yes; N=no; -=not relevant *=SET FILE MASK of test section is used.					

The constant fields of the IORCB are completed first; then the following variable fields are completed, as specified by the calling program.

- The DECB address field. This will point to an OLTS-defined Test Event Control block (TECB) (Appendix D). Status data will be placed in the TECB by the OLTAM posting routine.
- The 2-byte, 4-digit system symbolic device address field.
- The DEB pointer field is used to save the starting VM address of the CCW list. This is used by OLTAM posting to convert the final CSW address from a real to a virtual address.
- The CCW list length field.
- The CAW key is set depending on the privilege of the calling program.

Then the TECB in the calling program is cleared.

If a specific path is associated with this request, the IORCB specific path flag is set, the physical address is entered in the IORCB, and the IORCB "ignore down indicator" flag is turned on. This flag tells PATHFINDER routine to override a down status indication for this device.

The CCW list is scanned and a page list and page count are generated and placed into the IORCB. OLTAM does not buffer any I/O transfers in the IORCB.

Next, the origin of the CCW list in the IORCB is calculated and the CCW pointer fields are completed.

Then, the virtual storage CCWs are reformatted and placed in the IORCB.

Finally, the length of the IORCB is calculated and inserted, and the HIO, software command chaining, and post PCI flags are turned on, if applicable. Now the build of the IORCB is complete. If a reset is indicated, the RESET SVC is executed. Before the IOCAL is executed, the SKTFLG is tested for the device type. If the device is a terminal, the CKALOC macro is executed to test for MTT operation. On return from the CKALOC SVC, register 0 is tested for a return code. If the code is 2, an ABEND1 is issued; if not the IOCAL SVC in the IORCB is executed.

Restrictions: Used only by OLTS programs.

Modules/Macros

IOCAL SVC	-	Perform I/O operation.
ABEND (CZACP)	-	Force ABEND of task.
RESET SVC	-	Reset.

Exit: No return code is provided. Return is to the calling program, via register 14.

OLTAM Posting Routine (CZATB)

This routine fields all synchronous I/O interrupts resulting from OLTAM-initiated I/O activity.

It sets the complete bit in the associated OLTAM-defined TECB, when applicable, and moves the status and sense data from fixed locations in lower virtual storage to the user's TECB. It also moves condition codes into the TECB.

Entry Points: CZATB1; type-I linkage from the task monitor.

Input: None.

Operation: This routine is the posting routine for all OLTAM I/O activity.

Entry is made from the task monitor. A check is made whether the user has privilege class E. A call to ABEND is made if he does not.

Flags in the IORCB for CCW specification errors or invalid path definition are tested. If either is set, a call is made to ABEND.

Then a check of the intercept flag is made. If this flag is set, the IORCB was not executed because of an unrecoverable error associated with a previous IORCB; an interrupt code is placed in the test program's TECB, the reject I/O flag is reset, and an exit is made to the task monitor.

If the IORCB was executed, the CSW, sense data, and condition code fields are moved from the ISA and the IORCB to the TECB, and the address in the returning CSW is converted into a virtual memory address. (The original VM address of the CCW list is placed in the DEB field of the IORCB by the OLTAM execute I/O routine to make this conversion possible.) Then the complete bit is set in the TECB, and the active SKT is located. The SKTFLG is tested for MTT, and if MTT is operating the CKALOC macro is issued to reset the lock byte (returning the terminal to RTAM), and control is returned to the calling routine. If MTT is not in operation exit is to the calling routine.

Restrictions: Used only by OLTS programs.

Module Called: ABEND (CZACP).

Exit: On exit, register 15 contains zero, indicating to the task monitor that no further processing is associated with this function.

OLTS Print (CMATC)

This routine prints hardware failure information as it occurs for OLTS test programs on a device designated by the customer engineer; it also prints some nonfailure information messages on the same device.

Entry Point: CMATC1; type-I linkage.

Input: Upon entry, register 1 contains a pointer to a print control table (Appendix C) which describes the print request.

Operation: The print control table pointed to by register 1 can contain requests for three different kinds of prints, heading (1), results (2), or comments (3) (Appendix C).

If a heading print (Appendix B1) is requested, a check is made for the error bit in the print control word. If it is set, an * is placed as the first character of the heading line. The program ID and active routine number are moved from fixed locations relative to the save area in the test program and placed in the line. Then, if requested, the pertinent instruction counter value, CCW list address, I/O path, system symbolic tag, and terminal identity are placed in the heading line.

Note: Both the instruction counter value and the CCW list address are referenced to the test program's assembly listing. All test programs are assembled at location zero. The instruction counter value points to the place in the listing from which the test can be retraced; the CCW address is the starting address of the list of failing CCWs.

If a results print (Appendix B2) is requested, the received CSW condition code and sense data is extracted from the TECB, and the expected data, or pointers to it, are extracted from the check field (Figure 5). Both received and expected results, or only received results, may be printed, depending on the request.

A comment (Appendix B3) is printed unchanged.

When a line of print is formed, a decision is made as to the device and method of output to be used. If the output device is the SYSIN-SYSOUT terminal, the GATE routine is used to transfer the message.

The print control table is scanned until there are no further entries.

Restrictions: All lines are limited to 74 characters to make display on a graphic device possible.

Modules/macros

OLTS convert routine (CMATE) - Conversions.

GATE (CZAAB) - Prints to SYSIN.

Exit Code: None.

OLTS Compare (CMATD)

This routine compares expected versus received results of I/O operations for OLTS test programs.

Entry Point: CMATD1; type-I linkage.

Input: On entry, register 1 points to a 2-word parameter list which is located in the calling test program.

Word 1 - Address of Check Field (Appendix D)

Word 2 - Error Exit Address

Operation: This routine interrogates the flag byte in the check field (Appendix D) to determine what fields are to be compared. Fields whose flag bits are active are compared. After all active fields have been compared, a bit pattern is placed in the low-order byte of register 15 which corresponds to the flag byte of the check field. If any noncomparisons are found, control is passed to the error exit address; otherwise, control is returned to the caller's next sequential instruction.

Restrictions: Used only by OLTS programs.

Modules Called: None.

Exit: On exit, register 15 contains a code that defines active noncomparing fields.

OLTS Convert (CMATE)

This routine converts between hexadecimal and EBCDIC for OLTS programs.

Entry Point: CMATE1; type-I linkage.

Input: On entry, register 1 points to a 3-word parameter list in the calling program:

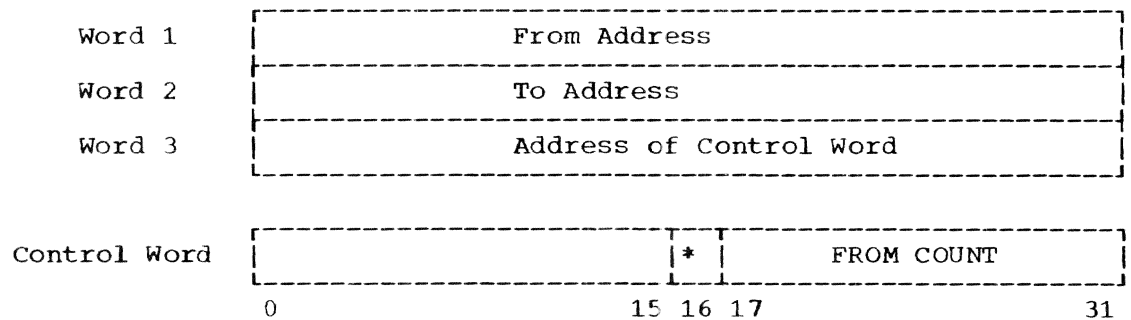

* = Flag: 1 if hexadecimal to EBCDIC; 0 if EBCDIC to hexadecimal.

Operation: Data in a "from" field is converted as requested and the converted data is placed in a "to" field. The "from" field is not disturbed unless it is also part of the "to" field. Illegal characters in a conversion from EBCDIC to hexadecimal are converted to hexadecimal 0.

Restrictions: None.

Modules Called: None.

Exit Code: If an illegal character is encountered in a conversion from EBCDIC to hexadecimal, register 15 is set to a positive number; otherwise, it is set to zero.

FLOWCHARTS

The flowcharts in this section are presented in the order in which the routines are described in the previous sections.

Chart AA. Setup Control (CMATF)

PAGE 001

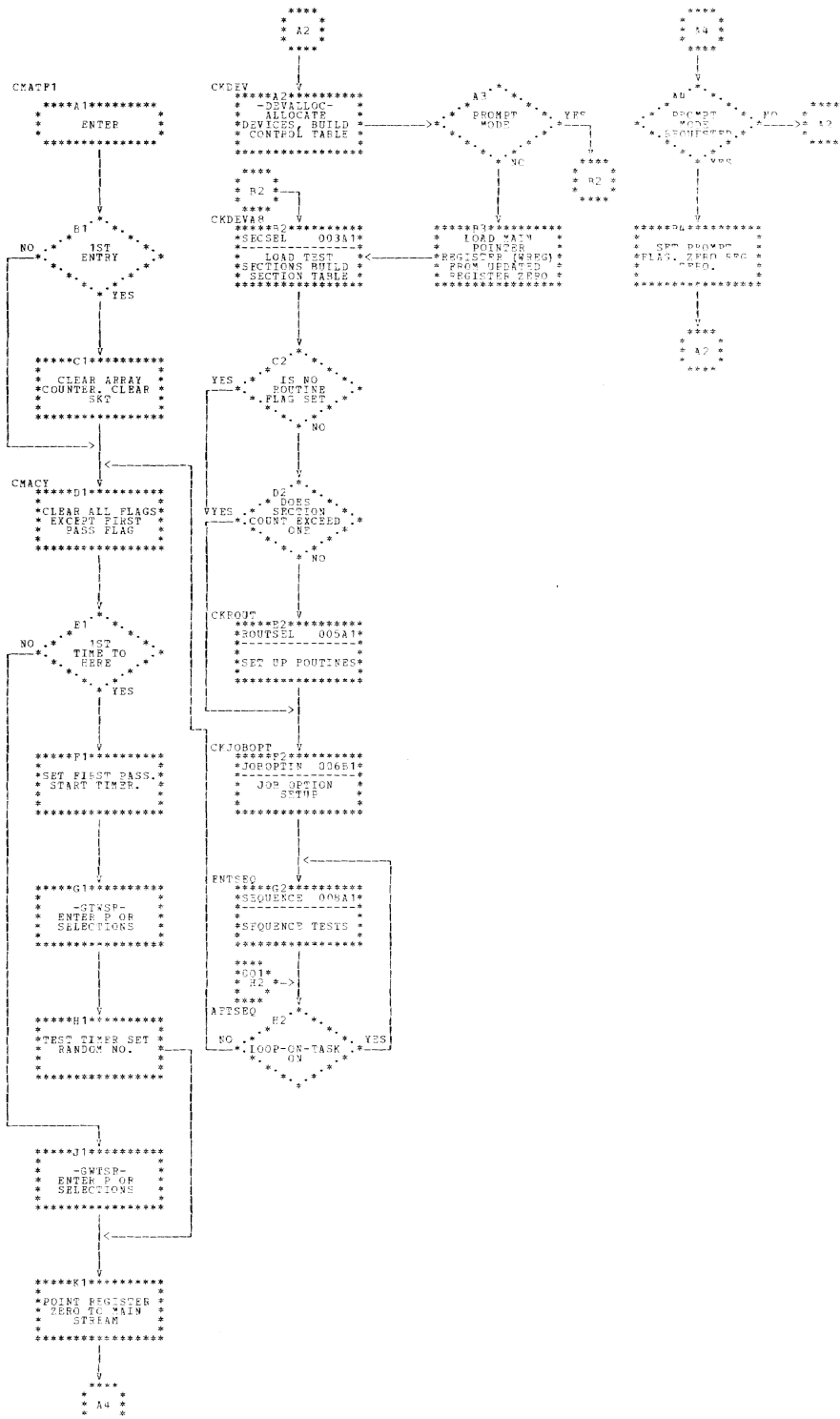

Chart AB. Attention Processor (CMATF)

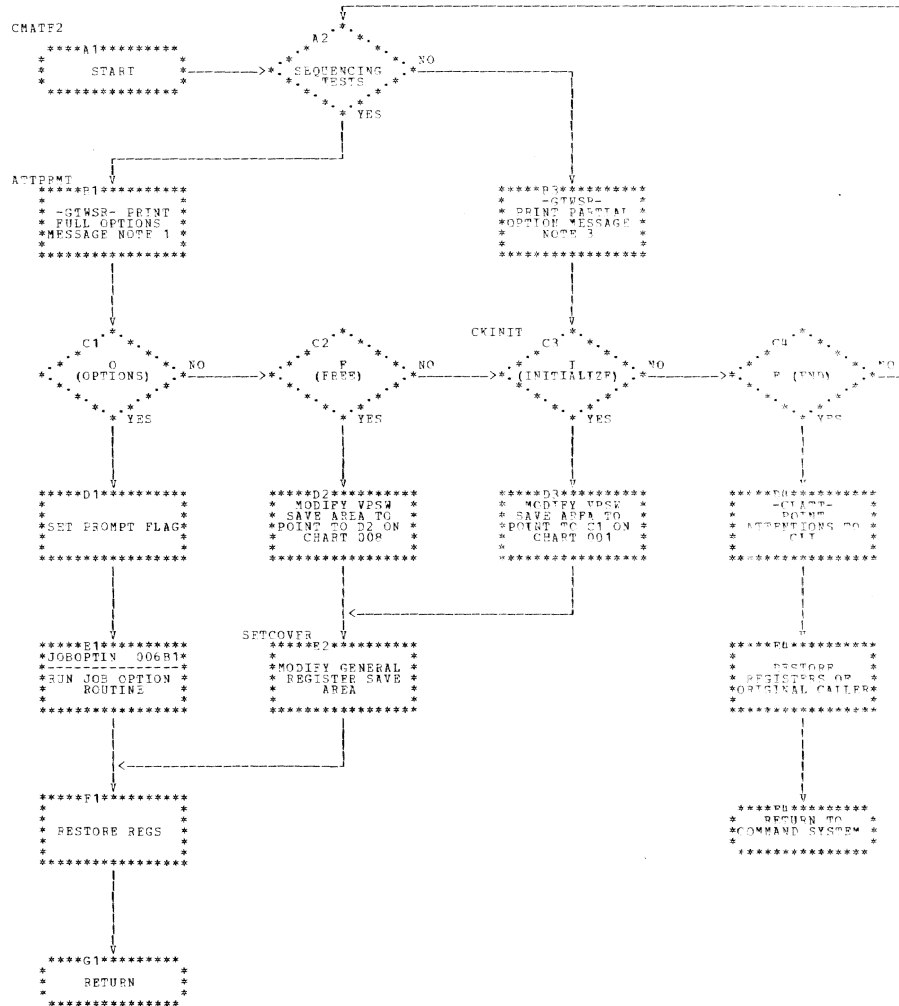

Chart AC. Section Selection (CMATF) (Part 1 of 2)

PAGE 003

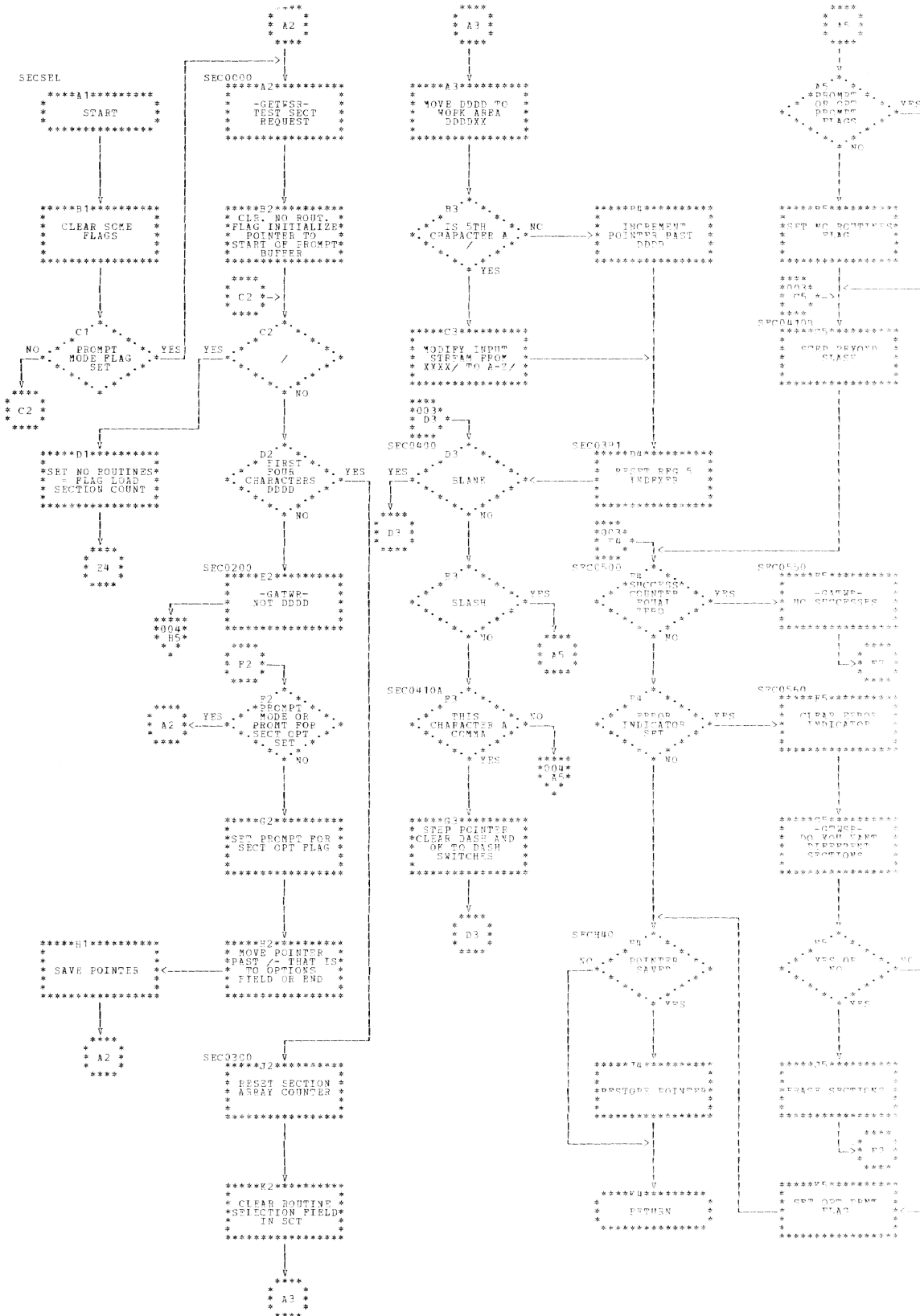

Chart AD. Section Selection (CMATF) (Part 2 of 2)

PAGE 204

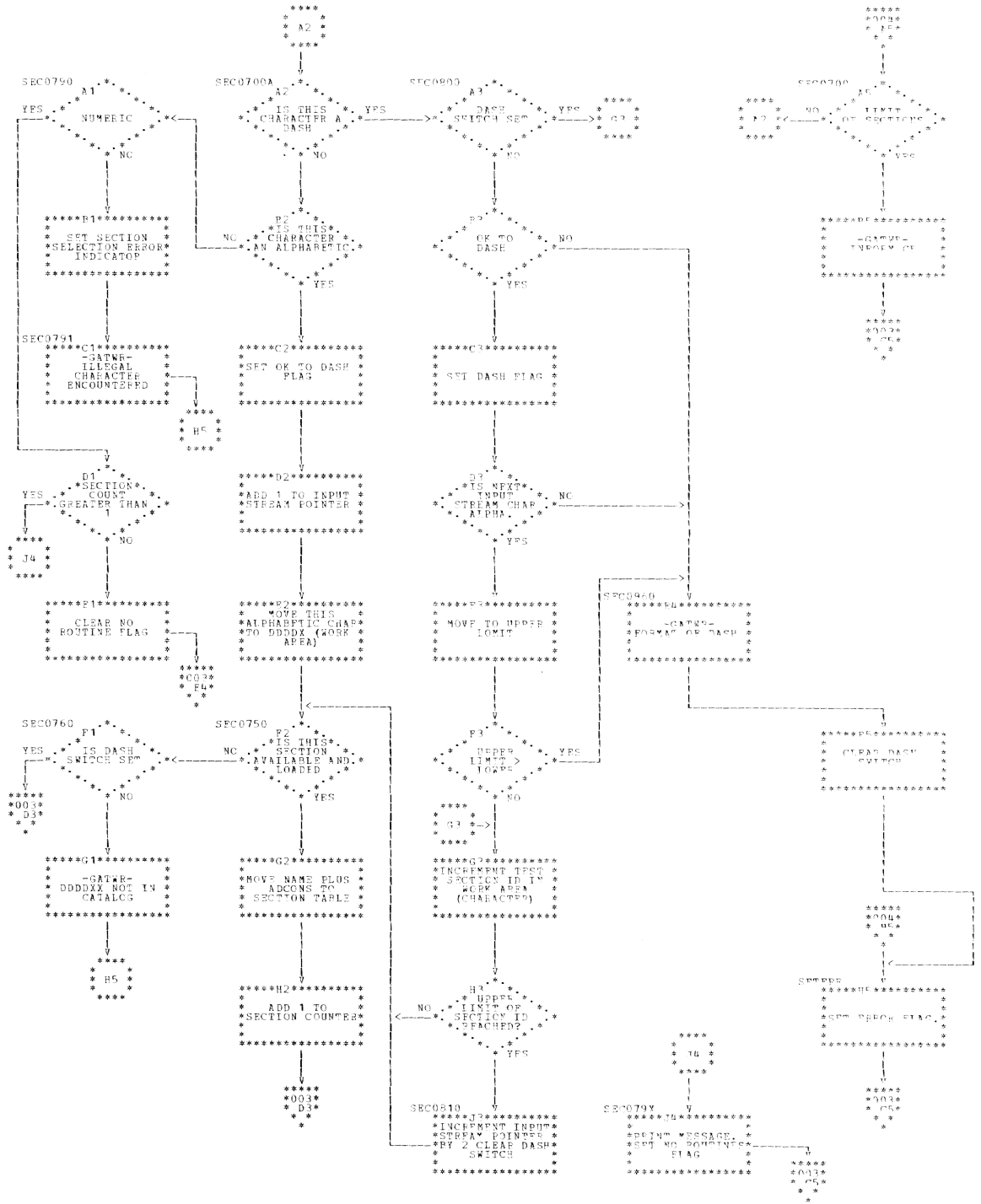
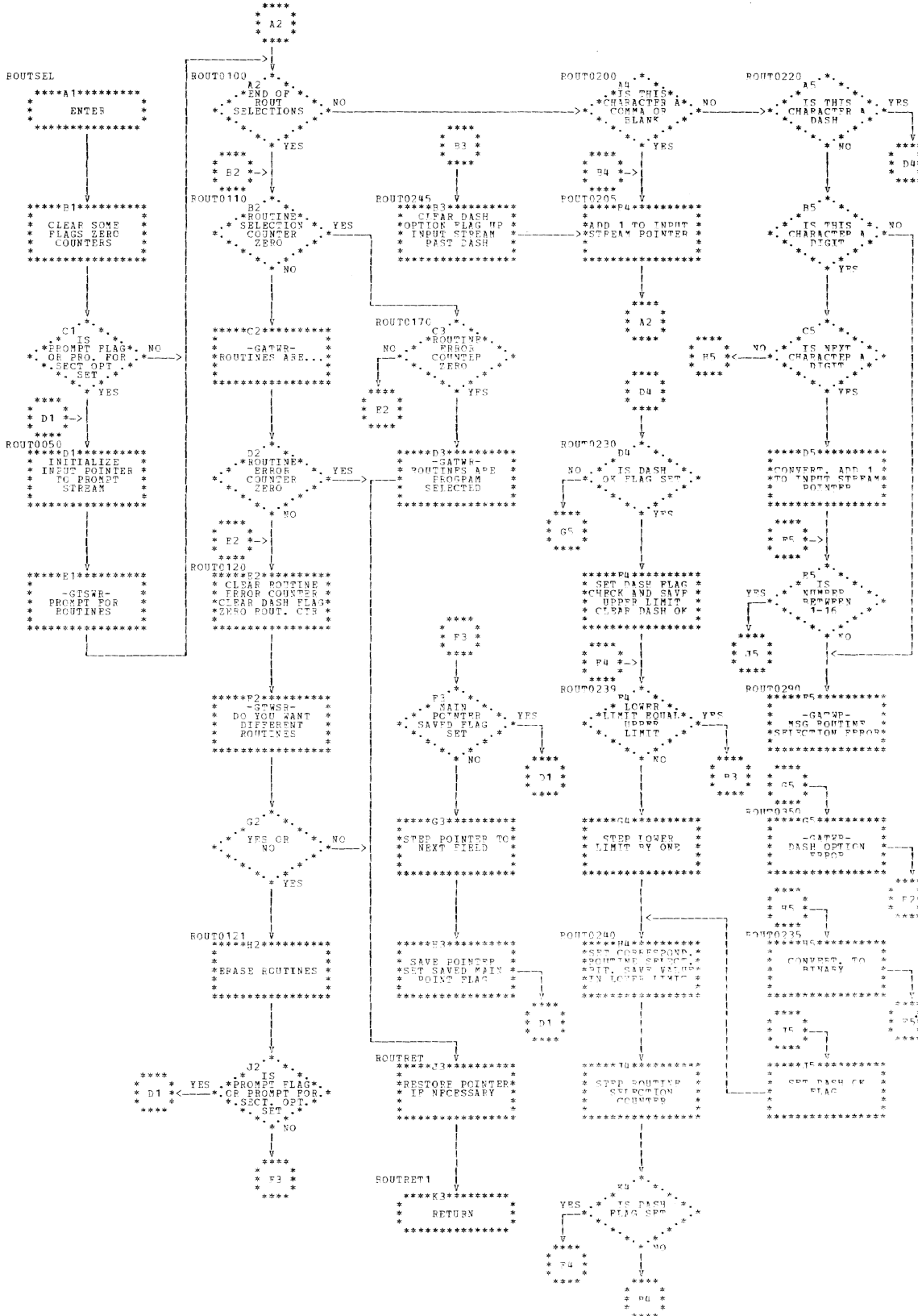

Chart AE. Routine Selection (CMATF)



• Chart AG. Job Option Selection (CMATF) (Part 2 of 2)

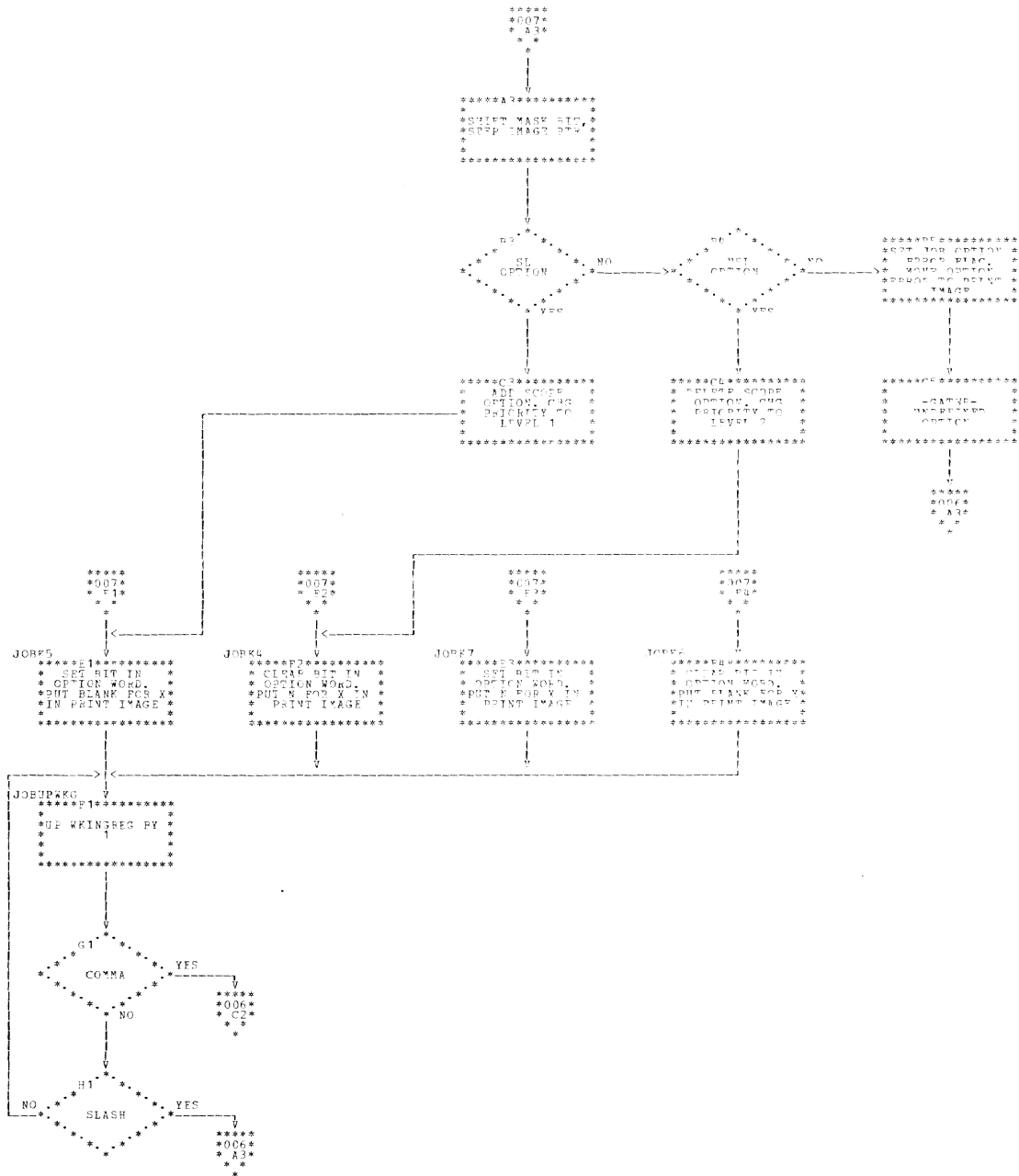
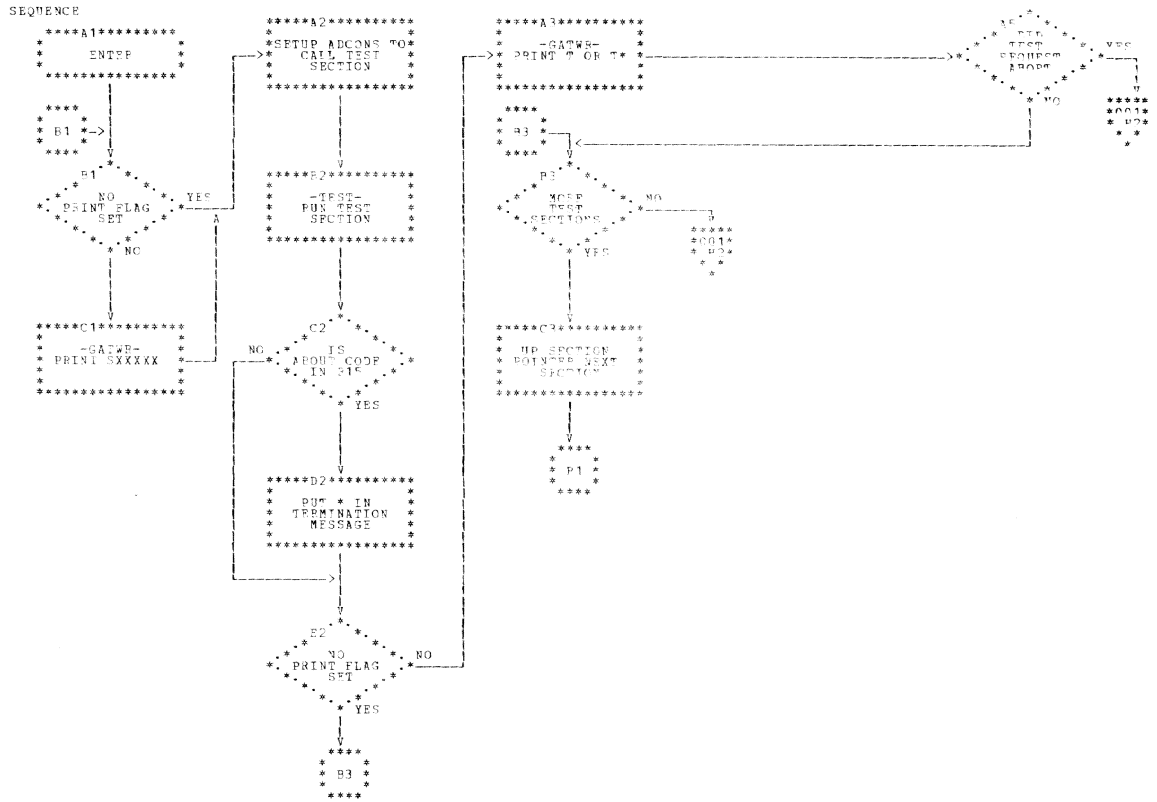

Chart AH. Sequencer (CMATF)



• Chart AJ. Device Allocation (CZATG) (Part 2 of 5)

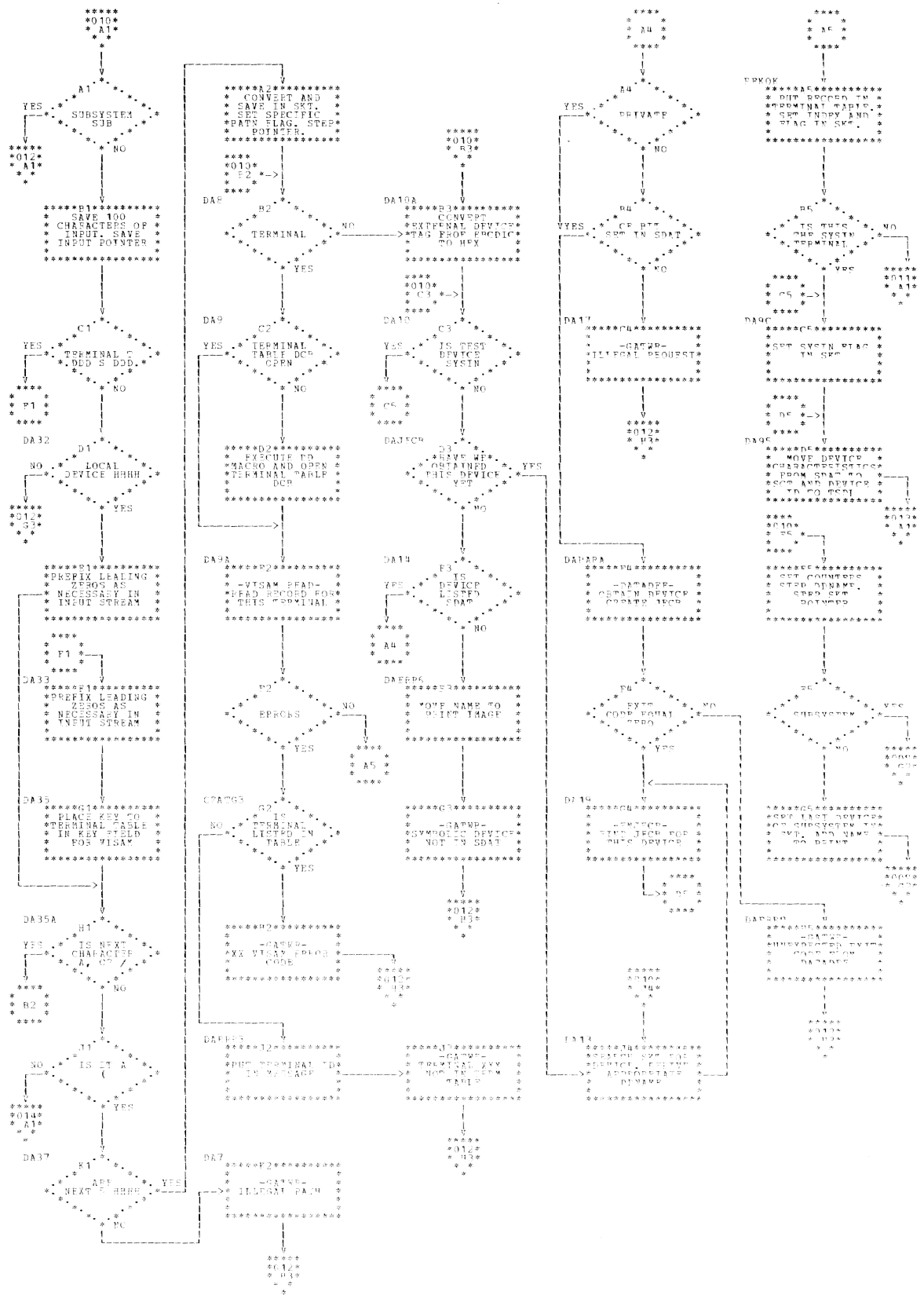

Chart AK. Device Allocation (CZATG) (Part 3 of 5)

PAGE 077

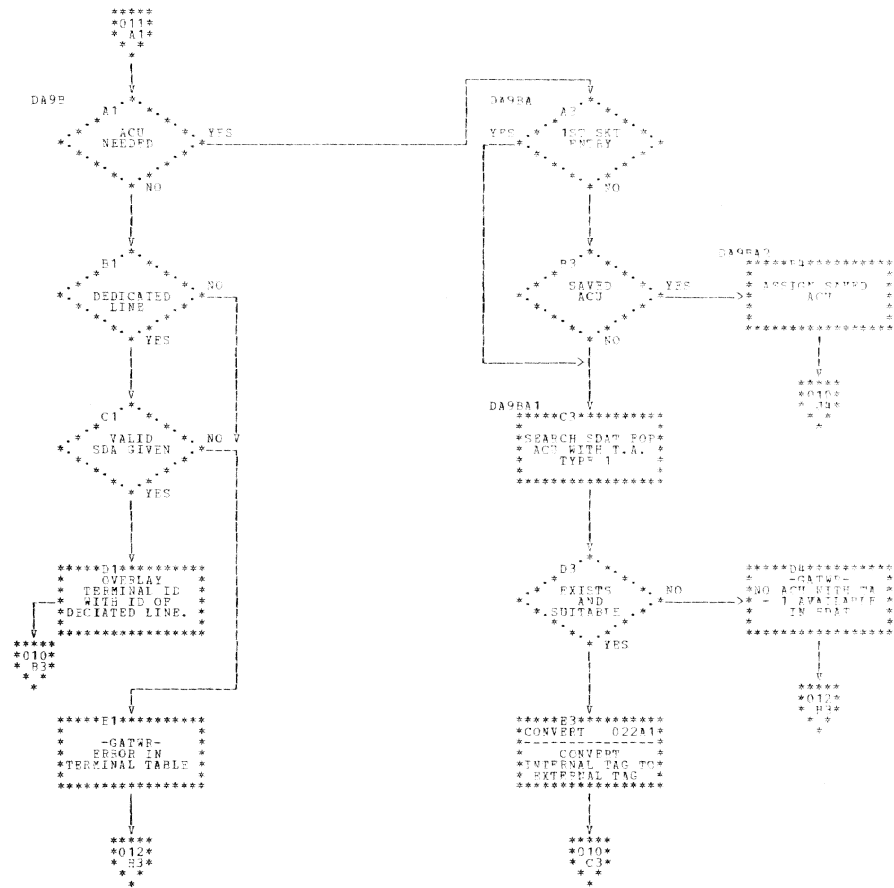

Chart AL. Device Allocation (CZATG) (Part 4 of 5)

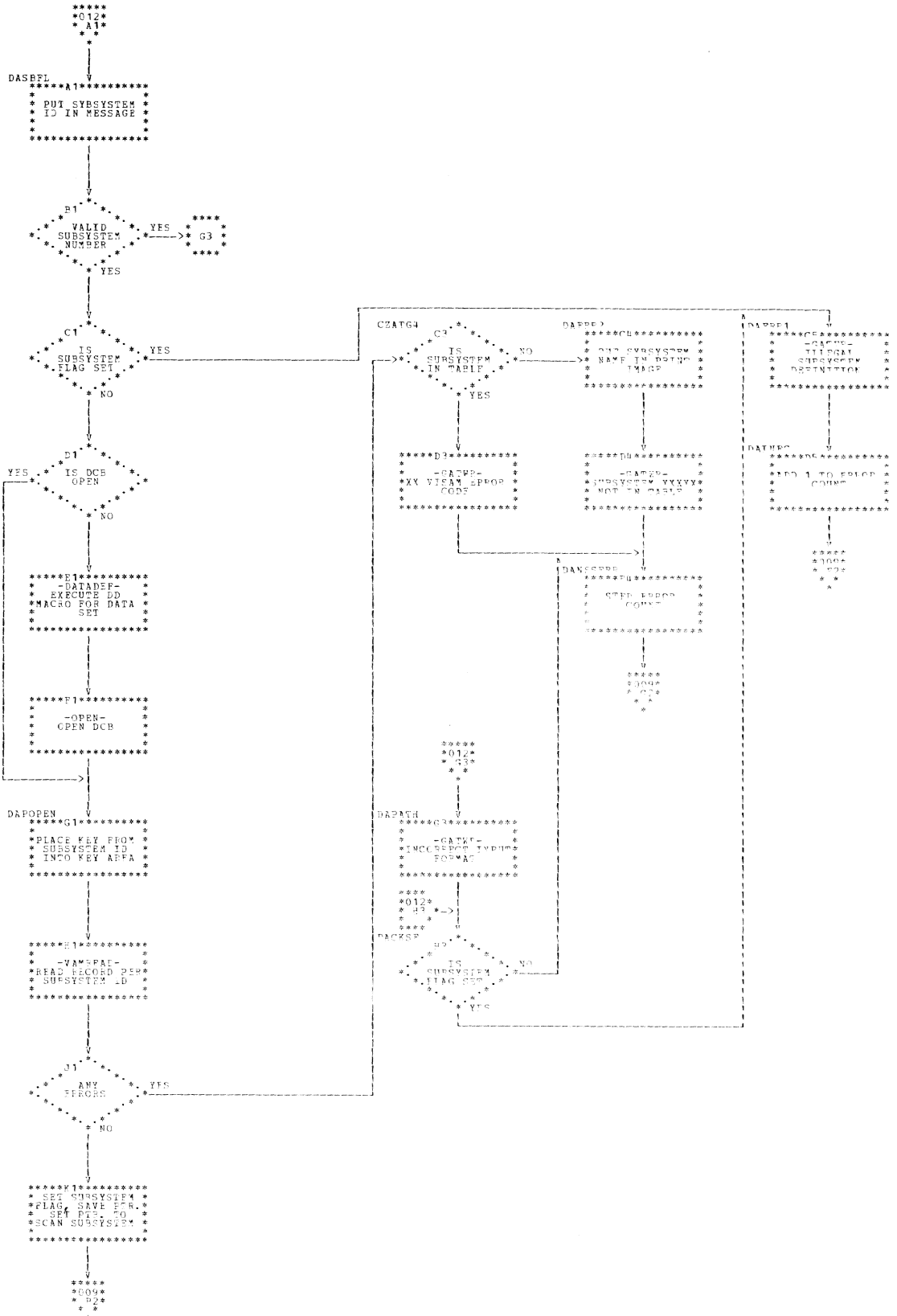

Chart AM. Device Allocation (CZATG) (Part 5 of 5)

PAGE 013

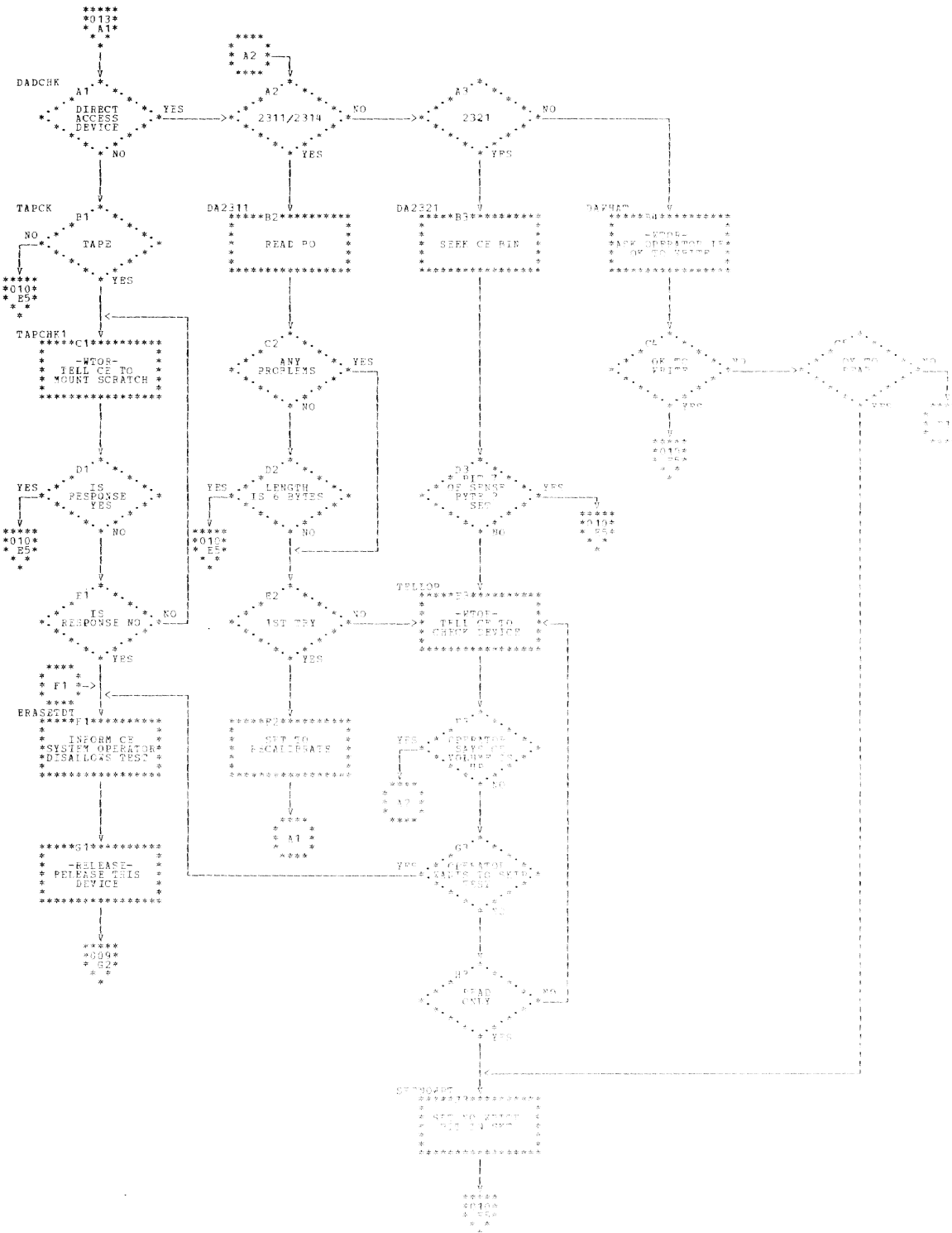
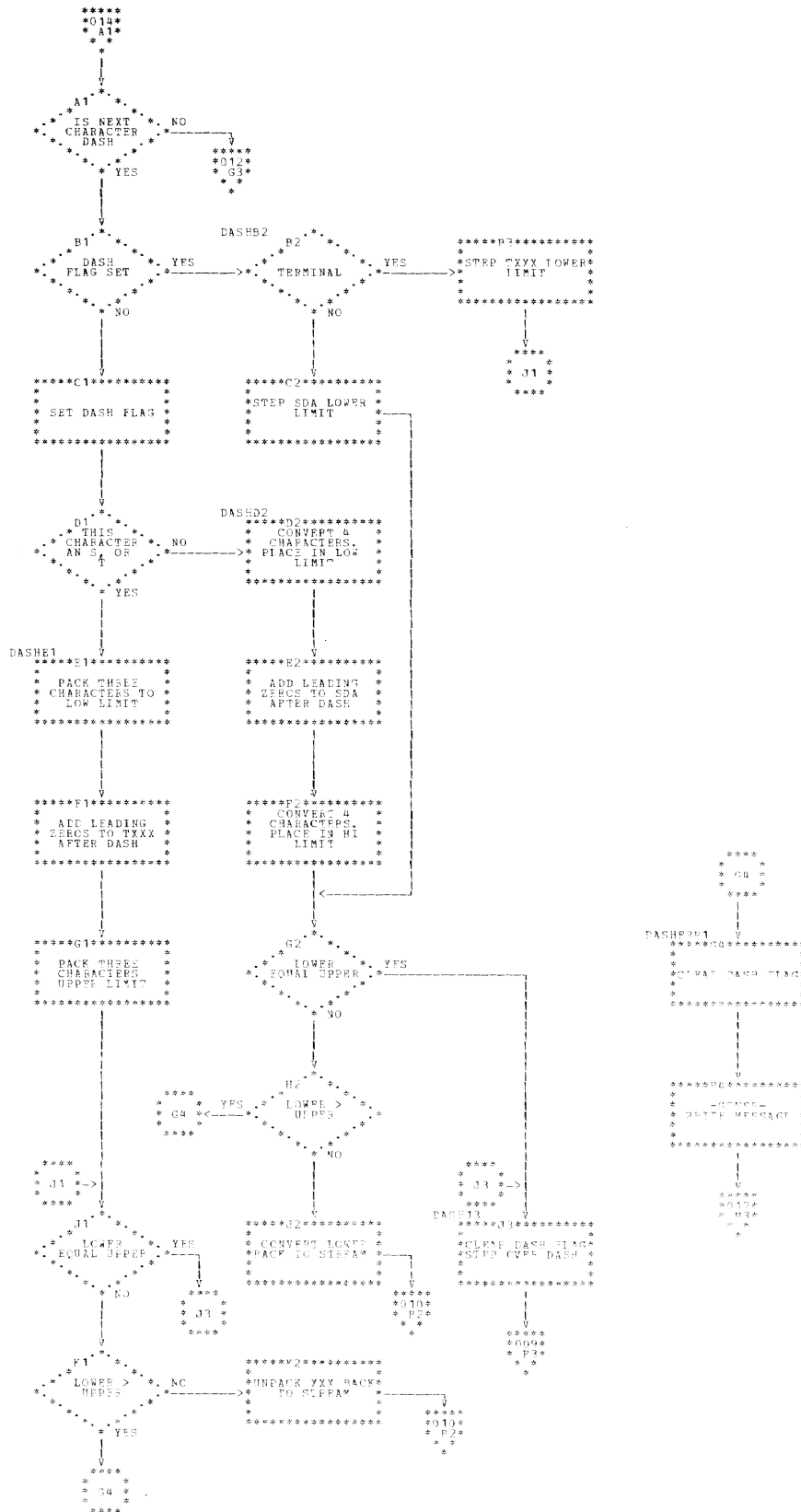

Chart AN. Process Dashed Pair (CZATG)



• Chart AO. OLTAH EXIO Routine (CZATA)

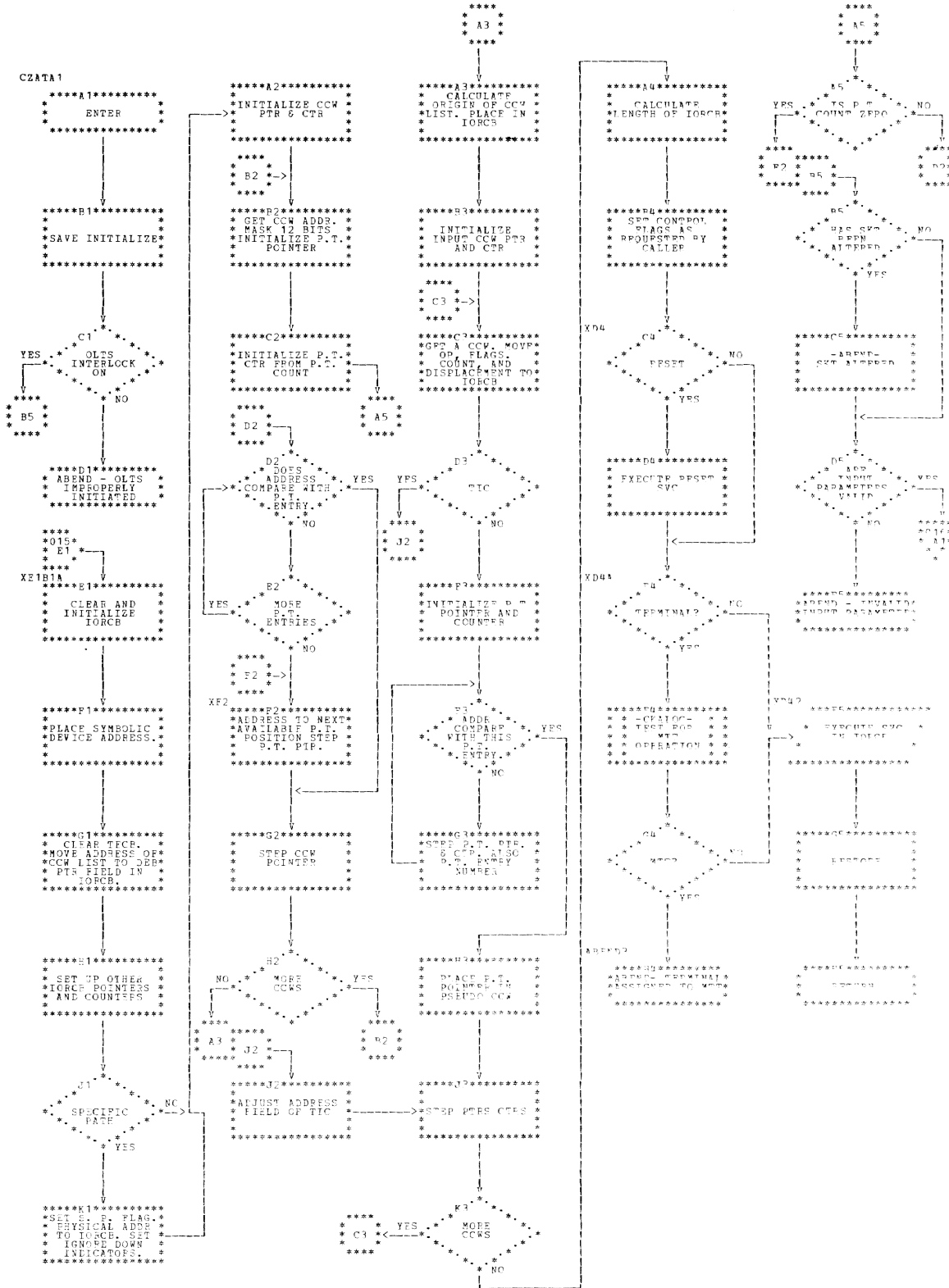
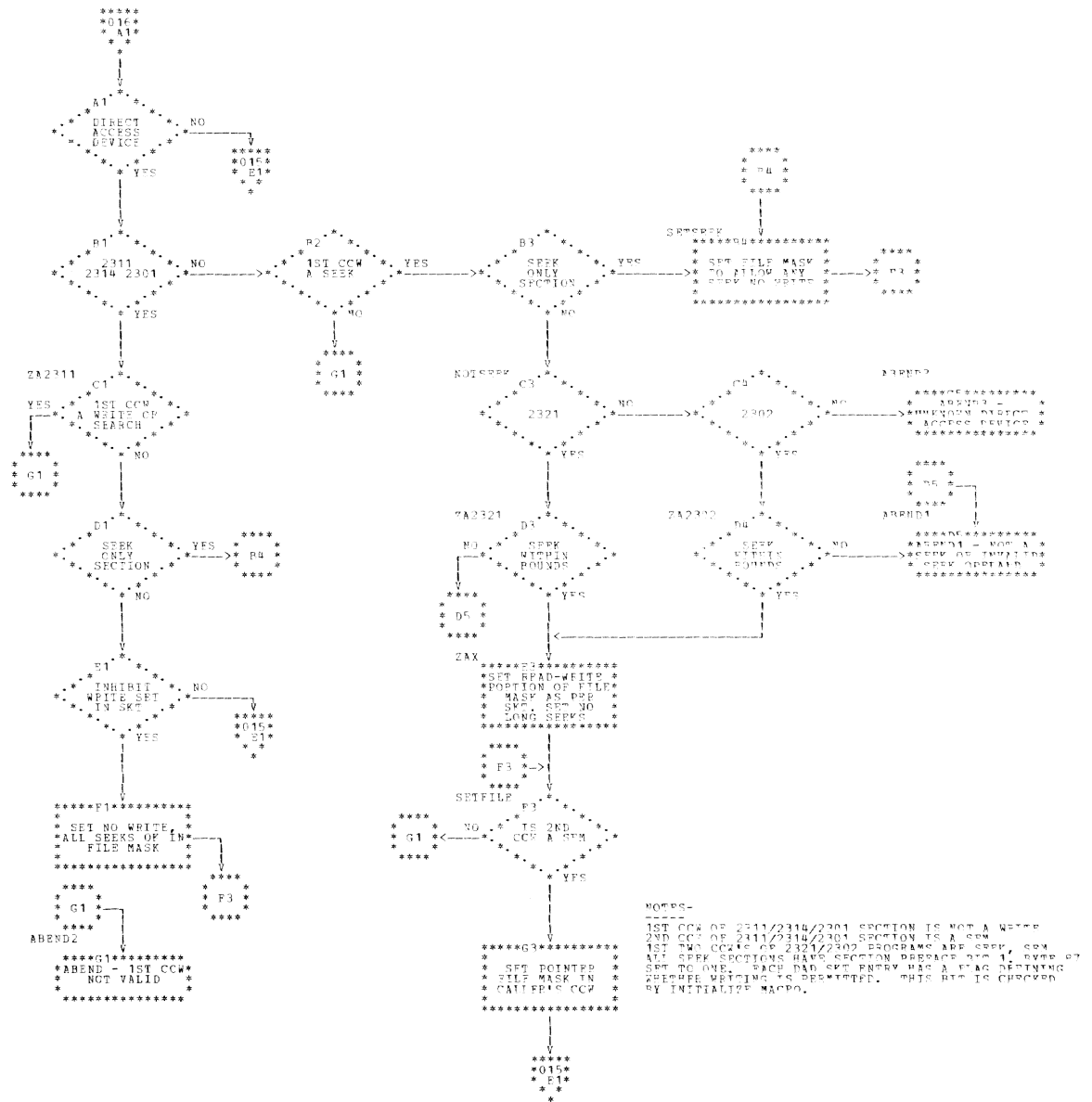

Chart AP. OLTA - Data Integrity (CZATA)



• Chart A9. OLTAM Posting Routine (CZATB)

PAGE 017

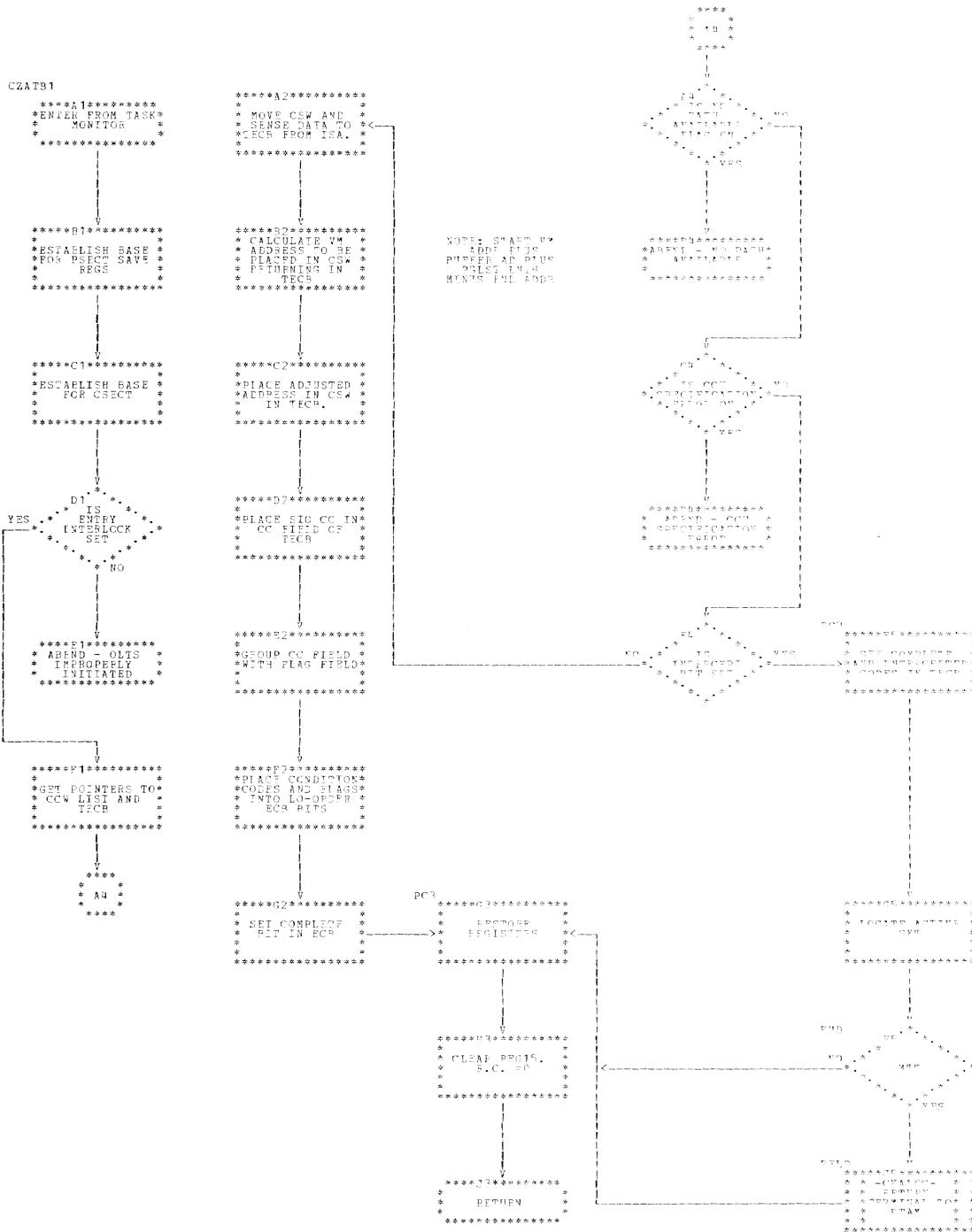

Chart AR. OLTS Print Routine (CMATC) (Part 1 of 3)

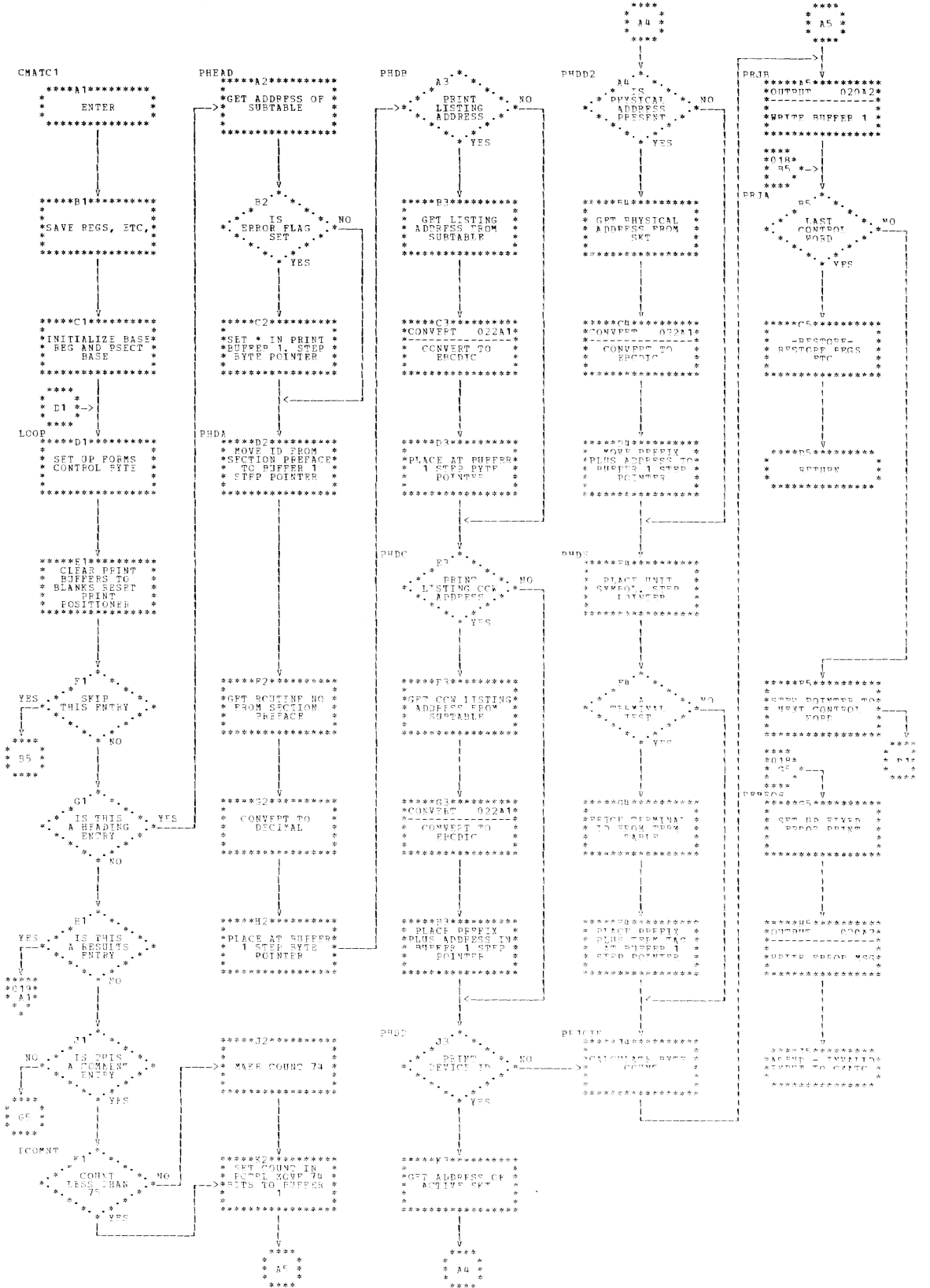
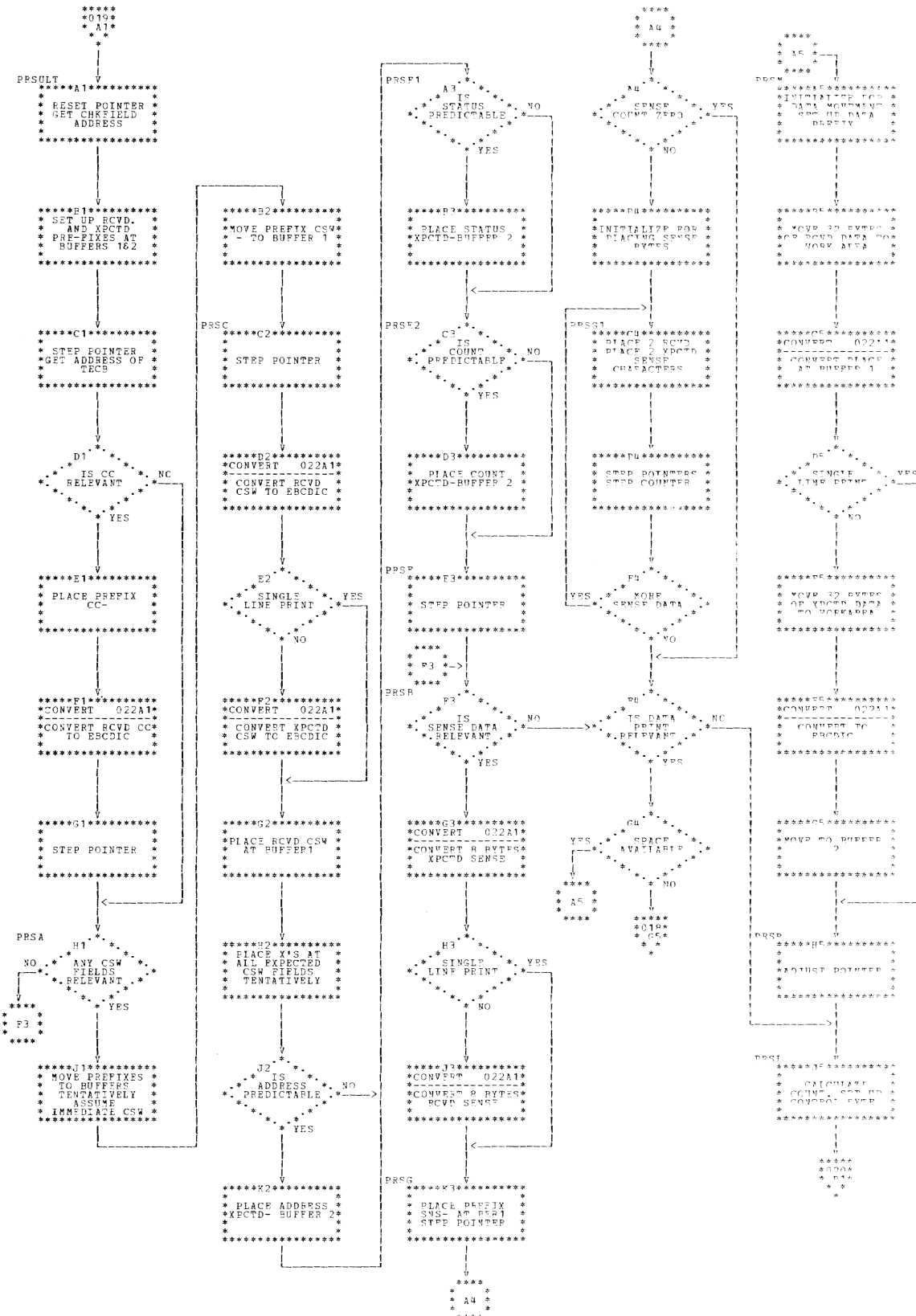

Chart AS. OLTS Print Routine (CMATC) (Part 2 of 3)



• Chart AT. OLTS Print Routine (CMATC) (Part 3 of 3)

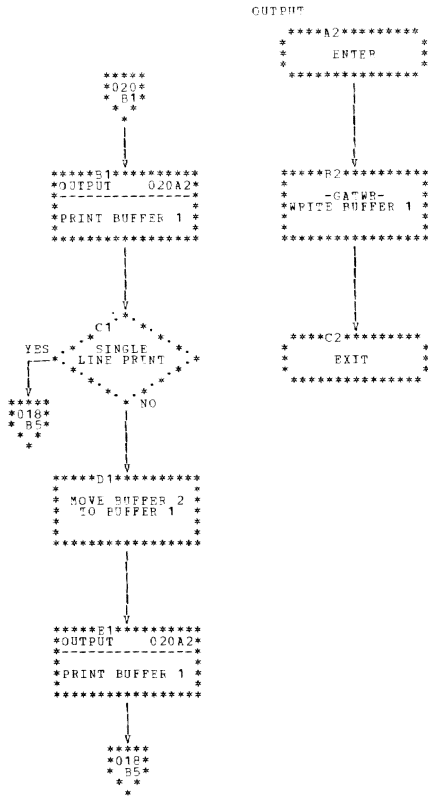

Chart AU. Compare (CMATD)

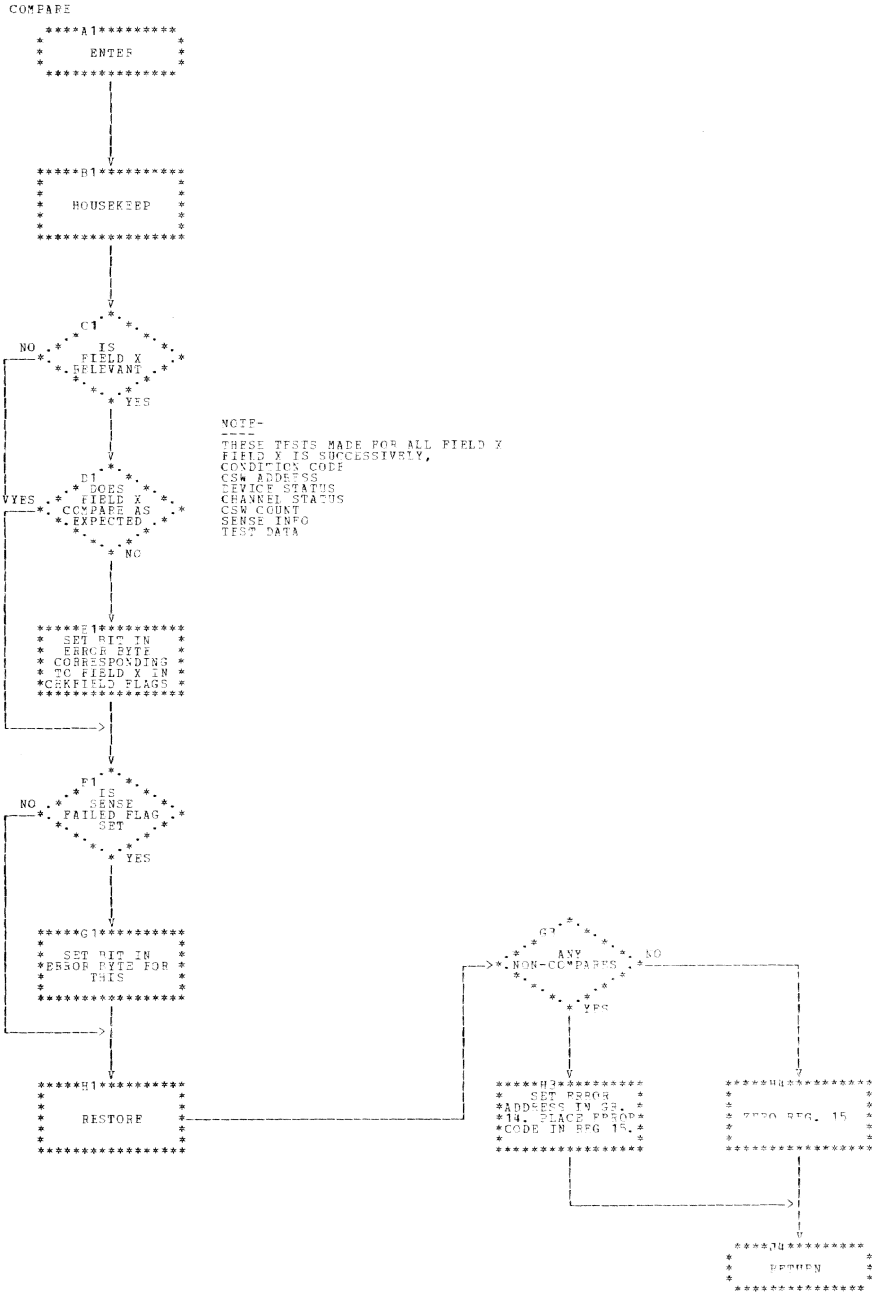

Chart AV. Conversions (CMATE) (Part 1 of 2)

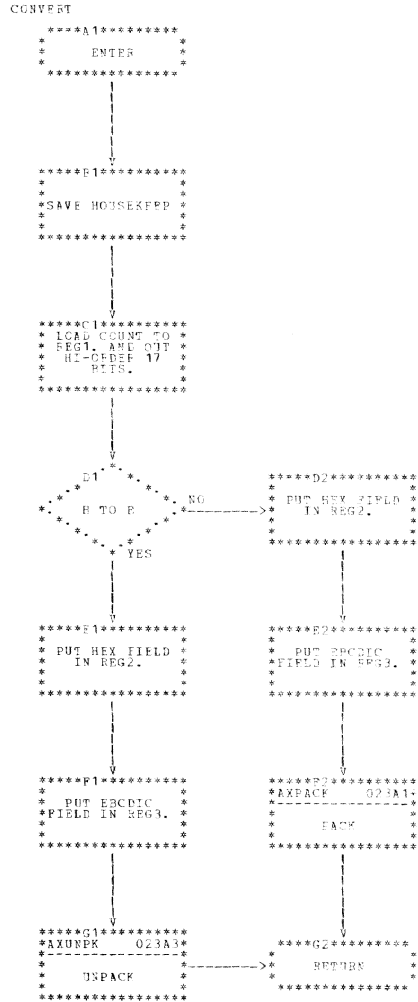
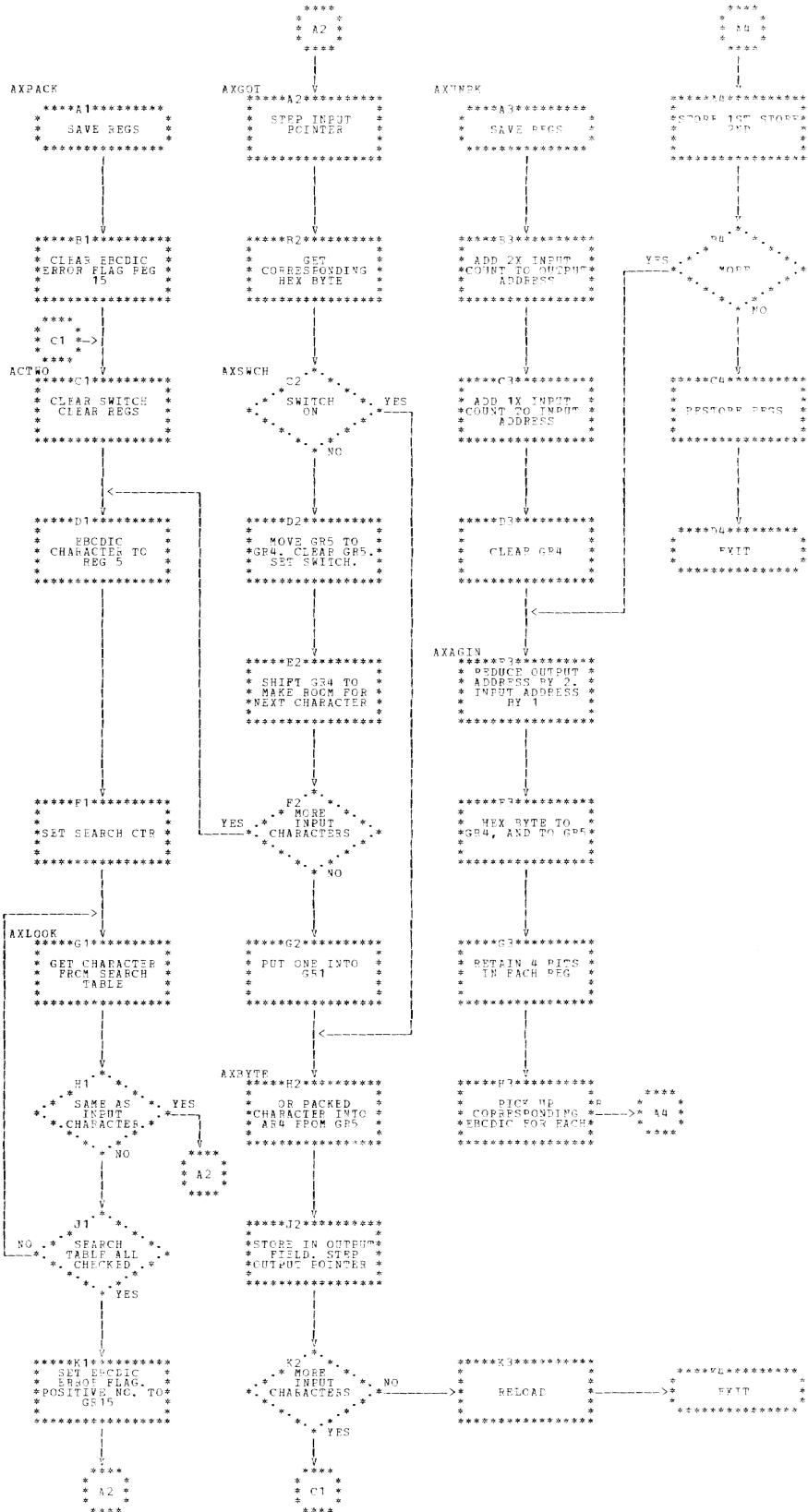

Chart AW. Conversions (CMATE) (Part 2 of 2)

PAGE 003



The Section Control table provides the section with all information required to perform the test. It is located in CMATF's PSECT. A protected copy is also kept in CZATA's PSECT.

SECTION CONTROL TABLE (SKT)					
	+0	+1	+2	+3	
SKT	(1) Random Number	Spare	(2) *	(2) Job Options	Word 0
+4	(3) Routine Selection	Spare			Word 1
+8	(4) Sys Sym Device Name	(5) Flags			Word 2
+12	(6) Term Table Index	(7) Physical Address			Word 3
+16	(8) Device Characteristics				Word 4
Words 2, 3, and 4 are a device entry used to describe the equipment under test. They may be repeated a maximum of 30 times to allow testing of many devices during one run.					
* See Note 1 below.					

NOTES TO SECTION CONTROL TABLE (SKT)

Word 0

1. Random Number: The first two bytes of the SKT contain random data inserted by the control program.

Bits 16-22 Unassigned

* Bit 24-Error Bit

* Bit 25-Program Found Error Bit

2. Job Options

Bit 23 Scope Loop

Bit 26 Reserved

Bit 28 No control print

Bit 29 No error print

Bit 30 Loop if error

Bit 31 Loop on test

Word 1:

3. Routine Selection: When a single test section is selected, specific routines (1-16) may be requested by the CE. Bits 0-15 will be set accordingly.

Word 2:

4. Bytes 0 and 1 - System Symbolic Device Name

5. Bytes 2 and 3 - flags

- Bit 0 Reserved
- Bit 1 Reserved
- Bit 2 SYSIN
- Bit 3 Last Device of Subsystem
- Bit 4 This device listed previously in SKT.
- Bit 5 Terminal (index present in field 7)
- Bit 6 Path Definition present in field 8
- Bit 7 Last Device of last subsystem to be tested by this section
- Bits 8-15 Unassigned

Word 3:

6. Bytes 0 and 1 - Terminal Table Index: Pointer to entry in terminal table if bit 5 of the flag field is set to one.

The terminal table record format is:

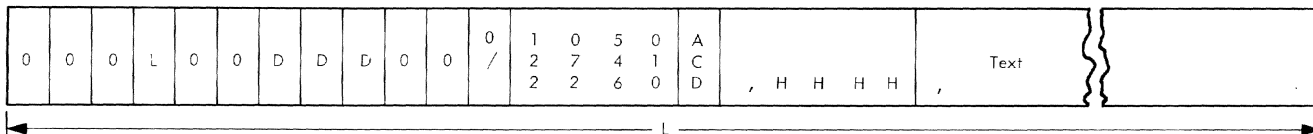

DDD is the terminal ID and also gives its position in the terminal table.

A/D/C tells whether the terminal can be reached by an auto call unit (A), a dedicated line (D), or whether the terminal is call-in-only (C).

If a dedicated line must be used, HHHH is present, and HHHH is the SDA of the dedicated line; otherwise, HHHH is absent.

7. Bytes 2 and 3 define a specific path to this device if bit 6 of the flag field is set to one. (OLTAM will use this path only for I/O operations.)

Word 4:

8. Device Characteristics: Moved here from SDAT table.

These characteristics are defined in IBM System/360 Time Sharing System: System Control Blocks PLM, Form Y28-2011.

Notes:

1. Number of devices in SKT is variable (1-31). End of list is reached when "last device of last subsystem" flag is set.
2. A subsystem is one or more devices logically connected.
3. For programs that use standard access methods, each SKT entry has a potential ddname. If the SYSIN flag is set, the ddname is SYSIN; otherwise, it is SYSOLTnn, where nn is the entry number.

The On Line Test Control program has three print formats:

1. *PPPPPPPP RR IC-LLLLL CCW-XXXXX IOADDR-AAAA UNIT-XXXX TERM-NNN

2. RCVD CC-1 CSW-XX AAAAAA SSSS CCCC SNS-SS SS SS SS SS SS SS DATA-
DDDDDD

XPCTD 0 XX AAAAAA SSSS CCCC SS SS SS SS SS SS SS SS
DDDDDD

3. ANY COMMENT (74 characters, maximum)

In 1, a heading, the programmer supplies (via the print control table) the listing main program address LLLLL, the listing CCW address XXXXX, and the address of the active SKT entry from which the device address (path) AAAA, the unit symbol XXXX, and the terminal ID NNN can be derived. Any of the parameters may be omitted except program ID and routine number. The * is inserted automatically on an error print call if a heading is to be printed.

A "results" printout, form 2, is done by use of a check field in the test program. This field contains the "expected" status, sense, cc, and data, as well as pointers to those actually received. All fields are optional. Unpredictable items in the XPCTD field of the CCW are printed as Xs. A "single line print" flag in the check field causes only the RCVD line to print. When fields are omitted, the print image is squeezed left.

Form 3 enables the printing of any comment.

APPENDIX C: PRINT CONTROL TABLE

Word Boundary <-1 byte-> <-1 byte-> <-1 byte-> <-1 byte-> <-1 word->

Control	Forms	A	B	Address
0 7	8 15			

FLAGS IN CONTROL BYTES

Bit Meaning if bit is set to 1.

- 0 Last Entry - return control after this entry.
- 1 Heading Print - address field points to subtable.
- 2 Results Print - address field points to a check field.
- 3 Print Override - if this bit is set, no printing will take place for this control word, regardless of other bit settings. The "last entry" flag will be checked, normally.
- 4 Comments Print - B field has count; address field has starting address.
- 5 Error Flag -
- 6 - Reserved
- 7 - Spare
- 8-15 - Spare

SUBTABLE (HEADING PARAMETERS)

<-----1-----><-----4----->

Fullword	0 7	Listing Instruction Counter Address	Word 0
	Control		
Boundary		Listing CCW Address *	Word 1
		Address of a word that points to the Active SKT entry	Word 2
*word is absent if corresponding control flag not present.			

<u>Control Bit</u>	<u>Meaning</u>
0	Print device ID.
1	Listing address present.
3	CCW Address Present.

APPENDIX D: OLTS TEST EVENT CONTROL BLOCK AND CHECK FIELD

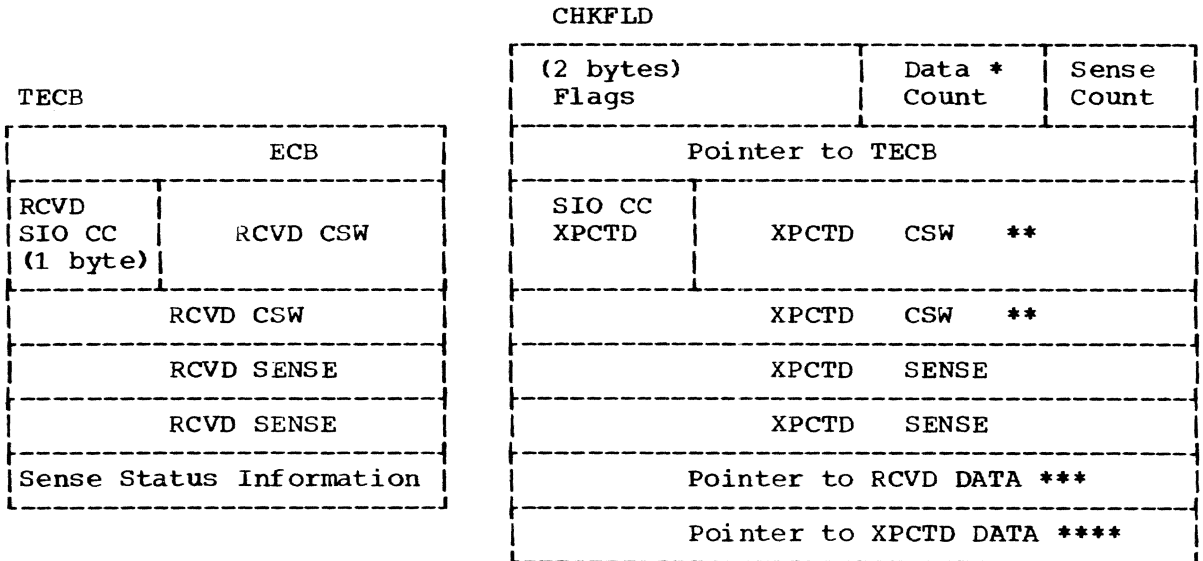

CHECKFIELD FLAGS

Byte 0

<u>Bit</u>	<u>Active Field (if flag bit = 1)</u>
0	CC
1	CSW ADDR Field**
2	Device Status**
3	Channel Status**
4	CSW Count**
1,2,3,4	Entire CSW
5	Sense Data is relevant
6	Not Used
7	Data is relevant

Byte 1

<u>Bit</u>	<u>Meaning (bit = 1)</u>
0	Single-Line Print (vs. Two-Line Print) of received information, as defined by other flags.

Notes:

Setting any CSW field flag causes entire RCVD CSW to print. Xs will be printed on the XPCTD line for all fields not active.

* Data Count < 256 for compare routine.
 ≤ 74 - X for print routine, where X is everything else on line.

** Last seven bytes of CSW only.

*** May be absent if data is not relevant.

**** May be absent if data is not relevant or single-line print set. Condition code is two low-order bits (binary).

APPENDIX E: OLTS TERMINAL TABLE

The OLTS terminal table is a list describing all OLTS-supported terminals for a given installation. It lists supported devices characterized by a level of addressing beyond that handled in the address field of a computer I/O instruction, namely remote 1050, 2741, and 2260 devices.

Since the table varies with each installation, it must be generated and maintained by the customer engineer at the installation. The DATA and MODIFY commands of the command language are used to do this; thus, the records are in the VISAM format.

A terminal is uniquely identified within the terminal table by its line number; the name of a terminal is formed by concatenating the three significant low-order characters of its line number with the character T. Thus a terminal name is of the form TDDD, where D is a decimal digit.

The table will be located on a permanently mounted public volume.

Use: The table is referenced by the OLTS device allocation routine (CZATG) in setting up a test request. It is referenced by the test program in testing the terminal and by the OLTS print routine (CMATC) in identifying the terminal in a failure print.

The terminal table record format is:

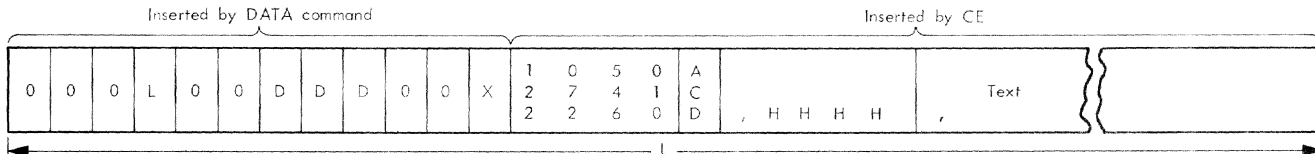

DDD is the terminal ID, and also gives its position in the terminal table.

A/D/C tells whether the terminal can be reached by an auto call unit (A), a dedicated line (D), or whether the terminal is call-in-only (C).

If a dedicated line must be used, HHHH is present, and HHHH is the SDA of the dedicated line; otherwise, HHHH is absent.

X = 0 for card reader input; 1 for typewriter input.

0 = zero.

1050/2741/2260 gives the terminal type.

The OLTS subsystem table contains an entry for each defined physical subsystem in a time sharing system. The CE may define these subsystems as he sees convenient.

Each defined subsystem has a name. By pointing to the subsystem, the CE can point at once to all of its components. The components are listed by either their system symbolic device name, if they are local I/O devices, or by their identity in the OLTS terminal table, if they are terminals.

A subsystem table is generated and maintained by the customer engineer, using the DATA and MODIFY commands; therefore, the records are in VISAM format.

A subsystem is uniquely identified within the subsystem table by its line number; its name is formed by concatenating the two significant low-order characters of its line number with the characters SUB. Thus, a subsystem name is of the form SUBDD. The device entries in the records must conform exactly with the format specified for a device field in the CE Guide.

Use: When the CE specifies that a subsystem is to be tested, each of its elements is entered into the section control table for the test program involved.

Format:

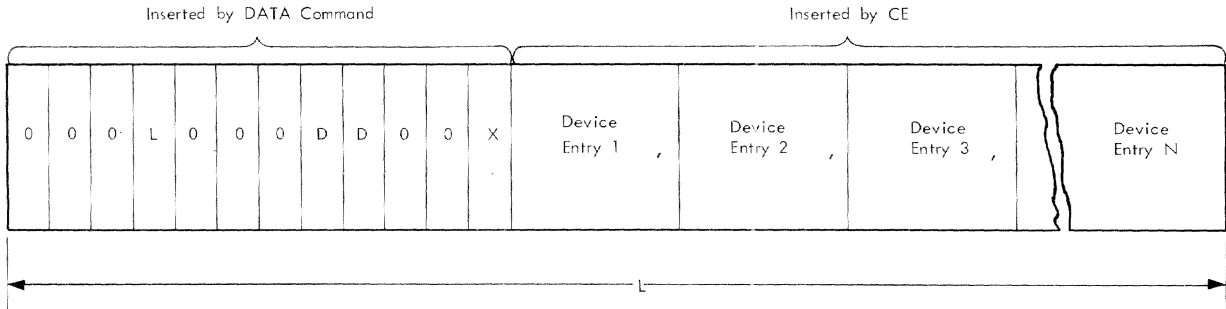

DD is the subsystem ID and also gives its position in the subsystem table.

0 = zero.

X = 0 for card reader input; 1 for typewriter input.

Device Entry Formats:

- HHHH Local device
- HHHH (HHHH) Local device via specific path
- TDDD Terminal
- TDDD Terminal via specific path

APPENDIX G: SYSTEM TABLE DATA REFERENCES

Table	Module							
	C M A T F	C Z A T G	C M A T C	C M A T D	C M A T E	C Z A T A	C Z A T B	
Interrupt Storage Area (ISA)	-	C	-	-	-	R	R	
I/O Record Control Block (IORCB)	-	-	-	-	-	C	R	
Symbolic Device Allocation Table (SDAT)	-	R	-	-	-	-	-	
Adcon DSECT (ADC)	C	-	-	-	-	-	-	
Task Data Definition Table (TDT)	-	R	-	-	-	-	-	
Task Common Table (TCM)	-	R	-	-	-	R	R	
Data Control Block DSECT (DCB)		C	C	-	-	-	-	
OLTS Section Control Table (SKT)	C	C	R	-	-	R	-	
OLTS Test Event Control Block (TECB)	-	C	-	-	-	C	C	
R - Reference only; C - Change								

Where more than one page reference is given, the major reference is first.

ACU (Autocall Unit) 9
 Appendix A: Section Control Table 39
 Appendix B: OLTS Print Formats 41
 Appendix C: Print Control Table 42
 Appendix D: OLTS Test Event Control Block and Check Field 43
 Appendix E: OLTS Terminal Table 44
 Appendix F: OLTS Subsystem Table 45
 Appendix G: System Table Data Reference 46
 Autocall Unit (ACU) 9

Charts

CMATC (Print routine) 33
 CMATD (Compare routine) 36
 CMATE (Convert routine) 37
 CMATF (Setup Control routine) 16
 CZATA (Execute I/O routine) 30
 CZATB (Posting routine) 32
 CZATG (Device Allocation routine) 24

Check field 43

CHKFLD 43

CMATC (OLTS Print routine) 14

CMATD (OLTS Compare routine) 14

CMATE (OLTS Convert routine) 15

CMATF (Setup Control routine) 5

Comments print 14,41

Compare Routine 14

Control Tables

Print Control Table 42

Section Control Table (SKT) 39

Subsystem Table 45

Terminal Table 44

Test Event Control Block (TECB) 43

Convert Routine 15

CZATA (OLTAM Execute I/O routine) 11

CZATB (OLTAM Posting routine) 13

CZATG (OLTAM Device Allocation routine) 8

Data integrity measures 12

Device Allocation routine 8

Device entry, types of 8

Dynamic control 4

Execute I/O routine 11

Functions of the on line test control program 1

Heading print 14,41

Initiation and job setup 1
 Integrity measures 12
 Interface to hardware 4

Job setup 1

Local device entry 8

Major subroutines of Setup routine 5
 Option Selection subroutine 6
 Routine Selection subroutine 6
 Section Selection subroutine 5
 Sequence subroutine 7

Modules, setup 5

OLTAM (On Line Test Access Method) 4

OLTAM Device Allocation routine 8

OLTAM Execute I/O routine 11

OLTAM Posting routine 13

OLTAM interface to hardware 4

OLTCP (On Line Test Control Program) 1

Functions 1

Initiation and job setup 1

Interfaces 3

Organization 4

Output 4

Test sequencing 4

OLTS (On Line Test System) 1

OLTS check field 43

OLTS Compare routine 14

OLTS Convert routine 15

OLTS Device Allocation routine 8

OLTS print formats 41

OLTS Print routine 14

OLTS Subsystem Table 45

OLTS Terminal Table 44

OLTS Test Event Control Block 43

On Line Test Access Method (OLTAM) 4

On Line Test Control Program (OLTCP) 1

On Line Test System (OLTS) 1

Option Selection subroutine 6

Organization of OLTCP 4

Output 4

Posting routine 13

Print Control Table 42

Print formats 41

Print routine 14

comments print 14

heading print 14

results print 14

Purposes and uses of OLTS 1

Results print 14,41
Routine Selection subroutine 6

Section Control Table (SKT) 39
Section Selection Subroutine 5
Sequence subroutine 7
Sequencing, test 4
Setup Control routine 16
SKT (Section Control Table) 39
Subsystem device entry 8
Subsystem table 45
System table data reference 46

TECB (Test Event Control Block) 43
Terminal device entry 8
Terminal table 44
Test Event Control Block (TECB) 43
Test sequencing 4
Types of device entry 8

Utilities 4



International Business Machines Corporation
Data Processing Division
112 East Post Road, White Plains, N.Y. 10601
[USA Only]

IBM World Trade Corporation
821 United Nations Plaza, New York, New York 10017
[International]