

Instructions



XD 60TM, XD 70TM, XD 80TM Power Rewind Hose Reels

332630D

EN

Used in applications requiring long range dispense, transfer or evacuation of motor oils, diesel fuels*, lubricants, water, waste oil and air.

Not for use with gasoline or other flammable fluid. Not approved for use in hazardous or explosive atmosphere locations. For professional use only.

**less than 20% biofuel content*

Models

(see page 2 for model information including Maximum Working Pressure)



Important Safety Instructions

Read all warnings and instructions in this manual. Save these instructions.

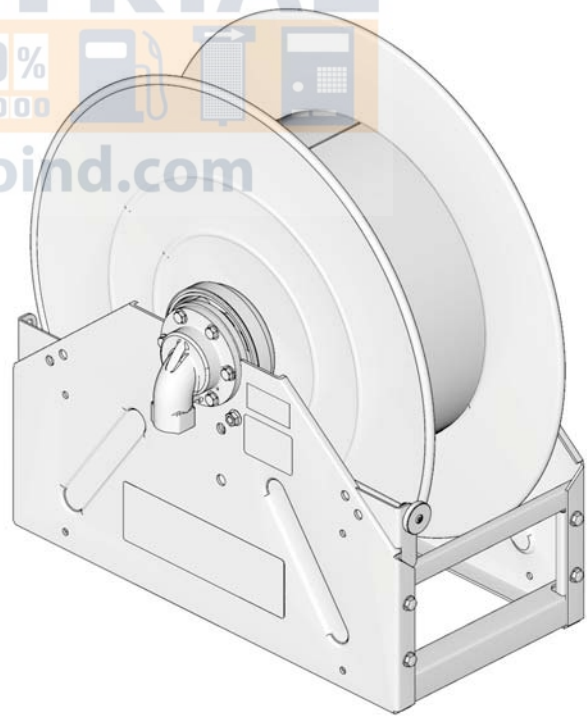
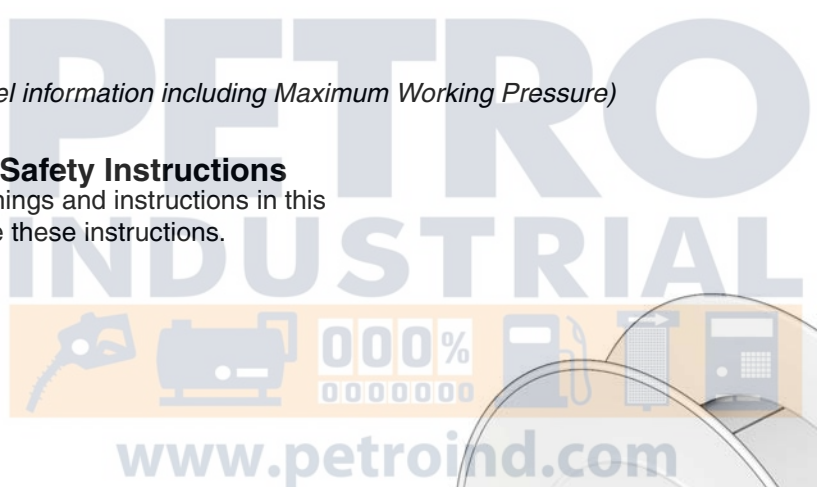
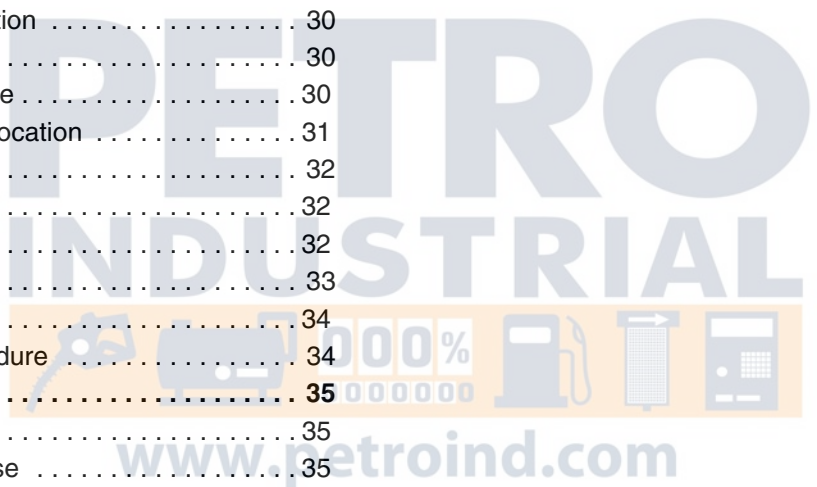

Table of Contents

Models	3
Warnings	14
Installation	16
Installation Notes	16
Grounding	16
Typical Layout	17
Inlet Orientation	17
Installing Inlet Hose	18
Motor Module Installation	18
Powering the Hose Reel	19
Electric Models	19
Pneumatic Models	23
Hydraulic Models	25
Outlet Orientation and Motor Rotation	28
Reversing Motor Rotation	30
Motor Brake	30
Adjusting the Brake	30
Changing Brake Location	31
Mounting Options	32
All Mountings	32
Lifting Hose Reel	32
Hose Installation	33
Flushing	34
Pressure Relief Procedure	34
Operation	35
Unwinding Hose	35
Retracting the Hose	35
Disconnecting Motor Power Source	36
Electric Powered Motors	36
Pneumatic Powered Motors	36
Hydraulic Powered Motors	36
Troubleshooting	37
Parts	39
Repair and Accessory Kits	40
Motor-less Reel Parts	45
Motor Module	46
Technical Data	47
Weights	50
Dimensions:	53
Mounting Hole Pattern	54
Graco Standard Warranty	56



Models

Understanding the Motor-less Reel Model Number

Motor-less reels are assigned a model number. This number identifies the frame size, port size, spring and pressure associated with that reel. For example an XD 6010LP model is an XD Model hose reel, size 60 frame, 1 in. port, low pressure.

- XD Frame Sizes: 60, 70, 80
- Port Sizes: 10 = 1 in. / 15 = 1.5 in. / 20 = 2 in.
- Pressures: LP - Low Pressure applications such as Air/Water, Fuel, and Waste Oil Evacuation typically under 300 psi (2.1 MPa, 21 bar) / MP - Medium Pressure applications such as Oil Dispense typically under 2000 psi (13.8 MPa, 138 bar)

XD 60, 70, 80 Motor-less Reels

NOTE: All reels have NPT inlets/outlets

Part No.	XD 60/70/80 Models	Color	Maximum Working Pressure	
			psi	MPa (bar)
24T104	XD 6010LP	Blue	600	4.1 (41 bar)
24T105	XD 6010LP	Yellow	600	4.1 (41 bar)
24T106	XD 6010LP	White	600	4.1 (41 bar)
24T107	XD 6010MP	Blue	3000	20.7 (207 bar)
24T108	XD 6010MP	Yellow	3000	20.7 (207 bar)
24T109	XD 6010MP	White	3000	20.7 (207 bar)
24T110	XD 7010LP	Blue	600	4.1 (41 bar)
24T111	XD 7010LP	Yellow	600	4.1 (41 bar)
24T112	XD 7010LP	White	600	4.1 (41 bar)
24T113	XD 7010MP	Blue	3000	20.7 (207 bar)
24T114	XD 7010MP	Yellow	3000	20.7 (207 bar)
24T115	XD 7010MP	White	3000	20.7 (207 bar)
24T116	XD 7015LP	Blue	600	4.1 (41 bar)
24T117	XD 7015LP	Yellow	600	4.1 (41 bar)
24T118	XD 7015LP	White	600	4.1 (41 bar)
24T119	XD 7020LP	Blue	600	4.1 (41 bar)
24T120	XD 7020LP	Yellow	600	4.1 (41 bar)
24T121	XD 7020LP	White	600	4.1 (41 bar)
24T122	XD 8010LP	Blue	600	4.1 (41 bar)
24T123	XD 8010LP	Yellow	600	4.1 (41 bar)
24T124	XD 8010LP	White	600	4.1 (41 bar)
24T125	XD 8010MP	Blue	3000	20.7 (207 bar)
24T126	XD 8010MP	Yellow	3000	20.7 (207 bar)
24T127	XD 8010MP	White	3000	20.7 (207 bar)
24T128	XD 8015LP	Blue	600	4.1 (41 bar)
24T129	XD 8015LP	Yellow	600	4.1 (41 bar)
24T130	XD 8015LP	White	600	4.1 (41 bar)
24T131	XD 8020LP	Blue	600	4.1 (41 bar)
24T132	XD 8020LP	Yellow	600	4.1 (41 bar)
24T133	XD 8020LP	White	600	4.1 (41 bar)

Model XD 6010 Part Numbers: Air/Water, Fuel and Waste Oil Evacuation Applications

Part No.	Power Source	CE	Color	Maximum Working Pressure		Recommended Hose Sizes* inch diameter x feet			
				PSI	MPa (bar)				
24R404	12 VDC	X	Blue	600	4.1 (41 bar)	1/2 x 100	3/4 x 75	3/4 x 100	1 x 50◆
24R405	12 VDC	X	Yellow	600	4.1 (41 bar)	1/2 x 100	3/4 x 75	3/4 x 100	1 x 50◆
24R406	12 VDC	X	White	600	4.1 (41 bar)	1/2 x 100	3/4 x 75	3/4 x 100	1 x 50◆
24R407	24 VDC	X	Blue	600	4.1 (41 bar)	1/2 x 100	3/4 x 75	3/4 x 100	1 x 50◆
24R408	24 VDC	X	Yellow	600	4.1 (41 bar)	1/2 x 100	3/4 x 75	3/4 x 100	1 x 50◆
24R409	24 VDC	X	White	600	4.1 (41 bar)	1/2 x 100	3/4 x 75	3/4 x 100	1 x 50◆
24R410	115 VAC	NA	Blue	600	4.1 (41 bar)	1/2 x 100	3/4 x 75	3/4 x 100	1 x 50◆
24R412	115 VAC	NA	Yellow	600	4.1 (41 bar)	1/2 x 100	3/4 x 75	3/4 x 100	1 x 50◆
24R413	115 VAC	NA	White	600	4.1 (41 bar)	1/2 x 100	3/4 x 75	3/4 x 100	1 x 50◆
24T207	230 VAC	X	Blue	600	4.1 (41 bar)	1/2 x 100	3/4 x 75	3/4 x 100	1 x 50◆
24T208	230 VAC	X	Yellow	600	4.1 (41 bar)	1/2 x 100	3/4 x 75	3/4 x 100	1 x 50◆
24T209	230 VAC	X	White	600	4.1 (41 bar)	1/2 x 100	3/4 x 75	3/4 x 100	1 x 50◆
24R414	Hydraulic	X	Blue	600	4.1 (41 bar)	1/2 x 100	3/4 x 75	3/4 x 100	1 x 50◆
24R415	Hydraulic	X	Yellow	600	4.1 (41 bar)	1/2 x 100	3/4 x 75	3/4 x 100	1 x 50◆
24R416	Hydraulic	X	White	600	4.1 (41 bar)	1/2 x 100	3/4 x 75	3/4 x 100	1 x 50◆
24R419	Pneumatic	X	Blue	600	4.1 (41 bar)	1/2 x 100	3/4 x 75	3/4 x 100	1 x 50◆
24R420	Pneumatic	X	Yellow	600	4.1 (41 bar)	1/2 x 100	3/4 x 75	3/4 x 100	1 x 50◆
24R421	Pneumatic	X	White	600	4.1 (41 bar)	1/2 x 100	3/4 x 75	3/4 x 100	1 x 50◆

* Always use the correct hose for your application. Adhere to hose manufacturer's recommendations to ensure you are using the correct hose.

◆ Only hose size recommended for use with Waste Oil Evacuation Applications.

Model XD 6010 Part Numbers: Oil and Grease Applications

Part No.	Power Source	CE	Color	Maximum Working Pressure		Recommended Hose Sizes* inch diameter x feet			
				PSI	MPa (bar)				
24R422	12 VDC	X	Blue	3000	20.7 (207 bar)	1/2 x 100	3/4 x 75	3/4 x 100	1 x 50†
24R423	12 VDC	X	Yellow	3000	20.7 (207 bar)	1/2 x 100	3/4 x 75	3/4 x 100	1 x 50†
24R424	12 VDC	X	White	3000	20.7 (207 bar)	1/2 x 100	3/4 x 75	3/4 x 100	1 x 50†
24R425	24 VDC	X	Blue	3000	20.7 (207 bar)	1/2 x 100	3/4 x 75	3/4 x 100	1 x 50†
24R426	24 VDC	X	Yellow	3000	20.7 (207 bar)	1/2 x 100	3/4 x 75	3/4 x 100	1 x 50†
24R427	24 VDC	X	White	3000	20.7 (207 bar)	1/2 x 100	3/4 x 75	3/4 x 100	1 x 50†
24R428	115 VAC	NA	Blue	3000	20.7 (207 bar)	1/2 x 100	3/4 x 75	3/4 x 100	1 x 50†
24R429	115 VAC	NA	Yellow	3000	20.7 (207 bar)	1/2 x 100	3/4 x 75	3/4 x 100	1 x 50†
24R430	115 VAC	NA	White	3000	20.7 (207 bar)	1/2 x 100	3/4 x 75	3/4 x 100	1 x 50†
24T210	230 VAC	X	Blue	3000	20.7 (207 bar)	1/2 x 100	3/4 x 75	3/4 x 100	1 x 50†
24T211	230 VAC	X	Yellow	3000	20.7 (207 bar)	1/2 x 100	3/4 x 75	3/4 x 100	1 x 50†
24T212	230 VAC	X	White	3000	20.7 (207 bar)	1/2 x 100	3/4 x 75	3/4 x 100	1 x 50†
24R431	Hydraulic	X	Blue	3000	20.7 (207 bar)	1/2 x 100	3/4 x 75	3/4 x 100	1 x 50†
24R432	Hydraulic	X	Yellow	3000	20.7 (207 bar)	1/2 x 100	3/4 x 75	3/4 x 100	1 x 50†
24R433	Hydraulic	X	White	3000	20.7 (207 bar)	1/2 x 100	3/4 x 75	3/4 x 100	1 x 50†
24R434	Pneumatic	X	Blue	3000	20.7 (207 bar)	1/2 x 100	3/4 x 75	3/4 x 100	1 x 50†
24R435	Pneumatic	X	Yellow	3000	20.7 (207 bar)	1/2 x 100	3/4 x 75	3/4 x 100	1 x 50†
24R436	Pneumatic	X	White	3000	20.7 (207 bar)	1/2 x 100	3/4 x 75	3/4 x 100	1 x 50†

* Always use the correct hose for your application. Adhere to hose manufacturer's recommendations to ensure you are using the correct hose.

† Only hose recommended for use in grease applications. Minimum operating temperature 0°F (-17.8°C).

Model XD 7010 Part Numbers: Air/Water and Fuel Applications

Part No.	Power Source	CE	Color	Maximum Working Pressure		Recommended Hose Sizes* inch diameter x feet	
				PSI	MPa (bar)		
24R437	12 VDC	X	Blue	600	4.1 (41 bar)	1 x 75	1 x 100
24R438	12 VDC	X	Yellow	600	4.1 (41 bar)	1 x 75	1 x 100
24R439	12 VDC	X	White	600	4.1 (41 bar)	1 x 75	1 x 100
24R440	24 VDC	X	Blue	600	4.1 (41 bar)	1 x 75	1 x 100
24R441	24 VDC	X	Yellow	600	4.1 (41 bar)	1 x 75	1 x 100
24R442	24 VDC	X	White	600	4.1 (41 bar)	1 x 75	1 x 100
24R443	115 VAC	NA	Blue	600	4.1 (41 bar)	1 x 75	1 x 100
24R444	115 VAC	NA	Yellow	600	4.1 (41 bar)	1 x 75	1 x 100
24R445	115 VAC	NA	White	600	4.1 (41 bar)	1 x 75	1 x 100
24T213	230 VAC	X	Blue	600	4.1 (41 bar)	1 x 75	1 x 100
24T215	230 VAC	X	Yellow	600	4.1 (41 bar)	1 x 75	1 x 100
24T216	230 VAC	X	White	600	4.1 (41 bar)	1 x 75	1 x 100
24R446	Hydraulic	X	Blue	600	4.1 (41 bar)	1 x 75	1 x 100
24R447	Hydraulic	X	Yellow	600	4.1 (41 bar)	1 x 75	1 x 100
24R448	Hydraulic	X	White	600	4.1 (41 bar)	1 x 75	1 x 100
24R449	Pneumatic	X	Blue	600	4.1 (41 bar)	1 x 75	1 x 100
24R450	Pneumatic	X	Yellow	600	4.1 (41 bar)	1 x 75	1 x 100
24R451	Pneumatic	X	White	600	4.1 (41 bar)	1 x 75	1 x 100

* Always use the correct hose for your application. Adhere to hose manufacturer's recommendations to ensure you are using the correct hose.

www.petroind.com

Model XD 7010 Part Numbers: Oil

Part No.	Power Source	CE	Color	Maximum Working Pressure		Recommended Hose Sizes* inch diameter x feet	
				PSI	MPa (bar)		
24R452	12 VDC	X	Blue	3000	20.7 (207 bar)	1 x 75	1 x 100
24R453	12 VDC	X	Yellow	3000	20.7 (207 bar)	1 x 75	1 x 100
24R454	12 VDC	X	White	3000	20.7 (207 bar)	1 x 75	1 x 100
24R455	24 VDC	X	Blue	3000	20.7 (207 bar)	1 x 75	1 x 100
24R456	24 VDC	X	Yellow	3000	20.7 (207 bar)	1 x 75	1 x 100
24R457	24 VDC	X	White	3000	20.7 (207 bar)	1 x 75	1 x 100
24R458	115 VAC	NA	Blue	3000	20.7 (207 bar)	1 x 75	1 x 100
24R459	115 VAC	NA	Yellow	3000	20.7 (207 bar)	1 x 75	1 x 100
24R460	115 VAC	NA	White	3000	20.7 (207 bar)	1 x 75	1 x 100
24T218	230 VAC	X	Blue	3000	20.7 (207 bar)	1 x 75	1 x 100
24T219	230 VAC	X	Yellow	3000	20.7 (207 bar)	1 x 75	1 x 100
24T220	230 VAC	X	White	3000	20.7 (207 bar)	1 x 75	1 x 100
24R461	Hydraulic	X	Blue	3000	20.7 (207 bar)	1 x 75	1 x 100
24R462	Hydraulic	X	Yellow	3000	20.7 (207 bar)	1 x 75	1 x 100
24R463	Hydraulic	X	White	3000	20.7 (207 bar)	1 x 75	1 x 100
24R464	Pneumatic	X	Blue	3000	20.7 (207 bar)	1 x 75	1 x 100
24R465	Pneumatic	X	Yellow	3000	20.7 (207 bar)	1 x 75	1 x 100
24R466	Pneumatic	X	White	3000	20.7 (207 bar)	1 x 75	1 x 100

* Always use the correct hose for your application. Adhere to hose manufacturer's recommendations to ensure you are using the correct hose.

www.petroind.com

Model XD 7015 Part Numbers: Fuel and Waste Oil Evacuation Applications

Part No.	Power Source	CE	Color	Maximum Working Pressure		Recommended Hose Sizes*			
				PSI	MPa (bar)	inch diameter x feet			
24R503	12 VDC	X	Blue	600	4.1 (41 bar)	1.25 x 35	1.25 x 50	1.5 x 50	1.5 x 65‡
24R504	12 VDC	X	Yellow	600	4.1 (41 bar)	1.25 x 35	1.25 x 50	1.5 x 50	1.5 x 65‡
24R505	12 VDC	X	White	600	4.1 (41 bar)	1.25 x 35	1.25 x 50	1.5 x 50	1.5 x 65‡
24R506	24 VDC	X	Blue	600	4.1 (41 bar)	1.25 x 35	1.25 x 50	1.5 x 50	1.5 x 65‡
24R507	24 VDC	X	Yellow	600	4.1 (41 bar)	1.25 x 35	1.25 x 50	1.5 x 50	1.5 x 65‡
24R508	24 VDC	X	White	600	4.1 (41 bar)	1.25 x 35	1.25 x 50	1.5 x 50	1.5 x 65‡
24R509	115 VAC	NA	Blue	600	4.1 (41 bar)	1.25 x 35	1.25 x 50	1.5 x 50	1.5 x 65‡
24R510	115 VAC	NA	Yellow	600	4.1 (41 bar)	1.25 x 35	1.25 x 50	1.5 x 50	1.5 x 65‡
24R511	115 VAC	NA	White	600	4.1 (41 bar)	1.25 x 35	1.25 x 50	1.5 x 50	1.5 x 65‡
24T221	230 VAC	X	Blue	600	4.1 (41 bar)	1.25 x 35	1.25 x 50	1.5 x 50	1.5 x 65‡
24T222	230 VAC	X	Yellow	600	4.1 (41 bar)	1.25 x 35	1.25 x 50	1.5 x 50	1.5 x 65‡
24T223	230 VAC	X	White	600	4.1 (41 bar)	1.25 x 35	1.25 x 50	1.5 x 50	1.5 x 65‡
24R512	Hydraulic	X	Blue	600	4.1 (41 bar)	1.25 x 35	1.25 x 50	1.5 x 50	1.5 x 65‡
24R513	Hydraulic	X	Yellow	600	4.1 (41 bar)	1.25 x 35	1.25 x 50	1.5 x 50	1.5 x 65‡
24R515	Hydraulic	X	White	600	4.1 (41 bar)	1.25 x 35	1.25 x 50	1.5 x 50	1.5 x 65‡
24R516	Pneumatic	X	Blue	600	4.1 (41 bar)	1.25 x 35	1.25 x 50	1.5 x 50	1.5 x 65‡
24R517	Pneumatic	X	Yellow	600	4.1 (41 bar)	1.25 x 35	1.25 x 50	1.5 x 50	1.5 x 65‡
24R518	Pneumatic	X	White	600	4.1 (41 bar)	1.25 x 35	1.25 x 50	1.5 x 50	1.5 x 65‡

* Always use the correct hose for your application. Adhere to hose manufacturer's recommendations to ensure you are using the correct hose.

‡Not recommended for use with Waste Oil Evacuation Applications.

Model XD 7020 Part Numbers: Fuel Applications

Part No.	Power Source	CE	Color	Maximum Working Pressure		Recommended Hose Sizes* inch diameter x feet
				PSI	MPa (bar)	
24T011	12 VDC	X	Blue	600	4.1 (41 bar)	2 x 33
24T012	12 VDC	X	Yellow	600	4.1 (41 bar)	2 x 33
24T013	12 VDC	X	White	600	4.1 (41 bar)	2 x 33
24T014	24 VDC	X	Blue	600	4.1 (41 bar)	2 x 33
24T015	24 VDC	X	Yellow	600	4.1 (41 bar)	2 x 33
24T016	24 VDC	X	White	600	4.1 (41 bar)	2 x 33
24T017	115 VAC	NA	Blue	600	4.1 (41 bar)	2 x 33
24T018	115 VAC	NA	Yellow	600	4.1 (41 bar)	2 x 33
24T019	115 VAC	NA	White	600	4.1 (41 bar)	2 x 33
24T224	230 VAC	X	Blue	600	4.1 (41 bar)	2 x 33
24T225	230 VAC	X	Yellow	600	4.1 (41 bar)	2 x 33
24T226	230 VAC	X	White	600	4.1 (41 bar)	2 x 33
24T020	Hydraulic	X	Blue	600	4.1 (41 bar)	2 x 33
24T021	Hydraulic	X	Yellow	600	4.1 (41 bar)	2 x 33
24T022	Hydraulic	X	White	600	4.1 (41 bar)	2 x 33
24T023	Pneumatic	X	Blue	600	4.1 (41 bar)	2 x 33
24T024	Pneumatic	X	Yellow	600	4.1 (41 bar)	2 x 33
24T025	Pneumatic	X	White	600	4.1 (41 bar)	2 x 33

* Always use the correct hose for your application. Adhere to hose manufacturer's recommendations to ensure you are using the correct hose.

www.petroind.com

Model XD 8010 Part Numbers: Air/Water and Fuel Applications

Part No.	Power Source	CE	Color	Maximum Working Pressure		Recommended Hose Sizes* inch diameter x feet
				PSI	MPa (bar)	
24R519	12 VDC	X	Blue	600	4.1 (41 bar)	1 x 150
24R520	12 VDC	X	Yellow	600	4.1 (41 bar)	1 x 150
24R521	12 VDC	X	White	600	4.1 (41 bar)	1 x 150
24R522	24 VDC	X	Blue	600	4.1 (41 bar)	1 x 150
24R523	24 VDC	X	Yellow	600	4.1 (41 bar)	1 x 150
24R524	24 VDC	X	White	600	4.1 (41 bar)	1 x 150
24R525	115 VAC	NA	Blue	600	4.1 (41 bar)	1 x 150
24R526	115 VAC	NA	Yellow	600	4.1 (41 bar)	1 x 150
24R527	115 VAC	NA	White	600	4.1 (41 bar)	1 x 150
24T227	230 VAC	X	Blue	600	4.1 (41 bar)	1 x 150
24T228	230 VAC	X	Yellow	600	4.1 (41 bar)	1 x 150
24T229	230 VAC	X	White	600	4.1 (41 bar)	1 x 150
24R528	Hydraulic	X	Blue	600	4.1 (41 bar)	1 x 150
24R529	Hydraulic	X	Yellow	600	4.1 (41 bar)	1 x 150
24R530	Hydraulic	X	White	600	4.1 (41 bar)	1 x 150
24R531	Pneumatic	X	Blue	600	4.1 (41 bar)	1 x 150
24R532	Pneumatic	X	Yellow	600	4.1 (41 bar)	1 x 150
24R533	Pneumatic	X	White	600	4.1 (41 bar)	1 x 150

* Always use the correct hose for your application. Adhere to hose manufacturer's recommendations to ensure you are using the correct hose.

www.petroind.com

Model XD 8010 Part Numbers: Oil Applications

Part No.	Power Source	CE	Color	Maximum Working Pressure		Recommended Hose Sizes* inch diameter x feet
				PSI	MPa (bar)	
24R534	12 VDC	X	Blue	3000	20.7 (207 bar)	1 x 150
24R535	12 VDC	X	Yellow	3000	20.7 (207 bar)	1 x 150
24R536	12 VDC	X	White	3000	20.7 (207 bar)	1 x 150
24R537	24 VDC	X	Blue	3000	20.7 (207 bar)	1 x 150
24R538	24 VDC	X	Yellow	3000	20.7 (207 bar)	1 x 150
24R539	24 VDC	X	White	3000	20.7 (207 bar)	1 x 150
24R540	115 VAC	NA	Blue	3000	20.7 (207 bar)	1 x 150
24R541	115 VAC	NA	Yellow	3000	20.7 (207 bar)	1 x 150
24R542	115 VAC	NA	White	3000	20.7 (207 bar)	1 x 150
24T230	230 VAC	X	Blue	3000	20.7 (207 bar)	1 x 150
24T231	230 VAC	X	Yellow	3000	20.7 (207 bar)	1 x 150
24T232	230 VAC	X	White	3000	20.7 (207 bar)	1 x 150
24R543	Hydraulic	X	Blue	3000	20.7 (207 bar)	1 x 150
24R544	Hydraulic	X	Yellow	3000	20.7 (207 bar)	1 x 150
24R545	Hydraulic	X	White	3000	20.7 (207 bar)	1 x 150
24R546	Pneumatic	X	Blue	3000	20.7 (207 bar)	1 x 150
24R547	Pneumatic	X	Yellow	3000	20.7 (207 bar)	1 x 150
24R548	Pneumatic	X	White	3000	20.7 (207 bar)	1 x 150

* Always use the correct hose for your application. Adhere to hose manufacturer's recommendations to ensure you are using the correct hose.

www.petroind.com

Model XD 8015 Part Numbers: Fuel Applications

Part No.	Power Source	CE	Color	Maximum Working Pressure		Recommended Hose Sizes* inch diameter x feet	
				PSI	MPa (bar)		
24R549	12 VDC	X	Blue	600	4.1 (41 bar)	1.5 x 75	1.5 x 100
24R550	12 VDC	X	Yellow	600	4.1 (41 bar)	1.5 x 75	1.5 x 100
24R551	12 VDC	X	White	600	4.1 (41 bar)	1.5 x 75	1.5 x 100
24R552	24 VDC	X	Blue	600	4.1 (41 bar)	1.5 x 75	1.5 x 100
24R553	24 VDC	X	Yellow	600	4.1 (41 bar)	1.5 x 75	1.5 x 100
24R554	24 VDC	X	White	600	4.1 (41 bar)	1.5 x 75	1.5 x 100
24R555	115 VAC	NA	Blue	600	4.1 (41 bar)	1.5 x 75	1.5 x 100
24R556	115 VAC	NA	Yellow	600	4.1 (41 bar)	1.5 x 75	1.5 x 100
24R557	115 VAC	NA	White	600	4.1 (41 bar)	1.5 x 75	1.5 x 100
24T233	230 VAC	X	Blue	600	4.1 (41 bar)	1.5 x 75	1.5 x 100
24T234	230 VAC	X	Yellow	600	4.1 (41 bar)	1.5 x 75	1.5 x 100
24T235	230 VAC	X	White	600	4.1 (41 bar)	1.5 x 75	1.5 x 100
24R558	Hydraulic	X	Blue	600	4.1 (41 bar)	1.5 x 75	1.5 x 100
24R559	Hydraulic	X	Yellow	600	4.1 (41 bar)	1.5 x 75	1.5 x 100
24R560	Hydraulic	X	White	600	4.1 (41 bar)	1.5 x 75	1.5 x 100
24R561	Pneumatic	X	Blue	600	4.1 (41 bar)	1.5 x 75	1.5 x 100
24R562	Pneumatic	X	Yellow	600	4.1 (41 bar)	1.5 x 75	1.5 x 100
24R563	Pneumatic	X	White	600	4.1 (41 bar)	1.5 x 75	1.5 x 100

* Always use the correct hose for your application. Adhere to hose manufacturer's recommendations to ensure you are using the correct hose.

www.petroind.com

Model XD 8020 Part Numbers: Fuel Applications





Part No.	Power Source	CE	Color	Maximum Working Pressure		Recommended Hose Sizes* inch diameter x feet
				PSI	MPa (bar)	
24R564	12 VDC	X	Blue	600	4.1 (41 bar)	2 x 50
24R565	12 VDC	X	Yellow	600	4.1 (41 bar)	2 x 50
24R566	12 VDC	X	White	600	4.1 (41 bar)	2 x 50
24R567	24 VDC	X	Blue	600	4.1 (41 bar)	2 x 50
24R568	24 VDC	X	Yellow	600	4.1 (41 bar)	2 x 50
24R569	24 VDC	X	White	600	4.1 (41 bar)	2 x 50
24R570	115 VAC	NA	Blue	600	4.1 (41 bar)	2 x 50
24R571	115 VAC	NA	Yellow	600	4.1 (41 bar)	2 x 50
24R572	115 VAC	NA	White	600	4.1 (41 bar)	2 x 50
24T236	230 VAC	X	Blue	600	4.1 (41 bar)	2 x 50
24T237	230 VAC	X	Yellow	600	4.1 (41 bar)	2 x 50
24T238	230 VAC	X	White	600	4.1 (41 bar)	2 x 50
24R573	Hydraulic	X	Blue	600	4.1 (41 bar)	2 x 50
24R574	Hydraulic	X	Yellow	600	4.1 (41 bar)	2 x 50
24R575	Hydraulic	X	White	600	4.1 (41 bar)	2 x 50
24R576	Pneumatic	X	Blue	600	4.1 (41 bar)	2 x 50
24R577	Pneumatic	X	Yellow	600	4.1 (41 bar)	2 x 50
24R578	Pneumatic	X	White	600	4.1 (41 bar)	2 x 50

* Always use the correct hose for your application. Adhere to hose manufacturer's recommendations to ensure you are using the correct hose.





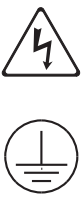

www.petroind.com

Warnings

The following warnings are for the setup, use, grounding, maintenance, and repair of this equipment. The exclamation point symbol alerts you to a general warning and the hazard symbols refer to procedure-specific risks. When these symbols appear in the body of this manual or on warning labels, refer back to these Warnings. Product-specific hazard symbols and warnings not covered in this section may appear throughout the body of this manual where applicable.

 WARNING	
	<p>FIRE AND EXPLOSION HAZARD</p> <p>When flammable fluids are present in the work area, such as gasoline and windshield wiper fluid, be aware that flammable fumes can ignite or explode. To help prevent fire and explosion:</p> <ul style="list-style-type: none"> • Use equipment only in well ventilated area. • Eliminate all ignition sources, such as cigarettes and portable electric lamps. • Keep work area free of debris, including rags and spilled or open containers of solvent and gasoline. • Do not plug or unplug power cords or turn lights on or off when flammable fumes are present. • Ground all equipment in the work area. • Use only grounded hoses. • Stop operation immediately if static sparking occurs or you feel a shock. Do not use equipment until you identify and correct the problem. • Keep a working fire extinguisher in the work area.
	<p>ELECTRIC SHOCK HAZARD</p> <p>This equipment must be grounded. Improper grounding, setup, or usage of the system can cause electric shock.</p> <ul style="list-style-type: none"> • Turn off and disconnect power at main switch before disconnecting any cables and before servicing or installing equipment. • Connect only to grounded power source. • All electrical wiring must be done by a qualified electrician and comply with all local codes and regulations.
	<p>SKIN INJECTION HAZARD</p> <p>High-pressure fluid from dispensing device, hose leaks, or ruptured components will pierce skin. This may look like just a cut, but it is a serious injury that can result in amputation. Get immediate surgical treatment.</p> <ul style="list-style-type: none"> • Do not point dispensing device at anyone or at any part of the body. • Do not put your hand over the fluid outlet. • Do not stop or deflect leaks with your hand, body, glove, or rag. • Follow the Pressure Relief Procedure when you stop dispensing and before cleaning, checking, or servicing equipment. • Tighten all fluid connections before operating the equipment. • Check hoses and couplings daily. Replace worn or damaged parts immediately.

! WARNING



 	<p>EQUIPMENT MISUSE HAZARD</p> <p>Misuse can cause death or serious injury.</p> <ul style="list-style-type: none"> Do not operate the unit when fatigued or under the influence of drugs or alcohol. Do not exceed the maximum working pressure or temperature rating of the lowest rated system component. See Technical Data in all equipment manuals. Use fluids and solvents that are compatible with equipment wetted parts. See Technical Data in all equipment manuals. Read fluid and solvent manufacturer's warnings. For complete information about your material, request MSDS from distributor or retailer. Do not leave the work area while equipment is energized or under pressure. Turn off all equipment and follow the Pressure Relief Procedure when equipment is not in use. Check equipment daily. Repair or replace worn or damaged parts immediately with genuine manufacturer's replacement parts only. Do not alter or modify equipment. Alterations or modifications may void agency approvals and create safety hazards. Make sure all equipment is rated and approved for the environment in which you are using it. Use equipment only for its intended purpose. Call your distributor for information. Route hoses and cables away from traffic areas, sharp edges, moving parts, and hot surfaces. Do not kink or over bend hoses or use hoses to pull equipment. Keep children and animals away from work area. Comply with all applicable safety regulations.
	<p>PRESSURIZED ALUMINUM PARTS HAZARD</p> <p>Use of fluids that are incompatible with aluminum in pressurized equipment can cause serious chemical reaction and equipment rupture. Failure to follow this warning can result in death, serious injury, or property damage.</p> <ul style="list-style-type: none"> Do not use 1,1,1-trichloroethane, methylene chloride, other halogenated hydrocarbon solvents or fluids containing such solvents. Many other fluids may contain chemicals that can react with aluminum. Contact your material supplier for compatibility.
 	<p>MOVING PARTS HAZARD</p> <p>Moving parts can pinch, cut or amputate fingers and other body parts.</p> <ul style="list-style-type: none"> Keep clear of moving parts. Do not operate equipment with protective guards or covers removed. Pressurized equipment can start without warning. Before checking, moving, or servicing equipment, follow the Pressure Relief Procedure and disconnect all power sources.
	<p>TOXIC FLUID OR FUMES HAZARD</p> <p>Toxic fluids or fumes can cause serious injury or death if splashed in the eyes or on skin, inhaled, or swallowed.</p> <ul style="list-style-type: none"> Read MSDSs to know the specific hazards of the fluids you are using. Store hazardous fluid in approved containers, and dispose of it according to applicable guidelines.
	<p>PERSONAL PROTECTIVE EQUIPMENT</p> <p>Wear appropriate protective equipment when in the work area to help prevent serious injury, including eye injury, hearing loss, inhalation of toxic fumes, and burns. This protective equipment includes but is not limited to:</p> <ul style="list-style-type: none"> Protective eye wear, and hearing protection. Respirators, protective clothing, and gloves as recommended by the fluid and solvent manufacturer

Installation

Installation Notes

- Before installing the hose reel, inspect it for shipping damage.
- The following user supplied materials are needed for installation:
 - Appropriately sized supply lines.
 - Pneumatic Lines: 3/8 in. ID or larger for powering pneumatic motors.
 - Hydraulic Lines: 1/2 in. ID or larger for powering hydraulic motors.
 - Pneumatic powered reels only: an air line filter/regulator/lubricator is required.
 - Insulated cable rated for use with motor amperage (See Technical Data, page 47).
 - Insulated ring terminal and wire nut connectors
 - Union fitting
 - Flexible inlet supply hose
- A flexible supply hose connection must be used between the hose reel inlet and the source of the fluid supply to prevent possible misalignment and binding during operation.

Grounding

						
<p>The reel must be bonded (grounded) directly to the truck (FIG. 1). For non-mobile installation locations the reel must be grounded. Grounding reduces the risk of static shock due to static build up on the equipment.</p>						

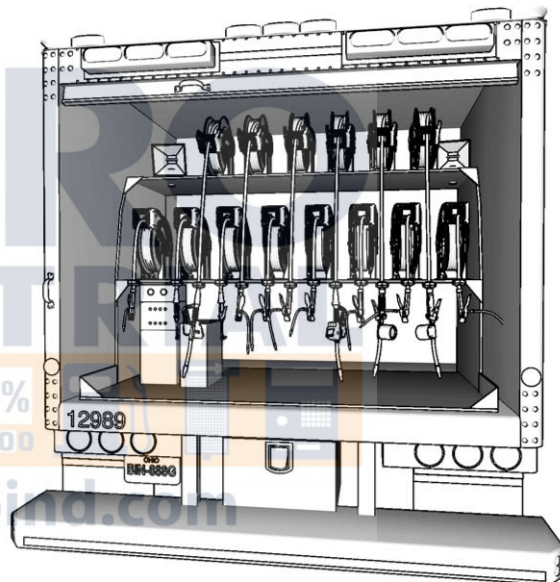

FIG. 1

Typical Layout

The installation shown in FIG. 2 is only a guide. Contact your Graco distributor for assistance in designing a system to suit your needs.

Truck-bed or Floor

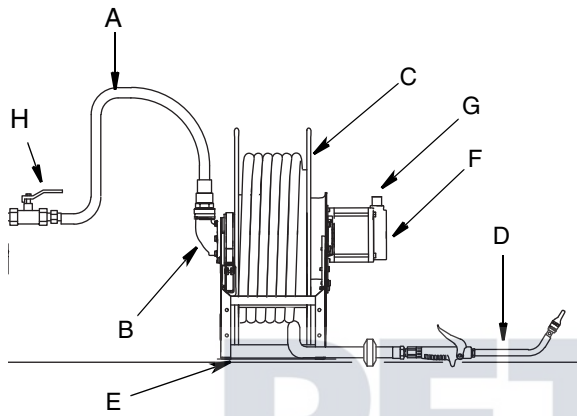

FIG. 2

Key:

- A From Fluid Pump
- B Fluid Inlet
- C Hose Reel
- D Dispense Valve
- E Mounting Base
- F Reel Rewind Motor
- G Reel Motor Power Supply
- H Fluid Shut Off Valve (required)

Inlet Orientation



1. If reel has been in service, relieve pressure, page 34.
2. **ALWAYS** verify that power to hose reel is disconnected. See Disconnecting Motor Power Source for Electric, Pneumatic or Hydraulic Power Rewind Motors, page 36.

For the following steps, refer to FIG. 3.

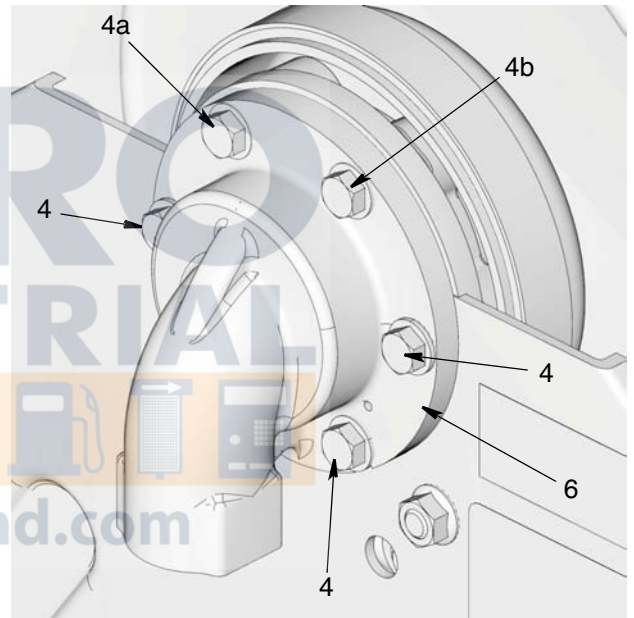

FIG. 3

3. Remove bolts (4).
4. Remove and rotate swivel (6) to desired location.

NOTE: The swivel can be rotated and set to 6 possible positions.

5. First install the top 2 bolts (4a and 4b) as shown in FIG. 3. Tighten bolts just enough to hold everything in place.
6. Then install the remaining bolts (4). Hand tighten and then torque all bolts to 25 to 35 ft. lbs (33.9 to 47.45 N•m).

Installing Inlet Hose

Inlet Hose Kits (100) - 24R111, 24R112, 24R115, 24R117, 24R118 and 24T858 are available from Graco. See Miscellaneous Kits, page 41.

NOTICE

A flexible hose connection must be used between the hose reel inlet and the fluid supply hose to prevent possible misalignment and binding during operation.

1. Apply pipe thread sealant or wrap PTFE tape around the threads of a union (100a).
2. Attach union adapter to inlet (6) (FIG. 4).
3. Apply pipe thread sealant or wrap PTFE tape around the threads (6) of inlet hose (100b) (if needed).
4. Attach union adapter (100a) to inlet hose (100b) (FIG. 4). Use a wrench to tighten the connection.
5. Use a wrench to support the inlet fitting while tightening the adapter.

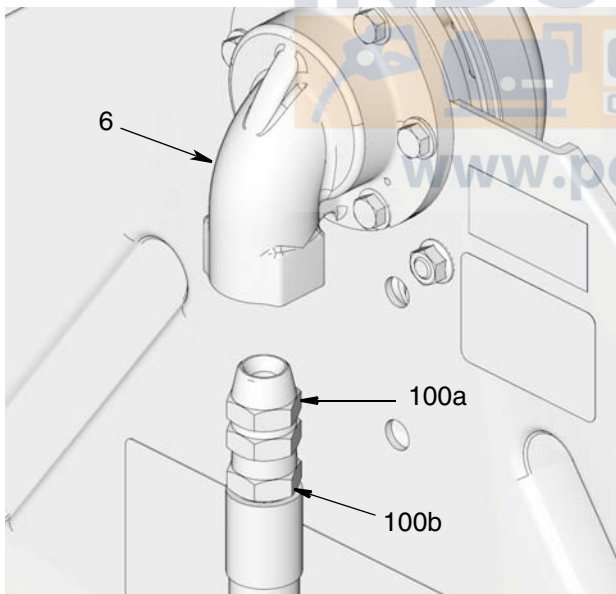

FIG. 4

Motor Module Installation

The following instructions are for first time installations only. If your hose reel has been in service and you are replacing the motor module, see the XD 60, XD 70, XD 80 Powered Hose Reel Repair manual for instructions.

1. Ensure splined shaft (26a) on motor module (26) is greased.

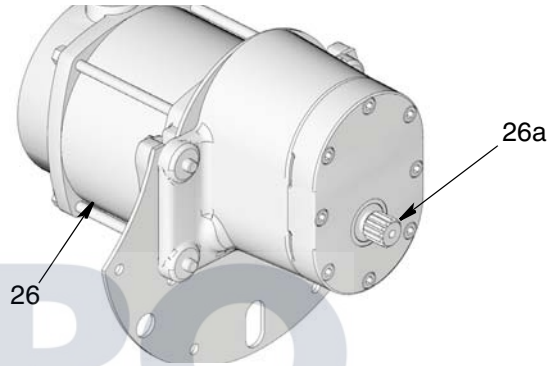

FIG. 5: Electric Motor Shown

2. Remove four of the mounting bolts (9a and 9b, FIG. 6) from the motor mounting bracket (21). These holes will be used to secure the motor module (26) to the motor mounting bracket (21).

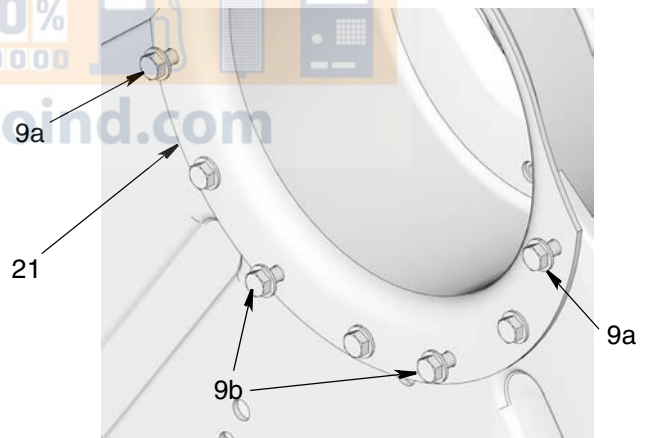

FIG. 6

3. Insert shaft of motor module into power shaft (20). Rotate as needed to align shaft splines.
4. Install 4 mounting bolts (9a and 9b) finger tight only.

- Support end of motor to align sheet metal mounting plate (26b) on motor module (26) to reel frame.

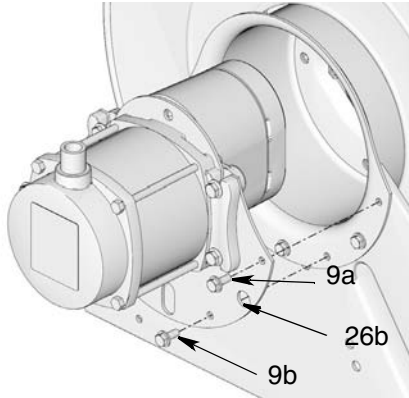

FIG. 7: Electric Motor Shown

- Tighten bolts (9a), top two, first. Then tighten bottom two bolts (9b).
- Torque bolts to 25-35 ft. lbs (34-47.5 N.m).

Powering the Hose Reel

The hose reel must be installed before powering the reel.

Electric Models

12 VDC or 24 VDC Models

All electrical wiring must be done by a qualified electrician and comply with all local codes and regulations						

Instructions

- Disconnect battery.
- Follow wiring diagram provided in FIG. 8 and Wiring Schematic provided in FIG. 9.
- Connect battery.
- Verify motor rotation (see Reversing Motor Rotation, page 30).

Wiring Diagram

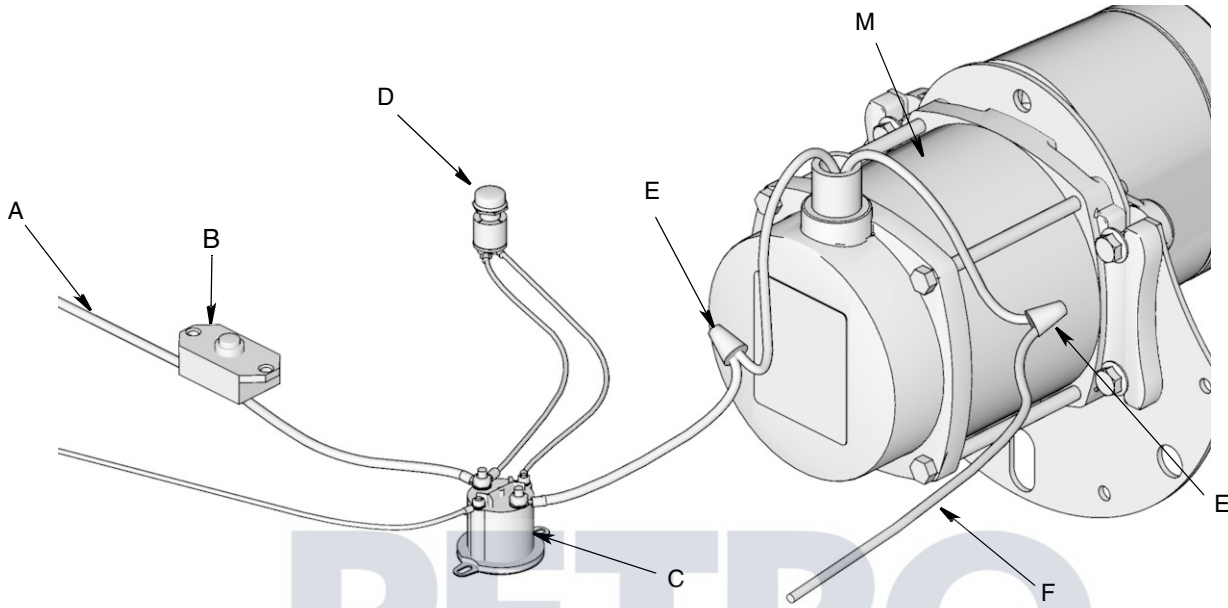

FIG. 8

- | | | | |
|---|--|---|--------------------------------------|
| A | Motor cable to battery (positive terminal) | E | Wire nut |
| B | Circuit breaker | F | Cable to battery (negative terminal) |
| C | Solenoid | M | Motor |
| D | Momentary push button switch | | |

Wiring Schematic

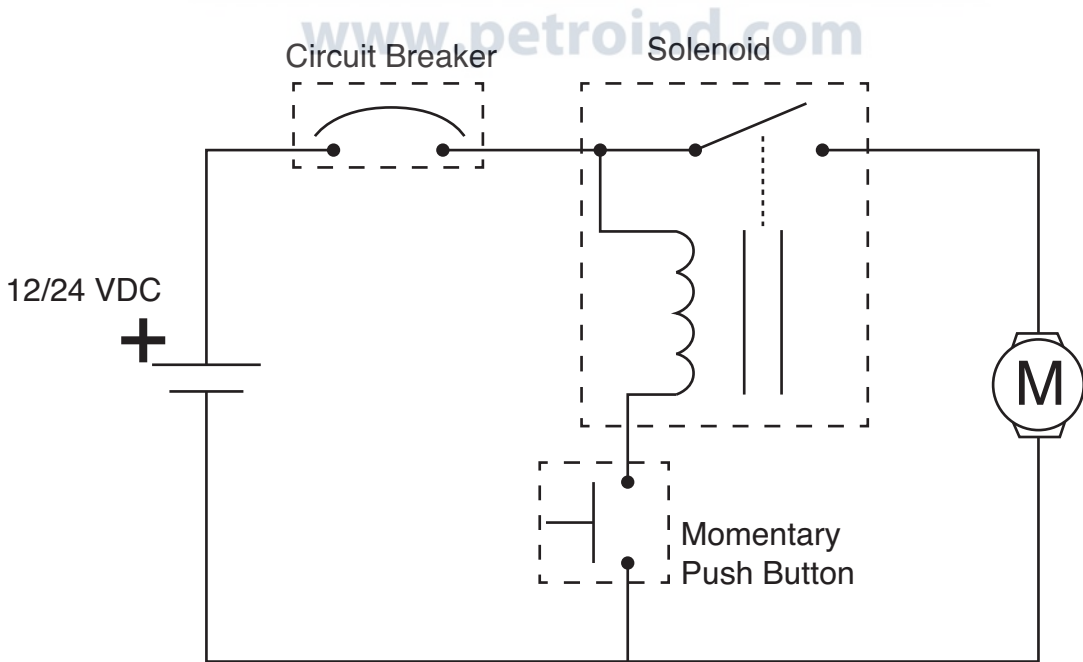

FIG. 9

115 or 230 VAC Models

⚠	⚡	⏚				
<p>All electrical wiring must be done by a qualified electrician and comply with all local codes and regulations.</p>						

NOTICE
<ul style="list-style-type: none"> AC motors are rectified DC motors and generate approximately 90VDC. Proper wiring must be followed to prevent damage to rectifier. Ensure motor is connected to a secondary protected circuit, properly rated for motor amperage to prevent damage to the motor.

Required Accessories:

- Hard service cord: Size cord per amperage on motor name plate. Choose proper cord type for operating environment.
- Junction box.
- 3/4 inch plugs.
- 3/4 inch, strain relief connectors.
- Double Pole, Single Throw (DPST) Push Button Switch.
- Wire nuts.

Instructions

Follow wiring diagram provided in FIG. 10 and wiring schematic FIG. 11.

Wiring Diagram

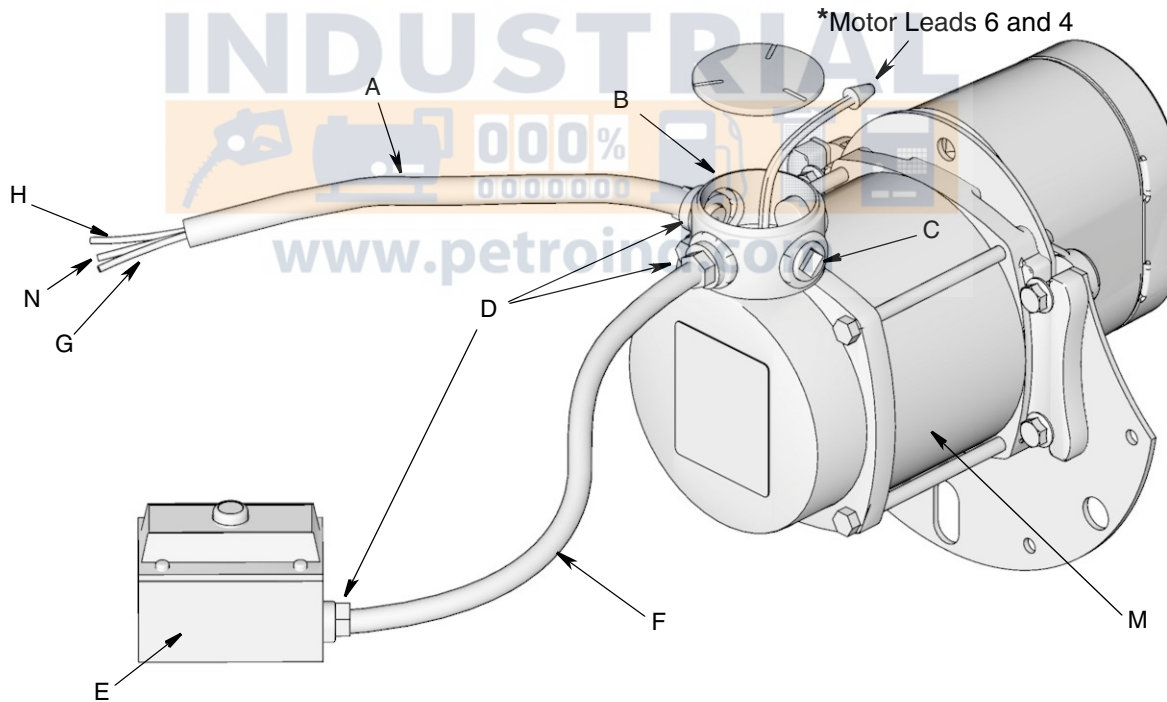

FIG. 10

- | | |
|--|---|
| <p>A Hard service cord - 3 conductors</p> <p>B Junction Box</p> <p>C 3/4 inch Plug</p> <p>D Strain Relief</p> <p>E Double Pole, Single Throw (DPST) Push Button Switch</p> <p>F Hard Service Cord - 5 conductors</p> | <p>G Cable, Ground</p> <p>H Cable, Hot</p> <p>M Motor</p> <p>N Cable, Neutral</p> |
|--|---|

Wiring Schematic

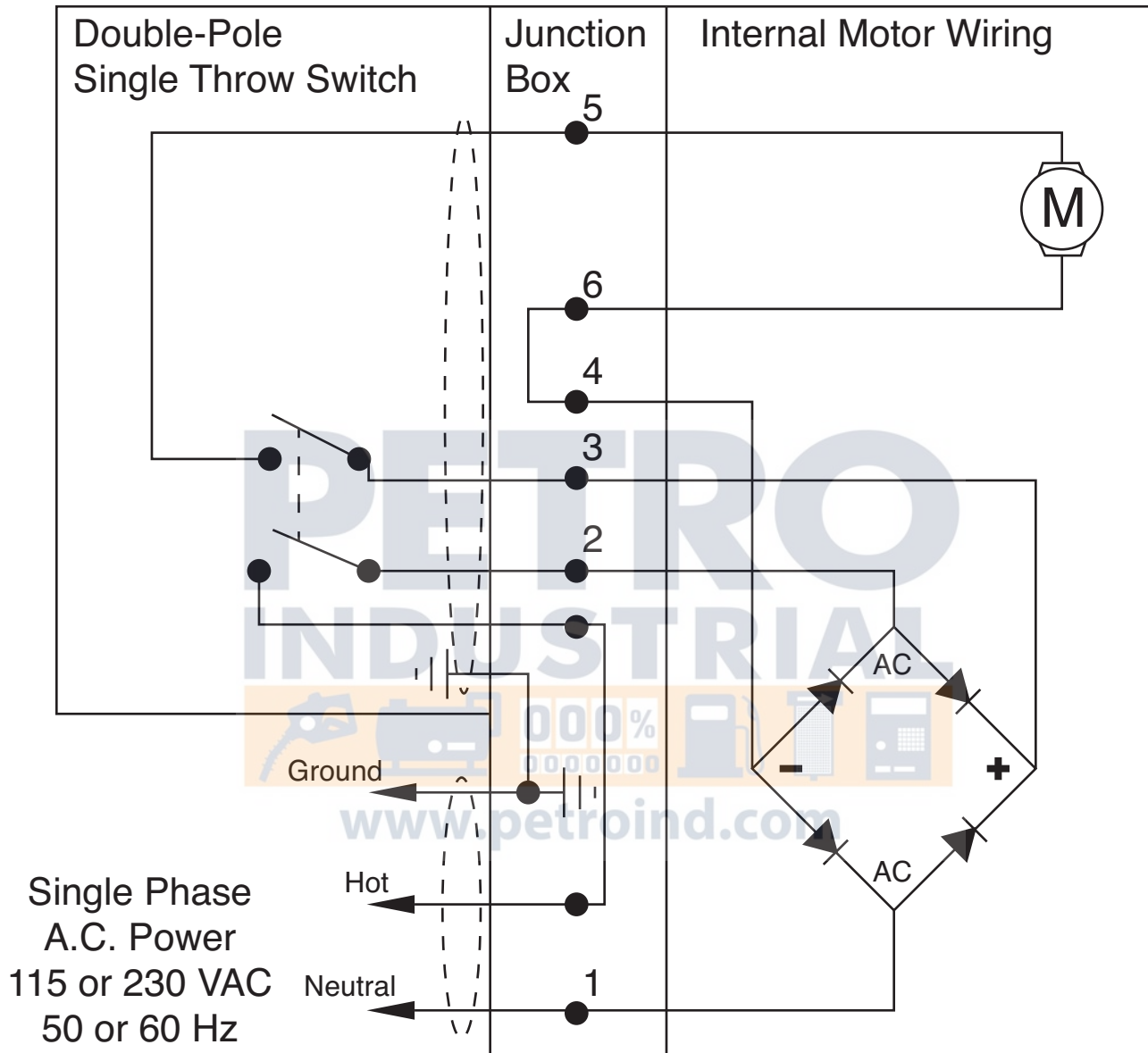

FIG. 11

Pneumatic Models

1. Connect pneumatic power supply line to the pneumatic motor. Install air line oiler (required).

NOTE: When the reel is powered the spool should wind in the direction that allows the hose to wind up onto the spool. The factory default reel configuration is counter-clockwise rotation of the motor when viewed from the motor side of the spool (end opposite the motor shaft). See FIG. 12.

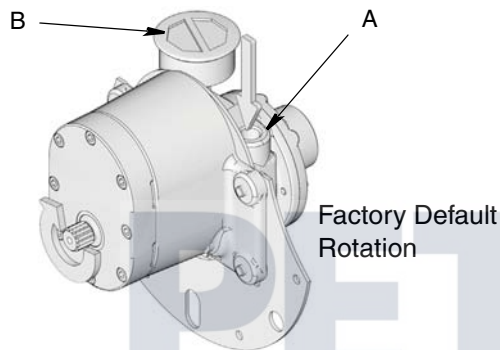

FIG. 12

- A Air Inlet
- B Muffler

2. Install the muffler supplied with the reel pneumatic motor in the opposite port as the power supply.
3. Turn on power supply and verify rotation is correct. Reverse connections to reverse motor rotation.
4. Install pneumatic control (Graco PN 127271. See Miscellaneous Kits, page 41).

- a. Connect port 1 to the pneumatic power supply line (FIG. 13).

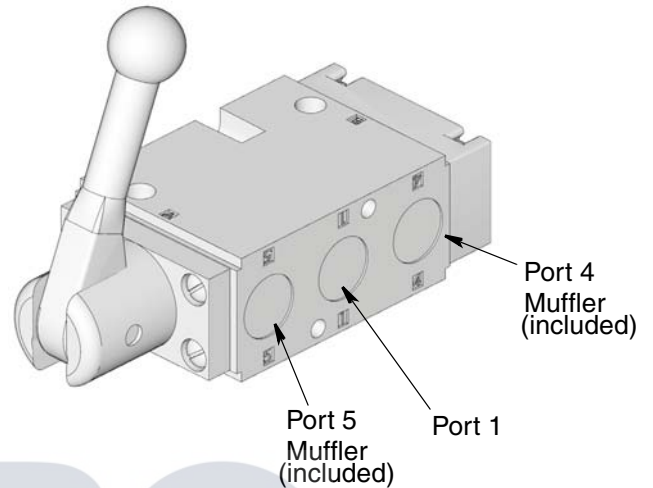

FIG. 13

- b. Connect port 2 to the reel air motor (FIG. 14).

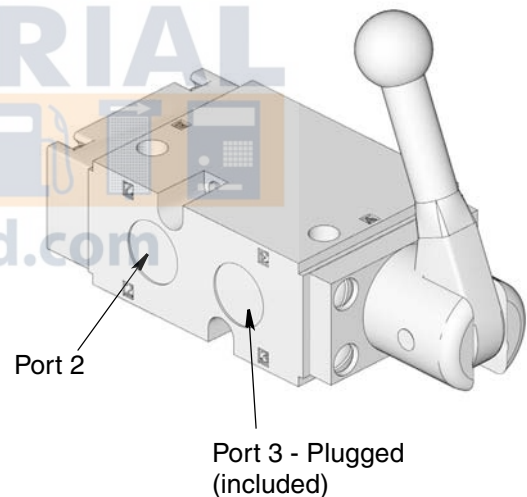

FIG. 14

Control Operation

The control is a 2 position control:

- Normal Position: allows free-spool rotation (FIG. 15).

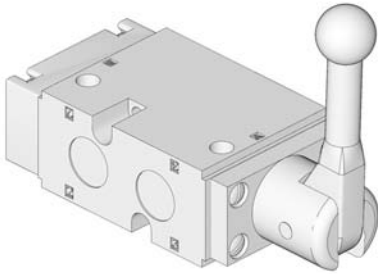

FIG. 15

- Handle Pulled: energizes the reel (FIG. 16).

NOTE: The Pull direction is spring returned. When it is released, the pneumatic power to the reel is stopped.

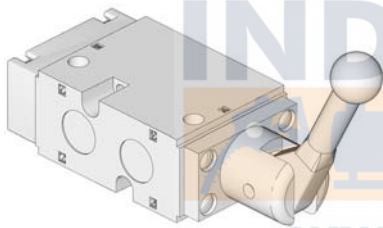

FIG. 16

Hydraulic Models

1. Connect hydraulic control supply line to the hydraulic motor.

NOTE: When the reel is powered the spool should wind in the direction that allows the hose to wind up onto the spool. The factory default reel configuration is counter-clockwise rotation of the motor when viewed from the motor side of the spool (end opposite the motor shaft). See FIG. 17.

2. Connect the opposite motor port to the tank return line.
3. Turn on power supply and verify correct rotation. Reverse connections to reverse motor rotation.

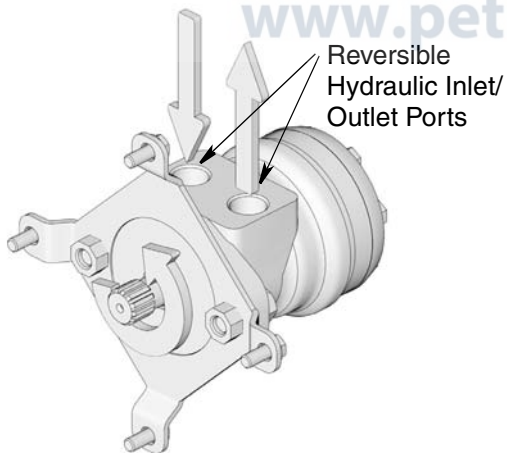
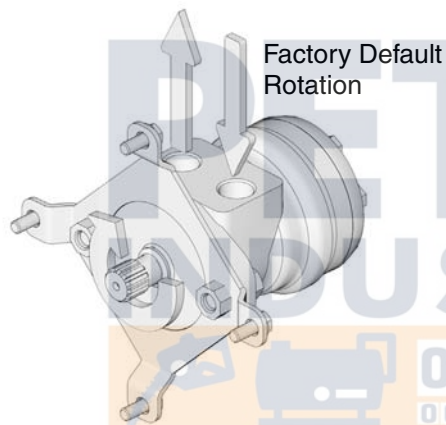

FIG. 17

User Supplied Hydraulic Controls

NOTICE

- Do not use a valve that allows oil from the hydraulic motor to bleed back into the tank without replenishing it such as a closed center spool or tandem center spool valve. This could seriously damage or seize the motor.
- Always use a filter in the hydraulic system. Failure to use a filter will void the Graco warranty on the reel and hydraulic motor.

Installations with Fixed Displacement Pump

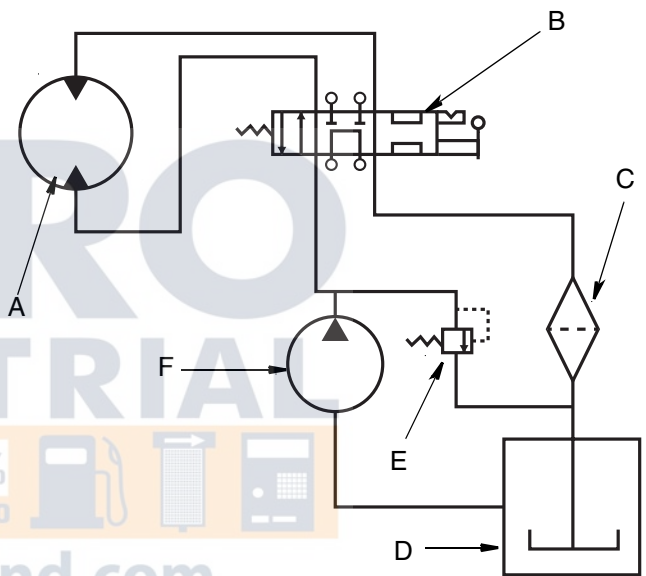



FIG. 18

- A Reel Motor
- B 4-Way Valve (appropriately sized to match pump output)
- C Return Line Filter
- D Reservoir
- E Relief Valve
- F Pump

Graco Hydraulic Controls (Optional)

NOTE: Users may use their own hydraulic controller or Graco Hydraulic Control Kits 127224 and 127225 are available. See Miscellaneous Kits, page 41 or contact Graco Customer Support or your Graco Distributor for information about ordering these kits.

						
<p>Hydraulic control modules 127224 and 127225 are designed for use with an internally pressure compensated hydraulic pump only. Do not use with a hydraulic supply pump without pressure relief.</p>						

1. Install hydraulic control (Graco PN 127224 - 12V or 127225 - 24V. See Miscellaneous Kits, page 41) (FIG. 19).

- a. Connect hydraulic power supply to hydraulic pressure inlet (A).
- b. Connect tank return hose to tank port (B).
- c. Connect hydraulic pressure outlet (C) to proper hydraulic motor inlet on reel for the desired rotation direction.
- d. Connect tank return (D) to remaining port on reel motor.
- e. Reverse connections on hydraulic motor to reverse rotation.

2. Wire switch to solenoids on hydraulic control module as shown in (FIG. 20 and FIG. 21).

- H is the solenoid to energize the hydraulic circuit to apply power to the rewind motor.
- J is the solenoid to energize the hydraulic circuit to allow the reel spool to “free spool” to allow for hose extension.
- The center switch position is the normal position and does not energize either solenoid. The spool rotation is restricted in this switch position.

3. Turn on power supply and verify correct rotation. Reverse hydraulic motor connections to reverse motor rotation.

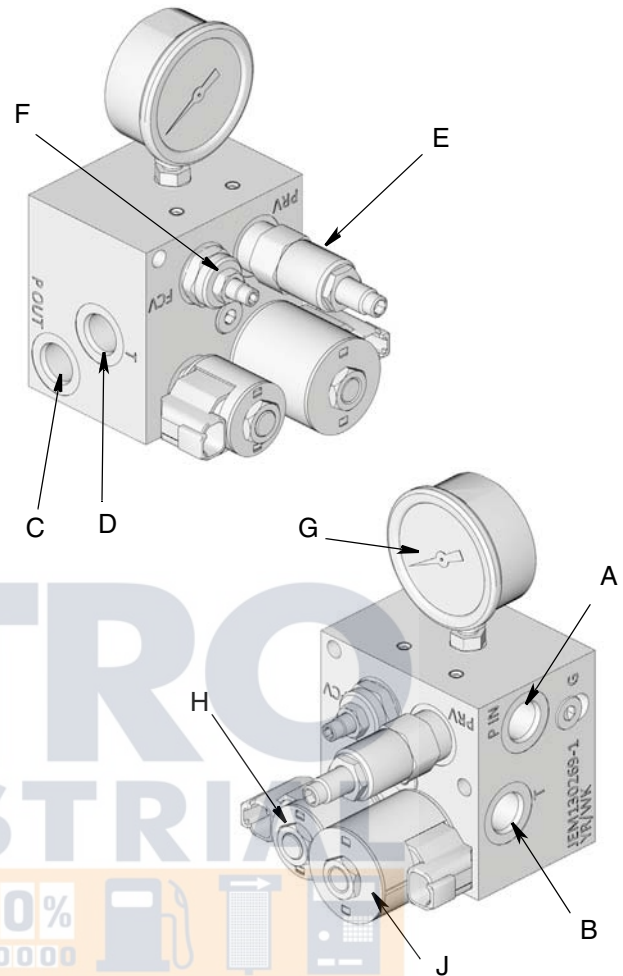

FIG. 19

Function Diagram

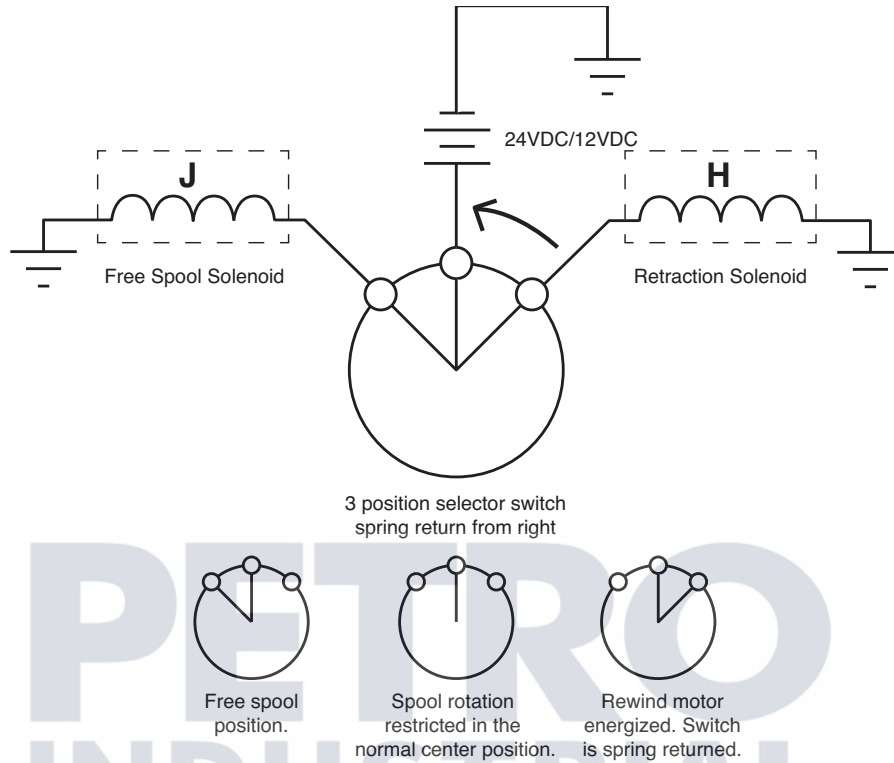

FIG. 20

Switch Wiring Diagram

View from backside of switch

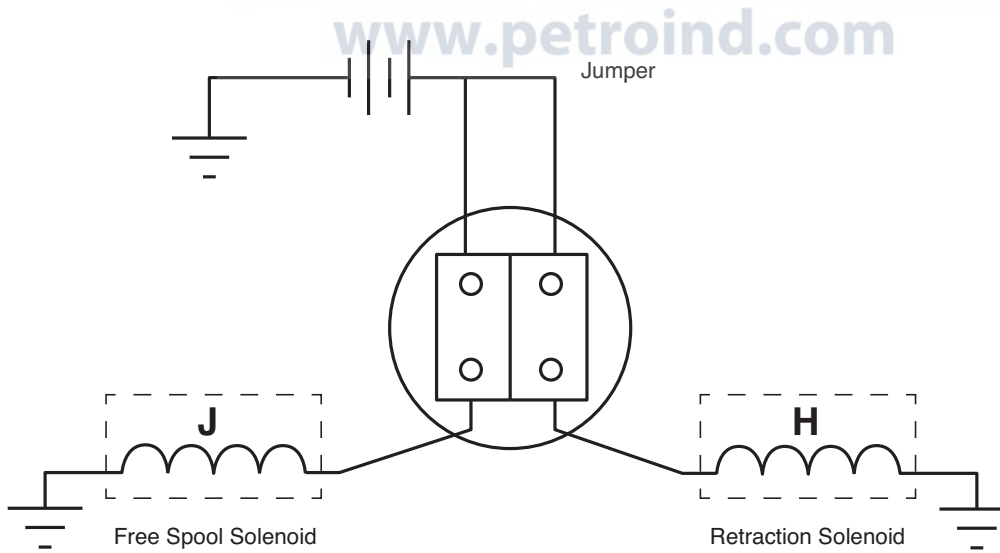

FIG. 21

Outlet Orientation and Motor Rotation

The outlet (17) orientation and motor (26) rotation can be altered as shown in FIG. 22-FIG. 23.

In the configurations shown in FIG. 22 the motor turns counter-clockwise under power when viewed from the motor side of the reel. All four configurations shown in FIG. 22 have the factory standard motor rotation and outlet orientation.

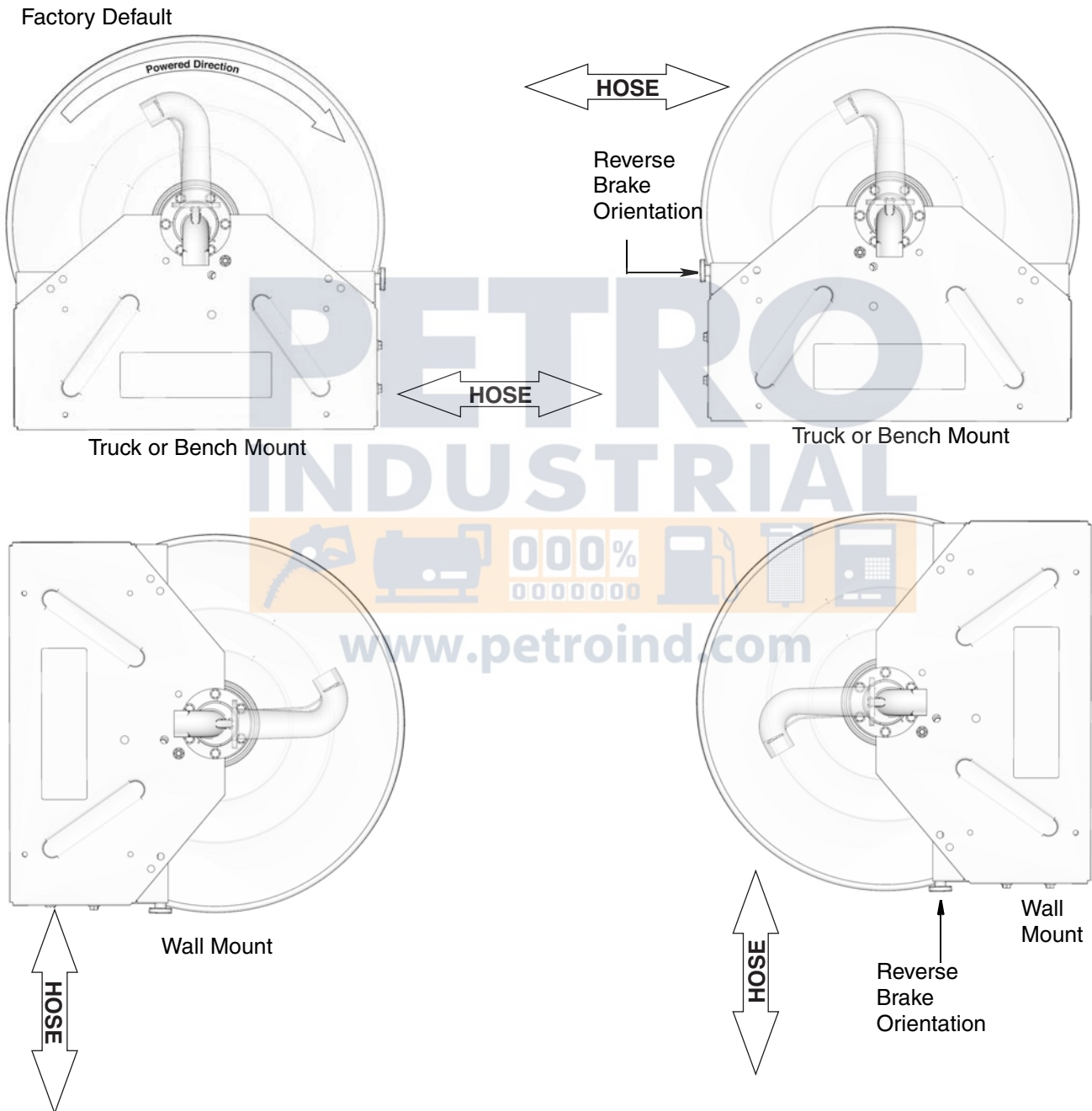

FIG. 22: Inlet Side Shown

In the configurations shown in FIG. 23 the motor turns clockwise under power when viewed from the motor side of the reel. All four configurations shown in FIG. 23 require motor (26) rotation reversal and outlet (17) reversal.

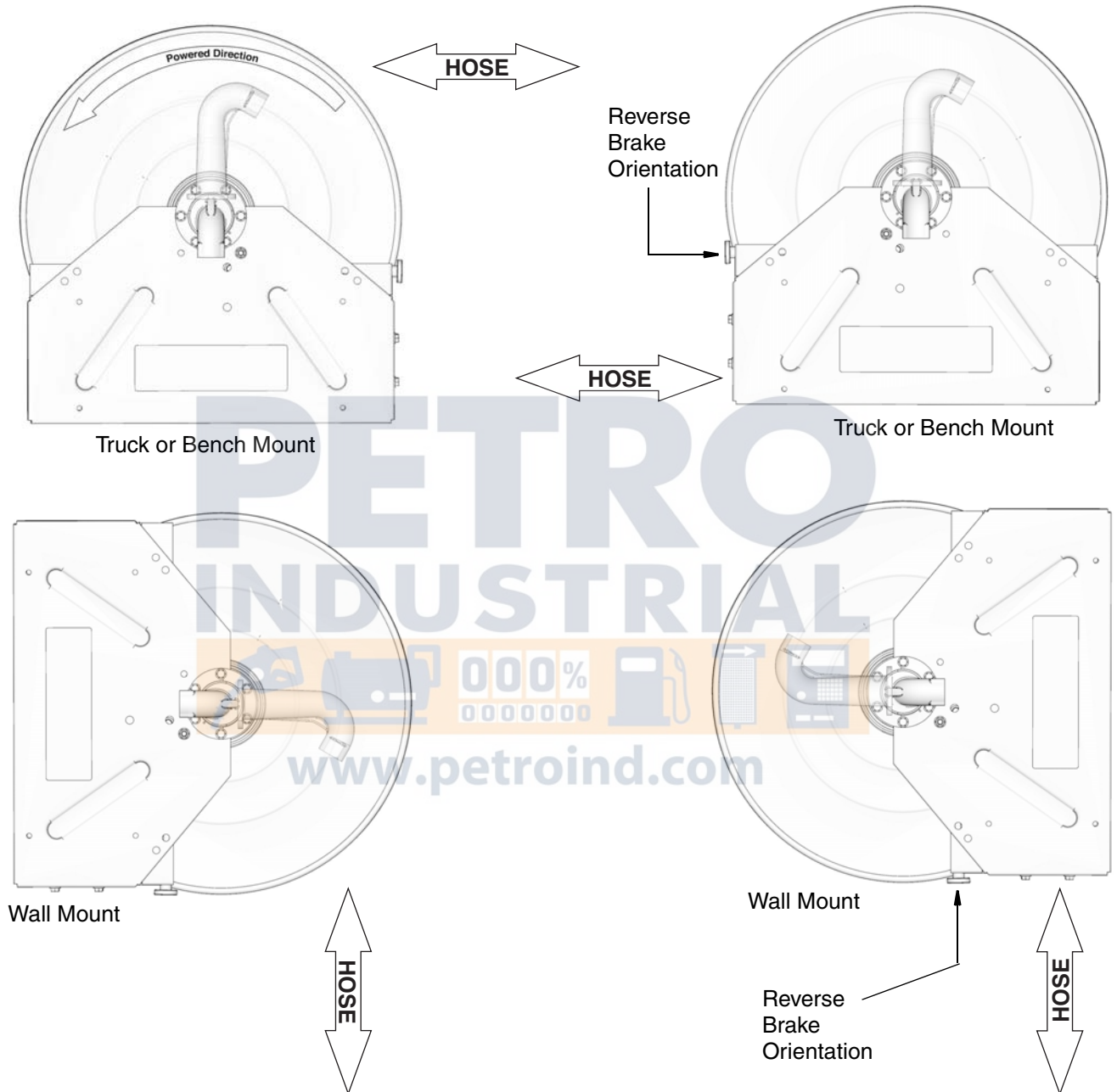

FIG. 23: Inlet Side Shown

Reversing Motor Rotation

The following instructions are for first time installations only. If your hose reel has been in service, the hose must be removed from the reel prior to performing this procedure. See instructions for removing the hose from the reel, in the XD 60, XD 70, XD 80 Powered Hose Reel Repair manual.

1. Reverse direction of outlet (17).
 - a. Remove bolts (19) and outlet (17) from reel (FIG. 24).

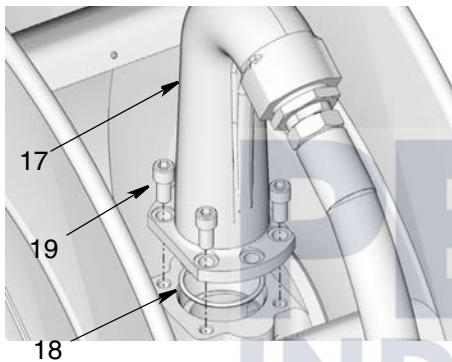

FIG. 24

- b. Turn outlet (17) 180° as shown in FIG. 25.

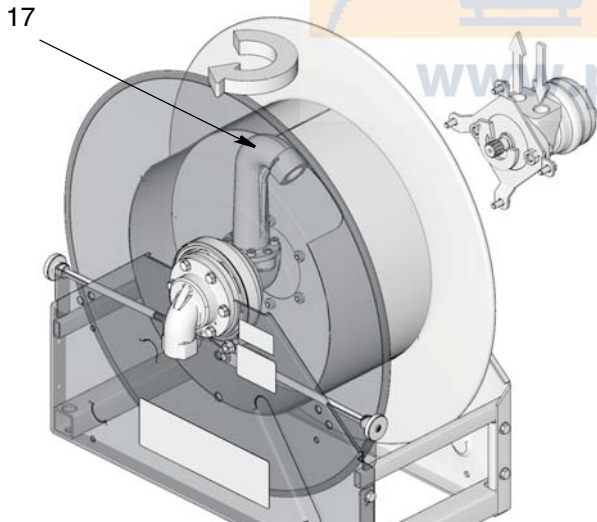

FIG. 25

- c. Apply a light coating of grease to the o-ring (18).
 - d. Install outlet (17) on reel.

- e. Reinstall bolts (19). Tighten all four bolts securely. Torque bolts to 24 to 30 ft. pounds (32.54 to 40.67 N.m)
2. Reverse motor direction.
 - Electric Motors - AC Models Swap leads 5 and 6 (FIG. 11, page 22).
 - DC Models - Swap leads exiting directly from motor (FIG. 9, page 20).
 - Pneumatic Motors - Reverse input and muffler parts on pneumatic motor (FIG. 12, page 23).
 - Hydraulic Motors - Reverse input and return to tank lines on hydraulic motor (FIG. 19, page 26).
3. Reverse brake orientation (if needed). See Changing Brake Location, page 31.

Motor Brake

Adjusting the Brake

The hose reel is equipped with a brake. The brake can be used to:

- Secure the reel and hold it stationary when in transit.
- Create resistance to help user maintain control of the hose when unwinding the hose from reel.

Turn brake knob (41) (FIG. 26) left or right to loosen or tighten the brake tension.

- Turn knob (41) to the right to increase / tighten brake tension.
- Turn knob (41) to the left to decrease / loosen brake tension.



FIG. 26

Changing Brake Location

For some installation locations, it may be necessary to change the location of the brake.



1. Disconnect power to hose reel. See Disconnecting Motor Power Source for either Electric Motors, Pneumatic Motors or Hydraulic Motors, page 17.
2. Turn knob (41) counter-clockwise to remove brake tension.
3. Loosen and remove screw (42) from end of knob (41) (FIG. 27).

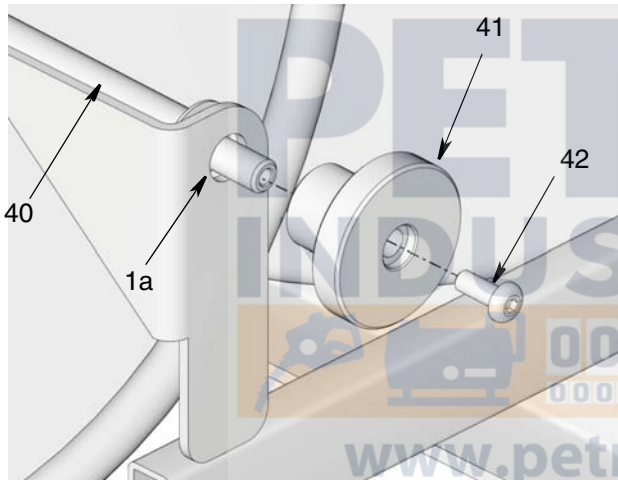

FIG. 27

4. Remove knob (41) from end of rod (40) (FIG. 27).
5. Loosen and remove nut (24) and pull band clip (34a) off anchor pin (37).

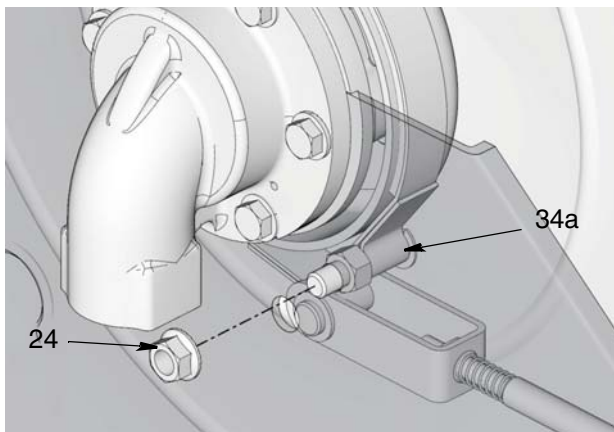

FIG. 28

6. Remove clip (36) from anchor pin (37) (FIG. 29).

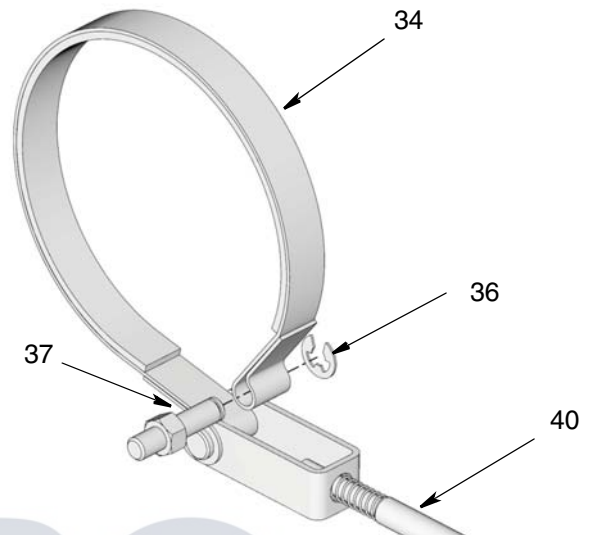

FIG. 29

7. Remove (37) from band (34) (FIG. 29).
8. Remove band (34) from brake hub (12).
9. Pull end of rod (40) out of frame (1a) (FIG. 27).
10. Rotate entire brake assembly 180° (FIG. 30).

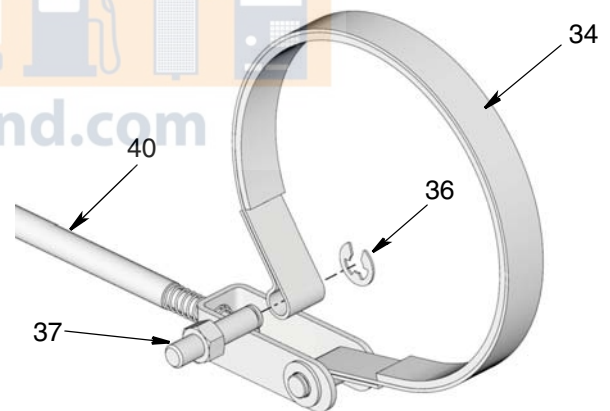

FIG. 30

11. Install band (34) around brake hub (12).
12. Install anchor pin (37) through (34) making sure clip end is in position shown in FIG. 30.
13. Reinstall clip (36) (FIG. 30).
14. Feed end of rod (40) through hole (27b) (FIG. 27).
15. Reinstall knob (41) over end of rod (40). Install screw (42). Tighten screw securely to hold knob in

place (FIG. 27).

16. Install anchor pin (37) to frame (FIG. 31). Reinstall nut (24) over anchor pin (37) and tighten securely (FIG. 31).

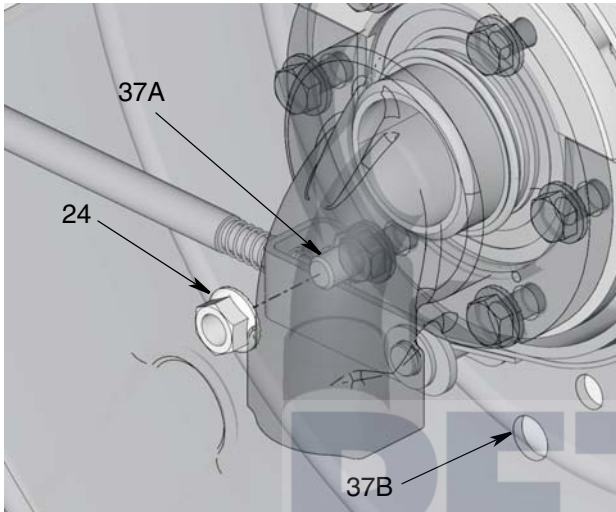

FIG. 31: 37A shows the new location of anchor pin (37). 37B shows the previous location of anchor pin (37).

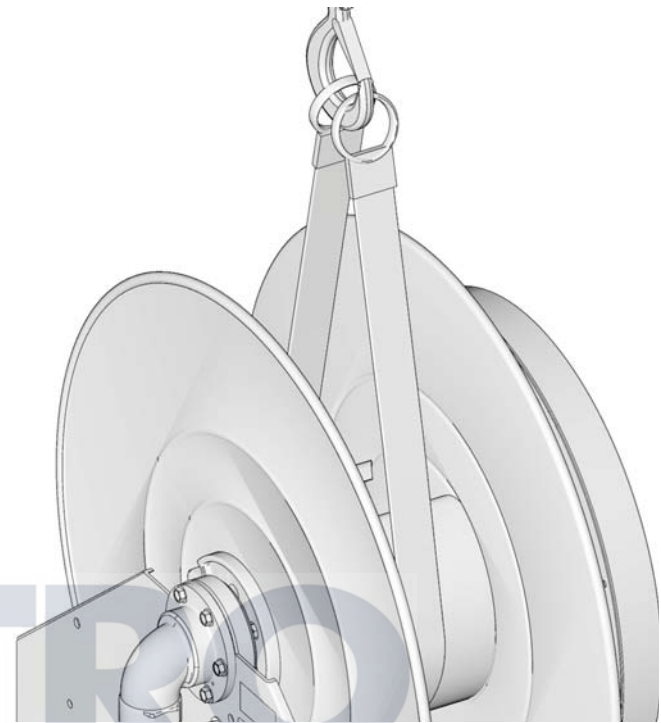

FIG. 32

17. Turn knob (41) to adjust tension as needed.

Mounting Options

All Mountings

NOTE:

- Always use large flat washers and four, 3/8 inch diameter bolts to mount the hose reel pedestal to the surface.
- Adjust inlet orientation prior to installing the hose reel. See Inlet Orientation, page 17.
- The maximum recommended installation height is 8 feet (2.4 meters)

Lifting Hose Reel

Always use a hoist or other suitable lifting device to raise hose reel into position.

Secure a lifting strap around spool as shown in FIG. 32. or place a strap over the inlet and motor as shown in FIG. 33. See Technical Data (page 47) for hose reel weights.

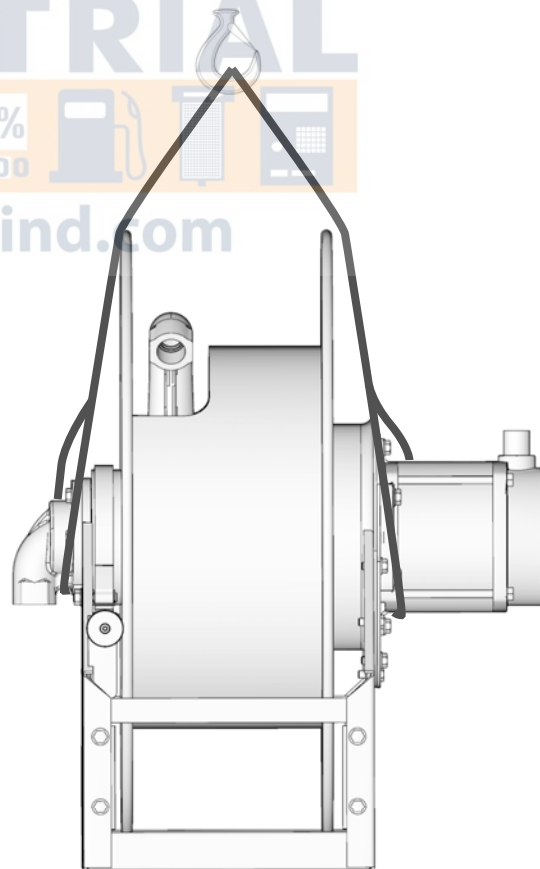
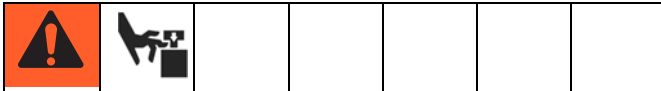

FIG. 33

Hose Installation

NOTE: The hose reel must be installed and the power connected before hose is installed.

The following instructions are for first time installations only. If your hose reel has been in service and you are replacing the hose, see the XD 60, XD 70, XD 80 Powered Hose Reel Repair manual for instructions.



1. Disconnect motor power source. See Disconnecting Motor Power Source, page 36.
2. Remove bolts (19) and outlet (17) from reel (FIG. 34).

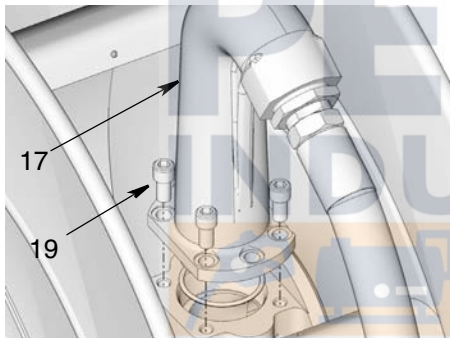

FIG. 34

3. Determine correct orientation for outlet (17) for your installation location. Refer to Outlet Orientation and Motor Rotation, FIG. 22, page 28 and FIG. 23, page 29.
4. Apply pipe thread sealant or wrap hose threads with PTFE tape.
5. Attach end of the hose to the outlet (17) using two wrenches on the flats, working in opposite directions, to securely tighten the hose to the outlet fitting

(FIG. 35).

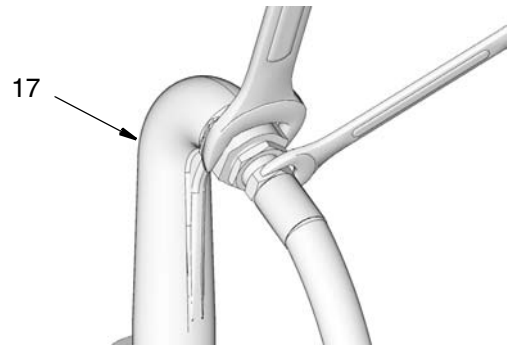

FIG. 35

6. Reinstall outlet (17) to spool. Replace and tighten bolts (19) securely. Torque bolts to 24 to 30 ft. pounds (32.54 to 40.67 N.m) (FIG. 36).

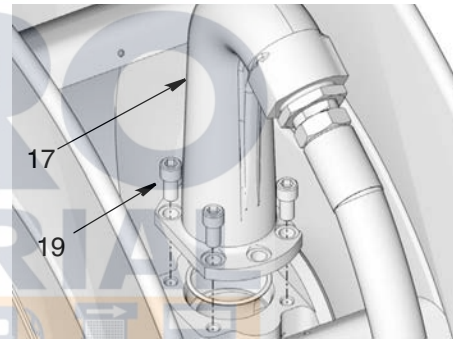





FIG. 36

NOTICE

Failure to pressurize hose before winding hose on reel, can damage spool.

7. Pressurize hose before winding it on the reel.
8. Flush system by pumping dispensing fluid through line until all solvent has been flushed out (See Flushing instructions, page 34.)
9. Connect motor power.
10. Actuate button or valve to wind hose onto reel.

Flushing

						
To avoid fire and explosion always ground equipment and waste container. To avoid injury from splashing, always flush at lowest possible pressure.						

Before installing dispense valve to end of hose, flush supply line with a solvent compatible with the fluid you are dispensing.

1. Place end of hose in a waste container.

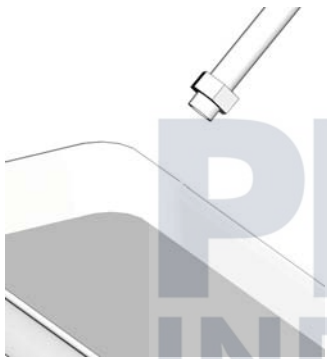

FIG. 37

2. Blow out entire lubricant supply line with air.

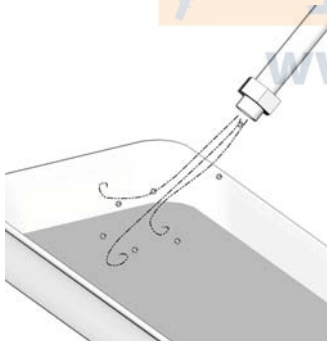

FIG. 38

3. Flush equipment with a compatible solvent until fluid runs clear.



FIG. 39

4. Pump dispensing lubricant through line until all solvent is flushed out.



FIG. 40

Pressure Relief Procedure

Follow the Pressure Relief Procedure whenever you see this symbol.





						
---	---	--	---	---	--	--

This equipment stays pressurized until pressure is manually relieved. To help prevent serious injury from pressurized fluid, such as skin injection, splashing fluid and moving parts, follow the Pressure Relief Procedure when you stop dispensing and before cleaning, checking, or servicing the equipment.

1. Turn off power supply to fluid pump.
2. Isolate the supply pump fluid supply line by turning off (closing) the fluid shut off valve (H, page 17).
3. Open the dispensing valve until pressure is fully relieved.

If you suspect the dispensing valve or extension is clogged or that pressure has not been fully relieved after following the steps above, VERY SLOWLY loosen coupler or hose end coupling to relieve pressure gradually, then loosen completely. Clear the obstruction.





Operation

						
SLIPPERY SURFACE HAZARD						
Wet, snow-covered or icy surfaces could result in serious injury due to slipping or falling when pulling the hose off the reel. To prevent injury:						
<ul style="list-style-type: none"> • If possible walk on a dry or stable surface. • If you must walk on a slippery surface, wear proper footwear for better traction. 						

Unwinding Hose

1. Turn on dispense fluid or air supply to pressurize service hose.
2. Actuate free spool and release brake. See Adjusting the Brake instructions, page 30.
 - For Pneumatic Models: Position pneumatic lever in free spool position, page 24.
 - For Hydraulic Models: Turn switch to free spool position, page 27.
3. Adjust brake tension as needed to prevent hose from unwinding too fast. See Adjusting the Brake instructions, page 30.
4. Pull hose off reel.

Retracting the Hose

						
<ul style="list-style-type: none"> • Always wear heavy gloves to protect your hands from being cut on the hose or reel. • Do not grip the hose. Only use your hand to guide the hose as it is retracting. To avoid injury, keep your hands away from the frame and spool. 						

NOTICE
<ul style="list-style-type: none"> • To prevent damage to the meter or dispense valve and hose reel, before retracting the hose reel, walk the dispense device back to the reel.

1. Turn brake knob (41) to release brake tension. (See Adjusting the Brake instructions, page 30.)
2. Actuate switch or valve to allow the hose to retract.

NOTICE
The duty cycle of electric motors is 5 minutes. To prevent damage to the motor, always allow the motor to return to ambient temperature prior to starting a new duty cycle.

3. To adjust retraction speed:
 - Electric Models: lightly tap or “bump” the switch.
 - Pneumatic Models: Decrease (lower) the air pressure to the pneumatic motor.
 - Hydraulic Models: Adjust the flow control valve on the hydraulic control module.

Disconnecting Motor Power Source

Electric Powered Motors



1. Disconnect power to hose reel at main power source.

Pneumatic Powered Motors

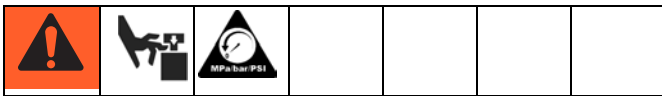

1. Isolate the air supply line to the motor by turning off (closing) the supply, bleed-type master air valve.
2. Activate air control lever to bleed off any additional remaining pressure.
3. Disconnect air supply hose from reel motor.

Hydraulic Powered Motors

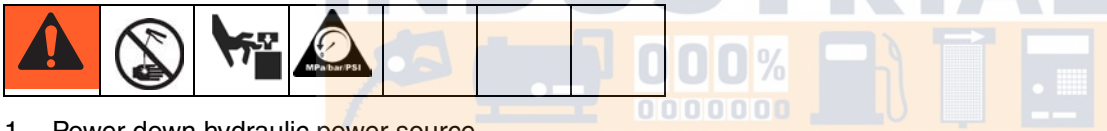

1. Power down hydraulic power source.
2. Isolate hydraulic power source from hydraulic control by closing isolation valve.
3. Activate hydraulic control to bleed off any additional pressure.
4. If free-spool mode is needed either:
 - Disconnect the hydraulic supply and return lines from the reel motor.

OR

- Activate the free-spool circuit. Hydraulic power is not required to activate the free-spool circuit. It can be accomplished by energizing the free-spool solenoid on the hydraulic control module or placing the manual valve in the free-spool position.

Troubleshooting



Problem	Cause	Solution
Button or valve is actuated, reel does not operate	External power source is not energized	Check that all power connections are made and in working condition. Tighten any loose connections. Replace broken or damaged parts.
	Power circuits are interrupted or damaged	Check connections for proper routing. Correct routing. Replace broken or damaged parts and fuses.
	Hose or reel spool is jammed	Check that spool will rotate when using your hand to turn it. Unwind hose from spool and use your hand to guide it back onto the spool to avoid stacking problems.
	Motor is not operating	Replace motor module. See Repair manual.
Poor Retraction	Pneumatic/Hydraulic Reels only: Low supply pressure and flow	Adjust pressure and flow. Verify all lines are correctly sized. See Installation Notes, page 16 or Technical Data page 47.
	Hose too stiff	Use correct hose for application. NOTE: Wrapped hoses are more difficult to retract than smooth hoses.
	Excessive swivel friction and hose bending torque	Reduce operating pressure.
	Hose or reel spool is jammed	Check that spool will rotate when using your hand to turn it. Unwind hose from spool and use your hand to guide it back onto the spool to avoid stacking problems.
	Spool bearing failure	Rebuild or replace inlet bearing and/or power shaft bearing. See XD 60, XD 70, XD 80 Power Rewind Hose Reel Repair Manual.
	Brake too tight	Loosen brake tension
	Dispense valve dragging while retracting hose	Walk dispense valve back to reel before retracting hose.
Excessive Hose Extension Forces	Brake is too tight	Loosen brake tension.
	Excessive swivel friction	Reduce operating pressure.
Oil Hoses Only: Pressure increases while winding hose onto reel	Wrapping hose on spool bends hose and increases pressure inside hose	Install pressure relief valve.

Problem	Cause	Solution
Fluid leakage from inlet housing or weep hole	Worn inlet seal	Replace inlet seal. See Inlet / Inlet Seal and O-Ring Replacement instructions provided in the XD 60, XD 70, XD 80 Power Rewind Hose Reel Repair Manual.
	Loose inlet hose	Tighten inlet hose connection
Fluid leakage from outlet seal	Seal failed	Replace outlet seal. See Outlet / Outlet Seal Replacement instructions provided in the XD 60, XD 70, XD 80 Power Rewind Hose Reel Repair Manual.
	Loose service hose	Tighten service hose connection

**PETRO
INDUSTRIAL**



www.petroind.com

Parts

Ref	Part No.	Description	Qty
1		BASE	1
2		SPOOL	1
3	16P906	SWIVEL, low pressure models	1
	16P907	SWIVEL, med pressure models	1
4	126596	SCREW, cap, hex head, low pressure models	6
	112586	SCREW, cap, hex head, med pressure models	6
5	16P901	RETAINER, bearing, medium pressure models only	1
6		SWIVEL, inlet, 1.0 in.	1
		SWIVEL, inlet, 1.5 in.	1
		SWIVEL, inlet, 2.0 in.	1
7	126787	SEAL, inlet	1
8	126643	RING, retaining, 1.969 shaft	1
9	110963	SCREW, cap, flange head	18
10	126739	SHIM, frame, medium pressure models only	1
11	24R514	BEARING, retainer, low pressure models only	1
12	126808	HUB, brake	1
13	16P898	INSERT, bearing, medium pressure models only	1
14	16W910	O-RING, 147, buna, medium pressure models only	1
15	126731	O-RING, 135, buna, medium pressure models only	1
16	555371	BALL, chrome, stainless steel, medium pressure models only	21
17		SWIVEL, outlet, 1 in., tall, XD 60 and XD 8010 models	1
		SWIVEL, outlet, 1 in., XD 7010 models	1
		SWIVEL, outlet, 1.5 in., XD 7015 models	1
		SWIVEL, outlet, 2 in., XD 7020 models	1
		SWIVEL, outlet, 1.5 in., tall, XD 8015 models	1
	SWIVEL, outlet, 2 in., XD 8020	1	
18	105318	PACKING, o-ring	1
19	558673	SCREW, SHCS, 5/16-18 x 0.75, low pressure models	4
		SCREW, SHCS, 5/16-18 x 0.75, medium pressure models	6
20		SHAFT, power	1
21		BRACKET, motor mount	1

Ref	Part No.	Description	Qty
22	127151	FLANGE, bearing	2
23	112953	BEARING, ball	1
24	112958	NUT, hex, flange	3
25	158019	SHIM, washer	1
26a*	24T886	MOTOR, assembly, 12 VDC	1
26b*	24T888	MOTOR, assembly, 24 VDC	1
26c*	24T910	MOTOR, assembly, 12 VDC, 2/3 hp	1
26d*	24T911	MOTOR, assembly, 24 VDC, 2/3 hp	1
26e*	24T889	MOTOR, assembly, 115 VAC	1
26f*	24T890	MOTOR, assembly, 230 VAC	1
26g*	24T892	MOTOR, assembly, pneumatic	1
26h*	24T891	MOTOR, assembly, hydraulic	1
27	16V902	PLATE, wear	2
28	111801	SCREW, cap, hex head	4
29	110996	NUT, hex, flange head	4
30	106082	RING, retaining	1
33	112914	WASHER, plain	2
34		BAND, brake	1
35		CLEVIS, brake	1
36	101134	RING, retaining	2
37		PIN, brake, anchor	1
38		PIN, clevis, grooved, 0.375 x 1.65	1
39		SPRING, compression	1
40	16U506	ROD, brake, All XD 60 and XD 70 models only	1
	16U430	ROD, brake, All XD 80 models only	1
41	16W151	KNOB	1
42	555608	SCREW, #10-24 x 0.50 soc	1
43	16T815	LABEL, identification	1
46	15W036	LABEL, warning	1

* Models 24T104 - 24T133 do not include a motor. See Motor Kits, page 40

Repair and Accessory Kits

Motor Kits (26)

Ref	Part No.	Description	Qty
26a	24T886	MOTOR, assembly, 12 VDC, includes:	
	112785	• SCREW, hex head	4
	126991	• MOTOR, 12 VDC, 1/2 HP, 650 rpm	1
	16U141	• PLATE, motor mount, black	1
	24P951❖	• KIT, GEAR REDUCER	1
26b	24T888	MOTOR, assembly, 24 VDC, includes:	
	112785	• SCREW, hex head	4
	126992	• MOTOR, 24 VDC, 1/2 HP, 650 rpm	1
	16U141	• PLATE, motor mount, black	1
	24P951❖	• KIT, GEAR REDUCER	1
26c	24T910	MOTOR, assembly, 12 VDC, includes:	
	112785	• SCREW, hex head	4
	127247	• MOTOR, 12 VDC, 2/3 HP, 700 rpm	1
	16U141	• PLATE, motor mount, black	1
	24P951❖	• KIT, GEAR REDUCER	1
26d	24T911	MOTOR, assembly, 24 VDC, includes:	
	112785	• SCREW, hex head	4
	127248	• MOTOR, 24 VDC, 2/3 HP, 700 rpm	1
	16U141	• PLATE, motor mount, black	1
	24P951❖	• KIT, GEAR REDUCER	1
26e	24T889	MOTOR, assembly, 115 VAC, includes:	
	112785	• SCREW, hex head	4
	126990	• MOTOR, 115 VAC, 40 HP, 500 rpm	1
	16U141	• PLATE, motor mount, black	1
	24P951❖	• KIT, GEAR REDUCER	1

Ref	Part No.	Description	Qty
26f	24T890	MOTOR, assembly, 230 VAC, includes:	
	112785	• SCREW, hex head	4
	127211	• MOTOR, 230 VAC, 1/2 HP, 650 rpm	1
	16U141	• PLATE, motor mount, black	1
	24P951❖	• KIT, GEAR REDUCER	1
26g	24T892	MOTOR, assembly, pneumatic, includes:	
	111192	• SCREW, cap, flange head	4
	111801	SCREW, cap, hex head	3
	126994	• MOTOR, pneumatic, 4 hp	1
	16U141	• PLATE, motor mount	1
24P951◆	• KIT, GEAR REDUCER	1	
26h	24T891	MOTOR, assembly, hydraulic, includes:	
	110963	• SCREW, cap, flange head	4
	113961	SCREW, cap, hex head	2
	16W740	• MOTOR, hydraulic, 14 HP, 755 rpm	1
	101	126963	• ADAPTER, hydraulic motor
❖	24P951	KIT, gear reducer	1
		• PIN, dowel	2
		• BEARING, roller	3
		• SCREW, cap, socket head	8
		• BEARING, thrust	3
		• BEARING, needle, 37 mm od	2
		• WASHER, 1.43 in. x 1.188 in. x 0.063 in.	1
		• HOUSING, gearbox	1
		• COVER, housing, gearbox	1
		• SHAFT, output	1
		• GEAR, driven, second stage	1
	• GEAR, input drive	1	
	• BEARING, thrust	1	
	• GEAR, driving, second stage	1	
	• GEAR, driven, second stage	1	

Hose Kits

Part No.	Description
126505	HOSE, coupled, 1.0 in. x 100 ft., oil
127167	HOSE, coupled, 2.0 in. x 33 ft., fuel
127173	HOSE, coupled, 1.5 in. x 50 ft., waste oil evacuation
24T252	HOSE, 1.0 in. x 150 ft., fuel
24T253	HOSE, 1.5 in. x 100 ft., fuel
24T254	HOSE, 2 in. x 50 ft., fuel
126359	HOSE, coupled, 1/2 in. x 100 ft, air/water, npt
126360	HOSE, coupled, 3/4 in. x 75 ft, air/water, npt
126361	HOSE, coupled, 3/4 in. x 100 ft, air/water, npt
126362	HOSE, coupled, 1 in. x 50 ft, air/water, npt
126375	HOSE, coupled, 1/2 in. x 100 ft, oil, npt
126376	HOSE, coupled, 3/4 in. x 75 ft, oil, npt
126377	HOSE, coupled, 3/4 in. x 100 ft, oil, npt
126503	HOSE, coupled, 1 in. x 50 ft, oil, npt
126379	HOSE, coupled, 1 in. x 50 ft, waste oil evacuation, npt
24R102	HOSE, coupled, 1 in. x 50 ft, fuel, npt
126363	HOSE, coupled, 1 in. x 75 ft, air/water, npt
126364	HOSE, coupled, 1 in. x 100 ft, air/water, npt
126504	HOSE, coupled, 1 in. x 75 ft, oil, npt
126380	HOSE, coupled, 1.25 in. x 35 ft, waste oil evacuation, npt
126688	HOSE, coupled, 1.25 in. x 50 ft, waste oil evacuation, npt
24R103	HOSE, coupled, 1 in. x 75 ft, fuel, npt
24R106	HOSE, coupled, 1 in. x 100 ft, fuel, npt
24R108	HOSE, coupled, 1.25 in. x 35 ft, fuel, npt
24R110	HOSE, coupled, 1.25 in. x 50 ft, fuel, npt
24R114	HOSE, coupled, 1.25 in. x 50 ft, fuel, npt

Miscellaneous Kits

Ref	Part No.	Description	Qty
100	24R111	KIT, inlet hose, 1 in., air/water and oil, includes:	1
100a		• FITTING, swivel, 1 in., MXF	1
100b		• HOSE, coupled, 1 in. x 28 in., oil	1
100	24R112	KIT, inlet hose, 1 in., waste oil evacuation, includes:	1
100a		• FITTING, swivel, 1 in. MXF	1
100b		• HOSE, coupled, 1 in. x 28 in. WOE	1

Ref	Part No.	Description	Qty
100	24R115	KIT, inlet hose, 1 in., fuel, includes:	1
100a		• FITTING, swivel, 1 in. MXF	1
100b		• HOSE, coupled, 1 in. x 28 in. fuel	1
100	24R117	KIT, inlet hose, 1.5 in., fuel, includes:	1
100a		• UNION, swivel, 1.5 in. npt	1
100b		• HOSE, coupled, 1.5 in. x 28 in. fuel	1
100	24R118	KIT, inlet hose, includes:	
100a		• UNION, swivel, male 2.0 in.	1
100b		• HOSE, coupled, 2.0 in. x 28 in., fuel	1
100	24T858	KIT, inlet hose, 1.5 in. WOE, includes:	1
100a		• UNION, swivel, 1.5 in. NPT	
100b		• HOSE, coupled, 1.5 in. x 28 in., WOE	
101	126963	KIT, adapter, hydraulic motor, included in kit 24T858	1
	24R067	KIT, swivel, 1 in., includes 4, 6, 7	1
	24R068	KIT, swivel, 1.5 in., includes, 4, 6, 7	1
	24R116	KIT, swivel, 2 in., includes 4, 6, 7	1
	24R070	KIT, repair, low pressure bearing, inlet side, includes 4, 5, 8,	
	24R071	KIT, repair, medium pressure bearing, inlet side, includes 4, 5, 8, 13-16	1
	24R053	KIT, outlet, 1/2 in., npt, models XD 6010 and XD 8010, includes 17-19	1
	24R055	KIT, outlet, 3/4 in., npt, models XD 6010 and XD 8010, includes 17-19	1
	24R056	KIT, outlet, 1 in., npt, models XD 6010 and XD 8010, includes 17-19	1
	24R057	KIT, outlet, replacement, 1 in., npt, models XD 7010, includes 17-19	1
	24R058	KIT, outlet, replacement, 1-1/4 in., npt, XD 7015, includes 17-19	1
	24R059	KIT, outlet, replacement, 1.5 in., npt, used with XD 7015 models, includes 17-19	1
	24T339	KIT, outlet replacement, 1.5 in., npt, used with XD 8015 models, includes 17-19	1

Ref	Part No.	Description	Qty
	24T340	KIT, outlet replacement, 2 in., npt, used with XD 7020 models, includes 17-19	1
	24T341	KIT, outlet replacement, 2.0 in., npt, used with XD 8020 models, includes 17-19	1
	24T338	KIT, power side shaft replacement, includes 9, 20	1
	24T432	KIT, power side bearing replacement, includes 22-24	1
	24T857	KIT, brake repair, includes 24, 33-39	1
	127214	SWITCH, momentary, with cover	1
	127217	KIT, SWITCH, hazardous location, ON/OFF	1
	127260	• COVER, explosion proof junction box	1
	127261	• BASE, explosion proof box	1
	127262	• BUTTON, hazardous location rated	1
	127218	BOX, outlet, hazardous location	1
	127219	CONTACT, 12 VDC, intermittent duty	1
	127220	CONTACT, 24 VDC intermittent duty	1
	127221	CIRCUIT BREAKER, 50 AMP	1
	127222	CIRCUIT BREAKER, 25 AMP	1
	24T327◆	KIT, SST fairlead, XD 60	1
	24T328◆	KIT, SST fairlead, XD 70	1
	24T329◆	KIT, SST fairlead, XD 80	1
		• REEL, fairlead, non-roller	1
		• SCREW, cap, hex head	4
		• NUT, hex, flange head	4

◆ Parts not compatible with ball stops - 1/2 in. (PN222225), 3/4 in. (PN218341), and 1 in. (PN 237872).

Ref	Part No.	Description	Qty
	24R072	KIT, roller guide with bracket, XD 60 models	1
	24T330	KIT, roller guide with bracket, XD 70 models	1
	24T331	KIT, roller guide with bracket, XD 80 models	1
		• SCREW, cap, flange head	4
		• NUT, hex, flange head	8
		• SCREW, cap, flange head	4
		• POST, corner	4
		• PLATE, roller	1
		• PIN, roller, short	2
		• TUBE, roller, short	2
		• PIN, roller, long	2
		• TUBE, roller, long	2
		• CAP, roller	8
	24T332◆	KIT, arms, XD 60, with SST guide	1
	24T333◆	KIT, arms, XD 70, with SST guide	1
		• WASHER, plain	4
		• SCREW, cap, flange head	12
		• NUT, hex, flange head	12
		• REEL, fairlead, non-roller	1
		• SUPPORT, roller arm 1	1
		• SUPPORT, roller arm 2	1
	24T334◆	KIT, arms, XD 80, with SST guide	1
		• SCREW, cap, flange head	12
		• NUT, hex, flange head	12
		• REEL, fairlead, non-roller	1
		• SUPPORT, roller arm 1	1
		• SUPPORT, roller arm 2	1

Ref	Part No.	Description	Qty
	24T335	KIT, arms, XD 60, with roller guide	1
	24T336	KIT, arms, XD 70, with roller guide	1
		• WASHER, plain	4
		• SCREW, cap, flange head	12
		• NUT, hex, flange head	16
		• SCREW, cap, flange head	4
		• POST, corner	4
		• SUPPORT, roller arm 1	1
		• SUPPORT, roller arm 2	1
		• PIN, roller, short	2
		• TUBE, roller, short	2
		• PIN, roller, long	2
		• TUBE, roller, long	2
		• CAP, roller	8
		• PLATE, roller	1
	24T337	KIT, arms, XD 80, with roller guide	1
		• SCREW, cap, flange head	12
		• NUT, hex, flange head	16
		• SCREW, cap, flange head	4
		• POST, corner	4
		• SUPPORT, roller arm 1	1
		• SUPPORT, roller arm 2	1
		• PIN, roller, short	2
		• TUBE, roller, short	2
		• PIN, roller, long	2
		• TUBE, roller, long	2
		• CAP, roller	8
		• PLATE, roller	1
	24T359	KIT, BSPP conversion, 1 in. LONG, XD 60 / XD 80 models	1
		• PACKING, o-ring	1
		• SWIVEL, outlet, 1.0 in., mach, BSPP	1
		• ADAPTER, 1 in. NPT x 1 in. BSPP	1
		• SCREW, 5/16-18 x 0.75 in.	6
	24T360	KIT, BSPT conversion, 1 in. LONG, XD 60 / XD 80 models	1
		• PACKING, o-ring	1
		• SWIVEL, outlet, 1.0 in., mach, BSPT	1
		• ADAPTER, 1 in. NPT x 1 in. BSPT	1
		• SCREW, 5/16-18 x 0.75 in.	6

Ref	Part No.	Description	Qty
	24T361	KIT, BSPP conversion, 1 in. SHORT, XD 70 models	1
		• PACKING, o-ring	1
		• SWIVEL, outlet, 1.0 in., mach, BSPP	1
		• ADAPTER, 1 in. NPT x 1 in. BSPP	1
		• SCREW, 5/16-18 x 0.75 in.	6
	24T362	KIT, BSPT conversion, 1 in. SHORT, XD 70 models	1
		• PACKING, o-ring	1
		• SWIVEL, outlet, 1.0 in., mach, BSPT	1
		• ADAPTER, 1 in. NPT x 1 in. BSPT	1
		• SCREW, 5/16-18 x 0.75 in.	6
	24T363	KIT, BSPP conversion, 1.5 in. LONG, XD 80 models	1
		• PACKING, o-ring	1
		• SWIVEL, outlet, 1.5 in., BSPP	1
		• ADAPTER, 1.5 in. NPT x 1.5 in. BSPP	1
		• SCREW, 5/16-18 x 0.75 in.	4
	24T364	KIT, BSPT conversion, 1.5 in. LONG, XD 80 models	1
		• PACKING, o-ring	1
		• SWIVEL, outlet, 1.5 in., BSPT	1
		• ADAPTER, 1.5 in. NPT x 1.5 in. BSPT	1
		• SCREW, 5/16-18 x 0.75 in.	4
	24T365	KIT, BSPP conversion, 1.5 in. SHORT, XD 70 models	1
		• PACKING, o-ring	1
		• SWIVEL, outlet, 1.5 in., BSPP	1
		• ADAPTER, 1.5 in. NPT x 1.5 in. BSPP	1
		• SCREW, 5/16-18 x 0.75 in.	4
	24T366	KIT, BSPT conversion, 1.5 in. SHORT, XD 70 models	1
		• PACKING, o-ring	1
		• SWIVEL, outlet, 1.5 in., BSPT	1
		• ADAPTER, 1.5 in. NPT x 1.5 in. BSPT	1
		• SCREW, 5/16-18 x 0.75 in.	4

Ref	Part No.	Description	Qty
	24T367	KIT, BSPT conversion, 2 in. LONG, XD 80 models	1
		• PACKING, o-ring	1
		• SWIVEL, outlet, 2 in., BSPT	1
		• ADAPTER, 2 in. NPT x 2 in. BSPT	1
		• SCREW, 5/16-18 x 0.75 in.	4
	24T368	KIT, BSPT conversion, 2 in. SHORT, XD 70 models	1
		• PACKING, o-ring	1
		• SWIVEL, outlet, 2 in., BSPT	1
		• ADAPTER, 2 in. NPT x 2 in. BSPT	1
		• SCREW, 5/16-18 x 0.75 in.	4
	24T855	KIT, BSPP conversion, 2 in. LONG, XD 80 models	1
		• PACKING, o-ring	1
		• SWIVEL, outlet, 2 in., BSPP	1
		• ADAPTER, 2 in. NPT x 2 in. BSPP	1
		• SCREW, 5/16-18 x 0.75 in.	4
	24T856	KIT, BSPP conversion, 2 in. SHORT, XD 70 models	1
		• PACKING, o-ring	1
		• SWIVEL, outlet, 2 in., BSPP	1
		• ADAPTER, 2 in. NPT x 2 in. BSPP	1
		• SCREW, 5/16-18 x 0.75 in.	4
	127224	CONTROL, hydraulic, 12V	1
		• VALVE, poppet, 2 way	1
		• VALVE, poppet, 2 way	1
		• VALVE, spool, pressure reducing	1
		• VALVE, cartridge, flow regulator	1
		• LATCH, mounting	1
		• SWITCH, hydraulic selector	1
		• BLOCK, contact	1
	127225	CONTROL, hydraulic, 24V	1
		• VALVE, poppet, 2 way	1
		• VALVE, poppet, 2 way	1
		• VALVE, spool, pressure reducing	1
		• VALVE, cartridge, flow regulator	1
		• LATCH, mounting	1
		• SWITCH, hydraulic selector	1
		• BLOCK, contact	1
	24U118	KIT, switch, hydraulic	1
	218341	KIT, ball stop, 3/4 in. OD	1

Ref	Part No.	Description	Qty
	222225	KIT, ball stop, 1/2 in. OD	1
	237872	KIT, ball stop, 1 in. OD	1
	24R060	KIT, ball stop, 1-3/4 in. OD	1
	24R061	KIT, ball stop, 2 in. OD	1
	127271	CONTROL, pneumatic	1

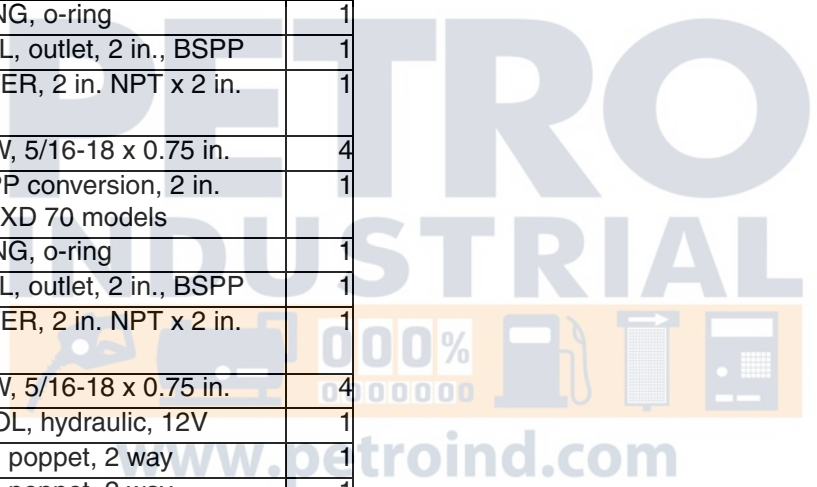

Motor-less Reel Parts

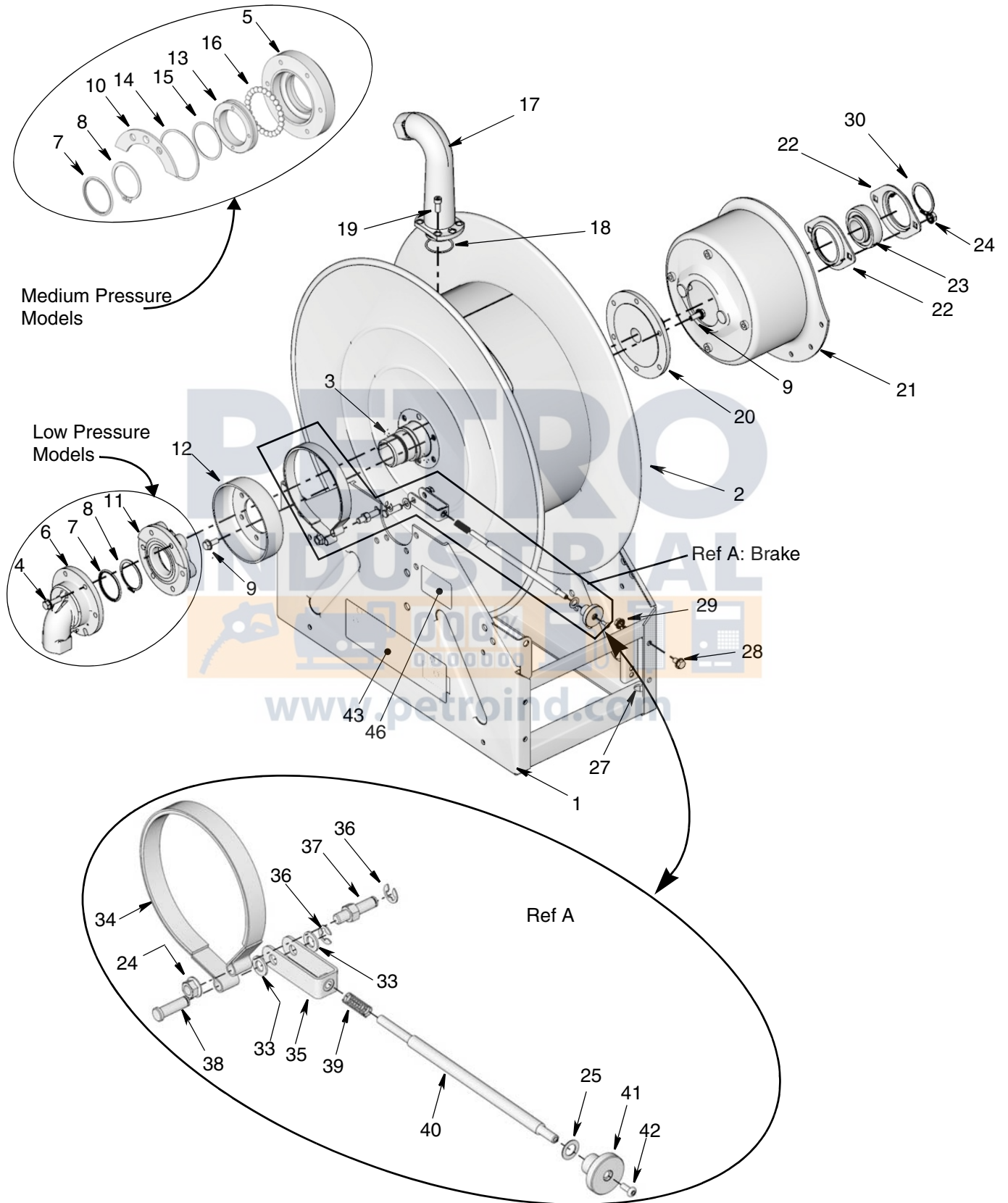

Motor Module (26)

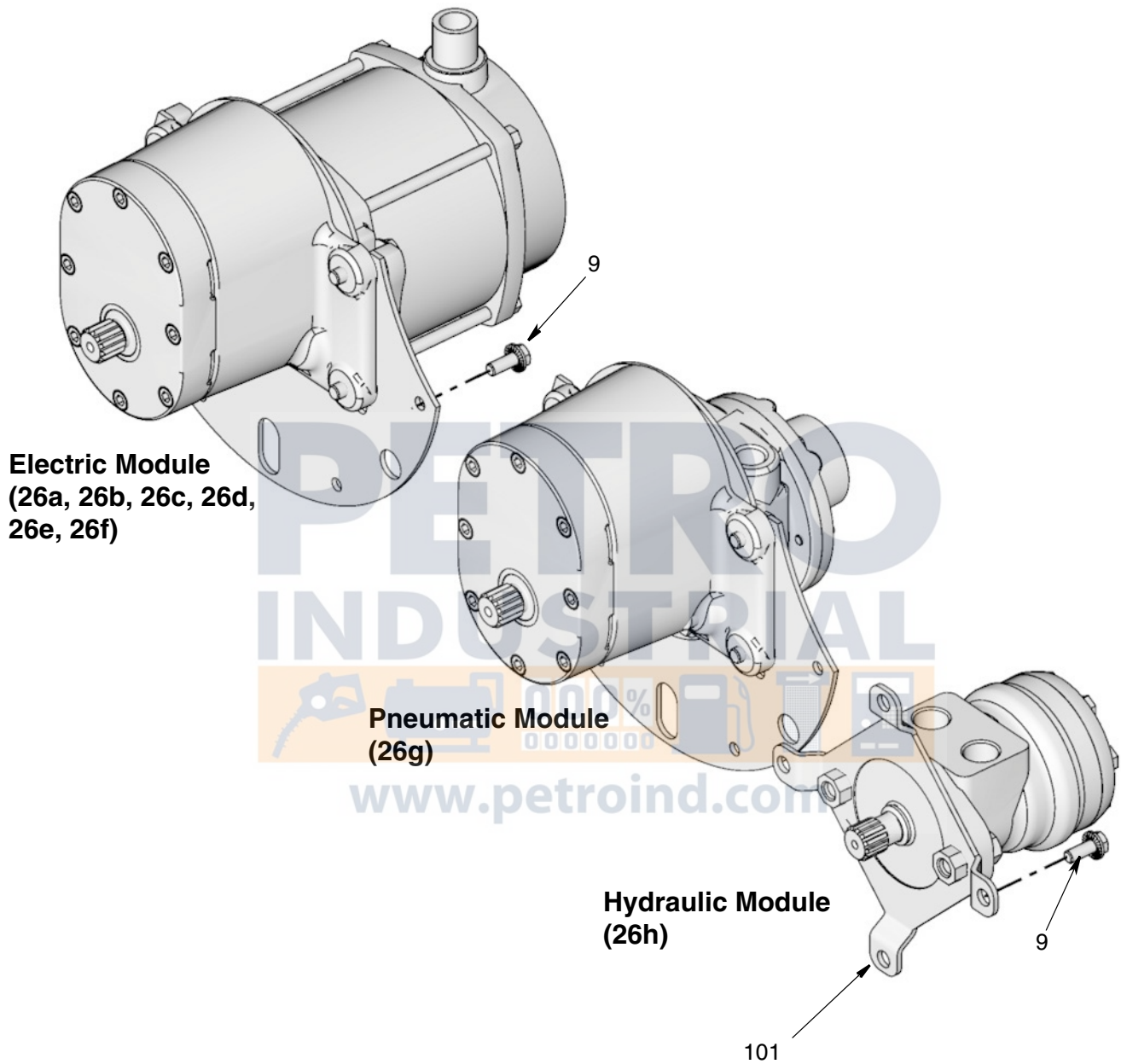

Technical Data

XD 60, XD 70, XD 80 Power Rewind Hose Reels		
	US	Metric
Maximum Service Fluid Working Pressure	See Models Table, page 2	
Operating Temperature		
Motor-less Reels	-40°F to 180°F	-40°C to 82°C
Air / Water Applications	-40°F to 180°F	-40°C to 82°C
Waste Oil Evacuation Applications	-40°F to 180°F	-40°C to 82°C
Oil Applications	-40°F to 180°F	-40°C to 82°C
Grease Applications	0°F to 180°F	-17.8°C to 82°C
Diesel Fuel Applications	-40°F to 140°F	-40°C to 60°C
Inlet/Outlet Sizes		
XD 6010 / 7010 / 8010	1 in. npt(f)	
XD 7015 / 8015	1-1/2 in. npt(f)	
XD 8020	2 in. npt(f)	
Materials of Construction		
Reel wetted materials	nickel plated cast iron, cast iron, Buna-N rubber, polyethylene	
Weight: See Tables, page 50 and 52		
Noise (dBa)		
Electric and Hydraulic Motors Sound Pressure Level†	<80 dBa	
Pneumatic Motors Sound Pressure Level†	84.6 dBa	
Pneumatic Motors Sound Power Level‡	89.9 dBa	
Notes		
† Measured at a distance of 1 meter from measurements taken per ISO 9614-2 @ an assumed retraction/extension rate of 20 spool revolutions per minute.		
‡ Measured per ISO 9614-2 @ an assumed retraction/extension rate of 20 spool revolutions per minute.		

Electric Motors: 12 VDC, 1/2 hp		
	US	Metric
Operating Voltage	12 VDC	
Rating Current	53 Amps	
Rated Speed	650 RPM	
Rated Power	0.5 hp	0.4 kw

Electric Motors: 24 VDC, 1/2 hp		
	US	Metric
Operating Voltage	24 VDC	
Rating Current	26 Amps	
Rated Speed	650 RPM	
Rated Power	0.5 hp	0.4 kw

Electric Motors: 12 VDC, 2/3 hp		
	US	Metric
Operating Voltage	12 VDC	
Rating Current	75 Amps	
Rated Speed	500 RPM	
Rated Power	0.67 hp	0.5 kw

Electric Motors: 24 VDC, 2/3 hp		
	US	Metric
Operating Voltage	24 VDC	
Rating Current	38 Amps	
Rated Speed	500 RPM	
Rated Power	0.67 hp	0.5 kw

Electric Motors: 115 VAC, 2/5 hp		
	US	Metric
Operating Voltage	115 VAC	
Frequency	50/60 Hz	
Rating Current	6.5 Amps	
Rated Speed	500 RPM	
Rated Power	0.4 hp	0.3 kw

Electric Motors: 230 VAC, 1/2 hp		
	US	Metric
Operating Voltage	230 VAC	
Frequency	50/60 Hz	
Rating Current	3.7 Amps	
Rated Speed	650 RPM	
Rated Power	0.5 hp	0.4 kw

Pneumatic Motors		
	US	Metric
Maximum Working Pressure	100 psi	6.7 bar, 0.7 MPa
Inlet/Outlet	1/2 in. npt	
Recommended Flow and Pressure	30 cfm @ 100 psi	0.85 m ³ /minute @ 6.7 bar, 0.7 MPa
Wetted Materials	steel, cast iron, Kevlar [®] , Buna-N rubber	

Pneumatic Control (PN 127271)		
	US	Metric
Maximum Working Pressure	200 psi	13.8 bar, 1.3 MPa
Temperature	0°F to 120°F	-17°C to 49°C
Port Size	3/8 in. npt	
Wetted Materials	designed for compressed air applications	

Hydraulic Motors		
	US	Metric
Maximum working pressure	2000 psi	137.9 bar, 13.8 MPa
Inlet/Outlet	7/8-14 UNF (o-ring boss port)	
Recommended Flow and Pressure	1 gpm @ 2000 psi	3.79 lpm @ 137.9 bar, 13.8 MPa
Wetted materials	steel, cast iron, Buna-N rubber	
Recommended Hydraulic Fluid Filtration	0.4 mil	10 microns

Hydraulic Control (PN 127224, 127225)		
	US	Metric
Maximum Working Pressure	3000 psi	206.8 bar, 20.6 MPa
Regulated Pressure Range	0 to 2000 psi	0 to 137.9 bar, 13.79 MPa
Regulated Flow Rate	0 to 3.5 gpm	0 to 13.25 lpm
Temperature	-40°F to 180°F	-40°C to 82°C
Port Size	SAE-8	
Solenoid Power Consumption	15-20W	
Wetted Materials	anodized aluminum, steel, zinc plated steel, Buna-N rubber, tetrafluoro ethylene, polyester elastomer	

Weights

Motor-less Reels

Model	Description	US (lbs)	Metric			
24T104 24T105 24T106	XD 6010, LP	87	39			
24T107 24T108 24T109				XD 6010, MP	88	39
24T110 24T111 24T112						
24T113 24T114 24T115	XD 7010, MP	87	39			
24T116 24T117 24T118				XD 7015, LP	87	39
24T119 24T120 24T121						
24T122 24T123 24T124	XD 8010, LP	127	57			
24T125 24T126 24T127				XD 8010, MP	129	58
24T128 24T129 24T130						
24T131 24T132 24T133	XD 8020, LP	133	60			

Pneumatic Reels

Model	Description	US (lbs)	Metric			
24R419 24R420 24R421	XD 6010, LP	123	55			
24R434 24R435 24R436				XD 6010, MP	125	56
24R449 24R450 24R451						

Model	Description	US (lbs)	Metric			
24R464 24R465 24R466	XD 7010, MP	124	56			
24R516 24R517 24R518				XD 7015, LP	124	56
24T023 24T024 24T025						
24R531 24R532 24R533	XD 8010, LP	164	74			
24R546 24R547 24R548				XD 8010, MP	165	74
24R561 24R562 24R563						
24R576 24R577 24R578	XD 8020, LP	169	76			

Hydraulic Reels

Model	Description	US (lbs)	Metric			
24R414 24R415 24R416	XD 6010, LP	101	45			
24R431 24R432 24R433				XD 6010, MP	103	46
24R446 24R447 24R448						
24R461 24R462 24R463	XD 7010, MP	102	46			
24R512 24R513 24R514				XD 7015, LP	102	46
24T020 24T021 24T022						
24R528 24R529 24R530	XD 8010, LP	142	64			

Model	Description	US (lbs)	Metric
24R543 24R544 24R545	XD 8010, MP	143	64
24R558 24R559 24R560	XD 8015, LP	143	64
24R573 24R574 24R575	XD 8020, LP	147	66

12V Reels

Model	Description	US (lbs)	Metric
24R404 24R405 24R406	XD 6010, LP	133	60
24R422 24R423 24R424	XD 6010, MP	134	60
24R437 24R538 24R539	XD 7010, LP	132	59
24R452 24R453 24R454	XD 7010, MP	133	60
24R503 24R504 24R505	XD 7015, LP	133	60
24T011 24T012 24T013	XD 7020, LP	137	62
24R519 24R520 24R521	XD 8010, LP	173	78
24R534 24R535 24R536	XD 8010, MP	175	79
24R549 24R550 24R551	XD 8015, LP	175	79
24R564 24R565 24R566	XD 8020, LP	179	81

24V Reels

Model	Description	US (lbs)	Metric
24R407 24R408 24R409	XD 6010, LP	133	60.3
24R425 24R426 24R427	XD 6010, MP	134	60
24R440 24R441 24R442	XD 7010, LP	132	59
24R455 24R456 24R457	XD 7010, MP	133	60
24R506 24R507 24R508	XD 7015, LP	133	60
24T014 24T015 24T016	XD 7020, LP	137	62
24R522 24R523 24R524	XD 8010, LP	173	78
24R537 24R538 24R539	XD 8010, MP	175	79
24R552 24R553 24R554	XD 8015, LP	175	79
24R567 24R568 24R569	XD 8020, LP	179	81

115AC Reels

Model	Description	US (lbs)	Metric
24R410 24R411 24R412	XD 6010, LP	133	60
24R428 24R429 24R430	XD 6010, MP	134	60
24R443 24R444 24R445	XD 7010, LP	132	59
24R458 24R459 24R460	XD 7010, MP	133	60

Model	Description	US (lbs)	Metric
24R509 24R510 24R511	XD 7015, LP	133	60
24T017 24T018 24T019	XD 7020, LP	137	62
24R525 24R526 24R527	XD 8010, LP	173	78
24R540 24R541 24R542	XD 8010, MP	175	79
24R555 24R556 24R557	XD 8015, LP	175	79
24R570 24R571 24R572	XD 8020, LP	179	81

Model	Description	US (lbs)	Metric (kg)
24T233 24T234 24T235	XD 8015, LP	175	79
24T236 24T237 24T238	XD 8020, LP	179	81

230AC Reels

Model	Description	US (lbs)	Metric (kg)
24T207 24T208 24T209	XD 6010, LP	133	60
24T210 24T211 24T212	XD 6010, MP	134	60
24T213 24T214 24T215	XD 7010, LP	132	59
24T218 24T219 24T220	XD 7010, MP	133	60
24T221 24T222 24T223	XD 7015, LP	133	60
24T224 24T225 24T226	XD 7020, LP	137	62
24T227 24T228 24T229	XD 8010, LP	173	78
24T230 24T231 24T232	XD 8010, MP	175	79

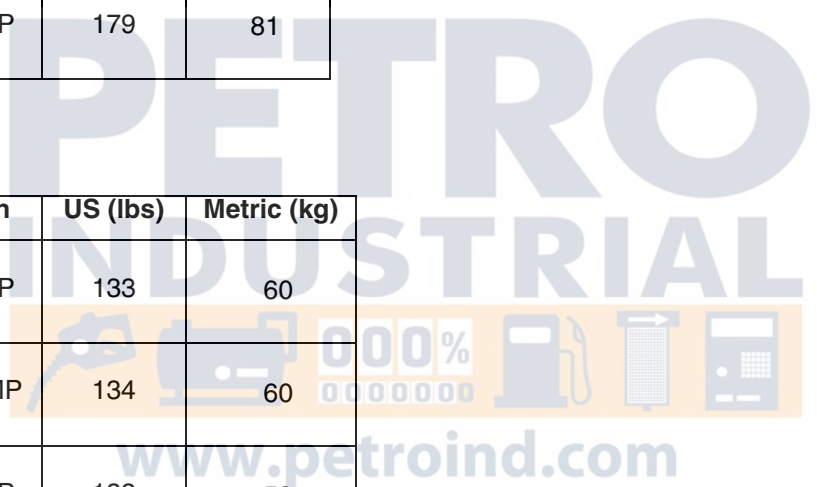

Dimensions (inches):

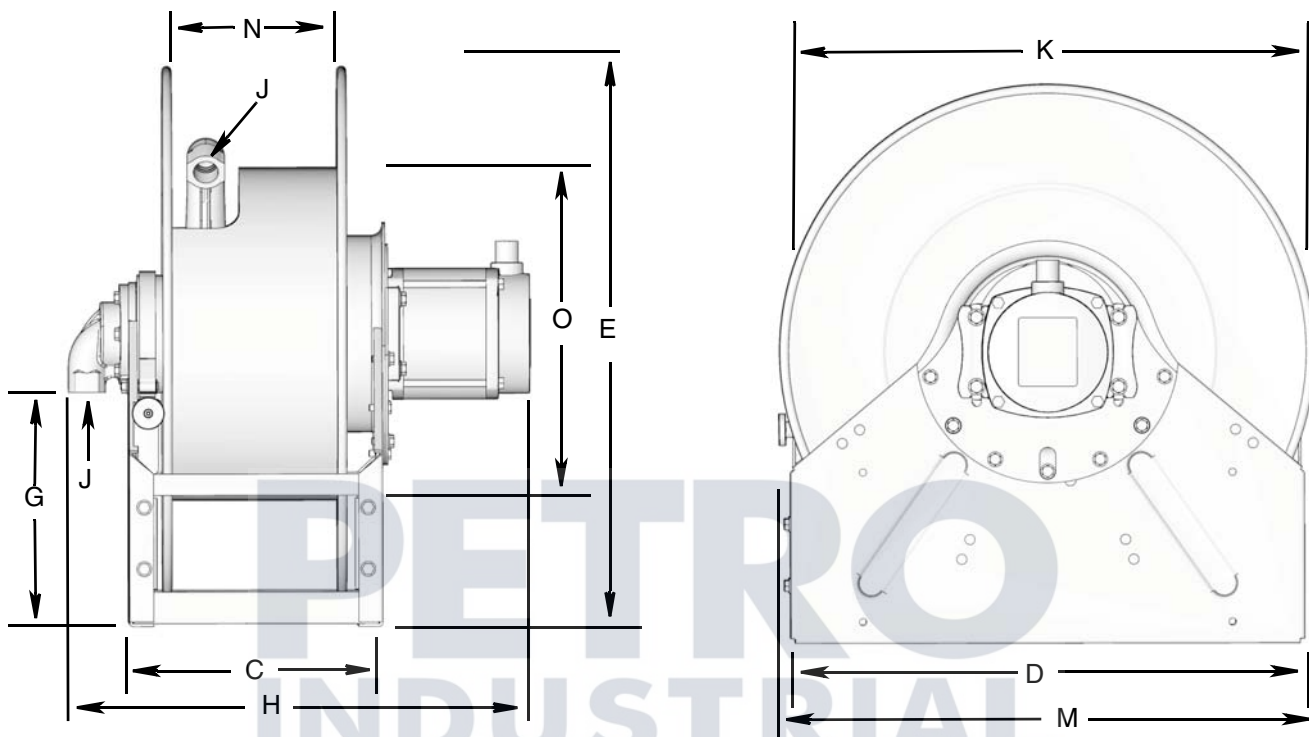

XD Model	*	A \diamond	B1 \diamond	B2 \diamond	C	D	E	F	G	H	J NPT	K	M	N	O	P \diamond
6010	P	10.45	22.25	na	11.8	24.0	26.1	2.8	10.9	20.4	1.0	25.0	26.0	7.8	15.5	0.437
6010	H	10.45	22.25	na	11.8	24.0	26.1	2.8	10.9	15.7	1.0	25.0	26.0	7.8	15.5	0.437
6010	E	10.45	22.25	na	11.8	24.0	26.1	2.8	10.9	21.6	1.0	25.0	26.0	7.8	15.5	0.437
7010	P	12.95	22.25	na	14.3	24.0	26.1	2.8	10.9	22.9	1.0	25.0	26.0	10.0	10.0	0.437
7010	H	12.95	22.25	na	14.3	24.0	26.1	2.8	10.9	18.2	1.0	25.0	26.0	10.0	10.0	0.437
7010	E	12.95	22.25	na	14.3	24.0	26.1	2.8	10.9	24.1	1.0	25.0	26.0	10.0	10.0	0.437
7015	P	12.95	22.25	na	14.3	24.0	26.1	3.6	10.9	23.7	1.5	25.0	26.0	10.0	10.0	0.437
7015	H	12.95	22.25	na	14.3	24.0	26.1	3.6	10.9	19.0	1.5	25.0	26.0	10.0	10.0	0.437
7015	E	12.95	22.25	na	14.3	24.0	26.1	3.6	10.9	24.8	1.5	25.0	26.0	10.0	10.0	0.437
7020	P	12.95	22.25	na	14.3	24.0	26.1	4.0	10.2	24.1	2.0	25.0	26.0	10.0	10.0	0.437
7020	H	12.95	22.25	na	14.3	24.0	26.1	4.0	10.2	19.4	2.0	25.0	26.0	10.0	10.0	0.437
7020	E	12.95	22.25	na	14.3	24.0	26.1	4.0	10.2	25.2	2.0	25.0	26.0	10.0	10.0	0.437
8010	P	20.68	22.25	26.73	22.1	28.5	30.1	2.8	13.4	30.7	1.0	28.0	30.4	18.0	15.5	0.437
8010	H	20.68	22.25	26.73	22.1	28.5	30.1	2.8	13.4	26.0	1.0	28.0	30.4	18.0	15.5	0.437
8010	E	20.68	22.25	26.73	22.1	28.5	30.1	2.8	13.4	31.8	1.0	28.0	30.4	18.0	15.5	0.437
8015	P	20.68	22.25	26.73	22.1	28.5	30.1	3.6	13.4	31.4	1.5	28.0	30.4	18.0	15.5	0.437
8015	H	20.68	22.25	26.73	22.1	28.5	30.1	3.6	13.4	26.7	1.5	28.0	30.4	18.0	15.5	0.437
8015	E	20.68	22.25	26.73	22.1	28.5	30.1	3.6	13.4	32.5	1.5	28.0	30.4	18.0	15.5	0.437
8020	P	20.68	22.25	26.73	22.1	28.5	30.1	4.0	12.7	31.9	2.0	28.0	30.4	18.0	15.5	0.437
8020	H	20.68	22.25	26.73	22.1	28.5	30.1	4.0	12.7	27.1	2.0	28.0	30.4	18.0	15.5	0.437
8020	E	20.68	22.25	26.73	22.1	28.5	30.1	4.0	12.7	33.0	2.0	28.0	30.4	18.0	15.5	0.437

* Power Source: P = Pneumatic; H = Hydraulic; E = Electric

\diamond See Mounting Hole Pattern, page 55

Dimensions (mm):

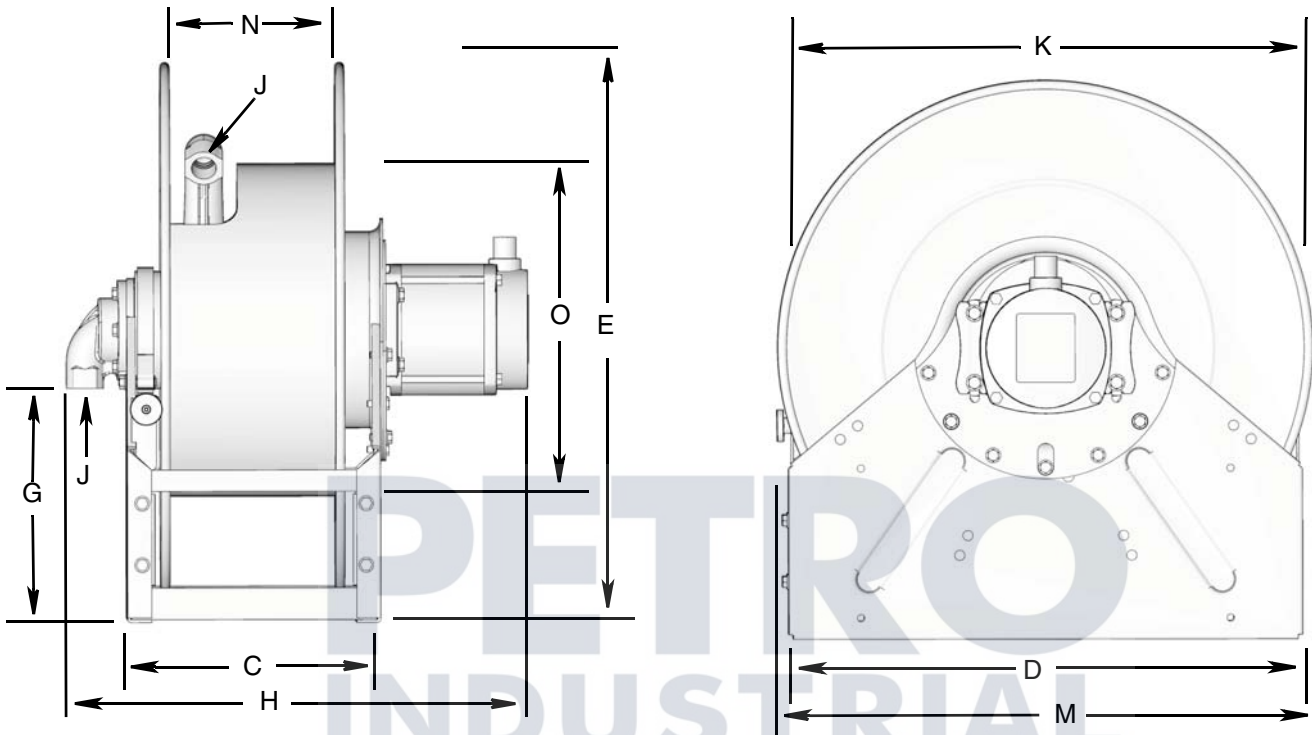

XD Model	*	A❖	B1❖	B2❖	C	D	E	F	G	H	J NPT	K	M	N	O	P❖
6010	P	265	565	na	300	610	663	71	277	519	1.0	635	660	198	394	11
6010	H	265	565	na	300	610	663	71	277	400	1.0	635	660	198	394	11
6010	E	265	565	na	300	610	663	71	277	547	1.0	635	660	198	394	11
7010	P	329	565	na	363	610	663	71	277	583	1.0	635	660	254	254	11
7010	H	329	565	na	363	610	663	71	277	463	1.0	635	660	254	254	11
7010	E	329	565	na	363	610	663	71	277	611	1.0	635	660	254	254	11
7015	P	329	565	na	363	610	663	91	277	603	1.5	635	660	254	254	11
7015	H	329	565	na	363	610	663	91	277	483	1.5	635	660	254	254	11
7015	E	329	565	na	363	610	663	91	277	631	1.5	635	660	254	254	11
7020	P	329	565	na	363	610	663	102	259	613	2.0	635	660	254	254	11
7020	H	329	565	na	363	610	663	102	259	493	2.0	635	660	254	254	11
7020	E	329	565	na	363	610	663	102	259	641	2.0	635	660	254	254	11
8010	P	525	565	679	561	724	765	71	340	779	1.0	711	772	457	394	11
8010	H	525	565	679	561	724	765	71	340	659	1.0	711	772	457	394	11
8010	E	329	565	679	561	724	765	71	340	807	1.0	711	772	457	394	11
8015	P	329	565	679	561	724	765	91	340	799	1.5	711	772	457	394	11
8015	H	329	565	679	561	724	765	91	340	679	1.5	711	772	457	394	11
8015	E	329	565	679	561	724	765	91	340	827	1.5	711	772	457	394	11
8020	P	329	565	679	561	724	765	102	323	809	2.0	711	772	457	394	11
8020	H	329	565	679	561	724	765	102	323	689	2.0	711	772	457	394	11
8020	E	329	565	679	561	724	765	102	323	837	2.0	711	772	457	394	11

* Power Source: P = Pneumatic; H = Hydraulic; E = Electric

❖ See Mounting Hole Pattern, page 55

Mounting Hole Pattern

XD60 / XD 70 Reels

XD 80 Reels

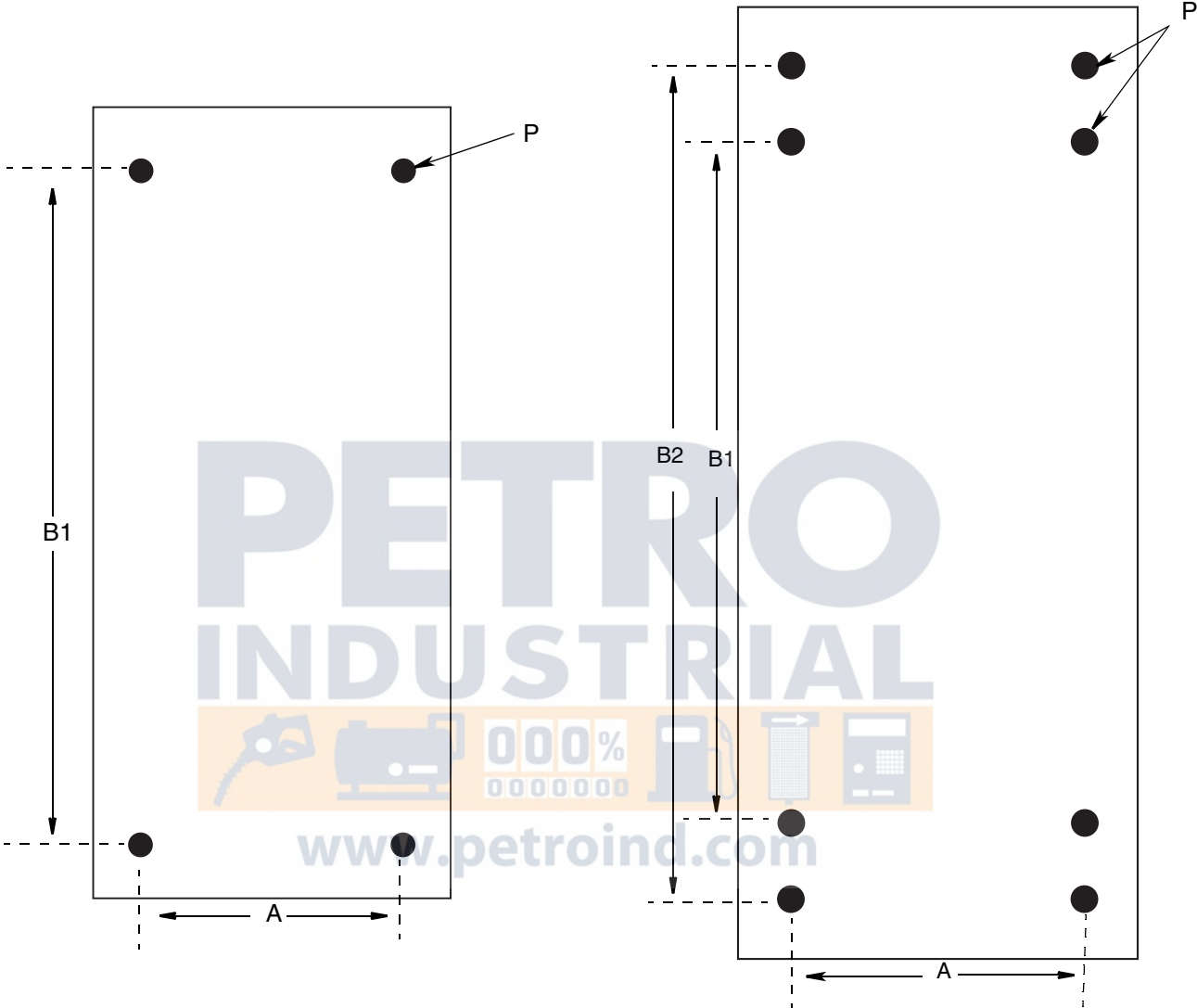

Graco XD 60 / XD 70 / XD 80 Hose Reel Warranty

Graco warrants all equipment referenced in this document which is manufactured by Graco and bearing its name to be free from defects in material and workmanship on the date of sale to the original purchaser for use. With the exception of any special, extended or limited warranty published by Graco, Graco will, for a period as defined in the table below from the date of sale, repair or replace equipment covered by this warranty and determined by Graco to be defective. This warranty applies only when the equipment is installed, operated and maintained in accordance with Graco's written recommendations.

Component	Warranty Period
Wear parts, including but not limited to: hose, swivel seals, roller guide, bearings, latch, gear drive, motors	12 months
Hose reel frame: welded base and spool only	84 months

This warranty does not cover, and Graco shall not be liable for general wear and tear, or any malfunction, damage or wear caused by faulty installation, misapplication, abrasion, corrosion, inadequate or improper maintenance, negligence, accident, tampering, or substitution of non-Graco component parts. Nor shall Graco be liable for malfunction, damage or wear caused by the incompatibility of Graco equipment with structures, accessories, equipment or materials not supplied by Graco, or the improper design, manufacture, installation, operation or maintenance of structures, accessories, equipment or materials not supplied by Graco.

This warranty is conditioned upon the prepaid return of the equipment claimed to be defective to an authorized Graco distributor for verification of the claimed defect. If the claimed defect is verified, Graco will repair or replace free of charge any defective parts. The equipment will be returned to the original purchaser transportation prepaid. If inspection of the equipment does not disclose any defect in material or workmanship, repairs will be made at a reasonable charge, which charges may include the costs of parts, labor, and transportation.

THIS WARRANTY IS EXCLUSIVE, AND IS IN LIEU OF ANY OTHER WARRANTIES, EXPRESS OR IMPLIED, INCLUDING BUT NOT LIMITED TO WARRANTY OF MERCHANTABILITY OR WARRANTY OF FITNESS FOR A PARTICULAR PURPOSE.

Graco's sole obligation and buyer's sole remedy for any breach of warranty shall be as set forth above. The buyer agrees that no other remedy (including, but not limited to, incidental or consequential damages for lost profits, lost sales, injury to person or property, or any other incidental or consequential loss) shall be available. Any action for breach of warranty must be brought within 48 months of the date of sale, or 24 months for all other parts.

GRACO MAKES NO WARRANTY, AND DISCLAIMS ALL IMPLIED WARRANTIES OF MERCHANTABILITY AND FITNESS FOR A PARTICULAR PURPOSE, IN CONNECTION WITH ACCESSORIES, EQUIPMENT, MATERIALS OR COMPONENTS SOLD BUT NOT MANUFACTURED BY GRACO. These items sold, but not manufactured by Graco (such as electric motors, switches, hose, etc.), are subject to the warranty, if any, of their manufacturer. Graco will provide purchaser with reasonable assistance in making any claim for breach of these warranties.

In no event will Graco be liable for indirect, incidental, special or consequential damages resulting from Graco supplying equipment hereunder, or the furnishing, performance, or use of any products or other goods sold hereto, whether due to a breach of contract, breach of warranty, the negligence of Graco, or otherwise.

FOR GRACO CANADA CUSTOMERS

The Parties acknowledge that they have required that the present document, as well as all documents, notices and legal proceedings entered into, given or instituted pursuant hereto or relating directly or indirectly hereto, be drawn up in English.

Graco Information

For the latest information about Graco products, visit www.graco.com.

TO PLACE AN ORDER, contact your Graco distributor or call to identify the nearest distributor.

Phone: 612-623-6928 **or Toll Free:** 1-800-533-9655, **Fax:** 612-378-3590

*All written and visual data contained in this document reflects the latest product information available at the time of publication.
Graco reserves the right to make changes at any time without notice.*

For patent information, see www.graco.com/patents.

Original instructions. This manual contains English. MM 332630

Graco Headquarters: Minneapolis
International Offices: Belgium, China, Japan, Korea

GRACO INC. AND SUBSIDIARIES • P.O. BOX 1441 • MINNEAPOLIS MN 55440-1441 • USA

Copyright 2013, Graco Inc. All Graco manufacturing locations are registered to ISO 9001.

www.graco.com
revised September 2013