

HP Color LaserJet 3000/3600/ 3800/CP3505 Series Printer

Service Manual

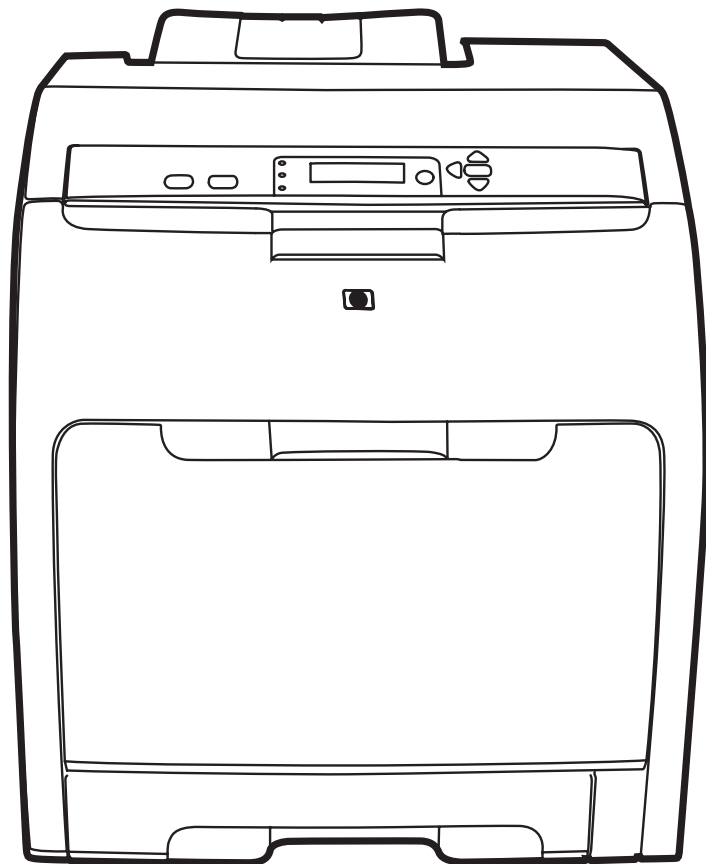

HP Color LaserJet 3000/3600/3800/CP3505
Series Printer
Service Manual



Copyright and license

© 2007 Copyright Hewlett-Packard Development Company, L.P.

Reproduction, adaptation, or translation without prior written permission is prohibited, except as allowed under the copyright laws.

The information contained herein is subject to change without notice.

The only warranties for HP products and services are set forth in the express warranty statements accompanying such products and services. Nothing herein should be construed as constituting an additional warranty. HP shall not be liable for technical or editorial errors or omissions contained herein.

Edition 1, 12/2007

Part number Q5982-91038

Trademark credits

Microsoft® and Windows® are U.S. registered trademarks of Microsoft Corporation.

Linux is a U.S. registered trademark of Linus Torvalds.

PostScript® is a trademarks of Adobe Systems Incorporated.

UNIX® is a registered trademark of The Open Group.

Energy Star® and the Energy Star® logo are U.S. registered marks of the United States Environmental Protection Agency.



Table of contents

1 Product information

| | |
|--|----|
| Quick access to printer information | 2 |
| Printers at a glance | 3 |
| HP Color LaserJet 3000 Series printer | 3 |
| HP Color LaserJet 3600 Series printer | 4 |
| HP Color LaserJet 3800 Series printer | 4 |
| HP Color LaserJet CP3505 Series printer | 5 |
| Features at a glance | 6 |
| Walkaround | 8 |
| Control-panel overview | 10 |
| Control-panel indicator lights | 11 |
| Display | 11 |
| Printer software | 13 |
| HP Color LaserJet 3000 Series printer, HP Color LaserJet 3800 Series printer, and HP Color LaserJet CP3505 Series printer drivers | 13 |
| HP Color LaserJet 3600 Series printer drivers | 14 |
| Additional drivers | 14 |
| Software for networks | 14 |
| HP Web Jetadmin | 15 |
| UNIX | 15 |
| Linux | 15 |
| Utilities | 15 |
| HP Easy Printer Care Software | 15 |
| Embedded Web server | 15 |
| Other components and utilities | 16 |
| Print-media specifications | 17 |
| Supported paper and print media sizes | 17 |
| Media type and tray loading | 18 |

2 Installation and configuration

| | |
|---|----|
| What is in the box | 22 |
| Site requirements | 23 |
| Physical specifications | 23 |
| Connecting to a network or a computer | 24 |

| | |
|------------------------------------|----|
| Printer memory | 26 |
| Installing memory DIMMs | 26 |
| To install memory DIMMs | 26 |
| Enabling memory | 29 |
| To enable memory for Windows | 29 |
| Checking DIMM installation | 29 |
| To check DIMM installation | 29 |

3 Maintenance

| | |
|---|----|
| Understanding approximate supplies-replacement intervals | 32 |
| Replacing supplies | 33 |
| Locating supplies | 33 |
| Supply replacement guidelines | 33 |
| Managing the print cartridge | 34 |
| HP print cartridges | 34 |
| Non-HP print cartridges | 34 |
| Print-cartridge authentication | 34 |
| Print-cartridge storage | 34 |
| Print-cartridge life expectancy | 34 |
| Checking the supply level | 34 |
| Using the control panel | 35 |
| Using the embedded Web server | 35 |
| Using HP Web Jetadmin | 35 |
| Replacing print cartridges | 35 |
| To replace the print cartridge | 36 |
| Cleaning the printer | 38 |
| Cleaning spilled toner | 38 |
| Vacuum specifications | 38 |
| Calibrating the printer | 39 |
| Tools for troubleshooting | 40 |
| Using printer information pages | 40 |
| Configuring e-mail alerts | 41 |
| Using the embedded Web server | 41 |
| To open the embedded Web server by using a network connection | 42 |
| Embedded Web server sections | 42 |
| Using the HP Easy Printer Care Software | 44 |
| Supported operating systems | 44 |
| To use the HP Easy Printer Care Software | 44 |
| HP Easy Printer Care Software sections | 44 |
| Using the HP Printer Utility for Macintosh | 45 |
| To open the HP Printer Utility in Mac OS X V10.2 | 45 |
| To open the HP Printer Utility in Mac OS X V10.3 | 46 |
| HP Printer Utility features | 46 |

4 Theory of operation

| | |
|---|----|
| Engine control system | 48 |
| Power-on sequence | 49 |
| Motors, fans, and solenoids | 50 |
| Laser/scanner system | 52 |
| Pickup-and-feed-system | 53 |
| Sensors in the pickup-and-feed system trays (cassettes) | 54 |
| Cassette pickup mechanism | 55 |
| Multipurpose-tray pickup mechanism | 56 |
| Feed-speed control | 56 |
| Sensor jam detection | 58 |
| Image-formation system | 61 |
| Image-formation process | 62 |
| Latent-image formation stage | 63 |
| Step 1: pre-exposure | 64 |
| Step 2: primary charging | 64 |
| Step 3: laser-beam exposure | 64 |
| Developing stage | 64 |
| Step 4: developing | 64 |
| Transfer stage | 65 |
| Step 5: media feed | 65 |
| Step 6: image transfer | 65 |
| Step 7: separation from the drum | 66 |
| Step 8: separation from the ETB | 66 |
| Fusing stage | 66 |
| Step 9: fusing | 66 |
| Cleaning stage | 67 |
| Step 10: drum cleaning | 67 |
| Print cartridge | 67 |
| Print-cartridge activation | 68 |

5 Removal and replacement

| | |
|--|----|
| Removal and replacement strategy | 70 |
| Introduction | 70 |
| Required tools | 71 |
| Types of screws | 72 |
| Service approach | 73 |
| Before performing service | 73 |
| After performing service | 73 |
| Print cartridges | 74 |
| External doors, covers, and panels | 75 |
| Front cover | 75 |
| Upper cover (fuser door) | 80 |

| | |
|--|-----|
| Rear lower cover | 83 |
| Left cover | 84 |
| Right cover | 87 |
| Rear upper cover | 91 |
| Internal assemblies | 92 |
| Formatter cage | 92 |
| Electrostatic transfer belt (ETB) | 94 |
| Fuser | 95 |
| Duplex fan | 96 |
| Print-cartridge drive motors | 99 |
| Duplex-reverse-drive assembly | 100 |
| Duplex-feed-drive assembly | 103 |
| Fuser drive assembly | 105 |
| Developing separation-drive assembly | 108 |
| Pickup-and-feed assembly | 111 |
| Pickup-drive assembly | 117 |
| Laser/scanner assembly | 126 |
| Main fan | 130 |
| Printed circuit assemblies (PCAs) | 132 |
| Low-voltage power-supply PCA | 132 |
| DC controller PCA | 136 |
| High-voltage power supply | 138 |
| Memory-controller PCA | 140 |
| Driver PCA | 142 |
| Control panel | 144 |
| Pickup-and-feed driver PCA | 146 |
| Duplex-driver PCA | 148 |
| Sensors | 150 |
| Cassette media sensor (HP LaserJet 3600/3800/CP3505) | 150 |
| Temperature sensor | 152 |
| Paper and registration sensor covers | 153 |
| Cartridge-sensor PCA | 154 |
| 500-sheet feeder | 157 |
| 500-sheet feeder right cover | 157 |
| 500-sheet feeder left cover | 159 |
| 500-sheet feeder rear cover | 162 |
| 500-sheet feeder driver PCA | 164 |
| Media sensor (500-sheet feeder) | 166 |
| 6 Troubleshooting | |
| Troubleshooting process | 170 |
| Pre-troubleshooting checklist | 170 |
| Troubleshooting flowchart | 172 |

| | |
|--|-----|
| Power-on checks | 172 |
| Control-panel messages | 174 |
| Jams | 198 |
| Jam recovery | 198 |
| Avoiding jams | 199 |
| Clearing jams | 199 |
| Image-formation troubleshooting | 210 |
| Print-quality problems associated with media | 210 |
| Defects on overhead transparencies | 211 |
| Print-quality problems that are related to the environment | 211 |
| Print-quality problems that are related to jams | 212 |
| Print-quality problems from toner buildup | 212 |
| Print-quality troubleshooting pages | 212 |
| Image defects | 213 |
| Light image | 214 |
| Light color | 214 |
| Dark image | 215 |
| Dark color | 215 |
| Completely blank image | 216 |
| All black or solid color | 216 |
| Dots in vertical lines | 216 |
| Dirt on back of paper | 217 |
| Dirt on front of paper | 217 |
| Vertical lines | 217 |
| White vertical lines | 218 |
| Horizontal line | 218 |
| White horizontal line | 218 |
| Color missing | 219 |
| Blank spots | 219 |
| Poor fusing | 219 |
| Image distortion | 220 |
| Color misregistration | 220 |
| Smearing | 221 |
| Misplaced image | 221 |
| Reversed color | 221 |
| Snail tracks | 222 |
| Repetitive-defects troubleshooting | 223 |
| Interface troubleshooting | 225 |
| Communication checks | 225 |
| EIO troubleshooting | 225 |
| Service menu | 226 |
| Using the Service menu | 226 |
| Clear event log | 226 |
| Total page count | 226 |

| | |
|---|-----|
| Serial number | 226 |
| Diagnostics menu | 227 |
| Diagnostics | 228 |
| LED diagnostics | 228 |
| Diagnostics mode | 228 |
| Diagnostics that put the engine into the special diagnostics mode | 229 |
| Diagnostic tests | 229 |
| Individual diagnostic tests | 230 |
| Print the event log page | 230 |
| View the event log on the control-panel display | 230 |
| Print the print-quality (PQ) troubleshooting pages | 231 |
| Disable cartridge check (special mode test) | 231 |
| Paper-path sensor test | 231 |
| Paper-path test | 231 |
| Manual sensor test (special mode test) | 232 |
| Component test (special mode test) | 233 |
| Print/Stop test | 235 |
| Test pages | 236 |
| Engine test page | 236 |
| Formatter test | 236 |
| Half-self test | 236 |
| Drum-rotation test | 237 |
| Engine resets | 238 |
| Engine resets | 238 |
| Cold reset | 238 |
| NVRAM initialization | 238 |
| Hard-disk initialization | 239 |
| Service ID | 240 |
| Converting the Service ID to an actual date | 240 |
| Restoring the Service ID | 240 |
| Troubleshooting diagrams | 241 |
| Connector locations | 241 |
| Major assemblies | 243 |
| DC controller connectors | 248 |
| Timing diagram | 249 |
| Circuit diagrams | 251 |

7 Parts and diagrams

| | |
|---|-----|
| Ordering parts and supplies | 254 |
| Parts | 254 |
| How to use the parts lists and diagrams | 254 |
| Types of screws | 254 |
| Related documentation and software | 255 |

| | |
|--|-----|
| Accessories and supplies | 255 |
| External panels and covers | 260 |
| Internal components | 268 |
| Paper-pickup drive assembly | 278 |
| Duplexing-feed drive assembly (duplex models) | 280 |
| Duplexing reverse-drive assembly (duplex models) | 282 |
| Developing separation-drive assembly | 284 |
| Fuser drive assembly | 286 |
| Cassette (tray 2) | 288 |
| Paper-pickup assembly (HP CLJ 3600/3800/CP3505) | 290 |
| Paper-pickup assembly (HP CLJ 3000) | 292 |
| Electronic transfer belt (simplex models) | 294 |
| Electronic transfer belt (duplex models) | 296 |
| Multipurpose tray assembly (tray 1) | 298 |
| Duplex-paper feed assembly (duplex models) | 300 |
| Fuser | 302 |
| PCAs | 304 |
| 500-sheet feeder cassette (tray 3) | 306 |
| 500-sheet feeder paper-pickup assembly | 308 |
| 500-sheet feeder PCA | 310 |
| Alphabetical parts list | 312 |
| Numerical parts list | 322 |

Appendix A Printer specifications

| | |
|--|-----|
| Electrical specifications | 334 |
| Power-consumption specifications | 335 |
| Acoustic specifications | 336 |
| Operating-environment specifications | 337 |

Appendix B Product warranty statements

| | |
|--|-----|
| Hewlett-Packard Limited Warranty Statement | 340 |
| Availability of support and service | 341 |
| HP maintenance agreements | 341 |
| Next-Day Onsite Service | 341 |

Appendix C Regulatory statements

| | |
|---|-----|
| FCC regulations | 344 |
| Declaration of conformity (HP Color LaserJet 3000 Series printer) | 345 |
| Declaration of conformity (HP Color LaserJet 3600 Series and HP Color LaserJet 3800 Series printer) | 346 |
| Declaration of conformity (HP Color LaserJet CP3505 Series printer) | 347 |
| Safety statements | 348 |
| Laser safety | 348 |

| | |
|------------------------------------|-----|
| Canadian DOC regulations | 348 |
| EMI statement (Korea) | 348 |
| VCCI statement (Japan) | 348 |
| Power cord statement (Japan) | 348 |
| Laser statement for Finland | 349 |

| | |
|--------------------|------------|
| Index | 351 |
|--------------------|------------|

1 Product information

- [Quick access to printer information](#)
- [Printers at a glance](#)
- [Features at a glance](#)
- [Walkaround](#)
- [Control-panel overview](#)
- [Printer software](#)
- [Print-media specifications](#)

Quick access to printer information

Several references are available for use with this printer.

- **HP Color LaserJet 3000 Series printer:** <http://www.hp.com/support/clj3000>.
- **HP Color LaserJet 3600 Series printer:** <http://www.hp.com/support/clj3600>.
- **HP Color LaserJet 3800 Series printer:** <http://www.hp.com/support/clj3800>.
- **HP Color LaserJet CP3505 Series printer:** <http://www.hp.com/support/cljcp3505>.

Table 1-1 Printer guides





| Guide | Description |
|--|--|
| Getting started guide | Provides step-by-step instructions for installing and setting up the printer. |
| HP Jetdirect Embedded Print Server Administrators Guide | Provides instructions to configure and troubleshoot the HP Jetdirect print server. |
| Accessory and consumable installation guides | Provide step-by-step instructions for installing the accessories and supplies. These guides are supplied with the optional printer accessories and supplies. |
| User guide | Provides detailed information for using and troubleshooting the printer. Available on the printer CD. |
| Online Help | Provides information about options that are available in the printer drivers. To view a Help file, open the online Help through the printer driver. |

Printers at a glance

The HP Color LaserJet 3000, 3600, 3800, and CP3505 Series printers are available in the following configurations.



HP Color LaserJet 3000 Series printer

Table 1-2 HP Color LaserJet 3000 Series printer configurations

| HP Color LaserJet 3000 printer | HP Color LaserJet 3000n printer | HP Color LaserJet 3000dn printer | HP Color LaserJet 3000dtn printer |
|--|--|--|---|
|  |  |  |  |
| <ul style="list-style-type: none"> • Prints up to 30 pages per minute (ppm) on letter-size media or 29 ppm on A4-size media in monochrome (black and white) and 15 ppm in color • 100-sheet multipurpose tray (tray 1) and 250-sheet input tray (tray 2) • Hi-Speed universal serial bus (USB) 2.0 port and enhanced input/output (EIO) slot • 64 MB RAM | <p>The features of the HP Color LaserJet 3000 printer, plus:</p> <ul style="list-style-type: none"> • 64 MB RAM (128 total) • HP Jetdirect full-featured embedded print server to connect to 10Base-T/100 Base-TX networks | <p>The features of the HP Color LaserJet 3000 printer, plus:</p> <ul style="list-style-type: none"> • 192 MB RAM (256 total) • HP Jetdirect full-featured embedded print server to connect to 10Base-T/100 Base-TX networks • Automatic 2-sided (duplex) printing | <p>The features of the HP Color LaserJet 3000 printer, plus:</p> <ul style="list-style-type: none"> • 192 MB RAM (256 total) • HP Jetdirect full-featured embedded print server to connect to 10Base-T/100 Base-TX networks • Automatic 2-sided (duplex) printing • 500-sheet input tray (tray 3) |





HP Color LaserJet 3600 Series printer

Table 1-3 HP Color LaserJet 3600 Series printer configurations

| HP Color LaserJet 3600 printer | HP Color LaserJet 3600n printer | HP Color LaserJet 3600dn printer |
|--|--|---|
|  |  |  |
| <ul style="list-style-type: none"> • 17 ppm print speed • 100-sheet multipurpose tray (tray 1) and 250-sheet input tray (tray 2) • Hi-Speed USB 2.0 port • 64 MB RAM | <p>The features of the HP Color LaserJet 3600 printer, plus:</p> <ul style="list-style-type: none"> • HP Jetdirect value-featured embedded print server to connect to 10Base-T/100Base-TX networks • 64 MB RAM | <p>The features of the HP Color LaserJet 3600 printer, plus:</p> <ul style="list-style-type: none"> • 64 MB RAM (128 total) • Automatic 2-sided (duplex) printing • HP Jetdirect value-featured embedded print server to connect to 10Base-T/100Base-TX networks |

HP Color LaserJet 3800 Series printer





Table 1-4 HP Color LaserJet 3800 Series printer configurations

| HP Color LaserJet 3800 printer | HP Color LaserJet 3800n printer | HP Color LaserJet 3800dn printer | HP Color LaserJet 3800dtn printer |
|--|---|---|--|
|  |  |  |  |
| <ul style="list-style-type: none"> • 22 ppm (letter-size) or 21 ppm (A4) print speed • 100-sheet multipurpose tray (tray 1) and 250-sheet input tray (tray 2) • Hi-Speed USB 2.0 port and EIO slot • 96 MB RAM | <p>The features of the HP Color LaserJet 3800 printer, plus:</p> <ul style="list-style-type: none"> • 64 MB RAM (160 total) • HP Jetdirect full-featured embedded print server to connect to 10Base-T/100Base-TX networks | <p>The features of the HP Color LaserJet 3800 printer, plus:</p> <ul style="list-style-type: none"> • 192 MB RAM (288 total) • Automatic 2-sided (duplex) printing • HP Jetdirect full-featured embedded print server to connect to 10Base-T/100Base-TX networks | <p>The features of the HP Color LaserJet 3800 printer, plus:</p> <ul style="list-style-type: none"> • 192 MB RAM (288 total) • Automatic 2-sided (duplex) printing • HP Jetdirect full-featured embedded print server to connect to 10Base-T/100Base-TX networks • 500-sheet input tray (tray 3) |

HP Color LaserJet CP3505 Series printer

The HP Color LaserJet CP3505 is available in the configurations described below.

Table 1-5 HP Color LaserJet CP3505 configurations

| HP Color LaserJet CP3505 | HP Color LaserJet CP3505n | HP Color LaserJet CP3505dn | HP Color LaserJet CP3505x |
|---|--|---|---|
|  |  |  |  |
| <ul style="list-style-type: none"> ● 22 ppm (letter-size) or 21 ppm (A4) print speed ● 100-sheet multipurpose tray (tray 1) and 250-sheet input tray (tray 2) ● Hi-Speed USB 2.0 port and EIO slot ● 256 megabytes (MB) of random access memory (RAM) | <p>HP Color LaserJet CP3505, plus:</p> <ul style="list-style-type: none"> ● HP Jetdirect full-featured embedded print server to connect to 10Base-T/100Base-TX networks | <p>HP Color LaserJet CP3505, plus:</p> <ul style="list-style-type: none"> ● 384 MB RAM ● Automatic 2-sided (duplex) printing ● HP Jetdirect full-featured embedded print server to connect to 10Base-T/100Base-TX networks | <p>HP Color LaserJet CP3505, plus:</p> <ul style="list-style-type: none"> ● Automatic 2-sided (duplex) printing ● HP Jetdirect full-featured embedded print server to connect to 10Base-T/100Base-TX networks ● 500-sheet input tray (tray 3). |

Features at a glance

Table 1-6 Features

| Feature | HP Color LaserJet 3000 Series printer and HP Color LaserJet 3800 Series printer | HP Color LaserJet 3600 Series printer | HP Color LaserJet CP3505 Series printer |
|------------------------|--|--|---|
| Performance | <ul style="list-style-type: none"> 533 MHz processor | <ul style="list-style-type: none"> 360 MHz processor | <ul style="list-style-type: none"> 450 MHz processor |
| User interface | <ul style="list-style-type: none"> Graphic display Control-panel help HP Easy Printer Care Software (a Windows®- or Macintosh-based status and troubleshooting tool) Windows and Macintosh printer drivers Embedded Web server to gain access to support and to order supplies (administrator tool for network-connected models only) HP formatter | <ul style="list-style-type: none"> Graphic display Control-panel help HP Easy Printer Care Software (a Windows- or Macintosh-based status and troubleshooting tool) Windows and Macintosh printer drivers Embedded Web server to configure network settings only (administrator tool for network-connected models only) Host formatter | <ul style="list-style-type: none"> Graphic display Control-panel help HP Easy Printer Care Software (a Windows- or Macintosh-based status and troubleshooting tool) Windows and Macintosh printer drivers Embedded Web server to gain access to support and to order supplies (administrator tool for network-connected models only) HP formatter |
| Printer drivers | <ul style="list-style-type: none"> HP PCL 5c HP PCL 6 PostScript® 3 emulation | HP JetReady 4.2 | <ul style="list-style-type: none"> HP PCL 5c HP PCL 6 PostScript 3 emulation |
| Job storage | <ul style="list-style-type: none"> Fonts, forms, and other macros Job retention | None | <ul style="list-style-type: none"> Fonts, forms, and other macros Job retention |
| Fonts | <ul style="list-style-type: none"> 80 internal fonts available for both PCL and PostScript 3 emulation 80 printer-matching screen fonts in TrueType format available with the software solution | None | <ul style="list-style-type: none"> 80 internal fonts available for both PCL and PostScript 3 emulation 80 printer-matching screen fonts in TrueType format available with the software solution |
| Expandability | <ul style="list-style-type: none"> Optional 500-sheet input tray (tray 3) (standard on the HP Color LaserJet 3000dtn and HP Color LaserJet 3800dtn printers) Dual inline memory modules (DIMMs) 1 slot open for DDR memory | <ul style="list-style-type: none"> Optional 500-sheet input tray (tray 3) | <ul style="list-style-type: none"> Optional 500-sheet input tray (tray 3) (standard on the CP3505 printers) Dual inline memory modules (DIMMs) 1 slot open for DDR2 memory |

Table 1-6 Features (continued)

| Feature | HP Color LaserJet 3000 Series printer and HP Color LaserJet 3800 Series printer | HP Color LaserJet 3600 Series printer | HP Color LaserJet CP3505 Series printer |
|-------------------------------|--|---|--|
| Connectivity | <ul style="list-style-type: none"> ● Hi-Speed USB 2.0 cable interface ● HP Jetdirect full-featured embedded print server (standard on the HP Color LaserJet 3000n, 3000dn, and 3000dtn printers) ● HP Web Jetadmin software (standard on the HP Color LaserJet 3000n, 3000dn, and 3000dtn printers) ● Enhanced input/output (EIO) slot | <ul style="list-style-type: none"> ● Hi-Speed USB 2.0 cable interface ● HP Jetdirect value-featured embedded print server (standard on the HP Color LaserJet 3600n and 3600dn printers) ● HP Web Jetadmin software (standard on the HP Color LaserJet 3600n and 3600dn printers) | <ul style="list-style-type: none"> ● Hi-Speed USB 2.0 cable interface ● HP Jetdirect full-featured embedded print server (standard on the HP Color LaserJet 3800n, 3800dn, and 3800dtn printers and the HP Color LaserJet CP3505n, CP3505dn, and CP3505x printers) ● HP Web Jetadmin software (standard on the HP Color LaserJet CP3505n, CP3505dn, and CP3505x printers) ● Enhanced input/output (EIO) slot |
| Environmental features | <ul style="list-style-type: none"> ● Sleep-mode setting ● High content of recyclable components and materials ● ENERGY STAR® qualified models; see http://www.hp.com/go/energystar | | |
| Paper handling | <ul style="list-style-type: none"> ● Input <ul style="list-style-type: none"> ○ Tray 1 (multipurpose tray): A multipurpose tray for paper, transparencies, labels, and envelopes. Holds up to 100 sheets of paper or 20 envelopes. ○ Tray 2: 250-sheet tray that automatically detects standard paper sizes up to legal and allows printing on custom-size paper. ○ Tray 3: 500-sheet tray that automatically detect standard paper sizes up to legal and allows printing on custom-size paper. ● Output <ul style="list-style-type: none"> ○ Face-up output bin ○ Face-down output bin | | |
| Supplies | <ul style="list-style-type: none"> ● Supplies status page contains information about toner level, page count, and estimated pages remaining ● No-shake cartridge design ● Printer checks for authentic HP print cartridges at cartridge installation ● Internet-enabled supply-ordering capabilities (using HP Easy Printer Care Software) | | |
| Accessibility | <ul style="list-style-type: none"> ● The online user guide is compatible with text screen-readers. ● Print cartridges can be installed and removed by using one hand. ● All doors and covers can be opened by using one hand. ● Media can be loaded in tray 1 by using one hand. | | |

Walkaround

Figure 1-1 Front view (shown with optional 500-sheet paper feeder)

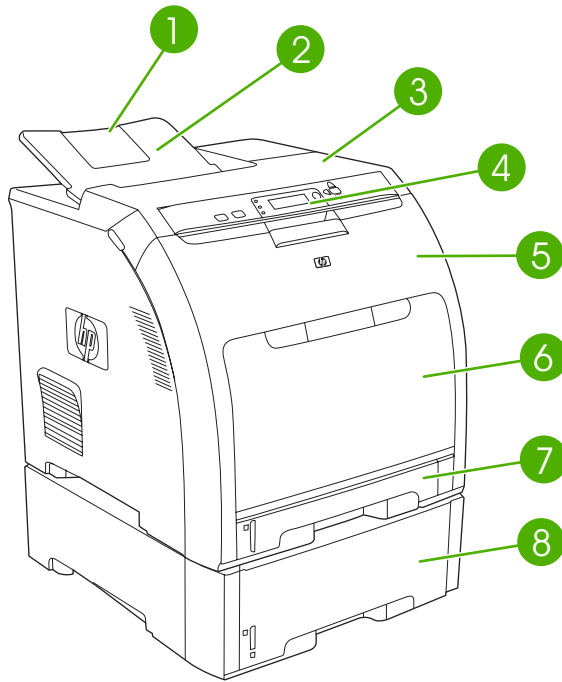

| | |
|---|--|
| 1 | Output bin extender |
| 2 | Output bin |
| 3 | Top cover (This part is called the upper cover in this service manual.) |
| 4 | Printer control panel |
| 5 | Front door (This part is called the front cover in this service manual.) |
| 6 | Tray 1 (holds 100 sheets of standard paper) (This part is called the multipurpose-tray assembly in this service manual.) |
| 7 | Tray 2 cassette (holds 250 sheets of standard paper) |
| 8 | Tray 3 cassette (optional; holds 500 sheets of standard paper) |

Figure 1-2 Back and side view

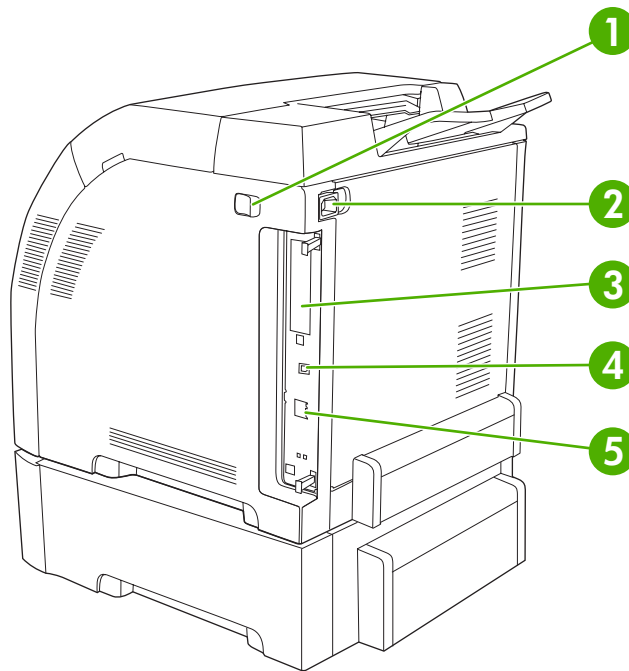

| | |
|----------|--|
| 1 | On/off switch |
| 2 | Power connection |
| 3 | EIO slot (available on the HP Color LaserJet 3000, 3800, and CP3505 Series printers) |
| 4 | Hi-Speed USB 2.0 port |
| 5 | Network port (available on the HP Color LaserJet 3000n, 3000dn, 3000dtn, 3600n, 3600dn, 3800n, 3800dn, 3800dtn, CP3505n, CP3505dn, and CP3505x printers) |

Control-panel overview

The control panel provides controls for printer functions and shows messages about the printer, print jobs, and supplies status.

Figure 1-3 Control panel buttons and lights

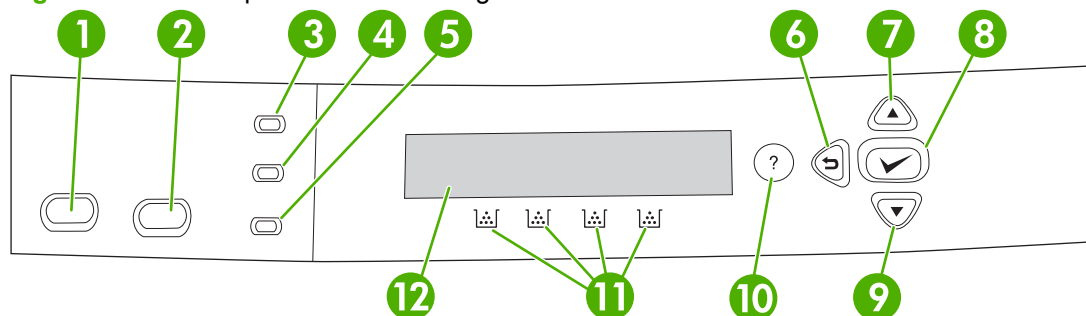

| Number | Button or light | Function |
|--------|-----------------------|--|
| 1 | Stop button | Halts the current job, presents a choice to resume or cancel the current print job, clears media from the printer, and clears any continuable errors that are associated with the halted job. If the printer is not printing a job, pressing Stop pauses the printer. |
| 2 | Menu button | Opens and closes menus. |
| 3 | Ready light | Indicates that the printer is online or offline. See Control-panel indicator lights on page 11 . |
| 4 | Data light | Indicates whether or not the printer is receiving data. See Control-panel indicator lights on page 11 . |
| 5 | Attention light | Indicates that a critical error has occurred. See Control-panel indicator lights on page 11 . |
| 6 | Back arrow (↶) button | Navigates backward in nested menus. |
| 7 | Up arrow (▲) button | Navigates menus and text, and increases the values of numerical items in the display. |
| 8 | Select (✓) button | Makes selections, resumes printing after continuable errors, and overrides a non-HP print cartridge. |
| 9 | Down arrow (▼) button | Navigates menus and text, and decreases the values of numerical items in the display. |
| 10 | Help (?) button | Provides detailed information about printer messages or menus. |
| 11 | Supplies gauge | Shows the print cartridge-consumption levels. See Display on page 11 . |
| 12 | Display | Shows status information, menus, help information, and error messages. See Display on page 11 . |

The printer communicates through the display and the lights on the control panel. The display shows status information, menus, help information, and error messages. The Ready, Data, and Attention lights provide at-a-glance information about the printer state.

You can perform most routine printing tasks from the computer through the printer driver or any software program. Use the control panel to access printer features that the printer driver or software program do not support. Any changes that you make from the computer override the printer control-panel settings. For information about using the printer driver, see [Printer software on page 13](#).

Control-panel indicator lights

| Indicator | On | Off | Flashing |
|----------------------|--|--|---|
| Ready (green) | The printer is online (can accept and process data). | The printer is offline (paused), or is turned off. | The printer is attempting to stop printing and go offline. This usually results from a user's request to pause the current job. |
| Data (green) | The processed data is present in the printer, but more data is needed to complete the job, or the job is paused or waiting for errors to be cleared. | The printer is not processing or receiving data. | The printer is processing and receiving data. |
| Attention (amber) | A critical error has occurred. The printer requires attention. | No conditions exist that require attention. | An error has occurred. The printer requires attention. |

Display

The printer display gives you complete, timely information about the printer and print jobs. Graphics illustrate levels of supplies. Menus provide access to printer functions and detailed information.

The top-level screen on the display has two areas: message/prompt and supplies gauge.

Figure 1-4 Printer display

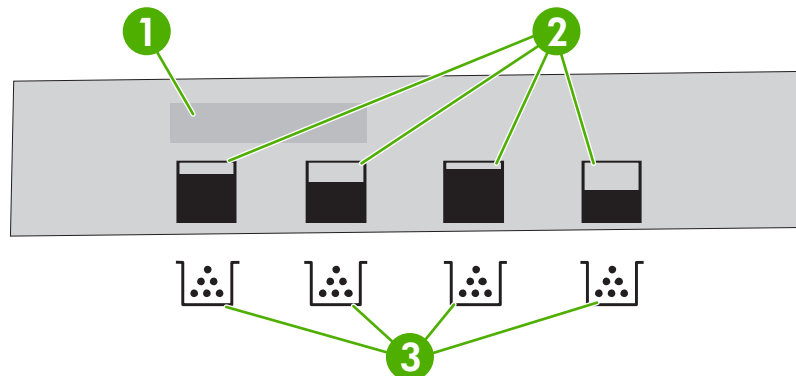

| | |
|---|---|
| 1 | Message/prompt area |
| 2 | Supplies gauge |
| 3 | Print cartridge colors from left to right: black, yellow, cyan, and magenta |

The message and prompt areas of the display alert you to the state of the printer and tell you how to respond.

The supplies gauge shows the consumption levels of print cartridges (black, cyan, magenta, and yellow). When a non-HP print cartridge is installed, a ? might appear instead of the consumption level. The supplies gauge appears whenever the printer shows the **Ready** state, and whenever the printer shows a warning or error message concerning a cartridge.

Printer software

The printing-system software is included with the printer. See the getting started guide for installation instructions.

The printing system includes software for end users and network administrators, and printer drivers for access to the printer features and communication with the computer.

For a list of printer drivers and updated HP printer software, go to the following Web sites:

- HP Color LaserJet 3000 Series printer, go to http://www.hp.com/go/clj3000_software
- HP Color LaserJet 3600 Series printer, go to http://www.hp.com/go/clj3600_software
- HP Color LaserJet 3800 Series printer, go to http://www.hp.com/go/clj3800_software
- HP Color LaserJet CP3505 Series printer, go to http://www.hp.com/go/cljcp3505_software

HP Color LaserJet 3000 Series printer, HP Color LaserJet 3800 Series printer, and HP Color LaserJet CP3505 Series printer drivers

The HP Color LaserJet 3000, 3800, and CP3505 Series printers use the PCL 5c, PCL 6, and PostScript 3 emulation PDL drivers.

 **NOTE:** For Windows 2000, Windows XP, and Windows Server 2003, the HP Color LaserJet 3000 and 3800 Series printers include a monochrome PCL 6 driver that can be installed for users who will be printing only black-and-white print jobs.

Table 1-7 Available printer drivers

| Operating system ¹ | PCL 5c | PCL 6 ² | PS 3 emulation |
|---|--------|--------------------|----------------|
| Windows 98, Windows Me (HP Color LaserJet 3000 and 3800 only) | ✓ | ✓ | ✓ |
| Windows 2000 ³ | ✓ | ✓ | ✓ |
| Windows XP (32-bit) ⁴ | ✓ | ✓ | ✓ |
| Windows Server 2003 (32-bit) | ✓ | ✓ | ✓ |
| Windows Server 2003 (64-bit) | ✓ | ✓ | ✓ |
| Windows Vista (32-bit) | ✓ | ✓ | ✓ |
| Windows Vista (64-bit) | ✓ | ✓ | ✓ |
| Mac OS X V10.2 and later (HP CLJ 3000 and 3800) | | | ✓ |

Table 1-7 Available printer drivers (continued)

| Operating system ¹ | PCL 5c | PCL 6 ² | PS 3 emulation |
|--|--------|--------------------|----------------|
| Mac OS X V10.2.8 and later (HP CLJ CP3505) | | | ✓ |

¹ Not all printer features are available from all drivers or operating systems.

² The HP Color LaserJet 3000 and 3800 Series printers include both a monochrome and color PCL 6 driver for Windows 2000, Windows XP, and Windows Server 2003 users.

³ For Windows 2000 and Windows XP (32-bit and 64-bit), download the PCL 5 driver from http://www.hp.com/go/clj3000_software or http://www.hp.com/go/clj3800_software.

⁴ For Windows XP (64-bit), download the PCL 6 driver from http://www.hp.com/go/clj3000_software or http://www.hp.com/go/clj3800_software.

HP Color LaserJet 3600 Series printer drivers

The HP Color LaserJet 3600 Series printer uses the HP JetReady 4.2 Page Description Language (PDL), a host-based printer language. HP JetReady 4.2 uses the combined power of the computer and the printer to render the printed page in a Windows or Macintosh system environment. HP JetReady 4.2 transfers the prerendered pages from the host computer to the printer and communicates instructions to the printer about how to convert the pages to data that can be printed.

The HP JetReady 4.2 PDL driver is available on the installation CD for the following operating systems:

- Windows 98, Windows Millennium Edition (Me)
- Windows 2000
- Windows XP (32-bit and 64-bit)
- Windows Server 2003 (32-bit and 64-bit)
- Macintosh OS X V10.2 and later

 **NOTE:** Not all printer features are available from all drivers or operating systems.

If your system did not automatically check the Internet for the latest drivers during software installation, download them from http://www.hp.com/go/clj3600_software.

Additional drivers

The following drivers are not included on the CD, but are available from http://www.hp.com/go/clj3000_software or http://www.hp.com/go/clj3800_software. These drivers are for the HP Color LaserJet 3000 and 3800 Series printers only.

- UNIX® model scripts
- Linux drivers
- OS/2 PS and PCL printer driver

 **NOTE:** The OS/2 drivers are available from IBM and are packaged with OS/2. They are not available for Traditional Chinese, Simplified Chinese, Korean, and Japanese languages.

Software for networks

For a summary of available HP network installation and configuration software solutions, see the *HP Jetdirect Print Server Administrators Guide*. You can find this guide on the printer CD.

HP Web Jetadmin

HP Web Jetadmin is a browser-based management tool for HP Jetdirect-connected printers within your intranet, and it should be installed only on the network administrator's computer.

To download a current version of HP Web Jetadmin and for the latest list of supported host systems, visit <http://www.hp.com/go/webjetadmin>.

When HP Web Jetadmin is installed on a host server, any client can gain access to it by using a supported Web browser (such as Microsoft® Internet Explorer 4.x or Netscape Navigator 4.x or later) by navigating to the HP Web Jetadmin host.

UNIX

For HP-UX and Solaris networks, go to http://www.hp.com/support/net_printing to download the HP Jetdirect printer installer for UNIX.

 **NOTE:** The HP Color LaserJet 3600 Series printer does not support UNIX printing. However, if UNIX is running CUPS and has the HPLIP or HPIJS system on it, the CLJ3600 can be used to print. See <http://www.linuxprinting.org> and look up the HP CLJ3600 for additional information.

Linux

For information, go to <http://www.hp.com/go/linuxprinting>.

Utilities

The HP Color LaserJet 3000, 3600, 3800, and CP3505 Series printers are equipped with several utilities that make it easy to monitor and manage the printer on a network.

HP Easy Printer Care Software

The HP Easy Printer Care Software is a software program that you can use for the following tasks:

- Checking the printer status
- Checking the supplies status
- Setting up alerts
- Viewing printer documentation
- Gaining access to troubleshooting and maintenance tools
- HP Printer Utility for Mac

You can view the HP Easy Printer Care Software when the printer is directly connected to your computer or when it is connected to a network. Perform a complete software installation in order to use the HP Easy Printer Care Software.

Embedded Web server

 **NOTE:** The HP Color LaserJet 3600 Series printer embedded Web server provides network configuration and status information only.

The printers are equipped with an embedded Web server, which provides access to information about printer and network activities. This information appears in a Web browser, such as Microsoft Internet Explorer or Netscape Navigator.

The embedded Web server resides on the printer. It is not loaded on a network server.

See [Using the embedded Web server on page 35](#) for more information.

Other components and utilities

Several software programs are available for Windows and Macintosh users.

| Windows | Macintosh OS |
|---|---|
| <ul style="list-style-type: none">• Software installer automates the printing system installation• Online Web registration | <ul style="list-style-type: none">• PostScript Printer Description files (PPDs) for use with the Apple PostScript drivers that come with the Mac OS• Use the HP Printer Utility to change printer settings, view the current status, and receive printer event updates from a Macintosh computers. This utility is supported for Mac OS X V10.2 and V10.3. |

Print-media specifications

For optimum results, HP recommends using HP media that is designed for HP Color LaserJet printers. Use media with a weight between 75 g/m² to 120 g/m² (20 to 32 lb bond). Although the printer supports media with weights between 60 g/m² to 176 g/m² (16 to 47 lb bond), using lighter or heavier media could impact the paper-jam rate and the optimal print-quality performance.

Always use the correct media-type setting in the printer driver, and configure the trays for the correct media type. HP recommends testing any paper before buying it in large quantities.

Supported paper and print media sizes

This product supports a number of paper sizes, and it adapts to various media.

 **NOTE:** To obtain best print results, select the appropriate paper size and type in your print driver before printing.

Table 1-8 Supported paper and print media sizes

| Size | Dimensions | Tray 1 | Tray 2 | Optional tray 3 |
|-------------------|--|--------|--------|-----------------|
| Letter | 216 x 279 mm (8.5 x 11 inches) | ✓ | ✓ | ✓ |
| Legal | 216 x 356 mm (8.5 x 14 inches) | ✓ | ✓ | ✓ |
| A4 | 210 x 297 mm (8.27 x 11.69 inches) | ✓ | ✓ | ✓ |
| Executive | 184 x 267 mm (7.24 x 10.51 inches) | ✓ | ✓ | ✓ |
| A3 | 297 x 420 mm (11.69 x 16.54 inches) | ✓ | | |
| A5 | 148 x 210 mm (5.83 x 8.27 inches) | ✓ | ✓ | ✓ |
| A6 | 105 x 148 mm (4.13 x 5.83 inches) | ✓ | | |
| B5 (JIS) | 182 x 257 mm (7.17 x 10.12 inches) | ✓ | ✓ | ✓ |
| B5 (ISO) | 176 x 250 mm (6.93 x 9.84 inches) | ✓ | ✓ | ✓ |
| B6 (ISO) | 125 x 176 mm (4.92 x 6.93 inches) | ✓ | | |
| 16k | 197 x 273 mm (7.75 x 10.75 inches) | ✓ | | |
| 16k | 184 x 260 mm (7.24 x 10.23 inches) | ✓ | | |
| 16k | 195 x 270 mm (7.68 x 10.63 inches) | ✓ | | |
| 8.5 x 13 (custom) | 216 x 330 mm (8.5 x 13 inches) | ✓ | | |
| Custom | (148 - 216) x (210 - 356) mm ((5.83 - 8.5) x (8.27 - 14) inches) | ✓ | | |

Table 1-9 Supported envelopes and postcards

| Size | Dimensions | Tray 1 | Tray 2 | Optional tray 3 |
|------------------|-----------------------------------|--------|--------|-----------------|
| Envelope #10 | 105 x 241 mm (4.13 x 9.49 inches) | ✓ | | |
| Envelope DL | 110 x 220 mm (4.33 x 8.66 inches) | ✓ | | |
| Envelope C5 | 162 x 229 mm (6.93 x 9.84 inches) | ✓ | | |
| Envelope B5 | 176 x 250 mm (6.7 x 9.8 inches) | ✓ | | |
| Envelope Monarch | 98 x 191 mm (3.9 x 7.5 inches) | ✓ | | |

Media type and tray loading

Minimum media dimensions are 76 x 127 mm (3 x 5 inches).

Maximum media dimensions are 216 x 356 mm (8.5 x 14 inches).

Table 1-10 Tray 1 media information

| Media type | Media specifications | Media quantity | Driver settings | Paper orientation |
|-------------------------------------|--|--|--|--|
| Paper and cardstock, standard sizes | Range: 60 g/m ² (16 lb) bond to 163 g/m ² (43 lb) bond | Maximum stack height: 10 mm (0.6 inch) Equivalent to 100 sheets of 75 g/m ² (20 lb) bond. | Plain or unspecified | N/A |
| Envelopes | Less than 60 g/m ² (16 lb) bond to 90 g/m ² (24 lb) bond | Up to 10 envelopes | Envelope | Short edge leading, flap on right side facing up |
| Labels | Maximum 0.23 mm (0.009 in.) thick | Maximum stack height: 10 mm (0.6 inch) | Labels | Side to be printed on facing down |
| Transparencies | Minimum 0.13 mm (0.005 in.) thick | Maximum stack height: 10 mm (0.6 inch) | Transparencies | Side to be printed on facing down |
| Heavy | 0.13 mm (0.005 in.) thick | Maximum stack height: 10 mm (0.6 in.) | Light glossy, glossy, or heavy glossy | Side to be printed on facing down |
| Glossy | Range: 75 g/m ² (20 lb) bond to 176 g/m ² (47 lb) bond | Maximum stack height: 10 mm (0.6 in.) | Light glossy, glossy, or heavy glossy | Side to be printed on facing down |
| Cardstock | Range: 163 g/m ² (43 lb) bond to 176 g/m ² (47 lb) cover | 60 sheets | Cardstock | Side to be printed on facing down |

Table 1-11 Tray 2, tray 3, and tray 4 media information

| Media type | Media specifications | Media quantity | Driver settings | Paper orientation | Output |
|-------------------------------------|--|---|---------------------------------------|---------------------------------|--------|
| Paper and cardstock, standard sizes | Range: 60 g/m ² (16 lb) bond to 120 g/m ² (32 lb) bond | Equivalent to 250 sheets (tray 2) or 500 sheets (tray 3) of 75 g/m ² (20 lb) bond. | Plain or unspecified | N/A | |
| Labels | Maximum 0.13 mm (0.005 in.) thick | Maximum stack height: 50 sheets (tray 2), or 100 sheets (tray 3) | Labels | Side to be printed on facing up | |
| Transparencies | Minimum 0.13 mm (0.005 in.) thick | Maximum stack height: 50 sheets (tray 2), or 100 sheets (tray 3) | Transparencies | Side to be printed on facing up | |
| Heavy | 0.13 mm (0.005 in.) thick | Maximum stack height: 100 sheets (tray 2), or 200 sheets (tray 3) | Light glossy, glossy, or heavy glossy | Side to be printed on facing up | |
| Glossy | Range: 106 g/m ² (28 lb) bond to 120 g/m ² (32 lb) bond | Maximum stack height: 100 sheets (tray 2), or 200 sheets (tray 3) | Light glossy, glossy, or heavy glossy | Side to be printed on facing up | |

2 Installation and configuration

- [What is in the box](#)
- [Site requirements](#)
- [Connecting to a network or a computer](#)
- [Printer memory](#)

What is in the box

The following items come in the box with the printer.

Figure 2-1 What is in the shipping box

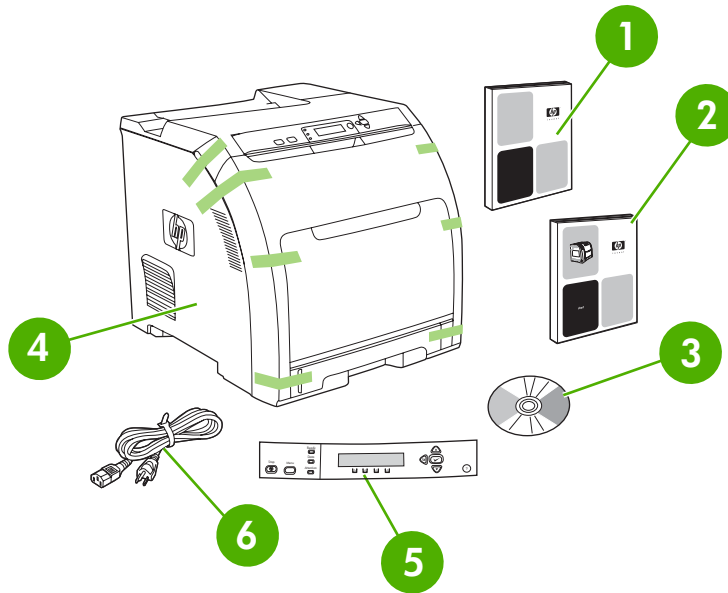

1. Getting started guide
2. Warranty booklet
3. User guide on CD
4. Printer
5. Control-panel overlays (optional)
6. Power cord

Site requirements

Select a sturdy, well-ventilated, dust-free area that is away from direct sunlight to position the printer. Allow enough space around the printer to open the doors and trays.

Physical specifications

Table 2-1 Physical dimensions for the HP Color LaserJet 3000/3600/3800/CP3505 Series printers

| Product | Height | Depth | Width | Weight ¹ |
|--|------------------|------------------|------------------|-----------------------|
| Base model | 400 mm (15.7 in) | 450 mm (17.7 in) | 400 mm (15.7 in) | 20.3 kg (44.8 lbs) |
| Base model plus duplexer | 423 mm (16.7 in) | 450 mm (17.7 in) | 400 mm (15.7 in) | 21.5 kg (47.4 lbs) |
| Base model plus optional tray 3 | 540 mm (21.3 in) | 450 mm (17.7 in) | 400 mm (15.7 in) | 25.4 kg (56 lbs) |
| Base model plus duplexer and optional tray 3 | 563 mm (22.2 in) | 450 mm (17.7 in) | 400 mm (15.7 in) | 26.6 kg (58.6 lbs) |

¹ Printer weight does not include print cartridges.

Connecting to a network or a computer

To connect to a network

1. Connect the network cable to the printer.
2. Find the IP address. On the control panel, press **Menu**. Select **INFORMATION**, and then select **PRINT CONFIGURATION**. The IP address is on the embedded Jetdirect page, under “TCP/IP”.

 **NOTE:** You might need to assign an IP address depending on the type of network that is installed.

3. Configure an IP address (if necessary). On the control panel, press **Menu**. Select **CONFIGURE DEVICE**, select **I/O**, and then select **EMBEDDED JETDIRECT**. Select **TCP/IP**, select **CONFIG METHOD**, select **MANUAL**, and then select **MANUAL SETTINGS**. Use the control-panel buttons to specify the IP address.
4. Prepare for software installation. Quit all of the programs (including terminate-and-stay resident [TSR], antivirus, and firewall programs) on the print server or on each computer that will use the printer.
5. Install the software. Insert the CD that came with the printer, and then click **Install Printer** on the welcome screen. (If the welcome screen does not appear, click **Start**, and then click **Run**. Type **X:SETUP**, replace X with the CD-ROM drive letter, and then click **OK**.)
6. Follow the onscreen instructions. When prompted, select **Wired Networking**. The installer shows available printers. Select the appropriate IP address.
7. On the **Installation Type** screen select **Full Installation** to install the most common drivers and software, select **Basic Installation** to install the minimum set of drivers and software (recommended), or select **Custom Installation**.

 **NOTE:** See the *HP Jetdirect Print Server Administrators Guide* for more information. You can find this guide on the printer CD.

To use Windows with a direct connection (USB)

1. Install the software from the CD before connecting the cable to the printer.
2. On the welcome screen, click **Install Printer**. The Setup Wizard appears.

 **NOTE:** If the welcome screen does not appear, click **Start**, and then click **Run**. Type **X:SETUP**, replace X with the CD-ROM drive letter, and then click **OK**.

3. Follow the onscreen instructions. When prompted, connect a USB cable between the printer and the computer.

 **NOTE:** HP does not recommend using USB hubs. Use a USB cable that is no longer than 2 meters (6.5 feet).

4. Click **Finish**. If prompted, restart the computer.
5. Test the software installation. Print a page from any program to make sure that the software is correctly installed.

 **NOTE:** If the installation failed, reinstall the software.

NOTE: If the **New Hardware Found** message appears, insert the CD, follow the onscreen instructions, and accept the default selections.

To connect to a Macintosh computer

 **NOTE:** The HP Color LaserJet CP3505 supports Macintosh OS X V10.2.8, V10.3, V10.4 or later. For Macintosh OS X V10.4, PPC and Intel core processor Macintosh are supported.

1. Connect a USB cable between the printer and the computer.

 **NOTE:** HP does not recommend using USB hubs. Use a USB cable that is no longer than 2 meters (6.5 feet).

2. Place the CD in the CD-ROM drive. For OS V9.1 to V9.2.x, go to step 3. For OS X, go to step 7.
3. Run the Installer and complete a custom install. Select all options, including **USB Components** (Classic). When prompted, restart the computer.
4. Run the Apple Desktop Printer Utility from HD/Applications/Utilities. Double-click **HP Printer (USB)**, and then click **OK**. Next to the **USB Printer Selection**, click **Change**.
5. Select the printer, and then click **OK**. Next to **Postscript Printer Description (PPD) File**, click **Auto Setup**, and then click **Create**. Save the printer setup.
6. On the desktop, highlight the printer. Click the **Printing** menu, and then click **Set Default Printer**. Go to step 10.
7. Run the Installer and complete an easy install.

 **NOTE:** If OS X and OS V9.1 (Classic) to V9.2.x (Classic) are installed on the same computer, the installer shows both the Classic and the OS X installation options.

8. From HD/Applications/Utilities/Print Center, start the Print Center. If the printer appears in the **Printer List**, delete the printer. Click **Add**. On the next page, click the drop-down menu, and then select **USB**.
9. From the **Printer Model** drop-down list, select **HP**. Under **Model Name**, select the printer, and then click **Add**.
10. Test the software installation. Print a page from any program to make sure that the software is correctly installed.

 **NOTE:** If the installation failed, reinstall the software.

Printer memory

 **NOTE:** This information applies to the HP Color LaserJet 3000, 3800, and CP3505 Series printers only.

The HP Color LaserJet 3000, 3800, and CP3505 Series printers have one DIMM slot. The HP Color LaserJet 3000 and HP Color LaserJet 3800 use DDR memory. The CP3505 Series printers use DDR2 memory.

- More printer memory DIMMs are available in 128, 256, 512 MB , and 1 GB (CP3505 Series printers only) increments.
- Other DIMM-based printer languages and printer options are available.

 **NOTE:** Single in-line memory modules (SIMMs) that are used on previous HP LaserJet printers are not compatible with these printers.

You might want to add more memory to the printer if you often print complex graphics or PostScript documents, if you use many downloaded fonts, or if a Jetdirect EIO print server will be installed for network printing capabilities. Additional memory also allows the printer to print multiple collated copies at the maximum speed.

Before ordering additional memory, see how much memory is currently installed by printing a configuration page. See [Using printer information pages on page 40](#).

Installing memory DIMMs

You can install more memory for the printer, and you can also install a font DIMM to print characters for languages such as Chinese or the Cyrillic alphabet.

 **CAUTION:** Static electricity can damage DIMMs. When handling DIMMs, either wear an antistatic wrist strap or frequently touch the surface of the DIMM antistatic package and then touch bare metal on the printer.

To install memory DIMMs

1. Turn the printer off, and then disconnect all power and interface cables.

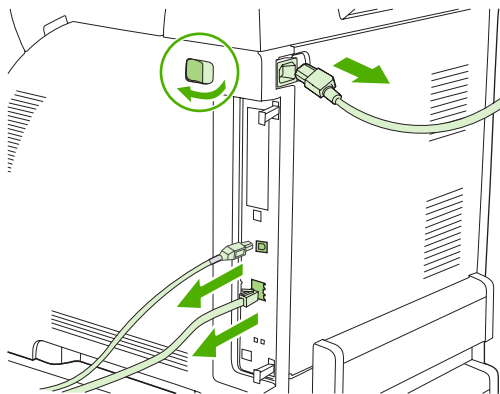

2. On the right side of the printer, gently pull the black tabs together, and then pull the formatter assembly from the printer.

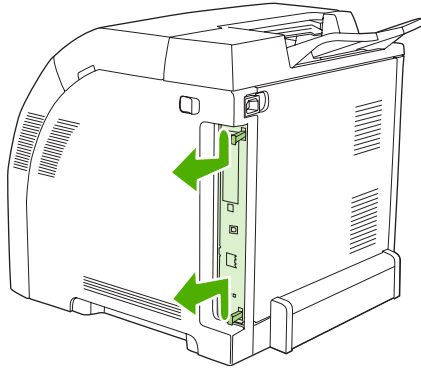

3. Place the formatter board on a clean, flat, grounded surface.

To replace a DIMM that is currently installed, spread the latches apart on each side of the DIMM slot, lift the DIMM up at an angle, and pull it out.

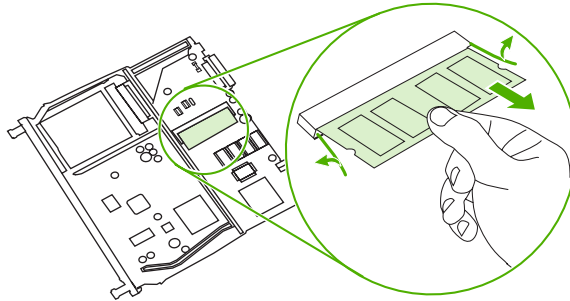

4. Remove the new DIMM from the antistatic package, and then locate the alignment notch on the bottom edge of the DIMM.

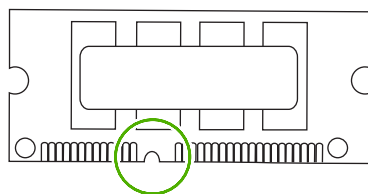

5. Holding the DIMM by the edges, align the notch on the DIMM with the bar in the DIMM slot at an angle and firmly press the DIMM into the slot until it is fully seated. When installed correctly, the metal contacts are not visible.

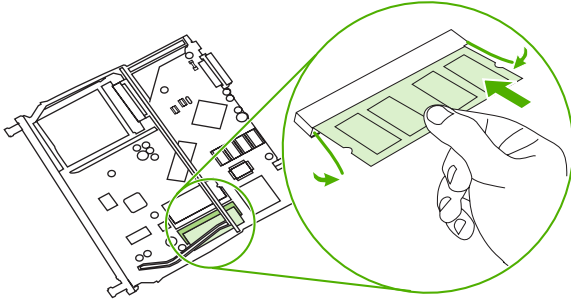

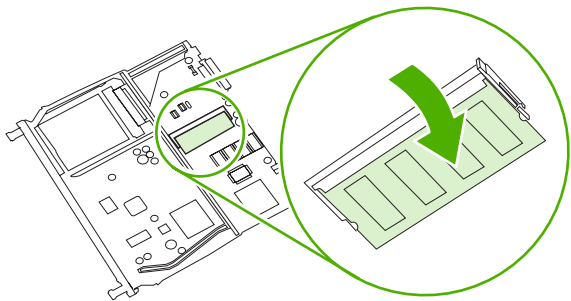

6. Push down on the DIMM until both latches engage the DIMM.

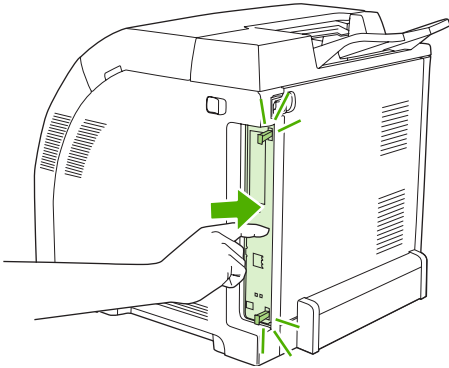

 **NOTE:** If you have difficulty inserting the DIMM, make sure that the notch on the bottom of the DIMM is aligned with the bar in the slot. If the DIMM still does not go in, make sure that you are using the correct DIMM type.

7. Align the edge of the formatter board in the tracks at the top and bottom of the slot, and then slide the board into the printer. Push the formatter firmly until you hear the formatter latches click into place.



 **NOTE:** After replacing the formatter, make sure that the control panel is functioning. If the printer fans and motors are operating correctly but the control panel is not, turn the power off, and then remove the formatter and reinstall it. You might have to repeat this step several times to seat the formatter correctly.

8. Reconnect the power cable and USB or network cable, and then turn on the printer.
9. After installing a memory DIMM, see [Enabling memory on page 29](#).

Enabling memory

If you installed a memory DIMM, set the printer driver to recognize the newly added memory.

To enable memory for Windows

1. On the **Start** menu, point to **Settings**, and click **Printers** or **Printers and Faxes**.
2. Select this printer and select **Properties**.
3. On the **Configure** tab, click **More**.
4. In the **Total Memory** field, type or select the total amount of memory that is now installed.
5. Click **OK**.
6. Go to [Checking DIMM installation on page 29](#).

Checking DIMM installation

Check that the DIMMs are installed correctly and working.

To check DIMM installation

1. Turn the printer on. Check that the printer is in the **Ready** state after it has gone through the startup sequence. If an error message appears, a DIMM might have been incorrectly installed.
2. Print a configuration page. See [Using printer information pages on page 40](#).
3. Check the Installed Personalities and Options section on the configuration page and compare it with the configuration page that you printed before the DIMM installation.
4. If the information on the configuration page has *not* changed, one of the following situations exists:
The DIMM might not be installed correctly. Repeat the installation procedure.
-or-
The DIMM might be defective. Try a new DIMM.

3 Maintenance

- [Understanding approximate supplies-replacement intervals](#)
- [Replacing supplies](#)
- [Managing the print cartridge](#)
- [Cleaning the printer](#)
- [Calibrating the printer](#)
- [Tools for troubleshooting](#)

Understanding approximate supplies-replacement intervals

The following table lists the estimated replacement intervals for supplies and the control-panel messages that prompt you to replace each item. Usage conditions and print patterns can cause results to vary.

| Item | Printer message | Page count (HP Color LaserJet 3000) | Page count (HP Color LaserJet 3600) | Page count (HP Color LaserJet 3800 and CP3505) |
|------------------|--|-------------------------------------|-------------------------------------|--|
| Black cartridges | REPLACE BLACK CARTRIDGE | 6,500 pages ¹ | 6,000 pages ¹ | 6,000 pages ¹ |
| Color cartridges | REPLACE <COLOR> CARTRIDGE | 3,500 pages ¹ | 4,000 pages ¹ | 6,000 pages ¹ |

¹ Approximate average A4-/letter-size page count based on 5% coverage of individual colors

You can use the embedded Web server to order supplies. See [Using the embedded Web server on page 41](#).

Replacing supplies

When you use genuine HP supplies, the printer automatically notifies you when supplies are nearly depleted. The notification to order supplies allows ample time to order new supplies before they need to be replaced.

Locating supplies

Supplies are identified by their labeling and their blue plastic handles.

The following figure illustrates the location of the print cartridges.

Figure 3-1 Supply-item locations

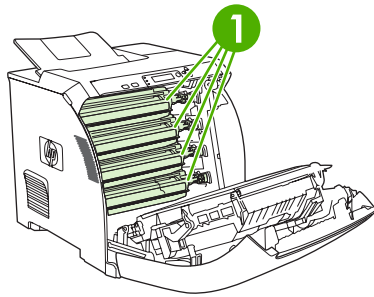

1

Print cartridges

Supply replacement guidelines

To facilitate the replacement of supplies, keep the following guidelines in mind when setting up the printer.

- Allow sufficient space above and in the front of the printer for removing supplies.
- Place the printer on a flat, sturdy surface.

For instructions about installing supplies, see the installation guides that came with each supply item, or see more information at <http://www.hp.com/support/clj3000>, <http://www.hp.com/support/clj3600>, <http://www.hp.com/support/clj3800>, or <http://www.hp.com/support/cljcp3505>. When you connect, select **Troubleshoot a Problem**.

- △ **CAUTION:** Hewlett-Packard Company recommends the use of genuine HP products in this printer. Use of non-HP products might cause problems requiring service that is not covered by the Hewlett-Packard extended warranty or service agreements.

Managing the print cartridge

This section provides information about HP print cartridges, including their life expectancies, how to store them, and how to identify genuine HP supplies. Information also appears about non-HP print cartridges.

HP print cartridges

When you use a genuine HP print cartridge, you can obtain several types of information:

- Amount of toner remaining
- Estimated number of pages remaining
- Number of pages printed

Non-HP print cartridges

Hewlett-Packard Company cannot recommend use of non-HP print cartridges, either new or remanufactured. Because they are not HP products, HP cannot influence their design or control their quality. Service or repair that is required as a result of using a non-HP print cartridge will *not* be covered under the printer warranty.

When you use a non-HP print cartridge, certain features, such as remaining toner-volume data, might not be available.

Using genuine HP supplies ensures the availability of all HP printing features.

Print-cartridge authentication

A message appears on the printer control-panel display if you insert a print cartridge that is not a genuine HP print cartridge. If you believe that you purchased a genuine HP supply, go to <http://www.hp.com/go/anticounterfeit>.

Print-cartridge storage

Do not remove the print cartridge from its package until you are ready to use it.

Always store the print cartridge in the correct environment. The storage temperature should be between -20°C and 40°C (-4°F to 104°F). The relative humidity should be between 10% and 90%.

△ **CAUTION:** To prevent damage to the print cartridge, do not expose it to light for more than a few minutes.

Print-cartridge life expectancy

The life of the print cartridge depends on the amount of toner that print jobs require and the length of life for the components inside the cartridge. The page-yield specification that HP provides is a general guideline. Actual yield can vary according to usage conditions.

At any time, you can verify life expectancy by checking the supply level.

Checking the supply level

You can check the toner-supply level by using the control panel, the embedded Web server, or HP Web Jetadmin.

Using the control panel

1. Press **Menu** to open the **MENUS**.
2. Press **▼** to highlight **INFORMATION**.
3. Press **▼** to highlight **PRINT SUPPLIES STATUS**.

Using the embedded Web server

1. In your browser, type the IP address for the printer home page. This takes you to the printer status page.
2. On the left side of the screen, click **Supplies Status**. This takes you to the supplies status page, which provides print-cartridge information.

Using HP Web Jetadmin

In HP Web Jetadmin, select the printer. The device status page shows print-cartridge information.

Replacing print cartridges

When a print cartridge approaches the end of its useful life, a message to order a replacement appears on the control-panel display. The printer can continue to print with the current print cartridge until the control-panel message instructs you to replace the cartridge.

Replace a print cartridge when a **REPLACE <COLOR> CARTRIDGE** message appears on the printer control panel. The control-panel display indicates the color that should be replaced (if a genuine HP cartridge is currently installed).

△ **CAUTION:** If toner gets on clothing, wipe it off with a dry cloth and wash the clothes in cold water. Hot water sets toner into fabric.

 **NOTE:** For information about recycling used print cartridges, visit the HP LaserJet Supplies Web site at <http://www.hp.com/go/recycle>.

To replace the print cartridge

1. Open the front cover and ETB unit.



△ **CAUTION:** Do not place any item on the transfer unit while it is open. If the transfer unit is punctured, print-quality problems could result.

2. Remove the used print cartridge from the printer.



3. Remove the new print cartridge from the bag, and remove the tape-seal. Place the used print cartridge in the bag for recycling.

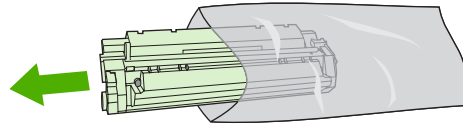

4. Align the print cartridge with the tracks inside the printer and insert the cartridge until it is completely seated.

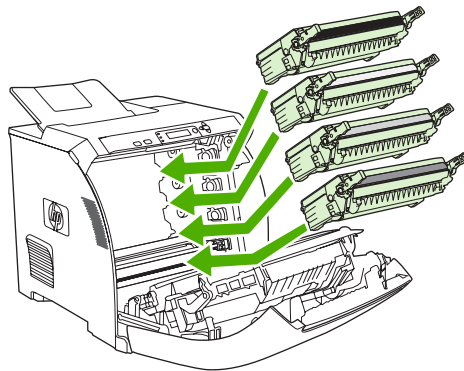

 **NOTE:** Use the blue cartridge handles when installing the new cartridge in the printer. Touching other areas of the print cartridge can damage the image drum and cause print-quality defects.

NOTE: If a cartridge is in the wrong slot, the message **INCORRECT COLOR CARTRIDGE** appears on the control panel.

5. Close the front cover and then close the top cover. After a short while, **Ready** appears on the control panel.
6. Installation is complete. Place the used print cartridge in the box that the new cartridge came in. See the enclosed recycling guide for recycling instructions.
7. If you are using a non-HP print cartridge, check the control panel for further instructions.

For additional help, go to <http://www.hp.com/support/clj3000>, <http://www.hp.com/support/clj3600>, <http://www.hp.com/support/clj3800>, or <http://www.hp.com/support/cljcp3505>.

Cleaning the printer

Clean the outer surfaces with an HP Toner Cleaning Cloth or a water-dampened cloth.

- ⚠ **WARNING!** Before you begin these steps, turn the printer off and unplug all power cords to avoid shock hazard. Be careful when cleaning around the fuser area. It might be hot.
- ⚠ **CAUTION:** To avoid permanent damage to the print cartridge, do not use ammonia-based cleaners on or around the printer. If toner gets on your clothes, wipe it off with a dry cloth and wash your clothes in cold water. Hot water sets toner into fabric.

| Component | Cleaning Method |
|----------------------|---|
| Outer covers | Use an HP Toner Cleaning Cloth (part number 5090-3379) or a water-dampened cloth. Do not use solvents or ammonia-based cleaners. |
| Inside, general | With a dry, lint-free cloth, wipe any dust, spilled toner, and paper particles from the paper path area, the registration roller, and the print-cartridge cavity. |
| ETB attaching roller | Clean with lint-free paper. If dirt cannot be removed, dampen the paper with alcohol. |
| Paper-pickup rollers | Clean with lint-free paper. If dirt cannot be removed, dampen the paper with alcohol. |

Cleaning spilled toner

Defective print cartridges can develop leaks. Also, after a jam has occurred, some toner might remain on the rollers and guides inside the printer. The pages that print immediately after the jam can pick up this toner. Use a vacuum that is designed for picking up fine particles. See [Vacuum specifications on page 38](#).

- ⚠ **CAUTION:** When cleaning the printer, do not touch the ETB with the damp cloth or with your fingers.

Vacuum specifications

Do not use a conventional vacuum to vacuum the printer or any spilled toner. The toner particles used in this product might be too fine for effective vacuuming and could result in damage to conventional vacuums.

You can use a vacuum specifically designed for cleaning if it can filter fine particles (5 microns in diameter).

Calibrating the printer

Calibration is a printer function that optimizes print quality. If you experience any print-quality problems, calibrate the printer.

1. Press **Menu**.
2. Press ▼ to highlight **CONFIGURE DEVICE**, and then press ✓.
3. Press ▼ to highlight **PRINT QUALITY**, and then press ✓.
4. Press ▼ to highlight **FULL CALIBRATE NOW**, and then press ✓.

Tools for troubleshooting

Using printer information pages

 **NOTE:** Printer information pages for the HP Color LaserJet 3600 Series printer are available in English only.

| Page description | How to print the page |
|---|---|
| Menu map Shows the control-panel menus and available settings | <ol style="list-style-type: none">1. Press Menu.2. Press ▼ to highlight INFORMATION, and then press ✓.3. If PRINT MENU MAP is not highlighted, press ▲ or ▼ until it is highlighted, and then press ✓. <p>The content of the menu map varies, depending on the options currently installed in the printer.</p> |
| Configuration page Shows printer settings and installed accessories | <ol style="list-style-type: none">1. Press Menu.2. Press ▼ to highlight INFORMATION, and then press ✓.3. Press ▼ to highlight PRINT CONFIGURATION, and then press ✓. <p>NOTE: If the printer contains an HP Jetdirect print server or an optional hard-disk accessory, an additional configuration page prints that provides information about those devices.</p> |
| Supplies status page Shows print-cartridge toner levels | <ol style="list-style-type: none">1. Press Menu.2. Press ▼ to highlight INFORMATION, and then press ✓.3. Press ▼ to highlight PRINT SUPPLIES STATUS PAGE, and then press ✓. |
| Usage page (HP Color LaserJet 3000, 3800, and CP3505 Series printers only) Shows a page count for each size of paper printed, the number of one-sided (simplex) or two-sided (duplexed) pages, and the average percentage of coverage for each color | <ol style="list-style-type: none">1. Press Menu.2. Press ▼ to highlight INFORMATION, and then press ✓.3. Press ▼ to highlight PRINT USAGE PAGE, and then press ✓. |
| Demo page Shows a color photograph that allows you to check print quality | <ol style="list-style-type: none">1. Press Menu.2. Press ▼ to highlight INFORMATION, and then press ✓.3. Press ▼ to highlight PRINT DEMO, and then press ✓. |
| Color usage log Shows color-use statistics for the printer | <ol style="list-style-type: none">1. Press Menu.2. Press ▼ to highlight INFORMATION, and then press ✓.3. Press ▼ to highlight PRINT COLOR USAGE JOB LOG, and then press ✓. |
| File directory (HP Color LaserJet 3000, 3800, and CP3505 Series printers only) | <ol style="list-style-type: none">1. Press Menu.2. Press ▼ to highlight INFORMATION, and then press ✓.3. Press ▼ to highlight PRINT FILE DIRECTORY, and then press ✓. |

| Page description | How to print the page |
|---|--|
| Shows information for all installed mass-storage devices | NOTE: This option does not appear if no mass-storage devices are installed. |
| PCL or PS font list (HP Color LaserJet 3000, 3800, and CP3505 Series printers only) Shows which fonts are currently installed in the printer | <ol style="list-style-type: none"> 1. Press Menu. 2. Press ▼ to highlight INFORMATION, and then press ✓. 3. Press ▼ to highlight PRINT PCL FONT LIST or PRINT PS FONT LIST, and then press ✓. <p>NOTE: The font lists also show which fonts are resident on an optional hard-disk accessory or flash DIMM.</p> |

Configuring e-mail alerts

 **NOTE:** If your host software does not support e-mail, this feature might not be available on the HP Color LaserJet 3600 Series printer.

You can use HP Web Jetadmin or the embedded Web server to configure the system to alert you of problems with the printer. The alerts take the form of e-mail messages to the e-mail account(s) that you specify.

Configure the following items:

- The printer(s) that you want to monitor
- The alerts that you want to receive (for example, alerts for jams, paper out, supplies status, and cover open)
- The e-mail account(s) to which the alerts should be forwarded

| Software | Information location |
|---------------------|---|
| HP Web Jetadmin | See HP Web Jetadmin on page 15 for general information about HP Web Jetadmin. See the HP Web Jetadmin Help system for details about alerts and how to set them up. |
| Embedded Web server | See Using the embedded Web server on page 41 for general information about the embedded Web server. See the embedded Web server Help system for details about alerts and how to set them up. |

Using the embedded Web server

 **NOTE:** The HP Color LaserJet 3600 Series printer embedded Web server provides network configuration and status information only.

NOTE: When the printer is directly connected to a computer, use the HP Easy Printer Care Software to view the printer status.

- View printer-control status information.
- Set the type of media that is loaded in each tray.
- Determine the remaining life of all supplies and order new ones.

- View and change tray configurations.
- View and change the printer control-panel menu configuration.
- View and print internal pages.
- Receive notification of printer and supplies events.
- View and change network configuration.
- View support content that is specific to the current state of the printer.
- Restrict access to color printing features (HP Color LaserJet 3000, 3800, and CP3505 Series printers only).

When the printer is connected to the network, the embedded Web server is automatically available. You can open the embedded Web server from Windows 95 and later.

Use the embedded Web server to view printer and network status and to manage printing functions from your computer instead of from the printer control panel.

To use the embedded Web server, you must have Microsoft Internet Explorer 4 and later or Netscape Navigator 4 and later. The embedded Web server works when the printer is connected to an IP-based network. The embedded Web server does not support IPX-based or AppleTalk printer connections. You do not need Internet access to open and use the embedded Web server.

To open the embedded Web server by using a network connection

1. In a supported Web browser on your computer, type the IP address for the printer in the URL field. (To find the IP address, print a configuration page. See [Using printer information pages on page 40.](#))



NOTE: After you open the URL, you can bookmark it so that you can return to it quickly in the future.

2. The embedded Web server has three tabs that contain settings and information about the printer: the **Information** tab, the **Settings** tab, and the **Networking** tab. Click the tab that you want to view.

See the following section for more information about each tab.

Embedded Web server sections

| Tab or section | Description |
|---|---|
| Information tab Provides printer, status, and configuration information | <ul style="list-style-type: none"> ● Device Status: Shows the printer status and shows the life remaining of HP supplies, with 0% indicating that a supply is empty. The page also shows the type and size of print media set for each tray. To change the default settings, click Change Settings. ● Configuration Page: Shows the information that is on the printer configuration page. ● Supplies Status: Shows the life remaining of HP supplies, with 0% indicating that a supply is empty. This page also provides supplies part numbers. To order new supplies, click Order Supplies in the Other Links area on the left side of the window. ● Event log: Shows a list of all printer events and errors. ● Usage page: Shows a summary of the number of pages the printer has printed, grouped by size and type. |

| Tab or section | Description |
|---|--|
| Settings tab Provides the ability to configure the printer from your computer | <ul style="list-style-type: none"> ● Diagnostics Page: Provides information about printer calibration, color density, and other parameters. ● Device Information: Shows the printer network name, address, and model information. To change these entries, click Device Information on the Settings tab. ● Control Panel: Shows messages from the printer control panel. ● Color Usage Job Log: Shows color print jobs on a job-by-job basis. ● Print: Use to send print jobs to the printer. <hr/> <ul style="list-style-type: none"> ● Configure Device: Use to configure printer settings. This page contains the traditional menus found on printers using a control-panel display. ● E-mail Server: Network only. Use in conjunction with the Alerts page to set up incoming and outgoing e-mail, as well as to set e-mail alerts. ● Alerts: Network only. Use to set up to receive e-mail alerts for various printer and supplies events. ● AutoSend: Use to configure the printer to send automated e-mails regarding printer configuration and supplies to specific e-mail addresses. ● Security: Use to set a password that must be typed to gain access to the Settings and Networking tabs. Enable and disable certain features of the embedded Web server. ● Edit Other Links: Use to add or customize a link to another Web site. This link is displayed in the Other Links area on all embedded Web server pages. ● Device Information: Use to name the printer and assign an asset number to it. Type the name and e-mail address for the primary contact who will receive information about the printer. ● Language: Use to specify the language in which to display the embedded Web server information. ● Date & Time: Synchronizes with a network time server. ● Wake Time: Use to set or edit a wake time for the printer. ● Restrict Color: Use to set color-print-job user restrictions. <p>NOTE: The Settings tab can be password-protected. If this printer is on a network, always consult with the printer administrator before changing settings on this tab.</p> |
| Networking tab Provides the ability to change network settings from your computer | <p>Network administrators can use this tab to control network-related settings for the printer when it is connected to an IP-based network. This tab does not appear if the printer is directly connected to a computer, or if the printer is connected to a network using anything other than an HP Jetdirect print server.</p> <p>NOTE: The Networking tab can be password-protected. If this printer is on a network, always consult with the printer administrator before changing settings on this tab.</p> |
| Other links Contains links that connect you to the Internet | <ul style="list-style-type: none"> ● HP Instant Support™: Connects to the HP Web site to help you find solutions. This service analyzes the printer error log and configuration information to provide diagnostic and support information specific to your printer. ● Order Supplies: Connects to the HP Web site to order genuine HP supplies. ● Product Support: Connects to the support site for the printer for help regarding general topics. |

| Tab or section | Description |
|----------------|--|
| | NOTE: Internet access is necessary in order to use any of these links. If you use a dial-up connection and did not connect when you first opened the embedded Web server, you must connect before you can visit these Web sites. Connecting might require that you close the embedded Web server and reopen it. |

Using the HP Easy Printer Care Software

Use the HP Easy Printer Care Software for the following tasks:

- Check the printer status.
- Check supplies status.
- Set up alerts.
- Gain access to troubleshooting and maintenance tools.

Use the HP Easy Printer Care Software when the printer is directly connected to your computer or when it is connected to a network. A complete software installation is necessary in order to use the HP Easy Printer Care Software.

 **NOTE:** You do not have to have Internet access to open and use the HP Easy Printer Care Software. However, if you click a Web-based link, you must have Internet access to go to the site that is associated with the link.

Supported operating systems

The HP Easy Printer Care Software is supported for Windows 2000 and Windows XP.

To use the HP Easy Printer Care Software

Use one of the following methods to open HP Easy Printer Care Software:

- On the **Start** menu, select **Programs**, select **HP**, and then select **HP Easy Printer Care Software**.
- In the Windows system tray (in the lower-right corner of the desktop), double-click the HP Easy Printer Care Software icon.
- Double-click the desktop icon.

HP Easy Printer Care Software sections

| Section | Description |
|---|--|
| Overview tab | <ul style="list-style-type: none"> • Devices list: Shows the printers that you can select. |
| Contains basic status information for the printer | <ul style="list-style-type: none"> • Device Status section: Shows printer status information, including printer alert conditions, such as an empty print cartridge; device-identification information; control-panel messages; and print-cartridge levels. After correcting a printer problem, click  to update the section. • Supplies Status section: Shows detailed supplies status, such as the percentage of toner remaining in the print cartridges and the status of the media that is loaded in each tray. • Supplies Details link: Opens the supplies status page to view more detailed information about printer supplies, ordering information, and recycling information. |

| Section | Description |
|---|--|
| <p>Support tab</p> <p>Provides help information and links</p> | <ul style="list-style-type: none"> Provides device information, including alerts for items that need attention. Provides links to troubleshooting information and tools. Provides links to the HP Web site for registration and support, and for ordering supplies. <p>NOTE: Connect to the Internet to visit these Web sites.</p> |
| <p>Supplies Ordering window</p> <p>Provides access to online or e-mail supplies ordering</p> | <ul style="list-style-type: none"> Ordering list: Shows the supplies that can be ordered for each printer. To order a certain item, click the Order check box for that item in the supplies list. Shop Online for Supplies: Opens the HP supplies Web site in a new browser window. The information about selected items can be transferred to the Web site. Print Shopping List: Prints the information about the selected supplies. Email Shopping List: Creates a text list of selected items. The list can be copied into an e-mail message that is sent to a supplier. <p>NOTE: Connect to the Internet to visit these Web sites.</p> |
| <p>Alert Settings window</p> <p>Use to configure the printer to automatically notify of printer issues</p> | <ul style="list-style-type: none"> Activate or deactivate the alerts feature for a certain printer. Set when you want alerts to appear—either when printing to that particular printer, or whenever a printer event occurs. Set alerts for only critical errors or for any error, including continuable errors. Set what type of alert should appear (pop-up message or system tray alert, and e-mail message). |
| <p>Device List tab</p> <p>Shows information about each printer in the Devices list</p> | <ul style="list-style-type: none"> Printer information, including printer name, make, and model An icon (if the View as drop-down box is set to Tiles, which is the default setting) Any current alerts for the printer <p>If you click a printer in the list, the HP Easy Printer Care Software opens the Overview tab for that printer.</p> |
| <p>Find Other Printers window</p> <p>Use to add more printers to the printer list</p> | <p>Clicking the Find Other Printers link in the Devices list opens the Find Other Printers window. The window provides a utility that detects other network printers that can be added to the Devices list and then monitored from a computer.</p> |

Using the HP Printer Utility for Macintosh

To open the HP Printer Utility in Mac OS X V10.2

1. Open the Finder and click **Applications**.
2. Click **Library** and click **Printers**.
3. Click **hp** and click **Utilities**.
4. Double-click **HP Printer Selector** to open the HP Printer Selector.
5. Select the printer that you want to configure, and then click **Utility**.

To open the HP Printer Utility in Mac OS X V10.3

1. In the Dock, click the **Printer Setup Utility** icon.



NOTE: If the **Printer Setup Utility** icon does not appear in the Dock, open the Finder, click **Applications**, click **Utilities**, and then double-click **Printer Setup Utility**.

2. Select the printer that you want to configure, and then click **Utility**.

HP Printer Utility features

The HP Printer Utility consists of pages that you open by clicking in the **Configuration Settings** list. The following table describes the tasks that you can perform from these pages.

| Item | Description |
|--------------------------------|---|
| Color Cleaning | Prints a cleaning page. |
| Configuration Page | Prints a configuration page. |
| Supplies Status | Shows the printer supplies status and provides links for online supplies-ordering. |
| HP Support | Provides access to technical assistance, online supplies ordering, online registration, and recycling and return information. |
| File Upload | Transfers files from the computer to the printer. |
| Upload Fonts | Transfers font files from the computer to the printer. |
| Firmware Update | Transfers updated firmware files from the computer to the printer. |
| Duplex Mode | Turns on the automatic two-sided printing mode. |
| Economode Toner Density | Turns on the Economode setting to conserve toner, or adjusts toner density. |
| Resolution | Changes the resolution settings, including the REt setting. |
| Lock Resources | Locks or unlocks storage devices, such as a hard disk. |
| Stored Jobs | Manages print jobs that are stored on the printer hard disk. |
| Trays Configuration | Changes the default printer tray settings. |
| IP Settings | Changes the printer network settings and provides access to the embedded Web server. |
| Additional Settings | Provides access to the embedded Web server. |
| E-mail Alerts | Configures the printer to send e-mail notices for certain events. |

4 Theory of operation

This chapter presents an overview of the major components of the HP Color LaserJet 3000/3600/3800/CP3505 Series printers, and includes a detailed discussion of the image-formation system.

- [Engine control system](#)
- [Laser/scanner system](#)
- [Pickup-and-feed-system](#)
- [Image-formation system](#)

Engine control system

The engine control system coordinates all printer functions and drives the other three systems.

The engine control system contains these components:

- DC controller
- High-voltage power-supply PCB
- Low-voltage power unit

Figure 4-1 Engine control system components

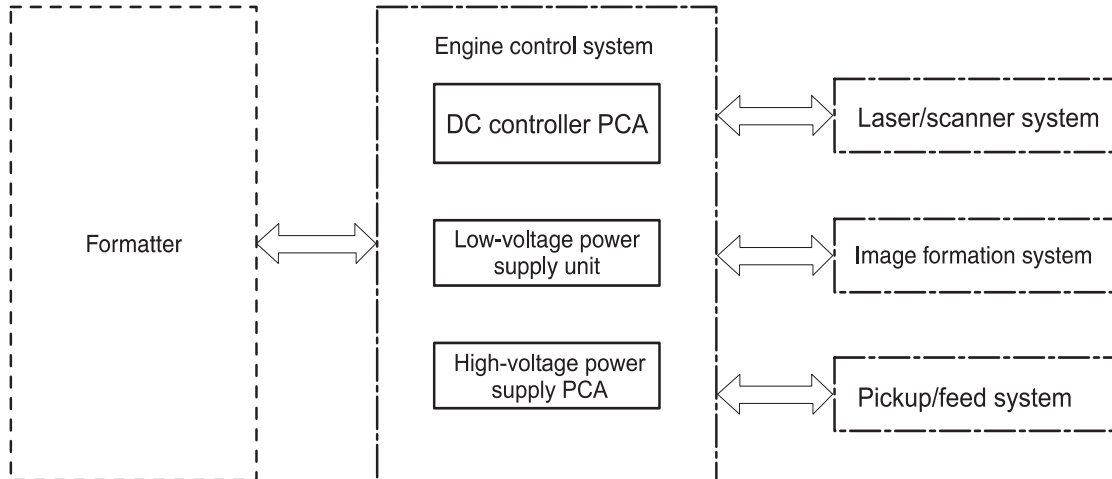

Table 4-1 Sequence of operation

| Period | Duration | Purpose | Remarks |
|-------------------------|--|--|---|
| WAIT | From the time the power is turned on or the door is closed until the drum-phase adjustment is complete | Clears the potential from the drum surface, adjusts the drum phase, and cleans the ETB | Detects the toner level, cartridge presence, and environment; completes any required calibration (color registration control and image stability) |
| STBY (Standby period) | From end of the WAIT or LSTR period until either the print command is received from the formatter or the power is turned off | Maintains the printer in readiness for a print command | The printer enters sleep mode when the formatter sends a sleep command, and performs color registration and the image stability control when the formatter sends those commands |
| INTR (Initial rotation) | From the time the print command is received until the media is picked up | Prepares the photosensitive drum for printing | |
| PRINT | From the end of INTR period until the fuser paper delivery sensor detects the trailing edge of paper | Forms the images on the photosensitive drum and transfers the toner image to the print media | Performs image stabilization at a specified print interval or at specified times |
| LSTR (Last rotation) | From the end of the PRINT period until the delivery motor stops rotating | Moves the printed sheet out of the printer | The printer enters the INTR period as soon as the |

Table 4-1 Sequence of operation (continued)

| Period | Duration | Purpose | Remarks |
|--------|----------|---------|---------------------------------------|
| | | | formatter sends another print command |

Power-on sequence

Figure 4-2 Power-on sequence

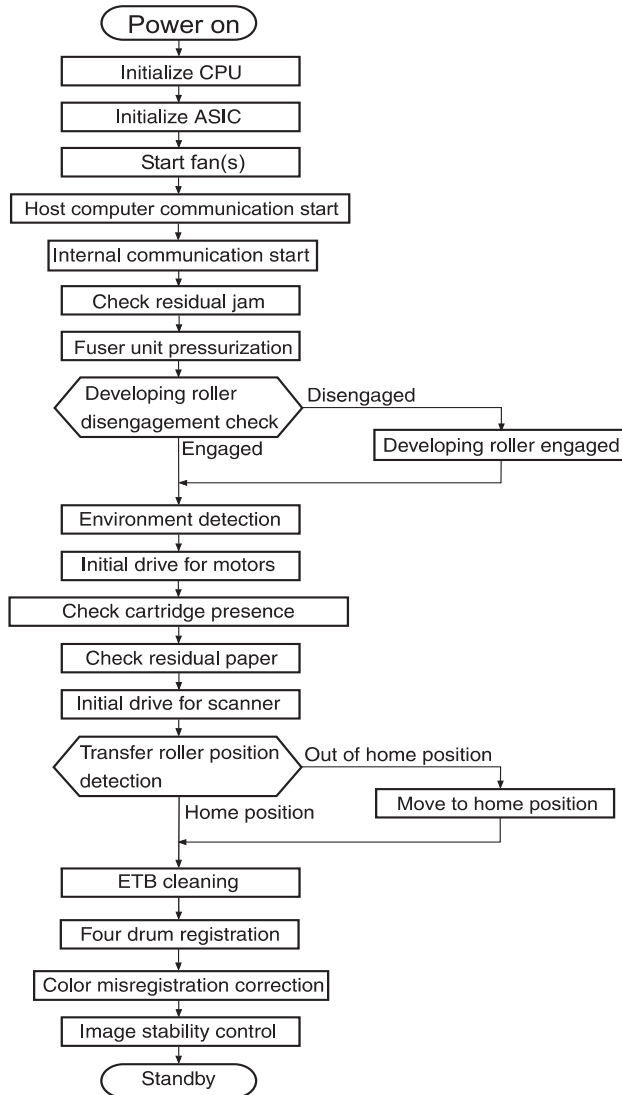

Motors, fans, and solenoids

Figure 4-3 Motors, fans, and solenoids

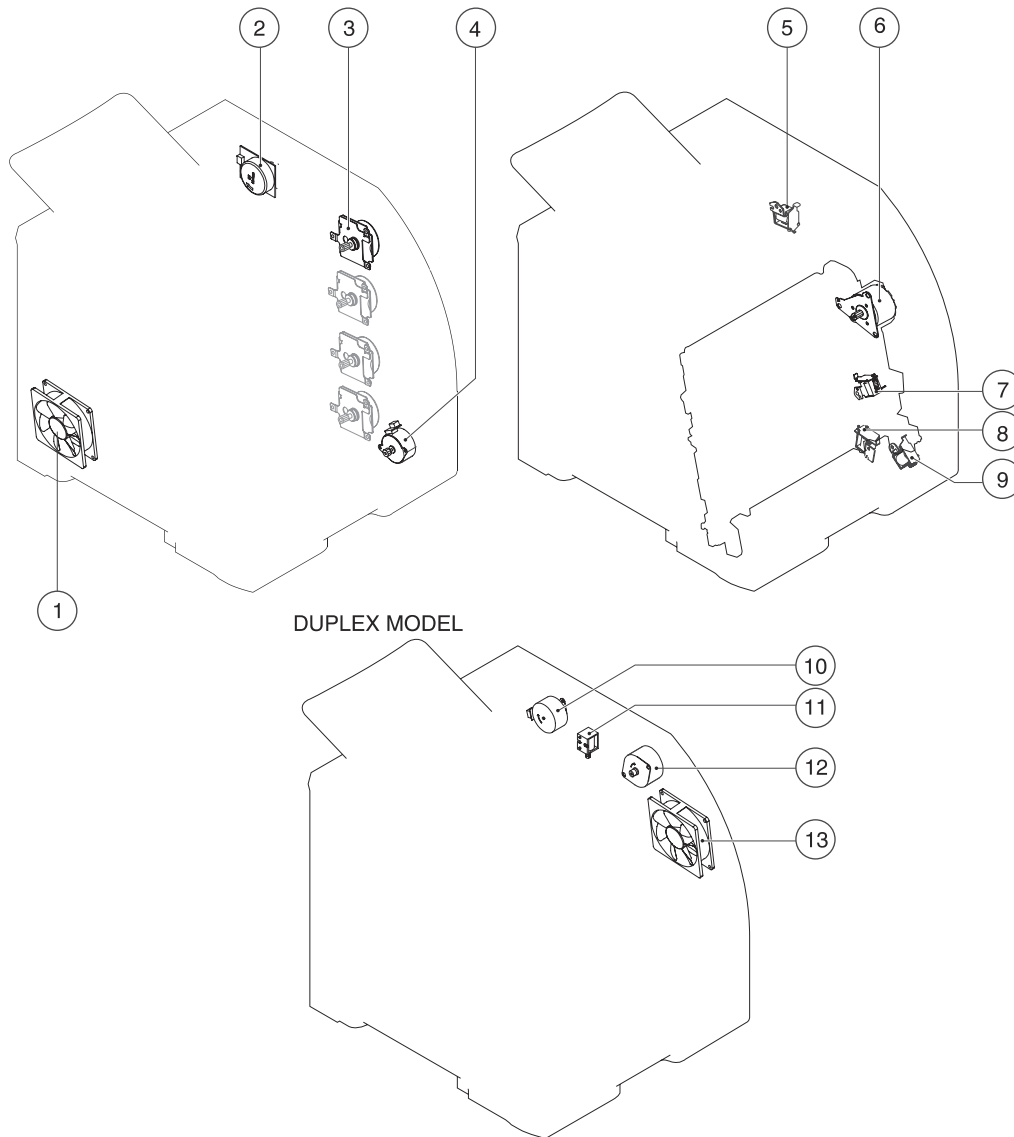

1. Main fan (FM1)
2. Fuser drive motor (M1)
3. Print-cartridge drive motors (M6, M7, M8, M9)
4. Pickup-and-feed motor (M4)
5. Developing separation solenoids (SL5014, SL5015)
6. ETB drive motor (M5)
7. Developing separation solenoid (SL5011)
8. Cassette pickup solenoid (SL5012)

9. Multipurpose tray pickup solenoid (SL5013)

 **NOTE:** The following parts are included *only* on duplexing printer models.

- 10. Duplex reverse-drive motor (M11)
- 11. Duplex flapper solenoid (SL10)
- 12. Duplex-feed-drive motor (M10)
- 13. Door fan (duplex models only) (FM2)

Laser/scanner system

The formatter sends video signals to the DC controller, which controls the laser/scanner. When the laser/scanner system receives those signals it converts them to latent images on the photosensitive drum.

Figure 4-4 Laser/scanner system

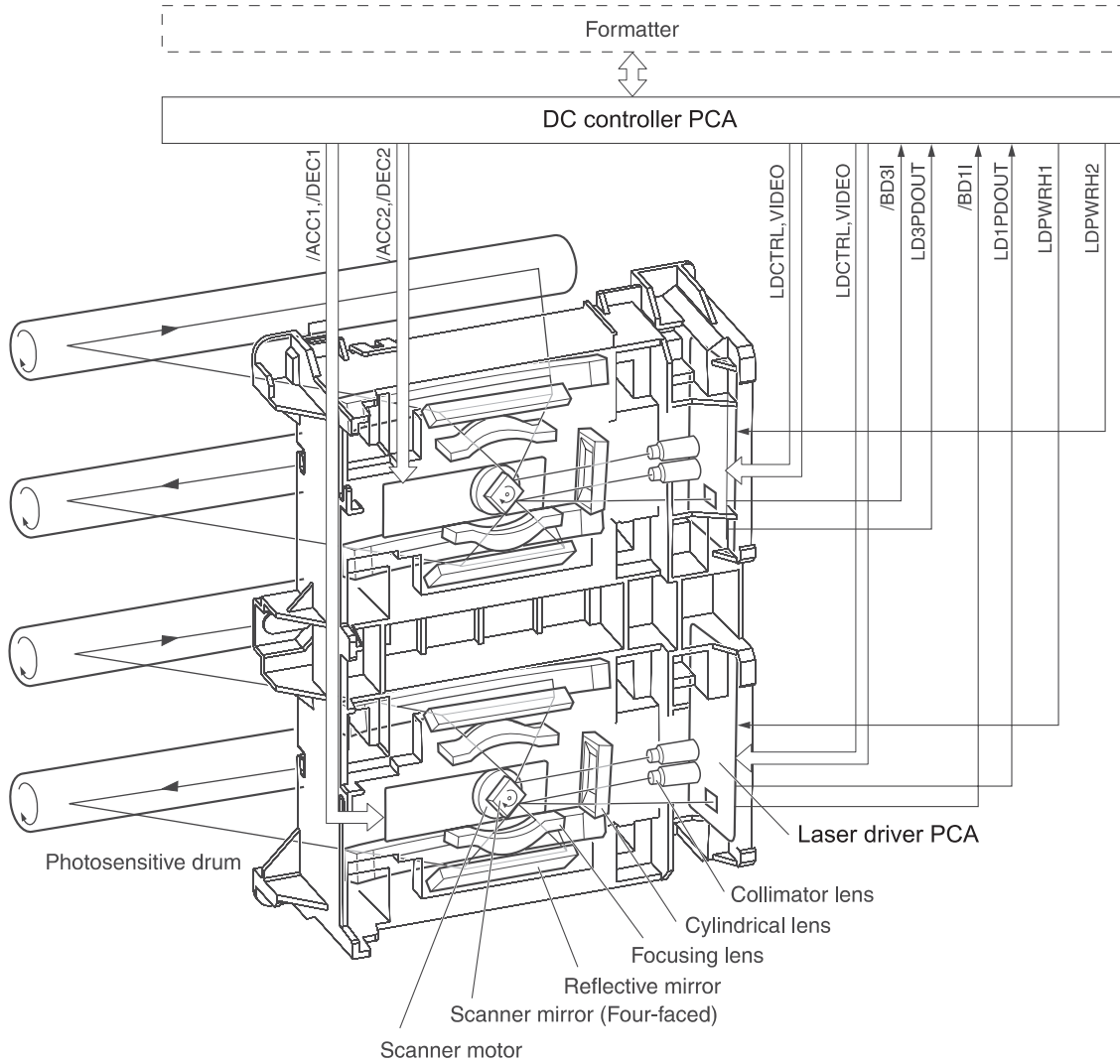

Sensors in the pickup-and-feed system trays (cassettes)

Paper sensors detect media in the trays. Other sensors react to the media as it moves through the paper path. If the media does not reach or pass each sensor within a specified time period, the DC controller determines that a jam has occurred and alerts the formatter. In models that include an automatic duplex accessory, the paper path contains additional sensors that detect movement through the duplex path.

Figure 4-6 Pickup-and-feed system sensors

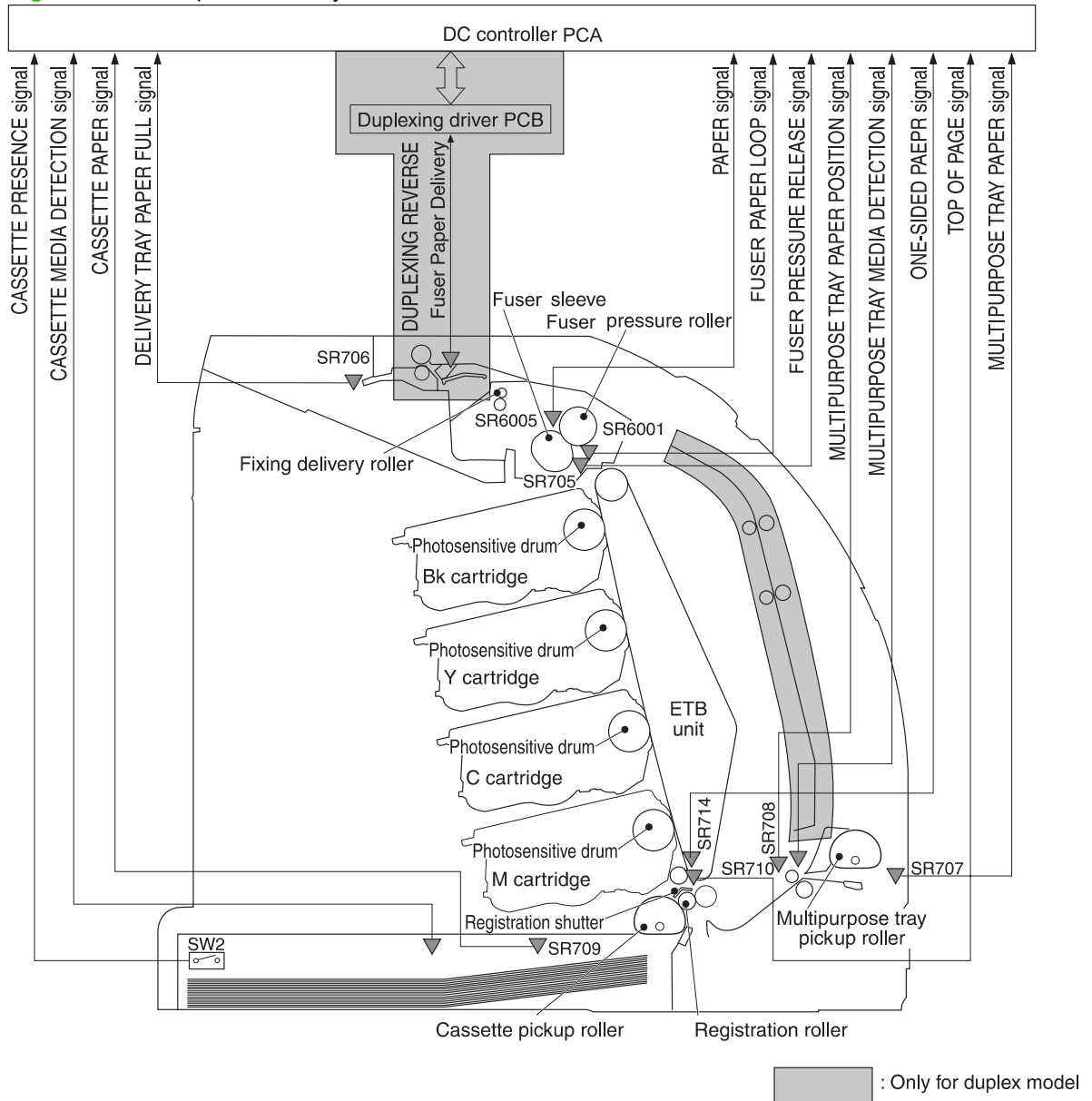

| | |
|-------|---|
| SR705 | Fuser pressure-release sensor |
| SR706 | Output-bin-full sensor |
| SR707 | Multipurpose-tray paper sensor |
| SR708 | Multipurpose-tray paper-position sensor (HP Color LaserJet 3000, 3800, and CP3505 Series printers only) |
| SR709 | Cassette paper-presence sensor |

| | |
|--------|-----------------------------|
| SR710 | Top-of-page sensor |
| SR714 | One-sided paper sensor |
| SR6001 | Paper-loop sensor |
| SR6005 | Fuser paper delivery sensor |
| SW2 | Cassette-presence switch |

Cassette pickup mechanism

When the cassette is correctly installed, SW2 detects its presence. The cassette paper sensor (SR709) detects whether media is present in the cassette, and the cassette media sensor detects the type of media. When the cassette is correctly installed and the correct media type is present, the cassette pickup operation begins.

1. The DC controller receives a print command from the formatter, and then begins rotating the pickup-and-feed motor (M4) at the correct speed for the media type.
2. After the motor reaches the correct speed and the fuser is at the correct temperature, the cassette pickup solenoid (SL5012) turns on and the cassette pickup roller begins rotating.
3. The cassette lifting plate lifts the paper stack, and the cassette pickup roller picks up one sheet of media. The separation pad prevents multi-feeds.

Figure 4-7 Cassette pickup mechanism

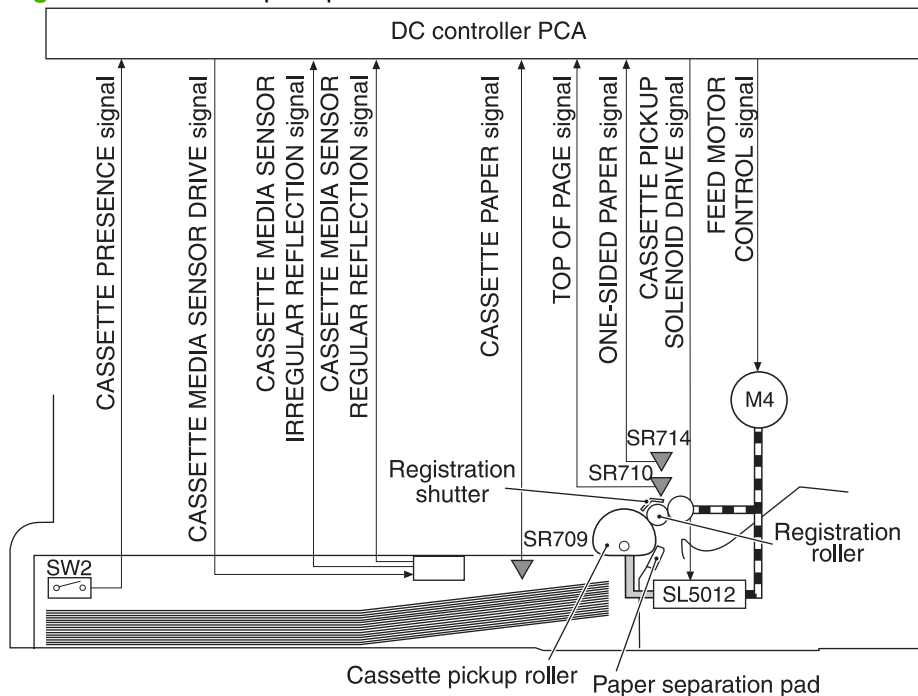

Multipurpose-tray pickup mechanism

The cassette must be installed in order for the multipurpose (MP) tray to operate. The MP tray paper sensor (SR707) detects whether media is present in the MP tray. When the cassette is correctly installed and media is present, the MP tray pickup operation begins.

1. The DC controller receives a print command from the formatter, and then begins rotating the pickup-and-feed motor (M4) at the correct speed for the media type.
2. After the motor reaches the correct speed and the fuser is at the correct temperature, the MP pickup solenoid (SL5013) turns on and the MP pickup roller begins rotating.
3. The MP pickup roller picks up one sheet of media. The separation pad prevents multi-feeds.
4. When the media reaches SR708, motor M4 stops, the MP tray media sensor detects the media, and then motor M4 restarts and resumes feeding media into the printer.

Figure 4-8 Multipurpose-tray pickup mechanism

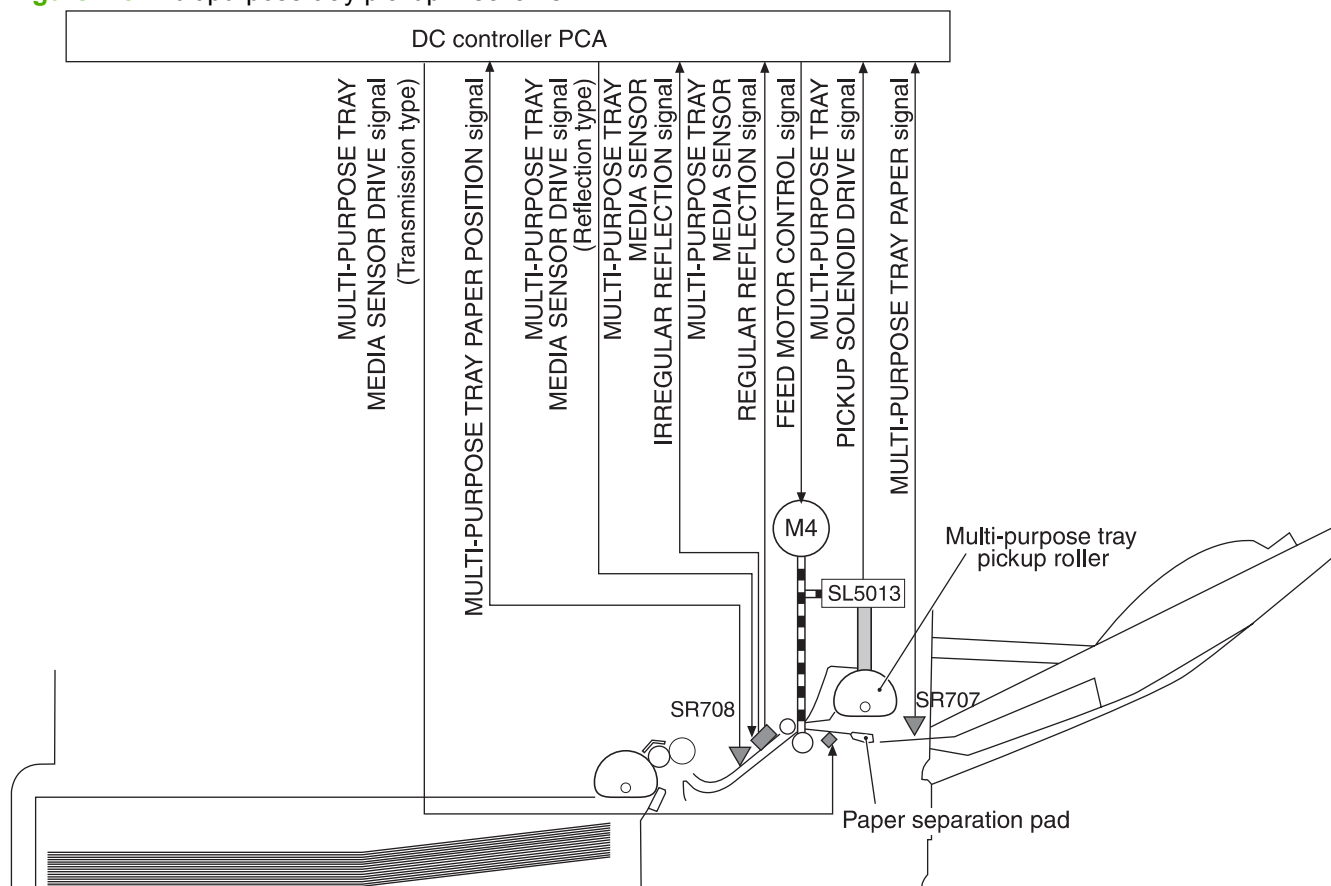

Feed-speed control

To optimize print quality, the pickup-and-feed motor rotates at different speeds depending on the type of media.

-  **NOTE:** In the following table, normal speed is 22 ppm for the HP CLJ 3800 and CP3505 models, and normal speed is 18 ppm for the HP CLJ 3600 models. Normal speed is 30 ppm for the HP CLJ 3000 model (black mode only).

| Media type | HP CLJ 3800 and CP3505 | HP CLJ 3600 | HP CLJ 3000 (full-color mode) | HP CLJ 3000 (monochrome mode) |
|--------------------|------------------------|----------------|-------------------------------|-------------------------------|
| Plain | 22 ppm | 17.6 to 18 ppm | 15 ppm | 30 ppm |
| Rough | 17.6 to 18 ppm | 17.6 to 18 ppm | 15 ppm | 15 ppm |
| Thin | 22 ppm | 17.6 to 18 ppm | 15 ppm | 30 ppm |
| Thick | 17.6 to 18 ppm | 17.6 to 18 ppm | 15 ppm | 15 ppm |
| Thicker | 17.6 to 18 ppm | 17.6 to 18 ppm | 15 ppm | 15 ppm |
| Postcard | 17.6 to 18 ppm | 17.6 to 18 ppm | 15 ppm | 15 ppm |
| Thicker postcard | 11 ppm | 11 ppm | 15 ppm | 15 ppm |
| Glossy | 17.6 to 18 ppm | 17.6 to 18 ppm | 15 ppm | 15 ppm |
| Heavy Glossy | 11 ppm | 11 ppm | 15 ppm | 15 ppm |
| Extra Heavy glossy | 8.8 to 9 ppm | 8.8 to 9 ppm | 15 ppm | 15 ppm |
| Envelope | 17.6 to 18 ppm | 17.6 to 18 ppm | 15 ppm | 15 ppm |
| Label | 17.6 to 18 ppm | 17.6 to 18 ppm | 15 ppm | 15 ppm |
| Gloss film | 3.6 ppm | 3.6 ppm | 15 ppm | 15 ppm |
| Transparency | 3.6 ppm | 3.6 ppm | 15 ppm | 15 ppm |

Sensor jam detection

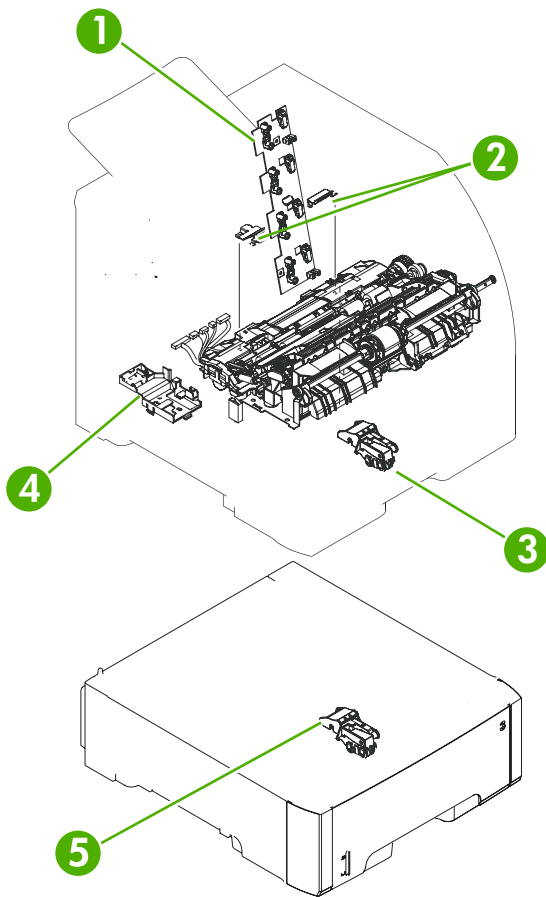

1. Cartridge sensor assembly
2. Paper and registration sensor covers
3. Cassette media sensor (HP Color LaserJet 3600, 3800, CP3505 only)
4. Temperature sensor
5. Media-sensor assembly (500-sheet feeder)

The following jams can occur during operation:

- Pick-up delay jam. The printer makes three attempts to pick up media from a tray. When the top-of-page sensor (SR710) does not detect the leading edge of a page within a specific time after the third attempt, the printing operation stops. The time varies depending on the printer model and the media source, as follows.

HP CLJ 3000: 1.3 seconds from the cassette; 2.2 seconds from the multipurpose tray (tray 1); 2.3 seconds from the paper feeder

HP CLJ 3600: for black printing, 1.0, 1.5, or 1.6 seconds; for color printing, 1.7, 2.7, or 2.9 seconds

HP CLJ 3800 and CP3505: 1.3 seconds from the cassette; 2.2 seconds from the multipurpose tray (tray 1); 2.3 seconds from the paper feeder
- Pick-up stationary jam. The printing operation stops when the top-of-page sensor (SR710) does not detect the trailing edge of a page within a specific time after it has detected the leading edge.

HP CLJ 3000: approximately 3.2 seconds

HP CLJ 3600: for black printing in Normal mode, 2.3 seconds; for color printing in Normal mode, 4.6 seconds

HP CLJ 3800 and CP3505: approximately 4.0 seconds
- Delivery delay jam. The printing operation stops when the fuser paper delivery sensor (SR6005) does not detect the leading edge of a page within a specific time after it has detected the leading edge.

HP CLJ 3000: approximately 3.0 seconds (in Normal print mode)

HP CLJ 3600: for black printing in Normal mode, 2.2 seconds; for color printing in Normal mode, 3.8 seconds

HP CLJ 3800 and CP3505: approximately 3.8 seconds (in Normal print mode)
- Wrapping jam. The printing operation stops when the fuser paper delivery sensor (SR6005) does not detect any media within a specific time. The time varies depending on the length of the media that the top-of-page sensor (SR710) detected.

HP CLJ 3000: approximately 1.9 seconds (in Normal print mode with letter-size media)

HP CLJ 3600: for black printing in Normal mode with letter-size media, 1.3 seconds; for color printing in Normal mode with letter-size media, 2.4 seconds

HP CLJ 3800 and CP3505: approximately 2.4 seconds (in Normal print mode with letter-size media)
- Delivery stationary jam. The printing operation stops when the fuser paper delivery sensor (SR6005) continues to detect paper for a specific time after the top-of-page sensor (SR710) detected its presence.

HP CLJ 3000: approximately 3.1 seconds (in Normal print mode)

HP CLJ 3600: for black printing in Normal mode, 2.2 seconds; for color printing, 3.9 seconds

HP CLJ 3800 and CP3505: approximately 3.9 seconds (in Normal print mode)
- Duplexing pickup delay jam (for models that include an automatic duplex accessory). The printing operation stops when the top-of-page sensor (SR710) does not detect the leading edge of the second side of the paper within a specific time after the duplexing feed motor (M10) started rotating.

HP CLJ 3000: approximately 2.0 seconds (in Normal print mode)

HP CLJ 3600: for black printing in Normal mode, 1.4 seconds; for color printing, 2.5 seconds

HP CLJ 3800 and CP3505: approximately 2.5 seconds (in Normal print mode)

- Residual-paper jam. The printing operation stops when any of the following sensors detects media during the initial sequence period:

Top-of-page sensor (SR710)

Paper-loop sensor (SR6001)

Fuser paper delivery sensor (SR6005)

Duplexing reverse sensor (SR823)

Multipurpose tray (MPT) paper-position sensor (SR708)

- Door-open jam. The printing operation stops when the DC controller detects that a printer door is open.

Image-formation system

The image-formation system, which forms a toner image on media, consists of several interdependent systems:

- Electrostatic latent-image-formation
- Developing
- Transfer
- Fuser
- Drum cleaning

The printer includes four print cartridges that contain the toner used to create the image on the media. Toner is applied in the following order, using only the colors necessary for a specific image: magenta (M), cyan (C), yellow (Y), and black (Bk).

Figure 4-9 Image formation system

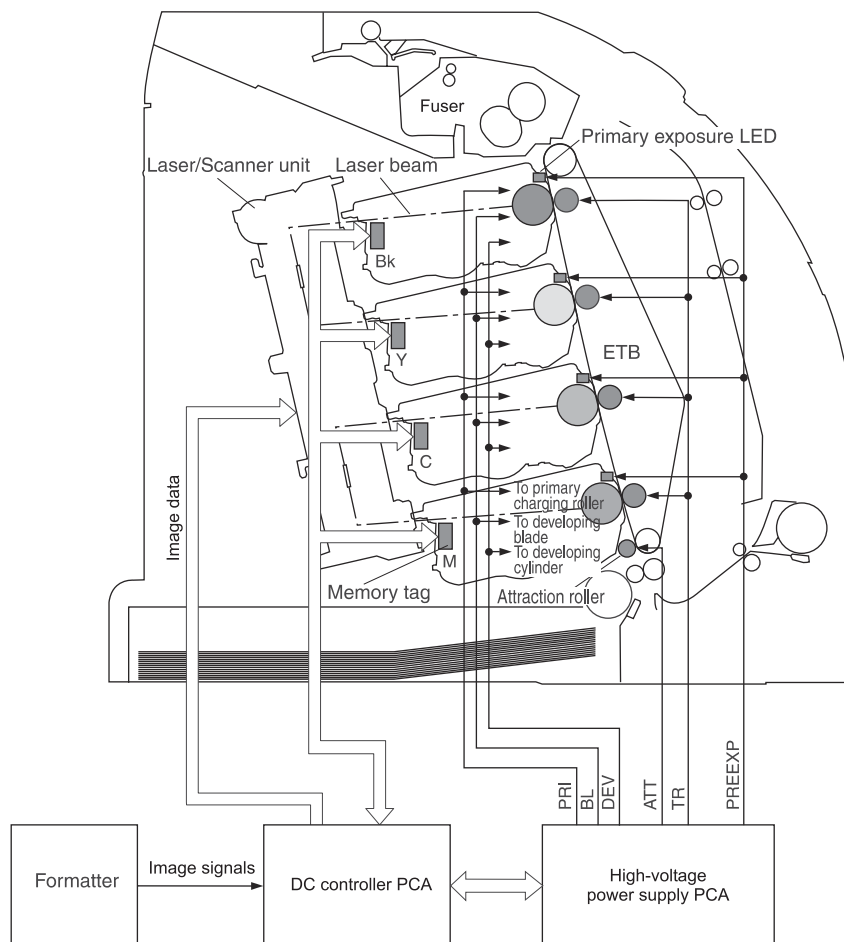

Image-formation process

Laser printing requires the interaction of several different technologies including electronics, optics, and electrographics to provide a printed page. Each process functions independently and must be coordinated with the other processes. Image formation consists of the following five processes:

1. Latent-image formation
2. Developing
3. Image transfer
4. Fusing
5. Transfer-belt cleaning

These processes are divided into ten steps, which are shown in [Figure 4-10 Image-formation steps on page 63](#) and described in the following sections.

Figure 4-10 Image-formation steps

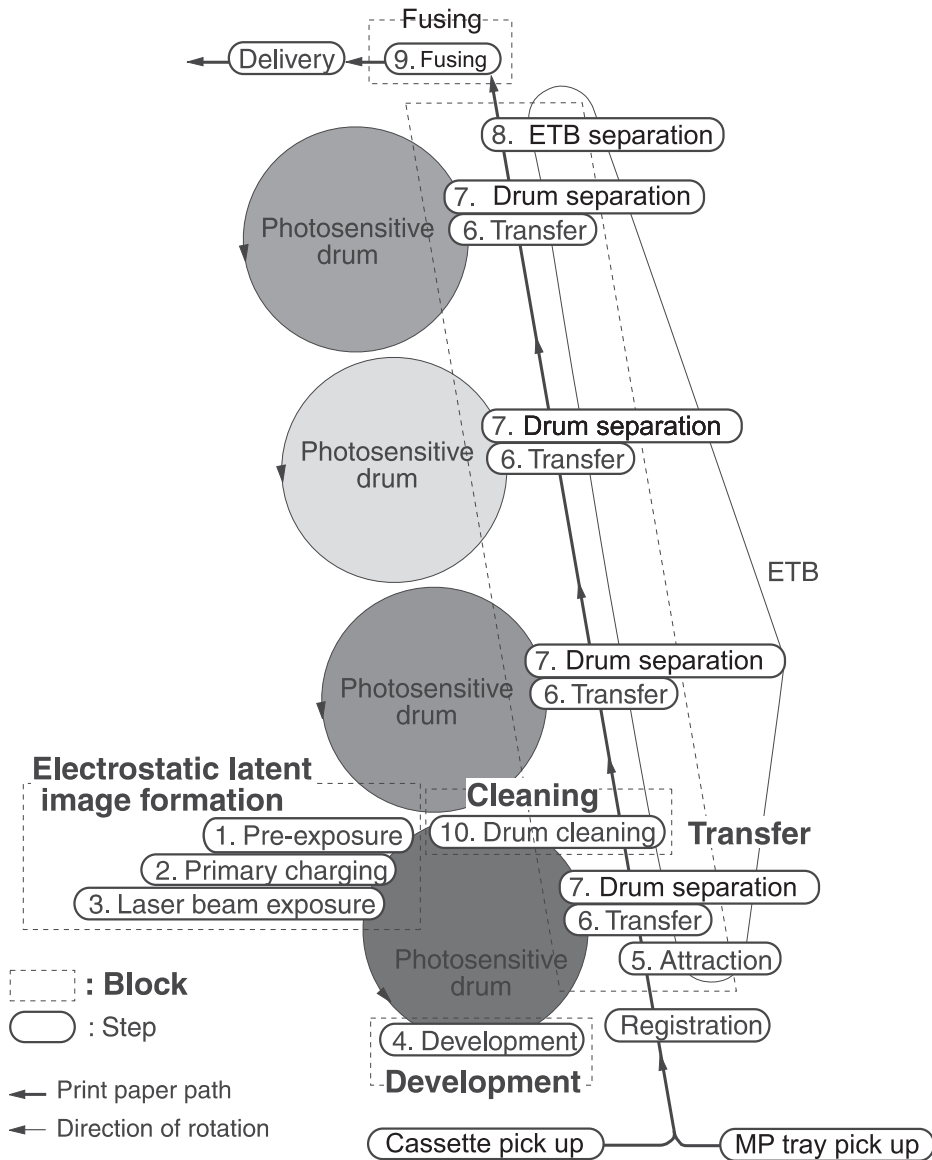

Latent-image formation stage

During the three steps that comprise this stage, a latent image is formed by applying a negative charge to the photosensitive drum. You cannot see this image on the drum.

Step 1: pre-exposure

The pre-exposure LED hits the photosensitive drum surface and eliminates any residual charge on the surface.

Figure 4-11 Pre-exposure

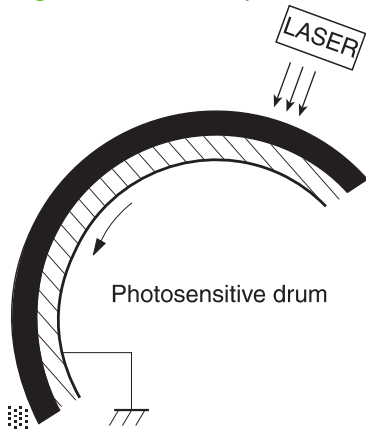

Step 2: primary charging

A high-voltage dc bias is applied to the primary charging roller, which is made of conductive rubber and is in contact with the drum surface. As the roller moves across the drum, it applies the negative charge to that surface.

Step 3: laser-beam exposure

The laser beam scans the photosensitive drum to neutralize the negative charge on portions of the drum surface. An electrostatic latent image is formed where the negative charge was neutralized.

Figure 4-12 Laser-beam exposure

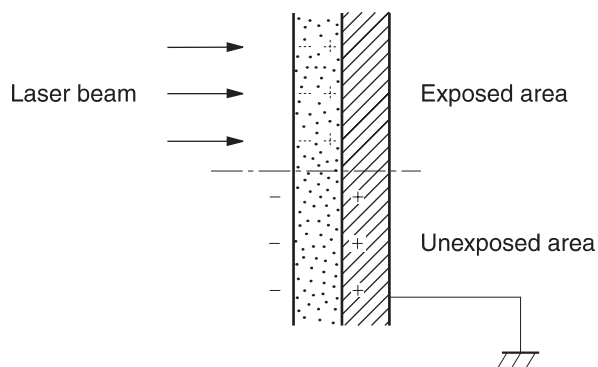

Developing stage

The developing cylinder comes in contact with the photosensitive drum and deposits toner on the electrostatic latent image.

Step 4: developing

Toner acquires a negative charge as a result of the friction from the developing cylinder rotating against the developing blade. When the negatively charged toner comes in contact with the drum, it adheres to the electrostatic latent image. When the toner is on the drum the image becomes visible.

Transfer stage

Step 5: media feed

The printer generates electrostatic force to pull a sheet of print media to the ETB. The sheet adheres to the belt and travels between the ETB engaged motor and the attraction roller.

The attraction roller transfer positive dc bias to the media so that the negatively charged toner can be easily transferred from the drum to the sheet.

Figure 4-13 Media feed

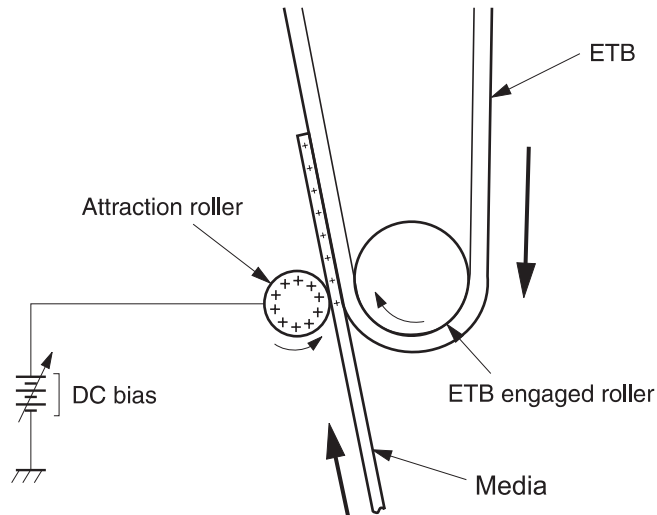

Step 6: image transfer

The ETB carries the positively charged media over the photosensitive drum. As it passes between the transfer roller and the drum, the transfer roller applies a positive dc bias to the belt. Negatively charged media attracts negatively charged toner from the drum surface. This process is repeated for each toner color.

Figure 4-14 Image transfer

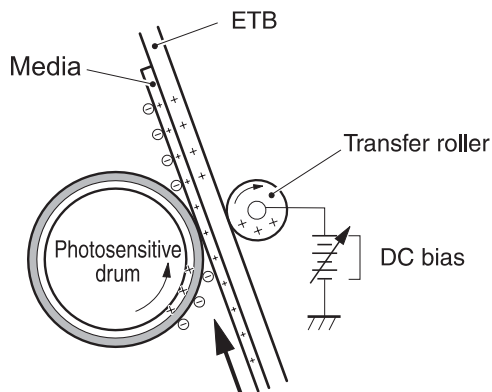

Step 7: separation from the drum

The beam strength or stiffness of media combined with the ETB holding force causes the media to separate from the drum. The sheet remains on the ETB and continues to travel through the printer.

Figure 4-15 Separation from the drum

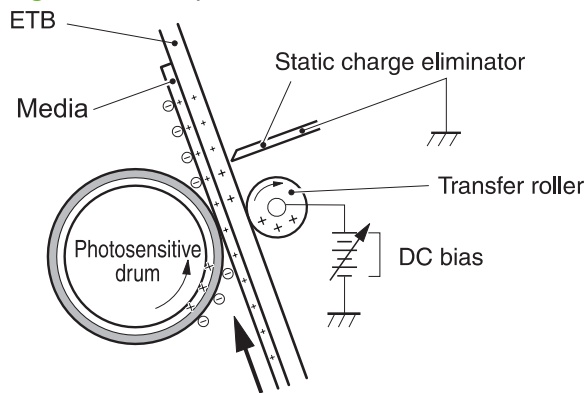

Step 8: separation from the ETB

The elasticity of the print media causes it to separate from the ETB. The static-charge eliminator is not involved during this step.

Fusing stage

Until the fusing stage is complete, the image is not permanently affixed to the print media. The toner can be easily smudged until the heat and pressure of the fusing process fix the image to the sheet.

Step 9: fusing

The printer uses a ceramic heater to accomplish the color-on-demand fusing process. The heater has a low heat capacity, which results in a short warm-up period and yields energy savings.

Figure 4-16 Fusing

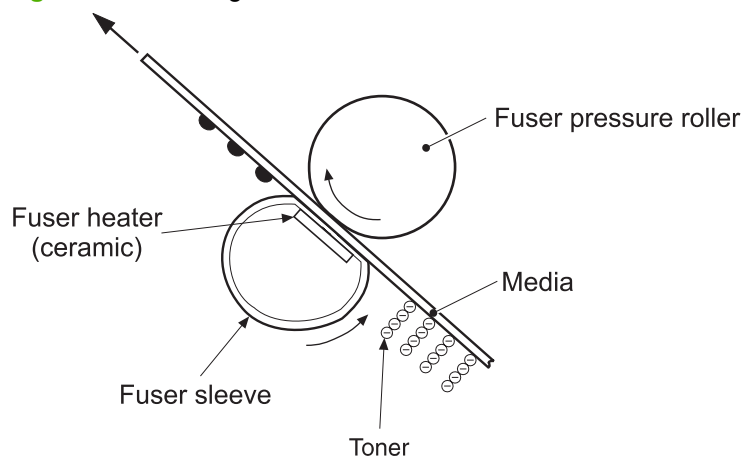

Cleaning stage

Not all of the toner is removed from the photosensitive drum during the transfer stage. During the cleaning stage, the residual, or waste, toner is cleared from the drum surface to prepare the surface for the next latent-image formation.

Step 10: drum cleaning

The cleaning blade scrapes the residual toner off the surface of the photosensitive drum and deposits it in the waste-toner container. The drum is now clear, and is ready for the next image-formation process.

Print cartridge

This printer has four print cartridges: magenta (M), cyan (C), yellow (Y), and black (Bk). Each cartridge holds non-magnetic, single-component toner that is composed of resins in the four colors.

In addition to the toner, each cartridge contains a developing cylinder, toner-feed roller, and stirrer. The developer motor rotates these parts so that each print cartridge can deposit toner to form a visible image on the photosensitive drum.

Figure 4-17 Print cartridge

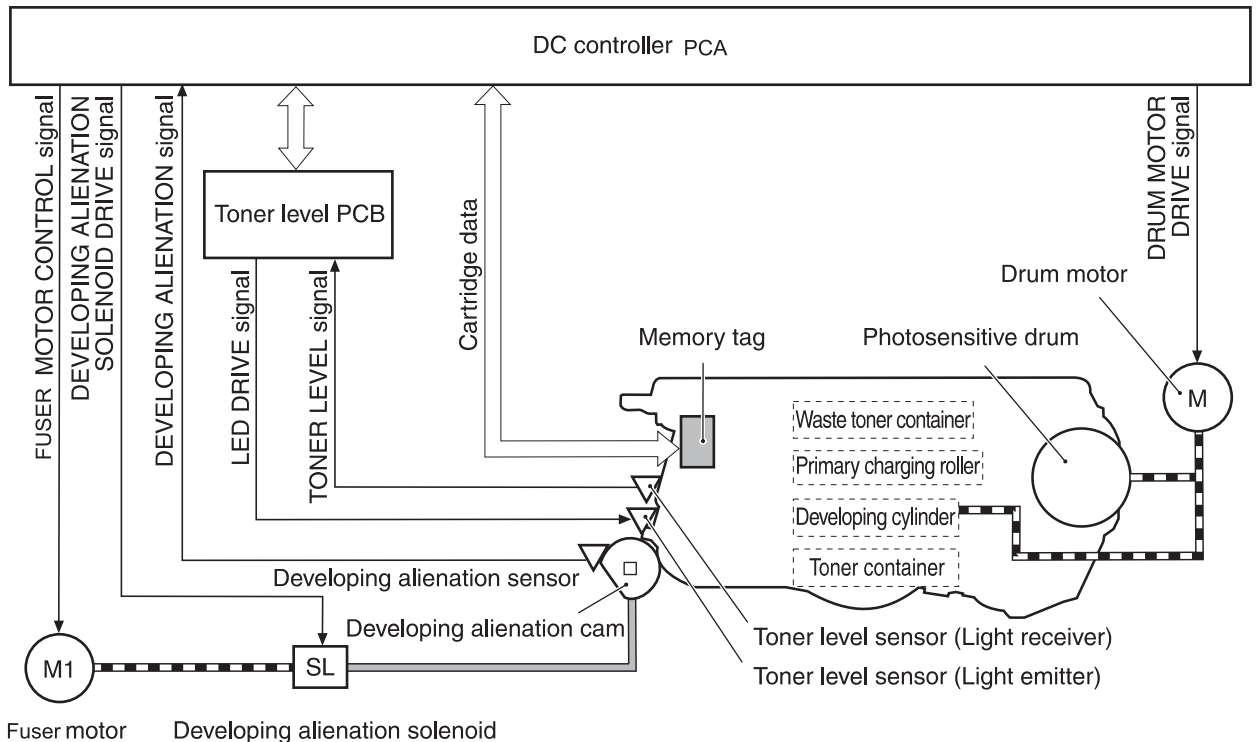

The cartridges in this printer include the photosensitive drum, the primary charging roller, and the developing roller. Each cartridge performs these functions:

- Memory tag control
- Cartridge presence detection
- Developer roller engagement and disengagement control

Print-cartridge activation

A memory tag is a nonvolatile memory that is built into the print cartridge. The DC controller reads and writes data that is stored in the memory tag. The DC controller reads data at the following times:

- When the power is turned on
- When someone closes the front cover
- When it receives a command from the formatter

The DC controller writes information at the following times:

- At a specified interval during printing
- When it receives a command from the formatter

When the read/write operation fails or the wrong data is read or written, the DC controller determines that an error has occurred and notifies the formatter of a cartridge-memory abnormality. Printing then stops.

Figure 4-18 Print-cartridge activation

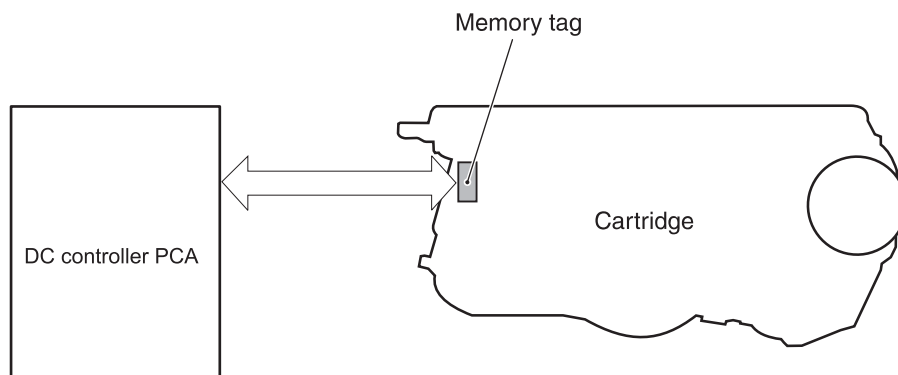

5 Removal and replacement

- [Removal and replacement strategy](#)
- [External doors, covers, and panels](#)
- [Internal assemblies](#)
- [Printed circuit assemblies \(PCAs\)](#)
- [Sensors](#)
- [500-sheet feeder](#)

Removal and replacement strategy

Introduction

This chapter describes the removal and replacement of field-replaceable units (FRUs) only.

Replacing FRUs is generally the reverse of removal. Occasionally, notes are included to provide directions for difficult or critical replacement procedures.

HP does not support repairing individual subassemblies or troubleshooting to the component level.

- ⚠ **WARNING!** Turn the printer off, wait 5 seconds, and then remove the power cord before attempting to service the printer. If this warning is not followed, severe injury can result, as well as damage to the device. The power must be on for certain functional checks during troubleshooting. However, the power supply should be disconnected during parts removal.

Never operate or service the printer with the protective cover removed from the laser/scanner assembly. The reflected beam, although invisible, can damage your eyes.

The sheet-metal parts can have sharp edges. Be careful when handling sheet-metal parts.

△



CAUTION: Some parts are sensitive to electrostatic discharge (ESD). Look for the ESD reminder when removing printer parts. Always perform service work at an ESD-protected workstation or mat. If an ESD workstation or mat is not available, ground yourself by touching the sheet-metal chassis *before* touching an ESD-sensitive part.

Protect the ESD-sensitive parts by placing them in ESD pouches when they are out of the printer.

CAUTION: Do not bend or fold the flat flexible cables (FFCs) during removal or installation.

- 📝 **NOTE:** To install a self-tapping screw, first turn it counterclockwise to align it with the existing thread pattern, and then carefully turn it clockwise to tighten. Do not overtighten. If a self-tapping screw-hole becomes stripped, repair the screw-hole or replace the affected assembly.

The printer shown in this chapter is a duplex model. It has a duplex fan mounted to the front cover, a duplex-feed-drive assembly, and a duplexing-reverse-drive assembly mounted under the upper (top) cover. Simplex model printers do not have these parts.

The electrostatic transfer belt (ETB) shown in this chapter is for the duplex model printer. The ETB for the simplex model looks different.

Required tools

- #2 Phillips screwdriver with a magnetic tip and a 152-mm (6-inch) shaft length
- Small flatblade screwdriver
- Needle-nose pliers
- ESD mat (if one is available)
- Penlight (optional)



△ **CAUTION:** Always use a Phillips screwdriver (callout 1). Do not use a pozidrive screwdriver (callout 2) or any motorized screwdriver. These can damage screws or screw threads.

CAUTION: Do *not* pull directly on the wires to disconnect them. *Always* pull on the plastic body of a connector to avoid damaging the connector wires.

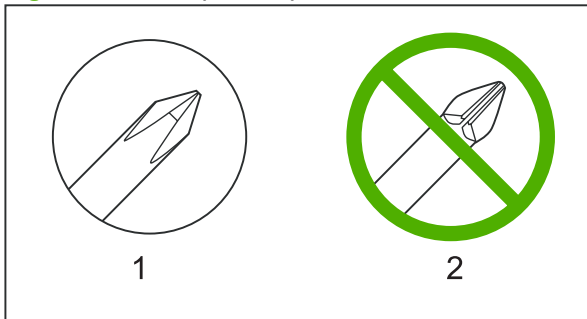
Figure 5-1 Phillips and pozidrive screwdriver comparison

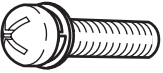

Types of screws

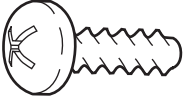
| Illustration | Description | Size | Part Number | Use |
|---|----------------------------|---------------|----------------|---|
|  | Screw with washer | M3X8 | XA9-1420-000CN | Used to secure metal components to metal components (for example, a ground wire to the frame) |
|  | Screw, RS | M3X6 M3X10 | XA9-1499-000CN | Used to secure metal to metal |
|  | Screw, tapping, truss head | M4X10 | XB4-7401-000CN | Used to secure anything to plastic |

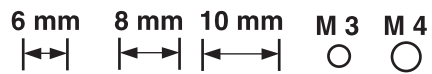

Service approach

Printer repair normally begins by using the printer internal diagnostics and the following two-step process:

1. Isolate the problem to the major system (for example, the network or server, or the printer).
2. Troubleshoot the problem by using the procedures in chapter 6.

After a faulty part is located, the printer can usually be repaired at the assembly level by replacing field-replaceable units (FRUs). Some mechanical assemblies might need to be repaired at the subassembly level. Hewlett-Packard Company does not support replacement of components on the printed circuit assemblies.

Before performing service

- Remove all media.
- Unplug the power cable.
- Place the product on an ESD mat (if available).
- Remove the print cartridges.
- Remove the tray 2 cassette.

After performing service

- Return all media to the trays.
- Plug in the power cable.
- Reinstall the print cartridges.
- Reinstall the tray 2 cassette.

Print cartridges

1. Open the front cover.

Figure 5-2 Remove the print cartridges (1 of 2)



2. Grasp the two blue handles on the print cartridge, and pull the cartridge out of the printer.

Figure 5-3 Remove the print cartridges (2 of 2)



External doors, covers, and panels

Front cover

This part is called the front door in the user documentation and in chapter 1, “Product information.”

 **NOTE:** The printer shown in the following procedure is a duplex model, and has a fan mounted to the front-cover assembly. Simplex model printers do not have one.

NOTE: The ETB shown in this procedure is for the duplex model printer. The ETB for the simplex model looks different.

1. Open the front cover.
2. Push in the two blue ETB latch buttons (callout 1) and pull the ETB out of the printer.

Figure 5-4 Remove the front cover (1 of 7)

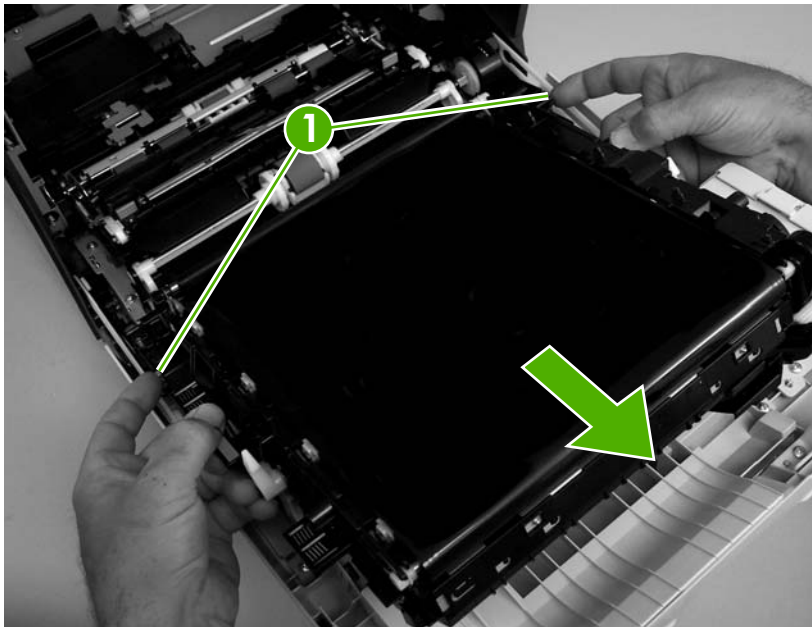

3. Move the two ETB connectors (callout 2) to the raised position (as when the front cover is closed).

Figure 5-5 Remove the front cover (2 of 7)

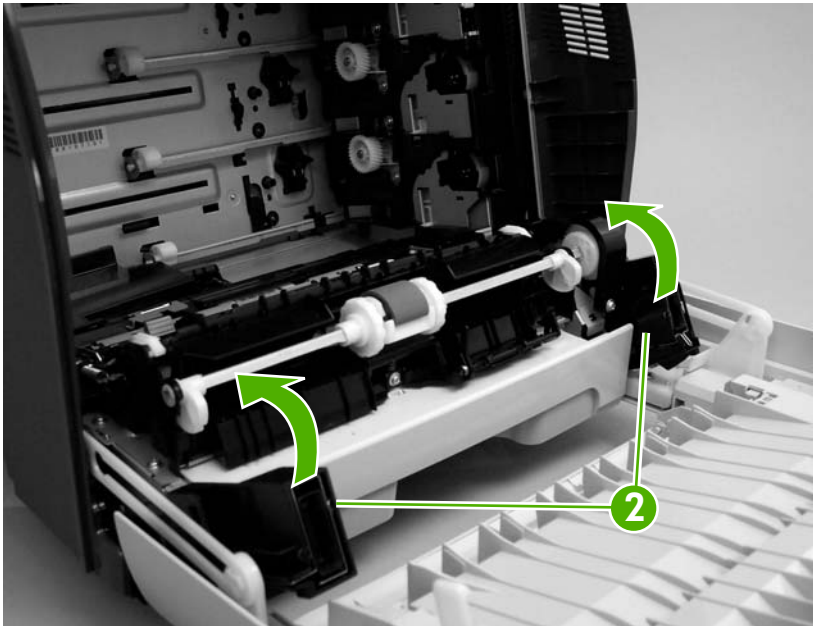

4. Lift the front cover slightly, and then gently pry the retainer arms off of the clips.

Figure 5-6 Remove the front cover (3 of 7)

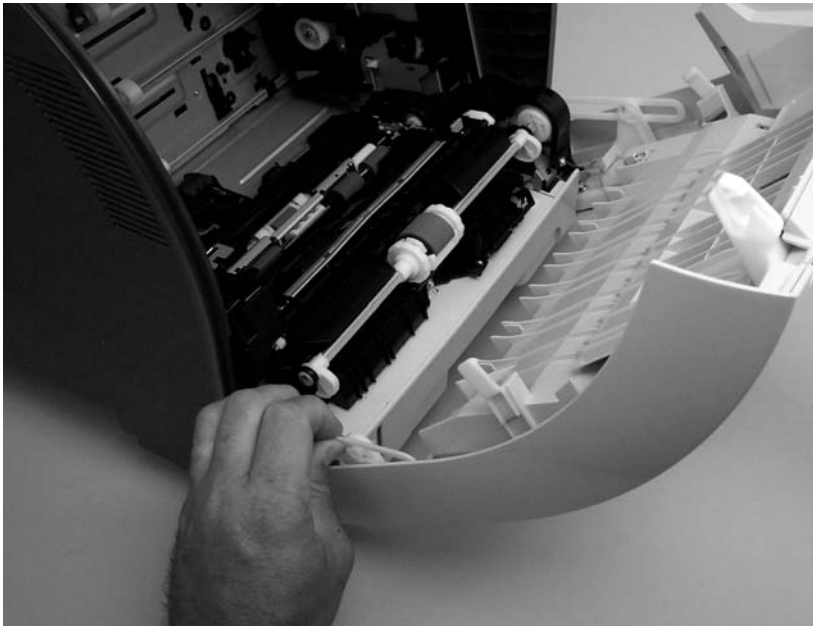

5. For duplex models, use the following procedure to remove the fan. For simplex models, skip to the next step.
 - a. Remove two screws (callout 3) that secure the fan to the cover and one screw that secures the wire-harness cover (callout 4).

Figure 5-7 Remove the front cover (4 of 7)

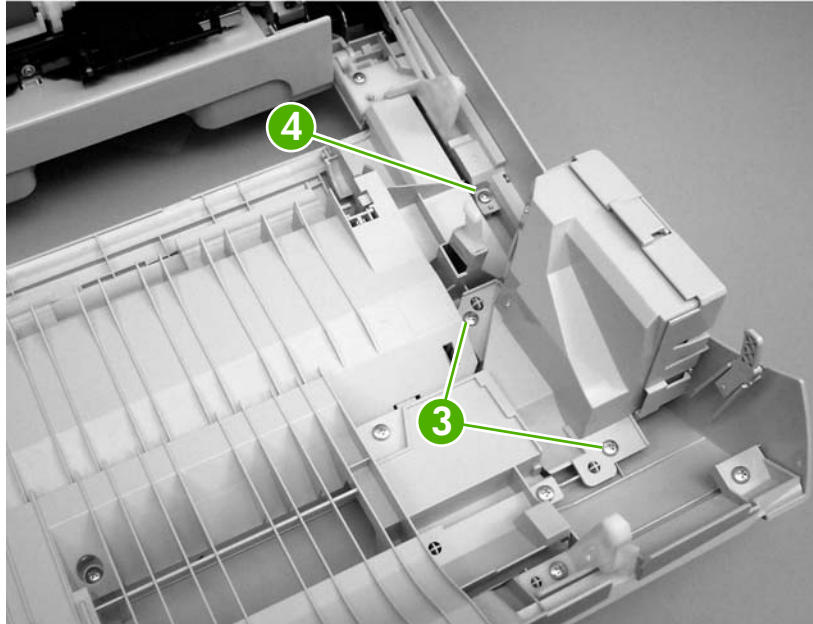

- b. Use a small flatblade screwdriver to release the wire-harness-cover locking tab (callout 5) and remove the wire-harness cover.

Remove the fan and set it next to the printer.

Figure 5-8 Remove the front cover (5 of 7)

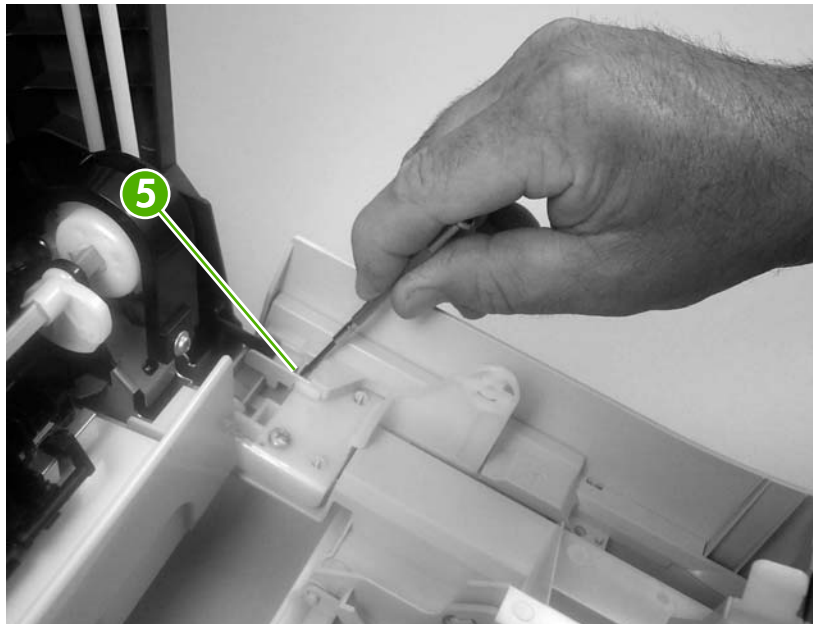

6. Support the door and remove four screws (callout 6).

Figure 5-9 Remove the front cover (6 of 7)

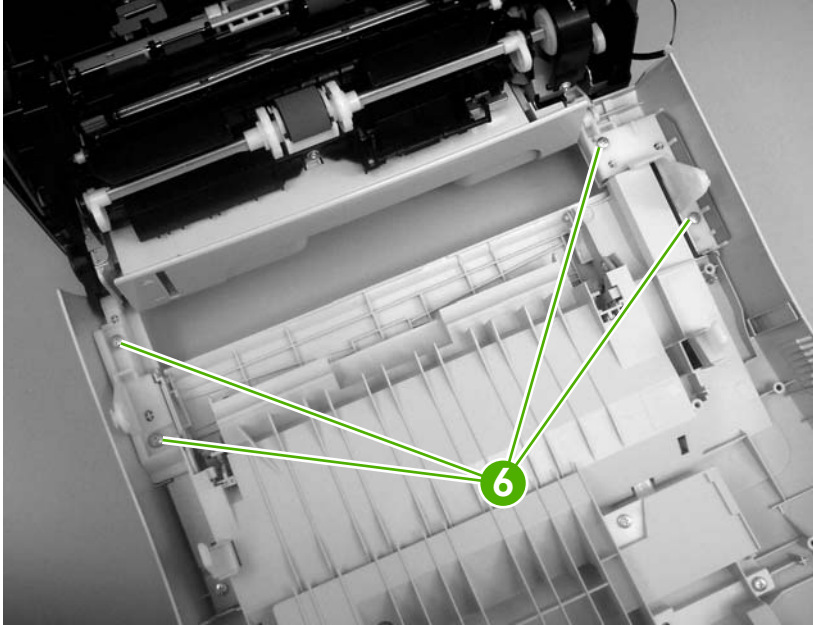

7. Pull the front cover forward to remove it.

Figure 5-10 Remove the front cover (7 of 7)

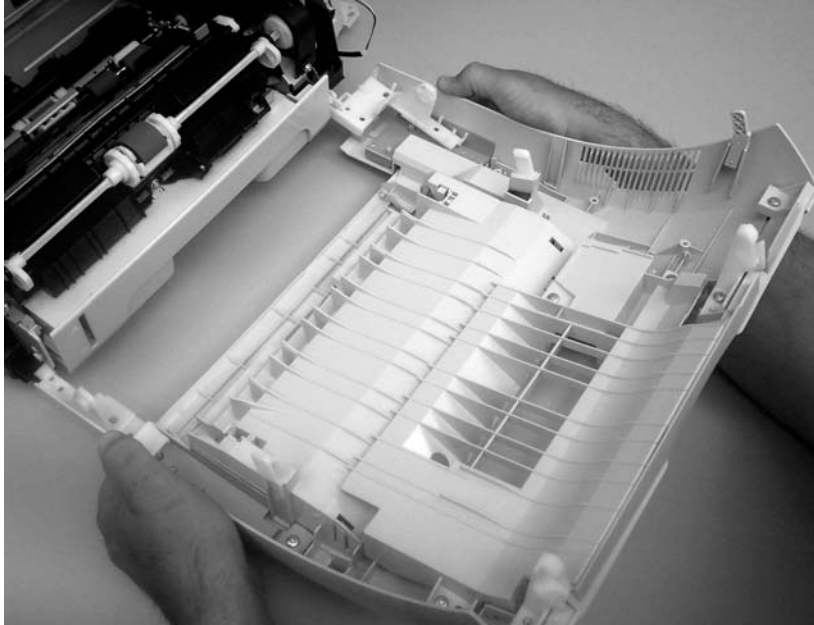

 **TIP: Duplex model only:** When you reinstall the duplex-fan wire-harness, make sure that the wire-harness is clipped correctly to the door.

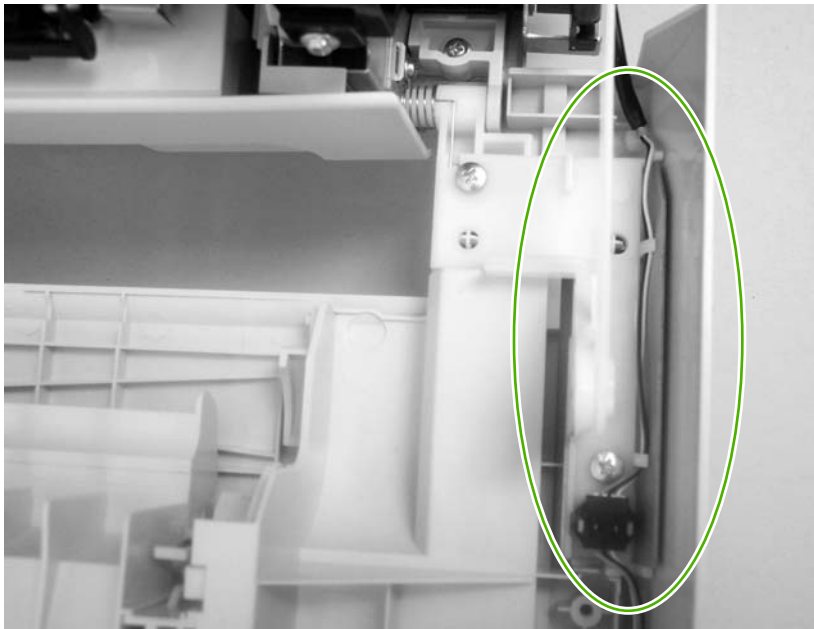

Upper cover (fuser door)

1. Rotate the output bin towards the front of the printer and remove it.

Figure 5-11 Remove the upper cover (1 of 5)



2. Open the upper cover, and then squeeze the two blue fuser-locking levers to release the fuser. Rotate the fuser up and out of the printer.

△ **CAUTION:** The fuser might be hot. Wait for the fuser to cool *before* you remove it.

Figure 5-12 Remove the upper cover (2 of 5)



3. Support the upper cover and remove four screws (callout 1).

 **NOTE:** The screw in the recessed area (see [Figure 5-13 Remove the upper cover \(3 of 5\)](#) on page 81) is longer than the other three mounting screws. Make sure to replace this screw in the correct location when installing the upper cover.

Figure 5-13 Remove the upper cover (3 of 5)



4. Lift up slightly on the right of the upper cover and disconnect one connector (callout 2).

Figure 5-14 Remove the upper cover (4 of 5)

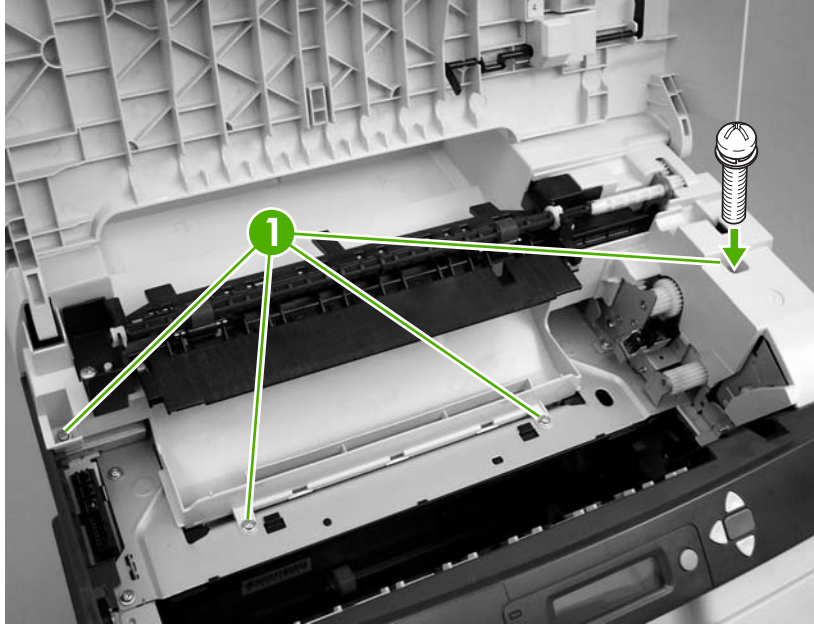
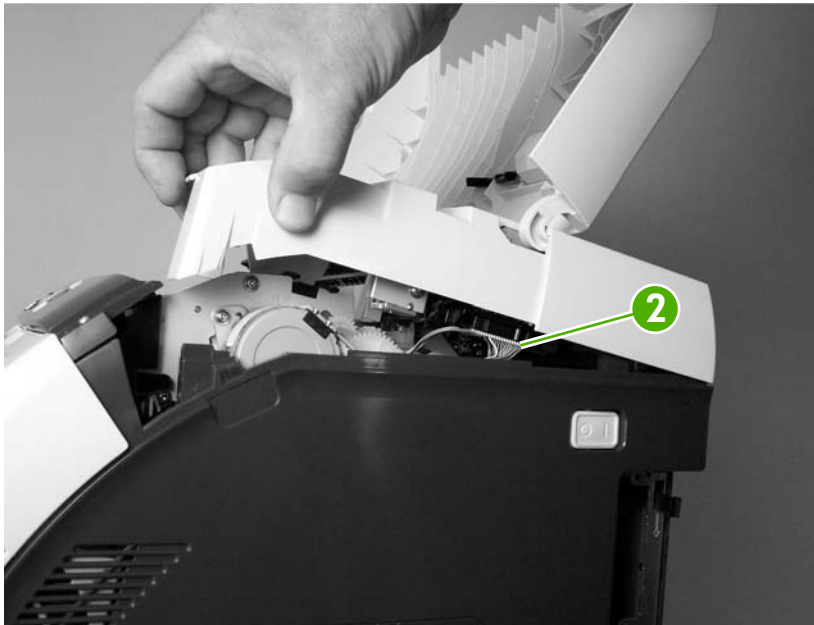

5. Lift the upper cover to remove it.

Figure 5-15 Remove the upper cover (5 of 5)





 **TIP:** Make sure that the upper cover is seated correctly when it is reinstalled. Wire-harness cables can block the cover alignment pin and become pinched or frayed when the cover is fastened to the chassis.

Rear lower cover

1. Carefully flex the hinge bracket until you can dislodge the hinge pin. Move the rear lower cover away from the bracket to remove it.

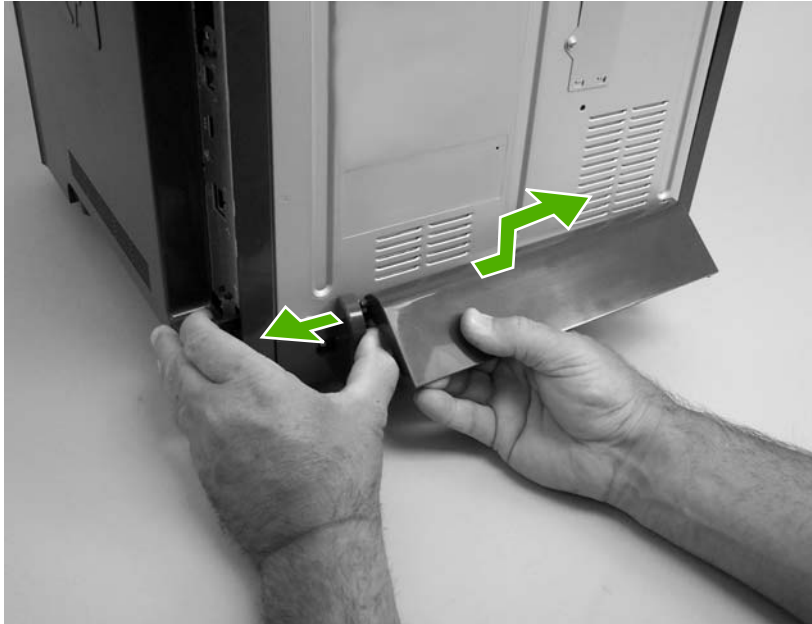
Figure 5-16 Remove the rear lower cover (1 of 2)



 **NOTE:** Step 2 is only necessary if you are removing the rear upper cover or installing a replacement hinge bracket.

2. Remove one screw (callout 1), and then remove the hinge bracket (callout 2).

Figure 5-17 Remove the rear lower cover (2 of 2)

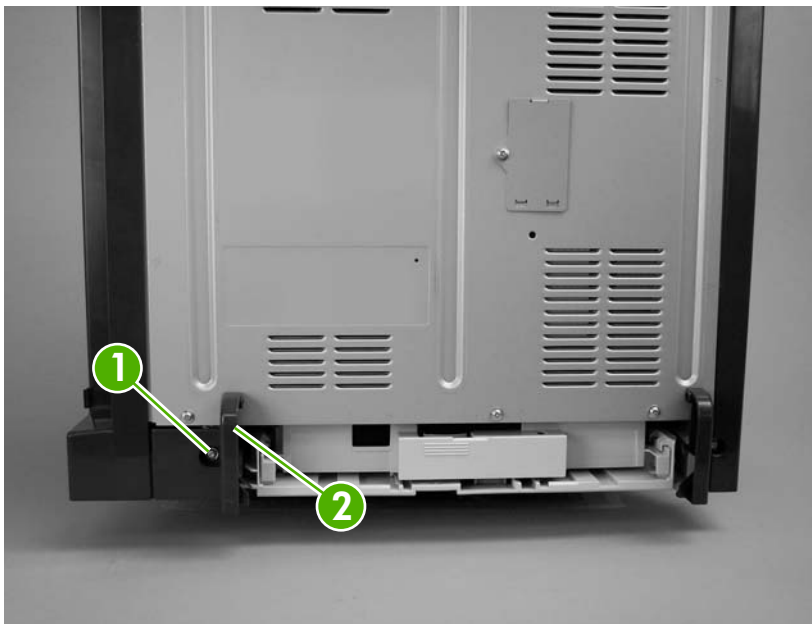

Left cover

1. Remove the following components:
 - Upper cover. See [Upper cover \(fuser door\) on page 80.](#)
 - Rear lower cover. See [Rear lower cover on page 83.](#)
2. Remove two screws (callout 1).

Figure 5-18 Remove the left cover (1 of 5)

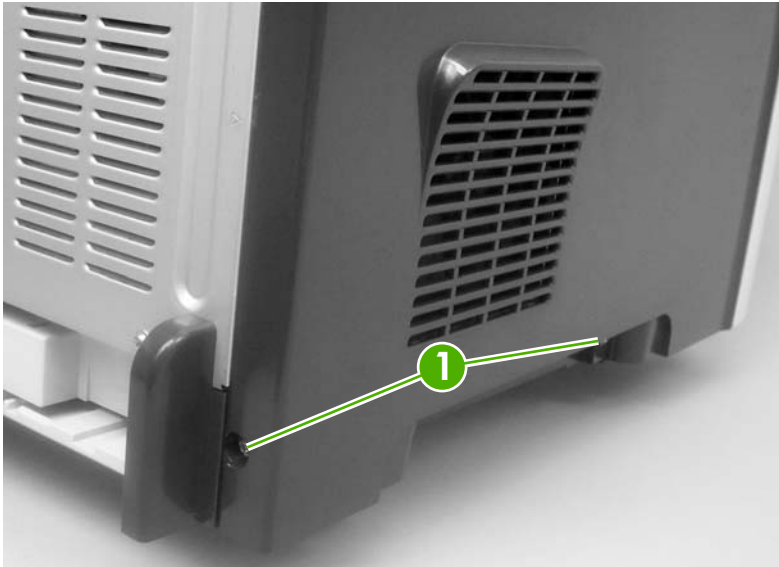

3. Open the front cover.
4. Use a flatblade screwdriver to release the three locking tabs (callout 2) at the front of the left cover.

Figure 5-19 Remove the left cover (2 of 5)

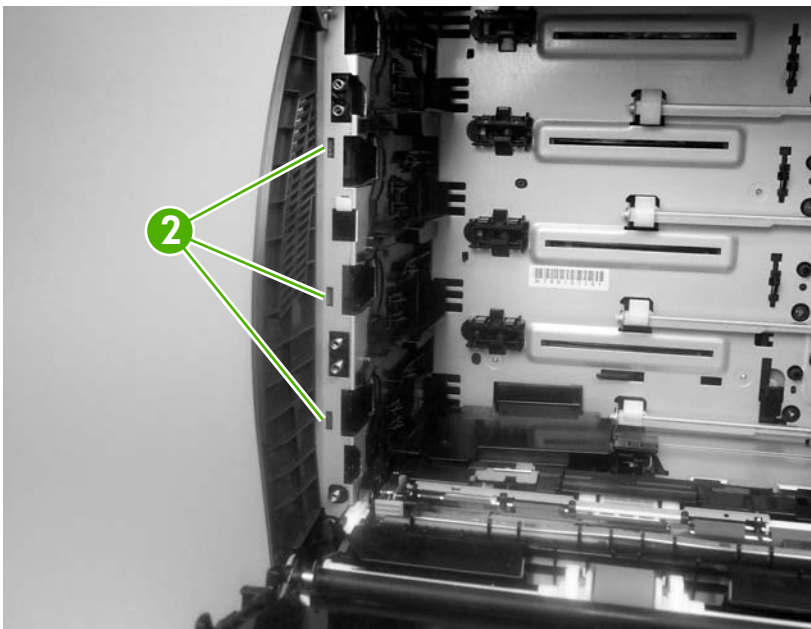

5. Release the locking tab (callout 3) at the upper front of the left cover.

Figure 5-20 Remove the left cover (3 of 5)

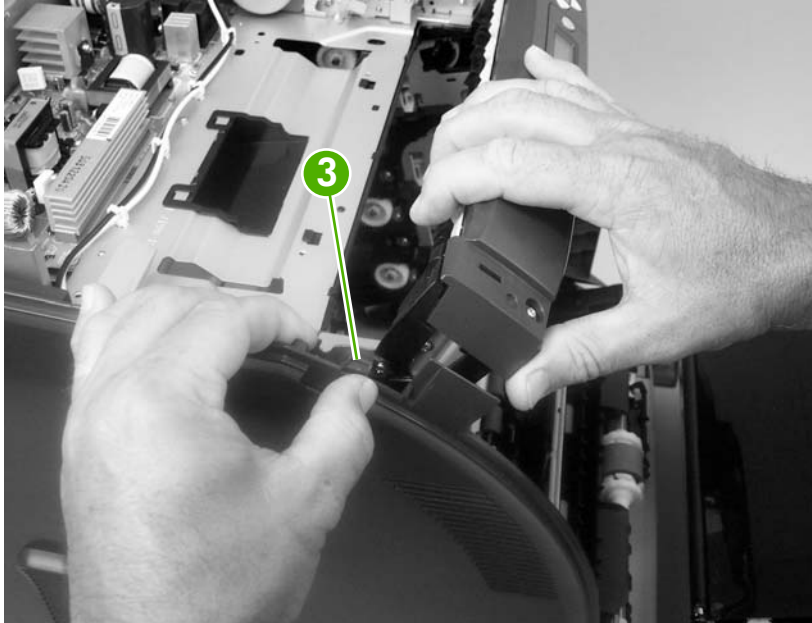

6. Release the two locking tabs at the rear of the left cover.

Figure 5-21 Remove the left cover (4 of 5)

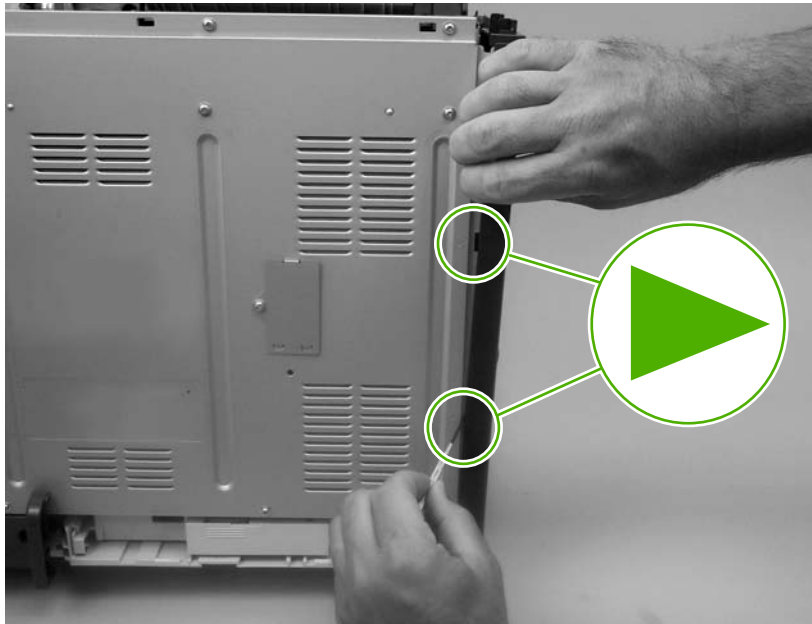

7. Rotate the back of the cover away from the printer, and then slide the cover to the rear to disengage the two front locking tabs and release the cover.

Figure 5-22 Remove the left cover (5 of 5)

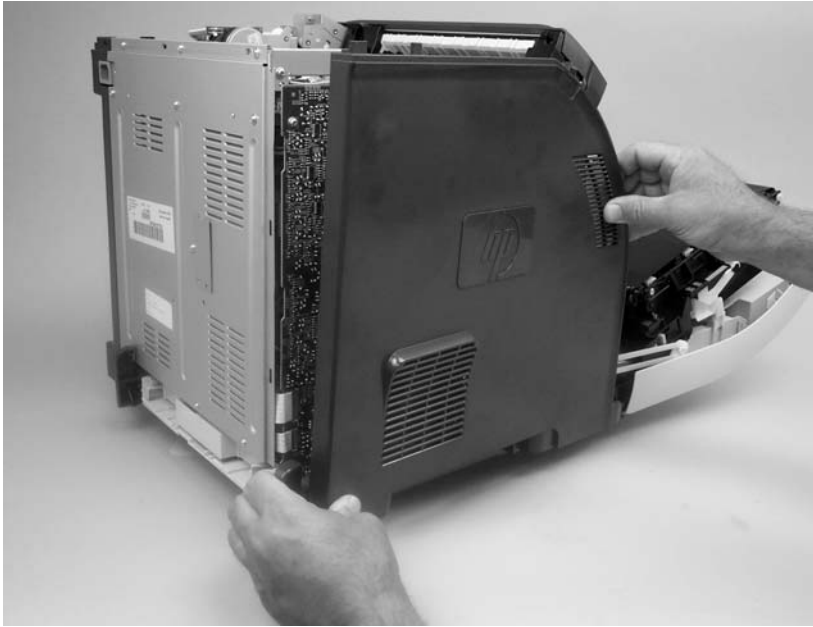

 **NOTE:** This photograph shows the two front locking tabs low on the inside of the left cover.

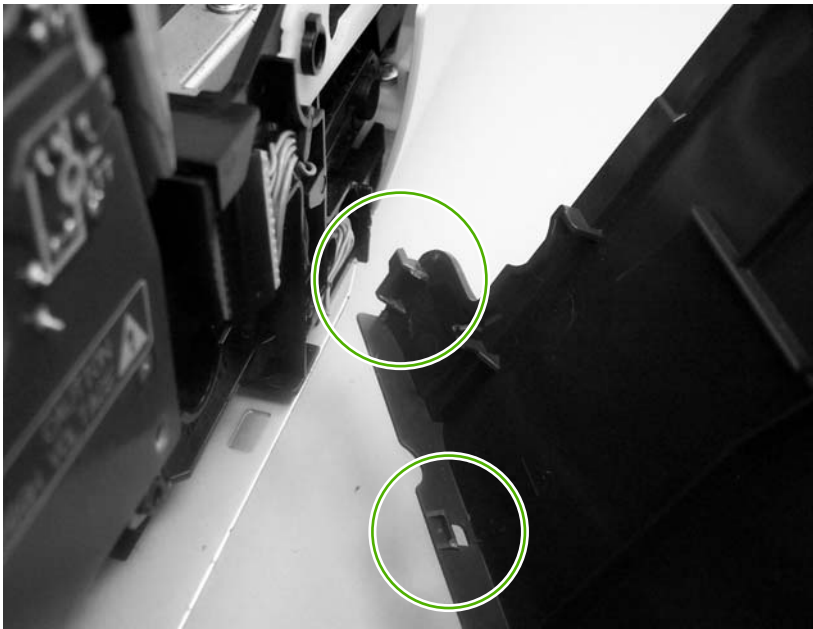

Right cover

1. Remove the following components:
 - Upper cover. See [Upper cover \(fuser door\) on page 80](#).
 - Formatter cage. See [Formatter cage on page 92](#).
2. Remove one screw (callout 1).

Figure 5-23 Remove the right cover (1 of 4)



3. Open the front cover.

4. Use a flatblade screwdriver to release the two locking tabs (callout 2) on the front of the right cover, and the tab on the printer chassis (callout 3).

Figure 5-24 Remove the right cover (2 of 4)

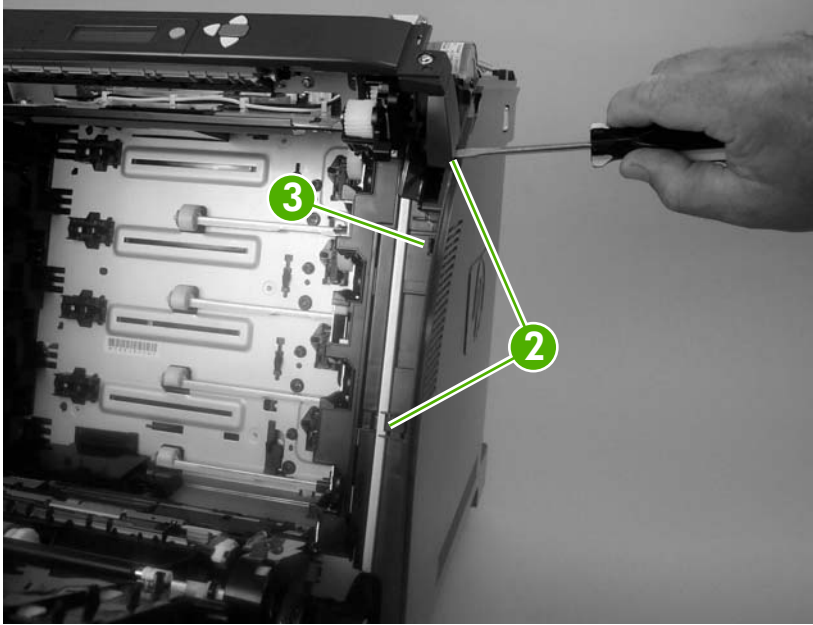

 **NOTE:** This photograph shows the front locking tabs on the inside of the right cover.

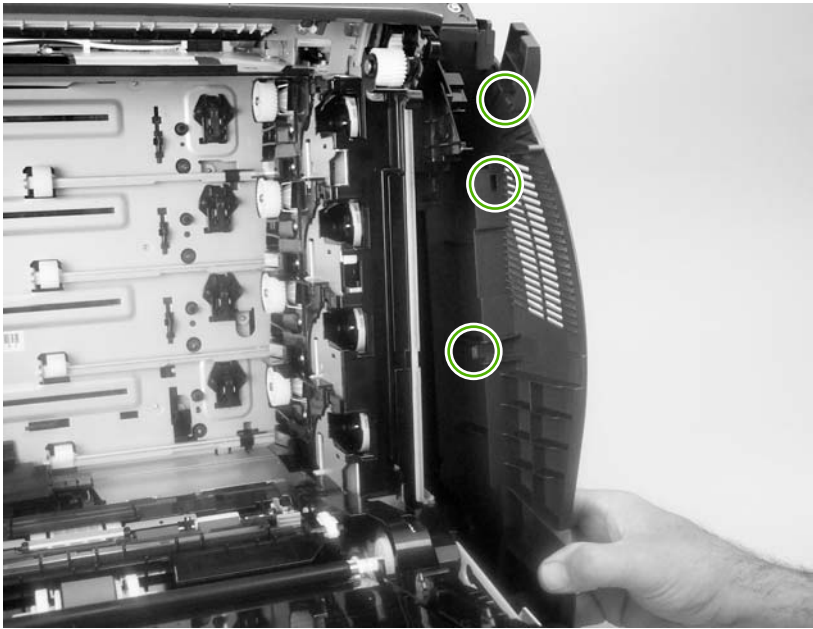

5. Remove the power-switch arm.

Figure 5-25 Remove the right cover (3 of 4)

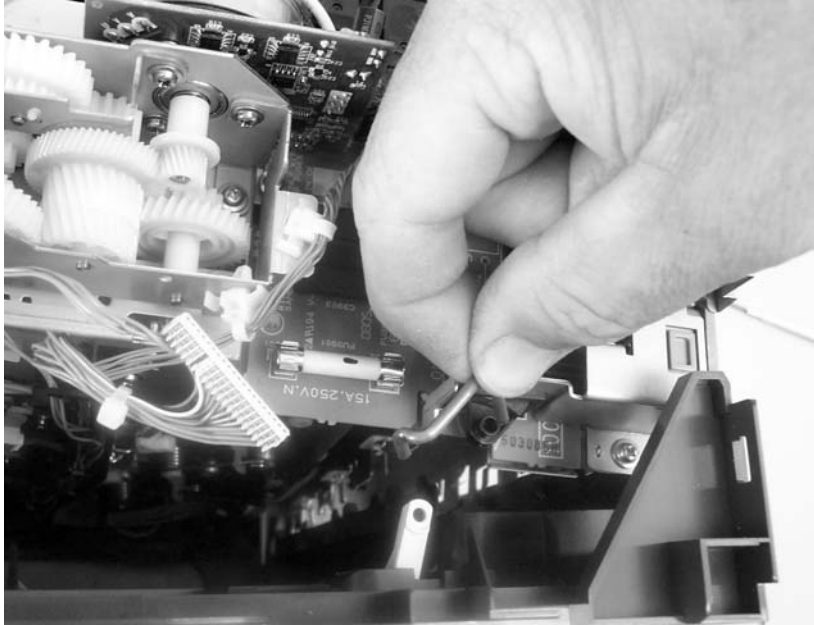

6. Remove the cover by releasing the two rear locking tabs.

Figure 5-26 Remove the right cover (4 of 4)

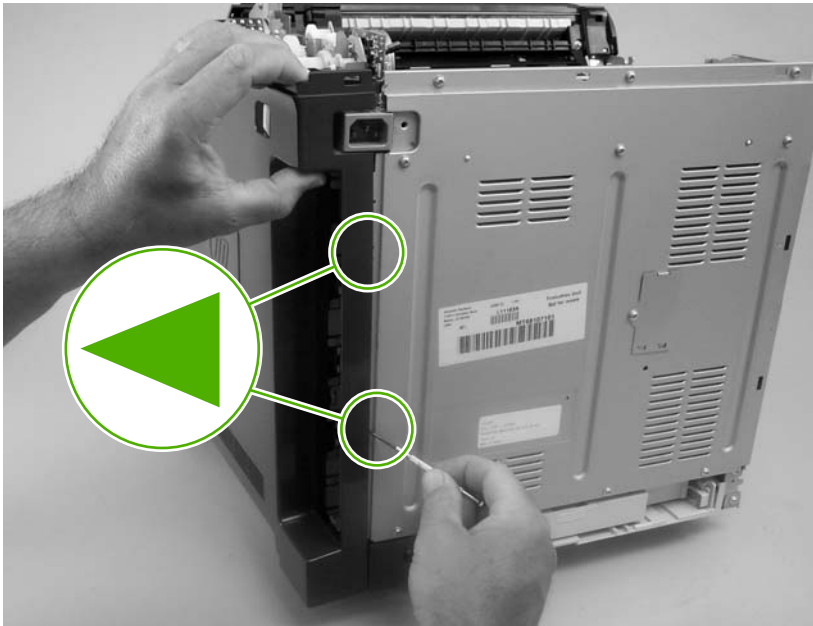

TIP: When installing the right cover, make sure that the metal power-switch arm is engaged with the power switch.

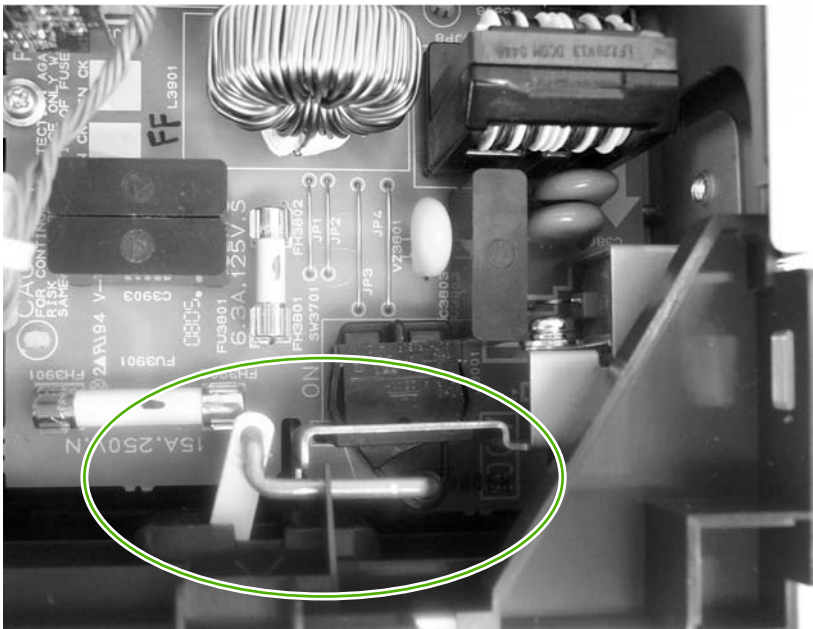

Rear upper cover

1. Remove the following components:
 - Upper cover. See [Upper cover \(fuser door\) on page 80](#).
 - Rear lower cover. See [Rear lower cover on page 83](#).
 - Left cover. See [Left cover on page 84](#).
 - Right cover. See [Right cover on page 87](#).
2. Release the cover by removing 10 screws (callout 1).

Figure 5-27 Remove the rear upper cover

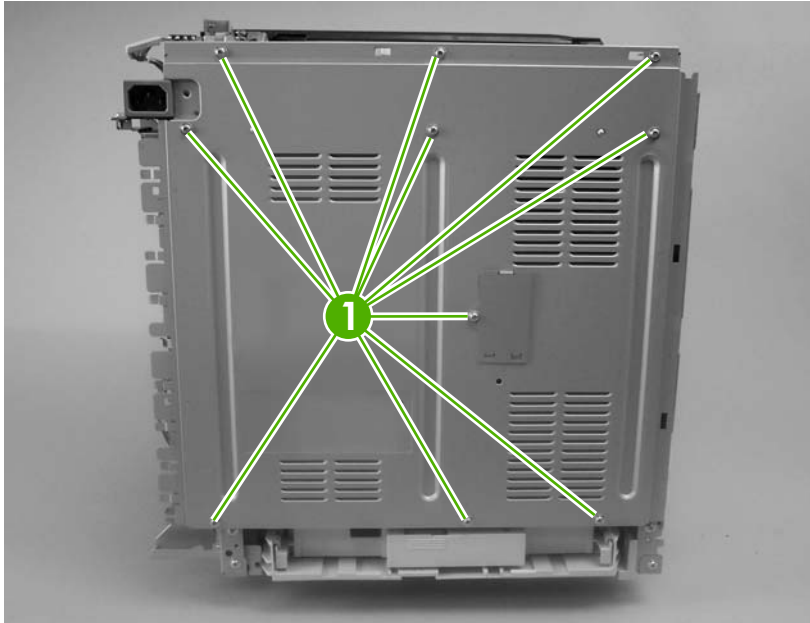

Internal assemblies

Formatter cage

⚠ **WARNING!** Do *not* replace the formatter and the DC controller at the same time. Install the replacement formatter and then turn the power on. After the printer initializes, turn the power off and install the replacement DC controller.

△



CAUTION: PCAs are sensitive to electrostatic discharge (ESD). Look for the ESD reminder when removing PCAs. Always perform service work at an ESD-protected workstation or mat. If an ESD workstation or mat is not available, ground yourself by touching the sheet-metal chassis *before* touching an ESD-sensitive part.

Protect the ESD-sensitive parts by placing them in ESD pouches when they are out of the printer.

1. Before you install a replacement formatter, open the service menu (see [Service menu on page 226](#)) and record the following values:
 - Mono cycle count
 - Color cycle count
 - Refurbish cycle count
 - Serial number
 - Service ID
2. Push in on the two black locking levers.
3. Pull the formatter cage away from the printer to remove it.

Figure 5-28 Remove the formatter cage

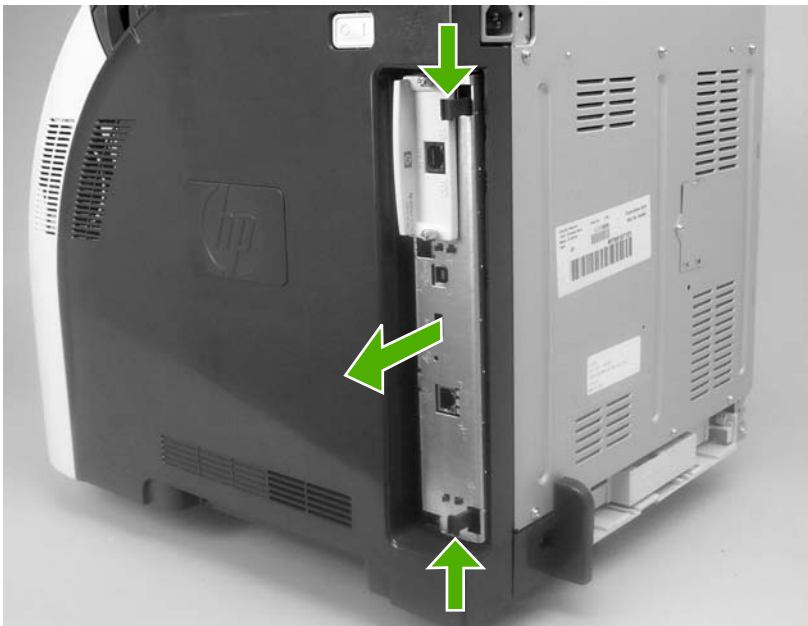

4. Open the service menu (see [Service menu on page 226](#)) and transfer the values from step 1 to the replacement formatter.
5. When you install a replacement formatter, you must calibrate the printer. See [Calibrating the printer on page 39](#).

 **NOTE:** After replacing the formatter cage, make sure that the control panel is functioning. If the printer fans and motors are operating correctly but the control panel is not, turn the power off, and then remove the formatter cage and reinstall it. You might have to repeat this step several times to seat the formatter correctly.

Electrostatic transfer belt (ETB)

 **NOTE:** The ETB shown in this procedure is for the duplex model. The ETB for the simplex model looks different, but the procedure for removing it is the same as for the duplex model.

1. Open the front cover.
2. Push in the two blue latch buttons (callout 1) and pull the ETB out of the printer.

Figure 5-29 Remove the front ETB

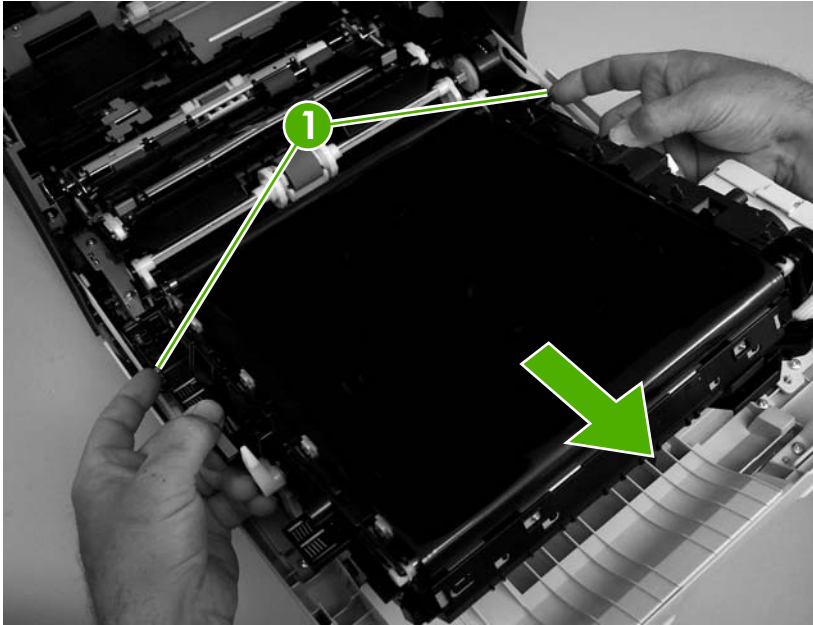

Fuser

△ **CAUTION:** The fuser might be hot. Wait for the fuser to cool *before* you remove it.

1. Open the upper (top) cover (fuser door).
2. Squeeze the two blue fuser locking levers to release the fuser.
3. Rotate the fuser up and out of the printer.

Figure 5-30 Remove the fuser



Duplex fan

 **NOTE:** The printer shown is the duplex model, and has a duplex fan mounted to the front-cover assembly. Simplex model printers do not have this part. If you are repairing a simplex model printer, ignore this procedure.

1. Open the front cover.
2. Remove the two screws (callout 1) that secure the fan to the front cover and one screw that secures the wire-harness cover (callout 2).

Figure 5-31 Remove the duplex fan (1 of 3)

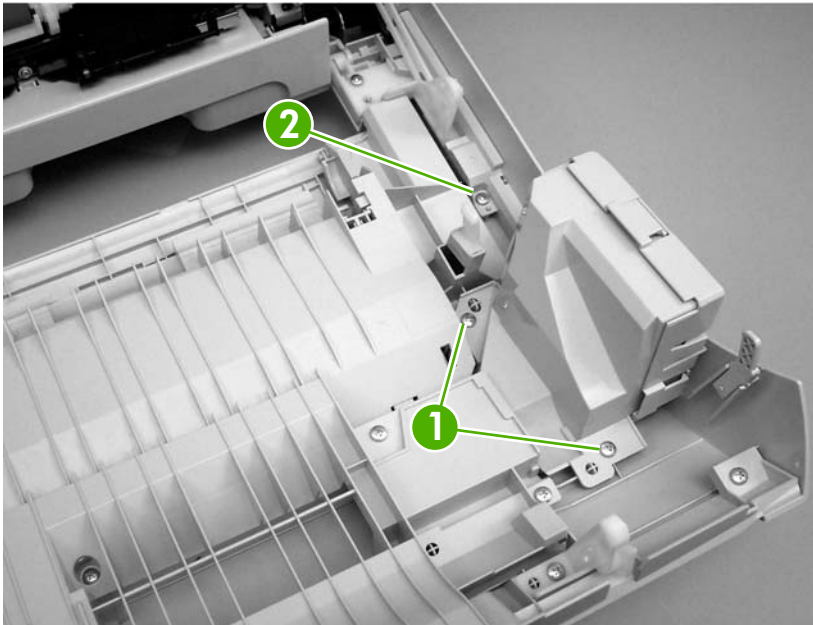

3. Use a small flatblade screwdriver to release the wire-harness-cover locking tab (callout 3). Remove the harness cover.

Figure 5-32 Remove the duplex fan (2 of 3)

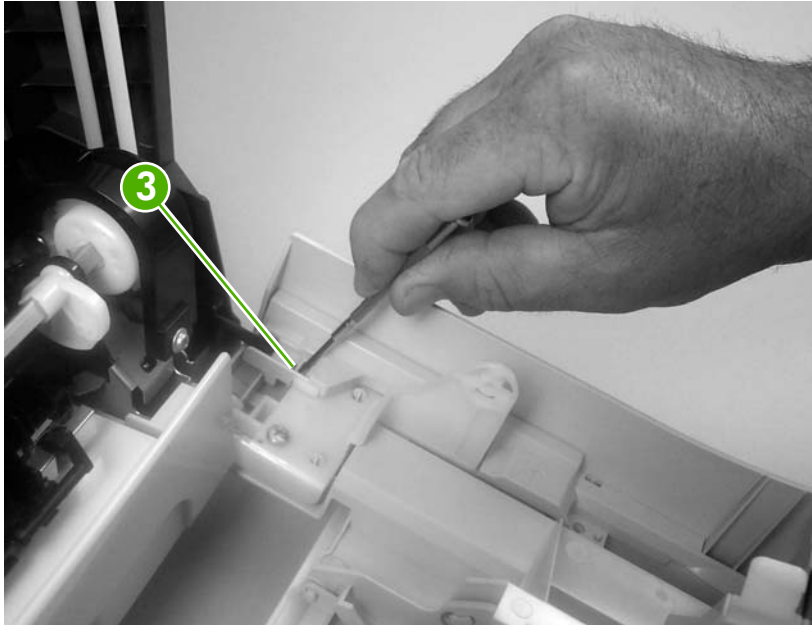

 **NOTE:** When you reinstall the duplex-fan wire harness, make sure that the wire-harness is clipped correctly to the door.



4. Disconnect one connector (callout 4) and remove the fan.

Figure 5-33 Remove the duplex fan (3 of 3)

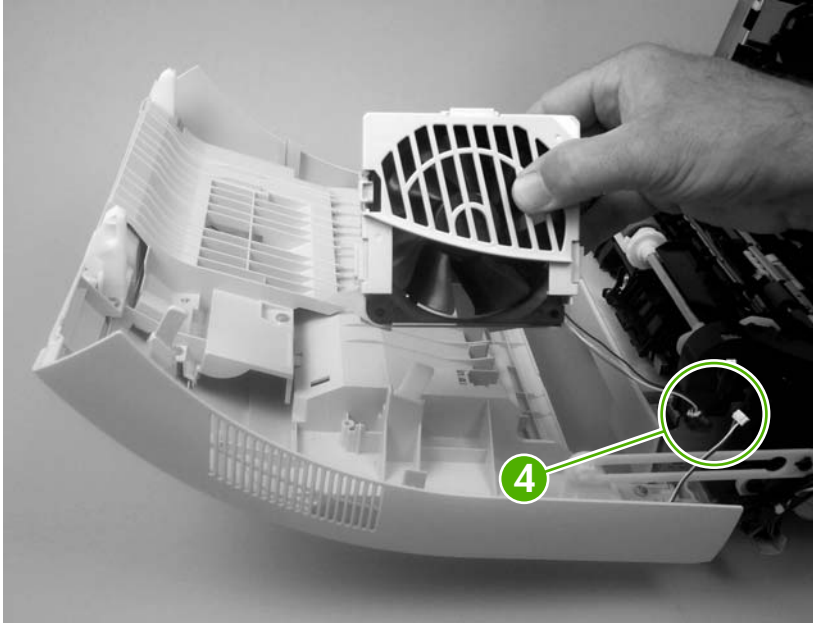

TIP: When you reinstall the duplex-fan wire-harness, make sure that the wire-harness is clipped correctly to the door.



Print-cartridge drive motors

 **NOTE:** The HP Color LaserJet 3000 uses a different black-print-cartridge drive motor from the HP Color LaserJet 3600/3800/CP3505 printer. You must use the correct black-print-cartridge drive motor for the HP Color LaserJet 3000. Make sure that you order the black-print-cartridge drive motor that is appropriate for the model. (The black-print-cartridge drive motor for the HP Color LaserJet 3000 has one additional pin in the wire-harness connector.)

1. Remove the right cover. See [Right cover on page 87](#).
2. To remove the motor, disconnect one connector (callout 1) and remove three screws (callout 2). Repeat this procedure for the remaining print-cartridge motors.

Figure 5-34 Remove the print-cartridge motor

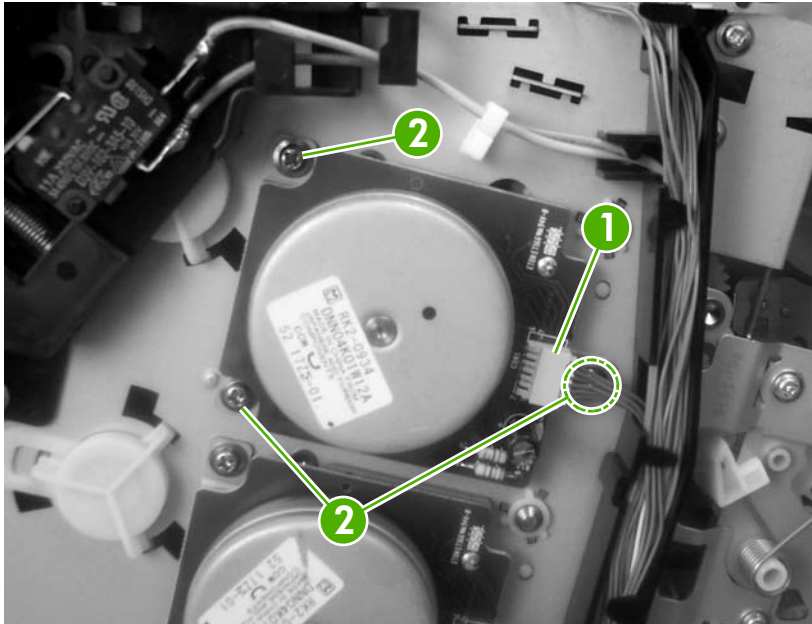

Duplex-reverse-drive assembly

 **NOTE:** The printer shown is the duplex model, and contains a duplex-reverse-drive assembly. Simplex model printers do not have this part. If you are repairing simplex model printer, ignore the following procedure.

1. Remove the upper cover. See [Upper cover \(fuser door\) on page 80](#).
2. Turn the upper cover over and place it on a flat surface.
3. Remove the duplex driver PCA. See [Duplex-driver PCA on page 148](#).
4. Release the tab on the delivery-roller retainer, and rotate the retainer up into the unlocked position and remove it.

Figure 5-35 Remove the duplex-reverse-drive assembly (1 of 5)

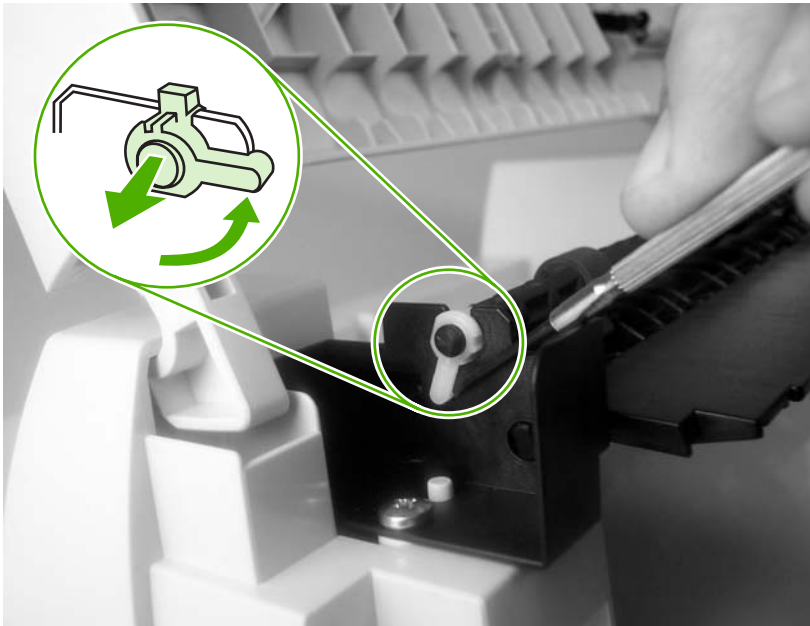

5. Slide the delivery roller and retainer out of the upper cover.

 **NOTE:** When you reinstall the roller, make sure that the locking tabs on the right roller collar are inserted into the slots in the assembly.

Figure 5-36 Remove the duplex-reverse-drive assembly (2 of 5)



6. Remove two screws (callout 1), and then remove the delivery-guide assembly (callout 2).

Figure 5-37 Remove the duplex-reverse-drive assembly (3 of 5)

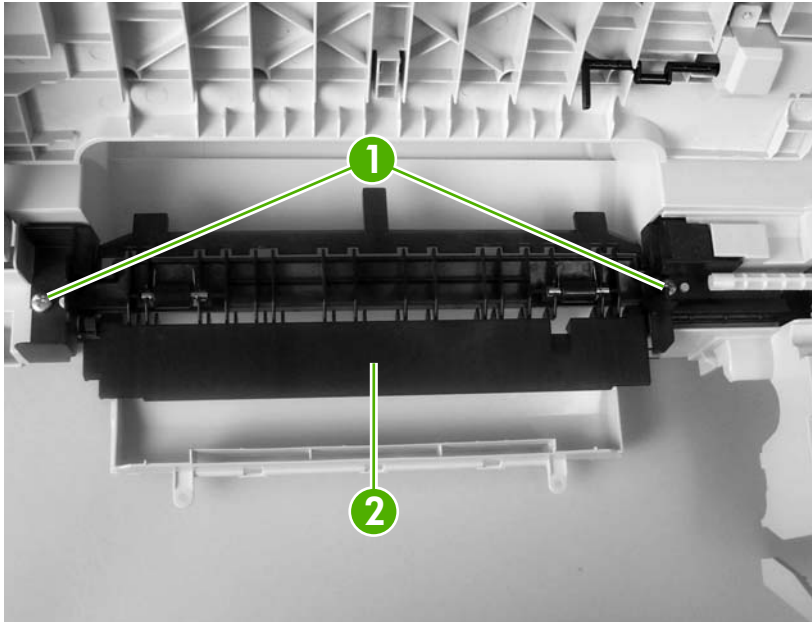

7. Remove two screws (callout 3).

Figure 5-38 Remove the duplex-reverse-drive assembly (4 of 5)

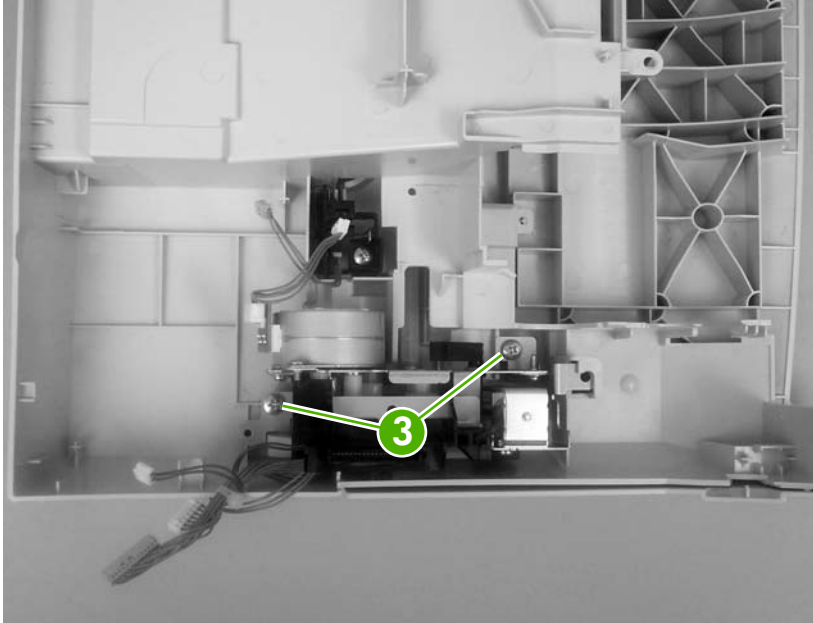

8. Rotate the duplex-reverse-drive assembly up and out of the upper cover.

Figure 5-39 Remove the duplex-reverse-drive assembly (5 of 5)

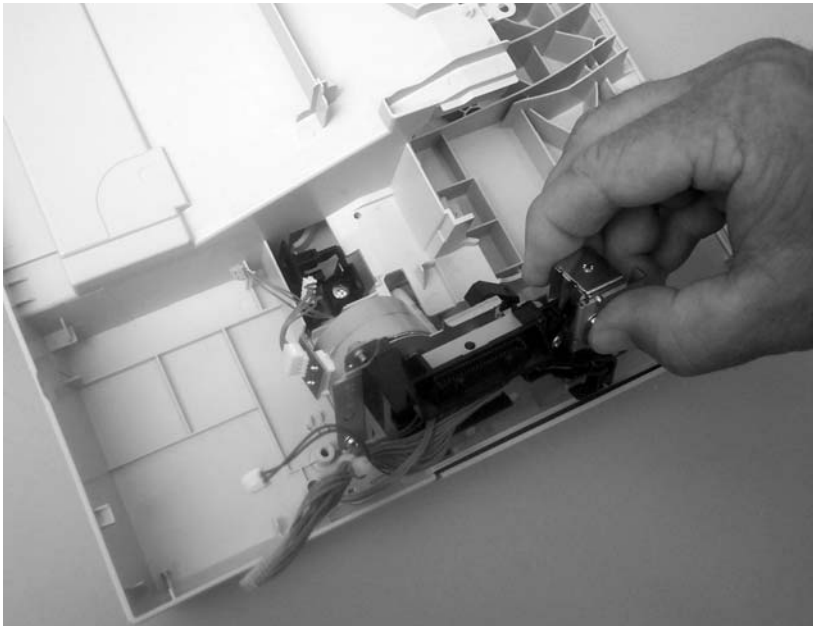

Duplex-feed-drive assembly

 **NOTE:** The printer shown is the duplex model, and contains a duplex-feed drive assembly. Simplex model printers do not have this part. If you are repairing a simplex model printer, ignore the following procedure.

1. Remove the following components:
 - Upper cover. See [Upper cover \(fuser door\) on page 80](#).
 - Right cover. See [Right cover on page 87](#).
2. Disconnect one connector (callout 1) and remove three screws (callout 2).

Figure 5-40 Remove the duplex-feed-drive assembly (1 of 2)

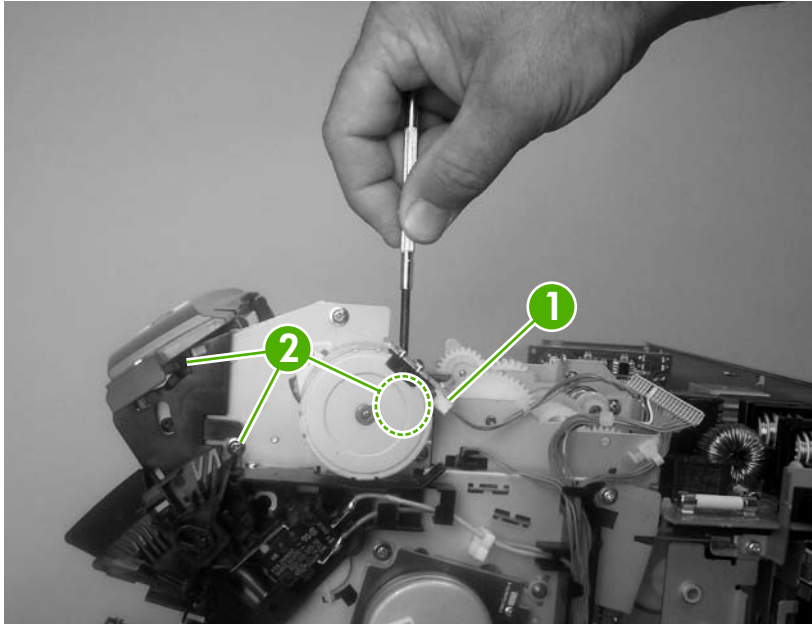

3. Carefully lift and rotate the duplex-feed-drive assembly to remove it.

Figure 5-41 Remove the duplex-feed-drive assembly (2 of 2)

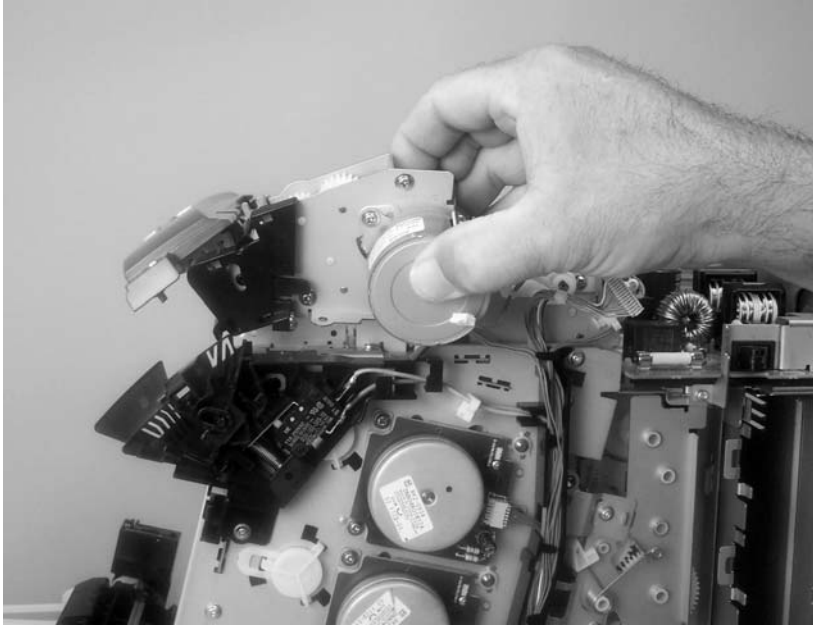

Fuser drive assembly

1. Remove the following components:
 - Upper cover. See [Upper cover \(fuser door\) on page 80](#).
 - Right cover. See [Right cover on page 87](#).
 - Duplex-feed-drive assembly (duplex model only). See [Duplex-feed-drive assembly on page 103](#).
2. Disconnect one connector (callout 1) and release two cable clamps (callout 2).

Figure 5-42 Remove the fuser drive assembly (1 of 4)

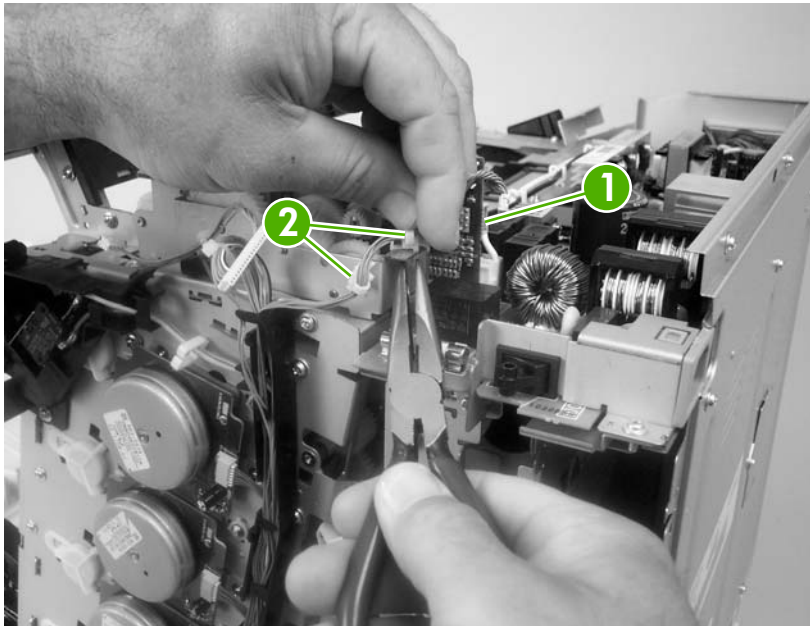

3. Remove four screws (callout 3).

Figure 5-43 Remove the fuser drive assembly (2 of 4)

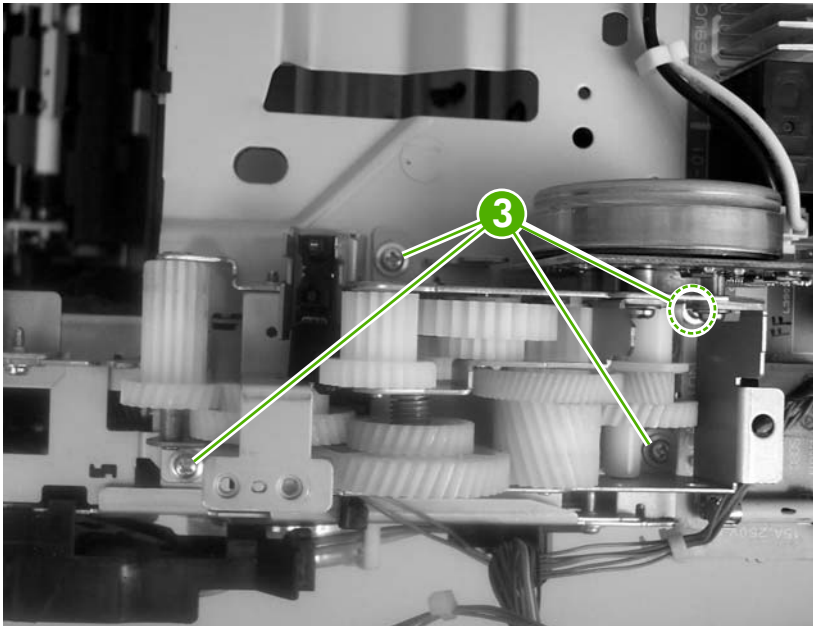

4. Disconnect one connector (callout 4; J213) on the driver PCA assembly and remove the wire-harness from the guide (callout 5).

Figure 5-44 Remove the fuser drive assembly (3 of 4)

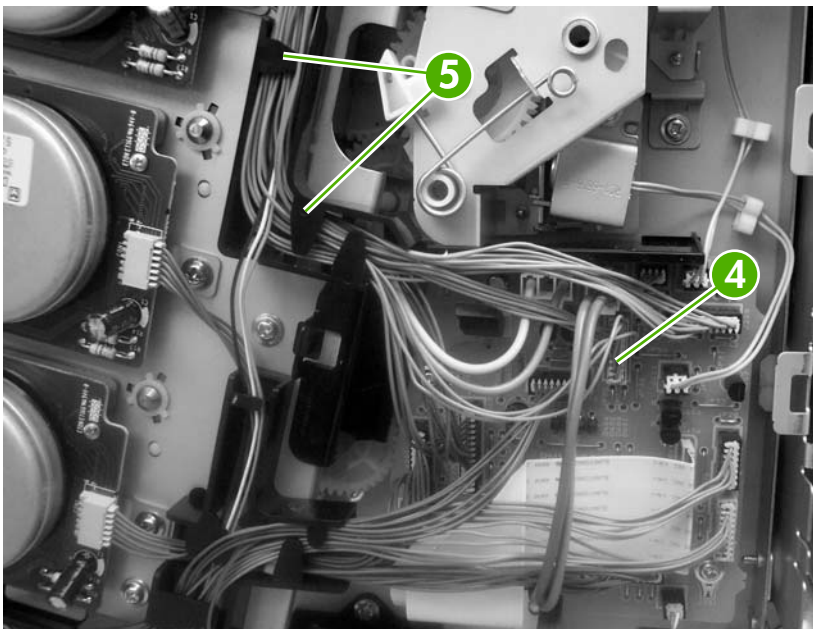

 **TIP:** You might have to use needle-nose pliers to reattach the cable straps to the two cable clamps.

5. Lift the fuser drive assembly off of the printer chassis.

Figure 5-45 Remove the fuser drive assembly (4 of 4)

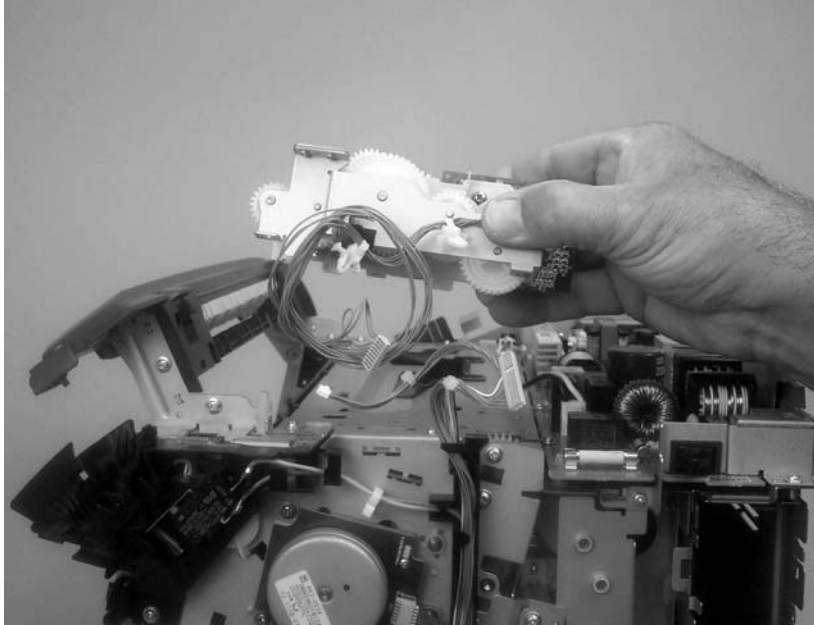

Developing separation-drive assembly

1. Remove the following components:
 - Upper cover. See [Upper cover \(fuser door\) on page 80](#).
 - Right cover. See [Right cover on page 87](#).
 - Fuser. See [Fuser on page 95](#).
2. Use a small flatblade screwdriver to release the wire-guide locking tab (callout 1), and then move the guide slightly towards the front of the printer.

Figure 5-46 Remove the developing separation-drive assembly (1 of 4)

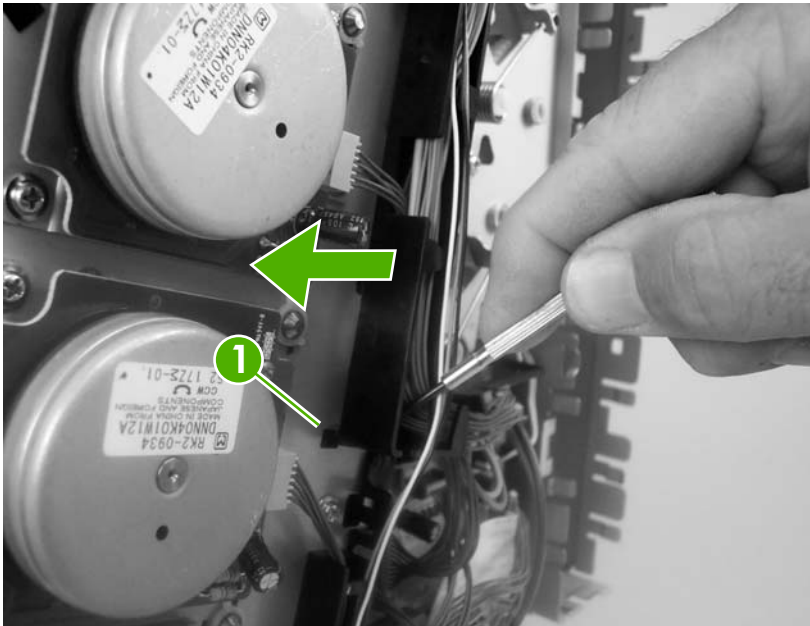

3. Remove three screws (callout 2) and the sheet-metal plate (callout 3).

Figure 5-47 Remove the developing separation-drive assembly (2 of 4)

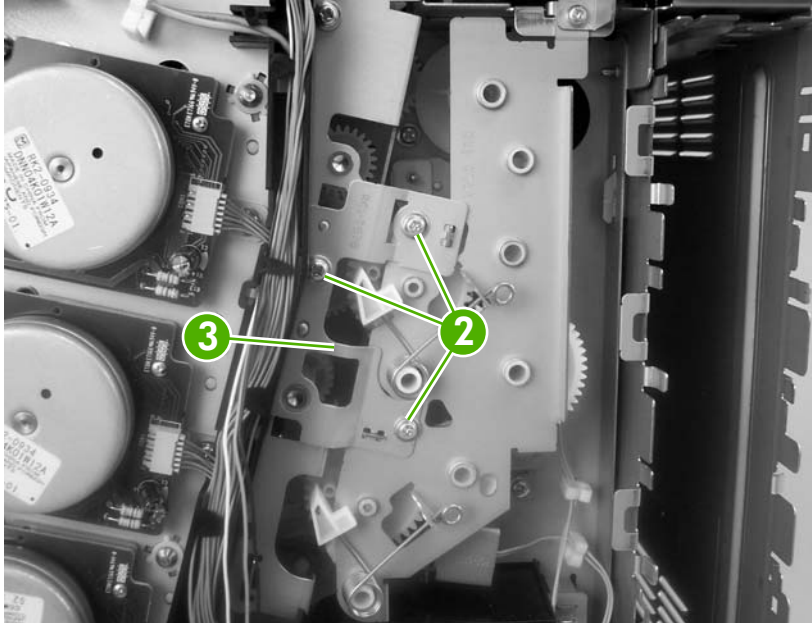

4. Disconnect two connectors (callout 4; J403 and J405) on the driver PCA and remove the wire-harnesses from the two retainers (callout 5).

Figure 5-48 Remove the developing separation-drive assembly (3 of 4)

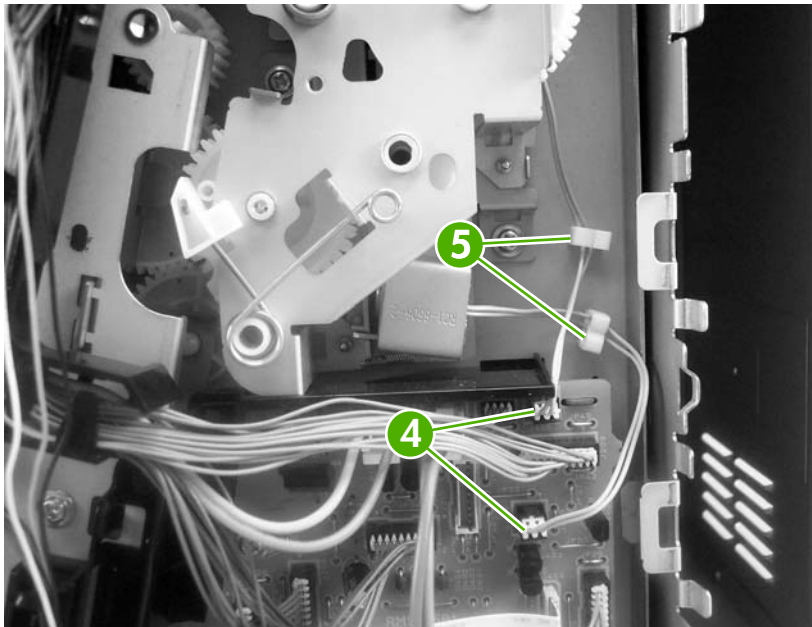

TIP: When you reinstall the developing separation-drive assembly, the upper solenoid wire-harness connects to J405 and the lower solenoid wire-harness connects to J403.

5. Remove three screws (callout 6) to release the developing separation-drive assembly.

Figure 5-49 Remove the developing separation-drive assembly (4 of 4)

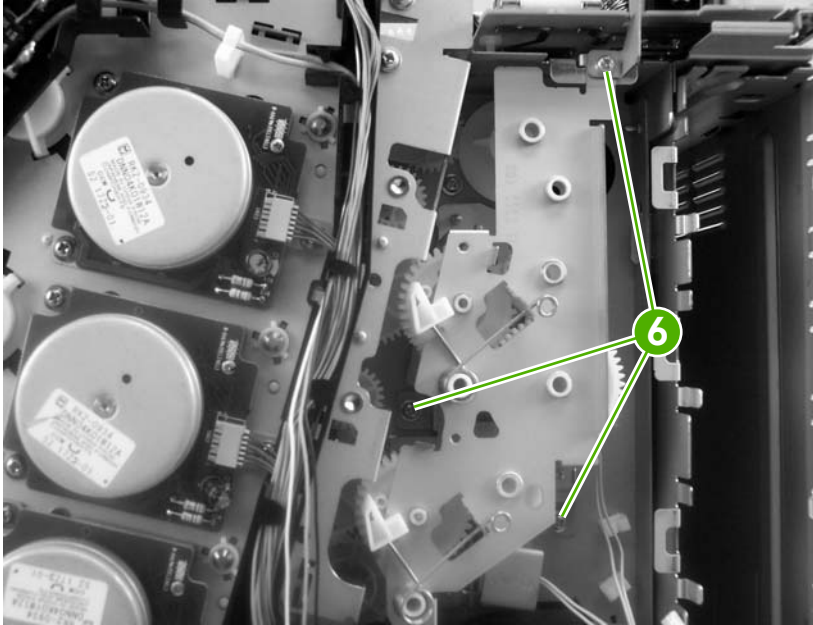

 **NOTE:** The upper drive gear (callout 7) behind the developing separation-drive assembly is *not* captive. Be careful not to lose the gear.

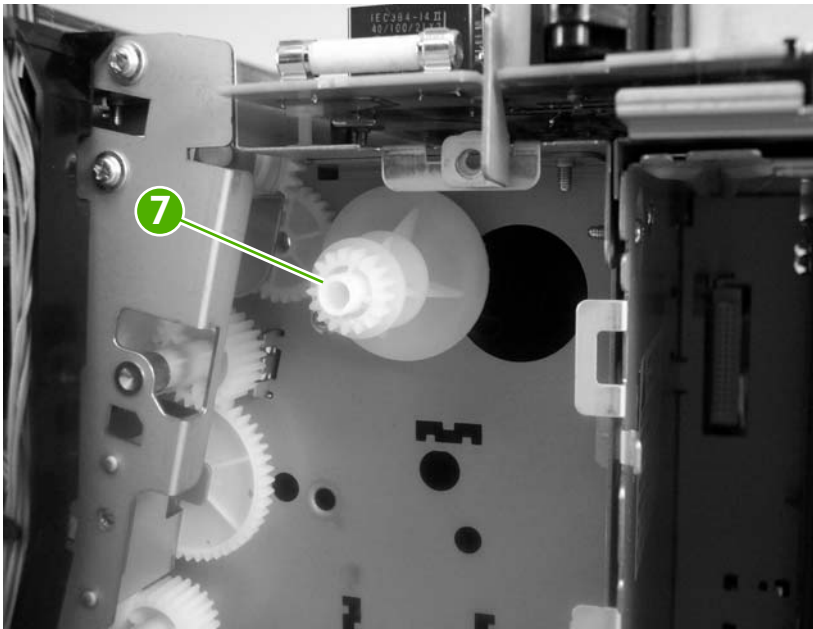

Pickup-and-feed assembly

 **NOTE:** After replacing the pickup-and-feed assembly you must perform a media-sensor calibration. Failure to do so can lead to print-quality issues.

1. Remove the following components:
 - Front cover. See [Front cover on page 75](#).
 - Left cover. See [Left cover on page 84](#).
2. Disconnect one connector (callout 1) on the left side of the printer.

 **TIP:** Remove the wire-harness from the guide on the pickup-and-feed assembly to make it easier to detach the connector.

Figure 5-50 Remove the pickup-and-feed assembly (1 of 8)



3. Remove one screw (callout 2), and then remove the gear cover.

Figure 5-51 Remove the pickup-and-feed assembly (2 of 8)

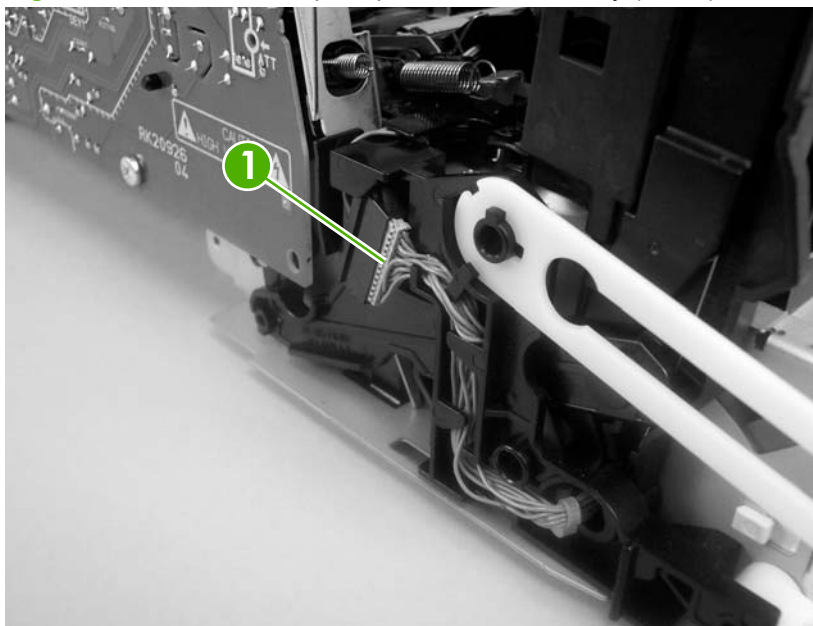
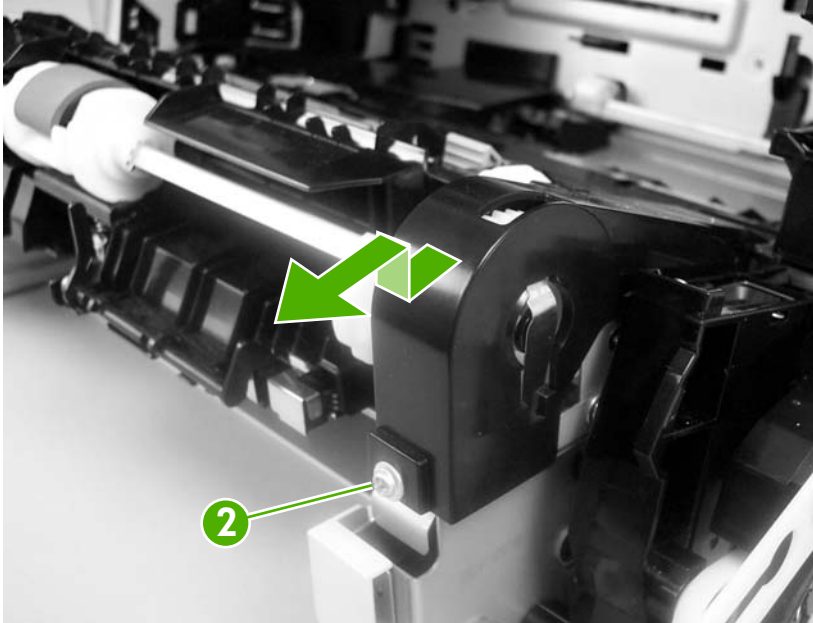

4. Remove two screws (callout 3), and then remove the two sheet-metal covers (callout 4).

△ **CAUTION:** Do not bend the locator tabs on the covers.

Figure 5-52 Remove the pickup-and-feed assembly (3 of 8)

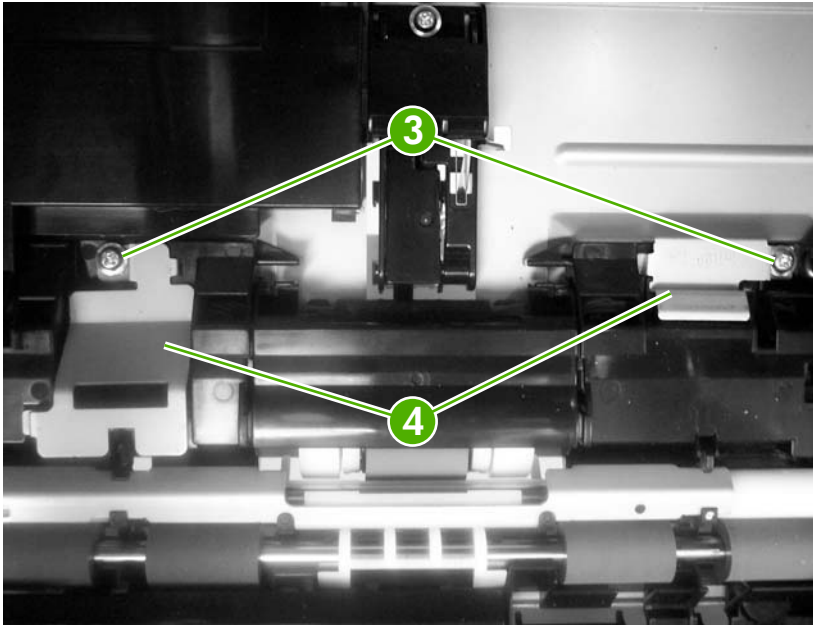

5. Release the locking tab (callout 5) on the pickup-and-feed driver PCA cover (callout 6), and then remove the cover.

△ **CAUTION:** Do not damage or bend the print-cartridge high-voltage springs (callout 7) when you remove the cover.

💡 **TIP:** It might be easier to remove the cover if you squeeze the right end of the cover, and then lift it slightly up and to the right to release it.

Figure 5-53 Remove the pickup-and-feed assembly (4 of 8)

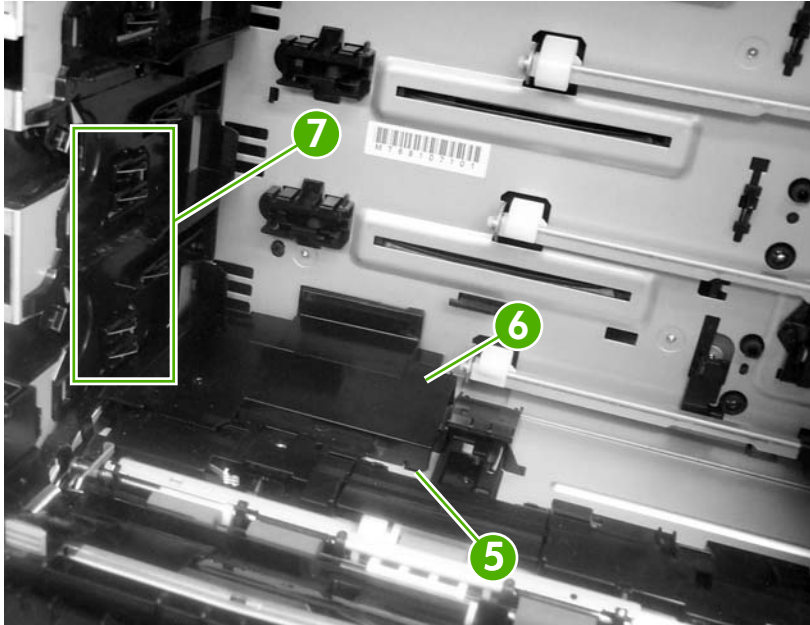

6. Disconnect five connectors (callout 8).

Figure 5-54 Remove the pickup-and-feed assembly (5 of 8)

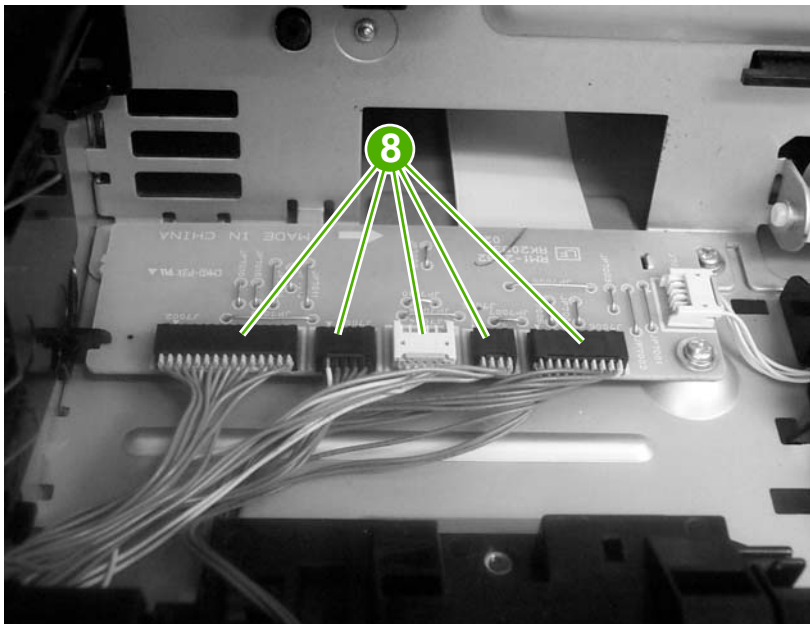

7. Remove two screws (callout 9) from the left side of the assembly.

Figure 5-55 Remove the pickup-and-feed assembly (6 of 8)

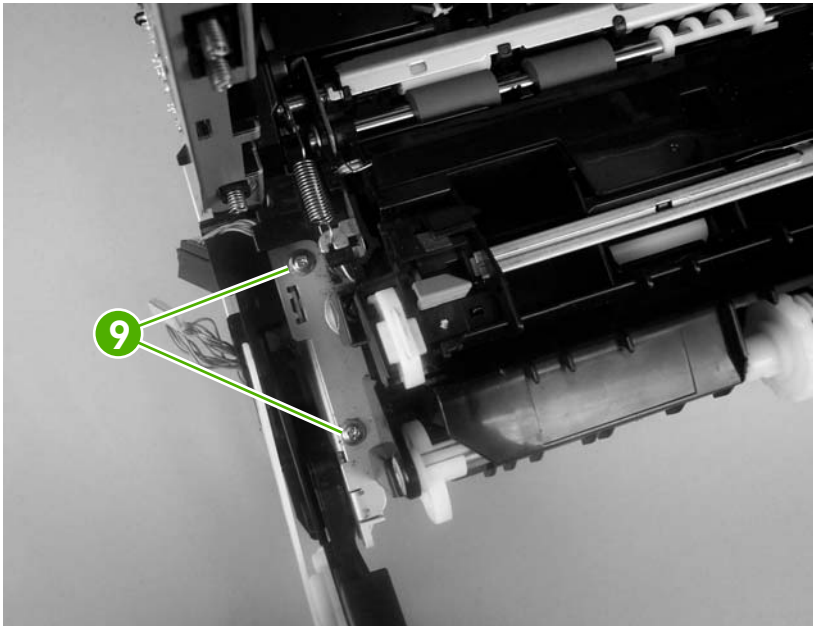

8. Remove two screws (callout 10) from the right side of the assembly.

 **TIP:** When you reinstall the lower screw, you might need to rotate the cam so it does not block access to the screw-hole.

Figure 5-56 Remove the pickup-and-feed assembly (7 of 8)



9. Lift the pickup-and-feed assembly out of the printer.

Figure 5-57 Remove the pickup-and-feed assembly (8 of 8)

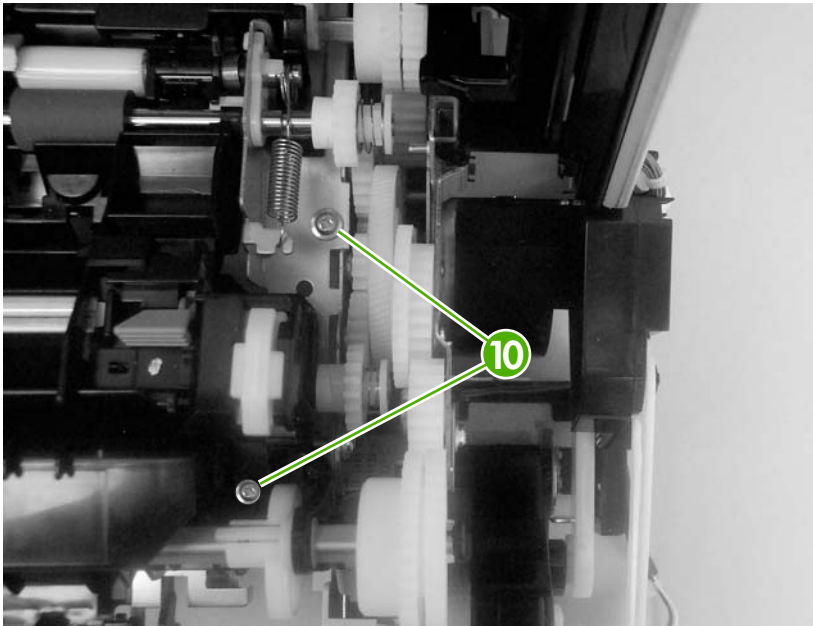

TIP: Slightly flex the chassis when you reinstall the pickup-and-feed assembly. Make sure that the assembly is flush with the chassis after it is installed.

NOTE: After replacing the pickup-and-feed assembly you must perform a media-sensor calibration. Failure to do so can lead to print-quality issues.

Calibrate the media sensor

Use the SERVICE menu to calibrate the media sensor. The SERVICE menu is locked and requires a PIN:

HP Color LaserJet 3000 Series printers: 11300005

HP Color LaserJet 3600 Series printers: 11360005

HP Color LaserJet 3800 Series printers: 11380005

HP Color LaserJet CP3505 Series printers: 06350507

1. Press **Menu**.
2. Press **▼** to highlight SERVICE, and then press **✓**.
3. Press **▲** or **▼** until the first digit of the PIN appears.
4. Press **✓** to save the digit. The control-panel display replaces the digit with an asterisk. Press **↵** at any time to move to the previous digit.
5. Repeat steps 3 and 4 until all eight digits are typed.
6. Press **▲** or **▼** to select NEW TRAY 1 MEDIA SENSOR.

7. Select TRAY 1.
8. Select YES.

Pickup-drive assembly

1. Remove the following components:
 - Front cover. See [Front cover on page 75](#).
 - Right cover. See [Right cover on page 87](#).
 - Pickup-and-feed assembly. See [Pickup-and-feed assembly on page 111](#).

2. Release the locking tab (callout 1) on the cassette guide rail to the right, and slide the rail forward to remove it.

Figure 5-58 Remove the pickup-drive assembly (1 of 13)

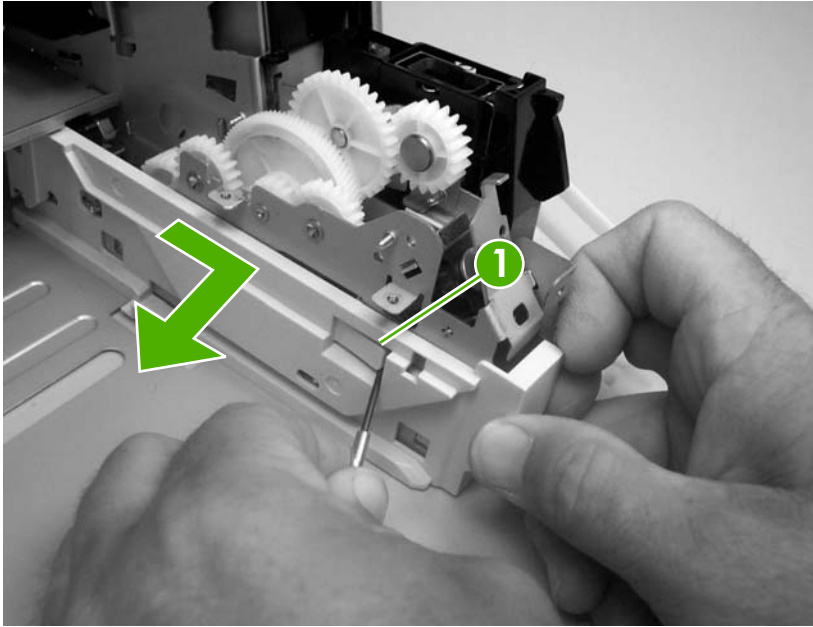

 **NOTE:** This photograph shows the locking tab and retainers on the guide rail.

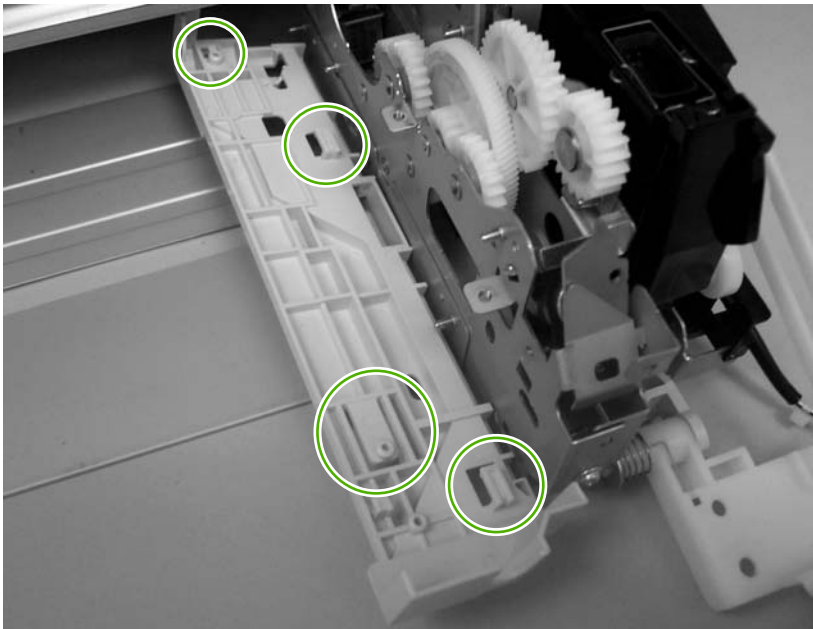

3. Remove one screw (callout 2) and remove the front-cover hinge (callout 3).

Figure 5-59 Remove the pickup-drive assembly (2 of 13)

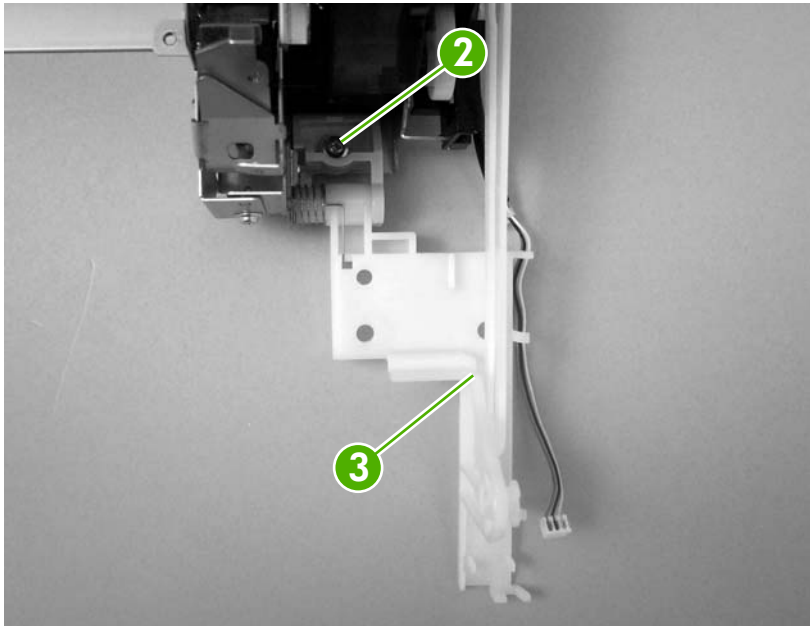

4. Rotate the retainer arm (callout 4) up until the tab on the pivot pin (callout 5) is aligned with the slot in the retainer arm, and then slide the retainer off of the pivot pin.

Figure 5-60 Remove the pickup-drive assembly (3 of 13)

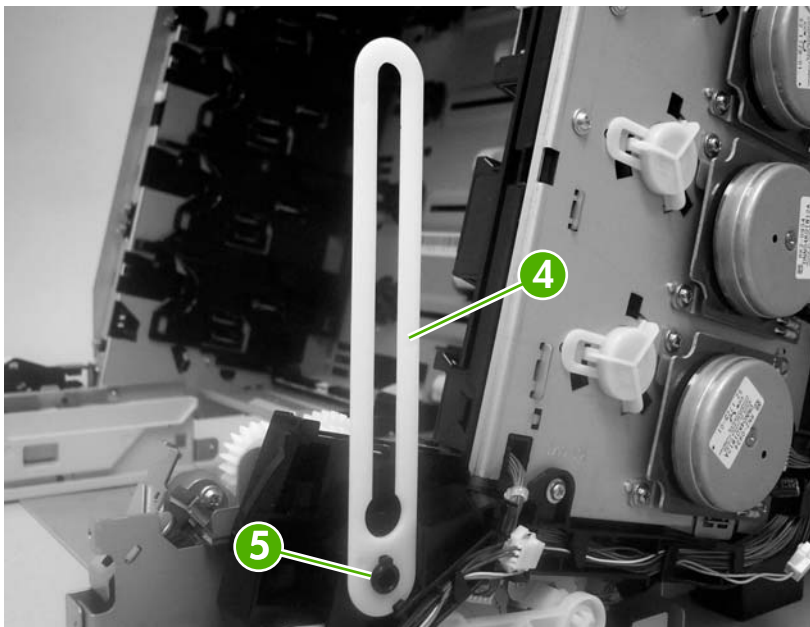

5. Remove all of the wire-harnesses from the guide (callout 6).

Figure 5-61 Remove the pickup-drive assembly (4 of 13)

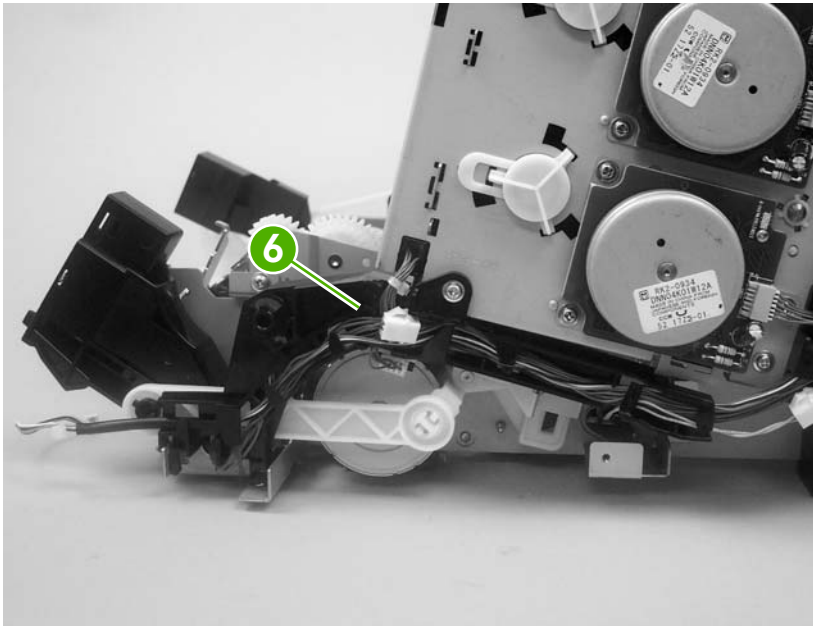

6. Disconnect three connectors (callout 7).

Figure 5-62 Remove the pickup-drive assembly (5 of 13)

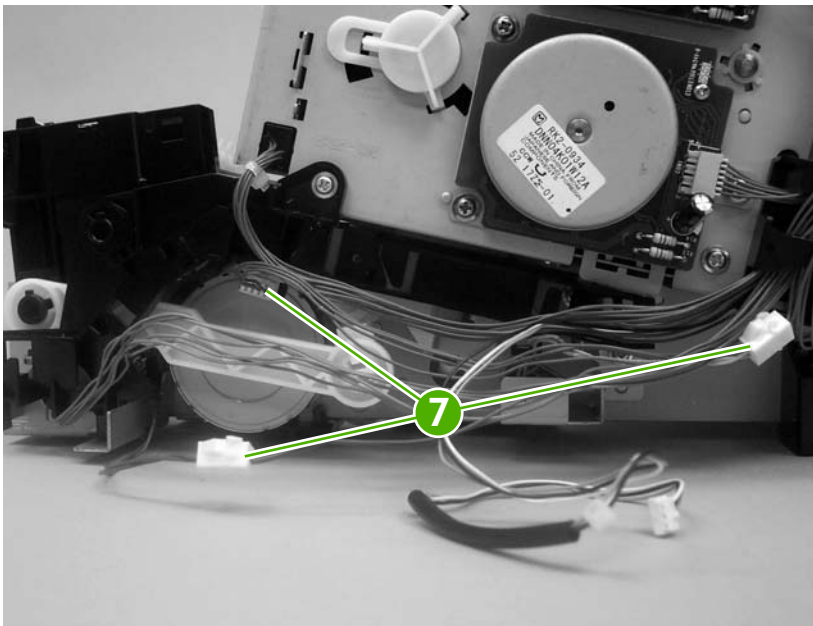

7. Remove one screw (callout 8), and then lift up on the locking tab (callout 9) to release it. Remove the guide (callout 10).

Figure 5-63 Remove the pickup-drive assembly (6 of 13)

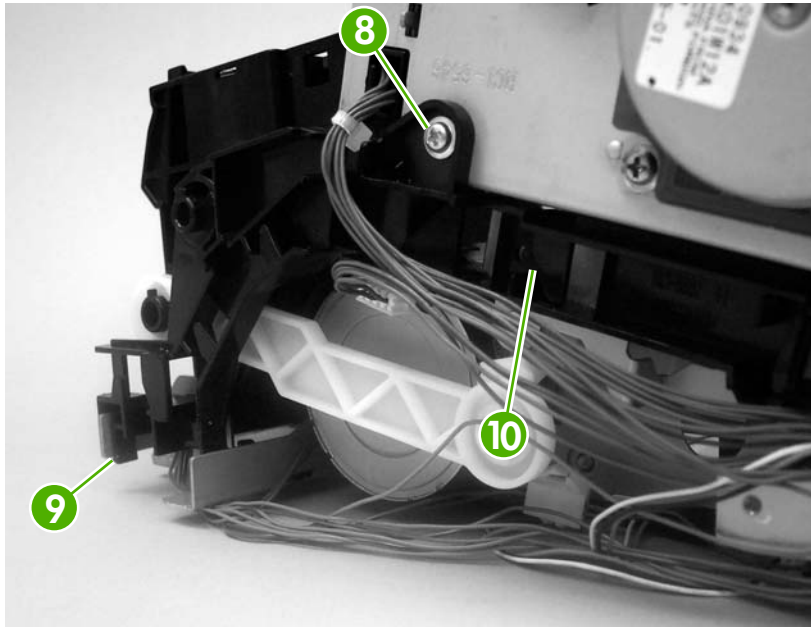

TIP: When you reinstall the guide, make sure that the rear locking tab is seated in the sheet-metal

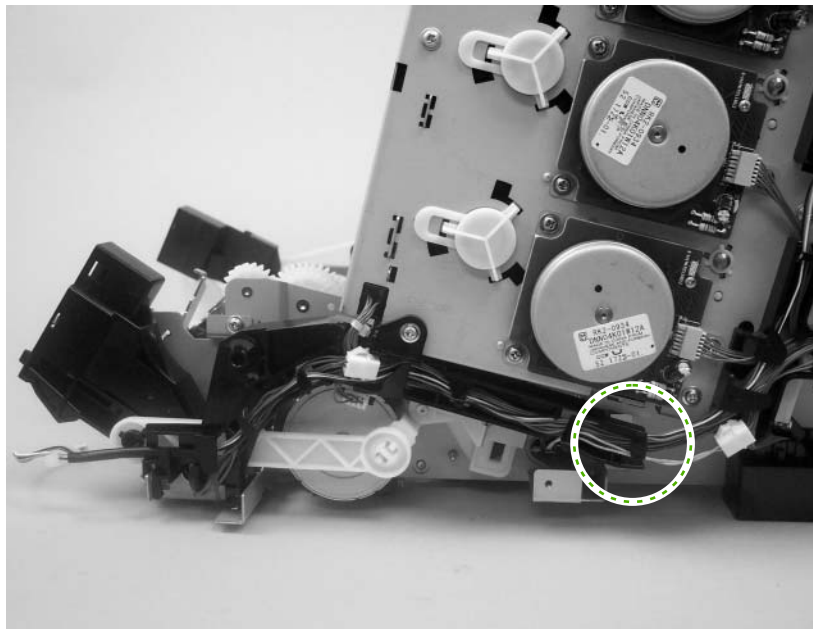

chassis.

8. Release the retainer tabs on the ETB connector link arm (callout 11) and slide the link arm off of the pivot pin.

Figure 5-64 Remove the pickup-drive assembly (7 of 13)

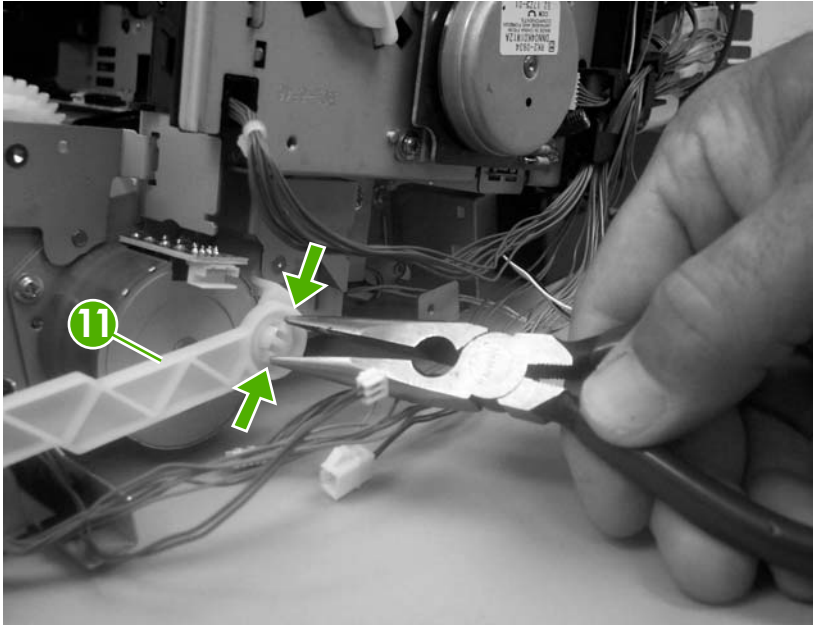

9. Rotate the link arm until the tab on the pivot pin (callout 12) is aligned with the slot in the link arm. Remove the link arm.

TIP: The link arm causes the print-cartridge-shutter doors to open when the front cover is closed. If the shutter doors are not operating correctly, make sure that the link arm is correctly installed.

Figure 5-65 Remove the pickup-drive assembly (8 of 13)

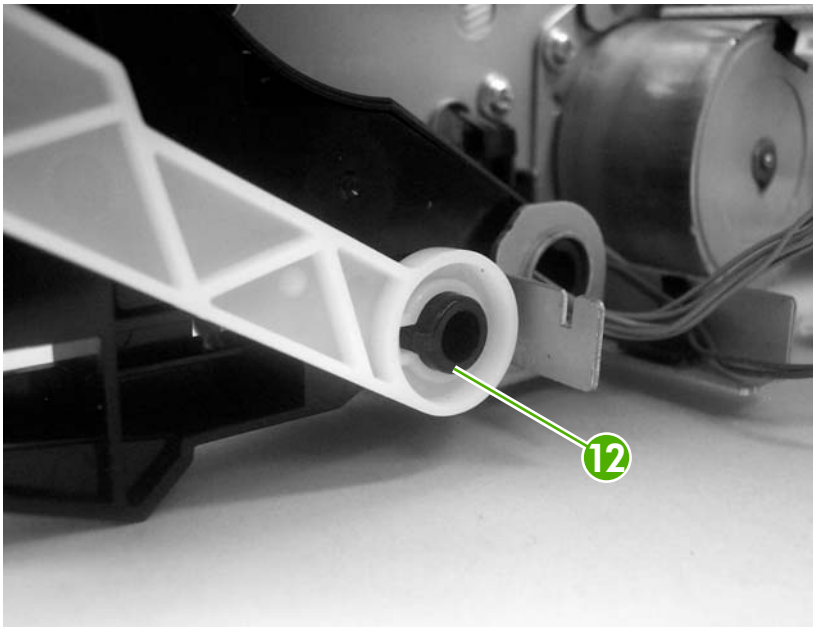

10. Remove two screws (callout 13), and then remove the ETB connector bracket (callout 14).

Figure 5-66 Remove the pickup-drive assembly (9 of 13)

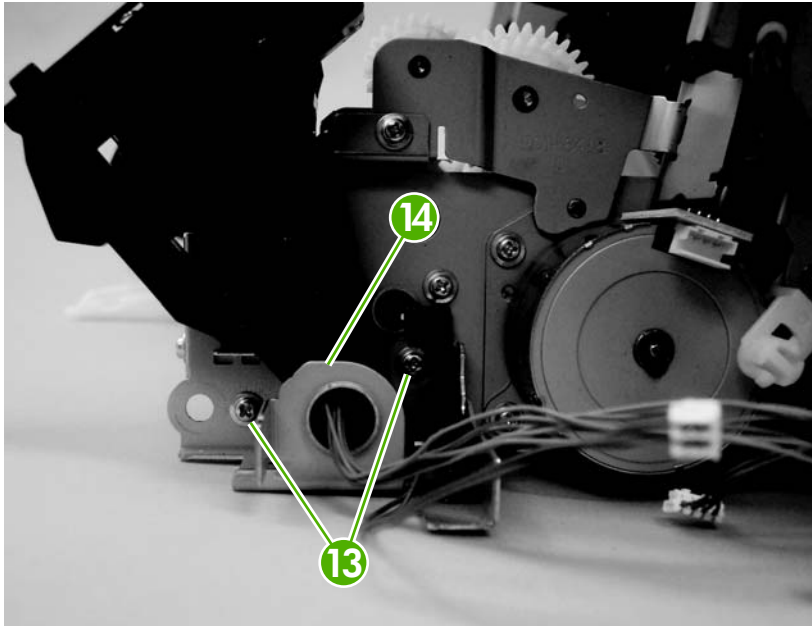

11. Remove one screw (callout 15), and then remove the sheet-metal support bracket (callout 16).

Figure 5-67 Remove the pickup-drive assembly (10 of 13)

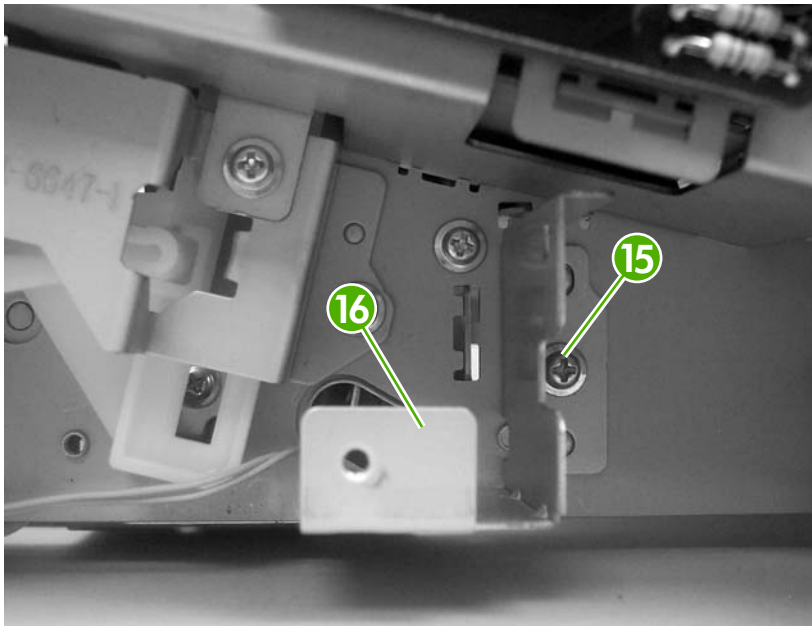

12. Remove four screws (callout 17).

Figure 5-68 Remove the pickup-drive assembly (11 of 13)

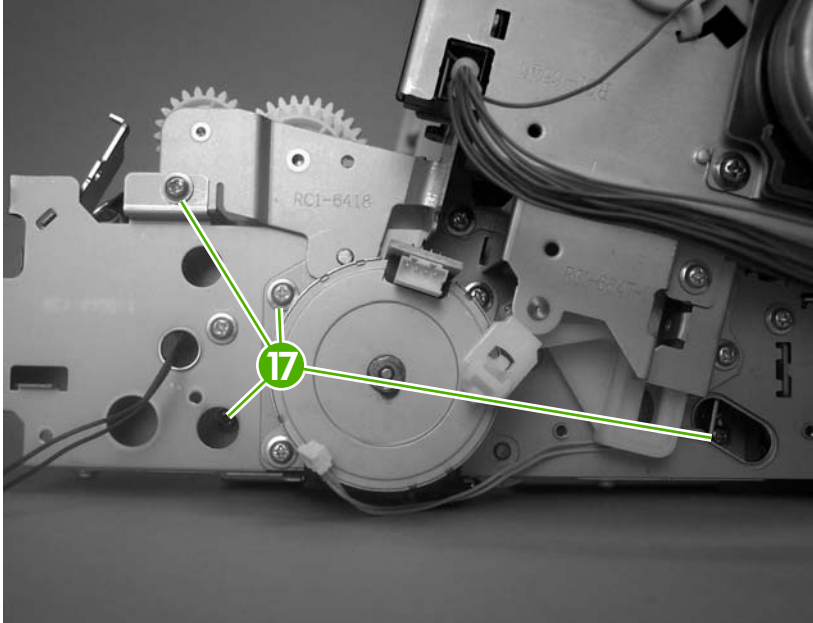

13. Carefully turn the printer onto its right side. Gently pry the sheet-metal bottom plate off of its locator pins (callout 18) and away from the pickup-drive assembly (callout 19).

 **NOTE:** The plastic printer foot can be dislodged when the bottom plate is separated from the chassis. Be careful to not lose the printer foot.

Figure 5-69 Remove the pickup-drive assembly (12 of 13)



14. Remove two screws (callout 20) to release the pickup-drive assembly.

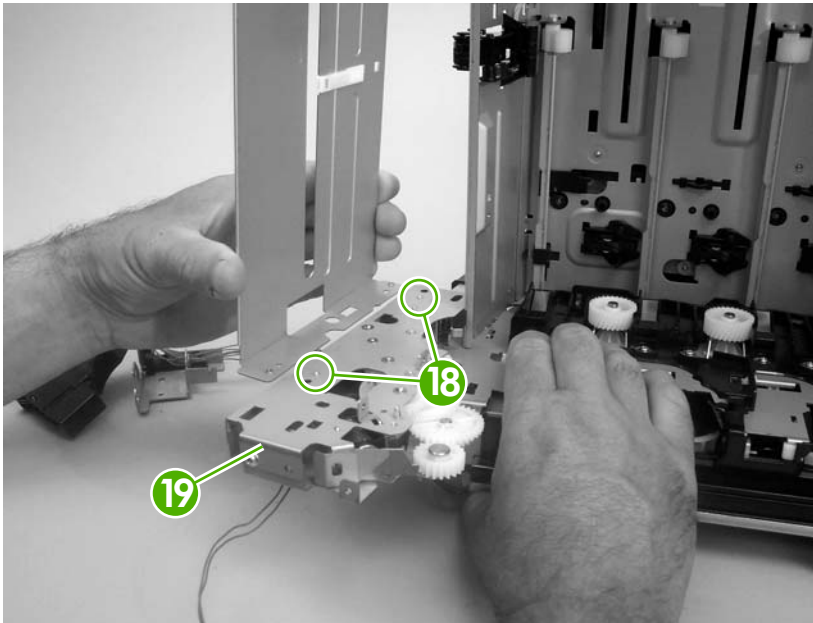

 **NOTE:** Figure 5-70 Remove the pickup-drive assembly (13 of 13) on page 125 shows the pickup drive assembly from the tray 2 cassette side.

Figure 5-70 Remove the pickup-drive assembly (13 of 13)



 **CAUTION:** The small gear assembly above the pickup-drive-assembly motor is *not* captive. Do not lose the gears when you remove the drive assembly.

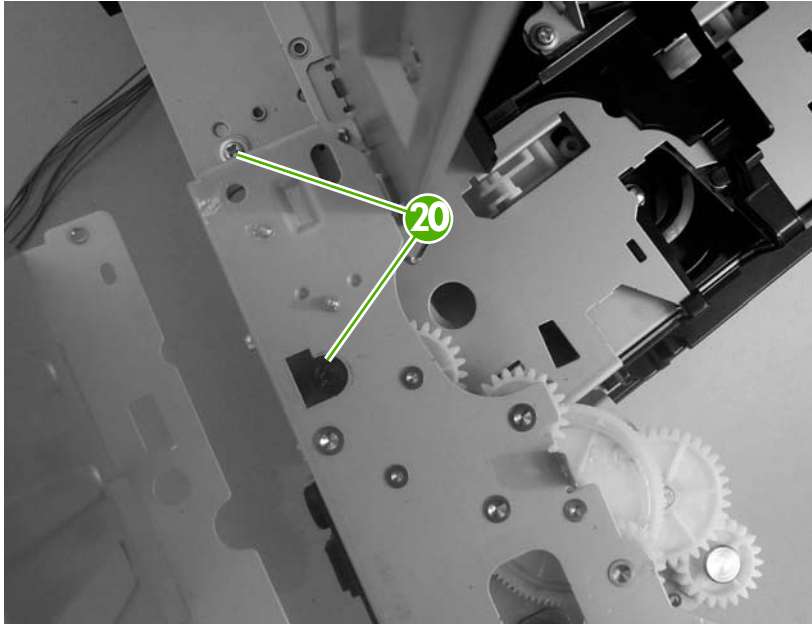

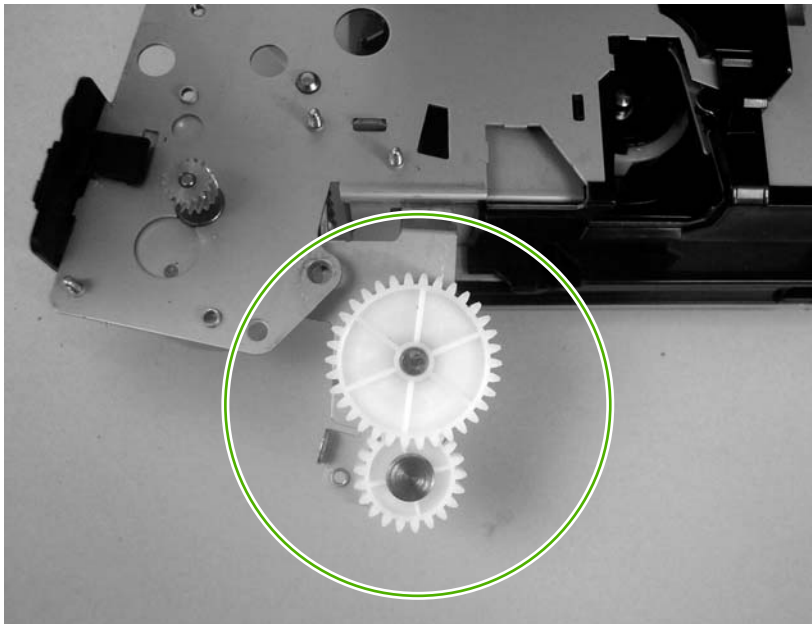
Laser/scanner assembly

 **NOTE:** Always perform a full calibration procedure when you replace the laser/scanner assembly.

1. Remove the following components:
 - Upper cover. See [Upper cover \(fuser door\) on page 80](#).
 - Rear lower cover. See [Rear lower cover on page 83](#).
 - Left cover. See [Left cover on page 84](#).
 - Right cover. See [Right cover on page 87](#).
 - Rear upper cover. See [Rear upper cover on page 91](#).
2. Remove four screws (callout 1) and remove the sheet-metal shield (callout 2).

 **NOTE:** Only three screws secure the sheet-metal shield, but removing the fourth screw is necessary for tasks later in this procedure.

Figure 5-71 Remove the laser/scanner assembly (1 of 6)



3. Disconnect all of the wire-harness connectors and flat flexible cables (FFCs) on the DC controller PCA (eight wire-harness connectors and eight FFCs).

△ **CAUTION:** Do not bend or fold the FFCs during removal or installation.

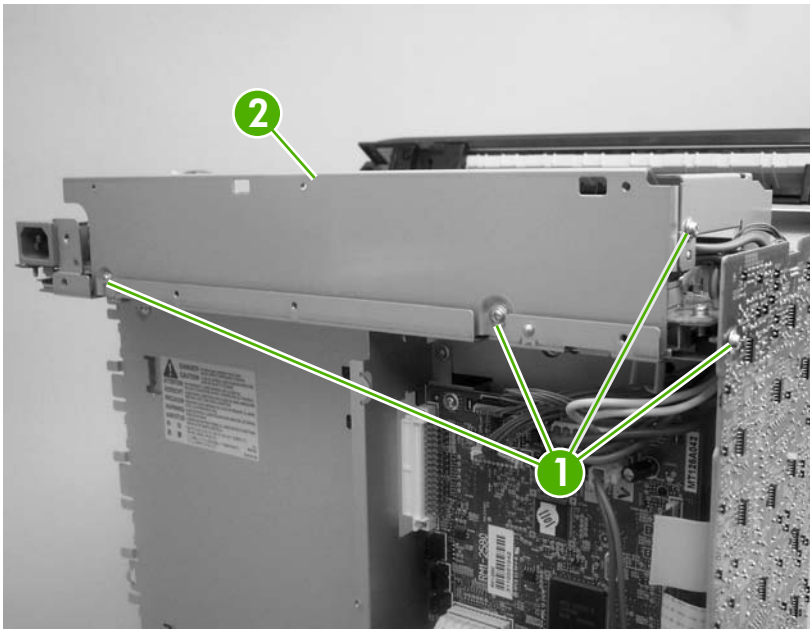
📄 **NOTE:** Remove the wire-harnesses from all of the retainers near the DC controller.

Figure 5-72 Remove the laser/scanner assembly (2 of 6)

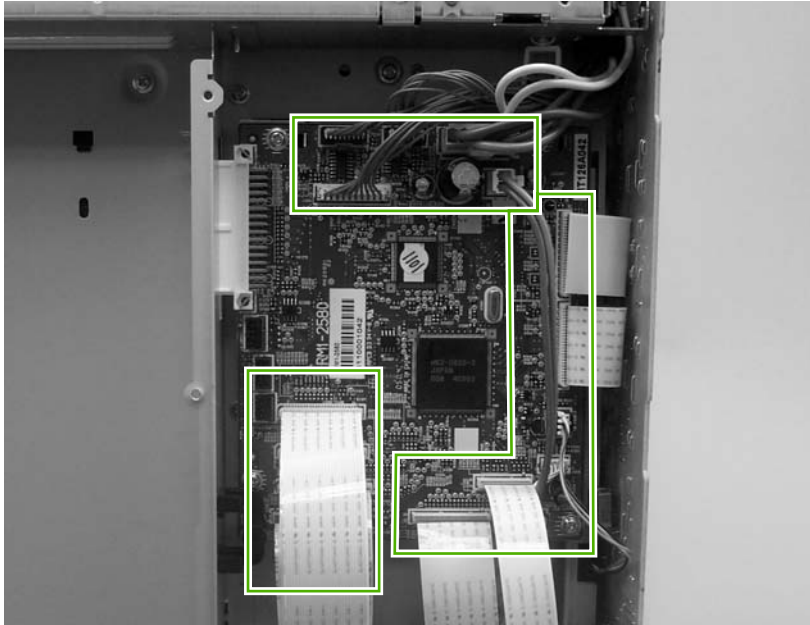

4. Remove 10 screws (callout 3). Push up on the sheet-metal shield to release it from the printer chassis, and remove it.

Figure 5-73 Remove the laser/scanner assembly (3 of 6)

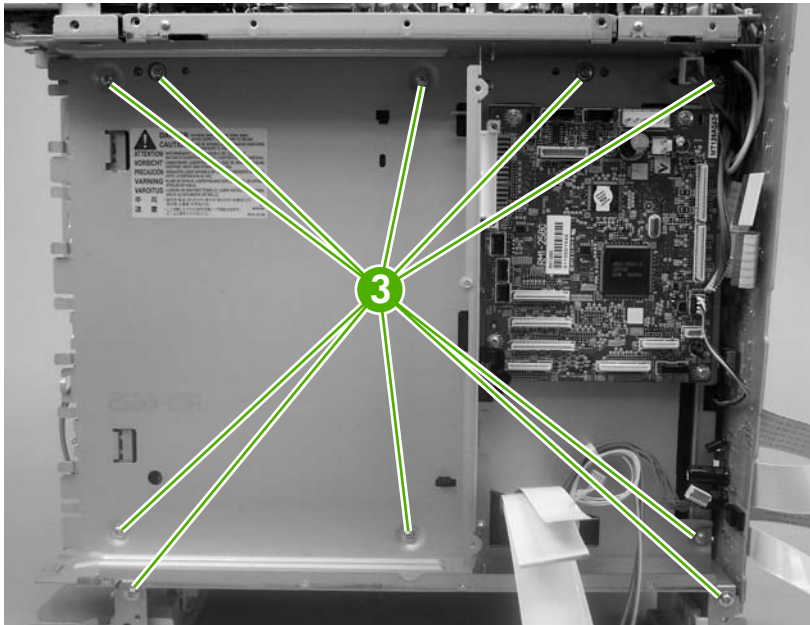

5. Remove the laser/scanner wire-harness from the guide (callout 4) and the retainer (callout 5).

Figure 5-74 Remove the laser/scanner assembly (4 of 6)

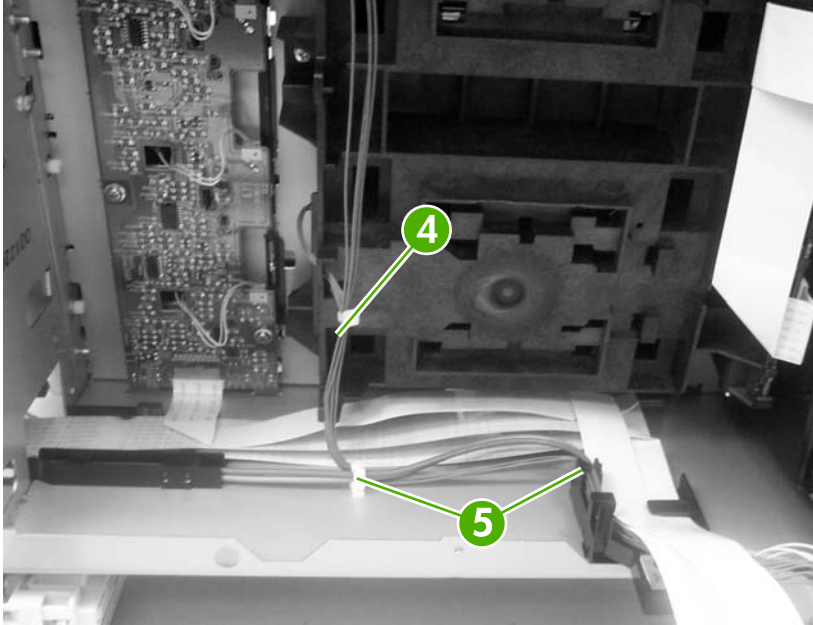

6. Disconnect two FFCs (callout 6), and then remove five screws (callout 7). Remove the laser/scanner.

△ **CAUTION:** Do not bend or fold the FFCs during removal or installation.

Figure 5-75 Remove the laser/scanner assembly (5 of 6)

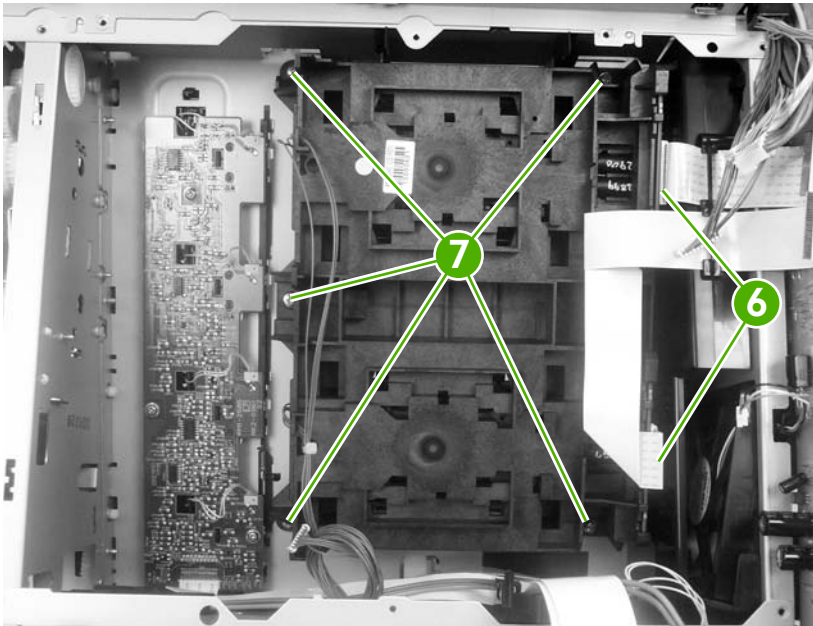

💡 **TIP:** When you reinstall the laser/scanner, the longest FFC connects to the bottom connector, and the short FFC connects to the top connector on the laser/scanner.

7. Disconnect two wire-harnesses (callout 8).

△ **CAUTION:** To prevent ESD damage, do not touch the laser/scanner PCAs (callout 9) or the laser/scanner lenses (callout 10).

Figure 5-76 Remove the laser/scanner assembly (6 of 6)

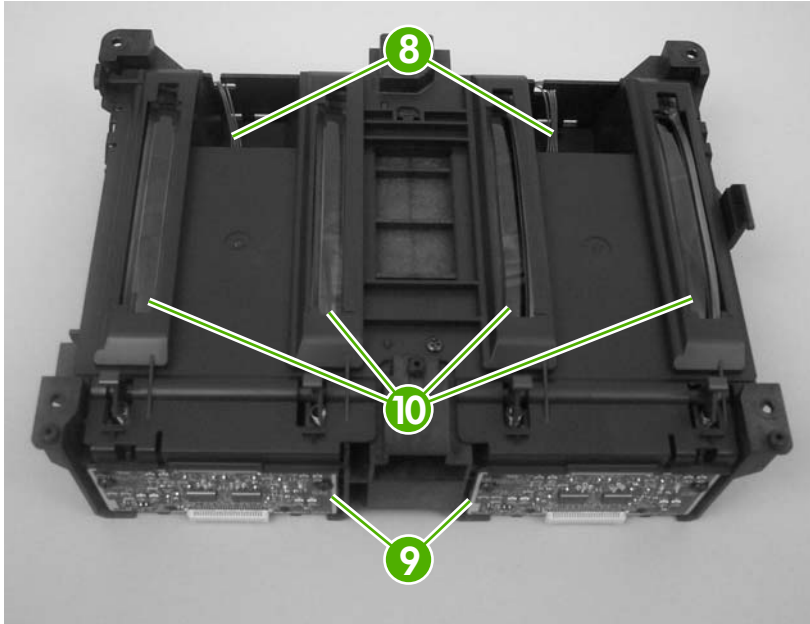

Main fan

1. Remove the following components:
 - Fuser. See [Fuser on page 95](#).
 - Upper cover. See [Upper cover \(fuser door\) on page 80](#).
 - Rear lower cover. See [Rear lower cover on page 83](#).
 - Left cover. See [Left cover on page 84](#).
 - Rear upper cover. See [Rear upper cover on page 91](#).
 - High-voltage power supply. See [High-voltage power supply on page 138](#).
2. Disconnect one connector (callout 1; J1008) on the DC controller.

Figure 5-77 Remove the main fan (1 of 2)

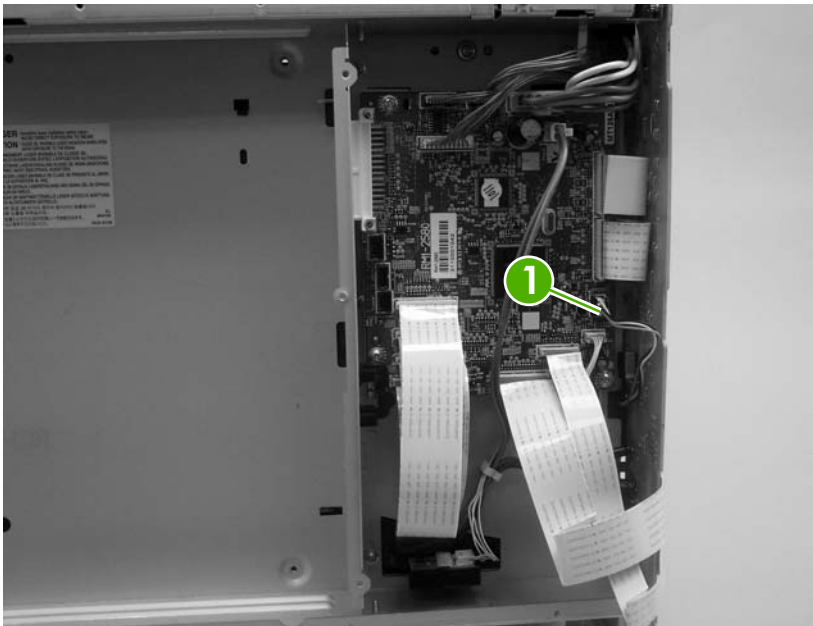

3. Remove one screw (callout 2) to release the fan.

Figure 5-78 Remove the main fan (2 of 2)

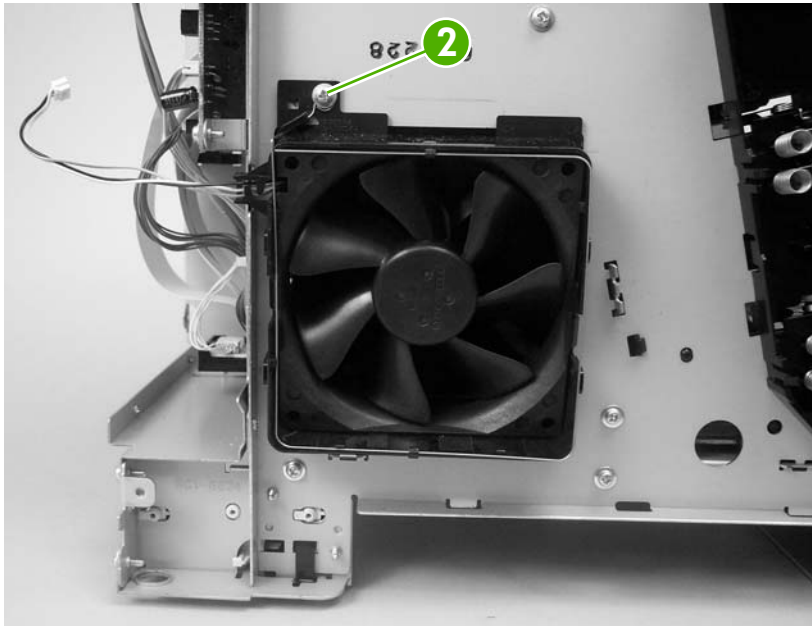

Printed circuit assemblies (PCAs)

 **NOTE:** For information about removing the 500-sheet feeder PCA, see [500-sheet feeder driver PCA on page 164](#) in the 500-sheet feeder section of this chapter.

Low-voltage power-supply PCA

△



CAUTION: PCAs are sensitive to electrostatic discharge (ESD). Look for the ESD reminder when removing PCAs. Always perform service work at an ESD-protected workstation or mat. If an ESD workstation or mat is not available, ground yourself by touching the sheet-metal chassis *before* touching an ESD-sensitive part.

Protect the ESD-sensitive parts by placing them in ESD pouches when they are out of the printer.

1. Remove the following components:
 - Fuser. See [Fuser on page 95](#).
 - Upper cover. See [Upper cover \(fuser door\) on page 80](#).
 - Rear lower cover. See [Rear lower cover on page 83](#).
 - Left cover. See [Left cover on page 84](#).
 - Right cover. See [Right cover on page 87](#).
 - Rear upper cover. See [Rear upper cover on page 91](#).
2. Disconnect four wire-harness (callout 1; J1004, J1005, J1002 and J1006) on the DC controller PCA and remove the wire-harnesses from the retainer.

Figure 5-79 Remove the low-voltage power-supply PCA (1 of 6)

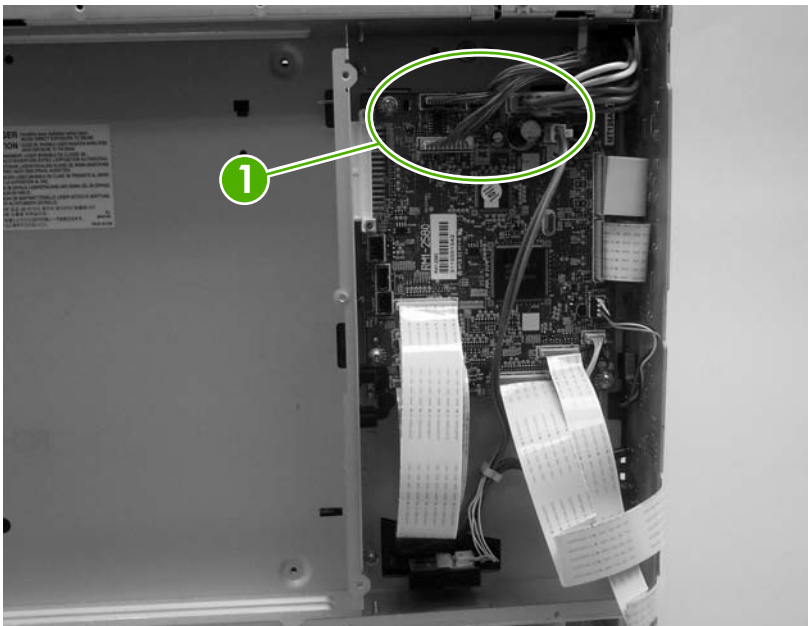

3. Remove four screws (callout 2), and then remove the sheet-metal shield (callout 3).

 **NOTE:** It might not appear that you need to remove the screw securing the high-voltage power supply to the chassis, but it must be removed to feed the low-voltage power supply wire-harnesses out of the printer later in this procedure.

Figure 5-80 Remove the low-voltage power-supply PCA (2 of 6)



4. Remove one screw (callout 4).

Figure 5-81 Remove the low-voltage power-supply PCA (3 of 6)

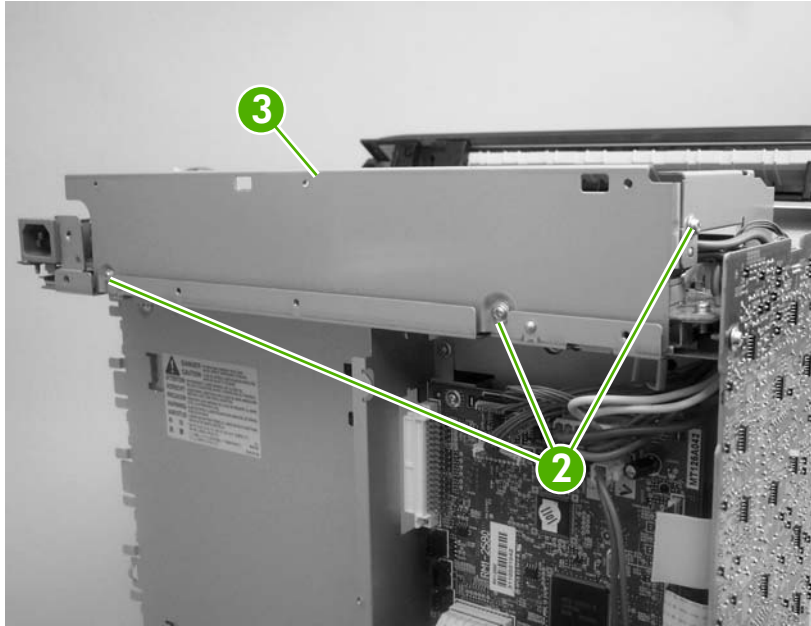
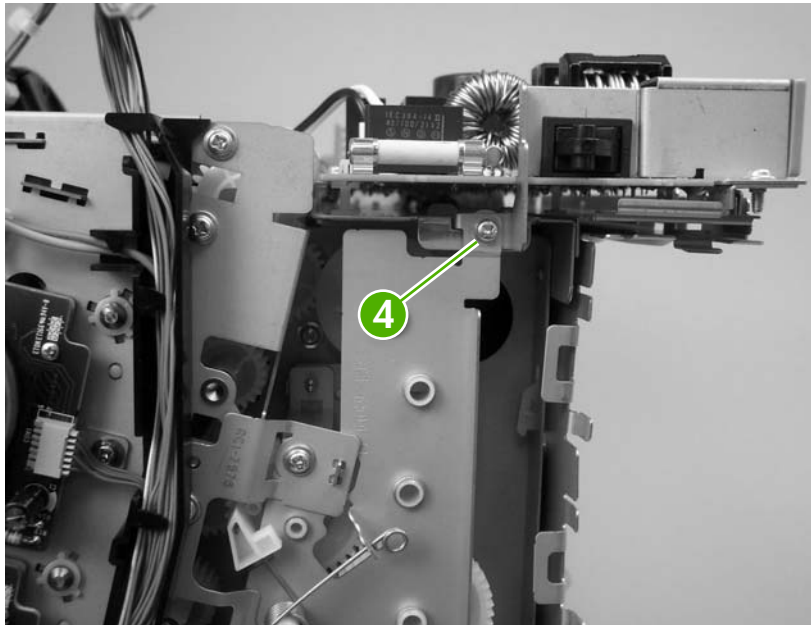

5. Disconnect one connector (callout 5), and remove five screws (callout 6).

 **NOTE:** Two of the screws have washers attached to them. Make sure that these screws are reinstalled in the same place that they are removed from.

Figure 5-82 Remove the low-voltage power-supply PCA (4 of 6)



6. Use needle-nose pliers to gently squeeze the retainer tabs on the PCA standoff, and carefully pull up on the PCA to release it.

Figure 5-83 Remove the low-voltage power-supply PCA (5 of 6)

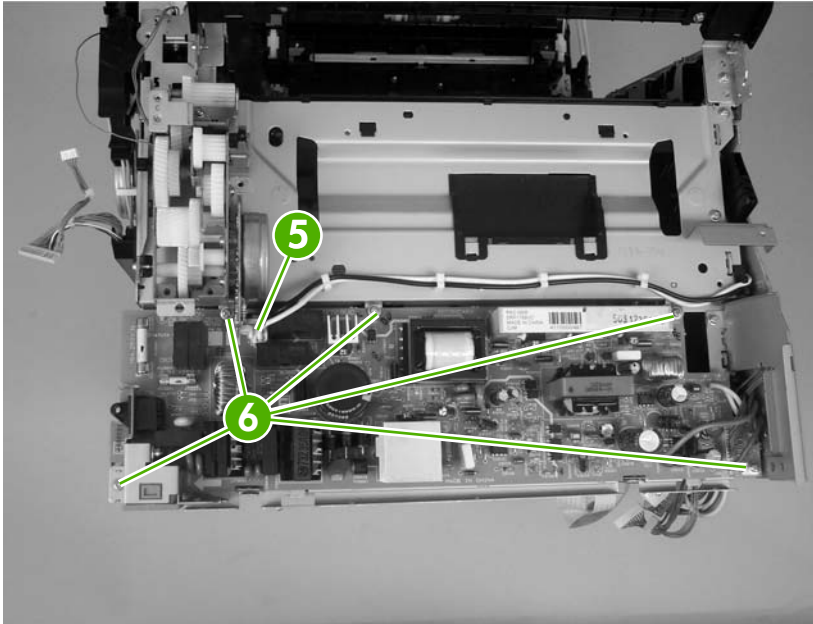
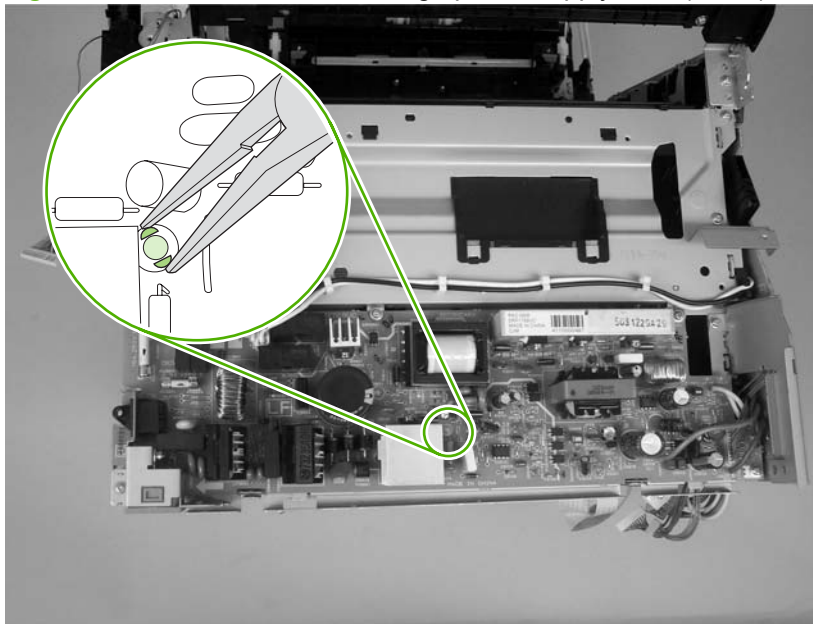

7. Lift the low-voltage power-supply PCA off of the printer chassis.

Figure 5-84 Remove the low-voltage power-supply PCA (6 of 6)

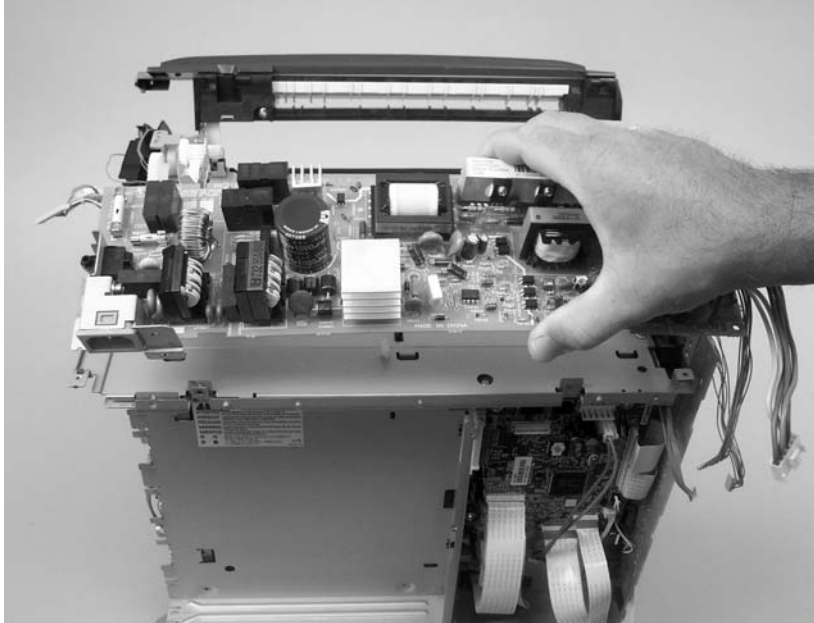

DC controller PCA



CAUTION: PCAs are sensitive to electrostatic discharge (ESD). Look for the ESD reminder when removing PCAs. Always perform service work at an ESD-protected workstation or mat. If an ESD workstation or mat is not available, ground yourself by touching the sheet-metal chassis *before* touching an ESD-sensitive part.

Protect the ESD-sensitive parts by placing them in ESD pouches when they are out of the printer.

1. Remove the following components:
 - Formatter cage. See [Formatter cage on page 92](#).
 - Fuser. See [Fuser on page 95](#).
 - Upper cover. See [Upper cover \(fuser door\) on page 80](#).
 - Rear lower cover. See [Rear lower cover on page 83](#).
 - Left cover. See [Left cover on page 84](#).
 - Rear upper cover. See [Rear upper cover on page 91](#).
2. Disconnect all of the wire-harness connectors and FFCs on the DC controller PCA (eight wire-harness connectors and eight FFCs).

△ **CAUTION:** Do not bend or fold the FFCs during removal or installation.

Figure 5-85 Remove the DC controller PCA (1 of 3)

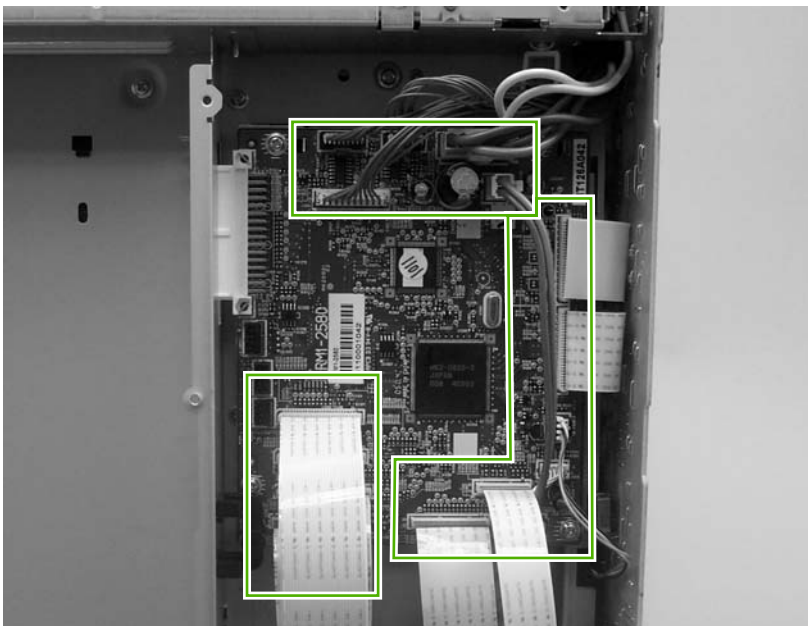

3. Release four locking tabs (callout 1), and then remove the engine-test print switch (callout 2).

Figure 5-86 Remove the DC controller PCA (2 of 3)

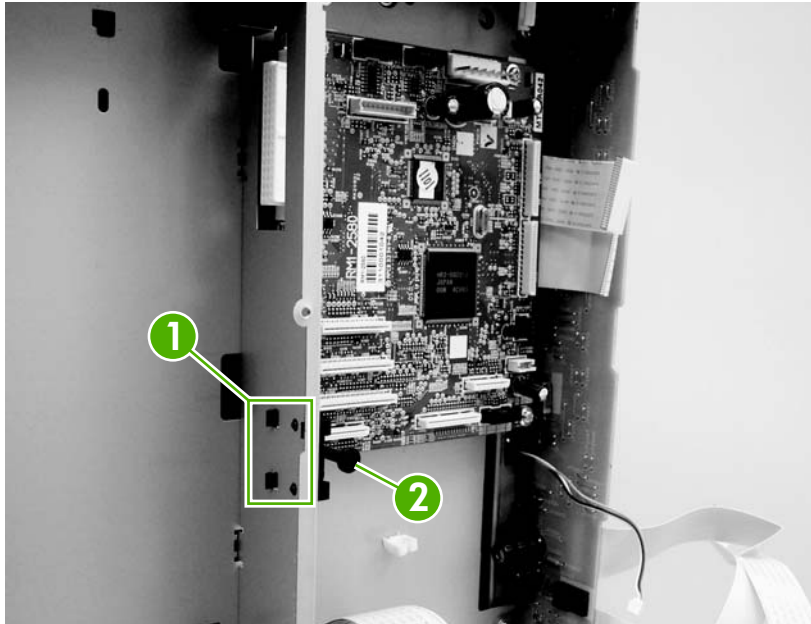

4. Remove four screws (callout 3) to release the DC controller PCA.

Figure 5-87 Remove the DC controller PCA (3 of 3)

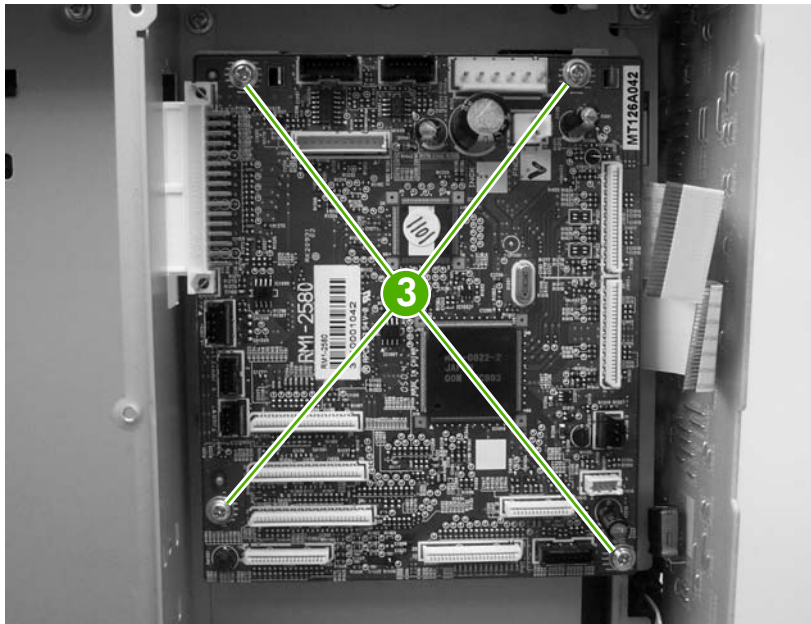

High-voltage power supply



CAUTION: PCAs are sensitive to electrostatic discharge (ESD). Look for the ESD reminder when removing PCAs. Always perform service work at an ESD-protected workstation or mat. If an ESD workstation or mat is not available, ground yourself by touching the sheet-metal chassis *before* touching an ESD-sensitive part.

Protect the ESD-sensitive parts by placing them in ESD pouches when they are out of the printer.

1. Remove the following components:
 - Fuser. See [Fuser on page 95](#).
 - Upper cover. See [Upper cover \(fuser door\) on page 80](#).
 - Rear lower cover. See [Rear lower cover on page 83](#).
 - Left cover. See [Left cover on page 84](#).
 - Rear upper cover. See [Rear upper cover on page 91](#).
2. Disconnect two FFCs (callout 1, J1009, and J1019) on the DC controller.

△ **CAUTION:** Do not bend or fold the FFCs during removal or installation.

Figure 5-88 Remove the high-voltage power supply (1 of 3)

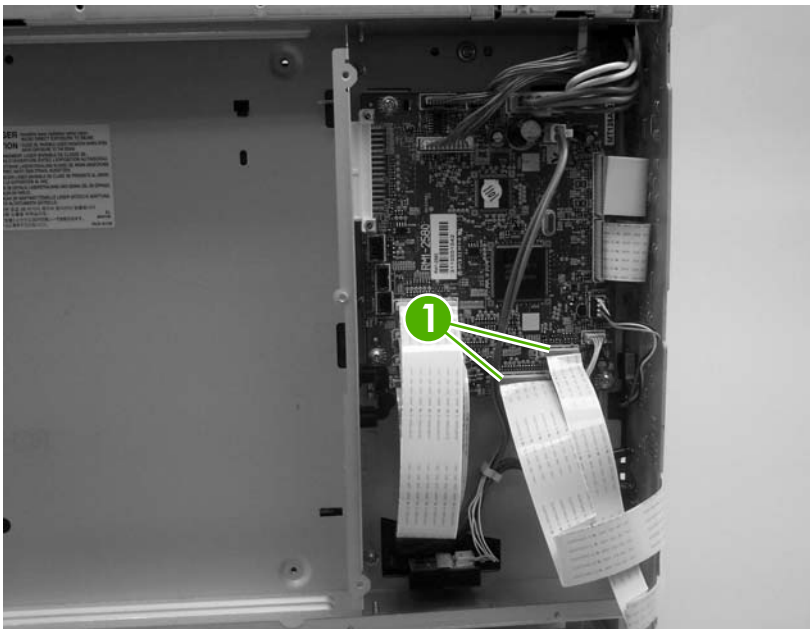

3. Remove four screws (callout 2), and then disconnect two connectors (callout 3).

Figure 5-89 Remove the high-voltage power supply (2 of 3)

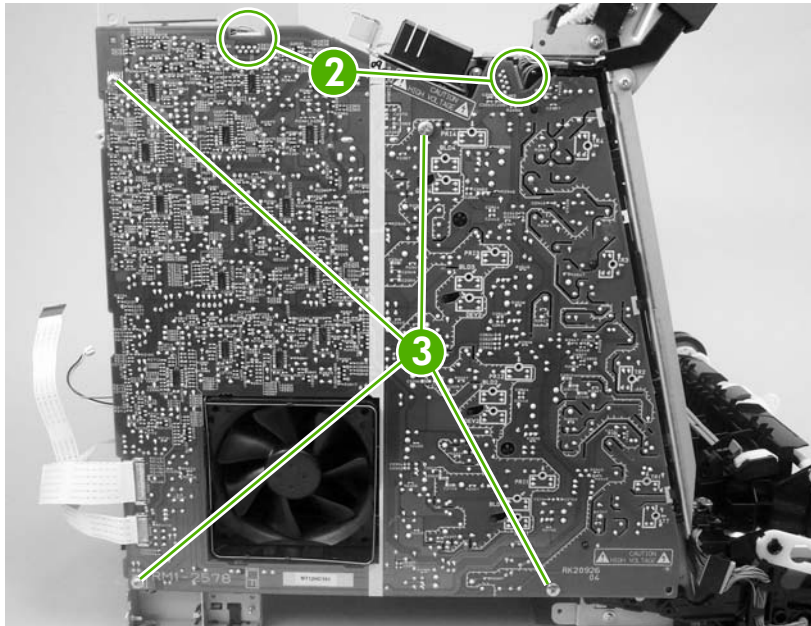

4. Release seven locking tabs (callout 4), and then remove the high-voltage power supply.

Figure 5-90 Remove the high-voltage power supply (3 of 3)

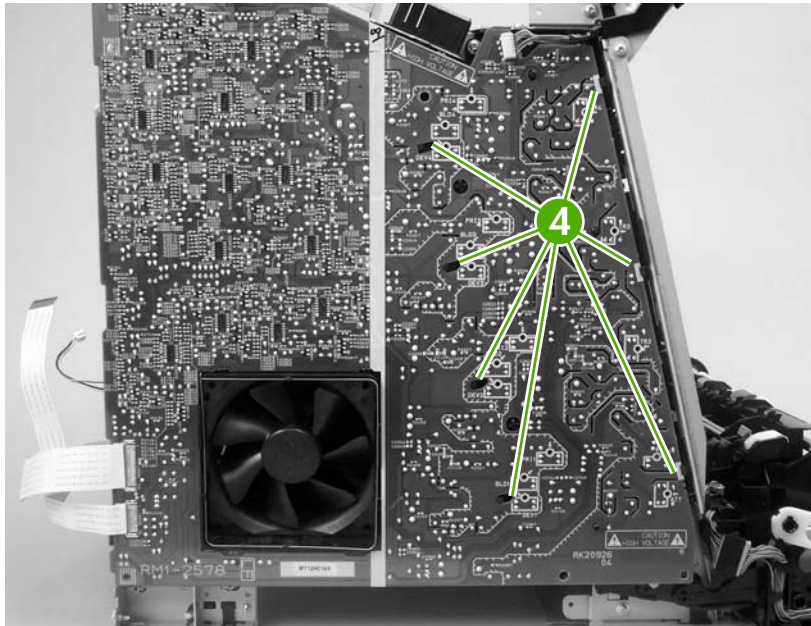

Memory-controller PCA

△



CAUTION: PCAs are sensitive to electrostatic discharge (ESD). Look for the ESD reminder when removing PCAs. Always perform service work at an ESD-protected workstation or mat. If an ESD workstation or mat is not available, ground yourself by touching the sheet-metal chassis *before* touching an ESD-sensitive part.

Protect the ESD-sensitive parts by placing them in ESD pouches when they are out of the printer.

1. Remove the following components:
 - Fuser. See [Fuser on page 95](#).
 - Upper cover. See [Upper cover \(fuser door\) on page 80](#).
 - Rear lower cover. See [Rear lower cover on page 83](#).
 - Left cover. See [Left cover on page 84](#).
 - Right cover. See [Right cover on page 87](#).
 - Rear upper cover. See [Rear upper cover on page 91](#).
2. Remove one FFC (callout 1) from the cable guide (callout 2).

△ **CAUTION:** Do not bend or fold the FFCs during removal or installation.

Figure 5-91 Remove the memory-controller PCA (1 of 2)

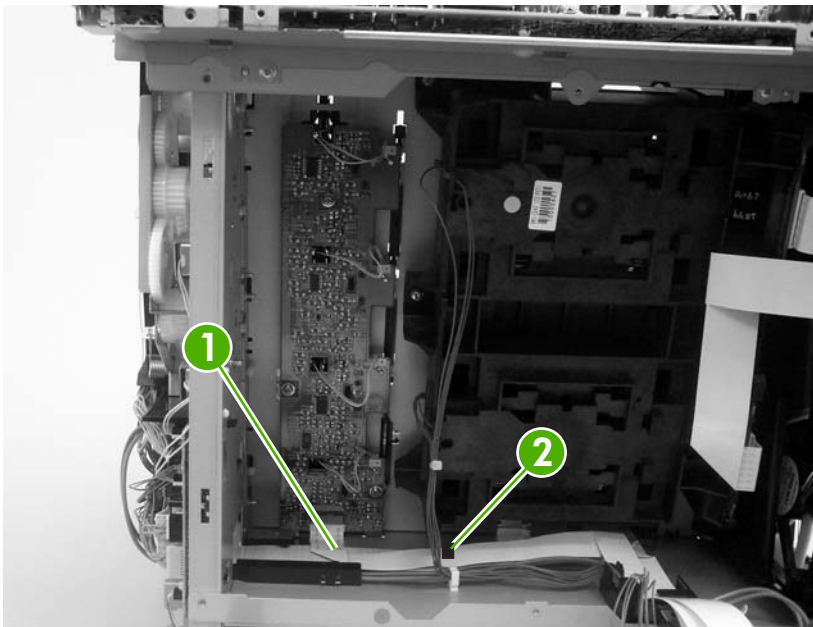

3. Disconnect four connectors (callout 3), and then remove three screws (callout 4) to release the memory-controller PCA.

Figure 5-92 Remove the memory-controller PCA (2 of 2)

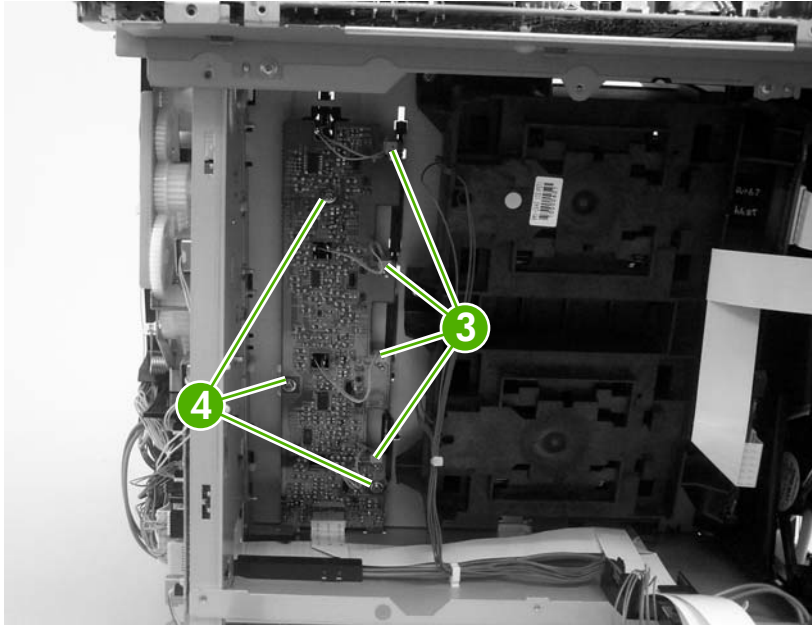

Driver PCA



CAUTION: PCAs are sensitive to electrostatic discharge (ESD). Look for the ESD reminder when removing PCAs. Always perform service work at an ESD-protected workstation or mat. If an ESD workstation or mat is not available, ground yourself by touching the sheet-metal chassis *before* touching an ESD-sensitive part.

Protect the ESD-sensitive parts by placing them in ESD pouches when they are out of the printer.

1. Remove the following components:
 - Fuser. See [Fuser on page 95](#).
 - Upper cover. See [Upper cover \(fuser door\) on page 80](#).
 - Right cover. See [Right cover on page 87](#).
2. Disconnect all of the connectors and FFCs on the driver PCA.

△ **CAUTION:** Do not bend or fold the FFCs during removal or installation.

Figure 5-93 Remove the driver PCA (1 of 2)

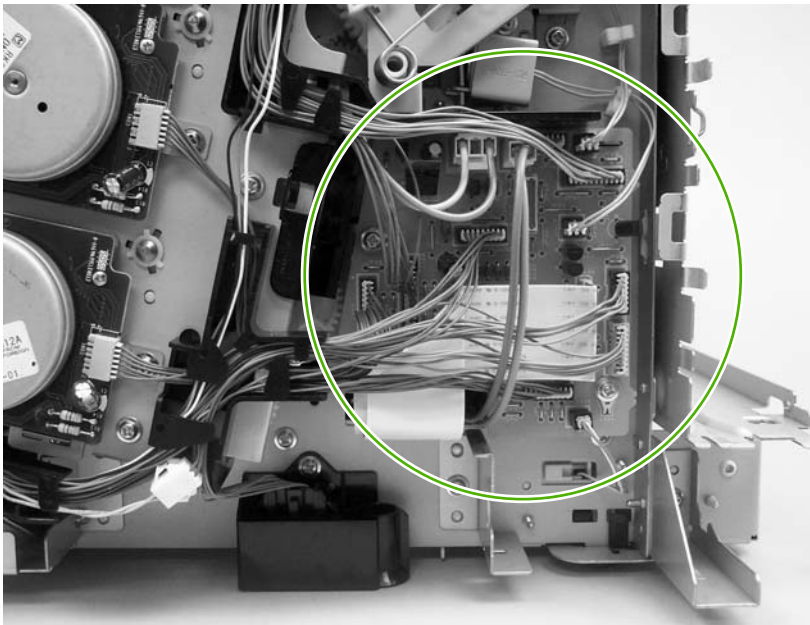

3. Remove two screws (callout 1) to release the driver PCA.

Figure 5-94 Remove the driver PCA (2 of 2)

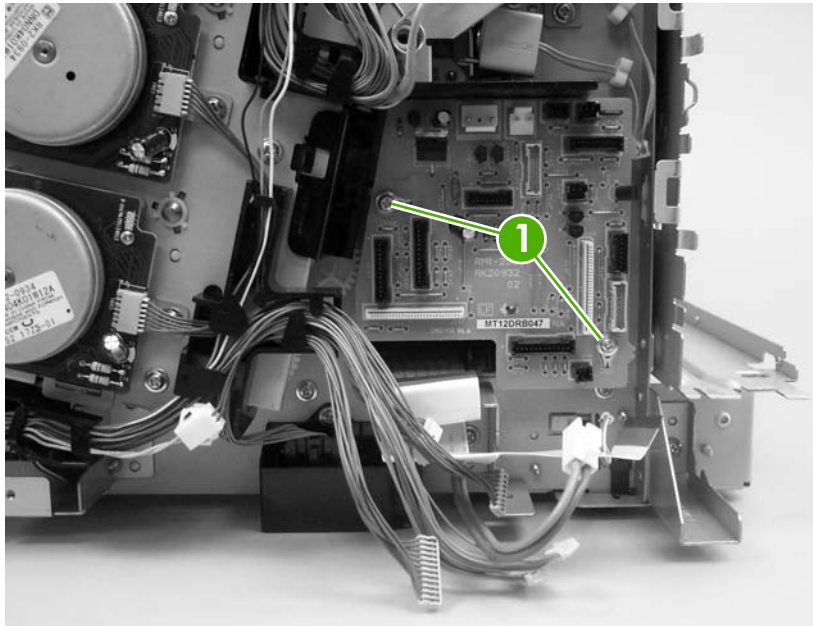

Control panel



CAUTION: PCAs are sensitive to electrostatic discharge (ESD). Look for the ESD reminder when removing PCAs. Always perform service work at an ESD-protected workstation or mat. If an ESD workstation or mat is not available, ground yourself by touching the sheet-metal chassis *before* touching an ESD-sensitive part.

Protect the ESD-sensitive parts by placing them in ESD pouches when they are out of the printer.

1. Remove the following components:
 - Fuser. See [Fuser on page 95](#).
 - Upper cover. See [Upper cover \(fuser door\) on page 80](#).
 - Left cover. See [Left cover on page 84](#).
2. Release the guide locking tab (callout 1) and disconnect one connector (callout 2).

Figure 5-95 Remove the control panel (1 of 2)

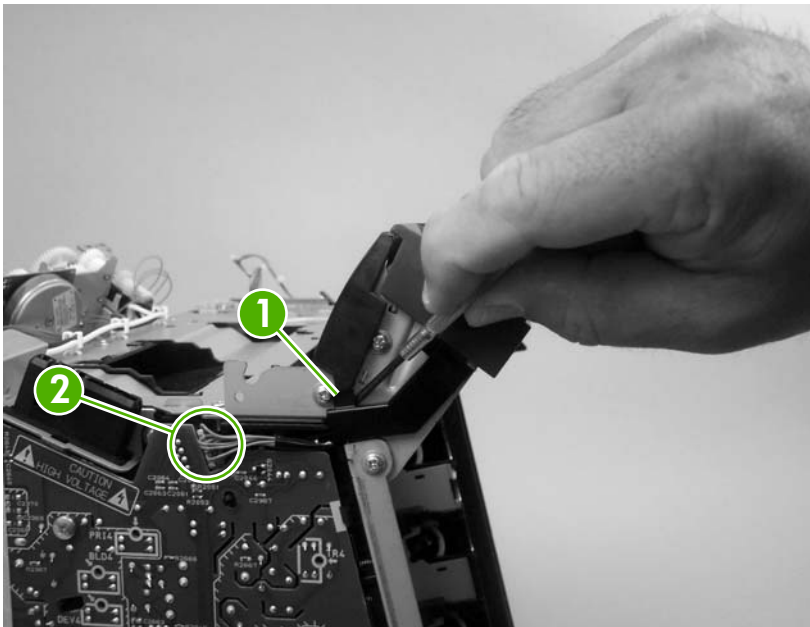

3. Remove two screws (callout 3) to release the control panel.

Figure 5-96 Remove the control panel (2 of 2)

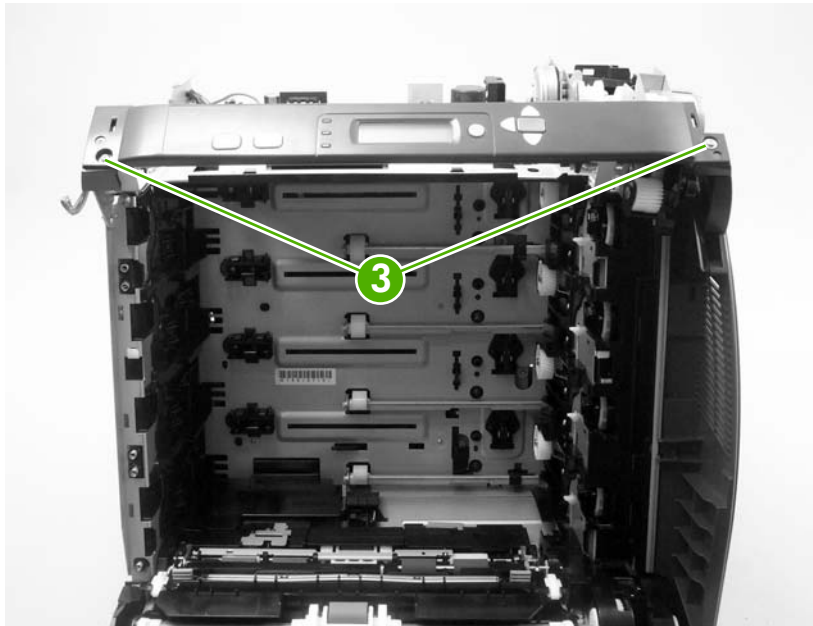

Pickup-and-feed driver PCA

△



CAUTION: PCAs are sensitive to electrostatic discharge (ESD). Look for the ESD reminder when removing PCAs. Always perform service work at an ESD-protected workstation or mat. If an ESD workstation or mat is not available, ground yourself by touching the sheet-metal chassis *before* touching an ESD-sensitive part.

Protect the ESD-sensitive parts by placing them in ESD pouches when they are out of the printer.

1. Open the front cover.
2. Release the locking tab (callout 1) on the pickup-and-feed driver PCA cover (callout 2), and then remove the cover.

△ **CAUTION:** Do not damage or bend the print-cartridge high-voltage springs (callout 3) when you remove the cover.

Figure 5-97 Remove the pickup-and-feed driver PCA (1 of 3)

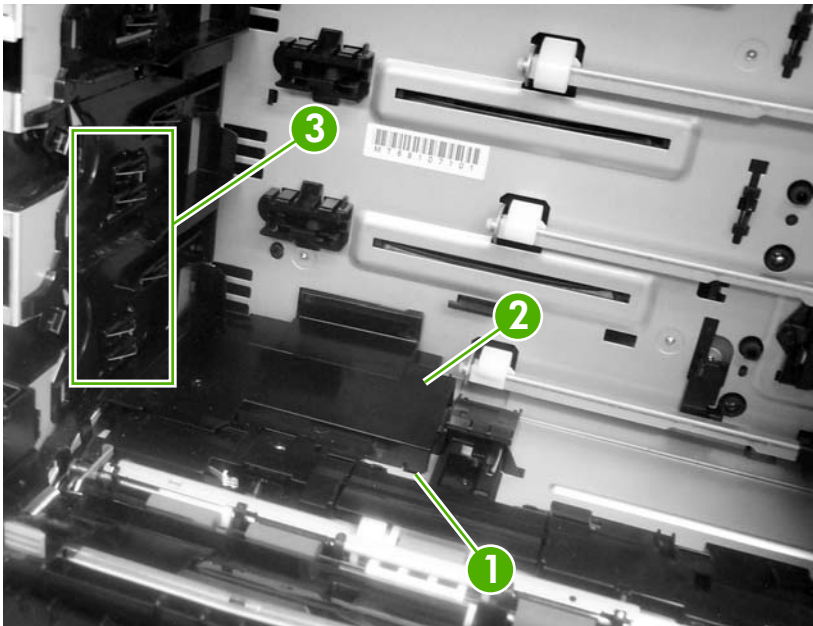

3. Disconnect one FFC (callout 4; J014) on the DC controller.

Figure 5-98 Remove the pickup-and-feed driver PCA (2 of 3)

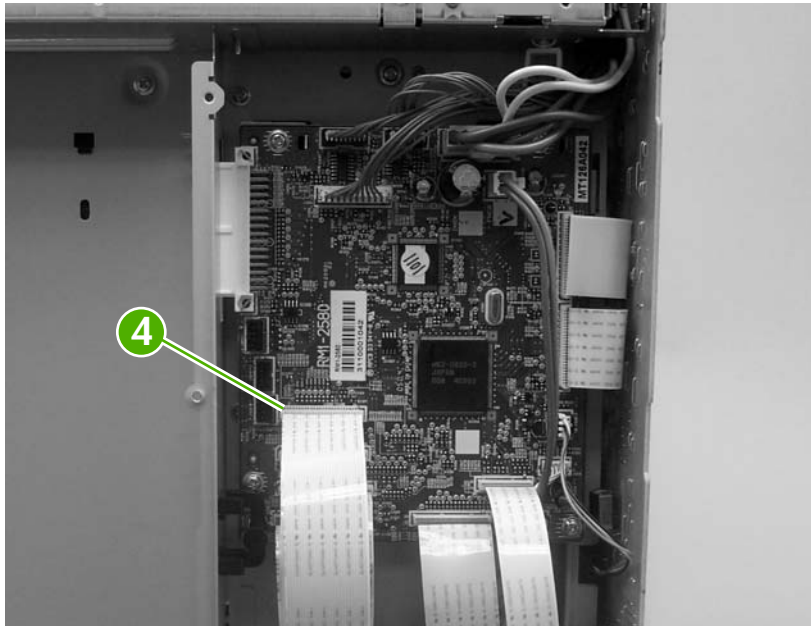

4. Disconnect six connectors (callout 4), and remove one screw (callout 5) to release the pickup-and-feed driver PCA.

 **NOTE:** The HP Color LaserJet 3000 will not have the two white media-sensor connectors.

Figure 5-99 Remove the pickup-and-feed driver PCA (3 of 3)



Duplex-driver PCA

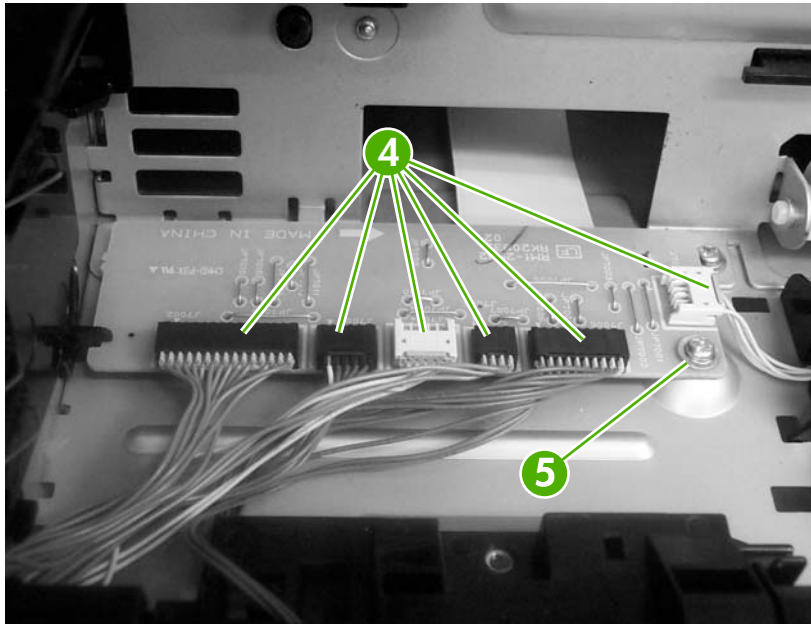

CAUTION: PCAs are sensitive to electrostatic discharge (ESD). Look for the ESD reminder when removing PCAs. Always perform service work at an ESD-protected workstation or mat. If an ESD workstation or mat is not available, ground yourself by touching the sheet-metal chassis *before* touching an ESD-sensitive part.

Protect the ESD-sensitive parts by placing them in ESD pouches when they are out of the printer.

1. Remove the following components:
 - Fuser. See [Fuser on page 95](#).
 - Remove the upper cover. See [Upper cover \(fuser door\) on page 80](#).
2. Disconnect six connectors (callout 1).

Figure 5-100 Remove the duplex-driver PCA (1 of 3)

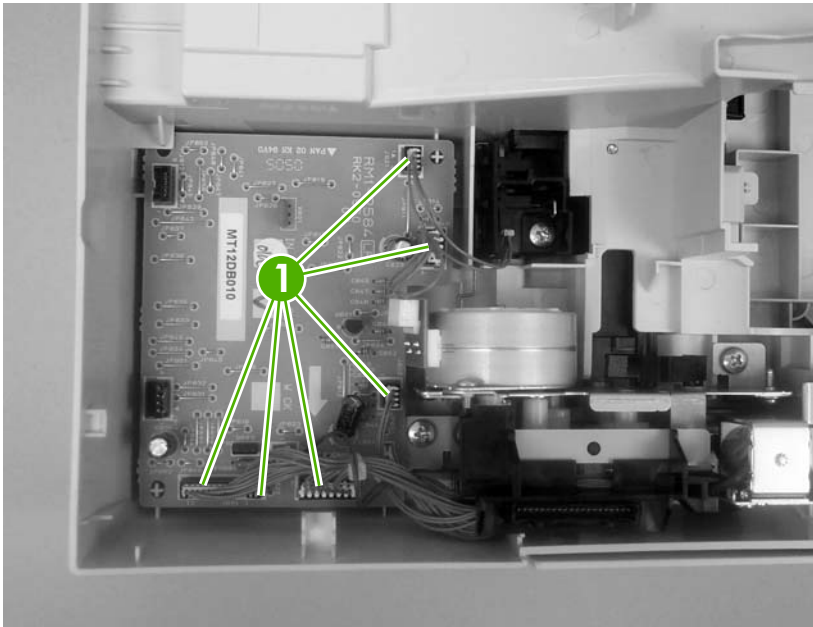

3. Remove one screw (callout 2).

Figure 5-101 Remove the duplex-driver PCA (2 of 3)

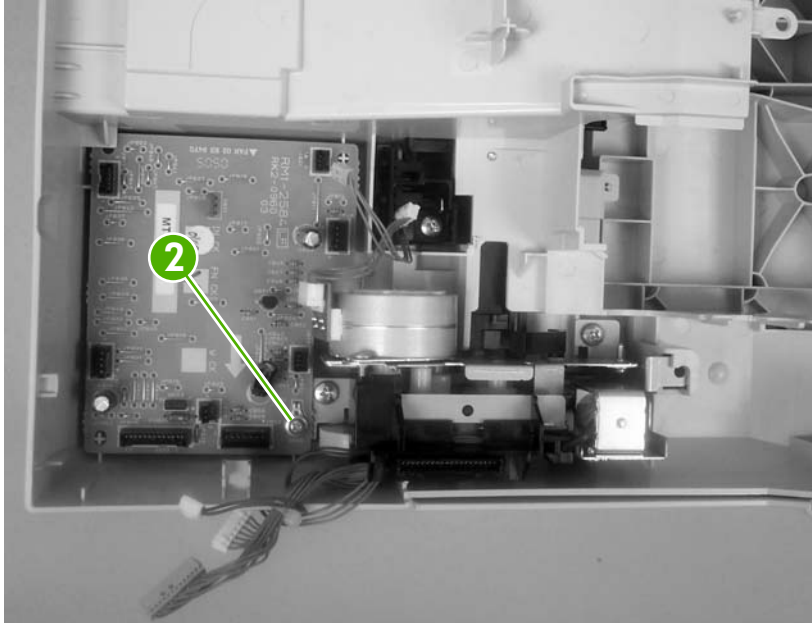

4. Lift the duplex-driver PCA out of the upper cover.

Figure 5-102 Remove the duplex-driver PCA (3 of 3)

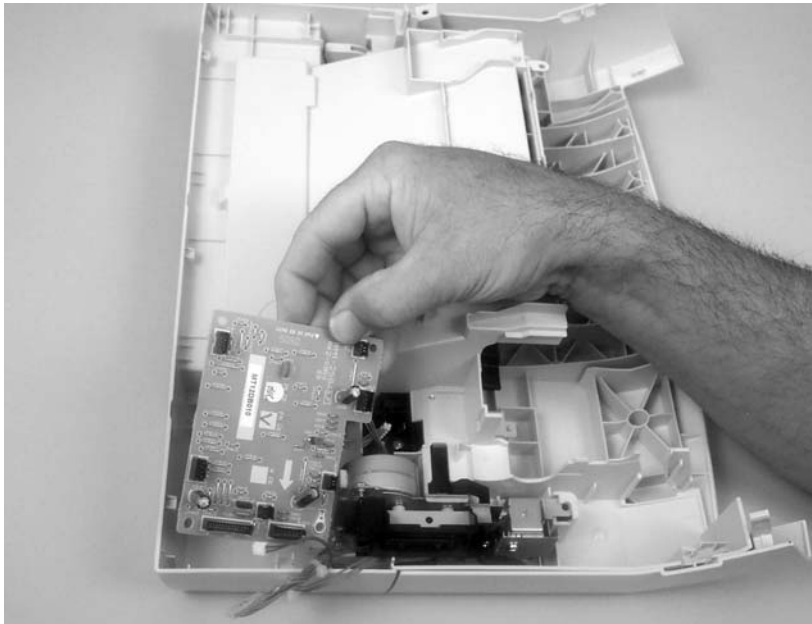

Sensors

 **NOTE:** For information about removing the 500-sheet media sensor, see [Media sensor \(500-sheet feeder\) on page 166](#) in this chapter.

Cassette media sensor (HP LaserJet 3600/3800/CP3505)

 **NOTE:** Always perform a full calibration procedure when you replace the cassette media sensor.

△



CAUTION: PCAs are sensitive to electrostatic discharge (ESD). Look for the ESD reminder when removing PCAs. Always perform service work at an ESD-protected workstation or mat. If an ESD workstation or mat is not available, ground yourself by touching the sheet-metal chassis *before* touching an ESD-sensitive part.

Protect the ESD-sensitive parts by placing them in ESD pouches when they are out of the printer.

1. Open the front cover and remove the ETB. See [Electrostatic transfer belt \(ETB\) on page 94](#).
2. Release the locking tab (callout 1) on the pickup-and-feed driver PCA cover (callout 2), and then remove the cover.

△ **CAUTION:** Do not damage or bend the print-cartridge high-voltage springs (callout 3) when you remove the cover.

Figure 5-103 Remove the cassette media sensor (1 of 2)

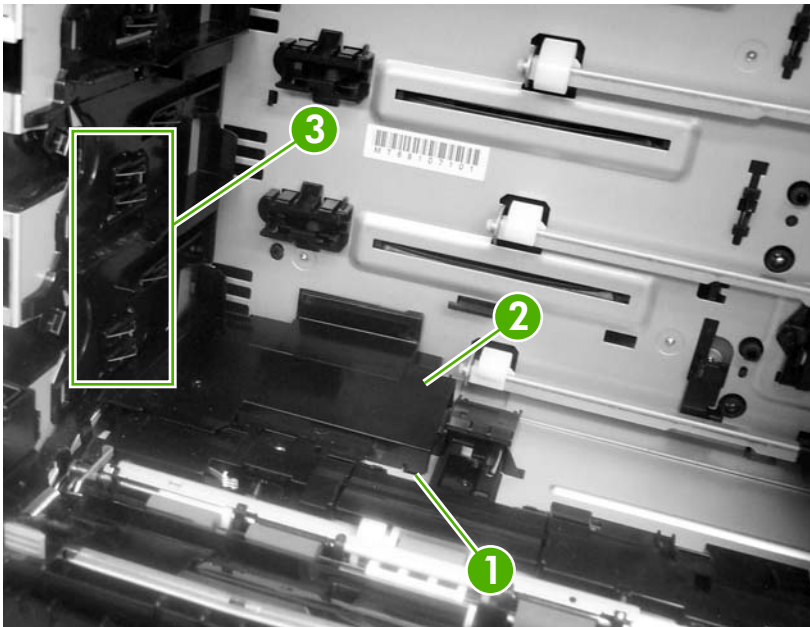

3. Disconnect one connector (callout 4) and remove one screw (callout 5). Lift the cassette media sensor (callout 6) out of the printer.

Figure 5-104 Remove the cassette media sensor (2 of 2)

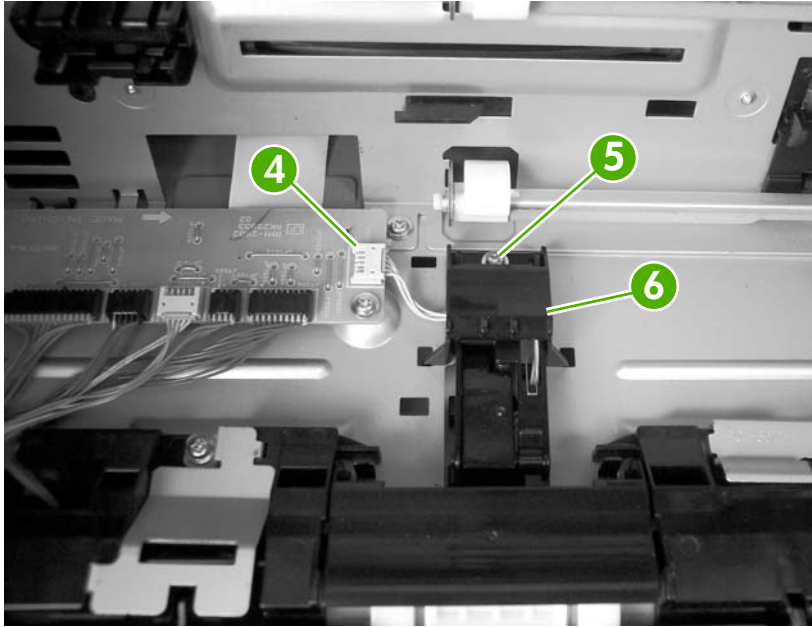

Temperature sensor



CAUTION: PCAs are sensitive to electrostatic discharge (ESD). Look for the ESD reminder when removing PCAs. Always perform service work at an ESD-protected workstation or mat. If an ESD workstation or mat is not available, ground yourself by touching the sheet-metal chassis *before* touching an ESD-sensitive part.

Protect the ESD-sensitive parts by placing them in ESD pouches when they are out of the printer.

1. Remove the following components:
 - Upper cover. See [Upper cover \(fuser door\) on page 80](#).
 - Rear lower cover. See [Rear lower cover on page 83](#).
 - Left cover. See [Left cover on page 84](#).
 - Right cover. See [Right cover on page 87](#).
 - Rear upper cover. See [Rear upper cover on page 91](#).
2. Disconnect one connector (callout 1; J1018) and release the locking tab (callout 2). Remove the temperature sensor (callout 3).

Figure 5-105 Remove the temperature sensor

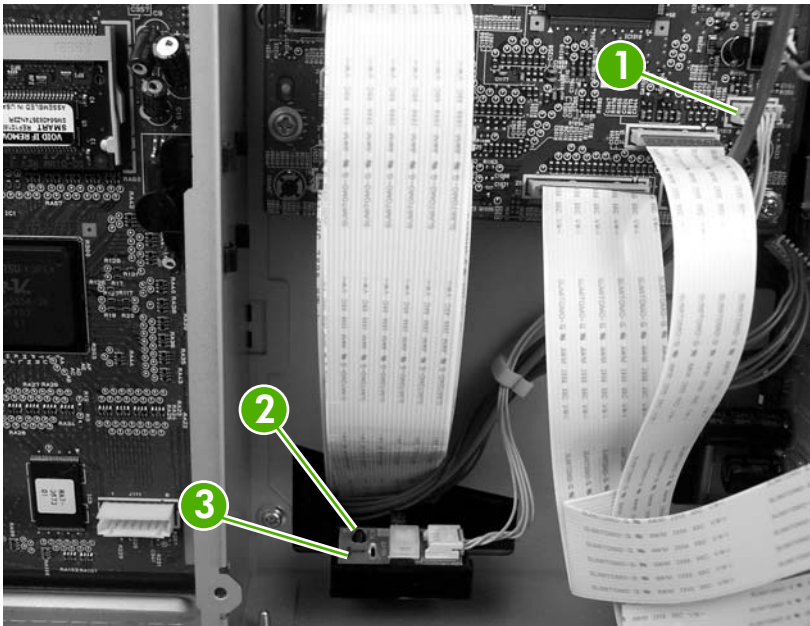

Paper and registration sensor covers

1. Open the front cover and remove the ETB. See [Electrostatic transfer belt \(ETB\) on page 94](#).
2. Remove two screws (callout 1) and the paper and registration sensor covers (callout 2).

△ **CAUTION:** Do not bend the locator tabs on the covers.

Figure 5-106 Remove the paper and registration sensor covers

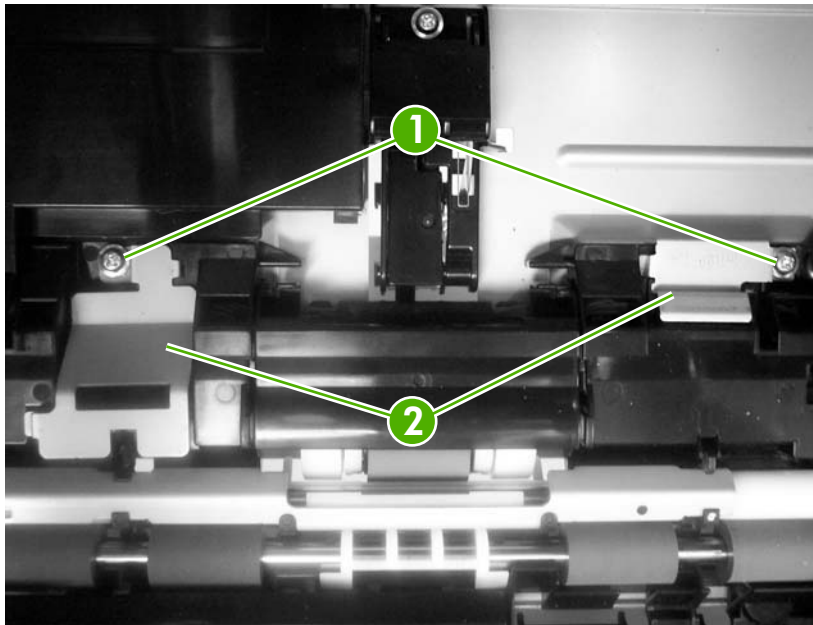

Cartridge-sensor PCA



CAUTION: PCAs are sensitive to electrostatic discharge (ESD). Look for the ESD reminder when removing PCAs. Always perform service work at an ESD-protected workstation or mat. If an ESD workstation or mat is not available, ground yourself by touching the sheet-metal chassis *before* touching an ESD-sensitive part.

Protect the ESD-sensitive parts by placing them in ESD pouches when they are out of the printer.

1. Remove the following components:
 - Upper cover. See [Upper cover \(fuser door\) on page 80](#).
 - Rear lower cover. See [Rear lower cover on page 83](#).
 - Left cover. See [Left cover on page 84](#).
 - Right cover. See [Right cover on page 87](#).
 - Rear upper cover. See [Rear upper cover on page 91](#).
2. Remove four screws (callout 1) and remove the sheet-metal shield (callout 2).

Figure 5-107 Remove the cartridge-sensor PCA (1 of 4)

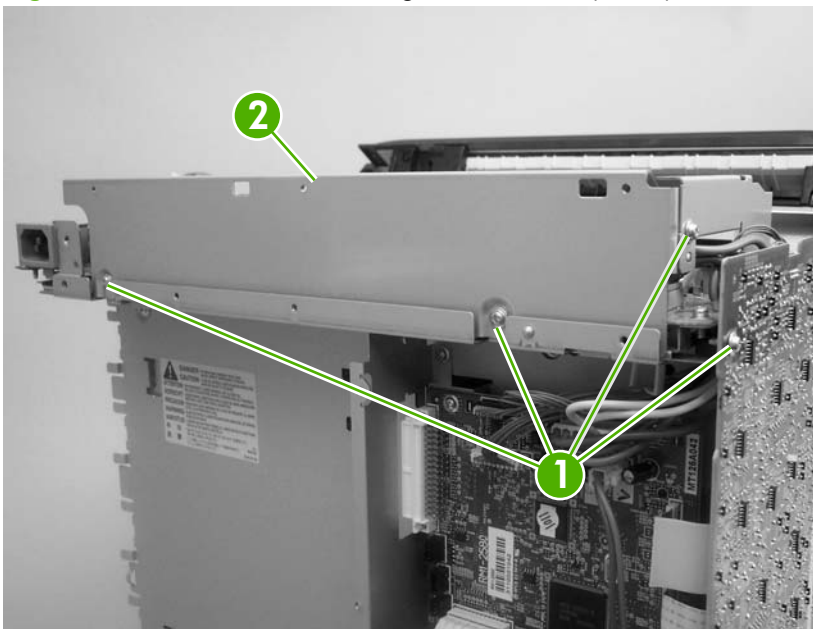

3. Disconnect all of the wire-harness connectors and flat flexible cables (FFCs) on the DC controller PCA (eight wire-harness connectors and eight FFCs).

△ **CAUTION:** Do not bend or fold the FFCs during removal or installation.

📄 **NOTE:** Remove the wire-harnesses from all of the retainers near the DC controller.

Figure 5-108 Remove the cartridge-sensor PCA (2 of 4)

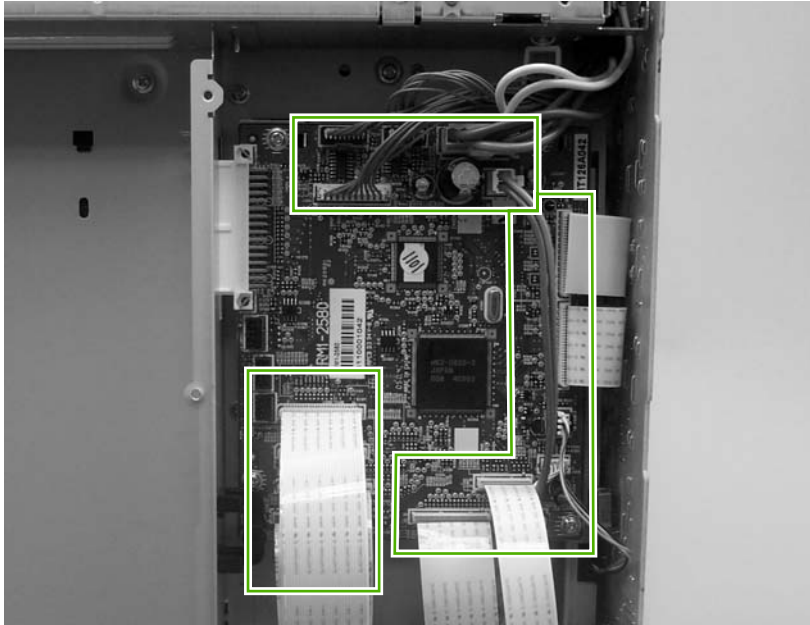

4. Remove 10 screws (callout 3). Push up on the sheet-metal shield to release it from the printer chassis, and remove it.

Figure 5-109 Remove the cartridge-sensor PCA (3 of 4)

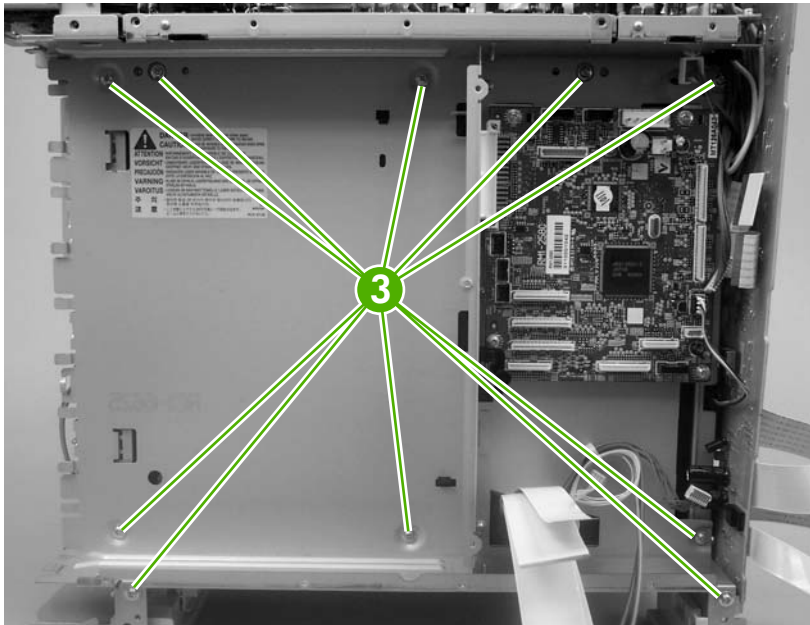

5. Disconnect four connectors (callout 4) and remove three screws (callout 5). Remove the cartridge-sensor PCA from the printer.

Figure 5-110 Remove the cartridge-sensor PCA (4 of 4)

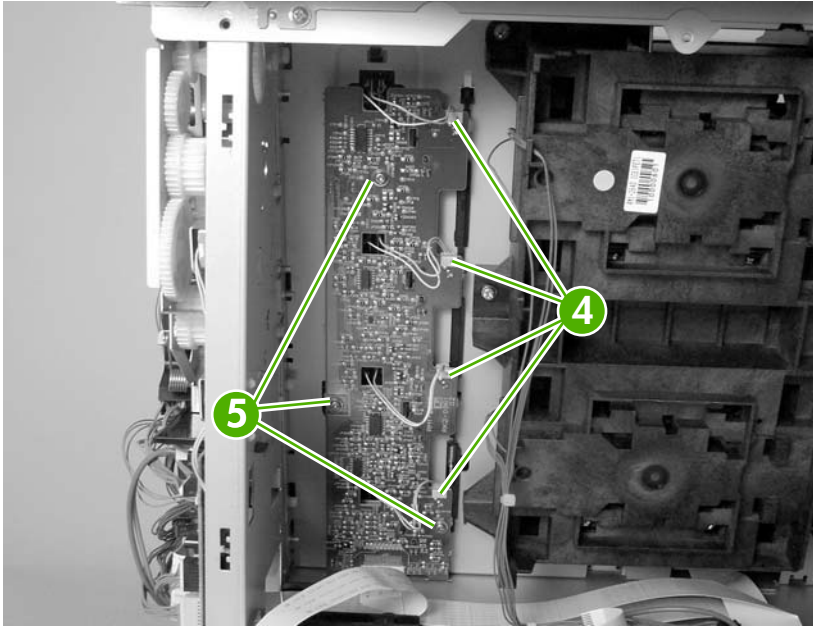

500-sheet feeder

500-sheet feeder right cover

1. Remove one screw (callout 1).

Figure 5-111 Remove the 500-sheet feeder right cover (1 of 3)

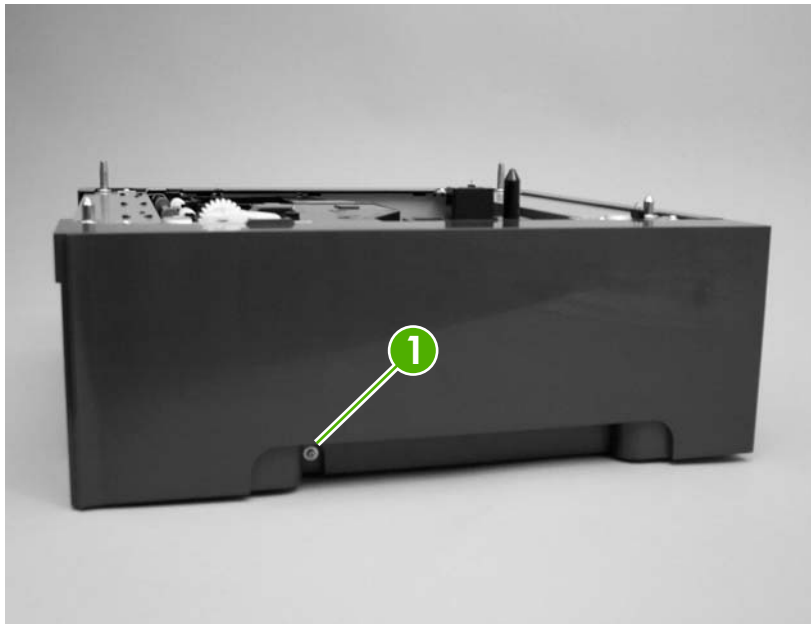

TIP: Before proceeding, look at the following figure and note the location of the locking tabs on the right cover.

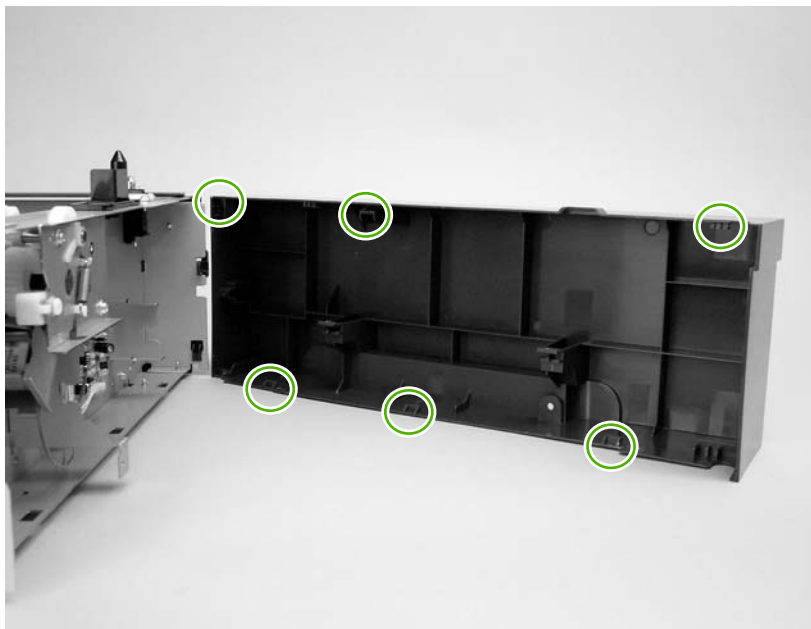

2. Carefully pry loose the two locking tabs along the top of the cover.

Figure 5-112 Remove the 500-sheet feeder right cover (2 of 3)



3. Rotate the top of the cover away from the feeder to release three locking tabs along the bottom of the cover.

Figure 5-113 Remove the 500-sheet feeder right cover (3 of 3)

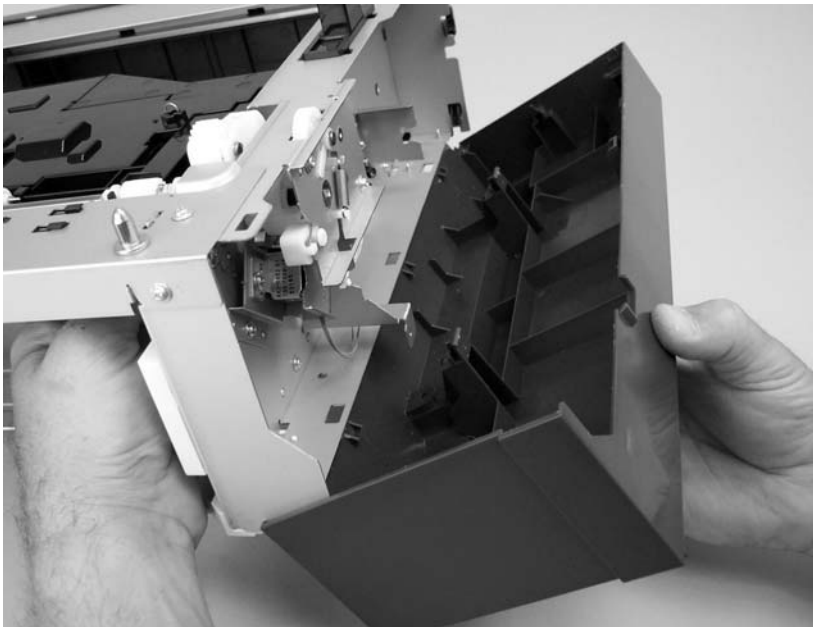

500-sheet feeder left cover

1. Remove one screw (callout 1).

Figure 5-114 Remove the 500-sheet feeder left cover (1 of 5)

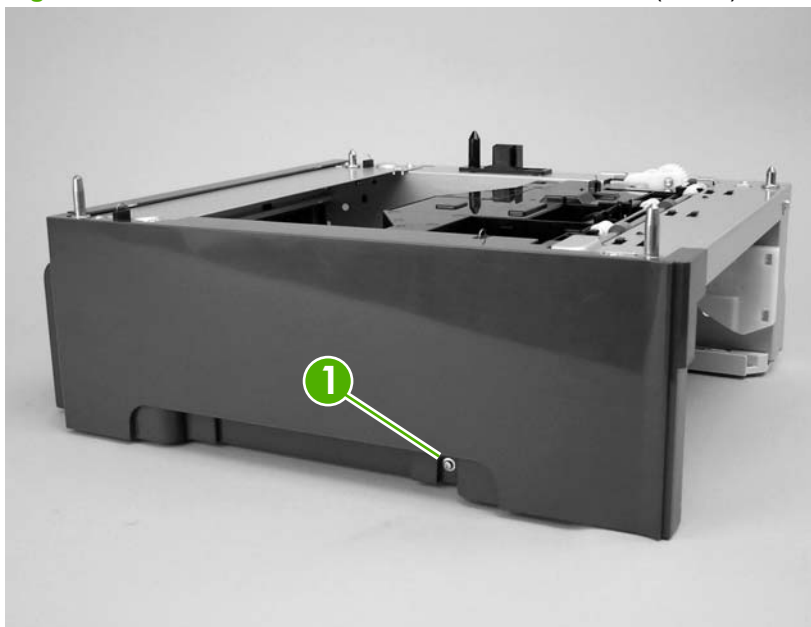

 **TIP:** Before proceeding, look at the following figure and note the location of the locking tabs on the left cover.

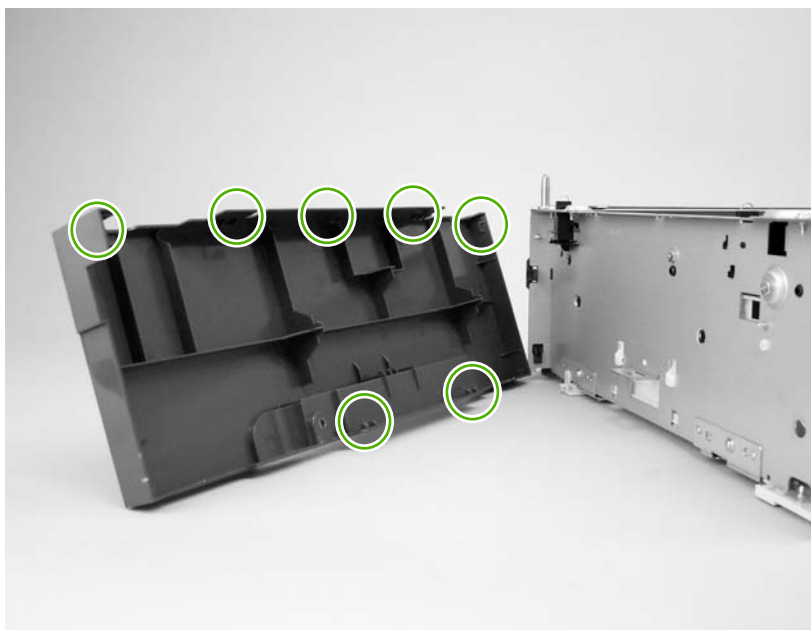

2. Carefully pry loose the three locking tabs along the top of the cover.

Figure 5-115 Remove the 500-sheet feeder left cover (2 of 5)



3. Use a flatblade screwdriver to release the locking tab at the front of the cover.

Figure 5-116 Remove the 500-sheet feeder left cover (3 of 5)



4. Use a flatblade screwdriver to release the locking tab at the rear of the cover.

Figure 5-117 Remove the 500-sheet feeder left cover (4 of 5)

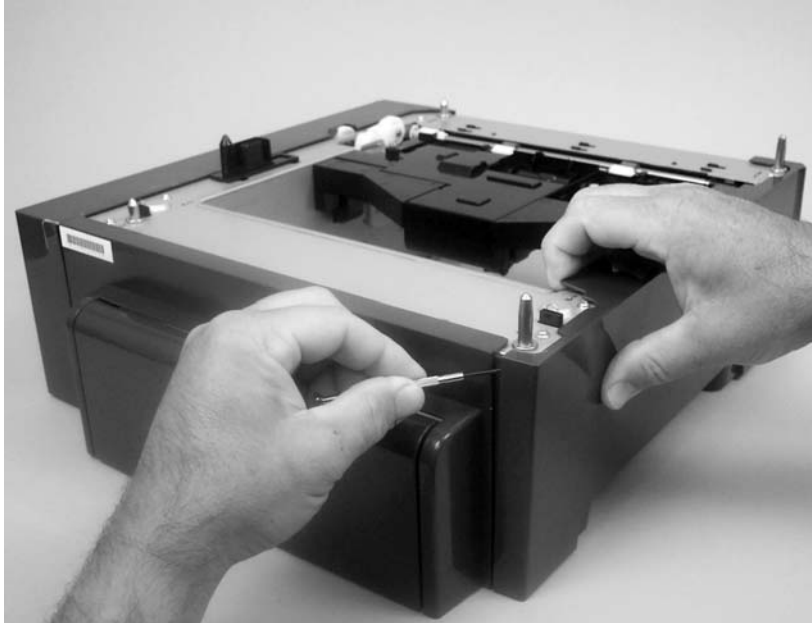

5. Rotate the top of the cover away from the feeder to release two locking tabs along the bottom of the cover.

Figure 5-118 Remove the 500-sheet feeder left cover (5 of 5)

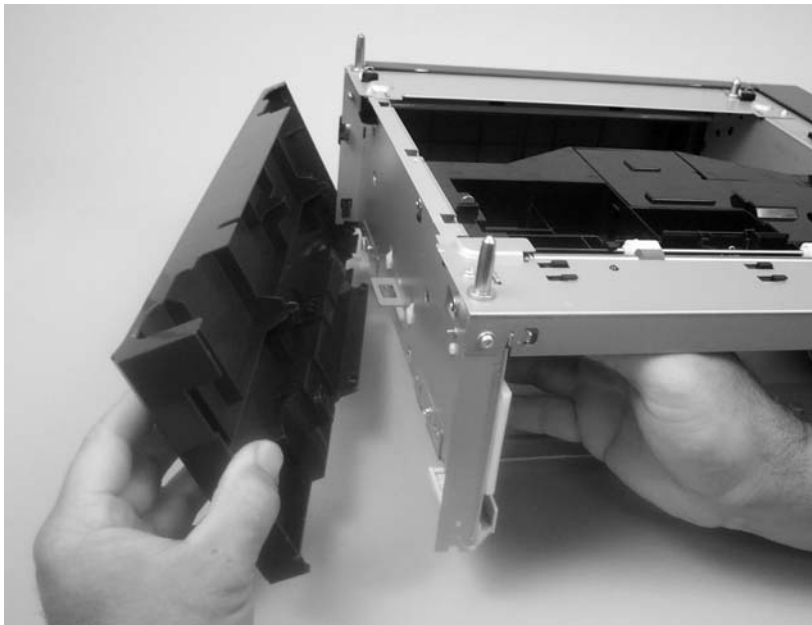

500-sheet feeder rear cover

1. Remove the following components:
 - 500-sheet feeder right cover. See [500-sheet feeder right cover on page 157](#).
 - 500-sheet feeder left cover. See [500-sheet feeder left cover on page 159](#).
2. Release the two locking tabs along the side of the cover.

Figure 5-119 Remove the 500-sheet feeder rear cover (1 of 3)

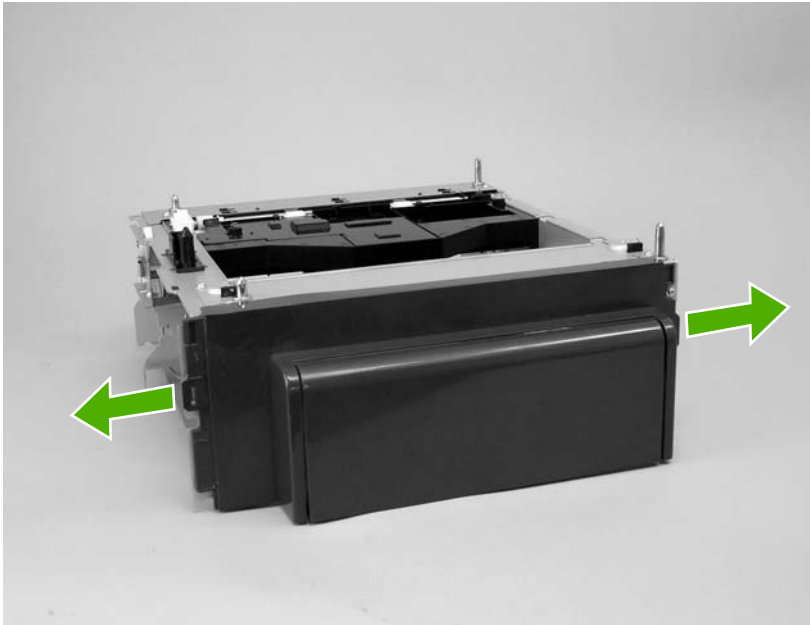

 **TIP:** Before proceeding, look at the following figure and note the location of the locking tabs on the rear cover.

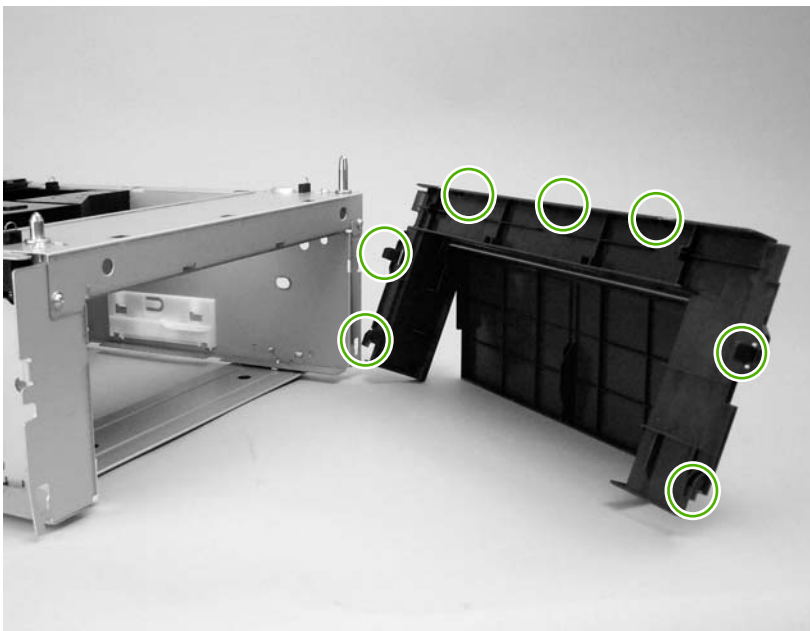

3. Carefully pry loose the three locking tabs along the top of the cover.

Figure 5-120 Remove the 500-sheet feeder rear cover (2 of 3)

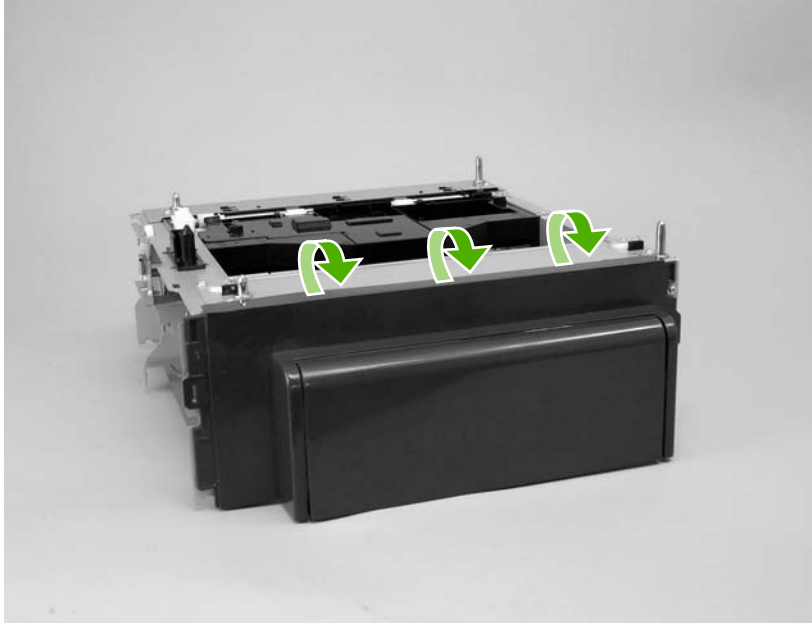

4. Rotate the cover up and away from the feeder chassis to remove it.

Figure 5-121 Remove the 500-sheet feeder rear cover (3 of 3)

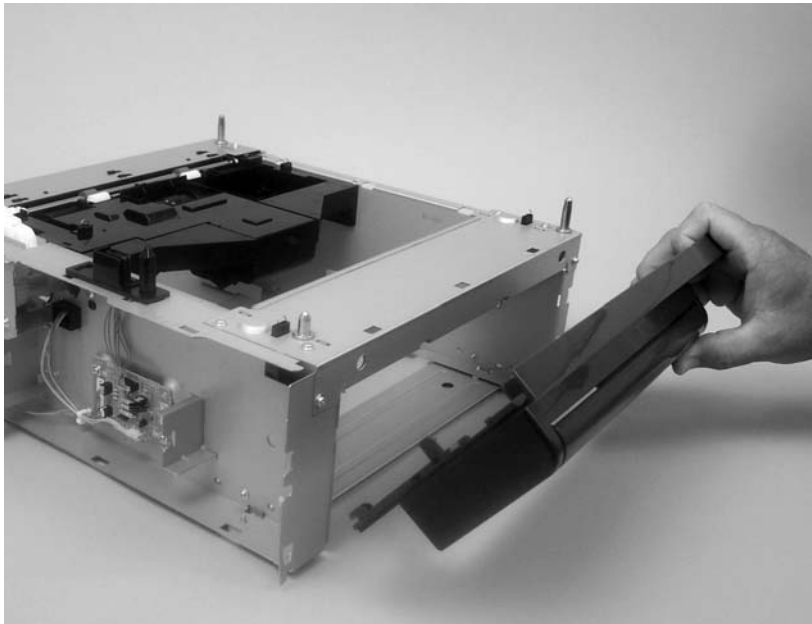

500-sheet feeder driver PCA



CAUTION: PCAs are sensitive to electrostatic discharge (ESD). Look for the ESD reminder when removing PCAs. Always perform service work at an ESD-protected workstation or mat. If an ESD workstation or mat is not available, ground yourself by touching the sheet-metal chassis *before* touching an ESD-sensitive part.

Protect the ESD-sensitive parts by placing them in ESD pouches when they are out of the printer.

1. Remove the 500-sheet feeder right cover. See [500-sheet feeder right cover on page 157](#).
2. Disconnect four connectors (callout 1)

Figure 5-122 Remove the 500-sheet-feeder driver PCA (1 of 2)

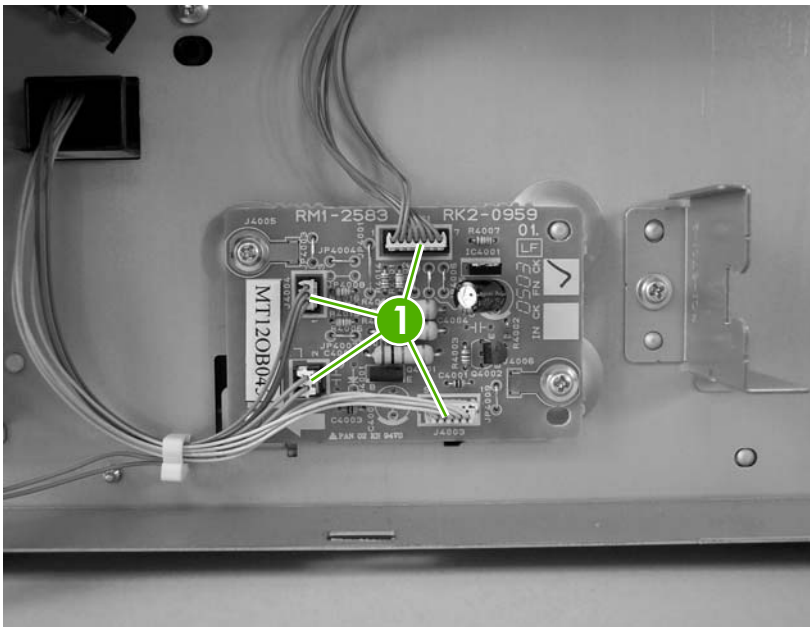

3. Release the 500-sheet-feeder PCA by removing two screws (callout 2).

Figure 5-123 Remove the 500-sheet-feeder driver PCA (2 of 2)

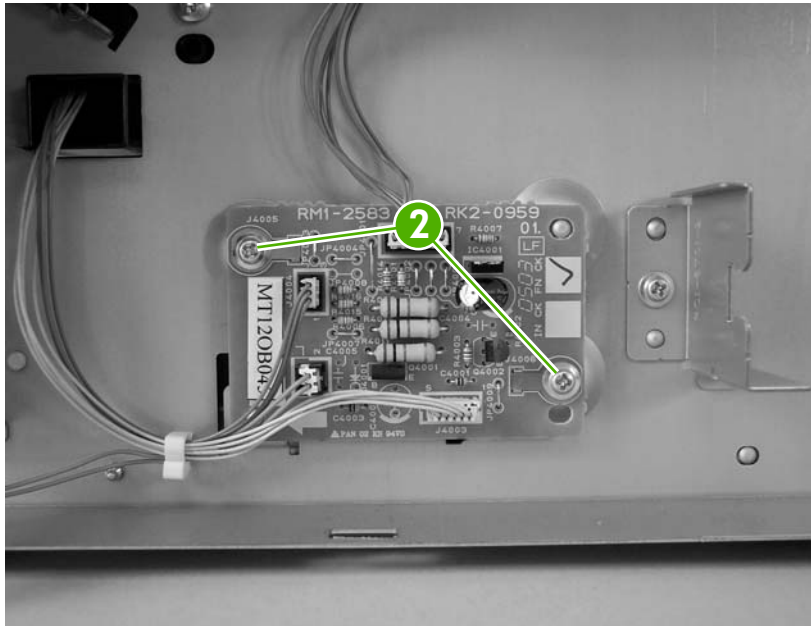

Media sensor (500-sheet feeder)



CAUTION: PCAs are sensitive to electrostatic discharge (ESD). Look for the ESD reminder when removing PCAs. Always perform service work at an ESD-protected workstation or mat. If an ESD workstation or mat is not available, ground yourself by touching the sheet-metal chassis *before* touching an ESD-sensitive part.

Protect the ESD-sensitive parts by placing them in ESD pouches when they are out of the printer.

1. Remove the 500-sheet feeder right cover. See [500-sheet feeder right cover on page 157](#).
2. Disconnect one connector (callout 1; J4003).

Figure 5-124 Remove the media sensor (500-sheet feeder) (1 of 4)

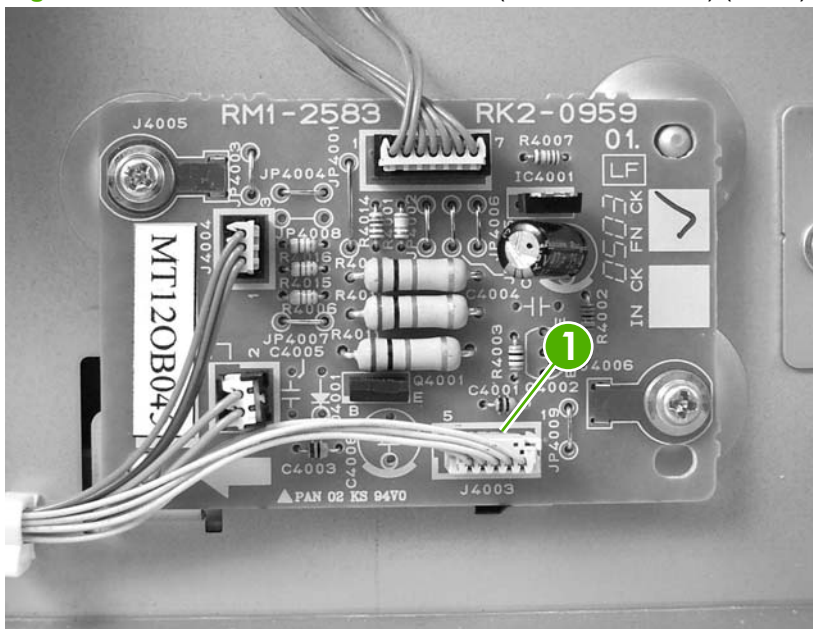

3. Use a small flatblade screwdriver to release the top cover on the 500-sheet feeder pickup-and-feed assembly, and then remove the cover.

△ **CAUTION:** Be careful not to lose the grounding springs that are under this cover.

Figure 5-125 Remove the media sensor (500-sheet feeder) (2 of 4)

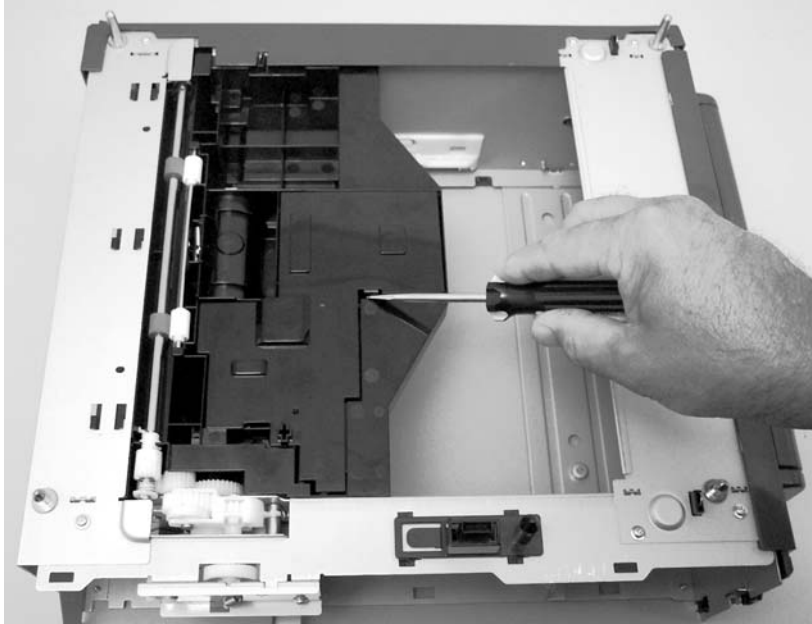

4. Remove the media sensor torsion spring (callout 2).

Figure 5-126 Remove the media sensor (500-sheet feeder) (3 of 4)

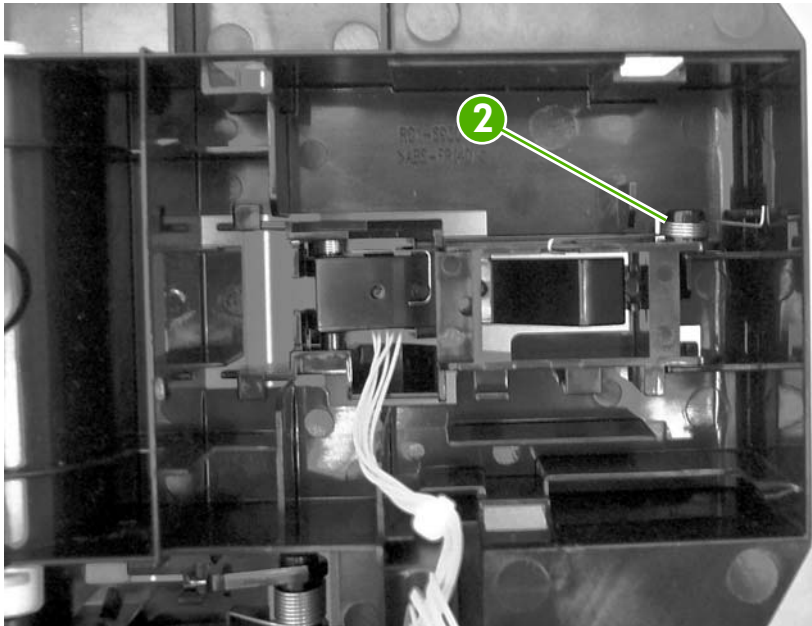

5. Raise the media sensor, and then slide it off of the hinges to remove it.

Figure 5-127 Remove the media sensor (500-sheet feeder) (4 of 4)



6 Troubleshooting

To use the information in this chapter, you should have a basic understanding of the HP LaserJet printing process. Explanations of each mechanical assembly, the printer systems, and the basic theory of operation are contained in [Theory of operation on page 47](#). Do not perform any of these troubleshooting processes unless you understand the function of each printer component.

- [Troubleshooting process](#)
- [Control-panel messages](#)
- [Jams](#)
- [Image defects](#)
- [Repetitive-defects troubleshooting](#)
- [Interface troubleshooting](#)
- [Service menu](#)
- [Diagnostics menu](#)
- [Diagnostics](#)
- [Test pages](#)
- [Engine resets](#)
- [Service ID](#)

Troubleshooting process

When the printer malfunctions or encounters an unexpected situation, the printer control panel alerts you to the situation. This chapter also contains information to help diagnose and solve problems.

- Use the pre-troubleshooting checklist to evaluate the source of the problem and to reduce the number of steps that are required to fix the problem.
- Use the troubleshooting flowchart to pinpoint the root cause of hardware malfunctions. The flowchart guides you to the section of this chapter that contains steps for correcting the malfunction.

Before beginning any troubleshooting procedure, check the following issues:

- Are supply items within their rated life?
- Does the configuration page reveal any configuration errors?

 **NOTE:** The customer is responsible for checking supplies and for using supplies that are in good condition.

Pre-troubleshooting checklist

The following table includes basic questions to ask the customer to quickly help define the problem(s).

| General topic | Questions |
|-------------------------|--|
| Environment | <ul style="list-style-type: none">● Is the printer installed on a solid, level surface (+/- 1°)?● Is the power-supply voltage within ± 10 volts of the specified power source?● Is the power-supply plug inserted in the printer and the outlet?● Is the operating environment within the specified parameters that are listed in chapter 1?● Is the printer exposed to ammonia gas, such as that produced by diazo copiers or office cleaning materials?● Is the printer exposed to direct sunlight? |
| Media | <ul style="list-style-type: none">● Does the customer use only supported media?● Is the media in good condition (no curls, folds, or distortion)?● Is the media stored correctly and within environmental limits? |
| Input trays | <ul style="list-style-type: none">● Is the amount of media in the tray within specifications?● Is the media correctly placed in the tray?● Are the paper guides aligned with the stack?● Is the cassette installed in the printer correctly? |
| Print cartridges | <ul style="list-style-type: none">● Is each print cartridge installed correctly? |
| Transfer unit and fuser | <ul style="list-style-type: none">● Are the transfer unit and fuser installed correctly? |
| Covers | <ul style="list-style-type: none">● Is the front cover closed? |

| General topic | Questions |
|---------------|---|
| Condensation | <ul style="list-style-type: none"><li data-bbox="679 228 1465 306">• Does condensation occur following a temperature change (particularly in winter following cold storage)? If so, wipe affected parts dry or leave the printer on for 10 to 20 minutes.<li data-bbox="679 331 1465 384">• Was a print cartridge opened soon after being moved from a cold to a warm room? If so, allow the print cartridge to sit at room temperature for 1 to 2 hours. |
| Miscellaneous | <ul style="list-style-type: none"><li data-bbox="679 409 1465 462">• Check for and remove any non-HP components (print cartridges, memory modules, and EIO cards) from the printer.<li data-bbox="679 487 1465 560">• If the hardware or software configuration has not changed or the problem is not associated with any specific software, contact the Customer Care Center (see chapter 1).<li data-bbox="679 585 1465 638">• Remove the printer from the network and ensure that the failure is associated with the printer before beginning troubleshooting.<li data-bbox="679 663 1465 688">• For any print-quality issues, calibrate the printer. |

3. Make sure that the fan is running, which indicates that the system is operational.
4. Verify that the firmware DIMM and the formatter are seated and operating correctly.
5. Remove any HP Jetdirect or other devices, then try to turn the printer on again.
6. Make sure that the control-panel display is connected.
7. Run an engine test page to verify that the printer is functioning. Use a small pointed object to depress the test-page switch on the back of the printer.
8. Check the two fuses on the power supply.
9. If necessary, replace the power supply.
10. If necessary, replace the DC controller.

Control-panel messages

| Control-panel message | Description | Recommended action |
|---|---|--|
| <p>10.32.00 UNAUTHORIZED SUPPLY</p> <p>Unauthorized supply in use</p> <p>alternates with</p> <p>For help press ?</p> | <p>A new, non-HP supply has been installed. This message appears until an HP supply is installed or you press ✓.</p> | <p>If you believe that you purchased an HP supply, go to www.hp.com/go/anticounterfeit.</p> <p>Service or repairs that are required as a result of using non-HP supplies are not covered under HP warranty.</p> <p>To continue printing, press ✓. The first pending print job will be cancelled.</p> |
| <p>10.92.YY CARTRIDGES NOT ENGAGED</p> | <p>The print cartridges are not engaged correctly.</p> <p>YY Description:</p> <p>00 Black</p> <p>01 Cyan</p> <p>02 Magenta</p> <p>03 Yellow</p> | <ol style="list-style-type: none"> 1. Open and then close the front door. 2. Make sure all the print cartridges are seated correctly. 3. Turn the printer off and then on. 4. Inspect each cartridge lock-lever (on the right side). Open the front door and remove all cartridges and the ETB. Then use the ETB holder on the right side to move the lock-levers up and down. Replace the cartridge lock if it is broken. 5. Inspect the right side cam. This piece controls the movement of the cartridge engagement arm, the cartridge shutters, and the OPC drive. You can inspect this piece without taking off the covers by wiggling the white rod arm on the right side of the ETB. If it moves easily, the part is broken and should be replaced. 6. Inspect the ribbon cables. Folded or damaged ribbon cables can cause a short that generates an error. 7. Inspect the cartridge guide rails to see if any are damaged. 8. Upgrade the DC controller firmware. 9. Clean the contacts on the memory-controller PCA. 10. Verify that contact is being made with the E-label PCA on the print cartridge. Replace the print cartridge if the E-label PCA is missing. 11. On the DC controller, make sure that connectors J1022 and J1023 are seated correctly. On the driver PCA, make sure that connectors J201 and J401 are seated correctly. 12. Check the gears on the print-cartridge drive motors. Replace defective motors. |

| Control-panel message | Description | Recommended action |
|---|--|---|
| 10.94.YY REMOVE SHIPPING LOCKS FROM ALL CARTRIDGES | If all the shipping locks have been removed, the problem might be with the connectors on the DC controller. | <ol style="list-style-type: none"> 1. Remove all the print cartridges and check for orange shipping locks at each end of each cartridge. Remove any that remain. 2. Reinstall the print cartridges. 3. On the DC controller, make sure that connector J1020 is seated correctly 4. Replace the DC controller. |
| 10.XX.YY SUPPLY MEMORY ERROR For help press ? | The printer cannot read or write to at least one print cartridge memory tag, or at least one memory tag is missing. XX Description: 00 e-label memory error YY Description: 00 Black 01 Cyan 02 Magenta 03 Yellow | <ol style="list-style-type: none"> 1. Open the front door. 2. Remove the print cartridges, and then reinstall them. 3. Close the front door. 4. Turn the printer off and then on. 5. Clean the memory controller PCB contacts to the memory tag if they are dirty. 6. Replace the memory controller PCB if necessary. 7. Replace the DC controller PCB if necessary. |
| 11.XX INTERNAL CLOCK ERROR alternates with To continue press ✓ | The printer's internal clock is not working correctly. Printing can continue, but you are prompted to set the date and time each time you turn the printer on. XX Description: 01 Dead clock battery 02 Dead real-time clock | Turn the printer off and then on. If the error persists, replace the formatter. |
| 13.01.00 JAM IN TRAY 1 alternates with Clear jam then press ✓ | A page is jammed in the multipurpose tray. The printer attempted to feed paper from tray 1 (MP tray), but the leading edge did not get to the top-of-page sensor in time. | <ol style="list-style-type: none"> 1. Verify that tray 2 is fully inserted into the engine. A portion of the tray 1 paper path dips into tray 2. 2. For media greater than 120 g/m², verify that the media-type settings in the control panel and driver are set to Cardstock. This enables the special mode that applies additional force for feeding heavier media. This printer is not capable of handling media heavier than 176 g/m². 3. If media is not loaded in tray 1 but an error is displayed, check the MP tray paper-present sensor by pressing the sensor and releasing it. If it springs back, it is operating properly; if it does not spring back, check the spring for the sensor. |

| Control-panel message | Description | Recommended action |
|---|--|---|
| | | <ol style="list-style-type: none"> 4. Check the registration flap for proper orientation; it should pivot freely to allow paper to feed from tray 2 or tray 1/3. 5. Inspect ribbing (where accessible). If it is damaged, replace it. |
| 13.01.00 JAM IN TRAY 2 alternates with Clear jam then press ✓ | A page is jammed in tray 2. The printer attempted to feed paper from tray 2 (main cassette), but the leading edge did not get to the top-of-page sensor in time. | <ol style="list-style-type: none"> 1. Check the registration flap for proper orientation; it should pivot freely to allow paper to feed from tray 2 or tray 1/3. 2. Check the T2 pick roller lock mechanism. 3. If using OHT, Label, or 120 g/m² media, follow restricted loading procedures (only 50 sheets of OHT/Label media or 100 sheets of 120 g/m² media may be loaded at one time). The lift plate springs are not stiff enough to handle greater quantities. 4. Verify that the media basis weight does not exceed 120 g/m². If it does, run media from tray 1. 5. Inspect the paper-length adjustment guide and verify that it is set correctly. 6. Inspect the tray 2 paper-present sensor to make sure it is not stuck in the up position. Rotate the sensor upward and release; if it drops without hesitation, it is operating properly. |
| 13.01.00 JAM IN TRAY 3 alternates with Clear jam then press ✓ | A page is jammed in the multipurpose tray or tray 3. The printer attempted to feed paper from tray 3 (optional tray), but the leading edge did not get to the top-of-page sensor in time. | <ol style="list-style-type: none"> 1. Verify that tray 2 is fully inserted into the engine. A portion of the tray 3 paper path is in tray 2. 2. Verify that the pick roller is installed correctly. 3. If using OHT, Label, or 120 g/m² media, follow restricted loading procedures (only 100 sheets of OHT/Label media or 200 sheets of 120 g/m² media may be loaded at one time). The lift plate springs are not stiff enough to handle greater quantities. 4. Inspect the tray 3 paper-present sensor to make sure it is not stuck in the up position. Rotate the sensor upward and release; if it drops without hesitation, it is operating properly. |
| 13.05.00 JAM INSIDE FRONT DOOR alternates with For help press ? | A jam has occurred inside the front door. The printer fed a sheet of paper from one of the trays and the paper made it to the top-of-page sensor in time. However, the paper did not subsequently reach the fuser paper-delivery sensor in time. | <ol style="list-style-type: none"> 1. Inspect the PIU for damage. This is a delay jam; although the paper stopped in the fuser, the root cause is more likely a paper feed/pickup issue. 2. Inspect the fuser for pressure-roll cover damage. |

| Control-panel message | Description | Recommended action |
|--|---|---|
| 13.06.00 FUSER JAM INSIDE TOP COVER alternates with For help press ? | A jam has occurred in the fuser. The printer fed a sheet of paper from one of the trays and it made it to the top-of-page sensor in time. However, the paper did not reach the fuser paper-delivery sensor in time. | <ol style="list-style-type: none"> 1. Look for media in the fuser. 2. Remove curled sheets in the output bin. Curled sheets can cause jams, especially if using light media (less than 75 g/m²). 3. For duplex engines, inspect the duplex diverter for proper orientation. If the duplex diverter is stuck in the down position, inspect the torsion spring on the left side of the diverter. If the diverter is operating sluggishly, replace it. 4. Inspect the fuser for pressure-roll-cover damage. |
| 13.10.00 JAM INSIDE TOP COVER alternates with For help press ? | A page is jammed underneath the top cover. The printer fed a sheet of paper from one of the trays and the paper made it to the duplex switchback sensor in time. However, the paper remained there too long. | Open the top cover and remove any jammed media. Inspect the duplex switchback sensor for proper operation. Push the sensor flag and release it; it should spring back. |
| 13.12.00 DUPLEX PATH JAM FRONT DOOR alternates with For help press ? | A jam has occurred in the duplex output area inside the front door. | Open the front door and clear the jam. |
| 13.20.00 FUSER JAM INSIDE TOP COVER alternates with For help press ? | During a checking-printer cycle, the printer detected the presence of paper at the fuser paper-delivery sensor. | <ol style="list-style-type: none"> 1. Remove the fuser and look for media. 2. Inspect the fuser paper-delivery sensor for proper orientation. |
| 13.20.00 FUSER JAM INSIDE TOP COVER alternates with For help press ? | During a checking-printer cycle, the printer detected the presence of paper at the duplex switchback sensor. | <ol style="list-style-type: none"> 1. Open the top cover and look for the presence of media in the duplex paper path. 2. Inspect the sensor for proper orientation. |
| 13.20.00 JAM INSIDE FRONT DOOR | During a checking-printer cycle, the printer detected the presence of paper at the paper-loop sensor. | <ol style="list-style-type: none"> 1. Open the front door and look for media. 2. Inspect the paper-loop sensor for proper orientation. 3. If no paper is present, the root cause is more likely a PIU issue. Inspect the PIU registration shutter for proper operation. |
| 13.20.00 PAPER PATH JAM FRONT DOOR alternates with For help press ? | A page is jammed in the paper path. During a checking-printer cycle, the printer detected the presence of paper at either the top-of-page sensor or the MP-tray-media-position sensor. | <ol style="list-style-type: none"> 1. Inspect the T2 pick-roller left-cam retention claw. 2. Inspect the TOP sensor for proper orientation. |

| Control-panel message | Description | Recommended action |
|---|---|---|
| | | <ol style="list-style-type: none"> Inspect the MP-tray-media-position sensor for proper orientation (HP CLJ 3600/3800/CP3505 only). If no paper is present, the root cause is more likely a PIU issue. Inspect the PIU registration shutter for proper operation. |
| 20 INSUFFICIENT MEMORY alternates with For help press ? To continue press ✓ | The printer has received more data from the computer than fits in available memory. | <ol style="list-style-type: none"> Press ✓ to continue printing. NOTE: Data will be lost. Reduce the complexity of the print job to avoid this error. Adding memory to the printer might accommodate printing of more complex pages. |
| 22 EIO X BUFFER OVERFLOW alternates with To continue press ✓ | For the HP Color LaserJet 3000, 3800, and CP3505 Series printers with an EIO device only The printer EIO card in slot X has overflowed its I/O buffer during a busy state. | Press ✓ to continue printing. NOTE: Data will be lost. |
| 22 EMBEDDED I/O BUFFER OVERFLOW | For the HP Color LaserJet 3000, 3800, and CP3505 Series printers only The embedded HP Jetdirect print server buffer has overflowed during a busy state. | Press ✓ to continue printing. NOTE: Data will be lost. |
| 22 PARALLEL I/O BUFFER OVERFLOW alternates with To continue press ✓ | For the HP Color LaserJet 3000, 3800, and CP3505 Series printers only The printer parallel buffer has overflowed during a busy state. | Press ✓ to continue printing. NOTE: Data will be lost. |
| 22 SERIAL I/O BUFFER OVERFLOW alternates with To continue press ✓ | For the HP Color LaserJet 3000, 3800, and CP3505 Series printers with an EIO device only The printer serial buffer has overflowed during a busy state. | Press ✓ to continue printing. NOTE: Data will be lost. |
| 22 USB I/O BUFFER OVERFLOW alternates with To continue press ✓ | The printer USB buffer has overflowed during a busy state. | Press ✓ to continue printing. NOTE: Data will be lost. |
| 40 BAD SERIAL TRANSMISSION alternates with To continue press ✓ | For the HP Color LaserJet 3000, 3800, and CP3505 Series printers only. A serial data error (parity, framing, or line overrun) occurred while the printer was receiving data. | Press ✓ to continue printing. NOTE: Data will be lost. |
| 40 EIO X BAD TRANSMISSION alternates with To continue press ✓ | For the HP Color LaserJet 3000, 3800, and CP3505 Series printers with an EIO device only The connection with the card in the EIO slot has broken. | Press ✓ to continue printing. NOTE: Data will be lost. |

| Control-panel message | Description | Recommended action |
|--|--|---|
| 40 EMBEDDED I/O BAD TRANSMISSION alternates with To continue press ✓ | The connection with the HP Jetdirect embedded print server has broken. | Press ✓ to continue printing. |
| 41.3 UNEXPECTED SIZE IN TRAY X alternates with LOAD TRAY X <TYPE> <SIZE> | Media is loaded that is longer or shorter in the feed direction than the size configured for the tray. | <ol style="list-style-type: none"> 1. Press ✓ to print from a different tray. 2. To print from the current tray, load the tray with the size and type indicated. <p>Ensure that all trays are configured correctly before printing again.</p> |
| 41.5 UNEXPECTED TYPE IN TRAY X alternates with LOAD TRAY X <TYPE> <SIZE> | The printer senses a different media type from what is configured in the tray. | <ol style="list-style-type: none"> 1. Press ✓ to print from a different tray. 2. To print from the current tray, load the tray with the size and type indicated. 3. If the paper pickup has been replaced, perform a media-sensor calibration (see the instructions at the end of the Pickup-and-feed assembly on page 111 section). <p>Ensure that all trays are configured correctly before printing again.</p> |
| 41.X ERROR alternates with To continue press ✓ | A printer error has occurred. X Description: 2 Beam-detected misprint error | <ol style="list-style-type: none"> 1. Press ✓ to continue or press ? for more information. 2. If the message persists after exiting the help, turn the printer off and then on. |
| 49.XXXXX ERROR alternates with To continue turn off then on | A critical firmware error has occurred. | <ol style="list-style-type: none"> 1. Turn the printer off and then on. 2. Try printing a job from a different program. If the job prints, try printing a different file from the original program. If the message appears only with a certain program or print job, contact the software vendor for assistance. 3. If the message persists with different programs and print jobs, disconnect all of the printer cables that connect to the network or the computer. 4. Turn the printer off. 5. Remove all memory DIMMs or third-party DIMMs from the printer. (Do not remove the firmware DIMM in the lower slot J1). 6. Remove the printer EIO card. 7. Turn the printer on. 8. If the error does not persist, install each DIMM and EIO device one at a time. Turn the printer off and then on again after installing each device. |

| Control-panel message | Description | Recommended action |
|-------------------------|--|--|
| | | <ol style="list-style-type: none"> 9. Replace DIMMs and EIO devices as necessary. 10. Reconnect all of the printer cables. 11. If the error persists, replace the firmware DIMM. 12. Replace the formatter and calibrate the printer. |
| 50.X FUSER ERROR | A fuser error has occurred. | WARNING! The fuser is hot. Turn the printer off and allow it to cool for approximately 10 minutes before removing the fuser. |
| For help press ? | X Description: | |
| | 1 Low fuser temperature | 50.1 Error: |
| | 2 Fuser-warmup service | <ol style="list-style-type: none"> 1. Verify the fuser is installed correctly and fully seated. |
| | 3 High fuser temperature | <ol style="list-style-type: none"> 2. Check that connector J6007 on the fuser is seated correctly. Replace the connector as necessary. |
| | 4 Faulty fuser | <ol style="list-style-type: none"> 3. Turn off the printer. |
| | 7 Fuser pressure release mechanism failure | <ol style="list-style-type: none"> 4. Remove the fuser. |
| | 8 Low fuser temperature (subthermistor) | <ol style="list-style-type: none"> 5. If there is <i>no</i> conduction in the main thermistor, measure the resistance between fuser connectors J6007LA-1 and J6007LA-3. If the resistance is not 100 kohms to 3 Mohms, replace the fuser. |
| | 9 High fuser temperature (subthermistor) | <ol style="list-style-type: none"> 6. If there is <i>no</i> conduction in the fuser heater, measure the resistance between fuser connectors J6007LAF-1 and J6007-2. If the resistance is not 5 ohms to 1 kohms (100 to 127 V) or 20 ohms to 1 kohms (220 to 240 V), replace the fuser. 7. Upgrade the DC controller firmware. 8. Replace the DC controller PCA. |
| | | 50.2 Error: |
| | | <ol style="list-style-type: none"> 1. Verify the fuser is installed correctly and fully seated. 2. Check that connector J6007 on the fuser is seated correctly. Replace the connector as necessary. 3. Turn off the printer. 4. Remove the fuser. 5. If there is <i>no</i> conduction in the subthermistor, measure the resistance between fuser connectors J6007LA-2 and J6007LA-3. If the resistance is not |

| Control-panel message | Description | Recommended action |
|-----------------------|-------------|---|
| | | <p>100 kohms to 3 Mohms, replace the fuser.</p> <p>6. If there is <i>no</i> conduction in the fuser heater, measure the resistance between fuser connectors J6007LAF-1 and J6007-2. If the resistance is not 5 ohms to 1 kohms (100 to 127 V) or 20 ohms to 1 kohms (220 to 240 V), replace the fuser.</p> <p>7. Replace the DC controller PCA.</p> <p>50.3 Error:</p> <p>1. Verify the fuser is installed correctly and fully seated.</p> <p>2. Check that connector J6007 on the fuser is seated correctly. Replace the connector as necessary.</p> <p>3. Turn off the printer.</p> <p>4. Remove the fuser.</p> <p>5. Measure the resistance between fuser connectors J6007LA-1 and J6007LA-3. If the resistance is not 100 kohms to 3 Mohms, replace the fuser.</p> <p>6. Upgrade the DC controller firmware.</p> <p>7. Replace the DC controller PCA.</p> <p>50.4 Error:</p> <p>1. Improve the power supply if the power supply frequency is not 40 to 70 Hz.</p> <p>2. Verify that the proper fuser mode is set (especially for envelope printing).</p> <p>3. Replace the low-voltage power-supply PCA.</p> <p>4. Replace the DC controller PCA.</p> <p>50.7 Error:</p> <p>1. Verify the fuser is installed correctly and fully seated.</p> <p>2. Check that fuser connector J705, fuser motor connector J5008, and driver PCA connector J213 are seated correctly.</p> <p>3. Replace the fuser drive assembly.</p> <p>4. Replace the DC controller PCA.</p> |

| Control-panel message | Description | Recommended action |
|-------------------------------------|-------------------------------|---|
| | | 50.8 Error: |
| | | <ol style="list-style-type: none"> 1. Verify the fuser is installed correctly and fully seated. 2. Check that connector J6007 on the fuser is seated correctly. Replace the connector as necessary. 3. Turn off the printer. 4. Remove the fuser. 5. If there is <i>no</i> conduction in the subthermistor, measure the resistance between fuser connectors J6007LA-1 and J6007LA-3. If the resistance is not 100 kohms to 3 Mohms, replace the fuser. 6. If there is <i>no</i> conduction in the fuser heater, measure the resistance between fuser connectors J6007LAF-1 and J6007-2. If the resistance is not 5 ohms to 1 kohms (100 to 127 V) or 20 ohms to 1 kohms (220 to 240 V), replace the fuser. 7. Upgrade the DC controller firmware. 8. Replace the DC controller PCA. |
| | | 50.9 Error: |
| | | <ol style="list-style-type: none"> 1. Verify the fuser is installed correctly and fully seated. 2. Check that connector J6007 on the fuser is seated correctly. Replace the connector as necessary. 3. Turn off the printer. 4. Remove the fuser. 5. Measure the resistance between fuser connectors J6007LA-2 and J6007LA-3. If the resistance is not 100 kohms to 3 Mohms, replace the fuser. 6. Replace the DC controller PCA. |
| 51.XY ERROR | A printer error has occurred. | <ol style="list-style-type: none"> 1. Press ✓ to continue. |
| alternates with | X Description: | <ol style="list-style-type: none"> 2. If the message persists, turn the printer off and then on. |
| To continue turn off then on | 2 laser | <ol style="list-style-type: none"> 3. Reseat DC controller connectors J1010, J1012, and J1021. |
| | Y Description: | <ol style="list-style-type: none"> 4. Replace the flat cable. |
| | 0 Black | <ol style="list-style-type: none"> 5. Replace the DC controller PCB as necessary. |
| | 1 Cyan | |
| | 2 Yellow | |

| Control-panel message | Description | Recommended action |
|---|---|--|
| | 3 Magenta | |
| 53.10.01 ERROR UNSUPPORTED RAM | For the HP Color LaserJet 3000, 3800, and CP3505 Series printers only The memory DIMM is not a supported DIMM. | Install a supported DIMM. |
| 53.XY.ZZ alternates with CHECK RAM DIMM SLOT | For the HP Color LaserJet 3600 Series printer only A printer error has occurred. | <ol style="list-style-type: none"> 1. Turn the printer off and then on. 2. If the message persists, replace the DIMM. 3. Replace the formatter. |
| 54.XX ERROR | An error has occurred with one of the toner-level sensors. XX Description: 15 Yellow 16 Magenta 17 Cyan 18 Black | <ol style="list-style-type: none"> 1. Make sure that connector J1020 on the DC controller is seated correctly. 2. Replace the DC controller. |
| 55.XX.YY DC CONTROLLER ERROR alternates with To continue turn off then on | A communication error between the DC controller and the formatter has occurred. | <ol style="list-style-type: none"> 1. Turn the printer off. 2. Reconnect the connector between the DC controller and the formatter. 3. Verify that the formatter is seated correctly. 4. Replace the formatter. |
| 57.XX PRINTER ERROR alternates with To continue turn off then on | A printer fan error has occurred. XX Description: 04 Main fan 06 Duplex fan | <p>57.04 Error:</p> <ol style="list-style-type: none"> 1. Check that connector J1008 on the DC controller is seated correctly. 2. Replace the fan. 3. Replace the DC controller. <p>57.06 Error:</p> <ol style="list-style-type: none"> 1. Check that connectors J802, J823, and J850 on the duplex-driver PCA are seated correctly. 2. Replace the fan. 3. Replace the duplex-driver PCA. |
| 59.30 ERROR 59.40 ERROR | An error occurred with the fuser motor during startup or rotation. | <ol style="list-style-type: none"> 1. Check that connectors J5008 on the fuser motor and J213 on the driver PCA are seated correctly. 2. Replace the fuser. 3. Replace the DC controller. |

| Control-panel message | Description | Recommended action |
|----------------------------|--|---|
| 59.50 ERROR 59.60 ERROR | An error occurred with the black print-cartridge drive motor during startup or rotation. | <ol style="list-style-type: none"> 1. Check that connectors J5006 on the black print-cartridge drive motor and J208 on the driver PCA are seated correctly. 2. Replace the black print-cartridge drive motor. 3. Replace the driver PCA. |
| 59.51 ERROR 59.61 ERROR | An error occurred with the cyan print-cartridge drive motor during startup or rotation. | <ol style="list-style-type: none"> 1. Check that connectors J5004 on the cyan print-cartridge drive motor and J207 on the driver PCA are seated correctly. 2. Replace the cyan print-cartridge drive motor. 3. Replace the driver PCA. |
| 59.52 ERROR 59.62 ERROR | An error occurred with the magenta print-cartridge drive motor during startup or rotation. | <ol style="list-style-type: none"> 1. Check that connectors J5003 on the magenta print-cartridge drive motor and J207 on the driver PCA are seated correctly. 2. Replace the magenta print-cartridge drive motor. 3. Replace the driver PCA. |
| 59.53 ERROR 59.63 ERROR | An error occurred with the yellow print-cartridge drive motor during startup or rotation. | <ol style="list-style-type: none"> 1. Check that connectors J5005 on the yellow print-cartridge drive motor and J208 on the driver PCA are seated correctly. 2. Replace the yellow print-cartridge drive motor. 3. Replace the driver PCA. |
| 59.90 ERROR 59.A0 ERROR | An error occurred with the ETB motor during startup or rotation. | <ol style="list-style-type: none"> 1. Check that connectors J5002 on the ETB motor and J206 on the driver PCA are seated correctly. 2. Replace the ETB. 3. Replace the driver PCA. |
| 59.C0 ERROR | An error occurred with the developing separation-drive assembly. | <ol style="list-style-type: none"> 1. If the main drive assembly has been removed for service repair, verify that the main drive assembly is calibrated correctly. 2. Check that the following connectors on the driver PCA are seated correctly: J403, J405, J213. 3. Check that connector J1020 on the DC controller is seated correctly. 4. Check that connector J5008 on the fuser motor is seated correctly. |

| Control-panel message | Description | Recommended action |
|--|---|--|
| | | <ol style="list-style-type: none"> Replace the developing separation-drive assembly. If the developing separation drive assembly has been replaced and the error still occurs, calibrate the developing separation drive assembly. |
| 59.F0 ERROR | The transfer rollers in the ETB are not engaged. | <ol style="list-style-type: none"> Check that the following connectors on the driver PCA are seated correctly: <ul style="list-style-type: none"> J5002 on the ETB motor J5011 on the transfer-roller separation solenoid J206 on the driver PCA J1019 on the DC controller Replace the ETB motor. Replace solenoid SL5011. Upgrade the DC controller firmware. Replace the ETB. Replace the high-voltage power supply PCA. |
| 62 NO SYSTEM | No system was found. | <ol style="list-style-type: none"> Turn the printer off and then on. Reseat the firmware DIMM. Make sure that it is in slot 1 (the bottom slot). Download new firmware. Replace the firmware DIMM. |
| 64 ERROR For help press ? alternates with To continue turn off then on | For the HP Color LaserJet 3600 Series printers only A scan buffer error has occurred. | <ol style="list-style-type: none"> Turn the printer off and then on. Replace the firmware DIMM. Replace the formatter PCB. |
| 68.X PERMANENT STORAGE FULL alternates with To continue press ✓ | A nonvolatile storage device is full. Press ✓ to clear the message. Printing can continue, but unexpected behavior could result. X Description: 0 Onboard NVRAM 1 Removable disk (flash or hard) | <ol style="list-style-type: none"> Press ✓ to continue. For 68.0 errors, turn the printer off and then on. If the error persists, perform an NVRAM initialization. For 68.1 errors, use the HP Web Jetadmin software to delete files from the disk drive. |
| 68.X PERMANENT STORAGE WRITE FAIL alternates with To continue press ✓ | A nonvolatile storage device is full. Press ✓ to clear the message. Printing can continue, but unexpected behavior could result. | <ol style="list-style-type: none"> Press ✓ to continue. For 68.0 errors, turn the printer off and then on. |

| Control-panel message | Description | Recommended action |
|---|---|---|
| | X Description: 0 Onboard NVRAM 1 Removable disk | <ol style="list-style-type: none"> If the error persists, perform an NVRAM initialization. For 68.1 errors, use the HP Web Jetadmin software to delete files from the disk drive. |
| 68.X STORAGE ERROR SETTINGS CHANGED alternates with To continue press ✓ | One or more printer settings that were saved in the nonvolatile storage device are invalid and have been reset to the factory default. Press ✓ to clear the message. Printing can continue, but unexpected behavior could result. | <ol style="list-style-type: none"> Press ✓ to continue. Turn the printer off and then on. Check the printer settings to determine which settings have been changed. |
| 79.XXXX ERROR alternates with To continue turn off then on | For the HP Color LaserJet 3000, 3800, and CP3505 Series printers only A critical hardware error has occurred. | <ol style="list-style-type: none"> Turn the printer off and then on. Reseat the firmware DIMM. Reseat the formatter PCB. Replace the firmware DIMM. Replace the formatter PCB. |
| 8X.YYYY EIO ERROR | For the HP Color LaserJet 3000, 3800, and CP3505 Series printers only The EIO accessory card has encountered a critical error. | <ol style="list-style-type: none"> Turn the printer off and then on. Reseat the EIO card. Replace the EIO card. |
| 8X.YYYY EMBEDDED JETDIRECT ERROR | The HP Jetdirect embedded print server has encountered a critical error. | Turn the printer off and then on. |
| <Date> <Time> To change press ✓ To skip, press STOP | The printer has an internal clock that tracks the date and time. You are prompted to set the correct date and time the first time you turn on the printer. | Press ✓ to change the date and time. Press Stop to skip this step. You can set the date and time later by using the SYSTEM SETUP menu. |
| Access Denied MENUS LOCKED | Because the printer administrator has enabled the control-panel security mechanism, you cannot modify control-panel settings. The message disappears after a few seconds, and the printer returns to READY or BUSY state. | Contact the printer administrator to change settings. Perform a cold reset to clear passwords. |
| ACTION NOT CURRENTLY AVAILABLE FOR TRAY X alternates with Tray size cannot be ANY SIZE/ANY CUSTOM | You are trying to set duplex registration for a tray that is configured for ANY SIZE or ANY CUSTOM . Duplex registration is not available when the tray size is set to either of these settings. | Change the size setting for the tray. |
| BAD DUPLEXER CONNECTION alternates with To continue turn off then on | The duplexer is not installed correctly. | <ol style="list-style-type: none"> Check that connector J850 is seated correctly. Check that the connectors to the duplex-driver PCA are seated correctly. Replace the duplex-drive PCA. |
| Calibrating... | The printer is calibrating. | Upgrade the DC controller firmware. |

| Control-panel message | Description | Recommended action |
|--|---|--|
| Canceling... <JOB NAME> | For the HP Color LaserJet 3600 Series printers only The printer is in the process of canceling a job. The message appears while the job is stopped, the paper path is flushed, and any remaining incoming data on the active data channel is received and discarded. | No action necessary. |
| Checking paper path | The engine is turning the rollers to check for possible jams. | No action necessary. |
| Checking printer | The engine is performing an internal test. | No action necessary. |
| CHOSEN PERSONALITY NOT AVAILABLE alternates with To continue press ✓ | The printer encountered a request for a personality that did not exist in the printer. The job is cancelled and no pages are printed. | <ol style="list-style-type: none"> 1. Press ✓ to continue. 2. Try a different driver. <p>NOTE: For the HP Color LaserJet 3600 Series printers, you must use HP JetReady 4.2, the driver that was specifically designed for these printers.</p> |
| CLEANING DISK X% COMPLETE alternates with DO NOT POWER OFF | For the HP Color LaserJet 3000, 3800, and CP3505 Series printers only The memory disk is being cleaned. This process might take up to an hour. During this time, no jobs can be printed. | Do not turn off the printer. Wait for the process to complete. The printer automatically restarts at the end of the cleaning process. |
| Cleaning... | The printer is performing a cleaning cycle. | No action necessary. |
| Cleaning...Do not grab paper | The printer is processing a cleaning page. | No action necessary. |
| Clearing event log | This message appears while the event log is cleared. The printer then returns to the SERVICE menu. | No action necessary. |
| Clearing paper path | The printer jammed or detected misplaced media. The printer is attempting to eject these pages automatically. | No action necessary. |
| CLOSE TOP COVER AND FRONT DOOR | If the top cover and front door are closed, the problem might be with the connections for the door-detection switch or the front door interlock lever. | <p>Close the top cover and front door.</p> <ol style="list-style-type: none"> 1. Make sure the top cover and front door are closed. 2. Verify that the interlock lever is snapped in place and is not broken or missing. 3. Verify that the following connectors are seated correctly: On the driver PCA: connectors J201, J202, and J203. On the DC controller: connectors J1022 and J1024. 4. Replace the DC controller. |
| CODE CRC ERROR | For the HP Color LaserJet 3000, 3800, and CP3505 Series printers only | Reinstall the firmware. |

| Control-panel message | Description | Recommended action |
|---|---|--|
| | An error has occurred during a firmware upgrade. | |
| COLOR RFU FAILED | An error has occurred during a firmware upgrade. | Reinstall the firmware. |
| Creating...CLEANING PAGE | The printer is generating a cleaning page. The printer returns to the Ready state after the cleaning page is printed. | <ol style="list-style-type: none"> 1. Load the cleaning page into the multipurpose tray. 2. Press Menu. 3. Select PRINT QUALITY, and then press ✓. 4. Select PROCESS CLEANING PAGE, and then press ✓. |
| DATA RECEIVED alternates with Ready | The printer received data and is waiting for a form feed. When the printer receives another file, the message disappears. The printer is paused. | If the printer is waiting for a form feed, press ✓ to continue. If the printer is paused, press Stop to continue. |
| Duplexing... Do not grab paper | During duplex printing, the paper emerges for a short time before it is pulled back into the printer. | Do not pick up pages until they come to rest in the output bin. |
| Event Log Empty | SHOW EVENT LOG was selected from the control panel, and the event log is empty. | No action necessary. |
| Genuine HP supplies installed | A new HP cartridge has been installed. The printer returns to the Ready state after approximately 10 seconds. | No action necessary. |
| GENUINE HP SUPPLIES DESIGNED FOR <PROD> alternates with Ready | This genuine HP supply was not designed for this printer and is not supported. The printer can print with this supply, but print quality might be affected. | Replace this supply with a genuine HP supply that is designed for this printer. |
| Incorrect | The PIN number is incorrect. | Contact the network administrator. |
| INCORRECT <COLOR> CARTRIDGE alternates with For help press ? | A color cartridge is installed in an incorrect slot. | Press ? for help. See Replacing print cartridges on page 35 for more information. |
| INCORRECT SUPPLIES For status press ✓ | Two or more print cartridges are installed in the incorrect slot. | Press ✓ and then press ? for help. See Replacing supplies on page 33 for more information. |
| INFLATE FAILURE | For the HP Color LaserJet 3000, 3800, and CP3505 Series printers only An error has occurred during a firmware upgrade. | Reinstall the firmware. |
| Initializing permanent storage | This message appears when the printer is turned on to show that permanent storage is being initialized. | No action necessary. |

| Control-panel message | Description | Recommended action |
|--|---|---|
| Initializing... | This message appears when the printer is turned on and begins initialization. | No action necessary. |
| INSERT OR CLOSE TRAY X | A tray is open and the printer is trying to print from another tray. | Close the tray indicated so that printing can continue. NOTE: Tray 2 must be correctly installed in order to print from the MP tray. |
| INSTALL <COLOR> CARTRIDGE alternates with For help press ? | The cartridge is either not installed or not correctly installed in the printer. | <ol style="list-style-type: none"> 1. Inspect each cartridge lock-lever (on the right side). Open the front door and remove all cartridges and the ETB. Then use the ETB holder on the right side to move the lock-levers up and down. 2. Make sure all the print cartridges are seated correctly. 3. Upgrade the DC controller firmware. <p>See Replacing print cartridges on page 35 for more information.</p> |
| INSTALL FUSER For help press ? | The fuser is either not installed or not correctly installed in the printer. | <ol style="list-style-type: none"> 1. Press ? for help. 2. Make sure that the fuser is completely seated in its slot. 3. Reseat the fuser. 4. Turn the printer off and remove the fuser. Measure the resistance between the fuser connectors J5013LA-2 (MAINTH) and J5013LA-1 (GND). If it is not within the range of 330k to 50k ohms (at ambient temperature), replace the fuser. 5. Measure the resistance between the fuser connectors J5013L-2 (FSRH) and J5013L-1 (FSRN). If it is not within the range of 12 to 52 ohms (at ambient temperature), replace the fuser. 6. Replace the DC controller PCB. |
| INSTALL SUPPLIES For status press ✓ | Two or more cartridges are missing. | Install the missing cartridges. Press ✓ and then press ? for help. See Supply replacement guidelines on page 33 for more information. |
| INSUFFICIENT MEMORY TO LOAD FONTS/DATA | For the HP Color LaserJet 3000, 3800, and CP3505 Series printers only This message alternates with the name of the storage device. The storage device does not have enough memory to load the fonts or other data. | Press ✓ to continue printing without using the data. To solve the problem, increase the amount of memory for the device. Press ? for more information. |
| LOAD TRAY X <TYPE> <SIZE> alternates with | Tray X is either empty or configured for a type and size other than that specified in the job. No other tray is available. | Press ? for help. |

| Control-panel message | Description | Recommended action |
|---|---|---|
| For help press ? | | |
| LOAD TRAY X <TYPE> <SIZE> alternates with | Tray X is either empty or configured for a type and size other than that specified in the job. | Press ? for help, or press ✓ to print from another tray. |
| To use another tray press ✓ | | |
| Loading program X alternates with | For the HP Color LaserJet 3000, 3800, and CP3505 Series printers only | No action necessary. |
| DO NOT POWER OFF | Programs and fonts can be stored on the printer file system and are loaded into RAM when the printer is turned on. The X specifies a sequence number indicating the current program being loaded. | |
| MANUALLY FEED <TYPE> <SIZE> alternates with | The multipurpose tray is empty and no other tray is available. | Load media into the multipurpose tray, and press ✓ to continue. Press ? for help. |
| For help press ? | | |
| MANUALLY FEED <TYPE> <SIZE> alternates with | Media is in the multipurpose tray, but the print job requires a specific type and size that is not currently available. | Press ✓ to print from the tray, or press ? for help. |
| To continue press ✓ | | |
| MANUALLY FEED <TYPE> <SIZE> alternates with | No media is in the multipurpose tray, and a print job requires a specific type and size that is available in another tray. | Press ✓ to print from another tray, or press ? for help. |
| To use another tray press ✓ | | |
| MANUALLY FEED OUTPUT STACK alternates with | The first side of a manual 2-sided print job has been printed and the printer is paused until the output stack is reinserted. | Take the printed stack out of the output bin and reinsert it in the multipurpose tray to print the second side of the 2-sided print job. Press ✓ to continue. |
| Then press ✓ to print second sides | | |
| MEM TEST FAILURE REPLACE DIMM 1 | For the HP Color LaserJet 3000, 3800, and CP3505 Series printers only The memory DIMM has failed. | Install a supported memory DIMM. |
| Moving solenoid alternates with | The printer is testing a solenoid. | No action necessary. |
| To exit press STOP | | |
| NON HP SUPPLY IN USE alternates with | The printer has detected that a non-HP supply is currently installed but ✓ was pressed to override. | If you believe you purchased an HP supply, go to www.hp.com/go/anticounterfeit . Service or repairs that are required as a result of using non-HP supplies are not covered under HP warranty. |
| Ready | | |
| NON HP SUPPLY INSTALLED alternates with | A new, non-HP supply has been installed. This message appears until an HP supply is installed or you press ✓. | If you believe you purchased an HP supply, go to www.hp.com/go/anticounterfeit . Service or repairs that are required as a result of using non-HP supplies are not covered under HP warranty. |
| For help press ? | | |

| Control-panel message | Description | Recommended action |
|---|---|---|
| | | To continue printing, press ✓. |
| ORDER <COLOR> CARTRIDGE alternates with Ready | The identified print cartridge is nearing the end of its useful life. The printer is ready and will print for the estimated number of pages indicated. | Order the identified print cartridge. Printing will continue until REPLACE <COLOR> CARTRIDGE appears. NOTE: Estimated pages remaining is based on historical page coverage with this supply. NOTE: To prevent this message from appearing, in the SYSTEM SETUP menu, set ORDER AT to 0%. |
| ORDER SUPPLIES alternates with Ready | More than one supply item is low. | <ol style="list-style-type: none"> 1. Press ✓ to identify which supplies should be ordered. 2. Order the supplies. Printing can continue until REPLACE SUPPLIES appears. Press ? for help. |
| PERFORMING UPGRADE <X : YYY>% COMPLETE alternates with DO NOT POWER OFF | A firmware upgrade is in process. | No action necessary. Do not turn off the printer. |
| Performing... PAPER PATH TEST | The printer is performing a paper-path test. | No action necessary. |
| PRINTING STOPPED To continue press ✓ | This message appears when a Print/Stop test runs and the time expires. | Press ✓ to continue printing. |
| Printing... CMYK SAMPLES | For the HP Color LaserJet 3000, 3800, and CP3505 Series printers only The printer is generating the CMYK samples page and will return to the Ready state when the page is printed. | No action necessary. |
| Printing... COLOR USAGE LOG | For the HP Color LaserJet 3000, 3800, and CP3505 Series printers only The printer is generating the color-usage log page and will return to the Ready state when the page is printed. | No action necessary. |
| Printing... CONFIGURATION | The printer is generating the configuration page and will return to the Ready state when the page is printed. | No action necessary. |
| Printing... DEMO PAGE | The printer is generating the demo page and will return to the Ready state when the page is printed. | No action necessary. |
| Printing... DIAGNOSTICS PAGE | The printer is generating the diagnostics page and will return to the Ready state when the page is printed. | No action necessary. |
| Printing... EVENT LOG | For the HP Color LaserJet 3000, 3800, and CP3505 Series printers only | No action necessary. |

| Control-panel message | Description | Recommended action |
|--|---|---|
| | The printer is generating the event log page and will return to the Ready state when the page is printed. | |
| Printing... FILE DIRECTORY | For the HP Color LaserJet 3000, 3800, and CP3505 Series printers only The printer is generating the mass-storage-directory page and will return to the Ready state when the page is printed. | No action necessary. |
| Printing... FONT LIST | For the HP Color LaserJet 3000, 3800, and CP3505 Series printers only The printer is generating either the PCL or PS personality typeface list and will return to the Ready state when the page is printed. | No action necessary. |
| Printing... MENU MAP | The printer is generating the printer menu map and will return to the Ready state when the page is printed. | No action necessary. |
| Printing... PQ troubleshooting | The printer is generating the print-quality troubleshooting pages and will return to the Ready state when the pages are printed. | Follow the instructions on the printed pages. |
| Printing... REGISTRATION PAGE | The printer is generating the registration page and will return to the SET REGISTRATION menu when the page is printed. | Follow the instructions on the printed pages. |
| Printing... RGB SAMPLES | The printer is generating the RGB samples page and will return to the Ready state when the page is printed. | No action necessary. |
| Printing... SUPPLIES STATUS | The printer is generating the supplies status page and will return to the Ready state when the page is printed. | No action necessary. |
| Printing... USAGE PAGE | For the HP Color LaserJet 3000, 3800, and CP3505 Series printers only The printer is generating the usage page and will return to the online Ready state when the page is printed. | No action necessary. |
| Processing... | The printer is currently processing a job but is not yet picking pages. When the media begins to move, this message is replaced by a message that indicates the job status. | No action necessary. |
| Processing... from tray <X> | The printer is actively processing a job from the designated tray. | No action necessary. |
| RAM DISK DEVICE FAILURE alternates with Ready To clear press ✓ | For the HP Color LaserJet 3000, 3800, and CP3505 Series printers only The RAM disk has failed. | 1. Printing can continue for jobs that do not require the RAM disk. 2. To clear this message, press ✓. |

| Control-panel message | Description | Recommended action |
|---|---|--|
| <p>RAM DISK FILE OPERATION FAILED</p> <p>alternates with</p> <p>Ready</p> <p>To clear press ✓</p> | <p>For the HP Color LaserJet 3000, 3800, and CP3505 Series printers only</p> <p>The printer received a PJL file system command that attempted to perform an illogical operation (for example, to download a file to a nonexistent directory).</p> | <ol style="list-style-type: none"> 1. Printing can continue. 2. To clear this message, press ✓. 3. If the message reappears, a problem might exist with the software program. |
| <p>RAM DISK FILE SYSTEM IS FULL</p> <p>alternates with</p> <p>Ready</p> <p>To clear press ✓</p> | <p>For the HP Color LaserJet 3000, 3800, and CP3505 Series printers only</p> <p>The printer received a PJL file system command to store something on the file system, but the file system is full.</p> | <ol style="list-style-type: none"> 1. Use HP Web Jetadmin software to delete files from the RAM disk memory and try again. 2. To clear this message, press ✓. |
| <p>RAM DISK IS WRITE PROTECTED</p> <p>alternates with</p> <p>Ready</p> <p>To clear press ✓</p> | <p>For the HP Color LaserJet 3000, 3800, and CP3505 Series printers only</p> <p>The file system is protected and no new files can be written to it.</p> | <ol style="list-style-type: none"> 1. To enable writing to the RAM disk memory, use HP Web Jetadmin to turn off write protection. 2. To clear this message, press ✓. |
| <p>RAM DISK X Initializing</p> <p>alternates with</p> <p>DO NOT POWER OFF</p> | <p>For the HP Color LaserJet 3000, 3800, and CP3505 Series printers only</p> <p>The new RAM disk installed in slot X is initializing.</p> | <p>No action necessary.</p> |
| <p>Receiving upgrade</p> | <p>A firmware upgrade is in progress.</p> | <p>Do not turn the printer off until the printer returns to Ready.</p> |
| <p>REMOVE ALL PRINT CARTRIDGES</p> <p>alternates with</p> <p>To exit press STOP key</p> | <p>The printer is performing a component test.</p> | <p>Remove all print cartridges.</p> <p>After diagnostics are complete, reinstall all print cartridges.</p> |
| <p>REMOVE AT LEAST ONE PRINT CARTRIDGE</p> <p>alternates with</p> <p>To exit press STOP key</p> | <p>The printer is performing a disable-cartridge check or component test.</p> | <p>Remove one print cartridge.</p> <p>After the test is complete, reinstall the print cartridge.</p> |
| <p>REPLACE <COLOR> CARTRIDGE (out)</p> <p>alternates with</p> <p>For help press ?</p> | <p>The print cartridge has reached its end of life. Printing will not continue until the cartridge is replaced.</p> | <p>Press ? for help.</p> <p>Or, if the cartridge is new:</p> <ol style="list-style-type: none"> 1. Replace the memory controller PCB. 2. Replace the DC controller PCB. |
| <p>REPLACE <COLOR> CARTRIDGE (REPLACE SUPPLIES = STOP AT LOW)</p> <p>alternates with</p> <p>To continue press ✓.</p> | <p>The print cartridge is nearing the end of its useful life and the REPLACE SUPPLIES setting in SYSTEM SETUP is set to STOP AT LOW. To override, press ✓.</p> | <ol style="list-style-type: none"> 1. Order the print cartridge. 2. Press ✓ to continue, or press ? for help. |
| <p>REPLACE SUPPLIES</p> <p>alternates with</p> | <p>At least two print cartridges are out and need to be replaced.</p> | <ol style="list-style-type: none"> 1. Press ✓ to identify which supplies should be replaced. 2. Press ? for help. |

| Control-panel message | Description | Recommended action |
|---|--|--|
| <p>For status press ✓</p> <hr/> <p>REPLACE SUPPLIES alternates with</p> <p>To continue press ✓</p> | <p>More than one supply item is low, and the REPLACE SUPPLIES setting in SYSTEM SETUP is set to STOP AT LOW.</p> | <ol style="list-style-type: none"> 1. Press Menu and navigate to the SUPPLIES STATUS menu to identify which supplies should be ordered. 2. Order the supplies. 3. Press ✓ to continue printing. |
| <p>REPLACE SUPPLIES Override in use alternates with</p> <p>Ready</p> | <p>At least one print cartridge is out, but printing is continuing. Print-quality problems might occur.</p> | <ol style="list-style-type: none"> 1. Press ✓ to identify which supplies should be ordered. 2. Order the identified supplies. |
| <p>REPLACE SUPPLIES Using black only alternates with</p> <p>Ready</p> | <p>At least one color print cartridge is out. Printing can continue, but only the black cartridge is being used.</p> | <ol style="list-style-type: none"> 1. Press ✓ to identify which supplies should be ordered. 2. Order the identified supplies. |
| <p>Request accepted please wait</p> | <p>The printer has accepted a request to print an internal page, but the current job must finish printing before the internal page will print.</p> | <p>No action necessary.</p> |
| <p>Resend upgrade</p> | <p>The firmware upgrade was not successful.</p> | <p>Attempt the upgrade again.</p> |
| <p>Restoring factory settings</p> | <p>The printer is restoring factory settings.</p> | <p>No action necessary.</p> |
| <p>Restoring...</p> | <p>The printer is restoring settings.</p> | <p>No action necessary.</p> |
| <p>RESTRICTED FROM PRINTING IN COLOR alternates with</p> <p>Ready</p> | <p>For the HP Color LaserJet 3000, 3800, and CP3505 Series printers only</p> <p>HP Color LaserJet 3000: The printer is set to print in black only, but the job is in color.</p> <p>HP Color LaserJet 3800 and CP3505: The message appears when the printer is set to COLOR IF ALLOWED and permissions do not exist to print in color.</p> | <p>HP Color LaserJet 3000: Enable color printing on the SYSTEM SETUP menu. Set RESTRICT COLOR USE to ENABLE COLOR.</p> <p>HP Color LaserJet 3800 and CP3505: Ask the network administrator to set the user or program permissions for color printing.</p> |
| <p>RFU LOAD ERROR</p> | <p>For the HP Color LaserJet 3000, 3800, and CP3505 Series printers only</p> <p>An error has occurred during a firmware upgrade.</p> | <p>Reinstall the firmware.</p> |
| <p>Rotating <COLOR> motor alternates with</p> <p>To exit press STOP key</p> | <p>A component test is in progress; the component selected is <color> Cartridge motor.</p> | <p>Press Stop to stop this test.</p> |
| <p>Rotating motor alternates with</p> <p>To exit press STOP key</p> | <p>The printer is testing a motor.</p> | <p>Press Stop to stop this test.</p> |

| Control-panel message | Description | Recommended action |
|---|---|---|
| SANITIZING DISK X% COMPLETE alternates with DO NOT POWER OFF | For the HP Color LaserJet 3000, 3800, and CP3505 Series printers only The memory disk is being sanitized. This process might take up to an hour. During this time, no jobs can be printed. | Do not turn off the printer. Wait for the process to complete. The printer automatically restarts at the end of the sanitation process. |
| Setting saved | A menu selection has been saved. | No action necessary. |
| SIZE MISMATCH IN TRAY X alternates with Ready | The tray is loaded with a media size that is different from the size for which the tray is configured. Printing can continue from other trays, but not from this one. | <ol style="list-style-type: none"> 1. Make sure the media guides are adjusted correctly. 2. On the PAPER HANDLING menu, configure the tray for the correct size. |
| Sleep mode on | The printer is in the sleep mode. Any button press or data received clears the sleep mode. | No action necessary. The printer automatically exits sleep mode. |
| STANDARD TOP BIN FULL alternates with Remove all paper from bin | The output bin is full. Printing cannot continue. | Empty the output bin. Printing resumes automatically. If the message persists, inspect the delivery-tray paper-full sensor. |
| To return to Ready press the STOP key | The printer has paused. | Press Stop to resume printing. |
| TRAY X <TYPE> <SIZE> alternates with To change size or type press ✓ | The printer is reporting the current configuration of tray X. | No action necessary. Press ↵ to clear the message. Press ✓ to change the type or size. |
| TRAY X EMPTY <TYPE> <SIZE> alternates with Ready | Tray 3 is empty, but the current print job does not require this tray. | Fill the tray. The message indicates the type and size of media for which the tray is currently configured. |
| TRAY X OPEN For help press ? alternates with Ready | The tray is open, but printing can continue. NOTE: If tray 2 is open, printing <i>cannot</i> continue. | Close the tray. |
| TRAY X OPEN OR EMPTY alternates with Ready | The tray is open or empty, but the current print job does not require this tray. | Close or fill the tray. |
| TYPE MISMATCH IN TRAY X alternates with Ready | The tray is loaded with a media type that is different from the type for which the tray is configured. Printing can continue from other trays. | On the PAPER HANDLING menu, configure the tray for the correct type. |
| Unauthorized supply in use alternates with Ready | The printer has detected that a non-HP supply is currently installed and ✓ was pressed to override. | If you believe you purchased an HP supply, go to www.hp.com/go/antcounterfeit . Service or repairs that are required as a result of using non-HP supplies are not covered under HP warranty. |

| Control-panel message | Description | Recommended action |
|--|--|---|
| USB ACCESSORY ERROR | For the HP Color LaserJet 3000, 3800, and CP3505 Series printers only The printer has detected too much current on the USB storage accessory. | <ol style="list-style-type: none"> 1. Turn the printer off. 2. Remove the USB storage accessory. 3. Replace the USB storage accessory. 4. Turn the printer on. |
| USB Storage <X> initializing | For the HP Color LaserJet 3000, 3800, and CP3505 Series printers only The USB storage device is initializing. | No action necessary. |
| USB STORAGE <X> NOT FUNCTIONAL | For the HP Color LaserJet 3000, 3800, and CP3505 Series printers only The USB storage device is not working. | Replace the USB storage device. |
| USB STORAGE DEVICE FAILURE alternates with Ready To clear press ✓ | For the HP Color LaserJet 3000, 3800, and CP3505 Series printers only The USB storage device has failed. | <ol style="list-style-type: none"> 1. Printing can continue for jobs that do not require the storage device. 2. To remove this message from the display, press ✓. 3. If the message persists, turn the printer off, remove and re-install the storage device, and then turn the printer on. 4. If the message persists, replace the storage device. |
| USB STORAGE FILE OPERATION FAILED alternates with Ready To clear press ✓ | For the HP Color LaserJet 3000, 3800, and CP3505 Series printers only The printer received a PJL file system command that attempted to perform an illogical operation (for example, to download a file to a nonexistent directory). | <ol style="list-style-type: none"> 1. Printing can continue. 2. To remove this message from the display, press ✓. 3. If the message reappears, a problem might exist in the software program. |
| USB STORAGE FILE SYSTEM IS FULL alternates with Ready To clear press ✓ | For the HP Color LaserJet 3000, 3800, and CP3505 Series printers only The printer received a PJL file system command that attempted to store something on the file system but was unsuccessful because the file system is full. | <ol style="list-style-type: none"> 1. Use HP Web Jetadmin software to delete files from the storage device, and then try again. 2. To clear this message, press ✓. |
| USB STORAGE IS WRITE PROTECTED alternates with Ready To clear press ✓ | For the HP Color LaserJet 3000, 3800, and CP3505 Series printers only The file system is protected and no new files can be written to it. | <ol style="list-style-type: none"> 1. To enable writing to the storage device, use HP Web Jetadmin to turn off write protection. 2. To clear this message, turn the printer off and then on. |

| Control-panel message | Description | Recommended action |
|---|--|--|
| USB STORAGE X REMOVED | <p>For the HP Color LaserJet 3000, 3800, and CP3505 Series printers only</p> <p>The USB storage accessory was removed while the printer was turned on.</p> | <ol style="list-style-type: none"> 1. Turn the printer off. 2. To continue using the USB storage accessory, reinstall it. 3. Turn the printer on. |
| USE TRAY X <TYPE> <SIZE> | <p>The printer is offering a selection of alternative media to use for the print job.</p> | <ol style="list-style-type: none"> 1. Use ▲ and ▼ to highlight a different size or type, and then press ✓ to select the size or type. 2. Press ↶ to return to the previous size or type. |

Jams

Use this illustration to troubleshoot jams in the printer. For instructions to clear jams, see [Clearing jams on page 199](#).

Figure 6-1 Jam locations (printer shown without optional tray 3)

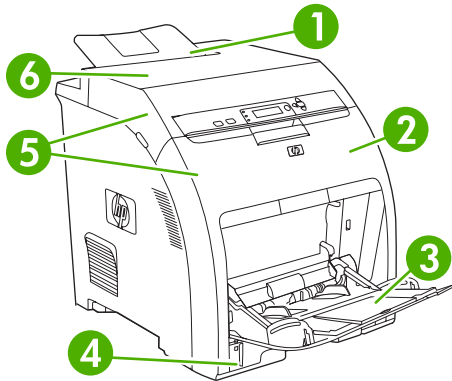

| | |
|---|--|
| 1 | Output bin |
| 2 | Paper path (inside the front cover) |
| 3 | Multipurpose tray (tray 1) |
| 4 | Trays 2, 3 |
| 5 | Duplex path (inside the upper cover and the front cover of duplex models only) |
| 6 | Fuser (inside the top cover) |

Jam recovery

This printer automatically provides jam recovery, a feature that specifies whether the printer should attempt to automatically reprint jammed pages.

- **AUTO** instructs the printer to attempt to reprint jammed pages.
- **OFF** instructs the printer not to attempt to reprint jammed pages.

 **NOTE:** During the recovery process, the printer might reprint pages that were printed before the jam occurred. Be sure to remove any duplicated pages.

To improve print speed and increase memory resources, disable the jam recovery.

To turn off jam recovery

1. Press **Menu**.
2. Press **▼** to highlight **CONFIGURE DEVICE**, and then press **✓**.
3. Press **▼** to highlight **SYSTEM SETUP**, and then press **✓**.
4. Press **▼** to highlight **JAM RECOVERY**, and then press **✓**.
5. Press **▼** to highlight **OFF**, and then press **✓**.
6. Press **Menu** to return to the **Ready** state.

Avoiding jams

The table below lists common causes of jams and suggests solutions for resolving jams.

Table 6-2 Common causes of jams

| Cause | Solution |
|---|---|
| The media does not meet HP-recommended specifications. | Use only media that meets HP specifications. |
| A supply item is installed incorrectly, causing repeated jams. | Verify that all print cartridges, the transfer unit, and the fuser are correctly installed. |
| You are reloading media that has already passed through a printer or copier. | Do not use media that has been previously printed on or copied. |
| A tray is loaded incorrectly. | Remove any excess media from the input tray. Be sure that the stack does not exceed the maximum stack height mark in the input tray. |
| The media is skewed. | The tray guides are not adjusted correctly. Adjust the guides so they hold the stack firmly in place without bending it. |
| The media is binding or sticking together. | Remove the stack and flex it, rotate it 180°, or flip it over. Reload the stack into the tray. NOTE: Do not fan paper. Fanning can create static electricity which can cause paper to stick together. |
| The media is removed before it settles into the output bin. | Reset the printer. Wait until the page completely settles in the output bin before removing it. |
| When duplexing, the paper is removed before the second side of the document is printed. | Reset the printer and print the document again. Wait until the page completely settles in the output bin before removing it. |
| The media is in poor condition. | Replace the media. |
| The internal rollers do not pick up media from tray 2 or tray 3. | Remove the top sheet of media. If it is heavier than 163 g/m ² (43 lb), it might not be picked from the tray. |
| The media has rough or jagged edges. | Replace the media. |
| The media is perforated or embossed. | This type of media does not separate easily. You might need to feed single sheets from the multipurpose tray. |
| The supplies have reached the end of their useful life. | Check the printer control panel for messages prompting you to replace supplies, or print a supplies status page to verify the remaining life of the supplies. |
| The media was not stored correctly. | Replace the media. Media should be stored in the original packaging in a controlled environment. |

Clearing jams

Procedures in the following sections correspond with a jam message that might appear on the control panel.

Jam in the multipurpose tray (tray 1)

1. Remove the media from the tray.

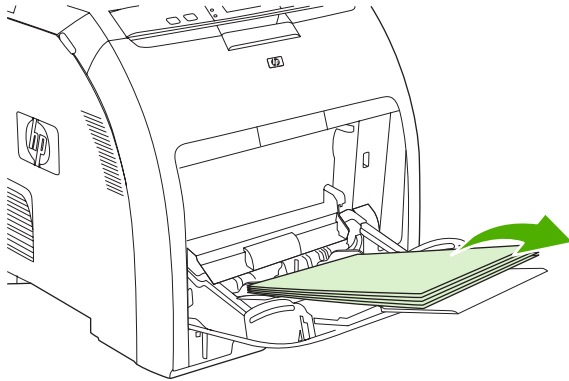

2. Grasp the jammed sheet by both corners and pull.

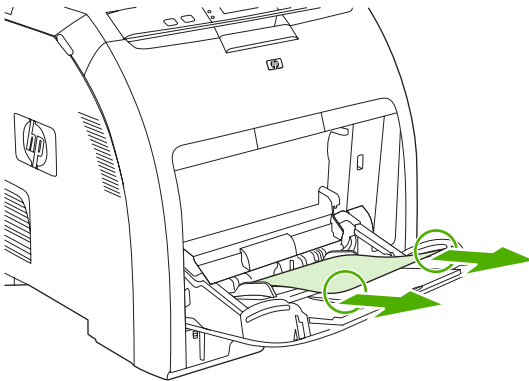

3. Place the media stack in the tray.

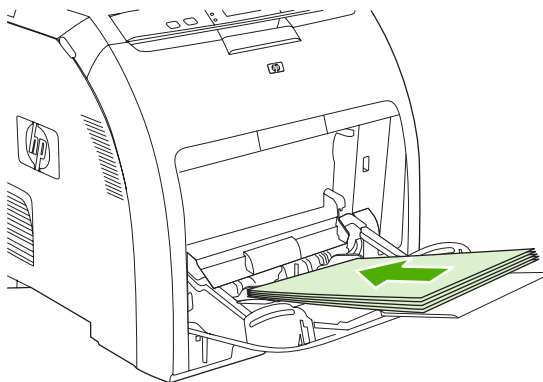

4. Confirm that the media guides are against the stack without bending it and that the stack does not extend above the fill tabs.

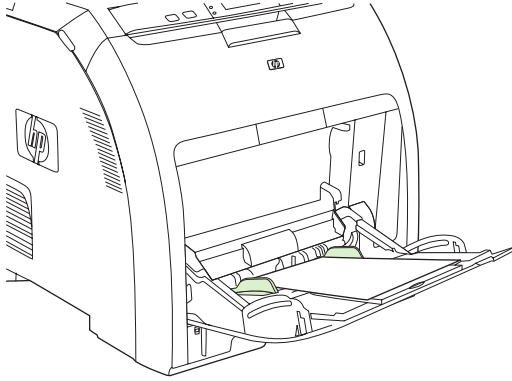

5. Press ✓ to resume printing.

Jam in tray 2 or tray 3

1. If the optional tray 3 is installed, pull it out and place it on a flat surface. If the jammed sheet is visible, remove it.

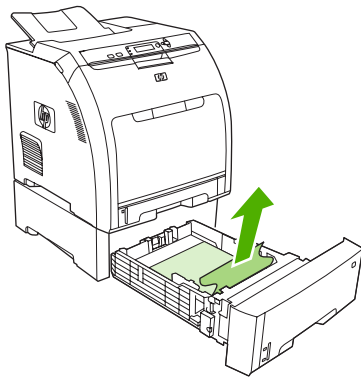

2. If the sheet is not visible, check inside the printer at the top of the tray opening. Remove any jammed media.
3. Pull out tray 2 and place it on a flat surface.

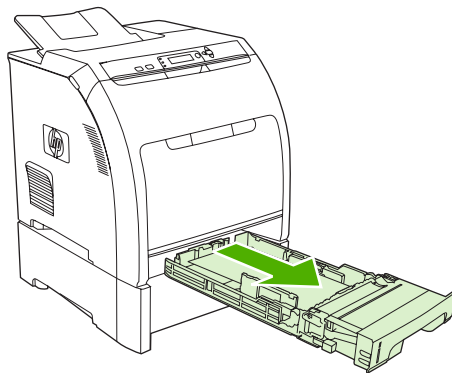

4. If the jammed sheet is visible, remove it.

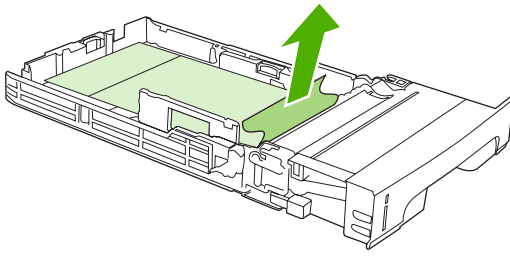

5. If the sheet is not visible, check inside the printer at the top of the tray opening. Remove any jammed media.



6. Replace tray 2 and optional tray 3.

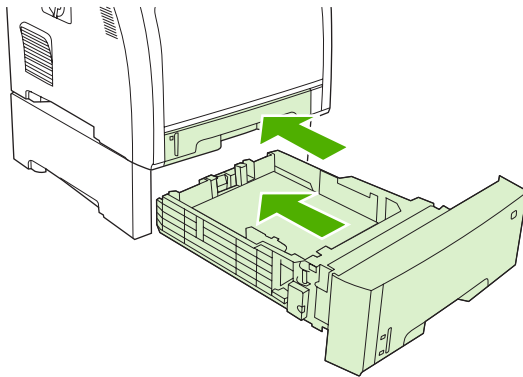

 **NOTE:** Use the multipurpose tray when printing on heavier paper.

7. Press ✓ to resume printing.

 **NOTE:** When printing from tray 2, printing resumes automatically.

Jam inside the fuser area (upper cover)

1. Open the upper cover.

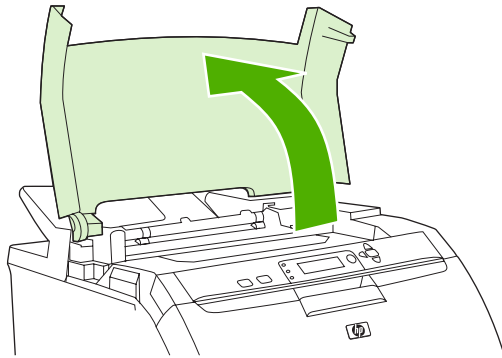

2. If the jammed sheet is visible, remove it and then close the upper cover.

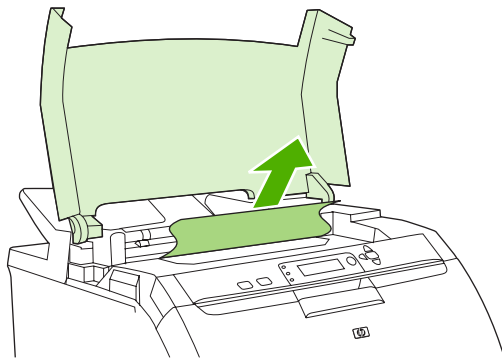

3. If the sheet is not visible, turn off the printer.

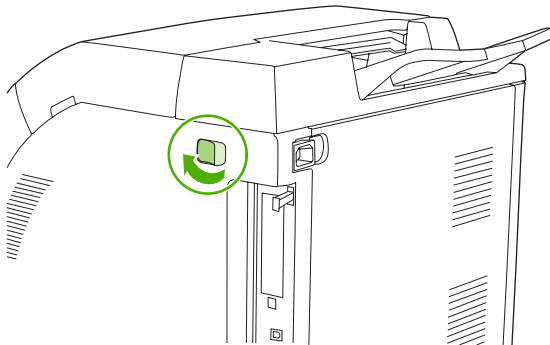

⚠ WARNING! The fuser will be hot. Wait 10 minutes before proceeding.

4. Place your thumbs on the fuser latches, squeeze the latches, and pull up on the fuser to remove it.

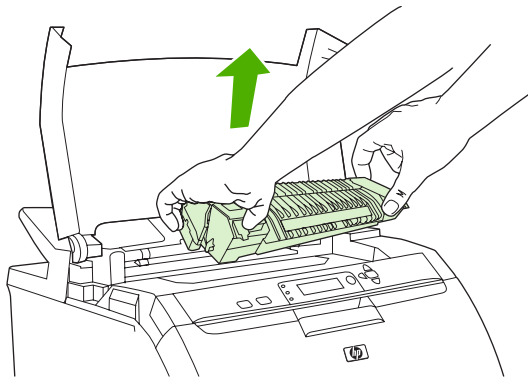

5. On the fuser, lift the shutter door.

△ **CAUTION:** Do not open the shutter door while the fuser is in the printer.

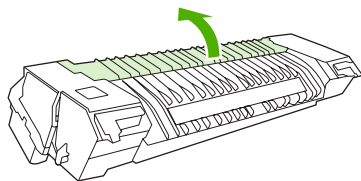

6. Remove any jammed sheets.

📄 **NOTE:** If the sheet tears, make sure that all fragments are removed before you resume printing.

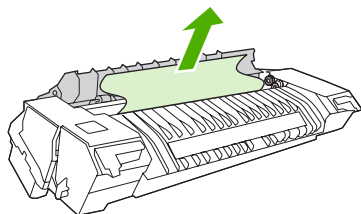

7. Hold the fuser with your thumbs on the latches, and then push both sides of the fuser into the printer. Press the fuser down until it clicks into place.

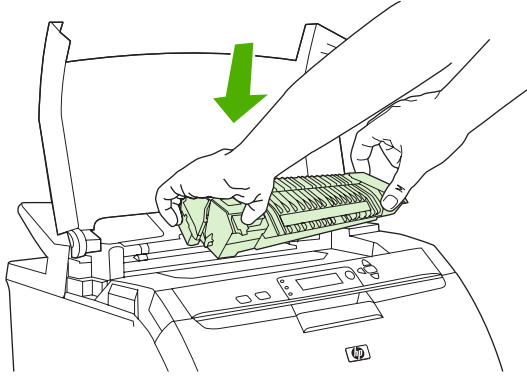

8. Close the upper cover and then turn on the printer.

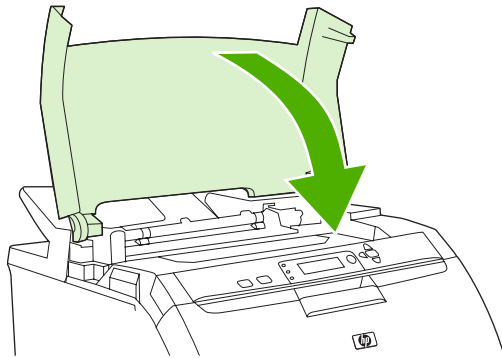



Jam inside the front cover

 **NOTE:** This part is called the front door in the user documentation and in chapter 1, “Product information”.

1. Open the front cover.



 **CAUTION:** Do not place anything on the transfer unit. Do not touch the top of the transfer unit or the contacts on the left side of it.

 **NOTE:** If the sheet tears, make sure that all fragments are removed before resuming printing.

2. Remove any visible media.

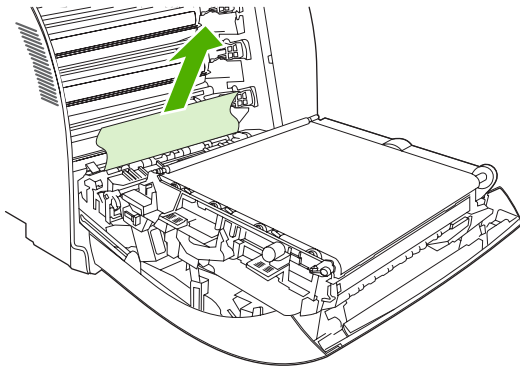

3. Locate the green registration-plate tabs that are below the bottom print cartridge.

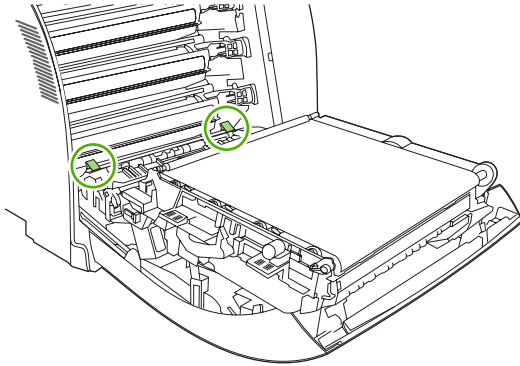

4. Press the tabs, and then lift the registration plate. Remove any jammed media, and then return the registration plate to its closed position.

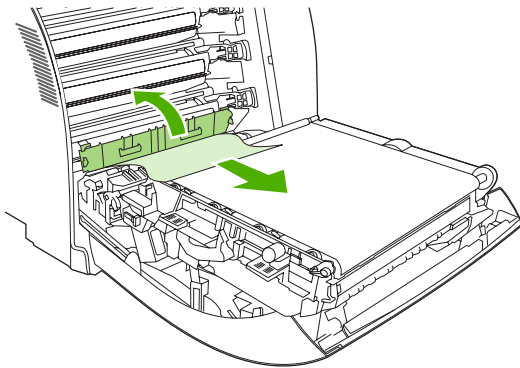

 **NOTE:** If the sheet tears, make sure that all fragments are removed before resuming printing.

5. Close the front cover.

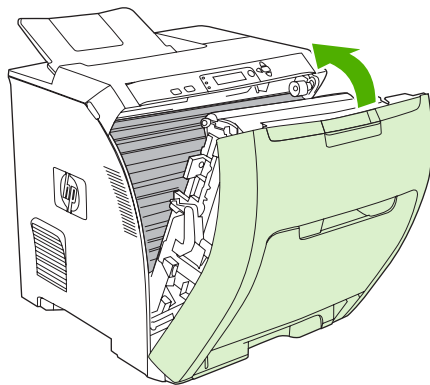

Jam in the duplex path

 **NOTE:** This issue occurs only in duplex models.

1. Turn off the printer, and open the upper cover.

If any media is visible, remove it.

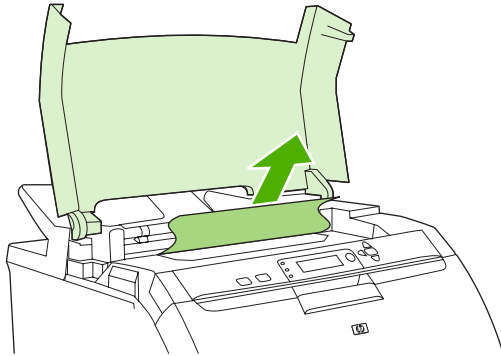

2. Open the front cover.



3. Rotate the transfer unit up and away from the front cover.

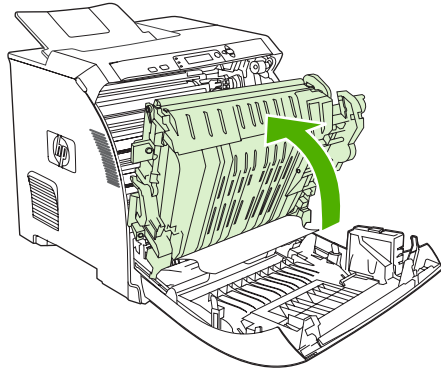

4. Remove any jammed sheets from under the transfer unit.

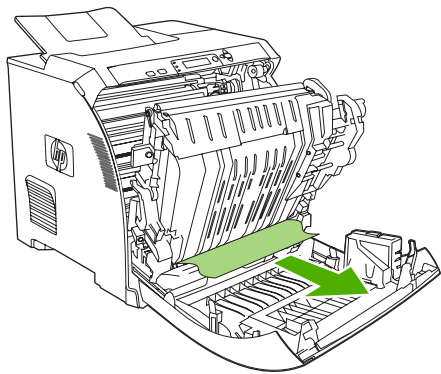

5. Locate the green registration-plate tabs that are below the bottom print cartridge.

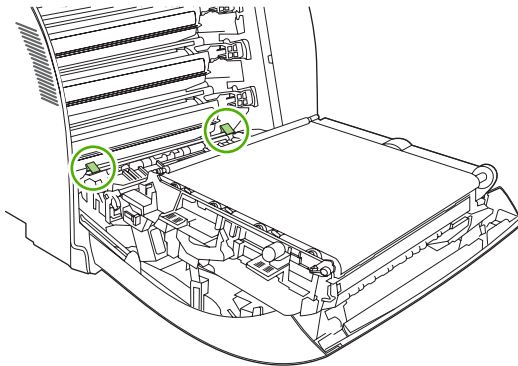

6. Press the tabs, and then lift the registration plate. Remove any jammed media, and then return the registration plate to its closed position.

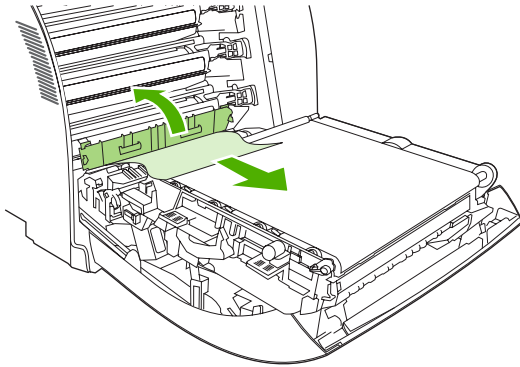

 **NOTE:** If the sheet tears, make sure that all fragments are removed before resuming printing.

7. Close the front cover and then turn on the printer.

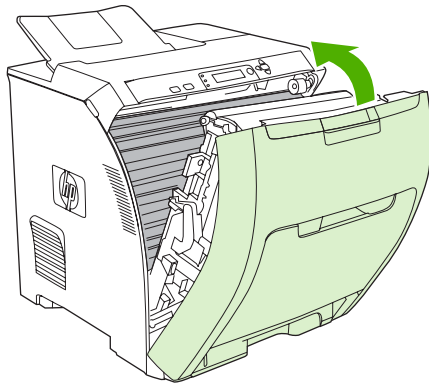

Image-formation troubleshooting

This section identifies issues that can affect print quality. For additional information, see the *HP LaserJet Printer Family Print Media Guide*.

Print-quality problems associated with media

Some print-quality problems arise from use of inappropriate print media.

- Use media that meets HP paper specifications.
- The gloss and transparency films are very smooth. Use paper that meets HP paper specifications.
- The driver setting is incorrect. To change the paper-type setting, see **Type and Size**.
- The media you are using is too heavy for the paper-type setting you selected, and the toner is not fusing to the paper.
- The moisture content of the paper is uneven, too high, or too low. Use paper from a different source, from an unopened ream of paper, or dry out the paper (100°C [212°F] for 24 hours).
- Some areas of the paper reject toner. Use paper from a different source or from an unopened ream of paper.

- The letterhead you are using is printed on rough paper. Use a smoother, xerographic paper. If this solves your problem, consult with the supplier of your letterhead to verify that the paper used meets the specifications for this printer.
- The paper is excessively rough. Use a smoother, xerographic paper.
- Avoid media containing metallic laminates or conductive surfaces.

Defects on overhead transparencies

Overhead transparencies can show the image-quality problems as any other type of media, as well as defects that are specific to printing on transparencies. Because transparencies are pliable while in the print path, the paper-handling components can also mark them.

 **NOTE:** Allow transparencies to cool for at least 30 seconds before handling them.

- Change the pre-rotation setting in CONFIGURE DEVICE/PRINT QUALITY/OPTIMIZE/PRE-ROTATION=ON. This enhances transparency print quality by raising the fuser pressure roller temperature to more closely match the sleeve temperature.
- Change the transparency mode in CONFIGURE DEVICE/PRINT QUALITY/PRINT MODES/TRANSPARENCY to B TRNSPRNCY (Best Transparency) mode. This optimizes transparency print quality and minimizes transparency curl.

 **NOTE:** If the printer media sensor rejects a supported color laserjet transparency, make sure that the transparency is not from an old box. Try a new box.

- In the printer driver **Paper** tab, select **Transparency** as the paper type. Also, make sure that the tray is correctly configured for transparencies.
- Check that the transparencies meet the specifications for this printer. For more information about media specifications and for ordering information, consult the *HP LaserJet Printer Family Print Media Specification Guide*.
- If print-quality defects occur, then make sure that the transparencies are designed for correct toner adhesion. Use only transparencies that are designed for HP Color LaserJet printers.
- Handle transparencies by the edges. Oil from fingers can cause spots and smudges on the transparencies.
- Small, random, dark areas on the trailing edge of solid fill pages might be caused by transparencies sticking together in the output bin. Try printing the job in smaller batches.
- If the selected colors are not what you want when printed, then select different colors in the program or printer driver.
- If you are using a reflective overhead projector, then use a standard overhead projector instead.

Print-quality problems that are related to the environment

If the printer is operating in excessively humid or dry conditions, verify that the printing environment is within specifications. See the getting started guide for this printer for information about operating-environment specifications.

Print-quality problems that are related to jams

Make sure that all media is cleared from the paper path.

- If the printer recently jammed, print two to three pages to clean the printer.
- If the media does not pass through the fuser, image defects appear on subsequent documents. Print two to three pages to clean the printer.

Print-quality problems from toner buildup

Over time, toner and other particles can build up inside the printer. This buildup can cause the following print-quality problems:

- Marks at even intervals on the printed side of the page
- Toner that smears easily
- Toner specks on the page
- Vertical streaks or bands on the page

To correct these types of problems, clean the printer. See [Cleaning the printer on page 38](#).

Print-quality troubleshooting pages

Use the built-in print-quality troubleshooting pages to help diagnose and solve print-quality problems.

1. Press **Menu**.
2. Press **▼** to highlight **DIAGNOSTICS**, and then press **✓**.
3. Press **▼** to highlight **PQ TROUBLESHOOTING**, and then press **✓** to print the pages.

Image defects

If specific defects occur repeatedly, print a Print Quality Troubleshooting page and follow the instructions on the first page. If you cannot resolve the problem, use the information in this section to identify the root cause of the problem.

Image defects fall into the following categories. Links to possible causes and recommended solutions are included. In general, the items are listed in order, from minor repairs to major repairs. Check each item in the order in which it appears.

 **NOTE:** Verify that all firmware has been upgraded to the latest version.

Table 6-3 Image defects

| Image defect | Description | More information |
|------------------------|--|---|
| Light image | Image light in all colors | See Table 6-4 Causes for light images on page 214 . |
| Light color | Image light in a particular color | See Table 6-5 Causes for one color printing light on page 215 . |
| Dark image | Image dark in all colors | See Table 6-6 Causes for dark images on page 215 . |
| Dark color | Image dark in a particular color | See Table 6-7 Causes for one color printing darker than others on page 215 . |
| Completely blank | No image prints | See Table 6-8 Causes for a completely blank image on page 216 . |
| All black/solid color | Image is all black or solid color | See Table 6-9 Causes for an all black or solid colored image that extends to the edge of the page on page 216 . |
| Dots in vertical lines | White dots appear in image | See Table 6-10 Causes for vertical lines of white dots on page 216 . |
| Dirt on back of paper | Dirt on the back of the page | See Table 6-11 Causes for dirt on the back of the paper on page 217 . |
| Dirt on front of paper | Dirt on the front of the page | See Table 6-12 Causes for dirt on the front of the paper on page 217 . |
| Vertical lines | Vertical line appears in image | See Table 6-13 Causes for vertical lines on page 217 . |
| White vertical lines | White vertical line appears in image | See Table 6-14 Causes for white vertical lines on page 218 . |
| Horizontal lines | Horizontal line appears in image | See Table 6-15 Causes for horizontal line on page 218 . |
| White horizontal lines | White horizontal line appears in image | See Table 6-16 Causes for white horizontal lines on page 218 . |
| Missing color | Image in a particular color does not come out in color | See Table 6-17 Causes for a missing color on page 219 . |

Table 6-3 Image defects (continued)

| Image defect | Description | More information |
|-----------------------|--|---|
| Blank spots | Blank spots appear in image | See Table 6-18 Causes for blank spots on page 219 . |
| Poor fusing | Toner image is not fully fixed on the media | See Table 6-19 Causes for poor fusing on page 219 . |
| Distorted Image | Image is distorted | See Table 6-19 Causes for poor fusing on page 219 . |
| Color misregistration | Some color is misregistered | See Table 6-21 Causes for color misregistration on page 220 . |
| Smearing | Image smeared in whole or in part | See Table 6-22 Causes for smearing on page 221 . |
| Misplaced image | Whole image is incorrectly placed | See Table 6-23 Causes for a misplaced image on page 221 . |
| Reversed color | White in image is output in color, and color is output in white | See Table 6-24 Causes for reversed color on page 221 . |
| Snail tracks | Streaks on the page (that look like snail tracks); the media might wrinkle | See Table 6-25 Causes for snail tracks on page 222 . |

Light image

Table 6-4 Causes for light images

| Cause | Solution |
|--|--|
| The image density is not adjusted correctly | Calibrate the printer. |
| The transfer unit has deteriorated | If the transfer unit is at the end of its life or its surface has deteriorated, replace the transfer unit. NOTE: A large white streak appearing slightly off-center of the transfer unit is not a defect. The transfer unit does not need to be replaced in this case. |
| Poor secondary-transfer-bias contacts exist | On the secondary transfer roller, check the bias contacts to the high-voltage PCB. Clean them, if necessary. Replace defective parts and deformed or damaged contacts. |
| The secondary transfer charging roller is deformed or has deteriorated | Replace the secondary transfer charging roller. |
| The high-voltage PCB is defective | Replace the high-voltage PCB. |
| The DC controller PCB is defective | Replace the DC controller PCB. |
| Contamination buildup on the scanner mirror or lenses | Replace the scanner assembly. |

Light color

Use an external device to print a solid-filled image as an example of the problem. As the sample prints, turn the printer off and remove the cartridge. Open the cartridge shutter. If the toner image on the drum before transfer is light for more than one color, go to step A. If the toner image on the photosensitive drum is not fully transferring to the transfer unit, go to step B in the following table.

Table 6-5 Causes for one color printing light

| | Cause | Solution |
|---------------|---|--|
| Step A | Poor developing-bias contacts | Check the developing-bias contacts to the high-voltage PCB. Clean the contacts as necessary. Replace any deformed or damaged contacts. |
| | Contamination buildup on the scanner mirror or lenses | Replace the scanner assembly. |
| | Deteriorated cartridge (photosensitive drum) | Replace the cartridge that produces the light color. |
| | Defective high-voltage PCB | Replace the high-voltage PCB. |
| | Defective DC controller PCB | Replace the DC controller PCB. |
| Step B | Poor primary-transfer-bias contacts | On the transfer unit, check the primary transfer-bias-contacts to the high-voltage PCB. Clean the contacts as necessary. Replace any deformed or damaged contacts. |
| | Deformed or deteriorated primary-transfer charging roller | Replace the transfer unit. |
| | Defective high-voltage PCB | Replace the high-voltage PCB. |
| | Defective laser/scanner unit | Replace the laser/scanner unit. |
| | Defective DC controller PCB | Replace the DC controller PCB. |

Dark image

Table 6-6 Causes for dark images

| Cause | Solution |
|--|--|
| Image density is not adjusted correctly | Calibrate the printer. |
| Color misregistration sensor lens is dirty | Clean the color misregistration sensor lens. |
| Color misregistration sensor is defective | Replace the color misregistration sensor. |
| Environmental sensor is defective | Replace the environmental sensor. |
| DC controller PCB is defective | Replace the DC controller PCB. |

Dark color

Table 6-7 Causes for one color printing darker than others

| Cause | Solution |
|--|---|
| Poor contacts with the primary-charging bias, developing bias, or drum grounding | On the cartridge that is producing the darker color, check the primary-charging bias and developing-bias contacts to the high-voltage PCB, or the drum-grounding contacts. Clean the contacts as necessary. Replace any deformed or damaged contacts. |

Table 6-7 Causes for one color printing darker than others (continued)

| Cause | Solution |
|--------------------------------|--------------------------------|
| High-voltage PCB is defective | Replace the high-voltage PCB. |
| DC controller PCB is defective | Replace the DC controller PCB. |

Completely blank image

Table 6-8 Causes for a completely blank image

| Cause | Solution |
|---|---|
| High-voltage PCB is defective (no developing-bias output) | Replace the high-voltage PCB. |
| DC controller PCB is defective | Replace the DC controller PCB. Calibrate the printer after replacing the DC controller. |

All black or solid color

Table 6-9 Causes for an all black or solid colored image that extends to the edge of the page

| Cause | Solution |
|--|--|
| The formatter is not fully seated, or it is defective. | Print an engine test page to make sure that the printer is functioning. If the defect does not appear on the engine test page, replace the formatter. |
| Poor contacts with the primary-charging bias, developing bias, or drum grounding | On the cartridge that is producing the solid color, check the primary-charging bias and developing-bias contacts to the high-voltage PCB, or the drum-grounding contacts. Clean the contacts as necessary. Replace any deformed or damaged contacts. |
| Cartridge (primary-charging roller) is defective | Replace the cartridge that is producing the solid color. |
| High-voltage PCB is defective | Replace the high-voltage PCB. |
| DC controller PCB is defective | Replace the DC controller PCB. Calibrate the printer after replacing the DC controller. |

Dots in vertical lines

Table 6-10 Causes for vertical lines of white dots

| Cause | Solution |
|---|---|
| Transfer unit or primary-transfer charging roller is deformed or deteriorated | Replace the transfer unit. |
| Secondary-transfer charging roller is deformed or deteriorated | Replace the secondary-transfer charging roller. |
| High-voltage PCB is defective | Replace the high-voltage PCB. |
| DC controller PCB is defective | Replace the DC controller PCB. Calibrate the printer after replacing the DC controller. |

Dirt on back of paper

If the defect is repetitive dirt, go to step A; if not, go to step B.

Table 6-11 Causes for dirt on the back of the paper

| Cause | Solution |
|---|--|
| A Repetitive debris (debris on the registration roller, pressure roller, feed roller, fuser delivery roller, or face-down delivery sub-roller) | See Table 6-26 Causes of repetitive defects on page 223 to identify the roller with which the problem is associated. Clean the dirty roller. Replace the roller if the dirt does not come off. |
| B Dirty cassette pickup roller, feed guide, fuser inlet guide, or fuser delivery guide | Clean any dirt from the rollers. Replace the roller if the dirt does not come off. |

Dirt on front of paper

If the defect appears in a particular color, go to step A. If it does *not* appear in a particular color *and* it is repetitive, go to step B. If it is not repetitive, go to step C.

Table 6-12 Causes for dirt on the front of the paper

| Cause | Solution |
|--|--|
| A Defective cartridge (deteriorated toner or scratches on the developing cylinder, photosensitive drum, or primary charging roller) | Replace the cartridge of the color that matches the defect. |
| B Repetitive dirt (dirty registration sub-roller, fuser sleeve, feed sub-roller, or face-down delivery roller) | See Table 6-26 Causes of repetitive defects on page 223 to identify the roller with which the problem is associated. Clean the dirty roller. Replace the roller if the dirt does not come off. |
| C Dirty multipurpose tray pickup roller | Clean dirt from the roller. Replace the roller if the dirt does not come off. |
| Defective transfer unit | Check the transfer-unit surface. If it is scratched or dented, replace it. |
| Defective transfer-unit cleaning blade | Replace the transfer unit. |

Vertical lines

Table 6-13 Causes for vertical lines

| Cause | Solution |
|--|---|
| Photosensitive drum has grooves on the circumference | Replace the cartridge that produces the vertical lines. For both the OPC and the fuser, these “grooves” might just be dark lines going around the roller. The OPC and fuser can be cleaned in some instances. Use a fine lint-free cloth or coffee filter to gently rub the dark line off the OPC or fuser roller. |
| Fuser sleeve has grooves on the circumference | Replace the fuser. |

White vertical lines

If the lines appear in a particular color, go to step A. If they appear in a full-color print, go to step B.

Table 6-14 Causes for white vertical lines

| Cause | Solution |
|--|------------------------------|
| A Scratches on the circumference of the developing cylinder (print cartridge) | Replace the print cartridge. |
| Scratches on the circumference of the photosensitive drum | Replace the print cartridge. |
| B Vertical scratches on the transfer unit | Replace the transfer unit. |
| Vertical scratches on the fuser sleeve | Replace the fuser. |

Horizontal line

If the line appears in a particular color, go to step A. If it appears in the full-color print, go to step B.

Table 6-15 Causes for horizontal line

| Cause | Solution |
|--|--|
| A The developing cylinder is deformed by remaining engaged with the photosensitive drum for too long. | See Table 6-26 Causes of repetitive defects on page 223 to determine whether a developing cylinder is involved. If so, print about 20 pages to solve the problem. If the problem is not resolved, replace the cartridge. Additionally, waiting overnight might help. Print several pages and then let the printer sit overnight. This allows the roller to reform, which can solve the issue. |
| Horizontal scratches on the photosensitive drum (cartridge) | See Table 6-26 Causes of repetitive defects on page 223 to determine whether a photosensitive drum is involved. If so, replace the cartridge. |
| The print-cartridge cleaning blade leaves a line of toner on the drum (C-blade blur). The line repeats every 77 mm (3.0 inches). | At the printer control panel, set CONFIGURE DEVICE/ PRINT QUALITY/OPTIMIZE/ PRE-ROTATION=ON. |
| B Horizontal scratches on the fuser sleeve | See Table 6-26 Causes of repetitive defects on page 223 to determine whether a fuser sleeve is involved. If so, replace the fuser. |

White horizontal line

If the line appears in a particular color, go to A. If it appears in full color, go to B.

Table 6-16 Causes for white horizontal lines

| Cause | Solution |
|--|---|
| A Horizontal scratches on the photosensitive drum (cartridge) | See Table 6-26 Causes of repetitive defects on page 223 to determine whether a photosensitive drum is involved. If so, replace the print cartridge. |

Table 6-16 Causes for white horizontal lines (continued)

| Cause | Solution |
|--|--|
| B Horizontal scratches on the transfer unit | Check the transfer unit surface for horizontal scratches. If any, replace the transfer unit. |
| C The fuser sleeve is deformed by remaining engaged with the pressure roller for too long | See Table 6-26 Causes of repetitive defects on page 223 to determine whether the fuser sleeve is involved. If so, replace the fuser. |

Color missing

Table 6-17 Causes for a missing color

| Cause | Solution |
|---|--|
| Defective laser shutter | Check the problem color laser shutter. Clean the shutter as necessary. Replace the shutter if it is deformed or damaged. |
| Poor developing-bias contacts | For the cartridge with the problem (color missing), check the developing-bias contacts to the high-voltage PCB. Clean contacts, if dirty. Replace defective parts if the contacts are deformed or damaged. |
| Defective cartridge (primary-charging roller) | Replace the problem (color missing) color cartridge. |
| Laser/scanner unit is defective | Replace the laser/scanner for any missing color. Calibrate the printer after replacing the laser/scanner. |
| High-voltage PCB is defective | Replace the high-voltage PCB. |
| DC controller PCB is defective | Replace the DC controller PCB. Calibrate the printer after replacing the DC controller. |

Blank spots

Table 6-18 Causes for blank spots

| Cause | Solution |
|---------------------------------------|---|
| Poor secondary-transfer-bias contacts | On the secondary-transfer roller, check the bias contacts to the high-voltage PCB. Clean the contacts as necessary. Replace any deformed or damaged contacts. |
| High-voltage PCB is defective | Replace the high-voltage PCB. |
| DC controller PCB is defective | Replace the DC controller PCB. Calibrate the printer after replacing the DC controller. |

Poor fusing

Table 6-19 Causes for poor fusing

| Cause | Solution |
|--|--|
| Printer is not properly set for media type | Check the media setting in the driver and in the control panel. Set the printer for the media type being used. |
| Media is not within specifications | Use media that meets specifications. |

Table 6-19 Causes for poor fusing (continued)

| Cause | Solution |
|--|--|
| Fuser is not within nip-width specifications | See Table 6-26 Causes of repetitive defects on page 223 to determine whether a fuser sleeve is involved. If so, replace the fuser sleeve unit. |
| Fuser sleeve is scarred or damaged | Replace the fuser. |
| Pressure roller is scarred or damaged | See Table 6-26 Causes of repetitive defects on page 223 to determine if a pressure roller is involved. If so, replace the fuser. |
| Thermistor is deteriorated | Replace the fuser. |
| DC controller PCB is defective | Replace the DC controller PCB. Calibrate the printer after replacing the DC controller. |

Image distortion

Table 6-20 Causes for distortion or blurring

| Cause | Solution |
|--|---|
| Transfer unit is defective | Replace the transfer unit. Calibrate the printer after replacing the transfer unit. |
| Secondary-transfer roller is defective | If it does not rotate smoothly or is deformed, replace the secondary-transfer roller. |
| DC controller PCB is defective | Replace the DC controller PCB. Calibrate the printer after replacing the DC controller. |

Color misregistration

If the misregistration occurs in a particular color, go to A. If it occurs in all colors, go to step B. If another misregistration issue is evident, perform the steps in order.

Table 6-21 Causes for color misregistration

| Cause | Solution |
|--|--|
| The printer is not calibrated correctly | Open the front door and remove the ETB shipping locks on each side of the ETB assembly, toward the bottom. Calibrate the printer. |
| Media is not within specifications. | Verify that media meets specifications. |
| A Cartridge is defective | Check if the photosensitive drum in the problem cartridge rotates smoothly. If not, replace the cartridge. |
| Cartridge drive gears are worn or chipped | Check the drive gears connected to the problem cartridge. If a gear is worn or chipped, replace the gear. |
| B Color misregistration sensor is dirty | Clean the color misregistration sensor lens. |
| Color misregistration sensor is defective | Replace the color misregistration sensor. |
| Transfer unit is defective | If the transfer unit does not rotate smoothly, replace it. |
| Drive gears are worn or chipped | Check the drive gears between the image drive unit and the drum motor. If one is worn or chipped, replace it. |

Table 6-21 Causes for color misregistration (continued)

| Cause | Solution |
|---------------------------------|---------------------------------|
| Image drive unit is defective | Replace the image drive unit. |
| Laser/scanner unit is defective | Replace the laser/scanner unit. |
| DC controller PCB is defective | Replace the DC controller PCB. |

Smearing

Table 6-22 Causes for smearing

| Cause | Solution |
|--|--|
| Poor contacts exist to each cartridge and printer grounding | Use media that is within specifications. Verify that the proper fuser mode is set. Clean the grounding contacts on each cartridge and the printer. If the problem remains after cleaning, check the contacts for damage. Replace any deformed or damaged parts. Make sure that all contacts are connected correctly. |
| The movement of the fuser front paper sensor lever is not smooth | Reseat the lever to make the movement smooth. |
| Foreign substances or dirt on the fuser inlet guide | Clean the fuser inlet guide. |

Misplaced image

Table 6-23 Causes for a misplaced image

| Cause | Solution |
|--|---|
| The oblique rollers are worn (if problem only occurs on the back side of duplex printing only) | Replace the oblique rollers. |
| DC controller PCB is defective | Replace the DC controller PCB. Calibrate the printer after replacing the DC controller. |

Reversed color

Table 6-24 Causes for reversed color

| Cause | Solution |
|---|--|
| The FFC that connects the DC controller to the formatter is not correctly connected | Reseat the FFC to the DC controller PCB J1001. |
| DC controller PCB is defective | Replace the DC controller PCB. |

Snail tracks

Table 6-25 Causes for snail tracks

| Cause | Solution |
|--|--|
| This occurs in high-temperature, high-humidity environments on the second side of duplexing jobs when the fuser pressure roller is bent. | Use media that is within specifications. Verify that the proper fuser mode is set. See if the defect occurs when printing with light coverage. If so, reduce the toner coverage on the page. Replace the fuser. NOTE: This defect might be seen when using A4 media in duplex mode. |

 **NOTE:** See the print modes in CONFIGURE DEVICE/ PRINT QUALITY/ PRINT MODES to associate each paper type with a specific print mode. For example, several “BEST” print modes can be set for a specific media type to enhance print quality. Results will vary, depending on the media being used.

See the OPTIMIZE setting for additional print-quality adjustments.

Repetitive-defects troubleshooting

Defects on printer rollers can cause image defects to appear at regular intervals on the page. Use [Table 6-26 Causes of repetitive defects on page 223](#) to determine which roller is causing the defect. To resolve the problem, try cleaning the roller. If the roller remains dirty after cleaning or if it is damaged, replace it.

Repetitive defects for the transfer unit normally appear on every other page, because the transfer belt is longer than a page. However, the period of the repetitive defect can vary depending on the type of media, and a repetitive defect can occur more than once on the same page.

CAUTION: Do not use solvents or oils to clean rollers. Instead, use lint-free paper to clean the roller. If dirt is difficult to remove, dampen the paper with rubbing alcohol.

NOTE: Defects on the tray 2 pickup roller or the multipurpose-tray pickup roller do not cause a repetitive defect, but instead cause a defect on the leading edge of the page.

Table 6-26 Causes of repetitive defects

| Problem Area | Period of defect (mm) | Problem | | | |
|-------------------------------|-----------------------|---------------|-------------|--------------|------------|
| | | Dirt on front | Blank spots | Dirt on back | Poor fuser |
| Primary charging roller | About 27 | X | X | | |
| Developing cylinder | About 27 | X | X | | |
| Registration roller (inside) | About 35 | X | | | |
| Registration roller (outside) | About 36 | | | X | |
| Transfer roller | About 44 | | X | X | |
| Fuser sleeve | About 75 | X | X | | X |
| Photosensitive drum | About 76 | X | X | | |
| Fuser pressure roller | About 79 | X | | X | X |

Repetitive print defects are usually caused by a specific roller, cylinder, or drum in the printer or the print cartridge. Use the following figure to isolate the cause of repetitive print defects. Align the first occurrence of the defect with the top of the “ruler” (at the top or bottom of the misprinted page), and measure to the next occurrence of the defect to determine which roller, cylinder, or drum is causing the defect. When the defect pattern matches the pattern of the ruler, replace the indicated part.

Figure 6-2 Repetitive defect ruler

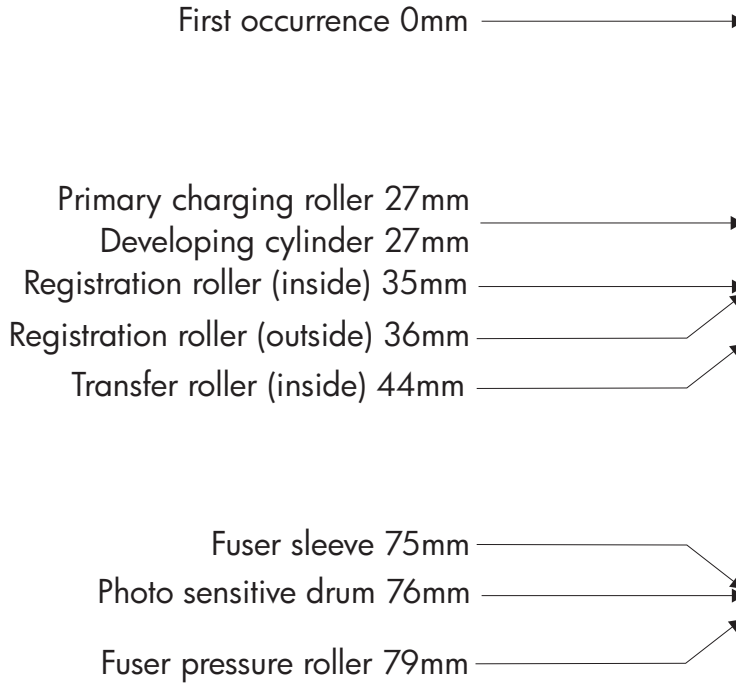

 **NOTE:** Transfer unit defects usually appear on every other page because the transfer belt is longer than a page. However, the defect distance might vary depending on the type of media that is being used. It is possible to see a repetitive defect more than once on the same page.

Interface troubleshooting

Communication checks

 **NOTE:** Communication problems are normally the customer's responsibility. Time spent attempting to resolve these problems might not be covered by the Hewlett-Packard warranty.

Refer the customer to the network administrator for assistance in troubleshooting network problems.

If the printer is *not* connected to an MS-DOS-based host, use the following table to check the connection.

Table 6-27 Communication check

| Check | Action |
|---|---|
| Does the computer configuration match the parameters described in the configuration instructions? | Verify that the configuration of the computer's communications port matches these parameters. View the Jetdirect configuration page for print server status, and to verify configuration parameters for operation on your network. NOTE: If these parameters are not set correctly, an error message might appear on the control panel. |

EIO troubleshooting

If the printer contains an optional HP Jetdirect print server and you cannot communicate with the printer over the network, verify the operation of the print server. Print a configuration page. If the Jetdirect card does not appear under "Installed personalities and options" on the configuration page, see the troubleshooting section of the *HP Jetdirect Print Server Administrators Guide* supplied with the print server.

If the host system and printer still do not communicate, replace the formatter PCB or the EIO card and reconfigure the printer. If the problem persists, use a protocol analyzer to find the source of the problem.

 **CAUTION:** HP LaserJet printers are not designed to work with mechanical switch-box products that do not have surge protection. These devices generate high transient voltages that cause permanent damage to the formatter PCB. This circumstance is not covered under the Hewlett-Packard warranty.

Service menu

Using the Service menu

The **Service** menu is PIN protected for added security. Only authorized service technicians have access to the Service menu. When you select SERVICE from the list of menus, you are prompted to type your 8-digit PIN number. The following are the appropriate PIN numbers:

HP Color LaserJet 3000 Series printers: 11300005

HP Color LaserJet 3600 Series printers: 11360005

HP Color LaserJet 3800 Series printers: 11380005

HP Color LaserJet CP3505 Series printers: 06350507

1. Press **Menu** to open the **MENUS**.
2. Press **▼** to highlight **SERVICE**, and then press **✓**.
3. Press **▲** or **▼** until the first digit of the PIN appears.
4. Press **✓** to save the digit. The control-panel display replaces the digit with an asterisk.
Press **↶** at any time to move to the previous digit.
5. Repeat steps 3 and 4 until all eight digits are typed.

Clear event log

Use this item to clear the printer internal event log.

Total page count

The page count that is stored in NVRAM and printed on the configuration page represents the number of pages that the formatter has formatted (not including engine-test prints). If you install a new formatter when repairing a printer, use this menu item to reset the page count to the previous value. In this way, the page count reflects the number of pages that the engine has printed rather than restarting the count for the new formatter. The page count is in two categories: total mono pages and total color pages.

Serial number

If you replace the formatter, use this item to reset the serial number of the printer.

Diagnostics menu

| Menu item | Description |
|--------------------------------|---|
| PRINT EVENT LOG | Prints an event log that shows the last 50 entries in the printer event log, starting with the most recent. |
| SHOW EVENT LOG | Shows the last 50 printer events on the control-panel display, starting with the most recent. |
| PQ TROUBLESHOOTING | Prints a series of print-quality assessment pages that help troubleshoot many print-quality problems. |
| PRINT DIAGNOSTICS PAGE | Prints the diagnostics page. |
| DISABLE CARTRIDGE CHECK | Prints with one or more cartridges removed so that you can diagnose print cartridge-related problems. |
| PAPER PATH SENSORS | Shows the values of the sensors. Values are updated as media passes each sensor. Jobs can be initiated from the control panel or sent from the computer. |
| PAPER PATH TEST | Tests the printer paper-handling features, such as the configuration of the trays. |
| MANUAL SENSOR TEST | Tests the paper-path sensors and switches for correct operation. |
| COMPONENT TEST | Activates individual parts independently to isolate noise, leaking, and other hardware issues. |
| PRINT/STOP TEST | Isolates print-quality issues more accurately by stopping the printer in mid-print cycle. Stopping the printer in mid-print cycle causes a jam that might need to be removed manually. <i>Only a service representative should perform this test.</i> |

Diagnostics

The following section describes the printer's diagnostics.

LED diagnostics

Use the following procedure to help identify the cause of high-level printer problems. These problems are indicated by abnormalities in the printer's power-on sequence. The LED that the procedure refers to is on the formatter. This is the “heartbeat” LED that blinks on and off when the formatter is operating correctly.

Does the LED blink with four fast bursts at power on? If not, then perform the following checks:

- Check the firmware.
- Check the memory.
- Check the formatter.

Does the LED blink at a fast, steady rate during memory testing (one blink per 8 MB)? If not, then perform the following checks:

- Check the control-panel display for an error code.
- Check the memory.
- Check the formatter.

Is the LED off for about eight seconds, while the boot code is decompressing, before the display turns on? If not, then perform the following checks:

- Check the firmware.
- Check the control-panel display for correct connections and operation.
- Check the control-panel display for an error code.

Does the LED blink at a steady rate of one blink per second? If not, then perform the following checks:

- Check the firmware.
- Check the formatter.
- Check the control-panel display for an error code.

If the control-panel display does not illuminate, perform an engine test to check the engine. You must have media loaded in tray 2 for the engine test.

Diagnostics mode

Some of the diagnostics tests automatically put the printer into a special diagnostics mode. During the special diagnostics mode the printer performs actions that normally cause the printer to enter an error state. Always follow the control panel directions in the **DIAGNOSTICS** menu to exit the special diagnostics mode correctly and return the printer to a normal state.

Diagnostics that put the engine into the special diagnostics mode

Four diagnostics tests put the engine into a special state:

- Disable cartridge check
- Sensor test
- Manual sensor test
- Component test

While the printer is in the special diagnostics mode, the following message should appear:

READY DIAGNOSTICS MODE

TO EXIT PRESS STOP KEY

When the printer is in the special diagnostics mode, these four tests appear in the menu and are available to be run. To gain access into other diagnostic tests or to leave the special state, press **Stop**, and then select **Exit**. The printer resets itself, and then returns to the normal state.

 **NOTE:** You need to have a good understanding of how the printer operates in order to use the engine diagnostics successfully. Before proceeding with these diagnostic tests, make sure that you understand the information in chapter 4 of this manual.

Diagnostic tests

Different tests can be used to isolate different types of issues. For component or noise isolation, you can run the diagnostic test after removing the covers. Removing the covers provides a better view of the areas that are being tested. To operate the printer with the covers removed, the door switch lever (SW1, callout 1) must be depressed (this is the door-closed position).



 **WARNING!** Be careful when performing printer diagnostics to avoid the risk of injury. Only trained service personnel should open and run the diagnostics with the covers removed. Never touch any of the power supplies when the printer is turned on.

Figure 6-3 Door switch and fuser interlock

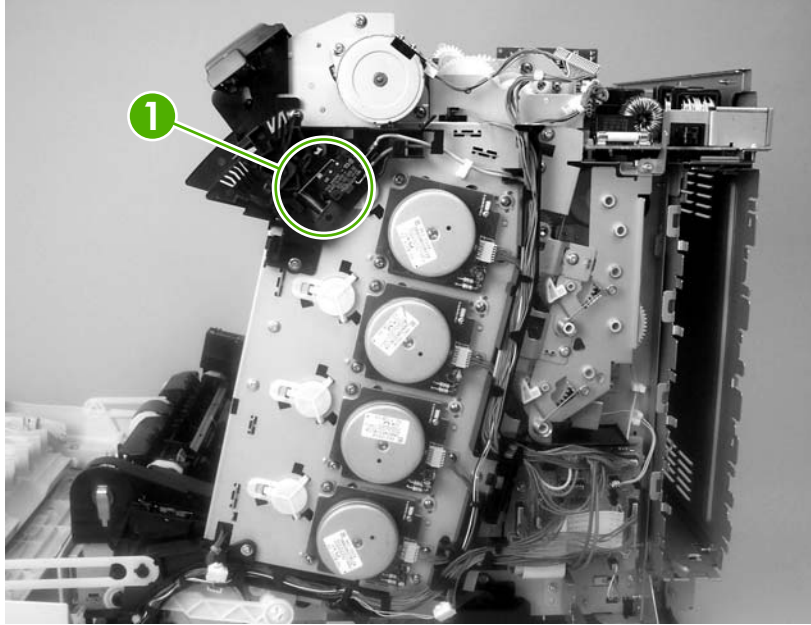

 **NOTE:** Any time that a cartridge is installed or removed while the covers are removed, the door interlock must be cycled to simulate opening and closing the top cover in order for the engine to recognize the change. When the covers are installed, the door switch and fuser interlock are automatically operated. When the covers are removed, you must perform these steps manually.

Individual diagnostic tests

The following sections explain in more detail how to operate the various diagnostics correctly.

Print the event log page

The event log lists the printer events, including jams, service errors, and other printer conditions.

1. Press **Menu** to open the **MENUS**.
2. Press **▼** to highlight **DIAGNOSTICS**, and then press **✓**.
3. Press **▼** to highlight **PRINT EVENT LOG**, and then press **✓**.

The message **Printing... EVENT LOG** appears on the display until the printer finishes printing the event log. The printer returns to the **Ready** state after printing the event log.

View the event log on the control-panel display

The event log lists the last 50 printer events on the control-panel display. (The most recent event is listed first.)

1. Press **Menu** to open the **MENUS**.
2. Press **▼** to highlight **DIAGNOSTICS**, and then press **✓**.
3. Press **▼** to highlight **SHOW EVENT LOG**, and then press **✓**.

Print the print-quality (PQ) troubleshooting pages

The PQ troubleshooting pages are print-quality assessment pages that you can use to troubleshoot print-quality problems. Follow the instructions on the first page of the print-quality troubleshooting pages to solve print-quality problems.

1. Press **Menu** to open the **MENUS**.
2. Press **▼** to highlight **DIAGNOSTICS**, and then press **✓**.
3. Press **▼** to highlight **PQ TROUBLESHOOTING**, and then press **✓**.

The message **PRINTING... PQ TROUBLESHOOTING** appears on the control-panel display until the printer finishes printing the PQ troubleshooting pages. The printer returns to the **Ready** state after printing the PQ troubleshooting pages.

Disable cartridge check (special mode test)

Use this diagnostic test to print internal pages or send an external job to the printer when one or more print cartridges are removed or exchanged. Because the cartridges are not keyed, the diagnostic test can be run when one to four cartridges have been removed or moved to another location (exchanged). Consumable supply errors are ignored while the printer is in this mode.

When the printer is in this mode, you can navigate the menus and print internal pages or send an external print job to the printer. This diagnostic test can be used to isolate print-quality problems that are related to individual cartridges and to isolate individual cartridge problems, such as noise.

 **NOTE:** Any time that a cartridge is installed or removed while the covers are removed, the door interlock must be cycled to simulate opening and closing the top cover in order for the engine to recognize the change. When the covers are installed, the door switch and fuser interlock are automatically operated. When the covers are removed, you must perform these steps manually.

1. Press **Menu** to open the **MENUS**.
2. Press **▼** to highlight **DIAGNOSTICS**, and then press **✓**.
3. Press **▼** to highlight **DISABLE CARTRIDGE CHECK**, and then press **✓**.

To exit this diagnostic test, press **Stop** and then select **EXIT DIAGNOSTICS**.

Paper-path sensor test

This test shows the status of each paper-path sensor.

1. Press **Menu** to open the **MENUS**.
2. Press **▼** to highlight **DIAGNOSTICS**, and then press **✓**.
3. Press **▼** to highlight **PAPER PATH SENSORS**, and then press **✓**.
4. Print an internal page, and observe the status of the sensors as the page moves through the printer.

Paper-path test

This diagnostic test generates one or more test pages that you can use to isolate the cause of jams.

To isolate a problem, specify which input tray to use, specify whether to use the duplex path, and specify the number of copies to print. Print multiple copies to help isolate intermittent problems. The following options become available after you start the diagnostic feature:

- **PRINT TEST PAGE.** Run the paper-path test from the default settings: tray 2, no duplex, and one copy. To specify other settings, scroll down the menu and select the setting, and then scroll back up and select **PRINT TEST PAGE** to start the test.
 - **SOURCE.** Select tray 1, tray 2, or optional tray 3.
 - **DUPLEX.** Enable or disable 2-sided printing.
 - **COPIES.** Select the number of sheets to use during the test.
1. Press **Menu** to open the **MENUS**.
 2. Press **▼** to highlight **DIAGNOSTICS**, and then press **✓**.
 3. Press **▼** to highlight **PAPER PATH TEST**, and then press **✓**.
 4. Select the paper-path test options when the printer prompts you.

Manual sensor test (special mode test)

Use this diagnostic test to test the printer sensors and switches.

 **NOTE:** To eliminate the flickering on the control-panel display during this test, leave the door switch in the open state.

1. Press **Menu** to open the **MENUS**.
2. Press **▼** to highlight **DIAGNOSTICS**, and then press **✓**.
3. Press **▼** to highlight **MANUAL SENSOR TEST**, and then press **✓**.

To exit this diagnostic, press the **Stop** button, and then select **EXIT DIAGNOSTICS**.

Menus cannot be opened during component tests, so **✓** serves the same function as the **Stop** button.

To toggle a sensor, find and move the sensor flags in the following locations.

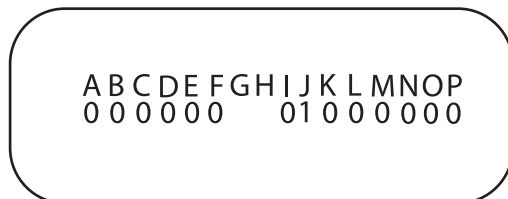

Table 6–28 shows how these letter designations correspond to the paper-path sensors. For a diagram that shows the physical location of these sensors, see [Sensors in the pickup-and-feed system trays \(cassettes\) on page 54](#).

 **NOTE:** Sensor P is only present when the optional 500-sheet feeder is attached.

Table 6-28 Manual sensor test

| | Name | Symbol | Paper-path sensors ¹ | Manual sensor test ¹ |
|---|--------------------|--------|---------------------------------|---------------------------------|
| A | Top-of-page sensor | SR710 | 0 or 1 | 0 or 1 |

Table 6-28 Manual sensor test (continued)

| | Name | Symbol | Paper-path sensors ¹ | Manual sensor test ¹ |
|---|--|--------|----------------------------------|---------------------------------|
| B | Paper loop sensor | SR6001 | 0 or 1 | 0 or 1 |
| C | N/A | N/A | 0 | 0 |
| D | Fuser paper delivery sensor | SR6005 | 0 or 1 | 0 or 1 |
| E | Delivery-tray paper-full sensor | SR706 | 0 or 1 | 0 or 1 |
| F | Fuser pressure-release sensor | SR705 | 0 or 1 | 0 or 1 |
| G | Media sensor | J7007 | 0, 1, 3, 4, 5, 6, 7 ² | N/A |
| H | N/A | N/A | N/A | N/A |
| I | Multipurpose tray paper sensor | SR707 | N/A | 0 or 1 |
| J | Cassette paper sensor | SR709 | N/A | 0 or 1 |
| K | Door open detection switch | SW1 | N/A | 0 or 1 |
| L | Developing estrangement sensor (Yellow, magenta, and cyan) | SR712 | N/A | 0 or 1 |
| M | Developing estrangement sensor (Black) | SR711 | N/A | 0 or 1 |
| N | Multipurpose tray media-position sensor | SR708 | N/A | 0 or 1 |
| O | Duplex reverse sensor | SR823 | 0 or 1 | 0 or 1 |
| P | Paper present sensor | SR4013 | N/A | 0 or 1 |

¹ 0 = off; 1 = on

² 0 = unknown media; 1 = normal media; 3 = overhead transparency; 4 = glossy; 5 = glossy film; 6 = heavy media; 7 = light media

Component test (special mode test)

Use the component test to exercise individual parts independently to isolate problems.

Each component test can be performed once or repeatedly. If **CONTINUOUS** is selected from the drop-down menu as the repeat option, the test will cycle the component on and off. This process continues for 2 minutes, and then the test ends.



NOTE: The door interlock switch must be defeated to run any of the component tests. If covers are removed, the door switch must be manually cycled during some tests in order for the engine to recognize a change. The ETB assembly can be open, closed, or removed while some of these tests are executing. Print cartridges can be installed or removed during certain tests. The control-panel display prompts for the removal of some or all of the cartridges during certain tests in order to rotate and isolate certain components, and to protect the cartridges and ETB.

1. Press **Menu** to open the **MENUS**.
2. Press **▼** to highlight **DIAGNOSTICS**, and then press **✓**.
3. Press **▼** to highlight **COMPONENT TEST**, and then press **✓**.
4. Select the component test options when the printer prompts you.

Menus cannot be opened during component tests, so **✓** serves the same function as the **Stop** button.

You can perform the following component tests:

- **Transfer motors.** This test turns the components that are involved in the image-transfer process: the cartridge motors, the ETB motor and belt, and the print cartridges (if the ETB is closed). You can remove or install print cartridges during this test.
- **Belt only.** This test turns only the ETB motor and belt. The control-panel display prompts you to remove the cartridges because the ETB belt contacts the photosensitive drums and cannot turn without them also rotating the drums. Rotating the photosensitive drums can damage the belt or photosensitive drums. If covers are removed, you must manually activate the door switch after removing the cartridges in order to run the test.
- **Cartridge motors.** This test rotates only the print-cartridge drive motors. The control-panel display prompts you to remove at least one cartridge because the ETB belt contacts the photosensitive drums and cannot turn without also rotating the drums. The engine rotates the cartridge motor(s) for only the cartridges that are removed. To rotate all motors sequentially, remove all of the cartridges; to isolate one motor, remove only that cartridge. If covers are removed, you must manually activate the door switch after removing the cartridges in order to perform the test. Always start this test with all of the cartridges installed, and activate the door switch so that the printer recognizes the configuration. Then you can proceed with the test by removing one or more cartridges.
- **Black, Magenta, Yellow, Cyan laser/scanners.** Use these tests to rotate each scanner motor individually.
- **Fuser motor.** Use this test to rotate the fuser motor and drive gears.
- **Fuser pressure release motor.** Use this test to rotate the fuser pressure-release motor.
- **Alienation motor (also called the developing disengaging motor).** This test moves the developing disengaging motor, clutches and gears, and plates through their positions.
- **ETB contact/alienation.** This test activates the ETB motors and solenoid.
- **Tray 1 pickup solenoid.** This test activates and releases the multipurpose tray (tray 1) pickup solenoid.
- **Tray 2 pickup motor.** This test activates and moves the tray 2 pickup motor and gear train.
- **Tray 2 pickup solenoid.** This test activates and releases the tray 2 pickup solenoid.

- **Tray 3 pickup motors and solenoids.** These tests run the same way as the tray 2 pickup motor and solenoid test.

 **NOTE:** You must have the tray partially installed or must manually lift the pickup roller assembly/lifter plate.

- **Duplexer pickup motor.** This test activates and moves the duplexer pickup motor.

Print/Stop test

Use this diagnostic test to isolate the cause of problems such as image-formation defects and jams in the engine. During this test you can stop the paper anywhere along the printer paper path. The test can be programmed to stop printing internal pages or an external print job when the paper reaches a certain position. The test can also be programmed to stop from 0 to 60,000 mS. If the timer is set to a value that is greater than the job print time, you can recover the printer the following ways:

- After the print job is complete, press **Stop** to return to the **DIAGNOSTICS** menu before the timer times out.
- After the timer times out, press **Stop**. Activate the door switch to restart the engine and return it to a normal state.

When the timer trips, the message **Printing stopped Press ✓ to continue** appears on the control-panel display. Press **Menu** to print the previously selected job. If you do not want the previous job to print, press **Stop** and then press **Menu**.

 **NOTE:** Do not attempt to perform a **Print/Stop test** while the printer is calibrating because you will be required to turn the printer off and then on again. If a jam message appears on the control-panel display during testing, activate the door switch.

Test pages

Engine test page

Print an engine test page to make sure that the printer is functioning. Use a small, pointed object to depress the test-page switch on the back of the printer.

Figure 6-4 Engine test page



Formatter test

Print a configuration page to make sure that the formatter is functioning.

1. Press **Menu** to open the **MENUS**.
2. Press **▼** to highlight **INFORMATION**, and then press **✓**.
3. Press **▼** to highlight **PRINT CONFIGURATION**, and then press **✓**.

Half-self test

Perform a half-self test to determine which stage of the print process is malfunctioning.

1. Press **Menu**.
2. Press **▼** to highlight **INFORMATION**, and then press **✓**.
3. Press **▼** to highlight **PRINT DEMO**, and then press **✓** to print a demo page.
4. Open the front cover when the leading edge of the paper exits the printer.
5. Remove the print cartridges.
6. Open the print-cartridge drum shield to view the drum surface. If a dark and distinct toner image is present on the drum surface, then the two functions of the electrophotographic process are

functioning (image-formation and development). Any failure is occurring in the transfer or fusing stage.

Drum-rotation test

The photosensitive drum, located in the print cartridge, must rotate in order for the print process to work. The photosensitive drum receives its drive from the main motor through a system of gears on the right side of the printer.

 **NOTE:** This test is especially important if refilled print cartridges have been used.

1. Open the front door.
2. Remove the print cartridges.
3. Mark the drive gear on the cartridge with a felt-tipped marker. Make note of the position of the mark.
4. Install the print cartridges and close the front door. The startup sequence should rotate the drum enough to move the mark.
5. Open the front door and inspect the gear that was marked in step 3. Verify that the mark moved.

If the mark did not move, inspect the drive shaft that moves into the print-cartridge area when the front door is closed to make sure that it is meshing with the print cartridge. If the drive shaft looks functional and the drum does not move, then replace the print cartridge. If the drive shaft is damaged, then replace the printer.

Engine resets

Use the following information to perform system-wide reset procedures. Customers do not have access to this information.

Engine resets



Cold reset

A cold reset unlocks menus that have been previously locked and resets all control-panel menu items to the factory defaults. A cold reset does *not* clear the values in the Service menu, such as the serial number and the page counts.

 **NOTE:** Before performing a cold reset, print a menu map and a configuration page. Use the information on these pages to reset customer-specific settings.

 **CAUTION:** All HP Jetdirect settings are also reset. Be sure to print a configuration page before performing a cold reset. Make note of the IP address that is listed on the Jetdirect configuration page. You might need to restore the IP address after performing a cold reset.

To perform a cold reset

1. Turn the printer off and then on.
2. When the printer begins its initialization sequence, press and hold  until all LEDs are lit.
3. Press  until **COLD RESET** appears, and then press .

NVRAM initialization





 **CAUTION:** All HP Jetdirect settings are also reset. Be sure to print a configuration page before performing an NVRAM initialization. Make note of the IP address that is listed on the Jetdirect configuration page. You need to restore the IP address after performing an NVRAM initialization.

Performing an NVRAM initialization resets the following settings and information:

- All menu settings are reset to factory default values.
- All localization settings, including language and country/region, are reset.

After performing an NVRAM initialization, reconfigure any computers that print to this printer so that the computers can recognize the printer.

To perform an NVRAM initialization



1. Turn the printer off and then on.
2. When the printer begins its initialization sequence, press and hold  until all LEDs are lit.
3. Press  one time, and then press **Menu**.
4. Press  until **NVRAM INIT** appears, and then press .

Hard-disk initialization

A hard-disk initialization erases and reformats the hard disk. Perform a hard-disk initialization only if an error message on the control panel indicates a disk error. Always try initializing the hard disk before replacing it.

 **NOTE:** Before performing a hard-disk initialization, print a menu map and a configuration page. Use the information on these pages to reset any customer-specific settings.

To perform a hard-disk initialization

1. Turn the printer off and then on.
2. When the printer begins its initialization sequence, press and hold **Menu** until all LEDs are lit.
3. Press  one time. **INITIALIZE DISK** appears on the control-panel display.
4. Press  one time. A series of asterisks appears on the control-panel display. Wait for the printer to complete its initialization sequence.

Service ID

When printing from an HP Color LaserJet 3000/3600/3800/CP3505 Series printer, this information appears on the configuration page, which eliminates the need for customers to keep paper receipts for proof of the warranty. Because the printer has an internal clock, the availability of the service ID date depends on the printer being connected to a source that can provide the date, in this case a time server that is on the same network as the printer. When the printer is not connected to a date source, the service ID is not available, and **00000** appears on the configuration page.

Converting the Service ID to an actual date

You can use the printer Service ID number to determine whether the printer is still under warranty. Use the following procedure to convert the Service ID into the installation date.

1. Add 1990 to YY to determine the actual year that the printer was installed.
2. Divide DDD by 30 (and, if there is a remainder, add 1 to the quotient) to determine the month the printer was installed.
3. The remainder from the calculation in step 2 is the day of the month. If no remainder resulted from the calculation in step 2, then the day of the month is the 30th.

Using the Service ID 12287 as an example, the date conversion is as follows:

1. $12 + 1990 = 2002$, so the year is 2002.
2. $287 \div 30 = 9$ with a remainder of 17. Add 1 to 9 to get 10, so the month is October.
3. The remainder (from the above calculation) is 17, so that is the day of the month.
4. The complete date is 17-October-2002.

A 6-day grace period is built into the date system.

Restoring the Service ID

If you replace the formatter, the Service ID is lost and must be restored. Use this menu item to reset the Service ID, which is calculated based on the date the printer was first used. The date format is YYDDD. Use the following procedure to calculate the Service ID.

1. To calculate YY, subtract 1990 from the calendar year.
2. To calculate DDD, use the following formula: $30 * (\text{calendar month} - 1) + \text{calendar day} = \text{DDD}$. (If the calendar day is 31, use 30 instead.)

Using October 17, 2002, as the date the printer was first used, the service ID conversion is as follows:

- a. $2002 \text{ minus } 1990 = 12$, so YY = 12.
- b. $10 \text{ minus } 1 \text{ (calendar month minus } 1) = 9$.
- c. $9 \text{ times } 30 = 270$.
- d. $270 \text{ plus } 17 \text{ (the calendar day)} = 287$, so DDD = 287.
- e. The complete service ID number is 12287.

Troubleshooting diagrams

The diagrams in this section include connector locations, DC controller connectors, major assembly locations, printer timing, and printed circuit block diagrams.

Connector locations

Use these diagrams to identify connector locations.

Figure 6-5 Printer connector locations

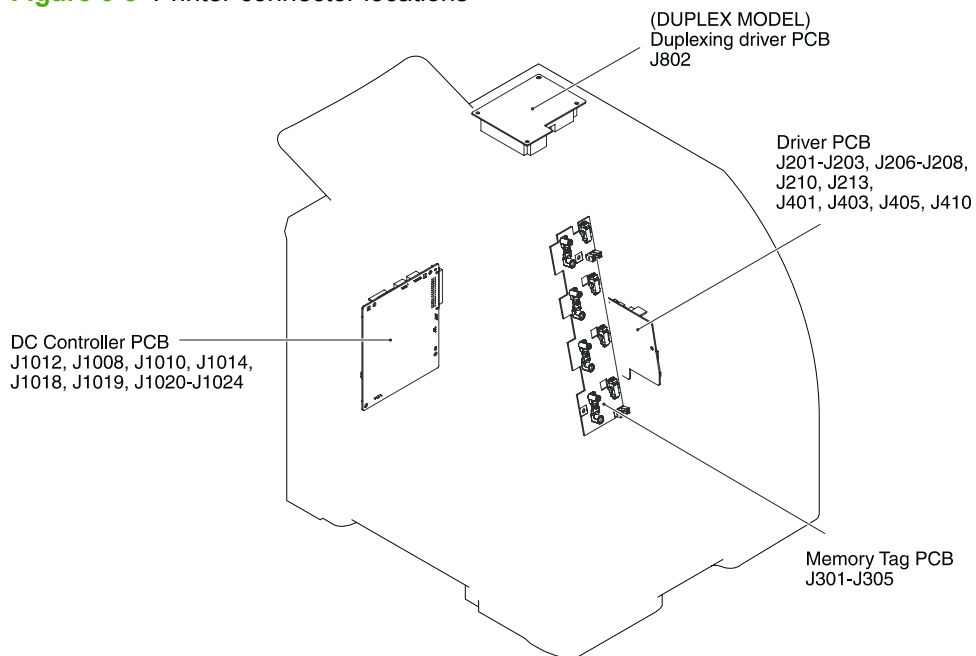
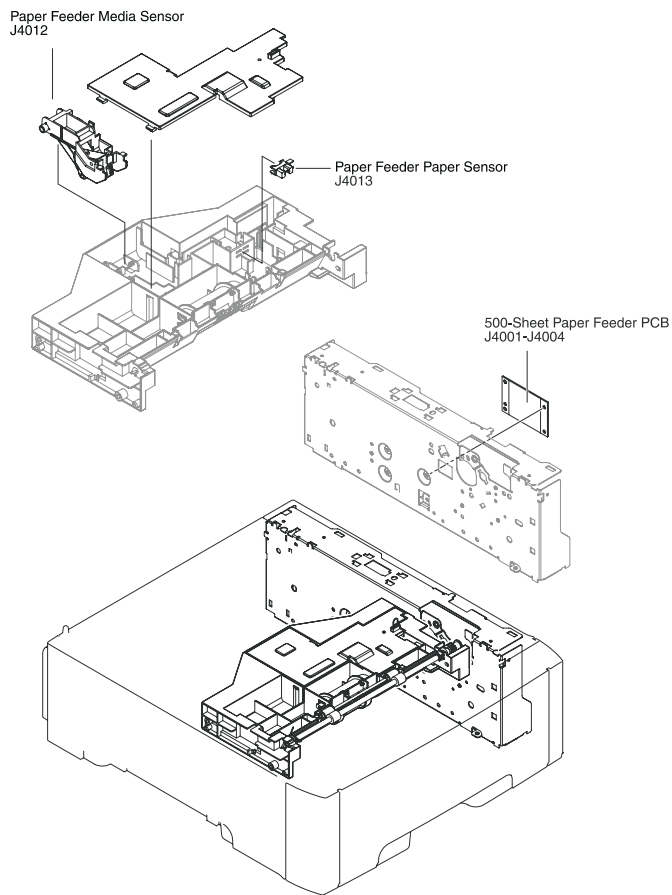

Figure 6-6 500-sheet tray connector locations



Major assemblies

Use this diagram to identify major assemblies in the printer.

Figure 6-7 Major assemblies (1 of 5)

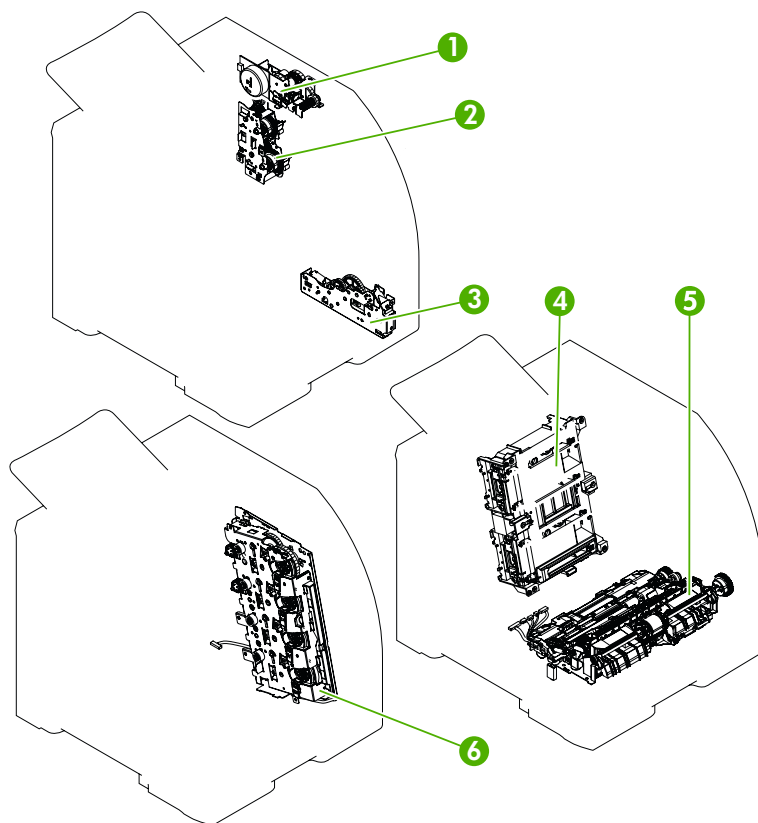

1. Fuser drive assembly
2. Developing-separation drive assembly
3. Pickup drive assembly
4. Laser/scanner assembly
5. Pickup-and-feed assembly
6. Main drive assembly

Figure 6-8 Major assemblies (2 of 5)

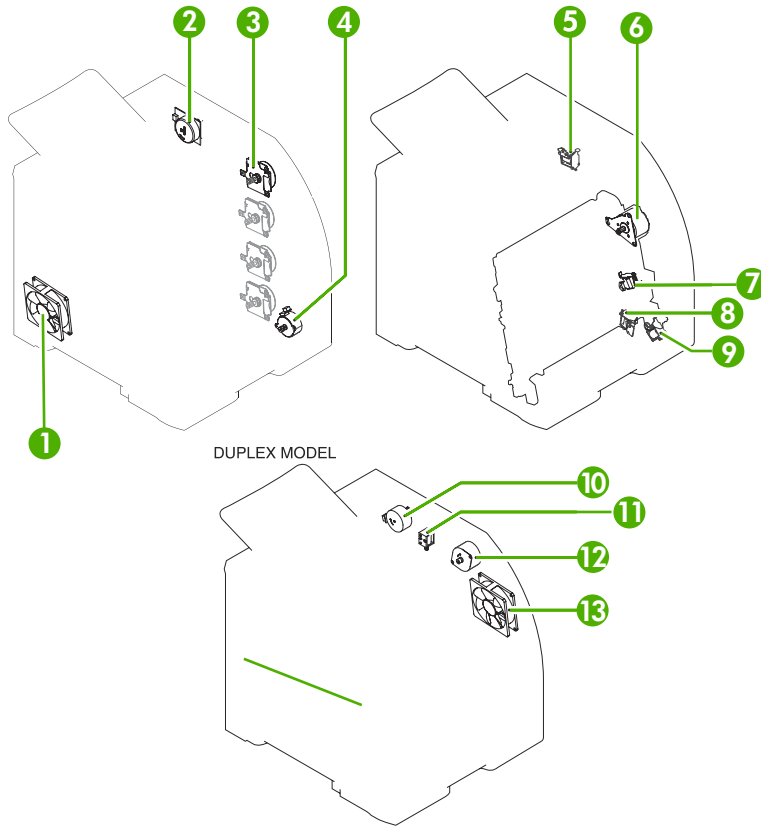

1. Main fan
2. Fuser drive motor
3. Print cartridge drive motors (M6, M7, M8, M9)
4. Pickup-and-feed motor (M4)
5. Developing separation solenoids (SL5014 and SL5015)
6. ETB drive motor (M5)
7. Developing separation solenoid (SL5011)
8. Cassette pickup solenoid (SL5012)
9. Multipurpose tray pickup solenoid (SL5013)
10. Duplex reverse-drive motor
11. Duplex flapper solenoid (SL10)
12. Duplex-feed-drive motor (M11)
13. Door fan (duplex models only)

Figure 6-9 Major assemblies (3 of 5)

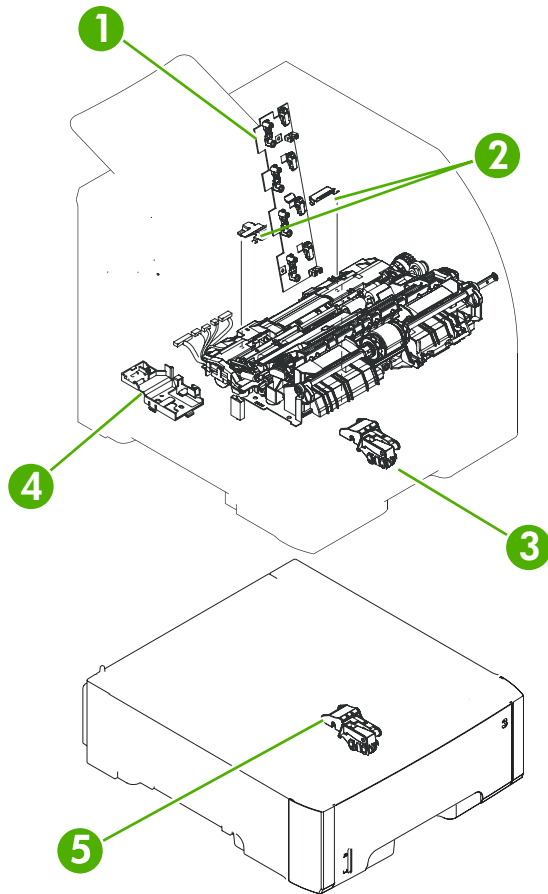

1. Cartridge sensor assembly
2. Paper and registration sensor covers
3. Cassette media sensor (HP Color LaserJet 3600, 3800, and CP3505 only)
4. Temperature sensor
5. Media sensor assembly (500-sheet feeder)

Figure 6-10 Major assemblies (4 of 5)

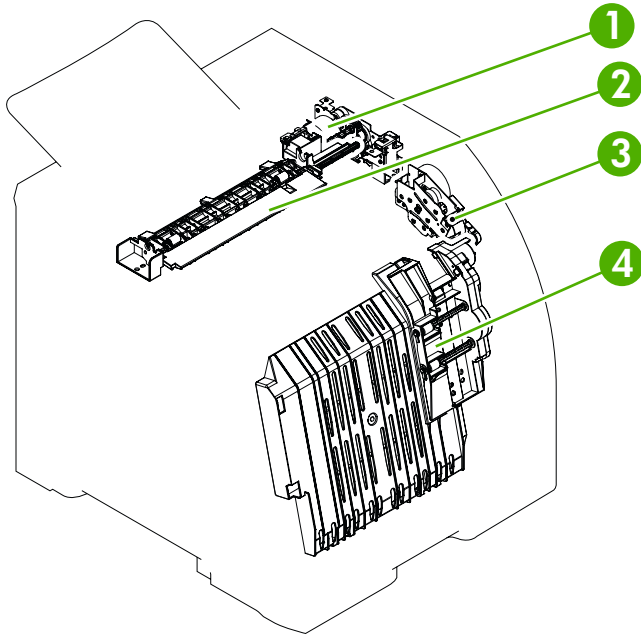

1. Duplex-reverse-drive assembly
2. Duplex-delivery-drive assembly
3. Duplex-feed-drive assembly
4. Position guide and duplex paper-feed assemblies

Figure 6-11 Major assemblies (5 of 5)

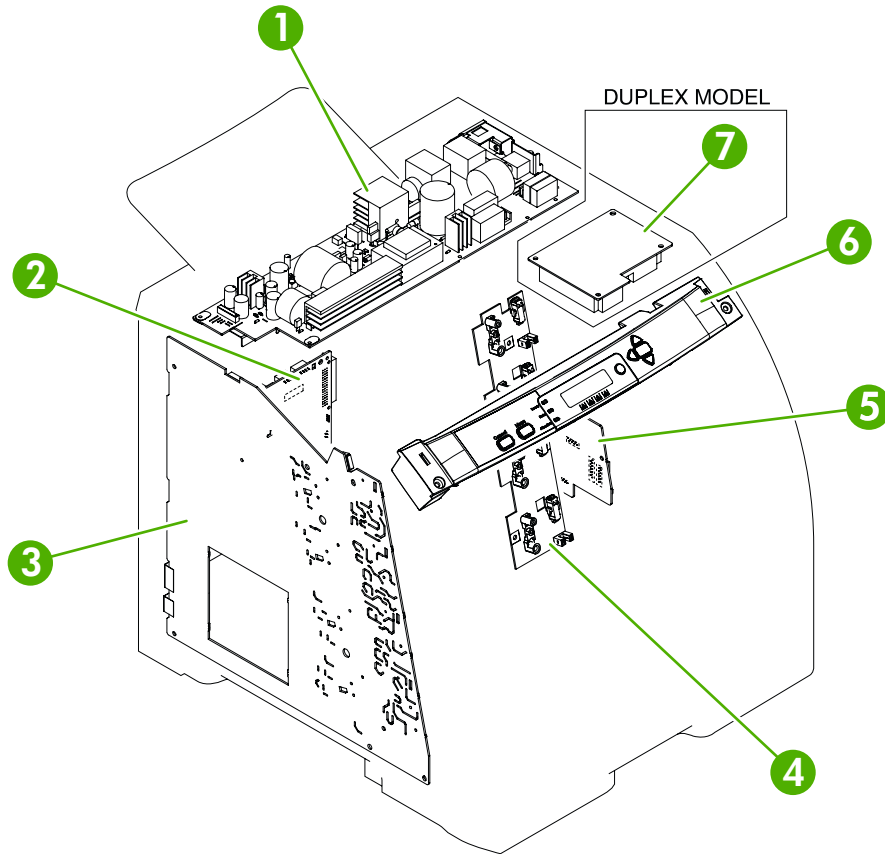

1. Low-voltage power supply
2. DC controller PCA
3. High-voltage power supply
4. Memory-controller PCA
5. Driver PCA
6. Control panel
7. Duplex-driver PCA

DC controller connectors

This diagram shows the connectors on the DC controller PCA.

Figure 6-12 DC controller connectors

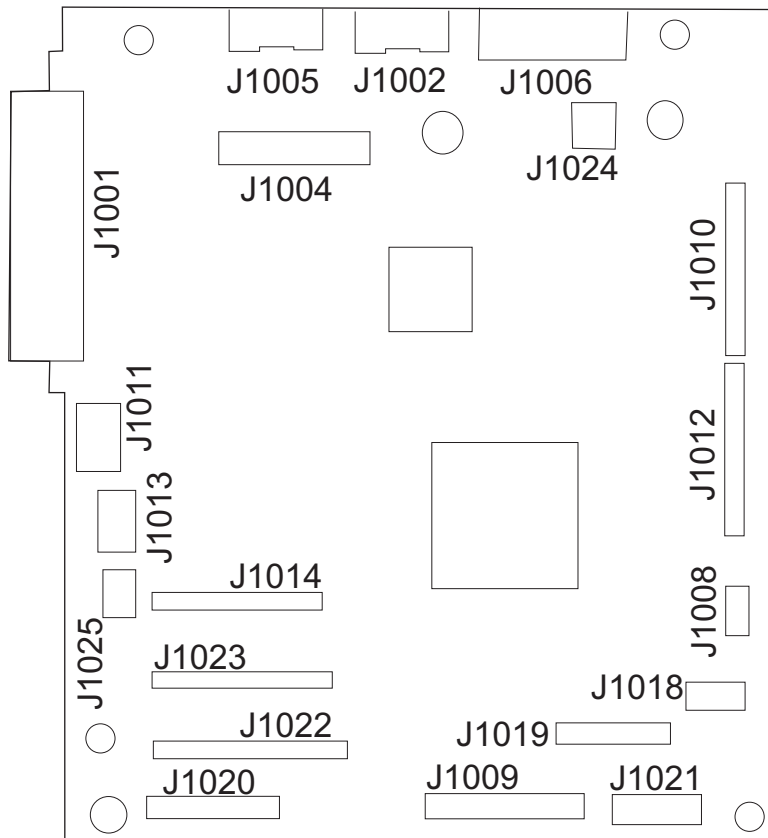

Timing diagram

Figure 6-13 Timing diagram (HP LaserJet 3000/3800/CP3505)

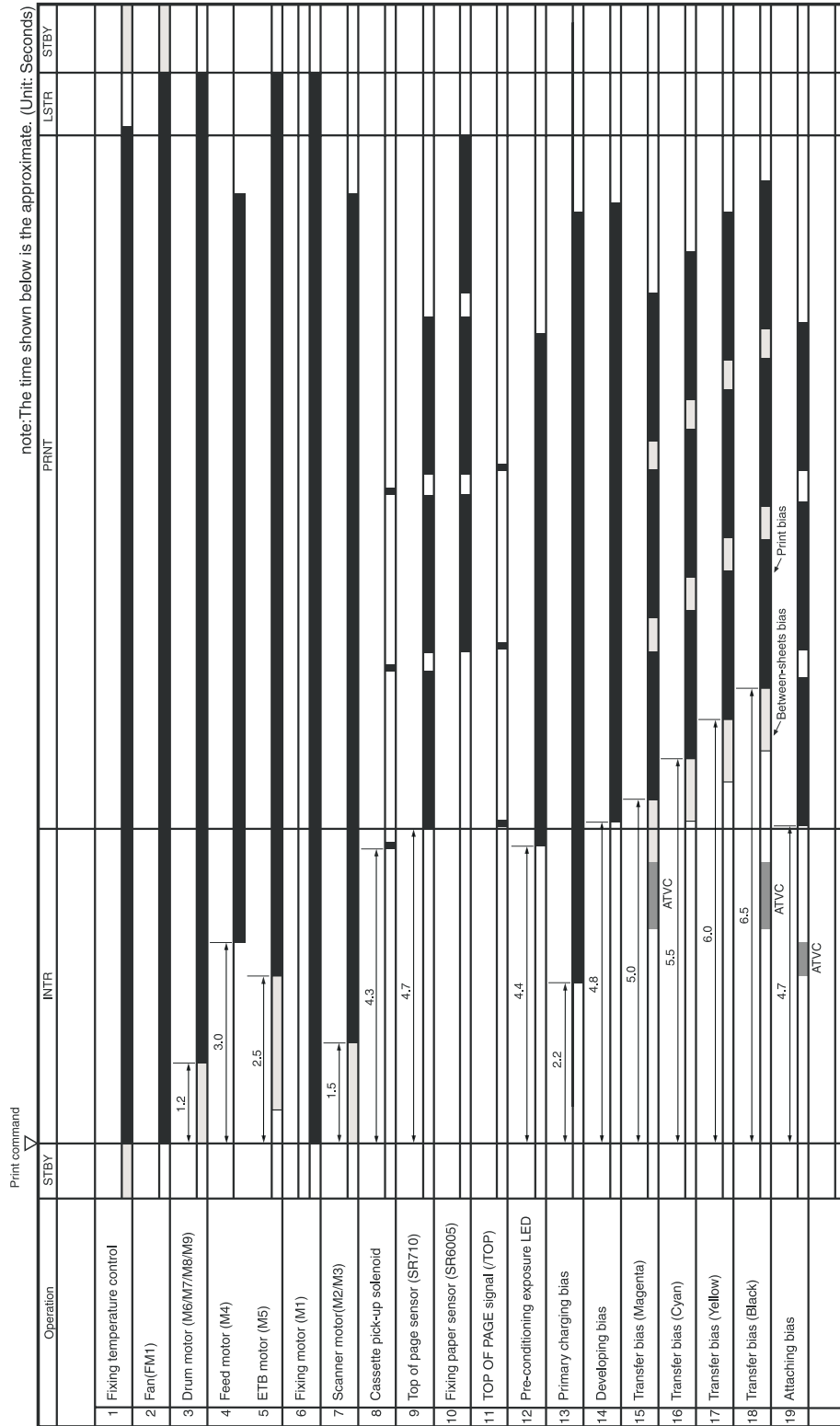

• Timing chart for three consecutive prints on LTR paper (Full-color 1/1 speed mode)

Figure 16-16 General circuit diagram (2 of 2)

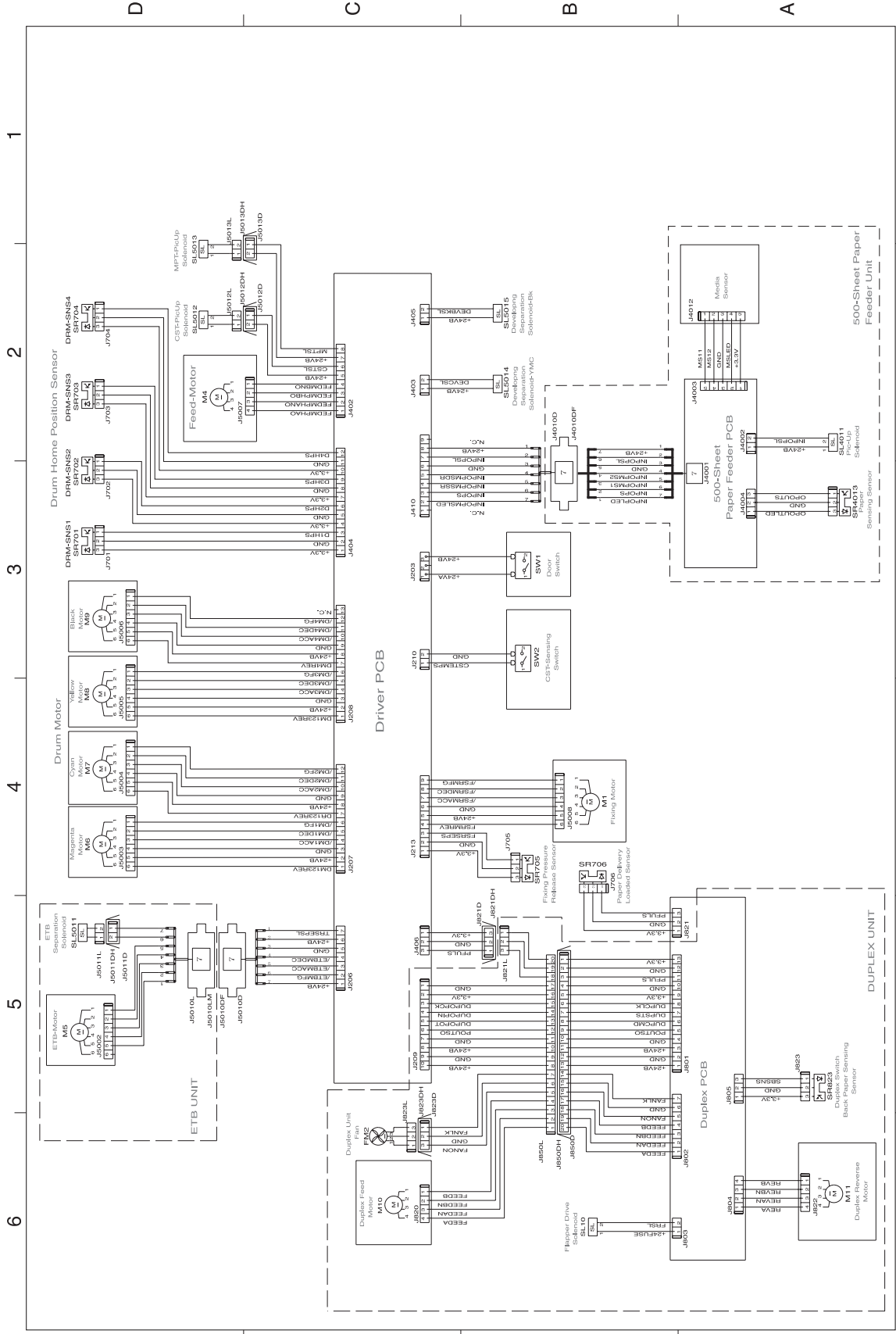

7 Parts and diagrams

- [Ordering parts and supplies](#)
- [External panels and covers](#)
- [Internal components](#)
- [Paper-pickup drive assembly](#)
- [Duplexing-feed drive assembly \(duplex models\)](#)
- [Duplexing reverse-drive assembly \(duplex models\)](#)
- [Developing separation-drive assembly](#)
- [Fuser drive assembly](#)
- [Cassette \(tray 2\)](#)
- [Paper-pickup assembly \(HP CLJ 3600/3800/CP3505\)](#)
- [Paper-pickup assembly \(HP CLJ 3000\)](#)
- [Electronic transfer belt \(simplex models\)](#)
- [Electronic transfer belt \(duplex models\)](#)
- [Multipurpose tray assembly \(tray 1\)](#)
- [Duplex-paper feed assembly \(duplex models\)](#)
- [Fuser](#)
- [PCAs](#)
- [500-sheet feeder cassette \(tray 3\)](#)
- [500-sheet feeder paper-pickup assembly](#)
- [500-sheet feeder PCA](#)
- [Alphabetical parts list](#)
- [Numerical parts list](#)

Ordering parts and supplies

This section describes Web resources for ordering parts and for technical support and resources for ordering related documentation and software.

Parts

Order replacement parts from the following Web sites:

- http://www.hp.com/ssg/parts/direct_order.html
- HP Parts Store: <http://www.hp.com/buy/parts>
- Partsurfer: <http://partsurfer.hp.com>
- HP Parts Portal: <http://www.hp.com/go/HPparts>



How to use the parts lists and diagrams

The figures in this chapter show the major subassemblies in the printer and their component parts. A parts list table follows each exploded-view assembly diagram. Each table lists the item number, the associated part number, and the description of each part. If a part is not listed in the table, then it is not a field replacement unit (FRU).

△ **CAUTION:** Be sure to order the correct part. When looking for part numbers for electrical components, pay careful attention to the voltage that is listed in the description column to ensure that the part number selected is for the correct printer model.

📄 **NOTE:** In this manual, the abbreviation “PCA” stands for “printed circuit board assembly.” components described as a PCA might consist of a single circuit board or a circuit board plus other parts, such as cables and sensors.

Types of screws

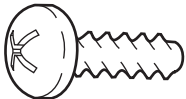
| Illustration | Description | Size | Part Number | Use |
|---|----------------------------|---------------|----------------|---|
|  | Screw w/washer | M3X8 | XA9-1420-000CN | Used to secure metal components to metal components (for example, a ground wire to the frame) |
|  | Screw, RS | M3X6 M3X10 | XA9-1499-000CN | Used to secure metal to metal |
|  | Screw, tapping, truss head | M4X10 | XB4-7401-000CN | Used to secure anything to plastic |

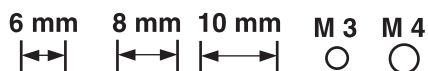

Related documentation and software

Table 7-1 Technical support Web sites

| | |
|--|---|
| HP Customer Care Online | http://www.hp.com/go/support |
| Software drivers, support documentation, and answers to frequently asked questions | |
| HP Technical Training (North America) | http://www.hp.com/go/resellertraining |
| Classes and schedules | |

Accessories and supplies

Table 7-2 Accessories and supplies

| Item | Part number | Service/exchange number | Description |
|---|---------------------------|-------------------------|------------------------------------|
| Memory (DIMMs) | Q7721A | Q7721-67951 | Synchronous 128 MB DDR SDRAM DIMM |
| (HP Color LaserJet 3000/3800 Series only) | Q7722A | Q7722-67951 | Synchronous 256 MB DDR SDRAM DIMM |
| | Q7723A | Q7723-67951 | Synchronous 512 MB DDR SDRAM DIMM |
| | CC409A | | Synchronous 128 MB DDR2 SDRAM DIMM |
| Memory (DIMMs) CP3505 Series printers only | CC410A | | Synchronous 256 MB DDR2 SDRAM DIMM |
| | CC411A | | Synchronous 512 MB DDR2 SDRAM DIMM |
| | CC412A | | Synchronous 1 GB DDR2 SDRAM DIMM |
| | 500-sheet feeder (tray 3) | Q5985A | Q5985-67901 |

Table 7-2 Accessories and supplies (continued)

| Item | Part number | Service/exchange number | Description |
|--|-------------|-------------------------|---|
| Internal (EIO) connectivity for the HP Color LaserJet 3000, 3800, and CP3505 Series printers | J6073A | | HP EIO high-performance hard disk |
| | J7989G | | HP Jetdirect 620n print server (10/100-TX Ethernet) |
| | J7960A | | HP Jetdirect 625n print server (10/100/1000T Ethernet) |
| | J7961A | | HP Jetdirect 635n IPv6/IPsec/Gigabit print server |
| | J7972G | | HP 1284 parallel card |
| | J7988G | | HP Jetdirect en1700 USB 2.0 print server |
| | J7942A | | HP Jetdirect en3700 print server (fast Ethernet, 10/100-TX, USB 2.0) |
| Printer supplies for the HP Color LaserJet 3000 Series printer | J7951A | | HP Jetdirect ew2400 wired/wireless print server (fast Ethernet, value feature set, USB 2.0) |
| | Q7560A | Q7560-67901 | Black print cartridge |
| | Q7561A | Q7561-67901 | Cyan print cartridge |
| | Q7562A | Q7562-67901 | Yellow print cartridge |
| Printer supplies for the HP Color LaserJet 3600 Series printer | Q7563A | Q7563-67901 | Magenta print cartridge |
| | Q6470A | Q6470-67901 | Black print cartridge |
| | Q6471A | Q6471-67901 | Cyan print cartridge |
| | Q6472A | Q6472-67901 | Yellow print cartridge |
| Printer supplies for the HP Color LaserJet 3800 and CP3505 Series printers | Q6473A | Q6473-67901 | Magenta print cartridge |
| | Q6470A | Q6470-67901 | Black print cartridge |
| | Q7581A | Q7581-67901 | Cyan print cartridge |
| | Q7582A | Q7582-67901 | Yellow print cartridge |
| Cable | Q7583A | Q7583-67901 | Magenta print cartridge |
| | C6518A | | USB 2.0 printer cable (2-meter [6.5-foot] standard) |

Table 7-2 Accessories and supplies (continued)

| Item | Part number | Service/exchange number | Description | |
|---------------------------------------|---|-------------------------|---|---|
| Media | C2934A | | 50 sheets HP Color LaserJet Transparencies (letter) | |
| | C2936A | | 50 sheets HP Color LaserJet Transparencies (A4) | |
| | Q2419A | | 50 sheets HP LaserJet High Gloss paper (letter) | |
| | C4179A | | 200 sheets HP LaserJet High Gloss paper (letter) | |
| | C4179B | | 200 sheets HP LaserJet High Gloss paper (A4) | |
| | Q1298A | | HP LaserJet Tough paper (letter) | |
| | Q1298B | | HP LaserJet Tough paper (A4) | |
| | HPU1132 | | HP Premium Choice LaserJet paper (letter) | |
| | CHP410 | | HP Premium Choice LaserJet paper (A4) | |
| | HPJ1124 | | HP LaserJet paper (letter) | |
| | CHP310 | | HP LaserJet paper (A4) | |
| | Reference, service, and training materials | 5851-1468 | | <i>HP LaserJet Printer Family Print Media Specification Guide</i> |
| | | 5021-0337 | | <i>PCL/PLJ Technical Reference Package</i> For downloadable versions, go to http://www.hp.com/ support/clj3000 , http://www.hp.com/ support/ clj3600 , http://www.hp.com/ support/clj3800 , or http://www.hp.com/ support/ cljcp3505 . When connected, select Manuals . |
| Assembly, service, and training CD | | Q5982-60114 | CD based service and training information (English) | |
| Service manual (this manual) | | Q5982-90970 | Printed copy of this manual | |

Table 7-2 Accessories and supplies (continued)

| Item | Part number | Service/exchange number | Description |
|--|-------------|-------------------------|---|
| Control-panel overlays (HP Color LaserJet 3000 Series only) | | Q7533-60112 | German, French, Italian |
| | | Q7533-60113 | Spanish, Dutch, Portuguese, Catalan |
| | | Q7533-60114 | Finnish, Norwegian, Swedish, Slovak |
| | | Q7533-60115 | Czech, Hungarian, Polish |
| Control-panel overlays (HP Color LaserJet 3600/3800/CP3505 Series only) | | Q5982-60107 | French, Spanish, Portuguese |
| | | Q5982-60108 | German, French, Italian |
| | | Q5982-60109 | Spanish, Dutch, Portuguese, Catalan |
| | | Q5982-60110 | Finnish, Norwegian, Swedish, Slovak |
| | | Q5982-60111 | Czech, Hungarian, Polish |
| Formatter | Q5982-67907 | | base and N models (new) |
| HP Color LaserJet 3000 Series | | Q5982-69001 | base and N models (exchange) |
| | Q5982-67908 | | DN and DTN models (new) |
| | | Q5982-69002 | DN and DTN models (exchange) |
| Formatter | Q5982-67907 | | base and N models (new) |
| HP Color LaserJet 3800 Series | | Q5982-69001 | base and N models (exchange) |
| | Q5982-67908 | | DN and DTN models (new) |
| | | Q5982-69002 | DN and DTN models (exchange) |
| Formatter | CB441-67901 | | new |
| HP Color LaserJet CP3505 Series | | CB441-69001 | exchange |
| I controller (formatter) HP Color LaserJet 3600 Series only | Q5987-67903 | | I controller |
| Power cord | 8120-5301 | | Power cord, OPT-903 3-COND 1.9-M-LG ROHS (110v) |

External panels and covers

Figure 7-1 External panels and covers (1 of 2)

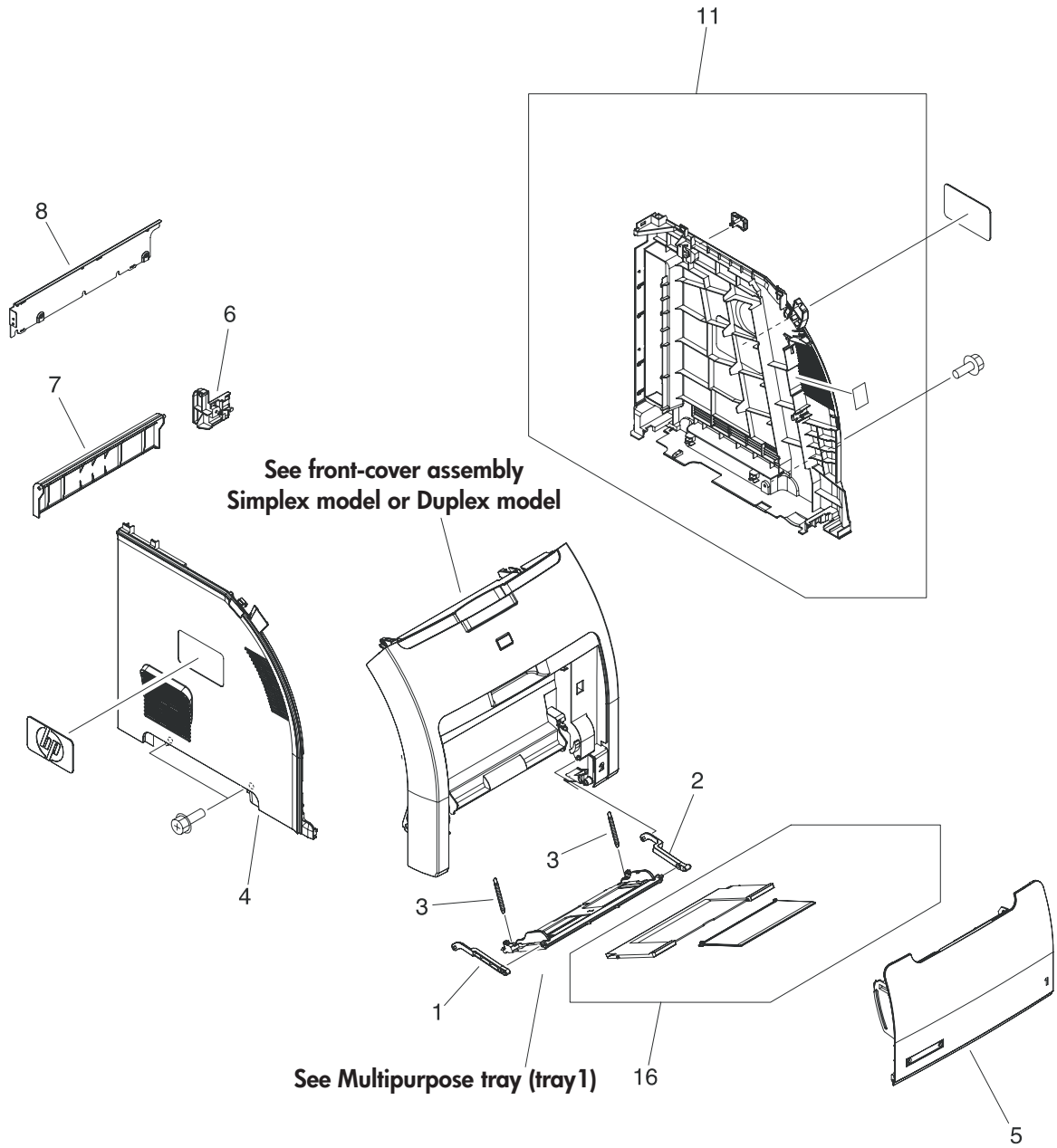

Table 7-3 External panels and covers (1 of 2)

| Ref | Description | Part number | Qty |
|------------|--|--------------------|------------|
| 1 | Link, multipurpose tray (tray 1) hinge left | RC1-6381-000CN | 1 |
| 2 | Link, multipurpose tray (tray 1) hinge right | RC1-6382-000CN | 1 |
| 3 | Spring, tension | RC1-6383-000CN | 2 |
| 4 | Cover, left | RC1-6687-000CN | 1 |
| 5 | Cover, multipurpose tray (tray 1) | RC1-6690-000CN | 1 |
| 6 | Cover, cassette rear right (hinge) | RC1-6691-000CN | 1 |
| 7 | Cover, cassette rear left | RC1-6792-000CN | 1 |
| 8 | Cover, rear lower | RC1-7550-000CN | 1 |
| 11 | Cover, right | RM1-2669-000CN | 1 |
| 16 | Multipurpose tray (tray 1) extension tray assembly | RM1-2710-000CN | 1 |

Figure 7-2 External panels and covers (2 of 2)

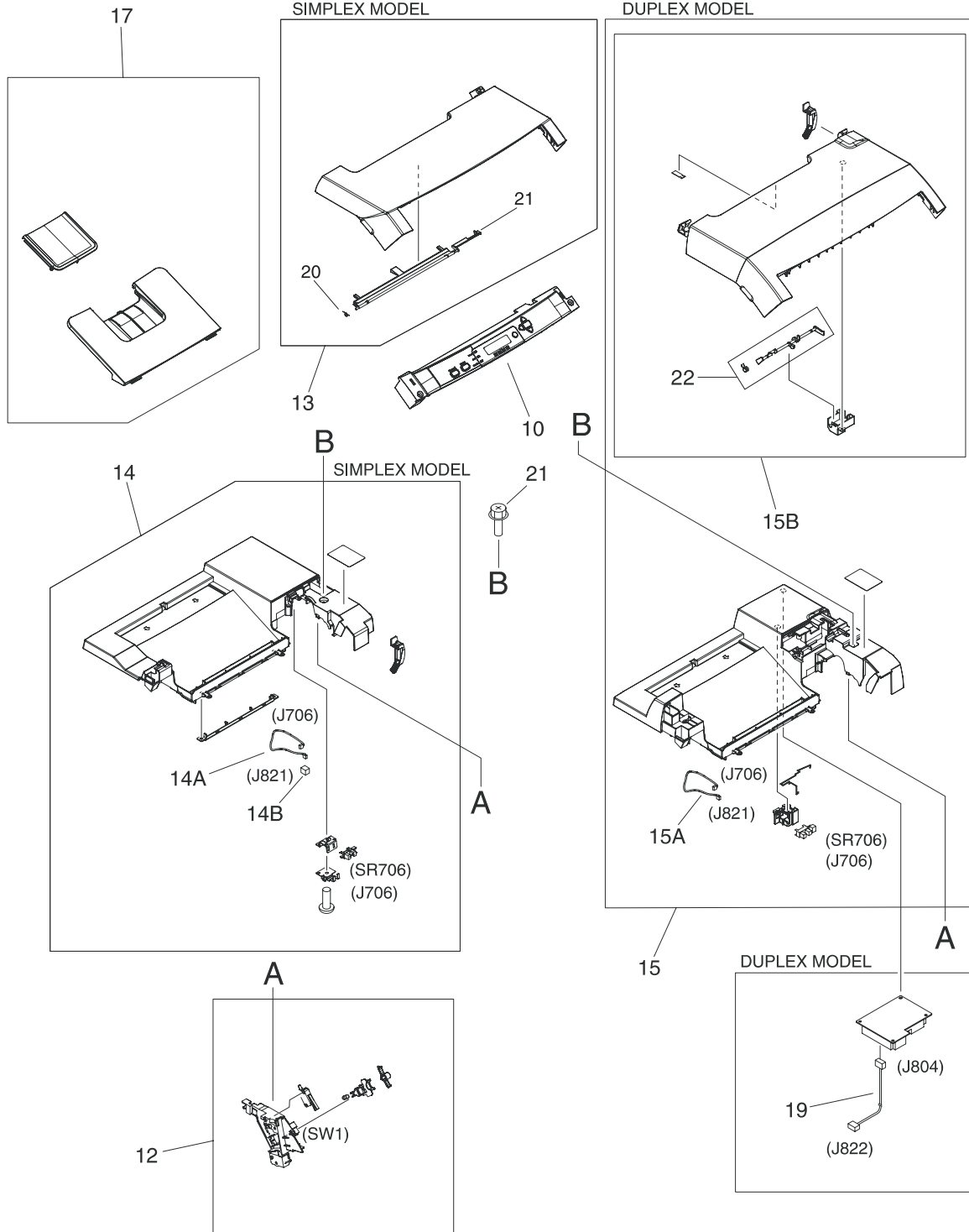

Table 7-4 External panels, and covers (2 of 2)

| Ref | Description | Part number | Qty |
|------------|--|--------------------|------------|
| 12 | Interlock-switch assembly | RM1-2670-000CN | 1 |
| 13 | Upper cover assembly (fuser door) (simplex models) | RM1-2671-000CN | 1 |
| 14 | Top-cover assembly (simplex models) | RM1-2672-030CN | 1 |
| 14A | Cable, paper-full (simplex models) | RM1-2630-000CN | 1 |
| 14B | Connector, snap-tight (simplex models) | VS1-7207-003CN | 1 |
| 15 | Top-cover assembly (duplex models) | RM1-2713-020CN | 1 |
| 15A | Cable, paper-full (duplex models) | RM1-2620-000CN | 1 |
| 15B | Upper cover assembly (fuser door) (duplex models) | RM1-2714-000CN | 1 |
| 17 | Face-down tray assembly (HP CLJ 3000) | RM1-2777-020CN | 1 |
| 17 | Face-down tray assembly (HP CLJ 3600/3800/CP3505) | RM1-2750-020CN | 1 |
| 19 | Cable, duplexing (duplex models) | RM1-2617-000CN | 1 |
| 20 | Torsion spring | RC1-7628-000CN | 1 |
| 21 | Simplex page-delivery flag | RC1-6286-000CN | 1 |
| 22 | Duplex page, duplex flag | RC1-6755-000CN | 1 |

Figure 7-3 Front-cover assembly (simplex model)

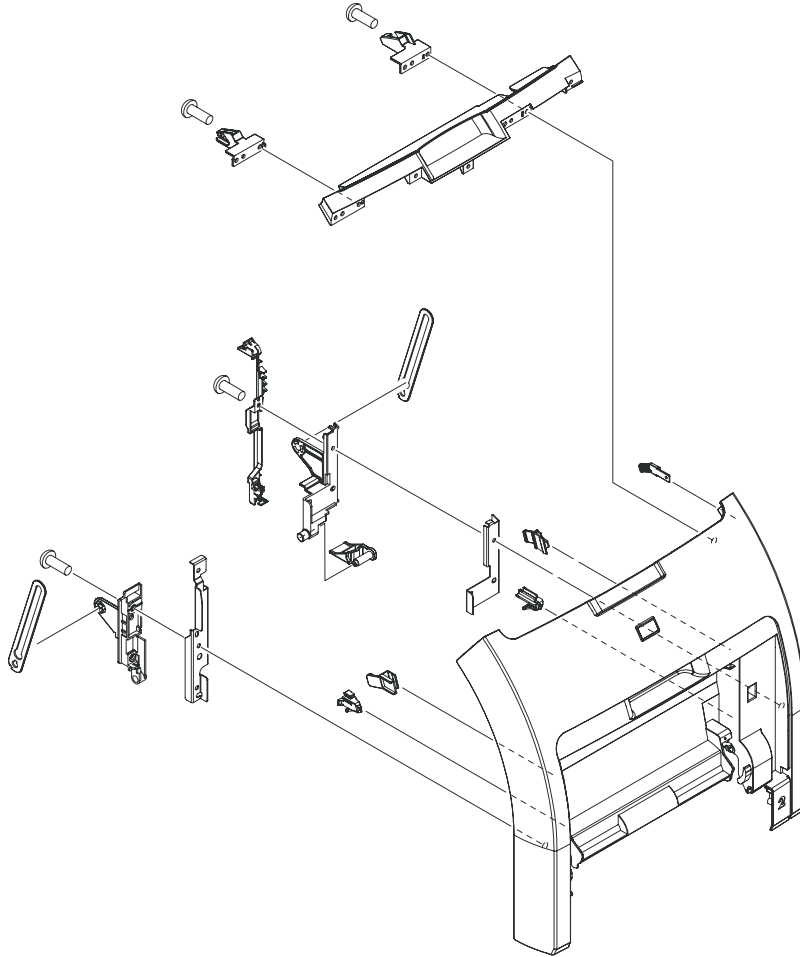

Table 7-5 Front-cover assembly (simplex model)

| Ref | Description | Part number | Qty |
|-----|---------------------------------------|----------------|-----|
| All | Front-cover assembly (simplex models) | RM1-2673-000CN | 1 |

Table 7-6 Front-cover assembly (duplex model)

| Ref | Description | Part number | Qty |
|------------|--------------------------------------|--------------------|------------|
| All | Front-cover assembly (duplex models) | RM1-2715-000CN | 1 |
| 1 | Fan (duplex models) | RK2-0954-000CN | 1 |

Internal components

Figure 7-5 Internal components (1 of 5)

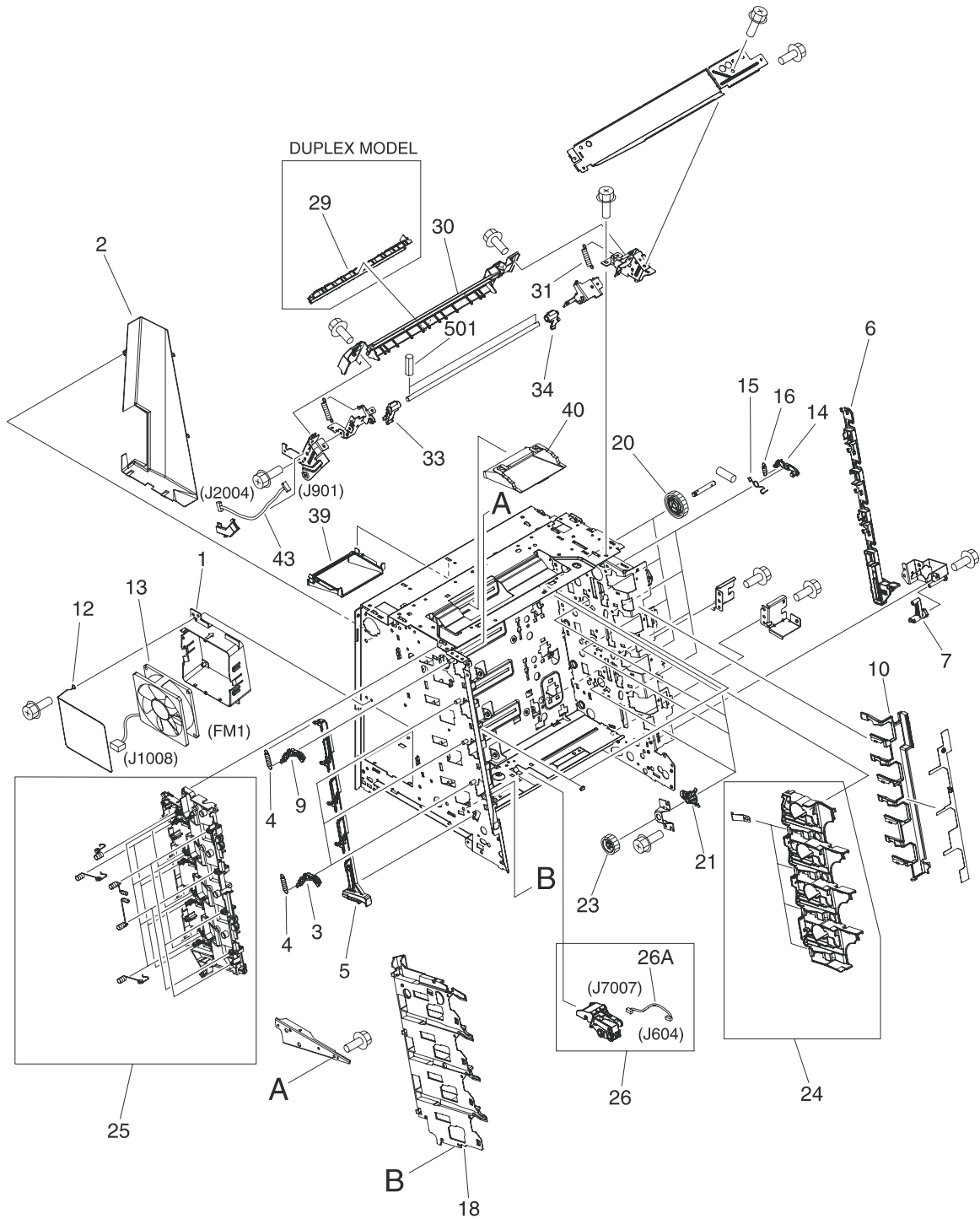

Table 7-7 Internal components (1 of 5)

| Ref | Description | Part number | Qty |
|-----|---|----------------|-----|
| 1 | Holder, fan | RC1-6631-000CN | 1 |
| 2 | Duct, fan | RC1-6632-000CN | 1 |
| 3 | Lever lock, left | RC1-6633-000CN | 3 |
| 4 | Spring, tension | RC1-6634-000CN | 4 |
| 5 | Lever, lock slide, left | RC1-6636-000CN | 1 |
| 6 | Lever, lock slide, right | RC1-6643-000CN | 1 |
| 7 | Cam, slide, right | RC1-6645-000CN | 1 |
| 9 | Lever, lock, left upper | RC1-7618-000CN | 1 |
| 10 | Cover, slide plate, right | RC1-6824-000CN | 1 |
| 12 | Spring, grounding | RC1-7583-000CN | 1 |
| 13 | Fan | RK2-0954-000CN | 1 |
| 14 | Lever, lock, right | RC1-6640-000CN | 4 |
| 15 | Spring, grounding | RC1-6641-000CN | 4 |
| 16 | Spring, tension | RC1-6677-000CN | 4 |
| 18 | Guide, cartridge, left | RC1-6629-000CN | 1 |
| 20 | Gear, 58T | RC1-6571-000CN | 4 |
| 21 | Bushing | RC1-6573-000CN | 4 |
| 23 | Gear, 29T | RC1-6575-000CN | 4 |
| 24 | Cartridge, guide, right assembly | RM1-2771-000CN | 1 |
| 25 | Contact-holder assembly | RM1-2683-000CN | 1 |
| 26 | Media-sensor cassette assembly (HP CLJ 3600/3800/CP3505) | RM1-2756-000CN | 1 |
| 26A | Cable, media sensor cassette assembly (HP CLJ 3600/3800/CP3505) | RM1-2589-000CN | 1 |
| 29 | Guide, duplexing external (duplex models) | RC1-6744-000CN | 1 |
| 30 | Cover, guide crossmember | RC1-6795-000CN | 1 |
| 31 | Spring, tension | RC1-7552-000CN | 2 |
| 33 | Latch, left | RC1-7554-000CN | 1 |
| 34 | Latch, right | RC1-7555-000CN | 1 |
| 39 | Duct, 2 | RC1-7547-000CN | 1 |
| 40 | Duct, 3 | RC1-7548-000CN | 1 |
| 43 | Cable, panel | RM1-2596-000CN | 1 |

Figure 7-6 Internal components (2 of 5)

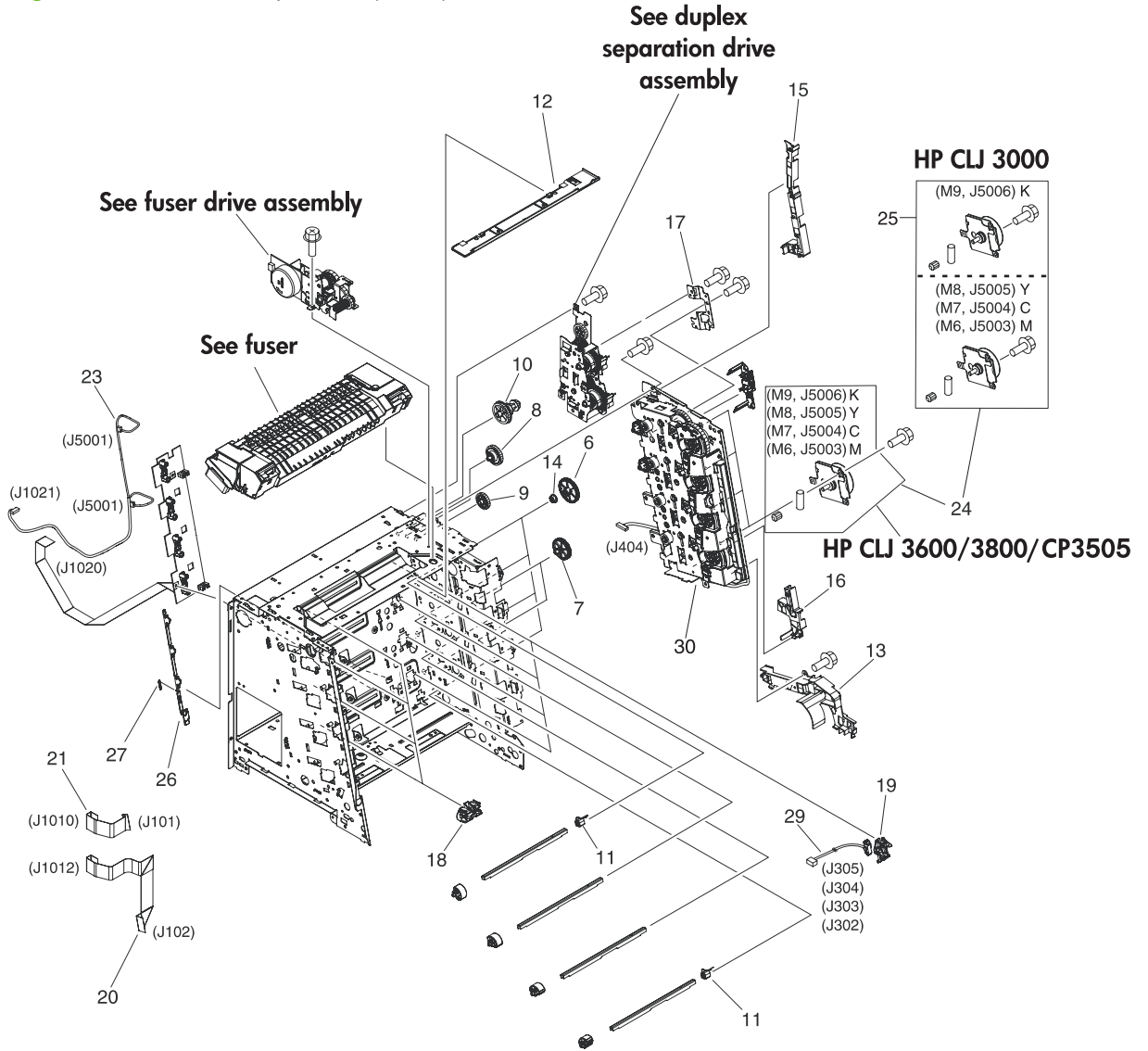

Table 7-8 Internal components (2 of 5)

| Ref | Description | Part number | Qty |
|-----|---|----------------|-----|
| 6 | Cam, gear. 48T | RC1-6584-000CN | 4 |
| 7 | Gear, 41T | RC1-6589-000CN | 2 |
| 8 | Gear, 19T/30T | RC1-6593-000CN | 1 |
| 9 | Gear, 31T | RC1-6594-000CN | 1 |
| 10 | Gear, 17T/41T | RC1-6596-000CN | 1 |
| 11 | Flag, developing estrangement (developing separation) | RC1-6605-000CN | 2 |
| 12 | Cover, crossmember, upper | RC1-6668-000CN | 1 |
| 13 | Guide, cable, right 1 | RC1-6682-000CN | 1 |
| 14 | Bushing | RC1-6823-000CN | 4 |
| 15 | Guide, cable, right 3 | RC1-7544-000CN | 1 |
| 16 | Guide, cable, right 4 | RC1-7545-000CN | 1 |
| 17 | Crossmember, drive side plate | RC1-7576-000CN | 1 |
| 18 | Cover, shutter, left | RC1-6651-000CN | 4 |
| 19 | Holder, toner cartridge | RC1-6771-000CN | 4 |
| 20 | Cable, scanner flat (long (HP CLJ 3000) | RK2-0971-000CN | 1 |
| 20 | Cable, scanner flat (long (HP CLJ 3600/3800/CP3505) | RK2-0966-000CN | 1 |
| 21 | Cable, scanner flat short | RK2-0967-000CN | 1 |
| 23 | Cable, scanner | RM1-2594-000CN | 1 |
| 24 | Drive-motor assembly, print-cartridge (HP CLJ 3600/3800/ CP3505: K, Y, C, M cartridges; HP CLJ 3000: Y, C, M cartridges only) | RM1-2689-000CN | 1 |
| 25 | Drive-motor assembly, print-cartridge (HP CLJ 3000: K cartridge only) | RM1-2773-000CN | 1 |
| 26 | Lever, sensing | RC1-7597-000CN | 1 |
| 27 | Spring, tension | RC1-7598-000CN | 1 |
| 29 | Cable, memory tag | RM1-2627-000CN | 1 |
| 30 | Main drive assembly | RM1-2751-000CN | 1 |

Figure 7-7 Internal components (3 of 5)

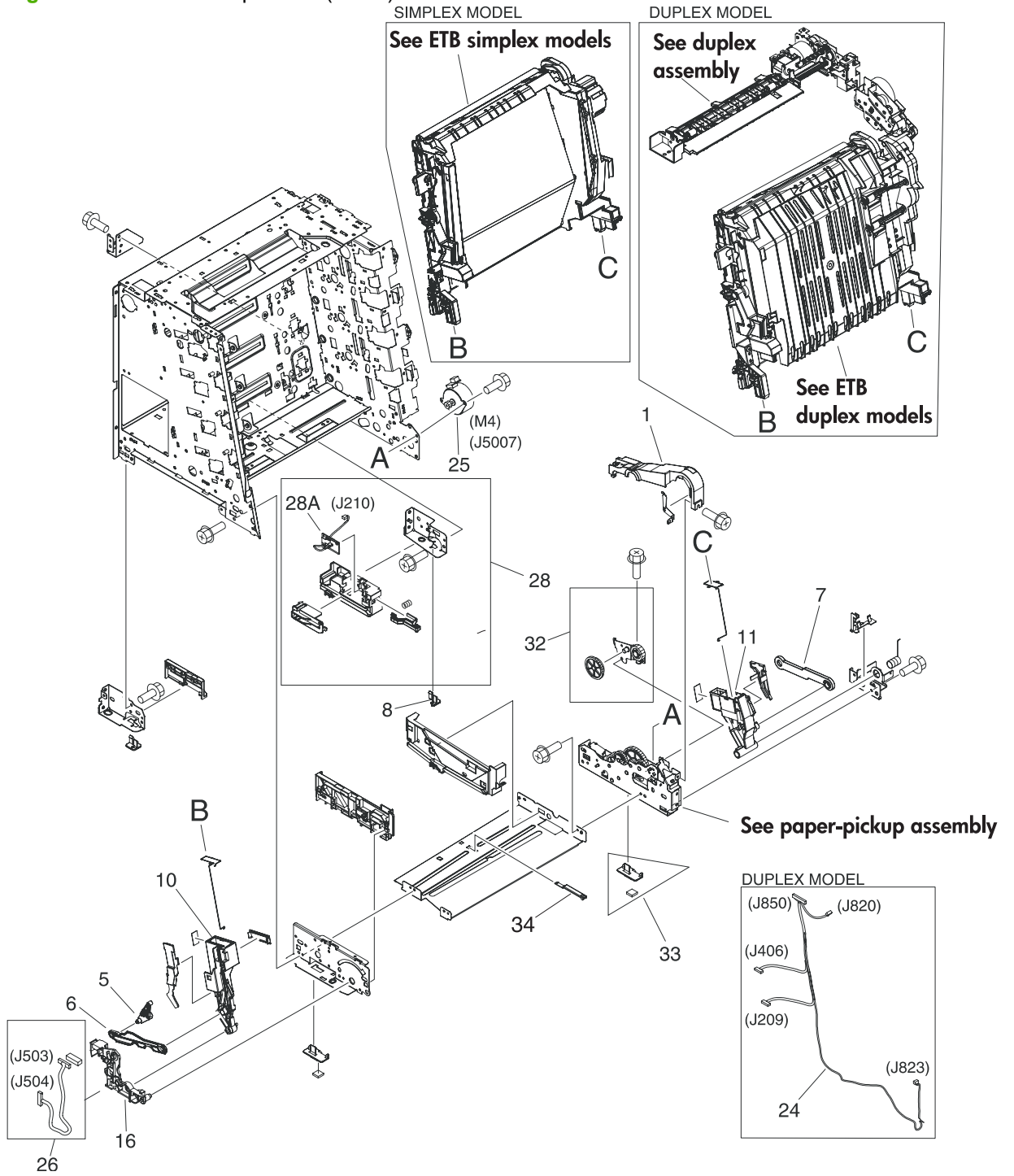

Table 7-9 Internal components (3 of 5)

| Ref | Description | Part number | Qty |
|------------|------------------------------|--------------------|------------|
| 1 | Cover, gear | RC1-6405-000CN | 1 |
| 5 | Cam, slide, left | RC1-6638-000CN | 1 |
| 6 | Rod, link, left | RC1-6639-000CN | 1 |
| 7 | Rod, link, right | RC1-6646-000CN | 1 |
| 8 | Foot, rear | RC1-6650-000CN | 2 |
| 10 | Holder, ETB, left | RC1-6673-000CN | 1 |
| 11 | Holder, ETB, right | RC1-6674-000CN | 1 |
| 16 | Mount, hinge, left | RC1-6684-000CN | 1 |
| 24 | Cable, duplex docking | RM1-2609-000CN | 1 |
| 25 | Motor, AC 24V, 9W | RK2-0939-000CN | 1 |
| 26 | Cable, sensor | RM1-2603-000CN | 1 |
| 28 | Right-rear base assembly | RM1-2678-000CN | 1 |
| 28A | Cassette sensor PCA | RM1-2576-000CN | 1 |
| 32 | Plate, gear 3 | RL1-1069-000CN | 1 |
| 33 | Foot, rubber assembly, front | RL1-1067-000CN | 2 |
| 34 | Plate lock release | RC1-6833-000CN | 1 |

Figure 7-8 Internal components (4 of 5)

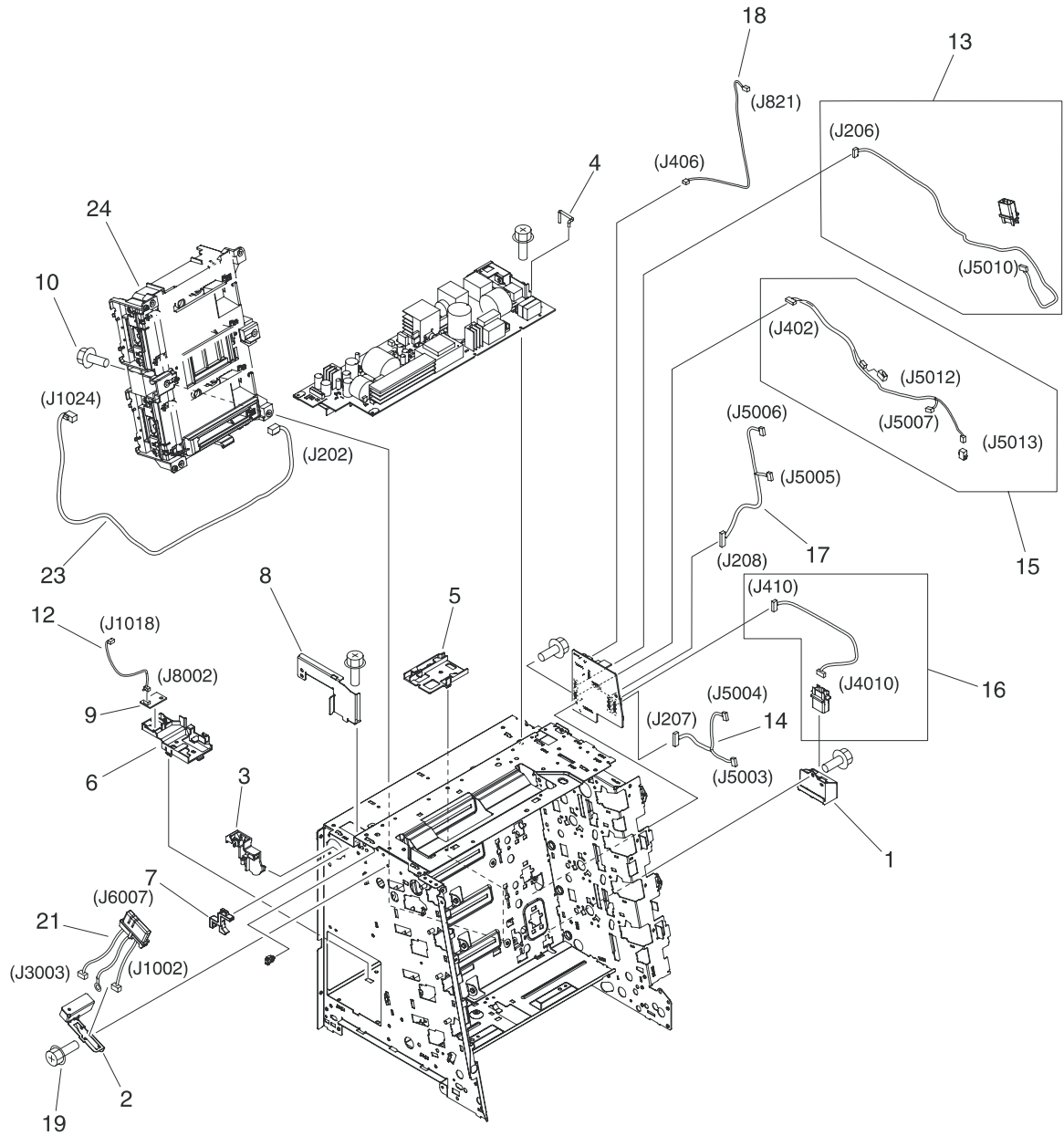

Table 7-10 Internal components (4 of 5)

| Ref | Description | Part number | Qty |
|-----|---|----------------|-----|
| 1 | Holder, drawer connector | RC1-6652-000CN | 1 |
| 2 | Holder, drawer | RC1-6653-000CN | 1 |
| 3 | Guide, cable, left | RC1-6681-000CN | 1 |
| 4 | Arm, switch-link | RC1-6700-000CN | 1 |
| 5 | Guide, flexible flat cable 1 | RC1-6772-000CN | 1 |
| 6 | Guide, flexible flat cable 2 | RC1-6773-000CN | 1 |
| 7 | Guard, cable | RC1-6825-000CN | 1 |
| 8 | Bracket, left, rear | RC1-7551-000CN | 1 |
| 9 | Sensor, temperature | WP2-5214-000CN | 1 |
| 12 | Cable, environment sensor | RM1-2595-000CN | 1 |
| 13 | Cable, ETB | RM1-2608-000CN | 1 |
| 14 | Cable, drum motor | RM1-2610-000Cn | 1 |
| 15 | Cable, solenoid | RM1-2611-000CN | 1 |
| 16 | Cable, cassette | RM1-2613-000CN | 1 |
| 17 | Cable, drum motor (HP CLJ 3000) | RM1-2629-000CN | 1 |
| 17 | Cable, drum motor (HP CLJ 3600/3800/CP3505) | RM1-2614-000CN | 1 |
| 18 | Cable, paper-full | RM1-2628-000CN | 1 |
| 21 | Fuser cable assembly | RM1-2597-000CN | 1 |
| 23 | Cable, drive power | RM1-2605-000CN | 1 |
| 24 | Scanner assembly (HP CLJ 3000) | RM1-2952-000CN | 1 |
| 24 | Scanner assembly (HP CLJ 3600/3800/CP3505) | RM1-2640-000CN | 1 |

Figure 7-9 Internal components (5 of 5)

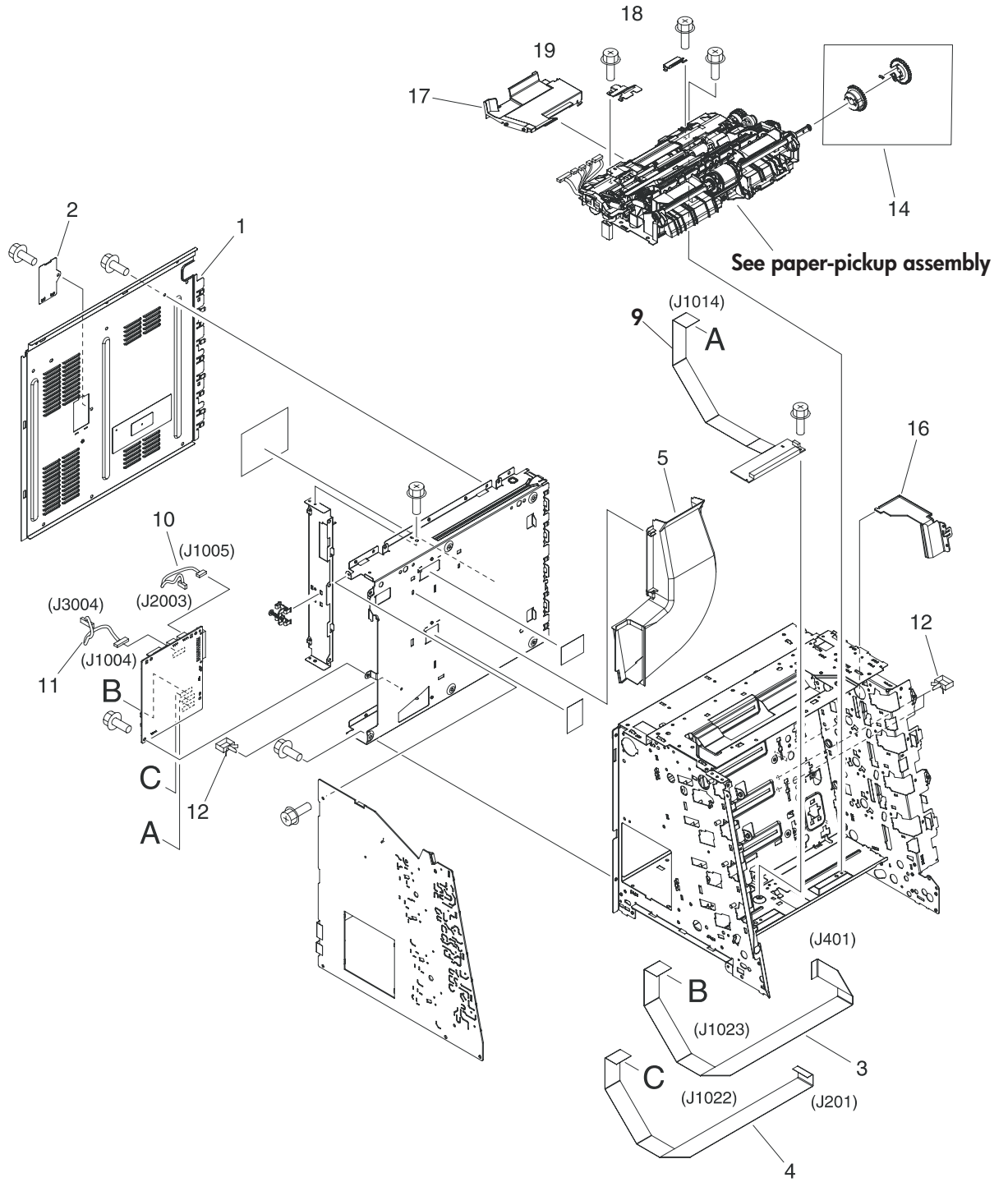

Table 7-11 Internal components (5 of 5)

| Ref | Description | Part number | Qty |
|-----|--|----------------|-----|
| 1 | Cover, rear | RC1-6627-000CN | 1 |
| 2 | Cover | RC1-7577-000CN | 1 |
| 3 | Cable, drive flat 1 | RK2-0969-000CN | 1 |
| 4 | Cable, drive flat 2 | RK2-0970-000CN | 1 |
| 5 | Duct 1 | RC1-7546-000CN | 1 |
| 9 | Relay, PCA (HP CLJ 3000 only) | RM1-2582-000CN | 1 |
| 9 | Relay, PCA (HP CLJ 3600/3800/CP3505 only) | RM1-2632-000CN | 1 |
| 10 | Cable, panel connecting | RM1-2587-000CN | 1 |
| 11 | Cable, power control | RM1-2592-000CN | 1 |
| 12 | Cable, clamp | WT2-5944-000CN | 2 |
| 14 | Multipurpose tray paper-pickup gear assembly | RM1-2704-000CN | 1 |
| 16 | Shield, PCA | RC1-7599-000CN | 1 |
| 17 | Cover, connector | RC1-6607-000CN | 1 |
| 18 | Cover, paper sensor | RC1-6611-000CN | 1 |
| 19 | Cover, registration sensor | RC1-6612-000CN | 1 |

Paper-pickup drive assembly

Figure 7-10 Paper-pickup drive assembly

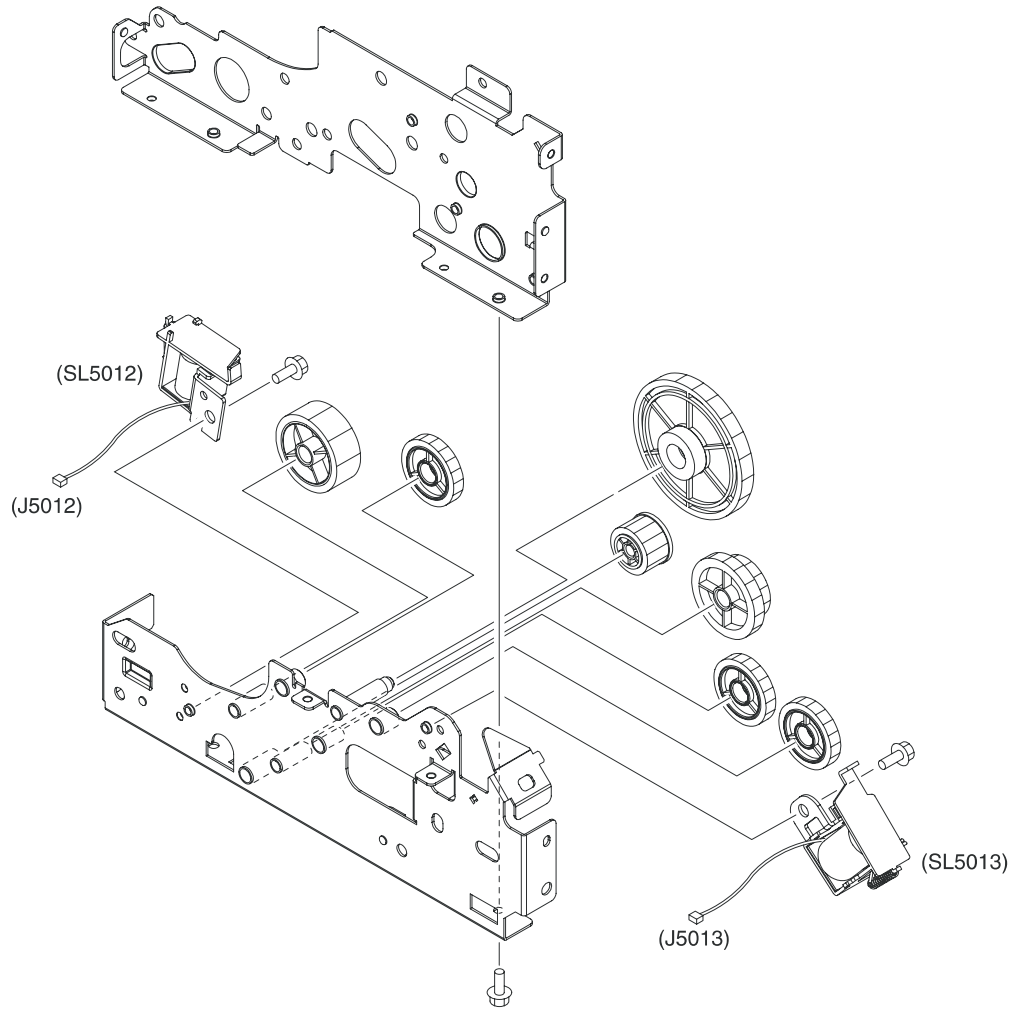

Table 7-12 Paper-pickup drive assembly

| Ref | Description | Part number | Qty |
|-----|-----------------------------|----------------|-----|
| All | Paper-pickup drive assembly | RM1-2679-000CN | 1 |

Duplexing-feed drive assembly (duplex models)

Figure 7-11 Duplexing-feed drive assembly (duplex models)

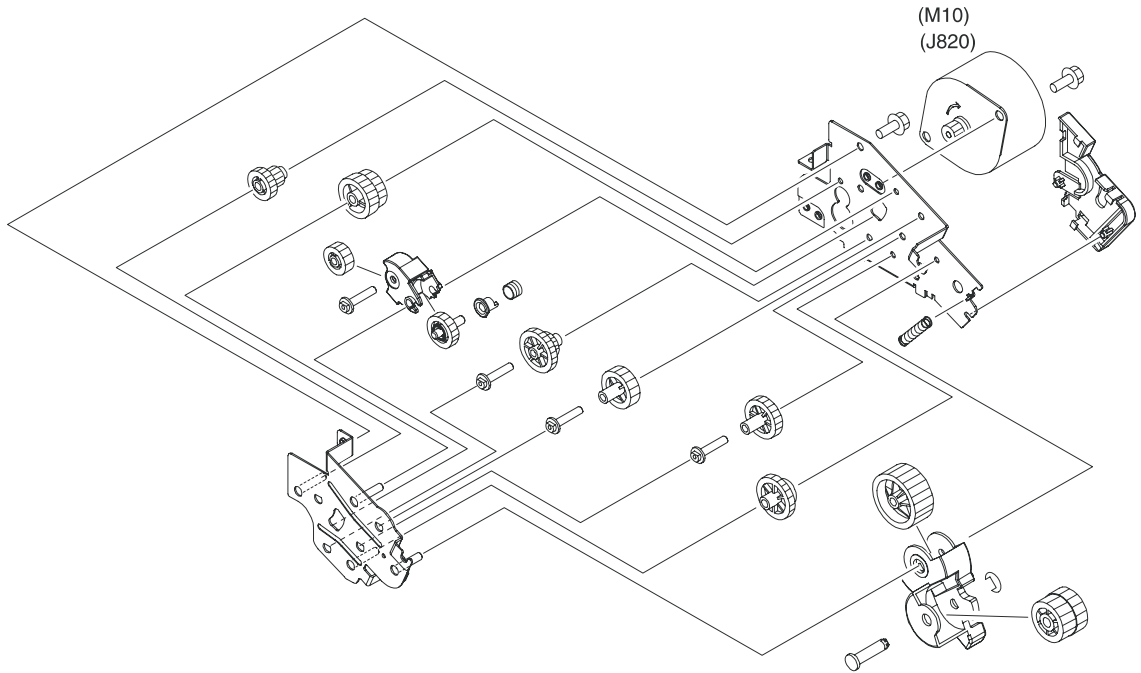

Table 7-13 Duplexing-feed drive assembly (duplex models)

| Ref | Description | Part number | Qty |
|-----|---|----------------|-----|
| All | Duplexing-feed drive assembly (duplex models) | RM1-2720-000CN | 1 |

Duplexing reverse-drive assembly (duplex models)

Figure 7-12 Duplexing reverse-drive assembly (duplex models)

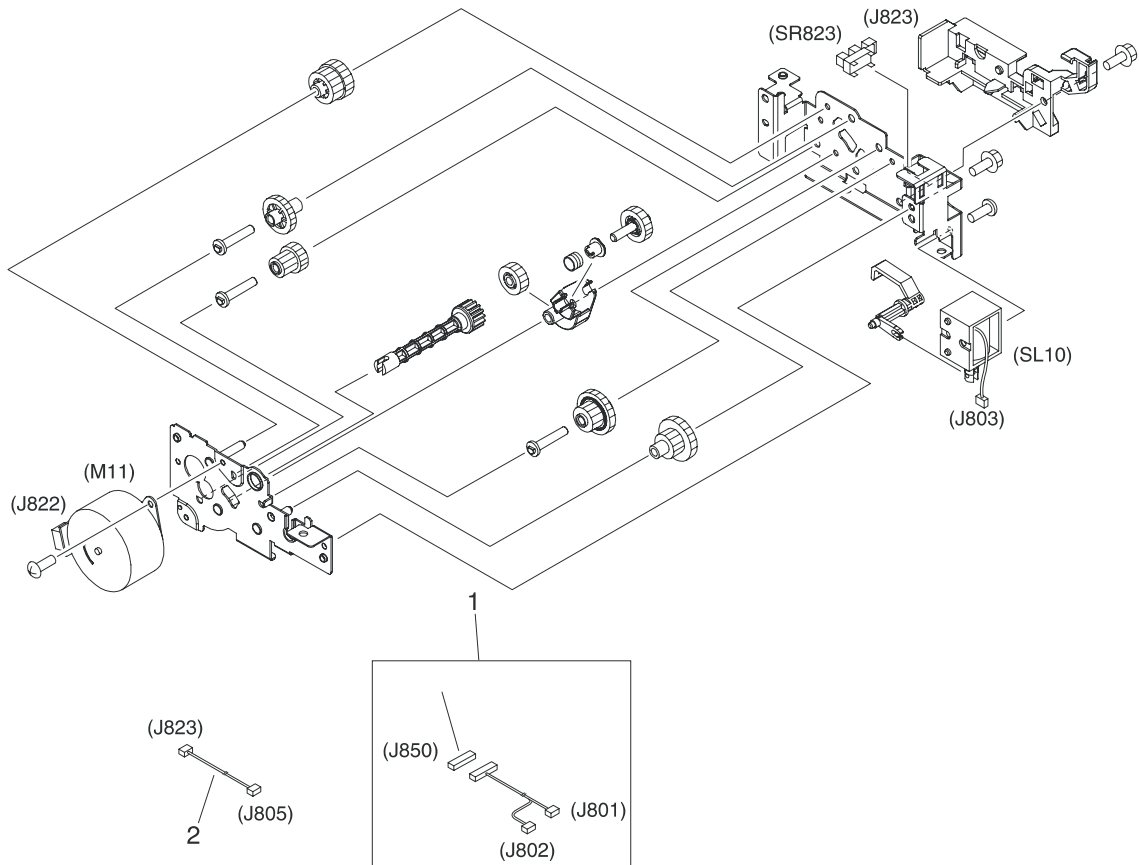

Table 7-14 Duplexing reverse-drive assembly (duplex models)

| Ref | Description | Part number | Qty |
|------------|--|--------------------|------------|
| All | Duplexing reverse-drive assembly (duplex models) | RM1-2721-000CN | 1 |
| 1 | Cable, duplexing (duplex models) | RM1-2616-000CN | 1 |
| 2 | Cable, duplexing sensor (duplex models) | RM1-2618-000CN | 1 |

Developing separation-drive assembly

Figure 7-13 Developing separation-drive assembly

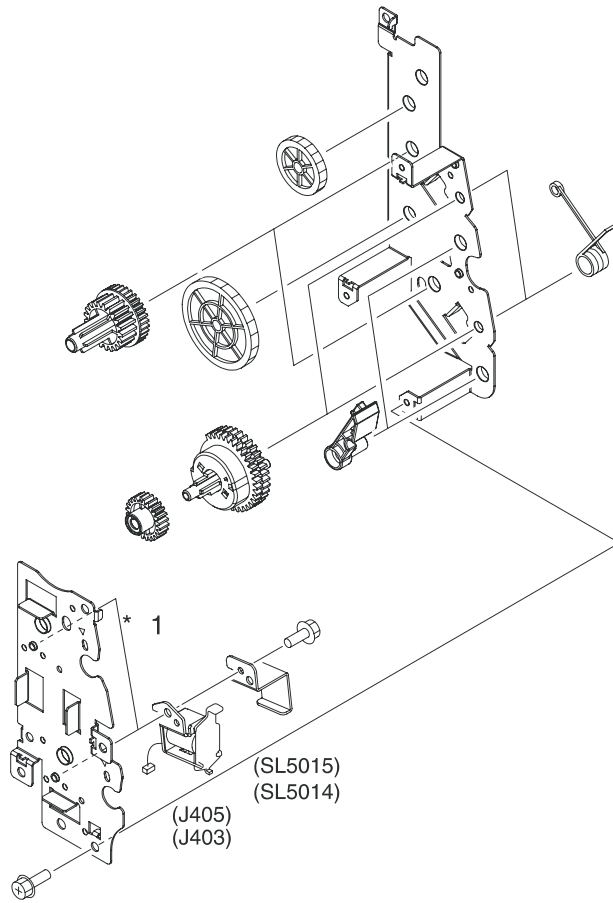

Table 7-15 Developing separation-drive assembly

| Ref | Description | Part number | Qty |
|-----|---|----------------|-----|
| All | Developing separation (estrangement) drive assembly | RM1-2687-000CN | 1 |

Fuser drive assembly

Figure 7-14 Fuser drive assembly

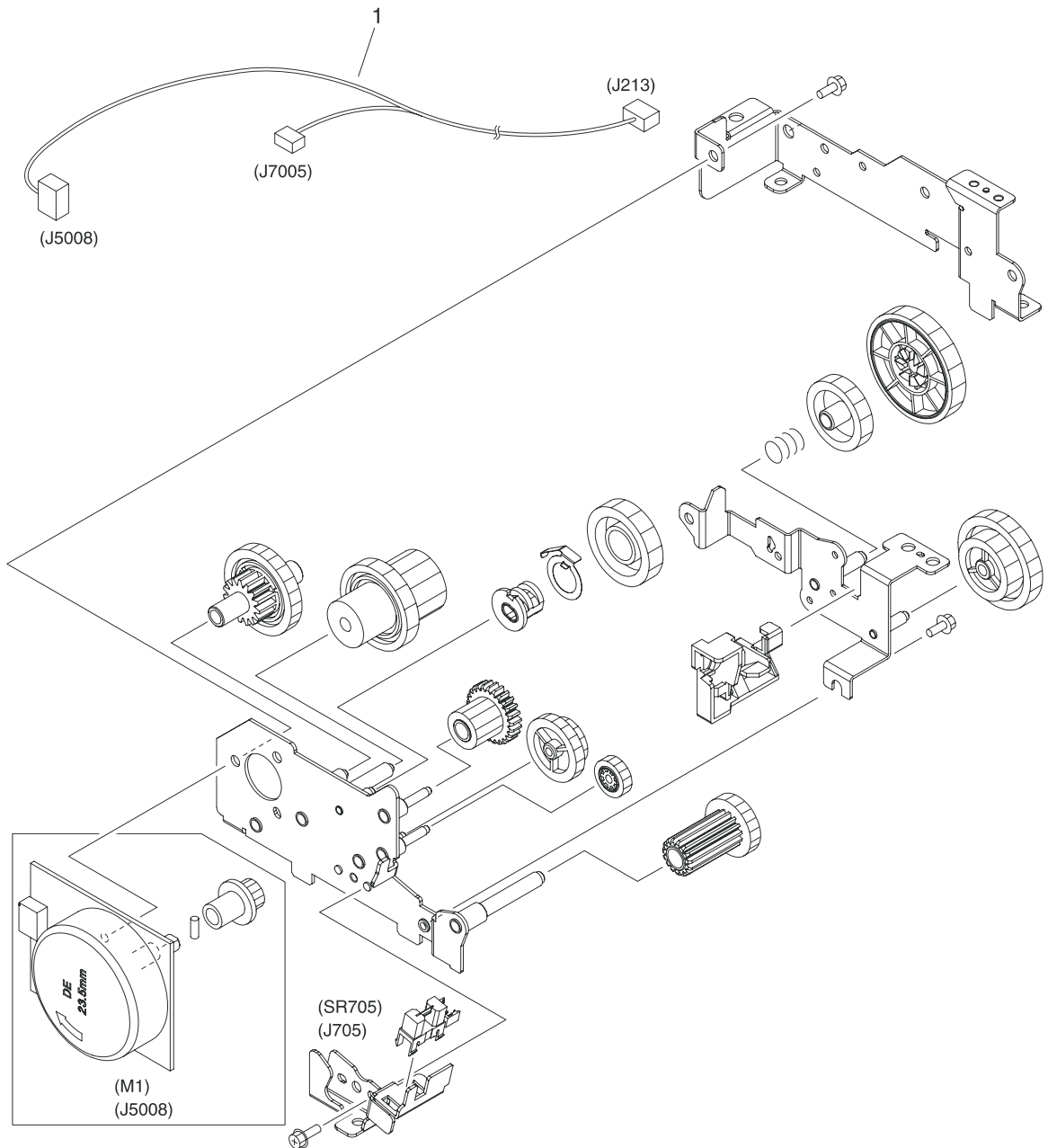

Table 7-16 Fuser drive assembly

| Ref | Description | Part number | Qty |
|------------|----------------------|--------------------|------------|
| All | Fuser drive assembly | RM1-2668-000CN | 1 |
| 1 | Cable, fuser drive | RM1-2619-000CN | 1 |

Cassette (tray 2)

Figure 7-15 Cassette (tray 2)

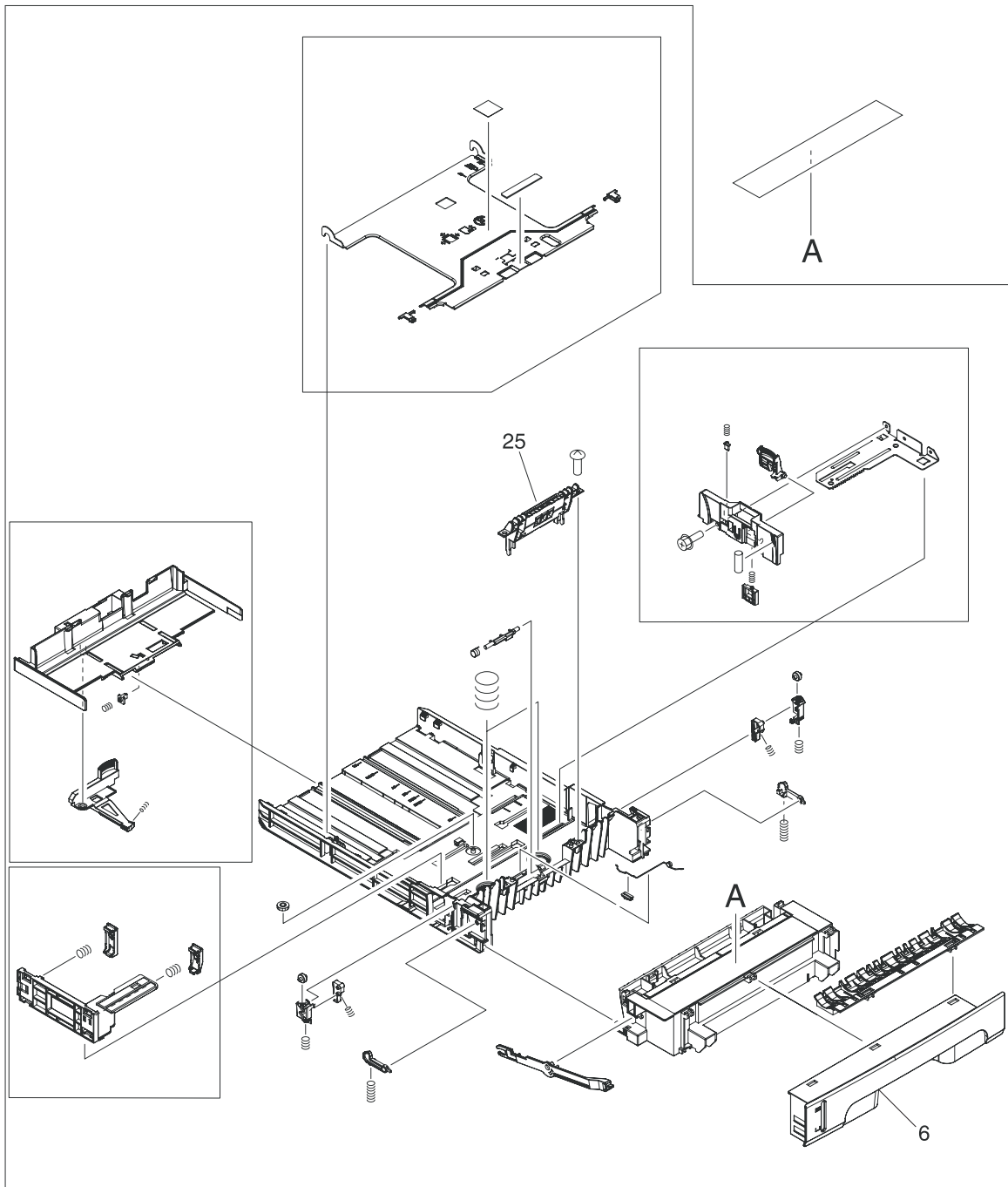

Table 7-17 Cassette (tray 2)

| Ref | Description | Part number | Qty |
|------------|-------------------------|--------------------|------------|
| All | Cassette, 250-sheet | RM1-2705-000CN | 1 |
| 6 | Cover, cassette, front | RC1-6491-000CN | 1 |
| 25 | Separation-pad assembly | RM1-2709-000CN | 1 |
| NA | Lift plate activator | RC1-6833-020CN | 1 |

Paper-pickup assembly (HP CLJ 3600/3800/CP3505)

Figure 7-16 Paper-pickup assembly (HP CLJ 3600/3800/CP3505)

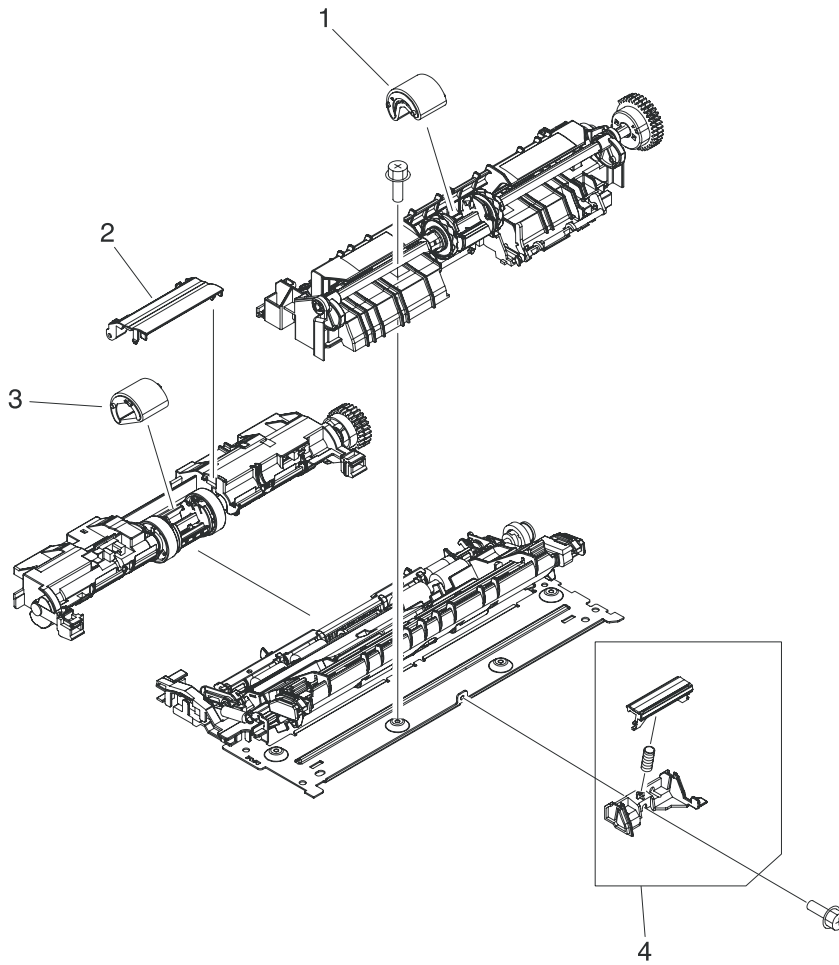

Table 7-18 Paper-pickup assembly (HP CLJ 3600/3800/CP3505)

| Ref | Description | Part number | Qty |
|------------|---|--------------------|------------|
| All | Paper-pickup assembly (HP CLJ 3600/3800/CP3505) | RM1-2755-060CN | 1 |
| 1 | Multipurpose tray roller (HP CLJ 3600/3800/CP3505) | RM1-2741-000CN | 1 |
| 2 | Cover, cassette roller assembly (HP CLJ 3600/3800/CP3505) | RC1-6609-000CN | 1 |
| 3 | Cassette | RM1-2702-000CN | 1 |
| 4 | Multipurpose tray separation-pad assembly (HP CLJ 3600/3800/CP3505) | RM1-2699-000CN | 1 |

Paper-pickup assembly (HP CLJ 3000)

Figure 7-17 Paper-pickup assembly (HP CLJ 3000)

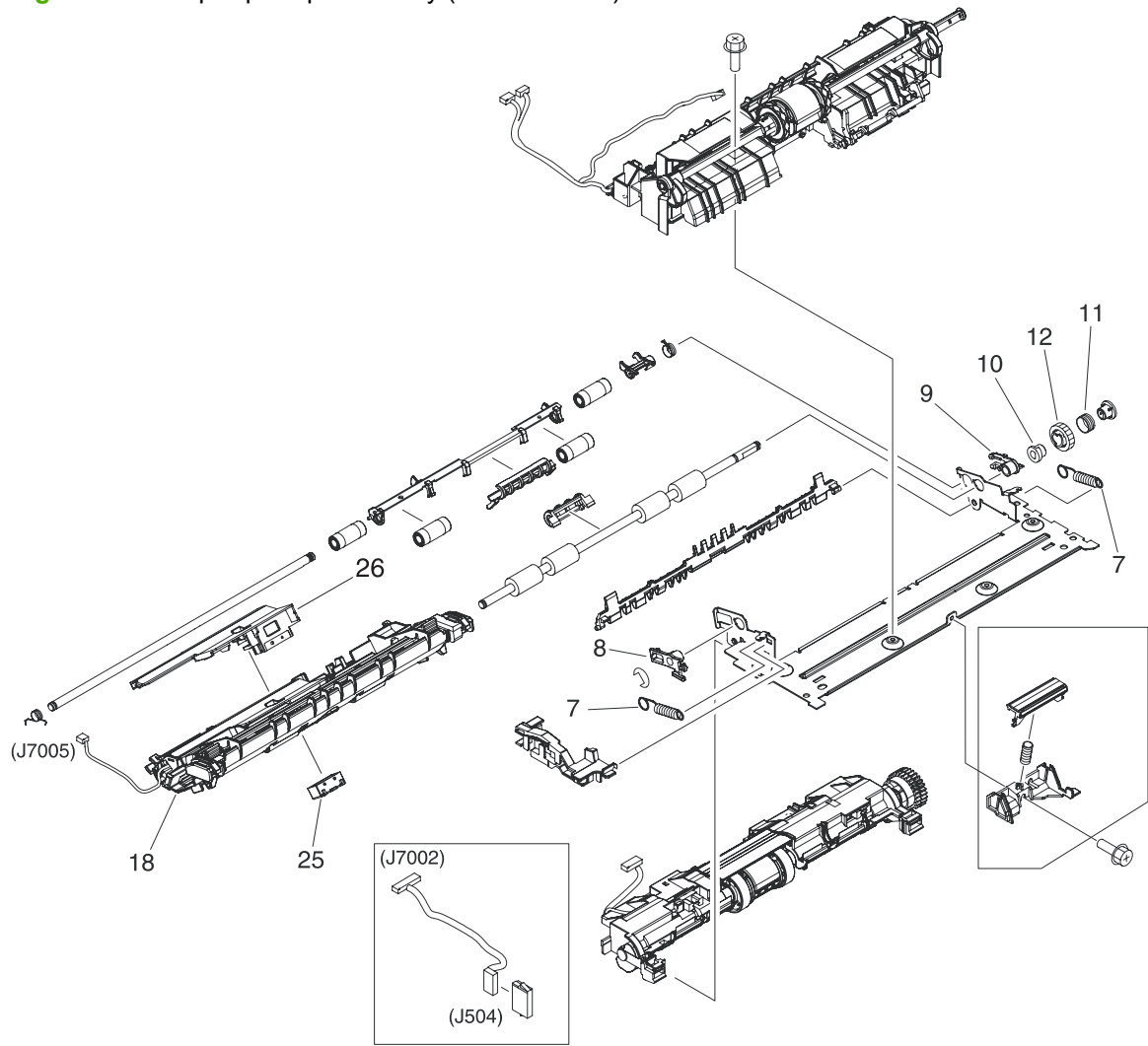

Table 7-19 Paper-pickup assembly (HP CLJ 3000)

| Ref | Description | Part number | Qty |
|------------|--|--------------------|------------|
| All | Paper-pickup assembly (HP CLJ 3000) | RM1-2774-060CN | 1 |
| 7 | Spring, tension (HP CLJ 3000) | RM1-6516-000CN | 2 |
| 8 | Bushing (HP CLJ 3000) | RC1-6517-000CN | 1 |
| 9 | Bushing (HP CLJ 3000) | RC1-6518-000CN | 1 |
| 10 | Pre-registration ratchet (HP CLJ 3000) | RC1-6444-000CN | 1 |
| 11 | Spring, compression (HP CLJ 3000) | RC1-6520-000CN | 1 |
| 12 | Gear, 18T (HP CLJ 3000) | RC1-6521-000CN | 1 |
| 18 | Preregistration-guide assembly (HP CLJ 3000) | RM1-2775-000CN | 1 |
| 25 | Block, Multipurpose path (HP CLJ 3000) | RC1-7959-000CN | |
| 26 | Media sensor case | RC1-6394-000CN | 1 |

Electronic transfer belt (simplex models)

Figure 7-18 Electronic transfer belt (simplex models)

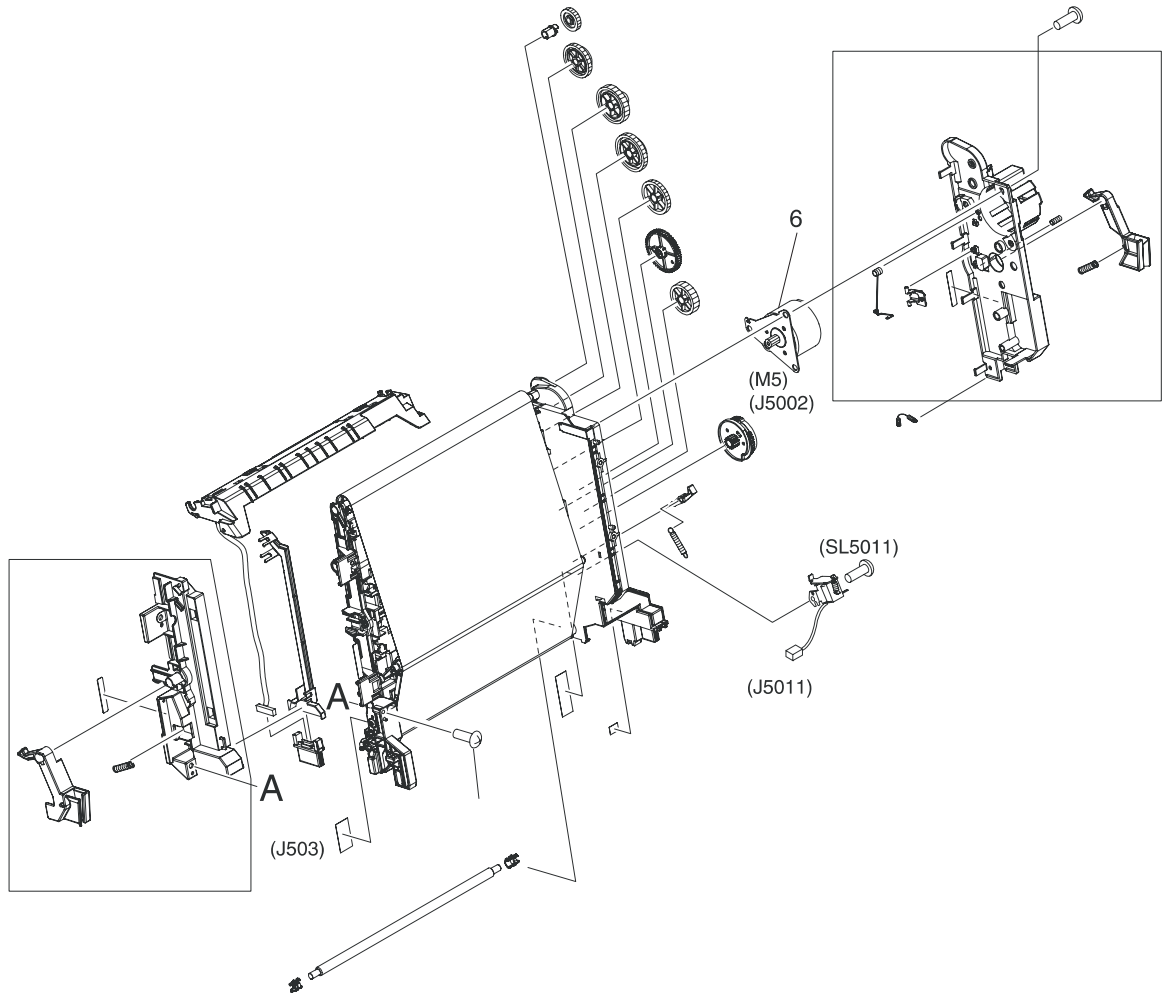

Table 7-20 Electronic transfer belt (simplex models)

| Ref | Description | Part number | Qty |
|------------|---|--------------------|------------|
| All | Electronic transfer belt (simplex models) | RM1-2759-090CN | 1 |
| 6 | Motor, DC (ETB) (simplex models) | RK2-0937-000CN | 1 |

Electronic transfer belt (duplex models)

Figure 7-19 Electronic transfer belt (duplex models)

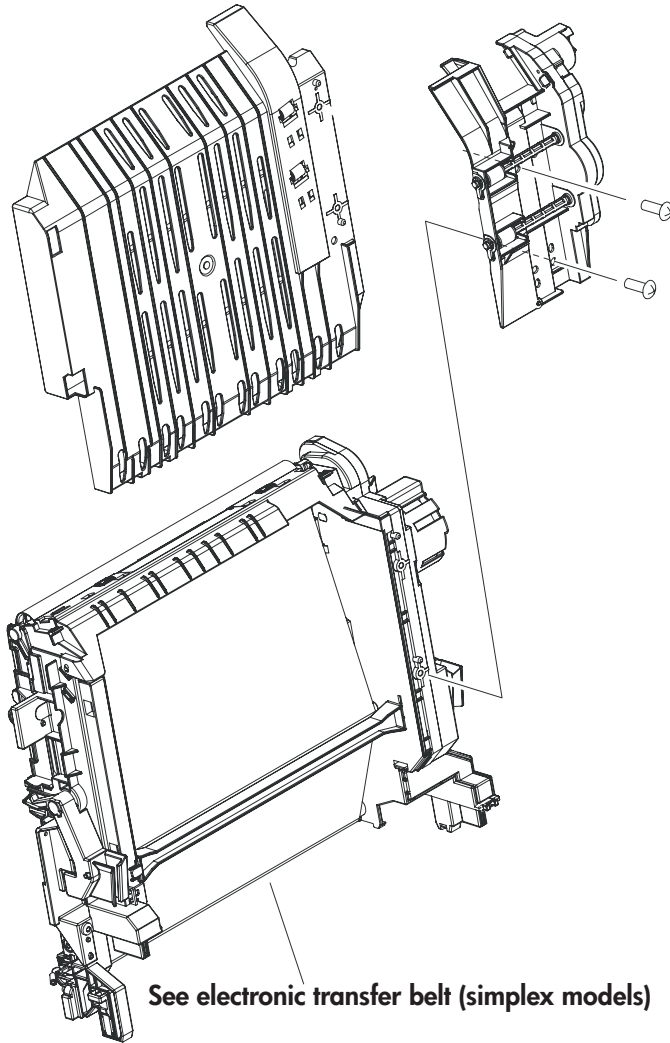

Table 7-21 Electronic transfer belt (duplex models)

| Ref | Description | Part number | Qty |
|------------|--|--------------------|------------|
| All | Electronic transfer belt (duplex models) | RM1-2752-100CN | 1 |

Multipurpose tray assembly (tray 1)

Figure 7-20 Multipurpose tray assembly (tray 1)

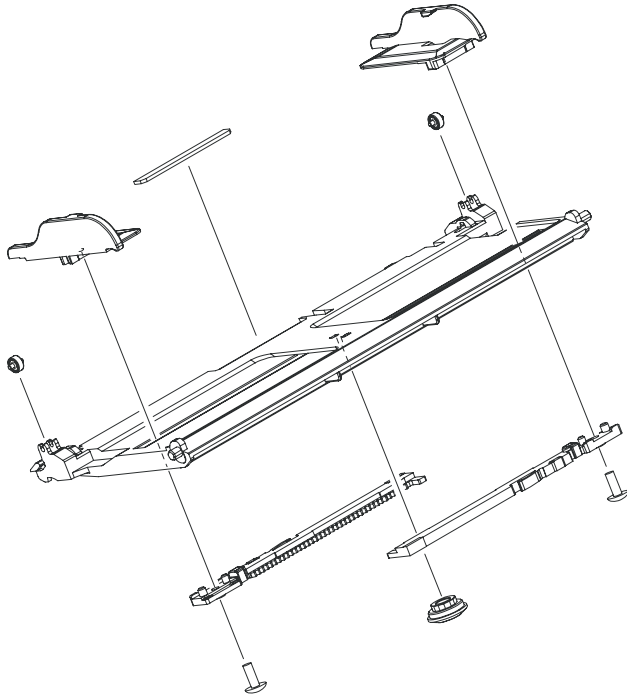

Table 7-22 Multipurpose tray assembly (tray 1)

| Ref | Description | Part number | Qty |
|-----|-------------------------------------|----------------|-----|
| All | Multipurpose tray assembly (tray 1) | RM1-2711-030CN | 1 |

Duplex-paper feed assembly (duplex models)

Figure 7-21 Duplex-paper feed assembly (duplex models)

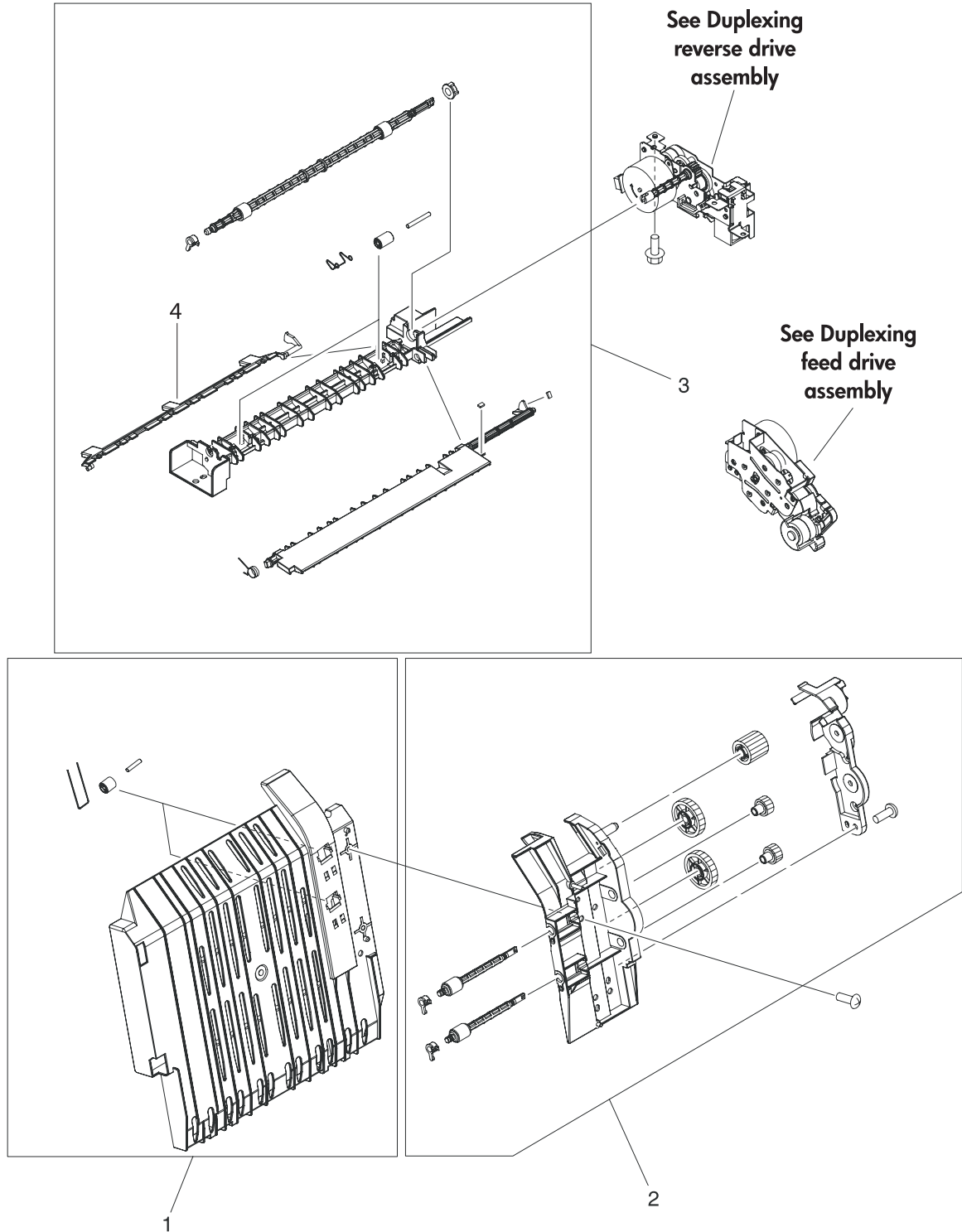

Table 7-23 Duplex-paper feed assembly (duplex models)

| Ref | Description | Part number | Qty |
|------------|--|--------------------|------------|
| 1 | Duplex-paper feed assembly (duplex models) | RM1-2718-030CN | 1 |
| 2 | Position-guide assembly (duplex models) | RM1-2719-000CN | 1 |
| 3 | Lower guide assembly (duplex models) | RM1-2722-000CN | 1 |
| 4 | Duplex-output bin full flag | RC1-6755-000CN | 1 |

Fuser

Figure 7-22 Fuser

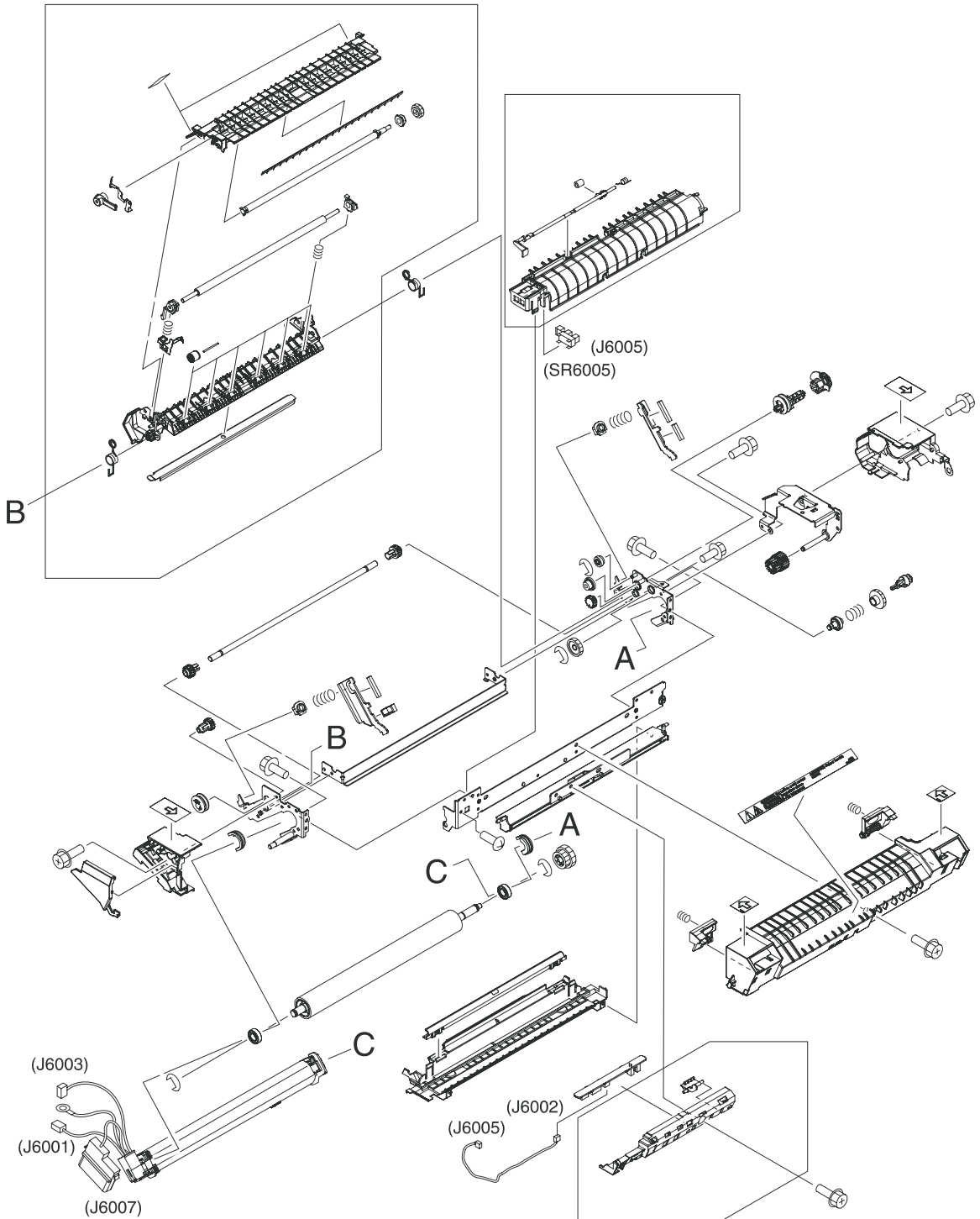

Table 7-24 Fuser

| Ref | Description | Part number | Qty |
|------------|--------------------------|--------------------|------------|
| All | Fuser assembly 110V-127V | RM1-2665-180CN | 1 |
| All | Fuser assembly 220V-240V | RM1-2743-220CN | 1 |

PCAs

Figure 7-23 PCAs

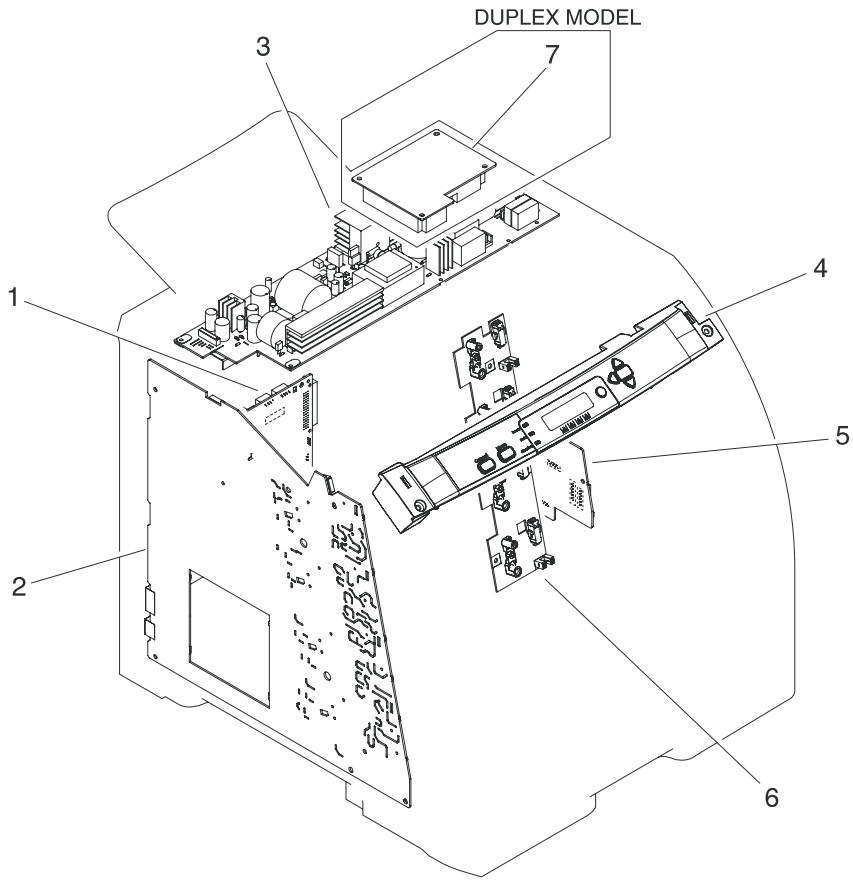



Table 7-25 PCAs

| Ref | Description | Part number | Qty |
|-----|--|----------------|-----|
| 1 | DC controller PCA assembly (HP CLJ 3000) | RM1-2600-000CN | 1 |
| 1 | DC controller PCA assembly (HP CLJ 3600/3800/CP3505) | RM1-2580-000CN | 1 |
| 2 | High-voltage PCA assembly | RM1-2578-000CN | 1 |
| 3 | Low-voltage power PCA assembly (110V-127V) | RM1-4377-000CN | 1 |
| 3 | Low-voltage power PCA assembly (220V-240V) | RM1-4378-000CN | 1 |
| 4 | Control panel-assembly (HP CLJ 3000) | RK2-0996-000CN | 1 |
| 4 | Control-panel assembly (HP CLJ 3600/3800/CP3505) | RK2-0989-000CN | 1 |
| 5 | Driver PCA | RM1-2581-000CN | 1 |
| 6 | Cartridge-sensor PCA | RM1-2585-000CN | 1 |
| 7 | Duplexing PCA assembly (duplex models) | RM1-2584-000CN | 1 |
| | Formatter, new, HP Color LaserJet 3000 and 3000n Series only (128 MB) | Q5982-67907 | 1 |
| | Formatter, exchange, HP Color LaserJet 3000 and 3000n Series only (128 MB) | Q5982-69001 | 1 |
| | Formatter, new, HP Color LaserJet 3000dn and 3000dtn Series only (256 MB) | Q5982-67908 | 1 |
| | Formatter, exchange, HP Color LaserJet 3000dn and 3000dtn Series only (256 MB) | Q5982-69002 | 1 |
| | Formatter, new, HP Color LaserJet 3800 and 3800n printers only (128 MB) | Q5982-67907 | 1 |
| | Formatter, exchange, HP Color LaserJet 3800 and 3800n printers only (128 MB) | Q5982-69001 | 1 |
| | Formatter, new, HP Color LaserJet 3800dn and 3800dtn printers only (256 MB) | Q5982-67908 | 1 |
| | Formatter, exchange, HP Color LaserJet 3800dn and 3800dtn printers only (256 MB) | Q5982-69002 | 1 |
| | Formatter, new, HP Color LaserJet CP3505 | CB441-67901 | 1 |
| | Formatter, exchange, HP Color LaserJet CP3505 | CB441-69001 | 1 |
| | I controller (formatter), HP Color LaserJet 3600 Series only | Q5987-67901 | 1 |
| | Firmware, Compact Flash, HP Color LaserJet 3000 Series only | Q7725-67903 | 1 |
| | Firmware, Compact Flash, HP Color LaserJet 3600/3800 Series only | CB399-67907 | 1 |
| | DIMM, 64 MB DDR SDRAM, HP Color LaserJet 3600 Series only | Q7800-67951 | 1 |

 **NOTE:** This illustration does not show the relay PCA. See callout 9 in [Figure 7-9 Internal components \(5 of 5\) on page 276](#).

500-sheet feeder cassette (tray 3)

Figure 7-24 500-sheet feeder cassette (tray 3)

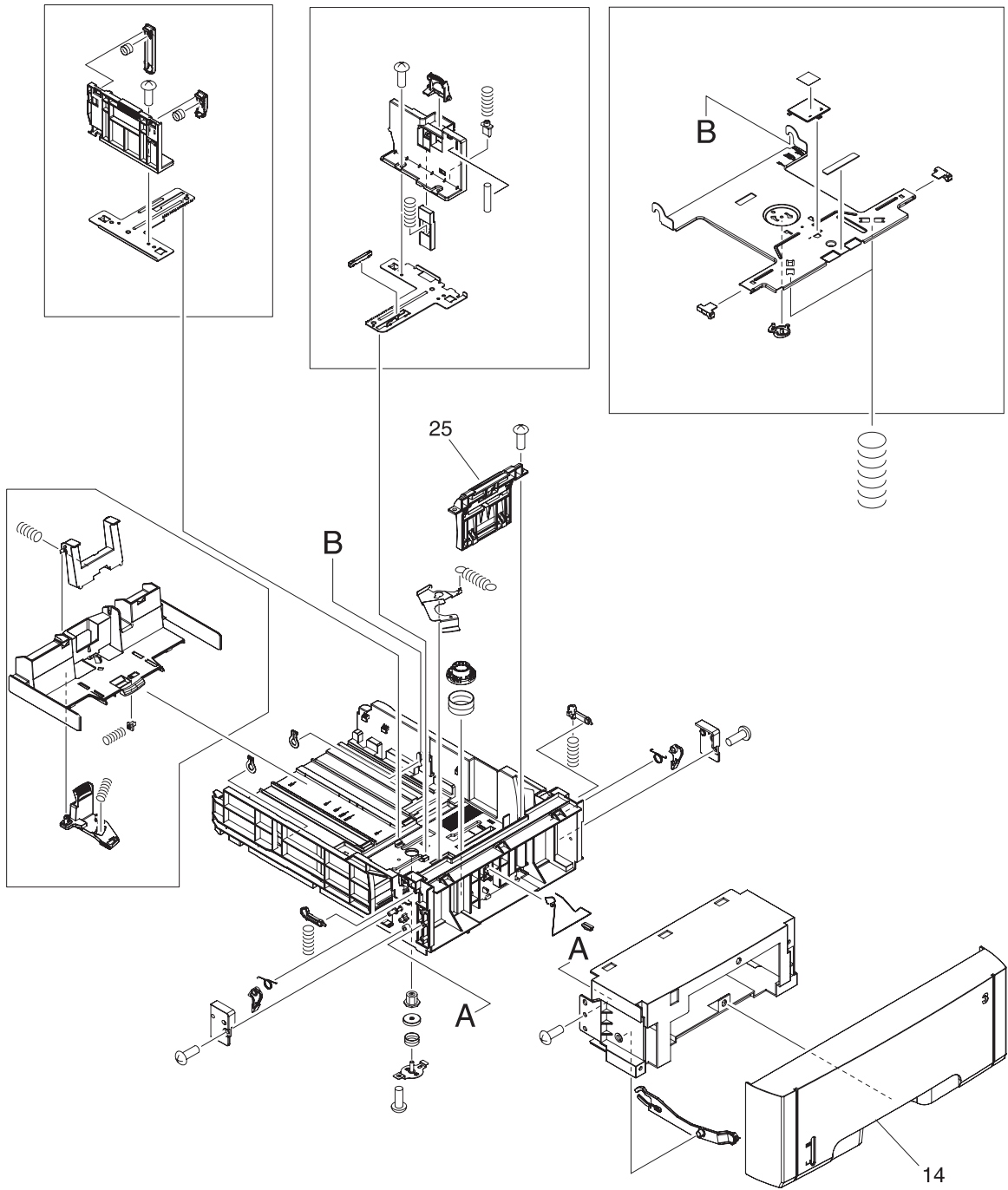

Table 7-26 500-sheet feeder cassette (tray 3)

| Ref | Description | Part number | Qty |
|------------|---|--------------------|------------|
| | 500-sheet feeder and cassette | Q5985-67901 | 1 |
| All | 500-sheet cassette (only), tray 3 | RM1-2732-000CN | 1 |
| 14 | Cover, 500-sheet cassette | RM1-2732-030CN | 1 |
| 25 | Separation-pad-holder assembly (500-sheet feeder) | RM1-2735-000CN | |

500-sheet feeder paper-pickup assembly

Figure 7-25 500-sheet feeder paper-pickup assembly

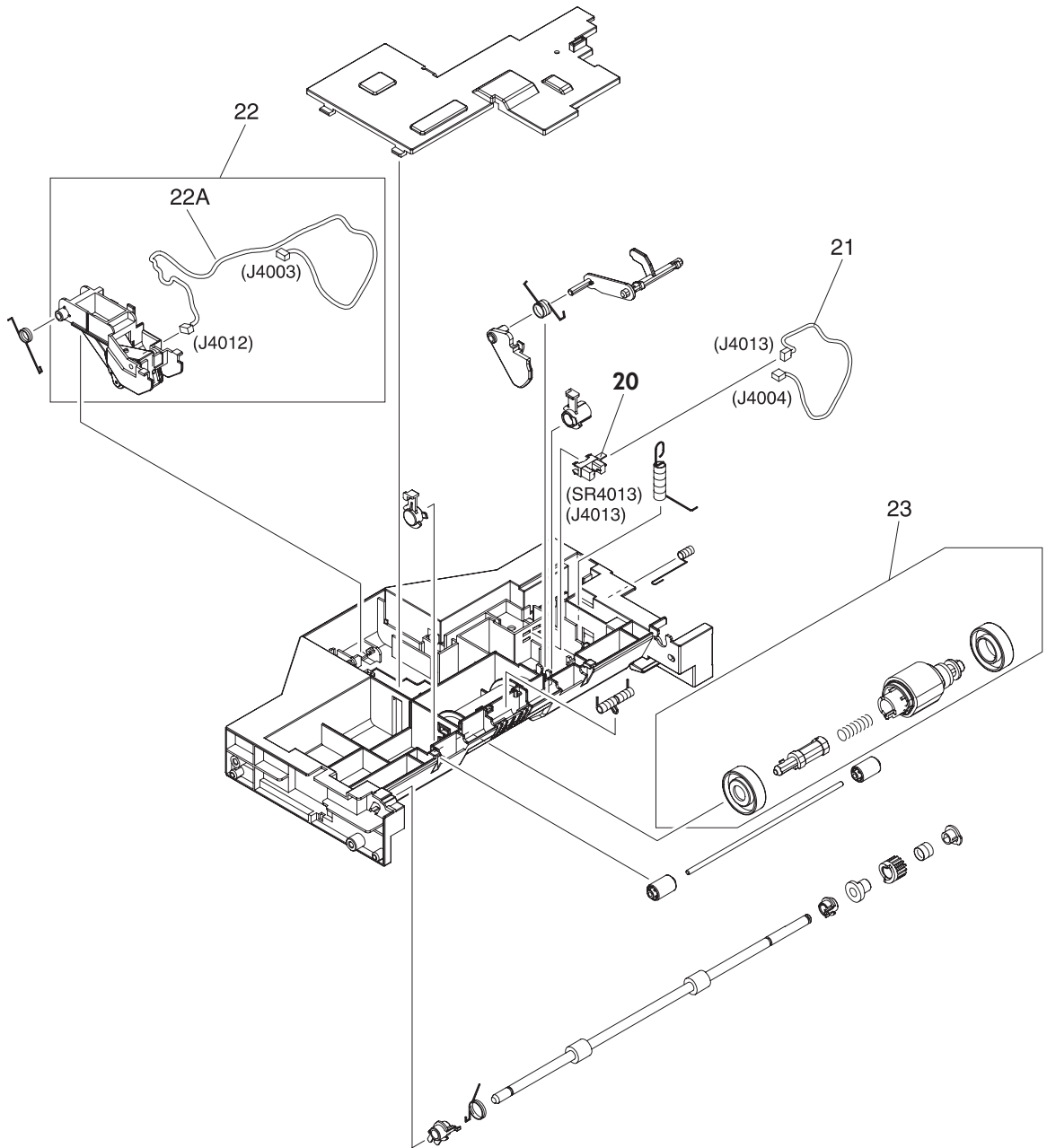

Table 7-27 500-sheet feeder paper-pickup assembly

| Ref | Description | Part number | Qty |
|------------|---|--------------------|------------|
| All | 500-sheet feeder paper-pickup assembly | RM1-2725-000CN | 1 |
| 20 | Photointerruptor | RM1-2725-020CN | 1 |
| 21 | Cable, option sensor | RM1-2625-000CN | 1 |
| 22 | Sensor, media assembly | RM1-2757-000CN | 1 |
| 22A | Cable, option media sensor (500-sheet feeder) | RM1-2624-000CN | 1 |
| 23 | Paper-pickup-roller assembly (500-sheet feeder) | RM1-2727-000CN | 1 |

500-sheet feeder PCA

Figure 7-26 500-sheet feeder PCA

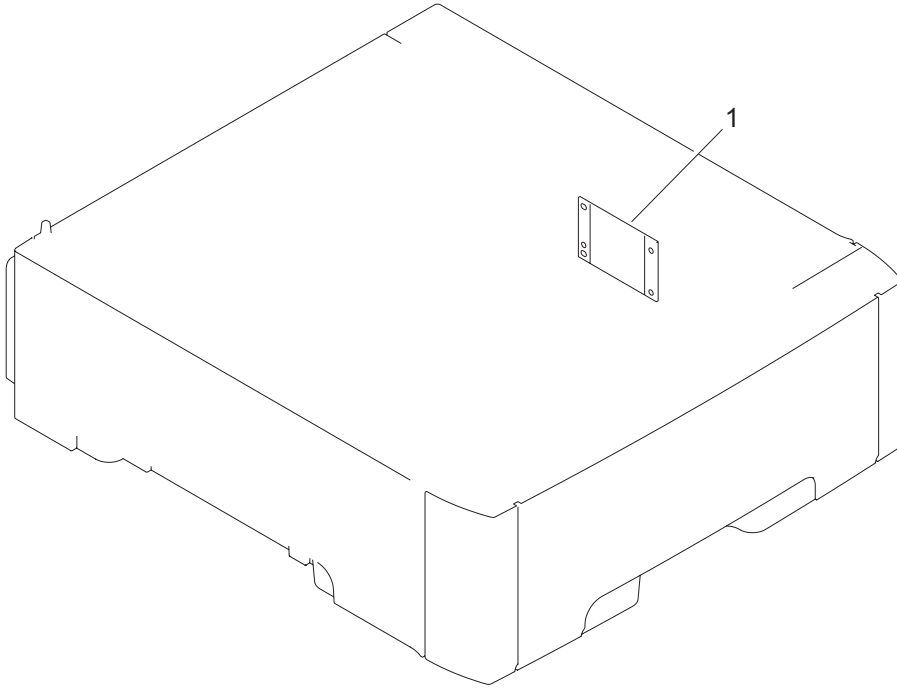

Table 7-28 500-sheet feeder PCA

| Ref | Description | Part number | Qty |
|-----|---------------------------------|----------------|-----|
| 1 | PCA assembly (500-sheet feeder) | RM1-2583-000CN | 1 |

Alphabetical parts list

Table 7-29 Alphabetical parts list

| Description | Part number | Table and page |
|---|----------------|--|
| 500-sheet feeder paper-pickup assembly | RM1-2725-000CN | 500-sheet feeder paper-pickup assembly on page 309 |
| 500-sheet cassette (only), tray 3 | RM1-2732-000CN | 500-sheet feeder cassette (tray 3) on page 307 |
| 500-sheet feeder and cassette | Q5985-67901 | 500-sheet feeder cassette (tray 3) on page 307 |
| Arm, switch-link | RC1-6700-000CN | Internal components (4 of 5) on page 275 |
| Block, Multipurpose path (HP CLJ 3000) | RC1-7959-000CN | Paper-pickup assembly (HP CLJ 3000) on page 293 |
| Bracket, left, rear | RC1-7551-000CN | Internal components (4 of 5) on page 275 |
| Bushing | RC1-6573-000CN | Internal components (1 of 5) on page 269 |
| Bushing | RC1-6823-000CN | Internal components (2 of 5) on page 271 |
| Bushing (HP CLJ 3000) | RC1-6517-000CN | Paper-pickup assembly (HP CLJ 3000) on page 293 |
| Bushing (HP CLJ 3000) | RC1-6518-000CN | Paper-pickup assembly (HP CLJ 3000) on page 293 |
| Cable, cassette | RM1-2613-000CN | Internal components (4 of 5) on page 275 |
| Cable, clamp | WT2-5944-000CN | Internal components (5 of 5) on page 277 |
| Cable, drive flat 1 | RK2-0969-000CN | Internal components (5 of 5) on page 277 |
| Cable, drive flat 2 | RK2-0970-000CN | Internal components (5 of 5) on page 277 |
| Cable, drive power | RM1-2605-000CN | Internal components (4 of 5) on page 275 |
| Cable, drum motor | RM1-2610-000Cn | Internal components (4 of 5) on page 275 |
| Cable, drum motor (HP CLJ 3000) | RM1-2629-000CN | Internal components (4 of 5) on page 275 |
| Cable, drum motor (HP CLJ 3600/3800/CP3505) | RM1-2614-000CN | Internal components (4 of 5) on page 275 |
| Cable, duplex docking | RM1-2609-000CN | Internal components (3 of 5) on page 273 |
| Cable, duplexing (duplex models) | RM1-2617-000CN | External panels, and covers (2 of 2) on page 263 |

Table 7-29 Alphabetical parts list (continued)

| Description | Part number | Table and page |
|---|----------------|--|
| Cable, duplexing (duplex models) | RM1-2616-000CN | Duplexing reverse-drive assembly (duplex models) on page 283 |
| Cable, duplexing sensor (duplex models) | RM1-2618-000CN | Duplexing reverse-drive assembly (duplex models) on page 283 |
| Cable, environment sensor | RM1-2595-000CN | Internal components (4 of 5) on page 275 |
| Cable, ETB | RM1-2608-000CN | Internal components (4 of 5) on page 275 |
| Cable, fuser drive | RM1-2619-000CN | Fuser drive assembly on page 287 |
| Cable, media sensor cassette assembly (HP CLJ 3600/3800/CP3505) | RM1-2589-000CN | Internal components (1 of 5) on page 269 |
| Cable, memory tag | RM1-2627-000CN | Internal components (2 of 5) on page 271 |
| Cable, option media sensor (500-sheet feeder) | RM1-2624-000CN | 500-sheet feeder paper-pickup assembly on page 309 |
| Cable, option sensor | RM1-2625-000CN | 500-sheet feeder paper-pickup assembly on page 309 |
| Cable, panel | RM1-2596-000CN | Internal components (1 of 5) on page 269 |
| Cable, panel connecting | RM1-2587-000CN | Internal components (5 of 5) on page 277 |
| Cable, paper-full | RM1-2628-000CN | Internal components (4 of 5) on page 275 |
| Cable, paper-full (duplex models) | RM1-2620-000CN | External panels, and covers (2 of 2) on page 263 |
| Cable, paper-full (simplex models) | RM1-2630-000CN | External panels, and covers (2 of 2) on page 263 |
| Cable, power control | RM1-2592-000CN | Internal components (5 of 5) on page 277 |
| Cable, scanner | RM1-2594-000CN | Internal components (2 of 5) on page 271 |
| Cable, scanner flat (long (HP CLJ 3000)) | RK2-0971-000CN | Internal components (2 of 5) on page 271 |
| Cable, scanner flat (long (HP CLJ 3600/3800/CP3505)) | RK2-0966-000CN | Internal components (2 of 5) on page 271 |
| Cable, scanner flat short | RK2-0967-000CN | Internal components (2 of 5) on page 271 |
| Cable, sensor | RM1-2603-000CN | Internal components (3 of 5) on page 273 |
| Cable, solenoid | RM1-2611-000CN | Internal components (4 of 5) on page 275 |

Table 7-29 Alphabetical parts list (continued)

| Description | Part number | Table and page |
|---|----------------|---|
| Cam, gear, 48T | RC1-6584-000CN | Internal components (2 of 5) on page 271 |
| Cam, slide, left | RC1-6638-000CN | Internal components (3 of 5) on page 273 |
| Cam, slide, right | RC1-6645-000CN | Internal components (1 of 5) on page 269 |
| Cartridge, guide, right assembly | RM1-2771-000CN | Internal components (1 of 5) on page 269 |
| Cartridge-sensor PCA | RM1-2585-000CN | PCAs on page 305 |
| Cassette | RM1-2702-000CN | Paper-pickup assembly (HP CLJ 3600/3800/CP3505) on page 291 |
| Cassette sensor PCA | RM1-2576-000CN | Internal components (3 of 5) on page 273 |
| Cassette, 250-sheet | RM1-2705-000CN | Cassette (tray 2) on page 289 |
| Connector, snap-tight (simplex models) | VS1-7207-003CN | External panels, and covers (2 of 2) on page 263 |
| Contact-holder assembly | RM1-2683-000CN | Internal components (1 of 5) on page 269 |
| Control panel-assembly (HP CLJ 3000) | RK2-0996-000CN | PCAs on page 305 |
| Control-panel assembly (HP CLJ 3600/3800/CP3505) | RK2-0989-000CN | PCAs on page 305 |
| Cover | RC1-7577-000CN | Internal components (5 of 5) on page 277 |
| Cover, 500-sheet cassette | RM1-2732-030CN | 500-sheet feeder cassette (tray 3) on page 307 |
| Cover, cassette rear left | RC1-6792-000CN | External panels and covers (1 of 2) on page 261 |
| Cover, cassette rear right (hinge) | RC1-6691-000CN | External panels and covers (1 of 2) on page 261 |
| Cover, cassette roller assembly (HP CLJ 3600/3800/CP3505) | RC1-6609-000CN | Paper-pickup assembly (HP CLJ 3600/3800/CP3505) on page 291 |
| Cover, cassette, front | RC1-6491-000CN | Cassette (tray 2) on page 289 |
| Cover, connector | RC1-6607-000CN | Internal components (5 of 5) on page 277 |
| Cover, crossmember, upper | RC1-6668-000CN | Internal components (2 of 5) on page 271 |
| Cover, gear | RC1-6405-000CN | Internal components (3 of 5) on page 273 |
| Cover, guide crossmember | RC1-6795-000CN | Internal components (1 of 5) on page 269 |
| Cover, left | RC1-6687-000CN | External panels and covers (1 of 2) on page 261 |

Table 7-29 Alphabetical parts list (continued)

| Description | Part number | Table and page |
|--|----------------|--|
| Cover, multipurpose tray (tray 1) | RC1-6690-000CN | External panels and covers (1 of 2) on page 261 |
| Cover, paper sensor | RC1-6611-000CN | Internal components (5 of 5) on page 277 |
| Cover, rear | RC1-6627-000CN | Internal components (5 of 5) on page 277 |
| Cover, rear lower | RC1-7550-000CN | External panels and covers (1 of 2) on page 261 |
| Cover, registration sensor | RC1-6612-000CN | Internal components (5 of 5) on page 277 |
| Cover, right | RM1-2669-000CN | External panels and covers (1 of 2) on page 261 |
| Cover, shutter, left | RC1-6651-000CN | Internal components (2 of 5) on page 271 |
| Cover, slide plate, right | RC1-6824-000CN | Internal components (1 of 5) on page 269 |
| Crossmember, drive side plate | RC1-7576-000CN | Internal components (2 of 5) on page 271 |
| DC controller PCA assembly (HP CLJ 3000) | RM1-2600-000CN | PCAs on page 305 |
| DC controller PCA assembly (HP CLJ 3600/3800/CP3505) | RM1-2580-000CN | PCAs on page 305 |
| Developing separation (estrangement) drive assembly | RM1-2687-000CN | Developing separation-drive assembly on page 285 |
| DIMM, 64 MB DDR SDRAM, HP Color LaserJet 3600 Series only | Q7800-67951 | PCAs on page 305 |
| Drive-motor assembly, print-cartridge (HP CLJ 3000: K cartridge only) | RM1-2773-000CN | Internal components (2 of 5) on page 271 |
| Drive-motor assembly, print-cartridge (HP CLJ 3600/3800/CP3505: K, Y, C, M cartridges; HP CLJ 3000: Y, C, M cartridges only) | RM1-2689-000CN | Internal components (2 of 5) on page 271 |
| Driver PCA | RM1-2581-000CN | PCAs on page 305 |
| Duct 1 | RC1-7546-000CN | Internal components (5 of 5) on page 277 |
| Duct, 2 | RC1-7547-000CN | Internal components (1 of 5) on page 269 |
| Duct, 3 | RC1-7548-000CN | Internal components (1 of 5) on page 269 |
| Duct, fan | RC1-6632-000CN | Internal components (1 of 5) on page 269 |
| Duplex page, duplex flag | RC1-6755-000CN | External panels, and covers (2 of 2) on page 263 |
| Duplex-output bin full flag | RC1-6755-000CN | Duplex-paper feed assembly (duplex models) on page 301 |
| Duplex-paper feed assembly (duplex models) | RM1-2718-030CN | Duplex-paper feed assembly (duplex models) on page 301 |

Table 7-29 Alphabetical parts list (continued)

| Description | Part number | Table and page |
|--|----------------|--|
| Duplexing PCA assembly (duplex models) | RM1-2584-000CN | PCAs on page 305 |
| Duplexing reverse-drive assembly (duplex models) | RM1-2721-000CN | Duplexing reverse-drive assembly (duplex models) on page 283 |
| Duplexing-feed drive assembly (duplex models) | RM1-2720-000CN | Duplexing-feed drive assembly (duplex models) on page 281 |
| Electronic transfer belt (duplex models) | RM1-2752-100CN | Electronic transfer belt (duplex models) on page 297 |
| Electronic transfer belt (simplex models) | RM1-2759-090CN | Electronic transfer belt (simplex models) on page 295 |
| Face-down tray assembly (HP CLJ 3000) | RM1-2777-020CN | External panels, and covers (2 of 2) on page 263 |
| Face-down tray assembly (HP CLJ 3600/3800/CP3505) | RM1-2750-020CN | External panels, and covers (2 of 2) on page 263 |
| Fan | RK2-0954-000CN | Internal components (1 of 5) on page 269 |
| Fan (duplex models) | RK2-0954-000CN | Front-cover assembly (duplex model) on page 267 |
| Firmware, Compact Flash, HP Color LaserJet 3000 Series only | Q7725-67903 | PCAs on page 305 |
| Firmware, Compact Flash, HP Color LaserJet 3600/3800 Series only | CB399-67907 | PCAs on page 305 |
| Flag, developing estrangement (developing separation) | RC1-6605-000CN | Internal components (2 of 5) on page 271 |
| Foot, rear | RC1-6650-000CN | Internal components (3 of 5) on page 273 |
| Foot, rubber assembly, front | RL1-1067-000CN | Internal components (3 of 5) on page 273 |
| Formatter, exchange, HP Color LaserJet 3000 and 3000n Series only (128 MB) | Q5982-69001 | PCAs on page 305 |
| Formatter, exchange, HP Color LaserJet 3000dn and 3000dtn Series only (256 MB) | Q5982-69002 | PCAs on page 305 |
| Formatter, exchange, HP Color LaserJet 3800 and 3800n printers only (128 MB) | Q5982-69001 | PCAs on page 305 |
| Formatter, exchange, HP Color LaserJet 3800dn and 3800dtn printers only (256 MB) | Q5982-69002 | PCAs on page 305 |
| Formatter, exchange, HP Color LaserJet CP3505 | CB441-69001 | PCAs on page 305 |
| Formatter, new, HP Color LaserJet 3000 and 3000n Series only (128 MB) | Q5982-67907 | PCAs on page 305 |
| Formatter, new, HP Color LaserJet 3000dn and 3000dtn Series only (256 MB) | Q5982-67908 | PCAs on page 305 |
| Formatter, new, HP Color LaserJet 3800 and 3800n printers only (128 MB) | Q5982-67907 | PCAs on page 305 |
| Formatter, new, HP Color LaserJet 3800dn and 3800dtn printers only (256 MB) | Q5982-67908 | PCAs on page 305 |

Table 7-29 Alphabetical parts list (continued)

| Description | Part number | Table and page |
|---|--------------------|--|
| Formatter, new, HP Color LaserJet CP3505 | CB441-67901 | PCAs on page 305 |
| Front-cover assembly (duplex models) | RM1-2715-000CN | Front-cover assembly (duplex model) on page 267 |
| Front-cover assembly (simplex models) | RM1-2673-000CN | Front-cover assembly (simplex model) on page 265 |
| Fuser assembly 110V-127V | RM1-2665-180CN | Fuser on page 303 |
| Fuser assembly 220V-240V | RM1-2743-220CN | Fuser on page 303 |
| Fuser cable assembly | RM1-2597-000CN | Internal components (4 of 5) on page 275 |
| Fuser drive assembly | RM1-2668-000CN | Fuser drive assembly on page 287 |
| Gear, 17T/41T | RC1-6596-000CN | Internal components (2 of 5) on page 271 |
| Gear, 18T (HP CLJ 3000) | RC1-6521-000CN | Paper-pickup assembly (HP CLJ 3000) on page 293 |
| Gear, 19T/30T | RC1-6593-000CN | Internal components (2 of 5) on page 271 |
| Gear, 29T | RC1-6575-000CN | Internal components (1 of 5) on page 269 |
| Gear, 31T | RC1-6594-000CN | Internal components (2 of 5) on page 271 |
| Gear, 41T | RC1-6589-000CN | Internal components (2 of 5) on page 271 |
| Gear, 58T | RC1-6571-000CN | Internal components (1 of 5) on page 269 |
| Guard, cable | RC1-6825-000CN | Internal components (4 of 5) on page 275 |
| Guide, cable, left | RC1-6681-000CN | Internal components (4 of 5) on page 275 |
| Guide, cable, right 1 | RC1-6682-000CN | Internal components (2 of 5) on page 271 |
| Guide, cable, right 3 | RC1-7544-000CN | Internal components (2 of 5) on page 271 |
| Guide, cable, right 4 | RC1-7545-000CN | Internal components (2 of 5) on page 271 |
| Guide, cartridge, left | RC1-6629-000CN | Internal components (1 of 5) on page 269 |
| Guide, duplexing external (duplex models) | RC1-6744-000CN | Internal components (1 of 5) on page 269 |
| Guide, flexible flat cable 1 | RC1-6772-000CN | Internal components (4 of 5) on page 275 |
| Guide, flexible flat cable 2 | RC1-6773-000CN | Internal components (4 of 5) on page 275 |

Table 7-29 Alphabetical parts list (continued)

| Description | Part number | Table and page |
|--|----------------|--|
| High-voltage PCA assembly | RM1-2578-000CN | PCAs on page 305 |
| Holder, drawer | RC1-6653-000CN | Internal components (4 of 5) on page 275 |
| Holder, drawer connector | RC1-6652-000CN | Internal components (4 of 5) on page 275 |
| Holder, ETB, left | RC1-6673-000CN | Internal components (3 of 5) on page 273 |
| Holder, ETB, right | RC1-6674-000CN | Internal components (3 of 5) on page 273 |
| Holder, fan | RC1-6631-000CN | Internal components (1 of 5) on page 269 |
| Holder, toner cartridge | RC1-6771-000CN | Internal components (2 of 5) on page 271 |
| I controller (formatter), HP Color LaserJet 3600 Series only | Q5987-67901 | PCAs on page 305 |
| Interlock-switch assembly | RM1-2670-000CN | External panels, and covers (2 of 2) on page 263 |
| Latch, left | RC1-7554-000CN | Internal components (1 of 5) on page 269 |
| Latch, right | RC1-7555-000CN | Internal components (1 of 5) on page 269 |
| Lever lock, left | RC1-6633-000CN | Internal components (1 of 5) on page 269 |
| Lever, lock slide, left | RC1-6636-000CN | Internal components (1 of 5) on page 269 |
| Lever, lock slide, right | RC1-6643-000CN | Internal components (1 of 5) on page 269 |
| Lever, lock, left upper | RC1-7618-000CN | Internal components (1 of 5) on page 269 |
| Lever, lock, right | RC1-6640-000CN | Internal components (1 of 5) on page 269 |
| Lever, sensing | RC1-7597-000CN | Internal components (2 of 5) on page 271 |
| Lift plate activator | RC1-6833-020CN | Cassette (tray 2) on page 289 |
| Link, multipurpose tray (tray 1) hinge left | RC1-6381-000CN | External panels and covers (1 of 2) on page 261 |
| Link, multipurpose tray (tray 1) hinge right | RC1-6382-000CN | External panels and covers (1 of 2) on page 261 |
| Low-voltage power PCA assembly (110V-127V) | RM1-4377-000CN | PCAs on page 305 |
| Low-voltage power PCA assembly (220V-240V) | RM1-4378-000CN | PCAs on page 305 |
| Lower guide assembly (duplex models) | RM1-2722-000CN | Duplex-paper feed assembly (duplex models) on page 301 |
| Main drive assembly | RM1-2751-000CN | Internal components (2 of 5) on page 271 |

Table 7-29 Alphabetical parts list (continued)

| Description | Part number | Table and page |
|---|----------------|---|
| Media sensor case | RC1-6394-000CN | Paper-pickup assembly (HP CLJ 3000) on page 293 |
| Media-sensor cassette assembly (HP CLJ 3600/3800/CP3505) | RM1-2756-000CN | Internal components (1 of 5) on page 269 |
| Motor, AC 24V, 9W | RK2-0939-000CN | Internal components (3 of 5) on page 273 |
| Motor, DC (ETB) (simplex models) | RK2-0937-000CN | Electronic transfer belt (simplex models) on page 295 |
| Mount, hinge, left | RC1-6684-000CN | Internal components (3 of 5) on page 273 |
| Multipurpose tray (tray 1) extension tray assembly | RM1-2710-000CN | External panels and covers (1 of 2) on page 261 |
| Multipurpose tray assembly (tray 1) | RM1-2711-030CN | Multipurpose tray assembly (tray 1) on page 299 |
| Multipurpose tray paper-pickup gear assembly | RM1-2704-000CN | Internal components (5 of 5) on page 277 |
| Multipurpose tray roller (HP CLJ 3600/3800/CP3505) | RM1-2741-000CN | Paper-pickup assembly (HP CLJ 3600/3800/CP3505) on page 291 |
| Multipurpose tray separation-pad assembly (HP CLJ 3600/3800/CP3505) | RM1-2699-000CN | Paper-pickup assembly (HP CLJ 3600/3800/CP3505) on page 291 |
| Paper-pickup assembly (HP CLJ 3000) | RM1-2774-060CN | Paper-pickup assembly (HP CLJ 3000) on page 293 |
| Paper-pickup assembly (HP CLJ 3600/3800/CP3505) | RM1-2755-060CN | Paper-pickup assembly (HP CLJ 3600/3800/CP3505) on page 291 |
| Paper-pickup drive assembly | RM1-2679-000CN | Paper-pickup drive assembly on page 279 |
| Paper-pickup-roller assembly (500-sheet feeder) | RM1-2727-000CN | 500-sheet feeder paper-pickup assembly on page 309 |
| PCA assembly (500-sheet feeder) | RM1-2583-000CN | 500-sheet feeder PCA on page 311 |
| Photointerruptor | RM1-2725-020CN | 500-sheet feeder paper-pickup assembly on page 309 |
| Plate lock release | RC1-6833-000CN | Internal components (3 of 5) on page 273 |
| Plate, gear 3 | RL1-1069-000CN | Internal components (3 of 5) on page 273 |
| Position-guide assembly (duplex models) | RM1-2719-000CN | Duplex-paper feed assembly (duplex models) on page 301 |
| Pre-registration ratchet (HP CLJ 3000) | RC1-6444-000CN | Paper-pickup assembly (HP CLJ 3000) on page 293 |
| Preregistration-guide assembly (HP CLJ 3000) | RM1-2775-000CN | Paper-pickup assembly (HP CLJ 3000) on page 293 |

Table 7-29 Alphabetical parts list (continued)

| Description | Part number | Table and page |
|---|----------------|--|
| Relay, PCA (HP CLJ 3000 only) | RM1-2582-000CN | Internal components (5 of 5) on page 277 |
| Relay, PCA (HP CLJ 3600/3800/CP3505 only) | RM1-2632-000CN | Internal components (5 of 5) on page 277 |
| Right-rear base assembly | RM1-2678-000CN | Internal components (3 of 5) on page 273 |
| Rod, link, left | RC1-6639-000CN | Internal components (3 of 5) on page 273 |
| Rod, link, right | RC1-6646-000CN | Internal components (3 of 5) on page 273 |
| Scanner assembly (HP CLJ 3000) | RM1-2952-000CN | Internal components (4 of 5) on page 275 |
| Scanner assembly (HP CLJ 3600/3800/CP3505) | RM1-2640-000CN | Internal components (4 of 5) on page 275 |
| Sensor, media assembly | RM1-2757-000CN | 500-sheet feeder paper-pickup assembly on page 309 |
| Sensor, temperature | WP2-5214-000CN | Internal components (4 of 5) on page 275 |
| Separation-pad assembly | RM1-2709-000CN | Cassette (tray 2) on page 289 |
| Separation-pad-holder assembly (500-sheet feeder) | RM1-2735-000CN | 500-sheet feeder cassette (tray 3) on page 307 |
| Shield, PCA | RC1-7599-000CN | Internal components (5 of 5) on page 277 |
| Simplex page-delivery flag | RC1-6286-000CN | External panels, and covers (2 of 2) on page 263 |
| Spring, compression (HP CLJ 3000) | RC1-6520-000CN | Paper-pickup assembly (HP CLJ 3000) on page 293 |
| Spring, grounding | RC1-7583-000CN | Internal components (1 of 5) on page 269 |
| Spring, grounding | RC1-6641-000CN | Internal components (1 of 5) on page 269 |
| Spring, tension | RC1-6383-000CN | External panels and covers (1 of 2) on page 261 |
| Spring, tension | RC1-6634-000CN | Internal components (1 of 5) on page 269 |
| Spring, tension | RC1-6677-000CN | Internal components (1 of 5) on page 269 |
| Spring, tension | RC1-7552-000CN | Internal components (1 of 5) on page 269 |
| Spring, tension | RC1-7598-000CN | Internal components (2 of 5) on page 271 |
| Spring, tension (HP CLJ 3000) | RM1-6516-000CN | Paper-pickup assembly (HP CLJ 3000) on page 293 |

Table 7-29 Alphabetical parts list (continued)

| Description | Part number | Table and page |
|--|----------------|--|
| Top-cover assembly (duplex models) | RM1-2713-020CN | External panels, and covers (2 of 2) on page 263 |
| Top-cover assembly (simplex models) | RM1-2672-030CN | External panels, and covers (2 of 2) on page 263 |
| Torsion spring | RC1-7628-000CN | External panels, and covers (2 of 2) on page 263 |
| Upper cover assembly (fuser door) (duplex models) | RM1-2714-000CN | External panels, and covers (2 of 2) on page 263 |
| Upper cover assembly (fuser door) (simplex models) | RM1-2671-000CN | External panels, and covers (2 of 2) on page 263 |

Numerical parts list

Table 7-30 Numerical parts list

| Part number | Description | Table and page |
|----------------|--|--|
| CB399-67907 | Firmware, Compact Flash, HP Color LaserJet 3600/3800 Series only | PCAs on page 305 |
| CB441-67901 | Formatter, new, HP Color LaserJet CP3505 | PCAs on page 305 |
| CB441-69001 | Formatter, exchange, HP Color LaserJet CP3505 | PCAs on page 305 |
| Q5982-67907 | Formatter, new, HP Color LaserJet 3000 and 3000n Series only (128 MB) | PCAs on page 305 |
| Q5982-67907 | Formatter, new, HP Color LaserJet 3800 and 3800n printers only (128 MB) | PCAs on page 305 |
| Q5982-67908 | Formatter, new, HP Color LaserJet 3000dn and 3000dtn Series only (256 MB) | PCAs on page 305 |
| Q5982-67908 | Formatter, new, HP Color LaserJet 3800dn and 3800dtn printers only (256 MB) | PCAs on page 305 |
| Q5982-69001 | Formatter, exchange, HP Color LaserJet 3000 and 3000n Series only (128 MB) | PCAs on page 305 |
| Q5982-69001 | Formatter, exchange, HP Color LaserJet 3800 and 3800n printers only (128 MB) | PCAs on page 305 |
| Q5982-69002 | Formatter, exchange, HP Color LaserJet 3000dn and 3000dtn Series only (256 MB) | PCAs on page 305 |
| Q5982-69002 | Formatter, exchange, HP Color LaserJet 3800dn and 3800dtn printers only (256 MB) | PCAs on page 305 |
| Q5985-67901 | 500-sheet feeder and cassette | 500-sheet feeder cassette (tray 3) on page 307 |
| Q5987-67901 | I controller (formatter), HP Color LaserJet 3600 Series only | PCAs on page 305 |
| Q7725-67903 | Firmware, Compact Flash, HP Color LaserJet 3000 Series only | PCAs on page 305 |
| Q7800-67951 | DIMM, 64 MB DDR SDRAM, HP Color LaserJet 3600 Series only | PCAs on page 305 |
| RC1-6286-000CN | Simplex page-delivery flag | External panels, and covers (2 of 2) on page 263 |
| RC1-6381-000CN | Link, multipurpose tray (tray 1) hinge left | External panels and covers (1 of 2) on page 261 |
| RC1-6382-000CN | Link, multipurpose tray (tray 1) hinge right | External panels and covers (1 of 2) on page 261 |
| RC1-6383-000CN | Spring, tension | External panels and covers (1 of 2) on page 261 |
| RC1-6394-000CN | Media sensor case | Paper-pickup assembly (HP CLJ 3000) on page 293 |
| RC1-6405-000CN | Cover, gear | Internal components (3 of 5) on page 273 |
| RC1-6444-000CN | Pre-registration ratchet (HP CLJ 3000) | Paper-pickup assembly (HP CLJ 3000) on page 293 |
| RC1-6491-000CN | Cover, cassette, front | Cassette (tray 2) on page 289 |

Table 7-30 Numerical parts list (continued)

| Part number | Description | Table and page |
|--------------------|---|---|
| RC1-6517-000CN | Bushing (HP CLJ 3000) | Paper-pickup assembly (HP CLJ 3000) on page 293 |
| RC1-6518-000CN | Bushing (HP CLJ 3000) | Paper-pickup assembly (HP CLJ 3000) on page 293 |
| RC1-6520-000CN | Spring, compression (HP CLJ 3000) | Paper-pickup assembly (HP CLJ 3000) on page 293 |
| RC1-6521-000CN | Gear, 18T (HP CLJ 3000) | Paper-pickup assembly (HP CLJ 3000) on page 293 |
| RC1-6573-000CN | Bushing | Internal components (1 of 5) on page 269 |
| RC1-6575-000CN | Gear, 29T | Internal components (1 of 5) on page 269 |
| RC1-6584-000CN | Cam, gear. 48T | Internal components (2 of 5) on page 271 |
| RC1-6589-000CN | Gear, 41T | Internal components (2 of 5) on page 271 |
| RC1-6593-000CN | Gear, 19T/30T | Internal components (2 of 5) on page 271 |
| RC1-6594-000CN | Gear, 31T | Internal components (2 of 5) on page 271 |
| RC1-6596-000CN | Gear, 17T/41T | Internal components (2 of 5) on page 271 |
| RC1-6605-000CN | Flag, developing estrangement (developing separation) | Internal components (2 of 5) on page 271 |
| RC1-6607-000CN | Cover, connector | Internal components (5 of 5) on page 277 |
| RC1-6609-000CN | Cover, cassette roller assembly (HP CLJ 3600/3800/CP3505) | Paper-pickup assembly (HP CLJ 3600/3800/CP3505) on page 291 |
| RC1-6611-000CN | Cover, paper sensor | Internal components (5 of 5) on page 277 |
| RC1-6612-000CN | Cover, registration sensor | Internal components (5 of 5) on page 277 |
| RC1-6627-000CN | Cover, rear | Internal components (5 of 5) on page 277 |
| RC1-6629-000CN | Guide, cartridge, left | Internal components (1 of 5) on page 269 |
| RC1-6631-000CN | Holder, fan | Internal components (1 of 5) on page 269 |
| RC1-6632-000CN | Duct, fan | Internal components (1 of 5) on page 269 |
| RC1-6633-000CN | Lever lock, left | Internal components (1 of 5) on page 269 |
| RC1-6634-000CN | Spring, tension | Internal components (1 of 5) on page 269 |

Table 7-30 Numerical parts list (continued)

| Part number | Description | Table and page |
|--------------------|------------------------------------|---|
| RC1-6636-000CN | Lever, lock slide, left | Internal components (1 of 5) on page 269 |
| RC1-6638-000CN | Cam, slide, left | Internal components (3 of 5) on page 273 |
| RC1-6639-000CN | Rod, link, left | Internal components (3 of 5) on page 273 |
| RC1-6640-000CN | Lever, lock, right | Internal components (1 of 5) on page 269 |
| RC1-6641-000CN | Spring, grounding | Internal components (1 of 5) on page 269 |
| RC1-6643-000CN | Lever, lock slide, right | Internal components (1 of 5) on page 269 |
| RC1-6645-000CN | Cam, slide, right | Internal components (1 of 5) on page 269 |
| RC1-6646-000CN | Rod, link, right | Internal components (3 of 5) on page 273 |
| RC1-6650-000CN | Foot, rear | Internal components (3 of 5) on page 273 |
| RC1-6651-000CN | Cover, shutter, left | Internal components (2 of 5) on page 271 |
| RC1-6652-000CN | Holder, drawer connector | Internal components (4 of 5) on page 275 |
| RC1-6653-000CN | Holder, drawer | Internal components (4 of 5) on page 275 |
| RC1-6668-000CN | Cover, crossmember, upper | Internal components (2 of 5) on page 271 |
| RC1-6673-000CN | Holder, ETB, left | Internal components (3 of 5) on page 273 |
| RC1-6674-000CN | Holder, ETB, right | Internal components (3 of 5) on page 273 |
| RC1-6677-000CN | Spring, tension | Internal components (1 of 5) on page 269 |
| RC1-6681-000CN | Guide, cable, left | Internal components (4 of 5) on page 275 |
| RC1-6682-000CN | Guide, cable, right 1 | Internal components (2 of 5) on page 271 |
| RC1-6684-000CN | Mount, hinge, left | Internal components (3 of 5) on page 273 |
| RC1-6687-000CN | Cover, left | External panels and covers (1 of 2) on page 261 |
| RC1-6690-000CN | Cover, multipurpose tray (tray 1) | External panels and covers (1 of 2) on page 261 |
| RC1-6691-000CN | Cover, cassette rear right (hinge) | External panels and covers (1 of 2) on page 261 |

Table 7-30 Numerical parts list (continued)

| Part number | Description | Table and page |
|--------------------|---|--|
| RC1-6700-000CN | Arm, switch-link | Internal components (4 of 5) on page 275 |
| RC1-6744-000CN | Guide, duplexing external (duplex models) | Internal components (1 of 5) on page 269 |
| RC1-6755-000CN | Duplex page, duplex flag | External panels, and covers (2 of 2) on page 263 |
| RC1-6755-000CN | Duplex-output bin full flag | Duplex-paper feed assembly (duplex models) on page 301 |
| RC1-6771-000CN | Holder, toner cartridge | Internal components (2 of 5) on page 271 |
| RC1-6772-000CN | Guide, flexible flat cable 1 | Internal components (4 of 5) on page 275 |
| RC1-6773-000CN | Guide, flexible flat cable 2 | Internal components (4 of 5) on page 275 |
| RC1-6792-000CN | Cover, cassette rear left | External panels and covers (1 of 2) on page 261 |
| RC1-6795-000CN | Cover, guide crossmember | Internal components (1 of 5) on page 269 |
| RC1-6823-000CN | Bushing | Internal components (2 of 5) on page 271 |
| RC1-6824-000CN | Cover, slide plate, right | Internal components (1 of 5) on page 269 |
| RC1-6825-000CN | Guard, cable | Internal components (4 of 5) on page 275 |
| RC1-6833-000CN | Plate lock release | Internal components (3 of 5) on page 273 |
| RC1-6833-020CN | Lift plate activator | Cassette (tray 2) on page 289 |
| RC1-7544-000CN | Guide, cable, right 3 | Internal components (2 of 5) on page 271 |
| RC1-7545-000CN | Guide, cable, right 4 | Internal components (2 of 5) on page 271 |
| RC1-7546-000CN | Duct 1 | Internal components (5 of 5) on page 277 |
| RC1-7547-000CN | Duct, 2 | Internal components (1 of 5) on page 269 |
| RC1-7548-000CN | Duct, 3 | Internal components (1 of 5) on page 269 |
| RC1-7550-000CN | Cover, rear lower | External panels and covers (1 of 2) on page 261 |
| RC1-7551-000CN | Bracket, left, rear | Internal components (4 of 5) on page 275 |
| RC1-7552-000CN | Spring, tension | Internal components (1 of 5) on page 269 |

Table 7-30 Numerical parts list (continued)

| Part number | Description | Table and page |
|----------------|--|---|
| RC1-7554-000CN | Latch, left | Internal components (1 of 5) on page 269 |
| RC1-7555-000CN | Latch, right | Internal components (1 of 5) on page 269 |
| RC1-7576-000CN | Crossmember, drive side plate | Internal components (2 of 5) on page 271 |
| RC1-7577-000CN | Cover | Internal components (5 of 5) on page 277 |
| RC1-7583-000CN | Spring, grounding | Internal components (1 of 5) on page 269 |
| RC1-7597-000CN | Lever, sensing | Internal components (2 of 5) on page 271 |
| RC1-7598-000CN | Spring, tension | Internal components (2 of 5) on page 271 |
| RC1-7599-000CN | Shield, PCA | Internal components (5 of 5) on page 277 |
| RC1-7618-000CN | Lever, lock, left upper | Internal components (1 of 5) on page 269 |
| RC1-7628-000CN | Torsion spring | External panels, and covers (2 of 2) on page 263 |
| RC1-7959-000CN | Block, Multipurpose path (HP CLJ 3000) | Paper-pickup assembly (HP CLJ 3000) on page 293 |
| RC1-6571-000CN | Gear, 58T | Internal components (1 of 5) on page 269 |
| RK2-0937-000CN | Motor, DC (ETB) (simplex models) | Electronic transfer belt (simplex models) on page 295 |
| RK2-0939-000CN | Motor, AC 24V, 9W | Internal components (3 of 5) on page 273 |
| RK2-0954-000CN | Fan (duplex models) | Front-cover assembly (duplex model) on page 267 |
| RK2-0954-000CN | Fan | Internal components (1 of 5) on page 269 |
| RK2-0966-000CN | Cable, scanner flat (long (HP CLJ 3600/3800/CP3505)) | Internal components (2 of 5) on page 271 |
| RK2-0967-000CN | Cable, scanner flat short | Internal components (2 of 5) on page 271 |
| RK2-0969-000CN | Cable, drive flat 1 | Internal components (5 of 5) on page 277 |
| RK2-0970-000CN | Cable, drive flat 2 | Internal components (5 of 5) on page 277 |
| RK2-0971-000CN | Cable, scanner flat (long (HP CLJ 3000)) | Internal components (2 of 5) on page 271 |
| RK2-0989-000CN | Control-panel assembly (HP CLJ 3600/3800/CP3505) | PCAs on page 305 |
| RK2-0996-000CN | Control panel-assembly (HP CLJ 3000) | PCAs on page 305 |

Table 7-30 Numerical parts list (continued)

| Part number | Description | Table and page |
|--------------------|---|--|
| RL1-1067-000CN | Foot, rubber assembly, front | Internal components (3 of 5) on page 273 |
| RL1-1069-000CN | Plate, gear 3 | Internal components (3 of 5) on page 273 |
| RM1-2576-000CN | Cassette sensor PCA | Internal components (3 of 5) on page 273 |
| RM1-2578-000CN | High-voltage PCA assembly | PCAs on page 305 |
| RM1-2580-000CN | DC controller PCA assembly (HP CLJ 3600/3800/CP3505) | PCAs on page 305 |
| RM1-2581-000CN | Driver PCA | PCAs on page 305 |
| RM1-2582-000CN | Relay, PCA (HP CLJ 3000 only) | Internal components (5 of 5) on page 277 |
| RM1-2583-000CN | PCA assembly (500-sheet feeder) | 500-sheet feeder PCA on page 311 |
| RM1-2584-000CN | Duplexing PCA assembly (duplex models) | PCAs on page 305 |
| RM1-2585-000CN | Cartridge-sensor PCA | PCAs on page 305 |
| RM1-2587-000CN | Cable, panel connecting | Internal components (5 of 5) on page 277 |
| RM1-2589-000CN | Cable, media sensor cassette assembly (HP CLJ 3600/3800/CP3505) | Internal components (1 of 5) on page 269 |
| RM1-2592-000CN | Cable, power control | Internal components (5 of 5) on page 277 |
| RM1-2594-000CN | Cable, scanner | Internal components (2 of 5) on page 271 |
| RM1-2595-000CN | Cable, environment sensor | Internal components (4 of 5) on page 275 |
| RM1-2596-000CN | Cable, panel | Internal components (1 of 5) on page 269 |
| RM1-2597-000CN | Fuser cable assembly | Internal components (4 of 5) on page 275 |
| RM1-2600-000CN | DC controller PCA assembly (HP CLJ 3000) | PCAs on page 305 |
| RM1-2603-000CN | Cable, sensor | Internal components (3 of 5) on page 273 |
| RM1-2605-000CN | Cable, drive power | Internal components (4 of 5) on page 275 |
| RM1-2608-000CN | Cable, ETB | Internal components (4 of 5) on page 275 |
| RM1-2609-000CN | Cable, duplex docking | Internal components (3 of 5) on page 273 |
| RM1-2610-000Cn | Cable, drum motor | Internal components (4 of 5) on page 275 |
| RM1-2611-000CN | Cable, solenoid | Internal components (4 of 5) on page 275 |

Table 7-30 Numerical parts list (continued)

| Part number | Description | Table and page |
|----------------|--|--|
| RM1-2613-000CN | Cable, cassette | Internal components (4 of 5) on page 275 |
| RM1-2614-000CN | Cable, drum motor (HP CLJ 3600/3800/CP3505) | Internal components (4 of 5) on page 275 |
| RM1-2616-000CN | Cable, duplexing (duplex models) | Duplexing reverse-drive assembly (duplex models) on page 283 |
| RM1-2617-000CN | Cable, duplexing (duplex models) | External panels, and covers (2 of 2) on page 263 |
| RM1-2618-000CN | Cable, duplexing sensor (duplex models) | Duplexing reverse-drive assembly (duplex models) on page 283 |
| RM1-2619-000CN | Cable, fuser drive | Fuser drive assembly on page 287 |
| RM1-2620-000CN | Cable, paper-full (duplex models) | External panels, and covers (2 of 2) on page 263 |
| RM1-2624-000CN | Cable, option media sensor (500-sheet feeder) | 500-sheet feeder paper-pickup assembly on page 309 |
| RM1-2625-000CN | Cable, option sensor | 500-sheet feeder paper-pickup assembly on page 309 |
| RM1-2627-000CN | Cable, memory tag | Internal components (2 of 5) on page 271 |
| RM1-2628-000CN | Cable, paper-full | Internal components (4 of 5) on page 275 |
| RM1-2629-000CN | Cable, drum motor (HP CLJ 3000) | Internal components (4 of 5) on page 275 |
| RM1-2630-000CN | Cable, paper-full (simplex models) | External panels, and covers (2 of 2) on page 263 |
| RM1-2632-000CN | Relay, PCA (HP CLJ 3600/3800/CP3505 only) | Internal components (5 of 5) on page 277 |
| RM1-2640-000CN | Scanner assembly (HP CLJ 3600/3800/CP3505) | Internal components (4 of 5) on page 275 |
| RM1-2665-180CN | Fuser assembly 110V-127V | Fuser on page 303 |
| RM1-2668-000CN | Fuser drive assembly | Fuser drive assembly on page 287 |
| RM1-2670-000CN | Interlock-switch assembly | External panels, and covers (2 of 2) on page 263 |
| RM1-2671-000CN | Upper cover assembly (fuser door) (simplex models) | External panels, and covers (2 of 2) on page 263 |
| RM1-2672-030CN | Top-cover assembly (simplex models) | External panels, and covers (2 of 2) on page 263 |
| RM1-2673-000CN | Front-cover assembly (simplex models) | Front-cover assembly (simplex model) on page 265 |
| RM1-2678-000CN | Right-rear base assembly | Internal components (3 of 5) on page 273 |

Table 7-30 Numerical parts list (continued)

| Part number | Description | Table and page |
|--------------------|--|--|
| RM1-2679-000CN | Paper-pickup drive assembly | Paper-pickup drive assembly on page 279 |
| RM1-2683-000CN | Contact-holder assembly | Internal components (1 of 5) on page 269 |
| RM1-2687-000CN | Developing separation (estrangement) drive assembly | Developing separation-drive assembly on page 285 |
| RM1-2689-000CN | Drive-motor assembly, print-cartridge (HP CLJ 3600/3800/CP3505: K, Y, C, M cartridges; HP CLJ 3000: Y, C, M cartridges only) | Internal components (2 of 5) on page 271 |
| RM1-2699-000CN | Multipurpose tray separation-pad assembly (HP CLJ 3600/3800/CP3505) | Paper-pickup assembly (HP CLJ 3600/3800/CP3505) on page 291 |
| RM1-2702-000CN | Cassette | Paper-pickup assembly (HP CLJ 3600/3800/CP3505) on page 291 |
| RM1-2704-000CN | Multipurpose tray paper-pickup gear assembly | Internal components (5 of 5) on page 277 |
| RM1-2705-000CN | Cassette, 250-sheet | Cassette (tray 2) on page 289 |
| RM1-2709-000CN | Separation-pad assembly | Cassette (tray 2) on page 289 |
| RM1-2710-000CN | Multipurpose tray (tray 1) extension tray assembly | External panels and covers (1 of 2) on page 261 |
| RM1-2711-030CN | Multipurpose tray assembly (tray 1) | Multipurpose tray assembly (tray 1) on page 299 |
| RM1-2713-020CN | Top-cover assembly (duplex models) | External panels, and covers (2 of 2) on page 263 |
| RM1-2714-000CN | Upper cover assembly (fuser door) (duplex models) | External panels, and covers (2 of 2) on page 263 |
| RM1-2715-000CN | Front-cover assembly (duplex models) | Front-cover assembly (duplex model) on page 267 |
| RM1-2718-030CN | Duplex-paper feed assembly (duplex models) | Duplex-paper feed assembly (duplex models) on page 301 |
| RM1-2719-000CN | Position-guide assembly (duplex models) | Duplex-paper feed assembly (duplex models) on page 301 |
| RM1-2720-000CN | Duplexing-feed drive assembly (duplex models) | Duplexing-feed drive assembly (duplex models) on page 281 |
| RM1-2721-000CN | Duplexing reverse-drive assembly (duplex models) | Duplexing reverse-drive assembly (duplex models) on page 283 |
| RM1-2722-000CN | Lower guide assembly (duplex models) | Duplex-paper feed assembly (duplex models) on page 301 |
| RM1-2725-000CN | 500-sheet feeder paper-pickup assembly | 500-sheet feeder paper-pickup assembly on page 309 |
| RM1-2725-020CN | Photointerruptor | 500-sheet feeder paper-pickup assembly on page 309 |

Table 7-30 Numerical parts list (continued)

| Part number | Description | Table and page |
|----------------|---|---|
| RM1-2732-000CN | 500-sheet cassette (only), tray 3 | 500-sheet feeder cassette (tray 3) on page 307 |
| RM1-2732-030CN | Cover, 500-sheet cassette | 500-sheet feeder cassette (tray 3) on page 307 |
| RM1-2735-000CN | Separation-pad-holder assembly (500-sheet feeder) | 500-sheet feeder cassette (tray 3) on page 307 |
| RM1-2741-000CN | Multipurpose tray roller (HP CLJ 3600/3800/CP3505) | Paper-pickup assembly (HP CLJ 3600/3800/CP3505) on page 291 |
| RM1-2743-220CN | Fuser assembly 220V-240V | Fuser on page 303 |
| RM1-2750-020CN | Face-down tray assembly (HP CLJ 3600/3800/CP3505) | External panels, and covers (2 of 2) on page 263 |
| RM1-2751-000CN | Main drive assembly | Internal components (2 of 5) on page 271 |
| RM1-2752-100CN | Electronic transfer belt (duplex models) | Electronic transfer belt (duplex models) on page 297 |
| RM1-2755-060CN | Paper-pickup assembly (HP CLJ 3600/3800/CP3505) | Paper-pickup assembly (HP CLJ 3600/3800/CP3505) on page 291 |
| RM1-2756-000CN | Media-sensor cassette assembly (HP CLJ 3600/3800/CP3505) | Internal components (1 of 5) on page 269 |
| RM1-2757-000CN | Sensor, media assembly | 500-sheet feeder paper-pickup assembly on page 309 |
| RM1-2759-090CN | Electronic transfer belt (simplex models) | Electronic transfer belt (simplex models) on page 295 |
| RM1-2771-000CN | Cartridge, guide, right assembly | Internal components (1 of 5) on page 269 |
| RM1-2773-000CN | Drive-motor assembly, print-cartridge (HP CLJ 3000: K cartridge only) | Internal components (2 of 5) on page 271 |
| RM1-2774-060CN | Paper-pickup assembly (HP CLJ 3000) | Paper-pickup assembly (HP CLJ 3000) on page 293 |
| RM1-2775-000CN | Preregistration-guide assembly (HP CLJ 3000) | Paper-pickup assembly (HP CLJ 3000) on page 293 |
| RM1-2777-020CN | Face-down tray assembly (HP CLJ 3000) | External panels, and covers (2 of 2) on page 263 |
| RM1-2952-000CN | Scanner assembly (HP CLJ 3000) | Internal components (4 of 5) on page 275 |
| RM1-4377-000CN | Low-voltage power PCA assembly (110V-127V) | PCAs on page 305 |
| RM1-4378-000CN | Low-voltage power PCA assembly (220V-240V) | PCAs on page 305 |
| RM1-6516-000CN | Spring, tension (HP CLJ 3000) | Paper-pickup assembly (HP CLJ 3000) on page 293 |
| RM1-2669-000CN | Cover, right | External panels and covers (1 of 2) on page 261 |

Table 7-30 Numerical parts list (continued)

| Part number | Description | Table and page |
|--------------------|---|--|
| RM1-2727-000CN | Paper-pickup-roller assembly (500-sheet feeder) | 500-sheet feeder paper-pickup assembly on page 309 |
| VS1-7207-003CN | Connector, snap-tight (simplex models) | External panels, and covers (2 of 2) on page 263 |
| WP2-5214-000CN | Sensor, temperature | Internal components (4 of 5) on page 275 |
| WT2-5944-000CN | Cable, clamp | Internal components (5 of 5) on page 277 |

A Printer specifications

- [Electrical specifications](#)
- [Power-consumption specifications](#)
- [Acoustic specifications](#)
- [Operating-environment specifications](#)

Electrical specifications

⚠ WARNING! Power requirements are based on the country/region where the printer is sold. Do not convert operating voltages. This can damage the printer and void the product warranty.

Table A-1 Electrical specifications for the HP Color LaserJet 3000 Series printers

| Item | 110-volt models | 220-volt models |
|--------------------------------------|-----------------------|-----------------------|
| Power requirements | 100 to 127 V (+/-10%) | 220 to 240 V (+/-10%) |
| | 50 to 60 Hz (+/-2 Hz) | 50 to 60 Hz (+/-2 Hz) |
| Minimum recommended circuit capacity | 6.5 A | 3.5 A |

Table A-2 Electrical specifications for the HP Color LaserJet 3600 Series printer

| Item | 110-volt models | 220-volt models |
|--------------------------------------|-----------------------|-----------------------|
| Power requirements | 100 to 127 V (+/-10%) | 220 to 240 V (+/-10%) |
| | 50 to 60 Hz (+/-2 Hz) | 50 to 60 Hz (+/-2 Hz) |
| Minimum recommended circuit capacity | 6.5 A | 3.5 A |

Table A-3 Electrical specifications for the HP Color LaserJet 3800 and HP Color LaserJet CP3505 Series printers

| Item | 110-volt models | 220-volt models |
|--------------------------------------|-----------------------|-----------------------|
| Power requirements | 100 to 127 V (+/-10%) | 220 to 240 V (+/-10%) |
| | 50 to 60 Hz (+/-2 Hz) | 50 to 60 Hz (+/-2 Hz) |
| Minimum recommended circuit capacity | 6.5 A | 3.5 A |

Power-consumption specifications

Table A-4 Power consumption (average, in watts)¹

| Product Model | Printing ² | Ready ³ | Sleep ⁴ | Off | Heat output-Ready (BTU/hour) ⁵ |
|----------------------------|-----------------------|--------------------|--------------------|-----|---|
| HP Color LaserJet 3000 | 409 | 29 | 13 | 0.5 | 100 |
| HP Color LaserJet 3000n | 409 | 29 | 13 | 0.5 | 100 |
| HP Color LaserJet 3000dn | 409 | 29 | 13 | 0.5 | 100 |
| HP Color LaserJet 3000dtn | 409 | 29 | 13 | 0.5 | 100 |
| HP Color LaserJet 3600 | 337 | 51 | 15 | 0.5 | 171 |
| HP Color LaserJet 3600n | 337 | 51 | 15 | 0.5 | 171 |
| HP Color LaserJet 3600dn | 337 | 51 | 15 | 0.5 | 171 |
| HP Color LaserJet 3800 | 437 | 48 | 15 | 0.5 | 162 |
| HP Color LaserJet CP3505 | | | | | |
| HP Color LaserJet 3800n | 437 | 48 | 15 | 0.5 | 162 |
| HP Color LaserJet CP3505n | | | | | |
| HP Color LaserJet 3800dn | 437 | 48 | 15 | 0.5 | 162 |
| HP Color LaserJet CP3505dn | | | | | |
| HP Color LaserJet 3800dtn | 407 | 46 | 15 | 0.7 | 162 |
| HP Color LaserJet CP3505x | | | | | |

- ¹ The power consumption reflects the highest values measured for color and monochrome printing when using standard voltages.
- ² HP Color LaserJet 3000: The printing speed is 15 ppm for letter-size media and 29 ppm for A4-size media. HP Color LaserJet 3600: The printing speed is 17 ppm for letter-size media and 17 ppm for A4-size media. HP Color LaserJet 3800 and CP3505: The printing speed is 20 ppm for letter-size media and 21 ppm for A4-size media.
- ³ The default activation time from ready mode to sleep mode is 30 minutes.
- ⁴ The recovery time from sleep mode to the start of printing is 6 seconds.
- ⁵ Maximum heat dissipation for all models in ready mode is 171 BTU per hour.

 **NOTE:** These values are subject to change.

Acoustic specifications

Table A-5 Acoustic emissions for the HP Color LaserJet 3000 Series printers¹

| Sound power level | Declared per ISO 9296 |
|--|--------------------------------------|
| Printing (15 ppm) ² | $L_{wAd} = 6.9$ Bels (A) [69 dB (A)] |
| Ready | $L_{wAd} = 5.3$ Bels (A) [53 dB (A)] |
| Sound pressure level: bystander position | Declared per ISO 9296 |
| Printing (15 ppm) ² | $L_{pAm} = 55$ dB (A) |
| Ready | $L_{pAm} = 39$ dB (A) |

¹ The HP Color LaserJet 3000dn was tested in simplex mode with A4-size media.

² The color printing speed is 15 ppm for letter-size media and A4-size media. The monochrome printing speed is 30 ppm for letter-size media and 29 ppm for A4-size media.

Table A-6 Acoustic emissions for the HP Color LaserJet 3600 Series printer¹

| Sound power level | Declared per ISO 9296 |
|--|--------------------------------------|
| Printing (17 ppm) ² | $L_{wAd} = 6.4$ Bels (A) [64 dB (A)] |
| Sound pressure level: bystander position | Declared per ISO 9296 |
| Printing (17 ppm) ² | $L_{pAm} = 49$ dB (A) |

¹ The HP Color LaserJet 3600 printer was tested in simplex monochrome mode with A4-size media.

² The printing speed is 17 ppm for letter-size media and 17 ppm for A4-size media.

Table A-7 Acoustic emissions for the HP Color LaserJet 3800 and HP Color LaserJet CP3505 Series printers¹

| Sound power level | Declared per ISO 9296 |
|--|--------------------------------------|
| Printing (20 ppm) ² | $L_{wAd} = 6.4$ Bels (A) [64 dB (A)] |
| Ready | $L_{wAd} = 5.4$ Bels (A) [54 dB (A)] |
| Sound pressure level: bystander position | Declared per ISO 9296 |
| Printing (20 ppm) ² | $L_{pAm} = 50$ dB (A) |
| Ready | $L_{pAm} = 40$ dB (A) |

¹ The HP Color LaserJet 3800n was tested in simplex mode with A4-size media.

² The printing speed is 20 ppm for letter-size media and 21 ppm for A4-size media.

 **NOTE:** These values are subject to change.

Operating-environment specifications

Table A-8 Operating environment specifications

| Environment | Recommended | Allowed |
|-------------|----------------------------------|------------------------------|
| Temperature | 17 to 25°C (62.6 to 77°F) | 10 to 27°C (50 to 81°F) |
| Humidity | 20 to 60% relative humidity (RH) | 10 to 70% RH |
| Altitude | Not applicable | 0 to 2,600 m (0 to 8,530 ft) |

 **NOTE:** These values are subject to change.

B Product warranty statements

- [Hewlett-Packard Limited Warranty Statement](#)
- [Availability of support and service](#)
- [HP maintenance agreements](#)

Hewlett-Packard Limited Warranty Statement

| HP PRODUCT | DURATION OF LIMITED WARRANTY |
|---|------------------------------|
| HP 3000/3600/3800/CP3505 Series printer | 1 year, Onsite service |

HP warrants to you, the end-user customer, that HP hardware and accessories will be free from defects in materials and workmanship after the date of purchase, for the period specified above. If HP receives notice of such defects during the warranty period, HP will, at its option, either repair or replace products which prove to be defective. Replacement products might be either new or equivalent in performance to new.

HP warrants to you that HP software will not fail to execute its programming instructions after the date of purchase, for the period specified above, due to defects in material and workmanship when properly installed and used. If HP receives notice of such defects during the warranty period, HP will replace software which does not execute its programming instructions due to such defects.

HP does not warrant that the operation of HP products will be uninterrupted or error free. If HP is unable, within a reasonable time, to repair or replace any product to a condition as warranted, you will be entitled to a refund of the purchase price upon prompt return of the product.

HP products might contain remanufactured parts equivalent to new in performance or might have been subject to incidental use.

Warranty does not apply to defects resulting from (a) improper or inadequate maintenance or calibration, (b) software, interfacing, parts or supplies not supplied by HP, (c) unauthorized modification or misuse, (d) operation outside of the published environmental specifications for the product, or (e) improper site preparation or maintenance.

TO THE EXTENT ALLOWED BY LOCAL LAW, THE ABOVE WARRANTIES ARE EXCLUSIVE AND NO OTHER WARRANTY OR CONDITION, WHETHER WRITTEN OR ORAL, IS EXPRESSED OR IMPLIED AND HP SPECIFICALLY DISCLAIMS ANY IMPLIED WARRANTIES OR CONDITIONS OF MERCHANTABILITY, SATISFACTORY QUALITY, AND FITNESS FOR A PARTICULAR PURPOSE. Some countries/regions, states or provinces do not allow limitations on the duration of an implied warranty, so the above limitation or exclusion might not apply to you. This warranty gives you specific legal rights and you might also have other rights that vary from country/region to country/region, state to state, or province to province. HP's limited warranty is valid in any country/region or locality where HP has a support presence for this product and where HP has marketed this product. The level of warranty service you receive might vary according to local standards. HP will not alter form, fit or function of the product to make it operate in a country/region for which it was never intended to function for legal or regulatory reasons.

TO THE EXTENT ALLOWED BY LOCAL LAW, THE REMEDIES IN THIS WARRANTY STATEMENT ARE YOUR SOLE AND EXCLUSIVE REMEDIES. EXCEPT AS INDICATED ABOVE, IN NO EVENT WILL HP OR ITS SUPPLIERS BE LIABLE FOR LOSS OF DATA OR FOR DIRECT, SPECIAL, INCIDENTAL, CONSEQUENTIAL (INCLUDING LOST PROFIT OR DATA), OR OTHER DAMAGE, WHETHER BASED IN CONTRACT, TORT, OR OTHERWISE. Some countries/regions, states or provinces do not allow the exclusion or limitation of incidental or consequential damages, so the above limitation or exclusion might not apply to you.

THE WARRANTY TERMS CONTAINED IN THIS STATEMENT, EXCEPT TO THE EXTENT LAWFULLY PERMITTED, DO NOT EXCLUDE, RESTRICT OR MODIFY AND ARE IN ADDITION TO THE MANDATORY STATUTORY RIGHTS APPLICABLE TO THE SALE OF THIS PRODUCT TO YOU.

Availability of support and service

Around the world, HP provides a variety of service and support options for purchase. Availability of these programs will vary depending upon your location.

HP maintenance agreements

Hewlett-Packard Company has several types of maintenance agreements that meet a wide range of support needs. Maintenance agreements are not part of the standard warranty. Support services vary by location. Contact HP Customer Care to determine the services that are available and for more information about maintenance agreements. In general, the printer will have the following maintenance agreement:

Next-Day Onsite Service

This agreement provides support by the next working day following a service request. Extended coverage hours and extended travel beyond HP's designated service zones are available on most onsite agreements (for additional charges).

C Regulatory statements

- [FCC regulations](#)
- [Declaration of conformity \(HP Color LaserJet 3000 Series printer\)](#)
- [Declaration of conformity \(HP Color LaserJet 3600 Series and HP Color LaserJet 3800 Series printer\)](#)
- [Declaration of conformity \(HP Color LaserJet CP3505 Series printer\)](#)
- [Safety statements](#)

FCC regulations

This equipment has been tested and found to comply with the limits for a Class B digital device, pursuant to Part 15 of the FCC rules. These limits are designed to provide reasonable protection against harmful interference in a residential installation. This equipment generates, uses, and can radiate radio frequency energy. If this equipment is not installed and used in accordance with the instructions, it may cause harmful interference to radio communications. However, there is no guarantee that interference will not occur in a particular installation. If this equipment does cause harmful interference to radio or television reception, which can be determined by turning the equipment off and on, the user is encouraged to try to correct the interference by one or more of the following measures:

- Reorient or relocate the receiving antenna.
- Increase separation between equipment and receiver.
- Connect equipment to an outlet on a circuit different from that to which the receiver is located.
- Consult your dealer or an experienced radio/TV technician.

 **NOTE:** Any changes or modifications to the printer that are not expressly approved by HP could void the users authority to operate this equipment.

Use of a shielded interface cable is required to comply with the Class B limits of Part 15 of FCC rules.

Declaration of conformity (HP Color LaserJet 3000 Series printer)

Declaration of Conformity

according to ISO/IEC Guide 22 and EN 45014

Manufacturers Name: Hewlett-Packard Company
Manufacturer's Address: 11311 Chinden Boulevard,
Boise, Idaho 83714-1021, USA

declares, that the product

Product Name: HP Color LaserJet 3000 Series
Regulatory Model:³⁾ BOISB-0504-01

Including

Product Options: Q5985A Optional 500 Sheet Input Tray
ALL
Print Cartridges: Q7560A, Q7561A, Q7562A, Q7563A

conforms to the following Product Specifications:

SAFETY: IEC 60950-1:2001 / EN60950-1: 2001 +A11
IEC 60825-1:1993 +A1+A2 / EN 60825-1:1994 +A1 +A2 (Class 1 Laser/LED Product) GB4943-2001

EMC: CISPR22:1993 +A1 +A2 / EN55022:1994 +A1 +A2 - Class B¹⁾
EN 61000-3-2:2000
EN 61000-3-3:1995 +A1
EN 55024:1998 +A1 +A2
FCC Title 47 CFR, Part 15 Class B2) / ICES-003, Issue 4 GB9254-1998, GB17625.1-2003

Supplementary Information:

The product herewith complies with the requirements of the EMC Directive 89/336/EEC and the Low Voltage Directive 73/23/EEC, and carries the CE-Marking accordingly.

- 1) The product was tested in a typical configuration with Hewlett-Packard Personal Computer Systems.
- 2) This Device complies with Part 15 of the FCC Rules. Operation is subject to the following two Conditions: (1) this device may not cause harmful interference, and (2) this device must accept any interference received, including interference that may cause undesired operation.
- 3) For regulatory purposes, these products are assigned a Regulatory model number. This number should not be confused with the product name or the product number(s).

Boise, Idaho 83713, USA

16 May, 2005

For Regulatory Topics Only:

Australia Contact Product Regulations Manager, Hewlett-Packard Australia Ltd., 31-41 Joseph Street., Blackburn, Victoria 3130, Australia

European Contact Your Local Hewlett-Packard Sales and Service Office or Hewlett-Packard GmbH, Department HQ-TRE / Standards Europe, Herrenberger Strasse 140, Bblingen, D-71034, Germany, (FAX+49-7031-14-3143)

USA Contact Product Regulations Manager, Hewlett-Packard Company, PO Box 15, Mail Stop 160, Boise, ID 83707-0015, USA, (Phone: 208-396-6000)

Declaration of conformity (HP Color LaserJet 3600 Series and HP Color LaserJet 3800 Series printer)

Declaration of Conformity

according to ISO/IEC Guide 22 and EN 45014

Manufacturers Name: Hewlett-Packard Company
Manufacturer's Address: 11311 Chinden Boulevard,
Boise, Idaho 83714-1021, USA

declares, that the product

Product Names:⁴⁾ HP Color LaserJet 3600 series / HP Color LaserJet 3800 Series

Regulatory Model:³⁾ BOISB-0504-00

Including

Q5985A Optional 500 Sheet Input Tray

Product Options: ALL

Print Cartridges: Q6470A, Q6471A, Q6472A, Q6473A, Q7581A, Q7582A, Q7583A

conforms to the following Product Specifications:

SAFETY: IEC 60950-1:2001 / EN60950-1: 2001 +A11
IEC 60825-1:1993 +A1 +A2 / EN 60825-1:1994 +A1 +A2 (Class 1 Laser/LED Product)
GB4943-2001

EMC: CISPR22:1993 +A1 +A2 / EN55022:1994 +A1 +A2 - Class B¹⁾
EN 61000-3-2:2000
EN 61000-3-3:1995 +A1
EN 55024:1998 +A1 +A2
FCC Title 47 CFR, Part 15 Class B²⁾ / ICES-003, Issue 4
GB9254-1998, GB17625.1-2003

Supplementary Information:

The product herewith complies with the requirements of the EMC Directive 89/336/EEC and the Low Voltage Directive 73/23/EEC, and carries the CE-Marking accordingly.

- 1) The product was tested in a typical configuration with Hewlett-Packard Personal Computer Systems.
- 2) This Device complies with Part 15 of the FCC Rules. Operation is subject to the following two Conditions: (1) this device may not cause harmful interference, and (2) this device must accept any interference received, including interference that may cause undesired operation.
- 3) For regulatory purposes, these products are assigned a Regulatory model number. This number should not be confused with the product name or the product number(s).
- 4) CLJ3600 series, CLJ3800 series, and CLJ CP3505 series are similar in design, but use various interface boards.

Boise, Idaho 83713, USA

16 May, 2005

For Regulatory Topics Only:

Australia Contact Product Regulations Manager, Hewlett-Packard Australia Ltd., 31-41 Joseph Street,, Blackburn, Victoria 3130, Australia
European Contact Your Local Hewlett-Packard Sales and Service Office or Hewlett-Packard GmbH, Department HQ-TRE / Standards Europe, Herrenberger Strasse 140, Bblingen, D-71034, Germany, (FAX +49-7031-14-3143)
USA Contact Product Regulations Manager, Hewlett-Packard Company, PO Box 15, Mail Stop 160, Boise, ID 83707-0015, USA, (Phone: 208-396-6000)

Declaration of conformity (HP Color LaserJet CP3505 Series printer)

Declaration of Conformity

according to ISO/IEC 17050-1 and EN 17050-1

Manufacturer's Name: Hewlett-Packard Company
Manufacturer's Address: 11311 Chinden Boulevard,
Boise, Idaho 83714-1021, USA

declares, that the product

Product Names:³⁾ HP Color LaserJet CP3505 Series

Regulatory Model:²⁾ BOISB-0504-00

Including

Q5985A - Optional 500 Sheet Input Tray

ALL

Product Options:

Print Cartridges: Q6470A, Q7581A, Q7582A, Q7583A

conforms to the following Product Specifications:

SAFETY: IEC 60950-1:2001 / EN60950-1: 2001 +A11
IEC 60825-1:1993 +A1 +A2 / EN 60825-1:1994 +A1 +A2 (Class 1 Laser/LED Product)
GB4943-2001

EMC: CISPR22:2005 / EN55022:2006 - Class B¹⁾
EN 61000-3-2:2000
EN 61000-3-3:1995 +A1
EN 55024:1998 +A1 +A2
FCC Title 47 CFR, Part 15 Class B / ICES-003, Issue 4
GB9254-1998, GB17625.1-2003

Supplementary Information:

The product herewith complies with the requirements of the EMC Directive 89/336/EEC and the Low Voltage Directive 73/23/EEC, and carries the CE-Marking accordingly.

This Device complies with Part 15 of the FCC Rules. Operation is subject to the following two Conditions: (1) this device may not cause harmful interference, and (2) this device must accept any interference received, including interference that may cause undesired operation.

1) The product was tested in a typical configuration with Hewlett-Packard Personal Computer Systems.

2) For regulatory purposes, these products are assigned a Regulatory model number. This number should not be confused with the product name or the product number(s).

3) CLJ3600 series and CLJ3800 series are similar in design, but using various interface boards.

Boise, Idaho 83713, USA

February 1, 2007

For Regulatory Topics only, contact:

European Contact Your Local Hewlett-Packard Sales and Service Office or Hewlett-Packard GmbH, Department HQ-TRE / Standards Europe, Herrenberger Strasse 140, Böblingen, D-71034, Germany, (FAX +49-7031-14-3143)

USA Contact Product Regulations Manager, Hewlett-Packard Company, PO Box 15, Mail Stop 160, Boise, ID 83707-0015, USA, (Phone: 208-396-6000)

Safety statements

Laser safety

The Center for Devices and Radiological Health (CDRH) of the U.S. Food and Drug Administration has implemented regulations for laser products manufactured since August 1, 1976. Compliance is mandatory for products marketed in the United States. The printer is certified as a Class 1 laser product under the U.S. Department of Health and Human Services (DHHS) Radiation Performance Standard according to the Radiation Control for Health and Safety Act of 1968. Since radiation emitted inside the printer is completely confined within protective housings and external covers, the laser beam cannot escape during any phase of normal user operation.

⚠ WARNING! Using controls, making adjustments, or performing procedures other than those specified in this user guide may result in exposure to hazardous radiation.

Canadian DOC regulations

Complies with Canadian EMC Class B requirements.

Conforme la classe B des normes canadiennes de compatibilit lectromagntiques. CEM.

EMI statement (Korea)

B급 기기 (가정용 정보통신기기)

이 기기는 가정용으로 전자파적합등록을 한 기기로서
주거지역에서는 물론 모든지역에서 사용할 수 있습니다.

VCCI statement (Japan)

この装置は、情報処理装置等電波障害自主規制協議会（VCCI）の基準に基づくクラスB情報技術装置です。この装置は、家庭環境で使用することを目的としていますが、この装置がラジオやテレビジョン受信機に近接して使用されると、受信障害を引き起こすことがあります。
取扱説明書に従って正しい取り扱いをして下さい。

Power cord statement (Japan)

製品には、同梱された電源コードをお使い下さい。
同梱された電源コードは、他の製品では使用出来ません。

Laser statement for Finland

Luokan 1 laserlaite

Klass 1 Laser Apparat

HP Color LaserJet 3000, 3000n, 3000dn, 3000dtn, 3600, 3600n, 3600dn, 3800, 3800n, 3800dn, 3800dtn, CP3505, CP3505n, CP3505dn, CP3505x, laserkirjoitin on käyttäjän kannalta turvallinen luokan 1 laserlaite. Normaalisissa käytössä kirjoittimen suojakotelointi estää lasersteen pääsyn laitteen ulkopuolelle. Laitteen turvallisuusluokka on määritetty standardin EN 60825-1 (1994) mukaisesti.

VAROITUS !

Laitteen käyttäminen muulla kuin käyttöohjeessa mainitulla tavalla saattaa altistaa käyttäjän turvallisuusluokan 1 ylittävälle näkyvälle lasersteilylle.

VARNING !

Om apparaten används på annat sätt än i bruksanvisning specificerats, kan användaren utsättas för osynlig laserstrålning, som överstiger gränsen för laserklass 1.

HUOLTO

HP Color LaserJet 3000, 3000n, 3000dn, 3000dtn, 3600, 3600n, 3600dn, 3800, 3800n, 3800dn, 3800dtn, CP3505, CP3505n, CP3505dn, CP3505x -kirjoittimen sisällä ei ole käyttäjän huollettavissa olevia kohteita. Laitteen saa avata ja huoltaa ainoastaan sen huoltamiseen koulutettu henkilö. Tilaiseksi huoltotoimenpiteeksi ei katsota väriainekasetin vaihtamista, paperiradan puhdistusta tai muita käyttäjän käsikirjassa lueteltuja, käyttäjän tehtäviksi tarkoitettuja ylläpitotoimia, jotka voidaan suorittaa ilman erikoistykaluja.

VARO !

Mikäli kirjoittimen suojakotelo avataan, olet alttiina näkyvälle lasersteilylle laitteen ollessa toiminnassa. Katso ohjeeseen.

VARNING !

Om laserprinterns skyddshölje öppnas vid apparaten är i funktion, utsätts användaren för osynlig laserstrålning. Beträkta ej strålen. Tiedot laitteesta kytkettävällä laserdiodin säteilyominaisuuksista: Aallonpituus 775-795 nm Teho 5 mW Luokan 3B laser.

Index

Symbols/Numerics

500-sheet feeder

- connector locations 242
- driver PCA, removing 164
- left cover, removing 159
- rear cover, removing 162
- right cover, removing 157

A

- accessibility features 7
- acoustic specifications 336
- after service checklist 73
- agreements, maintenance 341
- alerts, e-mail 41
- anticounterfeit Web site 34
- assembly diagrams 243

B

- bad transmission errors 178
- bin, output
 - full message 195
 - locating 8
- black or solid color pages, troubleshooting 216
- blank images, troubleshooting 216
- blank spots, troubleshooting 219
- box, contents 22
- buffer overflow, troubleshooting 178
- buttons, control panel 10

C

- calibrating the printer 39
- Canadian DOC regulations 348
- cartridges
 - drive motors, removing 99
 - drum-rotation test 237
 - features 7
 - Genuine HP message 188

- image-formation system 61
- incorrect installation message 188
- install message 189
- jam locations 198
- life expectancy 34
- non-HP 34, 190
- operations 67
- order message 191
- remove all message 193
- removing 74
- replace message 193
- replacement intervals 32
- replacing 35
- status messages 11
- storing 34
- supply level, checking 34
- testing 231

cassette

- capacity 3
- jams 201
- locating 8
- pickup mechanism 55
- sensors 54
- solenoids 50

checklists

- after service 73
- pre-troubleshooting 170
- preservice 73

chosen personality not

- available 187

circuit diagrams 251

classes, HP Technical Training 255

cleaning stage, image formation operations 67

cleaning the printer 38

clearing event log 226

clock errors 175

code CRC errors 187

cold reset 238

color RFU failed 188

color usage log 40

color, troubleshooting

- dark 215
- light 214
- misregistration 220
- missing 219
- restricted message 194
- reversed 221
- solid pages 216

communications,

troubleshooting 225

component test 233

configuration page 40

connector diagrams

- 500-sheet tray 242
- DC controller 248
- printer 241

consumables. *See* supplies

contracts, maintenance 341

control panel

- access denied 186
 - blank, troubleshooting 172
 - buttons 10
 - Diagnostics menu 227
 - display 11
 - lights 11
 - locating 8
 - menu map 40
 - messages 174
 - print cartridge supply level, checking 35
 - removing 144
 - Service menu 226
- counterfeit supplies 34

covers
500-sheet feeder,
removing 157
cleaning 38
front, removing 75
left, removing 84
rear lower, removing 83
rear upper, removing 91
right, removing 87
upper, removing 80
Customer Care Online 255

D

dark color, troubleshooting 215
dark images, troubleshooting 215
date, converting Service ID 240
DC controller
connectors 248
engine control system 48
errors 183
jam detection operations 54
laser/scanner system
operations 52
pickup-and-feed system
operations 53
DC controller PCA, removing 136
Declaration of Conformity 345,
346
default settings, restoring
cold reset 238
NVRAM initialization 238
demo page 40
developing separation-drive
assembly
removing 108
developing stage 64
diagnostics
components 233
disable cartridge check 231
drum-rotation 237
engine test page 236
event log 230
formatter 236
half-self 236
LED 228
mode 228
paper-path sensor 231
paper-path test 231
print quality pages 231
Print/Stop test 235

sensor 232
tests, types of 229
Diagnostics menu 227
diagrams
500-sheet feeder connector
locations 242
assemblies 243
circuit 251
connector locations 241
DC controller connectors 248
timing 249
DIMMs
checking installation 29
enabling 29
failure 190
installing 26
dirt on paper,
troubleshooting 217
disable cartridge check 231
disk initialization 239
display, control panel
messages 11
distorted images,
troubleshooting 220
documentation 2
doors, locating 8
dots, troubleshooting 216
downloading software 13
drive assemblies, removing
developing separation 108
duplex-feed 103
duplex-reverse 100
fuser 105
pickup 117
driver PCA, removing 142
drivers
downloading 13
supported 6
drum, image formation
operations 63
drum-rotation test 237
duplex errors 186
duplex fan, removing 96
duplex path jams, clearing 208
duplex-driver PCA, removing 148
duplex-feed-drive assembly
removing 103
duplex-reverse-drive assembly
removing 100

E

e-mail alerts 41
Easy Printer Care Software 15,
44
EIO bad transmission error 178
EIO buffer overflow 178
EIO slot 9
EIO troubleshooting 225
electrical specifications 334
electrostatic discharge (ESD) 70
electrostatic transfer belt (ETB),
removing 94
embedded I/O bad transmission
errors 179
embedded I/O buffer
overflow 178
embedded Web server
about 15
e-mail alerts 41
print cartridge supply level,
checking 35
settings 42
using 41
energy specifications 334
Energy Star compliance 7
engine control system 48
engine test page 236
environment for printer
specifications 337
troubleshooting 211
error messages, control
panel 11, 174
ETB (electrostatic transfer belt),
removing 94
ETB separation stage 66
event log
clearing 226
printing 230
viewing 230

F

factory defaults, restoring
cold reset 238
NVRAM initialization 238
faded color, troubleshooting 214
faded images,
troubleshooting 214
fans, removing
duplex 96
main 130

- FCC regulations 344
- features
 - HP Color LaserJet 3000 3, 6
 - HP Color LaserJet 3600 4, 6
 - HP Color LaserJet 3800 4, 6
- field-replaceable units 70
- file directory page 40
- Finland, laser safety statement 349
- firmware upgrades, troubleshooting 187, 188, 194
- flowchart, troubleshooting 172
- fonts
 - DIMMs, installing 26
 - included 6
 - list, printing 41
- formatter
 - LED 228
 - resetting counts 226
 - restoring Service IDrestor 240
 - service ID 240
 - testing 236
- formatter cage, removing 92
- front cover
 - jams, clearing 206
 - locating 8
 - removing 75
- fuser
 - errors 180
 - install message 189
 - removing 95
- fuser door
 - jams, clearing 203
 - removing 80
- fuser drive assembly
 - removing 105
- fusing stage 66
- fusing, poor 219

G

- Genuine HP supplies installed message 188
- guides, printer information 2

H

- half-self test 236
- hard disk initialization 239
- high-voltage power-supply PCA, removing 138

- horizontal lines, troubleshooting 218
- HP Customer Care Online 255
- HP Easy Printer Care Software 44
- HP Easy Printer Care software 15
- HP Jetdirect print server errors 186
 - HP Color LaserJet 3000 features 3
 - HP Color LaserJet 3600 features 4
 - HP Color LaserJet 3800 features 4
 - NVRAM initialization 238
 - troubleshooting 225
- HP JetReady 13
- HP Printer Utility, Macintosh 16, 45
- HP Technical Training 255
- HP Web Jetadmin
 - downloading 15
 - e-mail alerts 41
 - print cartridge level, checking 35
- HP-UX software 15
- humidity
 - specifications 337
 - troubleshooting 211

I

- I/O buffer overflow 178
- image defects, troubleshooting 213
- image formation
 - cleaning stage 67
 - developing stage 64
 - fusing stage 66
 - latent-image stage 63
 - process 62
 - systems 61
 - transfer stage 65
 - troubleshooting 210
- image quality. *See* print quality, troubleshooting
- image transfer stage 65
- incorrect supplies error 188
- inflate failure 188

- initialization
 - hard-disk 239
 - NVRAM 238
- install cartridge error 189
- install fuser error 189
- install supplies error 189
- installation 22
- internal clock errors 175

J

- jams
 - cleaning spilled toner 38
 - control panel messages 176
 - detection operations 58
 - duplex path, clearing 208
 - e-mail alerts 41
 - front cover, clearing 206
 - fuser area, clearing 203
 - locations 198
 - preventing 199
 - print quality after 212
 - recovery 198
 - tray 1, clearing 200
 - tray 2 or 3, clearing 201
- Japanese VCCI statement 348
- Jetadmin, HP Web
 - downloading 15
 - print cartridge level, checking 35
- Jetdirect print server errors 186
 - HP Color LaserJet 3000 features 3
 - HP Color LaserJet 3600 features 4
 - HP Color LaserJet 3800 features 4
 - NVRAM initialization 238
 - troubleshooting 225

K

- Korean EMI statement 348

L

- laser safety statments 348
- laser-beam exposure stage 64
- laser/scanner assembly, removing 126
- laser/scanner system operations 52
- latent-image formation stage 63

- LED diagnostics 228
- left cover, removing 84
- light color, troubleshooting 214
- light diagnostics 228
- light images, troubleshooting 214
- lights, control panel 11
- lines, troubleshooting
 - dotted 216
 - horizontal 218
 - vertical 217
- Linux drivers 14
- load tray message 190
- locked menus, control panel 186
- low-voltage power-supply PCA, removing 132

M

- Macintosh
 - connecting to 25
 - HP Printer Utility 45
 - PPDs 16
 - versions supported 13
- main fan, removing 130
- maintenance agreements 341
- manually feed message 190
- manuals 2
- media
 - dirty, troubleshooting 217
 - duplex path jams 208
 - front cover jams 206
 - fuser area jams 203
 - jam detection operations 58
 - jam prevention 199
 - supported sizes 17
 - transparencies 211
 - tray 1 jams 200
 - tray 2 or 3 jams 201
 - tray operations 54
 - troubleshooting 210
 - unexpected size error 179
 - unexpected type error 179
- media feed stage 65
- memory
 - checking installation 29
 - DIMM failures 190
 - enabling 29
 - HP Color LaserJet 3000 3
 - HP Color LaserJet 3600 4
 - HP Color LaserJet 3800 4
 - installing 26

- insufficient 178, 189
- NVRAM initialization 238
- print cartridges 68
- RAM errors 183, 192
- sanitizing disk message 195
- memory-controller PCA, removing 140
- menu map 40
- menus locked, control panel 186
- messages, control panel 11, 174
- misplaced images, troubleshooting 221
- misregistration, color 220
- missing color, troubleshooting 219
- motors
 - locations 50
 - print cartridge, removing 99
- multipurpose tray
 - capacity 3
 - jams 200
 - locating 8
 - pickup and feed operations 56
 - sensor test 232
 - solenoids 50

N

- networks
 - connecting to 24
 - HP Color LaserJet 3000
 - features 3
 - HP Color LaserJet 3600
 - features 4
 - HP Color LaserJet 3800
 - features 4
 - HP Jetdirect print server
 - errors 186
 - ports, locating 9
 - software 14
 - troubleshooting 225
- next-day onsite service 341
- noise specifications 336
- non-HP supplies 34, 174, 190
- NVRAM initialization 238

O

- on/off switch 9
- Online Customer Care, HP 255
- onsite service 341
- operating systems supported 13

- operating-environment specifications 337
- operations
 - engine control system 48
 - image-formation system 61
 - jam detection 58
 - laser/scanner system 52
 - motors 50
 - pickup-and-feed system 53
 - power-on 49
 - print cartridges 67
 - sequence of 48
 - solenoids 50
 - trays 54
- order supplies message 191
- OS/2 drivers 14
- output bin
 - full message 195
 - locating 8
- output quality. See print quality, troubleshooting

P

- page count 226
- pages per minute
 - HP Color LaserJet 3000 3
 - HP Color LaserJet 3600 4
 - HP Color LaserJet 3800 4
- paper
 - dirty, troubleshooting 217
 - duplex path jams 208
 - front cover jams 206
 - fuser area jams 203
 - jam detection operations 58
 - jam locations 198
 - jam prevention 199
 - supported sizes 17
 - tray 1 jams 200
 - tray 2 or 3 jams 201
 - tray operations 54
 - troubleshooting 210
 - unexpected size error 179
 - unexpected type error 179
- paper-path sensor test 231
- paper-path test 231
- parallel buffer overflow 178
- PCAs, removing
 - 500-sheet feeder driver 164
 - control panel 144
 - DC controller 136

- driver 142
 - duplex-driver 148
 - high-voltage power-supply 138
 - low-voltage power-supply 132
 - memory-controller 140
 - pickup-and-feed driver 146
 - PCL drivers 13
 - PCL font list, printing 41
 - PDL driver 13
 - permanent storage errors 185
 - personality not available error 187
 - photosensitive drum
 - image formation operations 63
 - rotation test 237
 - physical specifications 23
 - pickup-and-feed assembly, removing 111
 - pickup-and-feed driver PCA, removing 146
 - pickup-and-feed system operations 53
 - pickup-drive assembly removing 117
 - pliers, required 71
 - ports
 - HP Color LaserJet 3000 3
 - HP Color LaserJet 3600 4
 - HP Color LaserJet 3800 4
 - locating 9
 - supported 7
 - power specifications 334
 - power switch 9
 - power-on operations 49
 - troubleshooting 172
 - PPDs, Macintosh 16
 - pre-exposure stage 64
 - pre-troubleshooting checklist 170
 - preservice checklist 73
 - primary charging stage 64
 - print cartridge drive motors, removing 99
 - print cartridges
 - drum-rotation test 237
 - features 7
 - Genuine HP message 188
 - image-formation system 61
 - incorrect installation message 188
 - install message 189
 - jam locations 198
 - life expectancy 34
 - non-HP 34, 190
 - operations 67
 - order message 191
 - remove all message 193
 - removing 74
 - replace message 193
 - replacement intervals 32
 - replacing 35
 - status messages 11
 - storing 34
 - supply level, checking 34
 - testing 231
 - print media supported 17
 - print quality, troubleshooting
 - black or solid color pages 216
 - blank images 216
 - blank spots 219
 - color misregistration 220
 - color missing 219
 - dark color 215
 - dark images 215
 - diagnostic pages 212, 231
 - dirt on paper 217
 - distorted images 220
 - dots in vertical lines 216
 - environment 211
 - fusing, poor 219
 - horizontal lines 218
 - image defects 213
 - jams, after 212
 - light color 214
 - light images 214
 - media 210
 - misplaced images 221
 - repetitive defects 223
 - reversed color 221
 - smearing 221
 - snail tracks 222
 - toner buildup 212
 - transparencies 211
 - vertical lines 217
 - white horizontal lines 218
 - white vertical lines 218
 - Print/Stop test 235
 - printing system software 13
 - processor speed 6
 - PS Emulation drivers 13
 - PS font list, printing 41
- Q**
- quality. See print quality, troubleshooting
- R**
- RAM errors 183, 192
 - rear lower cover, removing 83
 - rear upper cover, removing 91
 - regulatory statement 344
 - remove all print cartridges error 193
 - removing parts
 - 500-sheet feeder 157
 - about 70
 - after service checklist 73
 - control panel 144
 - DC controller PCA 136
 - developing separation-drive assembly 108
 - driver PCA 142
 - duplex fan 96
 - duplex-driver PCA 148
 - duplex-feed-drive assembly 103
 - duplex-reverse-drive assembly 100
 - electrostatic transfer belt (ETB) 94
 - formatter cage 92
 - front cover 75
 - fuser 95
 - fuser drive assembly 105
 - high-voltage power-supply PCA 138
 - laser/scanner assembly 126
 - left cover 84
 - low-voltage power-supply PCA 132
 - main fan 130
 - memory-controller PCA 140
 - pickup-and-feed assembly 111
 - pickup-and-feed driver PCA 146
 - pickup-drive assembly 117

- preservice checklist 73
 - print cartridge drive motors 99
 - print cartridges 74
 - rear lower cover 83
 - rear upper cover 91
 - right cover 87
 - screws, types of 72
 - service approach 73
 - tools, required 71
 - upper cover 80
 - repair approach 73
 - replace cartridge message 193
 - replacement intervals, supplies 32
 - replacing
 - field-replaceable units 70
 - formatter 226
 - print cartridges 35
 - resets
 - cold 238
 - NVRAM initialization 238
 - restoring default settings
 - cold reset 238
 - NVRAM initialization 238
 - restricted from printing in color error 194
 - reversed color, troubleshooting 221
 - RFU loaderror 194
 - right cover, removing 87
 - rollers
 - image formation operations 63
 - repetitive defects 223
- S**
- safety statements 348
 - sanitizing disk message 195
 - schedules, HP Technical Training 255
 - screwdrivers, required 71
 - screws
 - self-tapping 70
 - types of 72
 - sensors
 - automatic testing 232
 - jam detection 58
 - paper-path, testing 231
 - trays 54
 - separation stage, image formation 66
 - sequence of operations 48
 - serial buffer overflow 178
 - serial data errors 178
 - serial number 226
 - service agreements 341
 - service approach 73
 - service ID 240
 - Service menu 226
 - Service menu, PIN 226
 - setup 22
 - site requirements 23
 - size mismatch error 195
 - smear print, troubleshooting 221
 - snail tracks, troubleshooting 222
 - software
 - applications 16
 - drivers 13
 - Easy Printer Care 44
 - embedded Web server 15, 41
 - HP Easy Printer Care 15
 - HP Printer Utility for Macintosh 45
 - HP Web Jetadmin 15
 - included 7
 - network 14
 - Web sites 13
 - Solaris software 15
 - solenoids, locations 50
 - space requirements 23
 - specifications
 - acoustic 336
 - electrical 334
 - features 6
 - operating environment 337
 - physical 23
 - speed
 - HP Color LaserJet 3000 3
 - HP Color LaserJet 3600 4
 - HP Color LaserJet 3800 4
 - static discharge 70
 - status
 - e-mail alerts 41
 - supplies 11
 - storing print cartridges 34
 - supplies
 - anticounterfeit Web site 34
 - e-mail alerts 41
 - features 7
 - Genuine HP message 188
 - incorrect installation message 188
 - install message 189
 - locating 33
 - non-HP 34, 174, 190
 - order message 191
 - print cartridges, checking level 34
 - replace message 193
 - replacement guidelines 33
 - replacement intervals 32
 - status messages 11
 - supplies status page 40
 - support, technical 255
 - supported media 17
 - switch boxes 225
- T**
- technical support 255
 - Technical Training 255
 - temperature specifications 337
 - tests
 - components 233
 - Diagnostics menu 227
 - diagnostics mode 228
 - disable cartridge check 231
 - drum-rotation 237
 - engine 236
 - event log 230
 - formatter 236
 - half-self 236
 - paper-path 231
 - paper-path sensor 231
 - print quality 231
 - Print/Stop 235
 - sensor 232
 - types of 229
 - timing diagrams 249
 - toner
 - buildup, troubleshooting 212
 - cleaning spilled 38
 - poor fusing 219
 - smearing 221
 - toner cartridges. See print cartridges
 - tools, required 71

- top cover
 - locating 8
 - removing 80
- total page count 226
- Training, HP Technical 255
- transfer stage 65
- transparencies
 - print quality, troubleshooting 211
- trays
 - action not currently available error 186
 - configuring 195
 - empty 195
 - HP Color LaserJet 3000, included 3
 - HP Color LaserJet 3600, included 4
 - HP Color LaserJet 3800, included 4
 - jams, clearing 200, 201
 - load message 190
 - locating 8
 - manual feed message 190
 - open 195
 - optional 6
 - paper-path test 231
 - sensors 54
 - size mismatch error 195
 - type mismatch error 195
 - unexpected size errors 179
 - unexpected type errors 179
- troubleshooting
 - about 170
 - access denied 186
 - action not currently available error 186
 - assembly diagrams 243
 - black or solid color pages 216
 - blank images 216
 - blank spots 219
 - buffer overflow 178
 - cartridges 189, 193
 - checklist 170
 - chosen personality not available error 187
 - circuit diagrams 251
 - code CRC error 187
 - cold reset 238
 - color misregistration 220
 - color missing 219
 - color restrictions 194
 - communications 225
 - component test 233
 - connector locations 241
 - control-panel messages 174
 - dark color 215
 - dark images 215
 - DC controller connectors 248
 - DC controller errors 183
 - Diagnostics menu 227
 - diagnostics mode 228
 - DIMMs 190
 - dirt on paper 217
 - disable cartridge check 231
 - distorted images 220
 - dots in vertical lines 216
 - drum-rotation test 237
 - duplexer errors 186
 - EIO cards 225
 - engine test page 236
 - environment 211
 - event log 230
 - firmware upgrades 187, 188, 194
 - flowchart 172
 - formatter test 236
 - fuser 189
 - fusing, poor 219
 - half-self test 236
 - horizontal lines 218
 - HP Jetdirect print server 186
 - image defects 213
 - image formation 210
 - incorrect supplies error 188
 - internal clock errors 175
 - jams 198
 - jams, control panel messages 176
 - LED diagnostics 228
 - light color 214
 - light images 214
 - media 210
 - memory 189
 - memory errors 178
 - misplaced images 221
 - non-HP supplies 190
 - NVRAM initialization 238
 - paper-path sensor test 231
 - paper-path test 231
 - permanent storage errors 185
 - power-on 172
 - print quality diagnostic pages 212, 231
 - Print/Stop test 235
 - RAM 192
 - RAM errors 183
 - repetitive defects 223
 - reversed color 221
 - sanitizing disk message 195
 - sensor test 232
 - serial data errors 178
 - Service menu 226
 - size mismatch error 195
 - smear print 221
 - snail tracks 222
 - supplies 189
 - timing diagram 249
 - toner buildup 212
 - transparencies 211
 - trays 190, 195
 - type mismatch error 195
 - unexpected size error 179
 - unexpected type error 179
 - USB storage device failure 196
 - vertical lines 217
 - white horizontal lines 218
 - white vertical lines 218
 - type mismatch error 195

U

- unexpected size error 179
- unexpected type error 179
- UNIX model scripts 14
- upper cover
 - jams, clearing 203
 - removing 80
- usage page 40
- USB I/O buffer overflow 178
- USB port
 - locating 9
 - Macintosh setup 25
 - supported 7
 - Windows setup 24
- USB storage device failure 196

V

- vacuuming toner 38

- vertical lines, troubleshooting
 - black or colored 217
 - dotted 216
 - white 218
- voltage specifications 334

W

- warranty 340
- washing toner off clothing 38
- Web sites
 - anticounterfeit 34
 - documentation 2
 - printer features 6
 - software, downloading 13
 - supply replacement
 - guidelines 33
- white lines, troubleshooting
 - horizontal 218
 - vertical 218
- Windows
 - direct connection, setting up 24
 - versions supported 13

© 2007 Hewlett-Packard Development Company, L.P.

www.hp.com



Q5982-91038