

PCB STACK UP

- LAYER 1 : TOP
- LAYER 2 : SGND1
- LAYER 3 : IN1
- LAYER 4 : IN2
- LAYER 5 : VCC
- LAYER 6 : IN3
- LAYER 7 : SGND2
- LAYER 8 : BOT

Cable Docking

- TV_OUT
- VGA
- RJ-45
- CIR/Pwr btn
- SPDIF Out
- Stereo MIC
- Headphone Jack
- USB Port
- VOL Cntr

PG 31

ARES/ARTEMIS

Block Diagram

SI - PHASE

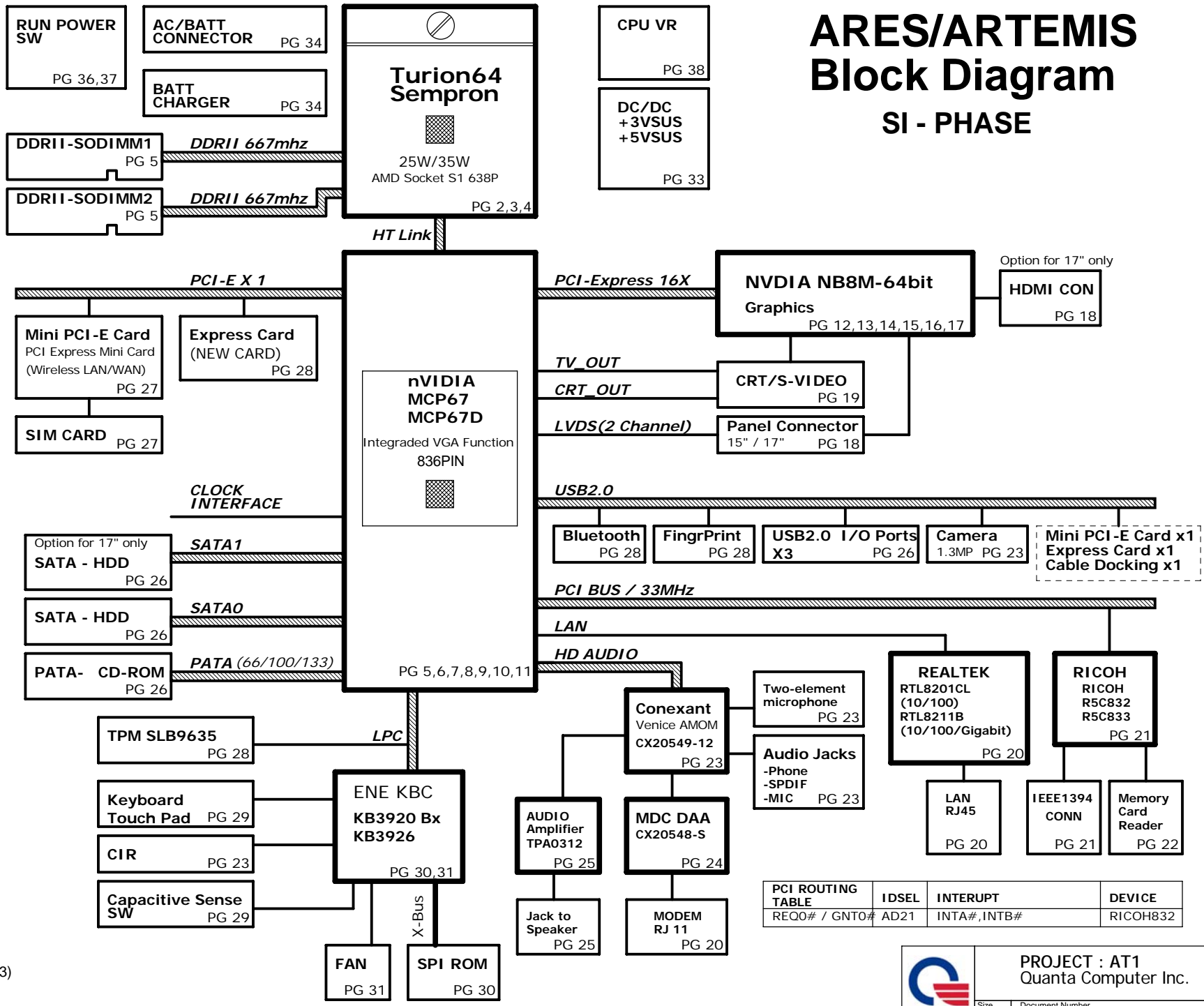

VAULE DEFINE
 A=0603,B=0805,C=1206,F=1%,
 OTHER IS 0402
 V=Y5V,U=Y5U,R=X5R,S=X6S,
 X=X7R,G=COG,O=NPO

EXAMPLE
 10R=10ohm(0402)
 10A=10ohm(0603)
 10B=10ohm(0805)
 10C=10ohm(1206)
 10/F=10ohm(0402 and 1%)

EXAMPLE
 0.1U/16V/R=0.1U/16V/X5R(0402)
 0.47UA/10V/X=0.47U/10V/X7R(0603)
 10UB/10V/U=10U/10V/Y5U(0805)

PCI ROUTING TABLE	IDSEL	INTERUPT	DEVICE
REQ0# / GNT0#	AD21	INTA#,INTB#	RICOH832

PROJECT : AT1
Quanta Computer Inc.

Size Custom	Document Number BLOCK DIAGRAM	Rev C2A
Date: Friday, December 29, 2006		Sheet 1 of 40

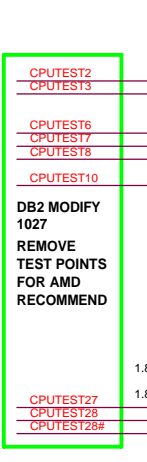
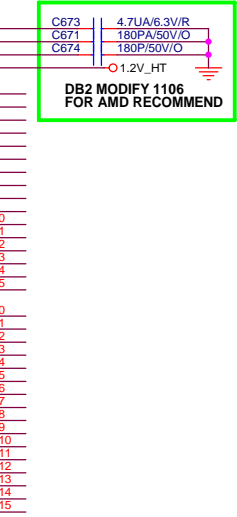
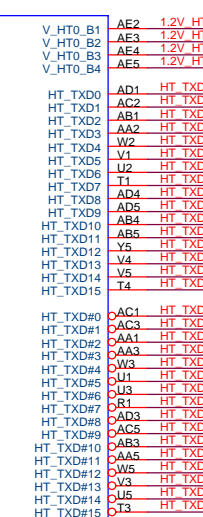
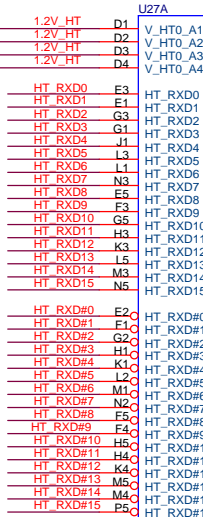
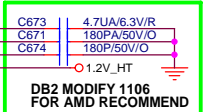
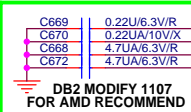
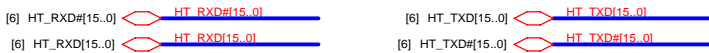

TEST PU/PL MUST FOLLOW ERRATUM 133 REVISION GUIDE FROM AMD NPT 0Ph CPU

REMOVE TEST POINTS FOR AMD RECOMMEND

ROUTE TRACES 80ohm DIFF IMPEDENCE 8/5/20 SPACING

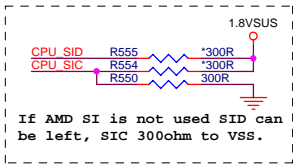

If AMD SI is not used SID can be left, SIC 300ohm to VSS.

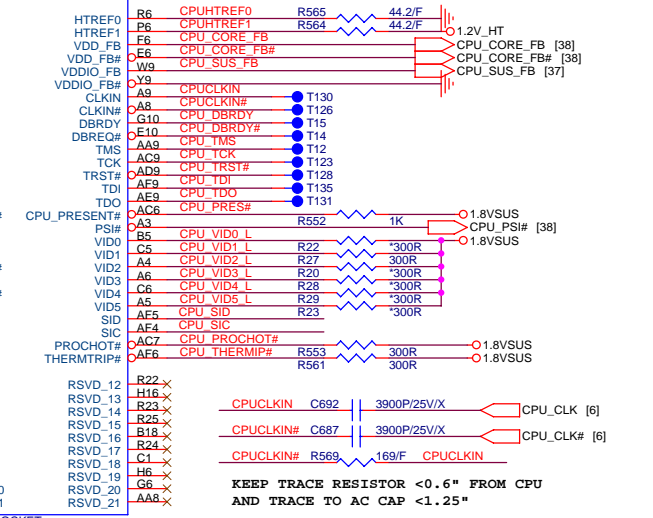
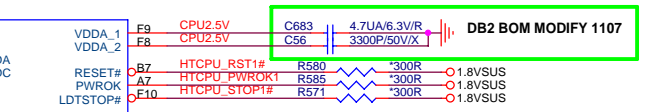
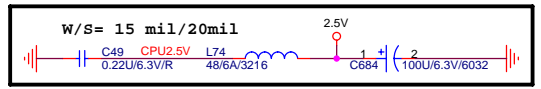

KEEP TRACE RESISTOR <0.6" FROM CPU AND TRACE TO AC CAP <1.25" CPUVID1 PU REQUIRED FOR COMPATIBILITY WITH FUTURE CPU

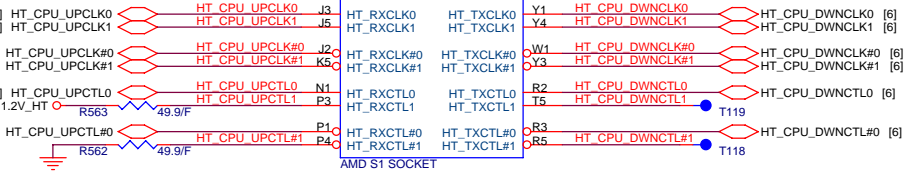

HT_RXCTL1/HT_RXCLR#1 MUST <1.5" FROM CPU PIN

CPU THERMAL SENSOR & CONTROL

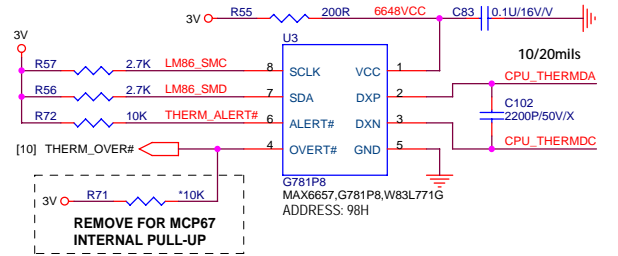

REMOVE FOR MCP67 INTERNAL PULL-UP

HT LINK CONTROL LEVEL SHIFTER

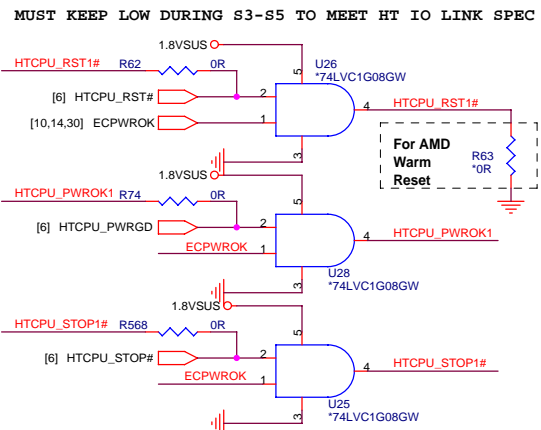

MUST KEEP LOW DURING S3-S5 TO MEET HT IO LINK SPEC

For AMD Warm Reset

FOLLOW AMD AND NVIDIA RECOMMEND 0904

OVER TEMP CONTROL

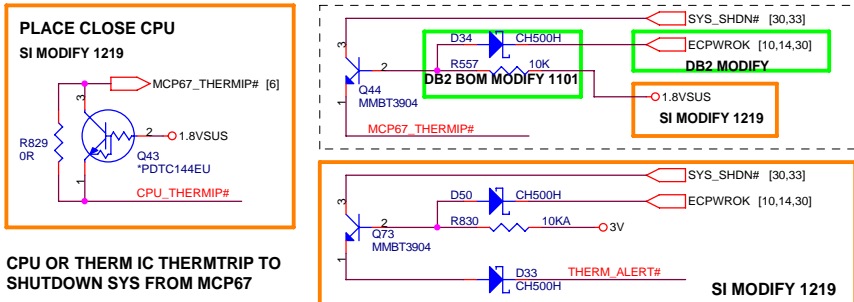

PLACE CLOSE CPU SI MODIFY 1219

CPU OR THERM IC THERMTRIP TO SHUTDOWN SYS FROM MCP67

CPU PROCHOT INPUT FROM THERMAL IC OR SODIMM SENSOR

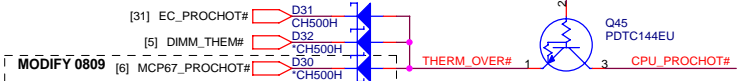

MODIFY 0809

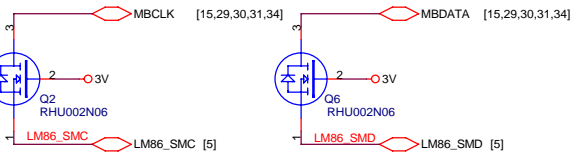

MBCLK/MBDATA NEED PU TO 3VPCU

NEED TO CONFIRM NVIDIA FOR THE USAGE CONNECTION TO SB

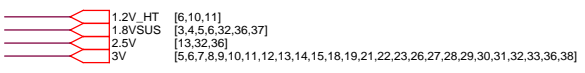
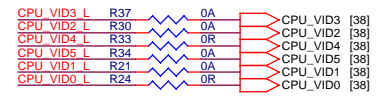

PROJECT : AT1 Quanta Computer Inc.

Table with 3 columns: Size, Document Number, Rev. Row 1: Custom, CPU (HT_I/F_CTL), C2A. Row 2: Date: Friday, December 29, 2006, Sheet 2 of 40.

U27B

M A DQ63	AA12	MA_DATA[63]
M A DQ62	AB12	MA_DATA[62]
M A DQ61	AA14	MA_DATA[61]
M A DQ60	AB14	MA_DATA[60]
M A DQ59	Y11	MA_DATA[59]
M A DQ58	Y12	MA_DATA[58]
M A DQ57	AD13	MA_DATA[57]
M A DQ56	AB13	MA_DATA[56]
M A DQ55	AD15	MA_DATA[55]
M A DQ54	AB15	MA_DATA[54]
M A DQ53	AB17	MA_DATA[53]
M A DQ52	Y17	MA_DATA[52]
M A DQ51	Y14	MA_DATA[51]
M A DQ50	W14	MA_DATA[50]
M A DQ49	W16	MA_DATA[49]
M A DQ48	AD17	MA_DATA[48]
M A DQ47	Y18	MA_DATA[47]
M A DQ46	AD19	MA_DATA[46]
M A DQ45	AD21	MA_DATA[45]
M A DQ44	AB21	MA_DATA[44]
M A DQ43	AB18	MA_DATA[43]
M A DQ42	AA18	MA_DATA[42]
M A DQ41	AA20	MA_DATA[41]
M A DQ40	Y20	MA_DATA[40]
M A DQ39	AA22	MA_DATA[39]
M A DQ38	Y22	MA_DATA[38]
M A DQ37	W21	MA_DATA[37]
M A DQ36	W22	MA_DATA[36]
M A DQ35	AA21	MA_DATA[35]
M A DQ34	AB22	MA_DATA[34]
M A DQ33	AB24	MA_DATA[33]
M A DQ32	Y24	MA_DATA[32]
M A DQ31	H22	MA_DATA[31]
M A DQ30	H20	MA_DATA[30]
M A DQ29	E22	MA_DATA[29]
M A DQ28	E21	MA_DATA[28]
M A DQ27	J19	MA_DATA[27]
M A DQ26	H24	MA_DATA[26]
M A DQ25	F22	MA_DATA[25]
M A DQ24	F20	MA_DATA[24]
M A DQ23	C23	MA_DATA[23]
M A DQ22	B22	MA_DATA[22]
M A DQ21	F18	MA_DATA[21]
M A DQ20	E18	MA_DATA[20]
M A DQ19	E20	MA_DATA[19]
M A DQ18	D22	MA_DATA[18]
M A DQ17	C19	MA_DATA[17]
M A DQ16	G18	MA_DATA[16]
M A DQ15	G17	MA_DATA[15]
M A DQ14	C17	MA_DATA[14]
M A DQ13	F14	MA_DATA[13]
M A DQ12	E14	MA_DATA[12]
M A DQ11	H17	MA_DATA[11]
M A DQ10	E17	MA_DATA[10]
M A DQ9	E15	MA_DATA[9]
M A DQ8	H15	MA_DATA[8]
M A DQ7	E13	MA_DATA[7]
M A DQ6	C13	MA_DATA[6]
M A DQ5	H12	MA_DATA[5]
M A DQ4	H11	MA_DATA[4]
M A DQ3	G14	MA_DATA[3]
M A DQ2	H14	MA_DATA[2]
M A DQ1	F12	MA_DATA[1]
M A DQ0	G12	MA_DATA[0]

Y13	M A DQM7
AB16	M A DQM6
Y19	M A DQM5
AC24	M A DQM4
F24	M A DQM3
E19	M A DQM2
C15	M A DQM1
E12	M A DQM0

W12	M A DQS7
Y15	M A DQS6
AB19	M A DQS5
AD23	M A DQS4
G22	M A DQS3
G16	M A DQS1
G13	M A DQS0

W13	M A DQS#7
W15	M A DQS#6
AB20	M A DQS#5
AC23	M A DQS#4
G21	M A DQS#3
C21	M A DQS#2
G15	M A DQS#1
H13	M A DQS#0

E16	M A CLK1
F16	M A CLK1#

Y16	M A CLK2
AA16	M A CLK2#

K22	M A BA2
R20	M A BA1
T22	M A BA0

T20	M A RAS#
U20	M A CAS#
U21	M A WE#

V19	M A CS#3
J22	M A CS#2
V22	M A CS#1
T19	M A CS#0

J20	M A CEK1
J21	M A CEK0

V20	M A ODT1
U19	M A ODT0

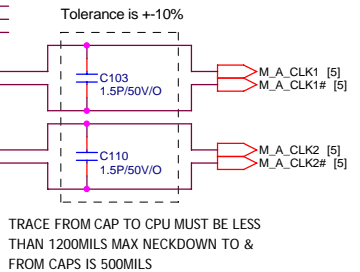

U27C

M B DQ63	AD11	MB_DATA[63]
M B DQ62	AE11	MB_DATA[62]
M B DQ61	AF14	MB_DATA[61]
M B DQ60	AE14	MB_DATA[60]
M B DQ59	Y11	MB_DATA[59]
M B DQ58	AB11	MB_DATA[58]
M B DQ57	AC12	MB_DATA[57]
M B DQ56	AF13	MB_DATA[56]
M B DQ55	AE15	MB_DATA[55]
M B DQ54	AF16	MB_DATA[54]
M B DQ53	AC18	MB_DATA[53]
M B DQ52	AE19	MB_DATA[52]
M B DQ51	AD14	MB_DATA[51]
M B DQ50	AC14	MB_DATA[50]
M B DQ49	AE18	MB_DATA[49]
M B DQ48	AD18	MB_DATA[48]
M B DQ47	AD20	MB_DATA[47]
M B DQ46	AC20	MB_DATA[46]
M B DQ45	AE23	MB_DATA[45]
M B DQ44	AF24	MB_DATA[44]
M B DQ43	AE20	MB_DATA[43]
M B DQ42	AE20	MB_DATA[42]
M B DQ41	AD22	MB_DATA[41]
M B DQ40	AC22	MB_DATA[40]
M B DQ39	AE25	MB_DATA[39]
M B DQ38	AD26	MB_DATA[38]
M B DQ37	AA25	MB_DATA[37]
M B DQ36	AA26	MB_DATA[36]
M B DQ35	AE24	MB_DATA[35]
M B DQ34	AD24	MB_DATA[34]
M B DQ33	AA23	MB_DATA[33]
M B DQ32	AA24	MB_DATA[32]
M B DQ31	G24	MB_DATA[31]
M B DQ30	G23	MB_DATA[30]
M B DQ29	D26	MB_DATA[29]
M B DQ28	C26	MB_DATA[28]
M B DQ27	G26	MB_DATA[27]
M B DQ26	G25	MB_DATA[26]
M B DQ25	C25	MB_DATA[25]
M B DQ24	E23	MB_DATA[24]
M B DQ23	C24	MB_DATA[23]
M B DQ22	B24	MB_DATA[22]
M B DQ21	C20	MB_DATA[21]
M B DQ20	B20	MB_DATA[20]
M B DQ19	C25	MB_DATA[19]
M B DQ18	D24	MB_DATA[18]
M B DQ17	A21	MB_DATA[17]
M B DQ16	D20	MB_DATA[16]
M B DQ15	D18	MB_DATA[15]
M B DQ14	C18	MB_DATA[14]
M B DQ13	D14	MB_DATA[13]
M B DQ12	C14	MB_DATA[12]
M B DQ11	A20	MB_DATA[11]
M B DQ10	A19	MB_DATA[10]
M B DQ9	A16	MB_DATA[9]
M B DQ8	A15	MB_DATA[8]
M B DQ7	A13	MB_DATA[7]
M B DQ6	D12	MB_DATA[6]
M B DQ5	E11	MB_DATA[5]
M B DQ4	G11	MB_DATA[4]
M B DQ3	B14	MB_DATA[3]
M B DQ2	A14	MB_DATA[2]
M B DQ1	A11	MB_DATA[1]
M B DQ0	C11	MB_DATA[0]

AD12	M B DQM7
AC16	M B DQM6
AE22	M B DQM5
AB26	M B DQM4
E25	M B DQM3
A22	M B DQM2
B16	M B DQM1
A12	M B DQM0

AF12	M B DQS7
AE16	M B DQS6
AF21	M B DQS5
AC25	M B DQS4
F26	M B DQS3
A24	M B DQS2
D16	M B DQS1
C12	M B DQS0

AF12	M B DQS#7
AD16	M B DQS#6
AF22	M B DQS#5
AC26	M B DQS#4
E26	M B DQS#3
A23	M B DQS#2
C16	M B DQS#1
B12	M B DQS#0

A17	M B CLK1
A18	M B CLK1#

AF18	M B CLK2
AF17	M B CLK2#

K26	M B BA2
T26	M B BA1
U26	M B BA0

U24	M B RAS#
V26	M B CAS#
U22	M B WE#

Y26	M B CS#3
J24	M B CS#2
W24	M B CS#1
U23	M B CS#0

H26	M B CEK1
J23	M B CEK0

W23	M B ODT1
W26	M B ODT0

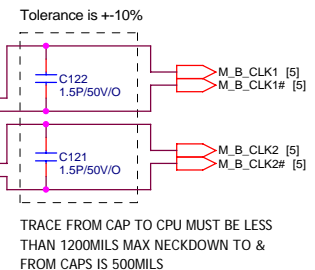

- [5] M_A_DQ[0..63] <-> M_A_DQ[0..63]
- [4..5] M_A_A[0..15] <-> M_A_A[0..15]
- [5] M_A_DQM[0..7] <-> M_A_DQM[0..7]
- [5] M_A_DQS[0..7] <-> M_A_DQS[0..7]
- [5] M_A_DQS#[0..7] <-> M_A_DQS#[0..7]
- [4..5] M_A_BA[0..2] <-> M_A_BA[0..2]
- [4..5] M_A_CS#[0..3] <-> M_A_CS#[0..3]

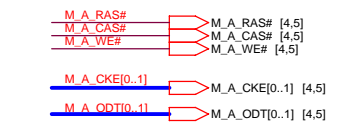

- [5] M_B_DQ[0..63] <-> M_B_DQ[0..63]
- [4..5] M_B_A[0..15] <-> M_B_A[0..15]
- [5] M_B_DQM[0..7] <-> M_B_DQM[0..7]
- [5] M_B_DQS[0..7] <-> M_B_DQS[0..7]
- [5] M_B_DQS#[0..7] <-> M_B_DQS#[0..7]
- [4..5] M_B_BA[0..2] <-> M_B_BA[0..2]
- [4..5] M_B_CS#[0..3] <-> M_B_CS#[0..3]

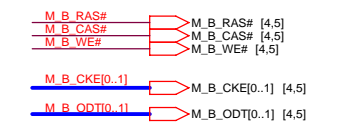

1.8VSUS [2,4,5,6,32,36,37]

PROJECT : AT1
Quanta Computer Inc.

Size Custom	Document Number CPU (MEM_I/F)	Rev C2A
Date: Friday, December 29, 2006 Sheet 3 of 40		

CPU POWER PLANE AND BY PASS CAP

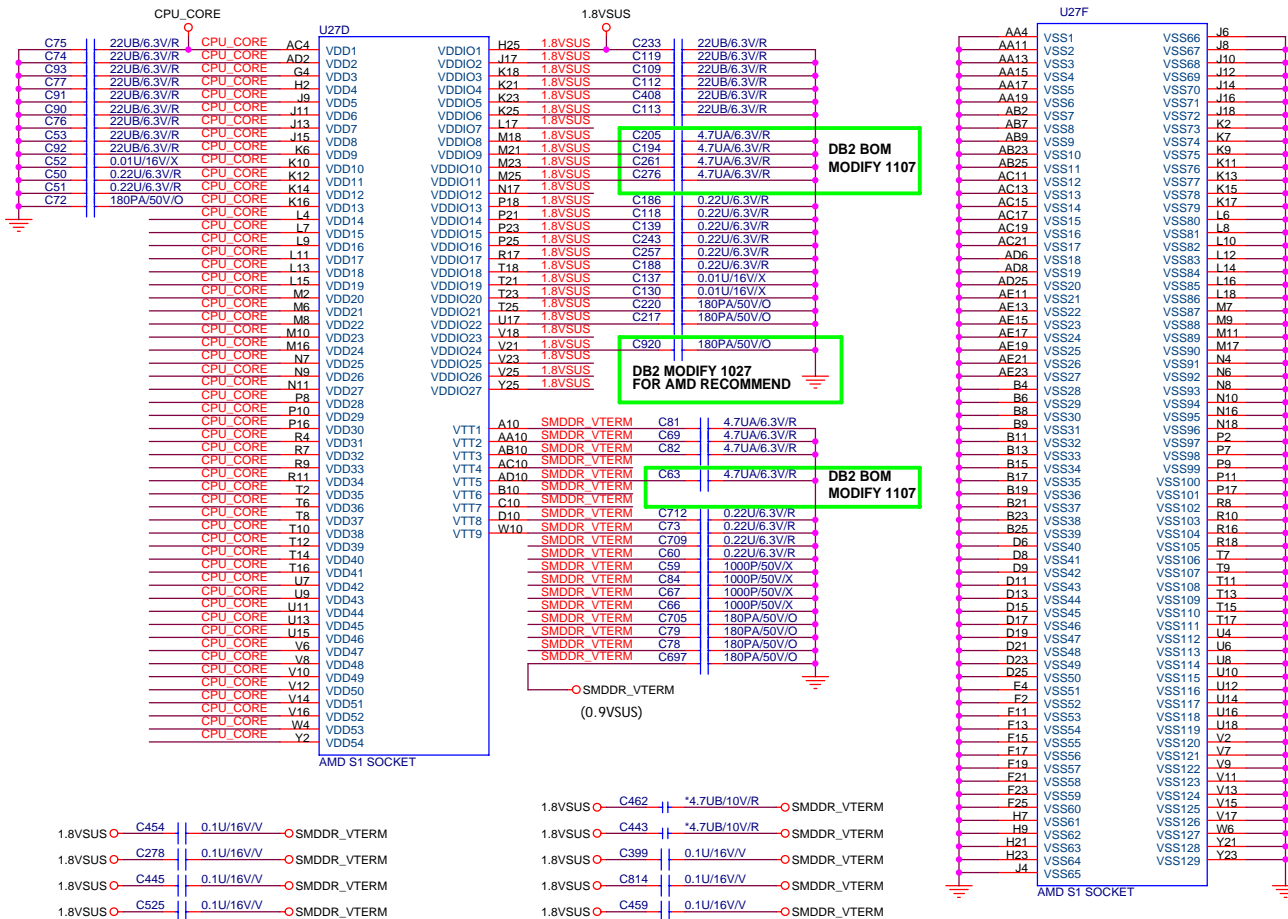

DDR2 TERMINATION BYPASS CAP

04

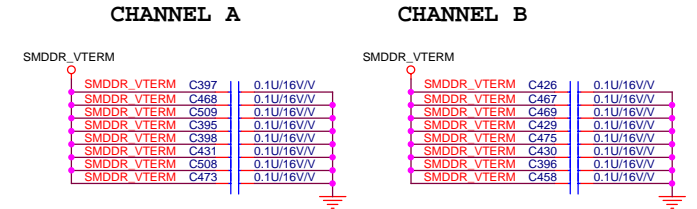

Layout note: Place one cap close to every 2 pullup resistors terminated to SMDRR_VTERM

DDR2 CHANNEL B TERMINATION

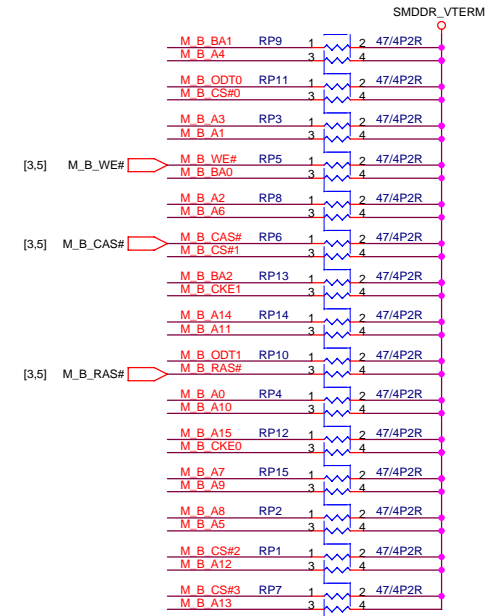

DDR2 CHANNEL A TERMINATION

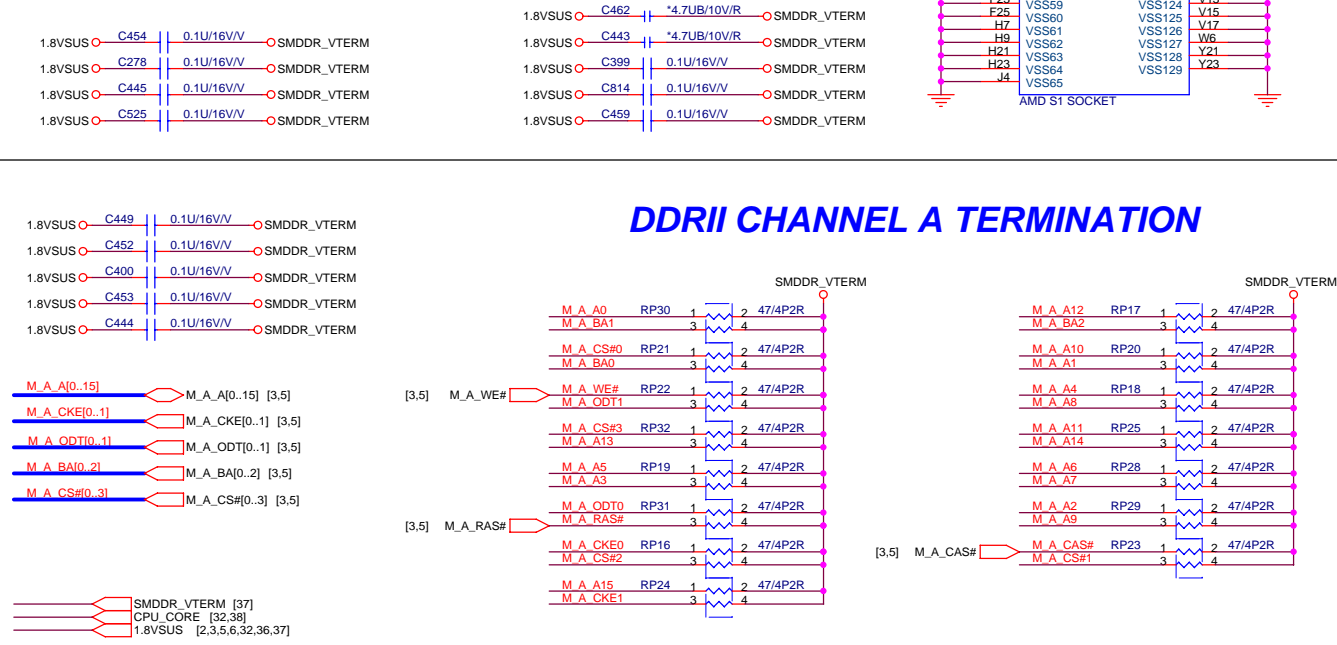

PROJECT : AT1
Quanta Computer Inc.

Size Custom	Document Number CPU (POWER,GND),DDR2_TERM	Rev C2A
Date: Friday, December 29, 2006	Sheet 4	of 40

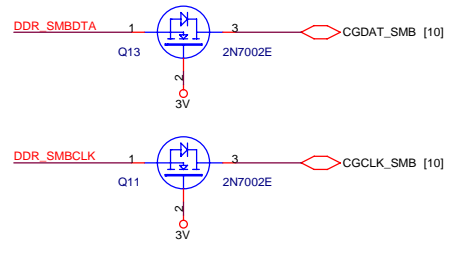
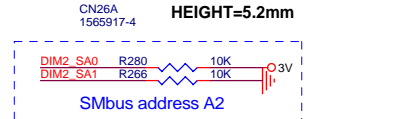
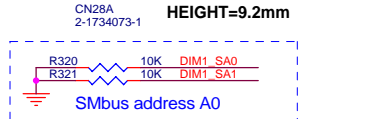
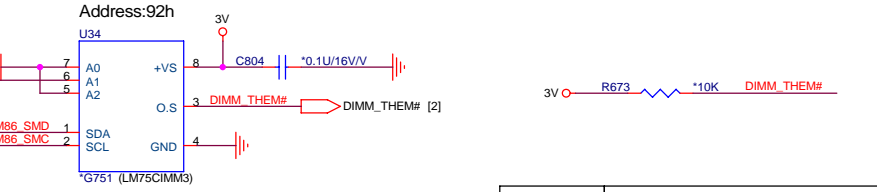
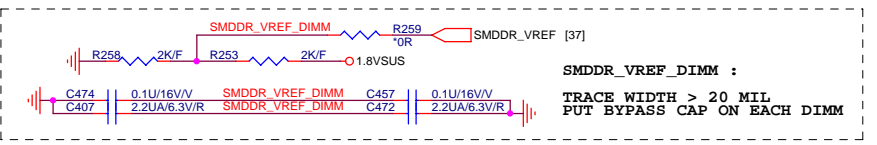
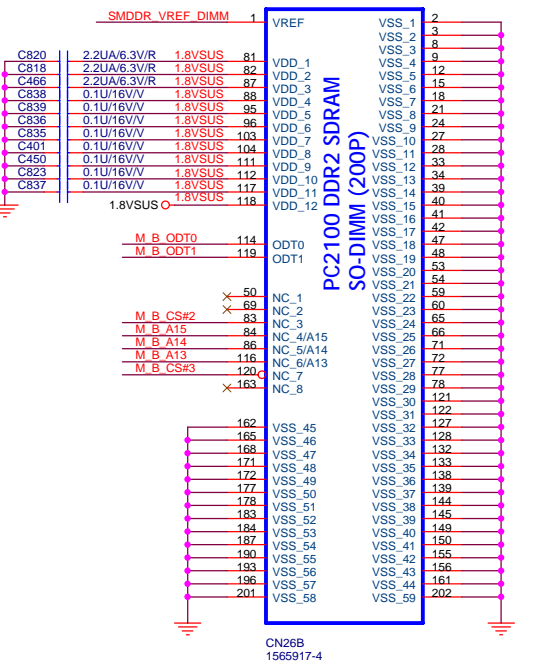
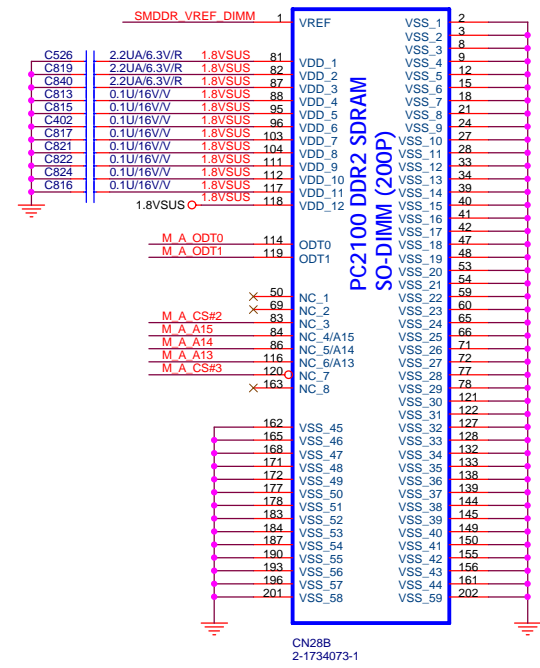
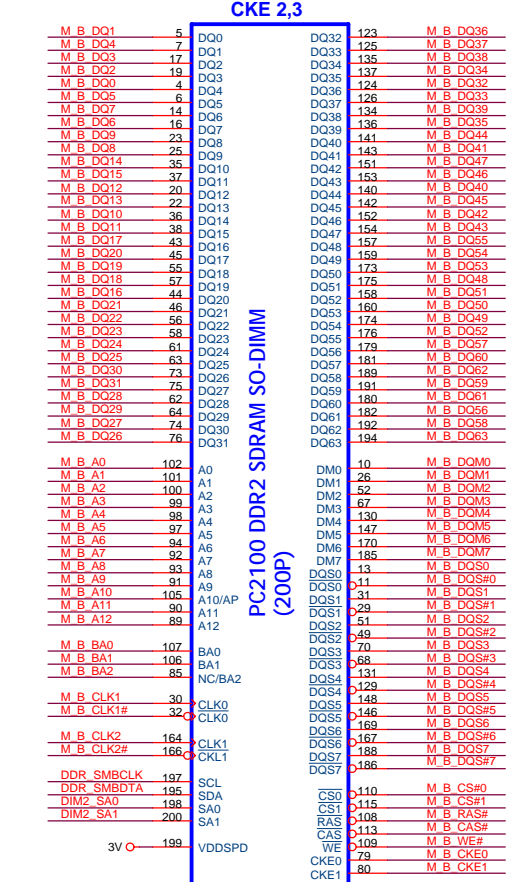
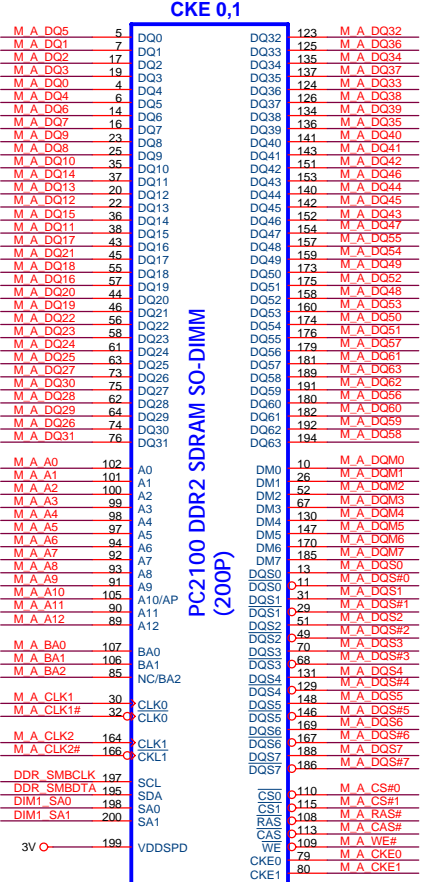
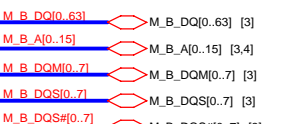
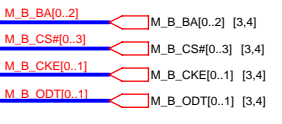
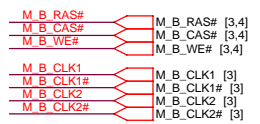
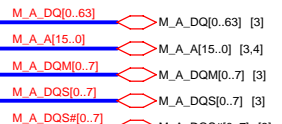
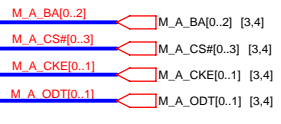
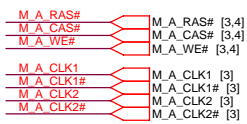

1.8VSUS [2,3,4,6,32,36,37]
3V [2,6,7,8,9,10,11,12,13,14,15,18,19,21,22,23,26,27,28,29,30,31,32,33,36,38]

PROJECT : AT1
Quanta Computer Inc.
Size Custom Document Number DDR SO-DIMMx2 (200P) Rev C2A
Date: Friday, December 29, 2006 Sheet 5 of 40

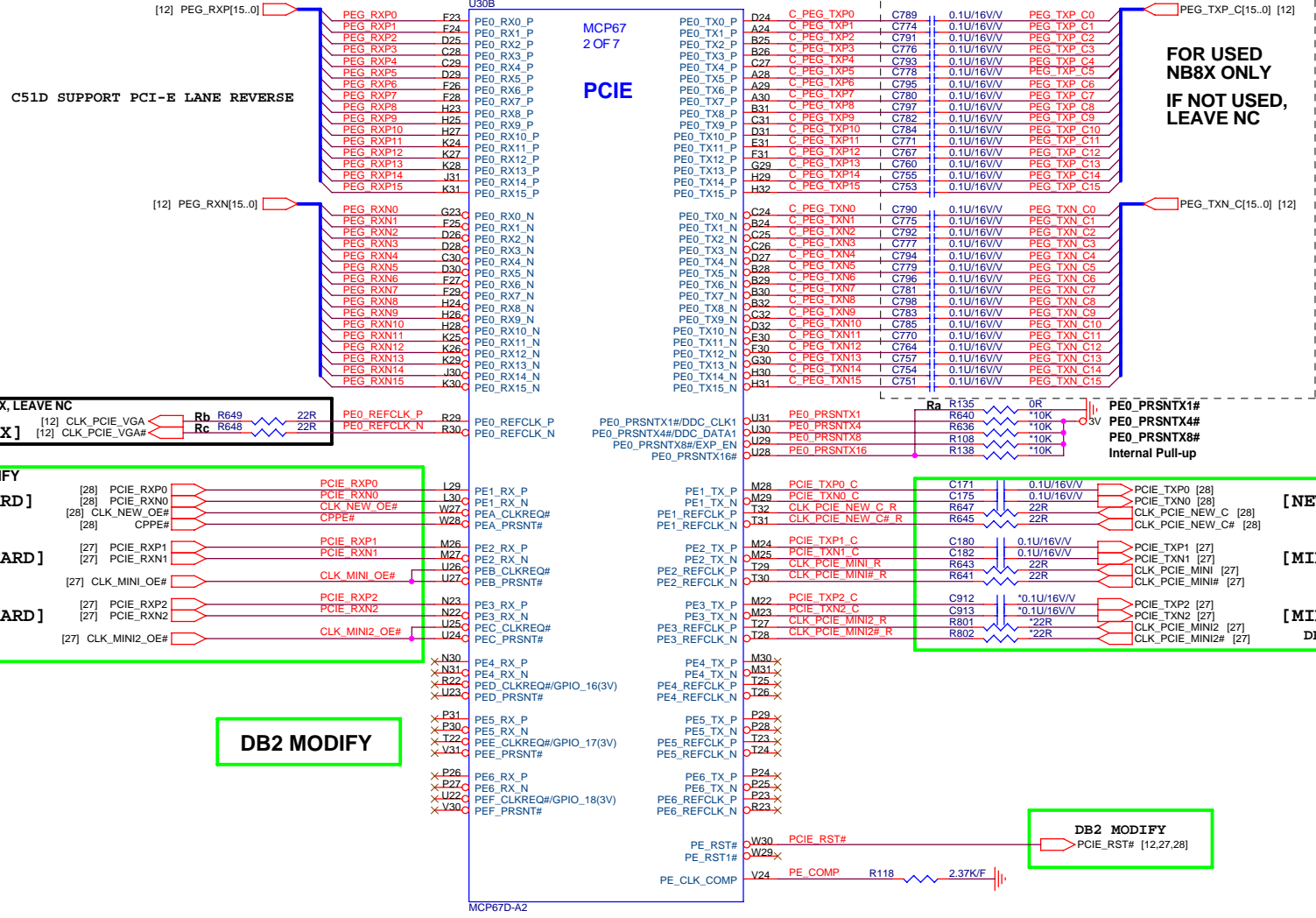

**FOR USED NB8X ONLY
IF NOT USED, LEAVE NC**

MCP67D & MCP67M DIFFERENCE TABLE			
LOCATION	MCP67M (UMA)	MCP67M (DISCRETE)	MCP67D (DISCRETE)
Ra	NC	0R	0R
Rb Rc	NC NC	22R 22R	22R 22R

NET NAME	MCP67D (DISCRETE)	MCP67M (GPU)
PE0_PRSNTX16	LOW	NC

IF NOT USED NB8X, LEAVE NC
 [12] CLK_PCIE_VGA# Rb R649 22R PE0_REFCLK_P R29
 [12] CLK_PCIE_VGA# Rc R648 22R PE0_REFCLK_N R30

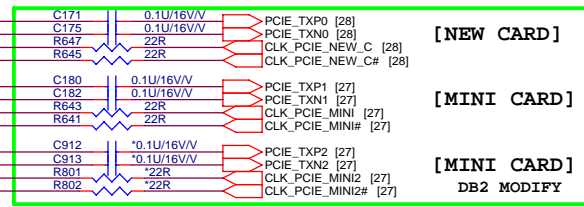
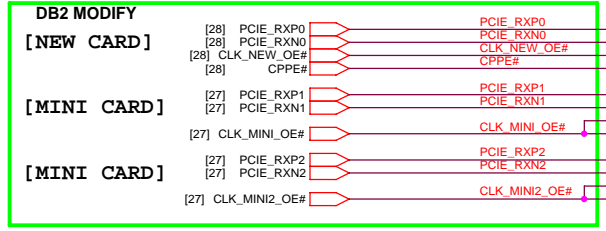

DB2 MODIFY

DB2 MODIFY
PCIE_RST# [12,27,28]

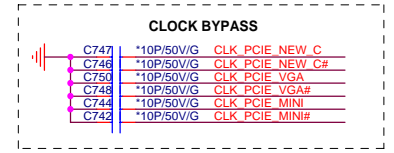
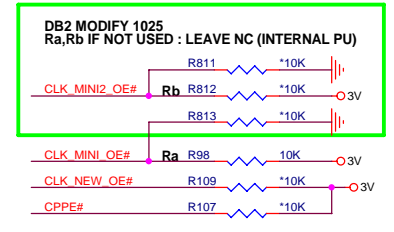

PROJECT : AT1
Quanta Computer Inc.

Size Custom	Document Number MCP67 (PCI-E I/F)	Rev C2A
Date: Friday, December 29, 2006	Sheet 7 of 40	

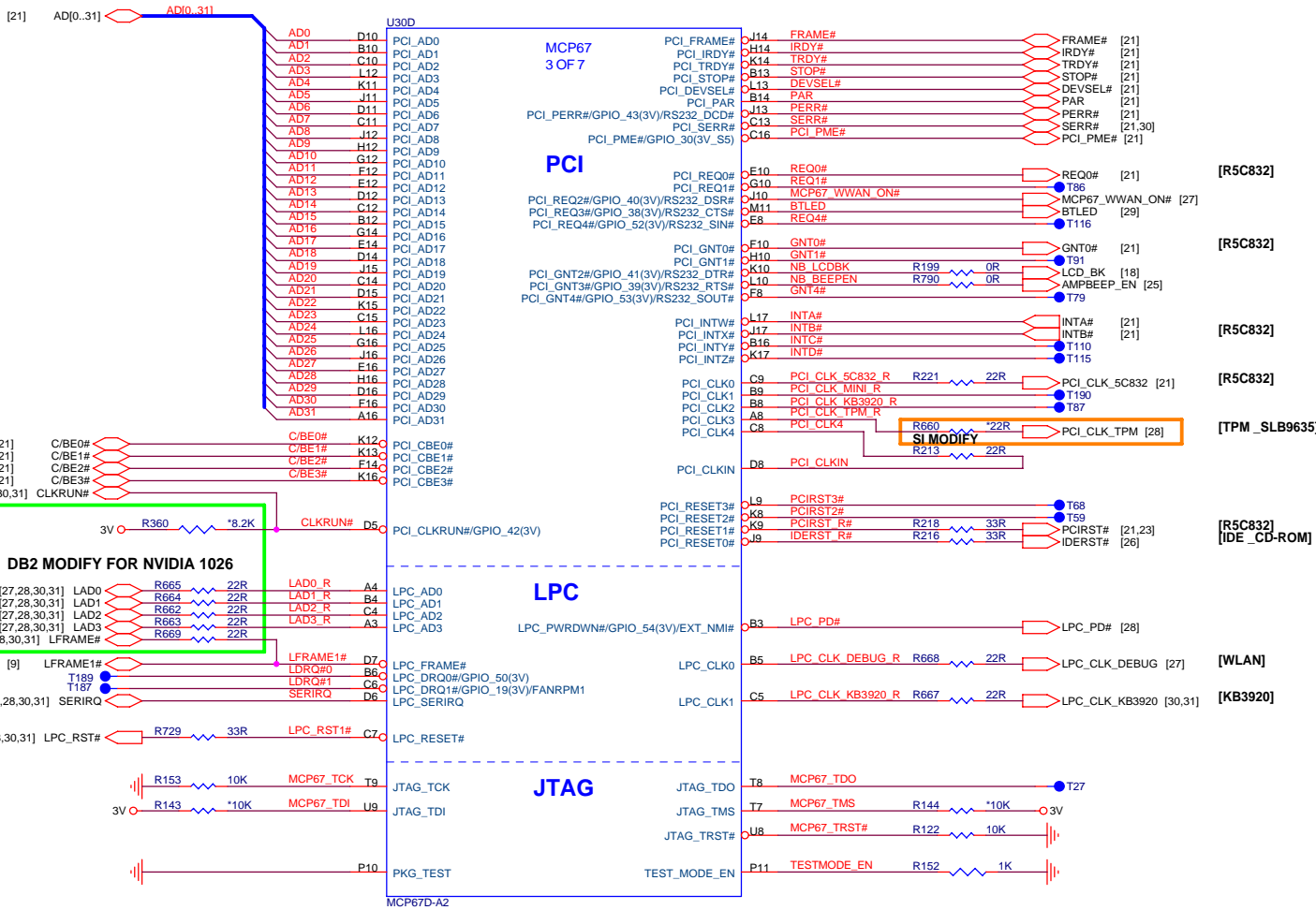

PCI/LPC PULL-UP

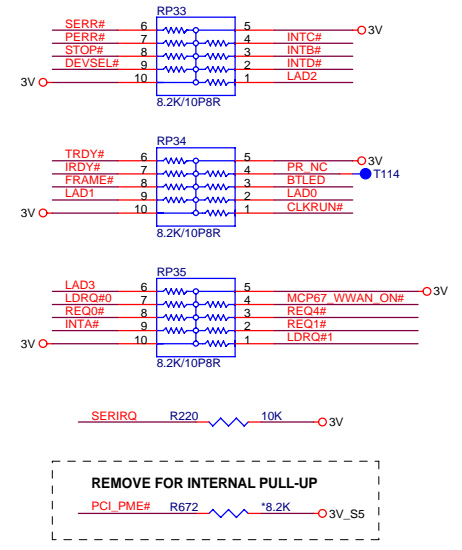

CLOCK BYPASS

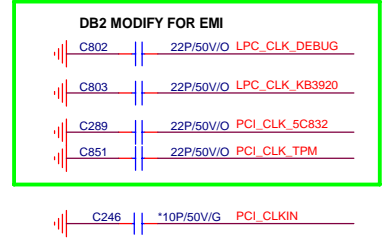

3V [2,5,6,7,9,10,11,12,13,14,15,18,19,21,22,23,26,27,28,29,30,31,32,33,36,38]
 3V_S5 [9,10,11,20,28,30,32,33,37]

10/100 - GIAG LAN STUFF OPTION

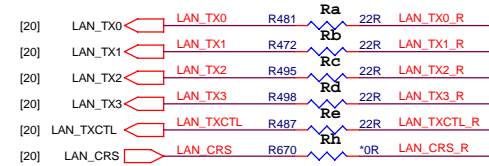

MODIFY 0824

Table with 3 columns: Component, 10/100, GIGA. Rows include Ra, Rb, Rc, Rd, Re, Rf, Rg, Rh.

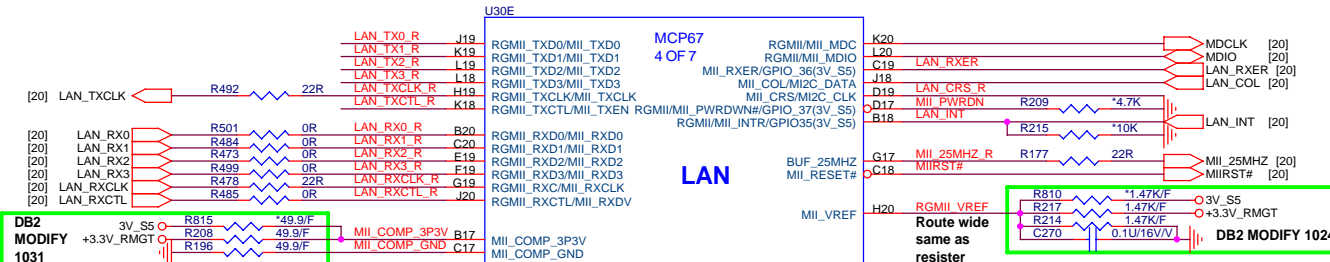
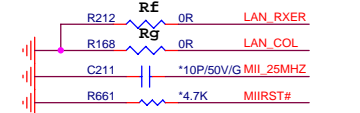

DB2 MODIFY 1031

Route wide same as resistor

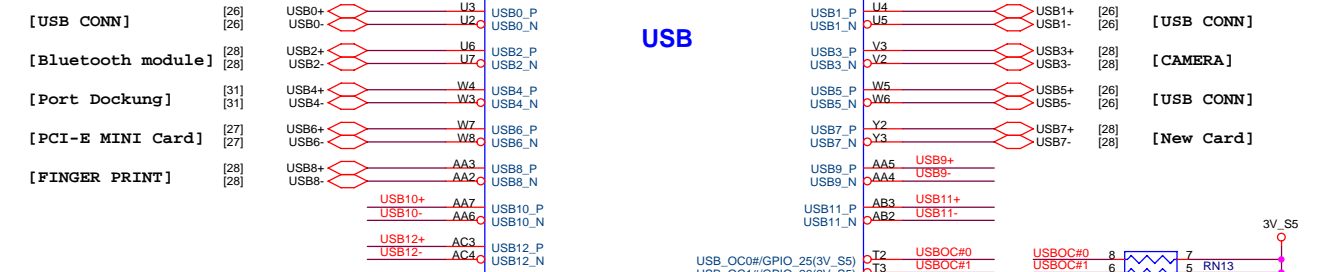
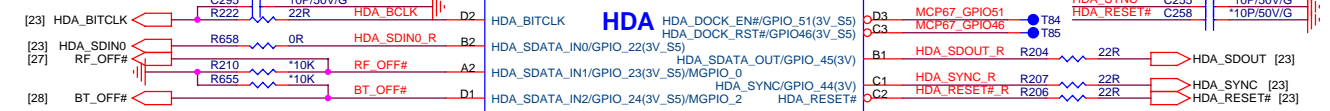

MCP67D : 1.1K/F, MCP67M : 1.3K/F

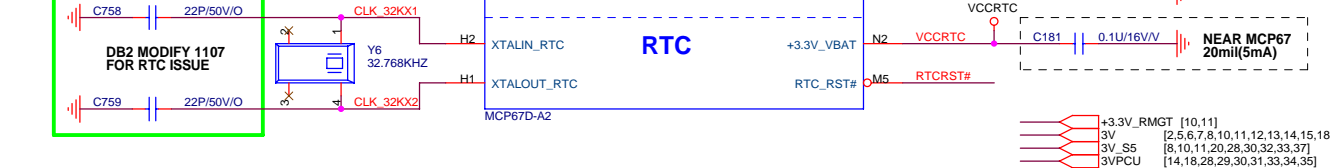
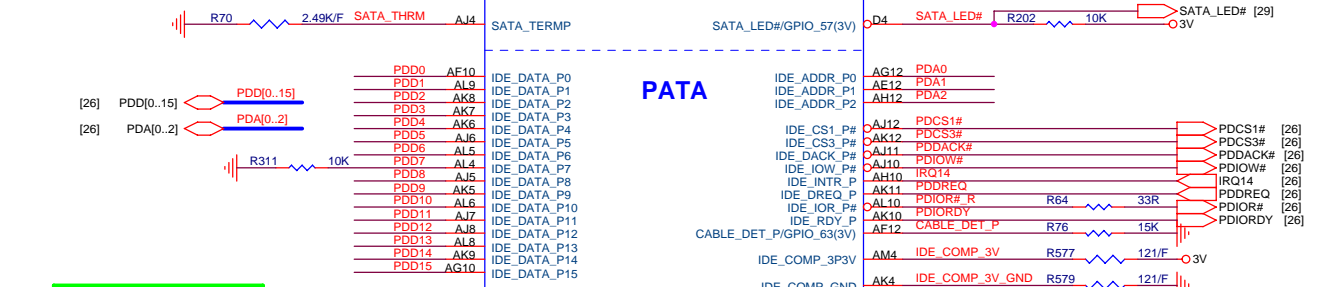
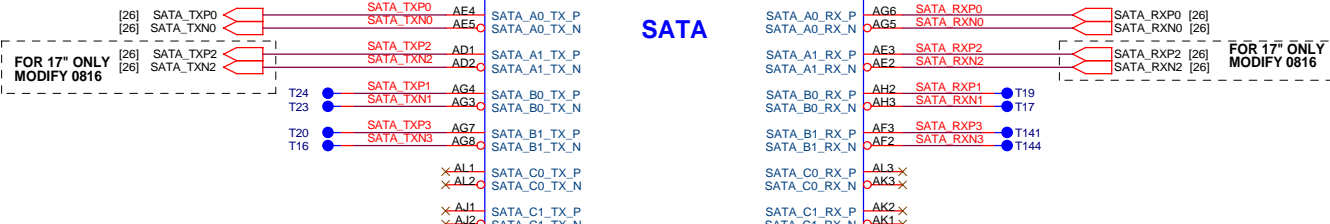

DB2 MODIFY 1107 FOR RTC ISSUE

MODIFY 0823

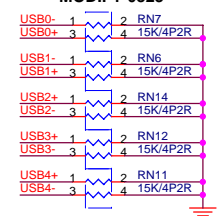

USB PULL-DOWN

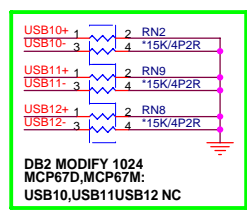
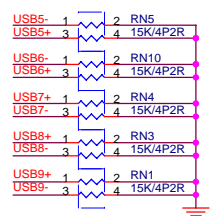

MCP67 STRAPPING

Table with 2 columns: Component, Value. Rows include HDA_RESET#, HDA_SDOUR, MCP_SPKR, HDA_SYNC, SPI_DO, SPI_CLK.

MODIFY 0824

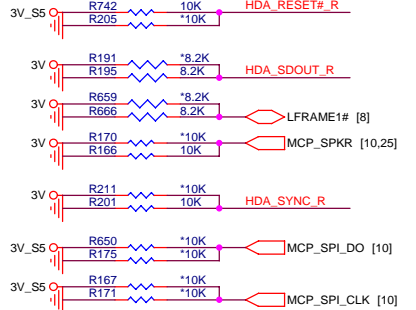

RTC

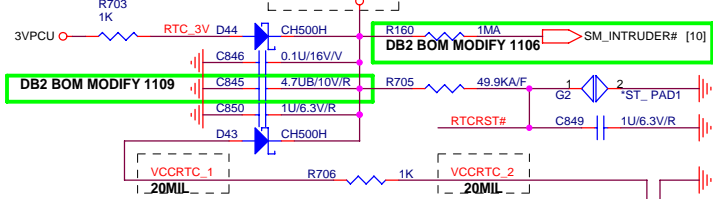

BATTERY HOLDER TYPE: USED BATTERY 2P CONNECTOR, USED BATTERY HOLDER

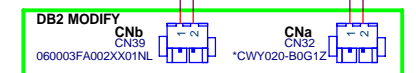

PROJECT : AT1 Quanta Computer Inc.

Table with 3 columns: Size, Document Number, Rev. Row 1: Custom, MCP67 (LAN,HDA,USB,ATA,RTC), C2A. Row 2: Date: Friday, December 29, 2006, Sheet 9 of 40.

CORE POWER CIRCUIT FOR SLEEP MODE MCP67M SUPPORT ONLY

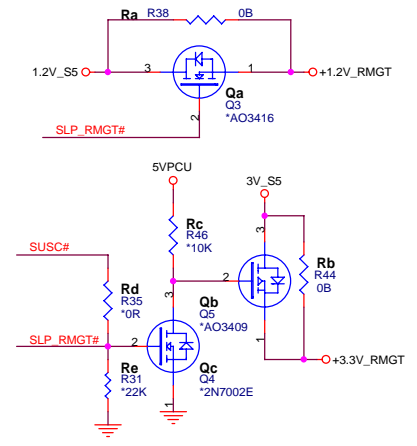

	MCP67M UMA	MCP67D DISCRETE
Ra	NC	STUFF
Rb	NC	STUFF
Rc	STUFF	NC
Rd	NC	NC
Re	STUFF	NC
Qa	STUFF	NC
Qb	STUFF	NC
Qc	STUFF	NC

PMU PULL-UP

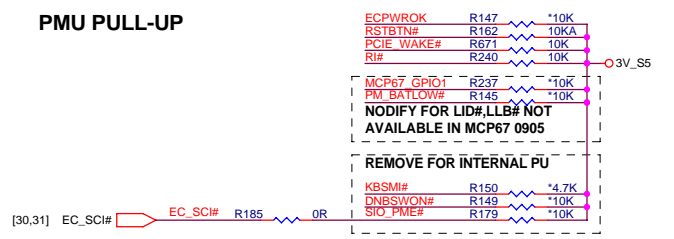

CPU LEGACY PULL-UP

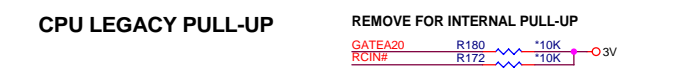

SMB/I2C PULL-UP

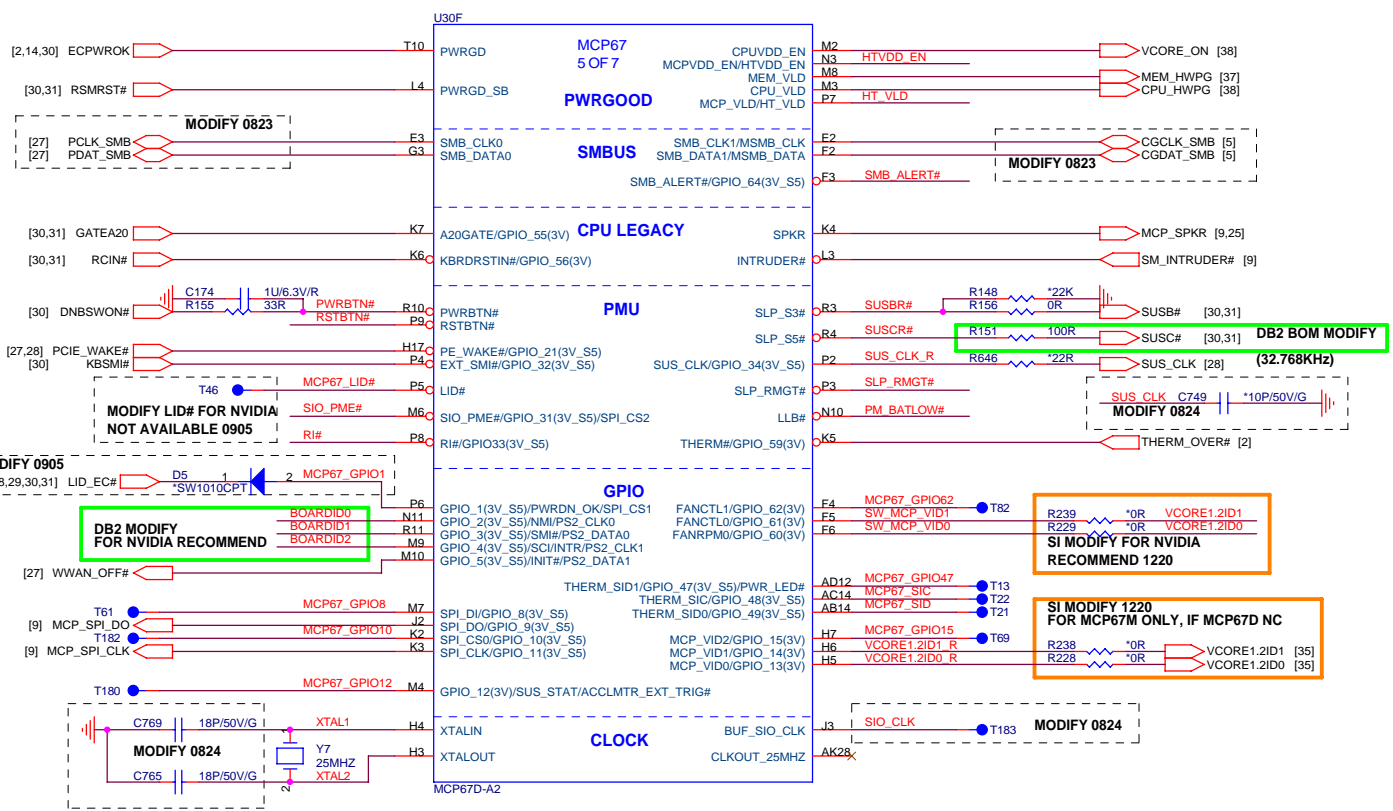
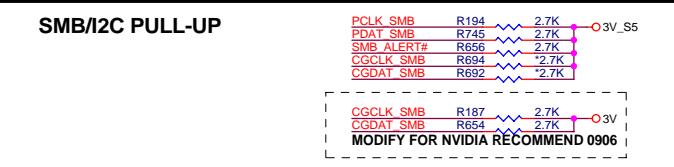

SKU (BOARD ID)	AT1A (DISCRETE)	AT1A (UMA)	AT1B (UMA ONLY)	AT2A (DISCRETE)	AT2A (UMA)
Board ID	010	X00	X00	111	X01
ID0 STUFF	Rd1	Rd1	Rd1	Ru1	Ru1
ID1 STUFF	Ru2	Rd2	Rd2	Ru2	Rd2
ID2 STUFF	Rd3			Ru3	

Board ID :	0/1	0/1	0/1
DIFINE	RESERVE / RESERVE	UMA / DISCRETE	AT1 / AT2

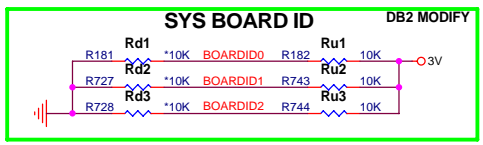

HyperTransport Link 1.2 V_HT Power Valid

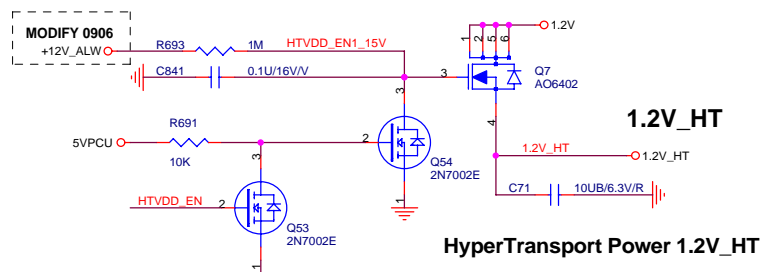
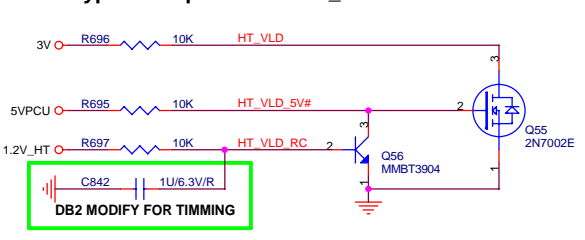

- +1.2V_RMGT [11]
- 1.2V_S5 [11,32,35]
- 1.2V_HT [2,6,11]
- 1.2V [11,12,13,15,36]
- +3.3V_RMGT [9,11]
- 3V_S5 [2,5,6,7,8,9,11,12,13,14,15,18,19,21,22,23,26,27,28,29,30,31,32,33,36,38]
- 3V_V [23,33,34,35,36,37,38]
- +1.2V_ALW [18,32,33]

PROJECT : AT1
Quanta Computer Inc.

Size Custom	Document Number MCP67 (PG,SMB,PMU,GPIO,CLK)	Rev C2A
Date: Friday, December 29, 2006	Sheet 10	of 40

MCP67 POWER PLANE/GND & BYPASS

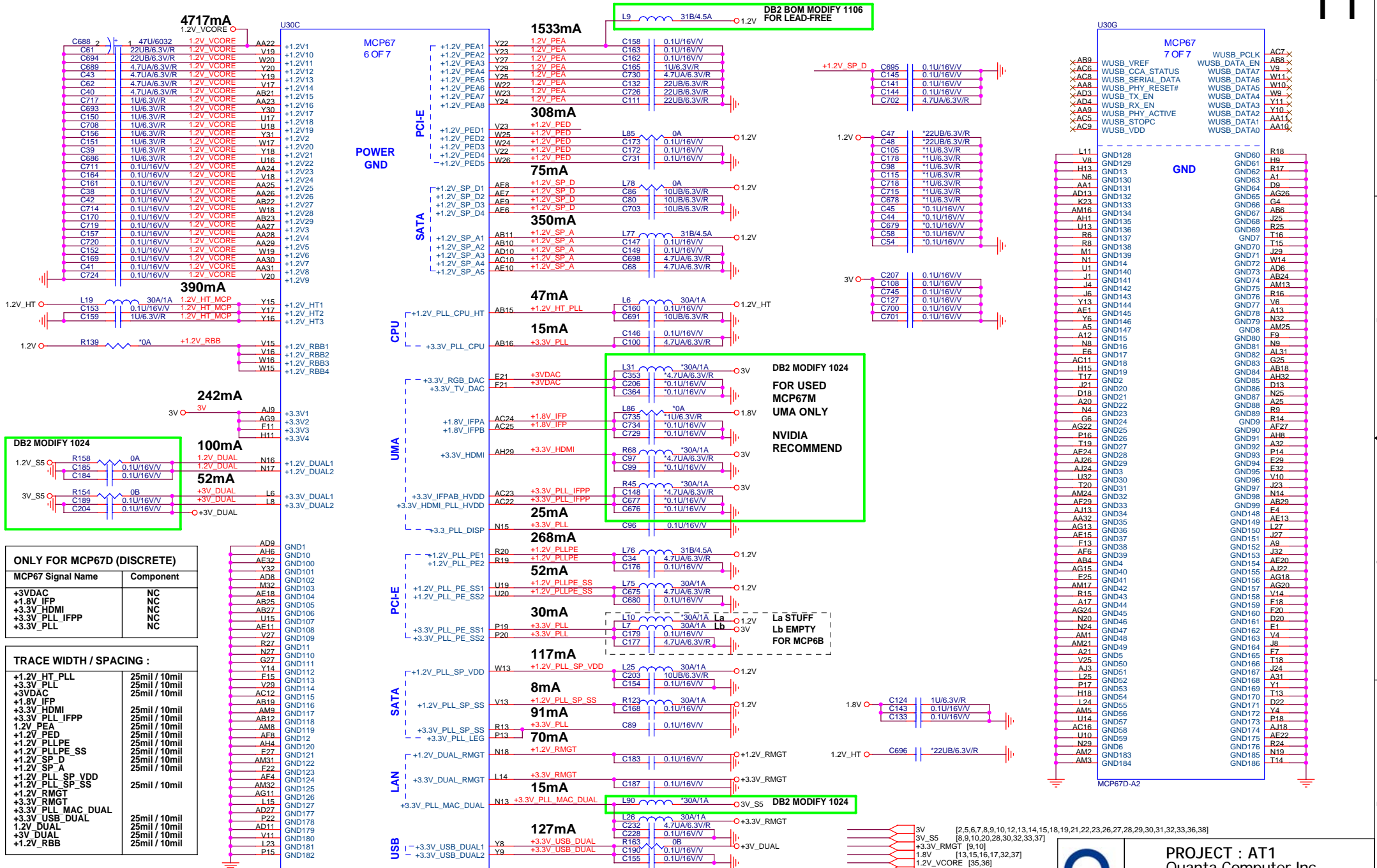

ONLY FOR MCP67D (DISCRETE)

MCP67 Signal Name	Component
+3VDAC	NC
+1.8V_IFP	NC
+3.3V_HDMI	NC
+3.3V_PLL_IFPP	NC
+3.3V_PLL	NC

TRACE WIDTH / SPACING :

+1.2V_HT_PLL	25mil / 10mil
+3.3V_PLL	25mil / 10mil
+3VDAC	25mil / 10mil
+1.8V_IFP	25mil / 10mil
+3.3V_HDMI	25mil / 10mil
+3.3V_PLL_IFPP	25mil / 10mil
+1.2V_PEA	25mil / 10mil
+1.2V_PED	25mil / 10mil
+1.2V_PLLPE	25mil / 10mil
+1.2V_PLLPE_SS	25mil / 10mil
+1.2V_SP_D	25mil / 10mil
+1.2V_SP_A	25mil / 10mil
+1.2V_PLL_SP_VDD	25mil / 10mil
+1.2V_PLL_SP_SS	25mil / 10mil
+1.2V_RMGT	25mil / 10mil
+3.3V_RMGT	25mil / 10mil
+3.3V_PLL_MAC_DUAL	25mil / 10mil
+3.3V_USB_DUAL	25mil / 10mil
+1.2V_DUAL	25mil / 10mil
+3V_DUAL	25mil / 10mil
+1.2V_RBB	25mil / 10mil



PROJECT : AT1
Quanta Computer Inc.

Size Custom	Document Number MCP67 (POWER,GND)	Rev C2A
Date: Friday, December 29, 2006	Sheet 11 of 40	

- 3V [2,5,6,7,8,9,10,12,13,14,15,18,19,21,22,23,26,27,28,29,30,31,32,33,36,38]
- 3V_S5 [8,9,10,20,28,30,32,33,37]
- 1.8V [13,15,16,17,32,37]
- 1.2V_VCORE [35,36]
- 1.2V [10,12,13,15,36]
- 1.2V_HT [2,6,10]
- 1.2V_S5 [10,32,35]
- +1.2V_RMGT [10]

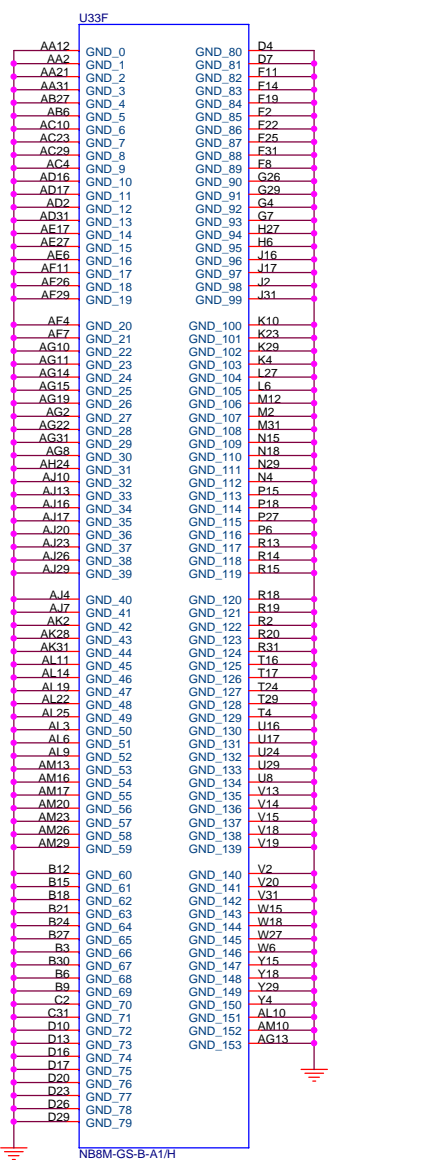

[7]	PEG_RXP0	PEG_RXN0	PEG_RXP0	C215	0.1U/16V/V	C PEG_RXP0	AJ15	PEX_TX0	U33A	PEX_IOVDD_0	AD23	0.1U/16V/V	1.2V
[7]	PEG_RXP1	PEG_RXN1	PEG_RXP1	C222	0.1U/16V/V	C PEG_RXP1	AH16	PEX_TX1		PEX_IOVDD_1	AE23	0.1U/16V/V	
[7]	PEG_RXP2	PEG_RXN2	PEG_RXP2	C238	0.1U/16V/V	C PEG_RXP2	AG17	PEX_TX2		PEX_IOVDD_2	AE24	0.1U/16V/V	
[7]	PEG_RXP3	PEG_RXN3	PEG_RXP3	C252	0.1U/16V/V	C PEG_RXP3	AG18	PEX_TX3		PEX_IOVDD_3	AE25	1U/6.3V/R	
[7]	PEG_RXP4	PEG_RXN4	PEG_RXP4	C269	0.1U/16V/V	C PEG_RXP4	AJ18	PEX_TX4		PEX_IOVDD_4	AG24	1U/6.3V/R	
[7]	PEG_RXP5	PEG_RXN5	PEG_RXP5	C275	0.1U/16V/V	C PEG_RXP5	AJ19	PEX_TX5		PEX_IOVDD_5	AG25	4.7U/6.3V/R	
[7]	PEG_RXP6	PEG_RXN6	PEG_RXP6	C310	0.1U/16V/V	C PEG_RXP6	AG20	PEX_TX6		PEX_IOVDD_6			
[7]	PEG_RXP7	PEG_RXN7	PEG_RXP7	C285	0.1U/16V/V	C PEG_RXP7	AG21	PEX_TX7		PEX_IOVDD_7			
[7]	PEG_RXP8	PEG_RXN8	PEG_RXP8	C309	0.1U/16V/V	C PEG_RXP8	AK21	PEX_TX8		PEX_IOVDD_8			
[7]	PEG_RXP9	PEG_RXN9	PEG_RXP9	C326	0.1U/16V/V	C PEG_RXP9	AJ22	PEX_TX9		PEX_IOVDD_9			
[7]	PEG_RXP10	PEG_RXN10	PEG_RXP10	C334	0.1U/16V/V	C PEG_RXP10	AH23	PEX_TX10		PEX_IOVDD_10			
[7]	PEG_RXP11	PEG_RXN11	PEG_RXP11	C346	0.1U/16V/V	C PEG_RXP11	AK24	PEX_TX11		VDD_0	K16	0.1U/16V/V	VGA_CORE
[7]	PEG_RXP12	PEG_RXN12	PEG_RXP12	C359	0.1U/16V/V	C PEG_RXP12	AJ25	PEX_TX12		VDD_1	N13	0.1U/16V/V	
[7]	PEG_RXP13	PEG_RXN13	PEG_RXP13	C373	0.1U/16V/V	C PEG_RXP13	AH26	PEX_TX13		VDD_2	N14	0.1U/16V/V	
[7]	PEG_RXP14	PEG_RXN14	PEG_RXP14	C367	0.1U/16V/V	C PEG_RXP14	AK27	PEX_TX14		VDD_3	N16	0.1U/16V/V	
[7]	PEG_RXP15	PEG_RXN15	PEG_RXP15	C375	0.1U/16V/V	C PEG_RXP15	AJ28	PEX_TX15		VDD_4	N17	0.1U/16V/V	
[7]	PEG_TXP_C0	PEG_TXN_C0	PEG_TXP_C0				AK13	PEX_RX0		VDD_5	N19	0.1U/16V/V	
[7]	PEG_TXP_C1	PEG_TXN_C1	PEG_TXP_C1				AM14	PEX_RX1		VDD_6	P13	10U/6.3V/R	
[7]	PEG_TXP_C2	PEG_TXN_C2	PEG_TXP_C2				AL15	PEX_RX2		VDD_7	P14	0.1U/16V/V	
[7]	PEG_TXP_C3	PEG_TXN_C3	PEG_TXP_C3				AK16	PEX_RX3		VDD_8	P16	1U/6.3V/R	
[7]	PEG_TXP_C4	PEG_TXN_C4	PEG_TXP_C4				AL17	PEX_RX4		VDD_9	P17	0.1U/16V/V	
[7]	PEG_TXP_C5	PEG_TXN_C5	PEG_TXP_C5				AM18	PEX_RX5		VDD_10	P19	0.1U/16V/V	
[7]	PEG_TXP_C6	PEG_TXN_C6	PEG_TXP_C6				AK19	PEX_RX6		VDD_11	R16	0.1U/16V/V	
[7]	PEG_TXP_C7	PEG_TXN_C7	PEG_TXP_C7				AL20	PEX_RX7		VDD_12	R17	0.1U/16V/V	
[7]	PEG_TXP_C8	PEG_TXN_C8	PEG_TXP_C8				AM21	PEX_RX8		VDD_13	T14	10U/6.3V/R	
[7]	PEG_TXP_C9	PEG_TXN_C9	PEG_TXP_C9				AK22	PEX_RX9		VDD_14	T15	0.47U/10V/X	
[7]	PEG_TXP_C10	PEG_TXN_C10	PEG_TXP_C10				AL23	PEX_RX10		VDD_15	T18	0.47U/10V/X	
[7]	PEG_TXP_C11	PEG_TXN_C11	PEG_TXP_C11				AM25	PEX_RX11		VDD_16	T19	0.47U/10V/X	
[7]	PEG_TXP_C12	PEG_TXN_C12	PEG_TXP_C12				AK25	PEX_RX12		VDD_17	U13	0.47U/10V/X	
[7]	PEG_TXP_C13	PEG_TXN_C13	PEG_TXP_C13				AL26	PEX_RX13		VDD_18	U14	1U/6.3V/R	
[7]	PEG_TXP_C14	PEG_TXN_C14	PEG_TXP_C14				AM27	PEX_RX14		VDD_19	U15	1U/6.3V/R	
[7]	PEG_TXP_C15	PEG_TXN_C15	PEG_TXP_C15				AL28	PEX_RX15		VDD_20	U18	0.47U/10V/X	
[7]	CLK_PCIE_VGA	CLK_PCIE_VGA#	CLK_PCIE_VGA				AH14	PEX_REFCLK		VDD_21	U19	0.47U/10V/X	
[7]	CLK_PCIE_VGA#						AH14	PEX_REFCLK#		VDD_22	U19	0.47U/10V/X	

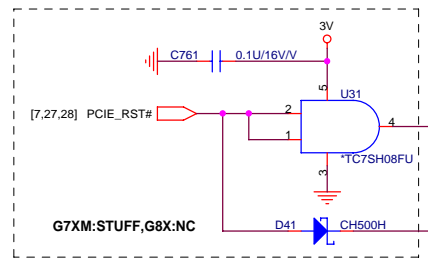
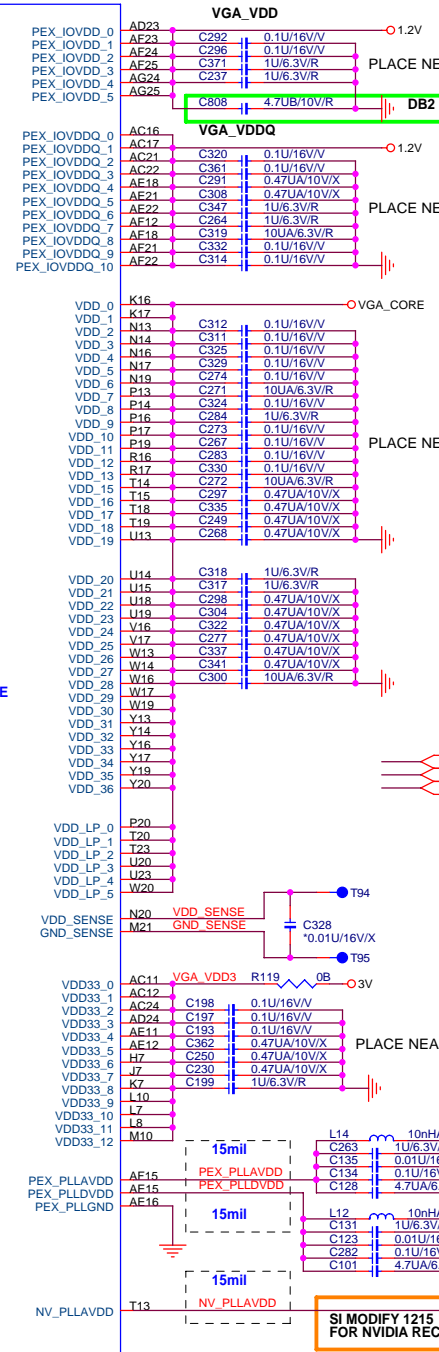

- T88 ● VGA RFU0 AG12
- T93 ● VGA RFU1 AH13
- T186 ● PEX TSTCK AM12
- T184 ● PEX TSTCK# AM11

PROJECT : AT1
Quanta Computer Inc.

Size Custom	Document Number NV_NB8M (PCIE_I/F,GND)	Rev C2A
Date: Friday, December 29, 2006	Sheet 12 of 40	

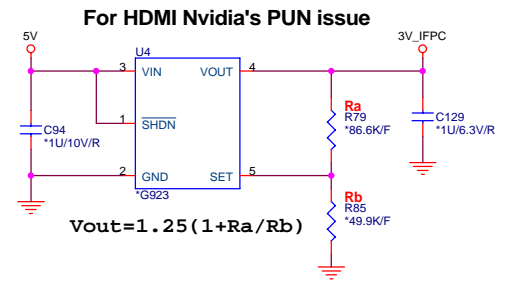
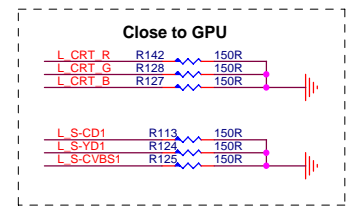
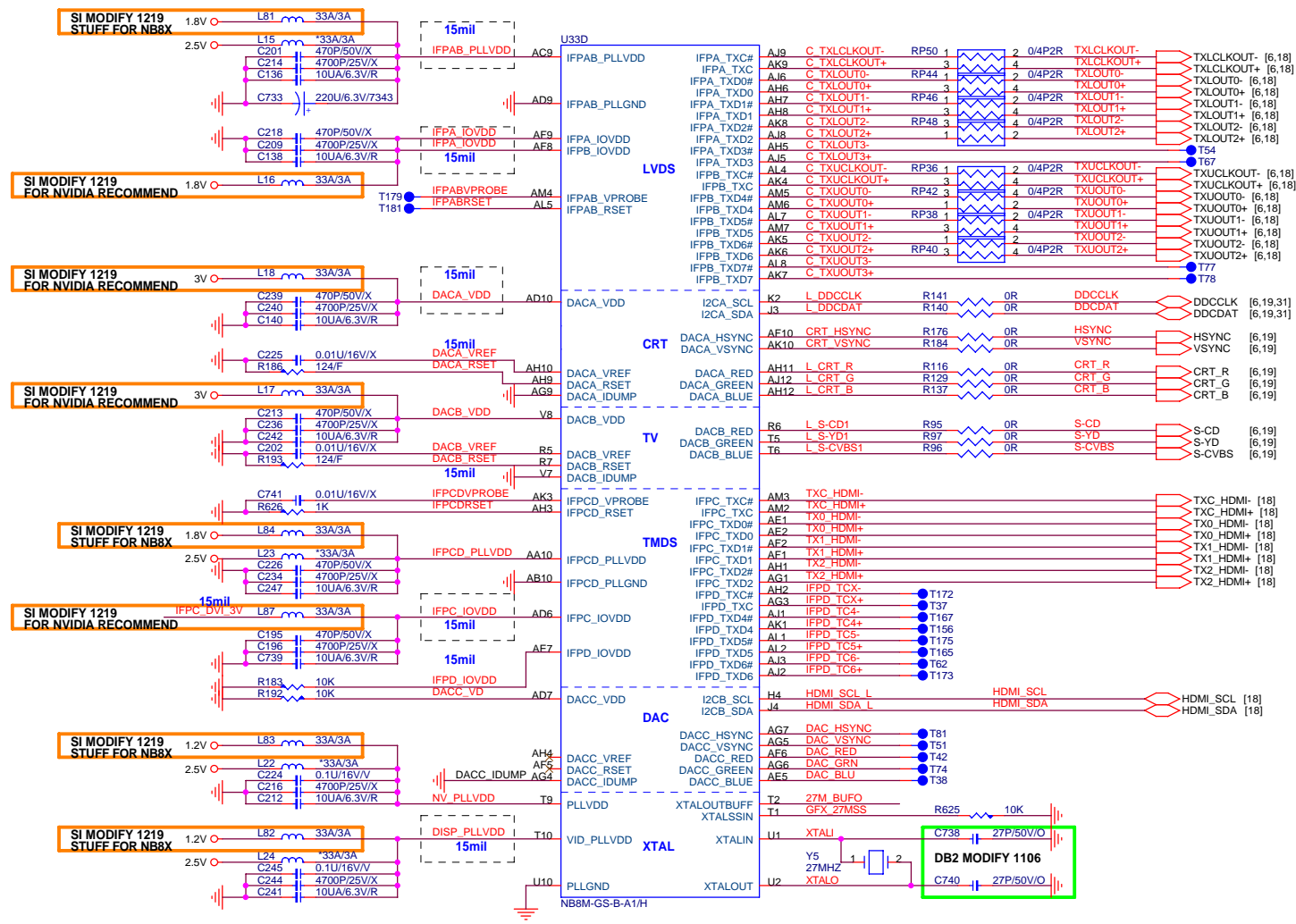

FOR IFPC VDD LEAKAGE CIRCUIT

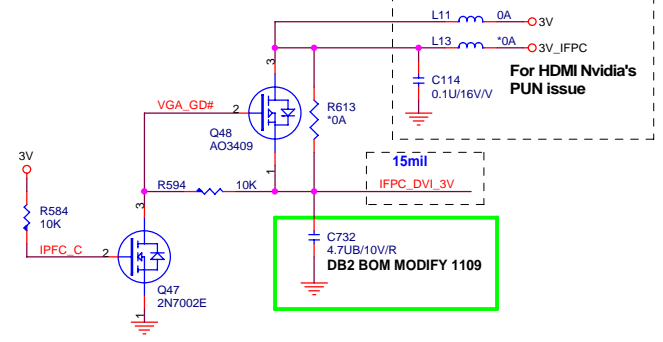

- 1.2V [10,11,12,15,36]
- 1.8V [11,15,16,17,32,37]
- 2.5V [2,32,36]
- 3V [2,5,6,7,8,9,10,11,12,14,15,18,19,21,22,23,26,27,28,29,30,31,32,33,36,38]
- 5V [18,19,22,23,25,26,27,28,29,31,32,33,36,38]

PROJECT : AT1
Quanta Computer Inc.

Size Custom Document Number NV_NB8M (LVDS,CRT,TV,HDMI) Rev C2A

Date: Friday, December 29, 2006 Sheet 13 of 40

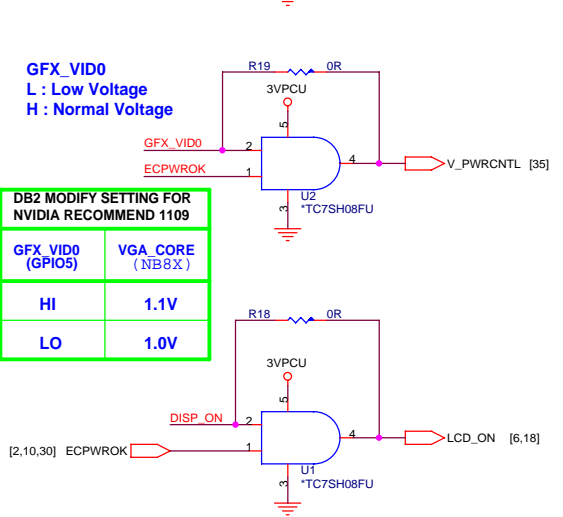
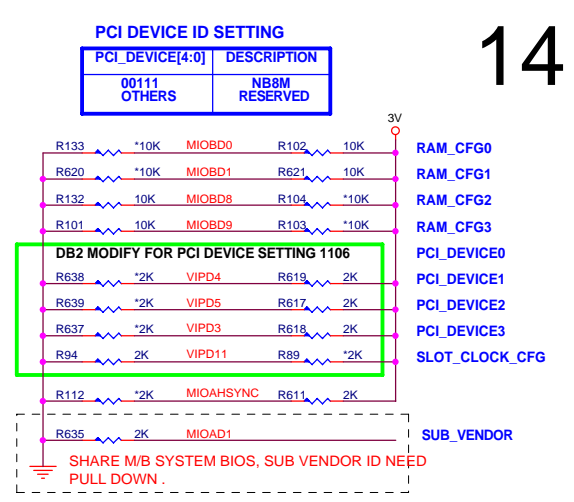
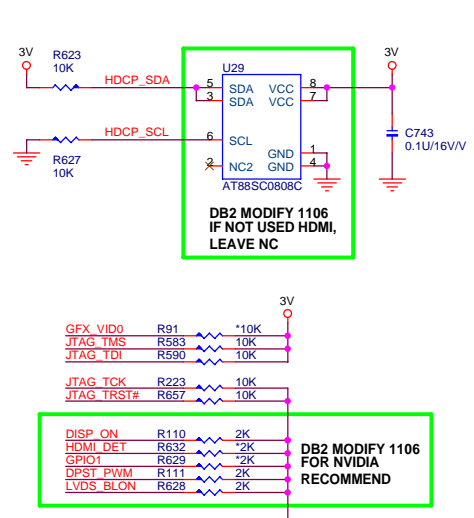
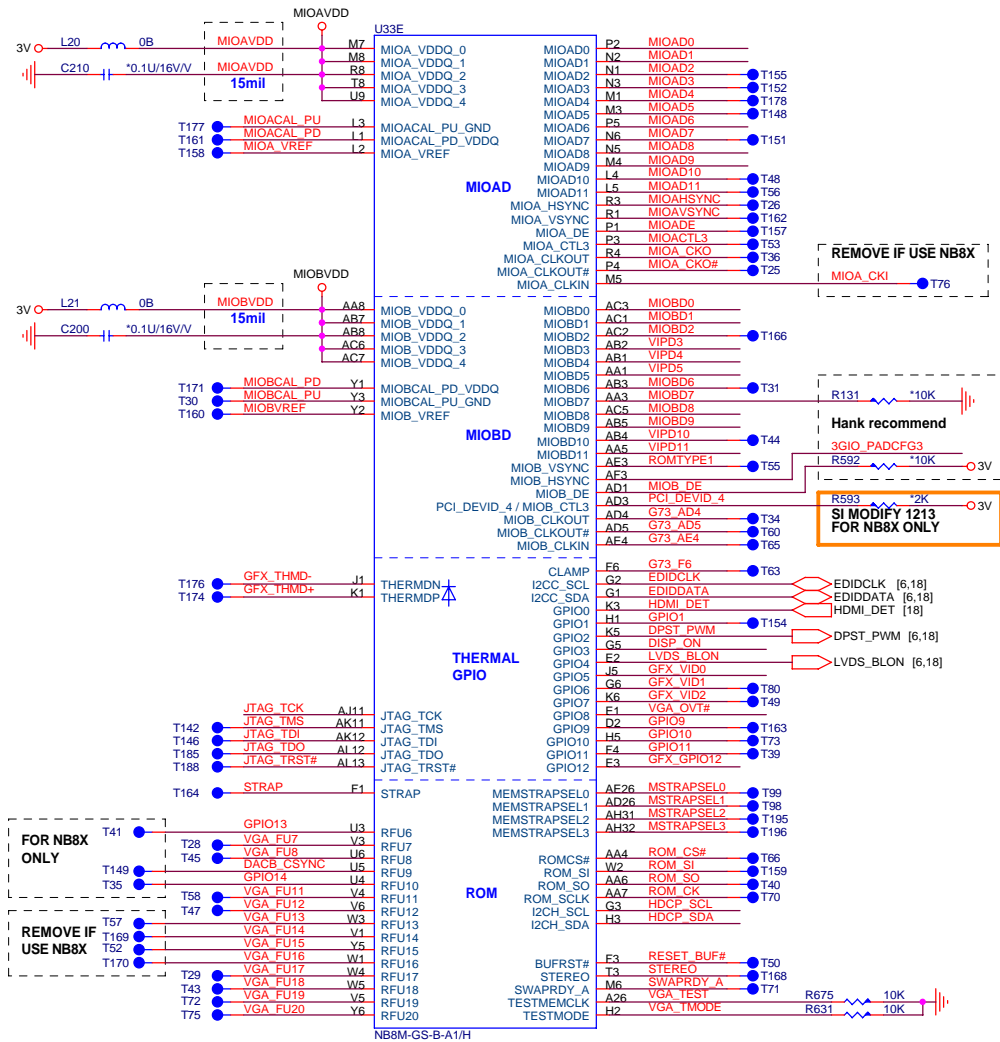

NB8X 64bit VRAM Configuration Table

RAM_CFG3[3:0]	DESCRIPTION	Vendor
0000	DDR2 16Mx16x4, 64bit, 128MB	Elpida
0001	DDR2 16Mx16x4, 64bit, 128MB	Samsung
0010	DDR2 16Mx16x4, 64bit, 128MB	Infinion
0011	DDR2 16Mx16x4, 64bit, 128MB	Hynix
0100	Reserved	
0101	DDR2 32Mx16x4, 64bit, 256MB	Samsung
0110	DDR2 32Mx16x4, 64bit, 256MB	Infinion
0111	DDR2 32Mx16x4, 64bit, 256MB	Hynix
1000	DDR2 16Mx16x2, 32bit, 64MB	Elpida
1001	DDR2 16Mx16x2, 32bit, 64MB	Samsung
1010	DDR2 16Mx16x2, 32bit, 64MB	Infinion
1011	DDR2 16Mx16x2, 32bit, 64MB	Hynix
others	Reserved	

NB8X 128bit VRAM Configuration Table

RAM_CFG3[3:0]	DESCRIPTION	Vendor
0000	DDR2 16Mx16x8, 128bit, 256MB	Elpida
0001	DDR2 16Mx16x8, 128bit, 256MB	Samsung
0010	DDR2 16Mx16x8, 128bit, 256MB	Infinion
0011	DDR2 16Mx16x8, 128bit, 256MB	Hynix
0100	Reserved	
0101	DDR2 32Mx16x8, 128bit, 512MB	Samsung
0110	DDR2 32Mx16x8, 128bit, 512MB	Infinion
0111	DDR2 32Mx16x8, 128bit, 512MB	Hynix
1000	DDR2 16Mx16x4, 64bit, 128MB	Elpida
1001	DDR2 16Mx16x4, 64bit, 128MB	Samsung
1010	DDR2 16Mx16x4, 64bit, 128MB	Infinion
1011	DDR2 16Mx16x4, 64bit, 128MB	Hynix
1100	Reserved	
1101	DDR2 32Mx16x4, 64bit, 256MB	Samsung
1110	DDR2 32Mx16x4, 64bit, 256MB	Infinion
1111	DDR2 32Mx16x4, 64bit, 256MB	Hynix

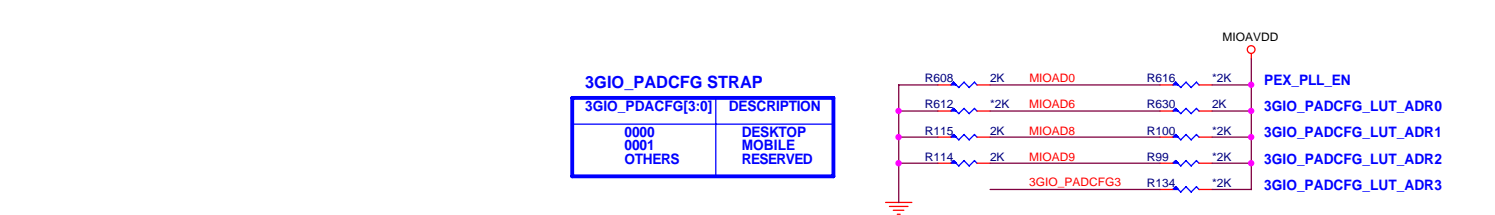
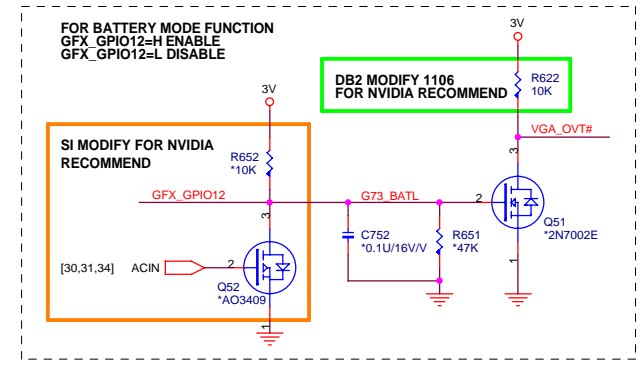

Channel C is available for 128bit only

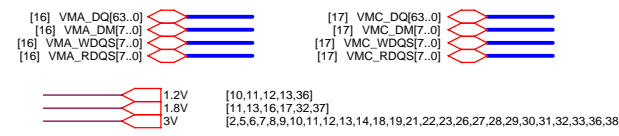
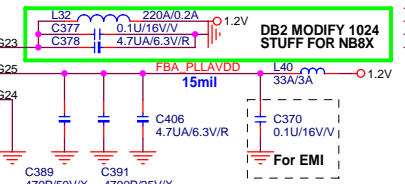
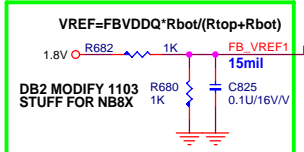
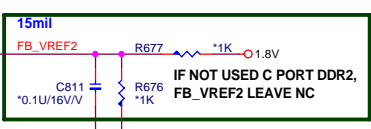
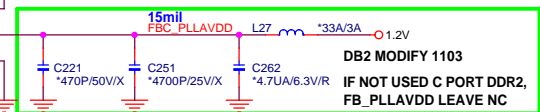
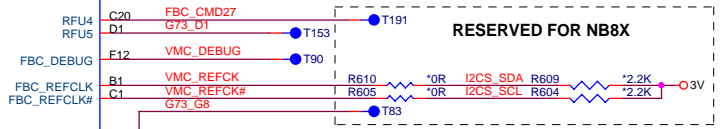
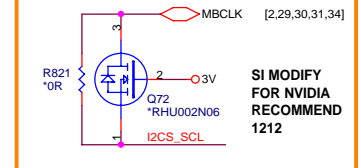
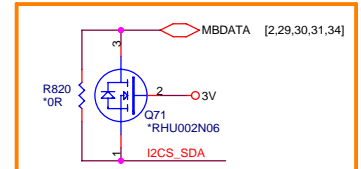
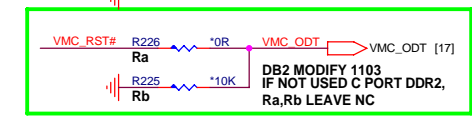
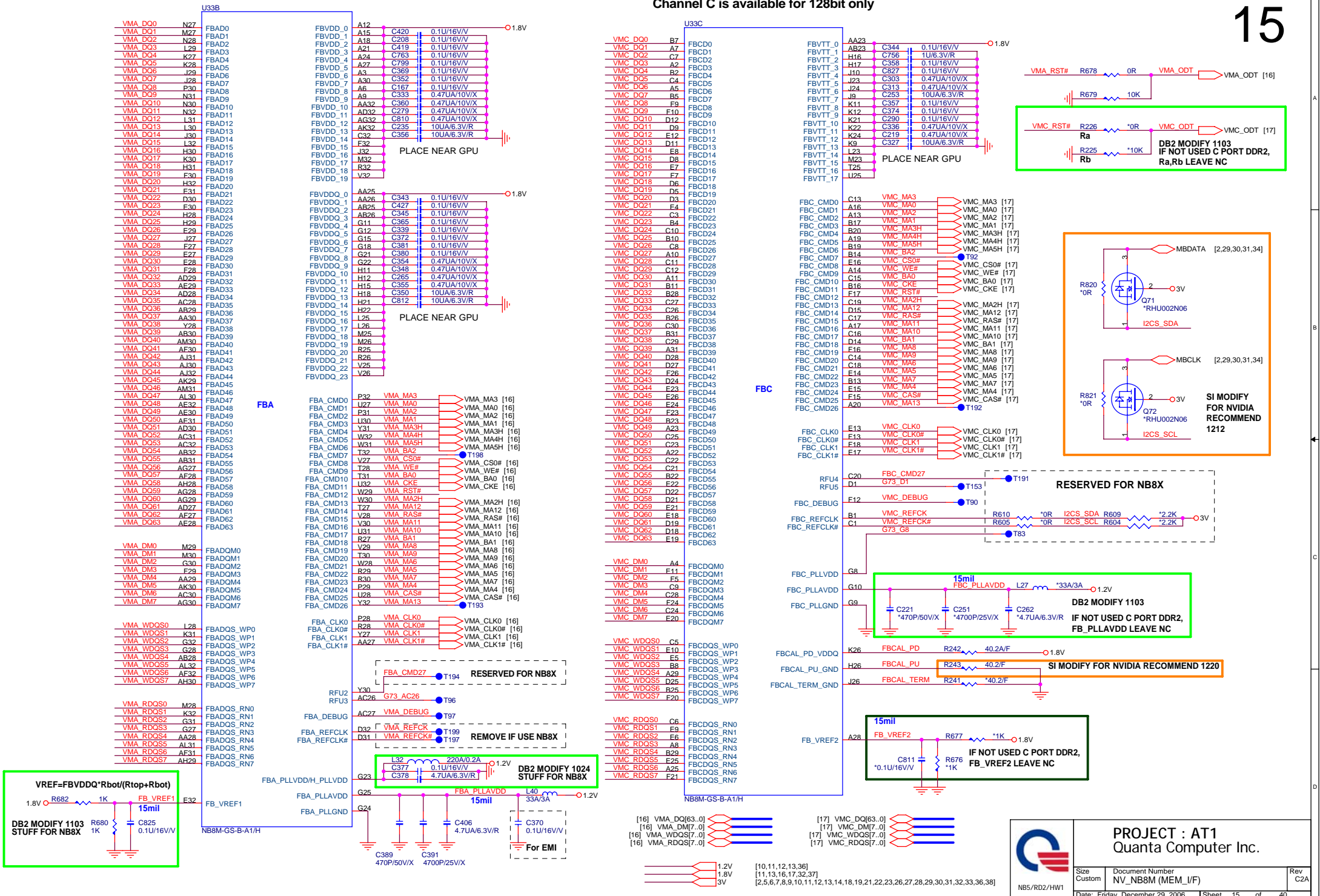

PROJECT : AT1
Quanta Computer Inc.
Size Custom Document Number NV_NB8M (MEM_I/F) Rev C2A
Date: Friday, December 29, 2006 Sheet 15 of 40

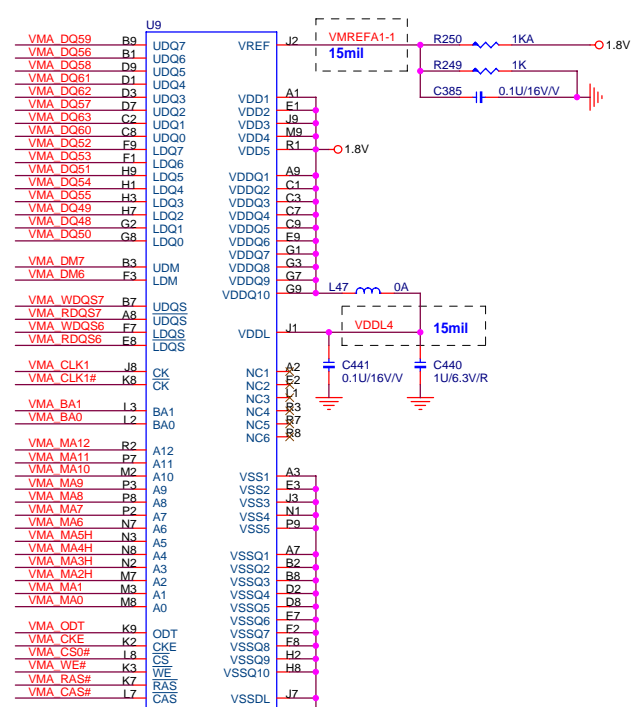
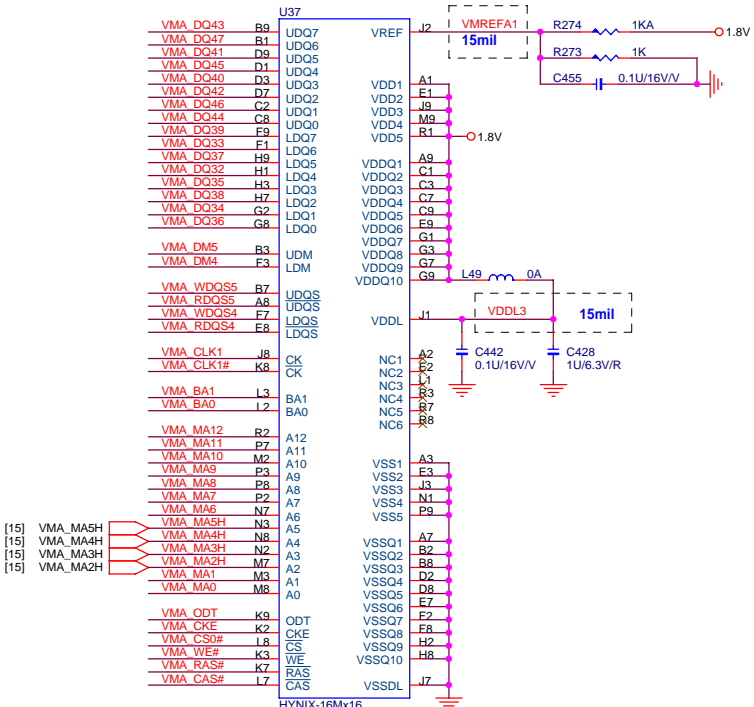
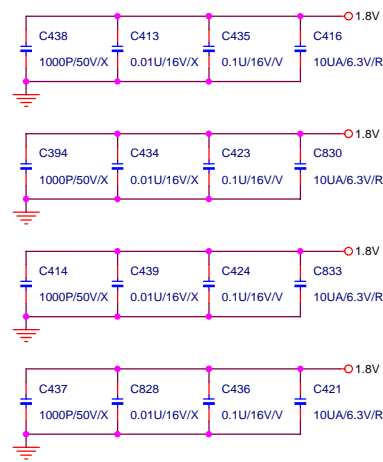
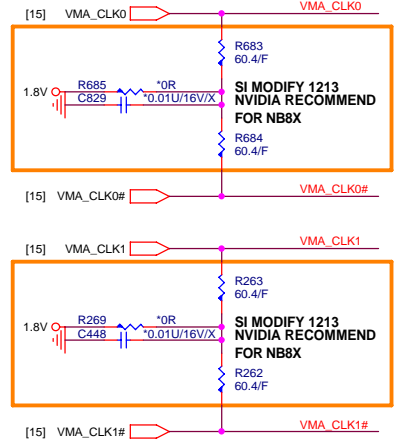
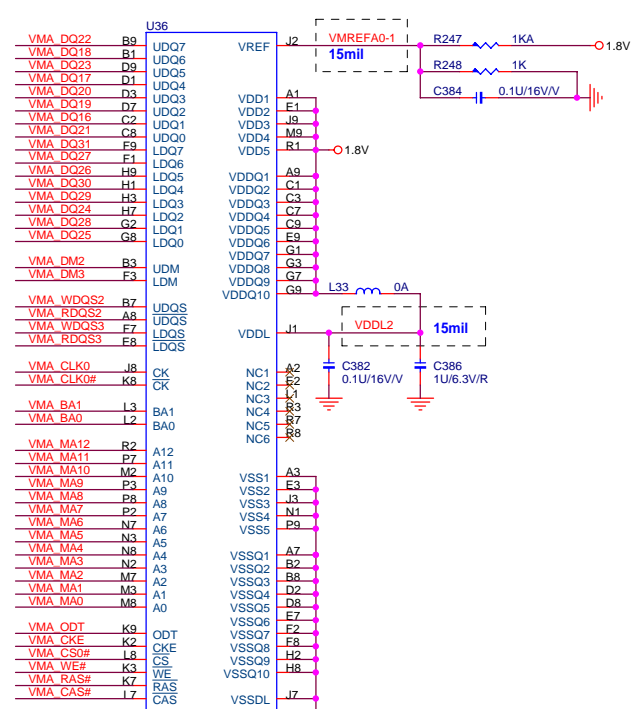
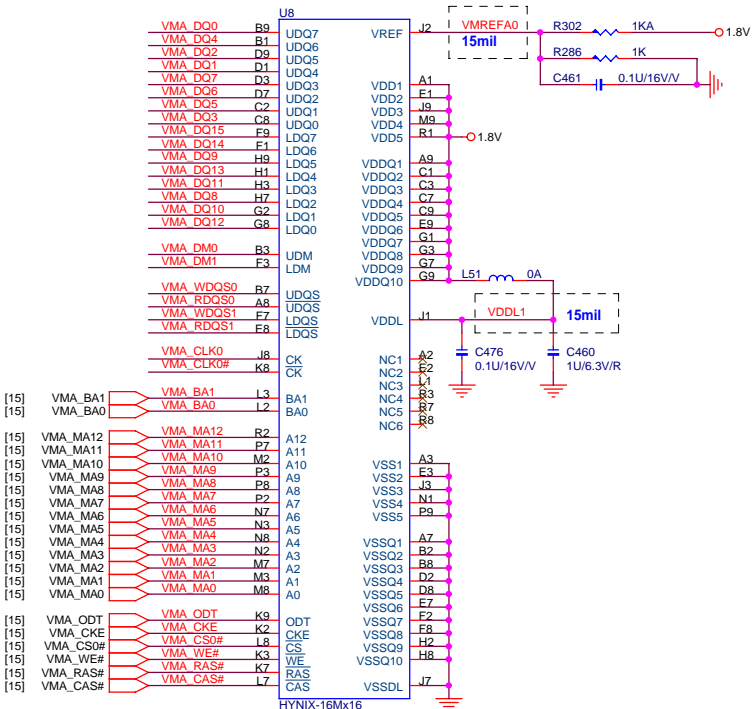

HYNIX-16Mx16 : AKD5JG-TW12 (HY5PS561621AFP-25_1.8V)
 INFINEON-16Mx16 : AKD5JG-T*08 (HYB18T256161AFL25)
 SAMSUNG-16Mx16 : AKD5JG-T514 (K4N56163QG-ZC25_1.8V)



PROJECT : AT1
 Quanta Computer Inc.

Size Custom	Document Number NV_NB8M VRAM-1(GDDR2 BGA84)	Rev C2A
Date: Friday, December 29, 2006	Sheet 16 of 40	

[11,13,15,17,32,37]

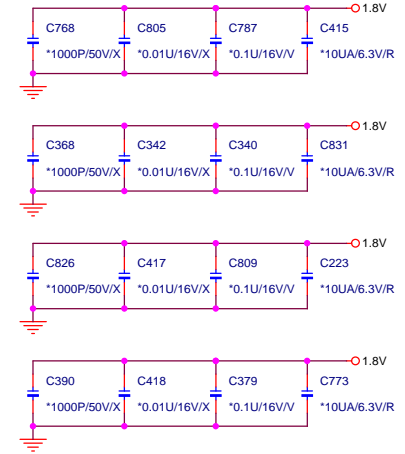
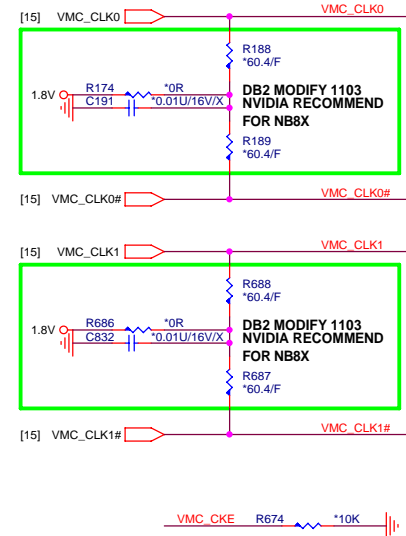
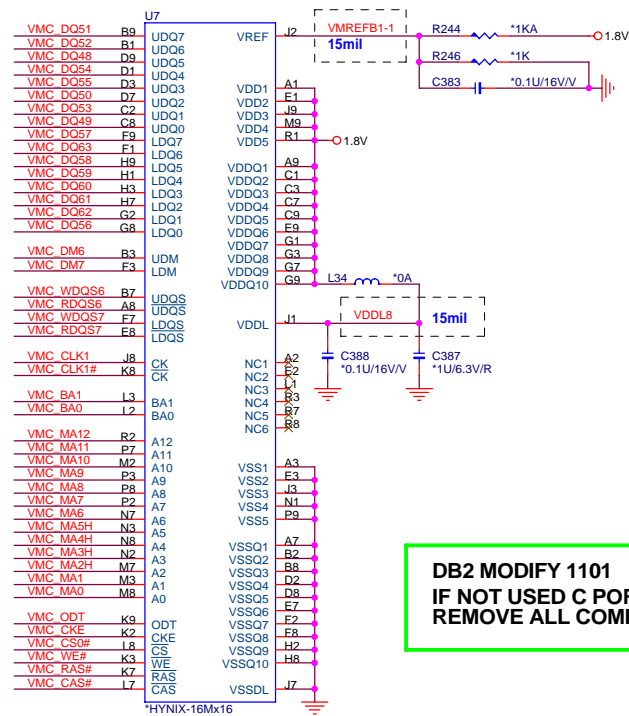
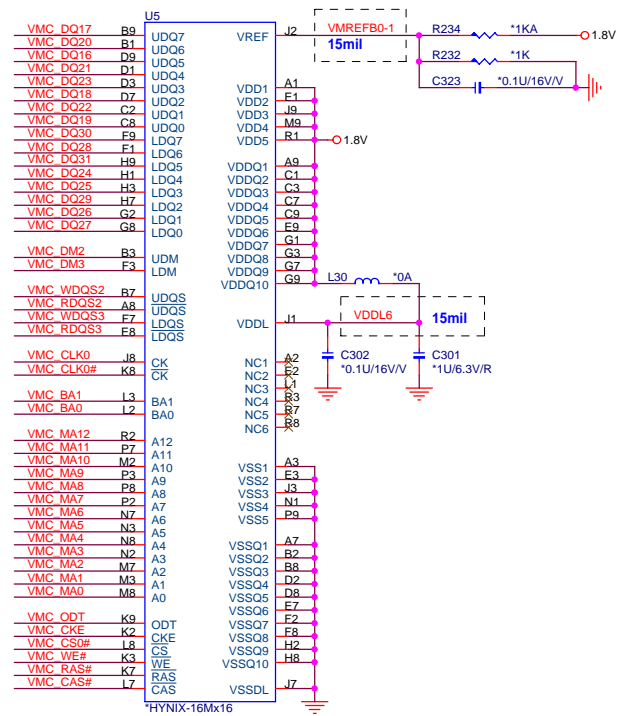
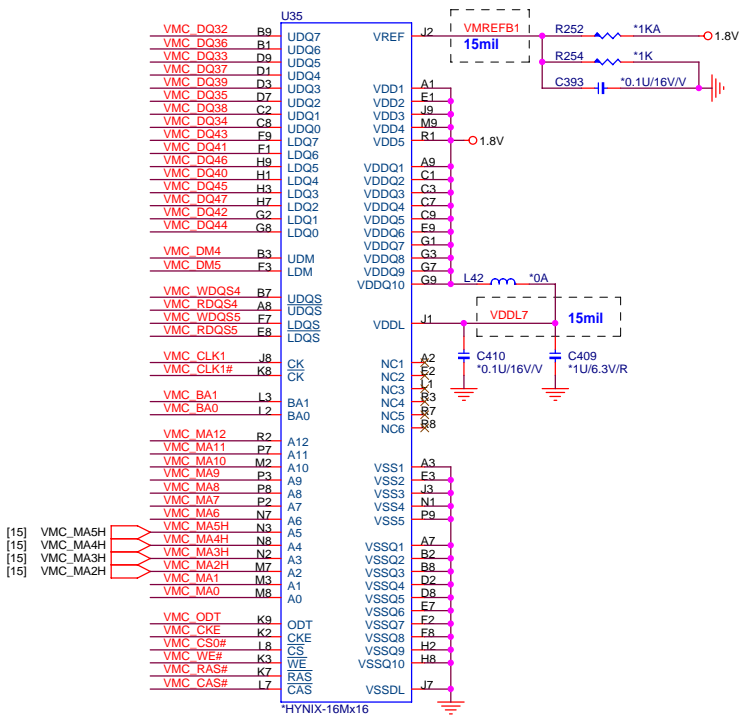
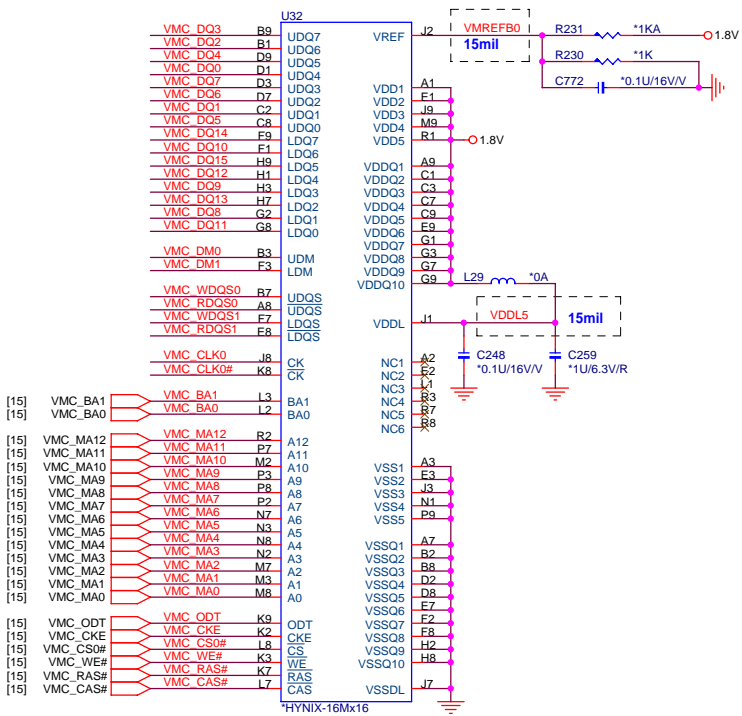

- [15] VMC_DQ[63..0]
- [15] VMC_DM[7..0]
- [15] VMC_WDQS[7..0]
- [15] VMC_RDQS[7..0]

**DB2 MODIFY 1101
IF NOT USED C PORT DDR2,
REMOVE ALL COMPONENTS**

HYNIX-16Mx16 : AKD5JG-TW12 (HYSP561621AFP-25_1.8V)
INFINEON-16Mx16 : AKD5JG-T*08 (HYB18T256161AFL25)
SAMSUNG-16Mx16 : AKD5JG-T514 (K4N56163QG-ZC25_1.8V)



**PROJECT : AT1
Quanta Computer Inc.**

Size Custom	Document Number NV_NB8M VRAM-2(GDDR2 BGA84)	Rev C2A
Date: Friday, December 29, 2006	Sheet 17	of 40

1.8V [11,13,15,16,32,37]

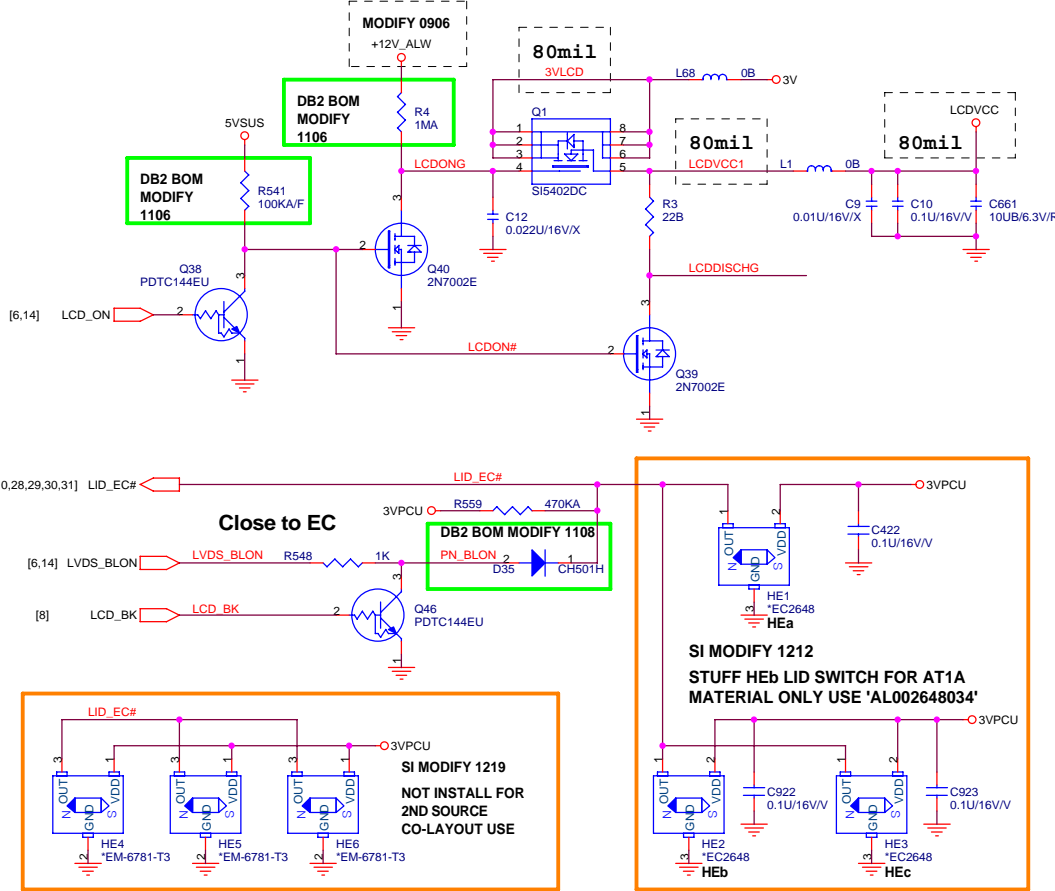

LCD CONNECTOR

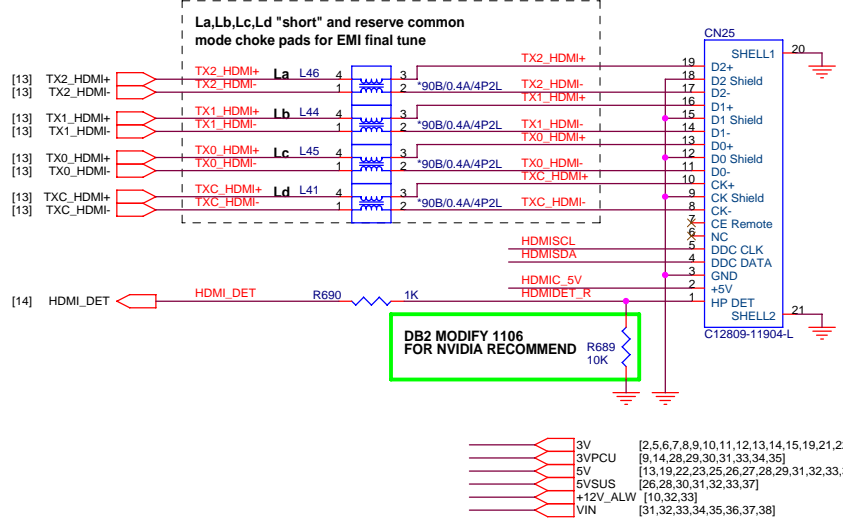
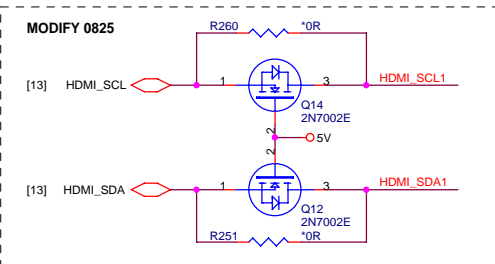
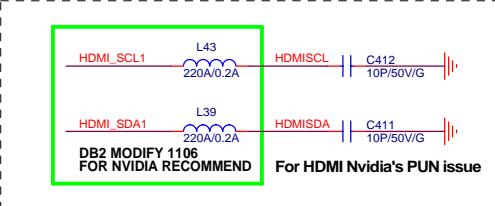
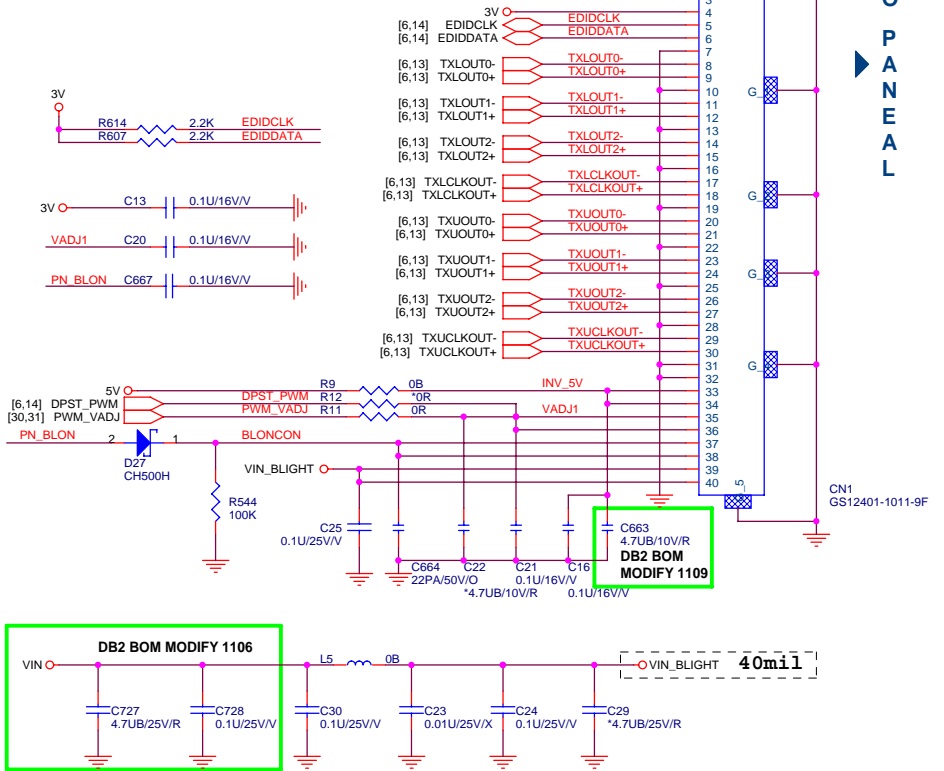

HDMI PORT

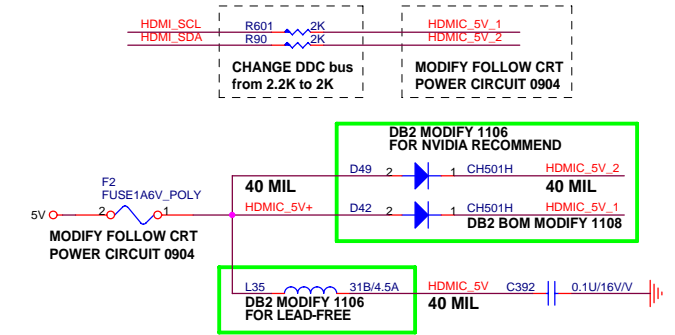

- 3V [2,5,6,7,8,9,10,11,12,13,14,15,19,21,22,23,25,26,27,28,29,30,31,32,33,36,38]
- 3VPCU [9,14,28,29,30,31,33,34,35]
- 5V [13,19,22,23,25,26,27,28,29,31,32,33,36,38]
- 5VSUS [26,28,30,31,32,33,37]
- +12V_ALW [10,32,33]
- VIN [31,32,33,34,35,36,37,38]

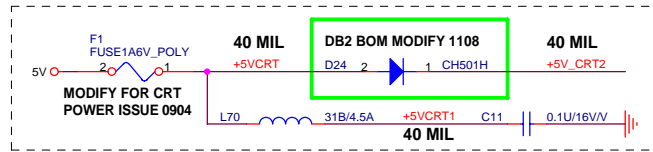
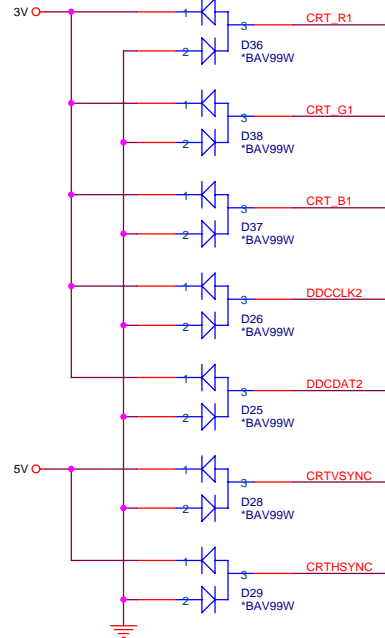

CRT PORT

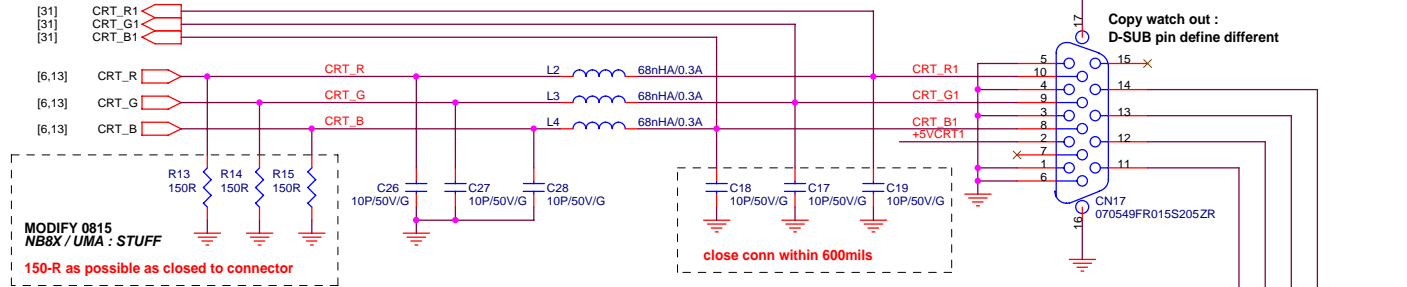

MODIFY 0815
NB8X / UMA : STUFF
150-R as possible as closed to connector

close conn within 600mils

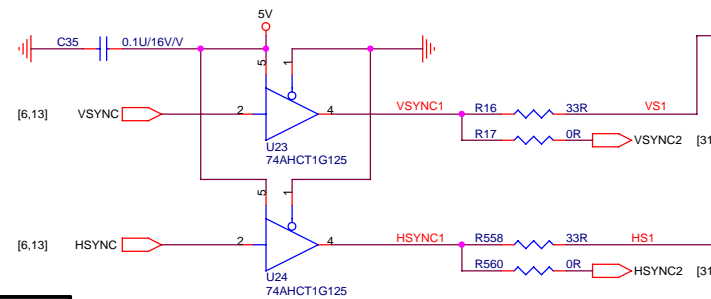

NB8X & MCP67M DIFFERENCE		
LOCATION	NB8X (DISCRETE)	MCP67M (UMA)
Ra	2.2K	NC
Rb	NC	2.2K
Rc	2.2K	NC
Rd	NC	2.2K

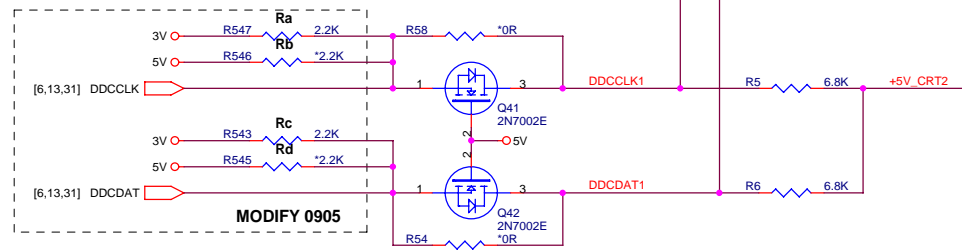

3V [2,5,6,7,8,9,10,11,12,13,14,15,18,21,22,23,26,27,28,29,30,31,32,33,36,38]
5V [13,18,22,23,25,26,27,28,29,31,32,33,36,38]

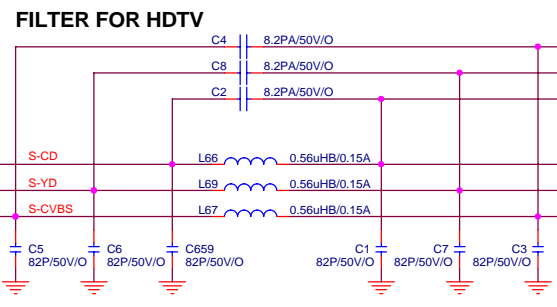
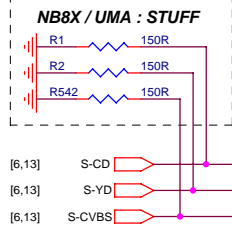
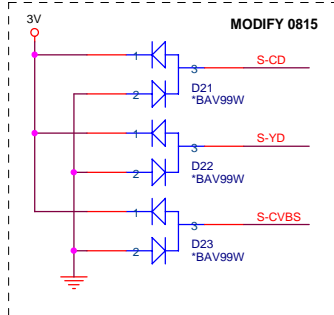

TV_OUT

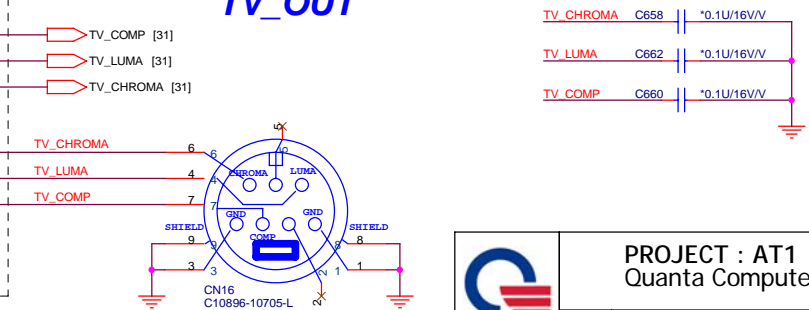

PROJECT : AT1
Quanta Computer Inc.

Size Custom	Document Number CRT_TV_OUT	Rev C2A
Date: Friday, December 29, 2006		Sheet 19 of 40

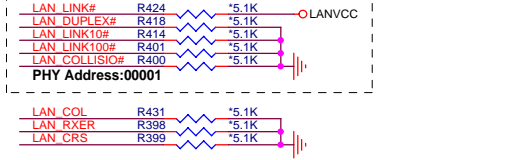
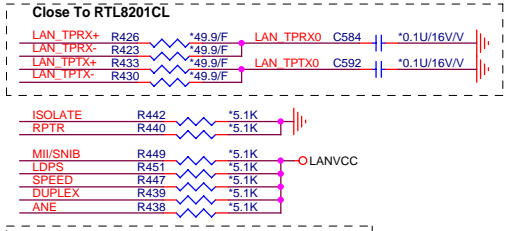
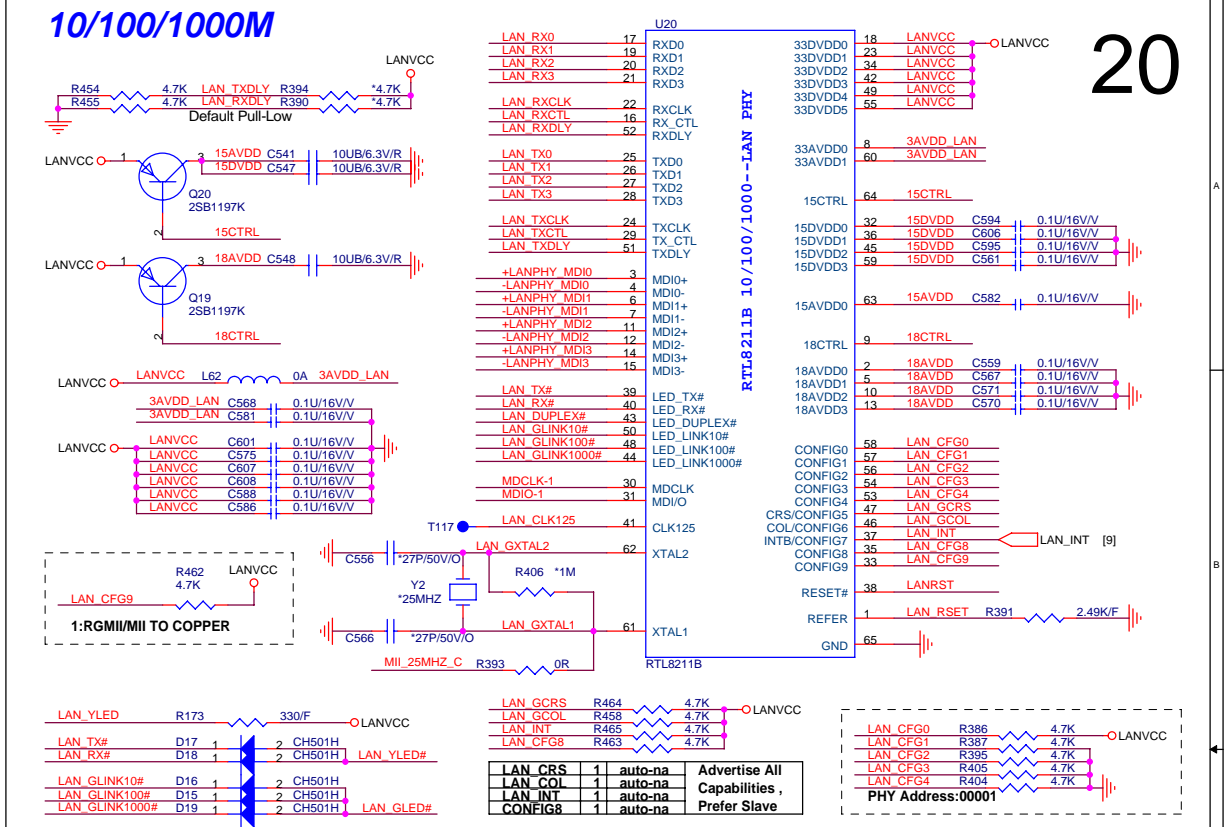
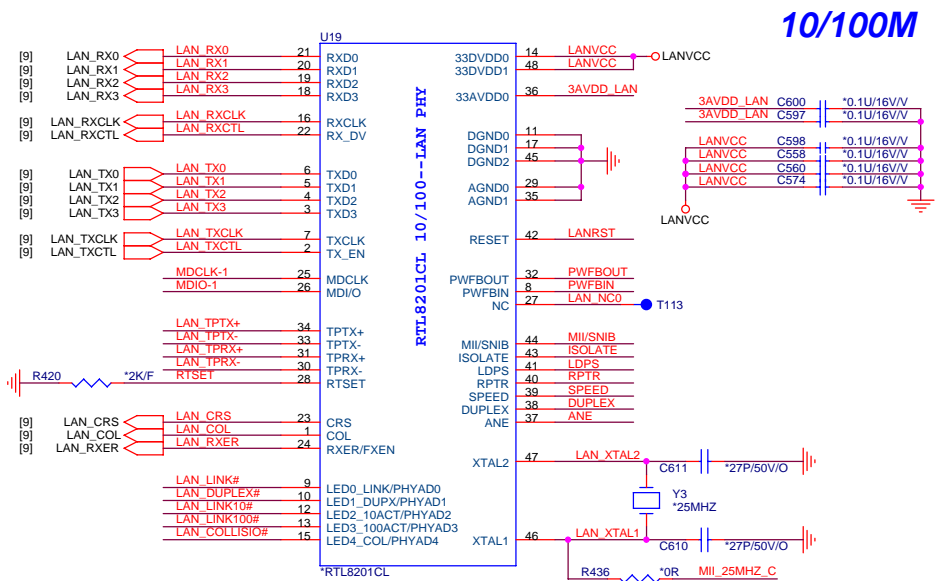

LAN_COL	1	Default	RTL8201BL LED
LAN_RXER_R	0	Default	RTL8201CL LED
LAN_CRIS	0	Default	Fiber Mode
			UTP Mode
			Ensure operating at normal mode

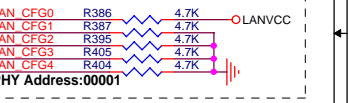
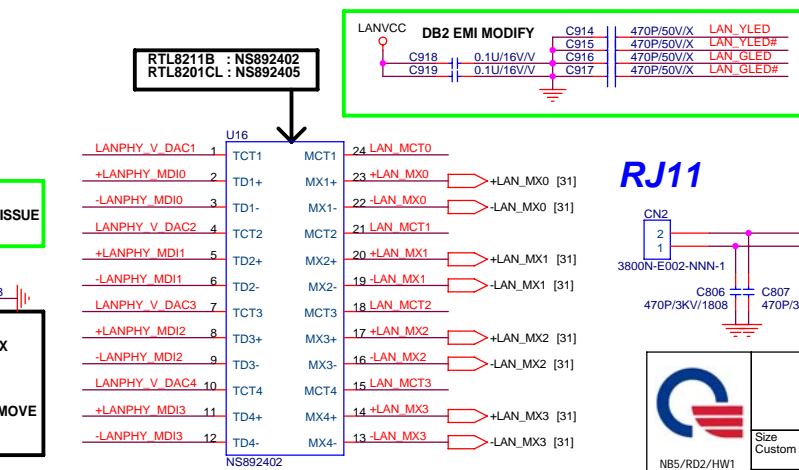
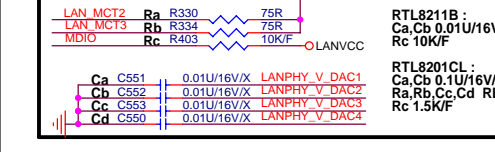
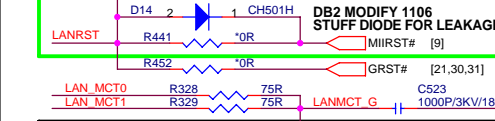
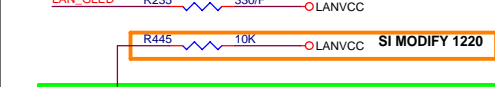
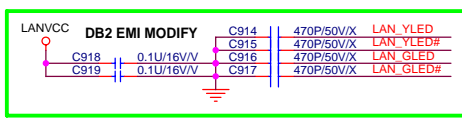
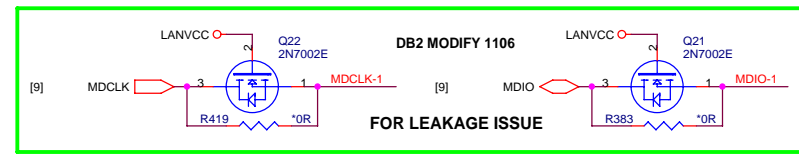
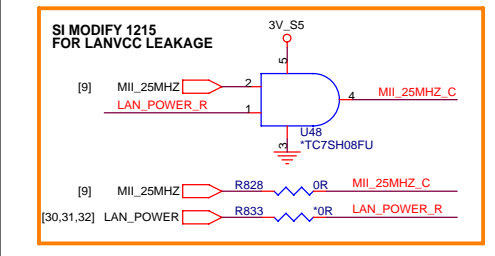
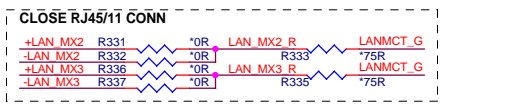
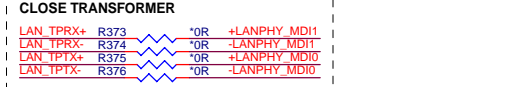

RJ45

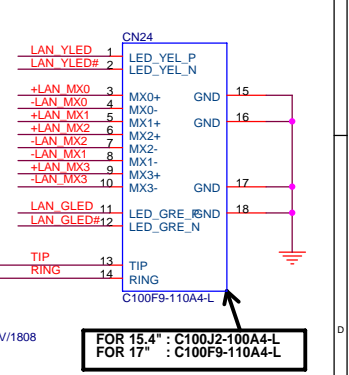

PROJECT : AT1
Quanta Computer Inc.

Size Custom Document Number: RTL8211B,8201CL,RJ45,RJ11 Rev: C2A

Date: Friday, December 29, 2006 Sheet 20 of 40

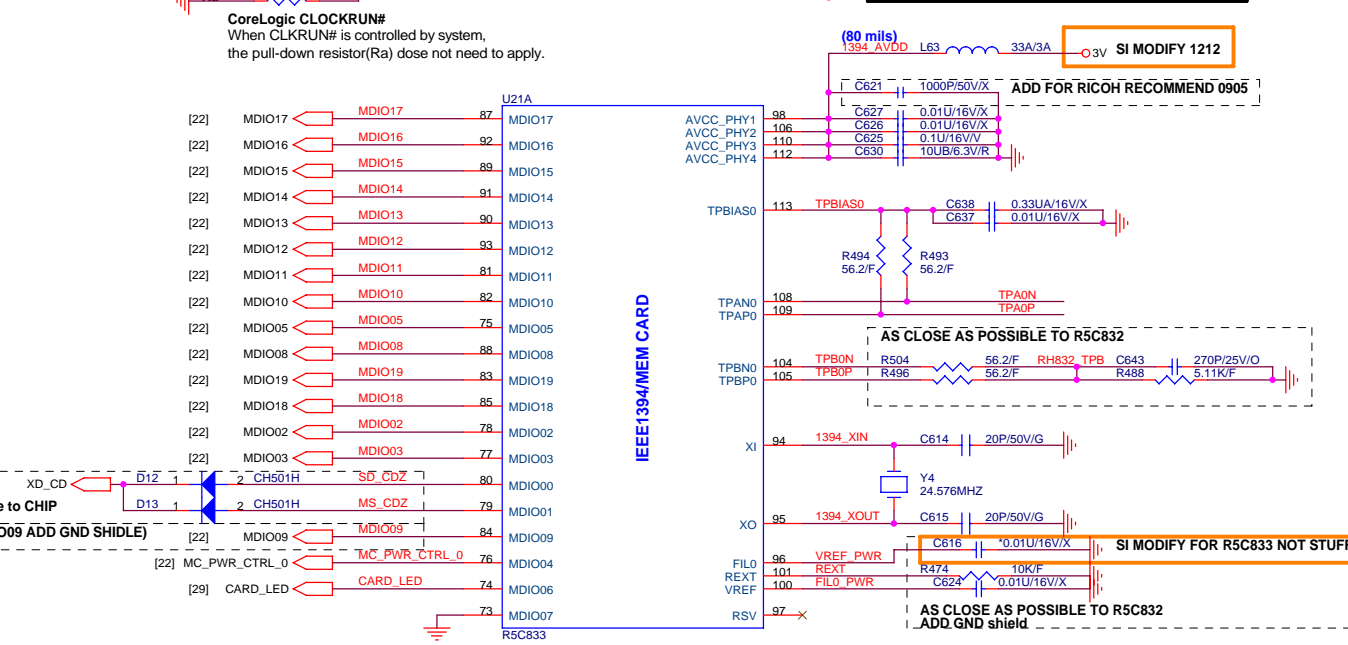
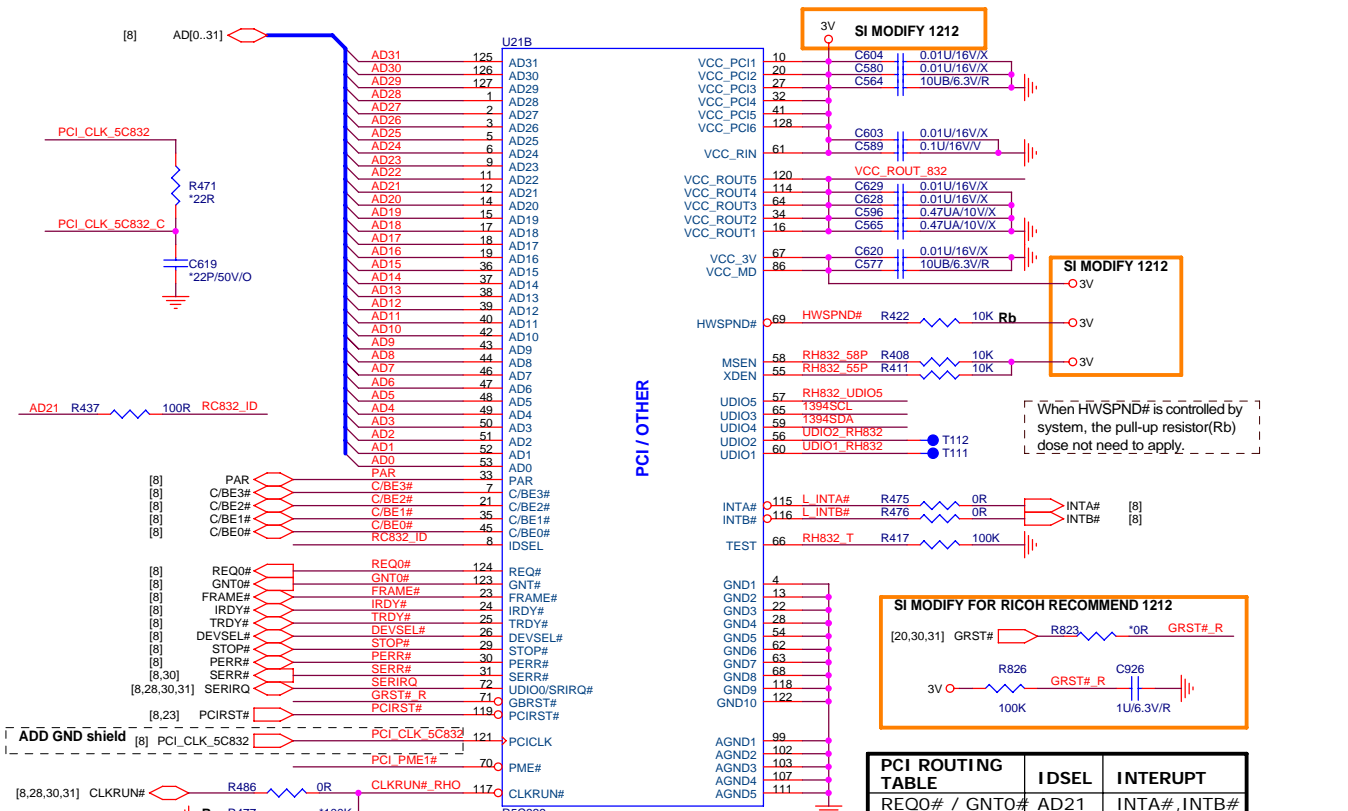

Serial EEPROM

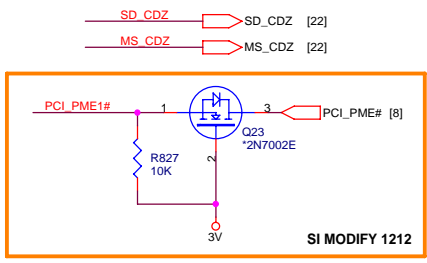
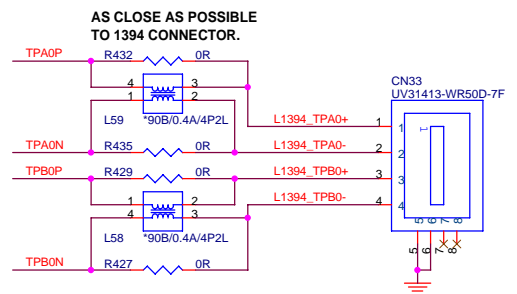
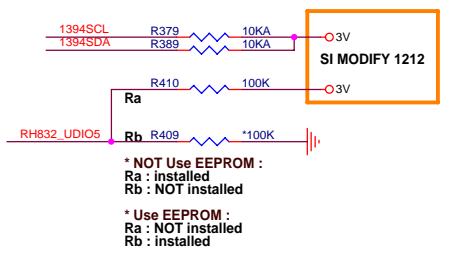

4 IN1 CARD READER XD,MMC/SD,MS/MP

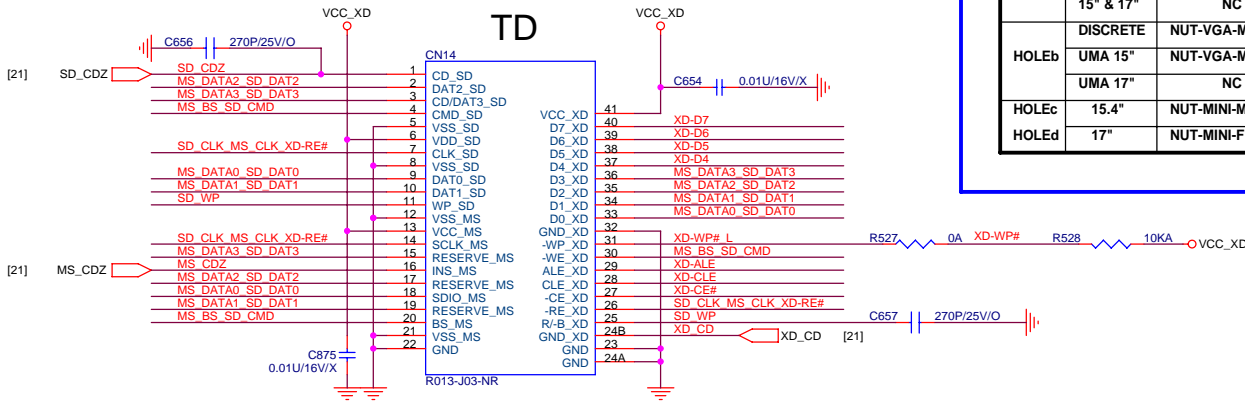

Note: Need to add WP# and CD# pad for Proconn

15.4" & 17" AND DISCRETE & UMA		
HOLE	STATUS	NUT
HOLEa	DISCRETE	NUT-VGA-MBAT8002
	15" & 17"	NC
	DISCRETE	NUT-VGA-MBAT8002
HOLEb	UMA 15"	NUT-VGA-MBAT8002
	UMA 17"	NC
HOLEc	15.4"	NUT-MINI-MBAT8004
HOLED	17"	NUT-MINI-FBAT9035

SCREW HOLE

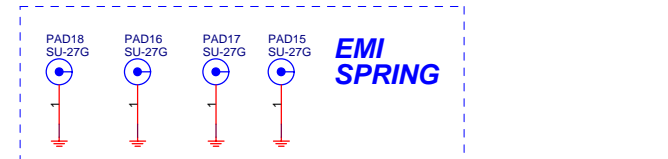
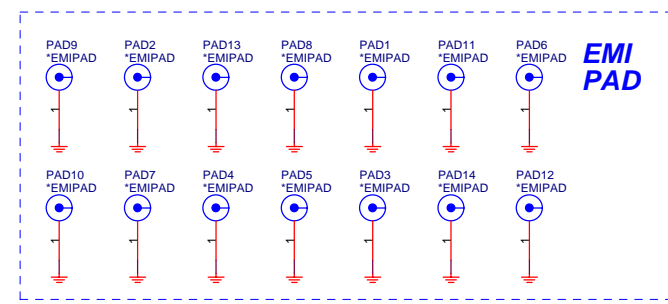
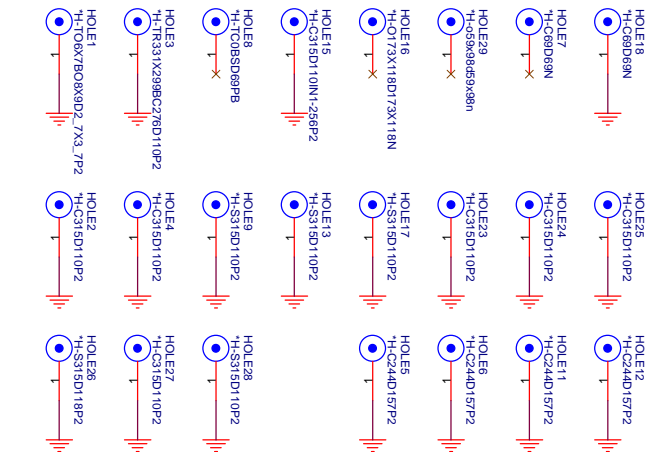
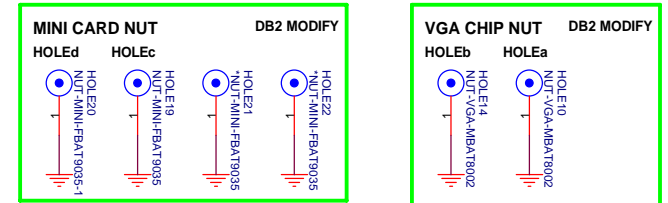

[2,5,6,7,8,9,10,11,12,13,14,15,18,19,21,23,26,27,28,29,30,31,32,33,36,38]
[13,18,19,23,25,26,27,28,29,31,32,33,36,38]

2ND SOURCE

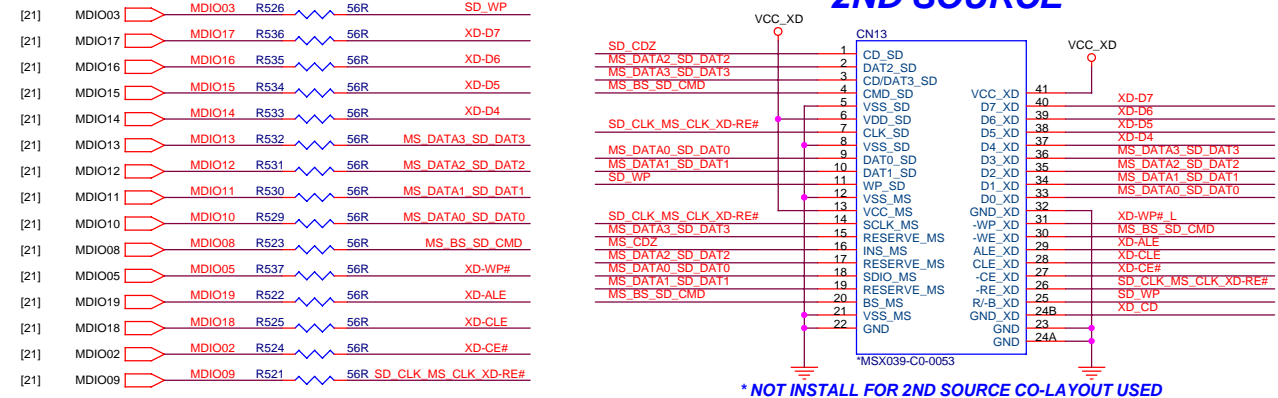

* NOT INSTALL FOR 2ND SOURCE CO-LAYOUT USED

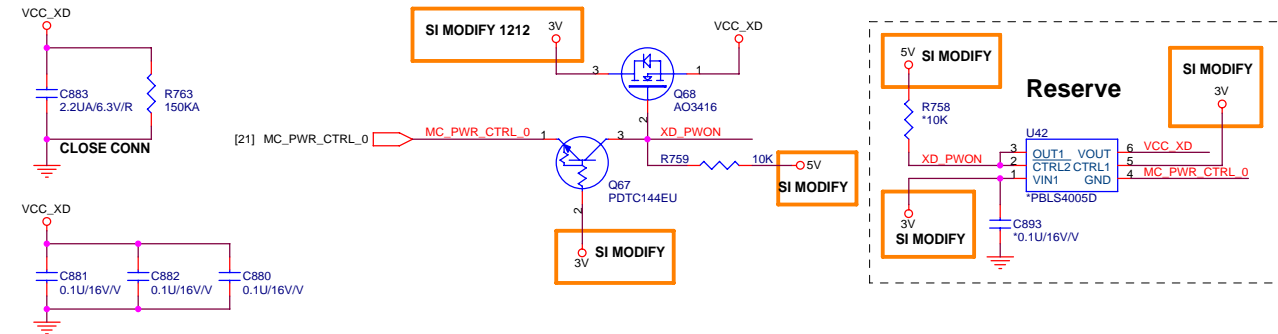

PROJECT : AT1
Quanta Computer Inc.

Size Custom	Document Number CARD_READER,HOLE,NUT,SPRING	Rev C2A
Date: Friday, December 29, 2006		Sheet 22 of 40

VDDIO is used in determining which HD Audio bus voltage is present on the system. When VDDIO is +1.5V, the device will use 1.5v signaling on the HDA interface pins; when VDDIO is +3.3v, the device will use 3.3v signaling on the HDA interface pins.

For associated Line Side Device portion of this design see Conexant RD02-D450 reference schematic

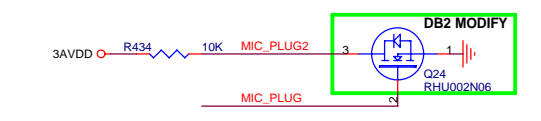
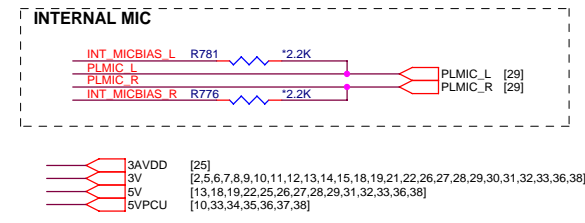
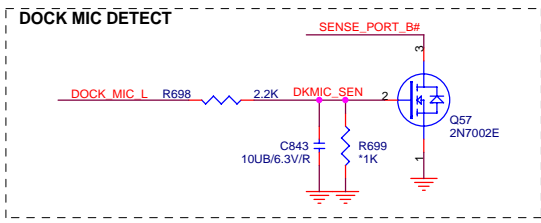
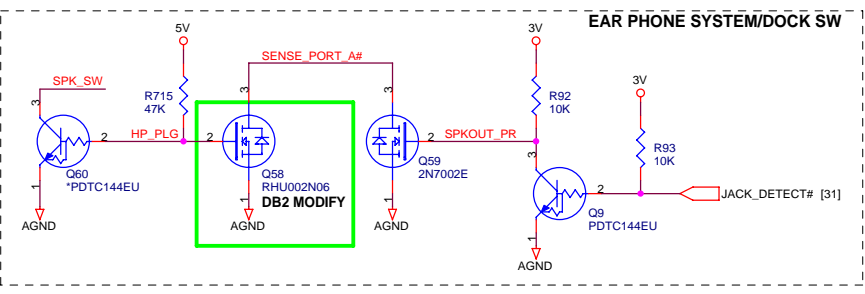
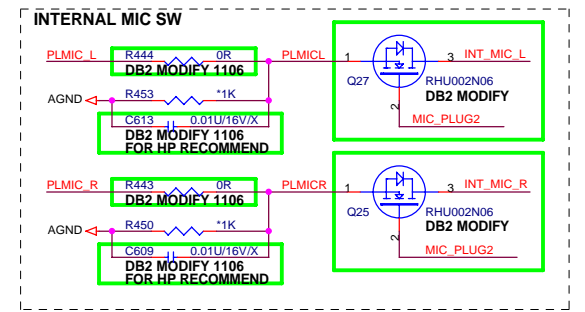
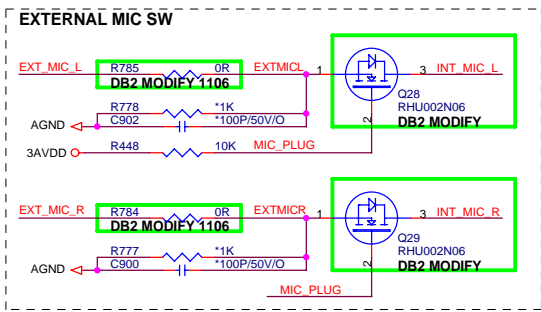
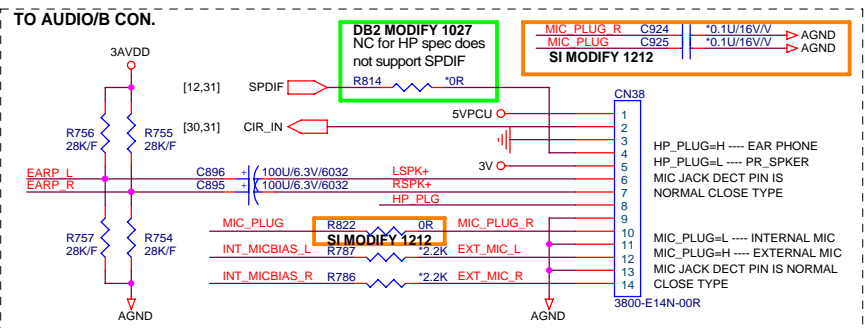
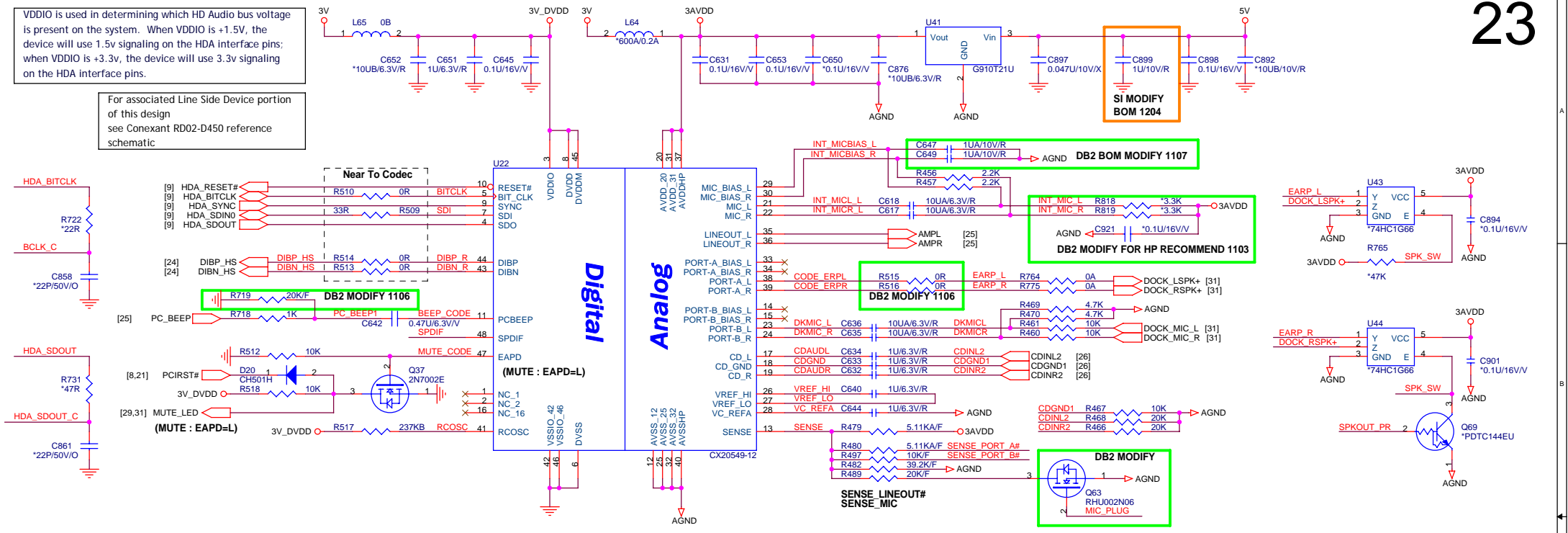

	PROJECT : AT1 Quanta Computer Inc.	
	Size Custom Document Number HDA_CX20549-12_AUDIO_BOARD Date: Friday, December 29, 2006	Rev C2A Sheet 23 of 40

Revision History		
REV	Description	Date
0	Initial Release	April 26, 2005
4		

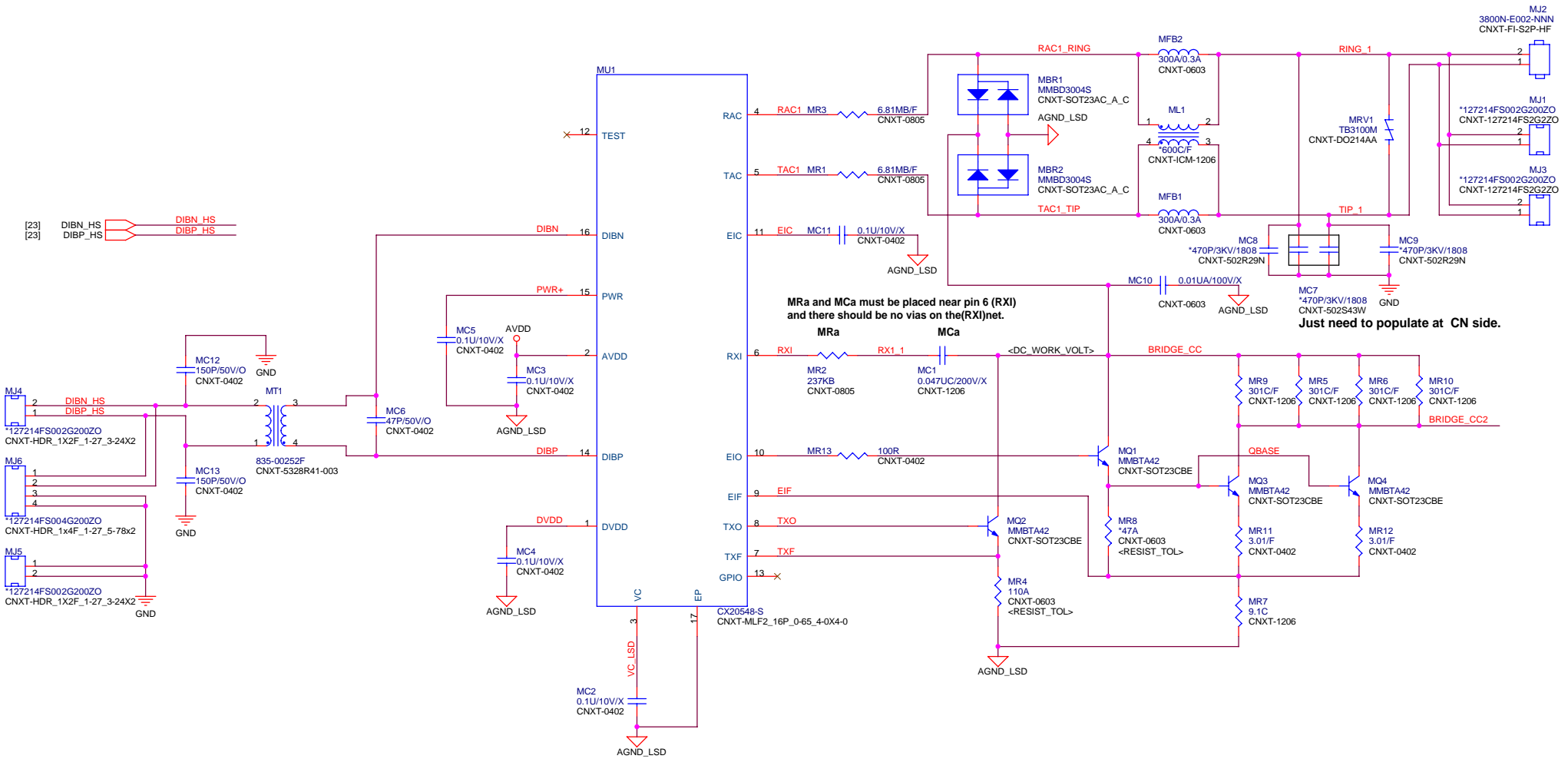

	PROJECT : AT1 Quanta Computer Inc.		
	Size Custom	Document Number MODEM(DAA)_CX20548-S	Rev C2A
	Date: Friday, December 29, 2006	Sheet 24 of 40	

AUDIO AMPLIFIER

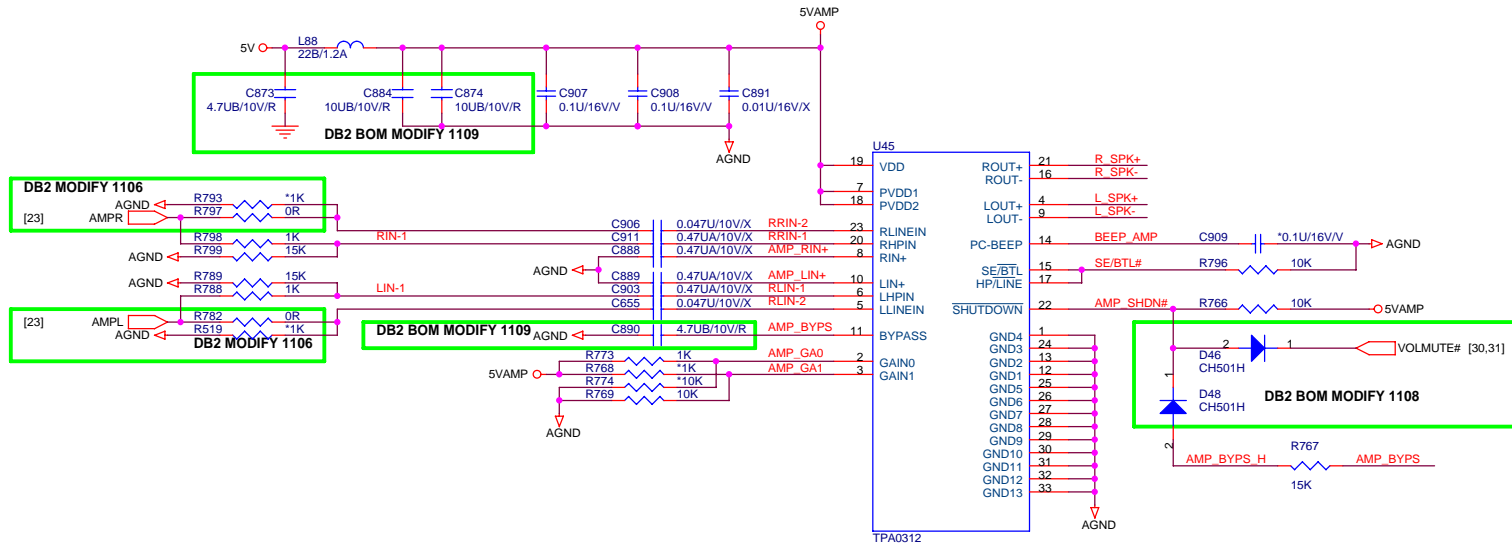

0312 Gain Table

GAIN0	GAIN1	SE/BTL	AV(INV)
0	0	0	6dB
0	1	0	10dB
1	0	0	15.6dB
1	1	0	21.6dB
x	x	1	4.1dB

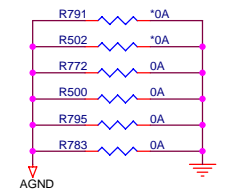

INT. SPEAKER

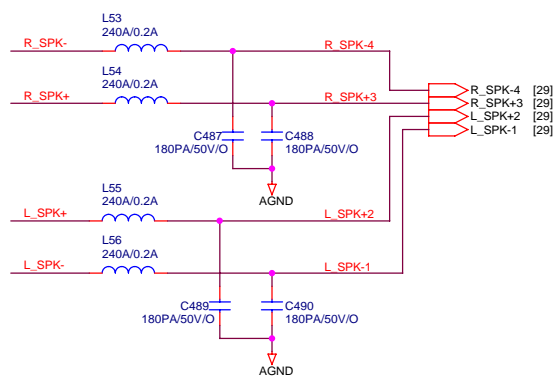

PCSPK BEEP

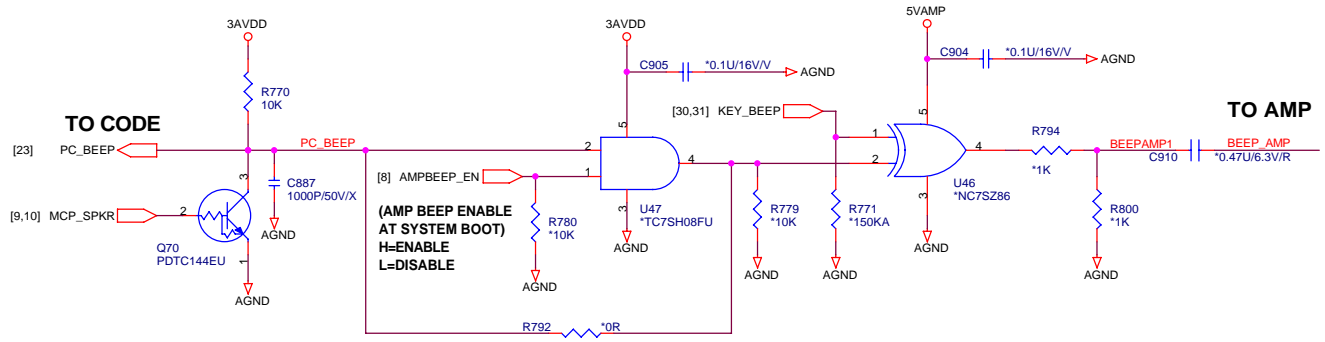

3AVDD [23] (13,18,19,22,23,26,27,28,29,31,32,33,36,38)
5V

PROJECT : AT1
Quanta Computer Inc.

Size Custom	Document Number AMP_TPA0312	Rev C2A
Date: Friday, December 29, 2006		Sheet 25 of 40

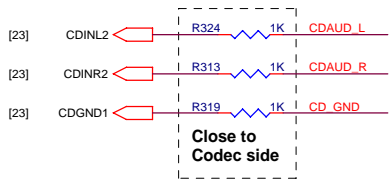

CD-ROM

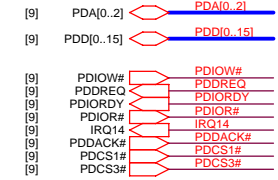
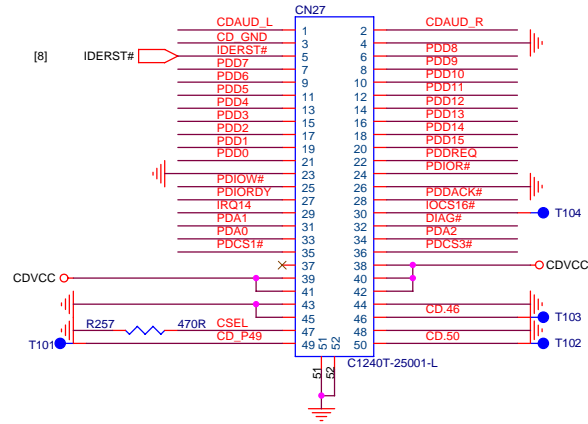

MODIFY 0823

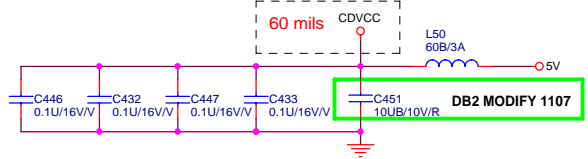
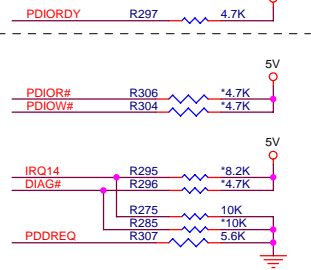

USB DIP CONNECTOR X 2

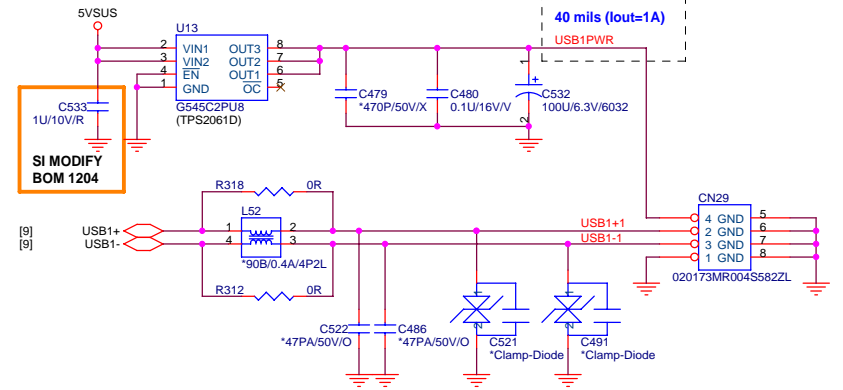
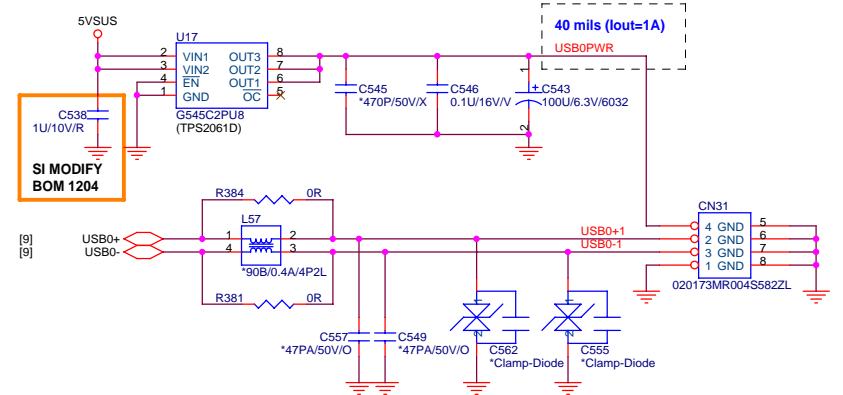

SATA_1 CONNECTOR

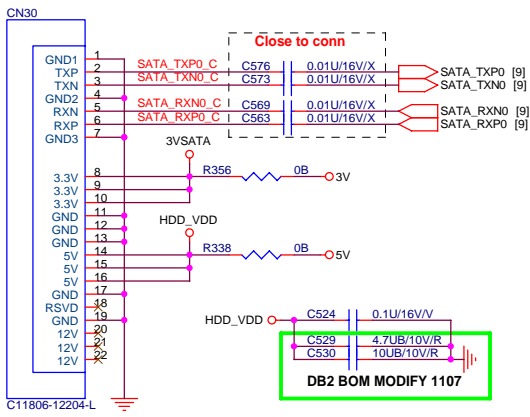

For 17" W Second HDD
SATA_2 CONNECTOR

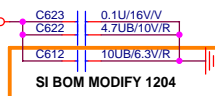
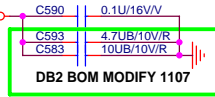
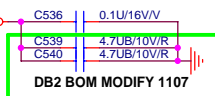
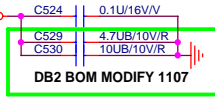
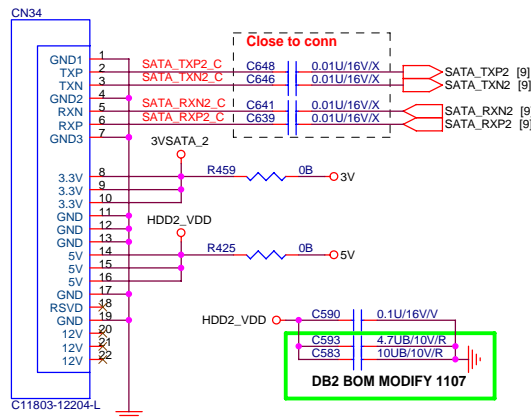

USB WIRE TO DC BOARD X 1

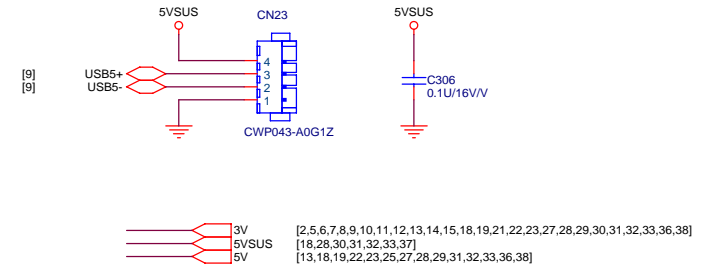

PROJECT : AT1
Quanta Computer Inc.

Size Custom	Document Number SATA HDDx2,CD-ROM,USBx3	Rev C2A
Date: Friday, December 29, 2006	Sheet 26	of 40

Mini PCI-E Card 1 WLAN

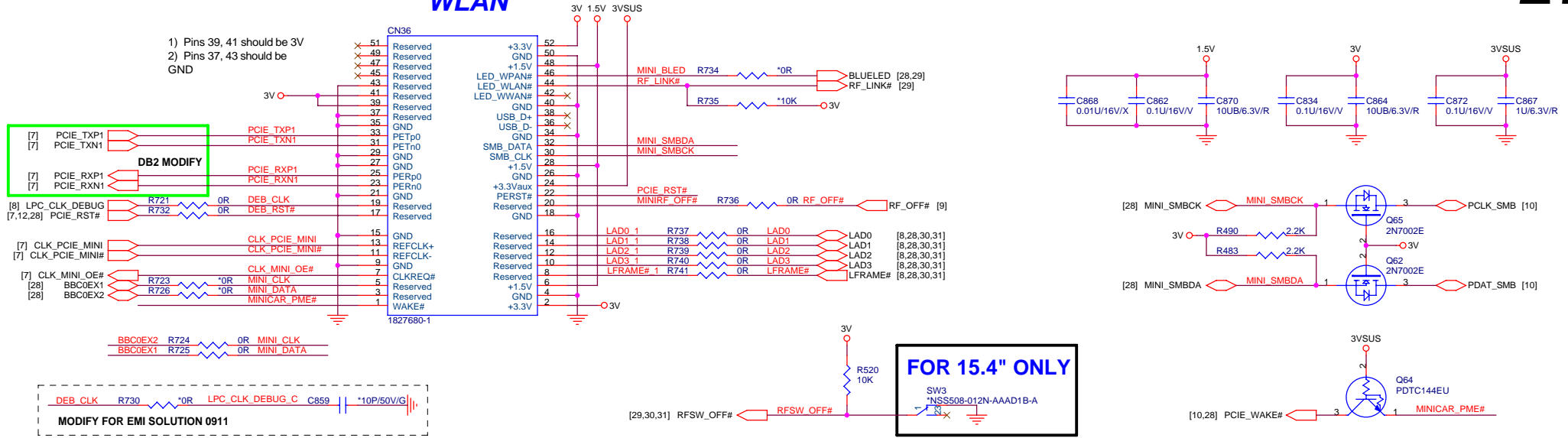

Mini PCI-E Card 2 (WWAN/SIM) FOR 15.4" ONLY (RESERVE)

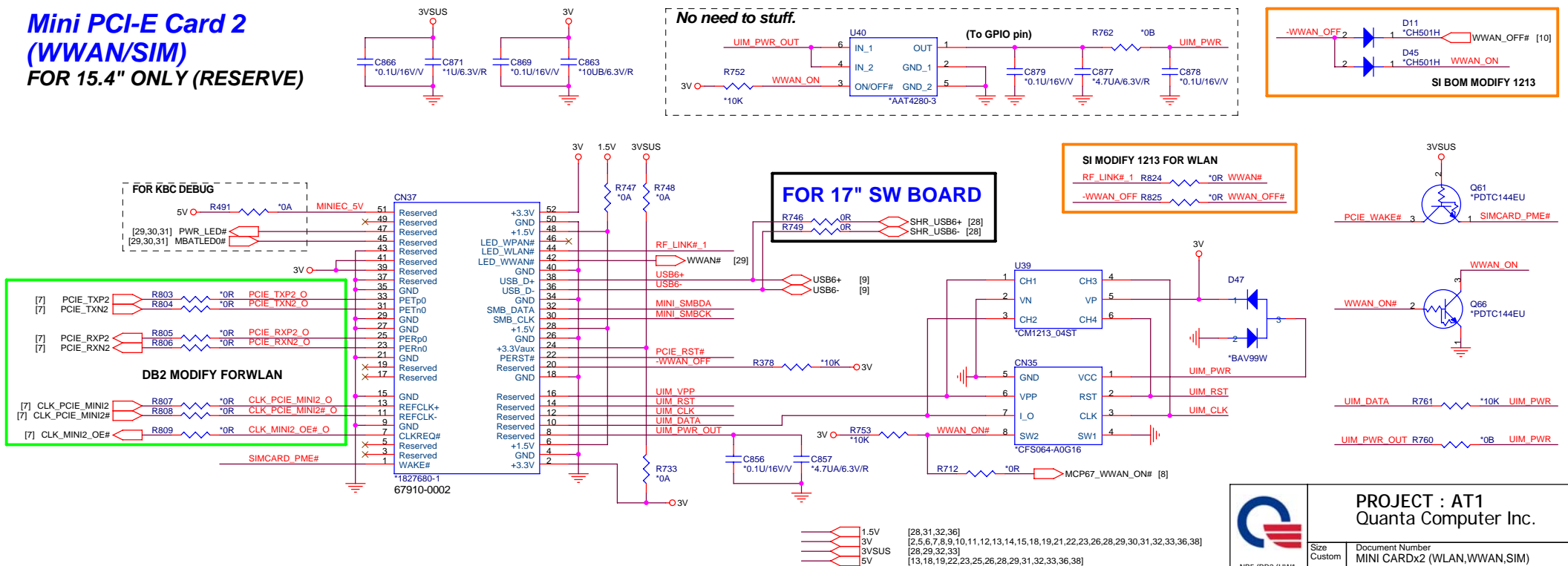

FINGER PRINT

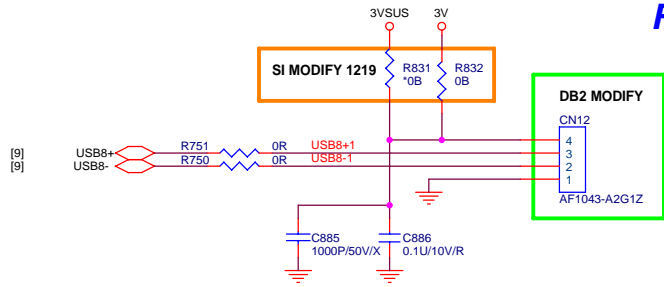

NEW CARD

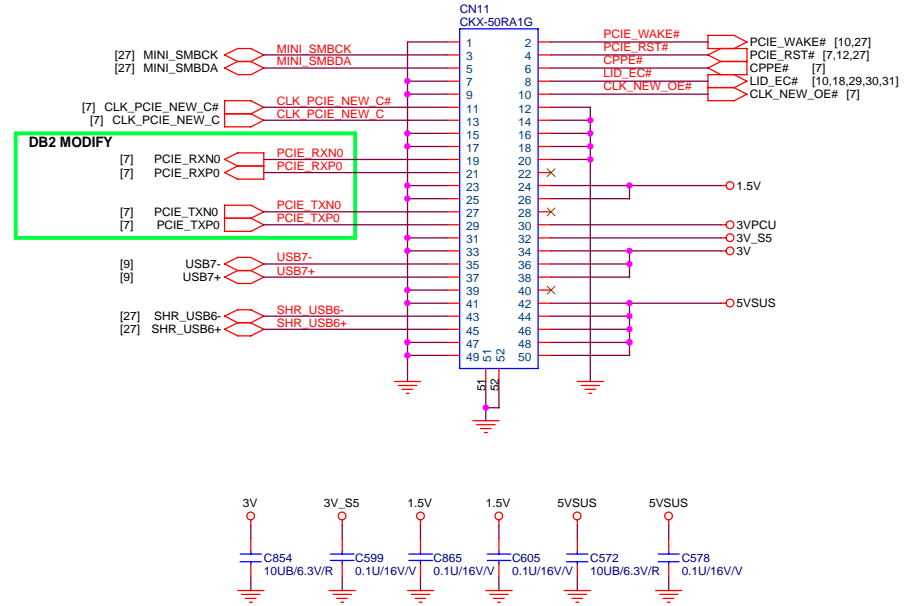

CAMERA

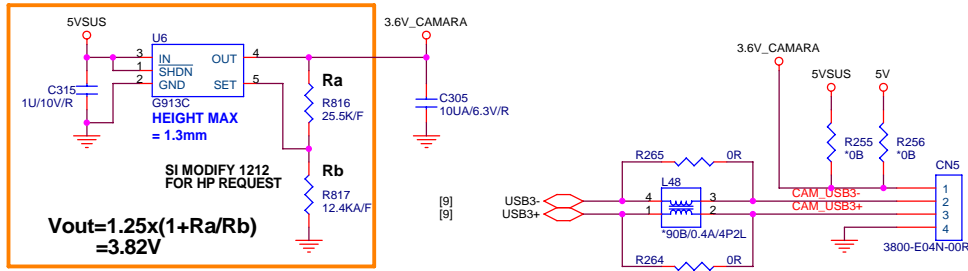

BLUETOOTH

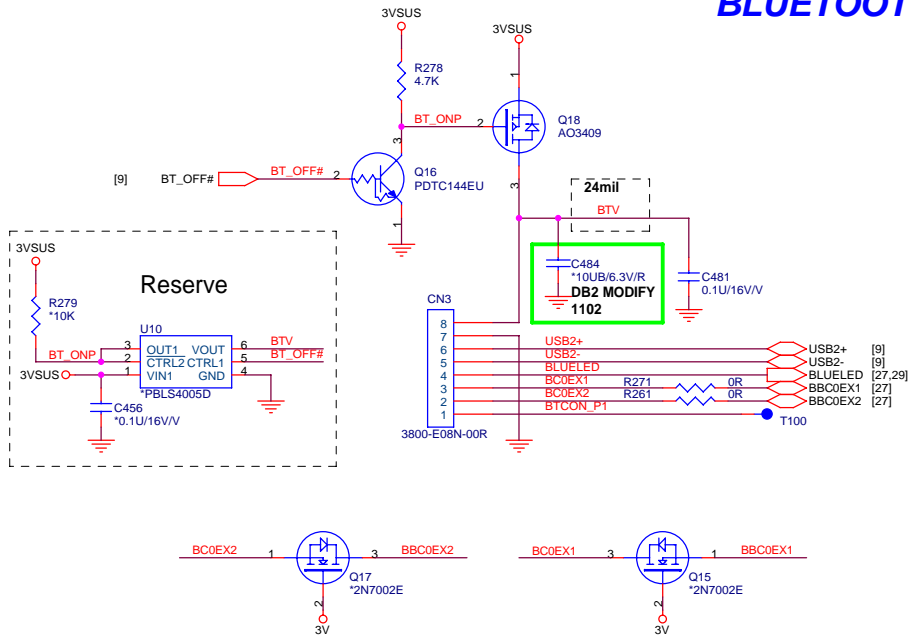

TPM (1.2)

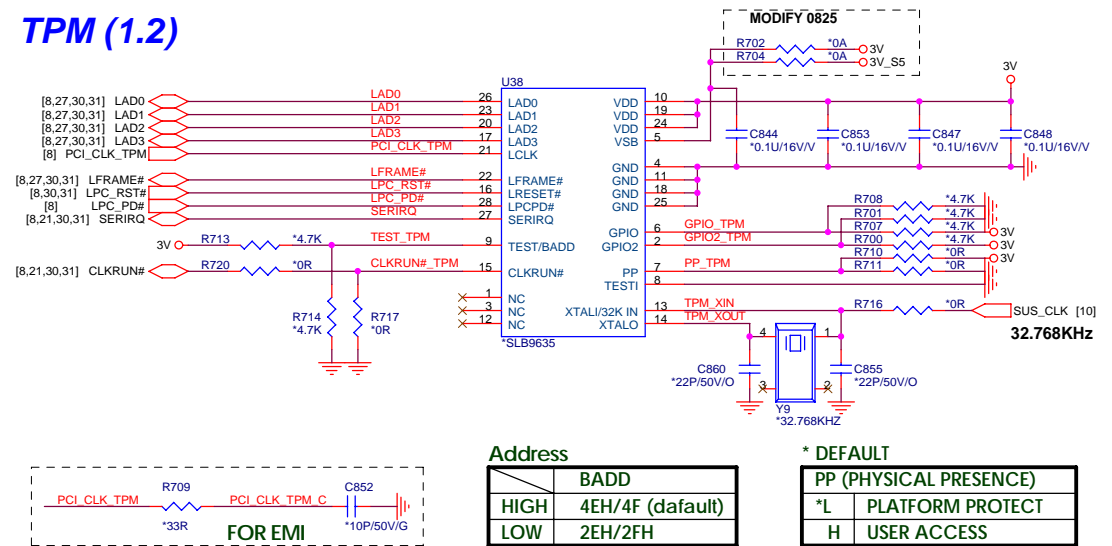

* DEFAULT	
PP (PHYSICAL PRESENCE)	
*L PLATFORM PROTECT	
H USER ACCESS	

PROJECT : AT1
Quanta Computer Inc.

Size Custom Document Number NEW CARD,CAMER,TPM,F/P,B/T Rev C2A
Date: Friday, December 29, 2006 Sheet 28 of 40

FOR POWER ON AND INTERNAL SPK / MIC SW BOARD

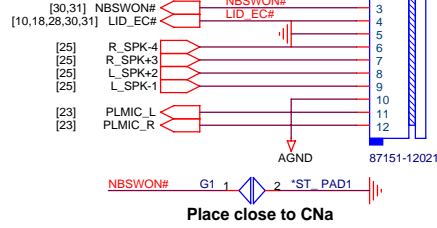
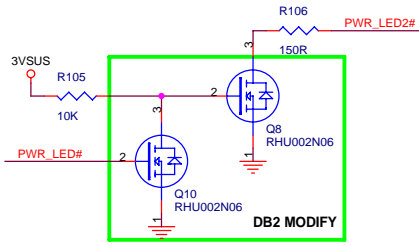

2ND SOURCE

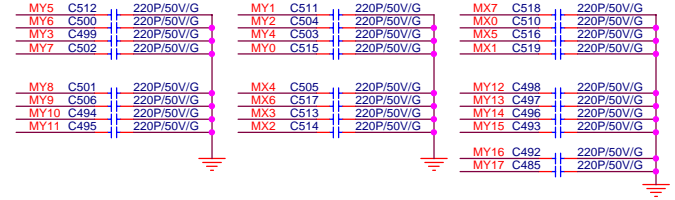
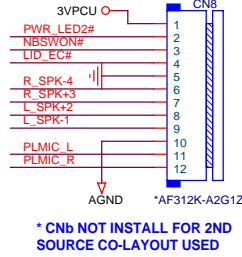

KEYBOARD PULL-UP

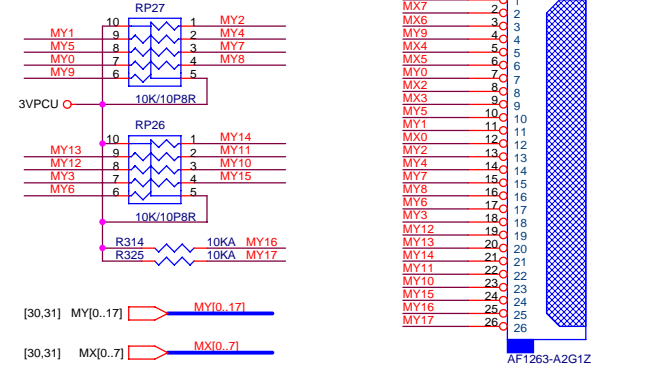

FOR 17" LED AND WIRLESS SW BOARD

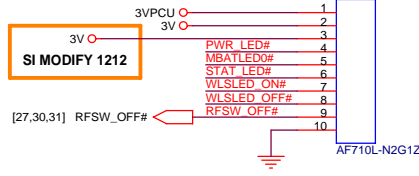

FOR QLB SW BOARD

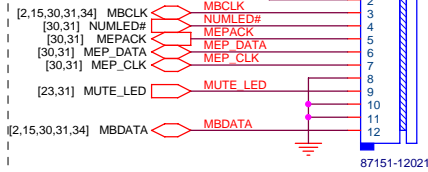

2ND SOURCE

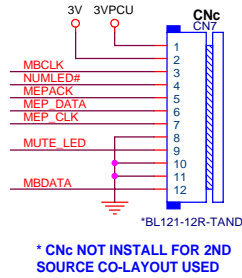

STUFF FOR 15.4" LED USED

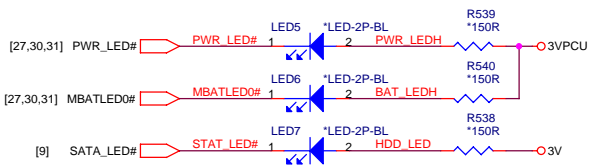

FOR 15.4" LCD : STUFF LEDa, Ra

STUFF FOR 15.4" CAPS LOCK LED



FOR 17" LCD : STUFF LEDb, Rb

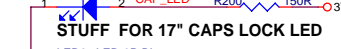

FOR CARD Reader LED

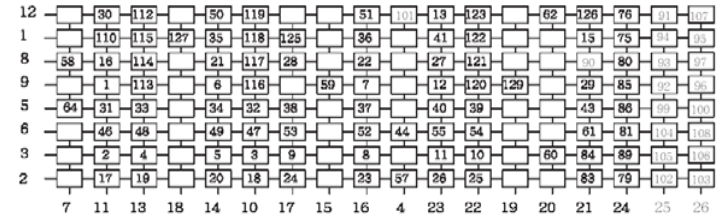
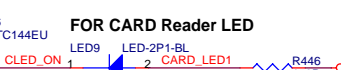

FOR WLAN LED

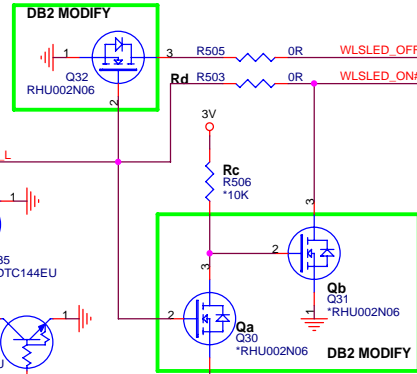
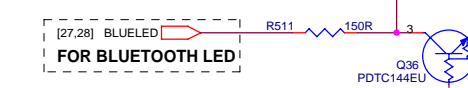
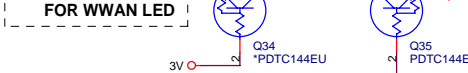
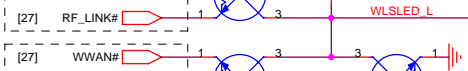

STUFF FOR 15.4" LED



FOR LED DRIVING ISSUE

STUFF	Rc, Qa, Qb, LEDc
NC	Rd

FAN CONNECTOR

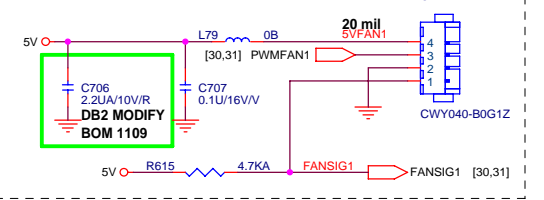

EC - KB3920

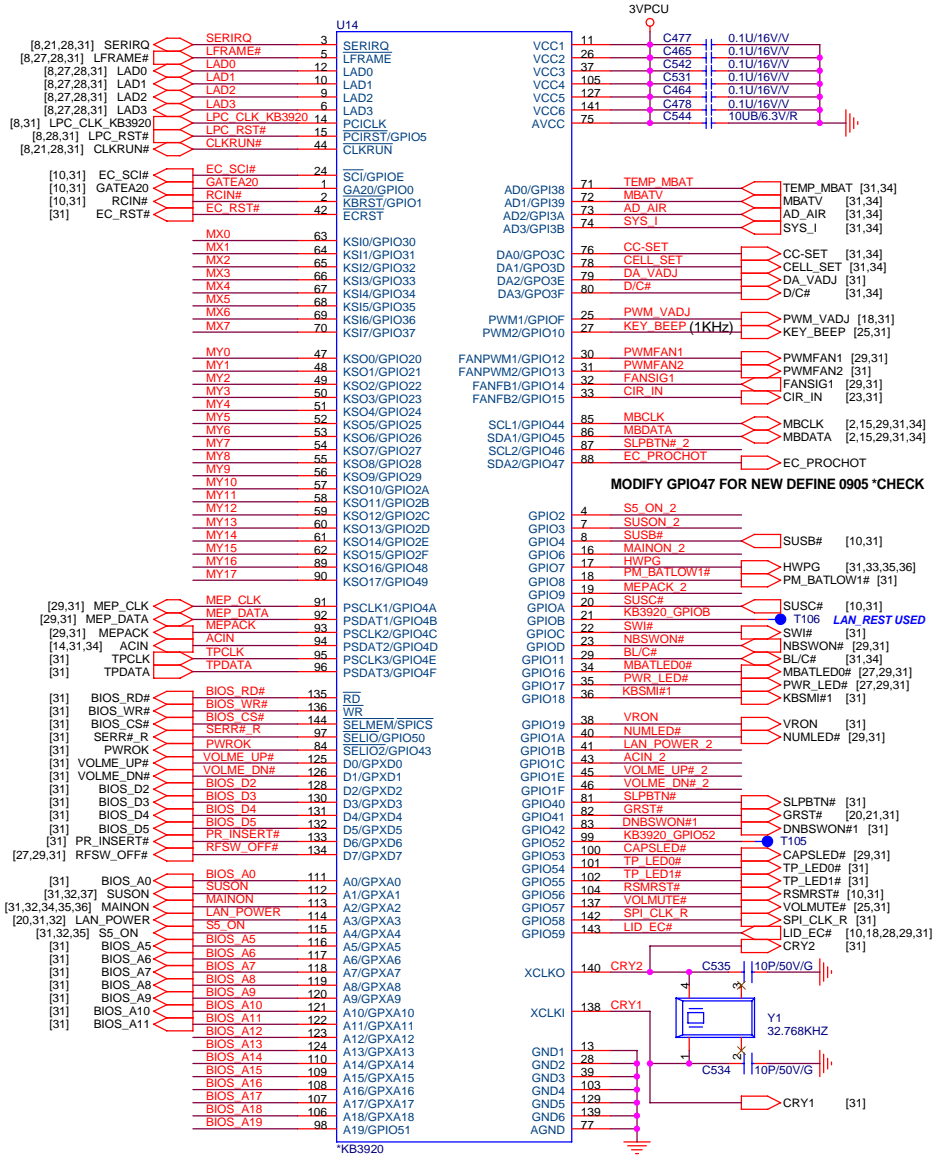

[29,31] MY0[0..17] MY0..17

[29,31] MX0[0..7] MX0..7

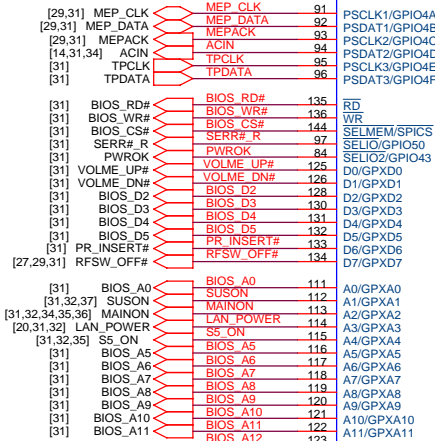

IF USED KB3920 : Ra stuff 0 ohm		IF USED KB3920 : Ra leave NC			
MY0	47	TP_TEST: Clock Test Mode Low: Test Mode. HIGH: *32kHz clock in normal training	MY2	49	TP_SPI: Default flash access Low: Boot from SPI flash part HIGH: *Boot from ISA flash part
MY1	48	TP_PLL: DPLL Test Mode Low: Test Mode. HIGH: *Normal operation	MY3	50	TP_ISP: In System Programming Mode Low: ISP mode HIGH: *Normal Mode

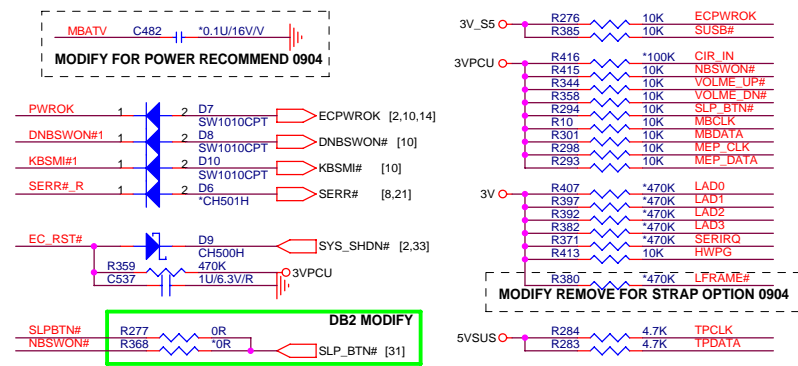

DB2 MODIFY

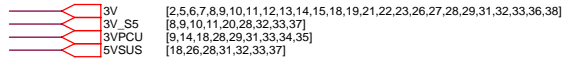

PROJECT : AT1
Quanta Computer Inc.

Size Custom	Document Number KB3920_SPI_ROM	Rev C2A
Date: Friday, December 29, 2006		Sheet 30 of 40

EC - KB3926

CABLE DOCK

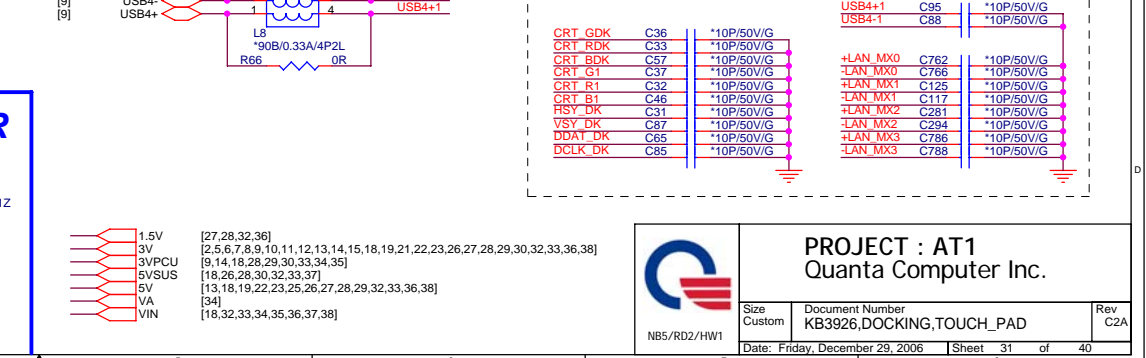
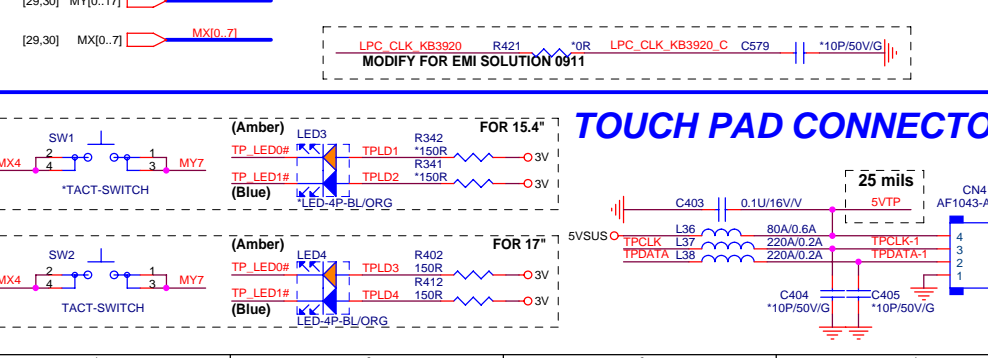
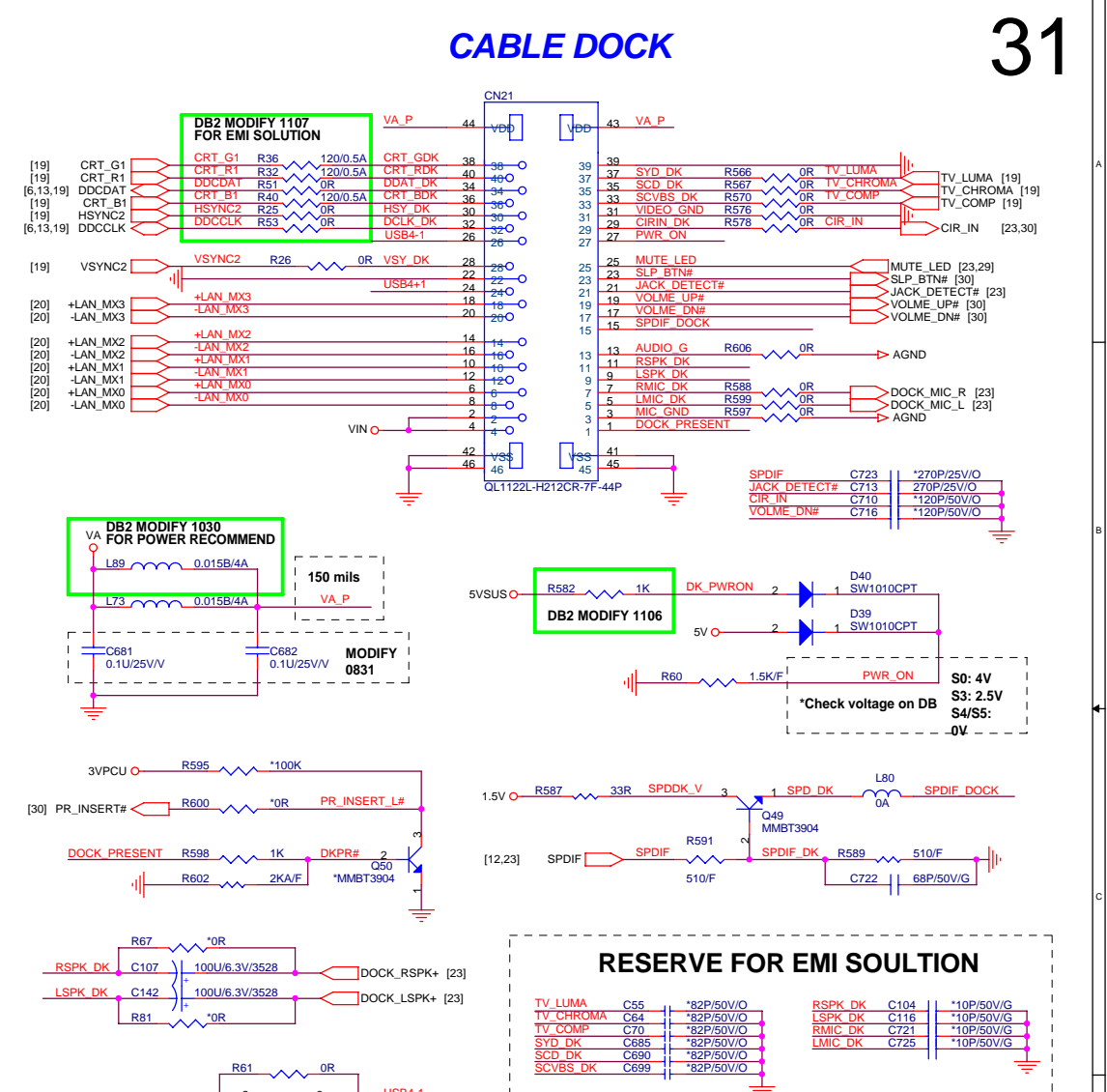
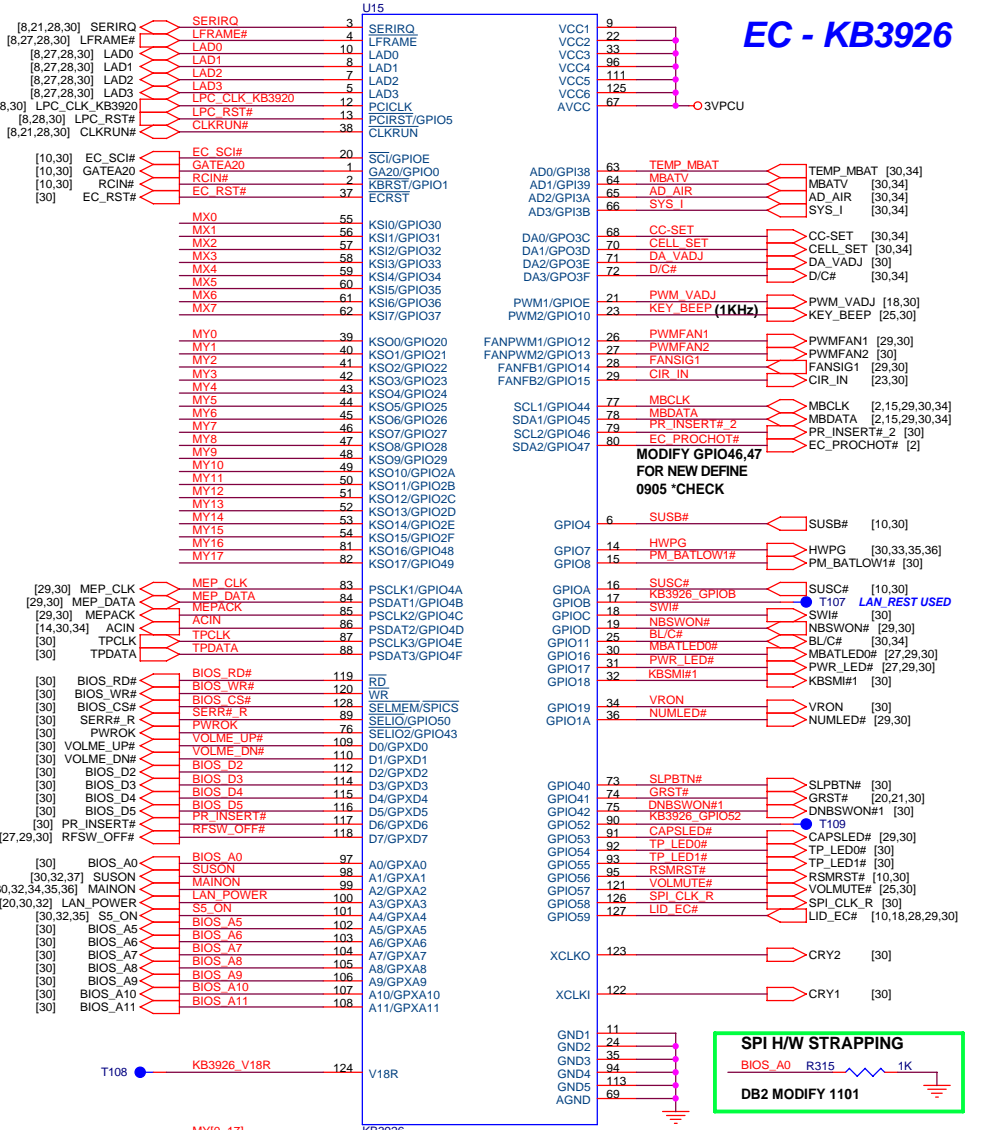

DISCHARGE

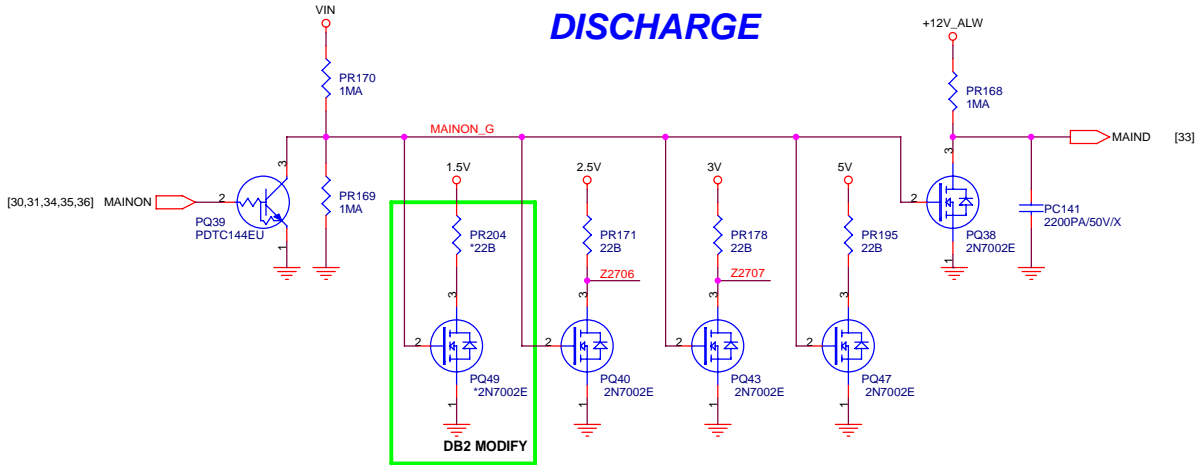

SI POWER MODIFY

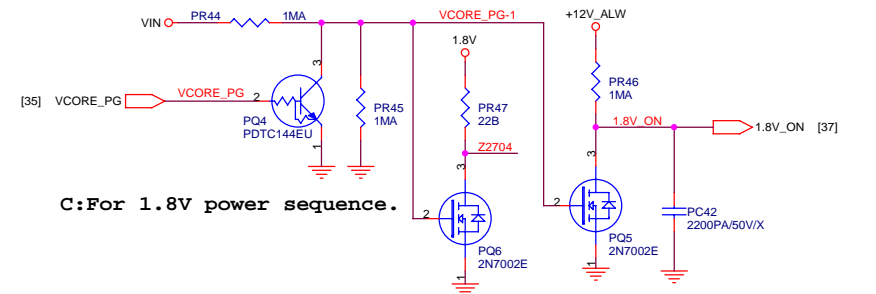
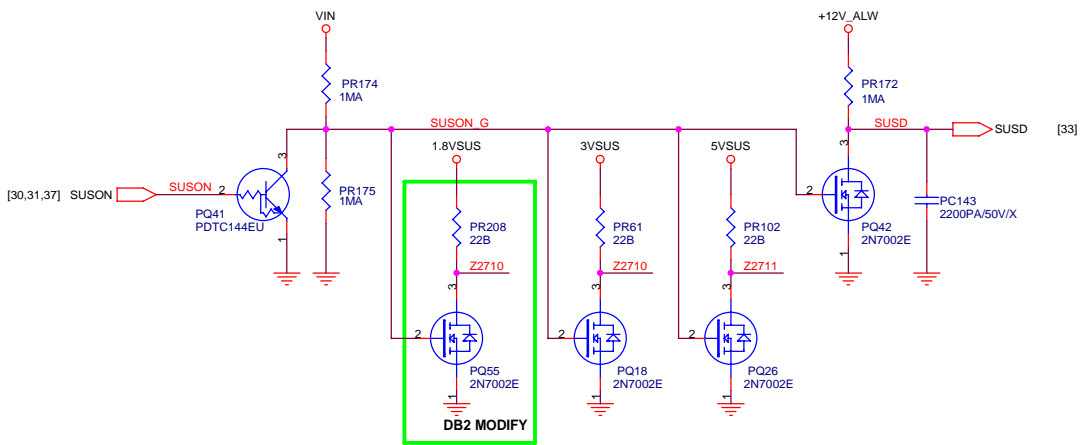

C:For 1.8V power sequence.

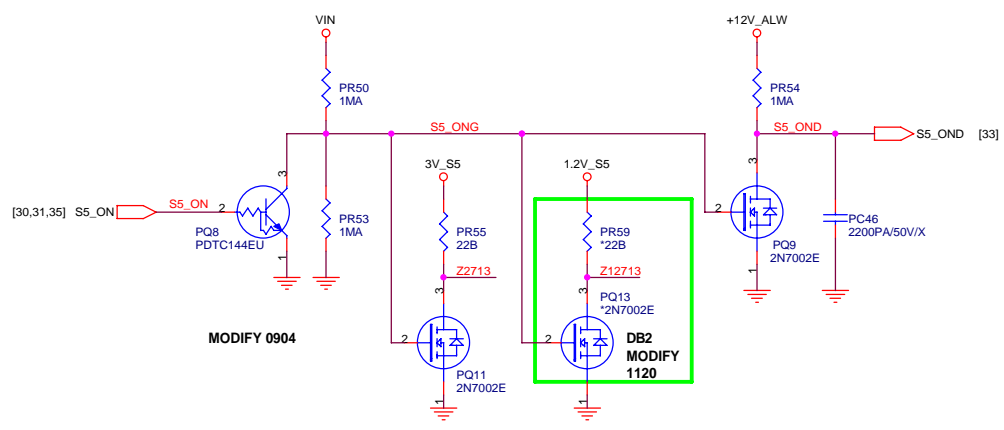

LAN_POWER (WOL FUNCTION)

POWER STATES	AC MODE	DC MODE
S4 / S5	OFF	OFF
S3	ON	OFF
S0	ON	ON

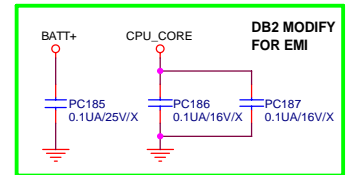
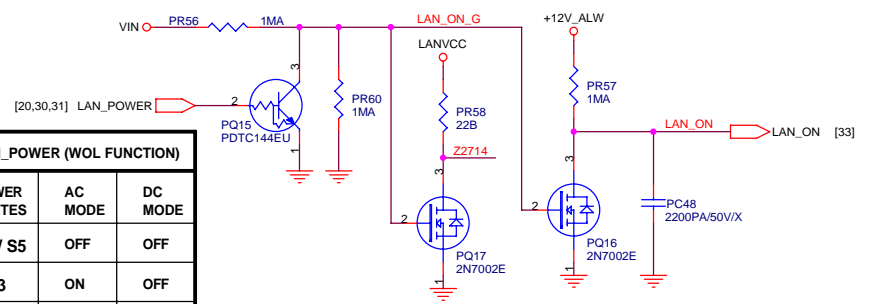

- CPU_CORE [4,38]
- 1.2V_S5 [10,11,35]
- 1.5V [27,28,31,36]
- 1.8V [11,13,15,16,17,37]
- 1.8VSUS [2,3,4,5,6,36,37]
- 2.5V [2,13,36]
- LANVCC [20,33]
- 3V [2,5,6,7,8,9,10,11,12,13,14,15,18,19,21,22,23,26,27,28,29,30,31,33,36,38]
- 3VSUS [27,28,29,33]
- 3V_S5 [8,9,10,11,20,28,30,33,37]
- 5V [13,18,19,22,23,25,26,27,28,29,31,33,36,38]
- 5VSUS [18,26,29,30,31,33,37]
- +12V_ALW [10,18,33]
- VIN [18,31,33,34,35,36,37,38]

MODIFY 0904

DB2 MODIFY 1120

PROJECT : AT1
Quanta Computer Inc.

Size Custom	Document Number DISCHARGE	Rev C2A
Date: Friday, December 29, 2006		
Sheet 32 of 40		

Adapter
19V/3.4A/65W
19V/4.75A/90W

Battery 6/8/12cell
MAX8724

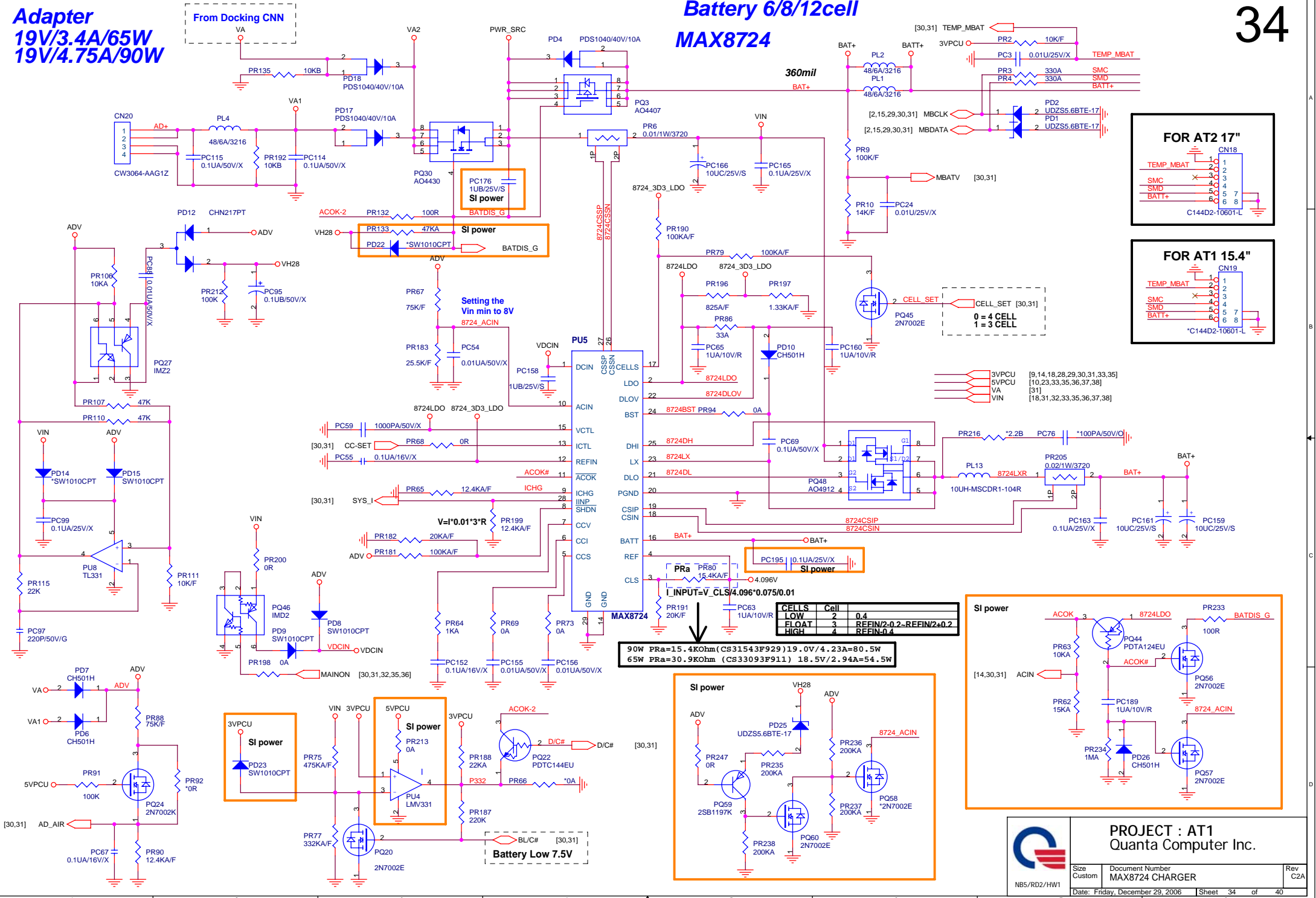

VGA_CORE
C/C:12A
P/C:15A
OCP minimum 23A

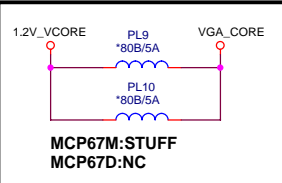
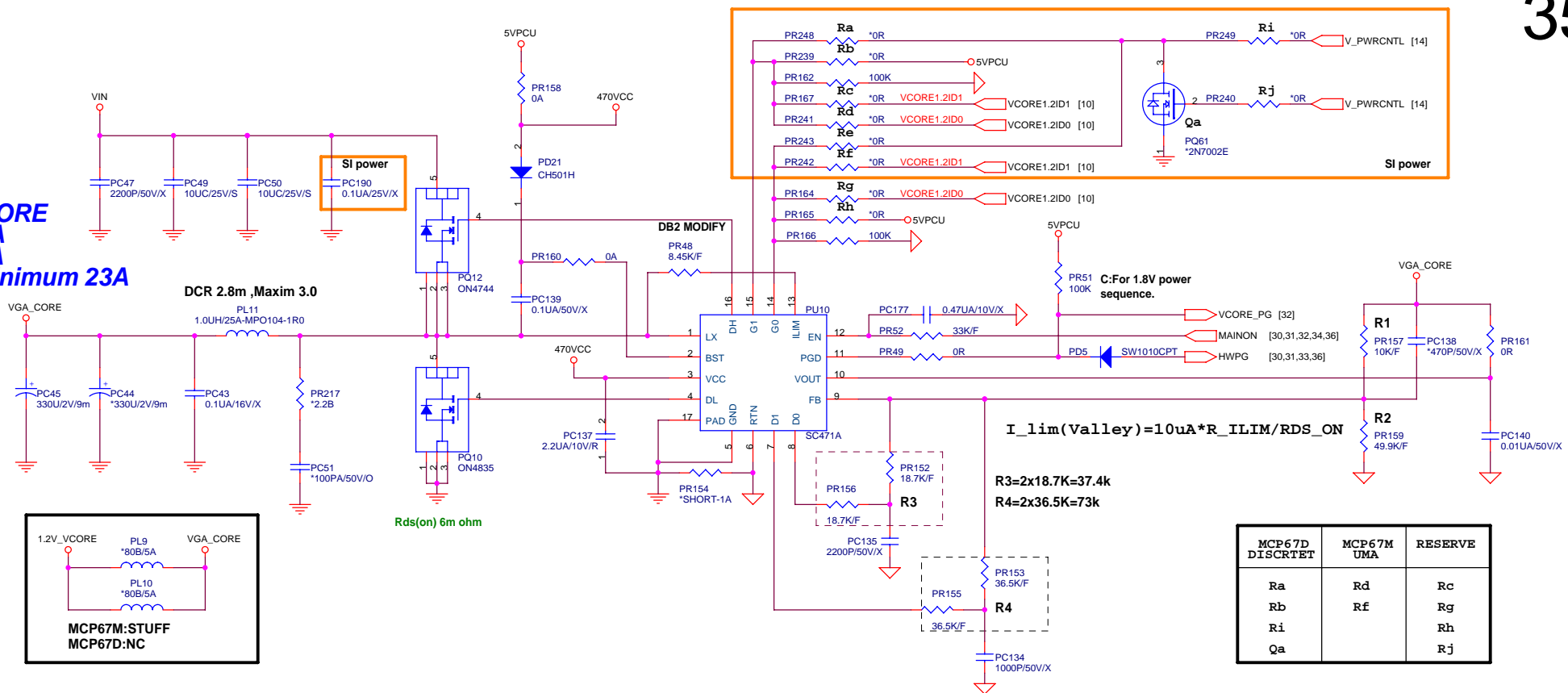

Rds(on) 6m ohm

$I_{lim}(\text{Valley}) = 10\mu\text{A} \cdot R_{ILIM} / R_{DS_ON}$

$R3 = 2 \times 18.7\text{K} = 37.4\text{k}$

$R4 = 2 \times 36.5\text{K} = 73\text{k}$

MCP67D DISCRETET	MCP67M UMA	RESERVE
Ra	Rd	Rc
Rb	Rf	Rg
Ri		Rh
Qa		Rj

INPUTS		OUTPUTS			VGA_CORE
G0	G1	OD1	OD2	OD3	
0	0	$0.75 \times (1 + R1/R2 + R1/R3 + R1/R4)$			1.2V
0	1	$0.75 \times (1 + R1/R2 + R1/R3)$			1.1V
1	0	$0.75 \times (1 + R1/R2 + R1/R4)$			1.0V
1	1	$0.75 \times (1 + R1/R2)$			0.9V

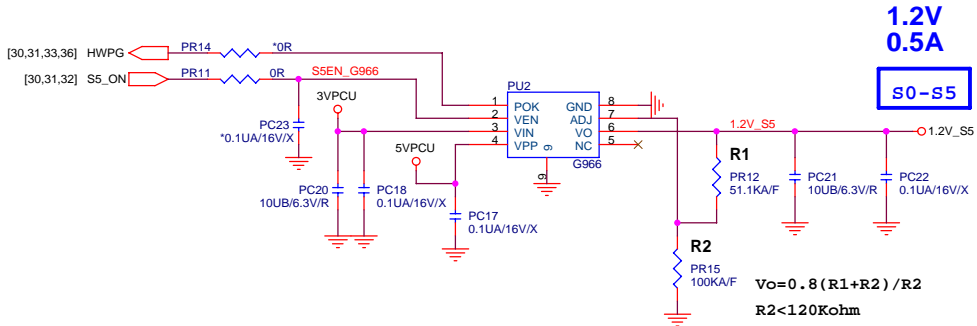

1.2V
0.5A
S0-S5

$V_o = 0.8 \cdot (R1 + R2) / R2$

$R2 < 120\text{Kohm}$

GF_X_VID0
H: Normal Voltage
L: Low Voltage

VGACORECTL	NB8X	R2	R3/PR294	PR1293/PR295
HI	1.2V	CS43012FB10	NA	Mounted
LO	1.XV			

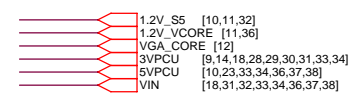

PROJECT : AT1
Quanta Computer Inc.

Size Custom	Document Number SC471A (VGA_CORE), 1.2V_S5	Rev C2A
Date: Friday, December 29, 2006	Sheet 35	of 40

S0-S3

1.8VSUS
C/C:12A
P/C:15.2A
OCP minimum 25A

1.8 Volt +/-5%
 1.8VSUS

DCR 2.8m ,Maxim 3.0

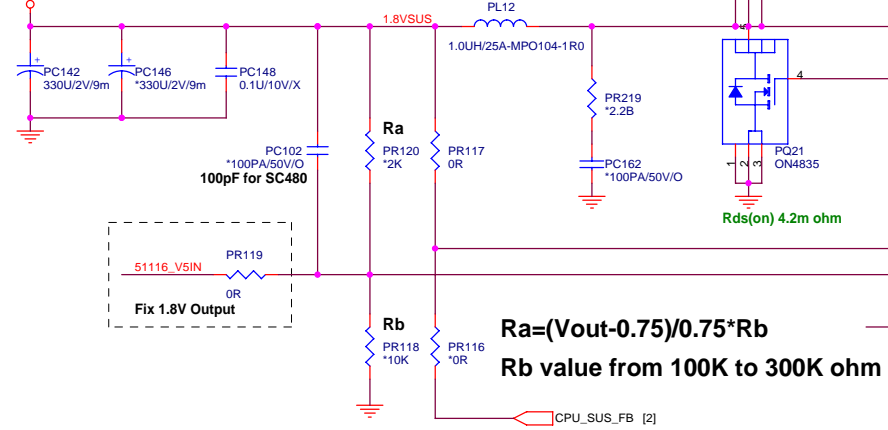

51116_V5IN PR119
 OR
 Fix 1.8V Output

$R_a = (V_{out} - 0.75) / 0.75 * R_b$
Rb value from 100K to 300K ohm

$I_{lim}(Valley) = 10\mu A * R_{ILIM} / RDS_{ON}$

S0-S3

SMDDR_VTERM
1.53A / 0.9V

SI MODIFY FOR POWER SEQUENCE 1211

0.9 Volt +/-5%
Design Current:1.5A
Maximum Current: 1.8A

Mode	Discharge Mode
V5IN	No discharge
VDDQ	Tracking discharge
Gnd	Non-tracking discharge

$V_{TRIP} (mV) = R_{TRIP} (Kohm) * 10 (uA)$
 $I_{OCP} = V_{trip} / Rds_{on} + I_{Ripple} / 2$

VDDQSET	VDDQ(V)	VTREF and Vtt	Note
GND	2.5	V_ vddqsns/2	DDR
V5IN	1.8	V_ vddqsns/2	DDR2
FB	adjustable	V_VDDQSNS/2	1.5V<VDDQ<3V

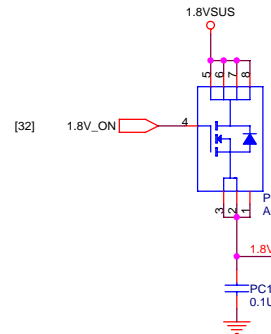

1.8V
4.75A
S0-S1

S0-S3

SMDDR_VTERM
0.9V
?A

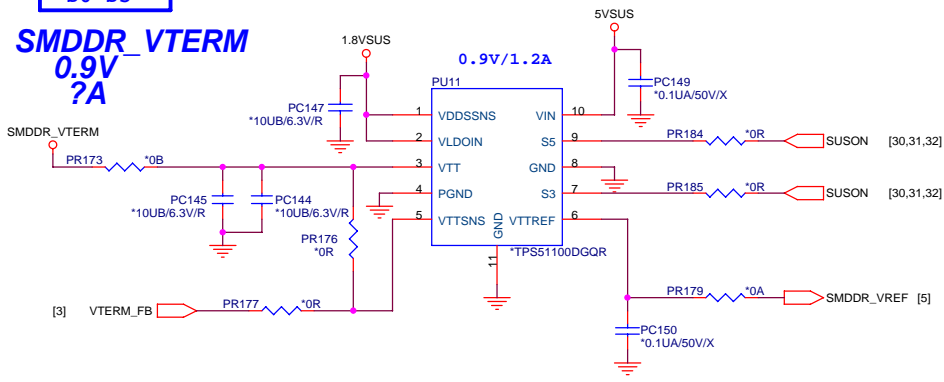

- SMDDR_VTERM [4]
- 1.8V [11,13,15,16,17,32]
- 1.8VSUS [2,3,4,5,6,32,36]
- 3V_S5 [8,9,10,11,20,28,30,32,33]
- 5VSUS [18,26,28,30,31,32,33]
- 5VPCU [10,23,33,34,35,36,38]
- VIN [18,31,32,33,34,35,36,38]



PROJECT : AT1
Quanta Computer Inc.

Size Custom	Document Number T151116 (1.8VSUS,VTER),1.8V	Rev C2A
Date: Friday, December 29, 2006	Sheet 37	of 40

CPU_CORE MAX8774

Slew rate=(12.5mV/us)*(71.5K/R_TIME)
 VFB=V_VID+0.125(VREF-V_OFS)
 VRHOT is low when VTHRM below 1.5V
 Tsw=16.26pF(R_TON+6.5K)ohm
 CCV CAP=470pF*(2/total phase)*300kHz/fsw

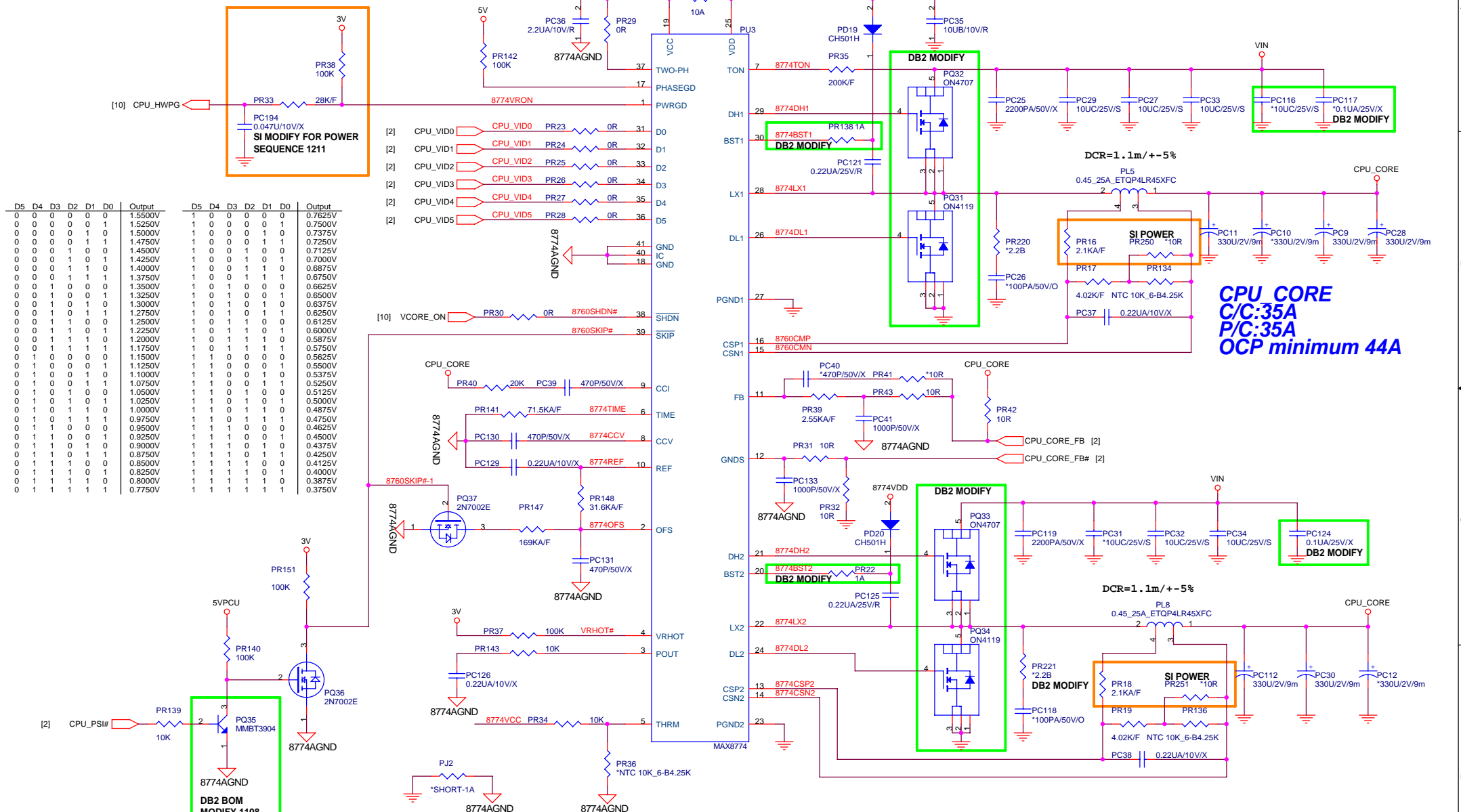

D5	D4	D3	D2	D1	D0	Output	D5	D4	D3	D2	D1	D0	Output
0	0	0	0	0	0	1.5500V	1	0	0	0	0	0	0.7625V
0	0	0	0	0	1	1.5250V	1	0	0	0	0	1	0.7500V
0	0	0	0	1	0	1.5000V	1	0	0	0	1	0	0.7375V
0	0	0	0	1	1	1.4750V	1	0	0	0	1	1	0.7250V
0	0	0	1	0	0	1.4500V	1	0	0	1	0	0	0.7125V
0	0	0	1	0	1	1.4250V	1	0	0	1	0	1	0.7000V
0	0	0	1	1	0	1.4000V	1	0	0	1	1	0	0.6875V
0	0	0	1	1	1	1.3750V	1	0	0	1	1	1	0.6750V
0	0	1	0	0	0	1.3500V	1	0	1	0	0	0	0.6625V
0	0	1	0	0	1	1.3250V	1	0	1	0	0	1	0.6500V
0	0	1	0	1	0	1.3000V	1	0	1	0	1	0	0.6375V
0	0	1	0	1	1	1.2750V	1	0	1	0	1	1	0.6250V
0	0	1	1	0	0	1.2500V	1	0	1	1	0	0	0.6125V
0	0	1	1	0	1	1.2250V	1	0	1	1	0	1	0.6000V
0	0	1	1	1	0	1.2000V	1	0	1	1	0	0	0.5875V
0	0	1	1	1	1	1.1750V	1	0	1	1	1	0	0.5750V
0	1	0	0	0	0	1.1500V	1	1	0	0	0	0	0.5625V
0	1	0	0	0	1	1.1250V	1	1	0	0	0	1	0.5500V
0	1	0	0	1	0	1.1000V	1	1	0	0	1	0	0.5375V
0	1	0	0	1	1	1.0750V	1	1	0	0	1	1	0.5250V
0	1	0	1	0	0	1.0500V	1	1	0	1	0	0	0.5125V
0	1	0	1	0	1	1.0250V	1	1	0	1	0	1	0.5000V
0	1	0	1	1	0	1.0000V	1	1	0	1	0	0	0.4875V
0	1	0	1	1	1	0.9750V	1	1	0	1	1	0	0.4750V
0	1	1	0	0	0	0.9500V	1	1	1	0	0	0	0.4625V
0	1	1	0	0	1	0.9250V	1	1	1	0	1	0	0.4500V
0	1	1	0	1	0	0.9000V	1	1	1	0	1	1	0.4375V
0	1	1	0	1	1	0.8750V	1	1	1	0	1	1	0.4250V
0	1	1	1	0	0	0.8500V	1	1	1	1	0	0	0.4125V
0	1	1	1	0	1	0.8250V	1	1	1	1	0	1	0.4000V
0	1	1	1	1	0	0.8000V	1	1	1	1	0	1	0.3875V
0	1	1	1	1	1	0.7750V	1	1	1	1	1	0	0.3750V

PROJECT : AT1
 Quanta Computer Inc.

Size Custom	Document Number MAX8774 (CPU_CORE)	Rev C2A
Date: Friday, December 29, 2006	Sheet 38	of 40

- CPU_CORE [4,32]
- 3V [2,5,6,7,8,9,10,11,12,13,14,15,18,19,21,22,23,26,27,28,29,30,31,32,33,36]
- 5V [13,18,19,22,23,25,26,27,28,29,31,32,33,36]
- 5VPCU [10,23,33,34,35,36,37]
- VIN [18,31,32,33,34,35,36,37]