

Technical Description

703010En, Ed. 5, Rev B

November 2012

TankRadar REX

High Precision Tank Gauging System



ROSEMOUNT[®]
Tank Gauging

www.rosemount-tg.com

EMERSON[™]
Process Management

TankRadar Rex

Contents

Available technical documentation for TankRadar Rex:	4
Abbreviations used in this document:	5
TankRadar Rex	
– the industry standard tank gauging system	6
Applications	6
Summary of functions & system overview	7
Installation and commissioning of the TankRadar Rex System	8
Radar level gauging	9
The FMCW method	9
Accuracy enhancement	10
Temperature control	10
Digital reference	10
Drip-off means no condensation	10
Measurement close to tank wall	10
Patented method for detecting the surface echo	11
No risk to be exposed to the microwaves from the TankRadar Rex antenna	11
Lightning Protection	11
SIL 2 Safety Functions	11
Reach more tanks at less cost with Smart Wireless solution	11
Better Utilization of Tank Capacity	12
Intelligent Self-organizing Mesh Network Increases Reliability	12
Smart Wireless for More Secure Data Transmission	12
Wireless Connection of Tank Gauging Equipment	12
Radar Tank Gauges	13
Transmitter Head	13
Transmitter Head Electronics	13
Metrological Seal (option)	14
Cable Connections to the Transmitter Head	16
Horn Antenna Gauge RTG 3920	18
Parabolic Antenna Gauge RTG 3930	19
Still-Pipe Array Antenna Gauge RTG 3950	20
LPG/LNG Gauge RTG 3960	21
Temperature measurement	23
Water interface measurement	26
Data Acquisition Unit, DAU 2100	27
Local Read-out	27
Remote Display Unit, RDU 40	28
Field Communication Unit, FCU 2160	29
Field Bus Modem, FBM 2180	33

Junction Boxes	34
JB 140-11 and JB 140-15 for EEx i and EEx e environments	34
JB 36 and JB42 for connection of temperature sensors	34
Junction Box Integrated with Temperature Sensor or Water Level Sensor	34
Junction Boxes with Conduit Outlets	34
TankMaster HMI software	35
TankMaster I/O Terminals	39
Tank inventory and density through hybrid calculations in the Rex system	40
TankRadar Rex System Configurations	41
The TRL2 Bus - A fast and reliable data bus	41
Stand-Alone Application	42
Systems with a TankMaster Work Station	42
Connecting the Field Communication Unit FCU 2160	42
Redundancy	43
Wireless Mesh Network Always Finds a Way to Communicate	44
Example of a General System	45
Connection to other systems	46
Emulation	47
Gauge Emulation	47
Seamless control room connectivity	47
Certificates	48
Accuracy approvals / Legal metrological certificates	48
EX Approvals	48
Safety Approvals and Acknowledgements	48
Emission Approvals	48
Miscellaneous Approvals	49
Vapor Influence on Radar Measurement	49
Ordering information	50
Radar Tank Gauge (RTG 3900)	50
Data Acquisition Unit (DAU 2100)	55
Remote Display Unit (RDU 40)	55
Junction Box and Protective Hose Kit	55
Field Communication Unit (FCU 2160)	56
Field Bus Modems	57
TankMaster™ Software	58
Temperature and Water Level Sensors for the US and Canada	63
Pressure Transmitters	66
Wireless	68

TankRadar Rex

Copyright © November 2012
by Rosemount Tank Radar AB, Sweden.
Ref. no. 703010En, Ed 5, Rev B

Technical data is subject to change without prior notice. Rosemount Tank Radar AB accepts no responsibility for any errors that may appear in this description.

Allen-Bradley, Bailey, DEC, Enraf, Fisher, Foxboro, GPE, Honeywell, IBM, L&J, Profibus, Rosemount, TankRadar, Siemens, Tiway, Varec, Vega, Whessoe, and Yokogawa are registered trademarks and trademarks of these organizations and companies.

Viton is a registered trademark of Du Pont Performance Elastomers.

Available technical documentation for TankRadar Rex:

- Technical Description
- Installation Manual
- TankMaster WinSetup User's Guide
- TankMaster WinOpi User's Guide
- Commissioning Manual & Checklist
- Installation Drawings
- Service Manual

The Technical Description includes technical data on the various parts of the TankRadar Rex system.

The Installation Manual is used for planning and performing the installation.

The Commissioning Manual & Commissioning Checklist include information on how to commission the TankRadar Rex System. They are used together with the TankMaster WinSetup User's Guide.

The TankMaster WinSetup User's Guide describes how to start-up the system using the WinSetup software on a personal computer. TankMaster is the Human Machine Interface (HMI) software for TankRadar Rex. It includes the WinSetup and WinOpi software modules.

The TankMaster WinOpi User's Guide describes the inventory and display functions included in the optional TankMaster WinOpi software.

The Service Manual is used for service and trouble shooting.

Abbreviations used in this document:

APC	Analog Processing Card
API	American Petroleum Institute
DAU	Data Acquisition Unit
DCS	Digital Control System.
EEPROM	Electrically Erasable Programmable Read Only Memory
FBM	Field Bus Modem
FCC	Field Communication Card
FCU	Field Communication Unit
FMCW	Frequency Modulated Continuous Wave
FSK	Frequency Shift Keyed
HMI	Human Machine Interface
IS	Intrinsically Safe
ISO	International Standard Organization
JB	Junction Box
LCD	Liquid Crystal Display
OIML	International Organization of Legal Metrology
PC	Personal Computer
PCB	Printed Circuit Board
PROM	Programmable Read Only Memory
PTB	Physikalisch Technische Bundesanstalt
PTFE	Polytetrafluoroethylene.
RDU	Remote Display Unit
RF-head	A device for emitting and receiving microwaves.
ROC	Relay Output Card
RTD	Resistance Temperature Detectors
RTG	Radar Tank Gauge
SCADA	Supervisory Control and Data Acquisition System
SPC	Signal Processing Card
TH	Transmitter Head
THE	Transmitter Head Electronics
TIC	Transmitter Interface Card
TM	TankMaster
TMC	Transmitter Multiplexer Card
TRC	Transformer Rectifier Card
TRL	TankRadar L (First generation)
TÜV	Technischer Überwachungs-Verein
VAC	Volts Alternating Current
VDC	Volts Direct Current

TankRadar Rex

TankRadar Rex – the industry standard tank gauging system

TankRadar Rex is a state-of-the art inventory and custody transfer radar tank gauging system for storage tanks. It fulfills the highest requirements on performance and safety. The development of TankRadar Rex is based on 25 years experience in radar level gauging. More than 100 000 radar gauges have been delivered.

Features

- Excellent reliability (gauge MTBF is 112 years)
- Highest accuracy with custody transfer approvals, including OIML certificate
- Drip-off antennas acc. to API ch. 3.1B ed. 1
- Antennas for all types of tanks
- Proven performance and installations at all major oil companies
- Method for accurate measurements in still-pipes, invented and patented for the TankRadar products
- Overfill protection certified by TÜV for high environmental safety
- Gauge emulation for cost-effective installation in systems supplied by other vendors
- All functions for complete tank farm monitoring available in one system
- OPC compatible HMI software
- Worldwide service and support

Applications

Bulk liquid storage tanks at/in:

- Refineries
- Independent tank terminals
- Marketing terminals
- Pipeline terminals
- Petrochemical industry
- Liquefied gas terminals (LPG/LNG)
- Aviation fuel depots
- Biofuel plants

The extensive range of TankRadar Rex RTG 3900 Series level gauges fits all types of tanks, fixed or floating roofs, pressurized or non-pressurized. The TankRadar Rex system measures the entire storage tank site.



Technical Description

703010En, Ed. 5, Rev B

November 2012

TankRadar Rex

Summary of functions & system overview

TankRadar Rex system measures and calculates tank data for:

- Inventory calculations
- Custody transfer
- Oil movement
- Loss control
- Operational & blending control
- Leak detection and overfill protection

The system is configured with the functions as required by the user. Available functions are:

- Level, temperature, and water interface level measurement
- Vapor pressure and hydrostatic pressure measurement

- Total Observed Volume (TOV), and observed density calculations in the gauge
- Net volume calculations according to API chapter 12.1.1
- Hybrid tank measurement calculations according to API chapter 3.6
- Complete inventory, hybrid and custody transfer functions (with the TankMaster software package)
- Profibus DP, Tiway and proprietary TRL2 bus communication
- Emulation of other field buses for cost efficient installation in older systems delivered by other vendors
- Built-in multiple temperature inputs, analog inputs/outputs, HART inputs for pressure transmitters and relay outputs in radar gauge
- Local field display

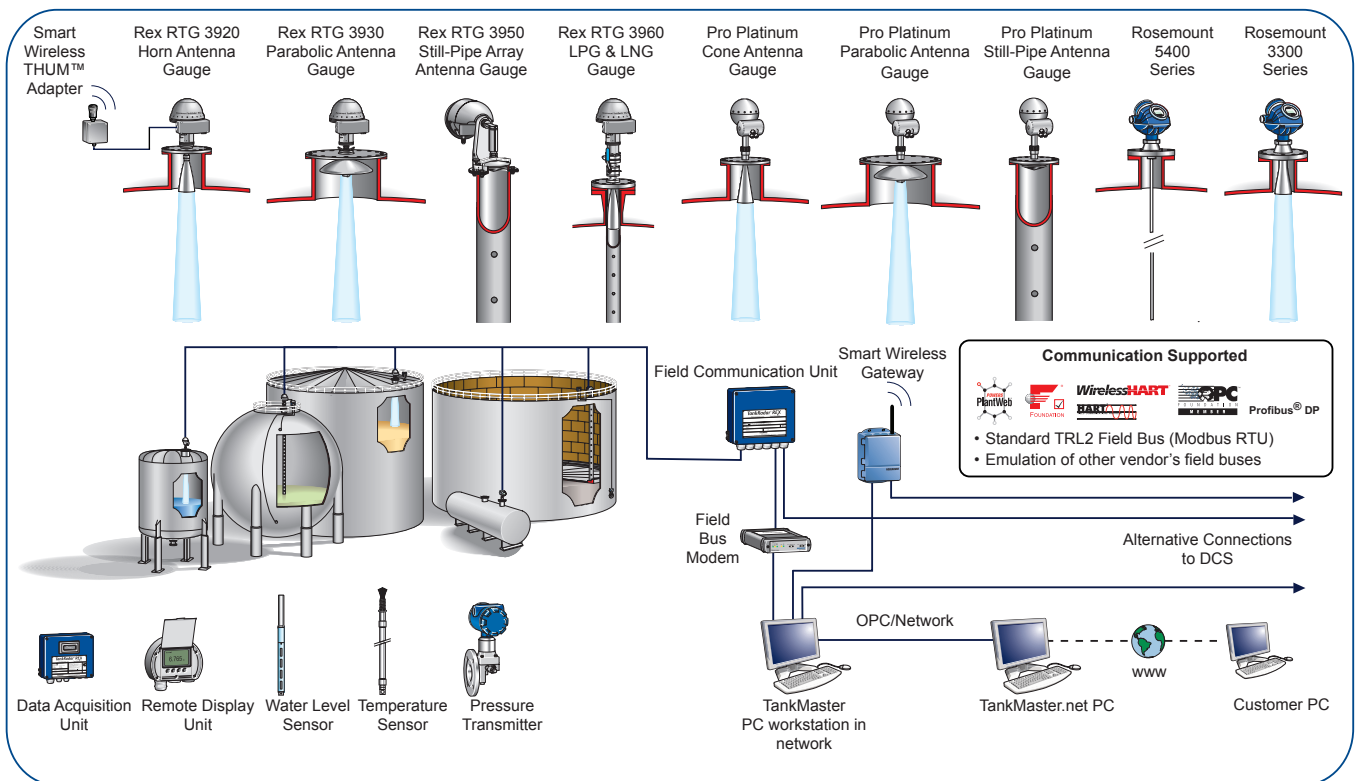

TankRadar Rex system overview.

TankRadar Rex

Measured values are communicated on a field bus or directly to a PC. In larger systems there are Field Communication Units (FCU:s) that collect data from separate field buses. In this way both stand- alone gauges and large systems with several hundred gauges are economical and have an excellent performance.

The TankRadar Rex system is configured and operated using the OPC compatible TankMaster software package. Its a user-friendly Human Machine Interface (HMI) software that gives the operator a good overview and quick access to any measured values. The software also provides a wide range of inventory and custody transfer functions such as net standard volumes according to API standards, reporting, alarms, graphics, trends etc.

A whole range of plant host computer systems, DCS or SCADA systems can be connected to the TankRadar Rex system for display of measured and calculated values. Protocols for communication with major suppliers of plant host computers have been developed and certified. TankMaster Rex gauges can also be incorporated in other tank gauging manufacturers' systems using the emulation features.

The TankRadar Rex System can include various integrated equipment, such as:

- Multiple spot temperature sensors
- Water Interface measurement sensors integrated with temperature sensors
- Vapor pressure transmitters
- Hydrostatic pressure transmitters
- TankMaster PC workstations in network
- Local data display on the Data Acquisition Units or on the Remote Display Units

Installation and commissioning of the TankRadar Rex System

The TankRadar Rex system is easily installed by the customer or the customer's contractor. No special tools are required and all parts can be carried onto the tank roof.

Normally existing field cabling is used.

There are clear instructions in the Installation Manual and installation drawings. Installation can be done with the tanks in operation, except for pressurized tanks such as LPG tanks.

Commissioning is normally done by a trained engineer from our local representative, or in some cases by the customer.

The TankMaster WinSetup PC software is used to configure the system.



Rex gauges are installed using existing nozzles and manways.

Radar level gauging

TankRadar Rex gauges provide outstanding reliability using non-contact radar measurement with no moving parts and only the antenna inside the tank atmosphere.

For radar level measurement, there are mainly two modulation techniques:

- Pulse method. Measures the time it takes for a pulse to travel to the surface and back. Pulse radar level gauges are mainly available or lower accuracy applications
- Frequency Modulated Continuous Wave, FMCW. This method is used by high performance radar level gauges

The FMCW method

The radar gauge transmits microwaves towards the surface of the liquid. The microwave signal has a continuously varying frequency around 10 GHz. When the signal has travelled down to the liquid surface and back to the antenna, it is mixed with the signal that is being transmitted at that moment. The frequency of the transmitted signal has changed slightly during the time it takes for the echo signal to travel down to the surface and back again. When mixing the transmitted and the received signal the result is a signal with a low frequency proportional to the distance to the surface. This signal provides a measured value with high accuracy. The method is called the FMCW-method (Frequency Modulated Continuous Wave).



This gauge is still operating and gauging accurately despite the heavy contamination. The parabolic antenna has for several months been exposed to blown bitumen heated to 160 °C (320 °F).

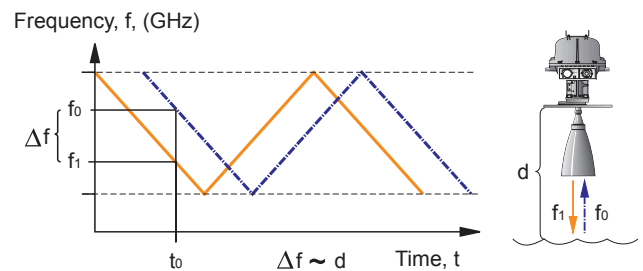

The FMCW method is based on a radar sweep with varying frequency.

TankRadar Rex

Accuracy enhancement

To enhance accuracy further, TankRadar Rex has some built-in unique features:

Temperature control

TankRadar Rex gauges are designed to operate in all climates. The gauge is continuously controlling the temperature of the electronics and keeps it constant. This is one of the reasons for the 65 years of mean time between failure (MTBF) for the gauge.

Digital reference

A radar gauge needs an internal reference to make the radar sweep absolutely linear. Each deviation from the linearity produces a corresponding inaccuracy. To achieve highest precision, TankRadar Rex uses a digital crystal oscillator. This gives the most stable reference that is available with today's technology.

Drip-off means no condensation

If the antenna has an inclined polished PTFE-surface where the microwaves are emitted, it will be less susceptible to condensed water or product. The drops of condensation will not coat the active part of the antenna. In this way the radar signal will be less weakened resulting in higher accuracy and better reliability.

Measurement close to tank wall

A standard manway (or flange) is normally 0.3-1 m (1-3 feet) from the tank wall. Both the RTG 3920 Horn Antenna Gauge and the RTG 3930 Parabolic Antenna Gauge are specially designed to be mounted close to the wall.

The RTG 3920 Horn Antenna Gauge radar signal is polarized so that the direct reflection from the liquid surface is the only detectable reflection. Any wall disturbance will be blanked out. The RTG 3930 Parabolic Antenna has a narrow radar beam due to the large 20-inch antenna diameter resulting in a small and uncritical wall echo.

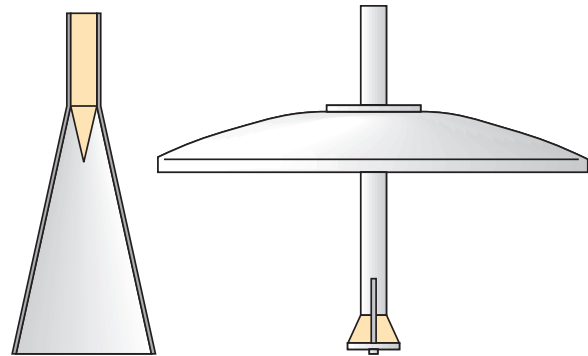

Antenna design with no horizontal surfaces according to the American Petroleum Institute Standard (API ch. 3.1B).

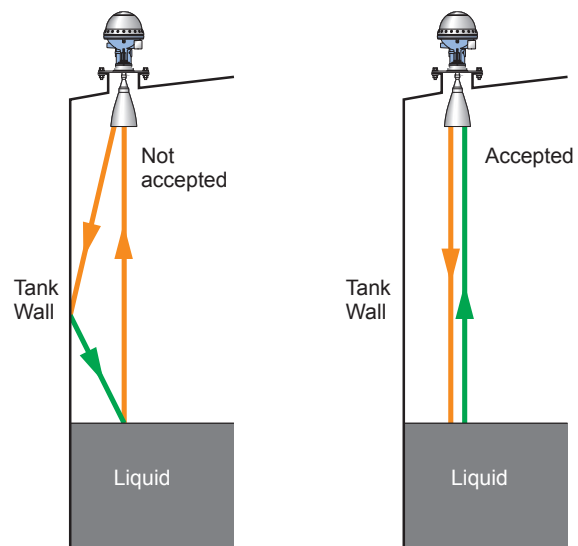

Gauges emitting microwaves with circular polarization can be installed closer to the tank wall.

Technical Description

703010En, Ed. 5, Rev B

November 2012

TankRadar Rex

Patented method for detecting the surface echo

TankRadar Rex uses a patented method for detecting the surface echo. The measured signal passes through a digital filter. First, one filter removes any echoes smaller than a threshold value. Then a narrow filter “window” is placed around the frequency corresponding to the surface echo. The remaining frequency is compared with the frequency calculated in the previous radar sweep, resulting in a very accurate measurement. This method uses the calculating power of the processor very efficiently and focuses on accuracy as well as fast and reliable results.

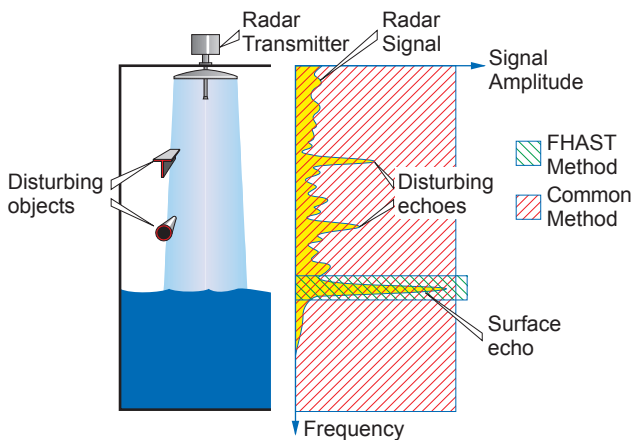

The FHAST™ filter limits the region around the liquid surface to be analyzed, resulting in a much more efficient signal processing.

No risk to be exposed to the microwaves from the TankRadar Rex antenna

There are no health hazards from the TankRadar microwave output. As the emitted power from each transmitter is very low, there is no health hazard even when you are very close to the antenna. A few figures will illustrate this:

most international standards state that a power density of up to 1 mW/cm² is considered safe for continuous human exposure. The power density close to the antenna is 0.001 mW/cm², and further down in the tank it is much lower.

The transmitted microwave power is less than 0.1 mW. As a comparison, the normal sunshine a person is exposed to a sunny day corresponds to a power density of 100-150 mW/cm².

Lightning Protection

Lightning strikes can induce very high voltages in tank farm field cables. The TankRadar Rex system has been designed to minimize the risk of lightning damage to the equipment.

- Every node of the system is galvanically isolated on both the mains supply and the TRL2 bus
- Standard protection components and filters are able to handle fast transients
- Multiple varistors (fast transient protection) and gas tube arrestors (surge protection) inside the gauge protect the electronics from over-voltages. Since any sparking will occur inside the flameproof enclosure, the tank is also protected from explosion hazard
- Mains supply is protected by fuses

SIL 2 Safety Functions

The Rosemount TankRadar Rex (RTG 3900 Series) has been assessed by third party and considered suitable for use in SIL 2 safety functions according to IEC 61508/61511. The decision on the usage of proven-in-use devices, however, is always with the end-user.

The safety function is based on the relay outputs which can be used for overfill or dry run protection.

Reach more tanks at less cost with Smart Wireless solution

The Raptor system supports Emerson's Smart Wireless solution, based on IEC 62591 (*WirelessHART*), the industry standard for wireless field networks.

Greatly reducing field wiring leads to large savings in infrastructure, design and labor required for installation and commissioning.

No hot work is required and production downtime is minimized.

In addition, compared to other systems, the time between project start-up and an up-and-running wireless system is drastically reduced. No costly site surveys are required.

Wireless tank gauging allows for cost savings up to 70%, but lower cost is only part of the equation.

TankRadar Rex

Better Utilization of Tank Capacity

Wireless functionality allows tank gauging data from remotely located tanks, previously collected manually or not at all, to be integrated into the system. This results in a more efficient tank capacity utilization, better inventory and loss control.

Intelligent Self-organizing Field Network Increases Reliability

A Smart Wireless device can transmit its own data as well as relay information from other devices in the network.

The self-organizing field network automatically finds the best way around any fixed or temporary obstacle.

Nodes can identify a network, join it, and self-organize into dynamic communication paths. Reliability actually increases when the network expands – the more devices, the more communication paths.

This results in a data reliability of more than 99% – even in a harsh and dynamic environment.

Smart Wireless for More Secure Data Transmission

Emerson’s Smart Wireless field network is designed for best-in-class security. Data is protected by 128-bit encryption, authentication, verification, anti-jamming, and key management.

With this type of design, the field network can offer a higher level of security than many traditional wired networks.

Wireless Connection of Tank Gauging Equipment

The Smart Wireless Gateway is the network manager that provides an interface between field devices and the TankMaster inventory software or host / DCS systems.

A single gateway supports up to 100 nodes.

Each wireless node in the tank gauging system consists of a TankRadar Rex gauge connected to mains power and supplied with a Smart Wireless THUM™ Adapter.

The wireless transmission supports important measurement data handled by the gauge, such as level, temperature, water level and pressure.

The tank gauging system can be complemented with other wireless devices, such as pressure transmitters and temperature sensors.

The THUM adapter can route any data to the radar gauge which allows full configuration and diagnostics using the AMS software or a Field Communicator.

The THUM adapter is supplied with a mounting kit when delivered together with TankRadar Rex. The mounting kit allows the THUM adapter to be installed on a 1-2-in. pipe, away from the radar gauge, at the best possible tank roof position.



TankRadar Rex with the Smart Wireless THUM™ Adapter.

The THUM adapter burst rate is user selectable from 8 seconds to 60 minutes.

See also section “TankRadar Rex System Configurations” and “Ordering Information”.

For more technical details on the Gateway and THUM™ Adapter, see their respective Product Data Sheets (00813-0200-4420 and 00813-0100-4075).

Technical Description

703010En, Ed. 5, Rev B

November 2012

Radar Tank Gauges

There are five types of RTG 3900 Series Radar Tank Gauges to fit any storage tank:

- **Horn Antenna Gauge, RTG 3920**, for fixed roof installation without still-pipe
- **Parabolic Antenna Gauge, RTG 3930**, for installation without still-pipe, for general use and in demanding environments
- **Still-pipe Array Antenna Gauge, RTG 3950**, for measurement in existing still-pipes
- **LPG/LNG Gauge, RTG 3960**, for liquefied gas, LPG and LNG

The Radar Tank Gauge (RTG) measures the distance to the surface of the product in the tank. Using tank distances stored locally in the memory of the gauge, it calculates the level of the liquid's surface. The level is communicated on the digital TRL2 field bus to the Field Communication Units and to the PC workstations or other host computers.

Transmitter Head

The radar gauges are built up by the Transmitter Head (TH) and the antenna. The same Transmitter Head is used on all types of Rex tank gauges minimizing spare parts requirements. It is freely interchangeable between different gauges, regardless of antenna type. The Transmitter Head weight is only 8 kg (18 lbs).

The enclosure of the Transmitter Head is a rugged air and watertight protection against salt spray atmosphere in coastal areas.

Transmitter Head Electronics

The Transmitter Head Electronics (THE) is a separate unit located inside the safety enclosure of the Transmitter Head. It is easily exchangeable and not in contact with the tank atmosphere. The THE includes the microwave unit, circuit boards for signal processing, data communication, power supply and transient protection.

The unit contains no analog reference lines that can cause drift by age or temperature changes. It uses a digitally synthesized feedback channel from the microwave unit as a reference for the measurement. The Rex gauge requires no recalibration, not even after the THE has been exchanged.

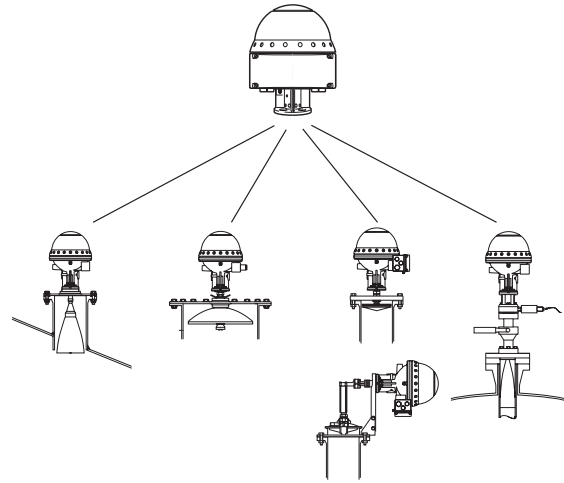

The RTG 3900 transmitter head with different antennas.



Transmitter head with optional junction box for deliveries according to CENELEC standards.

TankRadar Rex

The following circuit boards are included in the THE:

Signal Processing Card (SPC)

The SPC card includes a high performance signal processor plus memories for tank specific data set via remote programming.

Analog Processing Card (APC)

The APC card is used for filtering and multiplexing of analog input signals. Keeping the analog circuitry on a separate card improves measuring accuracy by giving a high signal to noise ratio.

Transmitter Interface Card (TIC)

The Transmitter Interface Card (TIC) is required for intrinsically safe inputs. The TIC card includes:

- Two supply zener barriers and two return barriers for 4-20 mA current loops
- One supply zener barrier for a Data Acquisition Unit or a Remote Display Unit
- Signal/supply connection for optional Temperature Multiplexer Card (TMC)

Temperature Multiplexer Card (TMC)

The Temperature Multiplexer Card (TMC) is used to connect up to 6 temperature sensors directly to the RTG.

Relay Output Card (ROC)

The Relay Output Card (ROC) includes two relays. It allows controlling external devices such as valves, pumps, heating coils, overfill protection according to TÜV etc.

Field Communication Card (FCC)

The FCC card handles communication with external devices. There are different versions of the FCC card allowing the use of various types of communication protocols and also emulation of gauges from other vendors.

Metrological Seal (option)

An optional metrological seal prevents unauthorized changes in the database. Two versions are available; One external seal verifiable from the outside, and one internal seal located inside the Transmitter Head. The metrological seal is a requirement from fiscal authorities in some countries.

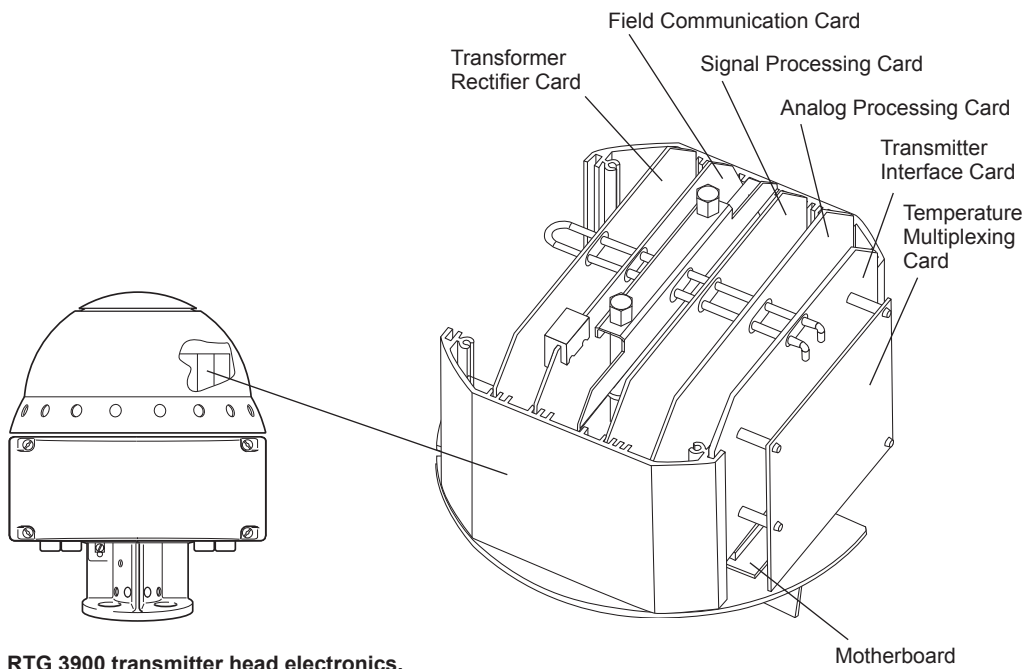

RTG 3900 transmitter head electronics.

Technical Description

703010En, Ed. 5, Rev B

November 2012

TankRadar Rex

Technical Data for the Transmitter Head

Instrument accuracy:	RTG 3900: $\pm 0.5 \text{ mm} \pm (0.020 \text{ in.})$ RTG 3900 L: $\pm 3 \text{ mm} \pm (0.12 \text{ in.})$
Ambient operating temperature:	-40 to +70 °C (-40 to +158 °F)
Hazardous location certifications:	ATEX: $\text{Ex} \text{ II } 1/2 \text{ G Ex d[ia] IIB Ga/Gb T6 (T}_{\text{amb}} \text{ -40}^\circ\text{C to +70}^\circ\text{C)}$ IECEX: $\text{Ex d[ia] IIB Ga/Gb T6 (T}_{\text{amb}} \text{ -40}^\circ\text{C to +70}^\circ\text{C)}$ UL/UL-C: Class I, Div 1, Groups C&D See also the list on page 46, "Certificates"
Ingress protection:	IP 66 & 67
Housing material:	Anodized Aluminium
Power supply:	100-240 VAC, 50-60 Hz, average 15 W (max. 80 W at gauge power up, and in temperatures below the freezing point if the built-in heater is on) 34-70 VAC (option) 20-28 VDC, max 30 W (option) 48-99 VDC (option)
Analog outputs:	One output 4-20 mA passive or active (non-intrinsically safe)
Analog inputs:	alt 1) One or two 4-20 mA alt 2) One 4-20 mA input plus one digital HART input The RTG is the HART master. Each RTG can have maximum 3 HART slaves
Relay outputs:	Max 2 relays, only 1 output available if analog outputs are included Type: Normally open or closed Contact rating: 250 V, 4 A, resistive load See also "Field bus (options)" and "Other vendor's communication protocols" below
Field bus (standard):	1) TRL2 Bus (FSK, half duplex, two wires, galvanically isolated, 4800 Baud, Modbus based) 2) RS485 (Modbus based)
Field bus (options):	1) Profibus DP 2) Tiway <i>(Only one relay available, analog out not available)</i>
Other vendors' communication protocols:	1) Enraf <i>(Requires special Field Bus Modem, EBM)</i> 2) Varec <i>(Only one relay available, analog output not available)</i> 3) L&J <i>(Only one relay available, analog output not available)</i> 4) Whessoe <i>(Only one relay available, analog output not available)</i> 5) GPE <i>(Only one relay available, analog output not available)</i> 6) Sakura <i>(Only one relay available, analog output not available)</i> 7) Tokyo Keiso (TIC) <i>(Only one relay available, analog output not available)</i>
Temperature inputs:	Up to 6 Pt-100 Resistance Temperature Detector (RTD) inputs with common return or 3 RTD inputs with individual wiring, directly in TH. Up to 14 RTD inputs via separate Data Acquisition Unit, see page 27
Temperature conversion accuracy:	$\pm 0.1 \text{ }^\circ\text{C}$ for -50 to +250 °C (-58 to +482 °F) Note! Temperature range for PTB approval is -20 to +90 °C (-4 to +194 °F)
Transmitter head weight	12 kg (26 lbs)
Field data display:	In separate DAU (page 27) or RDU (page 28)

TankRadar Rex

Cable Connections to the Transmitter Head

The Transmitter Head is either delivered with an integrated junction box (JBi) for cable connections, or with two cable outlets only. The JBi includes two connection terminals; one for power, field bus and relays, and one for intrinsically safe connections from temperature, pressure and water bottom sensors, Data Acquisition Unit, Remote Display Unit etc.

If the JBi is **not** included, the gauge is delivered with two separate cable outlets as follows:

For power and field bus:

Number of wires: 8

Length: 2.5 m (8 ft)

[Optional cable length 20 m (50 ft)]

For IS connections such as temperature:

Number of wires: 8 or 15

Length: 2.5 m (8 ft)

[Optional cable length is 20 m (50 ft)]

The TH version with cables and no JBi is always delivered with shipments to the USA (UL certification).

The field bus uses a 2-core twisted and shielded standard instrument cable for distances up to 4 km (2.5 miles).

For more details about installation, see separate installation manual and installation drawings.

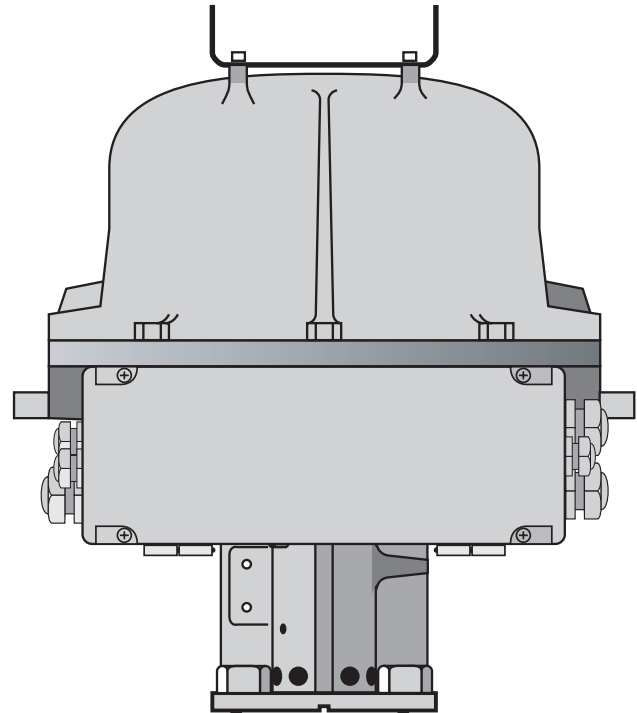

Transmitter head with JBi.

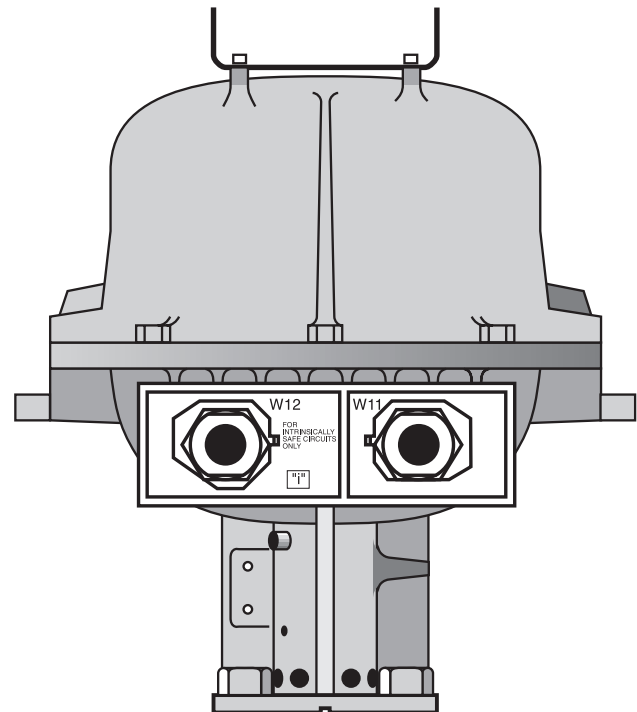

Transmitter head with cable outlets and no JBi.

Technical Description

703010En, Ed. 5, Rev B
November 2012

TankRadar Rex

Technical data for integrated junction box (JBi)

For data on available separate junction boxes, see page 32.

Hazardous location certifications:	ATEX: Ex II 2G Ex e d ia IIC T6 Gb IECEX: Ex e d ia IIC T6 Gb (T _{amb} : -55°C to +70°C) There is one Exe side for power and bus cables (W11 wire terminal), and one Exi side for intrinsically safe connections (W12 wire terminal)
Ingress protection:	IP 65
Material:	Cast aluminium coated with grey polyester
Temperature range:	-40 °C to +70 °C (-40 °F to +158 °F)
Cable inlets Exe side (W11):	Standard: 2 pcs M25, 1 pc M20 Option: 2 pcs ¾-in. with NPT thread and 1 pc ½-in. with NPT thread
Wire terminals Exe side (W11):	8 terminals. (For power and field bus)
Cable inlets Exi side IS cabling (W12):	Standard: 1 pc M25, 2 pcs M20 Option: 1 pc ¾-in. with NPT thread, 2 pcs ½-in. with NPT thread
Wire terminals Exi side (W12):	15 terminals. (For intrinsically safe cables, e.g. to a DAU, temp sensors etc.)
Cable glands:	All cable glands must be of Exe type. Each cable inlet is, as standard, sealed with an Ex approved metal blind plug at delivery

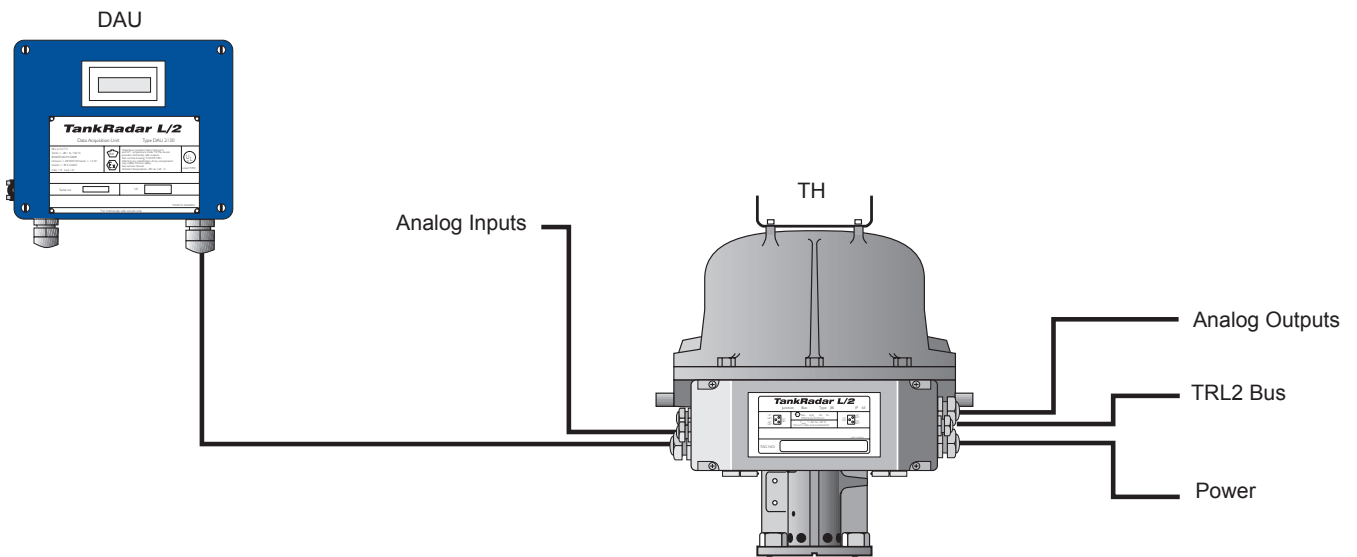

Typical TH connections.

TankRadar Rex

Horn Antenna Gauge RTG 3920

The horn antenna gauge is designed for easy installation on 200 mm (8-inch) or larger nozzles on tanks with fixed roofs.

It measures on a variety of oil products and chemicals except for asphalt and similar products for which the parabolic antenna gauge (RTG 3930) is recommended.

RTG 3920 is delivered with a flange for straight installation or one for inclined installation. The inclined flange is used when the gauge is installed close to the tank wall and highest accuracy is required. Otherwise the straight flange is used.

The entire horn antenna is inside the tank and has almost the same temperature as the tank atmosphere preventing condensation on the inside of the antenna.

Installation is normally made without taking the tank out of operation.

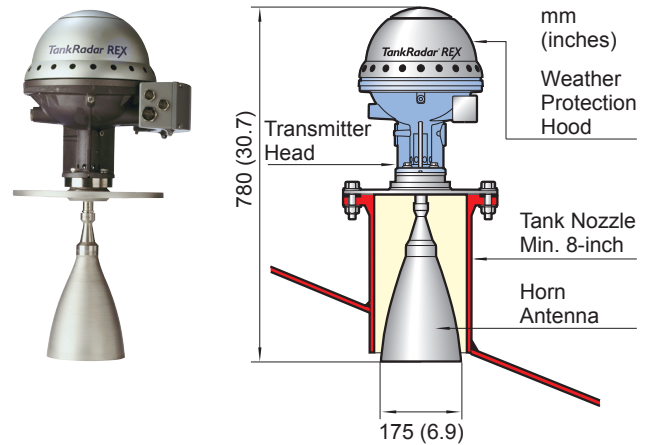

RTG 3920 Horn Antenna Gauge.

Technical Data for RTG 3920

See also technical data for the Transmitter Head.

Instrument accuracy:	RTG 3920 ± 0.5 mm ± (0.020 in.) RTG 3920 L ± 3 mm ± (0.12 in.)
Operating temperature in tank:	Max. +230 °C (+445 °F)
Measuring range (standard):	0.8 to 20 m (2.6 to 65 ft) below flange
Measuring range (option):	0.3 to 30 m (1 to 100 ft) below flange with reduced accuracy
Pressure:	-0.2 to 2 bar (-2.9 to 29 psig)
Total weight:	Appr. 20 kg (44 lbs)
Material exposed to tank atmosphere:	Antenna and flange: material corresponds to AISI 316/316L and EN 1.4401 /1.4404 Sealing: PTFE O-ring: FPM (Viton)
Antenna dimension:	175 mm (7 in.)
Nozzle diameter:	Minimum 200 mm (8 in.)
Flange:	8 in. hole pattern according to ANSI 8 in. Class 150 / DN 200 PN 10 The flange can be horizontal or 4° inclined for installation close to the tank wall Other flanges are available on request
Field data display:	In separate DAU (page 27) or RDU (page 28)

Technical Description

703010En, Ed. 5, Rev B

November 2012

TankRadar Rex

Parabolic Antenna Gauge RTG 3930

The RTG 3930 gauge is designed for installation on tanks with fixed roofs. It measures levels of products ranging from clean products to bitumen/asphalt. The design of the parabolic antenna gives extreme tolerance against sticky and condensing products.

The large antenna diameter provides high antenna gain and a high signal to noise ratio. The parabolic antenna gauge can be installed on existing manhole covers. The standard parabolic reflector has a diameter of 440 mm (17 inch) and it fits onto, for example, a 20 inch manway. For easy access in extremely dirty applications, the gauge can be installed on a manhole cover with hinges.

RTG 3930 can also be used on tanks with floating roofs. It is then installed at the tank top and measures the distance down to a target plate on the floating roof.

Installation is normally made without taking the tank out of operation.

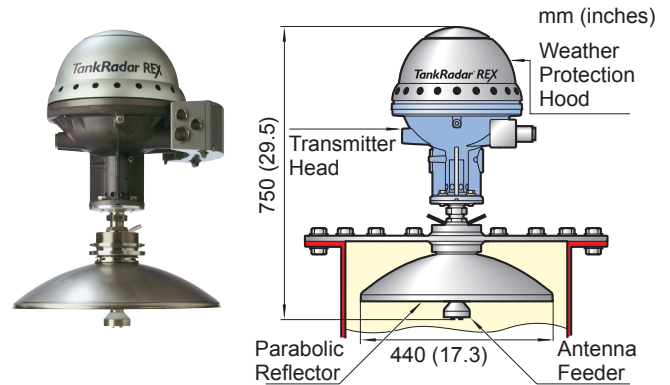

RTG 3930 Parabolic Antenna Gauge.

Technical Data for RTG 3930

See also technical data for the Transmitter Head.

Instrument accuracy:	RTG 3930 $\pm 0.5 \text{ mm} \pm (0.020 \text{ in.})$ RTG 3930 L $\pm 3 \text{ mm} \pm (0.12 \text{ in.})$
Operating temperature in tank:	Max. $+230 \text{ }^\circ\text{C} (+445 \text{ }^\circ\text{F})$
Measuring range:	0.8 to 40 m (2.6 to 130 ft) below flange. For longer measuring range, please consult your Rosemount Tank Gauging representative
Pressure:	Clamped: -0.2 to $0.2 \text{ bar} (-2.9$ to $2.9 \text{ psig})$ Welded: -0.2 to $10 \text{ bar} (-2.9$ to $145 \text{ psig})$
Total weight:	Appr. 25 kg (55 lbs)
Material exposed to tank atmosphere:	Antenna: material corresponds to AISI 316/316L and EN 1.4401 /1.4404 Sealing: PTFE O-ring: FPM (Viton)
Antenna dimension:	440 mm (17 in.)
Manway size:	Min. 500 mm (20 in.)
Tank connection:	The gauge is clamped in a 96 mm (3.78 in.) diameter hole, or welded in a 117 mm (4.61 in.) diameter hole
Field data display:	In separate DAU (page 27) or RDU (page 28)

TankRadar Rex

Still-Pipe Array Antenna Gauge RTG 3950

RTG 3950 with its small-sized array antenna is made for installation on existing still-pipes. Typical applications are crude oil tanks with floating roofs and gasoline/product tanks with or without inner floating roofs.

To get custody transfer accuracy, the gauge uses the Low Loss Mode technology, invented for the TankRadar products, to transmit the radar waves in the center of the pipe. This virtually eliminates degradation of the accuracy due to rust and product deposits inside the pipe.

RTG 3950 is available for 5-, 6-, 8-, 10- and 12-inch pipes.

There are two versions of RTG 3950; fixed and inclined. The inclined version has a hinged hatch, enabling full pipe size product sampling or verification hand-dips.

Installation is normally made without taking the tank out of operation.

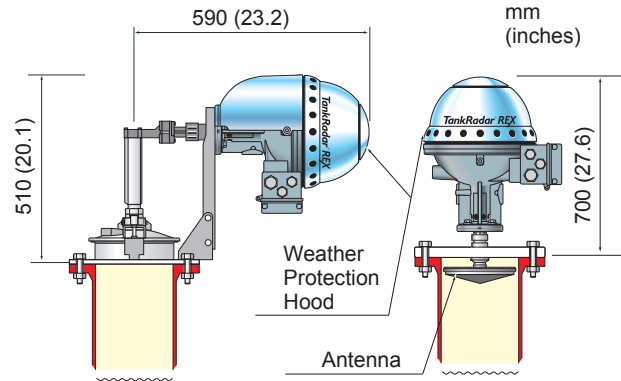

RTG 3950 Still-Pipe Array Antenna Gauge, inclined and fixed versions.



Pipe seen from above

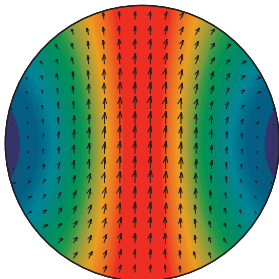

H_1 is the normal radar mode of a circular waveguide.

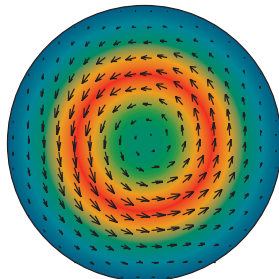

Low Loss Mode: Very low losses from rust or deposits.

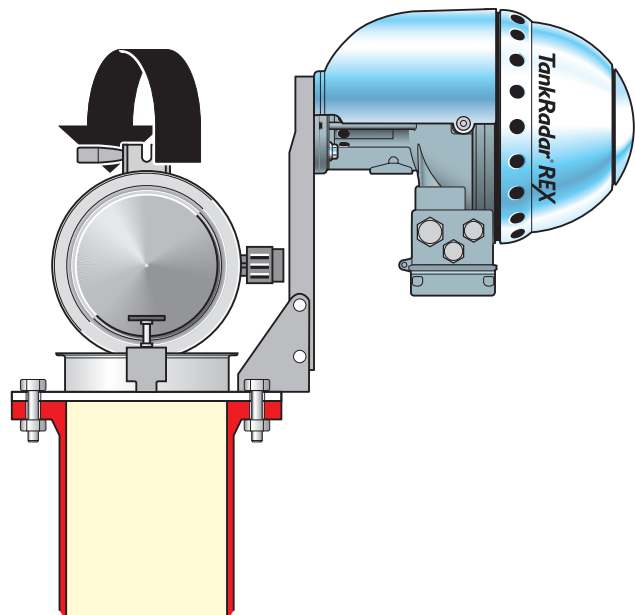

Removable waveguide unit allows hand dips and sampling.

Technical Description

703010En, Ed. 5, Rev B

November 2012

TankRadar Rex

Technical Data for RTG 3950

See also technical data for the Transmitter Head.

Instrument accuracy:	RTG 3950 ± 0.5 mm ± (0.020 in.) RTG 3950 L ± 3 mm ± (0.12 in.)
Operating temperature in tank:	Max. -40 to +120 °C (-40 to +248 °F)
Measuring range:	0.8 to 40 m (2.6 to 130 ft) from antenna end. For longer measuring range, please consult your Rosemount Tank Gauging representative
Pressure (two versions available):	Fixed version: -0.2 to 2 bar (-2.9 to 29 psig) at 20 °C Inclined version: 5 to 8 in. pipes, -0.2 to 0.5 bar (-2.9 to 7.2 psig) 10 and 12 in. pipes, -0.2 to 0.25 bar (-2.9 to 3.6 psig) Note: If pressure >0.5 bar, a flange with suitable rating must be used
Total weight:	21.5-32 kg for fixed version and 28.5-41.5 kg for inclined version, depending on dimension
Material exposed to tank atmosphere:	Antenna: Polyphenylenesulphide (PPS) Sealing: PTFE O-ring: Fluorosilicone Flange: material corresponds to AISI 316/316L and EN 1.4401 /1.4404
Still-pipe dimensions:	5-, 6-, 8-, 10- or 12 in.
Field data display:	In separate DAU (page 27) or RDU (page 28)

LPG/LNG Gauge RTG 3960

The RTG 3960 gauge is designed for level measurement of liquefied gas in LPG or LNG tanks.

A still-pipe enables the gauge to have a sufficiently strong echo even under surface boiling conditions.

The radar signals are transmitted inside the still pipe.

The pressure sealing is a quartz/ceramic window approved for use in pressurized vessels.

As an option the gauge is equipped with a fire-proof ball valve and a vapor space pressure sensor. The pressure sensor is required for highest accuracy.

A patented reference device function enables measurement verification with the tank in operation.

A reference pin mounted in a still-pipe hole, and a deflection plate with a reflection ring at the lower pipe end provides measured distance values which are compared with stored positions.

Installation is made with the pressurized tank taken out of operation.

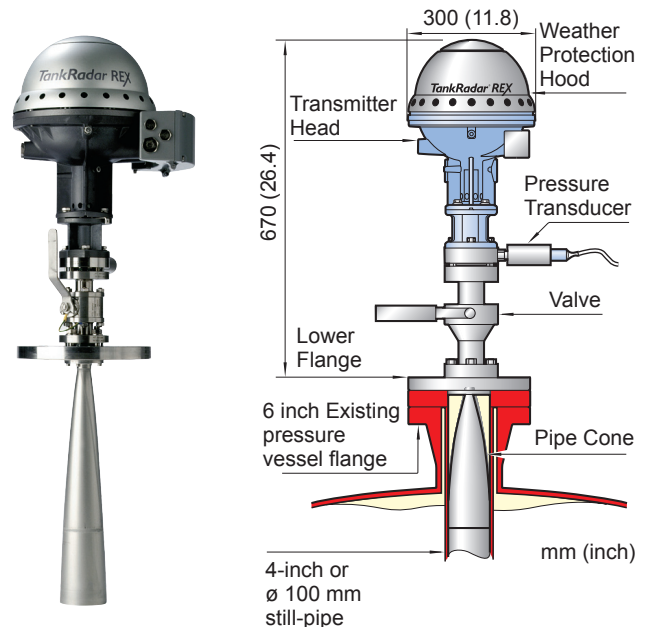

TankRadar Rex

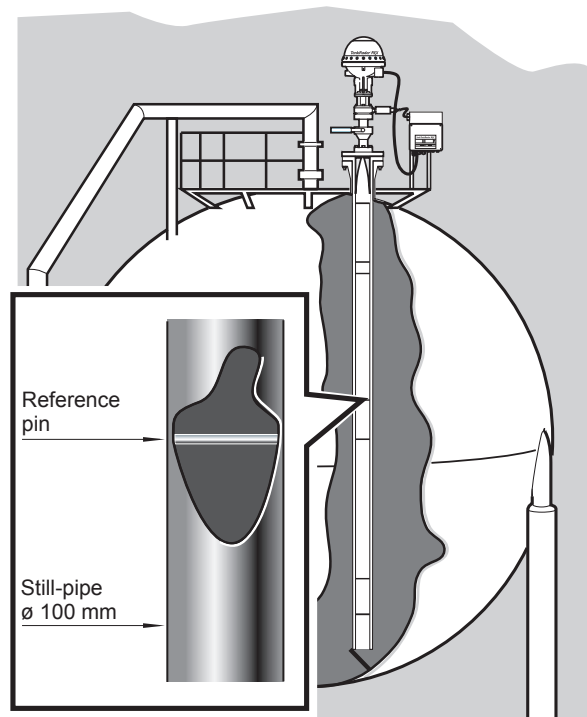

The reference pin mounted inside the 4-inch still-pipe and a bottom reflection ring enable the measurement to be checked during operation.

Technical Data for RTG 3960

See also technical data for the Transmitter Head.

Instrument accuracy:	RTG 3960 ± 0.5 mm ± (0.020 in.) RTG 3960 L ± 3 mm ± (0.12 in.)
Operating temperature at ball valve:	-55 to 90 °C (-67 to 194 °F)
Operating temperature in tank:	-170 to 90 °C (-274 to 194 °F)
Measuring range:	0.5 to 60 m (1.6 to 200 ft) from cone end For longer measuring range, please consult your Rosemount Tank Gauging representative
Pressure range:	-1 to 25 bar (-14.5 to 365 psig) Note: Flanges may have higher pressure rating than 25 bar, but maximum tank pressure is still 25 bar
Pressure sensor (option):	Druck PTX 621
Flange size and rating:	4 in. class 150/300 6 in. class 150/300 8 in. class 150/300 Other flange sizes/ratings are available on request
Still-pipe dimension alternatives:	4-in. sch. 10 or sch 40 100 mm (99 mm inner diameter)
Total weight (examples):	38 kg (84 lbs) for 6-in. 150 psi 48 kg (106 lbs) for 6-in. 300 psi
Material exposed to tank atmosphere:	Antenna and flange: material corresponds to AISI 316/316L and EN 1.4401 /1.4404 Sealing: Quartz and PTFE
Ball valve sealing kit (option):	20 bar (290 psi)
Field data display:	In separate DAU (page 27) or RDU (page 28)

Temperature measurement

Product temperature is an important parameter for accurate custody transfer and inventory measurement in liquid bulk storage tanks. High quality Multiple Spot Temperature (MST) sensors can be included in the Rex system delivery as an essential part.

The MST measures temperature with a number of Pt-100 spot elements placed at different heights to provide a tank temperature profile and an average temperature. Only the elements that are fully immersed are used to determine the product temperature. The spot elements are placed in a flexible gas tight protection tube made from convoluted stainless steel. A flange can be attached to a top fitting and the tube can be anchored to the bottom.

API chapter 7 recommends minimum one element per 10 feet (3 m) tank height for custody transfer applications.

The temperature sensor is easy to install, even if the tank is in service. In pressurized tanks the MST can be installed in a closed thermowell so that it can be removed for service or inspection while the tank is in operation. For LPG tanks single spot temperatures sensors in thermowells are used. Temperature sensors can be connected in two ways to the RTG:

- Directly into the RTG with common return connection (up to six temperature elements)
- Via the DAU (up to 14 temperature elements)

A water level sensor can be integrated in the MST, see page 26. It is also possible to have an integrated junction box (see picture below).

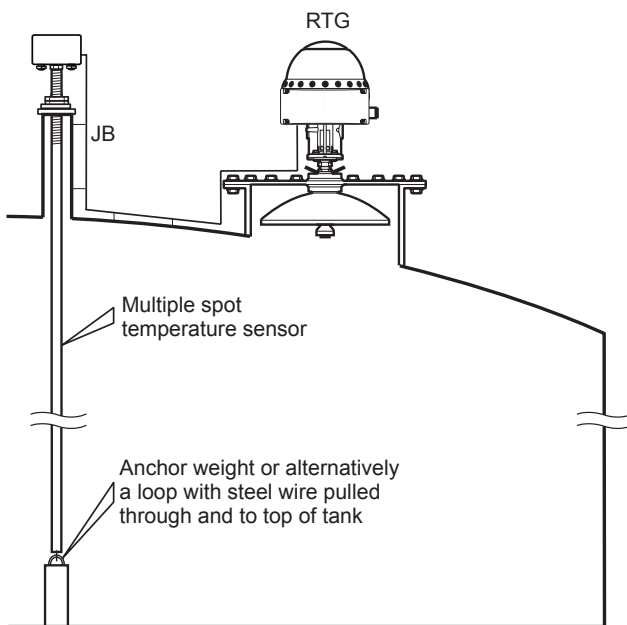

Up to 6 temperature elements can be connected directly to the radar gauge.

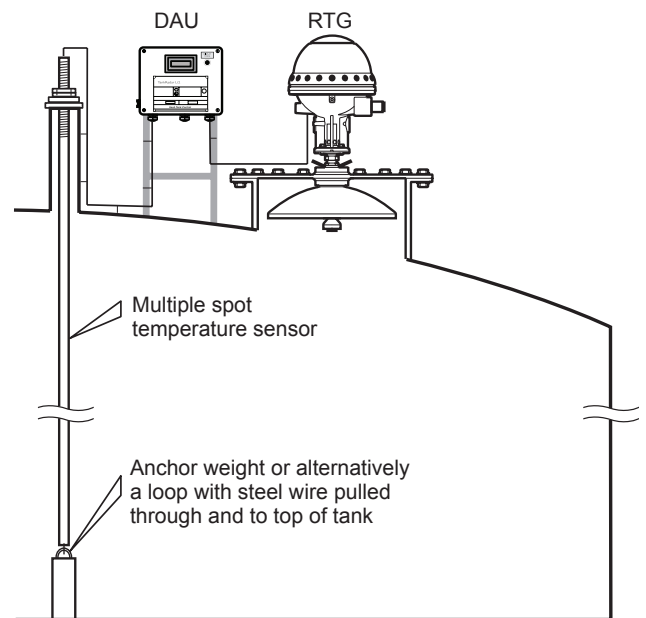

When the number of temperature elements is above 6 they are connected via a Data Acquisition Unit. Maximum 14 temperature elements can be connected.

TankRadar Rex

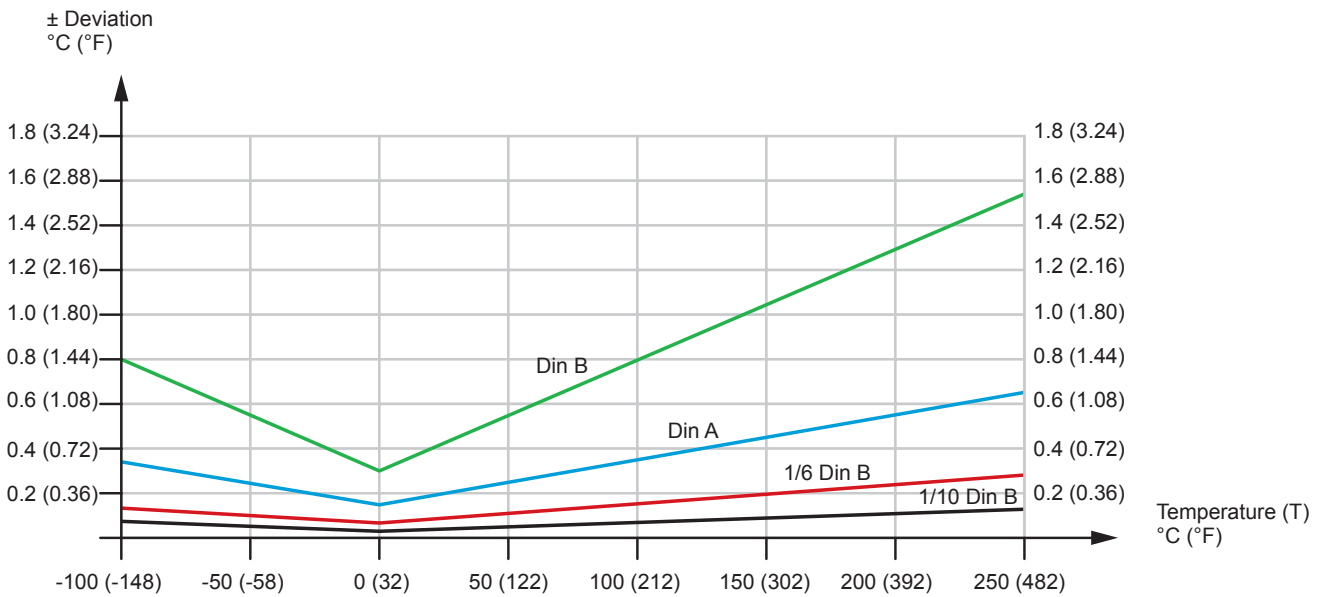
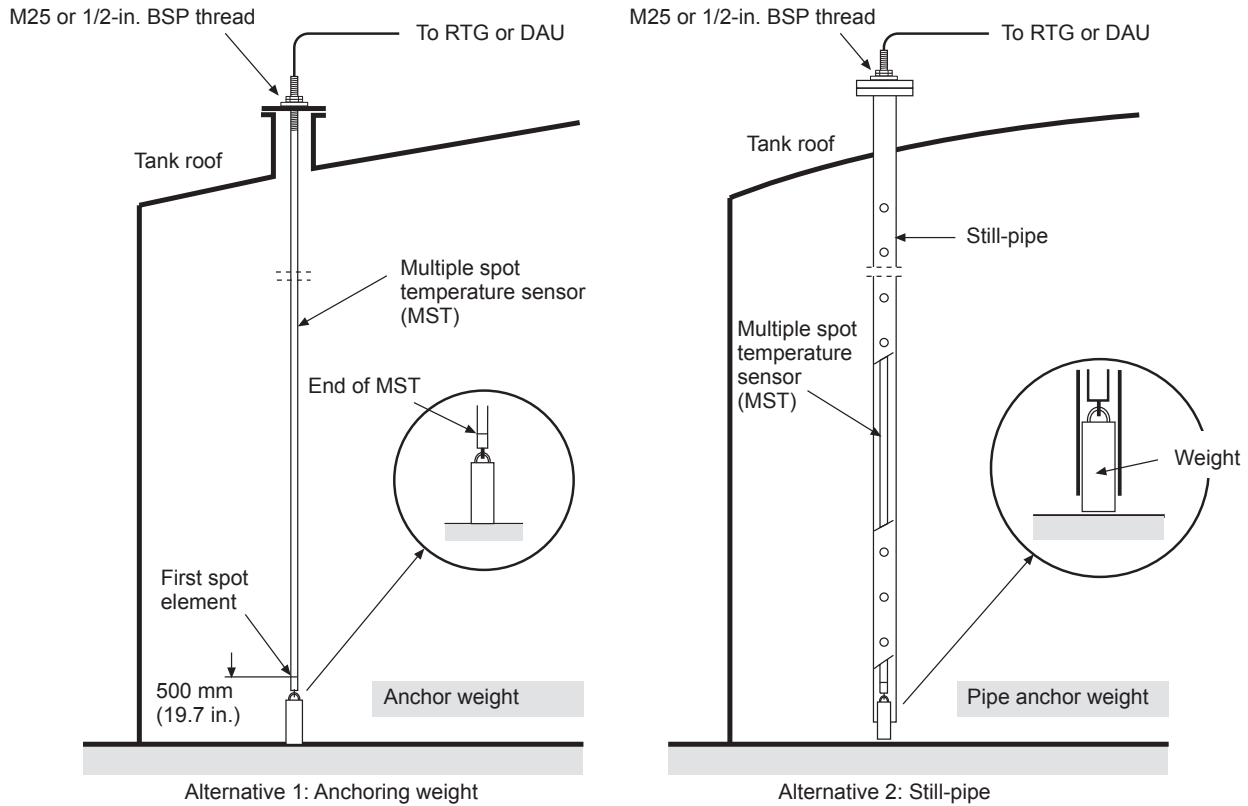

For many users DIN Class A and DIN Class B temperature accuracy is not sufficient. Temperature sensor elements are therefore available with 1/6 DIN B as standard, and 1/10 as an option.

$$\text{DIN A} = \pm (0.15 + 0.002 * |T|)$$

$$\text{DIN B} = \pm (0.30 + 0.005 * |T|)$$

$$\text{1/6 DIN B} = \pm (0.30 + 0.005 * |T|) * 1/6$$

$$\text{1/10 DIN B} = \pm (0.30 + 0.005 * |T|) * 1/10$$



Technical Description

703010En, Ed. 5, Rev B

November 2012

TankRadar Rex

Technical Data for Multiple Spot Temperature Sensor

Elements type:	Pt-100 spot elements according to EN 60751
Accuracy:	1/6 DIN Class B (standard), 1/10 DIN Class B (option). See diagram on previous page
Overall temperature range (standard):	-50 to 120 °C (-58 to 248 °F)
Overall temperature range (optional):	-20 to 250 °C (-4 to 482 °F) -170 to 100 °C (-274 to 212 °F)
Number of elements:	6 elements per MST as standard, and 14 elements as maximum for each MST
Overall length:	0.95-70 m (3.1-230 ft)
Sheath diameter:	¾-in. (standard), 1-in. (always with WLS)
Top fitting:	Steel pipe with M25 x 1.5 or 1/2-in. BSP thread. Thread length 253 mm (10.0 in.)
Tank opening:	Min. ø 2-in. (50.8 mm)
Outer material:	Stainless steel, AISI 316
Flange (option):	1½ to 4 in.
Lead wire length:	3 m (9.8 ft). Longer wires optional, max 10 m (32.8 ft)
No of wires:	3 independent wires per element or 1 wire per element plus 2 common return wires
Bottom weight:	2.5-15 kg (5.5-33 lbs). 2.5-4 kg (5.5-9 lbs) for still-pipe installation
Connection to Rex system:	Max. 14 elements via DAU, or max 6 elements with common return directly to Rex Gauge (max. 3 elements with independent wires)
Hazardous location certifications:	MST:  II 1G Ex ia IIC T2/T4. T4 for standard temperature range Cryo:  II 1G Ex ia IIC T5
Designed according to:	IEC 751 and ATEX Directive 94/9/EC

Technical Data for Single Spot Temperature Sensor – LPG tanks

Element type:	Pt-100, 1/6 DIN Class B or optional 1/10 DIN Class B, 3 wire
Temperature range (standard):	-50 to 260 °C (-58 to 500 °F)
Temperature range (optional):	-50 to 400 °C (-58 to 752 °F)
Sheath:	8 mm (0.31 in.), 9 mm (0.35 in.) or 11 mm (0.43 in.) outer diameter
Sheath material:	Stainless steel AISI 316TI
Mounting thread:	½-in. NPT or BSP thread
Length (standard):	500 mm (20 in.)
Thermowell:	16 mm (0.63 in.) outer diameter as standard
Thermowell material:	Stainless steel AISI 316TI
Designed according to:	IEC 751 and ATEX Directive 94/9/EC

TankRadar Rex

Water interface measurement

The capacitive Water Level Sensor (WLS) continuously measures free water level below the oil surface and provides input for on-line net inventory. The sensor is integrated with the MST, see page 23. It has a heavy duty design with no moving parts. The WLS output is an analog 4-20 mA signal, which is connected directly to a radar gauge. There is a Pt-100 temperature sensor inside the probe allowing temperature measurements at low levels. The WLS is welded to the MST to get a hermetic design. The open model WLS is suitable for crude oil applications and the closed model is suitable for lighter fuels such as diesel oil etc.

A junction box can be integrated with the WLS.

Offset calibration can be done via HART communication.

Technical Data for WLS

Open model:	Suitable for crude oil applications
Closed model:	Suitable for lighter fuels such as diesel oil
Active measuring range:	500 mm (20 in.), or 1000 mm (40 in.) Optional: 1500 mm (60 in.)
Output analog:	2-wire, 4 - 20 mA with $I_{max} = 23$ mA
Accuracy:	± 2 mm (0.08 in.), 500 mm active length ± 4 mm (0.16 in.), 1000 mm active length
Factory calibration:	Calibrated under conditions $\epsilon_r = 2.3$ (diesel) via 2 wire loop (Other calibrations on request)
Operating temperature:	0 - 120 °C (32 to 250 °F) Maximum temperature at flange is 80 °C (180 °F)
Mechanical dimensions:	Connection thread M33x1.5 mm
Length of WLS:	Active length + 140 mm (5.5 in.)
Outer diameter of WLS:	Closed, $\varnothing 38$ mm (1.5 in.) Open, $\varnothing 48$ mm (1.9 in.)
Immersed materials:	AISI 316, FEP, PTFE and PEEK with 30% glass
Max. pressure:	6 bar (90 psig)
Hazardous location certifications:	ATEX: $\text{Ex II 1G Ex ia IIC T4}$ IECEX: Ex ia IIB T4 FM/FM-C: Class I, Div 1, Groups C&D, Class I, Zone 0, Group IIB T4

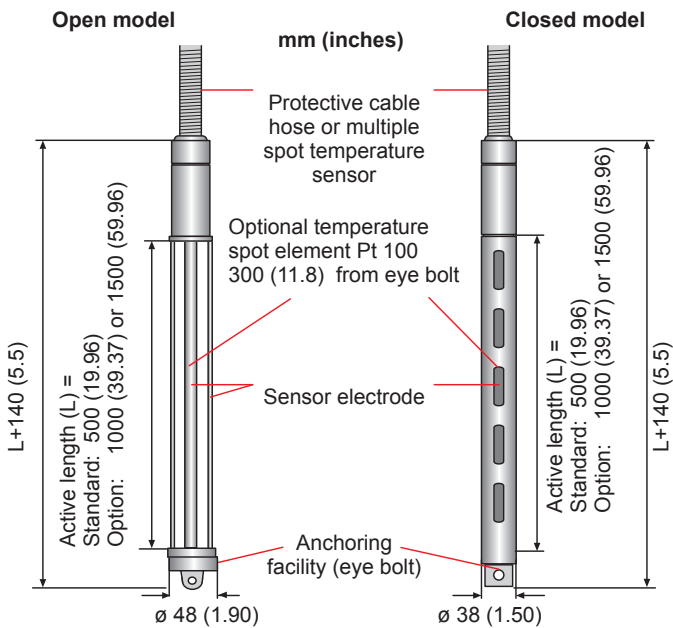

A typical application:

The WLS is installed together with an MST to be hung from the top of the tank. The vertical position is chosen according to the actual bottom water range. The WLS should be anchored to the tank bottom to ensure a fixed position in case of turbulence. To get the active part of the sensor even closer to the bottom, it is possible to remove the eye bolt and instead use a top weight for stabilization.

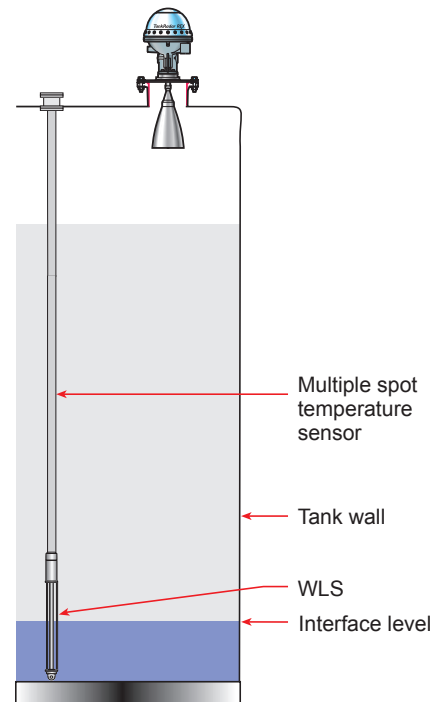
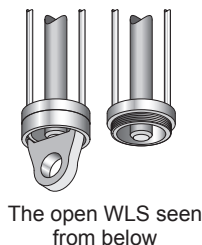

An anchoring weight can be mounted in the bottom eye bolt or above the WLS in which case the weight is hollow and fitted on the MST.

Technical Description

703010En, Ed. 5, Rev B

November 2012

Data Acquisition Unit, DAU 2100

DAU 2100 is used together with an associated radar level gauge for local read-out and for connection of temperature sensors.

A multiple spot temperature sensor with up to 14 temperature elements can be connected to the DAU. The unit is powered from, and communicates through the radar gauge to which it is connected. The DAU is intrinsically safe using zener barriers on the Transmitter Interface Card (TIC) in the gauge.

The weatherproof box houses a printed circuit board with a cable terminal for connection of the temperature sensors, as well as the power and communication cable. Cable glands are located at the bottom of the box.

Local Read-out

The DAU can be equipped with a read-out display showing level, temperature and other measured values. With the DAU placed at the foot of the tank, these values can be viewed at the tank without having to climb to the tank top.

If required, the DAU can also be placed at the tank top.



The DAU with local read-out display mounted at the foot of a tank.

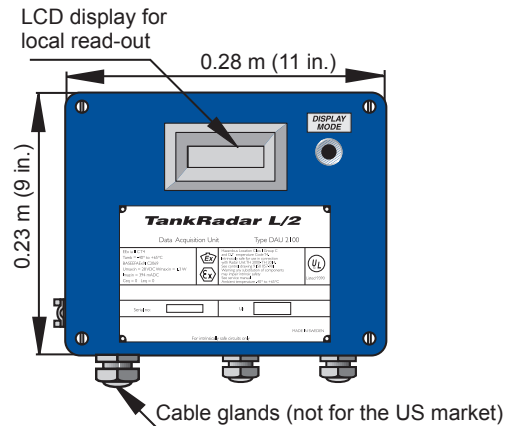

Technical Data for DAU 2100

Ambient operating temperature:	-40 °C to 70 °C (-40 °F to +158 °F)
Number of sensor elements:	Max. 14 per DAU
Temperature ranges:	Range 1: -50 to 125 °C (-58 to 257 °F) Range 2: -50 to 300 °C (-58 to 572 °F) Range 3: -200 to +150 °C (-330 to 302 °F) Note: Temperature range for PTB approval is -20 to +90 °C (-4 to +194 °F)
Temperature resolution:	0.1 °C (0.18 °F)
Accuracy (excl. sensor):	±0.2 °C (±0.36 °F), for temperature range -20 to 100 °C (-4 to 212 °F) ±0.5 °C (±0.9 °F), for other ranges
Sensor elements:	Pt-100 single or multiple spot
Display (optional):	LCD with 6 digits
Available data on display:	Level, Ullage, Spot Temperature, Average Temperature, Level Rate, Signal Strength
Ingress protection:	IP 66 & 67
Hazardous location certifications:	ATEX: Ex II 1G Ex ia IIB T4 Ga (T_{amb} : -40 °C to +65 °C) IECEX: Ex ia IIB T4 (T_{amb} : -40 °C to +65 °C) UL/UL-C: Class I, Div 1, Groups C&D See also the list on page 46, "Certificates"
Power supply:	Intrinsically safe supply from gauge
Field bus:	Intrinsically safe local line from gauge

TankRadar Rex

Remote Display Unit, RDU 40

RDU 40 is a robust display unit for outdoor use in hazardous area. If the number of temperature elements per tank is 6 or less, the RDU 40 is the most cost-effective solution for field display. In this case the temperature elements can be connected directly to the radar level gauge without using a Data Acquisition Unit (DAU). The display functions are software controlled by the connected TankRadar gauge. It is easy to work with via the 4-key display keyboard. Each screen view can display 7 text lines with 16 characters per line.

The RDU 40 is connected by a 3-wire cable up to 100 m (330 ft) from the RTG. Up to two units can be connected to one TankRadar Rex gauge. It displays calculated data, such as level, average temperature, volume, signal strength, etc. The data can be displayed in lists or as single values in very easily readable 25 mm (1 inch) solid fonts. The operator can set up a user-defined window where the most useful information is presented. This window will be shown as the default view. The RDU 40 can view up to six spot temperature elements connected to a TankRadar Rex gauge.



The rugged design of the RDU 40 makes it withstand many years of outdoor use under harsh environmental conditions.

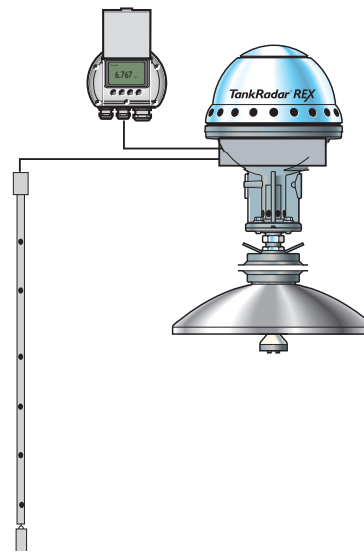

The RDU is connected to the TankRadar Rex gauge.

Technical Data for RDU 40

View/software:	Available data:	Level, Ullage, Spot Temperature , Average Temperature, Volume, Level Rate, Signal Strength
Electrical:	Display type: Ambient temperature: Hazardous location certifications:	LCD display, 128 x 64 pixels -20 to 55 °C (-4 to 130 °F) ATEX: Ex II 2 G Ex ib IIC T4 Gb IECEX: Ex ib IIC T4 Gb FM: Class I, Div 1, Groups A, B, C&D (T _a -40 to +70 °C)
	Max cable length:	100 m (328 ft), total length if two units are connected to the same gauge
Mechanical:	Material housing: Dimensions (widthxheightxdepth): Weight: Cable entry:	Die cast aluminium 150 x 120 x 70 mm (6 x 4 x 3 inch) 1.2 kg (2.6 lbs) 2 x M20, cable diameter 7-14 mm (specified in order) 1x M25, cable diameter 9-18 mm (specified in order)
	Optional: Ingress protection:	½-inch NPT and ¾-inch NPT by external adapters IP 66 & 67

Technical Description

703010En, Ed. 5, Rev B

November 2012

Field Communication Unit, FCU 2160

The Field Communication Unit (FCU) is a data concentrator that continuously polls data from field devices such as radar level gauges, Data Acquisition Units and Remote Display Units and stores values in a buffer memory. Whenever a request for data is received, the FCU can immediately send data from a group of tanks from the updated buffer memory.

The FCU acts as a slave on the group bus and as a master on the field bus. The unit has six communication ports. These ports can be individually configured as either group bus ports or as field bus ports according to one of the alternatives below:

Alternative	No. of field bus ports	No. of group bus ports
1	4	2
2	3	3
3	2	4

An interface board can be connected for each communication port. These boards can be either FCM boards for the TRL2 Bus or FCI boards for RS485 communication. Two group bus ports can also be configured as RS232 by connecting a jumper connector instead of an FCM or FCI board. As standard the Field Communication Unit is delivered with six FCM boards and two RS232 jumper connectors.

Each device has an individual address on the field bus except for the RDU 40 which uses the same address as the RTG it is connected to.

Two FCU:s can be connected in parallel with one unit operational and one working as "hot" redundant backup for the other. The units are software monitored and the backup unit is automatically triggered and activated in case of primary unit failure. See page 41 for more information.

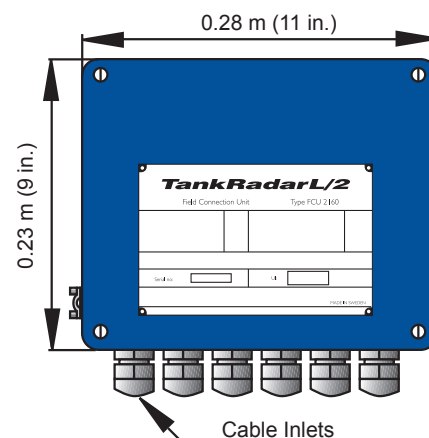
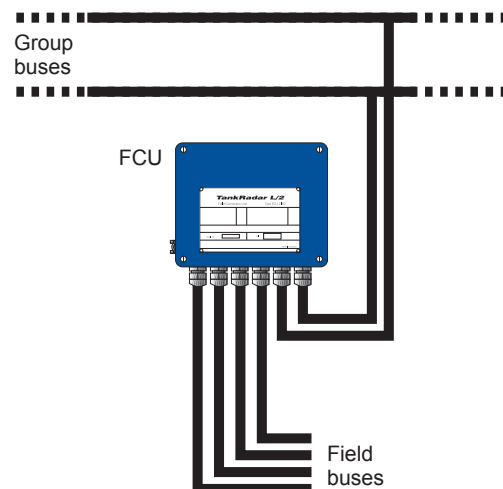

FCU 2160 Field Communication Unit.

TankRadar Rex

Technical Data for FCU 2160

Explosion protection:	None	
Ambient operating temperature:	-40 to 70 °C (-40 to 158 °F)	
Power supply:	115 or 230 VAC, +10% to -15%, 50-60 Hz, max. 10 W	
Ingress protection:	IP 65	
Communication:	Field bus ports:	TRL2 Bus with Modbus protocol
	Number of RTG:s per field bus port:	Max 8 is recommended
	Group bus ports:	TRL2 Bus, RS232 or RS485 with Modbus protocol
	Group bus baud rate:	Programmable up to 19 200 Baud
	Host communication via group bus ports:	Various protocols available, see page 44
Number of tanks per FCU:	Max 32 (max 8 per field bus is recommended)	



The FCU works as a data concentrator for a group of tanks ensuring fast data communication from the tanks to the control room.

Technical Description

703010En, Ed. 5, Rev B

November 2012

TankRadar Rex

Field Bus Modem, FBM 2180

The FBM 2180 is used for connecting a TankMaster PC to the TRL2 Bus.

The FBM 2180 is connected to the PC using either the RS232 or the USB interface (TankMaster version 4.F1 or higher required for the USB interface functionality), and has LEDs indicating power-on and communication. For the TRL2 interface, there are front panel switches to set gain and termination if required. FBM 2170 and FBM 2171 can easily be replaced by the FBM 2180 in existing installations.

Installation of the FBM 2180 is performed using the mounting kit included in all deliveries. This kit enables fitting of the FBM 2180 to a standard DIN rail.

The Field Bus Modem is delivered with cables for RS232 and USB connection to the PC. The USB cable also supplies power to the FBM 2180. A separate power supply cable (included in delivery) is only necessary for the RS232 option.



Technical Data for FBM 2180

Explosion protection: None

Power supply (only used for RS232): AC/DC converter supplied for Rosemount TankRadar products (7-12 V, 50 mA)

Cable to PC: RS232, USB: 3 m (10 ft)
Included in delivery

Field bus over voltage protection: Galvanic insulation, and transient suppressors

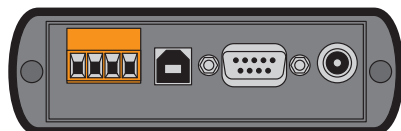
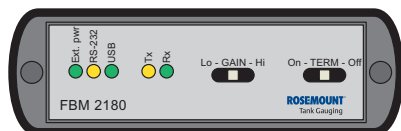

FBM 2180 Field Bus Modem.

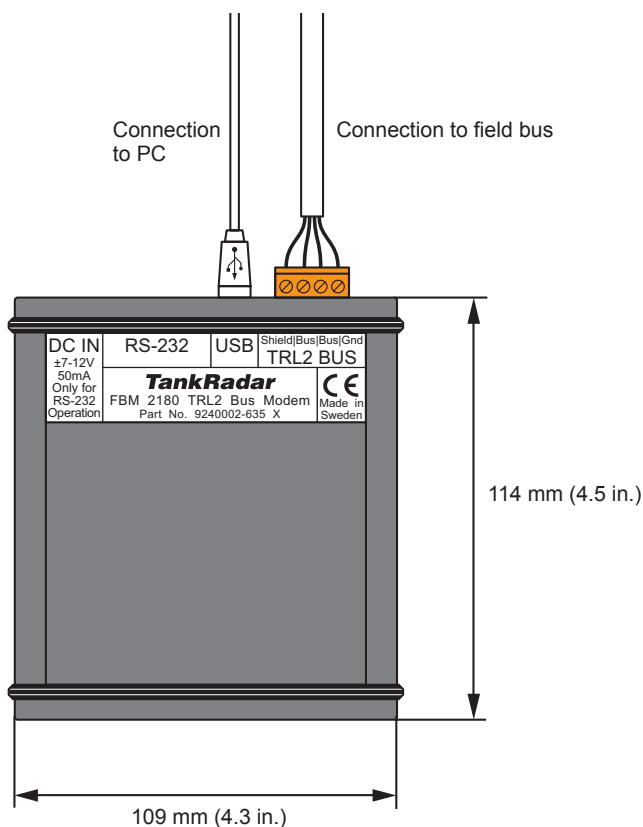

TankRadar Rex

Junction Boxes

As optional equipment a series of junction boxes can be delivered with the TankRadar Rex system. These are used to connect the various system units. (The junction box integrated in the Transmitter Head is described on page 16.)

JB 140-11 and JB 140-15 for EEx e and EEx i environments

JB 140-11 (EEx e) is used to connect power and the TRL2 Bus to the RTG.

JB 140-15 (EEx i) is used when a DAU or an RDU 40 is located more than 2 m away from the RTG and should only be used for intrinsically safe connections.

JB 140-15 has six openings for M25 glands and JB 140-11 has five openings for M25 glands, all suitable for 9-16 mm cable diameter.

Note: JB 140-11 is not an approved protection on all markets.

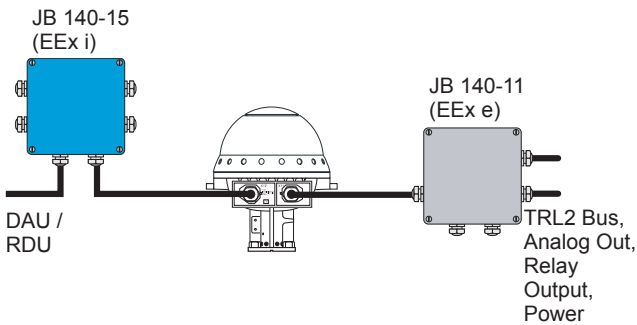

Junction boxes for EEx e and EEx i environments.

JB 36 and JB42 for connection of temperature sensors

JB 36 and JB42 are used for intrinsically safe connection of up to 14 temperature sensors to a Data Acquisition Unit (12 for JB 36 if 3-wire connection is used).

JB 36 and JB42 have three openings for M25 glands, suitable for 9-16 mm cable diameter.

There are two alternative connections of temperature sensors to the Junction Box:

- Connection via cable
- Direct connection

If the DAU is situated on the tank top, temperature sensors can be connected directly to the DAU.

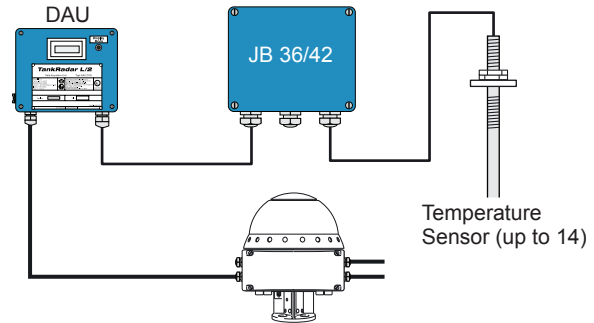

Junction box for connection of temperature sensors via cable.

Junction Box Integrated with Temperature Sensor or Water Level Sensor

There is also a Junction Box available which can be integrated with the temperature sensor or water level sensor.

Junction Boxes with Conduit Outlets

In the US wires from the transmitter head must be enclosed in a protective steel braided hose.

Further connection to conduit pipes requires an explosion proof Junction Box with L or T-shaped outlets, both variants available with 12 or 15-pin terminal blocks for wiring.

The three-foot hose, EXP-FLEX, and Junction Boxes (GUA-L and GUA-T) can be supplied together with the Rex gauge.

The Junction Box can be installed directly on the transmitter head by using a suitable adapter with 3/4-inch male fitting facing the transmitter head outputs.

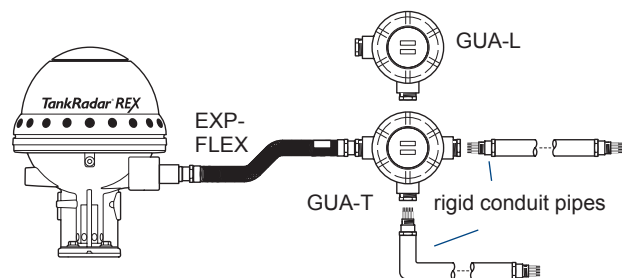

Connection to rigid pipes via a Junction Box with conduit outlets.

TankMaster HMI software

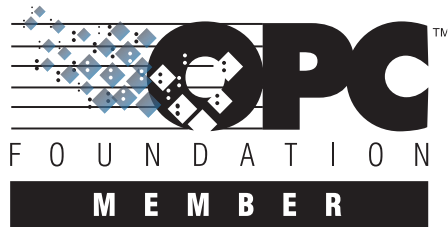

TankMaster is a powerful Windows-based Human Machine Interface (HMI) for complete tank inventory management. It provides configuration, service and set up, inventory and custody transfer functions for TankRadar Rex systems. All calculations are based on current API and ISO standards.

TankMaster follows the OPC standard and can communicate with Microsoft programs and OPC compatible systems like DeltaV, ABB, Intellution's iFIX and Wonderware's InTouch.

TankMaster has customized views with graphic plant layouts, and advanced group configuration in geographical or product groups etc.

TankMaster includes a user manager with different access levels for personnel.

TankMaster consists of two main software modules:

- WinSetup is the software package used for configuration of the total Rex system. The WinSetup package is included with all TankRadar Rex deliveries as a set-up and configuration tool (other functions are options depending on which package is used)
- WinOpi is a complete inventory software package

TankMaster has a set-up wizard for interactive configuration and installation.

TankMaster is easily translated to other languages than English.

Inventory and custody transfer functions

- Real time tank gauging data such as level, temperature, water interface level and pressure
- Real time, gross and net volume inventory calculations based on API and ISO
- Hybrid tank gauging with pressure inputs giving data for density and mass calculation
- Metrologically sealed data
- API calculator
- Batch Handling makes it possible to control and follow transferred volumes, from the control room

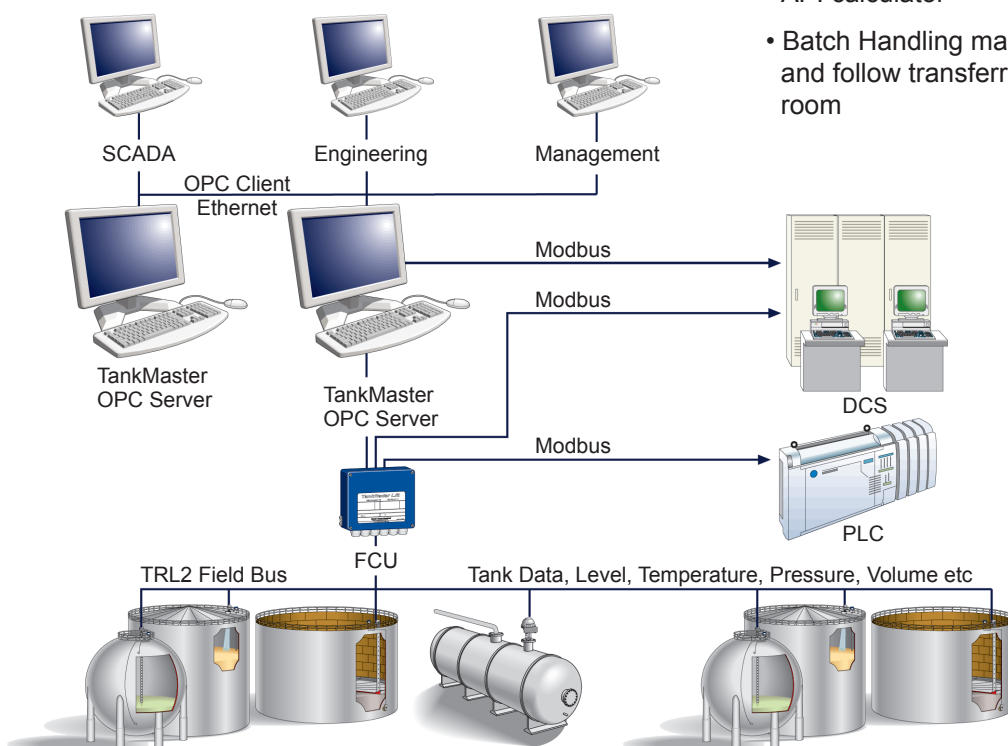

TankMaster distributes essential inventory tank gauging data.

TankRadar Rex

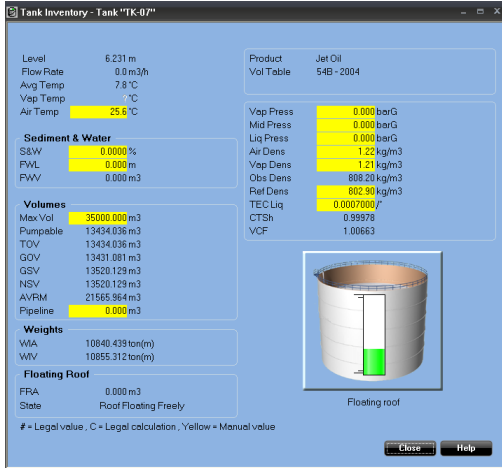

TankMaster gives the most important inventory data for a specific tank in one easy-to-read window.

Networking and interfacing

- OPC server with browser for easy interface with other plant computer systems
- Full network capabilities
- SCADA / DCS communication via MODBUS
- SCADA / DCS communication via OPC
- Integration with other tank gauging systems by taking in and displaying data from other vendors' gauges

Reports and data sampling

- Batch report for internal and external transfers.
- Customized Reports to Microsoft Office programs
- Automatic reports
- Reports via e-mail
- Audit log for events
- Historical data sampling

Alarms

- Reliable alarm handling of measured values with high, high-high, low and low-low level alarms
- Alarms to mobile phones
- Alarms via e-mail
- Leakage alarms based on net volume

Emulation

TankMaster supports a wide range of protocols for gauge and control room emulation. See pages 15, 45 and 48.

TankMaster hydrostatic tank gauging

The TankMaster HTG system is an intelligent direct mass measuring system which uses product hydrostatic pressure measurement to derive both the specific gravity and liquid level. See TankMaster HTG Technical Description for more information.

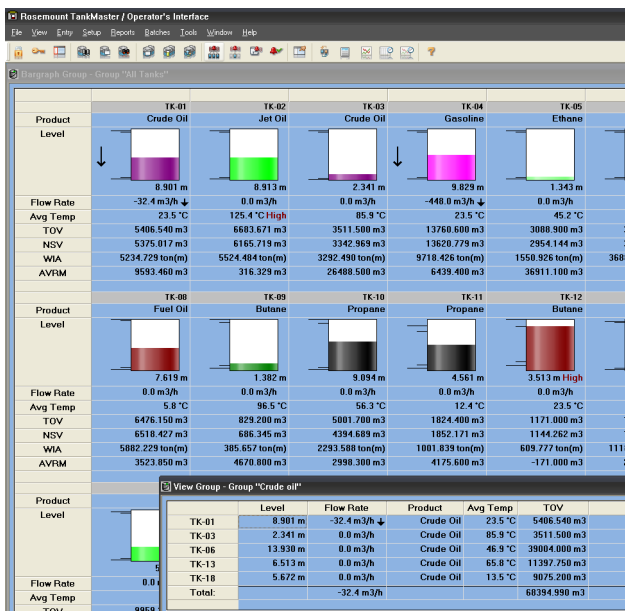

You can easily organize the tanks in e.g. geographical or product groups, with associated sub-groups. For example you can choose to see the actual tank gauging and inventory data in a bargraph group, giving a quick overview of tank farm activity.

Technical Description

703010En, Ed. 5, Rev B

November 2012

TankRadar Rex

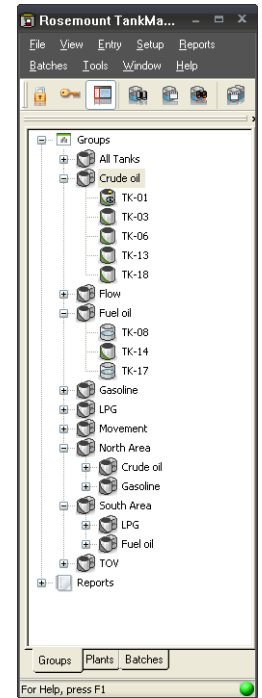
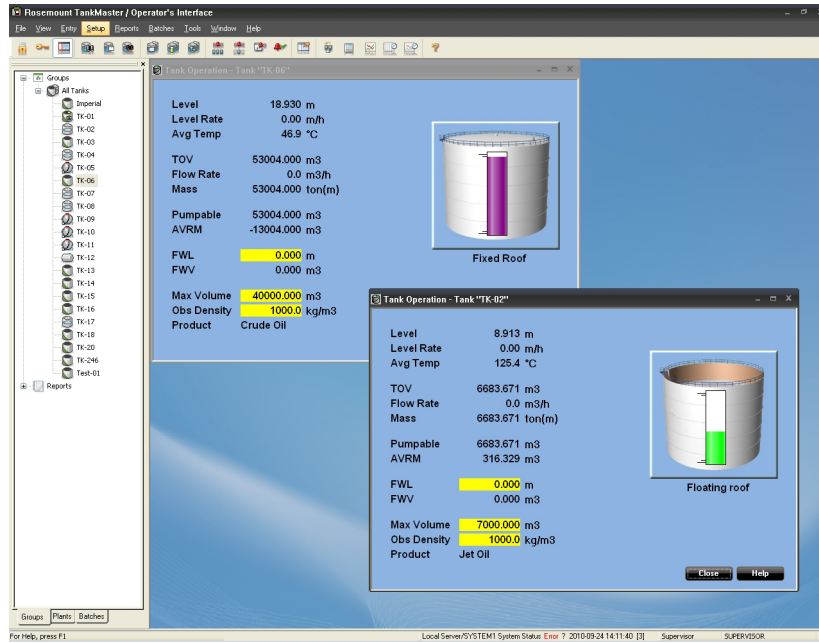

The "tank farm explorer" makes it easy to navigate in TankMaster. It is possible to expand and minimize fields and get direct group and tank access by double-clicking the specific group or tank icon.

TankRadar Rex

Technical data for TankMaster WinOpi, WinSetup, and WinView

Operating system requirements:	English version of any of the following: <ul style="list-style-type: none"> • Windows XP Professional, 32-bit version with service pack 3 (SP 3) • Windows Vista, 32-bit version with service pack 1 (SP 1) • Windows 7 Professional, 32- and 64-bit versions, with service pack 1 (SP 1) • Windows Server 2003 Standard, 32-bit version with service pack 2 (SP 2) • Windows Server 2008 Standard, 32- and 64-bit versions, with service pack 2 (SP 2)
---------------------------------------	--

TankMaster PC hardware requirements

Processor:	Windows XP: 2 GHz multi-core processor Windows Vista / Windows 7 / Windows 2003 Server / Windows 2008 Server: 2.5 GHz, multi-core processor
RAM memory:	Windows XP: 1 GB for client PCs, and 2 GB for server PCs Windows Vista / Windows 7 / Windows 2003 Server / Windows 2008 Server: 3 GB
Disk drive:	40 GB (TankMaster combined with SQL Server 2005 Express, needs approximately 600 MB)
Graphics card:	1152*864 pixels, 65536 colors (16 bit)
Serial port:	RS232, or USB if FBM 2180 is used
Hardware key:	The server needs one USB port for the hardware key. If TankMaster is ordered with custody transfer functions, a parallel port is also required

Technical data for TankMaster.net

Operating system:	English version of: <ul style="list-style-type: none"> • Windows XP Professional, 32-bit version with service pack 3 (SP 3) • Windows Vista Business, 32-bit version with service pack 2 (SP 2) • Windows 7 Professional, 32-bit version with service pack 1 (SP 1) • Windows Server 2008 Standard, 32-bit version with service pack 2 (SP 2) Installation of Internet Information Services (IIS) is recommended for TankMaster.net servers
--------------------------	---

Server PC hardware requirements

Processor:	1.8 GHz (single processor) or better
RAM memory:	256 MB (1024 MB recommended)
Disk drive:	20 GB
Graphics card:	1152*864 pixels, 65536 colors (16 bit)
Bandwidth to each TankMaster PC:	20 kbps for each connected tank
Internet bandwidth:	64 kbps (256 kbps recommended)

Client PC hardware requirements

Processor:	1.3 GHz (single processor) or better
RAM memory:	256 MB (1024 MB recommended)
Disk drive:	20 GB
Graphics card:	1152*864 pixels, 65536 colors (16 bit)
Network connection:	LAN or internet
Internet bandwidth:	64 kbps (256 kbps recommended)

Required TankMaster.net client Palm or phone hardware

Network connection:	WAP 2.0, internet connectivity
----------------------------	--------------------------------

TankMaster I/O Terminals

The I/O Terminals can be used for communication between TankMaster and field equipment, for a more versatile system. The four versions are:

- IOT 5110 for Analog Inputs
- IOT 5120 for Analog Outputs
- IOT 5130 for Digital Inputs
- IOT 5140 for Digital Outputs

The analog inputs open up TankMaster for all 4-20 mA devices, such as pressure and temperature sensors.

The analog outputs enable mapping of values to analog indicators.

The digital inputs can for example be used to display alarms from external equipment in TankMaster.

The digital outputs can be used for alarm panels, horns, signal lamps etc.

The I/O terminals are complements to the TankMaster system, and are not designed to be used as stand-alone devices for critical operations.

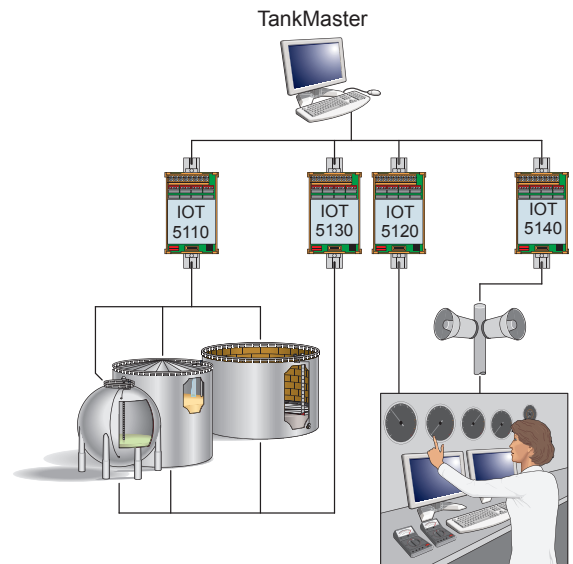

Technical Data for TankMaster IOT 5110-5140

Communication type:	RS485
Communication speed:	115 kbit/s
Isolation:	Opto-coupled (in I/O box)
Terminal size:	160x100x80 mm (6.3x3.9x3.2 in.)
Mounting method:	DIN rail 35 mm (1.4 in.) clip
Supply voltage:	24 VDC
Approved environment:	0 to + 55 °C (0 to +130 °F)

IOT 5110 Analog In; 4-20 mA, 0-10 V

Channels:	16 single ended
Input load:	50 Ω (current), 10 k Ω (voltage)
Accuracy (current and voltage):	Max ± 0.5 % of full range
Temperature drift (current and voltage):	Accuracy valid for 0 to + 55 °C (0 to +130 °F)

IOT 5120 Analog Out; 4-20 mA, 0-10 V

Channels:	16 single ended
Load impedance:	50 Ω / max 500 Ω
Load current:	< 5 mA for 0-10 VDC
Accuracy (current):	Max ± 0.5 % of full range
Accuracy (voltage):	Max ± 0.2 % of full range
Temperature drift (current and voltage):	Accuracy valid for 0 to + 55 °C (0 to +130 °F)

IOT 5130 Digital In

Channels:	16 negative common
Voltage range input:	0 to +35 VDC
Source type:	Potential free contact
Input current:	Max 0.6 mA

IOT 5140 Digital Out

Channels:	8 pot free SPDT
Capacity:	Max 250 VAC, 2A

TankRadar Rex

Tank inventory and density through hybrid calculations in the Rex system

The TankRadar Rex gauge, with its high capacity signal processor is designed to make basic inventory calculations directly in the gauge.

The gauge can receive and process signals from analog and digital pressure transmitters, water bottom sensors etc. Measured data is transmitted on the field bus and can be further processed in the control room by the TankMaster PC software or by the plant's host computer/DCS system.

Density measurement with pressure transmitters

When the RTG is connected with a pressure transmitter near the bottom of the tank, the density of the product can be calculated and presented on-line. The accuracy of the density calculation largely depends on the accuracy of the pressure transmitter. TankRadar Rex can interface to any pressure transmitter with a standard output of 4-20 mA or HART. The 4-20 mA signal is converted from analog to digital form in the RTG.

The gauge calculates (or receives inputs for) the following data:

- Total Observed Volume (TOV) using the tank strapping table (100 strapping points)
- Observed density (if pressure sensor connected)
- Level (corrected for thermal tank wall expansion)
- Temperature
- Oil/Water interface level

Data is calculated according to updated API and ISO standards. Temperature calculations include API algorithms to handle elements close to the bottom. The level value is software corrected for changes in tank reference height.

Both metric and USA/UK units are supported.

If very high accuracy net volume calculations (up to 5000 strapping points) are required, the TankMaster PC software package is used. Normally less than 100 points per tank are necessary for 1 liter accuracy.

TankMaster is using quadratic interpolation for spheres and horizontal cylinders, which increases volume accuracy and reduces number of strapping points.

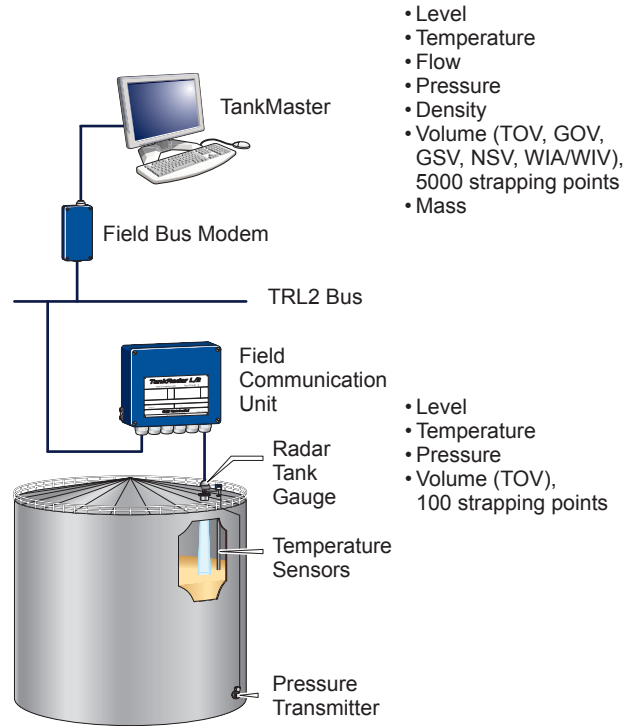

- Level
- Temperature
- Flow
- Pressure
- Density
- Volume (TOV, GOV, GSV, NSV, WIA/WIV), 5000 strapping points
- Mass

- Level
- Temperature
- Pressure
- Volume (TOV), 100 strapping points

By complementing the level measurement with temperature and pressure measurement, the density and volume of the product in the tank can be continuously calculated and provided on-line.

TankRadar Rex System Configurations

The TankRadar Rex system can be applied to a single tank or to large and very complex systems. All system configurations are based on the same basic parts.

The TRL2 Bus - A fast and reliable data bus

In the descriptions below the TRL2 Bus is divided into two parts:

- Group bus
- Field bus

Both buses work in the same way with the same technical specifications. However, the Group Bus is defined as the TRL2 Bus between the TankMaster/ host computer (DCS) and the FCU:s, while the field buses connect the DAU:s, RDU:s and the RTG:s with the FCU:s.

TankMaster communicates on the TRL2 Bus via a Field Bus Modem. The Field Bus Modem translates the signals from RS232 to TRL2 Bus and vice versa.

The TRL2 Bus was developed to minimize the updating times as well as to provide a robust and reliable field bus for transferring the measured values from the tanks to the control room.

Each Field Communication Unit continuously collects data from up to four TRL2 field buses and stores the values in a buffer memory. When a query reaches the Field Communication Unit from the TankMaster or from a plant host computer on the group bus, it can quickly send data directly from the database.

Each device has an individual address on the field bus except for the RDU 40 which uses the same address as the RTG it is connected to.

The recommended maximum number of RTG:s on one field bus is 8 (The maximum number of RTG:s per FCU is 32).

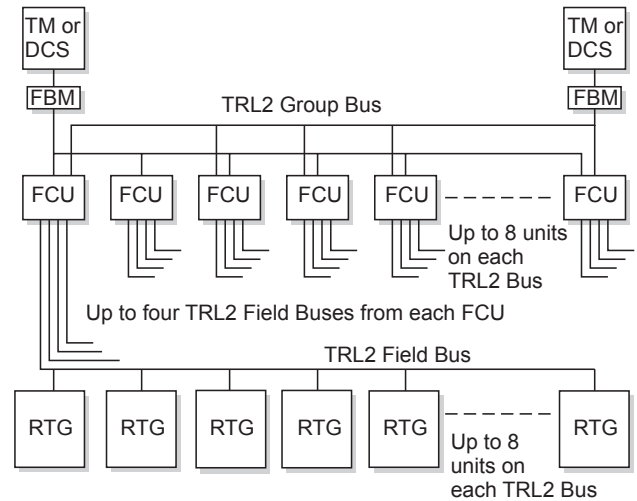

Figure showing how the TRL2 Bus is used in the TankRadar Rex system.

Technical Data for TRL2 field bus

Number of units:	Max 8 RTG:s with associated DAU 2100 units or RDU:s are recommended on one TRL2 Bus (see also next page)
Cable:	Twisted and shielded pair
Cable area:	Min 0.50 mm ² AWG 20
Cable length:	Max 4 km (2.5 miles)
Modulation type:	FSK (frequency shift keyed), half duplex

TankRadar Rex

Stand-Alone Application

A stand-alone Radar Tank Gauge can be used to measure on a single tank. The measured level is output on the field bus or as an analog 4-20 mA signal. The RTG can also include 4-20 mA inputs or temperature inputs.

A DAU 2100 or an RDU can be connected to the stand-alone gauge.

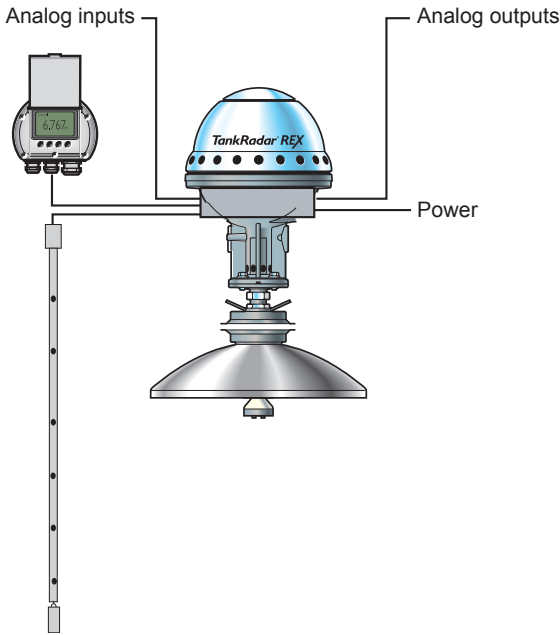

In a stand-alone configuration the analog output can be used to connect an analog display. If connecting a DAU 2100 or the RDU 40, all measured values can be displayed.

Systems with a TankMaster Work Station

The TankMaster PC can be connected via RS232 directly (without a Field Bus Modem) to one Field Communication Unit if the FCU is placed close to the PC. If more than one FCU is used, FBM:s or RS485 communication is required.

Normally the Field Bus Modem, FBM, is connected to the TankMaster PC. The FBM is then connected to the FCU and uses the TRL2 Bus. The FCU does not need to be close to the TankMaster PC in this case.

Both communication ports of the TankMaster can be used to connect TRL2 group buses.

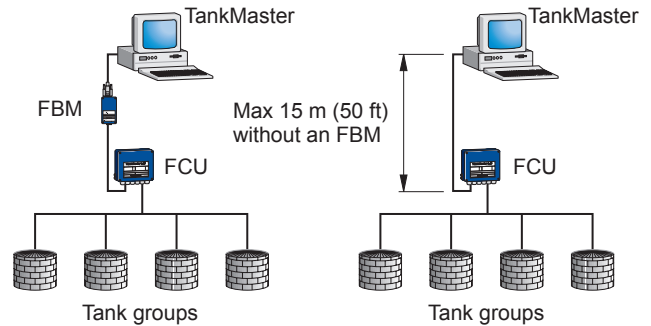

The connection between TankMaster and FCU.

Connecting the Field Communication Unit FCU 2160

The FCU is very flexible. There are six communication ports on the FCU. Normally four of these ports are used for field buses. However, it can have up to four group bus ports.

The FCU can handle up to 32 RTG:s plus associated DAU 2100 units or RDU:s. Each field bus could connect up to 16 RTG:s. However in order to ensure robust data communication maximum 8 RTG:s are recommended per field bus.

To increase the updating speed of the FCU, the number of connected RTG:s should be approximately the same on each field bus connected to one FCU.

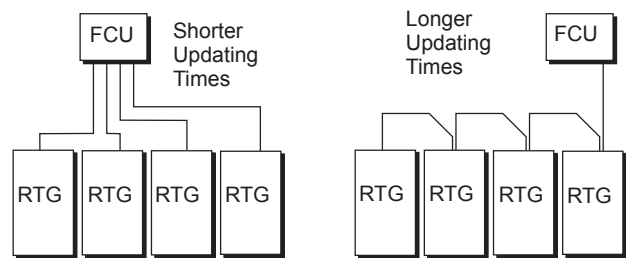

The updating times are improved if the units are evenly spread out on the field buses of the FCU.

Technical Description

703010En, Ed. 5, Rev B

November 2012

Redundancy

In order to reduce the risk of communication failure between the TankMaster/DCS system and the units connected to the TRL2 field bus, redundancy can be made in several ways.

Several Group Buses

An FCU can connect up to four group buses with different masters, like TankMaster PC:s and DCS units, asking the FCU for data.

A system can for example have two TankMaster PC:s connected via two different group buses.

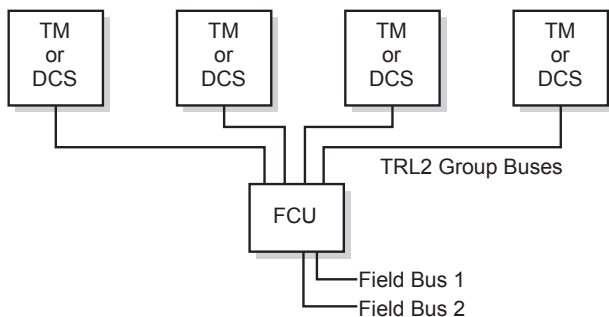

There can be up to four connections to TankMaster (TM) or DCS units on the group bus ports of the FCU.

Redundant FCU:s

Using two FCU:s provides redundancy on both FCU and host computer level. With two FCU:s connected in parallel to the field buses, one of the FCU:s will be configured as the primary FCU and will be in an active state. The other FCU will be in a backup state.

A control signal is sent between the two units. If the backup unit is not receiving this signal, or if the primary unit is having a problem, then the backup unit will take over the active role.

A message is sent to the TankMaster (or DCS) that the primary FCU has failed and that the backup FCU has taken over the communication.

Double FCU:s and workstations

A complete redundancy from control room to RTG:s is achieved by using double FCU:s as well as double TankMaster work stations.

Redundant FCU:s, FBM:s and workstations

With two FBM:s, safe communication between the TankMaster workstation and the FCU is achieved.

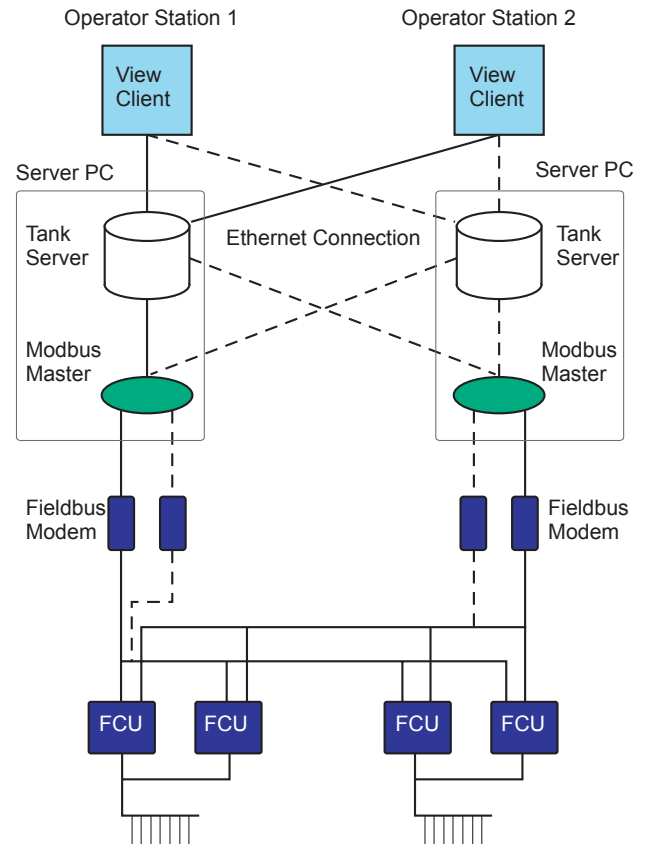

The flexible TankRadar Rex system supports several possible combinations to achieve redundancy, from control room to the different field units and RTG:s.



FCU:s connected to run in parallel provide automatic redundancy. If one unit fails the other will take over the communication.

TankRadar Rex

Smart Wireless Field Network Always Finds a Way to Communicate

A Smart Wireless network can form its own network or join an existing network. A tank gauging system can include both wireless and wired configurations.

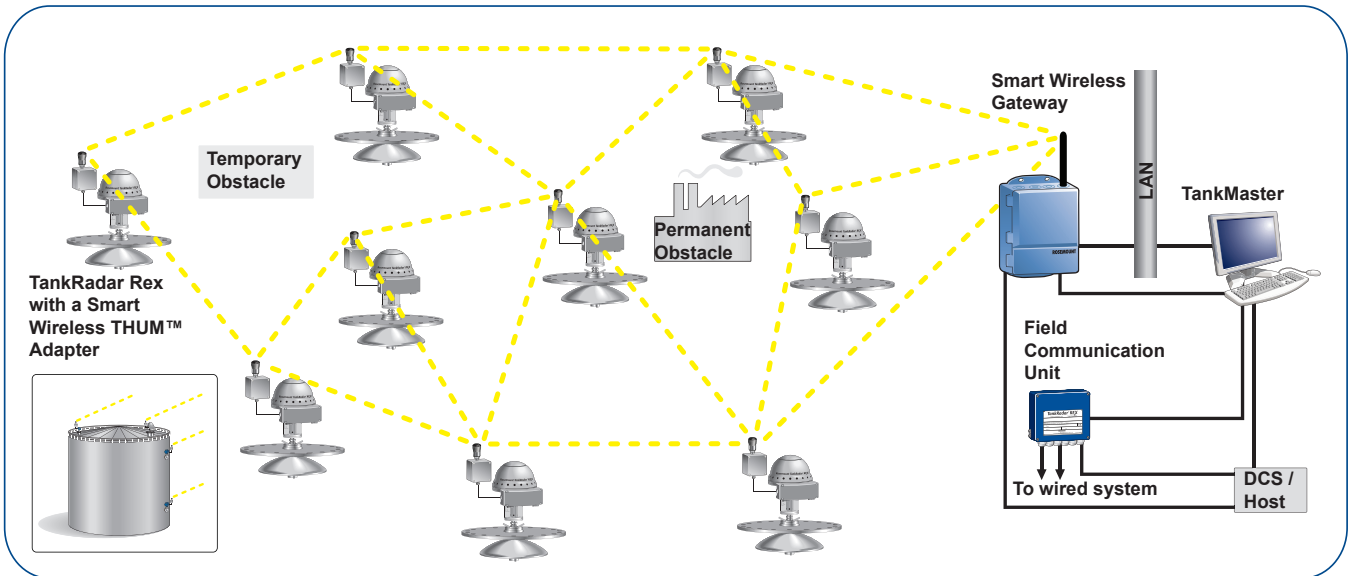

With a Smart Wireless tank gauging system, there is no need for a line-of-sight communication path between nodes. The self-organizing field network automatically finds the best way around any permanent or temporary obstacles.

Technical Description

703010En, Ed. 5, Rev B
November 2012

TankRadar Rex

Example of a General System

The figure below shows an example of a general TankRadar Rex system.

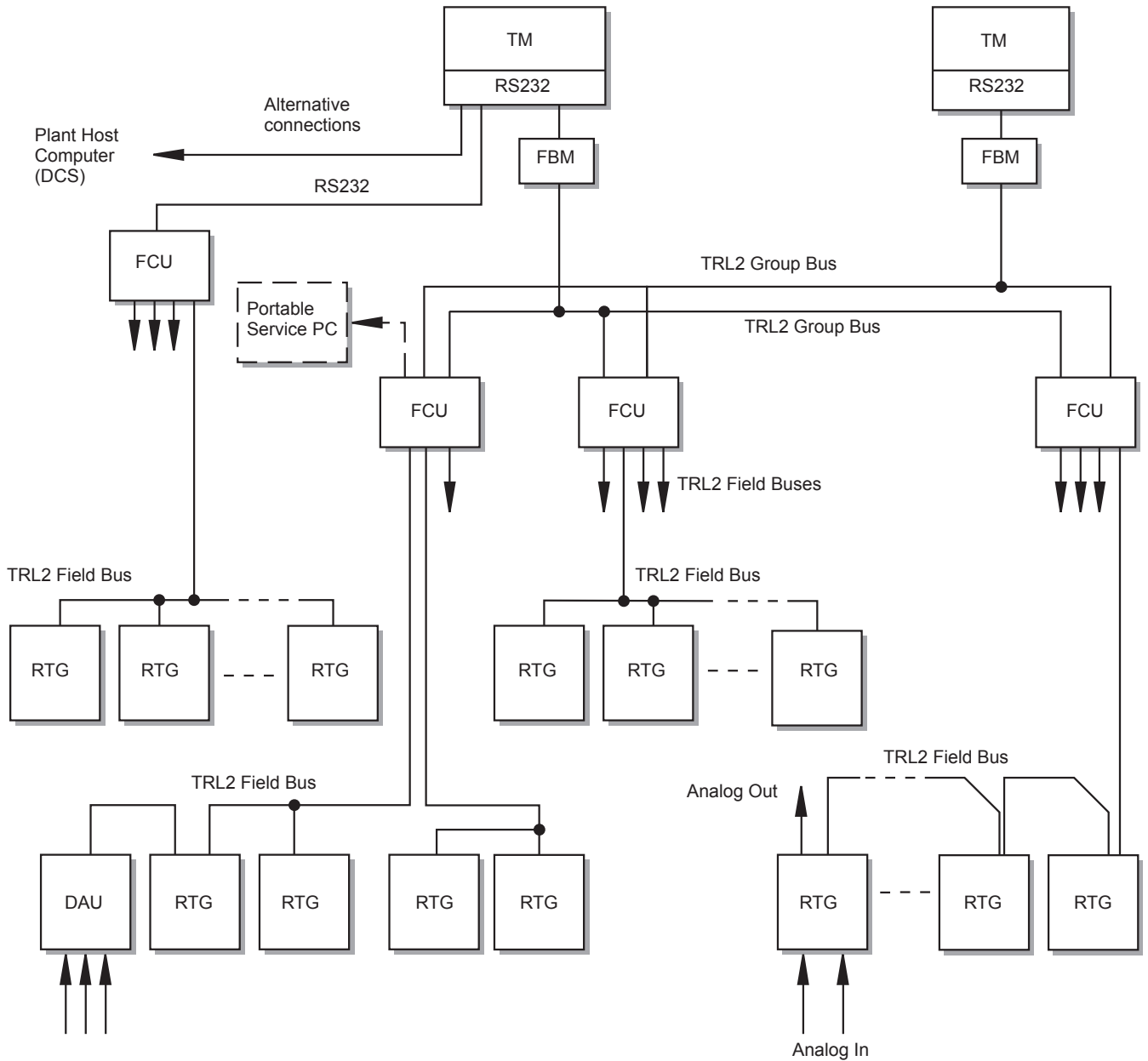

TankRadar Rex

Connection to other systems

The TankRadar Rex system can be connected to all major suppliers of DCS, SCADA systems, plant host computers or terminal automation systems.

The connection can be made in two ways:

- To a TankMaster PC workstation
- Directly to a Field Communication Unit

The advantage of connecting to a TankMaster workstation is that not only the measured values, but also the values calculated by the TankMaster can be communicated.

Examples of available protocols are given below. Certified test reports are available for most of the protocols.

If you require a protocol which is not included in the list, contact Emerson Process Management / Rosemount Tank Gauging as new protocols are developed on a regular basis.

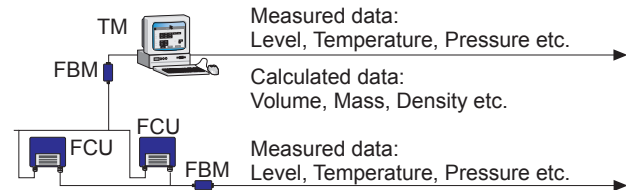

The host computer can be connected either to a TankMaster (TM) PC or directly to the FCU.

Examples of Vendors and Interfaces

Vendor / Application	Interface	Vendor / Application	Interface
ABB	Modbus, OPC	ENRAF	GPU
A-B / CSI TMS	Modbus	Fisher	Modbus
AEG Viewstar	Modbus	Foxboro	Modbus
Allen-Bradley	Data Highway Plus, Modbus	GE Fanuc PLC	Modbus
Asea Master System	Modbus	Honeywell	Modbus, OPC
Bailey	Modbus	Intellution FIX	Modbus, OPC
CSI	Modbus	Rosemount	Modbus
E+H	Modbus, OPC	Siemens CS7 TMS	Modbus
Emerson Dantas	Modbus	Tokyo Keiso / CATAMS	Modbus
Emerson Delta V	Modbus, OPC	Yokogawa Centum CS	Modbus

Communication Protocols

Enraf	GPP, GPU, 45C
GPE	GPE
L&J	TankWay
Motherwell	2800, 4000
Sakura	MDP
Texas Instruments	Tiway
Varec	1800, 1900
Whessoe	WM 500, WM 550
Generic	<ul style="list-style-type: none"> • Analog & Digital I/O • HART • Profibus DP • 4-20 mA

Emulation

The Rosemount Tank Gauging system is compatible with all other major tank gauge vendors. Step-by-step modernization of your current tank gauging system is possible thanks to flexible field and control room solutions.

Gauge Emulation

The TankRadar Rex gauge is designed with an open interface, covering everything from electrical interface and communication protocol to utilization of many different power sources.

This feature makes it possible to replace old mechanical or servo gauges with modern Rex gauges, using existing tank openings, and without having to replace the control system or field cabling – no hot work is required.

The gauge is normally installed with the tank in operation. Simply “plug-and-gauge”.

See section “Radar Tank Gauges” (Technical Data for the Transmitter Head) for information on communication protocols.

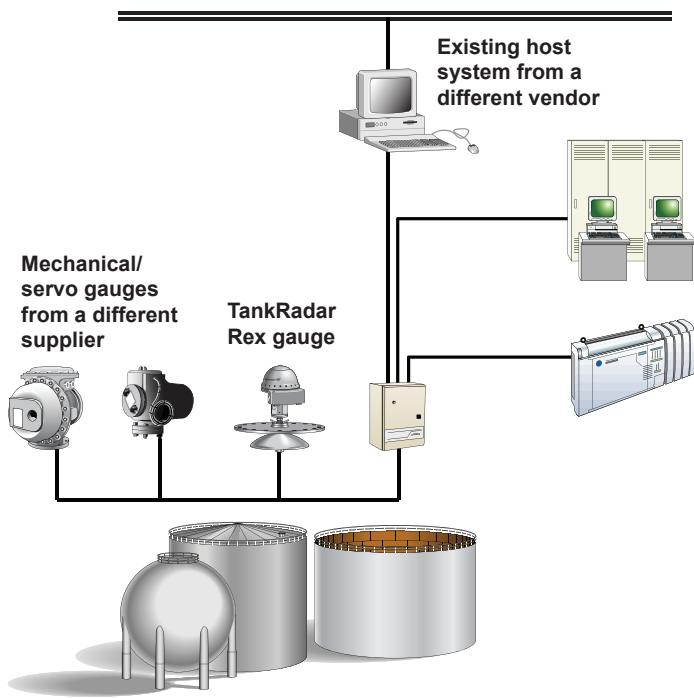

With TankRadar Rex you are no longer stuck with your old system. By replacing old servo gauges, re-calibration and expenses for spare parts and maintenance can be avoided.

Seamless control room connectivity

It is also possible to seamlessly replace other tank management systems with the powerful Rosemount TankMaster software solution.

Data from all types of units is collected and displayed.

The Field Communication Unit allows emulation of different host systems and other control room devices.

Rosemount TankMaster can replace an existing inventory management system, still being able to communicate with the field devices in use.

This solution provides seamless connectivity, problem-free communication with existing field devices, and a lean-and-clean installation.

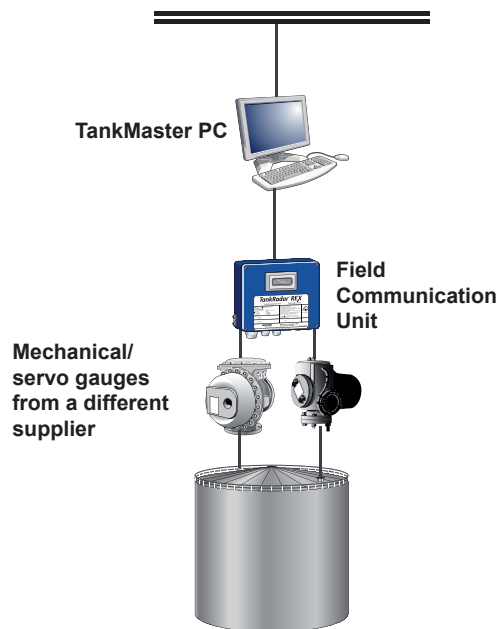

You can replace your old tank monitoring system with Rosemount TankMaster and a Field Communication Unit.

TankRadar Rex

Certificates

The list below includes certificates and approvals for the TankRadar Rex system. It does not give any detailed information on each certificate or approval.

There may be restrictions such that a certificate may be valid for only parts of the system.

Contact Emerson Process Management / Rosemount Tank Gauging if you require more information on any of the certificates.

Accuracy approvals / Legal metrological certificates

- International: OIML R85 (E)
- Germany: PTB
- France: LNE
- Italy: Metric office
- Portugal: IPQ
- The Netherlands: NMI
- Belgium: BMS
- Austria: BEV
- Switzerland: METAS
- Hungary: OMH
- Czech Republic: CMI
- Croatia: DZM
- Serbia/Montenegro: FBMPM
- Romania: BRML
- Poland: GUM
- Estonia: TJI
- Russia, Belarus, Ukraine, Kazakhstan: GOST Standard
- Algeria: ONML
- China: CMI
- India: W&M
- Indonesia: MIGAS
- Malaysia: SIRIM
- Thailand: Thai Excise and Customs
- Bosnia and Herzegovina: MI
- Bulgaria: Measuring Instrument Type Approval Certificate

In addition to the listed accuracy approvals, many countries are presently in the process to define custody transfer requirements.

EX Approvals

- EU: ATEX directive
- International: IEC Ex
- USA: UL
- Canada: C-UL
- Brazil: CEPEL
- Russia, Belarus, Ukraine, Kazakhstan: GOST Standard
- China: CNAACL
- Korea: KOSHA
- Japan: JIS
- India: Nagpur
- TÜV, Austria

Safety Approvals and Acknowledgements

- SIL 2 suitable
- Belgium: Vlare II
- Germany: WHG approval for overfill prevention, tested by TÜV

Emission Approvals

The listed approvals below deal with how much radiated power that is sent out from the radar gauge.

In most countries there are no formulated requirements on equipment like a radar gauge, due to the very low output power and the fact that it is normally installed in a metallic tank.

TankRadar gauges have been tested in accordance with CISPR-22 and CISPR-16.

Technical Description

703010En, Ed. 5, Rev B

November 2012

TankRadar Rex

The certificates listed below are exceptions for specific countries:

- Bundes Ministerium für Post und Telekommunikationen, BMPT, Germany
- Federal Communications Commission, FCC, USA
- Post und Telegraph Direktion, Austria
- Department of Trade and Industry / Radio Communication Agency DTI / RCA, United Kingdom

Miscellaneous Approvals

- SIL 2 Safety Functions
- CE Mark, European Community
- TÜV Overfilling Protection, Germany
- TÜV Pressure Approval, Germany
- TÜV Firesafe Approval, Germany

In addition to the list above, there are a number of certificates or approvals for optional equipment which can be delivered.

Junction boxes, pressure transducers, water interface sensors, etc. have approvals in the name of their manufacturers. Copies of these can be requested from Emerson Process Management / Rosemount Tank Gauging.

Vapor Influence on Radar Measurement

For a few specific products there can be a measurable influence on the level accuracy, if the composition of the vapor varies between no vapor and fully saturated vapor condition. However, there is no noticeable influence, if the vapor variation is small.

For these specific products it is in many cases sufficient that the pressure and temperature is measured. The software in the Radar Tank Gauge then automatically corrects for the influence from

the vapor. This is for example performed when measuring in LPG tanks.

Gases that are known to affect the transmission of radar waves are:

- Propylene oxide
- Ethylether
- Propylether
- Acetaldehyde
- Propionaldehyde
- Isobutyraldehyde
- Acetone
- 2-Butanone
- Methanol

One gas that dampens (or attenuates) the radar signal is ammonia. In applications where ammonia is involved, Emerson Process Management / Rosemount Tank Gauging should always be contacted for evaluation of the application.

Ordering information

If you require other options than listed here, consult your local Rosemount Tank Gauging sales representative.

Radar Tank Gauge (RTG 3900)

Transmitter Head (TH)

Pos	Item	Code	Description	Note
1	Transmitter Head	A	Transmitter Head RTG 3900, ± 0.5 mm instrument accuracy	
		L	Transmitter Head RTG 3900 L, ± 3 mm instrument accuracy ⁽¹⁾	
2	Ex. and Safety Certification	0	None	
		B	Baseefa (ATEX)	
		T	Baseefa (ATEX) + TÜV ⁽²⁾ overfill	
		S	Baseefa (ATEX) + SIL 2 ⁽²⁾	
		U	UL/ULc	
		L	UL/ULc + SIL 2 ⁽²⁾	
		G	Baseefa (ATEX) + Gost (Russia)	
		E	IECEX	
		P	IECEX + TÜV ⁽²⁾ overfill	
		K	IECEX + SIL 2 ⁽²⁾	
3	Accuracy Certification	0	None	
		R	OIML R85 E ⁽³⁾	
		M	BMS ⁽³⁾	Belgium
		N	NMI ⁽³⁾	The Netherlands
		C	PTB Eich ⁽³⁾	Germany
		Q	IPQ ⁽³⁾	Portugal
		L	LNE ⁽³⁾	France
		S	GOSStandard ⁽³⁾	Russia
		A	CMI ⁽³⁾	China
4	Power Supply	S	100-240 VAC	
		A	34-70 VAC / 48-99 VDC	
		L	20-28 VDC	
5	Analog Output (Non-IS)	0	None	
		P	One 4-20 mA, passive. ⁽⁴⁾ Requires external voltage supply.	
		A	One 4-20 mA, active. ⁽⁴⁾ Voltage supply from gauge.	
6	Analog Input (IS)	0	None	
		A	One 4-20 mA	
		B	Two 4-20 mA	
		1	One HART	
		2	Two – One working as HART master	
7	Communication	R	TRL2 bus (Standard)	
		E	Enraf	Requires EBM modem during commissioning
		L	L&J ⁽⁴⁾⁽⁵⁾⁽⁷⁾	Supports water level input
		V	Varec ⁽⁴⁾⁽⁵⁾	
		W	Whessoe ⁽⁴⁾⁽⁵⁾	
		T	TIWAY ⁽⁴⁾⁽⁵⁾	
		G	GPE ⁽⁴⁾⁽⁵⁾⁽⁷⁾	
		U	Sakura ⁽⁴⁾⁽⁵⁾⁽⁶⁾	
		P	Profibus DP ⁽⁴⁾⁽⁵⁾	
		4	RS485 Modbus	
		C	Tokyo Keiso ⁽⁴⁾⁽⁵⁾⁽¹⁰⁾	
		S	Smart Wireless (IS) ⁽¹¹⁾	See wireless options on pages 65-66
		J	Smart Wireless (IS) + Enraf ⁽¹¹⁾	See wireless options on pages 65-66
K	Smart Wireless (IS) + other ⁽¹¹⁾	See wireless options on pages 65-66		
8	Relay Output	0	None	

Technical Description

703010En, Ed. 5, Rev B

November 2012

TankRadar Rex

Pos	Item	Code	Description	Note
		1	One Relay Output	
		2	Two ^{(5) (9)}	
9	Integrated Junction Box (JBi)	0	None	
		1	Integrated Junction Box with NPT thread. ⁽¹⁰⁾ (EEx e/EEEx i)	Plugs & glands included
		2	Integrated Junction Box with mm thread. ⁽¹⁰⁾ (EEx e/EEEx i)	Plugs & glands included
		X	Other specified in order	
10	Cable	C	Default according to selected configuration.	
		B	Default for the US market (always with 15-wire cable at W12)	
11	Metrological Seal	0	None	
		E	External ⁽²⁾	
		N	Internal ⁽²⁾	
12	Report	0	None	
		1	Test & Delivery Certificate with measuring range print-out (1 copy). ⁽²⁾	
		2	SP Test & Delivery Certificate with measuring range print-out (1 copy). ⁽²⁾	Witnessed by Swedish Certifying Authority
13	Temperature Inputs (IS)	0	No temperature inputs	
		1	1-14 Temperature inputs via Data Aquisition Unit (DAU)	
		6	1-6 temperature inputs directly connected to gauge. Common return. -50 °C to +250 °C (-58 °F to +482 °F)	
		3	1-3 temperature inputs directly connected to gauge. individual wiring. -50 °C to +250 °C (-58 °F to +482 °F)	
14	Support for Remote Display Unit, RDU 40 (IS)	0	No	
		R	Yes	
15	Special	0	None	
		T	Printed TAG for unit identification	
		S	Stainless Steel TAG for unit identification	Must be specified 3 weeks prior to delivery

- (1) Requires code 0 in Pos 3, 11 and 12.
- (2) Requires Pos 8 "Relay Output" code 1 or 2.
- (3) Requires Pos 1 "Transmitter Head" code A.
- (4) Not available with Pos 8 "Relay Output" code 2.
- (5) Requires Pos 5 "Analog Output" code 0.
- (6) Requires Pos 6 "Analog Input" code 0.
- (7) Not available with Pos 6 "Analog Input" code B, 1 and 2.
- (8) Not available with Pos 6 "Analog Input" code B and 2.
- (9) Not Available with Pos 7 "Communication" code L, V, W, T, G, U, P, F and C.
- (10) Not available with Pos 2 "Ex. and Safety Certification" code U.
- (11) Not available with Pos 6 "Analog Input (IS)" code B, 1 or 2.
Not available with Pos 14 "Support for Remote Display Unit" code R.
TRL2 bus available via wired connection.

Antennas

RTG 3920 (Horn antenna)

Pos	Item	Code	Description	Material
16	Antenna Type	20	Horn antenna	
17	Pressure Rating	S	- 0.2 to 2 bar (-2.9 to 29 psig)	
18	Antenna Size and Material	1A	8 in. (Ø175 mm)	SST ⁽²⁾
19	Sealing	P	PTFE	
20	O-ring	V	FPM (Viton)	
21	Special	0	None	
		M	Material Certificate	
22	Accessory	0	Not applicable	
23	Flange / Connection	1A	8 in. Hole pattern according to ANSI 8 in. Class 150 / DN 200 PN 10 ⁽¹⁾	SST ⁽²⁾
		1B	8 in. 4° Inclined. Hole pattern according to ANSI 8 in. Class 150 / DN 200 PN 10 ⁽¹⁾	

(1) Flat faced flange with 13 mm (0.51 in.) thickness.

(2) Material type corresponding to EN 1.4401 / AISI 316, EN 1.4404 / AISI 316L.

RTG 3930 (Parabolic antenna)

Pos	Item	Code	Description	Material
16	Antenna Type	30	Parabolic antenna	
17	Pressure Rating	S	- 0.2 to 0.2 bar (-2.9 to 2.9 psig)	
		H	- 0.2 to 10 bar (2.9 to 145 psig) ⁽¹⁾	
18	Antenna Size and Material	1A	Ø 440 mm (17 in.)	SST ⁽²⁾
19	Sealing	P	PTFE	
20	O-ring	V	FPM (Viton)	
21	Special	0	None	
		M	Material Certificate	
22	Accessory	0	Not applicable	
23	Flange / Connection	2A	Welded installation	SST ⁽²⁾
		2B	Threaded installation	SST ⁽²⁾

(1) Requires Pos 23 "Flange / Connection" code 2A (welded installation).

(2) Material type corresponding to EN 1.4401 / AISI 316, EN 1.4404 / AISI 316L.

Technical Description

703010En, Ed. 5, Rev B

November 2012

TankRadar Rex

RTG 3950 (Still-pipe Array antenna)

Pos	Item	Code	Description	Material
16	Antenna Type	50	Still-pipe Array antenna	
17	Pressure Rating	S	Pressure according to antenna mounting (Pos 19)	
18	Antenna Size and Material	1A	5 in.	EN 1.4404 / AISI 316L and PPS
		2A	6 in.	EN 1.4404 / AISI 316L and PPS
		3A	8 in.	EN 1.4404 / AISI 316L and PPS
		4A	10 in.	EN 1.4404 / AISI 316L and PPS
		5A	12 in.	EN 1.4404 / AISI 316L and PPS
19	Mounting	1	Fixed installation, - 0.2 to 2 bar (-2.9 to 29 psig)	
		3	Inclined Installation, - 0.2 to 0.25 bar (-2.9 to 3.6 psig)	Enables hand-dipping
20	O-ring	0	Not applicable	
21	Special	0	None	
		M	Material Certificate	
22	Accessory	0	None	
		C	Clamp Flange (for pipes without flange)	Galvanized Steel
		A	Adapter kit for insertion pipe ⁽¹⁾	
23	Flange / Connection	4A	Hole pattern according to ANSI 5 in. Class 150 ^{(2) (3)}	EN 1.4404 / AISI 316L
		4B	Hole pattern according to ANSI 6 in. Class 150 / DN 150 PN 16 ^{(2) (3)}	EN 1.4404 / AISI 316L
		4C	Hole pattern according to ANSI 8 in. Class 150 / DN 200 PN 10 ^{(2) (3)}	EN 1.4404 / AISI 316L
		4D	Hole pattern according to ANSI 10 in. Class 150 / DN 250 PN 16 ^{(2) (3)}	EN 1.4404 / AISI 316L
		4E	Hole pattern according to ANSI 12 in. Class 150 ^{(2) (3)}	EN 1.4404 / AISI 316L

(1) Requires Pos 18 "Antenna Size & Material" code 1A and Pos 23 "Flange / Connection" code 4A.

(2) Welded to hatch if inclined installation, Pos 19 "Mounting" code 3.

(3) Flat faced flange with 12 mm (0.47 in.) thickness.

RTG 3960 (LPG/LNG antenna)

Pos	Item	Code	Description	Rating	Material
16	Antenna Type	60	LPG/LNG Antenna		
17	Pressure Rating	A	Up to 25 bar, depending on flange rating in position 23		
18	Antenna Size and Material	1A	Cone 4 in. SCH 10		SST ⁽¹⁾
		1B	Cone DI = 99 mm		SST ⁽¹⁾
		1C	Cone 4 in. SCH 40		SST ⁽¹⁾
19	Sealing	Q	Quartz		
20	Reference Measurement	R	Reference measurement with Reflector Kit (1 pin included)		SST ⁽¹⁾
21	Special	0	None		
		M	Material Certificate for all pressurized details		
22	Accessory	2	Pressure Transmitter, including ball valve, PV Kit ⁽²⁾		
		7	Pressure Transmitter, other		
23	Flange / Connection	4A	ANSI 6 in. Class 150 ⁽³⁾		SST ⁽¹⁾
		4B	ANSI 6 in. Class 300 ⁽³⁾		SST ⁽¹⁾
		4D	ANSI 4 in. Class 150 ⁽³⁾		SST ⁽¹⁾
		4E	ANSI 4 in. Class 300 ⁽³⁾		SST ⁽¹⁾
		4F	ANSI 8 in. Class 150 ⁽³⁾		SST ⁽¹⁾
		4G	ANSI 8 in. Class 300 ⁽³⁾		SST ⁽¹⁾

(1) Corresponds to EN 1.4401 / AISI 316, EN 1.4404 / AISI 316L.

(2) Requires Pos 6 "Analog Input" code A, B, 1 or 2.

(3) Raised face flange, gasket group 1A or 1B according to ASME B 16.5.

Model Code Example

TH - Antenna: RTG 3900 - A B 0 S A 0 R 0 2 C 0 0 6 R 0 - 30 S 1A P V M 0 2A

Technical Description

703010En, Ed. 5, Rev B

November 2012

TankRadar Rex

Data Acquisition Unit (DAU 2100)

Pos	Item	Code	Description	Note
1	Type	00	Data Acquisition Unit	
2	Power Supply	0	Powered by RTG	
3	Temperature Range	1	- 50 °C to +125 °C (-58 °F to +257 °F)	
		2	- 50 °C to +300 °C (-58 °F to +572 °F)	
		3	- 200 °C to +150 °C (-328 °F to +302 °F)	
4	Adapter for German "Eich"	0	None. Standard Pt-100 version.	
		3	Pt-100 (Eich) ⁽¹⁾	
		4	Cu-90 (Eich) ⁽¹⁾	
5	Aluminium Housing	A	Included	
6	Display	0	None	
		Y	Included	
7	Ex. Certification	U	Baseefa (ATEX) / UL / ULc (Std)	
		E	IECEX	
8	Other Certification	0	None	
		S	German "Eich" Sign & Seal	
		N	NMI	
		X	Other specified in order	
9	Accessory	0	None	
		W	Sun Shelter Kit	
		T	Printed TAG for unit identification	
		S	Stainless Steel TAG for unit identification	

(1) Only for systems with Pos 3 "Accuracy Certification" code C, Eich (German), for Transmitter Head.

Model Code Example

DAU 2100 - 00 0 1 0 A Y U 0 S

Remote Display Unit (RDU 40)

Item	Model/Code	Description	Note
Display Unit	RDU 40	Remote Display Unit	

Junction Box and Protective Hose Kit

Item	Model/Code	Description	Note
Junction Box	JB 1401	Junction Box, EEx e (JB 140-11)	
	JB 1405	Junction Box, EEx i (JB 140-15)	
	JB 36	Junction Box, for connection of temperature sensors to DAU	Up to 12 sensors if 3-wire
	JB 42	Junction Box, for connection of temperature sensors to DAU	Up to 14 sensors if 3-wire
Miscellaneous	PHK 39S	Protective Hose Kit (PHK), 2 m (6.6 ft) ⁽¹⁾	
	PHK 392	Protective Hose Kit (PHK), 20 m (65.6 ft) ⁽¹⁾	

(1) Between Rex gauge and Junction Box.

Field Communication Unit (FCU 2160)

Pos	Item	Code	Description	Note
1	Version	60	OPI/2 & TankMaster compatible	FCU is TRL2 / Rex compatible
2	Power Supply	1	115 VAC	
		2	230 VAC	
3	Port 1	G1	GroupBus, TRL2 bus	
		G3	GroupBus, RS485 bus	
		G5	GroupBus, RS232 bus	
4	Port 2	G1	GroupBus, TRL2 bus	
		G3	GroupBus, RS485 bus	
		G5	GroupBus, RS232 bus	
5	Port 3	F1	FieldBus, TRL2 bus	
6	Port 4	F1	FieldBus, TRL2 bus	
7	Port 5	F1	FieldBus, TRL2 bus	
		G1	GroupBus, TRL2 bus	
		G3	GroupBus, RS485 bus	
8	Port 6	F1	FieldBus, TRL2 bus	
		G1	GroupBus, TRL2 bus	
		G3	GroupBus, RS485 bus	
9	Communication Protocol	S	OPI / TankMaster	
		M	Modbus to other Host	Required for communication with Host
10	Extended Function	0	None	
		R	Redundancy Function	Requires a second FCU with Redundancy
		B	Buddy Mode	
11	Special	0	None	
12	Accessory	0	None	
		W	Sun Shelter Kit	
13	Sign	S	Standard sign	
		M	NMI	
		X	Other specified in order	

Model Code Example

FCU 2160 - 60 2 G1 G5 F1 F1 F1 F1 S R 0 W S

Field Bus Modems

Item	Model/Code	Description	Note
Field Bus Modem	FBM 2180	Standard Rex. RS232, USB, Modbus	
	EBM 3180	For configuration of Rex on Enraf fieldbus	

TankMaster™ Software

(TankMaster WinOpi, WinSetup, and WinView are always delivered with a USB dongle)

Pos	Item	Code	Description	Note
1	Licence	DM	TankMaster Demo	No dongle included
		05	TankMaster WinOpi, with TankServer for up to 5 tanks ⁽¹⁾	
		20	TankMaster WinOpi, with TankServer for up to 20 tanks ⁽¹⁾	
		50	TankMaster WinOpi, with TankServer for up to 50 tanks ⁽¹⁾	
		MX	TankMaster WinOpi Max ⁽¹⁾	Unlimited number of tanks
		V2	TankMaster WinView, with TankServer for up to 20 tanks ⁽²⁾	
		V5	TankMaster WinView, with TankServer for up to 50 tanks ⁽²⁾	
		WS	TankMaster WinSetup ⁽³⁾	Configuration only
2	Host Communication	0	None	
		C	TankMaster Communication Module ⁽⁴⁾	
		S	TankMaster Communication Module with Office link ^{(4) (5)}	
3	Network	0	None	
		1	One TankMaster client can connect and read data ⁽⁶⁾	
		2	Two TankMaster clients can connect and read data ⁽⁶⁾	
		3	Three TankMaster clients can connect and read data ⁽⁶⁾	
		4	Four TankMaster clients can connect and read data ⁽⁶⁾	
		5	Five TankMaster clients can connect and read data ⁽⁶⁾	
		6	Six TankMaster clients can connect and read data ⁽⁶⁾	
		7	Seven TankMaster clients can connect and read data ⁽⁶⁾	
		X	Specify number of clients ⁽⁶⁾	
4	Custody Transfer	0	None	
		C	TankMaster custody transfer functions ⁽⁷⁾	
		P	TankMaster custody transfer functions PTB Eich ⁽⁸⁾	
5	Batch Handling	0	Default batch functions	
		B	Extended batch functions ⁽⁹⁾	
6	HTG	0	None	
		P	TankMaster hydrostatic tank gauging functions and calculations	
7	Customization	0	None	
		C	Customized views	
8	Redundancy	00	None	
		RT	TankMaster redundancy ⁽¹⁰⁾	

- (1) Configuration, view and alarm handling. Volume calculations according to API. Includes WinSetup.
- (2) Configuration, view, alarm handling and limited inventory calculations. Includes WinSetup. Requires code "0" or "00" for Pos 3-8.
- (3) Configuration and installation of devices and tanks.
- (4) For connection between TankMaster and SCADA / DCS/PLC via Modbus (RS232) and/or OPC DA. Requires WinOpi.
- (5) For connection between TankMaster and Microsoft Office via OPC server. Includes OPC Office Client / Site Server License.
- (6) Number of other TankMaster PCs that can connect and read data. This other TankMaster PC can be a TankMaster client or another TankMaster server.
- (7) Custody transfer windows. Includes hardware key, custody transfer seal and metrological seal for custody transfer approvals.
- (8) Custody transfer windows. Includes hardware key, PTB sticker, custody transfer seal and metrological seal for custody transfer approvals.
- (9) Stores closed batches up to 365 days, re-calculation of delivery ticket, Microsoft Access database files and "Tank Transfer Calculator".
- (10) Requires two identical dongles (can be ordered separately), meaning duplicate redundancy licenses as well as other options (one per dongle).

Model Code Example: TM - 20 S N C C P C RT

TankMaster.net Software & I/O Terminals

Item	Model/Code	Description	Note
TankMaster.net	RTM39EL	TankMaster.net ⁽¹⁾ , Single Licence (one user).	
	RTM39EM	TankMaster.net ⁽¹⁾ , Limited Licence (up to 3 users).	
	RTM39ES	TankMaster.net ⁽¹⁾ , Site Licence (unlimited number of users).	

- (1) Tank data availability through Internet / Intranet. Requires TankMaster WinOpi.

Temperature and Water Level Sensors

For the US and Canadian markets, see page 60. Spot positions should be specified separately in Required System Information (RSI).

Single Spot Temperature Sensor (SST)

Pos	Item	Code	Description	Note
1	Resistance Thermometer Type	1	Type B, with extension length & removable insert	
		2	Type BF, with extension length & fixed insert	
		3	Type OPE, with EExdIIC head, extension length & removable insert	
2	Length	0500	500 mm (1.6 ft) as standard	
		0200-2000	Customized. Length in millimetres, specified in 10 mm increments	
3	Sheath Dimension	A	Ø=8 mm (0.31 in.), 1 mm (0.04 in.) thickness ⁽¹⁾	Type BF only
		B	Ø=9 mm (0.35 in.), 1 mm (0.04 in.) thickness	
		C	Ø= 11 mm (0.43 in.), 1 mm (0.04 in.) thickness ⁽²⁾⁽³⁾	Type B only
4	Extension Length	000	None ⁽⁴⁾	Type B, BF only
		080	80 mm (3.15 in.)	
		145	145 mm (5.71 in.) ⁽⁴⁾	Type B, BF only
5	Mounting Thread	1	½-in. BSP	Type B, BF only
		2	¾-in. BSP ⁽³⁾⁽⁴⁾	Type B, BF only
		4	½-in. NPT	
6	Number of Wires	3	Three	
7	Number of Elements	1	1xPt	
		2	2xPt	
8	Element Type	P	Pt-100	
9	Temperature Accuracy Class	1	1/6 DIN ± 0.05 °C (± 0.09 °F)	
10	Temperature Range	1	-50 to +260 °C (-58 to +500 °F) ⁽⁴⁾	
		2	-50 to +400 °C (-58 to +752 °F)	
11	Cable Outlet	1	½-in. NPT ⁽⁵⁾	
		2	½-in. BSP ⁽⁵⁾	
		3	M20 ⁽⁴⁾	

(1) Requires Pos 1 "Resistance Thermometer Type" code 2.

(2) Requires Pos 1 "Resistance Thermometer Type" code 1.

(3) Can not be combined with Thermowell.

(4) Requires Pos 1 "Resistance Thermometer Type" code 1 or 2.

(5) Requires Pos 1 "Resistance Thermometer Type" code 3.

Thermowell for Single Spot Temperature Sensor (SSTW), pressurized tanks

Pos	Item	Code	Description	Note
1	Thermowell Length	0250-2000	Specify length in millimetres	Made of 316 SST
2	Thermowell Sheath Dimension	A	Ø=16 mm (0.63 in.), 3 mm (0.12 in.) thickness	
		B	Ø=21.3 mm (0.84 in.), 2.65 mm (0.10 in.) thickness	
3	Thermowell Flange Connection	1	1.5 in. ANSI 150 Psi	
		2	2 in. ANSI 150 Psi	
		3	1.5 in. ANSI 300 Psi	
		4	2 in. ANSI 300 Psi	
		5	DN50 / PN10 - PN16	
		6	DN50 / PN40	
4	SST Mounting Thread	1	½-in. NPT	
		2	½-in. BSP	

Model Code Examples: SST - 3 1500 B 080 4 3 1 1 1 2 1, SSTW - 1515 A 2 1

Technical Description

703010En, Ed. 5, Rev B

November 2012

TankRadar Rex

Multiple Spot Temperature Sensor (MST)

Pos	Item	Code	Description	Note
1	Overall Length, Temperature Sensor	05000-70000	Length in millimetres, specified in 10 mm increments	
2	Sheath Type	A	1 in. AISI 316	
		B	Standard. ¾ in. AISI 316 ⁽¹⁾	
3	Connection Type	1	Threaded, ½ in. BSP	
		5	Flange, 1 ½ in. ANSI 150 psi	
		6	Flange, 2 in. ANSI 150 psi	
		7	Flange, 3 in. ANSI 150 psi	
		8	DN 100 / PN 10	
4	Temperature Sensor Wiring	3	3-wire, Individual	
		C	Common return	
5	Number of Temperature Spot Elements	01 to 14	Specify number	
6	Element Type	P	Pt-100	
7	Temperature Accuracy Class	1	1/6 DIN Class B	
		2	1/10 DIN Class B	
8	Temperature Range	1	- 50 to +120 °C (-58 to +248 °F)	
		2	-20 to +250 °C (-4 to +482 °F)	
9	Lead Wire, Temperature Sensor	01	500 mm (1.6 ft) for Junction Box connection	Cut if ordered with JB, Pos 11 code 1
		03	Standard. 3 m (10 ft)	
		04 to 10	Specify other length in metres	Maximum 10 m (33 ft) is recommended
10	Anchor Weight	0	None	
		A	2.5 kg (5.5 lbs), Ø= 40 x 200 mm (1.6 x 7.9 in.)	For still-pipes
		B	3 kg (6.6 lbs), Ø= 50 x 200 mm (2.0 x 7.9 in.)	For still-pipes
		C	4 kg (8.8 lbs), Ø= 45 x 330 mm (1.8 x 13.0 in.)	For still-pipes
		D	5 kg (11 lbs), Ø= 100 x 85 mm (3.9 x 3.3 in.)	For free-hanging
		E	10 kg (22 lbs), Ø= 95 x 175 mm (3.7 x 6.9 in.)	For free-hanging
		F	15 kg (33 lbs), Ø= 140 x 130 mm (5.5 x 5.1 in.)	For free-hanging
11	Junction Box	0	None	
		1	Junction Box integrated with temperature sensor ⁽²⁾	Up to 11 spots with 3-wire return, or 14 with common return
		3	JB 42	
12a	Hose Kit	0	None	
		A	Hose kit including glands, 3 m (10 ft) as standard	
		B	Hose kit including glands, 10 m (33 ft)	
12b	Hose Kit Connection	0	None	
		1	M20 x 1.5	
		2	M25 x 1.5	
		3	M32 x 1.5	
		4	½-in. NPT	
		5	¾-in. NPT	
		6	1-in. NPT	
13	Vapor Boot	0	None	
		1	Vapor boot for a 2-in. NPS threaded tank connection	
		2	Vapor boot for a 3-in. NPS threaded tank connection	
		3	Vapor boot, which fits a 3-in. ANSI 150 psi flange	
		4	Vapor boot, which fits a 4-in. ANSI 150 psi flange	
		6	Vapor boot, which fits a 6-in. ANSI 150 psi flange	
		8	Vapor boot, which fits a 8-in. ANSI 150 psi flange	

(1) Requires Pos 4 "Temperature Sensor Wiring" code C (common return) for more than 8 spot elements.

(2) Requires Pos 9 "Lead Wire, Temperature Sensor" code 01.

Model Code Example: MST - 18000 A 1 C 06 P 1 1 01 E 1 0 0 0

Multiple Spot Temperature Sensor for Cryogenic Use

Pos	Item	Code	Description	Note
1	Overall Length, Temperature Sensor	05000-70000	Length in millimetres, specified in 10 mm increments	
2	Sheath Type	A	1-in. AISI 316	
		B	Standard. ¾-in. AISI 316	
3	Connection Type	A	M33x1.5 with flange, 2-in. ANSI 150 psi	
		B	M33x1.5 with flange, 2-in. ANSI 300 psi	
		C	M33x1.5 with flange, 3-in. ANSI 300 psi	
4	Temperature Sensor Wiring	3	3-wire, Individual	Maximum 6 spot elements
		C	Common return	Maximum 16 spot elements
5	Number of Temperature Spot Elements	01 to 14	Specify number	
6	Element Type	P	Pt-100	
7	Temperature Accuracy Class	A	DIN Class A	
8	Temperature Range	3	-170 to +100 °C (-274 to +212 °F)	
9	Lead Wire, Temperature Sensor	01	500 mm (1.6 ft) for Junction Box connection	Cut if ordered with JB, Pos 11 code 1
		03	Standard. 3 m (10 ft)	
		04 to 10	Specify other length in metres	Max 10 m (33 ft) is recommended
10	Anchor Weight	0	None	
		A	2.5 kg (5.5 lbs), Ø= 40 x 200 mm (1.6 x 7.9 in.)	For still-pipes
		B	3 kg (6.6 lbs), Ø= 50 x 200 mm (2.0 x 7.9 in.)	For still-pipes
		C	4 kg (8.8 lbs), Ø= 45 x 330 mm (1.8 x 13.0 in.)	For still-pipes
		D	5 kg (11 lbs), Ø= 100 x 85 mm (3.9 x 3.3 in.)	For free-hanging
		E	10 kg (22 lbs), Ø= 95 x 175 mm (3.7 x 6.9 in.)	For free-hanging
11	Junction Box	0	None	
		1	Junction Box integrated with temperature sensor ⁽¹⁾	
		3	JB 42	
12 a	Hose Kit	0	None	
		A	Hose kit including glands, 3 m (10 ft) as standard	
12 b	Hose Kit Connection	B	Hose kit including glands, 10 m (33 ft)	
		0	None	
		1	M20 x 1.5	
		2	M25 x 1.5	
		3	M32 x 1.5	
		4	½-in. NPT	
		5	¾-in. NPT	
6	1-in. NPT			
13	Drain Nipple	0	None	
		9	Drain nipple on flange	

1) Requires Pos 9 "Lead Wire, Temperature Sensor" code 01. Can have up to 6 spots with 3-wire return, or 14 spots with common return.

Model Code Example: NL-Cryo - 45000 A A C 14 P A 3 01 E 1 A 1 0

Technical Description

703010En, Ed. 5, Rev B

November 2012

TankRadar Rex

Water Level Sensor Integrated with Multiple Spot Temperature Sensor (MSTW)

Pos	Item	Code	Description	Note
1	Overall Length, Temperature Sensor	05000-70000	Length in millimetres, specified in 10 mm increments	
2	Sheath Type	A	1 in. AISI 316	
3	Connection Type	4	M33x1.5	
		5	Flange, 1 ½ in. ANSI 150 psi	
		6	Flange, 2 in. ANSI 150 psi	
		7	Flange, 3 in. ANSI 150 psi	
		8	DN 100 / PN 10	
4	Temperature Sensor Wiring	3	3-wire, Individual	
		C	Common return	
5	Number of Temperature Spot Elements	00	No temperature sensor – Water Level Sensor (WLS) only	
		01 to 14	Specify number	
6	Element Type	0	None	
		P	Pt-100	
7	Temperature Accuracy Class	0	None	
		1	1/6 DIN Class B	
		2	1/10 DIN Class B	
8	Temperature Range	0	None	
		1	0 to +120 °C (+32 to +248 °F)	
9	Lead Wire, Temperature Sensor	01	500 mm (1.6 ft) for Junction Box connection	Cut if ordered with JB, Pos 11 code 1
		03	Standard. 3 m (10 ft)	
		04 to 10	Specify other length in metres	Max. 10 m (33 ft)
10	Anchor Weight	0	None	
		D	5 kg (11 lbs), Ø=100x85 mm (3.9 x 3.3 in.)	For free-hanging installation
		E	10 kg (22 lbs), Ø=95x175 mm (3.7 x 6.9 in.)	For free-hanging installation
		X	Customized	
11	Junction Box	0	None	
		1	Junction Box integrated with temperature sensor ⁽¹⁾	
		3	JB 42	
12 a	Hose Kit	0	None	
		A	Hose kit including glands, 3 m (10 ft) as standard	
		B	Hose kit including glands, 10 m (33 ft)	
12 b	Hose Kit Connection	0	None	
		1	M20 x 1.5	
		2	M25 x 1.5	
		3	M32 x 1.5	
		4	½-in. NPT	
		6	1-in. NPT	
13	Vapor Boot	0	None	
		1	Vapor boot for a 2-in. NPS threaded tank connection	
		2	Vapor boot for a 3-in. NPS threaded tank connection	
		3	Vapor boot, which fits a 3-in. ANSI 150 psi flange	
		4	Vapor boot, which fits a 4-in. ANSI 150 psi flange	
		6	Vapor boot, which fits a 6-in. ANSI 150 psi flange	
		8	Vapor boot, which fits a 8-in. ANSI 150 psi flange	
		14	Water Level Sensor (integrated)	C05
C10	Closed; for light products, 1000 mm (39.4 in.) range			
H05	Open; for heavy products, 500 mm (19.7 in.) range			
H10	Open; for heavy products, 1000 mm (39.4 in.) range			
15	Water Level Sensor, Top Weight	0	None	
		T	5 kg (11 lbs)	

(1) Requires Pos 9 "Lead Wire, Temperature Sensor" code 01. Can have up to 10 spots with 3-wire return, or 14 spots with common return.

Model Code Example: MSTW - 21000 A 4 C 06 P 1 1 03 D 0 A 1 0 C05 T

TankRadar Rex

Temperature and Water Level Sensors for the US and Canada

Single Spot Temperature Sensor (SSTUS) for the US and Canada

Pos	Item	Code	Description	Note
1	Resistance Thermometer Type	3	Type OPE, with Ex head and extension length plus fixed insert. Standard.	
2	Length	U036	36 in.	
		U008-U080	Customized. Specify length in even inches only	
3	Sheath Dimension	D	Ø=0.24 in.	
4	Extension Length	080	3.15 in.	
		145	5.71 in.	
5	Mounting Thread	4	½-in. NPT	
6	Number of Wires	3	Three	
7	Number of Elements	1	1xPt	
		2	2xPt	
8	Element Type	P	Pt-100	
9	Temperature Accuracy Class	1	1/6 DIN ± 0.09 °F	
10	Temperature Range	4	-58 to +932 °F	
11	Cable Outlet	1	½-in. NPT	

Model Code Example

SSTUS - 3 U036 D 080 4 3 1 P 1 4 1

Thermo Well for Single Spot Temperature Sensor (SSTWUS), pressurized tanks, for the US and Canada

Pos	Item	Code	Description	Note
1	Thermowell Length	U008-U080	Specify length in even inches only	Made of 316 SST
2	Thermowell Sheath Dimension	B	Ø=0.84 in, 0.10 in. thickness	
3	Thermowell Flange Connection	1	1.5 in. ANSI 150 Psi	
		2	2 in. ANSI 150 Psi	
		3	1.5 in. ANSI 300 Psi	
		4	2 in. ANSI 300 Psi	
		5	DN50 / PN10 - PN16	
		6	DN50 / PN40	
		7	1 in. NPT	
4	SST Mounting Thread	1	½-in. NPT	

Model Code Example

SSTWUS - U036 B 2 1

Technical Description

703010En, Ed. 5, Rev B

November 2012

TankRadar Rex

Multiple Spot Temperature Sensor (MSTUS) for the US and Canada

Pos	Item	Code	Description	Note
1	Overall Length, Temperature Sensor	U0038- U2756	Specify length in even inches only	
2	Sheath Type	A	1 in. AISI 316	
		B	¾ in. AISI 316 ⁽¹⁾	
3	Connection Type	0	Threaded, ½ in. BSP	
		5	Flange, 1 ½ in. ANSI 150 psi	
		6	Flange, 2 in. ANSI 150 psi	
		7	Flange, 3 in. ANSI 150 psi	
		C	Flange, 4 in. ANSI 150 psi	
		D	Flange, 6 in. ANSI 150 psi	
		E	Flange, 8 in. ANSI 150 psi	
		F	Flange, 10 in. ANSI 150 psi	
4	Temperature Sensor Wiring	3	3-wire, individual	
		C	Common return	
5	Number of Temperature Spot Elements	01 to 14	Specify number	
6	Element Type	P	Pt-100	
7	Temperature Accuracy Class	1	1/6 DIN Class B	
		2	1/10 DIN Class B	
8	Temperature Range ⁽²⁾	1	-58 to +248 °F	
		2	-4 to +482 °F	
9	Lead Wire, Temperature Sensor	01	1.6 ft for Junction Box connection	Cut if ordered with JB, Pos 11 code 1
		03	Standard. 10 ft	
		13 to 33	Specify other length in even feet only	Maximum 33 ft is recommended
10	Anchor Weight	00	None	
		01	5 lbs, for still-pipes and 2 in. openings	
		02	20 lbs, for still-pipes and 2 in. openings	
		03	30 lbs, for still-pipes and 2 in. openings	
		04	6 lbs (Ø=2 in.), for free-hanging	
		05	11 lbs (Ø=3.9 in.), for free-hanging	
		06	22 lbs (Ø=3.7 in.), for free-hanging	
		07	33 lbs (Ø=5.5 in.), for free-hanging	
11	Junction Box	0	None	
		4	Junction Box integrated with temperature sensor	For up to 11 spots with 3-wire return, or 14 spots with common return
12	Hose Kit	00	None	
13	Vapor Boot	0	None	
		1	Vapor boot for a 2-in. NPS threaded tank connection	
		2	Vapor boot for a 3-in. NPS threaded tank connection	
		3	Vapor boot, which fits a 3-in. ANSI 150 psi flange	
		4	Vapor boot, which fits a 4-in. ANSI 150 psi flange	
		6	Vapor boot, which fits a 6-in. ANSI 150 psi flange	
		8	Vapor boot, which fits a 8-in. ANSI 150 psi flange	

(1) Requires Pos 4 "Temperature Sensor Wiring" code C (common return) for more than 8 spot elements.

(2) Version available for -274 to +212 °F. This temperature sensor (NL-Cryo) is specified separately. See page 58.

Model Code Example

MSTUS - U0480 B 5 C 06 P 1 2 01 06 4 00 0

Water Level Sensor Integrated with Multiple Spot Temperature Sensor (MSTWUS) for the US and Canada

Pos	Item	Code	Description	Note
1	Overall Length, Temperature Sensor	U0038-U2756	Specify length in even inches only	
2	Sheath Type	A	1 in. AISI 316	Maximum 20 spot elements
3	Connection Type	5	Flange, 1 ½ in. ANSI 150 psi	
		6	Flange, 2 in. ANSI 150 psi	
		7	Flange, 3 in. ANSI 150 psi	
		C	Flange, 4 in. ANSI 150 psi	
		D	Flange, 6 in. ANSI 150 psi	
		E	Flange, 8 in. ANSI 150 psi	
		F	Flange, 10 in. ANSI 150 psi	
4	Temperature Sensor Wiring	3	3-wire, Individual	
		C	Common return	
5	Number of Temperature Spot Elements	00	No temperature sensor – Water Level Sensor (WLS) only	
		01 to 14	Specify number	
6	Element Type	P	Pt-100	
7	Temperature Accuracy Class	1	1/6 DIN Class B	
		2	1/10 DIN Class B	
8	Temperature Range	1	+32 °F to +248 °F	
9	Lead Wire, Temperature Sensor	01	1.6 ft for Junction Box connection	Cut if ordered with JB, Pos 11 code 1
		03	Standard. 10 ft	
		13 to 33	Specify other length in even feet only	Maximum 33 ft is recommended
10	Anchor Weight	00	None	
		01	5 lbs, for still-pipes and 2 in. openings	
		04	6 lbs (Ø=2 in.), for free-hanging	
		05	11 lbs (Ø=3.9 in.), for free-hanging	
11	Junction Box	0	None	
		4	Junction Box integrated with temperature sensor	US version for up to 10 spots with 3-wire return + WLS, or 14 spots with common return + WLS
12	Hose Kit	00	None	
13	Vapor Boot	0	None	
		1	Vapor boot for a 2-in. NPS threaded tank connection	
		2	Vapor boot for a 3-in. NPS threaded tank connection	
		3	Vapor boot, which fits a 3-in. ANSI 150 psi flange	
		4	Vapor boot, which fits a 4-in. ANSI 150 psi flange	
		6	Vapor boot, which fits a 6-in. ANSI 150 psi flange	
		8	Vapor boot, which fits a 8-in. ANSI 150 psi flange	
14	Water Level Sensor (integrated)	C05	Closed; for light products, 19.7 in. range	
		C10	Closed; for light products, 39.4 in. range	
		H05	Open; for heavy products, 19.7 in. range	
		H10	Open; for heavy products, 39.4 in. range	
15	Water Level Sensor, Top Weight	0	None	
		1	10 lbs	

Note: Spot positions should be specified separately in Required System Information (RSI).

Model Code Example

MSTWUS - U0480 A 5 C 06 P 1 1 01 00 4 00 0 C05 1

Technical Description

703010En, Ed. 5, Rev B

November 2012

TankRadar Rex

Pressure Transmitters

For more information on pressure transmitters, see the Rosemount 3051S Product Data Sheet (00813-0100-4801) or www.rosemount.com.

Pressure Transmitter, Rosemount 3051S Series Liquid Level

Pos	Item	Code	Description	Note
1	Product Description	3051SAL	Scalable Advanced Level Transmitter for Liquid Level Applications	
2	Performance Class	1	Ultra: 0.065 % span accuracy, 100:1 rangedown	
		2	Classic: 0.065% span accuracy, 100:1 rangedown	
3	Configuration Type	C	Liquid Level Transmitter	
4	Pressure Module and Sensor Type	G	Coplanar module; Gage sensor	
5	Pressure Range	3A	-393 to 1000 inH ₂ O (-0.98 to 2.5 bar)	1000 inH ₂ O <=> 25 mH ₂ O
6	Transmitter Output	A	4-20 mA with digital signal based on HART protocol	
7	Housing and Cable / Conduit Connections	2A	Junction Box Housing, Aluminium, 1/2-14 NPT	
		2B	Junction Box Housing, Aluminium, M20 x 1.5	
8	Direct-mount Extension (between transmitter flange and seal)	10	No extension	
9	Transmitter Reference Pressure Connection	20	316 L SST isolator with SST transmitter flange	
10	Seal Fill Fluid	D	Silicone 200	
11	Tank Connection	FF	Flush flanged seal	
12	Tank Connection Size (High Side)	G	2-in. / DN50	
		7	3-in.	
13	Flange Rating (High Side)	1	ANSI/ASME B16.5 Class 150	
		2	ANSI/ASME B16.5 Class 300	
14	Material: Isolating Diaphragm, Upper Housing and Flange	DA	316L SST, 316L SST, and flange in 316 SST	
15	Flushing Connection Ring (lower housing)	A	316 SST	
		0	None	
16	Flushing Connection Quantity & Size	3	Two 1/4-18 NPT	
		0	None	
17+	Options	SG	SST plug(s) for flushing connection(s)	
		SH	SST drain/vent(s) for flushing connection(s)	
		ST	Wetted materials compliance to NACE MR0175/ISO 1516, MR0103	
		I1	ATEX Intrinsic Safety	
		I5	FM Intrinsically Safe, Division 2	
		I6	CSA Intrinsically Safe	
		I7	IECEx Intrinsic Safety	
		P1	Hydrostatic testing with certificate	
		Q4	Calibration certificate	
		Q8	Material Traceability Certification per EN 10204 3.1B	
		GE	M12, 4-pin, male connector (Eurofast)	
GM	A size Mini, 4-pin, male connector (Minifast)			

Pressure Transmitter , Rosemount 3051S Series Coplanar

Pos	Item	Code	Description	Note
1	Product Description	3051S	Scalable pressure transmitter	
2	Performance Class	1	Ultra: 0.025 % span accuracy, 200:1 rangedown	10-year stability
		2	Classic: 0.055% span accuracy, 100:1 rangedown	5-year stability
3	Connection Type	C	Coplanar	
4	Measurement Type	G	Gage	
5	Pressure Range	1A	-25 to 25 inH ₂ O (-62.2 to 62.2 mbar), 1000 inH ₂ O <=> 25 mH ₂ O	For vapor pressure measurement (P3)
		3A	-393 to 1000 inH ₂ O (-0.98 to 2.5 bar), 1000 inH ₂ O <=> 25 mH ₂ O	For liquid pressure measurement (P1)
6	Isolating Diaphragm / Tank Connection Material	2	316L SST	
7	Tank Connection	Connection for Vapor Pressure Transmitter (SST/316 SST)		
		E12	1/4 - 18 NPT	
		Vertical Mount ANSI Flanges (SST/316 SST)		
		G11	2 in. Class 150	
		G12	2 in. Class 300	
		G21	3 in. Class 150	
		G22	3 in. Class 300	
		Vertical Mount EN Flanges (SST/316 SST)		
		G31	DN50 PN40	
G41	DN80 PN40			
8	Transmitter Output	A	4-20 mA with digital signal based on HART protocol	
9	Housing and Cable / Conduit Connections	2A	Junction Box Housing, Aluminium, 1/2-14 NPT	
		2B	Junction Box Housing, Aluminium, M20 x 1.5	
10+	Options – none or multiple selections are possible	I1	ATEX Intrinsically Safe	
		I5	FM Intrinsically Safe	
		I6	CSA Intrinsically Safe	
		I7	IECEX Intrinsically Safe	
		P1	Hydrostatic testing with certificate	
		Q4	Calibration certificate	
		Q8	Material Traceability Certification per EN 10204 3.1B	
		GE	M12, 4-pin, male connector (Eurofast)	
GM	A size Mini, 4-pin, male connector (Minifast)			

Model Code Example

3051SAL1CG3AA2A1020DFFG1DA00I1Q4

3051S1CG3A2G11A2A11Q4

Technical Description

703010En, Ed. 5, Rev B

November 2012

TankRadar Rex

Wireless

For more information on the Smart Wireless THUM™ Adapter and the Wireless Gateway, see the following Rosemount Product Data Sheets, 00813-0100-4075 and 00813-0200-4420. These publications can be found on www.rosemount.com.

Smart Wireless THUM™ Adapter

Pos	Item	Code	Description	Note
1	Product Description	775	Smart Wireless THUM Adapter	
2	Output	X	Wireless	
3	Housing	D	Aluminum	
4	Mounting Connection	2	M20 conduit adapter	
5	Plantweb Functionality	1	HART data	
6	Certification	NA	No approval	
		I1	ATEX intrinsically safe	
		I2	INMETRO intrinsically safe	
		I3	NEPSI	
		I4	TIIS	
		I5	FM intrinsically safe, non-incendive	
		I6	CSA intrinsically safe	
		I7	IECEX intrinsically safe	
		N1	ATEX Type n	
		N2	INMETRO Type n	
		N7	IECEX Type n	
		IP	KOSHA intrinsically safe	
IW	CCOE intrinsically safe			
IM	GOST intrinsically safe			
7	Wireless Transmit Rate	WA	User configurable burst rate	
8	Operating Frequency and Protocol	3	2.4 GHz DSSS, <i>WirelessHART</i>	
9	Wireless Antenna	WK	Omnidirectional integral antenna	
10	SmartPower™ Options	9	Power scavenging	

Smart Wireless Tank Gauging Options

Pos	Item	Code	Description	Note
11	Device Connection	R	TankRadar Rex	Factory mounted, 680 ohm 4 W loop resistor
12	Cable / Conduit Connection	0	None (M20x1.5 female thread)	
		J	Metal cable gland M20x1.5	Min. temperature -20 °C (-4 °F), ATEX / IECEX
		F	½ NPT Adapter (female thread)	
13	Options	PT	Printed tag for unit identification	

Model code example, Smart wireless THUM™ adapter with options

775 - X D 2 1 I1 WA 3 WK 9 - R J PT

Smart Wireless Gateway

Pos	Item	Code	Description
1	Product Description	1420	Smart Wireless Gateway
2	Power Input	A	24 VDC nominal (10.5-30 VDC)
3	Ethernet Communication – Physical Connection	1	Ethernet ⁽¹⁾⁽²⁾
		2	Dual Ethernet ⁽³⁾⁽⁴⁾
4	Wireless Update Rate, Operating Frequency and Protocol	A3	User configurable update rate, 2.4 GHz DSSS, <i>WirelessHART</i> ™
5	Serial Communication	N	None
		A	Modbus RTU via RS485 ⁽⁵⁾
6	Ethernet Communication – Data Protocol	2	Webserver, Modbus TCP/IP, AMS Ready, HART-IP
		4	Webserver, Modbus TCP/IP, AMS Ready, HART-IP, OPC
		5	DeltaV Ready ⁽⁶⁾
7	Options	Product Certifications	
		N1	ATEX Type n
		N3	China Type n
		N4	TIIS Type n
		N5	FM Division 2, Non-incendive
		N6	CSA Division 2, Non-incendive
		N7	IECEX Type n
		ND	ATEX Dust
		NF	IECEX Dust
		KD	FM & CSA Division 2, Non-incendive and ATEX Type n
		Redundancy	
		RD	Gateway redundancy ⁽⁷⁾⁽⁸⁾
		Adapters	
		J1	CM 20 conduit adapters
		J2	PG 13.5 conduit adapters
		J3	¾ NPT conduit adapters
		Antenna Options ⁽⁹⁾	
		WL2	Remote Omni-antenna kit, 15.2 m (50 ft) cable, lightning arrestor
		WL3	Remote Omni-antenna kit, 6.1 m (20 ft) and 9.1 m (30 ft) cables, lightning arrestor
		WL4	Remote Omni-antenna kit, 3 m (10 ft) and 12.2 m (40 ft) cables, lightning arrestor

(1) Single active 10/100 baseT Ethernet port with RJ45 connector.

(2) Additional ports disabled.

(3) Dual active 10/100 baseT Ethernet ports with RJ45 connectors.

(4) Multiple active ports have separate IP addresses, firewall isolation, and no packet forwarding.

(5) Convertible to RS232 via adapter.

(6) Includes Webserver, Modbus TCP/IP, AMS Ready, HART-IP, OPC.

(7) Requires Pos 3 "Ethernet Communication - Physical Connection" code 2 (dual Ethernet).

(8) Not available with Pos 6 "Ethernet Communication - Data Protocol" code 5 (DeltaV ready).

(9) The WL2-WL4 options require minor assembly.

Model code example, Gateway with option

1420 - A 1 A3 A 4 -KD

Accessories and Spare Parts

Item	Model/Code	Description	Note
AMS Wireless SNAP-ON	01420-1644-0001	One gateway license	
	01420-1644-0002	Five gateway licenses	
	01420-1644-0003	Ten gateway licenses	
	01420-1644-0004	5-10 upgrade licenses	

TankRadar Rex

Technical Description

703010En, Ed. 5, Rev B

November 2012

Emerson Process Management
Rosemount Tank Gauging
Box 13045
S-402 51 Göteborg
SWEDEN



Phone: +46 31 337 00 00
Fax: +46 31 25 30 22
E-mail: sales.rtg@Emerson.com
www.rosemount-tg.com

2012 Rosemount Tank Radar AB, Sweden. All rights reserved.

