

ControlWave® ExpressPAC

SCADA RTU Package

ControlWave® ExpressPAC, from Emerson Process Management, is a highly integrated pre-engineered package solution that combines the new ControlWave Express SCADA RTU with a variety of options commonly required in SCADA applications.

These include a compact Nema 4X rated enclosure, power supply and solar panel options with battery backup, operator display/keypad input options, and wireless communication options. Standardization eliminates the need for in-house panel and packaging design and fabrication resulting in lower initial installation cost. This also standardizes the maintenance effort to reduce the long term cost of ownership.

As an integrated RTU in a SCADA system, ControlWave ExpressPAC has the unique attributes required for wide area networks, without sacrificing process control performance.

- Pre-engineered SCADA RTU package solution reduces integration and maintenance costs
- Multiple serial communication ports for network, local and multi-vendor connectivity
- Built-in BSAP, Modbus & DNP protocols for broad network compatibility
- Report-By-Exception for communication efficiency
- Modbus Store and Forward capability for geographic flexibility with radio networks
- Ultra low power modes minimizes cost of solar/battery power systems
- Wide operating temperature range for remote outdoor locations

Application Suitability

Based on years of experience in water, gas and SCADA related industries, ControlWave Express has the technology, functional benefits and open architecture to excel in many applications.



Water distribution: Pump, tank, well and reservoir control

Wastewater: Lift station and storm water monitoring

Natural Gas: Gas well, storage and plunger lift control

Features

- ARM processor provides exceptional performance and low power consumption
- IEC 61131-3 programming with ACCOL III process control function block library
- Optional 100/10 MB Ethernet port
- Three serial communication ports
- Flexible fixed I/OI configurations
- 4 Digital inputs
- 2 Digital outputs
- 2 selectable Digital inputs/outputs
- 2 selectable Digital inputs/counters
- 2 selectable Digital/Pulse inputs on CPU
- 3 optional Analog inputs
- 1 optional Analog output

ControlWave ExpressPAC Integrated Solution

ControlWave ExpressPAC is delivered in a compact, Lexan enclosure that includes the RTU electronics, optional operator display/keypad, battery/solar power system and a broad selection of modem and radio communications options.

Features – Package

- Dimensions, Lexan Housing: 15.77” H x 7.8” W x 9” D (40.1cm X 19.8cm X 22.9cm)
- Nema Rating: Nema 3R (Nema 4x except with a battery vent)
- Mounting: Pipe-mounted, or wall-mounted
- Solar Panel Mounting: All solar panels are delivered with all hardware necessary for 2” pipe or mast-mounting

Integrated LCD Display/Keypad Option

ControlWave ExpressPAC offers a convenient local operator interface. The 2-button display allows an operator to view site, configuration and process data. The screens are organized in a series of lists. The operator can select a list and then manually scroll through the data. Additionally, a “scroll list” can be defined. The ControlWave ExpressPAC can be set to automatically sequence through this list.

The 25-button Display/Keypad performs the same functions and additionally allows the operator to view and modify ControlWave ExpressPAC inputs, process variables, calculated variables, setpoints, tuning parameters, and outputs used in a measurement or control application. Status bits include the alarm state, alarm acknowledge, control, and manual (Auto/Man). Providing access to such variable information allows the user complete control over the process operation.

The standard LCD provides 4 line x 20 character display with either a two-button read-only or 25-button read-write keypad. Both display/keypad assemblies have the same “footprint” on the front door.

Features – Display/Keypads

- 4 line by 20 character backlit liquid crystal display
- Adjustable display contrast
- Membrane keys with tactile feedback
- Self-adhesive overlay mounts to the enclosure door or panel (ControlWave ExpressPAC is delivered with this assembly installed on the door)
- Easy configuration via ACCOL III Function Block
- Scrolling display mode
- Adjustable timer turns off display when not in use

Specifications – Display/Keypads

- Window size: 1.1” H x 3.1”W (2.8cm x 7.9cm)
- Character size: 4mm H x 3mm W
- Dimensions: 7.4”H x 5.5”W (18.8cm x 14.4cm)
- Power consumption: 2.5 mA @ 3.3V (0.008 watts)
- Operating Temperature: -4 to 158°F (-20 to 70°C)



Shown, above, is the LCD with 25-button keypad. The 2-button version is similar but includes only two “arrow” buttons to sequence through lists.

Scalability

ControlWave ExpressPAC can also be combined seamlessly with other members in the ControlWave family of products. For remote applications requiring more I/O flexibility, ControlWave Micro provides a modular RTU/PLC expandable up to 14 I/O modules.

For natural gas well site and measurement station automation, ControlWave single and multi-run flow computers share a common architecture with the ControlWave family of products and all meet API 21.1 requirements for multiple meter runs.

For in-plant control applications, ControlWave and ControlWave Micro are powerful, flexible PLCs. ControlWave offers the greatest local and remote I/O expansion to hundreds of I/O points, up to three Ethernet ports for network segmentation, plus CPU, communication and I/O redundancy capability.

The combined benefits of the ControlWave family of products integrates your wide area network with your local area network.

Open Standards For Programming, Network Configuration and Communication

Only ControlWave brings the perfect combination of industry standards to minimize learning, engineering and implementation costs.

By adhering to such industry standards as Ethernet, TCP/IP, Microsoft Windows®, COM/DCOM, FTP, OLE and ActiveX, ControlWave is able to achieve the highest degree of openness in control system architecture and bring the optimal process efficiency and productivity needed to ensure a successful system implementation.

ControlWave Designer with ACCOL III

To minimize your engineering and development time, we have adopted the international standard for PLC programming, IEC 61131-3. ControlWave Designer is a fully IEC 61131-3 compliant programming environment for the ControlWave family of products. ControlWave Designer includes all five

IEC 61131-3 process languages for batch, continuous and discrete control: Function Block Diagram, Structured Text, Sequential Function Chart, Ladder Logic Diagram and Instruction List.

ControlWave Designer includes an extensive library of more than 200 basic IEC 61131-3 functions and function blocks common to many IEC 61131-3 based products. These include:

- Flip-flops, Counters & Timers
- Ladder diagram functions – coils and contacts, etc.
- Numerical, Arithmetic & Boolean functions – Sine, Cosine, Add, Sub, Square Root, And, Or, etc.
- Selection & Comparison – Min, Max, Greater than, Equal, Less than, etc.
- Type conversions – Integer to Real, Boolean to Word, etc.

ACCOL III

In addition to the basic functions and function blocks, ControlWave Designer brings the benefit of over twenty years of SCADA and plant control experience in Emerson's Bristol ACCOL III function block library. ACCOL III includes over sixty function blocks valuable for use in oil & gas, water & waste and process measurement & control applications. Further, ACCOL III is designed to take full advantage of the significant features offered by ControlWave.

Briefly, this library includes function blocks for:

- Average, Compare, Totalize
- Scheduling & Sequencing
- PID & Lead/Lag
- AGA gas flow and liquids calculations
- File handling

In addition, ControlWave ensures data integrity, in the event of a communication interruption, by storing critical time-stamped alarm and historical data in the controller memory. This data is then securely retrieved when communication is restored.

Specifications

CPU

- 32-bit ARM processor: 14 & 33 MHz CPUs
- Sleep mode for low power applications
- Real time clock/memory battery backup: 9000 hours
- Program execution and Data Memory : 2 MB battery backed SRAM memory
- Data and file storage memory: 8 MB Flash for Program source, historical Archive and Audit storage
- Historical Archive memory: Stored in flash
- Optional solar power regulator
- LED status indicators – Watchdog and CPU Idle LEDs

Communication

- Two RS-232 and one selectable RS-232/RS-485 serial communication port supporting baud rates up to 115.2 KB
- One optional 100/10 Base-T Ethernet port with RJ45 connector
- One RJ45 connector for interface to ControlWave LCD Display/Keypad

Power Input

- 5.4 to 16 Vdc power input with 14 MHz CPU
- Surge suppression 16 V transorb
- 11.4 to 28.0 Vdc power input with 33 MHz CPU
- Surge suppression 30 V transorb
- Power-fail detection and recovery sequencer
- Battery voltage monitor
- Reverse voltage protection

Environmental Specifications

- **Operating Temperature range:**
40 to 70°C (-40 to 158°F), 85°C storage
-20 to 70°C (-4 to 158°F) with display/ keypad
-20 to 60°C (-4 to 140°F) with Lead Acid Cell Batteries
- **Relative Humidity:** 15-95% non-condensing
- **Vibration:** 2.0g for 10-150 Hz – 1.0g for 150Hz to 2000Hz
- **RFI Susceptibility:** 3V/m – 80 MHz to 1000Mhz (EN50082-2)
- **Electrostatic Discharge:** Meets IEC EN 60001-4-2, EN 61326

CPU RFI

- Immunity: ENV 50140 Radio-frequency
- Electromagnetic field amplitude modulated EMC
- Emissions: EN 55022:1998 Class A ITE emissions requirements (EU)
- ICES-003 Issue 3 Class A Digital Apparatus emissions requirements (Canada)
- AS/NZS3548:1995/CISPR Class A ITE emissions requirements (Australia)

I/O RFI Susceptibility:

3V/m – 80 MHz to 1000Mhz (IEC 1000-4-3)

Hazardous Area Approvals

- Approved as non-incendive for operation in Class I, Division 2

ControlWave ExpressPAC is approved by UL as an instrument. This certification does not allow installation of any other hardware, not indicated by the model number, in the instrument enclosure. Wiring to and from the I/O, communication and power connections inside the enclosure, per the ControlWave ExpressPAC manual, are, of course, allowed.

Power Consumption

- 14 MHz CPU: 0.036 watt
- 33 MHz CPU w/o Ethernet: 0.12 watt
- 33 MHz CPU with Ethernet: 1.0 watt
- DIO card: 0.018 watt
- DIO plus AIO card: 0.021 watt

ControlWave ExpressPAC Process I/O

ControlWave Express I/O module is designed to maximize usability while minimizing installation and maintenance.

The I/O module provides a mix of analog and digital inputs and outputs that are a perfect fit for small RTU applications.

- 2 DI/PI (on CPU)
- 1 RTD input on 14 MHz CPU
- 4 DI
- 2 DO
- 2 selectable DI or DO
- 2 selectable DI or HSC
- Optional 3 AI or 3 AI and 1 AO

Features

- Convenient pluggable local
- All configuration jumpers and switches accessible without disassembly of circuit boards
- Termination points for external loop power supply

Specifications

All I/O

- I/O access: 50 ms with 33 MHz CPU, 250 ms with 14 MHz CPU
- 1 second for 2 DI/PI inputs on CPU board

- Surge protection: Meets C37.90-1978 30 Vdc transorb between signal and ground
- Terminations are pluggable and accept a maximum wire size of 16 gauge
- Power consumption is stated for each I/O module type measured at the input supply and does not include loop power

Pulse/Digital Inputs

- Inputs located on base CPU board
- Number of points: up to 2 non-interrupting inputs
- Internally sourced, dry contact single ended inputs
- Scan rate: Once per second
- Input filter: 20 microSec
- Voltage Range: Internally sourced dry contact input - 3.3 Vdc
- On state: >1.6 V, Off state <1.3V
- Input current : 200 μ A for low power applications
- Power consumption:
200 μ A input, all inputs ON: 0.002 watt

Used as Pulse Input:

- Frequency Range: 0-10 kHz
- Debounce: None
- Accumulator: 16 bit

RTD Input

- Input available on 14 MHz Ultra Low Power CPU only
Specifications are for the interface, only, not including the RTD probe or wiring
- RTD Conversion Accuracy: $\pm 0.1^{\circ}\text{C}$, or $\pm 0.1\%$ of reading, whichever is greater
- Ambient temperature effect on RTD measurement: $\pm 0.01^{\circ}\text{C} / ^{\circ}\text{C}$ max
- Long Term Stability at Constant Conditions: $\pm 0.25^{\circ}\text{C} / \text{month}$ max

Digital Inputs

- Number of points: up to 4 dedicated DI and 4 selectable DI (2 DI/DO, 2 DI/HSC)
- Non-interrupting inputs
- Internally sourced, dry contact single ended inputs
- Input Voltage Range: Internally sourced dry contact input - 3.3 Vdc
- On state: >1.6 V, Off state <1.3V
- Input current :
 - 4 DI selectable 60 μ A for low power applications or 2 mA for in-plant noise immunity
 - 2 DI/DO selectable 200 μ A or 2.2 mA
 - 2 DI/HSC selectable 200 μ A or 2.2 mA
- Input filtering: 15 ms time constant (contact bounce)
- Power consumption:
 - All 8 inputs ON: 0.005 watt
(4 inputs @ 66 μ A and 4 @ 200 μ A)
 - All 8 inputs ON: 0.075 watt
(4 inputs @ 2 mA and 4 @ 2.2 mA)

Digital Outputs

- Number of points: 2 dedicated, 2 selectable DO (2 DI/DO)
- Output type: solid state open drain MOSFET
- Operating voltage range: 10 - 31Vdc
- Maximum operating frequency: 20 Hz
- Current sink capability: 400 mA at 16 V (6 V system), 400 mA at 30 V (12/24 V system)
- Power consumption:
 - Not applicable to DOs

Analog Inputs

- Number points: 3 AI optional
- AI Resolution: 14 bit
- Input Configuration: Externally sourced. Single-ended inputs - jumper selectable 4–20 mA or 1–5 Vdc. Terminal block connections provided for external source.
- Input Impedance: 1 meg Ω - 1.5 Vdc;
- 250 Ω - 4-20 mA
- Input Filtering: 12 Hz
- Channel Settling Time: 600 ms to be within 0.01% of input signal
- Input accuracy:
 - 0.1% of span at 25°C
 - 0.2% of span -40 °C to 70 °C
- Power consumption:
 - Not applicable

Analog Output

- Number of Channels: 1 AO optional
- Output configurations: Selectable externally sourced 4-20 mA or 1-5 Vdc:
 - 250 ohm with 12 V external source
 - 650 ohm with 24 V external source
 - 1-5 Vdc @ 5mA max., 11 to 30 Vdc external source
- D/A resolution: 12 bit
- Accuracy:
 - 0.1% of span @ 25°C for current output;
 - 0.1% + 3% of span @ 25°C for voltage
 - 0.3% of span @ -40 to 70 °C for current
 - 0.3% + 3% of span @ -40 to 70 °C for voltage
- Power consumption – 1 outputs:
 - Analog current output: 0.1 watt
 - Analog voltage output: 0.1 watt

High Speed Counters

- Number of points: 2 selectable as HSC or DI
- Frequency Range: 0-10 kHz
- Input Voltage Range:
Internally sourced: 3.3 Vdc
Externally sourced: 3 Vdc to 24 Vdc
- On state: >1.6 V, Off state <1.3V
- Input filter: 20 microSec for 10 kHz HSC
1 ms for 300 Hz LSC
- Input current : selectable 200 μ A for low power applications or 2.2 mA for in-plant noise immunity
- Accumulator: 16 bit
- Power consumption:
200 μ A input, all inputs ON: 0.004 watt
2.2 mA input, all inputs ON: 0.039 watt

Power System, Charge Regulator and AUX Output

ControlWave ExpressPAC offers a variety of internal power systems that includes lithium batteries and rechargeable, lead acid cell batteries. The lead acid batteries are matched with solar panels as charging sources.

Related to the power system, a charge regulator circuit and, in the 12 Vdc versions only, an auxiliary output (AUX Output) is available in ControlWave ExpressPAC (except models with Ethernet). The AUX Output is typically used to control power to the radio.

Specifications – Charge Regulator and AUX Output

- Input Voltage Range: 5.0 to 18.0 Vdc
- Fuses: 1.5 A from charge regulator, 3.5 A for each battery input, 1.0 A to the CPU assembly

- Surge suppression: 18 V transorb. Meets ANSI/IEEE C37.90-1978
- Charge regulator: Temperature-compensated charge control with cut-off
- Standby charging circuit limits: 6.33V max, 6.09V min for 6V battery and 12.4V max, 11.9V min for a 12V battery
- Threshold voltage for shunt at 23°C: 7.3V for a 6V battery and 14.6V for a 12V battery
- AUX Output Max Load Current: 1.8 A continuous, 2.5 A momentary
- AUX Output “on” Resistance: 0.37 Ohms typical, 0.5 Ohms max

Available Power Options

- 7.2 Vdc Lithium battery (single or dual)
- 6 Vdc, 1 watt solar panel, 7 AH lead acid battery
- 6 Vdc, 4.3 watt solar panel, 7 AH lead acid battery
- 12 Vdc, 4.5 watt solar panel, 7 AH lead acid battery

Power systems are sized for operation with all I/O but without powering field devices. The 12 Vdc supply is sized to operate a radio in “slow duty cycle” mode.

Modem Specifications

The optional auto-dial / auto-answer modem provides a sleep mode that conserves power while allowing it to wake up when a call comes in.

- Function: Provides PSTN (Public Switched Telephone Network) communications
- Operating Modes: Sync or Async. 2-wire switched network - Half or Full Duplex
- Line Type: Two-wire loop start lines
- Modem Configuration: “AT” based commands
- Data Rate: V.32 bis - 9600 bps, V.32 - 9600 bps, V.22 bis - 2400 bps, V.22 - 1200 bps or 600 bps, V.21 - 300 bps, Bell 103J - 300 bps, Bell 212A - 1200 bps

- Telephone Functions: Dialing and answering by AT commands. Automatic answering is also programmable
- Approvals: Telephone - FCC Part 68 (also suitable for approval within Canada)
- Trans. Output Levels: -10 dBm fixed (USA) - (0-15 dBm adjustable – firmware dependent)
- PSTN Arrangements: Loop Start arrangement (transmission output does not exceed -10 dBm). Allows connection to any voice telephone jack
- Isolation: Data Access Arrangement (DAA) with 1000 Vac (Modem to PSTN)
- Sleep Mode Current: 0.5 mA (max) @ 12V (Input Voltage); 1.0 mA (Max) @ 6V (Input Voltage)
- Surge Capability: Withstand surge of 100A with 10 x 160 microsecond waveform
- Temperature: Operating Range: -40° to +60°C (-40° to 140°F); Storage Range: -40° to +85°C (-40° to 185°F)
- Relative Humidity: 15% to 90%, non-condensing

Radio Option

The ControlWave ExpressPAC is available with one optional FreeWave or MDS radio.

Since some users prefer to procure the radios separately, Emerson offers "radio-ready" configurations for each of the standard radio models.

Radio-ready models include literally everything except for the radio. The mounting bracket as well as all cables and connections are in place. The user or integrator/installer must simply mount the radio to the bracket and make connections.

It is important to match the radio-ready configuration with the specific radio the user expects to install because cables and connections for the antenna,

RS 232 port and power all vary by radio model.

The optional Polyphaser surge protector is recommended with any radio selected.

Power Consumption for the Radios

NOTE: When conserving power, ControlWave Express turns power to the radios completely off instead of operating them in the sleep mode.

Freewave FGR Spread Spectrum Radio Figures at 12 Vdc:

- Receive: 75 mA
- Transmit: 500 mA
- Idle: 20 mA

MDS TransNet 900 Spread Spectrum Radio Figures at 13.8 Vdc:

- Receive: 115 mA
- Transmit: 510 mA

MDS models 4710 and 9710 Licensed, UHF Radios with figures at 13.8 Vdc:

- Receive: 125 mA
- Transmit: 2000 mA

MDS entraNet 900 IP Radio Figures at 13.8 Vdc:

- Receive: 100 mA
- Transmit: 510 mA

MDS iNet 900 Ethernet/IP Radio Figures at 13.8 Vdc:

- Receive: 203 mA
- Transmit: 580 mA

OpenBSI

Simply Creative

Emerson's OpenBSI (Open Bristol System Interface) is a set of network setup, communication diagnostic, and data viewing utilities that provide access to ControlWave controllers, flow computers and RTUs. OpenBSI is the only product available in the industry to bring such unique functionality and ease of use to the network level. At the core is the communication interface, written as a Windows communication server API through which other client applications communicate with the Bristol networks.

OpenBSI supports both serial BSAP protocol and Ethernet Internet Protocol communication to ControlWave controllers, flow computers and RTUs.

OpenBSI Utilities

Above this communication layer are a group of applications known as OpenBSI Utilities. These client utilities communicate through the server to collect and manage data gathered from the network, generate files based on collected historical data, collect alarms, and monitor and control OpenBSI communications.

- Communication engine for PC applications
- Supports ControlWave serial and IP protocols
- RS 232, Dial-line, cellular, radio, satellite, and Ethernet connections
- Provides on-line download & signal variable changes
- Allows network configuration through NetView
- PC and Network communication diagnostics
- OPC Server for interfacing to most HMI software
- Harvester collects historical data on request or scheduled basis

NetView is the basic configuration and application interface for all network operations. NetView uses a tree structure for network graphical display in the Windows Explorer style. Network nodes can be added on-line by simply dragging the node Icon into the tree. This invokes a configuration Wizard simplifying network setup. Through the NetView Wizard, the necessary network parameters are entered for node and IP address, alarm and message routing, and network communication media. Once configured, selecting any node allows direct access to the common OpenBSI utilities to reprogram, download a new application to the node, review communication statistics, view real-time data through DataViewer, and edit controller/RTU properties.

Local Configuration Wizard allows local communication with any attached ControlWave controller or RTU to download system flashware upgrades, configure cold download parameters, and configure IP and soft-switch parameters.

DataView is an on-line utility used to collect and display several types of process data, including signal values, data array values, signal lists, and audit trail information.

Operators have the ability to alter signal values. Multiple DataView windows may be open simultaneously.

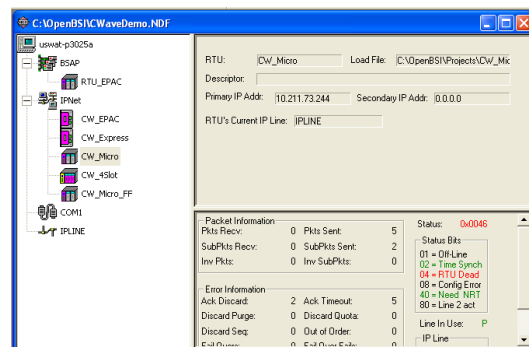

Netview - Network configuration and application Launchpad



Configuration Wizard simplifies Network setup

WebBSI - WebBSI is a powerful and flexible software product bringing web technology to all of Remote Automation Solutions' automation and SCADA products. WebBSI includes a set of ActiveX Controls for reading and writing real-time and historical data, trending, recipe editing and custom display generation. Through these controls, you can use the standard Microsoft Internet Explorer web browser to access ControlWave products through a set of supplied HTML web pages.

Real-time ActiveX Controls

One of the many benefits OpenBSI brings to you is our use of open standards such as ActiveX Controls. ActiveX is another of the Microsoft standards, which allow plug and play with any ActiveX container, using Microsoft ActiveX container technology such as Visual Basic, HTML web pages, and Microsoft Excel

The set of available ActiveX Controls provides the basic functions necessary to communicate and collect data from ControlWave.

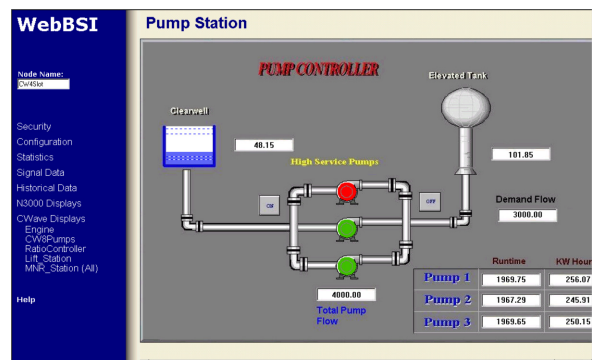

Custom built web page interface using a standard web browser

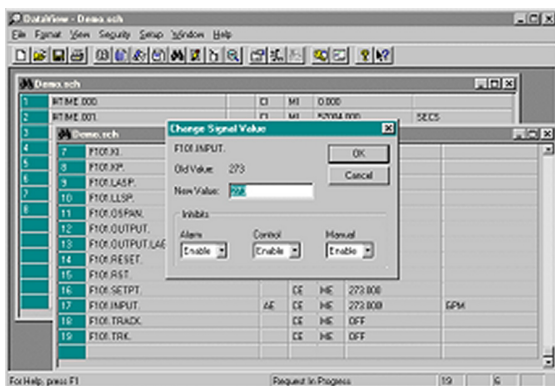

DataView for Real-time data display

ActiveX Controls

- Security – 56-bit encryption - allows the user to sign on to the RTU
- Signal Value – displays signal values in various formats
- Comm Statistics – works with a standard page that displays the RTU's communication statistics
- Configuration Info – works with a standard page that displays and allows the user to change RTU Configuration information
- Historical – Collect and view historical archive and audit files

The IP compliant ControlWave opens the door for owner controlled access via Web Pages. Any generic web page builder can be employed to create user defined pages to access ControlWave. The web pages are populated with these pre-configured ActiveX controls.

Required Software

- Microsoft Internet Explorer
- Bristol ActiveX controls
- OpenBSI LocalView or NetView

Historical Data Collection

High Historical Data Integrity

The ControlWave Historical Data Collection system offers exceptional historical data integrity by providing time-stamped historical data storage in ControlWave flash memory. The historical data is collected, through OpenBSI on a scheduled or demand basis and converted to .CSV and ODBC compliant file formats for use in spreadsheets and reports. If data is missed due to a communication failure, it is collected when the communication is reestablished and the PC historical database is backfilled with the missing data. This distributed historical database architecture provides the greatest data reliability and integrity during communication or PC failure.

Another important historical feature is the Audit storage and collection system. The Audit Trail is a file stored in ControlWave flash memory containing significant events and time-stamped alarms. The alarms stored in the Audit system provide a historical archive in addition to the real-time alarm reporting system.

This file is also collected through OpenBSI and presented as a text file in the PC. This functionality is extremely useful in providing an event trail during communication or PC downtime or other system problem.

- Archive Collection – collection and storage to disk of the ControlWave archive data
- Audit Collection - collection and storage to disk of the ControlWave audit data.
- Exports data files to third party, .CSV & ODBC applications
- DDE compliant for use with other popular Windows applications

OPC Server

With industry demand for open standards, ControlWave answers the call by embracing technologies that open the door for maximizing your efficiency and productivity. The OPC standard was developed by the OPC Foundation comprised of hardware and software suppliers from the process control community. OPC allows the engineer to select best in class hardware and software with confidence in their interoperability. Our OpenBSI OPC Server was among the first to comply with the OPC Foundation alarm and event server specification.

- OPC Data Access 1.0a & 2.0 compatible
- WindowsXP
- Compatible with ControlWave systems
- 32 bit multi-threading, multi-processor design
- Automatic database builder
- Integrated real-time data monitor
- Supports OPC Browse interface
- Supports both serial comm and IP Ethernet connections
- Supports COM/DCOM & OLE Automation
- Primary and Background polling scheme
- OPC Alarm & Event Server support

ControlWave Open Network Connectivity

By embracing the open system network technologies available through TCP/IP, Ethernet, OPC, and Microsoft DNA, as well as pseudo standards such as Modbus and Open Modbus, ControlWave can provide a total Process Automation Management Solution for in-plant LAN based networks and Wide Area Network SCADA systems.

With the exceptional connectivity provided by the ControlWave network, access to real-time data and operating conditions, historical data, maintenance and performance data are all available to the global network. ControlWave provides the needed information to the plant floor technician, operator, engineer, supervisor and corporate management, even external customers.

Communication Protocols

Like all of Emerson's Bristol products, ControlWave supports BSAP (Bristol Standard Asynchronous Protocol), Modbus, DFI, CIP, DNP3, and serial ASCII as standard functions.

These protocols are implemented in Flashware so no additional hardware is required to use any one or a combination of all protocols.

BSAP Protocol

BSAP - BSAP is widely accepted as providing exceptional data integrity and greatly simplifies communication between controllers. BSAP is provided with interfaces for Master/Slave, vertical networks, and Client/Server, horizontal networks. In either case, variable lists are created in each controller that are easily passed from server to client or slave to master.

BSAP meets the definition of an industry-standard, open architecture protocol because it conforms to ISO standards 2629, 1745 and 2111, it is not proprietary in that Emerson does not charge a license fee and makes the protocol and documentation available to anyone.

While BSAP is an open protocol, the added functionality of the messages provide much more capability than is found in other networks.

- Global time-synchronization
- Time-stamped Alarm reporting
- Historical archive data transfer
- Audit file transfer
- On-line program editing
- Diagnostics
- Communication statistics

Modbus Protocol

Modbus - Modbus is often considered a de-facto standard protocol because of its broad usage as

either the primary or a secondary offering in many measurement and control related products. Even with its common use, Modbus protocol actually has many variations. Consider Modbus RTU and Modbus ASCII, Master & Slave, Serial and TCP/IP Open Modbus. In addition there are considerations regarding supported function codes, floating point values and byte order. Bristol products support the following:

- Modbus serial and TCP/IP Open Modbus (Ethernet)
- Master and Slave
- Modbus RTU and ASCII
- Modes 1 - 7, 8, 15 & 16
- IP modes 51, 52 & 53
- Integer and IEEE 4 byte floating point

Generic Serial Interface

The Generic Serial Interface is a user programmable Master and Slave protocol used to send and receive messages typically with third party serial ASCII devices. This protocol can be used to interface with such devices and message boards, card readers and many measurement devices.

Multi-user Security Access

Security is an essential element of any open system, particularly those with Internet access. ControlWave employs a User Name/Password access system protected by a 56-bit encryption technique through the TCP connection. There can be up to thirty-two users, who sign-in using their name and password. Both the name and the password can be up to sixteen characters.

The security system provides for up to sixty-four access rights to read and write data values and files via FTP, access and configure historical and audit data information, edit configuration, run internal diagnostics, read and reset system status. It further allows the programming software to read, write and download the ControlWave.

The Secure Data Advantage

ControlWave sets a new standard for providing intelligent control at the point where control is needed. Whether you need control on the plant floor or at a remote site in the “middle of nowhere” ControlWave is the solution for control, communication and secure data to help you make the right operating decisions.

ControlWave was designed to provide the optimum level of data security using a distributed database architecture. All data including time & date stamped alarms, alarm limits, and historical data are stored locally in each industrially rugged ControlWave, thereby distributing your data integrity risk. To further ensure that the data is always current and historically accurate, the historical data is stored in non-volatile flash memory within ControlWave. Historical data is even maintained during and after program downloading.

When historical data is collected from ControlWave, it is converted and appended to .CSV and/or ODBC compliant databases but does not destroy the original historical data stored in ControlWave, thus providing a flexible and secure historical data system that is clearly recognized as a benefit to virtually every industrial application.

The Bridge Between Systems

Continuing our tradition of introducing innovative new solutions while maintaining compatibility with existing systems, Emerson again provides a migration path for existing customers by bridging the new ControlWave system with Network 3000 systems already in place. The network bridge is enabled by employing the open architecture technologies afforded by TCP/IP and OPC in both networks. TCP/IP allows seamless Ethernet connectivity to both networks as well as the corporate Intranet so both ControlWave and Network 3000 controllers can reside and communicate on the same LAN. Emerson’s Bristol OpenBSI OPC Server facilitates the merging of the two networks for technical, engineering and operator data access. The data source, configuration and path are completely transparent to the OPC client. Real-time data can also be passed between the two communication networks making this a total Plant Automation Management Solution.

Product Data Document

420DS-7e / D301312X012

June 2011 - Page 14

ControlWave ExpressPAC

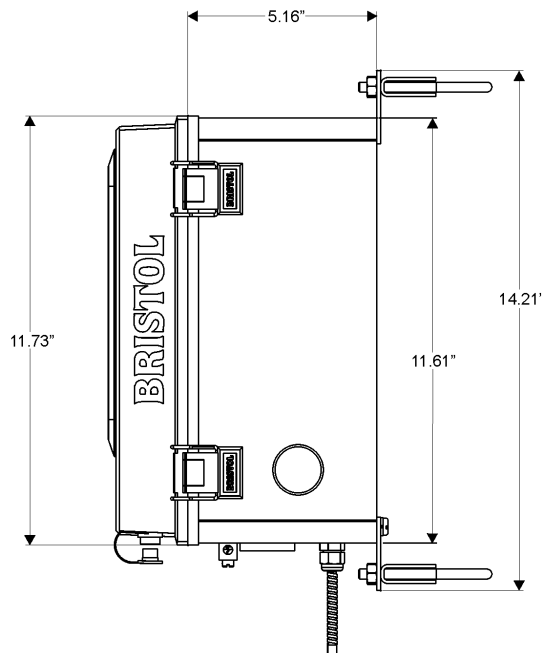
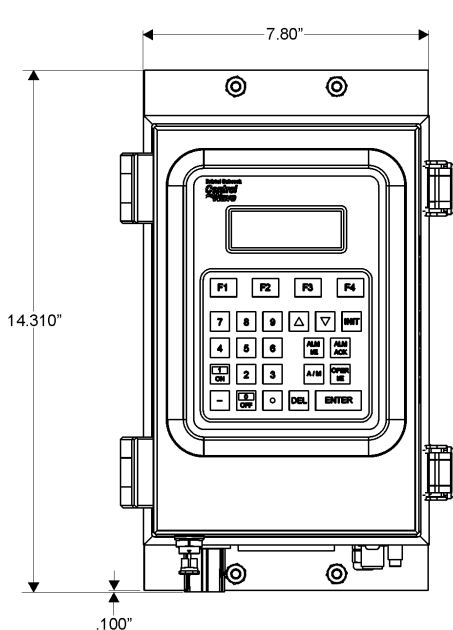
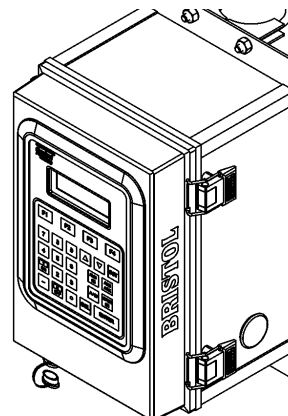
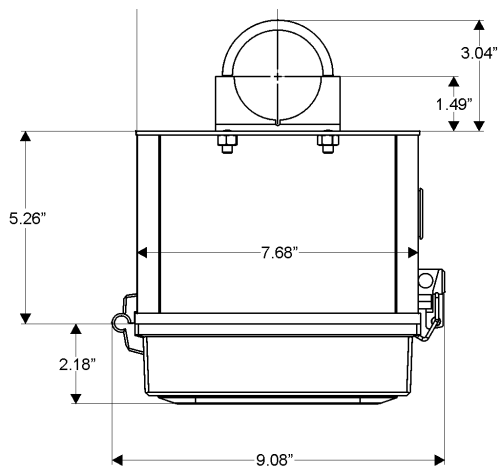

© 2009-2011 Remote Automation Solutions, division of Emerson Process Management. All rights reserved.

Bristol, Inc., Bristol Canada, BBI SA de CV, the Flow Computer Division, and Emerson Process Management Ltd, Remote Automation Solutions division (UK), are wholly owned subsidiaries of Emerson Electric Co. doing business as Remote Automation Solutions, a division of Emerson Process Management. FloBoss, ROCLINK, Bristol, Bristol Babcock, ControlWave, TeleFlow and Helicoid are trademarks of Remote Automation Solutions. AMS, PlantWeb and the PlantWeb logo are marks of Emerson Electric Co. The Emerson logo is a trademark and service mark of the Emerson Electric Co. All other marks are property of their respective owners.

The contents of this publication are presented for informational purposes only. While every effort has been made to ensure informational accuracy, they are not to be construed as warranties or guarantees, express or implied, regarding the products or services described herein or their use or applicability. Remote Automation Solutions reserves the right to modify or improve the designs or specifications of such products at any time without notice. All sales are governed by Remote Automation Solutions' terms and conditions which are available upon request. Remote Automation Solutions does not assume responsibility for the selection, use or maintenance of any product. Responsibility for proper selection, use and maintenance of any Remote Automation Solutions product remains solely with the purchaser and end-user.

Emerson Process Management Remote Automation Solutions

Watertown, CT 06795 USA
Mississauga, ON 06795 Canada
Worcester WR3 8YB UK

T 1 (860) 945-2200
T 1 (905) 362-0880
T 44 (1) 905-856950

Website: www.EmersonProcess.com/Remote

