

# 3808 MVT Multivariable Transmitter

## Model 3808-10A With P/T Variables

### Featuring:

- Excellent measurement performance over the full range of operating pressure and temperature conditions
- Extremely low power consumption — perfect for remote sites with battery and solar power systems
- “Bilingual” Networking via BSAP and Modbus protocols with RS 485 interface — operates as an RTU node on SCADA networks
- Intrinsically safe and explosion proof for operation in Class I, Division 1 hazardous areas
- “Wet end” sensor assembly is independent of the “top end” assembly
- Two versions: RS485 with RS232 port for configuration or Analog Output with FSK signal.

### Introduction

The 3808 MVT is Emerson Process Management’s answer to industry demands for a transmitter with high reliability, high performance over real world remote pressure and temperature conditions, ease in use, “networkability” and very low power consumption. The 3808 MVT has been designed to provide the highest value in terms of all user considerations, including purchasing, installation, operation and maintenance.

To maximize measurement accuracy, the 3808 combines a wet end with a low reference uncertainty of 0.075% URL, with a design that minimizes effects of pressure and temperature over the full range of operating conditions.

For remote sites such as those in the energy and water industries, power consumption has been a key consideration. Costs of batteries and solar panels are proportional to current draw and



**The 3808 MVT Multivariable Transmitter features accurate measurement of gauge pressure and temperature.**

many users are surprised at the capital expenses associated with electronics, which have not been designed to conserve power. The sophisticated design employed by the 3808 MVT keeps current draw well below 2 mA and with a power source as low as 5 Vdc.

For remote sites, power budgeting is often very tight. Since the power consumption is so low, the 3808 MVT can even be added to existing sites, which were designed with no extra capacity for power.

While the BSAP (Bristol Synchronous and Asynchronous) protocol ensures compatibility with Emerson’s measurement and SCADA systems, Modbus provides compatibility with a wide variety of controllers, flow computers, RTU devices and SCADA systems from numerous suppliers.

### Functionality Overview

Emerson’s 3808 MVT provides the following basic operations

- Conversion of sensor readings from the “wet

end” pressure sensor assembly into accurate floating point pressure values. Conversion calculations utilize correction coefficients contained in the sensor assembly and are performed once per second for each process variable

- Conversion of raw readings from an on-board A/D into an accurate floating point RTD value. RTD conversions are performed once per second
- Up to 19200 baud, 2-wire RS-485 serial communications interface, or a 1200 baud, FSK modem interface via the 4-20ma current loop for Network communication
- Local RS-232 serial communications interface fixed at 19200 baud. (Connecting to the RS-232 communications interface disables the RS-485 communications.)
- A subset of the Emerson BSAP RDB and Peer-to-Peer communications interface:
  - Complete set of User/Host Interface functions for Configuration, Calibration, and Data Collection
  - Floating point values returned individually, or in pre-defined Lists
  - Floating point values available for GP, T, Sensor Temperature, and Error Status
  - Floating point, Logical, or String values also available for other user configuration parameters
- Optional, 4-to-20 mA Analog Output:
  - Linear or Square Root Mode
  - Reversible Output Action
  - May be controlled externally to provide a remote AO
- Optional, on-board LCD display with P and T information

## Physical Overview

Service: Level, pressure, temperature measurements for liquids and gases.

Diaphragm Material: 316 SS or Hastelloy C

Connection Material: 316 SS or Hastelloy C

Fill Media: DC 200 Silicone Oil

Process Connections: ½” - 14 NPT male pipe tap and ⅛” - 27 NPT female pipe thread on single connection

Electrical Connections: ½” NPT Conduit Connection

Housing: Low Copper Aluminum with epoxy paint NEMA 4X explosion proof.

Local indication: 4-½-Digit LCD display linear or square root in engineering units.

RTD sensor: 3-wire platinum 100-ohm per DIN 43760 25 feet max.

User connections: 10-terminal (2-rows) tri-barrier strip for + power, -power, RTD +, RTD-, RTD-, TXD, and RXD.

## Power Supply Information

Operating Voltage Range: 5 – 42 Vdc

### Current Draw:

With RS 485: Less than 2 mA

With FSK, but with 4 – 20 mA output disabled: Less than 3.2 mA

### Turn-on time:

Measured input variables will be within specifications less than two seconds after power is applied to the 3808 MVT.

# 3808 Multivariable Transmitter

## Accuracy and Performance Specifications

All specifications are for the digital, floating-point signal.

### Gauge Pressure

Combined effects of nonlinearity, nonrepeatability and hysteresis at reference pressure and over the operating temperature range:

GP linear mode:  $\pm 0.075\%$  of Calibrated Span or  $0.015\%$  of URL, whichever is greater.

Temperature effect on gauge pressure:

$\pm 0.21\%$  URL maximum combined shift of zero and span with an ambient temperature change of  $60^\circ\text{C}$  ( $108^\circ\text{F}$ )

Long Term Stability at Constant Conditions:

$\pm 0.1\%$  URL/Year typical

Ripple and noise: Per ISA 50.1 Section 4.6

### Process Temperature - RTD Interface

A three-wire platinum RTD per DIN 43760 is supported. The temperature, T, in degrees Celsius is calculated using the Resistance vs. Temperature Tables according to the DIN EN 60751 standard for Class A & B RTDs. The DIN EN 60751 equation is:

$$R(t) = R_0 * (1 + At + Bt^2)$$

Where:

$$A = 3.9083 * 10^{-3} \text{ } ^\circ\text{C}^{-1}$$

$$B = -5.775 * 10^{-7} \text{ } ^\circ\text{C}^{-2}$$

$$R_0 = 100\text{ohms}$$

In addition, the user may enter the  $R_0$ , A, and B coefficients of a custom calibrated RTD, another platinum standard or a different material (Nickel, Balco or Copper). During the RTD calibration, the User will be able to set the  $R_0$ , A, and B coefficients, restore the factory default for these coefficients, and calibrate the internal Reference resistor.

## Process Temperature Input Specifications

(for the interface, only, not including the RTD probe or wiring)

RTD Conversion Accuracy:  $\pm 0.1^\circ\text{C}$ , or  $\pm 0.1\%$  of reading, whichever is greater

Ambient temperature effect on RTD measurement:

$\pm 0.01^\circ\text{C}$  /  $^\circ\text{C}$  max

Long Term Stability at Constant Conditions:

$\pm 0.25^\circ\text{C}$  / month max

## Analog Output Specifications

Non-linearity:  $0.1\%$  max

Temperature effects:  $\pm 0.25\%$  Full Scale over  $60$  degrees C.

## Environmental Specifications

Over Pressure Limit: Equal to the gauge pressure upper range limit (URL).

Temperature limits:

Wet End:  $-40$  to  $+85^\circ\text{C}$

Electronics:  $-40$  to  $+85^\circ\text{C}$

With Display:  $-30$  to  $+70^\circ\text{C}$

Storage Temperature:  $-40$  to  $+100^\circ\text{C}$

Humidity limits: When covers are properly installed, unit will withstand  $0$  to  $100\%$  RH (NEMA 4X enclosure)

Vibration:  $\pm 0.1\%$  URL/g max  $10$ - $500$  Hz in any axis per SAMA PMC-33-1C

Electromagnetic compatibility:

Conditions: Current output (only) twisted pair wires includes RTD. Covers installed and wiring run in grounded conduit.  $10\text{V}/\text{M}$ ,  $20$ - $500$  MHZ per SAMA PMC-33-1C:

GP:  $\pm 0.25\%$  URL

RTD Temperature:  $\pm 1^\circ\text{C}$

## Liquid Crystal Display (LCD)

The LCD displays the measured variables for P and T. The display will continually cycle through all measured variables. The value and Engineering Units for a particular variable will be displayed for three seconds. An annunciator indicates which pressure variable is being displayed.

The LCD provides 4 1/2 digits of display precision with a decimal point. The following Engineering Units are included:

- °C
- °F
- BAR
- psi
- in H<sub>2</sub>O @60°F
- kg/cm<sup>2</sup>
- kPa

## User Interface for the 3808 MVT

Using a lap-top personal computer, field personnel can quickly calibrate and configure a 3808 MVT transmitter. The personal computer interfaces to the RS 232 port. Meanwhile, the RS 485 port wiring need not be disconnected. RS 485 communication is disabled only while the PC cable is connected to the RS 232 terminals.

Emerson's LocalView Calibration Tool includes all calibration and configuration operations. This tool will be familiar with users of Smartkit as well as all other Emerson flow computers and provides users of all Emerson measurement products a consistent and compatible Human-Machine Interface (HMI).

A variety of User Interface features are provided by the 3808 MVT. These include:

- Set Communications Baud Rate
- Set BSAP Local Address
- Set BSAP Group Number

- Set Modbus Node Address
- Set Modbus Mode (ASCII/RTU)
- Enable/Disable Static Pressure Reading
- Enable/Disable RTD Temperature Reading
- Read current DP/GP, SP, T, Sensor Temperature, and Status values
- Read DP/GP and SP Upper Range Limits
- Calibrate Zero/Span for DP/GP and SP
- Calibrate Zero for RTD
- Configure RTD Coefficients
- Configure 4-20ma Analog Output
  - Enable/Disable
  - Select Forward/Reverse Acting
  - Select Output Variable (DP/GP, SP, User Defined, or None)
  - Calibrate Zero/Span
- Select Engineering Units for DP/GP, SP, T
- Set Floating Point Damping Factor
- Display Transmitter Information (Traceability information, Range Codes, Firmware Revision)

## Communication Interface

### BSAP Interface

The 3808 MVT will act as an immediate response BSAP Slave device. The 3808 MVT will function as a terminal node only in a BSAP Network. BSAP Global messages received with the 3808 MVT's Local Address will be processed by the 3808 MVT. Note that pass through, or routing, of BSAP Global messages, Expanded BSAP messages, and Time-Sync/Node Routing Table messages are not supported.

A subset of the RDB and Peer-to-peer messages are supported. This will provide the user both RDB and Peer-to-Peer List access to the 3808 MVT Process variables and parameters.

# 3808 Multivariable Transmitter

## MODBUS Interface

The 3808 MVT will act as a Modbus compatible, slave device. The 3808 MVT provides support for both Modbus ASCII and Modbus Remote Terminal Unit (RTU) transmission modes, utilizing a subset of the Read/Write commands available via Modbus.

To provide support for a variety of Modbus compatible host controllers, the 3808 MVT data available via Modbus are mapped into Modbus Coils/Registers. To accommodate the different types of Modbus hosts available (i.e. standard Modbus, ENRON Modbus) floating point data items are mapped to several different Modbus Register address ranges. This provides both 16-bit and 32-bit register access using the appropriate register address and function code.

## Accessories

Emerson's OpenBSI/LocalView – Calibration and configuration software for a PC

CD part number: 395575-02-8

PC-to-3808-MVT Cable – Connects to the RS 232 port on the 3808 MVT, 10 foot, part number: 396596-01-0

Transmitter Interface Unit (TIU) – For compatibility with the 3508, this module is used to connect a PC to the FSK signal on the 3808 MVT.

Part Number 389959-01-4

For the TIU, please specify the modem cable length:

6 foot – part number 390929-01-8

12 foot – part number 390929-02-6

25 foot – part number 390929-03-4

## Bendable RTD

The user can select a bendable RTD that attaches to the transmitter via an armored cable of 6-foot, 15-foot or 25-foot length. The individual wires connect to terminations on the termination plate. The RTD assembly also includes a fitting, which is installed in the conduit port.

If ordered along with the transmitter, the bendable RTD assembly will be shipped in the same box as the transmitter.

The bendable RTD is a “one size fits all” solution that is perfect for most applications and excellent for depot-level inventory situations in which the ultimate installation (and, therefore, thermowell depth) is not necessarily known.

The 12” probe can quickly be inserted in a thermowell, whereupon the user can tighten the included fitting to lock it in place and bend the excess length out of the way.

Note that a thermowell is required for this bendable RTD!

Note also that the bendable RTD assembly is approved only for use in Class I, Division 2 hazardous areas and is not explosion proof.



**Product Data Document**

225DS-26J / D301301X012

June 2013

**3808 Multivariable Transmitter**

**Model Number: 3808-10A - A - B - C - D - E - F - G - H - J - J1 - K**

**3808-10A**

	DESCRIPTION	CODE
<b>A B</b>	<b>Input Range (Gauge Pressure) PSI</b>	<b>3808MVT</b> <b>A B</b>
10	0-15 "H <sub>2</sub> O to 300 "H <sub>2</sub> O	14
	0-1.25 to 0-25 PSI	20
	0-5 to 0-100 PSI	22
	0-15 to 0-300 PSI	23
	0-50 to 0-1000 PSI	25
	0-150 to 0-3000 PSI	26
	0-250 to 0-5000 PSI (with indication to 10,000 PSI)	27
	0-100 to 0-2000 PSI	28
	0-200 to 0-4000 PSI	29
<b>C</b>	<b>Diaphragm Material</b>	<b>X3508DIAPH</b> <b>C</b>
20	316 Stainless Steel	1
	Hastelloy C	2
<b>D</b>	<b>Filling Media</b>	<b>D</b>
30	DC 200 Silicone	1
<b>E</b>	<b>Comm / Output Options</b>	<b>E</b>
40	4-20 mA current output / FSK Note: Local calibration requires TIU.	1
	RS 485 Note: Local calibration requires RS 232 cable.	2
<b>F</b>	<b>Local Indication</b>	<b>X3808LIND</b> <b>F</b>
50	None	0
	4 1/2 Digit LCD	1
<b>G</b>	<b>Mounting Bracket</b>	<b>XTRANMTBKT</b> <b>G</b>
60	None	0
	With Mounting Bracket	1
<b>H</b>	<b>Certification</b>	<b>H</b>
70	UL/CUL Class I, Division 1, Groups C & D; Class I, Division 2, Groups A,B,C,D	1

# 3808 Multivariable Transmitter

**Model Number: 3808-10A - A - B - C - D - E - F - G - H - J - J1 - K**

**3808-10A** Model Specification Continued

<b>J Warning Plate</b>		<b>J</b>	
80	None	0	
	Russian	1	
<b>J1 RTD / Cable Assembly</b>		<b>J1</b>	
85	None	<b>Please refer to the notes, below, concerning the RTD Cable Assemblies.</b>	0
	With RTD and 6-foot Cable		1
	With RTD and 15-foot Cable		2
	With RTD and 25-foot Cable		3

<b>DESCRIPTION</b>		<b>CODE</b>
<p>If selected in "J1" above, the RTD/Cable assembly will be shipped in the same box as the transmitter. Due to UL restrictions, they cannot be shipped "pre-connected."</p> <p><b>IMPORTANT:</b> These particular RTD assemblies are not explosion-proof but are approved for Class I, Division 2 hazardous areas. For explosion-proof RTD components, please refer to "RTD Sensors and Related Accessories" in the price book.</p>		
<b>K Factory Configuration Options</b>		<b>K</b>
88	Use the Standard, Defaults - <b>Please DO NOT fill-in attachment 3800-A010</b>	0
	Specify Other Configuration Settings - <b>Please proceed to attachment 3800-A010.</b>	1

To specify a 3808 MVT that is approved by Industry Canada for custody transfer installations when used in conjunction with a ControlWave EFM or ControlWave XFC, please use the following model number and attachment number:

3808-10A-28-112-001-000

3808-B-1

**Product Data Document**

225DS-26J / D301301X012

June 2013

**3808 Multivariable Transmitter**

**Attachment Number: 3800-A - AB - CD - E - F - GH - J - KL - M - N - P - R - I - U**

**3800-A**

DESCRIPTION		CODE		
<b>A B</b>	<b>DP Units for 3808-30A or GP units for 3808-10A</b>	<b>A B</b>		
90/160	In H2O (Default)	00		
	PSI	01		
	mmH2O	02		
	ftH2O	03		
	<i>Special Note for 25 PSI DP range: If you use this attachment, "In H2O" become the default units. If you want "PSI," you must specify that, here.</i>			
			inHg	04
			mmHg	05
			KPa	06
			MPa	07
	BAR		08	
			mBAR	09
g/cm2			10	
kg/cm2			11	
<b>C D</b>	<b>SP Units for 3808-30A - Please note that this field is N/A for the 3808-10A</b>	<b>CD</b>		
92/170	In H2O	00		
	PSI (Default)	01		
	mmH2O	02		
	ftH2O	03		
	inHg		04	
			mmHg	05
			KPa	06
			MPa	07
			BAR	
	mBAR	09		
	g/cm2	10		
kg/cm2	11			
<b>E</b>	<b>Temperature Units for RTD Input</b>	<b>E</b>		
94/200	Degrees C (Default)	0		
	Degrees F	1		
<b>F</b>	<b>Communications Baud Rate</b>	<b>F</b>		
96/205	9600 (Default)	0		
	1200	1		
	2400	2		
	4800	3		
	19,200	4		



## 3808 Multivariable Transmitter

Attachment Number: 3800-A - AB - CD - E - F - GH - J - KL - M - N - P - R - I - U

## 3800-A

	DESCRIPTION	CODE
<b>G H</b>	<b>BSAP Local Address</b>	<b>GH</b>
98/210	Using two digits, including a leading zero for 1 - 9, please specify the address in 'GH,' ie. "01" through "32." For reference, the default address is 1.	
<b>J</b>	<b>BSAP Group Number</b>	<b>J</b>
100/300	Please fill-in a single-digit between 1 and 8 in 'J.' Group 1 is the default.	
<b>K L</b>	<b>MODBUS Node Address</b>	<b>KL</b>
102/310	Using two digits, including a leading zero for 1 - 9, please specify the address in 'GH,' e.g. "01" through "32." For reference, the default address is 1.	
<b>M</b>	<b>MODBUS Mode</b>	<b>M</b>
	ASCII (Default)	0
104/320	RTU	1
<b>N</b>	<b>ENABLE / DISABLE 4 - 20 mA Output</b>	<b>N</b>
	ENABLE (Default)	0
106/330	DISABLE	1
<b>P</b>	<b>4 - 20 mA LINEAR or SQUARE ROOT</b>	<b>P</b>
	LINEAR (Default)	0
108/340	SQUARE ROOT	1
<b>R</b>	<b>4 - 20 mA FORWARD or REVERSE ACTING</b>	<b>R</b>
	FORWARD (Default)	0
110/350	REVERSE	1
<b>T</b>	<b>4 - 20 mA OUTPUT VARIABLE</b>	<b>T</b>
	DP (in 3808-30A) or GP (in 3808-10A) (Default)	0
112/360	SP (3808-30A only)	1
	TEMPERATURE	2
<b>U</b>	<b>RTS DELAY</b>	<b>U</b>
	10 ms Default	0
115/365	50 ms that is known to work best for Chesapeake CW LP using Modbus	1

**Product Data Document**

225DS-26J / D301301X012

June 2013

# 3808 Multivariable Transmitter

## DIMENSIONED DRAWING

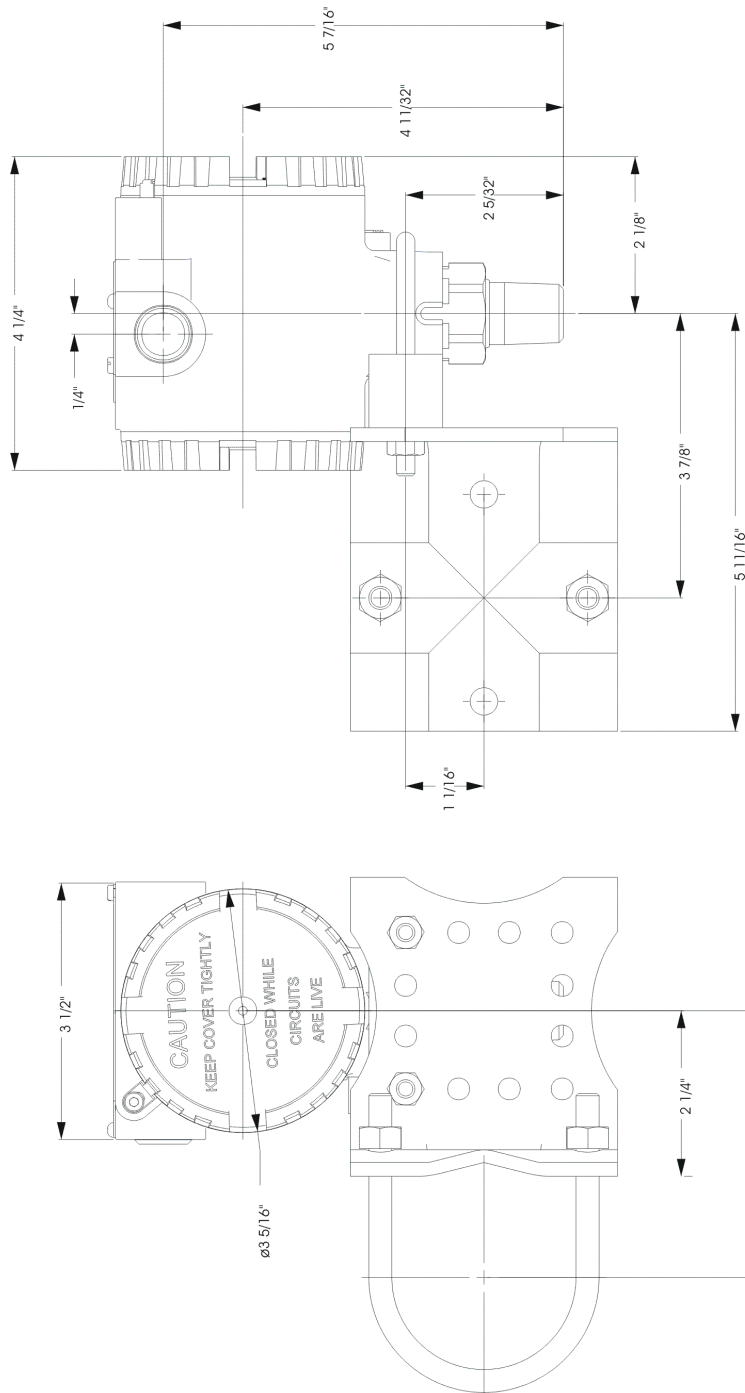

**3808-10A with Mounting Bracket Shown**

# 3808 Multivariable Transmitter

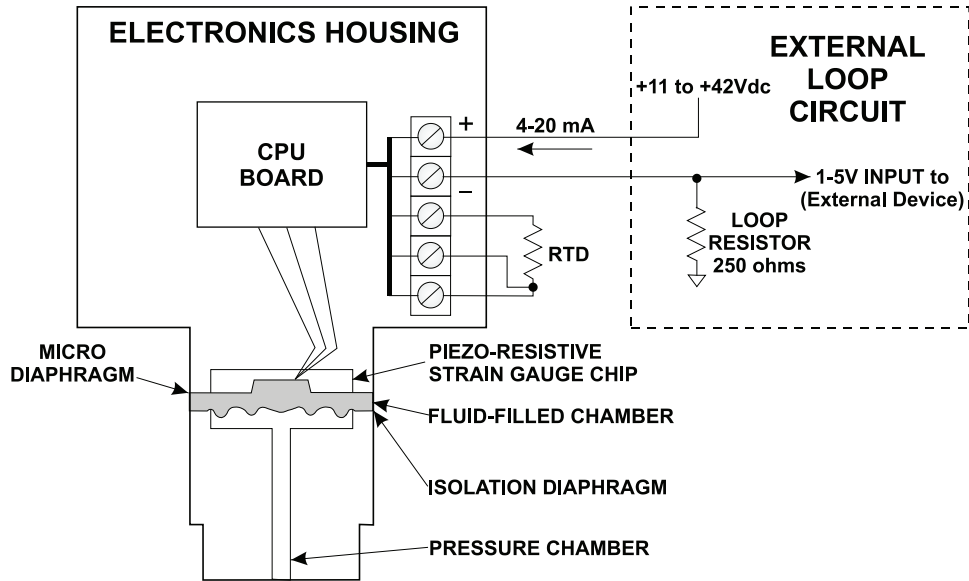

Simplified Diagram of 3808 MVT with 4 – 20 mA Signal

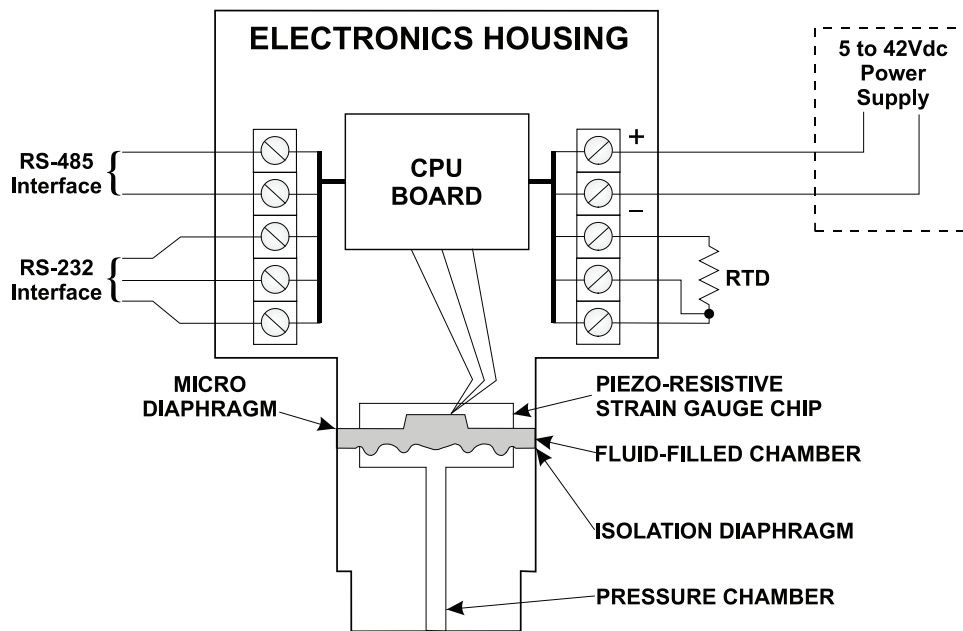

Simplified Diagram of 3808 MVT with RS 232 and RS 485 Interface

**Product Data Document**

225DS-26J / D301301X012

June 2013

**3808 Multivariable Transmitter**

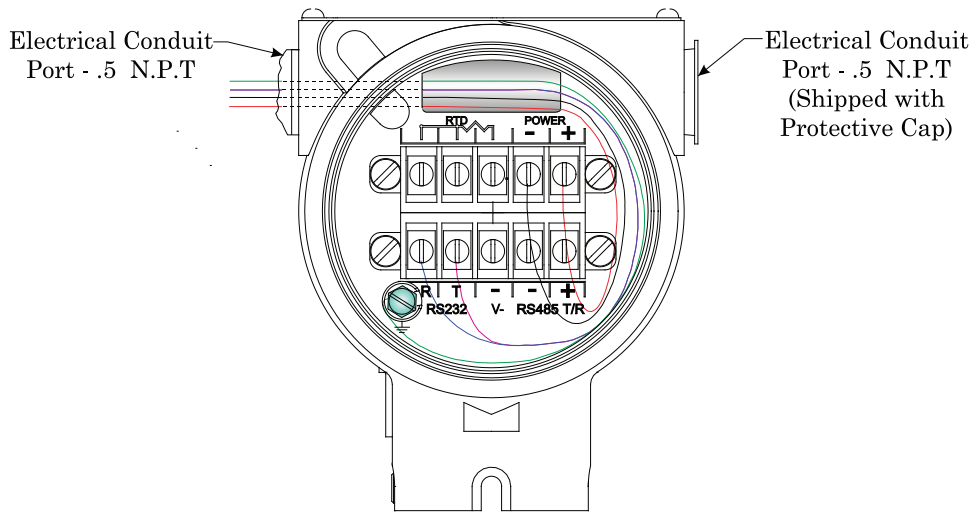

**3808 MVT Wire Routing**

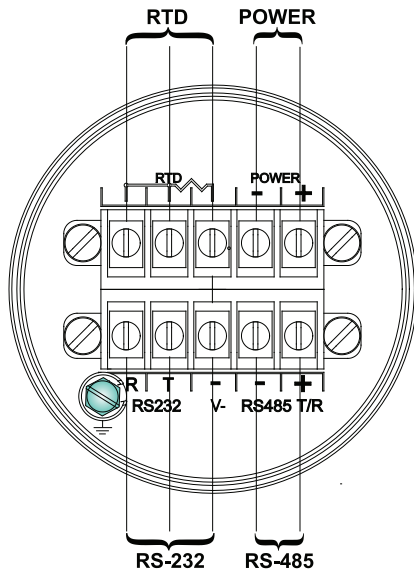

**3808 MVT DIGITAL MODEL**

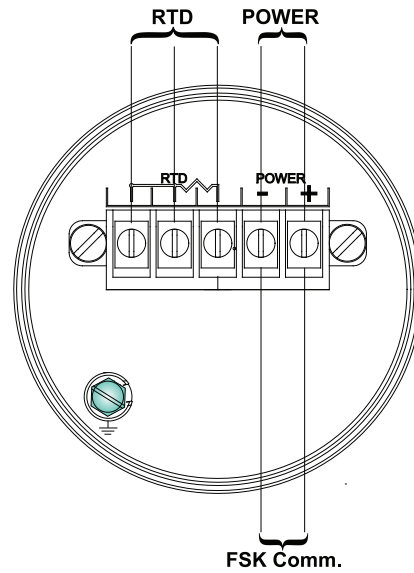

**3808 MVT ANALOG MODEL**

**3808 MVT Terminal Block Assignments**

# Multivariable Transmitter

---

Headquarters:

**Emerson Process Management**

Remote Automation Solutions  
6005 Rogerdale Road  
Houston, TX 77072 U.S.A.  
T +1 281 879 2699 | F +1 281 988 4445  
[www.EmersonProcess.com/Remote](http://www.EmersonProcess.com/Remote)

Europe:

**Emerson Process Management**

Remote Automation Solutions  
Unit 8, Waterfront Business Park  
Dudley Road, Brierly Hill  
Dudley UK DY5 1LX  
T +44 1384 487200 | F +44 1384 487258  
[www.EmersonProcess.com/Remote](http://www.EmersonProcess.com/Remote)

North American/Latin America:

**Emerson Process Management**

Remote Automation Solutions  
6005 Rogerdale Road  
Houston TX USA 77072  
T +1 281 879 2699 | F +1 281 988 4445  
[www.EmersonProcess.com/Remote](http://www.EmersonProcess.com/Remote)

Middle East/Africa:

**Emerson Process Management**

Remote Automation Solutions  
Emerson FZE  
P.O. Box 17033  
Jebel Ali Free Zone – South 2  
Dubai U.A.E.  
T +971 4 8118100 | F +971 4 8865465  
[www.EmersonProcess.com/Remote](http://www.EmersonProcess.com/Remote)

Asia-Pacific:

**Emerson Process Management**

Remote Automation Solutions  
1 Pandan Crescent  
Singapore 128461  
T +65 6777 8211 | F +65 6777 0947  
[www.EmersonProcess.com/Remote](http://www.EmersonProcess.com/Remote)

© 2008-2013 Remote Automation Solutions, a business unit of Emerson Process Management. All rights reserved.

Bristol, Inc., Bristol Canada, BBI SA de CV and Emerson Process Management Ltd, Remote Automation Solutions division (UK), are wholly owned subsidiaries of Emerson Electric Co. doing business as Remote Automation Solutions, a business unit of Emerson Process Management. FloBoss, ROCLINK, Bristol, Bristol Babcock, ControlWave, TeleFlow, Helicoid, OpenEnterprise, and METCO are trademarks of Remote Automation Solutions. AMS, PlantWeb and the PlantWeb logo are marks of Emerson Electric Co. The Emerson logo is a trademark and service mark of the Emerson Electric Co. All other marks are property of their respective owners.

The contents of this publication are presented for informational purposes only. While every effort has been made to ensure informational accuracy, they are not to be construed as warranties or guarantees, express or implied, regarding the products or services described herein or their use or applicability. Remote Automation Solutions reserves the right to modify or improve the designs or specifications of such products at any time without notice. All sales are governed by Remote Automation Solutions' terms and conditions which are available upon request. Remote Automation Solutions does not assume responsibility for the selection, use or maintenance of any product. Responsibility for proper selection, use and maintenance of any Remote Automation Solutions product remains solely with the purchaser and end-user.