

Assembly Instructions

Item No.:LH-TA-42104-BSD-C

Description:42"×80"-104" LEG TABLE

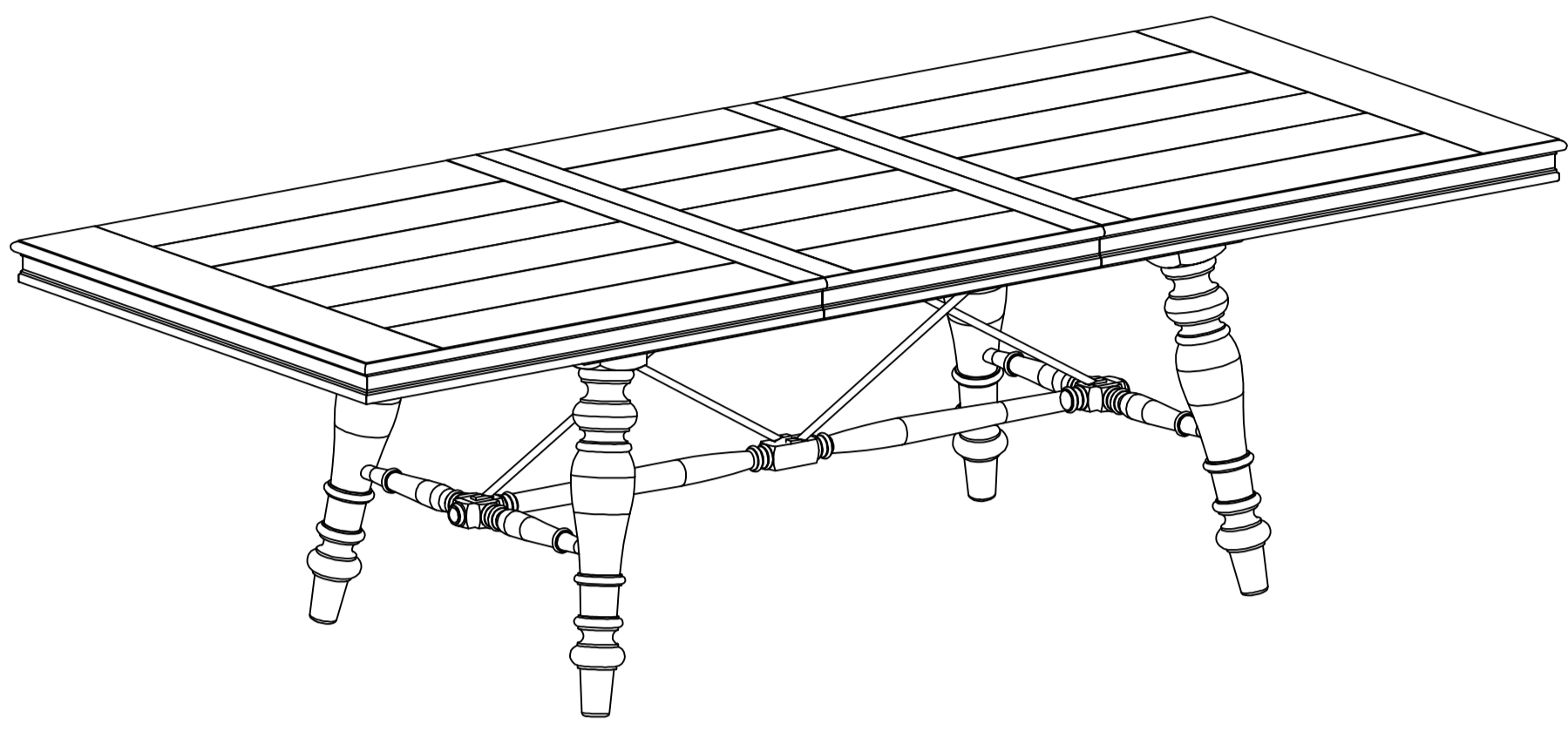

IMPORTANT NOTES:

- Place all wooden parts on a clean and smooth surface such as a rug or carpet to prevent the parts from being scratched.
- Check to be sure that you have all parts and hardware.
- Remove all wrapping materials, including staples and packing straps before you start to assemble.
- Do not tighten all screws and bolts until completely assembled.
- Keep all hardware out of the reach of children.

PARTS LIST

NO.		QTY
1	TABLE TOP	1
2	LEG	4
3	SIDE WOOD STRETCHER	2
4	MIDDLE WOOD STRETCHER	1
5	LONG METAL STRETCHER	2
6	SHOT METAL STRETCHER	2

HARDWARE LIST

NO.		SIZE	QTY
A	BOLT #1	5/16×2-1/2	4
B	BOLT #2	5/16×4	4
C	SCREWS	Ø8×Ø4.2×1 1/2	4
D	SCREWS	Ø8×Ø4.2×1	2
E	SCREWS	Ø8×Ø4.2×3/4	8
F	FLAT WASHER	5/16×3/4	8
G	SPRING	5/16×1/2	8
H	WRENCH	5/16	1

YOU MUST REMOVE THE METAL STOP BEFORE USING

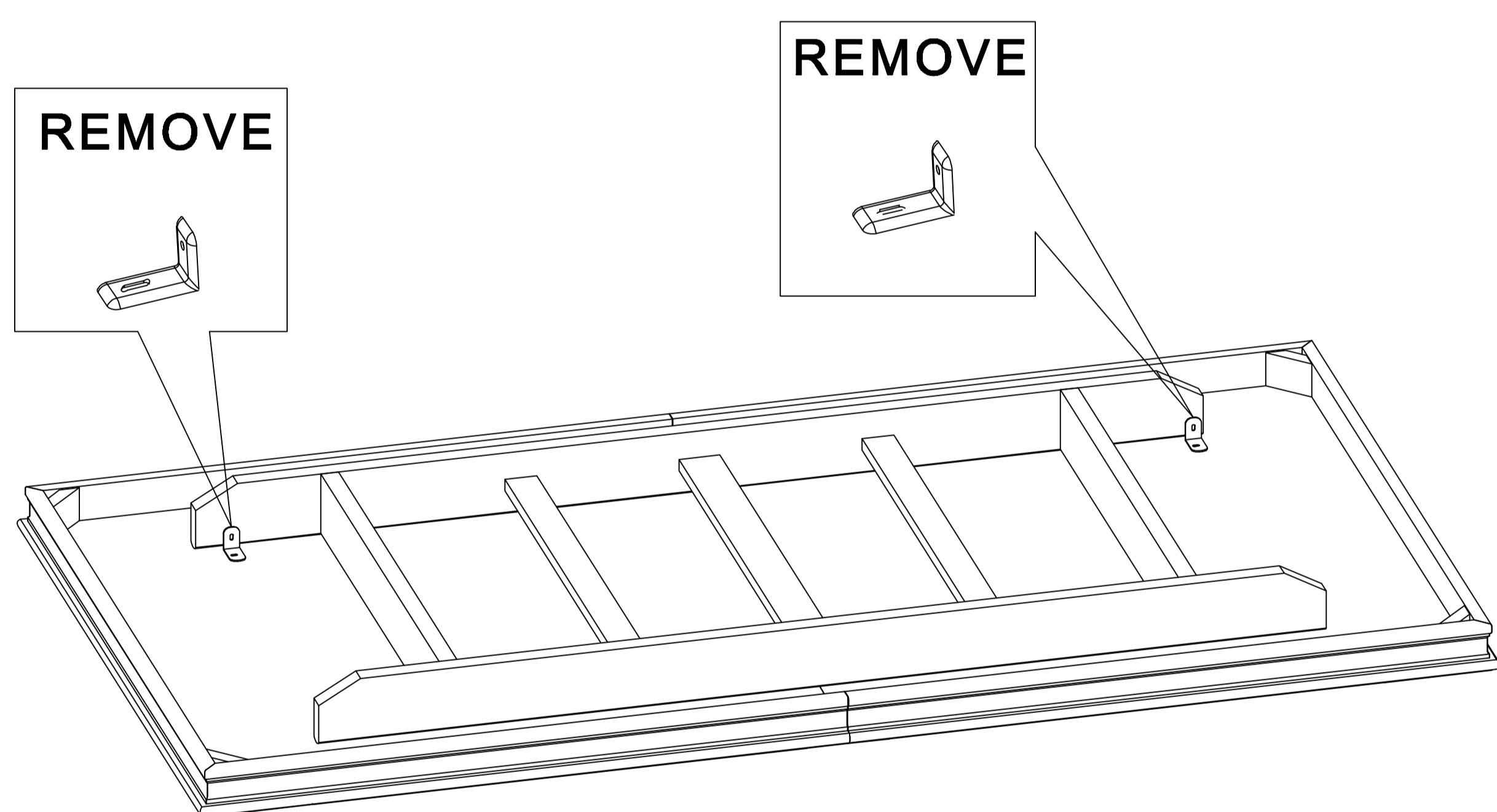

Figure 1

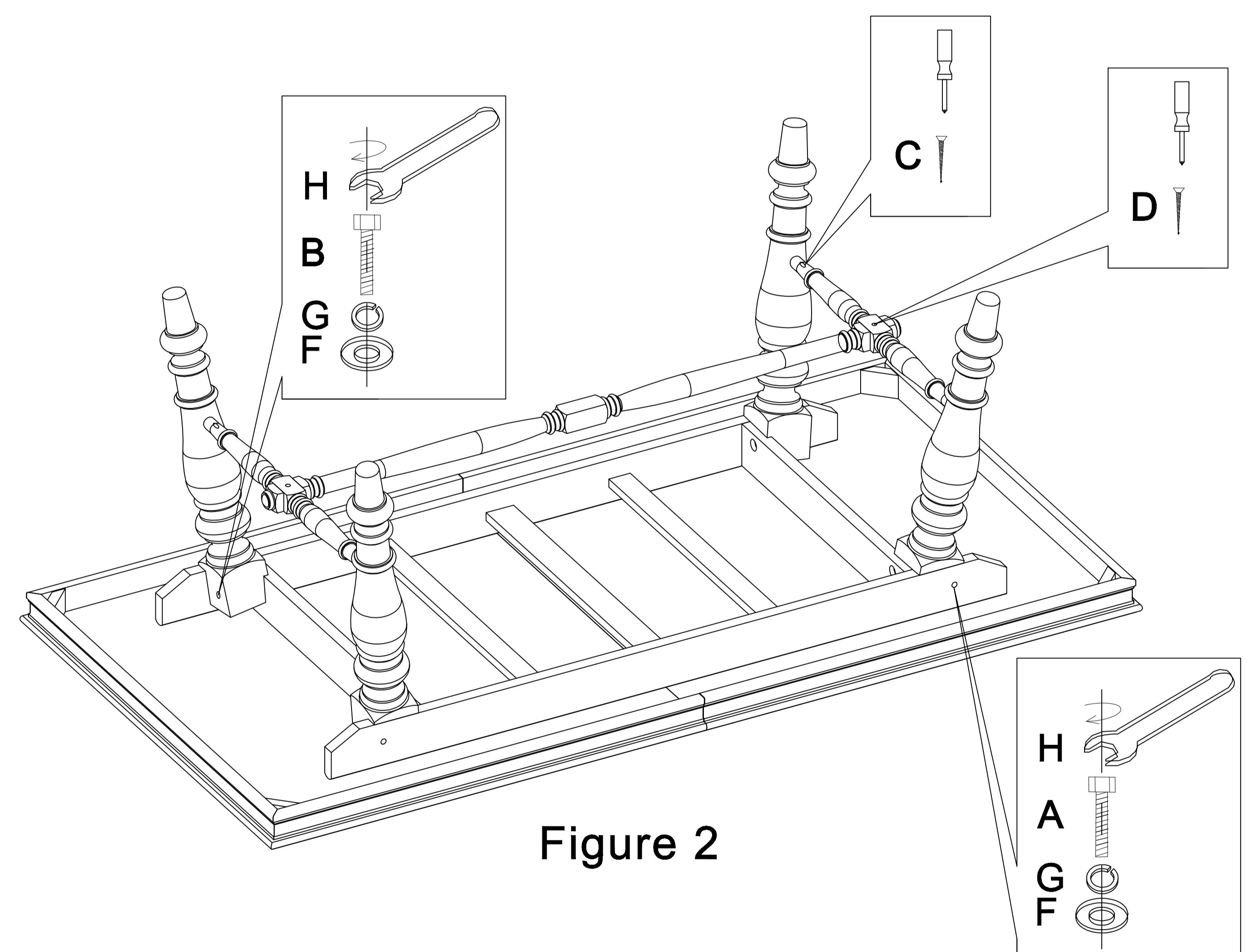

Figure 2

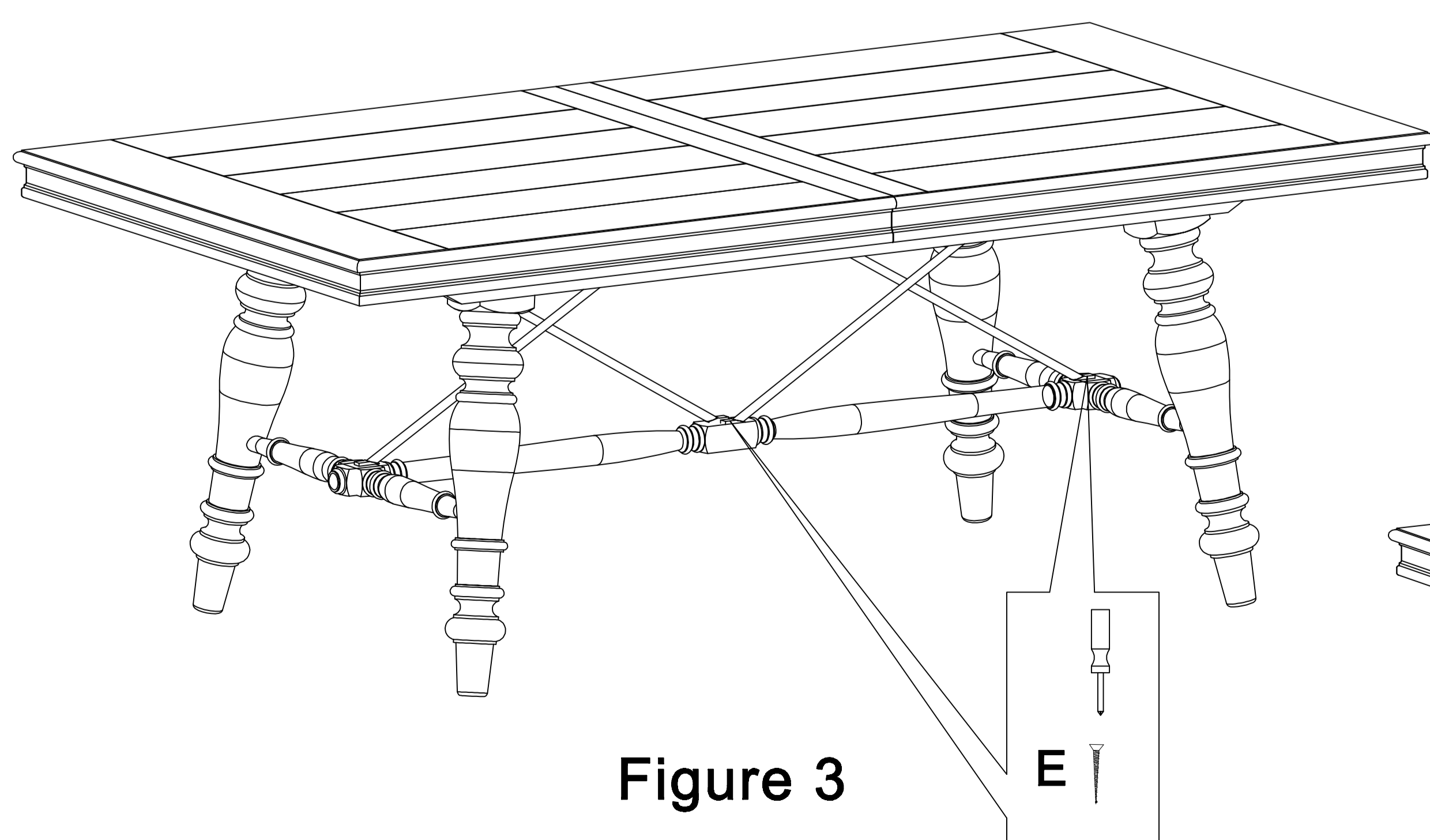

Figure 3

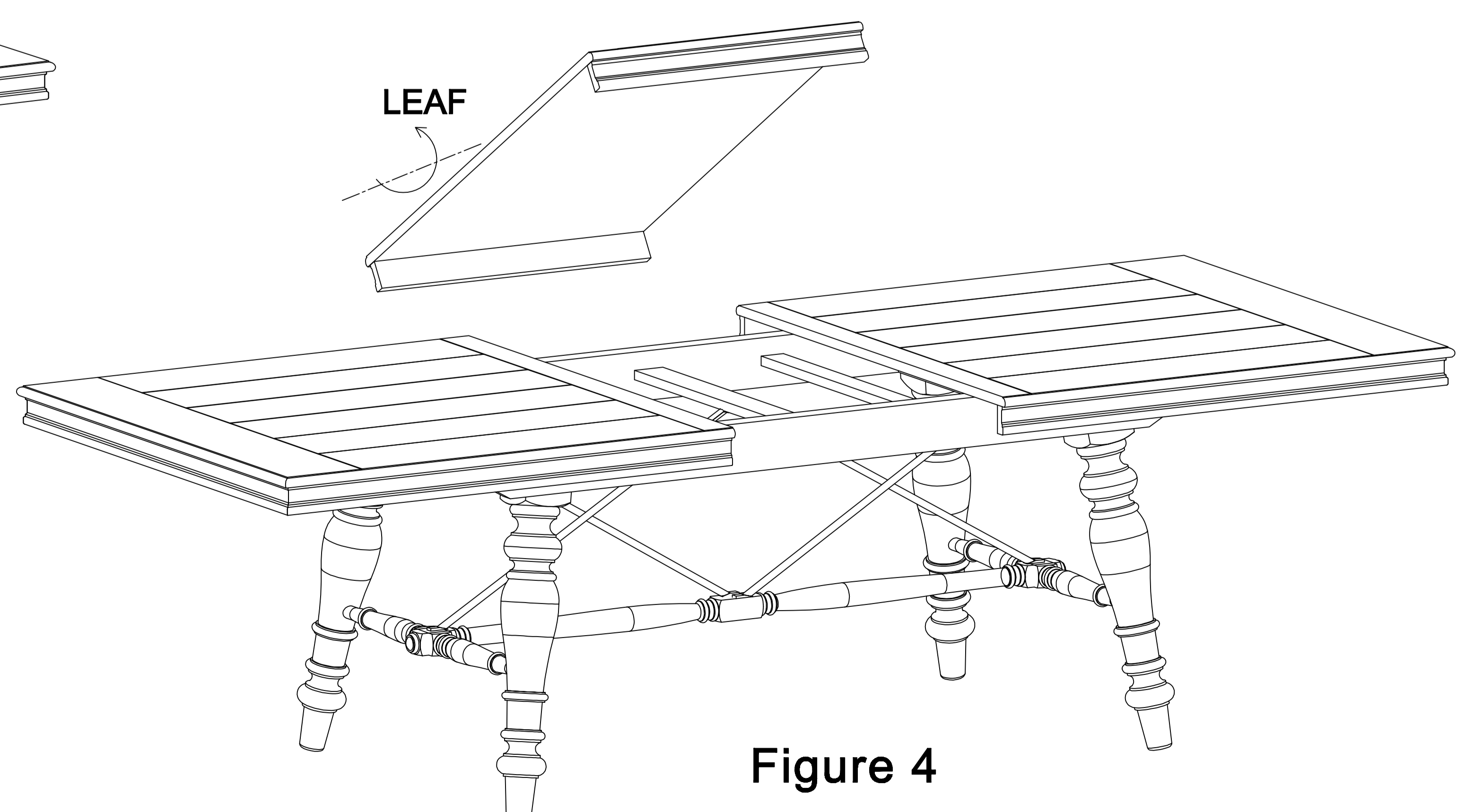

Figure 4