

# CONTENTS

Introduction	1
Chapter 1. Functions	2
Chapter 2. Limits and Continuity	43
Chapter 3. The Derivative	65
Chapter 4. Logarithmic and Exponential Functions	99
Chapter 5. Analysis of Functions and Their Graphs	139
Chapter 6. Applications of the Derivative	177
Chapter 7. Integration	209
Chapter 8. Applications of the Definite Integral in Geometry, Science, and Engineering	256
Chapter 9. Principles of Integral Evaluation	292
Chapter 10. Mathematical Modeling with Differential Equations	343
Chapter 11. Infinite Series	361
Chapter 12. Analytic Geometry in Calculus	408
Chapter 13. Three-Dimensional Space; Vectors	448
Chapter 14. Vector-Valued Functions	490
Chapter 15. Partial Derivatives	524
Chapter 16. Multiple Integrals	573
Chapter 17. Topics in Vector Calculus	608
Appendix A. Real Numbers, Intervals, and Inequalities	640
Appendix B. Absolute Value	647
Appendix C. Coordinate Planes and Lines	650
Appendix D. Distance, Circles, and Quadratic Equations	658
Appendix E. Trigonometry Review	668
Appendix F. Solving Polynomial Equations	674

# CALCULUS:

## A New Horizon from Ancient Roots

### EXERCISE SET FOR INTRODUCTION

1. (a)  $x = 0.123123123\dots$ ;  $1000x = 123.123123123\dots = 123 + x$ ;  $999x = 123$ ;  $x = \frac{123}{999} = \frac{41}{333}$   
 (b)  $x = 12.7777\dots$ ;  $10x = 127.7777\dots$ , so  $9x = 10x - x = 115$ ;  $x = \frac{115}{9}$   
 (c)  $x = 38.07818181\dots$ ;  $100x = 3807.818181\dots$ ;  $99x = 3769.74$ ;  

$$x = \frac{3769.74}{99} = \frac{376974}{9900} = \frac{41886}{1100} = \frac{20943}{550}$$
  
 (d)  $0.4296000\dots = 0.4296 = \frac{4296}{10000} = \frac{537}{1250}$
2. (a)  $\pi$  is irrational, and thus has a nonrepeating decimal expansion, whereas  $\frac{22}{7} = 3.\overbrace{142857}^{\text{repeats}}\dots$   
 (b)  $\frac{22}{7} > \pi$
3. (a)  $\frac{223}{71} < \frac{333}{106} < \frac{63}{25} \left( \frac{17 + 15\sqrt{5}}{7 + 15\sqrt{5}} \right) < \frac{355}{113} < \frac{22}{7}$       (b)  $\frac{63}{25} \left( \frac{17 + 15\sqrt{5}}{7 + 15\sqrt{5}} \right)$   
 (c)  $\frac{333}{106}$       (d)  $\frac{63}{25} \left( \frac{17 + 15\sqrt{5}}{7 + 15\sqrt{5}} \right)$
4. (a) If  $r$  is the radius, then  $D = 2r$  so  $\left(\frac{8}{9}D\right)^2 = \left(\frac{16}{9}r\right)^2 = \frac{256}{81}r^2$ . The area of a circle of radius  $r$  is  $\pi r^2$  so  $256/81$  was the approximation used for  $\pi$ .  
 (b)  $256/81 \approx 3.16049$ ,  $22/7 \approx 3.14268$ , and  $\pi \approx 3.14159$  so  $256/81$  is worse than  $22/7$ .
5. The first series, taken to ten terms, adds to 3.0418; the second, as printed, adds to 3.1416.
6. (a)  $\frac{1}{9} = 0.111111\dots = \frac{1}{10} + \frac{1}{100} + \frac{1}{1000} + \frac{1}{10000} + \frac{1}{100000} + \frac{1}{1000000} + \dots$   
 (b)  $\frac{2}{27} = 0.185185\dots = \frac{1}{10} + \frac{8}{100} + \frac{5}{1000} + \frac{1}{10000} + \frac{8}{100000} + \frac{5}{1000000} + \dots$   
 (c)  $\frac{14}{45} = 0.311111\dots = \frac{3}{10} + \frac{1}{100} + \frac{1}{1000} + \frac{1}{10000} + \frac{1}{100000} + \frac{1}{1000000} + \dots$
7. (a)  $\frac{7}{11} = 0.636363\dots = \frac{6}{10} + \frac{3}{100} + \frac{6}{1000} + \frac{3}{10000} + \frac{6}{100000} + \frac{3}{1000000} + \dots$   
 (b)  $\frac{8}{33} = 0.242424\dots = \frac{2}{10} + \frac{4}{100} + \frac{2}{1000} + \frac{4}{10000} + \frac{2}{100000} + \frac{4}{1000000} + \dots$   
 (c)  $\frac{5}{12} = 0.416666\dots = \frac{4}{10} + \frac{1}{100} + \frac{6}{1000} + \frac{6}{10000} + \frac{6}{100000} + \frac{6}{1000000} + \dots$
8. (a) 1, 2, 1.75, 1.7321      (b) 1, 3, 2.33, 2.238, 2.2361
9. (a) 1, 4, 2.875, 2.6549, 2.6458      (b) 1, 25.5, 13.7, 8.69, 7.22, 7.0726, 7.0711
10. (a) Let  $x_1 = \frac{1}{2}(a + b)$ ,  $x_2 = \frac{1}{2}(a + x_1)$ ,  $x_3 = \frac{1}{2}(a + x_2)$ , etc. Then  $b > x_1 > x_2 > \dots > x_{n-1} > x_n > a$  so all the  $x_i$ 's are distinct, there are infinitely many of them and they all lie between  $a$  and  $b$ .  
 (b)  $x = 0.99999\dots$ ,  $10x = 9.99999\dots$ ,  $9x = 9$ ,  $x = 1$   
 (c)  $(1.99999\dots)/2 = 0.99999\dots = 1$ ; yes it is consistent, as all three are equal.  
 (d)  $10x = 9 + x$ , so  $x = 9/9 = 1$ . They are equal.

# CHAPTER 1

## Functions

### EXERCISE SET 1.1

1. (a) around 1943 (b) 1960; 4200  
 (c) no; you need the year's population (d) war; marketing techniques  
 (e) news of health risk; social pressure, antismoking campaigns, increased taxation
2. (a) 1989; \$35,600 (b) 1983; \$32,000 (c) the first two years; the curve is steeper (downhill)
3. (a)  $-2.9, -2.0, 2.35, 2.9$  (b) none (c)  $y = 0$   
 (d)  $-1.75 \leq x \leq 2.15$  (e)  $y_{\max} = 2.8$  at  $x = -2.6$ ;  $y_{\min} = -2.2$  at  $x = 1.2$
4. (a)  $x = -1, 4$  (b) none (c)  $y = -1$   
 (d)  $x = 0, 3, 5$  (e)  $y_{\max} = 9$  at  $x = 6$ ;  $y_{\min} = -2$  at  $x = 0$
5. (a)  $x = 2, 4$  (b) none (c)  $x \leq 2; 4 \leq x$  (d)  $y_{\min} = -1$ ; no maximum value
6. (a)  $x = 9$  (b) none (c)  $x \geq 25$  (d)  $y_{\min} = 1$ ; no maximum value
7. (a) Breaks could be caused by war, pestilence, flood, earthquakes, for example.  
 (b)  $C$  decreases for eight hours, takes a jump upwards, and then repeats.
8. (a) Yes, if the thermometer is not near a window or door or other source of sudden temperature change.  
 (b) The number is always an integer, so the changes are in movements (jumps) of at least one unit.
9. (a) If the side adjacent to the building has length  $x$  then  $L = x + 2y$ . Since  $A = xy = 1000$ ,  
 $L = x + 2000/x$ .  
 (b)  $x > 0$  and  $x$  must be smaller than the width of the building, which was not given.  
 (c) 120 (d)  $L_{\min} \approx 89.44$

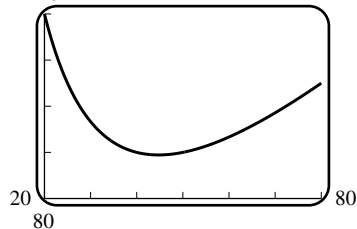

10. (a)  $V = lwh = (6 - 2x)(6 - 2x)x$  (b) From the figure it is clear that  $0 < x < 3$ .  
 (c) 20 (d)  $V_{\max} \approx 16$

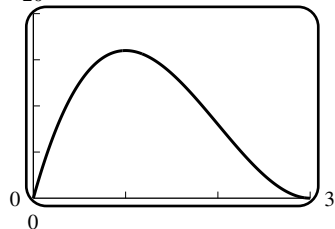

11. (a)  $V = 500 = \pi r^2 h$  so  $h = \frac{500}{\pi r^2}$ . Then  
 $C = (0.02)(2)\pi r^2 + (0.01)2\pi r h = 0.04\pi r^2 + 0.02\pi r \frac{500}{\pi r^2}$   
 $= 0.04\pi r^2 + \frac{10}{r}$ ;  $C_{\min} \approx 4.39$  at  $r \approx 3.4$ ,  $h \approx 13.8$ .

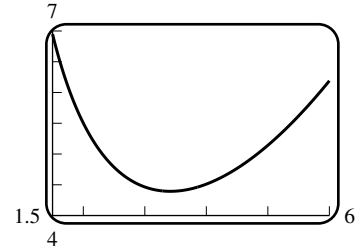

- (b)  $C = (0.02)(2)(2r)^2 + (0.01)2\pi r h = 0.16r^2 + \frac{10}{r}$ . Since  $0.04\pi < 0.16$ , the top and bottom now get more weight. Since they cost more, we diminish their sizes in the solution, and the cans become taller.

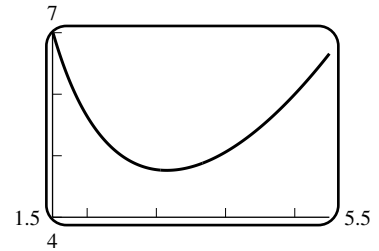

- (c)  $r \approx 3.1$ ,  $h \approx 16.0$ ,  $C \approx 4.76$

12. (a) The length of a track with straightaways of length  $L$  and semicircles of radius  $r$  is  $P = (2)L + (2)(\pi r)$  ft. Let  $L = 360$  and  $r = 80$  to get  $P = 720 + 160\pi = 1222.65$  ft. Since this is less than 1320 ft (a quarter-mile), a solution is possible.
- (b)  $P = 2L + 2\pi r = 1320$  and  $2r = 2x + 160$ , so  
 $L = \frac{1}{2}(1320 - 2\pi r) = \frac{1}{2}(1320 - 2\pi(80 + x)) = 660 - 80\pi - \pi x$ .

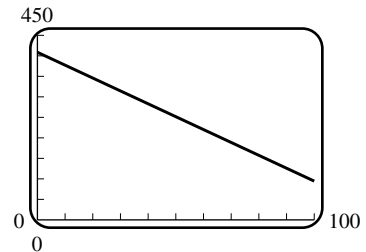

- (c) The shortest straightaway is  $L = 360$ , so  $x = 15.49$  ft.
- (d) The longest straightaway occurs when  $x = 0$ , so  $L = 660 - 80\pi = 408.67$  ft.

## EXERCISE SET 1.2

1. (a)  $f(0) = 3(0)^2 - 2 = -2$ ;  $f(2) = 3(2)^2 - 2 = 10$ ;  $f(-2) = 3(-2)^2 - 2 = 10$ ;  $f(3) = 3(3)^2 - 2 = 25$ ;  
 $f(\sqrt{2}) = 3(\sqrt{2})^2 - 2 = 4$ ;  $f(3t) = 3(3t)^2 - 2 = 27t^2 - 2$
- (b)  $f(0) = 2(0) = 0$ ;  $f(2) = 2(2) = 4$ ;  $f(-2) = 2(-2) = -4$ ;  $f(3) = 2(3) = 6$ ;  $f(\sqrt{2}) = 2\sqrt{2}$ ;  
 $f(3t) = 1/3t$  for  $t > 1$  and  $f(3t) = 6t$  for  $t \leq 1$ .
2. (a)  $g(3) = \frac{3+1}{3-1} = 2$ ;  $g(-1) = \frac{-1+1}{-1-1} = 0$ ;  $g(\pi) = \frac{\pi+1}{\pi-1}$ ;  $g(-1.1) = \frac{-1.1+1}{-1.1-1} = \frac{-0.1}{-2.1} = \frac{1}{21}$ ;  
 $g(t^2 - 1) = \frac{t^2 - 1 + 1}{t^2 - 1 - 1} = \frac{t^2}{t^2 - 2}$
- (b)  $g(3) = \sqrt{3+1} = 2$ ;  $g(-1) = 3$ ;  $g(\pi) = \sqrt{\pi+1}$ ;  $g(-1.1) = 3$ ;  $g(t^2 - 1) = 3$  if  $t^2 < 2$  and  
 $g(t^2 - 1) = \sqrt{t^2 - 1 + 1} = |t|$  if  $t^2 \geq 2$ .
3. (a)  $x \neq 3$  (b)  $x \leq -\sqrt{3}$  or  $x \geq \sqrt{3}$

(c)  $x^2 - 2x + 5 = 0$  has no real solutions so  $x^2 - 2x + 5$  is always positive or always negative. If  $x = 0$ , then  $x^2 - 2x + 5 = 5 > 0$ ; domain:  $(-\infty, +\infty)$ .

(d)  $x \neq 0$

(e)  $\sin x \neq 1$ , so  $x \neq (2n + \frac{1}{2})\pi$ ,  
 $n = 0, \pm 1, \pm 2, \dots$

4. (a)  $x \neq -\frac{7}{5}$

(b)  $x - 3x^2$  must be nonnegative;  $y = x - 3x^2$  is a parabola that crosses the  $x$ -axis at  $x = 0, \frac{1}{3}$  and opens downward, thus  $0 \leq x \leq \frac{1}{3}$

(c)  $\frac{x^2 - 4}{x - 4} > 0$ , so  $x^2 - 4 > 0$  and  $x - 4 > 0$ , thus  $x > 4$ ; or  $x^2 - 4 < 0$  and  $x - 4 < 0$ , thus  $-2 < x < 2$

(d)  $x \neq -1$

(e)  $\cos x \leq 1 < 2, 2 - \cos x > 0$ , all  $x$

5. (a)  $x \leq 3$       (b)  $-2 \leq x \leq 2$       (c)  $x \geq 0$       (d) all  $x$       (e) all  $x$

6. (a)  $x \geq \frac{2}{3}$       (b)  $-\frac{3}{2} \leq x \leq \frac{3}{2}$       (c)  $x \geq 0$       (d)  $x \neq 0$       (e)  $x \geq 0$

7. (a) yes

(b) yes

(c) no (vertical line test fails)

(d) no (vertical line test fails)

8. The sine of  $\theta/2$  is  $(L/2)/10$  (side opposite over hypotenuse), so that  $L = 20 \sin(\theta/2)$ .

9. The cosine of  $\theta$  is  $(L - h)/L$  (side adjacent over hypotenuse), so  $h = L(1 - \cos \theta)$ .

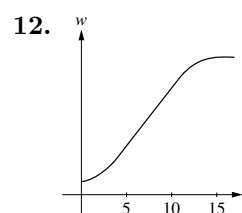
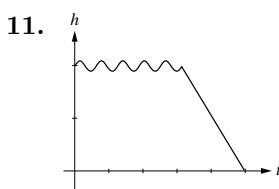
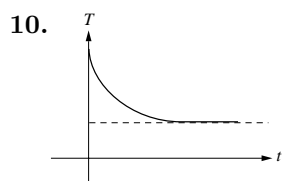

13. (a) If  $x < 0$ , then  $|x| = -x$  so  $f(x) = -x + 3x + 1 = 2x + 1$ . If  $x \geq 0$ , then  $|x| = x$  so  $f(x) = x + 3x + 1 = 4x + 1$ ;

$$f(x) = \begin{cases} 2x + 1, & x < 0 \\ 4x + 1, & x \geq 0 \end{cases}$$

(b) If  $x < 0$ , then  $|x| = -x$  and  $|x - 1| = 1 - x$  so  $g(x) = -x + 1 - x = 1 - 2x$ . If  $0 \leq x < 1$ , then  $|x| = x$  and  $|x - 1| = 1 - x$  so  $g(x) = x + 1 - x = 1$ . If  $x \geq 1$ , then  $|x| = x$  and  $|x - 1| = x - 1$  so  $g(x) = x + x - 1 = 2x - 1$ ;

$$g(x) = \begin{cases} 1 - 2x, & x < 0 \\ 1, & 0 \leq x < 1 \\ 2x - 1, & x \geq 1 \end{cases}$$

14. (a) If  $x < 5/2$ , then  $|2x - 5| = 5 - 2x$  so  $f(x) = 3 + (5 - 2x) = 8 - 2x$ . If  $x \geq 5/2$ , then  $|2x - 5| = 2x - 5$  so  $f(x) = 3 + (2x - 5) = 2x - 2$ ;

$$f(x) = \begin{cases} 8 - 2x, & x < 5/2 \\ 2x - 2, & x \geq 5/2 \end{cases}$$

- (b) If  $x < -1$ , then  $|x - 2| = 2 - x$  and  $|x + 1| = -x - 1$  so  $g(x) = 3(2 - x) - (-x - 1) = 7 - 2x$ . If  $-1 \leq x < 2$ , then  $|x - 2| = 2 - x$  and  $|x + 1| = x + 1$  so  $g(x) = 3(2 - x) - (x + 1) = 5 - 4x$ . If  $x \geq 2$ , then  $|x - 2| = x - 2$  and  $|x + 1| = x + 1$  so  $g(x) = 3(x - 2) - (x + 1) = 2x - 7$ ;

$$g(x) = \begin{cases} 7 - 2x, & x < -1 \\ 5 - 4x, & -1 \leq x < 2 \\ 2x - 7, & x \geq 2 \end{cases}$$

15. (a)  $V = (8 - 2x)(15 - 2x)x$  (b)  $-\infty < x < +\infty, -\infty < V < +\infty$  (c)  $0 < x < 4$   
 (d) minimum value at  $x = 0$  or at  $x = 4$ ; maximum value somewhere in between (can be approximated by zooming with graphing calculator)
16. (a)  $x = 3000 \tan \theta$  (b)  $\theta \neq n\pi + \pi/2$  for  $n$  an integer,  $-\infty < n < \infty$   
 (c)  $0 \leq \theta < \pi/2, 0 \leq x < +\infty$  (d) 3000 ft

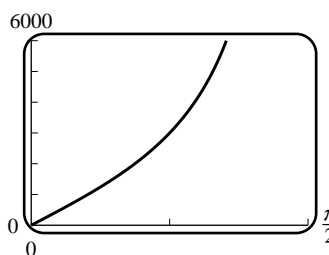

17. (i)  $x = 1, -2$  causes division by zero (ii)  $g(x) = x + 1$ , all  $x$
18. (i)  $x = 0$  causes division by zero (ii)  $g(x) = \sqrt{x} + 1$  for  $x \geq 0$
19. (a)  $25^\circ\text{F}$  (b)  $2^\circ\text{F}$  (c)  $-15^\circ\text{F}$
20. If  $v = 48$  then  $-60 = \text{WCI} = 1.6T - 55$ ; thus  $T = (-60 + 55)/1.6 \approx -3^\circ\text{F}$ .
21. If  $v = 8$  then  $-10 = \text{WCI} = 91.4 + (91.4 - T)(0.0203(8) - 0.304\sqrt{8} - 0.474)$ ; thus  $T = 91.4 + (10 + 91.4)/(0.0203(8) - 0.304\sqrt{8} - 0.474)$  and  $T = 5^\circ\text{F}$
22. The WCI is given by three formulae, but the first and third don't work with the data. Hence  $-15 = \text{WCI} = 91.4 + (91.4 - 20)(0.0203v - 0.304\sqrt{v} - 0.474)$ ; set  $x = \sqrt{v}$  so that  $v = x^2$  and obtain  $0.0203x^2 - 0.304x - 0.474 + (15 + 91.4)/(91.4 - 20) = 0$ . Use the quadratic formula to find the two roots. Square them to get  $v$  and discard the spurious solution, leaving  $v \approx 25$ .
23. Let  $t$  denote time in minutes after 9:23 AM. Then  $D(t) = 1000 - 20t$  ft.

### EXERCISE SET 1.3

1. (e) seems best, though only (a) is bad. 2. (e) seems best, though only (a) is bad and (b) is not good.

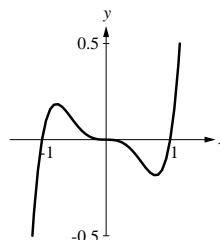
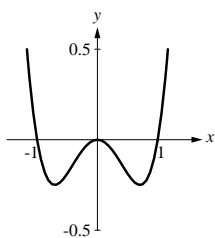

3. (b) and (c) are good; (a) is very bad.

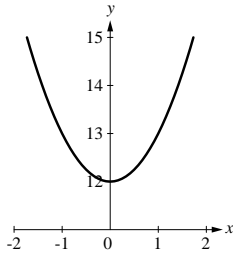

4. (b) and (c) are good; (a) is very bad.

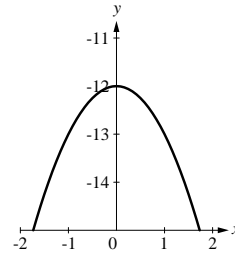

5.  $[-3, 3] \times [0, 5]$

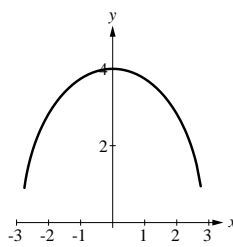

6.  $[-4, 2] \times [0, 3]$

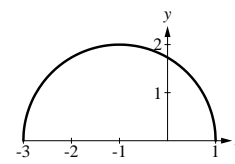

7. (a) window too narrow, too short  
(c) good window, good spacing

(b) window wide enough, but too short  
(d) window too narrow, too short

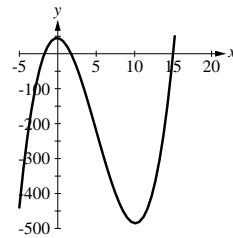

(e) window too narrow, too short

8. (a) window too narrow  
(c) good window, good tick spacing

(b) window too short  
(d) window too narrow, too short

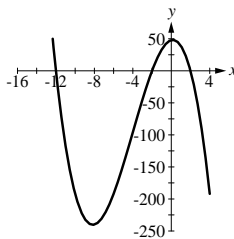

(e) shows one local minimum only, window too narrow, too short

9.  $[-5, 14] \times [-60, 40]$

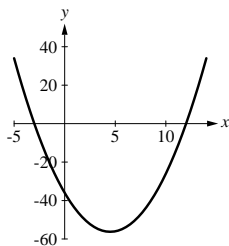

10.  $[6, 12] \times [-100, 100]$

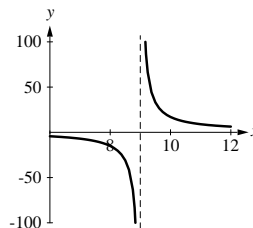

11.  $[-0.1, 0.1] \times [-3, 3]$

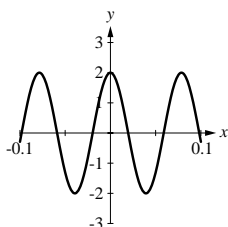

12.  $[-1000, 1000] \times [-13, 13]$

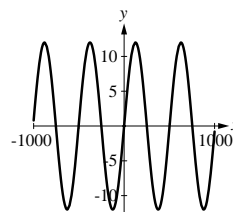

13.  $[-250, 1050] \times [-1500000, 600000]$

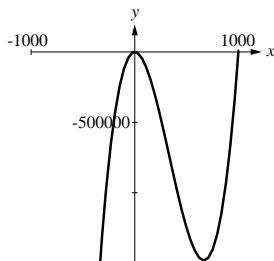

14.  $[-3, 20] \times [-3500, 3000]$

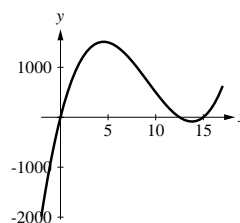

15.  $[-2, 2] \times [-20, 20]$

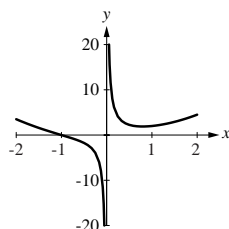

16.  $[1.6, 2] \times [0, 2]$

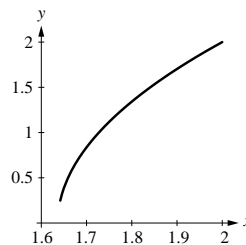

17. depends on graphing utility

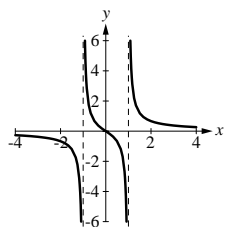

18. depends on graphing utility

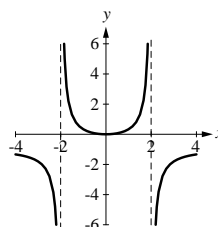



19. (a)  $f(x) = \sqrt{16 - x^2}$

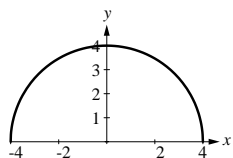

(b)  $f(x) = -\sqrt{16 - x^2}$

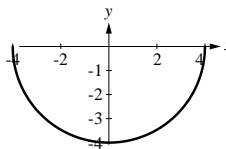

(c)

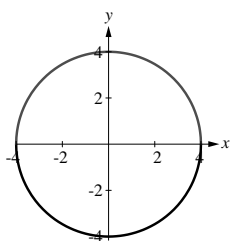

(d)

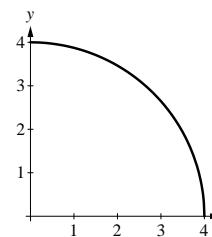

(e) No; the vertical line test fails.

20. (a)  $y = \pm 3\sqrt{1 - x^2}/4$

(b)  $y = \pm\sqrt{x^2 + 1}$

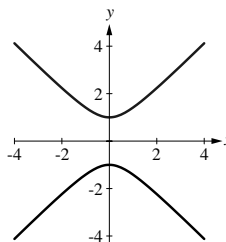

21. (a)

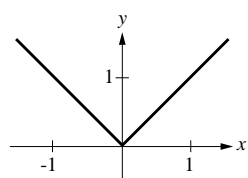

(b)

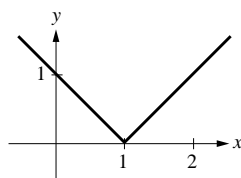

(c)

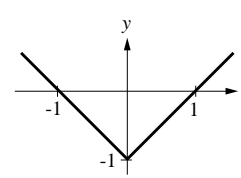

(d)

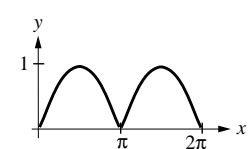

(e)

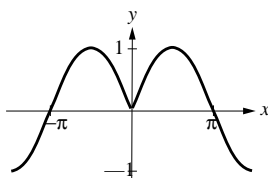

(f)

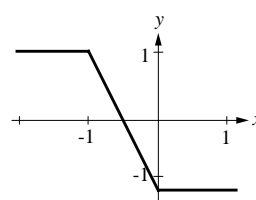

22.

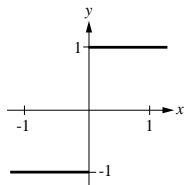

23. The portions of the graph of  $y = f(x)$  which lie below the  $x$ -axis are reflected over the  $x$ -axis to give the graph of  $y = |f(x)|$ .

24. Erase the portion of the graph of  $y = f(x)$  which lies in the left-half plane and replace it with the reflection over the  $y$ -axis of the portion in the right-half plane (symmetry over the  $y$ -axis) and you obtain the graph of  $y = f(|x|)$ .

25. (a) for example, let  $a = 1.1$

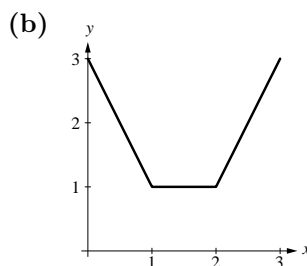
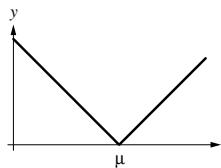

26. They are identical.

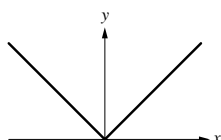

27.

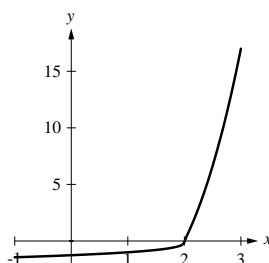

28. This graph is very complex. We show three views, small (near the origin), medium and large:

(a)

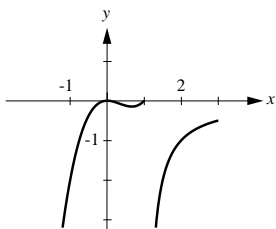

(b)

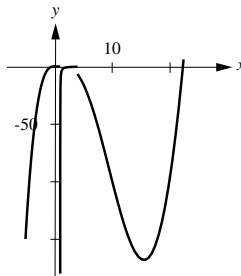

(c)

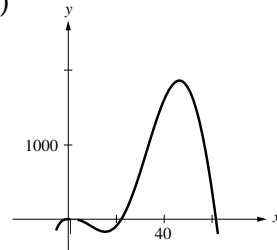

29. (a)

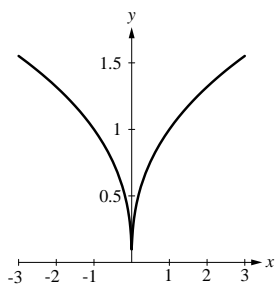

(b)

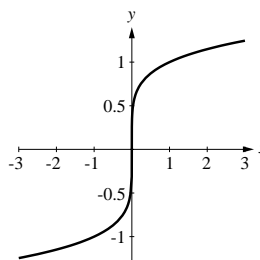

(c)

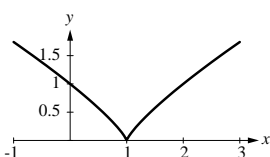

(d)

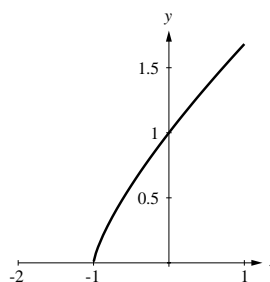

30.

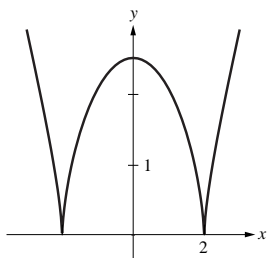

31. (a) stretches or shrinks the graph in the  $y$ -direction; flips it if  $c$  changes sign

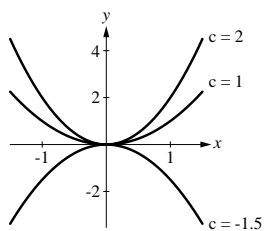

(b) As  $c$  increases, the parabola moves down and to the left. If  $c$  increases, up and right.

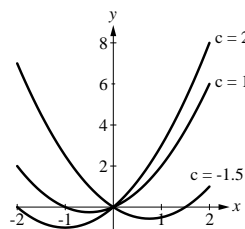

(c) The graph rises or falls in the  $y$ -direction with changes in  $c$ .

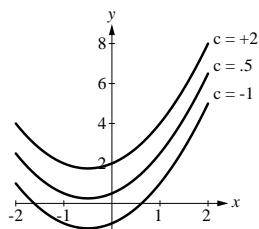

32. (a)

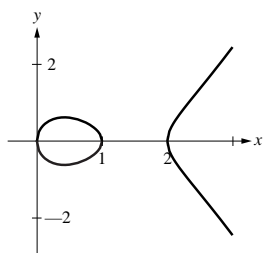

(b)  $x$ -intercepts at  $x = 0, a, b$ . Assume  $a < b$  and let  $a$  approach  $b$ . The two branches of the curve come together. If  $a$  moves past  $b$  then  $a$  and  $b$  switch roles.

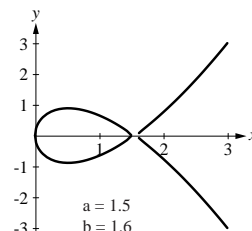
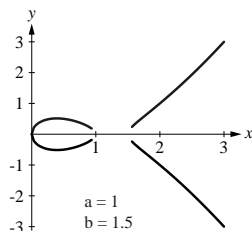
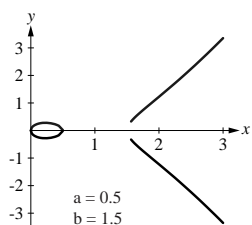

33. The curve oscillates between the lines  $y = x$  and  $y = -x$  with increasing rapidity as  $|x|$  increases.

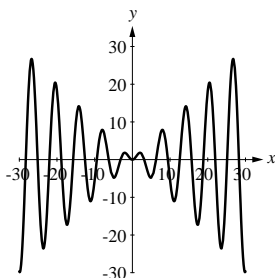

34. The curve oscillates between the lines  $y = +1$  and  $y = -1$ , infinitely many times in any neighborhood of  $x = 0$ .

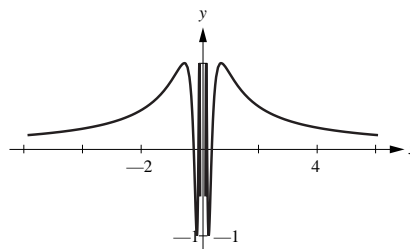

35. Plot  $f(x)$  on  $[-10, 10]$ ; then on  $[-1, 0]$ ,  $[-0.7, -0.6]$ ,  $[-0.65, -0.64]$ ,  $[-0.646, -0.645]$ ; for the other root use  $[4, 5]$ ,  $[4.6, 4.7]$ ,  $[4.64, 4.65]$ ,  $[4.645, 4.646]$ ; roots  $-0.6455, 4.6455$ .
36. Plot  $f(x)$  on  $[-10, 10]$ ; then on  $[-4, -3]$ ,  $[-3.7, -3.6]$ ,  $[-3.61, -3.60]$ ,  $[-3.606, -3.605]$ ; for the other root use  $[3, 4]$ ,  $[3.6, 3.7]$ ,  $[3.60, 3.61]$ ,  $[3.605, 3.606]$ ; roots  $3.6055, -3.6055$ .

### EXERCISE SET 1.4

1. (a)

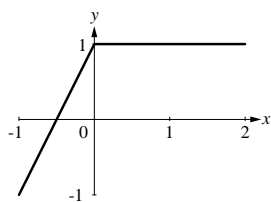

(b)

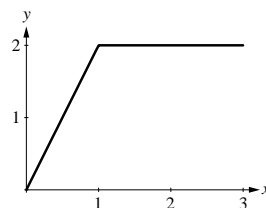

(c)

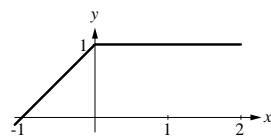

(d)

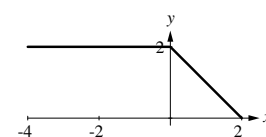

2. (a)

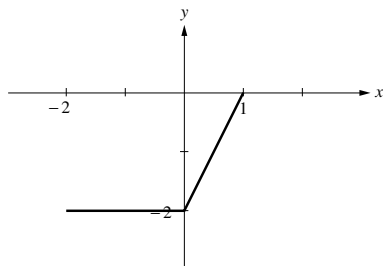

(b)

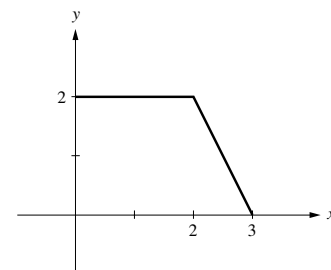

(c)

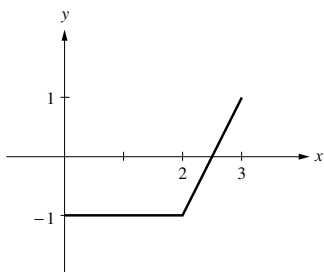

(d)

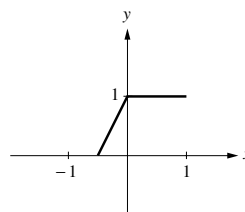

3. (a)

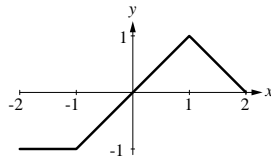

(b)

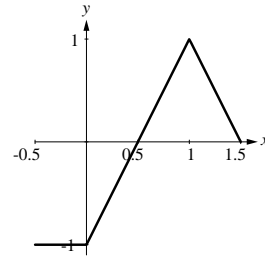

(c)

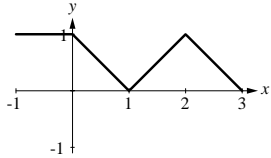

(d)

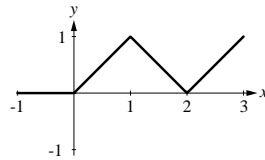

4.

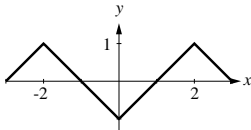

5. Translate right 2 units, and up one unit.

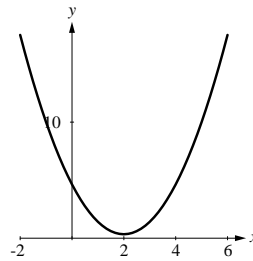

6. Translate left 1 unit, reflect over  $x$ -axis, and translate up 2 units.

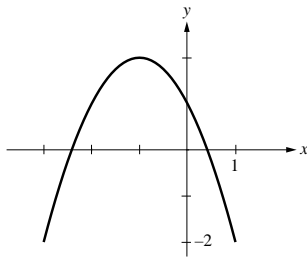

7. Translate left 1 unit, stretch vertically by a factor of 2, reflect over  $x$ -axis, translate down 3 units.

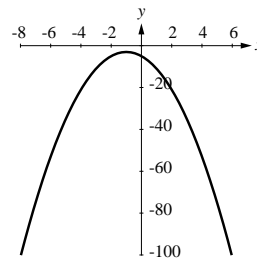

8. Translate right 3 units, compress vertically by a factor of  $\frac{1}{2}$ , and translate up 2 units.

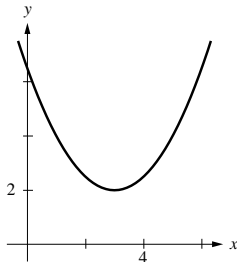

9.  $y = (x + 3)^2 - 9$ ; translate left 3 units and down 9 units.

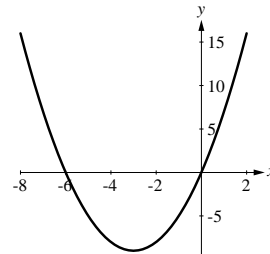

10.  $y = (x + 3)^2 - 19$ ; translate left 3 units and down 19 units.

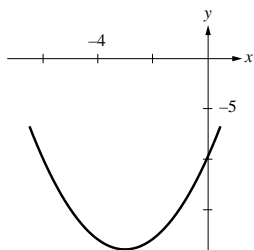

11.  $y = -(x - 1)^2 + 2$ ; translate right 1 unit, reflect over  $x$ -axis, translate up 2 units.

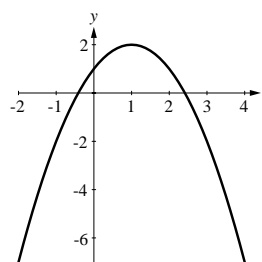

12.  $y = \frac{1}{2}[(x - 1)^2 + 2]$ ; translate left 1 unit and up 2 units, compress vertically by a factor of  $\frac{1}{2}$ .

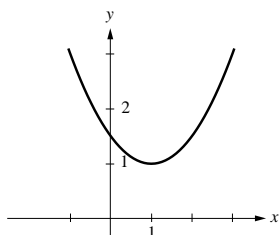

13. Translate left 1 unit, reflect over  $x$ -axis, translate up 3 units.

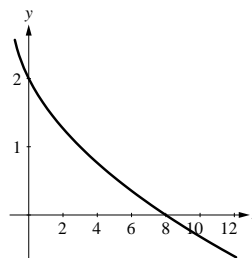

14. Translate right 4 units and up 1 unit.

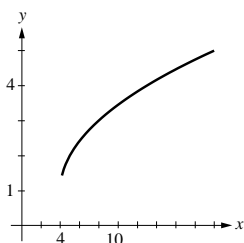

15. Compress vertically by a factor of  $\frac{1}{2}$ , translate up 1 unit.

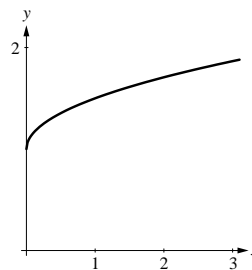

16. Stretch vertically by a factor of  $\sqrt{3}$  and reflect over  $x$ -axis.

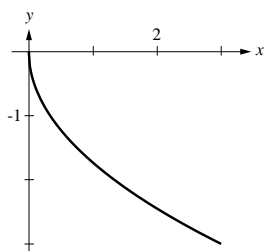

17. Translate right 3 units.

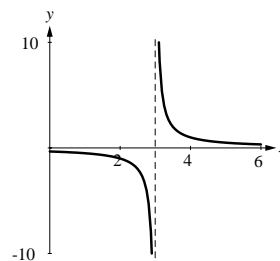

18. Translate right 1 unit and reflect over  $x$ -axis.

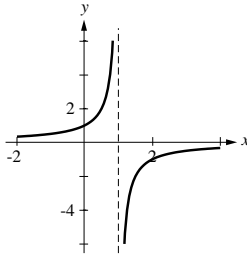

19. Translate left 1 unit, reflect over  $x$ -axis, translate up 2 units.

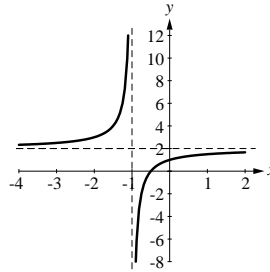

20.  $y = 1 - 1/x$ ; reflect over  $x$ -axis, translate up 1 unit.

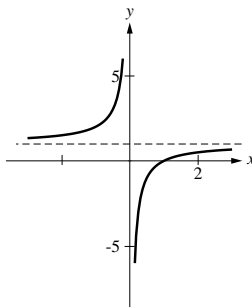

21. Translate left 2 units and down 2 units.

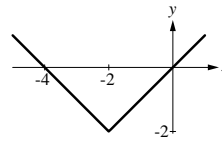

22. Translate right 3 units, reflect over  $x$ -axis, translate up 1 unit.

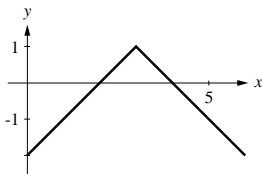

23. Stretch vertically by a factor of 2, translate right 1 unit and up 1 unit.

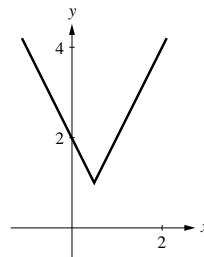

24.  $y = |x - 2|$ ; translate right 2 units.

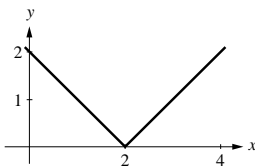

25. Stretch vertically by a factor of 2, reflect over  $x$ -axis, translate up 2 units.

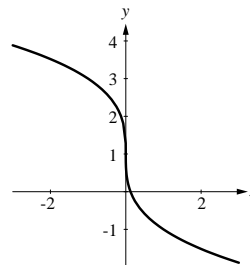

26. Translate right 2 units and down 3 units.

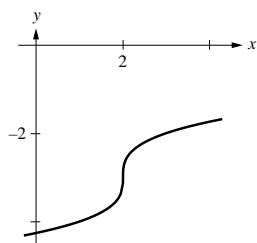

27. Translate left 1 unit and up 2 units.

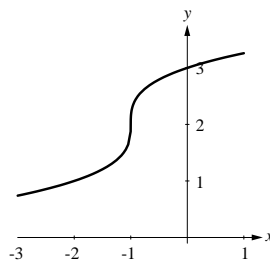

28. Translate right 2 units, reflect over  $x$ -axis.

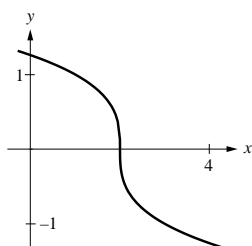

29. (a)

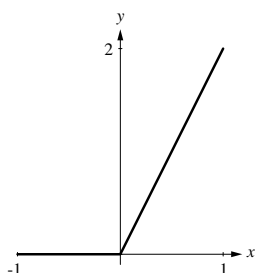

(b)  $y = \begin{cases} 0 & \text{if } x \leq 0 \\ 2x & \text{if } 0 < x \end{cases}$

30.

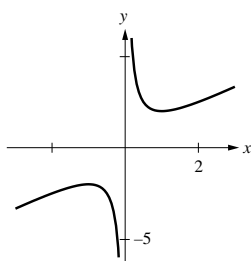

31.  $x^2 + 2x + 1$ , all  $x$ ;  $2x - x^2 - 1$ , all  $x$ ;  $2x^3 + 2x$ , all  $x$ ;  $2x/(x^2 + 1)$ , all  $x$

32.  $3x - 2 + |x|$ , all  $x$ ;  $3x - 2 - |x|$ , all  $x$ ;  $3x|x| - 2|x|$ , all  $x$ ;  $(3x - 2)/|x|$ , all  $x \neq 0$

33.  $3\sqrt{x-1}$ ,  $x \geq 1$ ;  $\sqrt{x-1}$ ,  $x \geq 1$ ;  $2x - 2$ ,  $x \geq 1$ ;  $2$ ,  $x > 1$

34.  $(2x^2 + 1)/x(x^2 + 1)$ , all  $x \neq 0$ ;  $-1/x(x^2 + 1)$ , all  $x \neq 0$ ;  $1/(x^2 + 1)$ , all  $x \neq 0$ ;  $x^2/(x^2 + 1)$ , all  $x \neq 0$

35. (a) 3                                      (b) 9                                      (c) 2                                      (d) 2

36. (a)  $\pi - 1$                                       (b) 0                                      (c)  $-\pi^2 + 3\pi - 1$                                       (d) 1



37. (a)  $t^4 + 1$  (b)  $t^2 + 4t + 5$  (c)  $x^2 + 4x + 5$  (d)  $\frac{1}{x^2} + 1$   
 (e)  $x^2 + 2xh + h^2 + 1$  (f)  $x^2 + 1$  (g)  $x + 1$  (h)  $9x^2 + 1$

38. (a)  $\sqrt{5s + 2}$  (b)  $\sqrt{\sqrt{x} + 2}$  (c)  $3\sqrt{5x}$  (d)  $1/\sqrt{x}$   
 (e)  $\sqrt[4]{x}$  (f)  $0$  (g)  $1/\sqrt[4]{x}$  (h)  $|x - 1|$

39.  $2x^2 - 2x + 1$ , all  $x$ ;  $4x^2 + 2x$ , all  $x$       40.  $2 - x^6$ , all  $x$ ;  $-x^6 + 6x^4 - 12x^2 + 8$ , all  $x$

41.  $1 - x$ ,  $x \leq 1$ ;  $\sqrt{1 - x^2}$ ,  $|x| \leq 1$       42.  $\sqrt{\sqrt{x^2 + 3} - 3}$ ,  $|x| \geq \sqrt{6}$ ;  $\sqrt{x}$ ,  $x \geq 3$

43.  $\frac{1}{1 - 2x}$ ,  $x \neq \frac{1}{2}$ ,  $1$ ;  $-\frac{1}{2x} - \frac{1}{2}$ ,  $x \neq 0, 1$       44.  $\frac{x}{x^2 + 1}$ ,  $x \neq 0$ ;  $\frac{1}{x} + x$ ,  $x \neq 0$

45.  $x^{-6} + 1$       46.  $\frac{x}{x + 1}$

47. (a)  $g(x) = \sqrt{x}$ ,  $h(x) = x + 2$       (b)  $g(x) = |x|$ ,  $h(x) = x^2 - 3x + 5$

48. (a)  $g(x) = x + 1$ ,  $h(x) = x^2$       (b)  $g(x) = 1/x$ ,  $h(x) = x - 3$

49. (a)  $g(x) = x^2$ ,  $h(x) = \sin x$       (b)  $g(x) = 3/x$ ,  $h(x) = 5 + \cos x$

50. (a)  $g(x) = 3 \sin x$ ,  $h(x) = x^2$       (b)  $g(x) = 3x^2 + 4x$ ,  $h(x) = \sin x$

51. (a)  $f(x) = x^3$ ,  $g(x) = 1 + \sin x$ ,  $h(x) = x^2$       (b)  $f(x) = \sqrt{x}$ ,  $g(x) = 1 - x$ ,  $h(x) = \sqrt[3]{x}$

52. (a)  $f(x) = 1/x$ ,  $g(x) = 1 - x$ ,  $h(x) = x^2$       (b)  $f(x) = |x|$ ,  $g(x) = 5 + x$ ,  $h(x) = 2x$

53.       54.  $\{-2, -1, 0, 1, 2, 3\}$

55. Note that  $f(g(-x)) = f(-g(x)) = f(g(x))$ , so  $f(g(x))$  is even.

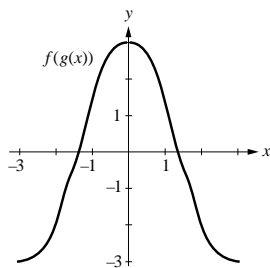

56. Note that  $g(f(-x)) = g(f(x))$ , so  $g(f(x))$  is even.

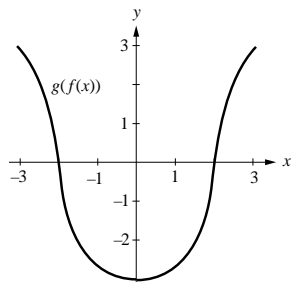

57.  $f(g(x)) = 0$  when  $g(x) = \pm 2$ , so  $x = \pm 1.4$ ;  $g(f(x)) = 0$  when  $f(x) = 0$ , so  $x = \pm 2$ .

58.  $f(g(x)) = 0$  at  $x = -1$  and  $g(f(x)) = 0$  at  $x = -1$

59. 
$$\frac{3(x+h)^2 - 5 - (3x^2 - 5)}{h} = \frac{6xh + 3h^2}{h} = 6x + 3h$$

60. 
$$\frac{(x+h)^2 + 6(x+h) - (x^2 + 6x)}{h} = \frac{2xh + h^2 + 6h}{h} = 2x + h + 6$$

61. 
$$\frac{1/(x+h) - 1/x}{h} = \frac{x - (x+h)}{xh(x+h)} = \frac{-1}{x(x+h)}$$

62. 
$$\frac{1/(x+h)^2 - 1/x^2}{h} = \frac{x^2 - (x+h)^2}{x^2h(x+h)^2} = -\frac{2x+h}{x^2(x+h)^2}$$

63. (a) the origin      (b) the  $x$ -axis      (c) the  $y$ -axis      (d) none

64. (a)

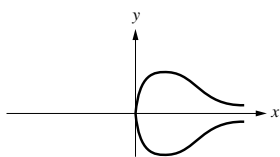

- (b)

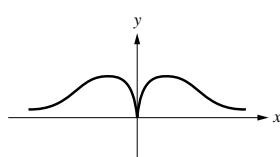

- (c)

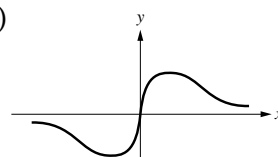

65. (a)

$x$	-3	-2	-1	0	1	2	3
$f(x)$	1	-5	-1	0	-1	-5	1

- (b)

$x$	-3	-2	-1	0	1	2	3
$f(x)$	1	5	-1	0	1	-5	-1

66. (a)

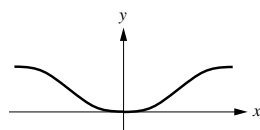

- (b)

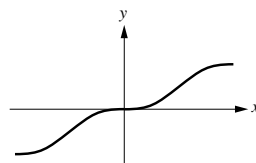

67. (a) even      (b) odd      (c) odd      (d) neither

68. neither; odd; even

69. (a)  $f(-x) = (-x)^2 = x^2 = f(x)$ , even      (b)  $f(-x) = (-x)^3 = -x^3 = -f(x)$ , odd

- (c)  $f(-x) = |-x| = |x| = f(x)$ , even

- (d)  $f(-x) = -x + 1$ , neither

- (e)  $f(-x) = \frac{(-x)^3 - (-x)}{1 + (-x)^2} = -\frac{x^3 + x}{1 + x^2} = -f(x)$ , odd

- (f)  $f(-x) = 2 = f(x)$ , even

70. (a)  $x$ -axis, because  $x = 5(-y)^2 + 9$  gives  $x = 5y^2 + 9$   
 (b)  $x$ -axis,  $y$ -axis, and origin, because  $x^2 - 2(-y)^2 = 3$ ,  $(-x)^2 - 2y^2 = 3$ , and  $(-x)^2 - 2(-y)^2 = 3$  all give  $x^2 - 2y^2 = 3$   
 (c) origin, because  $(-x)(-y) = 5$  gives  $xy = 5$
71. (a)  $y$ -axis, because  $(-x)^4 = 2y^3 + y$  gives  $x^4 = 2y^3 + y$   
 (b) origin, because  $(-y) = \frac{(-x)}{3 + (-x)^2}$  gives  $y = \frac{x}{3 + x^2}$   
 (c)  $x$ -axis,  $y$ -axis, and origin because  $(-y)^2 = |x| - 5$ ,  $y^2 = |-x| - 5$ , and  $(-y)^2 = |-x| - 5$  all give  $y^2 = |x| - 5$

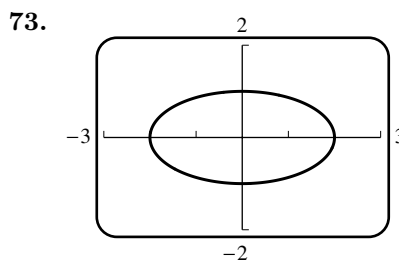
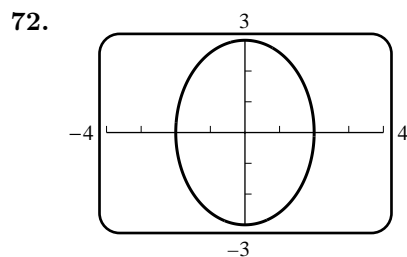

74. (a) Whether we replace  $x$  with  $-x$ ,  $y$  with  $-y$ , or both, we obtain the same equation, so by Theorem 1.4.3 the graph is symmetric about the  $x$ -axis, the  $y$ -axis and the origin.  
 (b)  $y = (1 - x^{2/3})^{3/2}$   
 (c) For quadrant II, the same; for III and IV use  $y = -(1 - x^{2/3})^{3/2}$ . (For graphing it may be helpful to use the tricks that precede Exercise 29 in Section 1.3.)

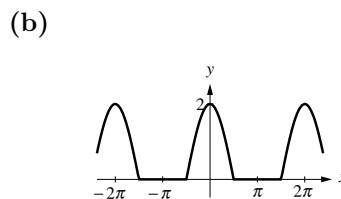
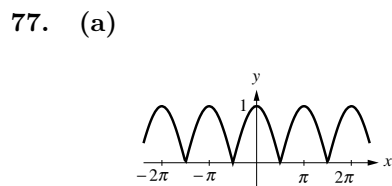
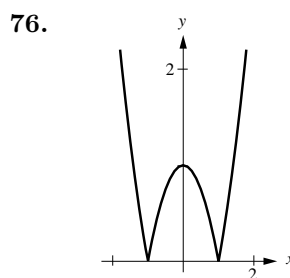
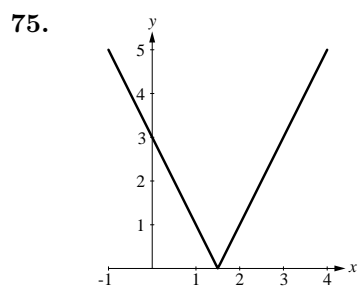

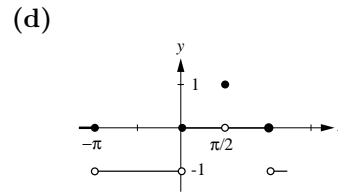
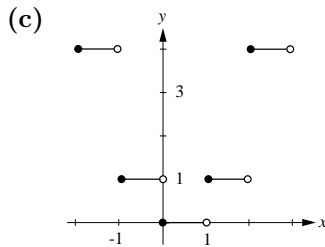
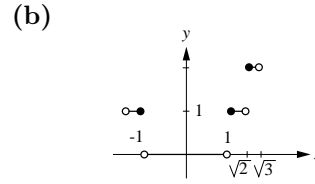
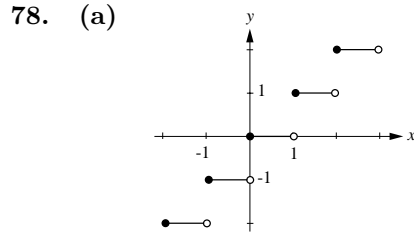

79. Yes, e.g.  $f(x) = x^k$  and  $g(x) = x^n$  where  $k$  and  $n$  are integers.

80. If  $x \geq 0$  then  $|x| = x$  and  $f(x) = g(x)$ . If  $x < 0$  then  $f(x) = |x|^{p/q}$  if  $p$  is even and  $f(x) = -|x|^{p/q}$  if  $p$  is odd; in both cases  $f(x)$  agrees with  $g(x)$ .

### EXERCISE SET 1.5

1. (a)  $\frac{3-0}{0-2} = -\frac{3}{2}$ ,  $\frac{3-(8/3)}{0-6} = -\frac{1}{18}$ ,  $\frac{0-(8/3)}{2-6} = \frac{2}{3}$

(b) Yes; the first and third slopes above are negative reciprocals of each other.

2. (a)  $\frac{-1-(-1)}{-3-5} = 0$ ,  $\frac{-1-3}{5-7} = 2$ ,  $\frac{3-3}{7-(-1)} = 0$ ,  $\frac{-1-3}{-3-(-1)} = 2$

(b) Yes; there are two pairs of equal slopes, so two pairs of parallel lines.

3. III < II < IV < I

4. III < IV < I < II

5. (a)  $\frac{1-(-5)}{1-(-2)} = 2$ ,  $\frac{-5-(-1)}{-2-0} = 2$ ,  $\frac{1-(-1)}{1-0} = 2$ . Since the slopes connecting all pairs of points are equal, they lie on a line.

(b)  $\frac{4-2}{-2-0} = -1$ ,  $\frac{2-5}{0-1} = 3$ ,  $\frac{4-5}{-2-1} = \frac{1}{3}$ . Since the slopes connecting the pairs of points are not equal, the points do not lie on a line.

6. The slope,  $m = -2$ , is obtained from  $\frac{y-5}{x-7}$ , and thus  $y-5 = -2(x-7)$ .

(a) If  $x = 9$  then  $y = 1$ .

(b) If  $y = 12$  then  $x = 7/2$ .

7. The slope,  $m = 3$ , is equal to  $\frac{y-2}{x-1}$ , and thus  $y-2 = 3(x-1)$ .

(a) If  $x = 5$  then  $y = 14$ .

(b) If  $y = -2$  then  $x = -1/3$ .

8. (a) Compute the slopes:  $\frac{y-0}{x-0} = \frac{1}{2}$  or  $y = x/2$ . Also  $\frac{y-5}{x-7} = 2$  or  $y = 2x - 9$ . Solve simultaneously to obtain  $x = 6, y = 3$ .

9. (a) The first slope is  $\frac{2-0}{1-x}$  and the second is  $\frac{5-0}{4-x}$ . Since they are negatives of each other we get  $2(4-x) = -5(1-x)$  or  $7x = 13, x = 13/7$ .

10. (a)  $27^\circ$  (b)  $135^\circ$  (c)  $63^\circ$  (d)  $91^\circ$

11. (a)  $153^\circ$  (b)  $45^\circ$  (c)  $117^\circ$  (d)  $89^\circ$

12. (a)  $m = \tan \phi = -\sqrt{3}/3$ , so  $\phi = 150^\circ$  (b)  $m = \tan \phi = 4$ , so  $\phi = 76^\circ$

13. (a)  $m = \tan \phi = \sqrt{3}$ , so  $\phi = 60^\circ$  (b)  $m = \tan \phi = -2$ , so  $\phi = 117^\circ$

14.  $y = 0$  and  $x = 0$  respectively

15.  $y = -2x + 4$

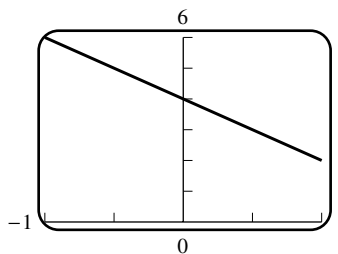

16.  $y = 5x - 3$

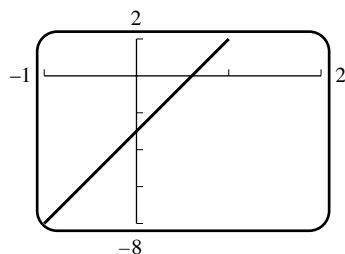

17. Parallel means the lines have equal slopes, so  $y = 4x + 7$ .

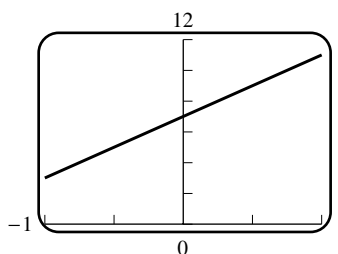

18. The slope of both lines is  $-3/2$ , so  $y - 2 = (-3/2)(x - (-1))$ , or  $3x + 2y = 1$

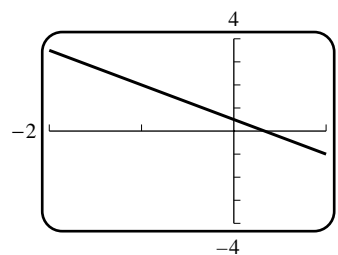

19. The negative reciprocal of 5 is  $-1/5$ , so  $y = -\frac{1}{5}x + 6$ .

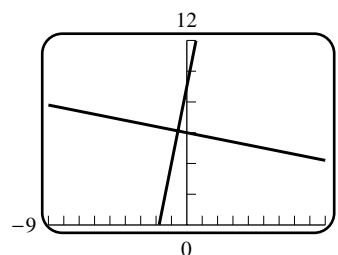

20. The slope of  $x - 4y = 7$  is  $1/4$  whose negative reciprocal is  $-4$ , so  $y - (-4) = -4(x - 3)$  or  $y + 4x = 8$ .

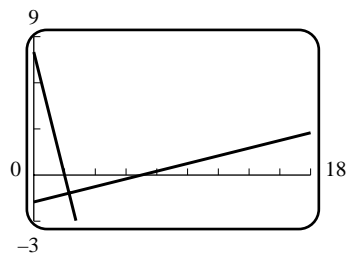

21.  $\frac{y - (-7)}{x - 1} = \frac{4 - (-7)}{2 - 1}$ , or  $y = 11x - 18$

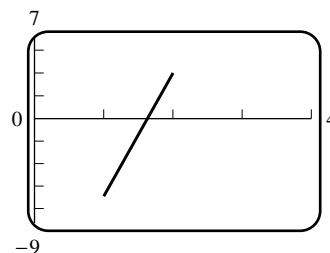

22.  $\frac{y - 1}{x - (-2)} = \frac{6 - 1}{-3 - (-2)}$ , or  $y = -5x - 9$

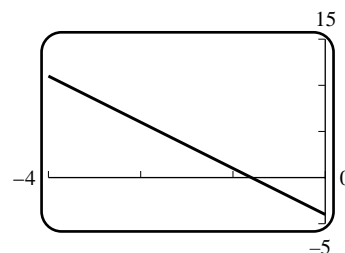

23. (a)  $m_1 = m_2 = 4$ , parallel  
 (b)  $m_1 = 2 = -1/m_2$ , perpendicular  
 (c)  $m_1 = m_2 = 5/3$ , parallel  
 (d) If  $A \neq 0$  and  $B \neq 0$  then  $m_1 = -A/B = -1/m_2$ , perpendicular; if  $A = 0$  or  $B = 0$  (not both) then one line is horizontal, the other vertical, so perpendicular.  
 (e) neither
24. (a)  $m_1 = m_2 = -5$ , parallel  
 (b)  $m_1 = 2 = -1/m_2$ , perpendicular  
 (c)  $m_1 = -4/5 = -1/m_2$ , perpendicular  
 (d) If  $B \neq 0$ ,  $m_1 = m_2 = -A/B$ ; if  $B = 0$  both are vertical, so parallel  
 (e) neither
25. (a)  $m = (0 - (-3))/(2 - 0) = 3/2$  so  $y = 3x/2 - 3$   
 (b)  $m = (-3 - 0)/(4 - 0) = -3/4$  so  $y = -3x/4$
26. (a)  $m = (0 - 2)/(2 - 0) = -1$  so  $y = -x + 2$   
 (b)  $m = (2 - 0)/(3 - 0) = 2/3$  so  $y = 2x/3$
27. (a) The velocity is the slope, which is  $\frac{5 - (-4)}{10 - 0} = 9/10$  ft/s.  
 (b)  $x = -4$   
 (c) The line has slope  $9/10$  and passes through  $(0, -4)$ , so has equation  $x = 9t/10 - 4$ ; at  $t = 2$ ,  $x = -2.2$ .  
 (d)  $t = 80/9$

28. (a)  $v = \frac{5-1}{4-2} = 2$  m/s      (b)  $x - 1 = 2(t - 2)$  or  $x = 2t - 3$       (c)  $x = -3$

29. (a) The acceleration is the slope of the velocity, so  $a = \frac{3 - (-1)}{1 - 4} = -\frac{4}{3}$  ft/s<sup>2</sup>.

(b)  $v - 3 = -\frac{4}{3}(t - 1)$ , or  $v = -\frac{4}{3}t + \frac{13}{3}$       (c)  $v = \frac{13}{3}$  ft/s

30. (a) The acceleration is the slope of the velocity, so  $a = \frac{0 - 5}{10 - 0} = -\frac{5}{10} = -\frac{1}{2}$  ft/s<sup>2</sup>.

(b)  $v = 5$  ft/s      (c)  $v = 4$  ft/s      (d)  $t = 4$  s

31. (a) It moves (to the left) 6 units with velocity  $v = -3$  cm/s, then remains motionless for 5 s, then moves 3 units to the left with velocity  $v = -1$  cm/s.

(b)  $v_{\text{ave}} = \frac{0 - 9}{10 - 0} = -\frac{9}{10}$  cm/s

(c) Since the motion is in one direction only, the speed is the negative of the velocity, so  $s_{\text{ave}} = \frac{9}{10}$  cm/s.

32. It moves right with constant velocity  $v = 5$  km/h; then accelerates; then moves with constant, though increased, velocity again; then slows down.

33. (a) If  $x_1$  denotes the final position and  $x_0$  the initial position, then  $v = (x_1 - x_0)/(t_1 - t_0) = 0$  mi/h, since  $x_1 = x_0$ .

(b) If the distance traveled in one direction is  $d$ , then the outward journey took  $t = d/40$  h. Thus

$$s_{\text{ave}} = \frac{\text{total dist}}{\text{total time}} = \frac{2d}{t + (2/3)t} = \frac{80t}{t + (2/3)t} = 48 \text{ mi/h.}$$

(c)  $t + (2/3)t = 5$ , so  $t = 3$  and  $2d = 80t = 240$  mi round trip

34. (a) down, since  $v < 0$       (b)  $v = 0$  at  $t = 2$       (c) It's constant at 32 ft/s<sup>2</sup>.

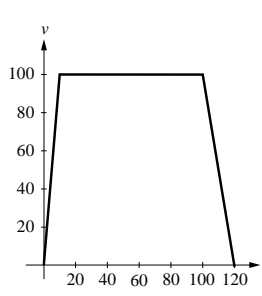
35. (a)  (b) 
$$v = \begin{cases} 10t & \text{if } 0 \leq t \leq 10 \\ 100 & \text{if } 10 \leq t \leq 100 \\ 600 - 5t & \text{if } 100 \leq t \leq 120 \end{cases}$$

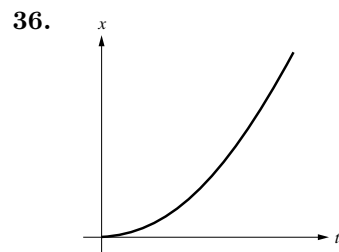

37. (a)  $y = 20 - 15 = 5$  when  $x = 45$ , so  $5 = 45k$ ,  
 $k = 1/9$ ,  $y = x/9$

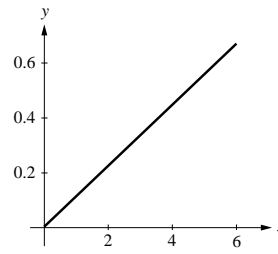

- (c)  $l = 15 + y = 15 + 100(1/9) = 26.11$  in. (d) If  $y_{\max} = 15$  then solve  $15 = kx = x/9$  for  $x = 135$  lb.

38. (a) Since  $y = 0.2 = (1)k$ ,  $k = 1/5$  and  $y = x/5$

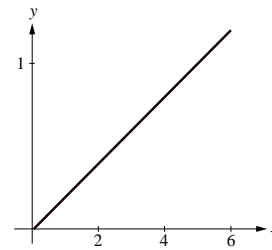

- (c)  $y = 3k = 3/5$  so 0.6 ft. (d)  $y_{\max} = (1/2)3 = 1.5$  so solve  $1.5 = x/5$  for  $x = 7.5$  tons

39. Each increment of 1 in the value of  $x$  yields the increment of 1.2 for  $y$ , so the relationship is linear. If  $y = mx + b$  then  $m = 1.2$ ; from  $x = 0$ ,  $y = 2$ , follows  $b = 2$ , so  $y = 1.2x + 2$

40. Each increment of 1 in the value of  $x$  yields the increment of  $-2.1$  for  $y$ , so the relationship is linear. If  $y = mx + b$  then  $m = -2.1$ ; from  $x = 0$ ,  $y = 10.5$  follows  $b = 10.5$ , so  $y = -2.1x + 10.5$

41. (a) With  $T_F$  as independent variable, we have  $\frac{T_C - 100}{T_F - 212} = \frac{0 - 100}{32 - 212}$ , so  $T_C = \frac{5}{9}(T_F - 32)$ .

(b)  $5/9$  (c) Set  $T_F = T_C = \frac{5}{9}(T_F - 32)$  and solve for  $T_F$ :  $T_F = T_C = -40^\circ$  (F or C).

(d)  $37^\circ$  C

42. (a) One degree Celsius is one degree Kelvin, so the slope is the ratio  $1/1 = 1$ . Thus  $T_C = T_K - 273.15$ .

(b)  $T_C = 0 - 273.15 = -273.15^\circ$  C

43. (a)  $\frac{p - 1}{h - 0} = \frac{5.9 - 1}{50 - 0}$ , or  $p = 0.098h + 1$  (b) when  $p = 2$ , or  $h = 1/0.098 \approx 10.20$  m

44. (a)  $\frac{R - 123.4}{T - 20} = \frac{133.9 - 123.4}{45 - 20}$ , so  $R = 0.42T + 115$ .

(b)  $T = 32.38^\circ$  C

45. (a)  $\frac{r - 0.80}{t - 0} = \frac{0.75 - 0.80}{4 - 0}$ , so  $r = -0.0125t + 0.8$

(b) 64 days

46. (a) Let the position at rest be  $y_0$ . Then  $y_0 + y = y_0 + kx$ ; with  $x = 11$  we get  $y_0 + kx = y_0 + 11k = 40$ , and with  $x = 24$  we get  $y_0 + kx = y_0 + 24k = 60$ . Solve to get  $k = 20/13$  and  $y_0 = 300/13$ .

(b)  $300/13 + (20/13)W = 30$ , so  $W = (390 - 300)/20 = 9/2$  g.



47. (a) For  $x$  trips we have  $C_1 = 2x$  and  $C_2 = 25 + x/4$

- (b)  $2x = 25 + x/4$ , or  $x = 100/7$ , so the commuter pass becomes worthwhile at  $x = 15$ .

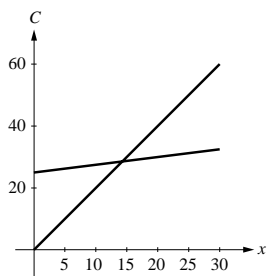

48. If the student drives  $x$  miles, then the total costs would be  $C_A = 4000 + (1.25/20)x$  and  $C_B = 5500 + (1.25/30)x$ . Set  $4000 + 5x/80 = 5500 + 5x/120$  and solve for  $x = 72,000$  mi.

49. (a)  $H \approx 20000/110 \approx 181$

(b) One light year is  $9.408 \times 10^{12}$  km and  $t = \frac{d}{v} = \frac{1}{H} = \frac{1}{20\text{km/s/Mly}} = \frac{9.408 \times 10^{18}\text{km}}{20\text{km/s}} = 4.704 \times 10^{17}$  s =  $1.492 \times 10^{10}$  years.

- (c) The Universe would be even older.

EXERCISE SET 1.6

1. (a)  $y = 3x + b$

(b)  $y = 3x + 6$

(c)

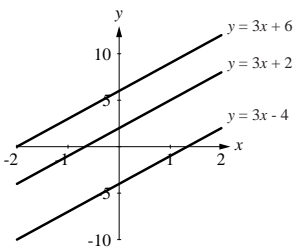

2. Since the slopes are negative reciprocals,  $y = -\frac{1}{3}x + b$ .

3. (a)  $y = mx + 2$

(b)  $m = \tan \phi = \tan 135^\circ = -1$ , so  $y = -x + 2$

(c)

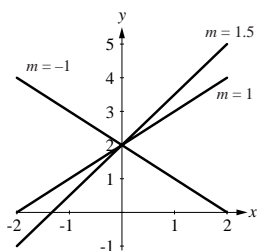

4. (a)  $y = mx$

(b)  $y = m(x - 1)$

(c)  $y = -2 + m(x - 1)$

(d)  $2x + 4y = C$

5. (a) The slope is  $-1$ .

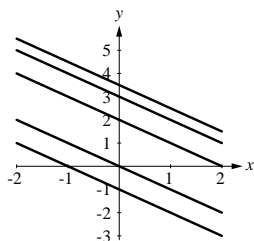

- (b) The  $y$ -intercept is  $y = -1$ .

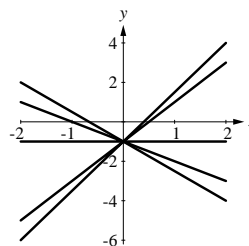

- (c) They pass through the point  $(-4, 2)$ .

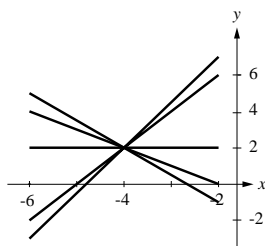

- (d) The  $x$ -intercept is  $x = 1$ .

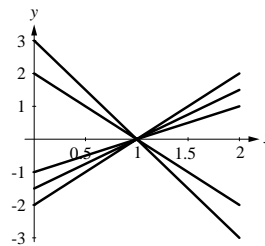

6. (a) horizontal lines

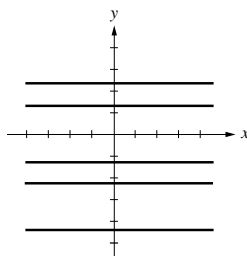

- (b) The  $y$ -intercept is  $y = -1/2$ .

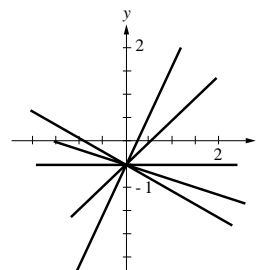

- (c) The  $x$ -intercept is  $x = -1/2$ .

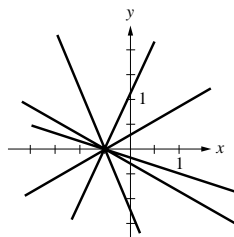

- (d) They pass through  $(-1, 1)$ .

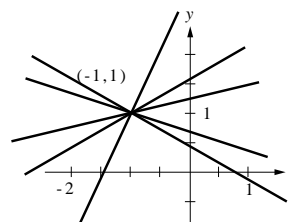

7. Let the line be tangent to the circle at the point  $(x_0, y_0)$  where  $x_0^2 + y_0^2 = 9$ . The slope of the tangent line is the negative reciprocal of  $y_0/x_0$  (why?), so  $m = -x_0/y_0$  and  $y = -(x_0/y_0)x + b$ . Substituting the point  $(x_0, y_0)$  as well as  $y_0 = \pm\sqrt{9 - x_0^2}$  we get  $y = \pm \frac{9 - x_0x}{\sqrt{9 - x_0^2}}$ .

8. Solve the simultaneous equations to get the point  $(-2, 1/3)$  of intersection. Then  $y = \frac{1}{3} + m(x + 2)$ .

9. The  $x$ -intercept is  $x = 10$  so that with depreciation at 10% per year the final value is always zero, and hence  $y = m(x - 10)$ . The  $y$ -intercept is the original value.

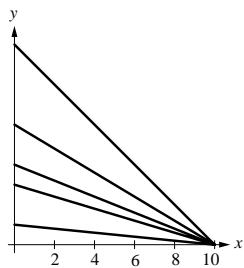

10. A line through  $(6, -1)$  has the form  $y + 1 = m(x - 6)$ . The intercepts are  $x = 6 + 1/m$  and  $y = -6m - 1$ . Set  $-(6 + 1/m)(6m + 1) = 3$ , or  $36m^2 + 15m + 1 = (12m + 1)(3m + 1) = 0$  with roots  $m = -1/12, -1/3$ ; thus  $y + 1 = -(1/3)(x - 6)$  and  $y + 1 = -(1/12)(x - 6)$ .

11. (a) VI                      (b) IV                      (c) III                      (d) V                      (e) I                      (f) II

12. In all cases  $k$  must be positive, or negative values would appear in the chart. Only  $kx^{-3}$  decreases, so that must be  $f(x)$ . Next,  $kx^2$  grows faster than  $kx^{3/2}$ , so that would be  $g(x)$ , which grows faster than  $h(x)$  (to see this, consider ratios of successive values of the functions). Finally, experimentation (a spreadsheet is handy) for values of  $k$  yields (approximately)  $f(x) = 10x^{-3}$ ,  $g(x) = x^2/2$ ,  $h(x) = 2x^{1.5}$ .

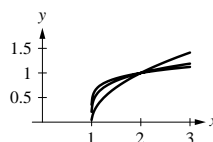
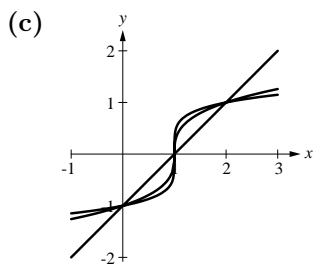
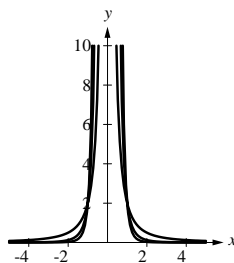
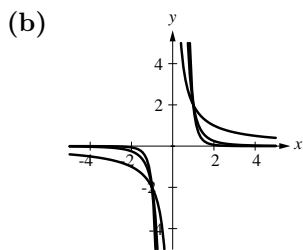
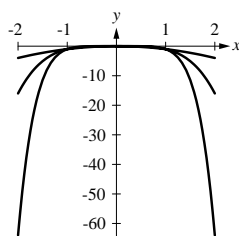
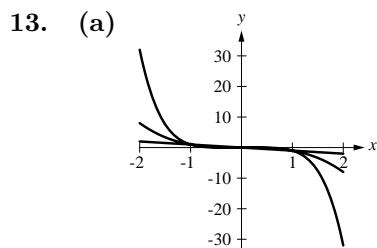

14. (a)

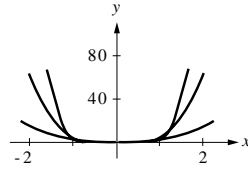
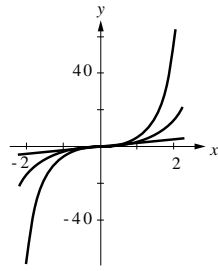

(b)

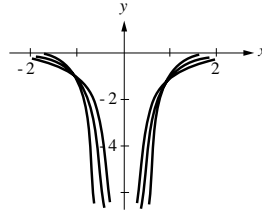
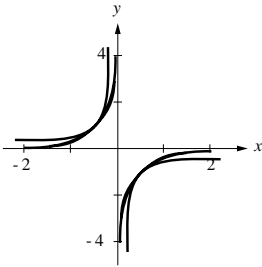

(c)

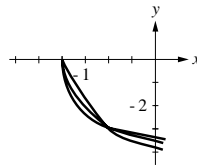
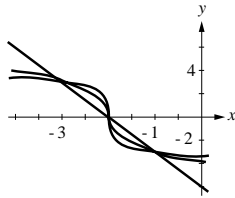

15. (a)

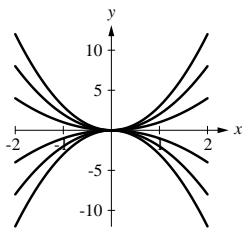

(b)

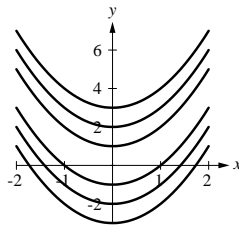

(c)

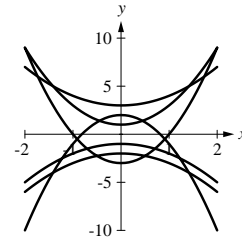

16. (a)

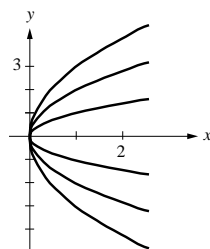

(b)

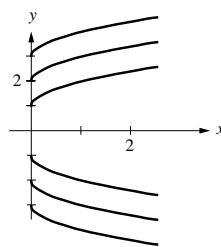

(c)

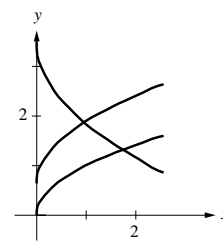

17. (a)

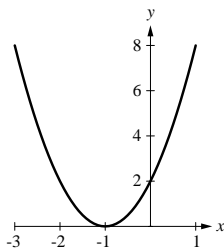

(b)

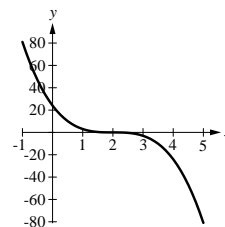

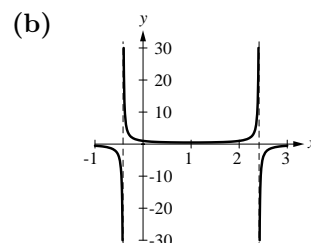
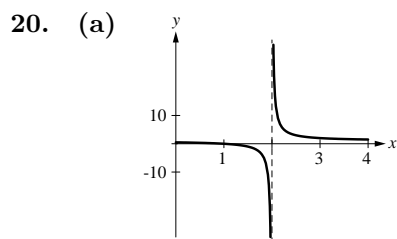
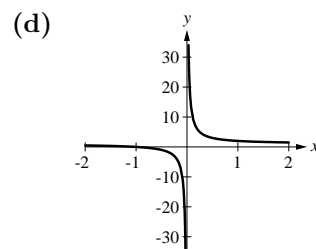
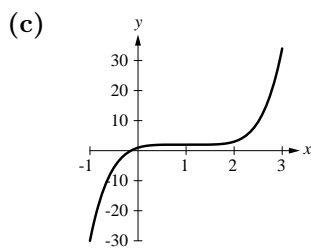
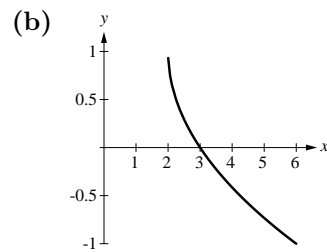
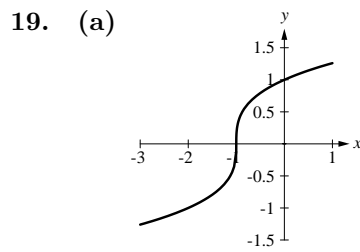
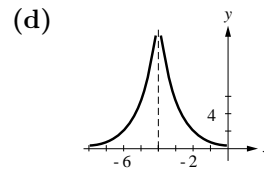
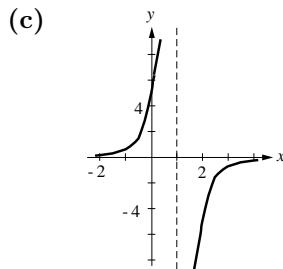
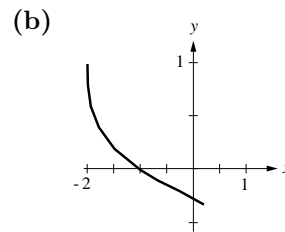
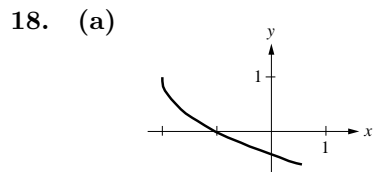
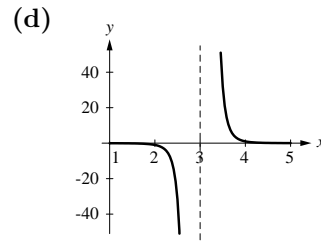
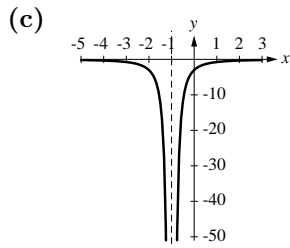



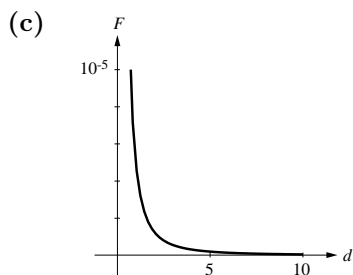

(d) When they approach one another, the force becomes infinite; when they get far apart it tends to zero.

28. (a)  $2000 = C/(4000)^2$ , so  $C = 3.2 \times 10^{10}$  lb·mi<sup>2</sup>

(b)  $W = C/5000^2 = (3.2 \times 10^{10})/(25 \times 10^6) = 1280$  lb.

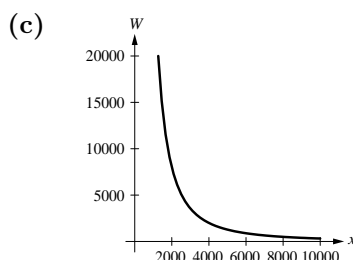

(d) No, but  $W$  is very small when  $x$  is large.

29. (a) II;  $y = 1$ ,  $x = -1, 2$

(b) I;  $y = 0$ ,  $x = -2, 3$

(c) IV;  $y = 2$

(d) III;  $y = 0$ ,  $x = -2$

30. The denominator has roots  $x = \pm 1$ , so  $x^2 - 1$  is the denominator. To determine  $k$  use the point  $(0, -1)$  to get  $k = 1$ ,  $y = 1/(x^2 - 1)$ .

31. Order the six trigonometric functions as sin, cos, tan, cot, sec, csc:

(a) pos, pos, pos, pos, pos, pos

(b) neg, zero, undef, zero, undef, neg

(c) pos, neg, neg, neg, neg, pos

(d) neg, pos, neg, neg, pos, neg

(e) neg, neg, pos, pos, neg, neg

(f) neg, pos, neg, neg, pos, neg

32. (a) neg, zero, undef, zero, undef, neg

(b) pos, neg, neg, neg, neg, pos

(c) zero, neg, zero, undef, neg, undef

(d) pos, zero, undef, zero, undef, pos

(e) neg, neg, pos, pos, neg, neg

(f) neg, neg, pos, pos, neg, neg

33. (a)  $\sin(\pi - x) = \sin x$ ; 0.588

(b)  $\cos(-x) = \cos x$ ; 0.924

(c)  $\sin(2\pi + x) = \sin x$ ; 0.588

(d)  $\cos(\pi - x) = -\cos x$ ; -0.924

(e)  $\sin 2x = \pm 2 \sin x \sqrt{1 - \sin^2 x}$ ; use the + sign for  $x$  small and positive; 0.951

(f)  $\cos^2 x = 1 - \sin^2 x$ ; 0.654

34. (a)  $\sin(3\pi + x) = -\sin x$ ; -0.588

(b)  $\cos(-x - 2\pi) = \cos x$ ; 0.924

(c)  $\sin(8\pi + x) = \sin x$ ; 0.588

(d)  $\sin(x/2) = \pm \sqrt{(1 - \cos x)/2}$ ; use the negative sign for  $x$  small and negative; -0.195

(e)  $\cos(3\pi + 3x) = -4 \cos^3 x + 3 \cos x$ ; -0.384

(f)  $\tan^2 x = \frac{1 - \cos^2 x}{\cos^2 x}$ ; 0.172

35. (a)  $-a$

(b)  $b$

(c)  $-c$

(d)  $\pm \sqrt{1 - a^2}$

(e)  $-b$

(f)  $-a$

(g)  $\pm 2b\sqrt{1 - b^2}$

(h)  $2b^2 - 1$

(i)  $1/b$

(j)  $-1/a$

(k)  $1/c$

(l)  $(1 - b)/2$

36. (a) The distance is  $36/360 = 1/10$ th of a great circle, so it is  $(1/10)2\pi r = 2,513.27$  mi. (b)  $36/360 = 1/10$
37. If the arc length is 1, then solve the ratio  $\frac{x}{1} = \frac{2\pi r}{29.5}$  to get  $x \approx 80,936$  km.
38. The distance travelled is equal to the length of that portion of the circumference of the wheel which touches the road, and that is the fraction  $225/360$  of a circumference, so a distance of  $(225/360)(2\pi)3 = 11.78$  ft
39. The second quarter revolves twice ( $720^\circ$ ) about its own center.
40. Add  $r$  to itself until you exceed  $2\pi r$ ; since  $6r < 2\pi r < 7r$ , you can cut off 6 pieces of pie, but there's not enough for a full seventh piece. We conclude that there is no exact solution of the equation 'One pie =  $2\pi r$ '.
41. (a)  $y = 3 \sin(x/2)$  (b)  $y = 4 \cos 2x$  (c)  $y = -5 \sin 4x$
42. (a)  $y = 1 + \cos \pi x$  (b)  $y = 1 + 2 \sin x$  (c)  $y = -5 \cos 4x$
43. (a)  $y = \sin(x + \pi/2)$   
 (b)  $y = 3 + 3 \sin(2x/9)$   
 (c)  $y = 1 + 2 \sin(2(x - \pi/4))$

44.  $V = 120\sqrt{2} \sin(120\pi t)$

45. (a)  $3, \pi/2, 0$

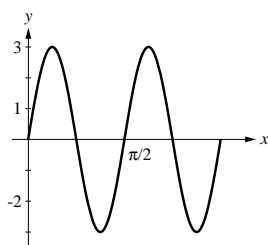

(b)  $2, 2, 0$

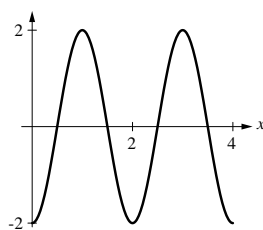

(c)  $1, 4\pi, 0$

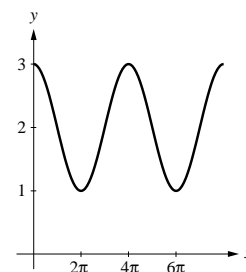

46. (a)  $4, \pi, 0$

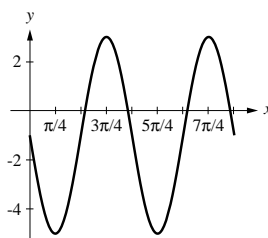

(b)  $1/2, 2\pi/3, \pi/3$

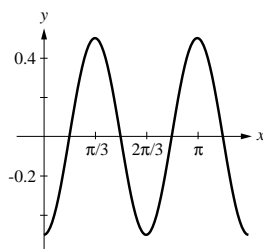

(c)  $4, 6\pi, -6\pi$

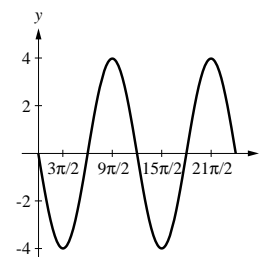

47. (a)  $A \sin(\omega t + \theta) = A \sin(\omega t) \cos \theta + A \cos(\omega t) \sin \theta = A_1 \sin(\omega t) + A_2 \cos(\omega t)$

(b)  $A_1 = A \cos \theta, A_2 = A \sin \theta$ , so  $A = \sqrt{A_1^2 + A_2^2}$  and  $\theta = \tan^{-1}(A_2/A_1)$ .

(c)  $A = 5\sqrt{13}/2, \theta = \tan^{-1} \frac{1}{2\sqrt{3}}$ ;

$$x = \frac{5\sqrt{13}}{2} \sin\left(2\pi t + \tan^{-1} \frac{1}{2\sqrt{3}}\right)$$

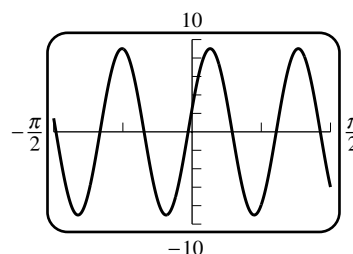



48. three;  $x = 0, x = \pm 1.8955$

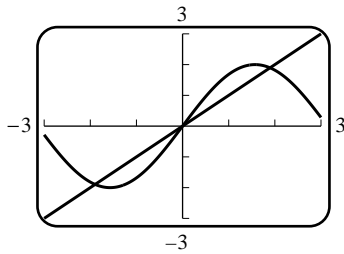

**EXERCISE SET 1.7**

1. (a)  $x + 1 = t = y - 1, y = x + 2$

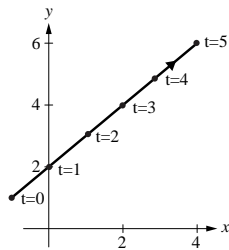

(c)

$t$	0	1	2	3	4	5
$x$	-1	0	1	2	3	4
$y$	1	2	3	4	5	6

2. (a)  $x^2 + y^2 = 1$

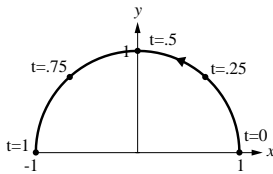

(c)

$t$	0	0.2500	0.50	0.7500	1
$x$	1	0.7071	0.00	-0.7071	-1
$y$	0	0.7071	1.00	0.7071	0

3.  $t = (x + 4)/3; y = 2x + 10$

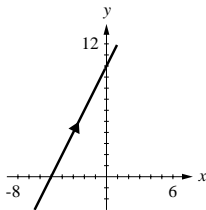

4.  $t = x + 3; y = 3x + 2, -3 \leq x \leq 0$

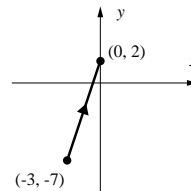

5.  $\cos t = x/2, \sin t = y/5; x^2/4 + y^2/25 = 1$

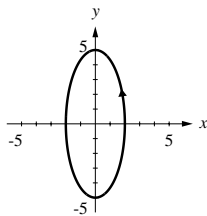

6.  $t = x^2; y = 2x^2 + 4, x \geq 0$

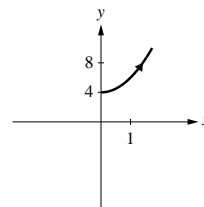

7.  $\cos t = (x - 3)/2, \sin t = (y - 2)/4;$   
 $(x - 3)^2/4 + (y - 2)^2/16 = 1$

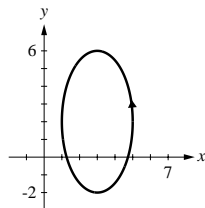

8.  $\sec^2 t - \tan^2 t = 1; x^2 - y^2 = 1,$   
 $x \leq -1$  and  $y \geq 0$

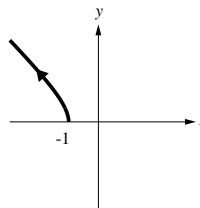

9.  $\cos 2t = 1 - 2\sin^2 t; x = 1 - 2y^2, -1 \leq y \leq 1$

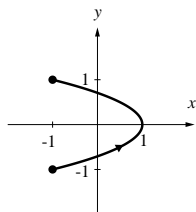

10.  $t = (x - 3)/4; y = (x - 3)^2 - 9$

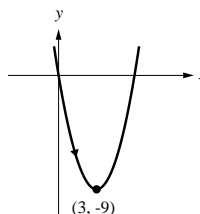

11.  $x/2 + y/3 = 1, 0 \leq x \leq 2, 0 \leq y \leq 3$

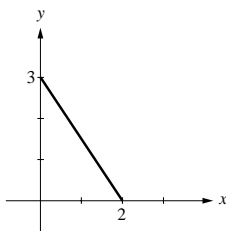

12.  $y = x - 1, x \geq 1, y \geq 0$

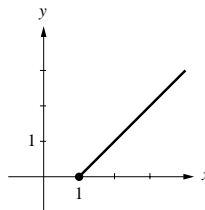

13.  $x = 5 \cos t, y = -5 \sin t, 0 \leq t \leq 2\pi$

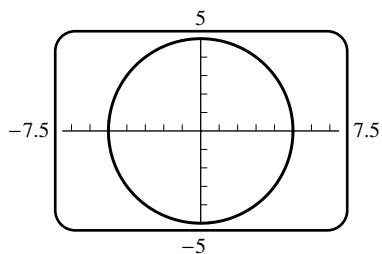

14.  $x = \cos t, y = \sin t, \pi \leq t \leq 3\pi/2$

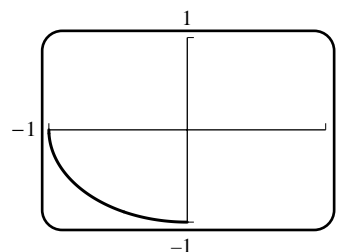

15.  $x = 2, y = t$

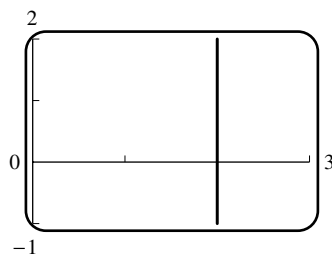

16.  $x = 2 \cos t, y = 3 \sin t, 0 \leq t \leq 2\pi$

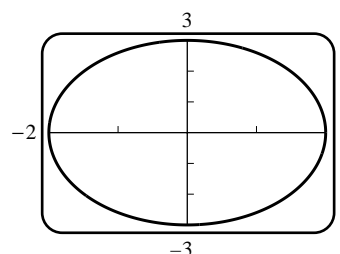

17.  $x = t^2, y = t, -1 \leq t \leq 1$

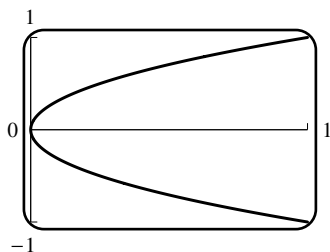

18.  $x = 1 + 4 \cos t, y = -3 + 4 \sin t, 0 \leq t \leq 2\pi$

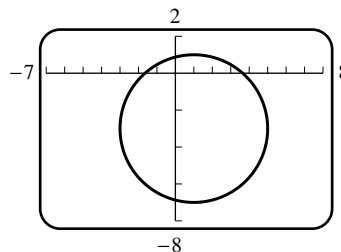

19. (a) IV, because  $x$  always increases whereas  $y$  oscillates.  
 (b) II, because  $(x/2)^2 + (y/3)^2 = 1$ , an ellipse.  
 (c) V, because  $x^2 + y^2 = t^2$  increases in magnitude while  $x$  and  $y$  keep changing sign.  
 (d) VI; examine the cases  $t < -1$  and  $t > -1$  and you see the curve lies in the first, second and fourth quadrants only.  
 (e) III because  $y > 0$ .  
 (f) I; since  $x$  and  $y$  are bounded, the answer must be I or II; but as  $t$  runs, say, from 0 to  $\pi$ ,  $x$  goes directly from 2 to  $-2$ , but  $y$  goes from 0 to 1 to 0 to  $-1$  and back to 0, which describes I but not II.
20. (a) from left to right  
 (b) counterclockwise  
 (c) counterclockwise  
 (d) As  $t$  travels from  $-\infty$  to  $-1$ , the curve goes from (near) the origin in the third quadrant and travels up and left. As  $t$  travels from  $-1$  to  $+\infty$  the curve comes from way down in the second quadrant, hits the origin at  $t = 0$ , and then makes the loop clockwise and finally approaches the origin again as  $t \rightarrow +\infty$ .  
 (e) from left to right  
 (f) Starting, say, at  $(1, 0)$ , the curve goes up into the first quadrant, loops back through the origin and into the third quadrant, and then continues the figure-eight.

21. (a)

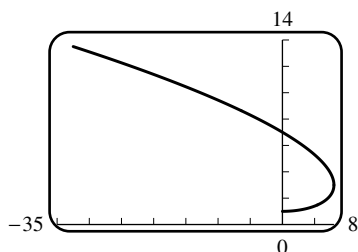

(b)

$t$	0	1	2	3	4	5
$x$	0	5.5	8	4.5	-8	-32.5
$y$	1	1.5	3	5.5	9	13.5

- (c)  $x = 0$  when  $t = 0, 2\sqrt{3}$ . (d) for  $0 < t < 2\sqrt{2}$  (e) at  $t = 2$

22. (a)

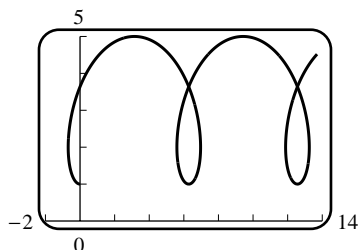

- (b)  $y$  is always  $\geq 1$  since  $\cos t \leq 1$   
 (c) greater than 5, since  $\cos t \geq -1$

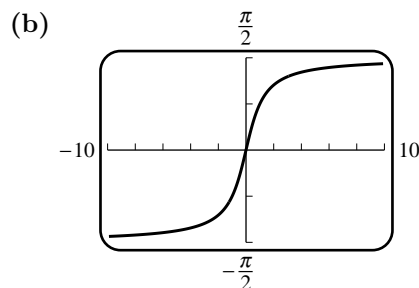
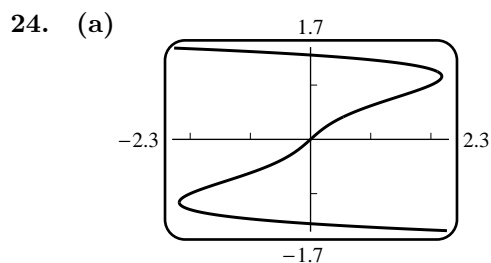
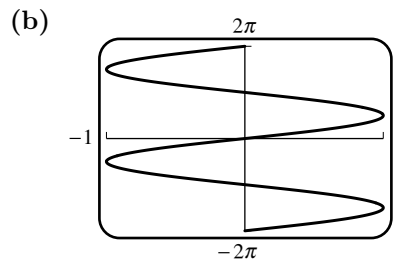
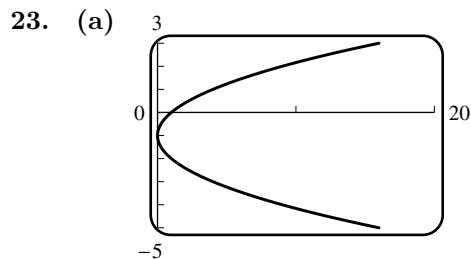

25. (a)  $\frac{x - x_0}{x_1 - x_0} = \frac{y - y_0}{y_1 - y_0}$

(c)  $x = 1 + t, y = -2 + 6t$

(b) Set  $t = 0$  to get  $(x_0, y_0)$ ;  $t = 1$  for  $(x_1, y_1)$ .

(d)  $x = 2 - t, y = 4 - 6t$

26. (a)  $x = -3 - 2t, y = -4 + 5t$

(b)  $x = at, y = b(1 - t)$

27. (a)  $|R - P|^2 = (x - x_0)^2 + (y - y_0)^2 = t^2[(x_1 - x_0)^2 + (y_1 - y_0)^2]$  and  $|Q - P|^2 = (x_1 - x_0)^2 + (y_1 - y_0)^2$ , so  $r = |R - P| = |Q - P|t = qt$ .

(b)  $t = 1/2$

(c)  $t = 3/4$

28.  $x = 2 + t, y = -1 + 2t$

(a)  $(5/2, 0)$

(b)  $(9/4, -1/2)$

(c)  $(11/4, 1/2)$

29. The two branches corresponding to  $-1 \leq t \leq 0$  and  $0 \leq t \leq 1$  coincide.

30. (a) Eliminate  $\frac{t - t_0}{t_1 - t_0}$  to obtain  $\frac{y - y_0}{x - x_0} = \frac{y_1 - y_0}{x_1 - x_0}$ .

(b) from  $(x_0, y_0)$  to  $(x_1, y_1)$

(c)  $x = 3 - 2(t - 1), y = -1 + 5(t - 1)$

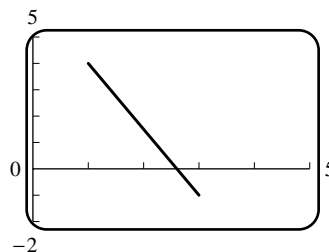

31. (a)  $\frac{x - b}{a} = \frac{y - d}{c}$

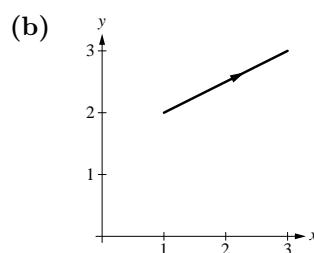

32. (a) If  $a = 0$  the line segment is vertical; if  $c = 0$  it is horizontal.  
 (b) The curve degenerates to the point  $(b, d)$ .

33.

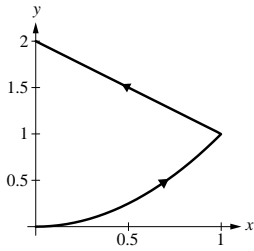

34.  $x = 1/2 - 4t, \quad y = 1/2 \quad \text{for } 0 \leq t \leq 1/4$   
 $x = -1/2, \quad y = 1/2 - 4(t - 1/4) \quad \text{for } 1/4 \leq t \leq 1/2$   
 $x = -1/2 + 4(t - 1/2), \quad y = -1/2 \quad \text{for } 1/2 \leq t \leq 3/4$   
 $x = 1/2, \quad y = -1/2 + 4(t - 3/4) \quad \text{for } 3/4 \leq t \leq 1$

35. (a)  $x = 4 \cos t, y = 3 \sin t$

- (b)  $x = -1 + 4 \cos t, y = 2 + 3 \sin t$

(c)

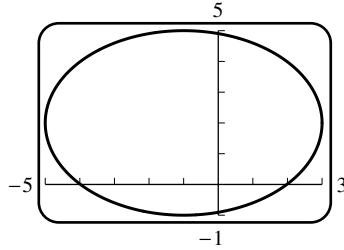
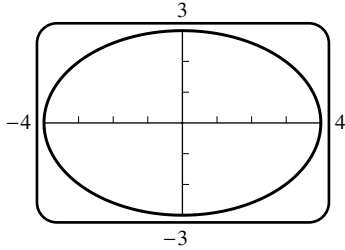

36. (a)  $t = x/(v_0 \cos \alpha)$ , so  $y = x \tan \alpha - gx^2/(2v_0^2 \cos^2 \alpha)$ .

(b)

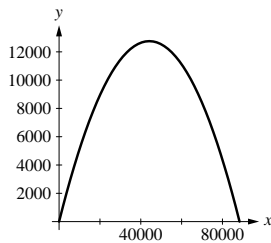

37. (a) From Exercise 36,  $x = 400\sqrt{2}t, y = 400\sqrt{2}t - 4.9t^2$ . (b) 16,326.53 m (c) 65,306.12 m

38. (a)

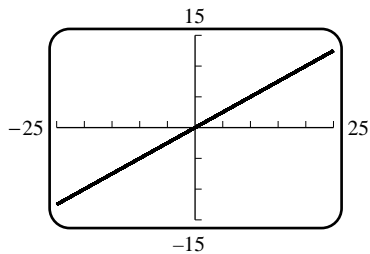

(b)

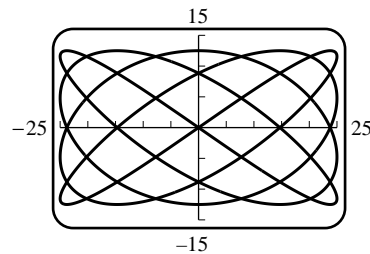

(c)

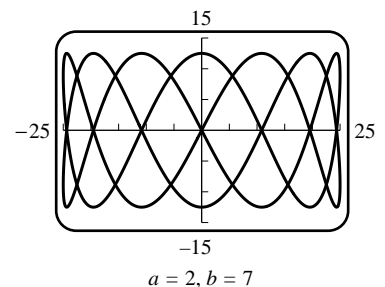
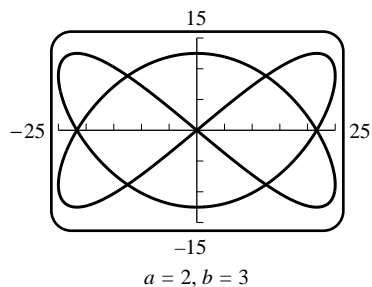
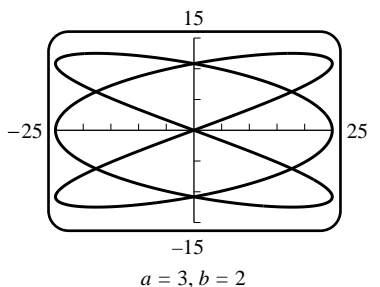

39. Assume that  $a \neq 0$  and  $b \neq 0$ ; eliminate the parameter to get  $(x-h)^2/a^2 + (y-k)^2/b^2 = 1$ . If  $|a| = |b|$  the curve is a circle with center  $(h, k)$  and radius  $|a|$ ; if  $|a| \neq |b|$  the curve is an ellipse with center  $(h, k)$  and major axis parallel to the  $x$ -axis when  $|a| > |b|$ , or major axis parallel to the  $y$ -axis when  $|a| < |b|$ .

- (a) ellipses with a fixed center and varying axes of symmetry  
 (b) (assume  $a \neq 0$  and  $b \neq 0$ ) ellipses with varying center and fixed axes of symmetry  
 (c) circles of radius 1 with centers on the line  $y = x - 1$

40. Refer to the diagram to get  $b\theta = a\phi$ ,  $\theta = a\phi/b$  but  $\theta - \alpha = \phi + \pi/2$   
 so  $\alpha = \theta - \phi - \pi/2 = (a/b - 1)\phi - \pi/2$

$$\begin{aligned} x &= (a-b)\cos\phi - b\sin\alpha \\ &= (a-b)\cos\phi + b\cos\left(\frac{a-b}{b}\phi\right), \\ y &= (a-b)\sin\phi - b\cos\alpha \\ &= (a-b)\sin\phi - b\sin\left(\frac{a-b}{b}\phi\right). \end{aligned}$$

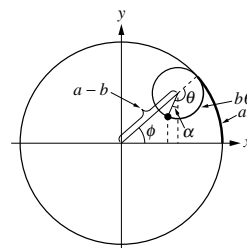

41. (a)

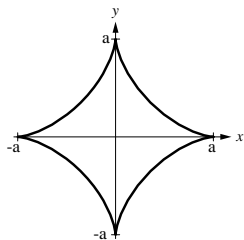

- (b) Use  $b = a/4$  in the equations of Exercise 40 to get

$$x = \frac{3}{4}a\cos\phi + \frac{1}{4}a\cos 3\phi, \quad y = \frac{3}{4}a\sin\phi - \frac{1}{4}a\sin 3\phi;$$

but trigonometric identities yield  $\cos 3\phi = 4\cos^3\phi - 3\cos\phi$ ,  $\sin 3\phi = 3\sin\phi - 4\sin^3\phi$ ,

so  $x = a\cos^3\phi$ ,  $y = a\sin^3\phi$ .

- (c)  $x^{2/3} + y^{2/3} = a^{2/3}(\cos^2\phi + \sin^2\phi) = a^{2/3}$

- 42.

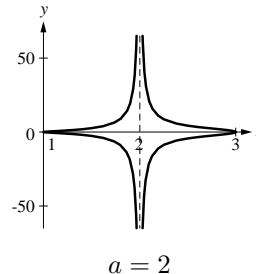
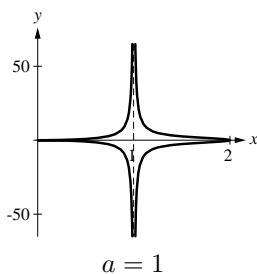
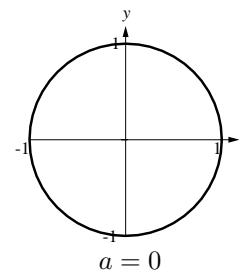
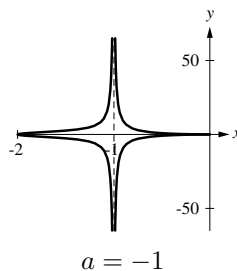
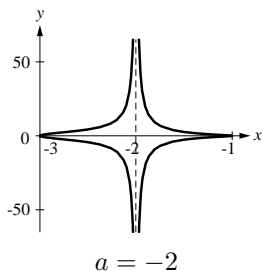

### CHAPTER 1 SUPPLEMENTARY EXERCISES

1. 1940-45; the greatest five-year slope

2. (a)  $f(-1) = 3.3, g(3) = 2$

(c)  $x < -2, x > 3$

(e) the domain is  $-4 \leq x \leq 4.1$ , the range is  $-3 \leq y \leq 5$

(b)  $x = -3, 3$

(d) the domain is  $-5 \leq x \leq 5$  and the range is  $-5 \leq y \leq 4$

(f)  $f(x) = 0$  at  $x = -3, 5; g(x) = 0$  at  $x = -3, 2$

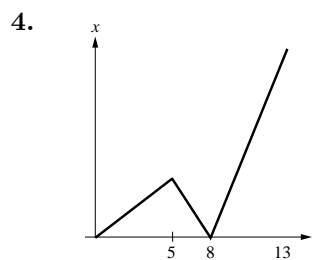
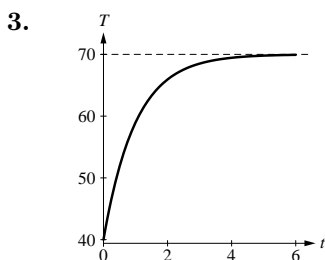

5. If the side has length  $x$  and height  $h$ , then  $V = 8 = x^2h$ , so  $h = 8/x^2$ . Then the cost  $C = 5x^2 + 2(4)(xh) = 5x^2 + 64/x$ .

6. Assume that the paint is applied in a thin veneer of uniform thickness, so that the quantity of paint to be used is proportional to the area covered. If  $P$  is the amount of paint to be used,  $P = k\pi r^2$ . The constant  $k$  depends on physical factors, such as the thickness of the paint, absorption of the wood, etc.

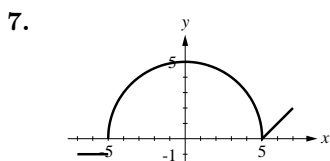

8. Suppose the radius of the uncoated ball is  $r$  and that of the coated ball is  $r + h$ . Then the plastic has volume equal to the difference of the volumes, i.e.  $V = \frac{4}{3}\pi(r + h)^3 - \frac{4}{3}\pi r^3 = \frac{4}{3}\pi h[3r^2 + 3rh + h^2]$  in<sup>3</sup>.

9. (a) The base has sides  $(10 - 2x)/2$  and  $6 - 2x$ , and the height is  $x$ , so  $V = (6 - 2x)(5 - x)x$  ft<sup>3</sup>.

(b) From the picture we see that  $x < 5$  and  $2x < 6$ , so  $0 < x < 3$ .

(c) 3.57 ft  $\times$  3.79 ft  $\times$  1.21 ft

10.  $\{x \neq 0\}$  and  $\emptyset$  (the empty set)

11. impossible; we would have to solve  $2(3x - 2) - 5 = 3(2x - 5) - 2$ , or  $-9 = -17$

12. (a)  $(3 - x)/x$

(b) no;  $f(g(x))$  can be defined at  $x = 1$ , whereas  $g$ , and therefore  $f \circ g$ , requires  $x \neq 1$

13.  $1/(2 - x^2)$

14.  $g(x) = x^2 + 2x$

15.

$x$	-4	-3	-2	-1	0	1	2	3	4
$f(x)$	0	-1	2	1	3	-2	-3	4	-4
$g(x)$	3	2	1	-3	-1	-4	4	-2	0
$(f \circ g)(x)$	4	-3	-2	-1	1	0	-4	2	3
$(g \circ f)(x)$	-1	-3	4	-4	-2	1	2	0	3

16. (a)  $y = |x - 1|$ ,  $y = |(-x) - 1| = |x + 1|$ ,  
 $y = 2|x + 1|$ ,  $y = 2|x + 1| - 3$ ,  
 $y = -2|x + 1| + 3$

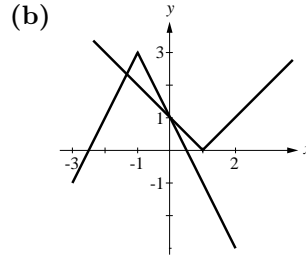

17. (a) even  $\times$  odd = odd  
(c) even + odd is neither

(b) a square is even  
(d) odd  $\times$  odd = even

18. (a)  $y = \cos x - 2 \sin x \cos x = (1 - 2 \sin x) \cos x$ , so  $x = \pm \frac{\pi}{2}, \pm \frac{3\pi}{2}, \frac{\pi}{6}, \frac{5\pi}{6}, -\frac{7\pi}{6}, -\frac{11\pi}{6}$

(b)  $(\pm \frac{\pi}{2}, 0), (\pm \frac{3\pi}{2}, 0), (\frac{\pi}{6}, \sqrt{3}/2), (\frac{5\pi}{6}, \sqrt{3}/2), (-\frac{7\pi}{6}, -\sqrt{3}/2), (-\frac{11\pi}{6}, -\sqrt{3}/2)$

19. (a) If  $x$  denotes the distance from  $A$  to the base of the tower, and  $y$  the distance from  $B$  to the base, then  $x^2 + d^2 = y^2$ . Moreover  $h = x \tan \alpha = y \tan \beta$ , so  $d^2 = y^2 - x^2 = h^2(\cot^2 \beta - \cot^2 \alpha)$ ,  

$$h^2 = \frac{d^2}{\cot^2 \beta - \cot^2 \alpha} = \frac{d^2 \sin^2 \alpha \sin^2 \beta}{\sin^2 \alpha \cos^2 \beta - \cos^2 \alpha \sin^2 \beta}$$
. The trigonometric identity

$$\sin(\alpha + \beta) \sin(\alpha - \beta) = \sin^2 \alpha \cos^2 \beta - \cos^2 \alpha \sin^2 \beta \text{ yields } h = \frac{d \sin \alpha \sin \beta}{\sqrt{\sin(\alpha + \beta) \sin(\alpha - \beta)}}.$$

(b) 295.72 ft.

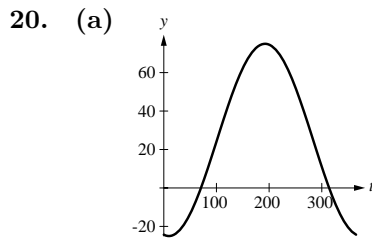

(b) when  $\frac{2\pi}{365}(t - 101) = \frac{3\pi}{2}$ , or  $t = 374.75$ , which is the same date as  $t = 9.75$ , so during the night of January 10th-11th

(c) from  $t = 0$  to  $t = 70.58$  and from  $t = 313.92$  to  $t = 365$  (the same date as  $t = 0$ ), for a total of about 122 days

21.  $C$  is the highest nearby point on the graph; zoom to find that the coordinates of  $C$  are  $(2.0944, 1.9132)$ . Similarly,  $D$  is the lowest nearby point, and its coordinates are  $(4.1888, 1.2284)$ . Since  $f(x) = \frac{1}{2}x - \sin x$  is an odd function, the coordinates of  $B$  are  $(-2.0944, -1.9132)$  and those of  $A$  are  $(-4.1888, -1.2284)$ .

22. Let  $y = A + B \sin(at + b)$ . Since the maximum and minimum values of  $y$  are 35 and 5,  $A + B = 35$  and  $A - B = 5$ , so  $A = 20$ ,  $B = 15$ . The period is 12 hours, so  $12a = 2\pi$  and  $a = \pi/6$ . The maximum occurs at  $t = 2$ , so  $1 = \sin(2a + b) = \sin(\pi/3 + b)$ ,  $\pi/3 + b = \pi/2$ ,  $b = \pi/2 - \pi/3 = \pi/6$  and  $y = 20 + 15 \sin(\pi t/6 + \pi/6)$ .

23. (a) The circle of radius 1 centered at  $(a, a^2)$ ; therefore, the family of all circles of radius 1 with centers on the parabola  $y = x^2$ .

(b) All parabolas which open up, have latus rectum equal to 1 and vertex on the line  $y = x/2$ .

24. (a)  $x = f(1 - t)$ ,  $y = g(1 - t)$

25.

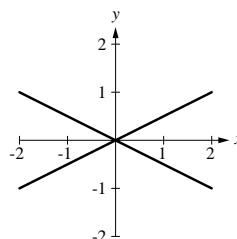



26. Let  $y = ax^2 + bx + c$ . Then  $4a + 2b + c = 0$ ,  $64a + 8b + c = 18$ ,  $64a - 8b + c = 18$ , from which  $b = 0$  and  $60a = 18$ , or finally  $y = \frac{3}{10}x^2 - \frac{6}{5}$ .

27.

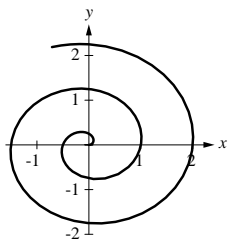

28. (a)  $R = R_0$  is the  $R$ -intercept,  $R_0k$  is the slope, and  $T = -1/k$  is the  $T$ -intercept  
 (b)  $-1/k = -273$ , or  $k = 1/273$   
 (c)  $1.1 = R_0(1 + 20/273)$ , or  $R_0 = 1.025$   
 (d)  $T = 126.55^\circ\text{C}$

29.  $d = \sqrt{(x-1)^2 + (\sqrt{x}-2)^2}$ ;  
 $d = 9.1$  at  $x = 1.358094$

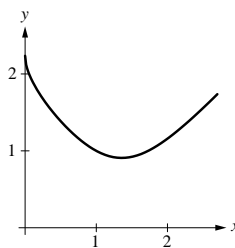

30.  $d = \sqrt{(x-1)^2 + 1/x^2}$ ;  
 $d = 0.82$  at  $x = 1.380278$

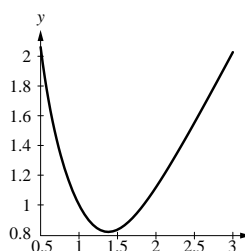

31.  $w = 63.9V$ ,  $w = 63.9\pi h^2(5/2 - h/3)$ ;  $h = 0.48$  ft when  $w = 108$  lb

32. (a)

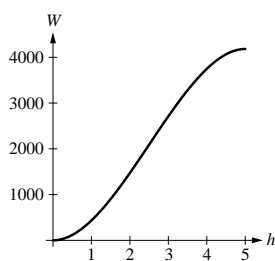

- (b)  $w = 63.9\pi h^2(5/2 - h/3)$ ; at  $h = 5/2$ ,  
 $w = 2091.12$  lb

33. (a)

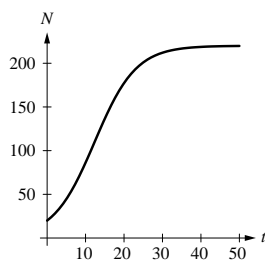

- (b)  $N = 80$  when  $t = 9.35$  yrs  
 (c) 220 sheep

34. (a)

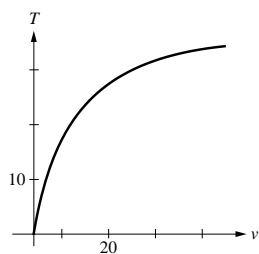
(b)  $T = 17^\circ\text{F}, 27^\circ\text{F}, 32^\circ\text{F}$ 

35. (a)

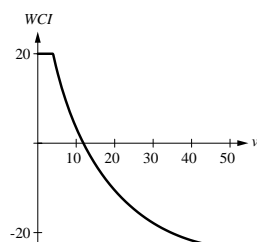
(b)  $T = 3^\circ\text{F}, -11^\circ\text{F}, -18^\circ\text{F}, -22^\circ\text{F}$ (c)  $v = 35, 19, 12, 7$  mi/h36. The domain is the set of all  $x$ , the range is  $-0.1746 \leq y \leq 0.1227$ .37. The domain is the set  $-0.7245 \leq x \leq 1.2207$ , the range is  $-1.0551 \leq y \leq 1.4902$ .38. (a) The potato is done in the interval  $27.65 < t < 32.71$ .

(b) 91.54 min.

39. (a)

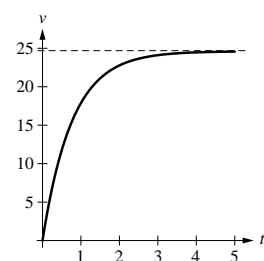
(b) As  $t \rightarrow \infty$ ,  $(0.273)^t \rightarrow 0$ , and thus  $v \rightarrow 24.61$  ft/s.(c) For large  $t$  the velocity approaches  $c$ .

(d) No; but it comes very close (arbitrarily close).

(e) 3.013 s

## CHAPTER 1 HORIZON MODULE

1. (a)  $0.25, 6.25 \times 10^{-2}, 3.91 \times 10^{-3}, 1.53 \times 10^{-5}, 2.32 \times 10^{-10}, 5.42 \times 10^{-20}, 2.94 \times 10^{-39}, 8.64 \times 10^{-78}, 7.46 \times 10^{-155}, 5.56 \times 10^{-309};$   
 $1, 1, 1, 1, 1, 1, 1, 1, 1, 1;$   
 $4, 16, 256, 65536, 4.29 \times 10^9, 1.84 \times 10^{19}, 3.40 \times 10^{38}, 1.16 \times 10^{77}, 1.34 \times 10^{154}, 1.80 \times 10^{308}$

2.  $2, 2.25, 2.2361111, 2.23606798, 2.23606798, \dots$

3. (a)  $\frac{1}{2}, \frac{1}{4}, \frac{1}{8}, \frac{1}{16}, \frac{1}{32}, \frac{1}{64}$

(b)  $y_n = \frac{1}{2^n}$ 

4. (a)  $y_{n+1} = 1.05y_n$

(b)  $y_0 = \$1000, y_1 = \$1050, y_2 = \$1102.50, y_3 = \$1157.62, y_4 = \$1215.51, y_5 = \$1276.28$ (c)  $y_{n+1} = 1.05y_n$  for  $n \geq 1$ (d)  $y_n = (1.05)^n 1000; y_{15} = \$2078.93$

5. (a)  $x^{1/2}, x^{1/4}, x^{1/8}, x^{1/16}, x^{1/32}$

(b) They tend to the horizontal line  $y = 1$ , with a hole at  $x = 0$ .

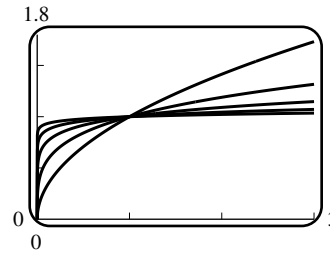

6. (a)  $\frac{1}{2}, \frac{2}{3}, \frac{3}{5}, \frac{5}{8}, \frac{8}{13}, \frac{13}{21}, \frac{21}{34}, \frac{34}{55}, \frac{55}{89}, \frac{89}{144}$

(b) 1, 2, 3, 5, 8, 13, 21, 34, 55, 89 ;  
each new numerator is the sum of the previous two numerators.

(c)  $\frac{144}{233}, \frac{233}{377}, \frac{377}{610}, \frac{610}{987}, \frac{987}{1597}, \frac{1597}{2584}, \frac{2584}{4181}, \frac{4181}{6765}, \frac{6765}{10946}, \frac{10946}{17711}$

(d)  $F_0 = 1, F_1 = 1, F_n = F_{n-1} + F_{n-2}$  for  $n \geq 2$ .

(e) the positive solution

7. (a)  $y_1 = cr, y_2 = cy_1 = cr^2, y_3 = cr^3, y_4 = cr^4$

(b)  $y_n = cr^n$

(c) If  $r = 1$  then  $y_n = c$  for all  $n$ ; if  $r < 1$  then  $y_n$  tends to zero; if  $r > 1$ , then  $y_n$  gets ever larger (tends to  $+\infty$ ).

8. The first point on the curve is  $(c, kc(1 - c))$ , so  $y_1 = kc(1 - c)$  and hence  $y_1$  is the first iterate. The point on the line to the right of this point has equal coordinates  $(y_1, y_1)$ , and so the point above it on the curve has coordinates  $(y_1, ky_1(1 - y_1))$ ; thus  $y_2 = ky_1(1 - y_1)$ , and  $y_2$  is the second iterate, etc.

9. (a) 0.261, 0.559, 0.715, 0.591, 0.701

(b) It appears to approach a point somewhere near 0.65.

## CHAPTER 2

# Limits and Continuity

### EXERCISE SET 2.1

1. (a)  $-1$  (b)  $3$  (c) does not exist  
(d)  $1$  (e)  $-1$  (f)  $3$
2. (a)  $2$  (b)  $0$  (c) does not exist  
(d)  $2$  (e)  $0$  (f)  $2$
3. (a)  $1$  (b)  $1$  (c)  $1$  (d)  $1$  (e)  $-\infty$  (f)  $+\infty$
4. (a)  $3$  (b)  $3$  (c)  $3$  (d)  $3$  (e)  $+\infty$  (f)  $+\infty$
5. (a)  $0$  (b)  $0$  (c)  $0$  (d)  $3$  (e)  $+\infty$  (f)  $+\infty$
6. (a)  $2$  (b)  $2$  (c)  $2$  (d)  $3$  (e)  $-\infty$  (f)  $+\infty$
7. (a)  $-\infty$  (b)  $+\infty$  (c) does not exist  
(d) undef (e)  $2$  (f)  $0$
8. (a)  $+\infty$  (b)  $+\infty$  (c)  $+\infty$  (d) undef (e)  $0$  (f)  $-1$
9. (a)  $-\infty$  (b)  $-\infty$  (c)  $-\infty$  (d)  $1$  (e)  $1$  (f)  $2$
10. (a)  $1$  (b)  $-\infty$  (c) does not exist  
(d)  $-2$  (e)  $+\infty$  (f)  $+\infty$
11. (a)  $0$  (b)  $0$  (c)  $0$   
(d)  $0$  (e) does not exist (f) does not exist
12. (a)  $3$  (b)  $3$  (c)  $3$   
(d)  $3$  (e) does not exist (f)  $0$
13. for all  $x_0 \neq -4$
14. for all  $x_0 \neq -6, 3$
15. (a) At  $x = 3$  the one-sided limits fail to exist.  
(b) At  $x = -2$  the two-sided limit exists but is not equal to  $F(-2)$ .  
(c) At  $x = 3$  the limit fails to exist.
16. (a) At  $x = 2$  the two-sided limit fails to exist.  
(b) At  $x = 3$  the two-sided limit exists but is not equal to  $F(3)$ .  
(c) At  $x = 0$  the two-sided limit fails to exist.

17. (a)

2	1.5	1.1	1.01	1.001	0	0.5	0.9	0.99	0.999
0.1429	0.2105	0.3021	0.3300	0.3330	1.0000	0.5714	0.3690	0.3367	0.3337

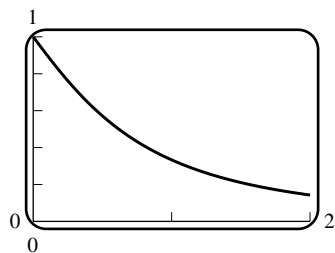

The limit is  $1/3$ .

(b)

2	1.5	1.1	1.01	1.001	1.0001
0.4286	1.0526	6.344	66.33	666.3	6666.3

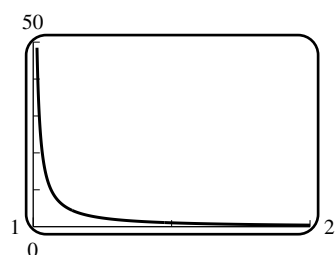

The limit is  $+\infty$ .

(c)

0	0.5	0.9	0.99	0.999	0.9999
-1	-1.7143	-7.0111	-67.001	-667.0	-6667.0

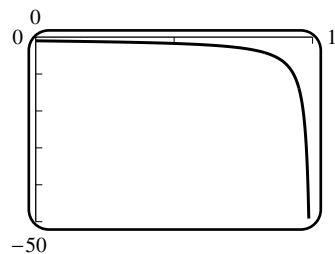

The limit is  $-\infty$ .

18. (a)

-0.25	-0.1	-0.001	-0.0001	0.0001	0.001	0.1	0.25
0.5359	0.5132	0.5001	0.5000	0.5000	0.4999	0.4881	0.4721

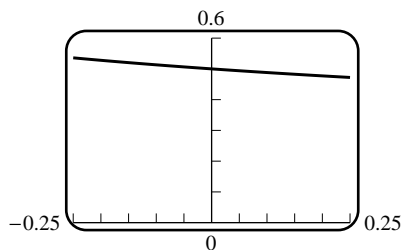

The limit is  $1/2$ .

(b)

0.25	0.1	0.001	0.0001
8.4721	20.488	2000.5	20001

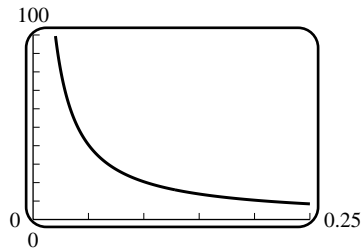

The limit is  $+\infty$ .

(c)

-0.25	-0.1	-0.001	-0.0001
-7.4641	-19.487	-1999.5	-20000

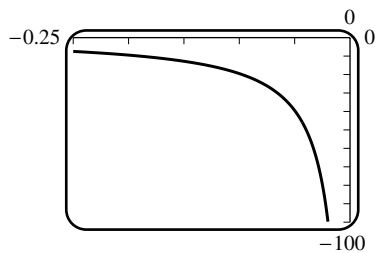

The limit is  $-\infty$ .

19. (a)

-0.25	-0.1	-0.001	-0.0001	0.0001	0.001	0.1	0.25
2.7266	2.9552	3.0000	3.0000	3.0000	3.0000	2.9552	2.7266

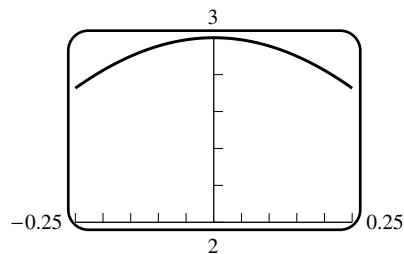

The limit is 3.

(b)

0	-0.5	-0.9	-0.99	-0.999	-1.5	-1.1	-1.01	-1.001
1	1.7552	6.2161	54.87	541.1	-0.1415	-4.536	-53.19	-539.5

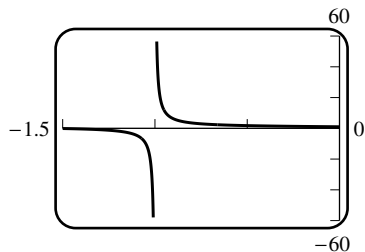

The limit does not exist.

20. (a)

0	-0.5	-0.9	-0.99	-0.999	-1.5	-1.1	-1.01	-1.001
1.5574	1.0926	1.0033	1.0000	1.0000	1.0926	1.0033	1.0000	1.0000

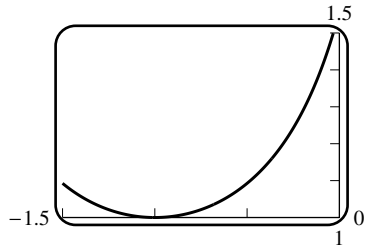

The limit is 1.

(b)

-0.25	-0.1	-0.001	-0.0001	0.0001	0.001	0.1	0.25
1.9794	2.4132	2.5000	2.5000	2.5000	2.5000	2.4132	1.9794

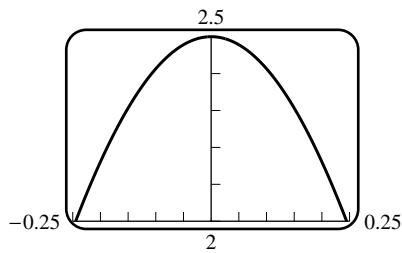

The limit is  $5/2$ .

21. (a)

-100,000,000	-100,000	-1000	-100	-10	10	100	1000
2.0000	2.0001	2.0050	2.0521	2.8333	1.6429	1.9519	1.9950

100,000	100,000,000
2.0000	2.0000

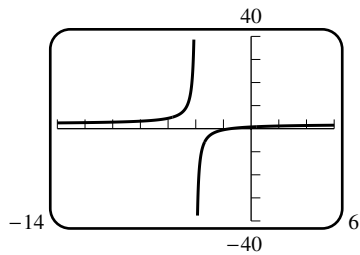

asymptote  $y = 2$  as  $x \rightarrow \pm\infty$

(b)

-100,000,000	-100,000	-1000	-100	-10	10	100	1000
20.0855	20.0864	20.1763	21.0294	35.4013	13.7858	19.2186	19.9955

100,000	100,000,000
20.0846	20.0855

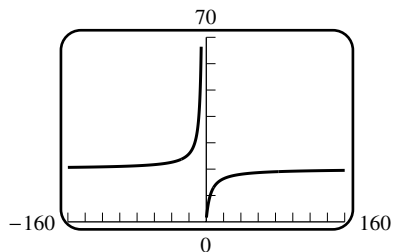

asymptote  $y = 20.086$ .

(c)

-100,000,000	-100,000	-1000	-100	-10	10	100	1000	100,000	100,000,000
-100,000,001	-100,000	-1001	-101.0	-11.2	9.2	99.0	999.0	99,999	99,999,999

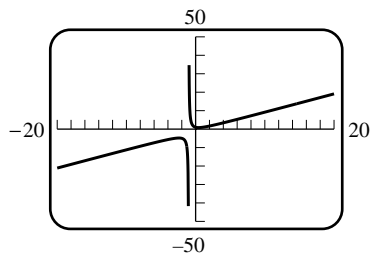

no horizontal asymptote

22. (a)

-100,000,000	-100,000	-1000	-100	-10	10	100	1000	100,000	100,000,000
0.2000	0.2000	0.2000	0.2000	0.1976	0.1976	0.2000	0.2000	0.2000	0.2000

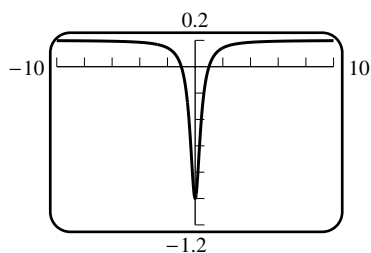

asymptote  $y = 1/5$  as  $x \rightarrow \pm\infty$

(b)

-100,000,000	-100,000	-1000	-100	-10	10	100
0.0000	0.0000	0.0000	0.0000	0.0016	1668.0	$2.09 \times 10^{18}$

1000	100,000	100,000,000
$1.77 \times 10^{301}$	?	?

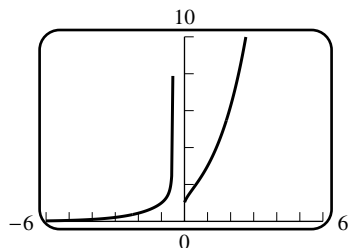

asymptote  $y = 0$  as  $x \rightarrow -\infty$ , none as  $x \rightarrow +\infty$

(c)

-100,000,000	-100,000	-1000	-100	-10	10	100
0.0000	0.0000	0.0008	-0.0051	-0.0544	-0.0544	-0.0051

1000	100,000	100,000,000
0.0008	0.0000	0.0000

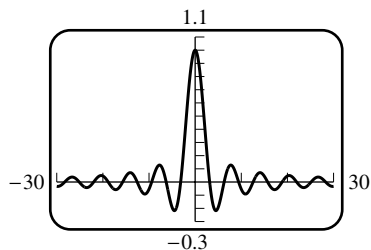

asymptote  $y = 0$  as  $x \rightarrow \pm\infty$

23. (a)  $\lim_{x \rightarrow 0^+} \frac{\sin x}{x}$

(b)  $\lim_{x \rightarrow 0^+} \frac{x-1}{x+1}$

(c)  $\lim_{x \rightarrow 0^-} (1+2x)^{1/x}$



24. (a)  $\lim_{x \rightarrow 0^+} \frac{\cos x}{x}$                       (b)  $\lim_{x \rightarrow 0^+} \frac{1}{x+1}$                       (c)  $\lim_{x \rightarrow 0^-} \left(1 + \frac{2}{x}\right)^x$

25. (a)  (b) yes; for example  $f(x) = (\sin x)/x$

26. (a) no  
 (b) yes;  $\tan x$  and  $\sec x$  at  $x = n\pi + \pi/2$ , and  $\cot x$  and  $\csc x$  at  $x = n\pi$ ,  $n = 0, \pm 1, \pm 2, \dots$
29. (a) The plot over the interval  $[-a, a]$  becomes subject to catastrophic subtraction if  $a$  is small enough (the size depending on the machine).  
 (c) It does not.

**EXERCISE SET 2.2**

1. (a) -6                      (b) 13                      (c) -8                      (d) 16                      (e) 2                      (f) -1/2  
 (g) The limit doesn't exist because the denominator tends to zero but the numerator doesn't.  
 (h) The limit doesn't exist because the denominator tends to zero but the numerator doesn't.
2. (a) 0  
 (b) The limit doesn't exist because  $\lim f$  doesn't exist and  $\lim g$  does.  
 (c) 0    (d) 3    (e) 0  
 (f) The limit doesn't exist because the denominator tends to zero but the numerator doesn't.  
 (g) The limit doesn't exist because  $\sqrt{f(x)}$  is not defined for  $0 \leq x < 2$ .  
 (h) 1
3. (a) 7                      (b) -3                      (c)  $\pi$                       (d) -6                      (e) 36                      (f)  $-\infty$
4. (a) 1                      (b) -1                      (c) 1                      (d) -1                      (e) 1                      (f) -1
5. 0                                      6. 3/4                                      7. 8                                      8. -3                                      9. 4
10. 12                                      11. -4/5                                      12. 0                                      13. 3/2                                      14. 4/3
15. 0                                      16. 0                                      17. 0                                      18. 5/3                                      19.  $-\sqrt{5}$
20.  $\sqrt[3]{3/2}$                                       21.  $1/\sqrt{6}$                                       22.  $\sqrt{5}$                                       23.  $\sqrt{3}$                                       24.  $-1/\sqrt{6}$
25.  $+\infty$                                       26.  $\sqrt{3}$                                       27. does not exist                                      28.  $-\infty$                                       29.  $-\infty$
30.  $+\infty$                                       31.  $+\infty$                                       32. does not exist                                      33. does not exist                                      34.  $-\infty$
35.  $+\infty$                                       36.  $-\infty$                                       37.  $-\infty$                                       38. does not exist                                      39. -1/7
40.  $+\infty$                                       41. 6                                      42.  $+\infty$                                       43.  $+\infty$                                       44. 4

45.  $+\infty$                       46.  $+\infty$                       47.  $-\infty$                       48.  $+\infty$

49. (a) 2                                      (b) 2                                      (c) 2

50. (a) -2                                      (b) 0                                      (c) does not exist

51. (a) 3                                      (b)

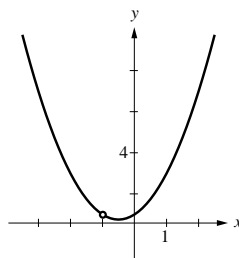

52. (a) -6                                      (b)  $F(x) = x - 3$

53. (a) Theorem 2.2.2(a) doesn't apply; moreover one cannot add/subtract infinities.

(b)  $\lim_{x \rightarrow 0^+} \left( \frac{1}{x} - \frac{1}{x^2} \right) = \lim_{x \rightarrow 0^+} \left( \frac{x-1}{x^2} \right) = -\infty$

54.  $\lim_{x \rightarrow 0^-} \left( \frac{1}{x} + \frac{1}{x^2} \right) = \lim_{x \rightarrow 0^-} \frac{x+1}{x^2} = +\infty$

55.  $\lim_{x \rightarrow 0} \frac{x}{x(\sqrt{x+4}+2)} = \frac{1}{4}$

56.  $\lim_{x \rightarrow 0} \frac{x^2}{x(\sqrt{x+4}+2)} = 0$

57.  $\lim_{x \rightarrow +\infty} (\sqrt{x^2+3} - x) \frac{\sqrt{x^2+3} + x}{\sqrt{x^2+3} + x} = \lim_{x \rightarrow +\infty} \frac{3}{\sqrt{x^2+3} + x} = 0$

58.  $\lim_{x \rightarrow +\infty} (\sqrt{x^2-3x} - x) \frac{\sqrt{x^2-3x} + x}{\sqrt{x^2-3x} + x} = \lim_{x \rightarrow +\infty} \frac{-3x}{\sqrt{x^2-3x} + x} = -3/2$

59.  $\lim_{x \rightarrow +\infty} (\sqrt{x^2+ax} - x) \frac{\sqrt{x^2+ax} + x}{\sqrt{x^2+ax} + x} = \lim_{x \rightarrow +\infty} \frac{ax}{\sqrt{x^2+ax} + x} = a/2$

60.  $\lim_{x \rightarrow +\infty} (\sqrt{x^2+ax} - \sqrt{x^2+bx}) \frac{\sqrt{x^2+ax} + \sqrt{x^2+bx}}{\sqrt{x^2+ax} + \sqrt{x^2+bx}} = \lim_{x \rightarrow +\infty} \frac{(a-b)x}{\sqrt{x^2+ax} + \sqrt{x^2+bx}} = \frac{a-b}{2}$

61.  $\lim_{x \rightarrow +\infty} p(x) = (-1)^n \infty$  and  $\lim_{x \rightarrow -\infty} p(x) = +\infty$

62. If  $m > n$  the limits are both zero. If  $m = n$  the limits are both 1. If  $n > m$  the limits are  $(-1)^{n+m} \infty$  and  $+\infty$ , respectively.

63. If  $m > n$  the limits are both zero. If  $m = n$  the limits are both equal to  $a_m$ , the leading coefficient of  $p$ . If  $n > m$  the limits are  $\pm \infty$  where the sign depends on the sign of  $a_m$  and whether  $n$  is even or odd.

64. (a)  $p(x) = q(x) = x$                                       (b)  $p(x) = x, q(x) = x^2$   
 (c)  $p(x) = x^2, q(x) = x$                                       (d)  $p(x) = x + 3, q(x) = x$

65. The left and/or right limits could be plus or minus infinity; or the limit could exist, or equal any preassigned real number. For example, let  $q(x) = x - x_0$  and let  $p(x) = a(x - x_0)^n$  where  $n$  takes on the values 0, 1, 2.

66. If  $m > n$  the limit is zero. If  $m = n$  the limit is  $c_m/d_m$ . If  $n > m$  the limit is  $\pm\infty$ , where the sign depends on the signs of  $c_n$  and  $d_m$ .

### EXERCISE SET 2.3

1. (a)  $|f(x) - f(0)| = |x + 2 - 2| = |x| < 0.1$  if and only if  $|x| < 0.1$   
 (b)  $|f(x) - f(3)| = |(4x - 5) - 7| = 4|x - 3| < 0.1$  if and only if  $|x - 3| < (0.1)/4 = 0.0025$   
 (c)  $|f(x) - f(4)| = |x^2 - 16| < \epsilon$  if  $|x - 4| < \delta$ . We get  $f(x) = 16 + \epsilon = 16.001$  at  $x = 4.000124998$ , which corresponds to  $\delta = 0.000124998$ ; and  $f(x) = 16 - \epsilon = 15.999$  at  $x = 3.999874998$ , for which  $\delta = 0.000125002$ . Use the smaller  $\delta$ : thus  $|f(x) - 16| < \epsilon$  provided  $|x - 4| < 0.000125$  (to six decimals).
2. (a)  $|f(x) - f(0)| = |2x + 3 - 3| = 2|x| < 0.1$  if and only if  $|x| < 0.05$   
 (b)  $|f(x) - f(0)| = |2x + 3 - 3| = 2|x| < 0.01$  if and only if  $|x| < 0.005$   
 (c)  $|f(x) - f(0)| = |2x + 3 - 3| = 2|x| < 0.0012$  if and only if  $|x| < 0.0006$
3. (a)  $x_1 = (1.95)^2 = 3.8025, x_2 = (2.05)^2 = 4.2025$   
 (b)  $\delta = \min(|4 - 3.8025|, |4 - 4.2025|) = 0.1975$
4. (a)  $x_1 = 1/(1.1) = 0.909090\dots, x_2 = 1/(0.9) = 1.111111\dots$   
 (b)  $\delta = \min(|1 - 0.909090|, |1 - 1.111111|) = 0.090909\dots$
5.  $|2x - 8| = 2|x - 4| < 0.1$  if  $|x - 4| < 0.05, \delta = 0.05$
6.  $|x/2 + 1| = (1/2)|x - (-2)| < 0.1$  if  $|x + 2| < 0.2, \delta = 0.2$
7.  $|7x + 5 - (-2)| = 7|x - (-1)| < 0.01$  if  $|x + 1| < \frac{1}{700}, \delta = \frac{1}{700}$
8.  $|5x - 2 - 13| = 5|x - 3| < 0.01$  if  $|x - 3| < \frac{1}{500}, \delta = \frac{1}{500}$
9.  $\left| \frac{x^2 - 4}{x - 2} - 4 \right| = \left| \frac{x^2 - 4 - 4x + 8}{x - 2} \right| = |x - 2| < 0.05$  if  $|x - 2| < 0.05, \delta = 0.05$
10.  $\left| \frac{x^2 - 1}{x + 1} - (-2) \right| = \left| \frac{x^2 - 1 + 2x + 2}{x + 1} \right| = |x + 1| < 0.05$  if  $|x + 1| < 0.05, \delta = 0.05$
11. if  $\delta < 1$  then  $|x^2 - 16| = |x - 4||x + 4| < 9|x - 4| < 0.001$  if  $|x - 4| < \frac{1}{9000}, \delta = \frac{1}{9000}$
12. if  $\delta < 1$  then  $|\sqrt{x} - 3| \left| \frac{\sqrt{x} + 3}{\sqrt{x} + 3} \right| = \frac{|x - 9|}{|\sqrt{x} + 3|} < \frac{|x - 9|}{\sqrt{8} + 3} < \frac{1}{4}|x - 9| < 0.001$  if  $|x - 9| < 0.004, \delta = 0.004$
13. if  $\delta \leq 1$  then  $\left| \frac{1}{x} - \frac{1}{5} \right| = \frac{|x - 5|}{5|x|} \leq \frac{|x - 5|}{20} < 0.05$  if  $|x - 5| < 1, \delta = 1$
14.  $|x - 0| = |x| < 0.05$  if  $|x| < 0.05, \delta = 0.05$
15.  $|3x - 15| = 3|x - 5| < \epsilon$  if  $|x - 5| < \frac{1}{3}\epsilon, \delta = \frac{1}{3}\epsilon$
16.  $|(4x - 5) - 7| = |4x - 12| = 4|x - 3| < \epsilon$  if  $|x - 3| < \frac{1}{4}\epsilon, \delta = \frac{1}{4}\epsilon$
17.  $|2x - 7 - (-3)| = 2|x - 2| < \epsilon$  if  $|x - 2| < \frac{1}{2}\epsilon, \delta = \frac{1}{2}\epsilon$

18.  $|2 - 3x - 5| = 3|x + 1| < \epsilon$  if  $|x + 1| < \frac{1}{3}\epsilon$ ,  $\delta = \frac{1}{3}\epsilon$
19.  $\left| \frac{x^2 + x}{x} - 1 \right| = |x| < \epsilon$  if  $|x| < \epsilon$ ,  $\delta = \epsilon$       20.  $\left| \frac{x^2 - 9}{x + 3} - (-6) \right| = |x + 3| < \epsilon$  if  $|x + 3| < \epsilon$ ,  $\delta = \epsilon$
21. if  $\delta < 1$  then  $|2x^2 - 2| = 2|x - 1||x + 1| < 6|x - 1| < \epsilon$  if  $|x - 1| < \frac{1}{6}\epsilon$ ,  $\delta = \min(1, \frac{1}{6}\epsilon)$
22. if  $\delta < 1$  then  $|x^2 - 5 - 4| = |x - 3||x + 3| < 7|x - 3| < \epsilon$  if  $|x - 3| < \frac{1}{7}\epsilon$ ,  $\delta = \min(1, \frac{1}{7}\epsilon)$
23. if  $\delta < \frac{1}{6}$  then  $\left| \frac{1}{x} - 3 \right| = \frac{3|x - \frac{1}{3}|}{|x|} < 18|x - \frac{1}{3}| < \epsilon$  if  $|x - \frac{1}{3}| < \frac{1}{18}\epsilon$ ,  $\delta = \min(\frac{1}{6}, \frac{1}{18}\epsilon)$
24. If  $\delta < \frac{1}{2}$  and  $|x - (-2)| < \delta$  then  $-\frac{5}{2} < x < -\frac{3}{2}$ ,  $x + 1 < -\frac{1}{2}$ ,  $|x + 1| > \frac{1}{2}$ ; then  
 $\left| \frac{1}{x + 1} - (-1) \right| = \frac{|x + 2|}{|x + 1|} < 2|x + 2| < \epsilon$  if  $|x + 2| < \frac{1}{2}\epsilon$ ,  $\delta = \min(\frac{1}{2}, \frac{1}{2}\epsilon)$
25.  $|\sqrt{x} - 2| = \left| (\sqrt{x} - 2) \frac{\sqrt{x} + 2}{\sqrt{x} + 2} \right| = \left| \frac{x - 4}{\sqrt{x} + 2} \right| < \frac{1}{2}|x - 4| < \epsilon$  if  $|x - 4| < 2\epsilon$ ,  $\delta = 2\epsilon$
26.  $|\sqrt{x + 3} - 3| \left| \frac{\sqrt{x + 3} + 3}{\sqrt{x + 3} + 3} \right| = \frac{|x - 6|}{\sqrt{x + 3} + 3} \leq \frac{1}{3}|x - 6| < \epsilon$  if  $|x - 6| < 3\epsilon$ ,  $\delta = 3\epsilon$
27.  $|f(x) - 3| = |x + 2 - 3| = |x - 1| < \epsilon$  if  $0 < |x - 1| < \epsilon$ ,  $\delta = \epsilon$
28. If  $\delta < 1$  then  $|(x^2 + 3x - 1) - 9| = |(x - 2)(x + 5)| < 8|x - 2| < \epsilon$  if  $|x - 2| < \frac{1}{8}\epsilon$ ,  $\delta = \min(1, \frac{1}{8}\epsilon)$
29. (a)  $|f(x) - L| = \frac{1}{x^2} < 0.1$  if  $x > \sqrt{10}$ ,  $N = \sqrt{10}$   
 (b)  $|f(x) - L| = \left| \frac{x}{x + 1} - 1 \right| = \left| \frac{1}{x + 1} \right| < 0.01$  if  $x + 1 > 100$ ,  $N = 99$   
 (c)  $|f(x) - L| = \left| \frac{1}{x^3} \right| < \frac{1}{1000}$  if  $|x| > 10$ ,  $x < -10$ ,  $N = -10$   
 (d)  $|f(x) - L| = \left| \frac{x}{x + 1} - 1 \right| = \left| \frac{1}{x + 1} \right| < 0.01$  if  $|x + 1| > 100$ ,  $-x - 1 > 100$ ,  $x < -101$ ,  $N = -101$
30. (a)  $\left| \frac{1}{x^3} \right| < 0.1$ ,  $x > 10^{1/3}$ ,  $N = 10^{1/3}$       (b)  $\left| \frac{1}{x^3} \right| < 0.01$ ,  $x > 100^{1/3}$ ,  $N = 100^{1/3}$   
 (c)  $\left| \frac{1}{x^3} \right| < 0.001$ ,  $x > 10$ ,  $N = 10$
31. (a)  $\frac{x_1^2}{1 + x_1^2} = 1 - \epsilon$ ,  $x_1 = -\sqrt{\frac{1 - \epsilon}{\epsilon}}$ ;  $\frac{x_2^2}{1 + x_2^2} = 1 - \epsilon$ ,  $x_2 = \sqrt{\frac{1 - \epsilon}{\epsilon}}$   
 (b)  $N = \sqrt{\frac{1 - \epsilon}{\epsilon}}$       (c)  $N = -\sqrt{\frac{1 - \epsilon}{\epsilon}}$
32. (a)  $x_1 = -1/\epsilon^3$ ;  $x_2 = 1/\epsilon^3$       (b)  $N = 1/\epsilon^3$       (c)  $N = -1/\epsilon^3$
33.  $\frac{1}{x^2} < 0.01$  if  $|x| > 10$ ,  $N = 10$

34.  $\frac{1}{x+2} < 0.005$  if  $|x+2| > 200$ ,  $x > 198$ ,  $N = 198$
35.  $\left| \frac{x}{x+1} - 1 \right| = \left| \frac{1}{x+1} \right| < 0.001$  if  $|x+1| > 1000$ ,  $x > 999$ ,  $N = 999$
36.  $\left| \frac{4x-1}{2x+5} - 2 \right| = \left| \frac{11}{2x+5} \right| < 0.1$  if  $|2x+5| > 110$ ,  $2x > 105$ ,  $N = 52.5$
37.  $\left| \frac{1}{x+2} - 0 \right| < 0.005$  if  $|x+2| > 200$ ,  $-x-2 > 200$ ,  $x < -202$ ,  $N = -202$
38.  $\left| \frac{1}{x^2} \right| < 0.01$  if  $|x| > 10$ ,  $-x > 10$ ,  $x < -10$ ,  $N = -10$
39.  $\left| \frac{4x-1}{2x+5} - 2 \right| = \left| \frac{11}{2x+5} \right| < 0.1$  if  $|2x+5| > 110$ ,  $-2x-5 > 110$ ,  $2x < -115$ ,  $x < -57.5$ ,  $N = -57.5$
40.  $\left| \frac{x}{x+1} - 1 \right| = \left| \frac{1}{x+1} \right| < 0.001$  if  $|x+1| > 1000$ ,  $-x-1 > 1000$ ,  $x < -1001$ ,  $N = -1001$
41.  $\left| \frac{1}{x^2} \right| < \epsilon$  if  $|x| > \frac{1}{\sqrt{\epsilon}}$ ,  $N = \frac{1}{\sqrt{\epsilon}}$
42.  $\left| \frac{1}{x} \right| < \epsilon$  if  $|x| > \frac{1}{\epsilon}$ ,  $-x > \frac{1}{\epsilon}$ ,  $x < -\frac{1}{\epsilon}$ ,  $N = -\frac{1}{\epsilon}$
43.  $\left| \frac{1}{x+2} \right| < \epsilon$  if  $|x+2| > \frac{1}{\epsilon}$ ,  $-x-2 < \frac{1}{\epsilon}$ ,  $x > -2 - \frac{1}{\epsilon}$ ,  $N = -2 - \frac{1}{\epsilon}$
44.  $\left| \frac{1}{x+2} \right| < \epsilon$  if  $|x+2| > \frac{1}{\epsilon}$ ,  $x+2 > \frac{1}{\epsilon}$ ,  $x > \frac{1}{\epsilon} - 2$ ,  $N = \frac{1}{\epsilon} - 2$
45.  $\left| \frac{x}{x+1} - 1 \right| = \left| \frac{1}{x+1} \right| < \epsilon$  if  $|x+1| > \frac{1}{\epsilon}$ ,  $x > \frac{1}{\epsilon} - 1$ ,  $N = \frac{1}{\epsilon} - 1$
46.  $\left| \frac{x}{x+1} - 1 \right| = \left| \frac{1}{x+1} \right| < \epsilon$  if  $|x+1| > \frac{1}{\epsilon}$ ,  $-x-1 > \frac{1}{\epsilon}$ ,  $x < -1 - \frac{1}{\epsilon}$ ,  $N = -1 - \frac{1}{\epsilon}$
47.  $\left| \frac{4x-1}{2x+5} - 2 \right| = \left| \frac{11}{2x+5} \right| < \epsilon$  if  $|2x+5| > \frac{11}{\epsilon}$ ,  $-2x-5 > \frac{11}{\epsilon}$ ,  $2x < -\frac{11}{\epsilon} - 5$ ,  $x < -\frac{11}{2\epsilon} - \frac{5}{2}$ ,  $N = -\frac{5}{2} - \frac{11}{2\epsilon}$
48.  $\left| \frac{4x-1}{2x+5} - 2 \right| = \left| \frac{11}{2x+5} \right| < \epsilon$  if  $|2x+5| > \frac{11}{\epsilon}$ ,  $2x > \frac{11}{\epsilon} - 5$ ,  $x > \frac{11}{2\epsilon} - \frac{5}{2}$ ,  $N = \frac{11}{2\epsilon} - \frac{5}{2}$
49. (a)  $\frac{1}{x^2} > 100$  if  $|x| < \frac{1}{10}$
- (b)  $\frac{1}{|x-1|} > 1000$  if  $|x-1| < \frac{1}{1000}$
- (c)  $\frac{-1}{(x-3)^2} < -1000$  if  $|x-3| < \frac{1}{10\sqrt{10}}$
- (d)  $-\frac{1}{x^4} < -10000$  if  $x^4 < \frac{1}{10000}$ ,  $|x| < \frac{1}{10}$
50. (a)  $\frac{1}{(x-1)^2} > 10$  if and only if  $|x-1| < \frac{1}{\sqrt{10}}$
- (b)  $\frac{1}{(x-1)^2} > 1000$  if and only if  $|x-1| < \frac{1}{10\sqrt{10}}$
- (c)  $\frac{1}{(x-1)^2} > 100000$  if and only if  $|x-1| < \frac{1}{100\sqrt{10}}$
51. if  $M > 0$  then  $\frac{1}{(x-3)^2} > M$ ,  $0 < (x-3)^2 < \frac{1}{M}$ ,  $0 < |x-3| < \frac{1}{\sqrt{M}}$ ,  $\delta = \frac{1}{\sqrt{M}}$

52. if  $M < 0$  then  $\frac{-1}{(x-3)^2} < M$ ,  $0 < (x-3)^2 < -\frac{1}{M}$ ,  $0 < |x-3| < \frac{1}{\sqrt{-M}}$ ,  $\delta = \frac{1}{\sqrt{-M}}$
53. if  $M > 0$  then  $\frac{1}{|x|} > M$ ,  $0 < |x| < \frac{1}{M}$ ,  $\delta = \frac{1}{M}$
54. if  $M > 0$  then  $\frac{1}{|x-1|} > M$ ,  $0 < |x-1| < \frac{1}{M}$ ,  $\delta = \frac{1}{M}$
55. if  $M < 0$  then  $-\frac{1}{x^4} < M$ ,  $0 < x^4 < -\frac{1}{M}$ ,  $|x| < \frac{1}{(-M)^{1/4}}$ ,  $\delta = \frac{1}{(-M)^{1/4}}$
56. if  $M > 0$  then  $\frac{1}{x^4} > M$ ,  $0 < x^4 < \frac{1}{M}$ ,  $x < \frac{1}{M^{1/4}}$ ,  $\delta = \frac{1}{M^{1/4}}$
57. if  $x > 2$  then  $|x+1-3| = |x-2| = x-2 < \epsilon$  if  $2 < x < 2+\epsilon$ ,  $\delta = \epsilon$
58. if  $x < 1$  then  $|3x+2-5| = |3x-3| = 3|x-1| = 3(1-x) < \epsilon$  if  $1-x < \frac{1}{3}\epsilon$ ,  $1-\frac{1}{3}\epsilon < x < 1$ ,  $\delta = \frac{1}{3}\epsilon$
59. if  $x > 4$  then  $\sqrt{x-4} < \epsilon$  if  $x-4 < \epsilon^2$ ,  $4 < x < 4+\epsilon^2$ ,  $\delta = \epsilon^2$
60. if  $x < 0$  then  $\sqrt{-x} < \epsilon$  if  $-x < \epsilon^2$ ,  $-\epsilon^2 < x < 0$ ,  $\delta = \epsilon^2$
61. if  $x > 2$  then  $|f(x)-2| = |x-2| = x-2 < \epsilon$  if  $2 < x < 2+\epsilon$ ,  $\delta = \epsilon$
62. if  $x < 2$  then  $|f(x)-6| = |3x-6| = 3|x-2| = 3(2-x) < \epsilon$  if  $2-x < \frac{1}{3}\epsilon$ ,  $2-\frac{1}{3}\epsilon < x < 2$ ,  $\delta = \frac{1}{3}\epsilon$
63. (a) if  $M < 0$  and  $x > 1$  then  $\frac{1}{1-x} < M$ ,  $x-1 < -\frac{1}{M}$ ,  $1 < x < 1-\frac{1}{M}$ ,  $\delta = -\frac{1}{M}$   
 (b) if  $M > 0$  and  $x < 1$  then  $\frac{1}{1-x} > M$ ,  $1-x < \frac{1}{M}$ ,  $1-\frac{1}{M} < x < 1$ ,  $\delta = \frac{1}{M}$
64. (a) if  $M > 0$  and  $x > 0$  then  $\frac{1}{x} > M$ ,  $x < \frac{1}{M}$ ,  $0 < x < \frac{1}{M}$ ,  $\delta = \frac{1}{M}$   
 (b) if  $M < 0$  and  $x < 0$  then  $\frac{1}{x} < M$ ,  $-x < -\frac{1}{M}$ ,  $\frac{1}{M} < x < 0$ ,  $\delta = -\frac{1}{M}$
65. (a) Given any  $M > 0$  there corresponds  $N > 0$  such that if  $x > N$  then  $f(x) > M$ ,  $x+1 > M$ ,  $x > M-1$ ,  $N = M-1$ .  
 (b) Given any  $M < 0$  there corresponds  $N < 0$  such that if  $x < N$  then  $f(x) < M$ ,  $x+1 < M$ ,  $x < M-1$ ,  $N = M-1$ .
66. (a) Given any  $M > 0$  there corresponds  $N > 0$  such that if  $x > N$  then  $f(x) > M$ ,  $x^2-3 > M$ ,  $x > \sqrt{M+3}$ ,  $N = \sqrt{M+3}$ .  
 (b) Given any  $M < 0$  there corresponds  $N < 0$  such that if  $x < N$  then  $f(x) < M$ ,  $x^3+5 < M$ ,  $x < (M-5)^{1/3}$ ,  $N = (M-5)^{1/3}$ .
67. if  $\delta \leq 2$  then  $|x-3| < 2$ ,  $-2 < x-3 < 2$ ,  $1 < x < 5$ , and  $|x^2-9| = |x+3||x-3| < 8|x-3| < \epsilon$  if  $|x-3| < \frac{1}{8}\epsilon$ ,  $\delta = \min(2, \frac{1}{8}\epsilon)$
68. (a) We don't care about the value of  $f$  at  $x = a$ , because the limit is only concerned with values of  $x$  near  $a$ . The condition that  $f$  be defined for all  $x$  (except possibly  $x = a$ ) is necessary, because if some points were excluded then the limit may not exist; for example, let  $f(x) = x$  if  $1/x$  is not an integer and  $f(1/n) = 6$ . Then  $\lim_{x \rightarrow 0} f(x)$  does not exist but it would if the points  $1/n$  were excluded.  
 (b) when  $x < 0$  then  $\sqrt{x}$  is not defined (c) yes; if  $\delta \leq 0.01$  then  $x > 0$ , so  $\sqrt{x}$  is defined

69.  $|(x^3 - 4x + 5) - 2| < 0.05$ ,  $-0.05 < (x^3 - 4x + 5) - 2 < 0.05$ ,  $1.95 < x^3 - 4x + 5 < 2.05$ ;  $x^3 - 4x + 5 = 1.95$  at  $x = 1.0616$ ,  $x^3 - 4x + 5 = 2.05$  at  $x = 0.9558$ ;  $\delta = \min(1.0616 - 1, 1 - 0.9558) = 0.0442$

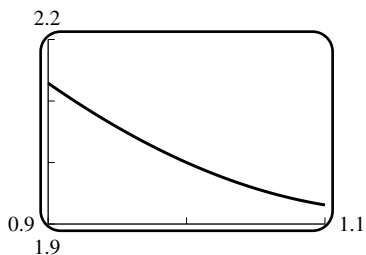

70.  $\sqrt{5x + 1} = 3.5$  at  $x = 2.25$ ,  $\sqrt{5x + 1} = 4.5$  at  $x = 3.85$ , so  $\delta = \min(3 - 2.25, 3.85 - 3) = 0.75$

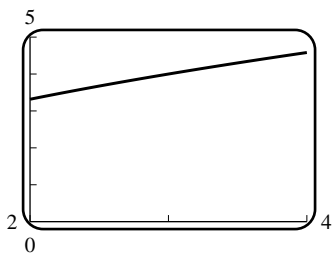

**EXERCISE SET 2.4**

- |                       |                 |                 |         |
|-----------------------|-----------------|-----------------|---------|
| 1. (a) no, $x = 2$    | (b) no, $x = 2$ | (c) no, $x = 2$ | (d) yes |
| (e) yes               | (f) yes         |                 |         |
| 2. (a) no, $x = 2$    | (b) no, $x = 2$ | (c) no, $x = 2$ | (d) yes |
| (e) no, $x = 2$       | (f) yes         |                 |         |
| 3. (a) no, $x = 1, 3$ | (b) yes         | (c) no, $x = 1$ | (d) yes |
| (e) no, $x = 3$       | (f) yes         |                 |         |
| 4. (a) no, $x = 3$    | (b) yes         | (c) yes         | (d) yes |
| (e) no, $x = 3$       | (f) yes         |                 |         |
| 5. (a) 3              | (b) 3           |                 |         |
| 6. $-2/5$             |                 |                 |         |

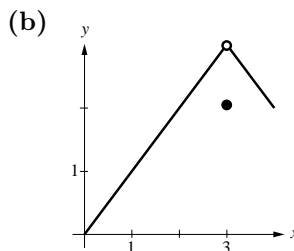
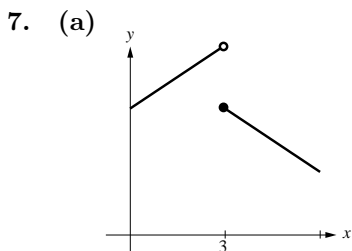

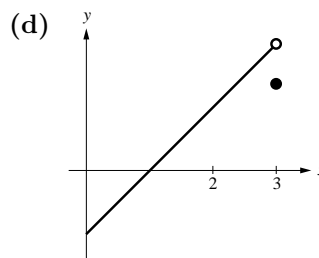
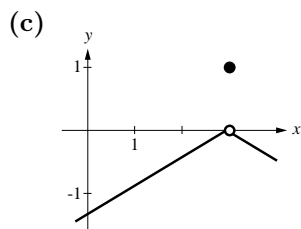

8.  $f(x) = 1/x, g(x) = \begin{cases} 0 & \text{if } x = 0 \\ \sin \frac{1}{x} & \text{if } x \neq 0 \end{cases}$

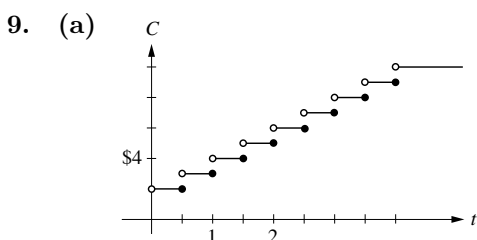

(b) One second could cost you one dollar.

10. (a) no; disasters (war, flood, famine, pestilence, for example) can cause discontinuities

(b) continuous

(c) not usually continuous; see Exercise 9

(d) continuous

11. none

12. none

13. none

14.  $f$  is not defined at  $x = \pm 1$

15.  $f$  is not defined at  $x = \pm 4$

16.  $f$  is not defined at  $x = \frac{-7 \pm \sqrt{57}}{2}$

17.  $f$  is not defined at  $x = \pm 3$

18.  $f$  is not defined at  $x = 0, -4$

19. none

20.  $f$  is not defined at  $x = 0, -3$

21. none;  $f(x) = 2x + 3$  is continuous on  $x < 4$  and  $f(x) = 7 + \frac{16}{x}$  is continuous on  $4 < x$ ;  
 $\lim_{x \rightarrow 4^-} f(x) = \lim_{x \rightarrow 4^+} f(x) = f(4) = 11$  so  $f$  is continuous at  $x = 4$

22.  $\lim_{x \rightarrow 1} f(x)$  does not exist so  $f$  is discontinuous at  $x = 1$

23. (a)  $f$  is continuous for  $x < 1$ , and for  $x > 1$ ;  $\lim_{x \rightarrow 1^-} f(x) = 5$ ,  $\lim_{x \rightarrow 1^+} f(x) = k$ , so if  $k = 5$  then  $f$  is continuous for all  $x$

(b)  $f$  is continuous for  $x < 2$ , and for  $x > 2$ ;  $\lim_{x \rightarrow 2^-} f(x) = 4k$ ,  $\lim_{x \rightarrow 2^+} f(x) = 4 + k$ , so if  $4k = 4 + k$ ,  $k = 4/3$  then  $f$  is continuous for all  $x$

24. (a) no,  $f$  is not defined at  $x = 2$

(b) no,  $f$  is not defined for  $x \leq 2$

(c) yes

(d) no,  $f$  is not defined for  $x \leq 2$



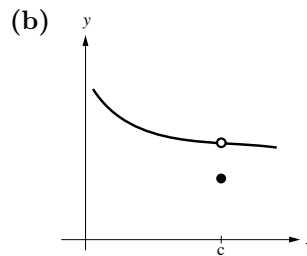
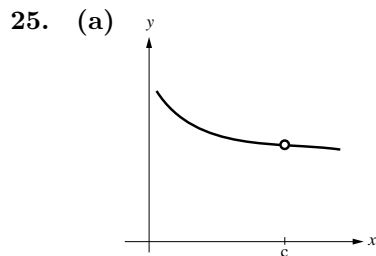

26. (a)  $f(c) = \lim_{x \rightarrow c} f(x)$

(b)  $\lim_{x \rightarrow 1} f(x) = 2$

$\lim_{x \rightarrow 1} g(x) = 1$

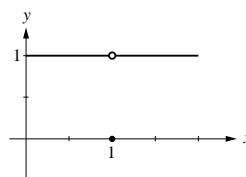
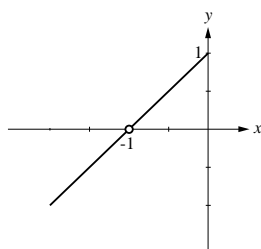

(c) Define  $f(1) = 2$  and redefine  $g(1) = 1$ .

27. (a)  $x = 0$ ,  $\lim_{x \rightarrow 0^-} f(x) = -1 \neq +1 = \lim_{x \rightarrow 0^+} f(x)$  so the discontinuity is not removable

(b)  $x = -3$ ; define  $f(-3) = -3 = \lim_{x \rightarrow -3} f(x)$ , then the discontinuity is removable

(c)  $f$  is undefined at  $x = \pm 2$ ; at  $x = 2$ ,  $\lim_{x \rightarrow 2} f(x) = 1$ , so define  $f(2) = 1$  and  $f$  becomes continuous there; at  $x = -2$ ,  $\lim_{x \rightarrow -2}$  does not exist, so the discontinuity is not removable

28. (a)  $f$  is not defined at  $x = 2$ ;  $\lim_{x \rightarrow 2} f(x) = \lim_{x \rightarrow 2} \frac{x+2}{x^2+2x+4} = \frac{1}{3}$ , so define  $f(2) = \frac{1}{3}$  and  $f$  becomes continuous there

(b)  $\lim_{x \rightarrow 2^-} f(x) = 1 \neq 4 = \lim_{x \rightarrow 2^+} f(x)$ , so  $f$  has a nonremovable discontinuity at  $x = 2$

(c)  $\lim_{x \rightarrow 1} f(x) = 8 \neq f(1)$ , so  $f$  has a removable discontinuity at  $x = 1$

29. (a) discontinuity at  $x = 1/2$ , not removable; at  $x = -3$ , removable

(b)  $2x^2 + 5x - 3 = (2x - 1)(x + 3)$

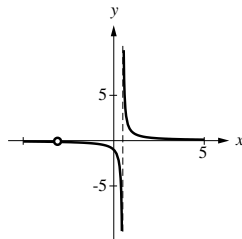

30. (a) there appears to be one discontinuity near  $x = -1.52$  (b) one discontinuity at  $x = -1.52$

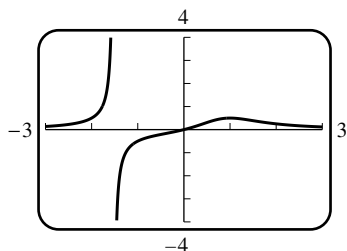

31. For  $x > 0$ ,  $f(x) = x^{3/5} = (x^3)^{1/5}$  is the composition (Theorem 2.4.6) of the two continuous functions  $g(x) = x^3$  and  $h(x) = x^{1/5}$  and is thus continuous. For  $x < 0$ ,  $f(x) = f(-x)$  which is the composition of the continuous functions  $f(x)$  (for positive  $x$ ) and the continuous function  $y = -x$ . Hence  $f(-x)$  is continuous for all  $x > 0$ . At  $x = 0$ ,  $f(0) = \lim_{x \rightarrow 0} f(x) = 0$ .
32.  $x^4 + 7x^2 + 1 \geq 1 > 0$ , thus  $f(x)$  is the composition of the polynomial  $x^4 + 7x^2 + 1$ , the square root  $\sqrt{x}$ , and the function  $1/x$  and is therefore continuous by Theorem 2.4.6.
33. (a) Let  $f(x) = k$  for  $x \neq c$  and  $f(c) = 0$ ;  $g(x) = l$  for  $x \neq c$  and  $g(c) = 0$ . If  $k = -l$  then  $f + g$  is continuous; otherwise it's not.  
 (b)  $f(x) = k$  for  $x \neq c$ ,  $f(c) = 1$ ;  $g(x) = l \neq 0$  for  $x \neq c$ ,  $g(c) = 1$ . If  $kl = 1$ , then  $fg$  is continuous; otherwise it is not.
34. A rational function is the quotient  $f(x)/g(x)$  of two polynomials  $f(x)$  and  $g(x)$ . By Theorem 2.4.2  $f$  and  $g$  are continuous everywhere; by Theorem 2.4.3  $f/g$  is continuous except when  $g(x) = 0$ .
35. Since  $f$  and  $g$  are continuous at  $x = c$  we know that  $\lim_{x \rightarrow c} f(x) = f(c)$  and  $\lim_{x \rightarrow c} g(x) = g(c)$ . In the following we use Theorem 2.2.2.  
 (a)  $f(c) + g(c) = \lim_{x \rightarrow c} f(x) + \lim_{x \rightarrow c} g(x) = \lim_{x \rightarrow c} (f(x) + g(x))$  so  $f + g$  is continuous at  $x = c$ .  
 (b) same as (a) except the  $+$  sign becomes a  $-$  sign  
 (c)  $\frac{f(c)}{g(c)} = \frac{\lim_{x \rightarrow c} f(x)}{\lim_{x \rightarrow c} g(x)} = \lim_{x \rightarrow c} \frac{f(x)}{g(x)}$  so  $\frac{f}{g}$  is continuous at  $x = c$
36.  $h(x) = f(x) - g(x)$  satisfies  $h(a) > 0$ ,  $h(b) < 0$ . Use the Intermediate Value Theorem or Theorem 2.4.9.
37. Of course such a function must be discontinuous. Let  $f(x) = 1$  on  $0 \leq x < 1$ , and  $f(x) = -1$  on  $1 \leq x \leq 2$ .
38. A square whose diagonal has length  $r$  has area  $f(r) = r^2/2$ . Note that  $f(r) = r^2/2 < \pi r^2/2 < 2r^2 = f(2r)$ . By the Intermediate Value Theorem there must be a value  $c$  between  $r$  and  $2r$  such that  $f(c) = \pi r^2/2$ , i.e. a square of diagonal  $c$  whose area is  $\pi r^2/2$ .
39. The cone has volume  $\pi r^2 h/3$ . The function  $V(r) = \pi r^2 h$  (for variable  $r$  and fixed  $h$ ) gives the volume of a right circular cylinder of height  $h$  and radius  $r$ , and satisfies  $V(0) < \pi r^2 h/3 < V(r)$ . By the Intermediate Value Theorem there is a value  $c$  between  $0$  and  $r$  such that  $V(c) = \pi r^2 h/3$ , so the cylinder of radius  $c$  (and height  $h$ ) has volume equal to that of the cone.
40. If  $f(x) = x^3 - 4x + 1$  then  $f(0) = 1$ ,  $f(1) = -2$ . Use Theorem 2.4.9.
41. If  $f(x) = x^3 + x^2 - 2x$  then  $f(-1) = 2$ ,  $f(1) = 0$ . Use the Intermediate Value Theorem.

42. Since  $\lim_{x \rightarrow -\infty} p(x) = -\infty$  and  $\lim_{x \rightarrow +\infty} p(x) = +\infty$  (or vice versa, if the leading coefficient of  $p$  is negative), it follows that for  $M = -1$  there corresponds  $N_1 < 0$ , and for  $M = 1$  there is  $N_2 > 0$ , such that  $p(x) < -1$  for  $x < N_1$  and  $p(x) > 1$  for  $x > N_2$ . Choose  $x_1 < N_1$  and  $x_2 > N_2$  and use Theorem 2.4.9 on the interval  $[x_1, x_2]$  to find a solution of  $p(x) = 0$ .
43. For the negative root, use intervals on the  $x$ -axis as follows:  $[-2, -1]$ ; since  $f(-1.3) < 0$  and  $f(-1.2) > 0$ , the midpoint  $x = -1.25$  of  $[-1.3, -1.2]$  is the required approximation of the root. For the positive root use the interval  $[0, 1]$ ; since  $f(0.7) < 0$  and  $f(0.8) > 0$ , the midpoint  $x = 0.75$  of  $[0.7, 0.8]$  is the required approximation.
44.  $x = -1.25$  and  $x = 0.75$ .

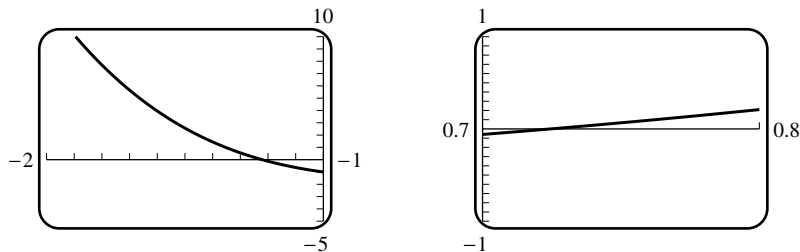

45. For the negative root, use intervals on the  $x$ -axis as follows:  $[-2, -1]$ ; since  $f(-1.7) < 0$  and  $f(-1.6) > 0$ , use the interval  $[-1.7, -1.6]$ . Since  $f(-1.61) < 0$  and  $f(-1.60) > 0$  the midpoint  $x = -1.605$  of  $[-1.61, -1.60]$  is the required approximation of the root. For the positive root use the interval  $[1, 2]$ ; since  $f(1.3) > 0$  and  $f(1.4) < 0$ , use the interval  $[1.3, 1.4]$ . Since  $f(1.37) > 0$  and  $f(1.38) < 0$ , the midpoint  $x = 1.375$  of  $[1.37, 1.38]$  is the required approximation.
46.  $x = -1.605$  and  $x = 1.375$ .

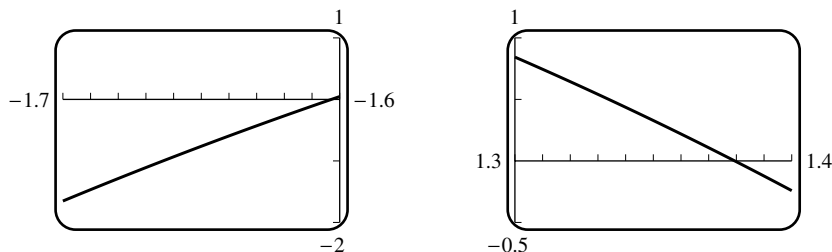

47.  $x = 2.24$ .
48. Set  $f(x) = \frac{a}{x-1} + \frac{b}{x-3}$ . Since  $\lim_{x \rightarrow 1^+} f(x) = +\infty$  and  $\lim_{x \rightarrow 3^-} f(x) = -\infty$  there exist  $x_1 > 1$  and  $x_2 < 3$  (with  $x_2 > x_1$ ) such that  $f(x) > 1$  for  $1 < x < x_1$  and  $f(x) < -1$  for  $x_2 < x < 3$ . Choose  $x_3$  in  $(1, x_1)$  and  $x_4$  in  $(x_2, 3)$  and apply Theorem 2.4.9 on  $[x_3, x_4]$ .
49. The uncoated sphere has volume  $4\pi(x-1)^3/3$  and the coated sphere has volume  $4\pi x^3/3$ . If the volume of the uncoated sphere and of the coating itself are the same, then the coated sphere has twice the volume of the uncoated sphere. Thus  $2(4\pi(x-1)^3/3) = 4\pi x^3/3$ , or  $x^3 - 6x^2 + 6x - 2 = 0$ , with the solution  $x = 4.847$  cm.
50. Let  $g(t)$  denote the altitude of the monk at time  $t$  measured in hours from noon of day one, and let  $f(t)$  denote the altitude of the monk at time  $t$  measured in hours from noon of day two. Then  $g(0) < f(0)$  and  $g(12) > f(12)$ . Use Exercise 36.
51. We must show  $\lim_{x \rightarrow c} f(x) = f(c)$ . Let  $\epsilon > 0$ ; then there exists  $\delta > 0$  such that if  $|x - c| < \delta$  then  $|f(x) - f(c)| < \epsilon$ . But this certainly satisfies Definition 2.3.3.



32.  $\lim_{x \rightarrow 0^+} \sin\left(\frac{1}{x}\right) = \lim_{t \rightarrow +\infty} \sin t$ ;  
limit does not exist

33.  $\lim_{x \rightarrow 0^+} \cos\left(\frac{1}{x}\right) = \lim_{t \rightarrow +\infty} \cos t$ ;  
limit does not exist

34.  $\lim_{x \rightarrow 0} x - 3 \lim_{x \rightarrow 0} \frac{\sin x}{x} = -3$

35.  $2 + \lim_{x \rightarrow 0} \frac{\sin x}{x} = 3$

36.  $k = f(0) = \lim_{x \rightarrow 0} \frac{\sin 3x}{x} = 3 \lim_{x \rightarrow 0} \frac{\sin 3x}{3x} = 3$ , so  $k = 3$

37.  $\lim_{x \rightarrow 0^-} f(x) = k \lim_{x \rightarrow 0} \frac{\sin kx}{kx \cos kx} = k$ ,  $\lim_{x \rightarrow 0^+} f(x) = 2k^2$ , so  $k = 2k^2$ ,  $k = \frac{1}{2}$

38. No;  $\sin x/|x|$  has unequal one-sided limits.

39. (a)  $\lim_{t \rightarrow 0^+} \frac{\sin t}{t} = 1$

(b)  $\lim_{t \rightarrow 0^-} \frac{1 - \cos t}{t} = 0$  (Theorem 2.5.3)

(c)  $\sin(\pi - t) = \sin t$ , so  $\lim_{x \rightarrow \pi} \frac{\pi - x}{\sin x} = \lim_{t \rightarrow 0} \frac{t}{\sin t} = 1$

40.  $\cos\left(\frac{\pi}{2} - t\right) = \sin t$ , so  $\lim_{x \rightarrow 2} \frac{\cos(\pi/x)}{x - 2} = \lim_{t \rightarrow 0} \frac{(\pi - 2t) \sin t}{4t} = \lim_{t \rightarrow 0} \frac{\pi - 2t}{4} \lim_{t \rightarrow 0} \frac{\sin t}{t} = \frac{\pi}{4}$

41.  $t = x - 1$ ;  $\sin(\pi x) = \sin(\pi t + \pi) = -\sin \pi t$ ; and  $\lim_{x \rightarrow 1} \frac{\sin(\pi x)}{x - 1} = -\lim_{t \rightarrow 0} \frac{\sin \pi t}{t} = -\pi$

42.  $t = x - \pi/4$ ;  $\tan x - 1 = \frac{2 \sin t}{\cos t - \sin t}$ ;  $\lim_{x \rightarrow \pi/4} \frac{\tan x - 1}{x - \pi/4} = \lim_{t \rightarrow 0} \frac{2 \sin t}{t(\cos t - \sin t)} = 2$

43.  $-x \leq x \cos\left(\frac{50\pi}{x}\right) \leq x$

44.  $-x^2 \leq x^2 \sin\left(\frac{50\pi}{\sqrt[3]{x}}\right) \leq x^2$

45.  $\lim_{x \rightarrow 0} f(x) = 1$  by the Squeezing Theorem

46.  $\lim_{x \rightarrow +\infty} f(x) = 0$  by the Squeezing Theorem

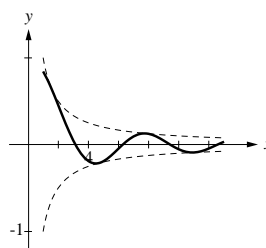
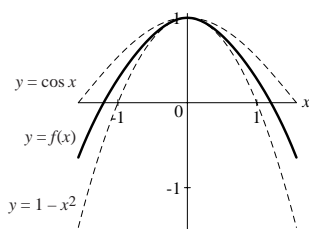

47. Let  $g(x) = -\frac{1}{x}$  and  $h(x) = \frac{1}{x}$ ; thus  $\lim_{x \rightarrow +\infty} \frac{\sin x}{x} = 0$  by the Squeezing Theorem.

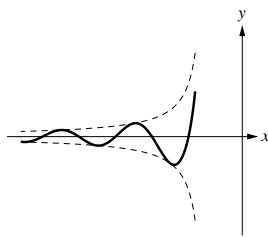
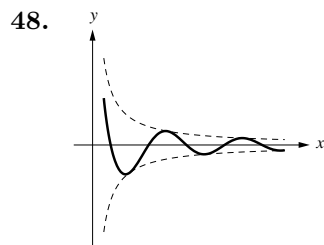

49. (a)  $\sin x = \sin t$  where  $x$  is measured in degrees,  $t$  is measured in radians and  $t = \frac{\pi x}{180}$ . Thus

$$\lim_{x \rightarrow 0} \frac{\sin x}{x} = \lim_{t \rightarrow 0} \frac{\sin t}{(180t/\pi)} = \frac{\pi}{180}.$$

50.  $\cos x = \cos t$  where  $x$  is measured in degrees,  $t$  in radians, and  $t = \frac{\pi x}{180}$ . Thus

$$\lim_{x \rightarrow 0} \frac{1 - \cos x}{x} = \lim_{t \rightarrow 0} \frac{1 - \cos t}{(180t/\pi)} = 0.$$

51. (a)  $\sin 10^\circ = 0.17365$  (b)  $\sin 10^\circ = \sin \frac{\pi}{18} \approx \frac{\pi}{18} = 0.17453$

52. (a)  $\cos \theta = \cos 2\alpha = 1 - 2\sin^2(\theta/2)$   
 $\approx 1 - 2(\theta/2)^2 = 1 - \frac{1}{2}\theta^2$  (b)  $\cos 10^\circ = 0.98481$

(c)  $\cos 10^\circ = 1 - \frac{1}{2} \left(\frac{\pi}{18}\right)^2 \approx 0.98477$

53. (a) 0.08749 (b)  $\tan 5^\circ \approx \frac{\pi}{36} = 0.08727$

54. (a)  $h = 52.55$  ft (b) Since  $\alpha$  is small,  $\tan \alpha^\circ \approx \frac{\pi \alpha}{180}$  is a good approximation.

(c)  $h \approx 52.36$  ft

55. (a) Let  $f(x) = x - \cos x$ ;  $f(0) = -1$ ,  $f(\pi/2) = \pi/2$ . By the IVT there must be a solution of  $f(x) = 0$ .

- (b)  (c) 0.739

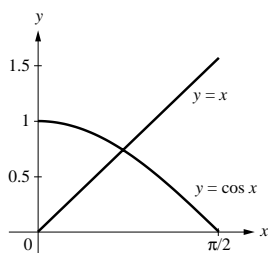

56. (a)  $f(x) = x + \sin x - 1$ ;  $f(0) = -1$ ,  $f(\pi/6) = \pi/6 - 1/2 > 0$ . By the IVT there must be a solution of  $f(x) = 0$ .

- (b)  (c)  $x = 0.511$ .

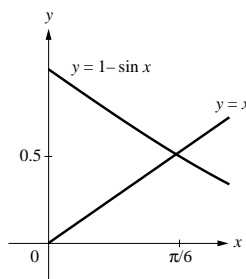

57. (a) There is symmetry about the equatorial plane.

- (b) Let  $g(\phi)$  be the given function. Then  $g(38) < 9.8$  and  $g(39) > 9.8$ , so by the Intermediate Value Theorem there is a value  $c$  between 38 and 39 for which  $g(c) = 9.8$  exactly.

58. (a) does not exist

- (b) the limit is zero

- (c) For part (a) consider the fact that given any  $\delta > 0$  there are infinitely many rational numbers  $x$  satisfying  $|x| < \delta$  and there are infinitely many irrational numbers satisfying the same condition. Thus if the limit were to exist, it could not be zero because of the rational numbers, and it could not be 1 because of the irrational numbers, and it could not be anything else because of *all* the numbers. Hence the limit cannot exist. For part (b) use the Squeezing Theorem with  $+x$  and  $-x$  as the 'squeezers'.

**CHAPTER 2 SUPPLEMENTARY EXERCISES**

1. (a) 1                      (b) no limit                      (c) no limit                      (d) 1                      (e) 3  
 (f) 0                      (g) 0                      (h) 2                      (i) 1/2

2. (a)  $f(x) = 2x/(x - 1)$

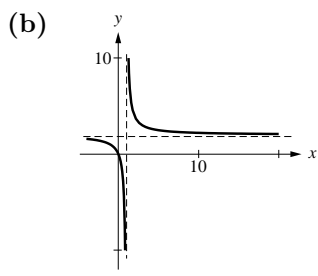

4.  $f(x) = -1$  for  $a \leq x < \frac{a+b}{2}$  and  $f(x) = 1$  for  $\frac{a+b}{2} \leq x \leq b$ .

5. (a) 0.222..., 0.24390, 0.24938, 0.24994, 0.24999, 0.25000; for  $x \neq 2$ ,  $f(x) = \frac{1}{x+2}$ , so the limit is 1/4; the limit is 4.

(b) 1.15782, 4.22793, 4.00213, 4.00002, 4.00000, 4.00000; to prove, use  $\frac{\tan 4x}{x} = \frac{\sin 4x}{x \cos 4x} = \frac{4}{\cos 4x} \frac{\sin 4x}{4x}$ .

6. (a)  $y = 0$                       (b) none                      (c)  $y = 2$

7. (a)

x	1	0.1	0.01	0.001	0.0001	0.00001	0.000001
f(x)	1.000	0.443	0.409	0.406	0.406	0.405	0.405

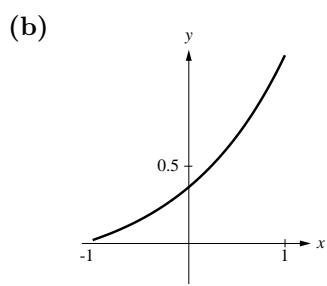

8. (a) 0.4 amperes                      (b) [0.3947, 0.4054]                      (c)  $\left[ \frac{3}{7.5 + \delta}, \frac{3}{7.5 - \delta} \right]$   
 (d) 0.0187                      (e) It becomes infinite.

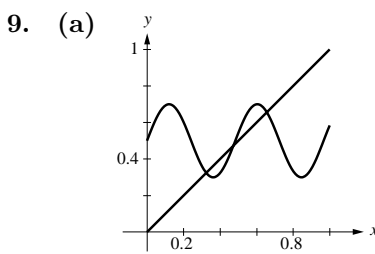

(b) Let  $g(x) = x - f(x)$ . Then  $g(1) \geq 0$  and  $g(0) \leq 0$ ; by the Intermediate Value Theorem there is a solution  $c$  in  $[0, 1]$  of  $g(c) = 0$ .

10. (a)  $\lim_{\theta \rightarrow 0} \tan \left( \frac{1 - \cos \theta}{\theta} \right) = \tan \left( \lim_{\theta \rightarrow 0} \frac{1 - \cos \theta}{\theta} \right) = \tan \left( \lim_{\theta \rightarrow 0} \frac{1 - \cos^2 \theta}{\theta(1 + \cos \theta)} \right) = \tan 0 = 0$
- (b)  $\frac{t-1}{\sqrt{t}-1} = \frac{t-1}{\sqrt{t}-1} \frac{\sqrt{t}+1}{\sqrt{t}+1} = \frac{(t-1)(\sqrt{t}+1)}{t-1} = \sqrt{t}+1$ ;  $\lim_{t \rightarrow 1} \frac{t-1}{\sqrt{t}-1} = \lim_{t \rightarrow 1} (\sqrt{t}+1) = 2$
- (c)  $\frac{(2x-1)^5}{(3x^2+2x-7)(x^3-9x)} = \frac{(2-1/x)^5}{(3+2/x-7/x^2)(1-9/x^2)} \rightarrow 2^5/3 = 32/3$  as  $x \rightarrow +\infty$
- (d)  $\sin(\theta + \pi) = \sin \theta \cos \pi - \cos \theta \sin \pi = -\sin \theta$ , so  $\lim_{\theta \rightarrow 0} \cos \left( \frac{\sin(\theta + \pi)}{2\theta} \right) = \lim_{\theta \rightarrow 0} \cos \left( \frac{-\sin \theta}{2\theta} \right)$   
 $= \cos \left( \lim_{\theta \rightarrow 0} \frac{-\sin \theta}{2\theta} \right) = \cos \left( -\frac{1}{2} \right)$

11. If, on the contrary,  $f(x_0) < 0$  for some  $x_0$  in  $[0, 1]$ , then by the Intermediate Value Theorem we would have a solution of  $f(x) = 0$  in  $[0, x_0]$ , contrary to the hypothesis.

12. For  $x < 2$   $f$  is a polynomial and is continuous; for  $x > 2$   $f$  is a polynomial and is continuous. At  $x = 2$ ,  $f(2) = -13 \neq 13 = \lim_{x \rightarrow 2^+} f(x)$  so  $f$  is not continuous there.

13.  $f(-6) = 185$ ,  $f(0) = -1$ ,  $f(2) = 65$ ; apply Theorem 2.4.9 twice, once on  $[-6, 0]$  and once on  $[0, 2]$

14. 3.317

15. Let  $\epsilon = f(x_0)/2 > 0$ ; then there corresponds  $\delta > 0$  such that if  $|x - x_0| < \delta$  then  $|f(x) - f(x_0)| < \epsilon$ ,  $-\epsilon < f(x) - f(x_0) < \epsilon$ ,  $f(x) > f(x_0) - \epsilon = f(x_0)/2 > 0$  for  $x_0 - \delta < x < x_0 + \delta$ .

16.

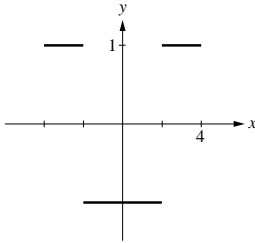

17. (a) 1.449 ( $x$  must be  $\geq -1$ ) (b)  $x = 0, \pm 1.896$
18. Since  $\lim_{x \rightarrow 0} \sin(1/x)$  does not exist, no conclusions can be drawn.
19. (a)  $\sqrt{5}$ , no limit,  $\sqrt{10}$ ,  $\sqrt{10}$ , no limit,  $+\infty$ , no limit (b) 5, 10, 0, 0, 10,  $-\infty$ ,  $+\infty$
20. (a)  $-1/5, +\infty, -1/10, -1/10$ , no limit, 0, 0 (b)  $-1, +1, -1, -1$ , no limit,  $-1, +1$
21. a/b 22. 1 23. does not exist
24. 2 25. 0 26.  $k^2$  27.  $3 - k$
28. The numerator satisfies:  $|2x + x \sin 3x| \leq |2x| + |x| = 3|x|$ . Since the denominator grows like  $x^2$ , the limit is 0.

30. (a)  $\frac{\sqrt{x^2+4}-2}{x^2} \frac{\sqrt{x^2+4}+2}{\sqrt{x^2+4}+2} = \frac{x^2}{x^2(\sqrt{x^2+4}+2)} = \frac{1}{\sqrt{x^2+4}+2}$ , so  
 $\lim_{x \rightarrow 0} \frac{\sqrt{x^2+4}-2}{x^2} = \lim_{x \rightarrow 0} \frac{1}{\sqrt{x^2+4}+2} = \frac{1}{4}$



(b)

$x$	1	0.1	0.01	0.001	0.0001	0.00001
$f(x)$	0.236	0.2498	0.2500	0.2500	0.25000	0.00000

The division may entail division by zero (e.g. on an HP 42S), or the numerator may be inaccurate (catastrophic subtraction, e.g.).

(c) in the 3d picture, catastrophic subtraction

31.

$x$	0.1	0.01	0.001	0.0001	0.00001	0.000001
$f(x)$	2.59	2.70	2.717	2.718	2.7183	2.71828

32.

$x$	3.1	3.01	3.001	3.0001	3.00001	3.000001
$f(x)$	5.74	5.56	5.547	5.545	5.5452	5.54518

33.

$x$	1.1	1.01	1.001	1.0001	1.00001	1.000001
$f(x)$	0.49	0.54	0.540	0.5403	0.54030	0.54030

34.

$x$	0.1	0.01	0.001	0.0001	0.00001	0.000001
$f(x)$	99.0	9048.8	368063.3	4562.7	$3.9 \times 10^{-34}$	0

35.

$x$	100	1000	$10^4$	$10^5$	$10^6$	$10^7$
$f(x)$	0.48809	0.49611	0.49876	0.49961	0.49988	0.49996

36. For large values of  $x$  (not much more than 100) the computer can't handle  $5^x$  or  $3^x$ , yet the limit is 5.

37.  $\delta = 0.07747$

38. \$2,001.60, \$2,009.66, \$2,013.62, \$2013.75

39. (a)  $x^3 - x - 1 = 0$ ,  $x^3 = x + 1$ ,  $x = \sqrt[3]{x + 1}$ .

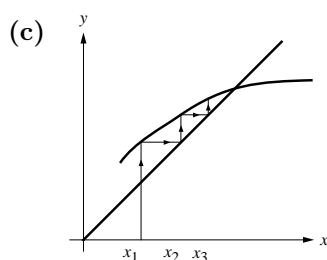
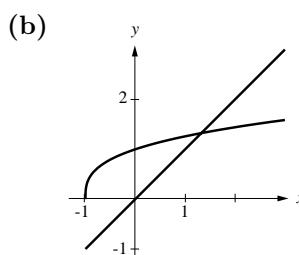

(d) 1, 1.26, 1.31, 1.322, 1.324, 1.3246, 1.3247

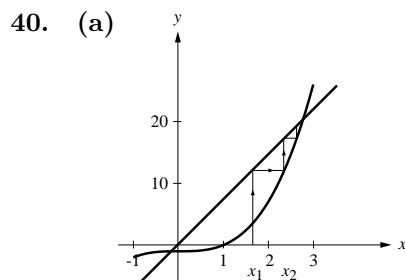

(b) 0, -1, -2, -9, -730

41.  $x = \sqrt[5]{x + 2}$ ; 1.267168

42.  $x = \cos x$ ; 0.739085 (after 33 iterations!).

# CHAPTER 3

## The Derivative

### EXERCISE SET 3.1

1. (a)  $m_{\text{sec}} = \frac{f(4) - f(3)}{4 - 3} = \frac{(4)^2/2 - (3)^2/2}{1} = \frac{7}{2}$

(b)  $m_{\text{tan}} = \lim_{x_1 \rightarrow 3} \frac{f(x_1) - f(3)}{x_1 - 3} = \lim_{x_1 \rightarrow 3} \frac{x_1^2/2 - 9/2}{x_1 - 3}$   
 $= \lim_{x_1 \rightarrow 3} \frac{x_1^2 - 9}{2(x_1 - 3)} = \lim_{x_1 \rightarrow 3} \frac{(x_1 + 3)(x_1 - 3)}{2(x_1 - 3)} = \lim_{x_1 \rightarrow 3} \frac{x_1 + 3}{2} = 3$

(c)  $m_{\text{tan}} = \lim_{x_1 \rightarrow x_0} \frac{f(x_1) - f(x_0)}{x_1 - x_0}$   
 $= \lim_{x_1 \rightarrow x_0} \frac{x_1^2/2 - x_0^2/2}{x_1 - x_0}$   
 $= \lim_{x_1 \rightarrow x_0} \frac{x_1^2 - x_0^2}{2(x_1 - x_0)}$   
 $= \lim_{x_1 \rightarrow x_0} \frac{x_1 + x_0}{2} = x_0$

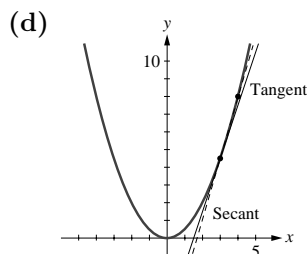

2. (a)  $m_{\text{sec}} = \frac{f(2) - f(1)}{2 - 1} = \frac{2^3 - 1^3}{1} = 7$

(b)  $m_{\text{tan}} = \lim_{x_1 \rightarrow 1} \frac{f(x_1) - f(1)}{x_1 - 1} = \lim_{x_1 \rightarrow 1} \frac{x_1^3 - 1}{x_1 - 1} = \lim_{x_1 \rightarrow 1} \frac{(x_1 - 1)(x_1^2 + x_1 + 1)}{x_1 - 1}$   
 $= \lim_{x_1 \rightarrow 1} (x_1^2 + x_1 + 1) = 3$

(c)  $m_{\text{tan}} = \lim_{x_1 \rightarrow x_0} \frac{f(x_1) - f(x_0)}{x_1 - x_0}$   
 $= \lim_{x_1 \rightarrow x_0} \frac{x_1^3 - x_0^3}{x_1 - x_0}$   
 $= \lim_{x_1 \rightarrow x_0} (x_1^2 + x_1x_0 + x_0^2)$   
 $= 3x_0^2$

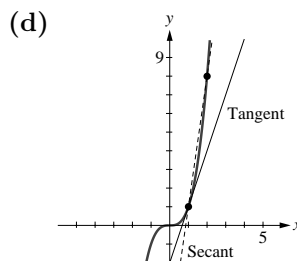

3. (a)  $m_{\text{sec}} = \frac{f(3) - f(2)}{3 - 2} = \frac{1/3 - 1/2}{1} = -\frac{1}{6}$

(b)  $m_{\text{tan}} = \lim_{x_1 \rightarrow 2} \frac{f(x_1) - f(2)}{x_1 - 2} = \lim_{x_1 \rightarrow 2} \frac{1/x_1 - 1/2}{x_1 - 2}$   
 $= \lim_{x_1 \rightarrow 2} \frac{2 - x_1}{2x_1(x_1 - 2)} = \lim_{x_1 \rightarrow 2} \frac{-1}{2x_1} = -\frac{1}{4}$

(c)  $m_{\text{tan}} = \lim_{x_1 \rightarrow x_0} \frac{f(x_1) - f(x_0)}{x_1 - x_0}$   
 $= \lim_{x_1 \rightarrow x_0} \frac{1/x_1 - 1/x_0}{x_1 - x_0}$   
 $= \lim_{x_1 \rightarrow x_0} \frac{x_0 - x_1}{x_0x_1(x_1 - x_0)}$   
 $= \lim_{x_1 \rightarrow x_0} \frac{-1}{x_0x_1} = -\frac{1}{x_0^2}$

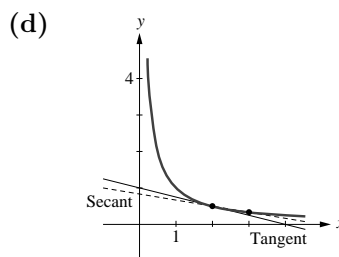

4. (a)  $m_{\text{sec}} = \frac{f(2) - f(1)}{2 - 1} = \frac{1/4 - 1}{1} = -\frac{3}{4}$

(b)  $m_{\text{tan}} = \lim_{x_1 \rightarrow 1} \frac{f(x_1) - f(1)}{x_1 - 1} = \lim_{x_1 \rightarrow 1} \frac{1/x_1^2 - 1}{x_1 - 1}$   
 $= \lim_{x_1 \rightarrow 1} \frac{1 - x_1^2}{x_1^2(x_1 - 1)} = \lim_{x_1 \rightarrow 1} \frac{-(x_1 + 1)}{x_1^2} = -2$

(c)  $m_{\text{tan}} = \lim_{x_1 \rightarrow x_0} \frac{f(x_1) - f(x_0)}{x_1 - x_0}$   
 $= \lim_{x_1 \rightarrow x_0} \frac{1/x_1^2 - 1/x_0^2}{x_1 - x_0}$   
 $= \lim_{x_1 \rightarrow x_0} \frac{x_0^2 - x_1^2}{x_0^2 x_1^2 (x_1 - x_0)}$   
 $= \lim_{x_1 \rightarrow x_0} \frac{-(x_1 + x_0)}{x_0^2 x_1^2} = -\frac{2}{x_0^3}$

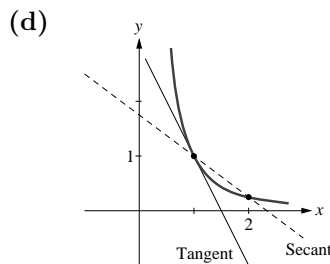

5. (a)  $m_{\text{tan}} = \lim_{x_1 \rightarrow x_0} \frac{f(x_1) - f(x_0)}{x_1 - x_0} = \lim_{x_1 \rightarrow x_0} \frac{(x_1^2 + 1) - (x_0^2 + 1)}{x_1 - x_0}$   
 $= \lim_{x_1 \rightarrow x_0} \frac{x_1^2 - x_0^2}{x_1 - x_0} = \lim_{x_1 \rightarrow x_0} (x_1 + x_0) = 2x_0$

(b)  $m_{\text{tan}} = 2(2) = 4$

6. (a)  $m_{\text{tan}} = \lim_{x_1 \rightarrow x_0} \frac{f(x_1) - f(x_0)}{x_1 - x_0} = \lim_{x_1 \rightarrow x_0} \frac{(x_1^2 + 3x_1 + 2) - (x_0^2 + 3x_0 + 2)}{x_1 - x_0}$   
 $= \lim_{x_1 \rightarrow x_0} \frac{(x_1^2 - x_0^2) + 3(x_1 - x_0)}{x_1 - x_0} = \lim_{x_1 \rightarrow x_0} (x_1 + x_0 + 3) = 2x_0 + 3$

(b)  $m_{\text{tan}} = 2(2) + 3 = 7$

7. (a)  $m_{\text{tan}} = \lim_{x_1 \rightarrow x_0} \frac{f(x_1) - f(x_0)}{x_1 - x_0} = \lim_{x_1 \rightarrow x_0} \frac{\sqrt{x_1} - \sqrt{x_0}}{x_1 - x_0}$   
 $= \lim_{x_1 \rightarrow x_0} \frac{1}{\sqrt{x_1} + \sqrt{x_0}} = \frac{1}{2\sqrt{x_0}}$

(b)  $m_{\text{tan}} = \frac{1}{2\sqrt{1}} = \frac{1}{2}$

8. (a)  $m_{\text{tan}} = \lim_{x_1 \rightarrow x_0} \frac{f(x_1) - f(x_0)}{x_1 - x_0} = \lim_{x_1 \rightarrow x_0} \frac{1/\sqrt{x_1} - 1/\sqrt{x_0}}{x_1 - x_0}$   
 $= \lim_{x_1 \rightarrow x_0} \frac{\sqrt{x_0} - \sqrt{x_1}}{\sqrt{x_0} \sqrt{x_1} (x_1 - x_0)} = \lim_{x_1 \rightarrow x_0} \frac{-1}{\sqrt{x_0} \sqrt{x_1} (\sqrt{x_1} + \sqrt{x_0})} = -\frac{1}{2x_0^{3/2}}$

(b)  $m_{\text{tan}} = -\frac{1}{2(4)^{3/2}} = -\frac{1}{16}$

9. (a)  $m_{\text{tan}} = (50 - 10)/(15 - 5)$   
 $= 40/10$   
 $= 4 \text{ m/s}$

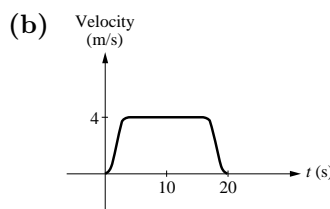

10. (a)  $(10 - 10)/(3 - 0) = 0$  cm/s  
 (b)  $t = 0$ ,  $t = 2$ , and  $t = 4.2$  (horizontal tangent line)  
 (c) maximum:  $t = 1$  (slope  $> 0$ ) minimum:  $t = 3$  (slope  $< 0$ )  
 (d)  $(3 - 18)/(4 - 2) = -7.5$  cm/s (slope of estimated tangent line to curve at  $t = 3$ )

11. From the figure:

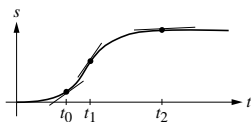

- (a) The particle is moving faster at time  $t_0$  because the slope of the tangent to the curve at  $t_0$  is greater than that at  $t_2$ .  
 (b) The initial velocity is 0 because the slope of a horizontal line is 0.  
 (c) The particle is speeding up because the slope increases as  $t$  increases from  $t_0$  to  $t_1$ .  
 (d) The particle is slowing down because the slope decreases as  $t$  increases from  $t_1$  to  $t_2$ .

- 12.

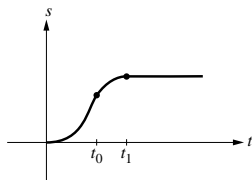

13. It is a straight line with slope equal to the velocity.
14. (a) decreasing (slope of tangent line decreases with increasing time)  
 (b) increasing (slope of tangent line increases with increasing time)  
 (c) increasing (slope of tangent line increases with increasing time)  
 (d) decreasing (slope of tangent line decreases with increasing time)
15. (a)  $72^\circ\text{F}$  at about 4:30 P.M. (b) about  $(67 - 43)/6 = 4^\circ\text{F/h}$   
 (c) decreasing most rapidly at about 9 P.M.; rate of change of temperature is about  $-7^\circ\text{F/h}$  (slope of estimated tangent line to curve at 9 P.M.)
16. For  $V = 10$  the slope of the tangent line is about  $-0.25$  atm/L, for  $V = 25$  the slope is about  $-0.04$  atm/L.
17. (a) during the first year after birth  
 (b) about 6 cm/year (slope of estimated tangent line at age 5)  
 (c) the growth rate is greatest at about age 14; about 10 cm/year

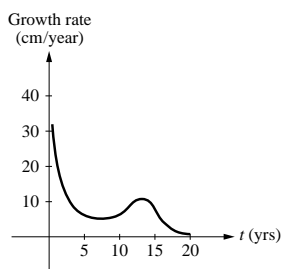

18. (a) The rock will hit the ground when  $16t^2 = 576$ ,  $t^2 = 36$ ,  $t = 6$  s (only  $t \geq 0$  is meaningful)
- (b)  $v_{\text{ave}} = \frac{16(6)^2 - 16(0)^2}{6 - 0} = 96$  ft/s
- (c)  $v_{\text{ave}} = \frac{16(3)^2 - 16(0)^2}{3 - 0} = 48$  ft/s
- (d)  $v_{\text{inst}} = \lim_{t_1 \rightarrow 6} \frac{16t_1^2 - 16(0)^2}{t_1 - 0} = \lim_{t_1 \rightarrow 6} \frac{16(t_1^2 - 36)}{t_1 - 6}$   
 $= \lim_{t_1 \rightarrow 6} 16(t_1 + 6) = 192$  ft/s
19. (a)  $5(40)^3 = 320,000$  ft
- (b)  $v_{\text{ave}} = 320,000/40 = 8,000$  ft/s
- (c)  $5t^3 = 135$  when the rocket has gone 135 ft, so  $t^3 = 27$ ,  $t = 3$  s;  
 $v_{\text{ave}} = 135/3 = 45$  ft/s.
- (d)  $v_{\text{inst}} = \lim_{t_1 \rightarrow 40} \frac{5t_1^3 - 5(40)^3}{t_1 - 40} = \lim_{t_1 \rightarrow 40} \frac{5(t_1^3 - 40^3)}{t_1 - 40}$   
 $= \lim_{t_1 \rightarrow 40} 5(t_1^2 + 40t_1 + 1600) = 24,000$  ft/s
20. (a)  $v_{\text{ave}} = \frac{[3(3)^2 + 3] - [3(1)^2 + 1]}{3 - 1} = 13$  mi/h
- (b)  $v_{\text{inst}} = \lim_{t_1 \rightarrow 1} \frac{(3t_1^2 + t_1) - 4}{t_1 - 1} = \lim_{t_1 \rightarrow 1} \frac{(3t_1 + 4)(t_1 - 1)}{t_1 - 1} = \lim_{t_1 \rightarrow 1} (3t_1 + 4) = 7$  mi/h
21. (a)  $v_{\text{ave}} = \frac{6(4)^4 - 6(2)^4}{4 - 2} = 720$  ft/min
- (b)  $v_{\text{inst}} = \lim_{t_1 \rightarrow 2} \frac{6t_1^4 - 6(2)^4}{t_1 - 2} = \lim_{t_1 \rightarrow 2} \frac{6(t_1^4 - 16)}{t_1 - 2}$   
 $= \lim_{t_1 \rightarrow 2} \frac{6(t_1^2 + 4)(t_1^2 - 4)}{t_1 - 2} = \lim_{t_1 \rightarrow 2} 6(t_1^2 + 4)(t_1 + 2) = 192$  ft/min

**EXERCISE SET 3.2**

1.  $f'(1) = 2$ ,  $f'(3) = 0$ ,  $f'(5) = -2$ ,  $f'(6) = -1/2$
2.  $f'(4) < f'(0) < f'(2) < 0 < f'(-3)$
3. (b)  $f'(2) = m = 3$  (c) the same,  $f'(2) = 3$
4.  $f'(-1) = m = \frac{4 - 3}{0 - (-1)} = 1$

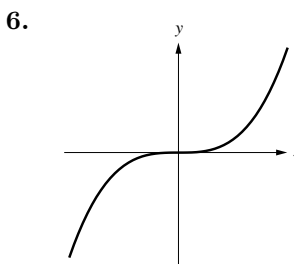
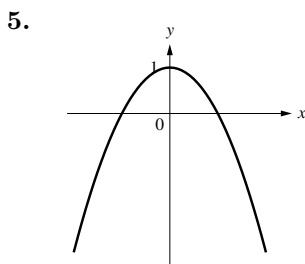

7.  $y - (-1) = 5(x - 3)$ ,  $y = 5x - 16$
8.  $y - 3 = -4(x + 2)$ ,  $y = -4x - 5$
9.  $f'(x) = \lim_{h \rightarrow 0} \frac{f(x+h) - f(x)}{h} = \lim_{h \rightarrow 0} \frac{3(x^2 + 2xh + h^2) - 3x^2}{h} = \lim_{h \rightarrow 0} 3(2x + h) = 6x$ ;  $f(3) = 3(3)^2 = 27$ ,  
 $f'(3) = 18$  so  $y - 27 = 18(x - 3)$ ,  $y = 18x - 27$

10.  $f'(x) = \lim_{h \rightarrow 0} \frac{f(x+h) - f(x)}{h} = \lim_{h \rightarrow 0} \frac{(x+h)^2 - (x+h) - (x^2 - x)}{h} = \lim_{h \rightarrow 0} (2x + h - 1) = 2x - 1;$   
 $f(2) = 2^2 - 2 = 2, f'(2) = 3$  so  $y - 2 = 3(x - 2), y = 3x - 4$
11.  $f'(x) = \lim_{h \rightarrow 0} \frac{f(x+h) - f(x)}{h} = \lim_{h \rightarrow 0} \frac{(x+h)^3 - x^3}{h} = 3x^2; f(0) = 0^3 = 0,$   
 $f'(0) = 0$  so  $y - 0 = (0)(x - 0), y = 0$
12.  $f'(x) = \lim_{h \rightarrow 0} \frac{f(x+h) - f(x)}{h} = \lim_{h \rightarrow 0} \frac{2(x+h)^3 + 1 - (2x^3 + 1)}{h} = \lim_{h \rightarrow 0} (6x^2 + 6xh + 2h^2) = 6x^2;$   
 $f(-1) = 2(-1)^3 + 1 = -1, f'(-1) = 6$  so  $y + 1 = 6(x + 1), y = 6x + 5$
13.  $f'(x) = \lim_{h \rightarrow 0} \frac{f(x+h) - f(x)}{h} = \lim_{h \rightarrow 0} \frac{\sqrt{x+1+h} - \sqrt{x+1}}{h}$   
 $= \lim_{h \rightarrow 0} \frac{\sqrt{x+1+h} - \sqrt{x+1}}{h} \cdot \frac{\sqrt{x+1+h} + \sqrt{x+1}}{\sqrt{x+1+h} + \sqrt{x+1}} = \lim_{h \rightarrow 0} \frac{1}{\sqrt{x+1+h} + \sqrt{x+1}} = \frac{1}{2\sqrt{x+1}};$   
 $f(8) = \sqrt{8+1} = 3, f'(8) = \frac{1}{6}$  so  $y - 3 = \frac{1}{6}(x - 8), y = \frac{1}{6}x + \frac{5}{3}$
14.  $f'(x) = \lim_{h \rightarrow 0} \frac{f(x+h) - f(x)}{h} = \lim_{h \rightarrow 0} \frac{(x+h)^4 - x^4}{h} = \lim_{h \rightarrow 0} (4x^3 + 6x^2h + 4xh^2 + h^3) = 4x^3;$   
 $f(-2) = (-2)^4 = 16, f'(-2) = -32$  so  $y - 16 = -32(x + 2), y = -32x - 48$
15.  $f'(x) = \lim_{\Delta x \rightarrow 0} \frac{\frac{1}{x+\Delta x} - \frac{1}{x}}{\Delta x} = \lim_{\Delta x \rightarrow 0} \frac{\frac{x - (x + \Delta x)}{x(x + \Delta x)}}{\Delta x}$   
 $= \lim_{\Delta x \rightarrow 0} \frac{-\Delta x}{x\Delta x(x + \Delta x)} = \lim_{\Delta x \rightarrow 0} -\frac{1}{x(x + \Delta x)} = -\frac{1}{x^2}$
16.  $f'(x) = \lim_{\Delta x \rightarrow 0} \frac{\frac{1}{(x+\Delta x)^2} - \frac{1}{x^2}}{\Delta x} = \lim_{\Delta x \rightarrow 0} \frac{\frac{x^2 - (x + \Delta x)^2}{x^2(x + \Delta x)^2}}{\Delta x}$   
 $= \lim_{\Delta x \rightarrow 0} \frac{x^2 - x^2 - 2x\Delta x - \Delta x^2}{x^2\Delta x(x + \Delta x)^2} = \lim_{\Delta x \rightarrow 0} \frac{-2x\Delta x - \Delta x^2}{x^2\Delta x(x + \Delta x)^2} = \lim_{\Delta x \rightarrow 0} \frac{-2x - \Delta x}{x^2(x + \Delta x)^2} = -\frac{2}{x^3}$
17.  $f'(x) = \lim_{\Delta x \rightarrow 0} \frac{[a(x + \Delta x)^2 + b] - [ax^2 + b]}{\Delta x} = \lim_{\Delta x \rightarrow 0} \frac{ax^2 + 2ax\Delta x + a(\Delta x)^2 + b - ax^2 - b}{\Delta x}$   
 $= \lim_{\Delta x \rightarrow 0} \frac{2ax\Delta x + a(\Delta x)^2}{\Delta x} = \lim_{\Delta x \rightarrow 0} (2ax + a\Delta x) = 2ax$
18.  $f'(x) = \lim_{\Delta x \rightarrow 0} \frac{\frac{1}{(x+\Delta x)+1} - \frac{1}{x+1}}{\Delta x} = \lim_{\Delta x \rightarrow 0} \frac{\frac{(x+1) - (x+\Delta x+1)}{(x+1)(x+\Delta x+1)}}{\Delta x}$   
 $= \lim_{\Delta x \rightarrow 0} \frac{x+1 - x - \Delta x - 1}{\Delta x(x+1)(x+\Delta x+1)} = \lim_{\Delta x \rightarrow 0} \frac{-\Delta x}{\Delta x(x+1)(x+\Delta x+1)}$   
 $= \lim_{\Delta x \rightarrow 0} \frac{-1}{(x+1)(x+\Delta x+1)} = -\frac{1}{(x+1)^2}$
19.  $f'(x) = \lim_{\Delta x \rightarrow 0} \frac{\frac{1}{\sqrt{x+\Delta x}} - \frac{1}{\sqrt{x}}}{\Delta x} = \lim_{\Delta x \rightarrow 0} \frac{\sqrt{x} - \sqrt{x+\Delta x}}{\Delta x\sqrt{x}\sqrt{x+\Delta x}}$   
 $= \lim_{\Delta x \rightarrow 0} \frac{x - (x + \Delta x)}{\Delta x\sqrt{x}\sqrt{x+\Delta x}(\sqrt{x} + \sqrt{x+\Delta x})} = \lim_{\Delta x \rightarrow 0} \frac{-1}{\sqrt{x}\sqrt{x+\Delta x}(\sqrt{x} + \sqrt{x+\Delta x})} = -\frac{1}{2x^{3/2}}$

20.  $f'(x) = \lim_{\Delta x \rightarrow 0} \frac{(x + \Delta x)^{1/3} - x^{1/3}}{\Delta x}$ , but  $a^3 - b^3 = (a - b)(a^2 + ab + b^2)$  so with  $a = (x + \Delta x)^{1/3}$  and  $b = x^{1/3}$

$$f'(x) = \lim_{\Delta x \rightarrow 0} \frac{(x + \Delta x) - x}{\Delta x[(x + \Delta x)^{2/3} + (x + \Delta x)^{1/3}x^{1/3} + x^{2/3}]}$$

$$= \lim_{\Delta x \rightarrow 0} \frac{1}{(x + \Delta x)^{2/3} + (x + \Delta x)^{1/3}x^{1/3} + x^{2/3}} = \frac{1}{3x^{2/3}}$$

21.  $f'(t) = \lim_{h \rightarrow 0} \frac{f(t+h) - f(t)}{h} = \lim_{h \rightarrow 0} \frac{[4(t+h)^2 + (t+h)] - [4t^2 + t]}{h}$

$$= \lim_{h \rightarrow 0} \frac{4t^2 + 8th + 4h^2 + t + h - 4t^2 - t}{h}$$

$$= \lim_{h \rightarrow 0} \frac{8th + 4h^2 + h}{h} = \lim_{h \rightarrow 0} (8t + 4h + 1) = 8t + 1$$

22.  $\frac{dV}{dr} = \lim_{h \rightarrow 0} \frac{\frac{4}{3}\pi(r+h)^3 - \frac{4}{3}\pi r^3}{h} = \lim_{h \rightarrow 0} \frac{\frac{4}{3}\pi(r^3 + 3r^2h + 3rh^2 + h^3 - r^3)}{h}$

$$= \lim_{h \rightarrow 0} \frac{4}{3}\pi(3r^2 + 3rh + h^2) = 4\pi r^2$$

23. (a) D      (b) F      (c) B      (d) C      (e) A      (f) E

24. Any function of the form  $f(x) = x + k$  has slope 1, and thus the derivative must be equal to 1 everywhere.

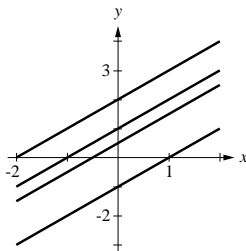

25. (a)

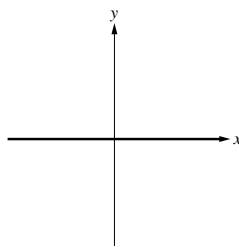

(b)

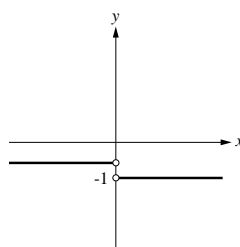

(c)

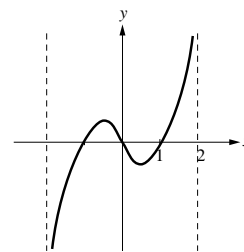

26. (a)

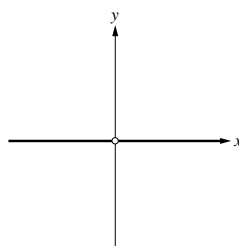

(b)

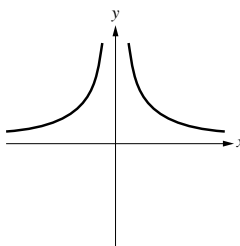

(c)

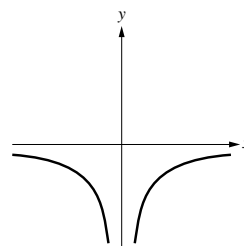

27. (a)  $f(x) = x^2$  and  $a = 3$

(b)  $f(x) = \sqrt{x}$  and  $a = 1$

28. (a)  $f(x) = \cos x$  and  $a = \pi$  (b)  $f(x) = x^7$  and  $a = 1$

$$29. \frac{dy}{dx} = \lim_{h \rightarrow 0} \frac{[4(x+h)^2 + 1] - [4x^2 + 1]}{h} = \lim_{h \rightarrow 0} \frac{4x^2 + 8xh + 4h^2 + 1 - 4x^2 - 1}{h} = \lim_{h \rightarrow 0} (8x + 4h) = 8x$$

$$\left. \frac{dy}{dx} \right|_{x=1} = 8(1) = 8$$

$$30. \frac{dy}{dx} = \lim_{h \rightarrow 0} \frac{\left(\frac{5}{x+h} + 1\right) - \left(\frac{5}{x} + 1\right)}{h} = \lim_{h \rightarrow 0} \frac{\frac{5}{x+h} - \frac{5}{x}}{h} = \lim_{h \rightarrow 0} \frac{5x - 5(x+h)}{x(x+h)h}$$

$$= \lim_{h \rightarrow 0} \frac{5x - 5x - 5h}{hx(x+h)} = \lim_{h \rightarrow 0} \frac{-5}{x(x+h)} = -\frac{5}{x^2}$$

$$\left. \frac{dy}{dx} \right|_{x=-2} = -\frac{5}{(-2)^2} = -\frac{5}{4}$$

31.  $y = -2x + 1$

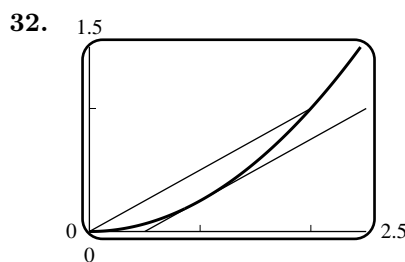
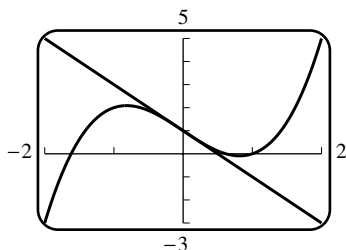

33. (b)

$h$	0.5	0.1	0.01	0.001	0.0001	0.00001
$(f(1+h) - f(1))/h$	1.6569	1.4355	1.3911	1.3868	1.3863	1.3863

34. (b)

$h$	0.5	0.1	0.01	0.001	0.0001	0.00001
$(f(1+h) - f(1))/h$	0.50489	0.67060	0.70356	0.70675	0.70707	0.70710

35. (a) dollars/ft  
 (b) As you go deeper the price per foot may increase dramatically, so  $f'(x)$  is roughly the price per additional foot.  
 (c) If each additional foot costs extra money (this is to be expected) then  $f'(x)$  remains positive.  
 (d) From the approximation  $1000 = f'(300) \approx \frac{f(301) - f(300)}{301 - 300}$  we see that  $f(301) \approx f(300) + 1000$ , so the extra foot will cost around \$1000.

36. (a) gallons/dollar  
 (b) The increase in the amount of paint that would be sold for one extra dollar.  
 (c) It should be negative since an increase in the price of paint would decrease the amount of paint sold.  
 (d) From  $-100 = f'(10) \approx \frac{f(11) - f(10)}{11 - 10}$  we see that  $f(11) \approx f(10) - 100$ , so an increase of one dollar would decrease the amount of paint sold by around 100 gallons.

37. (a)  $F \approx 200$  lb,  $dF/d\theta \approx 60$  lb/rad (b)  $\mu = (dF/d\theta)/F \approx 60/200 = 0.3$

38. (a)  $dN/dt \approx 34$  million/year; in 1950 the world population was increasing at the rate of about 34 million per year.  
 (b)  $\frac{dN/dt}{N} \approx \frac{34}{2490} \approx 0.014 = 1.4$  %/year



39. (a)  $T \approx 120^\circ\text{F}$ ,  $dT/dt \approx -4.5^\circ\text{F}/\text{min}$   
 (b)  $k = (dT/dt)/(T - T_0) \approx (-4.5)/(120 - 75) = -0.1$
41.  $\lim_{x \rightarrow 0} f(x) = \lim_{x \rightarrow 0} \sqrt[3]{x} = 0 = f(0)$ , so  $f$  is continuous at  $x = 0$ .  
 $\lim_{h \rightarrow 0} \frac{f(0+h) - f(0)}{h} = \lim_{h \rightarrow 0} \frac{\sqrt[3]{h} - 0}{h} = \lim_{h \rightarrow 0} \frac{1}{h^{2/3}} = +\infty$ , so  $f'(0)$  does not exist.

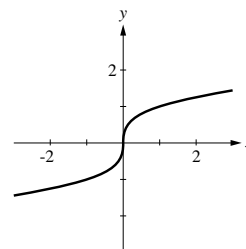

42.  $\lim_{x \rightarrow 2} f(x) = \lim_{x \rightarrow 2} (x - 2)^{2/3} = 0 = f(2)$  so  $f$  is continuous at  $x = 2$ .  
 $\lim_{h \rightarrow 0} \frac{f(2+h) - f(2)}{h} = \lim_{h \rightarrow 0} \frac{h^{2/3} - 0}{h} = \lim_{h \rightarrow 0} \frac{1}{h^{1/3}}$  which does not exist so  $f'(2)$  does not exist.

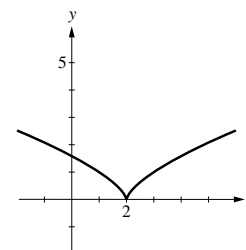

43.  $\lim_{x \rightarrow 1^-} f(x) = \lim_{x \rightarrow 1^+} f(x) = f(1)$ , so  $f$  is continuous at  $x = 1$ .  
 $\lim_{h \rightarrow 0^-} \frac{f(1+h) - f(1)}{h} = \lim_{h \rightarrow 0^-} \frac{[(1+h)^2 + 1] - 2}{h} = \lim_{h \rightarrow 0^-} (2+h) = 2$ ;  
 $\lim_{h \rightarrow 0^+} \frac{f(1+h) - f(1)}{h} = \lim_{h \rightarrow 0^+} \frac{2(1+h) - 2}{h} = \lim_{h \rightarrow 0^+} 2 = 2$ , so  $f'(1) = 2$ .

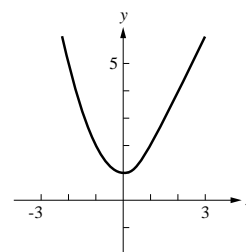

44.  $\lim_{x \rightarrow 1^-} f(x) = \lim_{x \rightarrow 1^+} f(x) = f(1)$  so  $f$  is continuous at  $x = 1$ .  
 $\lim_{h \rightarrow 0^-} \frac{f(1+h) - f(1)}{h} = \lim_{h \rightarrow 0^-} \frac{[(1+h)^2 + 2] - 3}{h} = \lim_{h \rightarrow 0^-} (2+h) = 2$ ;  
 $\lim_{h \rightarrow 0^+} \frac{f(1+h) - f(1)}{h} = \lim_{h \rightarrow 0^+} \frac{[(1+h) + 2] - 3}{h} = \lim_{h \rightarrow 0^+} 1 = 1$ , so  $f'(1)$  does not exist.

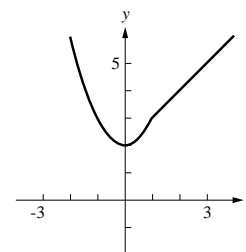

45.  $f$  is continuous at  $x = 1$  because it is differentiable there, thus  $\lim_{h \rightarrow 0} f(1+h) = f(1)$  and so  $f(1) = 0$  because  $\lim_{h \rightarrow 0} \frac{f(1+h)}{h}$  exists;  $f'(1) = \lim_{h \rightarrow 0} \frac{f(1+h) - f(1)}{h} = \lim_{h \rightarrow 0} \frac{f(1+h)}{h} = 5$ .

46. Let  $x = y = 0$  to get  $f(0) = f(0) + f(0) + 0$  so  $f(0) = 0$ .  $f'(x) = \lim_{h \rightarrow 0} \frac{f(x+h) - f(x)}{h}$ , but (with  $y = h$ )  $f(x+h) = f(x) + f(h) + 5xh$  so  $f(x+h) - f(x) = f(h) + 5xh$  and  $f'(x) = \lim_{h \rightarrow 0} \frac{f(h) + 5xh}{h} = \lim_{h \rightarrow 0} \left( \frac{f(h)}{h} + 5x \right) = 3 + 5x$ .

47.  $f'(x) = \lim_{h \rightarrow 0} \frac{f(x+h) - f(x)}{h} = \lim_{h \rightarrow 0} \frac{f(x)f(h) - f(x)}{h} = \lim_{h \rightarrow 0} \frac{f(x)[f(h) - 1]}{h} = f(x) \lim_{h \rightarrow 0} \frac{f(h) - f(0)}{h} = f(x)f'(0) = f(x)$

## EXERCISE SET 3.3

1.  $28x^6$                       2.  $-36x^{11}$                       3.  $24x^7 + 2$                       4.  $2x^3$
5. 0                              6.  $\sqrt{2}$                               7.  $-\frac{1}{3}(7x^6 + 2)$                       8.  $\frac{2}{5}x$
9.  $3ax^2 + 2bx + c$               10.  $\frac{1}{a}\left(2x + \frac{1}{b}\right)$               11.  $24x^{-9} + 1/\sqrt{x}$               12.  $-42x^{-7} - \frac{5}{2\sqrt{x}}$
13.  $-3x^{-4} - 7x^{-8}$                       14.  $\frac{1}{2\sqrt{x}} - \frac{1}{x^2}$
15.  $f'(x) = (3x^2 + 6)\frac{d}{dx}\left(2x - \frac{1}{4}\right) + \left(2x - \frac{1}{4}\right)\frac{d}{dx}(3x^2 + 6) = (3x^2 + 6)(2) + \left(2x - \frac{1}{4}\right)(6x)$   
 $= 18x^2 - \frac{3}{2}x + 12$
16.  $f'(x) = (2 - x - 3x^3)\frac{d}{dx}(7 + x^5) + (7 + x^5)\frac{d}{dx}(2 - x - 3x^3) = (2 - x - 3x^3)(5x^4) + (7 + x^5)(-1 - 9x^2)$   
 $= -24x^7 - 6x^5 + 10x^4 - 63x^2 - 7$
17.  $f'(x) = (x^3 + 7x^2 - 8)\frac{d}{dx}(2x^{-3} + x^{-4}) + (2x^{-3} + x^{-4})\frac{d}{dx}(x^3 + 7x^2 - 8)$   
 $= (x^3 + 7x^2 - 8)(-6x^{-4} - 4x^{-5}) + (2x^{-3} + x^{-4})(3x^2 + 14x) = -15x^{-2} - 14x^{-3} + 48x^{-4} + 32x^{-5}$
18.  $f'(x) = (x^{-1} + x^{-2})\frac{d}{dx}(3x^3 + 27) + (3x^3 + 27)\frac{d}{dx}(x^{-1} + x^{-2})$   
 $= (x^{-1} + x^{-2})(9x^2) + (3x^3 + 27)(-x^{-2} - 2x^{-3}) = 3 + 6x - 27x^{-2} - 54x^{-3}$
19.  $12x(3x^2 + 1)$                       20.  $f(x) = x^{10} + 4x^6 + 4x^2, f'(x) = 10x^9 + 24x^5 + 8x$
21.  $\frac{dy}{dx} = \frac{(5x - 3)\frac{d}{dx}(1) - (1)\frac{d}{dx}(5x - 3)}{(5x - 3)^2} = -\frac{5}{(5x - 3)^2}; y'(1) = -5/4$
22.  $\frac{dy}{dx} = \frac{(\sqrt{x} + 2)\frac{d}{dx}(3) - 3\frac{d}{dx}(\sqrt{x} + 2)}{(\sqrt{x} + 2)^2} = -3/(2\sqrt{x}(\sqrt{x} + 2)^2); y'(1) = -3/18 = -1/6$
23.  $\frac{dx}{dt} = \frac{(2t + 1)\frac{d}{dt}(3t) - (3t)\frac{d}{dt}(2t + 1)}{(2t + 1)^2} = \frac{(2t + 1)(3) - (3t)(2)}{(2t + 1)^2} = \frac{3}{(2t + 1)^2}$
24.  $\frac{dx}{dt} = \frac{(3t)\frac{d}{dt}(t^2 + 1) - (t^2 + 1)\frac{d}{dt}(3t)}{(3t)^2} = \frac{(3t)(2t) - (t^2 + 1)(3)}{9t^2} = \frac{t^2 - 1}{3t^2}$
25.  $\frac{dy}{dx} = \frac{(x + 3)\frac{d}{dx}(2x - 1) - (2x - 1)\frac{d}{dx}(x + 3)}{(x + 3)^2} = \frac{(x + 3)(2) - (2x - 1)(1)}{(x + 3)^2} = \frac{7}{(x + 3)^2}; \frac{dy}{dx}\Big|_{x=1} = \frac{7}{16}$
26.  $\frac{dy}{dx} = \frac{(x^2 - 5)\frac{d}{dx}(4x + 1) - (4x + 1)\frac{d}{dx}(x^2 - 5)}{(x^2 - 5)^2} = \frac{(x^2 - 5)(4) - (4x + 1)(2x)}{(x^2 - 5)^2} = -\frac{4x^2 + 2x + 20}{(x^2 - 5)^2};$   
 $\frac{dy}{dx}\Big|_{x=1} = \frac{13}{8}$

$$\begin{aligned}
 27. \quad \frac{dy}{dx} &= \left(\frac{3x+2}{x}\right) \frac{d}{dx}(x^{-5}+1) + (x^{-5}+1) \frac{d}{dx}\left(\frac{3x+2}{x}\right) \\
 &= \left(\frac{3x+2}{x}\right)(-5x^{-6}) + (x^{-5}+1) \left[\frac{x(3) - (3x+2)(1)}{x^2}\right] = \left(\frac{3x+2}{x}\right)(-5x^{-6}) + (x^{-5}+1) \left(-\frac{2}{x^2}\right); \\
 \left.\frac{dy}{dx}\right|_{x=1} &= 5(-5) + 2(-2) = -29
 \end{aligned}$$

$$\begin{aligned}
 28. \quad \frac{dy}{dx} &= (2x^7 - x^2) \frac{d}{dx}\left(\frac{x-1}{x+1}\right) + \left(\frac{x-1}{x+1}\right) \frac{d}{dx}(2x^7 - x^2) \\
 &= (2x^7 - x^2) \left[\frac{(x+1)(1) - (x-1)(1)}{(x+1)^2}\right] + \left(\frac{x-1}{x+1}\right)(14x^6 - 2x) \\
 &= (2x^7 - x^2) \cdot \frac{2}{(x+1)^2} + \left(\frac{x-1}{x+1}\right)(14x^6 - 2x); \\
 \left.\frac{dy}{dx}\right|_{x=1} &= (2-1)\frac{2}{4} + 0(14-2) = \frac{1}{2}
 \end{aligned}$$

29.  $32t$

30.  $2\pi$

31.  $3\pi r^2$

32.  $-2\alpha^{-2} + 1$

$$33. \quad \text{(a)} \quad \frac{dV}{dr} = 4\pi r^2 \qquad \text{(b)} \quad \left.\frac{dV}{dr}\right|_{r=5} = 4\pi(5)^2 = 100\pi$$

$$35. \quad \text{(a)} \quad g'(x) = \sqrt{x}f'(x) + \frac{1}{2\sqrt{x}}f(x), \quad g'(4) = (2)(-5) + \frac{1}{4}(3) = -37/4$$

$$\text{(b)} \quad g'(x) = \frac{xf'(x) - f(x)}{x^2}, \quad g'(4) = \frac{(4)(-5) - 3}{16} = -23/16$$

$$36. \quad \text{(a)} \quad g'(x) = 6x - 5f'(x), \quad g'(3) = 6(3) - 5(4) = -2$$

$$\text{(b)} \quad g'(x) = \frac{2f(x) - (2x+1)f'(x)}{f^2(x)}, \quad g'(3) = \frac{2(-2) - 7(4)}{(-2)^2} = -8$$

$$37. \quad \text{(a)} \quad F'(x) = 5f'(x) + 2g'(x), \quad F'(2) = 5(4) + 2(-5) = 10$$

$$\text{(b)} \quad F'(x) = f'(x) - 3g'(x), \quad F'(2) = 4 - 3(-5) = 19$$

$$\text{(c)} \quad F'(x) = f(x)g'(x) + g(x)f'(x), \quad F'(2) = (-1)(-5) + (1)(4) = 9$$

$$\text{(d)} \quad F'(x) = [g(x)f'(x) - f(x)g'(x)]/g^2(x), \quad F'(2) = [(1)(4) - (-1)(-5)]/(1)^2 = -1$$

$$38. \quad \frac{dy}{dx} = \frac{(1+x)(-1) - (1-x)(1)}{(1+x)^2} = -\frac{2}{(1+x)^2}, \quad \left.\frac{dy}{dx}\right|_{x=2} = -\frac{2}{9} \text{ and } y = -\frac{1}{3} \text{ for } x = 2 \text{ so an equation of the tangent line is } y - \left(-\frac{1}{3}\right) = -\frac{2}{9}(x-2), \text{ or } y = -\frac{2}{9}x + \frac{1}{9}.$$

39.  $y - 2 = 5(x + 3), y = 5x + 17$

$$40. \quad \frac{d}{d\lambda} \left[ \frac{\lambda\lambda_0 + \lambda^6}{2 - \lambda_0} \right] = \frac{1}{2 - \lambda_0} \frac{d}{d\lambda}(\lambda\lambda_0 + \lambda^6) = \frac{1}{2 - \lambda_0}(\lambda_0 + 6\lambda^5) = \frac{\lambda_0 + 6\lambda^5}{2 - \lambda_0}$$

41. (a)  $dy/dx = 21x^2 - 10x + 1, d^2y/dx^2 = 42x - 10$

(b)  $dy/dx = 24x - 2, d^2y/dx^2 = 24$

(c)  $dy/dx = -1/x^2, d^2y/dx^2 = 2/x^3$

(d)  $y = 35x^5 - 16x^3 - 3x, dy/dx = 175x^4 - 48x^2 - 3, d^2y/dx^2 = 700x^3 - 96x$

42. (a)  $y' = 28x^6 - 15x^2 + 2$ ,  $y'' = 168x^5 - 30x$   
 (b)  $y' = 3$ ,  $y'' = 0$   
 (c)  $y' = \frac{2}{5x^2}$ ,  $y'' = -\frac{4}{5x^3}$   
 (d)  $y = 2x^4 + 3x^3 - 10x - 15$ ,  $y' = 8x^3 + 9x^2 - 10$ ,  $y'' = 24x^2 + 18x$
43. (a)  $y' = -5x^{-6} + 5x^4$ ,  $y'' = 30x^{-7} + 20x^3$ ,  $y''' = -210x^{-8} + 60x^2$   
 (b)  $y = x^{-1}$ ,  $y' = -x^{-2}$ ,  $y'' = 2x^{-3}$ ,  $y''' = -6x^{-4}$   
 (c)  $y' = 3ax^2 + b$ ,  $y'' = 6ax$ ,  $y''' = 6a$
44. (a)  $dy/dx = 10x - 4$ ,  $d^2y/dx^2 = 10$ ,  $d^3y/dx^3 = 0$   
 (b)  $dy/dx = -6x^{-3} - 4x^{-2} + 1$ ,  $d^2y/dx^2 = 18x^{-4} + 8x^{-3}$ ,  $d^3y/dx^3 = -72x^{-5} - 24x^{-4}$   
 (c)  $dy/dx = 4ax^3 + 2bx$ ,  $d^2y/dx^2 = 12ax^2 + 2b$ ,  $d^3y/dx^3 = 24ax$
45. (a)  $f'(x) = 6x$ ,  $f''(x) = 6$ ,  $f'''(x) = 0$ ,  $f'''(2) = 0$   
 (b)  $\frac{dy}{dx} = 30x^4 - 8x$ ,  $\frac{d^2y}{dx^2} = 120x^3 - 8$ ,  $\left. \frac{d^2y}{dx^2} \right|_{x=1} = 112$   
 (c)  $\frac{d}{dx} [x^{-3}] = -3x^{-4}$ ,  $\frac{d^2}{dx^2} [x^{-3}] = 12x^{-5}$ ,  $\frac{d^3}{dx^3} [x^{-3}] = -60x^{-6}$ ,  $\frac{d^4}{dx^4} [x^{-3}] = 360x^{-7}$ ,  
 $\left. \frac{d^4}{dx^4} [x^{-3}] \right|_{x=1} = 360$
46. (a)  $y' = 16x^3 + 6x^2$ ,  $y'' = 48x^2 + 12x$ ,  $y''' = 96x + 12$ ,  $y'''(0) = 12$   
 (b)  $y = 6x^{-4}$ ,  $\frac{dy}{dx} = -24x^{-5}$ ,  $\frac{d^2y}{dx^2} = 120x^{-6}$ ,  $\frac{d^3y}{dx^3} = -720x^{-7}$ ,  $\frac{d^4y}{dx^4} = 5040x^{-8}$ ,  
 $\left. \frac{d^4y}{dx^4} \right|_{x=1} = 5040$
47.  $y' = 3x^2 + 3$ ,  $y'' = 6x$ , and  $y''' = 6$  so  
 $y''' + xy'' - 2y' = 6 + x(6x) - 2(3x^2 + 3) = 6 + 6x^2 - 6x^2 - 6 = 0$
48.  $y = x^{-1}$ ,  $y' = -x^{-2}$ ,  $y'' = 2x^{-3}$  so  
 $x^3y'' + x^2y' - xy = x^3(2x^{-3}) + x^2(-x^{-2}) - x(x^{-1}) = 2 - 1 - 1 = 0$
49.  $F'(x) = xf'(x) + f(x)$ ,  $F''(x) = xf''(x) + f'(x) + f'(x) = xf''(x) + 2f'(x)$
51. The graph has a horizontal tangent at points where  $\frac{dy}{dx} = 0$ , but  
 $\frac{dy}{dx} = x^2 - 3x + 2 = (x - 1)(x - 2) = 0$  if  $x = 1, 2$ . The corresponding values of  $y$  are  $5/6$  and  $2/3$  so the tangent line is horizontal at  $(1, 5/6)$  and  $(2, 2/3)$ .

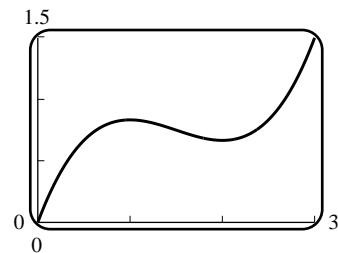

52.  $\frac{dy}{dx} = \frac{9 - x^2}{(x^2 + 9)^2}$ ;  $\frac{dy}{dx} = 0$  when  $x^2 = 9$  so  $x = \pm 3$ . The points are  $(3, 1/6)$  and  $(-3, -1/6)$ .

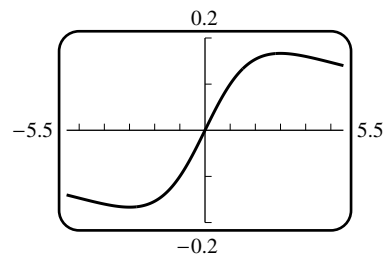

53.  $f'(1) \approx \frac{f(1.01) - f(1)}{0.01} = \frac{0.999699 - (-1)}{0.01} = 0.0301$ , and by differentiation,  $f'(1) = 3(1)^2 - 3 = 0$

54.  $f'(1) \approx \frac{f(1.01) - f(1)}{0.01} = \frac{1.01504 - 1}{0.01} = 1.504$ , and by differentiation,

$$f'(1) = \left( \sqrt{x} + \frac{x}{2\sqrt{x}} \right) \Big|_{x=1} = 1.5$$

55.  $f'(1) = 0$

56.  $f'(1) = 1$

57. The  $y$ -intercept is  $-2$  so the point  $(0, -2)$  is on the graph;  $-2 = a(0)^2 + b(0) + c$ ,  $c = -2$ . The  $x$ -intercept is  $1$  so the point  $(1, 0)$  is on the graph;  $0 = a + b - 2$ . The slope is  $dy/dx = 2ax + b$ ; at  $x = 0$  the slope is  $b$  so  $b = -1$ , thus  $a = 3$ . The function is  $y = 3x^2 - x - 2$ .

58. Let  $P(x_0, y_0)$  be the point where  $y = x^2 + k$  is tangent to  $y = 2x$ . The slope of the curve is  $\frac{dy}{dx} = 2x$  and the slope of the line is  $2$  thus at  $P$ ,  $2x_0 = 2$  so  $x_0 = 1$ . But  $P$  is on the line, so  $y_0 = 2x_0 = 2$ . Because  $P$  is also on the curve we get  $y_0 = x_0^2 + k$  so  $k = y_0 - x_0^2 = 2 - (1)^2 = 1$ .

59. The points  $(-1, 1)$  and  $(2, 4)$  are on the secant line so its slope is  $(4 - 1)/(2 + 1) = 1$ . The slope of the tangent line to  $y = x^2$  is  $y' = 2x$  so  $2x = 1$ ,  $x = 1/2$ .

60. The points  $(1, 1)$  and  $(4, 2)$  are on the secant line so its slope is  $1/3$ . The slope of the tangent line to  $y = \sqrt{x}$  is  $y' = 1/(2\sqrt{x})$  so  $1/(2\sqrt{x}) = 1/3$ ,  $2\sqrt{x} = 3$ ,  $x = 9/4$ .

61.  $y' = -2x$ , so at any point  $(x_0, y_0)$  on  $y = 1 - x^2$  the tangent line is  $y - y_0 = -2x_0(x - x_0)$ , or  $y = -2x_0x + x_0^2 + 1$ . The point  $(2, 0)$  is to be on the line, so  $0 = -4x_0 + x_0^2 + 1$ ,  $x_0^2 - 4x_0 + 1 = 0$ . Use the quadratic formula to get  $x_0 = \frac{4 \pm \sqrt{16 - 4}}{2} = 2 \pm \sqrt{3}$ .

62. Let  $P_1(x_1, ax_1^2)$  and  $P_2(x_2, ax_2^2)$  be the points of tangency.  $y' = 2ax$  so the tangent lines at  $P_1$  and  $P_2$  are  $y - ax_1^2 = 2ax_1(x - x_1)$  and  $y - ax_2^2 = 2ax_2(x - x_2)$ . Solve for  $x$  to get  $x = \frac{1}{2}(x_1 + x_2)$  which is the  $x$ -coordinate of a point on the vertical line halfway between  $P_1$  and  $P_2$ .

63.  $y' = 3ax^2 + b$ ; the tangent line at  $x = x_0$  is  $y - y_0 = (3ax_0^2 + b)(x - x_0)$  where  $y_0 = ax_0^3 + bx_0$ . Solve with  $y = ax^3 + bx$  to get

$$\begin{aligned} (ax^3 + bx) - (ax_0^3 + bx_0) &= (3ax_0^2 + b)(x - x_0) \\ ax^3 + bx - ax_0^3 - bx_0 &= 3ax_0^2x - 3ax_0^3 + bx - bx_0 \\ x^3 - 3x_0^2x + 2x_0^3 &= 0 \\ (x - x_0)(x^2 + xx_0 - 2x_0^2) &= 0 \\ (x - x_0)^2(x + 2x_0) &= 0, \text{ so } x = -2x_0. \end{aligned}$$

64. Let  $(x_0, y_0)$  be the point of tangency. Refer to the solution to Exercise 65 to see that the endpoints of the line segment are at  $(2x_0, 0)$  and  $(0, 2y_0)$ , so  $(x_0, y_0)$  is the midpoint of the segment.

65.  $y' = -\frac{1}{x^2}$ ; the tangent line at  $x = x_0$  is  $y - y_0 = -\frac{1}{x_0^2}(x - x_0)$ , or  $y = -\frac{x}{x_0^2} + \frac{2}{x_0}$ . The tangent line crosses the  $x$ -axis at  $2x_0$ , the  $y$ -axis at  $2/x_0$ , so that the area of the triangle is  $\frac{1}{2}(2/x_0)(2x_0) = 2$ .

66.  $f'(x) = 3ax^2 + 2bx + c$ ; there is a horizontal tangent where  $f'(x) = 0$ . Use the quadratic formula on  $3ax^2 + 2bx + c = 0$  to get  $x = (-b \pm \sqrt{b^2 - 3ac})/(3a)$  which gives two real solutions, one real solution, or none if

(a)  $b^2 - 3ac > 0$

(b)  $b^2 - 3ac = 0$

(c)  $b^2 - 3ac < 0$

67.  $F = GmMr^{-2}$ ,  $\frac{dF}{dr} = -2GmMr^{-3} = -\frac{2GmM}{r^3}$

68.  $dR/dT = 0.04124 - 3.558 \times 10^{-5}T$  which decreases as  $T$  increases from 0 to 700. When  $T = 0$ ,  $dR/dT = 0.04124 \Omega/^\circ\text{C}$ ; when  $T = 700$ ,  $dR/dT = 0.01633 \Omega/^\circ\text{C}$ . The resistance is most sensitive to temperature changes at  $T = 0^\circ\text{C}$ , least sensitive at  $T = 700^\circ\text{C}$ .

69.  $f'(x) = 1 + 1/x^2 > 0$  for all  $x$

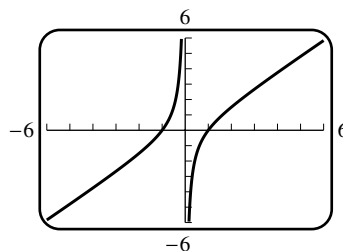

70.  $f'(x) = -5\frac{x^2 - 4}{(x^2 + 4)^2}$ ;

$f'(x) > 0$  when  $x^2 < 4$ , i.e. on  $-2 < x < 2$

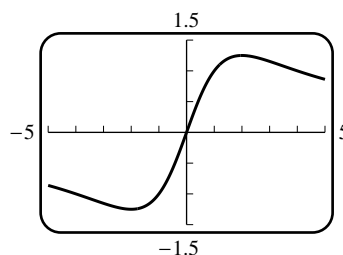

71.  $(f \cdot g \cdot h)' = [(f \cdot g) \cdot h]' = (f \cdot g)h' + h(f \cdot g)' = (f \cdot g)h' + h[fg' + f'g] = fgh' + fg'h + f'gh$

72.  $(f_1 f_2 \cdots f_n)' = (f_1' f_2 \cdots f_n) + (f_1 f_2' \cdots f_n) + \cdots + (f_1 f_2 \cdots f_n')$

73. (a)  $2(1 + x^{-1})(x^{-3} + 7) + (2x + 1)(-x^{-2})(x^{-3} + 7) + (2x + 1)(1 + x^{-1})(-3x^{-4})$

(b)  $(x^7 + 2x - 3)^3 = (x^7 + 2x - 3)(x^7 + 2x - 3)(x^7 + 2x - 3)$  so

$$\begin{aligned} \frac{d}{dx}(x^7 + 2x - 3)^3 &= (7x^6 + 2)(x^7 + 2x - 3)(x^7 + 2x - 3) \\ &\quad + (x^7 + 2x - 3)(7x^6 + 2)(x^7 + 2x - 3) \\ &\quad + (x^7 + 2x - 3)(x^7 + 2x - 3)(7x^6 + 2) \\ &= 3(7x^6 + 2)(x^7 + 2x - 3)^2 \end{aligned}$$

74. (a)  $-5x^{-6}(x^2 + 2x)(4 - 3x)(2x^9 + 1) + x^{-5}(2x + 2)(4 - 3x)(2x^9 + 1) + x^{-5}(x^2 + 2x)(-3)(2x^9 + 1) + x^{-5}(x^2 + 2x)(4 - 3x)(18x^8)$

(b)  $(x^2 + 1)^{50} = (x^2 + 1)(x^2 + 1) \cdots (x^2 + 1)$ , where  $(x^2 + 1)$  occurs 50 times so

$$\begin{aligned} \frac{d}{dx}(x^2 + 1)^{50} &= [(2x)(x^2 + 1) \cdots (x^2 + 1)] + [(x^2 + 1)(2x) \cdots (x^2 + 1)] \\ &\quad + \cdots + [(x^2 + 1)(x^2 + 1) \cdots (2x)] \\ &= 2x(x^2 + 1)^{49} + 2x(x^2 + 1)^{49} + \cdots + 2x(x^2 + 1)^{49} \\ &= 100x(x^2 + 1)^{49} \text{ because } 2x(x^2 + 1)^{49} \text{ occurs 50 times.} \end{aligned}$$

75.  $f$  is continuous at 1 because  $\lim_{x \rightarrow 1^-} f(x) = \lim_{x \rightarrow 1^+} f(x) = f(1)$ , also  $\lim_{x \rightarrow 1^-} f'(x) = \lim_{x \rightarrow 1^-} 2x = 2$  and

$$\lim_{x \rightarrow 1^+} f'(x) = \lim_{x \rightarrow 1^+} \frac{1}{2\sqrt{x}} = \frac{1}{2} \text{ so } f \text{ is not differentiable at 1.}$$

76.  $f$  is continuous at  $1/2$  because  $\lim_{x \rightarrow 1/2^-} f(x) = \lim_{x \rightarrow 1/2^+} f(x) = f(1/2)$ , also

$$\lim_{x \rightarrow 1/2^-} f'(x) = \lim_{x \rightarrow 1/2^-} 3x^2 = 3/4 \text{ and } \lim_{x \rightarrow 1/2^+} f'(x) = \lim_{x \rightarrow 1/2^+} 3x/2 = 3/4 \text{ so } f'(1/2) = 3/4.$$

77. If  $f$  is differentiable at  $x = 1$ , then  $f$  is continuous there;

$$\lim_{x \rightarrow 1^+} f(x) = \lim_{x \rightarrow 1^-} f(x) = f(1) = 3, \quad a + b = 3; \quad \lim_{x \rightarrow 1^+} f'(x) = a \text{ and}$$

$$\lim_{x \rightarrow 1^-} f'(x) = 6 \text{ so } a = 6 \text{ and } b = 3 - 6 = -3.$$

78. (a)  $\lim_{x \rightarrow 0^-} f'(x) = \lim_{x \rightarrow 0^-} 2x = 0$  and  $\lim_{x \rightarrow 0^+} f'(x) = \lim_{x \rightarrow 0^+} 2x = 0$ ;  $f'(0)$  does not exist because  $f$  is not continuous at  $x = 0$ .

(b)  $\lim_{x \rightarrow 0^-} f'(x) = \lim_{x \rightarrow 0^+} f'(x) = 0$  and  $f$  is continuous at  $x = 0$ , so  $f'(0) = 0$ ;

$$\lim_{x \rightarrow 0^-} f''(x) = \lim_{x \rightarrow 0^-} (2) = 2 \text{ and } \lim_{x \rightarrow 0^+} f''(x) = \lim_{x \rightarrow 0^+} 6x = 0, \text{ so } f''(0) \text{ does not exist.}$$

79. (a)  $f(x) = 3x - 2$  if  $x \geq 2/3$ ,  $f(x) = -3x + 2$  if  $x < 2/3$  so  $f$  is differentiable everywhere except perhaps at  $2/3$ .  $f$  is continuous at  $2/3$ , also  $\lim_{x \rightarrow 2/3^-} f'(x) = \lim_{x \rightarrow 2/3^-} (-3) = -3$  and  $\lim_{x \rightarrow 2/3^+} f'(x) =$

$$\lim_{x \rightarrow 2/3^+} (3) = 3 \text{ so } f \text{ is not differentiable at } x = 2/3.$$

(b)  $f(x) = x^2 - 4$  if  $|x| \geq 2$ ,  $f(x) = -x^2 + 4$  if  $|x| < 2$  so  $f$  is differentiable everywhere except perhaps at  $\pm 2$ .  $f$  is continuous at  $-2$  and  $2$ , also  $\lim_{x \rightarrow 2^-} f'(x) = \lim_{x \rightarrow 2^-} (-2x) = -4$  and  $\lim_{x \rightarrow 2^+} f'(x) = \lim_{x \rightarrow 2^+} (2x) = 4$  so  $f$  is not differentiable at  $x = 2$ . Similarly,  $f$  is not differentiable at  $x = -2$ .

80. (a)  $f'(x) = -(1)x^{-2}$ ,  $f''(x) = (2 \cdot 1)x^{-3}$ ,  $f'''(x) = -(3 \cdot 2 \cdot 1)x^{-4}$

$$f^{(n)}(x) = (-1)^n \frac{n(n-1)(n-2) \cdots 1}{x^{n+1}}$$

(b)  $f'(x) = -2x^{-3}$ ,  $f''(x) = (3 \cdot 2)x^{-4}$ ,  $f'''(x) = -(4 \cdot 3 \cdot 2)x^{-5}$

$$f^{(n)}(x) = (-1)^n \frac{(n+1)(n)(n-1) \cdots 2}{x^{n+2}}$$

81. (a)  $\frac{d^2}{dx^2}[cf(x)] = \frac{d}{dx} \left[ \frac{d}{dx}[cf(x)] \right] = \frac{d}{dx} \left[ c \frac{d}{dx}[f(x)] \right] = c \frac{d}{dx} \left[ \frac{d}{dx}[f(x)] \right] = c \frac{d^2}{dx^2}[f(x)]$

$$\frac{d^2}{dx^2}[f(x) + g(x)] = \frac{d}{dx} \left[ \frac{d}{dx}[f(x) + g(x)] \right] = \frac{d}{dx} \left[ \frac{d}{dx}[f(x)] + \frac{d}{dx}[g(x)] \right] = \frac{d^2}{dx^2}[f(x)] + \frac{d^2}{dx^2}[g(x)]$$

(b) yes, by repeated application of the procedure illustrated in part (a)

82.  $(f \cdot g)' = fg' + gf'$ ,  $(f \cdot g)'' = fg'' + g'f' + gf'' + f'g' = f''g + 2f'g' + fg''$

83. (a)  $f'(x) = nx^{n-1}$ ,  $f''(x) = n(n-1)x^{n-2}$ ,  $f'''(x) = n(n-1)(n-2)x^{n-3}, \dots$ ,

$$f^{(n)}(x) = n(n-1)(n-2) \cdots 1$$

(b) from part (a),  $f^{(k)}(x) = k(k-1)(k-2) \cdots 1$  so  $f^{(k+1)}(x) = 0$  thus  $f^{(n)}(x) = 0$  if  $n > k$

(c) from parts (a) and (b),  $f^{(n)}(x) = a_n n(n-1)(n-2) \cdots 1$

84.  $\lim_{h \rightarrow 0} \frac{f'(2+h) - f'(2)}{h} = f''(2)$ ;  $f'(x) = 8x^7 - 2$ ,  $f''(x) = 56x^6$ , so  $f''(2) = 56(2^6) = 3584$ .

85. (a) If a function is differentiable at a point then it is continuous at that point, thus  $f'$  is continuous on  $(a, b)$  and consequently so is  $f$ .

(b)  $f$  and all its derivatives up to  $f^{(n-1)}(x)$  are continuous on  $(a, b)$

### EXERCISE SET 3.4

1.  $f'(x) = -2 \sin x - 3 \cos x$

2.  $f'(x) = \sin x(-\sin x) + \cos x(\cos x) = \cos^2 x - \sin^2 x = \cos 2x$

3.  $f'(x) = \frac{x(\cos x) - \sin x(1)}{x^2} = \frac{x \cos x - \sin x}{x^2}$

4.  $f'(x) = x^2(-\sin x) + (\cos x)(2x) = -x^2 \sin x + 2x \cos x$

5.  $f'(x) = x^3(\cos x) + (\sin x)(3x^2) - 5(-\sin x) = x^3 \cos x + (3x^2 + 5) \sin x$

6.  $f(x) = \frac{\cot x}{x}$  (because  $\frac{\cos x}{\sin x} = \cot x$ ),  $f'(x) = \frac{x(-\csc^2 x) - (\cot x)(1)}{x^2} = -\frac{x \csc^2 x + \cot x}{x^2}$

7.  $f'(x) = \sec x \tan x - \sqrt{2} \sec^2 x$

8.  $f'(x) = (x^2 + 1) \sec x \tan x + (\sec x)(2x) = (x^2 + 1) \sec x \tan x + 2x \sec x$

9.  $f'(x) = \sec x(\sec^2 x) + (\tan x)(\sec x \tan x) = \sec^3 x + \sec x \tan^2 x$

10.  $f'(x) = \frac{(1 + \tan x)(\sec x \tan x) - (\sec x)(\sec^2 x)}{(1 + \tan x)^2} = \frac{\sec x \tan x + \sec x \tan^2 x - \sec^3 x}{(1 + \tan x)^2}$   
 $= \frac{\sec x(\tan x + \tan^2 x - \sec^2 x)}{(1 + \tan x)^2} = \frac{\sec x(\tan x - 1)}{(1 + \tan x)^2}$

11.  $f'(x) = (\csc x)(-\csc^2 x) + (\cot x)(-\csc x \cot x) = -\csc^3 x - \csc x \cot^2 x$

12.  $f'(x) = 1 + 4 \csc x \cot x - 2 \csc^2 x$

13.  $f'(x) = \frac{(1 + \csc x)(-\csc^2 x) - \cot x(0 - \csc x \cot x)}{(1 + \csc x)^2} = \frac{\csc x(-\csc x - \csc^2 x + \cot^2 x)}{(1 + \csc x)^2}$  but

$1 + \cot^2 x = \csc^2 x$  (identity) thus  $\cot^2 x - \csc^2 x = -1$  so

$$f'(x) = \frac{\csc x(-\csc x - 1)}{(1 + \csc x)^2} = -\frac{\csc x}{1 + \csc x}$$

14.  $f'(x) = \frac{\tan x(-\csc x \cot x) - \csc x(\sec^2 x)}{\tan^2 x} = -\frac{\csc x(1 + \sec^2 x)}{\tan^2 x}$

15.  $f(x) = \sin^2 x + \cos^2 x = 1$  (identity) so  $f'(x) = 0$

16.  $f(x) = \frac{1}{\cot x} = \tan x$ , so  $f'(x) = \sec^2 x$



17.  $f(x) = \frac{\tan x}{1 + x \tan x}$  (because  $\sin x \sec x = (\sin x)(1/\cos x) = \tan x$ ),  
 $f'(x) = \frac{(1 + x \tan x)(\sec^2 x) - \tan x[x(\sec^2 x) + (\tan x)(1)]}{(1 + x \tan x)^2}$   
 $= \frac{\sec^2 x - \tan^2 x}{(1 + x \tan x)^2} = \frac{1}{(1 + x \tan x)^2}$  (because  $\sec^2 x - \tan^2 x = 1$ )
18.  $f(x) = \frac{(x^2 + 1) \cot x}{3 - \cot x}$  (because  $\cos x \csc x = (\cos x)(1/\sin x) = \cot x$ ),  
 $f'(x) = \frac{(3 - \cot x)[2x \cot x - (x^2 + 1) \csc^2 x] - (x^2 + 1) \cot x \csc^2 x}{(3 - \cot x)^2}$   
 $= \frac{6x \cot x - 2x \cot^2 x - 3(x^2 + 1) \csc^2 x}{(3 - \cot x)^2}$
19.  $dy/dx = -x \sin x + \cos x$ ,  $d^2y/dx^2 = -x \cos x - \sin x - \sin x = -x \cos x - 2 \sin x$
20.  $dy/dx = -\csc x \cot x$ ,  $d^2y/dx^2 = -[(\csc x)(-\csc^2 x) + (\cot x)(-\csc x \cot x)] = \csc^3 x + \csc x \cot^2 x$
21.  $dy/dx = x(\cos x) + (\sin x)(1) - 3(-\sin x) = x \cos x + 4 \sin x$ ,  
 $d^2y/dx^2 = x(-\sin x) + (\cos x)(1) + 4 \cos x = -x \sin x + 5 \cos x$
22.  $dy/dx = x^2(-\sin x) + (\cos x)(2x) + 4 \cos x = -x^2 \sin x + 2x \cos x + 4 \cos x$ ,  
 $d^2y/dx^2 = -[x^2(\cos x) + (\sin x)(2x)] + 2[x(-\sin x) + \cos x] - 4 \sin x = (2 - x^2) \cos x - 4(x + 1) \sin x$
23.  $dy/dx = (\sin x)(-\sin x) + (\cos x)(\cos x) = \cos^2 x - \sin^2 x$ ,  
 $d^2y/dx^2 = (\cos x)(-\sin x) + (\cos x)(-\sin x) - [(\sin x)(\cos x) + (\sin x)(\cos x)] = -4 \sin x \cos x$
24.  $dy/dx = \sec^2 x$ ;  $d^2y/dx^2 = 2 \sec^2 x \tan x$
26. Let  $f(x) = \sin x$ , then  $f'(x) = \cos x$ .  
 (a)  $f(0) = 0$  and  $f'(0) = 1$  so  $y - 0 = (1)(x - 0)$ ,  $y = x$   
 (b)  $f(\pi) = 0$  and  $f'(\pi) = -1$  so  $y - 0 = (-1)(x - \pi)$ ,  $y = -x + \pi$   
 (c)  $f\left(\frac{\pi}{4}\right) = \frac{1}{\sqrt{2}}$  and  $f'\left(\frac{\pi}{4}\right) = \frac{1}{\sqrt{2}}$  so  $y - \frac{1}{\sqrt{2}} = \frac{1}{\sqrt{2}}\left(x - \frac{\pi}{4}\right)$ ,  $y = \frac{1}{\sqrt{2}}x - \frac{\pi}{4\sqrt{2}} + \frac{1}{\sqrt{2}}$
27. Let  $f(x) = \tan x$ , then  $f'(x) = \sec^2 x$ .  
 (a)  $f(0) = 0$  and  $f'(0) = 1$  so  $y - 0 = (1)(x - 0)$ ,  $y = x$ .  
 (b)  $f\left(\frac{\pi}{4}\right) = 1$  and  $f'\left(\frac{\pi}{4}\right) = 2$  so  $y - 1 = 2\left(x - \frac{\pi}{4}\right)$ ,  $y = 2x - \frac{\pi}{2} + 1$ .  
 (c)  $f\left(-\frac{\pi}{4}\right) = -1$  and  $f'\left(-\frac{\pi}{4}\right) = 2$  so  $y + 1 = 2\left(x + \frac{\pi}{4}\right)$ ,  $y = 2x + \frac{\pi}{2} - 1$ .
28. (a) If  $y = \cos x$  then  $y' = -\sin x$  and  $y'' = -\cos x$  so  $y'' + y = (-\cos x) + (\cos x) = 0$ ;  
 if  $y = \sin x$  then  $y' = \cos x$  and  $y'' = -\sin x$  so  $y'' + y = (-\sin x) + (\sin x) = 0$ .  
 (b)  $y' = A \cos x - B \sin x$ ,  $y'' = -A \sin x - B \cos x$  so  
 $y'' + y = (-A \sin x - B \cos x) + (A \sin x + B \cos x) = 0$ .
29. (a)  $f'(x) = \cos x = 0$  at  $x = \pm\pi/2, \pm 3\pi/2$ .  
 (b)  $f'(x) = 1 - \sin x = 0$  at  $x = -3\pi/2, \pi/2$ .  
 (c)  $f'(x) = \sec^2 x \geq 1$  always, so no horizontal tangent line.  
 (d)  $f'(x) = \sec x \tan x = 0$  when  $\sin x = 0$ ,  $x = \pm 2\pi, \pm\pi, 0$

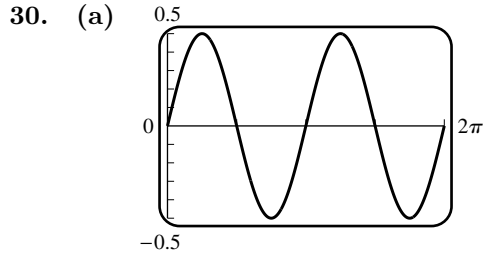

- (b)  $y = \sin x \cos x = (1/2) \sin 2x$  and  $y' = \cos 2x$ . So  $y' = 0$  when  $2x = (2n + 1)\pi/2$  for  $n = 0, 1, 2, 3$  or  $x = \pi/4, 3\pi/4, 5\pi/4, 7\pi/4$

31.  $x = 10 \sin \theta$ ,  $dx/d\theta = 10 \cos \theta$ ; if  $\theta = 60^\circ$ , then  
 $dx/d\theta = 10(1/2) = 5 \text{ ft/rad} = \pi/36 \text{ ft/deg} \approx 0.087 \text{ ft/deg}$

32.  $s = 3800 \csc \theta$ ,  $ds/d\theta = -3800 \csc \theta \cot \theta$ ; if  $\theta = 30^\circ$ , then  
 $ds/d\theta = -3800(2)(\sqrt{3}) = -7600\sqrt{3} \text{ ft/rad} = -380\sqrt{3}\pi/9 \text{ ft/deg} \approx -230 \text{ ft/deg}$

33.  $D = 50 \tan \theta$ ,  $dD/d\theta = 50 \sec^2 \theta$ ; if  $\theta = 45^\circ$ , then  
 $dD/d\theta = 50(\sqrt{2})^2 = 100 \text{ m/rad} = 5\pi/9 \text{ m/deg} \approx 1.75 \text{ m/deg}$

34. (a) From the right triangle shown,  $\sin \theta = r/(r + h)$  so  $r + h = r \csc \theta$ ,  $h = r(\csc \theta - 1)$ .

- (b)  $dh/d\theta = -r \csc \theta \cot \theta$ ; if  $\theta = 30^\circ$ , then  
 $dh/d\theta = -6378(2)(\sqrt{3}) \approx -22,094 \text{ km/rad} \approx -386 \text{ km/deg}$

35. (a)  $\frac{d^4}{dx^4} \sin x = \sin x$ , so  $\frac{d^{4k}}{dx^{4k}} \sin x = \sin x$ ;  $\frac{d^{87}}{dx^{87}} \sin x = \frac{d^3}{dx^3} \frac{d^{4 \cdot 21}}{dx^{4 \cdot 21}} \sin x = \frac{d^3}{dx^3} \sin x = -\cos x$

- (b)  $\frac{d^{100}}{dx^{100}} \cos x = \frac{d^{4k}}{dx^{4k}} \cos x = \cos x$

36.  $\frac{d}{dx}[x \sin x] = x \cos x + \sin x$   $\frac{d^2}{dx^2}[x \sin x] = -x \sin x + 2 \cos x$

$$\frac{d^3}{dx^3}[x \sin x] = -x \cos x - 3 \sin x$$
 $\frac{d^4}{dx^4}[x \sin x] = x \sin x - 4 \cos x$

By mathematical induction one can show

$$\frac{d^{4k}}{dx^{4k}}[x \sin x] = x \sin x - (4k) \cos x; \quad \frac{d^{4k+1}}{dx^{4k+1}}[x \sin x] = x \cos x + (4k + 1) \sin x;$$

$$\frac{d^{4k+2}}{dx^{4k+2}}[x \sin x] = -x \sin x + (4k + 2) \cos x; \quad \frac{d^{4k+3}}{dx^{4k+3}}[x \sin x] = -x \cos x - (4k + 3) \sin x;$$

Since  $17 = 4 \cdot 4 + 1$ ,  $\frac{d^{17}}{dx^{17}}[x \sin x] = x \cos x + 17 \sin x$

37. (a) all  $x$  (b) all  $x$   
 (c)  $x \neq \pi/2 + n\pi$ ,  $n = 0, \pm 1, \pm 2, \dots$  (d)  $x \neq n\pi$ ,  $n = 0, \pm 1, \pm 2, \dots$   
 (e)  $x \neq \pi/2 + n\pi$ ,  $n = 0, \pm 1, \pm 2, \dots$  (f)  $x \neq n\pi$ ,  $n = 0, \pm 1, \pm 2, \dots$   
 (g)  $x \neq (2n + 1)\pi$ ,  $n = 0, \pm 1, \pm 2, \dots$  (h)  $x \neq n\pi/2$ ,  $n = 0, \pm 1, \pm 2, \dots$   
 (i) all  $x$

$$\begin{aligned}
 38. \quad (a) \quad \frac{d}{dx}[\cos x] &= \lim_{h \rightarrow 0} \frac{\cos(x+h) - \cos x}{h} = \lim_{h \rightarrow 0} \frac{\cos x \cos h - \sin x \sin h - \cos x}{h} \\
 &= \lim_{h \rightarrow 0} \left[ \cos x \left( \frac{\cos h - 1}{h} \right) - \sin x \left( \frac{\sin h}{h} \right) \right] = (\cos x)(0) - (\sin x)(1) = -\sin x \\
 (b) \quad \frac{d}{dx}[\sec x] &= \frac{d}{dx} \left[ \frac{1}{\cos x} \right] = \frac{\cos x(0) - (1)(-\sin x)}{\cos^2 x} = \frac{\sin x}{\cos^2 x} = \sec x \tan x \\
 (c) \quad \frac{d}{dx}[\cot x] &= \frac{d}{dx} \left[ \frac{\cos x}{\sin x} \right] = \frac{\sin x(-\sin x) - \cos x(\cos x)}{\sin^2 x} \\
 &= \frac{-\sin^2 x - \cos^2 x}{\sin^2 x} = \frac{-1}{\sin^2 x} = -\csc^2 x \\
 (d) \quad \frac{d}{dx}[\csc x] &= \frac{d}{dx} \left[ \frac{1}{\sin x} \right] = \frac{\sin x(0) - (1)(\cos x)}{\sin^2 x} = -\frac{\cos x}{\sin^2 x} = -\csc x \cot x
 \end{aligned}$$

39.  $f'(x) = -\sin x$ ,  $f''(x) = -\cos x$ ,  $f'''(x) = \sin x$ , and  $f^{(4)}(x) = \cos x$  with higher order derivatives repeating this pattern, so  $f^{(n)}(x) = \sin x$  for  $n = 3, 7, 11, \dots$

$$\begin{aligned}
 40. \quad (a) \quad \lim_{h \rightarrow 0} \frac{\tan h}{h} &= \lim_{h \rightarrow 0} \frac{\left( \frac{\sin h}{\cos h} \right)}{h} = \lim_{h \rightarrow 0} \frac{\left( \frac{\sin h}{h} \right)}{\cos h} = \frac{1}{1} = 1 \\
 (b) \quad \frac{d}{dx}[\tan x] &= \lim_{h \rightarrow 0} \frac{\tan(x+h) - \tan x}{h} = \lim_{h \rightarrow 0} \frac{\frac{\tan x + \tan h}{1 - \tan x \tan h} - \tan x}{h} \\
 &= \lim_{h \rightarrow 0} \frac{\tan x + \tan h - \tan x + \tan^2 x \tan h}{h(1 - \tan x \tan h)} = \lim_{h \rightarrow 0} \frac{\tan h(1 + \tan^2 x)}{h(1 - \tan x \tan h)} \\
 &= \lim_{h \rightarrow 0} \frac{\tan h \sec^2 x}{h(1 - \tan x \tan h)} = \sec^2 x \lim_{h \rightarrow 0} \frac{\frac{\tan h}{h}}{1 - \tan x \tan h} \\
 &= \sec^2 x \frac{\lim_{h \rightarrow 0} \frac{\tan h}{h}}{\lim_{h \rightarrow 0} (1 - \tan x \tan h)} = \sec^2 x
 \end{aligned}$$

$$41. \quad \lim_{x \rightarrow 0} \frac{\tan(x+y) - \tan y}{x} = \lim_{h \rightarrow 0} \frac{\tan(y+h) - \tan y}{h} = \frac{d}{dy}(\tan y) = \sec^2 y$$

43. Let  $t$  be the radian measure, then  $h = \frac{180}{\pi}t$  and  $\cos h = \cos t$ ,  $\sin h = \sin t$ .

$$(a) \quad \lim_{h \rightarrow 0} \frac{\cos h - 1}{h} = \lim_{t \rightarrow 0} \frac{\cos t - 1}{180t/\pi} = \frac{\pi}{180} \lim_{t \rightarrow 0} \frac{\cos t - 1}{t} = 0$$

$$(b) \quad \lim_{h \rightarrow 0} \frac{\sin h}{h} = \lim_{t \rightarrow 0} \frac{\sin t}{180t/\pi} = \frac{\pi}{180} \lim_{t \rightarrow 0} \frac{\sin t}{t} = \frac{\pi}{180}$$

$$(c) \quad \frac{d}{dx}[\sin x] = \sin x \lim_{h \rightarrow 0} \frac{\cos h - 1}{h} + \cos x \lim_{h \rightarrow 0} \frac{\sin h}{h} = \sin x(0) + \cos x(\pi/180) = \frac{\pi}{180} \cos x$$

### EXERCISE SET 3.5

$$1. \quad f'(x) = 37(x^3 + 2x)^{36} \frac{d}{dx}(x^3 + 2x) = 37(x^3 + 2x)^{36}(3x^2 + 2)$$

$$2. \quad f'(x) = 6(3x^2 + 2x - 1)^5 \frac{d}{dx}(3x^2 + 2x - 1) = 6(3x^2 + 2x - 1)^5(6x + 2) = 12(3x^2 + 2x - 1)^5(3x + 1)$$

3.  $f'(x) = -2 \left(x^3 - \frac{7}{x}\right)^{-3} \frac{d}{dx} \left(x^3 - \frac{7}{x}\right) = -2 \left(x^3 - \frac{7}{x}\right)^{-3} \left(3x^2 + \frac{7}{x^2}\right)$
4.  $f(x) = (x^5 - x + 1)^{-9}$ ,  
 $f'(x) = -9(x^5 - x + 1)^{-10} \frac{d}{dx}(x^5 - x + 1) = -9(x^5 - x + 1)^{-10}(5x^4 - 1) = -\frac{9(5x^4 - 1)}{(x^5 - x + 1)^{10}}$
5.  $f(x) = 4(3x^2 - 2x + 1)^{-3}$ ,  
 $f'(x) = -12(3x^2 - 2x + 1)^{-4} \frac{d}{dx}(3x^2 - 2x + 1) = -12(3x^2 - 2x + 1)^{-4}(6x - 2) = \frac{24(1 - 3x)}{(3x^2 - 2x + 1)^4}$
6.  $f'(x) = \frac{1}{2\sqrt{x^3 - 2x + 5}} \frac{d}{dx}(x^3 - 2x + 5) = \frac{3x^2 - 2}{2\sqrt{x^3 - 2x + 5}}$
7.  $f'(x) = \frac{1}{2\sqrt{4 + 3\sqrt{x}}} \frac{d}{dx}(4 + 3\sqrt{x}) = \frac{3}{4\sqrt{x}\sqrt{4 + 3\sqrt{x}}}$
8.  $f'(x) = 3\sin^2 x \frac{d}{dx}(\sin x) = 3\sin^2 x \cos x$
9.  $f'(x) = \cos(x^3) \frac{d}{dx}(x^3) = 3x^2 \cos(x^3)$
10.  $f'(x) = 2\cos(3\sqrt{x}) \frac{d}{dx}[\cos(3\sqrt{x})] = -2\cos(3\sqrt{x})\sin(3\sqrt{x}) \frac{d}{dx}(3\sqrt{x}) = -\frac{3\cos(3\sqrt{x})\sin(3\sqrt{x})}{\sqrt{x}}$
11.  $f'(x) = \sec^2(4x^2) \frac{d}{dx}(4x^2) = 8x \sec^2(4x^2)$
12.  $f'(x) = 12\cot^3 x \frac{d}{dx}(\cot x) = 12\cot^3 x(-\csc^2 x) = -12\cot^3 x \csc^2 x$
13.  $f'(x) = 20\cos^4 x \frac{d}{dx}(\cos x) = 20\cos^4 x(-\sin x) = -20\cos^4 x \sin x$
14.  $f'(x) = -\csc(x^3) \cot(x^3) \frac{d}{dx}(x^3) = -3x^2 \csc(x^3) \cot(x^3)$
15.  $f'(x) = \cos(1/x^2) \frac{d}{dx}(1/x^2) = -\frac{2}{x^3} \cos(1/x^2)$
16.  $f'(x) = 4\tan^3(x^3) \frac{d}{dx}[\tan(x^3)] = 4\tan^3(x^3) \sec^2(x^3) \frac{d}{dx}(x^3) = 12x^2 \tan^3(x^3) \sec^2(x^3)$
17.  $f'(x) = 4\sec(x^7) \frac{d}{dx}[\sec(x^7)] = 4\sec(x^7) \sec(x^7) \tan(x^7) \frac{d}{dx}(x^7) = 28x^6 \sec^2(x^7) \tan(x^7)$
18.  $f'(x) = 3\cos^2\left(\frac{x}{x+1}\right) \frac{d}{dx} \cos\left(\frac{x}{x+1}\right) = 3\cos^2\left(\frac{x}{x+1}\right) \left[-\sin\left(\frac{x}{x+1}\right)\right] \frac{(x+1)(1) - x(1)}{(x+1)^2}$   
 $= -\frac{3}{(x+1)^2} \cos^2\left(\frac{x}{x+1}\right) \sin\left(\frac{x}{x+1}\right)$
19.  $f'(x) = \frac{1}{2\sqrt{\cos(5x)}} \frac{d}{dx}[\cos(5x)] = -\frac{5\sin(5x)}{2\sqrt{\cos(5x)}}$
20.  $f'(x) = \frac{1}{2\sqrt{3x - \sin^2(4x)}} \frac{d}{dx}[3x - \sin^2(4x)] = \frac{3 - 8\sin(4x)\cos(4x)}{2\sqrt{3x - \sin^2(4x)}}$

21.  $f'(x) = -3 [x + \csc(x^3 + 3)]^{-4} \frac{d}{dx} [x + \csc(x^3 + 3)]$   
 $= -3 [x + \csc(x^3 + 3)]^{-4} \left[ 1 - \csc(x^3 + 3) \cot(x^3 + 3) \frac{d}{dx} (x^3 + 3) \right]$   
 $= -3 [x + \csc(x^3 + 3)]^{-4} [1 - 3x^2 \csc(x^3 + 3) \cot(x^3 + 3)]$
22.  $f'(x) = -4 [x^4 - \sec(4x^2 - 2)]^{-5} \frac{d}{dx} [x^4 - \sec(4x^2 - 2)]$   
 $= -4 [x^4 - \sec(4x^2 - 2)]^{-5} \left[ 4x^3 - \sec(4x^2 - 2) \tan(4x^2 - 2) \frac{d}{dx} (4x^2 - 2) \right]$   
 $= -16x [x^4 - \sec(4x^2 - 2)]^{-5} [x^2 - 2 \sec(4x^2 - 2) \tan(4x^2 - 2)]$
23.  $f'(x) = x^2 \cdot \frac{-2x}{2\sqrt{5-x^2}} + 2x\sqrt{5-x^2} = \frac{x(10-3x^2)}{\sqrt{5-x^2}}$
24.  $f'(x) = \frac{\sqrt{1-x^2}(1) - x(-x/\sqrt{1-x^2})}{1-x^2} = \frac{1}{(1-x^2)^{3/2}}$
25.  $\frac{dy}{dx} = x^3(2 \sin 5x) \frac{d}{dx} (\sin 5x) + 3x^2 \sin^2 5x = 10x^3 \sin 5x \cos 5x + 3x^2 \sin^2 5x$
26.  $\frac{dy}{dx} = \sqrt{x} \left[ 3 \tan^2(\sqrt{x}) \sec^2(\sqrt{x}) \frac{1}{2\sqrt{x}} \right] + \frac{1}{2\sqrt{x}} \tan^3(\sqrt{x}) = \frac{3}{2} \tan^2(\sqrt{x}) \sec^2(\sqrt{x}) + \frac{1}{2\sqrt{x}} \tan^3(\sqrt{x})$
27.  $\frac{dy}{dx} = x^5 \sec\left(\frac{1}{x}\right) \tan\left(\frac{1}{x}\right) \frac{d}{dx} \left(\frac{1}{x}\right) + \sec\left(\frac{1}{x}\right) (5x^4) = x^5 \sec\left(\frac{1}{x}\right) \tan\left(\frac{1}{x}\right) \left(-\frac{1}{x^2}\right) + 5x^4 \sec\left(\frac{1}{x}\right)$   
 $= -x^3 \sec\left(\frac{1}{x}\right) \tan\left(\frac{1}{x}\right) + 5x^4 \sec\left(\frac{1}{x}\right)$
28.  $\frac{dy}{dx} = \frac{\sec(3x+1) \cos x - 3 \sin x \sec(3x+1) \tan(3x+1)}{\sec^2(3x+1)} = \frac{\cos x - 3 \sin x \tan(3x+1)}{\sec(3x+1)}$
29.  $\frac{dy}{dx} = -\sin(\cos x) \frac{d}{dx} (\cos x) = -\sin(\cos x)(-\sin x) = \sin(\cos x) \sin x$
30.  $\frac{dy}{dx} = \cos(\tan 3x) \frac{d}{dx} (\tan 3x) = 3 \sec^2 3x \cos(\tan 3x)$
31.  $\frac{dy}{dx} = 3 \cos^2(\sin 2x) \frac{d}{dx} [\cos(\sin 2x)] = 3 \cos^2(\sin 2x) [-\sin(\sin 2x)] \frac{d}{dx} (\sin 2x)$   
 $= -6 \cos^2(\sin 2x) \sin(\sin 2x) \cos 2x$
32.  $\frac{dy}{dx} = \frac{(1 - \cot x^2)(-2x \csc x^2 \cot x^2) - (1 + \csc x^2)(2x \csc^2 x^2)}{(1 - \cot x^2)^2} = -2x \csc x^2 \frac{1 + \cot x^2 \csc x^2}{(1 - \cot x^2)^2}$
33.  $\frac{dy}{dx} = (5x+8)^{13} 12(x^3+7x)^{11} \frac{d}{dx} (x^3+7x) + (x^3+7x)^{12} 13(5x+8)^{12} \frac{d}{dx} (5x+8)$   
 $= 12(5x+8)^{13} (x^3+7x)^{11} (3x^2+7) + 65(x^3+7x)^{12} (5x+8)^{12}$
34.  $\frac{dy}{dx} = (2x-5)^2 3(x^2+4)^2 (2x) + (x^2+4)^3 2(2x-5)(2) = 6x(2x-5)^2 (x^2+4)^2 + 4(2x-5)(x^2+4)^3$   
 $= 2(2x-5)(x^2+4)^2 (8x^2-15x+8)$

35.  $\frac{dy}{dx} = 3 \left[ \frac{x-5}{2x+1} \right]^2 \frac{d}{dx} \left[ \frac{x-5}{2x+1} \right] = 3 \left[ \frac{x-5}{2x+1} \right]^2 \cdot \frac{11}{(2x+1)^2} = \frac{33(x-5)^2}{(2x+1)^4}$
36.  $\frac{dy}{dx} = 17 \left( \frac{1+x^2}{1-x^2} \right)^{16} \frac{d}{dx} \left( \frac{1+x^2}{1-x^2} \right) = 17 \left( \frac{1+x^2}{1-x^2} \right)^{16} \frac{(1-x^2)(2x) - (1+x^2)(-2x)}{(1-x^2)^2}$   
 $= 17 \left( \frac{1+x^2}{1-x^2} \right)^{16} \frac{4x}{(1-x^2)^2} = \frac{68x(1+x^2)^{16}}{(1-x^2)^{18}}$
37.  $\frac{dy}{dx} = \frac{(4x^2-1)^8(3)(2x+3)^2(2) - (2x+3)^3(8)(4x^2-1)^7(8x)}{(4x^2-1)^{16}}$   
 $= \frac{2(2x+3)^2(4x^2-1)^7[3(4x^2-1) - 32x(2x+3)]}{(4x^2-1)^{16}} = -\frac{2(2x+3)^2(52x^2+96x+3)}{(4x^2-1)^9}$
38.  $\frac{dy}{dx} = 12[1 + \sin^3(x^5)]^{11} \frac{d}{dx} [1 + \sin^3(x^5)]$   
 $= 12[1 + \sin^3(x^5)]^{11} 3 \sin^2(x^5) \frac{d}{dx} \sin(x^5) = 180x^4 [1 + \sin^3(x^5)]^{11} \sin^2(x^5) \cos(x^5)$
39.  $\frac{dy}{dx} = 5 [x \sin 2x + \tan^4(x^7)]^4 \frac{d}{dx} [x \sin 2x \tan^4(x^7)]$   
 $= 5 [x \sin 2x + \tan^4(x^7)]^4 \left[ x \cos 2x \frac{d}{dx} (2x) + \sin 2x + 4 \tan^3(x^7) \frac{d}{dx} \tan(x^7) \right]$   
 $= 5 [x \sin 2x + \tan^4(x^7)]^4 [2x \cos 2x + \sin 2x + 28x^6 \tan^3(x^7) \sec^2(x^7)]$
40.  $\frac{dy}{dx} = \cos(3x^2) \frac{d}{dx} (3x^2) = 6x \cos(3x^2)$ ,  
 $\frac{d^2y}{dx^2} = 6x(-\sin(3x^2)) \frac{d}{dx} (3x^2) + 6 \cos(3x^2) = -36x^2 \sin(3x^2) + 6 \cos(3x^2)$
41.  $\frac{dy}{dx} = x(-\sin(5x)) \frac{d}{dx} (5x) + \cos(5x) - 2 \sin x \frac{d}{dx} (\sin x)$   
 $= -5x \sin(5x) + \cos(5x) - 2 \sin x \cos x = -5x \sin(5x) + \cos(5x) - \sin(2x)$ ,  
 $\frac{d^2y}{dx^2} = -5x \cos(5x) \frac{d}{dx} (5x) - 5 \sin(5x) - \sin(5x) \frac{d}{dx} (5x) - \cos(2x) \frac{d}{dx} (2x)$   
 $= -25x \cos(5x) - 10 \sin(5x) - 2 \cos(2x)$
42.  $\frac{dy}{dx} = x \sec^2 \left( \frac{1}{x} \right) \frac{d}{dx} \left( \frac{1}{x} \right) + \tan \left( \frac{1}{x} \right) = -\frac{1}{x} \sec^2 \left( \frac{1}{x} \right) + \tan \left( \frac{1}{x} \right)$ ,  
 $\frac{d^2y}{dx^2} = -\frac{2}{x} \sec \left( \frac{1}{x} \right) \frac{d}{dx} \sec \left( \frac{1}{x} \right) + \frac{1}{x^2} \sec^2 \left( \frac{1}{x} \right) + \sec^2 \left( \frac{1}{x} \right) \frac{d}{dx} \left( \frac{1}{x} \right) = \frac{2}{x^3} \sec^2 \left( \frac{1}{x} \right) \tan \left( \frac{1}{x} \right)$
43.  $\frac{dy}{dx} = \frac{(1-x) + (1+x)}{(1-x)^2} = \frac{2}{(1-x)^2} = 2(1-x)^{-2}$  and  $\frac{d^2y}{dx^2} = -2(2)(-1)(1-x)^{-3} = 4(1-x)^{-3}$
45.  $\frac{dy}{dx} = -3x \sin 3x + \cos 3x$ ; if  $x = \pi$  then  $y = -\pi$  and  $\frac{dy}{dx} = -1$  so  $y + \pi = -(x - \pi)$ ,  $y = -x$
46.  $\frac{dy}{dx} = 3x^2 \cos(1+x^3)$ ; if  $x = -3$  then  $y = \sin(-26) = -\sin 26$  and  $\frac{dy}{dx} = 27 \cos 26$   
so  $y + \sin 26 = 27(\cos 26)(x + 3)$

47.  $\frac{dy}{dx} = -3 \sec^3(\pi/2 - x) \tan(\pi/2 - x)$ ; if  $x = -\pi/2$  then  $y = -1$  and  $\frac{dy}{dx} = 0$   
 so  $y + 1 = (0)(x + \pi/2)$ ,  $y = -1$

48.  $\frac{dy}{dx} = 3(x - 1/x)^2(1 + 1/x^2)$ ; if  $x = 2$  then  $y = 27/8$  and  $\frac{dy}{dx} = 135/16$   
 so  $y - \frac{27}{8} = \frac{135}{16}(x - 2)$ ,  $y = \frac{135}{16}x - \frac{27}{2}$

49.  $y = \cot^3(\pi - \theta) = -\cot^3 \theta$  so  $dy/dx = 3 \cot^2 \theta \csc^2 \theta$

50.  $6 \left( \frac{au + b}{cu + d} \right)^5 \frac{ad - bc}{(cu + d)^2}$

51.  $\frac{d}{d\omega} [a \cos^2 \pi\omega + b \sin^2 \pi\omega] = -2\pi a \cos \pi\omega \sin \pi\omega + 2\pi b \sin \pi\omega \cos \pi\omega$   
 $= \pi(b - a)(2 \sin \pi\omega \cos \pi\omega) = \pi(b - a) \sin 2\pi\omega$

52.  $2 \csc^2(\pi/3 - y) \cot(\pi/3 - y)$

53. (a)

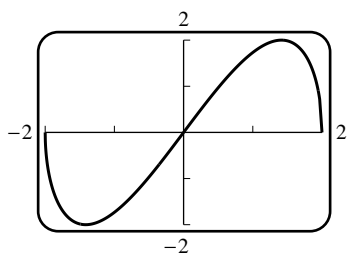

(c)  $f'(x) = x \frac{-x}{\sqrt{4-x^2}} + \sqrt{4-x^2} = \frac{4-2x^2}{\sqrt{4-x^2}}$

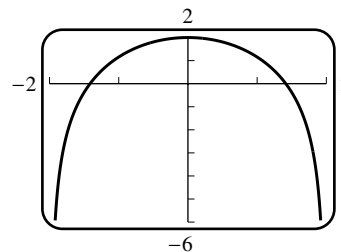

(d)  $f(1) = \sqrt{3}$  and  $f'(1) = \frac{2}{\sqrt{3}}$  so the tangent line has the equation  $y - \sqrt{3} = \frac{2}{\sqrt{3}}(x - 1)$ .

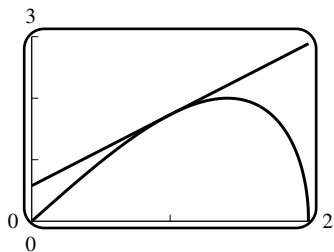

54. (a)

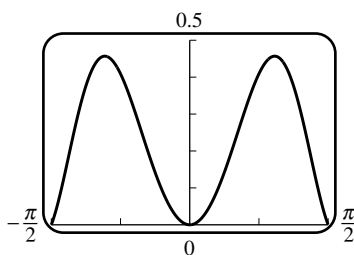

(c)  $f'(x) = 2x \cos x^2 \cos x - \sin x \sin x^2$

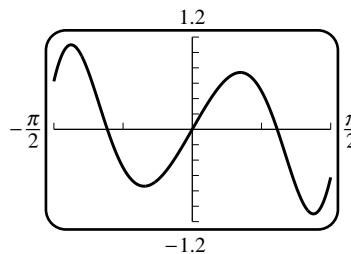

- (d)  $f(1) = \sin 1 \cos 1$  and  $f'(1) = 2 \cos^2 1 - \sin^2 1$ , so the tangent line has the equation  $y - \sin 1 \cos 1 = (2 \cos^2 1 - \sin^2 1)(x - 1)$ .

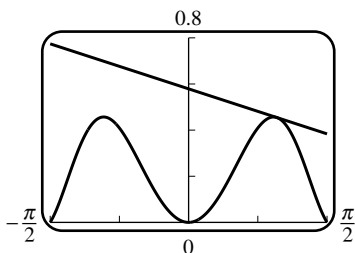

55. (a)  $dy/dt = -A\omega \sin \omega t$ ,  $d^2y/dt^2 = -A\omega^2 \cos \omega t = -\omega^2 y$   
 (b) one complete oscillation occurs when  $\omega t$  increases over an interval of length  $2\pi$ , or if  $t$  increases over an interval of length  $2\pi/\omega$   
 (c)  $f = 1/T$   
 (d) amplitude = 0.6 cm,  $T = 2\pi/15$  s/oscillation,  $f = 15/(2\pi)$  oscillations/s
56.  $dy/dt = 3A \cos 3t$ ,  $d^2y/dt^2 = -9A \sin 3t$ , so  $-9A \sin 3t + 2A \sin 3t = 4 \sin 3t$ ,  
 $-7A \sin 3t = 4 \sin 3t$ ,  $-7A = 4$ ,  $A = -4/7$
57. (a)  $p \approx 10$  lb/in<sup>2</sup>,  $dp/dh \approx -2$  lb/in<sup>2</sup>/mi  
 (b)  $\frac{dp}{dt} = \frac{dp}{dh} \frac{dh}{dt} \approx (-2)(0.3) = -0.6$  lb/in<sup>2</sup>/s
58. (a)  $F = \frac{45}{\cos \theta + 0.3 \sin \theta}$ ,  $\frac{dF}{d\theta} = -\frac{45(-\sin \theta + 0.3 \cos \theta)}{(\cos \theta + 0.3 \sin \theta)^2}$ ;  
 if  $\theta = 30^\circ$ , then  $dF/d\theta \approx 10.5$  lb/rad  $\approx 0.18$  lb/deg  
 (b)  $\frac{dF}{dt} = \frac{dF}{d\theta} \frac{d\theta}{dt} \approx (0.18)(-0.5) = -0.09$  lb/s
59. With  $u = \sin x$ ,  $\frac{d}{dx}(|\sin x|) = \frac{d}{dx}(|u|) = \frac{d}{du}(|u|) \frac{du}{dx} = \frac{d}{du}(|u|) \cos x = \begin{cases} \cos x, & u > 0 \\ -\cos x, & u < 0 \end{cases}$   
 $= \begin{cases} \cos x, & \sin x > 0 \\ -\cos x, & \sin x < 0 \end{cases} = \begin{cases} \cos x, & 0 < x < \pi \\ -\cos x, & -\pi < x < 0 \end{cases}$
60.  $\frac{d}{dx}(\cos x) = \frac{d}{dx}[\sin(\pi/2 - x)] = -\cos(\pi/2 - x) = -\sin x$
61. (a) for  $x \neq 0$ ,  $f'(x) = x \left( \cos \frac{1}{x} \right) \left( -\frac{1}{x^2} \right) + \sin \frac{1}{x} = -\frac{1}{x} \cos \frac{1}{x} + \sin \frac{1}{x}$   
 (b)  $\lim_{x \rightarrow 0} x \sin \frac{1}{x} = 0 = f(0)$   
 (c)  $\lim_{h \rightarrow 0} \frac{f(0+h) - f(0)}{h} = \lim_{h \rightarrow 0} \frac{h \sin \frac{1}{h}}{h} = \lim_{h \rightarrow 0} \sin \frac{1}{h}$ , which does not exist
62. (a)  $f'(x) = x^2 \left( \cos \frac{1}{x} \right) \left( -\frac{1}{x^2} \right) + 2x \sin \frac{1}{x} = -\cos \frac{1}{x} + 2x \sin \frac{1}{x}$ ,  $x \neq 0$   
 (b)  $\lim_{x \rightarrow 0} x^2 \sin \frac{1}{x} = 0 = f(0)$



(c)  $f'(0) = \lim_{h \rightarrow 0} \frac{f(0+h) - f(0)}{h} = \lim_{h \rightarrow 0} \frac{h^2 \sin \frac{1}{h}}{h} = \lim_{h \rightarrow 0} h \sin \frac{1}{h} = 0$

(d)  $\lim_{x \rightarrow 0} f'(x)$  does not exist because  $\cos \frac{1}{x}$  oscillates between 1 and  $-1$

63. (a)  $g'(x) = 3[f(x)]^2 f'(x)$ ,  $g'(2) = 3[f(2)]^2 f'(2) = 3(1)^2(7) = 21$

(b)  $h'(x) = f'(x^3)(3x^2)$ ,  $h'(2) = f'(8)(12) = (-3)(12) = -36$

64. (a)  $F'(x) = f'(g(x))g'(x)$ ,  $F'(-1) = f'(g(-1))g'(-1) = f'(2)(-3) = (4)(-3) = -12$

(b)  $G'(x) = g'(f(x))f'(x)$ ,  $G'(-1) = g'(f(-1))f'(-1) = g'(2)(3) = (-5)(3) = -15$

65.  $(f \circ g)'(x) = f'(g(x))g'(x)$  so  $(f \circ g)'(0) = f'(g(0))g'(0) = f'(0)(3) = (2)(3) = 6$

66.  $F'(x) = f'(g(x))g'(x) = \sqrt{3(x^2-1)+4}(2x) = 2x\sqrt{3x^2+1}$

67.  $F'(x) = f'(g(x))g'(x) = f'(\sqrt{3x-1}) \frac{3}{2\sqrt{3x-1}} = \frac{\sqrt{3x-1}}{(3x-1)+1} \frac{3}{2\sqrt{3x-1}} = \frac{1}{2x}$

68.  $\frac{d}{dx}[f(x^2)] = f'(x^2)(2x)$ , thus  $f'(x^2)(2x) = x^2$  so  $f'(x^2) = x/2$  if  $x \neq 0$

69.  $\frac{d}{dx}[f(3x)] = f'(3x) \frac{d}{dx}(3x) = 3f'(3x) = 6x$ , so  $f'(3x) = 2x$ . Let  $u = 3x$  to get  $f'(u) = \frac{2}{3}u$ ;

$\frac{d}{dx}[f(x)] = f'(x) = \frac{2}{3}x$ .

70. (a) If  $f(-x) = f(x)$ , then  $\frac{d}{dx}[f(-x)] = \frac{d}{dx}[f(x)]$ ,  $f'(-x)(-1) = f'(x)$ ,  $f'(-x) = -f'(x)$  so  $f'$  is odd.

(b) If  $f(-x) = -f(x)$ , then  $\frac{d}{dx}[f(-x)] = -\frac{d}{dx}[f(x)]$ ,  $f'(-x)(-1) = -f'(x)$ ,  $f'(-x) = f'(x)$  so  $f'$  is even.

71. For an even function, the graph is symmetric about the  $y$ -axis; the slope of the tangent line at  $(a, f(a))$  is the negative of the slope of the tangent line at  $(-a, f(-a))$ . For an odd function, the graph is symmetric about the origin; the slope of the tangent line at  $(a, f(a))$  is the same as the slope of the tangent line at  $(-a, f(-a))$ .

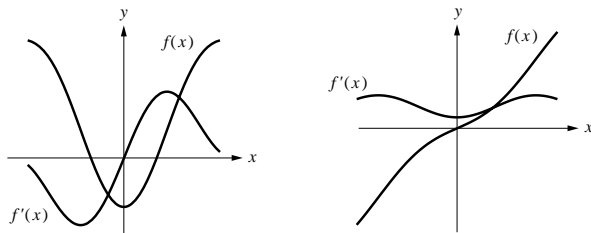

72.  $\frac{dy}{dx} = \frac{dy}{du} \frac{du}{dv} \frac{dv}{dw} \frac{dw}{dx}$

73.  $\frac{d}{dx}[f(g(h(x)))] = \frac{d}{dx}[f(g(u))]$ ,  $u = h(x)$   
 $= \frac{d}{du}[f(g(u))] \frac{du}{dx} = f'(g(u))g'(u) \frac{du}{dx} = f'(g(h(x)))g'(h(x))h'(x)$

## EXERCISE SET 3.6

1. (a)  $dy = f'(x)dx = 2x dx = 4(1) = 4$  and  
 $\Delta y = (x + \Delta x)^2 - x^2 = (2 + 1)^2 - 2^2 = 5$

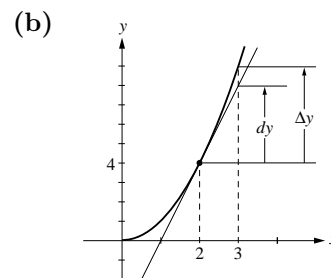

2. (a)  $dy = 3x^2 dx = 3(1)^2(1) = 3$  and  
 $\Delta y = (x + \Delta x)^3 - x^3 = (1 + 1)^3 - 1^3 = 7$

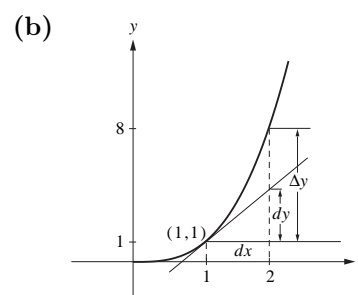

3. (a)  $dy = (-1/x^2)dx = (-1)(-0.5) = 0.5$  and  
 $\Delta y = 1/(x + \Delta x) - 1/x = 1/(1 - 0.5) - 1/1 = 2 - 1 = 1$

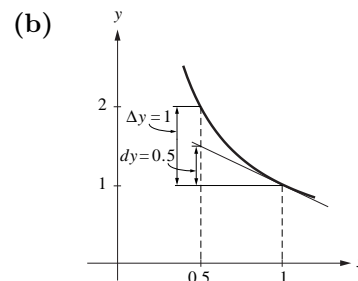

4. (a)  $dy = (1/2\sqrt{x})dx = (1/(2 \cdot 3))(-1) = -1/6 \approx -0.167$  and  
 $\Delta y = \sqrt{x + \Delta x} - \sqrt{x} = \sqrt{9 + (-1)} - \sqrt{9} = \sqrt{8} - 3 \approx -0.172$

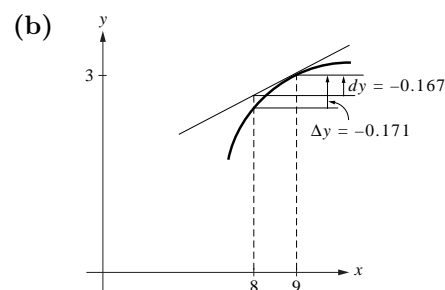

5.  $dy = 3x^2 dx$ ;

$$\Delta y = (x + \Delta x)^3 - x^3 = x^3 + 3x^2\Delta x + 3x(\Delta x)^2 + (\Delta x)^3 - x^3 = 3x^2\Delta x + 3x(\Delta x)^2 + (\Delta x)^3$$

6.  $dy = 8dx$ ;  $\Delta y = [8(x + \Delta x) - 4] - [8x - 4] = 8\Delta x$

7.  $dy = (2x - 2)dx$ ;

$$\begin{aligned} \Delta y &= [(x + \Delta x)^2 - 2(x + \Delta x) + 1] - [x^2 - 2x + 1] \\ &= x^2 + 2x\Delta x + (\Delta x)^2 - 2x - 2\Delta x + 1 - x^2 + 2x - 1 = 2x\Delta x + (\Delta x)^2 - 2\Delta x \end{aligned}$$

8.  $dy = \cos x dx$ ;  $\Delta y = \sin(x + \Delta x) - \sin x$

9. (a)  $dy = (12x^2 - 14x)dx$

(b)  $dy = x d(\cos x) + \cos x dx = x(-\sin x)dx + \cos x dx = (-x \sin x + \cos x)dx$

10. (a)  $dy = (-1/x^2)dx$

(b)  $dy = 5 \sec^2 x dx$

11. (a)  $dy = \left( \sqrt{1-x} - \frac{x}{2\sqrt{1-x}} \right) dx = \frac{2-3x}{2\sqrt{1-x}} dx$

(b)  $dy = -17(1+x)^{-18} dx$

12. (a)  $dy = \frac{(x^3-1)d(0) - (1)d(x^3-1)}{(x^3-1)^2} = \frac{(x^3-1)(0) - (1)3x^2 dx}{(x^3-1)^2} = -\frac{3x^2}{(x^3-1)^2} dx$

(b)  $dy = \frac{(2-x)(-3x^2)dx - (1-x^3)(-1)dx}{(2-x)^2} = \frac{2x^3 - 6x^2 + 1}{(2-x)^2} dx$

13. (a)  $f(x) \approx f(1) + f'(1)(x-1) = 1 + 3(x-1)$       (b)  $f(1 + \Delta x) \approx f(1) + f'(1)\Delta x = 1 + 3\Delta x$

(c) From part (a),  $(1.02)^3 \approx 1 + 3(0.02) = 1.06$ . From part (b),  $(1.02)^3 \approx 1 + 3(0.02) = 1.06$ .

14. (a)  $f(x) \approx f(2) + f'(2)(x-2) = 1/2 + (-1/2^2)(x-2) = (1/2) - (1/4)(x-2)$

(b)  $f(2 + \Delta x) \approx f(2) + f'(2)\Delta x = 1/2 - (1/4)\Delta x$

(c) From part (a),  $1/2.05 \approx 0.5 - 0.25(0.05) = 0.4875$ , and from part (b),  $1/2.05 \approx 0.5 - 0.25(0.05) = 0.4875$ .

15. (a)  $f(x) \approx f(x_0) + f'(x_0)(x-x_0) = 1 + (1/(2\sqrt{1}))(x-0) = 1 + (1/2)x$ , so with  $x_0 = 0$  and  $x = -0.1$ , we have  $\sqrt{0.9} = f(-0.1) \approx 1 + (1/2)(-0.1) = 1 - 0.05 = 0.95$ . With  $x = 0.1$  we have  $\sqrt{1.1} = f(0.1) \approx 1 + (1/2)(0.1) = 1.05$ .

(b)

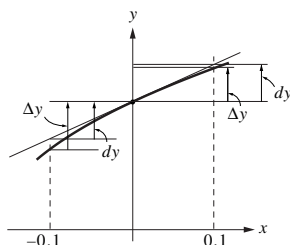

16. (a)  $f(x) \approx f(x_0) + f'(x_0)(x-x_0) = 1/2 - [1/(2 \cdot 4^{3/2})](x-4) = 1/2 - (x-4)/16$ , so with  $x_0 = 4$  and  $x = 3.9$  we have  $1/\sqrt{3.9} = f(3.9) \approx 0.5 - (-0.1)/16 = 0.50625$ . If  $x_0 = 4$  and  $x = 4.1$  then  $1/\sqrt{4.1} = f(4.1) \approx 0.5 - (0.1)/16 = 0.49375$

(b)

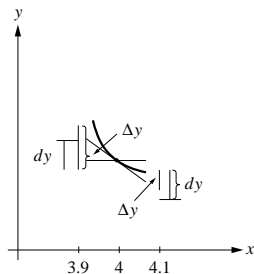

17.  $f(x) = (1+x)^{15}$  and  $x_0 = 0$ . Thus  $(1+x)^{15} \approx f(x_0) + f'(x_0)(x-x_0) = 1 + 15(1)^{14}(x-0) = 1 + 15x$ .

18.  $f(x) = \frac{1}{\sqrt{1-x}}$  and  $x_0 = 0$ , so  $\frac{1}{\sqrt{1-x}} \approx f(x_0) + f'(x_0)(x-x_0) = 1 + \frac{1}{2(1-0)^{3/2}}(x-0) = 1 + x/2$

19.  $\tan x \approx \tan(0) + \sec^2(0)(x - 0) = x$       20.  $\frac{1}{1+x} \approx 1 + \frac{-1}{(1+0)^2}(x-0) = 1-x$
21.  $x^4 \approx (1)^4 + 4(1)^3(x-1)$ . Set  $\Delta x = x - 1$ ; then  $x = \Delta + 1$  and  $(1 + \Delta x)^4 = 1 + 4\Delta x$ .
22.  $\sqrt{x} \approx \sqrt{1} + \frac{1}{2\sqrt{1}}(x-1)$ , and  $x = 1 + \Delta x$ , so  $\sqrt{1 + \Delta x} \approx 1 + \Delta x/2$
23.  $\frac{1}{2+x} = \frac{1}{2+1} - \frac{1}{(2+1)^2}(x-1)$ , and  $2+x = 3 + \Delta x$ , so  $\frac{1}{3+\Delta x} = \frac{1}{3} - \frac{1}{9}\Delta x$
24.  $(4+x)^3 = (4+1)^3 + 3(4+1)^2(x-1)$  so, with  $4+x = 5 + \Delta x$  we get  $(5 + \Delta x)^3 = 125 + 75\Delta x$
25. (a) The local linear approximation  $\sin x \approx x$  gives  $\sin 1^\circ = \sin(\pi/180) \approx \pi/180 = 0.0174533$  and a calculator gives  $\sin 1^\circ = 0.0174524$ . The relative error  $|\sin(\pi/180) - (\pi/180)|/(\sin \pi/180) = 0.000051$  is very small, so for such a small value of  $x$  the approximation is very good.
- (b) Use  $x_0 = 45^\circ$  (this assumes you know, or can approximate,  $\sqrt{2}/2$ ).
- (c)  $44^\circ = \frac{44\pi}{180}$  radians, and  $45^\circ = \frac{45\pi}{180} = \frac{\pi}{4}$  radians. With  $x = \frac{44\pi}{180}$  and  $x_0 = \frac{\pi}{4}$  we obtain  $\sin 44^\circ = \sin \frac{44\pi}{180} \approx \sin \frac{\pi}{4} + \left(\cos \frac{\pi}{4}\right) \left(\frac{44\pi}{180} - \frac{\pi}{4}\right) = \frac{\sqrt{2}}{2} + \frac{\sqrt{2}}{2} \left(\frac{-\pi}{180}\right) = 0.694765$ . With a calculator,  $\sin 44^\circ = 0.694658$ .
26. (a)  $\tan x \approx \tan 0 + \sec^2 0(x-0) = x$ , so  $\tan 2^\circ = \tan(2\pi/180) \approx 2\pi/180 = 0.034907$ , and with a calculator  $\tan 2^\circ = 0.034921$
- (b) use  $x_0 = \pi/3$  because we know  $\tan 60^\circ = \tan(\pi/3) = \sqrt{3}$
- (c) with  $x_0 = \frac{\pi}{3} = \frac{60\pi}{180}$  and  $x = \frac{61\pi}{180}$  we have  $\tan 61^\circ = \tan \frac{61\pi}{180} \approx \tan \frac{\pi}{3} + \left(\sec^2 \frac{\pi}{3}\right) \left(\frac{61\pi}{180} - \frac{\pi}{3}\right) = \sqrt{3} + 4 \frac{\pi}{180} = 1.8019$ , and with a calculator  $\tan 61^\circ = 1.8040$
27.  $f(x) = x^4$ ,  $f'(x) = 4x^3$ ,  $x_0 = 3$ ,  $\Delta x = 0.02$ ;  $(3.02)^4 \approx 3^4 + (108)(0.02) = 81 + 2.16 = 83.16$
28.  $f(x) = x^3$ ,  $f'(x) = 3x^2$ ,  $x_0 = 2$ ,  $\Delta x = -0.03$ ;  $(1.97)^3 \approx 2^3 + (12)(-0.03) = 8 - 0.36 = 7.64$
29.  $f(x) = \sqrt{x}$ ,  $f'(x) = \frac{1}{2\sqrt{x}}$ ,  $x_0 = 64$ ,  $\Delta x = 1$ ;  $\sqrt{65} \approx \sqrt{64} + \frac{1}{16}(1) = 8 + \frac{1}{16} = 8.0625$
30.  $f(x) = \sqrt{x}$ ,  $f'(x) = \frac{1}{2\sqrt{x}}$ ,  $x_0 = 25$ ,  $\Delta x = -1$ ;  $\sqrt{24} \approx \sqrt{25} + \frac{1}{10}(-1) = 5 - 0.1 = 4.9$
31.  $f(x) = \sqrt{x}$ ,  $f'(x) = \frac{1}{2\sqrt{x}}$ ,  $x_0 = 81$ ,  $\Delta x = -0.1$ ;  $\sqrt{80.9} \approx \sqrt{81} + \frac{1}{18}(-0.1) \approx 8.9944$
32.  $f(x) = \sqrt{x}$ ,  $f'(x) = \frac{1}{2\sqrt{x}}$ ,  $x_0 = 36$ ,  $\Delta x = 0.03$ ;  $\sqrt{36.03} \approx \sqrt{36} + \frac{1}{12}(0.03) = 6 + 0.0025 = 6.0025$
33.  $f(x) = \sin x$ ,  $f'(x) = \cos x$ ,  $x_0 = 0$ ,  $\Delta x = 0.1$ ;  $\sin 0.1 \approx \sin 0 + (\cos 0)(0.1) = 0.1$
34.  $f(x) = \tan x$ ,  $f'(x) = \sec^2 x$ ,  $x_0 = 0$ ,  $\Delta x = 0.2$ ;  $\tan 0.2 \approx \tan 0 + (\sec^2 0)(0.2) = 0.2$
35.  $f(x) = \cos x$ ,  $f'(x) = -\sin x$ ,  $x_0 = \pi/6$ ,  $\Delta x = \pi/180$ ;  
 $\cos 31^\circ \approx \cos 30^\circ + \left(-\frac{1}{2}\right) \left(\frac{\pi}{180}\right) = \frac{\sqrt{3}}{2} - \frac{\pi}{360} \approx 0.8573$

36. (a) Let  $f(x) = (1+x)^k$  and  $x_0 = 0$ . Then  $(1+x)^k \approx 1^k + k(1)^{k-1}(x-0) = 1+kx$ . Set  $k = 37$  and  $x = 0.001$  to obtain  $(1.001)^{37} \approx 1.037$ .  
 (b) With a calculator  $(1.001)^{37} = 1.03767$ .  
 (c) The approximation is  $(1.1)^{37} \approx 1 + 37(0.1) = 4.7$ , and the calculator value is 34.004. The error is due to the relative largeness of  $f'(1)\Delta x = 37(0.1) = 3.7$ .

37.  $f(x) = \sqrt{x+3}$  and  $x_0 = 0$ , so  
 $\sqrt{x+3} \approx \sqrt{3} + \frac{1}{2\sqrt{3}}(x-0) = \sqrt{3} + \frac{1}{2\sqrt{3}}x$ , and  
 $\left| f(x) - \left( \sqrt{3} + \frac{1}{2\sqrt{3}}x \right) \right| < 0.1$  if  $|x| < 1.692$ .

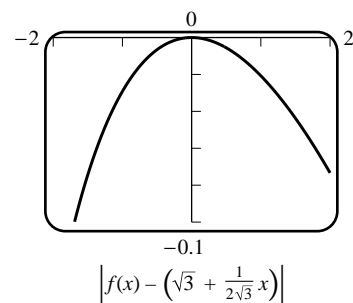

38.  $f(x) = \frac{1}{\sqrt{9-x}}$  so  $\frac{1}{\sqrt{9-x}} \approx \frac{1}{\sqrt{9}} + \frac{1}{2(9-0)^{3/2}}(x-0) = \frac{1}{3} + \frac{1}{54}x$ ,  
 and  $\left| f(x) - \left( \frac{1}{3} + \frac{1}{54}x \right) \right| < 0.1$  if  $|x| < 5.5114$

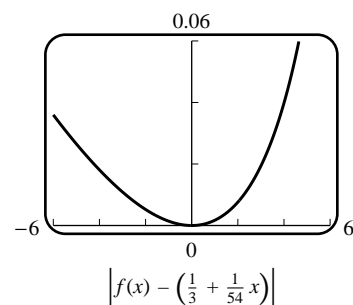

39.  $\tan x \approx \tan 0 + (\sec^2 0)(x-0) = x$ , and  $|\tan x - x| < 0.1$  if  $|x| < 0.6316$

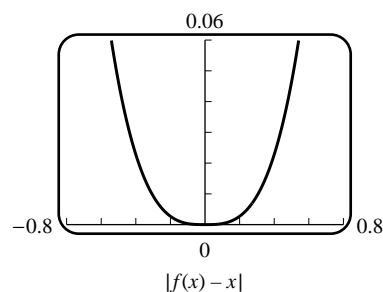

40.  $\frac{1}{(1+2x)^5} \approx \frac{1}{(1+2 \cdot 0)^5} + \frac{-5(2)}{(1+2 \cdot 0)^6}(x-0) = 1 - 10x$ , and  
 $|f(x) - (1 - 10x)| < 0.1$  if  $|x| < 0.0372$

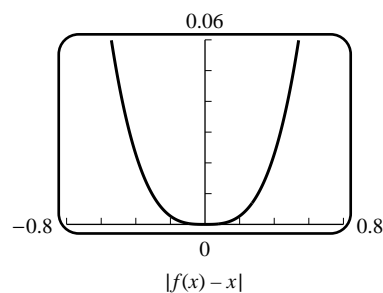

41.  $dy = \frac{3}{2\sqrt{3x-2}}dx$ ,  $x = 2$ ,  $dx = 0.03$ ;  $\Delta y \approx dy = \frac{3}{4}(0.03) = 0.0225$

42.  $dy = \frac{x}{\sqrt{x^2+8}}dx$ ,  $x = 1$ ,  $dx = -0.03$ ;  $\Delta y \approx dy = (1/3)(-0.03) = -0.01$

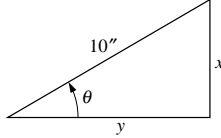
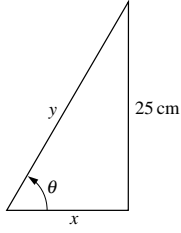
43.  $dy = \frac{1-x^2}{(x^2+1)^2} dx$ ,  $x = 2$ ,  $dx = -0.04$ ;  $\Delta y \approx dy = \left(-\frac{3}{25}\right)(-0.04) = 0.0048$
44.  $dy = \left(\frac{4x}{\sqrt{8x+1}} + \sqrt{8x+1}\right) dx$ ,  $x = 3$ ,  $dx = 0.05$ ;  $\Delta y \approx dy = (37/5)(0.05) = 0.37$
45. (a)  $A = x^2$  where  $x$  is the length of a side;  $dA = 2x dx = 2(10)(\pm 0.1) = \pm 2 \text{ ft}^2$ .  
 (b) relative error in  $x$  is  $\approx \frac{dx}{x} = \frac{\pm 0.1}{10} = \pm 0.01$  so percentage error in  $x$  is  $\approx \pm 1\%$ ; relative error in  $A$  is  $\approx \frac{dA}{A} = \frac{2x dx}{x^2} = 2\frac{dx}{x} = 2(\pm 0.01) = \pm 0.02$  so percentage error in  $A$  is  $\approx \pm 2\%$
46. (a)  $V = x^3$  where  $x$  is the length of a side;  $dV = 3x^2 dx = 3(25)^2(\pm 1) = \pm 1875 \text{ cm}^3$ .  
 (b) relative error in  $x$  is  $\approx \frac{dx}{x} = \frac{\pm 1}{25} = \pm 0.04$  so percentage error in  $x$  is  $\approx \pm 4\%$ ; relative error in  $V$  is  $\approx \frac{dV}{V} = \frac{3x^2 dx}{x^3} = 3\frac{dx}{x} = 3(\pm 0.04) = \pm 0.12$  so percentage error in  $V$  is  $\approx \pm 12\%$
47. (a)  $x = 10 \sin \theta$ ,  $y = 10 \cos \theta$  (see figure),  
 $dx = 10 \cos \theta d\theta = 10 \left(\cos \frac{\pi}{6}\right) \left(\pm \frac{\pi}{180}\right) = 10 \left(\frac{\sqrt{3}}{2}\right) \left(\pm \frac{\pi}{180}\right)$   
 $\approx \pm 0.151 \text{ in}$ ,  
 $dy = -10(\sin \theta)d\theta = -10 \left(\sin \frac{\pi}{6}\right) \left(\pm \frac{\pi}{180}\right) = -10 \left(\frac{1}{2}\right) \left(\pm \frac{\pi}{180}\right)$   
 $\approx \pm 0.087 \text{ in}$
- 
- (b) relative error in  $x$  is  $\approx \frac{dx}{x} = (\cot \theta)d\theta = \left(\cot \frac{\pi}{6}\right) \left(\pm \frac{\pi}{180}\right) = \sqrt{3} \left(\pm \frac{\pi}{180}\right) \approx \pm 0.030$   
 so percentage error in  $x$  is  $\approx \pm 3.0\%$ ;  
 relative error in  $y$  is  $\approx \frac{dy}{y} = -\tan \theta d\theta = -\left(\tan \frac{\pi}{6}\right) \left(\pm \frac{\pi}{180}\right) = -\frac{1}{\sqrt{3}} \left(\pm \frac{\pi}{180}\right) \approx \pm 0.010$   
 so percentage error in  $y$  is  $\approx \pm 1.0\%$
48. (a)  $x = 25 \cot \theta$ ,  $y = 25 \csc \theta$  (see figure);  
 $dx = -25 \csc^2 \theta d\theta = -25 \left(\csc^2 \frac{\pi}{3}\right) \left(\pm \frac{\pi}{360}\right)$   
 $= -25 \left(\frac{4}{3}\right) \left(\pm \frac{\pi}{360}\right) \approx \pm 0.291 \text{ cm}$ ,  
 $dy = -25 \csc \theta \cot \theta d\theta = -25 \left(\csc \frac{\pi}{3}\right) \left(\cot \frac{\pi}{3}\right) \left(\pm \frac{\pi}{360}\right)$   
 $= -25 \left(\frac{2}{\sqrt{3}}\right) \left(\frac{1}{\sqrt{3}}\right) \left(\pm \frac{\pi}{360}\right) \approx \pm 0.145 \text{ cm}$
- 
- (b) relative error in  $x$  is  $\approx \frac{dx}{x} = -\frac{\csc^2 \theta}{\cot \theta} d\theta = -\frac{4/3}{1/\sqrt{3}} \left(\pm \frac{\pi}{360}\right) \approx \pm 0.020$  so percentage error in  $x$  is  $\approx \pm 2.0\%$ ; relative error in  $y$  is  $\approx \frac{dy}{y} = -\cot \theta d\theta = -\frac{1}{\sqrt{3}} \left(\pm \frac{\pi}{360}\right) \approx \pm 0.005$   
 so percentage error in  $y$  is  $\approx \pm 0.5\%$
49.  $\frac{dR}{R} = \frac{(-2k/r^3)dr}{(k/r^2)} = -2\frac{dr}{r}$ , but  $\frac{dr}{r} \approx \pm 0.05$  so  $\frac{dR}{R} \approx -2(\pm 0.05) = \pm 0.10$ ; percentage error in  $R$  is  $\approx \pm 10\%$
50.  $h = 12 \sin \theta$  thus  $dh = 12 \cos \theta d\theta$  so, with  $\theta = 60^\circ = \pi/3$  radians and  $d\theta = -1^\circ = -\pi/180$  radians,  
 $dh = 12 \cos(\pi/3)(-\pi/180) = -\pi/30 \approx -0.105 \text{ ft}$

51.  $A = \frac{1}{4}(4)^2 \sin 2\theta = 4 \sin 2\theta$  thus  $dA = 8 \cos 2\theta d\theta$  so, with  $\theta = 30^\circ = \pi/6$  radians and  $d\theta = \pm 15' = \pm 1/4^\circ = \pm \pi/720$  radians,  $dA = 8 \cos(\pi/3)(\pm \pi/720) = \pm \pi/180 \approx \pm 0.017 \text{ cm}^2$
52.  $A = x^2$  where  $x$  is the length of a side;  $\frac{dA}{A} = \frac{2x dx}{x^2} = 2 \frac{dx}{x}$ , but  $\frac{dx}{x} \approx \pm 0.01$  so  $\frac{dA}{A} \approx 2(\pm 0.01) = \pm 0.02$ ; percentage error in  $A$  is  $\approx \pm 2\%$
53.  $V = x^3$  where  $x$  is the length of a side;  $\frac{dV}{V} = \frac{3x^2 dx}{x^3} = 3 \frac{dx}{x}$ , but  $\frac{dx}{x} \approx \pm 0.02$  so  $\frac{dV}{V} \approx 3(\pm 0.02) = \pm 0.06$ ; percentage error in  $V$  is  $\approx \pm 6\%$ .
54.  $\frac{dV}{V} = \frac{4\pi r^2 dr}{4\pi r^3/3} = 3 \frac{dr}{r}$ , but  $\frac{dV}{V} \approx \pm 0.03$  so  $3 \frac{dr}{r} \approx \pm 0.03$ ,  $\frac{dr}{r} \approx \pm 0.01$ ; maximum permissible percentage error in  $r$  is  $\approx \pm 1\%$ .
55.  $A = \frac{1}{4}\pi D^2$  where  $D$  is the diameter of the circle;  $\frac{dA}{A} = \frac{(\pi D/2)dD}{\pi D^2/4} = 2 \frac{dD}{D}$ , but  $\frac{dA}{A} \approx \pm 0.01$  so  $2 \frac{dD}{D} \approx \pm 0.01$ ,  $\frac{dD}{D} \approx \pm 0.005$ ; maximum permissible percentage error in  $D$  is  $\approx \pm 0.5\%$ .
56.  $V = x^3$  where  $x$  is the length of a side; approximate  $\Delta V$  by  $dV$  if  $x = 1$  and  $dx = \Delta x = 0.02$ ,  $dV = 3x^2 dx = 3(1)^2(0.02) = 0.06 \text{ in}^3$ .
57.  $V = \text{volume of cylindrical rod} = \pi r^2 h = \pi r^2(15) = 15\pi r^2$ ; approximate  $\Delta V$  by  $dV$  if  $r = 2.5$  and  $dr = \Delta r = 0.001$ .  $dV = 30\pi r dr = 30\pi(2.5)(0.001) \approx 0.236 \text{ cm}^3$ .
58.  $P = \frac{2\pi}{\sqrt{g}}\sqrt{L}$ ,  $dP = \frac{2\pi}{\sqrt{g}} \frac{1}{2\sqrt{L}} dL = \frac{\pi}{\sqrt{g}\sqrt{L}} dL$ ,  $\frac{dP}{P} = \frac{1}{2} \frac{dL}{L}$  so the relative error in  $P \approx \frac{1}{2}$  the relative error in  $L$ . Thus the percentage error in  $P$  is  $\approx \frac{1}{2}$  the percentage error in  $L$ .
59. (a)  $\alpha = \Delta L/(L\Delta T) = 0.006/(40 \times 10) = 1.5 \times 10^{-5}/^\circ\text{C}$   
 (b)  $\Delta L = 2.3 \times 10^{-5}(180)(25) \approx 0.1 \text{ cm}$ , so the pole is about 180.1 cm long.
60.  $\Delta V = 7.5 \times 10^{-4}(4000)(-20) = -60$  gallons; the truck delivers  $4000 - 60 = 3940$  gallons.

## CHAPTER 3 SUPPLEMENTARY EXERCISES

4. (a) 
$$\frac{dy}{dx} = \lim_{h \rightarrow 0} \frac{\sqrt{9-4(x+h)} - \sqrt{9-4x}}{h} = \lim_{h \rightarrow 0} \frac{(9-4(x+h)) - (9-4x)}{h(\sqrt{9-4(x+h)} + \sqrt{9-4x})}$$

$$= \lim_{h \rightarrow 0} \frac{-4h}{h(\sqrt{9-4(x+h)} + \sqrt{9-4x})} = \frac{-4}{2\sqrt{9-4x}} = \frac{-2}{\sqrt{9-4x}}$$
- (b) 
$$\frac{dy}{dx} = \lim_{h \rightarrow 0} \frac{\frac{x+h}{x+h+1} - \frac{x}{x+1}}{h} = \lim_{h \rightarrow 0} \frac{(x+h)(x+1) - x(x+h+1)}{h(x+h+1)(x+1)}$$

$$= \lim_{h \rightarrow 0} \frac{1}{h(x+h+1)(x+1)} = \frac{1}{(x+1)^2}$$

5. Set  $f'(x) = 0$ :  $f'(x) = 6(2)(2x+7)^5(x-2)^5 + 5(2x+7)^6(x-2)^4 = 0$ , so  $2x+7 = 0$  or  $x-2 = 0$  or, factoring out  $(2x+7)^5(x-2)^4$ ,  $12(x-2) + 5(2x+7) = 0$ . This reduces to  $x = -7/2$ ,  $x = 2$ , or  $22x+11 = 0$ , so the tangent line is horizontal at  $x = -7/2, 2, -1/2$ .
6. Set  $f'(x) = 0$ :  $f'(x) = \frac{4(x^2+2x)(x-3)^3 - (2x+2)(x-3)^4}{(x^2+2x)^2}$ , and a fraction can equal zero only if its numerator equals zero. So either  $x-3 = 0$  or, after factoring out  $(x-3)^3$ ,  $4(x^2+2x) - (2x+2)(x-3) = 0$ ,  $2x^2 + 12x + 6 = 0$ , whose roots are (by the quadratic formula)  $x = \frac{-6 \pm \sqrt{36 - 4 \cdot 3}}{2} = -3 \pm \sqrt{6}$ . So the tangent line is horizontal at  $x = 3, -3 \pm \sqrt{6}$ .
7. Set  $f'(x) = \frac{3}{2\sqrt{3x+1}}(x-1)^2 + 2\sqrt{3x+1}(x-1) = 0$ . If  $x = 1$  then  $y' = 0$ . If  $x \neq 1$  then divide out  $x-1$  and multiply through by  $2\sqrt{3x+1}$  (at points where  $f$  is differentiable we must have  $\sqrt{3x+1} \neq 0$ ) to obtain  $3(x-1) + 4(3x+1) = 0$ , or  $15x+1 = 0$ . So the tangent line is horizontal at  $x = 1, -1/15$ .
8.  $f'(x) = 3 \left( \frac{3x+1}{x^2} \right)^2 \frac{d}{dx} \frac{3x+1}{x^2} = 3 \left( \frac{3x+1}{x^2} \right)^2 \frac{x^2(3) - (3x+1)(2x)}{x^4} = -3 \left( \frac{3x+1}{x^2} \right)^2 \frac{3x^2+2x}{x^4} = 0$ . If  $f'(x) = 0$  then  $(3x+1)^2(3x^2+2x) = 0$ . The tangent line is horizontal at  $x = -1/3, -2/3$  ( $x = 0$  is ruled out from the definition of  $f$ ).
9. (a)  $x = -2, -1, 1, 3$  (b)  $(-\infty, -2), (-1, 1), (3, +\infty)$  (c)  $(-2, -1), (1, 3)$   
 (d)  $g''(x) = f''(x) \sin x + 2f'(x) \cos x - f(x) \sin x$ ;  $g''(0) = 2f'(0) \cos 0 = 2(2)(1) = 4$
10. (a)  $f'(1)g(1) + f(1)g'(1) = 3(-2) + 1(-1) = -7$   
 (b)  $\frac{g(1)f'(1) - f(1)g'(1)}{g(1)^2} = \frac{-2(3) - 1(-1)}{(-2)^2} = -\frac{5}{4}$   
 (c)  $\frac{1}{2\sqrt{f(1)}}f'(1) = \frac{1}{2\sqrt{1}}3 = \frac{3}{2}$  (d) 0 (because  $f(1)g'(1)$  is constant)
11. The equations of such a line has the form  $y = mx$ . The points  $(x_0, y_0)$  which lie on both the line and the parabola and for which the slopes of both curves are equal satisfy  $y_0 = mx_0 = x_0^3 - 9x_0^2 - 16x_0$ , so that  $m = x_0^2 - 9x_0 - 16$ . By differentiating, the slope is also given by  $m = 3x_0^2 - 18x_0 - 16$ . Equating, we have  $x_0^2 - 9x_0 - 16 = 3x_0^2 - 18x_0 - 16$ , or  $2x_0^2 - 9x_0 = 0$ . The root  $x_0 = 0$  corresponds to  $m = -16, y_0 = 0$  and the root  $x_0 = 9/2$  corresponds to  $m = -145/4, y_0 = -1305/8$ . So the line  $y = -16x$  is tangent to the curve at the point  $(0, 0)$ , and the line  $y = -145x/4$  is tangent to the curve at the point  $(9/2, -1305/8)$ .
12. The slope of the line  $x + 4y = 10$  is  $m_1 = -1/4$ , so we set the negative reciprocal  
 $4 = m_2 = \frac{d}{dx}(2x^3 - x^2) = 6x^2 - 2x$  and obtain  $6x^2 - 2x - 4 = 0$  with roots  $x = \frac{1 \pm \sqrt{1+24}}{6} = 1, -2/3$ .
13. The line  $y - x = 2$  has slope  $m_1 = 1$  so we set  $m_2 = \frac{d}{dx}(3x - \tan x) = 3 - \sec^2 x = 1$ , or  $\sec^2 x = 2$ ,  $\sec x = \pm\sqrt{2}$  so  $x = n\pi \pm \pi/4$  where  $n = 0, \pm 1, \pm 2, \dots$
14.  $f(x)$  is continuous and differentiable at any  $x \neq 1$ , so we consider  $x = 1$ .
- (a)  $\lim_{x \rightarrow 1^-} (x^2 - 1) = \lim_{x \rightarrow 1^+} k(x - 1) = 0 = f(1)$ , so any value of  $k$  gives continuity at  $x = 1$ .
- (b)  $\lim_{x \rightarrow 1^-} f'(x) = \lim_{x \rightarrow 1^-} 2x = 2$ , and  $\lim_{x \rightarrow 1^+} f'(x) = \lim_{x \rightarrow 1^+} k = k$ , so only if  $k = 2$  is  $f(x)$  differentiable at  $x = 1$ .



15. The slope of the tangent line is the derivative

$$y' = 2x \Big|_{x=\frac{1}{2}(a+b)} = a + b. \text{ The slope of the secant is}$$

$$\frac{a^2 - b^2}{a - b} = a + b, \text{ so they are equal.}$$

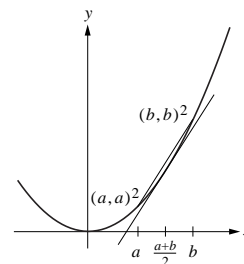

16. To average 60 mi/h one would have to complete the trip in two hours. At 50 mi/h, 100 miles are completed after two hours. Thus time is up, and the speed for the remaining 20 miles would have to be infinite.

17. (a)  $\Delta x = 1.5 - 2 = -0.5$ ;  $dy = \frac{-1}{(x-1)^2} \Delta x = \frac{-1}{(2-1)^2}(-0.5) = 0.5$ ; and

$$\Delta y = \frac{1}{(1.5-1)} - \frac{1}{(2-1)} = 2 - 1 = 1.$$

(b)  $\Delta x = 0 - (-\pi/4) = \pi/4$ ;  $dy = (\sec^2(-\pi/4))(\pi/4) = \pi/2$ ; and  $\Delta y = \tan 0 - \tan(-\pi/4) = 1$ .

(c)  $\Delta x = 3 - 0 = 3$ ;  $dy = \frac{-x}{\sqrt{25-x^2}} = \frac{-0}{\sqrt{25-(0)^2}}(3) = 0$ ; and

$$\Delta y = \sqrt{25-3^2} - \sqrt{25-0^2} = 4 - 5 = -1.$$

18. (a)  $\frac{4^3 - 2^3}{4 - 2} = \frac{56}{2} = 28$

(b)  $(dV/d\ell)|_{\ell=5} = 3\ell^2|_{\ell=5} = 3(5)^2 = 75$

19. (a)  $\frac{dW}{dt} = 200(t-15)$ ; at  $t = 5$ ,  $\frac{dW}{dt} = -2000$ ; the water is running out at the rate of 2000 gal/min.

(b)  $\frac{W(5) - W(0)}{5 - 0} = \frac{10000 - 22500}{5} = -2500$ ; the average rate of flow out is 2500 gal/min.

20.  $\cot 46^\circ = \cot \frac{46\pi}{180}$ ; let  $x_0 = \frac{\pi}{4}$  and  $x = \frac{46\pi}{180}$ . Then

$$\cot 46^\circ = \cot x = \cot \frac{\pi}{4} - \left(\csc^2 \frac{\pi}{4}\right) \left(x - \frac{\pi}{4}\right) = 1 - 2 \left(\frac{46\pi}{180} - \frac{\pi}{4}\right) = 0.9651;$$

with a calculator,  $\cot 46^\circ = 0.9657$ .

21. (a)  $h = 115 \tan \phi$ ,  $dh = 115 \sec^2 \phi d\phi$ ; with  $\phi = 51^\circ = \frac{51}{180}\pi$  radians and  $d\phi = \pm 0.5^\circ = \pm 0.5 \left(\frac{\pi}{180}\right)$  radians,  $h \pm dh = 115(1.2349) \pm 2.5340 = 142.0135 \pm 2.5340$ , so the height lies between 139.48 m and 144.55 m.

(b) If  $|dh| \leq 5$  then  $|d\phi| \leq \frac{5}{115} \cos^2 \frac{51}{180}\pi \approx 0.017$  radians, or  $|d\phi| \leq 0.98^\circ$ .

22. (a)  $\frac{dT}{dL} = \frac{2}{\sqrt{g}} \frac{1}{2\sqrt{L}} = \frac{1}{\sqrt{gL}}$

(b) s/m

(c) Since  $\frac{dT}{dL} > 0$  an increase in  $L$  gives an increase in  $T$ , which is the period. To speed up a clock, decrease the period; to decrease  $T$ , decrease  $L$ .

(d)  $\frac{dT}{dg} = -\frac{\sqrt{L}}{g^{3/2}} < 0$ ; a decrease in  $g$  will increase  $T$  and the clock runs slower

(e)  $\frac{dT}{dg} = 2\sqrt{L} \left(\frac{-1}{2}\right) g^{-3/2} = -\frac{\sqrt{L}}{g^{3/2}}$

(f)  $s^3/m$

23. (a)  $f'(x) = 2x, f'(1.8) = 3.6$   
 (b)  $f'(x) = (x^2 - 4x)/(x - 2)^2, f'(3.5) \approx -0.777778$
24. (a)  $f'(x) = 3x^2 - 2x, f'(2.3) = 11.27$       (b)  $f'(x) = (1 - x^2)/(x^2 + 1)^2, f'(-0.5) = 0.48$
25.  $f'(x) = 2^x \ln 2; f'(2) \approx 2.772589$
26.  $f'(x) = x^{\sin x} (\cos x \ln x + \sin x/x); f'(2) = 0.312141$

27.  $v_{\text{inst}} = \lim_{h \rightarrow 0} \frac{3(h+1)^{2.5} + 580h - 3}{10h} = 58 + \frac{1}{10} \frac{d}{dx} 3x^{2.5} \Big|_{x=1} = 58 + \frac{1}{10} (2.5)(3)(1)^{1.5} = 58.75 \text{ ft/s}$

28. 164 ft/s

29. Solve  $3x^2 - \cos x = 0$  to get  $x = \pm 0.535428$ .

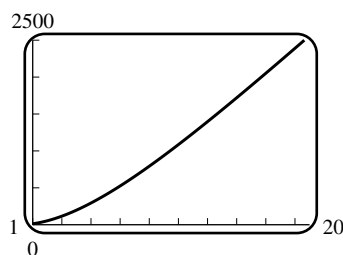

30. When  $x^4 - x - 1 > 0$ ,  $f(x) = x^4 - 2x - 1$ ; when  $x^4 - x - 1 < 0$ ,  $f(x) = -x^4 + 1$ , and  $f$  is differentiable in both cases. The roots of  $x^4 - x - 1 = 0$  are  $x_1 = -0.724492$ ,  $x_2 = 1.220744$ . So  $x^4 - x - 1 > 0$  on  $(-\infty, x_1)$  and  $(x_2, +\infty)$ , and  $x^4 - x - 1 < 0$  on  $(x_1, x_2)$ . Then
- $\lim_{x \rightarrow x_1^-} f'(x) = \lim_{x \rightarrow x_1^-} (4x^3 - 2) = 4x_1^3 - 2$  and
- $\lim_{x \rightarrow x_1^+} f'(x) = \lim_{x \rightarrow x_1^+} -4x^3 = -4x_1^3$  which is not equal to  $4x_1^3 - 2$ , so  $f$  is not differentiable at  $x = x_1$ ; similarly  $f$  is not differentiable at  $x = x_2$ .

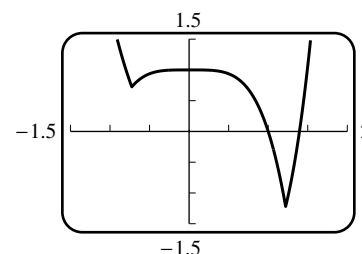

31. (a)  $f'(x) = 5x^4$       (b)  $f'(x) = -1/x^2$       (c)  $f'(x) = -1/2x^{3/2}$   
 (d)  $f'(x) = -3/(x-1)^2$       (e)  $f'(x) = 3x/\sqrt{3x^2+5}$       (f)  $f'(x) = 3 \cos 3x$

32.  $f'(x) = 2x \sin x + x^2 \cos x$       33.  $f'(x) = \frac{1 - 2\sqrt{x} \sin 2x}{2\sqrt{x}}$

34.  $f'(x) = \frac{6x^2 + 8x - 17}{(3x+2)^2}$       35.  $f'(x) = \frac{(1+x^2) \sec^2 x - 2x \tan x}{(1+x^2)^2}$

36.  $f'(x) = \frac{x^2 \cos \sqrt{x} - 2x^{3/2} \sin \sqrt{x}}{2x^{7/2}}$

37.  $f'(x) = \frac{-2x^5 \sin x - 2x^4 \cos x + 4x^4 + 6x^2 \sin x + 6x - 3x \cos x - 4x \sin x + 4 \cos x - 8}{2x^2 \sqrt{x^4 - 3} + 2(2 - \cos x)^2}$

**CHAPTER 3 HORIZON MODULE**

1.  $x_1 = l_1 \cos \theta_1, x_2 = l_2 \cos(\theta_1 + \theta_2)$ , so  $x = x_1 + x_2 = l_1 \cos \theta_1 + l_2 \cos(\theta_1 + \theta_2)$  (see Figure 3 in text); similarly  $y_1 = l_1 \sin \theta_1 + l_2 \sin(\theta_1 + \theta_2)$ .
2. Fix  $\theta_1$  for the moment and let  $\theta_2$  vary; then the distance  $r$  from  $(x, y)$  to the origin (see Figure 3 in text) is at most  $l_1 + l_2$  and at least  $l_1 - l_2$  if  $l_1 \geq l_2$  and  $l_2 - l_1$  otherwise. For any fixed  $\theta_2$  let  $\theta_1$  vary and the point traces out a circle of radius  $r$ .
  - (a)  $\{(x, y) : 0 \leq x^2 + y^2 \leq 2l_1\}$
  - (b)  $\{(x, y) : l_1 - l_2 \leq x^2 + y^2 \leq l_1 + l_2\}$
  - (c)  $\{(x, y) : l_2 - l_1 \leq x^2 + y^2 \leq l_1 + l_2\}$

3.  $(x, y) = (l_1 \cos \theta + l_2 \cos(\theta_1 + \theta_2), l_1 \sin \theta + l_2 \sin(\theta_1 + \theta_2))$   
 $= (\cos(\pi/4) + 3 \cos(5\pi/12), \sin(\pi/4) + 3 \sin(5\pi/12)) = \left( \frac{\sqrt{2} + 3\sqrt{6}}{4}, \frac{7\sqrt{2} + 3\sqrt{6}}{4} \right)$

4.  $x = (1) \cos 2t + (1) \cos(2t + 3t) = \cos 2t + \cos 5t$ ,  
 $y = (1) \sin 2t + (1) \sin(2t + 3t) = \sin 2t + \sin 5t$

5.

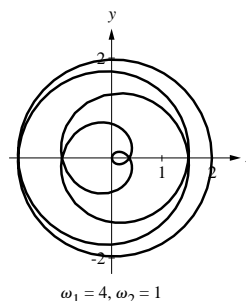
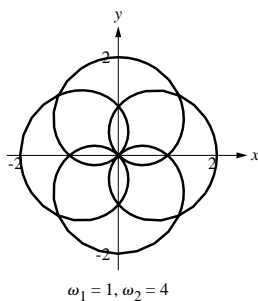
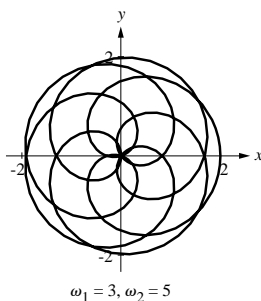

6.  $x = 2 \cos t, y = 2 \sin t$ , a circle of radius 2
7. (a)  $9 = [3 \sin(\theta_1 + \theta_2)]^2 + [3 \cos(\theta_1 + \theta_2)]^2 = [5 - 3 \sin \theta_1]^2 + [3 - 3 \cos \theta_1]^2$   
 $= 25 - 30 \sin \theta_1 + 9 \sin^2 \theta_1 + 9 - 18 \cos \theta_1 + 9 \cos^2 \theta_1 = 43 - 30 \sin \theta_1 - 18 \cos \theta_1$ ,  
 so  $15 \sin \theta_1 + 9 \cos \theta_1 = 17$ 
  - (b)  $1 = \sin^2 \theta_1 + \cos^2 \theta_2 = \left( \frac{17 - 9 \cos \theta_1}{15} \right)^2 + \cos \theta_1$ , or  $306 \cos^2 \theta_1 - 306 \cos \theta_1 = -64$
  - (c)  $\cos \theta_1 = \left( 153 \pm \sqrt{(153)^2 - 4(153)(32)} \right) / 306 = \frac{1}{2} \pm \frac{5\sqrt{17}}{102}$
  - (e) If  $\theta_1 = 0.792436$  rad, then  $\theta_2 = 0.475882$  rad  $\approx 27.2660^\circ$ ;  
 if  $\theta_1 = 1.26832$  rad, then  $\theta_2 = -0.475882$  rad  $\approx -27.2660^\circ$ .
8.  $\frac{dx}{dt} = -3 \sin \theta_1 \frac{d\theta_1}{dt} - (3 \sin(\theta_1 + \theta_2)) \left( \frac{d\theta_1}{dt} + \frac{d\theta_2}{dt} \right) = -3 \frac{d\theta_1}{dt} (\sin \theta_1 + \sin(\theta_1 + \theta_2)) - 3 (\sin(\theta_1 + \theta_2)) \frac{d\theta_2}{dt}$   
 $= -y \frac{d\theta_1}{dt} - 3 (\sin(\theta_1 + \theta_2)) \frac{d\theta_2}{dt}$ ; similarly  $\frac{dy}{dt} = x \frac{d\theta_1}{dt} + 3 (\cos(\theta_1 + \theta_2)) \frac{d\theta_2}{dt}$ . Now set  $\frac{dx}{dt} = 0, \frac{dy}{dt} = 1$ .
9. (a)  $x = 3 \cos(\pi/3) + 3 \cos(-\pi/3) = 6 \frac{1}{2} = 3$  and  $y = 3 \sin(\pi/3) - 3 \sin(\pi/3) = 0$ ; equations (4)  
 become  $3 \sin(\pi/3) \frac{d\theta_2}{dt} = 0, 3 \frac{d\theta_1}{dt} + 3 \cos(\pi/3) \frac{d\theta_2}{dt} = 1$  with solution  $d\theta_2/dt = 0, d\theta_1/dt = 1/3$ .
  - (b)  $x = -3, y = 3$ , so  $-3 \frac{d\theta_1}{dt} = 0$  and  $-3 \frac{d\theta_1}{dt} - 3 \frac{d\theta_2}{dt} = 1$ , with solution  $d\theta_1/dt = 0, d\theta_2/dt = -1/3$ .

## CHAPTER 4

# Logarithmic and Exponential Functions

### EXERCISE SET 4.1

1. (a)  $f(g(x)) = 4(x/4) = x$ ,  $g(f(x)) = (4x)/4 = x$ ,  $f$  and  $g$  are inverse functions
- (b)  $f(g(x)) = 3(3x - 1) + 1 = 9x - 2 \neq x$  so  $f$  and  $g$  are not inverse functions
- (c)  $f(g(x)) = \sqrt[3]{(x^3 + 2) - 2} = x$ ,  $g(f(x)) = (x - 2) + 2 = x$ ,  $f$  and  $g$  are inverse functions
- (d)  $f(g(x)) = (x^{1/4})^4 = x$ ,  $g(f(x)) = (x^4)^{1/4} = |x| \neq x$ ,  $f$  and  $g$  are not inverse functions

2. (a) They are inverse functions.

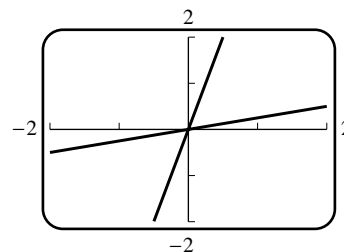

- (b) The graphs are not reflections of each other about the line  $y = x$ .

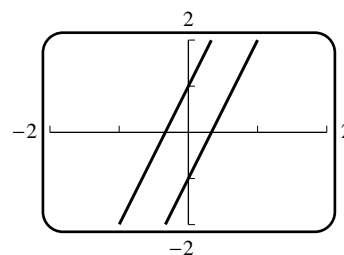

- (c) They are inverse functions provided the domain of  $g$  is restricted to  $[0, +\infty)$

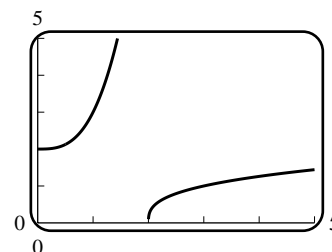

- (d) They are inverse functions provided the domain of  $f(x)$  is restricted to  $[0, +\infty)$

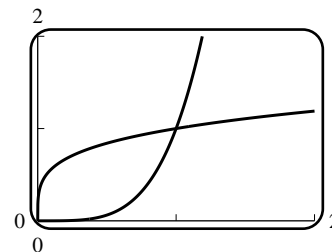

3. (a) yes; all outputs (the elements of row two) are distinct
- (b) no;  $f(1) = f(6)$
4. (a) no; it is easy to conceive of, say, 8 people in line at two different times
- (b) no; perhaps your weight remains constant for more than a year
- (c) yes, since the function is increasing, in the sense that the greater the volume, the greater the weight

5. (a) yes      (b) yes      (c) no      (d) yes      (e) no      (f) no
6. (a) no, the horizontal line test fails      (b) yes, horizontal line test

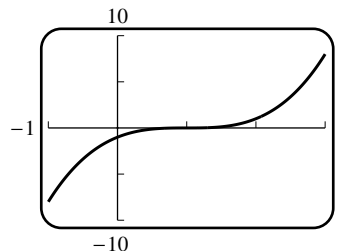
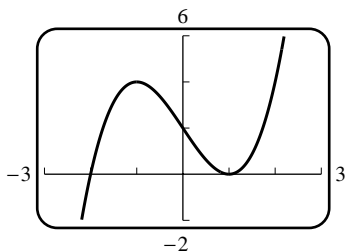

7. (a) no, the horizontal line test fails  
 (b) no, the horizontal line test fails  
 (c) yes, horizontal line test
8. (a) no, the horizontal line test fails  
 (b) no, the horizontal line test fails  
 (c) yes, horizontal line test
9. (a)  $f$  has an inverse because the graph passes the horizontal line test. To compute  $f^{-1}(2)$  start at 2 on the  $y$ -axis and go to the curve and then down, so  $f^{-1}(2) = 8$ ; similarly,  $f^{-1}(-1) = -1$  and  $f^{-1}(0) = 0$ .
- (b) domain of  $f^{-1}$  is  $[-2, 2]$ , range is  $[-8, 8]$       (c)

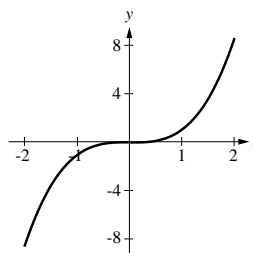

10. (a) the horizontal line test fails  
 (b)  $-\infty < x \leq -1$ ;  $-1 \leq x \leq 2$ ; and  $2 \leq x < +\infty$ .
11. (a)  $f'(x) = 2x + 8$ ;  $f' < 0$  on  $(-\infty, -4)$  and  $f' > 0$  on  $(-4, +\infty)$ ; not one-to-one  
 (b)  $f'(x) = 10x^4 + 3x^2 + 3 \geq 3 > 0$ ;  $f'(x)$  is positive for all  $x$ , so  $f$  is one-to-one  
 (c)  $f'(x) = 2 + \cos x \geq 1 > 0$  for all  $x$ , so  $f$  is one-to-one
12. (a)  $f'(x) = 3x^2 + 6x = x(3x + 6)$  changes sign at  $x = -2, 0$ , so  $f$  is not one-to-one  
 (b)  $f'(x) = 5x^4 + 24x^2 + 2 \geq 2 > 0$ ;  $f'$  is positive for all  $x$ , so  $f$  is one-to-one  
 (c)  $f'(x) = \frac{1}{(x+1)^2}$ ;  $f$  is one-to-one because:  
 if  $x_1 < x_2 < -1$  then  $f' > 0$  on  $[x_1, x_2]$ , so  $f(x_1) \neq f(x_2)$   
 if  $-1 < x_1 < x_2$  then  $f' > 0$  on  $[x_1, x_2]$ , so  $f(x_1) \neq f(x_2)$   
 if  $x_1 < -1 < x_2$  then  $f(x_1) > 1 > f(x_2)$  since  $f(x) > 1$  on  $(-\infty, -1)$  and  $f(x) < 1$  on  $(-1, +\infty)$
13.  $y = f^{-1}(x)$ ,  $x = f(y) = y^5$ ,  $y = x^{1/5} = f^{-1}(x)$
14.  $y = f^{-1}(x)$ ,  $x = f(y) = 6y$ ,  $y = \frac{1}{6}x = f^{-1}(x)$
15.  $y = f^{-1}(x)$ ,  $x = f(y) = 7y - 6$ ,  $y = \frac{1}{7}(x + 6) = f^{-1}(x)$
16.  $y = f^{-1}(x)$ ,  $x = f(y) = \frac{y+1}{y-1}$ ,  $xy - x = y + 1$ ,  $(x-1)y = x + 1$ ,  $y = \frac{x+1}{x-1} = f^{-1}(x)$

17.  $y = f^{-1}(x)$ ,  $x = f(y) = 3y^3 - 5$ ,  $y = \sqrt[3]{(x+5)/3} = f^{-1}(x)$
18.  $y = f^{-1}(x)$ ,  $x = f(y) = \sqrt[5]{4y+2}$ ,  $y = \frac{1}{4}(x^5 - 2) = f^{-1}(x)$
19.  $y = f^{-1}(x)$ ,  $x = f(y) = \sqrt[3]{2y-1}$ ,  $y = (x^3 + 1)/2 = f^{-1}(x)$
20.  $y = f^{-1}(x)$ ,  $x = f(y) = \frac{5}{y^2 + 1}$ ,  $y = \sqrt{\frac{5-x}{x}} = f^{-1}(x)$
21.  $y = f^{-1}(x)$ ,  $x = f(y) = 3/y^2$ ,  $y = -\sqrt{3/x} = f^{-1}(x)$
22.  $y = f^{-1}(x)$ ,  $x = f(y) = \begin{cases} 2y, & y \leq 0 \\ y^2, & y > 0 \end{cases}$ ,  $y = f^{-1}(x) = \begin{cases} x/2, & x \leq 0 \\ \sqrt{x}, & x > 0 \end{cases}$
23.  $y = f^{-1}(x)$ ,  $x = f(y) = \begin{cases} 5/2 - y, & y < 2 \\ 1/y, & y \geq 2 \end{cases}$ ,  $y = f^{-1}(x) = \begin{cases} 5/2 - x, & x > 1/2 \\ 1/x, & 0 < x \leq 1/2 \end{cases}$
24.  $y = p^{-1}(x)$ ,  $x = p(y) = y^3 - 3y^2 + 3y - 1 = (y-1)^3$ ,  $y = x^{1/3} + 1 = p^{-1}(x)$
25.  $y = f^{-1}(x)$ ,  $x = f(y) = (y+2)^4$  for  $y \geq 0$ ,  $y = f^{-1}(x) = x^{1/4} - 2$  for  $x \geq 16$
26.  $y = f^{-1}(x)$ ,  $x = f(y) = \sqrt{y+3}$  for  $y \geq -3$ ,  $y = f^{-1}(x) = x^2 - 3$  for  $x \geq 0$
27.  $y = f^{-1}(x)$ ,  $x = f(y) = -\sqrt{3-2y}$  for  $y \leq 3/2$ ,  $y = f^{-1}(x) = (3-x^2)/2$  for  $x \leq 0$
28.  $y = f^{-1}(x)$ ,  $x = f(y) = 3y^2 + 5y - 2$  for  $y \geq 0$ ,  $3y^2 + 5y - 2 - x = 0$  for  $y \geq 0$ ,  
 $y = f^{-1}(x) = (-5 + \sqrt{12x + 49})/6$  for  $x \geq -2$
29.  $y = f^{-1}(x)$ ,  $x = f(y) = y - 5y^2$  for  $y \geq 1$ ,  $5y^2 - y + x = 0$  for  $y \geq 1$ ,  
 $y = f^{-1}(x) = (1 + \sqrt{1-20x})/10$  for  $x \leq -4$
30. (a)  $C = \frac{5}{9}(F - 32)$   
 (b) how many degrees Celsius given the Fahrenheit temperature  
 (c)  $C = -273.15^\circ \text{C}$  is equivalent to  $F = -459.67^\circ \text{F}$ , so the domain is  $F \geq -459.67$ , the range is  $C \geq -273.15$
31. (a)  $y = f(x) = (6.214 \times 10^{-4})x$  (b)  $x = f^{-1}(y) = \frac{10^4}{6.214}y$   
 (c) how many meters in  $y$  miles
32.  $f$  and  $f^{-1}$  are continuous so  $f(3) = \lim_{x \rightarrow 3} f(x) = 7$ ; then  $f^{-1}(7) = 3$ , and  
 $\lim_{x \rightarrow 7} f^{-1}(x) = f^{-1}(\lim_{x \rightarrow 7} x) = f^{-1}(7) = 3$
33. (a)  $f(g(x)) = f(\sqrt{x})$   
 $= (\sqrt{x})^2 = x, x > 1$ ;  
 $g(f(x)) = g(x^2)$   
 $= \sqrt{x^2} = x, x > 1$

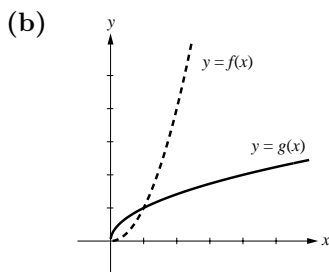

(c) no, because  $f(g(x)) = x$  for every  $x$  in the domain of  $g$  is not satisfied (the domain of  $g$  is  $x \geq 0$ )

34.  $y = f^{-1}(x)$ ,  $x = f(y) = ay^2 + by + c$ ,  $ay^2 + by + c - x = 0$ , use the quadratic formula to get  $y = \frac{-b \pm \sqrt{b^2 - 4a(c-x)}}{2a}$ ;

(a)  $f^{-1}(x) = \frac{-b + \sqrt{b^2 - 4a(c-x)}}{2a}$

(b)  $f^{-1}(x) = \frac{-b - \sqrt{b^2 - 4a(c-x)}}{2a}$

35. (a)  $f(f(x)) = \frac{3 - \frac{3-x}{1-x}}{1 - \frac{3-x}{1-x}} = \frac{3 - 3x - 3 + x}{1 - x - 3 + x} = x$  so  $f = f^{-1}$

(b) symmetric about the line  $y = x$

36.  $y = m(x - x_0)$  is an equation of the line. The graph of the inverse of  $f(x) = m(x - x_0)$  will be the reflection of this line about  $y = x$ . Solve  $y = m(x - x_0)$  for  $x$  to get  $x = y/m + x_0 = f^{-1}(y)$  so  $y = f^{-1}(x) = x/m + x_0$ .

37. (a)  $f(x) = x^3 - 3x^2 + 2x = x(x-1)(x-2)$  so  $f(0) = f(1) = f(2) = 0$  thus  $f$  is not one-to-one.

(b)  $f'(x) = 3x^2 - 6x + 2$ ,  $f'(x) = 0$  when  $x = \frac{6 \pm \sqrt{36 - 24}}{6} = 1 \pm \sqrt{3}/3$ .  $f'(x) > 0$  ( $f$  is increasing) if  $x < 1 - \sqrt{3}/3$ ,  $f'(x) < 0$  ( $f$  is decreasing) if  $1 - \sqrt{3}/3 < x < 1 + \sqrt{3}/3$ , so  $f(x)$  takes on values less than  $f(1 - \sqrt{3}/3)$  on both sides of  $1 - \sqrt{3}/3$  thus  $1 - \sqrt{3}/3$  is the largest value of  $k$ .

38. (a)  $f(x) = x^3(x-2)$  so  $f(0) = f(2) = 0$  thus  $f$  is not one to one.

(b)  $f'(x) = 4x^3 - 6x^2 = 4x^2(x - 3/2)$ ,  $f'(x) = 0$  when  $x = 0$  or  $3/2$ ;  $f$  is decreasing on  $(-\infty, 3/2]$  and increasing on  $[3/2, +\infty)$  so  $3/2$  is the smallest value of  $k$ .

39. if  $f^{-1}(x) = 1$ , then  $x = f(1) = 2(1)^3 + 5(1) + 3 = 10$

40. if  $f^{-1}(x) = 2$ , then  $x = f(2) = (2)^3 / [(2)^2 + 1] = 8/5$

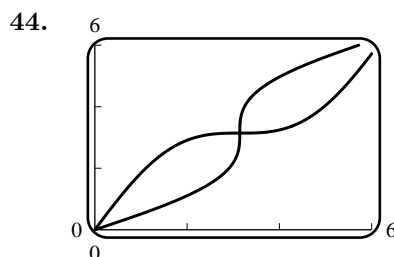
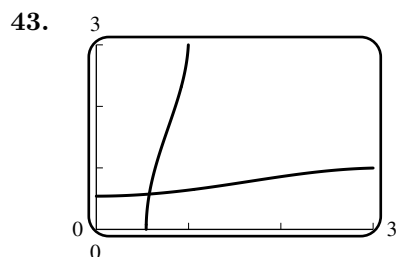
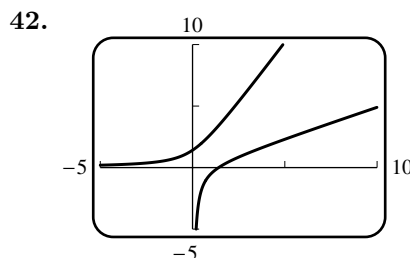
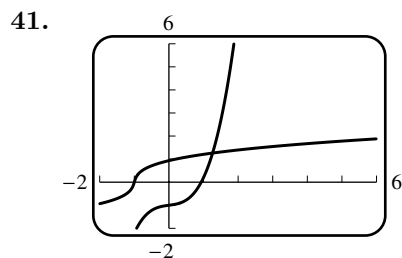

45.  $f(f(x)) = x$  thus  $f = f^{-1}$  so the graph is symmetric about  $y = x$ .

46. (a) Suppose  $x_1 \neq x_2$  where  $x_1$  and  $x_2$  are in the domain of  $g$  and  $g(x_1), g(x_2)$  are in the domain of  $f$  then  $g(x_1) \neq g(x_2)$  because  $g$  is one-to-one so  $f(g(x_1)) \neq f(g(x_2))$  because  $f$  is one-to-one thus  $f \circ g$  is one-to-one because  $(f \circ g)(x_1) \neq (f \circ g)(x_2)$  if  $x_1 \neq x_2$ .

- (b)  $f$ ,  $g$ , and  $f \circ g$  all have inverses because they are all one-to-one. Let  $h = (f \circ g)^{-1}$  then  $(f \circ g)(h(x)) = f[g(h(x))] = x$ , apply  $f^{-1}$  to both sides to get  $g(h(x)) = f^{-1}(x)$ , then apply  $g^{-1}$  to get  $h(x) = g^{-1}(f^{-1}(x)) = (g^{-1} \circ f^{-1})(x)$ , so  $h = g^{-1} \circ f^{-1}$

47.

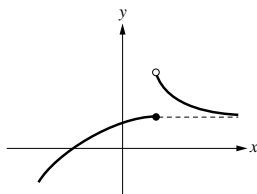

48. Suppose that  $g$  and  $h$  are both inverses of  $f$  then  $f(g(x)) = x$ ,  $h[f(g(x))] = h(x)$ , but  $h[f(g(x))] = g(x)$  because  $h$  is an inverse of  $f$  so  $g(x) = h(x)$ .
49.  $F'(x) = 2f'(2g(x))g'(x)$  so  $F'(3) = 2f'(2g(3))g'(3)$ . By inspection  $f(1) = 3$ , so  $g(3) = f^{-1}(3) = 1$  and  $g'(3) = (f^{-1})'(3) = 1/f'(f^{-1}(3)) = 1/f'(1) = 1/7$  because  $f'(x) = 4x^3 + 3x^2$ . Thus  $F'(3) = 2f'(2)(1/7) = 2(44)(1/7) = 88/7$ .

## EXERCISE SET 4.2

1. (a)  $-4$  (b)  $4$  (c)  $1/4$
2. (a)  $1/16$  (b)  $8$  (c)  $1/3$
3. (a)  $2.9690$  (b)  $0.0341$
4. (a)  $1.8882$  (b)  $0.9381$
5. (a)  $\log_2 16 = \log_2(2^4) = 4$  (b)  $\log_2\left(\frac{1}{32}\right) = \log_2(2^{-5}) = -5$   
(c)  $\log_4 4 = 1$  (d)  $\log_9 3 = \log_9(9^{1/2}) = 1/2$
6. (a)  $\log_{10}(0.001) = \log_{10}(10^{-3}) = -3$  (b)  $\log_{10}(10^4) = 4$   
(c)  $\ln(e^3) = 3$  (d)  $\ln(\sqrt{e}) = \ln(e^{1/2}) = 1/2$
7. (a)  $1.3655$  (b)  $-0.3011$
8. (a)  $-0.5229$  (b)  $1.1447$
9. (a)  $2 \ln a + \frac{1}{2} \ln b + \frac{1}{2} \ln c = 2r + s/2 + t/2$  (b)  $\ln b - 3 \ln a - \ln c = s - 3r - t$
10. (a)  $\frac{1}{3} \ln c - \ln a - \ln b = t/3 - r - s$  (b)  $\frac{1}{2}(\ln a + 3 \ln b - 2 \ln c) = r/2 + 3s/2 - t$
11. (a)  $1 + \log x + \frac{1}{2} \log(x-3)$  (b)  $2 \ln |x| + 3 \ln \sin x - \frac{1}{2} \ln(x^2 + 1)$
12. (a)  $\frac{1}{3} \log(x+2) - \log \cos 5x$  (b)  $\frac{1}{2} \ln(x^2 + 1) - \frac{1}{2} \ln(x^3 + 5)$
13.  $\log \frac{2^4(16)}{3} = \log(256/3)$  14.  $\log \sqrt{x} - \log(\sin^3 2x) + \log 100 = \log \frac{100\sqrt{x}}{\sin^3 2x}$



15.  $\ln \frac{\sqrt[3]{x}(x+1)^2}{\cos x}$
17.  $\sqrt{x} = 10^{-1} = 0.1, x = 0.01$
19.  $1/x = e^{-2}, x = e^2$
21.  $2x = 8, x = 4$
23.  $\log_{10} x = 5, x = 10^5$
24.  $\ln 4x - \ln x^6 = \ln 2, \ln \frac{4}{x^5} = \ln 2, \frac{4}{x^5} = 2, x^5 = 2, x = \sqrt[5]{2}$
25.  $\ln 2x^2 = \ln 3, 2x^2 = 3, x^2 = 3/2, x = \sqrt{3/2}$  (we discard  $-\sqrt{3/2}$  because it does not satisfy the original equation)
26.  $\ln 3^x = \ln 2, x \ln 3 = \ln 2, x = \frac{\ln 2}{\ln 3}$
27.  $\ln 5^{-2x} = \ln 3, -2x \ln 5 = \ln 3, x = -\frac{\ln 3}{2 \ln 5}$
28.  $e^{-2x} = 5/3, -2x = \ln(5/3), x = -\frac{1}{2} \ln(5/3)$
29.  $e^{3x} = 7/2, 3x = \ln(7/2), x = \frac{1}{3} \ln(7/2)$
30.  $e^x(1 - 2x) = 0$  so  $e^x = 0$  (impossible) or  $1 - 2x = 0, x = 1/2$
31.  $e^{-x}(x + 2) = 0$  so  $e^{-x} = 0$  (impossible) or  $x + 2 = 0, x = -2$
32.  $e^{2x} - e^x - 6 = (e^x - 3)(e^x + 2) = 0$  so  $e^x = -2$  (impossible) or  $e^x = 3, x = \ln 3$
33.  $e^{-2x} - 3e^{-x} + 2 = (e^{-x} - 2)(e^{-x} - 1) = 0$  so  $e^{-x} = 2, x = -\ln 2$  or  $e^{-x} = 1, x = 0$

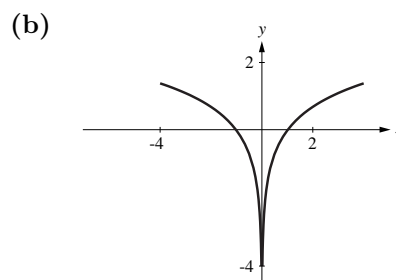
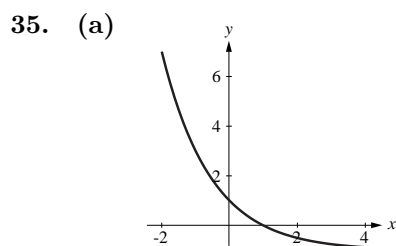
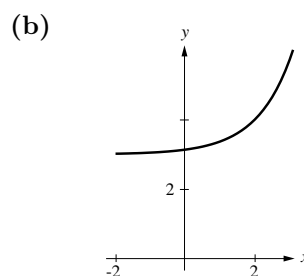
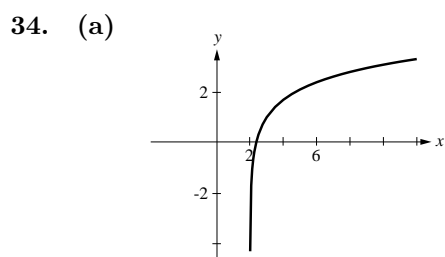

36. (a)

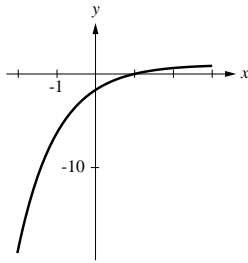

(b)

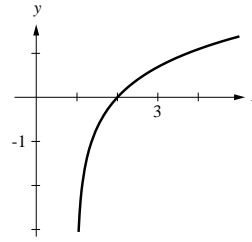

37.  $\log_2 7.35 = (\log 7.35)/(\log 2) = (\ln 7.35)/(\ln 2) \approx 2.8777$ ;  
 $\log_5 0.6 = (\log 0.6)/(\log 5) = (\ln 0.6)/(\ln 5) \approx -0.3174$

38.

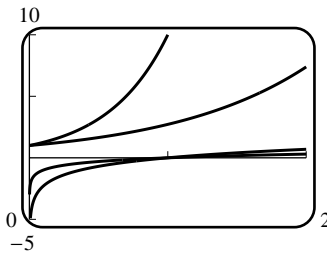

39.

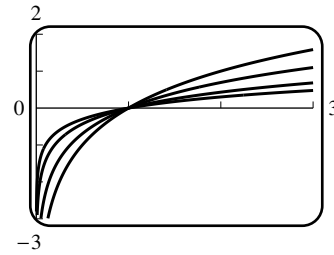

40. (a) Let  $X = \log_b x$  and  $Y = \log_a x$ . Then  $b^X = x$  and  $a^Y = x$  so  $a^Y = b^X$ , or  $a^{Y/X} = b$ , which means  $\log_a b = Y/X$ . Substituting for  $Y$  and  $X$  yields  $\frac{\log_a x}{\log_b x} = \log_a b$ ,  $\log_b x = \frac{\log_a x}{\log_a b}$ .

(b) Let  $x = a$  to get  $\log_b a = (\log_a a)/(\log_a b) = 1/(\log_a b)$  so  $(\log_a b)(\log_b a) = 1$ .  
 $(\log_2 81)(\log_3 32) = (\log_2[3^4])(\log_3[2^5]) = (4 \log_2 3)(5 \log_3 2) = 20(\log_2 3)(\log_3 2) = 20$

41.  $x = 3.6541, y = 1.2958$

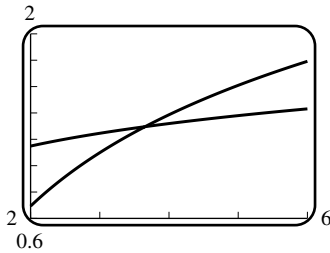

42. Since the units are billions, one trillion is 1,000 units. Solve  $1000 = 0.051517(1.1306727)^x$  for  $x$  by taking common logarithms, resulting in  $3 = \log 0.051517 + x \log 1.1306727$ , which yields  $x \approx 77.4$ , so the debt first reached one trillion dollars around 1977.

43. (a) no, the curve passes through the origin  
 (c)  $y = 2^{-x}$

(b)  $y = 2^{x/4}$   
 (d)  $y = (\sqrt{5})^x$

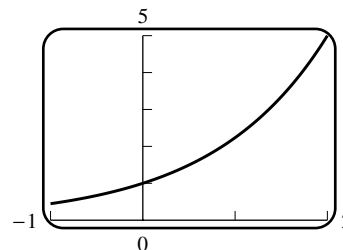

44. (a) As  $x \rightarrow +\infty$  the function grows very slowly, but it is always increasing and tends to  $+\infty$ .  
As  $x \rightarrow 1^+$  the function tends to  $-\infty$ .

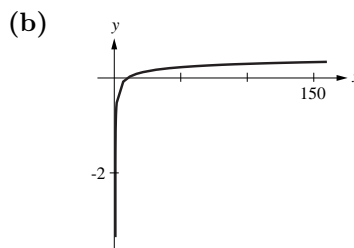

45.  $\log(1/2) < 0$  so  $3 \log(1/2) < 2 \log(1/2)$

46. Let  $x = \log_b a$  and  $y = \log_b c$ , so  $a = b^x$  and  $c = b^y$ .  
First,  $ac = b^x b^y = b^{x+y}$  or equivalently,  $\log_b(ac) = x + y = \log_b a + \log_b c$ .  
Secondly,  $a/c = b^x/b^y = b^{x-y}$  or equivalently,  $\log_b(a/c) = x - y = \log_b a - \log_b c$ .  
Next,  $a^r = (b^x)^r = b^{rx}$  or equivalently,  $\log_b a^r = rx = r \log_b a$ .  
Finally,  $1/c = 1/b^y = b^{-y}$  or equivalently,  $\log_b(1/c) = -y = -\log_b c$ .

47.  $75e^{-t/125} = 15, t = -125 \ln(1/5) = 125 \ln 5 \approx 201$  days.

48. (a) If  $t = 0$ , then  $Q = 12$  grams (b)  $Q = 12e^{-0.055(4)} = 12e^{-0.22} \approx 9.63$  grams  
(c)  $12e^{-0.055t} = 6, e^{-0.055t} = 0.5, t = -(\ln 0.5)/(0.055) \approx 12.6$  hours

49. (a) 7.4; basic (b) 4.2; acidic (c) 6.4; acidic (d) 5.9; acidic

50. (a)  $\log[H^+] = -2.44, [H^+] = 10^{-2.44} \approx 3.6 \times 10^{-3}$  mol/L  
(b)  $\log[H^+] = -8.06, [H^+] = 10^{-8.06} \approx 8.7 \times 10^{-9}$  mol/L

51. (a) 140 dB; damage (b) 120 dB; damage  
(c) 80 dB; no damage (d) 75 dB; no damage

52. Suppose that  $I_1 = 3I_2$  and  $\beta_1 = 10 \log_{10} I_1/I_0, \beta_2 = 10 \log_{10} I_2/I_0$ . Then  
 $I_1/I_0 = 3I_2/I_0, \log_{10} I_1/I_0 = \log_{10} 3I_2/I_0 = \log_{10} 3 + \log_{10} I_2/I_0, \beta_1 = 10 \log_{10} 3 + \beta_2,$   
 $\beta_1 - \beta_2 = 10 \log_{10} 3 \approx 4.8$  decibels.

53. Let  $I_A$  and  $I_B$  be the intensities of the automobile and blender, respectively. Then  
 $\log_{10} I_A/I_0 = 7$  and  $\log_{10} I_B/I_0 = 9.3, I_A = 10^7 I_0$  and  $I_B = 10^{9.3} I_0$ , so  $I_B/I_A = 10^{2.3} \approx 200$ .

54. The decibel level of the  $n$ th echo is  $120(2/3)^n$ ;  
 $120(2/3)^n < 10$  if  $(2/3)^n < 1/12, n > \frac{\log(1/12)}{\log(2/3)} = \frac{\log 12}{\log 1.5} \approx 6.13$  so 6 echoes can be heard.

55. (a)  $\log E = 4.4 + 1.5(8.2) = 16.7, E = 10^{16.7} \approx 5 \times 10^{16}$  J  
(b) Let  $M_1$  and  $M_2$  be the magnitudes of earthquakes with energies of  $E$  and  $10E$ , respectively. Then  $1.5(M_2 - M_1) = \log(10E) - \log E = \log 10 = 1,$   
 $M_2 - M_1 = 1/1.5 = 2/3 \approx 0.67$ .

56. Let  $E_1$  and  $E_2$  be the energies of earthquakes with magnitudes  $M$  and  $M + 1$ , respectively. Then  
 $\log E_2 - \log E_1 = \log(E_2/E_1) = 1.5, E_2/E_1 = 10^{1.5} \approx 31.6$ .

57. If  $t = -2x$ , then  $x = -t/2$  and  $\lim_{x \rightarrow 0} (1 - 2x)^{1/x} = \lim_{t \rightarrow 0} (1 + t)^{-2/t} = \lim_{t \rightarrow 0} [(1 + t)^{1/t}]^{-2} = e^{-2}$ .

58. If  $t = 3/x$ , then  $x = 3/t$  and  $\lim_{x \rightarrow +\infty} (1 + 3/x)^x = \lim_{t \rightarrow 0^+} (1 + t)^{3/t} = \lim_{t \rightarrow 0^+} [(1 + t)^{1/t}]^3 = e^3$ .

## EXERCISE SET 4.3

1.  $y = (2x - 5)^{1/3}$ ;  $dy/dx = \frac{2}{3}(2x - 5)^{-2/3}$
2.  $dy/dx = \frac{1}{3} [2 + \tan(x^2)]^{-2/3} \sec^2(x^2)(2x) = \frac{2}{3}x \sec^2(x^2) [2 + \tan(x^2)]^{-2/3}$
3.  $dy/dx = \frac{3}{2} \left[ \frac{x-1}{x+2} \right]^{1/2} \frac{d}{dx} \left[ \frac{x-1}{x+2} \right] = \frac{9}{2(x+2)^2} \left[ \frac{x-1}{x+2} \right]^{1/2}$
4.  $dy/dx = \frac{1}{2} \left[ \frac{x^2+1}{x^2-5} \right]^{-1/2} \frac{d}{dx} \left[ \frac{x^2+1}{x^2-5} \right] = \frac{1}{2} \left[ \frac{x^2+1}{x^2-5} \right]^{-1/2} \frac{-12x}{(x^2-5)^2} = -\frac{6x}{(x^2-5)^2} \left[ \frac{x^2+1}{x^2-5} \right]^{-1/2}$
5.  $dy/dx = x^3 \left( -\frac{2}{3} \right) (5x^2 + 1)^{-5/3} (10x) + 3x^2 (5x^2 + 1)^{-2/3} = \frac{1}{3} x^2 (5x^2 + 1)^{-5/3} (25x^2 + 9)$
6.  $dy/dx = \frac{x^2 \frac{4}{3} (3-2x)^{1/3} (-2) - (3-2x)^{4/3} (2x)}{x^4} = \frac{2(3-2x)^{1/3} (2x-9)}{3x^3}$
7.  $dy/dx = \frac{5}{2} [\sin(3/x)]^{3/2} [\cos(3/x)] (-3/x^2) = -\frac{15[\sin(3/x)]^{3/2} \cos(3/x)}{2x^2}$
8.  $dy/dx = -\frac{1}{2} [\cos(x^3)]^{-3/2} [-\sin(x^3)] (3x^2) = \frac{3}{2} x^2 \sin(x^3) [\cos(x^3)]^{-3/2}$
9. (a)  $3x^2 + x \frac{dy}{dx} + y - 2 = 0$ ,  $\frac{dy}{dx} = \frac{2-3x^2-y}{x}$   
 (b)  $y = \frac{1+2x-x^3}{x} = \frac{1}{x} + 2 - x^2$  so  $\frac{dy}{dx} = -\frac{1}{x^2} - 2x$   
 (c) from part (a),  $\frac{dy}{dx} = \frac{2-3x^2-y}{x} = \frac{2-3x^2-(1/x+2-x^2)}{x} = -2x - \frac{1}{x^2}$
10. (a)  $\frac{1}{2} y^{-1/2} \frac{dy}{dx} - e^x = 0$  or  $\frac{dy}{dx} = 2e^x \sqrt{y}$   
 (b)  $y = (2 + e^x)^2 = 2 + 4e^x + e^{2x}$  so  $\frac{dy}{dx} = 4e^x + 2e^{2x}$   
 (c) from part (a),  $\frac{dy}{dx} = 2e^x \sqrt{y} = 2e^x (2 + e^x) = 4e^x + 2e^{2x}$
11.  $2x + 2y \frac{dy}{dx} = 0$  so  $\frac{dy}{dx} = -\frac{x}{y}$
12.  $3x^2 - 3y^2 \frac{dy}{dx} = 6(x \frac{dy}{dx} + y)$ ,  $-(3y^2 + 6x) \frac{dy}{dx} = 6y - 3x^2$  so  $\frac{dy}{dx} = \frac{x^2 - 2y}{y^2 + 2x}$
13.  $x^2 \frac{dy}{dx} + 2xy + 3x(3y^2) \frac{dy}{dx} + 3y^3 - 1 = 0$   
 $(x^2 + 9xy^2) \frac{dy}{dx} = 1 - 2xy - 3y^3$  so  $\frac{dy}{dx} = \frac{1 - 2xy - 3y^3}{x^2 + 9xy^2}$
14.  $x^3(2y) \frac{dy}{dx} + 3x^2 y^2 - 5x^2 \frac{dy}{dx} - 10xy + 1 = 0$   
 $(2x^3 y - 5x^2) \frac{dy}{dx} = 10xy - 3x^2 y^2 - 1$  so  $\frac{dy}{dx} = \frac{10xy - 3x^2 y^2 - 1}{2x^3 y - 5x^2}$

$$15. \quad -\frac{1}{y^2} \frac{dy}{dx} - \frac{1}{x^2} = 0 \text{ so } \frac{dy}{dx} = -\frac{y^2}{x^2}$$

$$16. \quad 2x = \frac{(x-y)(1+dy/dx) - (x+y)(1-dy/dx)}{(x-y)^2},$$

$$2x(x-y)^2 = -2y + 2x \frac{dy}{dx} \text{ so } \frac{dy}{dx} = \frac{x(x-y)^2 + y}{x}$$

$$17. \quad \cos(x^2y^2) \left[ x^2(2y) \frac{dy}{dx} + 2xy^2 \right] = 1, \quad \frac{dy}{dx} = \frac{1 - 2xy^2 \cos(x^2y^2)}{2x^2y \cos(x^2y^2)}$$

$$18. \quad 2x = \frac{(1 + \csc y)(-\csc^2 y)(dy/dx) - (\cot y)(-\csc y \cot y)(dy/dx)}{(1 + \csc y)^2},$$

$$2x(1 + \csc y)^2 = -\csc y(\csc y + \csc^2 y - \cot^2 y) \frac{dy}{dx},$$

but  $\csc^2 y - \cot^2 y = 1$ , so  $\frac{dy}{dx} = -\frac{2x(1 + \csc y)}{\csc y}$

$$19. \quad 3 \tan^2(xy^2 + y) \sec^2(xy^2 + y) \left( 2xy \frac{dy}{dx} + y^2 + \frac{dy}{dx} \right) = 1$$

so  $\frac{dy}{dx} = \frac{1 - 3y^2 \tan^2(xy^2 + y) \sec^2(xy^2 + y)}{3(2xy + 1) \tan^2(xy^2 + y) \sec^2(xy^2 + y)}$

$$20. \quad \frac{(1 + \sec y)[3xy^2(dy/dx) + y^3] - xy^3(\sec y \tan y)(dy/dx)}{(1 + \sec y)^2} = 4y^3 \frac{dy}{dx},$$

multiply through by  $(1 + \sec y)^2$  and solve for  $\frac{dy}{dx}$

to get  $\frac{dy}{dx} = \frac{y(1 + \sec y)}{4y(1 + \sec y)^2 - 3x(1 + \sec y) + xy \sec y \tan y}$

$$21. \quad \frac{dy}{dx} = \frac{3x}{4y}, \quad \frac{d^2y}{dx^2} = \frac{(4y)(3) - (3x)(4dy/dx)}{16y^2} = \frac{12y - 12x(3x/(4y))}{16y^2} = \frac{12y^2 - 9x^2}{16y^3} = \frac{-3(3x^2 - 4y^2)}{16y^3},$$

but  $3x^2 - 4y^2 = 7$  so  $\frac{d^2y}{dx^2} = \frac{-3(7)}{16y^3} = -\frac{21}{16y^3}$

$$22. \quad \frac{dy}{dx} = -\frac{x^2}{y^2}, \quad \frac{d^2y}{dx^2} = -\frac{y^2(2x) - x^2(2ydy/dx)}{y^4} = -\frac{2xy^2 - 2x^2y(-x^2/y^2)}{y^4} = -\frac{2x(y^3 + x^3)}{y^5},$$

but  $x^3 + y^3 = 1$  so  $\frac{d^2y}{dx^2} = -\frac{2x}{y^5}$

$$23. \quad \frac{dy}{dx} = -\frac{y}{x}, \quad \frac{d^2y}{dx^2} = -\frac{x(dy/dx) - y(1)}{x^2} = -\frac{x(-y/x) - y}{x^2} = \frac{2y}{x^2}$$

$$24. \quad \frac{dy}{dx} = \frac{y}{y-x},$$

$$\frac{d^2y}{dx^2} = \frac{(y-x)(dy/dx) - y(dy/dx - 1)}{(y-x)^2} = \frac{(y-x) \left( \frac{y}{y-x} \right) - y \left( \frac{y}{y-x} - 1 \right)}{(y-x)^2}$$

$$= \frac{y^2 - 2xy}{(y-x)^3} \text{ but } y^2 - 2xy = -3, \text{ so } \frac{d^2y}{dx^2} = -\frac{3}{(y-x)^3}$$

$$25. \quad \frac{dy}{dx} = (1 + \cos y)^{-1}, \quad \frac{d^2y}{dx^2} = -(1 + \cos y)^{-2}(-\sin y) \frac{dy}{dx} = \frac{\sin y}{(1 + \cos y)^3}$$

$$26. \quad \frac{dy}{dx} = \frac{\cos y}{1 + x \sin y},$$

$$\frac{d^2y}{dx^2} = \frac{(1 + x \sin y)(-\sin y)(dy/dx) - (\cos y)[(x \cos y)(dy/dx) + \sin y]}{(1 + x \sin y)^2}$$

$$= -\frac{2 \sin y \cos y + (x \cos y)(2 \sin^2 y + \cos^2 y)}{(1 + x \sin y)^3},$$

but  $x \cos y = y$ ,  $2 \sin y \cos y = \sin 2y$ , and  $\sin^2 y + \cos^2 y = 1$  so

$$\frac{d^2y}{dx^2} = -\frac{\sin 2y + y(\sin^2 y + 1)}{(1 + x \sin y)^3}$$

27. By implicit differentiation,  $2x + 2y(dy/dx) = 0$ ,  $\frac{dy}{dx} = -\frac{x}{y}$ ; at  $(1/\sqrt{2}, 1/\sqrt{2})$ ,  $\frac{dy}{dx} = -1$ ; at  $(1/\sqrt{2}, -1/\sqrt{2})$ ,  $\frac{dy}{dx} = +1$ . Directly, at the upper point  $y = \sqrt{1-x^2}$ ,  $\frac{dy}{dx} = \frac{-x}{\sqrt{1-x^2}} = -1$  and at the lower point  $y = -\sqrt{1-x^2}$ ,  $\frac{dy}{dx} = \frac{x}{\sqrt{1-x^2}} = +1$ .

28. If  $y^2 - x + 1 = 0$ , then  $y = \sqrt{x-1}$  goes through the point  $(10, 3)$  so  $dy/dx = 1/(2\sqrt{x-1})$ . By implicit differentiation  $dy/dx = 1/(2y)$ . In both cases,  $dy/dx|_{(10,3)} = 1/6$ . Similarly  $y = -\sqrt{x-1}$  goes through  $(10, -3)$  so  $dy/dx = -1/(2\sqrt{x-1}) = -1/6$  which yields  $dy/dx = 1/(2y) = -1/6$ .

29.  $4x^3 + 4y^3 \frac{dy}{dx} = 0$ , so  $\frac{dy}{dx} = -\frac{x^3}{y^3} = -\frac{1}{15^{3/4}} \approx -0.1312$ .

30.  $3y^2 \frac{dy}{dx} + x^2 \frac{dy}{dx} + 2xy + 2x - 6y \frac{dy}{dx} = 0$ , so  $\frac{dy}{dx} = -2x \frac{y+1}{3y^2 + x^2 - 6y} = 0$  at  $x = 0$

31.  $4(x^2 + y^2) \left(2x + 2y \frac{dy}{dx}\right) = 25 \left(2x - 2y \frac{dy}{dx}\right)$ ,

$$\frac{dy}{dx} = \frac{x[25 - 4(x^2 + y^2)]}{y[25 + 4(x^2 + y^2)]}; \text{ at } (3, 1) \frac{dy}{dx} = -9/13$$

32.  $\frac{2}{3} \left(x^{-1/3} + y^{-1/3} \frac{dy}{dx}\right) = 0$ ,  $\frac{dy}{dx} = -\frac{y^{1/3}}{x^{1/3}} = \sqrt{3}$  at  $(-1, 3\sqrt{3})$

34. (a)

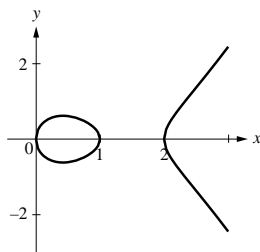

(b)  $2y \frac{dy}{dx} = (x-a)(x-b) + x(x-b) + x(x-a) = 3x^2 - 2(a+b)x + ab$ . If  $\frac{dy}{dx} = 0$  then  $3x^2 - 2(a+b)x + ab = 0$ . By the quadratic formula

$$x = \frac{2(a+b) \pm \sqrt{4(a+b)^2 - 4 \cdot 3ab}}{6} = \frac{1}{3} [a+b \pm (a^2 + b^2 - ab)^{1/2}].$$

(c)  $y = \pm \sqrt{x(x-a)(x-b)}$ . The square root is only defined for nonnegative arguments, so it is necessary that all three of the factors  $x$ ,  $x-a$ ,  $x-b$  be nonnegative, or that two of them be nonpositive. If, for example,  $0 < a < b$  then the function is defined on the disjoint intervals  $0 < x < a$  and  $b < x < +\infty$ , so there are two parts.

35. (a)

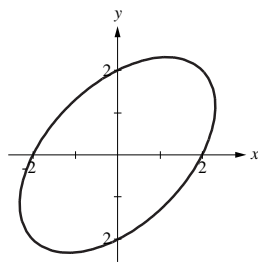

(b)  $\pm 1.1547$

(c) Implicit differentiation yields  $2x - x \frac{dy}{dx} - y + 2y \frac{dy}{dx} = 0$ . Solve for  $\frac{dy}{dx} = \frac{y - 2x}{2y - x}$ . If  $\frac{dy}{dx} = 0$  then  $y - 2x = 0$  or  $y = 2x$ . Thus  $4 = x^2 - xy + y^2 = x^2 - 2x^2 + 4x^2 = 3x^2$ ,  $x = \pm \frac{2}{\sqrt{3}}$ .

36.  $\frac{1}{2}u^{-1/2} \frac{du}{dv} + \frac{1}{2}v^{-1/2} = 0$  so  $\frac{du}{dv} = -\frac{\sqrt{u}}{\sqrt{v}}$

37.  $4a^3 \frac{da}{dt} - 4t^3 = 6 \left( a^2 + 2at \frac{da}{dt} \right)$ , solve for  $\frac{da}{dt}$  to get  $\frac{da}{dt} = \frac{2t^3 + 3a^2}{2a^3 - 6at}$

38.  $1 = (\cos x) \frac{dx}{dy}$  so  $\frac{dx}{dy} = \frac{1}{\cos x} = \sec x$

39.  $2a^2\omega \frac{d\omega}{d\lambda} + 2b^2\lambda = 0$  so  $\frac{d\omega}{d\lambda} = -\frac{b^2\lambda}{a^2\omega}$

40. Let  $P(x_0, y_0)$  be the required point. The slope of the line  $4x - 3y + 1 = 0$  is  $4/3$  so the slope of the tangent to  $y^2 = 2x^3$  at  $P$  must be  $-3/4$ . By implicit differentiation  $dy/dx = 3x^2/y$ , so at  $P$ ,  $3x_0^2/y_0 = -3/4$ , or  $y_0 = -4x_0^2$ . But  $y_0^2 = 2x_0^3$  because  $P$  is on the curve  $y^2 = 2x^3$ . Elimination of  $y_0$  gives  $16x_0^4 = 2x_0^3$ ,  $x_0^3(8x_0 - 1) = 0$ , so  $x_0 = 0$  or  $1/8$ . From  $y_0 = -4x_0^2$  it follows that  $y_0 = 0$  when  $x_0 = 0$ , and  $y_0 = -1/16$  when  $x_0 = 1/8$ . It does not follow, however, that  $(0, 0)$  is a solution because  $dy/dx = 3x^2/y$  (the slope of the curve as determined by implicit differentiation) is valid only if  $y \neq 0$ . Further analysis shows that the curve is tangent to the  $x$ -axis at  $(0, 0)$ , so the point  $(1/8, -1/16)$  is the only solution.

41. The point  $(1,1)$  is on the graph, so  $1 + a = b$ . The slope of the tangent line at  $(1,1)$  is  $-4/3$ ; use implicit differentiation to get  $\frac{dy}{dx} = -\frac{2xy}{x^2 + 2ay}$  so at  $(1,1)$ ,  $-\frac{2}{1 + 2a} = -\frac{4}{3}$ ,  $1 + 2a = 3/2$ ,  $a = 1/4$  and hence  $b = 1 + 1/4 = 5/4$ .

42. Use implicit differentiation to get  $dy/dx = (y - 3x^2)/(3y^2 - x)$ , so  $dy/dx = 0$  if  $y = 3x^2$ . Substitute this into  $x^3 - xy + y^3 = 0$  to obtain  $27x^6 - 2x^3 = 0$ ,  $x^3 = 2/27$ ,  $x = \sqrt[3]{2/3}$  and hence  $y = \sqrt[3]{4/3}$ .

43. Let  $P(x_0, y_0)$  be a point where a line through the origin is tangent to the curve  $x^2 - 4x + y^2 + 3 = 0$ . Implicit differentiation applied to the equation of the curve gives  $dy/dx = (2 - x)/y$ . At  $P$  the slope of the curve must equal the slope of the line so  $(2 - x_0)/y_0 = y_0/x_0$ , or  $y_0^2 = 2x_0 - x_0^2$ . But  $x_0^2 - 4x_0 + y_0^2 + 3 = 0$  because  $(x_0, y_0)$  is on the curve, and elimination of  $y_0^2$  in the latter two equations gives  $x_0^2 - 4x_0 + (2x_0 - x_0^2) + 3 = 0$ ,  $x_0 = 3/2$  which when substituted into  $y_0^2 = 2x_0 - x_0^2$  yields  $y_0^2 = 3/4$ , so  $y_0 = \pm\sqrt{3}/2$ . The slopes of the lines are  $(\pm\sqrt{3}/2)/(3/2) = \pm\sqrt{3}/3$  and their equations are  $y = (\sqrt{3}/3)x$  and  $y = -(\sqrt{3}/3)x$ .

44. By implicit differentiation,  $dy/dx = k/(2y)$  so the slope of the tangent to  $y^2 = kx$  at  $(x_0, y_0)$  is  $k/(2y_0)$  if  $y_0 \neq 0$ . The tangent line in this case is  $y - y_0 = \frac{k}{2y_0}(x - x_0)$ , or  $2y_0y - 2y_0^2 = kx - kx_0$ . But  $y_0^2 = kx_0$  because  $(x_0, y_0)$  is on the curve  $y^2 = kx$ , so the equation of the tangent line becomes  $2y_0y - 2kx_0 = kx - kx_0$  which gives  $y_0y = k(x + x_0)/2$ . If  $y_0 = 0$ , then  $x_0 = 0$ ; the graph of  $y^2 = kx$  has a vertical tangent at  $(0, 0)$  so its equation is  $x = 0$ , but  $y_0y = k(x + x_0)/2$  gives the same result when  $x_0 = y_0 = 0$ .

45. By the chain rule,  $\frac{dy}{dx} = \frac{dy}{dt} \frac{dt}{dx}$ . Use implicit differentiation on  $2y^3t + t^3y = 1$  to get  $\frac{dy}{dt} = -\frac{2y^3 + 3t^2y}{6ty^2 + t^3}$ , but  $\frac{dt}{dx} = \frac{1}{\cos t}$  so  $\frac{dy}{dx} = -\frac{2y^3 + 3t^2y}{(6ty^2 + t^3) \cos t}$ .
46.  $2x^3y \frac{dy}{dt} + 3x^2y^2 \frac{dx}{dt} + \frac{dy}{dt} = 0$ ,  $\frac{dy}{dt} = -\frac{3x^2y^2}{2x^3y + 1} \frac{dx}{dt}$
47.  $2xy \frac{dy}{dt} = y^2 \frac{dx}{dt} = 3(\cos 3x) \frac{dx}{dt}$ ,  $\frac{dy}{dt} = \frac{3 \cos 3x - y^2}{2xy} \frac{dx}{dt}$
48. (a)  $f'(x) = \frac{4}{3}x^{1/3}$ ,  $f''(x) = \frac{4}{9}x^{-2/3}$   
 (b)  $f'(x) = \frac{7}{3}x^{4/3}$ ,  $f''(x) = \frac{28}{9}x^{1/3}$ ,  $f'''(x) = \frac{28}{27}x^{-2/3}$   
 (c) generalize parts (a) and (b) with  $k = (n - 1) + 1/3 = n - 2/3$
49.  $y' = rx^{r-1}$ ,  $y'' = r(r-1)x^{r-2}$  so  $3x^2[r(r-1)x^{r-2}] + 4x(rx^{r-1}) - 2x^r = 0$ ,  
 $3r(r-1)x^r + 4rx^r - 2x^r = 0$ ,  $(3r^2 + r - 2)x^r = 0$ ,  
 $3r^2 + r - 2 = 0$ ,  $(3r - 2)(r + 1) = 0$ ;  $r = -1, 2/3$
50.  $y' = rx^{r-1}$ ,  $y'' = r(r-1)x^{r-2}$  so  $16x^2[r(r-1)x^{r-2}] + 24x(rx^{r-1}) + x^r = 0$ ,  
 $16r(r-1)x^r + 24rx^r + x^r = 0$ ,  $(16r^2 + 8r + 1)x^r = 0$ ,  
 $16r^2 + 8r + 1 = 0$ ,  $(4r + 1)^2 = 0$ ;  $r = -1/4$
51. We shall find when the curves intersect and check that the slopes are negative reciprocals. For the intersection solve the simultaneous equations  $x^2 + (y - c)^2 = c^2$  and  $(x - k)^2 + y^2 = k^2$  to obtain  $cy = kx = \frac{1}{2}(x^2 + y^2)$ . Thus  $x^2 + y^2 = cy + kx$ , or  $y^2 - cy = -x^2 + kx$ , and  $\frac{y - c}{x} = -\frac{x - k}{y}$ . Differentiating the two families yields (black)  $\frac{dy}{dx} = -\frac{x}{y - c}$ , and (gray)  $\frac{dy}{dx} = -\frac{x - k}{y}$ . But it was proven that these quantities are negative reciprocals of each other.
52. Differentiating, we get the equations (black)  $x \frac{dy}{dx} + y = 0$  and (gray)  $2x - 2y \frac{dy}{dx} = 0$ . The first says the (black) slope is  $-\frac{y}{x}$  and the second says the (gray) slope is  $\frac{x}{y}$ , and these are negative reciprocals of each other.
53.  $y = f^{-1}(x)$ ,  $x = f(y) = 5y^3 + y - 7$ ,  $\frac{dx}{dy} = 15y^2 + 1$ ,  $\frac{dy}{dx} = \frac{1}{15y^2 + 1}$ ;  
 check:  $1 = 15y^2 \frac{dy}{dx} + \frac{dy}{dx}$ ,  $\frac{dy}{dx} = \frac{1}{15y^2 + 1}$
54.  $y = f^{-1}(x)$ ,  $x = f(y) = 1/y^2$ ,  $\frac{dx}{dy} = -2y^{-3}$ ,  $\frac{dy}{dx} = -y^3/2$ ;  
 check:  $1 = -2y^{-3} \frac{dy}{dx}$ ,  $\frac{dy}{dx} = -y^3/2$
55.  $y = f^{-1}(x)$ ,  $x = f(y) = 2y^5 + y^3 + 1$ ,  $\frac{dx}{dy} = 10y^4 + 3y^2$ ,  $\frac{dy}{dx} = \frac{1}{10y^4 + 3y^2}$ ;  
 check:  $1 = 10y^4 \frac{dy}{dx} + 3y^2 \frac{dy}{dx}$ ,  $\frac{dy}{dx} = \frac{1}{10y^4 + 3y^2}$



$$56. \quad y = f^{-1}(x), \quad x = f(y) = 5y - \sin 2y, \quad \frac{dx}{dy} = 5 - 2 \cos 2y, \quad \frac{dy}{dx} = \frac{1}{5 - 2 \cos 2y};$$

$$\text{check: } 1 = (5 - 2 \cos 2y) \frac{dy}{dx}, \quad \frac{dy}{dx} = \frac{1}{5 - 2 \cos 2y}$$

## EXERCISE SET 4.4

1.  $\frac{1}{2x}(2) = 1/x$
2.  $\frac{1}{x^3}(3x^2) = 3/x$
3.  $2(\ln x) \left(\frac{1}{x}\right) = \frac{2 \ln x}{x}$
4.  $\frac{1}{\sin x}(\cos x) = \cot x$
5.  $\frac{1}{\tan x}(\sec^2 x) = \frac{\sec^2 x}{\tan x}$
6.  $\frac{1}{2 + \sqrt{x}} \left(\frac{1}{2\sqrt{x}}\right) = \frac{1}{2\sqrt{x}(2 + \sqrt{x})}$
7.  $\frac{1}{x(1+x^2)} \left[ \frac{(1+x^2)(1) - x(2x)}{(1+x^2)^2} \right] = \frac{1-x^2}{x(1+x^2)}$
8.  $\frac{1}{\ln x} \left(\frac{1}{x}\right) = \frac{1}{x \ln x}$
9.  $\frac{3x^2 - 14x}{x^3 - 7x^2 - 3}$
10.  $x^3 \left(\frac{1}{x}\right) + (3x^2) \ln x = x^2(1 + 3 \ln x)$
11.  $\frac{1}{2}(\ln x)^{-1/2} \left(\frac{1}{x}\right) = \frac{1}{2x\sqrt{\ln x}}$
12.  $\frac{\frac{1}{2}2(\ln x)(1/x)}{\sqrt{1 + \ln^2 x}} = \frac{\ln x}{x\sqrt{1 + \ln^2 x}}$
13.  $-\frac{1}{x} \sin(\ln x)$
14.  $2 \sin(\ln x) \cos(\ln x) \frac{1}{x} = \frac{\sin(\ln x^2)}{x}$
15.  $3x^2 \log_2(3-2x) + \frac{-2x^3}{(\ln 2)(3-2x)}$
16.  $[\log_2(x^2 - 2x)]^3 + 3x [\log_2(x^2 - 2x)]^2 \frac{2x-2}{(x^2-2x) \ln 2}$
17.  $\frac{2x(1 + \log x) - x/(\ln 10)}{(1 + \log x)^2}$
18.  $1/[x(\ln 10)(1 + \log x)^2]$
19.  $7e^{7x}$
20.  $-10xe^{-5x^2}$
21.  $x^3e^x + 3x^2e^x = x^2e^x(x+3)$
22.  $-\frac{1}{x^2}e^{1/x}$
23.  $\frac{dy}{dx} = \frac{(e^x + e^{-x})(e^x + e^{-x}) - (e^x - e^{-x})(e^x - e^{-x})}{(e^x + e^{-x})^2}$   
 $= \frac{(e^{2x} + 2 + e^{-2x}) - (e^{2x} - 2 + e^{-2x})}{(e^x + e^{-x})^2} = 4/(e^x + e^{-x})^2$
24.  $e^x \cos(e^x)$
25.  $(x \sec^2 x + \tan x)e^{x \tan x}$
26.  $\frac{dy}{dx} = \frac{(\ln x)e^x - e^x(1/x)}{(\ln x)^2} = \frac{e^x(x \ln x - 1)}{x(\ln x)^2}$
27.  $(1 - 3e^{3x})e^{(x-e^{3x})}$
28.  $\frac{15}{2}x^2(1 + 5x^3)^{-1/2} \exp(\sqrt{1 + 5x^3})$
29.  $\frac{(x-1)e^{-x}}{1 - xe^{-x}} = \frac{x-1}{e^x - x}$
30.  $\frac{1}{\cos(e^x)}[-\sin(e^x)]e^x = -e^x \tan(e^x)$

31.  $\frac{dy}{dx} + \frac{1}{xy} \left( x \frac{dy}{dx} + y \right) = 0, \frac{dy}{dx} = -\frac{y}{x(y+1)}$
32.  $\frac{dy}{dx} = \frac{1}{x \tan y} \left( x \sec^2 y \frac{dy}{dx} + \tan y \right), \frac{dy}{dx} = \frac{\tan y}{x(\tan y - \sec^2 y)}$
33.  $\frac{d}{dx} \left[ \ln \cos x - \frac{1}{2} \ln(4 - 3x^2) \right] = -\tan x + \frac{3x}{4 - 3x^2}$
34.  $\frac{d}{dx} \left( \frac{1}{2} [\ln(x-1) - \ln(x+1)] \right) = \frac{1}{2} \left( \frac{1}{x-1} - \frac{1}{x+1} \right)$
35.  $\ln |y| = \ln |x| + \frac{1}{3} \ln |1 + x^2|, \frac{dy}{dx} = x \sqrt[3]{1 + x^2} \left[ \frac{1}{x} + \frac{2x}{3(1 + x^2)} \right]$
36.  $\ln |y| = \frac{1}{5} [\ln |x-1| - \ln |x+1|], \frac{dy}{dx} = \frac{1}{5} \sqrt[5]{\frac{x-1}{x+1}} \left[ \frac{1}{x-1} - \frac{1}{x+1} \right]$
37.  $\ln |y| = \frac{1}{3} \ln |x^2 - 8| + \frac{1}{2} \ln |x^3 + 1| - \ln |x^6 - 7x + 5|$   
 $\frac{dy}{dx} = \frac{(x^2 - 8)^{1/3} \sqrt{x^3 + 1}}{x^6 - 7x + 5} \left[ \frac{2x}{3(x^2 - 8)} + \frac{3x^2}{2(x^3 + 1)} - \frac{6x^5 - 7}{x^6 - 7x + 5} \right]$
38.  $\ln |y| = \ln |\sin x| + \ln |\cos x| + 3 \ln |\tan x| - \frac{1}{2} \ln |x|$   
 $\frac{dy}{dx} = \frac{\sin x \cos x \tan^3 x}{\sqrt{x}} \left[ \cot x - \tan x + \frac{3 \sec^2 x}{\tan x} - \frac{1}{2x} \right]$
39.  $f'(x) = 2^x \ln 2; y = 2^x, \ln y = x \ln 2, \frac{1}{y} y' = \ln 2, y' = y \ln 2 = 2^x \ln 2$
40.  $f'(x) = -3^{-x} \ln 3; y = 3^{-x}, \ln y = -x \ln 3, \frac{1}{y} y' = -\ln 3, y' = -y \ln 3 = -3^{-x} \ln 3$
41.  $f'(x) = \pi^{\sin x} (\ln \pi) \cos x;$   
 $y = \pi^{\sin x}, \ln y = (\sin x) \ln \pi, \frac{1}{y} y' = (\ln \pi) \cos x, y' = \pi^{\sin x} (\ln \pi) \cos x$
42.  $f'(x) = \pi^{x \tan x} (\ln \pi) (x \sec^2 x + \tan x);$   
 $y = \pi^{x \tan x}, \ln y = (x \tan x) \ln \pi, \frac{1}{y} y' = (\ln \pi) (x \sec^2 x + \tan x)$   
 $y' = \pi^{x \tan x} (\ln \pi) (x \sec^2 x + \tan x)$
43.  $\ln y = (\ln x) \ln(x^3 - 2x), \frac{1}{y} \frac{dy}{dx} = \frac{3x^2 - 2}{x^3 - 2x} \ln x + \frac{1}{x} \ln(x^3 - 2x),$   
 $\frac{dy}{dx} = (x^3 - 2x)^{\ln x} \left[ \frac{3x^2 - 2}{x^3 - 2x} \ln x + \frac{1}{x} \ln(x^3 - 2x) \right]$
44.  $\ln y = (\sin x) \ln x, \frac{1}{y} \frac{dy}{dx} = \frac{\sin x}{x} + (\cos x) \ln x, \frac{dy}{dx} = x^{\sin x} \left[ \frac{\sin x}{x} + (\cos x) \ln x \right]$
45.  $\ln y = (\tan x) \ln(\ln x), \frac{1}{y} \frac{dy}{dx} = \frac{1}{x \ln x} \tan x + (\sec^2 x) \ln(\ln x),$   
 $\frac{dy}{dx} = (\ln x)^{\tan x} \left[ \frac{\tan x}{x \ln x} + (\sec^2 x) \ln(\ln x) \right]$

46.  $\ln y = (\ln x) \ln(x^2 + 3)$ ,  $\frac{1}{y} \frac{dy}{dx} = \frac{2x}{x^2 + 3} \ln x + \frac{1}{x} \ln(x^2 + 3)$ ,  
 $\frac{dy}{dx} = (x^2 + 3)^{\ln x} \left[ \frac{2x}{x^2 + 3} \ln x + \frac{1}{x} \ln(x^2 + 3) \right]$
47.  $y = Ae^{2x} + Be^{-4x}$ ,  $y' = 2Ae^{2x} - 4Be^{-4x}$ ,  $y'' = 4Ae^{2x} + 16Be^{-4x}$  so  
 $y'' + 2y' - 8y = (4Ae^{2x} + 16Be^{-4x}) + 2(2Ae^{2x} - 4Be^{-4x}) - 8(Ae^{2x} + Be^{-4x}) = 0$
48.  $y = Ae^{kt}$ ,  $dy/dt = kAe^{kt} = k(Ae^{kt}) = ky$
49. (a)  $f'(x) = ke^{kx}$ ,  $f''(x) = k^2e^{kx}$ ,  $f'''(x) = k^3e^{kx}, \dots, f^{(n)}(x) = k^n e^{kx}$   
 (b)  $f'(x) = -ke^{-kx}$ ,  $f''(x) = k^2e^{-kx}$ ,  $f'''(x) = -k^3e^{-kx}, \dots, f^{(n)}(x) = (-1)^n k^n e^{-kx}$
50.  $\frac{dy}{dt} = e^{-\lambda t}(\omega A \cos \omega t - \omega B \sin \omega t) + (-\lambda)e^{-\lambda t}(A \sin \omega t + B \cos \omega t)$   
 $= e^{-\lambda t}[(\omega A - \lambda B) \cos \omega t - (\omega B + \lambda A) \sin \omega t]$
51.  $f'(x) = \frac{1}{\sqrt{2\pi}\sigma} \exp \left[ -\frac{1}{2} \left( \frac{x - \mu}{\sigma} \right)^2 \right] \frac{d}{dx} \left[ -\frac{1}{2} \left( \frac{x - \mu}{\sigma} \right)^2 \right]$   
 $= \frac{1}{\sqrt{2\pi}\sigma} \exp \left[ -\frac{1}{2} \left( \frac{x - \mu}{\sigma} \right)^2 \right] \left[ - \left( \frac{x - \mu}{\sigma} \right) \left( \frac{1}{\sigma} \right) \right]$   
 $= -\frac{1}{\sqrt{2\pi}\sigma^3} (x - \mu) \exp \left[ -\frac{1}{2} \left( \frac{x - \mu}{\sigma} \right)^2 \right]$
52. (a)  $y' = -xe^{-x} + e^{-x} = e^{-x}(1 - x)$ ,  $xy' = xe^{-x}(1 - x) = y(1 - x)$   
 (b)  $y' = -x^2e^{-x^2/2} + e^{-x^2/2} = e^{-x^2/2}(1 - x^2)$ ,  $xy' = xe^{-x^2/2}(1 - x^2) = y(1 - x^2)$
53. (a)  $\log_x e = \frac{\ln e}{\ln x} = \frac{1}{\ln x}$ ,  $\frac{d}{dx} [\log_x e] = -\frac{1}{x(\ln x)^2}$   
 (b)  $\log_x 2 = \frac{\ln 2}{\ln x}$ ,  $\frac{d}{dx} [\log_x 2] = -\frac{\ln 2}{x(\ln x)^2}$
54.  $\beta = 10 \log I - 10 \log I_0$ ,  $\frac{d\beta}{dI} = \frac{10}{I \ln 10}$   
 (a)  $\left. \frac{d\beta}{dI} \right|_{I=10I_0} = \frac{1}{I_0 \ln 10} \text{ db/W/m}^2$       (b)  $\left. \frac{d\beta}{dI} \right|_{I=100I_0} = \frac{1}{10I_0 \ln 10} \text{ db/W/m}^2$   
 (c)  $\left. \frac{d\beta}{dI} \right|_{I=100I_0} = \frac{1}{100I_0 \ln 10} \text{ db/W/m}^2$
55.  $\frac{dk}{dT} = k_0 \exp \left[ -\frac{q(T - T_0)}{2T_0T} \right] \left( -\frac{q}{2T^2} \right) = -\frac{qk_0}{2T^2} \exp \left[ -\frac{q(T - T_0)}{2T_0T} \right]$
56. (a) because  $x^x$  is not of the form  $a^x$  where  $a$  is constant  
 (b)  $y = x^x$ ,  $\ln y = x \ln x$ ,  $\frac{1}{y} y' = 1 + \ln x$ ,  $y' = x^x(1 + \ln x)$
57.  $f'(x) = ex^{e-1}$

58. Let  $P(x_0, y_0)$  be a point on  $y = e^{3x}$  then  $y_0 = e^{3x_0}$ .  $dy/dx = 3e^{3x}$  so  $m_{\tan} = 3e^{3x_0}$  at  $P$  and an equation of the tangent line at  $P$  is  $y - y_0 = 3e^{3x_0}(x - x_0)$ ,  $y - e^{3x_0} = 3e^{3x_0}(x - x_0)$ . If the line passes through the origin then  $(0, 0)$  must satisfy the equation so  $-e^{3x_0} = -3x_0e^{3x_0}$  which gives  $x_0 = 1/3$  and thus  $y_0 = e$ . The point is  $(1/3, e)$ .

59. (a)  $f(x) = \ln x; f'(1) = \lim_{h \rightarrow 0} \frac{\ln(1+h) - \ln 1}{h} = \lim_{h \rightarrow 0} \frac{\ln(1+h)}{h} = \frac{1}{x} \Big|_{x=1} = 1$

(b)  $f(x) = 10^x; f'(0) = \lim_{h \rightarrow 0} \frac{10^h - 1}{h} = \frac{d}{dx}(10^x) \Big|_{x=0} = 10^x \ln 10 \Big|_{x=0} = \ln 10$

60. (a)  $f(x) = \ln x; f'(e^2) = \lim_{h \rightarrow 0} \frac{\ln(e^2+h) - 2}{h} = \frac{d}{dx}(\ln x) \Big|_{x=e^2} = \frac{1}{x} \Big|_{x=e^2} = e^{-2}$

(b)  $f(x) = 2^x; f'(1) = \lim_{x \rightarrow 1} \frac{2^x - 2}{x - 1} = \frac{d}{dx}(2^x) \Big|_{x=1} = 2^x \ln 2 \Big|_{x=1} = 2 \ln 2$

61. (b)

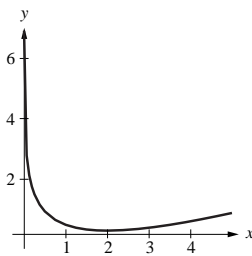

(c)  $\frac{dy}{dx} = \frac{1}{2} - \frac{1}{x}$  so  $\frac{dy}{dx} < 0$  at  $x = 1$  and  $\frac{dy}{dx} > 0$  at  $x = e$

(d) The slope is a continuous function which goes from a negative value to a positive value; therefore it must take the value zero in between, by the Intermediate Value Theorem.

(e)  $\frac{dy}{dx} = 0$  when  $x = 2$

62. (a)

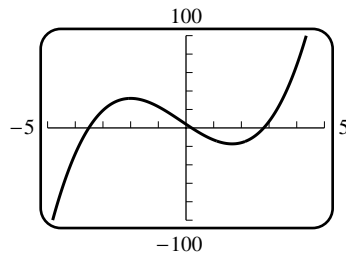

(c)

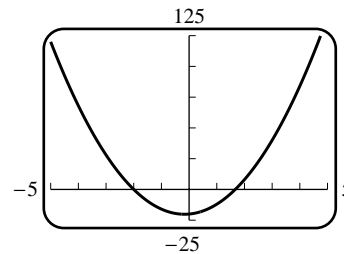

(d)  $x = -2, 5/3$

63. (a)  $e^x \cos \pi x$  oscillates between  $+e^x$  and  $-e^x$  as  $\cos \pi x$  oscillates between  $-1$  and  $+1$ .

(b)

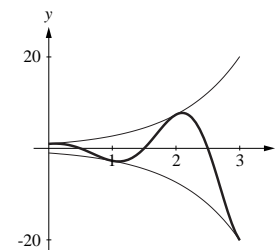

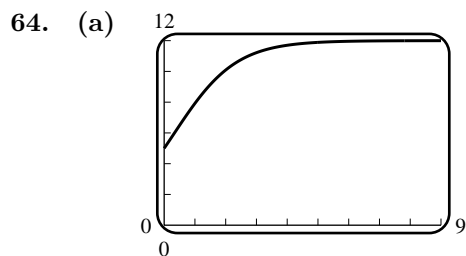

(b)  $P$  tends to 12 as  $t$  gets large;  $\lim_{t \rightarrow +\infty} P(t) = \lim_{t \rightarrow +\infty} \frac{60}{5 + 7e^{-t}} = \frac{60}{5 + 7 \lim_{t \rightarrow +\infty} e^{-t}} = \frac{60}{5} = 12$

(c) the rate of population growth tends to zero

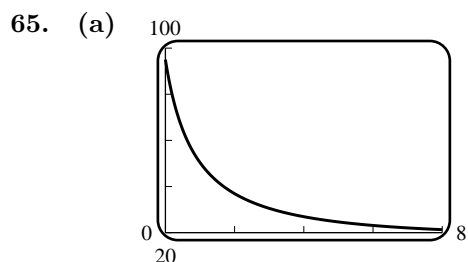
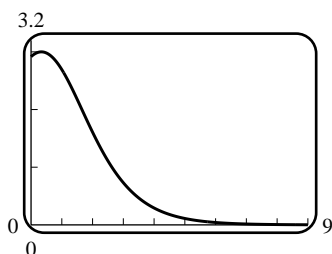

(b) as  $t$  tends to  $+\infty$ , the population tends to 19

$$\lim_{t \rightarrow +\infty} P(t) = \lim_{t \rightarrow +\infty} \frac{95}{5 - 4e^{-t/4}} = \frac{95}{5 - 4 \lim_{t \rightarrow +\infty} e^{-t/4}} = \frac{95}{5} = 19$$

(c) the rate of population growth tends to zero

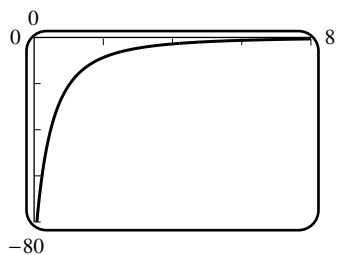

**EXERCISE SET 4.5**

1. (a)  $-\pi/2$                       (b)  $\pi$                               (c)  $-\pi/4$                           (d) 0
2. (a)  $\pi/3$                               (b)  $\pi/3$                               (c)  $\pi/4$                               (d)  $4\pi/3$
3.  $\theta = -\pi/3$ ;  $\cos \theta = 1/2$ ,  $\tan \theta = -\sqrt{3}$ ,  $\cot \theta = -1/\sqrt{3}$ ,  $\sec \theta = 2$ ,  $\csc \theta = -2/\sqrt{3}$

4.  $\theta = \pi/3$ ;  $\sin \theta = \sqrt{3}/2$ ,  $\tan \theta = \sqrt{3}$ ,  $\cot \theta = 1/\sqrt{3}$ ,  $\sec \theta = 2$ ,  $\csc \theta = 2/\sqrt{3}$

5.  $\tan \theta = 4/3$ ,  $0 < \theta < \pi/2$ ; use the triangle shown to get  $\sin \theta = 4/5$ ,  
 $\cos \theta = 3/5$ ,  $\cot \theta = 3/4$ ,  $\sec \theta = 5/3$ ,  $\csc \theta = 5/4$

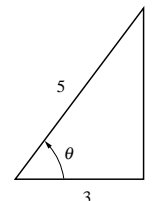

6.	domain	range
$\sin^{-1}$	$[-1, 1]$	$[-\pi/2, \pi/2]$
$\cos^{-1}$	$[-1, 1]$	$[0, \pi]$
$\tan^{-1}$	$(-\infty, +\infty)$	$(-\pi/2, \pi/2)$
$\cot^{-1}$	$(-\infty, +\infty)$	$(0, \pi)$
$\sec^{-1}$	$(-\infty, -1] \cup [1, +\infty)$	$[0, \pi/2] \cup [\pi, 3\pi/2]$
$\csc^{-1}$	$(-\infty, -1] \cup [1, +\infty)$	$(0, \pi/2] \cup (-\pi, -\pi/2]$

7. (a)  $\pi/7$  (b)  $\sin^{-1}(\sin \pi) = \sin^{-1}(\sin 0) = 0$

(c)  $\sin^{-1}(\sin(5\pi/7)) = \sin^{-1}(\sin(2\pi/7)) = 2\pi/7$

(d) Note that  $\pi/2 < 630 - 200\pi < \pi$  so  
 $\sin(630) = \sin(630 - 200\pi) = \sin(\pi - (630 - 200\pi)) = \sin(201\pi - 630)$  where  
 $0 < 201\pi - 630 < \pi/2$ ;  $\sin^{-1}(\sin 630) = \sin^{-1}(\sin(201\pi - 630)) = 201\pi - 630$ .

8. (a)  $\pi/7$  (b)  $\pi$

(c)  $\cos^{-1}(\cos(12\pi/7)) = \cos^{-1}(\cos(2\pi/7)) = 2\pi/7$

(d) Note that  $-\pi/2 < 200 - 64\pi < 0$  so  $\cos(200) = \cos(200 - 64\pi) = \cos(64\pi - 200)$  where  
 $0 < 64\pi - 200 < \pi/2$ ;  $\cos^{-1}(\cos 200) = \cos^{-1}(\cos(64\pi - 200)) = 64\pi - 200$ .

9. (a)  $0 \leq x \leq \pi$  (b)  $-1 \leq x \leq 1$   
(c)  $-\pi/2 < x < \pi/2$  (d)  $-\infty < x < +\infty$

10. Let  $\theta = \sin^{-1}(-3/4)$  then  $\sin \theta = -3/4$ ,  $-\pi/2 < \theta < 0$  and  
(see figure)  $\sec \theta = 4/\sqrt{7}$

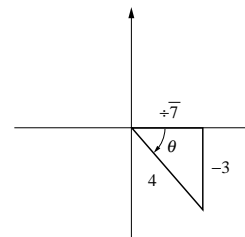

11. Let  $\theta = \cos^{-1}(3/5)$ ,  $\sin 2\theta = 2 \sin \theta \cos \theta = 2(4/5)(3/5) = 24/25$

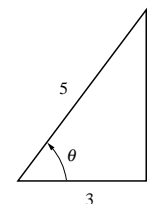

12. (a)  $\sin(\cos^{-1} x) = \sqrt{1-x^2}$

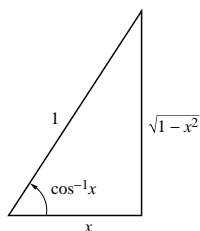

(b)  $\tan(\cos^{-1} x) = \frac{\sqrt{1-x^2}}{x}$

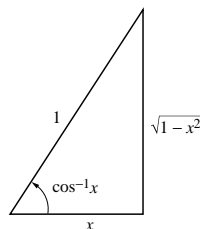

(c)  $\csc(\tan^{-1} x) = \frac{\sqrt{1+x^2}}{x}$

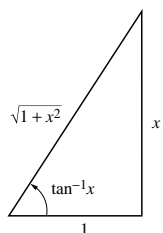

(d)  $\sin(\tan^{-1} x) = \frac{x}{\sqrt{1+x^2}}$

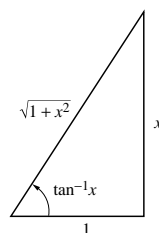

13. (a)  $\cos(\tan^{-1} x) = \frac{1}{\sqrt{1+x^2}}$

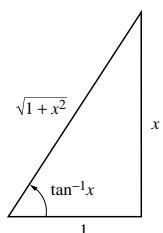

(b)  $\tan(\cot^{-1} x) = \frac{1}{x}$

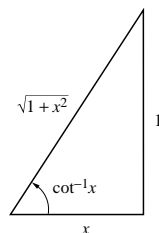

(c)  $\sin(\sec^{-1} x) = \frac{\sqrt{x^2-1}}{x}$

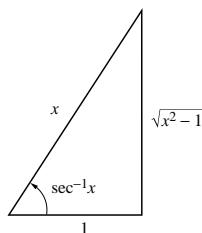

(d)  $\cot(\csc^{-1} x) = \sqrt{x^2-1}$

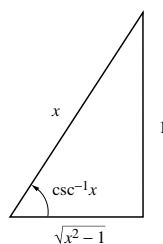

14. (a)

$x$	-1.00	-0.80	-0.6	-0.40	-0.20	0.00	0.20	0.40	0.60	0.80	1.00
$\sin^{-1} x$	-1.57	-0.93	-0.64	-0.41	-0.20	0.00	0.20	0.41	0.64	0.93	1.57
$\cos^{-1} x$	3.14	2.50	2.21	1.98	1.77	1.57	1.37	1.16	0.93	0.64	0.00

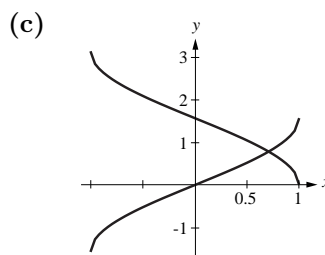
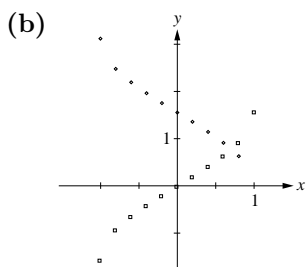

15. (a)

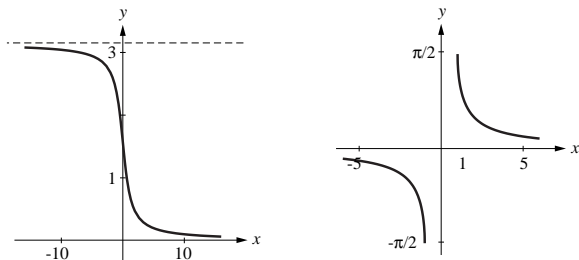

(b) The domain of  $\cot^{-1} x$  is  $(-\infty, +\infty)$ , the range is  $(0, \pi)$ ; the domain of  $\csc^{-1} x$  is  $(-\infty, -1] \cup [1, +\infty)$ , the range is  $[-\pi/2, 0) \cup (0, \pi/2]$ .

16. (a)  $y = \cot^{-1} x$ ,  $x = \cot y$ ,  $\tan y = 1/x$ ,  $y = \tan^{-1}(1/x)$

(b)  $y = \sec^{-1} x$ ,  $x = \sec y$ ,  $\cos y = 1/x$ ,  $y = \cos^{-1}(1/x)$

(c)  $y = \csc^{-1} x$ ,  $x = \csc y$ ,  $\sin y = 1/x$ ,  $y = \sin^{-1}(1/x)$

17. (a)  $55.0^\circ$

(b)  $33.6^\circ$

(c)  $25.8^\circ$

18. (a)  $x = \pi - \sin^{-1}(0.37) \approx 2.7626$  rad

(b)  $\theta = 180^\circ + \sin^{-1}(0.61) \approx 217.6^\circ$

19. (a)  $x = \pi + \cos^{-1}(0.85) \approx 3.6964$  rad

(b)  $\theta = -\cos^{-1}(0.23) \approx -76.7^\circ$

20. (a)  $x = \tan^{-1}(3.16) - \pi \approx -1.8773$

(b)  $\theta = 180^\circ - \tan^{-1}(0.45) \approx 155.8^\circ$

21. (a)  $\frac{1}{\sqrt{1-x^2/9}}(1/3) = 1/\sqrt{9-x^2}$

(b)  $-2/\sqrt{1-(2x+1)^2}$

22. (a)  $2x/(1+x^4)$

(b)  $-\frac{1}{1+x} \left( \frac{1}{2} x^{-1/2} \right) = -\frac{1}{2(1+x)\sqrt{x}}$

23. (a)  $\frac{1}{x^7\sqrt{x^{14}-1}}(7x^6) = \frac{7}{x\sqrt{x^{14}-1}}$

(b)  $-1/\sqrt{e^{2x}-1}$

24. (a)  $y = 1/\tan x = \cot x$ ,  $dy/dx = -\csc^2 x$

(b)  $y = (\tan^{-1} x)^{-1}$ ,  $dy/dx = -(\tan^{-1} x)^{-2} \left( \frac{1}{1+x^2} \right)$

25. (a)  $\frac{1}{\sqrt{1-1/x^2}}(-1/x^2) = -\frac{1}{|x|\sqrt{x^2-1}}$

(b)  $\frac{\sin x}{\sqrt{1-\cos^2 x}} = \frac{\sin x}{|\sin x|} = \begin{cases} 1, & \sin x > 0 \\ -1, & \sin x < 0 \end{cases}$

26. (a)  $-\frac{1}{(\cos^{-1} x)\sqrt{1-x^2}}$

(b)  $-\frac{1}{2\sqrt{\cot^{-1} x}(1+x^2)}$

27. (a)  $\frac{e^x}{x\sqrt{x^2-1}} + e^x \sec^{-1} x$

(b)  $\frac{3x^2(\sin^{-1} x)^2}{\sqrt{1-x^2}} + 2x(\sin^{-1} x)^3$

28. (a) 0

(b) 0

29.  $x^3 + x \tan^{-1} y = e^y$ ,  $3x^2 + \frac{x}{1+y^2} y' + \tan^{-1} y = e^y y'$ ,  $y' = \frac{(3x^2 + \tan^{-1} y)(1+y^2)}{(1+y^2)e^y - x}$



30.  $\sin^{-1}(xy) = \cos^{-1}(x - y), \frac{1}{\sqrt{1 - x^2y^2}}(xy' + y) = -\frac{1}{\sqrt{1 - (x - y)^2}}(1 - y'),$   
 $y' = \frac{y\sqrt{1 - (x - y)^2} + \sqrt{1 - x^2y^2}}{\sqrt{1 - x^2y^2} - x\sqrt{1 - (x - y)^2}}$

31. (a)

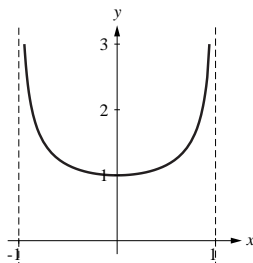

32. (a)

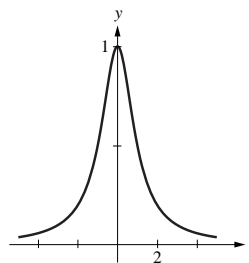

33. (a)

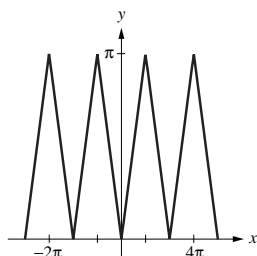

34. (a)  $\sin^{-1} 0.9 > 1$ , so it is not in the domain of  $\sin^{-1} x$

(b)  $-1 \leq \sin^{-1} x \leq 1$  is necessary, or  $-0.841471 \leq x \leq 0.841471$

35. (a)

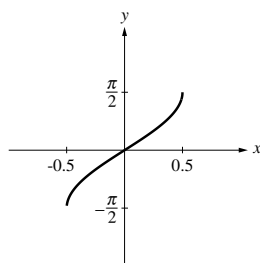

(b)

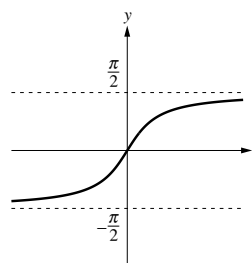

36. (a)  $x = 2\pi - \cos^{-1} k$

(b)  $x = \pi + \tan^{-1} k$

(c)  $2x = \sin^{-1} k$  or  $2x = \pi - \sin^{-1} k$  so  $x = \frac{1}{2} \sin^{-1} k$  or  $x = \pi/2 - \frac{1}{2} \sin^{-1} k$

37. (b)  $\theta = \sin^{-1} \frac{R}{R+h} = \sin^{-1} \frac{6378}{16,378} \approx 23^\circ$

38. (a) If  $\gamma = 90^\circ$ , then  $\sin \gamma = 1, \sqrt{1 - \sin^2 \phi \sin^2 \gamma} = \sqrt{1 - \sin^2 \phi} = \cos \phi,$   
 $D = \tan \phi \tan \lambda = (\tan 23.55^\circ)(\tan 65^\circ) \approx 0.934684245$  so  $h \approx 21.2$  hours.

(b) If  $\gamma = 270^\circ$ , then  $\sin \gamma = -1, D = -\tan \phi \tan \lambda \approx -0.934684245$  so  $h \approx 2.8$  hours.

39.  $\sin 2\theta = gR/v^2 = (9.8)(18)/(14)^2 = 0.9, 2\theta = \sin^{-1}(0.9)$  or  $2\theta = 180^\circ - \sin^{-1}(0.9)$  so  
 $\theta = \frac{1}{2} \sin^{-1}(0.9) \approx 32^\circ$  or  $\theta = 90^\circ - \frac{1}{2} \sin^{-1}(0.9) \approx 58^\circ$ . The ball will have a lower parabolic trajectory for  $\theta = 32^\circ$  and hence will result in the shorter time of flight.

40.  $4^2 = 2^2 + 3^2 - 2(2)(3) \cos \theta, \cos \theta = -1/4, \theta = \cos^{-1}(-1/4) \approx 104^\circ$

41.  $y = 0$  when  $x^2 = 6000v^2/g$ ,  $x = 10v\sqrt{60/g} = 1000\sqrt{30}$  for  $v = 400$  and  $g = 32$ ;  
 $\tan \theta = 3000/x = 3/\sqrt{30}$ ,  $\theta = \tan^{-1}(3/\sqrt{30}) \approx 29^\circ$ .

42.  $\theta = \alpha - \beta$ ,  $\cot \alpha = \frac{x}{a+b}$  and  $\cot \beta = \frac{x}{b}$  so  
 $\theta = \cot^{-1} \frac{x}{a+b} - \cot^{-1} \frac{x}{b}$

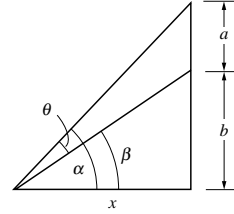

43. (a) Let  $\theta = \sin^{-1}(-x)$  then  $\sin \theta = -x$ ,  $-\pi/2 \leq \theta \leq \pi/2$ . But  $\sin(-\theta) = -\sin \theta$  and  $-\pi/2 \leq -\theta \leq \pi/2$  so  $\sin(-\theta) = -(-x) = x$ ,  $-\theta = \sin^{-1} x$ ,  $\theta = -\sin^{-1} x$ .  
 (b) proof is similar to that in part (a)
44. (a) Let  $\theta = \cos^{-1}(-x)$  then  $\cos \theta = -x$ ,  $0 \leq \theta \leq \pi$ . But  $\cos(\pi - \theta) = -\cos \theta$  and  $0 \leq \pi - \theta \leq \pi$  so  $\cos(\pi - \theta) = x$ ,  $\pi - \theta = \cos^{-1} x$ ,  $\theta = \pi - \cos^{-1} x$   
 (b) Let  $\theta = \sec^{-1}(-x)$  for  $x \geq 1$ ; then  $\sec \theta = -x$  and  $\pi/2 < \theta \leq \pi$ . So  $0 \leq \pi - \theta < \pi/2$  and  $\pi - \theta = \sec^{-1} \sec(\pi - \theta) = \sec^{-1}(-\sec \theta) = \sec^{-1} x$ , or  $\sec^{-1}(-x) = \pi - \sec^{-1} x$ .

45. (a)  $\sin^{-1} x = \tan^{-1} \frac{x}{\sqrt{1-x^2}}$

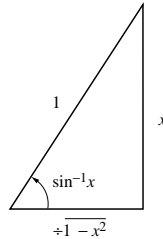

- (b)  $\sin^{-1} x + \cos^{-1} x = \pi/2$ ;  $\cos^{-1} x = \pi/2 - \sin^{-1} x = \pi/2 - \tan^{-1} \frac{x}{\sqrt{1-x^2}}$

46.  $\tan(\alpha + \beta) = \frac{\tan \alpha + \tan \beta}{1 - \tan \alpha \tan \beta}$ ,

$$\tan(\tan^{-1} x + \tan^{-1} y) = \frac{\tan(\tan^{-1} x) + \tan(\tan^{-1} y)}{1 - \tan(\tan^{-1} x) \tan(\tan^{-1} y)} = \frac{x + y}{1 - xy}$$

$$\text{so } \tan^{-1} x + \tan^{-1} y = \tan^{-1} \frac{x + y}{1 - xy}$$

47. (a)  $\tan^{-1} \frac{1}{2} + \tan^{-1} \frac{1}{3} = \tan^{-1} \frac{1/2 + 1/3}{1 - (1/2)(1/3)} = \tan^{-1} 1 = \pi/4$

$$(b) \quad 2 \tan^{-1} \frac{1}{3} = \tan^{-1} \frac{1}{3} + \tan^{-1} \frac{1}{3} = \tan^{-1} \frac{1/3 + 1/3}{1 - (1/3)(1/3)} = \tan^{-1} \frac{3}{4},$$

$$2 \tan^{-1} \frac{1}{3} + \tan^{-1} \frac{1}{7} = \tan^{-1} \frac{3}{4} + \tan^{-1} \frac{1}{7} = \tan^{-1} \frac{3/4 + 1/7}{1 - (3/4)(1/7)} = \tan^{-1} 1 = \pi/4$$

48.  $\sin(\sec^{-1} x) = \sin(\cos^{-1}(1/x)) = \sqrt{1 - \left(\frac{1}{x}\right)^2} = \frac{\sqrt{x^2 - 1}}{|x|}$

## EXERCISE SET 4.6

1. (b)  $A = x^2$  (c)  $\frac{dA}{dt} = 2x \frac{dx}{dt}$
- (d) Find  $\left. \frac{dA}{dt} \right|_{x=3}$  given that  $\left. \frac{dx}{dt} \right|_{x=3} = 2$ . From part (c),  $\left. \frac{dA}{dt} \right|_{x=3} = 2(3)(2) = 12 \text{ ft}^2/\text{min}$ .
2. (b)  $A = \pi r^2$  (c)  $\frac{dA}{dt} = 2\pi r \frac{dr}{dt}$
- (d) Find  $\left. \frac{dA}{dt} \right|_{r=5}$  given that  $\left. \frac{dr}{dt} \right|_{r=5} = 2$ . From part (c),  $\left. \frac{dA}{dt} \right|_{r=5} = 2\pi(5)(2) = 20\pi \text{ cm}^2/\text{s}$ .
3. (a)  $V = \pi r^2 h$ , so  $\frac{dV}{dt} = \pi \left( r^2 \frac{dh}{dt} + 2rh \frac{dr}{dt} \right)$ .
- (b) Find  $\left. \frac{dV}{dt} \right|_{\substack{h=6 \\ r=10}}$  given that  $\left. \frac{dh}{dt} \right|_{\substack{h=6 \\ r=10}} = 1$  and  $\left. \frac{dr}{dt} \right|_{\substack{h=6 \\ r=10}} = -1$ . From part (a),  
 $\left. \frac{dV}{dt} \right|_{\substack{h=6 \\ r=10}} = \pi[10^2(1) + 2(10)(6)(-1)] = -20\pi \text{ in}^3/\text{s}$ ; the volume is decreasing.
4. (a)  $\ell^2 = x^2 + y^2$ , so  $\frac{d\ell}{dt} = \frac{1}{\ell} \left( x \frac{dx}{dt} + y \frac{dy}{dt} \right)$ .
- (b) Find  $\left. \frac{d\ell}{dt} \right|_{\substack{x=3 \\ y=4}}$  given that  $\left. \frac{dx}{dt} \right|_{x=3} = \frac{1}{2}$  and  $\left. \frac{dy}{dt} \right|_{y=4} = -\frac{1}{4}$ .
- From part (a) and the fact that  $\ell = 5$  when  $x = 3$  and  $y = 4$ ,  
 $\left. \frac{d\ell}{dt} \right|_{\substack{x=3 \\ y=4}} = \frac{1}{5} \left[ 3 \left( \frac{1}{2} \right) + 4 \left( -\frac{1}{4} \right) \right] = \frac{1}{10} \text{ ft/s}$ ; the diagonal is increasing.
5. (a)  $\tan \theta = \frac{y}{x}$ , so  $\sec^2 \theta \frac{d\theta}{dt} = \frac{x \frac{dy}{dt} - y \frac{dx}{dt}}{x^2}$ ,  $\frac{d\theta}{dt} = \frac{\cos^2 \theta}{x^2} \left( x \frac{dy}{dt} - y \frac{dx}{dt} \right)$
- (b) Find  $\left. \frac{d\theta}{dt} \right|_{\substack{x=2 \\ y=2}}$  given that  $\left. \frac{dx}{dt} \right|_{\substack{x=2 \\ y=2}} = 1$  and  $\left. \frac{dy}{dt} \right|_{\substack{x=2 \\ y=2}} = -\frac{1}{4}$ .
- When  $x = 2$  and  $y = 2$ ,  $\tan \theta = 2/2 = 1$  so  $\theta = \frac{\pi}{4}$  and  $\cos \theta = \cos \frac{\pi}{4} = \frac{1}{\sqrt{2}}$ . Thus  
 from part (a),  $\left. \frac{d\theta}{dt} \right|_{\substack{x=2 \\ y=2}} = \frac{(1/\sqrt{2})^2}{2^2} \left[ 2 \left( -\frac{1}{4} \right) - 2(1) \right] = -\frac{5}{16} \text{ rad/s}$ ;  $\theta$  is decreasing.
6. Find  $\left. \frac{dz}{dt} \right|_{\substack{x=1 \\ y=2}}$  given that  $\left. \frac{dx}{dt} \right|_{\substack{x=1 \\ y=2}} = -2$  and  $\left. \frac{dy}{dt} \right|_{\substack{x=1 \\ y=2}} = 3$ .
- $\frac{dz}{dt} = 2x^3 y \frac{dy}{dt} + 3x^2 y^2 \frac{dx}{dt}$ ,  $\left. \frac{dz}{dt} \right|_{\substack{x=1 \\ y=2}} = (4)(3) + (12)(-2) = -12 \text{ units/s}$ ;  $z$  is decreasing
7. Let  $A$  be the area swept out, and  $\theta$  the angle through which the minute hand has rotated.  
 Find  $\frac{dA}{dt}$  given that  $\frac{d\theta}{dt} = \frac{\pi}{30} \text{ rad/min}$ ;  $A = \frac{1}{2} r^2 \theta = 8\theta$ , so  $\frac{dA}{dt} = 8 \frac{d\theta}{dt} = \frac{4\pi}{15} \text{ in}^2/\text{min}$ .

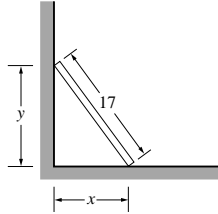
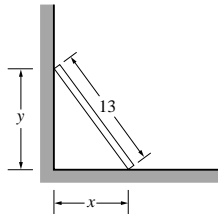
8. Let  $r$  be the radius and  $A$  the area enclosed by the ripple. We want  $\left. \frac{dA}{dt} \right|_{t=10}$  given that  $\frac{dr}{dt} = 3$ . We know that  $A = \pi r^2$ , so  $\frac{dA}{dt} = 2\pi r \frac{dr}{dt}$ . Because  $r$  is increasing at the constant rate of 3 ft/s, it follows that  $r = 30$  ft after 10 seconds so  $\left. \frac{dA}{dt} \right|_{t=10} = 2\pi(30)(3) = 180\pi$  ft<sup>2</sup>/s.
9. Find  $\left. \frac{dr}{dt} \right|_{A=9}$  given that  $\frac{dA}{dt} = 6$ . From  $A = \pi r^2$  we get  $\frac{dA}{dt} = 2\pi r \frac{dr}{dt}$  so  $\frac{dr}{dt} = \frac{1}{2\pi r} \frac{dA}{dt}$ . If  $A = 9$  then  $\pi r^2 = 9$ ,  $r = 3/\sqrt{\pi}$  so  $\left. \frac{dr}{dt} \right|_{A=9} = \frac{1}{2\pi(3/\sqrt{\pi})}(6) = 1/\sqrt{\pi}$  mi/h.
10. The volume  $V$  of a sphere of radius  $r$  is given by  $V = \frac{4}{3}\pi r^3$  or, because  $r = \frac{D}{2}$  where  $D$  is the diameter,  $V = \frac{4}{3}\pi \left(\frac{D}{2}\right)^3 = \frac{1}{6}\pi D^3$ . We want  $\left. \frac{dD}{dt} \right|_{r=1}$  given that  $\frac{dV}{dt} = 3$ . From  $V = \frac{1}{6}\pi D^3$  we get  $\frac{dV}{dt} = \frac{1}{2}\pi D^2 \frac{dD}{dt}$ ,  $\frac{dD}{dt} = \frac{2}{\pi D^2} \frac{dV}{dt}$ , so  $\left. \frac{dD}{dt} \right|_{r=1} = \frac{2}{\pi(2)^2}(3) = \frac{3}{2\pi}$  ft/min.
11. Find  $\left. \frac{dV}{dt} \right|_{r=9}$  given that  $\frac{dr}{dt} = -15$ . From  $V = \frac{4}{3}\pi r^3$  we get  $\frac{dV}{dt} = 4\pi r^2 \frac{dr}{dt}$  so  $\left. \frac{dV}{dt} \right|_{r=9} = 4\pi(9)^2(-15) = -4860\pi$ . Air must be removed at the rate of  $4860\pi$  cm<sup>3</sup>/min.
12. Let  $x$  and  $y$  be the distances shown in the diagram. We want to find  $\left. \frac{dy}{dt} \right|_{y=8}$  given that  $\frac{dx}{dt} = 5$ . From  $x^2 + y^2 = 17^2$  we get  $2x \frac{dx}{dt} + 2y \frac{dy}{dt} = 0$ , so  $\frac{dy}{dt} = -\frac{x}{y} \frac{dx}{dt}$ . When  $y = 8$ ,  $x^2 + 8^2 = 17^2$ ,  $x^2 = 289 - 64 = 225$ ,  $x = 15$  so  $\left. \frac{dy}{dt} \right|_{y=8} = -\frac{15}{8}(5) = -\frac{75}{8}$  ft/s; the top of the ladder is moving down the wall at a rate of  $75/8$  ft/s.
- 
13. Find  $\left. \frac{dx}{dt} \right|_{y=5}$  given that  $\frac{dy}{dt} = -2$ . From  $x^2 + y^2 = 13^2$  we get  $2x \frac{dx}{dt} + 2y \frac{dy}{dt} = 0$  so  $\frac{dx}{dt} = -\frac{y}{x} \frac{dy}{dt}$ . Use  $x^2 + y^2 = 169$  to find that  $x = 12$  when  $y = 5$  so  $\left. \frac{dx}{dt} \right|_{y=5} = -\frac{5}{12}(-2) = \frac{5}{6}$  ft/s.
- 
14. Let  $\theta$  be the acute angle, and  $x$  the distance of the bottom of the plank from the wall. Find  $\left. \frac{d\theta}{dt} \right|_{x=2}$  given that  $\left. \frac{dx}{dt} \right|_{x=2} = -\frac{1}{2}$  ft/s. The variables  $\theta$  and  $x$  are related by the equation  $\cos \theta = \frac{x}{10}$  so  $-\sin \theta \frac{d\theta}{dt} = \frac{1}{10} \frac{dx}{dt}$ ,  $\frac{d\theta}{dt} = -\frac{1}{10 \sin \theta} \frac{dx}{dt}$ . When  $x = 2$ , the top of the plank is  $\sqrt{10^2 - 2^2} = \sqrt{96}$  ft above the ground so  $\sin \theta = \sqrt{96}/10$  and  $\left. \frac{d\theta}{dt} \right|_{x=2} = -\frac{1}{\sqrt{96}} \left(-\frac{1}{2}\right) = \frac{1}{2\sqrt{96}} \approx 0.051$  rad/s.

15. Let  $x$  denote the distance from first base and  $y$  the distance from home plate. Then  $x^2 + 60^2 = y^2$  and  $2x \frac{dx}{dt} = 2y \frac{dy}{dt}$ . When  $x = 50$  then  $y = 10\sqrt{61}$  so  $\frac{dy}{dt} = \frac{x}{y} \frac{dx}{dt} = \frac{50}{10\sqrt{61}}(25) = \frac{125}{\sqrt{61}}$  ft/s.

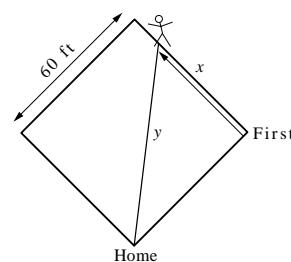

16. Find  $\frac{dx}{dt} \Big|_{x=4}$  given that  $\frac{dy}{dt} \Big|_{x=4} = 2000$ . From  $x^2 + 5^2 = y^2$  we get  $2x \frac{dx}{dt} = 2y \frac{dy}{dt}$  so  $\frac{dx}{dt} = \frac{y}{x} \frac{dy}{dt}$ . Use  $x^2 + 25 = y^2$  to find that  $y = \sqrt{41}$  when  $x = 4$  so  $\frac{dx}{dt} \Big|_{x=4} = \frac{\sqrt{41}}{4}(2000) = 500\sqrt{41}$  mi/h.

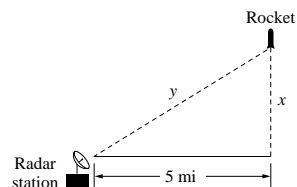

17. Find  $\frac{dy}{dt} \Big|_{x=4000}$  given that  $\frac{dx}{dt} \Big|_{x=4000} = 880$ . From  $y^2 = x^2 + 3000^2$  we get  $2y \frac{dy}{dt} = 2x \frac{dx}{dt}$  so  $\frac{dy}{dt} = \frac{x}{y} \frac{dx}{dt}$ . If  $x = 4000$ , then  $y = 5000$  so  $\frac{dy}{dt} \Big|_{x=4000} = \frac{4000}{5000}(880) = 704$  ft/s.

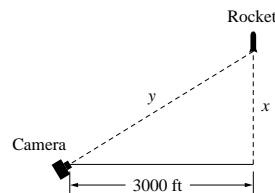

18. Find  $\frac{dx}{dt} \Big|_{\phi=\pi/4}$  given that  $\frac{d\phi}{dt} \Big|_{\phi=\pi/4} = 0.2$ . But  $x = 3000 \tan \phi$  so  $\frac{dx}{dt} = 3000(\sec^2 \phi) \frac{d\phi}{dt}$ ,  $\frac{dx}{dt} \Big|_{\phi=\pi/4} = 3000 \left( \sec^2 \frac{\pi}{4} \right) (0.2) = 1200$  ft/s.

19. (a) If  $x$  denotes the altitude, then  $r - x = 3960$ , the radius of the Earth.  $\theta = 0$  at perigee, so  $r = 4995/1.12 \approx 4460$ ; the altitude is  $x = 4460 - 3960 = 500$  miles.  $\theta = \pi$  at apogee, so  $r = 4995/0.88 \approx 5676$ ; the altitude is  $x = 5676 - 3960 = 1716$  miles.

- (b) If  $\theta = 120^\circ$ , then  $r = 4995/0.94 \approx 5314$ ; the altitude is  $5314 - 3960 = 1354$  miles. The rate of change of the altitude is given by

$$\frac{dx}{dt} = \frac{dr}{dt} = \frac{dr}{d\theta} \frac{d\theta}{dt} = \frac{4995(0.12 \sin \theta)}{(1 + 0.12 \cos \theta)^2} \frac{d\theta}{dt}$$

Use  $\theta = 120^\circ$  and  $d\theta/dt = 2.7^\circ/\text{min} = (2.7)(\pi/180)$  rad/min to get  $dr/dt \approx 27.7$  mi/min.

20. (a) Let  $x$  be the horizontal distance shown in the figure. Then  $x = 4000 \cot \theta$  and

$$\frac{dx}{dt} = -4000 \csc^2 \theta \frac{d\theta}{dt}, \text{ so } \frac{d\theta}{dt} = -\frac{\sin^2 \theta}{4000} \frac{dx}{dt}$$

Use  $\theta = 30^\circ$  and  $dx/dt = 300$  mi/h =  $300(5280/3600)$  ft/s = 440 ft/s to get  $d\theta/dt = -0.0275$  rad/s  $\approx -1.6^\circ/\text{s}$ ;  $\theta$  is decreasing at the rate of  $1.6^\circ/\text{s}$ .

- (b) Let  $y$  be the distance between the observation point and the aircraft. Then  $y = 4000 \csc \theta$  so  $dy/dt = -4000(\csc \theta \cot \theta)(d\theta/dt)$ . Use  $\theta = 30^\circ$  and  $d\theta/dt = -0.0275$  rad/s to get  $dy/dt \approx 381$  ft/s.

21. Find  $\left. \frac{dh}{dt} \right|_{h=16}$  given that  $\frac{dV}{dt} = 20$ . The volume of water in the tank at a depth  $h$  is  $V = \frac{1}{3}\pi r^2 h$ . Use similar triangles (see figure) to get  $\frac{r}{h} = \frac{10}{24}$  so  $r = \frac{5}{12}h$  thus  $V = \frac{1}{3}\pi \left(\frac{5}{12}h\right)^2 h = \frac{25}{432}\pi h^3$ ,  $\frac{dV}{dt} = \frac{25}{144}\pi h^2 \frac{dh}{dt}$ ;  $\frac{dh}{dt} = \frac{144}{25\pi h^2} \frac{dV}{dt}$ ,  $\left. \frac{dh}{dt} \right|_{h=16} = \frac{144}{25\pi(16)^2}(20) = \frac{9}{20\pi}$  ft/min.

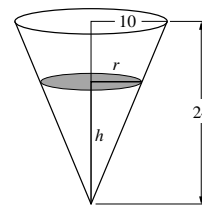

22. Find  $\left. \frac{dh}{dt} \right|_{h=6}$  given that  $\frac{dV}{dt} = 8$ .  $V = \frac{1}{3}\pi r^2 h$ , but  $r = \frac{1}{2}h$  so  $V = \frac{1}{3}\pi \left(\frac{h}{2}\right)^2 h = \frac{1}{12}\pi h^3$ ,  $\frac{dV}{dt} = \frac{1}{4}\pi h^2 \frac{dh}{dt}$ ,  $\frac{dh}{dt} = \frac{4}{\pi h^2} \frac{dV}{dt}$ ,  $\left. \frac{dh}{dt} \right|_{h=6} = \frac{4}{\pi(6)^2}(8) = \frac{8}{9\pi}$  ft/min.

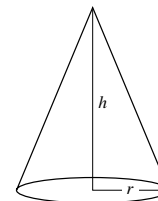

23. Find  $\left. \frac{dV}{dt} \right|_{h=10}$  given that  $\frac{dh}{dt} = 5$ .  $V = \frac{1}{3}\pi r^2 h$ , but  $r = \frac{1}{2}h$  so  $V = \frac{1}{3}\pi \left(\frac{h}{2}\right)^2 h = \frac{1}{12}\pi h^3$ ,  $\frac{dV}{dt} = \frac{1}{4}\pi h^2 \frac{dh}{dt}$ ,  $\left. \frac{dV}{dt} \right|_{h=10} = \frac{1}{4}\pi(10)^2(5) = 125\pi$  ft<sup>3</sup>/min.

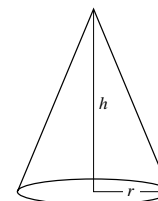

24. Let  $r$  and  $h$  be as shown in the figure. If  $C$  is the circumference of the base, then we want to find  $\left. \frac{dC}{dt} \right|_{h=8}$  given that  $\frac{dV}{dt} = 10$ . It is given that  $r = \frac{1}{2}h$ , thus  $C = 2\pi r = \pi h$  so

$$\frac{dC}{dt} = \pi \frac{dh}{dt} \quad (1)$$

Use  $V = \frac{1}{3}\pi r^2 h = \frac{1}{12}\pi h^3$  to get  $\frac{dV}{dt} = \frac{1}{4}\pi h^2 \frac{dh}{dt}$ , so

$$\frac{dh}{dt} = \frac{4}{\pi h^2} \frac{dV}{dt} \quad (2)$$

Substitution of (2) into (1) gives  $\frac{dC}{dt} = \frac{4}{h^2} \frac{dV}{dt}$  so

$$\left. \frac{dC}{dt} \right|_{h=8} = \frac{4}{64}(10) = \frac{5}{8} \text{ ft/min.}$$

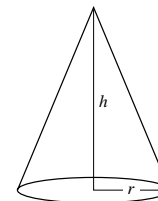

25. With  $s$  and  $h$  as shown in the figure, we want to find  $\frac{dh}{dt}$  given that  $\frac{ds}{dt} = 500$ . From the figure,  $h = s \sin 30^\circ = \frac{1}{2}s$  so  $\frac{dh}{dt} = \frac{1}{2} \frac{ds}{dt} = \frac{1}{2}(500) = 250$  mi/h.

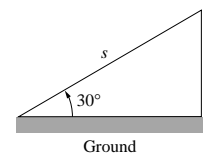

26. Find  $\frac{dx}{dt} \Big|_{y=125}$  given that  $\frac{dy}{dt} = -20$ . From  $x^2 + 10^2 = y^2$  we get  $2x \frac{dx}{dt} = 2y \frac{dy}{dt}$  so  $\frac{dx}{dt} = \frac{y}{x} \frac{dy}{dt}$ . Use  $x^2 + 100 = y^2$  to find that  $x = \sqrt{15,525} = 15\sqrt{69}$  when  $y = 125$  so  $\frac{dx}{dt} \Big|_{y=125} = \frac{125}{15\sqrt{69}}(-20) = -\frac{500}{3\sqrt{69}}$ . The boat is approaching the dock at the rate of  $\frac{500}{3\sqrt{69}}$  ft/min.

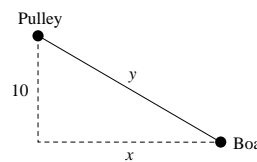

27. Find  $\frac{dy}{dt}$  given that  $\frac{dx}{dt} \Big|_{y=125} = -12$ . From  $x^2 + 10^2 = y^2$  we get  $2x \frac{dx}{dt} = 2y \frac{dy}{dt}$  so  $\frac{dy}{dt} = \frac{x}{y} \frac{dx}{dt}$ . Use  $x^2 + 100 = y^2$  to find that  $x = \sqrt{15,525} = 15\sqrt{69}$  when  $y = 125$  so  $\frac{dy}{dt} = \frac{15\sqrt{69}}{125}(-12) = -\frac{36\sqrt{69}}{25}$ . The rope must be pulled at the rate of  $\frac{36\sqrt{69}}{25}$  ft/min.

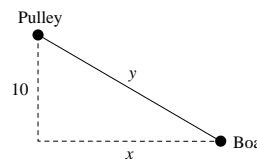

28. (a) Let  $x$  and  $y$  be as shown in the figure. It is required to find  $\frac{dx}{dt}$ , given that  $\frac{dy}{dt} = -3$ . By similar triangles,  $\frac{x}{6} = \frac{x+y}{18}$ ,  $18x = 6x + 6y$ ,  $12x = 6y$ ,  $x = \frac{1}{2}y$ , so  $\frac{dx}{dt} = \frac{1}{2} \frac{dy}{dt} = \frac{1}{2}(-3) = -\frac{3}{2}$  ft/s.

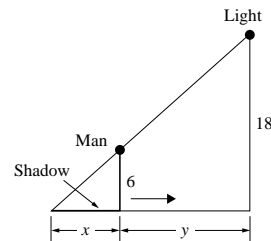

- (b) The tip of the shadow is  $z = x + y$  feet from the street light, thus the rate at which it is moving is given by  $\frac{dz}{dt} = \frac{dx}{dt} + \frac{dy}{dt}$ . In part (a) we found that  $\frac{dx}{dt} = -\frac{3}{2}$  when  $\frac{dy}{dt} = -3$  so  $\frac{dz}{dt} = (-3/2) + (-3) = -9/2$  ft/s; the tip of the shadow is moving at the rate of  $9/2$  ft/s toward the street light.

29. Find  $\frac{dx}{dt} \Big|_{\theta=\pi/4}$  given that  $\frac{d\theta}{dt} = \frac{2\pi}{10} = \frac{\pi}{5}$  rad/s. Then  $x = 4 \tan \theta$  (see figure) so  $\frac{dx}{dt} = 4 \sec^2 \theta \frac{d\theta}{dt}$ ,  $\frac{dx}{dt} \Big|_{\theta=\pi/4} = 4 \left( \sec^2 \frac{\pi}{4} \right) \left( \frac{\pi}{5} \right) = 8\pi/5$  km/s.

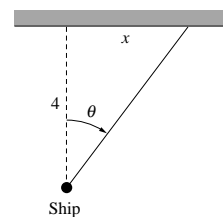

30. If  $x$ ,  $y$ , and  $z$  are as shown in the figure, then we want  $\left. \frac{dz}{dt} \right|_{\substack{x=2 \\ y=4}}$  given

that  $\frac{dx}{dt} = -600$  and  $\left. \frac{dy}{dt} \right|_{\substack{x=2 \\ y=4}} = -1200$ . But  $z^2 = x^2 + y^2$  so

$$2z \frac{dz}{dt} = 2x \frac{dx}{dt} + 2y \frac{dy}{dt}, \quad \frac{dz}{dt} = \frac{1}{z} \left( x \frac{dx}{dt} + y \frac{dy}{dt} \right).$$

When  $x = 2$  and  $y = 4$ ,  $z^2 = 2^2 + 4^2 = 20$ ,  $z = \sqrt{20} = 2\sqrt{5}$  so

$$\left. \frac{dz}{dt} \right|_{\substack{x=2 \\ y=4}} = \frac{1}{2\sqrt{5}} [2(-600) + 4(-1200)] = -\frac{3000}{\sqrt{5}} = -600\sqrt{5} \text{ mi/h; the}$$

distance between missile and aircraft is decreasing at the rate of  $600\sqrt{5}$  mi/h.

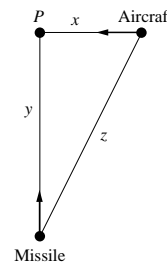

31. We wish to find  $\left. \frac{dz}{dt} \right|_{\substack{x=2 \\ y=4}}$  given  $\frac{dx}{dt} = -600$  and  $\left. \frac{dy}{dt} \right|_{\substack{x=2 \\ y=4}} = -1200$  (see

figure). From the law of cosines,

$$z^2 = x^2 + y^2 - 2xy \cos 120^\circ = x^2 + y^2 - 2xy(-1/2) = x^2 + y^2 + xy, \text{ so}$$

$$2z \frac{dz}{dt} = 2x \frac{dx}{dt} + 2y \frac{dy}{dt} + x \frac{dy}{dt} + y \frac{dx}{dt},$$

$$\frac{dz}{dt} = \frac{1}{2z} \left[ (2x + y) \frac{dx}{dt} + (2y + x) \frac{dy}{dt} \right].$$

When  $x = 2$  and  $y = 4$ ,

$$z^2 = 2^2 + 4^2 + (2)(4) = 28, \text{ so } z = \sqrt{28} = 2\sqrt{7}, \text{ thus}$$

$$\left. \frac{dz}{dt} \right|_{\substack{x=2 \\ y=4}} = \frac{1}{2(2\sqrt{7})} [(2(2) + 4)(-600) + (2(4) + 2)(-1200)] = -\frac{4200}{\sqrt{7}} =$$

$-600\sqrt{7}$  mi/h; the distance between missile and aircraft is decreasing at the rate of  $600\sqrt{7}$  mi/h.

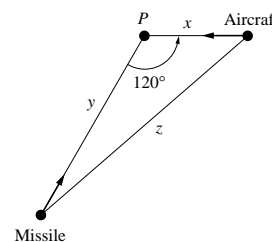

32. (a) Let  $x$ ,  $y$ , and  $z$  be the distances shown in the first figure. Find  $\left. \frac{dz}{dt} \right|_{\substack{x=2 \\ y=0}}$  given that  $\frac{dx}{dt} = -75$  and

$\frac{dy}{dt} = -100$ . In order to find an equation relating  $x$ ,  $y$ , and  $z$ , first draw the line segment that joins the point  $P$  to the car, as shown in the second figure. Because triangle  $OPC$  is a right triangle, it follows that  $PC$  has length  $\sqrt{x^2 + (1/2)^2}$ ; but triangle  $HPC$  is also a right triangle so  $z^2 = \left( \sqrt{x^2 + (1/2)^2} \right)^2 + y^2 = x^2 + y^2 + 1/4$  and  $2z \frac{dz}{dt} = 2x \frac{dx}{dt} + 2y \frac{dy}{dt} + 0$ ,

$\frac{dz}{dt} = \frac{1}{z} \left( x \frac{dx}{dt} + y \frac{dy}{dt} \right)$ . Now, when  $x = 2$  and  $y = 0$ ,  $z^2 = (2)^2 + (0)^2 + 1/4 = 17/4$ ,  $z = \sqrt{17}/2$

$$\text{so } \left. \frac{dz}{dt} \right|_{\substack{x=2 \\ y=0}} = \frac{1}{(\sqrt{17}/2)} [2(-75) + 0(-100)] = -300/\sqrt{17} \text{ mi/h}$$

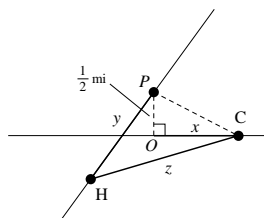
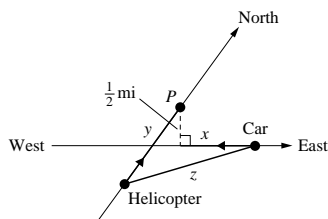

- (b) decreasing, because  $\frac{dz}{dt} < 0$ .



33. (a) We want  $\left. \frac{dy}{dt} \right|_{\substack{x=1 \\ y=2}}$ , given that  $\left. \frac{dx}{dt} \right|_{\substack{x=1 \\ y=2}} = 6$ . For convenience, first rewrite the equation as

$$xy^3 = \frac{8}{5} + \frac{8}{5}y^2 \text{ then } 3xy^2 \frac{dy}{dt} + y^3 \frac{dx}{dt} = \frac{16}{5}y \frac{dy}{dt}, \frac{dy}{dt} = \frac{y^3}{\frac{16}{5}y - 3xy^2} \frac{dx}{dt} \text{ so}$$

$$\left. \frac{dy}{dt} \right|_{\substack{x=1 \\ y=2}} = \frac{2^3}{\frac{16}{5}(2) - 3(1)2^2}(6) = -60/7 \text{ units/s.}$$

- (b) falling, because  $\frac{dy}{dt} < 0$

34. Find  $\left. \frac{dx}{dt} \right|_{(2,5)}$  given that  $\left. \frac{dy}{dt} \right|_{(2,5)} = 2$ . Square and rearrange to get  $x^3 = y^2 - 17$

$$\text{so } 3x^2 \frac{dx}{dt} = 2y \frac{dy}{dt}, \frac{dx}{dt} = \frac{2y}{3x^2} \frac{dy}{dt}, \left. \frac{dx}{dt} \right|_{(2,5)} = \left( \frac{5}{6} \right) (2) = \frac{5}{3} \text{ units/s.}$$

35. The coordinates of  $P$  are  $(x, 2x)$ , so the distance between  $P$  and the point  $(3, 0)$  is

$$D = \sqrt{(x-3)^2 + (2x-0)^2} = \sqrt{5x^2 - 6x + 9}. \text{ Find } \left. \frac{dD}{dt} \right|_{x=3} \text{ given that } \left. \frac{dx}{dt} \right|_{x=3} = -2.$$

$$\frac{dD}{dt} = \frac{5x-3}{\sqrt{5x^2-6x+9}} \frac{dx}{dt}, \text{ so } \left. \frac{dD}{dt} \right|_{x=3} = \frac{12}{\sqrt{36}}(-2) = -4 \text{ units/s.}$$

36. (a) Let  $D$  be the distance between  $P$  and  $(2, 0)$ . Find  $\left. \frac{dD}{dt} \right|_{x=3}$  given that  $\left. \frac{dx}{dt} \right|_{x=3} = 4$ .

$$D = \sqrt{(x-2)^2 + y^2} = \sqrt{(x-2)^2 + x} = \sqrt{x^2 - 3x + 4} \text{ so } \frac{dD}{dt} = \frac{2x-3}{2\sqrt{x^2-3x+4}};$$

$$\left. \frac{dD}{dt} \right|_{x=3} = \frac{3}{2\sqrt{4}} = \frac{3}{4} \text{ units/s.}$$

- (b) Let  $\theta$  be the angle of inclination. Find  $\left. \frac{d\theta}{dt} \right|_{x=3}$  given that  $\left. \frac{dx}{dt} \right|_{x=3} = 4$ .

$$\tan \theta = \frac{y}{x-2} = \frac{\sqrt{x}}{x-2} \text{ so } \sec^2 \theta \frac{d\theta}{dt} = -\frac{x+2}{2\sqrt{x}(x-2)^2} \frac{dx}{dt}, \frac{d\theta}{dt} = -\cos^2 \theta \frac{x+2}{2\sqrt{x}(x-2)^2} \frac{dx}{dt}.$$

$$\text{When } x=3, D=2 \text{ so } \cos \theta = \frac{1}{2} \text{ and } \left. \frac{d\theta}{dt} \right|_{x=3} = -\frac{1}{4} \frac{5}{2\sqrt{3}}(4) = -\frac{5}{2\sqrt{3}} \text{ rad/s.}$$

37. Solve  $\frac{dy}{dt} = 3\frac{dx}{dt}$  given  $y = x \ln x$ . Then  $\frac{dy}{dt} = \frac{dy}{dx} \frac{dx}{dt} = (1 + \ln x) \frac{dx}{dt}$ , so  $1 + \ln x = 3$ ,  $\ln x = 2$ ,  $x = e^2$ .

38.  $32x \frac{dx}{dt} + 18y \frac{dy}{dt} = 0$ ; if  $\frac{dy}{dt} = \frac{dx}{dt} \neq 0$ , then  $(32x + 18y) \frac{dx}{dt} = 0$ ,  $32x + 18y = 0$ ,  $y = -\frac{16}{9}x$  so  $16x^2 + 9 \frac{256}{81}x^2 = 144$ ,  $\frac{400}{9}x^2 = 144$ ,  $x^2 = \frac{81}{25}$ ,  $x = \pm \frac{9}{5}$ . If  $x = \frac{9}{5}$ , then  $y = -\frac{16}{9} \frac{9}{5} = -\frac{16}{5}$ . Similarly, if  $x = -\frac{9}{5}$ , then  $y = \frac{16}{5}$ . The points are  $(\frac{9}{5}, -\frac{16}{5})$  and  $(-\frac{9}{5}, \frac{16}{5})$ .

39. Find  $\left. \frac{dS}{dt} \right|_{s=10}$  given that  $\left. \frac{ds}{dt} \right|_{s=10} = -2$ . From  $\frac{1}{s} + \frac{1}{S} = \frac{1}{6}$  we get  $-\frac{1}{s^2} \frac{ds}{dt} - \frac{1}{S^2} \frac{dS}{dt} = 0$ , so  $\frac{dS}{dt} = -\frac{S^2}{s^2} \frac{ds}{dt}$ . If  $s = 10$ , then  $\frac{1}{10} + \frac{1}{S} = \frac{1}{6}$  which gives  $S = 15$ . So  $\left. \frac{dS}{dt} \right|_{s=10} = -\frac{225}{100}(-2) = 4.5 \text{ cm/s}$ .  
The image is moving away from the lens.

40. Suppose that the reservoir has height  $H$  and that the radius at the top is  $R$ . At any instant of time let  $h$  and  $r$  be the corresponding dimensions of the cone of water (see figure). We want to show that  $\frac{dh}{dt}$  is constant and independent of  $H$  and  $R$ , given that  $\frac{dV}{dt} = -kA$  where  $V$  is the volume of water,  $A$  is the area of a circle of radius  $r$ , and  $k$  is a positive constant. The volume of a cone of radius  $r$  and height  $h$  is  $V = \frac{1}{3}\pi r^2 h$ . By similar triangles  $\frac{r}{h} = \frac{R}{H}$ ,  $r = \frac{R}{H}h$  thus  $V = \frac{1}{3}\pi \left(\frac{R}{H}\right)^2 h^3$  so

$$\frac{dV}{dt} = \pi \left(\frac{R}{H}\right)^2 h^2 \frac{dh}{dt} \quad (1)$$

But it is given that  $\frac{dV}{dt} = -kA$  or, because  $A = \pi r^2 = \pi \left(\frac{R}{H}\right)^2 h^2$ ,

$$\frac{dV}{dt} = -k\pi \left(\frac{R}{H}\right)^2 h^2, \text{ which when substituted into equation (1) gives}$$

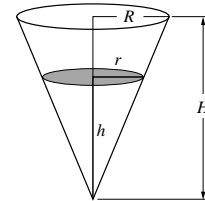
$$-k\pi \left(\frac{R}{H}\right)^2 h^2 = \pi \left(\frac{R}{H}\right)^2 h^2 \frac{dh}{dt}, \frac{dh}{dt} = -k.$$

41. Let  $r$  be the radius,  $V$  the volume, and  $A$  the surface area of a sphere. Show that  $\frac{dr}{dt}$  is a constant given that  $\frac{dV}{dt} = -kA$ , where  $k$  is a positive constant. Because  $V = \frac{4}{3}\pi r^3$ ,

$$\frac{dV}{dt} = 4\pi r^2 \frac{dr}{dt} \quad (1)$$

But it is given that  $\frac{dV}{dt} = -kA$  or, because  $A = 4\pi r^2$ ,  $\frac{dV}{dt} = -4\pi r^2 k$  which when substituted into equation (1) gives  $-4\pi r^2 k = 4\pi r^2 \frac{dr}{dt}$ ,  $\frac{dr}{dt} = -k$ .

42. Let  $x$  be the distance between the tips of the minute and hour hands, and  $\alpha$  and  $\beta$  the angles shown in the figure. Because the minute hand makes one revolution in 60 minutes,

$$\frac{d\alpha}{dt} = \frac{2\pi}{60} = \pi/30 \text{ rad/min; the hour hand makes one revolution in 12 hours (720 minutes), thus}$$

$$\frac{d\beta}{dt} = \frac{2\pi}{720} = \pi/360 \text{ rad/min. We want to find } \left. \frac{dx}{dt} \right|_{\substack{\alpha=2\pi \\ \beta=3\pi/2}} \text{ given that } \frac{d\alpha}{dt} = \pi/30 \text{ and } \frac{d\beta}{dt} = \pi/360.$$

Using the law of cosines on the triangle shown in the figure,

$$x^2 = 3^2 + 4^2 - 2(3)(4) \cos(\alpha - \beta) = 25 - 24 \cos(\alpha - \beta), \text{ so}$$

$$2x \frac{dx}{dt} = 0 + 24 \sin(\alpha - \beta) \left( \frac{d\alpha}{dt} - \frac{d\beta}{dt} \right),$$

$$\frac{dx}{dt} = \frac{12}{x} \left( \frac{d\alpha}{dt} - \frac{d\beta}{dt} \right) \sin(\alpha - \beta). \text{ When } \alpha = 2\pi \text{ and } \beta = 3\pi/2,$$

$$x^2 = 25 - 24 \cos(2\pi - 3\pi/2) = 25, x = 5; \text{ so}$$

$$\left. \frac{dx}{dt} \right|_{\substack{\alpha=2\pi \\ \beta=3\pi/2}} = \frac{12}{5} (\pi/30 - \pi/360) \sin(2\pi - 3\pi/2) = \frac{11\pi}{150} \text{ in/min.}$$

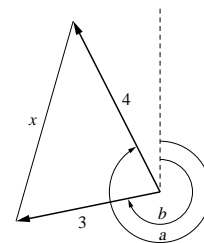

43. Extend sides of cup to complete the cone and let  $V_0$  be the volume of the portion added, then (see figure)  $V = \frac{1}{3}\pi r^2 h - V_0$  where

$$\frac{r}{h} = \frac{4}{12} = \frac{1}{3} \text{ so } r = \frac{1}{3}h \text{ and } V = \frac{1}{3}\pi \left(\frac{h}{3}\right)^2 h - V_0 = \frac{1}{27}\pi h^3 - V_0,$$

$$\frac{dV}{dt} = \frac{1}{9}\pi h^2 \frac{dh}{dt}, \frac{dh}{dt} = \frac{9}{\pi h^2} \frac{dV}{dt}, \left. \frac{dh}{dt} \right|_{h=9} = \frac{9}{\pi(9)^2} (20) = \frac{20}{9\pi} \text{ cm/s.}$$

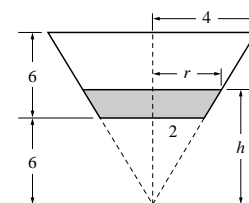

## EXERCISE SET 4.7

1. (a)  $\lim_{x \rightarrow 2} \frac{x^2 - 4}{x^2 + 2x - 8} = \lim_{x \rightarrow 2} \frac{(x-2)(x+2)}{(x+4)(x-2)} = \lim_{x \rightarrow 2} \frac{x+2}{x+4} = \frac{2}{3}$
- (b)  $\lim_{x \rightarrow +\infty} \frac{2x-5}{3x+7} = \frac{2 - \lim_{x \rightarrow +\infty} \frac{5}{x}}{3 + \lim_{x \rightarrow +\infty} \frac{7}{x}} = \frac{2}{3}$
2. (a)  $\frac{\sin x}{\tan x} = \sin x \frac{\cos x}{\sin x} = \cos x$  so  $\lim_{x \rightarrow 0} \frac{\sin x}{\tan x} = 0$
- (b)  $\frac{x^2 - 1}{x^3 - 1} = \frac{(x-1)(x+1)}{(x-1)(x^2+x+1)} = \frac{x+1}{x^2+x+1}$  so  $\lim_{x \rightarrow 1} \frac{x^2 - 1}{x^3 - 1} = \frac{2}{3}$
3.  $\lim_{x \rightarrow 1} \frac{1/x}{1} = 1$
4.  $\lim_{x \rightarrow 0} \frac{2 \cos 2x}{5 \cos 5x} = 2/5$
5.  $\lim_{x \rightarrow 0} \frac{e^x}{\cos x} = 1$
6.  $\lim_{x \rightarrow 3} \frac{1}{6x-13} = 1/5$
7.  $\lim_{\theta \rightarrow 0} \frac{\sec^2 \theta}{1} = 1$
8.  $\lim_{t \rightarrow 0} \frac{te^t + e^t}{-e^t} = -1$
9.  $\lim_{x \rightarrow \pi^+} \frac{\cos x}{1} = -1$
10.  $\lim_{x \rightarrow 0^+} \frac{\cos x}{2x} = +\infty$
11.  $\lim_{x \rightarrow +\infty} \frac{1/x}{1} = 0$
12.  $\lim_{x \rightarrow +\infty} \frac{3e^{3x}}{2x} = \lim_{x \rightarrow +\infty} \frac{9e^{3x}}{2} = +\infty$
13.  $\lim_{x \rightarrow 0^+} \frac{-\csc^2 x}{1/x} = \lim_{x \rightarrow 0^+} \frac{-x}{\sin^2 x} = \lim_{x \rightarrow 0^+} \frac{-1}{2 \sin x \cos x} = -\infty$
14.  $\lim_{x \rightarrow 0^+} \frac{-1/x}{(-1/x^2)e^{1/x}} = \lim_{x \rightarrow 0^+} \frac{x}{e^{1/x}} = 0$
15.  $\lim_{x \rightarrow +\infty} \frac{100x^{99}}{e^x} = \lim_{x \rightarrow +\infty} \frac{(100)(99)x^{98}}{e^x} = \dots = \lim_{x \rightarrow +\infty} \frac{(100)(99)(98) \cdots (1)}{e^x} = 0$
16.  $\lim_{x \rightarrow 0^+} \frac{\cos x / \sin x}{\sec^2 x / \tan x} = \lim_{x \rightarrow 0^+} \cos^2 x = 1$
17.  $\lim_{x \rightarrow 0} \frac{2/\sqrt{1-4x^2}}{1} = 2$
18.  $\lim_{x \rightarrow 0} \frac{1 - \frac{1}{1+x^2}}{3x^2} = \lim_{x \rightarrow 0} \frac{1}{3(1+x^2)} = \frac{1}{3}$
19.  $\lim_{x \rightarrow +\infty} x e^{-x} = \lim_{x \rightarrow +\infty} \frac{x}{e^x} = \lim_{x \rightarrow +\infty} \frac{1}{e^x} = 0$
20.  $\lim_{x \rightarrow \pi} (x - \pi) \tan(x/2) = \lim_{x \rightarrow \pi} \frac{x - \pi}{\cot(x/2)} = \lim_{x \rightarrow \pi} \frac{1}{-(1/2) \csc^2(x/2)} = -2$
21.  $\lim_{x \rightarrow +\infty} x \sin(\pi/x) = \lim_{x \rightarrow +\infty} \frac{\sin(\pi/x)}{1/x} = \lim_{x \rightarrow +\infty} \frac{(-\pi/x^2) \cos(\pi/x)}{-1/x^2} = \lim_{x \rightarrow +\infty} \pi \cos(\pi/x) = \pi$
22.  $\lim_{x \rightarrow 0^+} \tan x \ln x = \lim_{x \rightarrow 0^+} \frac{\ln x}{\cot x} = \lim_{x \rightarrow 0^+} \frac{1/x}{-\csc^2 x} = \lim_{x \rightarrow 0^+} \frac{-\sin^2 x}{x} = \lim_{x \rightarrow 0^+} \frac{-2 \sin x \cos x}{1} = 0$
23.  $\lim_{x \rightarrow (\pi/2)^-} \sec 3x \cos 5x = \lim_{x \rightarrow (\pi/2)^-} \frac{\cos 5x}{\cos 3x} = \lim_{x \rightarrow (\pi/2)^-} \frac{-5 \sin 5x}{-3 \sin 3x} = \frac{-5(+1)}{(-3)(-1)} = -\frac{5}{3}$

24.  $\lim_{x \rightarrow \pi} (x - \pi) \cot x = \lim_{x \rightarrow \pi} \frac{x - \pi}{\tan x} = \lim_{x \rightarrow \pi} \frac{1}{\sec^2 x} = 1$
25.  $y = (1 - 3/x)^x$ ,  $\lim_{x \rightarrow +\infty} \ln y = \lim_{x \rightarrow +\infty} \frac{\ln(1 - 3/x)}{1/x} = \lim_{x \rightarrow +\infty} \frac{-3}{1 - 3/x} = -3$ ,  $\lim_{x \rightarrow +\infty} y = e^{-3}$
26.  $y = (1 + 2x)^{-3/x}$ ,  $\lim_{x \rightarrow 0} \ln y = \lim_{x \rightarrow 0} -\frac{3 \ln(1 + 2x)}{x} = \lim_{x \rightarrow 0} -\frac{6}{1 + 2x} = -6$ ,  $\lim_{x \rightarrow 0} y = e^{-6}$
27.  $y = (e^x + x)^{1/x}$ ,  $\lim_{x \rightarrow 0} \ln y = \lim_{x \rightarrow 0} \frac{\ln(e^x + x)}{x} = \lim_{x \rightarrow 0} \frac{e^x + 1}{e^x + x} = 2$ ,  $\lim_{x \rightarrow 0} y = e^2$
28.  $y = (1 + a/x)^{bx}$ ,  $\lim_{x \rightarrow +\infty} \ln y = \lim_{x \rightarrow +\infty} \frac{b \ln(1 + a/x)}{1/x} = \lim_{x \rightarrow +\infty} \frac{ab}{1 + a/x} = ab$ ,  $\lim_{x \rightarrow +\infty} y = e^{ab}$
29.  $y = (2 - x)^{\tan(\pi x/2)}$ ,  $\lim_{x \rightarrow 1} \ln y = \lim_{x \rightarrow 1} \frac{\ln(2 - x)}{\cot(\pi x/2)} = \lim_{x \rightarrow 1} \frac{2 \sin^2(\pi x/2)}{\pi(2 - x)} = 2/\pi$ ,  $\lim_{x \rightarrow 1} y = e^{2/\pi}$
30.  $y = [\cos(2/x)]^{x^2}$ ,  $\lim_{x \rightarrow +\infty} \ln y = \lim_{x \rightarrow +\infty} \frac{\ln \cos(2/x)}{1/x^2} = \lim_{x \rightarrow +\infty} \frac{(-2/x^2)(-\tan(2/x))}{-2/x^3} = \lim_{x \rightarrow +\infty} \frac{-\tan(2/x)}{1/x}$   
 $= \lim_{x \rightarrow +\infty} \frac{(2/x^2) \sec^2(2/x)}{-1/x^2} = -2$ ,  $\lim_{x \rightarrow +\infty} y = e^{-2}$
31.  $\lim_{x \rightarrow 0} \left( \frac{1}{\sin x} - \frac{1}{x} \right) = \lim_{x \rightarrow 0} \frac{x - \sin x}{x \sin x} = \lim_{x \rightarrow 0} \frac{1 - \cos x}{x \cos x + \sin x} = \lim_{x \rightarrow 0} \frac{\sin x}{2 \cos x - x \sin x} = 0$
32.  $\lim_{x \rightarrow 0} \frac{1 - \cos 3x}{x^2} = \lim_{x \rightarrow 0} \frac{3 \sin 3x}{2x} = \lim_{x \rightarrow 0} \frac{9}{2} \cos 3x = \frac{9}{2}$
33.  $\lim_{x \rightarrow +\infty} \frac{(x^2 + x) - x^2}{\sqrt{x^2 + x} + x} = \lim_{x \rightarrow +\infty} \frac{x}{\sqrt{x^2 + x} + x} = \lim_{x \rightarrow +\infty} \frac{1}{\sqrt{1 + 1/x} + 1} = 1/2$
34.  $\lim_{x \rightarrow 0} \frac{e^x - 1 - x}{xe^x - x} = \lim_{x \rightarrow 0} \frac{e^x - 1}{xe^x + e^x - 1} = \lim_{x \rightarrow 0} \frac{e^x}{xe^x + 2e^x} = 1/2$
35.  $\lim_{x \rightarrow +\infty} [x - \ln(x^2 + 1)] = \lim_{x \rightarrow +\infty} [\ln e^x - \ln(x^2 + 1)] = \lim_{x \rightarrow +\infty} \ln \frac{e^x}{x^2 + 1}$ ,  
 $\lim_{x \rightarrow +\infty} \frac{e^x}{x^2 + 1} = \lim_{x \rightarrow +\infty} \frac{e^x}{2x} = \lim_{x \rightarrow +\infty} \frac{e^x}{2} = +\infty$  so  $\lim_{x \rightarrow +\infty} [x - \ln(x^2 + 1)] = +\infty$
36.  $\lim_{x \rightarrow +\infty} \ln \frac{x}{1 + x} = \lim_{x \rightarrow +\infty} \ln \frac{1}{1/x + 1} = \ln(1) = 0$
38. (a)  $\lim_{x \rightarrow +\infty} \frac{\ln x}{x^n} = \lim_{x \rightarrow +\infty} \frac{1/x}{nx^{n-1}} = \lim_{x \rightarrow +\infty} \frac{1}{nx^n} = 0$   
 (b)  $\lim_{x \rightarrow +\infty} \frac{x^n}{\ln x} = \lim_{x \rightarrow +\infty} \frac{nx^{n-1}}{1/x} = \lim_{x \rightarrow +\infty} nx^n = +\infty$
39. (a) L'Hôpital's Rule does not apply to the problem  $\lim_{x \rightarrow 1} \frac{3x^2 - 2x + 1}{3x^2 - 2x}$  because it is not a  $\frac{0}{0}$  form  
 (b)  $\lim_{x \rightarrow 1} \frac{3x^2 - 2x + 1}{3x^2 - 2x} = 2$
40.  $\lim_{x \rightarrow 1} \frac{4x^3 - 12x^2 + 12x - 4}{4x^3 - 9x^2 + 6x - 1} = \lim_{x \rightarrow 1} \frac{12x^2 - 24x + 12}{12x^2 - 18x + 6} = \lim_{x \rightarrow 1} \frac{24x - 24}{24x - 18} = 0$

41.  $\lim_{x \rightarrow +\infty} \frac{1/(x \ln x)}{1/(2\sqrt{x})} = \lim_{x \rightarrow +\infty} \frac{2}{\sqrt{x} \ln x} = 0$

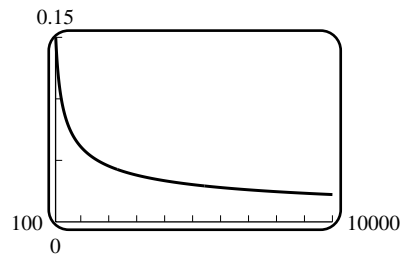

42.  $y = x^x, \lim_{x \rightarrow 0^+} \ln y = \lim_{x \rightarrow 0^+} \frac{\ln x}{1/x} = \lim_{x \rightarrow 0^+} -x = 0, \lim_{x \rightarrow 0^+} y = 1$

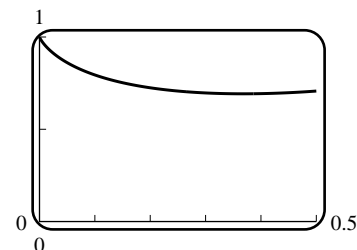

43.  $y = (\sin x)^{3/\ln x}, \lim_{x \rightarrow 0^+} \ln y = \lim_{x \rightarrow 0^+} \frac{3 \ln \sin x}{\ln x} = \lim_{x \rightarrow 0^+} (3 \cos x) \frac{x}{\sin x} = 3,$   
 $\lim_{x \rightarrow 0^+} y = e^3$

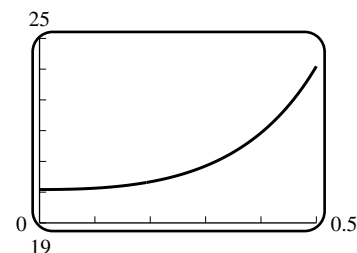

44.  $\lim_{x \rightarrow \pi/2^-} \frac{4 \sec^2 x}{\sec x \tan x} = \lim_{x \rightarrow \pi/2^-} \frac{4}{\sin x} = 4$

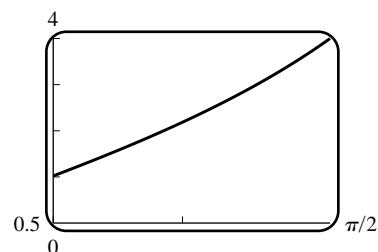

45.  $\ln x - e^x = \ln x - \frac{1}{e^{-x}} = \frac{e^{-x} \ln x - 1}{e^{-x}};$   
 $\lim_{x \rightarrow +\infty} e^{-x} \ln x = \lim_{x \rightarrow +\infty} \frac{\ln x}{e^x} = \lim_{x \rightarrow +\infty} \frac{1/x}{e^x} = 0$  by L'Hôpital's Rule, so  
 $\lim_{x \rightarrow +\infty} [\ln x - e^x] = \lim_{x \rightarrow +\infty} \frac{e^{-x} \ln x - 1}{e^{-x}} = -\infty$

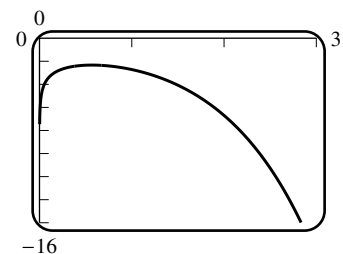

46.  $\lim_{x \rightarrow +\infty} [\ln e^x - \ln(1 + 2e^x)] = \lim_{x \rightarrow +\infty} \ln \frac{e^x}{1 + 2e^x}$   
 $= \lim_{x \rightarrow +\infty} \ln \frac{1}{e^{-x} + 2} = \ln \frac{1}{2};$   
 horizontal asymptote  $y = -\ln 2$

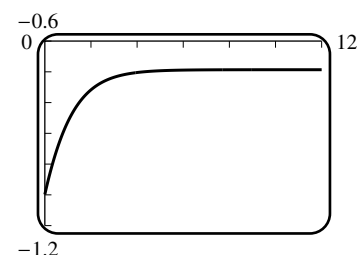

47.  $y = (\ln x)^{1/x}$ ,  $\lim_{x \rightarrow +\infty} \ln y = \lim_{x \rightarrow +\infty} \frac{\ln(\ln x)}{x} = \lim_{x \rightarrow +\infty} \frac{1}{x \ln x} = 0$ ;  
 $\lim_{x \rightarrow +\infty} y = 1$ ,  $y = 1$  is the horizontal asymptote

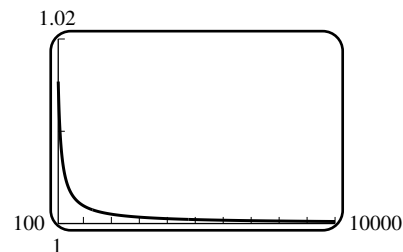

48.  $y = \left(\frac{x+1}{x+2}\right)^x$ ,  
 $\lim_{x \rightarrow +\infty} \ln y = \lim_{x \rightarrow +\infty} \frac{\ln \frac{x+1}{x+2}}{1/x} = \lim_{x \rightarrow +\infty} \frac{-x^2}{(x+1)(x+2)} = -1$ ;  
 $\lim_{x \rightarrow +\infty} y = e^{-1}$  is the horizontal asymptote

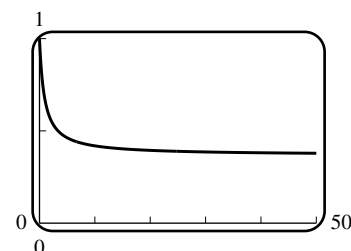

49. (a) 0      (b)  $+\infty$       (c) 0      (d)  $-\infty$       (e)  $+\infty$       (f)  $-\infty$

50. (a)  $y = x^{\frac{\ln a}{1+\ln x}}$ ;  $\lim_{x \rightarrow 0^+} \ln y = \lim_{x \rightarrow 0^+} \frac{(\ln a) \ln x}{1 + \ln x} = \lim_{x \rightarrow 0^+} \frac{(\ln a)/x}{1/x} = \lim_{x \rightarrow 0^+} \ln a = \ln a$ ,  $\lim_{x \rightarrow 0^+} y = e^{\ln a} = a$

(b) same as part (a) with  $x \rightarrow +\infty$

(c)  $y = (x+1)^{\frac{\ln a}{x}}$ ,  $\lim_{x \rightarrow 0} \ln y = \lim_{x \rightarrow 0} \frac{(\ln a) \ln(x+1)}{x} = \lim_{x \rightarrow 0} \frac{\ln a}{x+1} = \ln a$ ,  $\lim_{x \rightarrow 0} y = e^{\ln a} = a$

51.  $\lim_{x \rightarrow +\infty} \frac{1+2\cos 2x}{1}$  does not exist, nor is it  $\pm\infty$ ;  $\lim_{x \rightarrow +\infty} \frac{x + \sin 2x}{x} = \lim_{x \rightarrow +\infty} \left(1 + \frac{\sin 2x}{x}\right) = 1$

52.  $\lim_{x \rightarrow +\infty} \frac{2 - \cos x}{3 + \cos x}$  does not exist, nor is it  $\pm\infty$ ;  $\lim_{x \rightarrow +\infty} \frac{2x - \sin x}{3x + \sin x} = \lim_{x \rightarrow +\infty} \frac{2 - (\sin x)/x}{3 + (\sin x)/x} = \frac{2}{3}$

53.  $\lim_{x \rightarrow +\infty} (2 + x \cos 2x + \sin 2x)$  does not exist, nor is it  $\pm\infty$ ;  $\lim_{x \rightarrow +\infty} \frac{x(2 + \sin 2x)}{x+1} = \lim_{x \rightarrow +\infty} \frac{2 + \sin 2x}{1 + 1/x}$ , which does not exist because  $\sin 2x$  oscillates between  $-1$  and  $1$  as  $x \rightarrow +\infty$

54.  $\lim_{x \rightarrow +\infty} \left(\frac{1}{x} + \frac{1}{2} \cos x + \frac{\sin x}{2x}\right)$  does not exist, nor is it  $\pm\infty$ ;

$$\lim_{x \rightarrow +\infty} \frac{x(2 + \sin x)}{x^2 + 1} = \lim_{x \rightarrow +\infty} \frac{2 + \sin x}{x + 1/x} = 0$$

55.  $\lim_{R \rightarrow 0^+} \frac{Vt e^{-Rt/L}}{1} = \frac{Vt}{L}$

56. (a)  $\lim_{x \rightarrow \pi/2} (\pi/2 - x) \tan x = \lim_{x \rightarrow \pi/2} \frac{\pi/2 - x}{\cot x} = \lim_{x \rightarrow \pi/2} \frac{-1}{-\csc^2 x} = \lim_{x \rightarrow \pi/2} \sin^2 x = 1$

$$\begin{aligned} \text{(b)} \quad \lim_{x \rightarrow \pi/2} \left(\frac{1}{\pi/2 - x} - \tan x\right) &= \lim_{x \rightarrow \pi/2} \left(\frac{1}{\pi/2 - x} - \frac{\sin x}{\cos x}\right) = \lim_{x \rightarrow \pi/2} \frac{\cos x - (\pi/2 - x) \sin x}{(\pi/2 - x) \cos x} \\ &= \lim_{x \rightarrow \pi/2} \frac{-(\pi/2 - x) \cos x}{-(\pi/2 - x) \sin x - \cos x} \\ &= \lim_{x \rightarrow \pi/2} \frac{(\pi/2 - x) \sin x + \cos x}{-(\pi/2 - x) \cos x + 2 \sin x} = 0 \end{aligned}$$

(c)  $1/(\pi/2 - 1.57) \approx 1255.765849$ ,  $\tan 1.57 \approx 1255.765592$ ;  
 $1/(\pi/2 - 1.57) - \tan 1.57 \approx 0.000265$

57. (b)  $\lim_{x \rightarrow +\infty} x(k^{1/x} - 1) = \lim_{t \rightarrow 0^+} \frac{k^t - 1}{t} = \lim_{t \rightarrow 0^+} \frac{(\ln k)k^t}{1} = \ln k$

(c)  $\ln 0.3 = -1.20397$ ,  $1024 (\sqrt[1024]{0.3} - 1) = -1.20327$ ;  $\ln 2 = 0.69315$ ,  $1024 (\sqrt[1024]{2} - 1) = 0.69338$

58. (a) No;  $\sin(1/x)$  oscillates as  $x \rightarrow 0$ .

(b)

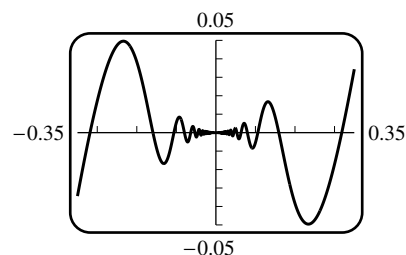

(c) For the limit as  $x \rightarrow 0^+$  use the Squeezing Theorem together with the inequalities  $-x^2 \leq x^2 \sin(1/x) \leq x^2$ . For  $x \rightarrow 0^-$  do the same; thus  $\lim_{x \rightarrow 0} f(x) = 0$ .

59. If  $k \neq -1$  then  $\lim_{x \rightarrow 0} (k + \cos \ell x) = k + 1 \neq 0$ , so  $\lim_{x \rightarrow 0} \frac{k + \cos \ell x}{x^2} = \pm\infty$ . Hence  $k = -1$ , and by the rule  
 $\lim_{x \rightarrow 0} \frac{-1 + \cos \ell x}{x^2} = \lim_{x \rightarrow 0} \frac{-\ell \sin \ell x}{2x} = \lim_{x \rightarrow 0} \frac{-\ell^2 \cos \ell x}{2} = -\frac{\ell^2}{2} = 4$  if  $\ell = \pm 2\sqrt{2}$ .

60. (a) Apply the rule to get  $\lim_{x \rightarrow 0} \frac{-\cos(1/x) + 2x \sin(1/x)}{\cos x}$  which does not exist (nor is it  $\pm\infty$ ).

(b) Rewrite as  $\lim_{x \rightarrow 0} \left[ \frac{x}{\sin x} \right] [x \sin(1/x)]$ , but  $\lim_{x \rightarrow 0} \frac{x}{\sin x} = \lim_{x \rightarrow 0} \frac{1}{\cos x} = 1$  and  $\lim_{x \rightarrow 0} x \sin(1/x) = 0$ , thus  
 $\lim_{x \rightarrow 0} \left[ \frac{x}{\sin x} \right] [x \sin(1/x)] = (1)(0) = 0$

61.  $\lim_{x \rightarrow 0^+} \frac{\sin(1/x)}{(\sin x)/x}$ ,  $\lim_{x \rightarrow 0^+} \frac{\sin x}{x} = 1$  but  $\lim_{x \rightarrow 0^+} \sin(1/x)$  does not exist because  $\sin(1/x)$  oscillates between  $-1$  and  $1$  as  $x \rightarrow +\infty$ , so  $\lim_{x \rightarrow 0^+} \frac{x \sin(1/x)}{\sin x}$  does not exist.

## CHAPTER 4 SUPPLEMENTARY EXERCISES

- (a)  $f(g(x)) = x$  for all  $x$  in the domain of  $g$ , and  $g(f(x)) = x$  for all  $x$  in the domain of  $f$ .

(b) They are reflections of each other through the line  $y = x$ .

(c) The domain of one is the range of the other and vice versa.

(d) The equation  $y = f(x)$  can always be solved for  $x$  as a function of  $y$ . Functions with no inverses include  $y = x^2$ ,  $y = \sin x$ .

(e) Yes,  $g$  is continuous; this is evident from the statement about the graphs in part (b) above.

(f) Yes,  $g$  must be differentiable (where  $f' \neq 0$ ); this can be inferred from the graphs. Note that if  $f' = 0$  at a point then  $g'$  cannot exist (infinite slope).
- (a) For  $\sin x$ ,  $-\pi/2 \leq x \leq \pi/2$ ; for  $\cos x$ ,  $0 \leq x \leq \pi$ ; for  $\tan x$ ,  $-\pi/2 < x < \pi/2$ ; for  $\sec x$ ,  $0 \leq x < \pi/2$  or  $\pi/2 < x \leq \pi$ .

(b)

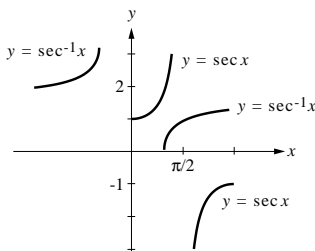
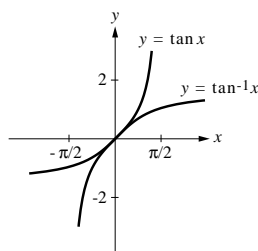
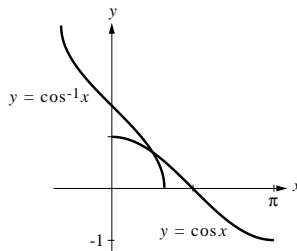
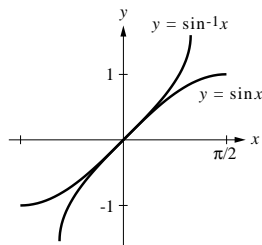

3. (a) when the limit takes the form  $0/0$  or  $\infty/\infty$   
 (b) Not necessarily; only if  $\lim f(x) = 0$ . Consider  $g(x) = x$ ;  $\lim_{x \rightarrow 0} g(x) = 0$ . For  $f(x)$  choose  $\cos x$ ,  $x^2$ , and  $|x|^{1/2}$ . There are three possibilities;  $\lim_{x \rightarrow 0} \frac{\cos x}{x}$  does not exist;  $\lim_{x \rightarrow 0} \frac{x^2}{x} = 0$ , and  $\lim_{x \rightarrow 0} \frac{|x|^{1/2}}{x^2} = +\infty$ .
4. In the case  $+\infty - (-\infty)$  the limit is  $+\infty$ ; in the case  $-\infty - (+\infty)$  the limit is  $-\infty$ , because large positive (negative) quantities are being added to large positive (negative) quantities. The cases  $+\infty - (+\infty)$  and  $-\infty - (-\infty)$  are indeterminate; large numbers of opposite sign are being subtracted, and more information about the sizes is needed.
5. (a)  $x = f(y) = 8y^3 - 1$ ;  $y = f^{-1}(x) = \left(\frac{x+1}{8}\right)^{1/3} = \frac{1}{2}(x+1)^{1/3}$   
 (b)  $f(x) = (x-1)^2$ ;  $f$  does not have an inverse because  $f$  is not one-to-one, for example  $f(0) = f(2) = 1$ .  
 (c)  $x = f(y) = (e^y)^2 + 1$ ;  $y = f^{-1}(x) = \ln \sqrt{x-1} = \frac{1}{2} \ln(x-1)$   
 (d)  $x = f(y) = \frac{y+2}{y-1}$ ;  $y = f^{-1}(x) = \frac{x+2}{x-1}$
6.  $f'(x) = \frac{ad-bc}{(cx+d)^2}$ ; if  $ad-bc = 0$  then the function represents a horizontal line, no inverse. If  $ad-bc \neq 0$  then  $f'(x) > 0$  or  $f'(x) < 0$  so  $f$  is invertible. If  $x = f(y) = \frac{ay+b}{cy+d}$  then  $y = f^{-1}(x) = \frac{b-xd}{xc-a}$ .
7. (a) Differentiating,  $\frac{2}{3}x^{-1/3} - \frac{2}{3}y^{-1/3}y' - y' = 0$ . At  $x = 1$  and  $y = -1$ ,  $y' = 2$ . The tangent line is  $y + 1 = 2(x - 1)$ .  
 (b)  $(xy' + y) \cos xy = y'$ . With  $x = \pi/2$  and  $y = 1$  this becomes  $y' = 0$ , so the equation of the tangent line is  $y - 1 = 0(x - \pi/2)$  or  $y = 1$ .
8. Draw equilateral triangles of sides 5, 12, 13, and 3, 4, 5. Then  $\sin[\cos^{-1}(4/5)] = 3/5$ ,  $\sin[\cos^{-1}(5/13)] = 12/13$ ,  $\cos[\sin^{-1}(4/5)] = 3/5$ ,  $\cos[\sin^{-1}(5/13)] = 12/13$
- (a)  $\cos[\cos^{-1}(4/5) + \sin^{-1}(5/13)] = \cos(\cos^{-1}(4/5)) \cos(\sin^{-1}(5/13)) - \sin(\cos^{-1}(4/5)) \sin(\sin^{-1}(5/13))$   
 $= \frac{4}{5} \frac{12}{13} - \frac{3}{5} \frac{5}{13} = \frac{33}{65}$ .



(b)  $\sin[\sin^{-1}(4/5) + \cos^{-1}(5/13)] = \sin(\sin^{-1}(4/5)) \cos(\cos^{-1}(5/13)) + \cos(\sin^{-1}(4/5)) \sin(\cos^{-1}(5/13))$   
 $= \frac{4}{5} \frac{5}{13} + \frac{3}{5} \frac{12}{13} = \frac{56}{65}.$

9.  $3 \ln(e^{2x}(e^x)^3) + 2 \exp(\ln 1) = 3 \ln e^{2x} + 3 \ln(e^x)^3 + 2 \cdot 1 = 3(2x) + (3 \cdot 3)x + 2 = 15x + 2$

10.  $Y = \ln(Ce^{kt}) = \ln C + \ln e^{kt} = \ln C + kt$ , a line with slope  $k$  and  $Y$ -intercept  $\ln C$

11. (a)  $\lim_{x \rightarrow +\infty} (e^x - x^2) = \lim_{x \rightarrow +\infty} x^2(e^x/x^2 - 1)$ , but  $\lim_{x \rightarrow +\infty} \frac{e^x}{x^2} = \lim_{x \rightarrow +\infty} \frac{e^x}{2x} = \lim_{x \rightarrow +\infty} \frac{e^x}{2} = +\infty$   
 so  $\lim_{x \rightarrow +\infty} (e^x/x^2 - 1) = +\infty$  and thus  $\lim_{x \rightarrow +\infty} x^2(e^x/x^2 - 1) = +\infty$

(b)  $\lim_{x \rightarrow 1} \frac{\ln x}{x^4 - 1} = \lim_{x \rightarrow 1} \frac{1/x}{4x^3} = \frac{1}{4}$ ;  $\lim_{x \rightarrow 1} \sqrt{\frac{\ln x}{x^4 - 1}} = \sqrt{\lim_{x \rightarrow 1} \frac{\ln x}{x^4 - 1}} = \frac{1}{2}$

(c)  $\lim_{x \rightarrow 0} a^x \ln a = \ln a$

12.  $y' = ae^{ax} \sin bx + be^{ax} \cos bx$  and  $y'' = (a^2 - b^2)e^{ax} \sin bx + 2abe^{ax} \cos bx$ , so  $y'' - 2ay' + (a^2 + b^2)y = (a^2 - b^2)e^{ax} \sin bx + 2abe^{ax} \cos bx - 2a(ae^{ax} \sin bx + be^{ax} \cos bx) + (a^2 + b^2)e^{ax} \sin bx = 0.$

13.  $\sin(\tan^{-1} x) = x/\sqrt{1+x^2}$  and  $\cos(\tan^{-1} x) = 1/\sqrt{1+x^2}$ , and  $y' = \frac{1}{1+x^2}$ ,  $y'' = \frac{-2x}{(1+x^2)^2}$ , hence  
 $y'' + 2 \sin y \cos^3 y = \frac{-2x}{(1+x^2)^2} + 2 \frac{x}{\sqrt{1+x^2}} \frac{1}{(1+x^2)^{3/2}} = 0.$

14.  $\ln y = 2x \ln 3 + 7x \ln 5$ ;  $\frac{dy}{dx}/y = 2 \ln 3 + 7 \ln 5$ , or  $\frac{dy}{dx} = (2 \ln 3 + 7 \ln 5)y$

15. Find  $\left. \frac{d\theta}{dt} \right|_{\substack{x=1 \\ y=1}}$  given  $\frac{dz}{dt} = a$  and  $\frac{dy}{dt} = -b$ . From the figure

$\sin \theta = y/z$ ; when  $x = y = 1$ ,  $z = \sqrt{2}$ . So  $\theta = \sin^{-1}(y/z)$  and  
 $\frac{d\theta}{dt} = \frac{1}{\sqrt{1-y^2/z^2}} \left( \frac{1}{z} \frac{dy}{dt} - \frac{y}{z^2} \frac{dz}{dt} \right) = -b - \frac{a}{\sqrt{2}}$  when  $x = y = 1$ .

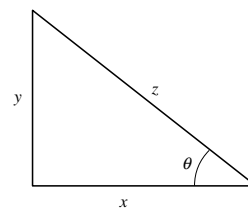

16. (a)  $f'(x) = -3/(x+1)^2$ . If  $x = f(y) = 3/(y+1)$  then  $y = f^{-1}(x) = (3/x) - 1$ , so  $\frac{d}{dx} f^{-1}(x) = \frac{-3}{x^2}$ ;  
 and  $\frac{1}{f'(f^{-1}(x))} = -\frac{(f^{-1}(x)+1)^2}{3} = -\frac{(3/x)^2}{3} = -\frac{3}{x^2}.$

(b)  $f(x) = e^{x/2}$ ,  $f'(x) = \frac{1}{2}e^{x/2}$ . If  $x = f(y) = e^{y/2}$  then  $y = f^{-1}(x) = 2 \ln x$ , so  $\frac{d}{dx} f^{-1}(x) = \frac{2}{x}$ ; and  
 $\frac{1}{f'(f^{-1}(x))} = 2e^{-f^{-1}(x)/2} = 2e^{-\ln x} = 2x^{-1} = \frac{2}{x}$

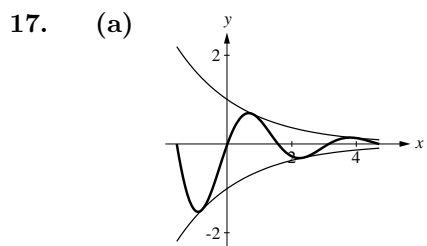

(b) The curve  $y = e^{-x/2} \sin 2x$  has  $x$ -intercepts at  $x = 0, \pi/2$ . It intersects the curve  $y = e^{-x/2}$  at  $x = \pi/4$ , and it intersects the curve  $y = -e^{-x/2}$  at  $x = -\pi/4, 3\pi/4$ .

18. (a)

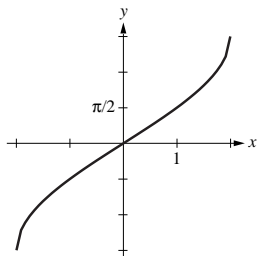

(b)

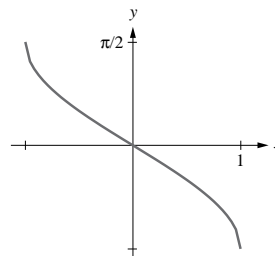

(c)

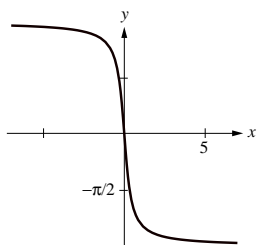

(d)

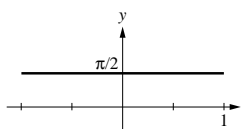

19. (a)  $\ln y = \frac{\ln(1+x)}{x}$ ,  $\frac{y'}{y} = \frac{x/(1+x) - \ln(1+x)}{x^2} = \frac{1}{x(1+x)} - \frac{\ln(1+x)}{x^2}$ ,

$$\frac{dy}{dx} = \frac{1}{x}(1+x)^{(1/x)-1} - \frac{(1+x)^{(1/x)}}{x^2} \ln(1+x)$$

(b)  $\ln y = e^x \ln x$ ,  $\frac{y'}{y} = e^x \left( \frac{1}{x} + \ln x \right)$ ,  $\frac{dy}{dx} = x^{e^x} e^x \left( \frac{1}{x} + \ln x \right) = e^x [x^{e^x-1} + x^{e^x} \ln x]$

(c)  $y = x^3 + 1$  so  $y' = 3x^2$ .

(d)  $y' = \frac{abe^{-x}}{(1+be^{-x})^2}$

(e)  $\frac{2}{3}xy^{-1/3}\frac{dy}{dx} + y^{2/3} + \frac{2}{3}yx^{-1/3} + x^{2/3}\frac{dy}{dx} = 2x$ . Multiply by  $3x^{1/3}y^{1/3}$ :

$$2x^{4/3}\frac{dy}{dx} + 3x^{1/3}y + 2y^{4/3} + 3xy^{1/3}\frac{dy}{dx} = 6x^{4/3}y^{1/3}. \text{ Regroup:}$$

$$\frac{dy}{dx} (2x^{4/3} + 3xy^{1/3}) = 6x^{4/3}y^{1/3} - 3x^{1/3}y - 2y^{4/3}, \quad \frac{dy}{dx} = \frac{6x^{4/3}y^{1/3} - 3x^{1/3}y - 2y^{4/3}}{2x^{4/3} + 3xy^{1/3}}.$$

(f)  $y = \frac{1}{2} \ln x + \frac{1}{3} \ln(x+1) - \ln \sin x + \ln \cos x$ , so

$$y' = \frac{1}{2x} + \frac{1}{3(x+1)} - \frac{\cos x}{\sin x} - \frac{\sin x}{\cos x} = \frac{5x+3}{6x(x+1)} - \cot x - \tan x.$$

20. (a) Find  $x$  when  $y = 5 \cdot 12 = 60$  in. Since  $y = \log x$ ,  $x = 10^y = 10^{60}$  in. This is approximately  $2.68 \times 10^{42}$  light-years, so even in astronomical terms it is a fabulously long distance.

(b) Find  $x$  when  $y = 100(5280)(12)$  in. Since  $y = 10^x$ ,  $x = \log y = 6.80$  in or 0.57 ft, approximately.

21. (a) The function  $\ln x - x^{0.2}$  is negative at  $x = 1$  and positive at  $x = 4$ , so it must be zero in between (IVT).

(b)  $x = 3.654$

22. (a) If  $x^k = e^x$  then  $k \ln x = x$ , or  $\frac{\ln x}{x} = \frac{1}{k}$ . The steps are reversible.

(b) By zooming it is seen that the maximum value of  $y$  is approximately 0.368 (actually,  $1/e$ ), so there are two distinct solutions of  $x^k = e^x$  whenever  $k > 1/0.368 \approx 2.717$ .

(c)  $x = 1.155$

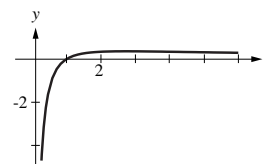

23. Set  $y = \log_b x$  and solve  $y' = 1$ :  $y' = \frac{1}{x \ln b} = 1$  so  $x = \frac{1}{\ln b}$ . The curves intersect when  $(x, x)$  lies on the graph of  $y = \log_b x$ , so  $x = \log_b x$ . From Formula (9), Section 4.2,  $\log_b x = \frac{\ln x}{\ln b}$  from which  $\ln x = 1$ ,  $x = e$ ,  $\ln b = 1/e$ ,  $b = e^{1/e} \approx 1.4447$ .

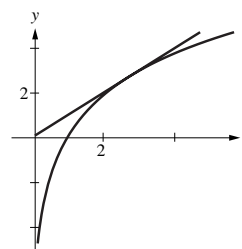

24. (a) Find the point of intersection:  $f(x) = \sqrt{x} + k = \ln x$ . The slopes are equal, so  $m_1 = \frac{1}{x} = m_2 = \frac{1}{2\sqrt{x}}$ ,  $\sqrt{x} = 2$ ,  $x = 4$ . Then  $\ln 4 = \sqrt{4} + k$ ,  $k = \ln 4 - 2$ .

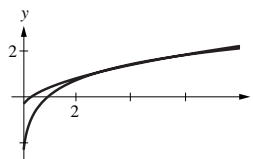

(b) Since the slopes are equal  $m_1 = \frac{k}{2\sqrt{x}} = m_2 = \frac{1}{x}$ , so  $k\sqrt{x} = 2$ . At the point of intersection  $k\sqrt{x} = \ln x$ ,  $2 = \ln x$ ,  $x = e^2$ ,  $k = 2/e$ .

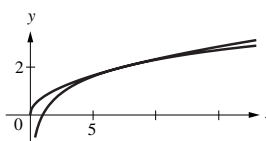

## CHAPTER 5

# Analysis of Functions and Their Graphs

### EXERCISE SET 5.1

1. (a)  $f' > 0$  and  $f'' > 0$

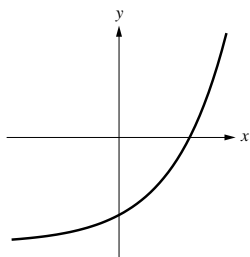

(b)  $f' > 0$  and  $f'' < 0$

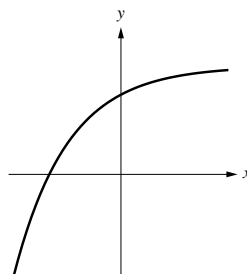

(c)  $f' < 0$  and  $f'' > 0$

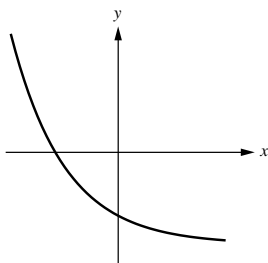

(d)  $f' < 0$  and  $f'' < 0$

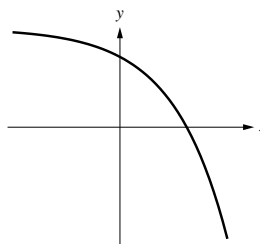

2. (a)

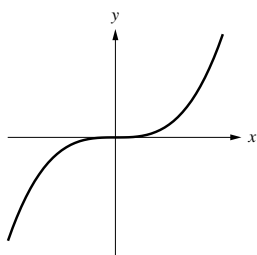

(b)

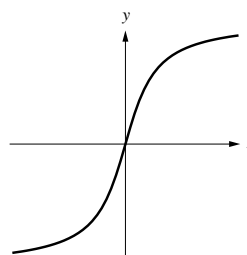

(c)

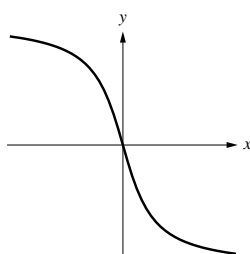

(d)

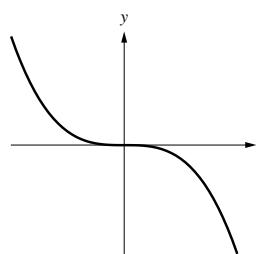

3. A:  $dy/dx < 0$ ,  $d^2y/dx^2 > 0$   
 B:  $dy/dx > 0$ ,  $d^2y/dx^2 < 0$   
 C:  $dy/dx < 0$ ,  $d^2y/dx^2 < 0$

4. A:  $dy/dx < 0$ ,  $d^2y/dx^2 < 0$   
 B:  $dy/dx < 0$ ,  $d^2y/dx^2 > 0$   
 C:  $dy/dx > 0$ ,  $d^2y/dx^2 < 0$

5. An inflection point occurs when  $f''$  changes sign: at  $x = -1, 0, 1$  and  $2$ .
6. (a)  $f(0) < f(1)$  since  $f' > 0$  on  $(0, 1)$ . (b)  $f(1) > f(2)$  since  $f' < 0$  on  $(1, 2)$ .  
 (c)  $f'(0) > 0$  by inspection. (d)  $f'(1) = 0$  by inspection.  
 (e)  $f''(0) < 0$  since  $f'$  is decreasing there. (f)  $f''(2) = 0$  since  $f'$  has a minimum there.

7. (a)  $[4, 6]$  (b)  $[1, 4]$  and  $[6, 7]$  (c)  $(1, 2)$  and  $(3, 5)$   
 (d)  $(2, 3)$  and  $(5, 7)$  (e)  $x = 2, 3, 5$

8.

	$(1, 2)$	$(2, 3)$	$(3, 4)$	$(4, 5)$	$(5, 6)$	$(6, 7)$
$f'$	-	-	-	+	+	-
$f''$	+	-	+	+	-	-

9.  $f'(x) = 2x - 5$  (a)  $[5/2, +\infty)$  (b)  $(-\infty, 5/2]$   
 $f''(x) = 2$  (c)  $(-\infty, +\infty)$  (d) none  
 (e) none
10.  $f'(x) = -2(x + 3/2)$  (a)  $(-\infty, -3/2]$  (b)  $[-3/2, +\infty)$   
 $f''(x) = -2$  (c) none (d)  $(-\infty, +\infty)$   
 (e) none
11.  $f'(x) = 3(x + 2)^2$  (a)  $(-\infty, +\infty)$  (b) none  
 $f''(x) = 6(x + 2)$  (c)  $(-2, +\infty)$  (d)  $(-\infty, -2)$   
 (e)  $-2$
12.  $f'(x) = 3(4 - x^2)$  (a)  $[-2, 2]$  (b)  $(-\infty, -2], [2, +\infty)$   
 $f''(x) = -6x$  (c)  $(-\infty, 0)$  (d)  $(0, +\infty)$   
 (e)  $0$
13.  $f'(x) = 12x^2(x - 1)$  (a)  $[1, +\infty)$  (b)  $(-\infty, 1]$   
 $f''(x) = 36x(x - 2/3)$  (c)  $(-\infty, 0), (2/3, +\infty)$  (d)  $(0, 2/3)$   
 (e)  $0, 2/3$
14.  $f'(x) = 4x(x^2 - 4)$  (a)  $[-2, 0], [2, +\infty)$  (b)  $(-\infty, -2], [0, 2]$   
 $f''(x) = 12(x^2 - 4/3)$  (c)  $(-\infty, -2/\sqrt{3}), (2/\sqrt{3}, +\infty)$  (d)  $(-2/\sqrt{3}, 2/\sqrt{3})$   
 (e)  $-2/\sqrt{3}, 2/\sqrt{3}$
15.  $f'(x) = \frac{4x}{(x^2 + 2)^2}$   $f''(x) = -4\frac{3x^2 - 2}{(x^2 + 2)^3}$   
 (a)  $[0, +\infty)$  (b)  $(-\infty, 0]$  (c)  $(-\sqrt{2/3}, +\sqrt{2/3})$   
 (d)  $(-\infty, -\sqrt{2/3}), (+\sqrt{2/3}, +\infty)$  (e)  $-\sqrt{2/3}, \sqrt{2/3}$
16.  $f'(x) = \frac{2 - x^2}{(x^2 + 2)^2}$   $f''(x) = \frac{2x(x^2 - 6)}{(x^2 + 2)^3}$   
 (a)  $[-\sqrt{2}, \sqrt{2}]$  (b)  $(-\infty, -\sqrt{2}], [\sqrt{2}, +\infty)$  (c)  $(-\sqrt{6}, 0), (\sqrt{6}, +\infty)$   
 (d)  $(-\infty, -\sqrt{6}), (0, \sqrt{6})$  (e)  $-\sqrt{6}, 0, \sqrt{6}$
17.  $f'(x) = \frac{1}{3}(x + 2)^{-2/3}$  (a)  $(-\infty, +\infty)$  (b) none  
 $f''(x) = -\frac{2}{9}(x + 2)^{-5/3}$  (c)  $(-\infty, -2)$  (d)  $(-2, +\infty)$   
 (e)  $-2$

18.  $f'(x) = \frac{2}{3}x^{-1/3}$   
 $f''(x) = -\frac{2}{9}x^{-4/3}$
- (a)  $[0, +\infty)$  (b)  $(-\infty, 0]$   
(c) none (d)  $(-\infty, 0), (0, +\infty)$   
(e) none
19.  $f'(x) = \frac{4(x+1)}{3x^{2/3}}$   
 $f''(x) = \frac{4(x-2)}{9x^{5/3}}$
- (a)  $[-1, +\infty)$  (b)  $(-\infty, -1]$   
(c)  $(-\infty, 0), (2, +\infty)$  (d)  $(0, 2)$   
(e)  $0, 2$
20.  $f'(x) = \frac{4(x-1/4)}{3x^{2/3}}$   
 $f''(x) = \frac{4(x+1/2)}{9x^{5/3}}$
- (a)  $[1/4, +\infty)$  (b)  $(-\infty, 1/4]$   
(c)  $(-\infty, -1/2), (0, +\infty)$  (d)  $(-1/2, 0)$   
(e)  $-1/2, 0$
21.  $f'(x) = -xe^{-x^2/2}$   
 $f''(x) = (-1+x^2)e^{-x^2/2}$
- (a)  $(-\infty, 0]$  (b)  $[0, +\infty)$   
(c)  $(-\infty, -1), (1, +\infty)$  (d)  $(-1, 1)$   
(e)  $-1, 1$
22.  $f'(x) = (2x^2+1)e^{x^2}$   
 $f''(x) = 2x(2x^2+3)e^{x^2}$
- (a)  $(-\infty, +\infty)$  (b) none  
(c)  $(0, +\infty)$  (d)  $(-\infty, 0)$   
(e)  $0$
23.  $f'(x) = \frac{2x}{1+x^2}$   
 $f''(x) = 2\frac{1-x^2}{(1+x^2)^2}$
- (a)  $[0, +\infty)$  (b)  $(-\infty, 0]$   
(c)  $(-1, 1)$  (d)  $(-\infty, -1), (1, +\infty)$   
(e)  $-1, 1$
24.  $f'(x) = x(2\ln x + 1)$   
 $f''(x) = 2\ln x + 3$
- (a)  $[e^{-1/2}, +\infty)$  (b)  $(0, e^{-1/2}]$   
(c)  $(e^{-3/2}, +\infty)$  (d)  $(0, e^{-3/2})$   
(e)  $e^{-3/2}$
25.  $f'(x) = -\sin x$   
 $f''(x) = -\cos x$
- (a)  $[\pi, 2\pi]$  (b)  $[0, \pi]$   
(c)  $(\pi/2, 3\pi/2)$  (d)  $(0, \pi/2), (3\pi/2, 2\pi)$   
(e)  $\pi/2, 3\pi/2$
26.  $f'(x) = 2\sin 4x$   
 $f''(x) = 8\cos 4x$
- (a)  $(0, \pi/4], [\pi/2, 3\pi/4]$  (b)  $[\pi/4, \pi/2], [3\pi/4, \pi]$   
(c)  $(0, \pi/8), (3\pi/8, 5\pi/8), (7\pi/8, \pi)$  (d)  $(\pi/8, 3\pi/8), (5\pi/8, 7\pi/8)$   
(e)  $\pi/8, 3\pi/8, 5\pi/8, 7\pi/8$

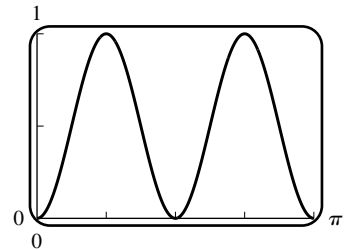
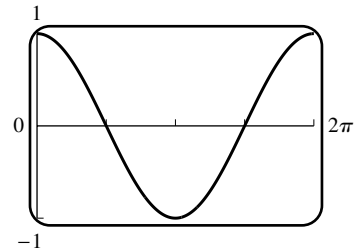

27.  $f'(x) = \sec^2 x$   
 $f''(x) = 2 \sec^2 x \tan x$   
 (a)  $(-\pi/2, \pi/2)$   
 (c)  $(0, \pi/2)$   
 (e) 0

- (b) none  
 (d)  $(-\pi/2, 0)$

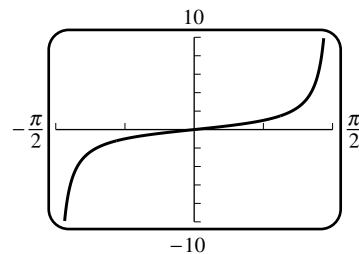

28.  $f'(x) = 2 - \csc^2 x$   
 $f''(x) = 2 \csc^2 x \cot x = 2 \frac{\cos x}{\sin^3 x}$   
 (a)  $[\pi/4, 3\pi/4]$   
 (c)  $(0, \pi/2)$   
 (e)  $\pi/2$

- (b)  $(0, \pi/4], [3\pi/4, \pi)$   
 (d)  $(\pi/2, \pi)$

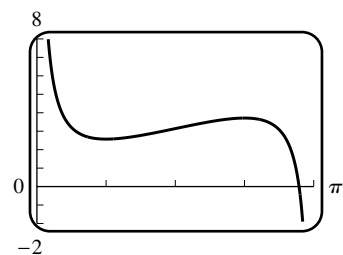

29.  $f'(x) = \cos 2x$   
 $f''(x) = -2 \sin 2x$   
 (a)  $[0, \pi/4], [3\pi/4, \pi]$   
 (c)  $(\pi/2, \pi)$   
 (e)  $\pi/2$

- (b)  $[\pi/4, 3\pi/4]$   
 (d)  $(0, \pi/2)$

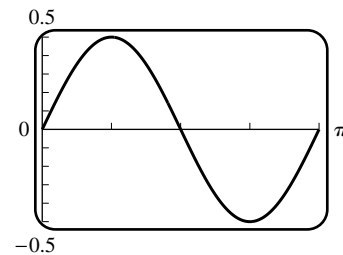

30.  $f'(x) = -2 \cos x \sin x - 2 \cos x = -2 \cos x(1 + \sin x)$   
 $f''(x) = 2 \sin x (\sin x + 1) - 2 \cos^2 x = 2 \sin x (\sin x + 1) - 2 + 2 \sin^2 x = 4(1 + \sin x)(\sin x - 1/2)$   
 Note:  $1 + \sin x \geq 0$

- (a)  $[\pi/2, 3\pi/2]$   
 (c)  $(\pi/6, 5\pi/6)$   
 (e)  $\pi/6, 5\pi/6$   
 (b)  $[0, \pi/2], [3\pi/2, 2\pi]$   
 (d)  $(0, \pi/6), (5\pi/6, 2\pi)$

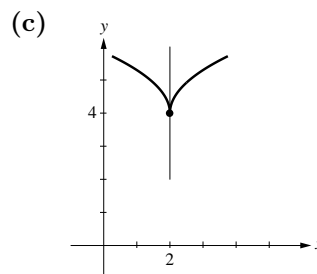
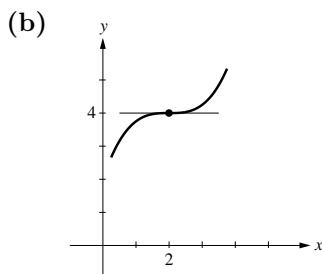
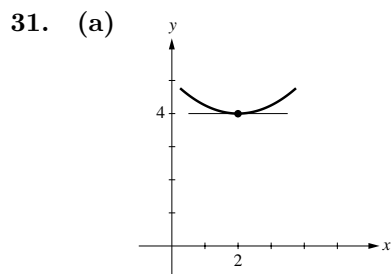
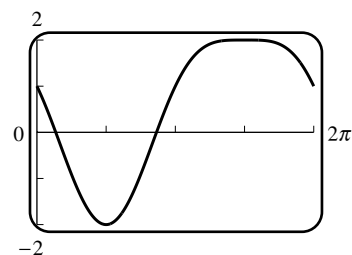

32. (a)

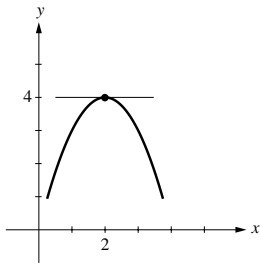

(b)

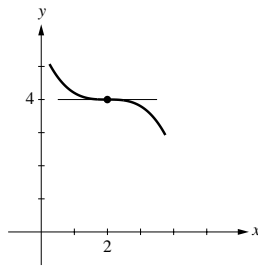

(c)

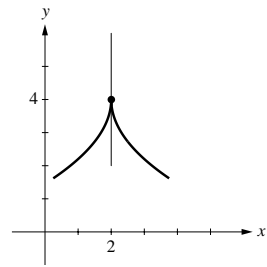
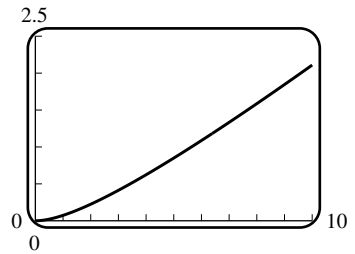
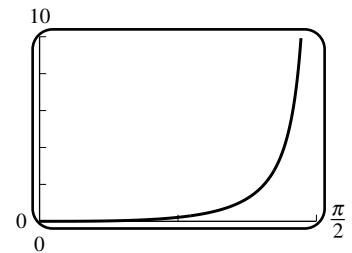
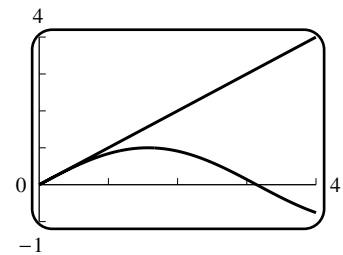
33. (a)  $f'(x) = 3(x-a)^2$ ,  $f''(x) = 6(x-a)$ ; inflection point is  $(a, 0)$ (b)  $f'(x) = 4(x-a)^3$ ,  $f''(x) = 12(x-a)^2$ ; no inflection points34. For  $n \geq 2$ ,  $f''(x) = n(n-1)(x-a)^{n-2}$ ; there is a sign change of  $f''$  (point of inflection) at  $(a, 0)$  if and only if  $n$  is odd. For  $n = 1$ ,  $y = x - a$ , so there is no point of inflection.35.  $f'(x) = 1/3 - 1/[3(1+x)^{2/3}]$  so  $f$  is increasing on  $[0, +\infty)$  thus if  $x > 0$ , then  $f(x) > f(0) = 0$ ,  $1 + x/3 - \sqrt[3]{1+x} > 0$ ,  $\sqrt[3]{1+x} < 1 + x/3$ .36.  $f'(x) = \sec^2 x - 1$  so  $f$  is increasing on  $[0, \pi/2)$  thus if  $0 < x < \pi/2$ , then  $f(x) > f(0) = 0$ ,  $\tan x - x > 0$ ,  $x < \tan x$ .37.  $x \geq \sin x$  on  $[0, +\infty)$ : let  $f(x) = x - \sin x$ . Then  $f(0) = 0$  and  $f'(x) = 1 - \cos x \geq 0$ , so  $f(x)$  is increasing on  $[0, +\infty)$ .38. (a) Let  $h(x) = e^x - 1 - x$  for  $x \geq 0$ . Then  $h(0) = 0$  and  $h'(x) = e^x - 1 \geq 0$  for  $x \geq 0$ , so  $h(x)$  is increasing.(b) Let  $h(x) = e^x - 1 - x - \frac{1}{2}x^2$ . Then  $h(0) = 0$  and  $h'(x) = e^x - 1 - x$ . By part (a),  $e^x - 1 - x \geq 0$  for  $x \geq 0$ , so  $h(x)$  is increasing.



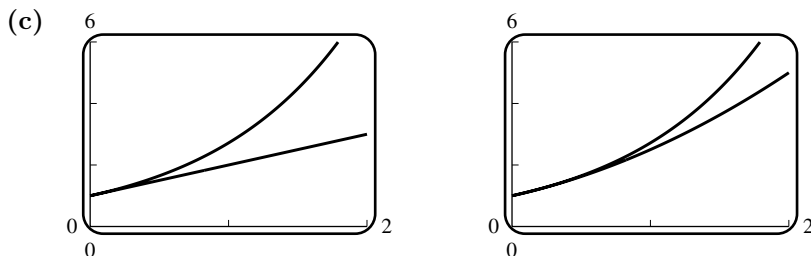

39. Points of inflection at  $x = -2, +2$ . Concave up on  $(-5, -2)$  and  $(2, 5)$ ; concave down on  $(-2, 2)$ . Increasing on  $[-3.5829, 0.2513]$  and  $[3.3316, 5]$ , and decreasing on  $[-5, -3.5829]$  and  $[0.2513, 3.3316]$ .

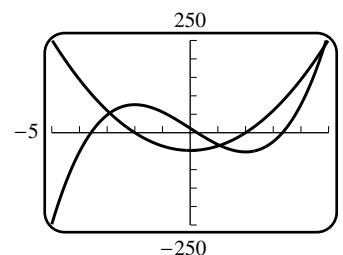

40. Points of inflection at  $x = \pm 1/\sqrt{3}$ . Concave up on  $(-5, -1/\sqrt{3})$  and  $(1/\sqrt{3}, 5)$ , and concave down on  $(-1/\sqrt{3}, 1/\sqrt{3})$ . Increasing on  $[-5, 0]$  and decreasing on  $[0, 5]$ .

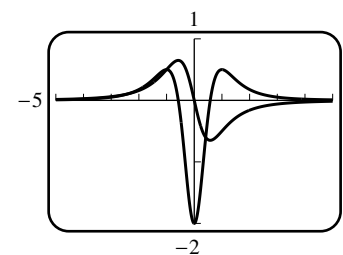

41. Break the interval  $[-5, 5]$  into ten subintervals and check  $f''(x)$  at each endpoint. We find  $f''(-1) > 0$  and  $f''(0) < 0$ . Refine  $[-1, 0]$  into ten subintervals;  $f''(-0.2) > 0$ ,  $f''(-0.1) < 0$ ; repeat,  $f''(-0.18) > 0$ ,  $f''(-0.17) < 0$ , so  $x = -0.175$  is correct to two decimal places. Note also that  $f''(1) = 0$  so there are two inflection points.

42. Break the interval  $[-5, 5]$  into ten subintervals and check  $f''(x)$  at each endpoint. We discover  $f''(-1) > 0$ ,  $f''(0) < 0$  and  $f''(1) > 0$ . Refine  $[-1, 0]$  into ten subintervals and we see that  $f''(-0.6) > 0$ ,  $f''(-0.5) < 0$ . Subdivide  $[-0.6, -0.5]$  into 10 subintervals and we see that  $f''(-0.58) > 0$  and  $f''(-0.57) < 0$ . Thus  $x = -0.575$  is within 0.005 of the true root and is thus correct to two decimal places. For the other root we could proceed in a similar manner, but it easier to note that  $f''(x)$  is an even function and thus the other root is  $x = 0.575$  to two decimal places.

43.  $f''(x) = 2 \frac{90x^3 - 81x^2 - 585x + 397}{(3x^2 - 5x + 8)^3}$ . The denominator has complex roots, so is always positive; hence the  $x$ -coordinates of the points of inflection of  $f(x)$  are the roots of the numerator (if it changes sign). A plot of the numerator over  $[-5, 5]$  shows roots lying in  $[-3, -2]$ ,  $[0, 1]$ , and  $[2, 3]$ . Breaking each of these intervals into ten subintervals locates the roots in  $[-2.5, -2.4]$ ,  $[0.6, 0.7]$  and  $[2.7, 2.8]$ . Thus to one decimal place the roots are  $x = -2.45, 0.65, 2.75$ .

44.  $f''(x) = \frac{2x^5 + 5x^3 + 14x^2 + 30x - 7}{(x^2 + 1)^{5/2}}$ . Points of inflection will occur when the numerator changes sign, since the denominator is always positive. A plot of  $y = 2x^5 + 5x^3 + 14x^2 + 30x - 7$  suggests that there is only one root and it lies in  $[0, 1]$ . Subdivide into ten subintervals and determine that the root lies between  $x = 0.2$  and  $x = 0.3$ . Thus to one decimal place the point of inflection is located at  $x = 0.25$ .

45.  $f(x_1) - f(x_2) = x_1^2 - x_2^2 = (x_1 + x_2)(x_1 - x_2) < 0$  if  $x_1 < x_2$  for  $x_1, x_2$  in  $[0, +\infty)$ , so  $f(x_1) < f(x_2)$  and  $f$  is thus increasing.

46.  $f(x_1) - f(x_2) = \frac{1}{x_1} - \frac{1}{x_2} = \frac{x_2 - x_1}{x_1 x_2} > 0$  if  $x_1 < x_2$  for  $x_1, x_2$  in  $(0, +\infty)$ , so  $f(x_1) > f(x_2)$  and thus  $f$  is decreasing.

47. (a) If  $x_1 < x_2$  where  $x_1$  and  $x_2$  are in  $I$ , then  $f(x_1) < f(x_2)$  and  $g(x_1) < g(x_2)$ , so  $f(x_1) + g(x_1) < f(x_2) + g(x_2)$ ,  $(f + g)(x_1) < (f + g)(x_2)$ . Thus  $f + g$  is increasing on  $I$ .
- (b) Case I: If  $f$  and  $g$  are  $\geq 0$  on  $I$ , and if  $x_1 < x_2$  where  $x_1$  and  $x_2$  are in  $I$ , then  $0 < f(x_1) < f(x_2)$  and  $0 < g(x_1) < g(x_2)$ , so  $f(x_1)g(x_1) < f(x_2)g(x_2)$ ,  $(f \cdot g)(x_1) < (f \cdot g)(x_2)$ . Thus  $f \cdot g$  is increasing on  $I$ .  
Case II: If  $f$  and  $g$  are not necessarily positive on  $I$  then no conclusion can be drawn: for example,  $f(x) = g(x) = x$  are both increasing on  $(-\infty, 0)$ , but  $(f \cdot g)(x) = x^2$  is decreasing there.
48. (a)  $f(x) = x, g(x) = 2x$       (b)  $f(x) = x, g(x) = x + 6$       (c)  $f(x) = 2x, g(x) = x$
49. (a)  $f''(x) = 6ax + 2b = 6a(x + \frac{b}{3a})$ ,  $f''(x) = 0$  when  $x = -\frac{b}{3a}$ .  $f$  changes its direction of concavity at  $x = -\frac{b}{3a}$  so  $-\frac{b}{3a}$  is an inflection point.
- (b) If  $f(x) = ax^3 + bx^2 + cx + d$  has three  $x$ -intercepts, then it has three roots, say  $x_1, x_2$  and  $x_3$ , so we can write  $f(x) = a(x - x_1)(x - x_2)(x - x_3) = ax^3 + bx^2 + cx + d$ , from which it follows that  $b = -a(x_1 + x_2 + x_3)$ . Thus  $-\frac{b}{3a} = \frac{1}{3}(x_1 + x_2 + x_3)$ , which is the average.
- (c)  $f(x) = x(x^2 - 3x^2 + 2) = x(x - 1)(x - 2)$  so the intercepts are 0, 1, and 2 and the average is 1.  $f''(x) = 6x - 6 = 6(x - 1)$  changes sign at  $x = 1$ .
50.  $f''(x) = 6x + 2b$ , so the point of inflection is at  $x = -\frac{b}{3}$ . Thus an increase in  $b$  moves the point of inflection to the left.
51. (a) Let  $x_1 < x_2$  belong to  $(a, b)$ . If both belong to  $(a, c]$  or both belong to  $[c, b)$  then we have  $f(x_1) < f(x_2)$  by hypothesis. So assume  $x_1 < c < x_2$ . We know by hypothesis that  $f(x_1) < f(c)$ , and  $f(c) < f(x_2)$ . We conclude that  $f(x_1) < f(x_2)$ .
- (b) Use the same argument as in part (a), but with inequalities reversed.
52. By Theorem 5.1.2,  $f$  is increasing on any interval  $((2n - 1)\pi, 2(n + 1)\pi)$  ( $n = 0, \pm 1, \pm 2, \dots$ ), because  $f'(x) = 1 + \cos x > 0$  on  $[(2n - 1)\pi, 2(n + 1)\pi]$ . By Exercise 51 (a) we can piece these intervals together to show that  $f(x)$  is increasing on  $(-\infty, +\infty)$ .

53.  $t = 7.67$

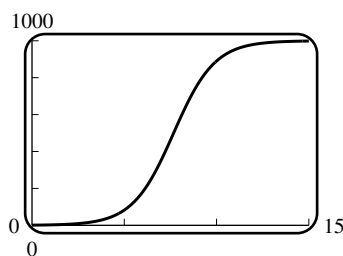

54. By zooming on the graph of  $y'(t)$ , maximum increase is at  $x = -0.577$  and maximum decrease is at  $x = 0.577$ .

- 55.

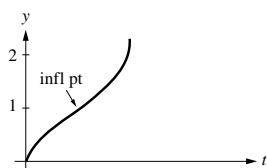

- 56.

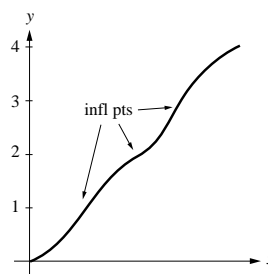

**EXERCISE SET 5.2**

1. (a)

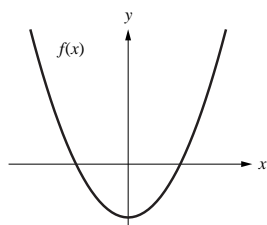

(b)

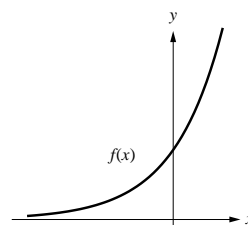

(c)

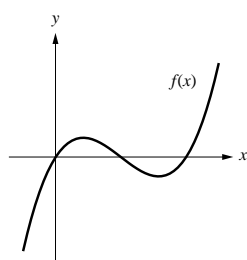

(d)

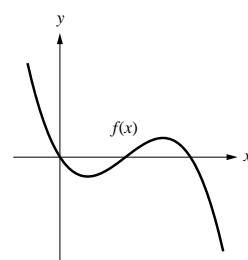

2. (a)

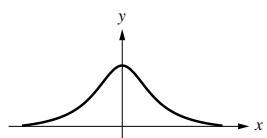

(b)

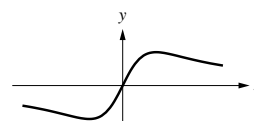

(c)

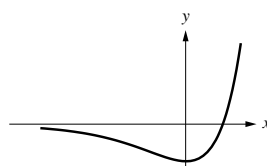

(d)

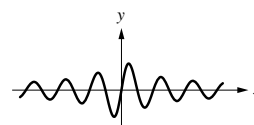

3. (a)  $f'(x) = 6x - 6$  and  $f''(x) = 6$ , with  $f'(1) = 0$ . For the first derivative test,  $f' < 0$  for  $x < 1$  and  $f' > 0$  for  $x > 1$ . For the second derivative test,  $f''(1) > 0$ .

(b)  $f'(x) = 3x^2 - 3$  and  $f''(x) = 6x$ .  $f'(x) = 0$  at  $x = \pm 1$ . First derivative test:  $f' > 0$  for  $x < -1$  and  $x > 1$ , and  $f' < 0$  for  $-1 < x < 1$ , so there is a relative maximum at  $x = -1$ , and a relative minimum at  $x = 1$ . Second derivative test:  $f'' < 0$  at  $x = -1$ , a relative maximum; and  $f'' > 0$  at  $x = 1$ , a relative minimum.

4. (a)  $f'(x) = 2 \sin x \cos x = \sin 2x$  (so  $f'(0) = 0$ ) and  $f''(x) = 2 \cos 2x$ . First derivative test: if  $x$  is near 0 then  $f' < 0$  for  $x < 0$  and  $f' > 0$  for  $x > 0$ , so a relative minimum at  $x = 0$ . Second derivative test:  $f''(0) = 2 > 0$ , so relative minimum at  $x = 0$ .

(b)  $g'(x) = 2 \tan x \sec^2 x$  (so  $g'(0) = 0$ ) and  $g''(x) = 2 \sec^2 x (\sec^2 x + 2 \tan^2 x)$ . First derivative test:  $g' < 0$  for  $x < 0$  and  $g' > 0$  for  $x > 0$ , so a relative minimum at  $x = 0$ . Second derivative test:  $g''(0) = 2 > 0$ , relative minimum at  $x = 0$ .

(c) Both functions are squares, and so are positive for values of  $x$  near zero; both functions are zero at  $x = 0$ , so that must be a relative minimum.

5. (a)  $f'(x) = 4(x - 1)^3$ ,  $g'(x) = 3x^2 - 6x + 3$  so  $f'(1) = g'(1) = 0$ .

(b)  $f''(x) = 12(x - 1)^2$ ,  $g''(x) = 6x - 6$ , so  $f''(1) = g''(1) = 0$ , which yields no information.

(c)  $f' < 0$  for  $x < 1$  and  $f' > 0$  for  $x > 1$ , so there is a relative minimum at  $x = 1$ ;  $g'(x) = 3(x - 1)^2 > 0$  on both sides of  $x = 1$ , so there is no relative extremum at  $x = 1$ .



(b) critical points:  $x = \pm 3/2, -1$ ;  $f'$ :  $\frac{+ + 0 - - \quad ? + + 0 - -}{-\frac{3}{2} \quad -1 \quad \frac{3}{2}}$

$x = \pm 3/2$ : relative maximum;  $x = -1$ : relative minimum

17.  $f'(x) = -2(x + 2)$ ; critical point  $x = -2$ ;  $f'(x)$ :  $\frac{+ + + 0 - - -}{-2}$

$f''(x) = -2$ ;  $f''(-2) < 0$ ,  $f(-2) = 5$ ; relative max of 5 at  $x = -2$

18.  $f'(x) = 6(x - 2)(x - 1)$ ; critical points  $x = 1, 2$ ;  $f'(x)$ :  $\frac{+ + + 0 - - - 0 + + +}{1 \quad 2}$

$f''(x) = 12x - 18$ ;  $f''(1) < 0$ ,  $f''(2) > 0$ ,  $f(1) = 5$ ,  $f(2) = 4$ ; relative min of 4 at  $x = 2$ , relative max of 5 at  $x = 1$

19.  $f'(x) = 2 \sin x \cos x = \sin 2x$ ; critical points  $x = \pi/2, \pi, 3\pi/2$ ;  $f'(x)$ :  $\frac{+ + 0 - - 0 + + 0 - -}{\frac{\pi}{2} \quad \pi \quad \frac{3\pi}{2}}$

$f''(x) = 2 \cos 2x$ ;  $f''(\pi/2) < 0$ ,  $f''(\pi) > 0$ ,  $f''(3\pi/2) < 0$ ,  $f(\pi/2) = f(3\pi/2) = 1$ ,  $f(\pi) = 0$ ; relative min of 0 at  $x = \pi$ , relative max of 1 at  $x = \pi/2, 3\pi/2$

20.  $f'(x) = 1/2 - \cos x$ ; critical points  $x = \pi/3, 5\pi/3$ ;  $f'(x)$ :  $\frac{- - 0 + + + + 0 - -}{\frac{\pi}{3} \quad \frac{5\pi}{3}}$

$f''(x) = -\sin x$ ;  $f''(\pi/3) < 0$ ,  $f''(5\pi/3) > 0$   
 $f(\pi/3) = \pi/6 - \sqrt{3}/2$ ,  $f(5\pi/3) = 5\pi/6 + \sqrt{3}/2$ ;  
 relative min of  $\pi/6 - \sqrt{3}/2$  at  $x = \pi/3$ , relative max of  $5\pi/6 + \sqrt{3}/2$  at  $x = 5\pi/3$

21.  $f'(x) = 3x^2 + 5$ ; no relative extrema because there are no critical points.

22.  $f'(x) = 4x(x^2 - 1)$ ; critical points  $x = 0, 1, -1$   
 $f''(x) = 12x^2 - 4$ ;  $f''(0) < 0$ ,  $f''(1) > 0$ ,  $f''(-1) > 0$   
 relative min of 6 at  $x = 1, -1$ , relative max of 7 at  $x = 0$

23.  $f'(x) = (x - 1)(3x - 1)$ ; critical points  $x = 1, 1/3$   
 $f''(x) = 6x - 4$ ;  $f''(1) > 0$ ,  $f''(1/3) < 0$   
 relative min of 0 at  $x = 1$ , relative max of  $4/27$  at  $x = 1/3$

24.  $f'(x) = 2x^2(2x + 3)$ ; critical points  $x = 0, -3/2$   
 relative min of  $-27/16$  at  $x = -3/2$  (first derivative test)

25.  $f'(x) = 4x(1 - x^2)$ ; critical points  $x = 0, 1, -1$   
 $f''(x) = 4 - 12x^2$ ;  $f''(0) > 0$ ,  $f''(1) < 0$ ,  $f''(-1) < 0$   
 relative min of 0 at  $x = 0$ , relative max of 1 at  $x = 1, -1$

26.  $f'(x) = 10(2x - 1)^4$ ; critical point  $x = 1/2$ ; no relative extrema (first derivative test)

27.  $f'(x) = \frac{4}{5}x^{-1/5}$ ; critical point  $x = 0$ ; relative min of 0 at  $x = 0$  (first derivative test)

28.  $f'(x) = 2 + \frac{2}{3}x^{-1/3}$ ; critical points  $x = 0, -1/27$   
 relative min of 0 at  $x = 0$ , relative max of  $1/27$  at  $x = -1/27$

29.  $f'(x) = 2x/(x^2 + 1)^2$ ; critical point  $x = 0$ ; relative min of 0 at  $x = 0$

30.  $f'(x) = 2/(x+2)^2$ ; no critical points ( $x = -2$  is not in the domain of  $f$ ) no relative extrema
31.  $f'(x) = 2x/(1+x^2)$ ; critical point at  $x = 0$ ; relative min of 0 at  $x = 0$  (first derivative test)
32.  $f'(x) = x(2+x)e^x$ ; critical points at  $x = 0, -2$ ; relative min of 0 at  $x = 0$  and relative max of  $4/e^2$  at  $x = -2$  (first derivative test)
33.  $f'(x) = 2x$  if  $|x| > 2$ ,  $f'(x) = -2x$  if  $|x| < 2$ ,  
 $f'(x)$  does not exist when  $x = \pm 2$ ; critical points  $x = 0, 2, -2$   
 relative min of 0 at  $x = 2, -2$ , relative max of 4 at  $x = 0$
34.  $f'(x) = -1$  if  $x < 3$ ,  $f'(x) = 2x$  if  $x > 3$ ,  $f'(3)$  does not exist;  
 critical point  $x = 3$ , relative min of 6 at  $x = 3$
35.  $f'(x) = 2 \cos 2x$  if  $\sin 2x > 0$ ,  $f'(x) = -2 \cos 2x$  if  $\sin 2x < 0$ ,  
 $f'(x)$  does not exist when  $x = \pi/2, \pi, 3\pi/2$ ;  
 critical points  $x = \pi/4, 3\pi/4, 5\pi/4, 7\pi/4, \pi/2, \pi, 3\pi/2$   
 relative min of 0 at  $x = \pi/2, \pi, 3\pi/2$ ; relative max of 1 at  
 $x = \pi/4, 3\pi/4, 5\pi/4, 7\pi/4$

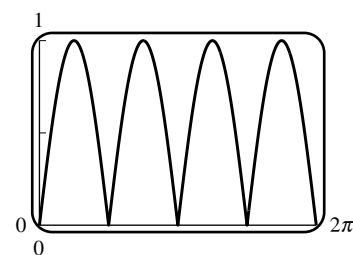

36.  $f'(x) = \sqrt{3} + 2 \cos x$ ; critical points  $x = 5\pi/6, 7\pi/6$   
 relative min of  $7\sqrt{3}\pi/6 - 1$  at  $x = 7\pi/6$ ; relative max of  
 $5\sqrt{3}\pi/6 + 1$  at  $x = 5\pi/6$

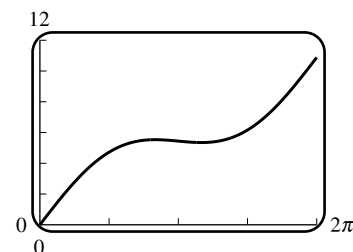

37.  $f'(x) = -\sin 2x$ ; critical points  $x = \pi/2, \pi, 3\pi/2$   
 relative min of 0 at  $x = \pi/2, 3\pi/2$ ; relative max of 1 at  $x = \pi$

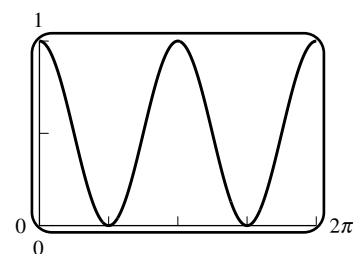

38.  $f'(x) = (2 \cos x - 1)/(2 - \cos x)^2$ ; critical points  $x = \pi/3, 5\pi/3$   
 relative max of  $\sqrt{3}/3$  at  $x = \pi/3$ , relative min of  
 $-\sqrt{3}/3$  at  $x = 5\pi/3$

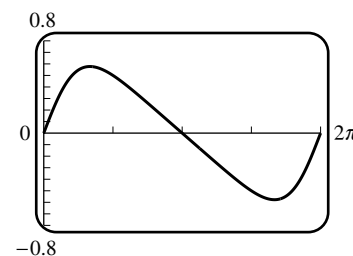

39.  $f'(x) = \ln x + 1$ ,  $f''(x) = 1/x$ ;  $f'(1/e) = 0$ ,  $f''(1/e) > 0$ ;  
relative min of  $-1/e$  at  $x = 1/e$

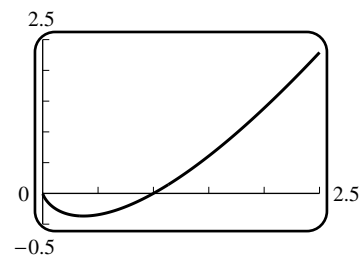

40.  $f'(x) = -2 \frac{e^x - e^{-x}}{(e^x + e^{-x})^2} = 0$  when  $x = 0$ . By the first derivative test  
 $f'(x) > 0$  for  $x < 0$  and  $f'(x) < 0$  for  $x > 0$ ; relative max of 1 at  
 $x = 0$

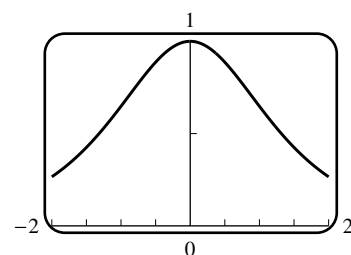

41.  $f'(x) = 2x(1-x)e^{-2x} = 0$  at  $x = 0, 1$ .  $f''(x) = (4x^2 - 8x + 2)e^{-2x}$ ;  
 $f''(0) > 0$  and  $f''(1) < 0$ , so a relative min of 0 at  $x = 0$  and a  
relative max of  $1/e^2$  at  $x = 1$ .

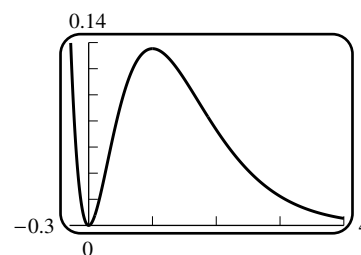

42.  $f'(x) = 10/x - 1 = 0$  at  $x = 10$ ;  $f''(x) = -10/x^2 < 0$ ;  
relative max of  $10(\ln(10) - 1) \approx 13.03$  at  $x = 10$

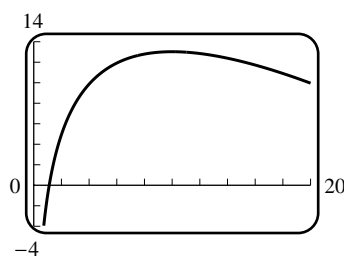

43. Relative minima at  $x = -3.58, 3.33$ ; relative max at  $x = 0.25$

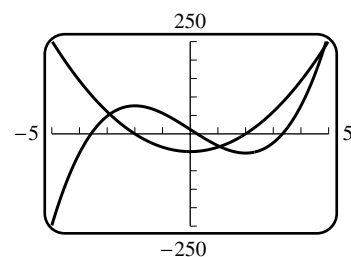

44. Relative min at  $x = -0.84$ ; relative max at  $x = 0.84$

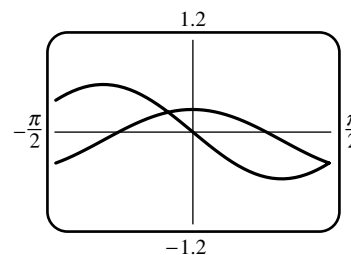

45. relative max at  $x = 0.255$

46. relative max at  $x = 0.845$

47. Relative min at  $x = -1.20$  and a relative max at  $x = 1.80$

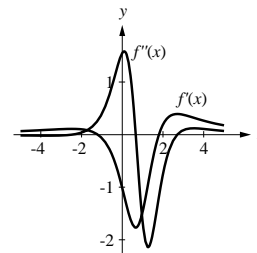

48. Relative max at  $x = -0.78$  and a relative min at  $x = 1.55$

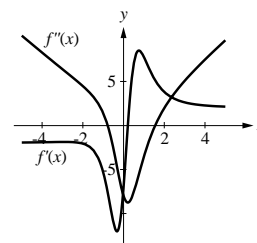

49. (a) Let  $f(x) = x^2 + \frac{k}{x}$ , then  $f'(x) = 2x - \frac{k}{x^2} = \frac{2x^3 - k}{x^2}$ .  $f$  has a relative extremum when  $2x^3 - k = 0$ , so  $k = 2x^3 = 2(3)^3 = 54$ .

(b) Let  $f(x) = \frac{x}{x^2 + k}$ , then  $f'(x) = \frac{k - x^2}{(x^2 + k)^2}$ .  $f$  has a relative extremum when  $k - x^2 = 0$ , so  $k = x^2 = 3^2 = 9$ .

50. (a) one relative maximum, located at  $x = n$

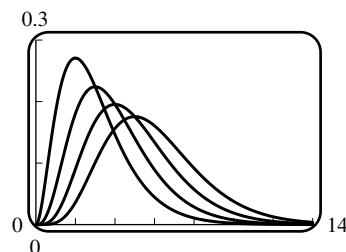

(b)  $f'(x) = cx^{n-1}(-x+n)e^{-x} = 0$  at  $x = n$ . Since  $f'(x) > 0$  for  $x < n$  and  $f'(x) < 0$  for  $x > n$  it's a maximum.

51. (a)  $f'(x) = -xf(x)$ . Since  $f(x)$  is always positive,  $f'(x) = 0$  at  $x = 0$ ,  $f'(x) > 0$  for  $x < 0$  and  $f'(x) < 0$  for  $x > 0$ , so  $x = 0$  is a maximum.

(b)

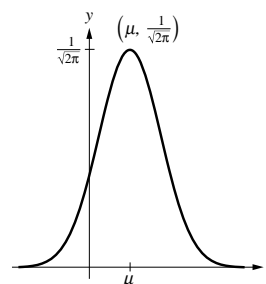



52. (a) relative minima at  $x = \pm 0.6436$ , relative max at  $x = 0$  (b)  $x = \pm 0.6436, 0$

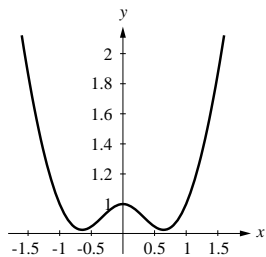

53.  $f'(x) = 3ax^2 + 2bx + c$  and  $f'(x)$  has roots at  $x = 0, 1$ , so  $f'(x)$  must be of the form  $f'(x) = 3ax(x - 1)$ ; thus  $c = 0$  and  $2b = -3a$ ,  $b = -3a/2$ .  $f''(x) = 6ax + 2b = 6ax - 3a$ , so  $f''(0) > 0$  and  $f''(1) < 0$  provided  $a < 0$ . Finally  $f(0) = d$ , so  $d = 0$ ; and  $f(1) = a + b + c + d = a + b = -a/2$  so  $a = -2$ . Thus  $f(x) = -2x^3 + 3x^2$ .
54. (a) Because  $h$  and  $g$  have relative maxima at  $x_0$ ,  $h(x) \leq h(x_0)$  for all  $x$  in  $I_1$  and  $g(x) \leq g(x_0)$  for all  $x$  in  $I_2$ , where  $I_1$  and  $I_2$  are open intervals containing  $x_0$ . If  $x$  is in  $I_1 \cap I_2$  then both inequalities are true and by addition so is  $h(x) + g(x) \leq h(x_0) + g(x_0)$  which shows that  $h + g$  has a relative maximum at  $x_0$ .
- (b) By counterexample; both  $h(x) = -x^2$  and  $g(x) = -2x^2$  have relative maxima at  $x = 0$  but  $h(x) - g(x) = x^2$  has a relative minimum at  $x = 0$  so in general  $h - g$  does not necessarily have a relative maximum at  $x_0$ .

55. (a) (b) (c)   
 $f(x_0)$  is not an extreme value.       $f(x_0)$  is a relative maximum.       $f(x_0)$  is a relative minimum.

EXERCISE SET 5.3

1.  $y = x^2 - 2x - 3$ ;  
 $y' = 2(x - 1)$ ;  
 $y'' = 2$

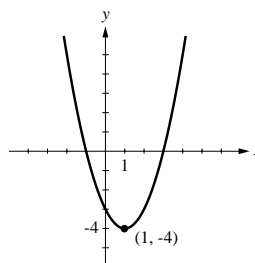

2.  $y = 1 + x - x^2$ ;  
 $y' = -2(x - 1/2)$ ;  
 $y'' = -2$

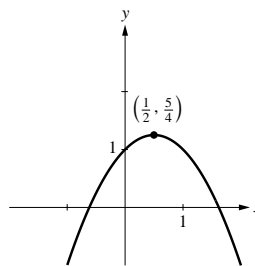

3.  $y = x^3 - 3x + 1$ ;  
 $y' = 3(x^2 - 1)$ ;  
 $y'' = 6x$

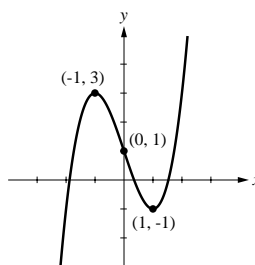

4.  $y = 2x^3 - 3x^2 + 12x + 9$ ;  
 $y' = 6(x^2 - x + 2)$ ;  
 $y'' = 12(x - 1/2)$

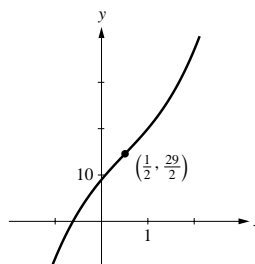

5.  $y = x^4 + 2x^3 - 1$ ;  
 $y' = 4x^2(x + 3/2)$ ;  
 $y'' = 12x(x + 1)$

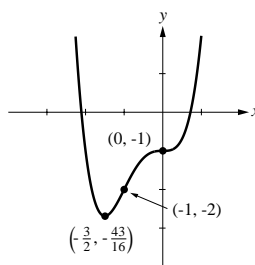

6.  $y = x^4 - 2x^2 - 12$ ;  
 $y' = 4x(x^2 - 1)$ ;  
 $y'' = 12(x^2 - 1/3)$

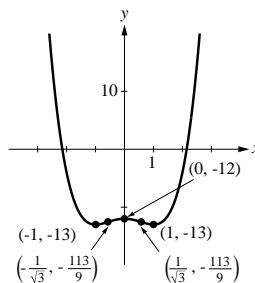

7.  $y = x^3(3x^2 - 5);$   
 $y' = 15x^2(x^2 - 1);$   
 $y'' = 30x(2x^2 - 1)$

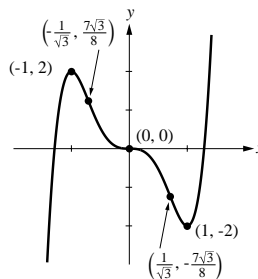

8.  $y = 3x^3(x + 4/3);$   
 $y' = 12x^2(x + 1);$   
 $y'' = 36x(x + 2/3)$

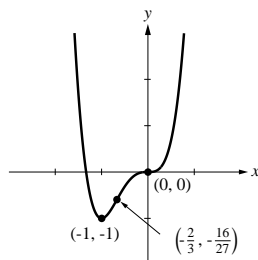

9.  $y = x(x - 1)^3;$   
 $y' = (4x - 1)(x - 1)^2;$   
 $y'' = 6(2x - 1)(x - 1)$

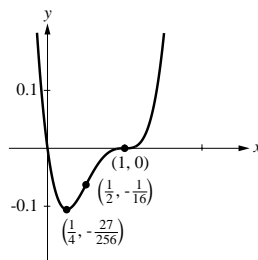

10.  $y = x^4(x + 5);$   
 $y' = 5x^3(x + 4);$   
 $y'' = 20x^2(x + 3)$

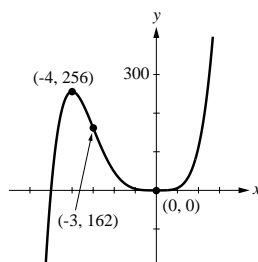

11.  $y = 2x/(x - 3);$   
 $y' = -6/(x - 3)^2;$   
 $y'' = 12/(x - 3)^3$

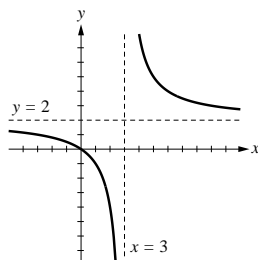

$$12. \quad y = \frac{x}{x^2 - 1};$$

$$y' = -\frac{x^2 + 1}{(x^2 - 1)^2};$$

$$y'' = \frac{2x(x^2 + 3)}{(x^2 - 1)^3}$$

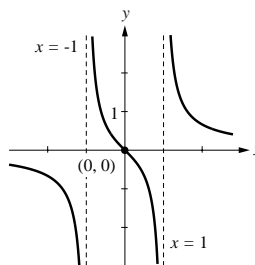

$$13. \quad y = \frac{x^2}{x^2 - 1};$$

$$y' = -\frac{2x}{(x^2 - 1)^2};$$

$$y'' = \frac{2(3x^2 + 1)}{(x^2 - 1)^3}$$

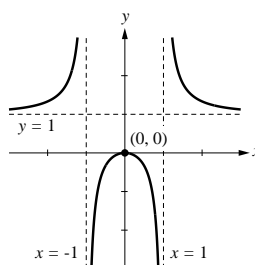

$$14. \quad y = \frac{x^2 - 1}{x^2 + 1};$$

$$y' = \frac{4x}{(x^2 + 1)^2};$$

$$y'' = \frac{4(1 - 3x^2)}{(x^2 + 1)^3}$$

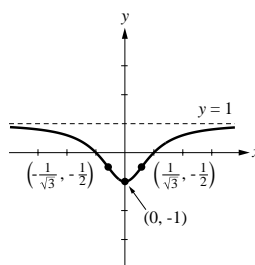

$$15. \quad y = x^2 - \frac{1}{x} = \frac{x^3 - 1}{x};$$

$$y' = \frac{2x^3 + 1}{x^2},$$

$$y' = 0 \text{ when } x = -\sqrt[3]{\frac{1}{2}} \approx -0.8;$$

$$y'' = \frac{2(x^3 - 1)}{x^3}$$

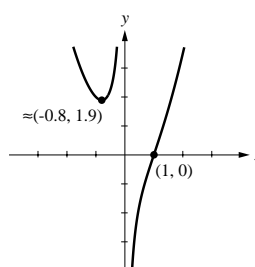

$$16. \quad y = \frac{2x^2 - 1}{x^2};$$

$$y' = \frac{2}{x^3};$$

$$y'' = -\frac{6}{x^4}$$

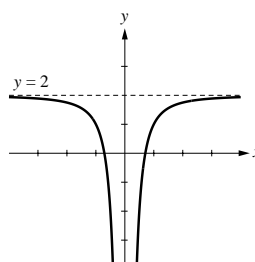

17.  $y = \frac{x^3 - 1}{x^3 + 1};$   
 $y' = \frac{6x^2}{(x^3 + 1)^2};$   
 $y'' = \frac{12x(1 - 2x^3)}{(x^3 + 1)^3}$

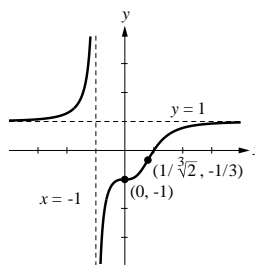

18.  $y = \frac{8}{4 - x^2};$   
 $y' = \frac{16x}{(4 - x^2)^2};$   
 $y'' = \frac{16(3x^2 + 4)}{(4 - x^2)^3}$

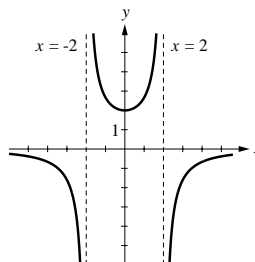

19.  $y = \frac{x - 1}{x^2 - 4};$   
 $y' = -\frac{x^2 - 2x + 4}{(x^2 - 4)^2}$

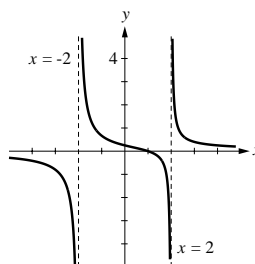

20.  $y = 3 - \frac{4}{x} - \frac{4}{x^2};$   
 $y' = \frac{4(x + 2)}{x^3};$   
 $y'' = -\frac{8(x + 3)}{x^4}$

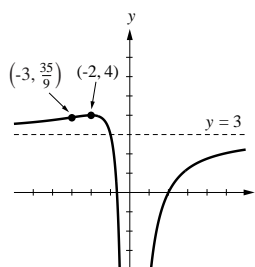

21.  $y = \frac{(x - 1)^2}{x^2};$   
 $y' = \frac{2(x - 1)}{x^3};$   
 $y'' = \frac{2(3 - 2x)}{x^4}$

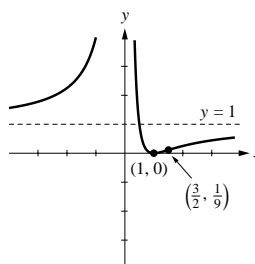

$$22. \quad y = 2 + \frac{3}{x} - \frac{1}{x^3};$$

$$y' = \frac{3(1-x^2)}{x^4};$$

$$y'' = \frac{6(x^2-2)}{x^5}$$

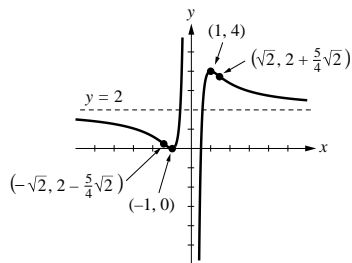

23. (a) VI      (b) I      (c) III      (d) V      (e) IV      (f) II

24. (a) When  $n$  is even the function is defined only for  $x \geq 0$ ; as  $n$  increases the graph approaches the line  $y = 1$  for  $x > 0$ .

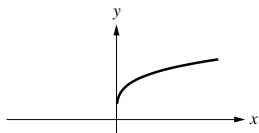

- (b) When  $n$  is odd the graph is symmetric with respect to the origin; as  $n$  increases the graph approaches the line  $y = 1$  for  $x > 0$  and the line  $y = -1$  for  $x < 0$ .

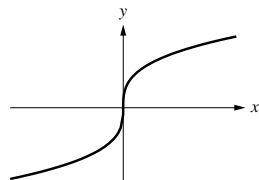

$$25. \quad y = \sqrt{x^2 - 1};$$

$$y' = \frac{x}{\sqrt{x^2 - 1}};$$

$$y'' = -\frac{1}{(x^2 - 1)^{3/2}}$$

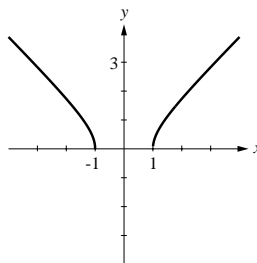

$$26. \quad y = \sqrt[3]{x^2 - 4};$$

$$y' = \frac{2x}{3(x^2 - 4)^{2/3}};$$

$$y'' = -\frac{2(3x^2 + 4)}{9(x^2 - 4)^{5/3}}$$

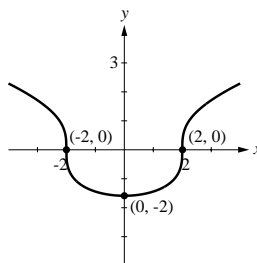

27.  $y = 2x + 3x^{2/3};$   
 $y' = 2 + 2x^{-1/3};$   
 $y'' = -\frac{2}{3}x^{-4/3}$

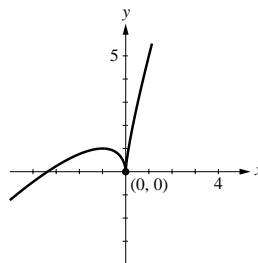

28.  $y = 4x - 3x^{4/3};$   
 $y' = 4 - 4x^{1/3};$   
 $y'' = -\frac{4}{3}x^{-2/3}$

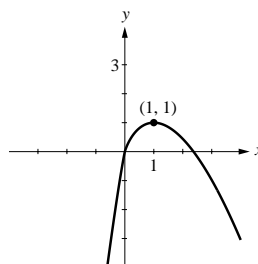

29.  $y = x(3 - x)^{1/2};$   
 $y' = \frac{3(2 - x)}{2\sqrt{3 - x}};$   
 $y'' = \frac{3(x - 4)}{4(3 - x)^{3/2}}$

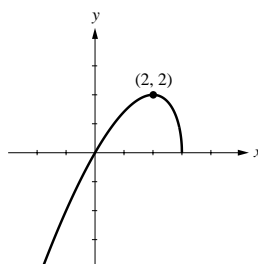

30.  $y = x^{1/3}(4 - x);$   
 $y' = \frac{4(1 - x)}{3x^{2/3}};$   
 $y'' = -\frac{4(x + 2)}{9x^{5/3}}$

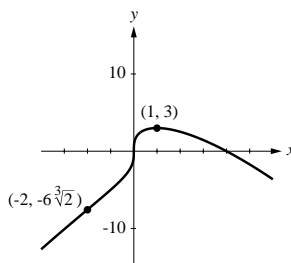

31.  $y = \frac{8(\sqrt{x} - 1)}{x};$   
 $y' = \frac{4(2 - \sqrt{x})}{x^2};$   
 $y'' = \frac{2(3\sqrt{x} - 8)}{x^3}$

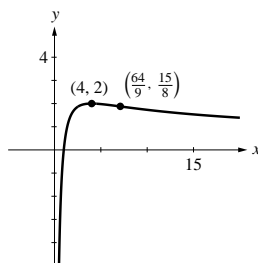

32.  $y = \frac{1 + \sqrt{x}}{1 - \sqrt{x}};$   
 $y' = \frac{1}{2\sqrt{x}(1 - \sqrt{x})};$   
 $y'' = \frac{3\sqrt{x} - 1}{2x^{3/2}(1 - \sqrt{x})^3}$

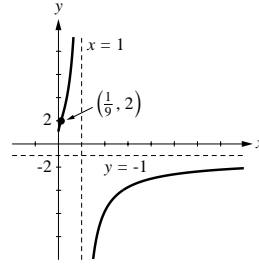

33.  $y = x + \sin x;$   
 $y' = 1 + \cos x, y' = 0 \text{ when } x = \pi + 2n\pi;$   
 $y'' = -\sin x; y'' = 0 \text{ when } x = n\pi$   
 $n = 0, \pm 1, \pm 2, \dots$

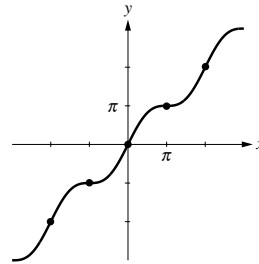

34.  $y = x - \cos x;$   
 $y' = 1 + \sin x;$   
 $y' = 0 \text{ when } x = -\pi/2 + 2n\pi;$   
 $y'' = \cos x;$   
 $y'' = 0 \text{ when } x = \pi/2 + n\pi$   
 $n = 0, \pm 1, \pm 2, \dots$

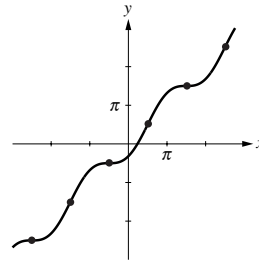

35.  $y = \sin x + \cos x;$   
 $y' = \cos x - \sin x;$   
 $y' = 0 \text{ when } x = \pi/4 + n\pi;$   
 $y'' = -\sin x - \cos x;$   
 $y'' = 0 \text{ when } x = 3\pi/4 + n\pi$

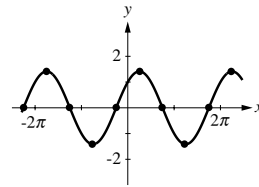

36.  $y = \sqrt{3} \cos x + \sin x;$   
 $y' = -\sqrt{3} \sin x + \cos x;$   
 $y' = 0 \text{ when } x = \pi/6 + n\pi;$   
 $y'' = -\sqrt{3} \cos x - \sin x;$   
 $y'' = 0 \text{ when } x = 2\pi/3 + n\pi$

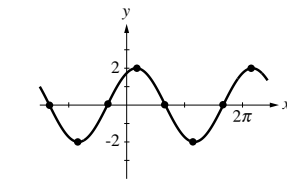



37.  $y = \sin^2 x, 0 \leq x \leq 2\pi;$   
 $y' = 2 \sin x \cos x = \sin 2x;$   
 $y'' = 2 \cos 2x$

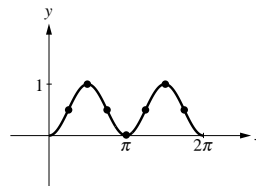

38.  $y = x \tan x, -\pi/2 < x < \pi/2;$   
 $y' = x \sec^2 x + \tan x;$   
 $y' = 0$  when  $x = 0;$   
 $y'' = 2 \sec^2 x(x \tan x + 1),$  which is always positive for  $-\pi/2 < x < \pi/2$

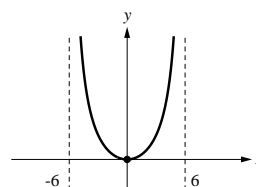

39. (a)  $\lim_{x \rightarrow +\infty} x e^x = +\infty, \lim_{x \rightarrow -\infty} x e^x = 0$   
 (b)  $y = x e^x;$   
 $y' = (x + 1)e^x;$   
 $y'' = (x + 2)e^x$

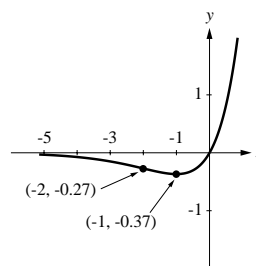

40. (a)  $\lim_{x \rightarrow +\infty} x e^{-2x} = 0, \lim_{x \rightarrow -\infty} x e^{-2x} = -\infty$   
 (b)  $y = x e^{-2x}; y' = -2 \left( x - \frac{1}{2} \right) e^{-2x}; y'' = 4(x - 1)e^{-2x}$

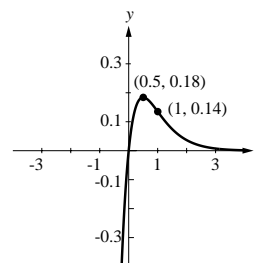

41. (a)  $\lim_{x \rightarrow +\infty} \frac{x^2}{e^{2x}} = 0, \lim_{x \rightarrow -\infty} \frac{x^2}{e^{2x}} = +\infty$   
 (b)  $y = x^2/e^{2x} = x^2 e^{-2x};$   
 $y' = 2x(1 - x)e^{-2x};$   
 $y'' = 2(2x^2 - 4x + 1)e^{-2x};$   
 $y'' = 0$  if  $2x^2 - 4x + 1 = 0,$  when  
 $x = \frac{4 \pm \sqrt{16 - 8}}{4} = 1 \pm \sqrt{2}/2 \approx 0.29, 1.71$

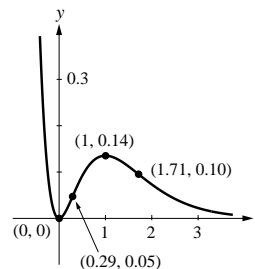

42. (a)  $\lim_{x \rightarrow +\infty} x^2 e^{2x} = +\infty, \lim_{x \rightarrow -\infty} x^2 e^{2x} = 0.$

- (b)  $y = x^2 e^{2x};$   
 $y' = 2x(x+1)e^{2x};$   
 $y'' = 2(2x^2 + 4x + 1)e^{2x};$   
 $y'' = 0$  if  $2x^2 + 4x + 1 = 0$ , when  
 $x = \frac{-4 \pm \sqrt{16-8}}{4} = -1 \pm \sqrt{2}/2 \approx -0.29, -1.71$

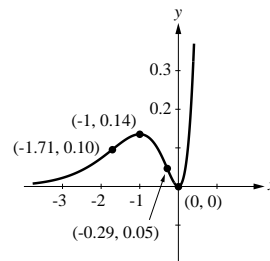

43. (a)  $\lim_{x \rightarrow +\infty} f(x) = +\infty, \lim_{x \rightarrow -\infty} f(x) = -\infty$

- (b)  $y = x e^{x^2};$   
 $y' = (1 + 2x^2)e^{x^2};$   
 $y'' = 2x(3 + 2x^2)e^{x^2}$   
 no relative extrema, inflection point at  $(0, 0)$

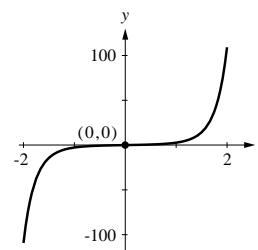

44. (a)  $\lim_{x \rightarrow \pm\infty} f(x) = 1$

- (b)  $f'(x) = 2x^{-3}e^{-1/x^2}$  so  $f'(x) < 0$  for  $x < 0$  and  $f'(x) > 0$  for  $x > 0$ . By L'Hôpital's Rule  $\lim_{x \rightarrow 0} f'(x) = 0$ , so (by the first derivative test)  $f(x)$  has a minimum at  $x = 0$ .  
 $f''(x) = (-6x^{-4} + 4x^{-6})e^{-1/x^2}$ , so  $f(x)$  has points of inflection at  $x = \pm\sqrt{2/3}$

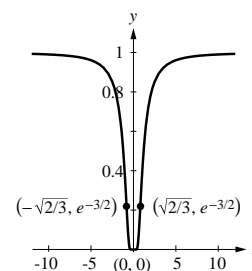

45. (a)  $\lim_{x \rightarrow 0^+} y = \lim_{x \rightarrow 0^+} x \ln x = \lim_{x \rightarrow 0^+} \frac{\ln x}{1/x} = \lim_{x \rightarrow 0^+} \frac{1/x}{-1/x^2} = 0;$   
 $\lim_{x \rightarrow +\infty} y = +\infty$

- (b)  $y = x \ln x,$   
 $y' = 1 + \ln x, y'' = 1/x,$   
 $y' = 0$  when  $x = e^{-1}$

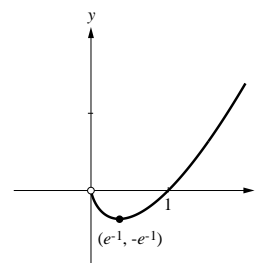

46. (a)  $\lim_{x \rightarrow 0^+} y = \lim_{x \rightarrow 0^+} \frac{\ln x}{1/x^2} = \lim_{x \rightarrow 0^+} \frac{1/x}{-2/x^3} = 0,$   
 $\lim_{x \rightarrow +\infty} y = +\infty$

- (b)  $y = x^2 \ln x, y' = x(1 + 2 \ln x),$   
 $y'' = 3 + 2 \ln x,$   
 $y' = 0$  if  $x = e^{-1/2},$   
 $y'' = 0$  if  $x = e^{-3/2},$   
 $\lim_{x \rightarrow 0^+} y' = 0$

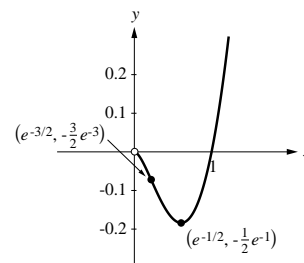

47. (a)  $\lim_{x \rightarrow 0^+} y = \lim_{x \rightarrow 0^+} \frac{\ln x}{x^2} = -\infty$ ;  
 $\lim_{x \rightarrow +\infty} y = \lim_{x \rightarrow +\infty} \frac{\ln x}{x^2} = \lim_{x \rightarrow +\infty} \frac{1/x}{2x} = 0$

(b)  $y = \frac{\ln x}{x^2}, y' = \frac{1 - 2 \ln x}{x^3},$   
 $y'' = \frac{6 \ln x - 5}{x^4},$   
 $y' = 0$  if  $x = e^{1/2},$   
 $y'' = 0$  if  $x = e^{5/6}$

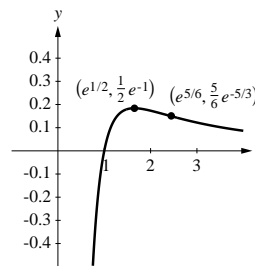

48. (a)  $\lim_{x \rightarrow 0^+} (\ln x)/\sqrt{x} = -\infty$  by inspection,  $\lim_{x \rightarrow +\infty} (\ln x)/\sqrt{x} = \lim_{x \rightarrow +\infty} \frac{1/x}{1/2\sqrt{x}} = \lim_{x \rightarrow +\infty} \frac{2}{\sqrt{x}} = 0$ , L'Hôpital's Rule.

(b)  $y = \frac{\ln x}{\sqrt{x}}, y' = \frac{2 - \ln x}{2x^{3/2}}$   
 $y'' = \frac{-8 + 3 \ln x}{4x^{5/2}}$   
 $y' = 0$  if  $x = e^2,$   
 $y'' = 0$  if  $x = e^{8/3}$

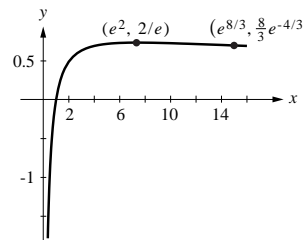

49. (a)  $\lim_{x \rightarrow -\infty} y = -\infty, \lim_{x \rightarrow +\infty} y = +\infty$ ;  
 curve crosses  $x$ -axis at  $x = 0, 1, -1$

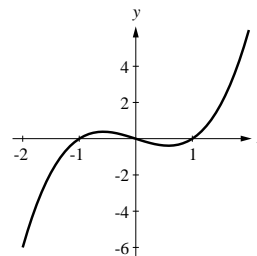

(b)  $\lim_{x \rightarrow \pm\infty} y = +\infty$ ;  
 curve never crosses  $x$ -axis

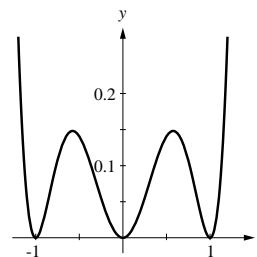

(c)  $\lim_{x \rightarrow -\infty} y = -\infty, \lim_{x \rightarrow +\infty} y = +\infty$ ;  
 curve crosses  $x$ -axis at  $x = -1$

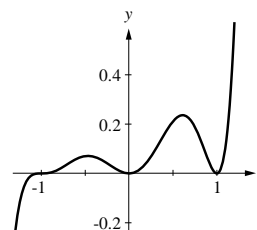

- (d)  $\lim_{x \rightarrow \pm\infty} y = +\infty$ ;  
 curve crosses  $x$ -axis at  $x = 0, 1$

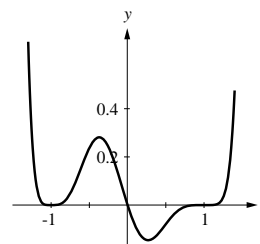

50. (a)

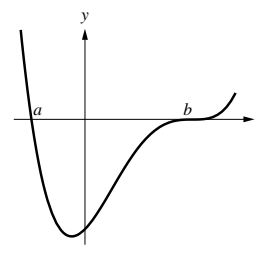
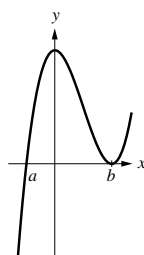
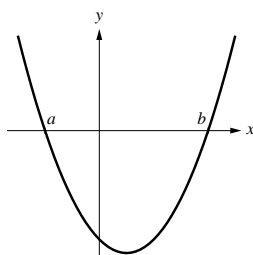

- (b)

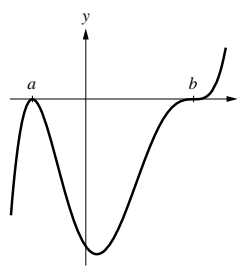
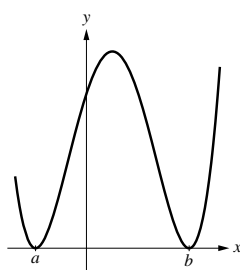

- (c)

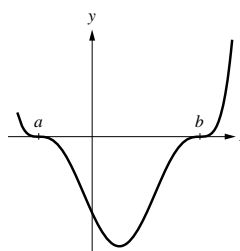

51. (a) horizontal asymptote  $y = 3$  as  $x \rightarrow \pm\infty$ , vertical asymptotes of  $x = \pm 2$

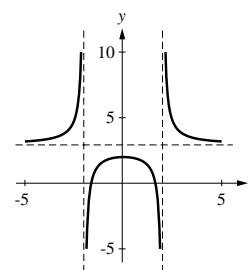

- (b) horizontal asymptote of  $y = 1$  as  $x \rightarrow \pm\infty$ , vertical asymptotes at  $x = \pm 1$

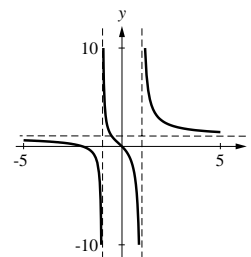

- (c) horizontal asymptote of  $y = -1$  as  $x \rightarrow \pm\infty$ , vertical asymptotes at  $x = -2, 1$

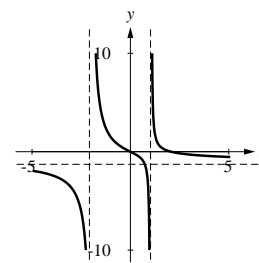

- (d) horizontal asymptote of  $y = 1$  as  $x \rightarrow \pm\infty$ , vertical asymptote at  $x = -1, 2$

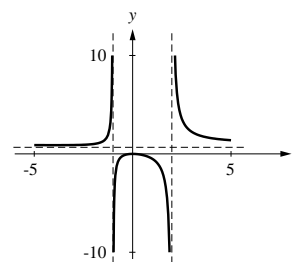

52.

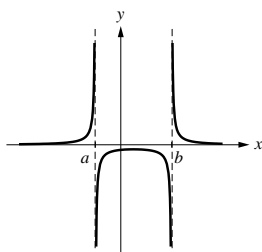

53.

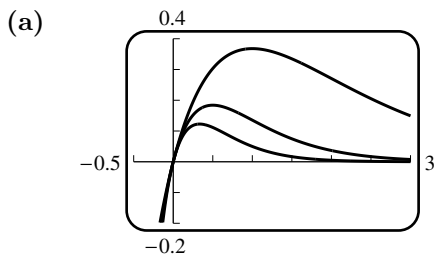

- (b)  $y' = (1 - bx)e^{-bx}$ ,  $y'' = b^2(x - 2/b)e^{-bx}$ ; relative max at  $x = 1/b$ ,  $y = 1/be$ ; point of inflection at  $x = 2/b$ ,  $y = 2/be^2$ . Increasing  $b$  moves the relative max and the point of inflection to the left and down, i.e. towards the origin.

54.

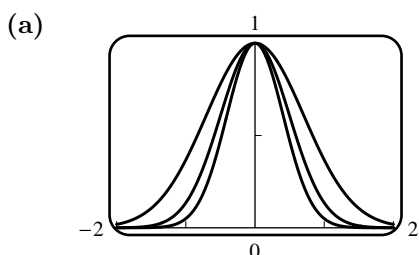

- (b)  $y' = -2bx e^{-bx^2}$ ,  $y'' = 2b(-1 + 2bx^2)e^{-bx^2}$ ; relative max at  $x = 0$ ,  $y = 1$ ; points of inflection at  $x = \pm\sqrt{1/2b}$ ,  $y = 1/\sqrt{e}$ . Increasing  $b$  moves the points of inflection towards the  $y$ -axis; the relative max doesn't move.

55. (a) The oscillations of  $e^x \cos x$  about zero increase as  $x \rightarrow \pm\infty$  so the limit does not exist.

(b)

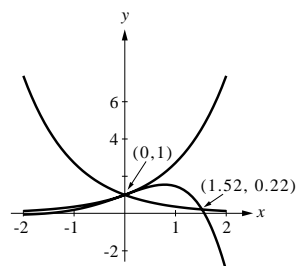

- (c) The curve  $y = e^{ax} \cos bx$  oscillates between  $y = e^{ax}$  and  $y = -e^{ax}$ . The frequency of oscillation increases when  $b$  increases.

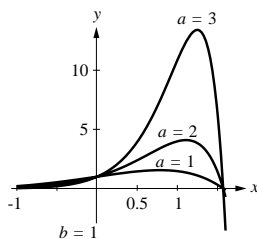
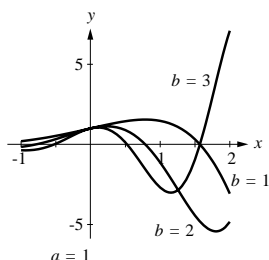

56.  $\lim_{x \rightarrow \pm\infty} \left[ \frac{P(x)}{Q(x)} - (ax + b) \right] = \lim_{x \rightarrow \pm\infty} \frac{R(x)}{Q(x)} = 0$  because the degree of  $R(x)$  is less than the degree of  $Q(x)$ .

57.  $y = \frac{x^2 - 2}{x} = x - \frac{2}{x}$  so  
 $y = x$  is an oblique asymptote;  
 $y' = \frac{x^2 + 2}{x^2}$ ,  
 $y'' = -\frac{4}{x^3}$

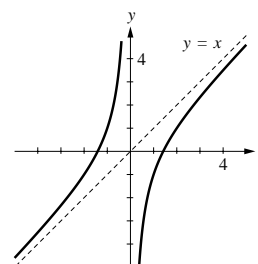

58.  $y = \frac{x^2 - 2x - 3}{x + 2} = x - 4 + \frac{5}{x + 2}$  so  
 $y = x - 4$  is an oblique asymptote;  
 $y' = \frac{x^2 + 4x - 1}{(x + 2)^2}$ ,  $y'' = \frac{10}{(x + 2)^3}$

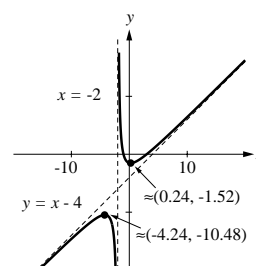

59.  $y = \frac{(x - 2)^3}{x^2} = x - 6 + \frac{12x - 8}{x^2}$  so  
 $y = x - 6$  is an oblique asymptote;  
 $y' = \frac{(x - 2)^2(x + 4)}{x^3}$ ,  
 $y'' = \frac{24(x - 2)}{x^4}$

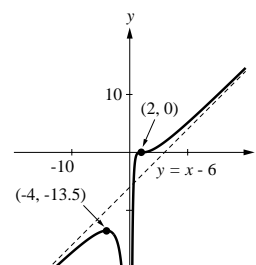

60.  $y = \frac{4 - x^3}{x^2},$   
 $y' = -\frac{x^3 + 8}{x^3},$   
 $y'' = \frac{24}{x^4}$

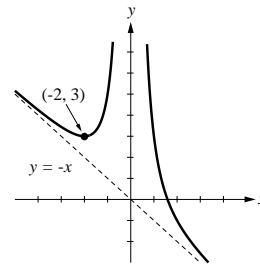

61.  $y = x + 1 - \frac{1}{x} - \frac{1}{x^2} = \frac{(x - 1)(x + 1)^2}{x^2},$   
 $y = x + 1$  is an oblique asymptote;  
 $y' = \frac{(x + 1)(x^2 - x + 2)}{x^3},$   
 $y'' = -\frac{2(x + 3)}{x^4}$

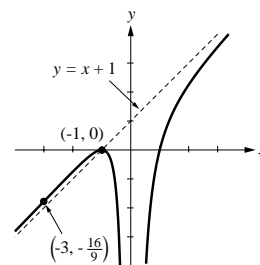

62. The oblique asymptote is  $y = 2x$  so  $(2x^3 - 3x + 4)/x^2 = 2x, -3x + 4 = 0, x = 4/3.$

63.  $\lim_{x \rightarrow \pm\infty} [f(x) - x^2] = \lim_{x \rightarrow \pm\infty} (1/x) = 0$   
 $y = x^2 + \frac{1}{x} = \frac{x^3 + 1}{x}, y' = 2x - \frac{1}{x^2} = \frac{2x^3 - 1}{x^2},$   
 $y'' = 2 + \frac{2}{x^3} = \frac{2(x^3 + 1)}{x^3}, y' = 0$  when  $x = 1/\sqrt[3]{2} \approx 0.8,$   
 $y = 3\sqrt[3]{2}/2 \approx 1.9; y'' = 0$  when  $x = -1, y = 0$

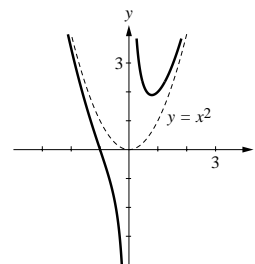

64.  $\lim_{x \rightarrow \pm\infty} [f(x) - (3 - x^2)] = \lim_{x \rightarrow \pm\infty} (2/x) = 0$   
 $y = 3 - x^2 + \frac{2}{x} = \frac{2 + 3x - x^3}{x}, y' = -2x - \frac{2}{x^2} = -\frac{2(x^3 + 1)}{x^2},$   
 $y'' = -2 + \frac{4}{x^3} = -\frac{2(x^3 - 2)}{x^3}, y' = 0$  when  $x = -1, y = 0;$   
 $y'' = 0$  when  $x = \sqrt[3]{2} \approx 1.3, y = 3$

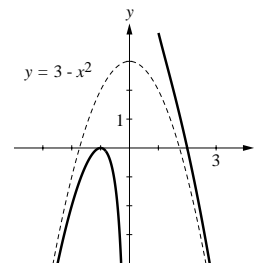

65. Let  $y$  be the length of the other side of the rectangle, then  
 $L = 2x + 2y$  and  $xy = 400$  so  $y = 400/x$  and hence  $L = 2x + 800/x.$   
 $L = 2x$  is an oblique asymptote (see Exercise 48)  
 $L = 2x + \frac{800}{x} = \frac{2(x^2 + 400)}{x}, L' = 2 - \frac{800}{x^2} = \frac{2(x^2 - 400)}{x^2},$   
 $L'' = \frac{1600}{x^3}, L' = 0$  when  $x = 20, L = 80$

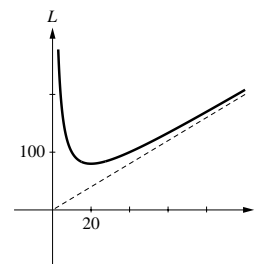

66. Let  $y$  be the height of the box, then  $S = x^2 + 4xy$  and  $x^2y = 500$  so  $y = 500/x^2$  and hence  $S = x^2 + 2000/x$ .

The graph approaches the curve  $S = x^2$  asymptotically

(see Exercise 63)

$$S = x^2 + \frac{2000}{x} = \frac{x^3 + 2000}{x}, \quad S' = 2x - \frac{2000}{x^2} = \frac{2(x^3 - 1000)}{x^2},$$

$$S'' = 2 + \frac{4000}{x^3} = \frac{2(x^3 + 2000)}{x^3}, \quad S'' = 0 \text{ when } x = 10, S = 300$$

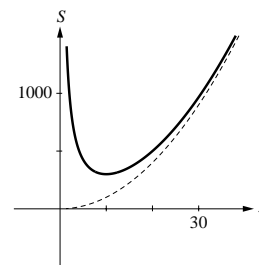

67.  $y' = 0.1x^4(6x - 5)$ ;  
critical points:  $x = 0, x = 5/6$ ;  
relative minimum at  $x = 5/6$ ,  
 $y \approx -6.7 \times 10^{-3}$

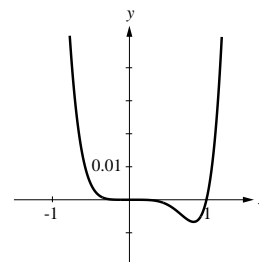

68.  $y' = 0.1x^4(x + 1)(7x + 5)$ ;  
critical points:  $x = 0, x = -1, x = -5/7$ ;  
relative maximum at  $x = -1, y = 0$ ;  
relative minimum at  $x = -5/7, y \approx -1.5 \times 10^{-3}$

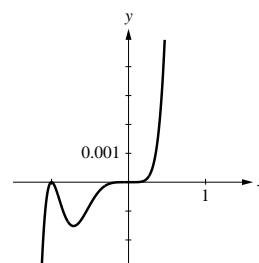

69. (a)  $P'(t) = \frac{kL^2 A e^{-kLt}}{(1 + A e^{-kLt})^2} S$ , so  $P'(0) = \frac{kL^2 A}{(1 + A)^2}$
- (b) The rate of growth increases to its maximum, which occurs when  $P$  is halfway between 0 and  $L$ , or when  $t = \frac{1}{Lk} \ln A$ ; it then decreases back towards zero.
- (c) From (6) one sees that  $\frac{dP}{dt}$  is maximized when  $P$  lies half way between 0 and  $L$ , i.e.  $P = L/2$ . This follows since the right side of (6) is a parabola (with  $P$  as independent variable) with  $P$ -intercepts  $P = 0, L$ . The value  $P = L/2$  corresponds to  $t = \frac{1}{Lk} \ln A$ , from (8).
70. Since  $0 < P < L$  the right-hand side of (7) can change sign only if the factor  $L - 2P$  changes sign, which it does when  $P = L/2$ . From (5) we have  $\frac{L}{2} = \frac{L}{1 + A e^{-kLt}}$ ,  $1 = A e^{-kLt}$ ,  $t = \frac{1}{Lk} \ln A$ .

## SUPPLEMENTARY EXERCISES FOR CHAPTER 5

4. (a) False; an example is  $y = \frac{x^3}{3} - \frac{x^2}{2}$  on  $[-2, 2]$ ;  $x = 0$  is a relative maximum and  $x = 1$  is a relative minimum, but  $y = 0$  is not the largest value of  $y$  on the interval, nor is  $y = -\frac{1}{6}$  the smallest.



- (b) true
- (c) False; for example  $y = x^3$  on  $(-1, 1)$  which has a critical point but no relative extrema

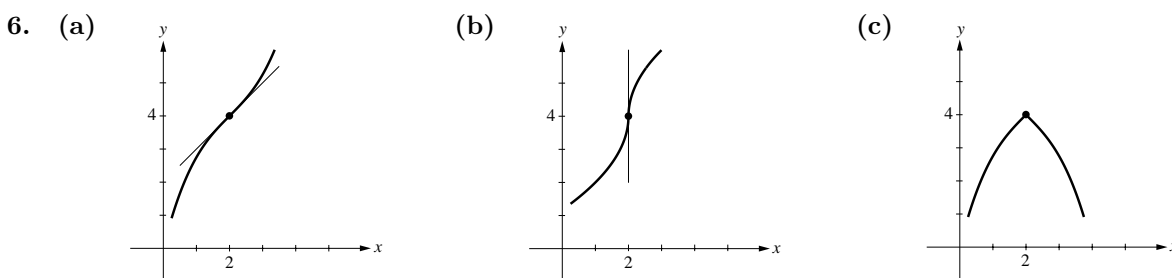

7. (a)  $f'(x) = \frac{7(x-7)(x-1)}{3x^{2/3}}$ ; critical points at  $x = 0, 1, 7$ ;  
neither at  $x = 0$ , relative max at  $x = 1$ , relative min at  $x = 7$  (first derivative test)
- (b)  $f'(x) = 2 \cos x(1 + 2 \sin x)$ ; critical points at  $x = \pi/2, 3\pi/2, 7\pi/6, 11\pi/6$ ;  
relative max at  $x = \pi/2, 3\pi/2$ , relative min at  $x = 7\pi/6, 11\pi/6$
- (c)  $f'(x) = 3 - \frac{3\sqrt{x-1}}{2}$ ; critical points at  $x = 5$ ; relative max at  $x = 5$
8. (a)  $f'(x) = \frac{x-9}{18x^{3/2}}, f''(x) = \frac{27-x}{36x^{5/2}}$ ; critical point at  $x = 9$ ;  $f''(9) > 0$ , relative min at  $x = 9$
- (b)  $f'(x) = 2\frac{x^3-4}{x^2}, f''(x) = 2\frac{x^3+8}{x^3}$ ;  
critical point at  $x = 4^{1/3}, f''(4^{1/3}) > 0$ , relative min at  $x = 4^{1/3}$
- (c)  $f'(x) = \sin x(2 \cos x + 1), f''(x) = 2 \cos^2 x - 2 \sin^2 x + \cos x$ ; critical points at  $x = 2\pi/3, \pi, 4\pi/3$ ;  
 $f''(2\pi/3) < 0$ , relative max at  $x = 2\pi/3$ ;  $f''(\pi) > 0$ , relative min at  $x = \pi$ ;  $f''(4\pi/3) < 0$ , relative max at  $x = 4\pi/3$

9.  $\lim_{x \rightarrow -\infty} f(x) = +\infty, \lim_{x \rightarrow +\infty} f(x) = +\infty$   
 $f'(x) = x(4x^2 - 9x + 6), f''(x) = 6(2x - 1)(x - 1)$   
 relative min at  $x = 0$ ,  
 points of inflection when  $x = 1/2, 1$ ,  
 no asymptotes

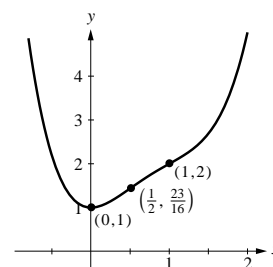

10.  $\lim_{x \rightarrow -\infty} f(x) = -\infty, \lim_{x \rightarrow +\infty} f(x) = +\infty$   
 $f(x) = x^3(x-2)^2, f'(x) = x^2(5x-6)(x-2),$   
 $f''(x) = 4x(5x^2 - 12x + 6)$   
 critical points at  $x = 0, \frac{8 \pm 2\sqrt{31}}{5}$   
 relative max at  $x = \frac{8 - 2\sqrt{31}}{5} = -0.63$   
 relative min at  $x = \frac{8 + 2\sqrt{31}}{5} = 3.83$   
 points of inflection at  $x = 0, \frac{6 \pm \sqrt{66}}{5} = 0, -0.42, 2.82$   
 no asymptotes

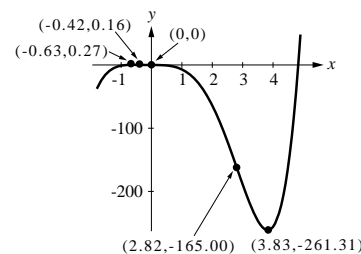

11.  $\lim_{x \rightarrow \pm\infty} f(x)$  doesn't exist

$$f'(x) = 2x \sec^2(x^2 + 1),$$

$$f''(x) = 2 \sec^2(x^2 + 1) [1 + 4x^2 \tan(x^2 + 1)]$$

critical point at  $x = 0$ ; relative min at  $x = 0$

point of inflection when  $1 + 4x^2 \tan(x^2 + 1) = 0$

vertical asymptotes at  $x = \pm \sqrt{\pi(n + \frac{1}{2}) - 1}$ ,  $n = 0, 1, 2, \dots$

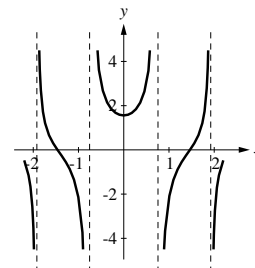

12.  $\lim_{x \rightarrow -\infty} f(x) = -\infty$ ,  $\lim_{x \rightarrow +\infty} f(x) = +\infty$

$$f'(x) = 1 + \sin x, \quad f''(x) = \cos x$$

critical points at  $x = 2n\pi + \pi/2$ ,  $n = 0, \pm 1, \pm 2, \dots$ ,

no extrema because  $f' \geq 0$  and by Exercise 51 of Section 5.1,

$f$  is increasing on  $(-\infty, +\infty)$

inflections points at  $x = n\pi + \pi/2$ ,  $n = 0, \pm 1, \pm 2, \dots$

no asymptotes

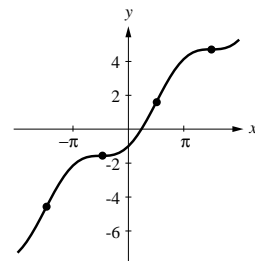

13.  $f'(x) = 2 \frac{x(x+5)}{(x^2+2x+5)^2}$ ,  $f''(x) = -2 \frac{2x^3+15x^2-25}{(x^2+2x+5)^3}$

critical points at  $x = -5, 0$ ;

relative max at  $x = -5$ ,

relative min at  $x = 0$

points of inflection at  $x = -7.26, -1.44, 1.20$

horizontal asymptote  $y = 1$  as  $x \rightarrow \pm\infty$

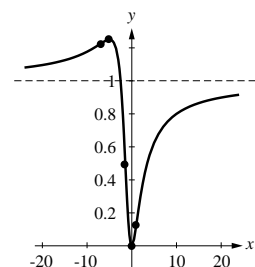

14.  $f'(x) = 3 \frac{3x^2-25}{x^4}$ ,  $f''(x) = -6 \frac{3x^2-50}{x^5}$

critical points at  $x = \pm 5\sqrt{3}/3$ ;

relative max at  $x = -5\sqrt{3}/3$ ,

relative min at  $x = +5\sqrt{3}/3$

inflection points at  $x = \pm 5\sqrt{2}/3$

horizontal asymptote of  $y = 0$  as  $x \rightarrow \pm\infty$ ,

vertical asymptote  $x = 0$

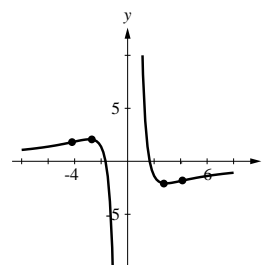

15.  $\lim_{x \rightarrow -\infty} f(x) = +\infty$ ,  $\lim_{x \rightarrow +\infty} f(x) = -\infty$

$$f'(x) = \begin{cases} x & \text{if } x \leq 0 \\ -2x & \text{if } x > 0 \end{cases}$$

critical point at  $x = 0$ , no extrema

inflection point at  $x = 0$  ( $f$  changes concavity)

no asymptotes

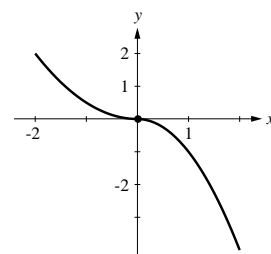

16.  $f'(x) = \frac{5 - 3x}{3(1+x)^{1/3}(3-x)^{2/3}}$ ,  
 $f''(x) = \frac{-32}{9(1+x)^{4/3}(3-x)^{5/3}}$   
 critical point at  $x = 5/3$ ;  
 relative max at  $x = 5/3$   
 cusp at  $x = -1$ ;  
 point of inflection at  $x = 3$   
 oblique asymptote  $y = -x$  as  $x \rightarrow \pm\infty$

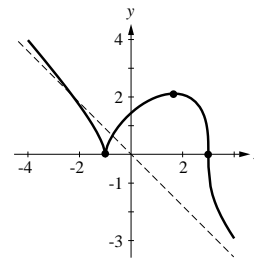

17.  $\lim_{x \rightarrow +\infty} f(x) = +\infty$   
 $f'(x) = 1 + \ln x$ ,  $f''(x) = 1/x$   
 $\lim_{x \rightarrow 0^+} f(x) = 0$ ,  $\lim_{x \rightarrow 0^+} f'(x) = -\infty$   
 critical point at  $x = 1/e$ ;  
 relative min at  $x = 1/e$   
 no points of inflection, no asymptotes

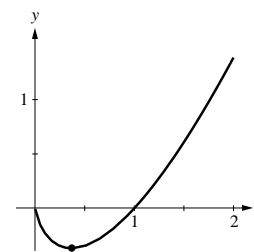

18.  $\lim_{x \rightarrow +\infty} f(x) = +\infty$   
 $f'(x) = x(2 \ln x + 1)$ ,  $f''(x) = 2 \ln x + 3$   
 $\lim_{x \rightarrow 0^+} f(x) = 0$ ,  $\lim_{x \rightarrow 0^+} f'(x) = 0$   
 critical point at  $x = e^{-1/2}$ ;  
 relative min at  $x = e^{-1/2}$   
 point of inflection at  $x = e^{-3/2}$

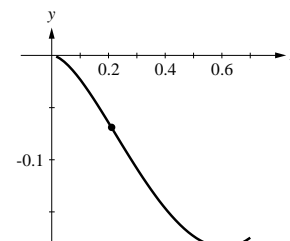

19.  $f'(x) = \frac{1 - 2 \ln x}{x^3}$ ,  $f''(x) = \frac{6 \ln x - 5}{x^4}$   
 critical point at  $x = e^{1/2}$ ,  
 relative max at  $x = e^{1/2}$   
 point of inflection at  $x = e^{5/6}$   
 horizontal asymptote  $y = 0$  as  $x \rightarrow +\infty$

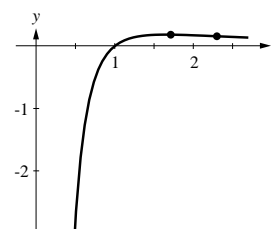

20.  $\lim_{x \rightarrow \pm\infty} f(x) = +\infty$   
 $f'(x) = \frac{2x}{x^2 + 1}$ ,  $f''(x) = 2 \frac{1 - x^2}{(x^2 + 1)^2}$   
 critical point at  $x = 0$ ;  
 relative min at  $x = 0$   
 points of inflection at  $x = \pm 1$   
 no asymptotes

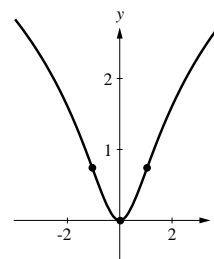

21.  $\lim_{x \rightarrow +\infty} f(x) = +\infty$

$$f'(x) = e^x \frac{x-1}{x^2}, \quad f''(x) = e^x \frac{x^2 - 2x + 2}{x^3}$$

critical point at  $x = 1$ ;

relative min at  $x = 1$

no points of inflection

vertical asymptote  $x = 0$ ,

horizontal asymptote  $y = 0$  for  $x \rightarrow -\infty$

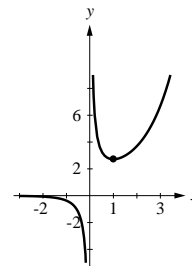

22.  $f'(x) = (1-x)e^{-x}$ ,  $f''(x) = (x-2)e^{-x}$

critical point at  $x = 1$ ; relative max at  $x = 1$

point of inflection at  $x = 2$

horizontal asymptote  $y = 0$  as  $x \rightarrow +\infty$ ,  $\lim_{x \rightarrow -\infty} f(x) = -\infty$

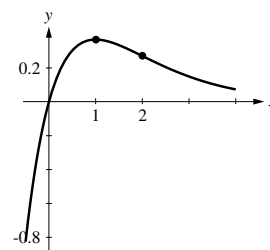

23.  $f'(x) = x(2-x)e^{1-x}$ ,  $f''(x) = (x^2 - 4x + 2)e^{1-x}$

critical points at  $x = 0, 2$ ;

relative min at  $x = 0$ ,

relative max at  $x = 2$

points of inflection at  $x = 2 \pm \sqrt{2}$

horizontal asymptote  $y = 0$  as  $x \rightarrow +\infty$ ,

$\lim_{x \rightarrow -\infty} f(x) = +\infty$

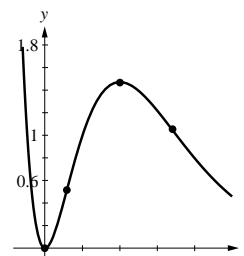

24.  $f'(x) = x^2(3+x)e^{x-1}$ ,  $f''(x) = x(x^2 + 6x + 6)e^{x-1}$

critical points at  $x = -3, 0$ ;

relative min at  $x = -3$

points of inflection at  $x = 0, -3 \pm \sqrt{3}$

horizontal asymptote  $y = 0$  as  $x \rightarrow -\infty$

$\lim_{x \rightarrow +\infty} f(x) = +\infty$

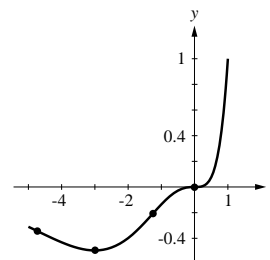

25. (a)

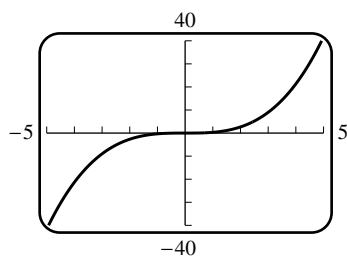

(b)  $f'(x) = x^2 - \frac{1}{400}$ ,  $f''(x) = 2x$

critical points at  $x = \pm \frac{1}{20}$ ;

relative max at  $x = -\frac{1}{20}$ ,

relative min at  $x = \frac{1}{20}$

- (c) The finer details can be seen when graphing over a much smaller  $x$ -window.

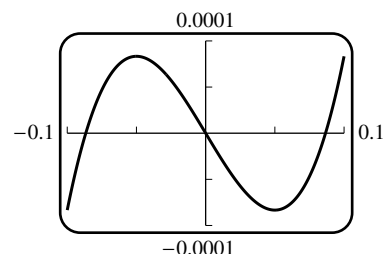

26. (a)

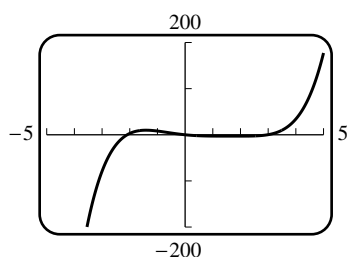

- (b) critical points at  $x = \pm\sqrt{2}, \frac{3}{2}, 2$ ;  
 relative max at  $x = -\sqrt{2}$ ,  
 relative min at  $x = \sqrt{2}$ ,  
 relative max at  $x = \frac{3}{2}$ ,  
 relative min at  $x = 2$

- (c)

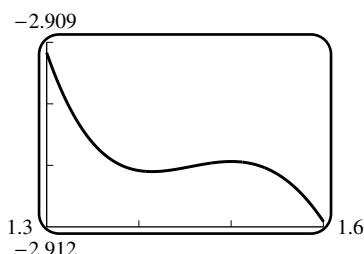
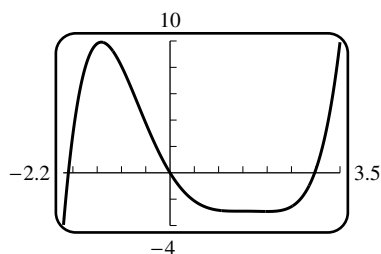

27. (a)

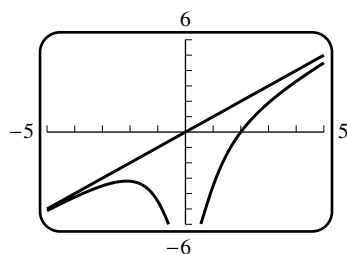

- (b) Divide  $y = x^2 + 1$  into  $y = x^3 - 8$  to get the asymptote  $ax + b = x$

28. (a)  $p(x) = x^3 - x$

(b)  $p(x) = x^4 - x^2$

(c)  $p(x) = x^5 - x^4 - x^3 + x^2$

(d)  $p(x) = x^5 - x^3$

29.  $f'(x) = 4x^3 - 18x^2 + 24x - 8, f''(x) = 12(x - 1)(x - 2)$   
 $f''(1) = 0, f'(1) = 2, f(1) = 2; f''(2) = 0, f'(2) = 0, f(2) = 3,$   
 so the tangent lines at the inflection points are  $y = 2x$  and  $y = 3$ .

30.  $\cos x - (\sin y)\frac{dy}{dx} = 2\frac{dy}{dx}; \frac{dy}{dx} = 0$  when  $\cos x = 0$ . Use the first derivative test:  $\frac{dy}{dx} = \frac{\cos x}{2 + \sin y}$  and  $2 + \sin y > 0$ , so critical points when  $\cos x = 0$ , relative maxima when  $x = 2n\pi + \pi/2$ , relative minima when  $x = 2n\pi - \pi/2, n = 0, \pm 1, \pm 2, \dots$

31.  $f(x) = \frac{(2x-1)(x^2+x-7)}{(2x-1)(3x^2+x-1)} = \frac{x^2+x-7}{3x^2+x-1}, \quad x \neq 1/2$   
 horizontal asymptote:  $y = 1/3$ ,  
 vertical asymptotes:  $x = (-1 \pm \sqrt{13})/6$

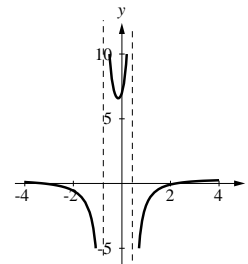

32. (a)  $f(x) = \frac{(x-2)(x^2+x+1)(x^2-2)}{(x-2)(x^2-2)^2(x^2+1)}$   
 $= \frac{x^2+x+1}{(x^2-2)(x^2+1)}$

(b)

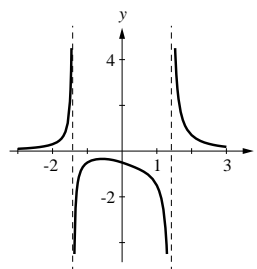

33. (a)  $\sin x = -1$  yields the smallest values, and  
 $\sin x = +1$  yields the largest

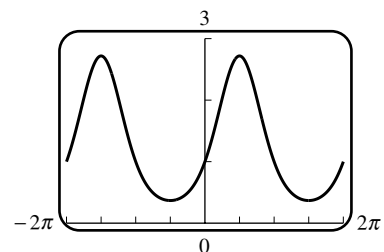

- (b)  $f'(x) = e^{\sin x} \cos x$ ; relative maxima at  $x = 2n\pi + \pi/2$ ,  $y = e$ ; relative minima at  $x = 2n\pi - \pi/2$ ,  $y = 1/e$ ;  $n = 0, \pm 1, \pm 2, \dots$  (first derivative test)  
 (c)  $f''(x) = (1 - \sin x - \sin^2 x)e^{\sin x}$ ;  $f''(x) = 0$  when  $\sin x = t$ , a root of  $t^2 + t - 1 = 0$ ,  
 $t = \frac{-1 \pm \sqrt{5}}{2}$ ;  $\sin x = \frac{-1 - \sqrt{5}}{2}$  is impossible. So the points of inflection on  $0 < x < 2\pi$  occur  
 when  $\sin x = \frac{-1 + \sqrt{5}}{2}$ , or  $x = 0.66624, 2.47535$

34.  $f'(x) = 3ax^2 + 2bx + c$ ;  $f'(x) > 0$  or  $f'(x) < 0$  on  $(-\infty, +\infty)$  if  $f'(x) = 0$  has no real solutions so from the quadratic formula  $(2b)^2 - 4(3a)c < 0$ ,  $4b^2 - 12ac < 0$ ,  $b^2 - 3ac < 0$ . If  $b^2 - 3ac = 0$ , then  $f'(x) = 0$  has only one real solution at, say,  $x = c$  so  $f$  is always increasing or always decreasing on both  $(-\infty, c]$  and  $[c, +\infty)$ , and hence on  $(-\infty, +\infty)$  because  $f$  is continuous everywhere. Thus  $f$  is always increasing or decreasing if  $b^2 - 3ac \leq 0$ .

35. (a) relative minimum  $-0.232466$  at  $x = 0.450184$

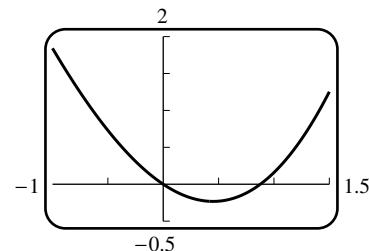

- (b) relative maximum 0 at  $x = 0$ ;  
relative minimum  $-0.107587$  at  $x = \pm 0.674841$

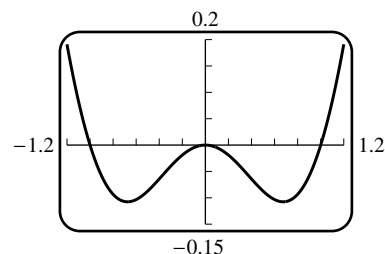

- (c) relative maximum 0.876839; at  $x = 0.886352$ ;  
relative minimum  $-0.355977$  at  $x = -1.244155$

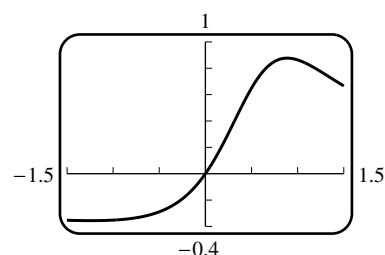

36. (a)  $f'(x) = 2 + 3x^2 - 4x^3$  has one real root at  $x = 1.14$ , a relative max; so  $f$  is one-to-one for  $x \leq 1.14$   
(b)  $f(1.14) = 3.07$  so the domain of  $f^{-1}$  is  $(-\infty, 3.07)$  and the range is  $(-\infty, 1.14)$ ;  $f^{-1}(-1) = -0.70$

37. (a)  (b)  $y = 0$  at  $x = 0$ ;  $\lim_{x \rightarrow +\infty} y = 0$

- (c) relative max at  $x = 1/a$ , inflection point at  $x = 2/a$   
(d) As  $a$  increases, the  $x$ -coordinate of the maximum and the inflection point move towards the origin.

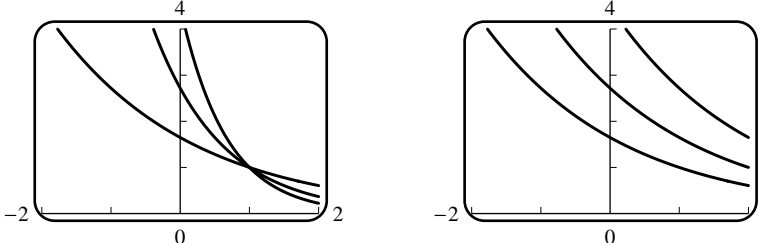
38. (a) 

- (b)  $y = 1$  at  $x = a$ ;  $\lim_{x \rightarrow -\infty} y = +\infty$ ,  $\lim_{x \rightarrow +\infty} y = 0$   
(c) Since  $y'$  is always negative and  $y''$  is always positive, there are no relative extrema and no inflection points.  
(d) An increase in  $b$  makes the graph flatter.  
(e) An increase in  $a$  shifts the graph to the right.

39.  $f'(x) = \ln(1 + 1/x) - \frac{1}{x}$  and  $f''(x) = \frac{1}{x^2(x+1)}$ ; so  $f'' > 0$  if  $x > 1$  and therefore  $f'$  is increasing on  $[1, +\infty)$ . Next,  $f'(1) = \ln 2 - 1 < 0$ . Then by L'Hôpital's Rule,

$$\lim_{x \rightarrow +\infty} x \ln(1 + 1/x) = \lim_{x \rightarrow +\infty} \frac{\ln(1 + 1/x)}{1/x} = \lim_{x \rightarrow +\infty} \frac{-1/x^2}{(1 + 1/x)(-1/x^2)} = 1$$

and thus  $\lim_{x \rightarrow +\infty} f'(x) = \lim_{x \rightarrow +\infty} \frac{x \ln(1 + 1/x) - 1}{x}$  is indeterminate.

$$\text{By L'Hôpital's Rule } \lim_{x \rightarrow +\infty} f'(x) = \lim_{x \rightarrow +\infty} \left[ \ln \left( 1 + \frac{1}{x} \right) - \frac{1}{x+1} \right] = 0.$$

Thus on  $[1, +\infty)$  the function  $f'$  starts negative and increases towards zero, so it is negative on the whole interval. So  $f(x)$  is decreasing, and  $f(x) > f(x+1)$ . Set  $x = n$  and obtain  $\ln(1 + 1/n)^{n+1} > \ln(1 + 1/(n+1))^{n+2}$ . Since  $\ln x$  and its inverse function  $e^x$  are both increasing, it follows that  $(1 + 1/n)^{n+1} > (1 + 1/(n+1))^{n+2}$ .

## CALCULUS HORIZON MODULE CHAPTER 5

1. The sum of the squares for the residuals for line I is approximately  $1^2 + 1^2 + 1^2 + 0^2 + 2^2 + 1^2 + 1^2 + 1^2 = 10$ , and the same for line II is approximately  $0^2 + (0.4)^2 + (1.2)^2 + 0^2 + (2.2)^2 + (0.6)^2 + (0.2)^2 + 0^2 = 6.84$ ; line II is the regression line.

2. (a)  $y = 5.035714286x - 4.232142857$

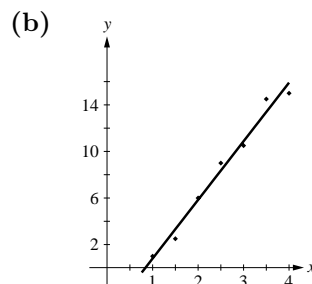

4.  $r = 0.9907002406$

5. (a)  $S = 2.155239850t + 190.3600714$ ;  $r = 0.9569426456$

(b) yes, because  $r$  is close to 1

(c) 244.241068 mi/h

(d) It is assumed that the line still gives a good estimate in the year 2000.

6. (a)  $Y = \ln y = bx + \ln a$  has slope  $b$  and  $Y$ -intercept  $\ln a$ .

(b)  $y = a + bX$  has slope  $b$  and  $y$ -intercept  $a$ .

(c)  $Y = \ln y = b \ln x + \ln a = bX + \ln a$  has slope  $b$  and  $Y$ -intercept  $\ln a$ .

(d) The same algebraic rules hold.

7. (a)  $y = 3.923208367 + e^{0.2934589528x}$

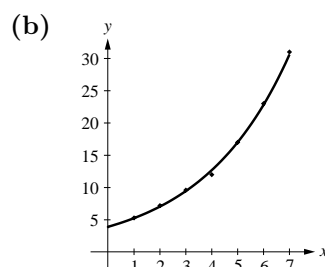



8. (a) It appears that  $\log T = a + b \log d$ , so  $T = 10^a d^b$ , an exponential model.  
(b)  $\log T = 1.719666407 \times 10^{-4} + 1.499661719 \log d$   
(c)  $T = 1.000396046 d^{1.499661719}$   
(d) "The squares of the periods of revolution of the planets are proportional to the cubes of their mean distances"
9. (a)  $T = 27 + 57.8 e^{-0.046t}$                       (b)  $T_0 = 84.9^\circ\text{C}$                       (c) 53.19 min

# CHAPTER 6

## Applications of the Derivative

### EXERCISE SET 6.1

- relative maxima at  $x = 2, 6$ ; absolute maximum at  $x = 6$ ; relative and absolute minimum at  $x = 4$
- relative maximum at  $x = 3$ ; absolute maximum at  $x = 7$ ; relative minima at  $x = 1, 5$ ; absolute minima at  $x = 1, 5$

3. (a)

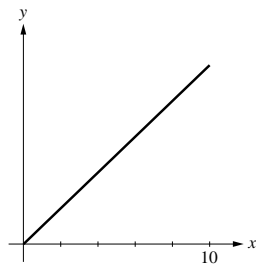

(b)

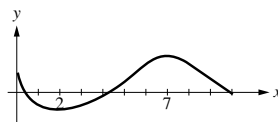

(c)

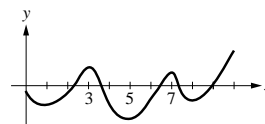

4. (a)

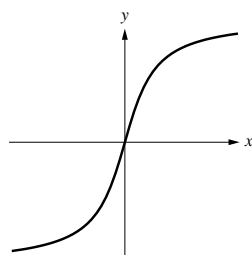

(b)

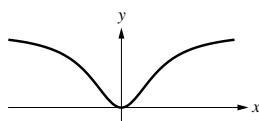

(c)

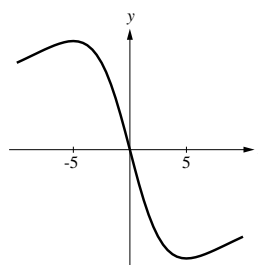

- $f'(x) = 8x - 4$ ,  $f'(x) = 0$  when  $x = 1/2$ ;  $f(0) = 1$ ,  $f(1/2) = 0$ ,  $f(1) = 1$  so the maximum value is 1 at  $x = 0, 1$  and the minimum value is 0 at  $x = 1/2$ .
- $f'(x) = 8 - 2x$ ,  $f'(x) = 0$  when  $x = 4$ ;  $f(0) = 0$ ,  $f(4) = 16$ ,  $f(6) = 12$  so the maximum value is 16 at  $x = 4$  and the minimum value is 0 at  $x = 0$ .
- $f'(x) = 3(x - 1)^2$ ,  $f'(x) = 0$  when  $x = 1$ ;  $f(0) = -1$ ,  $f(1) = 0$ ,  $f(4) = 27$  so the maximum value is 27 at  $x = 4$  and the minimum value is  $-1$  at  $x = 0$ .
- $f'(x) = 6x^2 - 6x - 12 = 6(x + 1)(x - 2)$ ,  $f'(x) = 0$  when  $x = -1, 2$ ;  $f(-2) = -4$ ,  $f(-1) = 7$ ,  $f(2) = -20$ ,  $f(3) = -9$  so the maximum value is 7 at  $x = -1$  and the minimum value is  $-20$  at  $x = 2$ .
- $f'(x) = 3/(4x^2 + 1)^{3/2}$ , no critical points;  $f(-1) = -3/\sqrt{5}$ ,  $f(1) = 3/\sqrt{5}$  so the maximum value is  $3/\sqrt{5}$  at  $x = 1$  and the minimum value is  $-3/\sqrt{5}$  at  $x = -1$ .
- $f'(x) = \frac{2(2x + 1)}{3(x^2 + x)^{1/3}}$ ,  $f'(x) = 0$  when  $x = -1/2$  and  $f'(x)$  does not exist when  $x = -1, 0$ ;  $f(-2) = 2^{2/3}$ ,  $f(-1) = 0$ ,  $f(-1/2) = 4^{-2/3}$ ,  $f(0) = 0$ ,  $f(3) = 12^{2/3}$  so the maximum value is  $12^{2/3}$  at  $x = 3$  and the minimum value is 0 at  $x = -1, 0$ .
- $f'(x) = 1 - \sec^2 x$ ,  $f'(x) = 0$  for  $x$  in  $(-\pi/4, \pi/4)$  when  $x = 0$ ;  $f(-\pi/4) = 1 - \pi/4$ ,  $f(0) = 0$ ,  $f(\pi/4) = \pi/4 - 1$  so the maximum value is  $1 - \pi/4$  at  $x = -\pi/4$  and the minimum value is  $\pi/4 - 1$  at  $x = \pi/4$ .

12.  $f'(x) = \cos x + \sin x$ ,  $f'(x) = 0$  for  $x$  in  $(0, \pi)$  when  $x = 3\pi/4$ ;  $f(0) = -1$ ,  $f(3\pi/4) = \sqrt{2}$ ,  $f(\pi) = 1$  so the maximum value is  $\sqrt{2}$  at  $x = 3\pi/4$  and the minimum value is  $-1$  at  $x = 0$ .

13.  $f(x) = 1 + |9 - x^2| = \begin{cases} 10 - x^2, & |x| \leq 3 \\ -8 + x^2, & |x| > 3 \end{cases}$ ,  $f'(x) = \begin{cases} -2x, & |x| < 3 \\ 2x, & |x| > 3 \end{cases}$  thus  $f'(x) = 0$  when  $x = 0$ ,  $f'(x)$  does not exist for  $x$  in  $(-5, 1)$  when  $x = -3$  because  $\lim_{x \rightarrow -3^-} f'(x) \neq \lim_{x \rightarrow -3^+} f'(x)$  (see Theorem preceding Exercise 75, Section 3.3);  $f(-5) = 17$ ,  $f(-3) = 1$ ,  $f(0) = 10$ ,  $f(1) = 9$  so the maximum value is 17 at  $x = -5$  and the minimum value is 1 at  $x = -3$ .

14.  $f(x) = |6 - 4x| = \begin{cases} 6 - 4x, & x \leq 3/2 \\ -6 + 4x, & x > 3/2 \end{cases}$ ,  $f'(x) = \begin{cases} -4, & x < 3/2 \\ 4, & x > 3/2 \end{cases}$ ,  $f'(x)$  does not exist when  $x = 3/2$  thus  $3/2$  is the only critical point in  $(-3, 3)$ ;  $f(-3) = 18$ ,  $f(3/2) = 0$ ,  $f(3) = 6$  so the maximum value is 18 at  $x = -3$  and the minimum value is 0 at  $x = 3/2$ .

15.  $f'(x) = 2x - 3$ ; critical point  $x = 3/2$ . Minimum value  $f(3/2) = -13/4$ , no maximum.

16.  $f'(x) = -4(x + 1)$ ; critical point  $x = -1$ . Maximum value  $f(-1) = 5$ , no minimum.

17.  $f'(x) = 12x^2(1 - x)$ ; critical points  $x = 0, 1$ . Maximum value  $f(1) = 1$ , no minimum because  $\lim_{x \rightarrow +\infty} f(x) = -\infty$ .

18.  $f'(x) = 4(x^3 + 1)$ ; critical point  $x = -1$ . Minimum value  $f(-1) = -3$ , no maximum.

19. No maximum or minimum because  $\lim_{x \rightarrow +\infty} f(x) = +\infty$  and  $\lim_{x \rightarrow -\infty} f(x) = -\infty$ .

20. No maximum or minimum because  $\lim_{x \rightarrow +\infty} f(x) = +\infty$  and  $\lim_{x \rightarrow -\infty} f(x) = -\infty$ .

21.  $f'(x) = x(x + 2)/(x + 1)^2$ ; critical point  $x = -2$  in  $(-5, -1)$ . Maximum value  $f(-2) = -4$ , no minimum.

22.  $f'(x) = -6/(x - 3)^2$ ; no critical points in  $[-5, 5]$  ( $x = 3$  is not in the domain of  $f$ ). No maximum or minimum because  $\lim_{x \rightarrow 3^+} f(x) = +\infty$  and  $\lim_{x \rightarrow 3^-} f(x) = -\infty$ .

23.  $(x^2 - 1)^2$  can never be less than zero because it is the square of  $x^2 - 1$ ; the minimum value is 0 for  $x = \pm 1$ , no maximum because  $\lim_{x \rightarrow +\infty} f(x) = +\infty$ .

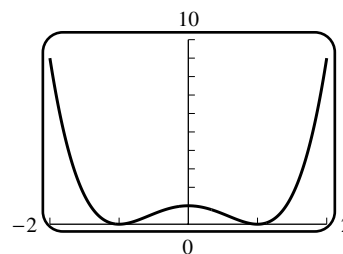

24.  $(x - 1)^2(x + 2)^2$  can never be less than zero because it is the product of two squares; the minimum value is 0 for  $x = 1$  or  $-2$ , no maximum because  $\lim_{x \rightarrow +\infty} f(x) = +\infty$ .

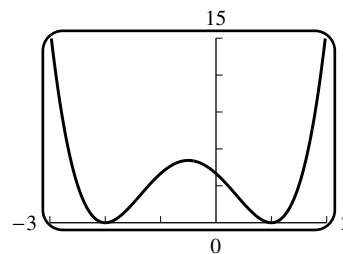

25.  $f'(x) = \frac{5(8-x)}{3x^{1/3}}$ ,  $f'(x) = 0$  when  $x = 8$  and  $f'(x)$  does not exist when  $x = 0$ ;  $f(-1) = 21$ ,  $f(0) = 0$ ,  $f(8) = 48$ ,  $f(20) = 0$  so the maximum value is 48 at  $x = 8$  and the minimum value is 0 at  $x = 0, 20$ .

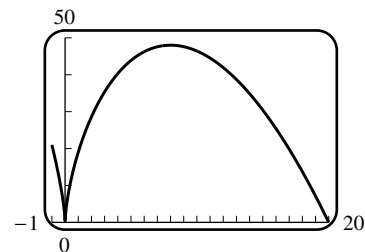

26.  $f'(x) = (2-x^2)/(x^2+2)^2$ ,  $f'(x) = 0$  for  $x$  in the interval  $(-1, 4)$  when  $x = \sqrt{2}$ ;  $f(-1) = -1/3$ ,  $f(\sqrt{2}) = \sqrt{2}/4$ ,  $f(4) = 2/9$  so the maximum value is  $\sqrt{2}/4$  at  $x = \sqrt{2}$  and the minimum value is  $-1/3$  at  $x = -1$ .

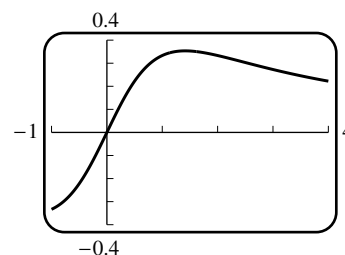

27.  $f'(x) = -1/x^2$ ; no maximum or minimum because there are no critical points in  $(0, +\infty)$ .

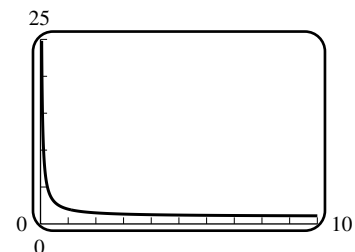

28.  $f'(x) = (1-x^2)/(x^2+1)^2$ ; critical point  $x = 1$ . Maximum value  $f(1) = 1/2$ , minimum value 0 because  $f(x)$  is never less than zero on  $[0, +\infty)$  and  $f(0) = 0$ .

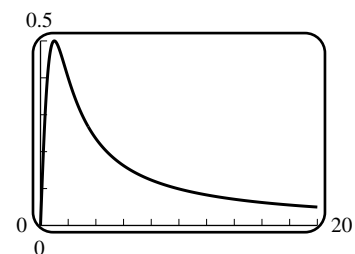

29.  $f'(x) = 2 \sec x \tan x - \sec^2 x = (2 \sin x - 1)/\cos^2 x$ ,  $f'(x) = 0$  for  $x$  in  $(0, \pi/4)$  when  $x = \pi/6$ ;  $f(0) = 2$ ,  $f(\pi/6) = \sqrt{3}$ ,  $f(\pi/4) = 2\sqrt{2} - 1$  so the maximum value is 2 at  $x = 0$  and the minimum value is  $\sqrt{3}$  at  $x = \pi/6$ .

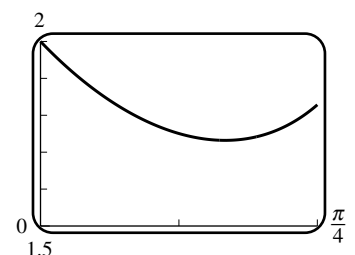

30.  $f'(x) = 2 \sin x \cos x - \sin x = \sin x(2 \cos x - 1)$ ,  $f'(x) = 0$  for  $x$  in  $(-\pi, \pi)$  when  $x = 0, \pm\pi/3$ ;  $f(-\pi) = -1$ ,  $f(-\pi/3) = 5/4$ ,  $f(0) = 1$ ,  $f(\pi/3) = 5/4$ ,  $f(\pi) = -1$  so the maximum value is  $5/4$  at  $x = \pm\pi/3$  and the minimum value is  $-1$  at  $x = \pm\pi$ .

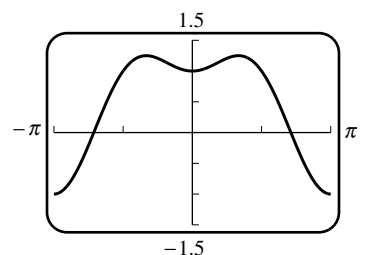

31.  $f'(x) = x^2(2x - 3)e^{-2x}$ ,  $f'(x) = 0$  for  $x$  in  $[1, 4]$  when  $x = 3/2$ ;  
 if  $x = 1, 3/2, 4$ , then  $f(x) = e^{-2}, \frac{27}{8}e^{-3}, 64e^{-8}$ ;  
 critical point at  $x = 3/2$ ; absolute maximum of  $\frac{27}{8}e^{-3}$  at  $x = 3/2$ ,  
 absolute minimum of  $64e^{-8}$  at  $x = 4$

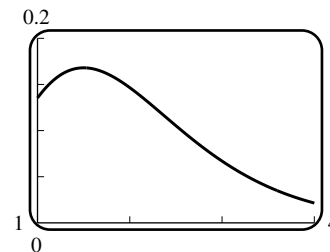

32.  $f'(x) = \frac{1 - \ln x}{x^2}$ ,  $f'(x) = 0$  when  $x = e$ ;  
 absolute minimum of 0 at  $x = 1$ ;  
 absolute maximum of  $1/e$  at  $x = e$

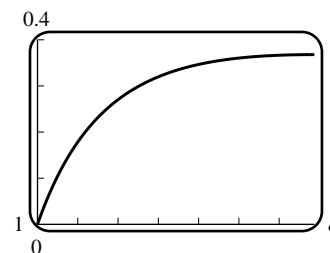

33.  $f'(x) = -[\cos(\cos x)] \sin x$ ;  $f'(x) = 0$  if  $\sin x = 0$  or if  $\cos(\cos x) = 0$ .  
 If  $\sin x = 0$ , then  $x = \pi$  is the critical point in  $(0, 2\pi)$ ;  $\cos(\cos x) = 0$   
 has no solutions because  $-1 \leq \cos x \leq 1$ . Thus  $f(0) = \sin(1)$ ,  
 $f(\pi) = \sin(-1) = -\sin(1)$ , and  $f(2\pi) = \sin(1)$  so the maximum  
 value is  $\sin(1) \approx 0.84147$  and the minimum value is  
 $-\sin(1) \approx -0.84147$ .

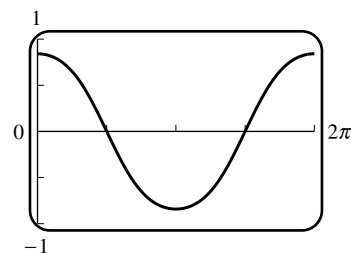

34.  $f'(x) = -[\sin(\sin x)] \cos x$ ;  $f'(x) = 0$  if  $\cos x = 0$  or if  $\sin(\sin x) = 0$ .  
 If  $\cos x = 0$ , then  $x = \pi/2$  is the critical point in  $(0, \pi)$ ;  
 $\sin(\sin x) = 0$  if  $\sin x = 0$ , which gives no critical points in  $(0, \pi)$ .  
 Thus  $f(0) = 1$ ,  $f(\pi/2) = \cos(1)$ , and  $f(\pi) = 1$  so the maximum  
 value is 1 and the minimum value is  $\cos(1) \approx 0.54030$ .

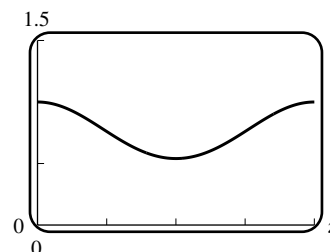

35.  $f'(x) = \begin{cases} 4, & x < 1 \\ 2x - 5, & x > 1 \end{cases}$  so  $f'(x) = 0$  when  $x = 5/2$ , and  $f'(x)$  does not exist when  $x = 1$  because  
 $\lim_{x \rightarrow 1^-} f'(x) \neq \lim_{x \rightarrow 1^+} f'(x)$  (see Theorem preceding Exercise 75, Section 3.3);  $f(1/2) = 0$ ,  $f(1) = 2$ ,  
 $f(5/2) = -1/4$ ,  $f(7/2) = 3/4$  so the maximum value is 2 and the minimum value is  $-1/4$ .

36.  $f'(x) = 2x + p$  which exists throughout the interval  $(0, 2)$  for all values of  $p$  so  $f'(1) = 0$  because  
 $f(1)$  is an extreme value, thus  $2 + p = 0$ ,  $p = -2$ .  $f(1) = 3$  so  $1^2 + (-2)(1) + q = 3$ ,  $q = 4$  thus  
 $f(x) = x^2 - 2x + 4$  and  $f(0) = 4$ ,  $f(2) = 4$  so  $f(1)$  is the minimum value.

37.  $\sin 2x$  has a period of  $\pi$ , and  $\sin 4x$  a period of  $\pi/2$  so  $f(x)$  is periodic with period  $\pi$ . Consider the  
 interval  $[0, \pi]$ .  $f'(x) = 4 \cos 2x + 4 \cos 4x$ ,  $f'(x) = 0$  when  $\cos 2x + \cos 4x = 0$ , but  $\cos 4x = 2 \cos^2 2x - 1$   
 (trig identity) so

$$\begin{aligned} 2 \cos^2 2x + \cos 2x - 1 &= 0 \\ (2 \cos 2x - 1)(\cos 2x + 1) &= 0 \\ \cos 2x = 1/2 \text{ or } \cos 2x = -1. \end{aligned}$$

From  $\cos 2x = 1/2$ ,  $2x = \pi/3$  or  $5\pi/3$  so  $x = \pi/6$  or  $5\pi/6$ . From  $\cos 2x = -1$ ,  $2x = \pi$  so  $x = \pi/2$ .  
 $f(0) = 0$ ,  $f(\pi/6) = 3\sqrt{3}/2$ ,  $f(\pi/2) = 0$ ,  $f(5\pi/6) = -3\sqrt{3}/2$ ,  $f(\pi) = 0$ . The maximum value is  $3\sqrt{3}/2$   
 at  $x = \pi/6 + n\pi$  and the minimum value is  $-3\sqrt{3}/2$  at  $x = 5\pi/6 + n\pi$ ,  $n = 0, \pm 1, \pm 2, \dots$

38.  $\cos \frac{x}{3}$  has a period of  $6\pi$ , and  $\cos \frac{x}{2}$  a period of  $4\pi$ , so  $f(x)$  has a period of  $12\pi$ . Consider the interval  $[0, 12\pi]$ .  $f'(x) = -\sin \frac{x}{3} - \sin \frac{x}{2}$ ,  $f'(x) = 0$  when  $\sin \frac{x}{3} + \sin \frac{x}{2} = 0$  thus, by use of the trig identity  $\sin a + \sin b = 2 \sin \frac{a+b}{2} \cos \frac{a-b}{2}$ ,  $2 \sin \left(\frac{5x}{12}\right) \cos \left(-\frac{x}{12}\right) = 0$  so  $\sin \frac{5x}{12} = 0$  or  $\cos \frac{x}{12} = 0$ . Solve  $\sin \frac{5x}{12} = 0$  to get  $x = 12\pi/5, 24\pi/5, 36\pi/5, 48\pi/5$  and then solve  $\cos \frac{x}{12} = 0$  to get  $x = 6\pi$ . The corresponding values of  $f(x)$  are  $-4.0450, 1.5450, 1.5450, -4.0450, 1, 5, 5$  so the maximum value is 5 and the minimum value is  $-4.0450$  (approximately).

39. Let  $f(x) = x - \sin x$ , then  $f'(x) = 1 - \cos x$  and so  $f'(x) = 0$  when  $\cos x = 1$  which has no solution for  $0 < x < 2\pi$  thus the minimum value of  $f$  must occur at 0 or  $2\pi$ .  $f(0) = 0$ ,  $f(2\pi) = 2\pi$  so 0 is the minimum value on  $[0, 2\pi]$  thus  $x - \sin x \geq 0$ ,  $\sin x \leq x$  for all  $x$  in  $[0, 2\pi]$ .

40. Let  $f(x) = \ln x - x + 1$ , then  $f'(x) = 1/x - 1$  and so  $f'(x) = 0$  at  $x = 1$ . Since  $\lim_{x \rightarrow 0^+} f(x) = -\infty$  and  $\lim_{x \rightarrow +\infty} f(x) = -\infty$ ,  $f(x)$  has a maximum of  $f(1) = 0$  at  $x = 1$  and so  $f(x) \leq 0$  for  $0 < x < +\infty$ , so  $\ln x \leq x - 1$  on  $(0, +\infty)$ .

41. Let  $m =$  slope at  $x$ , then  $m = f'(x) = 3x^2 - 6x + 5$ ,  $dm/dx = 6x - 6$ ; critical point for  $m$  is  $x = 1$ , minimum value of  $m$  is  $f'(1) = 2$

42. (a)  $f'(x) = -\frac{64 \cos x}{\sin^2 x} + \frac{27 \sin x}{\cos^2 x} = \frac{-64 \cos^3 x + 27 \sin^3 x}{\sin^2 x \cos^2 x}$ ,  $f'(x) = 0$  when  $27 \sin^3 x = 64 \cos^3 x$ ,  $\tan^3 x = 64/27$ ,  $\tan x = 4/3$  so the critical point is  $x = x_0$  where  $\tan x_0 = 4/3$  and  $0 < x_0 < \pi/2$ . To test  $x_0$  first rewrite  $f'(x)$  as  $f'(x) = \frac{27 \cos^3 x (\tan^3 x - 64/27)}{\sin^2 x \cos^2 x} = \frac{27 \cos x (\tan^3 x - 64/27)}{\sin^2 x}$ ; if  $x < x_0$  then  $\tan x < 4/3$  and  $f'(x) < 0$ , if  $x > x_0$  then  $\tan x > 4/3$  and  $f'(x) > 0$  so  $f(x_0)$  is the minimum value.  $f$  has no maximum because  $\lim_{x \rightarrow 0^+} f(x) = +\infty$ .

(b) If  $\tan x_0 = 4/3$  then (see figure)  
 $\sin x_0 = 4/5$  and  $\cos x_0 = 3/5$   
 so  $f(x_0) = 64/\sin x_0 + 27/\cos x_0$   
 $= 64/(4/5) + 27/(3/5)$   
 $= 80 + 45 = 125$

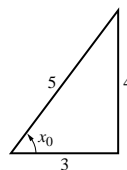

43.  $f'(x) = \frac{2x(x^3 - 24x^2 + 192x - 640)}{(x-8)^3}$ ; real root of  $x^3 - 24x^2 + 192x - 640$  at  $x = 4(2 + \sqrt[3]{2})$ . Since  $\lim_{x \rightarrow 8^+} f(x) = \lim_{x \rightarrow +\infty} f(x) = +\infty$  and there is only one relative extremum, it must be a minimum.

44. (a)  $\frac{dC}{dt} = \frac{K}{a-b} (ae^{-at} - be^{-bt})$  so  $\frac{dC}{dt} = 0$  at  $t = \frac{\ln(a/b)}{a-b}$ . This is the only stationary point and  $C(0) = 0$ ,  $\lim_{x \rightarrow +\infty} C(t) = 0$ ,  $C(t) > 0$  for  $0 < t < +\infty$ , so it is an absolute maximum.

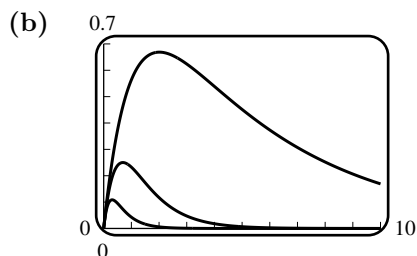

45. The slope of the line is  $-1$ , and the slope of the tangent to  $y = -x^2$  is  $-2x$  so  $-2x = -1$ ,  $x = 1/2$ . The line lies above the curve so the vertical distance is given by  $F(x) = 2 - x + x^2$ ;  $F(-1) = 4$ ,  $F(1/2) = 7/4$ ,  $F(3/2) = 11/4$ . The point  $(1/2, -1/4)$  is closest, the point  $(-1, -1)$  farthest.
46. The slope of the line is  $4/3$ ; and the slope of the tangent to  $y = x^3$  is  $3x^2$  so  $3x^2 = 4/3$ ,  $x^2 = 4/9$ ,  $x = \pm 2/3$ . The line lies below the curve so the vertical distance is given by  $F(x) = x^3 - 4x/3 + 1$ ;  $F(-1) = 4/3$ ,  $F(-2/3) = 43/27$ ,  $F(2/3) = 11/27$ ,  $F(1) = 2/3$ . The closest point is  $(2/3, 8/27)$ , the farthest is  $(-2/3, -8/27)$ .
47. The absolute extrema of  $y(t)$  can occur at the endpoints  $t = 0, 12$  or when  $dy/dt = 2 \sin t = 0$ , i.e.  $t = 0, 12, k\pi$ ,  $k = 1, 2, 3$ ; the absolute maximum is  $y = 4$  at  $t = \pi, 3\pi$ ; the absolute minimum is  $y = 0$  at  $t = 0, 2\pi$ .
48. (a) The absolute extrema of  $y(t)$  can occur at the endpoints  $t = 0, 2\pi$  or when  $dy/dt = 2 \cos 2t - 4 \sin t \cos t = 2 \cos 2t - 2 \sin 2t = 0$ ,  $t = 0, 2\pi, \pi/8, 5\pi/8, 9\pi/8, 13\pi/8$ ; the absolute maximum is  $y = 3.4142$  at  $t = \pi/8, 9\pi/8$ ; the absolute minimum is  $y = 0.5859$  at  $t = 5\pi/8, 13\pi/8$ .
- (b) The absolute extrema of  $x(t)$  occur at the endpoints  $t = 0, 2\pi$  or when  $\frac{dx}{dt} = -\frac{2 \sin t + 1}{(2 + \sin t)^2} = 0$ ,  $t = 7\pi/6, 11\pi/6$ . The absolute maximum is  $x = 0.5774$  at  $t = 11\pi/6$  and the absolute minimum is  $x = -0.5774$  at  $t = 7\pi/6$ .
49.  $f'(x) = 2ax + b$ ; critical point is  $x = -\frac{b}{2a}$
- $f''(x) = 2a > 0$  so  $f\left(-\frac{b}{2a}\right)$  is the minimum value of  $f$ , but
- $f\left(-\frac{b}{2a}\right) = a\left(-\frac{b}{2a}\right)^2 + b\left(-\frac{b}{2a}\right) + c = \frac{-b^2 + 4ac}{4a}$  thus  $f(x) \geq 0$  if and only if
- $f\left(-\frac{b}{2a}\right) \geq 0$ ,  $\frac{-b^2 + 4ac}{4a} \geq 0$ ,  $-b^2 + 4ac \geq 0$ ,  $b^2 - 4ac \leq 0$
50. Use the proof given in the text, replacing “maximum” by “minimum” and “largest” by “smallest” and reversing the order of all inequality symbols.

## EXERCISE SET 6.2

1. Let  $x =$  one number,  $y =$  the other number, and  $P = xy$  where  $x + y = 10$ . Thus  $y = 10 - x$  so  $P = x(10 - x) = 10x - x^2$  for  $x$  in  $[0, 10]$ .  $dP/dx = 10 - 2x$ ,  $dP/dx = 0$  when  $x = 5$ . If  $x = 0, 5, 10$  then  $P = 0, 25, 0$  so  $P$  is maximum when  $x = 5$  and, from  $y = 10 - x$ , when  $y = 5$ .
2. Let  $x$  and  $y$  be nonnegative numbers and  $z$  the sum of their squares, then  $z = x^2 + y^2$ . But  $x + y = 1$ ,  $y = 1 - x$  so  $z = x^2 + (1 - x)^2 = 2x^2 - 2x + 1$  for  $0 \leq x \leq 1$ .  $dz/dx = 4x - 2$ ,  $dz/dx = 0$  when  $x = 1/2$ . If  $x = 0, 1/2, 1$  then  $z = 1, 1/2, 1$  so
- (a)  $z$  is as large as possible when one number is 0 and the other is 1.
- (b)  $z$  is as small as possible when both numbers are  $1/2$ .
3. If  $y = x + 1/x$  for  $1/2 \leq x \leq 3/2$  then  $dy/dx = 1 - 1/x^2 = (x^2 - 1)/x^2$ ,  $dy/dx = 0$  when  $x = 1$ . If  $x = 1/2, 1, 3/2$  then  $y = 5/2, 2, 13/6$  so
- (a)  $y$  is as small as possible when  $x = 1$ . (b)  $y$  is as large as possible when  $x = 1/2$ .

4.  $A = xy$  where  $x + 2y = 1000$  so  $y = 500 - x/2$  and  $A = 500x - x^2/2$  for  $x$  in  $[0, 1000]$ ;  $dA/dx = 500 - x$ ,  $dA/dx = 0$  when  $x = 500$ . If  $x = 0$  or  $1000$  then  $A = 0$ , if  $x = 500$  then  $A = 125,000$  so the area is maximum when  $x = 500$  ft and  $y = 500 - 500/2 = 250$  ft.

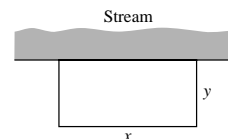

5. Let  $x$  and  $y$  be the dimensions shown in the figure and  $A$  the area, then  $A = xy$  subject to the cost condition  $3(2x) + 2(2y) = 6000$ , or  $y = 1500 - 3x/2$ . Thus  $A = x(1500 - 3x/2) = 1500x - 3x^2/2$  for  $x$  in  $[0, 1000]$ .  $dA/dx = 1500 - 3x$ ,  $dA/dx = 0$  when  $x = 500$ . If  $x = 0$  or  $1000$  then  $A = 0$ , if  $x = 500$  then  $A = 375,000$  so the area is greatest when  $x = 500$  ft and (from  $y = 1500 - 3x/2$ ) when  $y = 750$  ft.

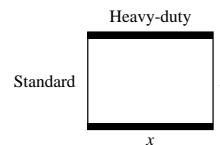

6. Let  $x$  and  $y$  be the dimensions shown in the figure and  $A$  the area of the rectangle, then  $A = xy$  and, by similar triangles,  $x/6 = (8 - y)/8$ ,  $y = 8 - 4x/3$  so  $A = x(8 - 4x/3) = 8x - 4x^2/3$  for  $x$  in  $[0, 6]$ .  $dA/dx = 8 - 8x/3$ ,  $dA/dx = 0$  when  $x = 3$ . If  $x = 0, 3, 6$  then  $A = 0, 12, 0$  so the area is greatest when  $x = 3$  in and (from  $y = 8 - 4x/3$ )  $y = 4$  in.

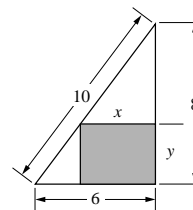

7. Let  $x, y,$  and  $z$  be as shown in the figure and  $A$  the area of the rectangle, then  $A = xy$  and, by similar triangles,  $z/10 = y/6$ ,  $z = 5y/3$ ; also  $x/10 = (8 - z)/8 = (8 - 5y/3)/8$  thus  $y = 24/5 - 12x/25$  so  $A = x(24/5 - 12x/25) = 24x/5 - 12x^2/25$  for  $x$  in  $[0, 10]$ .  $dA/dx = 24/5 - 24x/25$ ,  $dA/dx = 0$  when  $x = 5$ . If  $x = 0, 5, 10$  then  $A = 0, 12, 0$  so the area is greatest when  $x = 5$  in. and  $y = 12/5$  in.

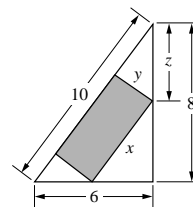

8.  $A = (2x)y = 2xy$  where  $y = 16 - x^2$  so  $A = 32x - 2x^3$  for  $0 \leq x \leq 4$ ;  $dA/dx = 32 - 6x^2$ ,  $dA/dx = 0$  when  $x = 4/\sqrt{3}$ . If  $x = 0, 4/\sqrt{3}, 4$  then  $A = 0, 256/(3\sqrt{3}), 0$  so the area is largest when  $x = 4/\sqrt{3}$  and  $y = 32/3$ . The dimensions of the rectangle with largest area are  $8/\sqrt{3}$  by  $32/3$ .

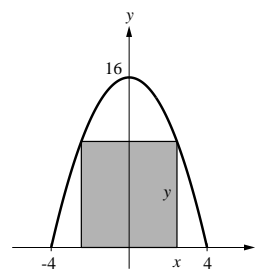

9.  $A = xy$  where  $x^2 + y^2 = 20^2 = 400$  so  $y = \sqrt{400 - x^2}$  and  $A = x\sqrt{400 - x^2}$  for  $0 \leq x \leq 20$ ;  $dA/dx = 2(200 - x^2)/\sqrt{400 - x^2}$ ,  $dA/dx = 0$  when  $x = \sqrt{200} = 10\sqrt{2}$ . If  $x = 0, 10\sqrt{2}, 20$  then  $A = 0, 200, 0$  so the area is maximum when  $x = 10\sqrt{2}$  and  $y = \sqrt{400 - 200} = 10\sqrt{2}$ .

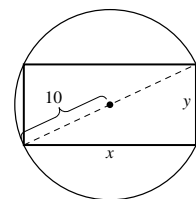

10. Let  $x$  and  $y$  be the dimensions shown in the figure, then the area of the rectangle is  $A = xy$ .

But  $\left(\frac{x}{2}\right)^2 + y^2 = R^2$ , thus  $y = \sqrt{R^2 - x^2/4} = \frac{1}{2}\sqrt{4R^2 - x^2}$  so

$A = \frac{1}{2}x\sqrt{4R^2 - x^2}$  for  $0 \leq x \leq 2R$ .  $dA/dx = (2R^2 - x^2)/\sqrt{4R^2 - x^2}$ ,

$dA/dx = 0$  when  $x = \sqrt{2}R$ . If  $x = 0, \sqrt{2}R, 2R$  then  $A = 0, R^2, 0$  so the greatest area occurs when  $x = \sqrt{2}R$  and  $y = \sqrt{2}R/2$ .

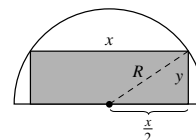



11. Let  $x$  = length of each side that uses the \$1 per foot fencing,  
 $y$  = length of each side that uses the \$2 per foot fencing.

The cost is  $C = (1)(2x) + (2)(2y) = 2x + 4y$ , but  $A = xy = 3200$  thus  $y = 3200/x$  so  
 $C = 2x + 12800/x$  for  $x > 0$ ,

$$dC/dx = 2 - 12800/x^2, \quad dC/dx = 0 \text{ when } x = 80, \quad d^2C/dx^2 > 0 \text{ so}$$

$C$  is least when  $x = 80, y = 40$ .

12.  $A = xy$  where  $2x + 2y = p$  so  $y = p/2 - x$  and  $A = px/2 - x^2$  for  $x$  in  $[0, p/2]$ ;  $dA/dx = p/2 - 2x$ ,  $dA/dx = 0$  when  $x = p/4$ . If  $x = 0$  or  $p/2$  then  $A = 0$ , if  $x = p/4$  then  $A = p^2/16$  so the area is maximum when  $x = p/4$  and  $y = p/2 - p/4 = p/4$ , which is a square.

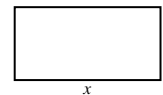

13. Let  $x$  and  $y$  be the dimensions of a rectangle; the perimeter is  $p = 2x + 2y$ . But  $A = xy$  thus  $y = A/x$  so  $p = 2x + 2A/x$  for  $x > 0$ ,  $dp/dx = 2 - 2A/x^2 = 2(x^2 - A)/x^2$ ,  $dp/dx = 0$  when  $x = \sqrt{A}$ ,  $d^2p/dx^2 = 4A/x^3 > 0$  if  $x > 0$  so  $p$  is a minimum when  $x = \sqrt{A}$  and  $y = \sqrt{A}$  and thus the rectangle is a square.

14. With  $x, y, r$ , and  $s$  as shown in the figure, the sum of the enclosed areas is  $A = \pi r^2 + s^2$  where  $r = \frac{x}{2\pi}$  and  $s = \frac{y}{4}$  because  $x$  is the circumference of the circle and  $y$  is the perimeter of the square, thus

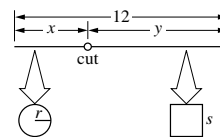

$A = \frac{x^2}{4\pi} + \frac{y^2}{16}$ . But  $x + y = 12$ , so  $y = 12 - x$  and

$$A = \frac{x^2}{4\pi} + \frac{(12 - x)^2}{16} = \frac{\pi + 4}{16\pi}x^2 - \frac{3}{2}x + 9 \text{ for } 0 \leq x \leq 12.$$

$$\frac{dA}{dx} = \frac{\pi + 4}{8\pi}x - \frac{3}{2}, \quad \frac{dA}{dx} = 0 \text{ when } x = \frac{12\pi}{\pi + 4}. \text{ If } x = 0, \frac{12\pi}{\pi + 4}, 12$$

then  $A = 9, \frac{36}{\pi + 4}, \frac{36}{\pi}$  so the sum of the enclosed areas is

- (a) a maximum when  $x = 12$  in. (when all of the wire is used for the circle)  
 (b) a minimum when  $x = 12\pi/(\pi + 4)$  in.

15. (a)  $\frac{dN}{dt} = 250(20 - t)e^{-t/20} = 0$  at  $t = 20$ ,  $N(0) = 125000$ ,  $N(20) \approx 161788$ , and  $N(100) \approx 128,369$ ;  
 the absolute maximum is  $N = 161788$  at  $t = 20$ , the absolute minimum is  $N = 125000$  at  $t = 0$ .

- (b) The absolute minimum of  $\frac{dN}{dt}$  occurs when  $\frac{d^2N}{dt^2} = 12.5(t - 40)e^{-t/20} = 0, t = 40$ .

16. The area of the window is  $A = 2rh + \pi r^2/2$ , the perimeter is  
 $p = 2r + 2h + \pi r$  thus  $h = \frac{1}{2}[p - (2 + \pi)r]$  so

$$A = r[p - (2 + \pi)r] + \pi r^2/2 = pr - (2 + \pi/2)r^2 \text{ for } 0 \leq r \leq p/(2 + \pi),$$

$dA/dr = p - (4 + \pi)r$ ,  $dA/dr = 0$  when  $r = p/(4 + \pi)$  and  $d^2A/dr^2 < 0$ , so  $A$  is maximum when  $r = p/(4 + \pi)$ .

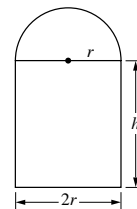

17.  $V = x(12 - 2x)^2$  for  $0 \leq x \leq 6$ ;  $dV/dx = 12(x - 2)(x - 6)$ ,  
 $dV/dx = 0$  when  $x = 2$  for  $0 < x < 6$ . If  $x = 0, 2, 6$  then  
 $V = 0, 128, 0$  so the volume is largest when  $x = 2$  in.

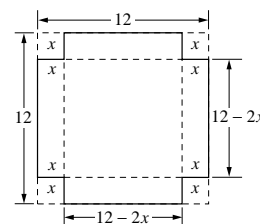

18. The dimensions of the box will be  $(k - 2x)$  by  $(k - 2x)$  by  $x$  so  $V = (k - 2x)^2x = 4x^3 - 4kx^2 + k^2x$  for  $x$  in  $[0, k/2]$ .  $dV/dx = 12x^2 - 8kx + k^2 = (6x - k)(2x - k)$ ,  $dV/dx = 0$  for  $x$  in  $(0, k/2)$  when  $x = k/6$ . If  $x = 0, k/6, k/2$  then  $V = 0, 2k^3/27, 0$  so  $V$  is maximum when  $x = k/6$ . The squares should have dimensions  $k/6$  by  $k/6$ .
19. Let  $x$  be the length of each side of a square, then  $V = x(3 - 2x)(8 - 2x) = 4x^3 - 22x^2 + 24x$  for  $0 \leq x \leq 3/2$ ;  $dV/dx = 12x^2 - 44x + 24 = 4(3x - 2)(x - 3)$ ,  $dV/dx = 0$  when  $x = 2/3$  for  $0 < x < 3/2$ . If  $x = 0, 2/3, 3/2$  then  $V = 0, 200/27, 0$  so the maximum volume is  $200/27 \text{ ft}^3$ .
20. Let  $x =$  length of each edge of base,  $y =$  height. The cost is  
 $C =$  (cost of top and bottom) + (cost of sides)  $= (2)(2x^2) + (3)(4xy) = 4x^2 + 12xy$ , but  
 $V = x^2y = 2250$  thus  $y = 2250/x^2$  so  $C = 4x^2 + 27000/x$  for  $x > 0$ ,  $dC/dx = 8x - 27000/x^2$ ,  
 $dC/dx = 0$  when  $x = \sqrt[3]{3375} = 15$ ,  $d^2C/dx^2 > 0$  so  $C$  is least when  $x = 15$ ,  $y = 10$ .
21. Let  $x =$  length of each edge of base,  $y =$  height,  $k =$  \$/cm<sup>2</sup> for the sides. The cost is  
 $C = (2k)(2x^2) + (k)(4xy) = 4k(x^2 + xy)$ , but  $V = x^2y = 2000$  thus  $y = 2000/x^2$  so  
 $C = 4k(x^2 + 2000/x)$  for  $x > 0$   $dC/dx = 4k(2x - 2000/x^2)$ ,  $dC/dx = 0$  when  
 $x = \sqrt[3]{1000} = 10$ ,  $d^2C/dx^2 > 0$  so  $C$  is least when  $x = 10$ ,  $y = 20$ .

22. Let  $x$  and  $y$  be the dimensions shown in the figure and  $V$  the volume, then  $V = x^2y$ . The amount of material is to be  $1000 \text{ ft}^2$ , thus (area of base) + (area of sides)  $= 1000$ ,  $x^2 + 4xy = 1000$ ,  
 $y = \frac{1000 - x^2}{4x}$  so  $V = x^2 \frac{1000 - x^2}{4x} = \frac{1}{4}(1000x - x^3)$  for  
 $0 < x \leq 10\sqrt{10}$ .  
 $\frac{dV}{dx} = \frac{1}{4}(1000 - 3x^2)$ ,  $\frac{dV}{dx} = 0$  when  $x = \sqrt{1000/3} = 10\sqrt{10/3}$ .  
If  $x = 0, 10\sqrt{10/3}, 10\sqrt{10}$  then  $V = 0, \frac{5000}{3}\sqrt{10/3}, 0$ ;  
the volume is greatest for  $x = 10\sqrt{10/3} \text{ ft}$  and  $y = 5\sqrt{10/3} \text{ ft}$ .

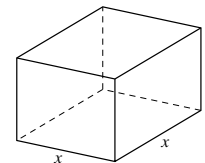

23. Let  $x =$  height and width,  $y =$  length. The surface area is  $S = 2x^2 + 3xy$  where  $x^2y = V$ , so  $y = V/x^2$  and  $S = 2x^2 + 3V/x$  for  $x > 0$ ;  $dS/dx = 4x - 3V/x^2$ ,  $dS/dx = 0$  when  $x = \sqrt[3]{3V/4}$ ,  $d^2S/dx^2 > 0$  so  $S$  is minimum when  $x = \sqrt[3]{\frac{3V}{4}}$ ,  $y = \frac{4}{3}\sqrt[3]{\frac{3V}{4}}$ .

24. Let  $r$  and  $h$  be the dimensions shown in the figure, then the volume of the inscribed cylinder is  $V = \pi r^2h$ . But

$$r^2 + \left(\frac{h}{2}\right)^2 = R^2 \text{ thus } r^2 = R^2 - \frac{h^2}{4}$$

$$\text{so } V = \pi \left(R^2 - \frac{h^2}{4}\right)h = \pi \left(R^2h - \frac{h^3}{4}\right)$$

$$\text{for } 0 \leq h \leq 2R. \quad \frac{dV}{dh} = \pi \left(R^2 - \frac{3}{4}h^2\right), \quad \frac{dV}{dh} = 0$$

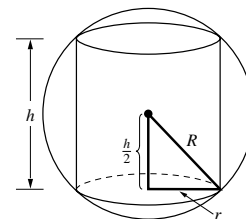

when  $h = 2R/\sqrt{3}$ . If  $h = 0, 2R/\sqrt{3}, 2R$  then  $V = 0, \frac{4\pi}{3\sqrt{3}}R^3, 0$  so the volume is largest when  $h = 2R/\sqrt{3}$  and  $r = \sqrt{2/3}R$ .

25. Let  $r$  and  $h$  be the dimensions shown in the figure, then the surface area is  $S = 2\pi rh + 2\pi r^2$ .

But  $r^2 + \left(\frac{h}{2}\right)^2 = R^2$  thus  $h = 2\sqrt{R^2 - r^2}$  so

$$S = 4\pi r\sqrt{R^2 - r^2} + 2\pi r^2 \text{ for } 0 \leq r \leq R,$$

$$\frac{dS}{dr} = \frac{4\pi(R^2 - 2r^2)}{\sqrt{R^2 - r^2}} + 4\pi r; \frac{dS}{dr} = 0 \text{ when}$$

$$\frac{R^2 - 2r^2}{\sqrt{R^2 - r^2}} = -r \tag{i}$$

$$R^2 - 2r^2 = -r\sqrt{R^2 - r^2}$$

$$R^4 - 4R^2r^2 + 4r^4 = r^2(R^2 - r^2)$$

$$5r^4 - 5R^2r^2 + R^4 = 0$$

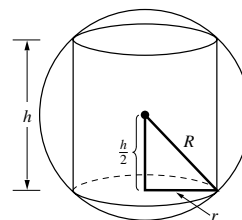

and using the quadratic formula  $r^2 = \frac{5R^2 \pm \sqrt{25R^4 - 20R^4}}{10} = \frac{5 \pm \sqrt{5}}{10}R^2$ ,  $r = \sqrt{\frac{5 \pm \sqrt{5}}{10}}R$ , of which

only  $r = \sqrt{\frac{5 + \sqrt{5}}{10}}R$  satisfies (i). If  $r = 0$ ,  $\sqrt{\frac{5 + \sqrt{5}}{10}}R$ ,  $0$  then  $S = 0, (5 + \sqrt{5})\pi R^2, 2\pi R^2$  so the surface

area is greatest when  $r = \sqrt{\frac{5 + \sqrt{5}}{10}}R$  and, from  $h = 2\sqrt{R^2 - r^2}$ ,  $h = 2\sqrt{\frac{5 - \sqrt{5}}{10}}R$ .

26. Let  $R$  and  $H$  be the radius and height of the cone, and  $r$  and  $h$  the radius and height of the cylinder (see figure), then the volume of the cylinder is  $V = \pi r^2 h$ . By similar triangles (see figure)  $\frac{H-h}{H} = \frac{r}{R}$

thus  $h = \frac{H}{R}(R-r)$  so  $V = \pi \frac{H}{R}(R-r)r^2 = \pi \frac{H}{R}(Rr^2 - r^3)$  for  $0 \leq r \leq R$ .

$$\frac{dV}{dr} = \pi \frac{H}{R}(2Rr - 3r^2) = \pi \frac{H}{R}r(2R - 3r), \frac{dV}{dr} = 0 \text{ for } 0 < r < R$$

when  $r = 2R/3$ . If  $r = 0, 2R/3, R$  then  $V = 0, 4\pi R^2 H/27, 0$  so the

maximum volume is  $\frac{4\pi R^2 H}{27} = \frac{4}{9} \frac{1}{3} \pi R^2 H = \frac{4}{9} \cdot (\text{volume of cone})$ .

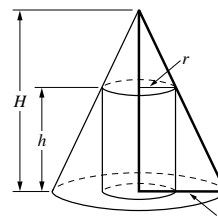

27. From (13),  $S = 2\pi r^2 + 2\pi rh$ . But  $V = \pi r^2 h$  thus  $h = V/(\pi r^2)$  and so  $S = 2\pi r^2 + 2V/r$  for  $r > 0$ .  $dS/dr = 4\pi r - 2V/r^2$ ,  $dS/dr = 0$  if  $r = \sqrt[3]{V/(2\pi)}$ . Since  $d^2S/dr^2 = 4\pi + 4V/r^3 > 0$ , the minimum surface area is achieved when  $r = \sqrt[3]{V/2\pi}$  and so  $h = V/(\pi r^2) = [V/(\pi r^3)]r = 2r$ .

28.  $V = \pi r^2 h$  where  $S = 2\pi r^2 + 2\pi rh$  so  $h = \frac{S - 2\pi r^2}{2\pi r}$ ,  $V = \frac{1}{2}(Sr - 2\pi r^3)$  for  $r > 0$ .

$$\frac{dV}{dr} = \frac{1}{2}(S - 6\pi r^2) = 0 \text{ if } r = \sqrt{S/(6\pi)}, \frac{d^2V}{dr^2} = -6\pi r < 0 \text{ so } V \text{ is maximum when}$$

$r = \sqrt{S/(6\pi)}$  and  $h = \frac{S - 2\pi r^2}{2\pi r} = \frac{S - 2\pi r^2}{2\pi r^2}r = \frac{S - S/3}{S/3}r = 2r$ , thus the height is equal to the diameter of the base.

29. The surface area is  $S = \pi r^2 + 2\pi rh$  where  $V = \pi r^2 h = 500$  so  $h = 500/(\pi r^2)$  and  $S = \pi r^2 + 1000/r$  for  $r > 0$ ;

$dS/dr = 2\pi r - 1000/r^2 = (2\pi r^3 - 1000)/r^2$ ,  $dS/dr = 0$  when  $r = \sqrt[3]{500/\pi}$ ,  $d^2S/dr^2 > 0$  for  $r > 0$  so  $S$  is minimum when

$$r = \sqrt[3]{500/\pi} \text{ and } h = \frac{500}{\pi r^2} = \frac{500}{\pi r^3} \quad r = \frac{500}{\pi(500/\pi)} \sqrt[3]{500/\pi}$$

$$= \sqrt[3]{500/\pi}.$$

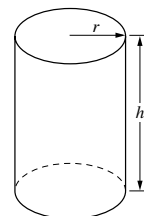

30. The total area of material used is

$$A = A_{\text{top}} + A_{\text{bottom}} + A_{\text{side}} = (2r)^2 + (2r)^2 + 2\pi rh = 8r^2 + 2\pi rh.$$

The volume is  $V = \pi r^2 h$  thus  $h = V/(\pi r^2)$  so  $A = 8r^2 + 2V/r$  for  $r > 0$ ,

$dA/dr = 16r - 2V/r^2 = 2(8r^3 - V)/r^2$ ,  $dA/dr = 0$  when  $r = \sqrt[3]{V}/2$ . This is the only critical point,  $d^2A/dr^2 > 0$  there so the least material is used when  $r = \sqrt[3]{V}/2$ ,  $\frac{r}{h} = \frac{r}{V/(\pi r^2)} = \frac{\pi}{V} r^3$  and, for  $r = \sqrt[3]{V}/2$ ,  $\frac{r}{h} = \frac{\pi V}{V} \frac{1}{8} = \frac{\pi}{8}$ .

31. Let  $x$  be the length of each side of the squares and  $y$  the height of the frame, then the volume is  $V = x^2 y$ . The total length of the wire is  $L$  thus  $8x + 4y = L$ ,  $y = (L - 8x)/4$  so  $V = x^2(L - 8x)/4 = (Lx^2 - 8x^3)/4$  for  $0 \leq x \leq L/8$ .  $dV/dx = (2Lx - 24x^2)/4$ ,  $dV/dx = 0$  for  $0 < x < L/8$  when  $x = L/12$ . If  $x = 0, L/12, L/8$  then  $V = 0, L^3/1728, 0$  so the volume is greatest when  $x = L/12$  and  $y = L/12$ .

32. (a) Let  $x =$  diameter of the sphere,  $y =$  length of an edge of the cube. The combined volume is

$V = \frac{1}{6}\pi x^3 + y^3$  and the surface area is  $S = \pi x^2 + 6y^2 = \text{constant}$ . Thus  $y = \frac{(S - \pi x^2)^{1/2}}{6^{1/2}}$  and

$$V = \frac{\pi}{6}x^3 + \frac{(S - \pi x^2)^{3/2}}{6^{3/2}} \text{ for } 0 \leq x \leq \sqrt{\frac{S}{\pi}};$$

$$\frac{dV}{dx} = \frac{\pi}{2}x^2 - \frac{3\pi}{6^{3/2}}x(S - \pi x^2)^{1/2} = \frac{\pi}{2\sqrt{6}}x(\sqrt{6}x - \sqrt{S - \pi x^2}). \quad \frac{dV}{dx} = 0 \text{ when } x = 0, \text{ or when}$$

$$\sqrt{6}x = \sqrt{S - \pi x^2}, \quad 6x^2 = S - \pi x^2, \quad x^2 = \frac{S}{6 + \pi}, \quad x = \sqrt{\frac{S}{6 + \pi}}. \text{ If } x = 0, \sqrt{\frac{S}{6 + \pi}}, \sqrt{\frac{S}{\pi}}, \text{ then}$$

$$V = \frac{S^{3/2}}{6^{3/2}}, \frac{S^{3/2}}{6\sqrt{6 + \pi}}, \frac{S^{3/2}}{6\sqrt{\pi}} \text{ so that } V \text{ is smallest when } x = \sqrt{\frac{S}{6 + \pi}}, \text{ and hence when } y = \sqrt{\frac{S}{6 + \pi}}, \text{ thus } x = y.$$

- (b) From part (a), the sum of the volumes is greatest when there is no cube.

33. Let  $h$  and  $r$  be the dimensions shown in the figure, then the volume

is  $V = \frac{1}{3}\pi r^2 h$ . But  $r^2 + h^2 = L^2$  thus  $r^2 = L^2 - h^2$  so

$$V = \frac{1}{3}\pi(L^2 - h^2)h = \frac{1}{3}\pi(L^2 h - h^3) \text{ for } 0 \leq h \leq L.$$

$$\frac{dV}{dh} = \frac{1}{3}\pi(L^2 - 3h^2). \quad \frac{dV}{dh} = 0 \text{ when } h = L/\sqrt{3}. \text{ If } h = 0, L/\sqrt{3}, 0$$

then  $V = 0, \frac{2\pi}{9\sqrt{3}}L^3, 0$  so the volume is as large as possible when

$$h = L/\sqrt{3} \text{ and } r = \sqrt{2/3}L.$$

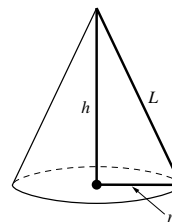

34. Let  $r$  and  $h$  be the radius and height of the cone (see figure). The slant height of any such cone will be  $R$ , the radius of the circular sheet. Refer to the solution of Exercise 33 to find that the largest volume is  $\frac{2\pi}{9\sqrt{3}}R^3$ .

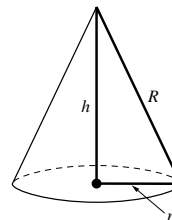

35. The area of the paper is  $A = \pi rL = \pi r\sqrt{r^2 + h^2}$ , but  $V = \frac{1}{3}\pi r^2 h = 10$  thus  $h = 30/(\pi r^2)$  so  $A = \pi r\sqrt{r^2 + 900/(\pi^2 r^4)}$ . To simplify the computations let  $S = A^2$ ,  $S = \pi^2 r^2 \left( r^2 + \frac{900}{\pi^2 r^4} \right) = \pi^2 r^4 + \frac{900}{r^2}$  for  $r > 0$ ,  $\frac{dS}{dr} = 4\pi^2 r^3 - \frac{1800}{r^3} = \frac{4(\pi^2 r^6 - 450)}{r^3}$ ,  $dS/dr = 0$  when  $r = \sqrt[6]{450/\pi^2}$ ,  $d^2S/dr^2 > 0$ , so  $S$  and hence  $A$  is least when  $r = \sqrt[6]{450/\pi^2}$ ,  $h = \frac{30}{\pi} \sqrt[3]{\pi^2/450}$ .

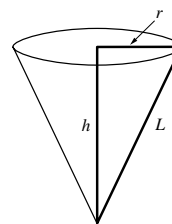

36. The area of the triangle is  $A = \frac{1}{2}hb$ . By similar triangles (see figure)  $\frac{b/2}{h} = \frac{R}{\sqrt{h^2 - 2Rh}}$ ,  $b = \frac{2Rh}{\sqrt{h^2 - 2Rh}}$  so  $A = \frac{Rh^2}{\sqrt{h^2 - 2Rh}}$  for  $h > 2R$ ,  $\frac{dA}{dh} = \frac{Rh^2(h - 3R)}{(h^2 - 2Rh)^{3/2}}$ ,  $\frac{dA}{dh} = 0$  for  $h > 2R$  when  $h = 3R$ , by the first derivative test  $A$  is minimum when  $h = 3R$ . If  $h = 3R$  then  $b = 2\sqrt{3}R$  (the triangle is equilateral).

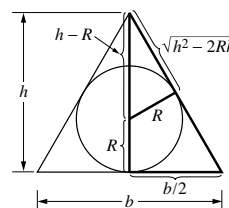

37. The volume of the cone is  $V = \frac{1}{3}\pi r^2 h$ . By similar triangles (see figure)  $\frac{r}{h} = \frac{R}{\sqrt{h^2 - 2Rh}}$ ,  $r = \frac{Rh}{\sqrt{h^2 - 2Rh}}$  so  $V = \frac{1}{3}\pi R^2 \frac{h^3}{h^2 - 2Rh} = \frac{1}{3}\pi R^2 \frac{h^2}{h - 2R}$  for  $h > 2R$ ,  $\frac{dV}{dh} = \frac{1}{3}\pi R^2 \frac{h(h - 4R)}{(h - 2R)^2}$ ,  $\frac{dV}{dh} = 0$  for  $h > 2R$  when  $h = 4R$ , by the first derivative test  $V$  is minimum when  $h = 4R$ . If  $h = 4R$  then  $r = \sqrt{2}R$ .

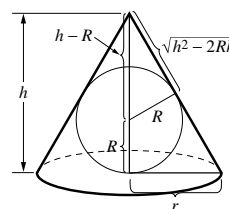

38. The area is (see figure)  $A = \frac{1}{2}(2 \sin \theta)(4 + 4 \cos \theta) = 4(\sin \theta + \sin \theta \cos \theta)$

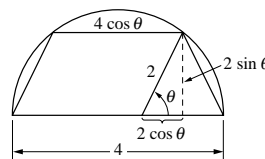

for  $0 \leq \theta \leq \pi/2$ ;  
 $dA/d\theta = 4(\cos \theta - \sin^2 \theta + \cos^2 \theta) = 4(\cos \theta - [1 - \cos^2 \theta] + \cos^2 \theta) = 4(2 \cos^2 \theta + \cos \theta - 1) = 4(2 \cos \theta - 1)(\cos \theta + 1)$   
 $dA/d\theta = 0$  when  $\theta = \pi/3$  for  $0 < \theta < \pi/2$ . If  $\theta = 0, \pi/3, \pi/2$  then  $A = 0, 3\sqrt{3}, 4$  so the maximum area is  $3\sqrt{3}$ .

39. Let  $b$  and  $h$  be the dimensions shown in the figure, then the cross-sectional area is  $A = \frac{1}{2}h(5 + b)$ . But  $h = 5 \sin \theta$  and  $b = 5 + 2(5 \cos \theta) = 5 + 10 \cos \theta$  so  $A = \frac{5}{2} \sin \theta(10 + 10 \cos \theta) = 25 \sin \theta(1 + \cos \theta)$  for  $0 \leq \theta \leq \pi/2$ .  $dA/d\theta = -25 \sin^2 \theta + 25 \cos \theta(1 + \cos \theta) = 25(-\sin^2 \theta + \cos \theta + \cos^2 \theta) = 25(-1 + \cos^2 \theta + \cos \theta + \cos^2 \theta) = 25(2 \cos^2 \theta + \cos \theta - 1) = 25(2 \cos \theta - 1)(\cos \theta + 1)$ .

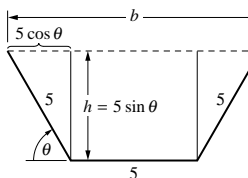

$dA/d\theta = 0$  for  $0 < \theta < \pi/2$  when  $\cos \theta = 1/2$ ,  $\theta = \pi/3$ . If  $\theta = 0, \pi/3, \pi/2$  then  $A = 0, 75\sqrt{3}/4, 25$  so the cross-sectional area is greatest when  $\theta = \pi/3$ .

40.  $I = k \frac{\cos \phi}{\ell^2}$ ,  $k$  the constant of proportionality. If  $h$  is the height of the lamp above the table then  $\cos \phi = h/\ell$  and  $\ell = \sqrt{h^2 + r^2}$  so  $I = k \frac{h}{\ell^3} = k \frac{h}{(h^2 + r^2)^{3/2}}$  for  $h > 0$ ,  $\frac{dI}{dh} = k \frac{r^2 - 2h^2}{(h^2 + r^2)^{5/2}}$ ,  $\frac{dI}{dh} = 0$  when  $h = r/\sqrt{2}$ , by the first derivative test  $I$  is maximum when  $h = r/\sqrt{2}$ .

41. Let  $L$ ,  $L_1$ , and  $L_2$  be as shown in the figure, then

$$L = L_1 + L_2 = 8 \csc \theta + \sec \theta,$$

$$\frac{dL}{d\theta} = -8 \csc \theta \cot \theta + \sec \theta \tan \theta, \quad 0 < \theta < \pi/2$$

$$= -\frac{8 \cos \theta}{\sin^2 \theta} + \frac{\sin \theta}{\cos^2 \theta} = \frac{-8 \cos^3 \theta + \sin^3 \theta}{\sin^2 \theta \cos^2 \theta};$$

$\frac{dL}{d\theta} = 0$  if  $\sin^3 \theta = 8 \cos^3 \theta$ ,  $\tan^3 \theta = 8$ ,  $\tan \theta = 2$  which gives the absolute minimum for  $L$  because  $\lim_{\theta \rightarrow 0^+} L = \lim_{\theta \rightarrow \pi/2^-} L = +\infty$ . If

$\tan \theta = 2$ , then  $\csc \theta = \sqrt{5}/2$  and  $\sec \theta = \sqrt{5}$  so

$$L = 8(\sqrt{5}/2) + \sqrt{5} = 5\sqrt{5} \text{ ft.}$$

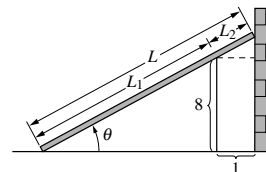

42. Let  $x$  = number of steers per acre  
 $w$  = average market weight per steer  
 $T$  = total market weight per acre

then  $T = xw$  where  $w = 2000 - 50(x - 20) = 3000 - 50x$

so  $T = x(3000 - 50x) = 3000x - 50x^2$  for  $0 \leq x \leq 60$ ,

$dT/dx = 3000 - 100x$  and  $dT/dx = 0$  when  $x = 30$ . If  $x = 0, 30, 60$  then  $T = 0, 45000, 0$  so the total market weight per acre is largest when 30 steers per acre are allowed.

43. (a) The daily profit is

$$P = (\text{revenue}) - (\text{production cost}) = 100x - (100,000 + 50x + 0.0025x^2) \\ = -100,000 + 50x - 0.0025x^2$$

for  $0 \leq x \leq 7000$ , so  $dP/dx = 50 - 0.005x$  and  $dP/dx = 0$  when  $x = 10,000$ . Because 10,000 is not in the interval  $[0, 7000]$ , the maximum profit must occur at an endpoint. When  $x = 0$ ,  $P = -100,000$ ; when  $x = 7000$ ,  $P = 127,500$  so 7000 units should be manufactured and sold daily.

- (b) Yes, because  $dP/dx > 0$  when  $x = 7000$  so profit is increasing at this production level.

44. (a)  $R(x) = px$  but  $p = 1000 - x$  so  $R(x) = (1000 - x)x$

(b)  $P(x) = R(x) - C(x) = (1000 - x)x - (3000 + 20x) = -3000 + 980x - x^2$

(c)  $P'(x) = 980 - 2x$ ,  $P'(x) = 0$  for  $0 < x < 500$  when  $x = 490$ ; test the points 0, 490, 500 to find that the profit is a maximum when  $x = 490$ .

(d)  $P(490) = 237,100$

(e)  $p = 1000 - x = 1000 - 490 = 510$ .

45. The profit is

$$P = (\text{profit on nondefective}) - (\text{loss on defective}) = 100(x - y) - 20y = 100x - 120y$$

but  $y = 0.01x + 0.00003x^2$  so  $P = 100x - 120(0.01x + 0.00003x^2) = 98.8x - 0.0036x^2$  for  $x > 0$ ,  $dP/dx = 98.8 - 0.0072x$ ,  $dP/dx = 0$  when  $x = 98.8/0.0072 \approx 13,722$ ,  $d^2P/dx^2 < 0$  so the profit is maximum at a production level of about 13,722 pounds.

46. The total cost  $C$  is  
 $C = c \cdot (\text{hours to travel } 3000 \text{ mi at a speed of } v \text{ mi/h})$   
 $= c \cdot \frac{3000}{v} = (a + bv^n) \frac{3000}{v} = 3000(av^{-1} + bv^{n-1})$  for  $v > 0$ ,  
 $dC/dv = 3000[-av^{-2} + b(n-1)v^{n-2}] = 3000[-a + b(n-1)v^n]/v^2$ ,  
 $dC/dv = 0$  when  $v = \left[ \frac{a}{b(n-1)} \right]^{1/n}$ . This is the only critical point and  $dC/dv$  changes sign from  $-$  to  $+$  at this point so the total cost is least when  $v = \left[ \frac{a}{b(n-1)} \right]^{1/n}$  mi/h.
47. The distance between the particles is  $D = \sqrt{(1-t-t)^2 + (t-2t)^2} = \sqrt{5t^2 - 4t + 1}$  for  $t \geq 0$ . For convenience, we minimize  $D^2$  instead, so  $D^2 = 5t^2 - 4t + 1$ ,  $dD^2/dt = 10t - 4$ , which is 0 when  $t = 2/5$ .  $d^2D^2/dt^2 > 0$  so  $D^2$  and hence  $D$  is minimum when  $t = 2/5$ . The minimum distance is  $D = 1/\sqrt{5}$ .
48. The distance between the particles is  $D = \sqrt{(2t-t)^2 + (2-t^2)^2} = \sqrt{t^4 - 3t^2 + 4}$  for  $t \geq 0$ . For convenience we minimize  $D^2$  instead so  $D^2 = t^4 - 3t^2 + 4$ ,  $dD^2/dt = 4t^3 - 6t = 4t(t^2 - 3/2)$ , which is 0 for  $t > 0$  when  $t = \sqrt{3/2}$ .  $d^2D^2/dt^2 = 12t^2 - 6 > 0$  when  $t = \sqrt{3/2}$  so  $D^2$  and hence  $D$  is minimum there. The minimum distance is  $D = \sqrt{7}/2$ .
49. Let  $P(x, y)$  be a point on the curve  $x^2 + y^2 = 1$ . The distance between  $P(x, y)$  and  $P_0(2, 0)$  is  $D = \sqrt{(x-2)^2 + y^2}$ , but  $y^2 = 1 - x^2$  so  $D = \sqrt{(x-2)^2 + 1 - x^2} = \sqrt{5 - 4x}$  for  $-1 \leq x \leq 1$ ,  $\frac{dD}{dx} = -\frac{2}{\sqrt{5-4x}}$  which has no critical points for  $-1 < x < 1$ . If  $x = -1, 1$  then  $D = 3, 1$  so the closest point occurs when  $x = 1$  and  $y = 0$ .
50. Let  $P(x, y)$  be a point on  $y = \sqrt{x}$ , then the distance  $D$  between  $P$  and  $(2, 0)$  is  
 $D = \sqrt{(x-2)^2 + y^2} = \sqrt{(x-2)^2 + x} = \sqrt{x^2 - 3x + 4}$ , for  $0 \leq x \leq 3$ . For convenience we find the extrema for  $D^2$  instead, so  $D^2 = x^2 - 3x + 4$ ,  $dD^2/dx = 2x - 3 = 0$  when  $x = 3/2$ . If  $x = 0, 3/2, 3$  then  $D^2 = 4, 7/4, 4$  so  $D = 2, \sqrt{7}/2, 2$ . The points  $(0, 0)$  and  $(3, \sqrt{3})$  are at the greatest distance, and  $(3/2, \sqrt{3/2})$  the shortest distance from  $(2, 0)$ .
51. Let  $(x, y)$  be a point on the curve, then the square of the distance between  $(x, y)$  and  $(0, 2)$  is  $S = x^2 + (y-2)^2$  where  $x^2 - y^2 = 1$ ,  $x^2 = y^2 + 1$  so  
 $S = (y^2 + 1) + (y-2)^2 = 2y^2 - 4y + 5$  for any  $y$ ,  $dS/dy = 4y - 4$ ,  $dS/dy = 0$  when  $y = 1$ ,  
 $d^2S/dy^2 > 0$  so  $S$  is least when  $y = 1$  and  $x = \pm\sqrt{2}$ .
52. The square of the distance between a point  $(x, y)$  on the curve and the point  $(0, 9)$  is  
 $S = x^2 + (y-9)^2$  where  $x = 2y^2$  so  $S = 4y^4 + (y-9)^2$  for any  $y$ ,  
 $dS/dy = 16y^3 + 2(y-9) = 2(8y^3 + y - 9)$ ,  $dS/dy = 0$  when  $y = 1$  (which is the only real solution),  
 $d^2S/dy^2 > 0$  so  $S$  is least when  $y = 1$ ,  $x = 2$ .
53. If  $P(x_0, y_0)$  is on the curve  $y = 1/x^2$ , then  $y_0 = 1/x_0^2$ . At  $P$  the slope of the tangent line is  $-2/x_0^3$  so its equation is  $y - \frac{1}{x_0^2} = -\frac{2}{x_0^3}(x - x_0)$ , or  $y = -\frac{2}{x_0^3}x + \frac{3}{x_0^2}$ . The tangent line crosses the  $y$ -axis at  $\frac{3}{x_0^2}$ , and the  $x$ -axis at  $\frac{3}{2}x_0$ . The length of the segment then is  $L = \sqrt{\frac{9}{x_0^4} + \frac{9}{4}x_0^2}$  for  $x_0 > 0$ . For convenience, we minimize  $L^2$  instead, so  $L^2 = \frac{9}{x_0^4} + \frac{9}{4}x_0^2$ ,  $\frac{dL^2}{dx_0} = -\frac{36}{x_0^5} + \frac{9}{2}x_0 = \frac{9(x_0^6 - 8)}{2x_0^5}$ , which is 0 when  $x_0^6 = 8$ ,  $x_0 = \sqrt{2}$ .  $\frac{d^2L^2}{dx_0^2} > 0$  so  $L^2$  and hence  $L$  is minimum when  $x_0 = \sqrt{2}$ ,  $y_0 = 1/2$ .

54. If  $P(x_0, y_0)$  is on the curve  $y = 1 - x^2$ , then  $y_0 = 1 - x_0^2$ . At  $P$  the slope of the tangent line is  $-2x_0$  so its equation is  $y - (1 - x_0^2) = -2x_0(x - x_0)$ , or  $y = -2x_0x + x_0^2 + 1$ . The  $y$ -intercept is  $x_0^2 + 1$  and the  $x$ -intercept is  $\frac{1}{2}(x_0 + 1/x_0)$  so the area  $A$  of the triangle is  $A = \frac{1}{4}(x_0^2 + 1)(x_0 + 1/x_0) = \frac{1}{4}(x_0^3 + 2x_0 + 1/x_0)$  for  $0 \leq x_0 \leq 1$ .

$$dA/dx_0 = \frac{1}{4}(3x_0^2 + 2 - 1/x_0^2) = \frac{1}{4}(3x_0^4 + 2x_0^2 - 1)/x_0^2 \text{ which is 0 when } x_0^2 = -1 \text{ (reject), or}$$

when  $x_0^2 = 1/3$  so  $x_0 = 1/\sqrt{3}$ .  $d^2A/dx_0^2 = \frac{1}{4}(6x_0 + 2/x_0^3) > 0$  at  $x_0 = 1/\sqrt{3}$  so a relative minimum and hence the absolute minimum occurs there.

55. At each point  $(x, y)$  on the curve the slope of the tangent line is  $m = \frac{dy}{dx} = -\frac{2x}{(1+x^2)^2}$  for any  $x$ ,  $\frac{dm}{dx} = \frac{2(3x^2 - 1)}{(1+x^2)^3}$ ,  $\frac{dm}{dx} = 0$  when  $x = \pm 1/\sqrt{3}$ , by the first derivative test the only relative maximum occurs at  $x = -1/\sqrt{3}$ , which is the absolute maximum because  $\lim_{x \rightarrow \pm\infty} m = 0$ . The tangent line has greatest slope at the point  $(-1/\sqrt{3}, 3/4)$ .

56. Let  $x$  be how far  $P$  is upstream from where the man starts (see figure), then the total time to reach  $T$  is

$$t = (\text{time from } M \text{ to } P) + (\text{time from } P \text{ to } T)$$

$$= \frac{\sqrt{x^2 + 1}}{r_R} + \frac{1-x}{r_W} \text{ for } 0 \leq x \leq 1,$$

where  $r_R$  and  $r_W$  are the rates at which he can row and walk, respectively.

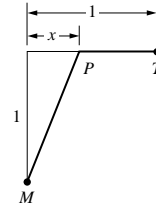

(a)  $t = \frac{\sqrt{x^2 + 1}}{3} + \frac{1-x}{5}$ ,  $\frac{dt}{dx} = \frac{x}{3\sqrt{x^2 + 1}} - \frac{1}{5}$  so  $\frac{dt}{dx} = 0$  when  $5x = 3\sqrt{x^2 + 1}$ ,

$25x^2 = 9(x^2 + 1)$ ,  $x^2 = 9/16$ ,  $x = 3/4$ . If  $x = 0, 3/4, 1$  then  $t = 8/15, 7/15, \sqrt{2}/3$  so the time is a minimum when  $x = 3/4$  mile.

(b)  $t = \frac{\sqrt{x^2 + 1}}{4} + \frac{1-x}{5}$ ,  $\frac{dt}{dx} = \frac{x}{4\sqrt{x^2 + 1}} - \frac{1}{5}$  so  $\frac{dt}{dx} = 0$  when  $x = 4/3$  which is not in the interval  $[0, 1]$ . Check the endpoints to find that the time is a minimum when  $x = 1$  (he should row directly to the town).

57. With  $x$  and  $y$  as shown in the figure, the maximum length of pipe will be the smallest value of  $L = x + y$ . By similar triangles

$$\frac{y}{8} = \frac{x}{\sqrt{x^2 - 16}}, y = \frac{8x}{\sqrt{x^2 - 16}} \text{ so}$$

$$L = x + \frac{8x}{\sqrt{x^2 - 16}} \text{ for } x > 4, \frac{dL}{dx} = 1 - \frac{128}{(x^2 - 16)^{3/2}}, \frac{dL}{dx} = 0 \text{ when}$$

$$(x^2 - 16)^{3/2} = 128$$

$$x^2 - 16 = 128^{2/3} = 16(2^{2/3})$$

$$x^2 = 16(1 + 2^{2/3})$$

$$x = 4(1 + 2^{2/3})^{1/2},$$

$$d^2L/dx^2 = 384x/(x^2 - 16)^{5/2} > 0 \text{ if } x > 4 \text{ so } L \text{ is smallest when } x = 4(1 + 2^{2/3})^{1/2}.$$

For this value of  $x$ ,  $L = 4(1 + 2^{2/3})^{3/2}$  ft.

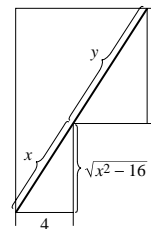



58.  $s = (x_1 - \bar{x})^2 + (x_2 - \bar{x})^2 + \cdots + (x_n - \bar{x})^2$ ,  
 $ds/d\bar{x} = -2(x_1 - \bar{x}) - 2(x_2 - \bar{x}) - \cdots - 2(x_n - \bar{x})$ ,  
 $ds/d\bar{x} = 0$  when

$$\begin{aligned} (x_1 - \bar{x}) + (x_2 - \bar{x}) + \cdots + (x_n - \bar{x}) &= 0 \\ (x_1 + x_2 + \cdots + x_n) - (\bar{x} + \bar{x} + \cdots + \bar{x}) &= 0 \\ (x_1 + x_2 + \cdots + x_n) - n\bar{x} &= 0 \end{aligned}$$

$$\bar{x} = \frac{1}{n}(x_1 + x_2 + \cdots + x_n),$$

$d^2s/d\bar{x}^2 = 2 + 2 + \cdots + 2 = 2n > 0$ , so  $s$  is minimum when  $\bar{x} = \frac{1}{n}(x_1 + x_2 + \cdots + x_n)$ .

59. Let  $x =$  distance from the weaker light source,  $I =$  the intensity at that point, and  $k$  the constant of proportionality. Then

$$I = \frac{kS}{x^2} + \frac{8kS}{(90-x)^2} \text{ if } 0 < x < 90;$$

$$\frac{dI}{dx} = -\frac{2kS}{x^3} + \frac{16kS}{(90-x)^3} = \frac{2kS[8x^3 - (90-x)^3]}{x^3(90-x)^3} = 18 \frac{kS(x-30)(x^2+2700)}{x^3(x-90)^3},$$

which is 0 when  $x = 30$ ;  $\frac{dI}{dx} < 0$  if  $x < 30$ , and  $\frac{dI}{dx} > 0$  if  $x > 30$ , so the intensity is minimum at a distance of 30 cm from the weaker source.

60. If  $f(x_0)$  is a maximum then  $f(x) \leq f(x_0)$  for all  $x$  in some open interval containing  $x_0$  thus  $\sqrt{f(x)} \leq \sqrt{f(x_0)}$  because  $\sqrt{x}$  is an increasing function, so  $\sqrt{f(x_0)}$  is a maximum of  $\sqrt{f(x)}$  at  $x_0$ . The proof is similar for a minimum value, simply replace  $\leq$  by  $\geq$ .

61. Let  $v =$  speed of light in the medium. The total time required for the light to travel from  $A$  to  $P$  to  $B$  is

$$t = (\text{total distance from } A \text{ to } P \text{ to } B)/v = \frac{1}{v}(\sqrt{(c-x)^2 + a^2} + \sqrt{x^2 + b^2}),$$

$$\frac{dt}{dx} = \frac{1}{v} \left[ -\frac{c-x}{\sqrt{(c-x)^2 + a^2}} + \frac{x}{\sqrt{x^2 + b^2}} \right]$$

and  $\frac{dt}{dx} = 0$  when  $\frac{x}{\sqrt{x^2 + b^2}} = \frac{c-x}{\sqrt{(c-x)^2 + a^2}}$ . But  $x/\sqrt{x^2 + b^2} = \sin \theta_2$  and

$$(c-x)/\sqrt{(c-x)^2 + a^2} = \sin \theta_1 \text{ thus } dt/dx = 0 \text{ when } \sin \theta_2 = \sin \theta_1 \text{ so } \theta_2 = \theta_1.$$

62. The total time required for the light to travel from  $A$  to  $P$  to  $B$  is

$$t = (\text{time from } A \text{ to } P) + (\text{time from } P \text{ to } B) = \frac{\sqrt{x^2 + a^2}}{v_1} + \frac{\sqrt{(c-x)^2 + b^2}}{v_2},$$

$$\frac{dt}{dx} = \frac{x}{v_1\sqrt{x^2 + a^2}} - \frac{c-x}{v_2\sqrt{(c-x)^2 + b^2}} \text{ but } x/\sqrt{x^2 + a^2} = \sin \theta_1 \text{ and}$$

$$(c-x)/\sqrt{(c-x)^2 + b^2} = \sin \theta_2 \text{ thus } \frac{dt}{dx} = \frac{\sin \theta_1}{v_1} - \frac{\sin \theta_2}{v_2} \text{ so } \frac{dt}{dx} = 0 \text{ when } \frac{\sin \theta_1}{v_1} = \frac{\sin \theta_2}{v_2}.$$

63. (a) The rate at which the farmer walks is analogous to the speed of light in Fermat's principle.

- (b) the best path occurs when  $\theta_1 = \theta_2$   
 (see figure).

- (c) by similar triangles,  
 $x/(1/4) = (1-x)/(3/4)$   
 $3x = 1-x$   
 $4x = 1$   
 $x = 1/4$  mi.

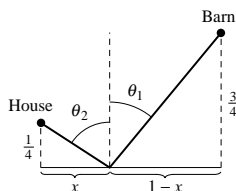

## EXERCISE SET 6.3

1. (a) positive, negative, slowing down                      (b) positive, positive, speeding up  
(c) negative, positive, slowing down
2. (a) positive, slowing down                                      (b) negative, slowing down  
(c) positive, speeding up
3. (a) left because  $v = ds/dt < 0$  at  $t_0$   
(b) negative because  $a = d^2s/dt^2$  and the curve is concave down at  $t_0$  ( $d^2s/dt^2 < 0$ )  
(c) speeding up because  $v$  and  $a$  have the same sign  
(d)  $v < 0$  and  $a > 0$  at  $t_1$  so the particle is slowing down because  $v$  and  $a$  have opposite signs.
4. (a)  $C$     (b)  $A$     (c)  $B$

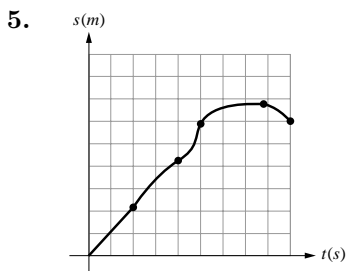

6. (a) when  $s \geq 0$ , so  $0 < t < 2$  and  $4 < t \leq 8$                       (b) when the slope is zero, at  $t = 3$   
(c) when  $s$  is decreasing, so  $0 \leq t < 3$

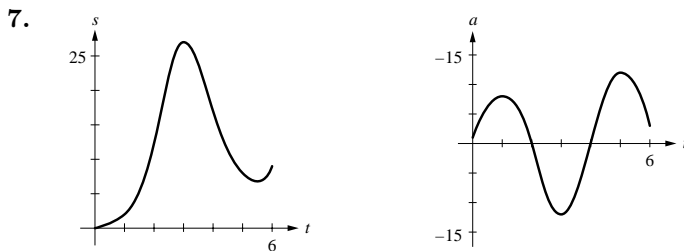

8. (a)  $v \approx (30 - 10)/(15 - 10) = 20/5 = 4$  m/s  
(b)

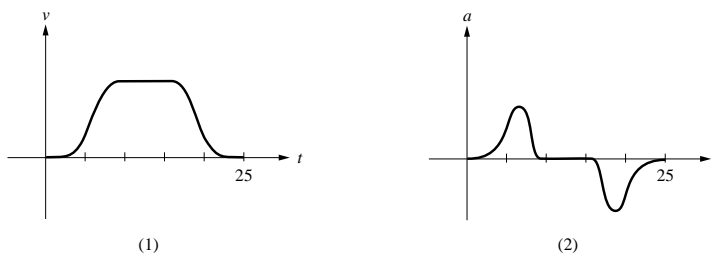

9. (a) At 60 mi/h the slope of the estimated tangent line is about 4.6 mi/h/s. Use  $1 \text{ mi} = 5,280 \text{ ft}$  and  $1 \text{ h} = 3600 \text{ s}$  to get  $a = dv/dt \approx 4.6(5,280)/(3600) \approx 6.7 \text{ ft/s}^2$ .  
(b) The slope of the tangent to the curve is maximum at  $t = 0$  s.

10. (a)

$t$	1	2	3	4	5
$s$	0.71	1.00	0.71	0.00	-0.71
$v$	0.56	0.00	-0.56	-0.79	-0.56
$a$	-0.44	-0.62	-0.44	0.00	0.44

- (b) to the right at  $t = 1$ , stopped at  $t = 2$ , otherwise to the left  
 (c) speeding up at  $t = 3$ ; slowing down at  $t = 1, 5$ ; neither at  $t = 2, 4$

11. (a)  $v(t) = 3t^2 - 12t$ ,  $a(t) = 6t - 12$   
 (b)  $s(1) = -5$  ft,  $v(1) = -9$  ft/s, speed = 9 ft/s,  $a(1) = -6$  ft/s<sup>2</sup>  
 (c)  $v = 0$  at  $t = 0, 4$   
 (d) for  $t \geq 0$ ,  $v(t)$  changes sign at  $t = 4$ , and  $a(t)$  changes sign at  $t = 2$ ; so the particle is speeding up for  $0 < t < 2$  and  $4 < t$  and is slowing down for  $2 < t < 4$   
 (e) total distance =  $|s(4) - s(0)| + |s(5) - s(4)| = |-32 - 0| + |-25 - (-32)| = 39$  ft

12. (a)  $v(t) = 4t^3 - 4$ ,  $a(t) = 12t^2$   
 (b)  $s(1) = -1$  ft,  $v(1) = 0$  ft/s, speed = 0 ft/s,  $a(1) = 12$  ft/s<sup>2</sup>  
 (c)  $v = 0$  at  $t = 1$   
 (d) speeding up for  $t > 1$ , slowing down for  $0 < t < 1$   
 (e) total distance =  $|s(1) - s(0)| + |s(5) - s(1)| = |-1 - 2| + |607 - (-1)| = 611$  ft

13. (a)  $v(t) = -(3\pi/2) \sin(\pi t/2)$ ,  $a(t) = -(3\pi^2/4) \cos(\pi t/2)$   
 (b)  $s(1) = 0$  ft,  $v(1) = -3\pi/2$  ft/s, speed =  $3\pi/2$  ft/s,  $a(1) = 0$  ft/s<sup>2</sup>  
 (c)  $v = 0$  at  $t = 0, 2, 4$   
 (d)  $v$  changes sign at  $t = 0, 2, 4$  and  $a$  changes sign at  $t = 1, 3, 5$ , so the particle is speeding up for  $0 < t < 1$ ,  $2 < t < 3$  and  $4 < t < 5$ , and it is slowing down for  $1 < t < 2$  and  $3 < t < 4$   
 (e) total distance =  $|s(2) - s(0)| + |s(4) - s(2)| + |s(5) - s(4)| = |-3 - 3| + |3 - (-3)| + |0 - 3| = 15$  ft

14. (a)  $v(t) = \frac{4 - t^2}{(t^2 + 4)^2}$ ,  $a(t) = \frac{2t(t^2 - 12)}{(t^2 + 4)^3}$   
 (b)  $s(1) = 1/5$  ft,  $v(1) = 3/25$  ft/s, speed =  $3/25$  ft/s,  $a(1) = -22/125$  ft/s<sup>2</sup>  
 (c)  $v = 0$  at  $t = 2$   
 (d)  $a$  changes sign at  $t = 2\sqrt{3}$ , so the particle is speeding up for  $2 < t < 2\sqrt{3}$  and it is slowing down for  $0 < t < 2$  and for  $2\sqrt{3} < t$   
 (e) total distance =  $|s(2) - s(0)| + |s(5) - s(2)| = \left| \frac{1}{4} - 0 \right| + \left| \frac{5}{29} - \frac{1}{4} \right| = \frac{19}{58}$  ft

15.  $v(t) = \frac{5 - t^2}{(t^2 + 5)^2}$ ,  $a(t) = \frac{2t(t^2 - 15)}{(t^2 + 5)^3}$

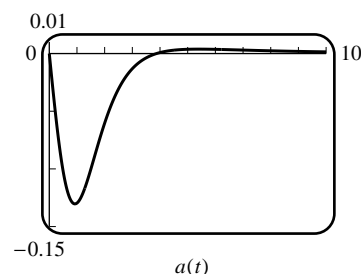
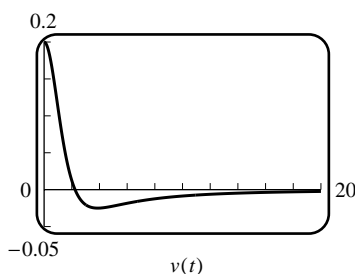
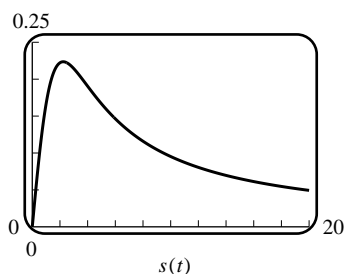

- (a)  $v = 0$  at  $t = \sqrt{5}$  (b)  $s = \sqrt{5}/10$  at  $t = \sqrt{5}$   
 (c)  $a$  changes sign at  $t = \sqrt{15}$ , so the particle is speeding up for  $\sqrt{5} < t < \sqrt{15}$  and slowing down for  $0 < t < \sqrt{5}$  and  $\sqrt{15} < t$

16.  $v(t) = (1 - t)e^{-t}$ ,  $a(t) = (t - 2)e^{-t}$

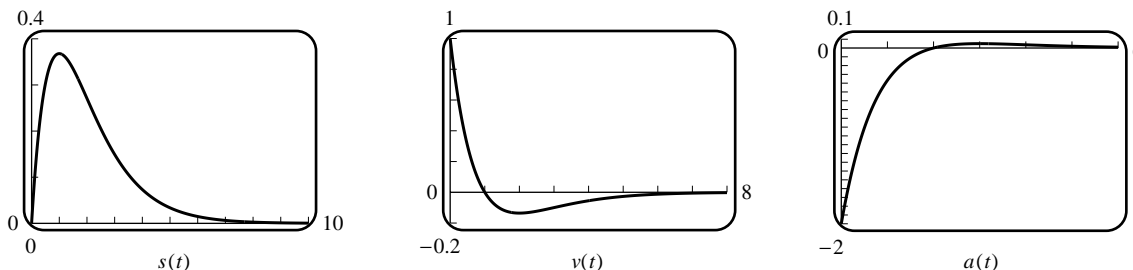

- (a)  $v = 0$  at  $t = 1$  (b)  $s = 1/e$  at  $t = 1$   
 (c)  $a$  changes sign at  $t = 2$ , so the particle is speeding up for  $1 < t < 2$  and slowing down for  $0 < t < 1$  and  $2 < t$

17.  $s = -3t + 2$   
 $v = -3$   
 $a = 0$

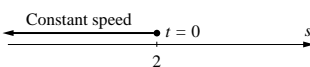

18.  $s = t^3 - 6t^2 + 9t + 1$   
 $v = 3(t - 1)(t - 3)$   
 $a = 6(t - 2)$

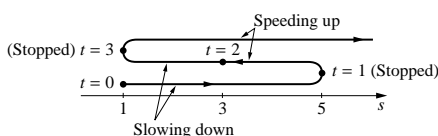

19.  $s = t^3 - 9t^2 + 24t$   
 $v = 3(t - 2)(t - 4)$   
 $a = 6(t - 3)$

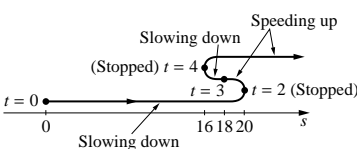

20.  $s = t + \frac{9}{t+1}$   
 $v = \frac{(t+4)(t-2)}{(t+1)^2}$   
 $a = \frac{18}{(t+1)^3}$

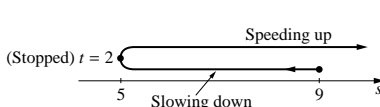

21.  $s = \begin{cases} \cos t, & 0 \leq t \leq 2\pi \\ 1, & t > 2\pi \end{cases}$   
 $v = \begin{cases} -\sin t, & 0 \leq t \leq 2\pi \\ 0, & t > 2\pi \end{cases}$   
 $a = \begin{cases} -\cos t, & 0 \leq t < 2\pi \\ 0, & t > 2\pi \end{cases}$

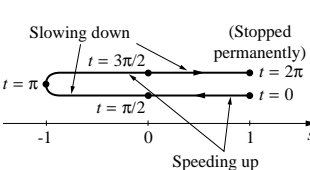

22.  $v(t) = \frac{5t^2 - 6t + 2}{\sqrt{t}}$  is always positive,  $a(t) = \frac{15t^2 - 6t - 2}{2t^{3/2}}$  has a positive root at  $t = \frac{3 + \sqrt{39}}{15}$

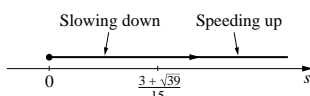

23. (a)  $v = 10t - 22$ , speed  $= |v| = |10t - 22|$ .  $d|v|/dt$  does not exist at  $t = 2.2$  which is the only critical point. If  $t = 1, 2.2, 3$  then  $|v| = 12, 0, 8$ . The maximum speed is 12 ft/s.
- (b) the distance from the origin is  $|s| = |5t^2 - 22t| = |t(5t - 22)|$ , but  $t(5t - 22) < 0$  for  $1 \leq t \leq 3$  so  $|s| = -(5t^2 - 22t) = 22t - 5t^2$ ,  $d|s|/dt = 22 - 10t$ , thus the only critical point is  $t = 2.2$ .  $d^2|s|/dt^2 < 0$  so the particle is farthest from the origin when  $t = 2.2$ . Its position is  $s = 5(2.2)^2 - 22(2.2) = -24.2$ .
24.  $v = -\frac{200t}{(t^2 + 12)^2}$ , speed  $= |v| = \frac{200t}{(t^2 + 12)^2}$  for  $t \geq 0$ .  $\frac{d|v|}{dt} = \frac{600(4 - t^2)}{(t^2 + 12)^3} = 0$  when  $t = 2$ , which is the only critical point in  $(0, +\infty)$ . By the first derivative test there is a relative maximum, and hence an absolute maximum, at  $t = 2$ . The maximum speed is 25/16 ft/s to the left.
25.  $s(t) = s_0 - \frac{1}{2}gt^2 = s_0 - 4.9t^2$  m,  $v = -9.8t$  m/s,  $a = -9.8$  m/s<sup>2</sup>
- (a)  $|s(1.5) - s(0)| = 11.025$  m
- (b)  $v(1.5) = -14.7$  m/s
- (c)  $|v(t)| = 12$  when  $t = 12/9.8 = 1.2245$  s
- (d)  $s(t) - s_0 = -100$  when  $4.9t^2 = 100$ ,  $t = 4.5175$  s
26. (a)  $s(t) = s_0 - \frac{1}{2}gt^2 = 800 - 16t^2$  ft,  $s(t) = 0$  when  $t = \sqrt{\frac{800}{16}} = 5\sqrt{2}$
- (b)  $v(t) = -32t$  and  $v(5\sqrt{2}) = -160\sqrt{2} \approx 226.27$  ft/s  $= 154.28$  mi/h
27.  $s(t) = s_0 + v_0t - \frac{1}{2}gt^2 = 60t - 4.9t^2$  m and  $v(t) = v_0 - gt = 60 - 9.8t$  m/s
- (a)  $v(t) = 0$  when  $t = 60/9.8 \approx 6.12$  s
- (b)  $s(60/9.8) \approx 183.67$  m
- (c) another 6.12 s; solve for  $t$  in  $s(t) = 0$  to get this result, or use the symmetry of the parabola  $s = 60t - 4.9t^2$  about the line  $t = 6.12$  in the  $t$ - $s$  plane
- (d) also 60 m/s, as seen from the symmetry of the parabola (or compute  $v(6.12)$ )
28. (a) they are the same
- (b)  $s(t) = v_0t - \frac{1}{2}gt^2$  and  $v(t) = v_0 - gt$ ;  $s(t) = 0$  when  $t = 0, 2v_0/g$ ;  
 $v(0) = v_0$  and  $v(2v_0/g) = v_0 - g(2v_0/g) = -v_0$  so the speed is the same at launch ( $t = 0$ ) and at return ( $t = 2v_0/g$ ).
29. If  $g = 32$  ft/s<sup>2</sup>,  $s_0 = 7$  and  $v_0$  is unknown, then  $s(t) = 7 + v_0t - 16t^2$  and  $v(t) = v_0 - 32t$ ;  $s = s_{\max}$  when  $v = 0$ , or  $t = v_0/32$ ; and  $s_{\max} = 208$  yields  $208 = s(v_0/32) = 7 + v_0(v_0/32) - 16(v_0/32)^2 = 7 + v_0^2/64$ , so  $v_0 = 8\sqrt{201} \approx 113.42$  ft/s.
30. (a) Use (6) and then (5) to get  $v^2 = v_0^2 - 2v_0gt + g^2t^2 = v_0^2 - 2g(v_0t - \frac{1}{2}gt^2) = v_0^2 - 2g(s - s_0)$ .
- (b) Add  $v_0$  to both sides of (6):  $2v_0 - gt = v_0 + v$ ,  $v_0 - \frac{1}{2}gt = \frac{1}{2}(v_0 + v)$ ;  
from (5)  $s = s_0 + t(v_0 - \frac{1}{2}gt) = s_0 + \frac{1}{2}(v_0 + v)t$
- (c) Add  $v$  to both sides of (6):  $2v + gt = v_0 + v$ ,  $v + \frac{1}{2}gt = \frac{1}{2}(v_0 + v)$ ; from part (b),  $s = s_0 + \frac{1}{2}(v_0 + v)t = s_0 + vt + \frac{1}{2}gt^2$
31.  $v_0 = 0$  and  $g = 9.8$ , so  $v^2 = -19.6(s - s_0)$ ; since  $v = 24$  when  $s = 0$  it follows that  $19.6s_0 = 24^2$  or  $s_0 = 29.39$  m.
32.  $s = 1000 + vt + \frac{1}{2}(32)t^2 = 1000 + vt + 16t^2$ ;  $s = 0$  when  $t = 5$ , so  $v = -(1000 + 16 \cdot 5^2)/5 = -280$  ft/s.

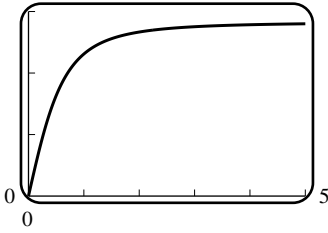
33. (a)  $s = s_{\max}$  when  $v = 0$ , so  $0 = v_0^2 - 2g(s_{\max} - s_0)$ ,  $s_{\max} = v_0^2/2g + s_0$ .  
 (b)  $s_0 = 7$ ,  $s_{\max} = 208$ ,  $g = 32$  and  $v_0$  is unknown, so from part (a)  $v_0^2 = 2g(208 - 7) = 64 \cdot 201$ ,  
 $v_0 = 8\sqrt{201} \approx 113.42$  ft/s.
34.  $s = t^3 - 6t^2 + 1$ ,  $v = 3t^2 - 12t$ ,  $a = 6t - 12$ .  
 (a)  $a = 0$  when  $t = 2$ ;  $s = -15$ ,  $v = -12$ .  
 (b)  $v = 0$  when  $3t^2 - 12t = 3t(t - 4) = 0$ ,  $t = 0$  or  $t = 4$ . If  $t = 0$ , then  $s = 1$  and  $a = -12$ ; if  $t = 4$ , then  $s = -31$  and  $a = 12$ .
35. (a)  (b)  $v = \frac{2t}{\sqrt{2t^2 + 1}}$ ,  $\lim_{t \rightarrow +\infty} v = \frac{2}{\sqrt{2}} = \sqrt{2}$
36. (a)  $a = \frac{dv}{dt} = \frac{dv}{ds} \frac{ds}{dt} = v \frac{dv}{ds}$  because  $v = \frac{ds}{dt}$   
 (b)  $v = \frac{3}{2\sqrt{3t+7}} = \frac{3}{2s}$ ;  $\frac{dv}{ds} = -\frac{3}{2s^2}$ ;  $a = -\frac{9}{4s^3} = -9/500$
37. (a)  $s_1 = s_2$  if they collide, so  $\frac{1}{2}t^2 - t + 3 = -\frac{1}{4}t^2 + t + 1$ ,  $\frac{3}{4}t^2 - 2t + 2 = 0$  which has no real solution.  
 (b) Find the minimum value of  $D = |s_1 - s_2| = |\frac{3}{4}t^2 - 2t + 2|$ . From part (a),  $\frac{3}{4}t^2 - 2t + 2$  is never zero, and for  $t = 0$  it is positive, hence it is always positive, so  $D = \frac{3}{4}t^2 - 2t + 2$ .  
 $\frac{dD}{dt} = \frac{3}{2}t - 2 = 0$  when  $t = \frac{4}{3}$ .  $\frac{d^2D}{dt^2} > 0$  so  $D$  is minimum when  $t = \frac{4}{3}$ ,  $D = \frac{2}{3}$ .  
 (c)  $v_1 = t - 1$ ,  $v_2 = -\frac{1}{2}t + 1$ .  $v_1 < 0$  if  $0 \leq t < 1$ ,  $v_1 > 0$  if  $t > 1$ ;  $v_2 < 0$  if  $t > 2$ ,  $v_2 > 0$  if  $0 \leq t < 2$ . They are moving in opposite directions during the intervals  $0 \leq t < 1$  and  $t > 2$ .
38. (a)  $s_A - s_B = 20 - 0 = 20$  ft  
 (b)  $s_A = s_B$ ,  $15t^2 + 10t + 20 = 5t^2 + 40t$ ,  $10t^2 - 30t + 20 = 0$ ,  $(t - 2)(t - 1) = 0$ ,  $t = 1$  or  $t = 2$  s.  
 (c)  $v_A = v_B$ ,  $30t + 10 = 10t + 40$ ,  $20t = 30$ ,  $t = 3/2$  s. When  $t = 3/2$ ,  $s_A = 275/4$  and  $s_B = 285/4$  so car  $B$  is ahead of car  $A$ .
39. (a) From the estimated tangent to the graph at the point where  $v = 2000$ ,  $dv/ds \approx -1.25$  ft/s/ft.  
 (b)  $a = v dv/ds \approx (2000)(-1.25) = -2500$  ft/s<sup>2</sup>
40.  $r'(t) = 2v(t)v'(t)/[2\sqrt{v^2(t)}] = v(t)a(t)/|v(t)|$  so  $r'(t) > 0$  (speed is increasing) if  $v$  and  $a$  have the same sign, and  $r'(t) < 0$  (speed is decreasing) if  $v$  and  $a$  have opposite signs.

## EXERCISE SET 6.4

1.  $f(x) = x^2 - 2$ ,  $f'(x) = 2x$ ,  $x_{n+1} = x_n - \frac{x_n^2 - 2}{2x_n}$   
 $x_1 = 1$ ,  $x_2 = 1.5$ ,  $x_3 = 1.416666667, \dots$ ,  $x_5 = x_6 = 1.414213562$

2.  $f(x) = x^2 - 7, f'(x) = 2x, x_{n+1} = x_n - \frac{x_n^2 - 7}{2x_n}$   
 $x_1 = 3, x_2 = 2.666666667, x_3 = 2.645833333, \dots, x_5 = x_6 = 2.645751311$

3.  $f(x) = x^3 - 6, f'(x) = 3x^2, x_{n+1} = x_n - \frac{x_n^3 - 6}{3x_n^2}$   
 $x_1 = 2, x_2 = 1.833333333, x_3 = 1.817263545, \dots, x_5 = x_6 = 1.817120593$

4.  $x^n - a = 0$

5.  $f(x) = x^3 - x + 3, f'(x) = 3x^2 - 1, x_{n+1} = x_n - \frac{x_n^3 - x_n + 3}{3x_n^2 - 1}$   
 $x_1 = -2, x_2 = -1.727272727, x_3 = -1.673691174, \dots, x_5 = x_6 = -1.671699882$

6.  $f(x) = x^3 + x - 1, f'(x) = 3x^2 + 1, x_{n+1} = x_n - \frac{x_n^3 + x_n - 1}{3x_n^2 + 1}$   
 $x_1 = 1, x_2 = 0.75, x_3 = 0.686046512, \dots, x_5 = x_6 = 0.682327804$

7.  $f(x) = x^5 + x^4 - 5, f'(x) = 5x^4 + 4x^3, x_{n+1} = x_n - \frac{x_n^5 + x_n^4 - 5}{5x_n^4 + 4x_n^3}$   
 $x_1 = 1, x_2 = 1.333333333, x_3 = 1.239420573, \dots, x_6 = x_7 = 1.224439550$

8.  $f(x) = x^5 - x + 1, f'(x) = 5x^4 - 1, x_{n+1} = x_n - \frac{x_n^5 - x_n + 1}{5x_n^4 - 1}$   
 $x_1 = -1, x_2 = -1.25, x_3 = -1.178459394, \dots, x_6 = x_7 = -1.167303978$

9.  $f(x) = x^4 + x - 3, f'(x) = 4x^3 + 1, x_{n+1} = x_n - \frac{x_n^4 + x_n - 3}{4x_n^3 + 1}$   
 $x_1 = -2, x_2 = -1.645161290,$   
 $x_3 = -1.485723955, \dots, x_6 = x_7 = -1.452626879$

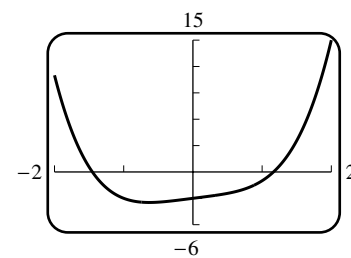

10.  $f(x) = x^5 - 5x^3 - 2, f'(x) = 5x^4 - 15x^2, x_{n+1} = x_n - \frac{x_n^5 - 5x_n^3 - 2}{5x_n^4 - 15x_n^2}$   
 $x_1 = 2, x_2 = 2.5, x_3 = 2.327384615, \dots, x_7 = x_8 = 2.273791732$

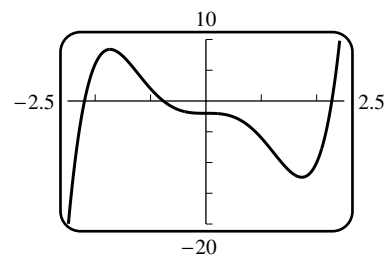

11.  $f(x) = 2 \sin x - x, f'(x) = 2 \cos x - 1, x_{n+1} = x_n - \frac{2 \sin x_n - x_n}{2 \cos x_n - 1}$   
 $x_1 = 2, x_2 = 1.900995594, x_3 = 1.895511645, x_4 = x_5 = 1.895494267$

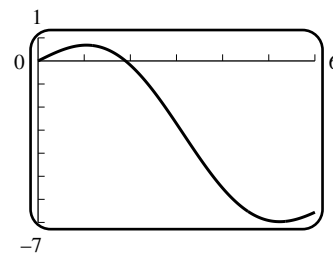

12.  $f(x) = \sin x - x^2$ ,  $f'(x) = \cos x - 2x$ ,  $x_{n+1} = x_n - \frac{\sin x_n - x_n^2}{\cos x_n - 2x_n}$   
 $x_1 = 1$ ,  $x_2 = 0.891395995$ ,  
 $x_3 = 0.876984845, \dots, x_5 = x_6 = 0.876726215$

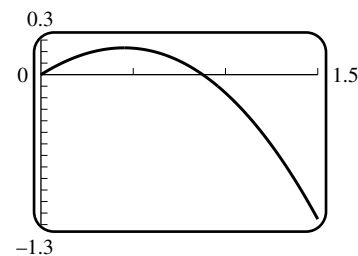

13.  $f(x) = x - \tan x$ ,  $f'(x) = 1 - \sec^2 x = -\tan^2 x$ ,  
 $x_{n+1} = x_n + \frac{x_n - \tan x_n}{\tan^2 x_n}$   
 $x_1 = 4.5$ ,  $x_2 = 4.493613903$ ,  $x_3 = 4.493409655$ ,  
 $x_4 = x_5 = 4.493409458$

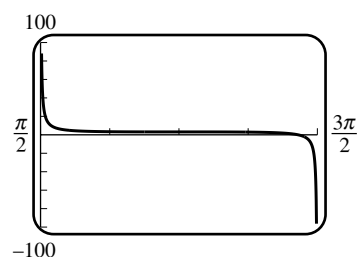

14.  $f(x) = 1 - e^x \cos x$ ,  $f'(x) = e^x(\sin x - \cos x)$ ,  
 $x_{n+1} = x_n + \frac{1 - e^x \cos x}{e^x(\sin x - \cos x)}$   
 $x_1 = 1$ ,  $x_2 = 1.572512605$ ,  $x_3 = 1.363631415$ ,  $x_7 = x_8 = 1.292695719$

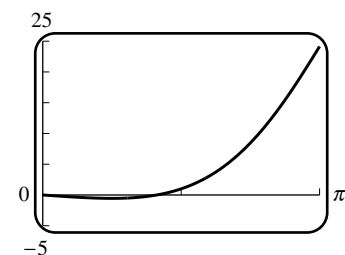

15. At the point of intersection,  $x^3 = 0.5x - 1$ ,  $x^3 - 0.5x + 1 = 0$ . Let  
 $f(x) = x^3 - 0.5x + 1$ . By graphing  $y = x^3$  and  $y = 0.5x - 1$  it is  
evident that there is only one point of intersection and it occurs in  
the interval  $[-2, -1]$ ; note that  $f(-2) < 0$  and  $f(-1) > 0$ .  
 $f'(x) = 3x^2 - 0.5$  so  
 $x_{n+1} = x_n - \frac{x_n^3 - 0.5x_n + 1}{3x_n^2 - 0.5}$ ;  $x_1 = -1$ ,  $x_2 = -1.2$ ,  
 $x_3 = -1.166492147, \dots$ ,  
 $x_5 = x_6 = -1.165373043$

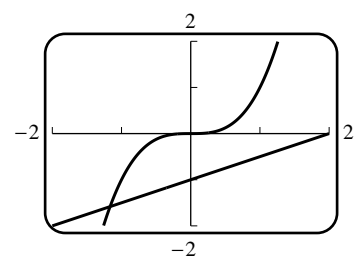

16. The graphs of  $y = e^{-x}$  and  $y = \ln x$  intersect near  $x = 1.3$ ; let  
 $f(x) = e^{-x} - \ln x$ ,  $f'(x) = -e^{-x} - 1/x$ ,  $x_1 = 1.3$ ,  
 $x_{n+1} = x_n + \frac{e^{-x_n} - \ln x_n}{e^{-x_n} + 1/x_n}$ ,  $x_2 = 1.309759929$ ,  $x_4 = x_5 = 1.309799586$

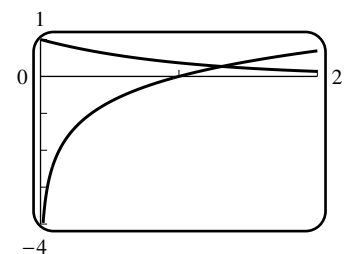

17. The graphs of  $y = x^2$  and  $y = \sqrt{2x+1}$  intersect at points near  
 $x = -0.5$  and  $x = 1$ ;  $x^2 = \sqrt{2x+1}$ ,  $x^4 - 2x - 1 = 0$ . Let  
 $f(x) = x^4 - 2x - 1$ , then  $f'(x) = 4x^3 - 2$  so  
 $x_{n+1} = x_n - \frac{x_n^4 - 2x_n - 1}{4x_n^3 - 2}$ .  
If  $x_1 = -0.5$ , then  $x_2 = -0.475$ ,  $x_3 = -0.474626695$ ,  
 $x_4 = x_5 = -0.474626618$ ; if  $x_1 = 1$ , then  $x_2 = 2$ ,  
 $x_3 = 1.633333333, \dots, x_8 = x_9 = 1.395336994$ .

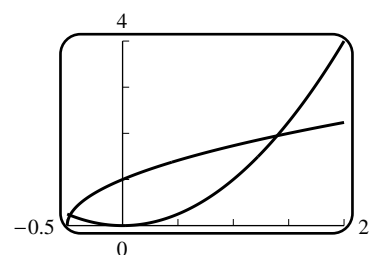



18. The graphs of  $y = x^3/8 + 1$  and  $y = \cos 2x$  intersect at  $x = 0$  and at a point near  $x = -2$ ;  
 $x^3/8 + 1 = \cos 2x$ ,  $x^3 - 8 \cos 2x + 8 = 0$ . Let  $f(x) = x^3 - 8 \cos 2x + 8$ ,  
then  $f'(x) = 3x^2 + 16 \sin 2x$  so  $x_{n+1} = x_n - \frac{x_n^3 - 8 \cos 2x_n + 8}{3x_n^2 + 16 \sin 2x_n}$ .  
 $x_1 = -2$ ,  $x_2 = -2.216897577$ ,  
 $x_3 = -2.193821581, \dots, x_5 = x_6 = -2.193618950$ .

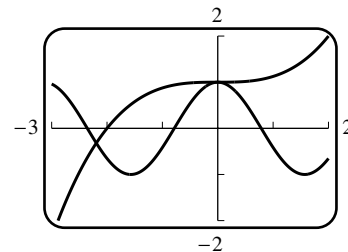

19. (a)  $f(x) = x^2 - a$ ,  $f'(x) = 2x$ ,  $x_{n+1} = x_n - \frac{x_n^2 - a}{2x_n} = \frac{1}{2} \left( x_n + \frac{a}{x_n} \right)$   
(b)  $a = 10$ ;  $x_1 = 3$ ,  $x_2 = 3.166666667$ ,  $x_3 = 3.162280702$ ,  $x_4 = x_5 = 3.162277660$
20. (a)  $f(x) = \frac{1}{x} - a$ ,  $f'(x) = -\frac{1}{x^2}$ ,  $x_{n+1} = x_n(2 - ax_n)$   
(b)  $a = 17$ ;  $x_1 = 0.05$ ,  $x_2 = 0.0575$ ,  $x_3 = 0.058793750$ ,  $x_5 = x_6 = 0.058823529$
21.  $f'(x) = x^3 + 2x + 5$ ; solve  $f'(x) = 0$  to find the critical points. Graph  $y = x^3$  and  $y = -2x - 5$  to see that they intersect at a point near  $x = -1$ ;  $f''(x) = 3x^2 + 2$  so  $x_{n+1} = x_n - \frac{x_n^3 + 2x_n + 5}{3x_n^2 + 2}$ .  
 $x_1 = -1$ ,  $x_2 = -1.4$ ,  $x_3 = -1.330964467, \dots, x_5 = x_6 = -1.328268856$  so the minimum value of  $f(x)$  occurs at  $x \approx -1.328268856$  because  $f''(x) > 0$ ; its value is approximately  $-4.098859132$ .
22. From a rough sketch of  $y = x \sin x$  we see that the maximum occurs at a point near  $x = 2$ , which will be a point where  $f'(x) = x \cos x + \sin x = 0$ .  $f''(x) = 2 \cos x - x \sin x$  so  
 $x_{n+1} = x_n - \frac{x_n \cos x_n + \sin x_n}{2 \cos x_n - x_n \sin x_n} = x_n - \frac{x_n + \tan x_n}{2 - x_n \tan x_n}$ .  
 $x_1 = 2$ ,  $x_2 = 2.029048281$ ,  $x_3 = 2.028757866$ ,  $x_4 = x_5 = 2.028757838$ ; the maximum value is approximately 1.819705741.
23. Let  $f(x)$  be the square of the distance between  $(1, 0)$  and any point  $(x, x^2)$  on the parabola, then  $f(x) = (x - 1)^2 + (x^2 - 0)^2 = x^4 + x^2 - 2x + 1$  and  $f'(x) = 4x^3 + 2x - 2$ . Solve  $f'(x) = 0$  to find the critical points;  $f''(x) = 12x^2 + 2$  so  $x_{n+1} = x_n - \frac{4x_n^3 + 2x_n - 2}{12x_n^2 + 2} = x_n - \frac{2x_n^3 + x_n - 1}{6x_n^2 + 1}$ .  $x_1 = 1$ ,  $x_2 = 0.714285714$ ,  $x_3 = 0.605168701, \dots, x_6 = x_7 = 0.589754512$ ; the coordinates are approximately  $(0.589754512, 0.347810385)$ .
24. The area is  $A = xy = x \cos x$  so  $dA/dx = \cos x - x \sin x$ . Find  $x$  so that  $dA/dx = 0$ ;  
 $d^2A/dx^2 = -2 \sin x - x \cos x$  so  $x_{n+1} = x_n + \frac{\cos x_n - x_n \sin x_n}{2 \sin x_n + x_n \cos x_n} = x_n + \frac{1 - x_n \tan x_n}{2 \tan x_n + x_n}$ .  
 $x_1 = 1$ ,  $x_2 = 0.864536397$ ,  $x_3 = 0.860339078$ ,  $x_4 = x_5 = 0.860333589$ ;  $y \approx 0.652184624$ .
25. (a) Let  $s$  be the arc length, and  $L$  the length of the chord, then  $s = 1.5L$ . But  $s = r\theta$  and  $L = 2r \sin(\theta/2)$  so  $r\theta = 3r \sin(\theta/2)$ ,  $\theta - 3 \sin(\theta/2) = 0$ .  
(b) Let  $f(\theta) = \theta - 3 \sin(\theta/2)$ , then  $f'(\theta) = 1 - 1.5 \cos(\theta/2)$  so  $\theta_{n+1} = \theta_n - \frac{\theta_n - 3 \sin(\theta_n/2)}{1 - 1.5 \cos(\theta_n/2)}$ .  
 $\theta_1 = 3$ ,  $\theta_2 = 2.991592920$ ,  $\theta_3 = 2.991563137$ ,  $\theta_4 = \theta_5 = 2.991563136$  rad so  $\theta \approx 171^\circ$ .
26.  $r^2(\theta - \sin \theta)/2 = \pi r^2/4$  so  $\theta - \sin \theta - \pi/2 = 0$ . Let  $f(\theta) = \theta - \sin \theta - \pi/2$ , then  $f'(\theta) = 1 - \cos \theta$  so  
 $\theta_{n+1} = \frac{\theta_n - \sin \theta_n - \pi/2}{1 - \cos \theta_n}$ .  
 $\theta_1 = 2$ ,  $\theta_2 = 2.339014106$ ,  $\theta_3 = 2.310063197, \dots, \theta_5 = \theta_6 = 2.309881460$  rad;  $\theta \approx 132^\circ$ .

27. If  $x = 1$ , then  $y^4 + y = 1$ ,  $y^4 + y - 1 = 0$ . Graph  $z = y^4$  and  $z = 1 - y$  to see that they intersect near  $y = -1$  and  $y = 1$ . Let  $f(y) = y^4 + y - 1$ , then  $f'(y) = 4y^3 + 1$  so  $y_{n+1} = y_n - \frac{y_n^4 + y_n - 1}{4y_n^3 + 1}$ .  
 If  $y_1 = -1$ , then  $y_2 = -1.333333333$ ,  $y_3 = -1.235807860, \dots, y_6 = y_7 = -1.220744085$ ;  
 if  $y_1 = 1$ , then  $y_2 = 0.8$ ,  $y_3 = 0.731233596, \dots, y_6 = y_7 = 0.724491959$ .
28. If  $x = 1$ , then  $2y - \cos y = 0$ . Graph  $z = 2y$  and  $z = \cos y$  to see that they intersect near  $y = 0.5$ . Let  $f(y) = 2y - \cos y$ , then  $f'(y) = 2 + \sin y$  so  $y_{n+1} = y_n - \frac{2y_n - \cos y_n}{2 + \sin y_n}$ .  
 $y_1 = 0.5$ ,  $y_2 = 0.450626693$ ,  $y_3 = 0.450183648$ ,  $y_4 = y_5 = 0.450183611$ .
29.  $S(25) = 250000 = \frac{5000}{i} [(1+i)^{25} - 1]$ ; set  $f(i) = 50i - (1+i)^{25} + 1$ ,  $f'(i) = 50 - 25(1+i)^{24}$ ; solve  $f(i) = 0$ . Set  $i_0 = .06$  and  $i_{k+1} = i_k - [50i - (1+i)^{25} + 1] / [50 - 25(1+i)^{24}]$ . Then  $i_1 = 0.05430$ ,  $i_2 = 0.05338$ ,  $i_3 = 0.05336, \dots, i = 0.053362$ .
30. (a)  $x_1 = 2$ ,  $x_2 = 5.3333$ ,  
 $x_3 = 11.055$ ,  $x_4 = 22.293$ ,  
 $x_5 = 44.676$

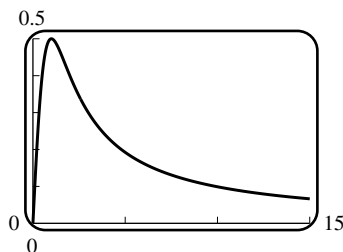

- (b)  $x_1 = 0.5$ ,  $x_2 = -0.3333$ ,  $x_3 = 0.0833$ ,  $x_4 = -0.0012$ ,  $x_5 = 0.0000$  (and  $x_n = 0$  for  $n \geq 6$ )
31. (a)
- | $x_1$  | $x_2$   | $x_3$  | $x_4$   | $x_5$   | $x_6$  | $x_7$   | $x_8$  | $x_9$  | $x_{10}$ |
|--------|---------|--------|---------|---------|--------|---------|--------|--------|----------|
| 0.5000 | -0.7500 | 0.2917 | -1.5685 | -0.4654 | 0.8415 | -0.1734 | 2.7970 | 1.2197 | 0.1999   |
- (b) The sequence  $x_n$  must diverge, since if it did converge then  $f(x) = x^2 + 1 = 0$  would have a solution. It seems the  $x_n$  are oscillating back and forth in a quasi-cyclical fashion.

## EXERCISE SET 6.5

- $f(0) = f(4) = 0$ ;  $f'(3) = 0$ ;  $[0, 4]$ ,  $c = 3$
- $f(-3) = f(3) = 0$ ;  $f'(0) = 0$
- $f(2) = f(4) = 0$ ,  $f'(x) = 2x - 6$ ,  $2c - 6 = 0$ ,  $c = 3$
- $f(0) = f(2) = 0$ ,  $f'(x) = 3x^2 - 6x + 2$ ,  $3c^2 - 6c + 2 = 0$ ;  $c = \frac{6 \pm \sqrt{36 - 24}}{6} = 1 \pm \sqrt{3}/3$
- $f(\pi/2) = f(3\pi/2) = 0$ ,  $f'(x) = -\sin x$ ,  $-\sin c = 0$ ,  $c = \pi$
- $f(-1) = f(1) = 0$ ,  $f'(x) = \frac{x^2 - 4x + 1}{(x-2)^2}$ ,  $\frac{c^2 - 4c + 1}{(c-2)^2} = 0$ ,  $c^2 - 4c + 1 = 0$   
 $c = \frac{4 \pm \sqrt{16 - 4}}{2} = 2 \pm \sqrt{3}$ , of which only  $c = 2 - \sqrt{3}$  is in  $(-1, 1)$
- $f(0) = f(4) = 0$ ,  $f'(x) = \frac{1}{2} - \frac{1}{2\sqrt{x}}$ ,  $\frac{1}{2} - \frac{1}{2\sqrt{c}} = 0$ ,  $c = 1$
- $f(1) = f(3) = 0$ ,  $f'(x) = -\frac{2}{x^3} + \frac{4}{3x^2}$ ,  $-\frac{2}{c^3} + \frac{4}{3c^2} = 0$ ,  $-6 + 4c = 0$ ,  $c = 3/2$

9.  $\frac{f(8) - f(0)}{8 - 0} = \frac{6}{8} = \frac{3}{4} = f'(1.54); c = 1.54$       10.  $\frac{f(4) - f(0)}{4 - 0} = 1.19 = f'(0.77)$

11.  $f(-4) = 12, f(6) = 42, f'(x) = 2x + 1, 2c + 1 = \frac{42 - 12}{6 - (-4)} = 3, c = 1$

12.  $f(-1) = -6, f(2) = 6, f'(x) = 3x^2 + 1, 3c^2 + 1 = \frac{6 - (-6)}{2 - (-1)} = 4, c^2 = 1, c = \pm 1$  of which only  $c = 1$  is in  $(-1, 2)$

13.  $f(0) = 1, f(3) = 2, f'(x) = \frac{1}{2\sqrt{x+1}}, \frac{1}{2\sqrt{c+1}} = \frac{2-1}{3-0} = \frac{1}{3}, \sqrt{c+1} = 3/2, c+1 = 9/4, c = 5/4$

14.  $f(3) = 10/3, f(4) = 17/4, f'(x) = 1 - 1/x^2, 1 - 1/c^2 = \frac{17/4 - 10/3}{4 - 3} = 11/12, c^2 = 12, c = \pm 2\sqrt{3}$  of which only  $c = 2\sqrt{3}$  is in  $(3, 4)$

15.  $f(-5) = 0, f(3) = 4, f'(x) = -\frac{x}{\sqrt{25-x^2}}, -\frac{c}{\sqrt{25-c^2}} = \frac{4-0}{3-(-5)} = \frac{1}{2}, -2c = \sqrt{25-c^2},$   
 $4c^2 = 25 - c^2, c^2 = 5, c = -\sqrt{5}$   
 (we reject  $c = \sqrt{5}$  because it does not satisfy the equation  $-2c = \sqrt{25 - c^2}$ )

16.  $f(2) = 1, f(5) = 1/4, f'(x) = -1/(x-1)^2, -\frac{1}{(c-1)^2} = \frac{1/4 - 1}{5 - 2} = -\frac{1}{4}, (c-1)^2 = 4, c-1 = \pm 2,$   
 $c = -1$  (reject), or  $c = 3$

17. (a)  $f(-2) = f(1) = 0$       (b)  $c = -1.29$

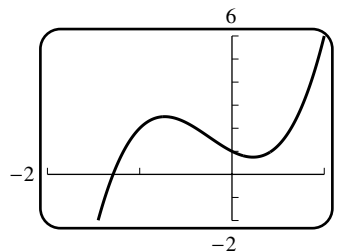

(c)  $x_0 = -1, x_1 = -1.5, x_2 = -1.32, x_3 = -1.290, x_4 = -1.2885843$

18. (a)  $m = \frac{f(-2) - f(1)}{-2 - 1} = \frac{-16 - 5}{-3} = 7$  so  $y - 5 = 7(x - 1),$   
 $y = 7x - 2$

(b)  $f'(x) = 3x^2 + 4 = 7$  has solutions  $x = \pm 1;$   
 discard  $x = 1,$  so  $c = -1$

(c)  $y - f(-1) = 7(x - (-1))$  or  $y = 7x + 2$

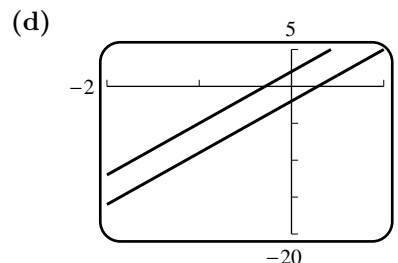

19. (a)  $f'(x) = \sec^2 x, \sec^2 c = 0$  has no solution      (b)  $\tan x$  is not continuous on  $[0, \pi]$

20. (a)  $f(-1) = 1, f(8) = 4, f'(x) = \frac{2}{3}x^{-1/3}$   
 $\frac{2}{3}c^{-1/3} = \frac{4 - 1}{8 - (-1)} = \frac{1}{3}, c^{1/3} = 2, c = 8$  which is not in  $(-1, 8).$

(b)  $x^{2/3}$  is not differentiable at  $x = 0,$  which is in  $(-1, 8).$

21. (a) Two  $x$ -intercepts of  $f$  determine two solutions  $a$  and  $b$  of  $f(x) = 0$ ; by Rolle's Theorem there exists a point  $c$  between  $a$  and  $b$  such that  $f'(c) = 0$ , i.e.  $c$  is an  $x$ -intercept for  $f'$ .
- (b)  $f(x) = \sin x = 0$  at  $x = n\pi$ , and  $f'(x) = \cos x = 0$  at  $x = n\pi + \pi/2$ , which lies between  $n\pi$  and  $(n+1)\pi$ , ( $n = 0, \pm 1, \pm 2, \dots$ )
22.  $\frac{f(x_1) - f(x_0)}{x_1 - x_0}$  is the average rate of change of  $y$  with respect to  $x$  on the interval  $[x_0, x_1]$ . By the Mean-Value Theorem there is a value  $c$  in  $(x_0, x_1)$  such that the instantaneous rate of change  $f'(c) = \frac{f(x_1) - f(x_0)}{x_1 - x_0}$ .
23. Let  $s(t)$  be the position function of the automobile for  $0 \leq t \leq 5$ , then by the Mean-Value Theorem there is at least one point  $c$  in  $(0, 5)$  where  
 $s'(c) = v(c) = [s(5) - s(0)]/(5 - 0) = 4/5 = 0.8 \text{ mi/min} = 48 \text{ mi/h}$ .
24. Let  $T(t)$  denote the temperature at time with  $t = 0$  denoting 11 AM, then  $T(0) = 76$  and  $T(12) = 52$ .
- (a) By the Mean-Value Theorem there is a value  $c$  between 0 and 12 such that  
 $T'(c) = [T(12) - T(0)]/(12 - 0) = (52 - 76)/(12) = -2^\circ \text{ F/h}$ .
- (b) Assume that  $T(t_1) = 88^\circ \text{F}$  where  $0 < t_1 < 12$ , then there is at least one point  $c$  in  $(t_1, 12)$  where  
 $T'(c) = [T(12) - T(t_1)]/(12 - t_1) = (52 - 88)/(12 - t_1) = -36/(12 - t_1)$ . But  $12 - t_1 < 12$  so  
 $T'(c) < -36/12 = -3^\circ \text{F/h}$ .
25. Let  $f(t)$  and  $g(t)$  denote the distances from the first and second runners to the starting point, and let  $h(t) = f(t) - g(t)$ . Since they start (at  $t = 0$ ) and finish (at  $t = t_1$ ) at the same time,  $h(0) = h(t_1) = 0$ , so by Rolle's Theorem there is a time  $t_2$  for which  $h'(t_2) = 0$ , i.e.  $f'(t_2) = g'(t_2)$ ; so they have the same velocity at time  $t_2$ .
26.  $f(x) = x^6 - 2x^2 + x$  satisfies  $f(0) = f(1) = 0$ , so by Rolle's Theorem  $f'(c) = 0$  for some  $c$  in  $(0, 1)$ .
27. (a) By the Constant Difference Theorem  $f(x) - g(x) = k$  for some  $k$ ; since  $f(x_0) = g(x_0)$ ,  $k = 0$ , so  $f(x) = g(x)$  for all  $x$ .
- (b) Set  $f(x) = \sin^2 x + \cos^2 x$ ,  $g(x) = 1$ ; then  $f'(x) = 2 \sin x \cos x - 2 \cos x \sin x = 0 = g'(x)$ . Since  $f(0) = 1 = g(0)$ ,  $f(x) = g(x)$  for all  $x$ .
28. (a) By the Constant Difference Theorem  $f(x) - g(x) = k$  for some  $k$ ; since  $f(x_0) - g(x_0) = c$ ,  $k = c$ , so  $f(x) - g(x) = c$  for all  $x$ .
- (b) Set  $f(x) = (x - 1)^3$ ,  $g(x) = (x^2 + 3)(x - 3)$ . Then  
 $f'(x) = 3(x - 1)^2$ ,  $g'(x) = (x^2 + 3) + 2x(x - 3) = 3x^2 - 6x + 3 = 3(x^2 - 2x + 1) = 3(x - 1)^2$ ,  
so  $f'(x) = g'(x)$  and hence  $f(x) - g(x) = k$ . Expand  $f(x)$  and  $g(x)$  to get  
 $h(x) = f(x) - g(x) = (x^3 - 3x^2 + 3x - 1) - (x^3 - 3x^2 + 3x - 9) = 8$ .
- (c)  $h(x) = x^3 - 3x^2 + 3x - 1 - (x^3 - 3x^2 + 3x - 9) = 8$
29. (a) If  $x, y$  belong to  $I$  and  $x < y$  then for some  $c$  in  $I$ ,  $\frac{f(y) - f(x)}{y - x} = f'(c)$ ,  
so  $|f(x) - f(y)| = |f'(c)||x - y| \leq M|x - y|$ ; if  $x > y$  exchange  $x$  and  $y$ ; if  $x = y$  the inequality also holds.
- (b)  $f(x) = \sin x$ ,  $f'(x) = \cos x$ ,  $|f'(x)| \leq 1 = M$ , so  $|f(x) - f(y)| \leq |x - y|$  or  $|\sin x - \sin y| \leq |x - y|$ .
30. (a) If  $x, y$  belong to  $I$  and  $x < y$  then for some  $c$  in  $I$ ,  $\frac{f(y) - f(x)}{y - x} = f'(c)$ ,  
so  $|f(x) - f(y)| = |f'(c)||x - y| \geq M|x - y|$ ; if  $x > y$  exchange  $x$  and  $y$ ; if  
 $x = y$  the inequality also holds.
- (b) If  $x$  and  $y$  belong to  $(-\pi/2, \pi/2)$  and  $f(x) = \tan x$ , then  $|f'(x)| = \sec^2 x \geq 1$  and  
 $|\tan x - \tan y| \geq |x - y|$

(c)  $y$  lies in  $(-\pi/2, \pi/2)$  if and only if  $-y$  does; use part (b) and replace  $y$  with  $-y$

31. (a) Let  $f(x) = \sqrt{x}$ . By the Mean-Value Theorem there is a number  $c$  between  $x$  and  $y$  such that

$$\frac{\sqrt{y} - \sqrt{x}}{y - x} = \frac{1}{2\sqrt{c}} < \frac{1}{2\sqrt{x}} \text{ for } c \text{ in } (x, y), \text{ thus } \sqrt{y} - \sqrt{x} < \frac{y - x}{2\sqrt{x}}$$

(b) multiply through and rearrange to get  $\sqrt{xy} < \frac{1}{2}(x + y)$ .

32. Suppose that  $f(x)$  has at least two distinct real solutions  $r_1$  and  $r_2$  in  $I$ . Then

$f(r_1) = f(r_2) = 0$  so by Rolle's Theorem there is at least one number between  $r_1$  and  $r_2$  where  $f'(x) = 0$ , but this contradicts the assumption that  $f'(x) \neq 0$ , so  $f(x) = 0$  must have fewer than two distinct solutions in  $I$ .

33. (a) If  $f(x) = x^3 + 4x - 1$  then  $f'(x) = 3x^2 + 4$  is never zero, so by Exercise 32  $f$  has at most one real root; since  $f$  is a cubic polynomial it has at least one real root, so it has exactly one real root.

(b) Let  $f(x) = ax^3 + bx^2 + cx + d$ . If  $f(x) = 0$  has at least two distinct real solutions  $r_1$  and  $r_2$ , then  $f(r_1) = f(r_2) = 0$  and by Rolle's Theorem there is at least one number between  $r_1$  and  $r_2$  where  $f'(x) = 0$ . But  $f'(x) = 3ax^2 + 2bx + c = 0$  for

$$x = \frac{-2b \pm \sqrt{4b^2 - 12ac}}{6a} = \frac{-b \pm \sqrt{b^2 - 3ac}}{3a}, \text{ which are not real if } b^2 - 3ac < 0$$

so  $f(x) = 0$  must have fewer than two distinct real solutions.

34.  $f'(x) = \frac{1}{2\sqrt{x}}, \frac{1}{2\sqrt{c}} = \frac{\sqrt{4} - \sqrt{3}}{4 - 3} = 2 - \sqrt{3}$ . But  $\frac{1}{4} < \frac{1}{2\sqrt{c}} < \frac{1}{2\sqrt{3}}$  for  $c$  in  $(3, 4)$  so

$$\frac{1}{4} < 2 - \sqrt{3} < \frac{1}{2\sqrt{3}}, 0.25 < 2 - \sqrt{3} < 0.29, -1.75 < -\sqrt{3} < -1.71, 1.71 < \sqrt{3} < 1.75.$$

35. (a)  $\frac{d}{dx}[f^2(x) + g^2(x)] = 2f(x)f'(x) + 2g(x)g'(x) = 2f(x)g(x) + 2g(x)[-f(x)] = 0$ ,

so  $f^2(x) + g^2(x)$  is constant.

(b)  $f(x) = \sin x$  and  $g(x) = \cos x$

36. (a)  $\frac{d}{dx}[f^2(x) - g^2(x)] = 2f(x)f'(x) - 2g(x)g'(x) = 2f(x)g(x) - 2g(x)f(x) = 0$  so  $f^2(x) - g^2(x)$  is constant.

(b)  $f'(x) = \frac{1}{2}(e^x - e^{-x}) = g(x)$  and  $g'(x) = \frac{1}{2}(e^x + e^{-x}) = f(x)$

37. If  $f'(x) = g'(x)$ , then  $f(x) = g(x) + k$ . Let  $x = 1$ ,

$$f(1) = g(1) + k = (1)^3 - 4(1) + 6 + k = 3 + k = 2, \text{ so } k = -1. f(x) = x^3 - 4x + 5.$$

38. Let  $h = f - g$ , then  $h$  is continuous on  $[a, b]$ , differentiable on  $(a, b)$ , and  $h(a) = f(a) - g(a) = 0$ ,  $h(b) = f(b) - g(b) = 0$ . By Rolle's Theorem there is some  $c$  in  $(a, b)$  where  $h'(c) = 0$ . But  $h'(c) = f'(c) - g'(c)$  so  $f'(c) - g'(c) = 0$ ,  $f'(c) = g'(c)$ .

39.

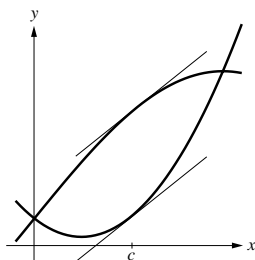

40. (a) Suppose  $f'(x) = 0$  more than once in  $(a, b)$ , say at  $c_1$  and  $c_2$ . Then  $f'(c_1) = f'(c_2) = 0$  and by using Rolle's Theorem on  $f'$ , there is some  $c$  between  $c_1$  and  $c_2$  where  $f''(c) = 0$ , which contradicts the fact that  $f''(x) > 0$  so  $f'(x) = 0$  at most once in  $(a, b)$ .
- (b) If  $f''(x) > 0$  for all  $x$  in  $(a, b)$ , then  $f$  is concave up on  $(a, b)$  and has at most one relative extremum, which would be a relative minimum, on  $(a, b)$ .
41. similar to the proof of part (a) with  $f'(c) < 0$
42. similar to the proof of part (a) with  $f'(c) = 0$

## CHAPTER 6 SUPPLEMENTARY EXERCISES

3. (a) If  $f$  has an absolute extremum at a point of  $(a, b)$  then it must, by Theorem 6.1.4, be at a critical point of  $f$ ; since  $f$  is differentiable on  $(a, b)$  the critical point is a stationary point.
- (b) It could occur at a critical point which is not a stationary point: for example,  $f(x) = |x|$  on  $[-1, 1]$  has an absolute minimum at  $x = 0$  but is not differentiable there.
4. No; speeding up means the velocity and acceleration have the same sign, i.e.  $av > 0$ ; the velocity is increasing when the acceleration is positive, i.e.  $a > 0$ . These are not the same thing. An example is  $s = t - t^2$  at  $t = 1$ , where  $v = -1$  and  $a = -2$ , so  $av > 0$  but  $a < 0$ .
5. Yes; by the Mean Value Theorem there is a point  $c$  in  $(a, b)$  such that  $f'(c) = \frac{f(b) - f(a)}{b - a} = 0$ .
7. (a)  $f'(x) = -1/x^2 \neq 0$ , no critical points; by inspection  $M = -1/2$  at  $x = -2$ ;  $m = -1$  at  $x = -1$
- (b)  $f'(x) = 3x^2 - 4x^3 = 0$  at  $x = 0, 3/4$ ;  $f(-1) = -2, f(0) = 0, f(3/4) = 27/256, f(3/2) = -27/16$ , so  $m = -2$  at  $x = -1, M = 27/256$  at  $x = 3/4$
- (c)  $f'(x) = \frac{x(7x - 12)}{3(x - 2)^{2/3}}$ , critical points at  $x = 12/7, 2$ ;  $m = f(12/7) = \frac{144}{49} \left(-\frac{2}{7}\right)^{1/3} \approx -1.9356$  at  $x = 12/7, M = 9$  at  $x = 3$
- (d)  $\lim_{x \rightarrow 0^+} f(x) = \lim_{x \rightarrow +\infty} f(x) = +\infty$  and  $f'(x) = \frac{e^x(x - 2)}{x^3}$ , stationary point at  $x = 2$ ; by Theorem 6.1.5  $f(x)$  has an absolute minimum at  $x = 2$ , and  $m = e^2/4$ .
8. (a)  $f'(x) = 2\frac{3 - x^2}{(x^2 + 3)^2}$ , critical point at  $x = \sqrt{3}$ . Since  $\lim_{x \rightarrow 0^+} f(x) = 0, f(x)$  has no minimum, and  $M = \sqrt{3}/3$  at  $x = \sqrt{3}$ .
- (b)  $f'(x) = 10x^3(x - 2)$ , critical points at  $x = 0, 2$ ;  $\lim_{x \rightarrow 3^-} f(x) = 88$ , so  $f(x)$  has no maximum;  $m = -9$  at  $x = 2$
- (c) critical point at  $x = 2$ ;  $m = -3$  at  $x = 3, M = 0$  at  $x = 2$
- (d)  $f'(x) = (1 + \ln x)x^x$ , critical point at  $x = 1/e$ ;  $\lim_{x \rightarrow 0^+} f(x) = \lim_{x \rightarrow 0^+} e^{x \ln x} = 1, \lim_{x \rightarrow +\infty} f(x) = +\infty$ ; no absolute maximum, absolute minimum  $m = e^{-1/e}$  at  $x = 1/e$
9.  $x = 2.3561945$
10.  $x = -2.11491, 0.25410, 1.86081$
11. (a) yes;  $f'(0) = 0$
- (b) no,  $f$  is not differentiable on  $(-1, 1)$
- (c) yes,  $f'(\sqrt{\pi/2}) = 0$
12. (a) no,  $f$  is not differentiable on  $(-2, 2)$
- (b) yes,  $\frac{f(3) - f(2)}{3 - 2} = -1 = f'(1 + \sqrt{2})$

- (c)  $\lim_{x \rightarrow 1^-} f(x) = 2, \lim_{x \rightarrow 1^+} f(x) = 2$  so  $f$  is continuous on  $[0, 2]$ ;  $\lim_{x \rightarrow 1^-} f'(x) = \lim_{x \rightarrow 1^-} -2x = -2$  and  $\lim_{x \rightarrow 1^+} f'(x) = \lim_{x \rightarrow 1^+} (-2/x^2) = -2$ , so  $f$  is differentiable on  $(0, 2)$ ; and  $\frac{f(2) - f(0)}{2 - 0} = -1 = f'(\sqrt{2})$

13. Let  $k$  be the amount of light admitted per unit area of clear glass. The total amount of light admitted by the entire window is

$$T = k \cdot (\text{area of clear glass}) + \frac{1}{2}k \cdot (\text{area of blue glass}) = 2krh + \frac{1}{4}\pi kr^2.$$

But  $P = 2h + 2r + \pi r$  which gives  $2h = P - 2r - \pi r$  so

$$T = kr(P - 2r - \pi r) + \frac{1}{4}\pi kr^2 = k \left[ Pr - \left( 2 + \pi - \frac{\pi}{4} \right) r^2 \right]$$

$$= k \left[ Pr - \frac{8 + 3\pi}{4} r^2 \right] \text{ for } 0 < r < \frac{P}{2 + \pi},$$

$$\frac{dT}{dr} = k \left( P - \frac{8 + 3\pi}{2} r \right), \frac{dT}{dr} = 0 \text{ when } r = \frac{2P}{8 + 3\pi}.$$

This is the only critical point and  $d^2T/dr^2 < 0$  there so the most light is admitted when  $r = 2P/(8 + 3\pi)$  ft.

14. If one corner of the rectangle is at  $(x, y)$  with  $x > 0, y > 0$ , then  $A = 4xy, y = 3\sqrt{1 - (x/4)^2}$ ,  $A = 12x\sqrt{1 - (x/4)^2} = 3x\sqrt{16 - x^2}, \frac{dA}{dx} = 6\frac{8 - x^2}{\sqrt{16 - x^2}}$ , critical point at  $x = 2\sqrt{2}$ . Since  $A = 0$  when  $x = 0, 4$  and  $A > 0$  otherwise, there is an absolute maximum  $A = 24$  at  $x = 2\sqrt{2}$ .

15. (a) If  $a = k$ , a constant, then  $v = kt + b$  where  $b$  is constant; so the velocity changes sign at  $t = -b/k$ .

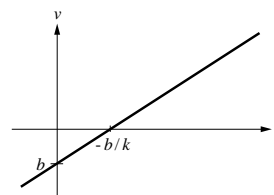

- (b) Consider the equation  $s = 5 - t^3/6, v = -t^2/2, a = -t$ . Then for  $t > 0, a$  is decreasing and  $av > 0$ , so the particle is speeding up.

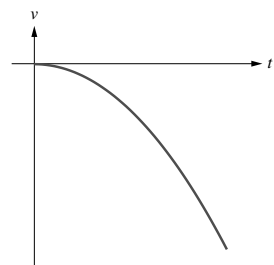

16.  $s(t) = t/(t^2 + 5), v(t) = (5 - t^2)/(t^2 + 5)^2, a(t) = 2t(t^2 - 15)/(t^2 + 5)^3$

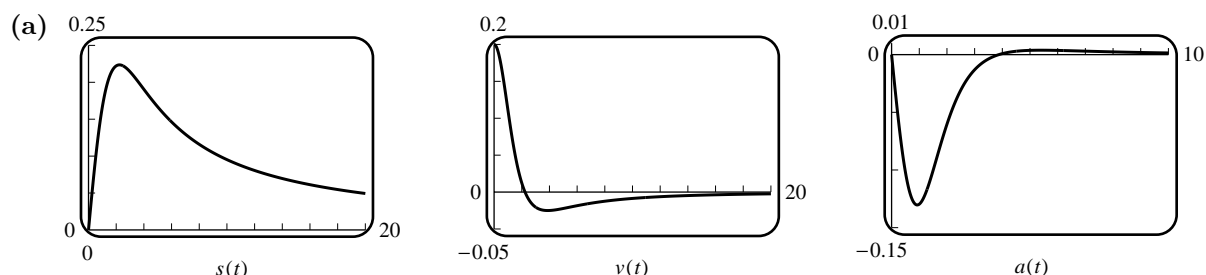

- (b)  $v$  changes sign at  $t = \sqrt{5}$

- (c)  $s = \sqrt{5}/10, v = 0, a = -\sqrt{5}/50$

- (d)  $a$  changes sign at  $t = \sqrt{15}$ , so the particle is speeding up for  $\sqrt{5} < t < \sqrt{15}$ , and it is slowing down for  $0 < t < \sqrt{5}$  and  $\sqrt{15} < t$
- (e)  $v(0) = 1/5$ ,  $\lim_{t \rightarrow +\infty} v(t) = 0$ ,  $v(t)$  has one  $t$ -intercept at  $t = \sqrt{5}$  and  $v(t)$  has one critical point at  $t = \sqrt{15}$ . Consequently the maximum velocity occurs when  $t = 0$  and the minimum velocity occurs when  $t = \sqrt{15}$ .

17. (a)  $s(t) = s_0 + v_0t - \frac{1}{2}gt^2 = v_0t - 4.9t^2$ ,  $v(t) = v_0 - 9.8t$ ;  $s_{\max}$  occurs when  $v = 0$ , i.e.  $t = v_0/9.8$ , and then  $0.76 = s_{\max} = v_0(v_0/9.8) - 4.9(v_0/9.8)^2 = v_0^2/19.6$ , so  $v_0 = \sqrt{0.76 \cdot 19.6} = 3.86$  m/s and  $s(t) = 3.86t - 4.9t^2$ . Then  $s(t) = 0$  when  $t = 0, 0.7878$ ,  $s(t) = 0.15$  when  $t = 0.0410, 0.7468$ , and  $s(t) = 0.76 - 0.15 = 0.61$  when  $t = 0.2188, 0.5689$ , so the player spends  $0.5689 - 0.2188 = 0.3501$  s in the top 15.0 cm of the jump and  $0.0410 + (0.7878 - 0.7468) = 0.0820$  s in the bottom 15.0 cm.
- (b) The height  $vs$  time plot is a parabola that opens down, and the slope is smallest near the top of the parabola, so a given change  $\Delta h$  in height corresponds to a large time change  $\Delta t$  near the top of the parabola and a narrower time change at points farther away from the top.

18. (a)  $s(t) = s_0 + v_0t - 4.9t^2$ ; assume  $s_0 = v_0 = 0$ , so  $s(t) = -4.9t^2$ ,  $v(t) = -9.8t$

$t$	0	1	2	3	4
$s$	0	-4.9	-19.6	-44.1	-78.4
$v$	0	-9.8	-19.6	-29.4	-39.2

- (b) The formula for  $v$  is linear (with no constant term).
- (c) The formula for  $s$  is quadratic (with no linear or constant term).

19. (a)  (b) minimum:  $(-2.111985, -0.355116)$   
maximum:  $(0.372591, 2.012931)$

20. (a)

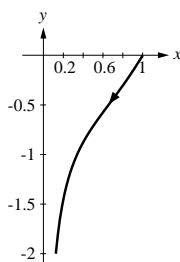

- (b) The distance between the boat and the origin is  $\sqrt{x^2 + y^2}$ , where  $y = (x^{10/3} - 1)/(2x^{2/3})$ . The minimum distance is 0.8247 mi when  $x = 0.6598$  mi. The boat gets swept downstream.
- (c) Use the equation of the path to obtain  $dy/dt = (dy/dx)(dx/dt)$ ,  $dx/dt = (dy/dt)/(dy/dx)$ . Let  $dy/dt = -4$  and find the value of  $dy/dx$  for the value of  $x$  obtained in part (b) to get  $dx/dt = -3$  mi/h.

21. (a)  $v = -2 \frac{t(t^4 + 2t^2 - 1)}{(t^4 + 1)^2}$ ,  $a = 2 \frac{3t^8 + 10t^6 - 12t^4 - 6t^2 + 1}{(t^4 + 1)^3}$



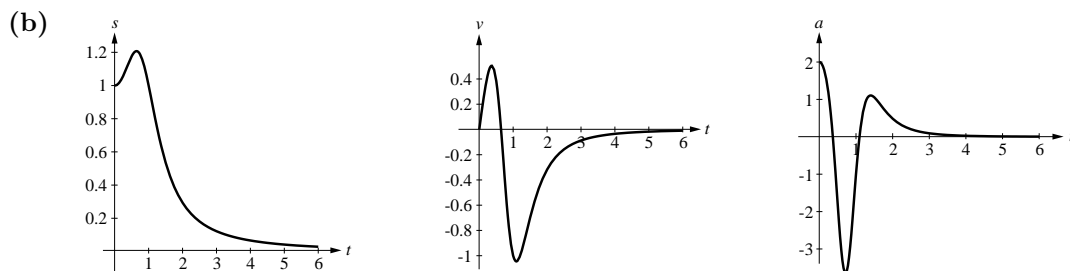

- (c) It is farthest from the origin at approximately  $t = 0.64$  (when  $v = 0$ ) and  $s = 1.2$
- (d) Find  $t$  so that the velocity  $v = ds/dt > 0$ . The particle is moving in the positive direction for  $0 \leq t \leq 0.64$  s.
- (e) It is speeding up when  $a, v > 0$  or  $a, v < 0$ , so for  $0 \leq t < 0.36$  and  $0.64 < t < 1.1$ , otherwise it is slowing down.
- (f) Find the maximum value of  $|v|$  to obtain: maximum speed = 1.05 m/s when  $t = 1.10$  s.
22. Find  $t$  so that  $N'(t)$  is maximum. The size of the population is increasing most rapidly when  $t = 8.4$  years.
23. Solve  $\phi - 0.0167 \sin \phi = 2\pi(90)/365$  to get  $\phi = 1.565978$  so  
 $r = 150 \times 10^6(1 - 0.0167 \cos \phi) = 149.988 \times 10^6$  km.
24. Solve  $\phi - 0.0934 \sin \phi = 2\pi(1)/1.88$  to get  $\phi = 3.325078$  so  
 $r = 228 \times 10^6(1 - 0.0934 \cos \phi) = 248.938 \times 10^6$  km.

# CHAPTER 7

## Integration

### EXERCISE SET 7.1

1.  $A = 1(1)/2 = 1/2$ ;  $\Delta x = (b - a)/n = 1/n$ ,  $x_k^* = k/n$ ,  $f(x_k^*) = k/n$ ,  $A_n = \left[ \frac{1}{n} + \frac{2}{n} + \cdots + \frac{n}{n} \right] \frac{1}{n}$

$n$	1	2	3	4	5	6	7	8	9	10
$A_n$	1.0000	0.7500	0.6666	0.6250	0.6000	0.5833	0.5714	0.5625	0.5556	0.5500

2.  $A = 4(2)/2 = 4$ ;  $\Delta x = (b - a)/n = 2/n$ ,  $x_k^* = 2k/n$ ,  $f(x_k^*) = 4 - 2(2k/n) = 4 - 4k/n = 4(1 - k/n)$ ,  
 $A_n = 4 \left[ \left(1 - \frac{1}{n}\right) + \left(1 - \frac{2}{n}\right) + \cdots + \left(1 - \frac{n}{n}\right) \right] \frac{2}{n}$

$n$	1	2	3	4	5	6	7	8	9	10
$A_n$	0.0000	2.0000	2.6667	3.0000	3.2000	3.3333	3.4286	3.50000	3.5556	3.6000

3.  $A = 2(2 + 14)/2 = 16$ ;  $\Delta x = (b - a)/n = 2/n$ ,  $x_k^* = 2k/n$ ,  $f(x_k^*) = 2 + 12k/n = 2(1 + 6k/n)$ ,  
 $A_n = 2 \left[ \left(1 + \frac{6}{n}\right) + \left(1 + \frac{12}{n}\right) + \cdots + \left(1 + \frac{6n}{n}\right) \right] \frac{2}{n}$

$n$	1	2	3	4	5	6	7	8	9	10
$A_n$	28.0000	22.0000	20.0000	19.0000	18.4000	18.0000	17.7143	17.5000	17.3333	17.2000

4.  $A = \pi(1)^2/4 = \pi/4$ ;  $\Delta x = (b - a)/n = 1/n$ ,  $x_k^* = k/n$ ,  $f(x_k^*) = \sqrt{1 - (k/n)^2}$ ,

$$A_n = \left[ \sqrt{1 + (1/n)^2} + \sqrt{1 + (2/n)^2} + \cdots + \sqrt{1 + (n/n)^2} \right] \frac{1}{n}$$

$n$	1	2	3	4	5	6	7	8	9	10
$A_n$	0.0000	0.4330	0.5627	0.6239	0.6593	0.6822	0.6982	0.7100	0.7190	0.7261

5.  $A(1) - A(0) = 1/2$

6.  $A(2) - A(0) = 4$

7.  $A(2) - A(0) = 16$

8.  $A(1) - A(0) = \frac{1}{2} \frac{\pi}{2} = \pi/4$

9.  $A(x) = e^x$ , area =  $A(1) - A(0) = e - 1$

10.  $A(x) = -\cos x$ , area =  $A(\pi) - A(0) = 2$

### EXERCISE SET 7.2

1. (a)  $\int \frac{x}{\sqrt{1+x^2}} dx = \sqrt{1+x^2} + C$       (b)  $\int (x+1)e^x dx = xe^x + C$

2. (a)  $\frac{d}{dx}(\sin x - x \cos x + C) = \cos x - \cos x + x \sin x = x \sin x$

(b)  $\frac{d}{dx} \left( \frac{x}{\sqrt{1-x^2}} + C \right) = \frac{\sqrt{1-x^2} + x^2/\sqrt{1-x^2}}{1-x^2} = \frac{1}{(1-x^2)^{3/2}}$

3.  $\frac{d}{dx} [\sqrt{x^3+5}] = \frac{3x^2}{2\sqrt{x^3+5}}$  so  $\int \frac{3x^2}{2\sqrt{x^3+5}} dx = \sqrt{x^3+5} + C$

4.  $\frac{d}{dx} \left[ \frac{x}{x^2+3} \right] = \frac{3-x^2}{(x^2+3)^2}$  so  $\int \frac{3-x^2}{(x^2+3)^2} dx = \frac{x}{x^2+3} + C$

5.  $\frac{d}{dx} [\sin(2\sqrt{x})] = \frac{\cos(2\sqrt{x})}{\sqrt{x}}$  so  $\int \frac{\cos(2\sqrt{x})}{\sqrt{x}} dx = \sin(2\sqrt{x}) + C$
6.  $\frac{d}{dx} [\sin x - x \cos x] = x \sin x$  so  $\int x \sin x dx = \sin x - x \cos x + C$
7. (a)  $x^9/9 + C$  (b)  $\frac{7}{12}x^{12/7} + C$  (c)  $\frac{2}{9}x^{9/2} + C$
8. (a)  $\frac{3}{5}x^{5/3} + C$  (b)  $-\frac{1}{5}x^{-5} + C = -\frac{1}{5x^5} + C$  (c)  $8x^{1/8} + C$
9. (a)  $\frac{1}{2} \int x^{-3} dx = -\frac{1}{4}x^{-2} + C$  (b)  $u^4/4 - u^2 + 7u + C$
10.  $\frac{3}{5}x^{5/3} - 5x^{4/5} + 4x + C$
11.  $\int (x^{-3} + x^{1/2} - 3x^{1/4} + x^2) dx = -\frac{1}{2}x^{-2} + \frac{2}{3}x^{3/2} - \frac{12}{5}x^{5/4} + \frac{1}{3}x^3 + C$
12.  $\int (7y^{-3/4} - y^{1/3} + 4y^{1/2}) dy = 28y^{1/4} - \frac{3}{4}y^{4/3} + \frac{8}{3}y^{3/2} + C$
13.  $\int (x + x^4) dx = x^2/2 + x^5/5 + C$
14.  $\int (4 + 4y^2 + y^4) dy = 4y + \frac{4}{3}y^3 + \frac{1}{5}y^5 + C$
15.  $\int x^{1/3}(4 - 4x + x^2) dx = \int (4x^{1/3} - 4x^{4/3} + x^{7/3}) dx = 3x^{4/3} - \frac{12}{7}x^{7/3} + \frac{3}{10}x^{10/3} + C$
16.  $\int (2 - x + 2x^2 - x^3) dx = 2x - \frac{1}{2}x^2 + \frac{2}{3}x^3 - \frac{1}{4}x^4 + C$
17.  $\int (x + 2x^{-2} - x^{-4}) dx = x^2/2 - 2/x + 1/(3x^3) + C$
18.  $\int (t^{-3} - 2) dt = -\frac{1}{2}t^{-2} - 2t + C$
19.  $2 \ln x + 3e^x + C$
20.  $\int \left[ \frac{1}{2}t^{-1} - \sqrt{2}e^t \right] dt = \frac{1}{2} \ln t - \sqrt{2}e^t + C$
21.  $-4 \cos x + 2 \sin x + C$
22.  $4 \tan x - \csc x + C$
23.  $\int (\sec^2 x + \sec x \tan x) dx = \tan x + \sec x + C$
24.  $\int (\sec x \tan x + 1) dx = \sec x + x + C$
25.  $\ln \theta - 2e^\theta + \cot \theta + C$
26.  $\int \sin y dy = -\cos y + C$
27.  $\int \sec x \tan x dx = \sec x + C$
28.  $\int (\phi + 2 \csc^2 \phi) d\phi = \phi^2/2 - 2 \cot \phi + C$
29.  $\int (1 + \sin \theta) d\theta = \theta - \cos \theta + C$

$$30. \int \frac{2 \sin x \cos x}{\cos x} dx = 2 \int \sin x dx = -2 \cos x + C$$

$$31. \int \frac{1 - \sin x}{1 - \sin^2 x} dx = \int \frac{1 - \sin x}{\cos^2 x} = \int (\sec^2 x - \sec x \tan x) dx = \tan x - \sec x + C$$

33. (a)

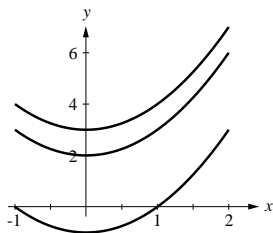

(b)  $f(x) = x^2/2 + 5$

34. (a)

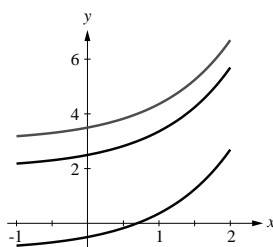

(b)  $f(x) = e^x/2 + 1/2$

35.

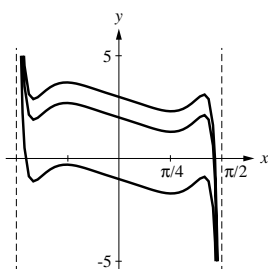

36.

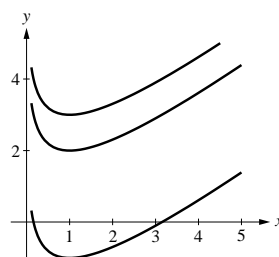

$$37. f'(x) = m = -\sin x \text{ so } f(x) = \int (-\sin x) dx = \cos x + C; f(0) = 2 = 1 + C \text{ so } C = 1, f(x) = \cos x + 1$$

$$38. f'(x) = m = (x+1)^2, \text{ so } f(x) = \int (x+1)^2 dx = \frac{1}{3}(x+1)^3 + C; f(-2) = 8 = \frac{1}{3}(-2+1)^3 + C = -\frac{1}{3} + C, \\ C = 8 + \frac{1}{3} = \frac{25}{3}, f(x) = \frac{1}{3}(x+1)^3 + \frac{25}{3}$$

$$39. \text{(a) } y(x) = \int x^{1/3} dx = \frac{3}{4}x^{4/3} + C, y(1) = \frac{3}{4} + C = 2, C = 5/4; y(x) = \frac{3}{4}x^{4/3} + \frac{5}{4}$$

$$\text{(b) } y(t) = \int t^{-1} dt = \ln|t| + C, y(-1) = C = 5, C = 5; y(t) = \ln|t| + 5$$

$$\text{(c) } y(x) = \int (x^{1/2} + x^{-1/2}) dx = \frac{2}{3}x^{3/2} + 2x^{1/2} + C, y(1) = 0 = \frac{8}{3} + C, C = -\frac{8}{3}, \\ y(x) = \frac{2}{3}x^{3/2} + 2x^{1/2} - \frac{8}{3}$$

$$40. \text{(a) } y(x) = \int \left(\frac{1}{8}x^{-3}\right) dx = -\frac{1}{16}x^{-2} + C, y(1) = 0 = -\frac{1}{16} + C, C = \frac{1}{16}; y(x) = -\frac{1}{16}x^{-2} + \frac{1}{16}$$

$$(b) \quad y(t) = \int (\sec^2 t - \sin t) dt = \tan t + \cos t + C, \quad y\left(\frac{\pi}{4}\right) = 1 = 1 + \frac{\sqrt{2}}{2} + C, \quad C = -\frac{\sqrt{2}}{2};$$

$$y(t) = \tan t + \cos t - \frac{\sqrt{2}}{2}$$

$$(c) \quad y(x) = \int x^{7/2} dx = \frac{2}{9}x^{9/2} + C, \quad y(0) = 0 = C, \quad C = 0; \quad y(x) = \frac{2}{9}x^{9/2}$$

$$41. \quad f'(x) = \frac{2}{3}x^{3/2} + C_1; \quad f(x) = \frac{4}{15}x^{5/2} + C_1x + C_2$$

$$42. \quad f'(x) = x^2/2 + \sin x + C_1, \text{ use } f'(0) = 2 \text{ to get } C_1 = 2 \text{ so } f'(x) = x^2/2 + \sin x + 2, \\ f(x) = x^3/6 - \cos x + 2x + C_2, \text{ use } f(0) = 1 \text{ to get } C_2 = 2 \text{ so } f(x) = x^3/6 - \cos x + 2x + 2$$

$$43. \quad dy/dx = 2x + 1, y = \int (2x + 1)dx = x^2 + x + C; \quad y = 0 \text{ when } x = -3$$

$$\text{so } (-3)^2 + (-3) + C = 0, C = -6 \text{ thus } y = x^2 + x - 6$$

$$44. \quad dy/dx = x^2, y = \int x^2 dx = x^3/3 + C; \quad y = 2 \text{ when } x = -1 \text{ so } (-1)^3/3 + C = 2, C = 7/3$$

$$\text{thus } y = x^3/3 + 7/3$$

$$45. \quad dy/dx = \int 6x dx = 3x^2 + C_1. \text{ The slope of the tangent line is } -3 \text{ so } dy/dx = -3 \text{ when } x = 1. \text{ Thus}$$

$$3(1)^2 + C_1 = -3, C_1 = -6 \text{ so } dy/dx = 3x^2 - 6, y = \int (3x^2 - 6)dx = x^3 - 6x + C_2; \text{ If } x = 1, \text{ then}$$

$$y = 5 - 3(1) = 2 \text{ so } (1)^2 - 6(1) + C_2 = 2, C_2 = 7 \text{ thus } y = x^3 - 6x + 7.$$

$$46. \quad dT/dx = C_1, T = C_1x + C_2; T = 25 \text{ when } x = 0 \text{ so } C_2 = 25, T = C_1x + 25. T = 85 \text{ when } x = 50 \text{ so}$$

$$50C_1 + 25 = 85, C_1 = 1.2, T = 1.2x + 25$$

$$47. \quad (a) \quad F'(x) = G'(x) = 3x + 4$$

$$(b) \quad F(0) = 16/6 = 8/3, G(0) = 0, \text{ so } F(0) - G(0) = 8/3$$

$$(c) \quad F(x) = (9x^2 + 24x + 16)/6 = 3x^2/2 + 4x + 8/3 = G(x) + 8/3$$

$$48. \quad (a) \quad F'(x) = G'(x) = 10x/(x^2 + 5)^2$$

$$(b) \quad F(0) = 0, G(0) = -1, \text{ so } F(0) - G(0) = 1$$

$$(c) \quad F(x) = \frac{x^2}{x^2 + 5} = \frac{(x^2 + 5) - 5}{x^2 + 5} = 1 - \frac{5}{x^2 + 5} = G(x) + 1$$

$$49. \quad \int (\sec^2 x - 1)dx = \tan x - x + C$$

$$50. \quad \int (\csc^2 x - 1)dx = -\cot x - x + C$$

$$51. \quad (a) \quad \frac{1}{2} \int (1 - \cos x)dx = \frac{1}{2}(x - \sin x) + C$$

$$(b) \quad \frac{1}{2} \int (1 + \cos x) dx = \frac{1}{2}(x + \sin x) + C$$

$$52. \quad (a) \quad F'(x) = G'(x) = f(x), \text{ where } f(x) = \begin{cases} 1, & x > 0 \\ -1, & x < 0 \end{cases}$$

$$(b) \quad G(x) - F(x) = \begin{cases} 2, & x > 0 \\ 3, & x < 0 \end{cases} \text{ so } G(x) \neq F(x) \text{ plus a constant}$$

$$(c) \quad \text{no, because } (-\infty, 0) \cup (0, +\infty) \text{ is not an interval}$$

$$53. \quad v = \frac{1087}{2\sqrt{273}} \int T^{-1/2} dT = \frac{1087}{\sqrt{273}} T^{1/2} + C, v(273) = 1087 = 1087 + C \text{ so } C = 0, v = \frac{1087}{\sqrt{273}} T^{1/2} \text{ ft/s}$$

## EXERCISE SET 7.3

1. (a)  $\int u^{23} du = u^{24}/24 + C = (x^2 + 1)^{24}/24 + C$   
 (b)  $-\int u^3 du = -u^4/4 + C = -(\cos^4 x)/4 + C$   
 (c)  $2 \int \sin u du = -2 \cos u + C = -2 \cos \sqrt{x} + C$   
 (d)  $\frac{3}{8} \int u^{-1/2} du = \frac{3}{4} u^{1/2} + C = \frac{3}{4} \sqrt{4x^2 + 5} + C$   
 (e)  $\frac{1}{3} \int u^{-1} du = \frac{1}{3} \ln u + C = \frac{1}{3} \ln(x^3 - 4) + C$
2. (a)  $\frac{1}{4} \int \sec^2 u du = \frac{1}{4} \tan u + C = \frac{1}{4} \tan(4x + 1) + C$   
 (b)  $\frac{1}{4} \int u^{1/2} du = \frac{1}{6} u^{3/2} + C = \frac{1}{6} (1 + 2y^2)^{3/2} + C$   
 (c)  $\frac{1}{\pi} \int u^{1/2} du = \frac{2}{3\pi} u^{3/2} + C = \frac{2}{3\pi} \sin^{3/2} \pi\theta + C$   
 (d)  $\int u^{4/5} du = \frac{5}{9} u^{9/5} + C = \frac{5}{9} (x^2 + 7x + 3)^{9/5} + C$   
 (e)  $\int \frac{du}{u} = \ln u + C = \ln(1 + e^x) + C$
3. (a)  $-\int u du = -\frac{1}{2} u^2 + C = -\frac{1}{2} \cot^2 x + C$   
 (b)  $\int u^9 du = \frac{1}{10} u^{10} + C = \frac{1}{10} (1 + \sin t)^{10} + C$   
 (c)  $\int \frac{1}{u} du = \ln |u| + C = \ln |\ln x| + C$   
 (d)  $-\frac{1}{5} \int e^u du = -\frac{1}{5} e^u + C = -\frac{1}{5} e^{-5x} + C$   
 (e)  $-\frac{1}{3} \int \frac{1}{u} du = -\frac{1}{3} \ln |u| + C = -\frac{1}{3} \ln |(1 + \cos 3\theta)| + C$
4. (a)  $\int (u-1)^2 u^{1/2} du = \int (u^{5/2} - 2u^{3/2} + u^{1/2}) du = \frac{2}{7} u^{7/2} - \frac{4}{5} u^{5/2} + \frac{2}{3} u^{3/2} + C$   
 $= \frac{2}{7} (1+x)^{7/2} - \frac{4}{5} (1+x)^{5/2} + \frac{2}{3} (1+x)^{3/2} + C$   
 (b)  $\int \csc^2 u du = -\cot u + C = -\cot(\sin x) + C$   
 (c)  $\int e^u du = e^u + C = e^{\tan x} + C$   
 (d)  $\frac{1}{2} \int u^{1/2} du = \frac{1}{3} u^{3/2} + C = \frac{1}{3} (1 + e^{2t})^{3/2} + C$   
 (e)  $\int \frac{1}{u} du = \ln |u| + C = \ln |x^5 + 1| + C$
5.  $u = 2x, du = 2dx; \frac{1}{2} \int e^u du = \frac{1}{2} e^u + C = \frac{1}{2} e^{2x} + C$

6.  $u = 2x, du = 2dx; \frac{1}{2} \int \frac{1}{u} du = \frac{1}{2} \ln |u| + C = \frac{1}{2} \ln |2x| + C$
7.  $u = 2 - x^2, du = -2x dx; -\frac{1}{2} \int u^3 du = -u^4/8 + C = -(2 - x^2)^4/8 + C$
8.  $u = 3x - 1, du = 3dx; \frac{1}{3} \int u^5 du = \frac{1}{18} u^6 + C = \frac{1}{18} (3x - 1)^6 + C$
9.  $u = 8x, du = 8dx; \frac{1}{8} \int \cos u du = \frac{1}{8} \sin u + C = \frac{1}{8} \sin 8x + C$
10.  $u = 3x, du = 3dx; \frac{1}{3} \int \sin u du = -\frac{1}{3} \cos u + C = -\frac{1}{3} \cos 3x + C$
11.  $u = 4x, du = 4dx; \frac{1}{4} \int \sec u \tan u du = \frac{1}{4} \sec u + C = \frac{1}{4} \sec 4x + C$
12.  $u = 5x, du = 5dx; \frac{1}{5} \int \sec^2 u du = \frac{1}{5} \tan u + C = \frac{1}{5} \tan 5x + C$
13.  $u = 7t^2 + 12, du = 14t dt; \frac{1}{14} \int u^{1/2} du = \frac{1}{21} u^{3/2} + C = \frac{1}{21} (7t^2 + 12)^{3/2} + C$
14.  $u = 4 - 5x^2, du = -10x dx; -\frac{1}{10} \int u^{-1/2} du = -\frac{1}{5} u^{1/2} + C = -\frac{1}{5} \sqrt{4 - 5x^2} + C$
15.  $u = x^3 + 1, du = 3x^2 dx; \frac{1}{3} \int u^{-1/2} du = \frac{2}{3} u^{1/2} + C = \frac{2}{3} \sqrt{x^3 + 1} + C$
16.  $u = 1 - 3x, du = -3dx; -\frac{1}{3} \int u^{-2} du = \frac{1}{3} u^{-1} + C = \frac{1}{3} (1 - 3x)^{-1} + C$
17.  $u = 4x^2 + 1, du = 8x dx; \frac{1}{8} \int u^{-3} du = -\frac{1}{16} u^{-2} + C = -\frac{1}{16} (4x^2 + 1)^{-2} + C$
18.  $u = 3x^2, du = 6x dx; \frac{1}{6} \int \cos u du = \frac{1}{6} \sin u + C = \frac{1}{6} \sin(3x^2) + C$
19.  $u = \sin x, du = \cos x dx; \int e^u du = e^u + C = e^{\sin x} + C$
20.  $u = x^4, du = 4x^3 dx; \frac{1}{4} \int e^u du = \frac{1}{4} e^u + C = \frac{1}{4} e^{x^4} + C$
21.  $u = -2x^3, du = -6x^2, -\frac{1}{6} \int e^u du = -\frac{1}{6} e^u + C = -\frac{1}{6} e^{-2x^3} + C$
22.  $u = e^x - e^{-x}, du = (e^x + e^{-x}) dx, \int \frac{1}{u} du = \ln |u| + C = \ln |e^x - e^{-x}| + C$
23.  $u = 5/x, du = -(5/x^2) dx; -\frac{1}{5} \int \sin u du = \frac{1}{5} \cos u + C = \frac{1}{5} \cos(5/x) + C$
24.  $u = \sqrt{x}, du = \frac{1}{2\sqrt{x}} dx; 2 \int \sec^2 u du = 2 \tan u + C = 2 \tan \sqrt{x} + C$
25.  $u = x^3, du = 3x^2 dx; \frac{1}{3} \int \sec^2 u du = \frac{1}{3} \tan u + C = \frac{1}{3} \tan(x^3) + C$

26.  $u = \cos 2t, du = -2 \sin 2t dt; -\frac{1}{2} \int u^3 du = -\frac{1}{8}u^4 + C = -\frac{1}{8} \cos^4 2t + C$
27.  $\int e^{-x} dx; u = -x, du = -dx; -\int e^u du = -e^u + C = -e^{-x} + C$
28.  $\int e^{x/2} dx; u = x/2, du = dx/2; 2 \int e^u du = 2e^u + C = 2e^{x/2} + C = 2\sqrt{e^x} + C$
29.  $u = \sin 3t, du = 3 \cos 3t dt; \frac{1}{3} \int u^5 du = \frac{1}{18}u^6 + C = \frac{1}{18} \sin^6 3t + C$
30.  $u = 5 + \cos 2\theta, du = -2 \sin 2\theta d\theta; -\frac{1}{2} \int u^{-3} du = \frac{1}{4}u^{-2} + C = \frac{1}{4}(5 + \cos 2\theta)^{-2} + C$
31.  $u = 2 - \sin 4\theta, du = -4 \cos 4\theta d\theta; -\frac{1}{4} \int u^{1/2} du = -\frac{1}{6}u^{3/2} + C = -\frac{1}{6}(2 - \sin 4\theta)^{3/2} + C$
32.  $u = \tan 5x, du = 5 \sec^2 5x dx; \frac{1}{5} \int u^3 du = \frac{1}{20}u^4 + C = \frac{1}{20} \tan^4 5x + C$
33.  $u = \sec 2x, du = 2 \sec 2x \tan 2x dx; \frac{1}{2} \int u^2 du = \frac{1}{6}u^3 + C = \frac{1}{6} \sec^3 2x + C$
34.  $u = \sin \theta, du = \cos \theta d\theta; \int \sin u du = -\cos u + C = -\cos(\sin \theta) + C$
35.  $u = \sqrt{y}, du = \frac{1}{2\sqrt{y}} dy, 2 \int e^u du = 2e^u + C = 2e^{\sqrt{y}} + C$
36.  $u = \sqrt{y}, du = \frac{1}{2\sqrt{y}} dy, 2 \int \frac{1}{e^u} du = 2 \int e^{-u} du = -2e^{-u} + C = -2e^{-\sqrt{y}} + C$
38.  $u = a + bx, du = b dx, dx = \frac{1}{b} du$   
 $\frac{1}{b} \int u^{1/n} du = \frac{n}{b(n+1)} u^{(n+1)/n} + C = \frac{n}{b(n+1)} (a + bx)^{(n+1)/n} + C$
39.  $u = \sin(a + bx), du = b \cos(a + bx) dx$   
 $\frac{1}{b} \int u^n du = \frac{1}{b(n+1)} u^{n+1} + C = \frac{1}{b(n+1)} \sin^{n+1}(a + bx) + C$
41.  $u = x - 3, x = u + 3, dx = du$   
 $\int (u + 3)u^{1/2} du = \int (u^{3/2} + 3u^{1/2}) du = \frac{2}{5}u^{5/2} + 2u^{3/2} + C = \frac{2}{5}(x - 3)^{5/2} + 2(x - 3)^{3/2} + C$
42.  $u = y + 1, y = u - 1, dy = du$   
 $\int \frac{u-1}{u^{1/2}} du = \int (u^{1/2} - u^{-1/2}) du = \frac{2}{3}u^{3/2} - 2u^{1/2} + C = \frac{2}{3}(y + 1)^{3/2} - 2(y + 1)^{1/2} + C$
43.  $u = 3\theta, du = 3 d\theta$   
 $\frac{1}{3} \int \tan^2 u du = \frac{1}{3} \int (\sec^2 u - 1) du = \frac{1}{3}(\tan u - u) + C = \frac{1}{3}(\tan 3\theta - 3\theta) + C$
44.  $\int \sin^2 2\theta \sin 2\theta d\theta = \int (1 - \cos^2 2\theta) \sin 2\theta d\theta; u = \cos 2\theta, du = -2 \sin 2\theta d\theta,$   
 $-\frac{1}{2} \int (1 - u^2) du = -\frac{1}{2}u + \frac{1}{6}u^3 + C = -\frac{1}{2} \cos 2\theta + \frac{1}{6} \cos^3 2\theta + C$



45.  $\int \left(1 + \frac{1}{t}\right) dt = t + \ln |t| + C$

46.  $e^{2\ln x} = e^{\ln x^2} = x^2, x > 0$ , so  $\int e^{2\ln x} dx = \int x^2 dx = \frac{1}{3}x^3 + C$

47.  $\ln(e^x) + \ln(e^{-x}) = \ln(e^x e^{-x}) = \ln 1 = 0$  so  $\int [\ln(e^x) + \ln(e^{-x})] dx = C$

48.  $\int \frac{\cos x}{\sin x} dx; u = \sin x, du = \cos x dx; \int \frac{1}{u} du = \ln |u| + C = \ln |\sin x| + C$

49. (a) with  $u = \sin x, du = \cos x dx; \int u du = \frac{1}{2}u^2 + C_1 = \frac{1}{2}\sin^2 x + C_1;$   
 with  $u = \cos x, du = -\sin x dx; -\int u du = -\frac{1}{2}u^2 + C_2 = -\frac{1}{2}\cos^2 x + C_2$

(b) because they differ by a constant:  
 $\left(\frac{1}{2}\sin^2 x + C_1\right) - \left(-\frac{1}{2}\cos^2 x + C_2\right) = \frac{1}{2}(\sin^2 x + \cos^2 x) + C_1 - C_2 = 1/2 + C_1 - C_2$

50. (a) First method:  $\int (25x^2 - 10x + 1) dx = \frac{25}{3}x^3 - 5x^2 + x + C_1;$

second method:  $\frac{1}{5} \int u^2 du = \frac{1}{15}u^3 + C_2 = \frac{1}{15}(5x - 1)^3 + C_2$

(b)  $\frac{1}{15}(5x - 1)^3 + C_2 = \frac{1}{15}(125x^3 - 75x^2 + 15x - 1) + C_2 = \frac{25}{3}x^3 - 5x^2 + x - \frac{1}{15} + C_2;$   
 the answers differ by a constant.

51.  $y(x) = \int \sqrt{3x+1} dx = \frac{2}{9}(3x+1)^{3/2} + C,$   
 $y(1) = \frac{16}{9} + C = 5, C = \frac{29}{9}$  so  $y(x) = \frac{2}{9}(3x+1)^{3/2} + \frac{29}{9}$

52.  $y(x) = \int (6 - 5 \sin 2x) dx = 6x + \frac{5}{2} \cos 2x + C,$   
 $y(0) = \frac{5}{2} + C = 3, C = \frac{1}{2}$  so  $y(x) = 6x + \frac{5}{2} \cos 2x + \frac{1}{2}$

53.  $f'(x) = m = \sqrt{3x+1}, f(x) = \int (3x+1)^{1/2} dx = \frac{2}{9}(3x+1)^{3/2} + C; f(0) = 1 = \frac{2}{9} + C, C = \frac{7}{9},$  so  
 $f(x) = \frac{2}{9}(3x+1)^{3/2} + \frac{7}{9}$

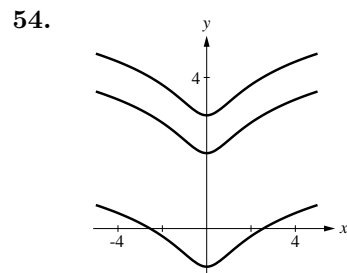

55.  $p(t) = \int (4 + 0.15t)^{3/2} dt = \frac{8}{3}(4 + 0.15t)^{5/2} + C$ ;  $p(0) = 100,000 = \frac{8}{3}4^{5/2} + C = \frac{256}{3} + C$ ,  
 $C = 100,000 - \frac{256}{3} \approx 99,915$ ,  $p(t) = \frac{8}{3}(4 + 0.15t)^{5/2} + 99,915$ ,  $p(5) = \frac{8}{3}(4.75)^{5/2} + 99,915 \approx 100,416$
56.  $\frac{dr}{dt} = -k\sqrt{t}$ ,  $r = -k \int t^{1/2} dt = -\frac{2}{3}kt^{3/2} + C$ ;  $r(0) = 10,000 = C$  so  $C = 10,000$  and  
 $r = -\frac{2}{3}kt^{3/2} + 10,000$ ;  $r(25) = 9,000 = -\frac{2}{3}k(25)^{3/2} + 10,000 = 10,000 - \frac{250}{3}k$ , so  
 $k = 12$ ,  $r = -8t^{3/2} + 10,000$ , and  $r(60) = 6281.94$  m

### EXERCISE SET 7.4

1. (a)  $1 + 8 + 27 = 36$  (b)  $5 + 8 + 11 + 14 + 17 = 55$   
 (c)  $20 + 12 + 6 + 2 + 0 + 0 = 40$  (d)  $1 + 1 + 1 + 1 + 1 + 1 = 6$   
 (e)  $1 - 2 + 4 - 8 + 16 = 11$  (f)  $0 + 0 + 0 + 0 + 0 + 0 = 0$
2. (a)  $1 + 0 - 3 + 0 = -2$  (b)  $1 - 1 + 1 - 1 + 1 - 1 = 0$   
 (c)  $e^2 + e^2 + \cdots + e^2 = 14e^2$  (d)  $2^4 + 2^5 + 2^6 = 112$   
 (14 terms)  
 (e)  $\ln 1 + \ln 2 + \ln 3 + \ln 4 + \ln 5 + \ln 6 = \ln(1 \cdot 2 \cdot 3 \cdot 4 \cdot 5 \cdot 6) = \ln 720$   
 (f)  $1 - 1 + 1 - 1 + 1 - 1 + 1 - 1 + 1 - 1 + 1 = 1$
3.  $\sum_{k=1}^{10} k$       4.  $\sum_{k=1}^{20} 3k$       5.  $\sum_{k=1}^{49} k(k+1)$       6.  $\sum_{k=0}^4 2^k$
7.  $\sum_{k=1}^{10} 2k$       8.  $\sum_{k=1}^8 (2k-1)$       9.  $\sum_{k=1}^6 (-1)^{k+1}(2k-1)$
10.  $\sum_{k=1}^5 (-1)^{k+1} \frac{1}{k}$       11.  $\sum_{k=1}^5 (-1)^k \frac{1}{k}$       12.  $\sum_{k=0}^3 \cos \frac{k\pi}{7}$
13. (a)  $\sum_1^{50} 2k$       (b)  $\sum_1^{50} (2k-1)$
14. (a)  $\sum_{k=1}^5 (-1)^{k+1} a_k$       (b)  $\sum_{k=0}^5 (-1)^{k+1} b_k$       (c)  $\sum_{k=0}^n a_k x^k$       (d)  $\sum_{k=0}^5 a^{5-k} b^k$
15.  $\frac{1}{2}(100)(100+1) = 5050$
16.  $\sum_{k=1}^{100} k - \sum_{k=1}^2 k = \frac{1}{2}(100)(100+1) - (1+2) = 5050 - 3 = 5047$
17.  $\frac{1}{6}(20)(21)(41) = 2,870$       18.  $7 \sum_{k=1}^{100} k + \sum_{k=1}^{100} 1 = \frac{7}{2}(100)(101) + 100 = 35,450$
19.  $4 \sum_{k=1}^6 k^3 - 2 \sum_{k=1}^6 k + \sum_{k=1}^6 1 = 4 \left[ \frac{1}{4}(6)^2(7)^2 \right] - 2 \left[ \frac{1}{2}(6)(7) \right] + 6 = 1728$

$$20. \sum_{k=1}^{20} k^2 - \sum_{k=1}^3 k^2 = 2,870 - 14 = 2,856$$

$$21. \sum_{k=1}^{30} k(k^2 - 4) = \sum_{k=1}^{30} (k^3 - 4k) = \sum_{k=1}^{30} k^3 - 4 \sum_{k=1}^{30} k = \frac{1}{4}(30)^2(31)^2 - 4 \cdot \frac{1}{2}(30)(31) = 214,365$$

$$22. \sum_{k=1}^6 k - \sum_{k=1}^6 k^3 = \frac{1}{2}(6)(7) - \frac{1}{4}(6)^2(7)^2 = -420$$

$$23. \sum_{k=1}^n (4k - 3) = 4 \sum_{k=1}^n k - \sum_{k=1}^n 3 = 4 \cdot \frac{1}{2}n(n+1) - 3n = 2n^2 - n$$

$$24. \sum_{k=1}^{n-1} k^2 = \frac{1}{6}(n-1)[(n-1)+1][2(n-1)+1] = \frac{1}{6}n(n-1)(2n-1)$$

$$25. \sum_{k=1}^n \frac{3k}{n} = \frac{3}{n} \sum_{k=1}^n k = \frac{3}{n} \cdot \frac{1}{2}n(n+1) = \frac{3}{2}(n+1)$$

$$26. \sum_{k=1}^{n-1} \frac{k^2}{n} = \frac{1}{n} \sum_{k=1}^{n-1} k^2 = \frac{1}{n} \cdot \frac{1}{6}(n-1)(n)(2n-1) = \frac{1}{6}(n-1)(2n-1)$$

$$27. \sum_{k=1}^{n-1} \frac{k^3}{n^2} = \frac{1}{n^2} \sum_{k=1}^{n-1} k^3 = \frac{1}{n^2} \cdot \frac{1}{4}(n-1)^2 n^2 = \frac{1}{4}(n-1)^2$$

$$28. \sum_{k=1}^n \left( \frac{5}{n} - \frac{2k}{n} \right) = \frac{5}{n} \sum_{k=1}^n 1 - \frac{2}{n} \sum_{k=1}^n k = \frac{5}{n}(n) - \frac{2}{n} \cdot \frac{1}{2}n(n+1) = 4 - n$$

$$\begin{aligned} 30. \quad S - rS &= \sum_{k=0}^n ar^k - \sum_{k=0}^n ar^{k+1} \\ &= (a + ar + ar^2 + \cdots + ar^n) - (ar + ar^2 + ar^3 + \cdots + ar^{n+1}) \\ &= a - ar^{n+1} = a(1 - r^{n+1}) \end{aligned}$$

so  $(1-r)S = a(1-r^{n+1})$ , hence  $S = a(1-r^{n+1})/(1-r)$

$$31. \quad (\text{a}) \sum_{k=0}^{19} 3^{k+1} = \sum_{k=0}^{19} 3(3^k) = \frac{3(1-3^{20})}{1-3} = \frac{3}{2}(3^{20}-1)$$

$$(\text{b}) \sum_{k=0}^{25} 2^{k+5} = \sum_{k=0}^{25} 2^5 2^k = \frac{2^5(1-2^{26})}{1-2} = 2^{31} - 2^5$$

$$(\text{c}) \sum_{k=0}^{100} (-1) \left( \frac{-1}{2} \right)^k = \frac{(-1)(1 - (-1/2)^{101})}{1 - (-1/2)} = -\frac{2}{3}(1 + 1/2^{101})$$

$$32. \quad (\text{a}) \quad 1.999023438, 1.999999046, 2.000000000; 2 \quad (\text{b}) \quad 2.831059456, 2.990486364, 2.999998301; 3$$

$$33. \quad \frac{1+2+3+\cdots+n}{n^2} = \sum_{k=1}^n \frac{k}{n^2} = \frac{1}{n^2} \sum_{k=1}^n k = \frac{1}{n^2} \cdot \frac{1}{2}n(n+1) = \frac{n+1}{2n}; \quad \lim_{n \rightarrow +\infty} \frac{n+1}{2n} = \frac{1}{2}$$

$$34. \frac{1^2 + 2^2 + 3^2 + \cdots + n^2}{n^3} = \sum_{k=1}^n \frac{k^2}{n^3} = \frac{1}{n^3} \sum_{k=1}^n k^2 = \frac{1}{n^3} \cdot \frac{1}{6} n(n+1)(2n+1) = \frac{(n+1)(2n+1)}{6n^2};$$

$$\lim_{n \rightarrow +\infty} \frac{(n+1)(2n+1)}{6n^2} = \lim_{n \rightarrow +\infty} \frac{1}{6} (1 + 1/n)(2 + 1/n) = \frac{1}{3}$$

$$35. \sum_{k=1}^n \frac{5k}{n^2} = \frac{5}{n^2} \sum_{k=1}^n k = \frac{5}{n^2} \cdot \frac{1}{2} n(n+1) = \frac{5(n+1)}{2n}; \quad \lim_{n \rightarrow +\infty} \frac{5(n+1)}{2n} = \frac{5}{2}$$

$$36. \sum_{k=1}^{n-1} \frac{2k^2}{n^3} = \frac{2}{n^3} \sum_{k=1}^{n-1} k^2 = \frac{2}{n^3} \cdot \frac{1}{6} (n-1)(n)(2n-1) = \frac{(n-1)(2n-1)}{3n^2};$$

$$\lim_{n \rightarrow +\infty} \frac{(n-1)(2n-1)}{3n^2} = \lim_{n \rightarrow +\infty} \frac{1}{3} (1 - 1/n)(2 - 1/n) = \frac{2}{3}$$

$$37. \quad \text{(a)} \sum_{j=0}^5 2^j \qquad \text{(b)} \sum_{j=1}^6 2^{j-1} \qquad \text{(c)} \sum_{j=2}^7 2^{j-2}$$

$$38. \quad \text{(a)} \sum_{k=1}^5 (k+4)2^{k+8} \qquad \text{(b)} \sum_{k=9}^{13} (k-4)2^k$$

$$39. \quad \text{(a)} \sum_{k=1}^{18} \sin\left(\frac{\pi}{k}\right) \qquad \text{(b)} \sum_{k=0}^6 e^k = \frac{e^7 - 1}{e - 1}$$

$$40. 1 + 3 + 5 + \cdots + (2n-1) = \sum_{k=1}^n (2k-1) = 2 \sum_{k=1}^n k - \sum_{k=1}^n 1 = 2 \cdot \frac{1}{2} n(n+1) - n = n^2$$

41. For  $1 \leq k \leq n$  the  $k$ -th  $L$ -shaped strip consists of the corner square, a strip above and a strip to the right for a combined area of  $1 + (k-1) + (k-1) = 2k-1$ , so the total area is  $\sum_{k=1}^n (2k-1) = n^2$ .

$$42. \frac{n(n+1)}{2} = 465, \quad n^2 + n - 930 = 0, \quad (n+31)(n-30) = 0, \quad n = 30.$$

$$43. (3^5 - 3^4) + (3^6 - 3^5) + \cdots + (3^{17} - 3^{16}) = 3^{17} - 3^4$$

$$44. \left(1 - \frac{1}{2}\right) + \left(\frac{1}{2} - \frac{1}{3}\right) + \cdots + \left(\frac{1}{50} - \frac{1}{51}\right) = \frac{50}{51}$$

$$45. \left(\frac{1}{2^2} - \frac{1}{1^2}\right) + \left(\frac{1}{3^2} - \frac{1}{2^2}\right) + \cdots + \left(\frac{1}{20^2} - \frac{1}{19^2}\right) = \frac{1}{20^2} - 1 = -\frac{399}{400}$$

$$46. (2^2 - 2) + (2^3 - 2^2) + \cdots + (2^{101} - 2^{100}) = 2^{101} - 2$$

$$47. \quad \text{(a)} \sum_{k=1}^n \frac{1}{(2k-1)(2k+1)} = \frac{1}{2} \sum_{k=1}^n \left( \frac{1}{2k-1} - \frac{1}{2k+1} \right)$$

$$= \frac{1}{2} \left[ \left(1 - \frac{1}{3}\right) + \left(\frac{1}{3} - \frac{1}{5}\right) + \left(\frac{1}{5} - \frac{1}{7}\right) + \cdots + \left(\frac{1}{2n-1} - \frac{1}{2n+1}\right) \right]$$

$$= \frac{1}{2} \left[ 1 - \frac{1}{2n+1} \right] = \frac{n}{2n+1}$$

$$\text{(b)} \lim_{n \rightarrow +\infty} \frac{n}{2n+1} = \frac{1}{2}$$

$$\begin{aligned}
 48. \quad (a) \quad \sum_{k=1}^n \frac{1}{k(k+1)} &= \sum_{k=1}^n \left( \frac{1}{k} - \frac{1}{k+1} \right) \\
 &= \left( 1 - \frac{1}{2} \right) + \left( \frac{1}{2} - \frac{1}{3} \right) + \left( \frac{1}{3} - \frac{1}{4} \right) + \cdots + \left( \frac{1}{n} - \frac{1}{n+1} \right) \\
 &= 1 - \frac{1}{n+1} = \frac{n}{n+1}
 \end{aligned}$$

$$(b) \quad \lim_{n \rightarrow +\infty} \frac{n}{n+1} = 1$$

49. both are valid

50. none is valid

$$\begin{aligned}
 51. \quad \sum_{i=1}^n (x_i - \bar{x}) &= \sum_{i=1}^n x_i - \sum_{i=1}^n \bar{x} = \sum_{i=1}^n x_i - n\bar{x} \text{ but } \bar{x} = \frac{1}{n} \sum_{i=1}^n x_i \text{ thus} \\
 \sum_{i=1}^n x_i &= n\bar{x} \text{ so } \sum_{i=1}^n (x_i - \bar{x}) = n\bar{x} - n\bar{x} = 0
 \end{aligned}$$

$$\begin{aligned}
 52. \quad \sum_{k=1}^n (a_k - b_k) &= (a_1 - b_1) + (a_2 - b_2) + \cdots + (a_n - b_n) \\
 &= (a_1 + a_2 + \cdots + a_n) - (b_1 + b_2 + \cdots + b_n) = \sum_{k=1}^n a_k - \sum_{k=1}^n b_k
 \end{aligned}$$

$$\begin{aligned}
 53. \quad \sum_{k=1}^n [(k+1)^4 - k^4] &= (n+1)^4 - 1 \text{ (telescoping sum), expand the} \\
 &\text{quantity in brackets to get } \sum_{k=1}^n (4k^3 + 6k^2 + 4k + 1) = (n+1)^4 - 1,
 \end{aligned}$$

$$4 \sum_{k=1}^n k^3 + 6 \sum_{k=1}^n k^2 + 4 \sum_{k=1}^n k + \sum_{k=1}^n 1 = (n+1)^4 - 1$$

$$\begin{aligned}
 \sum_{k=1}^n k^3 &= \frac{1}{4} \left[ (n+1)^4 - 1 - 6 \sum_{k=1}^n k^2 - 4 \sum_{k=1}^n k - \sum_{k=1}^n 1 \right] \\
 &= \frac{1}{4} [(n+1)^4 - 1 - n(n+1)(2n+1) - 2n(n+1) - n] \\
 &= \frac{1}{4} (n+1) [(n+1)^3 - n(2n+1) - 2n - 1] \\
 &= \frac{1}{4} (n+1)(n^3 + n^2) = \frac{1}{4} n^2 (n+1)^2
 \end{aligned}$$

$$54. \quad \text{If } n = 2m \text{ then } 2m + 2(m-1) + \cdots + 2 \cdot 2 + 2 = 2 \sum_{k=1}^m k = 2 \cdot \frac{m(m+1)}{2} = m(m+1) = \frac{n^2 + 2n}{4};$$

$$\begin{aligned}
 \text{if } n = 2m + 1 \text{ then } (2m+1) + (2m-1) + \cdots + 5 + 3 + 1 &= \sum_{k=1}^{m+1} (2k-1) \\
 = 2 \sum_{k=1}^{m+1} k - \sum_{k=1}^{m+1} 1 &= 2 \cdot \frac{(m+1)(m+2)}{2} - (m+1) = (m+1)^2 = \frac{n^2 + 2n + 1}{4}
 \end{aligned}$$

$$55. \quad 50 \cdot 30 + 49 \cdot 29 + \cdots + 22 \cdot 2 + 21 \cdot 1 = \sum_{k=1}^{30} k(k+20) = \sum_{k=1}^{30} k^2 + 20 \sum_{k=1}^{30} k = \frac{30 \cdot 31 \cdot 61}{6} + 20 \frac{30 \cdot 31}{2} = 18,755$$

## EXERCISE SET 7.5

1. (a)  $\frac{1}{2}bh = \frac{1}{2} \cdot 4 \cdot 4 = 8$

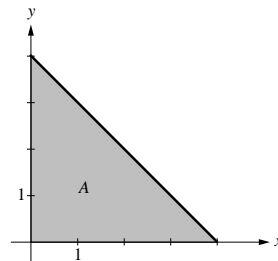

- (b) The approximation is greater than  $A$ , as the rectangles extend beyond the area.

$$\sum_{k=1}^4 f(x_k^*) \Delta x = (4 + 3 + 2 + 1)(1) = 10$$

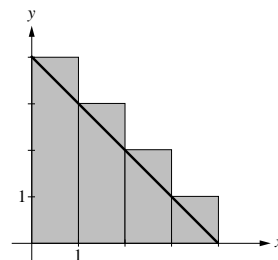

- (c) The approximation is less than  $A$ , as the rectangles lie inside the area.

$$\sum_{k=1}^4 f(x_k^*) \Delta x = (3 + 2 + 1 + 0)(1) = 6$$

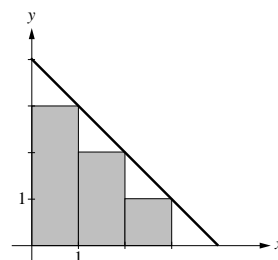

- (d) The approximation is equal to  $A$ , as can be seen by measuring congruent triangles.

$$\sum_{k=1}^4 f(x_k^*) \Delta x = (3.5 + 2.5 + 1.5 + 0.5)(1) = 8$$

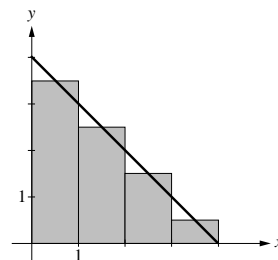

2. (a)  $\frac{1}{2}bh = \frac{1}{2} \cdot 4 \cdot 12 = 24$

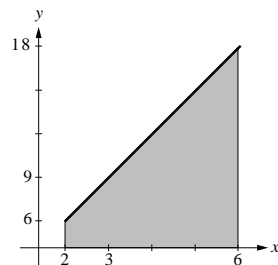

- (b) The approximation is less than  $A$ , as the rectangles lie inside the area.

$$\sum_{k=1}^4 f(x_k^*) \Delta x = (6 + 9 + 12 + 15)(1) = 42$$

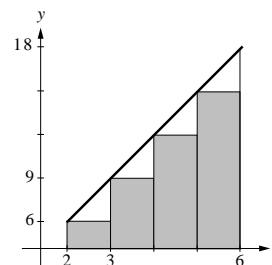

- (c) The approximation is greater than  $A$ , as the rectangles extend beyond the area.

$$\sum_{k=1}^4 f(x_k^*) \Delta x = (9 + 12 + 15 + 18)(1) = 54$$

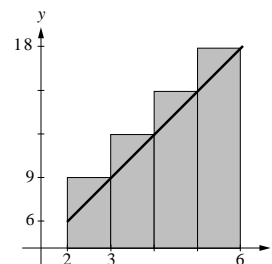

- (d) The approximation is equal to  $A$ , as can be seen by measuring congruent triangles.

$$\sum_{k=1}^4 f(x_k^*) \Delta x = (7.5 + 10.5 + 13.5 + 16.5)(1) = 48$$

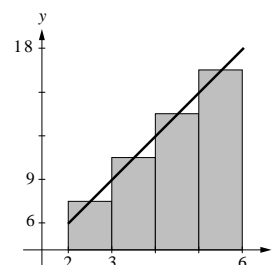

3. (a)  $x_k^* = 0, 1, 2, 3, 4$

$$\sum_{k=1}^5 f(x_k^*) \Delta x = (1 + 2 + 5 + 10 + 17)(1) = 35$$

- (b)  $x_k^* = 1, 2, 3, 4, 5$

$$\sum_{k=1}^5 f(x_k^*) \Delta x = (2 + 5 + 10 + 17 + 26)(1) = 60$$

- (c)  $x_k^* = 1/2, 3/2, 5/2, 7/2, 9/2$

$$\sum_{k=1}^5 f(x_k^*) \Delta x = (5/4 + 13/4 + 29/4 + 53/4 + 85/4)(1) = 185/4 = 46.25$$

4. (a)  $x_k^* = 1, 2, 3, 4, 5$

$$\sum_{k=1}^5 f(x_k^*) \Delta x = (1 + 8 + 27 + 64 + 125)(1) = 225$$

- (b)  $x_k^* = 2, 3, 4, 5, 6$

$$\sum_{k=1}^5 f(x_k^*) \Delta x = (8 + 27 + 64 + 125 + 216)(1) = 440$$

- (c)  $x_k^* = 3/2, 5/2, 7/2, 9/2, 11/2$

$$\sum_{k=1}^5 f(x_k^*) \Delta x = (27/8 + 125/8 + 343/8 + 729/8 + 1331/8)(1) = 2555/8 = 319.375$$

5. (a)  $x_k^* = -\pi/2, -\pi/4, 0, \pi/4$

$$\sum_{k=1}^4 f(x_k^*) \Delta x = (0 + 1/\sqrt{2} + 1 + 1/\sqrt{2})(\pi/4) = (1 + \sqrt{2})\pi/4 \approx 1.896$$

(b)  $x_k^* = -\pi/4, 0, \pi/4, \pi/2$

$$\sum_{k=1}^4 f(x_k^*) \Delta x = (1/\sqrt{2} + 1 + 1/\sqrt{2} + 0)(\pi/4) = (1 + \sqrt{2})\pi/4 \approx 1.896$$

(c)  $x_k^* = -3\pi/8, -\pi/8, \pi/8, 3\pi/8$

$$\sum_{k=1}^4 f(x_k^*) \Delta x = \left[ \cos \frac{3\pi}{8} + \cos \frac{\pi}{8} + \cos \frac{\pi}{8} + \cos \frac{3\pi}{8} \right] \frac{\pi}{4} = \pi \cos \frac{\pi}{4} \cos \frac{\pi}{8} = \left( \pi \sqrt{2} \cos \frac{\pi}{8} \right) / 2 \approx 2.052$$

6. (a)  $x_k^* = 0, 1, 2, 3, 4$

$$\sum_{k=1}^4 f(x_k^*) \Delta x = (e^0 + e^1 + e^2 + e^3 + e^4)(1) = (1 - e^5)/(1 - e) = 85.791$$

(b)  $x_k^* = 1, 2, 3, 4, 5$

$$\sum_{k=1}^4 f(x_k^*) \Delta x = (e^1 + e^2 + e^3 + e^4 + e^5)(1) = e(1 - e^5)/(1 - e) = 233.204$$

(c)  $x_k^* = 1/2, 3/2, 5/2, 7/2, 9/2$

$$\sum_{k=1}^4 f(x_k^*) \Delta x = (e^{1/2} + e^{3/2} + e^{5/2} + e^{7/2} + e^{9/2})(1) = e^{1/2}(1 - e^5)/(1 - e) = 141.446$$

7. left endpoints:  $x_k^* = 1, 2, 3, 4; \sum_{k=1}^4 f(x_k^*) \Delta x = (2 + 3 + 2 + 1)(1) = 8$

right endpoints:  $x_k^* = 2, 3, 4, 5; \sum_{k=1}^4 f(x_k^*) \Delta x = (3 + 2 + 1 + 2)(1) = 8$

8. (a)  $A = \frac{1}{2}(h_1 + h_2)w = \frac{1}{2}(4 + 16)(4) = 40$

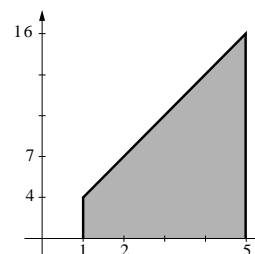

(b) (left)  $x_k^* = 1, 2, 3, 4; \sum_{k=1}^4 f(x_k^*) \Delta x = (4 + 7 + 10 + 13)(1) = 34$

(right)  $x_k^* = 2, 3, 4, 5; \sum_{k=1}^4 f(x_k^*) \Delta x = (7 + 10 + 13 + 16)(1) = 46$ ; the average is  $\frac{1}{2}(34 + 46) = 40$

(c) The right endpoint approximation exceeds the true area by four triangles; the true area exceeds the left endpoint approximation by four different, but congruent, triangles.

9. 0.718771403, 0.668771403, 0.692835360      10. 0.761923639, 0.584145862, 0.663501867

11. 0.919403170, 1.07648280, 1.001028825      12. 4.884074732, 5.684074732, 5.347070728

13. 0.351220577, 0.420535296, 0.386502483      14. 1.63379940, 1.805627583, 1.717566087



15.

	$n$	$1/x$	$1/x^2$	$\sin x$	$\sqrt{x}$	$\ln x$	$e^x$
(a)	25	0.693097198	0.666154270	1.000164512	5.336963538	0.386327689	1.718167282
(b)	50	0.693134682	0.666538346	1.000041125	5.334644416	0.386302694	1.718253191
(c)	100	0.693144056	0.666634573	1.000010281	5.333803776	0.3862964444	1.718274669

17. (a)  $A = \frac{1}{2}(3)(3) = 9/2$

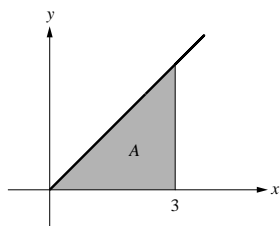

(b)  $-A = -\frac{1}{2}(1)(1+2) = -3/2$

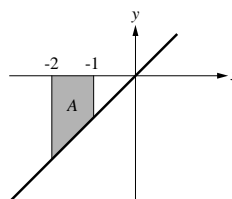

(c)  $-A_1 + A_2 = -\frac{1}{2} + 8 = 15/2$

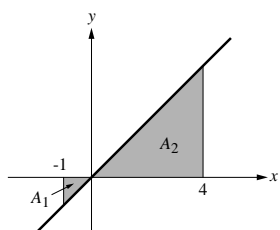

(d)  $-A_1 + A_2 = 0$

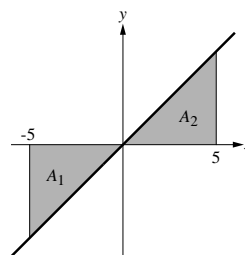

18. (a)  $A = \frac{1}{2}(1)(2) = 1$

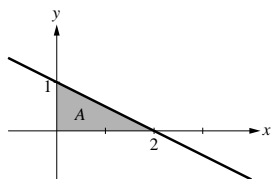

(b)  $A = \frac{1}{2}(2)(3/2 + 1/2) = 2$

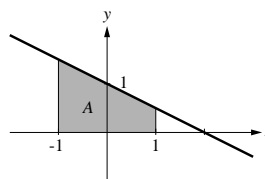

(c)  $-A = -\frac{1}{2}(1/2)(1) = -1/4$

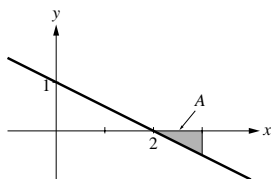

(d)  $A_1 - A_2 = 1 - 1/4 = 3/4$

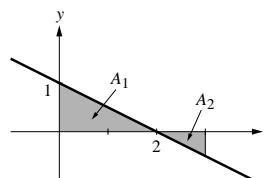

19. (a)  $A = 2(5) = 10$

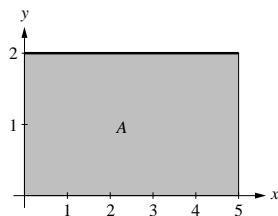

(b)  $0$ ;  $A_1 = A_2$  by symmetry

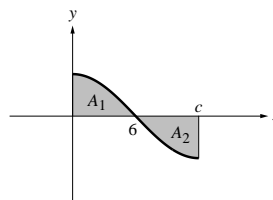

(c)  $A_1 + A_2 = \frac{1}{2}(5)(5/2) + \frac{1}{2}(1)(1/2)$   
 $= 13/2$

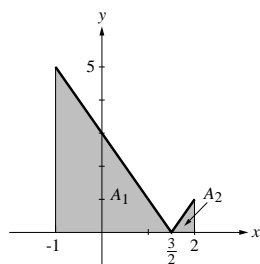

(d)  $\frac{1}{2}[\pi(1)^2] = \pi/2$

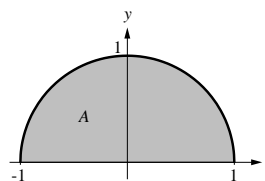

20. (a)  $A = (6)(5) = 30$

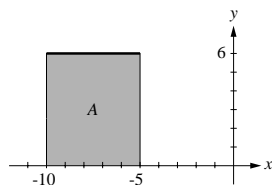

(b)  $-A_1 + A_2 = 0$  because  
 $A_1 = A_2$  by symmetry

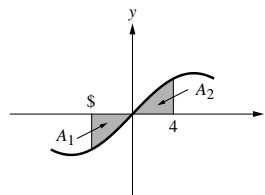

(c)  $A_1 + A_2 = \frac{1}{2}(2)(2) + \frac{1}{2}(1)(1) = 5/2$

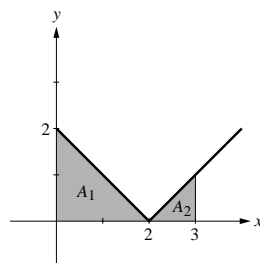

(d)  $\frac{1}{4}\pi(2)^2 = \pi$

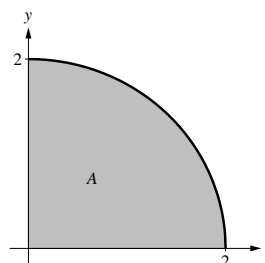

21. (a) 0.8

(b) -2.6

(c) -1.8

(d) -0.3

22. (a)  $\int_0^1 f(x)dx = \int_0^1 2xdx = x^2 \Big|_0^1 = 1$

(b)  $\int_{-1}^1 f(x)dx = \int_{-1}^1 2xdx = x^2 \Big|_{-1}^1 = 1^2 - (-1)^2 = 0$

$$(c) \int_1^{10} f(x)dx = \int_1^{10} 2dx = 2x \Big|_1^{10} = 18$$

$$(d) \int_{1/2}^5 f(x)dx = \int_{1/2}^1 2xdx + \int_1^5 2dx = x^2 \Big|_{1/2}^1 + 2x \Big|_1^5 = 1^2 - (1/2)^2 + 2 \cdot 5 - 2 \cdot 1 = 3/4 + 8 = 35/4$$

$$23. \int_{-1}^2 f(x)dx + 2 \int_{-1}^2 g(x)dx = 5 + 2(-3) = -1$$

$$24. 3 \int_1^4 f(x)dx - \int_1^4 g(x)dx = 3(2) - 10 = -4$$

$$25. \int_1^5 f(x)dx = \int_0^5 f(x)dx - \int_0^1 f(x)dx = 1 - (-2) = 3$$

$$26. \int_3^{-2} f(x)dx = - \int_{-2}^3 f(x)dx = - \left[ \int_{-2}^1 f(x)dx + \int_1^3 f(x)dx \right] = -(2 - 6) = 4$$

$$27. (a) \int_0^1 xdx + 2 \int_0^1 \sqrt{1-x^2}dx = 1/2 + 2(\pi/4) = (1 + \pi)/2$$

$$(b) 4 \int_{-1}^3 dx - 5 \int_{-1}^3 xdx = 4 \cdot 4 - 5(-1/2 + (3 \cdot 3)/2) = -4$$

$$28. (a) \int_{-3}^0 2dx + \int_{-3}^0 \sqrt{9-x^2}dx = 2 \cdot 3 + (\pi(3)^2)/4 = 6 + 9\pi/4$$

$$(b) \int_{-2}^2 dx - 3 \int_{-2}^2 |x|dx = 4 \cdot 1 - 3(2)(2 \cdot 2)/2 = -8$$

$$29. (a) \sqrt{x} > 0, 1 - x < 0 \text{ on } [2, 3] \text{ so the integral is negative}$$

$$(b) x^2 > 0, 3 - \cos x > 0 \text{ for all } x \text{ so the integral is positive}$$

$$30. (a) x^4 > 0, \sqrt{3-x} > 0 \text{ on } [-3, -1] \text{ so the integral is positive}$$

$$(b) x^3 - 9 < 0, |x| + 1 > 0 \text{ on } [-2, 2] \text{ so the integral is negative}$$

$$31. \int_0^{10} \sqrt{25 - (x-5)^2}dx = \pi(5)^2/2 = 25\pi/2$$

$$32. \int_0^3 \sqrt{9 - (x-3)^2}dx = \pi(3)^2/4 = 9\pi/4$$

$$33. (a) \int_{-3}^3 4x(1-3x)dx$$

$$(b) \int_0^1 e^x dx$$

$$34. (a) \int_1^2 x^3 dx$$

$$(b) \int_0^{\pi/2} \sin^2 x dx$$

$$35. \int_0^1 (3x+1)dx = 5/2$$

$$36. \int_{-2}^2 \sqrt{4-x^2}dx = \pi(2)^2/2 = 2\pi$$

$$37. (a) \lim_{\max \Delta x_k \rightarrow 0} \sum_{k=1}^n 2x_k^* \Delta x_k; a = 1, b = 2$$

$$(b) \lim_{\max \Delta x_k \rightarrow 0} \sum_{k=1}^n \frac{x_k^*}{x_k^* + 1} \Delta x_k; a = 0, b = 1$$

38. (a)  $\lim_{\max \Delta x_k \rightarrow 0} \sum_{k=1}^n \ln x_k^* \Delta x_k, a = 1, b = 2$
- (b)  $\lim_{\max \Delta x_k \rightarrow 0} \sum_{k=1}^n (1 + \cos x_k^*) \Delta x_k, a = -\pi/2, b = \pi/2$
39. (a)  $x_{k+1}^* = x_k^* + \frac{1}{n}$  and  $x_1^* = 1 + \frac{1}{n}$ , so  $x_2^* = x_1^* + \frac{1}{n} = 1 + \frac{2}{n}$ ,  $x_{k+1}^* = x_k^* + \frac{1}{n} = 1 + \frac{k+1}{n}$  for  $k = 2, 3, \dots, n-1$
- (b)  $f(x_k^*) = 1 + \frac{k}{n}$  and  $\Delta x = \frac{1}{n}$
- (c)  $\frac{1}{n} \sum_{k=1}^n 1 + \frac{1}{n^2} \sum_{k=1}^n k = \frac{1}{n} + \frac{1}{n^2} \frac{n(n+1)}{2} = \frac{3}{2} + \frac{1}{2n}$
- (d)  $\lim_{n \rightarrow +\infty} \left( \frac{3}{2} + \frac{1}{2n} \right) = \frac{3}{2}$  which is the area of the trapezoid with base 1 and sides 1 and 2
40.  $f(x_k^*) = 1 + \frac{k-1}{n}, \sum_{k=1}^n f(x_k^*) \Delta x = \sum_{k=1}^n \left( 1 + \frac{k-1}{n} \right) \frac{1}{n} = \frac{1}{n} n + \frac{1}{n^2} \frac{(n-1)n}{2} = \frac{3}{2} - \frac{1}{2n};$   
 $\lim_{n \rightarrow +\infty} \left( \frac{3}{2} - \frac{1}{2n} \right) = \frac{3}{2}$
41. (a) (right)  $\Delta x = \frac{b-a}{n} = \frac{1}{n}, x_k^* = \frac{k}{n},$   
 $\sum_{k=1}^n f(x_k^*) \Delta x = \sum_{k=1}^n \left( \frac{k}{n} \right)^2 \frac{1}{n} = \frac{1}{n^3} \sum_{k=1}^n k^2 = \frac{1}{n^3} \frac{n(n+1)(2n+1)}{6}; \lim_{n \rightarrow +\infty} \sum_{k=1}^n f(x_k^*) \Delta x = \frac{2}{6} = \frac{1}{3}$
- (b) (left)  $\Delta x = \frac{b-a}{n} = \frac{1}{n}, x_k^* = \frac{k-1}{n},$   
 $\sum_{k=1}^n f(x_k^*) \Delta x = \sum_{k=1}^n \left( \frac{k-1}{n} \right)^2 \frac{1}{n} = \frac{1}{n^3} \sum_{k=1}^n (k-1)^2 = \frac{1}{n^3} \frac{(n-1)n(2n-1)}{6};$   
 $\lim_{n \rightarrow +\infty} \sum_{k=1}^n f(x_k^*) \Delta x = \frac{2}{6} = \frac{1}{3}$
42. (a) (right)  $\Delta x = \frac{b-a}{n} = \frac{3}{n}, x_k^* = \frac{3k}{n},$   
 $\sum_{k=1}^n f(x_k^*) \Delta x = \sum_{k=1}^n \left( 4 - \frac{1}{4} \left( \frac{3k}{n} \right)^2 \right) \frac{3}{n} = \frac{12}{n} \sum_{k=1}^n 1 - \frac{27}{4n^3} \sum_{k=1}^n k^2 = 12 - \frac{27}{4n^3} \frac{n(n+1)(2n+1)}{6};$   
 $\lim_{n \rightarrow +\infty} \sum_{k=1}^n f(x_k^*) \Delta x = 12 - \frac{27(2)}{4(6)} = \frac{39}{4}$
- (b) (left)  $\Delta x = \frac{b-a}{n} = \frac{3}{n}, x_k^* = \frac{3(k-1)}{n},$   
 $\sum_{k=1}^n f(x_k^*) \Delta x = \sum_{k=1}^n \left( 4 - \frac{1}{4} \left( \frac{3(k-1)}{n} \right)^2 \right) \frac{3}{n} = \frac{12}{n} \sum_{k=1}^n 1 - \frac{27}{4n^3} \sum_{k=1}^n (k-1)^2 = 12 - \frac{27}{4n^3} \frac{(n-1)n(2n-1)}{6};$   
 $\lim_{n \rightarrow +\infty} \sum_{k=1}^n f(x_k^*) \Delta x = 12 - \frac{27(2)}{4(6)} = \frac{39}{4}$

43. (a) (right)  $\Delta x = \frac{b-a}{n} = \frac{4}{n}$ ,  $x_k^* = 2 + \frac{4k}{n}$ ,  

$$\sum_{k=1}^n f(x_k^*)\Delta x = \sum_{k=1}^n \left(2 + \frac{4k}{n}\right)^3 \frac{4}{n} = 32 + \frac{192}{n^2} \frac{n(n+1)}{2} + \frac{384}{n^3} \frac{n(n+1)(2n+1)}{6} + \frac{256}{n^4} \left(\frac{n(n+1)}{2}\right)^2;$$

$$\lim_{n \rightarrow +\infty} \sum_{k=1}^n f(x_k^*)\Delta x = 32 + \frac{192}{2} + \frac{384(2)}{6} + \frac{256}{4} = 320$$

(b) (left)  $\Delta x = \frac{b-a}{n} = \frac{4}{n}$ ,  $x_k^* = 2 + \frac{4(k-1)}{n}$ ,  

$$\sum_{k=1}^n f(x_k^*)\Delta x = \sum_{k=1}^n \left(2 + \frac{4(k-1)}{n}\right)^3 \frac{4}{n} = 32 + \frac{192}{n^2} \frac{(n-1)n}{2} + \frac{384}{n^3} \frac{(n-1)n(2n-1)}{6} + \frac{256}{n^4} \left(\frac{(n-1)n}{2}\right)^2;$$

$$\lim_{n \rightarrow +\infty} \sum_{k=1}^n f(x_k^*)\Delta x = 32 + \frac{192}{2} + \frac{384(2)}{6} + \frac{256}{4} = 320$$

44. (a) (right)  $\Delta x = \frac{b-a}{n} = \frac{2}{n}$ ,  $x_k^* = -3 + \frac{2k}{n}$ ,  

$$\sum_{k=1}^n f(x_k^*)\Delta x = \sum_{k=1}^n \left(1 - \left(\frac{2k}{n} - 3\right)^3\right) \frac{2}{n} = \frac{56}{n} \sum_{k=1}^n 1 - \frac{108}{n^2} \sum_{k=1}^n k + \frac{72}{n^3} \sum_{k=1}^n k^2 - \frac{16}{n^4} \sum_{k=1}^n k^3$$

$$= 56 - \frac{108}{n^2} \frac{n(n+1)}{2} + \frac{72}{n^3} \frac{n(n+1)(2n+1)}{6} - \frac{16}{n^4} \left(\frac{n(n+1)}{2}\right)^2;$$

$$\lim_{n \rightarrow +\infty} \sum_{k=1}^n f(x_k^*)\Delta x = 56 - 54 + \frac{72(2)}{6} - \frac{16}{4} = 22$$

(b) (left)  $\Delta x = \frac{b-a}{n} = \frac{2}{n}$ ,  $x_k^* = -3 + \frac{2(k-1)}{n}$ ,  

$$\sum_{k=1}^n f(x_k^*)\Delta x = \sum_{k=1}^n \left(1 - \left(\frac{2(k-1)}{n} - 3\right)^3\right) \frac{2}{n}$$

$$= \frac{56}{n} \sum_{k=1}^n 1 - \frac{108}{n^2} \sum_{k=1}^n (k-1) + \frac{72}{n^3} \sum_{k=1}^n (k-1)^2 - \frac{16}{n^4} \sum_{k=1}^n (k-1)^3$$

$$= 56 - \frac{108}{n^2} \frac{(n-1)n}{2} + \frac{72}{n^3} \frac{(n-1)n(2n-1)}{6} - \frac{16}{n^4} \left(\frac{(n-1)n}{2}\right)^2;$$

$$\lim_{n \rightarrow +\infty} \sum_{k=1}^n f(x_k^*)\Delta x = 56 - \frac{108}{2} + \frac{72(2)}{6} - \frac{16}{4} = 22$$

45. (a)  $f$  is continuous on  $[-1, 1]$  so  $f$  is integrable there by part (a) of Theorem 7.5.8  
 (b)  $|f(x)| \leq 1$  so  $f$  is bounded on  $[-1, 1]$ , and  $f$  has one point of discontinuity, so by part (b) of Theorem 7.5.8  $f$  is integrable on  $[-1, 1]$   
 (c)  $f$  is not bounded on  $[-1, 1]$  because  $\lim_{x \rightarrow 0} f(x) = +\infty$ , so  $f$  is not integrable on  $[0, 1]$   
 (d)  $f(x)$  is discontinuous at the point  $x = 0$  because  $\lim_{x \rightarrow 0} \sin \frac{1}{x}$  does not exist.  $f$  is continuous elsewhere.  $-1 \leq f(x) \leq 1$  for  $x$  in  $[-1, 1]$  so  $f$  is bounded there. By part (b), Theorem 7.5.8,  $f$  is integrable on  $[-1, 1]$ .

46. Each subinterval of a partition of  $[a, b]$  contains both rational and irrational numbers. If all  $x_k^*$  are chosen to be rational then

$$\sum_{k=1}^n f(x_k^*)\Delta x_k = \sum_{k=1}^n (1)\Delta x_k = \sum_{k=1}^n \Delta x_k = b - a \text{ so } \lim_{\max \Delta x_k \rightarrow 0} \sum_{k=1}^n f(x_k^*)\Delta x_k = b - a.$$

If all  $x_k^*$  are irrational then  $\lim_{\max \Delta x_k \rightarrow 0} \sum_{k=1}^n f(x_k^*)\Delta x_k = 0$ .  $f$  is not integrable on  $[a, b]$  because the preceding limits are not equal.

47. (a) Let  $S_n = \sum_{k=1}^n f(x_k^*)\Delta x_k$  and  $S = \int_a^b f(x)dx$  then  $\sum_{k=1}^n cf(x_k^*)\Delta x_k = cS_n$  and we want to prove that  $\lim_{\max \Delta x_k \rightarrow 0} cS_n = cS$ . If  $c = 0$  the result follows immediately, so suppose that  $c \neq 0$  then for any  $\epsilon > 0$ ,  $|cS_n - cS| = |c||S_n - S| < \epsilon$  if  $|S_n - S| < \epsilon/|c|$ . But because  $f$  is integrable on  $[a, b]$ , there is a number  $\delta > 0$  such that  $|S_n - S| < \epsilon/|c|$  whenever  $\max \Delta x_k < \delta$  so  $|cS_n - cS| < \epsilon$  and hence  $\lim_{\max \Delta x_k \rightarrow 0} cS_n = cS$ .
- (b) Let  $R_n = \sum_{k=1}^n f(x_k^*)\Delta x_k$ ,  $S_n = \sum_{k=1}^n g(x_k^*)\Delta x_k$ ,  $T_n = \sum_{k=1}^n [f(x_k^*) + g(x_k^*)]\Delta x_k$ ,  $R = \int_a^b f(x)dx$ , and  $S = \int_a^b g(x)dx$  then  $T_n = R_n + S_n$  and we want to prove that  $\lim_{\max \Delta x_k \rightarrow 0} T_n = R + S$ .  
 $|T_n - (R + S)| = |(R_n - R) + (S_n - S)| \leq |R_n - R| + |S_n - S|$   
 so for any  $\epsilon > 0$   $|T_n - (R + S)| < \epsilon$  if  $|R_n - R| + |S_n - S| < \epsilon$ .  
 Because  $f$  and  $g$  are integrable on  $[a, b]$ , there are numbers  $\delta_1$  and  $\delta_2$  such that  $|R_n - R| < \epsilon/2$  for  $\max \Delta x_k < \delta_1$  and  $|S_n - S| < \epsilon/2$  for  $\max \Delta x_k < \delta_2$ .  
 If  $\delta = \min(\delta_1, \delta_2)$  then  $|R_n - R| < \epsilon/2$  and  $|S_n - S| < \epsilon/2$  for  $\max \Delta x_k < \delta$  thus  $|R_n - R| + |S_n - S| < \epsilon$  and so  $|T_n - (R + S)| < \epsilon$  for  $\max \Delta x_k < \delta$  which shows that  $\lim_{\max \Delta x_k \rightarrow 0} T_n = R + S$ .
48. For the smallest, find  $x_k^*$  so that  $f(x_k^*)$  is minimum on each subinterval:  $x_1^* = 1$ ,  $x_2^* = 3/2$ ,  $x_3^* = 3$  so  $(2)(1) + (7/4)(2) + (4)(1) = 9.5$ . For the largest, find  $x_k^*$  so that  $f(x_k^*)$  is maximum on each subinterval:  $x_1^* = 0$ ,  $x_2^* = 3$ ,  $x_3^* = 4$  so  $(4)(1) + (4)(2) + (8)(1) = 20$ .

### EXERCISE SET 7.6

1. (a)  $\int_0^2 (2-x)dx = (2x - x^2/2)\Big|_0^2 = 4 - 4/2 = 2$   
 (b)  $\int_{-1}^1 2dx = 2x\Big|_{-1}^1 = 2(1) - 2(-1) = 4$   
 (c)  $\int_1^3 (x+1)dx = (x^2/2 + x)\Big|_1^3 = 9/2 + 3 - (1/2 + 1) = 6$
2. (a)  $\int_0^5 xdx = x^2/2\Big|_0^5 = 25/2$       (b)  $\int_3^9 5dx = 5x\Big|_3^9 = 5(9) - 5(3) = 30$   
 (c)  $\int_{-1}^2 (x+3)dx = (x^2/2 + 3x)\Big|_{-1}^2 = 4/2 + 6 - (1/2 - 3) = 21/2$
3.  $\int_2^3 x^3dx = x^4/4\Big|_2^3 = 81/4 - 16/4 = 65/4$       4.  $\int_{-1}^1 x^4dx = x^5/5\Big|_{-1}^1 = 1/5 - (-1)/5 = 2/5$
5.  $\int_1^9 \sqrt{x}dx = \frac{2}{3}x^{3/2}\Big|_1^9 = \frac{2}{3}(27 - 1) = 52/3$       6.  $\int_1^4 x^{-3/5}dx = \frac{5}{2}x^{2/5}\Big|_1^4 = \frac{5}{2}(4^{2/5} - 1)$
7.  $\int_1^3 e^x dx = e^x\Big|_1^3 = e^3 - e$       8.  $\int_1^5 \frac{1}{x} dx = \ln x\Big|_1^5 = \ln 5 - \ln 1 = \ln 5$
9.  $\left(\frac{1}{3}x^3 - 2x^2 + 7x\right)\Big|_{-3}^0 = 48$       10.  $\left(\frac{1}{2}x^2 + \frac{1}{5}x^5\right)\Big|_{-1}^2 = 81/10$

11.  $\int_1^3 x^{-2} dx = -\frac{1}{x} \Big|_1^3 = 2/3$
12.  $\int_1^2 x^{-6} dx = -\frac{1}{5x^5} \Big|_1^2 = 31/160$
13.  $\frac{4}{5} x^{5/2} \Big|_4^9 = 844/5$
14.  $\left(3x^{5/3} + \frac{4}{x}\right) \Big|_1^8 = 179/2$
15.  $-\cos \theta \Big|_{-\pi/2}^{\pi/2} = 0$
16.  $\tan \theta \Big|_0^{\pi/4} = 1$
17.  $\sin x \Big|_{-\pi/4}^{\pi/4} = \sqrt{2}$
18.  $\left(\frac{1}{2}x^2 - \sec x\right) \Big|_0^1 = 3/2 - \sec(1)$
19.  $5e^x \Big|_{\ln 2}^3 = 5e^3 - 5(2) = 5e^3 - 10$
20.  $(\ln x)/2 \Big|_{1/2}^1 = (\ln 2)/2$
21.  $\left(6\sqrt{t} - \frac{10}{3}t^{3/2} + \frac{2}{\sqrt{t}}\right) \Big|_1^4 = -55/3$
22.  $\left(8\sqrt{y} + \frac{4}{3}y^{3/2} - \frac{2}{3y^{3/2}}\right) \Big|_4^9 = 10819/324$
23.  $\left(\frac{1}{2}x^2 - 2 \cot x\right) \Big|_{\pi/6}^{\pi/2} = \pi^2/9 + 2\sqrt{3}$
24.  $\left(\ln x + \sqrt{2}e^x + \csc x\right) \Big|_1^2 = \ln 2 + \sqrt{2}(e^2 - e) + \csc 2 - \csc 1$
26.  $\left(a^{1/2}x - \frac{2}{3}x^{3/2}\right) \Big|_a^{4a} = -\frac{5}{3}a^{3/2}$
27. (a)  $\int_0^{3/2} (3-2x)dx + \int_{3/2}^2 (2x-3)dx = (3x-x^2) \Big|_0^{3/2} + (x^2-3x) \Big|_{3/2}^2 = 9/4 + 1/4 = 5/2$
- (b)  $\int_0^{\pi/2} \cos x dx + \int_{\pi/2}^{3\pi/4} (-\cos x)dx = \sin x \Big|_0^{\pi/2} - \sin x \Big|_{\pi/2}^{3\pi/4} = 2 - \sqrt{2}/2$
28. (a)  $\int_{-1}^0 \sqrt{2-x} dx + \int_0^2 \sqrt{2+x} dx = -\frac{2}{3}(2-x)^{3/2} \Big|_{-1}^0 + \frac{2}{3}(2+x)^{3/2} \Big|_0^2$   
 $= -\frac{2}{3}(2\sqrt{2}-3\sqrt{3}) + \frac{2}{3}(8-2\sqrt{2}) = \frac{2}{3}(8-4\sqrt{2}+3\sqrt{3})$
- (b)  $\int_{-1}^0 (1-e^x)dx + \int_0^1 (e^x-1)dx = (x-e^x) \Big|_{-1}^0 + (e^x-x) \Big|_0^1 = -1 - (-1-e^{-1}) + e - 1 - 1 = e + 1/e - 2$
29.  $\int_{-2}^0 x^2 dx + \int_0^3 (-x)dx = \frac{1}{3}x^3 \Big|_{-2}^0 - \frac{1}{2}x^2 \Big|_0^3 = -11/6$
30.  $\int_0^1 \sqrt{x} dx + \int_1^4 \frac{1}{x^2} dx = \frac{2}{3}x^{3/2} \Big|_0^1 - \frac{1}{x} \Big|_1^4 = 17/12$
31.  $0.665867079; \int_1^3 \frac{1}{x^2} dx = -\frac{1}{x} \Big|_1^3 = 2/3$
32.  $1.000257067; \int_0^{\pi/2} \sin x dx = -\cos x \Big|_0^{\pi/2} = 1$

$$33. \quad 1.098242635; \int_1^3 \frac{1}{x} dx = \ln x \Big|_1^3 = \ln 3 \approx 1.098612289$$

$$35. \quad A = \int_0^3 (x^2 + 1) dx = \left( \frac{1}{3}x^3 + x \right) \Big|_0^3 = 12$$

$$36. \quad A = \int_1^2 (-x^2 + 3x - 2) dx = \left( -\frac{1}{3}x^3 + \frac{3}{2}x^2 - 2x \right) \Big|_1^2 = 1/6$$

$$37. \quad A = \int_0^{2\pi/3} 3 \sin x dx = -3 \cos x \Big|_0^{2\pi/3} = 9/2 \quad 38. \quad A = - \int_{-2}^{-1} x^3 dx = -\frac{1}{4}x^4 \Big|_{-2}^{-1} = 15/4$$

$$39. \quad A_1 = \int_{-3}^{-2} (x^2 - 3x - 10) dx = \left( \frac{1}{3}x^3 - \frac{3}{2}x^2 - 10x \right) \Big|_{-3}^{-2} = 23/6,$$

$$A_2 = - \int_{-2}^5 (x^2 - 3x - 10) dx = 343/6,$$

$$A_3 = \int_5^8 (x^2 - 3x - 10) dx = 243/6, \quad A = A_1 + A_2 + A_3 = 203/2$$

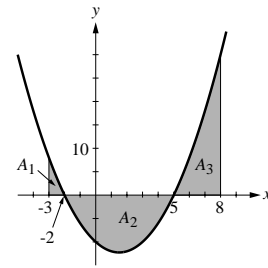

40. (a) the area is positive

$$(b) \quad \int_{-2}^5 \left( \frac{1}{100}x^3 - \frac{1}{20}x^2 - \frac{1}{25}x + \frac{1}{5} \right) dx = \left( \frac{1}{400}x^4 - \frac{1}{60}x^3 - \frac{1}{50}x^2 + \frac{1}{5}x \right) \Big|_{-2}^5 = \frac{343}{1200}$$

41. (a) the area between the curve and the  $x$ -axis breaks into equal parts, one above and one below the  $x$ -axis, so the integral is zero

$$(b) \quad \int_{-1}^1 x^3 dx = \frac{1}{4}x^4 \Big|_{-1}^1 = \frac{1}{4}(1^4 - (-1)^4) = 0;$$

$$\int_{-\pi/2}^{\pi/2} \sin x dx = -\cos x \Big|_{-\pi/2}^{\pi/2} = -\cos(\pi/2) + \cos(-\pi/2) = 0 + 0 = 0$$

(c) The area on the left side of the  $y$ -axis is equal to the area on the right side, so

$$\int_{-a}^a f(x) dx = 2 \int_0^a f(x) dx$$

$$(d) \quad \int_{-1}^1 x^2 dx = \frac{1}{3}x^3 \Big|_{-1}^1 = \frac{1}{3}(1^3 - (-1)^3) = \frac{2}{3} = 2 \int_0^1 x^2 dx;$$

$$\int_{-\pi/2}^{\pi/2} \cos x dx = \sin x \Big|_{-\pi/2}^{\pi/2} = \sin(\pi/2) - \sin(-\pi/2) = 1 + 1 = 2 = 2 \int_0^{\pi/2} \cos x dx$$

42. The numerator is an odd function and the denominator is an even function, so the integrand is an odd function and the integral is zero.

$$43. \quad (a) \quad x^3 + 1 \quad (b) \quad F(x) = \left( \frac{1}{4}t^4 + t \right) \Big|_1^x = \frac{1}{4}x^4 + x - \frac{5}{4}; \quad F'(x) = x^3 + 1$$

$$44. \quad (a) \quad \cos 2x \quad (b) \quad F(x) = \frac{1}{2} \sin 2t \Big|_{\pi/4}^x = \frac{1}{2} \sin 2x - \frac{1}{2}, \quad F'(x) = \cos 2x$$

$$45. \quad (a) \quad \sin \sqrt{x} \quad (b) \quad e^{x^2}$$



46. (a)  $\frac{1}{1 + \sqrt{x}}$

(b)  $\ln x$

47.  $-\frac{x}{\cos x}$

48.  $|u|$

49.  $F'(x) = \sqrt{3x^2 + 1}$ ,  $F''(x) = \frac{3x}{\sqrt{3x^2 + 1}}$

(a) 0

(b)  $\sqrt{13}$

(c)  $6/\sqrt{13}$

50.  $F'(x) = \frac{\cos x}{x^2 + 3}$ ,  $F''(x) = \frac{-(x^2 + 3)\sin x - 2x \cos x}{(x^2 + 3)^2}$

(a) 0

(b)  $1/3$

(c) 0

51. (a)  $F'(x) = \frac{x-3}{x^2+7} = 0$  when  $x = 3$ , which is a relative minimum, and hence the absolute minimum, by the first derivative test.

(b) increasing on  $[3, +\infty)$ , decreasing on  $(-\infty, 3]$

(c)  $F''(x) = \frac{7+6x-x^2}{(x^2+7)^2} = \frac{(7-x)(1+x)}{(x^2+7)^2}$ ; concave up on  $(-1, 7)$ , concave down on  $(-\infty, -1)$  and on  $(7, +\infty)$

52.

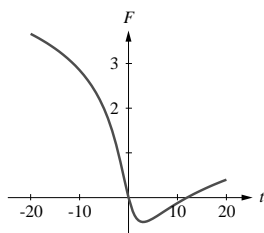

53. (a)  $(0, +\infty)$  because  $f$  is continuous there and 1 is in  $(0, +\infty)$

(b) at  $x = 1$  because  $F(1) = 0$

54. (a)  $(-3, 3)$  because  $f$  is continuous there and 1 is in  $(-3, 3)$

(b) at  $x = 1$  because  $F(1) = 0$

55. (a)  $f_{\text{ave}} = \frac{1}{9} \int_0^9 x^{1/2} dx = 2$ ;  $\sqrt{x^*} = 2$ ,  $x^* = 4$

(b)  $f_{\text{ave}} = \frac{1}{e-1} \int_1^e \frac{1}{x} dx = \frac{1}{e-1} \ln x \Big|_1^e = \frac{1}{e-1}$ ;  $\frac{1}{x^*} = \frac{1}{e-1}$ ,  $x^* = e-1$

56. (a)  $f_{\text{ave}} = \frac{1}{2\pi} \int_{-\pi}^{\pi} \sin x dx = 0$ ;  $\sin x^* = 0$ ,  $x^* = -\pi, 0, \pi$

(b)  $f_{\text{ave}} = \frac{1}{2} \int_1^3 \frac{1}{x^2} dx = \frac{1}{3}$ ;  $\frac{1}{(x^*)^2} = \frac{1}{3}$ ,  $x^* = \sqrt{3}$

57.  $\sqrt{2} \leq \sqrt{x^3 + 2} \leq \sqrt{29}$ , so  $3\sqrt{2} \leq \int_0^3 \sqrt{x^3 + 2} dx \leq 3\sqrt{29}$

58. Let  $f(x) = x \sin x$ ,  $f(0) = f(1) = 0$ ,  $f'(x) = \sin x + x \cos x = 0$  when  $x = -\tan x$ ,  $x \approx 2.0288$ , so  $f$  has an absolute maximum at  $x \approx 2.0288$ ;  $f(2.0288) \approx 1.8197$ , so  $0 \leq x \sin x \leq 1.82$  and

$0 \leq \int_0^{\pi} x \sin x dx \leq 1.82\pi = 5.72$

59.  $0 \leq \ln x \leq \ln 5$  for  $x$  in  $[1, 5]$ , so  $0 \leq \int_1^5 \ln x dx \leq 4 \ln 5$
60. (a)  $[cF(x)]_a^b = cF(b) - cF(a) = c[F(b) - F(a)] = c[F(x)]_a^b$
- (b)  $[F(x) + G(x)]_a^b = [F(b) + G(b)] - [F(a) + G(a)]$   
 $= [F(b) - F(a)] + [G(b) - G(a)] = F(x)_a^b + G(x)_a^b$
- (c)  $[F(x) - G(x)]_a^b = [F(b) - G(b)] - [F(a) - G(a)]$   
 $= [F(b) - F(a)] - [G(b) - G(a)] = F(x)_a^b - G(x)_a^b$

### EXERCISE SET 7.7

1. (a) the increase in height in inches, during the first ten years  
 (b) the change in the radius in centimeters, during the time interval  $t = 1$  to  $t = 2$  seconds  
 (c) the change in the speed of sound in ft/s, during an increase in temperature from  $t = 32^\circ\text{F}$  to  $t = 100^\circ\text{F}$   
 (d) the displacement of the particle in cm, during the time interval  $t = t_1$  to  $t = t_2$  seconds

2. (a)  $\int_0^1 V(t) dt$  gal  
 (b) the change  $f(x_1) - f(x_2)$  in the values of  $f$  over the interval

3. (a)  $\text{displ} = s(3) - s(0)$   
 $= \int_0^3 v(t) dt = \int_0^2 (1-t) dt + \int_2^3 (t-3) dt = (t - t^2/2) \Big|_0^2 + (t^2/2 - 3t) \Big|_2^3 = -1/2;$   
 $\text{dist} = \int_0^3 |v(t)| dt = (t - t^2/2) \Big|_0^1 + (t^2/2 - t) \Big|_1^2 + (t^2/2 - 3t) \Big|_2^3 = 1/2$

- (b)  $\text{displ} = s(3) - s(0)$   
 $= \int_0^3 v(t) dt = \int_0^1 t dt + \int_1^2 dt + \int_2^3 (5-2t) dt = t^2/2 \Big|_0^2 + t \Big|_1^2 + (5t - t^2) \Big|_2^3 = 5;$   
 $\text{dist} = \int_0^1 t dt + \int_1^2 dt + \int_2^{5/2} (5-2t) dt + \int_{5/2}^3 (2t-5) dt$   
 $= t^2/2 \Big|_0^1 + t \Big|_1^2 + (5t - t^2) \Big|_2^{5/2} + (t^2 - 5t) \Big|_{5/2}^3 = 5/2$

4.

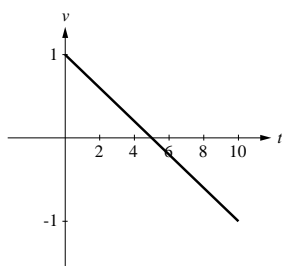

5. (a)  $v(t) = 20 + \int_0^t a(u) du$ ; add areas of the small blocks to get  
 $v(5) \approx 20 + \frac{1}{2}(1.5 + 2.7 + 4.6 + 6.2 + 7.6) = 31.3$

(b)  $v(10) = v(4) + \int_5^{10} a(u)du \approx 31.3 + \frac{1}{2}(8.6 + 9.3 + 9.7 + 10 + 10.1) = 55.15$

6.  $a > 0$  and therefore (Theorem 7.5.6(a))  $v > 0$ , so the particle is always speeding up for  $0 < t < 10$

7. (a)  $s(t) = \int (t^3 - 2t^2 + 1)dt = \frac{1}{4}t^4 - \frac{2}{3}t^3 + t + C,$   
 $s(0) = \frac{1}{4}(0)^4 - \frac{2}{3}(0)^3 + 0 + C = 1, C = 1, s(t) = \frac{1}{4}t^4 - \frac{2}{3}t^3 + t + 1$

(b)  $v(t) = \int 4 \cos 2t dt = 2 \sin 2t + C_1, v(0) = 2 \sin 0 + C_1 = -1, C_1 = -1,$   
 $v(t) = 2 \sin 2t - 1, s(t) = \int (2 \sin 2t - 1)dt = -\cos 2t - t + C_2,$   
 $s(0) = -\cos 0 - 0 + C_2 = -3, C_2 = -2, s(t) = -\cos 2t - t - 2$

8. (a)  $s(t) = \int (1 + \sin t)dt = t - \cos t + C, s(0) = 0 - \cos 0 + C = -3, C = -2, s(t) = t - \cos t - 2$

(b)  $v(t) = \int (t^2 - 3t + 1)dt = \frac{1}{3}t^3 - \frac{3}{2}t^2 + t + C_1,$   
 $v(0) = \frac{1}{3}(0)^3 - \frac{3}{2}(0)^2 + 0 + C_1 = 0, C_1 = 0, v(t) = \frac{1}{3}t^3 - \frac{3}{2}t^2 + t,$   
 $s(t) = \int \left(\frac{1}{3}t^3 - \frac{3}{2}t^2 + t\right) dt = \frac{1}{12}t^4 - \frac{1}{2}t^3 + \frac{1}{2}t^2 + C_2,$   
 $s(0) = \frac{1}{12}(0)^4 - \frac{1}{2}(0)^3 + \frac{1}{2}(0)^2 + C_2 = 0, C_2 = 0, s(t) = \frac{1}{12}t^4 - \frac{1}{2}t^3 + \frac{1}{2}t^2$

9. (a)  $s(t) = \int (2t - 3)dt = t^2 - 3t + C, s(1) = (1)^2 - 3(1) + C = 5, C = 7, s(t) = t^2 - 3t + 7$

(b)  $v(t) = \int \cos t dt = \sin t + C_1, v(\pi/2) = 2 = 1 + C_1, C_1 = 1, v(t) = \sin t + 1,$   
 $s(t) = \int (\sin t + 1)dt = -\cos t + t + C_2, s(\pi/2) = 0 = \pi/2 + C_2, C_2 = -\pi/2, s(t) = -\cos t + t - \pi/2$

10. (a)  $s(t) = \int t^{2/3} dt = \frac{3}{5}t^{5/3} + C, s(8) = 0 = \frac{3}{5}32 + C, C = -\frac{96}{5}, s(t) = \frac{3}{5}t^{5/3} - \frac{96}{5}$

(b)  $v(t) = \int \sqrt{t} dt = \frac{2}{3}t^{3/2} + C_1, v(4) = 1 = \frac{2}{3}8 + C_1, C_1 = -\frac{13}{3}, v(t) = \frac{2}{3}t^{3/2} - \frac{13}{3},$   
 $s(t) = \int \left(\frac{2}{3}t^{3/2} - \frac{13}{3}\right) dt = \frac{4}{15}t^{5/2} - \frac{13}{3}t + C_2, s(4) = -5 = \frac{4}{15}32 - \frac{13}{3}4 + C_2 = -\frac{44}{5} + C_2,$   
 $C_2 = \frac{19}{5}, s(t) = \frac{4}{15}t^{5/2} - \frac{13}{3}t + \frac{19}{5}$

11. (a) displacement =  $s(\pi/2) - s(0) = \int_0^{\pi/2} \sin t dt = -\cos t \Big|_0^{\pi/2} = 1$   
 distance =  $\int_0^{\pi/2} |\sin t| dt = 1$

(b) displacement =  $s(2\pi) - s(\pi/2) = \int_{\pi/2}^{2\pi} \cos t dt = \sin t \Big|_{\pi/2}^{2\pi} = -1$   
 distance =  $\int_{\pi/2}^{2\pi} |\cos t| dt = -\int_{\pi/2}^{3\pi/2} \cos t dt + \int_{3\pi/2}^{2\pi} \cos t dt = 3$

12. (a) displacement =  $s(6) - s(0) = \int_0^6 (2t - 4)dt = (t^2 - 4t) \Big|_0^6 = 12$   
distance  $\int_0^6 |2t - 4|dt = \int_0^2 (4 - 2t)dt + \int_2^6 (2t - 4)dt = (4t - t^2) \Big|_0^2 + (t^2 - 4t) \Big|_2^6 = 20$
- (b) displacement =  $\int_0^5 |t - 3|dt = \int_0^3 -(t - 3)dt + \int_3^5 (t - 3)dt = 13/2$   
distance =  $\int_0^5 |t - 3|dt = 13/2$
13. (a)  $v(t) = t^3 - 3t^2 + 2t = t(t - 1)(t - 2)$   
displacement =  $\int_0^3 (t^3 - 3t^2 + 2t)dt = 9/4$   
distance =  $\int_0^3 |v(t)|dt = \int_0^1 v(t)dt + \int_1^2 -v(t)dt + \int_2^3 v(t)dt = 11/4$
- (b) displacement =  $\int_0^3 (e^t - 2)dt = e^3 - 7$   
distance =  $\int_0^3 |v(t)|dt = -\int_0^{\ln 2} v(t)dt + \int_{\ln 2}^3 v(t)dt = e^3 - 9 + 4 \ln 2$
14. (a) displacement =  $\int_1^3 (\frac{1}{2} - \frac{1}{t})dt = 1 - \ln 3$   
distance =  $\int_1^3 |v(t)|dt = -\int_1^2 v(t)dt + \int_2^3 v(t)dt = 2 \ln 2 - \ln 3$
- (b) displacement =  $\int_4^9 3t^{-1/2}dt = 6$   
distance =  $\int_4^9 |v(t)|dt = \int_4^9 v(t)dt = 6$
15.  $v(t) = -2t + 3$   
displacement =  $\int_1^4 (-2t + 3)dt = -6$   
distance =  $\int_1^4 |-2t + 3|dt = \int_1^{3/2} (-2t + 3)dt + \int_{3/2}^4 (2t - 3)dt = 13/2$
16.  $v(t) = \frac{1}{2}t^2 - 2t$   
displacement =  $\int_1^5 (\frac{1}{2}t^2 - 2t)dt = -10/3$   
distance =  $\int_1^5 |\frac{1}{2}t^2 - 2t|dt = \int_1^4 -(\frac{1}{2}t^2 - 2t)dt + \int_4^5 (\frac{1}{2}t^2 - 2t)dt = 17/3$
17.  $v(t) = \frac{2}{5}\sqrt{5t + 1} + \frac{8}{5}$   
displacement =  $\int_0^3 (\frac{2}{5}\sqrt{5t + 1} + \frac{8}{5})dt = \frac{4}{75}(5t + 1)^{3/2} + \frac{8}{5}t \Big|_0^3 = 204/25$   
distance =  $\int_0^3 |v(t)|dt = \int_0^3 v(t)dt = 204/25$

18.  $v(t) = -\cos t + 2$

displacement =  $\int_{\pi/4}^{\pi/2} (-\cos t + 2) dt = (\pi + \sqrt{2} - 2)/2$

distance =  $\int_{\pi/4}^{\pi/2} |-\cos t + 2| dt = \int_{\pi/4}^{\pi/2} (-\cos t + 2) dt = (\pi + \sqrt{2} - 2)/2$

19. (a)  $s = \int \sin \frac{1}{2}\pi t dt = -\frac{2}{\pi} \cos \frac{1}{2}\pi t + C$

$s = 0$  when  $t = 0$  which gives  $C = \frac{2}{\pi}$  so  $s = -\frac{2}{\pi} \cos \frac{1}{2}\pi t + \frac{2}{\pi}$ .

$a = \frac{dv}{dt} = \frac{\pi}{2} \cos \frac{1}{2}\pi t$ . When  $t = 1 : s = 2/\pi, v = 1, |v| = 1, a = 0$ .

(b)  $v = -3 \int t dt = -\frac{3}{2}t^2 + C_1, v = 0$  when  $t = 0$  which gives  $C_1 = 0$  so  $v = -\frac{3}{2}t^2$

$s = -\frac{3}{2} \int t^2 dt = -\frac{1}{2}t^3 + C_2, s = 1$  when  $t = 0$  which gives  $C_2 = 1$  so  $s = -\frac{1}{2}t^3 + 1$ .

When  $t = 1 : s = 1/2, v = -3/2, |v| = 3/2, a = -3$ .

20. (a) negative, because  $v$  is decreasing

(b) speeding up when  $av > 0$ , so  $2 < t < 5$ ; slowing down when  $1 < t < 2$

(c) negative, because the area between the graph of  $v(t)$  and the  $t$ -axis appears to be greater where  $v < 0$  compared to where  $v > 0$

21.  $A = A_1 + A_2 = \int_0^1 (1 - x^2) dx + \int_1^3 (x^2 - 1) dx = 2/3 + 20/3 = 22/3$

22.  $A = A_1 + A_2 = \int_0^\pi \sin x dx - \int_\pi^{3\pi/2} \sin x dx = 2 + 1 = 3$

23.  $A = A_1 + A_2 = \int_{-1}^0 (1 - e^x) dx + \int_0^1 (e^x - 1) dx = 1/e + e - 2$

24.  $A = A_1 + A_2 = \int_{1/2}^1 \frac{1-x}{x} dx + \int_1^2 \frac{x-1}{x} dx = -\left(\frac{1}{2} - \ln 2\right) + (1 - \ln 2) = 1/2$

25.  $s(t) = \frac{20}{3}t^3 - 50t^2 + 50t + s_0, s(0) = 0$  gives  $s_0 = 0$ , so  $s(t) = \frac{20}{3}t^3 - 50t^2 + 50t, a(t) = 40t - 100$

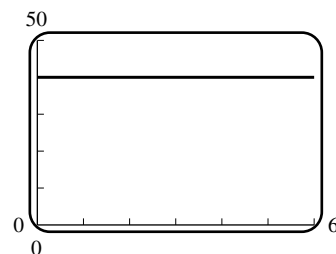
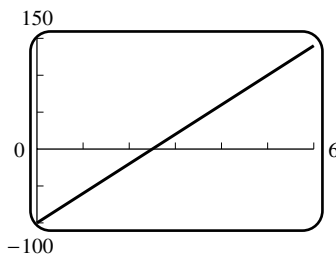
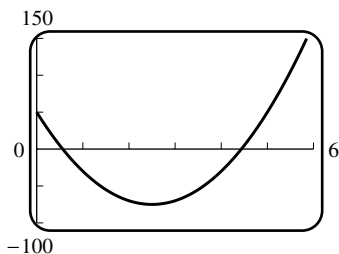

26.  $v(t) = 2t^2 - 30t + v_0$ ,  $v(0) = 3 = v_0$ , so  $v(t) = 2t^2 - 30t + 3$ ,  $s(t) = \frac{2}{3}t^3 - 15t^2 + 3t + s_0$ ,  $s(0) = -5 = s_0$ ,  
so  $s(t) = \frac{2}{3}t^3 - 15t^2 + 3t - 5$

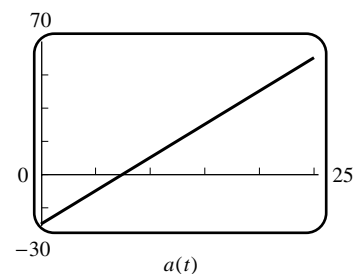
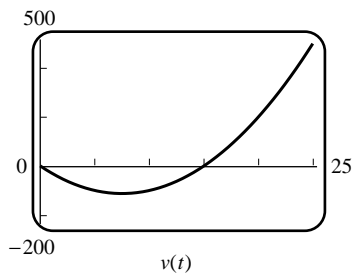
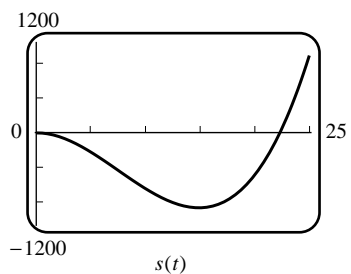

27. (a) from the graph the velocity is positive, so the displacement is always increasing and is therefore positive

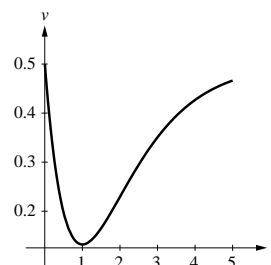

(b)  $s(t) = t/2 + (t + 1)e^{-t}$

28. (a) If  $t_0 < 1$  then the area between the velocity curve and the  $t$ -axis, between  $t = 0$  and  $t = t_0$ , will always be negative, so the displacement will be negative.

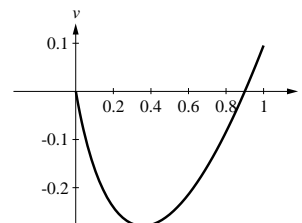

(b)  $s(t) = \left(\frac{t^2}{2} - \frac{1}{200}\right) \ln(t + 0.1) - \frac{t^2}{4} + \frac{t}{20} - \frac{1}{200} \ln 10$

29. (a)  $a(t) = \begin{cases} 0, & t < 4 \\ -10, & t > 4 \end{cases}$

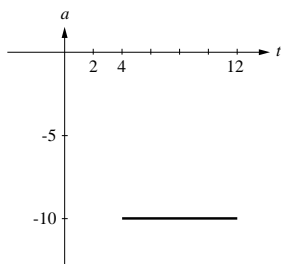

(b)  $v(t) = \begin{cases} 25, & t < 4 \\ 65 - 10t, & t > 4 \end{cases}$

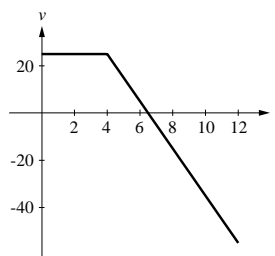

(c)  $x(t) = \begin{cases} 25t, & t < 4 \\ 65t - 5t^2 - 80, & t > 4 \end{cases}$ , so  $x(8) = 120$ ,  $x(12) = -20$

(d)  $x(6.5) = 131.25$

30. (a) From exercise 30 part (a), in Section 3 of Chapter 6,  $v^2 = v_0^2 - 2g(s - s_0)$ , so  $a = -g = \frac{v^2 - v_0^2}{2(s - s_0)}$
- (b) From exercise 30 part (b), in Section 3 of Chapter 6,  $s = s_0 + \frac{1}{2}(v_0 + v)t$ , so  $t = \frac{2(s - s_0)}{v_0 + v}$
- (c) From exercise 30 part (c), in Section 3 of Chapter 6,  $s = s_0 + vt + \frac{1}{2}gt^2 = s_0 + vt - \frac{1}{2}at^2$
31. (a)  $a = -1 \text{ mi/h/s} = -22/15 \text{ ft/s}^2$  (b)  $a = 30 \text{ km/h/min} = 1/7200 \text{ km/s}^2$
32. Take  $t = 0$  when deceleration begins, then  $a = -10$  so  $v = -10t + C_1$ , but  $v = 88$  when  $t = 0$  which gives  $C_1 = 88$  thus  $v = -10t + 88$ ,  $t \geq 0$
- (a)  $v = 45 \text{ mi/h} = 66 \text{ ft/s}$ ,  $66 = -10t + 88$ ,  $t = 2.2 \text{ s}$
- (b)  $v = 0$  (the car is stopped) when  $t = 8.8 \text{ s}$   
 $s = \int v dt = \int (-10t + 88)dt = -5t^2 + 88t + C_2$ , and taking  $s = 0$  when  $t = 0$ ,  $C_2 = 0$  so  
 $s = -5t^2 + 88t$ . At  $t = 8.8$ ,  $s = 387.2$ . The car travels 387.2 ft before coming to a stop.
33.  $a = a_0 \text{ ft/s}^2$ ,  $v = a_0t + v_0 = a_0t + 132 \text{ ft/s}$ ,  $s = a_0t^2/2 + 132t + s_0 = a_0t^2/2 + 132t$  ft;  $s = 200$  ft when  $v = 88 \text{ ft/s}$ . Solve  $88 = a_0t + 132$  and  $200 = a_0t^2/2 + 132t$  to get  $a_0 = -\frac{121}{5}$  when  $t = \frac{20}{11}$ , so  
 $s = -12.1t^2 + 132t$ ,  $v = -\frac{121}{5}t + 132$ .
- (a)  $a_0 = -\frac{121}{5} \text{ ft/s}^2$  (b)  $v = 55 \text{ mi/h} = \frac{242}{3} \text{ ft/s}$  when  $t = \frac{70}{33} \text{ s}$
- (c)  $v = 0$  when  $t = \frac{60}{11} \text{ s}$
34.  $dv/dt = 3$ ,  $v = 3t + C_1$ , but  $v = v_0$  when  $t = 0$  so  $C_1 = v_0$ ,  $v = 3t + v_0$ . From  $ds/dt = v = 3t + v_0$  we get  $s = 3t^2/2 + v_0t + C_2$  and, with  $s = 0$  when  $t = 0$ ,  $C_2 = 0$  so  $s = 3t^2/2 + v_0t$ .  $s = 40$  when  $t = 4$  thus  $40 = 3(4)^2/2 + v_0(4)$ ,  $v_0 = 4 \text{ m/s}$
35. Suppose  $s = s_0 = 0$ ,  $v = v_0 = 0$  at  $t = t_0 = 0$ ;  $s = s_1 = 120$ ,  $v = v_1$  at  $t = t_1$ ; and  $s = s_2$ ,  $v = v_2 = 12$  at  $t = t_2$ . From Exercise 30(a),  
 $2.6 = a = \frac{v_1^2 - v_0^2}{2(s_1 - s_0)}$ ,  $v_1^2 = 2as_1 = 5.2(120) = 624$ . Applying the formula again,  
 $-1.5 = a = \frac{v_2^2 - v_1^2}{2(s_2 - s_1)}$ ,  $v_2^2 = v_1^2 - 3(s_2 - s_1)$ , so  
 $s_2 = s_1 - (v_2^2 - v_1^2)/3 = 120 - (144 - 624)/3 = 280 \text{ m}$ .
36.  $a(t) = \begin{cases} 4, & t < 2 \\ 0, & t > 2 \end{cases}$ , so, with  $v_0 = 0$ ,  $v(t) = \begin{cases} 4t, & t < 2 \\ 8, & t > 2 \end{cases}$  and, since  $s_0 = 0$ ,  $s(t) = \begin{cases} 2t^2, & t < 2 \\ 8t - 8, & t > 2 \end{cases}$   
 $s = 100$  when  $8t - 8 = 100$ ,  $t = 108/8 = 13.5 \text{ s}$
37. The truck's velocity is  $v_T = 50$  and its position is  $s_T = 50t + 5000$ . The car's acceleration is  $a_C = 2$ , so  $v_C = 2t$ ,  $s_C = t^2$  (initial position and initial velocity of the car are both zero).  $s_T = s_C$  when  $50t + 5000 = t^2$ ,  $t^2 - 50t - 5000 = (t + 50)(t - 100) = 0$ ,  $t = 100 \text{ s}$  and  $s_C = s_T = t^2 = 10,000 \text{ ft}$
38. Let  $t = 0$  correspond to the time when the leader is 100 m from the finish line; let  $s = 0$  correspond to the finish line. Then  $v_C = 12$ ,  $s_C = 12t - 115$ ;  $a_L = 0.5$  for  $t > 0$ ,  $v_L = 0.5t + 8$ ,  $s_L = 0.25t^2 + 8t - 100$ .  $s_C = 0$  at  $t = 115/12 \approx 9.58 \text{ s}$ , and  $s_L = 0$  at  $t = -16 + 4\sqrt{41} \approx 9.61$ , so the challenger wins.
39.  $s = 0$  and  $v = 112$  when  $t = 0$  so  $v(t) = -32t + 112$ ,  $s(t) = -16t^2 + 112t$
- (a)  $v(3) = 16 \text{ ft/s}$ ,  $v(5) = -48 \text{ ft/s}$
- (b)  $v = 0$  when the projectile is at its maximum height so  $-32t + 112 = 0$ ,  $t = 7/2 \text{ s}$ ,  
 $s(7/2) = -16(7/2)^2 + 112(7/2) = 196 \text{ ft}$ .

- (c)  $s = 0$  when it reaches the ground so  $-16t^2 + 112t = 0$ ,  $-16t(t - 7) = 0$ ,  $t = 0, 7$  of which  $t = 7$  is when it is at ground level on its way down.  $v(7) = -112$ ,  $|v| = 112$  ft/s.
40.  $s = 112$  when  $t = 0$  so  $s(t) = -16t^2 + v_0t + 112$ . But  $s = 0$  when  $t = 2$  thus  $-16(2)^2 + v_0(2) + 112 = 0$ ,  $v_0 = -24$  ft/s.
41. (a)  $s(t) = 0$  when it hits the ground,  $s(t) = -16t^2 + 16t = -16t(t - 1) = 0$  when  $t = 1$  s.  
 (b) The projectile moves upward until it gets to its highest point where  $v(t) = 0$ ,  $v(t) = -32t + 16 = 0$  when  $t = 1/2$  s.
42. (a)  $s(t) = 0$  when the rock hits the ground,  $s(t) = -16t^2 + 555 = 0$  when  $t = \sqrt{555}/4$  s  
 (b)  $v(t) = -32t$ ,  $v(\sqrt{555}/4) = -8\sqrt{555}$ , the speed at impact is  $8\sqrt{555}$  ft/s
43. (a)  $s(t) = 0$  when the package hits the ground,  
 $s(t) = -16t^2 + 20t + 200 = 0$  when  $t = (5 + 5\sqrt{33})/8$  s  
 (b)  $v(t) = -32t + 20$ ,  $v[(5 + 5\sqrt{33})/8] = -20\sqrt{33}$ , the speed at impact is  $20\sqrt{33}$  ft/s
44. (a)  $s(t) = 0$  when the stone hits the ground,  
 $s(t) = -16t^2 - 96t + 112 = -16(t^2 + 6t - 7) = -16(t + 7)(t - 1) = 0$  when  $t = 1$  s  
 (b)  $v(t) = -32t - 96$ ,  $v(1) = -128$ , the speed at impact is 128 ft/s
45.  $s(t) = -4.9t^2 + 49t + 150$  and  $v(t) = -9.8t + 49$   
 (a) the projectile reaches its maximum height when  $v(t) = 0$ ,  $-9.8t + 49 = 0$ ,  $t = 5$  s  
 (b)  $s(5) = -4.9(5)^2 + 49(5) + 150 = 272.5$  m  
 (c) the projectile reaches its starting point when  $s(t) = 150$ ,  $-4.9t^2 + 49t + 150 = 150$ ,  $-4.9t(t - 10) = 0$ ,  $t = 10$  s  
 (d)  $v(10) = -9.8(10) + 49 = -49$  m/s  
 (e)  $s(t) = 0$  when the projectile hits the ground,  $-4.9t^2 + 49t + 150 = 0$  when (use the quadratic formula)  $t \approx 12.46$  s  
 (f)  $v(12.46) = -9.8(12.46) + 49 \approx -73.1$ , the speed at impact is about 73.1 m/s
46. take  $s = 0$  at the water level and let  $h$  be the height of the bridge, then  $s = h$  and  $v = 0$  when  $t = 0$  so  $s(t) = -16t^2 + h$   
 (a)  $s = 0$  when  $t = 4$  thus  $-16(4)^2 + h = 0$ ,  $h = 256$  ft  
 (b) First, find how long it takes for the stone to hit the water (find  $t$  for  $s = 0$ ):  $-16t^2 + h = 0$ ,  $t = \sqrt{h}/4$ . Next, find how long it takes the sound to travel to the bridge: this time is  $h/1080$  because the speed is constant at 1080 ft/s. Finally, use the fact that the total of these two times must be 4 s:  $\frac{h}{1080} + \frac{\sqrt{h}}{4} = 4$ ,  $h + 270\sqrt{h} = 4320$ ,  $h + 270\sqrt{h} - 4320 = 0$ , and by the quadratic formula  $\sqrt{h} = \frac{-270 \pm \sqrt{(270)^2 + 4(4320)}}{2}$ , reject the negative value to get  $\sqrt{h} \approx 15.15$ ,  $h \approx 229.5$  ft.
47.  $g = 9.8/6 = 4.9/3$  m/s<sup>2</sup>, so  $v = -(4.9/3)t$ ,  $s = -(4.9/6)t^2 + 5$ ,  $s = 0$  when  $t = \sqrt{30/4.9}$  and  $v = -(4.9/3)\sqrt{30/4.9} \approx -4.04$ , so the speed of the module upon landing is 4.04 m/s
48.  $s(t) = -\frac{1}{2}gt^2 + v_0t$ ;  $s = 1000$  when  $v = 0$ , so  $0 = v = -gt + v_0$ ,  $t = v_0/g$ ,  
 $1000 = s(v_0/g) = -\frac{1}{2}g(v_0/g)^2 + v_0(v_0/g) = \frac{1}{2}v_0^2/g$ , so  $v_0^2 = 2000g$ ,  $v_0 = \sqrt{2000g}$ .  
 The initial velocity on the Earth would have to be  $\sqrt{6}$  times faster than that on the Moon.



49.  $f_{\text{ave}} = \frac{1}{3-1} \int_1^3 3x \, dx = \frac{3}{4} x^2 \Big|_1^3 = 6$

50.  $f_{\text{ave}} = \frac{1}{2-(-1)} \int_{-1}^2 x^2 \, dx = \frac{1}{9} x^3 \Big|_{-1}^2 = 1$

51.  $f_{\text{ave}} = \frac{1}{\pi-0} \int_0^\pi \sin x \, dx = -\frac{1}{\pi} \cos x \Big|_0^\pi = 2/\pi$

52.  $f_{\text{ave}} = \frac{1}{\pi-0} \int_0^\pi \cos x \, dx = \frac{1}{\pi} \sin x \Big|_0^\pi = 0$

53.  $f_{\text{ave}} = \frac{1}{e-1} = \int_1^e \frac{1}{x} \, dx = \frac{1}{1-e} (\ln e - \ln 1) = \frac{1}{e-1}$

54.  $f_{\text{ave}} = \frac{1}{\ln 5 - (-1)} \int_{-1}^{\ln 5} e^x \, dx = \frac{1}{\ln 5 + 1} (5 - e^{-1}) = \frac{5 - e^{-1}}{1 + \ln 5}$

55. (a)  $f_{\text{ave}} = \frac{1}{2-0} \int_0^2 x^2 \, dx = 4/3$

(b)  $(x^*)^2 = 4/3, x^* = \pm 2/\sqrt{3}$ ,  
but only  $2/\sqrt{3}$  is in  $[0, 2]$

(c)

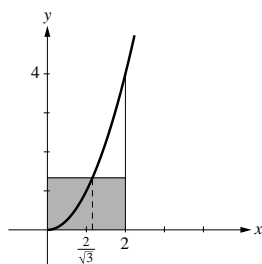

56. (a)  $f_{\text{ave}} = \frac{1}{4-0} \int_0^4 2x \, dx = 4$

(b)  $2x^* = 4, x^* = 2$

(c)

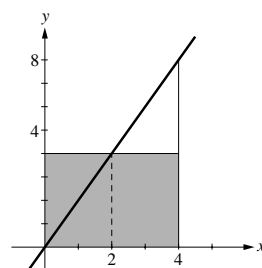

57. (a)  $v_{\text{ave}} = \frac{1}{4-1} \int_1^4 (3t^3 + 2) \, dt = \frac{1}{3} \frac{789}{4} = \frac{263}{4}$

(b)  $v_{\text{ave}} = \frac{s(4) - s(1)}{4-1} = \frac{100-7}{3} = 31$

58. (a)  $a_{\text{ave}} = \frac{1}{5-0} \int_0^5 (t+1) \, dt = 7/2$

(b)  $a_{\text{ave}} = \frac{v(\pi/4) - v(0)}{\pi/4 - 0} = \frac{\sqrt{2}/2 - 1}{\pi/4} = (2\sqrt{2} - 4)/\pi$

59. time to fill tank = (volume of tank)/(rate of filling) =  $[\pi(3)^2 5]/(1) = 45\pi$ , weight of water in tank at time  $t = (62.4) (\text{rate of filling})(\text{time}) = 62.4t$ ,

$\text{weight}_{\text{ave}} = \frac{1}{45\pi} \int_0^{45\pi} 62.4t \, dt = 1404\pi \text{ lb}$

60. (a) If  $x$  is the distance from the cooler end, then the temperature is  $T(x) = (15 + 1.5x)^\circ \text{C}$ , and  

$$T_{\text{ave}} = \frac{1}{10 - 0} \int_0^{10} (15 + 1.5x) dx = 22.5^\circ \text{C}$$
- (b) By the Mean-Value Theorem for Integrals there exists  $x^*$  in  $[0, 10]$  such that  

$$f(x^*) = \frac{1}{10 - 0} \int_0^{10} (15 + 1.5x) dx = 22.5, \quad 15 + 1.5x^* = 22.5, \quad x^* = 5$$
61. (a) amount of water = (rate of flow)(time) =  $4t$  gal, total amount =  $4(30) = 120$  gal
- (b) amount of water =  $\int_0^{60} (4 + t/10) dt = 420$  gal
- (c) amount of water =  $\int_0^{120} (10 + \sqrt{t}) dt = 1200 + 160\sqrt{30} \approx 2076.36$  gal
62. (a) The maximum value of  $R$  occurs at 4:30 P.M. when  $t = 0$ .
- (b)  $\int_0^{60} 100(1 - 0.0001t^2) dt = 5280$  cars
63. (a)  $\int_a^b [f(x) - f_{\text{ave}}] dx = \int_a^b f(x) dx - \int_a^b f_{\text{ave}} dx = \int_a^b f(x) dx - f_{\text{ave}}(b - a) = 0$   
because  $f_{\text{ave}}(b - a) = \int_a^b f(x) dx$
- (b) no, because if  $\int_a^b [f(x) - c] dx = 0$  then  $\int_a^b f(x) dx - c(b - a) = 0$  so  
 $c = \frac{1}{b - a} \int_a^b f(x) dx = f_{\text{ave}}$  is the only value

### EXERCISE SET 7.8

1. (a)  $\int_1^3 u^7 du$       (b)  $-\frac{1}{2} \int_7^4 u^{1/2} du$       (c)  $\frac{1}{\pi} \int_{-\pi}^{\pi} \sin u du$       (d)  $\int_{-3}^0 (u + 5)u^{20} du$
2. (a)  $\frac{1}{2} \int_{-1}^1 e^u du$       (b)  $\int_1^2 u du$   
(c)  $\int_0^1 u^2 du$       (d)  $\frac{1}{2} \int_3^4 (u - 3)u^{1/2} du$
3.  $u = 2x + 1, \frac{1}{2} \int_1^3 u^4 du = \frac{1}{10} u^5 \Big|_1^3 = 121/5$ , or  $\frac{1}{10} (2x + 1)^5 \Big|_0^1 = 121/5$
4.  $u = 4x - 2, \frac{1}{4} \int_2^6 u^3 du = \frac{1}{16} u^4 \Big|_2^6 = 80$ , or  $\frac{1}{16} (4x - 2)^4 \Big|_1^2 = 80$
5.  $u = 1 - 2x, -\frac{1}{2} \int_3^1 u^3 du = -\frac{1}{8} u^4 \Big|_3^1 = 10$ , or  $-\frac{1}{8} (1 - 2x)^4 \Big|_{-1}^0 = 10$
6.  $u = 4 - 3x, -\frac{1}{3} \int_1^{-2} u^8 du = -\frac{1}{27} u^9 \Big|_1^{-2} = 19$ , or  $-\frac{1}{27} (4 - 3x)^9 \Big|_1^2 = 19$

7.  $u = 1 + x$ ,  $\int_1^9 (u-1)u^{1/2} du = \int_1^9 (u^{3/2} - u^{1/2}) du = \left[ \frac{2}{5}u^{5/2} - \frac{2}{3}u^{3/2} \right]_1^9 = 1192/15$ ,  
 or  $\left[ \frac{2}{5}(1+x)^{5/2} - \frac{2}{3}(1+x)^{3/2} \right]_0^8 = 1192/15$
8.  $u = 4 - x$ ,  $\int_9^4 (u-4)u^{1/2} du = \int_9^4 (u^{3/2} - 4u^{1/2}) du = \left[ \frac{2}{5}u^{5/2} - \frac{8}{3}u^{3/2} \right]_9^4 = -506/15$   
 or  $\left[ \frac{2}{5}(4-x)^{5/2} - \frac{8}{3}(4-x)^{3/2} \right]_{-5}^0 = -506/15$
9.  $u = x/2$ ,  $8 \int_0^{\pi/4} \sin u du = -8 \cos u \Big|_0^{\pi/4} = 8 - 4\sqrt{2}$ , or  $-8 \cos(x/2) \Big|_0^{\pi/2} = 8 - 4\sqrt{2}$
10.  $u = 3x$ ,  $\frac{2}{3} \int_0^{\pi/2} \cos u du = \frac{2}{3} \sin u \Big|_0^{\pi/2} = 2/3$ , or  $\frac{2}{3} \sin 3x \Big|_0^{\pi/6} = 2/3$
11.  $u = e^x + 4$ ,  $du = e^x dx$ ,  $u = e^{-\ln 3} + 4 = \frac{1}{3} + 4 = \frac{13}{3}$  when  $x = -\ln 3$ ,  
 $u = e^{\ln 3} + 4 = 3 + 4 = 7$  when  $x = \ln 3$ ,  $\int_{13/3}^7 \frac{1}{u} du = \ln u \Big|_{13/3}^7 = \ln(7) - \ln(13/3) = \ln(21/13)$
12.  $u = 3 - 4e^x$ ,  $du = -4e^x dx$ ,  $u = -1$  when  $x = 0$ ,  $u = -17$  when  $x = \ln 5$   
 $-\frac{1}{4} \int_{-1}^{-17} u du = -\frac{1}{8} u^2 \Big|_{-1}^{-17} = -36$
13.  $\frac{1}{3} \int_0^5 \sqrt{25 - u^2} du = \frac{1}{3} \left[ \frac{1}{4} \pi (5)^2 \right] = \frac{25}{12} \pi$
14.  $\frac{1}{2} \int_0^4 \sqrt{16 - u^2} du = \frac{1}{2} \left[ \frac{1}{4} \pi (4)^2 \right] = 2\pi$
15.  $-\frac{1}{2} \int_1^0 \sqrt{1 - u^2} du = \frac{1}{2} \int_0^1 \sqrt{1 - u^2} du = \frac{1}{2} \cdot \frac{1}{4} [\pi(1)^2] = \pi/8$
16.  $\int_{-6}^6 \sqrt{36 - u^2} du = \pi(6)^2/2 = 18\pi$
17.  $\int_0^1 \sin \pi x dx = -\frac{1}{\pi} \cos \pi x \Big|_0^1 = -\frac{1}{\pi}(-1 - 1) = 2/\pi$
18.  $A = \int_0^{\pi/8} 3 \cos 2x dx = \frac{3}{2} \sin 2x \Big|_0^{\pi/8} = 3\sqrt{2}/4$
19.  $\int_3^7 (x+5)^{-2} = -(x+5)^{-1} \Big|_3^7 = -\frac{1}{12} + \frac{1}{8} = \frac{1}{24}$
20.  $A = \int_0^1 \frac{dx}{(3x+1)^2} = -\frac{1}{3(3x+1)} \Big|_0^1 = \frac{1}{4}$
21.  $f_{\text{ave}} = \frac{1}{4-0} \int_0^4 e^{-2x} dx = -\frac{1}{8} e^{-2x} \Big|_0^4 = \frac{1 - e^{-8}}{8}$

$$22. f_{\text{ave}} = \frac{1}{1/4 - (-1/4)} \int_{-1/4}^{1/4} \sec^2 \pi x dx = \frac{2}{\pi} \tan \pi x \Big|_{-1/4}^{1/4} = \frac{4}{\pi}$$

$$23. \left. \frac{2}{3}(3x+1)^{1/2} \right|_0^1 = 2/3$$

$$24. \left. \frac{2}{15}(5x-1)^{3/2} \right|_1^2 = 38/15$$

$$25. \left. \frac{2}{3}(x^3+9)^{1/2} \right|_{-1}^1 = \frac{2}{3}(\sqrt{10} - 2\sqrt{2})$$

$$26. \left. \frac{1}{10}(t^3+1)^{20} \right|_{-1}^0 = 1/10$$

$$27. u = x^2 + 4x + 7, \left. \frac{1}{2} \int_{12}^{28} u^{-1/2} du = u^{1/2} \right|_{12}^{28} = \sqrt{28} - \sqrt{12} = 2(\sqrt{7} - \sqrt{3})$$

$$28. \left. \int_1^2 \frac{1}{(x-3)^2} dx = -\frac{1}{x-3} \right|_1^2 = 1/2$$

$$29. \left. \frac{1}{2} \sin^2 x \right|_{-3\pi/4}^{\pi/4} = 0$$

$$30. \left. \frac{2}{3}(\tan x)^{3/2} \right|_0^{\pi/4} = 2/3$$

$$31. \left. \frac{5}{2} \sin(x^2) \right|_0^{\sqrt{\pi}} = 0$$

$$32. u = \sqrt{x}, \left. 2 \int_{\pi}^{2\pi} \sin u du = -2 \cos u \right|_{\pi}^{2\pi} = -4$$

$$33. u = 3\theta, \left. \frac{1}{3} \int_{\pi/4}^{\pi/3} \sec^2 u du = \frac{1}{3} \tan u \right|_{\pi/4}^{\pi/3} = (\sqrt{3} - 1)/3$$

$$34. u = \sin 3\theta, \left. \frac{1}{3} \int_0^{-1} u^2 du = \frac{1}{9} u^3 \right|_0^{-1} = -1/9$$

$$35. u = 4 - 3y, y = \frac{1}{3}(4 - u), dy = -\frac{1}{3} du$$

$$-\frac{1}{27} \int_4^1 \frac{16 - 8u + u^2}{u^{1/2}} du = \frac{1}{27} \int_1^4 (16u^{-1/2} - 8u^{1/2} + u^{3/2}) du$$

$$= \frac{1}{27} \left[ 32u^{1/2} - \frac{16}{3}u^{3/2} + \frac{2}{5}u^{5/2} \right]_1^4 = 106/405$$

$$36. u = 5 + x, \int_4^9 \frac{u-5}{\sqrt{u}} du = \int_4^9 (u^{1/2} - 5u^{-1/2}) du = \left. \frac{2}{3}u^{3/2} - 10u^{1/2} \right|_4^9 = 8/3$$

$$37. \ln(x+e) \Big|_0^e = \ln(2e) - \ln e = \ln 2$$

$$38. \left. -\frac{1}{2}e^{-x^2} \right|_1^{\sqrt{2}} = (e^{-1} - e^{-2})/2$$

$$40. \int_{-2}^2 \sqrt{4-u^2} du = \frac{1}{2}[\pi(2)^2] = 2\pi$$

$$41. \text{(a)} \quad u = 3x + 1, \frac{1}{3} \int_1^4 f(u) du = 5/3$$

$$\text{(b)} \quad u = 3x, \frac{1}{3} \int_0^9 f(u) du = 5/3$$

$$\text{(c)} \quad u = x^2, 1/2 \int_4^0 f(u) du = -1/2 \int_0^4 f(u) du = -1/2$$

$$42. u = 1 - x, \int_0^1 x^m(1-x)^n dx = -\int_1^0 (1-u)^m u^n du = \int_0^1 u^n(1-u)^m du = \int_0^1 x^n(1-x)^m dx$$

43.  $\sin x = \cos(\pi/2 - x)$ ,  

$$\int_0^{\pi/2} \sin^n x \, dx = \int_0^{\pi/2} \cos^n(\pi/2 - x) \, dx = - \int_{\pi/2}^0 \cos^n u \, du \quad (u = \pi/2 - x)$$

$$= \int_0^{\pi/2} \cos^n u \, du = \int_0^{\pi/2} \cos^n x \, dx \quad (\text{by replacing } u \text{ by } x)$$
44.  $u = 1 - x$ ,  $-\int_1^0 (1-u)u^n \, du = \int_0^1 (1-u)u^n \, du = \int_0^1 (u^n - u^{n+1}) \, du = \frac{1}{n+1} - \frac{1}{n+2} = \frac{1}{(n+1)(n+2)}$
45.  $y(t) = (802.137) \int e^{1.528t} \, dt = 524.959e^{1.528t} + C$ ;  $y(0) = 750 = 524.959 + C$ ,  $C = 225.041$ ,  
 $y(t) = 524.959e^{1.528t} + 225.041$ ,  $y(12) = 48,233,525,650$
46.  $V_{\text{ave}} = \frac{275000}{10-0} \int_0^{10} e^{-0.17t} \, dt = -161764.7059e^{-0.17t} \Big|_0^{10} = \$132,212.96$
47.  $s(t) = \int (25 + 10e^{-0.05t}) \, dt = 25t - 200e^{-0.05t} + C$   
 (a)  $s(10) - s(0) = 250 - 200(e^{-0.5} - 1) = 450 - 200/\sqrt{e} \approx 328.69$  ft  
 (b) yes; without it the distance would have been 250 ft
48.  $\int_0^k e^{2x} \, dx = 3$ ,  $\frac{1}{2}e^{2x} \Big|_0^k = 3$ ,  $\frac{1}{2}(e^{2k} - 1) = 3$ ,  $e^{2k} = 7$ ,  $k = \frac{1}{2} \ln 7$
49. (a)  $V_{\text{rms}}^2 = \frac{1}{1/f-0} \int_0^{1/f} V_p^2 \sin^2(2\pi ft) \, dt = \frac{1}{2}fV_p^2 \int_0^{1/f} [1 - \cos(4\pi ft)] \, dt$   
 $= \frac{1}{2}fV_p^2 \left[ t - \frac{1}{4\pi f} \sin(4\pi ft) \right]_0^{1/f} = \frac{1}{2}V_p^2$ , so  $V_{\text{rms}} = V_p/\sqrt{2}$   
 (b)  $V_p/\sqrt{2} = 120$ ,  $V_p = 120\sqrt{2} \approx 169.7$  V
50. Let  $u = t - x$ , then  $du = -dx$  and  
 $\int_0^t f(t-x)g(x) \, dx = - \int_t^0 f(u)g(t-u) \, du = \int_0^t f(u)g(t-u) \, du$ ;  
 the result follows by replacing  $u$  by  $x$  in the last integral.
51. (a)  $I = - \int_a^0 \frac{f(a-u)}{f(a-u)+f(u)} \, du = \int_0^a \frac{f(a-u)+f(u)-f(u)}{f(a-u)+f(u)} \, du$   
 $= \int_0^a du - \int_0^a \frac{f(u)}{f(a-u)+f(u)} \, du$ ,  $I = a - I$  so  $2I = a$ ,  $I = a/2$   
 (b)  $3/2$  (c)  $\pi/4$
52.  $x = \frac{1}{u}$ ,  $dx = -\frac{1}{u^2} \, du$ ,  $I = \int_{-1}^1 \frac{1}{1+1/u^2} (-1/u^2) \, du = - \int_{-1}^1 \frac{1}{u^2+1} \, du = -I$  so  $I = 0$  which is impossible  
 because  $\frac{1}{1+x^2}$  is positive on  $[-1, 1]$ . The substitution  $u = 1/x$  is not valid because  $u$  is not continuous for all  $x$  in  $[-1, 1]$ .
53.  $\int_0^1 \sin \pi x \, dx = 2/\pi$

55. (a) Let
- $u = -x$
- then

$$\int_{-a}^a f(x)dx = - \int_a^{-a} f(-u)du = \int_{-a}^a f(-u)du = - \int_{-a}^a f(u)du$$

so, replacing  $u$  by  $x$  in the latter integral,

$$\int_{-a}^a f(x)dx = - \int_{-a}^a f(x)dx, \quad 2 \int_{-a}^a f(x)dx = 0, \quad \int_{-a}^a f(x)dx = 0$$

The graph of  $f$  is symmetric about the origin so  $\int_{-a}^0 f(x)dx$  is the negative of  $\int_0^a f(x)dx$  thus

$$\int_{-a}^a f(x)dx = \int_{-a}^0 f(x)dx + \int_0^a f(x)dx = 0$$

- (b)
- $\int_{-a}^a f(x)dx = \int_{-a}^0 f(x)dx + \int_0^a f(x)dx$
- , let
- $u = -x$
- in
- $\int_{-a}^0 f(x)dx$
- to get

$$\int_{-a}^0 f(x)dx = - \int_a^0 f(-u)du = \int_0^a f(-u)du = \int_0^a f(u)du = \int_0^a f(x)dx$$

$$\text{so } \int_{-a}^a f(x)dx = \int_0^a f(x)dx + \int_0^a f(x)dx = 2 \int_0^a f(x)dx$$

The graph of  $f(x)$  is symmetric about the  $y$ -axis so there is as much signed area to the left of the  $y$ -axis as there is to the right.

## EXERCISE SET 7.9

1. (a)

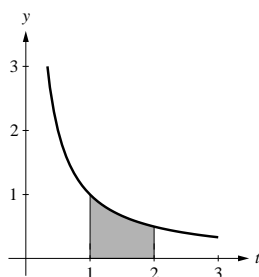

- (b)

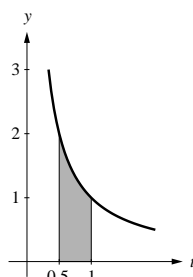

- (c)

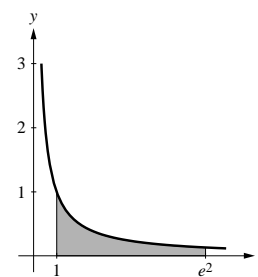

- 2.

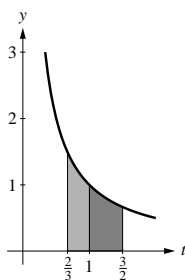

3. (a)  $\ln t \Big|_1^{ac} = \ln(ac) = \ln a + \ln c = 7$

(b)  $\ln t \Big|_1^{1/c} = \ln(1/c) = -5$

(c)  $\ln t \Big|_1^{a/c} = \ln(a/c) = 2 - 5 = -3$

(d)  $\ln t \Big|_1^{a^3} = \ln a^3 = 3 \ln a = 6$

4. (a)  $\ln t \Big|_1^{\sqrt{a}} = \ln a^{1/2} = 2$  (b)  $\ln t \Big|_1^{2a} = \ln 2 + 4$   
 (c)  $\ln t \Big|_1^{2/a} = \ln 2 - 4$  (d)  $\ln t \Big|_2^a = 4 - \ln 2$
5.  $\ln 5 \approx 1.603210678$ ;  $\ln 5 = 1.609437912$ ; magnitude of error is  $< 0.0063$
6.  $\ln 3 \approx 1.098242635$ ;  $\ln 3 = 1.098612289$ ; magnitude of error is  $< 0.0004$
7. (a)  $x^{-1}, x > 0$  (b)  $x^2, x \neq 0$   
 (c)  $-x^2, -\infty < x < +\infty$  (d)  $-x, -\infty < x < +\infty$   
 (e)  $x^3, x > 0$  (f)  $\ln x + x, x > 0$   
 (g)  $x - \sqrt[3]{x}, -\infty < x < +\infty$  (h)  $\frac{e^x}{x}, x > 0$
8. (a)  $f(\ln 3) = e^{-2 \ln 3} = e^{\ln(1/9)} = 1/9$   
 (b)  $f(\ln 2) = e^{\ln 2} + 3e^{-\ln 2} = 2 + 3e^{\ln(1/2)} = 2 + 3/2 = 7/2$
9. (a)  $3^\pi = e^{\pi \ln 3}$  (b)  $2^{\sqrt{2}} = e^{\sqrt{2} \ln 2}$
10. (a)  $\pi^{-x} = e^{-x \ln \pi}$  (b)  $x^{2x} = e^{2x \ln x}$
11. (a)  $\lim_{x \rightarrow +\infty} \left[ \left( 1 + \frac{1}{x} \right)^x \right]^2 = \left[ \lim_{x \rightarrow +\infty} \left( 1 + \frac{1}{x} \right)^x \right]^2 = e^2$   
 (b)  $y = 2x, \lim_{y \rightarrow 0} (1 + y)^{2/y} = \lim_{y \rightarrow 0} \left[ (1 + y)^{1/y} \right]^2 = e^2$
12. (a)  $y = 3x, \lim_{y \rightarrow +\infty} \left( 1 + \frac{1}{y} \right)^{y/3} = \lim_{y \rightarrow +\infty} \left[ \left( 1 + \frac{1}{y} \right)^y \right]^{1/3} = \left[ \lim_{y \rightarrow +\infty} \left( 1 + \frac{1}{y} \right)^y \right]^{1/3} = e^{1/3}$   
 (b)  $\lim_{x \rightarrow 0} (1 + x)^{1/3x} = \lim_{x \rightarrow 0} \left[ (1 + x)^{1/x} \right]^{1/3} = e^{1/3}$
13.  $g'(x) = x^2 - x$  14.  $g'(x) = 1 - \cos x$
15. (a)  $\frac{1}{x^3}(3x^2) = \frac{3}{x}$  (b)  $e^{\ln x} \frac{1}{x} = 1$
16. (a)  $2x\sqrt{x^2 + 1}$  (b)  $-\left(\frac{1}{x^2}\right) \sin\left(\frac{1}{x}\right)$
17.  $F'(x) = \frac{\cos x}{x^2 + 3}, F''(x) = \frac{-(x^2 + 3) \sin x - 2x \cos x}{(x^2 + 3)^2}$   
 (a) 0 (b)  $1/3$  (c) 0
18.  $F'(x) = \sqrt{3x^2 + 1}, F''(x) = \frac{3x}{\sqrt{3x^2 + 1}}$   
 (a) 0 (b)  $\sqrt{13}$  (c)  $6/\sqrt{13}$
19. (a)  $\frac{d}{dx} \int_1^{x^2} t\sqrt{1+t} dt = x^2\sqrt{1+x^2}(2x) = 2x^3\sqrt{1+x^2}$   
 (b)  $\int_1^{x^2} t\sqrt{1+t} dt = -\frac{2}{3}(x^2 + 1)^{3/2} + \frac{2}{5}(x^2 + 1)^{5/2} - \frac{4\sqrt{2}}{15}$

20. (a)  $\frac{d}{dx} \int_x^a f(t) dt = -\frac{d}{dx} \int_a^x f(t) dt = -f(x)$

(b)  $\frac{d}{dx} \int_{g(x)}^a f(t) dt = -\frac{d}{dx} \int_a^{g(x)} f(t) dt = -f(g(x))g'(x)$

21. (a)  $-\sin x^2$

(b)  $-\frac{\tan^2 x}{1 + \tan^2 x} \sec^2 x = -\tan^2 x$

22. (a)  $-(x^2 + 1)^{40}$

(b)  $-\cos^3\left(\frac{1}{x}\right)\left(-\frac{1}{x^2}\right) = \frac{\cos^3(1/x)}{x^2}$

23.  $-3\frac{3x-1}{9x^2+1} + 2x\frac{x^2-1}{x^4+1}$

24. If  $f$  is continuous on an open interval  $I$  and  $g(x)$ ,  $h(x)$ , and  $a$  are in  $I$  then

$$\int_{h(x)}^{g(x)} f(t) dt = \int_{h(x)}^a f(t) dt + \int_a^{g(x)} f(t) dt = -\int_a^{h(x)} f(t) dt + \int_a^{g(x)} f(t) dt$$

so  $\frac{d}{dx} \int_{h(x)}^{g(x)} f(t) dt = -f(h(x))h'(x) + f(g(x))g'(x)$

25. (a)  $\sin^2(x^3)(3x^2) - \sin^2(x^2)(2x) = 3x^2 \sin^2(x^3) - 2x \sin^2(x^2)$

(b)  $\frac{1}{1+x}(1) - \frac{1}{1-x}(-1) = \frac{2}{1-x^2}$

26.  $F'(x) = \frac{1}{3x}(3) - \frac{1}{x}(1) = 0$  so  $F(x)$  is constant on  $(0, +\infty)$ .  $F(1) = \ln 3$  so  $F(x) = \ln 3$  for all  $x > 0$ .

27. from geometry,  $\int_0^3 f(t) dt = 0$ ,  $\int_3^5 f(t) dt = 6$ ,  $\int_5^7 f(t) dt = 0$ ; and  $\int_7^{10} f(t) dt = \int_7^{10} (4t-37)/3 dt = -3$

(a)  $F(0) = 0$ ,  $F(3) = 0$ ,  $F(5) = 6$ ,  $F(7) = 6$ ,  $F(10) = 3$

(b)  $F$  is increasing where  $F' = f$  is positive, so on  $[3/2, 6]$  and  $[37/4, 10]$ , decreasing on  $[0, 3/2]$  and  $[6, 37/4]$

(c) critical points when  $F'(x) = f(x) = 0$ , so  $x = 3/2, 6, 37/4$ ; maximum  $15/2$  at  $x = 6$ , minimum  $-9/4$  at  $x = 3/2$

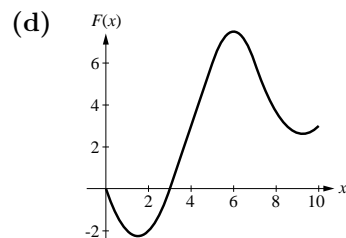

28.  $f_{\text{ave}} = \frac{1}{10-0} \int_0^{10} f(t) dt = \frac{1}{10} F(10) = 0.3$

29.  $x < 0 : F(x) = \int_{-1}^x (-t) dt = -\frac{1}{2}t^2 \Big|_{-1}^x = \frac{1}{2}(1-x^2),$

$x \geq 0 : F(x) = \int_{-1}^0 (-t) dt + \int_0^x t dt = \frac{1}{2} + \frac{1}{2}x^2; F(x) = \begin{cases} (1-x^2)/2, & x < 0 \\ (1+x^2)/2, & x \geq 0 \end{cases}$



30.  $0 \leq x \leq 2 : F(x) = \int_0^x t dt = \frac{1}{2}x^2,$   
 $x > 2 : F(x) = \int_0^2 t dt + \int_2^x 2 dt = 2 + 2(x - 2) = 2x - 2; F(x) = \begin{cases} x^2/2, & 0 \leq x \leq 2 \\ 2x - 2, & x > 2 \end{cases}$

31.  $y(x) = 2 + \int_1^x t^{1/3} dt = 2 + \frac{3}{4}t^{4/3} \Big|_1^x = \frac{5}{4} + \frac{3}{4}x^{4/3}$

32.  $y(x) = \int_1^x (t^{1/2} + t^{-1/2}) dt = \frac{2}{3}x^{3/2} - \frac{2}{3} + 2x^{1/2} - 2$

33.  $y(x) = 1 + \int_{\pi/4}^x (\sec^2 t - \sin t) dt = \tan x + \cos x - \sqrt{2}/2$

34.  $y(x) = \int_0^x te^{t^2} dt = \frac{1}{2}e^{-x^2} - \frac{1}{2}$

35.  $P(x) = P_0 + \int_0^x r(t) dt$  individuals

36.  $s(T) = s_1 + \int_1^T v(t) dt$

37. II has a minimum at  $x = 1$ , and I has a zero there, so I could be the derivative of II; on the other hand I has a minimum near  $x = 1/3$ , but II is not zero there, so II could not be the derivative of I

38. (b)  $\lim_{k \rightarrow 0} \frac{1}{k}(x^k - 1) = \ln x \lim_{k \rightarrow 0} x^k = \ln x$  by L'Hôpital's rule (with respect to  $k$ )

39. (a) where  $f(t) = 0$ ; by the first derivative test, at  $t = 3$

(b) where  $f(t) = 0$ ; by the first derivative test, at  $t = 1$

(c) at  $t = 0, 1$  or  $5$ ; from the graph it is evident that it is at  $t = 5$

(d) at  $t = 0, 3$  or  $5$ ; from the graph it is evident that it is at  $t = 3$

(e)  $F$  is concave up when  $F'' = f'$  is positive, i.e. where  $f$  is increasing, so on  $(0, 1/2)$  and  $(2, 4)$ ; it is concave down on  $(1/2, 2)$  and  $(4, 5)$

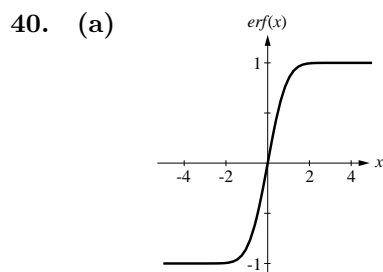
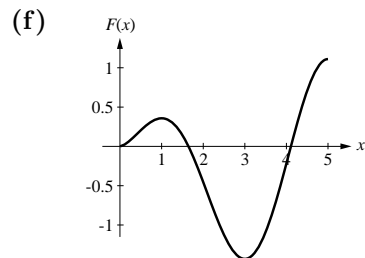

(c)  $\text{erf}'(x) > 0$  for all  $x$ , so there are no relative extrema

(e)  $\text{erf}''(x) = -4xe^{-x^2}/\sqrt{\pi}$  changes sign only at  $x = 0$  so that is the only point of inflection

(g)  $\lim_{x \rightarrow +\infty} \text{erf}(x) = +1, \lim_{x \rightarrow -\infty} \text{erf}(x) = -1$

41.  $C'(x) = \cos(\pi x^2/2)$ ,  $C''(x) = -\pi x \sin(\pi x^2/2)$
- (a)  $\cos t$  goes from negative to positive at  $2k\pi - \pi/2$ , and from positive to negative at  $t = 2k\pi + \pi/2$ , so  $C(x)$  has relative minima when  $\pi x^2/2 = 2k\pi - \pi/2$ ,  $x = \pm\sqrt{4k-1}$ ,  $k = 1, 2, \dots$ , and  $C(x)$  has relative maxima when  $\pi x^2/2 = (4k+1)\pi/2$ ,  $x = \pm\sqrt{4k+1}$ ,  $k = 0, 1, \dots$
- (b)  $\sin t$  changes sign at  $t = k\pi$ , so  $C(x)$  has inflection points at  $\pi x^2/2 = k\pi$ ,  $x = \pm\sqrt{2k}$ ,  $k = 1, 2, \dots$ ; the case  $k = 0$  is distinct due to the factor of  $x$  in  $C''(x)$ , but  $x$  changes sign at  $x = 0$  and  $\sin(\pi x^2/2)$  does not, so there is also a point of inflection at  $x = 0$
42. Let  $F(x) = \int_1^x \ln t dt$ ,  $F'(x) = \lim_{h \rightarrow 0} \frac{F(x+h) - F(x)}{h} = \lim_{h \rightarrow 0} \frac{1}{h} \int_x^{x+h} \ln t dt$ ; but  $F'(x) = \ln x$  so  

$$\lim_{h \rightarrow 0} \frac{1}{h} \int_x^{x+h} \ln t dt = \ln x$$
43. Differentiate:  $f(x) = 3e^{3x}$ , so  $2 + \int_a^x f(t) dt = 2 + \int_a^x 3e^{3t} dt = 2 + e^{3t} \Big|_a^x = 2 + e^{3x} - e^{3a} = e^{3x}$  provided  $e^{3a} = 2$ ,  $a = (\ln 2)/3$ .
44. (a) The area under  $1/t$  for  $x \leq t \leq x+1$  is less than the area of the rectangle with altitude  $1/x$  and base 1, but greater than the area of the rectangle with altitude  $1/(x+1)$  and base 1.
- (b)  $\int_x^{x+1} \frac{1}{t} dt = \ln t \Big|_x^{x+1} = \ln(x+1) - \ln x = \ln(1 + 1/x)$ , so  
 $1/(x+1) < \ln(1 + 1/x) < 1/x$  for  $x > 0$ .
- (c) from part (b),  $e^{1/(x+1)} < e^{\ln(1+1/x)} < e^{1/x}$ ,  $e^{1/(x+1)} < 1 + 1/x < e^{1/x}$ ,  
 $e^{x/(x+1)} < (1 + 1/x)^x < e$ ; by the Squeezing Theorem,  $\lim_{x \rightarrow +\infty} (1 + 1/x)^x = e$ .
- (d) Use the inequality  $e^{x/(x+1)} < (1 + 1/x)^x$  to get  $e < (1 + 1/x)^{x+1}$  so  
 $(1 + 1/x)^x < e < (1 + 1/x)^{x+1}$ .
45. From Exercise 44(d)  $\left| e - \left(1 + \frac{1}{50}\right)^{50} \right| < y(50)$ , and from the graph  $y(50) < 0.06$

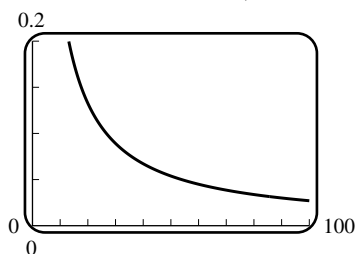

46.  $F'(x) = f(x)$ , thus  $F'(x)$  has a value at each  $x$  in  $I$  because  $f$  is continuous on  $I$  so  $F'$  is continuous on  $I$  because a function that is differentiable at a point is also continuous at that point

## CHAPTER 7 SUPPLEMENTARY EXERCISES

5. If the acceleration  $a = \text{const}$ , then  $v(t) = at + v_0$ ,  $s(t) = \frac{1}{2}at^2 + v_0t + s_0$
6. (a) Divide the base into  $n$  equal subintervals. Above each subinterval choose the lowest and highest points on the curved top. Draw a rectangle above the subinterval going through the lowest point, and another through the highest point. Add the rectangles that go through the lowest points to obtain a lower estimate of the area; add the rectangles through the highest points to obtain an upper estimate of the area.

(b)  $n = 10$ : 25.0 cm, 22.4 cm

(c)  $n = 20$ : 24.4 cm, 23.1 cm

7. (a)  $\frac{1}{2} + \frac{1}{4} = \frac{3}{4}$

(b)  $-1 - \frac{1}{2} = -\frac{3}{2}$

(c)  $5 \left(-1 - \frac{3}{4}\right) = -\frac{35}{4}$

(d)  $-2$

(e) not enough information

(f) not enough information

8. (a)  $\frac{1}{2} + 2 = \frac{5}{2}$

(b) not enough information

(c) not enough information

(d)  $4(2) - 3\frac{1}{2} = \frac{13}{2}$

9. (a)  $\int_{-1}^1 dx + \int_{-1}^1 \sqrt{1-x^2} dx = 2(1) + \pi(1)^2/2 = 2 + \pi/2$

(b)  $\frac{1}{3}(x^2 + 1)^{3/2} \Big|_0^3 - \pi(3)^2/4 = \frac{1}{3}(10^{3/2} - 1) - 9\pi/4$

(c)  $u = x^2, du = 2xdx; \frac{1}{2} \int_0^1 \sqrt{1-u^2} du = \frac{1}{2}\pi(1)^2/4 = \pi/8$

10.  $\frac{1}{2}$

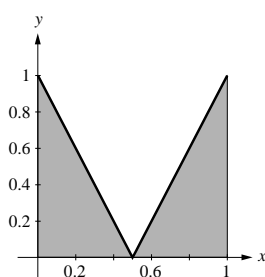

11. The rectangle with vertices  $(0, 0)$ ,  $(\pi, 0)$ ,  $(\pi, 1)$  and  $(0, 1)$  has area  $\pi$  and is much too large; so is the triangle with vertices  $(0, 0)$ ,  $(\pi, 0)$  and  $(\pi, 1)$  which has area  $\pi/2$ ;  $1 - \pi$  is negative; so the answer is  $35\pi/128$ .

12. Divide  $e^x + 3$  into  $e^{2x}$  to get  $\frac{e^{2x}}{e^x + 3} = e^x - \frac{3e^x}{e^x + 3}$  so

$$\int \frac{e^{2x}}{e^x + 3} dx = \int e^x dx - 3 \int \frac{e^x}{e^x + 3} dx = e^x - 3 \ln(e^x + 3) + C$$

13. Since  $y = e^x$  and  $y = \ln x$  are inverse functions, their graphs are symmetric with respect to the line  $y = x$ ; consequently the areas  $A_1$  and  $A_3$  are equal (see figure). But  $A_1 + A_2 = e$ , so

$$\int_1^e \ln x dx + \int_0^1 e^x dx = A_2 + A_3 = A_2 + A_1 = e$$

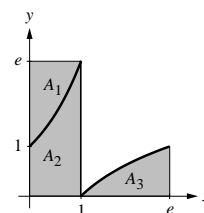

14. (a)  $\frac{1}{n} \sum_{k=1}^n \sqrt{\frac{k}{n}} = \sum_{k=1}^n f(x_k^*) \Delta x$  where  $f(x) = \sqrt{x}$ ,  $x_k^* = k/n$ , and  $\Delta x = 1/n$  for  $0 \leq x \leq 1$ . Thus

$$\lim_{n \rightarrow +\infty} \frac{1}{n} \sum_{k=1}^n \sqrt{\frac{k}{n}} = \int_0^1 x^{1/2} dx = \frac{2}{3}$$

(b)  $\frac{1}{n} \sum_{k=1}^n \left(\frac{k}{n}\right)^4 = \sum_{k=1}^n f(x_k^*) \Delta x$  where  $f(x) = x^4$ ,  $x_k^* = k/n$ , and  $\Delta x = 1/n$  for  $0 \leq x \leq 1$ . Thus

$$\lim_{n \rightarrow +\infty} \frac{1}{n} \sum_{k=1}^n \left(\frac{k}{n}\right)^4 = \int_0^1 x^4 dx = \frac{1}{5}$$

(c)  $\sum_{k=1}^n \frac{e^{k/n}}{n} = \sum_{k=1}^n f(x_k^*) \Delta x$  where  $f(x) = e^x$ ,  $x_k^* = k/n$ , and  $\Delta x = 1/n$  for  $0 \leq x \leq 1$ . Thus

$$\lim_{n \rightarrow +\infty} \sum_{k=1}^n \frac{e^{k/n}}{n} = \lim_{n \rightarrow +\infty} \sum_{k=1}^n f(x_k^*) \Delta x = \int_0^1 e^x dx = e - 1.$$

15. Since  $f(x) = \frac{1}{x}$  is positive and increasing on the interval  $[1, 2]$ , the left endpoint approximation overestimates the integral of  $\frac{1}{x}$  and the right endpoint approximation underestimates it.

(a) For  $n = 5$  this becomes

$$0.2 \left[ \frac{1}{1.2} + \frac{1}{1.4} + \frac{1}{1.6} + \frac{1}{1.8} + \frac{1}{2.0} \right] < \int_1^2 \frac{1}{x} dx < 0.2 \left[ \frac{1}{1.0} + \frac{1}{1.2} + \frac{1}{1.4} + \frac{1}{1.6} + \frac{1}{1.8} \right]$$

(b) For general  $n$  the left endpoint approximation to  $\int_1^2 \frac{1}{x} dx = \ln 2$  is

$$\frac{1}{n} \sum_{k=1}^n \frac{1}{1 + (k-1)/n} = \sum_{k=1}^n \frac{1}{n+k-1} = \sum_{k=0}^{n-1} \frac{1}{n+k}$$

and the right endpoint approximation is

$$\sum_{k=1}^n \frac{1}{n+k}.$$

This yields  $\sum_{k=1}^n \frac{1}{n+k} < \int_1^2 \frac{1}{x} dx < \sum_{k=0}^{n-1} \frac{1}{n+k}$  which is the desired inequality.

(c) By telescoping, the difference is  $\frac{1}{n} - \frac{1}{2n} = \frac{1}{2n}$  so  $\frac{1}{2n} \leq 0.1$ ,  $n \geq 5$

(d)  $n \geq 1,000$

16. The direction field is clearly an even function, which means that the solution is even, its derivative is odd. Since  $\sin x$  is periodic and the direction field is not, that eliminates all but  $x$ , the solution of which is the family  $y = x^2/2 + C$ .

17. (a)  $1 \cdot 2 + 2 \cdot 3 + \cdots + n(n+1) = \sum_{k=1}^n k(k+1) = \sum_{k=1}^n k^2 + \sum_{k=1}^n k$

$$= \frac{1}{6}n(n+1)(2n+1) + \frac{1}{2}n(n+1) = \frac{1}{3}n(n+1)(n+2)$$

(b)  $\sum_{k=1}^{n-1} \left(\frac{9}{n} - \frac{k}{n^2}\right) = \frac{9}{n} \sum_{k=1}^{n-1} 1 - \frac{1}{n^2} \sum_{k=1}^{n-1} k = \frac{9}{n}(n-1) - \frac{1}{n^2} \cdot \frac{1}{2}(n-1)(n) = \frac{17}{2} \left(\frac{n-1}{n}\right);$

$$\lim_{n \rightarrow +\infty} \frac{17}{2} \left(\frac{n-1}{n}\right) = \frac{17}{2}$$

(c)  $\sum_{i=1}^3 \left[ \sum_{j=1}^2 i + \sum_{j=1}^2 j \right] = \sum_{i=1}^3 \left[ 2i + \frac{1}{2}(2)(3) \right] = 2 \sum_{i=1}^3 i + \sum_{i=1}^3 3 = 2 \cdot \frac{1}{2}(3)(4) + (3)(3) = 21$

18. (a)  $\sum_{k=0}^{14} (k+4)(k+1)$

(b)  $\sum_{k=5}^{19} (k-1)(k-4)$

19. (a) If  $u = \sec x$ ,  $du = \sec x \tan x dx$ ,  $\int \sec^2 x \tan x dx = \int u du = u^2/2 + C_1 = (\sec^2 x)/2 + C_1$ ;  
if  $u = \tan x$ ,  $du = \sec^2 x dx$ ,  $\int \sec^2 x \tan x dx = \int u du = u^2/2 + C_2 = (\tan^2 x)/2 + C_2$ .

(b) They are equal only if  $\sec^2 x$  and  $\tan^2 x$  differ by a constant, which is true.

20.  $\frac{1}{2} \sec^2 x \Big|_0^{\pi/4} = \frac{1}{2}(2 - 1) = 1/2$  and  $\frac{1}{2} \tan^2 x \Big|_0^{\pi/4} = \frac{1}{2}(1 - 0) = 1/2$

21.  $\int \sqrt{1 + x^{-2/3}} dx = \int x^{-1/3} \sqrt{x^{2/3} + 1} dx$ ;  $u = x^{2/3} + 1$ ,  $du = \frac{2}{3} x^{-1/3} dx$   
 $\frac{3}{2} \int u^{1/2} du = u^{3/2} + C = (x^{2/3} + 1)^{3/2} + C$

22. (a)  $\int_a^b \sum_{k=1}^n f_k(x) dx = \sum_{k=1}^n \int_a^b f_k(x) dx$

(b) yes; substitute  $c_k f_k(x)$  for  $f_k(x)$  in part (a), and then use  $\int_a^b c_k f_k(x) dx = c_k \int_a^b f_k(x) dx$  from Theorem 7.5.4

23. (a)  $\int_1^x \frac{1}{1+t^2} dt$

(b)  $\int_{\tan(\pi/4-2)}^x \frac{1}{1+t^2} dt$

24. (a)  $F'(x) = \frac{x-3}{x^2+7}$ ; increasing on  $[3, +\infty)$ , decreasing on  $(-\infty, 3]$

(b)  $F''(x) = \frac{7+6x-x^2}{(x^2+7)^2} = \frac{(7-x)(1+x)}{(x^2+7)^2}$ ; concave up on  $(-1, 7)$ , concave down on  $(-\infty, -1)$  and  $(7, +\infty)$

(c)  $F'(x) = \frac{x-3}{x^2+7} = 0$  when  $x = 3$ , which is a relative minimum, and hence the absolute minimum, by the first derivative test.

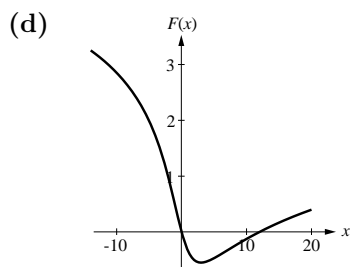

25.  $F'(x) = \frac{1}{1+x^2} + \frac{1}{1+(1/x)^2}(-1/x^2) = 0$  so  $F$  is constant on  $(0, +\infty)$ .

26.  $(-3, 3)$  because  $f$  is continuous there and 1 is in  $(-3, 3)$

27. (a) The domain is  $(-\infty, +\infty)$ ;  $F(x)$  is 0 if  $x = 1$ , positive if  $x > 1$ , and negative if  $x < 1$ , because the integrand is positive, so the sign of the integral depends on the orientation (forwards or backwards).

(b) The domain is  $[-2, 2]$ ;  $F(x)$  is 0 if  $x = -1$ , positive if  $-1 < x \leq 2$ , and negative if  $-2 \leq x < -1$ ; same reasons as in part (a).

28. The left endpoint of the top boundary is  $((b-a)/2, h)$  and the right endpoint of the top boundary is  $((b+a)/2, h)$  so

$$f(x) = \begin{cases} 2hx/(b-a), & x < (b-a)/2 \\ h, & (b-a)/2 < x < (b+a)/2 \\ 2h(x-b)/(a-b), & x > (b+a)/2 \end{cases}$$

The area of the trapezoid is given by

$$\int_0^{(b-a)/2} \frac{2hx}{b-a} dx + \int_{(b-a)/2}^{(b+a)/2} h dx + \int_{(b+a)/2}^b \frac{2h(x-b)}{a-b} dx = (b-a)h/4 + ah + (b-a)h/4 = h(a+b)/2.$$

29. (a)  $\int_0^{24} (2000e^{-t/48} + 500 \sin(\pi t/12)) dt = 96000(1 - 1/\sqrt{e}) \approx 37,773.06$

(b)  $\frac{1}{8-0} \int_0^8 (2000e^{-t/48} + 500 \sin(\pi t/12)) dt = 1125/\pi + 12000(1 - e^{-1/6}) \approx 2,200.32$

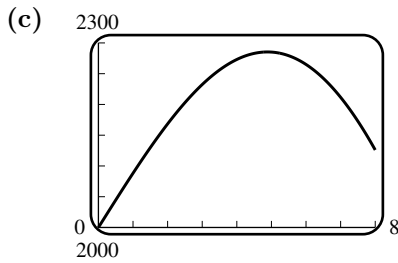

- (d) maximum rate is 2285.32 kW/h at  $t = 4.8861$

30.  $w_{\text{ave}} = \frac{1}{52-26} \int_{26}^{52} (t/7) dt = 39/7; t^*/7 = 39/7, t^* = 39$

31. (a) no, since the velocity curve is not a straight line  
 (b)  $25 < t < 40$   
 (c) 3.54 ft/s  
 (d) 141.5 ft  
 (e) no since the velocity is positive and the acceleration is never negative  
 (f) need the position at any one given time (e.g.  $s_0$ )

32. (a)  $x = ae^{kt} + be^{-kt}, dx/dt = ake^{kt} - bke^{-kt},$   
 $d^2x/dt^2 = ak^2e^{kt} + bk^2e^{-kt} = k^2(ae^{kt} + be^{-kt}) = k^2x$

(b) At  $t = 0, v = ak - bk = (a-b)k = v_0$  so  $k = v_0/(a-b)$  and  $a = k^2x = v_0^2x/(a-b)^2.$

33.  $u = 5 + 2 \sin 3x, du = 6 \cos 3x dx; \int \frac{1}{6\sqrt{u}} du = \frac{1}{3} u^{1/2} + C = \frac{1}{3} \sqrt{5 + 2 \sin 3x} + C$

34.  $u = 3 + \sqrt{x}, du = \frac{1}{2\sqrt{x}} dx; \int 2\sqrt{u} du = \frac{4}{3} u^{3/2} + C = \frac{4}{3} (3 + \sqrt{x})^{3/2} + C$

35.  $u = ax^3 + b, du = 3ax^2 dx; \int \frac{1}{3au^2} du = -\frac{1}{3au} + C = -\frac{1}{3a^2x^3 + 3ab} + C$

36.  $u = ax^2, du = 2ax dx; \frac{1}{2a} \int \sec^2 u du = \frac{1}{2a} \tan u + C = \frac{1}{2a} \tan(ax^2) + C$

37.  $\ln(e^x) + \ln(e^{-x}) = \ln(e^x e^{-x}) = \ln 1 = 0$  so  $\int [\ln(e^x) + \ln(e^{-x})] dx = C$

$$38. \left( -\frac{1}{3u^3} - \frac{3}{u} + \frac{1}{4u^4} \right) \Big|_{-2}^{-1} = 389/192$$

$$39. u = \ln x, du = (1/x)dx; \int_1^2 \frac{1}{u} du = \ln u \Big|_1^2 = \ln 2$$

$$40. \int_0^1 e^{-x/2} dx = 2(1 - 1/\sqrt{e})$$

$$41. u = e^{-2x}, du = -2e^{-2x}dx; -\frac{1}{2} \int_1^{1/4} (1 + \cos u) du = \frac{3}{8} + \frac{1}{2} \left( \sin 1 - \sin \frac{1}{4} \right)$$

$$42. \frac{1}{3\pi} \sin^3 \pi x \Big|_0^1 = 0$$

$$43. \text{With } b = 1.618034, \text{ area} = \int_0^b (x + x^2 - x^3) dx = 1.007514.$$

$$44. \text{(a)} f(x) = \frac{1}{3}x^2 \sin 3x - \frac{2}{27} \sin 3x + \frac{2}{9}x \cos 3x - 0.251607$$

$$\text{(b)} f(x) = \sqrt{4+x^2} + \frac{4}{\sqrt{4+x^2}} - 6$$

$$45. \text{(a)} \text{Solve } \frac{1}{4}k^4 - k - k^2 + \frac{7}{4} = 0 \text{ to get } k = 2.073948.$$

$$\text{(b)} \text{Solve } -\frac{1}{2} \cos 2k + \frac{1}{3}k^3 + \frac{1}{2} = 3 \text{ to get } k = 1.837992.$$

$$46. F(x) = \int_{-1}^x \frac{t}{\sqrt{2+t^3}} dt, F'(x) = \frac{x}{\sqrt{2+x^3}}, \text{ so } F \text{ is increasing on } [1, 3]; F_{\max} = F(3) \approx 1.152082854$$

and  $F_{\min} = F(1) \approx -0.07649493141$

$$47. \text{(a)} \quad \text{(b)} 0.7651976866 \quad \text{(c)} J_0(x) = 0 \text{ if } x = 2.404826$$

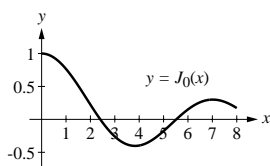

$$48. \text{(a)} A = \int_0^1 x^2 dx = \frac{1}{3}x^3 \Big|_0^1 = 1/3$$

$$\text{(b)} \sum_{k=1}^n \left( \frac{k-1}{n} \right)^2 \frac{1}{n} = \frac{1}{n^3} \left[ \sum_{k=1}^n k^2 - 2 \sum_{k=1}^n k + \sum_{k=1}^n 1 \right] = \frac{1}{n^3} \left( \frac{n(n+1)(2n+1)}{6} - 2 \frac{n(n+1)}{2} + n \right),$$

$$\lim_{n \rightarrow +\infty} \sum_{k=1}^n \left( \frac{k-1}{n} \right)^2 \frac{1}{n} = \frac{2}{6} = \frac{1}{3}$$

$$\text{(c)} \sum_{k=1}^n \left( \frac{k}{n} \right)^2 \frac{1}{n} = \frac{1}{n^3} \sum_{k=1}^n k^2 = \frac{1}{n^3} \frac{n(n+1)(2n+1)}{6} \text{ and } \lim_{n \rightarrow +\infty} \sum_{k=1}^n \left( \frac{k}{n} \right)^2 \frac{1}{n} = \frac{2}{6} = \frac{1}{3}$$

$$49. 100,000/(\ln 100,000) \approx 8,686; \int_2^{100,000} \frac{1}{\ln t} dt \approx 9,629, \text{ so the integral is better}$$

## CHAPTER 7 HORIZON MODULE

1.  $v_x(0) = 35 \cos \alpha$ , so from Equation (1),  $x(t) = (35 \cos \alpha)t$ ;  $v_y(0) = 35 \sin \alpha$ , so from Equation (2),  $y(t) = (35 \sin \alpha)t - 4.9t^2$ .

2. (a)  $v_x(t) = \frac{dx(t)}{dt} = 35 \cos \alpha$ ,  $v_y(t) = \frac{dy(t)}{dt} = 35 \sin \alpha - 9.8t$

(b)  $v_y(t) = 35 \sin \alpha - 9.8t$ ,  $v_y(t) = 0$  when  $t = 35 \sin \alpha / 9.8$ ;  
 $y = v_y(0)t - 4.9t^2 = (35 \sin \alpha)(35 \sin \alpha) / 9.8 - 4.9((35 \sin \alpha) / 9.8)^2 = 62.5 \sin^2 \alpha$ , so  
 $y_{\max} = 62.5 \sin^2 \alpha$ .

3.  $t = x / (35 \cos \alpha)$  so  $y = (35 \sin \alpha)(x / (35 \cos \alpha)) - 4.9(x / (35 \cos \alpha))^2 = (\tan \alpha)x - \frac{0.004}{\cos^2 \alpha}x^2$ ;  
the trajectory is a parabola because  $y$  is a quadratic function of  $x$ .

4.

15°	25°	35°	45°	55°	65°	75°	85°
no	yes	no	no	no	yes	no	no

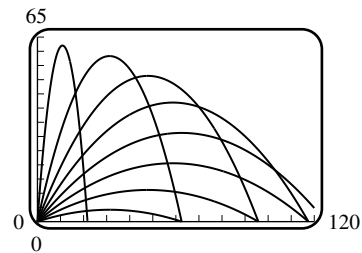

5.  $y(t) = (35 \sin \alpha)t - 4.9t^2 = 0$  when  $t = 35 \sin \alpha / 4.9$ , at which time  
 $x = (35 \cos \alpha)(35 \sin \alpha / 4.9) = 125 \sin 2\alpha$ ; this is the maximum value of  $x$ , so  $R = 125 \sin 2\alpha$  m.

6. (a)  $R = 95$  when  $\sin 2\alpha = 95/125 = 0.76$ ,  $\alpha = 0.4316565575, 1.139139769$  rad  $\approx 24.73^\circ, 65.27^\circ$ .

(b)  $y(t) < 50$  is required; but  $y(1.139) \approx 51.56$  m, so his height would be 56.56 m.

7.  $0.4019 < \alpha < 0.4636$  (radians), or  $23.03^\circ < \alpha < 26.57^\circ$



## CHAPTER 8

# Applications of the Definite Integral in Geometry, Science, and Engineering

### EXERCISE SET 8.1

$$1. A = \int_{-1}^2 (x^2 + 1 - x) dx = \left( \frac{x^3}{3} + x - \frac{x^2}{2} \right) \Big|_{-1}^2 = 9/2$$

$$2. A = \int_0^4 (\sqrt{x} + x/4) dx = \left( \frac{2x^{3/2}}{3} + x^2/8 \right) \Big|_0^4 = 22/3$$

$$3. A = \int_1^2 (y - 1/y^2) dy = \left( \frac{y^2}{2} + 1/y \right) \Big|_1^2 = 1$$

$$4. A = \int_0^2 (2 - y^2 + y) dy = \left( 2y - \frac{y^3}{3} + \frac{y^2}{2} \right) \Big|_0^2 = 10/3$$

$$5. \text{ (a) } A = \int_0^4 (4x - x^2) dx = 32/3$$

$$\text{ (b) } A = \int_0^{16} (\sqrt{y} - y/4) dy = 32/3$$

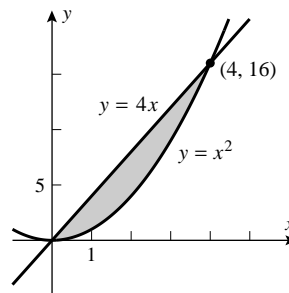

6. Eliminate  $x$  to get  $y^2 = 4(y + 4)/2$ ,  $y^2 - 2y - 8 = 0$ ,  $(y - 4)(y + 2) = 0$ ;  $y = -2, 4$  with corresponding values of  $x = 1, 4$ .

$$\begin{aligned} \text{(a) } A &= \int_0^1 [2\sqrt{x} - (-2\sqrt{x})] dx + \int_1^4 [2\sqrt{x} - (2x - 4)] dx \\ &= \int_0^1 4\sqrt{x} dx + \int_1^4 (2\sqrt{x} - 2x + 4) dx = 8/3 + 19/3 = 9 \end{aligned}$$

$$\text{(b) } A = \int_{-2}^4 [(y/2 + 2) - y^2/4] dy = 9$$

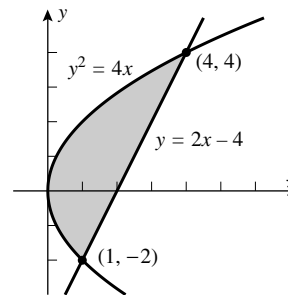

$$7. A = \int_{1/4}^1 (\sqrt{x} - x^2) dx = 49/192$$

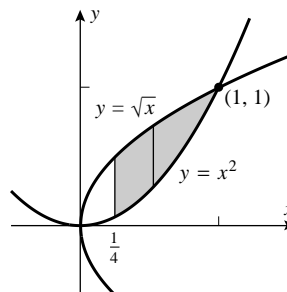

$$8. \quad A = \int_0^2 [0 - (x^3 - 4x)] dx \\ = \int_0^2 (4x - x^3) dx = 4$$

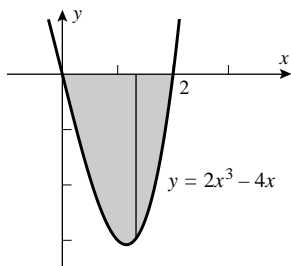

$$9. \quad A = \int_{\pi/4}^{\pi/2} (0 - \cos 2x) dx \\ = - \int_{\pi/4}^{\pi/2} \cos 2x dx = 1/2$$

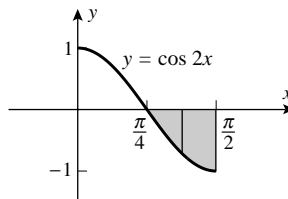

$$10. \quad \text{Equate } \sec^2 x \text{ and } 2 \text{ to get } \sec^2 x = 2,$$

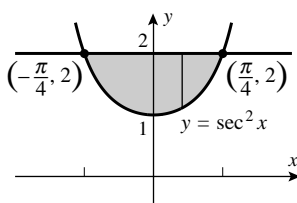

$$\sec x = \pm\sqrt{2}, \quad x = \pm\pi/4$$

$$A = \int_{-\pi/4}^{\pi/4} (2 - \sec^2 x) dx = \pi - 2$$

$$11. \quad A = \int_{\pi/4}^{3\pi/4} \sin y dy = \sqrt{2}$$

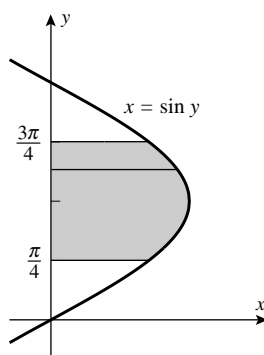

$$12. \quad A = \int_{-1}^2 [(x+2) - x^2] dx = 9/2$$

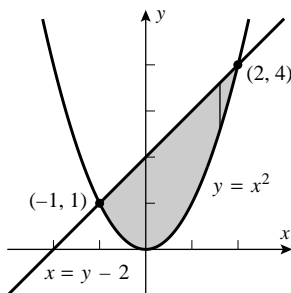

$$13. \quad A = \int_0^{\ln 2} (e^{2x} - e^x) dx = \left( \frac{1}{2}e^{2x} - e^x \right) \Big|_0^{\ln 2} \\ = 1/2$$

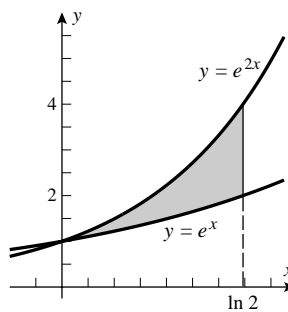

$$14. \quad A = \int_1^e \frac{dy}{y} = \ln y \Big|_1^e = 1$$

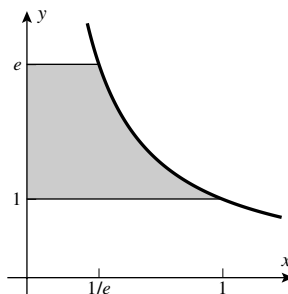

15.  $y = 2 + |x - 1| = \begin{cases} 3 - x, & x \leq 1 \\ 1 + x, & x \geq 1 \end{cases}$ ,

$$\begin{aligned} A &= \int_{-5}^1 \left[ \left( -\frac{1}{5}x + 7 \right) - (3 - x) \right] dx \\ &\quad + \int_1^5 \left[ \left( -\frac{1}{5}x + 7 \right) - (1 + x) \right] dx \\ &= \int_{-5}^1 \left( \frac{4}{5}x + 4 \right) dx + \int_1^5 \left( 6 - \frac{6}{5}x \right) dx \\ &= 72/5 + 48/5 = 24 \end{aligned}$$

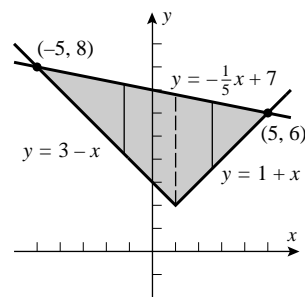

16.  $A = \int_0^{2/5} (4x - x) dx + \int_{2/5}^1 (-x + 2 - x) dx$   
 $= \int_0^{2/5} 3x dx + \int_{2/5}^1 (2 - 2x) dx = 3/5$

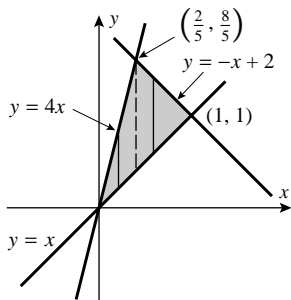

17.  $A = \int_0^1 (x^3 - 4x^2 + 3x) dx + \int_1^3 [-(x^3 - 4x^2 + 3x)] dx$   
 $= 5/12 + 32/12 = 37/12$

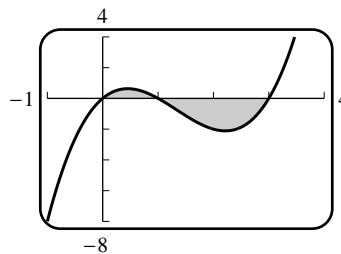

18. Equate  $y = x^3 - 2x^2$  and  $y = 2x^2 - 3x$  to get  $x^3 - 4x^2 + 3x = 0$ ,  
 $x(x - 1)(x - 3) = 0$ ;  $x = 0, 1, 3$   
 with corresponding values of  $y = 0, -1.9$ .

$$\begin{aligned} A &= \int_0^1 [(x^3 - 2x^2) - (2x^2 - 3x)] dx \\ &\quad + \int_1^3 [(2x^3 - 3x) - (x^3 - 2x^2)] dx \\ &= \int_0^1 (x^3 - 4x^2 + 3x) dx + \int_1^3 (-x^3 + 4x^2 - 3x) dx \\ &= \frac{5}{12} + \frac{8}{3} = \frac{37}{12} \end{aligned}$$

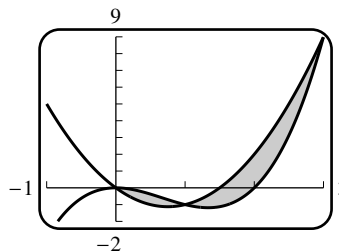

19. From the symmetry of the region

$$A = 2 \int_{\pi/4}^{5\pi/4} (\sin x - \cos x) dx = 4\sqrt{2}$$

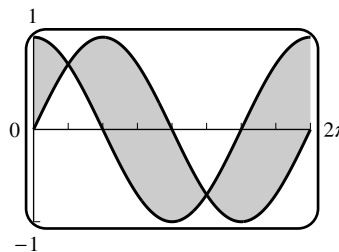

20. The region is symmetric about the origin so

$$A = 2 \int_{-2}^0 (x^3 - 4x) dx = 8$$

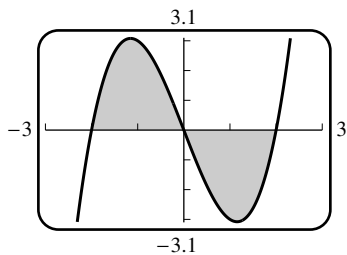

21.  $A = \int_{-1}^0 (y^3 - y) dy + \int_0^1 -(y^3 - y) dy$   
 $= 1/2$

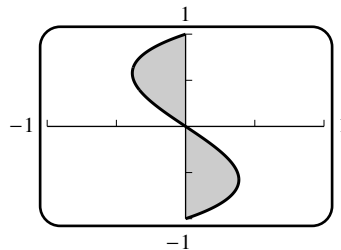

22.  $A = \int_0^1 [y^3 - 4y^2 + 3y - (y^2 - y)] dy$   
 $+ \int_1^4 [y^2 - y - (y^3 - 4y^2 + 3y)] dy$   
 $= 7/12 + 45/4 = 71/6$

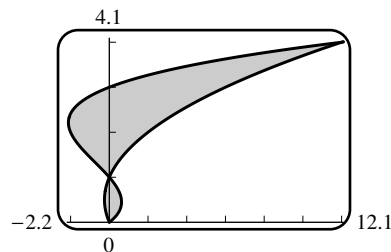

23. Solve  $3 - 2x = x^6 + 2x^5 - 3x^4 + x^2$  to find the real roots  $x = -3, 1$ ; from a plot it is seen that the line is above the polynomial when  $-3 < x < 1$ , so  $A = \int_{-3}^1 (3 - 2x - (x^6 + 2x^5 - 3x^4 + x^2)) dx = 9152/105$

24. Solve  $x^5 - 2x^3 - 3x = x^3$  to find the roots  $x = 0, \pm \frac{1}{2}\sqrt{6 + 2\sqrt{21}}$ . Thus, by symmetry,

$$A = 2 \int_0^{\sqrt{(6+2\sqrt{21})}/2} (x^3 - (x^5 - 2x^3 - 3x)) dx = \frac{27}{4} + \frac{7}{4}\sqrt{21}$$

25.  $\int_0^k 2\sqrt{y} dy = \int_k^9 2\sqrt{y} dy$

$$\int_0^k y^{1/2} dy = \int_k^9 y^{1/2} dy$$

$$\frac{2}{3}k^{3/2} = \frac{2}{3}(27 - k^{3/2})$$

$$k^{3/2} = 27/2$$

$$k = (27/2)^{2/3} = 9/\sqrt[3]{4}$$

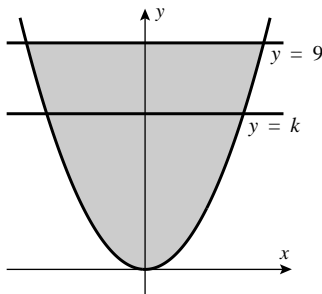

26.  $\int_0^k x^2 dx = \int_k^2 x^2 dx$

$$\frac{1}{3}k^3 = \frac{1}{3}(8 - k^3)$$

$$k^3 = 4$$

$$k = \sqrt[3]{4}$$

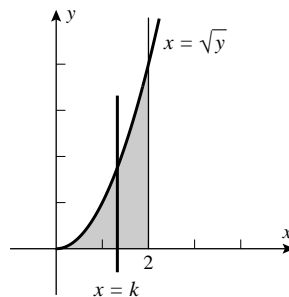

27. (a)  $A = \int_0^2 (2x - x^2) dx = 4/3$

(b)  $y = mx$  intersects  $y = 2x - x^2$  where  $mx = 2x - x^2, x^2 + (m - 2)x = 0, x(x + m - 2) = 0$  so  $x = 0$  or  $x = 2 - m$ . The area below the curve and above the line is

$$\int_0^{2-m} (2x - x^2 - mx) dx = \int_0^{2-m} [(2-m)x - x^2] dx = \left[ \frac{1}{2}(2-m)x^2 - \frac{1}{3}x^3 \right]_0^{2-m} = \frac{1}{6}(2-m)^3$$

so  $(2-m)^3/6 = (1/2)(4/3) = 2/3, (2-m)^3 = 4, m = 2 - \sqrt[3]{4}$ .

28. The line through  $(0, 0)$  and  $(5\pi/6, 1/2)$  is  $y = \frac{3}{5\pi}x$ ;

$$A = \int_0^{5\pi/6} \left( \sin x - \frac{3}{5\pi}x \right) dx = \frac{\sqrt{3}}{2} - \frac{5}{24}\pi + 1$$

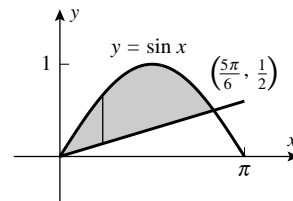

29. (a) It gives the area of the region that is between  $f$  and  $g$  when  $f(x) > g(x)$  minus the area of the region between  $f$  and  $g$  when  $f(x) < g(x)$ , for  $a \leq x \leq b$ .

(b) It gives the area of the region that is between  $f$  and  $g$  for  $a \leq x \leq b$ .

30. (b)  $\lim_{n \rightarrow +\infty} \int_0^1 (x^{1/n} - x) dx = \lim_{n \rightarrow +\infty} \left[ \frac{n}{n+1}x^{(n+1)/n} - \frac{x^2}{2} \right]_0^1 = \lim_{n \rightarrow +\infty} \left( \frac{n}{n+1} - \frac{1}{2} \right) = 1/2$

31. The curves intersect at  $x = 0$  and, by Newton's Method, at  $x \approx 2.595739080 = b$ , so

$$A \approx \int_0^b (\sin x - 0.2x) dx = -[\cos x + 0.1x^2]_0^b \approx 1.180898334$$

32. By Newton's Method, the points of intersection are at  $x \approx \pm 0.824132312$ , so with

$$b = 0.824132312 \text{ we have } A \approx 2 \int_0^b (\cos x - x^2) dx = 2(\sin x - x^3/3) \Big|_0^b \approx 1.094753609$$

33. distance =  $\int |v| dt$ , so

(a) distance =  $\int_0^{60} (3t - t^2/20) dt = 1800$  ft.

(b) If  $T \leq 60$  then distance =  $\int_0^T (3t - t^2/20) dt = \frac{3}{2}T^2 - \frac{1}{60}T^3$  ft.

34. Since  $a_1(0) = a_2(0) = 0$ ,  $A = \int_0^T (a_2(t) - a_1(t)) dt = v_2(T) - v_1(T)$  is the difference in the velocities of the two cars at time  $T$ .

35. Solve  $x^{1/2} + y^{1/2} = a^{1/2}$  for  $y$  to get

$$y = (a^{1/2} - x^{1/2})^2 = a - 2a^{1/2}x^{1/2} + x$$

$$A = \int_0^a (a - 2a^{1/2}x^{1/2} + x) dx = a^2/6$$

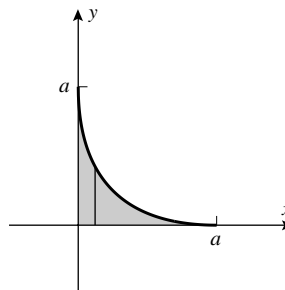

36. Solve for  $y$  to get  $y = (b/a)\sqrt{a^2 - x^2}$  for the upper half of the ellipse; make use of symmetry to get  $A = 4 \int_0^a \frac{b}{a} \sqrt{a^2 - x^2} dx = \frac{4b}{a} \int_0^a \sqrt{a^2 - x^2} dx = \frac{4b}{a} \times \frac{1}{4} \pi a^2 = \pi ab$ .
37. Let  $A$  be the area between the curve and the  $x$ -axis and  $A_R$  the area of the rectangle, then  $A = \int_0^b kx^m dx = \frac{k}{m+1} x^{m+1} \Big|_0^b = \frac{kb^{m+1}}{m+1}$ ,  $A_R = b(kb^m) = kb^{m+1}$ , so  $A/A_R = 1/(m+1)$ .

### EXERCISE SET 8.2

1.  $V = \pi \int_{-1}^3 (3-x) dx = 8\pi$

2.  $V = \pi \int_0^1 [(2-x^2)^2 - x^2] dx$   
 $= \pi \int_0^1 (4 - 5x^2 + x^4) dx$   
 $= 38\pi/15$

3.  $V = \pi \int_0^2 \frac{1}{4} (3-y)^2 dy = 13\pi/6$

4.  $V = \pi \int_{1/2}^2 (4 - 1/y^2) dy = 9\pi/2$

5.  $V = \pi \int_0^2 x^4 dx = 32\pi/5$

6.  $V = \pi \int_{\pi/4}^{\pi/3} \sec^2 x dx = \pi(\sqrt{3} - 1)$

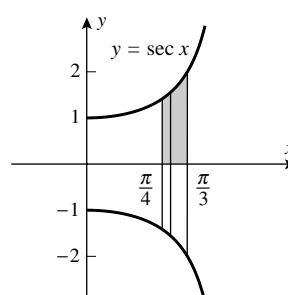
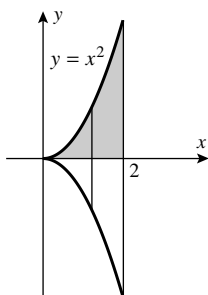

7.  $V = \pi \int_{\pi/4}^{\pi/2} \cos x dx = (1 - \sqrt{2}/2)\pi$

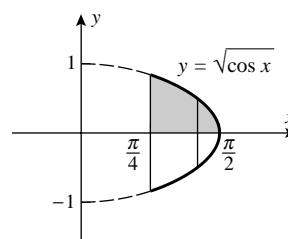

8.  $V = \pi \int_0^1 [(x^2)^2 - (x^3)^2] dx$   
 $= \pi \int_0^1 (x^4 - x^6) dx = 2\pi/35$

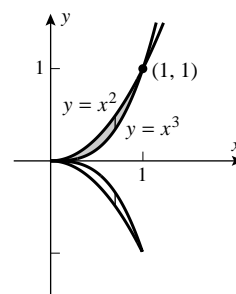

$$9. \quad V = \pi \int_{-4}^4 [(25 - x^2) - 9] dx$$

$$= 2\pi \int_0^4 (16 - x^2) dx = 256\pi/3$$

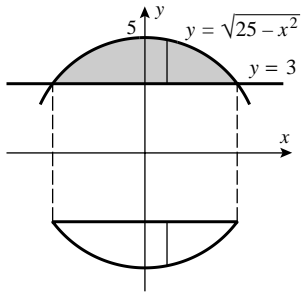

$$10. \quad V = \pi \int_{-3}^3 (9 - x^2)^2 dx$$

$$= \pi \int_{-3}^3 (81 - 18x^2 + x^4) dx = 1296\pi/5$$

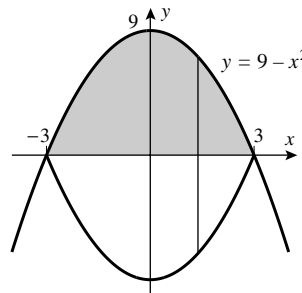

$$11. \quad V = \pi \int_0^{\ln 3} e^{2x} dx = \frac{\pi}{2} e^{2x} \Big|_0^{\ln 3} = 4\pi$$

$$12. \quad V = \pi \int_0^1 e^{-4x} dx = \frac{\pi}{4} (1 - e^{-4})$$

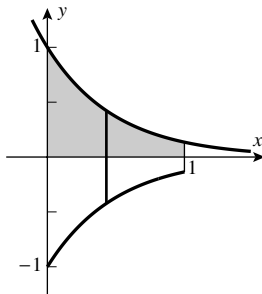

$$13. \quad V = \pi \int_0^4 [(4x)^2 - (x^2)^2] dx$$

$$= \pi \int_0^4 (16x^2 - x^4) dx = 2048\pi/15$$

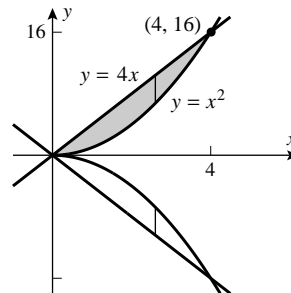

$$14. \quad V = \pi \int_0^{\pi/4} (\cos^2 x - \sin^2 x) dx$$

$$= \pi \int_0^{\pi/4} \cos 2x dx = \pi/2$$

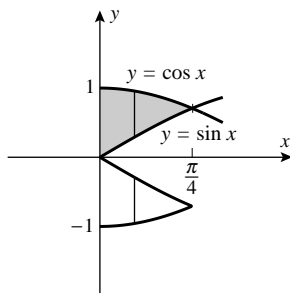

$$15. \quad V = \pi \int_0^1 y^{2/3} dy = 3\pi/5$$

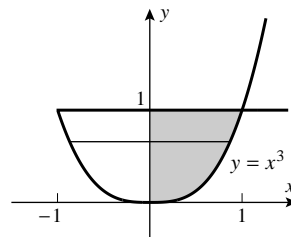

$$16. \quad V = \pi \int_{-1}^1 (1 - y^2)^2 dy$$

$$= \pi \int_{-1}^1 (1 - 2y^2 + y^4) dy = 16\pi/15$$

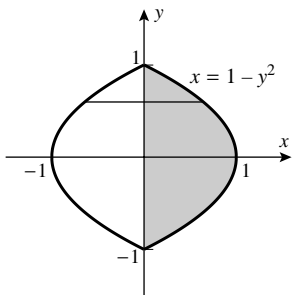

$$17. \quad V = \pi \int_{-1}^3 (1 + y) dy = 8\pi$$

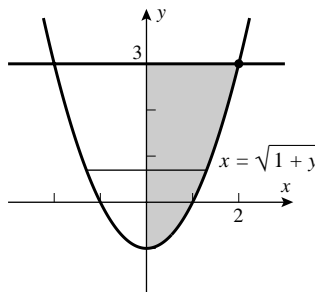

$$18. \quad V = \pi \int_0^3 [2^2 - (y + 1)] dy$$

$$= \pi \int_0^3 (3 - y) dy = 9\pi/2$$

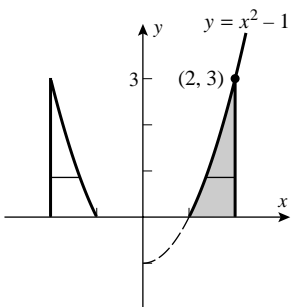

$$19. \quad V = \pi \int_{\pi/4}^{3\pi/4} \csc^2 y dy = 2\pi$$

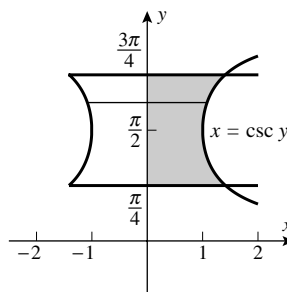

$$20. \quad V = \pi \int_0^1 (y - y^4) dy = 3\pi/10$$

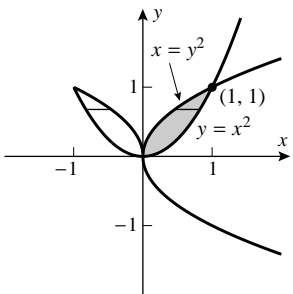

$$21. \quad V = \pi \int_{-1}^2 [(y + 2)^2 - y^4] dy = 72\pi/5$$

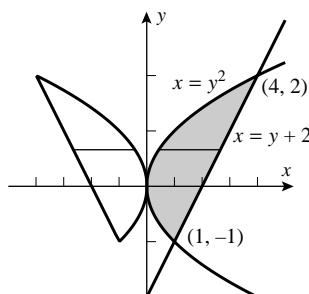

$$22. \quad V = \pi \int_{-1}^1 [(2 + y^2)^2 - (1 - y^2)^2] dy$$

$$= \pi \int_{-1}^1 (3 + 6y^2) dy = 10\pi$$

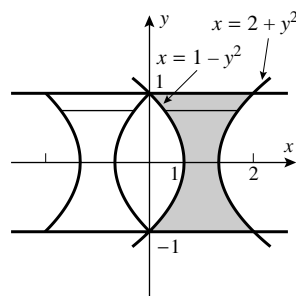



23.  $V = \pi \int_{-a}^a \frac{b^2}{a^2} (a^2 - x^2) dx = 4\pi ab^2/3$

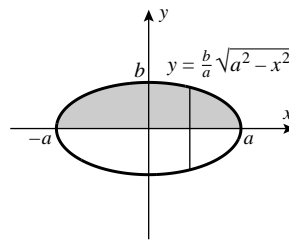

24.  $V = \pi \int_b^2 \frac{1}{x^2} dx = \pi(1/b - 1/2); \pi(1/b - 1/2) = 3, b = 2\pi/(\pi + 6)$

25.  $V = \pi \int_{-1}^0 (x+1) dx$   
 $+ \pi \int_0^1 [(x+1) - 2x] dx$   
 $= \pi/2 + \pi/2 = \pi$

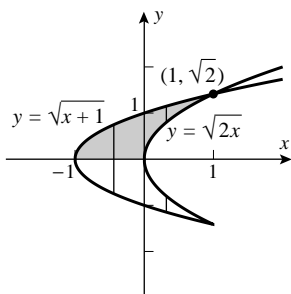

26.  $V = \pi \int_0^4 x dx + \pi \int_4^6 (6-x)^2 dx$   
 $= 8\pi + 8\pi/3 = 32\pi/3$

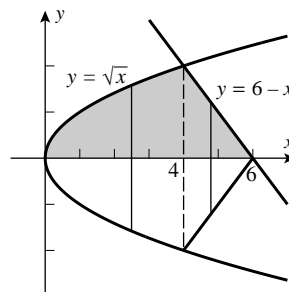

27.  $V = \pi \int_0^3 (9 - y^2)^2 dy$   
 $= \pi \int_0^3 (81 - 18y^2 + y^4) dy$   
 $= 648\pi/5$

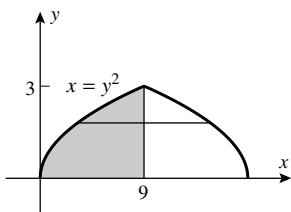

28.  $V = \pi \int_0^9 [3^2 - (3 - \sqrt{x})^2] dx$   
 $= \pi \int_0^9 (6\sqrt{x} - x) dx$   
 $= 135\pi/2$

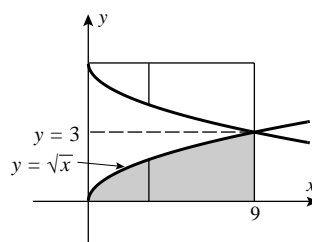

29.  $V = \pi \int_0^1 [(\sqrt{x} + 1)^2 - (x + 1)^2] dx$   
 $= \pi \int_0^1 (2\sqrt{x} - x - x^2) dx = \pi/2$

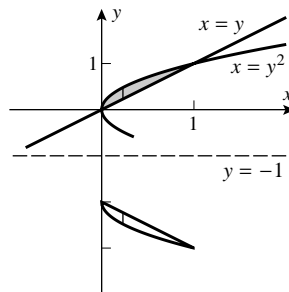

30. 
$$V = \pi \int_0^1 [(y+1)^2 - (y^2+1)^2] dy$$

$$= \pi \int_0^1 (2y - y^2 - y^4) dy = 7\pi/15$$

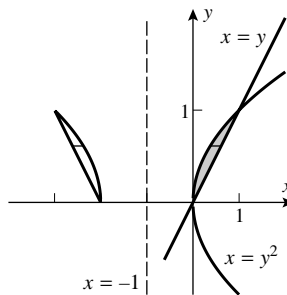

31. 
$$A(x) = \pi(x^2/4)^2 = \pi x^4/16,$$

$$V = \int_0^{20} (\pi x^4/16) dx = 40,000\pi \text{ ft}^3$$

32. 
$$V = \pi \int_0^1 (x - x^4) dx = 3\pi/10$$

33. 
$$V = \int_0^1 (x - x^2)^2 dx$$

$$= \int_0^1 (x^2 - 2x^3 + x^4) dx = 1/30$$

34. 
$$A(x) = \frac{1}{2}\pi \left(\frac{1}{2}\sqrt{x}\right)^2 = \frac{1}{8}\pi x,$$

$$V = \int_0^4 \frac{1}{8}\pi x dx = \pi$$

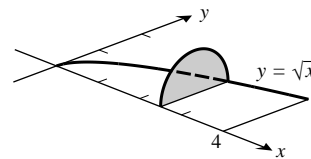
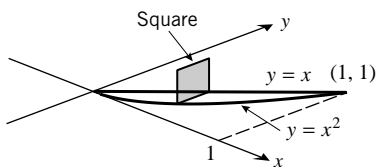

35. On the upper half of the circle,  $y = \sqrt{1-x^2}$ , so:

(a)  $A(x)$  is the area of a semicircle of radius  $y$ , so

$$A(x) = \pi y^2/2 = \pi(1-x^2)/2; V = \frac{\pi}{2} \int_{-1}^1 (1-x^2) dx = \pi \int_0^1 (1-x^2) dx = 2\pi/3$$

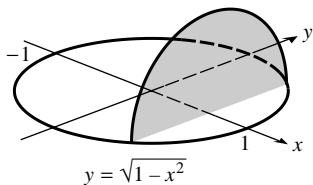

(b)  $A(x)$  is the area of a square of side  $2y$ , so

$$A(x) = 4y^2 = 4(1-x^2); V = 4 \int_{-1}^1 (1-x^2) dx = 8 \int_0^1 (1-x^2) dx = 16/3$$

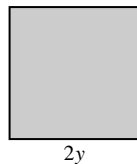
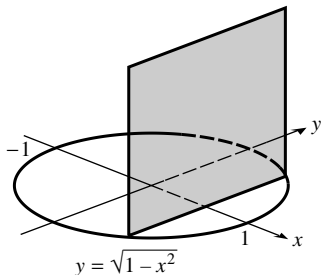

(c)  $A(x)$  is the area of an equilateral triangle with sides  $2y$ , so

$$A(x) = \frac{\sqrt{3}}{4}(2y)^2 = \sqrt{3}y^2 = \sqrt{3}(1-x^2);$$

$$V = \int_{-1}^1 \sqrt{3}(1-x^2) dx = 2\sqrt{3} \int_0^1 (1-x^2) dx = 4\sqrt{3}/3$$

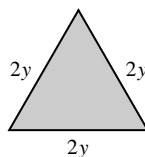
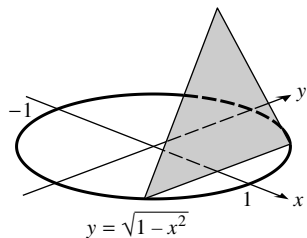

36. By similar triangles,  $R/r = y/h$  so

$$R = ry/h \text{ and } A(y) = \pi r^2 y^2 / h^2.$$

$$V = (\pi r^2 / h^2) \int_0^h y^2 dy = \pi r^2 h / 3$$

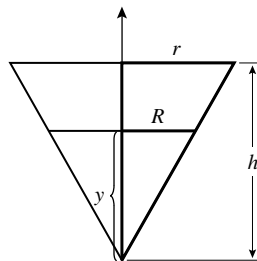

37. The two curves cross at  $x = b \approx 1.403288534$ , so

$$V = \pi \int_0^b ((2x/\pi)^2 - \sin^{16} x) dx + \pi \int_b^{\pi/2} (\sin^{16} x - (2x/\pi)^2) dx = 0.710172176.$$

38.  $V = \pi \int_1^e (1 - (\ln y)^2) dy = \pi$

39. (a)  $V = \pi \int_{r-h}^r (r^2 - y^2) dy = \pi(rh^2 - h^3/3) = \frac{1}{3}\pi h^2(3r - h)$

(b) By the Pythagorean Theorem,

$$r^2 = (r-h)^2 + \rho^2, \quad 2hr = h^2 + \rho^2; \text{ from part (a),}$$

$$\begin{aligned} V &= \frac{\pi h}{3}(3hr - h^2) = \frac{\pi h}{3} \left( \frac{3}{2}(h^2 + \rho^2) - h^2 \right) \\ &= \frac{1}{6}\pi h(h^2 + 3\rho^2). \end{aligned}$$

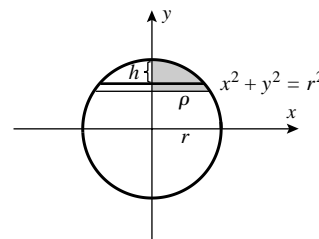

40. Find the volume generated by revolving the shaded region about the  $y$ -axis.

$$V = \pi \int_{-10}^{-10+h} (100 - y^2) dy = \frac{\pi}{3} h^2(30 - h)$$

Find  $dh/dt$  when  $h = 5$  given that  $dV/dt = 1/2$ .

$$V = \frac{\pi}{3}(30h^2 - h^3), \quad \frac{dV}{dt} = \frac{\pi}{3}(60h - 3h^2) \frac{dh}{dt},$$

$$\frac{1}{2} = \frac{\pi}{3}(300 - 75) \frac{dh}{dt}, \quad \frac{dh}{dt} = 1/(150\pi) \text{ ft/min}$$

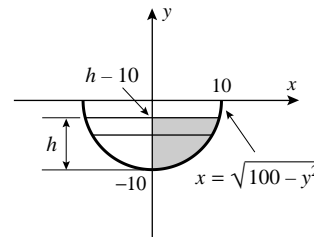

41. (b)  $\Delta x = \frac{5}{10} = 0.5$ ;  $\{y_0, y_1, \dots, y_{10}\} = \{0, 2.00, 2.45, 2.45, 2.00, 1.46, 1.26, 1.25, 1.25, 1.25, 1.25\}$ ;

$$\text{left} = \pi \sum_{i=0}^9 \left(\frac{y_i}{2}\right)^2 \Delta x \approx 11.157;$$

$$\text{right} = \pi \sum_{i=1}^{10} \left(\frac{y_i}{2}\right)^2 \Delta x \approx 11.771; V \approx \text{average} = 11.464 \text{ cm}^3$$

42. If  $x = r/2$  then from  $y^2 = r^2 - x^2$  we get  $y = \pm\sqrt{3}r/2$  as limits of integration; for  $-\sqrt{3} \leq y \leq \sqrt{3}$ ,

$$A(y) = \pi[(r^2 - y^2) - r^2/4] = \pi(3r^2/4 - y^2), \text{ thus}$$

$$\begin{aligned} V &= \pi \int_{-\sqrt{3}r/2}^{\sqrt{3}r/2} (3r^2/4 - y^2) dy \\ &= 2\pi \int_0^{\sqrt{3}r/2} (3r^2/4 - y^2) dy = \sqrt{3}\pi r^3/2. \end{aligned}$$

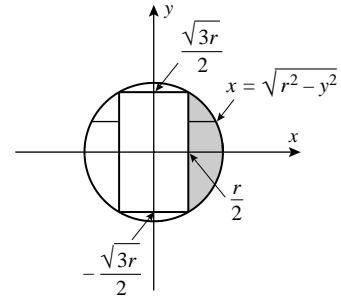

43. (a)

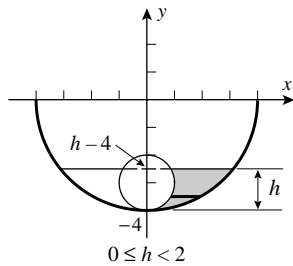

- (b)

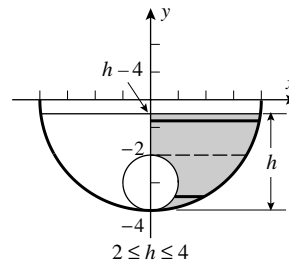

If the cherry is partially submerged then  $0 \leq h < 2$  as shown in Figure (a); if it is totally submerged then  $2 \leq h \leq 4$  as shown in Figure (b). The radius of the glass is 4 cm and that of the cherry is 1 cm so points on the sections shown in the figures satisfy the equations  $x^2 + y^2 = 16$  and  $x^2 + (y + 3)^2 = 1$ . We will find the volumes of the solids that are generated when the shaded regions are revolved about the  $y$ -axis.

For  $0 \leq h < 2$ ,

$$V = \pi \int_{-4}^{h-4} [(16 - y^2) - (1 - (y + 3)^2)] dy = 6\pi \int_{-4}^{h-4} (y + 4) dy = 3\pi h^2;$$

for  $2 \leq h \leq 4$ ,

$$\begin{aligned} V &= \pi \int_{-4}^{-2} [(16 - y^2) - (1 - (y + 3)^2)] dy + \pi \int_{-2}^{h-4} (16 - y^2) dy \\ &= 6\pi \int_{-4}^{-2} (y + 4) dy + \pi \int_{-2}^{h-4} (16 - y^2) dy = 12\pi + \frac{1}{3}\pi(12h^2 - h^3 - 40) \\ &= \frac{1}{3}\pi(12h^2 - h^3 - 4) \end{aligned}$$

so

$$V = \begin{cases} 3\pi h^2 & \text{if } 0 \leq h < 2 \\ \frac{1}{3}\pi(12h^2 - h^3 - 4) & \text{if } 2 \leq h \leq 4 \end{cases}$$

44.  $x = h \pm \sqrt{r^2 - y^2}$ ,

$$\begin{aligned} V &= \pi \int_{-r}^r \left[ (h + \sqrt{r^2 - y^2})^2 - (h - \sqrt{r^2 - y^2})^2 \right] dy \\ &= 4\pi h \int_{-r}^r \sqrt{r^2 - y^2} dy \\ &= 4\pi h \left( \frac{1}{2} \pi r^2 \right) = 2\pi^2 r^2 h \end{aligned}$$

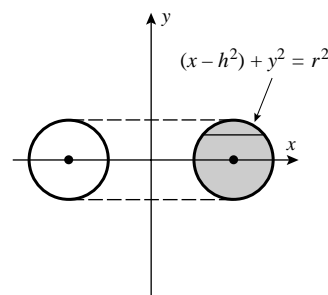

45.  $\tan \theta = h/x$  so  $h = x \tan \theta$ ,

$$A(y) = \frac{1}{2}hx = \frac{1}{2}x^2 \tan \theta = \frac{1}{2}(r^2 - y^2) \tan \theta$$

because  $x^2 = r^2 - y^2$ ,

$$\begin{aligned} V &= \frac{1}{2} \tan \theta \int_{-r}^r (r^2 - y^2) dy \\ &= \tan \theta \int_0^r (r^2 - y^2) dy = \frac{2}{3} r^3 \tan \theta \end{aligned}$$

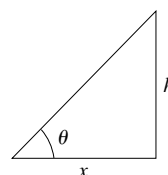

46.  $A(x) = (x \tan \theta)(2\sqrt{r^2 - x^2})$

$$= 2(\tan \theta)x\sqrt{r^2 - x^2},$$

$$V = 2 \tan \theta \int_0^r x\sqrt{r^2 - x^2} dx$$

$$= \frac{2}{3} r^3 \tan \theta$$

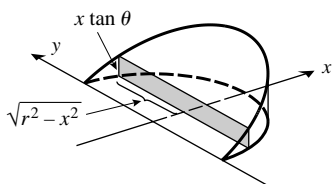

47. Each cross section perpendicular to the  $y$ -axis is a square so

$$A(y) = x^2 = r^2 - y^2,$$

$$\frac{1}{8}V = \int_0^r (r^2 - y^2) dy$$

$$V = 8(2r^3/3) = 16r^3/3$$

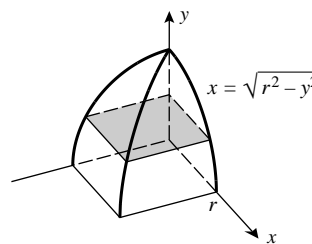

48. The regular cylinder of radius  $r$  and height  $h$  has the same circular cross sections as do those of the oblique cylinder, so by Cavalieri's Principle, they have the same volume:  $\pi r^2 h$ .

### EXERCISE SET 8.3

1.  $V = \int_1^2 2\pi x(x^2) dx = 2\pi \int_1^2 x^3 dx = 15\pi/2$

2.  $V = \int_0^{\sqrt{2}} 2\pi x(\sqrt{4-x^2} - x) dx = 2\pi \int_0^{\sqrt{2}} (x\sqrt{4-x^2} - x^2) dx = \frac{8\pi}{3}(2 - \sqrt{2})$

3.  $V = \int_0^1 2\pi y(2y - 2y^2) dy = 4\pi \int_0^1 (y^2 - y^3) dy = \pi/3$

$$4. V = \int_0^2 2\pi y[y - (y^2 - 2)]dy = 2\pi \int_0^2 (y^2 - y^3 + 2y)dy = 16\pi/3$$

$$5. V = \int_0^1 2\pi(x)(x^3)dx \\ = 2\pi \int_0^1 x^4 dx = 2\pi/5$$

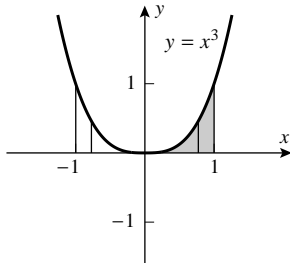

$$6. V = \int_4^9 2\pi x(\sqrt{x})dx \\ = 2\pi \int_4^9 x^{3/2} dx = 844\pi/5$$

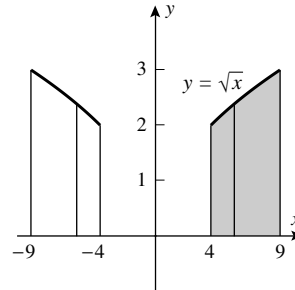

$$7. V = \int_1^3 2\pi x(1/x)dx = 2\pi \int_1^3 dx = 4\pi$$

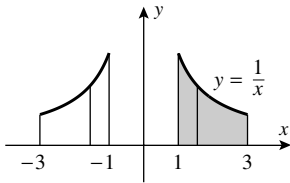

$$8. V = \int_0^{\sqrt{\pi}/2} 2\pi x \cos(x^2)dx = \pi/\sqrt{2}$$

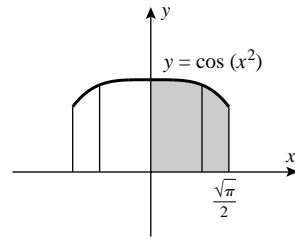

$$9. V = \int_1^2 2\pi x[(2x - 1) - (-2x + 3)]dx \\ = 8\pi \int_1^2 (x^2 - x)dx = 20\pi/3$$

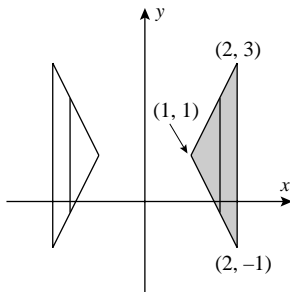

$$10. V = 2\pi \int_0^1 \frac{x}{x^2 + 1} dx \\ = \pi \ln(x^2 + 1) \Big|_0^1 = \pi \ln 2$$

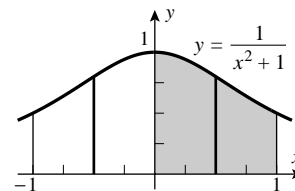

$$11. V = \int_1^{\sqrt{3}} 2\pi x e^{x^2} dx = \pi e^{x^2} \Big|_1^{\sqrt{3}} = \pi(e^3 - e)$$

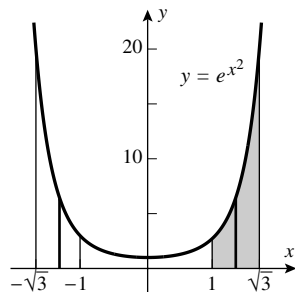

$$12. \quad V = \int_0^2 2\pi x(2x - x^2) dx$$

$$= 2\pi \int_0^2 (2x^2 - x^3) dx = \frac{8}{3}\pi$$

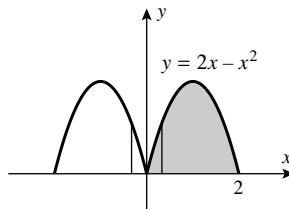

$$13. \quad V = \int_0^1 2\pi y^3 dy = \pi/2$$

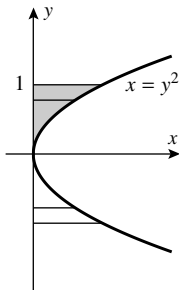

$$14. \quad V = \int_2^3 2\pi y(2y) dy = 4\pi \int_2^3 y^2 dy = 76\pi/3$$

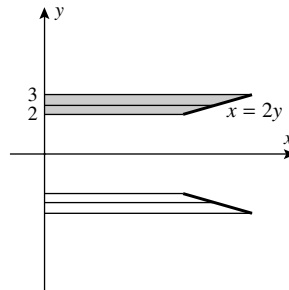

$$15. \quad V = \int_0^1 2\pi y(1 - \sqrt{y}) dy$$

$$= 2\pi \int_0^1 (y - y^{3/2}) dy = \pi/5$$

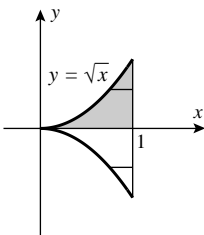

$$16. \quad V = \int_1^4 2\pi y(5 - y - 4/y) dy$$

$$= 2\pi \int_1^4 (5y - y^2 - 4) dy = 9\pi$$

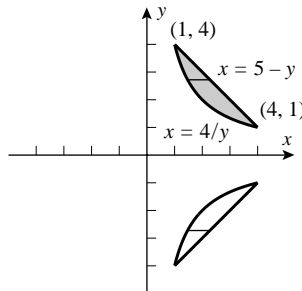

$$17. \quad V = 2\pi \int_0^\pi x \sin x dx = 2\pi^2$$

$$18. \quad V = 2\pi \int_0^{\pi/2} x \cos x dx = \pi^2 - 2\pi$$

$$19. \quad (a) \quad V = \int_0^1 2\pi x(x^3 - 3x^2 + 2x) dx = 7\pi/30$$

(b) much easier; the method of slicing would require that  $x$  be expressed in terms of  $y$ .

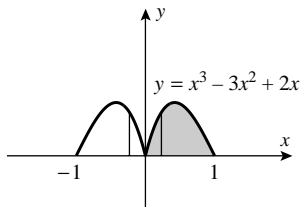

$$\begin{aligned}
 20. \quad V &= \int_1^2 2\pi(x+1)(1/x^3)dx \\
 &= 2\pi \int_1^2 (x^{-2} + x^{-3})dx = 7\pi/4
 \end{aligned}$$

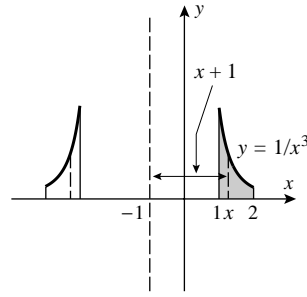

$$\begin{aligned}
 21. \quad V &= \int_0^1 2\pi(1-y)y^{1/3}dy \\
 &= 2\pi \int_0^1 (y^{1/3} - y^{4/3})dy = 9\pi/14
 \end{aligned}$$

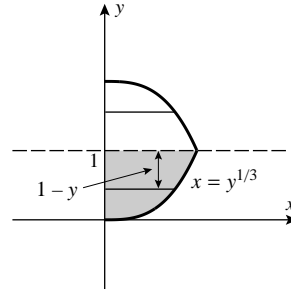

$$22. \quad \text{(a)} \quad \int_a^b 2\pi x[f(x) - g(x)]dx$$

$$\text{(b)} \quad \int_c^d 2\pi y[f(y) - g(y)]dy$$

23.  $x = \frac{h}{r}(r - y)$  is an equation of the line through  $(0, r)$  and  $(h, 0)$  so

$$\begin{aligned}
 V &= \int_0^r 2\pi y \left[ \frac{h}{r}(r - y) \right] dy \\
 &= \frac{2\pi h}{r} \int_0^r (ry - y^2)dy = \pi r^2 h/3
 \end{aligned}$$

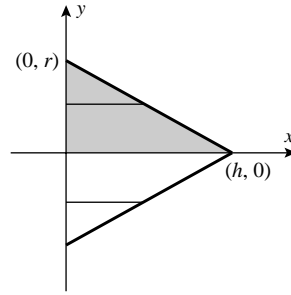

$$\begin{aligned}
 24. \quad V &= \int_0^{k/4} 2\pi(k/2 - x)2\sqrt{kx}dx \\
 &= 2\pi\sqrt{k} \int_0^{k/4} (kx^{1/2} - 2x^{3/2})dx = 7\pi k^3/60
 \end{aligned}$$

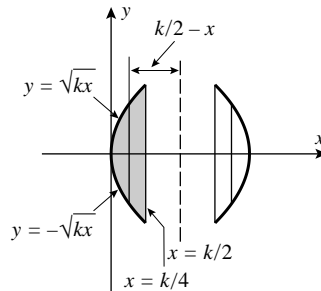

$$\begin{aligned}
 25. \quad V &= \int_0^a 2\pi x(2\sqrt{r^2 - x^2})dx = 4\pi \int_0^a x(r^2 - x^2)^{1/2}dx \\
 &= -\frac{4\pi}{3}(r^2 - x^2)^{3/2} \Big|_0^a = \frac{4\pi}{3} [r^3 - (r^2 - a^2)^{3/2}]
 \end{aligned}$$

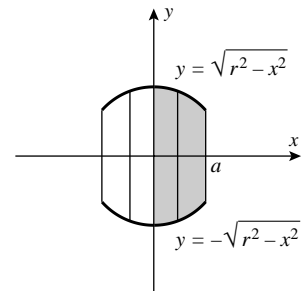



$$\begin{aligned}
 26. \quad V &= \int_{-a}^a 2\pi(b-x)(2\sqrt{a^2-x^2})dx \\
 &= 4\pi b \int_{-a}^a \sqrt{a^2-x^2}dx - 4\pi \int_{-a}^a x\sqrt{a^2-x^2}dx \\
 &= 4\pi b \cdot (\text{area of a semicircle of radius } a) - 4\pi(0) \\
 &= 2\pi^2 a^2 b
 \end{aligned}$$

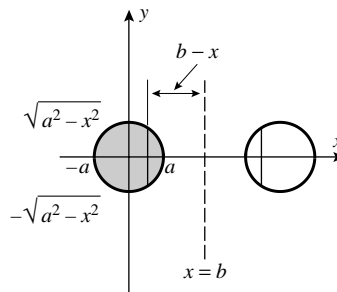

$$27. \quad V_x = \pi \int_{1/2}^b \frac{1}{x^2} dx = \pi(2 - 1/b), \quad V_y = 2\pi \int_{1/2}^b dx = \pi(2b - 1);$$

$$V_x = V_y \text{ if } 2 - 1/b = 2b - 1, \quad 2b^2 - 3b + 1 = 0, \text{ solve to get } b = 1/2 \text{ (reject) or } b = 1.$$

### EXERCISE SET 8.4

$$1. \quad (\text{a}) \quad \frac{dy}{dx} = 2, \quad L = \int_1^2 \sqrt{1+4} dx = \sqrt{5}$$

$$(\text{b}) \quad \frac{dx}{dy} = \frac{1}{2}, \quad L = \int_2^4 \sqrt{1+1/4} dy = 2\sqrt{5}/2 = \sqrt{5}$$

$$2. \quad \frac{dx}{dt} = 1, \quad \frac{dy}{dt} = 5, \quad L = \int_0^1 \sqrt{1^2 + 5^2} dt = \sqrt{26}$$

$$3. \quad f'(x) = \frac{9}{2}x^{1/2}, \quad 1 + [f'(x)]^2 = 1 + \frac{81}{4}x,$$

$$L = \int_0^1 \sqrt{1 + 81x/4} dx = \frac{8}{243} \left(1 + \frac{81}{4}x\right)^{3/2} \Big|_0^1 = (85\sqrt{85} - 8)/243$$

$$4. \quad g'(y) = y(y^2 + 2)^{1/2}, \quad 1 + [g'(y)]^2 = 1 + y^2(y^2 + 2) = y^4 + 2y^2 + 1 = (y^2 + 1)^2,$$

$$L = \int_0^1 \sqrt{(y^2 + 1)^2} dy = \int_0^1 (y^2 + 1) dy = 4/3$$

$$5. \quad \frac{dy}{dx} = \frac{2}{3}x^{-1/3}, \quad 1 + \left(\frac{dy}{dx}\right)^2 = 1 + \frac{4}{9}x^{-2/3} = \frac{9x^{2/3} + 4}{9x^{2/3}},$$

$$L = \int_1^8 \frac{\sqrt{9x^{2/3} + 4}}{3x^{1/3}} dx = \frac{1}{18} \int_{13}^{40} u^{1/2} du, \quad u = 9x^{2/3} + 4$$

$$= \frac{1}{27} u^{3/2} \Big|_{13}^{40} = \frac{1}{27} (40\sqrt{40} - 13\sqrt{13}) = \frac{1}{27} (80\sqrt{10} - 13\sqrt{13})$$

or (alternate solution)

$$x = y^{3/2}, \quad \frac{dx}{dy} = \frac{3}{2}y^{1/2}, \quad 1 + \left(\frac{dx}{dy}\right)^2 = 1 + \frac{9}{4}y = \frac{4 + 9y}{4},$$

$$L = \frac{1}{2} \int_1^4 \sqrt{4 + 9y} dy = \frac{1}{18} \int_{13}^{40} u^{1/2} du = \frac{1}{27} (80\sqrt{10} - 13\sqrt{13})$$

6.  $f'(x) = \frac{1}{4}x^3 - x^{-3}$ ,  $1 + [f'(x)]^2 = 1 + \left(\frac{1}{16}x^6 - \frac{1}{2} + x^{-6}\right) = \frac{1}{16}x^6 + \frac{1}{2} + x^{-6} = \left(\frac{1}{4}x^3 + x^{-3}\right)^2$ ,  
 $L = \int_2^3 \sqrt{\left(\frac{1}{4}x^3 + x^{-3}\right)^2} dx = \int_2^3 \left(\frac{1}{4}x^3 + x^{-3}\right) dx = 595/144$
7.  $f'(x) = \frac{1}{2}(e^x - e^{-x})$ ,  $1 + [f'(x)]^2 = 1 + \frac{1}{4}(e^{2x} - 2 + e^{-2x}) = \frac{1}{4}(e^{2x} + 2 + e^{-2x})$ , so  
 $L = \int_0^3 \sqrt{1 + (f'(x))^2} dx = \frac{1}{2} \int_0^3 (e^x + e^{-x}) dx = (e^3 - e^{-3})/2$
8.  $g'(y) = \frac{1}{2}y^3 - \frac{1}{2}y^{-3}$ ,  $1 + [g'(y)]^2 = 1 + \left(\frac{1}{4}y^6 - \frac{1}{2} + \frac{1}{4}y^{-6}\right) = \left(\frac{1}{2}y^3 + \frac{1}{2}y^{-3}\right)^2$ ,  
 $L = \int_1^4 \left(\frac{1}{2}y^3 + \frac{1}{2}y^{-3}\right) dy = 2055/64$
9.  $(dx/dt)^2 + (dy/dt)^2 = (t^2)^2 + (t)^2 = t^2(t^2 + 1)$ ,  $L = \int_0^1 t(t^2 + 1)^{1/2} dt = (2\sqrt{2} - 1)/3$
10.  $(dx/dt)^2 + (dy/dt)^2 = [2(1+t)]^2 + [3(1+t)^2]^2 = (1+t)^2[4 + 9(1+t)^2]$ ,  
 $L = \int_0^1 (1+t)[4 + 9(1+t)^2]^{1/2} dt = (80\sqrt{10} - 13\sqrt{13})/27$
11.  $(dx/dt)^2 + (dy/dt)^2 = (-2\sin 2t)^2 + (2\cos 2t)^2 = 4$ ,  $L = \int_0^{\pi/2} 2 dt = \pi$
12.  $(dx/dt)^2 + (dy/dt)^2 = (-\sin t + \sin t + t \cos t)^2 + (\cos t - \cos t + t \sin t)^2 = t^2$ ,  
 $L = \int_0^{\pi} t dt = \pi^2/2$
13.  $(dx/dt)^2 + (dy/dt)^2 = [e^t(\cos t - \sin t)]^2 + [e^t(\cos t + \sin t)]^2 = 2e^{2t}$ ,  
 $L = \int_0^{\pi/2} \sqrt{2}e^t dt = \sqrt{2}(e^{\pi/2} - 1)$
14.  $(dx/dt)^2 + (dy/dt)^2 = (2e^t \cos t)^2 + (-2e^t \sin t)^2 = 4e^{2t}$ ,  $L = \int_1^4 2e^t dt = 2(e^4 - e)$
15.  $dy/dx = \frac{\sec x \tan x}{\sec x} = \tan x$ ,  $\sqrt{1 + (y')^2} = \sqrt{1 + \tan^2 x} = \sec x$  when  $0 < x < \pi/4$ , so  
 $L = \int_0^{\pi/4} \sec x dx = \ln(1 + \sqrt{2})$
16.  $dy/dx = \frac{\cos x}{\sin x} = \cot x$ ,  $\sqrt{1 + (y')^2} = \sqrt{1 + \cot^2 x} = \csc x$  when  $\pi/4 < x < \pi/2$ , so  
 $L = \int_{\pi/4}^{\pi/2} \csc x dx = -\ln(\sqrt{2} - 1) = -\ln\left(\frac{\sqrt{2} - 1}{\sqrt{2} + 1}(\sqrt{2} + 1)\right) = \ln(1 + \sqrt{2})$
17. (a)  $(dx/d\theta)^2 + (dy/d\theta)^2 = (a(1 - \cos \theta))^2 + (a \sin \theta)^2 = a^2(2 - 2 \cos \theta)$ , so  
 $L = \int_0^{2\pi} \sqrt{(dx/d\theta)^2 + (dy/d\theta)^2} d\theta = a \int_0^{2\pi} \sqrt{2(1 - \cos \theta)} d\theta$

18. (a) Use the interval  $0 \leq \phi < 2\pi$ .

(b)  $(dx/d\phi)^2 + (dy/d\phi)^2 = (-3a \cos^2 \phi \sin \phi)^2 + (3a \sin^2 \phi \cos \phi)^2$   
 $= 9a^2 \cos^2 \phi \sin^2 \phi (\cos^2 \phi + \sin^2 \phi) = (9a^2/4) \sin^2 2\phi$ , so

$$L = (3a/2) \int_0^{2\pi} |\sin 2\phi| d\phi = 6a \int_0^{\pi/2} \sin 2\phi d\phi = -3a \cos 2\phi \Big|_0^{\pi/2} = 6a$$

19. (a)

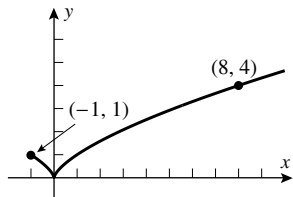

(b)  $dy/dx$  does not exist at  $x = 0$ .

(c)  $x = g(y) = y^{3/2}, g'(y) = \frac{3}{2} y^{1/2}$ ,

$$L = \int_0^1 \sqrt{1 + 9y/4} dy \quad (\text{portion for } -1 \leq x \leq 0)$$

$$+ \int_0^4 \sqrt{1 + 9y/4} dy \quad (\text{portion for } 0 \leq x \leq 8)$$

$$= \frac{8}{27} \left( \frac{13}{8} \sqrt{13} - 1 \right) + \frac{8}{27} (10\sqrt{10} - 1) = (13\sqrt{13} + 80\sqrt{10} - 16)/27$$

20. For (4), express the curve  $y = f(x)$  in the parametric form  $x = t, y = f(t)$  so  $dx/dt = 1$  and  $dy/dt = f'(t) = f'(x) = dy/dx$ . For (5), express  $x = g(y)$  as  $x = g(t), y = t$  so  $dx/dt = g'(t) = g'(y) = dx/dy$  and  $dy/dt = 1$ .

21.  $L = \int_0^2 \sqrt{1 + 4x^2} dx \approx 4.645975301$

22.  $L = \int_0^\pi \sqrt{1 + \cos^2 y} dy \approx 3.820197789$

23. Numerical integration yields: in Exercise 21,  $L \approx 4.646783762$ ; in Exercise 22,  $L \approx 3.820197788$ .

24.  $0 \leq m \leq f'(x) \leq M$ , so  $m^2 \leq [f'(x)]^2 \leq M^2$ , and  $1 + m^2 \leq 1 + [f'(x)]^2 \leq 1 + M^2$ ; thus

$$\sqrt{1 + m^2} \leq \sqrt{1 + [f'(x)]^2} \leq \sqrt{1 + M^2},$$

$$\int_a^b \sqrt{1 + m^2} dx \leq \int_a^b \sqrt{1 + [f'(x)]^2} dx \leq \int_a^b \sqrt{1 + M^2} dx, \text{ and}$$

$$(b - a)\sqrt{1 + m^2} \leq L \leq (b - a)\sqrt{1 + M^2}$$

25.  $f'(x) = \cos x, \sqrt{2}/2 \leq \cos x \leq 1$  for  $0 \leq x \leq \pi/4$  so

$$(\pi/4)\sqrt{1 + 1/2} \leq L \leq (\pi/4)\sqrt{1 + 1}, \frac{\pi}{4}\sqrt{3/2} \leq L \leq \frac{\pi}{4}\sqrt{2}.$$

26.  $(dx/dt)^2 + (dy/dt)^2 = (-a \sin t)^2 + (b \cos t)^2 = a^2 \sin^2 t + b^2 \cos^2 t$   
 $= a^2(1 - \cos^2 t) + b^2 \cos^2 t = a^2 - (a^2 - b^2) \cos^2 t$   
 $= a^2 \left[ 1 - \frac{a^2 - b^2}{a^2} \cos^2 t \right] = a^2 [1 - k^2 \cos^2 t],$

$$L = \int_0^{2\pi} a \sqrt{1 - k^2 \cos^2 t} dt = 4a \int_0^{\pi/2} \sqrt{1 - k^2 \cos^2 t} dt$$

27. (a)  $(dx/dt)^2 + (dy/dt)^2 = 4\sin^2 t + \cos^2 t = 4\sin^2 t + (1 - \sin^2 t) = 1 + 3\sin^2 t$ ,

$$L = \int_0^{2\pi} \sqrt{1 + 3\sin^2 t} dt = 4 \int_0^{\pi/2} \sqrt{1 + 3\sin^2 t} dt$$

(b) 9.69

(c) distance traveled  $= \int_{1.5}^{4.8} \sqrt{1 + 3\sin^2 t} dt \approx 5.16$  cm

28. The distance is  $\int_0^{4.6} \sqrt{1 + (2.09 - 0.82x)^2} dx \approx 6.65$  m

29.  $L = \int_0^\pi \sqrt{1 + (k \cos x)^2} dx$

$k$	1	2	1.84	1.83	1.832
$L$	3.8202	5.2704	5.0135	4.9977	5.0008

Experimentation yields the values in the table, which by the Intermediate-Value Theorem show that the true solution  $k$  to  $L = 5$  lies between  $k = 1.83$  and  $k = 1.832$ , so  $k = 1.83$  to two decimal places.

### EXERCISE SET 8.5

1.  $S = \int_0^1 2\pi(7x)\sqrt{1+49}dx = 70\pi\sqrt{2} \int_0^1 x dx = 35\pi\sqrt{2}$

2.  $f'(x) = \frac{1}{2\sqrt{x}}$ ,  $1 + [f'(x)]^2 = 1 + \frac{1}{4x}$

$$S = \int_1^4 2\pi\sqrt{x}\sqrt{1 + \frac{1}{4x}} dx = 2\pi \int_1^4 \sqrt{x + 1/4} dx = \pi(17\sqrt{17} - 5\sqrt{5})/6$$

3.  $f'(x) = -x/\sqrt{4-x^2}$ ,  $1 + [f'(x)]^2 = 1 + \frac{x^2}{4-x^2} = \frac{4}{4-x^2}$ ,

$$S = \int_{-1}^1 2\pi\sqrt{4-x^2}(2/\sqrt{4-x^2})dx = 4\pi \int_{-1}^1 dx = 8\pi$$

4.  $y = f(x) = x^3$  for  $1 \leq x \leq 2$ ,  $f'(x) = 3x^2$ ,

$$S = \int_1^2 2\pi x^3 \sqrt{1+9x^4} dx = \left. \frac{\pi}{27} (1+9x^4)^{3/2} \right|_1^2 = 5\pi(29\sqrt{145} - 2\sqrt{10})/27$$

5.  $S = \int_0^2 2\pi(9y+1)\sqrt{82}dy = 2\pi\sqrt{82} \int_0^2 (9y+1)dy = 40\pi\sqrt{82}$

6.  $g'(y) = 3y^2$ ,  $S = \int_0^1 2\pi y^3 \sqrt{1+9y^4} dy = \pi(10\sqrt{10} - 1)/27$

7.  $g'(y) = -y/\sqrt{9-y^2}$ ,  $1 + [g'(y)]^2 = \frac{9}{9-y^2}$ ,  $S = \int_{-2}^2 2\pi\sqrt{9-y^2} \cdot \frac{3}{\sqrt{9-y^2}} dy = 6\pi \int_{-2}^2 dy = 24\pi$

8.  $g'(y) = -(1-y)^{-1/2}$ ,  $1 + [g'(y)]^2 = \frac{2-y}{1-y}$ ,

$$S = \int_{-1}^0 2\pi(2\sqrt{1-y})\frac{\sqrt{2-y}}{\sqrt{1-y}} dy = 4\pi \int_{-1}^0 \sqrt{2-y} dy = 8\pi(3\sqrt{3} - 2\sqrt{2})/3$$

$$9. f'(x) = \frac{1}{2}x^{-1/2} - \frac{1}{2}x^{1/2}, 1 + [f'(x)]^2 = 1 + \frac{1}{4}x^{-1} - \frac{1}{2} + \frac{1}{4}x = \left(\frac{1}{2}x^{-1/2} + \frac{1}{2}x^{1/2}\right)^2,$$

$$S = \int_1^3 2\pi \left(x^{1/2} - \frac{1}{3}x^{3/2}\right) \left(\frac{1}{2}x^{-1/2} + \frac{1}{2}x^{1/2}\right) dx = \frac{\pi}{3} \int_1^3 (3 + 2x - x^2) dx = 16\pi/9$$

$$10. f'(x) = x^2 - \frac{1}{4}x^{-2}, 1 + [f'(x)]^2 = 1 + \left(x^4 - \frac{1}{2} + \frac{1}{16}x^{-4}\right) = \left(x^2 + \frac{1}{4}x^{-2}\right)^2,$$

$$S = \int_1^2 2\pi \left(\frac{1}{3}x^3 + \frac{1}{4}x^{-1}\right) \left(x^2 + \frac{1}{4}x^{-2}\right) dx = 2\pi \int_1^2 \left(\frac{1}{3}x^5 + \frac{1}{3}x + \frac{1}{16}x^{-3}\right) dx = 515\pi/64$$

$$11. x = g(y) = \frac{1}{4}y^4 + \frac{1}{8}y^{-2}, g'(y) = y^3 - \frac{1}{4}y^{-3},$$

$$1 + [g'(y)]^2 = 1 + \left(y^6 - \frac{1}{2} + \frac{1}{16}y^{-6}\right) = \left(y^3 + \frac{1}{4}y^{-3}\right)^2,$$

$$S = \int_1^2 2\pi \left(\frac{1}{4}y^4 + \frac{1}{8}y^{-2}\right) \left(y^3 + \frac{1}{4}y^{-3}\right) dy = \frac{\pi}{16} \int_1^2 (8y^7 + 6y + y^{-5}) dy = 16,911\pi/1024$$

$$12. x = g(y) = \sqrt{16-y}; g'(y) = -\frac{1}{2\sqrt{16-y}}, 1 + [g'(y)]^2 = \frac{65-4y}{4(16-y)},$$

$$S = \int_0^{15} 2\pi \sqrt{16-y} \sqrt{\frac{65-4y}{4(16-y)}} dy = \pi \int_0^{15} \sqrt{65-4y} dy = (65\sqrt{65} - 5\sqrt{5}) \frac{\pi}{6}$$

$$13. f'(x) = e^x, 1 + [f'(x)]^2 = 1 + e^{2x}, S = \int_0^1 2\pi e^x \sqrt{1 + e^{2x}} dx \approx 22.94$$

$$14. f'(x) = \cos x, 1 + [f'(x)]^2 = 1 + \cos^2 x, S = \int_0^\pi 2\pi \sin x \sqrt{1 + \cos^2 x} dx \approx 14.42$$

$$15. x = g(y) = \ln y, g'(y) = 1/y, 1 + [g'(y)]^2 = 1 + 1/y^2; S = \int_1^e 2\pi \sqrt{1 + 1/y^2} \ln y dy \approx 7.05$$

$$16. x = g(y) = \tan y, g'(y) = \sec^2 y, 1 + [g'(y)]^2 = 1 + \sec^4 y;$$

$$S = \int_0^{\pi/4} 2\pi \tan y \sqrt{1 + \sec^4 y} dy \approx 3.84$$

17. Revolve the line segment joining the points  $(0,0)$  and  $(h,r)$  about the  $x$ -axis. An equation of the line segment is  $y = (r/h)x$  for  $0 \leq x \leq h$  so

$$S = \int_0^h 2\pi(r/h)x \sqrt{1 + r^2/h^2} dx = \frac{2\pi r}{h^2} \sqrt{r^2 + h^2} \int_0^h x dx = \pi r \sqrt{r^2 + h^2}$$

$$18. f(x) = \sqrt{r^2 - x^2}, f'(x) = -x/\sqrt{r^2 - x^2}, 1 + [f'(x)]^2 = r^2/(r^2 - x^2),$$

$$S = \int_{-r}^r 2\pi \sqrt{r^2 - x^2} (r/\sqrt{r^2 - x^2}) dx = 2\pi r \int_{-r}^r dx = 4\pi r^2$$

$$19. g(y) = \sqrt{r^2 - y^2}, g'(y) = -y/\sqrt{r^2 - y^2}, 1 + [g'(y)]^2 = r^2/(r^2 - y^2),$$

$$(a) S = \int_{r-h}^r 2\pi \sqrt{r^2 - y^2} \sqrt{r^2/(r^2 - y^2)} dy = 2\pi r \int_{r-h}^r dy = 2\pi r h$$

(b) From part (a), the surface area common to two polar caps of height  $h_1 > h_2$  is  $2\pi r h_1 - 2\pi r h_2 = 2\pi r (h_1 - h_2)$ .

20. For (4), express the curve  $y = f(x)$  in the parametric form  $x = t, y = f(t)$  so  $dx/dt = 1$  and  $dy/dt = f'(t) = f'(x) = dy/dx$ . For (5), express  $x = g(y)$  as  $x = g(t), y = t$  so  $dx/dt = g'(t) = g'(y) = dx/dy$  and  $dy/dt = 1$ .

21.  $x' = 2t, y' = 2, (x')^2 + (y')^2 = 4t^2 + 4$

$$S = 2\pi \int_0^4 (2t)\sqrt{4t^2 + 4} dt = 8\pi \int_0^4 t\sqrt{t^2 + 1} dt = \frac{8\pi}{3}(17\sqrt{17} - 1)$$

22.  $x' = e^t(\cos t - \sin t), y' = e^t(\cos t + \sin t), (x')^2 + (y')^2 = 2e^{2t}$

$$\begin{aligned} S &= 2\pi \int_0^{\pi/2} (e^t \sin t) \sqrt{2e^{2t}} dt = 2\sqrt{2}\pi \int_0^{\pi/2} e^{2t} \sin t dt \\ &= 2\sqrt{2}\pi \left[ \frac{1}{5} e^{2t} (2 \sin t - \cos t) \right]_0^{\pi/2} = \frac{2\sqrt{2}}{5} \pi (2e^\pi + 1) \end{aligned}$$

23.  $x' = 1, y' = 4t, (x')^2 + (y')^2 = 1 + 16t^2, S = 2\pi \int_0^1 t\sqrt{1 + 16t^2} dt = \frac{\pi}{24}(17\sqrt{17} - 1)$

24.  $x' = -2 \sin t \cos t, y' = 2 \sin t \cos t, (x')^2 + (y')^2 = 8 \sin^2 t \cos^2 t$

$$S = 2\pi \int_0^{\pi/2} \cos^2 t \sqrt{8 \sin^2 t \cos^2 t} dt = 4\sqrt{2}\pi \int_0^{\pi/2} \cos^3 t \sin t dt = \sqrt{2}\pi$$

25.  $x' = -r \sin t, y' = r \cos t, (x')^2 + (y')^2 = r^2,$

$$S = 2\pi \int_0^\pi r \sin t \sqrt{r^2} dt = 2\pi r^2 \int_0^\pi \sin t dt = 4\pi r^2$$

26.  $\frac{dx}{d\phi} = a(1 - \cos \phi), \frac{dy}{d\phi} = a \sin \phi, \left(\frac{dx}{d\phi}\right)^2 + \left(\frac{dy}{d\phi}\right)^2 = 2a^2(1 - \cos \phi)$

$$S = 2\pi \int_0^{2\pi} a(1 - \cos \phi) \sqrt{2a^2(1 - \cos \phi)} d\phi = 2\sqrt{2}\pi a^2 \int_0^{2\pi} (1 - \cos \phi)^{3/2} d\phi,$$

but  $1 - \cos \phi = 2 \sin^2 \frac{\phi}{2}$  so  $(1 - \cos \phi)^{3/2} = 2\sqrt{2} \sin^3 \frac{\phi}{2}$  for  $0 \leq \phi \leq \pi$  and, taking advantage of the symmetry of the cycloid,  $S = 16\pi a^2 \int_0^\pi \sin^3 \frac{\phi}{2} d\phi = 64\pi a^2/3$ .

27. (a) length of arc of sector = circumference of base of cone,

$$\ell\theta = 2\pi r, \theta = 2\pi r/\ell; S = \text{area of sector} = \frac{1}{2}\ell^2(2\pi r/\ell) = \pi r\ell$$

(b)  $S = \pi r_2 \ell_2 - \pi r_1 \ell_1 = \pi r_2(\ell_1 + \ell) - \pi r_1 \ell_1 = \pi[(r_2 - r_1)\ell_1 + r_2\ell];$

Using similar triangles  $\ell_2/r_2 = \ell_1/r_1, r_1\ell_2 = r_2\ell_1, r_1(\ell_1 + \ell) = r_2\ell_1, (r_2 - r_1)\ell_1 = r_1\ell$   
so  $S = \pi(r_1\ell + r_2\ell) = \pi(r_1 + r_2)\ell$ .

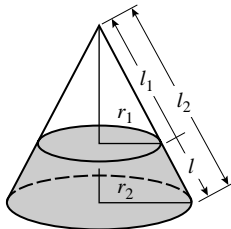

28.  $2\pi k\sqrt{1+[f'(x)]^2} \leq 2\pi f(x)\sqrt{1+[f'(x)]^2} \leq 2\pi K\sqrt{1+[f'(x)]^2}$ , so  

$$\int_a^b 2\pi k\sqrt{1+[f'(x)]^2} dx \leq \int_a^b 2\pi f(x)\sqrt{1+[f'(x)]^2} dx \leq \int_a^b 2\pi K\sqrt{1+[f'(x)]^2} dx,$$

$$2\pi k \int_a^b \sqrt{1+[f'(x)]^2} dx \leq S \leq 2\pi K \int_a^b \sqrt{1+[f'(x)]^2} dx, \quad 2\pi kL \leq S \leq 2\pi KL$$
29. (a)  $1 \leq \sqrt{1+[f'(x)]^2}$  so  $2\pi f(x) \leq 2\pi f(x)\sqrt{1+[f'(x)]^2}$ ,  

$$\int_a^b 2\pi f(x) dx \leq \int_a^b 2\pi f(x)\sqrt{1+[f'(x)]^2} dx, \quad 2\pi \int_a^b f(x) dx \leq S, \quad 2\pi A \leq S$$
- (b)  $2\pi A = S$  if  $f'(x) = 0$  for all  $x$  in  $[a, b]$  so  $f(x)$  is constant on  $[a, b]$ .

## EXERCISE SET 8.6

1. (a)  $W = F \cdot d = 30(7) = 210 \text{ ft}\cdot\text{lb}$   
 (b)  $W = \int_1^6 F(x) dx = \int_1^6 x^{-2} dx = -\frac{1}{x} \Big|_1^6 = 5/6 \text{ ft}\cdot\text{lb}$
2.  $W = \int_0^5 F(x) dx = \int_0^2 40 dx - \int_2^5 \frac{40}{3}(x-5) dx = 80 + 60 = 140 \text{ J}$
3. distance traveled  $= \int_0^5 v(t) dt = \int_0^5 \frac{4t}{5} dt = \frac{2}{5}t^2 \Big|_0^5 = 10 \text{ ft}$ . The force is a constant 10 lb, so the work done is  $10 \cdot 10 = 100 \text{ ft}\cdot\text{lb}$ .
4. (a)  $F(x) = kx, F(0.05) = 0.05k = 45, k = 900 \text{ N/m}$   
 (b)  $W = \int_0^{0.03} 900x dx = 0.405 \text{ J}$       (c)  $W = \int_{0.05}^{0.10} 900x dx = 3.375 \text{ J}$
5.  $F(x) = kx, F(0.2) = 0.2k = 100, k = 500 \text{ N/m}, W = \int_0^{0.8} 500x dx = 160 \text{ J}$
6.  $F(x) = kx, F(1/2) = k/2 = 6, k = 12 \text{ N/m}, W = \int_0^2 12x dx = 24 \text{ J}$
7.  $W = \int_0^1 kx dx = k/2 = 10, k = 20 \text{ lb/ft}$
8.  $W = \int_0^6 (9-x)62.4(25\pi) dx$   
 $= 1560\pi \int_0^6 (9-x) dx = 56,160\pi \text{ ft}\cdot\text{lb}$
9.  $W = \int_0^6 (9-x)\rho(25\pi) dx = 900\pi\rho \text{ ft}\cdot\text{lb}$

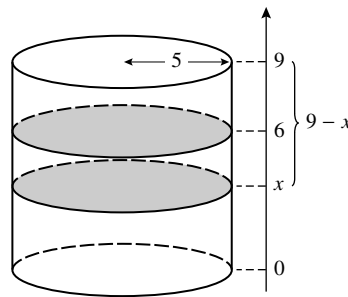

10.  $r/10 = x/15, r = 2x/3,$

$$\begin{aligned} W &= \int_0^{10} (15-x)62.4(4\pi x^2/9)dx \\ &= \frac{83.2}{3}\pi \int_0^{10} (15x^2 - x^3)dx \\ &= 208,000\pi/3 \text{ ft}\cdot\text{lb} \end{aligned}$$

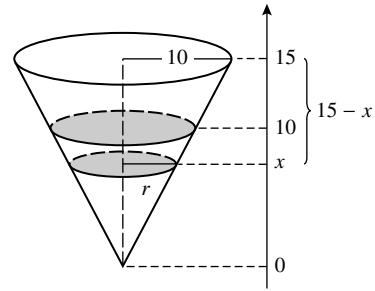

11.  $w/4 = x/3, w = 4x/3,$

$$\begin{aligned} W &= \int_0^2 (3-x)(9810)(4x/3)(6)dx \\ &= 78480 \int_0^2 (3x - x^2)dx \\ &= 261,600 \text{ J} \end{aligned}$$

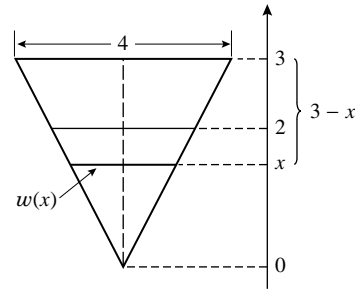

12.  $w = 2\sqrt{4-x^2}$

$$\begin{aligned} W &= \int_{-2}^2 (3-x)(50)(2\sqrt{4-x^2})(10)dx \\ &= 3000 \int_{-2}^2 \sqrt{4-x^2}dx - 1000 \int_{-2}^2 x\sqrt{4-x^2}dx \\ &= 3000[\pi(2)^2/2] - 0 = 6000\pi \text{ ft}\cdot\text{lb} \end{aligned}$$

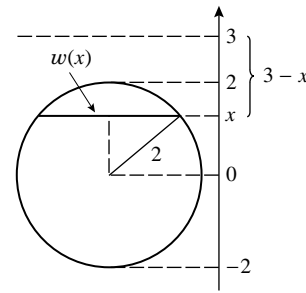

13. (a)  $W = \int_0^9 (10-x)62.4(300)dx$

$$\begin{aligned} &= 18,720 \int_0^9 (10-x)dx \\ &= 926,640 \text{ ft}\cdot\text{lb} \end{aligned}$$

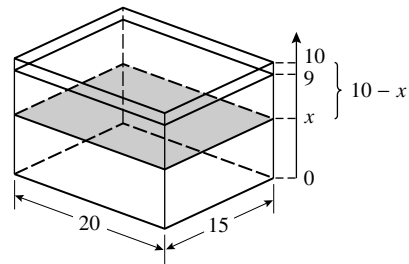

- (b) to empty the pool in one hour would require  $926,640/3600 = 257.4$  ft·lb of work per second  
so hp of motor =  $257.4/550 = 0.468$

14. When the rocket is  $x$  ft above the ground

$$\begin{aligned} \text{total weight} &= \text{weight of rocket} \\ &\quad + \text{weight of fuel} \\ &= 3 + [40 - 2(x/1000)] \\ &= 43 - x/500 \text{ tons,} \end{aligned}$$

$$W = \int_0^{3000} (43 - x/500)dx = 120,000 \text{ ft}\cdot\text{tons}$$

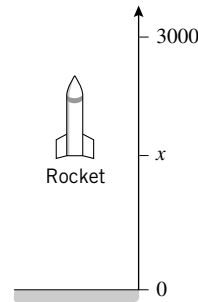



15. 
$$W = \int_0^{100} 15(100 - x) dx$$

$$= 75,000 \text{ ft}\cdot\text{lb}$$

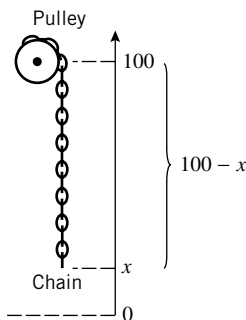

16. Let  $F(x)$  be the force needed to hold charge  $A$  at position  $x$ , then

$$F(x) = \frac{c}{(a - x)^2}, \quad F(-a) = \frac{c}{4a^2} = k,$$

so  $c = 4a^2k$ .

$$W = \int_{-a}^0 4a^2k(a - x)^{-2} dx = 2ak \text{ J}$$

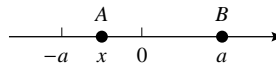

17. (a)  $150 = k/(4000)^2, k = 2.4 \times 10^9, w(x) = k/x^2 = 2,400,000,000/x^2 \text{ lb}$

(b)  $6000 = k/(4000)^2, k = 9.6 \times 10^{10}, w(x) = (9.6 \times 10^{10})/(x + 4000)^2 \text{ lb}$

(c) 
$$W = \int_{4000}^{5000} 9.6(10^{10})x^{-2} dx = 4,800,000 \text{ mi}\cdot\text{lb} = 2.5344 \times 10^{10} \text{ ft}\cdot\text{lb}$$

18. (a)  $20 = k/(1080)^2, k = 2.3328 \times 10^7, \text{ weight} = w(x + 1080) = 2.3328 \cdot 10^7/(x + 1080)^2 \text{ lb}$

(b) 
$$W = \int_0^{10.8} [2.3328 \cdot 10^7/(x + 1080)^2] dx = 213.86 \text{ mi}\cdot\text{lb} = 1,129,188 \text{ ft}\cdot\text{lb}$$

19.  $W = F \cdot d = (6.40 \times 10^5)(3.00 \times 10^3) = 1.92 \times 10^9 \text{ J}$ ; from Theorem 8.6.4,

$$v_f^2 = 2W/m + v_i^2 = 2(1.92 \cdot 10^9)/(4 \cdot 10^5) + 20^2 = 10,000, v_f = 100 \text{ m/s}$$

20.  $W = F \cdot d = (2.00 \times 10^5)(2.00 \times 10^5) = 4 \times 10^{10} \text{ J}$ ; from Theorem 8.6.4,

$$v_f^2 = 2W/m + v_i^2 = 8 \cdot 10^{10}/(2 \cdot 10^3) + 10^8 \approx 11.832 \text{ m/s}.$$

21. (a) The kinetic energy would have decreased by  $\frac{1}{2}mv^2 = \frac{1}{2}4 \cdot 10^6(15000)^2 = 4.5 \times 10^{14} \text{ J}$

(b)  $(4.5 \times 10^{14})/(4.2 \times 10^{15}) \approx 0.107$       (c)  $\frac{1000}{13}(0.107) \approx 8.24 \text{ bombs}$

**EXERCISE SET 8.7**

1. (a)  $F = \rho h A = 62.4(5)(100) = 31,200 \text{ lb}$   
 $P = \rho h = 62.4(5) = 312 \text{ lb/ft}^2$

(b)  $F = \rho h A = 9810(10)(25) = 2,452,500 \text{ N}$   
 $P = \rho h = 9810(10) = 98.1 \text{ kPa}$

2. (a)  $F = PA = 6 \cdot 10^5(160) = 9.6 \times 10^7 \text{ N}$

(b)  $F = PA = 100(60) = 6000 \text{ lb}$

3. 
$$F = \int_0^2 62.4x(4) dx$$

$$= 249.6 \int_0^2 x dx = 499.2 \text{ lb}$$

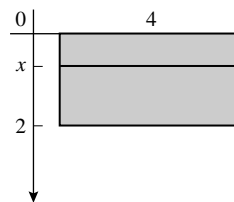

$$\begin{aligned}
 4. \quad F &= \int_1^3 9810x(4)dx \\
 &= 39240 \int_1^3 x dx \\
 &= 156,960 \text{ N}
 \end{aligned}$$

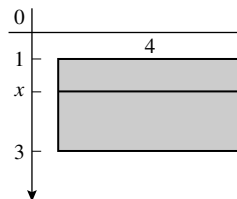

$$\begin{aligned}
 5. \quad F &= \int_0^5 9810x(2\sqrt{25-x^2})dx \\
 &= 19,620 \int_0^5 x(25-x^2)^{1/2}dx \\
 &= 8.175 \times 10^5 \text{ N}
 \end{aligned}$$

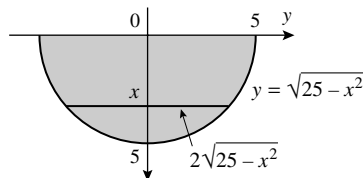

6. By similar triangles

$$\begin{aligned}
 \frac{w(x)}{4} &= \frac{2\sqrt{3}-x}{2\sqrt{3}}, \quad w(x) = \frac{2}{\sqrt{3}}(2\sqrt{3}-x), \\
 F &= \int_0^{2\sqrt{3}} 62.4x \left[ \frac{2}{\sqrt{3}}(2\sqrt{3}-x) \right] dx \\
 &= \frac{124.8}{\sqrt{3}} \int_0^{2\sqrt{3}} (2\sqrt{3}x - x^2) dx = 499.2 \text{ lb}
 \end{aligned}$$

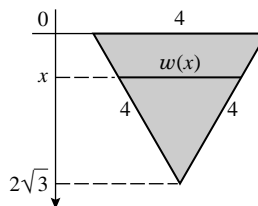

7. By similar triangles

$$\begin{aligned}
 \frac{w(x)}{6} &= \frac{10-x}{8} \\
 w(x) &= \frac{3}{4}(10-x), \\
 F &= \int_2^{10} 9810x \left[ \frac{3}{4}(10-x) \right] dx \\
 &= 7357.5 \int_2^{10} (10x - x^2) dx = 1,098,720 \text{ N}
 \end{aligned}$$

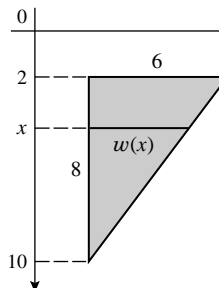

8.  $w(x) = 16 + 2u(x)$ , but

$$\begin{aligned}
 \frac{u(x)}{4} &= \frac{12-x}{8} \text{ so } u(x) = \frac{1}{2}(12-x), \\
 w(x) &= 16 + (12-x) = 28-x, \\
 F &= \int_4^{12} 62.4x(28-x)dx \\
 &= 62.4 \int_4^{12} (28x - x^2) dx = 77,209.6 \text{ lb.}
 \end{aligned}$$

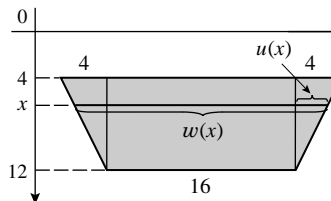

$$9. \text{ Yes: if } \rho_2 = 2\rho_1 \text{ then } F_2 = \int_a^b \rho_2 h(x) w(x) dx = \int_a^b 2\rho_1 h(x) w(x) dx = 2 \int_a^b \rho_1 h(x) w(x) dx = 2F_1.$$

$$\begin{aligned}
 10. \quad F &= \int_0^2 50x(2\sqrt{4-x^2})dx \\
 &= 100 \int_0^2 x(4-x^2)^{1/2}dx \\
 &= 800/3 \text{ lb}
 \end{aligned}$$

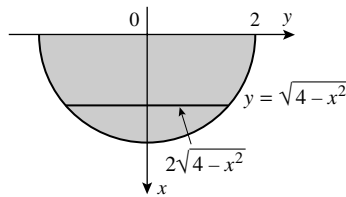

11. Find the forces on the upper and lower halves and add them:

$$\frac{w_1(x)}{\sqrt{2}a} = \frac{x}{\sqrt{2}a/2}, \quad w_1(x) = 2x$$

$$F_1 = \int_0^{\sqrt{2}a/2} \rho x(2x)dx = 2\rho \int_0^{\sqrt{2}a/2} x^2 dx = \sqrt{2}\rho a^3/6,$$

$$\frac{w_2(x)}{\sqrt{2}a} = \frac{\sqrt{2}a-x}{\sqrt{2}a/2}, \quad w_2(x) = 2(\sqrt{2}a-x)$$

$$F_2 = \int_{\sqrt{2}a/2}^{\sqrt{2}a} \rho x[2(\sqrt{2}a-x)]dx = 2\rho \int_{\sqrt{2}a/2}^{\sqrt{2}a} (\sqrt{2}ax - x^2)dx = \sqrt{2}\rho a^3/3,$$

$$F = F_1 + F_2 = \sqrt{2}\rho a^3/6 + \sqrt{2}\rho a^3/3 = \rho a^3/\sqrt{2} \text{ lb}$$

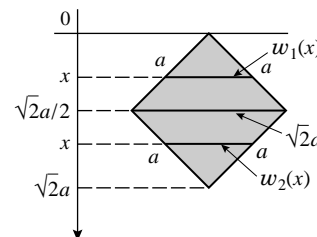

$$12. \quad h(x) = x \sin 60^\circ = \sqrt{3}x/2,$$

$$\begin{aligned}
 F &= \int_0^{100} 9810(\sqrt{3}x/2)(200)dx \\
 &= 981000\sqrt{3} \int_0^{100} x dx \\
 &= 4,905,000\sqrt{3} \text{ N}
 \end{aligned}$$

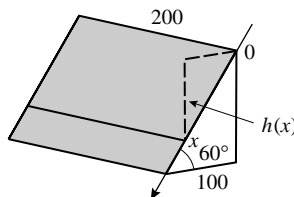

13.  $\sqrt{16^2 + 4^2} = \sqrt{272} = 4\sqrt{17}$  is the other dimension of the bottom.

$$(h(x) - 4)/4 = x/(4\sqrt{17})$$

$$h(x) = x/\sqrt{17} + 4,$$

$$\begin{aligned}
 F &= \int_0^{4\sqrt{17}} 62.4(x/\sqrt{17} + 4)10dx \\
 &= 624 \int_0^{4\sqrt{17}} (x/\sqrt{17} + 4)dx \\
 &= 14,976\sqrt{17} \text{ lb}
 \end{aligned}$$

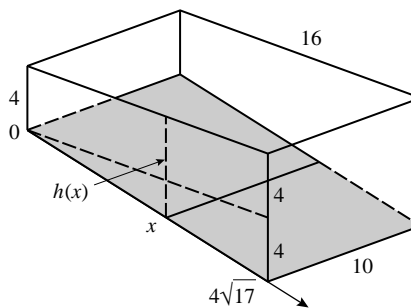

$$\begin{aligned}
 14. \quad F &= \int_h^{h+2} \rho_0 x(2)dx \\
 &= 2\rho_0 \int_h^{h+2} x dx \\
 &= 4\rho_0(h+1)
 \end{aligned}$$

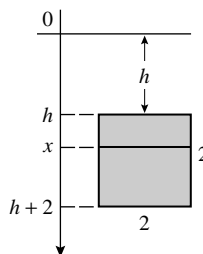

15. (a) From Exercise 14,  $F = 4\rho_0(h + 1)$  so (assuming that  $\rho_0$  is constant)  $dF/dt = 4\rho_0(dh/dt)$  which is a positive constant if  $dh/dt$  is a positive constant.  
 (b) If  $dh/dt = 20$  then  $dF/dt = 80\rho_0$  lb/min from part (a).

### EXERCISE SET 8.8

1. (a)  $\sinh 3 \approx 10.0179$  (b)  $\cosh(-2) \approx 3.7622$   
 (c)  $\tanh(\ln 4) = 15/17 \approx 0.8824$  (d)  $\sinh^{-1}(-2) \approx -1.4436$   
 (e)  $\cosh^{-1} 3 \approx 1.7627$  (f)  $\tanh^{-1} \frac{3}{4} \approx 0.9730$   
 2. (a)  $\operatorname{csch}(-1) \approx -0.8509$  (b)  $\operatorname{sech}(\ln 2) = 0.8$   
 (c)  $\operatorname{coth} 1 \approx 1.3130$  (d)  $\operatorname{sech}^{-1} \frac{1}{2} \approx 1.3170$   
 (e)  $\operatorname{coth}^{-1} 3 \approx 0.3466$  (f)  $\operatorname{csch}^{-1}(-\sqrt{3}) \approx -0.5493$

3. (a)  $\sinh(\ln 3) = \frac{1}{2}(e^{\ln 3} - e^{-\ln 3}) = \frac{1}{2}\left(3 - \frac{1}{3}\right) = \frac{4}{3}$   
 (b)  $\cosh(-\ln 2) = \frac{1}{2}(e^{-\ln 2} + e^{\ln 2}) = \frac{1}{2}\left(\frac{1}{2} + 2\right) = \frac{5}{4}$   
 (c)  $\tanh(2 \ln 5) = \frac{e^{2 \ln 5} - e^{-2 \ln 5}}{e^{2 \ln 5} + e^{-2 \ln 5}} = \frac{25 - 1/25}{25 + 1/25} = \frac{312}{313}$   
 (d)  $\sinh(-3 \ln 2) = \frac{1}{2}(e^{-3 \ln 2} - e^{3 \ln 2}) = \frac{1}{2}\left(\frac{1}{8} - 8\right) = -\frac{63}{16}$

4. (a)  $\frac{1}{2}(e^{\ln x} + e^{-\ln x}) = \frac{1}{2}\left(x + \frac{1}{x}\right) = \frac{x^2 + 1}{2x}, x > 0$   
 (b)  $\frac{1}{2}(e^{\ln x} - e^{-\ln x}) = \frac{1}{2}\left(x - \frac{1}{x}\right) = \frac{x^2 - 1}{2x}, x > 0$   
 (c)  $\frac{e^{2 \ln x} - e^{-2 \ln x}}{e^{2 \ln x} + e^{-2 \ln x}} = \frac{x^2 - 1/x^2}{x^2 + 1/x^2} = \frac{x^4 - 1}{x^4 + 1}, x > 0$   
 (d)  $\frac{1}{2}(e^{-\ln x} + e^{\ln x}) = \frac{1}{2}\left(\frac{1}{x} + x\right) = \frac{1 + x^2}{2x}, x > 0$

5.

	$\sinh x_0$	$\cosh x_0$	$\tanh x_0$	$\operatorname{coth} x_0$	$\operatorname{sech} x_0$	$\operatorname{csch} x_0$
(a)	2	$\sqrt{5}$	$2/\sqrt{5}$	$\sqrt{5}/2$	$1/\sqrt{5}$	1/2
(b)	3/4	5/4	3/5	5/3	4/5	4/3
(c)	4/3	5/3	4/5	5/4	3/5	3/4

- (a)  $\cosh^2 x_0 = 1 + \sinh^2 x_0 = 1 + (2)^2 = 5, \cosh x_0 = \sqrt{5}$   
 (b)  $\sinh^2 x_0 = \cosh^2 x_0 - 1 = \frac{25}{16} - 1 = \frac{9}{16}, \sinh x_0 = \frac{3}{4}$  (because  $x_0 > 0$ )  
 (c)  $\operatorname{sech}^2 x_0 = 1 - \tanh^2 x_0 = 1 - \left(\frac{4}{5}\right)^2 = 1 - \frac{16}{25} = \frac{9}{25}, \operatorname{sech} x_0 = \frac{3}{5},$   
 $\cosh x_0 = \frac{1}{\operatorname{sech} x_0} = \frac{5}{3},$  from  $\frac{\sinh x_0}{\cosh x_0} = \tanh x_0$  we get  $\sinh x_0 = \left(\frac{5}{3}\right)\left(\frac{4}{5}\right) = \frac{4}{3}$

$$6. \quad \frac{d}{dx} \operatorname{csch} x = \frac{d}{dx} \frac{1}{\sinh x} = -\frac{\cosh x}{\sinh^2 x} = -\coth x \operatorname{csch} x \text{ for } x \neq 0$$

$$\frac{d}{dx} \operatorname{sech} x = \frac{d}{dx} \frac{1}{\cosh x} = -\frac{\sinh x}{\cosh^2 x} = -\tanh x \operatorname{sech} x \text{ for all } x$$

$$\frac{d}{dx} \coth x = \frac{d}{dx} \frac{\cosh x}{\sinh x} = \frac{\sinh^2 x - \cosh^2 x}{\sinh^2 x} = -\operatorname{csch}^2 x \text{ for } x \neq 0$$

$$7. \quad (\text{a}) \quad y = \sinh^{-1} x \text{ if and only if } x = \sinh y; \quad 1 = \frac{dy}{dx} \frac{dx}{dy} = \frac{dy}{dx} \cosh y; \text{ so}$$

$$\frac{d}{dx} [\sinh^{-1} x] = \frac{dy}{dx} = \frac{1}{\cosh y} = \frac{1}{\sqrt{1 + \sinh^2 y}} = \frac{1}{\sqrt{1 + x^2}} \text{ for all } x.$$

$$(\text{b}) \quad \text{Let } x \geq 1. \text{ Then } y = \cosh^{-1} x \text{ if and only if } x = \cosh y; \quad 1 = \frac{dy}{dx} \frac{dx}{dy} = \frac{dy}{dx} \sinh y, \text{ so}$$

$$\frac{d}{dx} [\cosh^{-1} x] = \frac{dy}{dx} = \frac{1}{\sinh y} = \frac{1}{\sqrt{\cosh^2 y - 1}} = \frac{1}{x^2 - 1} \text{ for } x \geq 1.$$

$$(\text{c}) \quad \text{Let } -1 < x < 1. \text{ Then } y = \tanh^{-1} x \text{ if and only if } x = \tanh y; \text{ thus}$$

$$1 = \frac{dy}{dx} \frac{dx}{dy} = \frac{dy}{dx} \operatorname{sech}^2 y = \frac{dy}{dx} (1 - \tanh^2 y) = 1 - x^2, \text{ so } \frac{d}{dx} [\tanh^{-1} x] = \frac{dy}{dx} = \frac{1}{1 - x^2}.$$

$$9. \quad 4 \cosh(4x - 8)$$

$$10. \quad 4x^3 \sinh(x^4)$$

$$11. \quad -\frac{1}{x} \operatorname{csch}^2(\ln x)$$

$$12. \quad 2 \frac{\operatorname{sech}^2 2x}{\tanh 2x}$$

$$13. \quad \frac{1}{x^2} \operatorname{csch}(1/x) \coth(1/x)$$

$$14. \quad -2e^{2x} \operatorname{sech}(e^{2x}) \tanh(e^{2x})$$

$$15. \quad \frac{2 + 5 \cosh(5x) \sinh(5x)}{\sqrt{4x + \cosh^2(5x)}}$$

$$16. \quad 6 \sinh^2(2x) \cosh(2x)$$

$$17. \quad x^{5/2} \tanh(\sqrt{x}) \operatorname{sech}^2(\sqrt{x}) + 3x^2 \tanh^2(\sqrt{x})$$

$$18. \quad -3 \cosh(\cos 3x) \sin 3x$$

$$19. \quad \frac{1}{\sqrt{1 + x^2/9}} \left( \frac{1}{3} \right) = 1/\sqrt{9 + x^2}$$

$$20. \quad \frac{1}{\sqrt{1 + 1/x^2}} (-1/x^2) = -\frac{1}{|x|\sqrt{x^2 + 1}}$$

$$21. \quad 1/[(\cosh^{-1} x)\sqrt{x^2 - 1}]$$

$$22. \quad 1/\left[ \sqrt{(\sinh^{-1} x)^2 - 1} \sqrt{1 + x^2} \right]$$

$$23. \quad -(\tanh^{-1} x)^{-2}/(1 - x^2)$$

$$24. \quad 2(\coth^{-1} x)/(1 - x^2)$$

$$25. \quad \frac{\sinh x}{\sqrt{\cosh^2 x - 1}} = \frac{\sinh x}{|\sinh x|} = \begin{cases} 1, & x > 0 \\ -1, & x < 0 \end{cases}$$

$$26. \quad (\operatorname{sech}^2 x)/\sqrt{1 + \tanh^2 x}$$

$$27. \quad -\frac{e^x}{2x\sqrt{1-x}} + e^x \operatorname{sech}^{-1} x$$

$$28. \quad 10(1 + x \operatorname{csch}^{-1} x)^9 \left( -\frac{x}{|x|\sqrt{1 + x^2}} + \operatorname{csch}^{-1} x \right)$$

$$31. \quad \frac{1}{7} \sinh^7 x + C$$

$$32. \quad \frac{1}{2} \sinh(2x - 3) + C$$

$$33. \quad \frac{2}{3} (\tanh x)^{3/2} + C$$

$$34. -\frac{1}{3} \coth(3x) + C$$

$$35. \ln(\cosh x) + C$$

$$36. -\frac{1}{3} \coth^3 x + C$$

$$37. -\frac{1}{3} \operatorname{sech}^3 x \Big|_{\ln 2}^{\ln 3} = 37/375$$

$$38. \ln(\cosh x) \Big|_0^{\ln 3} = \ln 5 - \ln 3$$

$$39. u = 3x, \frac{1}{3} \int \frac{1}{\sqrt{1+u^2}} du = \frac{1}{3} \sinh^{-1} 3x + C$$

$$40. x = \sqrt{2}u, \int \frac{\sqrt{2}}{\sqrt{2u^2-2}} du = \int \frac{1}{\sqrt{u^2-1}} du = \cosh^{-1}(x/\sqrt{2}) + C$$

$$41. u = e^x, \int \frac{1}{u\sqrt{1-u^2}} du = -\operatorname{sech}^{-1}(e^x) + C$$

$$42. u = \cos \theta, -\int \frac{1}{\sqrt{1+u^2}} du = -\sinh^{-1}(\cos \theta) + C$$

$$43. u = 2x, \int \frac{du}{u\sqrt{1+u^2}} = -\operatorname{csch}^{-1}|u| + C = -\operatorname{csch}^{-1}|2x| + C$$

$$44. x = 5u/3, \int \frac{5/3}{\sqrt{25u^2-25}} du = \frac{1}{3} \int \frac{1}{\sqrt{u^2-1}} du = \frac{1}{3} \cosh^{-1}(3x/5) + C$$

$$45. \tanh^{-1} x \Big|_0^{1/2} = \tanh^{-1}(1/2) - \tanh^{-1}(0) = \frac{1}{2} \ln \frac{1+1/2}{1-1/2} = \frac{1}{2} \ln 3$$

$$46. \sinh^{-1} t \Big|_0^{\sqrt{3}} = \sinh^{-1} \sqrt{3} - \sinh^{-1} 0 = \ln(\sqrt{3} + 2)$$

$$49. A = \int_0^{\ln 3} \sinh 2x dx = \frac{1}{2} \cosh 2x \Big|_0^{\ln 3} = \frac{1}{2} [\cosh(2 \ln 3) - 1],$$

$$\text{but } \cosh(2 \ln 3) = \cosh(\ln 9) = \frac{1}{2}(e^{\ln 9} + e^{-\ln 9}) = \frac{1}{2}(9 + 1/9) = 41/9 \text{ so } A = \frac{1}{2}[41/9 - 1] = 16/9.$$

$$50. V = \pi \int_0^{\ln 2} \operatorname{sech}^2 x dx = \pi \tanh x \Big|_0^{\ln 2} = \pi \tanh(\ln 2) = 3\pi/5$$

$$51. V = \pi \int_0^5 (\cosh^2 2x - \sinh^2 2x) dx = \pi \int_0^5 dx = 5\pi$$

$$52. \int_0^1 \cosh ax dx = 2, \frac{1}{a} \sinh ax \Big|_0^1 = 2, \frac{1}{a} \sinh a = 2, \sinh a = 2a;$$

$$\text{let } f(a) = \sinh a - 2a, \text{ then } a_{n+1} = a_n - \frac{\sinh a_n - 2a_n}{\cosh a_n - 2}, a_1 = 2.2, \dots, a_4 = a_5 = 2.177318985.$$

$$53. y' = \sinh x, 1 + (y')^2 = 1 + \sinh^2 x = \cosh^2 x$$

$$L = \int_0^{\ln 2} \cosh x dx = \sinh x \Big|_0^{\ln 2} = \sinh(\ln 2) = \frac{1}{2}(e^{\ln 2} - e^{-\ln 2}) = \frac{1}{2} \left( 2 - \frac{1}{2} \right) = \frac{3}{4}$$

54.  $y' = \sinh(x/a)$ ,  $1 + (y')^2 = 1 + \sinh^2(x/a) = \cosh^2(x/a)$

$$L = \int_0^{x_1} \cosh(x/a) dx = a \sinh(x/a) \Big|_0^{x_1} = a \sinh(x_1/a)$$

55.  $\sinh(-x) = \frac{1}{2}(e^{-x} - e^x) = -\frac{1}{2}(e^x - e^{-x}) = -\sinh x$

$$\cosh(-x) = \frac{1}{2}(e^{-x} + e^x) = \frac{1}{2}(e^x + e^{-x}) = \cosh x$$

56. (a)  $\cosh x + \sinh x = \frac{1}{2}(e^x + e^{-x}) + \frac{1}{2}(e^x - e^{-x}) = e^x$

(b)  $\cosh x - \sinh x = \frac{1}{2}(e^x + e^{-x}) - \frac{1}{2}(e^x - e^{-x}) = e^{-x}$

(c)  $\sinh x \cosh y + \cosh x \sinh y = \frac{1}{4}(e^x - e^{-x})(e^y + e^{-y}) + \frac{1}{4}(e^x + e^{-x})(e^y - e^{-y})$   
 $= \frac{1}{4}[(e^{x+y} - e^{-x+y} + e^{x-y} - e^{-x-y}) + (e^{x+y} + e^{-x+y} - e^{x-y} - e^{-x-y})]$   
 $= \frac{1}{2}[e^{(x+y)} - e^{-(x+y)}] = \sinh(x+y)$

(d) Let  $y = x$  in part (c).

(e) The proof is similar to part (c), or: treat  $x$  as variable and  $y$  as constant, and differentiate the result in part (c) with respect to  $x$ .

(f) Let  $y = x$  in part (e).

(g) Use  $\cosh^2 x = 1 + \sinh^2 x$  together with part (f).

(h) Use  $\sinh^2 x = \cosh^2 x - 1$  together with part (f).

57. (a) Divide  $\cosh^2 x - \sinh^2 x = 1$  by  $\cosh^2 x$ .

(b)  $\tanh(x+y) = \frac{\sinh x \cosh y + \cosh x \sinh y}{\cosh x \cosh y + \sinh x \sinh y} = \frac{\frac{\sinh x}{\cosh x} + \frac{\sinh y}{\cosh y}}{1 + \frac{\sinh x \sinh y}{\cosh x \cosh y}} = \frac{\tanh x + \tanh y}{1 + \tanh x \tanh y}$

(c) Let  $y = x$  in part (b).

58. (a) Let  $y = \cosh^{-1} x$ ; then  $x = \cosh y = \frac{1}{2}(e^y + e^{-y})$ ,  $e^y - 2x + e^{-y} = 0$ ,  $e^{2y} - 2xe^y + 1 = 0$ ,  
 $e^y = \frac{2x \pm \sqrt{4x^2 - 4}}{2} = x \pm \sqrt{x^2 - 1}$ . To determine which sign to take, note that  $y \geq 0$   
so  $e^{-y} \leq e^y$ ,  $x = (e^y + e^{-y})/2 \leq (e^y + e^y)/2 = e^y$ , hence  $e^y \geq x$  thus  $e^y = x + \sqrt{x^2 - 1}$ ,  
 $y = \cosh^{-1} x = \ln(x + \sqrt{x^2 - 1})$ .

(b) Let  $y = \tanh^{-1} x$ ; then  $x = \tanh y = \frac{e^y - e^{-y}}{e^y + e^{-y}} = \frac{e^{2y} - 1}{e^{2y} + 1}$ ,  $xe^{2y} + x = e^{2y} - 1$ ,  
 $1 + x = e^{2y}(1 - x)$ ,  $e^{2y} = (1 + x)/(1 - x)$ ,  $2y = \ln \frac{1+x}{1-x}$ ,  $y = \frac{1}{2} \ln \frac{1+x}{1-x}$ .

59. (a)  $\frac{d}{dx}(\cosh^{-1} x) = \frac{1 + x/\sqrt{x^2 - 1}}{x + \sqrt{x^2 - 1}} = 1/\sqrt{x^2 - 1}$

(b)  $\frac{d}{dx}(\tanh^{-1} x) = \frac{d}{dx} \left[ \frac{1}{2}(\ln(1+x) - \ln(1-x)) \right] = \frac{1}{2} \left( \frac{1}{1+x} + \frac{1}{1-x} \right) = 1/(1-x^2)$

60. Let  $y = \operatorname{sech}^{-1} x$  then  $x = \operatorname{sech} y = 1/\cosh y$ ,  $\cosh y = 1/x$ ,  $y = \cosh^{-1}(1/x)$ ; the proofs for the remaining two are similar.

61. If  $|u| < 1$  then, by Theorem 8.8.6,  $\int \frac{du}{1-u^2} = \tanh^{-1} u + C$ .

For  $|u| > 1$ ,  $\int \frac{du}{1-u^2} = \operatorname{coth}^{-1} u + C = \tanh^{-1}(1/u) + C$ .

62. (a)  $\frac{d}{dx}(\operatorname{sech}^{-1}|x|) = \frac{d}{dx}(\operatorname{sech}^{-1}\sqrt{x^2}) = -\frac{1}{\sqrt{x^2}\sqrt{1-x^2}} \frac{x}{\sqrt{x^2}} = -\frac{1}{x\sqrt{1-x^2}}$

(b) Similar to solution of part (a)

63. (a)  $\lim_{x \rightarrow +\infty} \sinh x = \lim_{x \rightarrow +\infty} \frac{1}{2}(e^x - e^{-x}) = +\infty - 0 = +\infty$

(b)  $\lim_{x \rightarrow -\infty} \sinh x = \lim_{x \rightarrow -\infty} \frac{1}{2}(e^x - e^{-x}) = 0 - \infty = -\infty$

(c)  $\lim_{x \rightarrow +\infty} \tanh x = \lim_{x \rightarrow +\infty} \frac{e^x - e^{-x}}{e^x + e^{-x}} = 1$

(d)  $\lim_{x \rightarrow -\infty} \tanh x = \lim_{x \rightarrow -\infty} \frac{e^x - e^{-x}}{e^x + e^{-x}} = -1$

(e)  $\lim_{x \rightarrow +\infty} \sinh^{-1} x = \lim_{x \rightarrow +\infty} \ln(x + \sqrt{x^2 + 1}) = +\infty$

(f)  $\lim_{x \rightarrow 1^-} \tanh^{-1} x = \lim_{x \rightarrow 1^-} \frac{1}{2}[\ln(1+x) - \ln(1-x)] = +\infty$

64. (a)  $\lim_{x \rightarrow +\infty} (\cosh^{-1} x - \ln x) = \lim_{x \rightarrow +\infty} [\ln(x + \sqrt{x^2 - 1}) - \ln x]$   
 $= \lim_{x \rightarrow +\infty} \ln \frac{x + \sqrt{x^2 - 1}}{x} = \lim_{x \rightarrow +\infty} \ln(1 + \sqrt{1 - 1/x^2}) = \ln 2$

(b)  $\lim_{x \rightarrow +\infty} \frac{\cosh x}{e^x} = \lim_{x \rightarrow +\infty} \frac{e^x + e^{-x}}{2e^x} = \lim_{x \rightarrow +\infty} \frac{1}{2}(1 + e^{-2x}) = 1/2$

65. For  $|x| < 1$ ,  $y = \tanh^{-1} x$  is defined and  $dy/dx = 1/(1-x^2) > 0$ ;  $y'' = 2x/(1-x^2)^2$  changes sign at  $x = 0$ , so there is a point of inflection there.

66. Let  $x = -u$ ,  $\int \frac{1}{\sqrt{u^2 - 1}} du = -\int \frac{1}{\sqrt{x^2 - 1}} dx = -\cosh^{-1} x + C = -\cosh^{-1}(-u) + C$ .

$$-\cosh^{-1}(-u) = -\ln(-u + \sqrt{u^2 - 1}) = \ln \frac{1}{-u + \sqrt{u^2 - 1}}$$

$$= \ln(-u - \sqrt{u^2 - 1}) = \ln|u + \sqrt{u^2 - 1}|$$

67. Using  $\sinh x + \cosh x = e^x$  (Exercise 56a),  $(\sinh x + \cosh x)^n = (e^x)^n = e^{nx} = \sinh nx + \cosh nx$ .

68.  $\int_{-a}^a e^{tx} dx = \frac{1}{t} e^{tx} \Big|_{-a}^a = \frac{1}{t}(e^{at} - e^{-at}) = \frac{2 \sinh at}{t}$  for  $t \neq 0$ .

69. (a)  $y' = \sinh(x/a)$ ,  $1 + (y')^2 = 1 + \sinh^2(x/a) = \cosh^2(x/a)$

$$L = 2 \int_0^b \cosh(x/a) dx = 2a \sinh(x/a) \Big|_0^b = 2a \sinh(b/a)$$

(b) The highest point is at  $x = b$ , the lowest at  $x = 0$ , so  $S = a \cosh(b/a) - a \cosh(0) = a \cosh(b/a) - a$ .



70. From part (a) of Exercise 69,  $L = 2a \sinh(b/a)$  so  $120 = 2a \sinh(50/a)$ ,  $a \sinh(50/a) = 60$ . Let  $u = 50/a$ , then  $a = 50/u$  so  $(50/u) \sinh u = 60$ ,  $\sinh u = 1.2u$ . If  $f(u) = \sinh u - 1.2u$ , then  $u_{n+1} = u_n - \frac{\sinh u_n - 1.2u_n}{\cosh u_n - 1.2}$ ;  $u_1 = 1, \dots, u_5 = u_6 = 1.064868548 \approx 50/a$  so  $a \approx 46.95415231$ . From part (b),  $S = a \cosh(b/a) - a \approx 46.95415231[\cosh(1.064868548) - 1] \approx 29.2$  ft.
71. From part (b) of Exercise 69,  $S = a \cosh(b/a) - a$  so  $30 = a \cosh(200/a) - a$ . Let  $u = 200/a$ , then  $a = 200/u$  so  $30 = (200/u)[\cosh u - 1]$ ,  $\cosh u - 1 = 0.15u$ . If  $f(u) = \cosh u - 0.15u - 1$ , then  $u_{n+1} = u_n - \frac{\cosh u_n - 0.15u_n - 1}{\sinh u_n - 0.15}$ ;  $u_1 = 0.3, \dots, u_4 = u_5 = 0.297792782 \approx 200/a$  so  $a \approx 671.6079505$ . From part (a),  $L = 2a \sinh(b/a) \approx 2(671.6079505) \sinh(0.297792782) \approx 405.9$  ft.
72. (a) When the bow of the boat is at the point  $(x, y)$  and the person has walked a distance  $D$ , then the person is located at the point  $(0, D)$ , the line segment connecting  $(0, D)$  and  $(x, y)$  has length  $a$ ; thus  $a^2 = x^2 + (D - y)^2$ ,  $D = y + \sqrt{a^2 - x^2} = a \operatorname{sech}^{-1}(x/a)$ .
- (b) Find  $D$  when  $a = 15$ ,  $x = 10$ :  $D = 15 \operatorname{sech}^{-1}(10/15) = 15 \ln \left( \frac{1 + \sqrt{5/9}}{2/3} \right) \approx 14.44$  m.
- (c)  $dy/dx = -\frac{a^2}{x\sqrt{a^2 - x^2}} + \frac{x}{\sqrt{a^2 - x^2}} = \frac{1}{\sqrt{a^2 - x^2}} \left[ -\frac{a^2}{x} + x \right] = -\frac{1}{x} \sqrt{a^2 - x^2}$ ,  
 $1 + [y']^2 = 1 + \frac{a^2 - x^2}{x^2} = \frac{a^2}{x^2}$ ; with  $a = 15$  and  $x = 5$ ,  $L = \int_5^{15} \frac{225}{x^2} dx = -\frac{225}{x} \Big|_5^{15} = 30$  m.

## CHAPTER 8 SUPPLEMENTARY EXERCISES

6. (a)  $A = \int_0^2 (2 + x - x^2) dx$  (b)  $A = \int_0^2 \sqrt{y} dy + \int_2^4 [(\sqrt{y} - (y - 2))] dy$
- (c)  $V = \pi \int_0^2 [(2 + x)^2 - x^4] dx$
- (d)  $V = 2\pi \int_0^2 y\sqrt{y} dy + 2\pi \int_2^4 y[\sqrt{y} - (y - 2)] dy$
- (e)  $V = 2\pi \int_0^2 x(2 + x - x^2) dx$  (f)  $V = \pi \int_0^2 y dy + \int_2^4 \pi(y - (y - 2)^2) dy$
7. (a)  $A = \int_a^b (f(x) - g(x)) dx + \int_b^c (g(x) - f(x)) dx + \int_c^d (f(x) - g(x)) dx$
- (b)  $A = \int_{-1}^0 (x^3 - x) dx + \int_0^1 (x - x^3) dx + \int_1^2 (x^3 - x) dx = \frac{1}{4} + \frac{1}{4} + \frac{9}{4} = \frac{11}{4}$
8. (a)  $S = \int_0^{8/27} 2\pi x \sqrt{1 + x^{-4/3}} dx$  (b)  $S = \int_0^2 2\pi \frac{y^3}{27} \sqrt{1 + y^4/81} dy$
- (c)  $S = \int_0^2 2\pi(y + 2) \sqrt{1 + y^4/81} dy$
9. By implicit differentiation  $\frac{dy}{dx} = -\left(\frac{y}{x}\right)^{1/3}$ , so  $1 + \left(\frac{dy}{dx}\right)^2 = 1 + \left(\frac{y}{x}\right)^{2/3} = \frac{x^{2/3} + y^{2/3}}{x^{2/3}} = \frac{a^{2/3}}{x^{2/3}}$ ,  
 $L = \int_{-a}^{-a/8} \frac{a^{1/3}}{(-x^{1/3})} dx = -a^{1/3} \int_{-a}^{-a/8} x^{-1/3} dx = 9a/8$ .

10. The base of the dome is a hexagon of side  $r$ . An equation of the circle of radius  $r$  that lies in a vertical  $x$ - $y$  plane and passes through two opposite vertices of the base hexagon is  $x^2 + y^2 = r^2$ . A horizontal, hexagonal cross section at height  $y$  above the base has area

$$A(y) = \frac{3\sqrt{3}}{2}x^2 = \frac{3\sqrt{3}}{2}(r^2 - y^2), \text{ hence the volume is } V = \int_0^r \frac{3\sqrt{3}}{2}(r^2 - y^2) dy = \sqrt{3}r^3.$$

11. Let the sphere have radius  $R$ , the hole radius  $r$ . By the Pythagorean Theorem,  $r^2 + (L/2)^2 = R^2$ . Use cylindrical shells to calculate the volume of the solid obtained by rotating about the  $y$ -axis the region  $r < x < R$ ,  $-\sqrt{R^2 - x^2} < y < \sqrt{R^2 - x^2}$ :

$$V = \int_r^R (2\pi x) 2\sqrt{R^2 - x^2} dx = -\frac{4}{3}\pi(R^2 - x^2)^{3/2} \Big|_r^R = \frac{4}{3}\pi(L/2)^3,$$

so the volume is independent of  $R$ .

12.  $V = 2 \int_0^{L/2} \pi \frac{16R^2}{L^4} (x^2 - L^2/4)^2 dx = \frac{4\pi}{15} LR^2$

13. Set  $a = 68.7672$ ,  $b = 0.0100333$ ,  $c = 693.8597$ ,  $d = 299.2239$ .

(a)

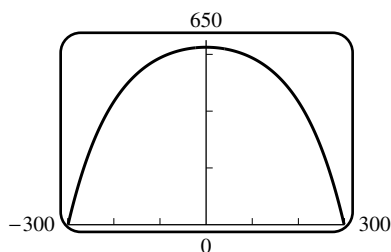

(b)  $L = 2 \int_0^d \sqrt{1 + a^2 b^2 \sinh^2 bx} dx$   
 $= 1480.2798 \text{ ft}$

(c)  $x = 283.6249 \text{ ft}$

(d)  $82^\circ$

14.  $y = 0$  at  $x = b = 30.585$ ; distance  $= \int_0^b \sqrt{1 + (12.54 - 0.82x)^2} dx = 196.306 \text{ yd}$

15. Let  $u = ax$  then  $du = a dx$ ,  $\int \frac{1}{\sqrt{a^2 + u^2}} du = \int \frac{a}{\sqrt{a^2 + a^2 x^2}} dx = \int \frac{1}{\sqrt{1 + x^2}} dx = \sinh^{-1}(u/a) + C$ ,

$$\int \frac{1}{\sqrt{u^2 - a^2}} du = \int \frac{1}{\sqrt{x^2 - 1}} dx = \cosh^{-1}(u/a) + C, \quad u > a,$$

$$\int \frac{1}{a^2 - u^2} du = \frac{1}{a} \int \frac{1}{1 - x^2} dx = \begin{cases} \frac{1}{a} \tanh^{-1}(u/a) + C, & |u| < a \\ \frac{1}{a} \coth^{-1}(u/a) + C, & |u| > a \end{cases} = \frac{1}{2a} \ln \left| \frac{a+u}{a-u} \right| + C$$

(a)  $\sinh^{-1}(x/2) + C$

(b)  $\cosh^{-1}(x/3) + C$

(c)  $\begin{cases} \frac{1}{\sqrt{2}} \tanh^{-1}(x/\sqrt{2}) + C, & |x| < \sqrt{2} \\ \frac{1}{\sqrt{2}} \coth^{-1}(x/\sqrt{2}) + C, & |x| > \sqrt{2} \end{cases} = \frac{1}{2\sqrt{2}} \ln \left| \frac{\sqrt{2} + x}{\sqrt{2} - x} \right| + C$

(d)  $\int \frac{dx}{\sqrt{16 + 5x^2}} = \frac{1}{\sqrt{5}} \int \frac{dx}{\sqrt{16/5 + x^2}} dx = \frac{1}{\sqrt{5}} \sinh^{-1} \left( \frac{\sqrt{5}x}{4} \right) + C$

16. (a)  $\cosh 3x = \cosh(2x + x) = \cosh 2x \cosh x + \sinh 2x \sinh x$   
 $= (2 \cosh^2 x - 1) \cosh x + (2 \sinh x \cosh x) \sinh x$   
 $= 2 \cosh^3 x - \cosh x + 2 \sinh^2 x \cosh x$   
 $= 2 \cosh^3 x - \cosh x + 2(\cosh^2 x - 1) \cosh x = 4 \cosh^3 x - 3 \cosh x$

(b) from Theorem 8.8.2 with  $x$  replaced by  $\frac{x}{2}$ :  $\cosh x = 2 \cosh^2 \frac{x}{2} - 1$ ,

$$2 \cosh^2 \frac{x}{2} = \cosh x + 1, \quad \cosh^2 \frac{x}{2} = \frac{1}{2}(\cosh x + 1),$$

$$\cosh \frac{x}{2} = \sqrt{\frac{1}{2}(\cosh x + 1)} \quad (\text{because } \cosh \frac{x}{2} > 0)$$

(c) from Theorem 8.8.2 with  $x$  replaced by  $\frac{x}{2}$ :  $\cosh x = 2 \sinh^2 \frac{x}{2} + 1$ ,

$$2 \sinh^2 \frac{x}{2} = \cosh x - 1, \quad \sinh^2 \frac{x}{2} = \frac{1}{2}(\cosh x - 1), \quad \sinh \frac{x}{2} = \pm \sqrt{\frac{1}{2}(\cosh x - 1)}$$

17. (a)  $F = kx, \frac{1}{2} = k\frac{1}{4}, k = 2, W = \int_0^{1/4} kx \, dx = 1/16 \text{ J}$

(b)  $25 = \int_0^L kx \, dx = kL^2/2, L = 5 \text{ m}$

18.  $F = 30x + 2000, W = \int_0^{150} (30x + 2000) \, dx = 15 \cdot 150^2 + 2000 \cdot 150 = 637,500 \text{ lb}\cdot\text{ft}$

19. (a)  $F = \int_0^1 \rho x^3 \, dx \text{ N}$

(b) By similar triangles  $\frac{w(x)}{4} = \frac{x}{2}, w(x) = 2x$ , so

$$F = \int_1^4 \rho(1+x)2x \, dx \text{ lb/ft}^2.$$

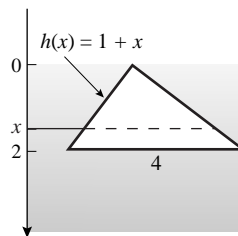

(c) A formula for the parabola is  $y = \frac{8}{125}x^2 - 10$ , so  $F = \int_{-10}^0 9810|y|2\sqrt{\frac{125}{8}(y+10)} \, dy \text{ N}$ .

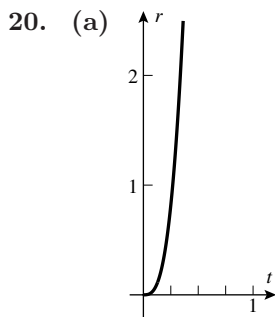

(b)  $r = 1$  when  $t \approx 0.673080 \text{ s}$ .

(c)  $dr/dt = 4.48 \text{ m/s}$ .

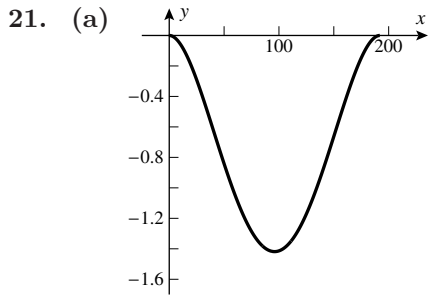

(b) The maximum deflection occurs at  $x = 96$  inches (the midpoint of the beam) and is about 1.42 in.

(c) The length of the centerline is  $\int_0^{192} \sqrt{1 + (dy/dx)^2} dx = 192.026$  in.

22. The  $x$ -coordinates of the points of intersection are  $a \approx -0.423028$  and  $b \approx 1.725171$ ; the area is  $\int_a^b (2 \sin x - x^2 + 1) dx \approx 2.542696$ .

23. Let  $(a, k)$ , where  $\pi/2 < a < \pi$ , be the coordinates of the point of intersection of  $y = k$  with  $y = \sin x$ . Thus  $k = \sin a$  and if the shaded areas are equal,

$$\int_0^a (k - \sin x) dx = \int_0^a (\sin a - \sin x) dx = a \sin a + \cos a - 1 = 0$$

Solve for  $a$  to get  $a \approx 2.331122$ , so  $k = \sin a \approx 0.724611$ .

24. The volume is given by  $2\pi \int_0^k x \sin x dx = 2\pi(\sin k - k \cos k) = 8$ ; solve for  $k$  to get  $k = 1.736796$ .

25. (a)  $\int_a^{a+2} \frac{x}{\sqrt{1+x^3}} dx$

(b) Use the result in Exercise 24, Section 7.9, to obtain

$$\frac{d}{da} \left[ \int_a^{a+2} \frac{x}{\sqrt{1+x^3}} dx \right] = \frac{a+2}{\sqrt{1+(a+2)^3}} - \frac{a}{\sqrt{1+a^3}} = 0; \text{ solve for } a \text{ to get } a \approx 0.683772.$$

The maximum work is  $\int_a^{a+2} \frac{x}{\sqrt{1+x^3}} dx \approx 1.347655$  J.

# CHAPTER 9

## Principles of Integral Evaluation

### EXERCISE SET 9.1

1.  $u = 3 - 2x, du = -2dx, \quad -\frac{1}{2} \int u^3 du = -\frac{1}{8}u^4 + C = -\frac{1}{8}(3 - 2x)^4 + C$
2.  $u = 4 + 9x, du = 9dx, \quad \frac{1}{9} \int u^{1/2} du = \frac{2}{3 \cdot 9}u^{3/2} + C = \frac{2}{27}(4 + 9x)^{3/2} + C$
3.  $u = x^2, du = 2xdx, \quad \frac{1}{2} \int \sec^2 u du = \frac{1}{2} \tan u + C = \frac{1}{2} \tan(x^2) + C$
4.  $u = x^2, du = 2xdx, \quad 2 \int \tan u du = -2 \ln |\cos u| + C = -2 \ln |\cos(x^2)| + C$
5.  $u = 2 + \cos 3x, du = -3 \sin 3xdx, \quad -\frac{1}{3} \int \frac{du}{u} = -\frac{1}{3} \ln |u| + C = -\frac{1}{3} \ln(2 + \cos 3x) + C$
6.  $u = \frac{3x}{2}, du = \frac{3}{2}dx, \quad \frac{2}{3} \int \frac{du}{4 + 4u^2} = \frac{1}{6} \int \frac{du}{1 + u^2} = \frac{1}{6} \tan^{-1} u + C = \frac{1}{6} \tan^{-1}(3x/2) + C$
7.  $u = e^x, du = e^x dx, \quad \int \sinh u du = \cosh u + C = \cosh e^x + C$
8.  $u = \ln x, du = \frac{1}{x} dx, \quad \int \sec u \tan u du = \sec u + C = \sec(\ln x) + C$
9.  $u = \cot x, du = -\csc^2 x dx, \quad -\int e^u du = -e^u + C = -e^{\cot x} + C$
10.  $u = x^2, du = 2xdx, \quad \frac{1}{2} \int \frac{du}{\sqrt{1-u^2}} = \frac{1}{2} \sin^{-1} u + C = \frac{1}{2} \sin^{-1}(x^2) + C$
11.  $u = \cos 7x, du = -7 \sin 7xdx, \quad -\frac{1}{7} \int u^5 du = -\frac{1}{42}u^6 + C = -\frac{1}{42} \cos^6 7x + C$
12.  $u = \sin x, du = \cos x dx, \quad \int \frac{du}{u\sqrt{u^2+1}} = -\ln \left| \frac{1 + \sqrt{1+u^2}}{u} \right| + C = -\ln \left| \frac{1 + \sqrt{1+\sin^2 x}}{\sin x} \right| + C$
13.  $u = e^x, du = e^x dx, \quad \int \frac{du}{\sqrt{4+u^2}} = \ln(u + \sqrt{u^2+4}) + C = \ln(e^x + \sqrt{e^{2x}+4}) + C$
14.  $u = \tan^{-1} x, du = \frac{1}{1+x^2} dx, \quad \int e^u du = e^u + C = e^{\tan^{-1} x} + C$
15.  $u = \sqrt{x-2}, du = \frac{1}{2\sqrt{x-2}} dx, \quad 2 \int e^u du = 2e^u + C = 2e^{\sqrt{x-2}} + C$
16.  $u = 3x^2 + 2x, du = (6x+2)dx, \quad \frac{1}{2} \int \cot u du = \frac{1}{2} \ln |\sin u| + C = \frac{1}{2} \ln \sin |3x^2 + 2x| + C$

17.  $u = \sqrt{x}, du = \frac{1}{2\sqrt{x}} dx, \quad \int 2 \cosh u \, du = 2 \sinh u + C = 2 \sinh \sqrt{x} + C$
18.  $u = \ln x, du = \frac{dx}{x}, \quad \int \frac{du}{u} = \ln |u| + C = \ln |\ln x| + C$
19.  $u = \sqrt{x}, du = \frac{1}{2\sqrt{x}} dx, \quad \int \frac{2 \, du}{3^u} = 2 \int e^{-u \ln 3} \, du = -\frac{2}{\ln 3} e^{-u \ln 3} + C = -\frac{2}{\ln 3} 3^{-\sqrt{x}} + C$
20.  $u = \sin \theta, du = \cos \theta \, d\theta, \quad \int \sec u \tan u \, du = \sec u + C = \sec(\sin \theta) + C$
21.  $u = \frac{2}{x}, du = -\frac{2}{x^2} dx, \quad -\frac{1}{2} \int \operatorname{csch}^2 u \, du = \frac{1}{2} \coth u + C = \frac{1}{2} \coth \frac{2}{x} + C$
22.  $\int \frac{dx}{\sqrt{x^2 - 3}} = \ln \left| x + \sqrt{x^2 - 3} \right| + C$
23.  $u = e^{-x}, du = -e^{-x} dx, \quad -\int \frac{du}{4 - u^2} = -\frac{1}{4} \ln \left| \frac{2 + u}{2 - u} \right| + C = -\frac{1}{4} \ln \left| \frac{2 + e^{-x}}{2 - e^{-x}} \right| + C$
24.  $u = \ln x, du = \frac{1}{x} dx, \quad \int \cos u \, du = \sin u + C = \sin(\ln x) + C$
25.  $u = e^x, du = e^x dx, \quad \int \frac{e^x dx}{\sqrt{1 - e^{2x}}} = \int \frac{du}{\sqrt{1 - u^2}} = \sin^{-1} u + C = \sin^{-1} e^x + C$
26.  $u = x^{-1/2}, du = -\frac{1}{2x^{3/2}} dx, \quad -\int 2 \sinh u \, du = -2 \cosh u + C = -2 \cosh(x^{-1/2}) + C$
27.  $u = x^2, du = 2x dx, \quad \frac{1}{2} \int \frac{du}{\sec u} = \frac{1}{2} \int \cos u \, du = \frac{1}{2} \sin u + C = \frac{1}{2} \sin(x^2) + C$
28.  $2u = e^x, 2du = e^x dx, \quad \int \frac{2du}{\sqrt{4 - 4u^2}} = \sin^{-1} u + C = \sin^{-1}(e^x/2) + C$
29.  $4^{-x^2} = e^{-x^2 \ln 4}, u = -x^2 \ln 4, du = -2x \ln 4 \, dx = -x \ln 16 \, dx,$   
 $-\frac{1}{\ln 16} \int e^u \, du = -\frac{1}{\ln 16} e^u + C = -\frac{1}{\ln 16} e^{-x^2 \ln 4} + C = -\frac{1}{\ln 16} 4^{-x^2} + C$
30.  $2^{\pi x} = e^{\pi x \ln 2}, \quad \int 2^{\pi x} dx = \frac{1}{\pi \ln 2} e^{\pi x \ln 2} + C = \frac{1}{\pi \ln 2} 2^{\pi x} + C$
31. (a) With  $u = x$  we get  
 from (15),  $\int \frac{dx}{\sqrt{1 - x^2}} = \sin^{-1} x + C \quad (|x| < 1)$   
 from (17),  $\int \frac{dx}{1 + x^2} = \tan^{-1} x + C$   
 from (19),  $\int \frac{dx}{x\sqrt{x^2 - 1}} = \sec^{-1} x + C \quad (x > 1)$

(b) With  $u = ax$ ,  $du = adx$ , we get (for  $a > 0$ )

$$\int \frac{du}{\sqrt{a^2 - u^2}} = \int \frac{adx}{a\sqrt{1 - x^2}} = \sin^{-1} x + C = \sin^{-1}(u/a) + C$$

$$\int \frac{du}{a^2 + u^2} = \frac{1}{a^2} \int \frac{adx}{1 + x^2} = \frac{1}{a} \tan^{-1} x + C = \frac{1}{a} \tan^{-1}(u/a) + C$$

$$\int \frac{du}{u\sqrt{u^2 - a^2}} = \int \frac{adx}{a^2 x \sqrt{x^2 - 1}} = \frac{1}{a} \sec^{-1} x + C = \frac{1}{a} \sec^{-1}(u/a) + C$$

## EXERCISE SET 9.2

1.  $u = x$ ,  $dv = e^{-x} dx$ ,  $du = dx$ ,  $v = -e^{-x}$ ;  $\int x e^{-x} dx = -x e^{-x} + \int e^{-x} dx = -x e^{-x} - e^{-x} + C$

2.  $u = x$ ,  $dv = e^{3x} dx$ ,  $du = dx$ ,  $v = \frac{1}{3} e^{3x}$ ;  $\int x e^{3x} dx = \frac{1}{3} x e^{3x} - \frac{1}{3} \int e^{3x} dx = \frac{1}{3} x e^{3x} - \frac{1}{9} e^{3x} + C$

3.  $u = x^2$ ,  $dv = e^x dx$ ,  $du = 2x dx$ ,  $v = e^x$ ;  $\int x^2 e^x dx = x^2 e^x - 2 \int x e^x dx$ .

For  $\int x e^x dx$  use  $u = x$ ,  $dv = e^x dx$ ,  $du = dx$ ,  $v = e^x$  to get

$$\int x e^x dx = x e^x - e^x + C_1 \text{ so } \int x^2 e^x dx = x^2 e^x - 2x e^x + 2e^x + C$$

4.  $u = x^2$ ,  $dv = e^{-2x} dx$ ,  $du = 2x dx$ ,  $v = -\frac{1}{2} e^{-2x}$ ;  $\int x^2 e^{-2x} dx = -\frac{1}{2} x^2 e^{-2x} + \int x e^{-2x} dx$

For  $\int x e^{-2x} dx$  use  $u = x$ ,  $dv = e^{-2x} dx$  to get

$$\int x e^{-2x} dx = -\frac{1}{2} x e^{-2x} + \frac{1}{2} \int e^{-2x} dx = -\frac{1}{2} x e^{-2x} - \frac{1}{4} e^{-2x} + C$$

$$\text{so } \int x^2 e^{-2x} dx = -\frac{1}{2} x^2 e^{-2x} - \frac{1}{2} x e^{-2x} - \frac{1}{4} e^{-2x} + C$$

5.  $u = x$ ,  $dv = \sin 2x dx$ ,  $du = dx$ ,  $v = -\frac{1}{2} \cos 2x$ ;

$$\int x \sin 2x dx = -\frac{1}{2} x \cos 2x + \frac{1}{2} \int \cos 2x dx = -\frac{1}{2} x \cos 2x + \frac{1}{4} \sin 2x + C$$

6.  $u = x$ ,  $dv = \cos 3x dx$ ,  $du = dx$ ,  $v = \frac{1}{3} \sin 3x$ ;

$$\int x \cos 3x dx = \frac{1}{3} x \sin 3x - \frac{1}{3} \int \sin 3x dx = \frac{1}{3} x \sin 3x + \frac{1}{9} \cos 3x + C$$

7.  $u = x^2$ ,  $dv = \cos x dx$ ,  $du = 2x dx$ ,  $v = \sin x$ ;  $\int x^2 \cos x dx = x^2 \sin x - 2 \int x \sin x dx$

For  $\int x \sin x dx$  use  $u = x$ ,  $dv = \sin x dx$  to get

$$\int x \sin x dx = -x \cos x + \sin x + C_1 \text{ so } \int x^2 \cos x dx = x^2 \sin x + 2x \cos x - 2 \sin x + C$$

8.  $u = x^2$ ,  $dv = \sin x dx$ ,  $du = 2x dx$ ,  $v = -\cos x$ ;

$$\int x^2 \sin x dx = -x^2 \cos x + 2 \int x \cos x dx; \text{ for } \int x \cos x dx \text{ use } u = x, dv = \cos x dx \text{ to get}$$

$$\int x \cos x dx = x \sin x + \cos x + C_1 \text{ so } \int x^2 \sin x dx = -x^2 \cos x + 2x \sin x + 2 \cos x + C$$

9.  $u = \ln x$ ,  $dv = \sqrt{x} dx$ ,  $du = \frac{1}{x} dx$ ,  $v = \frac{2}{3} x^{3/2}$ ;

$$\int \sqrt{x} \ln x dx = \frac{2}{3} x^{3/2} \ln x - \frac{2}{3} \int x^{1/2} dx = \frac{2}{3} x^{3/2} \ln x - \frac{4}{9} x^{3/2} + C$$

10.  $u = \ln x$ ,  $dv = x dx$ ,  $du = \frac{1}{x} dx$ ,  $v = \frac{1}{2} x^2$ ;  $\int x \ln x dx = \frac{1}{2} x^2 \ln x - \frac{1}{2} \int x dx = \frac{1}{2} x^2 \ln x - \frac{1}{4} x^2 + C$

11.  $u = (\ln x)^2$ ,  $dv = dx$ ,  $du = 2 \frac{\ln x}{x} dx$ ,  $v = x$ ;  $\int (\ln x)^2 dx = x(\ln x)^2 - 2 \int \ln x dx$ .

Use  $u = \ln x$ ,  $dv = dx$  to get  $\int \ln x dx = x \ln x - \int dx = x \ln x - x + C_1$  so

$$\int (\ln x)^2 dx = x(\ln x)^2 - 2x \ln x + 2x + C$$

12.  $u = \ln x$ ,  $dv = \frac{1}{\sqrt{x}} dx$ ,  $du = \frac{1}{x} dx$ ,  $v = 2\sqrt{x}$ ;  $\int \frac{\ln x}{\sqrt{x}} dx = 2\sqrt{x} \ln x - 2 \int \frac{1}{\sqrt{x}} dx = 2\sqrt{x} \ln x - 4\sqrt{x} + C$

13.  $u = \ln(2x + 3)$ ,  $dv = dx$ ,  $du = \frac{2}{2x + 3} dx$ ,  $v = x$ ;  $\int \ln(2x + 3) dx = x \ln(2x + 3) - \int \frac{2x}{2x + 3} dx$

but  $\int \frac{2x}{2x + 3} dx = \int \left(1 - \frac{3}{2x + 3}\right) dx = x - \frac{3}{2} \ln(2x + 3) + C_1$  so

$$\int \ln(2x + 3) dx = x \ln(2x + 3) - x + \frac{3}{2} \ln(2x + 3) + C$$

14.  $u = \ln(x^2 + 4)$ ,  $dv = dx$ ,  $du = \frac{2x}{x^2 + 4} dx$ ,  $v = x$ ;  $\int \ln(x^2 + 4) dx = x \ln(x^2 + 4) - 2 \int \frac{x^2}{x^2 + 4} dx$

but  $\int \frac{x^2}{x^2 + 4} dx = \int \left(1 - \frac{4}{x^2 + 4}\right) dx = x - 2 \tan^{-1} \frac{x}{2} + C_1$  so

$$\int \ln(x^2 + 4) dx = x \ln(x^2 + 4) - 2x + 4 \tan^{-1} \frac{x}{2} + C$$

15.  $u = \sin^{-1} x$ ,  $dv = dx$ ,  $du = 1/\sqrt{1 - x^2} dx$ ,  $v = x$ ;

$$\int \sin^{-1} x dx = x \sin^{-1} x - \int x/\sqrt{1 - x^2} dx = x \sin^{-1} x + \sqrt{1 - x^2} + C$$

16.  $u = \cos^{-1}(2x)$ ,  $dv = dx$ ,  $du = -\frac{2}{\sqrt{1 - 4x^2}} dx$ ,  $v = x$ ;

$$\int \cos^{-1}(2x) dx = x \cos^{-1}(2x) + \int \frac{2x}{\sqrt{1 - 4x^2}} dx = x \cos^{-1}(2x) - \frac{1}{2} \sqrt{1 - 4x^2} + C$$



17.  $u = \tan^{-1}(2x)$ ,  $dv = dx$ ,  $du = \frac{2}{1+4x^2}dx$ ,  $v = x$ ;

$$\int \tan^{-1}(2x)dx = x \tan^{-1}(2x) - \int \frac{2x}{1+4x^2}dx = x \tan^{-1}(2x) - \frac{1}{4} \ln(1+4x^2) + C$$

18.  $u = \tan^{-1} x$ ,  $dv = x dx$ ,  $du = \frac{1}{1+x^2}dx$ ,  $v = \frac{1}{2}x^2$ ;  $\int x \tan^{-1} x dx = \frac{1}{2}x^2 \tan^{-1} x - \frac{1}{2} \int \frac{x^2}{1+x^2}dx$

but  $\int \frac{x^2}{1+x^2}dx = \int \left(1 - \frac{1}{1+x^2}\right) dx = x - \tan^{-1} x + C_1$  so

$$\int x \tan^{-1} x dx = \frac{1}{2}x^2 \tan^{-1} x - \frac{1}{2}x + \frac{1}{2} \tan^{-1} x + C$$

19.  $u = e^x$ ,  $dv = \sin x dx$ ,  $du = e^x dx$ ,  $v = -\cos x$ ;  $\int e^x \sin x dx = -e^x \cos x + \int e^x \cos x dx$ .

For  $\int e^x \cos x dx$  use  $u = e^x$ ,  $dv = \cos x dx$  to get  $\int e^x \cos x = e^x \sin x - \int e^x \sin x dx$  so

$$\int e^x \sin x dx = -e^x \cos x + e^x \sin x - \int e^x \sin x dx,$$

$$2 \int e^x \sin x dx = e^x(\sin x - \cos x) + C_1, \int e^x \sin x dx = \frac{1}{2}e^x(\sin x - \cos x) + C$$

20.  $u = e^{2x}$ ,  $dv = \cos 3x dx$ ,  $du = 2e^{2x}dx$ ,  $v = \frac{1}{3} \sin 3x$ ;

$$\int e^{2x} \cos 3x dx = \frac{1}{3}e^{2x} \sin 3x - \frac{2}{3} \int e^{2x} \sin 3x dx. \text{ Use } u = e^{2x}, dv = \sin 3x dx \text{ to get}$$

$$\int e^{2x} \sin 3x dx = -\frac{1}{3}e^{2x} \cos 3x + \frac{2}{3} \int e^{2x} \cos 3x dx \text{ so}$$

$$\int e^{2x} \cos 3x dx = \frac{1}{3}e^{2x} \sin 3x + \frac{2}{9}e^{2x} \cos 3x - \frac{4}{9} \int e^{2x} \cos 3x dx,$$

$$\frac{13}{9} \int e^{2x} \cos 3x dx = \frac{1}{9}e^{2x}(3 \sin 3x + 2 \cos 3x) + C_1, \int e^{2x} \cos 3x dx = \frac{1}{13}e^{2x}(3 \sin 3x + 2 \cos 3x) + C$$

21.  $u = e^{ax}$ ,  $dv = \sin bx dx$ ,  $du = ae^{ax}dx$ ,  $v = -\frac{1}{b} \cos bx$  ( $b \neq 0$ );

$$\int e^{ax} \sin bx dx = -\frac{1}{b}e^{ax} \cos bx + \frac{a}{b} \int e^{ax} \cos bx dx. \text{ Use } u = e^{ax}, dv = \cos bx dx \text{ to get}$$

$$\int e^{ax} \cos bx dx = \frac{1}{b}e^{ax} \sin bx - \frac{a}{b} \int e^{ax} \sin bx dx \text{ so}$$

$$\int e^{ax} \sin bx dx = -\frac{1}{b}e^{ax} \cos bx + \frac{a}{b^2}e^{ax} \sin bx - \frac{a^2}{b^2} \int e^{ax} \sin bx dx,$$

$$\int e^{ax} \sin bx dx = \frac{e^{ax}}{a^2 + b^2}(a \sin bx - b \cos bx) + C$$

22. From Exercise 21 with  $a = -3$ ,  $b = 5$ ,  $x = \theta$ , answer =  $\frac{e^{-3\theta}}{\sqrt{34}}(-3 \sin 5\theta - 5 \cos 5\theta) + C$

23.  $u = \sin(\ln x)$ ,  $dv = dx$ ,  $du = \frac{\cos(\ln x)}{x} dx$ ,  $v = x$ ;

$$\int \sin(\ln x) dx = x \sin(\ln x) - \int \cos(\ln x) dx. \text{ Use } u = \cos(\ln x), dv = dx \text{ to get}$$

$$\int \cos(\ln x) dx = x \cos(\ln x) + \int \sin(\ln x) dx \text{ so}$$

$$\int \sin(\ln x) dx = x \sin(\ln x) - x \cos(\ln x) - \int \sin(\ln x) dx,$$

$$\int \sin(\ln x) dx = (x/2)[\sin(\ln x) - \cos(\ln x)] + C$$

24.  $u = \cos(\ln x)$ ,  $dv = dx$ ,  $du = -\frac{1}{x} \sin(\ln x) dx$ ,  $v = x$ ;

$$\int \cos(\ln x) dx = x \cos(\ln x) + \int \sin(\ln x) dx. \text{ Use } u = \sin(\ln x), dv = dx \text{ to get}$$

$$\int \sin(\ln x) dx = x \sin(\ln x) - \int \cos(\ln x) dx \text{ so}$$

$$\int \cos(\ln x) dx = x \cos(\ln x) + x \sin(\ln x) - \int \cos(\ln x) dx,$$

$$\int \cos(\ln x) dx = \frac{1}{2}x[\cos(\ln x) + \sin(\ln x)] + C$$

25.  $u = x$ ,  $dv = \sec^2 x dx$ ,  $du = dx$ ,  $v = \tan x$ ;

$$\int x \sec^2 x dx = x \tan x - \int \tan x dx = x \tan x - \int \frac{\sin x}{\cos x} dx = x \tan x + \ln |\cos x| + C$$

26.  $u = x$ ,  $dv = \tan^2 x dx = (\sec^2 x - 1) dx$ ,  $du = dx$ ,  $v = \tan x - x$ ;

$$\int x \tan^2 x dx = x \tan x - x^2 - \int (\tan x - x) dx$$

$$= x \tan x - x^2 + \ln |\cos x| + \frac{1}{2}x^2 + C = x \tan x - \frac{1}{2}x^2 + \ln |\cos x| + C$$

27.  $u = x^2$ ,  $dv = xe^{x^2} dx$ ,  $du = 2x dx$ ,  $v = \frac{1}{2}e^{x^2}$ ;

$$\int x^3 e^{x^2} dx = \frac{1}{2}x^2 e^{x^2} - \int xe^{x^2} dx = \frac{1}{2}x^2 e^{x^2} - \frac{1}{2}e^{x^2} + C$$

28.  $u = xe^x$ ,  $dv = \frac{1}{(x+1)^2} dx$ ,  $du = (x+1)e^x dx$ ,  $v = -\frac{1}{x+1}$ ;

$$\int \frac{xe^x}{(x+1)^2} dx = -\frac{xe^x}{x+1} + \int e^x dx = -\frac{xe^x}{x+1} + e^x + C = \frac{e^x}{x+1} + C$$

29.  $u = x$ ,  $dv = e^{-5x} dx$ ,  $du = dx$ ,  $v = -\frac{1}{5}e^{-5x}$ ;

$$\begin{aligned}\int_0^1 x e^{-5x} dx &= -\frac{1}{5} x e^{-5x} \Big|_0^1 + \frac{1}{5} \int_0^1 e^{-5x} dx \\ &= -\frac{1}{5} e^{-5} - \frac{1}{25} e^{-5x} \Big|_0^1 = -\frac{1}{5} e^{-5} - \frac{1}{25} (e^{-5} - 1) = (1 - 6e^{-5})/25\end{aligned}$$

30.  $u = x$ ,  $dv = e^{2x} dx$ ,  $du = dx$ ,  $v = \frac{1}{2}e^{2x}$ ;

$$\int_0^2 x e^{2x} dx = \frac{1}{2} x e^{2x} \Big|_0^2 - \frac{1}{2} \int_0^2 e^{2x} dx = e^4 - \frac{1}{4} e^{2x} \Big|_0^2 = e^4 - \frac{1}{4} (e^4 - 1) = (3e^4 + 1)/4$$

31.  $u = \ln x$ ,  $dv = x^2 dx$ ,  $du = \frac{1}{x} dx$ ,  $v = \frac{1}{3}x^3$ ;

$$\int_1^e x^2 \ln x dx = \frac{1}{3} x^3 \ln x \Big|_1^e - \frac{1}{3} \int_1^e x^2 dx = \frac{1}{3} e^3 - \frac{1}{9} x^3 \Big|_1^e = \frac{1}{3} e^3 - \frac{1}{9} (e^3 - 1) = (2e^3 + 1)/9$$

32.  $u = \ln x$ ,  $dv = \frac{1}{x^2} dx$ ,  $du = \frac{1}{x} dx$ ,  $v = -\frac{1}{x}$ ;

$$\begin{aligned}\int_{\sqrt{e}}^e \frac{\ln x}{x^2} dx &= -\frac{1}{x} \ln x \Big|_{\sqrt{e}}^e + \int_{\sqrt{e}}^e \frac{1}{x^2} dx \\ &= -\frac{1}{e} + \frac{1}{\sqrt{e}} \ln \sqrt{e} - \frac{1}{x} \Big|_{\sqrt{e}}^e = -\frac{1}{e} + \frac{1}{2\sqrt{e}} - \frac{1}{e} + \frac{1}{\sqrt{e}} = \frac{3\sqrt{e} - 4}{2e}\end{aligned}$$

33.  $u = \ln(x+3)$ ,  $dv = dx$ ,  $du = \frac{1}{x+3} dx$ ,  $v = x$ ;

$$\begin{aligned}\int_{-2}^2 \ln(x+3) dx &= x \ln(x+3) \Big|_{-2}^2 - \int_{-2}^2 \frac{x}{x+3} dx = 2 \ln 5 + 2 \ln 1 - \int_{-2}^2 \left[ 1 - \frac{3}{x+3} \right] dx \\ &= 2 \ln 5 - [x - 3 \ln(x+3)]_{-2}^2 = 2 \ln 5 - (2 - 3 \ln 5) + (-2 - 3 \ln 1) = 5 \ln 5 - 4\end{aligned}$$

34.  $u = \sin^{-1} x$ ,  $dv = dx$ ,  $du = \frac{1}{\sqrt{1-x^2}} dx$ ,  $v = x$ ;

$$\begin{aligned}\int_0^{1/2} \sin^{-1} x dx &= x \sin^{-1} x \Big|_0^{1/2} - \int_0^{1/2} \frac{x}{\sqrt{1-x^2}} dx = \frac{1}{2} \sin^{-1} \frac{1}{2} + \sqrt{1-x^2} \Big|_0^{1/2} \\ &= \frac{1}{2} \left( \frac{\pi}{6} \right) + \sqrt{\frac{3}{4}} - 1 = \frac{\pi}{12} + \frac{\sqrt{3}}{2} - 1\end{aligned}$$

35.  $u = \sec^{-1} \sqrt{\theta}$ ,  $dv = d\theta$ ,  $du = \frac{1}{2\theta\sqrt{\theta-1}} d\theta$ ,  $v = \theta$ ;

$$\begin{aligned}\int_2^4 \sec^{-1} \sqrt{\theta} d\theta &= \theta \sec^{-1} \sqrt{\theta} \Big|_2^4 - \frac{1}{2} \int_2^4 \frac{1}{\sqrt{\theta-1}} d\theta = 4 \sec^{-1} 2 - 2 \sec^{-1} \sqrt{2} - \sqrt{\theta-1} \Big|_2^4 \\ &= 4 \left( \frac{\pi}{3} \right) - 2 \left( \frac{\pi}{4} \right) - \sqrt{3} + 1 = \frac{5\pi}{6} - \sqrt{3} + 1\end{aligned}$$

36.  $u = \sec^{-1} x$ ,  $dv = x dx$ ,  $du = \frac{1}{x\sqrt{x^2-1}} dx$ ,  $v = \frac{1}{2}x^2$ ;

$$\begin{aligned} \int_1^2 x \sec^{-1} x dx &= \left. \frac{1}{2}x^2 \sec^{-1} x \right|_1^2 - \frac{1}{2} \int_1^2 \frac{x}{\sqrt{x^2-1}} dx \\ &= \frac{1}{2} [(4)(\pi/3) - (1)(0)] - \frac{1}{2} \left. \sqrt{x^2-1} \right|_1^2 = 2\pi/3 - \sqrt{3}/2 \end{aligned}$$

37.  $u = x$ ,  $dv = \sin 4x dx$ ,  $du = dx$ ,  $v = -\frac{1}{4} \cos 4x$ ;

$$\int_0^{\pi/2} x \sin 4x dx = \left. -\frac{1}{4}x \cos 4x \right|_0^{\pi/2} + \frac{1}{4} \int_0^{\pi/2} \cos 4x dx = -\pi/8 + \frac{1}{16} \sin 4x \Big|_0^{\pi/2} = -\pi/8$$

38.  $\int_0^\pi (x + x \cos x) dx = \left. \frac{1}{2}x^2 \right|_0^\pi + \int_0^\pi x \cos x dx = \frac{\pi^2}{2} + \int_0^\pi x \cos x dx$ ;

$$u = x, dv = \cos x dx, du = dx, v = \sin x$$

$$\int_0^\pi x \cos x dx = \left. x \sin x \right|_0^\pi - \int_0^\pi \sin x dx = \cos x \Big|_0^\pi = -2 \text{ so } \int_0^\pi (x + x \cos x) dx = \pi^2/2 - 2$$

39.  $u = \tan^{-1} \sqrt{x}$ ,  $dv = \sqrt{x} dx$ ,  $du = \frac{1}{2\sqrt{x}(1+x)} dx$ ,  $v = \frac{2}{3}x^{3/2}$ ;

$$\begin{aligned} \int_1^3 \sqrt{x} \tan^{-1} \sqrt{x} dx &= \left. \frac{2}{3}x^{3/2} \tan^{-1} \sqrt{x} \right|_1^3 - \frac{1}{3} \int_1^3 \frac{x}{1+x} dx \\ &= \left. \frac{2}{3}x^{3/2} \tan^{-1} \sqrt{x} \right|_1^3 - \frac{1}{3} \int_1^3 \left[ 1 - \frac{1}{1+x} \right] dx \\ &= \left[ \frac{2}{3}x^{3/2} \tan^{-1} \sqrt{x} - \frac{1}{3}x + \frac{1}{3} \ln |1+x| \right]_1^3 = (2\sqrt{3}\pi - \pi/2 - 2 + \ln 2)/3 \end{aligned}$$

40.  $u = \ln(x^2 + 1)$ ,  $dv = dx$ ,  $du = \frac{2x}{x^2+1} dx$ ,  $v = x$ ;

$$\begin{aligned} \int_0^2 \ln(x^2 + 1) dx &= \left. x \ln(x^2 + 1) \right|_0^2 - \int_0^2 \frac{2x^2}{x^2+1} dx = 2 \ln 5 - 2 \int_0^2 \left( 1 - \frac{1}{x^2+1} \right) dx \\ &= \left. 2 \ln 5 - 2(x - \tan^{-1} x) \right|_0^2 = 2 \ln 5 - 4 + 2 \tan^{-1} 2 \end{aligned}$$

41.  $t = \sqrt{x}$ ,  $t^2 = x$ ,  $dx = 2t dt$

(a)  $\int e^{\sqrt{x}} dx = 2 \int te^t dt$ ;  $u = t$ ,  $dv = e^t dt$ ,  $du = dt$ ,  $v = e^t$ ,

$$\int e^{\sqrt{x}} dx = 2te^t - 2 \int e^t dt = 2(t-1)e^t + C = 2(\sqrt{x}-1)e^{\sqrt{x}} + C$$

(b)  $\int \cos \sqrt{x} dx = 2 \int t \cos t dt$ ;  $u = t$ ,  $dv = \cos t dt$ ,  $du = dt$ ,  $v = \sin t$ ,

$$\int \cos \sqrt{x} dx = 2t \sin t - 2 \int \sin t dt = 2t \sin t + 2 \cos t + C = 2\sqrt{x} \sin \sqrt{x} + 2 \cos \sqrt{x} + C$$

$$43. \quad (\text{a}) \quad A = \int_1^e \ln x \, dx = (x \ln x - x) \Big|_1^e = 1$$

$$(\text{b}) \quad V = \pi \int_1^e (\ln x)^2 dx = \pi \left[ (x(\ln x)^2 - 2x \ln x + 2x) \right]_1^e = \pi(e - 2)$$

$$44. \quad A = \int_0^{\pi/2} (x - x \sin x) dx = \left[ \frac{1}{2}x^2 \right]_0^{\pi/2} - \int_0^{\pi/2} x \sin x \, dx = \frac{\pi^2}{8} - (-x \cos x + \sin x) \Big|_0^{\pi/2} = \pi^2/8 - 1$$

$$45. \quad V = 2\pi \int_0^{\pi} x \sin x \, dx = 2\pi(-x \cos x + \sin x) \Big|_0^{\pi} = 2\pi^2$$

$$46. \quad V = 2\pi \int_0^{\pi/2} x \cos x \, dx = 2\pi(\cos x + x \sin x) \Big|_0^{\pi/2} = \pi(\pi - 2)$$

$$47. \quad \text{distance} = \int_0^5 t^2 e^{-t} dt; u = t^2, dv = e^{-t} dt, du = 2t dt, v = -e^{-t},$$

$$\text{distance} = -t^2 e^{-t} \Big|_0^5 + 2 \int_0^5 t e^{-t} dt; u = 2t, dv = e^{-t} dt, du = 2 dt, v = -e^{-t},$$

$$\begin{aligned} \text{distance} &= -25e^{-5} - 2te^{-t} \Big|_0^5 + 2 \int_0^5 e^{-t} dt = -25e^{-5} - 10e^{-5} - 2e^{-t} \Big|_0^5 \\ &= -25e^{-5} - 10e^{-5} - 2e^{-5} + 2 = -37e^{-5} + 2 \end{aligned}$$

$$48. \quad u = 2t, dv = \sin(k\omega t) dt, du = 2dt, v = -\frac{1}{k\omega} \cos(k\omega t); \text{ the integrand is an even function of } t \text{ so}$$

$$\begin{aligned} \int_{-\pi/\omega}^{\pi/\omega} t \sin(k\omega t) dt &= 2 \int_0^{\pi/\omega} t \sin(k\omega t) dt = -\frac{2}{k\omega} t \cos(k\omega t) \Big|_0^{\pi/\omega} + 2 \int_0^{\pi/\omega} \frac{1}{k\omega} \cos(k\omega t) dt \\ &= \frac{2\pi(-1)^{k+1}}{k\omega^2} + \frac{2}{k^2\omega^2} \sin(k\omega t) \Big|_0^{\pi/\omega} = \frac{2\pi(-1)^{k+1}}{k\omega^2} \end{aligned}$$

$$49. \quad (\text{a}) \quad \int \sin^3 x \, dx = -\frac{1}{3} \sin^2 x \cos x + \frac{2}{3} \int \sin x \, dx = -\frac{1}{3} \sin^2 x \cos x - \frac{2}{3} \cos x + C$$

$$(\text{b}) \quad \int \sin^4 x \, dx = -\frac{1}{4} \sin^3 x \cos x + \frac{3}{4} \int \sin^2 x \, dx, \int \sin^2 x \, dx = -\frac{1}{2} \sin x \cos x + \frac{1}{2} x + C_1 \text{ so}$$

$$\begin{aligned} \int_0^{\pi/4} \sin^4 x \, dx &= \left[ -\frac{1}{4} \sin^3 x \cos x - \frac{3}{8} \sin x \cos x + \frac{3}{8} x \right]_0^{\pi/4} \\ &= -\frac{1}{4} (1/\sqrt{2})^3 (1/\sqrt{2}) - \frac{3}{8} (1/\sqrt{2})(1/\sqrt{2}) + 3\pi/32 = 3\pi/32 - 1/4 \end{aligned}$$

$$\begin{aligned} 50. \quad (\text{a}) \quad \int \cos^5 x \, dx &= \frac{1}{5} \cos^4 x \sin x + \frac{4}{5} \int \cos^3 x \, dx = \frac{1}{5} \cos^4 x \sin x + \frac{4}{5} \left[ \frac{1}{3} \cos^2 x \sin x + \frac{2}{3} \sin x \right] + C \\ &= \frac{1}{5} \cos^4 x \sin x + \frac{4}{15} \cos^2 x \sin x + \frac{8}{15} \sin x + C \end{aligned}$$

$$\begin{aligned}
 \text{(b)} \quad \int \cos^6 x \, dx &= \frac{1}{6} \cos^5 x \sin x + \frac{5}{6} \int \cos^4 x \, dx \\
 &= \frac{1}{6} \cos^5 x \sin x + \frac{5}{6} \left[ \frac{1}{4} \cos^3 x \sin x + \frac{3}{4} \int \cos^2 x \, dx \right] \\
 &= \frac{1}{6} \cos^5 x \sin x + \frac{5}{24} \cos^3 x \sin x + \frac{5}{8} \left[ \frac{1}{2} \cos x \sin x + \frac{1}{2} x \right] + C, \\
 &\quad \left[ \frac{1}{6} \cos^5 x \sin x + \frac{5}{24} \cos^3 x \sin x + \frac{5}{16} \cos x \sin x + \frac{5}{16} x \right]_0^{\pi/2} = 5\pi/32
 \end{aligned}$$

51.  $u = \sin^{n-1} x$ ,  $dv = \sin x \, dx$ ,  $du = (n-1) \sin^{n-2} x \cos x \, dx$ ,  $v = -\cos x$ ;

$$\begin{aligned}
 \int \sin^n x \, dx &= -\sin^{n-1} x \cos x + (n-1) \int \sin^{n-2} x \cos^2 x \, dx \\
 &= -\sin^{n-1} x \cos x + (n-1) \int \sin^{n-2} x (1 - \sin^2 x) \, dx \\
 &= -\sin^{n-1} x \cos x + (n-1) \int \sin^{n-2} x \, dx - (n-1) \int \sin^n x \, dx,
 \end{aligned}$$

$$n \int \sin^n x \, dx = -\sin^{n-1} x \cos x + (n-1) \int \sin^{n-2} x \, dx,$$

$$\int \sin^n x \, dx = -\frac{1}{n} \sin^{n-1} x \cos x + \frac{n-1}{n} \int \sin^{n-2} x \, dx$$

52. (a)  $u = \sec^{n-2} x$ ,  $dv = \sec^2 x \, dx$ ,  $du = (n-2) \sec^{n-2} x \tan x \, dx$ ,  $v = \tan x$ ;

$$\begin{aligned}
 \int \sec^n x \, dx &= \sec^{n-2} x \tan x - (n-2) \int \sec^{n-2} x \tan^2 x \, dx \\
 &= \sec^{n-2} x \tan x - (n-2) \int \sec^{n-2} x (\sec^2 x - 1) \, dx \\
 &= \sec^{n-2} x \tan x - (n-2) \int \sec^n x \, dx + (n-2) \int \sec^{n-2} x \, dx,
 \end{aligned}$$

$$(n-1) \int \sec^n x \, dx = \sec^{n-2} x \tan x + (n-2) \int \sec^{n-2} x \, dx,$$

$$\int \sec^n x \, dx = \frac{1}{n-1} \sec^{n-2} x \tan x + \frac{n-2}{n-1} \int \sec^{n-2} x \, dx$$

$$\begin{aligned}
 \text{(b)} \quad \int \tan^n x \, dx &= \int \tan^{n-2} x (\sec^2 x - 1) \, dx = \int \tan^{n-1} x \sec^2 x \, dx - \int \tan^{n-2} x \, dx \\
 &= \frac{1}{n-1} \tan^{n-1} x - \int \tan^{n-2} x \, dx
 \end{aligned}$$

(c)  $u = x^n$ ,  $dv = e^x \, dx$ ,  $du = nx^{n-1} \, dx$ ,  $v = e^x$ ;  $\int x^n e^x \, dx = x^n e^x - n \int x^{n-1} e^x \, dx$

53. (a)  $\int \tan^4 x \, dx = \frac{1}{3} \tan^3 x - \int \tan^2 x \, dx = \frac{1}{3} \tan^3 x - \tan x + \int dx = \frac{1}{3} \tan^3 x - \tan x + x + C$

(b)  $\int \sec^4 x \, dx = \frac{1}{3} \sec^2 x \tan x + \frac{2}{3} \int \sec^2 x \, dx = \frac{1}{3} \sec^2 x \tan x + \frac{2}{3} \tan x + C$

$$\begin{aligned} \text{(c)} \quad \int x^3 e^x dx &= x^3 e^x - 3 \int x^2 e^x dx = x^3 e^x - 3 \left[ x^2 e^x - 2 \int x e^x dx \right] \\ &= x^3 e^x - 3x^2 e^x + 6 \left[ x e^x - \int e^x dx \right] = x^3 e^x - 3x^2 e^x + 6x e^x - 6e^x + C \end{aligned}$$

54. (a)  $u = 3x$ ,

$$\begin{aligned} \int x^2 e^{3x} dx &= \frac{1}{27} \int u^2 e^u du = \frac{1}{27} \left[ u^2 e^u - 2 \int u e^u du \right] = \frac{1}{27} u^2 e^u - \frac{2}{27} \left[ u e^u - \int e^u du \right] \\ &= \frac{1}{27} u^2 e^u - \frac{2}{27} u e^u + \frac{2}{27} e^u + C = \frac{1}{3} x^2 e^{3x} - \frac{2}{9} x e^{3x} + \frac{2}{27} e^{3x} + C \end{aligned}$$

(b)  $u = -\sqrt{x}$ ,

$$\begin{aligned} \int_0^1 x e^{-\sqrt{x}} dx &= 2 \int_0^{-1} u^3 e^u du, \\ \int u^3 e^u du &= u^3 e^u - 3 \int u^2 e^u du = u^3 e^u - 3 \left[ u^2 e^u - 2 \int u e^u du \right] \\ &= u^3 e^u - 3u^2 e^u + 6 \left[ u e^u - \int e^u du \right] = u^3 e^u - 3u^2 e^u + 6u e^u - 6e^u + C, \\ 2 \int_0^{-1} u^3 e^u du &= 2(u^3 - 3u^2 + 6u - 6)e^u \Big|_0^{-1} = 12 - 32e^{-1} \end{aligned}$$

55.  $u = x, dv = f''(x)dx, du = dx, v = f'(x)$ ;

$$\begin{aligned} \int_{-1}^1 x f''(x) dx &= x f'(x) \Big|_{-1}^1 - \int_{-1}^1 f'(x) dx \\ &= f'(1) + f'(-1) - f(x) \Big|_{-1}^1 = f'(1) + f'(-1) - f(1) + f(-1) \end{aligned}$$

56. (a)  $u = f(x), dv = dx, du = f'(x), v = x$ ;

$$\int_a^b f(x) dx = x f(x) \Big|_a^b - \int_a^b x f'(x) dx = b f(b) - a f(a) - \int_a^b x f'(x) dx$$

(b) Substitute  $y = f(x), dy = f'(x) dx, x = a$  when  $y = f(a), x = b$  when  $y = f(b)$ ,

$$\int_a^b x f'(x) dx = \int_{f(a)}^{f(b)} x dy = \int_{f(a)}^{f(b)} f^{-1}(y) dy$$

(c) From  $a = f^{-1}(\alpha)$  and  $b = f^{-1}(\beta)$  we get

$$b f(b) - a f(a) = \beta f^{-1}(\beta) - \alpha f^{-1}(\alpha); \text{ then}$$

$$\int_{\alpha}^{\beta} f^{-1}(x) dx = \int_{\alpha}^{\beta} f^{-1}(y) dy = \int_{f(a)}^{f(b)} f^{-1}(y) dy,$$

which, by part (b), yields

$$\begin{aligned} \int_{\alpha}^{\beta} f^{-1}(x) dx &= b f(b) - a f(a) - \int_a^b f(x) dx \\ &= \beta f^{-1}(\beta) - \alpha f^{-1}(\alpha) - \int_{f^{-1}(\alpha)}^{f^{-1}(\beta)} f(x) dx \end{aligned}$$

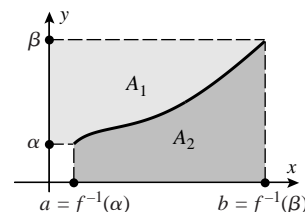

Note from the figure that  $A_1 = \int_{\alpha}^{\beta} f^{-1}(x) dx$ ,  $A_2 = \int_{f^{-1}(\alpha)}^{f^{-1}(\beta)} f(x) dx$ , and  $A_1 + A_2 = \beta f^{-1}(\beta) - \alpha f^{-1}(\alpha)$ , a "picture proof".

57. (a) Use Exercise 56(c);

$$\int_0^{1/2} \sin^{-1} x dx = \frac{1}{2} \sin^{-1} \left( \frac{1}{2} \right) - 0 \cdot \sin^{-1} 0 - \int_{\sin^{-1}(0)}^{\sin^{-1}(1/2)} \sin x dx = \frac{1}{2} \sin^{-1} \left( \frac{1}{2} \right) - \int_0^{\pi/6} \sin x dx$$

(b) Use Exercise 56(b);

$$\int_e^{e^2} \ln x dx = e^2 \ln e^2 - e \ln e - \int_{\ln e}^{\ln e^2} f^{-1}(y) dy = 2e^2 - e - \int_1^2 e^y dy = 2e^2 - e - \int_1^2 e^x dx$$

58. (a)  $\int x e^x dx = x(e^x + C_1) - \int (e^x + C_1) dx = x e^x + C_1 x - e^x - C_1 x + C = x e^x - e^x + C$

(b)  $u(v + C_1) - \int (v + C_1) du = uv + C_1 u - \int v du - C_1 u = uv - \int v du$

### EXERCISE SET 9.3

1.  $u = \cos x, -\int u^5 du = -\frac{1}{6} \cos^6 x + C$       2.  $u = \sin 3x, \frac{1}{3} \int u^4 du = \frac{1}{15} \sin^5 3x + C$

3.  $u = \sin ax, \frac{1}{a} \int u du = \frac{1}{2a} \sin^2 ax + C, \quad a \neq 0$

4.  $\int \cos^2 3x dx = \frac{1}{2} \int (1 + \cos 6x) dx = \frac{1}{2} x + \frac{1}{12} \sin 6x + C$

5.  $\int \sin^2 5\theta d\theta = \frac{1}{2} \int (1 - \cos 10\theta) d\theta = \frac{1}{2} \theta - \frac{1}{20} \sin 10\theta + C$

6.  $\int \cos^3 at dt = \int (1 - \sin^2 at) \cos at dt$   
 $= \int \cos at dt - \int \sin^2 at \cos at dt = \frac{1}{a} \sin at - \frac{1}{3a} \sin^3 at + C \quad (a \neq 0)$

7.  $\int \cos^5 \theta d\theta = \int (1 - \sin^2 \theta)^2 \cos \theta d\theta = \int (1 - 2\sin^2 \theta + \sin^4 \theta) \cos \theta d\theta$   
 $= \sin \theta - \frac{2}{3} \sin^3 \theta + \frac{1}{5} \sin^5 \theta + C$

8.  $\int \sin^3 x \cos^3 x dx = \int \sin^3 x (1 - \sin^2 x) \cos x dx$   
 $= \int (\sin^3 x - \sin^5 x) \cos x dx = \frac{1}{4} \sin^4 x - \frac{1}{6} \sin^6 x + C$

9.  $\int \sin^2 2t \cos^3 2t dt = \int \sin^2 2t (1 - \sin^2 2t) \cos 2t dt = \int (\sin^2 2t - \sin^4 2t) \cos 2t dt$   
 $= \frac{1}{6} \sin^3 2t - \frac{1}{10} \sin^5 2t + C$



10. 
$$\int \sin^3 2x \cos^2 2x \, dx = \int (1 - \cos^2 2x) \cos^2 2x \sin 2x \, dx$$

$$= \int (\cos^2 2x - \cos^4 2x) \sin 2x \, dx = -\frac{1}{6} \cos^3 2x + \frac{1}{10} \cos^5 2x + C$$
11. 
$$\int \sin^2 x \cos^2 x \, dx = \frac{1}{4} \int \sin^2 2x \, dx = \frac{1}{8} \int (1 - \cos 4x) \, dx = \frac{1}{8} x - \frac{1}{32} \sin 4x + C$$
12. 
$$\int \sin^2 x \cos^4 x \, dx = \frac{1}{8} \int (1 - \cos 2x)(1 + \cos 2x)^2 \, dx = \frac{1}{8} \int (1 - \cos^2 2x)(1 + \cos 2x) \, dx$$

$$= \frac{1}{8} \int \sin^2 2x \, dx + \frac{1}{8} \int \sin^2 2x \cos 2x \, dx = \frac{1}{16} \int (1 - \cos 4x) \, dx + \frac{1}{48} \sin^3 2x$$

$$= \frac{1}{16} x - \frac{1}{64} \sin 4x + \frac{1}{48} \sin^3 2x + C$$
13. 
$$\int \sin x \cos 2x \, dx = \frac{1}{2} \int (\sin 3x - \sin x) \, dx = -\frac{1}{6} \cos 3x + \frac{1}{2} \cos x + C$$
14. 
$$\int \sin 3\theta \cos 2\theta \, d\theta = \frac{1}{2} \int (\sin 5\theta + \sin \theta) \, d\theta = -\frac{1}{10} \cos 5\theta - \frac{1}{2} \cos \theta + C$$
15. 
$$\int \sin x \cos(x/2) \, dx = \frac{1}{2} \int [\sin(3x/2) + \sin(x/2)] \, dx = -\frac{1}{3} \cos(3x/2) - \cos(x/2) + C$$
16. 
$$u = \cos x, \quad -\int u^{1/5} \, du = -\frac{5}{6} \cos^{6/5} x + C$$
17. 
$$\int_0^{\pi/4} \cos^3 x \, dx = \int_0^{\pi/4} (1 - \sin^2 x) \cos x \, dx$$

$$= \left[ \sin x - \frac{1}{3} \sin^3 x \right]_0^{\pi/4} = (\sqrt{2}/2) - \frac{1}{3} (\sqrt{2}/2)^3 = 5\sqrt{2}/12$$
18. 
$$\int_0^{\pi/2} \sin^2(x/2) \cos^2(x/2) \, dx = \frac{1}{4} \int_0^{\pi/2} \sin^2 x \, dx = \frac{1}{8} \int_0^{\pi/2} (1 - \cos 2x) \, dx$$

$$= \frac{1}{8} \left( x - \frac{1}{2} \sin 2x \right) \Big|_0^{\pi/2} = \pi/16$$
19. 
$$\int_0^{\pi/3} \sin^4 3x \cos^3 3x \, dx = \int_0^{\pi/3} \sin^4 3x (1 - \sin^2 3x) \cos 3x \, dx = \left[ \frac{1}{15} \sin^5 3x - \frac{1}{21} \sin^7 3x \right]_0^{\pi/3} = 0$$
20. 
$$\int_{-\pi}^{\pi} \cos^2 5\theta \, d\theta = \frac{1}{2} \int_{-\pi}^{\pi} (1 + \cos 10\theta) \, d\theta = \frac{1}{2} \left( \theta + \frac{1}{10} \sin 10\theta \right) \Big|_{-\pi}^{\pi} = \pi$$
21. 
$$\int_0^{\pi/6} \sin 2x \cos 4x \, dx = \frac{1}{2} \int_0^{\pi/6} (\sin 6x - \sin 2x) \, dx = \left[ -\frac{1}{12} \cos 6x + \frac{1}{4} \cos 2x \right]_0^{\pi/6}$$

$$= [(-1/12)(-1) + (1/4)(1/2)] - [-1/12 + 1/4] = 1/24$$
22. 
$$\int_0^{2\pi} \sin^2 kx \, dx = \frac{1}{2} \int_0^{2\pi} (1 - \cos 2kx) \, dx = \frac{1}{2} \left( x - \frac{1}{2k} \sin 2kx \right) \Big|_0^{2\pi} = \pi - \frac{1}{4k} \sin 4\pi k \quad (k \neq 0)$$

$$23. \frac{1}{3} \tan(3x+1) + C$$

$$24. -\frac{1}{5} \ln |\cos 5x| + C$$

$$25. u = e^{-2x}, du = -2e^{-2x} dx; -\frac{1}{2} \int \tan u du = \frac{1}{2} \ln |\cos u| + C = \frac{1}{2} \ln |\cos(e^{-2x})| + C$$

$$26. \frac{1}{3} \ln |\sin 3x| + C$$

$$27. \frac{1}{2} \ln |\sec 2x + \tan 2x| + C$$

$$28. u = \sqrt{x}, du = \frac{1}{2\sqrt{x}} dx; \int 2 \sec u du = 2 \ln |\sec u + \tan u| + C = 2 \ln |\sec \sqrt{x} + \tan \sqrt{x}| + C$$

$$29. u = \tan x, \int u^2 du = \frac{1}{3} \tan^3 x + C$$

$$30. \int \tan^5 x (1 + \tan^2 x) \sec^2 x dx = \int (\tan^5 x + \tan^7 x) \sec^2 x dx = \frac{1}{6} \tan^6 x + \frac{1}{8} \tan^8 x + C$$

$$31. \int \tan^3 4x (1 + \tan^2 4x) \sec^2 4x dx = \int (\tan^3 4x + \tan^5 4x) \sec^2 4x dx = \frac{1}{16} \tan^4 4x + \frac{1}{24} \tan^6 4x + C$$

$$32. \int \tan^4 \theta (1 + \tan^2 \theta) \sec^2 \theta d\theta = \frac{1}{5} \tan^5 \theta + \frac{1}{7} \tan^7 \theta + C$$

$$33. \int \sec^4 x (\sec^2 x - 1) \sec x \tan x dx = \int (\sec^6 x - \sec^4 x) \sec x \tan x dx = \frac{1}{7} \sec^7 x - \frac{1}{5} \sec^5 x + C$$

$$34. \int (\sec^2 \theta - 1)^2 \sec \theta \tan \theta d\theta = \int (\sec^4 \theta - 2 \sec^2 \theta + 1) \sec \theta \tan \theta d\theta = \frac{1}{5} \sec^5 \theta - \frac{2}{3} \sec^3 \theta + \sec \theta + C$$

$$\begin{aligned} 35. \int (\sec^2 x - 1)^2 \sec x dx &= \int (\sec^5 x - 2 \sec^3 x + \sec x) dx = \int \sec^5 x dx - 2 \int \sec^3 x dx + \int \sec x dx \\ &= \frac{1}{4} \sec^3 x \tan x + \frac{3}{4} \int \sec^3 x dx - 2 \int \sec^3 x dx + \ln |\sec x + \tan x| \\ &= \frac{1}{4} \sec^3 x \tan x - \frac{5}{4} \left[ \frac{1}{2} \sec x \tan x + \frac{1}{2} \ln |\sec x + \tan x| \right] + \ln |\sec x + \tan x| + C \\ &= \frac{1}{4} \sec^3 x \tan x - \frac{5}{8} \sec x \tan x + \frac{3}{8} \ln |\sec x + \tan x| + C \end{aligned}$$

$$\begin{aligned} 36. \int [\sec^2(x/2) - 1] \sec^3(x/2) dx &= \int [\sec^5(x/2) - \sec^3(x/2)] dx \\ &= 2 \left[ \int \sec^5 u du - \int \sec^3 u du \right] && (u = x/2) \\ &= 2 \left[ \left( \frac{1}{4} \sec^3 u \tan u + \frac{3}{4} \int \sec^3 u du \right) - \int \sec^3 u du \right] && (\text{equation (20)}) \\ &= \frac{1}{2} \sec^3 u \tan u - \frac{1}{2} \int \sec^3 u du \\ &= \frac{1}{2} \sec^3 u \tan u - \frac{1}{4} \sec u \tan u - \frac{1}{4} \ln |\sec u + \tan u| + C && (\text{equation (20), (22)}) \\ &= \frac{1}{2} \sec^3 \frac{x}{2} \tan \frac{x}{2} - \frac{1}{4} \sec \frac{x}{2} \tan \frac{x}{2} - \frac{1}{4} \ln \left| \sec \frac{x}{2} + \tan \frac{x}{2} \right| + C \end{aligned}$$

$$37. \int \sec^2 2t(\sec 2t \tan 2t)dt = \frac{1}{6} \sec^3 2t + C \quad 38. \int \sec^4 x(\sec x \tan x)dx = \frac{1}{5} \sec^5 x + C$$

$$39. \int \sec^4 x dx = \int (1 + \tan^2 x) \sec^2 x dx = \int (\sec^2 x + \tan^2 x \sec^2 x)dx = \tan x + \frac{1}{3} \tan^3 x + C$$

40. Using equation (20),

$$\begin{aligned} \int \sec^5 x dx &= \frac{1}{4} \sec^3 x \tan x + \frac{3}{4} \int \sec^3 x dx \\ &= \frac{1}{4} \sec^3 x \tan x + \frac{3}{8} \sec x \tan x + \frac{3}{8} \ln |\sec x + \tan x| + C \end{aligned}$$

$$41. \text{ Use equation (19) to get } \int \tan^4 x dx = \frac{1}{3} \tan^3 x - \tan x + x + C$$

42.  $u = 4x$ , use equation (19) to get

$$\frac{1}{4} \int \tan^3 u du = \frac{1}{4} \left[ \frac{1}{2} \tan^2 u + \ln |\cos u| \right] + C = \frac{1}{8} \tan^2 4x + \frac{1}{4} \ln |\cos 4x| + C$$

$$43. \int \sqrt{\tan x}(1 + \tan^2 x) \sec^2 x dx = \frac{2}{3} \tan^{3/2} x + \frac{2}{7} \tan^{7/2} x + C$$

$$44. \int \sec^{1/2} x(\sec x \tan x)dx = \frac{2}{3} \sec^{3/2} x + C$$

$$45. \int_0^{\pi/6} (\sec^2 2x - 1)dx = \left[ \frac{1}{2} \tan 2x - x \right]_0^{\pi/6} = \sqrt{3}/2 - \pi/6$$

$$46. \int_0^{\pi/6} \sec^2 \theta(\sec \theta \tan \theta)d\theta = \frac{1}{3} \sec^3 \theta \Big|_0^{\pi/6} = (1/3)(2/\sqrt{3})^3 - 1/3 = 8\sqrt{3}/27 - 1/3$$

47.  $u = x/2$ ,

$$2 \int_0^{\pi/4} \tan^5 u du = \left[ \frac{1}{2} \tan^4 u - \tan^2 u - 2 \ln |\cos u| \right]_0^{\pi/4} = 1/2 - 1 - 2 \ln(1/\sqrt{2}) = -1/2 + \ln 2$$

$$48. u = \pi x, \frac{1}{\pi} \int_0^{\pi/4} \sec u \tan u du = \frac{1}{\pi} \sec u \Big|_0^{\pi/4} = (\sqrt{2} - 1)/\pi$$

$$49. \int (\csc^2 x - 1) \csc^2 x(\csc x \cot x)dx = \int (\csc^4 x - \csc^2 x)(\csc x \cot x)dx = -\frac{1}{5} \csc^5 x + \frac{1}{3} \csc^3 x + C$$

$$50. \int \frac{\cos^2 3t}{\sin^2 3t} \cdot \frac{1}{\cos 3t} dt = \int \csc 3t \cot 3t dt = -\frac{1}{3} \csc 3t + C$$

$$51. \int (\csc^2 x - 1) \cot x dx = \int \csc x(\csc x \cot x)dx - \int \frac{\cos x}{\sin x} dx = -\frac{1}{2} \csc^2 x - \ln |\sin x| + C$$

$$52. \int (\cot^2 x + 1) \csc^2 x dx = -\frac{1}{3} \cot^3 x - \cot x + C$$

$$53. \quad (a) \quad \int_0^{2\pi} \sin mx \cos nx \, dx = \frac{1}{2} \int_0^{2\pi} [\sin(m+n)x + \sin(m-n)x] dx = \left[ -\frac{\cos(m+n)x}{2(m+n)} - \frac{\cos(m-n)x}{2(m-n)} \right]_0^{2\pi}$$

but  $\cos(m+n)x \Big|_0^{2\pi} = 0, \cos(m-n)x \Big|_0^{2\pi} = 0.$

$$(b) \quad \int_0^{2\pi} \cos mx \cos nx \, dx = \frac{1}{2} \int_0^{2\pi} [\cos(m+n)x + \cos(m-n)x] dx;$$

since  $m \neq n$ , evaluate  $\sin$  at integer multiples of  $2\pi$  to get 0.

$$(c) \quad \int_0^{2\pi} \sin mx \sin nx \, dx = \frac{1}{2} \int_0^{2\pi} [\cos(m-n)x - \cos(m+n)x] dx;$$

since  $m \neq n$ , evaluate  $\sin$  at integer multiples of  $2\pi$  to get 0.

$$55. \quad y' = \tan x, \quad 1 + (y')^2 = 1 + \tan^2 x = \sec^2 x,$$

$$L = \int_0^{\pi/4} \sqrt{\sec^2 x} \, dx = \int_0^{\pi/4} \sec x \, dx = \ln |\sec x + \tan x| \Big|_0^{\pi/4} = \ln(\sqrt{2} + 1)$$

$$56. \quad V = \pi \int_0^{\pi/4} (1 - \tan^2 x) dx = \pi \int_0^{\pi/4} (2 - \sec^2 x) dx = \pi(2x - \tan x) \Big|_0^{\pi/4} = \frac{1}{2}\pi(\pi - 2)$$

$$57. \quad V = \pi \int_0^{\pi/4} (\cos^2 x - \sin^2 x) dx = \pi \int_0^{\pi/4} \cos 2x \, dx = \frac{1}{2}\pi \sin 2x \Big|_0^{\pi/4} = \pi/2$$

$$58. \quad V = \pi \int_0^{\pi} \sin^2 x \, dx = \frac{\pi}{2} \int_0^{\pi} (1 - \cos 2x) dx = \frac{\pi}{2} \left( x - \frac{1}{2} \sin 2x \right) \Big|_0^{\pi} = \pi^2/2$$

$$59. \quad \text{With } 0 < \alpha < \beta, D = D_\beta - D_\alpha = \frac{L}{2\pi} \int_\alpha^\beta \sec x \, dx = \frac{L}{2\pi} \ln |\sec x + \tan x| \Big|_\alpha^\beta = \frac{L}{2\pi} \ln \left| \frac{\sec \beta + \tan \beta}{\sec \alpha + \tan \alpha} \right|$$

$$60. \quad (a) \quad D = \frac{100}{2\pi} \ln(\sec 25^\circ + \tan 25^\circ) = 7.18 \text{ cm} \quad (b) \quad D = \frac{100}{2\pi} \ln \left| \frac{\sec 50^\circ + \tan 50^\circ}{\sec 30^\circ + \tan 30^\circ} \right| = 7.34 \text{ cm}$$

$$61. \quad (a) \quad \int \csc x \, dx = \int \sec(\pi/2 - x) dx = -\ln |\sec(\pi/2 - x) + \tan(\pi/2 - x)| + C$$

$$= -\ln |\csc x + \cot x| + C$$

$$(b) \quad -\ln |\csc x + \cot x| = \ln \frac{1}{|\csc x + \cot x|} = \ln \frac{|\csc x - \cot x|}{|\csc^2 x - \cot^2 x|} = \ln |\csc x - \cot x|,$$

$$-\ln |\csc x + \cot x| = -\ln \left| \frac{1}{\sin x} + \frac{\cos x}{\sin x} \right| = \ln \left| \frac{\sin x}{1 + \cos x} \right|$$

$$= \ln \left| \frac{2 \sin(x/2) \cos(x/2)}{2 \cos^2(x/2)} \right| = \ln |\tan(x/2)|$$

$$62. \quad \sin x + \cos x = \sqrt{2}[(1/\sqrt{2}) \sin x + (1/\sqrt{2}) \cos x]$$

$$= \sqrt{2}[\sin x \cos(\pi/4) + \cos x \sin(\pi/4)] = \sqrt{2} \sin(x + \pi/4),$$

$$\int \frac{dx}{\sin x + \cos x} = \frac{1}{\sqrt{2}} \int \csc(x + \pi/4) dx = -\frac{1}{\sqrt{2}} \ln |\csc(x + \pi/4) + \cot(x + \pi/4)| + C$$

$$= -\frac{1}{\sqrt{2}} \ln \left| \frac{\sqrt{2} + \cos x - \sin x}{\sin x + \cos x} \right| + C$$

$$63. \quad a \sin x + b \cos x = \sqrt{a^2 + b^2} \left[ \frac{a}{\sqrt{a^2 + b^2}} \sin x + \frac{b}{\sqrt{a^2 + b^2}} \cos x \right] = \sqrt{a^2 + b^2} (\sin x \cos \theta + \cos x \sin \theta)$$

where  $\cos \theta = a/\sqrt{a^2 + b^2}$  and  $\sin \theta = b/\sqrt{a^2 + b^2}$  so  $a \sin x + b \cos x = \sqrt{a^2 + b^2} \sin(x + \theta)$

$$\begin{aligned} \text{and } \int \frac{dx}{a \sin x + b \cos x} &= \frac{1}{\sqrt{a^2 + b^2}} \int \csc(x + \theta) dx = -\frac{1}{\sqrt{a^2 + b^2}} \ln |\csc(x + \theta) + \cot(x + \theta)| + C \\ &= -\frac{1}{\sqrt{a^2 + b^2}} \ln \left| \frac{\sqrt{a^2 + b^2} + a \cos x - b \sin x}{a \sin x + b \cos x} \right| + C \end{aligned}$$

$$64. \quad (\text{a}) \quad \int_0^{\pi/2} \sin^n x dx = -\frac{1}{n} \sin^{n-1} x \cos x \Big|_0^{\pi/2} + \frac{n-1}{n} \int_0^{\pi/2} \sin^{n-2} x dx = \frac{n-1}{n} \int_0^{\pi/2} \sin^{n-2} x dx$$

(b) By repeated application of the formula in part (a)

$$\begin{aligned} \int_0^{\pi/2} \sin^n x dx &= \left( \frac{n-1}{n} \right) \left( \frac{n-3}{n-2} \right) \int_0^{\pi/2} \sin^{n-4} x dx \\ &= \begin{cases} \left( \frac{n-1}{n} \right) \left( \frac{n-3}{n-2} \right) \left( \frac{n-5}{n-4} \right) \cdots \left( \frac{1}{2} \right) \int_0^{\pi/2} dx, n \text{ even} \\ \left( \frac{n-1}{n} \right) \left( \frac{n-3}{n-2} \right) \left( \frac{n-5}{n-4} \right) \cdots \left( \frac{2}{3} \right) \int_0^{\pi/2} \sin x dx, n \text{ odd} \end{cases} \\ &= \begin{cases} \frac{1 \cdot 3 \cdot 5 \cdots (n-1)}{2 \cdot 4 \cdot 6 \cdots n} \cdot \frac{\pi}{2}, n \text{ even} \\ \frac{2 \cdot 4 \cdot 6 \cdots (n-1)}{3 \cdot 5 \cdot 7 \cdots n}, n \text{ odd} \end{cases} \end{aligned}$$

$$65. \quad (\text{a}) \quad \int_0^{\pi/2} \sin^3 x dx = \frac{2}{3}$$

$$(\text{b}) \quad \int_0^{\pi/2} \sin^4 x dx = \frac{1 \cdot 3}{2 \cdot 4} \cdot \frac{\pi}{2} = 3\pi/16$$

$$(\text{c}) \quad \int_0^{\pi/2} \sin^5 x dx = \frac{2 \cdot 4}{3 \cdot 5} = 8/15$$

$$(\text{d}) \quad \int_0^{\pi/2} \sin^6 x dx = \frac{1 \cdot 3 \cdot 5}{2 \cdot 4 \cdot 6} \cdot \frac{\pi}{2} = 5\pi/32$$

66. Similar to proof in Exercise 64.

## EXERCISE SET 9.4

$$1. \quad x = 2 \sin \theta, \quad dx = 2 \cos \theta d\theta,$$

$$\begin{aligned} 4 \int \cos^2 \theta d\theta &= 2 \int (1 + \cos 2\theta) d\theta = 2\theta + \sin 2\theta + C \\ &= 2\theta + 2 \sin \theta \cos \theta + C = 2 \sin^{-1}(x/2) + \frac{1}{2} x \sqrt{4 - x^2} + C \end{aligned}$$

$$2. \quad x = \frac{1}{2} \sin \theta, \quad dx = \frac{1}{2} \cos \theta d\theta,$$

$$\begin{aligned} \frac{1}{2} \int \cos^2 \theta d\theta &= \frac{1}{4} \int (1 + \cos 2\theta) d\theta = \frac{1}{4} \theta + \frac{1}{8} \sin 2\theta + C \\ &= \frac{1}{4} \theta + \frac{1}{4} \sin \theta \cos \theta + C = \frac{1}{4} \sin^{-1} 2x + \frac{1}{2} x \sqrt{1 - 4x^2} + C \end{aligned}$$

3.  $x = 3 \sin \theta, dx = 3 \cos \theta d\theta,$

$$\begin{aligned} 9 \int \sin^2 \theta d\theta &= \frac{9}{2} \int (1 - \cos 2\theta) d\theta = \frac{9}{2} \theta - \frac{9}{4} \sin 2\theta + C = \frac{9}{2} \theta - \frac{9}{2} \sin \theta \cos \theta + C \\ &= \frac{9}{2} \sin^{-1}(x/3) - \frac{1}{2} x \sqrt{9 - x^2} + C \end{aligned}$$

4.  $x = 4 \sin \theta, dx = 4 \cos \theta d\theta,$

$$\frac{1}{16} \int \frac{1}{\sin^2 \theta} d\theta = \frac{1}{16} \int \csc^2 \theta d\theta = -\frac{1}{16} \cot \theta + C = -\frac{\sqrt{16 - x^2}}{16x} + C$$

5.  $x = 2 \tan \theta, dx = 2 \sec^2 \theta d\theta,$

$$\begin{aligned} \frac{1}{8} \int \frac{1}{\sec^2 \theta} d\theta &= \frac{1}{8} \int \cos^2 \theta d\theta = \frac{1}{16} \int (1 + \cos 2\theta) d\theta = \frac{1}{16} \theta + \frac{1}{32} \sin 2\theta + C \\ &= \frac{1}{16} \theta + \frac{1}{16} \sin \theta \cos \theta + C = \frac{1}{16} \tan^{-1} \frac{x}{2} + \frac{x}{8(4 + x^2)} + C \end{aligned}$$

6.  $x = \sqrt{5} \tan \theta, dx = \sqrt{5} \sec^2 \theta d\theta,$

$$\begin{aligned} 5 \int \tan^2 \theta \sec \theta d\theta &= 5 \int (\sec^3 \theta - \sec \theta) d\theta = 5 \left( \frac{1}{2} \sec \theta \tan \theta - \frac{1}{2} \ln |\sec \theta + \tan \theta| \right) + C_1 \\ &= \frac{1}{2} x \sqrt{5 + x^2} - \frac{5}{2} \ln \frac{\sqrt{5 + x^2} + x}{\sqrt{5}} + C_1 = \frac{1}{2} x \sqrt{5 + x^2} - \frac{5}{2} \ln(\sqrt{5 + x^2} + x) + C \end{aligned}$$

7.  $x = 3 \sec \theta, dx = 3 \sec \theta \tan \theta d\theta,$

$$3 \int \tan^2 \theta d\theta = 3 \int (\sec^2 \theta - 1) d\theta = 3 \tan \theta - 3\theta + C = \sqrt{x^2 - 9} - 3 \sec^{-1} \frac{x}{3} + C$$

8.  $x = 4 \sec \theta, dx = 4 \sec \theta \tan \theta d\theta,$

$$\frac{1}{16} \int \frac{1}{\sec \theta} d\theta = \frac{1}{16} \int \cos \theta d\theta = \frac{1}{16} \sin \theta + C = \frac{\sqrt{x^2 - 16}}{16x} + C$$

9.  $x = \sqrt{2} \sin \theta, dx = \sqrt{2} \cos \theta d\theta,$

$$\begin{aligned} 2\sqrt{2} \int \sin^3 \theta d\theta &= 2\sqrt{2} \int [1 - \cos^2 \theta] \sin \theta d\theta \\ &= 2\sqrt{2} \left( -\cos \theta + \frac{1}{3} \cos^3 \theta \right) + C = -2\sqrt{2 - x^2} + \frac{1}{3} (2 - x^2)^{3/2} + C \end{aligned}$$

10.  $x = \sqrt{5} \sin \theta, dx = \sqrt{5} \cos \theta d\theta,$

$$25\sqrt{5} \int \sin^3 \theta \cos^2 \theta d\theta = 25\sqrt{5} \left( -\frac{1}{3} \cos^3 \theta + \frac{1}{5} \cos^5 \theta \right) + C = -\frac{5}{3} (5 - x^2)^{3/2} + \frac{1}{5} (5 - x^2)^{5/2} + C$$

11.  $x = \frac{3}{2} \sec \theta, dx = \frac{3}{2} \sec \theta \tan \theta d\theta, \frac{2}{9} \int \frac{1}{\sec \theta} d\theta = \frac{2}{9} \int \cos \theta d\theta = \frac{2}{9} \sin \theta + C = \frac{\sqrt{4x^2 - 9}}{9x} + C$

12.  $t = \tan \theta, dt = \sec^2 \theta d\theta,$

$$\begin{aligned} \int \frac{\sec^3 \theta}{\tan \theta} d\theta &= \int \frac{\tan^2 \theta + 1}{\tan \theta} \sec \theta d\theta = \int (\sec \theta \tan \theta + \csc \theta) d\theta \\ &= \sec \theta + \ln |\csc \theta - \cot \theta| + C = \sqrt{1 + t^2} + \ln \frac{\sqrt{1 + t^2} - 1}{|t|} + C \end{aligned}$$

$$13. \quad x = \sin \theta, \quad dx = \cos \theta \, d\theta, \quad \int \frac{1}{\cos^2 \theta} d\theta = \int \sec^2 \theta \, d\theta = \tan \theta + C = x/\sqrt{1-x^2} + C$$

$$14. \quad x = 5 \tan \theta, \quad dx = 5 \sec^2 \theta \, d\theta, \quad \frac{1}{25} \int \frac{\sec \theta}{\tan^2 \theta} d\theta = \frac{1}{25} \int \csc \theta \cot \theta \, d\theta = -\frac{1}{25} \csc \theta + C = -\frac{\sqrt{x^2+25}}{25x} + C$$

$$15. \quad x = \sec \theta, \quad dx = \sec \theta \tan \theta \, d\theta, \quad \int \sec \theta \, d\theta = \ln |\sec \theta + \tan \theta| + C = \ln |x + \sqrt{x^2-1}| + C$$

$$16. \quad 1 + 2x^2 + x^4 = (1 + x^2)^2, \quad x = \tan \theta, \quad dx = \sec^2 \theta \, d\theta,$$

$$\begin{aligned} \int \frac{1}{\sec^2 \theta} d\theta &= \int \cos^2 \theta \, d\theta = \frac{1}{2} \int (1 + \cos 2\theta) d\theta = \frac{1}{2} \theta + \frac{1}{4} \sin 2\theta + C \\ &= \frac{1}{2} \theta + \frac{1}{2} \sin \theta \cos \theta + C = \frac{1}{2} \tan^{-1} x + \frac{x}{2(1+x^2)} + C \end{aligned}$$

$$17. \quad x = \frac{1}{3} \sec \theta, \quad dx = \frac{1}{3} \sec \theta \tan \theta \, d\theta,$$

$$\frac{1}{3} \int \frac{\sec \theta}{\tan^2 \theta} d\theta = \frac{1}{3} \int \csc \theta \cot \theta \, d\theta = -\frac{1}{3} \csc \theta + C = -x/\sqrt{9x^2-1} + C$$

$$18. \quad x = 5 \sec \theta, \quad dx = 5 \sec \theta \tan \theta \, d\theta,$$

$$\begin{aligned} 25 \int \sec^3 \theta \, d\theta &= \frac{25}{2} \sec \theta \tan \theta + \frac{25}{2} \ln |\sec \theta + \tan \theta| + C_1 \\ &= \frac{1}{2} x \sqrt{x^2-25} + \frac{25}{2} \ln |x + \sqrt{x^2-25}| + C \end{aligned}$$

$$19. \quad e^x = \sin \theta, \quad e^x dx = \cos \theta \, d\theta,$$

$$\int \cos^2 \theta \, d\theta = \frac{1}{2} \int (1 + \cos 2\theta) d\theta = \frac{1}{2} \theta + \frac{1}{4} \sin 2\theta + C = \frac{1}{2} \sin^{-1}(e^x) + \frac{1}{2} e^x \sqrt{1-e^{2x}} + C$$

$$20. \quad u = \sin \theta, \quad \int \frac{1}{\sqrt{2-u^2}} du = \sin^{-1} \left( \frac{\sin \theta}{\sqrt{2}} \right) + C$$

$$21. \quad x = 4 \sin \theta, \quad dx = 4 \cos \theta \, d\theta,$$

$$1024 \int_0^{\pi/2} \sin^3 \theta \cos^2 \theta \, d\theta = 1024 \left[ -\frac{1}{3} \cos^3 \theta + \frac{1}{5} \cos^5 \theta \right]_0^{\pi/2} = 1024(1/3 - 1/5) = 2048/15$$

$$22. \quad x = \frac{2}{3} \sin \theta, \quad dx = \frac{2}{3} \cos \theta \, d\theta,$$

$$\begin{aligned} \frac{1}{24} \int_0^{\pi/6} \frac{1}{\cos^3 \theta} d\theta &= \frac{1}{24} \int_0^{\pi/6} \sec^3 \theta \, d\theta = \left[ \frac{1}{48} \sec \theta \tan \theta + \frac{1}{48} \ln |\sec \theta + \tan \theta| \right]_0^{\pi/6} \\ &= \frac{1}{48} [(2/\sqrt{3})(1/\sqrt{3}) + \ln |2/\sqrt{3} + 1/\sqrt{3}|] = \frac{1}{48} \left( \frac{2}{3} + \frac{1}{2} \ln 3 \right) \end{aligned}$$

$$23. \quad x = \sec \theta, \quad dx = \sec \theta \tan \theta \, d\theta, \quad \int_{\pi/4}^{\pi/3} \frac{1}{\sec \theta} d\theta = \int_{\pi/4}^{\pi/3} \cos \theta \, d\theta = \sin \theta \Big|_{\pi/4}^{\pi/3} = (\sqrt{3} - \sqrt{2})/2$$

$$24. \quad x = \sqrt{2} \sec \theta, \quad dx = \sqrt{2} \sec \theta \tan \theta \, d\theta, \quad 2 \int_0^{\pi/4} \tan^2 \theta \, d\theta = \left[ 2 \tan \theta - 2\theta \right]_0^{\pi/4} = 2 - \pi/2$$

25.  $x = \sqrt{3} \tan \theta, dx = \sqrt{3} \sec^2 \theta d\theta,$

$$\begin{aligned} \frac{1}{9} \int_{\pi/6}^{\pi/3} \frac{\sec \theta}{\tan^4 \theta} d\theta &= \frac{1}{9} \int_{\pi/6}^{\pi/3} \frac{\cos^3 \theta}{\sin^4 \theta} d\theta = \frac{1}{9} \int_{\pi/6}^{\pi/3} \frac{1 - \sin^2 \theta}{\sin^4 \theta} \cos \theta d\theta = \frac{1}{9} \int_{1/2}^{\sqrt{3}/2} \frac{1 - u^2}{u^4} du \quad (u = \sin \theta) \\ &= \frac{1}{9} \int_{1/2}^{\sqrt{3}/2} (u^{-4} - u^{-2}) du = \frac{1}{9} \left[ -\frac{1}{3u^3} + \frac{1}{u} \right]_{1/2}^{\sqrt{3}/2} = \frac{10\sqrt{3} + 18}{243} \end{aligned}$$

26.  $x = \sqrt{3} \tan \theta, dx = \sqrt{3} \sec^2 \theta d\theta,$

$$\begin{aligned} \frac{\sqrt{3}}{3} \int_0^{\pi/3} \frac{\tan^3 \theta}{\sec^3 \theta} d\theta &= \frac{\sqrt{3}}{3} \int_0^{\pi/3} \sin^3 \theta d\theta = \frac{\sqrt{3}}{3} \int_0^{\pi/3} [1 - \cos^2 \theta] \sin \theta d\theta \\ &= \frac{\sqrt{3}}{3} \left[ -\cos \theta + \frac{1}{3} \cos^3 \theta \right]_0^{\pi/3} = \frac{\sqrt{3}}{3} \left[ \left( -\frac{1}{2} + \frac{1}{24} \right) - \left( -1 + \frac{1}{3} \right) \right] = 5\sqrt{3}/72 \end{aligned}$$

27.  $u = x^2 + 4, du = 2x dx,$

$$\frac{1}{2} \int \frac{1}{u} du = \frac{1}{2} \ln |u| + C = \frac{1}{2} \ln(x^2 + 4) + C; \text{ or } x = 2 \tan \theta, dx = 2 \sec^2 \theta d\theta,$$

$$\begin{aligned} \int \tan \theta d\theta &= \ln |\sec \theta| + C_1 = \ln \frac{\sqrt{x^2 + 4}}{2} + C_1 = \ln(x^2 + 4)^{1/2} - \ln 2 + C_1 \\ &= \frac{1}{2} \ln(x^2 + 4) + C \text{ with } C = C_1 - \ln 2 \end{aligned}$$

29.  $y' = \frac{1}{x}, 1 + (y')^2 = 1 + \frac{1}{x^2} = \frac{x^2 + 1}{x^2},$

$$L = \int_1^2 \sqrt{\frac{x^2 + 1}{x^2}} dx = \int_1^2 \frac{\sqrt{x^2 + 1}}{x} dx; x = \tan \theta, dx = \sec^2 \theta d\theta,$$

$$\begin{aligned} L &= \int_{\pi/4}^{\tan^{-1}(2)} \frac{\sec^3 \theta}{\tan \theta} d\theta = \int_{\pi/4}^{\tan^{-1}(2)} \frac{\tan^2 \theta + 1}{\tan \theta} \sec \theta d\theta = \int_{\pi/4}^{\tan^{-1}(2)} (\sec \theta \tan \theta + \csc \theta) d\theta \\ &= \left[ \sec \theta + \ln |\csc \theta - \cot \theta| \right]_{\pi/4}^{\tan^{-1}(2)} = \sqrt{5} + \ln \left( \frac{\sqrt{5}}{2} - \frac{1}{2} \right) - \left[ \sqrt{2} + \ln |\sqrt{2} - 1| \right] \\ &= \sqrt{5} - \sqrt{2} + \ln \frac{2 + 2\sqrt{2}}{1 + \sqrt{5}} \end{aligned}$$

30.  $y' = 2x, 1 + (y')^2 = 1 + 4x^2,$

$$L = \int_0^1 \sqrt{1 + 4x^2} dx; x = \frac{1}{2} \tan \theta, dx = \frac{1}{2} \sec^2 \theta d\theta,$$

$$\begin{aligned} L &= \frac{1}{2} \int_0^{\tan^{-1} 2} \sec^3 \theta d\theta = \frac{1}{2} \left( \frac{1}{2} \sec \theta \tan \theta + \frac{1}{2} \ln |\sec \theta + \tan \theta| \right) \Big|_0^{\tan^{-1} 2} \\ &= \frac{1}{4} (\sqrt{5})(2) + \frac{1}{4} \ln |\sqrt{5} + 2| = \frac{1}{2} \sqrt{5} + \frac{1}{4} \ln(2 + \sqrt{5}) \end{aligned}$$

31.  $y' = 2x, 1 + (y')^2 = 1 + 4x^2,$

$$S = 2\pi \int_0^1 x^2 \sqrt{1 + 4x^2} dx; x = \frac{1}{2} \tan \theta, dx = \frac{1}{2} \sec^2 \theta d\theta,$$



$$\begin{aligned}
 S &= \frac{\pi}{4} \int_0^{\tan^{-1} 2} \tan^2 \theta \sec^3 \theta \, d\theta = \frac{\pi}{4} \int_0^{\tan^{-1} 2} (\sec^2 \theta - 1) \sec^3 \theta \, d\theta = \frac{\pi}{4} \int_0^{\tan^{-1} 2} (\sec^5 \theta - \sec^3 \theta) \, d\theta \\
 &= \frac{\pi}{4} \left[ \frac{1}{4} \sec^3 \theta \tan \theta - \frac{1}{8} \sec \theta \tan \theta - \frac{1}{8} \ln |\sec \theta + \tan \theta| \right]_0^{\tan^{-1} 2} = \frac{\pi}{32} [18\sqrt{5} - \ln(2 + \sqrt{5})]
 \end{aligned}$$

32.  $V = \pi \int_0^1 y^2 \sqrt{1-y^2} \, dy; \quad y = \sin \theta, \quad dy = \cos \theta \, d\theta,$

$$V = \pi \int_0^{\pi/2} \sin^2 \theta \cos^2 \theta \, d\theta = \frac{\pi}{4} \int_0^{\pi/2} \sin^2 2\theta \, d\theta = \frac{\pi}{8} \int_0^{\pi/2} (1 - \cos 4\theta) \, d\theta = \frac{\pi}{8} \left( \theta - \frac{1}{4} \sin 4\theta \right) \Big|_0^{\pi/2} = \frac{\pi^2}{16}$$

33. (a)  $x = 3 \sinh u, \quad dx = 3 \cosh u \, du, \quad \int du = u + C = \sinh^{-1}(x/3) + C$

(b)  $x = 3 \tan \theta, \quad dx = 3 \sec^2 \theta \, d\theta,$

$$\int \sec \theta \, d\theta = \ln |\sec \theta + \tan \theta| + C = \ln(\sqrt{x^2+9}/3 + x/3) + C$$

but  $\sinh^{-1}(x/3) = \ln(x/3 + \sqrt{x^2/9 + 1}) = \ln(x/3 + \sqrt{x^2+9}/3)$  so the results agree.

(c)  $x = \cosh u, \quad dx = \sinh u \, du,$

$$\begin{aligned}
 \int \sinh^2 u \, du &= \frac{1}{2} \int (\cosh 2u - 1) \, du = \frac{1}{4} \sinh 2u - \frac{1}{2} u + C \\
 &= \frac{1}{2} \sinh u \cosh u - \frac{1}{2} u + C = \frac{1}{2} x \sqrt{x^2 - 1} - \frac{1}{2} \cosh^{-1} x + C
 \end{aligned}$$

because  $\cosh u = x$ , and  $\sinh u = \sqrt{\cosh^2 u - 1} = \sqrt{x^2 - 1}$

34.  $A = \frac{4b}{a} \int_0^a \sqrt{a^2 - x^2} \, dx; \quad x = a \cos \theta, \quad dx = -a \sin \theta \, d\theta,$

$$A = -\frac{4b}{a} \int_{\pi/2}^0 a^2 \sin^2 \theta \, d\theta = 4ab \int_0^{\pi/2} \sin^2 \theta \, d\theta = 2ab \int_0^{\pi/2} (1 - \cos 2\theta) \, d\theta = \pi ab$$

35.  $\int \frac{1}{(x-2)^2+9} \, dx = \frac{1}{3} \tan^{-1} \left( \frac{x-2}{3} \right) + C$       36.  $\int \frac{1}{\sqrt{1-(x-1)^2}} \, dx = \sin^{-1}(x-1) + C$

37.  $\int \frac{1}{\sqrt{9-(x-1)^2}} \, dx = \sin^{-1} \left( \frac{x-1}{3} \right) + C$

38.  $\int \frac{1}{16(x+1/2)^2+1} \, dx = \frac{1}{16} \int \frac{1}{(x+1/2)^2+1/16} \, dx = \frac{1}{4} \tan^{-1}(4x+2) + C$

39.  $\int \frac{1}{\sqrt{(x-3)^2+1}} \, dx = \ln \left( x-3 + \sqrt{(x-3)^2+1} \right) + C$

40.  $\int \frac{x}{(x+3)^2+1} \, dx, \quad \text{let } u = x+3,$

$$\begin{aligned}
 \int \frac{u-3}{u^2+1} \, du &= \int \left( \frac{u}{u^2+1} - \frac{3}{u^2+1} \right) \, du = \frac{1}{2} \ln(u^2+1) - 3 \tan^{-1} u + C \\
 &= \frac{1}{2} \ln(x^2+6x+10) - 3 \tan^{-1}(x+3) + C
 \end{aligned}$$

41.  $\int \sqrt{4 - (x + 1)^2} dx$ , let  $x + 1 = 2 \sin \theta$ ,

$$4 \int \cos^2 \theta d\theta = 2\theta + \sin 2\theta + C = 2\theta + 2 \sin \theta \cos \theta + C$$

$$= 2 \sin^{-1} \left( \frac{x + 1}{2} \right) + \frac{1}{2}(x + 1)\sqrt{3 - 2x - x^2} + C$$

42.  $\int \frac{e^x}{\sqrt{(e^x + 1/2)^2 + 3/4}} dx$ , let  $u = e^x + 1/2$ ,

$$\int \frac{1}{\sqrt{u^2 + 3/4}} du = \sinh^{-1}(2u/\sqrt{3}) + C = \sinh^{-1} \left( \frac{2e^x + 1}{\sqrt{3}} \right) + C$$

Alternate solution: let  $e^x + 1/2 = \frac{\sqrt{3}}{2} \tan \theta$ ,

$$\int \sec \theta d\theta = \ln |\sec \theta + \tan \theta| + C = \ln \left( \frac{2\sqrt{e^{2x} + e^x + 1}}{\sqrt{3}} + \frac{2e^x + 1}{\sqrt{3}} \right) + C_1$$

$$= \ln(2\sqrt{e^{2x} + e^x + 1} + 2e^x + 1) + C$$

43.  $\int \frac{1}{2(x + 1)^2 + 5} dx = \frac{1}{2} \int \frac{1}{(x + 1)^2 + 5/2} dx = \frac{1}{\sqrt{10}} \tan^{-1} \sqrt{2/5}(x + 1) + C$

44.  $\int \frac{2x + 3}{4(x + 1/2)^2 + 4} dx$ , let  $u = x + 1/2$ ,

$$\int \frac{2u + 2}{4u^2 + 4} du = \frac{1}{2} \int \left( \frac{u}{u^2 + 1} + \frac{1}{u^2 + 1} \right) du = \frac{1}{4} \ln(u^2 + 1) + \frac{1}{2} \tan^{-1} u + C$$

$$= \frac{1}{4} \ln(x^2 + x + 5/4) + \frac{1}{2} \tan^{-1}(x + 1/2) + C$$

45.  $\int_1^2 \frac{1}{\sqrt{4x - x^2}} dx = \int_1^2 \frac{1}{\sqrt{4 - (x - 2)^2}} dx = \left[ \sin^{-1} \frac{x - 2}{2} \right]_1^2 = \pi/6$

46.  $\int_0^1 \sqrt{4x - x^2} dx = \int_0^1 \sqrt{4 - (x - 2)^2} dx$ , let  $x - 2 = 2 \sin \theta$ ,

$$4 \int_{-\pi/2}^{-\pi/6} \cos^2 \theta d\theta = \left[ 2\theta + \sin 2\theta \right]_{-\pi/2}^{-\pi/6} = \frac{2\pi}{3} - \frac{\sqrt{3}}{2}$$

48.  $u = x \sin x$ ,  $du = (x \cos x + \sin x) dx$ ;

$$\int \sqrt{1 + u^2} du = \frac{1}{2} u \sqrt{1 + u^2} + \frac{1}{2} \sinh^{-1} u + C = \frac{1}{2} x \sin x \sqrt{1 + x^2 \sin^2 x} + \frac{1}{2} \sinh^{-1}(x \sin x) + C$$

49.  $u = \sin^2 x$ ,  $du = 2 \sin x \cos x dx$ ;

$$\frac{1}{2} \int \sqrt{1 - u^2} du = \frac{1}{4} [u \sqrt{1 - u^2} + \sin^{-1} u] + C = \frac{1}{4} [\sin^2 x \sqrt{1 - \sin^4 x} + \sin^{-1}(\sin^2 x)] + C$$

50.  $u = 3^x = e^{x \ln 3}$ ,  $du = (\ln 3)3^x dx$ ;

$$\frac{1}{\ln 3} \int_1^3 \sqrt{u^2 - 1} du = \frac{1}{2 \ln 3} \left[ u \sqrt{u^2 - 1} - \ln \left| u + \sqrt{u^2 - 1} \right| \right]_1^3 = \frac{6\sqrt{2} - \ln(3 + 2\sqrt{2})}{2 \ln 3}$$

### EXERCISE SET 9.5

1.  $\frac{A}{(x-2)} + \frac{B}{(x+5)}$

2.  $\frac{5}{x(x-3)(x+3)} = \frac{A}{x} + \frac{B}{x-3} + \frac{C}{x+3}$

3.  $\frac{2x-3}{x^2(x-1)} = \frac{A}{x} + \frac{B}{x^2} + \frac{C}{x-1}$

4.  $\frac{A}{x+2} + \frac{B}{(x+2)^2} + \frac{C}{(x+2)^3}$

5.  $\frac{A}{x} + \frac{B}{x^2} + \frac{C}{x^3} + \frac{Dx+E}{x^2+1}$

6.  $\frac{A}{x-1} + \frac{Bx+C}{x^2+5}$

7.  $\frac{Ax+B}{x^2+5} + \frac{Cx+D}{(x^2+5)^2}$

8.  $\frac{A}{x-2} + \frac{Bx+C}{x^2+1} + \frac{Dx+E}{(x^2+1)^2}$

9.  $\frac{1}{(x+4)(x-1)} = \frac{A}{x+4} + \frac{B}{x-1}$ ;  $A = -\frac{1}{5}$ ,  $B = \frac{1}{5}$  so

$$-\frac{1}{5} \int \frac{1}{x+4} dx + \frac{1}{5} \int \frac{1}{x-1} dx = -\frac{1}{5} \ln|x+4| + \frac{1}{5} \ln|x-1| + C = \frac{1}{5} \ln \left| \frac{x-1}{x+4} \right| + C$$

10.  $\frac{1}{(x+1)(x+7)} = \frac{A}{x+1} + \frac{B}{x+7}$ ;  $A = \frac{1}{6}$ ,  $B = -\frac{1}{6}$  so

$$\frac{1}{6} \int \frac{1}{x+1} dx - \frac{1}{6} \int \frac{1}{x+7} dx = \frac{1}{6} \ln|x+1| - \frac{1}{6} \ln|x+7| + C = \frac{1}{6} \ln \left| \frac{x+1}{x+7} \right| + C$$

11.  $\frac{11x+17}{(2x-1)(x+4)} = \frac{A}{2x-1} + \frac{B}{x+4}$ ;  $A = 5$ ,  $B = 3$  so

$$5 \int \frac{1}{2x-1} dx + 3 \int \frac{1}{x+4} dx = \frac{5}{2} \ln|2x-1| + 3 \ln|x+4| + C$$

12.  $\frac{5x-5}{(x-3)(3x+1)} = \frac{A}{x-3} + \frac{B}{3x+1}$ ;  $A = 1$ ,  $B = 2$  so

$$\int \frac{1}{x-3} dx + 2 \int \frac{1}{3x+1} dx = \ln|x-3| + \frac{2}{3} \ln|3x+1| + C$$

13.  $\frac{2x^2-9x-9}{x(x+3)(x-3)} = \frac{A}{x} + \frac{B}{x+3} + \frac{C}{x-3}$ ;  $A = 1$ ,  $B = 2$ ,  $C = -1$  so

$$\int \frac{1}{x} dx + 2 \int \frac{1}{x+3} dx - \int \frac{1}{x-3} dx = \ln|x| + 2 \ln|x+3| - \ln|x-3| + C = \ln \left| \frac{x(x+3)^2}{x-3} \right| + C$$

Note that the symbol  $C$  has been recycled; to save space this recycling is usually not mentioned.

14.  $\frac{1}{x(x+1)(x-1)} = \frac{A}{x} + \frac{B}{x+1} + \frac{C}{x-1}$ ;  $A = -1$ ,  $B = \frac{1}{2}$ ,  $C = \frac{1}{2}$  so  

$$-\int \frac{1}{x} dx + \frac{1}{2} \int \frac{1}{x+1} dx + \frac{1}{2} \int \frac{1}{x-1} dx = -\ln|x| + \frac{1}{2} \ln|x+1| + \frac{1}{2} \ln|x-1| + C$$

$$= \frac{1}{2} \ln \left| \frac{(x+1)(x-1)}{x^2} \right| + C = \frac{1}{2} \ln \frac{|x^2-1|}{x^2} + C$$
15.  $\frac{x^2+2}{x+2} = x-2 + \frac{6}{x+2}$ ,  $\int \left( x-2 + \frac{6}{x+2} \right) dx = \frac{1}{2}x^2 - 2x + 6 \ln|x+2| + C$
16.  $\frac{x^2-4}{x-1} = x+1 - \frac{3}{x-1}$ ,  $\int \left( x+1 - \frac{3}{x-1} \right) dx = \frac{1}{2}x^2 + x - 3 \ln|x-1| + C$
17.  $\frac{3x^2-10}{x^2-4x+4} = 3 + \frac{12x-22}{x^2-4x+4}$ ,  $\frac{12x-22}{(x-2)^2} = \frac{A}{x-2} + \frac{B}{(x-2)^2}$ ;  $A = 12$ ,  $B = 2$  so  

$$\int 3dx + 12 \int \frac{1}{x-2} dx + 2 \int \frac{1}{(x-2)^2} dx = 3x + 12 \ln|x-2| - 2/(x-2) + C$$
18.  $\frac{x^2}{x^2-3x+2} = 1 + \frac{3x-2}{x^2-3x+2}$ ,  $\frac{3x-2}{(x-1)(x-2)} = \frac{A}{x-1} + \frac{B}{x-2}$ ;  $A = -1$ ,  $B = 4$  so  

$$\int dx - \int \frac{1}{x-1} dx + 4 \int \frac{1}{x-2} dx = x - \ln|x-1| + 4 \ln|x-2| + C$$
19.  $\frac{x^5+2x^2+1}{x^3-x} = x^2+1 + \frac{2x^2+x+1}{x^3-x}$ ,  

$$\frac{2x^2+x+1}{x(x+1)(x-1)} = \frac{A}{x} + \frac{B}{x+1} + \frac{C}{x-1}$$
;  $A = -1$ ,  $B = 1$ ,  $C = 2$  so  

$$\int (x^2+1)dx - \int \frac{1}{x} dx + \int \frac{1}{x+1} dx + 2 \int \frac{1}{x-1} dx$$

$$= \frac{1}{3}x^3 + x - \ln|x| + \ln|x+1| + 2 \ln|x-1| + C = \frac{1}{3}x^3 + x + \ln \left| \frac{(x+1)(x-1)^2}{x} \right| + C$$
20.  $\frac{2x^5-x^3-1}{x^3-4x} = 2x^2+7 + \frac{28x-1}{x^3-4x}$ ,  

$$\frac{28x-1}{x(x+2)(x-2)} = \frac{A}{x} + \frac{B}{x+2} + \frac{C}{x-2}$$
;  $A = \frac{1}{4}$ ,  $B = -\frac{57}{8}$ ,  $C = \frac{55}{8}$  so  

$$\int (2x^2+7)dx + \frac{1}{4} \int \frac{1}{x} dx - \frac{57}{8} \int \frac{1}{x+2} dx + \frac{55}{8} \int \frac{1}{x-2} dx$$

$$= \frac{2}{3}x^3 + 7x + \frac{1}{4} \ln|x| - \frac{57}{8} \ln|x+2| + \frac{55}{8} \ln|x-2| + C$$
21.  $\frac{2x^2+3}{x(x-1)^2} = \frac{A}{x} + \frac{B}{x-1} + \frac{C}{(x-1)^2}$ ;  $A = 3$ ,  $B = -1$ ,  $C = 5$  so  

$$3 \int \frac{1}{x} dx - \int \frac{1}{x-1} dx + 5 \int \frac{1}{(x-1)^2} dx = 3 \ln|x| - \ln|x-1| - 5/(x-1) + C$$

22.  $\frac{3x^2 - x + 1}{x^2(x-1)} = \frac{A}{x} + \frac{B}{x^2} + \frac{C}{x-1}$ ;  $A = 0$ ,  $B = -1$ ,  $C = 3$  so  

$$-\int \frac{1}{x^2} dx + 3 \int \frac{1}{x-1} dx = 1/x + 3 \ln|x-1| + C$$
23.  $\frac{x^2 + x - 16}{(x+1)(x-3)^2} = \frac{A}{x+1} + \frac{B}{x-3} + \frac{C}{(x-3)^2}$ ;  $A = -1$ ,  $B = 2$ ,  $C = -1$  so  

$$-\int \frac{1}{x+1} dx + 2 \int \frac{1}{x-3} dx - \int \frac{1}{(x-3)^2} dx$$

$$= -\ln|x+1| + 2 \ln|x-3| + \frac{1}{x-3} + C = \ln \frac{(x-3)^2}{|x+1|} + \frac{1}{x-3} + C$$
24.  $\frac{2x^2 - 2x - 1}{x^2(x-1)} = \frac{A}{x} + \frac{B}{x^2} + \frac{C}{x-1}$ ;  $A = 3$ ,  $B = 1$ ,  $C = -1$  so  

$$3 \int \frac{1}{x} dx + \int \frac{1}{x^2} dx - \int \frac{1}{x-1} dx = 3 \ln|x| - \frac{1}{x} - \ln|x-1| + C$$
25.  $\frac{x^2}{(x+2)^3} = \frac{A}{x+2} + \frac{B}{(x+2)^2} + \frac{C}{(x+2)^3}$ ;  $A = 1$ ,  $B = -4$ ,  $C = 4$  so  

$$\int \frac{1}{x+2} dx - 4 \int \frac{1}{(x+2)^2} dx + 4 \int \frac{1}{(x+2)^3} dx = \ln|x+2| + \frac{4}{x+2} - \frac{2}{(x+2)^2} + C$$
26.  $\frac{2x^2 + 3x + 3}{(x+1)^3} = \frac{A}{x+1} + \frac{B}{(x+1)^2} + \frac{C}{(x+1)^3}$ ;  $A = 2$ ,  $B = -1$ ,  $C = 2$  so  

$$2 \int \frac{1}{x+1} dx - \int \frac{1}{(x+1)^2} dx + 2 \int \frac{1}{(x+1)^3} dx = 2 \ln|x+1| + \frac{1}{x+1} - \frac{1}{(x+1)^2} + C$$
27.  $\frac{2x^2 - 1}{(4x-1)(x^2+1)} = \frac{A}{4x-1} + \frac{Bx+C}{x^2+1}$ ;  $A = -14/17$ ,  $B = 12/17$ ,  $C = 3/17$  so  

$$\int \frac{2x^2 - 1}{(4x-1)(x^2+1)} dx = -\frac{7}{34} \ln|4x-1| + \frac{6}{17} \ln(x^2+1) + \frac{3}{17} \tan^{-1} x + C$$
28.  $\frac{1}{x(x^2+1)} = \frac{A}{x} + \frac{Bx+C}{x^2+1}$ ;  $A = 1$ ,  $B = -1$ ,  $C = 0$  so  

$$\int \frac{1}{x^3+x} dx = \ln|x| - \frac{1}{2} \ln(x^2+1) + C = \frac{1}{2} \ln \frac{x^2}{x^2+1} + C$$
29.  $\frac{x^3 + 3x^2 + x + 9}{(x^2+1)(x^2+3)} = \frac{Ax+B}{x^2+1} + \frac{Cx+D}{x^2+3}$ ;  $A = 0$ ,  $B = 3$ ,  $C = 1$ ,  $D = 0$  so  

$$\int \frac{x^3 + 3x^2 + x + 9}{(x^2+1)(x^2+3)} dx = 3 \tan^{-1} x + \frac{1}{2} \ln(x^2+3) + C$$
30.  $\frac{x^3 + x^2 + x + 2}{(x^2+1)(x^2+2)} = \frac{Ax+B}{x^2+1} + \frac{Cx+D}{x^2+2}$ ;  $A = D = 0$ ,  $B = C = 1$  so  

$$\int \frac{x^3 + x^2 + x + 2}{(x^2+1)(x^2+2)} dx = \tan^{-1} x + \frac{1}{2} \ln(x^2+2) + C$$

$$31. \frac{x^3 - 3x^2 + 2x - 3}{x^2 + 1} = x - 3 + \frac{x}{x^2 + 1},$$

$$\int \frac{x^3 - 3x^2 + 2x - 3}{x^2 + 1} dx = \frac{1}{2}x^2 - 3x + \frac{1}{2} \ln(x^2 + 1) + C$$

$$32. \frac{x^4 + 6x^3 + 10x^2 + x}{x^2 + 6x + 10} = x^2 + \frac{x}{x^2 + 6x + 10},$$

$$\int \frac{x}{x^2 + 6x + 10} dx = \int \frac{x}{(x+3)^2 + 1} dx = \int \frac{u-3}{u^2 + 1} du, \quad u = x + 3$$

$$= \frac{1}{2} \ln(u^2 + 1) - 3 \tan^{-1} u + C_1$$

$$\text{so } \int \frac{x^4 + 6x^3 + 10x^2 + x}{x^2 + 6x + 10} dx = \frac{1}{3}x^3 + \frac{1}{2} \ln(x^2 + 6x + 10) - 3 \tan^{-1}(x + 3) + C$$

$$33. \text{ Let } x = \sin \theta \text{ to get } \int \frac{1}{x^2 + 4x - 5} dx, \text{ and } \frac{1}{(x+5)(x-1)} = \frac{A}{x+5} + \frac{B}{x-1}; A = -1/6,$$

$$B = 1/6 \text{ so we get } -\frac{1}{6} \int \frac{1}{x+5} dx + \frac{1}{6} \int \frac{1}{x-1} dx = \frac{1}{6} \ln \left| \frac{x-1}{x+5} \right| + C = \frac{1}{6} \ln \left( \frac{1 - \sin \theta}{5 + \sin \theta} \right) + C.$$

$$34. \text{ Let } x = e^t; \text{ then } \int \frac{e^t}{e^{2t} - 4} dt = \int \frac{1}{x^2 - 4} dx,$$

$$\frac{1}{(x+2)(x-2)} = \frac{A}{x+2} + \frac{B}{x-2}; A = -1/4, B = 1/4 \text{ so}$$

$$-\frac{1}{4} \int \frac{1}{x+2} dx + \frac{1}{4} \int \frac{1}{x-2} dx = \frac{1}{4} \ln \left| \frac{x-2}{x+2} \right| + C = \frac{1}{4} \ln \left| \frac{e^t - 2}{e^t + 2} \right| + C.$$

$$35. V = \pi \int_0^2 \frac{x^4}{(9-x^2)^2} dx, \frac{x^4}{x^4 - 18x^2 + 81} = 1 + \frac{18x^2 - 81}{x^4 - 18x^2 + 81},$$

$$\frac{18x^2 - 81}{(9-x^2)^2} = \frac{18x^2 - 81}{(x+3)^2(x-3)^2} = \frac{A}{x+3} + \frac{B}{(x+3)^2} + \frac{C}{x-3} + \frac{D}{(x-3)^2};$$

$$A = -\frac{9}{4}, B = \frac{9}{4}, C = \frac{9}{4}, D = \frac{9}{4} \text{ so}$$

$$V = \pi \left[ x - \frac{9}{4} \ln|x+3| - \frac{9/4}{x+3} + \frac{9}{4} \ln|x-3| - \frac{9/4}{x-3} \right]_0^2 = \pi \left( \frac{19}{5} - \frac{9}{4} \ln 5 \right)$$

$$36. \text{ Let } u = e^x \text{ to get } \int_{-\ln 5}^{\ln 5} \frac{dx}{1+e^x} = \int_{-\ln 5}^{\ln 5} \frac{e^x dx}{e^x(1+e^x)} = \int_{1/5}^5 \frac{du}{u(1+u)},$$

$$\frac{1}{u(1+u)} = \frac{A}{u} + \frac{B}{1+u}; A = 1, B = -1; \int_{1/5}^5 \frac{du}{u(1+u)} = (\ln u - \ln(1+u)) \Big|_{1/5}^5 = \ln 5$$

$$37. \frac{x^2 + 1}{(x^2 + 2x + 3)^2} = \frac{Ax + B}{x^2 + 2x + 3} + \frac{Cx + D}{(x^2 + 2x + 3)^2}; A = 0, B = 1, C = D = -2 \text{ so}$$

$$\int \frac{x^2 + 1}{(x^2 + 2x + 3)^2} dx = \int \frac{1}{(x+1)^2 + 2} dx - \int \frac{2x + 2}{(x^2 + 2x + 3)^2} dx$$

$$= \frac{1}{\sqrt{2}} \tan^{-1} \frac{x+1}{\sqrt{2}} + 1/(x^2 + 2x + 3) + C$$

$$38. \frac{x^5 + x^4 + 4x^3 + 4x^2 + 4x + 4}{(x^2 + 2)^3} = \frac{Ax + B}{x^2 + 2} + \frac{Cx + D}{(x^2 + 2)^2} + \frac{Ex + F}{(x^2 + 2)^3};$$

$$A = B = 1, C = D = E = F = 0 \text{ so}$$

$$\int \frac{x+1}{x^2+2} dx = \frac{1}{2} \ln(x^2+2) + \frac{1}{\sqrt{2}} \tan^{-1}(x/\sqrt{2}) + C$$

$$39. x^4 - 3x^3 - 7x^2 + 27x - 18 = (x-1)(x-2)(x-3)(x+3),$$

$$\frac{1}{(x-1)(x-2)(x-3)(x+3)} = \frac{A}{x-1} + \frac{B}{x-2} + \frac{C}{x-3} + \frac{D}{x+3};$$

$$A = 1/8, B = -1/5, C = 1/12, D = -1/120 \text{ so}$$

$$\int \frac{dx}{x^4 - 3x^3 - 7x^2 + 27x - 18} = \frac{1}{8} \ln|x-1| - \frac{1}{5} \ln|x-2| + \frac{1}{12} \ln|x-3| - \frac{1}{120} \ln|x+3| + C$$

$$40. 16x^3 - 4x^2 + 4x - 1 = (4x-1)(4x^2+1),$$

$$\frac{1}{(4x-1)(4x^2+1)} = \frac{A}{4x-1} + \frac{Bx+C}{4x^2+1}; A = 4/5, B = -4/5, C = -1/5 \text{ so}$$

$$\int \frac{dx}{16x^3 - 4x^2 + 4x - 1} = \frac{1}{5} \ln|4x-1| - \frac{1}{10} \ln(4x^2+1) - \frac{1}{10} \tan^{-1}(2x) + C$$

$$41. \text{ (a) } x^4 + 1 = (x^4 + 2x^2 + 1) - 2x^2 = (x^2 + 1)^2 - 2x^2$$

$$= [(x^2 + 1) + \sqrt{2}x][(x^2 + 1) - \sqrt{2}x]$$

$$= (x^2 + \sqrt{2}x + 1)(x^2 - \sqrt{2}x + 1); a = \sqrt{2}, b = -\sqrt{2}$$

$$\text{ (b) } \frac{x}{(x^2 + \sqrt{2}x + 1)(x^2 - \sqrt{2}x + 1)} = \frac{Ax + B}{x^2 + \sqrt{2}x + 1} + \frac{Cx + D}{x^2 - \sqrt{2}x + 1};$$

$$A = 0, B = -\frac{\sqrt{2}}{4}, C = 0, D = \frac{\sqrt{2}}{4} \text{ so}$$

$$\begin{aligned} \int_0^1 \frac{x}{x^4+1} dx &= -\frac{\sqrt{2}}{4} \int_0^1 \frac{1}{x^2 + \sqrt{2}x + 1} dx + \frac{\sqrt{2}}{4} \int_0^1 \frac{1}{x^2 - \sqrt{2}x + 1} dx \\ &= -\frac{\sqrt{2}}{4} \int_0^1 \frac{1}{(x + \sqrt{2}/2)^2 + 1/2} dx + \frac{\sqrt{2}}{4} \int_0^1 \frac{1}{(x - \sqrt{2}/2)^2 + 1/2} dx \\ &= -\frac{\sqrt{2}}{4} \int_{\sqrt{2}/2}^{1+\sqrt{2}/2} \frac{1}{u^2 + 1/2} du + \frac{\sqrt{2}}{4} \int_{-\sqrt{2}/2}^{1-\sqrt{2}/2} \frac{1}{u^2 + 1/2} du \\ &= -\frac{1}{2} \tan^{-1} \sqrt{2}u \Big|_{\sqrt{2}/2}^{1+\sqrt{2}/2} + \frac{1}{2} \tan^{-1} \sqrt{2}u \Big|_{-\sqrt{2}/2}^{1-\sqrt{2}/2} \\ &= -\frac{1}{2} \tan^{-1}(\sqrt{2} + 1) + \frac{1}{2} \left(\frac{\pi}{4}\right) + \frac{1}{2} \tan^{-1}(\sqrt{2} - 1) - \frac{1}{2} \left(-\frac{\pi}{4}\right) \\ &= \frac{\pi}{4} - \frac{1}{2} [\tan^{-1}(\sqrt{2} + 1) - \tan^{-1}(\sqrt{2} - 1)] \\ &= \frac{\pi}{4} - \frac{1}{2} [\tan^{-1}(1 + \sqrt{2}) + \tan^{-1}(1 - \sqrt{2})] \\ &= \frac{\pi}{4} - \frac{1}{2} \tan^{-1} \left[ \frac{(1 + \sqrt{2}) + (1 - \sqrt{2})}{1 - (1 + \sqrt{2})(1 - \sqrt{2})} \right] \quad (\text{Exercise 46, Section 4.5}) \\ &= \frac{\pi}{4} - \frac{1}{2} \tan^{-1} 1 = \frac{\pi}{4} - \frac{1}{2} \left(\frac{\pi}{4}\right) = \frac{\pi}{8} \end{aligned}$$

$$42. \frac{1}{a^2 - x^2} = \frac{A}{a - x} + \frac{B}{a + x}; A = \frac{1}{2a}, B = \frac{1}{2a} \text{ so}$$

$$\frac{1}{2a} \int \left( \frac{1}{a - x} + \frac{1}{a + x} \right) dx = \frac{1}{2a} (-\ln|a - x| + \ln|a + x|) + C = \frac{1}{2a} \ln \left| \frac{a + x}{a - x} \right| + C$$

### EXERCISE SET 9.6

$$1. \text{ Formula (60): } \frac{3}{16} [4x + \ln|-1 + 4x|] + C \quad 2. \text{ Formula (62): } \frac{1}{9} \left[ \frac{2}{2 - 3x} + \ln|2 - 3x| \right] + C$$

$$3. \text{ Formula (65): } \frac{1}{5} \ln \left| \frac{x}{5 + 2x} \right| + C \quad 4. \text{ Formula (66): } -\frac{1}{x} - 5 \ln \left| \frac{1 - 5x}{x} \right| + C$$

$$5. \text{ Formula (102): } \frac{1}{5} (x + 1)(-3 + 2x)^{3/2} + C \quad 6. \text{ Formula (105): } \frac{2}{3} (-x - 4)\sqrt{2 - x} + C$$

$$7. \text{ Formula (108): } \frac{1}{2} \ln \left| \frac{\sqrt{4 - 3x} - 2}{\sqrt{4 - 3x} + 2} \right| + C \quad 8. \text{ Formula (108): } \tan^{-1} \frac{\sqrt{3x - 4}}{2} + C$$

$$9. \text{ Formula (69): } \frac{1}{2\sqrt{5}} \ln \left| \frac{x + \sqrt{5}}{x - \sqrt{5}} \right| + C \quad 10. \text{ Formula (70): } \frac{1}{6} \ln \left| \frac{x - 3}{x + 3} \right| + C$$

$$11. \text{ Formula (73): } \frac{x}{2} \sqrt{x^2 - 3} - \frac{3}{2} \ln|x + \sqrt{x^2 - 3}| + C$$

$$12. \text{ Formula (93): } -\frac{\sqrt{x^2 + 5}}{x} + \ln(x + \sqrt{x^2 + 5}) + C$$

$$13. \text{ Formula (95): } \frac{x}{2} \sqrt{x^2 + 4} - 2 \ln(x + \sqrt{x^2 + 4}) + C$$

$$14. \text{ Formula (90): } -\frac{\sqrt{x^2 - 2}}{2x} + C \quad 15. \text{ Formula (74): } \frac{x}{2} \sqrt{9 - x^2} + \frac{9}{2} \sin^{-1} \frac{x}{3} + C$$

$$16. \text{ Formula (80): } -\frac{\sqrt{4 - x^2}}{x} - \sin^{-1} \frac{x}{2} + C$$

$$17. \text{ Formula (79): } \sqrt{3 - x^2} - \sqrt{3} \ln \left| \frac{\sqrt{3} + \sqrt{9 - x^2}}{x} \right| + C$$

$$18. \text{ Formula (117): } -\frac{\sqrt{6x - x^2}}{3x} + C \quad 19. \text{ Formula (38): } -\frac{1}{10} \sin(5x) + \frac{1}{2} \sin x + C$$

$$20. \text{ Formula (40): } -\frac{1}{14} \cos(7x) + \frac{1}{6} \cos(3x) + C$$

$$21. \text{ Formula (50): } \frac{x^4}{16} [4 \ln x - 1] + C \quad 22. \text{ Formula (50): } 4\sqrt{x} \left[ \frac{1}{2} \ln x - 1 \right] + C$$

$$23. \text{ Formula (42): } \frac{e^{-2x}}{13} (-2 \sin(3x) - 3 \cos(3x)) + C$$



24. Formula (43):  $\frac{e^x}{5}(\cos(2x) + 2\sin(2x)) + C$
25.  $u = e^{2x}, du = 2e^{2x}dx$ , Formula (62):  $\frac{1}{2} \int \frac{u du}{(4-3u)^2} = \frac{1}{18} \left[ \frac{4}{4-3e^{2x}} + \ln|4-3e^{2x}| \right] + C$
26.  $u = \sin 2x, du = 2 \cos 2x dx$ , Formula (116):  $\int \frac{du}{2u(3-u)} = \frac{1}{6} \ln \left| \frac{\sin 2x}{3 - \sin 2x} \right| + C$
27.  $u = 3\sqrt{x}, du = \frac{3}{2\sqrt{x}}dx$ , Formula (68):  $\frac{2}{3} \int \frac{du}{u^2+4} = \frac{1}{3} \tan^{-1} \frac{3\sqrt{x}}{2} + C$
28.  $u = \sin 4x, du = 4 \cos 4x dx$ , Formula (68):  $\frac{1}{4} \int \frac{du}{9+u^2} = \frac{1}{12} \tan^{-1} \frac{\sin 4x}{3} + C$
29.  $u = 3x, du = 3dx$ , Formula (76):  $\frac{1}{3} \int \frac{du}{\sqrt{u^2-4}} = \frac{1}{3} \ln|3x + \sqrt{9x^2-4}| + C$
30.  $u = \sqrt{2}x^2, du = 2\sqrt{2}x dx$ , Formula (72):  
 $\frac{1}{2\sqrt{2}} \int \sqrt{u^2+3} du = \frac{x^2}{4} \sqrt{2x^4+3} + \frac{3}{4\sqrt{2}} \ln(\sqrt{2}x^2 + \sqrt{2x^4+3}) + C$
31.  $u = 3x^2, du = 6x dx, u^2 du = 54x^5 dx$ , Formula (81):  
 $\frac{1}{54} \int \frac{u^2 du}{\sqrt{5-u^2}} = -\frac{x^2}{36} \sqrt{5-9x^4} + \frac{5}{108} \sin^{-1} \frac{3x^2}{\sqrt{5}} + C$
32.  $u = 2x, du = 2dx$ , Formula (83):  $2 \int \frac{du}{u^2\sqrt{3-u^2}} = -\frac{1}{3x} \sqrt{3-4x^2} + C$
33.  $u = \ln x, du = dx/x$ , Formula (26):  $\int \sin^2 u du = \frac{1}{2} \ln x + \frac{1}{4} \sin(2 \ln x) + C$
34.  $u = e^{-2x}, du = -2e^{-2x}$ , Formula (27):  $-\frac{1}{2} \int \cos^2 u du = -\frac{1}{4} e^{-2x} - \frac{1}{8} \sin(2e^{-2x}) + C$
35.  $u = -2x, du = -2dx$ , Formula (51):  $\frac{1}{4} \int u e^u du = \frac{1}{4} (-2x-1)e^{-2x} + C$
36.  $u = 5x-1, du = 5dx$ , Formula (50):  $\frac{1}{5} \int \ln u du = \frac{1}{5} (u \ln u - u) + C = \frac{1}{5} (5x-1)[\ln(5x-1) - 1] + C$
37.  $u = \cos 3x, du = -3 \sin 3x$ , Formula (67):  $-\int \frac{du}{u(u+1)^2} = -\frac{1}{3} \left[ \frac{1}{1+\cos 3x} + \ln \left| \frac{\cos 3x}{1+\cos 3x} \right| \right] + C$
38.  $u = \ln x, du = \frac{1}{x} dx$ , Formula (105):  $\int \frac{u du}{\sqrt{4u-1}} = \frac{1}{12} (2 \ln x + 1) \sqrt{4 \ln x - 1} + C$
39.  $u = 4x^2, du = 8x dx$ , Formula (70):  $\frac{1}{8} \int \frac{du}{u^2-1} = \frac{1}{16} \ln \left| \frac{4x^2-1}{4x^2+1} \right| + C$
40.  $u = 2e^x, du = 2e^x dx$ , Formula (69):  $\frac{1}{2} \int \frac{du}{3-u^2} = \frac{1}{4\sqrt{3}} \ln \left| \frac{2e^x + \sqrt{3}}{2e^x - \sqrt{3}} \right| + C$

41.  $u = 2e^x, du = 2e^x dx$ , Formula (74):

$$\frac{1}{2} \int \sqrt{3-u^2} du = \frac{1}{4} u \sqrt{3-u^2} + \frac{3}{4} \sin^{-1}(u/\sqrt{3}) + C = \frac{1}{2} e^x \sqrt{3-4e^{2x}} + \frac{3}{4} \sin^{-1}(2e^x/\sqrt{3}) + C$$

42.  $u = 3x, du = 3dx$ , Formula (80):

$$3 \int \frac{\sqrt{4-u^2} du}{u^2} = -3 \frac{\sqrt{4-u^2}}{u} - 3 \sin^{-1}(u/2) + C = -\frac{\sqrt{4-9x^2}}{x} - 3 \sin^{-1}(3x/2) + C$$

43.  $u = 3x, du = 3dx$ , Formula (112):

$$\begin{aligned} \frac{1}{3} \int \sqrt{\frac{5}{3}u - u^2} du &= \frac{1}{6} \left(u - \frac{5}{6}\right) \sqrt{\frac{5}{3}u - u^2} + \frac{25}{216} \sin^{-1} \frac{u-5}{5} + C \\ &= \frac{18x-5}{36} \sqrt{5x-9x^2} + \frac{25}{216} \sin^{-1} \left(\frac{18x-5}{5}\right) + C \end{aligned}$$

44.  $u = \sqrt{5}x, du = \sqrt{5} dx$ , Formula (117):

$$\int \frac{du}{u \sqrt{(u/\sqrt{5}) - u^2}} = -\frac{\sqrt{(u/\sqrt{5}) - u^2}}{u/(2\sqrt{5})} + C = -2 \frac{\sqrt{x-5x^2}}{x} + C$$

45.  $u = 3x, du = 3dx$ , Formula (44):

$$\frac{1}{9} \int u \sin u du = \frac{1}{9} (\sin u - u \cos u) + C = \frac{1}{9} (\sin 3x - 3x \cos 3x) + C$$

46.  $u = \sqrt{x}, u^2 = x, 2udu = dx$ , Formula (45):  $2 \int u \cos u du = 2 \cos \sqrt{x} + 2\sqrt{x} \sin \sqrt{x} + C$

47.  $u = -\sqrt{x}, u^2 = x, 2udu = dx$ , Formula (51):  $2 \int u e^u du = -2(\sqrt{x} + 1)e^{-\sqrt{x}} + C$

48.  $u = 2 - 3x^2, du = -6xdx$ , Formula (50):

$$-\frac{1}{6} \int \ln u du = -\frac{1}{6} (u \ln u - u) + C = -\frac{1}{6} ((2-3x^2) \ln(2-3x^2) + \frac{1}{6} (2-3x^2)) + C$$

49.  $x^2 + 4x - 5 = (x+2)^2 - 9; u = x+2, du = dx$ , Formula (70):

$$\int \frac{du}{u^2-9} = \frac{1}{6} \ln \left| \frac{u-3}{u+3} \right| + C = \frac{1}{6} \ln \left| \frac{x-1}{x+5} \right| + C$$

50.  $x^2 + 2x - 3 = (x+1)^2 - 4, u = x+1, du = dx$ , Formula (77):

$$\begin{aligned} \int \sqrt{4-u^2} du &= \frac{1}{2} u \sqrt{4-u^2} + 2 \sin^{-1}(u/2) + C \\ &= \frac{1}{2} (x+1) \sqrt{3-2x-x^2} + 2 \sin^{-1}((x+1)/2) + C \end{aligned}$$

51.  $x^2 - 4x - 5 = (x-2)^2 - 9, u = x-2, du = dx$ , Formula (77):

$$\begin{aligned} \int \frac{u+2}{\sqrt{9-u^2}} du &= \int \frac{u du}{\sqrt{9-u^2}} + 2 \int \frac{du}{\sqrt{9-u^2}} = -\sqrt{9-u^2} + 2 \sin^{-1} \frac{u}{3} + C \\ &= -\sqrt{5+4x-x^2} + 2 \sin^{-1} \left(\frac{x-2}{3}\right) + C \end{aligned}$$

52.  $x^2 + 6x + 13 = (x + 3)^2 + 4$ ,  $u = x + 3$ ,  $du = dx$ , Formula (71):

$$\int \frac{(u-3) du}{u^2+4} = \frac{1}{2} \ln(u^2+4) - \frac{3}{2} \tan^{-1}(u/2) + C = \frac{1}{2} \ln(x^2+6x+13) - \frac{3}{2} \tan^{-1}((x+3)/2) + C$$

53.  $u = \sqrt{x-2}$ ,  $x = u^2 + 2$ ,  $dx = 2u du$ ;

$$\int 2u^2(u^2+2)du = 2 \int (u^4+2u^2)du = \frac{2}{5}u^5 + \frac{4}{3}u^3 + C = \frac{2}{5}(x-2)^{5/2} + \frac{4}{3}(x-2)^{3/2} + C$$

54.  $u = \sqrt{x+1}$ ,  $x = u^2 - 1$ ,  $dx = 2u du$ ;

$$2 \int (u^2-1)du = \frac{2}{3}u^3 - 2u + C = \frac{2}{3}(x+1)^{3/2} - 2\sqrt{x+1} + C$$

55.  $u = \sqrt{x^3+1}$ ,  $x^3 = u^2 - 1$ ,  $3x^2 dx = 2u du$ ;

$$\frac{2}{3} \int u^2(u^2-1)du = \frac{2}{3} \int (u^4-u^2)du = \frac{2}{15}u^5 - \frac{2}{9}u^3 + C = \frac{2}{15}(x^3+1)^{5/2} - \frac{2}{9}(x^3+1)^{3/2} + C$$

56.  $u = \sqrt{x^3-1}$ ,  $x^3 = u^2 + 1$ ,  $3x^2 dx = 2u du$ ;

$$\frac{2}{3} \int \frac{1}{u^2+1} du = \frac{2}{3} \tan^{-1} u + C = \frac{2}{3} \tan^{-1} \sqrt{x^3-1} + C$$

57.  $u = x^{1/6}$ ,  $x = u^6$ ,  $dx = 6u^5 du$ ;

$$\begin{aligned} \int \frac{6u^5}{u^3+u^2} du &= 6 \int \frac{u^3}{u+1} du = 6 \int \left[ u^2 - u + 1 - \frac{1}{u+1} \right] du \\ &= 2x^{1/2} - 3x^{1/3} + 6x^{1/6} - 6 \ln(x^{1/6} + 1) + C \end{aligned}$$

58.  $u = x^{1/5}$ ,  $x = u^5$ ,  $dx = 5u^4 du$ ;  $\int \frac{5u^4}{u^5-u^3} du = 5 \int \frac{u}{u^2-1} du = \frac{5}{2} \ln|x^{2/5}-1| + C$

59.  $u = x^{1/4}$ ,  $x = u^4$ ,  $dx = 4u^3 du$ ;  $4 \int \frac{1}{u(1-u)} du = 4 \int \left[ \frac{1}{u} + \frac{1}{1-u} \right] du = 4 \ln \frac{x^{1/4}}{|1-x^{1/4}|} + C$

60.  $u = x^{1/3}$ ,  $x = u^3$ ,  $dx = 3u^2 du$ ;  $3 \int \frac{u^4}{u^3+1} du = 3 \int \left( u - \frac{u}{u^3+1} \right) du$ ,

$$\frac{u}{u^3+1} = \frac{u}{(u+1)(u^2-u+1)} = \frac{-1/3}{u+1} + \frac{(1/3)u+1/3}{u^2-u+1} \text{ so}$$

$$\begin{aligned} 3 \int \left( u - \frac{u}{u^3+1} \right) du &= \int \left( 3u + \frac{1}{u+1} - \frac{u+1}{u^2-u+1} \right) du \\ &= \frac{3}{2}u^2 + \ln|u+1| - \frac{1}{2} \ln(u^2-u+1) - \sqrt{3} \tan^{-1} \frac{2u-1}{\sqrt{3}} + C \\ &= \frac{3}{2}x^{2/3} + \ln|x^{1/3}+1| - \frac{1}{2} \ln(x^{2/3}-x^{1/3}+1) - \sqrt{3} \tan^{-1} \frac{2x^{1/3}-1}{\sqrt{3}} + C \end{aligned}$$

61.  $u = x^{1/6}$ ,  $x = u^6$ ,  $dx = 6u^5 du$ ;

$$6 \int \frac{u^3}{u-1} du = 6 \int \left[ u^2 + u + 1 + \frac{1}{u-1} \right] du = 2x^{1/2} + 3x^{1/3} + 6x^{1/6} + 6 \ln|x^{1/6}-1| + C$$

62.  $u = \sqrt{x}$ ,  $x = u^2$ ,  $dx = 2u du$ ;

$$-2 \int \frac{u^2 + u}{u - 1} du = -2 \int \left( u + 2 + \frac{2}{u - 1} \right) du = -x - 4\sqrt{x} - 4 \ln |\sqrt{x} - 1| + C$$

63.  $u = \sqrt{1 + x^2}$ ,  $x^2 = u^2 - 1$ ,  $2x dx = 2u du$ ,  $x dx = u du$ ;

$$\int (u^2 - 1) du = \frac{1}{3}(1 + x^2)^{3/2} - (1 + x^2)^{1/2} + C$$

64.  $u = (x + 3)^{1/5}$ ,  $x = u^5 - 3$ ,  $dx = 5u^4 du$ ;

$$5 \int (u^8 - 3u^3) du = \frac{5}{9}(x + 3)^{9/5} - \frac{15}{4}(x + 3)^{4/5} + C$$

65.  $u = \sqrt{x}$ ,  $x = u^2$ ,  $dx = 2u du$ , Formula (44):  $2 \int u \sin u du = 2 \sin \sqrt{x} - 2\sqrt{x} \cos \sqrt{x} + C$

66.  $u = \sqrt{x}$ ,  $x = u^2$ ,  $dx = 2u du$ , Formula (51):  $2 \int u e^u du = 2\sqrt{x} e^{\sqrt{x}} - 2e^{\sqrt{x}} + C$

67.  $\int \frac{1}{1 + \frac{2u}{1 + u^2} + \frac{1 - u^2}{1 + u^2}} \frac{2}{1 + u^2} du = \int \frac{1}{u + 1} du = \ln |\tan(x/2) + 1| + C$

68.  $\int \frac{1}{2 + \frac{2u}{1 + u^2}} \frac{2}{1 + u^2} du = \int \frac{1}{u^2 + u + 1} du$   
 $= \int \frac{1}{(u + 1/2)^2 + 3/4} du = \frac{2}{\sqrt{3}} \tan^{-1} \left( \frac{2 \tan(x/2) + 1}{\sqrt{3}} \right) + C$

69.  $u = \tan(\theta/2)$ ,  $\int \frac{d\theta}{1 - \cos \theta} = \int \frac{1}{u^2} du = -\frac{1}{u} + C = -\cot(\theta/2) + C$

70.  $u = \tan(x/2)$ ,

$$\int \frac{2}{3u^2 + 8u - 3} du = \frac{2}{3} \int \frac{1}{(u + 4/3)^2 - 25/9} du = \frac{2}{3} \int \frac{1}{z^2 - 25/9} dz \quad (z = u + 4/3)$$

$$= \frac{1}{5} \ln \left| \frac{z - 5/3}{z + 5/3} \right| + C = \frac{1}{5} \ln \left| \frac{\tan(x/2) - 1/3}{\tan(x/2) + 3} \right| + C$$

71.  $u = \tan(x/2)$ ,  $2 \int \frac{1 - u^2}{(3u^2 + 1)(u^2 + 1)} du$ ;

$$\frac{1 - u^2}{(3u^2 + 1)(u^2 + 1)} = \frac{(0)u + 2}{3u^2 + 1} + \frac{(0)u - 1}{u^2 + 1} = \frac{2}{3u^2 + 1} - \frac{1}{u^2 + 1} \text{ so}$$

$$\int \frac{\cos x}{2 - \cos x} dx = \frac{4}{\sqrt{3}} \tan^{-1}[\sqrt{3} \tan(x/2)] - x + C$$

72.  $u = \tan(x/2)$ ,  $\frac{1}{2} \int \frac{1 - u^2}{u} du = \frac{1}{2} \int (1/u - u) du = \frac{1}{2} \ln |\tan(x/2)| - \frac{1}{4} \tan^2(x/2) + C$

73.  $\int_2^x \frac{1}{t(4-t)} dt = \frac{1}{4} \ln \frac{t}{4-t} \Big|_2^x$  (Formula (65),  $a = 4, b = -1$ )  
 $= \frac{1}{4} \left[ \ln \frac{x}{4-x} - \ln 1 \right] = \frac{1}{4} \ln \frac{x}{4-x}, \frac{1}{4} \ln \frac{x}{4-x} = 0.5, \ln \frac{x}{4-x} = 2,$   
 $\frac{x}{4-x} = e^2, x = 4e^2 - e^2x, x(1+e^2) = 4e^2, x = 4e^2/(1+e^2) \approx 3.523188312$
74.  $\int_1^x \frac{1}{t\sqrt{2t-1}} dt = 2 \tan^{-1} \sqrt{2t-1} \Big|_1^x$  (Formula (108),  $a = -1, b = 2$ )  
 $= 2 (\tan^{-1} \sqrt{2x-1} - \tan^{-1} 1) = 2 (\tan^{-1} \sqrt{2x-1} - \pi/4),$   
 $2(\tan^{-1} \sqrt{2x-1} - \pi/4) = 1, \tan^{-1} \sqrt{2x-1} = 1/2 + \pi/4, \sqrt{2x-1} = \tan(1/2 + \pi/4),$   
 $x = [1 + \tan^2(1/2 + \pi/4)]/2 \approx 6.307993516$
75.  $A = \int_0^4 \sqrt{25-x^2} dx = \left( \frac{1}{2} x \sqrt{25-x^2} + \frac{25}{2} \sin^{-1} \frac{x}{5} \right) \Big|_0^4$  (Formula (74),  $a = 5$ )  
 $= 6 + \frac{25}{2} \sin^{-1} \frac{4}{5} \approx 17.59119023$
76.  $A = \int_{2/3}^2 \sqrt{9x^2-4} dx; u = 3x,$   
 $A = \frac{1}{3} \int_2^6 \sqrt{u^2-4} du = \frac{1}{3} \left( \frac{1}{2} u \sqrt{u^2-4} - 2 \ln |u + \sqrt{u^2-4}| \right) \Big|_2^6$  (Formula (73),  $a^2 = 4$ )  
 $= \frac{1}{3} (3\sqrt{32} - 2 \ln(6 + \sqrt{32}) + 2 \ln 2) = 4\sqrt{2} - \frac{2}{3} \ln(3 + 2\sqrt{2}) \approx 4.481689467$
77.  $A = \int_0^1 \frac{1}{25-16x^2} dx; u = 4x,$   
 $A = \frac{1}{4} \int_0^4 \frac{1}{25-u^2} du = \frac{1}{40} \ln \left| \frac{u+5}{u-5} \right| \Big|_0^4 = \frac{1}{40} \ln 9 \approx 0.054930614$  (Formula (69),  $a = 5$ )
78.  $A = \int_1^4 \sqrt{x} \ln x dx = \frac{4}{9} x^{3/2} \left( \frac{3}{2} \ln x - 1 \right) \Big|_1^4$  (Formula (50),  $n = 1/2$ )  
 $= \frac{4}{9} (12 \ln 4 - 7) \approx 4.282458815$
79.  $V = 2\pi \int_0^{\pi/2} x \cos x dx = 2\pi (\cos x + x \sin x) \Big|_0^{\pi/2} = \pi(\pi - 2) \approx 3.586419094$  (Formula (45))
80.  $V = 2\pi \int_4^8 x \sqrt{x-4} dx = \frac{4\pi}{15} (3x+8)(x-4)^{3/2} \Big|_4^8$  (Formula (102),  $a = -4, b = 1$ )  
 $= \frac{1024}{15} \pi \approx 214.4660585$
81.  $V = 2\pi \int_0^3 x e^{-x} dx; u = -x,$   
 $V = 2\pi \int_0^{-3} u e^u du = 2\pi e^u (u-1) \Big|_0^{-3} = 2\pi(1 - 4e^{-3}) \approx 5.031899801$  (Formula (51))

$$\begin{aligned}
 82. \quad V &= 2\pi \int_1^5 x \ln x \, dx = \left. \frac{\pi}{2} x^2 (2 \ln x - 1) \right|_1^5 \\
 &= \pi(25 \ln 5 - 12) \approx 88.70584621 \quad (\text{Formula (50), } n = 1)
 \end{aligned}$$

$$\begin{aligned}
 83. \quad L &= \int_0^2 \sqrt{1 + 16x^2} \, dx; \quad u = 4x, \\
 L &= \frac{1}{4} \int_0^8 \sqrt{1 + u^2} \, du = \frac{1}{4} \left( \frac{u}{2} \sqrt{1 + u^2} + \frac{1}{2} \ln(u + \sqrt{1 + u^2}) \right) \Big|_0^8 \quad (\text{Formula (72), } a^2 = 1) \\
 &= \sqrt{65} + \frac{1}{8} \ln(8 + \sqrt{65}) \approx 8.409316783
 \end{aligned}$$

$$\begin{aligned}
 84. \quad L &= \int_1^3 \sqrt{1 + 9/x^2} \, dx = \int_1^3 \frac{\sqrt{x^2 + 9}}{x} \, dx = \left( \sqrt{x^2 + 9} - 3 \ln \left| \frac{3 + \sqrt{x^2 + 9}}{x} \right| \right) \Big|_1^3 \\
 &= 3\sqrt{2} - \sqrt{10} + 3 \ln \frac{3 + \sqrt{10}}{1 + \sqrt{2}} \approx 3.891581644 \quad (\text{Formula (89), } a = 3)
 \end{aligned}$$

$$\begin{aligned}
 85. \quad S &= 2\pi \int_0^\pi (\sin x) \sqrt{1 + \cos^2 x} \, dx; \quad u = \cos x, \\
 S &= -2\pi \int_1^{-1} \sqrt{1 + u^2} \, du = 4\pi \int_0^1 \sqrt{1 + u^2} \, du = 4\pi \left( \frac{u}{2} \sqrt{1 + u^2} + \frac{1}{2} \ln(u + \sqrt{1 + u^2}) \right) \Big|_0^1 \quad (a^2 = 1) \\
 &= 2\pi[\sqrt{2} + \ln(1 + \sqrt{2})] \approx 14.42359945 \quad (\text{Formula (72)})
 \end{aligned}$$

$$\begin{aligned}
 86. \quad S &= 2\pi \int_1^4 \frac{1}{x} \sqrt{1 + 1/x^4} \, dx = 2\pi \int_1^4 \frac{\sqrt{x^4 + 1}}{x^3} \, dx; \quad u = x^2, \\
 S &= \pi \int_1^{16} \frac{\sqrt{u^2 + 1}}{u^2} \, du = \pi \left( -\frac{\sqrt{u^2 + 1}}{u} + \ln(u + \sqrt{u^2 + 1}) \right) \Big|_1^{16} \\
 &= \pi \left( \sqrt{2} - \frac{\sqrt{257}}{16} + \ln \frac{16 + \sqrt{257}}{1 + \sqrt{2}} \right) \approx 9.417237485 \quad (\text{Formula (93), } a^2 = 1)
 \end{aligned}$$

$$\begin{aligned}
 87. \quad (\text{a}) \quad s(t) &= 2 + \int_0^t 20 \cos^6 u \sin^3 u \, du \\
 &= -\frac{20}{9} \sin^2 t \cos^7 t - \frac{40}{63} \cos^7 t + \frac{166}{63}
 \end{aligned}$$

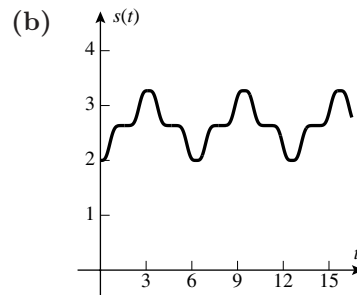

$$\begin{aligned}
 88. \quad (\text{a}) \quad v(t) &= \int_0^t a(u) \, du = -\frac{1}{10} e^{-t} \cos 2t + \frac{1}{5} e^{-t} \sin 2t + \frac{1}{74} e^{-t} \cos 6t - \frac{3}{37} e^{-t} \sin 6t + \frac{1}{10} - \frac{1}{74} \\
 s(t) &= 10 + \int_0^t v(u) \, du \\
 &= -\frac{3}{50} e^{-t} \cos 2t - \frac{2}{25} e^{-t} \sin 2t + \frac{35}{2738} e^{-t} \cos 6t + \frac{6}{1369} e^{-t} \sin 6t + \frac{16}{185} t + \frac{343866}{34225}
 \end{aligned}$$

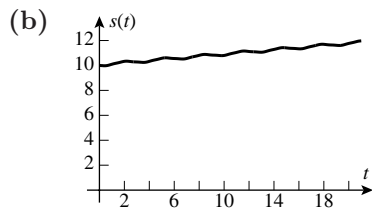

89. (a) 
$$\int \sec x \, dx = \int \frac{1}{\cos x} \, dx = \int \frac{2}{1-u^2} \, du = \ln \left| \frac{1+u}{1-u} \right| + C = \ln \left| \frac{1+\tan(x/2)}{1-\tan(x/2)} \right| + C$$

$$= \ln \left\{ \left| \frac{\cos(x/2) + \sin(x/2)}{\cos(x/2) - \sin(x/2)} \right| \left| \frac{\cos(x/2) + \sin(x/2)}{\cos(x/2) + \sin(x/2)} \right| \right\} + C = \ln \left| \frac{1 + \sin x}{\cos x} \right| + C$$

$$= \ln |\sec x + \tan x| + C$$

(b) 
$$\tan \left( \frac{\pi}{4} + \frac{x}{2} \right) = \frac{\tan \frac{\pi}{4} + \tan \frac{x}{2}}{1 - \tan \frac{\pi}{4} \tan \frac{x}{2}} = \frac{1 + \tan \frac{x}{2}}{1 - \tan \frac{x}{2}}$$

90. 
$$\int \csc x \, dx = \int \frac{1}{\sin x} \, dx = \int 1/u \, du = \ln |\tan(x/2)| + C \text{ but}$$

$$\ln |\tan(x/2)| = \frac{1}{2} \ln \frac{\sin^2(x/2)}{\cos^2(x/2)} = \frac{1}{2} \ln \frac{(1 - \cos x)/2}{(1 + \cos x)/2} = \frac{1}{2} \ln \frac{1 - \cos x}{1 + \cos x}; \text{ also,}$$

$$\frac{1 - \cos x}{1 + \cos x} = \frac{1 - \cos^2 x}{(1 + \cos x)^2} = \frac{1}{(\csc x + \cot x)^2} \text{ so } \frac{1}{2} \ln \frac{1 - \cos x}{1 + \cos x} = -\ln |\csc x + \cot x|$$

91. Let  $u = \tanh(x/2)$  then  $\cosh(x/2) = 1/\operatorname{sech}(x/2) = 1/\sqrt{1 - \tanh^2(x/2)} = 1/\sqrt{1 - u^2}$ ,

$$\sinh(x/2) = \tanh(x/2) \cosh(x/2) = u/\sqrt{1 - u^2}, \text{ so } \sinh x = 2 \sinh(x/2) \cosh(x/2) = 2u/(1 - u^2),$$

$$\cosh x = \cosh^2(x/2) + \sinh^2(x/2) = (1 + u^2)/(1 - u^2), \quad x = 2 \tanh^{-1} u, \quad dx = [2/(1 - u^2)] du;$$

$$\int \frac{dx}{2 \cosh x + \sinh x} = \int \frac{1}{u^2 + u + 1} \, du = \frac{2}{\sqrt{3}} \tan^{-1} \frac{2u + 1}{\sqrt{3}} + C = \frac{2}{\sqrt{3}} \tan^{-1} \frac{2 \tanh(x/2) + 1}{\sqrt{3}} + C.$$

### EXERCISE SET 9.7

- |  |  |
|--|--|
| 1. exact value = $14/3 \approx 4.666666667$            | 2. exact value = 2                                       |
| (a) 4.667600663, $ E_M  \approx 0.000933996$           | (a) 1.998377048, $ E_M  \approx 0.001622952$             |
| (b) 4.664795679, $ E_T  \approx 0.001870988$           | (b) 2.003260982, $ E_T  \approx 0.003260982$             |
| (c) 4.666651630, $ E_S  \approx 0.000015037$           | (c) 2.000072698, $ E_S  \approx 0.000072698$             |
| 3. exact value = 2                                     | 4. exact value = $\sin(1) \approx 0.841470985$           |
| (a) 2.008248408, $ E_M  \approx 0.008248408$           | (a) 0.841821700, $ E_M  \approx 0.000350715$             |
| (b) 1.983523538, $ E_T  \approx 0.016476462$           | (b) 0.840769642, $ E_T  \approx 0.000701343$             |
| (c) 2.000109517, $ E_S  \approx 0.000109517$           | (c) 0.841471453, $ E_S  \approx 0.000000468$             |
| 5. exact value = $e^{-1} - e^{-3} \approx 0.318092373$ | 6. exact value = $\frac{1}{2} \ln 5 \approx 0.804718956$ |
| (a) 0.317562837, $ E_M  \approx 0.000529536$           | (a) 0.801605339, $ E_M  \approx 0.003113617$             |
| (b) 0.319151975, $ E_T  \approx 0.001059602$           | (b) 0.811019505, $ E_T  \approx 0.006300549$             |
| (c) 0.318095187, $ E_S  \approx 0.000002814$           | (c) 0.805041497, $ E_S  \approx 0.000322541$             |

7.  $f(x) = \sqrt{x+1}$ ,  $f''(x) = -\frac{1}{4}(x+1)^{-3/2}$ ,  $f^{(4)}(x) = -\frac{15}{16}(x+1)^{-7/2}$ ;  $K_2 = 1/4$ ,  $K_4 = 15/16$
- (a)  $|E_M| \leq \frac{27}{2400}(1/4) = 0.002812500$       (b)  $|E_T| \leq \frac{27}{1200}(1/4) = 0.005625000$
- (c)  $|E_S| \leq \frac{243}{180 \times 10^4}(15/16) \approx 0.000126563$
8.  $f(x) = 1/\sqrt{x}$ ,  $f''(x) = \frac{3}{4}x^{-5/2}$ ,  $f^{(4)}(x) = \frac{105}{16}x^{-9/2}$ ;  $K_2 = 3/4$ ,  $K_4 = 105/16$
- (a)  $|E_M| \leq \frac{27}{2400}(3/4) = 0.008437500$       (b)  $|E_T| \leq \frac{27}{1200}(3/4) = 0.016875000$
- (c)  $|E_S| \leq \frac{243}{180 \times 10^4}(105/16) \approx 0.000885938$
9.  $f(x) = \sin x$ ,  $f''(x) = -\sin x$ ,  $f^{(4)}(x) = \sin x$ ;  $K_2 = K_4 = 1$
- (a)  $|E_M| \leq \frac{\pi^3}{2400}(1) \approx 0.012919282$       (b)  $|E_T| \leq \frac{\pi^3}{1200}(1) \approx 0.025838564$
- (c)  $|E_S| \leq \frac{\pi^5}{180 \times 10^4}(1) \approx 0.000170011$
10.  $f(x) = \cos x$ ,  $f''(x) = -\cos x$ ,  $f^{(4)}(x) = \cos x$ ;  $K_2 = K_4 = 1$
- (a)  $|E_M| \leq \frac{1}{2400}(1) \approx 0.000416667$       (b)  $|E_T| \leq \frac{1}{1200}(1) \approx 0.000833333$
- (c)  $|E_S| \leq \frac{1}{180 \times 10^4}(1) \approx 0.000000556$
11.  $f(x) = e^{-x}$ ,  $f''(x) = f^{(4)}(x) = e^{-x}$ ;  $K_2 = K_4 = e^{-1}$
- (a)  $|E_M| \leq \frac{8}{2400}(e^{-1}) \approx 0.001226265$       (b)  $|E_T| \leq \frac{8}{1200}(e^{-1}) \approx 0.002452530$
- (c)  $|E_S| \leq \frac{32}{180 \times 10^4}(e^{-1}) \approx 0.000006540$
12.  $f(x) = 1/(2x+3)$ ,  $f''(x) = 8(2x+3)^{-3}$ ,  $f^{(4)}(x) = 384(2x+3)^{-5}$ ;  $K_2 = 8$ ,  $K_4 = 384$
- (a)  $|E_M| \leq \frac{8}{2400}(8) \approx 0.026666667$       (b)  $|E_T| \leq \frac{8}{1200}(8) \approx 0.053333333$
- (c)  $|E_S| \leq \frac{32}{180 \times 10^4}(384) \approx 0.006826667$
13. (a)  $n > \left[ \frac{(27)(1/4)}{(24)(5 \times 10^{-4})} \right]^{1/2} \approx 23.7$ ;  $n = 24$       (b)  $n > \left[ \frac{(27)(1/4)}{(12)(5 \times 10^{-4})} \right]^{1/2} \approx 33.5$ ;  $n = 34$
- (c)  $n > \left[ \frac{(243)(15/16)}{(180)(5 \times 10^{-4})} \right]^{1/4} \approx 7.1$ ;  $n = 8$
14. (a)  $n > \left[ \frac{(27)(3/4)}{(24)(5 \times 10^{-4})} \right]^{1/2} \approx 41.1$ ;  $n = 42$       (b)  $n > \left[ \frac{(27)(3/4)}{(12)(5 \times 10^{-4})} \right]^{1/2} \approx 58.1$ ;  $n = 59$
- (c)  $n > \left[ \frac{(243)(105/16)}{(180)(5 \times 10^{-4})} \right]^{1/4} \approx 11.5$ ;  $n = 12$



15. (a)  $n > \left[ \frac{(\pi^3)(1)}{(24)(10^{-3})} \right]^{1/2} \approx 35.9; n = 36$  (b)  $n > \left[ \frac{(\pi^3)(1)}{(12)(10^{-3})} \right]^{1/2} \approx 50.8; n = 51$   
 (c)  $n > \left[ \frac{(\pi^5)(1)}{(180)(10^{-3})} \right]^{1/4} \approx 6.4; n = 8$
16. (a)  $n > \left[ \frac{(1)(1)}{(24)(10^{-3})} \right]^{1/2} \approx 6.5; n = 7$  (b)  $n > \left[ \frac{(1)(1)}{(12)(10^{-3})} \right]^{1/2} \approx 9.1; n = 10$   
 (c)  $n > \left[ \frac{(1)(1)}{(180)(10^{-3})} \right]^{1/4} \approx 1.5; n = 2$
17. (a)  $n > \left[ \frac{(8)(e^{-1})}{(24)(10^{-6})} \right]^{1/2} \approx 350.2; n = 351$  (b)  $n > \left[ \frac{(8)(e^{-1})}{(12)(10^{-6})} \right]^{1/2} \approx 495.2; n = 496$   
 (c)  $n > \left[ \frac{(32)(e^{-1})}{(180)(10^{-6})} \right]^{1/4} \approx 15.99; n = 16$
18. (a)  $n > \left[ \frac{(8)(8)}{(24)(10^{-6})} \right]^{1/2} \approx 1632.99; n = 1633$  (b)  $n > \left[ \frac{(8)(8)}{(12)(10^{-6})} \right]^{1/2} \approx 2309.4; n = 2310$   
 (c)  $n > \left[ \frac{(32)(384)}{(180)(10^{-6})} \right]^{1/4} \approx 90.9; n = 92$
19. 0.746824948, 20. 1.137631378, 21. 2.129861595,  
 0.746824133 1.137630147 2.129861293
22. 2.418388347, 23. 0.805376152, 24. 1.536963087,  
 2.418399152 0.804776489 1.544294774
25. (a) 3.142425985,  $|E_M| \approx 0.000833331$  26. (a) 3.152411433,  $|E_M| \approx 0.010818779$   
 (b) 3.139925989,  $|E_T| \approx 0.001666665$  (b) 3.104518326,  $|E_T| \approx 0.037074328$   
 (c) 3.141592614,  $|E_S| \approx 0.000000040$  (c) 3.127008159,  $|E_S| \approx 0.014584495$
27.  $S_{14} = 0.693147984$ ,  $|E_S| \approx 0.000000803 = 8.03 \times 10^{-7}$ ; the method used in Example 5 results in a value of  $n$  which ensures that the magnitude of the error will be less than  $10^{-6}$ , this is not necessarily the *smallest* value of  $n$ .
28. (a) greater, because the graph of  $e^{-x^2}$  is concave up on the interval  $(1, 2)$   
 (b) less, because the graph of  $e^{-x^2}$  is concave down on the interval  $(0, 0.5)$
29.  $f(x) = x \sin x$ ,  $f''(x) = 2 \cos x - x \sin x$ ,  $|f''(x)| \leq 2|\cos x| + |x| |\sin x| \leq 2 + 2 = 4$  so  $K_2 \leq 4$ ,  
 $n > \left[ \frac{(8)(4)}{(24)(10^{-4})} \right]^{1/2} \approx 115.5; n = 116$  (a smaller  $n$  might suffice)
30.  $f(x) = e^{\cos x}$ ,  $f''(x) = (\sin^2 x)e^{\cos x} - (\cos x)e^{\cos x}$ ,  $|f''(x)| \leq e^{\cos x}(\sin^2 x + |\cos x|) \leq 2e$  so  
 $K_2 \leq 2e$ ,  $n > \left[ \frac{(1)(2e)}{(24)(10^{-4})} \right]^{1/2} \approx 47.6; n = 48$  (a smaller  $n$  might suffice)
31.  $f(x) = \sqrt{x}$ ,  $f''(x) = -\frac{1}{4x^{3/2}}$ ,  $\lim_{x \rightarrow 0^+} |f''(x)| = +\infty$

$$32. f(x) = \sin \sqrt{x}, f''(x) = -\frac{\sqrt{x} \sin \sqrt{x} + \cos \sqrt{x}}{4x^{3/2}}, \lim_{x \rightarrow 0^+} |f''(x)| = +\infty$$

$$33. L = \int_0^\pi \sqrt{1 + \cos^2 x} dx \approx 3.820187623 \quad 34. L = \int_1^3 \sqrt{1 + 1/x^4} dx \approx 2.146822803$$

35.

$t$ (s)	0	5	10	15	20
$v$ (mi/hr)	0	40	60	73	84
$v$ (ft/s)	0	58.67	88	107.07	123.2

$$\int_0^{20} v dt \approx \frac{20}{(3)(4)} [0 + 4(58.67) + 2(88) + 4(107.07) + 123.2] \approx 1604 \text{ ft}$$

36.

$t$	0	1	2	3	4	5	6	7	8
$a$	0	0.02	0.08	0.20	0.40	0.60	0.70	0.60	0

$$\int_0^8 a dt \approx \frac{8}{(3)(8)} [0 + 4(0.02) + 2(0.08) + 4(0.20) + 2(0.40) + 4(0.60) + 2(0.70) + 4(0.60) + 0] \\ \approx 2.7 \text{ cm/s}$$

$$37. \int_0^{180} v dt \approx \frac{180}{(3)(6)} [0.00 + 4(0.03) + 2(0.08) + 4(0.16) + 2(0.27) + 4(0.42) + 0.65] = 37.9 \text{ mi}$$

$$38. \int_0^{1800} (1/v) dx \approx \frac{1800}{(3)(6)} \left[ \frac{1}{3100} + \frac{4}{2908} + \frac{2}{2725} + \frac{4}{2549} + \frac{2}{2379} + \frac{4}{2216} + \frac{1}{2059} \right] \approx 0.71 \text{ s}$$

$$39. V = \int_0^{16} \pi r^2 dy = \pi \int_0^{16} r^2 dy \approx \pi \frac{16}{(3)(4)} [(8.5)^2 + 4(11.5)^2 + 2(13.8)^2 + 4(15.4)^2 + (16.8)^2] \\ \approx 9270 \text{ cm}^3 \approx 9.3 \text{ L}$$

$$40. A = \int_0^{600} h dx \approx \frac{600}{(3)(6)} [0 + 4(7) + 2(16) + 4(24) + 2(25) + 4(16) + 0] = 9000 \text{ ft}^2, \\ V = 75A \approx 75(9000) = 675,000 \text{ ft}^3$$

$$41. \int_a^b f(x) dx \approx A_1 + A_2 + \cdots + A_n = \frac{b-a}{n} \left[ \frac{1}{2}(y_0 + y_1) + \frac{1}{2}(y_1 + y_2) + \cdots + \frac{1}{2}(y_{n-1} + y_n) \right] \\ = \frac{b-a}{2n} [y_0 + 2y_1 + 2y_2 + \cdots + 2y_{n-1} + y_n]$$

42. right endpoint, trapezoidal, midpoint, left endpoint

43. (a) The maximum value of  $|f''(x)|$  is approximately 3.844880.

(b)  $n = 18$

(c) 0.904741

44. (a) The maximum value of  $|f''(x)|$  is approximately 1.467890.

(b)  $n = 12$

(c) 1.112062

45. (a) The maximum value of  $|f^{(4)}(x)|$  is approximately 42.551816.  
 (b)  $n = 8$   
 (c) 0.904524
46. (a) The maximum value of  $|f^{(4)}(x)|$  is approximately 7.022710.  
 (b)  $n = 8$   
 (c) 1.111443

## EXERCISE SET 9.8

1. (a) improper; infinite discontinuity at  $x = 3$   
 (b) continuous integrand, not improper  
 (c) improper; infinite discontinuity at  $x = 0$   
 (d) improper; infinite interval of integration  
 (e) improper; infinite interval of integration and infinite discontinuity at  $x = 1$   
 (f) continuous integrand, not improper
2. (a) improper if  $p > 0$  (b) improper if  $1 < p < 2$   
 (c) integrand is continuous for all  $p$ , not improper
3.  $\lim_{\ell \rightarrow +\infty} \int_0^{\ell} (-e^{-x}) dx = \lim_{\ell \rightarrow +\infty} (-e^{-\ell} + 1) = 1$
4.  $\lim_{\ell \rightarrow +\infty} \int_{-1}^{\ell} \frac{1}{2} \ln(1+x^2) dx = \lim_{\ell \rightarrow +\infty} \frac{1}{2} [\ln(1+\ell^2) - \ln 2] = +\infty$ , divergent
5.  $\lim_{\ell \rightarrow +\infty} \ln \frac{x-1}{x+1} \Big|_4^{\ell} = \lim_{\ell \rightarrow +\infty} \left( \ln \frac{\ell-1}{\ell+1} - \ln \frac{3}{5} \right) = -\ln \frac{3}{5} = \ln \frac{5}{3}$
6.  $\lim_{\ell \rightarrow +\infty} \int_0^{\ell} -\frac{1}{2} e^{-x^2} dx = \lim_{\ell \rightarrow +\infty} \frac{1}{2} (-e^{-\ell^2} + 1) = 1/2$
7.  $\lim_{\ell \rightarrow +\infty} \int_e^{\ell} -\frac{1}{2 \ln^2 x} dx = \lim_{\ell \rightarrow +\infty} \left[ -\frac{1}{2 \ln^2 \ell} + \frac{1}{2} \right] = \frac{1}{2}$
8.  $\lim_{\ell \rightarrow +\infty} \int_2^{\ell} 2\sqrt{\ln x} dx = \lim_{\ell \rightarrow +\infty} (2\sqrt{\ln \ell} - 2\sqrt{\ln 2}) = +\infty$ , divergent
9.  $\lim_{\ell \rightarrow -\infty} \int_{\ell}^0 -\frac{1}{4(2x-1)^2} dx = \lim_{\ell \rightarrow -\infty} \frac{1}{4} [-1 + 1/(2\ell-1)^2] = -1/4$
10.  $\lim_{\ell \rightarrow -\infty} \int_{\ell}^2 \frac{1}{2} \tan^{-1} \frac{x}{2} dx = \lim_{\ell \rightarrow -\infty} \frac{1}{2} \left[ \frac{\pi}{4} - \tan^{-1} \frac{\ell}{2} \right] = \frac{1}{2} [\pi/4 - (-\pi/2)] = 3\pi/8$
11.  $\lim_{\ell \rightarrow -\infty} \int_{\ell}^0 \frac{1}{3} e^{3x} dx = \lim_{\ell \rightarrow -\infty} \left[ \frac{1}{3} - \frac{1}{3} e^{3\ell} \right] = \frac{1}{3}$
12.  $\lim_{\ell \rightarrow -\infty} \int_{\ell}^0 -\frac{1}{2} \ln(3-2e^x) dx = \lim_{\ell \rightarrow -\infty} \frac{1}{2} \ln(3-2e^{\ell}) = \frac{1}{2} \ln 3$

13.  $\int_{-\infty}^{+\infty} x^3 dx$  converges if  $\int_{-\infty}^0 x^3 dx$  and  $\int_0^{+\infty} x^3 dx$  both converge; it diverges if either (or both) diverge.  $\int_0^{+\infty} x^3 dx = \lim_{\ell \rightarrow +\infty} \left. \frac{1}{4} x^4 \right|_0^\ell = \lim_{\ell \rightarrow +\infty} \frac{1}{4} \ell^4 = +\infty$  so  $\int_{-\infty}^{+\infty} x^3 dx$  is divergent.
14.  $\int_0^{+\infty} \frac{x}{\sqrt{x^2+2}} dx = \lim_{\ell \rightarrow +\infty} \left. \sqrt{x^2+2} \right|_0^\ell = \lim_{\ell \rightarrow +\infty} (\sqrt{\ell^2+2} - \sqrt{2}) = +\infty$   
so  $\int_{-\infty}^{+\infty} \frac{x}{\sqrt{x^2+2}} dx$  is divergent.
15.  $\int_0^{+\infty} \frac{x}{(x^2+3)^2} dx = \lim_{\ell \rightarrow +\infty} \left. -\frac{1}{2(x^2+3)} \right|_0^\ell = \lim_{\ell \rightarrow +\infty} \frac{1}{2} [-1/(\ell^2+3) + 1/3] = \frac{1}{6}$ ,  
similarly  $\int_{-\infty}^0 \frac{x}{(x^2+3)^2} dx = -1/6$  so  $\int_{-\infty}^{+\infty} \frac{x}{(x^2+3)^2} dx = 1/6 + (-1/6) = 0$
16.  $\int_0^{+\infty} \frac{e^{-t}}{1+e^{-2t}} dt = \lim_{\ell \rightarrow +\infty} \left. -\tan^{-1}(e^{-t}) \right|_0^\ell = \lim_{\ell \rightarrow +\infty} \left[ -\tan^{-1}(e^{-\ell}) + \frac{\pi}{4} \right] = \frac{\pi}{4}$ ,  
 $\int_{-\infty}^0 \frac{e^{-t}}{1+e^{-2t}} dt = \lim_{\ell \rightarrow -\infty} \left. -\tan^{-1}(e^{-t}) \right|_\ell^0 = \lim_{\ell \rightarrow -\infty} \left[ -\frac{\pi}{4} + \tan^{-1}(e^{-\ell}) \right] = \frac{\pi}{4}$ ,  
 $\int_{-\infty}^{+\infty} \frac{e^{-t}}{1+e^{-2t}} dt = \frac{\pi}{4} + \frac{\pi}{4} = \frac{\pi}{2}$
17.  $\lim_{\ell \rightarrow 3^+} \left. -\frac{1}{x-3} \right|_\ell^4 = \lim_{\ell \rightarrow 3^+} \left[ -1 + \frac{1}{\ell-3} \right] = +\infty$ , divergent
18.  $\lim_{\ell \rightarrow 0^+} \left. \frac{3}{2} x^{2/3} \right|_\ell^8 = \lim_{\ell \rightarrow 0^+} \frac{3}{2} (4 - \ell^{2/3}) = 6$
19.  $\lim_{\ell \rightarrow \pi/2^-} \left. -\ln(\cos x) \right|_0^\ell = \lim_{\ell \rightarrow \pi/2^-} -\ln(\cos \ell) = +\infty$ , divergent
20.  $\lim_{\ell \rightarrow 9^-} \left. -2\sqrt{9-x} \right|_0^\ell = \lim_{\ell \rightarrow 9^-} 2(-\sqrt{9-\ell} + 3) = 6$
21.  $\lim_{\ell \rightarrow 1^-} \left. \sin^{-1} x \right|_0^\ell = \lim_{\ell \rightarrow 1^-} \sin^{-1} \ell = \pi/2$
22.  $\lim_{\ell \rightarrow -3^+} \left. -\sqrt{9-x^2} \right|_\ell^1 = \lim_{\ell \rightarrow -3^+} (-\sqrt{8} + \sqrt{9-\ell^2}) = -\sqrt{8}$
23.  $\lim_{\ell \rightarrow \pi/6^-} \left. -\sqrt{1-2\sin x} \right|_0^\ell = \lim_{\ell \rightarrow \pi/6^-} (-\sqrt{1-2\sin \ell} + 1) = 1$
24.  $\lim_{\ell \rightarrow \pi/4^-} \left. -\ln(1-\tan x) \right|_0^\ell = \lim_{\ell \rightarrow \pi/4^-} -\ln(1-\tan \ell) = +\infty$ , divergent
25.  $\int_0^2 \frac{dx}{x-2} = \lim_{\ell \rightarrow 2^-} \left. \ln|x-2| \right|_0^\ell = \lim_{\ell \rightarrow 2^-} (\ln|\ell-2| - \ln 2) = -\infty$ , divergent

26.  $\int_0^2 \frac{dx}{x^2} = \lim_{\ell \rightarrow 0^+} \left. -1/x \right]_{\ell}^2 = \lim_{\ell \rightarrow 0^+} (-1/2 + 1/\ell) = +\infty$  so  $\int_{-2}^2 \frac{dx}{x^2}$  is divergent
27.  $\int_0^8 x^{-1/3} dx = \lim_{\ell \rightarrow 0^+} \left. \frac{3}{2} x^{2/3} \right]_{\ell}^8 = \lim_{\ell \rightarrow 0^+} \frac{3}{2} (4 - \ell^{2/3}) = 6,$   
 $\int_{-1}^0 x^{-1/3} dx = \lim_{\ell \rightarrow 0^-} \left. \frac{3}{2} x^{2/3} \right]_{-1}^{\ell} = \lim_{\ell \rightarrow 0^-} \frac{3}{2} (\ell^{2/3} - 1) = -3/2$   
 so  $\int_{-1}^8 x^{-1/3} dx = 6 + (-3/2) = 9/2$
28.  $\int_0^2 \frac{dx}{(x-2)^{2/3}} = \lim_{\ell \rightarrow 2^-} \left. 3(x-2)^{1/3} \right]_0^{\ell} = \lim_{\ell \rightarrow 2^-} 3[(\ell-2)^{1/3} - (-2)^{1/3}] = 3\sqrt[3]{2},$   
 similarly  $\int_2^4 \frac{dx}{(x-2)^{2/3}} = \lim_{\ell \rightarrow 2^+} \left. 3(x-2)^{1/3} \right]_{\ell}^4 = 3\sqrt[3]{2}$  so  $\int_0^4 \frac{dx}{(x-2)^{2/3}} = 6\sqrt[3]{2}$
29. Define  $\int_0^{+\infty} \frac{1}{x^2} dx = \int_0^a \frac{1}{x^2} dx + \int_a^{+\infty} \frac{1}{x^2} dx$  where  $a > 0$ ; take  $a = 1$  for convenience,  
 $\int_0^1 \frac{1}{x^2} dx = \lim_{\ell \rightarrow 0^+} \left. (-1/x) \right]_{\ell}^1 = \lim_{\ell \rightarrow 0^+} (1/\ell - 1) = +\infty$  so  $\int_0^{+\infty} \frac{1}{x^2} dx$  is divergent.
30. Define  $\int_1^{+\infty} \frac{dx}{x\sqrt{x^2-1}} = \int_1^a \frac{dx}{x\sqrt{x^2-1}} + \int_a^{+\infty} \frac{dx}{x\sqrt{x^2-1}}$  where  $a > 1$ ,  
 take  $a = 2$  for convenience to get  
 $\int_1^2 \frac{dx}{x\sqrt{x^2-1}} = \lim_{\ell \rightarrow 1^+} \left. \sec^{-1} x \right]_{\ell}^2 = \lim_{\ell \rightarrow 1^+} (\pi/3 - \sec^{-1} \ell) = \pi/3,$   
 $\int_2^{+\infty} \frac{dx}{x\sqrt{x^2-1}} = \lim_{\ell \rightarrow +\infty} \left. \sec^{-1} x \right]_2^{\ell} = \pi/2 - \pi/3$  so  $\int_1^{+\infty} \frac{dx}{x\sqrt{x^2-1}} = \pi/2.$
31.  $\int_0^{+\infty} \frac{e^{-\sqrt{x}}}{\sqrt{x}} dx = 2 \int_0^{+\infty} e^{-u} du = 2 \lim_{\ell \rightarrow +\infty} \left. (-e^{-u}) \right]_0^{\ell} = 2 \lim_{\ell \rightarrow +\infty} (1 - e^{-\ell}) = 2$
32.  $\int_0^{+\infty} \frac{dx}{\sqrt{x}(x+4)} = 2 \int_0^{+\infty} \frac{du}{u^2+4} = 2 \lim_{\ell \rightarrow +\infty} \left. \frac{1}{2} \tan^{-1} \frac{u}{2} \right]_0^{\ell} = \lim_{\ell \rightarrow +\infty} \tan^{-1} \frac{\ell}{2} = \frac{\pi}{2}$
33.  $\int_0^{+\infty} \frac{e^{-x}}{\sqrt{1-e^{-2x}}} dx = \int_0^1 \frac{du}{\sqrt{u}} = \lim_{\ell \rightarrow 0^+} \left. 2\sqrt{u} \right]_{\ell}^1 = \lim_{\ell \rightarrow 0^+} 2(1 - \sqrt{\ell}) = 2$
34.  $\int_0^{+\infty} \frac{e^{-x}}{\sqrt{1-e^{-2x}}} dx = - \int_1^0 \frac{du}{\sqrt{1-u^2}} = \int_0^1 \frac{du}{\sqrt{1-u^2}} = \lim_{\ell \rightarrow 1} \left. \sin^{-1} u \right]_0^{\ell} = \lim_{\ell \rightarrow 1} \sin^{-1} \ell = \frac{\pi}{2}$
36.  $A = \int_0^{+\infty} x e^{-3x} dx = \lim_{\ell \rightarrow +\infty} \left. -\frac{1}{9} (3x+1)e^{-3x} \right]_0^{\ell} = 1/3$
37.  $\lim_{\ell \rightarrow +\infty} \int_0^{\ell} e^{-x} \cos x dx = \lim_{\ell \rightarrow +\infty} \left. \frac{1}{2} e^{-x} (\sin x - \cos x) \right]_0^{\ell} = 1/2$
39. (a) 2.726585                      (b) 2.804364                      (c) 0.219384                      (d) 0.504067

40.  $1 + \left(\frac{dy}{dx}\right)^2 = 1 + \frac{16x^2}{9 - 4x^2} = \frac{9 + 12x^2}{9 - 4x^2}$ ; the arc length is  $\int_0^{3/2} \sqrt{\frac{9 + 12x^2}{9 - 4x^2}} dx \approx 3.633168$

41.  $\int \ln x dx = x \ln x - x + C,$

$$\int_0^1 \ln x dx = \lim_{\ell \rightarrow 0^+} \int_{\ell}^1 \ln x dx = \lim_{\ell \rightarrow 0^+} (x \ln x - x) \Big|_{\ell}^1 = \lim_{\ell \rightarrow 0^+} (-1 - \ell \ln \ell + \ell),$$

but  $\lim_{\ell \rightarrow 0^+} \ell \ln \ell = \lim_{\ell \rightarrow 0^+} \frac{\ln \ell}{1/\ell} = \lim_{\ell \rightarrow 0^+} (-\ell) = 0$  so  $\int_0^1 \ln x dx = -1$

42.  $\int \frac{\ln x}{x^2} dx = -\frac{\ln x}{x} - \frac{1}{x} + C,$

$$\int_1^{+\infty} \frac{\ln x}{x^2} dx = \lim_{\ell \rightarrow +\infty} \int_1^{\ell} \frac{\ln x}{x^2} dx = \lim_{\ell \rightarrow +\infty} \left(-\frac{\ln x}{x} - \frac{1}{x}\right) \Big|_1^{\ell} = \lim_{\ell \rightarrow +\infty} \left(-\frac{\ln \ell}{\ell} - \frac{1}{\ell} + 1\right),$$

but  $\lim_{\ell \rightarrow +\infty} \frac{\ln \ell}{\ell} = \lim_{\ell \rightarrow +\infty} \frac{1}{\ell} = 0$  so  $\int_1^{+\infty} \frac{\ln x}{x^2} dx = 1$

43.  $\int xe^{-3x} dx = -\frac{1}{3}xe^{-3x} - \frac{1}{9}e^{-3x} + C,$

$$\begin{aligned} \int_0^{+\infty} xe^{-3x} dx &= \lim_{\ell \rightarrow +\infty} \int_0^{\ell} xe^{-3x} dx = \lim_{\ell \rightarrow +\infty} \left(-\frac{1}{3}xe^{-3x} - \frac{1}{9}e^{-3x}\right) \Big|_0^{\ell} \\ &= \lim_{\ell \rightarrow +\infty} \left(-\frac{1}{3}\ell e^{-3\ell} - \frac{1}{9}e^{-3\ell} + \frac{1}{9}\right) \end{aligned}$$

but  $\lim_{\ell \rightarrow +\infty} \ell e^{-3\ell} = \lim_{\ell \rightarrow +\infty} \frac{\ell}{e^{3\ell}} = \lim_{\ell \rightarrow +\infty} \frac{1}{3e^{3\ell}} = 0$  so  $\int_0^{+\infty} xe^{-3x} dx = 1/9$

44.  $A = \int_3^{+\infty} \frac{8}{x^2 - 4} dx = \lim_{\ell \rightarrow +\infty} 2 \ln \frac{x-2}{x+2} \Big|_3^{\ell} = \lim_{\ell \rightarrow +\infty} 2 \left[ \ln \frac{\ell-2}{\ell+2} - \ln \frac{1}{5} \right] = 2 \ln 5$

45. (a)  $V = \pi \int_0^{+\infty} e^{-2x} dx = -\frac{\pi}{2} \lim_{\ell \rightarrow +\infty} e^{-2x} \Big|_0^{\ell} = \pi/2$

(b)  $S = 2\pi \int_0^{+\infty} e^{-x} \sqrt{1 + e^{-2x}} dx$ , let  $u = e^{-x}$  to get

$$S = -2\pi \int_1^0 \sqrt{1 + u^2} du = 2\pi \left[ \frac{u}{2} \sqrt{1 + u^2} + \frac{1}{2} \ln |u + \sqrt{1 + u^2}| \right]_0^1 = \pi \left[ \sqrt{2} + \ln(1 + \sqrt{2}) \right]$$

47. (a) For  $x \geq 1, x^2 \geq x, e^{-x^2} \leq e^{-x}$

(b)  $\int_1^{+\infty} e^{-x} dx = \lim_{\ell \rightarrow +\infty} \int_1^{\ell} e^{-x} dx = \lim_{\ell \rightarrow +\infty} -e^{-x} \Big|_1^{\ell} = \lim_{\ell \rightarrow +\infty} (e^{-1} - e^{-\ell}) = 1/e$

(c) By parts (a) and (b) and Exercise 46(b),  $\int_1^{+\infty} e^{-x^2} dx$  is convergent and is  $\leq 1/e$ .

48. (a) If  $x \geq 0$  then  $e^x \geq 1, \frac{1}{2x+1} \leq \frac{e^x}{2x+1}$

(b)  $\lim_{\ell \rightarrow +\infty} \int_0^{\ell} \frac{dx}{2x+1} = \lim_{\ell \rightarrow +\infty} \frac{1}{2} \ln(2x+1) \Big|_0^{\ell} = +\infty$

(c) By parts (a) and (b) and Exercise 46(a),  $\int_0^{+\infty} \frac{e^x}{2x+1} dx$  is divergent.

$$49. V = \lim_{\ell \rightarrow +\infty} \int_1^\ell (\pi/x^2) dx = \lim_{\ell \rightarrow +\infty} -(\pi/x) \Big|_1^\ell = \lim_{\ell \rightarrow +\infty} (\pi - \pi/\ell) = \pi$$

$$A = \lim_{\ell \rightarrow +\infty} \int_1^\ell 2\pi(1/x)\sqrt{1+1/x^4} dx; \text{ use Exercise 46(a) with } f(x) = 2\pi/x, g(x) = (2\pi/x)\sqrt{1+1/x^4}$$

and  $a = 1$  to see that the area is infinite.

$$50. \text{ (a) } 1 \leq \frac{\sqrt{x^3+1}}{x} \text{ for } x \geq 2, \int_2^{+\infty} 1 dx = +\infty$$

$$\text{(b) } \int_2^{+\infty} \frac{x}{x^5+1} dx \leq \int_2^{+\infty} \frac{dx}{x^4} = \lim_{\ell \rightarrow +\infty} -\frac{1}{3x^3} \Big|_2^\ell = 1/24$$

$$\text{(c) } \frac{1}{2x+1} \leq \frac{e^x}{2x+1} \text{ for } x \geq 0, \int_0^{+\infty} \frac{1}{2x+1} dx = \lim_{\ell \rightarrow +\infty} \frac{1}{2} \ln(2x+1) \Big|_0^\ell = +\infty$$

$$51. \int_0^{2x} \sqrt{1+t^3} dt \geq \int_0^{2x} t^{3/2} dt = \frac{2}{5} t^{5/2} \Big|_0^{2x} = \frac{2}{5} (2x)^{5/2},$$

$$\lim_{x \rightarrow +\infty} \int_0^{2x} t^{3/2} dt = \lim_{x \rightarrow +\infty} \frac{2}{5} (2x)^{5/2} = +\infty \text{ so } \int_0^{+\infty} \sqrt{1+t^3} dt = +\infty; \text{ by L'Hôpital's Rule}$$

$$\lim_{x \rightarrow +\infty} \frac{\int_0^{2x} \sqrt{1+t^3} dt}{x^{5/2}} = \lim_{x \rightarrow +\infty} \frac{2\sqrt{1+(2x)^3}}{(5/2)x^{3/2}} = \lim_{x \rightarrow +\infty} \frac{2\sqrt{1/x^3+8}}{5/2} = 8\sqrt{2}/5$$

$$52. \text{ (b) } u = \sqrt{x}, \int_0^{+\infty} \frac{\cos \sqrt{x}}{\sqrt{x}} dx = 2 \int_0^{+\infty} \cos u du; \int_0^{+\infty} \cos u du \text{ diverges by part (a).}$$

$$53. \text{ Let } x = r \tan \theta \text{ to get } \int \frac{dx}{(r^2+x^2)^{3/2}} = \frac{1}{r^2} \int \cos \theta d\theta = \frac{1}{r^2} \sin \theta + C = \frac{x}{r^2 \sqrt{r^2+x^2}} + C$$

$$\text{so } u = \frac{2\pi N I r}{k} \lim_{\ell \rightarrow +\infty} \frac{x}{r^2 \sqrt{r^2+x^2}} \Big|_a^\ell = \frac{2\pi N I}{k r} \lim_{\ell \rightarrow +\infty} (\ell / \sqrt{r^2+\ell^2} - a / \sqrt{r^2+a^2})$$

$$= \frac{2\pi N I}{k r} (1 - a / \sqrt{r^2+a^2}).$$

$$54. \text{ Let } a^2 = \frac{M}{2RT} \text{ to get}$$

$$\text{(a) } \bar{v} = \frac{4}{\sqrt{\pi}} \left( \frac{M}{2RT} \right)^{3/2} \frac{1}{2} \left( \frac{M}{2RT} \right)^{-2} = \frac{2}{\sqrt{\pi}} \sqrt{\frac{2RT}{M}} = \sqrt{\frac{8RT}{\pi M}}$$

$$\text{(b) } v_{\text{rms}}^2 = \frac{4}{\sqrt{\pi}} \left( \frac{M}{2RT} \right)^{3/2} \frac{3\sqrt{\pi}}{8} \left( \frac{M}{2RT} \right)^{-5/2} = \frac{3RT}{M} \text{ so } v_{\text{rms}} = \sqrt{\frac{3RT}{M}}$$

$$55. \text{ (a) Satellite's weight} = w(x) = k/x^2 \text{ lb when } x = \text{distance from center of Earth; } w(4000) = 6000$$

$$\text{so } k = 9.6 \times 10^{10} \text{ and } W = \int_{4000}^{4000+\ell} 9.6 \times 10^{10} x^{-2} dx \text{ mi}\cdot\text{lb.}$$

$$\text{(b) } \int_{4000}^{+\infty} 9.6 \times 10^{10} x^{-2} dx = \lim_{\ell \rightarrow +\infty} -9.6 \times 10^{10} / x \Big|_{4000}^\ell = 2.4 \times 10^7 \text{ mi}\cdot\text{lb}$$

$$56. \text{ (a) } \mathcal{L}\{1\} = \int_0^{+\infty} e^{-st} dt = \lim_{\ell \rightarrow +\infty} -\frac{1}{s} e^{-st} \Big|_0^\ell = \frac{1}{s}$$

$$\text{(b) } \mathcal{L}\{e^{2t}\} = \int_0^{+\infty} e^{-st} e^{2t} dt = \int_0^{+\infty} e^{-(s-2)t} dt = \lim_{\ell \rightarrow +\infty} -\frac{1}{s-2} e^{-(s-2)t} \Big|_0^\ell = \frac{1}{s-2}$$

$$(c) \quad \mathcal{L}\{\sin t\} = \int_0^{+\infty} e^{-st} \sin t \, dt = \lim_{\ell \rightarrow +\infty} \left. \frac{e^{-st}}{s^2 + 1} (-s \sin t - \cos t) \right]_0^\ell = \frac{1}{s^2 + 1}$$

$$(d) \quad \mathcal{L}\{\cos t\} = \int_0^{+\infty} e^{-st} \cos t \, dt = \lim_{\ell \rightarrow +\infty} \left. \frac{e^{-st}}{s^2 + 1} (-s \cos t + \sin t) \right]_0^\ell = \frac{s}{s^2 + 1}$$

$$57. (a) \quad \mathcal{L}\{f(t)\} = \int_0^{+\infty} t e^{-st} \, dt = \lim_{\ell \rightarrow +\infty} \left. -(t/s + 1/s^2) e^{-st} \right]_0^\ell = \frac{1}{s^2}$$

$$(b) \quad \mathcal{L}\{f(t)\} = \int_0^{+\infty} t^2 e^{-st} \, dt = \lim_{\ell \rightarrow +\infty} \left. -(t^2/s + 2t/s^2 + 2/s^3) e^{-st} \right]_0^\ell = \frac{2}{s^3}$$

$$(c) \quad \mathcal{L}\{f(t)\} = \int_3^{+\infty} e^{-st} \, dt = \lim_{\ell \rightarrow +\infty} \left. -\frac{1}{s} e^{-st} \right]_3^\ell = \frac{e^{-3s}}{s}$$

58.

10	100	1000	10,000
0.8862269	0.8862269	0.8862269	0.8862269

$$59. (a) \quad u = \sqrt{a}x, \, du = \sqrt{a} \, dx, \, 2 \int_0^{+\infty} e^{-ax^2} \, dx = \frac{2}{\sqrt{a}} \int_0^{+\infty} e^{-u^2} \, du = \sqrt{\pi/a}$$

$$(b) \quad x = \sqrt{2}\sigma u, \, dx = \sqrt{2}\sigma \, du, \, \frac{2}{\sqrt{2\pi}\sigma} \int_0^{+\infty} e^{-x^2/2\sigma^2} \, dx = \frac{2}{\sqrt{\pi}} \int_0^{+\infty} e^{-u^2} \, du = 1$$

$$60. (a) \quad \int_0^3 e^{-x^2} \, dx \approx 0.8862; \quad \sqrt{\pi}/2 \approx 0.8862$$

$$(b) \quad \int_0^{+\infty} e^{-x^2} \, dx = \int_0^3 e^{-x^2} \, dx + \int_3^{+\infty} e^{-x^2} \, dx \text{ so } E = \int_3^{+\infty} e^{-x^2} \, dx < \int_3^{+\infty} x e^{-x^2} \, dx = \frac{1}{2} e^{-9} < 7 \times 10^{-5}$$

$$61. (a) \quad \int_0^4 \frac{1}{x^6 + 1} \, dx \approx 1.047; \quad \pi/3 \approx 1.047$$

$$(b) \quad \int_0^{+\infty} \frac{1}{x^6 + 1} \, dx = \int_0^4 \frac{1}{x^6 + 1} \, dx + \int_4^{+\infty} \frac{1}{x^6 + 1} \, dx \text{ so}$$

$$E = \int_4^{+\infty} \frac{1}{x^6 + 1} \, dx < \int_4^{+\infty} \frac{1}{x^6} \, dx = \frac{1}{5(4)^5} < 2 \times 10^{-4}$$

$$62. \text{ If } p = 0, \text{ then } \int_0^{+\infty} (1) \, dx = \lim_{\ell \rightarrow +\infty} \left. x \right]_0^\ell = +\infty,$$

$$\text{if } p \neq 0, \text{ then } \int_0^{+\infty} e^{px} \, dx = \lim_{\ell \rightarrow +\infty} \left. \frac{1}{p} e^{px} \right]_0^\ell = \lim_{\ell \rightarrow +\infty} \frac{1}{p} (e^{p\ell} - 1) = \begin{cases} -1/p, & p < 0 \\ +\infty, & p > 0 \end{cases}.$$

$$63. \text{ If } p = 1, \text{ then } \int_0^1 \frac{dx}{x} = \lim_{\ell \rightarrow 0^+} \left. \ln x \right]_\ell^1 = +\infty;$$

$$\text{if } p \neq 1, \text{ then } \int_0^1 \frac{dx}{x^p} = \lim_{\ell \rightarrow 0^+} \left. \frac{x^{1-p}}{1-p} \right]_\ell^1 = \lim_{\ell \rightarrow 0^+} [(1 - \ell^{1-p})/(1-p)] = \begin{cases} 1/(1-p), & p < 1 \\ +\infty, & p > 1 \end{cases}.$$

$$64. \quad u = \sqrt{1-x}, \, u^2 = 1-x, \, 2u \, du = -dx;$$

$$-2 \int_1^0 \sqrt{2-u^2} \, du = 2 \int_0^1 \sqrt{2-u^2} \, du = \left[ u\sqrt{2-u^2} + 2 \sin^{-1}(u/\sqrt{2}) \right]_0^1 = \sqrt{2} + \pi/2$$

$$65. \quad 2 \int_0^1 \cos(u^2) \, du \approx 1.809$$

$$66. \quad -2 \int_1^0 \sin(1-u^2) \, du = 2 \int_0^1 \sin(1-u^2) \, du \approx 1.187$$



## CHAPTER 9 SUPPLEMENTARY EXERCISES

1. (a) integration by parts,  $u = x$ ,  $dv = \sin x dx$       (b)  $u$ -substitution:  $u = \sin x$   
 (c) reduction formula      (d)  $u$ -substitution:  $u = \tan x$   
 (e)  $u$ -substitution:  $u = x^3 + 1$       (f)  $u$ -substitution:  $u = x + 1$   
 (g) integration by parts:  $dv = dx$ ,  $u = \tan^{-1} x$       (h) trigonometric substitution:  $x = 2 \sin \theta$   
 (i)  $u$ -substitution:  $u = 4 - x^2$

2. (a)  $x = 3 \tan \theta$       (b)  $x = 3 \sin \theta$       (c)  $x = \frac{1}{3} \sin \theta$   
 (d)  $x = 3 \sec \theta$       (e)  $x = \sqrt{3} \tan \theta$       (f)  $x = \frac{1}{9} \tan \theta$
5. (a) #40      (b) #57      (c) #113  
 (d) #108      (e) #52      (f) #71

6. (a)  $u = x^2$ ,  $dv = \frac{x}{\sqrt{x^2 + 1}} dx$ ,  $du = 2x dx$ ,  $v = \sqrt{x^2 + 1}$ ;

$$\begin{aligned} \int_0^1 \frac{x^3}{\sqrt{x^2 + 1}} dx &= \left[ x^2 \sqrt{x^2 + 1} \right]_0^1 - 2 \int_0^1 x(x^2 + 1)^{1/2} dx \\ &= \sqrt{2} - \frac{2}{3} (x^2 + 1)^{3/2} \Big|_0^1 = \sqrt{2} - \frac{2}{3} [2\sqrt{2} - 1] = (2 - \sqrt{2})/3 \end{aligned}$$

- (b)  $u^2 = x^2 + 1$ ,  $x^2 = u^2 - 1$ ,  $2x dx = 2u du$ ,  $x dx = u du$ ;

$$\begin{aligned} \int_0^1 \frac{x^3}{\sqrt{x^2 + 1}} dx &= \int_0^1 \frac{x^2}{\sqrt{x^2 + 1}} x dx = \int_1^{\sqrt{2}} \frac{u^2 - 1}{u} u du \\ &= \int_1^{\sqrt{2}} (u^2 - 1) du = \left( \frac{1}{3} u^3 - u \right) \Big|_1^{\sqrt{2}} = (2 - \sqrt{2})/3 \end{aligned}$$

7. (a)  $u = 2x$ ,

$$\begin{aligned} \int \sin^4 2x dx &= \frac{1}{2} \int \sin^4 u du = \frac{1}{2} \left[ -\frac{1}{4} \sin^3 u \cos u + \frac{3}{4} \int \sin^2 u du \right] \\ &= -\frac{1}{8} \sin^3 u \cos u + \frac{3}{8} \left[ -\frac{1}{2} \sin u \cos u + \frac{1}{2} \int du \right] \\ &= -\frac{1}{8} \sin^3 u \cos u - \frac{3}{16} \sin u \cos u + \frac{3}{16} u + C \\ &= -\frac{1}{8} \sin^3 2x \cos 2x - \frac{3}{16} \sin 2x \cos 2x + \frac{3}{8} x + C \end{aligned}$$

- (b)  $u = x^2$ ,

$$\begin{aligned} \int x \cos^4(x^2) dx &= \frac{1}{2} \int \cos^4 u du = \frac{1}{2} \left[ \frac{1}{4} \cos^3 u \sin u + \frac{3}{4} \int \cos^2 u du \right] \\ &= \frac{1}{8} \cos^3 u \sin u + \frac{3}{8} \left[ \frac{1}{2} \cos u \sin u + \frac{1}{2} \int du \right] \\ &= \frac{1}{8} \cos^3 u \sin u + \frac{3}{16} \cos u \sin u + \frac{3}{16} u + C \\ &= \frac{1}{8} \cos^3(x^2) \sin(x^2) + \frac{3}{16} \cos(x^2) \sin(x^2) + \frac{3}{16} x^2 + C \end{aligned}$$

8. (a) With  $x = \sec \theta$ :

$$\int \frac{1}{x^3 - x} dx = \int \cot \theta d\theta = \ln |\sin \theta| + C = \ln \frac{\sqrt{x^2 - 1}}{|x|} + C; \text{ valid for } |x| > 1.$$

(b) With  $x = \sin \theta$ :

$$\begin{aligned} \int \frac{1}{x^3 - x} dx &= - \int \frac{1}{\sin \theta \cos \theta} d\theta = - \int 2 \csc 2\theta d\theta \\ &= - \ln |\csc 2\theta - \cot 2\theta| + C = \ln |\cot \theta| + C = \ln \frac{\sqrt{1-x^2}}{|x|} + C, \quad 0 < |x| < 1. \end{aligned}$$

(c) By partial fractions:

$$\begin{aligned} \int \left( -\frac{1}{x} + \frac{1/2}{x+1} + \frac{1/2}{x-1} \right) dx &= -\ln |x| + \frac{1}{2} \ln |x+1| + \frac{1}{2} \ln |x-1| + C \\ &= \ln \frac{\sqrt{|x^2-1|}}{|x|} + C; \text{ valid for all } x \text{ except } x = 0, \pm 1. \end{aligned}$$

9. (a) With  $u = \sqrt{x}$ :

$$\int \frac{1}{\sqrt{x} \sqrt{2-x}} dx = 2 \int \frac{1}{\sqrt{2-u^2}} du = 2 \sin^{-1}(u/\sqrt{2}) + C = 2 \sin^{-1}(\sqrt{x/2}) + C;$$

with  $u = \sqrt{2-x}$ :

$$\int \frac{1}{\sqrt{x} \sqrt{2-x}} dx = -2 \int \frac{1}{\sqrt{2-u^2}} du = -2 \sin^{-1}(u/\sqrt{2}) + C = -2 \sin^{-1}(\sqrt{2-x}/\sqrt{2}) + C;$$

completing the square:

$$\int \frac{1}{\sqrt{1-(x-1)^2}} dx = \sin^{-1}(x-1) + C.$$

(b) In the three results in part (a) the antiderivatives differ by a constant, in particular

$$2 \sin^{-1}(\sqrt{x/2}) = \pi - 2 \sin^{-1}(\sqrt{2-x}/\sqrt{2}) = \pi/2 + \sin^{-1}(x-1).$$

10.  $A = \int_1^2 \frac{3-x}{x^3+x^2} dx, \frac{3-x}{x^2(x+1)} = \frac{A}{x} + \frac{B}{x^2} + \frac{C}{x+1}; A = -4, B = 3, C = 4$

$$\begin{aligned} A &= \left[ -4 \ln |x| - \frac{3}{x} + 4 \ln |x+1| \right]_1^2 \\ &= (-4 \ln 2 - \frac{3}{2} + 4 \ln 3) - (-4 \ln 1 - 3 + 4 \ln 2) = \frac{3}{2} - 8 \ln 2 + 4 \ln 3 = \frac{3}{2} + 4 \ln \frac{3}{4} \end{aligned}$$

11. Solve  $y = 1/(1+x^2)$  for  $x$  getting

$$x = \sqrt{\frac{1-y}{y}} \text{ and integrate with respect to}$$

$$\text{to } y \text{ to get } A = \int_0^1 \sqrt{\frac{1-y}{y}} dy \text{ (see figure)}$$

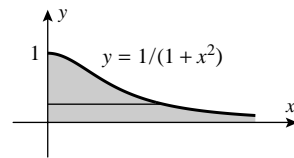

12.  $A = \int_e^{+\infty} \frac{\ln x - 1}{x^2} dx = \lim_{\ell \rightarrow +\infty} \left[ -\frac{\ln x}{x} \right]_e^\ell = 1/e$

13.  $V = 2\pi \int_0^{+\infty} x e^{-x} dx = 2\pi \lim_{\ell \rightarrow +\infty} \left[ -e^{-x}(x+1) \right]_0^\ell = 2\pi \lim_{\ell \rightarrow +\infty} [1 - e^{-\ell}(\ell+1)]$

but  $\lim_{\ell \rightarrow +\infty} e^{-\ell}(\ell+1) = \lim_{\ell \rightarrow +\infty} \frac{\ell+1}{e^\ell} = \lim_{\ell \rightarrow +\infty} \frac{1}{e^\ell} = 0$  so  $V = 2\pi$

14.  $\int_0^{+\infty} \frac{dx}{x^2+a^2} = \lim_{\ell \rightarrow +\infty} \left[ \frac{1}{a} \tan^{-1}(x/a) \right]_0^\ell = \lim_{\ell \rightarrow +\infty} \frac{1}{a} \tan^{-1}(\ell/a) = \frac{\pi}{2a} = 1, a = \pi/2$

$$15. \quad u = \cos \theta, \quad - \int u^{1/2} du = -\frac{2}{3} \cos^{3/2} \theta + C$$

$$16. \quad \text{Use Endpaper Formula (31) to get } \int \tan^7 \theta d\theta = \frac{1}{6} \tan^6 \theta - \frac{1}{4} \tan^4 \theta + \frac{1}{2} \tan^2 \theta + \ln |\cos \theta| + C.$$

$$17. \quad u = \tan(x^2), \quad \frac{1}{2} \int u^2 du = \frac{1}{6} \tan^3(x^2) + C$$

$$18. \quad x = (1/\sqrt{2}) \sin \theta, \quad dx = (1/\sqrt{2}) \cos \theta d\theta,$$

$$\begin{aligned} \frac{1}{\sqrt{2}} \int_{-\pi/2}^{\pi/2} \cos^4 \theta d\theta &= \frac{1}{\sqrt{2}} \left\{ \frac{1}{4} \cos^3 \theta \sin \theta \right\}_{-\pi/2}^{\pi/2} + \frac{3}{4} \int_{-\pi/2}^{\pi/2} \cos^2 \theta d\theta \Big\} \\ &= \frac{3}{4\sqrt{2}} \left\{ \frac{1}{2} \cos \theta \sin \theta \right\}_{-\pi/2}^{\pi/2} + \frac{1}{2} \int_{-\pi/2}^{\pi/2} d\theta \Big\} = \frac{3}{4\sqrt{2}} \frac{1}{2} \pi = \frac{3\pi}{8\sqrt{2}} \end{aligned}$$

$$19. \quad x = \sqrt{3} \tan \theta, \quad dx = \sqrt{3} \sec^2 \theta d\theta,$$

$$\frac{1}{3} \int \frac{1}{\sec \theta} d\theta = \frac{1}{3} \int \cos \theta d\theta = \frac{1}{3} \sin \theta + C = \frac{x}{3\sqrt{3+x^2}} + C$$

$$20. \quad \int \frac{\cos \theta}{(\sin \theta - 3)^2 + 3} d\theta, \quad \text{let } u = \sin \theta - 3, \quad \int \frac{1}{u^2 + 3} du = \frac{1}{\sqrt{3}} \tan^{-1}[(\sin \theta - 3)/\sqrt{3}] + C$$

$$21. \quad \int \frac{x+3}{\sqrt{(x+1)^2+1}} dx, \quad \text{let } u = x+1,$$

$$\begin{aligned} \int \frac{u+2}{\sqrt{u^2+1}} du &= \int \left[ u(u^2+1)^{-1/2} + \frac{2}{\sqrt{u^2+1}} \right] du = \sqrt{u^2+1} + 2 \sinh^{-1} u + C \\ &= \sqrt{x^2+2x+2} + 2 \sinh^{-1}(x+1) + C \end{aligned}$$

Alternate solution: let  $x+1 = \tan \theta$ ,

$$\begin{aligned} \int (\tan \theta + 2) \sec \theta d\theta &= \int \sec \theta \tan \theta d\theta + 2 \int \sec \theta d\theta = \sec \theta + 2 \ln |\sec \theta + \tan \theta| + C \\ &= \sqrt{x^2+2x+2} + 2 \ln(\sqrt{x^2+2x+2} + x + 1) + C. \end{aligned}$$

$$22. \quad \text{Let } x = \tan \theta \text{ to get } \int \frac{1}{x^3 - x^2} dx.$$

$$\frac{1}{x^2(x-1)} = \frac{A}{x} + \frac{B}{x^2} + \frac{C}{x-1}; \quad A = -1, \quad B = -1, \quad C = 1 \text{ so}$$

$$\begin{aligned} - \int \frac{1}{x} dx - \int \frac{1}{x^2} dx + \int \frac{1}{x-1} dx &= -\ln|x| + \frac{1}{x} + \ln|x-1| + C \\ &= \frac{1}{x} + \ln \left| \frac{x-1}{x} \right| + C = \cot \theta + \ln \left| \frac{\tan \theta - 1}{\tan \theta} \right| + C = \cot \theta + \ln |1 - \cot \theta| + C \end{aligned}$$

$$23. \quad \frac{1}{(x-1)(x+2)(x-3)} = \frac{A}{x-1} + \frac{B}{x+2} + \frac{C}{x-3}; \quad A = -\frac{1}{6}, \quad B = \frac{1}{15}, \quad C = \frac{1}{10} \text{ so}$$

$$\begin{aligned} -\frac{1}{6} \int \frac{1}{x-1} dx + \frac{1}{15} \int \frac{1}{x+2} dx + \frac{1}{10} \int \frac{1}{x-3} dx \\ = -\frac{1}{6} \ln|x-1| + \frac{1}{15} \ln|x+2| + \frac{1}{10} \ln|x-3| + C \end{aligned}$$

24.  $\frac{1}{x(x^2 + x + 1)} = \frac{A}{x} + \frac{Bx + C}{x^2 + x + 1}$ ;  $A = 1$ ,  $B = C = -1$  so

$$\int \frac{-x-1}{x^2+x+1} dx = -\int \frac{x+1}{(x+1/2)^2+3/4} dx = -\int \frac{u+1/2}{u^2+3/4} du, \quad u = x+1/2$$

$$= -\frac{1}{2} \ln(u^2+3/4) - \frac{1}{\sqrt{3}} \tan^{-1} 2u/\sqrt{3} + C_1$$

so  $\int \frac{dx}{x(x^2+x+1)} = \ln|x| - \frac{1}{2} \ln(x^2+x+1) - \frac{1}{\sqrt{3}} \tan^{-1} \frac{2x+1}{\sqrt{3}} + C$

25.  $u = \sqrt{x-4}$ ,  $x = u^2 + 4$ ,  $dx = 2u du$ ,

$$\int_0^2 \frac{2u^2}{u^2+4} du = 2 \int_0^2 \left[ 1 - \frac{4}{u^2+4} \right] du = \left[ 2u - 4 \tan^{-1}(u/2) \right]_0^2 = 4 - \pi$$

26.  $u = \sqrt{x}$ ,  $x = u^2$ ,  $dx = 2u du$ ,

$$2 \int_0^3 \frac{u^2}{u^2+9} du = 2 \int_0^3 \left( 1 - \frac{9}{u^2+9} \right) du = \left( 2u - 6 \tan^{-1} \frac{u}{3} \right) \Big|_0^3 = 6 - \frac{3}{2}\pi$$

27.  $u = \sqrt{e^x+1}$ ,  $e^x = u^2 - 1$ ,  $x = \ln(u^2 - 1)$ ,  $dx = \frac{2u}{u^2-1} du$ ,

$$\int \frac{2}{u^2-1} du = \int \left[ \frac{1}{u-1} - \frac{1}{u+1} \right] du = \ln|u-1| - \ln|u+1| + C = \ln \frac{\sqrt{e^x+1}-1}{\sqrt{e^x+1}+1} + C$$

28.  $u = \sqrt{e^x-1}$ ,  $e^x = u^2 + 1$ ,  $x = \ln(u^2 + 1)$ ,  $dx = \frac{2u}{u^2+1} du$ ,

$$\int_0^1 \frac{2u^2}{u^2+1} du = 2 \int_0^1 \left( 1 - \frac{1}{u^2+1} \right) du = \left( 2u - 2 \tan^{-1} u \right) \Big|_0^1 = 2 - \frac{\pi}{2}$$

29.  $\lim_{\ell \rightarrow +\infty} \left[ -\frac{1}{2(x^2+1)} \right]_a^\ell = \lim_{\ell \rightarrow +\infty} \left[ -\frac{1}{2(\ell^2+1)} + \frac{1}{2(a^2+1)} \right] = \frac{1}{2(a^2+1)}$

30.  $\lim_{\ell \rightarrow +\infty} \left[ \frac{1}{ab} \tan^{-1} \frac{bx}{a} \right]_0^\ell = \lim_{\ell \rightarrow +\infty} \frac{1}{ab} \tan^{-1} \frac{b\ell}{a} = \frac{\pi}{2ab}$

31. Let  $u = x^4$  to get  $\frac{1}{4} \int \frac{1}{\sqrt{1-u^2}} du = \frac{1}{4} \sin^{-1} u + C = \frac{1}{4} \sin^{-1}(x^4) + C$ .

32.  $\int (\cos^{32} x \sin^{30} x - \cos^{30} x \sin^{32} x) dx = \int \cos^{30} x \sin^{30} x (\cos^2 x - \sin^2 x) dx$

$$= \frac{1}{2^{30}} \int \sin^{30} 2x \cos 2x dx = \frac{\sin^{31} 2x}{31(2^{31})} + C$$

33.  $\int \sqrt{x - \sqrt{x^2 - 4}} dx = \frac{1}{\sqrt{2}} \int (\sqrt{x+2} - \sqrt{x-2}) dx = \frac{\sqrt{2}}{3} [(x+2)^{3/2} - (x-2)^{3/2}] + C$

34.  $\int \frac{1}{x^{10}(1+x^{-9})} dx = -\frac{1}{9} \int \frac{1}{u} du = -\frac{1}{9} \ln|u| + C = -\frac{1}{9} \ln|1+x^{-9}| + C$

35. (a)  $(x+4)(x-5)(x^2+1)^2; \frac{A}{x+4} + \frac{B}{x-5} + \frac{Cx+D}{x^2+1} + \frac{Ex+F}{(x^2+1)^2}$

(b)  $-\frac{3}{x+4} + \frac{2}{x-5} - \frac{x-2}{x^2+1} - \frac{3}{(x^2+1)^2}$

(c)  $-3 \ln|x+4| + 2 \ln|x-5| + 2 \tan^{-1}x - \frac{1}{2} \ln(x^2+1) - \frac{3}{2} \left( \frac{x}{x^2+1} + \tan^{-1}x \right)$

36. (a)  $\Gamma(1) = \int_0^{+\infty} e^{-t} dt = \lim_{\ell \rightarrow +\infty} -e^{-t} \Big|_0^\ell = \lim_{\ell \rightarrow +\infty} (-e^{-\ell} + 1) = 1$

(b)  $\Gamma(x+1) = \int_0^{+\infty} t^x e^{-t} dt$ ; let  $u = t^x$ ,  $dv = e^{-t} dt$  to get

$$\Gamma(x+1) = -t^x e^{-t} \Big|_0^{+\infty} + x \int_0^{+\infty} t^{x-1} e^{-t} dt = -t^x e^{-t} \Big|_0^{+\infty} + x\Gamma(x)$$

$$\lim_{t \rightarrow +\infty} t^x e^{-t} = \lim_{t \rightarrow +\infty} \frac{t^x}{e^t} = 0 \text{ (by multiple applications of L'Hôpital's rule)}$$

$$\text{so } \Gamma(x+1) = x\Gamma(x)$$

(c)  $\Gamma(2) = (1)\Gamma(1) = (1)(1) = 1$ ,  $\Gamma(3) = 2\Gamma(2) = (2)(1) = 2$ ,  $\Gamma(4) = 3\Gamma(3) = (3)(2) = 6$   
It appears that  $\Gamma(n) = (n-1)!$  if  $n$  is a positive integer.

(d)  $\Gamma\left(\frac{1}{2}\right) = \int_0^{+\infty} t^{-1/2} e^{-t} dt = 2 \int_0^{+\infty} e^{-u^2} du$  (with  $u = \sqrt{t}$ )  $= 2(\sqrt{\pi}/2) = \sqrt{\pi}$

(e)  $\Gamma\left(\frac{3}{2}\right) = \frac{1}{2}\Gamma\left(\frac{1}{2}\right) = \frac{1}{2}\sqrt{\pi}$ ,  $\Gamma\left(\frac{5}{2}\right) = \frac{3}{2}\Gamma\left(\frac{3}{2}\right) = \frac{3}{4}\sqrt{\pi}$

37. (a)  $t = -\ln x$ ,  $x = e^{-t}$ ,  $dx = -e^{-t} dt$ ,

$$\int_0^1 (\ln x)^n dx = - \int_{+\infty}^0 (-t)^n e^{-t} dt = (-1)^n \int_0^{+\infty} t^n e^{-t} dt = (-1)^n \Gamma(n+1)$$

(b)  $t = x^n$ ,  $x = t^{1/n}$ ,  $dx = (1/n)t^{1/n-1} dt$ ,

$$\int_0^{+\infty} e^{-x^n} dx = (1/n) \int_0^{+\infty} t^{1/n-1} e^{-t} dt = (1/n)\Gamma(1/n) = \Gamma(1/n+1)$$

38. (a)  $\sqrt{\cos \theta - \cos \theta_0} = \sqrt{2[\sin^2(\theta_0/2) - \sin^2(\theta/2)]} = \sqrt{2(k^2 - k^2 \sin^2 \phi)} = \sqrt{2k^2 \cos^2 \phi}$   
 $= \sqrt{2} k \cos \phi$ ;  $k \sin \phi = \sin(\theta/2)$  so  $k \cos \phi d\phi = \frac{1}{2} \cos(\theta/2) d\theta = \frac{1}{2} \sqrt{1 - \sin^2(\theta/2)} d\theta$   
 $= \frac{1}{2} \sqrt{1 - k^2 \sin^2 \phi} d\theta$ , thus  $d\theta = \frac{2k \cos \phi}{\sqrt{1 - k^2 \sin^2 \phi}} d\phi$  and hence

$$T = \sqrt{\frac{8L}{g}} \int_0^{\pi/2} \frac{1}{\sqrt{2k \cos \phi}} \cdot \frac{2k \cos \phi}{\sqrt{1 - k^2 \sin^2 \phi}} d\phi = 4\sqrt{\frac{L}{g}} \int_0^{\pi/2} \frac{1}{\sqrt{1 - k^2 \sin^2 \phi}} d\phi$$

(b) If  $L = 1.5$  ft and  $\theta_0 = (\pi/180)(20) = \pi/9$ , then

$$T = \frac{\sqrt{3}}{2} \int_0^{\pi/2} \frac{d\phi}{\sqrt{1 - \sin^2(\pi/18) \sin^2 \phi}} \approx 1.37 \text{ s.}$$

## CHAPTER 9 HORIZON MODULE

1. The depth of the cut equals the terrain elevation minus the track elevation. From Figure 2, the cross sectional area of a cut of depth  $D$  meters is  $10D + 2 \cdot \frac{1}{2}D^2 = D^2 + 10D$  square meters.

Distance from town A (m)	Terrain elevation (m)	Track elevation (m)	Depth of cut (m)	Cross-sectional area $f(x)$ of cut (m <sup>2</sup> )
0	100	100	0	0
2000	105	101	4	56
4000	108	102	6	96
6000	110	103	7	119
8000	104	104	0	0
10,000	106	105	1	11
12,000	120	106	14	336
14,000	122	107	15	375
16,000	124	108	16	416
18,000	128	109	19	551
20,000	130	110	20	600

The total volume of dirt to be excavated, in cubic meters, is  $\int_0^{2000} f(x) dx$ .

By Simpson's Rule, this is approximately

$$\frac{20,000 - 0}{3 \cdot 10} [0 + 4 \cdot 56 + 2 \cdot 96 + 4 \cdot 119 + 2 \cdot 0 + 4 \cdot 11 + 2 \cdot 336 + 4 \cdot 375 + 2 \cdot 416 + 4 \cdot 551 + 600] \\ = 4,496,000 \text{ m}^3.$$

Excavation costs \$4 per m<sup>3</sup>, so the total cost of the railroad from town A to  $M$  is about  $4 \cdot 4,496,000 = 17,984,000$  dollars.

2. (a)

Distance from town A (m)	Terrain elevation (m)	Track elevation (m)	Depth of cut (m)	Cross-sectional area $f(x)$ of cut (m <sup>2</sup> )
20,000	130	110	20	300
20,100	135	109.8	25.2	887.04
20,200	139	109.6	29.4	1158.36
20,300	142	109.4	32.6	1388.76
20,400	145	109.2	35.8	1639.64
20,500	147	109	38	1824
20,600	148	108.8	39.2	1928.64
20,700	146	108.6	37.4	1772.76
20,800	143	108.4	34.6	1543.16
20,900	139	108.2	30.8	1256.64
21,000	133	108	25	875

The total volume of dirt to be excavated, in cubic meters, is  $\int_{20,000}^{21,000} f(x) dx$ .

By Simpson's Rule this is approximately

$$\frac{21,000 - 20,000}{3 \cdot 10} [600 + 4 \cdot 887.04 + 2 \cdot 1158.36 + \dots + 4 \cdot 1256.64 + 875] = 1,417,713.33 \text{ m}^3.$$

The total cost of a trench from  $M$  to  $N$  is about  $4 \cdot 1,417,713.33 \approx 5,670,853$  dollars.

(b)

Distance from town A (m)	Terrain elevation (m)	Track elevation (m)	Depth of cut (m)	Cross-sectional area $f(x)$ of cut ( $\text{m}^2$ )
21,000	133	108	25	875
22,000	120	106	14	336
23,000	106	104	2	24
24,000	108	102	6	96
25,000	106	100	6	96
26,000	98	98	0	0
27,000	100	96	4	56
28,000	102	94	8	144
29,000	96	92	4	56
30,000	91	90	1	11
31,000	88	88	0	0

The total volume of dirt to be excavated, in cubic meters, is  $\int_{21,000}^{31,000} f(x) dx$ . By Simpson's Rule this is approximately

$$\frac{31,000 - 21,000}{3 \cdot 10} [875 + 4 \cdot 336 + 2 \cdot 24 + \dots + 4 \cdot 11 + 0] = 1,229,000 \text{ m}^3.$$

The total cost of the railroad from  $N$  to  $B$  is about  $4 \cdot 1,229,000 \approx 4,916,000$  dollars.

3. The total cost if trenches are used everywhere is about  $17,984,000 + 5,670,853 + 4,916,000 = 28,570,853$  dollars.
4. (a) The cross-sectional area of a tunnel is  $A_T = 80 + \frac{1}{2}\pi 5^2 \approx 119.27 \text{ m}^2$ . The length of the tunnel is 1000 m, so the volume of dirt to be removed is about  $1000A_T \approx 1,119,269.91 \text{ m}^3$ , and the drilling and dirt-piling costs are  $8 \cdot 1000A_T \approx 954,159$  dollars.
- (b) To extend the tunnel from a length of  $x$  meters to a length of  $x + dx$  meters, we must move a volume of  $A_T dx$  cubic meters of dirt a distance of about  $x$  meters. So the cost of this extension is about  $0.06 \times A_T dx$  dollars. The cost of moving all of the dirt in the tunnel is therefore
- $$\int_0^{1000} 0.06 \times A_T dx = 0.06A_T \left. \frac{x^2}{2} \right|_0^{1000} = 30,000A_T \approx 3,578,097 \text{ dollars.}$$
- (c) The total cost of the tunnel is about  $954,159 + 3,578,097 \approx 4,532,257$  dollars.
5. The total cost of the railroad, using a tunnel, is  $17,894,000 + 4,532,257 + 4,916,000 + 27,432,257$  dollars, which is smaller than the cost found in Exercise 3. It will be cheaper to build the railroad if a tunnel is used.

# CHAPTER 10

## Mathematical Modeling with Differential Equations

### EXERCISE SET 10.1

1.  $y' = 2x^2e^{x^3/3} = x^2y$  and  $y(0) = 2$  by inspection.
2.  $y' = x^3 - 2\sin x$ ,  $y(0) = 3$  by inspection.
3. (a) first order;  $\frac{dy}{dx} = c$ ;  $(1+x)\frac{dy}{dx} = (1+x)c = y$   
 (b) second order;  $y' = c_1 \cos t - c_2 \sin t$ ,  $y'' + y = -c_1 \sin t - c_2 \cos t + (c_1 \sin t + c_2 \cos t) = 0$
4. (a) first order;  $2\frac{dy}{dx} + y = 2\left(-\frac{c}{2}e^{-x/2} + 1\right) + ce^{-x/2} + x - 3 = x - 1$   
 (b) second order;  $y' = c_1e^t - c_2e^{-t}$ ,  $y'' - y = c_1e^t + c_2e^{-t} - (c_1e^t + c_2e^{-t}) = 0$
5.  $\frac{1}{y}\frac{dy}{dx} = x\frac{dy}{dx} + y$ ,  $\frac{dy}{dx}(1 - xy) = y^2$ ,  $\frac{dy}{dx} = \frac{y^2}{1 - xy}$
6.  $2x + y^2 + 2xy\frac{dy}{dx} = 0$ , by inspection.
7. (a) IF:  $\mu = e^{\int 3 dx} = e^{3x}$ ,  $\frac{d}{dx}[ye^{3x}] = 0$ ,  $ye^{3x} = C$ ,  $y = Ce^{-3x}$   
 separation of variables:  $\frac{dy}{y} = -3dx$ ,  $\ln|y| = -3x + C_1$ ,  $y = \pm e^{-3x}e^{C_1} = Ce^{-3x}$   
 (b) IF:  $\mu = e^{\int -2 dt} = e^{-2t}$ ,  $\frac{d}{dt}[ye^{-2t}] = 0$ ,  $ye^{-2t} = C$ ,  $y = Ce^{2t}$   
 separation of variables:  $\frac{dy}{y} = 2dt$ ,  $\ln|y| = 2t + C_1$ ,  $y = \pm e^{C_1}e^{2t} = Ce^{2t}$
8. (a) IF:  $\mu = e^{-4\int x dx} = e^{-2x^2}$ ,  $\frac{d}{dx}[ye^{-2x^2}] = 0$ ,  $y = Ce^{2x^2}$   
 separation of variables:  $\frac{dy}{y} = 4x dx$ ,  $\ln|y| = 2x^2 + C_1$ ,  $y = \pm e^{C_1}e^{2x^2} = Ce^{2x^2}$   
 (b) IF:  $\mu = e^{\int dt} = e^t$ ,  $\frac{d}{dt}[ye^t] = 0$ ,  $y = Ce^{-t}$   
 separation of variables:  $\frac{dy}{y} = -dt$ ,  $\ln|y| = -t + C_1$ ,  $y = \pm e^{C_1}e^{-t} = Ce^{-t}$
9.  $\frac{1}{y}dy = \frac{1}{x}dx$ ,  $\ln|y| = \ln|x| + C_1$ ,  $\ln\left|\frac{y}{x}\right| = C_1$ ,  $\frac{y}{x} = \pm e^{C_1} = C$ ,  $y = Cx$
10.  $\frac{dy}{1+y^2} = x^2 dx$ ,  $\tan^{-1} y = \frac{1}{3}x^3 + C$ ,  $y = \tan\left(\frac{1}{3}x^3 + C\right)$
11.  $\frac{dy}{1+y} = -\frac{x}{\sqrt{1+x^2}}dx$ ,  $\ln|1+y| = -\sqrt{1+x^2} + C_1$ ,  $1+y = \pm e^{-\sqrt{1+x^2}}e^{C_1} = Ce^{-\sqrt{1+x^2}}$ ,  
 $y = Ce^{-\sqrt{1+x^2}} - 1$



12.  $y dy = \frac{x^3 dx}{1+x^4}$ ,  $\frac{y^2}{2} = \frac{1}{4} \ln(1+x^4) + C_1$ ,  $2y^2 = \ln(1+x^4) + C$ ,  $y = \pm \sqrt{[\ln(1+x^4) + C]/2}$
13.  $\left(\frac{1}{y} + y\right) dy = e^x dx$ ,  $\ln|y| + y^2/2 = e^x + C$ ; by inspection,  $y = 0$
14.  $\frac{dy}{y} = -x dx$ ,  $\ln|y| = -x^2/2 + C_1$ ,  $y = \pm e^{C_1} e^{-x^2/2} = C e^{-x^2/2}$
15.  $e^y dy = \frac{\sin x}{\cos^2 x} dx = \sec x \tan x dx$ ,  $e^y = \sec x + C$ ,  $y = \ln(\sec x + C)$
16.  $\frac{dy}{1+y^2} = (1+x) dx$ ,  $\tan^{-1} y = x + \frac{x^2}{2} + C$ ,  $y = \tan(x + x^2/2 + C)$
17.  $\frac{dy}{y^2 - y} = \frac{dx}{\sin x}$ ,  $\int \left[-\frac{1}{y} + \frac{1}{y-1}\right] dy = \int \csc x dx$ ,  $\ln \left|\frac{y-1}{y}\right| = \ln|\csc x - \cot x| + C_1$ ,  
 $\frac{y-1}{y} = \pm e^{C_1} (\csc x - \cot x) = C(\csc x - \cot x)$ ,  $y = \frac{1}{1 - C(\csc x - \cot x)}$ ;  
 by inspection,  $y = 0$  is also a solution.
18.  $\frac{1}{\tan y} dy = \frac{3}{\sec x} dx$ ,  $\frac{\cos y}{\sin y} dy = 3 \cos x dx$ ,  $\ln|\sin y| = 3 \sin x + C_1$ ,  
 $\sin y = \pm e^{3 \sin x + C_1} = \pm e^{C_1} e^{3 \sin x} = C e^{3 \sin x}$
19.  $\mu = e^{\int 3 dx} = e^{3x}$ ,  $e^{3x} y = \int e^x dx = e^x + C$ ,  $y = e^{-2x} + C e^{-3x}$
20.  $\mu = e^{2 \int x dx} = e^{x^2}$ ,  $\frac{d}{dx} [y e^{x^2}] = x e^{x^2}$ ,  $y e^{x^2} = \frac{1}{2} e^{x^2} + C$ ,  $y = \frac{1}{2} + C e^{-x^2}$
21.  $\mu = e^{\int dx} = e^x$ ,  $e^x y = \int e^x \cos(e^x) dx = \sin(e^x) + C$ ,  $y = e^{-x} \sin(e^x) + C e^{-x}$
22.  $\frac{dy}{dx} + 2y = \frac{1}{2}$ ,  $\mu = e^{\int 2 dx} = e^{2x}$ ,  $e^{2x} y = \int \frac{1}{2} e^{2x} dx = \frac{1}{4} e^{2x} + C$ ,  $y = \frac{1}{4} + C e^{-2x}$
23.  $\frac{dy}{dx} + \frac{x}{x^2+1} y = 0$ ,  $\mu = e^{\int (x/(x^2+1)) dx} = e^{\frac{1}{2} \ln(x^2+1)} = \sqrt{x^2+1}$ ,  
 $\frac{d}{dx} [y \sqrt{x^2+1}] = 0$ ,  $y \sqrt{x^2+1} = C$ ,  $y = \frac{C}{\sqrt{x^2+1}}$
24.  $\frac{dy}{dx} + y = \frac{1}{1+e^x}$ ,  $\mu = e^{\int dx} = e^x$ ,  $e^x y = \int \frac{e^x}{1+e^x} dx = \ln(1+e^x) + C$ ,  $y = e^{-x} \ln(1+e^x) + C e^{-x}$
25.  $\frac{dy}{dx} + \frac{1}{x} y = 1$ ,  $\mu = e^{\int (1/x) dx} = e^{\ln x} = x$ ,  $\frac{d}{dx} [xy] = x$ ,  $xy = \frac{1}{2} x^2 + C$ ,  $y = x/2 + C/x$
- (a)  $2 = y(1) = \frac{1}{2} + C$ ,  $C = \frac{3}{2}$ ,  $y = x/2 + 3/(2x)$
- (b)  $2 = y(-1) = -1/2 - C$ ,  $C = -5/2$ ,  $y = x/2 - 5/(2x)$

26.  $\frac{dy}{y} = x dx$ ,  $\ln|y| = \frac{x^2}{2} + C_1$ ,  $y = \pm e^{C_1} e^{x^2/2} = C e^{x^2/2}$

(a)  $1 = y(0) = C$  so  $C = 1$ ,  $y = e^{x^2/2}$

(b)  $\frac{1}{2} = y(0) = C$ , so  $y = \frac{1}{2} e^{x^2/2}$

27.  $\mu = e^{-\int x dx} = e^{-x^2/2}$ ,  $e^{-x^2/2} y = \int x e^{-x^2/2} dx = -e^{-x^2/2} + C$ ,  
 $y = -1 + C e^{x^2/2}$ ,  $3 = -1 + C$ ,  $C = 4$ ,  $y = -1 + 4e^{x^2/2}$

28.  $\mu = e^{\int dt} = e^t$ ,  $e^t y = \int 2e^t dt = 2e^t + C$ ,  $y = 2 + C e^{-t}$ ,  $1 = 2 + C$ ,  $C = -1$ ,  $y = 2 - e^{-t}$

29.  $(y + \cos y) dy = 4x^2 dx$ ,  $\frac{y^2}{2} + \sin y = \frac{4}{3} x^3 + C$ ,  $\frac{\pi^2}{2} + \sin \pi = \frac{4}{3} (1)^3 + C$ ,  $\frac{\pi^2}{2} = \frac{4}{3} + C$ ,  
 $C = \frac{\pi^2}{2} - \frac{4}{3}$ ,  $3y^2 + 6 \sin y = 8x^3 + 3\pi^2 - 8$

30.  $\frac{dy}{dx} = (x+2)e^y$ ,  $e^{-y} dy = (x+2) dx$ ,  $-e^{-y} = \frac{1}{2} x^2 + 2x + C$ ,  $-1 = C$ ,  
 $-e^{-y} = \frac{1}{2} x^2 + 2x - 1$ ,  $e^{-y} = -\frac{1}{2} x^2 - 2x + 1$ ,  $y = -\ln \left( 1 - 2x - \frac{1}{2} x^2 \right)$

31.  $2(y-1) dy = (2t+1) dt$ ,  $y^2 - 2y = t^2 + t + C$ ,  $1 + 2 = C$ ,  $C = 3$ ,  $y^2 - 2y = t^2 + t + 3$

32.  $y' + \frac{\sinh x}{\cosh x} y = \cosh x$ ,  $\mu = e^{\int (\sinh x / \cosh x) dx} = e^{\ln \cosh x} = \cosh x$ ,  
 $(\cosh x) y = \int \cosh^2 x dx = \int \frac{1}{2} (\cosh 2x + 1) dx = \frac{1}{4} \sinh 2x + \frac{1}{2} x + C = \frac{1}{2} \sinh x \cosh x + \frac{1}{2} x + C$ ,  
 $y = \frac{1}{2} \sinh x + \frac{1}{2} x \operatorname{sech} x + C \operatorname{sech} x$ ,  $\frac{1}{4} = C$ ,  $y = \frac{1}{2} \sinh x + \frac{1}{2} x \operatorname{sech} x + \frac{1}{4} \operatorname{sech} x$

33. (a)  $\frac{dy}{y} = \frac{dx}{2x}$ ,  $\ln|y| = \frac{1}{2} \ln|x| + C_1$ ,  $|y| = C|x|^{1/2}$ ;  
 by inspection  $y = 0$  is also a solution.

(b)  $2 = C(1)^2$ ,  $C = 2$ ,  $x = 2y^2$

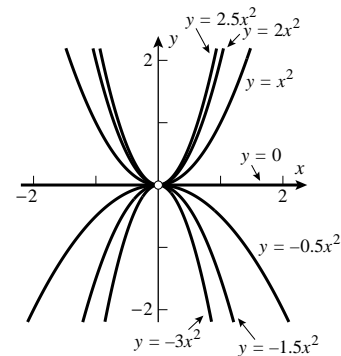

34. (a)  $y dy = -x dx$ ,  $\frac{y^2}{2} = -\frac{x^2}{2} + C_1$ ,  $y = \pm \sqrt{C^2 - x^2}$   
 (b)  $y = \sqrt{25 - x^2}$

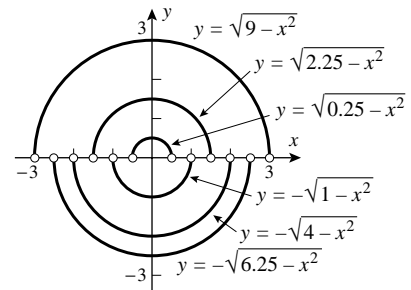

35.  $\frac{dy}{y} = -\frac{x dx}{x^2 + 4},$

$\ln |y| = -\frac{1}{2} \ln(x^2 + 4) + C_1,$

$y = \frac{C}{\sqrt{x^2 + 4}}$

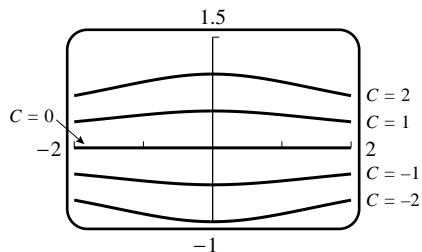

36.  $y' + 2y = 3e^t, \mu = e^{2 \int dt} = e^{2t},$

$\frac{d}{dt}[ye^{2t}] = 3e^{3t}, ye^{2t} = e^{3t} + C,$

$y = e^t + Ce^{-2t}$

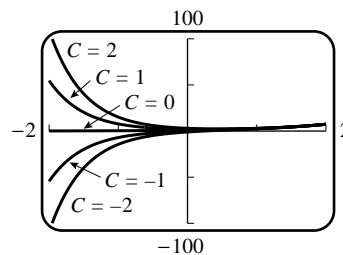

37.  $(1 - y^2) dy = x^2 dx,$

$y - \frac{y^3}{3} = \frac{x^3}{3} + C_1, x^3 + y^3 - 3y = C$

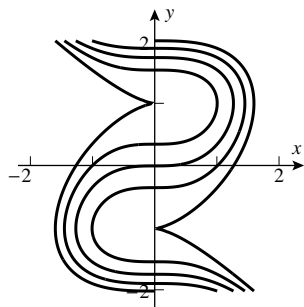

38.  $\left(\frac{1}{y} + y\right) dy = dx, \ln |y| + \frac{y^2}{2} = x + C_1,$

$ye^{y^2/2} = \pm e^{C_1} e^x = Ce^x$

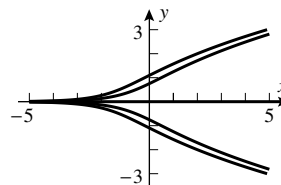

41.  $\frac{dy}{dx} = xe^y, e^{-y} dy = x dx, -e^{-y} = \frac{x^2}{2} + C, x = 2$  when  $y = 0$  so  $-1 = 2 + C, C = -3, x^2 + 2e^{-y} = 6$

42.  $\frac{dy}{dx} = \frac{3x^2}{2y}, 2y dy = 3x^2 dx, y^2 = x^3 + C, 1 = 1 + C, C = 0,$

$y^2 = x^3, y = x^{3/2}$  passes through  $(1, 1).$

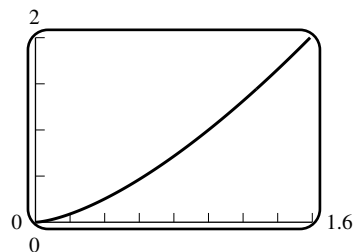

43.  $\frac{dy}{dt}$  = rate in - rate out, where  $y$  is the amount of salt at time  $t,$

$\frac{dy}{dt} = (4)(2) - \left(\frac{y}{50}\right)(2) = 8 - \frac{1}{25}y,$  so  $\frac{dy}{dt} + \frac{1}{25}y = 8$  and  $y(0) = 25.$

$\mu = e^{\int (1/25)dt} = e^{t/25}, e^{t/25}y = \int 8e^{t/25} dt = 200e^{t/25} + C,$

$y = 200 + Ce^{-t/25}, 25 = 200 + C, C = -175,$

(a)  $y = 200 - 175e^{-t/25}$  oz

(b) when  $t = 25, y = 200 - 175e^{-1} \approx 136$  oz

44.  $\frac{dy}{dt} = (5)(10) - \frac{y}{200}(10) = 50 - \frac{1}{20}y$ , so  $\frac{dy}{dt} + \frac{1}{20}y = 50$  and  $y(0) = 0$ .

$$\mu = e^{\int \frac{1}{20} dt} = e^{t/20}, e^{t/20}y = \int 50e^{t/20} dt = 1000e^{t/20} + C,$$

$$y = 1000 + Ce^{-t/20}, 0 = 1000 + C, C = -1000;$$

(a)  $y = 1000 - 1000e^{-t/20}$  lb                      (b) when  $t = 30$ ,  $y = 1000 - 1000e^{-1.5} \approx 777$  lb

45. The volume  $V$  of the (polluted) water is  $V(t) = 500 + (20 - 10)t = 500 + 10t$ ;

if  $y(t)$  is the number of pounds of particulate matter in the water,

then  $y(0) = 50$ , and  $\frac{dy}{dt} = 0 - 10\frac{y}{V} = -\frac{1}{50+t}y$ ,  $\frac{dy}{dt} + \frac{1}{50+t}y = 0$ ;  $\mu = e^{\int \frac{dt}{50+t}} = 50 + t$ ;

$$\frac{d}{dt}[(50 + t)y] = 0, (50 + t)y = C, 2500 = 50y(0) = C, y(t) = 2500/(50 + t).$$

The tank reaches the point of overflowing when  $V = 500 + 10t = 1000$ ,  $t = 50$  min, so  $y = 2500/(50 + 50) = 25$  lb.

46. The volume of the lake (in gallons) is  $V = 246\pi r^2 h = 246\pi(15)^2 3 = 166,050\pi$ . Let  $y(t)$  denote

the number of pounds of mercury salts at time  $t$ , then  $\frac{dy}{dt} = 0 - 10^3 \frac{y}{V} = -\frac{y}{166.05\pi}$  lb/h and

$$y_0 = 10^{-5}V = 1.6605\pi \text{ lb}; \frac{dy}{y} = -\frac{dt}{166.05\pi}, \ln y = -\frac{t}{166.05\pi} + C_1, y = Ce^{-t/(166.05\pi)}, \text{ and}$$

$$C = y(0) = y_0 = 1.6605\pi, y = 1.6605\pi e^{-t/(166.05\pi)}.$$

$t$	1	2	3	4	5	6	7	8	9	10	11	12
$y(t)$	5.2066	5.1967	5.1867	5.1768	5.1669	5.1570	5.1471	5.1372	5.1274	5.1176	5.1078	5.0980

47. (a)  $\frac{dv}{dt} + \frac{c}{m}v = -g, \mu = e^{(c/m) \int dt} = e^{ct/m}, \frac{d}{dt} [ve^{ct/m}] = -ge^{ct/m}, ve^{ct/m} = -\frac{gm}{c}e^{ct/m} + C,$

$$v = -\frac{gm}{c} + Ce^{-ct/m}, \text{ but } v_0 = v(0) = -\frac{gm}{c} + C, C = v_0 + \frac{gm}{c}, v = -\frac{gm}{c} + \left(v_0 + \frac{gm}{c}\right) e^{-ct/m}$$

(b) Replace  $\frac{mg}{c}$  with  $v_\tau$  and  $-ct/m$  with  $-gt/v_\tau$  in (23).

(c) From part (b),  $s(t) = C - v_\tau t - (v_0 + v_\tau) \frac{v_\tau}{g} e^{-gt/v_\tau}$ ;

$$s_0 = s(0) = C - (v_0 + v_\tau) \frac{v_\tau}{g}, C = s_0 + (v_0 + v_\tau) \frac{v_\tau}{g}, s(t) = s_0 - v_\tau t + \frac{v_\tau}{g} (v_0 + v_\tau) (1 - e^{-gt/v_\tau})$$

48. Given  $m = 240, g = 32, v_\tau = mg/c$ : with a closed parachute  $v_\tau = 120$  so  $c = 64$ , and with an open parachute  $v_\tau = 24, c = 320$ .

(a) Let  $t$  denote time elapsed in seconds after the moment of the drop. From Exercise 47(b), while the parachute is closed

$$v(t) = e^{-gt/v_\tau} (v_0 + v_\tau) - v_\tau = e^{-32t/120} (0 + 120) - 120 = 120 (e^{-4t/15} - 1) \text{ and thus}$$

$$v(25) = 120 (e^{-20/3} - 1) \approx -119.85, \text{ so the parachutist is falling at a speed of } 119.85 \text{ ft/s}$$

when the parachute opens. From Exercise 47(c),  $s(t) = s_0 - 120t + \frac{120}{32} 120 (1 - e^{-4t/15})$ ,

$$s(25) = 10000 - 120 \cdot 25 + 450 (1 - e^{-20/3}) \approx 7449.43 \text{ ft.}$$

(b) If  $t$  denotes time elapsed after the parachute opens, then, by Exercise 47(c),

$$s(t) = 7449.43 - 24t + \frac{24}{32} (-119.85 + 24) (1 - e^{-32t/24}) = 0, \text{ with the solution (Newton's Method) } t = 310.42 \text{ s, so the sky diver is in the air for about } 25 + 310 = 335 \text{ s.}$$

49.  $\frac{dI}{dt} + \frac{R}{L}I = \frac{V(t)}{L}, \mu = e^{(R/L)\int dt} = e^{Rt/L}, \frac{d}{dt}(e^{Rt/L}I) = \frac{V(t)}{L}e^{Rt/L},$   
 $Ie^{Rt/L} = I(0) + \frac{1}{L} \int_0^t V(u)e^{Ru/L} du, I(t) = I(0)e^{-Rt/L} + \frac{1}{L}e^{-Rt/L} \int_0^t V(u)e^{Ru/L} du.$

(a)  $I(t) = \frac{1}{4}e^{-5t/2} \int_0^t 12e^{5u/2} du = \frac{6}{5}e^{-5t/2} e^{5u/2} \Big|_0^t = \frac{6}{5} (1 - e^{-5t/2}) \text{ A.}$

(b)  $\lim_{t \rightarrow +\infty} I(t) = \frac{6}{5} \text{ A}$

50. From Exercise 49 and Endpaper Table #42,

$$I(t) = 15e^{-2t} + \frac{1}{3}e^{-2t} \int_0^t 3e^{2u} \sin u du = 15e^{-2t} + e^{-2t} \frac{e^{2u}}{5} (2 \sin u - \cos u) \Big|_0^t$$

$$= 15e^{-2t} + \frac{1}{5} (2 \sin t - \cos t) + \frac{1}{5} e^{-2t}.$$

51. (a)  $\frac{dv}{dt} = \frac{ck}{m_0 - kt} - g, v = -c \ln(m_0 - kt) - gt + C; v = 0$  when  $t = 0$  so  $0 = -c \ln m_0 + C,$   
 $C = c \ln m_0, v = c \ln m_0 - c \ln(m_0 - kt) - gt = c \ln \frac{m_0}{m_0 - kt} - gt.$

(b)  $m_0 - kt = 0.2m_0$  when  $t = 100$  so

$$v = 2500 \ln \frac{m_0}{0.2m_0} - 9.8(100) = 2500 \ln 5 - 980 \approx 3044 \text{ m/s.}$$

52. (a) By the chain rule,  $\frac{dv}{dt} = \frac{dv}{dx} \frac{dx}{dt} = \frac{dv}{dx} v$  so  $m \frac{dv}{dt} = mv \frac{dv}{dx}.$

(b)  $\frac{mv}{kv^2 + mg} dv = -dx, \frac{m}{2k} \ln(kv^2 + mg) = -x + C; v = v_0$  when  $x = 0$  so

$$C = \frac{m}{2k} \ln(kv_0^2 + mg), \frac{m}{2k} \ln(kv^2 + mg) = -x + \frac{m}{2k} \ln(kv_0^2 + mg), x = \frac{m}{2k} \ln \frac{kv_0^2 + mg}{kv^2 + mg}.$$

(c)  $x = x_{max}$  when  $v = 0$  so

$$x_{max} = \frac{m}{2k} \ln \frac{kv_0^2 + mg}{mg} = \frac{3.56 \times 10^{-3}}{2(7.3 \times 10^{-6})} \ln \frac{(7.3 \times 10^{-6})(988)^2 + (3.56 \times 10^{-3})(9.8)}{(3.56 \times 10^{-3})(9.8)} \approx 1298 \text{ m}$$

53. (a)  $A(h) = \pi(1)^2 = \pi, \pi \frac{dh}{dt} = -0.025\sqrt{h}, \frac{\pi}{\sqrt{h}} dh = -0.025dt, 2\pi\sqrt{h} = -0.025t + C; h = 4$  when  
 $t = 0,$  so  $4\pi = C, 2\pi\sqrt{h} = -0.025t + 4\pi, \sqrt{h} = 2 - \frac{0.025}{2\pi}t, h \approx (2 - 0.003979t)^2.$

(b)  $h = 0$  when  $t \approx 2/0.003979 \approx 502.6 \text{ s} \approx 8.4 \text{ min.}$

54. (a)  $A(h) = 6 [2\sqrt{4 - (h - 2)^2}] = 12\sqrt{4h - h^2},$   
 $12\sqrt{4h - h^2} \frac{dh}{dt} = -0.025\sqrt{h}, 12\sqrt{4 - h} dh = -0.025dt,$   
 $-8(4 - h)^{3/2} = -0.025t + C; h = 4$  when  $t = 0$  so  $C = 0,$   
 $(4 - h)^{3/2} = (0.025/8)t, 4 - h = (0.025/8)^{2/3} t^{2/3},$   
 $h \approx 4 - 0.021375t^{2/3} \text{ ft}$

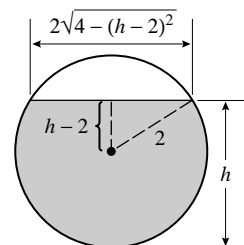

(b)  $h = 0$  when  $t = \frac{8}{0.025} (4 - 0)^{3/2} = 2560 \text{ s} \approx 42.7 \text{ min}$

55.  $\frac{dv}{dt} = -0.04v^2$ ,  $\frac{1}{v^2} dv = -0.04 dt$ ,  $-\frac{1}{v} = -0.04t + C$ ;  $v = 50$  when  $t = 0$  so  $-\frac{1}{50} = C$ ,  
 $-\frac{1}{v} = -0.04t - \frac{1}{50}$ ,  $v = \frac{50}{2t+1}$  cm/s. But  $v = \frac{dx}{dt}$  so  $\frac{dx}{dt} = \frac{50}{2t+1}$ ,  $x = 25 \ln(2t+1) + C_1$ ;  $x = 0$   
 when  $t = 0$  so  $C_1 = 0$ ,  $x = 25 \ln(2t+1)$  cm.
56.  $\frac{dv}{dt} = -0.02\sqrt{v}$ ,  $\frac{1}{\sqrt{v}} dv = -0.02 dt$ ,  $2\sqrt{v} = -0.02t + C$ ;  $v = 9$  when  $t = 0$  so  $6 = C$ ,  
 $2\sqrt{v} = -0.02t + 6$ ,  $v = (3 - 0.01t)^2$  cm/s. But  $v = \frac{dx}{dt}$  so  $\frac{dx}{dt} = (3 - 0.01t)^2$ ,  
 $x = -\frac{100}{3}(3 - 0.01t)^3 + C_1$ ;  $x = 0$  when  $t = 0$  so  $C_1 = 900$ ,  $x = 900 - \frac{100}{3}(3 - 0.01t)^3$  cm.
57. Differentiate to get  $\frac{dy}{dx} = -\sin x + e^{-x^2}$ ,  $y(0) = 1$ .
58.  $\int h(y) dy = \int h(y(x))y'(x) dx$ ; since  $h(y)\frac{dy}{dx} = g(x)$  it follows that  $\int h(y) dy = \int g(x) dx$ .

## EXERCISE SET 10.2

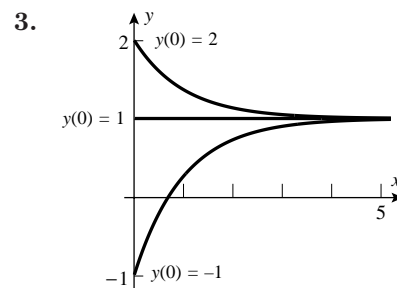
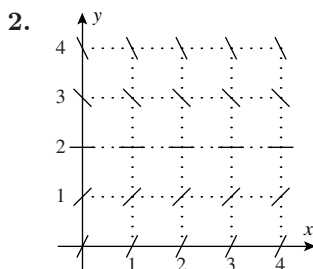
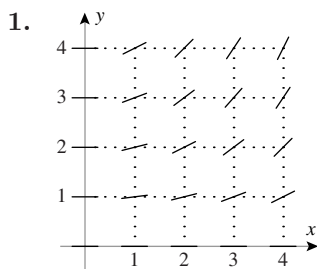

4.  $\frac{dy}{dx} + y = 1$ ,  $\mu = e^{\int dx} = e^x$ ,  
 $\frac{d}{dx}[ye^x] = e^x$ ,  
 $ye^x = e^x + C$ ,  $y = 1 + Ce^{-x}$

(a)  $-1 = 1 + C$ ,  $C = -2$ ,  $y = 1 - 2e^{-x}$

(b)  $1 = 1 + C$ ,  $C = 0$ ,  $y = 1$

(c)  $2 = 1 + C$ ,  $C = 1$ ,  $y = 1 + e^{-x}$

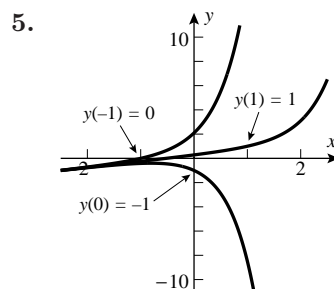

6.  $\frac{dy}{dx} - 2y = -x$ ,  $\mu = e^{-2\int dx} = e^{-2x}$ ,  $\frac{d}{dx}[ye^{-2x}] = -xe^{-2x}$ ,  $ye^{-2x} = \frac{1}{4}(2x+1)e^{-2x} + C$ ,  
 $y = \frac{1}{4}(2x+1) + Ce^{2x}$

(a)  $1 = 3/4 + Ce^2$ ,  $C = 1/4e^2$ ,  $y = \frac{1}{4}(2x+1) + \frac{1}{4}e^{2x-2}$

(b)  $-1 = 1/4 + C$ ,  $C = -5/4$ ,  $y = \frac{1}{4}(2x+1) - \frac{5}{4}e^{2x}$

(c)  $0 = -1/4 + Ce^{-2}$ ,  $C = e^2/4$ ,  $y = \frac{1}{4}(2x+1) + \frac{1}{4}e^{2x+2}$

7.  $\lim_{x \rightarrow +\infty} y = 1$

8.  $\lim_{x \rightarrow +\infty} y = \begin{cases} +\infty & \text{if } y_0 \geq 1/4 \\ -\infty, & \text{if } y_0 < 1/4 \end{cases}$

- 9. (a) IV, since the slope is positive for  $x > 0$  and negative for  $x < 0$ .
- (b) VI, since the slope is positive for  $y > 0$  and negative for  $y < 0$ .
- (c) V, since the slope is always positive.
- (d) II, since the slope changes sign when crossing the lines  $y = \pm 1$ .
- (e) I, since the slope can be positive or negative in each quadrant but is not periodic.
- (f) III, since the slope is periodic in both  $x$  and  $y$ .

11. (a)  $y_0 = 1,$   
 $y_{n+1} = y_n + (x_n + y_n)(0.2) = (x_n + 6y_n)/5$

$n$	0	1	2	3	4	5
$x_n$	0	0.2	0.4	0.6	0.8	1.0
$y_n$	1	1.20	1.48	1.86	2.35	2.98

(b)  $y' - y = x, \mu = e^{-x}, \frac{d}{dx} [ye^{-x}] = xe^{-x},$   
 $ye^{-x} = -(x+1)e^{-x} + C, 1 = -1 + C,$   
 $C = 2, y = -(x+1) + 2e^x$

$x_n$	0	0.2	0.4	0.6	0.8	1.0
$y(x_n)$	1	1.24	1.58	2.04	2.65	3.44
abs. error	0	0.04	0.10	0.19	0.30	0.46
perc. error	0	3	7	9	11	13

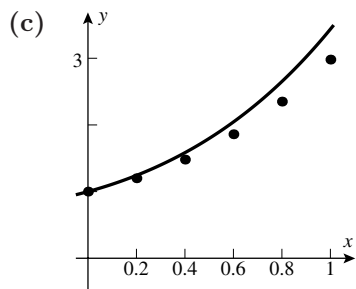

12.  $h = 0.1, y_{n+1} = (x_n + 11y_n)/10$

$n$	0	1	2	3	4	5	6	7	8	9	10
$x_n$	0	0.1	0.2	0.3	0.4	0.5	0.6	0.7	0.8	0.9	1.0
$y_n$	1.00	1.10	1.22	1.36	1.53	1.72	1.94	2.20	2.49	2.82	3.19

In Exercise 11,  $y(1) \approx 2.98$ ; in Exercise 12,  $y(1) \approx 3.19$ ; the true solution is  $y(1) \approx 3.44$ ; so the absolute errors are approximately 0.46 and 0.25 respectively.

13.  $y_0 = 1, y_{n+1} = y_n + \sqrt{y_n}/2$

$n$	0	1	2	3	4	5	6	7	8
$x_n$	0	0.5	1	1.5	2	2.5	3	3.5	4
$y_n$	1	1.50	2.11	2.84	3.68	4.64	5.72	6.91	8.23

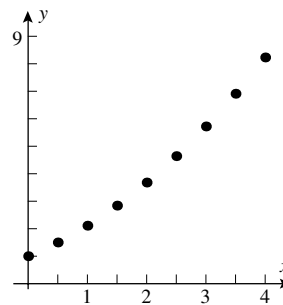

14.  $y_0 = 1, y_{n+1} = y_n + (x_n - y_n^2)/4$

$n$	0	1	2	3	4	5	6	7	8
$x_n$	0	0.25	0.50	0.75	1.00	1.25	1.50	1.75	2.00
$y_n$	1	0.75	0.67	0.68	0.75	0.86	0.99	1.12	1.24

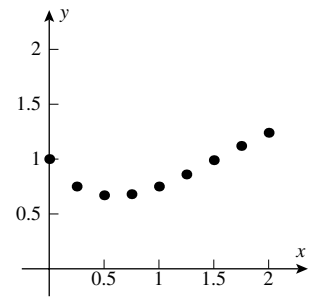

15.  $y_0 = 1, y_{n+1} = y_n + \frac{1}{2} \sin y_n$

$n$	0	1	2	3	4
$t_n$	0	0.5	1	1.5	2
$y_n$	1	1.42	1.92	2.39	2.73

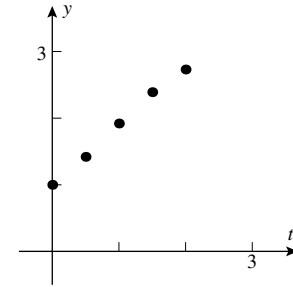

16.  $y_0 = 0, y_{n+1} = y_n + e^{-y_n}/10$

$n$	0	1	2	3	4	5	6	7	8	9	10
$t_n$	0	0.1	0.2	0.3	0.4	0.5	0.6	0.7	0.8	0.9	1.0
$y_n$	0	0.10	0.19	0.27	0.35	0.42	0.49	0.55	0.60	0.66	0.71

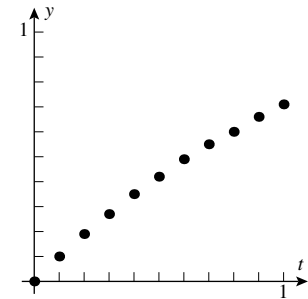

17.  $h = 1/5, y_0 = 1, y_{n+1} = y_n + \frac{1}{5} \cos(2\pi n/5)$

$n$	0	1	2	3	4	5
$t_n$	0	0.2	0.4	0.6	0.8	1.0
$y_n$	1.00	1.06	0.90	0.74	0.80	1.00

18. (a) By inspection,  $\frac{dy}{dx} = e^{-x^2}$  and  $y(0) = 0$ .

(b)  $y_{n+1} = y_n + e^{-x_n^2}/20 = y_n + e^{-(n/20)^2}/20$  and  $y_{20} = 0.7625$ . From a CAS,  $y(1) = 0.7468$ .

19. (b)  $y dy = -x dx, y^2/2 = -x^2/2 + C_1, x^2 + y^2 = C$ ; if  $y(0) = 1$  then  $C = 1$  so  $y(1/2) = \sqrt{3}/2$ .

20. (a)  $y_0 = 1, y_{n+1} = y_n + (\sqrt{y_n}/2)h$

$h = 0.2 : y_{n+1} = y_n + \sqrt{y_n}/10; y_5 \approx 1.5489$

$h = 0.1 : y_{n+1} = y_n + \sqrt{y_n}/20; y_{10} \approx 1.5556$

$h = 0.05 : y_{n+1} = y_n + \sqrt{y_n}/40; y_{20} \approx 1.5590$

(c)  $\frac{dy}{\sqrt{y}} = \frac{1}{2} dx, 2\sqrt{y} = x/2 + C, 2 = C,$

$\sqrt{y} = x/4 + 1, y = (x/4 + 1)^2,$

$y(1) = 25/16 = 1.5625$



## EXERCISE SET 10.3

1. (a)  $\frac{dy}{dt} = ky^2$ ,  $y(0) = y_0$ ,  $k > 0$  (b)  $\frac{dy}{dt} = -ky^2$ ,  $y(0) = y_0$ ,  $k > 0$
3. (a)  $\frac{ds}{dt} = \frac{1}{2}s$  (b)  $\frac{d^2s}{dt^2} = 2\frac{ds}{dt}$
4. (a)  $\frac{dv}{dt} = -2v^2$  (b)  $\frac{d^2s}{dt^2} = -2\left(\frac{ds}{dt}\right)^2$
5. (a)  $\frac{dy}{dt} = 0.01y$ ,  $y_0 = 10,000$  (b)  $y = 10,000e^{t/100}$   
 (c)  $T = \frac{1}{k} \ln 2 = \frac{1}{0.01} \ln 2 \approx 69.31$  hr (d)  $45,000 = 10,000e^{t/100}$ ,  
 $t = 100 \ln \frac{45,000}{10,000} \approx 150.41$  hr
6.  $k = \frac{1}{T} \ln 2 = \frac{1}{20} \ln 2$   
 (a)  $\frac{dy}{dt} = ((\ln 2)/20)y$ ,  $y(0) = 1$  (b)  $y(t) = e^{t(\ln 2)/20} = 2^{t/20}$   
 (c)  $y(120) = 2^6 = 64$  (d)  $1,000,000 = 2^{t/20}$ ,  
 $t = 20 \frac{\ln 10^6}{\ln 2} \approx 398.63$  min
7. (a)  $\frac{dy}{dt} = -ky$ ,  $y(0) = 5.0 \times 10^7$ ;  $3.83 = T = \frac{1}{k} \ln 2$ , so  $k = \frac{\ln 2}{3.83} \approx 0.1810$   
 (b)  $y = 5.0 \times 10^7 e^{-0.181t}$   
 (c)  $y(30) = 5.0 \times 10^7 e^{-0.1810(30)} \approx 219,297$   
 (d)  $y(t) = 0.1y_0 = y_0 e^{-kt}$ ,  $-kt = \ln 0.1$ ,  $t = -\frac{\ln 0.1}{0.1810} = 12.72$  days
8. (a)  $k = \frac{1}{T} \ln 2 = \frac{1}{140} \ln 2 \approx 0.0050$ , so  $\frac{dy}{dt} = -0.0050y$ ,  $y_0 = 10$ .  
 (b)  $y = 10e^{-0.0050t}$   
 (c) 10 weeks = 70 days so  $y = 10e^{-0.35} \approx 7$  mg.  
 (d)  $0.3y_0 = y_0 e^{-kt}$ ,  $t = -\frac{\ln 0.3}{0.0050} \approx 243.2$  days
9.  $100e^{0.02t} = 5000$ ,  $e^{0.02t} = 50$ ,  $t = \frac{1}{0.02} \ln 50 \approx 196$  days
10.  $y = 10,000e^{kt}$ , but  $y = 12,000$  when  $t = 10$  so  $10,000e^{10k} = 12,000$ ,  $k = \frac{1}{10} \ln 1.2$ .  $y = 20,000$  when  
 $2 = e^{kt}$ ,  $t = \frac{\ln 2}{k} = 10 \frac{\ln 2}{\ln 1.2} \approx 38$ , in the year 2025.
11.  $y(t) = y_0 e^{-kt} = 10.0e^{-kt}$ ,  $3.5 = 10.0e^{-k(5)}$ ,  $k = -\frac{1}{5} \ln \frac{3.5}{10.0} \approx 0.2100$ ,  $T = \frac{1}{k} \ln 2 \approx 3.30$  days

12.  $\frac{dy}{dt} = y_0 e^{-kt}$ ,  $0.6y_0 = y_0 e^{-5k}$ ,  $k = -\frac{1}{5} \ln 0.6 \approx 0.10$

(a)  $T = \frac{\ln 2}{k} \approx 6.8$  yr

(b)  $y(t) \approx y_0 e^{-0.10t}$ ,  $\frac{y}{y_0} \approx e^{-0.10t}$ , so  $e^{-0.10t} \times 100$  percent will remain.

13. (a)  $k = \frac{\ln 2}{5} \approx 0.1386$ ;  $y \approx 2e^{0.1386t}$  (b)  $y(t) = 5e^{0.015t}$

(c)  $y = y_0 e^{kt}$ ,  $1 = y_0 e^k$ ,  $100 = y_0 e^{10k}$ . Divide:  $100 = e^{9k}$ ,  $k = \frac{1}{9} \ln 100 \approx 0.5117$ ,  
 $y \approx y_0 e^{0.5117t}$ ; also  $y(1) = 1$ , so  $y_0 = e^{-0.5117} \approx 0.5995$ ,  $y \approx 0.5995 e^{0.5117t}$ .

(d)  $k = \frac{\ln 2}{T} \approx 0.1386$ ,  $1 = y(1) \approx y_0 e^{0.1386}$ ,  $y_0 \approx e^{-0.1386} \approx 0.8706$ ,  $y \approx 0.8706 e^{0.1386t}$

14. (a)  $k = \frac{\ln 2}{T} \approx 0.1386$ ,  $y \approx 10e^{-0.1386t}$  (b)  $y = 10e^{-0.015t}$

(c)  $100 = y_0 e^{-k}$ ,  $1 = y_0 e^{-10k}$ . Divide:  $e^{9k} = 100$ ,  $k = \frac{1}{9} \ln 100 \approx 0.5117$ ;  
 $y_0 = e^{10k} \approx e^{5.117} \approx 166.81$ ,  $y = 166.81 e^{-0.5117t}$ .

(d)  $k = \frac{\ln 2}{T} \approx 0.1386$ ,  $10 = y(1) \approx y_0 e^{-0.1386}$ ,  $y_0 \approx 10e^{0.1386} \approx 11.4866$ ,  $y \approx 11.4866 e^{-0.1386t}$

16. (a) None; the half-life is independent of the initial amount.

(b)  $kT = \ln 2$ , so  $T$  is inversely proportional to  $k$ .

17. (a)  $T = \frac{\ln 2}{k}$ ; and  $\ln 2 \approx 0.6931$ . If  $k$  is measured in percent,  $k' = 100k$ ,  
then  $T = \frac{\ln 2}{k} \approx \frac{69.31}{k'} \approx \frac{70}{k'}$ .

(b) 70 yr

(c) 20 yr

(d) 7%

18. Let  $y = y_0 e^{kt}$  with  $y = y_1$  when  $t = t_1$  and  $y = 3y_1$  when  $t = t_1 + T$ ; then  $y_0 e^{kt_1} = y_1$  (i) and  
 $y_0 e^{k(t_1+T)} = 3y_1$  (ii). Divide (ii) by (i) to get  $e^{kT} = 3$ ,  $T = \frac{1}{k} \ln 3$ .

19. From (12),  $y(t) = y_0 e^{-0.000121t}$ . If  $0.27 = \frac{y(t)}{y_0} = e^{-0.000121t}$  then  $t = -\frac{\ln 0.27}{0.000121} \approx 10,820$  yrs,  
and if  $0.30 = \frac{y(t)}{y_0}$  then  $t = -\frac{\ln 0.30}{0.000121} \approx 9950$ , or roughly between 9000 B.C. and 8000 B.C.

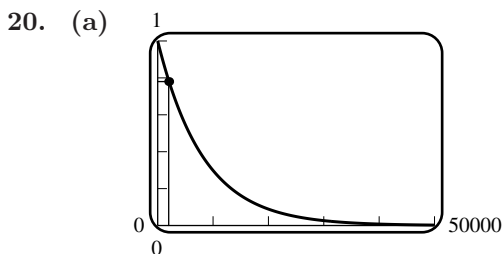

(b)  $t = 1988$  yields

$$y/y_0 = e^{-0.000121(1988)} \approx 79\%.$$

21.  $y_0 \approx 2$ ,  $L \approx 8$ ; since the curve  $y = \frac{2 \cdot 8}{2 + 6e^{-kt}}$  passes through the point  $(2, 4)$ ,  $4 = \frac{16}{2 + 6e^{-2k}}$ ,

$$6e^{-2k} = 2, \quad k = \frac{1}{2} \ln 3 \approx 0.5493.$$

22.  $y_0 \approx 400$ ,  $L \approx 1000$ ; since the curve  $y = \frac{400,000}{400 + 600e^{-kt}}$  passes through the point  $(200, 600)$ ,

$$600 = \frac{400,000}{400 + 600e^{-200k}}, \quad 600e^{-200k} = \frac{800}{3}, \quad k = \frac{1}{200} \ln 2.25 \approx 0.00405.$$

23. (a)  $y_0 = 5$  (b)  $L = 12$  (c)  $k = 1$

(d)  $L/2 = 6 = \frac{60}{5 + 7e^{-t}}, \quad 5 + 7e^{-t} = 10, \quad t = -\ln(5/7) \approx 0.3365$

(e)  $\frac{dy}{dt} = \frac{1}{12}y(12 - y), \quad y(0) = 5$

24. (a)  $y_0 = 1$  (b)  $L = 1000$  (c)  $k = 0.9$

(d)  $750 = \frac{1000}{1 + 999e^{-0.9t}}, \quad 3(1 + 999e^{-0.9t}) = 4, \quad t = \frac{1}{0.9} \ln(3 \cdot 999) \approx 8.8949$

(e)  $\frac{dy}{dt} = \frac{0.9}{1000}y(1000 - y), \quad y(0) = 1$

25. See (13):

(a)  $L = 10$  (b)  $k = 10$

(c)  $\frac{dy}{dt} = 10(1 - 0.1y)y = 25 - (y - 5)^2$  is maximized when  $y = 5$ .

26.  $\frac{dy}{dt} = 50y \left(1 - \frac{1}{50,000}y\right)$ ; from (13),  $k = 50$ ,  $L = 50,000$ .

(a)  $L = 50,000$  (b)  $k = 50$

(c)  $\frac{dy}{dt}$  is maximized when  $0 = \frac{d}{dy} \left(\frac{dy}{dt}\right) = 50 - y/500, y = 25,000$

27. Assume  $y(t)$  students have had the flu  $t$  days after semester break. Then  $y(0) = 20$ ,  $y(5) = 35$ .

(a)  $\frac{dy}{dt} = ky(L - y) = ky(1000 - y), \quad y_0 = 20$

(b) Part (a) has solution  $y = \frac{20000}{20 + 980e^{-1000kt}} = \frac{1000}{1 + 49e^{-1000kt}}$ ;

$$35 = \frac{1000}{1 + 49e^{-5000k}}, \quad k = 0.000115, \quad y \approx \frac{1000}{1 + 49e^{-0.115t}}$$

(c)

$t$	0	1	2	3	4	5	6	7	8	9	10	11	12	13	14
$y(t)$	20	22	25	28	31	35	39	44	49	54	61	67	75	83	93

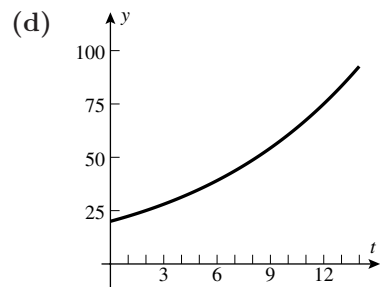

28. (a)  $\frac{dp}{dh} = -kh, p(0) = p_0$

(b)  $p_0 = 1$ , so  $p = e^{-kh}$ , but  $p = 0.83$  when  $h = 5000$  thus  $e^{-5000k} = 0.83$ ,

$$k = -\frac{\ln 0.83}{5000} \approx 0.0000373, p \approx e^{-0.0000373h} \text{ atm.}$$

29. (a)  $\frac{dT}{dt} = -k(T - 21), T(0) = 95, \frac{dT}{T - 21} = -k dt, \ln(T - 21) = -kt + C_1,$   
 $T = 21 + e^{C_1} e^{-kt} = 21 + C e^{-kt}, 95 = T(0) = 21 + C, C = 74, T = 21 + 74e^{-kt}$

(b)  $85 = T(1) = 21 + 74e^{-k}, k = -\ln \frac{64}{74} = -\ln \frac{32}{37}, T = 21 + 74e^{t \ln(32/37)} = 21 + 74 \left(\frac{32}{37}\right)^t,$

$$T = 51 \text{ when } \frac{30}{74} = \left(\frac{32}{37}\right)^t, t = \frac{\ln(30/74)}{\ln(32/37)} \approx 6.22 \text{ min}$$

30.  $\frac{dT}{dt} = k(70 - T), T(0) = 40; -\ln(70 - T) = kt + C, 70 - T = e^{-kt} e^{-C}, T = 40$  when  $t = 0$ , so

$$30 = e^{-C}, T = 70 - 30e^{-kt}; 52 = T(1) = 70 - 30e^{-k}, k = -\ln \frac{70 - 52}{30} = \ln \frac{5}{3} \approx 0.5,$$

$$T \approx 70 - 30e^{-0.5t}$$

31. Let  $T$  denote the body temperature of McHam's body at time  $t$ , the number of hours elapsed after 10:06 P.M.; then  $\frac{dT}{dt} = -k(T - 72), \frac{dT}{T - 72} = -k dt, \ln(T - 72) = -kt + C, T = 72 + e^C e^{-kt},$

$$77.9 = 72 + e^C, e^C = 5.9, T = 72 + 5.9e^{-kt}, 75.6 = 72 + 5.9e^{-k}, k = -\ln \frac{3.6}{5.9} \approx 0.4940,$$

$$T = 72 + 5.9e^{-0.4940t}. \text{ McHam's body temperature was last } 98.6^\circ \text{ when } t = -\frac{\ln(26.6/5.9)}{0.4940} \approx -3.05,$$

so around 3 hours and 3 minutes before 10:06; the death took place at approximately 7:03 P.M., while Moore was on stage.

32. If  $T_0 < T_a$  then  $\frac{dT}{dt} = k(T_a - T)$  where  $k > 0$ . If  $T_0 > T_a$  then  $\frac{dT}{dt} = -k(T - T_a)$  where  $k > 0$ ; both cases yield  $T(t) = T_a + (T_0 - T_a)e^{-kt}$  with  $k > 0$ .

33.  $k/m = 0.25/1 = 0.25$

(a) From (21),  $y = 0.3 \cos(t/2)$

(b)  $T = 2\pi \cdot 2 = 4\pi$  s,  $f = 1/T = 1/(4\pi)$  Hz

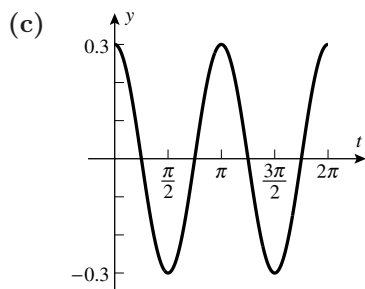

(d)  $y = 0$  at the equilibrium position, so  $t/2 = \pi/2, t = \pi$  s.

(e)  $t/2 = \pi$  at the maximum position below the equilibrium position, so  $t = 2\pi$  s.

34.  $64 = w = -mg, m = 2, k/m = 0.25/2 = 1/8, \sqrt{k/m} = 1/(2\sqrt{2})$

(a) From (21),  $y = \cos(t/(2\sqrt{2}))$

(b)  $T = 2\pi \sqrt{\frac{m}{k}} = 2\pi(2\sqrt{2}) = 4\pi\sqrt{2}$  s,  
 $f = 1/T = 1/(4\pi\sqrt{2})$  Hz

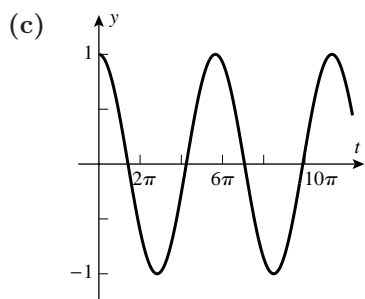

- (d)  $y = 0$  at the equilibrium position,  
so  $t/(2\sqrt{2}) = \pi/2, t = \pi\sqrt{2}$  s  
(e)  $t/(2\sqrt{2}) = \pi, t = 2\pi\sqrt{2}$  s

35.  $l = 0.05, k/m = g/l = 9.8/0.05 = 196 \text{ s}^{-2}$

(a) From (21),  $y = -0.12 \cos 14t$ .

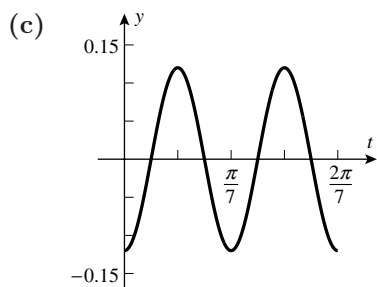

- (b)  $T = 2\pi\sqrt{m/k} = 2\pi/14 = \pi/7$  s,  
 $f = 7/\pi$  Hz  
(d)  $14t = \pi/2, t = \pi/28$  s  
(e)  $14t = \pi, t = \pi/14$  s

36.  $l = 0.5, k/m = g/l = 32/0.5 = 64, \sqrt{k/m} = 8$

(a) From (21),  $y = -1.5 \cos 8t$ .

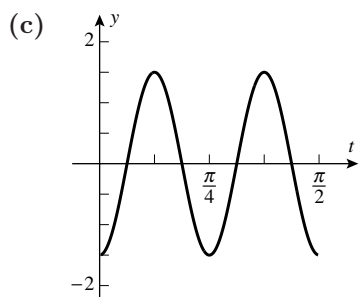

- (b)  $T = 2\pi\sqrt{m/k} = 2\pi/8 = \pi/4$  s;  
 $f = 1/T = 4/\pi$  Hz  
(d)  $8t = \pi/2, t = \pi/16$  s  
(e)  $8t = \pi, t = \pi/8$  s

37. Assume  $y = y_0 \cos \sqrt{\frac{k}{m}} t$ , so  $v = \frac{dy}{dt} = -y_0 \sqrt{\frac{k}{m}} \sin \sqrt{\frac{k}{m}} t$

(a) The maximum speed occurs when  $\sin \sqrt{\frac{k}{m}} t = \pm 1, \sqrt{\frac{k}{m}} t = n\pi + \pi/2$ ,  
so  $\cos \sqrt{\frac{k}{m}} t = 0, y = 0$ .

(b) The minimum speed occurs when  $\sin \sqrt{\frac{k}{m}} t = 0, \sqrt{\frac{k}{m}} t = n\pi$ , so  $\cos \sqrt{\frac{k}{m}} t = \pm 1, y = \pm y_0$ .

38. (a)  $T = 2\pi\sqrt{\frac{m}{k}}, k = \frac{4\pi^2}{T^2} m = \frac{4\pi^2}{T^2} w$ , so  $k = \frac{4\pi^2}{g} \frac{w}{9} = \frac{4\pi^2}{g} \frac{w+4}{25}, 25w = 9(w+4)$ ,  
 $25w = 9w + 36, w = \frac{9}{4}, k = \frac{4\pi^2}{g} \frac{w}{9} = \frac{4\pi^2}{32} \frac{1}{4} = \frac{\pi^2}{32}$

(b) From part (a),  $w = \frac{1}{4}$

39. By Hooke's Law,  $F(t) = -kx(t)$ , since the only force is the restoring force of the spring. Newton's Second Law gives  $F(t) = mx''(t)$ , so  $mx''(t) + kx(t) = 0$ ,  $x(0) = x_0$ ,  $x'(0) = 0$ .
40.  $0 = v(0) = y'(0) = c_2\sqrt{\frac{k}{m}}$ , so  $c_2 = 0$ ;  $y_0 = y(0) = c_1$ , so  $y = y_0 \cos \sqrt{\frac{k}{m}} t$ .
41. (a)  $y = y_0 b^t = y_0 e^{t \ln b} = y_0 e^{kt}$  with  $k = \ln b > 0$  since  $b > 1$ .  
 (b)  $y = y_0 b^t = y_0 e^{t \ln b} = y_0 e^{-kt}$  with  $k = -\ln b > 0$  since  $0 < b < 1$ .  
 (c)  $y = 4(2^t) = 4e^{t \ln 2}$  (d)  $y = 4(0.5^t) = 4e^{t \ln 0.5} = 4e^{-t \ln 2}$
42. If  $y = y_0 e^{kt}$  and  $y = y_1 = y_0 e^{kt_1}$  then  $y_1/y_0 = e^{kt_1}$ ,  $k = \frac{\ln(y_1/y_0)}{t_1}$ ; if  $y = y_0 e^{-kt}$  and  $y = y_1 = e^{-kt_1}$  then  $y_1/y_0 = e^{-kt_1}$ ,  $k = -\frac{\ln(y_1/y_0)}{t_1}$ .

## CHAPTER 10 SUPPLEMENTARY EXERCISES

4. The differential equation in part (c) is not separable; the others are.
5. (a) linear (b) linear and separable (c) separable (d) neither
6. IF:  $\mu = e^{-2x^2}$ ,  $\frac{d}{dx} [ye^{-2x^2}] = xe^{-2x^2}$ ,  $ye^{-2x^2} = -\frac{1}{4}e^{-2x^2} + C$ ,  $y = -\frac{1}{4} + Ce^{2x^2}$   
 Sep of var:  $\frac{dy}{4y+1} = x dx$ ,  $\frac{1}{4} \ln |4y+1| = \frac{x^2}{2} + C_1$ ,  $4y+1 = \pm e^{4C_1} e^{2x^2} = C_2 e^{2x^2}$ ;  $y = -\frac{1}{4} + Ce^{2x^2}$
7. The parabola  $ky(L-y)$  opens down and has its maximum midway between the  $y$ -intercepts, that is, at the point  $y = \frac{1}{2}(0+L) = L/2$ , where  $\frac{dy}{dt} = k(L/2)^2 = kL^2/4$ .
8. (a) If  $y = y_0 e^{kt}$ , then  $y_1 = y_0 e^{kt_1}$ ,  $y_2 = y_0 e^{kt_2}$ , divide:  $y_2/y_1 = e^{k(t_2-t_1)}$ ,  $k = \frac{1}{t_2-t_1} \ln(y_2/y_1)$ ,  
 $T = \frac{\ln 2}{k} = \frac{(t_2-t_1) \ln 2}{\ln(y_2/y_1)}$ . If  $y = y_0 e^{-kt}$ , then  $y_1 = y_0 e^{-kt_1}$ ,  $y_2 = y_0 e^{-kt_2}$ ,  
 $y_2/y_1 = e^{-k(t_2-t_1)}$ ,  $k = -\frac{1}{t_2-t_1} \ln(y_2/y_1)$ ,  $T = \frac{\ln 2}{k} = -\frac{(t_2-t_1) \ln 2}{\ln(y_2/y_1)}$ .
- In either case,  $T$  is positive, so  $T = \left| \frac{(t_2-t_1) \ln 2}{\ln(y_2/y_1)} \right|$ .
- (b) In part (a) assume  $t_2 = t_1 + 1$  and  $y_2 = 1.25y_1$ . Then  $T = \frac{\ln 2}{\ln 1.25} \approx 3.1$  h.
9.  $\frac{dV}{dt} = -kS$ ; but  $V = \frac{4\pi}{3} r^3$ ,  $\frac{dV}{dt} = 4\pi r^2 \frac{dr}{dt}$ ,  $S = 4\pi r^2$ , so  $dr/dt = -k$ ,  $r = -kt + C$ ,  $4 = C$ ,  
 $r = -kt + 4$ ,  $3 = -k + 4$ ,  $k = 1$ ,  $r = 4 - t$  m.

10. Assume the tank contains  $y(t)$  oz of salt at time  $t$ . Then  $y_0 = 0$  and for  $0 < t < 15$ ,

$$\frac{dy}{dt} = 5 \cdot 10 - \frac{y}{1000}10 = (50 - y/100) \text{ oz/min, with solution } y = 5000 + Ce^{-t/100}. \text{ But } y(0) = 0 \text{ so}$$

$$C = -5000, y = 5000(1 - e^{-t/100}) \text{ for } 0 \leq t \leq 15, \text{ and } y(15) = 5000(1 - e^{-0.15}). \text{ For } 15 < t < 30,$$

$$\frac{dy}{dt} = 0 - \frac{y}{1000}5, y = C_1e^{-t/200}, C_1e^{-0.075} = y(15) = 5000(1 - e^{-0.15}), C_1 = 5000(e^{0.075} - e^{-0.075}),$$

$$y = 5000(e^{0.075} - e^{-0.075})e^{-t/100}, y(30) = 5000(e^{0.075} - e^{-0.075})e^{-0.3} \approx 556.13 \text{ oz.}$$

11. (a) Assume the air contains  $y(t)$  ft<sup>3</sup> of carbon monoxide at time  $t$ . Then  $y_0 = 0$  and for  $t > 0$ ,
- $$\frac{dy}{dt} = 0.04(0.1) - \frac{y}{1200}(0.1) = 1/250 - y/12000, \frac{d}{dt} \left[ ye^{t/12000} \right] = \frac{1}{250}e^{t/12000},$$
- $$ye^{t/12000} = 48e^{t/12000} + C, y(0) = 0, C = -48; y = 48(1 - e^{-t/12000}). \text{ Thus the percentage}$$
- of carbon monoxide is  $P = \frac{y}{1200}100 = 4(1 - e^{-t/12000})$  percent.

(b)  $0.012 = 4(1 - e^{-t/12000}), t = 35.95 \text{ min}$

12.  $\frac{dy}{y^2 + 1} = dx, \tan^{-1} y = x + C, \pi/4 = C; y = \tan(x + \pi/4)$

13.  $\left(\frac{1}{y^5} + \frac{1}{y}\right) dy = \frac{dx}{x}, -\frac{1}{4}y^{-4} + \ln|y| = \ln|x| + C; -\frac{1}{4} = C, y^{-4} + 4\ln(x/y) = 1$

14.  $\frac{dy}{dx} + \frac{2}{x}y = 4x, \mu = e^{\int(2/x)dx} = x^2, \frac{d}{dx} [yx^2] = 4x^3, yx^2 = x^4 + C, y = x^2 + Cx^{-2},$   
 $2 = y(1) = 1 + C, C = 1, y = x^2 + 1/x^2$

15.  $\frac{dy}{y^2} = 4 \sec^2 2x dx, -\frac{1}{y} = 2 \tan 2x + C, -1 = 2 \tan 2\frac{\pi}{8} + C = 2 \tan \frac{\pi}{4} + C = 2 + C, C = -3,$   
 $y = \frac{1}{3 - 2 \tan 2x}$

16.  $\frac{dy}{y^2 - 5y + 6} = dx, \frac{dy}{(y-3)(y-2)} = dx, \left[\frac{1}{y-3} - \frac{1}{y-2}\right] dy = dx, \ln \left|\frac{y-3}{y-2}\right| = x + C_1,$   
 $\frac{y-3}{y-2} = Ce^x; y = \ln 2 \text{ if } x = 0, \text{ so } C = \frac{\ln 2 - 3}{\ln 2 - 2}; y = \frac{3 - 2Ce^x}{1 - ce^x} = \frac{3 \ln 2 - 6 - (2 \ln 2 - 6)e^x}{\ln 2 - 2 - (\ln 2 - 3)e^x}$

17. (a)  $\mu = e^{-\int dx} = e^{-x}, \frac{d}{dx} [ye^{-x}] = xe^{-x} \sin 3x,$

$$ye^{-x} = \int xe^{-x} \sin 3x dx = \left(-\frac{3}{10}x - \frac{3}{50}\right) e^{-x} \cos 3x + \left(-\frac{1}{10}x + \frac{2}{25}\right) e^{-x} \sin 3x + C;$$

$$1 = y(0) = -\frac{3}{50} + C, C = \frac{53}{50}, y = \left(-\frac{3}{10}x - \frac{3}{50}\right) \cos 3x + \left(-\frac{1}{10}x + \frac{2}{25}\right) \sin 3x + \frac{53}{50}e^x$$

(c)

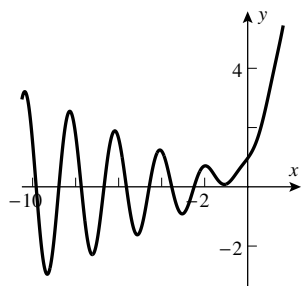

19. (a) Let  $T_1 = 5730 - 40 = 5690, k_1 = \frac{\ln 2}{T_1} \approx 0.00012182; T_2 = 5730 + 40 = 5770, k_2 \approx 0.00012013$ .  
 With  $y/y_0 = 0.92, 0.93, t_1 = -\frac{1}{k_1} \ln \frac{y}{y_0} = 684.5, 595.7; t_2 = -\frac{1}{k_2} \ln(y/y_0) = 694.1, 604.1$ ; in 1988 the shroud was at most 695 years old, which places its creation in or after the year 1293.

(b) If the true half-life is  $T$  with decay rate  $k$  and solution  $y(t) = y_0 e^{-kt}$ , and if the half-life is taken to be  $T_1 = T(1 + r/100)$  with decay rate  $k_1$  and solution  $y_1(t) = y_0 e^{-k_1 t}$ , then  
 $k_1 = \frac{\ln 2}{T_1} = \frac{\ln 2}{T(1 + r/100)} = \frac{k}{1 + r/100} = \frac{100k}{100 + r}; k - k_1 = k - \frac{100k}{100 + r} = k \frac{r}{100 + r}$  and the percentage error is given by  $100 \left| \frac{y_1 - y}{y} \right| = 100 |e^{(k-k_1)t} - 1| = 100 |e^{ktr/(100+r)} - 1|$  percent.

20. (a)  $y_{n+1} = y_n + 0.1(1 + 5t_n - y_n), y_0 = 5$

$n$	0	1	2	3	4	5	6	7	8	9	10
$t_n$	1	1.1	1.2	1.3	1.4	1.5	1.6	1.7	1.8	1.9	2
$y_n$	5.00	5.10	5.24	5.42	5.62	5.86	6.13	6.41	6.72	7.05	7.39

(b) The true solution is  $y(t) = 5t - 4 + 4e^{1-t}$ , so the percentage errors are given by

$t_n$	1	1.1	1.2	1.3	1.4	1.5	1.6	1.7	1.8	1.9	2
$y_n$	5.00	5.10	5.24	5.42	5.62	5.86	6.13	6.41	6.72	7.05	7.39
$y(t_n)$	5.00	5.12	5.27	5.46	5.68	5.93	6.20	6.49	6.80	7.13	7.47
abs. error	0.00	0.02	0.03	0.05	0.06	0.06	0.07	0.07	0.08	0.08	0.08
rel. error (%)	0.00	0.38	0.66	0.87	1.00	1.08	1.12	1.13	1.11	1.07	1.03

21. (b)  $y = C_1 e^x + C_2 e^{-x}$

(c)  $1 = y(0) = C_1 + C_2, 1 = y'(0) = C_1 - C_2; C_2 = 0, C_1 = 1, y = e^x$

22. (a)  $2ydy = dx, y^2 = x + C$ ; if  $y(0) = 1$  then  $C = 1, y^2 = x + 1, y = \sqrt{x + 1}$ ; if  $y(0) = -1$  then  $C = 1, y^2 = x + 1, y = -\sqrt{x + 1}$ .

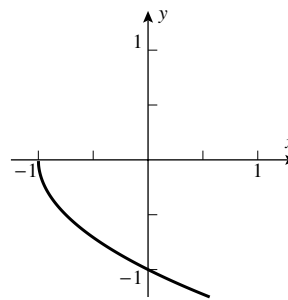
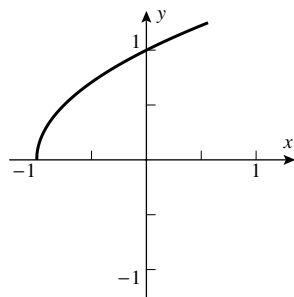

(b)  $\frac{dy}{y^2} = -2x dx, -\frac{1}{y} = -x^2 + C, -1 = C, y = 1/(x^2 + 1)$

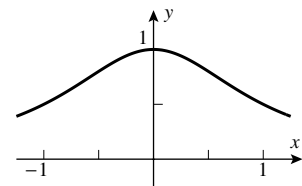

23. (a) Use (15) in Section 10.3 with  $y_0 = 19, L = 95: y(t) = \frac{1805}{19 + 76e^{-kt}}, 25 = y(1) = \frac{1805}{19 + 76e^{-k}}$ ,  
 $k \approx 0.3567$ ; when  $0.8L = y(t) = \frac{y_0 L}{19 + 76e^{-kt}}, 19 + 76e^{-kt} = \frac{5}{4}y_0 = \frac{95}{4}, t \approx 7.77$  yr.



(b) From (13),  $\frac{dy}{dt} = k\left(1 - \frac{y}{95}\right)y$ ,  $y(0) = 19$ .

24. (a)  $y_0 = y(0) = c_1$ ,  $v_0 = y'(0) = c_2\sqrt{\frac{k}{m}}$ ,  $c_2 = \sqrt{\frac{m}{k}}v_0$ ,  $y = y_0 \cos \sqrt{\frac{k}{m}}t + v_0\sqrt{\frac{m}{k}} \sin \sqrt{\frac{k}{m}}t$

(b)  $l = 0.5$ ,  $k/m = g/l = 9.8/0.5 = 19.6$ ,  
 $y = -\cos(\sqrt{19.6}t) + 0.25\frac{1}{\sqrt{19.6}} \sin(\sqrt{19.6}t)$

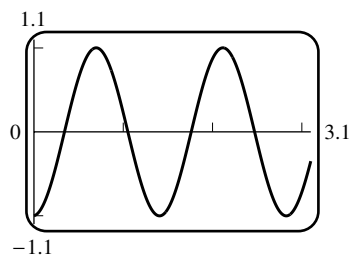

(c)  $v = y'(t) = \sqrt{19.6} \sin \sqrt{19.6}t + 0.25 \cos \sqrt{19.6}t = 0$  when  $\tan \sqrt{19.6}t = -\frac{0.25}{\sqrt{19.6}}$ , so

$$\sin \sqrt{19.6}t = \pm \frac{0.25}{\sqrt{19.6625}}, \quad \cos \sqrt{19.6}t = \mp \frac{\sqrt{19.6}}{\sqrt{19.6625}},$$

$$|y(t)| = \frac{\sqrt{19.6}}{\sqrt{19.6625}} + \frac{0.25}{\sqrt{19.6}} \frac{0.25}{\sqrt{19.6625}} = \frac{\sqrt{19.6625}}{\sqrt{19.6}}$$

$\approx 1.0016$  m is the maximum displacement.

25.  $y = y_0 \cos \sqrt{\frac{k}{m}}t$ ,  $T = 2\pi\sqrt{\frac{m}{k}}$ ,  $y = y_0 \cos \frac{2\pi t}{T}$

(a)  $v = y'(t) = -\frac{2\pi}{T}y_0 \sin \frac{2\pi t}{T}$  has maximum magnitude  $2\pi|y_0|/T$  and occurs when  $2\pi t/T = n\pi + \pi/2$ ,  $y = y_0 \cos(n\pi + \pi/2) = 0$ .

(b)  $a = h''(t) = -\frac{4\pi^2}{T^2}y_0 \cos \frac{2\pi t}{T}$  has maximum magnitude  $4\pi^2|y_0|/T^2$  and occurs when  $2\pi t/T = j\pi$ ,  $y = y_0 \cos j\pi = \pm y_0$ .

26. (a) In  $t$  years the interest will be compounded  $nt$  times at an interest rate of  $r/n$  each time. The value at the end of 1 interval is  $P + (r/n)P = P(1 + r/n)$ , at the end of 2 intervals it is  $P(1 + r/n) + (r/n)P(1 + r/n) = P(1 + r/n)^2$ , and continuing in this fashion the value at the end of  $nt$  intervals is  $P(1 + r/n)^{nt}$ .

(b) Let  $x = r/n$ , then  $n = r/x$  and  
 $\lim_{n \rightarrow +\infty} P(1 + r/n)^{nt} = \lim_{x \rightarrow 0^+} P(1 + x)^{rt/x} = \lim_{x \rightarrow 0^+} P[(1 + x)^{1/x}]^{rt} = Pe^{rt}$ .

(c) The rate of increase is  $dA/dt = rPe^{rt} = rA$ .

27. (a)  $A = 1000e^{(0.08)(5)} = 1000e^{0.4} \approx \$1,491.82$

(b)  $Pe^{(0.08)(10)} = 10,000$ ,  $Pe^{0.8} = 10,000$ ,  $P = 10,000e^{-0.8} \approx \$4,493.29$

(c) From (11) with  $k = r = 0.08$ ,  $T = (\ln 2)/0.08 \approx 8.7$  years.

# CHAPTER 11

## Infinite Series

### EXERCISE SET 11.1

- (a)  $\frac{1}{3^{n-1}}$       (b)  $\frac{(-1)^{n-1}}{3^{n-1}}$       (c)  $\frac{2n-1}{2n}$       (d)  $\frac{n^2}{\pi^{1/(n+1)}}$
- (a)  $(-r)^{n-1}; (-r)^n$       (b)  $(-1)^{n+1}r^n; (-1)^nr^{n+1}$
- (a) 2, 0, 2, 0      (b) 1, -1, 1, -1      (c)  $2(1 + (-1)^n); 2 + 2 \cos n\pi$
- (a)  $(2n)!$       (b)  $(2n - 1)!$
- $1/3, 2/4, 3/5, 4/6, 5/7, \dots; \lim_{n \rightarrow +\infty} \frac{n}{n+2} = 1$ , converges
- $1/3, 4/5, 9/7, 16/9, 25/11, \dots; \lim_{n \rightarrow +\infty} \frac{n^2}{2n+1} = +\infty$ , diverges
- $2, 2, 2, 2, 2, \dots; \lim_{n \rightarrow +\infty} 2 = 2$ , converges
- $\ln 1, \ln \frac{1}{2}, \ln \frac{1}{3}, \ln \frac{1}{4}, \ln \frac{1}{5}, \dots; \lim_{n \rightarrow +\infty} \ln(1/n) = -\infty$ , diverges
- $\frac{\ln 1}{1}, \frac{\ln 2}{2}, \frac{\ln 3}{3}, \frac{\ln 4}{4}, \frac{\ln 5}{5}, \dots;$   
 $\lim_{n \rightarrow +\infty} \frac{\ln n}{n} = \lim_{n \rightarrow +\infty} \frac{1}{n} = 0$  (apply L'Hôpital's Rule to  $\frac{\ln x}{x}$ ), converges
- $\sin \pi, 2 \sin(\pi/2), 3 \sin(\pi/3), 4 \sin(\pi/4), 5 \sin(\pi/5), \dots;$   
 $\lim_{n \rightarrow +\infty} n \sin(\pi/n) = \lim_{n \rightarrow +\infty} \frac{\sin(\pi/n)}{1/n} = \lim_{n \rightarrow +\infty} \frac{(-\pi/n^2) \cos(\pi/n)}{-1/n^2} = \pi$ , converges
- 0, 2, 0, 2, 0,  $\dots$ ; diverges
- $1, -1/4, 1/9, -1/16, 1/25, \dots; \lim_{n \rightarrow +\infty} \frac{(-1)^{n+1}}{n^2} = 0$ , converges
- $-1, 16/9, -54/28, 128/65, -250/126, \dots$ ; diverges because odd-numbered terms approach -2, even-numbered terms approach 2.
- $1/2, 2/4, 3/8, 4/16, 5/32, \dots; \lim_{n \rightarrow +\infty} \frac{n}{2^n} = \lim_{n \rightarrow +\infty} \frac{1}{2^n \ln 2} = 0$ , converges
- $6/2, 12/8, 20/18, 30/32, 42/50, \dots; \lim_{n \rightarrow +\infty} \frac{1}{2}(1 + 1/n)(1 + 2/n) = 1/2$ , converges
- $\pi/4, \pi^2/4^2, \pi^3/4^3, \pi^4/4^4, \pi^5/4^5, \dots; \lim_{n \rightarrow +\infty} (\pi/4)^n = 0$ , converges
- $\cos(3), \cos(3/2), \cos(1), \cos(3/4), \cos(3/5), \dots; \lim_{n \rightarrow +\infty} \cos(3/n) = 1$ , converges
- 0, -1, 0, 1, 0,  $\dots$ ; diverges

19.  $e^{-1}, 4e^{-2}, 9e^{-3}, 16e^{-4}, 25e^{-5}, \dots$ ;  $\lim_{x \rightarrow +\infty} x^2 e^{-x} = \lim_{x \rightarrow +\infty} \frac{x^2}{e^x} = 0$ , so  $\lim_{n \rightarrow +\infty} n^2 e^{-n} = 0$ , converges

20.  $1, \sqrt{10} - 2, \sqrt{18} - 3, \sqrt{28} - 4, \sqrt{40} - 5, \dots$ ;

$$\lim_{n \rightarrow +\infty} (\sqrt{n^2 + 3n} - n) = \lim_{n \rightarrow +\infty} \frac{3n}{\sqrt{n^2 + 3n} + n} = \lim_{n \rightarrow +\infty} \frac{3}{\sqrt{1 + 3/n} + 1} = \frac{3}{2}, \text{ converges}$$

21.  $2, (5/3)^2, (6/4)^3, (7/5)^4, (8/6)^5, \dots$ ; let  $y = \left[ \frac{x+3}{x+1} \right]^x$ , converges because

$$\lim_{x \rightarrow +\infty} \ln y = \lim_{x \rightarrow +\infty} \frac{\ln \frac{x+3}{x+1}}{1/x} = \lim_{x \rightarrow +\infty} \frac{2x^2}{(x+1)(x+3)} = 2, \text{ so } \lim_{n \rightarrow +\infty} \left[ \frac{n+3}{n+1} \right]^n = e^2$$

22.  $-1, 0, (1/3)^3, (2/4)^4, (3/5)^5, \dots$ ; let  $y = (1 - 2/x)^x$ , converges because

$$\lim_{x \rightarrow +\infty} \ln y = \lim_{x \rightarrow +\infty} \frac{\ln(1 - 2/x)}{1/x} = \lim_{x \rightarrow +\infty} \frac{-2}{1 - 2/x} = -2, \lim_{n \rightarrow +\infty} (1 - 2/n)^n = \lim_{x \rightarrow +\infty} y = e^{-2}$$

23.  $\left\{ \frac{2n-1}{2n} \right\}_{n=1}^{+\infty}$ ;  $\lim_{n \rightarrow +\infty} \frac{2n-1}{2n} = 1$ , converges

24.  $\left\{ \frac{n-1}{n^2} \right\}_{n=1}^{+\infty}$ ;  $\lim_{n \rightarrow +\infty} \frac{n-1}{n^2} = 0$ , converges

25.  $\left\{ \frac{1}{3^n} \right\}_{n=1}^{+\infty}$ ;  $\lim_{n \rightarrow +\infty} \frac{1}{3^n} = 0$ , converges

26.  $\{(-1)^n n\}_{n=1}^{+\infty}$ ; diverges because odd-numbered terms tend toward  $-\infty$ , even-numbered terms tend toward  $+\infty$ .

27.  $\left\{ \frac{1}{n} - \frac{1}{n+1} \right\}_{n=1}^{+\infty}$ ;  $\lim_{n \rightarrow +\infty} \left( \frac{1}{n} - \frac{1}{n+1} \right) = 0$ , converges

28.  $\{3/2^{n-1}\}_{n=1}^{+\infty}$ ;  $\lim_{n \rightarrow +\infty} 3/2^{n-1} = 0$ , converges

29.  $\{\sqrt{n+1} - \sqrt{n+2}\}_{n=1}^{+\infty}$ ; converges because

$$\lim_{n \rightarrow +\infty} (\sqrt{n+1} - \sqrt{n+2}) = \lim_{n \rightarrow +\infty} \frac{(n+1) - (n+2)}{\sqrt{n+1} + \sqrt{n+2}} = \lim_{n \rightarrow +\infty} \frac{-1}{\sqrt{n+1} + \sqrt{n+2}} = 0$$

30.  $\{(-1)^{n+1}/3^{n+4}\}_{n=1}^{+\infty}$ ;  $\lim_{n \rightarrow +\infty} (-1)^{n+1}/3^{n+4} = 0$ , converges

32.  $\lim_{n \rightarrow +\infty} \sqrt[n]{n} = 1$ , so  $\lim_{n \rightarrow +\infty} \sqrt[n]{n^3} = 1^3 = 1$

33. (a)  $1, 2, 1, 4, 1, 6$  (b)  $a_n = \begin{cases} n, & n \text{ odd} \\ 1/2^n, & n \text{ even} \end{cases}$  (c)  $a_n = \begin{cases} 1/n, & n \text{ odd} \\ 1/(n+1), & n \text{ even} \end{cases}$

(d) In part (a) the sequence diverges, since the even terms diverge to  $+\infty$  and the odd terms equal 1; in part (b) the sequence diverges, since the odd terms diverge to  $+\infty$  and the even terms tend to zero; in part (c)  $\lim_{n \rightarrow +\infty} a_n = 0$ .

34. The even terms are zero, so the odd terms must converge to zero, and this is true if and only if

$$\lim_{n \rightarrow +\infty} b^n = 0, \text{ or } -1 < b < 1.$$

35.  $\lim_{n \rightarrow +\infty} y_{n+1} = \lim_{n \rightarrow +\infty} \frac{1}{2}(y_n + p/y_n)$ ,  $L = \frac{1}{2}(L + p/L)$ ,  $L^2 = p$ ,  $L = \pm\sqrt{p}$ ;  
 $L = -\sqrt{p}$  (reject, because the terms in the sequence are positive) or  $L = \sqrt{p}$ ;  $\lim_{n \rightarrow +\infty} y_n = \sqrt{p}$ .
36. (a)  $a_{n+1} = \sqrt{6 + a_n}$   
 (b)  $\lim_{n \rightarrow +\infty} a_{n+1} = \lim_{n \rightarrow +\infty} \sqrt{6 + a_n}$ ,  $L = \sqrt{6 + L}$ ,  $L^2 - L - 6 = 0$ ,  $(L - 3)(L + 2) = 0$ ,  
 $L = -2$  (reject, because the terms in the sequence are positive) or  $L = 3$ ;  $\lim_{n \rightarrow +\infty} a_n = 3$ .
37. (a)  $1, \frac{1}{4} + \frac{2}{4}, \frac{1}{9} + \frac{2}{9} + \frac{3}{9}, \frac{1}{16} + \frac{2}{16} + \frac{3}{16} + \frac{4}{16} = 1, \frac{3}{4}, \frac{2}{3}, \frac{5}{8}$   
 (c)  $a_n = \frac{1}{n^2}(1 + 2 + \cdots + n) = \frac{1}{n^2} \frac{1}{2}n(n+1) = \frac{1}{2} \frac{n+1}{n}$ ,  $\lim_{n \rightarrow +\infty} a_n = 1/2$
38. (a)  $1, \frac{1}{8} + \frac{4}{8}, \frac{1}{27} + \frac{4}{27} + \frac{9}{27}, \frac{1}{64} + \frac{4}{64} + \frac{9}{64} + \frac{16}{64} = 1, \frac{5}{8}, \frac{14}{27}, \frac{15}{32}$   
 (c)  $a_n = \frac{1}{n^3}(1^2 + 2^2 + \cdots + n^2) = \frac{1}{n^3} \frac{1}{6}n(n+1)(2n+1) = \frac{1}{6} \frac{(n+1)(2n+1)}{n^2}$ ,  
 $\lim_{n \rightarrow +\infty} a_n = \lim_{n \rightarrow +\infty} \frac{1}{6}(1 + 1/n)(2 + 1/n) = 1/3$
39. Let  $a_n = 0, b_n = \frac{\sin^2 n}{n}, c_n = \frac{1}{n}$ ; then  $a_n \leq b_n \leq c_n$ ,  $\lim_{n \rightarrow +\infty} a_n = \lim_{n \rightarrow +\infty} c_n = 0$ , so  $\lim_{n \rightarrow +\infty} b_n = 0$ .
40. Let  $a_n = 0, b_n = \left(\frac{1+n}{2n}\right)^n, c_n = \left(\frac{3}{4}\right)^n$ ; then (for  $n \geq 2$ ),  $a_n \leq b_n \leq \left(\frac{n/2+n}{2n}\right)^n = c_n$ ,  
 $\lim_{n \rightarrow +\infty} a_n = \lim_{n \rightarrow +\infty} c_n = 0$ , so  $\lim_{n \rightarrow +\infty} b_n = 0$ .
41. (a)  $a_1 = (0.5)^2, a_2 = a_1^2 = (0.5)^4, \dots, a_n = (0.5)^{2^n}$   
 (c)  $\lim_{n \rightarrow +\infty} a_n = \lim_{n \rightarrow +\infty} e^{2^n \ln(0.5)} = 0$ , since  $\ln(0.5) < 0$ .  
 (d) Replace 0.5 in part (a) with  $a_0$ ; then the sequence converges for  $-1 \leq a_0 \leq 1$ , because if  $a_0 = \pm 1$ , then  $a_n = 1$  for  $n \geq 1$ ; if  $a_0 = 0$  then  $a_n = 0$  for  $n \geq 1$ ; and if  $0 < |a_0| < 1$  then  $a_1 = a_0^2 > 0$  and  $\lim_{n \rightarrow +\infty} a_n = \lim_{n \rightarrow +\infty} e^{2^{n-1} \ln a_1} = 0$  since  $0 < a_1 < 1$ .
42.  $f(0.2) = 0.4, f(0.4) = 0.8, f(0.8) = 0.6, f(0.6) = 0.2$  and then the cycle repeats, so the sequence does not converge.

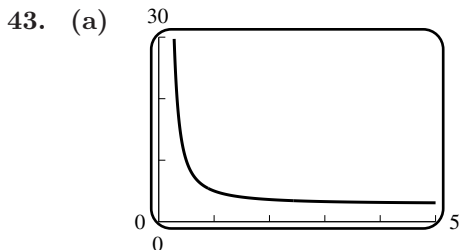

- (b) Let  $y = (2^x + 3^x)^{1/x}$ ,  $\lim_{x \rightarrow +\infty} \ln y = \lim_{x \rightarrow +\infty} \frac{\ln(2^x + 3^x)}{x} = \lim_{x \rightarrow +\infty} \frac{2^x \ln 2 + 3^x \ln 3}{2^x + 3^x}$   
 $= \lim_{x \rightarrow +\infty} \frac{(2/3)^x \ln 2 + \ln 3}{(2/3)^x + 1} = \ln 3$ , so  $\lim_{n \rightarrow +\infty} (2^n + 3^n)^{1/n} = e^{\ln 3} = 3$

44. Let  $f(x) = 1/(1+x)$ ,  $0 \leq x \leq 1$ . Take  $\Delta x_k = 1/n$  and  $x_k^* = k/n$  then

$$a_n = \sum_{k=1}^n \frac{1}{1+(k/n)}(1/n) = \sum_{k=1}^n \frac{1}{1+x_k^*} \Delta x_k \text{ so } \lim_{n \rightarrow +\infty} a_n = \int_0^1 \frac{1}{1+x} dx = \ln(1+x) \Big|_0^1 = \ln 2$$

45.  $a_n = \frac{1}{n-1} \int_1^n \frac{1}{x} dx = \frac{\ln n}{n-1}$ ,  $\lim_{n \rightarrow +\infty} a_n = \lim_{n \rightarrow +\infty} \frac{\ln n}{n-1} = \lim_{n \rightarrow +\infty} \frac{1}{n} = 0$ ,  
 (apply L'Hôpital's Rule to  $\frac{\ln n}{n-1}$ ), converges

46. (a) If  $n \geq 1$ , then  $a_{n+2} = a_{n+1} + a_n$ , so  $\frac{a_{n+2}}{a_{n+1}} = 1 + \frac{a_n}{a_{n+1}}$ .

(c) With  $L = \lim_{n \rightarrow +\infty} (a_{n+2}/a_{n+1}) = \lim_{n \rightarrow +\infty} (a_{n+1}/a_n)$ ,  $L = 1 + 1/L$ ,  $L^2 - L - 1 = 0$ ,  
 $L = (1 \pm \sqrt{5})/2$ , so  $L = (1 + \sqrt{5})/2$  because the limit cannot be negative.

47.  $\left| \frac{1}{n} - 0 \right| = \frac{1}{n} < \epsilon$  if  $n > 1/\epsilon$

(a)  $1/\epsilon = 1/0.5 = 2$ ,  $N = 3$

(b)  $1/\epsilon = 1/0.1 = 10$ ,  $N = 11$

(c)  $1/\epsilon = 1/0.001 = 1000$ ,  $N = 1001$

48.  $\left| \frac{n}{n+1} - 1 \right| = \frac{1}{n+1} < \epsilon$  if  $n+1 > 1/\epsilon$ ,  $n > 1/\epsilon - 1$

(a)  $1/\epsilon - 1 = 1/0.25 - 1 = 3$ ,  $N = 4$

(b)  $1/\epsilon - 1 = 1/0.1 - 1 = 9$ ,  $N = 10$

(c)  $1/\epsilon - 1 = 1/0.001 - 1 = 999$ ,  $N = 1000$

49. (a)  $\left| \frac{1}{n} - 0 \right| = \frac{1}{n} < \epsilon$  if  $n > 1/\epsilon$ , choose any  $N > 1/\epsilon$ .

(b)  $\left| \frac{n}{n+1} - 1 \right| = \frac{1}{n+1} < \epsilon$  if  $n > 1/\epsilon - 1$ , choose any  $N > 1/\epsilon - 1$ .

50. If  $|r| < 1$  then  $\lim_{n \rightarrow +\infty} r^n = 0$ ; if  $r > 1$  then  $\lim_{n \rightarrow +\infty} r^n = +\infty$ , if  $r < -1$  then  $r^n$  oscillates between positive and negative values that grow in magnitude so  $\lim_{n \rightarrow +\infty} r^n$  does not exist for  $|r| > 1$ ; if  $r = 1$  then  $\lim_{n \rightarrow +\infty} 1^n = 1$ ; if  $r = -1$  then  $(-1)^n$  oscillates between  $-1$  and  $1$  so  $\lim_{n \rightarrow +\infty} (-1)^n$  does not exist.

## EXERCISE SET 11.2

1.  $a_{n+1} - a_n = \frac{1}{n+1} - \frac{1}{n} = -\frac{1}{n(n+1)} < 0$  for  $n \geq 1$ , so strictly decreasing.

2.  $a_{n+1} - a_n = \left(1 - \frac{1}{n+1}\right) - \left(1 - \frac{1}{n}\right) = \frac{1}{n(n+1)} > 0$  for  $n \geq 1$ , so strictly increasing.

3.  $a_{n+1} - a_n = \frac{n+1}{2n+3} - \frac{n}{2n+1} = \frac{1}{(2n+1)(2n+3)} > 0$  for  $n \geq 1$ , so strictly increasing.

4.  $a_{n+1} - a_n = \frac{n+1}{4n+3} - \frac{n}{4n-1} = -\frac{1}{(4n-1)(4n+3)} < 0$  for  $n \geq 1$ , so strictly decreasing.
5.  $a_{n+1} - a_n = (n+1 - 2^{n+1}) - (n - 2^n) = 1 - 2^n < 0$  for  $n \geq 1$ , so strictly decreasing.
6.  $a_{n+1} - a_n = [(n+1) - (n+1)^2] - (n - n^2) = -2n < 0$  for  $n \geq 1$ , so strictly decreasing.
7.  $\frac{a_{n+1}}{a_n} = \frac{(n+1)/(2n+3)}{n/(2n+1)} = \frac{(n+1)(2n+1)}{n(2n+3)} = \frac{2n^2+3n+1}{2n^2+3n} > 1$  for  $n \geq 1$ , so strictly increasing.
8.  $\frac{a_{n+1}}{a_n} = \frac{2^{n+1}}{1+2^{n+1}} \cdot \frac{1+2^n}{2^n} = \frac{2+2^{n+1}}{1+2^{n+1}} = 1 + \frac{1}{1+2^{n+1}} > 1$  for  $n \geq 1$ , so strictly increasing.
9.  $\frac{a_{n+1}}{a_n} = \frac{(n+1)e^{-(n+1)}}{ne^{-n}} = (1+1/n)e^{-1} < 1$  for  $n \geq 1$ , so strictly decreasing.
10.  $\frac{a_{n+1}}{a_n} = \frac{10^{n+1}}{(2n+2)!} \cdot \frac{(2n)!}{10^n} = \frac{10}{(2n+2)(2n+1)} < 1$  for  $n \geq 1$ , so strictly decreasing.
11.  $\frac{a_{n+1}}{a_n} = \frac{(n+1)^{n+1}}{(n+1)!} \cdot \frac{n!}{n^n} = \frac{(n+1)^n}{n^n} = (1+1/n)^n > 1$  for  $n \geq 1$ , so strictly increasing.
12.  $\frac{a_{n+1}}{a_n} = \frac{5^{n+1}}{2^{(n+1)^2}} \cdot \frac{2^{n^2}}{5^n} = \frac{5}{2^{2n+1}} < 1$  for  $n \geq 1$ , so strictly decreasing.
13.  $f(x) = x/(2x+1)$ ,  $f'(x) = 1/(2x+1)^2 > 0$  for  $x \geq 1$ , so strictly increasing.
14.  $f(x) = 3 - 1/x$ ,  $f'(x) = 1/x^2 > 0$  for  $x \geq 1$ , so strictly increasing.
15.  $f(x) = 1/(x + \ln x)$ ,  $f'(x) = -\frac{1+1/x}{(x + \ln x)^2} < 0$  for  $x \geq 1$ , so strictly decreasing.
16.  $f(x) = xe^{-2x}$ ,  $f'(x) = (1-2x)e^{-2x} < 0$  for  $x \geq 1$ , so strictly decreasing.
17.  $f(x) = \frac{\ln(x+2)}{x+2}$ ,  $f'(x) = \frac{1 - \ln(x+2)}{(x+2)^2} < 0$  for  $x \geq 1$ , so strictly decreasing.
18.  $f(x) = \tan^{-1} x$ ,  $f'(x) = 1/(1+x^2) > 0$  for  $x \geq 1$ , so strictly increasing.
19.  $f(x) = 2x^2 - 7x$ ,  $f'(x) = 4x - 7 > 0$  for  $x \geq 2$ , so eventually strictly increasing.
20.  $f(x) = x^3 - 4x^2$ ,  $f'(x) = 3x^2 - 8x = x(3x-8) > 0$  for  $x \geq 3$ , so eventually strictly increasing.
21.  $f(x) = \frac{x}{x^2+10}$ ,  $f'(x) = \frac{10-x^2}{(x^2+10)^2} < 0$  for  $x \geq 4$ , so eventually strictly decreasing.
22.  $f(x) = x + \frac{17}{x}$ ,  $f'(x) = \frac{x^2-17}{x^2} > 0$  for  $x \geq 5$ , so eventually strictly increasing.
23.  $\frac{a_{n+1}}{a_n} = \frac{(n+1)!}{3^{n+1}} \cdot \frac{3^n}{n!} = \frac{n+1}{3} > 1$  for  $n \geq 3$ , so eventually strictly increasing.
24.  $f(x) = x^5e^{-x}$ ,  $f'(x) = x^4(5-x)e^{-x} < 0$  for  $x \geq 6$ , so eventually strictly decreasing.

25. (a) Yes: a monotone sequence is increasing or decreasing; if it is increasing, then it is increasing and bounded above, so by Theorem 11.2.3 it converges; if decreasing, then use Theorem 11.2.4. The limit lies in the interval  $[1, 2]$ .
- (b) Such a sequence may converge, in which case, by the argument in Part (a), its limit is  $\leq 2$ . But convergence may not happen: for example, the sequence  $\{-n\}_{n=1}^{+\infty}$  diverges.
26. (a)  $a_{n+1} = \frac{|x|^{n+1}}{(n+1)!} = \frac{|x|}{n+1} \frac{|x|^n}{n!} = \frac{|x|}{n+1} a_n$
- (b)  $a_{n+1}/a_n = |x|/(n+1) < 1$  if  $n > |x| - 1$ .
- (c) From Part (b) the sequence is eventually decreasing, and it is bounded below by 0, so by Theorem 11.2.4 it converges.
- (d) If  $\lim_{n \rightarrow +\infty} a_n = L$  then from Part (a),  $L = \frac{|x|}{\lim_{n \rightarrow +\infty} (n+1)} L = 0$ .
- (e)  $\lim_{n \rightarrow +\infty} \frac{|x|^n}{n!} = \lim_{n \rightarrow +\infty} a_n = 0$
27. (a)  $\sqrt{2}, \sqrt{2 + \sqrt{2}}, \sqrt{2 + \sqrt{2 + \sqrt{2}}}$
- (b)  $a_1 = \sqrt{2} < 2$  so  $a_2 = \sqrt{2 + a_1} < \sqrt{2 + 2} = 2$ ,  $a_3 = \sqrt{2 + a_2} < \sqrt{2 + 2} = 2$ , and so on indefinitely.
- (c)  $a_{n+1}^2 - a_n^2 = (2 + a_n) - a_n^2 = 2 + a_n - a_n^2 = (2 - a_n)(1 + a_n)$
- (d)  $a_n > 0$  and, from Part (b),  $a_n < 2$  so  $2 - a_n > 0$  and  $1 + a_n > 0$  thus, from Part (c),  $a_{n+1}^2 - a_n^2 > 0$ ,  $a_{n+1} - a_n > 0$ ,  $a_{n+1} > a_n$ ;  $\{a_n\}$  is a strictly increasing sequence.
- (e) The sequence is increasing and has 2 as an upper bound so it must converge to a limit  $L$ ,  $\lim_{n \rightarrow +\infty} a_{n+1} = \lim_{n \rightarrow +\infty} \sqrt{2 + a_n}$ ,  $L = \sqrt{2 + L}$ ,  $L^2 - L - 2 = 0$ ,  $(L - 2)(L + 1) = 0$  thus  $\lim_{n \rightarrow +\infty} a_n = 2$ .
28. (a) If  $f(x) = \frac{1}{2}(x + 3/x)$ , then  $f'(x) = (x^2 - 3)/(2x^2)$  and  $f'(x) = 0$  for  $x = \sqrt{3}$ ; the minimum value of  $f(x)$  for  $x > 0$  is  $f(\sqrt{3}) = \sqrt{3}$ . Thus  $f(x) \geq \sqrt{3}$  for  $x > 0$  and hence  $a_n \geq \sqrt{3}$  for  $n \geq 2$ .
- (b)  $a_{n+1} - a_n = (3 - a_n^2)/(2a_n) \leq 0$  for  $n \geq 2$  since  $a_n \geq \sqrt{3}$  for  $n \geq 2$ ;  $\{a_n\}$  is eventually decreasing.
- (c)  $\sqrt{3}$  is a lower bound for  $a_n$  so  $\{a_n\}$  converges;  $\lim_{n \rightarrow +\infty} a_{n+1} = \lim_{n \rightarrow +\infty} \frac{1}{2}(a_n + 3/a_n)$ ,  $L = \frac{1}{2}(L + 3/L)$ ,  $L^2 - 3 = 0$ ,  $L = \sqrt{3}$ .
29. (a) The altitudes of the rectangles are  $\ln k$  for  $k = 2$  to  $n$ , and their bases all have length 1 so the sum of their areas is  $\ln 2 + \ln 3 + \cdots + \ln n = \ln(2 \cdot 3 \cdots n) = \ln n!$ . The area under the curve  $y = \ln x$  for  $x$  in the interval  $[1, n]$  is  $\int_1^n \ln x \, dx$ , and  $\int_1^{n+1} \ln x \, dx$  is the area for  $x$  in the interval  $[1, n+1]$  so, from the figure,  $\int_1^n \ln x \, dx < \ln n! < \int_1^{n+1} \ln x \, dx$ .
- (b)  $\int_1^n \ln x \, dx = (x \ln x - x) \Big|_1^n = n \ln n - n + 1$  and  $\int_1^{n+1} \ln x \, dx = (n+1) \ln(n+1) - n$  so from Part (a),  $n \ln n - n + 1 < \ln n! < (n+1) \ln(n+1) - n$ ,  $e^{n \ln n - n + 1} < n! < e^{(n+1) \ln(n+1) - n}$ ,  $e^{n \ln n} e^{1-n} < n! < e^{(n+1) \ln(n+1)} e^{-n}$ ,  $\frac{n^n}{e^{n-1}} < n! < \frac{(n+1)^{n+1}}{e^n}$

(c) From part (b),  $\left[\frac{n^n}{e^{n-1}}\right]^{1/n} < \sqrt[n]{n!} < \left[\frac{(n+1)^{n+1}}{e^n}\right]^{1/n}$ ,

$$\frac{n}{e^{1-1/n}} < \sqrt[n]{n!} < \frac{(n+1)^{1+1/n}}{e}, \quad \frac{1}{e^{1-1/n}} < \frac{\sqrt[n]{n!}}{n} < \frac{(1+1/n)(n+1)^{1/n}}{e},$$

but  $\frac{1}{e^{1-1/n}} \rightarrow \frac{1}{e}$  and  $\frac{(1+1/n)(n+1)^{1/n}}{e} \rightarrow \frac{1}{e}$  as  $n \rightarrow +\infty$  (why?), so  $\lim_{n \rightarrow +\infty} \frac{\sqrt[n]{n!}}{n} = \frac{1}{e}$ .

30.  $n! > \frac{n^n}{e^{n-1}}$ ,  $\sqrt[n]{n!} > \frac{n}{e^{1-1/n}}$ ,  $\lim_{n \rightarrow +\infty} \frac{n}{e^{1-1/n}} = +\infty$  so  $\lim_{n \rightarrow +\infty} \sqrt[n]{n!} = +\infty$ .

### EXERCISE SET 11.3

1. (a)  $s_1 = 2, s_2 = 12/5, s_3 = \frac{62}{25}, s_4 = \frac{312}{125}, s_n = \frac{2 - 2(1/5)^n}{1 - 1/5} = \frac{5}{2} - \frac{5}{2}(1/5)^n$ ,

$$\lim_{n \rightarrow +\infty} s_n = \frac{5}{2}, \text{ converges}$$

(b)  $s_1 = \frac{1}{4}, s_2 = \frac{3}{4}, s_3 = \frac{7}{4}, s_4 = \frac{15}{4}, s_n = \frac{(1/4) - (1/4)2^n}{1 - 2} = -\frac{1}{4} + \frac{1}{4}(2^n)$ ,

$$\lim_{n \rightarrow +\infty} s_n = +\infty, \text{ diverges}$$

(c)  $\frac{1}{(k+1)(k+2)} = \frac{1}{k+1} - \frac{1}{k+2}, s_1 = \frac{1}{6}, s_2 = \frac{1}{4}, s_3 = \frac{3}{10}, s_4 = \frac{1}{3};$

$$s_n = \frac{1}{2} - \frac{1}{n+2}, \lim_{n \rightarrow +\infty} s_n = \frac{1}{2}, \text{ converges}$$

2. (a)  $s_1 = 1/4, s_2 = 5/16, s_3 = 21/64, s_4 = 85/256$

$$s_n = \frac{1}{4} \left( 1 + \frac{1}{4} + \dots + \left(\frac{1}{4}\right)^{n-1} \right) = \frac{1}{4} \frac{1 - (1/4)^n}{1 - 1/4} = \frac{1}{3} \left( 1 - \left(\frac{1}{4}\right)^n \right); \lim_{n \rightarrow +\infty} s_n = \frac{1}{3}$$

(b)  $s_1 = 1, s_2 = 5, s_3 = 21, s_4 = 85; s_n = \frac{4^n - 1}{3}, \text{ diverges}$

(c)  $s_1 = 1/20, s_2 = 1/12, s_3 = 3/28, s_4 = 1/8;$

$$s_n = \sum_{k=1}^n \left( \frac{1}{k+3} - \frac{1}{k+4} \right) = \frac{1}{4} - \frac{1}{n+4}, \lim_{n \rightarrow +\infty} s_n = 1/4$$

3. geometric,  $a = 1, r = -3/4, \text{ sum} = \frac{1}{1 - (-3/4)} = 4/7$

4. geometric,  $a = (2/3)^3, r = 2/3, \text{ sum} = \frac{(2/3)^3}{1 - 2/3} = 8/9$

5. geometric,  $a = 7, r = -1/6, \text{ sum} = \frac{7}{1 + 1/6} = 6$

6. geometric,  $r = -3/2, \text{ diverges}$

7.  $s_n = \sum_{k=1}^n \left( \frac{1}{k+2} - \frac{1}{k+3} \right) = \frac{1}{3} - \frac{1}{n+3}, \lim_{n \rightarrow +\infty} s_n = 1/3$



8.  $s_n = \sum_{k=1}^n \left( \frac{1}{2^k} - \frac{1}{2^{k+1}} \right) = \frac{1}{2} - \frac{1}{2^{n+1}}, \lim_{n \rightarrow +\infty} s_n = 1/2$
9.  $s_n = \sum_{k=1}^n \left( \frac{1/3}{3k-1} - \frac{1/3}{3k+2} \right) = \frac{1}{6} - \frac{1/3}{3n+2}, \lim_{n \rightarrow +\infty} s_n = 1/6$
10.  $s_n = \sum_{k=2}^{n+1} \left[ \frac{1/2}{k-1} - \frac{1/2}{k+1} \right] = \frac{1}{2} \left[ \sum_{k=2}^{n+1} \frac{1}{k-1} - \sum_{k=2}^{n+1} \frac{1}{k+1} \right]$   
 $= \frac{1}{2} \left[ \sum_{k=2}^{n+1} \frac{1}{k-1} - \sum_{k=4}^{n+3} \frac{1}{k-1} \right] = \frac{1}{2} \left[ 1 + \frac{1}{2} - \frac{1}{n+1} - \frac{1}{n+2} \right]; \lim_{n \rightarrow +\infty} s_n = \frac{3}{4}$
11.  $\sum_{k=3}^{\infty} \frac{1}{k-2} = \sum_{k=1}^{\infty} 1/k$ , the harmonic series, so the series diverges.
12. geometric,  $a = (e/\pi)^4$ ,  $r = e/\pi < 1$ ,  $\text{sum} = \frac{(e/\pi)^4}{1 - e/\pi} = \frac{e^4}{\pi^3(\pi - e)}$
13.  $\sum_{k=1}^{\infty} \frac{4^{k+2}}{7^{k-1}} = \sum_{k=1}^{\infty} 64 \left( \frac{4}{7} \right)^{k-1}$ ; geometric,  $a = 64$ ,  $r = 4/7$ ,  $\text{sum} = \frac{64}{1 - 4/7} = 448/3$
14. geometric,  $a = 125$ ,  $r = 125/7$ , diverges
15.  $0.4444 \dots = 0.4 + 0.04 + 0.004 + \dots = \frac{0.4}{1 - 0.1} = 4/9$
16.  $0.9999 \dots = 0.9 + 0.09 + 0.009 + \dots = \frac{0.9}{1 - 0.1} = 1$
17.  $5.373737 \dots = 5 + 0.37 + 0.0037 + 0.000037 + \dots = 5 + \frac{0.37}{1 - 0.01} = 5 + 37/99 = 532/99$
18.  $0.159159159 \dots = 0.159 + 0.000159 + 0.000000159 + \dots = \frac{0.159}{1 - 0.001} = 159/999 = 53/333$
19.  $0.782178217821 \dots = 0.7821 + 0.00007821 + 0.000000007821 + \dots = \frac{0.7821}{1 - 0.0001} = \frac{7821}{9999} = \frac{869}{1111}$
20.  $0.451141414 \dots = 0.451 + 0.00014 + 0.0000014 + 0.000000014 + \dots = 0.451 + \frac{0.00014}{1 - 0.01} = \frac{44663}{99000}$
22. (a) geometric;  $18/5$       (b) geometric; diverges      (c)  $\sum_{k=1}^{\infty} \frac{1}{2} \left( \frac{1}{2k-1} - \frac{1}{2k+1} \right) = 1/2$
23.  $d = 10 + 2 \cdot \frac{3}{4} \cdot 10 + 2 \cdot \frac{3}{4} \cdot \frac{3}{4} \cdot 10 + 2 \cdot \frac{3}{4} \cdot \frac{3}{4} \cdot \frac{3}{4} \cdot 10 + \dots$   
 $= 10 + 20 \left( \frac{3}{4} \right) + 20 \left( \frac{3}{4} \right)^2 + 20 \left( \frac{3}{4} \right)^3 + \dots = 10 + \frac{20(3/4)}{1 - 3/4} = 10 + 60 = 70$  meters

24. volume =  $1^3 + \left(\frac{1}{2}\right)^3 + \left(\frac{1}{4}\right)^3 + \cdots + \left(\frac{1}{2^n}\right)^3 + \cdots = 1 + \frac{1}{8} + \left(\frac{1}{8}\right)^2 + \cdots + \left(\frac{1}{8}\right)^n + \cdots$   
 $= \frac{1}{1 - (1/8)} = 8/7$
25. (a)  $s_n = \ln \frac{1}{2} + \ln \frac{2}{3} + \ln \frac{3}{4} + \cdots + \ln \frac{n}{n+1} = \ln \left( \frac{1}{2} \cdot \frac{2}{3} \cdot \frac{3}{4} \cdots \frac{n}{n+1} \right) = \ln \frac{1}{n+1} = -\ln(n+1)$ ,  
 $\lim_{n \rightarrow +\infty} s_n = -\infty$ , series diverges.
- (b)  $\ln(1 - 1/k^2) = \ln \frac{k^2 - 1}{k^2} = \ln \frac{(k-1)(k+1)}{k^2} = \ln \frac{k-1}{k} + \ln \frac{k+1}{k} = \ln \frac{k-1}{k} - \ln \frac{k}{k+1}$ ,  
 $s_n = \sum_{k=2}^{n+1} \left[ \ln \frac{k-1}{k} - \ln \frac{k}{k+1} \right]$   
 $= \left( \ln \frac{1}{2} - \ln \frac{2}{3} \right) + \left( \ln \frac{2}{3} - \ln \frac{3}{4} \right) + \left( \ln \frac{3}{4} - \ln \frac{4}{5} \right) + \cdots + \left( \ln \frac{n}{n+1} - \ln \frac{n+1}{n+2} \right)$   
 $= \ln \frac{1}{2} - \ln \frac{n+1}{n+2}$ ,  $\lim_{n \rightarrow +\infty} s_n = \ln \frac{1}{2} = -\ln 2$
26. (a)  $\sum_{k=0}^{\infty} (-1)^k x^k = 1 - x + x^2 - x^3 + \cdots = \frac{1}{1 - (-x)} = \frac{1}{1+x}$  if  $|-x| < 1$ ,  $|x| < 1$ ,  $-1 < x < 1$ .
- (b)  $\sum_{k=0}^{\infty} (x-3)^k = 1 + (x-3) + (x-3)^2 + \cdots = \frac{1}{1 - (x-3)} = \frac{1}{4-x}$  if  $|x-3| < 1$ ,  $2 < x < 4$ .
- (c)  $\sum_{k=0}^{\infty} (-1)^k x^{2k} = 1 - x^2 + x^4 - x^6 + \cdots = \frac{1}{1 - (-x^2)} = \frac{1}{1+x^2}$  if  $|-x^2| < 1$ ,  $|x| < 1$ ,  $-1 < x < 1$ .
27. (a) Geometric series,  $a = x$ ,  $r = -x^2$ . Converges for  $|-x^2| < 1$ ,  $|x| < 1$ ;  
 $S = \frac{x}{1 - (-x^2)} = \frac{x}{1+x^2}$ .
- (b) Geometric series,  $a = 1/x^2$ ,  $r = 2/x$ . Converges for  $|2/x| < 1$ ,  $|x| > 2$ ;  
 $S = \frac{1/x^2}{1 - 2/x} = \frac{1}{x^2 - 2x}$ .
- (c) Geometric series,  $a = e^{-x}$ ,  $r = e^{-x}$ . Converges for  $|e^{-x}| < 1$ ,  $e^{-x} < 1$ ,  $e^x > 1$ ,  $x > 0$ ;  
 $S = \frac{e^{-x}}{1 - e^{-x}} = \frac{1}{e^x - 1}$ .
28.  $\frac{\sqrt{k+1} - \sqrt{k}}{\sqrt{k^2+k}} = \frac{\sqrt{k+1} - \sqrt{k}}{\sqrt{k}\sqrt{k+1}} = \frac{1}{\sqrt{k}} - \frac{1}{\sqrt{k+1}}$ ,  
 $s_n = \sum_{k=1}^n \left( \frac{1}{\sqrt{k}} - \frac{1}{\sqrt{k+1}} \right) = \left( \frac{1}{\sqrt{1}} - \frac{1}{\sqrt{2}} \right) + \left( \frac{1}{\sqrt{2}} - \frac{1}{\sqrt{3}} \right) + \left( \frac{1}{\sqrt{3}} - \frac{1}{\sqrt{4}} \right)$   
 $+ \cdots + \left( \frac{1}{\sqrt{n}} - \frac{1}{\sqrt{n+1}} \right) = 1 - \frac{1}{\sqrt{n+1}}$ ;  $\lim_{n \rightarrow +\infty} s_n = 1$
29.  $s_n = (1 - 1/3) + (1/2 - 1/4) + (1/3 - 1/5) + (1/4 - 1/6) + \cdots + [1/n - 1/(n+2)]$   
 $= (1 + 1/2 + 1/3 + \cdots + 1/n) - (1/3 + 1/4 + 1/5 + \cdots + 1/(n+2))$   
 $= 3/2 - 1/(n+1) - 1/(n+2)$ ,  $\lim_{n \rightarrow +\infty} s_n = 3/2$

$$\begin{aligned}
 30. \quad s_n &= \sum_{k=1}^n \frac{1}{k(k+2)} = \sum_{k=1}^n \left[ \frac{1/2}{k} - \frac{1/2}{k+2} \right] = \frac{1}{2} \left[ \sum_{k=1}^n \frac{1}{k} - \sum_{k=1}^n \frac{1}{k+2} \right] \\
 &= \frac{1}{2} \left[ \sum_{k=1}^n \frac{1}{k} - \sum_{k=3}^{n+2} \frac{1}{k} \right] = \frac{1}{2} \left[ 1 + \frac{1}{2} - \frac{1}{n+1} - \frac{1}{n+2} \right]; \quad \lim_{n \rightarrow +\infty} s_n = \frac{3}{4}
 \end{aligned}$$

$$\begin{aligned}
 31. \quad s_n &= \sum_{k=1}^n \frac{1}{(2k-1)(2k+1)} = \sum_{k=1}^n \left[ \frac{1/2}{2k-1} - \frac{1/2}{2k+1} \right] = \frac{1}{2} \left[ \sum_{k=1}^n \frac{1}{2k-1} - \sum_{k=1}^n \frac{1}{2k+1} \right] \\
 &= \frac{1}{2} \left[ \sum_{k=1}^n \frac{1}{2k-1} - \sum_{k=2}^{n+1} \frac{1}{2k-1} \right] = \frac{1}{2} \left[ 1 - \frac{1}{2n+1} \right]; \quad \lim_{n \rightarrow +\infty} s_n = \frac{1}{2}
 \end{aligned}$$

32. Geometric series,  $a = \sin x$ ,  $r = -\frac{1}{2} \sin x$ . Converges for  $|\sin x| < 2$ , so converges for all values of  $x$ .  $S = \frac{\sin x}{1 + \frac{1}{2} \sin x} = \frac{2 \sin x}{2 + \sin x}$ .

$$\begin{aligned}
 33. \quad a_2 &= \frac{1}{2}a_1 + \frac{1}{2}, \quad a_3 = \frac{1}{2}a_2 + \frac{1}{2} = \frac{1}{2^2}a_1 + \frac{1}{2^2} + \frac{1}{2}, \quad a_4 = \frac{1}{2}a_3 + \frac{1}{2} = \frac{1}{2^3}a_1 + \frac{1}{2^3} + \frac{1}{2^2} + \frac{1}{2}, \\
 a_5 &= \frac{1}{2}a_4 + \frac{1}{2} = \frac{1}{2^4}a_1 + \frac{1}{2^4} + \frac{1}{2^3} + \frac{1}{2^2} + \frac{1}{2}, \dots, \quad a_n = \frac{1}{2^{n-1}}a_1 + \frac{1}{2^{n-1}} + \frac{1}{2^{n-2}} + \dots + \frac{1}{2}, \\
 \lim_{n \rightarrow +\infty} a_n &= \lim_{n \rightarrow +\infty} \frac{a_1}{2^{n-1}} + \sum_{n=1}^{\infty} \left(\frac{1}{2}\right)^n = 0 + \frac{1/2}{1 - 1/2} = 1
 \end{aligned}$$

$$\begin{aligned}
 34. \quad 0.a_1a_2 \dots a_n 9999 \dots &= 0.a_1a_2 \dots a_n + 0.9(10^{-n}) + 0.09(10^{-n}) + \dots \\
 &= 0.a_1a_2 \dots a_n + \frac{0.9(10^{-n})}{1 - 0.1} = 0.a_1a_2 \dots a_n + 10^{-n} \\
 &= 0.a_1a_2 \dots (a_n + 1) = 0.a_1a_2 \dots (a_n + 1) 0000 \dots
 \end{aligned}$$

35. The series converges to  $1/(1-x)$  only if  $-1 < x < 1$ .

36.  $P_0P_1 = a \sin \theta$ ,  
 $P_1P_2 = a \sin \theta \cos \theta$ ,  
 $P_2P_3 = a \sin \theta \cos^2 \theta$ ,  
 $P_3P_4 = a \sin \theta \cos^3 \theta, \dots$   
 (see figure)  
 Each sum is a geometric series.

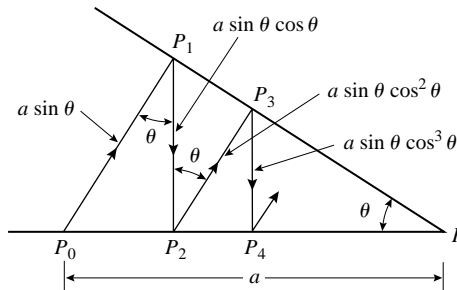

$$(a) \quad P_0P_1 + P_1P_2 + P_2P_3 + \dots = a \sin \theta + a \sin \theta \cos \theta + a \sin \theta \cos^2 \theta + \dots = \frac{a \sin \theta}{1 - \cos \theta}$$

$$\begin{aligned}
 (b) \quad P_0P_1 + P_2P_3 + P_4P_5 + \dots &= a \sin \theta + a \sin \theta \cos^2 \theta + a \sin \theta \cos^4 \theta + \dots \\
 &= \frac{a \sin \theta}{1 - \cos^2 \theta} = \frac{a \sin \theta}{\sin^2 \theta} = a \csc \theta
 \end{aligned}$$

$$\begin{aligned}
 (c) \quad P_1P_2 + P_3P_4 + P_5P_6 + \dots &= a \sin \theta \cos \theta + a \sin \theta \cos^3 \theta + \dots \\
 &= \frac{a \sin \theta \cos \theta}{1 - \cos^2 \theta} = \frac{a \sin \theta \cos \theta}{\sin^2 \theta} = a \cot \theta
 \end{aligned}$$

37. By inspection,  $\frac{\theta}{2} - \frac{\theta}{4} + \frac{\theta}{8} - \frac{\theta}{16} + \cdots = \frac{\theta/2}{1 - (-1/2)} = \theta/3$

38.  $A_1 + A_2 + A_3 + \cdots = 1 + 1/2 + 1/4 + \cdots = \frac{1}{1 - (1/2)} = 2$

39. (b) 
$$\frac{2^k A}{3^k - 2^k} + \frac{2^k B}{3^{k+1} - 2^{k+1}} = \frac{2^k (3^{k+1} - 2^{k+1}) A + 2^k (3^k - 2^k) B}{(3^k - 2^k)(3^{k+1} - 2^{k+1})}$$

$$= \frac{(3 \cdot 6^k - 2 \cdot 2^{2k}) A + (6^k - 2^{2k}) B}{(3^k - 2^k)(3^{k+1} - 2^{k+1})} = \frac{(3A + B)6^k - (2A + B)2^{2k}}{(3^k - 2^k)(3^{k+1} - 2^{k+1})}$$

so  $3A + B = 1$  and  $2A + B = 0$ ,  $A = 1$  and  $B = -2$ .

(c)  $s_n = \sum_{k=1}^n \left[ \frac{2^k}{3^k - 2^k} - \frac{2^{k+1}}{3^{k+1} - 2^{k+1}} \right] = \sum_{k=1}^n (a_k - a_{k+1})$  where  $a_k = \frac{2^k}{3^k - 2^k}$ .

But  $s_n = (a_1 - a_2) + (a_2 - a_3) + (a_3 - a_4) + \cdots + (a_n - a_{n+1})$  which is a telescoping sum,

$$s_n = a_1 - a_{n+1} = 2 - \frac{2^{n+1}}{3^{n+1} - 2^{n+1}}, \quad \lim_{n \rightarrow +\infty} s_n = \lim_{n \rightarrow +\infty} \left[ 2 - \frac{(2/3)^{n+1}}{1 - (2/3)^{n+1}} \right] = 2.$$

### EXERCISE SET 11.4

1. (a)  $\sum_{k=1}^{\infty} \frac{1}{2^k} = \frac{1/2}{1 - 1/2} = 1$ ;  $\sum_{k=1}^{\infty} \frac{1}{4^k} = \frac{1/4}{1 - 1/4} = 1/3$ ;  $\sum_{k=1}^{\infty} \left( \frac{1}{2^k} + \frac{1}{4^k} \right) = 1 + 1/3 = 4/3$

(b)  $\sum_{k=1}^{\infty} \frac{1}{5^k} = \frac{1/5}{1 - 1/5} = 1/4$ ;  $\sum_{k=1}^{\infty} \frac{1}{k(k+1)} = 1$  (Example 5, Section 11.3);

$$\sum_{k=1}^{\infty} \left[ \frac{1}{5^k} - \frac{1}{k(k+1)} \right] = 1/4 - 1 = -3/4$$

2. (a)  $\sum_{k=2}^{\infty} \frac{1}{k^2 - 1} = 3/4$  (Exercise 10, Section 11.3);  $\sum_{k=2}^{\infty} \frac{7}{10^{k-1}} = \frac{7/10}{1 - 1/10} = 7/9$ ;

so  $\sum_{k=2}^{\infty} \left[ \frac{1}{k^2 - 1} - \frac{7}{10^{k-1}} \right] = 3/4 - 7/9 = -1/36$

(b) with  $a = 9/7, r = 3/7$ , geometric,  $\sum_{k=1}^{\infty} 7^{-k} 3^{k+1} = \frac{9/7}{1 - (3/7)} = 9/4$ ;

with  $a = 4/5, r = 2/5$ , geometric,  $\sum_{k=1}^{\infty} \frac{2^{k+1}}{5^k} = \frac{4/5}{1 - (2/5)} = 4/3$ ;

$$\sum_{k=1}^{\infty} \left[ 7^{-k} 3^{k+1} - \frac{2^{k+1}}{5^k} \right] = 9/4 - 4/3 = 11/12$$

3. (a)  $p=3$ , converges      (b)  $p=1/2$ , diverges      (c)  $p=1$ , diverges      (d)  $p=2/3$ , diverges

4. (a)  $p=4/3$ , converges      (b)  $p=1/4$ , diverges      (c)  $p=5/3$ , converges      (d)  $p=\pi$ , converges

5. (a)  $\lim_{k \rightarrow +\infty} \frac{k^2 + k + 3}{2k^2 + 1} = \frac{1}{2}$ ; the series diverges. (b)  $\lim_{k \rightarrow +\infty} \left(1 + \frac{1}{k}\right)^k = e$ ; the series diverges.
- (c)  $\lim_{k \rightarrow +\infty} \cos k\pi$  does not exist; the series diverges. (d)  $\lim_{k \rightarrow +\infty} \frac{1}{k!} = 0$ ; no information
6. (a)  $\lim_{k \rightarrow +\infty} \frac{k}{e^k} = 0$ ; no information (b)  $\lim_{k \rightarrow +\infty} \ln k = +\infty$ ; the series diverges.
- (c)  $\lim_{k \rightarrow +\infty} \frac{1}{\sqrt{k}} = 0$ ; no information (d)  $\lim_{k \rightarrow +\infty} \frac{\sqrt{k}}{\sqrt{k} + 3} = 1$ ; the series diverges.
7. (a)  $\int_1^{+\infty} \frac{1}{5x+2} = \lim_{\ell \rightarrow +\infty} \frac{1}{5} \ln(5x+2) \Big|_1^\ell = +\infty$ , the series diverges by the Integral Test.
- (b)  $\int_1^{+\infty} \frac{1}{1+9x^2} dx = \lim_{\ell \rightarrow +\infty} \frac{1}{3} \tan^{-1} 3x \Big|_1^\ell = \frac{1}{3} (\pi/2 - \tan^{-1} 3)$ ,  
the series converges by the Integral Test.
8. (a)  $\int_1^{+\infty} \frac{x}{1+x^2} dx = \lim_{\ell \rightarrow +\infty} \frac{1}{2} \ln(1+x^2) \Big|_1^\ell = +\infty$ , the series diverges by the Integral Test.
- (b)  $\int_1^{+\infty} (4+2x)^{-3/2} dx = \lim_{\ell \rightarrow +\infty} -1/\sqrt{4+2x} \Big|_1^\ell = 1/\sqrt{6}$ ,  
the series converges by the Integral Test.
9.  $\sum_{k=1}^{\infty} \frac{1}{k+6} = \sum_{k=7}^{\infty} \frac{1}{k}$ , diverges because the harmonic series diverges.
10.  $\sum_{k=1}^{\infty} \frac{3}{5k} = \sum_{k=1}^{\infty} \frac{3}{5} \left(\frac{1}{k}\right)$ , diverges because the harmonic series diverges.
11.  $\sum_{k=1}^{\infty} \frac{1}{\sqrt{k+5}} = \sum_{k=6}^{\infty} \frac{1}{\sqrt{k}}$ , diverges because the  $p$ -series with  $p = 1/2 \leq 1$  diverges.
12.  $\lim_{k \rightarrow +\infty} \frac{1}{e^{1/k}} = 1$ , the series diverges because  $\lim_{k \rightarrow +\infty} u_k = 1 \neq 0$ .
13.  $\int_1^{+\infty} (2x-1)^{-1/3} dx = \lim_{\ell \rightarrow +\infty} \frac{3}{4} (2x-1)^{2/3} \Big|_1^\ell = +\infty$ , the series diverges by the Integral Test.
14.  $\frac{\ln x}{x}$  is decreasing for  $x \geq e$ , and  $\int_3^{+\infty} \frac{\ln x}{x} = \lim_{\ell \rightarrow +\infty} \frac{1}{2} (\ln x)^2 \Big|_3^\ell = +\infty$ ,  
so the series diverges by the Integral Test.
15.  $\lim_{k \rightarrow +\infty} \frac{k}{\ln(k+1)} = \lim_{k \rightarrow +\infty} \frac{1}{1/(k+1)} = +\infty$ , the series diverges because  $\lim_{k \rightarrow +\infty} u_k \neq 0$ .
16.  $\int_1^{+\infty} x e^{-x^2} dx = \lim_{\ell \rightarrow +\infty} -\frac{1}{2} e^{-x^2} \Big|_1^\ell = e^{-1}/2$ , the series converges by the Integral Test.

17.  $\lim_{k \rightarrow +\infty} (1 + 1/k)^{-k} = 1/e \neq 0$ , the series diverges.

18.  $\lim_{k \rightarrow +\infty} \frac{k^2 + 1}{k^2 + 3} = 1 \neq 0$ , the series diverges.

19.  $\int_1^{+\infty} \frac{\tan^{-1} x}{1 + x^2} dx = \lim_{\ell \rightarrow +\infty} \frac{1}{2} (\tan^{-1} x)^2 \Big|_1^\ell = 3\pi^2/32$ , the series converges by the Integral Test, since  
 $\frac{d}{dx} \frac{\tan^{-1} x}{1 + x^2} = \frac{1 - 2x \tan^{-1} x}{1 + x^2} < 0$  for  $x \geq 1$ .

20.  $\int_1^{+\infty} \frac{1}{\sqrt{x^2 + 1}} dx = \lim_{\ell \rightarrow +\infty} \sinh^{-1} x \Big|_1^\ell = +\infty$ , the series diverges by the Integral Test.

21.  $\lim_{k \rightarrow +\infty} k^2 \sin^2(1/k) = 1 \neq 0$ , the series diverges.

22.  $\int_1^{+\infty} x^2 e^{-x^3} dx = \lim_{\ell \rightarrow +\infty} -\frac{1}{3} e^{-x^3} \Big|_1^\ell = e^{-1}/3$ ,

the series converges by the Integral Test ( $x^2 e^{-x^3}$  is decreasing for  $x \geq 1$ ).

23.  $7 \sum_{k=5}^{\infty} k^{-1.01}$ ,  $p$ -series with  $p > 1$ , converges

24.  $\int_1^{+\infty} \operatorname{sech}^2 x dx = \lim_{\ell \rightarrow +\infty} \tanh x \Big|_1^\ell = 1 - \tanh(1)$ , the series converges by the Integral Test.

25.  $\frac{1}{x(\ln x)^p}$  is decreasing for  $x \geq e^{-p}$ , so use the Integral Test with  $\int_{e^{-p}}^{+\infty} \frac{dx}{x(\ln x)^p}$  to get

$$\lim_{\ell \rightarrow +\infty} \ln(\ln x) \Big|_{e^{-p}}^\ell = +\infty \text{ if } p = 1, \quad \lim_{\ell \rightarrow +\infty} \frac{(\ln x)^{1-p}}{1-p} \Big|_{e^{-p}}^\ell = \begin{cases} +\infty & \text{if } p < 1 \\ \frac{-1}{(-1)^p p^p (p-1)} & \text{if } p > 1 \end{cases}$$

Thus the series converges for  $p > 1$ .

26. Set  $g(x) = x(\ln x)[\ln(\ln x)]^p$ ,  $g'(x) = (1 + \ln x) \ln(\ln x) + p$ , so for fixed  $p$  there exists  $A > 0$  such that  $g'(x) > 0$ ,  $1/g(x)$  is decreasing for  $x > A$ ; use the Integral Test with  $\int_A^{+\infty} \frac{dx}{x(\ln x)[\ln(\ln x)]^p}$  to get

$$\lim_{\ell \rightarrow +\infty} \ln[\ln(\ln x)] \Big|_A^\ell = +\infty \text{ if } p = 1, \quad \lim_{\ell \rightarrow +\infty} \frac{[\ln(\ln x)]^{1-p}}{1-p} \Big|_A^\ell = \begin{cases} +\infty & \text{if } p < 1, \\ \frac{1}{(p-1)[\ln(\ln A)]^{p-1}} & \text{if } p > 1 \end{cases}$$

Thus the series converges for  $p > 1$ .

27. (a)  $3 \sum_{k=1}^{\infty} \frac{1}{k^2} - \sum_{k=1}^{\infty} \frac{1}{k^4} = \pi^2/2 - \pi^4/90$

(b)  $\sum_{k=1}^{\infty} \frac{1}{k^2} - 1 - \frac{1}{2^2} = \pi^2/6 - 5/4$

(c)  $\sum_{k=2}^{\infty} \frac{1}{(k-1)^4} = \sum_{k=1}^{\infty} \frac{1}{k^4} = \pi^4/90$

28. (a) Suppose  $\Sigma(u_k + v_k)$  converges; then so does  $\Sigma[(u_k + v_k) - u_k]$ , but  $\Sigma[(u_k + v_k) - u_k] = \Sigma v_k$ , so  $\Sigma v_k$  converges which contradicts the assumption that  $\Sigma v_k$  diverges. Suppose  $\Sigma(u_k - v_k)$  converges; then so does  $\Sigma[u_k - (u_k - v_k)] = \Sigma v_k$  which leads to the same contradiction as before.
- (b) Let  $u_k = 2/k$  and  $v_k = 1/k$ ; then both  $\Sigma(u_k + v_k)$  and  $\Sigma(u_k - v_k)$  diverge; let  $u_k = 1/k$  and  $v_k = -1/k$  then  $\Sigma(u_k + v_k)$  converges; let  $u_k = v_k = 1/k$  then  $\Sigma(u_k - v_k)$  converges.

29. (a) diverges because  $\sum_{k=1}^{\infty} (2/3)^{k-1}$  converges and  $\sum_{k=1}^{\infty} 1/k$  diverges.

(b) diverges because  $\sum_{k=1}^{\infty} 1/(3k+2)$  diverges and  $\sum_{k=1}^{\infty} 1/k^{3/2}$  converges.

(c) converges because both  $\sum_{k=2}^{\infty} \frac{1}{k(\ln k)^2}$  (Exercise 25) and  $\sum_{k=2}^{\infty} 1/k^2$  converge.

30. (a) If  $S = \sum_{k=1}^{\infty} u_k$  and  $s_n = \sum_{k=1}^n u_k$ , then  $S - s_n = \sum_{k=n+1}^{\infty} u_k$ . Interpret  $u_k$ ,  $k = n+1, n+2, \dots$ , as the areas of inscribed or circumscribed rectangles with height  $u_k$  and base of length one for the curve  $y = f(x)$  to obtain the result.

- (b) Add  $s_n = \sum_{k=1}^n u_k$  to each term in the conclusion of part (a) to get the desired result:

$$s_n + \int_{n+1}^{+\infty} f(x) dx < \sum_{k=1}^{+\infty} u_k < s_n + \int_n^{+\infty} f(x) dx$$

31. (a) In Exercise 30 above let  $f(x) = \frac{1}{x^2}$ . Then  $\int_n^{+\infty} f(x) dx = -\frac{1}{x} \Big|_n^{+\infty} = \frac{1}{n}$ ; use this result and the same result with  $n+1$  replacing  $n$  to obtain the desired result.

(b)  $s_3 = 1 + 1/4 + 1/9 = 49/36$ ;  $58/36 = s_3 + \frac{1}{4} < \frac{1}{6}\pi^2 < s_3 + \frac{1}{3} = 61/36$

(d)  $1/11 < \frac{1}{6}\pi^2 - s_{10} < 1/10$

32. Apply Exercise 30 with  $f(x) = \frac{1}{(2x+1)^2}$ ,  $\int_n^{+\infty} f(x) dx = \frac{1}{2(2n+1)}$ :

(a)  $\frac{1}{46} < \sum_{k=1}^{\infty} \frac{1}{(2k+1)^2} - s_{10} < \frac{1}{42}$

(b)  $\pi/2 - \tan^{-1}(11) < \sum_{k=1}^{\infty} \frac{1}{k^2+1} - s_{10} < \pi/2 - \tan^{-1}(10)$

(c)  $12e^{-11} < \sum_{k=1}^{\infty} \frac{k}{e^k} < 11e^{-10}$

33. (a)  $\int_n^{+\infty} \frac{1}{x^3} dx = \frac{1}{2n^2}$ ; use Exercise 30(b)

(b)  $\frac{1}{2n^2} - \frac{1}{2(n+1)^2} < 0.01$  for  $n = 5$ .

- (c) From Part (a) with  $n = 5$  obtain  $1.1995 < S < 1.2057$ , so  $S \approx 1.203$ .

34. (a)  $\int_n^{+\infty} \frac{1}{x^4} dx = \frac{1}{3n^3}$ ; choose  $n$  so that  $\frac{1}{3n^3} - \frac{1}{3(n+1)^3} < 0.005$ ,  $n = 4$ ;  $S \approx 1.084$
35. (a) Let  $F(x) = \frac{1}{x}$ , then  $\int_1^n \frac{1}{x} dx = \ln n$  and  $\int_1^{n+1} \frac{1}{x} dx = \ln(n+1)$ ,  $u_1 = 1$  so  
 $\ln(n+1) < s_n < 1 + \ln n$ .
- (b)  $\ln(1,000,001) < s_{1,000,000} < 1 + \ln(1,000,000)$ ,  $13 < s_{1,000,000} < 15$
- (c)  $s_{10^9} < 1 + \ln 10^9 = 1 + 9 \ln 10 < 22$
- (d)  $s_n > \ln(n+1) \geq 100$ ,  $n \geq e^{100} - 1 \approx 2.688 \times 10^{43}$ ;  $n = 2.69 \times 10^{43}$
36.  $p$ -series with  $p = \ln a$ ; convergence for  $p > 1, a > e$
37.  $x^2 e^{-x}$  is decreasing and positive for  $x > 2$  so the Integral Test applies:  
 $\int_1^{\infty} x^2 e^{-x} dx = (x^2 + 2x + 2)e^{-x} \Big|_1^{\infty} = 5e^{-1}$  so the series converges.
38. (a)  $f(x) = 1/(x^3 + 1)$  is decreasing and continuous on the interval  $[1, +\infty]$ , so the Integral Test applies.
- (c)
- |       |          |          |          |          |          |
|-------|----------|----------|----------|----------|----------|
| $n$   | 10       | 20       | 30       | 40       | 50       |
| $s_n$ | 0.681980 | 0.685314 | 0.685966 | 0.686199 | 0.686307 |
- 
- |       |          |          |          |          |          |
|-------|----------|----------|----------|----------|----------|
| $n$   | 60       | 70       | 80       | 90       | 100      |
| $s_n$ | 0.686367 | 0.686403 | 0.686426 | 0.686442 | 0.686454 |
- (e) Set  $g(n) = \int_n^{+\infty} \frac{1}{x^3 + 1} dx = \frac{\sqrt{3}}{6} \pi + \frac{1}{6} \frac{n^3 + 1}{(n+1)^3} - \frac{\sqrt{3}}{3} \tan^{-1} \left( \frac{2n-1}{\sqrt{3}} \right)$ ; for  $n \geq 10$ ,  
 $g(n) - g(n+1) \leq 0.001$ ;  $s_{10} + (g(10) + g(11))/2 \approx 0.6865$ , so the sum  $\approx 0.6865$  to three decimal places.

## EXERCISE SET 11.5

1. (a)  $f^{(k)}(x) = (-1)^k e^{-x}$ ,  $f^{(k)}(0) = (-1)^k$ ;  $e^{-x} \approx 1 - x + x^2/2$  (quadratic),  $e^{-x} \approx 1 - x$  (linear)
- (b)  $f'(x) = -\sin x$ ,  $f''(x) = -\cos x$ ,  $f(0) = 1$ ,  $f'(0) = 0$ ,  $f''(0) = -1$ ,  
 $\cos x \approx 1 - x^2/2$  (quadratic),  $\cos x \approx 1$  (linear)
- (c)  $f'(x) = \cos x$ ,  $f''(x) = -\sin x$ ,  $f(\pi/2) = 1$ ,  $f'(\pi/2) = 0$ ,  $f''(\pi/2) = -1$ ,  
 $\sin x \approx 1 - (x - \pi/2)^2/2$  (quadratic),  $\sin x \approx 1$  (linear)
- (d)  $f(1) = 1$ ,  $f'(1) = 1/2$ ,  $f''(1) = -1/4$ ;  
 $\sqrt{x} = 1 + \frac{1}{2}(x-1) - \frac{1}{8}(x-1)^2$  (quadratic),  $\sqrt{x} \approx 1 + \frac{1}{2}(x-1)$  (linear)
2. (a)  $p_2(x) = 1 + x + x^2/2$ ,  $p_1(x) = 1 + x$
- (b)  $p_2(x) = 3 + \frac{1}{6}(x-9) - \frac{1}{216}(x-9)^2$ ,  $p_1(x) = 3 + \frac{1}{6}(x-9)$
- (c)  $p_2(x) = \frac{\pi}{3} + \frac{\sqrt{3}}{6}(x-2) - \frac{7}{72}\sqrt{3}(x-2)^2$ ,  $p_1(x) = \frac{\pi}{3} + \frac{\sqrt{3}}{6}(x-2)$
- (d)  $p_2(x) = x$ ,  $p_1(x) = x$



3. (a)  $f'(x) = \frac{1}{2}x^{-1/2}$ ,  $f''(x) = -\frac{1}{4}x^{-3/2}$ ;  $f(1) = 1$ ,  $f'(1) = \frac{1}{2}$ ,  $f''(1) = -\frac{1}{4}$ ;  
 $\sqrt{x} \approx 1 + \frac{1}{2}(x-1) - \frac{1}{8}(x-1)^2$
- (b)  $x = 1.1$ ,  $x_0 = 1$ ,  $\sqrt{1.1} \approx 1 + \frac{1}{2}(0.1) - \frac{1}{8}(0.1)^2 = 1.04875$ , calculator value  $\approx 1.0488088$
4. (a)  $\cos x \approx 1 - x^2/2$
- (b)  $2^\circ = \pi/90$  rad,  $\cos 2^\circ = \cos(\pi/90) \approx 1 - \frac{\pi^2}{2 \cdot 90^2} \approx 0.99939077$ , calculator value  $\approx 0.99939083$
5.  $f(x) = \tan x$ ,  $61^\circ = \pi/3 + \pi/180$  rad;  $x_0 = \pi/3$ ,  $f'(x) = \sec^2 x$ ,  $f''(x) = 2 \sec^2 x \tan x$ ;  
 $f(\pi/3) = \sqrt{3}$ ,  $f'(\pi/3) = 4$ ,  $f''(x) = 8\sqrt{3}$ ;  $\tan x \approx \sqrt{3} + 4(x - \pi/3) + 4\sqrt{3}(x - \pi/3)^2$ ,  
 $\tan 61^\circ = \tan(\pi/3 + \pi/180) \approx \sqrt{3} + 4\pi/180 + 4\sqrt{3}(\pi/180)^2 \approx 1.80397443$ ,  
calculator value  $\approx 1.80404776$
6.  $f(x) = \sqrt{x}$ ,  $x_0 = 36$ ,  $f'(x) = \frac{1}{2}x^{-1/2}$ ,  $f''(x) = -\frac{1}{4}x^{-3/2}$ ;  
 $f(36) = 6$ ,  $f'(36) = \frac{1}{12}$ ,  $f''(36) = -\frac{1}{864}$ ;  $\sqrt{x} \approx 6 + \frac{1}{12}(x-36) - \frac{1}{1728}(x-36)^2$ ;  
 $\sqrt{36.03} \approx 6 + \frac{0.03}{12} - \frac{(0.03)^2}{1728} \approx 6.00249947917$ , calculator value  $\approx 6.00249947938$
7.  $f^{(k)}(x) = (-1)^k e^{-x}$ ,  $f^{(k)}(0) = (-1)^k$ ;  $p_0(x) = 1$ ,  $p_1(x) = 1 - x$ ,  $p_2(x) = 1 - x + \frac{1}{2}x^2$ ,  
 $p_3(x) = 1 - x + \frac{1}{2}x^2 - \frac{1}{3!}x^3$ ,  $p_4(x) = 1 - x + \frac{1}{2}x^2 - \frac{1}{3!}x^3 + \frac{1}{4!}x^4$ ;  $\sum_{k=0}^{\infty} \frac{(-1)^k}{k!} x^k$
8.  $f^{(k)}(x) = a^k e^{ax}$ ,  $f^{(k)}(0) = a^k$ ;  $p_0(x) = 1$ ,  $p_1(x) = 1 + ax$ ,  $p_2(x) = 1 + ax + \frac{a^2}{2}x^2$ ,  
 $p_3(x) = 1 + ax + \frac{a^2}{2}x^2 + \frac{a^3}{3!}x^3$ ,  $p_4(x) = 1 + ax + \frac{a^2}{2}x^2 + \frac{a^3}{3!}x^3 + \frac{a^4}{4!}x^4$ ;  $\sum_{k=0}^{\infty} \frac{a^k}{k!} x^k$
9.  $f^{(k)}(0) = 0$  if  $k$  is odd,  $f^{(k)}(0)$  is alternately  $\pi^k$  and  $-\pi^k$  if  $k$  is even;  $p_0(x) = 1$ ,  $p_1(x) = 1$ ,  
 $p_2(x) = 1 - \frac{\pi^2}{2!}x^2$ ;  $p_3(x) = 1 - \frac{\pi^2}{2!}x^2$ ,  $p_4(x) = 1 - \frac{\pi^2}{2!}x^2 + \frac{\pi^4}{4!}x^4$ ;  $\sum_{k=0}^{\infty} \frac{(-1)^k \pi^{2k}}{(2k)!} x^{2k}$
10.  $f^{(k)}(0) = 0$  if  $k$  is even,  $f^{(k)}(0)$  is alternately  $\pi^k$  and  $-\pi^k$  if  $k$  is odd;  $p_0(x) = 0$ ,  $p_1(x) = \pi x$ ,  
 $p_2(x) = \pi x$ ;  $p_3(x) = \pi x - \frac{\pi^3}{3!}x^3$ ,  $p_4(x) = \pi x - \frac{\pi^3}{3!}x^3$ ;  $\sum_{k=0}^{\infty} \frac{(-1)^k \pi^{2k+1}}{(2k+1)!} x^{2k+1}$
11.  $f^{(0)}(0) = 0$ ; for  $k \geq 1$ ,  $f^{(k)}(x) = \frac{(-1)^{k+1}(k-1)!}{(1+x)^k}$ ,  $f^{(k)}(0) = (-1)^{k+1}(k-1)!$ ;  $p_0(x) = 0$ ,  
 $p_1(x) = x$ ,  $p_2(x) = x - \frac{1}{2}x^2$ ,  $p_3(x) = x - \frac{1}{2}x^2 + \frac{1}{3}x^3$ ,  $p_4(x) = x - \frac{1}{2}x^2 + \frac{1}{3}x^3 - \frac{1}{4}x^4$ ;  $\sum_{k=1}^{\infty} \frac{(-1)^{k+1}}{k} x^k$
12.  $f^{(k)}(x) = (-1)^k \frac{k!}{(1+x)^{k+1}}$ ;  $f^{(k)}(0) = (-1)^k k!$ ;  $p_0(x) = 1$ ,  $p_1(x) = 1 - x$ ,  
 $p_2(x) = 1 - x + x^2$ ,  $p_3(x) = 1 - x + x^2 - x^3$ ,  $p_4(x) = 1 - x + x^2 - x^3 + x^4$ ;  $\sum_{k=0}^{\infty} (-1)^k x^k$

13.  $f^{(k)}(0) = 0$  if  $k$  is odd,  $f^{(k)}(0) = 1$  if  $k$  is even;  $p_0(x) = 1, p_1(x) = 1,$   
 $p_2(x) = 1 + x^2/2, p_3(x) = 1 + x^2/2, p_4(x) = 1 + x^2/2 + x^4/4!; \sum_{k=0}^{\infty} \frac{1}{(2k)!} x^{2k}$
14.  $f^{(k)}(0) = 0$  if  $k$  is even,  $f^{(k)}(0) = 1$  if  $k$  is odd;  $p_0(x) = 0, p_1(x) = x, p_2(x) = x,$   
 $p_3(x) = x + x^3/3!, p_4(x) = x + x^3/3!; \sum_{k=0}^{\infty} \frac{1}{(2k+1)!} x^{2k+1}$
15.  $f^{(k)}(x) = \begin{cases} (-1)^{k/2}(x \sin x - k \cos x) & k \text{ even} \\ (-1)^{(k-1)/2}(x \cos x + k \sin x) & k \text{ odd} \end{cases}, \quad f^{(k)}(0) = \begin{cases} (-1)^{1+k/2}k & k \text{ even} \\ 0 & k \text{ odd} \end{cases}$   
 $p_0(x) = 0, p_1(x) = 0, p_2(x) = x^2, p_3(x) = x^2, p_4(x) = x^2 - \frac{1}{6}x^4; \sum_{k=0}^{\infty} \frac{(-1)^k}{(2k+1)!} x^{2k+2}$
16.  $f^{(k)}(x) = (k+x)e^x, f^{(k)}(0) = k; p_0(x) = 0, p_1(x) = x, p_2(x) = x + x^2,$   
 $p_3(x) = x + x^2 + \frac{1}{2}x^3, p_4(x) = x + x^2 + \frac{1}{2}x^3 + \frac{1}{3!}x^4; \sum_{k=1}^{\infty} \frac{1}{(k-1)!} x^k$
17. (a)  $f(0) = 1, f'(0) = 2, f''(0) = -2, f'''(0) = 6, f^{(k)}(0) = 0$  for  $k \geq 4$ ;  
the Maclaurin series for  $f(x)$  is  $f(x)$ .
- (b)  $f^{(k)}(0) = k!c_k$  for  $k \leq n$ , and  $f^{(k)}(0) = 0$  for  $k > n$ ; the Maclaurin series for  $f(x)$  is  $f(x)$ .
19.  $f^{(k)}(x_0) = e; p_0(x) = e, p_1(x) = e + e(x-1),$   
 $p_2(x) = e + e(x-1) + \frac{e}{2}(x-1)^2, p_3(x) = e + e(x-1) + \frac{e}{2}(x-1)^2 + \frac{e}{3!}(x-1)^3,$   
 $p_4(x) = e + e(x-1) + \frac{e}{2}(x-1)^2 + \frac{e}{3!}(x-1)^3 + \frac{e}{4!}(x-1)^4; \sum_{k=0}^{\infty} \frac{e}{k!}(x-1)^k$
20.  $f^{(k)}(x) = (-1)^k e^{-x}, f^{(k)}(\ln 2) = (-1)^k \frac{1}{2}; p_0(x) = \frac{1}{2}, p_1(x) = \frac{1}{2} - \frac{1}{2}(x - \ln 2),$   
 $p_2(x) = \frac{1}{2} - \frac{1}{2}(x - \ln 2) + \frac{1}{2 \cdot 2}(x - \ln 2)^2, p_3(x) = \frac{1}{2} - \frac{1}{2}(x - \ln 2) + \frac{1}{2 \cdot 2}(x - \ln 2)^2 - \frac{1}{2 \cdot 3!}(x - \ln 2)^3,$   
 $p_4(x) = \frac{1}{2} - \frac{1}{2}(x - \ln 2) + \frac{1}{2 \cdot 2}(x - \ln 2)^2 - \frac{1}{2 \cdot 3!}(x - \ln 2)^3 + \frac{1}{2 \cdot 4!}(x - \ln 2)^4;$   
 $\sum_{k=0}^{\infty} \frac{(-1)^k}{2 \cdot k!}(x - \ln 2)^k$
21.  $f^{(k)}(x) = \frac{(-1)^k k!}{x^{k+1}}, f^{(k)}(-1) = -k!; p_0(x) = -1; p_1(x) = -1 - (x+1);$   
 $p_2(x) = -1 - (x+1) - (x+1)^2; p_3(x) = -1 - (x+1) - (x+1)^2 - (x+1)^3;$   
 $p_4(x) = -1 - (x+1) - (x+1)^2 - (x+1)^3 - (x+1)^4; \sum_{k=0}^{\infty} (-1)(x+1)^k$

22.  $f^{(k)}(x) = \frac{(-1)^k k!}{(x+2)^{k+1}}$ ,  $f^{(k)}(3) = \frac{(-1)^k k!}{5^{k+1}}$ ;  $p_0(x) = \frac{1}{5}$ ;  $p_1(x) = \frac{1}{5} - \frac{1}{25}(x-3)$ ;  
 $p_2(x) = \frac{1}{5} - \frac{1}{25}(x-3) + \frac{1}{125}(x-3)^2$ ;  $p_3(x) = \frac{1}{5} - \frac{1}{25}(x-3) + \frac{1}{125}(x-3)^2 - \frac{1}{625}(x-3)^3$ ;  
 $p_4(x) = \frac{1}{5} - \frac{1}{25}(x-3) + \frac{1}{125}(x-3)^2 - \frac{1}{625}(x-3)^3 + \frac{1}{3025}(x-3)^4$ ;  $\sum_{k=0}^{\infty} \frac{(-1)^k}{5^{k+1}}(x-3)^k$
23.  $f^{(k)}(1/2) = 0$  if  $k$  is odd,  $f^{(k)}(1/2)$  is alternately  $\pi^k$  and  $-\pi^k$  if  $k$  is even;  
 $p_0(x) = p_1(x) = 1$ ,  $p_2(x) = p_3(x) = 1 - \frac{\pi^2}{2}(x-1/2)^2$ ,  
 $p_4(x) = 1 - \frac{\pi^2}{2}(x-1/2)^2 + \frac{\pi^4}{4!}(x-1/2)^4$ ;  $\sum_{k=0}^{\infty} \frac{(-1)^k \pi^{2k}}{(2k)!}(x-1/2)^{2k}$
24.  $f^{(k)}(\pi/2) = 0$  if  $k$  is even,  $f^{(k)}(\pi/2)$  is alternately  $-1$  and  $1$  if  $k$  is odd;  $p_0(x) = 0$ ,  
 $p_1(x) = -(x-\pi/2)$ ,  $p_2(x) = -(x-\pi/2)$ ,  $p_3(x) = -(x-\pi/2) + \frac{1}{3!}(x-\pi/2)^3$ ,  
 $p_4(x) = -(x-\pi/2) + \frac{1}{3!}(x-\pi/2)^3$ ;  $\sum_{k=0}^{\infty} \frac{(-1)^{k+1}}{(2k+1)!}(x-\pi/2)^{2k+1}$
25.  $f(1) = 0$ , for  $k \geq 1$ ,  $f^{(k)}(x) = \frac{(-1)^{k-1}(k-1)!}{x^k}$ ;  $f^{(k)}(1) = (-1)^{k-1}(k-1)!$ ;  
 $p_0(x) = 0$ ,  $p_1(x) = (x-1)$ ;  $p_2(x) = (x-1) - \frac{1}{2}(x-1)^2$ ;  $p_3(x) = (x-1) - \frac{1}{2}(x-1)^2 + \frac{1}{3}(x-1)^3$ ,  
 $p_4(x) = (x-1) - \frac{1}{2}(x-1)^2 + \frac{1}{3}(x-1)^3 - \frac{1}{4}(x-1)^4$ ;  $\sum_{k=1}^{\infty} \frac{(-1)^{k-1}}{k}(x-1)^k$
26.  $f(e) = 1$ , for  $k \geq 1$ ,  $f^{(k)}(x) = \frac{(-1)^{k-1}(k-1)!}{x^k}$ ;  $f^{(k)}(e) = \frac{(-1)^{k-1}(k-1)!}{e^k}$ ;  
 $p_0(x) = 1$ ,  $p_1(x) = 1 + \frac{1}{e}(x-e)$ ;  $p_2(x) = 1 + \frac{1}{e}(x-e) - \frac{1}{2e^2}(x-e)^2$ ;  
 $p_3(x) = 1 + \frac{1}{e}(x-e) - \frac{1}{2e^2}(x-e)^2 + \frac{1}{3e^3}(x-e)^3$ ,  
 $p_4(x) = 1 + \frac{1}{e}(x-e) - \frac{1}{2e^2}(x-e)^2 + \frac{1}{3e^3}(x-e)^3 - \frac{1}{4e^4}(x-e)^4$ ;  $1 + \sum_{k=1}^{\infty} \frac{(-1)^{k-e}}{ke^k}(x-e)^k$
27. (a)  $f(1) = 1$ ,  $f'(1) = 2$ ,  $f''(1) = -2$ ,  $f'''(1) = 6$ ,  $f^{(k)}(1) = 0$  for  $k \geq 4$ ;  
the Taylor series for  $f(x)$  is  $f(x)$ .
- (b)  $f^{(k)}(x_0) = k!c_k$  for  $k \leq n$ ; for  $k > n$ ,  $f^{(k)}(x_0) = 0$ ; the Taylor series for  $f(x)$  is  $f(x)$ .

29.  $f^{(k)}(0) = (-2)^k$ ;  $p_0(x) = 1$ ,  $p_1(x) = 1 - 2x$ ,  
 $p_2(x) = 1 - 2x + 2x^2$ ,  $p_3(x) = 1 - 2x + 2x^2 - \frac{4}{3}x^3$

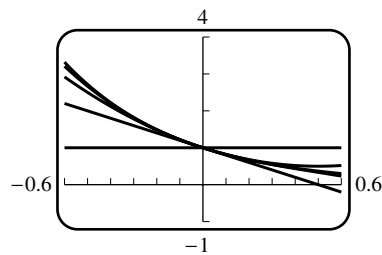

30.  $f^{(k)}(\pi/2) = 0$  if  $k$  is odd,  $f^{(k)}(\pi/2)$  is alternately 1 and  $-1$  if  $k$  is even;  $p_0(x) = 1$ ,  $p_2(x) = 1 - \frac{1}{2}(x - \pi/2)^2$ ,  
 $p_4(x) = 1 - \frac{1}{2}(x - \pi/2)^2 + \frac{1}{24}(x - \pi/2)^4$ ,  
 $p_6(x) = 1 - \frac{1}{2}(x - \pi/2)^2 + \frac{1}{24}(x - \pi/2)^4 - \frac{1}{720}(x - \pi/2)^6$

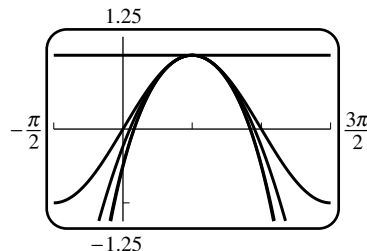

31.  $f^{(k)}(\pi) = 0$  if  $k$  is odd,  $f^{(k)}(\pi/2)$  is alternately  $-1$  and 1 if  $k$  is even;  $p_0(x) = -1$ ,  $p_2(x) = -1 + \frac{1}{2}(x - \pi)^2$ ,  
 $p_4(x) = -1 + \frac{1}{2}(x - \pi)^2 - \frac{1}{24}(x - \pi)^4$ ,  
 $p_6(x) = -1 + \frac{1}{2}(x - \pi)^2 - \frac{1}{24}(x - \pi)^4 + \frac{1}{720}(x - \pi)^6$

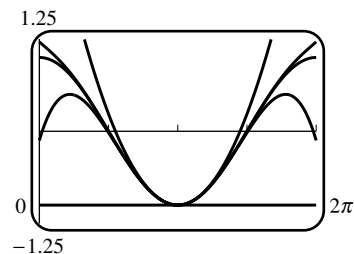

32.  $f(0) = 0$ ; for  $k \geq 1$ ,  $f^{(k)}(x) = \frac{(-1)^{k-1}(k-1)!}{(x+1)^k}$ ,  
 $f^{(k)}(0) = (-1)^{k-1}(k-1)!$ ;  $p_0(x) = 0$ ,  $p_1(x) = x$ ,  
 $p_2(x) = x - \frac{1}{2}x^2$ ,  $p_3(x) = x - \frac{1}{2}x^2 + \frac{1}{3}x^3$

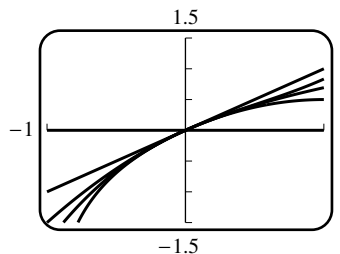

33.  $p(0) = 1$ ,  $p(x)$  has slope  $-1$  at  $x = 0$ , and  $p(x)$  is concave up at  $x = 0$ , eliminating I, II and III respectively and leaving IV.
34. Let  $p_0(x) = 2$ ,  $p_1(x) = p_2(x) = 1 - 3x$ ,  $p_3(x) = 1 - 3x + x^3$ , and, for any arbitrary integer  $n \geq 4$  and constants  $c_4, c_5, \dots, c_n$ , let  $p_n(x) = 2 - 3(x - 1) + (x - 1)^3 + \sum_{k=4}^n c_k(x - 1)^k$ ; then any of the polynomials  $p_0, p_1, \dots, p_n$  is a possible Taylor polynomial for  $f$  about  $x = 1$ .
35.  $f^{(k)}(\ln 4) = 15/8$  for  $k$  even,  $f^{(k)}(\ln 4) = 17/8$  for  $k$  odd, which can be written as

$$f^{(k)}(\ln 4) = \frac{16 - (-1)^k}{8}; \sum_{k=0}^{\infty} \frac{16 - (-1)^k}{8k!} (x - \ln 4)^k$$

36. (a)  $\cos \alpha \approx 1 - \alpha^2/2$ ;  $x = r - r \cos \alpha = r(1 - \cos \alpha) \approx r\alpha^2/2$   
 (b) In Figure Ex-36 let  $r = 4000$  mi and  $\alpha = 1/80$  so that the arc has length  $2r\alpha = 100$  mi.  
 Then  $x \approx r\alpha^2/2 = \frac{4000}{2 \cdot 80^2} = 5/16$  mi.

37. From Exercise 2(a),  $p_1(x) = 1 + x$ ,  $p_2(x) = 1 + x + x^2/2$

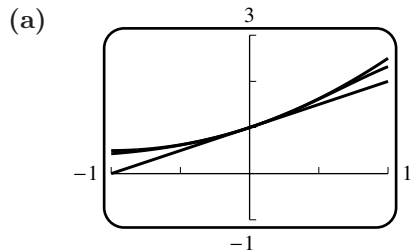

(b)

$x$	-1.000	-0.750	-0.500	-0.250	0.000	0.250	0.500	0.750	1.000
$f(x)$	0.431	0.506	0.619	0.781	1.000	1.281	1.615	1.977	2.320
$p_1(x)$	0.000	0.250	0.500	0.750	1.000	1.250	1.500	1.750	2.000
$p_2(x)$	0.500	0.531	0.625	0.781	1.000	1.281	1.625	2.031	2.500

(c)  $|e^{\sin x} - (1 + x)| < 0.01$   
 for  $-0.14 < x < 0.14$

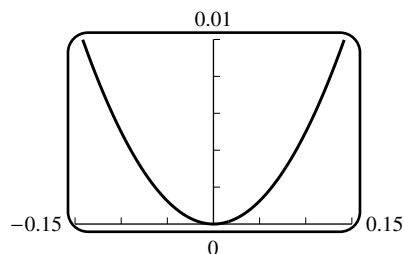

(d)  $|e^{\sin x} - (1 + x + x^2/2)| < 0.01$   
 for  $-0.50 < x < 0.50$

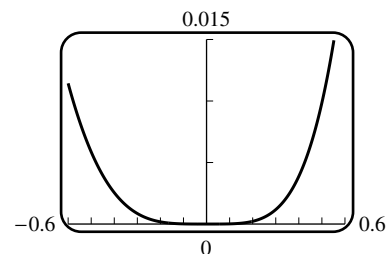

**EXERCISE SET 11.6**

1. (a)  $\frac{1}{5k^2 - k} \leq \frac{1}{5k^2 - k^2} = \frac{1}{4k^2}$ ,  $\sum_{k=1}^{\infty} \frac{1}{4k^2}$  converges

(b)  $\frac{3}{k - 1/4} > \frac{3}{k}$ ,  $\sum_{k=1}^{\infty} 3/k$  diverges

2. (a)  $\frac{k+1}{k^2 - k} > \frac{k}{k^2} = \frac{1}{k}$ ,  $\sum_{k=2}^{\infty} 1/k$  diverges

(b)  $\frac{2}{k^4 + k} < \frac{2}{k^4}$ ,  $\sum_{k=1}^{\infty} \frac{2}{k^4}$  converges

3. (a)  $\frac{1}{3^k + 5} < \frac{1}{3^k}$ ,  $\sum_{k=1}^{\infty} \frac{1}{3^k}$  converges

(b)  $\frac{5 \sin^2 k}{k!} < \frac{5}{k!}$ ,  $\sum_{k=1}^{\infty} \frac{5}{k!}$  converges

4. (a)  $\frac{\ln k}{k} > \frac{1}{k}$  for  $k \geq 3$ ,  $\sum_{k=1}^{\infty} \frac{1}{k}$  diverges

(b)  $\frac{k}{k^{3/2} - 1/2} > \frac{k}{k^{3/2}} = \frac{1}{\sqrt{k}}$ ;  $\sum_{k=1}^{\infty} \frac{1}{\sqrt{k}}$  diverges

5. compare with the convergent series  $\sum_{k=1}^{\infty} 1/k^5$ ,  $\rho = \lim_{k \rightarrow +\infty} \frac{4k^7 - 2k^6 + 6k^5}{8k^7 + k - 8} = 1/2$ , converges
6. compare with the divergent series  $\sum_{k=1}^{\infty} 1/k$ ,  $\rho = \lim_{k \rightarrow +\infty} \frac{k}{9k + 6} = 1/9$ , diverges
7. compare with the convergent series  $\sum_{k=1}^{\infty} 5/3^k$ ,  $\rho = \lim_{k \rightarrow +\infty} \frac{3^k}{3^k + 1} = 1$ , converges
8. compare with the divergent series  $\sum_{k=1}^{\infty} 1/k$ ,  $\rho = \lim_{k \rightarrow +\infty} \frac{k^2(k+3)}{(k+1)(k+2)(k+5)} = 1$ , diverges
9. compare with the divergent series  $\sum_{k=1}^{\infty} \frac{1}{k^{2/3}}$ ,  
 $\rho = \lim_{k \rightarrow +\infty} \frac{k^{2/3}}{(8k^2 - 3k)^{1/3}} = \lim_{k \rightarrow +\infty} \frac{1}{(8 - 3/k)^{1/3}} = 1/2$ , diverges
10. compare with the convergent series  $\sum_{k=1}^{\infty} 1/k^{17}$ ,  
 $\rho = \lim_{k \rightarrow +\infty} \frac{k^{17}}{(2k+3)^{17}} = \lim_{k \rightarrow +\infty} \frac{1}{(2+3/k)^{17}} = 1/2^{17}$ , converges
11.  $\rho = \lim_{k \rightarrow +\infty} \frac{3^{k+1}/(k+1)!}{3^k/k!} = \lim_{k \rightarrow +\infty} \frac{3}{k+1} = 0$ , the series converges
12.  $\rho = \lim_{k \rightarrow +\infty} \frac{4^{k+1}/(k+1)^2}{4^k/k^2} = \lim_{k \rightarrow +\infty} \frac{4k^2}{(k+1)^2} = 4$ , the series diverges
13.  $\rho = \lim_{k \rightarrow +\infty} \frac{k}{k+1} = 1$ , the result is inconclusive
14.  $\rho = \lim_{k \rightarrow +\infty} \frac{(k+1)(1/2)^{k+1}}{k(1/2)^k} = \lim_{k \rightarrow +\infty} \frac{k+1}{2k} = 1/2$ , the series converges
15.  $\rho = \lim_{k \rightarrow +\infty} \frac{(k+1)!/(k+1)^3}{k!/k^3} = \lim_{k \rightarrow +\infty} \frac{k^3}{(k+1)^2} = +\infty$ , the series diverges
16.  $\rho = \lim_{k \rightarrow +\infty} \frac{(k+1)/[(k+1)^2+1]}{k/(k^2+1)} = \lim_{k \rightarrow +\infty} \frac{(k+1)(k^2+1)}{k(k^2+2k+2)} = 1$ , the result is inconclusive.
17.  $\rho = \lim_{k \rightarrow +\infty} \frac{3k+2}{2k-1} = 3/2$ , the series diverges
18.  $\rho = \lim_{k \rightarrow +\infty} k/100 = +\infty$ , the series diverges
19.  $\rho = \lim_{k \rightarrow +\infty} \frac{k^{1/k}}{5} = 1/5$ , the series converges
20.  $\rho = \lim_{k \rightarrow +\infty} (1 - e^{-k}) = 1$ , the result is inconclusive

21. Ratio Test,  $\rho = \lim_{k \rightarrow +\infty} 7/(k+1) = 0$ , converges

22. Limit Comparison Test, compare with the divergent series  $\sum_{k=1}^{\infty} 1/k$

23. Ratio Test,  $\rho = \lim_{k \rightarrow +\infty} \frac{(k+1)^2}{5k^2} = 1/5$ , converges

24. Ratio Test,  $\rho = \lim_{k \rightarrow +\infty} (10/3)(k+1) = +\infty$ , diverges

25. Ratio Test,  $\rho = \lim_{k \rightarrow +\infty} e^{-1}(k+1)^{50}/k^{50} = e^{-1} < 1$ , converges

26. Limit Comparison Test, compare with the divergent series  $\sum_{k=1}^{\infty} 1/k$

27. Limit Comparison Test, compare with the convergent series  $\sum_{k=1}^{\infty} 1/k^{5/2}$ ,  $\rho = \lim_{k \rightarrow +\infty} \frac{k^3}{k^3+1} = 1$ , converges

28.  $\frac{4}{2+3^k k} < \frac{4}{3^k k}$ ,  $\sum_{k=1}^{\infty} \frac{4}{3^k k}$  converges (Ratio Test) so  $\sum_{k=1}^{\infty} \frac{4}{2+3^k k}$  converges by the Comparison Test

29. Limit Comparison Test, compare with the divergent series  $\sum_{k=1}^{\infty} 1/k$ ,  $\rho = \lim_{k \rightarrow +\infty} \frac{k}{\sqrt{k^2+k}} = 1$ , diverges

30.  $\frac{2+(-1)^k}{5^k} \leq \frac{3}{5^k}$ ,  $\sum_{k=1}^{\infty} 3/5^k$  converges so  $\sum_{k=1}^{\infty} \frac{2+(-1)^k}{5^k}$  converges

31. Limit Comparison Test, compare with the convergent series  $\sum_{k=1}^{\infty} 1/k^{5/2}$ ,

$$\rho = \lim_{k \rightarrow +\infty} \frac{k^3 + 2k^{5/2}}{k^3 + 3k^2 + 3k} = 1, \text{ converges}$$

32.  $\frac{4+|\cos k|}{k^3} < \frac{5}{k^3}$ ,  $\sum_{k=1}^{\infty} 5/k^3$  converges so  $\sum_{k=1}^{\infty} \frac{4+|\cos k|}{k^3}$  converges

33. Limit Comparison Test, compare with  $\sum_{k=1}^{\infty} 1/\sqrt{k}$

34. Ratio Test,  $\rho = \lim_{k \rightarrow +\infty} (1+1/k)^{-k} = 1/e < 1$ , converges

35. Ratio Test,  $\rho = \lim_{k \rightarrow +\infty} \frac{\ln(k+1)}{e \ln k} = \lim_{k \rightarrow +\infty} \frac{k}{e(k+1)} = 1/e < 1$ , converges

36. Ratio Test,  $\rho = \lim_{k \rightarrow +\infty} \frac{k+1}{e^{2k+1}} = \lim_{k \rightarrow +\infty} \frac{1}{2e^{2k+1}} = 0$ , converges

37. Ratio Test,  $\rho = \lim_{k \rightarrow +\infty} \frac{k+5}{4(k+1)} = 1/4$ , converges

38. Root Test,  $\rho = \lim_{k \rightarrow +\infty} \left(\frac{k}{k+1}\right)^k = \lim_{k \rightarrow +\infty} \frac{1}{(1+1/k)^k} = 1/e$ , converges
39. diverges because  $\lim_{k \rightarrow +\infty} \frac{1}{4+2^{-k}} = 1/4 \neq 0$
40.  $\sum_{k=1}^{\infty} \frac{\sqrt{k} \ln k}{k^3+1} = \sum_{k=2}^{\infty} \frac{\sqrt{k} \ln k}{k^3+1}$  because  $\ln 1 = 0$ ,  $\frac{\sqrt{k} \ln k}{k^3+1} < \frac{k \ln k}{k^3} = \frac{\ln k}{k^2}$ ,  
 $\int_2^{+\infty} \frac{\ln x}{x^2} dx = \lim_{\ell \rightarrow +\infty} \left(-\frac{\ln x}{x} - \frac{1}{x}\right) \Big|_2^{\ell} = \frac{1}{2}(\ln 2 + 1)$  so  $\sum_{k=2}^{\infty} \frac{\ln k}{k^2}$  converges and so does  $\sum_{k=1}^{\infty} \frac{\sqrt{k} \ln k}{k^3+1}$ .
41.  $\frac{\tan^{-1} k}{k^2} < \frac{\pi/2}{k^2}$ ,  $\sum_{k=1}^{\infty} \frac{\pi/2}{k^2}$  converges so  $\sum_{k=1}^{\infty} \frac{\tan^{-1} k}{k^2}$  converges
42.  $\frac{5^k+k}{k!+3} < \frac{5^k+5^k}{k!} = \frac{2(5^k)}{k!}$ ,  $\sum_{k=1}^{\infty} 2 \left(\frac{5^k}{k!}\right)$  converges (Ratio Test) so  $\sum_{k=1}^{\infty} \frac{5^k+k}{k!+3}$  converges
43. Ratio Test,  $\rho = \lim_{k \rightarrow +\infty} \frac{(k+1)^2}{(2k+2)(2k+1)} = 1/4$ , converges
44. Ratio Test,  $\rho = \lim_{k \rightarrow +\infty} \frac{2(k+1)^2}{(2k+4)(2k+3)} = 1/2$ , converges
45.  $u_k = \frac{k!}{1 \cdot 3 \cdot 5 \cdots (2k-1)}$ , by the Ratio Test  $\rho = \lim_{k \rightarrow +\infty} \frac{k+1}{2k+1} = 1/2$ ; converges
46.  $u_k = \frac{1 \cdot 3 \cdot 5 \cdots (2k-1)}{(2k-1)!}$ , by the Ratio Test  $\rho = \lim_{k \rightarrow +\infty} \frac{1}{2k} = 0$ ; converges
47. Root Test:  $\rho = \lim_{k \rightarrow +\infty} \frac{1}{3} (\ln k)^{1/k} = 1/3$ , converges
48. Root Test:  $\rho = \lim_{k \rightarrow +\infty} \frac{\pi(k+1)}{k^{1+1/k}} = \lim_{k \rightarrow +\infty} \pi \frac{k+1}{k} = \pi$ , diverges
49. (b)  $\rho = \lim_{k \rightarrow +\infty} \frac{\sin(\pi/k)}{\pi/k} = 1$  and  $\sum_{k=1}^{\infty} \pi/k$  diverges
50. (a)  $\cos x \approx 1 - x^2/2$ ,  $1 - \cos\left(\frac{1}{k}\right) \approx \frac{1}{2k^2}$       (b)  $\rho = \lim_{k \rightarrow +\infty} \frac{1 - \cos(1/k)}{1/k^2} = 2$ , converges
51. Set  $g(x) = \sqrt{x} - \ln x$ ;  $\frac{d}{dx} g(x) = \frac{1}{2\sqrt{x}} - \frac{1}{x} = 0$  when  $x = 4$ . Since  $\lim_{x \rightarrow 0^+} g(x) = \lim_{x \rightarrow +\infty} g(x) = +\infty$  it follows that  $g(x)$  has its minimum at  $x = 4$ ,  $g(4) = \sqrt{4} - \ln 4 > 0$ , and thus  $\sqrt{x} - \ln x > 0$  for  $x > 0$ .
- (a)  $\frac{\ln k}{k^2} < \frac{\sqrt{k}}{k^2} = \frac{1}{k^{3/2}}$ ,  $\sum_{k=1}^{\infty} \frac{1}{k^{3/2}}$  converges so  $\sum_{k=1}^{\infty} \frac{\ln k}{k^2}$  converges.
- (b)  $\frac{1}{(\ln k)^2} > \frac{1}{k}$ ,  $\sum_{k=2}^{\infty} \frac{1}{k}$  diverges so  $\sum_{k=2}^{\infty} \frac{1}{(\ln k)^2}$  diverges.



52. By the Root Test,  $\rho = \lim_{k \rightarrow +\infty} \frac{\alpha}{(k^{1/k})^\alpha} = \frac{\alpha}{1^\alpha} = \alpha$ , the series converges if  $\alpha < 1$  and diverges if  $\alpha > 1$ . If  $\alpha = 1$  then the series is  $\sum_{k=1}^{\infty} 1/k$  which diverges.
53. (a) If  $\sum b_k$  converges, then set  $M = \sum b_k$ . Then  $a_1 + a_2 + \cdots + a_n \leq b_1 + b_2 + \cdots + b_n \leq M$ ; apply Theorem 11.4.6 to get convergence of  $\sum a_k$ .
- (b) Assume the contrary, that  $\sum b_k$  converges; then use part (a) of the Theorem to show that  $\sum a_k$  converges, a contradiction.
54. (a) If  $\lim_{k \rightarrow +\infty} (a_k/b_k) = 0$  then for  $k \geq K$ ,  $a_k/b_k < 1$ ,  $a_k < b_k$  so  $\sum a_k$  converges by the Comparison Test.
- (b) If  $\lim_{k \rightarrow +\infty} (a_k/b_k) = +\infty$  then for  $k \geq K$ ,  $a_k/b_k > 1$ ,  $a_k > b_k$  so  $\sum a_k$  diverges by the Comparison Test.

### EXERCISE SET 11.7

- $a_{k+1} < a_k$ ,  $\lim_{k \rightarrow +\infty} a_k = 0$ ,  $a_k > 0$
- $\frac{a_{k+1}}{a_k} = \frac{k}{3(k+1)} < \frac{1}{3}$  for  $k > 0$ , so  $\{a_k\}$  is decreasing and tends to zero.
- diverges because  $\lim_{k \rightarrow +\infty} a_k = \lim_{k \rightarrow +\infty} \frac{k+1}{3k+1} = 1/3 \neq 0$
- diverges because  $\lim_{k \rightarrow +\infty} a_k = \lim_{k \rightarrow +\infty} \frac{k+1}{\sqrt{k+1}} = +\infty \neq 0$
- $\{e^{-k}\}$  is decreasing and  $\lim_{k \rightarrow +\infty} e^{-k} = 0$ , converges
- $\left\{\frac{\ln k}{k}\right\}$  is decreasing and  $\lim_{k \rightarrow +\infty} \frac{\ln k}{k} = 0$ , converges
- $\rho = \lim_{k \rightarrow +\infty} \frac{(3/5)^{k+1}}{(3/5)^k} = 3/5$ , converges absolutely
- $\rho = \lim_{k \rightarrow +\infty} \frac{2}{k+1} = 0$ , converges absolutely
- $\rho = \lim_{k \rightarrow +\infty} \frac{3k^2}{(k+1)^2} = 3$ , diverges
- $\rho = \lim_{k \rightarrow +\infty} \frac{k+1}{5k} = 1/5$ , converges absolutely
- $\rho = \lim_{k \rightarrow +\infty} \frac{(k+1)^3}{ek^3} = 1/e$ , converges absolutely
- $\rho = \lim_{k \rightarrow +\infty} \frac{(k+1)^{k+1}k!}{(k+1)!k^k} = \lim_{k \rightarrow +\infty} (1+1/k)^k = e$ , diverges

13. conditionally convergent,  $\sum_{k=1}^{\infty} \frac{(-1)^{k+1}}{3k}$  converges by the Alternating Series Test but  $\sum_{k=1}^{\infty} \frac{1}{3k}$  diverges
14. absolutely convergent,  $\sum_{k=1}^{\infty} \frac{1}{k^{4/3}}$  converges
15. divergent,  $\lim_{k \rightarrow +\infty} a_k \neq 0$
16. absolutely convergent, Ratio Test for absolute convergence
17.  $\sum_{k=1}^{\infty} \frac{\cos k\pi}{k} = \sum_{k=1}^{\infty} \frac{(-1)^k}{k}$  is conditionally convergent,  $\sum_{k=1}^{\infty} \frac{(-1)^k}{k}$  converges by the Alternating Series Test but  $\sum_{k=1}^{\infty} 1/k$  diverges.
18. conditionally convergent,  $\sum_{k=3}^{\infty} \frac{(-1)^k \ln k}{k}$  converges by the Alternating Series Test but  $\sum_{k=3}^{\infty} \frac{\ln k}{k}$  diverges (Limit Comparison Test with  $\sum 1/k$ ).
19. conditionally convergent,  $\sum_{k=1}^{\infty} (-1)^{k+1} \frac{k+2}{k(k+3)}$  converges by the Alternating Series Test but  $\sum_{k=1}^{\infty} \frac{k+2}{k(k+3)}$  diverges (Limit Comparison Test with  $\sum 1/k$ )
20. conditionally convergent,  $\sum_{k=1}^{\infty} \frac{(-1)^{k+1} k^2}{k^3+1}$  converges by the Alternating Series Test but  $\sum_{k=1}^{\infty} \frac{k^2}{k^3+1}$  diverges (Limit Comparison Test with  $\sum (1/k)$ )
21.  $\sum_{k=1}^{\infty} \sin(k\pi/2) = 1 + 0 - 1 + 0 + 1 + 0 - 1 + 0 + \dots$ , divergent ( $\lim_{k \rightarrow +\infty} \sin(k\pi/2)$  does not exist)
22. absolutely convergent,  $\sum_{k=1}^{\infty} \frac{|\sin k|}{k^3}$  converges (compare with  $\sum 1/k^3$ )
23. conditionally convergent,  $\sum_{k=2}^{\infty} \frac{(-1)^k}{k \ln k}$  converges by the Alternating Series Test but  $\sum_{k=2}^{\infty} \frac{1}{k \ln k}$  diverges (Integral Test)
24. conditionally convergent,  $\sum_{k=1}^{\infty} \frac{(-1)^k}{\sqrt{k(k+1)}}$  converges by the Alternating Series Test but  $\sum_{k=1}^{\infty} \frac{1}{\sqrt{k(k+1)}}$  diverges (Limit Comparison Test with  $\sum 1/k$ )
25. absolutely convergent,  $\sum_{k=2}^{\infty} (1/\ln k)^k$  converges by the Root Test

26. conditionally convergent,  $\sum_{k=1}^{\infty} \frac{(-1)^{k+1}}{\sqrt{k+1} + \sqrt{k}}$  converges by the Alternating Series Test but  $\sum_{k=1}^{\infty} \frac{1}{\sqrt{k+1} + \sqrt{k}}$  diverges (Limit Comparison Test with  $\sum 1/\sqrt{k}$ )
27. conditionally convergent, let  $f(x) = \frac{x^2 + 1}{x^3 + 2}$  then  $f'(x) = \frac{x(4 - 3x - x^3)}{(x^3 + 2)^2} \leq 0$  for  $x \geq 2$  so  $\{a_k\}_{k=2}^{+\infty} = \left\{ \frac{k^2 + 1}{k^3 + 2} \right\}_{k=2}^{+\infty}$  is nonincreasing,  $\lim_{k \rightarrow +\infty} a_k = 0$ ; the series converges by the Alternating Series Test but  $\sum_{k=2}^{\infty} \frac{k^2 + 1}{k^3 + 2}$  diverges (Limit Comparison Test with  $\sum 1/k$ )
28.  $\sum_{k=1}^{\infty} \frac{k \cos k\pi}{k^2 + 1} = \sum_{k=1}^{\infty} \frac{(-1)^k k}{k^2 + 1}$  is conditionally convergent,  $\sum_{k=1}^{\infty} \frac{(-1)^k k}{k^2 + 1}$  converges by the Alternating Series Test but  $\sum_{k=1}^{\infty} \frac{k}{k^2 + 1}$  diverges
29. absolutely convergent by the Ratio Test,  $\rho = \lim_{k \rightarrow +\infty} \frac{k+1}{(2k+1)(2k)} = 0$
30. divergent,  $\lim_{k \rightarrow +\infty} a_k = +\infty$
31.  $|\text{error}| < a_8 = 1/8 = 0.125$
32.  $|\text{error}| < a_6 = 1/6! < 0.0014$
33.  $|\text{error}| < a_{100} = 1/\sqrt{100} = 0.1$
34.  $|\text{error}| < a_4 = 1/(5 \ln 5) < 0.125$
35.  $|\text{error}| < 0.0001$  if  $a_{n+1} \leq 0.0001$ ,  $1/(n+1) \leq 0.0001$ ,  $n+1 \geq 10,000$ ,  $n \geq 9,999$ ,  $n = 9,999$
36.  $|\text{error}| < 0.00001$  if  $a_{n+1} \leq 0.00001$ ,  $1/(n+1)! \leq 0.00001$ ,  $(n+1)! \geq 100,000$ . But  $8! = 40,320$ ,  $9! = 362,880$  so  $(n+1)! \geq 100,000$  if  $n+1 \geq 9$ ,  $n \geq 8$ ,  $n = 8$
37.  $|\text{error}| < 0.005$  if  $a_{n+1} \leq 0.005$ ,  $1/\sqrt{n+1} \leq 0.005$ ,  $\sqrt{n+1} \geq 200$ ,  $n+1 \geq 40,000$ ,  $n \geq 39,999$ ,  $n = 39,999$
38.  $|\text{error}| < 0.05$  if  $a_{n+1} \leq 0.05$ ,  $1/[(n+2) \ln(n+2)] \leq 0.05$ ,  $(n+2) \ln(n+2) \geq 20$ . But  $9 \ln 9 \approx 19.8$  and  $10 \ln 10 \approx 23.0$  so  $(n+2) \ln(n+2) \geq 20$  if  $n+2 \geq 10$ ,  $n \geq 8$ ,  $n = 8$
39.  $a_k = \frac{3}{2^{k+1}}$ ,  $|\text{error}| < a_{11} = \frac{3}{2^{12}} < 0.00074$ ;  $s_{10} \approx 0.4995$ ;  $S = \frac{3/4}{1 - (-1/2)} = 0.5$
40.  $a_k = \left(\frac{2}{3}\right)^{k-1}$ ,  $|\text{error}| < a_{11} = \left(\frac{2}{3}\right)^{10} < 0.01735$ ;  $s_{10} \approx 0.5896$ ;  $S = \frac{1}{1 - (-2/3)} = 0.6$
41.  $a_k = \frac{1}{(2k-1)!}$ ,  $a_{n+1} = \frac{1}{(2n+1)!} \leq 0.005$ ,  $(2n+1)! \geq 200$ ,  $2n+1 \geq 6$ ,  $n \geq 2.5$ ;  $n = 3$ ,  $s_3 = 1 - 1/6 + 1/120 \approx 0.84$
42.  $a_k = \frac{1}{(2k-2)!}$ ,  $a_{n+1} = \frac{1}{(2n)!} \leq 0.005$ ,  $(2n)! \geq 200$ ,  $2n \geq 6$ ,  $n \geq 3$ ;  $n = 3$ ,  $s_3 \approx 0.54$

43.  $a_k = \frac{1}{k2^k}$ ,  $a_{n+1} = \frac{1}{(n+1)2^{n+1}} \leq 0.005$ ,  $(n+1)2^{n+1} \geq 200$ ,  $n+1 \geq 6$ ,  $n \geq 5$ ;  $n = 5$ ,  $s_5 \approx 0.41$

44.  $a_k = \frac{1}{(2k-1)^5 + 4(2k-1)}$ ,  $a_{n+1} = \frac{1}{(2n+1)^5 + 4(2n+1)} \leq 0.005$ ,  
 $(2n+1)^5 + 4(2n+1) \geq 200$ ,  $2n+1 \geq 3$ ,  $n \geq 1$ ;  $n = 1$ ,  $s_1 = 0.20$

45. (c)  $a_k = \frac{1}{2k-1}$ ,  $a_{n+1} = \frac{1}{2n+1} \leq 10^{-2}$ ,  $2n+1 \geq 100$ ,  $n \geq 49.5$ ;  $n = 50$

46.  $\sum(1/k^p)$  converges if  $p > 1$  and diverges if  $p \leq 1$ , so  $\sum_{k=1}^{\infty} (-1)^k \frac{1}{k^p}$  converges absolutely if  $p > 1$ , and converges conditionally if  $0 < p \leq 1$  since it satisfies the Alternating Series Test; it diverges for  $p \leq 0$  since  $\lim_{k \rightarrow +\infty} a_k \neq 0$ .

47.  $1 + \frac{1}{3^2} + \frac{1}{5^2} + \cdots = \left[1 + \frac{1}{2^2} + \frac{1}{3^2} + \cdots\right] - \left[\frac{1}{2^2} + \frac{1}{4^2} + \frac{1}{6^2} + \cdots\right]$   
 $= \frac{\pi^2}{6} - \frac{1}{2^2} \left[1 + \frac{1}{2^2} + \frac{1}{3^2} + \cdots\right] = \frac{\pi^2}{6} - \frac{1}{4} \frac{\pi^2}{6} = \frac{\pi^2}{8}$

48.  $1 + \frac{1}{3^4} + \frac{1}{5^4} + \cdots = \left[1 + \frac{1}{2^4} + \frac{1}{3^4} + \cdots\right] - \left[\frac{1}{2^4} + \frac{1}{4^4} + \frac{1}{6^4} + \cdots\right]$   
 $= \frac{\pi^4}{90} - \frac{1}{2^4} \left[1 + \frac{1}{2^4} + \frac{1}{3^4} + \cdots\right] = \frac{\pi^4}{90} - \frac{1}{16} \frac{\pi^4}{90} = \frac{\pi^4}{96}$

49. Every positive integer can be written in exactly one of the three forms  $2k-1$  or  $4k-2$  or  $4k$ , so a rearrangement is

$$\left(1 - \frac{1}{2} - \frac{1}{4}\right) + \left(\frac{1}{3} - \frac{1}{6} - \frac{1}{8}\right) + \left(\frac{1}{5} - \frac{1}{10} - \frac{1}{12}\right) + \cdots + \left(\frac{1}{2k-1} - \frac{1}{4k-2} - \frac{1}{4k}\right) + \cdots$$

$$= \left(\frac{1}{2} - \frac{1}{4}\right) + \left(\frac{1}{6} - \frac{1}{8}\right) + \left(\frac{1}{10} - \frac{1}{12}\right) + \cdots + \left(\frac{1}{4k-2} - \frac{1}{4k}\right) + \cdots = \frac{1}{2} \ln 2$$

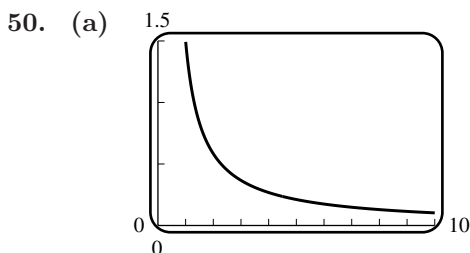

(b) Yes; since  $f(x)$  is decreasing for  $x \geq 1$  and  $\lim_{x \rightarrow +\infty} f(x) = 0$ , so the series satisfies the Alternating Series Test.

51. (a) The distance  $d$  from the starting point is

$$d = 180 - \frac{180}{2} + \frac{180}{3} - \cdots - \frac{180}{1000} = 180 \left[1 - \frac{1}{2} + \frac{1}{3} - \cdots - \frac{1}{1000}\right].$$

From Theorem 11.7.2,  $1 - \frac{1}{2} + \frac{1}{3} - \cdots - \frac{1}{1000}$  differs from  $\ln 2$  by less than  $1/1001$  so  $180(\ln 2 - 1/1001) < d < 180 \ln 2$ ,  $124.58 < d < 124.77$ .

- (b) The total distance traveled is  $s = 180 + \frac{180}{2} + \frac{180}{3} + \cdots + \frac{180}{1000}$ , and from inequality (2) in Section 11.4,

$$\int_1^{1001} \frac{180}{x} dx < s < 180 + \int_1^{1000} \frac{180}{x} dx$$

$$180 \ln 1001 < s < 180(1 + \ln 1000)$$

$$1243 < s < 1424$$

52. (a) Suppose  $\sum |a_k|$  converges, then  $\lim_{k \rightarrow +\infty} |a_k| = 0$  so  $|a_k| < 1$  for  $k \geq K$  and thus  $|a_k|^2 < |a_k|$ ,  $a_k^2 < |a_k|$  hence  $\sum a_k^2$  converges by the Comparison Test.
- (b) Let  $a_k = \frac{1}{k}$ , then  $\sum a_k^2$  converges but  $\sum a_k$  diverges.

### EXERCISE SET 11.8

- geometric series,  $\rho = \lim_{k \rightarrow +\infty} \left| \frac{u_{k+1}}{u_k} \right| = |x|$ , so the interval of convergence is  $-1 < x < 1$ , converges there to  $\frac{1}{1+x}$  (the series diverges for  $x = \pm 1$ )
- geometric series,  $\rho = \lim_{k \rightarrow +\infty} \left| \frac{u_{k+1}}{u_k} \right| = |x|^2$ , so the interval of convergence is  $-1 < x < 1$ , converges there to  $\frac{1}{1-x^2}$  (the series diverges for  $x = \pm 1$ )
- geometric series,  $\rho = \lim_{k \rightarrow +\infty} \left| \frac{u_{k+1}}{u_k} \right| = |x-2|$ , so the interval of convergence is  $1 < x < 3$ , converges there to  $\frac{1}{1-(x-2)} = \frac{1}{3-x}$  (the series diverges for  $x = 1, 3$ )
- geometric series,  $\rho = \lim_{k \rightarrow +\infty} \left| \frac{u_{k+1}}{u_k} \right| = |x+3|$ , so the interval of convergence is  $-4 < x < -2$ , converges there to  $\frac{1}{1+(x+3)} = \frac{1}{4+x}$  (the series diverges for  $x = -4, -2$ )
- (a) geometric series,  $\rho = \lim_{k \rightarrow +\infty} \left| \frac{u_{k+1}}{u_k} \right| = |x/2|$ , so the interval of convergence is  $-2 < x < 2$ , converges there to  $\frac{1}{1+x/2} = \frac{2}{2+x}$ ; (the series diverges for  $x = -2, 2$ )  
 (b)  $f(0) = 1$ ;  $f(1) = 2/3$
- (a) geometric series,  $\rho = \lim_{k \rightarrow +\infty} \left| \frac{u_{k+1}}{u_k} \right| = \left| \frac{x-5}{3} \right|$ , so the interval of convergence is  $2 < x < 8$ , converges to  $\frac{1}{1+(x-5)/3} = \frac{3}{x-2}$  (the series diverges for  $x = 2, 8$ )  
 (b)  $f(3) = 3$ ,  $f(6) = 3/4$

7.  $\rho = \lim_{k \rightarrow +\infty} \frac{k+1}{k+2} |x| = |x|$ , the series converges if  $|x| < 1$  and diverges if  $|x| > 1$ . If  $x = -1$ ,  $\sum_{k=0}^{\infty} \frac{(-1)^k}{k+1}$  converges by the Alternating Series Test; if  $x = 1$ ,  $\sum_{k=0}^{\infty} \frac{1}{k+1}$  diverges. The radius of convergence is 1, the interval of convergence is  $[-1, 1)$ .
8.  $\rho = \lim_{k \rightarrow +\infty} 3|x| = 3|x|$ , the series converges if  $3|x| < 1$  or  $|x| < 1/3$  and diverges if  $|x| > 1/3$ . If  $x = -1/3$ ,  $\sum_{k=0}^{\infty} (-1)^k$  diverges, if  $x = 1/3$ ,  $\sum_{k=0}^{\infty} (1)$  diverges. The radius of convergence is  $1/3$ , the interval of convergence is  $(-1/3, 1/3)$ .
9.  $\rho = \lim_{k \rightarrow +\infty} \frac{|x|}{k+1} = 0$ , the radius of convergence is  $+\infty$ , the interval is  $(-\infty, +\infty)$ .
10.  $\rho = \lim_{k \rightarrow +\infty} \frac{k+1}{2} |x| = +\infty$ , the radius of convergence is 0, the series converges only if  $x = 0$ .
11.  $\rho = \lim_{k \rightarrow +\infty} \frac{5k^2|x|}{(k+1)^2} = 5|x|$ , converges if  $|x| < 1/5$  and diverges if  $|x| > 1/5$ . If  $x = -1/5$ ,  $\sum_{k=1}^{\infty} \frac{(-1)^k}{k^2}$  converges; if  $x = 1/5$ ,  $\sum_{k=1}^{\infty} 1/k^2$  converges. Radius of convergence is  $1/5$ , interval of convergence is  $[-1/5, 1/5]$ .
12.  $\rho = \lim_{k \rightarrow +\infty} \frac{\ln k}{\ln(k+1)} |x| = |x|$ , the series converges if  $|x| < 1$  and diverges if  $|x| > 1$ . If  $x = -1$ ,  $\sum_{k=2}^{\infty} \frac{(-1)^k}{\ln k}$  converges; if  $x = 1$ ,  $\sum_{k=2}^{\infty} 1/(\ln k)$  diverges (compare to  $\sum(1/k)$ ). Radius of convergence is 1, interval of convergence is  $[-1, 1)$ .
13.  $\rho = \lim_{k \rightarrow +\infty} \frac{k|x|}{k+2} = |x|$ , converges if  $|x| < 1$ , diverges if  $|x| > 1$ . If  $x = -1$ ,  $\sum_{k=1}^{\infty} \frac{(-1)^k}{k(k+1)}$  converges; if  $x = 1$ ,  $\sum_{k=1}^{\infty} \frac{1}{k(k+1)}$  converges. Radius of convergence is 1, interval of convergence is  $[-1, 1]$ .
14.  $\rho = \lim_{k \rightarrow +\infty} 2 \frac{k+1}{k+2} |x| = 2|x|$ , converges if  $|x| < 1/2$ , diverges if  $|x| > 1/2$ . If  $x = -1/2$ ,  $\sum_{k=0}^{\infty} \frac{-1}{2(k+1)}$  diverges; if  $x = 1/2$ ,  $\sum_{k=0}^{\infty} \frac{(-1)^k}{2(k+1)}$  converges. Radius of convergence is  $1/2$ , interval of convergence is  $(-1/2, 1/2]$ .
15.  $\rho = \lim_{k \rightarrow +\infty} \frac{\sqrt{k}}{\sqrt{k+1}} |x| = |x|$ , converges if  $|x| < 1$ , diverges if  $|x| > 1$ . If  $x = -1$ ,  $\sum_{k=1}^{\infty} \frac{-1}{\sqrt{k}}$  diverges; if  $x = 1$ ,  $\sum_{k=1}^{\infty} \frac{(-1)^{k-1}}{\sqrt{k}}$  converges. Radius of convergence is 1, interval of convergence is  $(-1, 1]$ .

16.  $\rho = \lim_{k \rightarrow +\infty} \frac{|x|^2}{(2k+2)(2k+1)} = 0$ , radius of convergence is  $+\infty$ , interval of convergence is  $(-\infty, +\infty)$ .
17.  $\rho = \lim_{k \rightarrow +\infty} \frac{|x|^2}{(2k+3)(2k+2)} = 0$ , radius of convergence is  $+\infty$ , interval of convergence is  $(-\infty, +\infty)$ .
18.  $\rho = \lim_{k \rightarrow +\infty} \frac{k^{3/2}|x|^3}{(k+1)^{3/2}} = |x|^3$ , converges if  $|x| < 1$ , diverges if  $|x| > 1$ . If  $x = -1$ ,  $\sum_{k=0}^{\infty} \frac{1}{k^{3/2}}$  converges; if  $x = 1$ ,  $\sum_{k=2}^{\infty} \frac{(-1)^k}{k^{3/2}}$  converges. Radius of convergence is 1, interval of convergence is  $[-1, 1]$ .
19.  $\rho = \lim_{k \rightarrow +\infty} \frac{3|x|}{k+1} = 0$ , radius of convergence is  $+\infty$ , interval of convergence is  $(-\infty, +\infty)$ .
20.  $\rho = \lim_{k \rightarrow +\infty} \frac{k(\ln k)^2|x|}{(k+1)[\ln(k+1)]^2} = |x|$ , converges if  $|x| < 1$ , diverges if  $|x| > 1$ . If  $x = -1$ , then, by Exercise 11.4.25,  $\sum_{k=2}^{\infty} \frac{-1}{k(\ln k)^2}$  converges; if  $x = 1$ ,  $\sum_{k=2}^{\infty} \frac{(-1)^{k+1}}{k(\ln k)^2}$  converges. Radius of convergence is 1, interval of convergence is  $[-1, 1]$ .
21.  $\rho = \lim_{k \rightarrow +\infty} \frac{1+k^2}{1+(k+1)^2}|x| = |x|$ , converges if  $|x| < 1$ , diverges if  $|x| > 1$ . If  $x = -1$ ,  $\sum_{k=0}^{\infty} \frac{(-1)^k}{1+k^2}$  converges; if  $x = 1$ ,  $\sum_{k=0}^{\infty} \frac{1}{1+k^2}$  converges. Radius of convergence is 1, interval of convergence is  $[-1, 1]$ .
22.  $\rho = \lim_{k \rightarrow +\infty} \frac{1}{2}|x-3| = \frac{1}{2}|x-3|$ , converges if  $|x-3| < 2$ , diverges if  $|x-3| > 2$ . If  $x = 1$ ,  $\sum_{k=0}^{\infty} (-1)^k$  diverges; if  $x = 5$ ,  $\sum_{k=0}^{\infty} 1$  diverges. Radius of convergence is 2, interval of convergence is  $(1, 5)$ .
23.  $\rho = \lim_{k \rightarrow +\infty} \frac{k|x+1|}{k+1} = |x+1|$ , converges if  $|x+1| < 1$ , diverges if  $|x+1| > 1$ . If  $x = -2$ ,  $\sum_{k=1}^{\infty} \frac{-1}{k}$  diverges; if  $x = 0$ ,  $\sum_{k=1}^{\infty} \frac{(-1)^{k+1}}{k}$  converges. Radius of convergence is 1, interval of convergence is  $(-2, 0]$ .
24.  $\rho = \lim_{k \rightarrow +\infty} \frac{(k+1)^2}{(k+2)^2}|x-4| = |x-4|$ , converges if  $|x-4| < 1$ , diverges if  $|x-4| > 1$ . If  $x = 3$ ,  $\sum_{k=0}^{\infty} 1/(k+1)^2$  converges; if  $x = 5$ ,  $\sum_{k=0}^{\infty} (-1)^k/(k+1)^2$  converges. Radius of convergence is 1, interval of convergence is  $[3, 5]$ .

25.  $\rho = \lim_{k \rightarrow +\infty} (3/4)^k |x + 5| = \frac{3}{4} |x + 5|$ , converges if  $|x + 5| < 4/3$ , diverges if  $|x + 5| > 4/3$ . If  $x = -19/3$ ,  $\sum_{k=0}^{\infty} (-1)^k$  diverges; if  $x = -11/3$ ,  $\sum_{k=0}^{\infty} 1$  diverges. Radius of convergence is  $4/3$ , interval of convergence is  $(-19/3, -11/3)$ .

26.  $\rho = \lim_{k \rightarrow +\infty} \frac{(2k+3)(2k+2)k^3}{(k+1)^3} |x-2| = +\infty$ , radius of convergence is 0, series converges only at  $x = 2$ .

27.  $\rho = \lim_{k \rightarrow +\infty} \frac{k^2 + 4}{(k+1)^2 + 4} |x+1|^2 = |x+1|^2$ , converges if  $|x+1| < 1$ , diverges if  $|x+1| > 1$ . If  $x = -2$ ,  $\sum_{k=1}^{\infty} \frac{(-1)^{3k+1}}{k^2 + 4}$  converges; if  $x = 0$ ,  $\sum_{k=1}^{\infty} \frac{(-1)^k}{k^2 + 4}$  converges. Radius of convergence is 1, interval of convergence is  $[-2, 0]$ .

28.  $\rho = \lim_{k \rightarrow +\infty} \frac{k \ln(k+1)}{(k+1) \ln k} |x-3| = |x-3|$ , converges if  $|x-3| < 1$ , diverges if  $|x-3| > 1$ . If  $x = 2$ ,  $\sum_{k=1}^{\infty} \frac{(-1)^k \ln k}{k}$  converges; if  $x = 4$ ,  $\sum_{k=1}^{\infty} \frac{\ln k}{k}$  diverges. Radius of convergence is 1, interval of convergence is  $[2, 4)$ .

29.  $\rho = \lim_{k \rightarrow +\infty} \frac{\pi |x-1|^2}{(2k+3)(2k+2)} = 0$ , radius of convergence  $+\infty$ , interval of convergence  $(-\infty, +\infty)$ .

30.  $\rho = \lim_{k \rightarrow +\infty} \frac{1}{16} |2x-3| = \frac{1}{16} |2x-3|$ , converges if  $\frac{1}{16} |2x-3| < 1$  or  $|x-3/2| < 8$ , diverges if  $|x-3/2| > 8$ . If  $x = -13/2$ ,  $\sum_{k=0}^{\infty} (-1)^k$  diverges; if  $x = 19/2$ ,  $\sum_{k=0}^{\infty} 1$  diverges. Radius of convergence is 8, interval of convergence is  $(-13/2, 19/2)$ .

31.  $\rho = \lim_{k \rightarrow +\infty} \sqrt[k]{|u_k|} = \lim_{k \rightarrow +\infty} \frac{|x|}{\ln k} = 0$ , the series converges absolutely for all  $x$  so the interval of convergence is  $(-\infty, +\infty)$ .

32.  $\rho = \lim_{k \rightarrow +\infty} \frac{2k+1}{(2k)(2k-1)} |x| = 0$   
so  $R = +\infty$ .

33. (a)

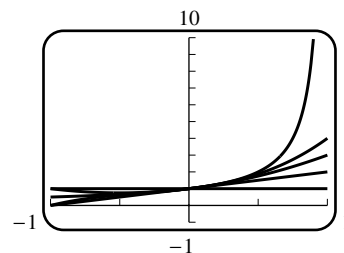



34. Ratio Test:  $\rho = \lim_{k \rightarrow +\infty} \frac{|x|^2}{4(k+1)(k+2)} = 0$ ,  $R = +\infty$

35. By the Ratio Test for absolute convergence,

$$\begin{aligned} \rho &= \lim_{k \rightarrow +\infty} \frac{(pk+p)!(k!)^p}{(pk)![k+1]^p} |x| = \lim_{k \rightarrow +\infty} \frac{(pk+p)(pk+p-1)(pk+p-2) \cdots (pk+p-[p-1])}{(k+1)^p} |x| \\ &= \lim_{k \rightarrow +\infty} p \left( p - \frac{1}{k+1} \right) \left( p - \frac{2}{k+1} \right) \cdots \left( p - \frac{p-1}{k+1} \right) |x| = p^p |x|, \end{aligned}$$

converges if  $|x| < 1/p^p$ , diverges if  $|x| > 1/p^p$ . Radius of convergence is  $1/p^p$ .

36. By the Ratio Test for absolute convergence,

$$\rho = \lim_{k \rightarrow +\infty} \frac{(k+1+p)!k!(k+q)!}{(k+p)!(k+1)!(k+1+q)!} |x| = \lim_{k \rightarrow +\infty} \frac{k+1+p}{(k+1)(k+1+q)} |x| = 0,$$

radius of convergence is  $+\infty$ .

37. (a) By Theorem 11.4.3(b) both series converge or diverge together, so they have the same radius of convergence.

(b) By Theorem 11.4.3(a) the series  $\sum (c_k + d_k)(x - x_0)^k$  converges if  $|x - x_0| < R$ ; if  $|x - x_0| > R$  then  $\sum (c_k + d_k)(x - x_0)^k$  cannot converge, as otherwise  $\sum c_k(x - x_0)^k$  would converge by the same Theorem. Hence the radius of convergence of  $\sum (c_k + d_k)(x - x_0)^k$  is  $R$ .

(c) Let  $r$  be the radius of convergence of  $\sum (c_k + d_k)(x - x_0)^k$ . If  $|x - x_0| < \min(R_1, R_2)$  then  $\sum c_k(x - x_0)^k$  and  $\sum d_k(x - x_0)^k$  converge, so  $\sum (c_k + d_k)(x - x_0)^k$  converges. Hence  $r \geq \min(R_1, R_2)$  (to see that  $r > \min(R_1, R_2)$  is possible consider the case  $c_k = -d_k = 1$ ). If in addition  $R_1 \neq R_2$ , and  $R_1 < |x - x_0| < R_2$  (or  $R_2 < |x - x_0| < R_1$ ) then  $\sum (c_k + d_k)(x - x_0)^k$  cannot converge, as otherwise all three series would converge. Thus in this case  $r = \min(R_1, R_2)$ .

38. By the Root Test for absolute convergence,

$$\rho = \lim_{k \rightarrow +\infty} |c_k|^{1/k} |x| = L|x|, L|x| < 1 \text{ if } |x| < 1/L \text{ so the radius of convergence is } 1/L.$$

39. By assumption  $\sum_{k=0}^{\infty} c_k x^k$  converges if  $|x| < R$  so  $\sum_{k=0}^{\infty} c_k x^{2k} = \sum_{k=0}^{\infty} c_k (x^2)^k$  converges if  $|x^2| < R$ ,

$|x| < \sqrt{R}$ . Moreover,  $\sum_{k=0}^{\infty} c_k x^{2k} = \sum_{k=0}^{\infty} c_k (x^2)^k$  diverges if  $|x^2| > R$ ,  $|x| > \sqrt{R}$ . Thus  $\sum_{k=0}^{\infty} c_k x^{2k}$

has radius of convergence  $\sqrt{R}$ .

40. The assumption is that  $\sum_{k=0}^{\infty} c_k R^k$  is convergent and  $\sum_{k=0}^{\infty} c_k (-R)^k$  is divergent. Suppose that  $\sum_{k=0}^{\infty} c_k R^k$

is absolutely convergent then  $\sum_{k=0}^{\infty} c_k (-R)^k$  is also absolutely convergent and hence convergent

because  $|c_k R^k| = |c_k (-R)^k|$ , which contradicts the assumption that  $\sum_{k=0}^{\infty} c_k (-R)^k$  is divergent so

$\sum_{k=0}^{\infty} c_k R^k$  must be conditionally convergent.

## EXERCISE SET 11.9

$$1. \sin 4^\circ = \sin\left(\frac{\pi}{45}\right) = \frac{\pi}{45} - \frac{(\pi/45)^3}{3!} + \frac{(\pi/45)^5}{5!} - \dots$$

$$(a) \text{ Method 1: } |R_n(\pi/45)| \leq \frac{(\pi/45)^{n+1}}{(n+1)!} < 0.000005 \text{ for } n+1 = 4, n = 3;$$

$$\sin 4^\circ \approx \frac{\pi}{45} - \frac{(\pi/45)^3}{3!} \approx 0.069756$$

(b) Method 2: The first term in the alternating series that is less than 0.000005 is  $\frac{(\pi/45)^5}{5!}$ , so the result is the same as in part (a).

$$2. \cos 3^\circ = \cos\left(\frac{\pi}{60}\right) = 1 - \frac{(\pi/60)^2}{2} + \frac{(\pi/60)^4}{4!} - \dots$$

$$(a) \text{ Method 1: } |R_n(\pi/60)| \leq \frac{(\pi/60)^{n+1}}{(n+1)!} < 0.0005 \text{ for } n = 2; \cos 3^\circ \approx 1 - \frac{(\pi/60)^2}{2} \approx 0.9986.$$

(b) Method 2: The first term in the alternating series that is less than 0.0005 is  $\frac{(\pi/60)^4}{4!}$ , so the result is the same as in part (a).

$$3. f^{(k)}(x) = e^x, |f^{(k)}(x)| \leq e^{1/2} < 2 \text{ on } [0, 1/2], \text{ let } M = 2, e^{1/2} = 1 + \frac{1}{2} + \frac{1}{8} + \frac{1}{48} + \frac{1}{24 \cdot 16} + \dots;$$

$$|R_n(1/2)| \leq \frac{M}{(n+1)!} (1/2)^{n+1} \leq \frac{2}{(n+1)!} (1/2)^{n+1} \leq 0.00005 \text{ for } n = 5;$$

$$e^{1/2} \approx 1 + \frac{1}{2} + \frac{1}{8} + \frac{1}{48} + \frac{1}{24 \cdot 16} \approx 1.64844, \text{ calculator value } 1.64872$$

$$4. f(x) = e^x, f^{(k)}(x) = e^x, |f^{(k)}(x)| \leq 1 \text{ on } [-1, 0], |R_n(x)| \leq \frac{1}{(n+1)!} (1)^{n+1} = \frac{1}{(n+1)!} < 0.5 \times 10^{-3}$$

$$\text{if } n = 6, \text{ so } e^{-1} \approx 1 - 1 + \frac{1}{2!} - \frac{1}{3!} + \frac{1}{4!} - \frac{1}{5!} + \frac{1}{6!} \approx 0.3681, \text{ calculator value } 0.3679$$

$$5. |R_n(0.1)| \leq \frac{(0.1)^{n+1}}{(n+1)!} \leq 0.000005 \text{ for } n = 3; \cos 0.1 \approx 1 - (0.1)^2/2 = 0.99500, \text{ calculator value } 0.995004\dots$$

$$6. (0.1)^3/3 < 0.5 \times 10^{-3} \text{ so } \tan^{-1}(0.1) \approx 0.100, \text{ calculator value } \approx 0.0997$$

$$7. \text{ Expand about } \pi/2 \text{ to get } \sin x = 1 - \frac{1}{2!}(x - \pi/2)^2 + \frac{1}{4!}(x - \pi/2)^4 - \dots, 85^\circ = 17\pi/36 \text{ radians,}$$

$$|R_n(x)| \leq \frac{|x - \pi/2|^{n+1}}{(n+1)!}, |R_n(17\pi/36)| \leq \frac{|17\pi/36 - \pi/2|^{n+1}}{(n+1)!} = \frac{(\pi/36)^{n+1}}{(n+1)!} < 0.5 \times 10^{-4}$$

$$\text{if } n = 3, \sin 85^\circ \approx 1 - \frac{1}{2}(-\pi/36)^2 \approx 0.99619, \text{ calculator value } 0.99619\dots$$

$$8. -175^\circ = -\pi + \pi/36 \text{ rad; } x_0 = -\pi, x = -\pi + \pi/36, \cos x = -1 + \frac{(x + \pi)^2}{2} - \frac{(x + \pi)^4}{4!} - \dots;$$

$$|R_n| \leq \frac{(\pi/36)^{n+1}}{(n+1)!} \leq 0.00005 \text{ for } n = 3; \cos(-\pi + \pi/36) = -1 + \frac{(\pi/36)^2}{2} \approx -0.99619,$$

calculator value  $-0.99619\dots$

9.  $f^{(k)}(x) = \cosh x$  or  $\sinh x$ ,  $|f^{(k)}(x)| \leq \cosh x \leq \cosh 0.5 = \frac{1}{2}(e^{0.5} + e^{-0.5}) < \frac{1}{2}(2 + 1) = 1.5$   
 so  $|R_n(x)| < \frac{1.5(0.5)^{n+1}}{(n+1)!} \leq 0.5 \times 10^{-3}$  if  $n = 4$ ,  $\sinh 0.5 \approx 0.5 + \frac{(0.5)^3}{3!} \approx 0.5208$ , calculator value 0.52109...
10.  $f^{(k)}(x) = \cosh x$  or  $\sinh x$ ,  $|f^{(k)}(x)| \leq \cosh x \leq \cosh 0.1 = \frac{1}{2}(e^{0.1} + e^{-0.1}) < 1.06$  so  $|R_n(x)| < \frac{1.06(0.1)^{n+1}}{(n+1)!} \leq 0.5 \times 10^{-3}$  for  $n = 2$ ,  $\cosh 0.1 \approx 1 + \frac{(0.1)^2}{2!} = 1.005$ , calculator value 1.0050...
11.  $f(x) = \sin x$ ,  $f^{(n+1)}(x) = \pm \sin x$  or  $\pm \cos x$ ,  $|f^{(n+1)}(x)| \leq 1$ ,  $|R_n(x)| \leq \frac{|x - \pi/4|^{n+1}}{(n+1)!}$ ,  
 $\lim_{n \rightarrow +\infty} \frac{|x - \pi/4|^{n+1}}{(n+1)!} = 0$ ; by the Squeezing Theorem,  $\lim_{n \rightarrow +\infty} |R_n(x)| = 0$   
 so  $\lim_{n \rightarrow +\infty} R_n(x) = 0$  for all  $x$ .
12.  $f(x) = e^x$ ,  $f^{(n+1)}(x) = e^x$ ; if  $x > 1$  then  $|R_n(x)| \leq \frac{e^x}{(n+1)!}|x - 1|^{n+1}$ ; if  $x < 1$  then  
 $|R_n(x)| \leq \frac{e}{(n+1)!}|x - 1|^{n+1}$ . But  $\lim_{n \rightarrow +\infty} \frac{|x - 1|^{n+1}}{(n+1)!} = 0$  so  $\lim_{n \rightarrow +\infty} R_n(x) = 0$ .
13. (a) Let  $x = 1/9$  in series (17).  
 (b)  $\ln 1.25 \approx 2 \left( 1/9 + \frac{(1/9)^3}{3} \right) = 2(1/9 + 1/3^7) \approx 0.223$ , which agrees with the calculator value 0.22314... to three decimal places.
14. (a) Let  $x = 1/2$  in series (17).  
 (b)  $\ln 3 \approx 2 \left( 1/2 + \frac{(1/2)^3}{3} \right) = 2(1/2 + 1/24) = 13/12 \approx 1.083$ ; the calculator value is 1.099 to three decimal places.
15. (a)  $(1/2)^9/9 < 0.5 \times 10^{-3}$  and  $(1/3)^7/7 < 0.5 \times 10^{-3}$  so  
 $\tan^{-1} 1/2 \approx 1/2 - \frac{(1/2)^3}{3} + \frac{(1/2)^5}{5} - \frac{(1/2)^7}{7} \approx 0.4635$   
 $\tan^{-1} 1/3 \approx 1/3 - \frac{(1/3)^3}{3} + \frac{(1/3)^5}{5} \approx 0.3218$   
 (b) From Formula (21),  $\pi \approx 4(0.4635 + 0.3218) = 3.1412$   
 (c) Let  $a = \tan^{-1} \frac{1}{2}$ ,  $b = \tan^{-1} \frac{1}{3}$ ; then  $|a - 0.4635| < 0.0005$  and  $|b - 0.3218| < 0.0005$ , so  
 $|4(a + b) - 3.140| \leq 4|a - 0.4635| + 4|b - 0.3218| < 0.004$ , so two decimal-place accuracy is guaranteed, but not three.
16.  $(27+x)^{1/3} = 3(1+x/3^3)^{1/3} = 3 \left( 1 + \frac{1}{3^4}x - \frac{1 \cdot 2}{3^8}x^2 + \frac{1 \cdot 2 \cdot 5}{3^{12}3!}x^3 + \dots \right)$ , alternates after first term,  
 $\frac{3 \cdot 2}{3^8 2} < 0.0005$ ,  $\sqrt{28} \approx 3 \left( 1 + \frac{1}{3^4} \right) \approx 3.0370$

17. (a)  $\sin x = x - \frac{x^3}{3!} + 0 \cdot x^4 + R_4(x)$ ,  
 $|R_4(x)| \leq \frac{|x|^5}{5!} < 0.5 \times 10^{-3}$  if  $|x|^5 < 0.06$ ,  
 $|x| < (0.06)^{1/5} \approx 0.569, (-0.569, 0.569)$

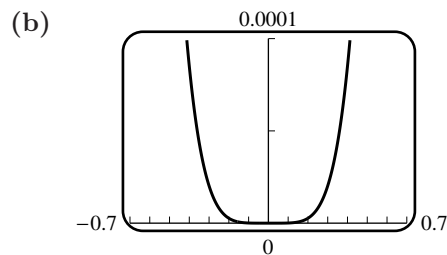

18. (a)  $f^{(k)}(x) = e^x \leq e^b$ ,  
 $|R_2(x)| \leq \frac{e^b b^3}{3!} < 0.0005$ ,  
 $e^b b^3 < 0.003$  if  $b < 0.137$  (by trial and error with a hand calculator), so  $[0, 0.136]$ .

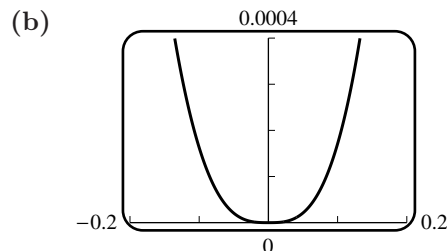

19. (a)  $\cos x = 1 - \frac{x^2}{2!} + \frac{x^4}{4!} + (0)x^5 + R_5(x)$ ,  
 $|R_5(x)| \leq \frac{|x|^6}{6!} \leq \frac{(0.2)^6}{6!} < 9 \times 10^{-8}$

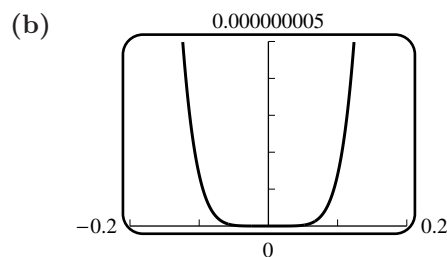

20. (a)  $f''(x) = -1/(1+x)^2$ ,  
 $f''(x) < 1/(0.99)^2 \leq 1.03$ ,  
 $|R_1(x)| \leq \frac{1.03|x|^2}{2} \leq \frac{1.03(0.01)^2}{2}$   
 $\leq 5.11 \times 10^{-5}$  for  $-0.01 \leq x \leq 0.01$

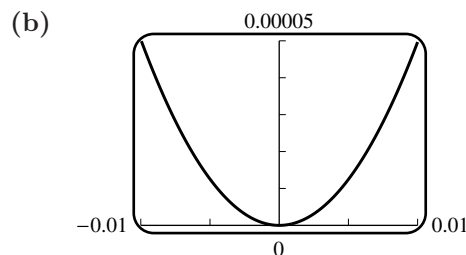

21. (a)  $(1+x)^{-1} = 1 - x + \frac{-1(-2)}{2!}x^2 + \frac{-1(-2)(-3)}{3!}x^3 + \dots + \frac{-1(-2)(-3)\dots(-k)}{k!}x^k + \dots$   
 $= \sum_{k=0}^{\infty} (-1)^k x^k$

(b)  $(1+x)^{1/3} = 1 + (1/3)x + \frac{(1/3)(-2/3)}{2!}x^2 + \frac{(1/3)(-2/3)(-5/3)}{3!}x^3 + \dots$   
 $+ \frac{(1/3)(-2/3)\dots(4-3k)/3}{k!}x^k + \dots = 1 + x/3 + \sum_{k=2}^{\infty} (-1)^{k-1} \frac{2 \cdot 5 \dots (3k-4)}{3^k k!} x^k$

(c)  $(1+x)^{-3} = 1 - 3x + \frac{(-3)(-4)}{2!}x^2 + \frac{(-3)(-4)(-5)}{3!}x^3 + \dots + \frac{(-3)(-4)\dots(-2-k)}{k!}x^k + \dots$   
 $= \sum_{k=0}^{\infty} (-1)^k \frac{(k+2)!}{2 \cdot k!} x^k = \sum_{k=0}^{\infty} (-1)^k \frac{(k+2)(k+1)}{2} x^k$

22.  $(1+x)^m = \binom{m}{0} + \sum_{k=1}^{\infty} \binom{m}{k} x^k = \sum_{k=0}^{\infty} \binom{m}{k} x^k$

23. (a)  $\frac{d}{dx} \ln(1+x) = \frac{1}{1+x}$ ,  $\frac{d^k}{dx^k} \ln(1+x) = (-1)^{k-1} \frac{(k-1)!}{(1+x)^k}$ ; similarly  $\frac{d}{dx} \ln(1-x) = -\frac{(k-1)!}{(1-x)^k}$ ,

so  $f^{(n+1)}(x) = n! \left[ \frac{(-1)^n}{(1+x)^{n+1}} + \frac{1}{(1-x)^{n+1}} \right]$ .

(b)  $|f^{(n+1)}(x)| \leq n! \left| \frac{(-1)^n}{(1+x)^{n+1}} \right| + n! \left| \frac{1}{(1-x)^{n+1}} \right| = n! \left[ \frac{1}{(1+x)^{n+1}} + \frac{1}{(1-x)^{n+1}} \right]$

(c) If  $|f^{(n+1)}(x)| \leq M$  on the interval  $[0, 1/3]$  then  $|R_n(1/3)| \leq \frac{M}{(n+1)!} \left(\frac{1}{3}\right)^{n+1}$ .

(d) If  $0 \leq x \leq 1/3$  then  $1+x \geq 1$ ,  $1-x \geq 2/3$ ,  $|f^{(n+1)}(x)| \leq M = n! \left[ 1 + \frac{1}{(2/3)^{n+1}} \right]$ .

(e)  $0.000005 \geq \frac{M}{(n+1)!} \left(\frac{1}{3}\right)^{n+1} = \frac{1}{n+1} \left[ \left(\frac{1}{3}\right)^{n+1} + \frac{(1/3)^{n+1}}{(2/3)^{n+1}} \right] = \frac{1}{n+1} \left[ \left(\frac{1}{3}\right)^{n+1} + \left(\frac{1}{2}\right)^{n+1} \right]$

24. Set  $x = 1/4$  in Formula (17). Follow the argument of Exercise 23: parts (a) and (b) remain unchanged; in part (c) replace  $(1/3)$  with  $(1/4)$ :  $\frac{M}{(n+1)!} \left(\frac{1}{4}\right)^{n+1} \leq 0.000005$  for  $x$  in the interval  $[0, 1/4]$ . From part (b), together with  $0 \leq x \leq 1/4$ ,  $1+x \geq 1$ ,  $1-x \geq 3/4$ , follows part (d):  $M = n! \left[ 1 + \frac{1}{(3/4)^{n+1}} \right]$ . Part (e) now becomes  $0.000005 \geq \frac{M}{(n+1)!} \left(\frac{1}{4}\right)^{n+1} = \frac{1}{n+1} \left[ \left(\frac{1}{4}\right)^{n+1} + \left(\frac{1}{3}\right)^{n+1} \right]$ , which is true for  $n = 9$ .

25.  $f(x) = \cos x$ ,  $f^{(n+1)}(x) = \pm \sin x$  or  $\pm \cos x$ ,  $|f^{(n+1)}(x)| \leq 1$ , set  $M = 1$ ,  
 $|R_n(x)| \leq \frac{1}{(n+1)!} |x-a|^{n+1}$ ,  $\lim_{n \rightarrow +\infty} \frac{|x-a|^{n+1}}{(n+1)!} = 0$  so  $\lim_{n \rightarrow +\infty} R_n(x) = 0$  for all  $x$ .

26.  $f(x) = \sin x$ ,  $f^{(n+1)}(x) = \pm \sin x$  or  $\pm \cos x$ ,  $|f^{(n+1)}(x)| \leq 1$ , follow Exercise 25.

27. (a) From Machin's formula and a CAS,  $\frac{\pi}{4} \approx 0.7853981633974483096156609$ , accurate to the 25th decimal place.

(b)

$n$	$s_n$
0	0.3183098 78 ...
1	0.3183098 861837906 067 ...
2	0.3183098 861837906 7153776 695 ...
3	0.3183098 861837906 7153776 752674502 34 ...
$1/\pi$	0.3183098 861837906 7153776 752674502 87 ...

28. (a)  $f'(0) = \lim_{h \rightarrow 0} \frac{f(h) - f(0)}{h} = \lim_{h \rightarrow 0} \frac{e^{-1/h^2}}{h}$ , let  $t = 1/h$  then  $h = 1/t$  and  
 $\lim_{h \rightarrow 0^+} \frac{e^{-1/h^2}}{h} = \lim_{t \rightarrow +\infty} t e^{-t^2} = \lim_{t \rightarrow +\infty} \frac{t}{e^{t^2}} = \lim_{t \rightarrow +\infty} \frac{1}{2te^{t^2}} = 0$ , similarly  $\lim_{h \rightarrow 0^-} \frac{e^{-1/h^2}}{h} = 0$  so  
 $f'(0) = 0$ .

- (b) The Maclaurin series is  $0 + 0 \cdot x + 0 \cdot x^2 + \dots = 0$ , but  $f(0) = 0$  and  $f(x) > 0$  if  $x \neq 0$  so the series converges to  $f(x)$  only at the point  $x = 0$ .

### EXERCISE SET 11.10

- (a) Replace  $x$  with  $-x$ :  $\frac{1}{1+x} = 1 - x + x^2 - \dots + (-1)^k x^k + \dots$ ;  $R = 1$ .

(b) Replace  $x$  with  $x^2$ :  $\frac{1}{1-x^2} = 1 + x^2 + x^4 + \dots + x^{2k} + \dots$ ;  $R = 1$ .

(c) Replace  $x$  with  $2x$ :  $\frac{1}{1-2x} = 1 + 2x + 4x^2 + \dots + 2^k x^k + \dots$ ;  $R = 1/2$ .

(d)  $\frac{1}{2-x} = \frac{1/2}{1-x/2}$ ; replace  $x$  with  $x/2$ :  $\frac{1}{2-x} = \frac{1}{2} + \frac{1}{2^2}x + \frac{1}{2^3}x^2 + \dots + \frac{1}{2^{k+1}}x^k + \dots$ ;  $R = 2$ .
- (a) Replace  $x$  with  $-x$ :  $\ln(1-x) = -x - x^2/2 - x^3/3 - \dots - x^k/k - \dots$ ;  $R = 1$ .

(b) Replace  $x$  with  $x^2$ :  $\ln(1+x^2) = x^2 - x^4/2 + x^6/3 - \dots + (-1)^{k-1} x^{2k}/k + \dots$ ;  $R = 1$ .

(c) Replace  $x$  with  $2x$ :  $\ln(1+2x) = 2x - (2x)^2/2 + (2x)^3/3 - \dots + (-1)^{k-1} (2x)^k/k + \dots$ ;  $R = 1/2$ .

(d)  $\ln(2+x) = \ln 2 + \ln(1+x/2)$ ; replace  $x$  with  $x/2$ :  
 $\ln(2+x) = \ln 2 + x/2 - (x/2)^2/2 + (x/2)^3/3 + \dots + (-1)^{k-1} (x/2)^k/k + \dots$ ;  $R = 2$ .
- (a) From Section 11.9, Example 5(b),  $\frac{1}{\sqrt{1+x}} = 1 - \frac{1}{2}x + \frac{1 \cdot 3}{2^2 \cdot 2!}x^2 - \frac{1 \cdot 3 \cdot 5}{2^3 \cdot 3!}x^3 + \dots$ , so  
 $(2+x)^{-1/2} = \frac{1}{\sqrt{2}\sqrt{1+x/2}} = \frac{1}{2^{1/2}} - \frac{1}{2^{5/2}}x + \frac{1 \cdot 3}{2^{9/2} \cdot 2!}x^2 - \frac{1 \cdot 3 \cdot 5}{2^{13/2} \cdot 3!}x^3 + \dots$

(b) Example 5(a):  $\frac{1}{(1+x)^2} = 1 - 2x + 3x^2 - 4x^3 + \dots$ , so  $\frac{1}{(1-x^2)^2} = 1 + 2x^2 + 3x^4 + 4x^6 + \dots$
- (a)  $\frac{1}{a-x} = \frac{1/a}{1-x/a} = 1/a + x/a^2 + x^2/a^3 + \dots + x^k/a^{k+1} + \dots$ ;  $R = |a|$ .

(b)  $1/(a+x)^2 = \frac{1}{a^2} \frac{1}{(1+x/a)^2} = \frac{1}{a^2} (1 - 2(x/a) + 3(x/a)^2 - 4(x/a)^3 + \dots)$   
 $= \frac{1}{a^2} - \frac{2}{a^3}x + \frac{3}{a^4}x^2 - \frac{4}{a^5}x^3 + \dots$
- (a)  $2x - \frac{2^3}{3!}x^3 + \frac{2^5}{5!}x^5 - \frac{2^7}{7!}x^7 + \dots$ ;  $R = +\infty$

(b)  $1 - 2x + 2x^2 - \frac{4}{3}x^3 + \dots$ ;  $R = +\infty$

(c)  $1 + x^2 + \frac{1}{2!}x^4 + \frac{1}{3!}x^6 + \dots$ ;  $R = +\infty$

(d)  $x^2 - \frac{\pi^2}{2}x^4 + \frac{\pi^4}{4!}x^6 - \frac{\pi^6}{6!}x^8 + \dots$ ;  $R = +\infty$
- (a)  $1 - \frac{2^2}{2!}x^2 + \frac{2^4}{4!}x^4 - \frac{2^6}{6!}x^6 + \dots$ ;  $R = +\infty$

(b)  $x^2 \left(1 + x + \frac{1}{2!}x^2 + \frac{1}{3!}x^3 + \dots\right) = x^2 + x^3 + \frac{1}{2!}x^4 + \frac{1}{3!}x^5 + \dots$ ;  $R = +\infty$

(c)  $x \left(1 - x + \frac{1}{2!}x^2 - \frac{1}{3!}x^3 + \dots\right) = x - x^2 + \frac{1}{2!}x^3 - \frac{1}{3!}x^4 + \dots$ ;  $R = +\infty$

(d)  $x^2 - \frac{1}{3!}x^6 + \frac{1}{5!}x^{10} - \frac{1}{7!}x^{14} + \dots$ ;  $R = +\infty$

7. (a)  $x^2(1 - 3x + 9x^2 - 27x^3 + \dots) = x^2 - 3x^3 + 9x^4 - 27x^5 + \dots; R = 1/3$
- (b)  $x\left(2x + \frac{2^3}{3!}x^3 + \frac{2^5}{5!}x^5 + \frac{2^7}{7!}x^7 + \dots\right) = 2x^2 + \frac{2^3}{3!}x^4 + \frac{2^5}{5!}x^6 + \frac{2^7}{7!}x^8 + \dots; R = +\infty$
- (c) Substitute  $3/2$  for  $m$  and  $-x^2$  for  $x$  in Equation (22) of Section 11.9, then multiply by  $x$ :  
 $x - \frac{3}{2}x^3 + \frac{3}{8}x^5 + \frac{1}{16}x^7 + \dots; R = 1$
8. (a)  $\frac{x}{x-1} = \frac{-x}{1-x} = -x(1 + x + x^2 + x^3 + \dots) = -x - x^2 - x^3 - x^4 - \dots; R = 1.$
- (b)  $3 + \frac{3}{2!}x^4 + \frac{3}{4!}x^8 + \frac{3}{6!}x^{12} + \dots; R = +\infty$
- (c) From Table 11.9 with  $m = -3$ ,  $(1+x)^{-3} = 1 - 3x + 6x^2 - 10x^3 + \dots$ , so  
 $x(1+2x)^{-3} = x - 6x^2 + 24x^3 - 80x^4 + \dots; R = 1/2$
9. (a)  $\sin^2 x = \frac{1}{2}(1 - \cos 2x) = \frac{1}{2}\left[1 - \left(1 - \frac{2^2}{2!}x^2 + \frac{2^4}{4!}x^4 - \frac{2^6}{6!}x^6 + \dots\right)\right]$   
 $= x^2 - \frac{2^3}{4!}x^4 + \frac{2^5}{6!}x^6 - \frac{2^7}{8!}x^8 + \dots$
- (b)  $\ln[(1+x^3)^{12}] = 12\ln(1+x^3) = 12x^3 - 6x^6 + 4x^9 - 3x^{12} + \dots$
10. (a)  $\cos^2 x = \frac{1}{2}(1 + \cos 2x) = \frac{1}{2}\left[1 + \left(1 - \frac{2^2}{2!}x^2 + \frac{2^4}{4!}x^4 - \frac{2^6}{6!}x^6 + \dots\right)\right]$   
 $= 1 - x^2 + \frac{2^3}{4!}x^4 - \frac{2^5}{6!}x^6 + \dots$
- (b) In Equation (17) of Section 11.9 replace  $x$  with  $-x$ :  $\ln\left(\frac{1-x}{1+x}\right) = -2\left(x + \frac{1}{3}x^3 + \frac{1}{5}x^5 + \dots\right)$
11. (a)  $\frac{1}{x} = \frac{1}{1-(1-x)} = 1 + (1-x) + (1-x)^2 + \dots + (1-x)^k + \dots$   
 $= 1 - (x-1) + (x-1)^2 - \dots + (-1)^k(x-1)^k + \dots$
- (b)  $(0, 2)$
12. (a)  $\frac{1}{x} = \frac{1/x_0}{1+(x-x_0)/x_0} = 1/x_0 - (x-x_0)/x_0^2 + (x-x_0)^2/x_0^3 - \dots + (-1)^k(x-x_0)^k/x_0^{k+1} + \dots$
- (b)  $(0, 2x_0)$
13. (a)  $(1+x+x^2/2+x^3/3!+x^4/4!+\dots)(x-x^3/3!+x^5/5!-\dots) = x+x^2+x^3/3-x^5/30+\dots$
- (b)  $(1+x/2-x^2/8+x^3/16-(5/128)x^4+\dots)(x-x^2/2+x^3/3-x^4/4+x^5/5-\dots)$   
 $= x-x^3/24+x^4/24-(71/1920)x^5+\dots$
14. (a)  $(1-x^2+x^4/2-x^6/6+\dots)\left(1-\frac{1}{2}x^2+\frac{1}{24}x^4-\frac{1}{720}x^6+\dots\right) = 1-\frac{3}{2}x^2+\frac{25}{24}x^4-\frac{331}{720}x^6+\dots$
- (b)  $\left(1+\frac{4}{3}x^2+\dots\right)\left(1+\frac{1}{3}x-\frac{1}{9}x^2+\frac{5}{81}x^3-\dots\right) = 1+\frac{1}{3}x+\frac{11}{9}x^2+\frac{41}{81}x^3+\dots$

15. (a)  $\frac{1}{\cos x} = 1 / \left( 1 - \frac{1}{2!}x^2 + \frac{1}{4!}x^4 - \frac{1}{6!}x^6 + \dots \right) = 1 + \frac{1}{2}x^2 + \frac{5}{24}x^4 + \frac{61}{720}x^6 + \dots$
- (b)  $\frac{\sin x}{e^x} = \left( x - \frac{x^3}{3!} + \frac{x^5}{5!} - \dots \right) / \left( 1 + x + \frac{x^2}{2!} + \frac{x^3}{3!} + \frac{x^4}{4!} + \dots \right) = x - x^2 + \frac{1}{3}x^3 - \frac{1}{30}x^5 + \dots$
16. (a)  $\frac{\tan^{-1} x}{1+x} = (x - x^3/3 + x^5/5 - \dots) / (1+x) = x - x^2 + \frac{2}{3}x^3 - \frac{2}{3}x^4 + \dots$
- (b)  $\frac{\ln(1+x)}{1-x} = (x - x^2/2 + x^3/3 - x^4/4 + \dots) / (1-x) = x + \frac{1}{2}x^2 + \frac{5}{6}x^3 + \frac{7}{12}x^4 + \dots$
17.  $e^x = 1 + x + x^2/2 + x^3/3! + \dots + x^k/k! + \dots$ ,  $e^{-x} = 1 - x + x^2/2 - x^3/3! + \dots + (-1)^k x^k/k! + \dots$ ;  
 $\sinh x = \frac{1}{2}(e^x - e^{-x}) = x + x^3/3! + x^5/5! + \dots + x^{2k+1}/(2k+1)! + \dots$ ,  $R = +\infty$   
 $\cosh x = \frac{1}{2}(e^x + e^{-x}) = 1 + x^2/2 + x^4/4! + \dots + x^{2k}/(2k)! + \dots$ ,  $R = +\infty$
18.  $\tanh x = \frac{x + x^3/3! + x^5/5! + \dots}{1 + x^2/2 + x^4/4! + \dots} = x - \frac{1}{3}x^3 + \frac{2}{15}x^5 - \frac{17}{315}x^7 + \dots$
19.  $\frac{4x-2}{x^2-1} = \frac{-1}{1-x} + \frac{3}{1+x} = -(1+x+x^2+x^3+x^4+\dots) + 3(1-x+x^2-x^3+x^4+\dots)$   
 $= 2 - 4x + 2x^2 - 4x^3 + 2x^4 + \dots$
20.  $\frac{x^3+x^2+2x-2}{x^2-1} = x+1 - \frac{1}{1-x} + \frac{2}{1+x}$   
 $= x+1 - (1+x+x^2+x^3+x^4+\dots) + 2(1-x+x^2-x^3+x^4+\dots)$   
 $= 2 - 2x + x^2 - 3x^3 + x^4 - \dots$
21. (a)  $\frac{d}{dx}(1 - x^2/2! + x^4/4! - x^6/6! + \dots) = -x + x^3/3! - x^5/5! + \dots = -\sin x$
- (b)  $\frac{d}{dx}(x - x^2/2 + x^3/3 - \dots) = 1 - x + x^2 - \dots = 1/(1+x)$
22. (a)  $\frac{d}{dx}(x + x^3/3! + x^5/5! + \dots) = 1 + x^2/2! + x^4/4! + \dots = \cosh x$
- (b)  $\frac{d}{dx}(x - x^3/3 + x^5/5 - x^7/7 + \dots) = 1 - x^2 + x^4 - x^6 + \dots = \frac{1}{1+x^2}$
23. (a)  $\int (1 + x + x^2/2! + \dots) dx = (x + x^2/2! + x^3/3! + \dots) + C_1$   
 $= (1 + x + x^2/2! + x^3/3! + \dots) + C_1 - 1 = e^x + C$
- (b)  $\int (x + x^3/3! + x^5/5! + \dots) dx = x^2/2! + x^4/4! + \dots + C_1$   
 $= 1 + x^2/2! + x^4/4! + \dots + C_1 - 1 = \cosh x + C$



24. (a) 
$$\int (x - x^3/3! + x^5/5! - \dots) dx = (x^2/2! - x^4/4! + x^6/6! - \dots) + C_1$$

$$= - (1 - x^2/2! + x^4/4! - x^6/6! + \dots) + C_1 + 1$$

$$= -\cos x + C$$

(b) 
$$\int (1 - x + x^2 - \dots) dx = (x - x^2/2 + x^3/3 - \dots) + C = \ln(1+x) + C$$
  
 (Note:  $-1 < x < 1$ , so  $|1+x| = 1+x$ )

25. (a) Substitute  $x^2$  for  $x$  in the Maclaurin Series for  $1/(1-x)$  (Table 11.9.1)

and then multiply by  $x$ : 
$$\frac{x}{1-x^2} = x \sum_{k=0}^{\infty} (x^2)^k = \sum_{k=0}^{\infty} x^{2k+1}$$

(b)  $f^{(5)}(0) = 5!c_5 = 5$ ,  $f^{(6)}(0) = 6!c_6 = 0$       (c)  $f^{(n)}(0) = n!c_n = \begin{cases} n! & \text{if } n \text{ odd} \\ 0 & \text{if } n \text{ even} \end{cases}$

26.  $x^2 \cos 2x = \sum_{k=0}^{\infty} \frac{(-1)^k 2^{2k}}{(2k)!} x^{2k+2}$ ;  $f^{(99)}(0) = 0$  because  $c_{99} = 0$ .

27. (a) 
$$\lim_{x \rightarrow 0} \frac{\sin x}{x} = \lim_{x \rightarrow 0} (1 - x^2/3! + x^4/5! - \dots) = 1$$

(b) 
$$\lim_{x \rightarrow 0} \frac{\tan^{-1} x - x}{x^3} = \lim_{x \rightarrow 0} \frac{(x - x^3/3 + x^5/5 - x^7/7 + \dots) - x}{x^3} = -1/3$$

28. (a) 
$$\frac{1 - \cos x}{\sin x} = \frac{1 - (1 - x^2/2! + x^4/4! - x^6/6! + \dots)}{x - x^3/3! + x^5/5! - \dots} = \frac{x^2/2! - x^4/4! + x^6/6! - \dots}{x - x^3/3! + x^5/5! - \dots}$$

$$= \frac{x/2! - x^3/4! + x^5/6! - \dots}{1 - x^2/3! + x^4/5! - \dots}, x \neq 0; \lim_{x \rightarrow 0} \frac{1 - \cos x}{\sin x} = \frac{0}{1} = 0$$

(b) 
$$\lim_{x \rightarrow 0} \frac{1}{x} [\ln \sqrt{1+x} - \sin 2x] = \lim_{x \rightarrow 0} \frac{1}{x} \left[ \frac{1}{2} \ln(1+x) - \sin 2x \right]$$

$$= \lim_{x \rightarrow 0} \frac{1}{x} \left[ \frac{1}{2} \left( x - \frac{1}{2}x^2 + \frac{1}{3}x^3 - \dots \right) - \left( 2x - \frac{4}{3}x^3 + \frac{4}{15}x^5 - \dots \right) \right]$$

$$= \lim_{x \rightarrow 0} \left( -\frac{3}{2} - \frac{1}{4}x + \frac{3}{2}x^2 + \dots \right) = -3/2$$

29. 
$$\int_0^1 \sin(x^2) dx = \int_0^1 \left( x^2 - \frac{1}{3!}x^6 + \frac{1}{5!}x^{10} - \frac{1}{7!}x^{14} + \dots \right) dx$$

$$= \left[ \frac{1}{3}x^3 - \frac{1}{7 \cdot 3!}x^7 + \frac{1}{11 \cdot 5!}x^{11} - \frac{1}{15 \cdot 7!}x^{15} + \dots \right]_0^1$$

$$= \frac{1}{3} - \frac{1}{7 \cdot 3!} + \frac{1}{11 \cdot 5!} - \frac{1}{15 \cdot 7!} + \dots,$$

but  $\frac{1}{15 \cdot 7!} < 0.5 \times 10^{-3}$  so  $\int_0^1 \sin(x^2) dx \approx \frac{1}{3} - \frac{1}{7 \cdot 3!} + \frac{1}{11 \cdot 5!} \approx 0.3103$

$$\begin{aligned}
 30. \quad \int_0^{1/2} \tan^{-1}(2x^2) dx &= \int_0^{1/2} \left( 2x^2 - \frac{8}{3}x^6 + \frac{32}{5}x^{10} - \frac{128}{7}x^{14} + \dots \right) dx \\
 &= \left. \frac{2}{3}x^3 - \frac{8}{21}x^7 + \frac{32}{55}x^{11} - \frac{128}{105}x^{15} + \dots \right]_0^{1/2} \\
 &= \frac{2}{3} \frac{1}{2^3} - \frac{8}{21} \frac{1}{2^7} + \frac{32}{55} \frac{1}{2^{11}} - \frac{128}{105} \frac{1}{2^{15}} - \dots,
 \end{aligned}$$

$$\text{but } \frac{128}{105 \cdot 2^{15}} < 0.5 \times 10^{-4} \text{ so } \int_0^{1/2} \tan^{-1}(2x^2) dx \approx \frac{2}{3 \cdot 2^3} - \frac{8}{21 \cdot 2^7} + \frac{32}{55 \cdot 2^{11}} \approx 0.0806$$

$$\begin{aligned}
 31. \quad \int_0^{0.2} (1+x^4)^{1/3} dx &= \int_0^{0.2} \left( 1 + \frac{1}{3}x^4 - \frac{1}{9}x^8 + \dots \right) dx \\
 &= \left. x + \frac{1}{15}x^5 - \frac{1}{81}x^9 + \dots \right]_0^{0.2} = 0.2 + \frac{1}{15}(0.2)^5 - \frac{1}{81}(0.2)^9 + \dots,
 \end{aligned}$$

$$\text{but } \frac{1}{15}(0.2)^5 < 0.5 \times 10^{-3} \text{ so } \int_0^{0.2} (1+x^4)^{1/3} dx \approx 0.200$$

$$\begin{aligned}
 32. \quad \int_0^{1/2} (1+x^2)^{-1/4} dx &= \int_0^{1/2} \left( 1 - \frac{1}{4}x^2 + \frac{5}{32}x^4 - \frac{15}{128}x^6 + \dots \right) dx \\
 &= \left. x - \frac{1}{12}x^3 + \frac{1}{32}x^5 - \frac{15}{896}x^7 + \dots \right]_0^{1/2} \\
 &= 1/2 - \frac{1}{12}(1/2)^3 + \frac{1}{32}(1/2)^5 - \frac{15}{896}(1/2)^7 + \dots,
 \end{aligned}$$

$$\text{but } \frac{15}{896}(1/2)^7 < 0.5 \times 10^{-3} \text{ so } \int_0^{1/2} (1+x^2)^{-1/4} dx \approx 1/2 - \frac{1}{12}(1/2)^3 + \frac{1}{32}(1/2)^5 \approx 0.4906$$

$$33. \quad (\text{a}) \quad \frac{x}{(1-x)^2} = x \frac{d}{dx} \left[ \frac{1}{1-x} \right] = x \frac{d}{dx} \left[ \sum_{k=0}^{\infty} x^k \right] = x \left[ \sum_{k=1}^{\infty} kx^{k-1} \right] = \sum_{k=1}^{\infty} kx^k$$

$$\begin{aligned}
 (\text{b}) \quad -\ln(1-x) &= \int \frac{1}{1-x} dx - C = \int \left[ \sum_{k=0}^{\infty} x^k \right] dx - C \\
 &= \sum_{k=0}^{\infty} \frac{x^{k+1}}{k+1} - C = \sum_{k=1}^{\infty} \frac{x^k}{k} - C, \quad -\ln(1-0) = 0 \text{ so } C = 0.
 \end{aligned}$$

$$(\text{c}) \quad \text{Replace } x \text{ with } -x \text{ in part (b): } \ln(1+x) = -\sum_{k=1}^{+\infty} \frac{(-1)^k}{k} x^k = \sum_{k=1}^{+\infty} \frac{(-1)^{k+1}}{k} x^k$$

$$(\text{d}) \quad \sum_{k=1}^{+\infty} \frac{(-1)^{k+1}}{k} \text{ converges by the Alternating Series Test.}$$

$$(\text{e}) \quad \text{By parts (c) and (d) and the remark, } \sum_{k=1}^{+\infty} \frac{(-1)^{k+1}}{k} x^k \text{ converges to } \ln(1+x) \text{ for } -1 < x \leq 1.$$

34. (a) In Exercise 33(a), set  $x = \frac{1}{3}$ ,  $S = \frac{1/3}{(1 - 1/3)^2} = \frac{3}{4}$

(b) In part (b) set  $x = 1/4$ ,  $S = \ln(4/3)$

(c) In part (e) set  $x = 1$ ,  $S = \ln 2$

35. (a)  $\sinh^{-1} x = \int (1 + x^2)^{-1/2} dx - C = \int \left(1 - \frac{1}{2}x^2 + \frac{3}{8}x^4 - \frac{5}{16}x^6 + \dots\right) dx - C$   
 $= \left(x - \frac{1}{6}x^3 + \frac{3}{40}x^5 - \frac{5}{112}x^7 + \dots\right) - C$ ;  $\sinh^{-1} 0 = 0$  so  $C = 0$ .

(b)  $(1 + x^2)^{-1/2} = 1 + \sum_{k=1}^{\infty} \frac{(-1/2)(-3/2)(-5/2)\dots(-1/2 - k + 1)}{k!} (x^2)^k$   
 $= 1 + \sum_{k=1}^{\infty} (-1)^k \frac{1 \cdot 3 \cdot 5 \dots (2k - 1)}{2^k k!} x^{2k},$

$$\sinh^{-1} x = x + \sum_{k=1}^{\infty} (-1)^k \frac{1 \cdot 3 \cdot 5 \dots (2k - 1)}{2^k k! (2k + 1)} x^{2k+1}$$

(c)  $R = 1$

36. (a)  $\sin^{-1} x = \int (1 - x^2)^{-1/2} dx - C = \int \left(1 + \frac{1}{2}x^2 + \frac{3}{8}x^4 + \frac{5}{16}x^6 + \dots\right) dx - C$   
 $= \left(x + \frac{1}{6}x^3 + \frac{3}{40}x^5 + \frac{5}{112}x^7 + \dots\right) - C$ ,  $\sin^{-1} 0 = 0$  so  $C = 0$

(b)  $(1 - x^2)^{-1/2} = 1 + \sum_{k=1}^{\infty} \frac{(-1/2)(-3/2)(-5/2)\dots(-1/2 - k + 1)}{k!} (-x^2)^k$   
 $= 1 + \sum_{k=1}^{\infty} \frac{(-1)^k (1/2)^k (1)(3)(5)\dots(2k - 1)}{k!} (-1)^k x^{2k}$   
 $= 1 + \sum_{k=1}^{\infty} \frac{1 \cdot 3 \cdot 5 \dots (2k - 1)}{2^k k!} x^{2k}$

$$\sin^{-1} x = x + \sum_{k=1}^{\infty} \frac{1 \cdot 3 \cdot 5 \dots (2k - 1)}{2^k k! (2k + 1)} x^{2k+1}$$

(c)  $R = 1$

37. (a)  $y(t) = y_0 \sum_{k=0}^{\infty} \frac{(-1)^k (0.000121)^k t^k}{k!}$

(b)  $y(1) \approx y_0(1 - 0.000121t) \Big|_{t=1} = 0.999879y_0$

(c)  $y_0 e^{-0.000121} \approx 0.9998790073y_0$

38. (a) If  $\frac{ct}{m} \approx 0$  then  $e^{-ct/m} \approx 1 - \frac{ct}{m}$ , and  $v(t) \approx \left(1 - \frac{ct}{m}\right) \left(v_0 + \frac{mg}{c}\right) - \frac{mg}{c} = v_0 - \left(\frac{cv_0}{m} + g\right)t$ .

(b) The quadratic approximation is

$$v_0 \approx \left(1 - \frac{ct}{m} + \frac{(ct)^2}{2m^2}\right) \left(v_0 + \frac{mg}{c}\right) - \frac{mg}{c} = v_0 - \left(\frac{cv_0}{m} + g\right)t + \frac{c^2}{2m^2} \left(v_0 + \frac{mg}{c}\right)t^2.$$

39.  $\theta_0 = 5^\circ = \pi/36$  rad,  $k = \sin(\pi/72)$

$$(a) \quad T \approx 2\pi\sqrt{\frac{L}{g}} = 2\pi\sqrt{1/9.8} \approx 2.00709 \qquad (b) \quad T \approx 2\pi\sqrt{\frac{L}{g}} \left(1 + \frac{k^2}{4}\right) \approx 2.008044621$$

$$(c) \quad 2.008045644$$

40. The third order model gives the same result as the second, because there is no term of degree three in (5). By the Wallis sine formula,  $\int_0^{\pi/2} \sin^4 \phi \, d\phi = \frac{1 \cdot 3}{2 \cdot 4} \frac{\pi}{2}$ , and

$$\begin{aligned} T &\approx 4\sqrt{\frac{L}{g}} \int_0^{\pi/2} \left(1 + \frac{1}{2}k^2 \sin^2 \phi + \frac{1 \cdot 3}{2^2 2!} k^4 \sin^4 \phi\right) d\phi = 4\sqrt{\frac{L}{g}} \left(\frac{\pi}{2} + \frac{k^2}{2} \frac{\pi}{4} + \frac{3k^4}{8} \frac{3\pi}{16}\right) \\ &= 2\pi\sqrt{\frac{L}{g}} \left(1 + \frac{k^2}{4} + \frac{9k^4}{64}\right) \end{aligned}$$

$$41. (a) \quad F = \frac{mgR^2}{(R+h)^2} = \frac{mg}{(1+h/R)^2} = mg(1 - 2h/R + 3h^2/R^2 - 4h^3/R^3 + \dots)$$

(b) If  $h = 0$ , then the binomial series converges to 1 and  $F = mg$ .

(c) Sum the series to the linear term,  $F \approx mg - 2mgh/R$ .

$$(d) \quad \frac{mg - 2mgh/R}{mg} = 1 - \frac{2h}{R} = 1 - \frac{2 \cdot 29,028}{4000 \cdot 5280} \approx 0.9973, \text{ so about } 0.27\% \text{ less.}$$

42. (a) We can differentiate term-by-term:

$$y' = \sum_{k=1}^{\infty} \frac{(-1)^k x^{2k-1}}{2^{2k-1} k!(k-1)!} = \sum_{k=0}^{\infty} \frac{(-1)^{k+1} x^{2k+1}}{2^{2k+1} (k+1)!k!}, \quad y'' = \sum_{k=0}^{\infty} \frac{(-1)^{k+1} (2k+1)x^{2k}}{2^{2k+1} (k+1)!k!}, \text{ and}$$

$$xy'' + y' + xy = \sum_{k=0}^{\infty} \frac{(-1)^{k+1} (2k+1)x^{2k+1}}{2^{2k+1} (k+1)!k!} + \sum_{k=0}^{\infty} \frac{(-1)^{k+1} x^{2k+1}}{2^{2k+1} (k+1)!k!} + \sum_{k=0}^{\infty} \frac{(-1)^k x^{2k+1}}{2^{2k} (k!)^2},$$

$$xy'' + y' + xy = \sum_{k=0}^{\infty} \frac{(-1)^{k+1} x^{2k+1}}{2^{2k} (k!)^2} \left[ \frac{2k+1}{2(k+1)} + \frac{1}{2(k+1)} - 1 \right] = 0$$

$$(b) \quad y' = \sum_{k=0}^{\infty} \frac{(-1)^k (2k+1)x^{2k}}{2^{2k+1} k!(k+1)!}, \quad y'' = \sum_{k=1}^{\infty} \frac{(-1)^k (2k+1)x^{2k-1}}{2^{2k} (k-1)!(k+1)!}.$$

Since  $J_1(x) = \sum_{k=0}^{\infty} \frac{(-1)^k x^{2k+1}}{2^{2k+1} k!(k+1)!}$  and  $x^2 J_1(x) = \sum_{k=1}^{\infty} \frac{(-1)^{k-1} x^{2k+1}}{2^{2k-1} (k-1)!k!}$ , it follows that

$$\begin{aligned} &x^2 y'' + xy' + (x^2 - 1)y \\ &= \sum_{k=1}^{\infty} \frac{(-1)^k (2k+1)x^{2k+1}}{2^{2k} (k-1)!(k+1)!} + \sum_{k=0}^{\infty} \frac{(-1)^k (2k+1)x^{2k+1}}{2^{2k+1} (k!)^2} + \sum_{k=1}^{\infty} \frac{(-1)^{k-1} x^{2k+1}}{2^{2k-1} (k-1)!k!} \\ &\quad - \sum_{k=0}^{\infty} \frac{(-1)^k x^{2k+1}}{2^{2k+1} k!(k+1)!} \\ &= \frac{x}{2} - \frac{x}{2} + \sum_{k=1}^{\infty} \frac{(-1)^k x^{2k+1}}{2^{2k-1} (k-1)!k!} \left( \frac{2k+1}{2(k+1)} + \frac{2k+1}{4k(k+1)} - 1 - \frac{1}{4k(k+1)} \right) = 0. \end{aligned}$$

(c) From part (a),  $J'_0(x) = \sum_{k=0}^{\infty} \frac{(-1)^{k+1} x^{2k+1}}{2^{2k+1} (k+1)! k!} = -J_1(x)$ .

43. If  $\sum_{k=0}^{\infty} a_k x^k = \sum_{k=0}^{\infty} b_k x^k$  for  $x$  in  $(-r, r)$  then  $\sum_{k=0}^{\infty} (a_k - b_k) x^k = 0$  so by Theorem 11.10.6  $\sum_{k=0}^{\infty} (a_k - b_k) x^k$  is the Taylor series for  $f(x) = 0$  about 0 and hence  $a_k - b_k = 0$ ,  $a_k = b_k$  for all  $k$ .

## CHAPTER 11 SUPPLEMENTARY EXERCISES

4. (a)  $\sum_{k=0}^{\infty} \frac{f^{(k)}(0)}{k!} x^k$  (b)  $\sum_{k=0}^{\infty} \frac{f^{(k)}(x_0)}{k!} (x - x_0)^k$
9. (a) always true by Theorem 11.4.2  
 (b) sometimes false, for example the harmonic series diverges but  $\sum(1/k^2)$  converges  
 (c) sometimes false, for example  $f(x) = \sin \pi x$ ,  $a_k = 0$ ,  $L = 0$   
 (d) always true by Example 3(d) of Section 11.1  
 (e) sometimes false, for example  $a_n = \frac{1}{2} + (-1)^n \frac{1}{4}$   
 (f) sometimes false, for example  $u_k = 1/2$   
 (g) always false by Theorem 11.4.3  
 (h) sometimes false, for example  $u_k = v_k = (2/k)$   
 (i) always true by the Comparison Test  
 (j) always true by the Comparison Test  
 (k) sometimes false, for example  $\sum(-1)^k/k$   
 (l) sometimes false, for example  $\sum(-1)^k/k$
10. (a) false,  $f(x)$  is not differentiable at  $x = 0$ , Definition 11.5.4  
 (b) true:  $s_n = 1$  if  $n$  is odd and  $s_{2n} = 1 + 1/(n+1)$ ;  $\lim_{n \rightarrow +\infty} s_n = 1$   
 (c) false,  $\lim a_k \neq 0$
11. (a) geometric,  $r = 1/5$ , converges (b)  $1/(5^k + 1) < 1/5^k$ , converges  
 (c)  $\frac{9}{\sqrt{k} + 1} \geq \frac{9}{\sqrt{k} + \sqrt{k}} = \frac{9}{2\sqrt{k}}$ ,  $\sum_{k=1}^{\infty} \frac{9}{2\sqrt{k}}$  diverges
12. (a) converges by Alternating Series Test  
 (b) absolutely convergent,  $\sum_{k=1}^{\infty} \left[ \frac{k+2}{3k-1} \right]^k$  converges by the Root Test.  
 (c)  $\frac{k^{-1/2}}{2 + \sin^2 k} > \frac{k^{-1}}{2+1} = \frac{1}{3k}$ ,  $\sum_{k=1}^{\infty} \frac{1}{3k}$  diverges
13. (a)  $\frac{1}{k^3 + 2k + 1} < \frac{1}{k^3}$ ,  $\sum_{k=1}^{\infty} 1/k^3$  converges, so  $\sum_{k=1}^{\infty} \frac{1}{k^3 + 2k + 1}$  converges by the Comparison Test  
 (b) Limit Comparison Test, compare with the divergent series  $\sum_{k=1}^{\infty} \frac{1}{k^{2/5}}$ , diverges

- (c)  $\left| \frac{\cos(1/k)}{k^2} \right| < \frac{1}{k^2}$ ,  $\sum_{k=1}^{\infty} \frac{1}{k^2}$  converges, so  $\sum_{k=1}^{\infty} \frac{\cos(1/k)}{k^2}$  converges absolutely
14. (a)  $\sum_{k=1}^{\infty} \frac{\ln k}{k\sqrt{k}} = \sum_{k=2}^{\infty} \frac{\ln k}{k\sqrt{k}}$  because  $\ln 1 = 0$ ,  
 $\int_2^{+\infty} \frac{\ln x}{x^{3/2}} dx = \lim_{\ell \rightarrow +\infty} \left[ -\frac{2 \ln x}{x^{1/2}} - \frac{4}{x^{1/2}} \right]_2^{\ell} = \sqrt{2}(\ln 2 + 2)$  so  $\sum_{k=2}^{\infty} \frac{\ln k}{k^{3/2}}$  converges
- (b)  $\frac{k^{4/3}}{8k^2 + 5k + 1} \geq \frac{k^{4/3}}{8k^2 + 5k^2 + k^2} = \frac{1}{14k^{2/3}}$ ,  $\sum_{k=1}^{\infty} \frac{1}{14k^{2/3}}$  diverges
- (c) absolutely convergent,  $\sum_{k=1}^{\infty} \frac{1}{k^2 + 1}$  converges (compare with  $\sum 1/k^2$ )
15.  $\sum_{k=0}^{\infty} \frac{1}{5^k} - \sum_{k=0}^{99} \frac{1}{5^k} = \sum_{k=100}^{\infty} \frac{1}{5^k} = \frac{1}{5^{100}} \sum_{k=0}^{\infty} \frac{1}{5^k} = \frac{1}{4 \cdot 5^{99}}$
16. no,  $\lim_{k \rightarrow +\infty} a_k = \frac{1}{2} \neq 0$  (Divergence Test)
17. (a)  $p_0(x) = 1, p_1(x) = 1 - 7x, p_2(x) = 1 - 7x + 5x^2, p_3(x) = 1 - 7x + 5x^2 - 4x^3,$   
 $p_4(x) = 1 - 7x + 5x^2 - 4x^3$
- (b) If  $f(x)$  is a polynomial of degree  $n$  and  $k \geq n$  then the Maclaurin polynomial of degree  $k$  is the polynomial itself; if  $k < n$  then it is the truncated polynomial.
18.  $\ln(1+x) = x - x^2/2 + \dots$ ; so  $|\ln(1+x) - x| \leq x^2/2$  by Theorem 11.7.2.
19.  $\sin x = x - x^3/3! + x^5/5! - x^7/7! + \dots$  is an alternating series, so  
 $|\sin x - x + x^3/3! - x^5/5!| \leq x^7/7! \leq \pi^7/(4^7 7!) \leq 0.00005$
20.  $\int_0^1 \frac{1 - \cos x}{x} dx = \left[ \frac{x^2}{2 \cdot 2!} - \frac{x^4}{4 \cdot 4!} + \frac{x^6}{6 \cdot 6!} - \dots \right]_0^1 = \frac{1}{2 \cdot 2!} - \frac{1}{4 \cdot 4!} + \frac{1}{6 \cdot 6!} - \dots$ , and  $\frac{1}{6 \cdot 6!} < 0.00005$ ,  
 so  $\int_0^1 \frac{1 - \cos x}{x} dx = \frac{1}{2 \cdot 2!} - \frac{1}{4 \cdot 4!} = 0.2396$  to three decimal-place accuracy.
21. (a)  $\rho = \lim_{k \rightarrow +\infty} \left( \frac{2^k}{k!} \right)^{1/k} = \lim_{k \rightarrow +\infty} \frac{2}{\sqrt[k]{k!}} = 0$ , converges
- (b)  $\rho = \lim_{k \rightarrow +\infty} u_k^{1/k} = \lim_{k \rightarrow +\infty} \frac{k}{\sqrt[k]{k!}} = e$ , diverges
22. (a)  $1^1 \geq 1!$ ; if  $k^k \geq k!$ , then  $(k+1)^{k+1} \geq (k+1)k^k \geq (k+1)k! = (k+1)!$ ; mathematical induction
- (b)  $\sum \frac{1}{k^k} \leq \sum \frac{1}{k!}$ , converges

- (c)  $\lim_{k \rightarrow +\infty} \left(\frac{1}{k^k}\right)^{1/k} = \lim_{k \rightarrow +\infty} \frac{1}{k} = 0$ , converges
23. (a)  $u_{100} = \sum_{k=1}^{100} u_k - \sum_{k=1}^{99} u_k = \left(2 - \frac{1}{100}\right) - \left(2 - \frac{1}{99}\right) = \frac{1}{9900}$
- (b)  $u_1 = 1$ ; for  $k \geq 2$ ,  $u_k = \left(2 - \frac{1}{k}\right) - \left(2 - \frac{1}{k-1}\right) = \frac{1}{k(k-1)}$ ,  $\lim_{k \rightarrow +\infty} u_k = 0$
- (c)  $\sum_{k=1}^{\infty} u_k = \lim_{n \rightarrow +\infty} \sum_{k=1}^n u_k = \lim_{n \rightarrow +\infty} \left(2 - \frac{1}{n}\right) = 2$
24. (a)  $\sum_{k=1}^{\infty} \left(\frac{3}{2^k} - \frac{2}{3^k}\right) = \sum_{k=1}^{\infty} \frac{3}{2^k} - \sum_{k=1}^{\infty} \frac{2}{3^k} = \left(\frac{3}{2}\right) \frac{1}{1 - (1/2)} - \left(\frac{2}{3}\right) \frac{1}{1 - (1/3)} = 2$  (geometric series)
- (b)  $\sum_{k=1}^n [\ln(k+1) - \ln k] = \ln(n+1)$ , so  $\sum_{k=1}^{\infty} [\ln(k+1) - \ln k] = \lim_{n \rightarrow +\infty} \ln(n+1) = +\infty$ , diverges
- (c)  $\lim_{n \rightarrow +\infty} \sum_{k=1}^n \frac{1}{2} \left(\frac{1}{k} - \frac{1}{k+2}\right) = \lim_{n \rightarrow +\infty} \frac{1}{2} \left(1 + \frac{1}{2} - \frac{1}{n+1} - \frac{1}{n+2}\right) = \frac{3}{4}$
- (d)  $\lim_{n \rightarrow +\infty} \sum_{k=1}^n [\tan^{-1}(k+1) - \tan^{-1} k] = \lim_{n \rightarrow +\infty} [\tan^{-1}(n+1) - \tan^{-1}(1)] = \frac{\pi}{2} - \frac{\pi}{4} = \frac{\pi}{4}$
25. (a)  $e^2 - 1$                       (b)  $\sin \pi = 0$                       (c)  $\cos e$                       (d)  $e^{-\ln 3} = 1/3$
26.  $a_{k+1} = \sqrt{a_k} = a_k^{1/2} = a_{k-1}^{1/4} = \dots = a_1^{1/2^k} = c^{1/2^{k+1}}$
- (a) If  $c = 1/2$  then  $\lim_{k \rightarrow +\infty} a_k = 1$ .                      (b) if  $c = 3/2$  then  $\lim_{k \rightarrow +\infty} a_k = 1$ .
27. Expand in a Maclaurin Series about  $x = 100$ :  $e^{-[(x-100)/16]^2} = 1 - \frac{(x-100)^2}{16^2} + \frac{(x-100)^4}{2 \cdot 16^4}$ , so
- $$p \approx \frac{1}{16\sqrt{2\pi}} \int_{100}^{110} \left(1 - \frac{(x-100)^2}{16^2} + \frac{(x-100)^4}{2 \cdot 16^4}\right) dx = \frac{1}{16\sqrt{2\pi}} \left(10 - \frac{10^3}{3 \cdot 16^2} + \frac{10^5}{2 \cdot 5 \cdot 16^4}\right)$$
- $\approx 0.220678$ , or about 22.07%.
28.  $f(x) = xe^x = x + x^2 + \frac{x^3}{2!} + \frac{x^4}{3!} + \dots = \sum_{k=0}^{\infty} \frac{x^{k+1}}{k!}$ ,
- $$f'(x) = (x+1)e^x = 1 + 2x + \frac{3x^2}{2!} + \frac{4x^3}{3!} + \dots = \sum_{k=0}^{\infty} \frac{k+1}{k!} x^k; \sum_{k=0}^{\infty} \frac{k+1}{k!} = f'(1) = 2e.$$
29. Let  $A = 1 - \frac{1}{2^2} + \frac{1}{3^2} - \frac{1}{4^2} + \dots$ ; since the series all converge absolutely,
- $$\frac{\pi^2}{6} - A = 2\frac{1}{2^2} + 2\frac{1}{4^2} + 2\frac{1}{6^2} + \dots = \frac{1}{2} \left(1 + \frac{1}{2^2} + \frac{1}{3^2} + \dots\right) = \frac{1}{2} \frac{\pi^2}{6}, \text{ so } A = \frac{1}{2} \frac{\pi^2}{6} = \frac{\pi^2}{12}.$$
30. Compare with  $1/k^p$ : converges if  $p > 1$ , diverges otherwise.

31. (a)  $x + \frac{1}{2}x^2 + \frac{3}{14}x^3 + \frac{3}{35}x^4 + \cdots$ ;  $\rho = \lim_{k \rightarrow +\infty} \frac{k+1}{3k+1}|x| = \frac{1}{3}|x|$ ,  
 converges if  $\frac{1}{3}|x| < 1$ ,  $|x| < 3$  so  $R = 3$ .
- (b)  $-x^3 + \frac{2}{3}x^5 - \frac{2}{5}x^7 + \frac{8}{35}x^9 - \cdots$ ;  $\rho = \lim_{k \rightarrow +\infty} \frac{k+1}{2k+1}|x|^2 = \frac{1}{2}|x|^2$ ,  
 converges if  $\frac{1}{2}|x|^2 < 1$ ,  $|x|^2 < 2$ ,  $|x| < \sqrt{2}$  so  $R = \sqrt{2}$ .
32. By the Ratio Test for absolute convergence,  $\rho = \lim_{k \rightarrow +\infty} \frac{|x - x_0|}{b} = \frac{|x - x_0|}{b}$ ; converges if  $|x - x_0| < b$ , diverges if  $|x - x_0| > b$ . If  $x = x_0 - b$ ,  $\sum_{k=0}^{\infty} (-1)^k$  diverges; if  $x = x_0 + b$ ,  $\sum_{k=0}^{\infty} 1$  diverges. The interval of convergence is  $(x_0 - b, x_0 + b)$ .
33. If  $x \geq 0$ , then  $\cos \sqrt{x} = 1 - \frac{(\sqrt{x})^2}{2!} + \frac{(\sqrt{x})^4}{4!} - \frac{(\sqrt{x})^6}{6!} + \cdots = 1 - \frac{x}{2!} + \frac{x^2}{4!} - \frac{x^3}{6!} + \cdots$ ; if  $x \leq 0$ , then  $\cosh(\sqrt{-x}) = 1 + \frac{(\sqrt{-x})^2}{2!} + \frac{(\sqrt{-x})^4}{4!} + \frac{(\sqrt{-x})^6}{6!} + \cdots = 1 + \frac{x}{2!} + \frac{x^2}{4!} + \frac{x^3}{6!} + \cdots$ .
34. By Exercise 70 of Section 3.5, the derivative of an odd (even) function is even (odd); hence all odd-numbered derivatives of an odd function are even, all even-numbered derivatives of an odd function are odd; a similar statement holds for an even function.
- (a) If  $f(x)$  is an even function, then  

$$2f'(0) = \lim_{h \rightarrow 0^+} \frac{f(0+h) - f(0)}{h} + \lim_{h \rightarrow 0^+} \frac{f(0) - f(0-h)}{h} = \lim_{h \rightarrow 0^+} \frac{f(0+h) - f(0-h)}{h} = 0$$
, so  $f'(0) = 0$ . If  $f(x)$  is even then so is  $f^{(2k)}$ , thus  $f^{(2k+1)}(0) = 0$ ,  $k = 0, 1, 2, \dots$ . Hence  $c_{2k+1} = f^{(2k+1)}(0)/(2k+1)! = 0$ .
- (b) If  $f(x)$  is an odd function, then  $f^{(2k-1)}$  is even ( $k = 1, 2, \dots$ ), and thus by Part (a),  $f^{(2k)}(0) = 0$ ,  $c_{2k} = f^{(2k)}(0)/(2k)! = 0$ .
35.  $\left(1 - \frac{v^2}{c^2}\right)^{-1/2} \approx 1 + \frac{v^2}{2c^2}$ , so  $K = m_0c^2 \left[ \frac{1}{\sqrt{1 - v^2/c^2}} - 1 \right] \approx m_0c^2(v^2/(2c^2)) = m_0v^2/2$
36. (a)  $\int_n^{+\infty} \frac{1}{x^{3.7}} dx < (0.5)10^{-5}$  if  $n > 63.7$ ; let  $n = 64$ .
- (b)  $s_n \approx 1.10628342$ ; CAS: 1.10628824



# CHAPTER 12

## Analytic Geometry in Calculus

### EXERCISE SET 12.1

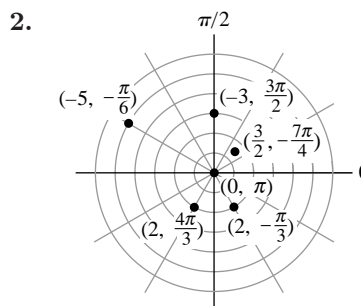
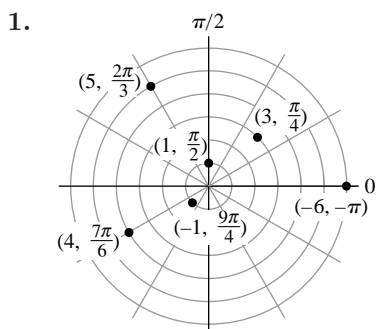

3. (a)  $(3\sqrt{3}, 3)$  (b)  $(-7/2, 7\sqrt{3}/2)$  (c)  $(3\sqrt{3}, 3)$   
 (d)  $(0, 0)$  (e)  $(-7\sqrt{3}/2, 7/2)$  (f)  $(-5, 0)$
4. (a)  $(-4\sqrt{2}, -4\sqrt{2})$  (b)  $(7\sqrt{2}/2, -7\sqrt{2}/2)$  (c)  $(4\sqrt{2}, 4\sqrt{2})$   
 (d)  $(5, 0)$  (e)  $(0, -2)$  (f)  $(0, 0)$
5. (a) both  $(5, \pi)$  (b)  $(4, 11\pi/6), (4, -\pi/6)$  (c)  $(2, 3\pi/2), (2, -\pi/2)$   
 (d)  $(8\sqrt{2}, 5\pi/4), (8\sqrt{2}, -3\pi/4)$  (e) both  $(6, 2\pi/3)$  (f) both  $(\sqrt{2}, \pi/4)$
6. (a)  $(2, 5\pi/6)$  (b)  $(-2, 11\pi/6)$  (c)  $(2, -7\pi/6)$  (d)  $(-2, -\pi/6)$
7. (a)  $(5, 0.6435)$  (b)  $(\sqrt{29}, 5.0929)$  (c)  $(1.2716, 0.6658)$
8. (a)  $(5, 2.2143)$  (b)  $(3.4482, 2.6260)$  (c)  $(\sqrt{4 + \pi^2/36}, 0.2561)$
9. (a)  $r^2 = x^2 + y^2 = 4$ ; circle (b)  $y = 4$ ; horizontal line  
 (c)  $r^2 = 3r \cos \theta, x^2 + y^2 = 3x, (x - 3/2)^2 + y^2 = 9/4$ ; circle  
 (d)  $3r \cos \theta + 2r \sin \theta = 6, 3x + 2y = 6$ ; line
10. (a)  $r \cos \theta = 5, x = 5$ ; vertical line  
 (b)  $r^2 = 2r \sin \theta, x^2 + y^2 = 2y, x^2 + (y - 1)^2 = 1$ ; circle  
 (c)  $r^2 = 4r \cos \theta + 4r \sin \theta, x^2 + y^2 = 4x + 4y, (x - 2)^2 + (y - 2)^2 = 8$ ; circle  
 (d)  $r = \frac{1}{\cos \theta} \frac{\sin \theta}{\cos \theta}, r \cos^2 \theta = \sin \theta, r^2 \cos^2 \theta = r \sin \theta, x^2 = y$ ; parabola
11. (a)  $r \cos \theta = 7$  (b)  $r = 3$   
 (c)  $r^2 - 6r \sin \theta = 0, r = 6 \sin \theta$   
 (d)  $4(r \cos \theta)(r \sin \theta) = 9, 4r^2 \sin \theta \cos \theta = 9, r^2 \sin 2\theta = 9/2$
12. (a)  $r \sin \theta = -3$  (b)  $r = \sqrt{5}$   
 (c)  $r^2 + 4r \cos \theta = 0, r = -4 \cos \theta$   
 (d)  $r^4 \cos^2 \theta = r^2 \sin^2 \theta, r^2 = \tan^2 \theta, r = \tan \theta$

13.

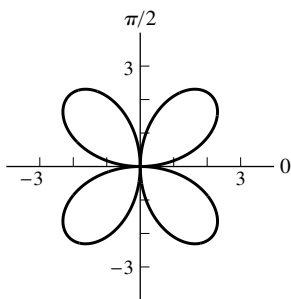

$$r = 3 \sin 2\theta$$

14.

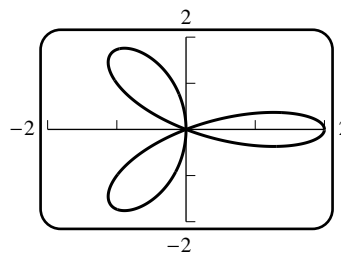

$$r = 2 \cos 3\theta$$

15.

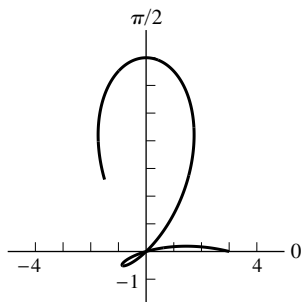

$$r = 3 - 4 \sin 3\theta$$

16.

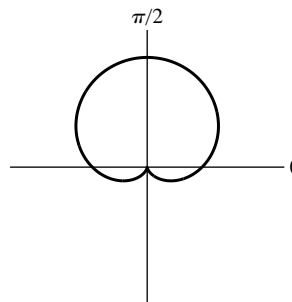

$$r = 2 + 2 \sin \theta$$

17. (a)  $r = 5$ (b)  $(x - 3)^2 + y^2 = 9$ ,  $r = 6 \cos \theta$ (c) Example 6,  $r = 1 - \cos \theta$ 

18. (a) From (8-9),  $r = a \pm b \sin \theta$  or  $r = a \pm b \cos \theta$ . The curve is not symmetric about the  $y$ -axis, so Theorem 12.2.1(a) eliminates the sine function, thus  $r = a \pm b \cos \theta$ . The cartesian point  $(-3, 0)$  is either the polar point  $(3, \pi)$  or  $(-3, 0)$ , and the cartesian point  $(-1, 0)$  is either the polar point  $(1, \pi)$  or  $(-1, 0)$ . A solution is  $a = 1, b = -2$ ; we may take the equation as  $r = 1 - 2 \cos \theta$ .

(b)  $x^2 + (y + 3/2)^2 = 9/4$ ,  $r = -3 \sin \theta$ (c) Figure 12.1.18,  $a = 1, n = 3, r = \sin 3\theta$ 19. (a) Figure 12.1.18,  $a = 3, n = 2, r = 3 \sin 2\theta$ (b) From (8-9), symmetry about the  $y$ -axis and Theorem 12.1.1(b), the equation is of the form  $r = a \pm b \sin \theta$ . The cartesian points  $(3, 0)$  and  $(0, 5)$  give  $a = 3$  and  $5 = a + b$ , so  $b = 2$  and  $r = 3 + 2 \sin \theta$ .(c) Example 8,  $r^2 = 9 \cos 2\theta$ 20. (a) Example 6 rotated through  $\pi/2$  radian:  $a = 3, r = 3 - 3 \sin \theta$ (b) Figure 12.1.18,  $a = 1, r = \cos 5\theta$ (c)  $x^2 + (y - 2)^2 = 4$ ,  $r = 4 \sin \theta$

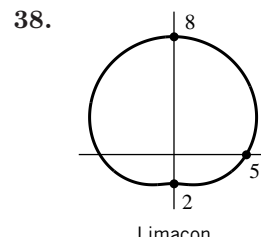
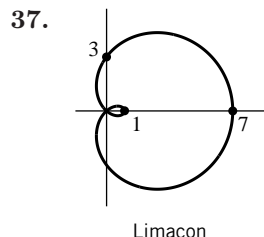
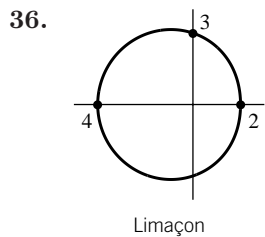
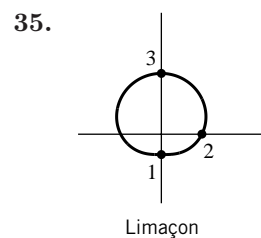
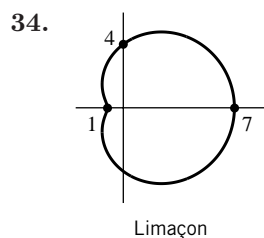
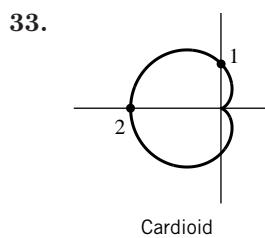
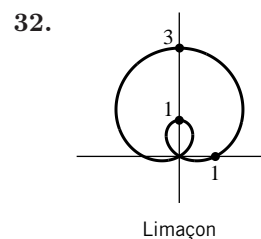
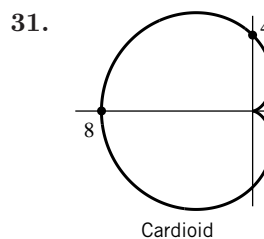
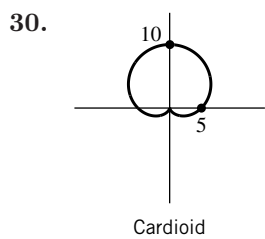
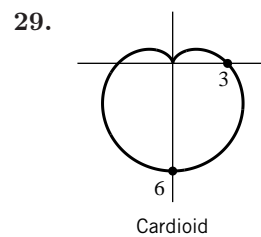
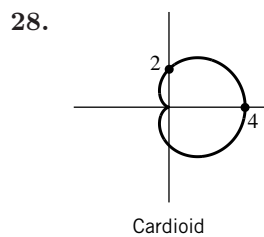
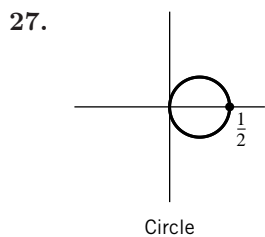
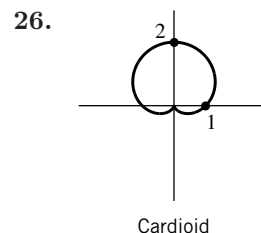
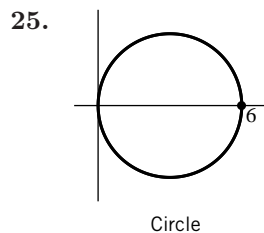
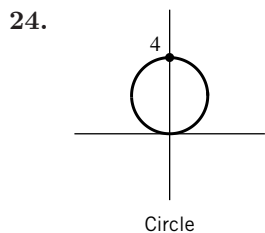
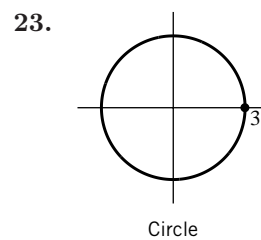
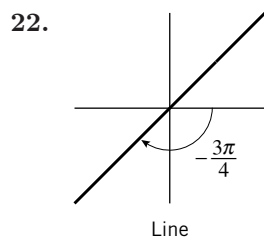
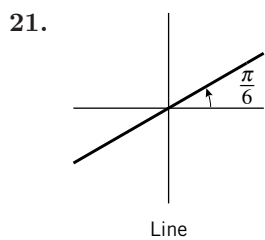

39.

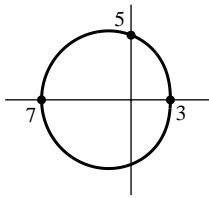

Limaçon

40.

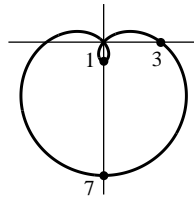

Limaçon

41.

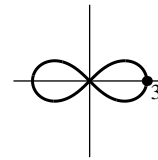

Lemniscate

42.

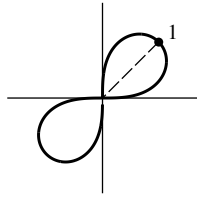

Lemniscate

43.

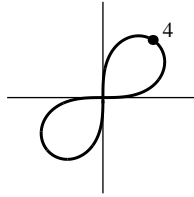

Lemniscate

44.

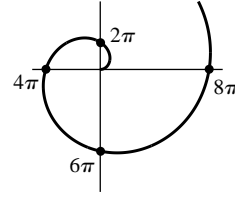

Spiral

45.

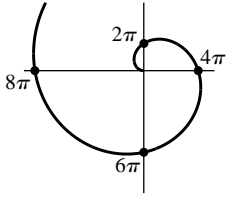

Spiral

46.

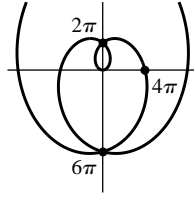

Spiral

47.

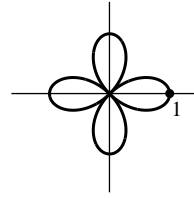

Four-petal rose

48.

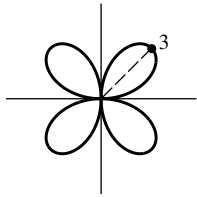

Four-petal rose

49.

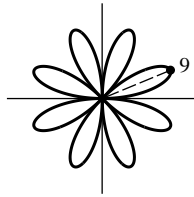

Eight-petal rose

50.

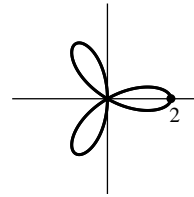

Three-petal rose

52.

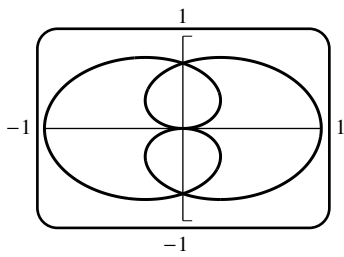

53.

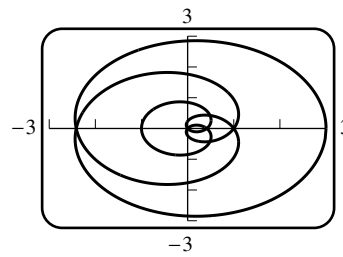

54.

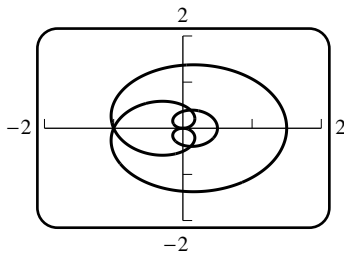

55.

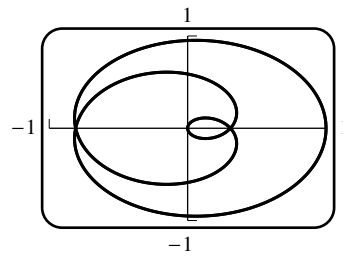

56.  $0 \leq \theta \leq 8\pi$

57. (a)  $-4\pi < \theta < 4\pi$

58. In I, along the  $x$ -axis,  $x = r$  grows ever slower with  $\theta$ . In II  $x = r$  grows linearly with  $\theta$ .  
Hence I:  $r = \sqrt{\theta}$ ; II:  $r = \theta$ .

59. (a)  $r = a/\cos \theta, x = r \cos \theta = a$ , a family of vertical lines

(b)  $r = b/\sin \theta, y = r \sin \theta = b$ , a family of horizontal lines

60. The image of  $(r_0, \theta_0)$  under a rotation through an angle  $\alpha$  is  $(r_0, \theta_0 + \alpha)$ . Hence  $(f(\theta), \theta)$  lies on the original curve if and only if  $(f(\theta), \theta + \alpha)$  lies on the rotated curve, i.e.  $(r, \theta)$  lies on the rotated curve if and only if  $r = f(\theta - \alpha)$ .

61. (a)  $r = 1 + \cos(\theta - \pi/4) = 1 + \frac{\sqrt{2}}{2}(\cos \theta + \sin \theta)$

(b)  $r = 1 + \cos(\theta - \pi/2) = 1 + \sin \theta$

(c)  $r = 1 + \cos(\theta - \pi) = 1 - \cos \theta$

(d)  $r = 1 + \cos(\theta - 5\pi/4) = 1 - \frac{\sqrt{2}}{2}(\cos \theta + \sin \theta)$

62.  $r^2 = 4 \cos 2(\theta - \pi/2) = -4 \cos 2\theta$

63. Either  $r - 1 = 0$  or  $\theta - 1 = 0$ ,  
so the graph consists of the  
circle  $r = 1$  and the line  $\theta = 1$ .

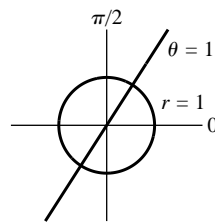

64. (a)  $r^2 = Ar \sin \theta + Br \cos \theta, x^2 + y^2 = Ay + Bx, (x - B/2)^2 + (y - A/2)^2 = (A^2 + B^2)/4$ , which is a circle of radius  $\frac{1}{4}\sqrt{A^2 + B^2}$ .

(b) Formula (4) follows by setting  $A = 0, B = 2a, (x - a)^2 + y^2 = a^2$ , the circle of radius  $a$  about  $(a, 0)$ . Formula (5) is derived in a similar fashion.

65.  $y = r \sin \theta = (1 + \cos \theta) \sin \theta = \sin \theta + \sin \theta \cos \theta,$

$dy/d\theta = \cos \theta - \sin^2 \theta + \cos^2 \theta = 2 \cos^2 \theta + \cos \theta - 1 = (2 \cos \theta - 1)(\cos \theta + 1);$

$dy/d\theta = 0$  if  $\cos \theta = 1/2$  or if  $\cos \theta = -1; \theta = \pi/3$  or  $\pi$ .

If  $\theta = \pi/3, \pi$ , then  $y = 3\sqrt{3}/4, 0$  so the maximum value of  $y$  is  $3\sqrt{3}/4$  and the polar coordinates of the highest point are  $(3/2, \pi/3)$ .

66.  $x = r \cos \theta = (1 + \cos \theta) \cos \theta = \cos \theta + \cos^2 \theta, dx/d\theta = -\sin \theta - 2 \sin \theta \cos \theta = -\sin \theta(1 + 2 \cos \theta),$   
 $dx/d\theta = 0$  if  $\sin \theta = 0$  or if  $\cos \theta = -1/2; \theta = 0, 2\pi/3, \pi$ . If  $\theta = 0, 2\pi/3, \pi$ , then  $x = 2, -1/4, 0$  so the minimum value of  $x$  is  $-1/4$ . The leftmost point has polar coordinates  $(1/2, 2\pi/3)$ .

67. (a) Let  $(x_1, y_1)$  and  $(x_2, y_2)$  be the rectangular coordinates of the points  $(r_1, \theta_1)$  and  $(r_2, \theta_2)$  then

$$d = \sqrt{(x_2 - x_1)^2 + (y_2 - y_1)^2} = \sqrt{(r_2 \cos \theta_2 - r_1 \cos \theta_1)^2 + (r_2 \sin \theta_2 - r_1 \sin \theta_1)^2}$$

$$= \sqrt{r_1^2 + r_2^2 - 2r_1r_2(\cos \theta_1 \cos \theta_2 + \sin \theta_1 \sin \theta_2)} = \sqrt{r_1^2 + r_2^2 - 2r_1r_2 \cos(\theta_1 - \theta_2)}.$$

(b) Let  $P$  and  $Q$  have polar coordinates  $(r_1, \theta_1), (r_2, \theta_2)$ , respectively, then the perpendicular from  $OQ$  to  $OP$  has length  $h = r_2 \sin(\theta_2 - \theta_1)$  and  $A = \frac{1}{2}hr_1 = \frac{1}{2}r_1r_2 \sin(\theta_2 - \theta_1)$ .

(c) From Part (a),  $d = \sqrt{9 + 4 - 2 \cdot 3 \cdot 2 \cos(\pi/6 - \pi/3)} = \sqrt{13 - 6\sqrt{3}} \approx 1.615$

(d)  $A = \frac{1}{2}2 \sin(5\pi/6 - \pi/3) = 1$

68. (a)  $0 = (x^2 + y^2 + a^2)^2 - a^4 - 4a^2x^2 = x^4 + y^4 + a^4 + 2x^2y^2 + 2x^2a^2 + 2y^2a^2 - a^4 - 4a^2x^2$   
 $= x^4 + y^4 + 2x^2y^2 - 2x^2a^2 + 2y^2a^2 = (x^2 + y^2)^2 + 2a^2(y^2 - x^2)$   
 $= r^4 + 2a^2r^2(\sin^2\theta - \cos^2\theta) = r^4 - 2a^2r^2 \cos 2\theta$ , so  $r^2 = 2a^2 \cos 2\theta$

(b)  $(x^2 + a^2 + y^2)^2 - 4x^2a^2 = a^4$ ;  $[(x - a)^2 + y^2][(x + a)^2 + y^2] = a^4$ ;  
 $\sqrt{(x + a)^2 + y^2} \sqrt{(x - a)^2 + y^2} = a^2$

69.  $\lim_{\theta \rightarrow 0^+} y = \lim_{\theta \rightarrow 0^+} r \sin \theta = \lim_{\theta \rightarrow 0^+} \frac{\sin \theta}{\theta} = 1$

70.  $\lim_{\theta \rightarrow 0^\pm} y = \lim_{\theta \rightarrow 0^\pm} r \sin \theta = \lim_{\theta \rightarrow 0^\pm} \frac{\sin \theta}{\theta^2} = \lim_{\theta \rightarrow 0^\pm} \frac{\sin \theta}{\theta} \lim_{\theta \rightarrow 0^\pm} \frac{1}{\theta} = 1 \cdot \lim_{\theta \rightarrow 0^\pm} \frac{1}{\theta}$ , so  $\lim_{\theta \rightarrow 0^\pm} y$  does not exist.

71. Note that  $r \rightarrow \pm\infty$  as  $\theta$  approaches odd multiples of  $\pi/2$ ;

$$x = r \cos \theta = 4 \tan \theta \cos \theta = 4 \sin \theta,$$

$$y = r \sin \theta = 4 \tan \theta \sin \theta$$

so  $x \rightarrow \pm 4$  and  $y \rightarrow \pm\infty$  as  $\theta$  approaches odd multiples of  $\pi/2$ .

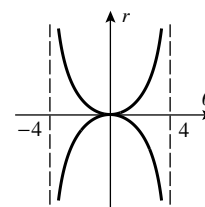

72.  $\lim_{\theta \rightarrow (\pi/2)^-} x = \lim_{\theta \rightarrow (\pi/2)^-} r \cos \theta = \lim_{\theta \rightarrow (\pi/2)^-} 2 \sin^2 \theta = 2$ ,  $x = 2$  is a vertical asymptote.

73. Let  $r = a \sin n\theta$  (the proof for  $r = a \cos n\theta$  is similar). If  $\theta$  starts at 0, then  $\theta$  would have to increase by some positive integer multiple of  $\pi$  radians in order to reach the starting point and begin to retrace the curve. Let  $(r, \theta)$  be the coordinates of a point  $P$  on the curve for  $0 \leq \theta < 2\pi$ . Now  $a \sin n(\theta + 2\pi) = a \sin(n\theta + 2\pi n) = a \sin n\theta = r$  so  $P$  is reached again with coordinates  $(r, \theta + 2\pi)$  thus the curve is traced out either exactly once or exactly twice for  $0 \leq \theta < 2\pi$ . If for  $0 \leq \theta < \pi$ ,  $P(r, \theta)$  is reached again with coordinates  $(-r, \theta + \pi)$  then the curve is traced out exactly once for  $0 \leq \theta < \pi$ , otherwise exactly once for  $0 \leq \theta < 2\pi$ . But

$$a \sin n(\theta + \pi) = a \sin(n\theta + n\pi) = \begin{cases} a \sin n\theta, & n \text{ even} \\ -a \sin n\theta, & n \text{ odd} \end{cases}$$

so the curve is traced out exactly once for  $0 \leq \theta < 2\pi$  if  $n$  is even, and exactly once for  $0 \leq \theta < \pi$  if  $n$  is odd.

## EXERCISE SET 12.2

1. (a)  $dy/dx = \frac{1/2}{2t} = 1/(4t)$ ;  $dy/dx|_{t=-1} = -1/4$ ;  $dy/dx|_{t=1} = 1/4$

(b)  $x = (2y)^2 + 1$ ,  $dx/dy = 8y$ ,  $dy/dx|_{y=\pm(1/2)} = \pm 1/4$

2. (a)  $dy/dx = (4 \cos t)/(-3 \sin t) = -(4/3) \cot t$ ;  $dy/dx|_{t=\pi/4} = -4/3$ ,  $dy/dx|_{t=7\pi/4} = 4/3$

(b)  $(x/3)^2 + (y/4)^2 = 1$ ,  $2x/9 + (2y/16)(dy/dx) = 0$ ,  $dy/dx = -16x/9y$ ,

$$dy/dx|_{\substack{x=3/\sqrt{2} \\ y=4/\sqrt{2}}} = -4/3; dy/dx|_{\substack{x=3/\sqrt{2} \\ y=-4/\sqrt{2}}} = 4/3$$

3.  $\frac{d^2y}{dx^2} = \frac{d}{dx} \frac{dy}{dx} = \frac{d}{dt} \left( \frac{dy}{dx} \right) \frac{dt}{dx} = -\frac{1}{4t^2} (1/2t) = -1/(8t^3)$ ; positive when  $t = -1$ ,  
negative when  $t = 1$
4.  $\frac{d^2y}{dx^2} = \frac{d}{dt} \left( \frac{dy}{dx} \right) \frac{dt}{dx} = \frac{-(4/3)(-\csc^2 t)}{-3 \sin t} = -\frac{4}{9} \csc^3 t$ ; negative at  $t = \pi/4$ , positive at  $t = 7\pi/4$ .
5.  $dy/dx = \frac{2}{1/(2\sqrt{t})} = 4\sqrt{t}$ ,  $d^2y/dx^2 = \frac{2/\sqrt{t}}{1/(2\sqrt{t})} = 4$ ,  $dy/dx|_{t=1} = 4$ ,  $d^2y/dx^2|_{t=1} = 4$
6.  $dy/dx = \frac{t^2}{t} = t$ ,  $d^2y/dx^2 = \frac{1}{t}$ ,  $dy/dx|_{t=2} = 2$ ,  $d^2y/dx^2|_{t=2} = 1/2$
7.  $dy/dx = \frac{\sec^2 t}{\sec t \tan t} = \csc t$ ,  $d^2y/dx^2 = \frac{-\csc t \cot t}{\sec t \tan t} = -\cot^3 t$ ,  
 $dy/dx|_{t=\pi/3} = 2/\sqrt{3}$ ,  $d^2y/dx^2|_{t=\pi/3} = -1/(3\sqrt{3})$
8.  $dy/dx = \frac{\sinh t}{\cosh t} = \tanh t$ ,  $\frac{d^2y}{dx^2} = \text{sech}^2 t / \cosh t = \text{sech}^3 t$ ,  $dy/dx|_{t=0} = 0$ ,  $d^2y/dx^2|_{t=0} = 1$
9.  $\frac{dy}{dx} = \frac{dy/d\theta}{dx/d\theta} = \frac{-\cos \theta}{2 - \sin \theta}$ ;  $\frac{d^2y}{dx^2} = \frac{d}{d\theta} \left( \frac{dy}{dx} \right) \frac{d\theta}{dx} = \frac{2}{(2 - \sin \theta)^2} \frac{1}{2 - \sin \theta} = \frac{1}{(2 - \sin \theta)^3}$ ;  
 $\frac{dy}{dx}|_{\theta=\pi/3} = \frac{-1/2}{2 - \sqrt{3}/2} = \frac{-1}{4 - \sqrt{3}}$ ;  $\frac{d^2y}{dx^2}|_{\theta=\pi/3} = \frac{1}{(2 - \sqrt{3}/2)^3} = \frac{8}{(4 - \sqrt{3})^3}$
10.  $\frac{dy}{dx} = \frac{3 \cos \phi}{-\sin \phi} = -3 \cot \phi$ ;  $\frac{d^2y}{dx^2} = \frac{d}{d\phi} (-3 \cot \phi) \frac{d\phi}{dx} = -3(-\csc^2 \phi)(-\csc \phi) = -3 \csc^3 \phi$ ;  
 $\frac{dy}{dx}|_{\phi=5\pi/6} = 3\sqrt{3}$ ;  $\frac{d^2y}{dx^2}|_{\phi=5\pi/6} = -24$
11. (a)  $dy/dx = \frac{-e^{-t}}{e^t} = -e^{-2t}$ ; for  $t = 1$ ,  $dy/dx = -e^{-2}$ ,  $(x, y) = (e, e^{-1})$ ;  $y - e^{-1} = -e^{-2}(x - e)$ ,  
 $y = -e^{-2}x + 2e^{-1}$
- (b)  $y = 1/x$ ,  $dy/dx = -1/x^2$ ,  $m = -1/e^2$ ,  $y - e^{-1} = -\frac{1}{e^2}(x - e)$ ,  $y = -\frac{1}{e^2}x + \frac{2}{e}$
12.  $dy/dx = \frac{16t - 2}{2} = 8t - 1$ ; for  $t = 1$ ,  $dy/dx = 7$ ,  $(x, y) = (6, 10)$ ;  $y - 10 = 7(x - 6)$ ,  $y = 7x - 32$
13.  $dy/dx = \frac{4 \cos t}{-2 \sin t} = -2 \cot t$
- (a)  $dy/dx = 0$  if  $\cot t = 0$ ,  $t = \pi/2 + n\pi$  for  $n = 0, \pm 1, \dots$
- (b)  $dx/dy = -\frac{1}{2} \tan t = 0$  if  $\tan t = 0$ ,  $t = n\pi$  for  $n = 0, \pm 1, \dots$
14.  $dy/dx = \frac{2t + 1}{6t^2 - 30t + 24} = \frac{2t + 1}{6(t - 1)(t - 4)}$
- (a)  $dy/dx = 0$  if  $t = -1/2$
- (b)  $dx/dy = \frac{6(t - 1)(t - 4)}{2t + 1} = 0$  if  $t = 1, 4$

15.  $x = y = 0$  when  $t = 0, \pi$ ;  $\frac{dy}{dx} = \frac{2 \cos 2t}{\cos t}$ ;  $\frac{dy}{dx}\Big|_{t=0} = 2$ ,  $\frac{dy}{dx}\Big|_{t=\pi} = -2$ , the equations of the tangent lines are  $y = -2x, y = 2x$ .
16.  $y(t) = 0$  has three solutions,  $t = 0, \pm\pi/2$ ; the last two correspond to the crossing point.  
For  $t = \pm\pi/2$ ,  $m = \frac{dy}{dx} = \frac{2}{\pm\pi}$ ; the tangent lines are given by  $y = \pm\frac{2}{\pi}(x - 2)$ .
17. If  $y = 4$  then  $t^2 = 4$ ,  $t = \pm 2$ ,  $x = 0$  for  $t = \pm 2$  so  $(0, 4)$  is reached when  $t = \pm 2$ .  
 $dy/dx = 2t/(3t^2 - 4)$ . For  $t = 2$ ,  $dy/dx = 1/2$  and for  $t = -2$ ,  $dy/dx = -1/2$ . The tangent lines are  $y = \pm x/2 + 4$ .
18. If  $x = 3$  then  $t^2 - 3t + 5 = 3$ ,  $t^2 - 3t + 2 = 0$ ,  $(t - 1)(t - 2) = 0$ ,  $t = 1$  or  $2$ . If  $t = 1$  or  $2$  then  $y = 1$  so  $(3, 1)$  is reached when  $t = 1$  or  $2$ .  $dy/dx = (3t^2 + 2t - 10)/(2t - 3)$ . For  $t = 1$ ,  $dy/dx = 5$ , the tangent line is  $y - 1 = 5(x - 3)$ ,  $y = 5x - 14$ . For  $t = 2$ ,  $dy/dx = 6$ , the tangent line is  $y - 1 = 6(x - 3)$ ,  $y = 6x - 17$ .

19. (a)

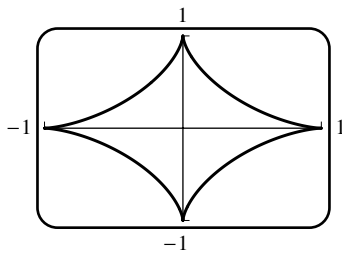

- (b)  $\frac{dx}{dt} = -3 \cos^2 t \sin t$  and  $\frac{dy}{dt} = 3 \sin^2 t \cos t$  are both zero when  $t = 0, \pi/2, \pi, 3\pi/2, 2\pi$ , so singular points occur at these values of  $t$ .

20. (a) when  $y = 0$

- (b)  $\frac{dy}{dx} = \frac{a \sin \theta}{a - a \cos \theta} = 0$  when  $\theta = 2n\pi + \pi/2, n = 0, 1, \dots$  (which is when  $y = 0$ ).

21. Substitute  $\theta = \pi/3$ ,  $r = 1$ , and  $dr/d\theta = -\sqrt{3}$  in equation (7) gives slope  $m = 1/\sqrt{3}$ .

22. As in Exercise 21,  $\theta = \pi/4$ ,  $dr/d\theta = \sqrt{2}/2$ ,  $r = 1 + \sqrt{2}/2$ ,  $m = -1 - \sqrt{2}$

23. As in Exercise 21,  $\theta = 2$ ,  $dr/d\theta = -1/4$ ,  $r = 1/2$ ,  $m = \frac{\tan 2 - 2}{2 \tan 2 + 1}$

24. As in Exercise 21,  $\theta = \pi/6$ ,  $dr/d\theta = 4\sqrt{3}a$ ,  $r = 2a$ ,  $m = 3\sqrt{3}/5$

25. As in Exercise 21,  $\theta = 3\pi/4$ ,  $dr/d\theta = -3\sqrt{2}/2$ ,  $r = \sqrt{2}/2$ ,  $m = -2$

26. As in Exercise 21,  $\theta = \pi$ ,  $dr/d\theta = 3$ ,  $r = 4$ ,  $m = 4/3$

27.  $m = \frac{dy}{dx} = \frac{r \cos \theta + (\sin \theta)(dr/d\theta)}{-r \sin \theta + (\cos \theta)(dr/d\theta)} = \frac{\cos \theta + 2 \sin \theta \cos \theta}{-\sin \theta + \cos^2 \theta - \sin^2 \theta}$ ; if  $\theta = 0, \pi/2, \pi$ , then  $m = 1, 0, -1$ .

28.  $m = \frac{dy}{dx} = \frac{\cos \theta(4 \sin \theta - 1)}{4 \cos^2 \theta + \sin \theta - 2}$ ; if  $\theta = 0, \pi/2, \pi$  then  $m = -1/2, 0, 1/2$ .



29.  $dx/d\theta = -a \sin \theta(1 + 2 \cos \theta)$ ,  $dy/d\theta = a(2 \cos \theta - 1)(\cos \theta + 1)$
- (a) horizontal if  $dy/d\theta = 0$  and  $dx/d\theta \neq 0$ .  $dy/d\theta = 0$  when  $\cos \theta = 1/2$  or  $\cos \theta = -1$  so  $\theta = \pi/3$ ,  $5\pi/3$ , or  $\pi$ ;  $dx/d\theta \neq 0$  for  $\theta = \pi/3$  and  $5\pi/3$ . For the singular point  $\theta = \pi$  we find that  $\lim_{\theta \rightarrow \pi} dy/dx = 0$ . There is a horizontal tangent line at  $(3a/2, \pi/3)$ ,  $(0, \pi)$ , and  $(3a/2, 5\pi/3)$ .
- (b) vertical if  $dy/d\theta \neq 0$  and  $dx/d\theta = 0$ .  $dx/d\theta = 0$  when  $\sin \theta = 0$  or  $\cos \theta = -1/2$  so  $\theta = 0, \pi, 2\pi/3$ , or  $4\pi/3$ ;  $dy/d\theta \neq 0$  for  $\theta = 0, 2\pi/3$ , and  $4\pi/3$ . The singular point  $\theta = \pi$  was discussed in part (a). There is a vertical tangent line at  $(2a, 0)$ ,  $(a/2, 2\pi/3)$ , and  $(a/2, 4\pi/3)$ .
30.  $dx/d\theta = a(\cos^2 \theta - \sin^2 \theta) = a \cos 2\theta$ ,  $dy/d\theta = 2a \sin \theta \cos \theta = a \sin 2\theta$
- (a) horizontal if  $dy/d\theta = 0$  and  $dx/d\theta \neq 0$ .  $dy/d\theta = 0$  when  $\theta = 0, \pi/2, \pi, 3\pi/2, 2\pi$ ;  $dx/d\theta \neq 0$  for  $(0, 0)$ ,  $(a, \pi/2)$ ,  $(0, \pi)$ ,  $(-a, 3\pi/2)$ ,  $(0, 2\pi)$ ; in reality only two distinct points
- (b) vertical if  $dy/d\theta \neq 0$  and  $dx/d\theta = 0$ .  $dx/d\theta = 0$  when  $\theta = \pi/4, 3\pi/4, 5\pi/4, 7\pi/4$ ;  $dy/d\theta \neq 0$  there, so vertical tangent line at  $(a/\sqrt{2}, \pi/4)$ ,  $(a/\sqrt{2}, 3\pi/4)$ ,  $(-a/\sqrt{2}, 5\pi/4)$ ,  $(-a/\sqrt{2}, 7\pi/4)$ , only two distinct points
31.  $dy/d\theta = (d/d\theta)(\sin^2 \theta \cos^2 \theta) = (\sin 4\theta)/2 = 0$  at  $\theta = 0, \pi/4, \pi/2, 3\pi/4, \pi$ ; at the same points,  $dx/d\theta = (d/d\theta)(\sin \theta \cos^3 \theta) = \cos^2 \theta(4 \cos^2 \theta - 3)$ . Next,  $\frac{dx}{d\theta} = 0$  at  $\theta = \pi/2$ , a singular point; and  $\theta = 0, \pi$  both give the same point, so there are just three points with a horizontal tangent.
32.  $dx/d\theta = 4 \sin^2 \theta - \sin \theta - 2$ ,  $dy/d\theta = \cos \theta(1 - 4 \sin \theta)$ .  $dy/d\theta = 0$  when  $\cos \theta = 0$  or  $\sin \theta = 1/4$  so  $\theta = \pi/2, 3\pi/2, \sin^{-1}(1/4)$ , or  $\pi - \sin^{-1}(1/4)$ ;  $dx/d\theta \neq 0$  at these points, so there is a horizontal tangent at each one.

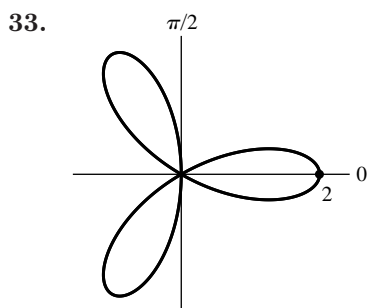

$\theta_0 = \pi/6, \pi/2, 5\pi/6$

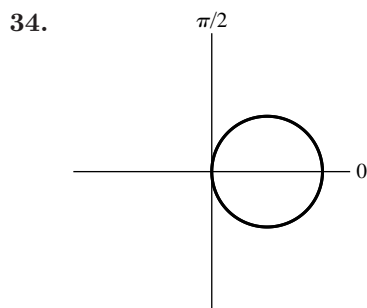

$\theta_0 = \pi/2$

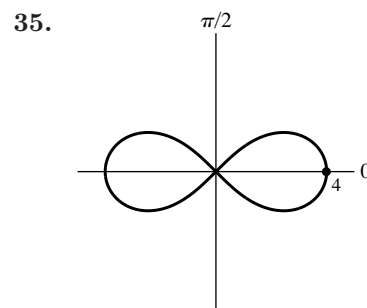

$\theta_0 = \pm\pi/4$

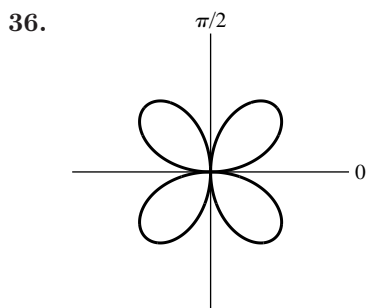

$\theta_0 = 0, \pi/2$

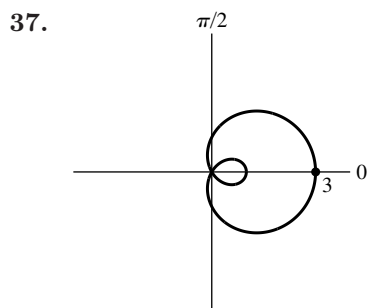

$\theta_0 = 2\pi/3, 4\pi/3$

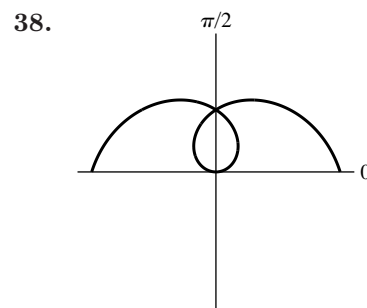

$\theta_0 = 0$

39.  $r^2 + (dr/d\theta)^2 = a^2 + 0^2 = a^2$ ,  $L = \int_0^{2\pi} a d\theta = 2\pi a$

40.  $r^2 + (dr/d\theta)^2 = (2a \cos \theta)^2 + (-2a \sin \theta)^2 = 4a^2$ ,  $L = \int_{-\pi/2}^{\pi/2} 2a d\theta = 2\pi a$

41.  $r^2 + (dr/d\theta)^2 = [a(1 - \cos \theta)]^2 + [a \sin \theta]^2 = 4a^2 \sin^2(\theta/2)$ ,  $L = 2 \int_0^\pi 2a \sin(\theta/2) d\theta = 8a$

42.  $r^2 + (dr/d\theta)^2 = [\sin^2(\theta/2)]^2 + [\sin(\theta/2) \cos(\theta/2)]^2 = \sin^2(\theta/2)$ ,  $L = \int_0^\pi \sin(\theta/2) d\theta = 2$

43.  $r^2 + (dr/d\theta)^2 = (e^{3\theta})^2 + (3e^{3\theta})^2 = 10e^{6\theta}$ ,  $L = \int_0^2 \sqrt{10} e^{3\theta} d\theta = \sqrt{10}(e^6 - 1)/3$

44.  $r^2 + (dr/d\theta)^2 = [\sin^3(\theta/3)]^2 + [\sin^2(\theta/3) \cos(\theta/3)]^2 = \sin^4(\theta/3)$ ,  
 $L = \int_0^{\pi/2} \sin^2(\theta/3) d\theta = (2\pi - 3\sqrt{3})/8$

45. (a) From (3),  $\frac{dy}{dx} = \frac{3 \sin t}{1 - 3 \cos t}$

(b) At  $t = 10$ ,  $\frac{dy}{dx} = \frac{3 \sin 10}{1 - 3 \cos 10} \approx -0.4640$ ,  $\theta \approx \tan^{-1}(-0.4640) = -0.4344$

46. (a)  $\frac{dy}{dx} = 0$  when  $\frac{dy}{dt} = 2 \sin t = 0$ ,  $t = 0, \pi, 2\pi, 3\pi$

(b)  $\frac{dx}{dt} = 0$  when  $1 - 2 \cos t = 0$ ,  $\cos t = 1/2$ ,  $t = \pi/3, 5\pi/3, 7\pi/3$

47. (a)  $r^2 + (dr/d\theta)^2 = (\cos n\theta)^2 + (-n \sin n\theta)^2 = \cos^2 n\theta + n^2 \sin^2 n\theta$   
 $= (1 - \sin^2 n\theta) + n^2 \sin^2 n\theta = 1 + (n^2 - 1) \sin^2 n\theta$ ,

$$L = 2 \int_0^{\pi/(2n)} \sqrt{1 + (n^2 - 1) \sin^2 n\theta} d\theta$$

(b)  $L = 2 \int_0^{\pi/4} \sqrt{1 + 3 \sin^2 2\theta} d\theta \approx 2.42$

(c)

$n$	2	3	4	5	6	7	8	9	10	11
$L$	2.42211	2.22748	2.14461	2.10100	2.07501	2.05816	2.04656	2.03821	2.03199	2.02721

$n$	12	13	14	15	16	17	18	19	20
$L$	2.02346	2.02046	2.01802	2.01600	2.01431	2.01288	2.01167	2.01062	2.00971

48. (a)

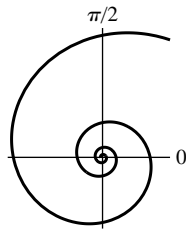

(b)  $r^2 + (dr/d\theta)^2 = (e^{-\theta})^2 + (-e^{-\theta})^2 = 2e^{-2\theta}$ ,  $L = \int_0^{+\infty} \sqrt{2} e^{-\theta} d\theta$

(c)  $L = \lim_{\theta_0 \rightarrow +\infty} \int_0^{\theta_0} \sqrt{2} e^{-\theta} d\theta = \lim_{\theta_0 \rightarrow +\infty} \sqrt{2}(1 - e^{-\theta_0}) = \sqrt{2}$

49.  $x' = 2t, y' = 2, (x')^2 + (y')^2 = 4t^2 + 4$

$$S = 2\pi \int_0^4 (2t)\sqrt{4t^2 + 4} dt = 8\pi \int_0^4 t\sqrt{t^2 + 1} dt = \frac{8\pi}{3} (t^2 + 1)^{3/2} \Big|_0^4 = \frac{8\pi}{3} (17\sqrt{17} - 1)$$

50.  $x' = e^t(\cos t - \sin t), y' = e^t(\cos t + \sin t), (x')^2 + (y')^2 = 2e^{2t}$

$$S = 2\pi \int_0^{\pi/2} (e^t \sin t)\sqrt{2e^{2t}} dt = 2\sqrt{2}\pi \int_0^{\pi/2} e^{2t} \sin t dt$$

$$= 2\sqrt{2}\pi \left[ \frac{1}{5} e^{2t} (2 \sin t - \cos t) \right]_0^{\pi/2} = \frac{2\sqrt{2}}{5} \pi (2e^\pi + 1)$$

51.  $x' = -2 \sin t \cos t, y' = 2 \sin t \cos t, (x')^2 + (y')^2 = 8 \sin^2 t \cos^2 t$

$$S = 2\pi \int_0^{\pi/2} \cos^2 t \sqrt{8 \sin^2 t \cos^2 t} dt = 4\sqrt{2}\pi \int_0^{\pi/2} \cos^3 t \sin t dt = -\sqrt{2}\pi \cos^4 t \Big|_0^{\pi/2} = \sqrt{2}\pi$$

52.  $x' = 1, y' = 4t, (x')^2 + (y')^2 = 1 + 16t^2, S = 2\pi \int_0^1 t\sqrt{1 + 16t^2} dt = \frac{\pi}{24} (17\sqrt{17} - 1)$

53.  $x' = -r \sin t, y' = r \cos t, (x')^2 + (y')^2 = r^2, S = 2\pi \int_0^\pi r \sin t \sqrt{r^2} dt = 2\pi r^2 \int_0^\pi \sin t dt = 4\pi r^2$

54.  $\frac{dx}{d\phi} = a(1 - \cos \phi), \frac{dy}{d\phi} = a \sin \phi, \left(\frac{dx}{d\phi}\right)^2 + \left(\frac{dy}{d\phi}\right)^2 = 2a^2(1 - \cos \phi)$

$$S = 2\pi \int_0^{2\pi} a(1 - \cos \phi) \sqrt{2a^2(1 - \cos \phi)} d\phi = 2\sqrt{2}\pi a^2 \int_0^{2\pi} (1 - \cos \phi)^{3/2} d\phi,$$

but  $1 - \cos \phi = 2 \sin^2 \frac{\phi}{2}$  so  $(1 - \cos \phi)^{3/2} = 2\sqrt{2} \sin^3 \frac{\phi}{2}$  for  $0 \leq \phi \leq \pi$  and, taking advantage of the symmetry of the cycloid,  $S = 16\pi a^2 \int_0^\pi \sin^3 \frac{\phi}{2} d\phi = 64\pi a^2/3$

55. (a)  $\frac{dr}{dt} = 2$  and  $\frac{d\theta}{dt} = 1$  so  $\frac{dr}{d\theta} = \frac{dr/dt}{d\theta/dt} = \frac{2}{1} = 2, r = 2\theta + C, r = 10$  when  $\theta = 0$  so  $10 = C, r = 2\theta + 10$ .

(b)  $r^2 + (dr/d\theta)^2 = (2\theta + 10)^2 + 4$ , during the first 5 seconds the rod rotates through an angle of  $(1)(5) = 5$  radians so  $L = \int_0^5 \sqrt{(2\theta + 10)^2 + 4} d\theta$ , let  $u = 2\theta + 10$  to get

$$L = \frac{1}{2} \int_{10}^{20} \sqrt{u^2 + 4} du = \frac{1}{2} \left[ \frac{u}{2} \sqrt{u^2 + 4} + 2 \ln |u + \sqrt{u^2 + 4}| \right]_{10}^{20}$$

$$= \frac{1}{2} \left[ 10\sqrt{404} - 5\sqrt{104} + 2 \ln \frac{20 + \sqrt{404}}{10 + \sqrt{104}} \right] \approx 75.7 \text{ mm}$$

56.  $x = r \cos \theta, y = r \sin \theta, \frac{dx}{d\theta} = \frac{dr}{d\theta} \cos \theta - r \sin \theta, \frac{dy}{d\theta} = r \cos \theta + \frac{dr}{d\theta} \sin \theta,$

$\left(\frac{dx}{d\theta}\right)^2 + \left(\frac{dy}{d\theta}\right)^2 = r^2 + \left(\frac{dr}{d\theta}\right)^2$ , and Formula (6) of Section 8.4 becomes

$$L = \int_\alpha^\beta \sqrt{r^2 + \left(\frac{dr}{d\theta}\right)^2} d\theta$$

## EXERCISE SET 12.3

$$1. \quad \begin{array}{lll} \text{(a)} & \int_{\pi/2}^{\pi} \frac{1}{2}(1 - \cos \theta)^2 d\theta & \text{(b)} \quad \int_0^{\pi/2} \frac{1}{2}4 \cos^2 \theta d\theta & \text{(c)} \quad \int_0^{\pi/2} \frac{1}{2} \sin^2 2\theta d\theta \\ \text{(d)} & \int_0^{2\pi} \frac{1}{2}\theta^2 d\theta & \text{(e)} \quad \int_{-\pi/2}^{\pi/2} \frac{1}{2}(1 - \sin \theta)^2 d\theta & \text{(f)} \quad 2 \int_0^{\pi/4} \frac{1}{2} \cos^2 2\theta d\theta \end{array}$$

$$2. \quad \begin{array}{lll} \text{(a)} & 3\pi/8 + 1 & \text{(b)} \quad \pi/2 & \text{(c)} \quad \pi/8 \\ \text{(d)} & 4\pi^3/3 & \text{(e)} \quad 3\pi/4 & \text{(f)} \quad \pi/8 \end{array}$$

$$3. \quad \begin{array}{ll} \text{(a)} & A = \int_0^{2\pi} \frac{1}{2}a^2 d\theta = \pi a^2 & \text{(b)} & A = \int_0^{\pi} \frac{1}{2}4a^2 \sin^2 \theta d\theta = \pi a^2 \\ \text{(c)} & A = \int_{-\pi/2}^{\pi/2} \frac{1}{2}4a^2 \cos^2 \theta d\theta = \pi a^2 & & \end{array}$$

$$4. \quad \begin{array}{l} \text{(a)} \quad r^2 = r \sin \theta + r \cos \theta, \quad x^2 + y^2 - y - x = 0, \quad \left(x - \frac{1}{2}\right)^2 + \left(y - \frac{1}{2}\right)^2 = \frac{1}{2} \\ \text{(b)} \quad A = \int_{-\pi/4}^{3\pi/4} \frac{1}{2}(\sin \theta + \cos \theta)^2 d\theta = \pi/2 \end{array}$$

$$5. \quad A = 2 \int_0^{\pi} \frac{1}{2}(2 + 2 \cos \theta)^2 d\theta = 6\pi \qquad 6. \quad A = \int_0^{\pi/2} \frac{1}{2}(1 + \sin \theta)^2 d\theta = 3\pi/8 + 1$$

$$7. \quad A = 6 \int_0^{\pi/6} \frac{1}{2}(16 \cos^2 3\theta) d\theta = 4\pi$$

$$8. \quad \text{The petal in the first quadrant has area } \int_0^{\pi/2} \frac{1}{2}4 \sin^2 2\theta d\theta = \pi/2, \text{ so total area} = 2\pi.$$

$$9. \quad A = 2 \int_{2\pi/3}^{\pi} \frac{1}{2}(1 + 2 \cos \theta)^2 d\theta = \pi - 3\sqrt{3}/2 \qquad 10. \quad A = \int_1^3 \frac{2}{\theta^2} d\theta = 4/3$$

$$11. \quad \text{area} = A_1 - A_2 = \int_0^{\pi/2} \frac{1}{2}4 \cos^2 \theta d\theta - \int_0^{\pi/4} \frac{1}{2} \cos 2\theta d\theta = \pi/2 - \frac{1}{4}$$

$$12. \quad \text{area} = A_1 - A_2 = \int_0^{\pi} \frac{1}{2}(1 + \cos \theta)^2 d\theta - \int_0^{\pi/2} \frac{1}{2} \cos^2 \theta d\theta = 5\pi/8$$

$$13. \quad \text{The circles intersect when } \cos t = \sqrt{3} \sin t, \tan t = 1/\sqrt{3}, t = \pi/6, \text{ so}$$

$$A = A_1 + A_2 = \int_0^{\pi/6} \frac{1}{2}(4\sqrt{3} \sin t)^2 dt + \int_{\pi/6}^{\pi/2} \frac{1}{2}(4 \cos t)^2 dt = 2\pi - 3\sqrt{3} + 4\pi/3 - \sqrt{3} = 10\pi/3 - 4\sqrt{3}.$$

$$14. \quad \text{The curves intersect when } 1 + \cos t = 3 \cos t, \cos t = 1/2, t = \pm\pi/3, \text{ and hence}$$

$$\text{total area} = 2 \int_0^{\pi/3} \frac{1}{2}(1 + \cos t)^2 dt + 2 \int_{\pi/3}^{\pi/2} \frac{1}{2}9 \cos^2 t dt = 2(\pi/4 + 9\sqrt{3}/16 + 3\pi/8 - 9\sqrt{3}/16) = 5\pi/4.$$

15.  $A = 2 \int_{\pi/6}^{\pi/2} \frac{1}{2} [25 \sin^2 \theta - (2 + \sin \theta)^2] d\theta = 8\pi/3 + \sqrt{3}$

16.  $A = 2 \int_0^{\pi} \frac{1}{2} [16 - (2 - 2 \cos \theta)^2] d\theta = 10\pi$

17.  $A = 2 \int_0^{\pi/3} \frac{1}{2} [(2 + 2 \cos \theta)^2 - 9] d\theta = 9\sqrt{3}/2 - \pi$

18.  $A = 2 \int_0^{\pi/4} \frac{1}{2} (16 \sin^2 \theta) d\theta = 2\pi - 4$

19.  $A = 2 \left[ \int_0^{2\pi/3} \frac{1}{2} (1/2 + \cos \theta)^2 d\theta - \int_{2\pi/3}^{\pi} \frac{1}{2} (1/2 + \cos \theta)^2 d\theta \right] = (\pi + 3\sqrt{3})/4$

20.  $A = 2 \int_0^{\pi/3} \frac{1}{2} \left[ (2 + 2 \cos \theta)^2 - \frac{9}{4} \sec^2 \theta \right] d\theta = 2\pi + \frac{9}{4}\sqrt{3}$

21.  $A = 2 \int_0^{\cos^{-1}(3/5)} \frac{1}{2} (100 - 36 \sec^2 \theta) d\theta = 100 \cos^{-1}(3/5) - 48$

22.  $A = 8 \int_0^{\pi/8} \frac{1}{2} (4a^2 \cos^2 2\theta - 2a^2) d\theta = 2a^2$

23. (a)  $r$  is not real for  $\pi/4 < \theta < 3\pi/4$  and  $5\pi/4 < \theta < 7\pi/4$

(b)  $A = 4 \int_0^{\pi/4} \frac{1}{2} a^2 \cos 2\theta d\theta = a^2$

(c)  $A = 4 \int_0^{\pi/6} \frac{1}{2} [4 \cos 2\theta - 2] d\theta = 2\sqrt{3} - \frac{2\pi}{3}$

24.  $A = 2 \int_0^{\pi/2} \frac{1}{2} \sin 2\theta d\theta = 1$

25.  $A = \int_{2\pi}^{4\pi} \frac{1}{2} a^2 \theta^2 d\theta - \int_0^{2\pi} \frac{1}{2} a^2 \theta^2 d\theta = 8\pi^3 a^2$

26. (a)  $x = r \cos \theta, y = r \sin \theta,$

$$(dx/d\theta)^2 + (dy/d\theta)^2 = (f'(\theta) \cos \theta - f(\theta) \sin \theta)^2 + (f'(\theta) \sin \theta + f(\theta) \cos \theta)^2 = f'(\theta)^2 + f(\theta)^2;$$

$$S = \int_{\alpha}^{\beta} 2\pi f(\theta) \sin \theta \sqrt{f'(\theta)^2 + f(\theta)^2} d\theta \text{ if about } \theta = 0; \text{ similarly for } \theta = \pi/2$$

(b)  $f', g'$  are continuous and no segment of the curve is traced more than once.

27.  $r^2 + \left(\frac{dr}{d\theta}\right)^2 = \cos^2 \theta + \sin^2 \theta = 1,$

so  $S = \int_{-\pi/2}^{\pi/2} 2\pi \cos^2 \theta d\theta = \pi^2.$

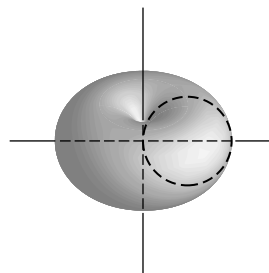

$$\begin{aligned}
 28. \quad S &= \int_0^{\pi/2} 2\pi e^\theta \cos \theta \sqrt{2e^{2\theta}} d\theta \\
 &= 2\sqrt{2}\pi \int_0^{\pi/2} e^{2\theta} \cos \theta d\theta = \frac{2\sqrt{2}\pi}{5}(e^\pi - 2)
 \end{aligned}$$

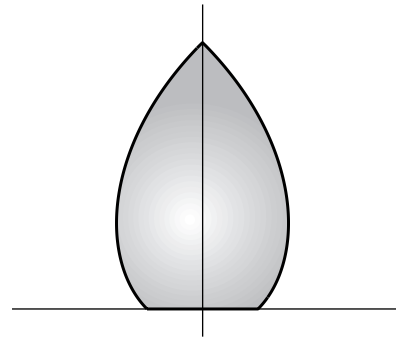

$$\begin{aligned}
 29. \quad S &= \int_0^\pi 2\pi(1 - \cos \theta) \sin \theta \sqrt{1 - 2\cos \theta + \cos^2 \theta + \sin^2 \theta} d\theta \\
 &= 2\sqrt{2}\pi \int_0^\pi \sin \theta (1 - \cos \theta)^{3/2} d\theta = \frac{2}{5} 2\sqrt{2}\pi (1 - \cos \theta)^{5/2} \Big|_0^\pi = 32\pi/5
 \end{aligned}$$

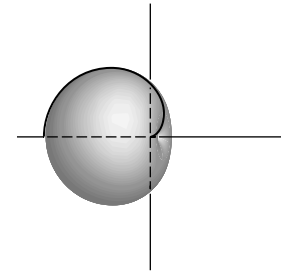

$$30. \quad S = \int_0^\pi 2\pi a \sin(\theta) a d\theta = 4\pi a^2$$

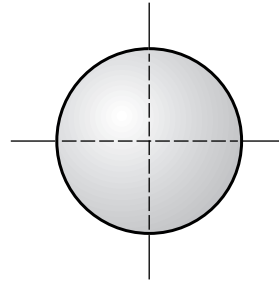

$$31. \quad (\text{a}) \quad r^3 \cos^3 \theta - 3r^2 \cos \theta \sin \theta + r^3 \sin^3 \theta = 0, \quad r = \frac{3 \cos \theta \sin \theta}{\cos^3 \theta + \sin^3 \theta}$$

$$32. \quad (\text{a}) \quad A = 2 \int_0^{\pi/(2n)} \frac{1}{2} a^2 \cos^2 n\theta d\theta = \frac{\pi a^2}{4n} \qquad (\text{b}) \quad A = 2 \int_0^{\pi/(2n)} \frac{1}{2} a^2 \cos^2 n\theta d\theta = \frac{\pi a^2}{4n}$$

$$(\text{c}) \quad \frac{1}{2n} \times \text{total area} = \frac{\pi a^2}{4n} \qquad (\text{d}) \quad \frac{1}{n} \times \text{total area} = \frac{\pi a^2}{4n}$$

33. If the upper right corner of the square is the point  $(a, a)$  then the large circle has equation  $r = \sqrt{2}a$  and the small circle has equation  $(x - a)^2 + y^2 = a^2$ ,  $r = 2a \cos \theta$ , so

$$\text{area of crescent} = 2 \int_0^{\pi/4} \frac{1}{2} [(2a \cos \theta)^2 - (\sqrt{2}a)^2] d\theta = a^2 = \text{area of square.}$$

34.  $A = \int_0^{2\pi} \frac{1}{2} (\cos 3\theta + 2)^2 d\theta = 9\pi/2$

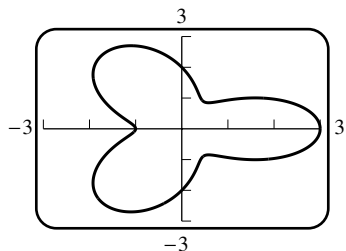

35.  $A = \int_0^{\pi/2} \frac{1}{2} 4 \cos^2 \theta \sin^4 \theta d\theta = \pi/16$

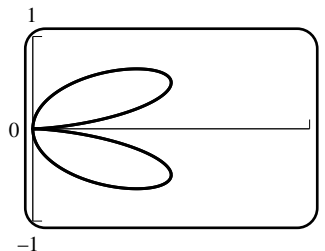

**EXERCISE SET 12.4**

1. (a)  $4px = y^2$ , point  $(1, 1)$ ,  $4p = 1$ ,  $x = y^2$       (b)  $-4py = x^2$ , point  $(3, -3)$ ,  $12p = 9$ ,  $-3y = x^2$   
 (c)  $a = 3, b = 2$ ,  $\frac{x^2}{9} + \frac{y^2}{4} = 1$       (d)  $a = 3, b = 2$ ,  $\frac{x^2}{4} + \frac{y^2}{9} = 1$   
 (e) asymptotes:  $y = \pm x$ , so  $a = b$ ; point  $(0, 1)$ , so  $y^2 - x^2 = 1$   
 (f) asymptotes:  $y = \pm x$ , so  $b = a$ ; point  $(2, 0)$ , so  $\frac{x^2}{4} - \frac{y^2}{4} = 1$

2. (a) part (a), vertex  $(0, 0)$ ,  $p = 1/4$ ; focus  $(1/4, 0)$ , directrix:  $x = -1/4$   
 part (b), vertex  $(0, 0)$ ,  $p = 3/4$ ; focus  $(0, -3/4)$ , directrix:  $y = 3/4$   
 (b) part (c),  $c = \sqrt{a^2 - b^2} = \sqrt{5}$ , foci  $(\pm\sqrt{5}, 0)$   
 part (d),  $c = \sqrt{a^2 - b^2} = \sqrt{5}$ , foci  $(0, \pm\sqrt{5})$   
 (c) part (e),  $c = \sqrt{a^2 + b^2} = \sqrt{2}$ , foci at  $(0, \pm\sqrt{2})$ ; asymptotes:  $y^2 - x^2 = 0$ ,  $y = \pm x$   
 part (f),  $c = \sqrt{a^2 + b^2} = \sqrt{8} = 2\sqrt{2}$ , foci at  $(\pm 2\sqrt{2}, 0)$ ; asymptotes:  $\frac{x^2}{4} - \frac{y^2}{4} = 0$ ,  $y = \pm x$

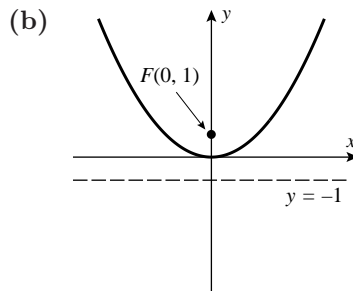
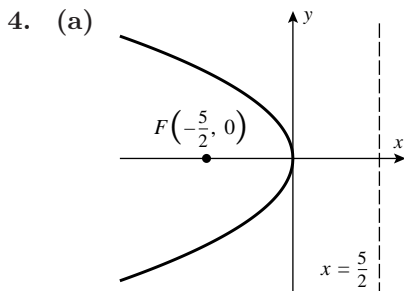
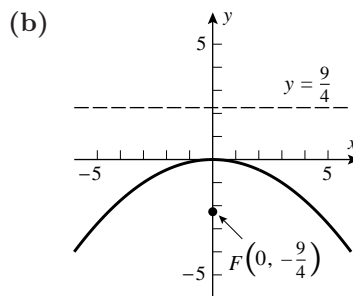
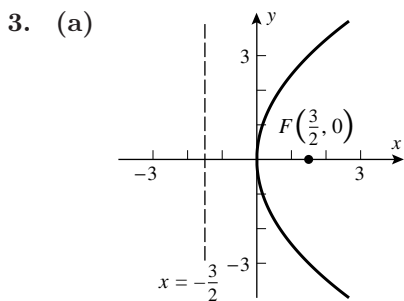

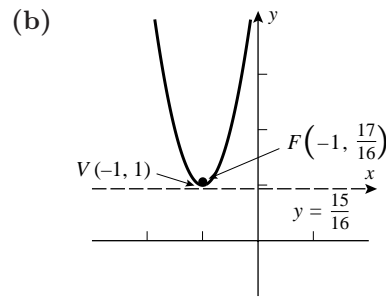
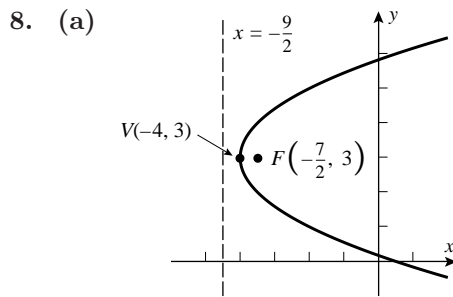
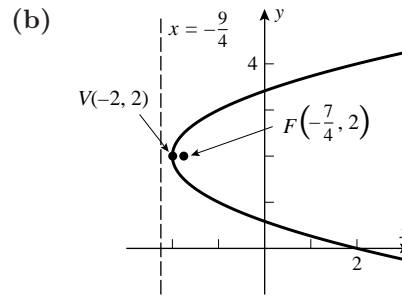
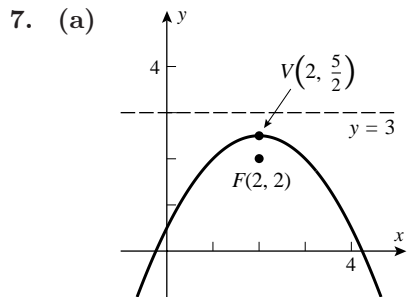
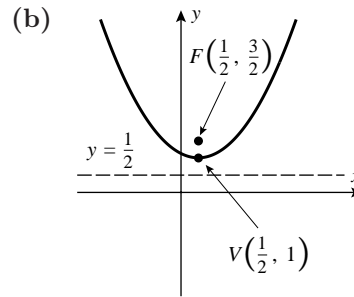
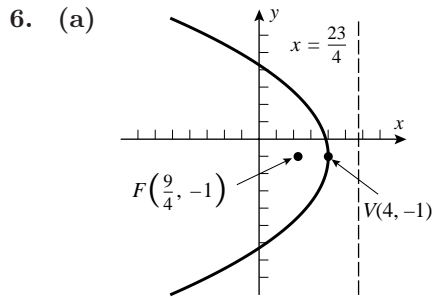
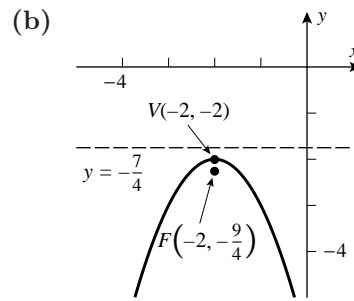
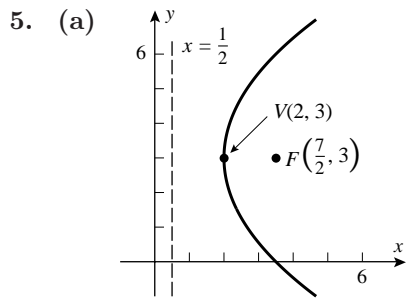

9. (a)  $c^2 = 16 - 9 = 7, c = \sqrt{7}$

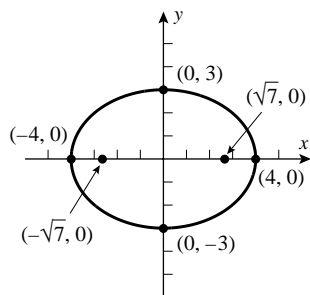

(b)  $\frac{x^2}{1} + \frac{y^2}{9} = 1$   
 $c^2 = 9 - 1 = 8, c = \sqrt{8}$

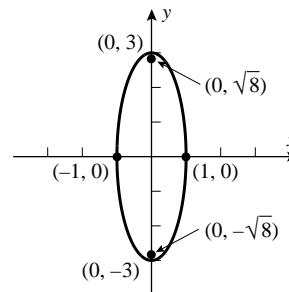



10. (a)  $c^2 = 25 - 4 = 21, c = \sqrt{21}$

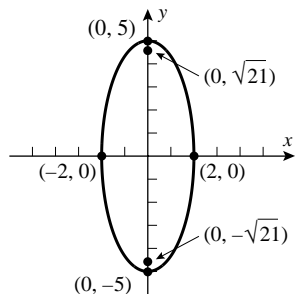

(b)  $\frac{x^2}{9} + \frac{y^2}{4} = 1$

$c^2 = 9 - 4 = 5, c = \sqrt{5}$

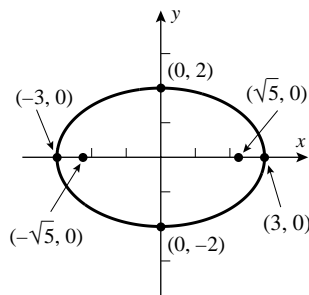

11. (a)  $\frac{(x-1)^2}{16} + \frac{(y-3)^2}{9} = 1$

$c^2 = 16 - 9 = 7, c = \sqrt{7}$

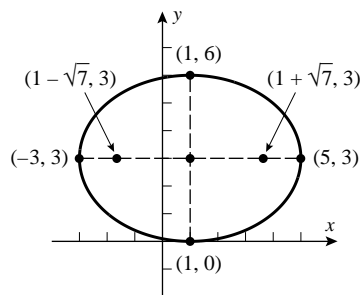

(b)  $\frac{(x+2)^2}{4} + \frac{(y+1)^2}{3} = 1$

$c^2 = 4 - 3 = 1, c = 1$

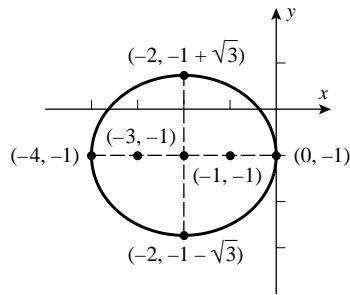

12. (a)  $\frac{(x+3)^2}{16} + \frac{(y-5)^2}{4} = 1$

$c^2 = 16 - 4 = 12, c = 2\sqrt{3}$

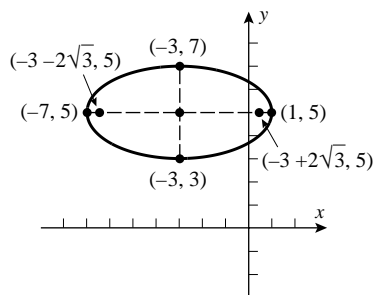

(b)  $\frac{x^2}{4} + \frac{(y+2)^2}{9} = 1$

$c^2 = 9 - 4 = 5, c = \sqrt{5}$

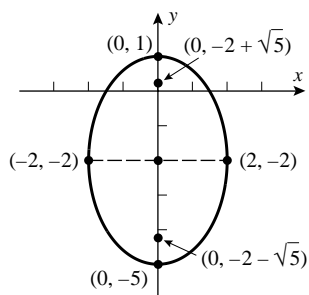

13. (a)  $\frac{(x+1)^2}{9} + \frac{(y-1)^2}{1} = 1$   
 $c^2 = 9 - 1 = 8, c = \sqrt{8}$

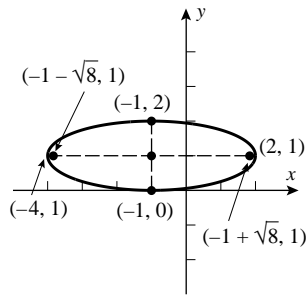

(b)  $\frac{(x+1)^2}{4} + \frac{(y-5)^2}{16} = 1$   
 $c^2 = 16 - 4 = 12, c = 2\sqrt{3}$

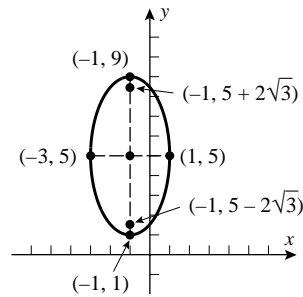

14. (a)  $\frac{(x+1)^2}{4} + \frac{(y-3)^2}{9} = 1$   
 $c^2 = 9 - 4 = 5, c = \sqrt{5}$

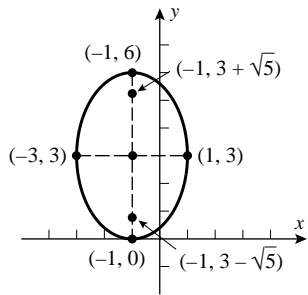

(b)  $\frac{(x-2)^2}{9} + \frac{(y+3)^2}{5} = 1$   
 $c^2 = 9 - 5 = 4, c = 2$

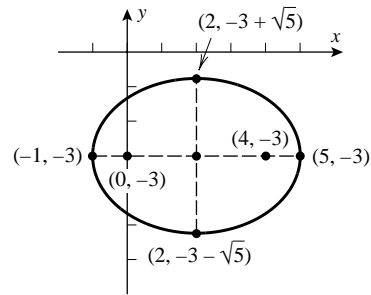

15. (a)  $c^2 = a^2 + b^2 = 16 + 4 = 20, c = 2\sqrt{5}$

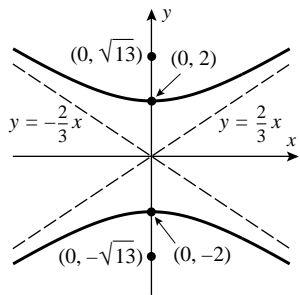

(b)  $y^2/4 - x^2/9 = 1$   
 $c^2 = 4 + 9 = 13, c = \sqrt{13}$

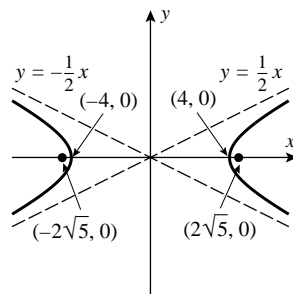

16. (a)  $c^2 = a^2 + b^2 = 9 + 25 = 34, c = \sqrt{34}$

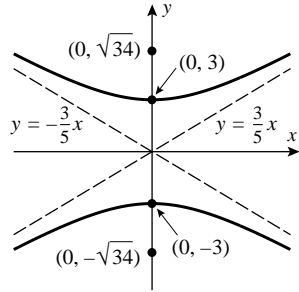

(b)  $x^2/25 - y^2/16 = 1$   
 $c^2 = 25 + 16 = 41, c = \sqrt{41}$

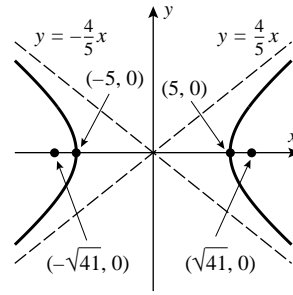

17. (a)  $c^2 = 9 + 4 = 13, c = \sqrt{13}$

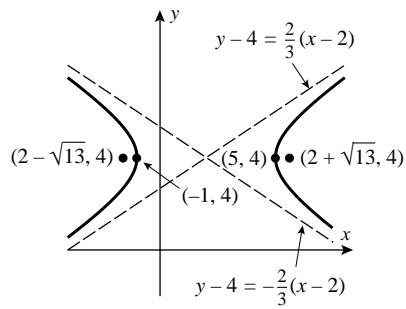

(b)  $(y + 3)^2/36 - (x + 2)^2/4 = 1$   
 $c^2 = 36 + 4 = 40, c = 2\sqrt{10}$

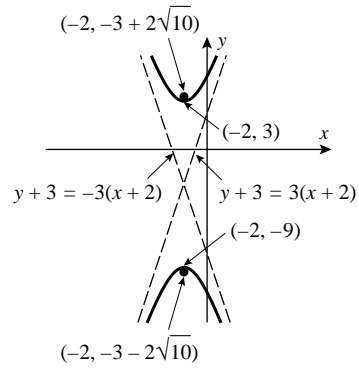

18. (a)  $c^2 = 3 + 5 = 8, c = 2\sqrt{2}$

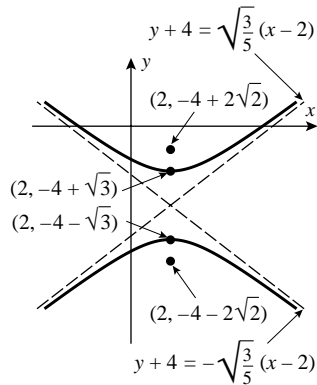

(b)  $(x + 1)^2/1 - (y - 3)^2/2 = 1$   
 $c^2 = 1 + 2 = 3, c = \sqrt{3}$

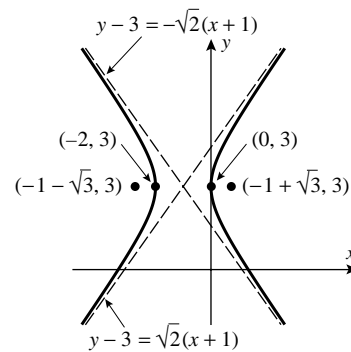

19. (a)  $(x+1)^2/4 - (y-1)^2/1 = 1$   
 $c^2 = 4 + 1 = 5, c = \sqrt{5}$

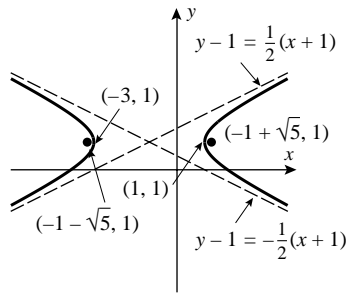

(b)  $(x-1)^2/4 - (y+3)^2/64 = 1$   
 $c^2 = 4 + 64 = 68, c = 2\sqrt{17}$

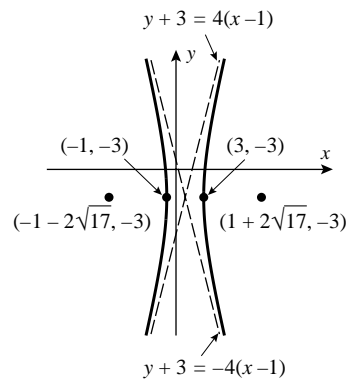

20. (a)  $(y-3)^2/4 - (x+2)^2/9 = 1$   
 $c^2 = 4 + 9 = 13, c = \sqrt{13}$

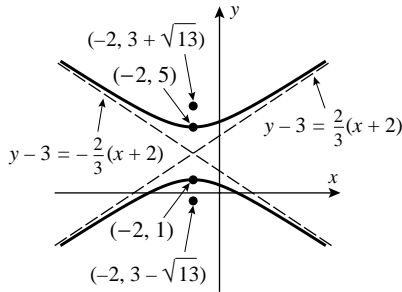

(b)  $(y+5)^2/9 - (x+2)^2/36 = 1$   
 $c^2 = 9 + 36 = 45, c = 3\sqrt{5}$

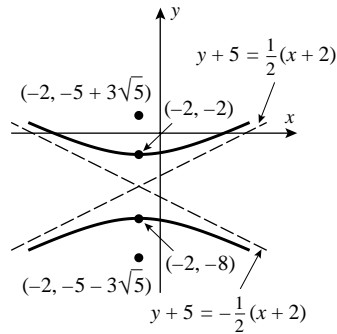

21. (a)  $y^2 = 4px, p = 3, y^2 = 12x$

(b)  $y^2 = -4px, p = 7, y^2 = -28x$

22. (a)  $x^2 = -4py, p = 4, x^2 = -16y$

(b)  $x^2 = -4py, p = 1/2, x^2 = -2y$

23. (a)  $x^2 = -4py, p = 3, x^2 = -12y$

(b) The vertex is 3 units above the directrix so  $p = 3, (x-1)^2 = 12(y-1)$ .

24. (a)  $y^2 = 4px, p = 6, y^2 = 24x$

(b) The vertex is half way between the focus and directrix so the vertex is at (2, 4), the focus is 3 units to the left of the vertex so  $p = 3, (y-4)^2 = -12(x-2)$

25.  $y^2 = a(x-h), 4 = a(3-h)$  and  $9 = a(2-h)$ , solve simultaneously to get  $h = 19/5, a = -5$  so  $y^2 = -5(x - 19/5)$

26.  $(x-5)^2 = a(y+3), (9-5)^2 = a(5+3)$  so  $a = 2, (x-5)^2 = 2(y+3)$

27. (a)  $x^2/9 + y^2/4 = 1$

(b)  $a = 26/2 = 13, c = 5, b^2 = a^2 - c^2 = 169 - 25 = 144; x^2/169 + y^2/144 = 1$

28. (a)  $x^2 + y^2/5 = 1$   
 (b)  $b = 8, c = 6, a^2 = b^2 + c^2 = 64 + 36 = 100; x^2/64 + y^2/100 = 1$
29. (a)  $c = 1, a^2 = b^2 + c^2 = 2 + 1 = 3; x^2/3 + y^2/2 = 1$   
 (b)  $b^2 = 16 - 12 = 4; x^2/16 + y^2/4 = 1$  and  $x^2/4 + y^2/16 = 1$
30. (a)  $c = 3, b^2 = a^2 - c^2 = 16 - 9 = 7; x^2/16 + y^2/7 = 1$   
 (b)  $a^2 = 9 + 16 = 25; x^2/25 + y^2/9 = 1$  and  $x^2/9 + y^2/25 = 1$
31. (a)  $a = 6, (2, 3)$  satisfies  $x^2/36 + y^2/b^2 = 1$  so  $4/36 + 9/b^2 = 1, b^2 = 81/8; x^2/36 + y^2/(81/8) = 1$   
 (b) The center is midway between the foci so it is at  $(1, 3)$ , thus  $c = 1, b = 1, a^2 = 1 + 1 = 2; (x - 1)^2 + (y - 3)^2/2 = 1$
32. (a) Substitute  $(3, 2)$  and  $(1, 6)$  into  $x^2/A + y^2/B = 1$  to get  $9/A + 4/B = 1$  and  $1/A + 36/B = 1$  which yields  $A = 10, B = 40; x^2/10 + y^2/40 = 1$   
 (b) The center is at  $(2, -1)$  thus  $c = 2, a = 3, b^2 = 9 - 4 = 5; (x - 2)^2/5 + (y + 1)^2/9 = 1$
33. (a)  $a = 2, c = 3, b^2 = 9 - 4 = 5; x^2/4 - y^2/5 = 1$   
 (b)  $a = 1, b/a = 2, b = 2; x^2 - y^2/4 = 1$
34. (a)  $a = 3, c = 5, b^2 = 25 - 9 = 16; y^2/9 - x^2/16 = 1$   
 (b)  $a = 3, a/b = 1, b = 3; y^2/9 - x^2/9 = 1$
35. (a) vertices along  $x$ -axis:  $b/a = 3/2$  so  $a = 8/3; x^2/(64/9) - y^2/16 = 1$   
 vertices along  $y$ -axis:  $a/b = 3/2$  so  $a = 6; y^2/36 - x^2/16 = 1$   
 (b)  $c = 5, a/b = 2$  and  $a^2 + b^2 = 25$ , solve to get  $a^2 = 20, b^2 = 5; y^2/20 - x^2/5 = 1$
36. (a) foci along the  $x$ -axis:  $b/a = 3/4$  and  $a^2 + b^2 = 25$ , solve to get  $a^2 = 16, b^2 = 9; x^2/16 - y^2/9 = 1$   
 foci along the  $y$ -axis:  $a/b = 3/4$  and  $a^2 + b^2 = 25$  which results in  $y^2/9 - x^2/16 = 1$   
 (b)  $c = 3, b/a = 2$  and  $a^2 + b^2 = 9$  so  $a^2 = 9/5, b^2 = 36/5; x^2/(9/5) - y^2/(36/5) = 1$
37. (a) the center is at  $(6, 4), a = 4, c = 5, b^2 = 25 - 16 = 9; (x - 6)^2/16 - (y - 4)^2/9 = 1$   
 (b) The asymptotes intersect at  $(1/2, 2)$  which is the center,  $(y - 2)^2/a^2 - (x - 1/2)^2/b^2 = 1$  is the form of the equation because  $(0, 0)$  is below both asymptotes,  $4/a^2 - (1/4)/b^2 = 1$  and  $a/b = 2$  which yields  $a^2 = 3, b^2 = 3/4; (y - 2)^2/3 - (x - 1/2)^2/(3/4) = 1$ .
38. (a) the center is at  $(1, -2); a = 2, c = 10, b^2 = 100 - 4 = 96; (y + 2)^2/4 - (x - 1)^2/96 = 1$   
 (b) the center is at  $(1, -1); 2a = 5 - (-3) = 8, a = 4, \frac{(x - 1)^2}{16} - \frac{(y + 1)^2}{16} = 1$
39. (a)  $y = ax^2 + b, (20, 0)$  and  $(10, 12)$  are on the curve so  $400a + b = 0$  and  $100a + b = 12$ . Solve for  $b$  to get  $b = 16$  ft = height of arch.  
 (b)  $\frac{x^2}{a^2} + \frac{y^2}{b^2} = 1, 400 = a^2, a = 20; \frac{100}{400} + \frac{144}{b^2} = 1,$   
 $b = 8\sqrt{3}$  ft = height of arch.

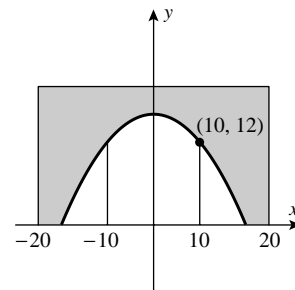

40. (a)  $(x - b/2)^2 = a(y - h)$ , but  $(0, 0)$  is on the parabola so  $b^2/4 = -ah$ ,  $a = -\frac{b^2}{4h}$ ,  
 $(x - b/2)^2 = -\frac{b^2}{4h}(y - h)$

(b) As in part (a),  $y = -\frac{4h}{b^2}(x - b/2)^2 + h$ ,  $A = \int_0^b \left[ -\frac{4h}{b^2}(x - b/2)^2 + h \right] dx = \frac{2}{3}bh$

41. We may assume that the vertex is  $(0, 0)$  and the parabola opens to the right. Let  $P(x_0, y_0)$  be a point on the parabola  $y^2 = 4px$ , then by the definition of a parabola,  $PF =$  distance from  $P$  to directrix  $x = -p$ , so  $PF = x_0 + p$  where  $x_0 \geq 0$  and  $PF$  is a minimum when  $x_0 = 0$  (the vertex).

42. Let  $p =$  distance (in millions of miles) between the vertex (closest point) and the focus  $F$ , then  $PD = PF$ ,  $2p + 20 = 40$ ,  $p = 10$  million miles.

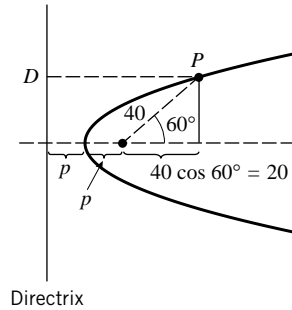

43. Use an  $xy$ -coordinate system so that  $y^2 = 4px$  is an equation of the parabola, then  $(1, 1/2)$  is a point on the curve so  $(1/2)^2 = 4p(1)$ ,  $p = 1/16$ . The light source should be placed at the focus which is  $1/16$  ft. from the vertex.

44. (a) Substitute  $x^2 = y/2$  into  $y^2 - 8x^2 = 5$  to get  $y^2 - 4y - 5 = 0$ ;  $y = -1, 5$ . Use  $x^2 = y/2$  to find that there is no solution if  $y = -1$  and that  $x = \pm\sqrt{5/2}$  if  $y = 5$ . The curves intersect at  $(\sqrt{5/2}, 5)$  and  $(-\sqrt{5/2}, 5)$ , and thus the area is

$$A = 2 \int_0^{\sqrt{5/2}} (\sqrt{5 + 8x^2} - \sqrt{2x}) dx$$

$$= \frac{5\sqrt{2}}{2}(\sqrt{5} - 1) + \frac{5}{4}\sqrt{2} \ln(2 + \sqrt{5})$$

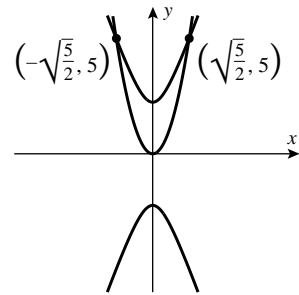

(b) Eliminate  $x$  to get  $y^2 = 1$ ,  $y = \pm 1$ . Use either equation to find that  $x = \pm 2$  if  $y = 1$  or if  $y = -1$ . The curves intersect at  $(2, 1)$ ,  $(2, -1)$ ,  $(-2, 1)$ , and  $(-2, -1)$ , and thus the area is

$$A = 4 \int_0^{\sqrt{5/3}} \frac{1}{3} \sqrt{1 + 2x^2} dx$$

$$+ 4 \int_{\sqrt{5/3}}^2 \left[ \frac{1}{3} \sqrt{1 + 2x^2} - \frac{1}{\sqrt{7}} \sqrt{3x^2 - 5} \right] dx$$

$$= \frac{1}{3} \sqrt{2} \ln(2\sqrt{2} + 3) + \frac{10}{21} \sqrt{21} \ln(2\sqrt{3} + \sqrt{7}) - \frac{5}{21} \ln 5$$

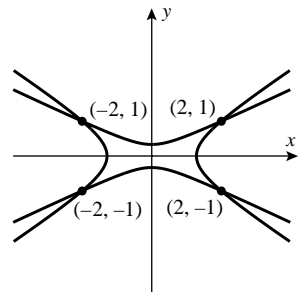

- (c) Add both equations to get  $x^2 = 4$ ,  $x = \pm 2$ .  
 Use either equation to find that  $y = \pm\sqrt{3}$  if  $x = 2$   
 or if  $x = -2$ . The curves intersect at  
 $(2, \sqrt{3})$ ,  $(2, -\sqrt{3})$ ,  $(-2, \sqrt{3})$ ,  $(-2, -\sqrt{3})$  and thus

$$A = 4 \int_0^1 \sqrt{7-x^2} dx + 4 \int_1^2 [\sqrt{7-x^2} - \sqrt{x^2-1}] dx$$

$$= 4\sqrt{3} + 14 \sin^{-1} \left( \frac{2}{7}\sqrt{7} \right) - 4\sqrt{3} + 2 \ln(2 + \sqrt{3})$$

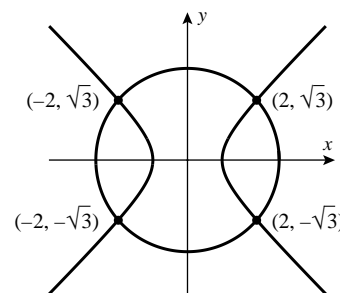

45. (a)  $P : (b \cos t, b \sin t)$ ;  $Q : (a \cos t, a \sin t)$ ;  $R : (a \cos t, b \sin t)$   
 (b) For a circle,  $t$  measures the angle between the positive  $x$ -axis and the line segment joining the origin to the point. For an ellipse,  $t$  measures the angle between the  $x$ -axis and  $OPQ$ , not  $OR$ .

46. (a) For any point  $(x, y)$ , the equation  $y = b \sinh t$  has a unique solution  $t$ ,  $-\infty < t < +\infty$ . On the hyperbola,  
 $\frac{x^2}{a^2} = 1 + \frac{y^2}{b^2} = 1 + \sinh^2 t$   
 $= \cosh^2 t$ , so  $x = \pm a \cosh t$ .

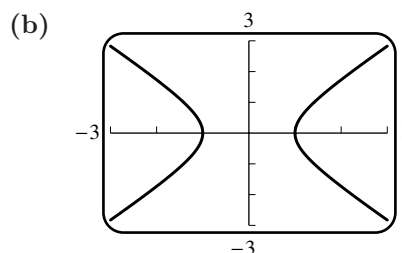

47. (a) For any point  $(x, y)$ , the equation  $y = b \tan t$  has a unique solution  $t$  where  $-\pi/2 < t < \pi/2$ .  
 On the hyperbola,  $\frac{x^2}{a^2} = 1 + \frac{y^2}{b^2} = 1 + \tan^2 t = \sec^2 t$ , so  $x = \pm a \sec t$ .

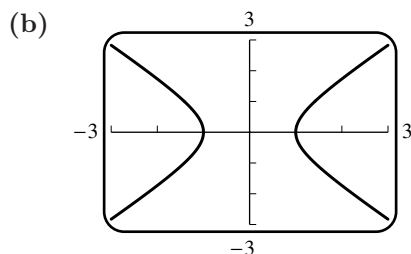

48. By Definition 12.4.1,  $(x + 1)^2 + (y - 4)^2 = (y - 1)^2$ ,  $(x + 1)^2 = 6y - 15$ ,  $(x + 1)^2 = 6(y - 5/2)$   
 49.  $(4, 1)$  and  $(4, 5)$  are the foci so the center is at  $(4, 3)$  thus  $c = 2$ ,  $a = 12/2 = 6$ ,  $b^2 = 36 - 4 = 32$ ;  
 $(x - 4)^2/32 + (y - 3)^2/36 = 1$   
 50. From the definition of a hyperbola,  $|\sqrt{(x - 1)^2 + (y - 1)^2} - \sqrt{x^2 + y^2}| = 1$ ,  
 $\sqrt{(x - 1)^2 + (y - 1)^2} - \sqrt{x^2 + y^2} = \pm 1$ , transpose the second radical to the right hand side of the  
 equation and square and simplify to get  $\pm 2\sqrt{x^2 + y^2} = -2x - 2y + 1$ , square and simplify again  
 to get  $8xy - 4x - 4y + 1 = 0$ .

51. Let the ellipse have equation  $\frac{4}{81}x^2 + \frac{y^2}{4} = 1$ , then  $A(x) = (2y)^2 = 16 \left( 1 - \frac{4x^2}{81} \right)$ ,  
 $V = 2 \int_0^{9/2} 16 \left( 1 - \frac{4x^2}{81} \right) dx = 96$

52. See Exercise 51,  $A(y) = \sqrt{3}x^2 = \sqrt{3}\frac{81}{4}\left(1 - \frac{y^2}{4}\right)$ ,  $V = \sqrt{3}\frac{81}{2}\int_0^2\left(1 - \frac{y^2}{4}\right)dy = 54\sqrt{3}$

53. Assume  $\frac{x^2}{a^2} + \frac{y^2}{b^2} = 1$ ,  $A = 4\int_0^a b\sqrt{1 - x^2/a^2} dx = \pi ab$

54. (a) Assume  $\frac{x^2}{a^2} + \frac{y^2}{b^2} = 1$ ,  $V = 2\int_0^a \pi b^2(1 - x^2/a^2) dx = \frac{4}{3}\pi ab^2$

(b) In Part (a) interchange  $a$  and  $b$  to obtain the result.

55. Assume  $\frac{x^2}{a^2} + \frac{y^2}{b^2} = 1$ ,  $\frac{dy}{dx} = -\frac{bx}{a\sqrt{a^2 - x^2}}$ ,  $1 + \left(\frac{dy}{dx}\right)^2 = \frac{a^4 - (a^2 - b^2)x^2}{a^2(a^2 - x^2)}$ ,

$$S = 2\int_0^a \frac{2\pi b}{a}\sqrt{1 - x^2/a^2}\sqrt{\frac{a^4 - (a^2 - b^2)x^2}{a^2 - x^2}} dx = 2\pi ab\left(\frac{b}{a} + \frac{a}{c}\sin^{-1}\frac{c}{a}\right), c = \sqrt{a^2 - b^2}$$

56. As in Exercise 55,  $1 + \left(\frac{dx}{dy}\right)^2 = \frac{b^4 + (a^2 - b^2)y^2}{b^2(b^2 - y^2)}$ ,

$$S = 2\int_0^b 2\pi a\sqrt{1 - y^2/b^2}\sqrt{\frac{b^4 + (a^2 - b^2)y^2}{b^2(b^2 - y^2)}} dy = 2\pi ab\left(\frac{a}{b} + \frac{b}{c}\ln\frac{a+c}{b}\right), c = \sqrt{a^2 - b^2}$$

57. Open the compass to the length of half the major axis, place the point of the compass at an end of the minor axis and draw arcs that cross the major axis to both sides of the center of the ellipse. Place the tacks where the arcs intersect the major axis.

58. Let  $P$  denote the pencil tip, and let  $R(x, 0)$  be the point below  $Q$  and  $P$  which lies on the line  $L$ . Then  $QP + PF$  is the length of the string and  $QR = QP + PR$  is the length of the side of the triangle. These two are equal, so  $PF = PR$ . But this is the definition of a parabola according to Definition 12.4.1.

59. Let  $P$  denote the pencil tip, and let  $k$  be the difference between the length of the ruler and that of the string. Then  $QP + PF_2 + k = QF_1$ , and hence  $PF_2 + k = PF_1$ ,  $PF_1 - PF_2 = k$ . But this is the definition of a hyperbola according to Definition 12.4.3.

60. In the  $x'y'$ -plane an equation of the circle is  $x'^2 + y'^2 = r^2$  where  $r$  is the radius of the cylinder. Let  $P(x, y)$  be a point on the curve in the  $xy$ -plane, then  $x' = x \cos \theta$  and  $y' = y \sin \theta$  so  $x^2 \cos^2 \theta + y^2 \sin^2 \theta = r^2$  which is an equation of an ellipse in the  $xy$ -plane.

61.  $L = 2a = \sqrt{D^2 + p^2 D^2} = D\sqrt{1 + p^2}$  (see figure), so  $a = \frac{1}{2}D\sqrt{1 + p^2}$ , but  $b = \frac{1}{2}D$ ,

$$T = c = \sqrt{a^2 - b^2} = \sqrt{\frac{1}{4}D^2(1 + p^2) - \frac{1}{4}D^2} = \frac{1}{2}pD.$$

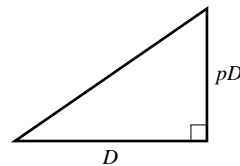

62.  $y = \frac{1}{4p}x^2$ ,  $dy/dx = \frac{1}{2p}x$ ,  $dy/dx|_{x=x_0} = \frac{1}{2p}x_0$ , the tangent line at  $(x_0, y_0)$  has the formula

$$y - y_0 = \frac{x_0}{2p}(x - x_0) = \frac{x_0}{2p}x - \frac{x_0^2}{2p}, \text{ but } \frac{x_0^2}{2p} = 2y_0 \text{ because } (x_0, y_0) \text{ is on the parabola } y = \frac{1}{4p}x^2.$$

Thus the tangent line is  $y - y_0 = \frac{x_0}{2p}x - 2y_0$ ,  $y = \frac{x_0}{2p}x - y_0$ .



63. By implicit differentiation,  $\left. \frac{dy}{dx} \right|_{(x_0, y_0)} = -\frac{b^2 x_0}{a^2 y_0}$  if  $y_0 \neq 0$ , the tangent line is
- $$y - y_0 = -\frac{b^2 x_0}{a^2 y_0}(x - x_0), \quad a^2 y_0 y - a^2 y_0^2 = -b^2 x_0 x + b^2 x_0^2, \quad b^2 x_0 x + a^2 y_0 y = b^2 x_0^2 + a^2 y_0^2,$$
- but  $(x_0, y_0)$  is on the ellipse so  $b^2 x_0^2 + a^2 y_0^2 = a^2 b^2$ ; thus the tangent line is  $b^2 x_0 x + a^2 y_0 y = a^2 b^2$ ,  $x_0 x/a^2 + y_0 y/b^2 = 1$ . If  $y_0 = 0$  then  $x_0 = \pm a$  and the tangent lines are  $x = \pm a$  which also follows from  $x_0 x/a^2 + y_0 y/b^2 = 1$ .
64. By implicit differentiation,  $\left. \frac{dy}{dx} \right|_{(x_0, y_0)} = \frac{b^2 x_0}{a^2 y_0}$  if  $y_0 \neq 0$ , the tangent line is  $y - y_0 = \frac{b^2 x_0}{a^2 y_0}(x - x_0)$ ,
- $$b^2 x_0 x - a^2 y_0 y = b^2 x_0^2 - a^2 y_0^2 = a^2 b^2, \quad x_0 x/a^2 - y_0 y/b^2 = 1. \quad \text{If } y_0 = 0 \text{ then } x_0 = \pm a \text{ and the tangent lines are } x = \pm a \text{ which also follow from } x_0 x/a^2 - y_0 y/b^2 = 1.$$
65. Use  $\frac{x^2}{a^2} + \frac{y^2}{b^2} = 1$  and  $\frac{x^2}{A^2} - \frac{y^2}{B^2} = 1$  as the equations of the ellipse and hyperbola. If  $(x_0, y_0)$  is a point of intersection then  $\frac{x_0^2}{a^2} + \frac{y_0^2}{b^2} = 1 = \frac{x_0^2}{A^2} - \frac{y_0^2}{B^2}$ , so  $x_0^2 \left( \frac{1}{A^2} - \frac{1}{a^2} \right) = y_0^2 \left( \frac{1}{B^2} + \frac{1}{b^2} \right)$  and  $a^2 A^2 y_0^2 (b^2 + B^2) = b^2 B^2 x_0^2 (a^2 - A^2)$ . Since the conics have the same foci,  $a^2 - b^2 = c^2 = A^2 + B^2$ , so  $a^2 - A^2 = b^2 + B^2$ . Hence  $a^2 A^2 y_0^2 = b^2 B^2 x_0^2$ . From Exercises 63 and 64, the slopes of the tangent lines are  $-\frac{b^2 x_0}{a^2 y_0}$  and  $\frac{B^2 x_0}{A^2 y_0}$ , whose product is  $-\frac{b^2 B^2 x_0^2}{a^2 A^2 y_0^2} = -1$ . Hence the tangent lines are perpendicular.
66. Use implicit differentiation on  $x^2 + 4y^2 = 8$  to get  $\left. \frac{dy}{dx} \right|_{(x_0, y_0)} = -\frac{x_0}{4y_0}$  where  $(x_0, y_0)$  is the point of tangency, but  $-x_0/(4y_0) = -1/2$  because the slope of the line is  $-1/2$  so  $x_0 = 2y_0$ .  $(x_0, y_0)$  is on the ellipse so  $x_0^2 + 4y_0^2 = 8$  which when solved with  $x_0 = 2y_0$  yields the points of tangency  $(2, 1)$  and  $(-2, -1)$ . Substitute these into the equation of the line to get  $k = \pm 4$ .
67. Let  $(x_0, y_0)$  be such a point. The foci are at  $(-\sqrt{5}, 0)$  and  $(\sqrt{5}, 0)$ , the lines are perpendicular if the product of their slopes is  $-1$  so  $\frac{y_0}{x_0 + \sqrt{5}} \cdot \frac{y_0}{x_0 - \sqrt{5}} = -1$ ,  $y_0^2 = 5 - x_0^2$  and  $4x_0^2 - y_0^2 = 4$ . Solve to get  $x_0 = \pm 3/\sqrt{5}$ ,  $y_0 = \pm 4/\sqrt{5}$ . The coordinates are  $(\pm 3/\sqrt{5}, 4/\sqrt{5})$ ,  $(\pm 3/\sqrt{5}, -4/\sqrt{5})$ .
68. Let  $(x_0, y_0)$  be one of the points; then  $\left. \frac{dy}{dx} \right|_{(x_0, y_0)} = 4x_0/y_0$ , the tangent line is  $y = (4x_0/y_0)x + 4$ , but  $(x_0, y_0)$  is on both the line and the curve which leads to  $4x_0^2 - y_0^2 + 4y_0 = 0$  and  $4x_0^2 - y_0^2 = 36$ , solve to get  $x_0 = \pm 3\sqrt{13}/2$ ,  $y_0 = -9$ .
69. Let  $d_1$  and  $d_2$  be the distances of the first and second observers, respectively, from the point where the gun was fired. Then  $t = (\text{time for sound to reach the second observer}) - (\text{time for sound to reach the first observer}) = d_2/v - d_1/v$  so  $d_2 - d_1 = vt$ . For constant  $v$  and  $t$  the difference of distances,  $d_2$  and  $d_1$  is constant so the gun was fired somewhere on a branch of a hyperbola whose foci are where the observers are. Since  $d_2 - d_1 = 2a$ ,  $a = \frac{vt}{2}$ ,  $b^2 = c^2 - \frac{v^2 t^2}{4}$ , and  $\frac{x^2}{v^2 t^2/4} - \frac{y^2}{c^2 - (v^2 t^2/4)} = 1$ .
70. As in Exercise 69,  $d_2 - d_1 = 2a = vt = 299,792,458 \times 10^{-7}$ ,  $a^2 = (vt/2)^2 \approx 224.6888$ ;  $c^2 = (50)^2 = 2500$ ,  $b^2 = c^2 - a^2 \approx 2275.3112$ ,  $\frac{x^2}{224.6888} - \frac{y^2}{2275.3112} = 1$ . But  $y = 200$  km, so  $x \approx 64.6$  km.

71. (a) Use  $\frac{x^2}{9} + \frac{y^2}{4} = 1$ ,  $x = \frac{3}{2}\sqrt{4-y^2}$ ,

$$V = \int_{-2}^{-2+h} (2)(3/2)\sqrt{4-y^2}(18)dy = 54 \int_{-2}^{-2+h} \sqrt{4-y^2} dy$$

$$= 54 \left[ \frac{y}{2}\sqrt{4-y^2} + 2\sin^{-1}\frac{y}{2} \right]_{-2}^{-2+h} = 27 \left[ 4\sin^{-1}\frac{h-2}{2} + (h-2)\sqrt{4h-h^2} + 2\pi \right] \text{ ft}^3$$

(b) When  $h = 4$  ft,  $V_{\text{full}} = 108\sin^{-1}1 + 54\pi = 108\pi \text{ ft}^3$ , so solve for  $h$  when  $V = (k/4)V_{\text{full}}$ ,  $k = 1, 2, 3$ , to get  $h = 1.19205, 2, 2.80795$  ft or  $14.30465, 24, 33.69535$  in.

72. We may assume  $A > 0$ , since if  $A < 0$  then one can multiply the equation by  $-1$ , and if  $A = 0$  then one can exchange  $A$  with  $C$  ( $C$  cannot be zero simultaneously with  $A$ ). Then

$$Ax^2 + Cy^2 + Dx + Ey + F = A \left( x + \frac{D}{2A} \right)^2 + C \left( y + \frac{E}{2C} \right)^2 + F - \frac{D^2}{4A} - \frac{E^2}{4C} = 0.$$

(a) Let  $AC > 0$ . If  $F < \frac{D^2}{4A} + \frac{E^2}{4C}$  the equation represents an ellipse (a circle if  $A = C$ ); if  $F = \frac{D^2}{4A} + \frac{E^2}{4C}$ , the point  $x = -D/(2A), y = -E/(2C)$ ; and if  $F > \frac{D^2}{4A} + \frac{E^2}{4C}$  then there is no graph.

(b) If  $AC < 0$  and  $F = \frac{D^2}{4A} + \frac{E^2}{4C}$ , then

$$\left[ \sqrt{A} \left( x + \frac{D}{2A} \right) + \sqrt{-C} \left( y + \frac{E}{2C} \right) \right] \left[ \sqrt{A} \left( x + \frac{D}{2A} \right) - \sqrt{-C} \left( y + \frac{E}{2C} \right) \right] = 0, \text{ a pair of lines;}$$

otherwise a hyperbola

(c) Assume  $C = 0$ , so  $Ax^2 + Dx + Ey + F = 0$ . If  $E \neq 0$ , parabola; if  $E = 0$  then  $Ax^2 + Dx + F = 0$ . If this polynomial has roots  $x = x_1, x_2$  with  $x_1 \neq x_2$  then a pair of parallel lines; if  $x_1 = x_2$  then one line; if no roots, then no graph. If  $A = 0, C \neq 0$  then a similar argument applies.

73. (a)  $(x-1)^2 - 5(y+1)^2 = 5$ , hyperbola

(b)  $x^2 - 3(y+1)^2 = 0, x = \pm\sqrt{3}(y+1)$ , two lines

(c)  $4(x+2)^2 + 8(y+1)^2 = 4$ , ellipse

(d)  $3(x+2)^2 + (y+1)^2 = 0$ , the point  $(-2, -1)$  (degenerate case)

(e)  $(x+4)^2 + 2y = 2$ , parabola

(f)  $5(x+4)^2 + 2y = -14$ , parabola

74. distance from the point  $(x, y)$  to the focus  $(0, p) =$  distance to the directrix  $y = -p$ , so  $x^2 + (y-p)^2 = (y+p)^2, x^2 = 4py$

75. distance from the point  $(x, y)$  to the focus  $(0, -c)$  plus distance to the focus  $(0, c) = \text{const} = 2a$ ,

$$\sqrt{x^2 + (y+c)^2} + \sqrt{x^2 + (y-c)^2} = 2a, x^2 + (y+c)^2 = 4a^2 + x^2 + (y-c)^2 - 4a\sqrt{x^2 + (y-c)^2},$$

$$\sqrt{x^2 + (y-c)^2} = a - \frac{c}{a}y, \text{ and since } a^2 - c^2 = b^2, \frac{x^2}{b^2} + \frac{y^2}{a^2} = 1$$

76. distance from the point  $(x, y)$  to the focus  $(-c, 0)$  less distance to the focus  $(c, 0)$  is equal to  $2a$ ,

$$\sqrt{(x+c)^2 + y^2} - \sqrt{(x-c)^2 + y^2} = \pm 2a, (x+c)^2 + y^2 = (x-c)^2 + y^2 + 4a^2 \pm 4a\sqrt{(x-c)^2 + y^2},$$

$$\sqrt{(x-c)^2 + y^2} = \pm \left( \frac{cx}{a} - a \right), \text{ and, since } c^2 - a^2 = b^2, \frac{x^2}{a^2} - \frac{y^2}{b^2} = 1$$

**EXERCISE SET 12.5**

1. (a)  $r = \frac{3/2}{1 - \cos \theta}, e = 1, d = 3/2$

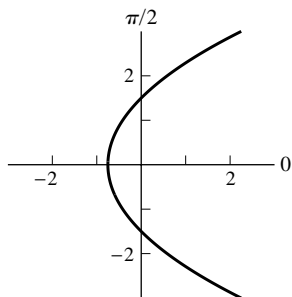

(b)  $r = \frac{3/2}{1 + \frac{1}{2} \sin \theta}, e = 1/2, d = 3$

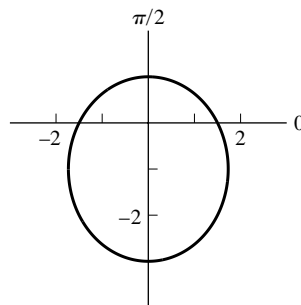

(c)  $r = \frac{2}{1 + \frac{3}{2} \cos \theta}, e = 3/2, d = 4/3$

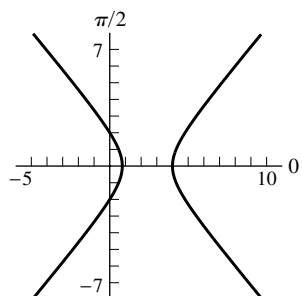

(d)  $r = \frac{5/3}{1 + \sin \theta}, e = 1, d = 5/3$

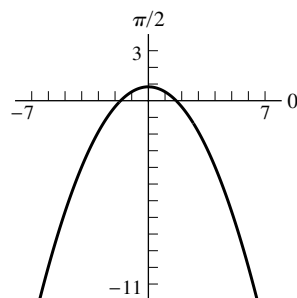

2. (a)  $r = \frac{4/3}{1 - \frac{2}{3} \cos \theta}, e = 2/3, d = 2$

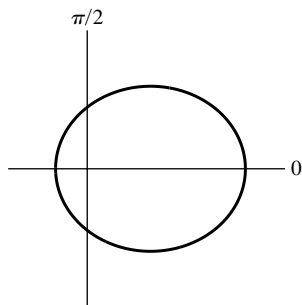

(b)  $r = \frac{1}{1 - \frac{4}{3} \sin \theta}, e = 4/3, d = 3/4$

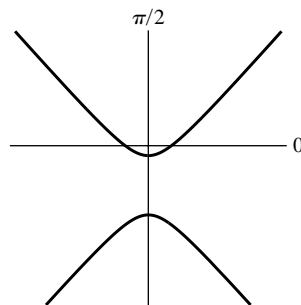

(c)  $r = \frac{1/3}{1 + \sin \theta}, e = 1, d = 1/3$

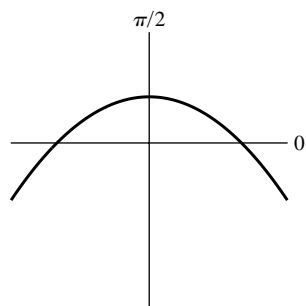

(d)  $r = \frac{1/2}{1 + 3 \sin \theta}, e = 3, d = 1/6$

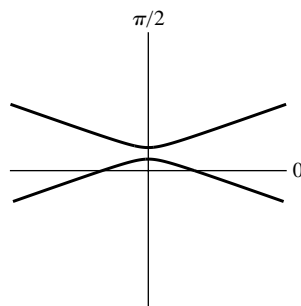

3. (a)  $e = 1, d = 8$ , parabola, opens up

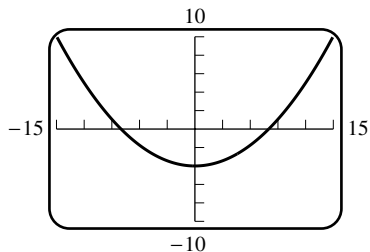

- (c)  $r = \frac{2}{1 - \frac{3}{2} \sin \theta}, e = 3/2, d = 4/3$ ,

hyperbola, directrix  $4/3$  units below the pole

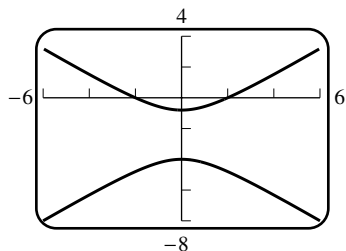

4. (a)  $e = 1, d = 15$ , parabola, opens left

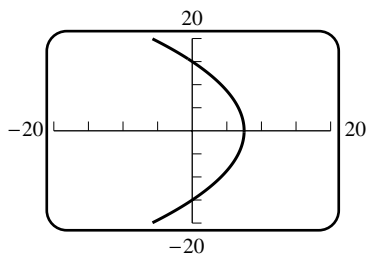

- (c)  $r = \frac{64/7}{1 - \frac{12}{7} \sin \theta}, e = 12/7, d = 16/3$ ,

hyperbola, directrix  $16/3$  units below pole

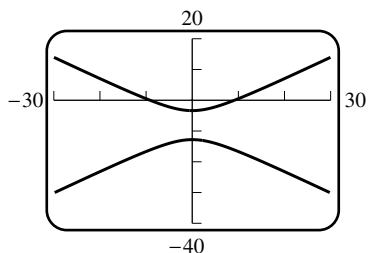

- (b)  $r = \frac{4}{1 + \frac{3}{4} \sin \theta}, e = 3/4, d = 16/3$ ,

ellipse, directrix  $16/3$  units above the pole

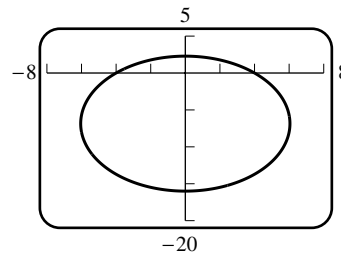

- (d)  $r = \frac{3}{1 + \frac{1}{4} \cos \theta}, e = 1/4, d = 12$ ,

ellipse, directrix 12 units to the right of the pole

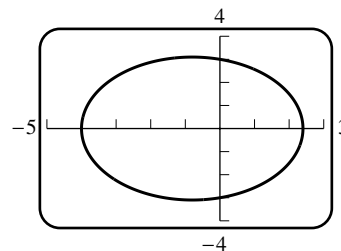

- (b)  $r = \frac{2/3}{1 + \cos \theta}, e = 1,$

$d = 2/3$ , parabola, opens left

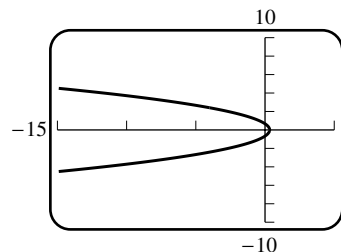

- (d)  $r = \frac{4}{1 - \frac{2}{3} \cos \theta}, e = 2/3, d = 6$ ,

ellipse, directrix 6 units left of the pole

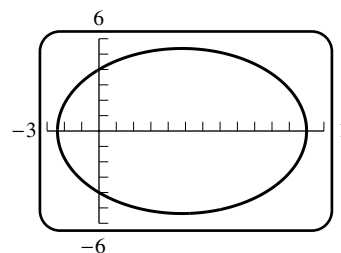

5. (a)  $d = 1, r = \frac{ed}{1 + e \cos \theta} = \frac{2/3}{1 + \frac{2}{3} \cos \theta} = \frac{2}{3 + 2 \cos \theta}$
- (b)  $e = 1, d = 1, r = \frac{ed}{1 - e \cos \theta} = \frac{1}{1 - \cos \theta}$
- (c)  $e = 3/2, d = 1, r = \frac{ed}{1 + e \sin \theta} = \frac{3/2}{1 + \frac{3}{2} \sin \theta} = \frac{3}{2 + 3 \sin \theta}$
6. (a)  $e = 2/3, d = 1, r = \frac{ed}{1 - e \sin \theta} = \frac{2/3}{1 - \frac{2}{3} \sin \theta} = \frac{2}{3 - 2 \sin \theta}$
- (b)  $e = 1, d = 1, r = \frac{ed}{1 + e \sin \theta} = \frac{1}{1 + \sin \theta}$
- (c)  $e = 4/3, d = 1, r = \frac{ed}{1 - e \cos \theta} = \frac{4/3}{1 - \frac{4}{3} \cos \theta} = \frac{4}{3 - 4 \cos \theta}$
7. (a)  $r = \frac{ed}{1 \pm e \cos \theta}, \theta = 0 : 6 = \frac{ed}{1 \pm e}, \theta = \pi : 4 = \frac{ed}{1 \mp e}, 6 \pm 6e = 4 \mp 4e, 2 = \mp 10e$ , use bottom sign to get  $e = 1/5, d = 24, r = \frac{24/5}{1 - \cos \theta} = \frac{24}{5 - 5 \cos \theta}$
- (b)  $e = 1, r = \frac{d}{1 - \sin \theta}, 1 = \frac{d}{2}, d = 2, r = \frac{2}{1 - \sin \theta}$
- (c)  $r = \frac{ed}{1 \pm e \sin \theta}, \theta = \pi/2 : 3 = \frac{ed}{1 \pm e}, \theta = 3\pi/2 : -7 = \frac{ed}{1 \mp e}, ed = 3 \pm 3e = -7 \pm 7e, 10 = \pm 4e$ ,  
 $e = 5/2, d = 21/5, r = \frac{21/2}{1 + (5/2) \sin \theta} = \frac{21}{2 + 5 \sin \theta}$
8. (a)  $r = \frac{ed}{1 \pm e \sin \theta}, 1 = \frac{ed}{1 \pm e}, 4 = \frac{ed}{1 \mp e}, 1 \pm e = 4 \mp 4e$ , upper sign yields  $e = 3/5, d = 8/3$ ,  
 $r = \frac{8/5}{1 + \frac{3}{5} \sin \theta} = \frac{8}{5 + 3 \sin \theta}$
- (b)  $e = 1, r = \frac{d}{1 - \cos \theta}, 3 = \frac{d}{2}, d = 6, r = \frac{6}{1 - \cos \theta}$
- (c)  $a = b = 5, e = c/a = \sqrt{50}/5 = \sqrt{2}, r = \frac{\sqrt{2}d}{1 + \sqrt{2} \cos \theta}; r = 5$  when  $\theta = 0$ , so  $d = 5 + \frac{5}{\sqrt{2}}$ ,  
 $r = \frac{5\sqrt{2} + 5}{1 + \sqrt{2} \cos \theta}$ .
9. (a)  $r = \frac{3}{1 + \frac{1}{2} \sin \theta}, e = 1/2, d = 6$ , directrix 6 units above pole; if  $\theta = \pi/2 : r_0 = 2$ ;  
 if  $\theta = 3\pi/2 : r_1 = 6, a = (r_0 + r_1)/2 = 4, b = \sqrt{r_0 r_1} = 2\sqrt{3}$ , center  $(0, -2)$  (rectangular coordinates),  $\frac{x^2}{12} + \frac{(y+2)^2}{16} = 1$
- (b)  $r = \frac{1/2}{1 - \frac{1}{2} \cos \theta}, e = 1/2, d = 1$ , directrix 1/2 unit left of pole; if  $\theta = \pi : r_0 = \frac{1/2}{3/2} = 1/3$ ;  
 if  $\theta = 0 : r_1 = 1, a = 2/3, b = 1/\sqrt{3}$ , center  $= (1/3, 0)$  (rectangular coordinates),  
 $\frac{9}{4}(x - 1/3)^2 + 3y^2 = 1$

10. (a)  $r = \frac{6/5}{1 + \frac{2}{5} \cos \theta}$ ,  $e = 2/5$ ,  $d = 3$ , directrix 3 units right of pole, if  $\theta = 0 : r_0 = 6/7$ ,  
 if  $\theta = \pi : r_1 = 2$ ,  $a = 10/7$ ,  $b = 2\sqrt{3}/\sqrt{7}$ , center  $(-4/7, 0)$  (rectangular coordinates),  
 $\frac{49}{100}(x + 4/7)^2 + \frac{7}{12}y^2 = 1$
- (b)  $r = \frac{2}{1 - \frac{3}{4} \sin \theta}$ ,  $e = 3/4$ ,  $d = 8/3$ , directrix  $8/3$  units below pole, if  $\theta = 3\pi/2 : r_0 = 8/7$ ,  
 if  $\theta = \pi/2 : r_1 = 8$ ,  $a = 32/7$ ,  $b = 8/\sqrt{7}$ , center:  $(0, 24/7)$  (rectangular coordinates),  
 $\frac{7}{64}x^2 + \frac{49}{1024} \left(y - \frac{24}{7}\right)^2 = 1$
11. (a)  $r = \frac{2}{1 + 3 \sin \theta}$ ,  $e = 3$ ,  $d = 2/3$ , hyperbola, directrix  $2/3$  units above pole, if  $\theta = \pi/2 :$   
 $r_0 = 1/2; \theta = 3\pi/2 : r_1 = 1$ , center  $(0, 3/4)$ ,  $a = 1/4$ ,  $b = 1/\sqrt{2}$ ,  $-2x^2 + 16 \left(y - \frac{3}{4}\right)^2 = 1$
- (b)  $r = \frac{5/3}{1 - \frac{3}{2} \cos \theta}$ ,  $e = 3/2$ ,  $d = 10/9$ , hyperbola, directrix  $3/2$  units left of pole, if  $\theta = \pi :$   
 $r_0 = 2/3; \theta = 0 : r_1 = \frac{5/3}{1/2} = 10/3$ , center  $(-2, 0)$ ,  $a = 4/3$ ,  $b = \sqrt{20/9}$ ,  $\frac{9}{16}(x+2)^2 - \frac{9}{20}y^2 = 1$
12. (a)  $r = \frac{4}{1 - 2 \sin \theta}$ ,  $e = 2$ ,  $d = 2$ , hyperbola, directrix 2 units below pole, if  $\theta = 3\pi/2 : r_0 = 4/3;$   
 $\theta = \pi/2 : r_1 = \left| \frac{4}{1-2} \right| = 4$ , center  $(0, -8/3)$ ,  $a = 4/3$ ,  $b = 4/\sqrt{3}$ ,  $\frac{9}{16} \left(y + \frac{8}{3}\right)^2 - \frac{3}{16}x^2 = 1$
- (b)  $r = \frac{15/2}{1 + 4 \cos \theta}$ ,  $e = 4$ ,  $d = 15/8$ , hyperbola, directrix  $15/8$  units right of pole, if  $\theta = 0 :$   
 $r_0 = 3/2; \theta = \pi : r_1 = \left| -\frac{5}{2} \right| = 5/2$ ,  $a = 1/2$ ,  $b = \frac{\sqrt{15}}{2}$ , center  $(2, 0)$ ,  $4(x-2)^2 - \frac{4}{15}y^2 = 1$
13. (a)  $r = \frac{\frac{1}{2}d}{1 + \frac{1}{2} \cos \theta} = \frac{d}{2 + \cos \theta}$ , if  $\theta = 0 : r_0 = d/3; \theta = \pi, r_1 = d$ ,  
 $8 = a = \frac{1}{2}(r_1 + r_0) = \frac{2}{3}d$ ,  $d = 12$ ,  $r = \frac{12}{2 + \cos \theta}$
- (b)  $r = \frac{\frac{3}{5}d}{1 - \frac{3}{5} \sin \theta} = \frac{3d}{5 - 3 \sin \theta}$ , if  $\theta = 3\pi/2 : r_0 = \frac{3}{8}d; \theta = \pi/2, r_1 = \frac{3}{2}d$ ,  
 $4 = a = \frac{1}{2}(r_1 + r_0) = \frac{15}{16}d$ ,  $d = \frac{64}{15}$ ,  $r = \frac{3(64/15)}{5 - 3 \sin \theta} = \frac{64}{25 - 15 \sin \theta}$
- (c)  $r = \frac{\frac{3}{5}d}{1 - \frac{3}{5} \cos \theta} = \frac{3d}{5 - 3 \cos \theta}$ , if  $\theta = \pi : r_0 = \frac{3}{8}d; \theta = 0, r_1 = \frac{3}{2}d, 4 = b = \frac{3}{4}d$ ,  
 $d = 16/3$ ,  $r = \frac{16}{5 - 3 \cos \theta}$
- (d)  $\frac{\frac{1}{5}d}{1 + \frac{1}{5} \sin \theta} = \frac{d}{5 + \sin \theta}$ , if  $\theta = \pi/2 : r_0 = d/6; \theta = 3\pi/2, r_1 = d/4$ ,  
 $5 = c = \frac{1}{2}d \left( \frac{1}{4} - \frac{1}{6} \right) = \frac{1}{24}d$ ,  $d = 120$ ,  $r = \frac{120}{5 + \sin \theta}$

14. (a)  $r = \frac{\frac{1}{2}d}{1 + \frac{1}{2}\sin\theta} = \frac{d}{2 + \sin\theta}$ , if  $\theta = \pi/2 : r_0 = d/3; \theta = 3\pi/2 : r_1 = d$ ,  
 $10 = a = \frac{1}{2}(r_0 + r_1) = \frac{2}{3}d, d = 15, r = \frac{15}{2 + \sin\theta}$

(b)  $r = \frac{\frac{1}{5}d}{1 - \frac{1}{5}\cos\theta} = \frac{d}{5 - \cos\theta}$ , if  $\theta = \pi : r_0 = d/6, \theta = 0 : r_1 = d/4$ ,  
 $6 = a = \frac{1}{2}(r_1 + r_0) = \frac{1}{2}d\left(\frac{1}{4} + \frac{1}{6}\right) = \frac{5}{24}d, d = 144/5, r = \frac{144/5}{5 - \cos\theta} = \frac{144}{25 - 5\cos\theta}$

(c)  $r = \frac{\frac{3}{4}d}{1 - \frac{3}{4}\sin\theta} = \frac{3d}{4 - 3\sin\theta}$ , if  $\theta = 3\pi/2 : r_0 = \frac{3}{7}d, \theta = \pi/2 : r_1 = 3d, 4 = b = 3d/\sqrt{7}$ ,  
 $d = \frac{4}{3}\sqrt{7}, r = \frac{4\sqrt{7}}{4 - 3\sin\theta}$

(d)  $r = \frac{\frac{4}{5}d}{1 + \frac{4}{5}\cos\theta} = \frac{4d}{5 + 4\cos\theta}$ , if  $\theta = 0 : r_0 = \frac{4}{9}d; \theta = \pi : r_1 = 4d$ ,  
 $c = 10 = \frac{1}{2}(r_1 - r_0) = \frac{1}{2}d\left(4 - \frac{4}{9}\right) = \frac{16}{9}d, d = \frac{45}{8}, r = \frac{45/2}{5 + 4\cos\theta} = \frac{45}{10 + 8\cos\theta}$

15. (a)  $e = c/a = \frac{\frac{1}{2}(r_1 - r_0)}{\frac{1}{2}(r_1 + r_0)} = \frac{r_1 - r_0}{r_1 + r_0}$

(b)  $e = \frac{r_1/r_0 - 1}{r_1/r_0 + 1}, e(r_1/r_0 + 1) = r_1/r_0 - 1, \frac{r_1}{r_0} = \frac{1 + e}{1 - e}$

16. (a)  $e = c/a = \frac{\frac{1}{2}(r_1 + r_0)}{\frac{1}{2}(r_1 - r_0)} = \frac{r_1 + r_0}{r_1 - r_0}$

(b)  $e = \frac{r_1/r_0 + 1}{r_1/r_0 - 1}, e(r_1/r_0 - 1) = r_1/r_0 + 1, \frac{r_1}{r_0} = \frac{e + 1}{e - 1}$

17. (a)  $T = a^{3/2} = 39.5^{1.5} \approx 248$  yr

(b)  $r_0 = a(-e) = 39.5(1 - 0.249) = 29.6645$  AU  $\approx 4,449,675,000$  km  
 $r_1 = a(1 + e) = 39.5(1 + 0.249) = 49.3355$  AU  $\approx 7,400,325,000$  km

(c)  $r = \frac{a(1 - e^2)}{1 + e\cos\theta} \approx \frac{39.5(1 - (0.249)^2)}{1 + 0.249\cos\theta} \approx \frac{37.05}{1 + 0.249\cos\theta}$  AU

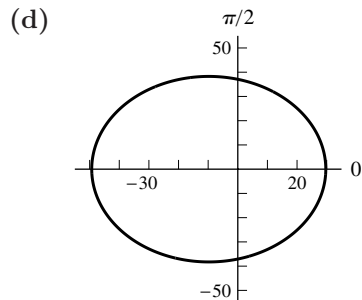

18. (a) In yr and AU,  $T = a^{3/2}$ ; in days and km,  $\frac{T}{365} = \left(\frac{a}{150 \times 10^6}\right)^{3/2}$ ,  
 so  $T = 365 \times 10^{-9} \left(\frac{a}{150}\right)^{3/2}$  days.

(b)  $T = 365 \times 10^{-9} \left( \frac{57.95 \times 10^6}{150} \right)^{3/2} \approx 87.6$  days

(c) From (17) the polar equation of the orbit has the form  $r = \frac{a(1 - e^2)}{1 + e \cos \theta} = \frac{37.82}{1 + 0.205 \cos \theta}$

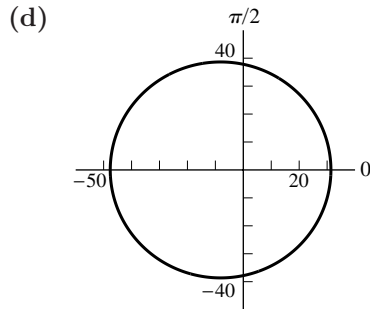

19. (a)  $a = T^{2/3} = 2380^{2/3} \approx 178.26$  AU

(b)  $r_0 = a(1 - e) \approx 0.8735$  AU,  $r_1 = a(1 + e) \approx 355.64$  AU

(c)  $r = \frac{a(1 - e^2)}{1 + e \cos \theta} \approx \frac{1.74}{1 + 0.9951 \cos \theta}$  AU

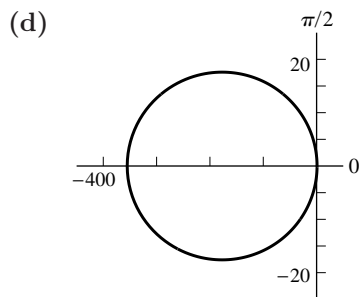

20. (a) By Exercise 15(a),  $e = \frac{r_1 - r_0}{r_1 + r_0} \approx 0.093$

(b)  $r = \frac{1}{2}(a_0 + a_1) = 225,400,000$  km  $\approx 1.503$  AU, so  $T = a^{3/2} \approx 1.84$  yr

(c)  $r = \frac{a(1 - e^2)}{1 + e \cos \theta} \approx \frac{1.49}{1 + 0.093 \cos \theta}$  AU

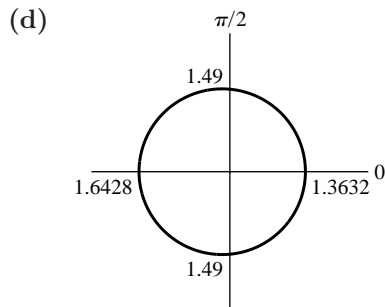

21.  $r_0 = a(1 - e) \approx 7003$  km,  $h_{\min} \approx 7003 - 6440 = 563$  km,

$r_1 = a(1 + e) \approx 10,726$  km,  $h_{\max} \approx 10,726 - 6440 = 4286$  km



22.  $r_0 = a(1 - e) \approx 651,736$  km,  $h_{\min} \approx 581,736$  km;  $r_1 = a(1 + e) \approx 6,378,102$  km,  
 $h_{\max} \approx 6,308,102$  km

23. Since the foci are fixed,  $a$  is constant; since  $e \rightarrow 0$ , the distance  $\frac{a}{e} \rightarrow +\infty$ .

Let  $d$  be the distance between the directrix and the focus, then  $d = a \left( \frac{1}{e} - e \right)$  and  $\lim_{e \rightarrow 0} d = +\infty$ ; but the center and the focus come together, so distance between the directrix and the center also tends to  $+\infty$ .

24. (a) From Figure 12.4.22,  $\frac{x^2}{a^2} - \frac{y^2}{b^2} = 1$ ,  $\frac{x^2}{a^2} - \frac{y^2}{c^2 - a^2} = 1$ ,  $(x - c)^2 + y^2 = \left( \frac{c}{a}x - a \right)^2$ ,  
 $\sqrt{(x - c)^2 + y^2} = \frac{c}{a}x - a$  for  $x > 0$ .

(b) From Part (a),  $PF = \frac{c}{a}PD$ ,  $\frac{PF}{PD} = c/a$ .

### CHAPTER 12 SUPPLEMENTARY EXERCISES

2. (a)  $(\sqrt{2}, 3\pi/4)$       (b)  $(-\sqrt{2}, 7\pi/4)$       (c)  $(\sqrt{2}, 3\pi/4)$       (d)  $(-\sqrt{2}, -\pi/4)$

3. (a) circle      (b) rose      (c) line      (d) limaçon  
 (e) limaçon      (f) none      (g) none      (h) spiral

4. (a)  $r = \frac{1/3}{1 + \frac{1}{3}\cos\theta}$ , ellipse, right of pole, distance = 1

(b) hyperbola, left of pole, distance = 1/3

(c)  $r = \frac{1/3}{1 + \sin\theta}$ , parabola, above pole, distance = 1/3

(d) parabola, below pole, distance = 3

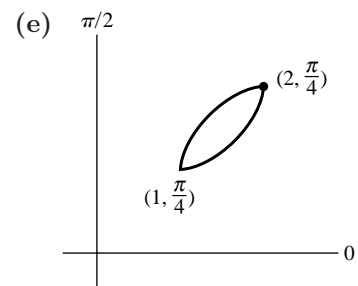
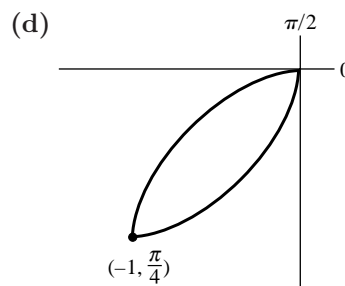
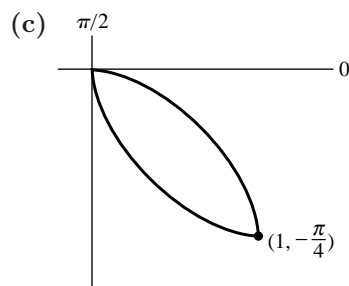
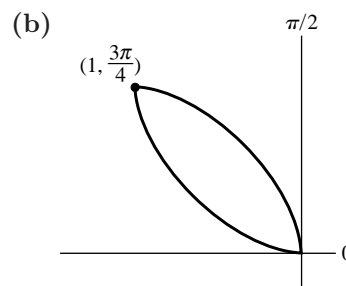
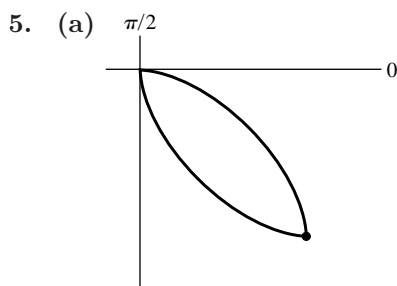

6. Family I:  $x^2 + (y - b)^2 = b^2, b < 0$ , or  $r = 2b \sin \theta$ ; Family II:  $(x - a)^2 + y^2 = a^2, a < 0$ , or  $r = 2a \cos \theta$
7. (a)  $r = 2a/(1 + \cos \theta), r + x = 2a, x^2 + y^2 = (2a - x)^2, y^2 = -4ax + 4a^2$ , parabola  
 (b)  $r^2(\cos^2 \theta - \sin^2 \theta) = x^2 - y^2 = a^2$ , hyperbola  
 (c)  $r \sin(\theta - \pi/4) = (\sqrt{2}/2)r(\sin \theta - \cos \theta) = 4, y - x = 4\sqrt{2}$ , line  
 (d)  $r^2 = 4r \cos \theta + 8r \sin \theta, x^2 + y^2 = 4x + 8y, (x - 2)^2 + (y - 4)^2 = 20$ , circle
9. (a)  $\frac{c}{a} = e = \frac{2}{7}$  and  $2b = 6, b = 3, a^2 = b^2 + c^2 = 9 + \frac{4}{49}a^2, \frac{45}{49}a^2 = 9, a = \frac{7}{\sqrt{5}}, \frac{5}{49}x^2 + \frac{1}{9}y^2 = 1$   
 (b)  $x^2 = -4py$ , directrix  $y = 4$ , focus  $(-4, 0), 2p = 8, x^2 = -16y$   
 (c) For the ellipse,  $a = 4, b = \sqrt{3}, c^2 = a^2 - b^2 = 16 - 3 = 13$ , foci  $(\pm\sqrt{13}, 0)$ ;  
 for the hyperbola,  $c = \sqrt{13}, b/a = 2/3, b = 2a/3, 13 = c^2 = a^2 + b^2 = a^2 + \frac{4}{9}a^2 = \frac{13}{9}a^2$ ,  
 $a = 3, b = 2, \frac{x^2}{9} - \frac{y^2}{4} = 1$
10. (a)  $e = 4/5 = c/a, c = 4a/5$ , but  $a = 5$  so  $c = 4, b = 3, \frac{(x + 3)^2}{25} + \frac{(y - 2)^2}{9} = 1$   
 (b) directrix  $y = 2, p = 2, (x + 2)^2 = -8y$   
 (c) center  $(-1, 5)$ , vertices  $(-1, 7)$  and  $(-1, 3), a = 2, a/b = 8, b = 1/4, \frac{(y - 5)^2}{4} - 16(x + 1)^2 = 1$

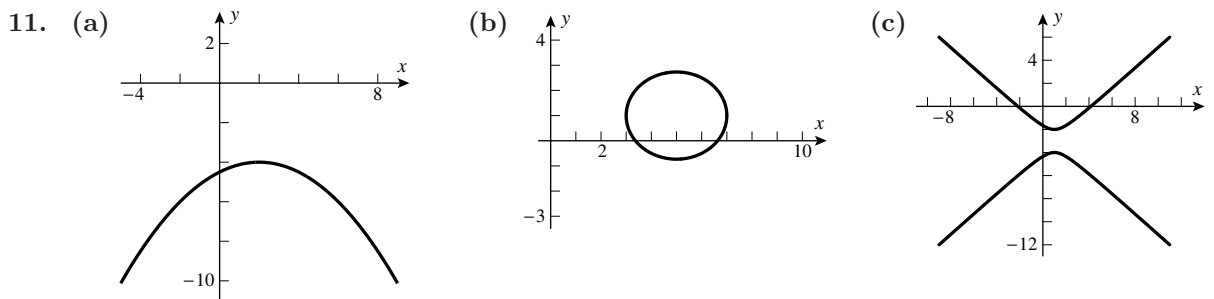

13. (a) The equation of the parabola is  $y = ax^2$  and it passes through  $(2100, 470)$ , thus  $a = \frac{470}{2100^2}$ ,  
 $y = \frac{470}{2100^2}x^2$ .
- (b)  $L = 2 \int_0^{2100} \sqrt{1 + \left(2 \frac{470}{2100^2} x\right)^2} dx \approx 4336.3$  ft
14. (a) As  $t$  runs from 0 to  $\pi$ , the upper portion of the curve is traced out from right to left; as  $t$  runs from  $\pi$  to  $2\pi$  the bottom portion of the curve is traced out from right to left. The loop occurs for  $\pi + \sin^{-1} \frac{1}{4} < t < 2\pi - \sin^{-1} \frac{1}{4}$ .
- (b)  $\lim_{t \rightarrow 0^+} x = +\infty, \lim_{t \rightarrow 0^+} y = 1; \lim_{t \rightarrow \pi^-} x = -\infty, \lim_{t \rightarrow \pi^-} y = 1; \lim_{t \rightarrow \pi^+} x = +\infty, \lim_{t \rightarrow \pi^+} y = 1;$   
 $\lim_{t \rightarrow 2\pi^-} x = -\infty, \lim_{t \rightarrow 2\pi^-} y = 1$ ; the horizontal asymptote is  $y = 1$ .
- (c) horizontal tangent line when  $dy/dx = 0$ , or  $dy/dt = 0$ , so  $\cos t = 0, t = \pi/2, 3\pi/2$ ;  
 vertical tangent line when  $dx/dt = 0$ , so  $-\csc^2 t - 4 \sin t = 0, t = \pi + \sin^{-1} \frac{1}{\sqrt{4}}, 2\pi - \sin^{-1} \frac{1}{\sqrt{4}},$   
 $t = 3.823, 5.602$

- (d)  $r^2 = x^2 + y^2 = (\cot t + 4 \cos t)^2 + (1 + 4 \sin t)^2 = (4 + \csc t)^2$ ,  $r = 4 + \csc t$ ; with  $t = \theta$ ,  
 $f(\theta) = 4 + \csc \theta$ ;  $m = dy/dx = (f(\theta) \cos \theta + f'(\theta) \sin \theta) / (-f(\theta) \sin \theta + f'(\theta) \cos \theta)$ ; when  
 $\theta = \pi + \sin^{-1}(1/4)$ ,  $m = \sqrt{15}/15$ , when  $\theta = 2\pi - \sin^{-1}(1/4)$ ,  $m = -\sqrt{15}/15$ , so the tangent  
lines to the conchoid at the pole have polar equations  $\theta = \pm\sqrt{15}/15$ .

$$15. \frac{A}{2} = \int_0^{\pi/6} \frac{1}{2} (2 \sin \theta)^2 d\theta + \int_{\pi/6}^{\pi/4} \frac{1}{2} 1^2 d\theta = 2 \left( \theta - \frac{1}{4} \sin 2\theta \right) \Big|_0^{\pi/6} + \frac{\pi}{24}, A = \frac{5\pi}{12} - \frac{\sqrt{3}}{2}$$

16. The circle has radius  $a/2$  and lies entirely inside the cardioid, so

$$A = \int_0^{2\pi} \frac{1}{2} a^2 (1 + \sin \theta)^2 d\theta - \pi a^2 / 4 = \frac{3a^2}{2} \pi - \frac{a^2}{4} \pi = \frac{5a^2}{4} \pi$$

17. (a)  $r = 1/\theta$ ,  $dr/d\theta = -1/\theta^2$ ,  $r^2 + (dr/d\theta)^2 = 1/\theta^2 + 1/\theta^4$ ,  $L = \int_{\pi/4}^{\pi/2} \frac{1}{\theta^2} \sqrt{1 + \theta^2} d\theta \approx 0.9457$  by  
Endpaper Table Formula 93.

- (b) The integral  $\int_1^{+\infty} \frac{1}{\theta^2} \sqrt{1 + \theta^2} d\theta$  diverges by the comparison test (with  $1/\theta$ ), and thus the  
arc length is infinite.

18. (a) When the point of departure of the thread from the circle has traversed an angle  $\theta$ , the  
amount of thread that has been unwound is equal to the arc length traversed by the point of  
departure, namely  $a\theta$ . The point of departure is then located at  $(a \cos \theta, a \sin \theta)$ , and the tip of  
the string, located at  $(x, y)$ , satisfies the equations  $x - a \cos \theta = a\theta \sin \theta$ ,  $y - a \sin \theta = -a\theta \cos \theta$ ;  
hence  $x = a(\cos \theta + \theta \sin \theta)$ ,  $y = a(\sin \theta - \theta \cos \theta)$ .

- (b) Assume for simplicity that  $a = 1$ . Then  $dx/d\theta = \theta \cos \theta$ ,  $dy/d\theta = \theta \sin \theta$ ;  $dx/d\theta = 0$  has  
solutions  $\theta = 0, \pi/2, 3\pi/2$ ; and  $dy/d\theta = 0$  has solutions  $\theta = 0, \pi, 2\pi$ . At  $\theta = \pi/2$ ,  $dy/d\theta > 0$ ,  
so the direction is North; at  $\theta = \pi$ ,  $dx/d\theta < 0$ , so West; at  $\theta = 3\pi/2$ ,  $dy/d\theta < 0$ , so South; at  
 $\theta = 2\pi$ ,  $dx/d\theta > 0$ , so East. Finally,  $\lim_{\theta \rightarrow 0^+} dy/dx = \lim_{\theta \rightarrow 0^+} \tan \theta = 0$ , so East.

(c)

$\theta$	0	$\pi/2$	$\pi$	$3\pi/2$	$2\pi$
$x$	1	$\pi/2$	-1	$-3\pi/2$	1
$y$	0	1	$\pi$	-1	$-2\pi$

Note that the parameter  $\theta$  in these equations does not satisfy equations (1) and (2) of Section  
12.1, since it measures the angle of the point of departure and not the angle of the tip of the  
thread.

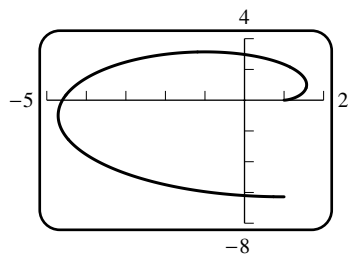

$$19. \text{ (a) } V = \int_a^{\sqrt{a^2+b^2}} \pi \left( b^2 x^2/a^2 - b^2 \right) dx$$

$$= \frac{\pi b^2}{3a^2} (b^2 - 2a^2) \sqrt{a^2 + b^2} + \frac{2}{3} ab^2 \pi$$

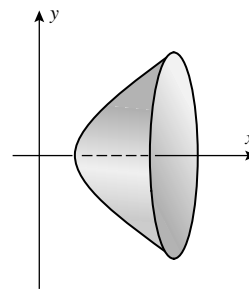

$$\text{(b) } V = 2\pi \int_a^{\sqrt{a^2+b^2}} x \sqrt{b^2 x^2/a^2 - b^2} dx = (2b^4/3a)\pi$$

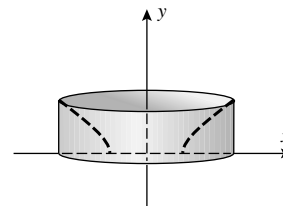

20. (a)

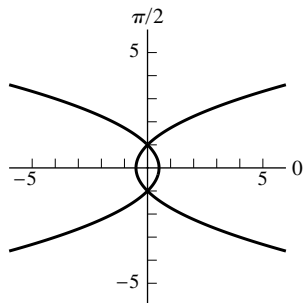
(b)  $\theta = \pi/2, 3\pi/2, r = 1$ 

$$\text{(c) } dy/dx = \frac{r \cos \theta + (dr/d\theta) \sin \theta}{-r \sin \theta + (dr/d\theta) \cos \theta}; \text{ at } \theta = \pi/2, m_1 = (-1)/(-1) = 1, m_2 = 1/(-1) = -1,$$

$$m_1 m_2 = -1; \text{ and at } \theta = 3\pi/2, m_1 = -1, m_2 = 1, m_1 m_2 = -1$$

22. The tips are located at  $r = 1, \theta = \pi/6, 5\pi/6, 3\pi/2$  and, for example,

$$d = \sqrt{1 + 1 - 2 \cos(5\pi/6 - \pi/6)} = \sqrt{2(1 - \cos(2\pi/3))} = \sqrt{3}$$

23. (a)  $x = r \cos \theta = \cos \theta + \cos^2 \theta, dx/d\theta = -\sin \theta - 2 \sin \theta \cos \theta = -\sin \theta(1 + 2 \cos \theta) = 0$  if  $\sin \theta = 0$  or  $\cos \theta = -1/2$ , so  $\theta = 0, \pi, 2\pi/3, 4\pi/3$ ; maximum  $x = 2$  at  $\theta = 0$ , minimum  $x = -1/4$  at  $\theta = \pi$

(b)  $y = r \sin \theta = \sin \theta + \sin \theta \cos \theta, dy/d\theta = 2 \cos^2 \theta + \cos \theta - 1 = 0$  at  $\cos \theta = 1/2, -1$ , so  $\theta = \pi/3, 5\pi/3, \pi$ ; maximum  $y = 3\sqrt{3}/4$  at  $\theta = \pi/3$ , minimum  $y = -3\sqrt{3}/4$  at  $\theta = 5\pi/3$

24. (a)  $y = r \sin \theta = (\sin \theta)/\sqrt{\theta}, dy/d\theta = \frac{2\theta \cos \theta - \sin \theta}{2\theta^{3/2}} = 0$  if  $2\theta \cos \theta = \sin \theta, \tan \theta = 2\theta$  which only happens once on  $(0, \pi]$ . Since  $\lim_{\theta \rightarrow 0^+} y = 0$  and  $y = 0$  at  $\theta = \pi$ ,  $y$  has a maximum when  $\tan \theta = 2\theta$ .

(b)  $\theta \approx 1.16556$ (c)  $y_{\max} = (\sin \theta)/\sqrt{\theta} \approx 0.85124$

25. The width is twice the maximum value of  $y$  for  $0 \leq \theta \leq \pi/4$ :  
 $y = r \sin \theta = \sin \theta \cos 2\theta = \sin \theta - 2 \sin^3 \theta$ ,  $dy/d\theta = \cos \theta - 6 \sin^2 \theta \cos \theta = 0$  when  $\cos \theta = 0$  or  $\sin \theta = 1/\sqrt{6}$ ,  $y = 1/\sqrt{6} - 2/(6\sqrt{6}) = \sqrt{6}/9$ , so the width of the petal is  $2\sqrt{6}/9$ .
26. (a)  $\frac{x^2}{225} - \frac{y^2}{1521} = 1$ , so  $V = 2 \int_0^{h/2} 225\pi \left(1 + \frac{y^2}{1521}\right) dy = \frac{25}{2028}\pi h^3 + 225\pi h \text{ ft}^3$ .
- (b)  $S = 2 \int_0^{h/2} 2\pi x \sqrt{1 + (dx/dy)^2} dy = 4\pi \int_0^{h/2} \sqrt{225 + y^2 \left(\frac{225}{1521} + \left(\frac{225}{1521}\right)^2\right)} dy$   
 $= \frac{5}{26}\pi h \sqrt{6084 + h^2} + 1170\pi \ln \left[ \frac{h + \sqrt{6084 + h^2}}{78} \right] \text{ ft}^2$
27. (a) The end of the inner arm traces out the circle  $x_1 = \cos t, y_1 = \sin t$ . Relative to the end of the inner arm, the outer arm traces out the circle  $x_2 = \cos 2t, y_2 = -\sin 2t$ . Add to get the motion of the center of the rider cage relative to the center of the inner arm:  
 $x = \cos t + \cos 2t, y = \sin t - \sin 2t$ .
- (b) Same as part (a), except  $x_2 = \cos 2t, y_2 = \sin 2t$ , so  $x = \cos t + \cos 2t, y = \sin t + \sin 2t$
- (c)  $L_1 = \int_0^{2\pi} \left[ \left(\frac{dx}{dt}\right)^2 + \left(\frac{dy}{dt}\right)^2 \right]^{1/2} dt = \int_0^{2\pi} \sqrt{5 - 4 \cos 3t} dt \approx 13.36489321$ ,  
 $L_2 = \int_0^{2\pi} \sqrt{5 + 4 \cos t} dt \approx 13.36489322$ ;  $L_1$  and  $L_2$  appear to be equal, and indeed, with the substitution  $u = 3t - \pi$  and the periodicity of  $\cos u$ ,  
 $L_1 = \frac{1}{3} \int_{-\pi}^{5\pi} \sqrt{5 - 4 \cos(u + \pi)} du = \int_0^{2\pi} \sqrt{5 + 4 \cos u} du = L_2$ .
29.  $C = 4 \int_0^{\pi/2} \left[ \left(\frac{dx}{dt}\right)^2 + \left(\frac{dy}{dt}\right)^2 \right]^{1/2} dt = 4 \int_0^{\pi/2} (a^2 \sin^2 t + b^2 \cos^2 t)^{1/2} dt$   
 $= 4 \int_0^{\pi/2} (a^2 \sin^2 t + (a^2 - c^2) \cos^2 t)^{1/2} dt = 4a \int_0^{\pi/2} (1 - e^2 \cos^2 t)^{1/2} dt$
30.  $a = 3, b = 2, c = \sqrt{5}, C = 4(3) \int_0^{\pi/2} \sqrt{1 - (5/9) \cos^2 u} du \approx 15.86543959$
31. (a)  $\frac{r_0}{r_1} = \frac{59}{61} = \frac{1-e}{1+e}, e = \frac{1}{60}$
- (b)  $a = 93 \times 10^6, r_0 = a(1-e) = \frac{59}{60} (93 \times 10^6) = 91,450,000 \text{ mi}$
- (c)  $C = 4 \times 93 \times 10^6 \int_0^{\pi/2} \left[ 1 - \left(\frac{\cos \theta}{60}\right)^2 \right]^{1/2} d\theta \approx 584,295,652.5 \text{ mi}$
32. (a)  $y = y_0 + (v_0 \sin \alpha) \frac{x}{v_0 \cos \alpha} - \frac{g}{2} \left(\frac{x}{v_0 \cos \alpha}\right)^2 = y_0 + x \tan \alpha - \frac{g}{2v_0^2 \cos^2 \alpha} x^2$
- (b)  $\frac{dy}{dx} = \tan \alpha - \frac{g}{v_0^2 \cos^2 \alpha} x, dy/dx = 0$  at  $x = \frac{v_0^2}{g} \sin \alpha \cos \alpha$ ,  
 $y = y_0 + \frac{v_0^2}{g} \sin^2 \alpha - \frac{g}{2v_0^2 \cos^2 \alpha} \left(\frac{v_0^2 \sin \alpha \cos \alpha}{g}\right)^2 = y_0 + \frac{v_0^2}{2g} \sin^2 \alpha$

33.  $\alpha = \pi/4, y_0 = 3, x = v_0 t/\sqrt{2}, y = 3 + v_0 t/\sqrt{2} - 16t^2$

(a) Assume the ball passes through  $x = 391, y = 50$ , then  $391 = v_0 t/\sqrt{2}, 50 = 3 + 391 - 16t^2$ ,  
 $16t^2 = 344, t = \sqrt{21.5}, v_0 = \sqrt{2}x/t \approx 119.3$  ft/s

(b)  $\frac{dy}{dt} = \frac{v_0}{\sqrt{2}} - 32t = 0$  when  $t = \frac{v_0}{32\sqrt{2}}, y_{\max} = 3 + \frac{v_0}{\sqrt{2}} \frac{v_0}{32\sqrt{2}} - 16 \frac{v_0^2}{2^{11}} = 3 + \frac{v_0^2}{128} \approx 114.2$  ft

(c)  $y = 0$  when  $t = \frac{-v_0/\sqrt{2} \pm \sqrt{v_0^2/2 + 192}}{-32}, t \approx -0.04$  (discard) and 5.31, dist = 447.9 ft

34. (a)

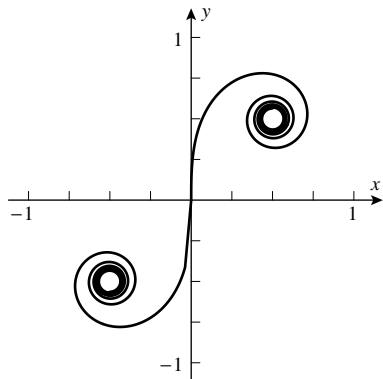

(c)  $L = \int_{-1}^1 \left[ \cos^2 \left( \frac{\pi t^2}{2} \right) + \sin^2 \left( \frac{\pi t^2}{2} \right) \right] dt = 2$

35.  $\tan \psi = \tan(\phi - \theta) = \frac{\tan \phi - \tan \theta}{1 + \tan \phi \tan \theta} = \frac{\frac{dy}{dx} - \frac{y}{x}}{1 + \frac{y}{x} \frac{dy}{dx}}$

$$= \frac{\frac{r \cos \theta + (dr/d\theta) \sin \theta}{-r \sin \theta + (dr/d\theta) \cos \theta} - \frac{\sin \theta}{\cos \theta}}{1 + \left( \frac{r \cos \theta + (dr/d\theta) \sin \theta}{-r \sin \theta + (dr/d\theta) \cos \theta} \right) \left( \frac{\sin \theta}{\cos \theta} \right)} = \frac{r}{dr/d\theta}$$

36. (a) From Exercise 35,

$$\tan \psi = \frac{r}{dr/d\theta} = \frac{1 - \cos \theta}{\sin \theta} = \tan \frac{\theta}{2},$$

so  $\psi = \theta/2$ .

(b)

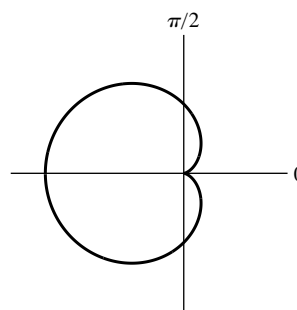

(c) At  $\theta = \pi/2, \psi = \theta/2 = \pi/4$ . At  $\theta = 3\pi/2, \psi = \theta/2 = 3\pi/4$ .

37.  $\tan \psi = \frac{r}{dr/d\theta} = \frac{ae^{b\theta}}{abe^{b\theta}} = \frac{1}{b}$  is constant, so  $\psi$  is constant.

## CHAPTER 12 HORIZON MODULE

1. For the Earth,  $a_E(1 - e_E^2) = 1(1 - 0.017^2) = 0.999711$ , so the polar equation is

$$r = \frac{a_E(1 - e_E^2)}{1 - e_E \cos \theta} = \frac{0.999711}{1 - 0.017 \cos \theta}.$$

For Rogue 2000,  $a_R(1 - e_R^2) = 5(1 - 0.98^2) = 0.198$ , so the polar equation is

$$r = \frac{a_R(1 - e_R^2)}{1 - e_R \cos \theta} = \frac{0.198}{1 - 0.98 \cos \theta}.$$

- 2.

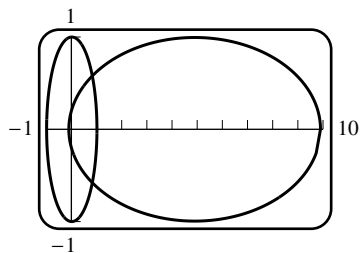

3. At the intersection point  $A$ ,  $\frac{k_E}{1 - e_E \cos \theta} = \frac{k_R}{1 - e_R \cos \theta}$ , so  $k_E - k_E e_R \cos \theta = k_R - k_R e_E \cos \theta$ .

$$\text{Solving for } \cos \theta \text{ gives } \cos \theta = \frac{k_E - k_R}{k_E e_R - k_R e_E}.$$

4. From Exercise 1,  $k_E = 0.999711$  and  $k_R = 0.198$ , so

$$\cos \theta = \frac{k_E - k_R}{k_E e_R - k_R e_E} = \frac{0.999711 - 0.198}{0.999711(0.98) - 0.198(0.017)} \approx 0.821130$$

and  $\theta = \cos^{-1} 0.821130 \approx 0.607408$  radian.

5. Substituting  $\cos \theta \approx 0.821130$  into the polar equation for the Earth gives

$$r \approx \frac{0.999711}{1 - 0.017(0.821130)} \approx 1.013864,$$

so the polar coordinates of intersection  $A$  are approximately  $(1.013864, 0.607408)$ .

6. By Theorem 12.3.2 the area of the elliptic sector is  $\int_{\theta_I}^{\theta_F} \frac{1}{2} r^2 d\theta$ . By Exercise 12.4.53 the area of the entire ellipse is  $\pi ab$ , where  $a$  is the semimajor axis and  $b$  is the semiminor axis. But

$$b = \sqrt{a^2 - c^2} = \sqrt{a^2 - (ea)^2} = a\sqrt{1 - e^2},$$

so Formula (1) becomes  $\frac{t}{T} = \frac{\int_{\theta_I}^{\theta_F} r^2 d\theta}{2\pi a^2 \sqrt{1 - e^2}}$ , which implies Formula (2).

7. In Formula (2) substitute  $T = 1$ ,  $\theta_I = 0$ , and  $\theta_F \approx 0.607408$ , and use the polar equation of the Earth's orbit found in Exercise 1:

$$t = \frac{\int_0^{\theta_F} \left( \frac{k_E}{1 - e_E \cos \theta} \right)^2 d\theta}{2\pi \sqrt{1 - e_E^2}} \approx \frac{\int_0^{0.607408} \left( \frac{0.999711}{1 - 0.017 \cos \theta} \right)^2 d\theta}{2\pi \sqrt{0.999711}} \approx 0.099792 \text{ yr.}$$

Note: This calculation can be done either by numerical integration or by using the integration formula

$$\int \frac{d\theta}{(1 - e \cos \theta)^2} = \frac{2 \tan^{-1} \left( \sqrt{\frac{1+e}{1-e}} \tan \frac{\theta}{2} \right)}{(1 - e^2)^{3/2}} + \frac{e \sin \theta}{(1 - e^2)(1 - e \cos \theta)} + C,$$

obtained by using a CAS or by the substitution  $u = \tan(\theta/2)$ .

8. In Formula (2) we substitute  $T = 5\sqrt{5}$  and  $\theta_I = 0.45$ , and use the polar equation of Rogue 2000's orbit found in Exercise 1:

$$t = \frac{T \int_{\theta_I}^{\theta_F} \left( \frac{a_R(1 - e_R^2)}{1 - e_R \cos \theta} \right)^2 d\theta}{2\pi a_R^2 \sqrt{1 - e_R^2}} = \frac{5\sqrt{5} \int_{0.45}^{\theta_F} \left( \frac{a_R(1 - e_R^2)}{1 - e_R \cos \theta} \right)^2 d\theta}{2\pi a_R^2 \sqrt{1 - e_R^2}},$$

so

$$\int_{0.45}^{\theta_F} \left( \frac{a_R(1 - e_R^2)}{1 - e_R \cos \theta} \right)^2 d\theta = \frac{2t\pi a_R^2 \sqrt{1 - e_R^2}}{5\sqrt{5}}.$$

9. (a) A CAS shows that

$$\int \left( \frac{a_R(1 - e_R^2)}{1 - e_R \cos \theta} \right)^2 d\theta = a_R^2 \left( 2\sqrt{1 - e_R^2} \tan^{-1} \left( \sqrt{\frac{1+e_R}{1-e_R}} \tan \frac{\theta}{2} \right) + \frac{e_R(1 - e_R^2) \sin \theta}{1 - e_R \cos \theta} \right) + C$$

- (b) Evaluating the integral above from  $\theta = 0.45$  to  $\theta = \theta_F$ , setting the result equal to the right side of (3), and simplifying gives

$$\tan^{-1} \left( \sqrt{\frac{1+e_R}{1-e_R}} \tan \frac{\theta}{2} \right) + \frac{e_R \sqrt{1 - e_R^2} \sin \theta}{2(1 - e_R \cos \theta)} \Big|_{0.45}^{\theta_F} = \frac{t\pi}{5\sqrt{5}}.$$

Using the known values of  $e_R$  and  $t$ , and solving numerically,  $\theta_F \approx 0.611346$ .

10. Substituting  $\theta_F \approx 0.611346$  in the equation for Rogue 2000's orbit gives  $r \approx 1.002525$  AU. So the polar coordinates of Rogue 2000 when the Earth is at intersection  $A$  are about  $(1.002525, 0.611346)$ .
11. Substituting the values found in Exercises 5 and 10 into the distance formula in Supplementary Exercise 22 gives  $d = \sqrt{r_1^2 + r_2^2 - 2r_1 r_2 \cos(\theta_1 - \theta_2)} \approx 0.012013$  AU  $\approx 1.797201 \times 10^6$  km. Since this is less than 4 million kilometers, a notification should be issued. (Incidentally, Rogue 2000's closest approach to the Earth does not occur when the Earth is at  $A$ , but about 9 hours earlier, at  $t \approx 0.098768$  yr, at which time the distance is about 1.219435 million kilometers.)





(c)  $r = \frac{1}{2}\sqrt{(-1-0)^2 + (2-2)^2 + (1-3)^2} = \frac{1}{2}\sqrt{5}$ , center  $(-1/2, 2, 2)$ ,  
 $(x + 1/2)^2 + (y - 2)^2 + (z - 2)^2 = 5/4$

10.  $r = |[\text{distance between } (0,0,0) \text{ and } (3, -2, 4)] \pm 1| = \sqrt{29} \pm 1$ ,  
 $x^2 + y^2 + z^2 = r^2 = (\sqrt{29} \pm 1)^2 = 30 \pm 2\sqrt{29}$

11.  $(x - 2)^2 + (y + 1)^2 + (z + 3)^2 = r^2$ ,

(a)  $r^2 = 3^2 = 9$

(b)  $r^2 = 1^2 = 1$

(c)  $r^2 = 2^2 = 4$

12. (a) The sides have length 1, so the radius is  $\frac{1}{2}$ ; hence  $(x + 2)^2 + (y - 1)^2 + (z - 3)^2 = \frac{1}{4}$

(b) The diagonal has length  $\sqrt{1 + 1 + 1} = \sqrt{3}$  and is a diameter, so  $(x + 2)^2 + (y - 1)^2 + (z - 3)^2 = \frac{3}{4}$ .

13.  $(x + 5)^2 + (y + 2)^2 + (z + 1)^2 = 49$ ; sphere,  $C(-5, -2, -1)$ ,  $r = 7$

14.  $x^2 + (y - 1/2)^2 + z^2 = 1/4$ ; sphere,  $C(0, 1/2, 0)$ ,  $r = 1/2$

15.  $(x - 1/2)^2 + (y - 3/4)^2 + (z + 5/4)^2 = 54/16$ ; sphere,  $C(1/2, 3/4, -5/4)$ ,  $r = 3\sqrt{6}/4$

16.  $(x + 1)^2 + (y - 1)^2 + (z + 1)^2 = 0$ ; the point  $(-1, 1, -1)$

17.  $(x - 3/2)^2 + (y + 2)^2 + (z - 4)^2 = -11/4$ ; no graph

18.  $(x - 1)^2 + (y - 3)^2 + (z - 4)^2 = 25$ ; sphere,  $C(1, 3, 4)$ ,  $r = 5$

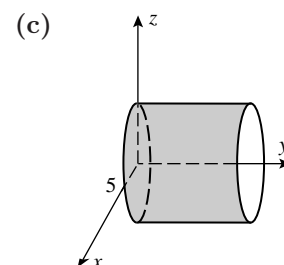
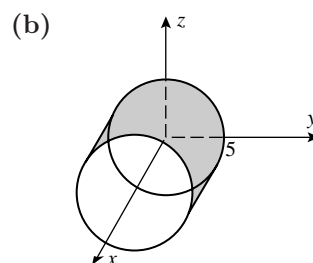
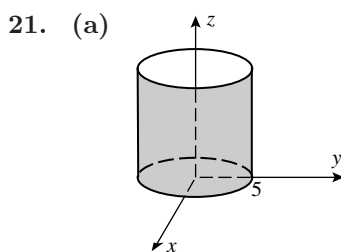
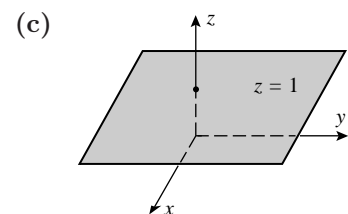
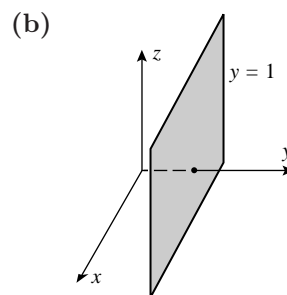
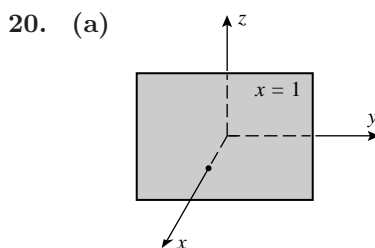
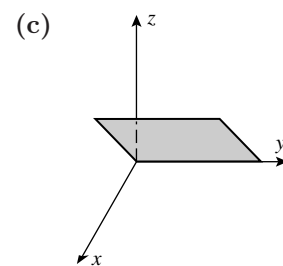
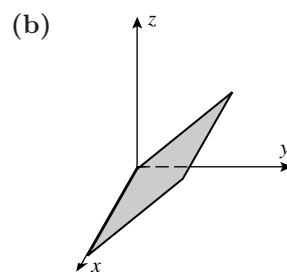
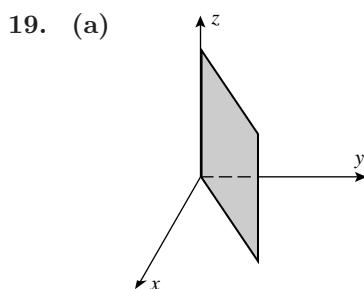

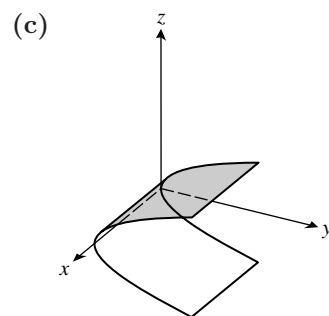
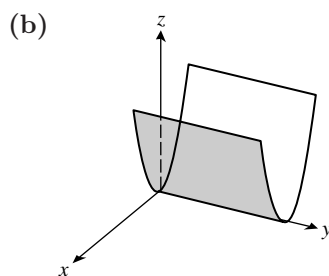
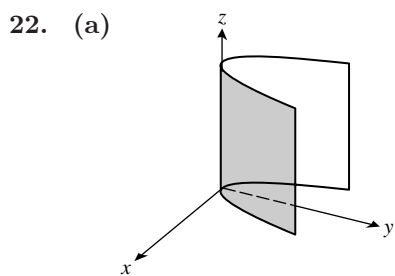

23. (a)  $-2y + z = 0$   
 (c)  $(x - 1)^2 + (y - 1)^2 = 1$

(b)  $-2x + z = 0$   
 (d)  $(x - 1)^2 + (z - 1)^2 = 1$

24. (a)  $(x - a)^2 + (z - a)^2 = a^2$   
 (b)  $(x - a)^2 + (y - a)^2 = a^2$   
 (c)  $(y - a)^2 + (z - a)^2 = a^2$

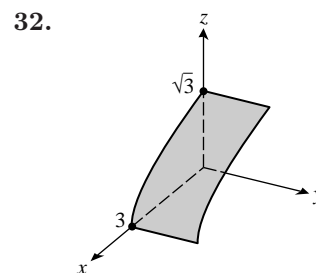
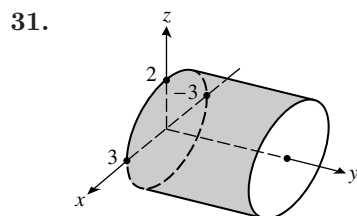
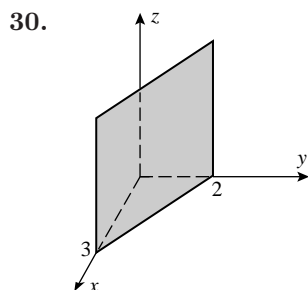
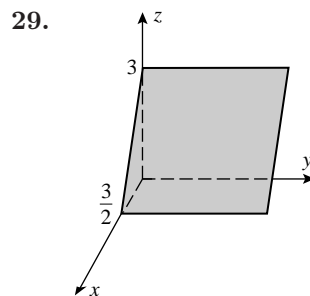
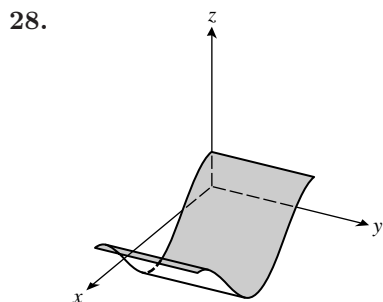
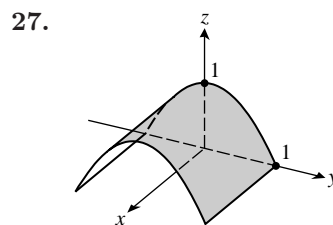
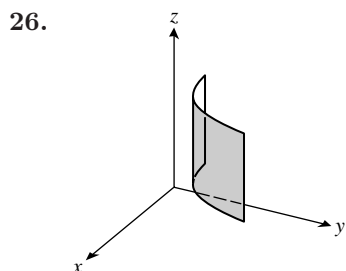
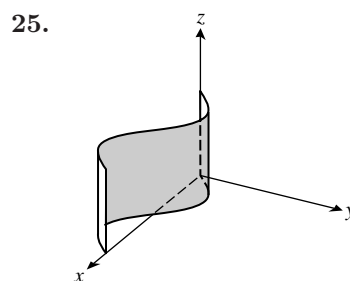

33.

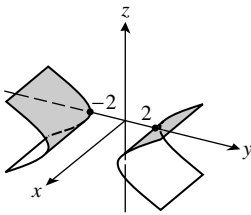

34.

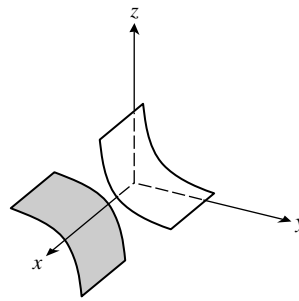

35. (a)

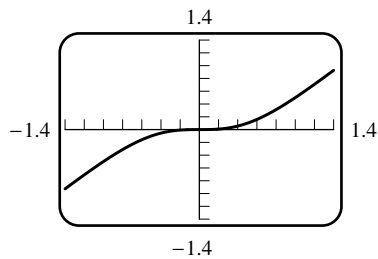

(b)

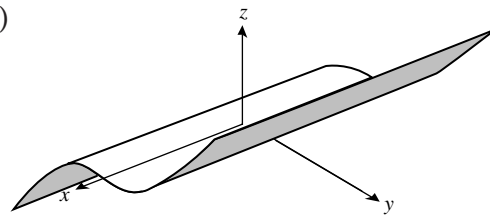

36. (a)

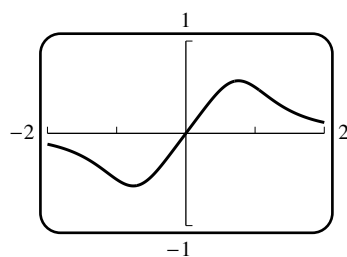

(b)

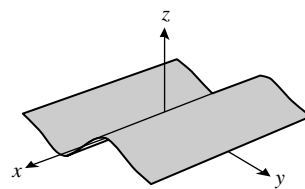

37. Complete the square to get  $(x + 1)^2 + (y - 1)^2 + (z - 2)^2 = 9$ ; center  $(-1, 1, 2)$ , radius 3. The distance between the origin and the center is  $\sqrt{6} < 3$  so the origin is inside the sphere. The largest distance is  $3 + \sqrt{6}$ , the smallest is  $3 - \sqrt{6}$ .

38.  $(x - 1)^2 + y^2 + (z + 4)^2 \leq 25$ ; all points on and inside the sphere of radius 5 with center at  $(1, 0, -4)$ .

39.  $(y + 3)^2 + (z - 2)^2 > 16$ ; all points outside the circular cylinder  $(y + 3)^2 + (z - 2)^2 = 16$ .

40.  $\sqrt{(x - 1)^2 + (y + 2)^2 + z^2} = 2\sqrt{x^2 + (y - 1)^2 + (z - 1)^2}$ , square and simplify to get  $3x^2 + 3y^2 + 3z^2 + 2x - 12y - 8z + 3 = 0$ , then complete the square to get  $(x + 1/3)^2 + (y - 2)^2 + (z - 4/3)^2 = 44/9$ ; center  $(-1/3, 2, 4/3)$ , radius  $2\sqrt{11}/3$ .

41. Let  $r$  be the radius of a styrofoam sphere. The distance from the origin to the center of the bowling ball is equal to the sum of the distance from the origin to the center of the styrofoam sphere nearest the origin and the distance between the center of this sphere and the center of the bowling ball so  $\sqrt{3}R = \sqrt{3}r + r + R$ ,  $(\sqrt{3} + 1)r = (\sqrt{3} - 1)R$ ,  $r = \frac{\sqrt{3} - 1}{\sqrt{3} + 1}R = (2 - \sqrt{3})R$ .

42. (a) Complete the square to get  $(x + G/2)^2 + (y + H/2)^2 + (z + I/2)^2 = K/4$ , so the equation represents a sphere when  $K > 0$ , a point when  $K = 0$ , and no graph when  $K < 0$ .

(b)  $C(-G/2, -H/2, -I/2)$ ,  $r = \sqrt{K}/2$

$$\begin{aligned}
 43. \quad (a \sin \phi \cos \theta)^2 + (a \sin \phi \sin \theta)^2 + (a \cos \phi)^2 &= a^2 \sin^2 \phi \cos^2 \theta + a^2 \sin^2 \phi \sin^2 \theta + a^2 \cos^2 \phi \\
 &= a^2 \sin^2 \phi (\cos^2 \theta + \sin^2 \theta) + a^2 \cos^2 \phi \\
 &= a^2 \sin^2 \phi + a^2 \cos^2 \phi = a^2 (\sin^2 \phi + \cos^2 \phi) = a^2
 \end{aligned}$$

**EXERCISE SET 13.2**

1. (a-c)

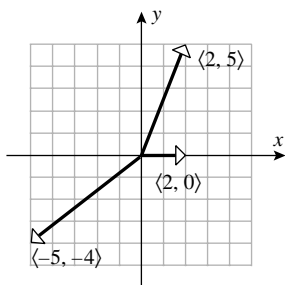

(d-f)

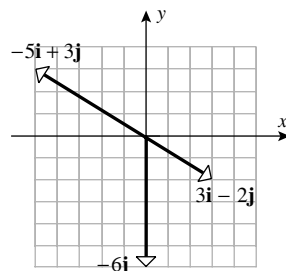

2. (a-c)

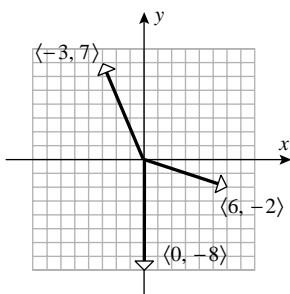

(d-f)

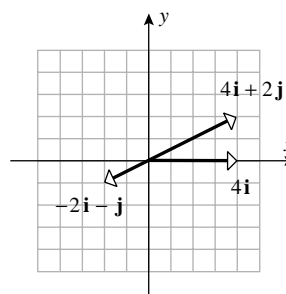

3. (a-b)

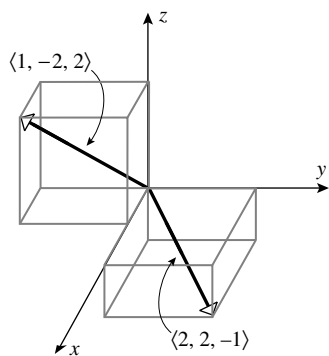

(c-d)

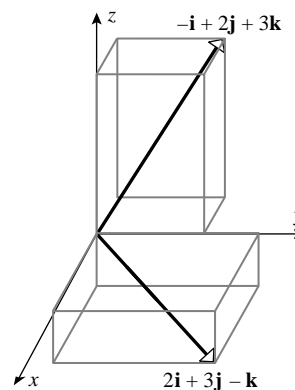

4. (a-b)

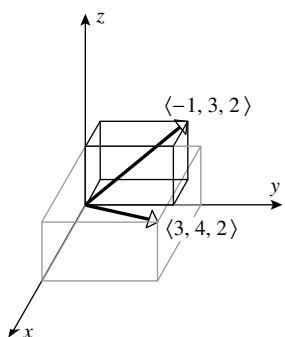

(c-d)

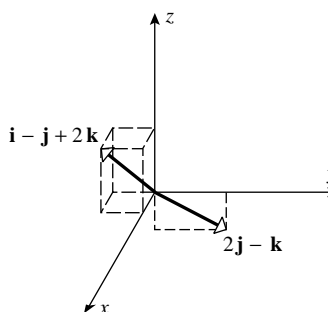

5. (a)  $\langle 4 - 1, 1 - 5 \rangle = \langle 3, -4 \rangle$

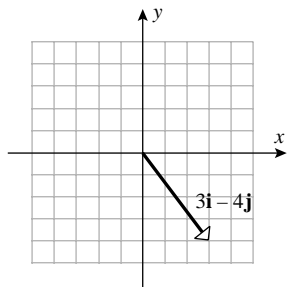

(b)  $\langle 0 - 2, 0 - 3, 4 - 0 \rangle = \langle -2, -3, 4 \rangle$

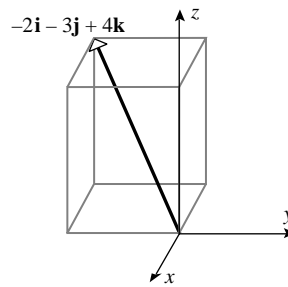

6. (a)  $\langle -3 - 2, 3 - 3 \rangle = \langle -5, 0 \rangle$

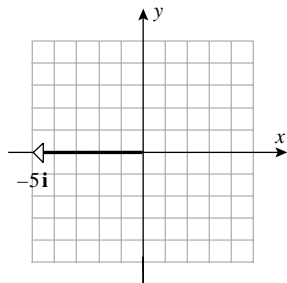

(b)  $\langle 0 - 3, 4 - 0, 4 - 4 \rangle = \langle -3, 4, 0 \rangle$

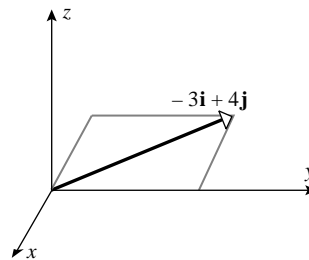

7. (a)  $\langle 2 - 3, 8 - 5 \rangle = \langle -1, 3 \rangle$

8. (a)  $\langle -4 - (-6), -1 - (-2) \rangle = \langle 2, 1 \rangle$

(b)  $\langle 0 - 7, 0 - (-2) \rangle = \langle -7, 2 \rangle$

(b)  $\langle -1, 6, 1 \rangle$

(c)  $\langle -3, 6, 1 \rangle$

(c)  $\langle 5, 0, 0 \rangle$

9. (a) Let  $(x, y)$  be the terminal point, then  $x - 1 = 3$ ,  $x = 4$  and  $y - (-2) = -2$ ,  $y = -4$ . The terminal point is  $(4, -4)$ .(b) Let  $(x, y, z)$  be the initial point, then  $5 - x = -3$ ,  $-y = 1$ , and  $-1 - z = 2$  so  $x = 8$ ,  $y = -1$ , and  $z = -3$ . The initial point is  $(8, -1, -3)$ .10. (a) Let  $(x, y)$  be the terminal point, then  $x - 2 = 7$ ,  $x = 9$  and  $y - (-1) = 6$ ,  $y = 5$ . The terminal point is  $(9, 5)$ .(b) Let  $(x, y, z)$  be the terminal point, then  $x + 2 = 1$ ,  $y - 1 = 2$ , and  $z - 4 = -3$  so  $x = -1$ ,  $y = 3$ , and  $z = 1$ . The terminal point is  $(-1, 3, 1)$ .

11. (a)  $-\mathbf{i} + 4\mathbf{j} - 2\mathbf{k}$

(b)  $18\mathbf{i} + 12\mathbf{j} - 6\mathbf{k}$

(c)  $-\mathbf{i} - 5\mathbf{j} - 2\mathbf{k}$

(d)  $40\mathbf{i} - 4\mathbf{j} - 4\mathbf{k}$

(e)  $-2\mathbf{i} - 16\mathbf{j} - 18\mathbf{k}$

(f)  $-\mathbf{i} + 13\mathbf{j} - 2\mathbf{k}$

12. (a)  $\langle 1, -2, 0 \rangle$

(b)  $\langle 28, 0, -14 \rangle + \langle 3, 3, 9 \rangle = \langle 31, 3, -5 \rangle$

(c)  $\langle 3, -1, -5 \rangle$

(d)  $3(\langle 2, -1, 3 \rangle - \langle 28, 0, -14 \rangle) = 3\langle -26, -1, 17 \rangle = \langle -78, -3, 51 \rangle$

(e)  $\langle -12, 0, 6 \rangle - \langle 8, 8, 24 \rangle = \langle -20, -8, -18 \rangle$

(f)  $\langle 8, 0, -4 \rangle - \langle 3, 0, 6 \rangle = \langle 5, 0, -10 \rangle$

13. (a)  $\|\mathbf{v}\| = \sqrt{1+1} = \sqrt{2}$

(b)  $\|\mathbf{v}\| = \sqrt{1+49} = 5\sqrt{2}$

(c)  $\|\mathbf{v}\| = \sqrt{21}$

(d)  $\|\mathbf{v}\| = \sqrt{14}$

14. (a)  $\|\mathbf{v}\| = \sqrt{9+16} = 5$

(b)  $\|\mathbf{v}\| = \sqrt{2+7} = 3$

(c)  $\|\mathbf{v}\| = 3$

(d)  $\|\mathbf{v}\| = \sqrt{3}$

15. (a)  $\|\mathbf{u} + \mathbf{v}\| = \|2\mathbf{i} - 2\mathbf{j} + 2\mathbf{k}\| = 2\sqrt{3}$  (b)  $\|\mathbf{u}\| + \|\mathbf{v}\| = \sqrt{14} + \sqrt{2}$   
 (c)  $\|-2\mathbf{u}\| + 2\|\mathbf{v}\| = 2\sqrt{14} + 2\sqrt{2}$  (d)  $\|3\mathbf{u} - 5\mathbf{v} + \mathbf{w}\| = \|-12\mathbf{j} + 2\mathbf{k}\| = 2\sqrt{37}$   
 (e)  $(1/\sqrt{6})\mathbf{i} + (1/\sqrt{6})\mathbf{j} - (2/\sqrt{6})\mathbf{k}$  (f) 1

16. If one vector is a positive multiple of the other, say  $\mathbf{u} = \alpha\mathbf{v}$  with  $\alpha > 0$ , then  $\mathbf{u}, \mathbf{v}$  and  $\mathbf{u} + \mathbf{v}$  are parallel and  $\|\mathbf{u} + \mathbf{v}\| = (1 + \alpha)\|\mathbf{v}\| = \|\mathbf{u}\| + \|\mathbf{v}\|$ .

17. (a)  $\|-\mathbf{i} + 4\mathbf{j}\| = \sqrt{17}$  so the required vector is  $(-1/\sqrt{17})\mathbf{i} + (4/\sqrt{17})\mathbf{j}$   
 (b)  $\|6\mathbf{i} - 4\mathbf{j} + 2\mathbf{k}\| = 2\sqrt{14}$  so the required vector is  $(-3\mathbf{i} + 2\mathbf{j} - \mathbf{k})/\sqrt{14}$   
 (c)  $\overrightarrow{AB} = 4\mathbf{i} + \mathbf{j} - \mathbf{k}$ ,  $\|\overrightarrow{AB}\| = 3\sqrt{2}$  so the required vector is  $(4\mathbf{i} + \mathbf{j} - \mathbf{k})/(3\sqrt{2})$

18. (a)  $\|3\mathbf{i} - 4\mathbf{j}\| = 5$  so the required vector is  $-\frac{1}{5}(3\mathbf{i} - 4\mathbf{j}) = -\frac{3}{5}\mathbf{i} + \frac{4}{5}\mathbf{j}$   
 (b)  $\|2\mathbf{i} - \mathbf{j} - 2\mathbf{k}\| = 3$  so the required vector is  $\frac{2}{3}\mathbf{i} - \frac{1}{3}\mathbf{j} - \frac{2}{3}\mathbf{k}$   
 (c)  $\overrightarrow{AB} = 4\mathbf{i} - 3\mathbf{j}$ ,  $\|\overrightarrow{AB}\| = 5$  so the required vector is  $\frac{4}{5}\mathbf{i} - \frac{3}{5}\mathbf{j}$

19. (a)  $-\frac{1}{2}\mathbf{v} = \langle -3/2, 2 \rangle$  (b)  $\|\mathbf{v}\| = \sqrt{85}$ , so  $\frac{\sqrt{17}}{\sqrt{85}}\mathbf{v} = \frac{1}{\sqrt{5}}\langle 7, 0, -6 \rangle$  has length  $\sqrt{17}$

20. (a)  $3\mathbf{v} = -6\mathbf{i} + 9\mathbf{j}$  (b)  $-\frac{2}{\|\mathbf{v}\|}\mathbf{v} = \frac{6}{\sqrt{26}}\mathbf{i} - \frac{8}{\sqrt{26}}\mathbf{j} - \frac{2}{\sqrt{26}}\mathbf{k}$

21. (a)  $\mathbf{v} = \|\mathbf{v}\|\langle \cos \pi/4, \sin \pi/4 \rangle = \langle 3\sqrt{2}/2, 3\sqrt{2}/2 \rangle$   
 (b)  $\mathbf{v} = \|\mathbf{v}\|\langle \cos 90^\circ, \sin 90^\circ \rangle = \langle 0, 2 \rangle$   
 (c)  $\mathbf{v} = \|\mathbf{v}\|\langle \cos 120^\circ, \sin 120^\circ \rangle = \langle -5/2, 5\sqrt{3}/2 \rangle$   
 (d)  $\mathbf{v} = \|\mathbf{v}\|\langle \cos \pi, \sin \pi \rangle = \langle -1, 0 \rangle$

22. From (12),  $\mathbf{v} = \langle \cos \pi/6, \sin \pi/6 \rangle = \langle \sqrt{3}/2, 1/2 \rangle$  and  $\mathbf{w} = \langle \cos 3\pi/4, \sin 3\pi/4 \rangle = \langle -\sqrt{2}/2, \sqrt{2}/2 \rangle$ , so  $\mathbf{v} + \mathbf{w} = ((\sqrt{3} - \sqrt{2})/2, (1 + \sqrt{2})/2)$ ,  $\mathbf{v} - \mathbf{w} = ((\sqrt{3} + \sqrt{2})/2, (1 - \sqrt{2})/2)$

23. From (12),  $\mathbf{v} = \langle \cos 30^\circ, \sin 30^\circ \rangle = \langle \sqrt{3}/2, 1/2 \rangle$  and  $\mathbf{w} = \langle \cos 135^\circ, \sin 135^\circ \rangle = \langle -\sqrt{2}/2, \sqrt{2}/2 \rangle$ , so  $\mathbf{v} + \mathbf{w} = ((\sqrt{3} - \sqrt{2})/2, (1 + \sqrt{2})/2)$

24.  $\mathbf{w} = \langle 1, 0 \rangle$ , and from (12),  $\mathbf{v} = \langle \cos 120^\circ, \sin 120^\circ \rangle = \langle -1/2, \sqrt{3}/2 \rangle$ , so  $\mathbf{v} + \mathbf{w} = \langle 1/2, \sqrt{3}/2 \rangle$

25. (a) The initial point of  $\mathbf{u} + \mathbf{v} + \mathbf{w}$  is the origin and the endpoint is  $(-2, 5)$ , so  $\mathbf{u} + \mathbf{v} + \mathbf{w} = \langle -2, 5 \rangle$ .  
 (b) The initial point of  $\mathbf{u} + \mathbf{v} + \mathbf{w}$  is  $(-5, 4)$  and the endpoint is  $(-2, -4)$ , so  $\mathbf{u} + \mathbf{v} + \mathbf{w} = \langle 3, -8 \rangle$ .

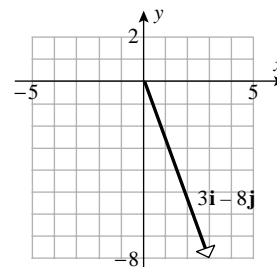
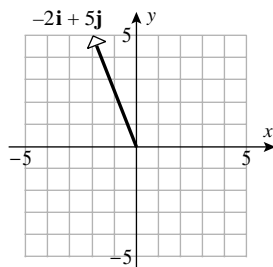





41. Since  $\phi = \pi/2$ , from (13) we get  $\|\mathbf{F}_1 + \mathbf{F}_2\|^2 = \|\mathbf{F}_1\|^2 + \|\mathbf{F}_2\|^2 = 3600 + 900$ ,  
 so  $\|\mathbf{F}_1 + \mathbf{F}_2\| = 30\sqrt{5}$  lb, and  $\sin \alpha = \frac{\|\mathbf{F}_2\|}{\|\mathbf{F}_1 + \mathbf{F}_2\|} \sin \phi = \frac{30}{30\sqrt{5}}$ ,  $\alpha \approx 26.57^\circ$ ,  $\theta = \alpha \approx 26.57^\circ$ .
42.  $\|\mathbf{F}_1 + \mathbf{F}_2\|^2 = \|\mathbf{F}_1\|^2 + \|\mathbf{F}_2\|^2 + 2\|\mathbf{F}_1\|\|\mathbf{F}_2\| \cos \phi = 14,400 + 10,000 + 2(120)(100)\frac{1}{2} = 36,400$ , so  
 $\|\mathbf{F}_1 + \mathbf{F}_2\| = 20\sqrt{91}$  N,  $\sin \alpha = \frac{\|\mathbf{F}_2\|}{\|\mathbf{F}_1 + \mathbf{F}_2\|} \sin \phi = \frac{100}{20\sqrt{91}} \sin 60^\circ = \frac{5\sqrt{3}}{2\sqrt{91}}$ ,  $\alpha \approx 27.16^\circ$ ,  
 $\theta = \alpha \approx 27.16^\circ$ .
43.  $\|\mathbf{F}_1 + \mathbf{F}_2\|^2 = \|\mathbf{F}_1\|^2 + \|\mathbf{F}_2\|^2 + 2\|\mathbf{F}_1\|\|\mathbf{F}_2\| \cos \phi = 160,000 + 160,000 - 2(400)(400)\frac{\sqrt{3}}{2}$ ,  
 so  $\|\mathbf{F}_1 + \mathbf{F}_2\| \approx 207.06$  N, and  $\sin \alpha = \frac{\|\mathbf{F}_2\|}{\|\mathbf{F}_1 + \mathbf{F}_2\|} \sin \phi \approx \frac{400}{207.06} \left(\frac{1}{2}\right)$ ,  $\alpha = 75.00^\circ$ ,  
 $\theta = \alpha - 30^\circ = 45.00^\circ$ .
44.  $\|\mathbf{F}_1 + \mathbf{F}_2\|^2 = \|\mathbf{F}_1\|^2 + \|\mathbf{F}_2\|^2 + 2\|\mathbf{F}_1\|\|\mathbf{F}_2\| \cos \phi = 16 + 4 + 2(4)(2) \cos 77^\circ$ , so  
 $\|\mathbf{F}_1 + \mathbf{F}_2\| \approx 4.86$  lb, and  $\sin \alpha = \frac{\|\mathbf{F}_2\|}{\|\mathbf{F}_1 + \mathbf{F}_2\|} \sin \phi = \frac{2}{4.86} \sin 77^\circ$ ,  $\alpha \approx 23.64^\circ$ ,  $\theta = \alpha - 27^\circ \approx -3.36^\circ$ .
45. Let  $\mathbf{F}_1, \mathbf{F}_2, \mathbf{F}_3$  be the forces in the diagram with magnitudes 40, 50, 75 respectively. Then  
 $\mathbf{F}_1 + \mathbf{F}_2 + \mathbf{F}_3 = (\mathbf{F}_1 + \mathbf{F}_2) + \mathbf{F}_3$ . Following the examples,  $\mathbf{F}_1 + \mathbf{F}_2$  has magnitude 45.83 N and  
 makes an angle  $79.11^\circ$  with the positive  $x$ -axis. Then  
 $\|(\mathbf{F}_1 + \mathbf{F}_2) + \mathbf{F}_3\|^2 \approx 45.83^2 + 75^2 + 2(45.83)(75) \cos 79.11^\circ$ , so  $\mathbf{F}_1 + \mathbf{F}_2 + \mathbf{F}_3$  has magnitude  $\approx 94.995$   
 N and makes an angle  $\theta = \alpha \approx 28.28^\circ$  with the positive  $x$ -axis.
46. Let  $\mathbf{F}_1, \mathbf{F}_2, \mathbf{F}_3$  be the forces in the diagram with magnitudes 150, 200, 100 respectively. Then  
 $\mathbf{F}_1 + \mathbf{F}_2 + \mathbf{F}_3 = (\mathbf{F}_1 + \mathbf{F}_2) + \mathbf{F}_3$ . Following the examples,  $\mathbf{F}_1 + \mathbf{F}_2$  has magnitude 279.34 N and  
 makes an angle  $91.24^\circ$  with the positive  $x$ -axis. Then  
 $\|\mathbf{F}_1 + \mathbf{F}_2 + \mathbf{F}_3\|^2 \approx 279.34^2 + 100^2 + 2(279.34)(100) \cos(270 - 91.24)^\circ$ , and  $\mathbf{F}_1 + \mathbf{F}_2 + \mathbf{F}_3$  has  
 magnitude  $\approx 179.37$  N and makes an angle  $91.94^\circ$  with the positive  $x$ -axis.
47. Let  $\mathbf{F}_1, \mathbf{F}_2$  be the forces in the diagram with magnitudes 8, 10 respectively. Then  $\|\mathbf{F}_1 + \mathbf{F}_2\|$  has  
 magnitude  $\sqrt{8^2 + 10^2 + 2 \cdot 8 \cdot 10 \cos 120^\circ} = 2\sqrt{21} \approx 9.165$  lb, and makes an angle  
 $60^\circ + \sin^{-1} \frac{\|\mathbf{F}_1\|}{\|\mathbf{F}_1 + \mathbf{F}_2\|} \sin 120^\circ \approx 109.11^\circ$  with the positive  $x$ -axis, so  $\mathbf{F}$  has magnitude 9.165 lb and  
 makes an angle  $-70.89^\circ$  with the positive  $x$ -axis.
48.  $\|\mathbf{F}_1 + \mathbf{F}_2\| = \sqrt{120^2 + 150^2 + 2 \cdot 120 \cdot 150 \cos 75^\circ} = 214.98$  N and makes an angle  $92.63^\circ$  with the  
 positive  $x$ -axis, and  $\|\mathbf{F}_1 + \mathbf{F}_2 + \mathbf{F}_3\| = 232.90$  N and makes an angle  $67.23^\circ$  with the positive  $x$ -axis,  
 hence  $\mathbf{F}$  has magnitude 232.90 N and makes an angle  $-112.77^\circ$  with the positive  $x$ -axis.
49.  $\mathbf{F}_1 + \mathbf{F}_2 + \mathbf{F} = \mathbf{0}$ , where  $\mathbf{F}$  has magnitude 250 and makes an angle  $-90^\circ$  with the positive  $x$ -axis.  
 Thus  $\|\mathbf{F}_1 + \mathbf{F}_2\|^2 = \|\mathbf{F}_1\|^2 + \|\mathbf{F}_2\|^2 + 2\|\mathbf{F}_1\|\|\mathbf{F}_2\| \cos 105^\circ = 250^2$  and  
 $45^\circ = \alpha = \sin^{-1} \left( \frac{\|\mathbf{F}_2\|}{250} \sin 105^\circ \right)$ , so  $\frac{\sqrt{2}}{2} \approx \frac{\|\mathbf{F}_2\|}{250} 0.9659$ ,  $\|\mathbf{F}_2\| \approx 183.02$  lb,  
 $\|\mathbf{F}_1\|^2 + 2(183.02)(-0.2588)\|\mathbf{F}_1\| + (183.02)^2 = 62,500$ ,  $\|\mathbf{F}_1\| = 224.13$  lb.
50. Similar to Exercise 49,  $\|\mathbf{F}_1\| = 100\sqrt{3}$  N,  $\|\mathbf{F}_2\| = 100$  N
51. (a)  $c_1\mathbf{v}_1 + c_2\mathbf{v}_2 = (2c_1 + 4c_2)\mathbf{i} + (-c_1 + 2c_2)\mathbf{j} = -4\mathbf{j}$ , so  $2c_1 + 4c_2 = 0$  and  $-c_1 + 2c_2 = -4$   
 which gives  $c_1 = 2$ ,  $c_2 = -1$ .
- (b)  $c_1\mathbf{v}_1 + c_2\mathbf{v}_2 = \langle c_1 - 2c_2, -3c_1 + 6c_2 \rangle = \langle 3, 5 \rangle$ , so  $c_1 - 2c_2 = 3$  and  $-3c_1 + 6c_2 = 5$   
 which has no solution.

52. (a) Equate corresponding components to get the system of equations  $c_1 + 3c_2 = -1$ ,  $2c_2 + c_3 = 1$ , and  $c_1 + c_3 = 5$ . Solve to get  $c_1 = 2$ ,  $c_2 = -1$ , and  $c_3 = 3$ .
- (b) Equate corresponding components to get the system of equations  $c_1 + 3c_2 + 4c_3 = 2$ ,  $-c_1 - c_3 = 1$ , and  $c_2 + c_3 = -1$ . From the second and third equations,  $c_1 = -1 - c_3$  and  $c_2 = -1 - c_3$ ; substitute these into the first equation to get  $-4 = 2$ , which is nonsense so the system has no solution.
53. Place  $\mathbf{u}$  and  $\mathbf{v}$  tip to tail so that  $\mathbf{u} + \mathbf{v}$  is the vector from the initial point of  $\mathbf{u}$  to the terminal point of  $\mathbf{v}$ . The shortest distance between two points is along the line joining these points so  $\|\mathbf{u} + \mathbf{v}\| \leq \|\mathbf{u}\| + \|\mathbf{v}\|$ .
54. (a):  $\mathbf{u} + \mathbf{v} = (u_1\mathbf{i} + u_2\mathbf{j}) + (v_1\mathbf{i} + v_2\mathbf{j}) = (v_1\mathbf{i} + v_2\mathbf{j}) + u_1\mathbf{i} + u_2\mathbf{j} = \mathbf{v} + \mathbf{u}$   
 (c):  $\mathbf{u} + \mathbf{0} = u_1\mathbf{i} + u_2\mathbf{j} + 0\mathbf{i} + 0\mathbf{j} = u_1\mathbf{i} + u_2\mathbf{j} = \mathbf{u}$   
 (e):  $k(l\mathbf{u}) = k(l(u_1\mathbf{i} + u_2\mathbf{j})) = k(lu_1\mathbf{i} + lu_2\mathbf{j}) = klu_1\mathbf{i} + klu_2\mathbf{j} = (kl)\mathbf{u}$
55. (d):  $\mathbf{u} + (-\mathbf{u}) = u_1\mathbf{i} + u_2\mathbf{j} + (-u_1\mathbf{i} - u_2\mathbf{j}) = (u_1 - u_1)\mathbf{i} + (u_2 - u_2)\mathbf{j} = \mathbf{0}$   
 (g):  $(k + l)\mathbf{u} = (k + l)(u_1\mathbf{i} + u_2\mathbf{j}) = ku_1\mathbf{i} + ku_2\mathbf{j} + lu_1\mathbf{i} + lu_2\mathbf{j} = k\mathbf{u} + l\mathbf{u}$   
 (h):  $1\mathbf{u} = 1(u_1\mathbf{i} + u_2\mathbf{j}) = 1u_1\mathbf{i} + 1u_2\mathbf{j} = u_1\mathbf{i} + u_2\mathbf{j} = \mathbf{u}$
56. Draw the triangles with sides formed by the vectors  $\mathbf{u}$ ,  $\mathbf{v}$ ,  $\mathbf{u} + \mathbf{v}$  and  $k\mathbf{u}$ ,  $k\mathbf{v}$ ,  $k\mathbf{u} + k\mathbf{v}$ . By similar triangles,  $k(\mathbf{u} + \mathbf{v}) = k\mathbf{u} + k\mathbf{v}$ .
57. Let  $\mathbf{a}$ ,  $\mathbf{b}$ ,  $\mathbf{c}$  be vectors along the sides of the triangle and A, B the midpoints of  $\mathbf{a}$  and  $\mathbf{b}$ , then  $\mathbf{u} = \frac{1}{2}\mathbf{a} - \frac{1}{2}\mathbf{b} = \frac{1}{2}(\mathbf{a} - \mathbf{b}) = \frac{1}{2}\mathbf{c}$  so  $\mathbf{u}$  is parallel to  $\mathbf{c}$  and half as long.

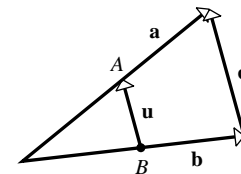

58. Let  $\mathbf{a}$ ,  $\mathbf{b}$ ,  $\mathbf{c}$ ,  $\mathbf{d}$  be vectors along the sides of the quadrilateral and A, B, C, D the corresponding midpoints, then  $\mathbf{u} = \frac{1}{2}\mathbf{b} + \frac{1}{2}\mathbf{c}$  and  $\mathbf{v} = \frac{1}{2}\mathbf{d} - \frac{1}{2}\mathbf{a}$  but  $\mathbf{d} = \mathbf{a} + \mathbf{b} + \mathbf{c}$  so  $\mathbf{v} = \frac{1}{2}(\mathbf{a} + \mathbf{b} + \mathbf{c}) - \frac{1}{2}\mathbf{a} = \frac{1}{2}\mathbf{b} + \frac{1}{2}\mathbf{c} = \mathbf{u}$  thus ABCD is a parallelogram because sides AD and BC are equal and parallel.

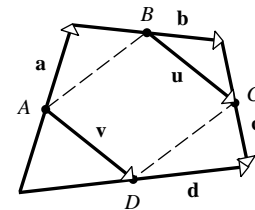

### EXERCISE SET 13.3

1. (a)  $(1)(6) + (2)(-8) = -10$ ;  $\cos \theta = (-10)/[(\sqrt{5})(10)] = -1/\sqrt{5}$   
 (b)  $(-7)(0) + (-3)(1) = -3$ ;  $\cos \theta = (-3)/[(\sqrt{58})(1)] = -3/\sqrt{58}$   
 (c)  $(1)(8) + (-3)(-2) + (7)(-2) = 0$ ;  $\cos \theta = 0$   
 (d)  $(-3)(4) + (1)(2) + (2)(-5) = -20$ ;  $\cos \theta = (-20)/[(\sqrt{14})(\sqrt{45})] = -20/(3\sqrt{70})$
2. (a)  $\mathbf{u} \cdot \mathbf{v} = 1(2) \cos(\pi/6) = \sqrt{3}$  (b)  $\mathbf{u} \cdot \mathbf{v} = 2(3) \cos 135^\circ = -3\sqrt{2}$
3. (a)  $\mathbf{u} \cdot \mathbf{v} = -34 < 0$ , obtuse (b)  $\mathbf{u} \cdot \mathbf{v} = 6 > 0$ , acute  
 (c)  $\mathbf{u} \cdot \mathbf{v} = -1 < 0$ , obtuse (d)  $\mathbf{u} \cdot \mathbf{v} = 0$ , orthogonal

4. Let the points be  $P, Q, R$  in order, then  $\vec{PQ} = \langle 2 - (-1), -2 - 2, 0 - 3 \rangle = \langle 3, -4, -3 \rangle$ ,  
 $\vec{QR} = \langle 3 - 2, 1 - (-2), -4 - 0 \rangle = \langle 1, 3, -4 \rangle$ ,  $\vec{RP} = \langle -1 - 3, 2 - 1, 3 - (-4) \rangle = \langle -4, 1, 7 \rangle$ ;  
 since  $\vec{QP} \cdot \vec{QR} = -3(1) + 4(3) + 3(-4) = -3 < 0$ ,  $\angle PQR$  is obtuse;  
 since  $\vec{RP} \cdot \vec{RQ} = -4(-1) + (-3) + 7(4) = 29 > 0$ ,  $\angle PRQ$  is acute;  
 since  $\vec{PR} \cdot \vec{PQ} = 4(3) - 1(-4) - 7(-3) = 37 > 0$ ,  $\angle RPQ$  is acute
5. Since  $\mathbf{v}_1 \cdot \mathbf{v}_i = \cos \phi_i$ , the answers are, in order,  $\sqrt{2}/2, 0, -\sqrt{2}/2, -1, -\sqrt{2}/2, 0, \sqrt{2}/2$
6. Proceed as in Exercise 5;  $25/2, -25/2, -25, -25/2, 25/2$
7. (a)  $\vec{AB} = \langle 1, 3, -2 \rangle, \vec{BC} = \langle 4, -2, -1 \rangle, \vec{AB} \cdot \vec{BC} = 0$  so  $\vec{AB}$  and  $\vec{BC}$  are orthogonal; it is a right triangle with the right angle at vertex  $B$ .
- (b) Let  $A, B$ , and  $C$  be the vertices  $(-1, 0)$ ,  $(2, -1)$ , and  $(1, 4)$  with corresponding interior angles  $\alpha, \beta$ , and  $\gamma$ , then

$$\cos \alpha = \frac{\vec{AB} \cdot \vec{AC}}{\|\vec{AB}\| \|\vec{AC}\|} = \frac{\langle 3, -1 \rangle \cdot \langle 2, 4 \rangle}{\sqrt{10}\sqrt{20}} = 1/(5\sqrt{2}), \alpha \approx 82^\circ$$

$$\cos \beta = \frac{\vec{BA} \cdot \vec{BC}}{\|\vec{BA}\| \|\vec{BC}\|} = \frac{\langle -3, 1 \rangle \cdot \langle -1, 5 \rangle}{\sqrt{10}\sqrt{26}} = 4/\sqrt{65}, \beta \approx 60^\circ$$

$$\cos \gamma = \frac{\vec{CA} \cdot \vec{CB}}{\|\vec{CA}\| \|\vec{CB}\|} = \frac{\langle -2, -4 \rangle \cdot \langle 1, -5 \rangle}{\sqrt{20}\sqrt{26}} = 9/\sqrt{130}, \gamma \approx 38^\circ$$

8.  $\vec{AB} \cdot \vec{AP} = [2\mathbf{i} + \mathbf{j} + 2\mathbf{k}] \cdot [(k-1)\mathbf{i} + (k+1)\mathbf{j} + (k-3)\mathbf{k}]$   
 $= 2(k-1) + (k+1) + 2(k-3) = 5k - 7 = 0, k = 7/5.$

9. (a)  $\mathbf{v} \cdot \mathbf{v}_1 = -ab + ba = 0; \mathbf{v} \cdot \mathbf{v}_2 = ab + b(-a) = 0$   
 (b) Let  $\mathbf{v}_1 = 2\mathbf{i} + 3\mathbf{j}, \mathbf{v}_2 = -2\mathbf{i} - 3\mathbf{j}$ ;

take  $\mathbf{u}_1 = \frac{\mathbf{v}_1}{\|\mathbf{v}_1\|} = \frac{2}{\sqrt{13}}\mathbf{i} + \frac{3}{\sqrt{13}}\mathbf{j}, \mathbf{u}_2 = -\mathbf{u}_1.$

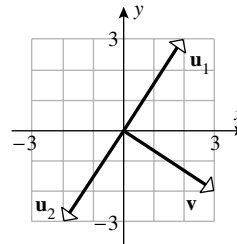

10. By inspection,  $3\mathbf{i} - 4\mathbf{j}$  is orthogonal to and has the same length as  $4\mathbf{i} + 3\mathbf{j}$   
 so  $\mathbf{u}_1 = (4\mathbf{i} + 3\mathbf{j}) + (3\mathbf{i} - 4\mathbf{j}) = 7\mathbf{i} - \mathbf{j}$  and  $\mathbf{u}_2 = (4\mathbf{i} + 3\mathbf{j}) + (-1)(3\mathbf{i} - 4\mathbf{j}) = \mathbf{i} + 7\mathbf{j}$  each make an angle of  $45^\circ$  with  $4\mathbf{i} + 3\mathbf{j}$ ; unit vectors in the directions of  $\mathbf{u}_1$  and  $\mathbf{u}_2$  are  $(7\mathbf{i} - \mathbf{j})/\sqrt{50}$  and  $(\mathbf{i} + 7\mathbf{j})/\sqrt{50}$ .
11. (a) The dot product of a vector  $\mathbf{u}$  and a scalar  $\mathbf{v} \cdot \mathbf{w}$  is not defined.  
 (b) The sum of a scalar  $\mathbf{u} \cdot \mathbf{v}$  and a vector  $\mathbf{w}$  is not defined.  
 (c)  $\mathbf{u} \cdot \mathbf{v}$  is not a vector.  
 (d) The dot product of a scalar  $k$  and a vector  $\mathbf{u} + \mathbf{v}$  is not defined.

12. (b):  $\mathbf{u} \cdot (\mathbf{v} + \mathbf{w}) = (6\mathbf{i} - \mathbf{j} + 2\mathbf{k}) \cdot ((2\mathbf{i} + 7\mathbf{j} + 4\mathbf{k}) + (\mathbf{i} + \mathbf{j} - 3\mathbf{k})) = (6\mathbf{i} - \mathbf{j} + 2\mathbf{k}) \cdot (3\mathbf{i} + 8\mathbf{j} + \mathbf{k}) = 12$ ;  
 $\mathbf{u} \cdot \mathbf{v} + \mathbf{u} \cdot \mathbf{w} = (6\mathbf{i} - \mathbf{j} + 2\mathbf{k}) \cdot (2\mathbf{i} + 7\mathbf{j} + 4\mathbf{k}) + (6\mathbf{i} - \mathbf{j} + 2\mathbf{k}) \cdot (\mathbf{i} + \mathbf{j} - 3\mathbf{k}) = 13 - 1 = 12$   
 (c):  $k(\mathbf{u} \cdot \mathbf{v}) = -5(13) = -65$ ;  $(k\mathbf{u}) \cdot \mathbf{v} = (-30\mathbf{i} + 5\mathbf{j} - 10\mathbf{k}) \cdot (2\mathbf{i} + 7\mathbf{j} + 4\mathbf{k}) = -65$ ;  
 $\mathbf{u} \cdot (k\mathbf{v}) = (6\mathbf{i} - \mathbf{j} + 2\mathbf{k}) \cdot (-10\mathbf{i} - 35\mathbf{j} - 20\mathbf{k}) = -65$

13. (a)  $\langle 1, 2 \rangle \cdot (\langle 28, -14 \rangle + \langle 6, 0 \rangle) = \langle 1, 2 \rangle \cdot \langle 34, -14 \rangle = 6$

(b)  $\|6\mathbf{w}\| = 6\|\mathbf{w}\| = 36$       (c)  $24\sqrt{5}$       (d)  $24\sqrt{5}$

14. false, for example  $\mathbf{a} = \langle 1, 2 \rangle$ ,  $\mathbf{b} = \langle -1, 0 \rangle$ ,  $\mathbf{c} = \langle 5, -3 \rangle$

15. (a)  $\|\mathbf{v}\| = \sqrt{3}$  so  $\cos \alpha = \cos \beta = 1/\sqrt{3}$ ,  $\cos \gamma = -1/\sqrt{3}$ ,  $\alpha = \beta \approx 55^\circ$ ,  $\gamma \approx 125^\circ$

(b)  $\|\mathbf{v}\| = 3$  so  $\cos \alpha = 2/3$ ,  $\cos \beta = -2/3$ ,  $\cos \gamma = 1/3$ ,  $\alpha \approx 48^\circ$ ,  $\beta \approx 132^\circ$ ,  $\gamma \approx 71^\circ$

16. (a)  $\|\mathbf{v}\| = 7$  so  $\cos \alpha = 3/7$ ,  $\cos \beta = -2/7$ ,  $\cos \gamma = -6/7$ ,  $\alpha \approx 65^\circ$ ,  $\beta \approx 107^\circ$ ,  $\gamma \approx 149^\circ$

(b)  $\|\mathbf{v}\| = 5$ ,  $\cos \alpha = 3/5$ ,  $\cos \beta = 0$ ,  $\cos \gamma = -4/5$ ,  $\alpha \approx 53^\circ$ ,  $\beta \approx 90^\circ$ ,  $\gamma \approx 143^\circ$

17.  $\cos^2 \alpha + \cos^2 \beta + \cos^2 \gamma = \frac{v_1^2}{\|\mathbf{v}\|^2} + \frac{v_2^2}{\|\mathbf{v}\|^2} + \frac{v_3^2}{\|\mathbf{v}\|^2} = (v_1^2 + v_2^2 + v_3^2) / \|\mathbf{v}\|^2 = \|\mathbf{v}\|^2 / \|\mathbf{v}\|^2 = 1$

18. Let  $\mathbf{v} = \langle x, y, z \rangle$ , then  $x = \sqrt{x^2 + y^2} \cos \theta$ ,  $y = \sqrt{x^2 + y^2} \sin \theta$ ,  $\sqrt{x^2 + y^2} = \|\mathbf{v}\| \cos \lambda$ , and  $z = \|\mathbf{v}\| \sin \lambda$ , so  $x/\|\mathbf{v}\| = \cos \theta \cos \lambda$ ,  $y/\|\mathbf{v}\| = \sin \theta \cos \lambda$ , and  $z/\|\mathbf{v}\| = \sin \lambda$ .

19.  $\cos \alpha = \frac{\sqrt{3}}{2} \frac{1}{2} = \frac{\sqrt{3}}{4}$ ,  $\cos \beta = \frac{\sqrt{3}}{2} \frac{\sqrt{3}}{2} = \frac{3}{4}$ ,  $\cos \gamma = \frac{1}{2}$ ;  $\alpha \approx 64^\circ$ ,  $\beta \approx 41^\circ$ ,  $\gamma = 60^\circ$

20. Let  $\mathbf{u}_1 = \|\mathbf{u}_1\| \langle \cos \alpha_1, \cos \beta_1, \cos \gamma_1 \rangle$ ,  $\mathbf{u}_2 = \|\mathbf{u}_2\| \langle \cos \alpha_2, \cos \beta_2, \cos \gamma_2 \rangle$ ,  $\mathbf{u}_1$  and  $\mathbf{u}_2$  are perpendicular if and only if  $\mathbf{u}_1 \cdot \mathbf{u}_2 = 0$  so  $\|\mathbf{u}_1\| \|\mathbf{u}_2\| (\cos \alpha_1 \cos \alpha_2 + \cos \beta_1 \cos \beta_2 + \cos \gamma_1 \cos \gamma_2) = 0$ ,  $\cos \alpha_1 \cos \alpha_2 + \cos \beta_1 \cos \beta_2 + \cos \gamma_1 \cos \gamma_2 = 0$ .

21. (a)  $\frac{\mathbf{b}}{\|\mathbf{b}\|} = \langle 3/5, 4/5 \rangle$ , so  $\text{proj}_{\mathbf{b}} \mathbf{v} = \langle 6/25, 8/25 \rangle$   
 and  $\mathbf{v} - \text{proj}_{\mathbf{b}} \mathbf{v} = \langle 44/25, -33/25 \rangle$

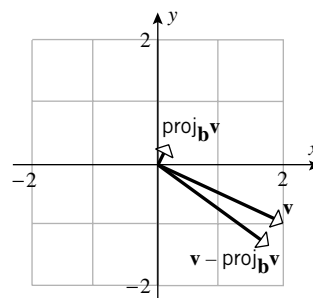

(b)  $\frac{\mathbf{b}}{\|\mathbf{b}\|} = \langle 1/\sqrt{5}, -2/\sqrt{5} \rangle$ , so  $\text{proj}_{\mathbf{b}} \mathbf{v} = \langle -6/5, 12/5 \rangle$   
 and  $\mathbf{v} - \text{proj}_{\mathbf{b}} \mathbf{v} = \langle 26/5, 13/5 \rangle$

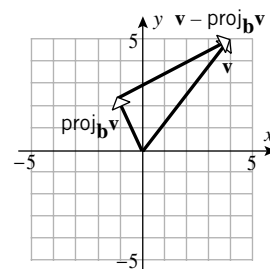

(c)  $\frac{\mathbf{b}}{\|\mathbf{b}\|} = \langle 2/\sqrt{5}, 1/\sqrt{5} \rangle$ , so  $\text{proj}_{\mathbf{b}}\mathbf{v} = \langle -16/5, -8/5 \rangle$   
 and  $\mathbf{v} - \text{proj}_{\mathbf{b}}\mathbf{v} = \langle 1/5, -2/5 \rangle$

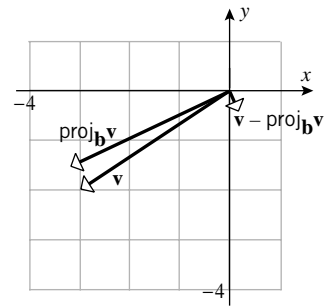

22. (a)  $\frac{\mathbf{b}}{\|\mathbf{b}\|} = \langle 1/3, 2/3, 2/3 \rangle$ , so  $\text{proj}_{\mathbf{b}}\mathbf{v} = \langle 2/3, 4/3, 4/3 \rangle$  and  $\mathbf{v} - \text{proj}_{\mathbf{b}}\mathbf{v} = \langle 4/3, -7/3, 5/3 \rangle$

(b)  $\frac{\mathbf{b}}{\|\mathbf{b}\|} = \langle 2/7, 3/7, -6/7 \rangle$ , so  $\text{proj}_{\mathbf{b}}\mathbf{v} = \langle -74/49, -111/49, 222/49 \rangle$   
 and  $\mathbf{v} - \text{proj}_{\mathbf{b}}\mathbf{v} = \langle 270/49, 62/49, 121/49 \rangle$

23. (a)  $\text{proj}_{\mathbf{b}}\mathbf{v} = \langle -1, -1 \rangle$ , so  $\mathbf{v} = \langle -1, -1 \rangle + \langle 3, -3 \rangle$

(b)  $\text{proj}_{\mathbf{b}}\mathbf{v} = \langle 16/5, 0, -8/5 \rangle$ , so  $\mathbf{v} = \langle 16/5, 0, -8/5 \rangle + \langle -1/5, 1, -2/5 \rangle$

24. (a)  $\text{proj}_{\mathbf{b}}\mathbf{v} = \langle 1, 1 \rangle$ , so  $\mathbf{v} = \langle 1, 1 \rangle + \langle -4, 4 \rangle$

(b)  $\text{proj}_{\mathbf{b}}\mathbf{v} = \langle 0, -8/5, 4/5 \rangle$ , so  $\mathbf{v} = \langle 0, -8/5, 4/5 \rangle + \langle -2, 13/5, 26/5 \rangle$

25.  $\vec{AP} = -\mathbf{i} + 3\mathbf{j}$ ,  $\vec{AB} = 3\mathbf{i} + 4\mathbf{j}$ ,  $\|\text{proj}_{\vec{AB}}\vec{AP}\| = |\vec{AP} \cdot \vec{AB}| / \|\vec{AB}\| = 9/5$   
 $\|\vec{AP}\| = \sqrt{10}$ ,  $\sqrt{10 - 81/25} = 13/5$

26.  $\vec{AP} = -4\mathbf{i} + 2\mathbf{k}$ ,  $\vec{AB} = -3\mathbf{i} + 2\mathbf{j} - 4\mathbf{k}$ ,  $\|\text{proj}_{\vec{AB}}\vec{AP}\| = |\vec{AP} \cdot \vec{AB}| / \|\vec{AB}\| = 4/\sqrt{29}$ .  
 $\|\vec{AP}\| = \sqrt{20}$ ,  $\sqrt{20 - 16/29} = \sqrt{564/29}$

27. Let  $\mathbf{F}$  be the downward force of gravity on the block, then  $\|\mathbf{F}\| = 10(9.8) = 98$  N, and if  $\mathbf{F}_1$  and  $\mathbf{F}_2$  are the forces parallel to and perpendicular to the ramp, then  $\|\mathbf{F}_1\| = \|\mathbf{F}_2\| = 49\sqrt{2}$  N. Thus the block exerts a force of  $49\sqrt{2}$  N against the ramp and it requires a force of  $49\sqrt{2}$  N to prevent the block from sliding down the ramp.

28. Let  $x$  denote the magnitude of the force in the direction of  $\mathbf{Q}$ . Then the force  $\mathbf{F}$  acting on the block is  $\mathbf{F} = x\mathbf{i} - 10\mathbf{j}$ . Let  $\mathbf{u} = -\frac{1}{\sqrt{2}}(\mathbf{i} + \mathbf{j})$  and  $\mathbf{v} = \frac{1}{\sqrt{2}}(\mathbf{i} - \mathbf{j})$  be the unit vectors in the directions along and against the ramp. Then  $\mathbf{F}$  decomposes as  $\mathbf{F} = -\frac{x-10}{\sqrt{2}}\mathbf{u} + \frac{x+10}{\sqrt{2}}\mathbf{v}$ , and thus the block will not slide down the ramp provided  $x \geq 10$  N.

29. Three forces act on the block: its weight  $-300\mathbf{j}$ ; the tension in cable A, which has the form  $a(-\mathbf{i} + \mathbf{j})$ ; and the tension in cable B, which has the form  $b(\sqrt{3}\mathbf{i} - \mathbf{j})$ , where  $a, b$  are positive constants. The sum of these forces is zero, which yields  $a = 450 + 150\sqrt{3}$ ,  $b = 150 + 150\sqrt{3}$ . Thus the forces along cables A and B are, respectively,  
 $\|150(3 + \sqrt{3})(\mathbf{i} - \mathbf{j})\| = 450\sqrt{2} + 150\sqrt{6}$  lb, and  $\|150(\sqrt{3} + 1)(\sqrt{3}\mathbf{i} - \mathbf{j})\| = 300 + 300\sqrt{3}$  lb.

30. (a) Let  $\mathbf{T}_A$  and  $\mathbf{T}_B$  be the forces exerted on the block by cables  $A$  and  $B$ . Then  $\mathbf{T}_A = a(-10\mathbf{i} + d\mathbf{j})$  and  $\mathbf{T}_B = b(20\mathbf{i} + d\mathbf{j})$  for some positive  $a, b$ . Since  $\mathbf{T}_A + \mathbf{T}_B - 100\mathbf{j} = \mathbf{0}$ , we find  $a = \frac{200}{3d}$ ,  $b = \frac{100}{3d}$ ,  $\mathbf{T}_A = -\frac{2000}{3d}\mathbf{i} + \frac{200}{3}\mathbf{j}$ , and  $\mathbf{T}_B = \frac{2000}{3d}\mathbf{i} + \frac{100}{3}\mathbf{j}$ .

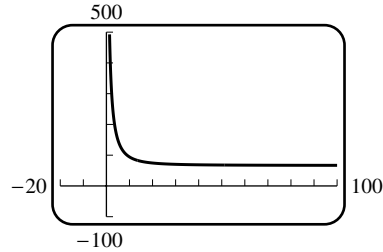

- (b) An increase in  $d$  will decrease both forces.

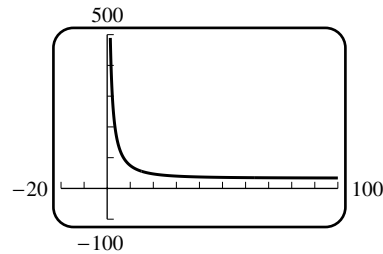

- (c) The inequality  $\|\mathbf{T}_A\| \leq 150$  is equivalent to  $d \geq \frac{40}{\sqrt{65}}$ , and  $\|\mathbf{T}_B\| \leq 150$  is equivalent to  $d \geq \frac{40}{\sqrt{77}}$ . Hence we must have  $d \geq \frac{40}{65}$ .

31. Let  $P$  and  $Q$  be the points  $(1,3)$  and  $(4,7)$  then  $\vec{PQ} = 3\mathbf{i} + 4\mathbf{j}$  so  $W = \mathbf{F} \cdot \vec{PQ} = -12 \text{ ft} \cdot \text{lb}$ .

32.  $W = \mathbf{F} \cdot \vec{PQ} = \|\mathbf{F}\| \|\vec{PQ}\| \cos 45^\circ = (500)(100) \left(\frac{\sqrt{2}}{2}\right) = 25,000\sqrt{2} \text{ N} \cdot \text{m}$

33.  $W = \mathbf{F} \cdot 15\mathbf{i} = 15 \cdot 50 \cos 60^\circ = 375 \text{ ft} \cdot \text{lb}$ .

34.  $W = \mathbf{F} \cdot (15/\sqrt{3})(\mathbf{i} + \mathbf{j} + \mathbf{k}) = -15/\sqrt{3} \text{ N} \cdot \text{m}$

35. With the cube as shown in the diagram, and  $a$  the length of each edge,  
 $\mathbf{d}_1 = a\mathbf{i} + a\mathbf{j} + a\mathbf{k}$ ,  $\mathbf{d}_2 = a\mathbf{i} + a\mathbf{j} - a\mathbf{k}$ ,  
 $\cos \theta = (\mathbf{d}_1 \cdot \mathbf{d}_2) / (\|\mathbf{d}_1\| \|\mathbf{d}_2\|) = 1/3$ ,  $\theta \approx 71^\circ$

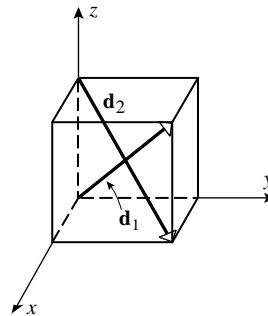

36. Take  $\mathbf{i}$ ,  $\mathbf{j}$ , and  $\mathbf{k}$  along adjacent edges of the box, then  $10\mathbf{i} + 15\mathbf{j} + 25\mathbf{k}$  is along a diagonal, and a unit vector in this direction is  $\frac{2}{\sqrt{38}}\mathbf{i} + \frac{3}{\sqrt{38}}\mathbf{j} + \frac{5}{\sqrt{38}}\mathbf{k}$ . The direction cosines are  $\cos \alpha = 2/\sqrt{38}$ ,  $\cos \beta = 3/\sqrt{38}$ , and  $\cos \gamma = 5/\sqrt{38}$  so  $\alpha \approx 71^\circ$ ,  $\beta \approx 61^\circ$ , and  $\gamma \approx 36^\circ$ .

37.  $\mathbf{u} + \mathbf{v}$  and  $\mathbf{u} - \mathbf{v}$  are vectors along the diagonals,

$$(\mathbf{u} + \mathbf{v}) \cdot (\mathbf{u} - \mathbf{v}) = \mathbf{u} \cdot \mathbf{u} - \mathbf{u} \cdot \mathbf{v} + \mathbf{v} \cdot \mathbf{u} - \mathbf{v} \cdot \mathbf{v} = \|\mathbf{u}\|^2 - \|\mathbf{v}\|^2 \text{ so } (\mathbf{u} + \mathbf{v}) \cdot (\mathbf{u} - \mathbf{v}) = 0$$

if and only if  $\|\mathbf{u}\| = \|\mathbf{v}\|$ .

38. The diagonals have lengths  $\|\mathbf{u} + \mathbf{v}\|$  and  $\|\mathbf{u} - \mathbf{v}\|$  but

$$\|\mathbf{u} + \mathbf{v}\|^2 = (\mathbf{u} + \mathbf{v}) \cdot (\mathbf{u} + \mathbf{v}) = \|\mathbf{u}\|^2 + 2\mathbf{u} \cdot \mathbf{v} + \|\mathbf{v}\|^2, \text{ and}$$

$\|\mathbf{u} - \mathbf{v}\|^2 = (\mathbf{u} - \mathbf{v}) \cdot (\mathbf{u} - \mathbf{v}) = \|\mathbf{u}\|^2 - 2\mathbf{u} \cdot \mathbf{v} + \|\mathbf{v}\|^2$ . If the parallelogram is a rectangle then  $\mathbf{u} \cdot \mathbf{v} = 0$  so  $\|\mathbf{u} + \mathbf{v}\|^2 = \|\mathbf{u} - \mathbf{v}\|^2$ ; the diagonals are equal. If the diagonals are equal, then  $4\mathbf{u} \cdot \mathbf{v} = 0$ ,  $\mathbf{u} \cdot \mathbf{v} = 0$  so  $\mathbf{u}$  is perpendicular to  $\mathbf{v}$  and hence the parallelogram is a rectangle.

39.  $\|\mathbf{u} + \mathbf{v}\|^2 = (\mathbf{u} + \mathbf{v}) \cdot (\mathbf{u} + \mathbf{v}) = \|\mathbf{u}\|^2 + 2\mathbf{u} \cdot \mathbf{v} + \|\mathbf{v}\|^2$  and

$$\|\mathbf{u} - \mathbf{v}\|^2 = (\mathbf{u} - \mathbf{v}) \cdot (\mathbf{u} - \mathbf{v}) = \|\mathbf{u}\|^2 - 2\mathbf{u} \cdot \mathbf{v} + \|\mathbf{v}\|^2, \text{ add to get}$$

$$\|\mathbf{u} + \mathbf{v}\|^2 + \|\mathbf{u} - \mathbf{v}\|^2 = 2\|\mathbf{u}\|^2 + 2\|\mathbf{v}\|^2$$

The sum of the squares of the lengths of the diagonals of a parallelogram is equal to twice the sum of the squares of the lengths of the sides.

40.  $\|\mathbf{u} + \mathbf{v}\|^2 = (\mathbf{u} + \mathbf{v}) \cdot (\mathbf{u} + \mathbf{v}) = \|\mathbf{u}\|^2 + 2\mathbf{u} \cdot \mathbf{v} + \|\mathbf{v}\|^2$  and

$$\|\mathbf{u} - \mathbf{v}\|^2 = (\mathbf{u} - \mathbf{v}) \cdot (\mathbf{u} - \mathbf{v}) = \|\mathbf{u}\|^2 - 2\mathbf{u} \cdot \mathbf{v} + \|\mathbf{v}\|^2, \text{ subtract to get}$$

$$\|\mathbf{u} + \mathbf{v}\|^2 - \|\mathbf{u} - \mathbf{v}\|^2 = 4\mathbf{u} \cdot \mathbf{v}, \text{ the result follows by dividing both sides by 4.}$$

41.  $\mathbf{v} = c_1\mathbf{v}_1 + c_2\mathbf{v}_2 + c_3\mathbf{v}_3$  so  $\mathbf{v} \cdot \mathbf{v}_i = c_i\mathbf{v}_i \cdot \mathbf{v}_i$  because  $\mathbf{v}_i \cdot \mathbf{v}_j = 0$  if  $i \neq j$ ,

thus  $\mathbf{v} \cdot \mathbf{v}_i = c_i\|\mathbf{v}_i\|^2$ ,  $c_i = \mathbf{v} \cdot \mathbf{v}_i / \|\mathbf{v}_i\|^2$  for  $i = 1, 2, 3$ .

42.  $\mathbf{v}_1 \cdot \mathbf{v}_2 = \mathbf{v}_1 \cdot \mathbf{v}_3 = \mathbf{v}_2 \cdot \mathbf{v}_3 = 0$  so they are mutually perpendicular. Let  $\mathbf{v} = \mathbf{i} - \mathbf{j} + \mathbf{k}$ , then

$$c_1 = \frac{\mathbf{v} \cdot \mathbf{v}_1}{\|\mathbf{v}_1\|^2} = \frac{3}{7}, c_2 = \frac{\mathbf{v} \cdot \mathbf{v}_2}{\|\mathbf{v}_2\|^2} = -\frac{1}{3}, \text{ and } c_3 = \frac{\mathbf{v} \cdot \mathbf{v}_3}{\|\mathbf{v}_3\|^2} = \frac{1}{21}.$$

43. (a)  $\mathbf{u} = x\mathbf{i} + (x^2 + 1)\mathbf{j}$ ,  $\mathbf{v} = x\mathbf{i} - (x + 1)\mathbf{j}$ ,  $\theta = \cos^{-1}[(\mathbf{u} \cdot \mathbf{v}) / (\|\mathbf{u}\|\|\mathbf{v}\|)]$ .

Solve  $d\theta/dx = 0$  to find that the minimum value of  $\theta$  occurs when  $x \approx -3.136742$  so the minimum angle is about  $40^\circ$ .

(b) Solve  $\mathbf{u} \cdot \mathbf{v} = 0$  for  $x$  to get  $x \approx -0.682328$ .

44. (a)  $\mathbf{u} = \cos\theta_1\mathbf{i} \pm \sin\theta_1\mathbf{j}$ ,  $\mathbf{v} = \pm \sin\theta_2\mathbf{j} + \cos\theta_2\mathbf{k}$ ,  $\cos\theta = \mathbf{u} \cdot \mathbf{v} = \pm \sin\theta_1 \sin\theta_2$

(b)  $\cos\theta = \pm \sin^2 45^\circ = \pm 1/2$ ,  $\theta = 60^\circ$

(c) Let  $\theta(t) = \cos^{-1}(\sin t \sin 2t)$ ; solve  $\theta'(t) = 0$  for  $t$  to find that  $\theta_{\max} \approx 140^\circ$  (reject, since  $\theta$  is acute) when  $t \approx 2.186276$  and that  $\theta_{\min} \approx 40^\circ$  when  $t \approx 0.955317$ ; for  $\theta_{\max}$  check the endpoints  $t = 0, \pi/2$  to obtain  $\theta_{\max} = \cos^{-1}(0) = \pi/2$ .

45. Let  $\mathbf{u} = \langle u_1, u_2, u_3 \rangle$ ,  $\mathbf{v} = \langle v_1, v_2, v_3 \rangle$ ,  $\mathbf{w} = \langle w_1, w_2, w_3 \rangle$ . Then

$$\begin{aligned} \mathbf{u} \cdot (\mathbf{v} + \mathbf{w}) &= \langle u_1(v_1 + w_1), u_2(v_2 + w_2), u_3(v_3 + w_3) \rangle = \langle u_1v_1 + u_1w_1, u_2v_2 + u_2w_2, u_3v_3 + u_3w_3 \rangle \\ &= \langle u_1v_1, u_2v_2, u_3v_3 \rangle + \langle u_1w_1, u_2w_2, u_3w_3 \rangle = \mathbf{u} \cdot \mathbf{v} + \mathbf{u} \cdot \mathbf{w} \end{aligned}$$

$$\mathbf{0} \cdot \mathbf{v} = 0 \cdot v_1 + 0 \cdot v_2 + 0 \cdot v_3 = 0$$

## EXERCISE SET 13.4

$$1. \quad (\text{a}) \quad \mathbf{i} \times (\mathbf{i} + \mathbf{j} + \mathbf{k}) = \begin{vmatrix} \mathbf{i} & \mathbf{j} & \mathbf{k} \\ 1 & 0 & 0 \\ 1 & 1 & 1 \end{vmatrix} = -\mathbf{j} + \mathbf{k}$$

$$(\text{b}) \quad \mathbf{i} \times (\mathbf{i} + \mathbf{j} + \mathbf{k}) = (\mathbf{i} \times \mathbf{i}) + (\mathbf{i} \times \mathbf{j}) + (\mathbf{i} \times \mathbf{k}) = -\mathbf{j} + \mathbf{k}$$

$$2. \quad (\text{a}) \quad \mathbf{j} \times (\mathbf{i} + \mathbf{j} + \mathbf{k}) = \begin{vmatrix} \mathbf{i} & \mathbf{j} & \mathbf{k} \\ 0 & 1 & 0 \\ 1 & 1 & 1 \end{vmatrix} = \mathbf{i} - \mathbf{k}$$

$$\mathbf{j} \times (\mathbf{i} + \mathbf{j} + \mathbf{k}) = (\mathbf{j} \times \mathbf{i}) + (\mathbf{j} \times \mathbf{j}) + (\mathbf{j} \times \mathbf{k}) = \mathbf{i} - \mathbf{k}$$

$$(\text{b}) \quad \mathbf{k} \times (\mathbf{i} + \mathbf{j} + \mathbf{k}) = \begin{vmatrix} \mathbf{i} & \mathbf{j} & \mathbf{k} \\ 0 & 0 & 1 \\ 1 & 1 & 1 \end{vmatrix} = -\mathbf{i} + \mathbf{j}$$

$$\mathbf{k} \times (\mathbf{i} + \mathbf{j} + \mathbf{k}) = (\mathbf{k} \times \mathbf{i}) + (\mathbf{k} \times \mathbf{j}) + (\mathbf{k} \times \mathbf{k}) = \mathbf{j} - \mathbf{i} + \mathbf{0} = -\mathbf{i} + \mathbf{j}$$

3.  $\langle 7, 10, 9 \rangle$

4.  $-\mathbf{i} - 2\mathbf{j} - 7\mathbf{k}$

5.  $\langle -4, -6, -3 \rangle$

6.  $\mathbf{i} + 2\mathbf{j} - 4\mathbf{k}$

7. (a)  $\mathbf{v} \times \mathbf{w} = \langle -23, 7, -1 \rangle, \mathbf{u} \times (\mathbf{v} \times \mathbf{w}) = \langle -20, -67, -9 \rangle$

(b)  $\mathbf{u} \times \mathbf{v} = \langle -10, -14, 2 \rangle, (\mathbf{u} \times \mathbf{v}) \times \mathbf{w} = \langle -78, 52, -26 \rangle$

(c)  $(\mathbf{u} \times \mathbf{v}) \times (\mathbf{v} \times \mathbf{w}) = \langle -10, -14, 2 \rangle \times \langle -23, 7, -1 \rangle = \langle 0, -56, -392 \rangle$

(d)  $(\mathbf{v} \times \mathbf{w}) \times (\mathbf{u} \times \mathbf{v}) = \langle 0, 56, 392 \rangle$

9.  $\mathbf{u} \times \mathbf{v} = (\mathbf{i} + \mathbf{j}) \times (\mathbf{i} + \mathbf{j} + \mathbf{k}) = \mathbf{k} - \mathbf{j} - \mathbf{k} + \mathbf{i} = \mathbf{i} - \mathbf{j}$ , the direction cosines are  $\frac{1}{\sqrt{2}}, -\frac{1}{\sqrt{2}}, 0$

10.  $\mathbf{u} \times \mathbf{v} = 12\mathbf{i} + 30\mathbf{j} - 6\mathbf{k}$ , so  $\pm \left( \frac{2}{\sqrt{30}}\mathbf{i} + \frac{\sqrt{5}}{\sqrt{6}}\mathbf{j} - \frac{1}{\sqrt{30}}\mathbf{k} \right)$

11.  $\mathbf{n} = \overrightarrow{AB} \times \overrightarrow{AC} = \langle 1, 1, -3 \rangle \times \langle -1, 3, -1 \rangle = \langle 8, 4, 4 \rangle$ , unit vectors are  $\pm \frac{1}{\sqrt{6}}\langle 2, 1, 1 \rangle$

12. A vector parallel to the  $yz$ -plane must be perpendicular to  $\mathbf{i}$ ;

$\mathbf{i} \times (3\mathbf{i} - \mathbf{j} + 2\mathbf{k}) = -2\mathbf{j} - \mathbf{k}$ ,  $\| -2\mathbf{j} - \mathbf{k} \| = \sqrt{5}$ , the unit vectors are  $\pm(2\mathbf{j} + \mathbf{k})/\sqrt{5}$ .

13.  $A = \|\mathbf{u} \times \mathbf{v}\| = \| -7\mathbf{i} - \mathbf{j} + 3\mathbf{k} \| = \sqrt{59}$

14.  $A = \|\mathbf{u} \times \mathbf{v}\| = \| -6\mathbf{i} + 4\mathbf{j} + 7\mathbf{k} \| = \sqrt{101}$

15.  $A = \frac{1}{2} \|\overrightarrow{PQ} \times \overrightarrow{PR}\| = \frac{1}{2} \|\langle -1, -5, 2 \rangle \times \langle 2, 0, 3 \rangle\| = \frac{1}{2} \|\langle -15, 7, 10 \rangle\| = \sqrt{374}/2$

16.  $A = \frac{1}{2} \|\overrightarrow{PQ} \times \overrightarrow{PR}\| = \frac{1}{2} \|\langle -1, 4, 8 \rangle \times \langle 5, 2, 12 \rangle\| = \frac{1}{2} \|\langle 32, 52, -22 \rangle\| = 9\sqrt{13}$

17. 80

18. 29

19. -3

20. 1

21.  $V = |\mathbf{u} \cdot (\mathbf{v} \times \mathbf{w})| = |-16| = 16$

22.  $V = |\mathbf{u} \cdot (\mathbf{v} \times \mathbf{w})| = |45| = 45$

23. (a)  $\mathbf{u} \cdot (\mathbf{v} \times \mathbf{w}) = 0$ , yes

(b)  $\mathbf{u} \cdot (\mathbf{v} \times \mathbf{w}) = 0$ , yes

(c)  $\mathbf{u} \cdot (\mathbf{v} \times \mathbf{w}) = 245$ , no



24. (a)  $\mathbf{u} \cdot (\mathbf{w} \times \mathbf{v}) = -\mathbf{u} \cdot (\mathbf{v} \times \mathbf{w}) = -3$  (b)  $(\mathbf{v} \times \mathbf{w}) \cdot \mathbf{u} = \mathbf{u} \cdot (\mathbf{v} \times \mathbf{w}) = 3$   
 (c)  $\mathbf{w} \cdot (\mathbf{u} \times \mathbf{v}) = \mathbf{u} \cdot (\mathbf{v} \times \mathbf{w}) = 3$  (d)  $\mathbf{v} \cdot (\mathbf{u} \times \mathbf{w}) = \mathbf{u} \cdot (\mathbf{w} \times \mathbf{v}) = -3$   
 (e)  $(\mathbf{u} \times \mathbf{w}) \cdot \mathbf{v} = \mathbf{u} \cdot (\mathbf{w} \times \mathbf{v}) = -3$  (f)  $\mathbf{v} \cdot (\mathbf{w} \times \mathbf{w}) = 0$  because  $\mathbf{w} \times \mathbf{w} = \mathbf{0}$

25. (a)  $V = |\mathbf{u} \cdot (\mathbf{v} \times \mathbf{w})| = |-9| = 9$  (b)  $A = \|\mathbf{u} \times \mathbf{w}\| = \|3\mathbf{i} - 8\mathbf{j} + 7\mathbf{k}\| = \sqrt{122}$   
 (c)  $\mathbf{v} \times \mathbf{w} = -3\mathbf{i} - \mathbf{j} + 2\mathbf{k}$  is perpendicular to the plane determined by  $\mathbf{v}$  and  $\mathbf{w}$ ; let  $\theta$  be the angle between  $\mathbf{u}$  and  $\mathbf{v} \times \mathbf{w}$  then

$$\cos \theta = \frac{\mathbf{u} \cdot (\mathbf{v} \times \mathbf{w})}{\|\mathbf{u}\| \|\mathbf{v} \times \mathbf{w}\|} = \frac{-9}{\sqrt{14}\sqrt{14}} = -9/14$$

so the acute angle  $\phi$  that  $\mathbf{u}$  makes with the plane determined by  $\mathbf{v}$  and  $\mathbf{w}$  is  $\phi = \theta - \pi/2 = \sin^{-1}(9/14)$ .

26. From the diagram,

$$d = \|\mathbf{u}\| \sin \theta = \frac{\|\mathbf{u}\| \|\mathbf{v}\| \sin \theta}{\|\mathbf{v}\|} = \frac{\|\mathbf{u} \times \mathbf{v}\|}{\|\mathbf{v}\|}$$

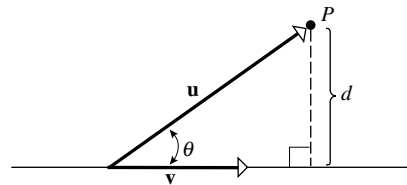

27. (a)  $\vec{u} = \vec{AP} = -4\mathbf{i} + 2\mathbf{k}$ ,  $\vec{v} = \vec{AB} = -3\mathbf{i} + 2\mathbf{j} - 4\mathbf{k}$ ,  $\mathbf{u} \times \mathbf{v} = -4\mathbf{i} - 22\mathbf{j} - 8\mathbf{k}$ ;  
 distance =  $\|\mathbf{u} \times \mathbf{v}\|/\|\mathbf{v}\| = 2\sqrt{141}/29$   
 (b)  $\vec{u} = \vec{AP} = 2\mathbf{i} + 2\mathbf{j}$ ,  $\vec{v} = \vec{AB} = -2\mathbf{i} + \mathbf{j}$ ,  $\mathbf{u} \times \mathbf{v} = 6\mathbf{k}$ ; distance =  $\|\mathbf{u} \times \mathbf{v}\|/\|\mathbf{v}\| = 6/\sqrt{5}$

28. Take  $\mathbf{v}$  and  $\mathbf{w}$  as sides of the (triangular) base, then area of base =  $\frac{1}{2}\|\mathbf{v} \times \mathbf{w}\|$  and height =  $\|\text{proj}_{\mathbf{v} \times \mathbf{w}} \mathbf{u}\| = \frac{|\mathbf{u} \cdot (\mathbf{v} \times \mathbf{w})|}{\|\mathbf{v} \times \mathbf{w}\|}$  so  $V = \frac{1}{3}$  (area of base) (height) =  $\frac{1}{6}|\mathbf{u} \cdot (\mathbf{v} \times \mathbf{w})|$

29.  $\vec{PQ} = \langle 3, -1, -3 \rangle$ ,  $\vec{PR} = \langle 2, -2, 1 \rangle$ ,  $\vec{PS} = \langle 4, -4, 3 \rangle$ ,  
 $V = \frac{1}{6} |\vec{PQ} \cdot (\vec{PR} \times \vec{PS})| = \frac{1}{6} |-4| = 2/3$

30. (a)  $\cos \theta = \frac{\mathbf{u} \cdot \mathbf{v}}{\|\mathbf{u}\| \|\mathbf{v}\|} = -\frac{23}{49}$  (b)  $\sin \theta = \frac{\|\mathbf{u} \times \mathbf{v}\|}{\|\mathbf{u}\| \|\mathbf{v}\|} = \frac{\|36\mathbf{i} - 24\mathbf{j}\|}{49} = \frac{12\sqrt{13}}{49}$   
 (c)  $\frac{23^2}{49^2} + \frac{144 \cdot 13}{49^2} = \frac{2401}{49^2} = 1$

31. From Theorems 13.3.3 and 13.4.5a it follows that  $\sin \theta = \cos \theta$ , so  $\theta = \pi/4$ .

32.  $\|\mathbf{u} \times \mathbf{v}\|^2 = \|\mathbf{u}\|^2 \|\mathbf{v}\|^2 \sin^2 \theta = \|\mathbf{u}\|^2 \|\mathbf{v}\|^2 (1 - \cos^2 \theta) = \|\mathbf{u}\|^2 \|\mathbf{v}\|^2 - (\mathbf{u} \cdot \mathbf{v})^2$

33. (a)  $\mathbf{F} = 10\mathbf{j}$  and  $\vec{PQ} = \mathbf{i} + \mathbf{j} + \mathbf{k}$ , so the vector moment of  $\mathbf{F}$  about  $P$  is

$$\vec{PQ} \times \mathbf{F} = \begin{vmatrix} \mathbf{i} & \mathbf{j} & \mathbf{k} \\ 1 & 1 & 1 \\ 0 & 10 & 0 \end{vmatrix} = -10\mathbf{i} + 10\mathbf{k}, \text{ and the scalar moment is } 10\sqrt{2} \text{ lb}\cdot\text{ft.}$$

The direction of rotation of the cube about  $P$  is counterclockwise looking along  $\vec{PQ} \times \mathbf{F} = -10\mathbf{i} + 10\mathbf{k}$  toward its initial point.

- (b)  $\mathbf{F} = 10\mathbf{j}$  and  $\overrightarrow{PQ} = \mathbf{j} + \mathbf{k}$ , so the vector moment of  $\mathbf{F}$  about  $P$  is

$$\overrightarrow{PQ} \times \mathbf{F} = \begin{vmatrix} \mathbf{i} & \mathbf{j} & \mathbf{k} \\ 0 & 1 & 1 \\ 0 & 10 & 0 \end{vmatrix} = -10\mathbf{i}, \text{ and the scalar moment is } 10 \text{ lb}\cdot\text{ft. The direction of rotation}$$

of the cube about  $P$  is counterclockwise looking along  $-10\mathbf{i}$  toward its initial point.

- (c)  $\mathbf{F} = 10\mathbf{j}$  and  $\overrightarrow{PQ} = \mathbf{j}$ , so the vector moment of  $\mathbf{F}$  about  $P$  is

$$\overrightarrow{PQ} \times \mathbf{F} = \begin{vmatrix} \mathbf{i} & \mathbf{j} & \mathbf{k} \\ 0 & 1 & 0 \\ 0 & 10 & 0 \end{vmatrix} = \mathbf{0}, \text{ and the scalar moment is } 0 \text{ lb}\cdot\text{ft. Since the force is parallel to}$$

the direction of motion, there is no rotation about  $P$ .

34. (a)  $\mathbf{F} = \frac{1000}{\sqrt{2}}(-\mathbf{i} + \mathbf{k})$  and  $\overrightarrow{PQ} = 2\mathbf{j} - \mathbf{k}$ , so the vector moment of  $\mathbf{F}$  about  $P$  is

$$\overrightarrow{PQ} \times \mathbf{F} = 500\sqrt{2} \begin{vmatrix} \mathbf{i} & \mathbf{j} & \mathbf{k} \\ 0 & 2 & -1 \\ -1 & 0 & 1 \end{vmatrix} = 500\sqrt{2}(2\mathbf{i} + \mathbf{j} + 2\mathbf{k}), \text{ and the scalar moment is } 1500\sqrt{2} \text{ N}\cdot\text{m.}$$

- (b) The direction angles of the vector moment of  $\mathbf{F}$  about the point  $P$  are  $\cos^{-1}(2/3) \approx 48^\circ$ ,  $\cos^{-1}(1/3) \approx 71^\circ$ , and  $\cos^{-1}(2/3) \approx 48^\circ$ .

35.  $\mathbf{F}$  makes an angle  $72^\circ$  with the positive  $x$ -axis, and  $\overrightarrow{PQ} = 0.2\mathbf{i} + 0.03\mathbf{j}$  makes an angle  $\alpha = \tan^{-1}(0.03/0.2)$  with the  $x$ -axis, so  $\phi \approx 72^\circ - 8.53^\circ = 63.47^\circ$  and  $\|\mathbf{F}\| = 200 \text{ N}$ , so  $\|\overrightarrow{PQ} \times \mathbf{F}\| = \|\overrightarrow{PQ}\|\|\mathbf{F}\|\sin 63.47^\circ = 200\|(0.2\mathbf{i} + 0.030\mathbf{j})\|\sin 63.47^\circ \approx 36.19 \text{ N}\cdot\text{m}$ .

36. Part (b): let  $\mathbf{u} = \langle u_1, u_2, u_3 \rangle$ ,  $\mathbf{v} = \langle v_1, v_2, v_3 \rangle$ , and  $\mathbf{w} = \langle w_1, w_2, w_3 \rangle$ ; show that  $\mathbf{u} \times (\mathbf{v} + \mathbf{w})$  and  $(\mathbf{u} \times \mathbf{v}) + (\mathbf{u} \times \mathbf{w})$  are the same.

$$\begin{aligned} \text{Part (c): } (\mathbf{u} + \mathbf{v}) \times \mathbf{w} &= -[\mathbf{w} \times (\mathbf{u} + \mathbf{v})] \text{ from part (a)} \\ &= -[(\mathbf{w} \times \mathbf{u}) + (\mathbf{w} \times \mathbf{v})] \text{ from part (b)} \\ &= (\mathbf{u} \times \mathbf{w}) + (\mathbf{v} \times \mathbf{w}) \text{ from part (a)} \end{aligned}$$

37. Let  $\mathbf{u} = \langle u_1, u_2, u_3 \rangle$  and  $\mathbf{v} = \langle v_1, v_2, v_3 \rangle$ ; show that  $k(\mathbf{u} \times \mathbf{v})$ ,  $(k\mathbf{u}) \times \mathbf{v}$ , and  $\mathbf{u} \times (k\mathbf{v})$  are all the same; Part (e) is proved in a similar fashion.

38. Suppose the first two rows are interchanged. Then by definition,

$$\begin{aligned} \begin{vmatrix} b_1 & b_2 & b_3 \\ a_1 & a_2 & a_3 \\ c_1 & c_2 & c_3 \end{vmatrix} &= b_1 \begin{vmatrix} a_2 & a_3 \\ c_2 & c_3 \end{vmatrix} - b_2 \begin{vmatrix} a_1 & a_3 \\ c_1 & c_3 \end{vmatrix} + b_3 \begin{vmatrix} a_1 & a_2 \\ c_1 & c_2 \end{vmatrix} \\ &= b_1(a_2c_3 - a_3c_2) - b_2(a_1c_3 - a_3c_1) + b_3(a_1c_2 - a_2c_1), \end{aligned}$$

which is the negative of the right hand side of (2) after expansion. If two other rows were to be exchanged, a similar proof would hold. Finally, suppose  $\Delta$  were a determinant with two identical rows. Then the value is unchanged if we interchange those two rows, yet  $\Delta = -\Delta$  by Part (b) of Theorem 13.4.1. Hence  $\Delta = -\Delta$ ,  $\Delta = 0$ .

39.  $-8\mathbf{i} - 20\mathbf{j} + 2\mathbf{k}, -8\mathbf{i} - 8\mathbf{k}$

40. (a) From the first formula in Exercise 39 it follows that  $\mathbf{u} \times (\mathbf{v} \times \mathbf{w})$  is a linear combination of  $\mathbf{v}$  and  $\mathbf{w}$  and hence lies in the plane determined by them.

- (b) Similar to (a).

41. If  $\mathbf{a}$ ,  $\mathbf{b}$ ,  $\mathbf{c}$ , and  $\mathbf{d}$  lie in the same plane then  $\mathbf{a} \times \mathbf{b}$  and  $\mathbf{c} \times \mathbf{d}$  are parallel so  $(\mathbf{a} \times \mathbf{b}) \times (\mathbf{c} \times \mathbf{d}) = \mathbf{0}$
42. Let  $\mathbf{u}$  and  $\mathbf{v}$  be the vectors from a point on the curve to the points  $(2, -1, 0)$  and  $(3, 2, 2)$ , respectively. Then  $\mathbf{u} = (2-x)\mathbf{i} + (-1-\ln x)\mathbf{j}$  and  $\mathbf{v} = (3-x)\mathbf{i} + (2-\ln x)\mathbf{j} + 2\mathbf{k}$ . The area of the triangle is given by  $A = (1/2)\|\mathbf{u} \times \mathbf{v}\|$ ; solve  $dA/dx = 0$  for  $x$  to get  $x = 2.091581$ . The minimum area is 1.887850.
43.  $\overrightarrow{PQ'} \times \mathbf{F} = \overrightarrow{PQ} \times \mathbf{F} + \overrightarrow{QQ'} \times \mathbf{F} = \overrightarrow{PQ} \times \mathbf{F}$ , since  $\mathbf{F}$  and  $\overrightarrow{QQ'}$  are parallel.

### EXERCISE SET 13.5

In many of the Exercises in this section other answers are also possible.

1. (a)  $L_1: P(1, 0), \mathbf{v} = \mathbf{j}, x = 1, y = t$   
 $L_2: P(0, 1), \mathbf{v} = \mathbf{i}, x = t, y = 1$   
 $L_3: P(0, 0), \mathbf{v} = \mathbf{i} + \mathbf{j}, x = t, y = t$
- (b)  $L_1: P(1, 1, 0), \mathbf{v} = \mathbf{k}, x = 1, y = 1, z = t$   
 $L_2: P(0, 1, 1), \mathbf{v} = \mathbf{i}, x = t, y = 1, z = 1$   
 $L_3: P(1, 0, 1), \mathbf{v} = \mathbf{j}, x = 1, y = t, z = 1$   
 $L_4: P(0, 0, 0), \mathbf{v} = \mathbf{i} + \mathbf{j} + \mathbf{k}, x = t,$   
 $y = t, z = t$
2. (a)  $L_1: x = t, y = 1, 0 \leq t \leq 1$   
 $L_2: x = 1, y = t, 0 \leq t \leq 1$   
 $L_3: x = t, y = t, 0 \leq t \leq 1$
- (b)  $L_1: x = 1, y = 1, z = t, 0 \leq t \leq 1$   
 $L_2: x = t, y = 1, z = 1, 0 \leq t \leq 1$   
 $L_3: x = 1, y = t, z = 1, 0 \leq t \leq 1$   
 $L_4: x = t, y = t, z = t, 0 \leq t \leq 1$
3. (a)  $\overrightarrow{P_1P_2} = \langle 2, 3 \rangle$  so  $x = 3 + 2t, y = -2 + 3t$  for the line; for the line segment add the condition  $0 \leq t \leq 1$ .
- (b)  $\overrightarrow{P_1P_2} = \langle -3, 6, 1 \rangle$  so  $x = 5 - 3t, y = -2 + 6t, z = 1 + t$  for the line; for the line segment add the condition  $0 \leq t \leq 1$ .
4. (a)  $\overrightarrow{P_1P_2} = \langle -3, -5 \rangle$  so  $x = -3t, y = 1 - 5t$  for the line; for the line segment add the condition  $0 \leq t \leq 1$ .
- (b)  $\overrightarrow{P_1P_2} = \langle 0, 0, -3 \rangle$  so  $x = -1, y = 3, z = 5 - 3t$  for the line; for the line segment add the condition  $0 \leq t \leq 1$ .
5. (a)  $x = 2 + t, y = -3 - 4t$
- (b)  $x = t, y = -t, z = 1 + t$
6. (a)  $x = 3 + 2t, y = -4 + t$
- (b)  $x = -1 - t, y = 3t, z = 2$
7. (a)  $\mathbf{r}_0 = 2\mathbf{i} - \mathbf{j}$  so  $P(2, -1)$  is on the line, and  $\mathbf{v} = 4\mathbf{i} - \mathbf{j}$  is parallel to the line.
- (b) At  $t = 0, P(-1, 2, 4)$  is on the line, and  $\mathbf{v} = 5\mathbf{i} + 7\mathbf{j} - 8\mathbf{k}$  is parallel to the line.
8. (a) At  $t = 0, P(-1, 5)$  is on the line, and  $\mathbf{v} = 2\mathbf{i} + 3\mathbf{j}$  is parallel to the line.
- (b)  $\mathbf{r}_0 = \mathbf{i} + \mathbf{j} - 2\mathbf{k}$  so  $P(1, 1, -2)$  is on the line, and  $\mathbf{v} = \mathbf{j}$  is parallel to the line.
9. (a)  $\langle x, y \rangle = \langle -3, 4 \rangle + t\langle 1, 5 \rangle; \mathbf{r} = -3\mathbf{i} + 4\mathbf{j} + t(\mathbf{i} + 5\mathbf{j})$
- (b)  $\langle x, y, z \rangle = \langle 2, -3, 0 \rangle + t\langle -1, 5, 1 \rangle; \mathbf{r} = 2\mathbf{i} - 3\mathbf{j} + t(-\mathbf{i} + 5\mathbf{j} + \mathbf{k})$
10. (a)  $\langle x, y \rangle = \langle 0, -2 \rangle + t\langle 1, 1 \rangle; \mathbf{r} = -2\mathbf{j} + t(\mathbf{i} + \mathbf{j})$
- (b)  $\langle x, y, z \rangle = \langle 1, -7, 4 \rangle + t\langle 1, 3, -5 \rangle; \mathbf{r} = \mathbf{i} - 7\mathbf{j} + 4\mathbf{k} + t(\mathbf{i} + 3\mathbf{j} - 5\mathbf{k})$
11.  $x = -5 + 2t, y = 2 - 3t$
12.  $x = t, y = 3 - 2t$

13.  $2x + 2yy' = 0$ ,  $y' = -x/y = -(3)/(-4) = 3/4$ ,  $\mathbf{v} = 4\mathbf{i} + 3\mathbf{j}$ ;  $x = 3 + 4t$ ,  $y = -4 + 3t$
14.  $y' = 2x = 2(-2) = -4$ ,  $\mathbf{v} = \mathbf{i} - 4\mathbf{j}$ ;  $x = -2 + t$ ,  $y = 4 - 4t$
15.  $x = -1 + 3t$ ,  $y = 2 - 4t$ ,  $z = 4 + t$                       16.  $x = 2 - t$ ,  $y = -1 + 2t$ ,  $z = 5 + 7t$
17. The line is parallel to the vector  $\langle 2, -1, 2 \rangle$  so  $x = -2 + 2t$ ,  $y = -t$ ,  $z = 5 + 2t$ .
18. The line is parallel to the vector  $\langle 1, 1, 0 \rangle$  so  $x = t$ ,  $y = t$ ,  $z = 0$ .
19. (a)  $y = 0$ ,  $2 - t = 0$ ,  $t = 2$ ,  $x = 7$                       (b)  $x = 0$ ,  $1 + 3t = 0$ ,  $t = -1/3$ ,  $y = 7/3$   
 (c)  $y = x^2$ ,  $2 - t = (1 + 3t)^2$ ,  $9t^2 + 7t - 1 = 0$ ,  $t = \frac{-7 \pm \sqrt{85}}{18}$ ,  $x = \frac{-1 \pm \sqrt{85}}{6}$ ,  $y = \frac{43 \mp \sqrt{85}}{18}$
20.  $(4t)^2 + (3t)^2 = 25$ ,  $25t^2 = 25$ ,  $t = \pm 1$ , the line intersects the circle at  $\pm \langle 4, 3 \rangle$
21. (a)  $z = 0$  when  $t = 3$  so the point is  $(-2, 10, 0)$   
 (b)  $y = 0$  when  $t = -2$  so the point is  $(-2, 0, -5)$   
 (c)  $x$  is always  $-2$  so the line does not intersect the  $yz$ -plane
22. (a)  $z = 0$  when  $t = 4$  so the point is  $(7, 7, 0)$   
 (b)  $y = 0$  when  $t = -3$  so the point is  $(-7, 0, 7)$   
 (c)  $x = 0$  when  $t = 1/2$  so the point is  $(0, 7/2, 7/2)$
23.  $(1 + t)^2 + (3 - t)^2 = 16$ ,  $t^2 - 2t - 3 = 0$ ,  $(t + 1)(t - 3) = 0$ ;  $t = -1, 3$ . The points of intersection are  $(0, 4, -2)$  and  $(4, 0, 6)$ .
24.  $2(3t) + 3(-1 + 2t) = 6$ ,  $12t = 9$ ;  $t = 3/4$ . The point of intersection is  $(5/4, 9/4, 1/2)$ .
25. The lines intersect if we can find values of  $t_1$  and  $t_2$  that satisfy the equations  $2 + t_1 = 2 + t_2$ ,  $2 + 3t_1 = 3 + 4t_2$ , and  $3 + t_1 = 4 + 2t_2$ . Solutions of the first two of these equations are  $t_1 = -1$ ,  $t_2 = -1$  which also satisfy the third equation so the lines intersect at  $(1, -1, 2)$ .
26. Solve the equations  $-1 + 4t_1 = -13 + 12t_2$ ,  $3 + t_1 = 1 + 6t_2$ , and  $1 = 2 + 3t_2$ . The third equation yields  $t_2 = -1/3$  which when substituted into the first and second equations gives  $t_1 = -4$  in both cases; the lines intersect at  $(-17, -1, 1)$ .
27. The lines are parallel, respectively, to the vectors  $\langle 7, 1, -3 \rangle$  and  $\langle -1, 0, 2 \rangle$ . These vectors are not parallel so the lines are not parallel. The system of equations  $1 + 7t_1 = 4 - t_2$ ,  $3 + t_1 = 6$ , and  $5 - 3t_1 = 7 + 2t_2$  has no solution so the lines do not intersect.
28. The vectors  $\langle 8, -8, 10 \rangle$  and  $\langle 8, -3, 1 \rangle$  are not parallel so the lines are not parallel. The lines do not intersect because the system of equations  $2 + 8t_1 = 3 + 8t_2$ ,  $6 - 8t_1 = 5 - 3t_2$ ,  $10t_1 = 6 + t_2$  has no solution.
29. The lines are parallel, respectively, to the vectors  $\mathbf{v}_1 = \langle -2, 1, -1 \rangle$  and  $\mathbf{v}_2 = \langle -4, 2, -2 \rangle$ ;  $\mathbf{v}_2 = 2\mathbf{v}_1$ ,  $\mathbf{v}_1$  and  $\mathbf{v}_2$  are parallel so the lines are parallel.
30. The lines are not parallel because the vectors  $\langle 3, -2, 3 \rangle$  and  $\langle 9, -6, 8 \rangle$  are not parallel.
31.  $\overrightarrow{P_1P_2} = \langle 3, -7, -7 \rangle$ ,  $\overrightarrow{P_2P_3} = \langle -9, -7, -3 \rangle$ ; these vectors are not parallel so the points do not lie on the same line.

32.  $\vec{P_1P_2} = \langle 2, -4, -4 \rangle$ ,  $\vec{P_2P_3} = \langle 1, -2, -2 \rangle$ ;  $\vec{P_1P_2} = 2 \vec{P_2P_3}$  so the vectors are parallel and the points lie on the same line.
33. If  $t_2$  gives the point  $\langle -1 + 3t_2, 9 - 6t_2 \rangle$  on the second line, then  $t_1 = 4 - 3t_2$  yields the point  $\langle 3 - (4 - 3t_2), 1 + 2(4 - 3t_2) \rangle = \langle -1 + 3t_2, 9 - 6t_2 \rangle$  on the first line, so each point of  $L_2$  is a point of  $L_1$ ; the converse is shown with  $t_2 = (4 - t_1)/3$ .
34. If  $t_1$  gives the point  $\langle 1 + 3t_1, -2 + t_1, 2t_1 \rangle$  on  $L_1$ , then  $t_2 = (1 - t_1)/2$  gives the point  $\langle 4 - 6(1 - t_1)/2, -1 - 2(1 - t_1)/2, 2 - 4(1 - t_1)/2 \rangle = \langle 1 + 3t_1, -2 + t_1, 2t_1 \rangle$  on  $L_2$ , so each point of  $L_1$  is a point of  $L_2$ ; the converse is shown with  $t_1 = 1 - 2t_2$ .
35. The line segment joining the points  $(1, 0)$  and  $(-3, 6)$ .
36. The line segment joining the points  $(-2, 1, 4)$  and  $(7, 1, 1)$ .
37.  $A(3, 0, 1)$  and  $B(2, 1, 3)$  are on the line, and (method of Exercise 25)  
 $\vec{AP} = -5\mathbf{i} + \mathbf{j}$ ,  $\vec{AB} = -\mathbf{i} + \mathbf{j} + 2\mathbf{k}$ ,  $\|\text{proj}_{\vec{AB}} \vec{AP}\| = |\vec{AP} \cdot \vec{AB}| / \|\vec{AB}\| = \sqrt{6}$  and  $\|\vec{AP}\| = \sqrt{26}$ ,  
 so distance  $= \sqrt{26 - 6} = 4\sqrt{5}$ . Using the method of Exercise 26, distance  $= \frac{\|\vec{AP} \times \vec{AB}\|}{\|\vec{AB}\|} = 2\sqrt{5}$ .
38.  $A(2, -1, 0)$  and  $B(3, -2, 3)$  are on the line, and (method of Exercise 25)  
 $\vec{AP} = -\mathbf{i} + 5\mathbf{j} - 3\mathbf{k}$ ,  $\vec{AB} = \mathbf{i} - \mathbf{j} + 3\mathbf{k}$ ,  $\|\text{proj}_{\vec{AB}} \vec{AP}\| = |\vec{AP} \cdot \vec{AB}| / \|\vec{AB}\| = \frac{15}{\sqrt{11}}$  and  
 $\|\vec{AP}\| = \sqrt{35}$ , so distance  $= \sqrt{35 - 225/11} = 4\sqrt{10/11}$ . Using the method of Exercise 26,  
 distance  $= \frac{\|\vec{AP} \times \vec{AB}\|}{\|\vec{AB}\|} = 4\sqrt{10/11}$ .
39. The vectors  $\mathbf{v}_1 = -\mathbf{i} + 2\mathbf{j} + \mathbf{k}$  and  $\mathbf{v}_2 = 2\mathbf{i} - 4\mathbf{j} - 2\mathbf{k}$  are parallel to the lines,  $\mathbf{v}_2 = -2\mathbf{v}_1$  so  $\mathbf{v}_1$  and  $\mathbf{v}_2$  are parallel. Let  $t = 0$  to get the points  $P(2, 0, 1)$  and  $Q(1, 3, 5)$  on the first and second lines, respectively. Let  $\mathbf{u} = \vec{PQ} = -\mathbf{i} + 3\mathbf{j} + 4\mathbf{k}$ ,  $\mathbf{v} = \frac{1}{2}\mathbf{v}_2 = \mathbf{i} - 2\mathbf{j} - \mathbf{k}$ ;  $\mathbf{u} \times \mathbf{v} = 5\mathbf{i} + 3\mathbf{j} - \mathbf{k}$ ; by the method of Exercise 26 of Section 13.4, distance  $= \|\mathbf{u} \times \mathbf{v}\| / \|\mathbf{v}\| = \sqrt{35/6}$ .
40. The vectors  $\mathbf{v}_1 = 2\mathbf{i} + 4\mathbf{j} - 6\mathbf{k}$  and  $\mathbf{v}_2 = 3\mathbf{i} + 6\mathbf{j} - 9\mathbf{k}$  are parallel to the lines,  $\mathbf{v}_2 = (3/2)\mathbf{v}_1$  so  $\mathbf{v}_1$  and  $\mathbf{v}_2$  are parallel. Let  $t = 0$  to get the points  $P(0, 3, 2)$  and  $Q(1, 0, 0)$  on the first and second lines, respectively. Let  $\mathbf{u} = \vec{PQ} = \mathbf{i} - 3\mathbf{j} - 2\mathbf{k}$ ,  $\mathbf{v} = \frac{1}{2}\mathbf{v}_1 = \mathbf{i} + 2\mathbf{j} - 3\mathbf{k}$ ;  $\mathbf{u} \times \mathbf{v} = 13\mathbf{i} + \mathbf{j} + 5\mathbf{k}$ , distance  $= \|\mathbf{u} \times \mathbf{v}\| / \|\mathbf{v}\| = \sqrt{195/14}$  (Exer. 26, Section 13.4).
41. (a) The line is parallel to the vector  $\langle x_1 - x_0, y_1 - y_0, z_1 - z_0 \rangle$  so  
 $x = x_0 + (x_1 - x_0)t$ ,  $y = y_0 + (y_1 - y_0)t$ ,  $z = z_0 + (z_1 - z_0)t$   
 (b) The line is parallel to the vector  $\langle a, b, c \rangle$  so  $x = x_1 + at$ ,  $y = y_1 + bt$ ,  $z = z_1 + ct$
42. Solve each of the given parametric equations (2) for  $t$  to get  $t = (x - x_0)/a$ ,  $t = (y - y_0)/b$ ,  
 $t = (z - z_0)/c$ , so  $(x, y, z)$  is on the line if and only if  $(x - x_0)/a = (y - y_0)/b = (z - z_0)/c$ .
43. (a) It passes through the point  $(1, -3, 5)$  and is parallel to  $\mathbf{v} = 2\mathbf{i} + 4\mathbf{j} + \mathbf{k}$   
 (b)  $\langle x, y, z \rangle = \langle 1 + 2t, -3 + 4t, 5 + t \rangle$
44. Let the desired point be  $P(x_0, y_0, z_0)$ , then  $\vec{P_1P} = (2/3) \vec{P_1P_2}$ ,  
 $\langle x_0 - 1, y_0 - 4, z_0 + 3 \rangle = (2/3)\langle 0, 1, 2 \rangle = \langle 0, 2/3, 4/3 \rangle$ ; equate corresponding components to get  
 $x_0 = 1$ ,  $y_0 = 14/3$ ,  $z_0 = -5/3$ .

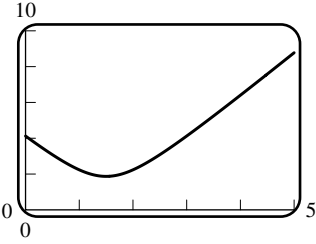
45. (a) Let  $t = 3$  and  $t = -2$ , respectively, in the equations for  $L_1$  and  $L_2$ .  
 (b)  $\mathbf{u} = 2\mathbf{i} - \mathbf{j} - 2\mathbf{k}$  and  $\mathbf{v} = \mathbf{i} + 3\mathbf{j} - \mathbf{k}$  are parallel to  $L_1$  and  $L_2$ ,  
 $\cos \theta = \mathbf{u} \cdot \mathbf{v} / (\|\mathbf{u}\| \|\mathbf{v}\|) = 1 / (3\sqrt{11}), \theta \approx 84^\circ$ .  
 (c)  $\mathbf{u} \times \mathbf{v} = 7\mathbf{i} + 7\mathbf{k}$  is perpendicular to both  $L_1$  and  $L_2$ , and hence so is  $\mathbf{i} + \mathbf{k}$ , thus  $x = 7 + t$ ,  
 $y = -1, z = -2 + t$ .
46. (a) Let  $t = 1/2$  and  $t = 1$ , respectively, in the equations for  $L_1$  and  $L_2$ .  
 (b)  $\mathbf{u} = 4\mathbf{i} - 2\mathbf{j} + 2\mathbf{k}$  and  $\mathbf{v} = \mathbf{i} - \mathbf{j} + 4\mathbf{k}$  are parallel to  $L_1$  and  $L_2$ ,  
 $\cos \theta = \mathbf{u} \cdot \mathbf{v} / (\|\mathbf{u}\| \|\mathbf{v}\|) = 14 / \sqrt{432}, \theta \approx 48^\circ$ .  
 (c)  $\mathbf{u} \times \mathbf{v} = -6\mathbf{i} - 14\mathbf{j} - 2\mathbf{k}$  is perpendicular to both  $L_1$  and  $L_2$ , and hence so is  $3\mathbf{i} + 7\mathbf{j} + \mathbf{k}$ ,  
 thus  $x = 2 + 3t, y = 7t, z = 3 + t$ .
47.  $(0, 1, 2)$  is on the given line ( $t = 0$ ) so  $\mathbf{u} = \mathbf{j} - \mathbf{k}$  is a vector from this point to the point  $(0, 2, 1)$ ,  
 $\mathbf{v} = 2\mathbf{i} - \mathbf{j} + \mathbf{k}$  is parallel to the given line.  $\mathbf{u} \times \mathbf{v} = -2\mathbf{j} - 2\mathbf{k}$ , and hence  $\mathbf{w} = \mathbf{j} + \mathbf{k}$ , is perpendicular  
 to both lines so  $\mathbf{v} \times \mathbf{w} = -2\mathbf{i} - 2\mathbf{j} + 2\mathbf{k}$ , and hence  $\mathbf{i} + \mathbf{j} - \mathbf{k}$ , is parallel to the line we seek. Thus  
 $x = t, y = 2 + t, z = 1 - t$  are parametric equations of the line.
48.  $(-2, 4, 2)$  is on the given line ( $t = 0$ ) so  $\mathbf{u} = 5\mathbf{i} - 3\mathbf{j} - 4\mathbf{k}$  is a vector from this point to the point  
 $(3, 1, -2)$ ,  $\mathbf{v} = 2\mathbf{i} + 2\mathbf{j} + \mathbf{k}$  is parallel to the given line.  $\mathbf{u} \times \mathbf{v} = 5\mathbf{i} - 13\mathbf{j} + 16\mathbf{k}$  is perpendicular to  
 both lines so  $\mathbf{v} \times (\mathbf{u} \times \mathbf{v}) = 45\mathbf{i} - 27\mathbf{j} - 36\mathbf{k}$ , and hence  $5\mathbf{i} - 3\mathbf{j} - 4\mathbf{k}$  is parallel to the line we seek.  
 Thus  $x = 3 + 5t, y = 1 - 3t, z = -2 - 4t$  are parametric equations of the line.
49. (a) When  $t = 0$  the bugs are at  $(4, 1, 2)$  and  $(0, 1, 1)$  so the distance between them is  
 $\sqrt{4^2 + 0^2 + 1^2} = \sqrt{17}$  cm.  
 (b)   
 (c) The distance has a minimum value.
- (d) Minimize  $D^2$  instead of  $D$  (the distance between the bugs).  
 $D^2 = [t - (4 - t)]^2 + [(1 + t) - (1 + 2t)]^2 + [(1 + 2t) - (2 + t)]^2 = 6t^2 - 18t + 17$ ,  
 $d(D^2)/dt = 12t - 18 = 0$  when  $t = 3/2$ ; the minimum  
 distance is  $\sqrt{6(3/2)^2 - 18(3/2) + 17} = \sqrt{14}/2$  cm.
50. The line intersects the  $xz$ -plane when  $t = -1$ , the  $xy$ -plane when  $t = 3/2$ . Along the line,  
 $T = 25t^2(1 + t)(3 - 2t)$  for  $-1 \leq t \leq 3/2$ . Solve  $dT/dt = 0$  for  $t$  to find that the maximum value  
 of  $T$  is about 50.96 when  $t \approx 1.073590$ .

### EXERCISE SET 13.6

- $x = 3, y = 4, z = 5$
- $x = x_0, y = y_0, z = z_0$
- $(x - 2) + 4(y - 6) + 2(z - 1) = 0, x + 4y + 2z = 28$
- $-(x + 1) + 7(y + 1) + 6(z - 2) = 0, -x + 7y + 6z = 6$



23. Find two points  $P_1$  and  $P_2$  on the line of intersection of the given planes and then find an equation of the plane that contains  $P_1$ ,  $P_2$ , and the given point  $P_0(-1, 4, 2)$ . Let  $(x_0, y_0, z_0)$  be on the line of intersection of the given planes; then  $4x_0 - y_0 + z_0 - 2 = 0$  and  $2x_0 + y_0 - 2z_0 - 3 = 0$ , eliminate  $y_0$  by addition of the equations to get  $6x_0 - z_0 - 5 = 0$ ; if  $x_0 = 0$  then  $z_0 = -5$ , if  $x_0 = 1$  then  $z_0 = 1$ . Substitution of these values of  $x_0$  and  $z_0$  into either of the equations of the planes gives the corresponding values  $y_0 = -7$  and  $y_0 = 3$  so  $P_1(0, -7, -5)$  and  $P_2(1, 3, 1)$  are on the line of intersection of the planes.  $\overrightarrow{P_0P_1} \times \overrightarrow{P_0P_2} = \langle 4, -13, 21 \rangle$  is normal to the desired plane whose equation is  $4x - 13y + 21z = -14$ .
24.  $\langle 1, 2, -1 \rangle$  is parallel to the line and hence normal to the plane  $x + 2y - z = 10$
25.  $\mathbf{n}_1 = \langle 2, 1, 1 \rangle$  and  $\mathbf{n}_2 = \langle 1, 2, 1 \rangle$  are normals to the given planes,  $\mathbf{n}_1 \times \mathbf{n}_2 = \langle -1, -1, 3 \rangle$  so  $\langle 1, 1, -3 \rangle$  is normal to the desired plane whose equation is  $x + y - 3z = 6$ .
26.  $\mathbf{n} = \langle 4, -1, 3 \rangle$  is normal to the given plane,  $\overrightarrow{P_1P_2} = \langle 3, -1, -1 \rangle$  is parallel to the line,  $\mathbf{n} \times \overrightarrow{P_1P_2} = \langle 4, 13, -1 \rangle$  is normal to the desired plane whose equation is  $4x + 13y - z = 1$ .
27.  $\mathbf{n}_1 = \langle 2, -1, 1 \rangle$  and  $\mathbf{n}_2 = \langle 1, 1, -2 \rangle$  are normals to the given planes,  $\mathbf{n}_1 \times \mathbf{n}_2 = \langle 1, 5, 3 \rangle$  is normal to the desired plane whose equation is  $x + 5y + 3z = -6$ .
28. Let  $t = 0$  and  $t = 1$  to get the points  $P_1(-1, 0, -4)$  and  $P_2(0, 1, -2)$  that lie on the line. Denote the given point by  $P_0$ , then  $\overrightarrow{P_0P_1} \times \overrightarrow{P_0P_2} = \langle 7, -1, -3 \rangle$  is normal to the desired plane whose equation is  $7x - y - 3z = 5$ .
29. The plane is the perpendicular bisector of the line segment that joins  $P_1(2, -1, 1)$  and  $P_2(3, 1, 5)$ . The midpoint of the line segment is  $(5/2, 0, 3)$  and  $\overrightarrow{P_1P_2} = \langle 1, 2, 4 \rangle$  is normal to the plane so an equation is  $x + 2y + 4z = 29/2$ .
30.  $\mathbf{n}_1 = \langle 2, -1, 1 \rangle$  and  $\mathbf{n}_2 = \langle 0, 1, 1 \rangle$  are normals to the given planes,  $\mathbf{n}_1 \times \mathbf{n}_2 = \langle -2, -2, 2 \rangle$  so  $\mathbf{n} = \langle 1, 1, -1 \rangle$  is parallel to the line of intersection of the planes.  $\mathbf{v} = \langle 3, 1, 2 \rangle$  is parallel to the given line,  $\mathbf{v} \times \mathbf{n} = \langle -3, 5, 2 \rangle$  so  $\langle 3, -5, -2 \rangle$  is normal to the desired plane. Let  $t = 0$  to find the point  $(0, 1, 0)$  that lies on the given line and hence on the desired plane. An equation of the plane is  $3x - 5y - 2z = -5$ .
31. The line is parallel to the line of intersection of the planes if it is parallel to both planes. Normals to the given planes are  $\mathbf{n}_1 = \langle 1, -4, 2 \rangle$  and  $\mathbf{n}_2 = \langle 2, 3, -1 \rangle$  so  $\mathbf{n}_1 \times \mathbf{n}_2 = \langle -2, 5, 11 \rangle$  is parallel to the line of intersection of the planes and hence parallel to the desired line whose equations are  $x = 5 - 2t$ ,  $y = 5t$ ,  $z = -2 + 11t$ .
32. Denote the points by  $A, B, C$ , and  $D$ , respectively. The points lie in the same plane if  $\overrightarrow{AB} \times \overrightarrow{AC}$  and  $\overrightarrow{AB} \times \overrightarrow{AD}$  are parallel (method 1).  $\overrightarrow{AB} \times \overrightarrow{AC} = \langle 0, -10, 5 \rangle$ ,  $\overrightarrow{AB} \times \overrightarrow{AD} = \langle 0, 16, -8 \rangle$ , these vectors are parallel because  $\langle 0, -10, 5 \rangle = (-10/16)\langle 0, 16, -8 \rangle$ . The points lie in the same plane if  $D$  lies in the plane determined by  $A, B, C$  (method 2), and since  $\overrightarrow{AB} \times \overrightarrow{AC} = \langle 0, -10, 5 \rangle$ , an equation of the plane is  $-2y + z + 1 = 0$ ,  $2y - z = 1$  which is satisfied by the coordinates of  $D$ .
33.  $\mathbf{v} = \langle 0, 1, 1 \rangle$  is parallel to the line.
- (a) For any  $t$ ,  $6 \cdot 0 + 4t - 4t = 0$ , so  $(0, t, t)$  is in the plane.
- (b)  $\mathbf{n} = \langle 5, -3, 3 \rangle$  is normal to the plane,  $\mathbf{v} \cdot \mathbf{n} = 0$  so the line is parallel to the plane.  $(0, 0, 0)$  is on the line,  $(0, 0, 1/3)$  is on the plane. The line is below the plane because  $(0, 0, 0)$  is below  $(0, 0, 1/3)$ .



- (c)  $\mathbf{n} = \langle 6, 2, -2 \rangle$ ,  $\mathbf{v} \cdot \mathbf{n} = 0$  so the line is parallel to the plane.  $(0,0,0)$  is on the line,  $(0,0,-3/2)$  is on the plane. The line is above the plane because  $(0,0,0)$  is above  $(0,0,-3/2)$ .
34. The intercepts correspond to the points  $A(a, 0, 0)$ ,  $B(0, b, 0)$ , and  $C(0, 0, c)$ .  $\overrightarrow{AB} \times \overrightarrow{AC} = \langle bc, ac, ab \rangle$  is normal to the plane so  $bcx + acy + abz = abc$  or  $x/a + y/b + z/c = 1$ .
35.  $\mathbf{v}_1 = \langle 1, 2, -1 \rangle$  and  $\mathbf{v}_2 = \langle -1, -2, 1 \rangle$  are parallel, respectively, to the given lines and to each other so the lines are parallel. Let  $t = 0$  to find the points  $P_1(-2, 3, 4)$  and  $P_2(3, 4, 0)$  that lie, respectively, on the given lines.  $\mathbf{v}_1 \times \overrightarrow{P_1P_2} = \langle -7, -1, -9 \rangle$  so  $\langle 7, 1, 9 \rangle$  is normal to the desired plane whose equation is  $7x + y + 9z = 25$ .
36. The system  $4t_1 - 1 = 12t_2 - 13$ ,  $t_1 + 3 = 6t_2 + 1$ ,  $1 = 3t_2 + 2$  has the solution (Exercise 26, Section 13.5)  $t_1 = -4$ ,  $t_2 = -1/3$  so  $(-17, -1, 1)$  is the point of intersection.  $\mathbf{v}_1 = \langle 4, 1, 0 \rangle$  and  $\mathbf{v}_2 = \langle 12, 6, 3 \rangle$  are (respectively) parallel to the lines,  $\mathbf{v}_1 \times \mathbf{v}_2 = \langle 3, -12, 12 \rangle$  so  $\langle 1, -4, 4 \rangle$  is normal to the desired plane whose equation is  $x - 4y + 4z = -9$ .
37.  $\mathbf{n}_1 = \langle -2, 3, 7 \rangle$  and  $\mathbf{n}_2 = \langle 1, 2, -3 \rangle$  are normals to the planes,  $\mathbf{n}_1 \times \mathbf{n}_2 = \langle -23, 1, -7 \rangle$  is parallel to the line of intersection. Let  $z = 0$  in both equations and solve for  $x$  and  $y$  to get  $x = -11/7$ ,  $y = -12/7$  so  $(-11/7, -12/7, 0)$  is on the line, a parametrization of which is  $x = -11/7 - 23t$ ,  $y = -12/7 + t$ ,  $z = -7t$ .
38. Similar to Exercise 37 with  $\mathbf{n}_1 = \langle 3, -5, 2 \rangle$ ,  $\mathbf{n}_2 = \langle 0, 0, 1 \rangle$ ,  $\mathbf{n}_1 \times \mathbf{n}_2 = \langle -5, -3, 0 \rangle$ .  $z = 0$  so  $3x - 5y = 0$ , let  $x = 0$  then  $y = 0$  and  $(0,0,0)$  is on the line, a parametrization of which is  $x = -5t$ ,  $y = -3t$ ,  $z = 0$ .
39.  $D = |2(1) - 2(-2) + (3) - 4|/\sqrt{4 + 4 + 1} = 5/3$
40.  $D = |3(0) + 6(1) - 2(5) - 5|/\sqrt{9 + 36 + 4} = 9/7$
41.  $(0,0,0)$  is on the first plane so  $D = |6(0) - 3(0) - 3(0) - 5|/\sqrt{36 + 9 + 9} = 5/\sqrt{54}$ .
42.  $(0,0,1)$  is on the first plane so  $D = |(0) + (0) + (1) + 1|/\sqrt{1 + 1 + 1} = 2/\sqrt{3}$ .
43.  $(1,3,5)$  and  $(4,6,7)$  are on  $L_1$  and  $L_2$ , respectively.  $\mathbf{v}_1 = \langle 7, 1, -3 \rangle$  and  $\mathbf{v}_2 = \langle -1, 0, 2 \rangle$  are, respectively, parallel to  $L_1$  and  $L_2$ ,  $\mathbf{v}_1 \times \mathbf{v}_2 = \langle 2, -11, 1 \rangle$  so the plane  $2x - 11y + z + 51 = 0$  contains  $L_2$  and is parallel to  $L_1$ ,  $D = |2(1) - 11(3) + (5) + 51|/\sqrt{4 + 121 + 1} = 25/\sqrt{126}$ .
44.  $(3,4,1)$  and  $(0,3,0)$  are on  $L_1$  and  $L_2$ , respectively.  $\mathbf{v}_1 = \langle -1, 4, 2 \rangle$  and  $\mathbf{v}_2 = \langle 1, 0, 2 \rangle$  are parallel to  $L_1$  and  $L_2$ ,  $\mathbf{v}_1 \times \mathbf{v}_2 = \langle 8, 4, -4 \rangle = 4\langle 2, 1, -1 \rangle$  so  $2x + y - z - 3 = 0$  contains  $L_2$  and is parallel to  $L_1$ ,  $D = |2(3) + (4) - (1) - 3|/\sqrt{4 + 1 + 1} = \sqrt{6}$ .
45. The distance between  $(2, 1, -3)$  and the plane is  $|2 - 3(1) + 2(-3) - 4|/\sqrt{1 + 9 + 4} = 11/\sqrt{14}$  which is the radius of the sphere; an equation is  $(x - 2)^2 + (y - 1)^2 + (z + 3)^2 = 121/14$ .
46. The vector  $2\mathbf{i} + \mathbf{j} - \mathbf{k}$  is normal to the plane and hence parallel to the line so parametric equations of the line are  $x = 3 + 2t$ ,  $y = 1 + t$ ,  $z = -t$ . Substitution into the equation of the plane yields  $2(3 + 2t) + (1 + t) - (-t) = 0$ ,  $t = -7/6$ ; the point of intersection is  $(2/3, -1/6, 7/6)$ .
47.  $\mathbf{v} = \langle 1, 2, -1 \rangle$  is parallel to the line,  $\mathbf{n} = \langle 2, -2, -2 \rangle$  is normal to the plane,  $\mathbf{v} \cdot \mathbf{n} = 0$  so  $\mathbf{v}$  is parallel to the plane because  $\mathbf{v}$  and  $\mathbf{n}$  are perpendicular.  $(-1, 3, 0)$  is on the line so  $D = |2(-1) - 2(3) - 2(0) + 3|/\sqrt{4 + 4 + 4} = 5/\sqrt{12}$

48. (a)

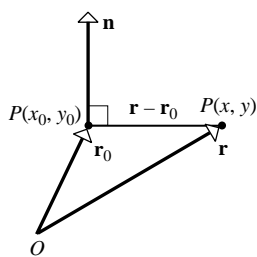

(b)  $\mathbf{n} \cdot (\mathbf{r} - \mathbf{r}_0) = a(x - x_0) + b(y - y_0) = 0$

(c) See the proof of Theorem 13.6.1. Since  $a$  and  $b$  are not both zero, there is at least one point  $(x_0, y_0)$  that satisfies  $ax + by + d = 0$ , so  $ax_0 + by_0 + d = 0$ . If  $(x, y)$  also satisfies  $ax + by + d = 0$  then, subtracting,  $a(x - x_0) + b(y - y_0) = 0$ , which is the equation of a line with  $\mathbf{n} = \langle a, b \rangle$  as normal.

(d) Let  $Q(x_1, y_1)$  be a point on the line, and position the normal  $\mathbf{n} = \langle a, b \rangle$ , with length  $\sqrt{a^2 + b^2}$ , so that its initial point is at  $Q$ . The distance is the orthogonal projection of  $\overrightarrow{QP_0} = \langle x_0 - x_1, y_0 - y_1 \rangle$  onto  $\mathbf{n}$ . Then

$$D = \|\text{proj}_{\mathbf{n}} \overrightarrow{QP_0}\| = \left\| \frac{\overrightarrow{QP_0} \cdot \mathbf{n}}{\|\mathbf{n}\|^2} \mathbf{n} \right\| = \frac{|ax_0 + by_0 + d|}{\sqrt{a^2 + b^2}}.$$

49.  $D = |2(-3) + (5) - 1|/\sqrt{4+1} = 2/\sqrt{5}$

50. (a) If  $\langle x_0, y_0, z_0 \rangle$  lies on the second plane, so that  $ax_0 + by_0 + cz_0 + d_2 = 0$ , then by Theorem 13.6.2, the distance between the planes is  $D = \frac{|ax_0 + by_0 + cz_0 + d_1|}{\sqrt{a^2 + b^2 + c^2}} = \frac{|-d_2 + d_1|}{\sqrt{a^2 + b^2 + c^2}}$

(b) The distance between the planes  $-2x + y + z = 0$  and  $-2x + y + z + \frac{5}{3} = 0$  is

$$D = \frac{|0 - 5/3|}{\sqrt{4+1+1}} = \frac{5}{3\sqrt{6}}.$$

### EXERCISE SET 13.7

- elliptic paraboloid,  $a = 2, b = 3$
  - hyperbolic paraboloid,  $a = 1, b = 5$
  - hyperboloid of one sheet,  $a = b = c = 4$
  - circular cone,  $a = b = 1$
  - elliptic paraboloid,  $a = 2, b = 1$
  - hyperboloid of two sheets,  $a = b = c = 1$
- ellipsoid,  $a = \sqrt{2}/2, b = 1/2, e = \sqrt{3}/3$
  - hyperbolic paraboloid,  $a = b = 1$
  - hyperboloid of one sheet,  $a = 1, b = 3, c = 1$
  - hyperboloid of two sheets,  $a = 1, b = 2, c = 1$
  - elliptic paraboloid,  $a = \sqrt{2}, b = \sqrt{2}/2$
  - elliptic cone,  $a = 2, b = \sqrt{3}$

3. (a)  $-z = x^2 + y^2$ , circular paraboloid opening down the negative  $z$ -axis

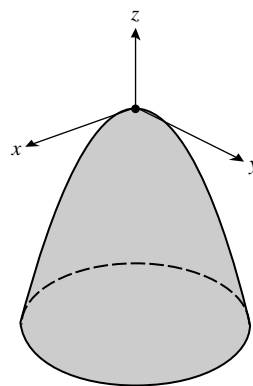

- (b)  $z = x^2 + y^2$ , circular paraboloid, no change  
 (c)  $z = x^2 + y^2$ , circular paraboloid, no change  
 (d)  $z = x^2 + y^2$ , circular paraboloid, no change

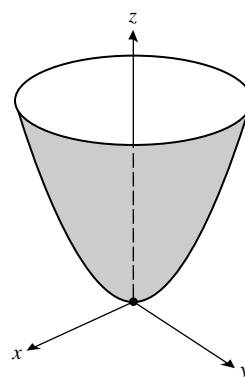

- (e)  $x = y^2 + z^2$ , circular paraboloid opening along the positive  $x$ -axis

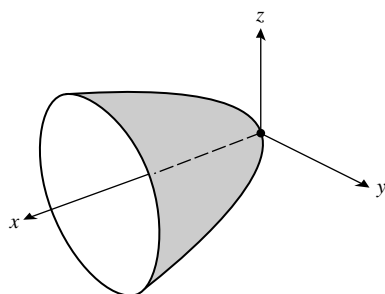

- (f)  $y = x^2 + z^2$ , circular paraboloid opening along the positive  $y$ -axis

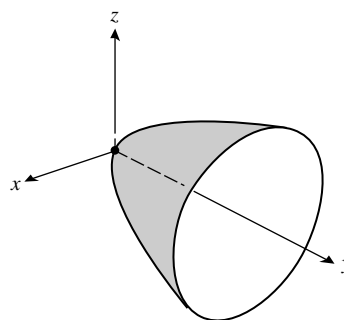

4. (a)  $x^2 + y^2 - z^2 = 1$ , no change  
 (b)  $x^2 + y^2 - z^2 = 1$ , no change  
 (c)  $x^2 + y^2 - z^2 = 1$ , no change  
 (d)  $x^2 + y^2 - z^2 = 1$ , no change

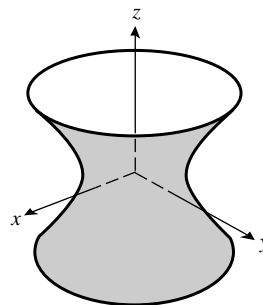



(c)  $x = 0 : \frac{y^2}{16} - \frac{z^2}{4} = 1; y = 0 : \frac{x^2}{9} - \frac{z^2}{4} = 1;$   
 $z = 0 : \frac{x^2}{9} + \frac{y^2}{16} = 1$

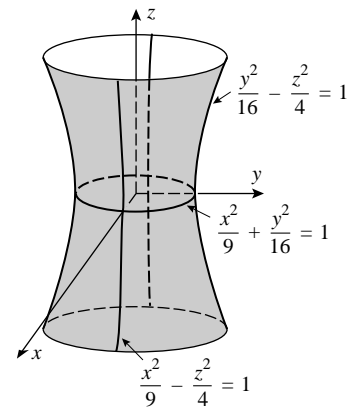

8. (a)  $x = 0 : y = z = 0; y = 0 : x = 9z^2; z = 0 : x = y^2$

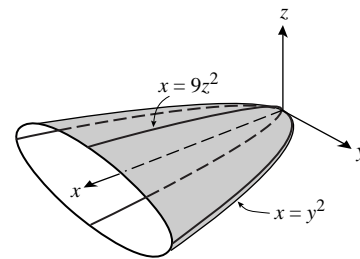

(b)  $x = 0 : -y^2 + 4z^2 = 4; y = 0 : x^2 + z^2 = 1;$   
 $z = 0 : 4x^2 - y^2 = 4$

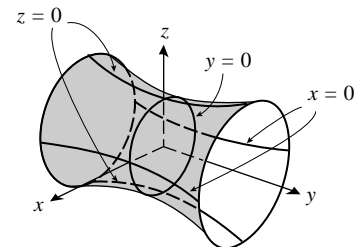

(c)  $x = 0 : z = \pm \frac{y}{2}; y = 0 : z = \pm x; z = 0 : x = y = 0$

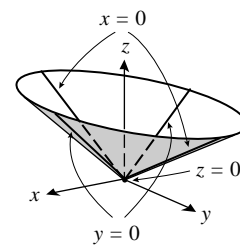

- |                                       |                                  |                                  |
|---------------------------------------|----------------------------------|----------------------------------|
| 9. (a) $4x^2 + z^2 = 3$ ; ellipse     | (b) $y^2 + z^2 = 3$ ; circle     | (c) $y^2 + z^2 = 20$ ; circle    |
| (d) $9x^2 - y^2 = 20$ ; hyperbola     | (e) $z = 9x^2 + 16$ ; parabola   | (f) $9x^2 + 4y^2 = 4$ ; ellipse  |
| 10. (a) $y^2 - 4z^2 = 27$ ; hyperbola | (b) $9x^2 + 4z^2 = 25$ ; ellipse | (c) $9z^2 - x^2 = 4$ ; hyperbola |
| (d) $x^2 + 4y^2 = 9$ ; ellipse        | (e) $z = 1 - 4y^2$ ; parabola    | (f) $x^2 - 4y^2 = 4$ ; hyperbola |

11.

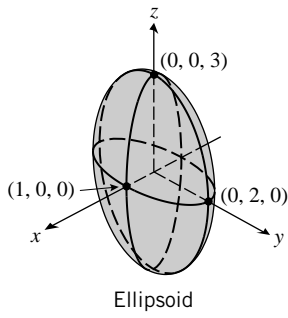

12.

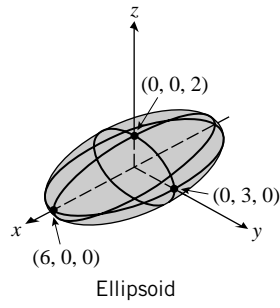

13.

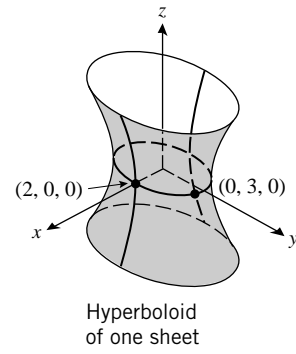

14.

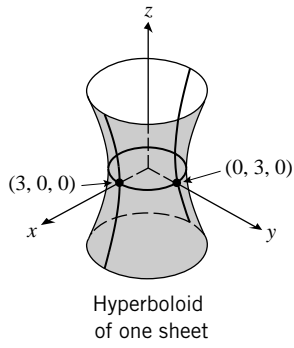

15.

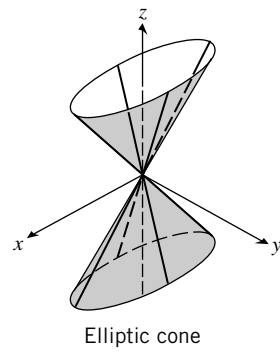

16.

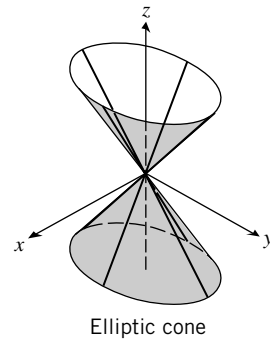

17.

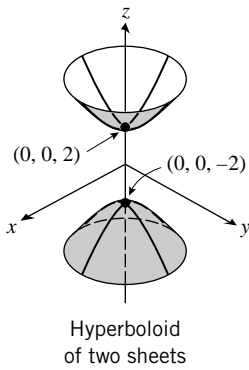

18.

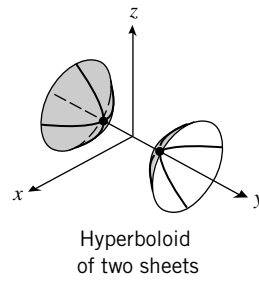

19.

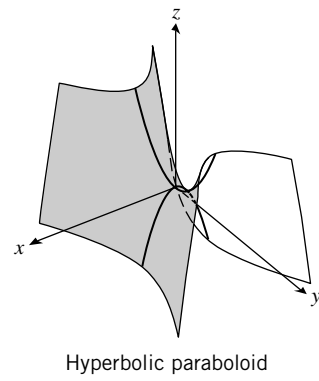

20.

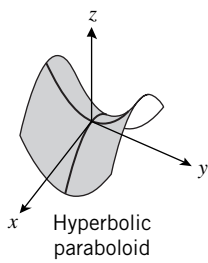

21.

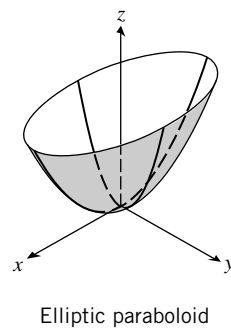

22.

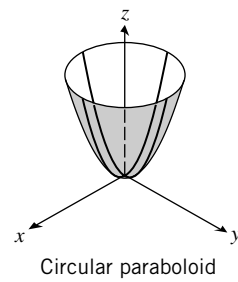

23.

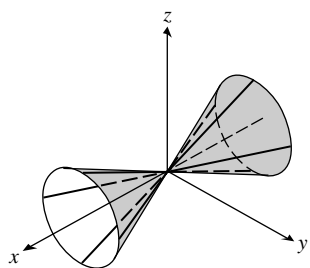

Circular cone

24.

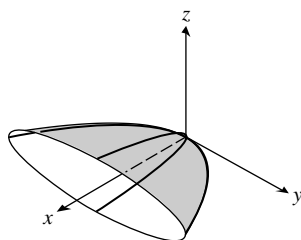

Elliptic paraboloid

25.

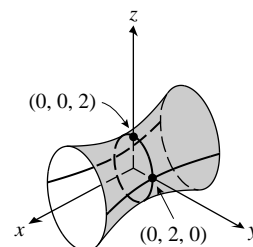

Hyperboloid of one sheet

26.

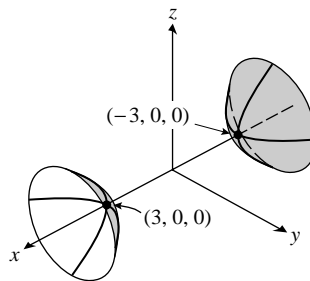

Hyperboloid of two sheets

27.

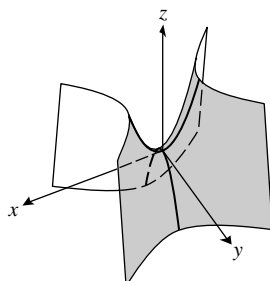

Hyperbolic paraboloid

28.

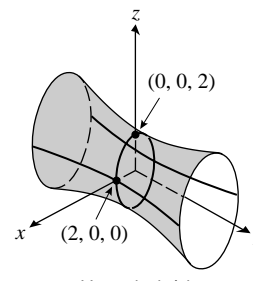

Hyperboloid of one sheet

29.

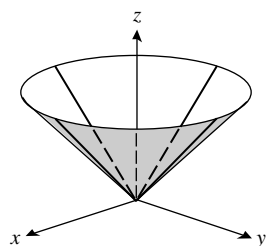

30.

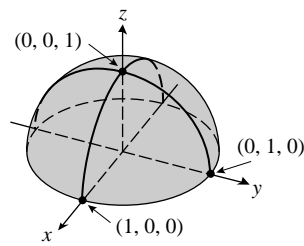

31.

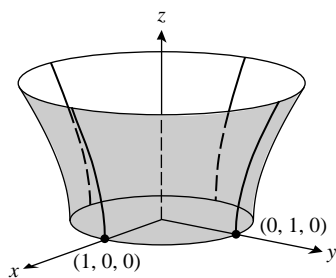

32.

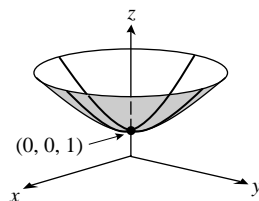

33.

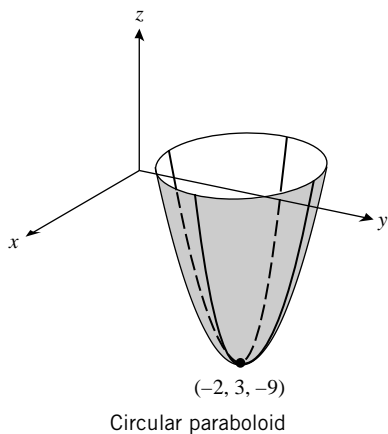

34.

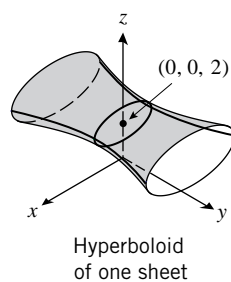

35.

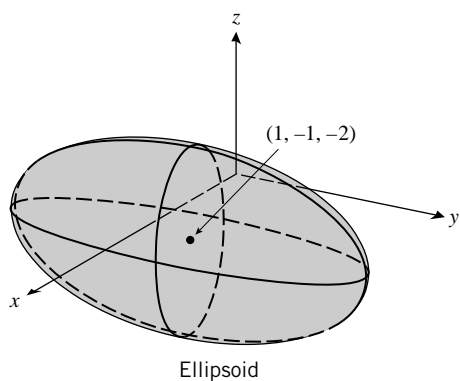

36.

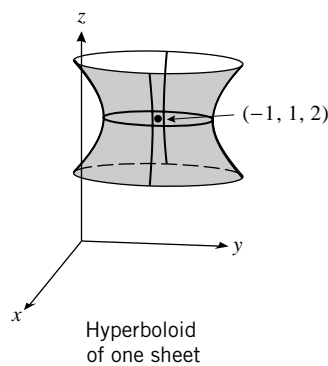

37. (a)  $\frac{x^2}{9} + \frac{y^2}{4} = 1$  (b) 6, 4 (c)  $(\pm\sqrt{5}, 0, \sqrt{2})$

(d) The focal axis is parallel to the  $x$ -axis.

38. (a)  $\frac{y^2}{4} + \frac{z^2}{2} = 1$  (b)  $4, 2\sqrt{2}$  (c)  $(3, \pm\sqrt{2}, 0)$

(d) The focal axis is parallel to the  $y$ -axis.

39. (a)  $\frac{y^2}{4} - \frac{x^2}{4} = 1$  (b)  $(0, \pm 2, 4)$  (c)  $(0, \pm 2\sqrt{2}, 4)$

(d) The focal axis is parallel to the  $y$ -axis.

40. (a)  $\frac{x^2}{4} - \frac{y^2}{4} = 1$  (b)  $(\pm 2, 0, -4)$  (c)  $(\pm 2\sqrt{2}, 0, -4)$

(e) The focal axis is parallel to the  $x$ -axis.

41. (a)  $z + 4 = y^2$  (b)  $(2, 0, -4)$  (c)  $(2, 0, -15/4)$

(d) The focal axis is parallel to the  $z$ -axis.

42. (a)  $z - 4 = -x^2$  (b)  $(0, 2, 4)$  (c)  $(0, 2, 15/4)$

(d) The focal axis is parallel to the  $z$ -axis.



43.  $x^2 + y^2 = 4 - x^2 - y^2, x^2 + y^2 = 2$ ; circle of radius  $\sqrt{2}$  in the plane  $z = 2$ , centered at  $(0, 0, 1)$

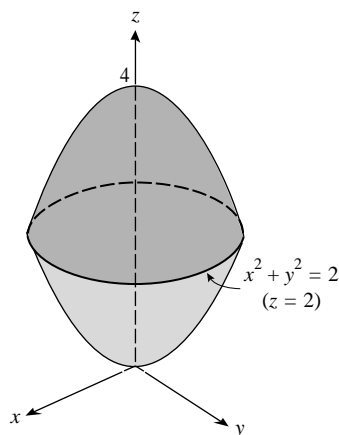

44.  $y^2 + z = 4 - 2(y^2 + z), y^2 + z = 4/3$ ; parabolas in the planes  $x = \pm 2/\sqrt{3}$  which open in direction of the negative  $y$ -axis

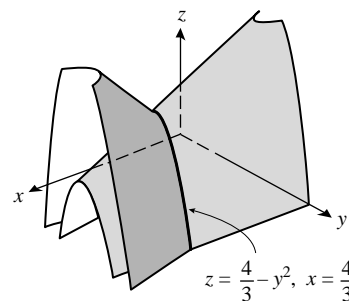

45.  $y = 4(x^2 + z^2)$

46.  $y^2 = 4(x^2 + z^2)$

47.  $|z - (-1)| = \sqrt{x^2 + y^2 + (z - 1)^2}, z^2 + 2z + 1 = x^2 + y^2 + z^2 - 2z + 1, z = (x^2 + y^2)/4$ ; circular paraboloid

48.  $|z + 1| = 2\sqrt{x^2 + y^2 + (z - 1)^2}, z^2 + 2z + 1 = 4(x^2 + y^2 + z^2 - 2z + 1),$   
 $4x^2 + 4y^2 + 3z^2 - 10z + 3 = 0, \frac{x^2}{4/3} + \frac{y^2}{4/3} + \frac{(z - 5/3)^2}{16/9} = 1$ ; ellipsoid, center at  $(0, 0, 5/3)$ .

49. If  $z = 0, \frac{x^2}{a^2} + \frac{y^2}{a^2} = 1$ ; if  $y = 0$  then  $\frac{x^2}{a^2} + \frac{z^2}{c^2} = 1$ ; since  $c < a$  the major axis has length  $2a$ , the minor axis length  $2c$ .

50.  $\frac{x^2}{a^2} + \frac{y^2}{a^2} + \frac{z^2}{b^2} = 1$ , where  $a = 6378.1370, b = 6356.5231$ .

51. Each slice perpendicular to the  $z$ -axis for  $|z| < c$  is an ellipse whose equation is

$$\frac{x^2}{a^2} + \frac{y^2}{b^2} = \frac{c^2 - z^2}{c^2}, \text{ or } \frac{x^2}{(a^2/c^2)(c^2 - z^2)} + \frac{y^2}{(b^2/c^2)(c^2 - z^2)} = 1, \text{ the area of which is}$$

$$\pi \left( \frac{a}{c} \sqrt{c^2 - z^2} \right) \left( \frac{b}{c} \sqrt{c^2 - z^2} \right) = \pi \frac{ab}{c^2} (c^2 - z^2) \text{ so } V = 2 \int_0^c \pi \frac{ab}{c^2} (c^2 - z^2) dz = \frac{4}{3} \pi abc.$$

## EXERCISE SET 13.8

1. (a)  $(8, \pi/6, -4)$  (b)  $(5\sqrt{2}, 3\pi/4, 6)$  (c)  $(2, \pi/2, 0)$  (d)  $(8, 5\pi/3, 6)$
2. (a)  $(2, 7\pi/4, 1)$  (b)  $(1, \pi/2, 1)$  (c)  $(4\sqrt{2}, 3\pi/4, -7)$  (d)  $(2\sqrt{2}, 7\pi/4, -2)$
3. (a)  $(2\sqrt{3}, 2, 3)$  (b)  $(-4\sqrt{2}, 4\sqrt{2}, -2)$  (c)  $(5, 0, 4)$  (d)  $(-7, 0, -9)$
4. (a)  $(3, -3\sqrt{3}, 7)$  (b)  $(0, 1, 0)$  (c)  $(0, 3, 5)$  (d)  $(0, 4, -1)$
5. (a)  $(2\sqrt{2}, \pi/3, 3\pi/4)$  (b)  $(2, 7\pi/4, \pi/4)$  (c)  $(6, \pi/2, \pi/3)$  (d)  $(10, 5\pi/6, \pi/2)$
6. (a)  $(8\sqrt{2}, \pi/4, \pi/6)$  (b)  $(2\sqrt{2}, 5\pi/3, 3\pi/4)$  (c)  $(2, 0, \pi/2)$  (d)  $(4, \pi/6, \pi/6)$
7. (a)  $(5\sqrt{6}/4, 5\sqrt{2}/4, 5\sqrt{2}/2)$  (b)  $(7, 0, 0)$   
(c)  $(0, 0, 1)$  (d)  $(0, -2, 0)$
8. (a)  $(-\sqrt{2}/4, \sqrt{6}/4, -\sqrt{2}/2)$  (b)  $(3\sqrt{2}/4, -3\sqrt{2}/4, -3\sqrt{3}/2)$   
(c)  $(2\sqrt{6}, 2\sqrt{2}, 4\sqrt{2})$  (d)  $0, 2\sqrt{3}, 2$
9. (a)  $(2\sqrt{3}, \pi/6, \pi/6)$  (b)  $(\sqrt{2}, \pi/4, 3\pi/4)$   
(c)  $(2, 3\pi/4, \pi/2)$  (d)  $(4\sqrt{3}, 1, 2\pi/3)$
10. (a)  $(4\sqrt{2}, 5\pi/6, \pi/4)$  (b)  $(2\sqrt{2}, 0, 3\pi/4)$   
(c)  $(5, \pi/2, \tan^{-1}(4/3))$  (d)  $(2\sqrt{10}, \pi, \tan^{-1} 3)$
11. (a)  $(5\sqrt{3}/2, \pi/4, -5/2)$  (b)  $(0, 7\pi/6, -1)$   
(c)  $(0, 0, 3)$  (d)  $(4, \pi/6, 0)$
12. (a)  $(0, \pi/2, -5/2)$  (b)  $(3\sqrt{2}, 0, -3\sqrt{2})$   
(c)  $(0, 3\pi/4, -3)$  (d)  $(5/2, 2\pi/3, -5\sqrt{3}/2)$

15.

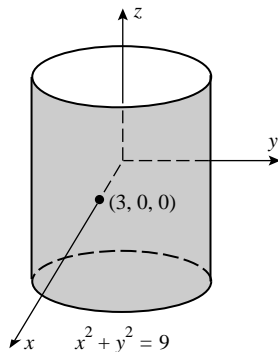

16.

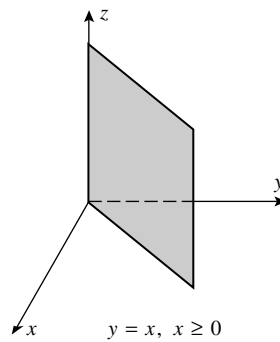

17.

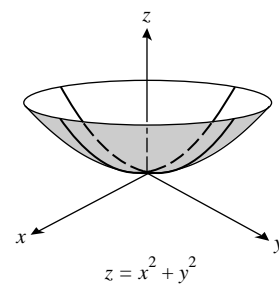

18.

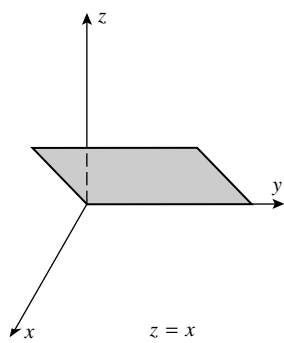

19.

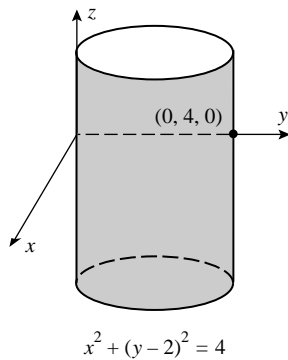

20.

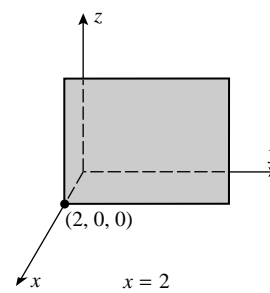

21.

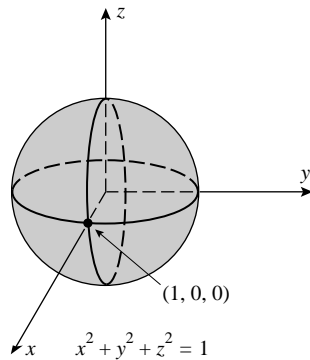

22.

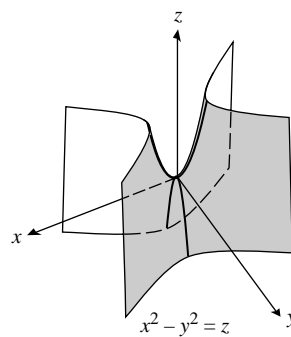

23.

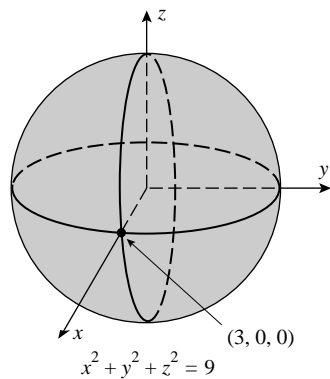

24.

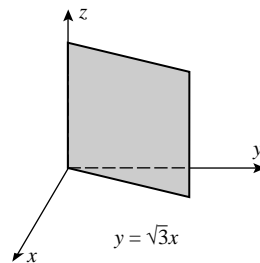

25.

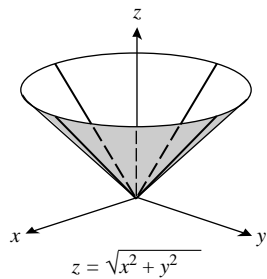

26.

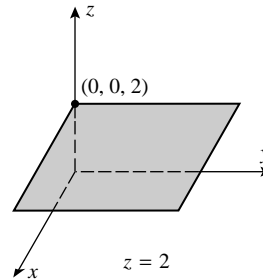

27.

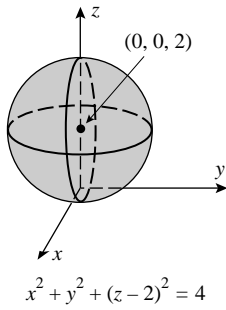

28.

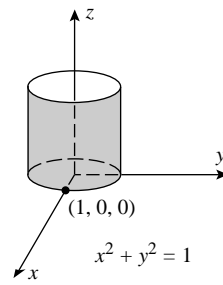

29.

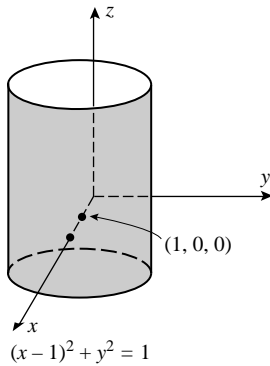

30.

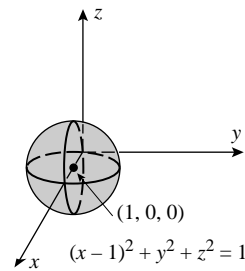

31. (a)  $z = 3$

(b)  $\rho \cos \phi = 3, \rho = 3 \sec \phi$

32. (a)  $r \sin \theta = 2, r = 2 \csc \theta$

(b)  $\rho \sin \phi \sin \theta = 2, \rho = 2 \csc \phi \csc \theta$

33. (a)  $z = 3r^2$

(b)  $\rho \cos \phi = 3\rho^2 \sin^2 \phi, \rho = \frac{1}{3} \csc \phi \cot \phi$

34. (a)  $z = \sqrt{3}r$

(b)  $\rho \cos \phi = \sqrt{3}\rho \sin \phi, \tan \phi = \frac{1}{\sqrt{3}}, \phi = \frac{\pi}{6}$

35. (a)  $r = 2$

(b)  $\rho \sin \phi = 2, \rho = 2 \csc \phi$

36. (a)  $r^2 - 6r \sin \theta = 0, r = 6 \sin \theta$

(b)  $\rho \sin \phi = 6 \sin \theta, \rho = 6 \sin \theta \csc \phi$

37. (a)  $r^2 + z^2 = 9$

(b)  $\rho = 3$

38. (a)  $z^2 = r^2 \cos^2 \theta - r^2 \sin^2 \theta = r^2(\cos^2 \theta - \sin^2 \theta), z^2 = r^2 \cos 2\theta$

(b) Use the result in part (a) with  $r = \rho \sin \phi, z = \rho \cos \phi$  to get  $\rho^2 \cos^2 \phi = \rho^2 \sin^2 \phi \cos 2\theta,$   
 $\cot^2 \phi = \cos 2\theta$

39. (a)  $2r \cos \theta + 3r \sin \theta + 4z = 1$

(b)  $2\rho \sin \phi \cos \theta + 3\rho \sin \phi \sin \theta + 4\rho \cos \phi = 1$

40. (a)  $r^2 - z^2 = 1$

(b) Use the result of part (a) with  $r = \rho \sin \phi, z = \rho \cos \phi$  to get  $\rho^2 \sin^2 \phi - \rho^2 \cos^2 \phi = 1,$   
 $\rho^2 \cos 2\phi = -1$

41. (a)  $r^2 \cos^2 \theta = 16 - z^2$   
 (b)  $x^2 = 16 - z^2$ ,  $x^2 + y^2 + z^2 = 16 + y^2$ ,  $\rho^2 = 16 + \rho^2 \sin^2 \phi \sin^2 \theta$ ,  $\rho^2 (1 - \sin^2 \phi \sin^2 \theta) = 16$

42. (a)  $r^2 + z^2 = 2z$  (b)  $\rho^2 = 2\rho \cos \phi$ ,  $\rho = 2 \cos \phi$

43. all points on or above the paraboloid  $z = x^2 + y^2$ , that are also on or below the plane  $z = 4$

44. a right circular cylindrical solid of height 3 and radius 1 whose axis is the line  $x = 0, y = 1$

45. all points on or between concentric spheres of radii 1 and 3

46. all points on or above the cone  $\phi = \pi/6$ , that are also on or below the sphere  $\rho = 2$

47.  $\theta = \pi/6$ ,  $\phi = \pi/6$ , spherical  $(4000, \pi/6, \pi/6)$ , rectangular  $(1000\sqrt{3}, 1000, 2000\sqrt{3})$

48. (a)  $y = r \sin \theta = a \sin \theta$  but  $az = a \sin \theta$  so  $y = az$ , which is a plane that contains the curve of intersection of  $z = \sin \theta$  and the circular cylinder  $r = a$ . From Exercise 60, Section 12.4, the curve of intersection of a plane and a circular cylinder is an ellipse.

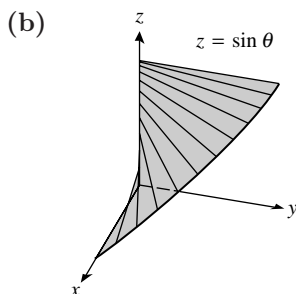

49. (a)  $(10, \pi/2, 1)$  (b)  $(0, 10, 1)$  (c)  $(\sqrt{101}, \pi/2, \tan^{-1} 10)$

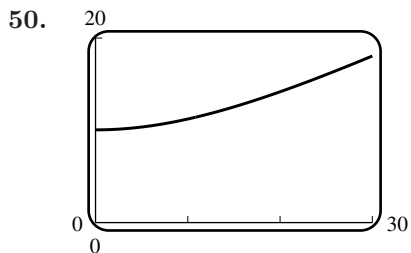

51. Using spherical coordinates: for point  $A$ ,  $\theta_A = 360^\circ - 60^\circ = 300^\circ$ ,  $\phi_A = 90^\circ - 40^\circ = 50^\circ$ ; for point  $B$ ,  $\theta_B = 360^\circ - 40^\circ = 320^\circ$ ,  $\phi_B = 90^\circ - 20^\circ = 70^\circ$ . Unit vectors directed from the origin to the points  $A$  and  $B$ , respectively, are

$$\mathbf{u}_A = \sin 50^\circ \cos 300^\circ \mathbf{i} + \sin 50^\circ \sin 300^\circ \mathbf{j} + \cos 50^\circ \mathbf{k},$$

$$\mathbf{u}_B = \sin 70^\circ \cos 320^\circ \mathbf{i} + \sin 70^\circ \sin 320^\circ \mathbf{j} + \cos 70^\circ \mathbf{k}$$

The angle  $\alpha$  between  $\mathbf{u}_A$  and  $\mathbf{u}_B$  is  $\alpha = \cos^{-1}(\mathbf{u}_A \cdot \mathbf{u}_B) \approx 0.459486$  so the shortest distance is  $6370\alpha \approx 2,927$  km.

## CHAPTER 13 SUPPLEMENTARY EXERCISES

2. (c)  $\mathbf{F} = -\mathbf{i} - \mathbf{j}$   
 (d)  $\|\langle 1, -2, 2 \rangle\| = 3$ , so  $\|\mathbf{r} - \langle 1, -2, 2 \rangle\| = 3$ , or  $(x - 1)^2 + (y + 2)^2 + (z - 2)^2 = 9$
3. (b)  $x = \cos 120^\circ = -1/2$ ,  $y = \pm \sin 120^\circ = \pm\sqrt{3}/2$   
 (d) true:  $\|\mathbf{u} \times \mathbf{v}\| = \|\mathbf{u}\|\|\mathbf{v}\|\sin(\theta) = 1$
4. (d)  $x + 2y - z = 0$
5. (b)  $(y, x, z), (x, z, y), (z, y, x)$   
 (c) circle of radius 5 in plane  $z = 1$  with center at  $(0, 0, 1)$  (rectangular coordinates)  
 (d) the two half-lines  $z = \pm x$ ,  $x \geq 0$  in the  $xz$ -plane
6.  $(x + 3)^2 + (y - 5)^2 + (z + 4)^2 = r^2$ ,  
 (a)  $r^2 = 4^2 = 16$                       (b)  $r^2 = 5^2 = 25$                       (c)  $r^2 = 3^2 = 9$
7. (a)  $\overrightarrow{AB} = -\mathbf{i} + 2\mathbf{j} + 2\mathbf{k}$ ,  $\overrightarrow{AC} = \mathbf{i} + \mathbf{j} - \mathbf{k}$ ,  $\overrightarrow{AB} \times \overrightarrow{AC} = -4\mathbf{i} + \mathbf{j} - 3\mathbf{k}$ , area  $= \frac{1}{2}\|\overrightarrow{AB} \times \overrightarrow{AC}\| = \sqrt{26}/2$   
 (b) area  $= \frac{1}{2}h\|\overrightarrow{AB}\| = \frac{3}{2}h = \frac{1}{2}\sqrt{26}$ ,  $h = \sqrt{26}/3$
8. The sphere  $x^2 + (y - 1)^2 + (z + 3)^2 = 16$  has center  $Q(0, 1, -3)$  and radius 4, and  
 $\|\overrightarrow{PQ}\| = \sqrt{1^2 + 4^2} = \sqrt{17}$ , so minimum distance is  $\sqrt{17} - 4$ , maximum distance is  $\sqrt{17} + 4$ .
9. (a)  $\mathbf{a} \cdot \mathbf{b} = 0$ ,  $4c + 3 = 0$ ,  $c = -3/4$   
 (b) Use  $\mathbf{a} \cdot \mathbf{b} = \|\mathbf{a}\|\|\mathbf{b}\|\cos\theta$  to get  $4c + 3 = \sqrt{c^2 + 1}(5)\cos(\pi/4)$ ,  $4c + 3 = 5\sqrt{c^2 + 1}/\sqrt{2}$   
 Square both sides and rearrange to get  $7c^2 + 48c - 7 = 0$ ,  $(7c - 1)(c + 7) = 0$  so  $c = -7$  (invalid) or  $c = 1/7$ .  
 (c) Proceed as in (b) with  $\theta = \pi/6$  to get  $11c^2 - 96c + 39 = 0$  and use the quadratic formula to get  $c = (48 \pm 25\sqrt{3})/11$ .  
 (d)  $\mathbf{a}$  must be a scalar multiple of  $\mathbf{b}$ , so  $c\mathbf{i} + \mathbf{j} = k(4\mathbf{i} + 3\mathbf{j})$ ,  $k = 1/3$ ,  $c = 4/3$ .
10.  $\overrightarrow{OS} = \overrightarrow{OP} + \overrightarrow{PS} = 3\mathbf{i} + 4\mathbf{j} + \overrightarrow{QR} = 3\mathbf{i} + 4\mathbf{j} + (4\mathbf{i} + \mathbf{j}) = 7\mathbf{i} + 5\mathbf{j}$
11. (a) the plane through the origin which is perpendicular to  $\mathbf{r}_0$   
 (b) the plane through the tip of  $\mathbf{r}_0$  which is perpendicular to  $\mathbf{r}_0$
12. The normals to the planes are given by  $\langle a_1, b_1, c_1 \rangle$  and  $\langle a_2, b_2, c_2 \rangle$ , so the condition is  $a_1a_2 + b_1b_2 + c_1c_2 = 0$ .
13. Since  $\overrightarrow{AC} \cdot (\overrightarrow{AB} \times \overrightarrow{AD}) = \overrightarrow{AC} \cdot (\overrightarrow{AB} \times \overrightarrow{CD}) + \overrightarrow{AC} \cdot (\overrightarrow{AB} \times \overrightarrow{AC}) = \mathbf{0} + \mathbf{0} = \mathbf{0}$ , the volume of the parallelepiped determined by  $\overrightarrow{AB}$ ,  $\overrightarrow{AC}$ , and  $\overrightarrow{AD}$  is zero, thus  $A, B, C$ , and  $D$  are coplanar (lie in the same plane). Since  $\overrightarrow{AB} \times \overrightarrow{CD} \neq \mathbf{0}$ , the lines are not parallel. Hence they must intersect.
14. The points  $P$  lie on the plane determined by  $A, B$  and  $C$ .
15. (a) false, for example  $\mathbf{i} \cdot \mathbf{j} = 0$                       (b) false, for example  $\mathbf{i} \times \mathbf{i} = \mathbf{0}$   
 (c) true;  $0 = \|\mathbf{u}\| \cdot \|\mathbf{v}\| \cos\theta = \|\mathbf{u}\| \cdot \|\mathbf{v}\| \sin\theta$ , so either  $\mathbf{u} = \mathbf{0}$  or  $\mathbf{v} = \mathbf{0}$  since  $\cos\theta = \sin\theta = 0$  is impossible.

16. (a) Replace  $\mathbf{u}$  with  $\mathbf{a} \times \mathbf{b}$ ,  $\mathbf{v}$  with  $\mathbf{c}$ , and  $\mathbf{w}$  with  $\mathbf{d}$  in the first formula of Exercise 39.  
 (b) From the second formula of Exercise 39,  
 $(\mathbf{a} \times \mathbf{b}) \times \mathbf{c} + (\mathbf{b} \times \mathbf{c}) \times \mathbf{a} + (\mathbf{c} \times \mathbf{a}) \times \mathbf{b}$   
 $= (\mathbf{c} \cdot \mathbf{a})\mathbf{b} - (\mathbf{c} \cdot \mathbf{b})\mathbf{a} + (\mathbf{a} \cdot \mathbf{b})\mathbf{c} - (\mathbf{a} \cdot \mathbf{c})\mathbf{b} + (\mathbf{b} \cdot \mathbf{c})\mathbf{a} - (\mathbf{b} \cdot \mathbf{a})\mathbf{c} = \mathbf{0}$
17.  $\|\mathbf{u} - \mathbf{v}\|^2 = (\mathbf{u} - \mathbf{v}) \cdot (\mathbf{u} - \mathbf{v}) = \|\mathbf{u}\|^2 + \|\mathbf{v}\|^2 - 2\|\mathbf{u}\|\|\mathbf{v}\|\cos\theta = 2(1 - \cos\theta) = 4\sin^2(\theta/2)$ , so  
 $\|\mathbf{u} - \mathbf{v}\| = 2\sin(\theta/2)$
18.  $\overrightarrow{AB} = \mathbf{i} - 2\mathbf{j} - 2\mathbf{k}$ ,  $\overrightarrow{AC} = -2\mathbf{i} - \mathbf{j} - 2\mathbf{k}$ ,  $\overrightarrow{AD} = \mathbf{i} + 2\mathbf{j} - 3\mathbf{k}$
- (a) From Theorem 13.4.6 and formula (9) of Section 13.4,  $\begin{vmatrix} 1 & -2 & -2 \\ -2 & -1 & -2 \\ 1 & 2 & -3 \end{vmatrix} = 29$ , so  $V = 29$ .
- (b) The plane containing  $A, B$ , and  $C$  has normal  $\overrightarrow{AB} \times \overrightarrow{AC} = 2\mathbf{i} + 6\mathbf{j} - 5\mathbf{k}$ , so the equation of the plane is  $2(x - 1) + 6(y + 1) - 5(z - 2) = 0$ ,  $2x + 6y - 5z = -14$ . From Theorem 13.6.2,  
 $D = \frac{|2(2) + 6(1) - 5(-1)|}{\sqrt{65}} = \frac{15}{\sqrt{65}}$ .
19. (a)  $\langle 2, 1, -1 \rangle \times \langle 1, 2, 1 \rangle = \langle 3, -3, 3 \rangle$ , so the line is parallel to  $\mathbf{i} - \mathbf{j} + \mathbf{k}$ . By inspection,  $(0, 2, -1)$  lies on both planes, so the line has an equation  $\mathbf{r} = 2\mathbf{j} - \mathbf{k} + t(\mathbf{i} - \mathbf{j} + \mathbf{k})$ , that is,  
 $x = t, y = 2 - t, z = -1 + t$ .
- (b)  $\cos\theta = \frac{\langle 2, 1, -1 \rangle \cdot \langle 1, 2, 1 \rangle}{\|\langle 2, 1, -1 \rangle\| \|\langle 1, 2, 1 \rangle\|} = 1/2$ , so  $\theta = \pi/3$

20. Let  $\alpha = 50^\circ, \beta = 70^\circ$ , then  $\gamma = \cos^{-1} \sqrt{1 - \cos^2 \alpha - \cos^2 \beta} \approx 47^\circ$ .

21.  $5\langle \cos 60^\circ, \cos 120^\circ, \cos 135^\circ \rangle = \langle 5/2, -5/2, -5\sqrt{2}/2 \rangle$

22. (a) Let  $k$  be the length of an edge and introduce a coordinate system as shown in the figure, then  $\mathbf{d} = \langle k, k, k \rangle, \mathbf{u} = \langle k, k, 0 \rangle$ ,  $\cos\theta = \frac{\mathbf{d} \cdot \mathbf{u}}{\|\mathbf{d}\| \|\mathbf{u}\|} = \frac{2k^2}{(k\sqrt{3})(k\sqrt{2})} = 2/\sqrt{6}$   
 so  $\theta = \cos^{-1}(2/\sqrt{6}) \approx 35^\circ$

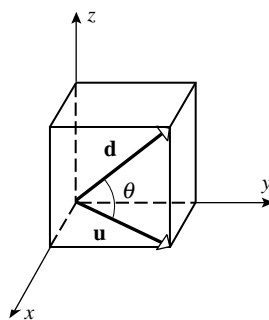

(b)  $\mathbf{v} = \langle -k, 0, k \rangle, \cos\theta = \frac{\mathbf{d} \cdot \mathbf{v}}{\|\mathbf{d}\| \|\mathbf{v}\|} = 0$  so  $\theta = \pi/2$  radians.

23. (a)  $(x - 3)^2 + 4(y + 1)^2 - (z - 2)^2 = 9$ , hyperboloid of one sheet

(b)  $(x + 3)^2 + (y - 2)^2 + (z + 6)^2 = 49$ , sphere

(c)  $(x - 1)^2 + (y + 2)^2 - z^2 = 0$ , circular cone

24. (a) perpendicular, since  $\langle 2, 1, 2 \rangle \cdot \langle -1, -2, 2 \rangle = 0$

(b)  $L_1: \langle x, y, z \rangle = \langle 1 + 2t, -\frac{3}{2} + t, -1 + 2t \rangle; L_2: \langle x, y, z \rangle = \langle 4 - t, 3 - 2t, -4 + 2t \rangle$

(c) Solve simultaneously  $1 + 2t_1 = 4 - t_2$ ,  $-\frac{3}{2} + t_1 = 3 - 2t_2$ ,  $-1 + 2t_1 = -4 + 2t_2$ , solution  $t_1 = \frac{1}{2}$ ,  $t_2 = 2$ ,  $x = 2$ ,  $y = -1$ ,  $z = 0$

25. (a)  $r^2 = z$ ;  $\rho^2 \sin^2 \phi = \rho \cos \phi$ ,  $\rho = \cot \phi \csc \phi$

(b)  $r^2(\cos^2 \theta - \sin^2 \theta) - z^2 = 0$ ,  $z^2 = r^2 \cos 2\theta$ ;  
 $\rho^2 \sin^2 \phi \cos^2 \theta - \rho^2 \sin^2 \phi \sin^2 \theta - \rho^2 \cos^2 \phi = 0$ ,  $\cos 2\theta = \cot^2 \phi$

26. (a)  $z = r^2 \cos^2 \theta - r^2 \sin^2 \theta = x^2 - y^2$

(b)  $(\rho \sin \phi \cos \theta)(\rho \cos \phi) = 1$ ,  $xz = 1$

27. (a)

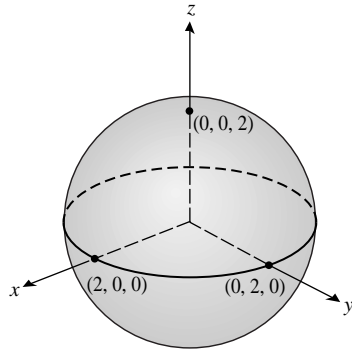

(b)

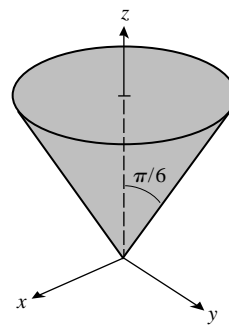

(c)

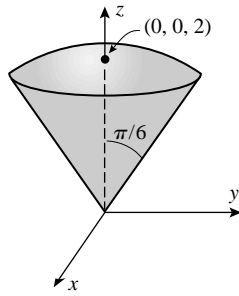

28. (a)

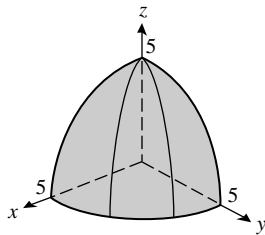

(b)

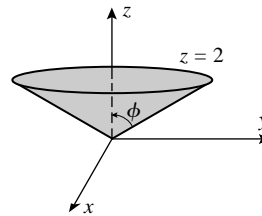

(c)

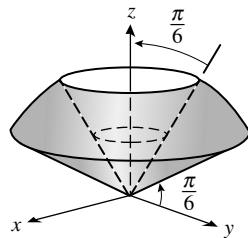



29. (a)

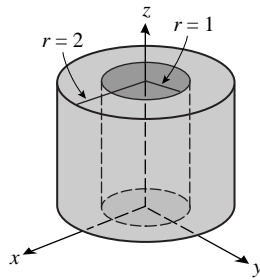

(b)

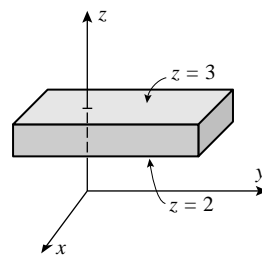

(c)

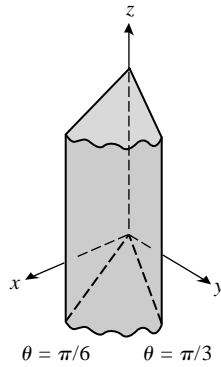

(d)

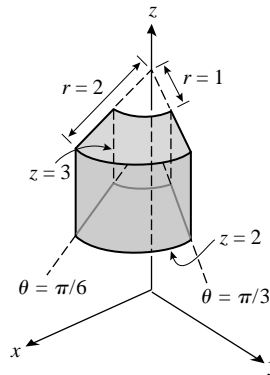

30. (a)

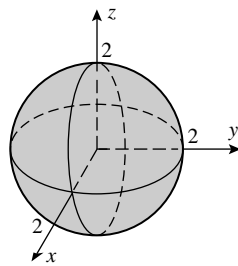

(b)

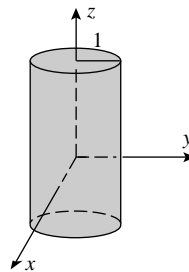

(c)

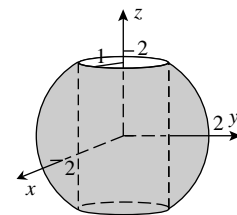

31. (a) At  $x = c$  the trace of the surface is the circle  $y^2 + z^2 = [f(c)]^2$ , so the surface is given by  $y^2 + z^2 = [f(x)]^2$

(b)  $y^2 + z^2 = e^{2x}$       (c)  $y^2 + z^2 = 4 - \frac{3}{4}x^2$ , so let  $f(x) = \sqrt{4 - \frac{3}{4}x^2}$

32. (a) Permute  $x$  and  $y$  in Exercise 31a:  $x^2 + z^2 = [f(y)]^2$

(b) Permute  $x$  and  $z$  in Exercise 31a:  $x^2 + y^2 = [f(z)]^2$

(c) Permute  $y$  and  $z$  in Exercise 31a:  $y^2 + z^2 = [f(x)]^2$

33.

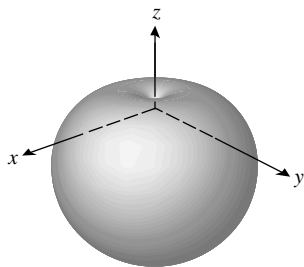

34.  $\vec{PQ} = \langle 1, -1, 6 \rangle$ , and  $W = \mathbf{F} \cdot \vec{PQ} = 13 \text{ lb}\cdot\text{ft}$

35.  $\mathbf{F} = \mathbf{F}_1 + \mathbf{F}_2 = 2\mathbf{i} - \mathbf{j} + 3\mathbf{k}$ ,  $\overrightarrow{PQ} = \mathbf{i} + 4\mathbf{j} - 3\mathbf{k}$ ,  $W = \mathbf{F} \cdot \overrightarrow{PQ} = -11 \text{ N}\cdot\text{m}$

36.  $\mathbf{F}_1 = 250 \cos 38^\circ \mathbf{i} + 250 \sin 38^\circ \mathbf{j}$ ,  $\mathbf{F} = 1000\mathbf{i}$ ,  $\mathbf{F}_2 = \mathbf{F} - \mathbf{F}_1 = (1000 - 250 \cos 38^\circ)\mathbf{i} - 250 \sin 38^\circ \mathbf{j}$ ;

$$\|F_2\| = 1000 \sqrt{\frac{17}{16} - \frac{1}{2} \cos 38^\circ} \approx 817.62 \text{ N}\cdot\text{m}, \theta = \tan^{-1} \frac{250 \sin 38^\circ}{250 \cos 38^\circ - 1000} \approx -11^\circ$$

37. (a)  $\mathbf{F} = -6\mathbf{i} + 3\mathbf{j} - 6\mathbf{k}$

(b)  $\overrightarrow{OA} = \langle 5, 0, 2 \rangle$ , so the vector moment is  $\overrightarrow{OA} \times \mathbf{F} = -6\mathbf{i} + 18\mathbf{j} + 15\mathbf{k}$

# CHAPTER 14

## Vector-Valued Functions

### EXERCISE SET 14.1

1.  $(-\infty, +\infty)$ ;  $\mathbf{r}(\pi) = -\mathbf{i} - 3\pi\mathbf{j}$
2.  $[-1/3, +\infty)$ ;  $\mathbf{r}(1) = \langle 2, 1 \rangle$
3.  $[2, +\infty)$ ;  $\mathbf{r}(3) = -\mathbf{i} - \ln 3\mathbf{j} + \mathbf{k}$
4.  $[-1, 1)$ ;  $\mathbf{r}(0) = \langle 2, 0, 0 \rangle$
5.  $\mathbf{r} = 3 \cos t\mathbf{i} + (t + \sin t)\mathbf{j}$
6.  $\mathbf{r} = (t^2 + 1)\mathbf{i} + e^{-2t}\mathbf{j}$
7.  $\mathbf{r} = 2t\mathbf{i} + 2 \sin 3t\mathbf{j} + 5 \cos 3t\mathbf{k}$
8.  $\mathbf{r} = t \sin t\mathbf{i} + \ln t\mathbf{j} + \cos^2 t\mathbf{k}$
9.  $x = 3t^2, y = -2, z = 0$
10.  $x = \sin^2 t, y = 1 - \cos 2t, z = 0$
11.  $x = 2t - 1, y = -3\sqrt{t}, z = \sin 3t$
12.  $x = te^{-t}, y = 0, z = -5t^2$
13. the line in 2-space through the point  $(2, 0)$  and parallel to the vector  $-3\mathbf{i} - 4\mathbf{j}$
14. the circle of radius 3 in the  $xy$ -plane, with center at the origin
15. the line in 3-space through the point  $(0, -3, 1)$  and parallel to the vector  $2\mathbf{i} + 3\mathbf{k}$
16. the circle of radius 2 in the plane  $x = 3$ , with center at  $(3, 0, 0)$
17. an ellipse in the plane  $z = -1$ , center at  $(0, 0, -1)$ , major axis of length 6 parallel to  $x$ -axis, minor axis of length 4 parallel to  $y$ -axis
18. a parabola in the plane  $x = -2$ , vertex at  $(-2, 0, -1)$ , opening upward
19. (a) The line is parallel to the vector  $-2\mathbf{i} + 3\mathbf{j}$ ; the slope is  $-3/2$ .  
 (b)  $y = 0$  in the  $xz$ -plane so  $1 - 2t = 0, t = 1/2$  thus  $x = 2 + 1/2 = 5/2$  and  $z = 3(1/2) = 3/2$ ; the coordinates are  $(5/2, 0, 3/2)$ .
20. (a)  $x = 3 + 2t = 0, t = -3/2$  so  $y = 5(-3/2) = -15/2$   
 (b)  $x = t, y = 1 + 2t, z = -3t$  so  $3(t) - (1 + 2t) - (-3t) = 2, t = 3/4$ ; the point of intersection is  $(3/4, 5/2, -9/4)$ .

21. (a)

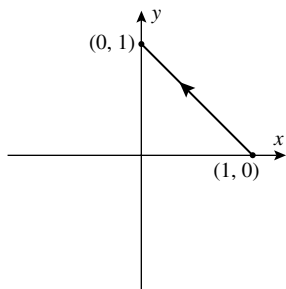

(b)

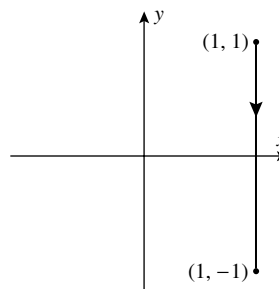

22. (a)

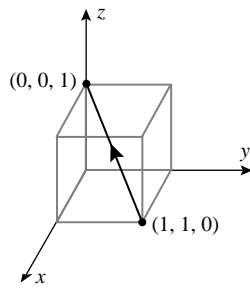

(b)

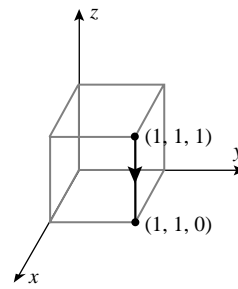

23.  $\mathbf{r} = (1-t)(3\mathbf{i} + 4\mathbf{j}), 0 \leq t \leq 1$

24.  $\mathbf{r} = (1-t)4\mathbf{k} + t(2\mathbf{i} + 3\mathbf{j}), 0 \leq t \leq 1$

25.  $x = 2$

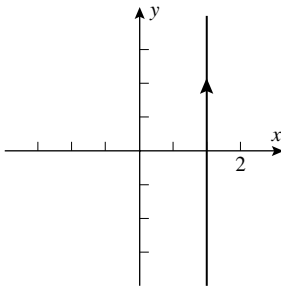

26.  $y = 2x + 10$

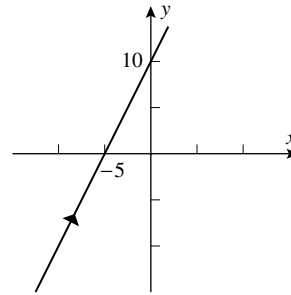

27.  $(x-1)^2 + (y-3)^2 = 1$

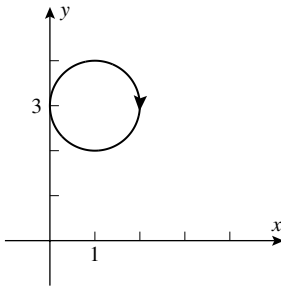

28.  $x^2/4 + y^2/25 = 1$

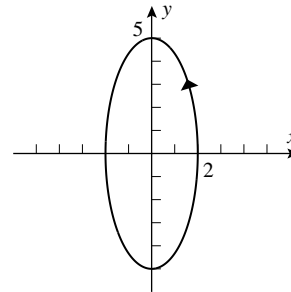

29.  $x^2 - y^2 = 1, x \geq 1$

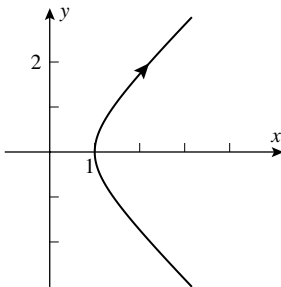

30.  $y = 2x^2 + 4, x \geq 0$

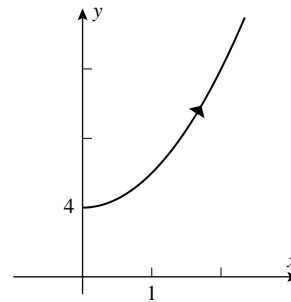

31.

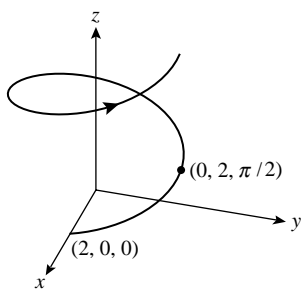

32.

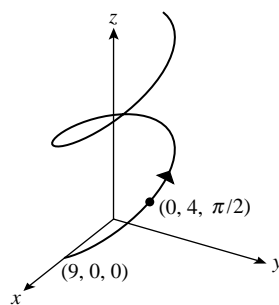

33.

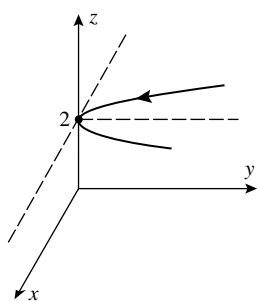

34.

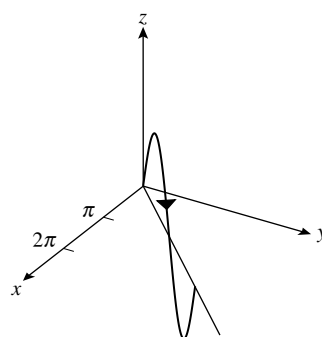

35.  $x = t, y = t, z = 2t^2$

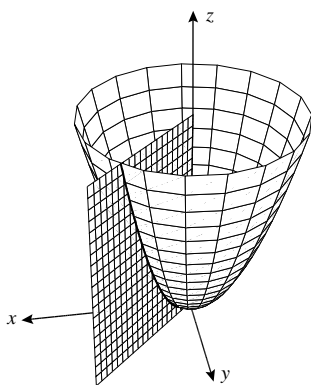

36.  $x = t, y = -t, z = \sqrt{2}\sqrt{1-t^2}$

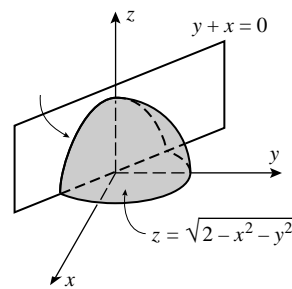

37.  $\mathbf{r} = t\mathbf{i} + t^2\mathbf{j} + \frac{1}{3}\sqrt{81-9t^2-t^4}\mathbf{k}$

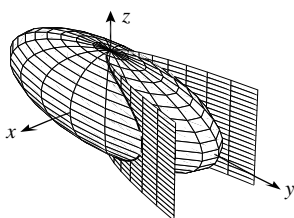

38.  $\mathbf{r} = t\mathbf{i} + t\mathbf{j} + (1-2t)\mathbf{k}$

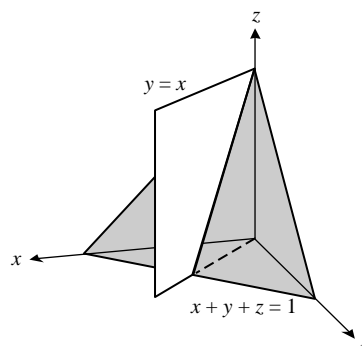

39.  $x^2 + y^2 = (t \sin t)^2 + (t \cos t)^2 = t^2(\sin^2 t + \cos^2 t) = t^2 = z$
40.  $x - y + z + 1 = t - (1 + t)/t + (1 - t^2)/t + 1 = [t^2 - (1 + t) + (1 - t^2) + t]/t = 0$
41.  $x = \sin t$ ,  $y = 2 \cos t$ ,  $z = \sqrt{3} \sin t$  so  $x^2 + y^2 + z^2 = \sin^2 t + 4 \cos^2 t + 3 \sin^2 t = 4$  and  $z = \sqrt{3}x$ ; it is the curve of intersection of the sphere  $x^2 + y^2 + z^2 = 4$  and the plane  $z = \sqrt{3}x$ , which is a circle with center at  $(0, 0, 0)$  and radius 2.
42.  $x = 3 \cos t$ ,  $y = 3 \sin t$ ,  $z = 3 \sin t$  so  $x^2 + y^2 = 9 \cos^2 t + 9 \sin^2 t = 9$  and  $z = y$ ; it is the curve of intersection of the circular cylinder  $x^2 + y^2 = 9$  and the plane  $z = y$ , which is an ellipse with major axis of length  $6\sqrt{2}$  and minor axis of length 6.
43. The helix makes one turn as  $t$  varies from 0 to  $2\pi$  so  $z = c(2\pi) = 3$ ,  $c = 3/(2\pi)$ .
44.  $0.2t = 10$ ,  $t = 50$ ; the helix has made one revolution when  $t = 2\pi$  so when  $t = 50$  it has made  $50/(2\pi) = 25/\pi \approx 7.96$  revolutions.
45.  $x^2 + y^2 = t^2 \cos^2 t + t^2 \sin^2 t = t^2$ ,  $\sqrt{x^2 + y^2} = t = z$ ; a conical helix.
46. The curve wraps around an elliptic cylinder with axis along the  $z$ -axis; an elliptical helix.
47. (a) III, since the curve is a subset of the plane  $y = -x$   
 (b) IV, since only  $x$  is periodic in  $t$ , and  $y, z$  increase without bound  
 (c) II, since all three components are periodic in  $t$   
 (d) I, since the projection onto the  $yz$ -plane is a circle and the curve increases without bound in the  $x$ -direction
49. (a) Let  $x = 3 \cos t$  and  $y = 3 \sin t$ , then  $z = 9 \cos^2 t$ .

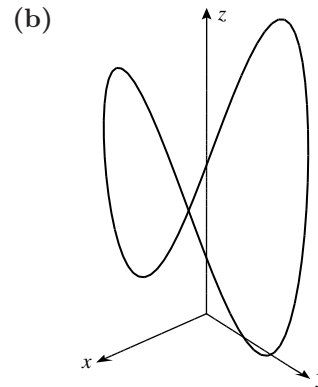

50. The plane is parallel to a line on the surface of the cone and does not go through the vertex so the curve of intersection is a parabola. Eliminate  $z$  to get  $y + 2 = \sqrt{x^2 + y^2}$ ,  $(y + 2)^2 = x^2 + y^2$ ,  $y = x^2/4 - 1$ ; let  $x = t$ , then  $y = t^2/4 - 1$  and  $z = t^2/4 + 1$ .

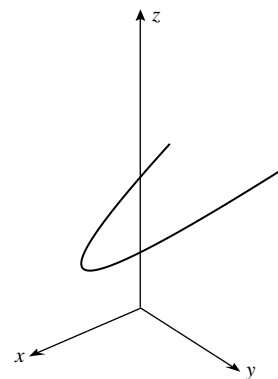

**EXERCISE SET 14.2**

1.

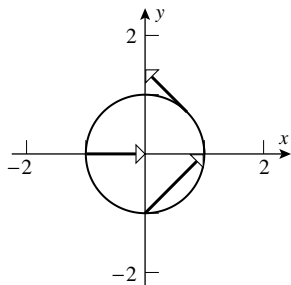

2.

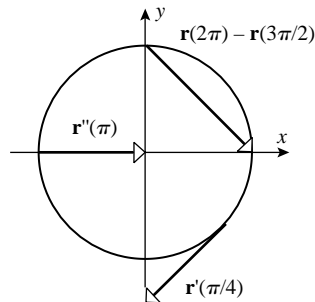

3.  $\mathbf{r}'(t) = 5\mathbf{i} + (1 - 2t)\mathbf{j}$

4.  $\mathbf{r}'(t) = \sin t\mathbf{j}$

5.  $\mathbf{r}'(t) = -\frac{1}{t^2}\mathbf{i} + \sec^2 t\mathbf{j} + 2e^{2t}\mathbf{k}$

6.  $\mathbf{r}'(t) = \frac{1}{1+t^2}\mathbf{i} + (\cos t - t \sin t)\mathbf{j} - \frac{1}{2\sqrt{t}}\mathbf{k}$

7.  $\mathbf{r}'(t) = \langle 1, 2t \rangle,$

$\mathbf{r}'(2) = \langle 1, 4 \rangle,$

$\mathbf{r}(2) = \langle 2, 4 \rangle$

8.  $\mathbf{r}'(t) = 3t^2\mathbf{i} + 2t\mathbf{j},$

$\mathbf{r}'(1) = 3\mathbf{i} + 2\mathbf{j}$

$\mathbf{r}(1) = \mathbf{i} + \mathbf{j}$

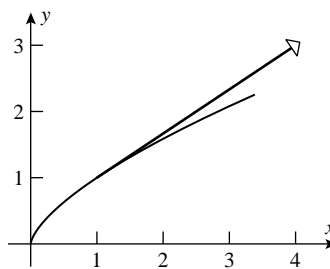
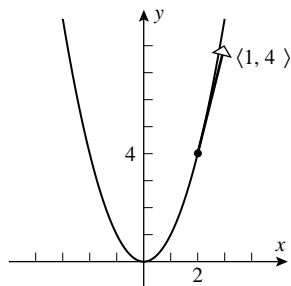

9.  $\mathbf{r}'(t) = \sec t \tan t \mathbf{i} + \sec^2 t \mathbf{j},$

$\mathbf{r}'(0) = \mathbf{j}$

$\mathbf{r}(0) = \mathbf{i}$

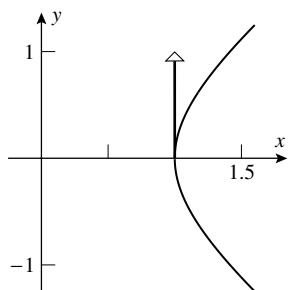

10.  $\mathbf{r}'(t) = 2 \cos t \mathbf{i} - 3 \sin t \mathbf{j},$

$\mathbf{r}'\left(\frac{\pi}{6}\right) = \sqrt{3}\mathbf{i} - \frac{3}{2}\mathbf{j}$

$\mathbf{r}\left(\frac{\pi}{6}\right) = \mathbf{i} + \frac{3\sqrt{3}}{2}\mathbf{j}$

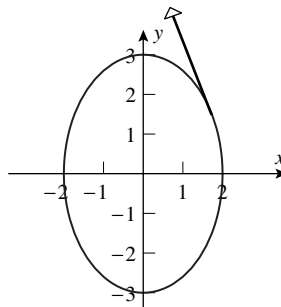

11.  $\mathbf{r}'(t) = 2 \cos t \mathbf{i} - 2 \sin t \mathbf{k}$ ,  
 $\mathbf{r}'(\pi/2) = -2\mathbf{k}$ ,  
 $\mathbf{r}(\pi/2) = 2\mathbf{i} + \mathbf{j}$

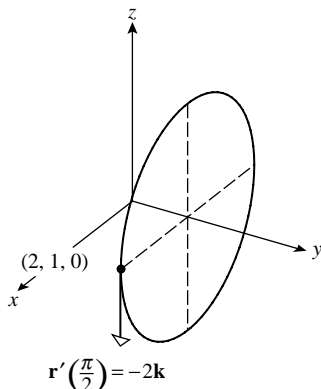

12.  $\mathbf{r}'(t) = -\sin t \mathbf{i} + \cos t \mathbf{j} + \mathbf{k}$ ,  
 $\mathbf{r}'(\pi/4) = -\frac{1}{\sqrt{2}}\mathbf{i} + \frac{1}{\sqrt{2}}\mathbf{j} + \mathbf{k}$ ,  
 $\mathbf{r}(\pi/4) = \frac{1}{\sqrt{2}}\mathbf{i} + \frac{1}{\sqrt{2}}\mathbf{j} + \frac{\pi}{4}\mathbf{k}$

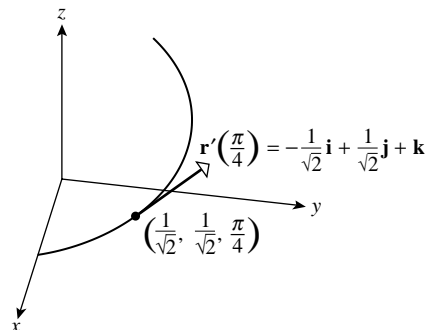

13.  $9\mathbf{i} + 6\mathbf{j}$

14.  $\langle \sqrt{2}/2, \sqrt{2}/2 \rangle$

15.  $\langle 1/3, 0 \rangle$

16.  $\mathbf{j}$

17.  $2\mathbf{i} - 3\mathbf{j} + 4\mathbf{k}$

18.  $\langle 3, 1/2, \sin 2 \rangle$

19. (a) continuous,  $\lim_{t \rightarrow 0} \mathbf{r}(t) = \mathbf{0} = \mathbf{r}(0)$

(b) not continuous,  $\lim_{t \rightarrow 0} \mathbf{r}(t)$  does not exist

20. (a) not continuous,  $\lim_{t \rightarrow 0} \mathbf{r}(t)$  does not exist.

(b) continuous,  $\lim_{t \rightarrow 0} \mathbf{r}(t) = 5\mathbf{i} - \mathbf{j} + \mathbf{k} = \mathbf{r}(0)$

21. (a)  $\lim_{t \rightarrow 0} (\mathbf{r}(t) - \mathbf{r}'(t)) = \mathbf{i} - \mathbf{j} + \mathbf{k}$

(b)  $\lim_{t \rightarrow 0} (\mathbf{r}(t) \times \mathbf{r}'(t)) = \lim_{t \rightarrow 0} (-\cos t \mathbf{i} - \sin t \mathbf{j} + \mathbf{k}) = -\mathbf{i} + \mathbf{k}$

(c)  $\lim_{t \rightarrow 0} (\mathbf{r}(t) \cdot \mathbf{r}'(t)) = 0$

22.  $\mathbf{r}(t) \cdot (\mathbf{r}'(t) \times \mathbf{r}''(t)) = \begin{vmatrix} t & t^2 & t^3 \\ 1 & 2t & 3t^2 \\ 0 & 2 & 6t \end{vmatrix} = 2t^3$ , so  $\lim_{t \rightarrow 1} \mathbf{r}(t) \cdot (\mathbf{r}'(t) \times \mathbf{r}''(t)) = 2$

23.  $\mathbf{r}'(t) = 2t\mathbf{i} - \frac{1}{t}\mathbf{j}$ ,  $\mathbf{r}'(1) = 2\mathbf{i} - \mathbf{j}$ ,  $\mathbf{r}(1) = \mathbf{i} + 2\mathbf{j}$ ;  $x = 1 + 2t$ ,  $y = 2 - t$ ,  $z = 0$

24.  $\mathbf{r}'(t) = 2e^{2t}\mathbf{i} + 6 \sin 3t\mathbf{j}$ ,  $\mathbf{r}'(0) = 2\mathbf{i}$ ,  $\mathbf{r}(0) = \mathbf{i} - 2\mathbf{j}$ ;  $x = 1 + 2t$ ,  $y = -2$ ,  $z = 0$

25.  $\mathbf{r}'(t) = -2\pi \sin \pi t \mathbf{i} + 2\pi \cos \pi t \mathbf{j} + 3\mathbf{k}$ ,  $\mathbf{r}'(1/3) = -\sqrt{3}\pi \mathbf{i} + \pi \mathbf{j} + 3\mathbf{k}$ ,  
 $\mathbf{r}(1/3) = \mathbf{i} + \sqrt{3}\mathbf{j} + \mathbf{k}$ ;  $x = 1 - \sqrt{3}\pi t$ ,  $y = \sqrt{3} + \pi t$ ,  $z = 1 + 3t$

26.  $\mathbf{r}'(t) = \frac{1}{t}\mathbf{i} - e^{-t}\mathbf{j} + 3t^2\mathbf{k}$ ,  $\mathbf{r}'(2) = \frac{1}{2}\mathbf{i} - e^{-2}\mathbf{j} + 12\mathbf{k}$ ,

$\mathbf{r}(2) = \ln 2 \mathbf{i} + e^{-2}\mathbf{j} + 8\mathbf{k}$ ;  $x = \ln 2 + \frac{1}{2}t$ ,  $y = e^{-2} - e^{-2}t$ ,  $z = 8 + 12t$



27.  $\mathbf{r}'(t) = 2\mathbf{i} + \frac{3}{2\sqrt{3t+4}}\mathbf{j}$ ,  $t = 0$  at  $P_0$  so  $\mathbf{r}'(0) = 2\mathbf{i} + \frac{3}{4}\mathbf{j}$ ,

$$\mathbf{r}(0) = -\mathbf{i} + 2\mathbf{j}; \mathbf{r} = (-\mathbf{i} + 2\mathbf{j}) + t\left(2\mathbf{i} + \frac{3}{4}\mathbf{j}\right)$$

28.  $\mathbf{r}'(t) = -4\sin t\mathbf{i} - 3\mathbf{j}$ ,  $t = \pi/3$  at  $P_0$  so  $\mathbf{r}'(\pi/3) = -2\sqrt{3}\mathbf{i} - 3\mathbf{j}$ ,

$$\mathbf{r}(\pi/3) = 2\mathbf{i} - \pi\mathbf{j}; \mathbf{r} = (2\mathbf{i} - \pi\mathbf{j}) + t(-2\sqrt{3}\mathbf{i} - 3\mathbf{j})$$

29.  $\mathbf{r}'(t) = 2t\mathbf{i} + \frac{1}{(t+1)^2}\mathbf{j} - 2t\mathbf{k}$ ,  $t = -2$  at  $P_0$  so  $\mathbf{r}'(-2) = -4\mathbf{i} + \mathbf{j} + 4\mathbf{k}$ ,

$$\mathbf{r}(-2) = 4\mathbf{i} + \mathbf{j}; \mathbf{r} = (4\mathbf{i} + \mathbf{j}) + t(-4\mathbf{i} + \mathbf{j} + 4\mathbf{k})$$

30.  $\mathbf{r}'(t) = \cos t\mathbf{i} + \sinh t\mathbf{j} + \frac{1}{1+t^2}\mathbf{k}$ ,  $t = 0$  at  $P_0$  so  $\mathbf{r}'(0) = \mathbf{i} + \mathbf{k}$ ,  $\mathbf{r}(0) = \mathbf{j}$ ;  $\mathbf{r} = t\mathbf{i} + \mathbf{j} + t\mathbf{k}$

31.  $3t\mathbf{i} + 2t^2\mathbf{j} + \mathbf{C}$

32.  $(\sin t)\mathbf{i} - (\cos t)\mathbf{j} + \mathbf{C}$

33.  $(-t \cos t + \sin t)\mathbf{i} + t\mathbf{j} + \mathbf{C}$

34.  $\langle (t-1)e^t, t(\ln t - 1) \rangle + \mathbf{C}$

35.  $(t^3/3)\mathbf{i} - t^2\mathbf{j} + \ln|t|\mathbf{k} + \mathbf{C}$

36.  $\langle -e^{-t}, e^t, t^3 \rangle + \mathbf{C}$

37.  $\left\langle \frac{1}{3}\sin 3t, \frac{1}{3}\cos 3t \right\rangle \Big|_0^{\pi/3} = \langle 0, -2/3 \rangle$

38.  $\left( \frac{1}{3}t^3\mathbf{i} + \frac{1}{4}t^4\mathbf{j} \right) \Big|_0^1 = \frac{1}{3}\mathbf{i} + \frac{1}{4}\mathbf{j}$

39.  $\int_0^2 \sqrt{t^2 + t^4} dt = \int_0^2 t(1+t^2)^{1/2} dt = \frac{1}{3} (1+t^2)^{3/2} \Big|_0^2 = (5\sqrt{5} - 1)/3$

40.  $\left\langle -\frac{2}{5}(3-t)^{5/2}, \frac{2}{5}(3+t)^{5/2}, t \right\rangle \Big|_{-3}^3 = \langle 72\sqrt{6}/5, 72\sqrt{6}/5, 6 \rangle$

41.  $\left( \frac{2}{3}t^{3/2}\mathbf{i} + 2t^{1/2}\mathbf{j} \right) \Big|_1^9 = \frac{52}{3}\mathbf{i} + 4\mathbf{j}$

42.  $\frac{1}{2}(e^2 - 1)\mathbf{i} + (1 - e^{-1})\mathbf{j} + \frac{1}{2}\mathbf{k}$

43.  $\mathbf{y}(t) = \int \mathbf{y}'(t) dt = \frac{1}{3}t^3\mathbf{i} + t^2\mathbf{j} + \mathbf{C}$ ,  $\mathbf{y}(0) = \mathbf{C} = \mathbf{i} + \mathbf{j}$ ,  $\mathbf{y}(t) = (\frac{1}{3}t^3 + 1)\mathbf{i} + (t^2 + 1)\mathbf{j}$

44.  $\mathbf{y}(t) = \int \mathbf{y}'(t) dt = (\sin t)\mathbf{i} - (\cos t)\mathbf{j} + \mathbf{C}$ ,

$$\mathbf{y}(0) = -\mathbf{j} + \mathbf{C} = \mathbf{i} - \mathbf{j} \text{ so } \mathbf{C} = \mathbf{i} \text{ and } \mathbf{y}(t) = (1 + \sin t)\mathbf{i} - (\cos t)\mathbf{j}.$$

45.  $\mathbf{y}'(t) = \int \mathbf{y}''(t) dt = t\mathbf{i} + e^t\mathbf{j} + \mathbf{C}_1$ ,  $\mathbf{y}'(0) = \mathbf{j} + \mathbf{C}_1 = \mathbf{j}$  so  $\mathbf{C}_1 = \mathbf{0}$  and  $\mathbf{y}'(t) = t\mathbf{i} + e^t\mathbf{j}$ .

$$\mathbf{y}(t) = \int \mathbf{y}'(t) dt = \frac{1}{2}t^2\mathbf{i} + e^t\mathbf{j} + \mathbf{C}_2, \mathbf{y}(0) = \mathbf{j} + \mathbf{C}_2 = 2\mathbf{i} \text{ so } \mathbf{C}_2 = 2\mathbf{i} - \mathbf{j} \text{ and}$$

$$\mathbf{y}(t) = \left( \frac{1}{2}t^2 + 2 \right) \mathbf{i} + (e^t - 1)\mathbf{j}$$

46.  $\mathbf{y}'(t) = \int \mathbf{y}''(t)dt = 4t^3\mathbf{i} - t^2\mathbf{j} + \mathbf{C}_1$ ,  $\mathbf{y}'(0) = \mathbf{C}_1 = \mathbf{0}$ ,  $\mathbf{y}'(t) = 4t^3\mathbf{i} - t^2\mathbf{j}$   
 $\mathbf{y}(t) = \int \mathbf{y}'(t)dt = t^4\mathbf{i} - \frac{1}{3}t^3\mathbf{j} + \mathbf{C}_2$ ,  $\mathbf{y}(0) = \mathbf{C}_2 = 2\mathbf{i} - 4\mathbf{j}$ ,  $\mathbf{y}(t) = (t^4 + 2)\mathbf{i} - (\frac{1}{3}t^3 + 4)\mathbf{j}$

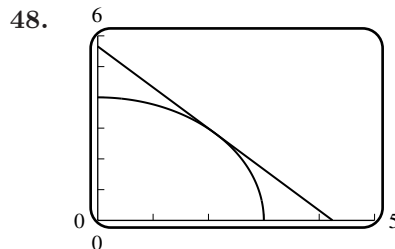
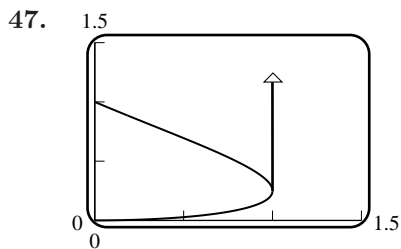

49.  $\mathbf{r}'(t) = -4\sin t\mathbf{i} + 3\cos t\mathbf{j}$ ,  $\|\mathbf{r}(t)\| = \sqrt{16\cos^2 t + 9\sin^2 t}$ ,  $\|\mathbf{r}'(t)\| = \sqrt{16\sin^2 t + 9\cos^2 t}$ ,  
 $\|\mathbf{r}\|\|\mathbf{r}'\| = \sqrt{144 + 49\sin^2 t \cos^2 t}$ ,  $\theta = \cos^{-1} \frac{-7\sin t \cos t}{\sqrt{144 + 49\sin^2 t \cos^2 t}}$

$\mathbf{r}$  and  $\mathbf{r}'$  are parallel when  $\theta = 0$ , so  $t = 0, \pi/2, \pi, 3\pi/2, 2\pi$ ; the angle between  $\mathbf{r}$  and  $\mathbf{r}'$  is greatest at  $\theta_{\max} = 0.28$  ( $t \approx 2.23, 5.53$ ) and  $\theta_{\min} = -0.28$ , ( $t \approx 0.77, 3.95$ ), so  $\mathbf{r}$  and  $\mathbf{r}'$  are never perpendicular.

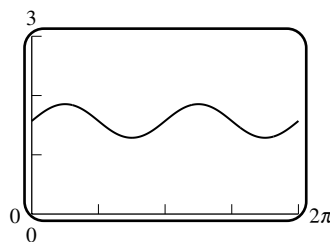

50.  $\mathbf{r}'(t) = 2t\mathbf{i} + 3t^2\mathbf{j}$ ,  $\|\mathbf{r}(t)\| = t^2\sqrt{1+t^2}$ ,  $\|\mathbf{r}'(t)\| = t\sqrt{4+9t^2}$ ,  $\cos \theta = \frac{2+3t^2}{\sqrt{1+t^2}\sqrt{4+9t^2}}$   
 $\cos \theta = 1$  when  $t = 0, \pm 2^{3/4}/\sqrt{3}$  and  $\mathbf{r}$  and  $\mathbf{r}'$  are parallel;  $\cos \theta > 0$ , so they are never perpendicular.

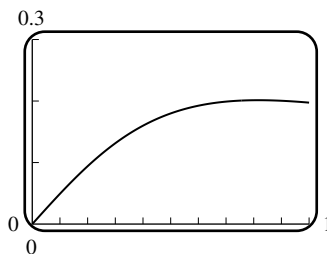

51. (a)  $2t - t^2 - 3t = -2$ ,  $t^2 + t - 2 = 0$ ,  $(t+2)(t-1) = 0$  so  $t = -2, 1$ . The points of intersection are  $(-2, 4, 6)$  and  $(1, 1, -3)$ .

(b)  $\mathbf{r}' = \mathbf{i} + 2t\mathbf{j} - 3\mathbf{k}$ ;  $\mathbf{r}'(-2) = \mathbf{i} - 4\mathbf{j} - 3\mathbf{k}$ ,  $\mathbf{r}'(1) = \mathbf{i} + 2\mathbf{j} - 3\mathbf{k}$ , and  $\mathbf{n} = 2\mathbf{i} - \mathbf{j} + \mathbf{k}$  is normal to the plane. Let  $\theta$  be the acute angle, then  
for  $t = -2$ :  $\cos \theta = |\mathbf{n} \cdot \mathbf{r}'| / (\|\mathbf{n}\| \|\mathbf{r}'\|) = 3/\sqrt{156}$ ,  $\theta \approx 76^\circ$ ;  
for  $t = 1$ :  $\cos \theta = |\mathbf{n} \cdot \mathbf{r}'| / (\|\mathbf{n}\| \|\mathbf{r}'\|) = 3/\sqrt{84}$ ,  $\theta \approx 71^\circ$ .

52.  $\mathbf{r}' = -2e^{-2t}\mathbf{i} - \sin t\mathbf{j} + 3\cos t\mathbf{k}$ ,  $t = 0$  at the point  $(1, 1, 0)$  so  $\mathbf{r}'(0) = -2\mathbf{i} + 3\mathbf{k}$  and hence the tangent line is  $x = 1 - 2t$ ,  $y = 1$ ,  $z = 3t$ . But  $x = 0$  in the  $yz$ -plane so  $1 - 2t = 0$ ,  $t = 1/2$ . The point of intersection is  $(0, 1, 3/2)$ .

53.  $\mathbf{r}_1(1) = \mathbf{r}_2(2) = \mathbf{i} + \mathbf{j} + 3\mathbf{k}$  so the graphs intersect at P;  $\mathbf{r}'_1(t) = 2t\mathbf{i} + \mathbf{j} + 9t^2\mathbf{k}$  and  $\mathbf{r}'_2(t) = \mathbf{i} + \frac{1}{2}t\mathbf{j} - \mathbf{k}$  so  $\mathbf{r}'_1(1) = 2\mathbf{i} + \mathbf{j} + 9\mathbf{k}$  and  $\mathbf{r}'_2(2) = \mathbf{i} + \mathbf{j} - \mathbf{k}$  are tangent to the graphs at P, thus  $\cos \theta = \frac{\mathbf{r}'_1(1) \cdot \mathbf{r}'_2(2)}{\|\mathbf{r}'_1(1)\| \|\mathbf{r}'_2(2)\|} = -\frac{6}{\sqrt{86}\sqrt{3}}$ ,  $\theta = \cos^{-1}(6/\sqrt{258}) \approx 68^\circ$ .

54.  $\mathbf{r}_1(0) = \mathbf{r}_2(-1) = 2\mathbf{i} + \mathbf{j} + 3\mathbf{k}$  so the graphs intersect at P;  $\mathbf{r}'_1(t) = -2e^{-t}\mathbf{i} - (\sin t)\mathbf{j} + 2t\mathbf{k}$  and  $\mathbf{r}'_2(t) = -\mathbf{i} + 2t\mathbf{j} + 3t^2\mathbf{k}$  so  $\mathbf{r}'_1(0) = -2\mathbf{i}$  and  $\mathbf{r}'_2(-1) = -\mathbf{i} - 2\mathbf{j} + 3\mathbf{k}$  are tangent to the graphs at P, thus  $\cos \theta = \frac{\mathbf{r}'_1(0) \cdot \mathbf{r}'_2(-1)}{\|\mathbf{r}'_1(0)\| \|\mathbf{r}'_2(-1)\|} = \frac{1}{\sqrt{14}}$ ,  $\theta \approx 74^\circ$ .

55. (a)  $\mathbf{r}'_1 = 2\mathbf{i} + 6t\mathbf{j} + 3t^2\mathbf{k}$ ,  $\mathbf{r}'_2 = 4t^3\mathbf{k}$ ,  $\mathbf{r}_1 \cdot \mathbf{r}_2 = t^7$ ;  $\frac{d}{dt}(\mathbf{r}_1 \cdot \mathbf{r}_2) = 7t^6 = \mathbf{r}_1 \cdot \mathbf{r}'_2 + \mathbf{r}'_1 \cdot \mathbf{r}_2$

(b)  $\mathbf{r}_1 \times \mathbf{r}_2 = 3t^6\mathbf{i} - 2t^5\mathbf{j}$ ;  $\frac{d}{dt}(\mathbf{r}_1 \times \mathbf{r}_2) = 18t^5\mathbf{i} - 10t^4\mathbf{j} = \mathbf{r}_1 \times \mathbf{r}'_2 + \mathbf{r}'_1 \times \mathbf{r}_2$

56. (a)  $\mathbf{r}'_1 = -\sin t\mathbf{i} + \cos t\mathbf{j} + \mathbf{k}$ ,  $\mathbf{r}'_2 = \mathbf{k}$ ,  $\mathbf{r}_1 \cdot \mathbf{r}_2 = \cos t + t^2$ ;  $\frac{d}{dt}(\mathbf{r}_1 \cdot \mathbf{r}_2) = -\sin t + 2t = \mathbf{r}_1 \cdot \mathbf{r}'_2 + \mathbf{r}'_1 \cdot \mathbf{r}_2$

(b)  $\mathbf{r}_1 \times \mathbf{r}_2 = t \sin t\mathbf{i} + t(1 - \cos t)\mathbf{j} - \sin t\mathbf{k}$ ,

$$\frac{d}{dt}(\mathbf{r}_1 \times \mathbf{r}_2) = (\sin t + t \cos t)\mathbf{i} + (1 + t \sin t - \cos t)\mathbf{j} - \cos t\mathbf{k} = \mathbf{r}_1 \times \mathbf{r}'_2 + \mathbf{r}'_1 \times \mathbf{r}_2$$

57.  $\frac{d}{dt}[\mathbf{r}(t) \times \mathbf{r}'(t)] = \mathbf{r}(t) \times \mathbf{r}''(t) + \mathbf{r}'(t) \times \mathbf{r}'(t) = \mathbf{r}(t) \times \mathbf{r}''(t) + \mathbf{0} = \mathbf{r}(t) \times \mathbf{r}''(t)$

58.  $\frac{d}{dt}[\mathbf{u} \cdot (\mathbf{v} \times \mathbf{w})] = \mathbf{u} \cdot \frac{d}{dt}[\mathbf{v} \times \mathbf{w}] + \frac{d\mathbf{u}}{dt} \cdot [\mathbf{v} \times \mathbf{w}] = \mathbf{u} \cdot \left( \mathbf{v} \times \frac{d\mathbf{w}}{dt} + \frac{d\mathbf{v}}{dt} \times \mathbf{w} \right) + \frac{d\mathbf{u}}{dt} \cdot [\mathbf{v} \times \mathbf{w}]$

$$= \mathbf{u} \cdot \left[ \mathbf{v} \times \frac{d\mathbf{w}}{dt} \right] + \mathbf{u} \cdot \left[ \frac{d\mathbf{v}}{dt} \times \mathbf{w} \right] + \frac{d\mathbf{u}}{dt} \cdot [\mathbf{v} \times \mathbf{w}]$$

59. In Exercise 60, write each scalar triple product as a determinant.

60. Let  $\mathbf{c} = c_1\mathbf{i} + c_2\mathbf{j}$ ,  $\mathbf{r}(t) = x(t)\mathbf{i} + y(t)\mathbf{j}$ ,  $\mathbf{r}_1(t) = x_1(t)\mathbf{i} + y_1(t)\mathbf{j}$ ,  $\mathbf{r}_2(t) = x_2(t)\mathbf{i} + y_2(t)\mathbf{j}$  and use properties of derivatives.

61. Let  $\mathbf{r}_1(t) = x_1(t)\mathbf{i} + y_1(t)\mathbf{j} + z_1(t)\mathbf{k}$  and  $\mathbf{r}_2(t) = x_2(t)\mathbf{i} + y_2(t)\mathbf{j} + z_2(t)\mathbf{k}$ , in both (8) and (9); show that the left and right members of the equalities are the same.

62. (a)  $\int k\mathbf{r}(t) dt = \int k(x(t)\mathbf{i} + y(t)\mathbf{j} + z(t)\mathbf{k}) dt$   
 $= k \int x(t) dt \mathbf{i} + k \int y(t) dt \mathbf{j} + k \int z(t) dt \mathbf{k} = k \int \mathbf{r}(t) dt$

(b) Similar to Part (a)

(c) Use Part (a) on Part (b) with  $k = -1$

## EXERCISE SET 14.3

1. (a) The tangent vector reverses direction at the four cusps.  
 (b)  $\mathbf{r}'(t) = -3 \cos^2 t \sin t \mathbf{i} + 3 \sin^2 t \cos t \mathbf{j} = \mathbf{0}$  when  $t = 0, \pi/2, \pi, 3\pi/2, 2\pi$ .
2.  $\mathbf{r}'(t) = \cos t \mathbf{i} + 2 \sin t \cos t \mathbf{j} = \mathbf{0}$  when  $t = \pi/2, 3\pi/2$ . The tangent vector reverses direction at  $(1, 1)$  and  $(-1, 1)$ .
3.  $\mathbf{r}'(t) = 3t^2 \mathbf{i} + (6t - 2) \mathbf{j} + 2t \mathbf{k}$ ; smooth
4.  $\mathbf{r}'(t) = -2t \sin(t^2) \mathbf{i} + 2t \cos(t^2) \mathbf{j} - e^{-t} \mathbf{k}$ ; smooth
5.  $\mathbf{r}'(t) = (1 - t)e^{-t} \mathbf{i} + (2t - 2) \mathbf{j} - \pi \sin(\pi t) \mathbf{k}$ ; not smooth,  $\mathbf{r}'(1) = \mathbf{0}$
6.  $\mathbf{r}'(t) = \pi \cos(\pi t) \mathbf{i} + (2 - 1/t) \mathbf{j} + (2t - 1) \mathbf{k}$ ; not smooth,  $\mathbf{r}'(1/2) = \mathbf{0}$
7.  $(dx/dt)^2 + (dy/dt)^2 + (dz/dt)^2 = (-3 \cos^2 t \sin t)^2 + (3 \sin^2 t \cos t)^2 + 0^2 = 9 \sin^2 t \cos^2 t$ ,  
 $L = \int_0^{\pi/2} 3 \sin t \cos t dt = 3/2$
8.  $(dx/dt)^2 + (dy/dt)^2 + (dz/dt)^2 = (-3 \sin t)^2 + (3 \cos t)^2 + 16 = 25$ ,  $L = \int_0^{\pi} 5 dt = 5\pi$
9.  $\mathbf{r}'(t) = \langle e^t, -e^{-t}, \sqrt{2} \rangle$ ,  $\|\mathbf{r}'(t)\| = e^t + e^{-t}$ ,  $L = \int_0^1 (e^t + e^{-t}) dt = e - e^{-1}$
10.  $(dx/dt)^2 + (dy/dt)^2 + (dz/dt)^2 = 1/4 + (1 - t)/4 + (1 + t)/4 = 3/4$ ,  $L = \int_{-1}^1 (\sqrt{3}/2) dt = \sqrt{3}$
11.  $\mathbf{r}'(t) = 3t^2 \mathbf{i} + \mathbf{j} + \sqrt{6} t \mathbf{k}$ ,  $\|\mathbf{r}'(t)\| = 3t^2 + 1$ ,  $L = \int_1^3 (3t^2 + 1) dt = 28$
12.  $\mathbf{r}'(t) = 3 \mathbf{i} - 2 \mathbf{j} + \mathbf{k}$ ,  $\|\mathbf{r}'(t)\| = \sqrt{14}$ ,  $L = \int_3^4 \sqrt{14} dt = \sqrt{14}$
13.  $\mathbf{r}'(t) = -3 \sin t \mathbf{i} + 3 \cos t \mathbf{j} + \mathbf{k}$ ,  $\|\mathbf{r}'(t)\| = \sqrt{10}$ ,  $L = \int_0^{2\pi} \sqrt{10} dt = 2\pi\sqrt{10}$
14.  $\mathbf{r}'(t) = 2t \mathbf{i} + t \cos t \mathbf{j} + t \sin t \mathbf{k}$ ,  $\|\mathbf{r}'(t)\| = \sqrt{5}t$ ,  $L = \int_0^{\pi} \sqrt{5}t dt = \pi^2\sqrt{5}/2$
15.  $(d\mathbf{r}/dt)(dt/d\tau) = (\mathbf{i} + 2t\mathbf{j})(4) = 4\mathbf{i} + 8t\mathbf{j} = 4\mathbf{i} + 8(4\tau + 1)\mathbf{j}$ ;  
 $\mathbf{r}(\tau) = (4\tau + 1)\mathbf{i} + (4\tau + 1)^2\mathbf{j}$ ,  $\mathbf{r}'(\tau) = 4\mathbf{i} + 2(4)(4\tau + 1)\mathbf{j}$
16.  $(d\mathbf{r}/dt)(dt/d\tau) = \langle -3 \sin t, 3 \cos t \rangle(\pi) = \langle -3\pi \sin \pi\tau, 3\pi \cos \pi\tau \rangle$ ;  
 $\mathbf{r}(\tau) = \langle 3 \cos \pi\tau, 3 \sin \pi\tau \rangle$ ,  $\mathbf{r}'(\tau) = \langle -3\pi \sin \pi\tau, 3\pi \cos \pi\tau \rangle$
17.  $(d\mathbf{r}/dt)(dt/d\tau) = (e^t \mathbf{i} - 4e^{-t} \mathbf{j})(2\tau) = 2\tau e^{\tau^2} \mathbf{i} - 8\tau e^{-\tau^2} \mathbf{j}$ ;  
 $\mathbf{r}(\tau) = e^{\tau^2} \mathbf{i} + 4e^{-\tau^2} \mathbf{j}$ ,  $\mathbf{r}'(\tau) = 2\tau e^{\tau^2} \mathbf{i} - 4(2)\tau e^{-\tau^2} \mathbf{j}$

$$18. \quad (dx/dt)(dt/d\tau) = \left(\frac{9}{2}t^{1/2}\mathbf{j} + \mathbf{k}\right) (-1/\tau^2) = -\frac{9}{2\tau^{5/2}}\mathbf{j} - \frac{1}{\tau^2}\mathbf{k};$$

$$\mathbf{r}(\tau) = \mathbf{i} + 3\tau^{-3/2}\mathbf{j} + \frac{1}{\tau}\mathbf{k}, \quad \mathbf{r}'(\tau) = -\frac{9}{2}\tau^{-5/2}\mathbf{j} - \frac{1}{\tau^2}\mathbf{k}$$

$$19. \quad (\text{a}) \quad \|\mathbf{r}'(t)\| = \sqrt{2}, s = \int_0^t \sqrt{2} dt = \sqrt{2}t; \mathbf{r} = \frac{s}{\sqrt{2}}\mathbf{i} + \frac{s}{\sqrt{2}}\mathbf{j}, x = \frac{s}{\sqrt{2}}, y = \frac{s}{\sqrt{2}}$$

$$(\text{b}) \quad \text{Similar to Part (a), } x = y = z = \frac{s}{\sqrt{3}}$$

$$20. \quad (\text{a}) \quad x = -\frac{s}{\sqrt{2}}, y = -\frac{s}{\sqrt{2}} \qquad (\text{b}) \quad x = -\frac{s}{\sqrt{3}}, y = -\frac{s}{\sqrt{3}}, z = -\frac{s}{\sqrt{3}}$$

$$21. \quad (\text{a}) \quad \mathbf{r}(t) = \langle 1, 3, 4 \rangle \text{ when } t = 0,$$

$$\text{so } s = \int_0^t \sqrt{1+4+4} du = 3t, x = 1 + s/3, y = 3 - 2s/3, z = 4 + 2s/3$$

$$(\text{b}) \quad \mathbf{r} \Big|_{s=25} = \langle 28/3, -41/3, 62/3 \rangle$$

$$22. \quad (\text{a}) \quad \mathbf{r}(t) = \langle -5, 0, 1 \rangle \text{ when } t = 0, \text{ so } s = \int_0^t \sqrt{9+4+1} du = \sqrt{14}t,$$

$$x = -5 + 3s/\sqrt{14}, y = 2s/\sqrt{14}, z = 5 + s/\sqrt{14}$$

$$(\text{b}) \quad \mathbf{r}(s) \Big|_{s=10} = \langle -5 + 30/\sqrt{14}, 20/\sqrt{14}, 5 + 10/\sqrt{14} \rangle$$

$$23. \quad x = 3 + \cos t, y = 2 + \sin t, (dx/dt)^2 + (dy/dt)^2 = 1,$$

$$s = \int_0^t du = t \text{ so } t = s, x = 3 + \cos s, y = 2 + \sin s \text{ for } 0 \leq s \leq 2\pi.$$

$$24. \quad x = \cos^3 t, y = \sin^3 t, (dx/dt)^2 + (dy/dt)^2 = 9\sin^2 t \cos^2 t,$$

$$s = \int_0^t 3\sin u \cos u du = \frac{3}{2}\sin^2 t \text{ so } \sin t = (2s/3)^{1/2}, \cos t = (1 - 2s/3)^{1/2},$$

$$x = (1 - 2s/3)^{3/2}, y = (2s/3)^{3/2} \text{ for } 0 \leq s \leq 3/2$$

$$25. \quad x = t^3/3, y = t^2/2, (dx/dt)^2 + (dy/dt)^2 = t^2(t^2 + 1),$$

$$s = \int_0^t u(u^2 + 1)^{1/2} du = \frac{1}{3}[(t^2 + 1)^{3/2} - 1] \text{ so } t = [(3s + 1)^{2/3} - 1]^{1/2},$$

$$x = \frac{1}{3}[(3s + 1)^{2/3} - 1]^{3/2}, y = \frac{1}{2}[(3s + 1)^{2/3} - 1] \text{ for } s \geq 0$$

$$26. \quad x = (1 + t)^2, y = (1 + t)^3, (dx/dt)^2 + (dy/dt)^2 = (1 + t)^2[4 + 9(1 + t)^2],$$

$$s = \int_0^t (1 + u)[4 + 9(1 + u)^2]^{1/2} du = \frac{1}{27}([4 + 9(1 + t)^2]^{3/2} - 13\sqrt{13}) \text{ so}$$

$$1 + t = \frac{1}{3}[(27s + 13\sqrt{13})^{2/3} - 4]^{1/2}, x = \frac{1}{9}[(27s + 13\sqrt{13})^{2/3} - 4],$$

$$y = \frac{1}{27}[(27s + 13\sqrt{13})^{2/3} - 4]^{3/2} \text{ for } 0 \leq s \leq (80\sqrt{10} - 13\sqrt{13})/27$$

27.  $x = e^t \cos t$ ,  $y = e^t \sin t$ ,  $(dx/dt)^2 + (dy/dt)^2 = 2e^{2t}$ ,  $s = \int_0^t \sqrt{2} e^u du = \sqrt{2}(e^t - 1)$  so  
 $t = \ln(s/\sqrt{2} + 1)$ ,  $x = (s/\sqrt{2} + 1) \cos[\ln(s/\sqrt{2} + 1)]$ ,  $y = (s/\sqrt{2} + 1) \sin[\ln(s/\sqrt{2} + 1)]$   
for  $0 \leq s \leq \sqrt{2}(e^{\pi/2} - 1)$

28.  $x = \sin(e^t)$ ,  $y = \cos(e^t)$ ,  $z = \sqrt{3}e^t$ ,  
 $(dx/dt)^2 + (dy/dt)^2 + (dz/dt)^2 = 4e^{2t}$ ,  $s = \int_0^t 2e^u du = 2(e^t - 1)$  so  
 $e^t = 1 + s/2$ ;  $x = \sin(1 + s/2)$ ,  $y = \cos(1 + s/2)$ ,  $z = \sqrt{3}(1 + s/2)$  for  $s \geq 0$

29.  $dx/dt = -a \sin t$ ,  $dy/dt = a \cos t$ ,  $dz/dt = c$ ,  
 $L = \int_0^{t_0} \sqrt{a^2 \sin^2 t + a^2 \cos^2 t + c^2} dt = \int_0^{t_0} \sqrt{a^2 + c^2} dt = t_0 \sqrt{a^2 + c^2}$

30.  $x = a \cos t$ ,  $y = a \sin t$ ,  $z = ct$ ,  $(dx/dt)^2 + (dy/dt)^2 + (dz/dt)^2 = a^2 + c^2 = w^2$ ,  
 $s = \int_0^t w du = wt$  so  $t = s/w$ ;  $x = a \cos(s/w)$ ,  $y = a \sin(s/w)$ ,  $z = cs/w$  for  $s \geq 0$

31.  $x = at - a \sin t$ ,  $y = a - a \cos t$ ,  $(dx/dt)^2 + (dy/dt)^2 = 4a^2 \sin^2(t/2)$ ,  
 $s = \int_0^t 2a \sin(u/2) du = 4a[1 - \cos(t/2)]$  so  $\cos(t/2) = 1 - s/(4a)$ ,  $t = 2 \cos^{-1}[1 - s/(4a)]$ ,  
 $\cos t = 2 \cos^2(t/2) - 1 = 2[1 - s/(4a)]^2 - 1$ ,  
 $\sin t = 2 \sin(t/2) \cos(t/2) = 2(1 - [1 - s/(4a)]^2)^{1/2}(2[1 - s/(4a)]^2 - 1)$ ,  
 $x = 2a \cos^{-1}[1 - s/(4a)] - 2a(1 - [1 - s/(4a)]^2)^{1/2}(2[1 - s/(4a)]^2 - 1)$ ,  
 $y = \frac{s(8a - s)}{8a}$  for  $0 \leq s \leq 8a$

32.  $\frac{dx}{dt} = \cos \theta \frac{dr}{dt} - r \sin \theta \frac{d\theta}{dt}$ ,  $\frac{dy}{dt} = \sin \theta \frac{dr}{dt} + r \cos \theta \frac{d\theta}{dt}$ ,  
 $\left(\frac{dx}{dt}\right)^2 + \left(\frac{dy}{dt}\right)^2 + \left(\frac{dz}{dt}\right)^2 = \left(\frac{dr}{dt}\right)^2 + r^2 \left(\frac{d\theta}{dt}\right)^2 + \left(\frac{dz}{dt}\right)^2$

33. (a)  $(dr/dt)^2 + r^2(d\theta/dt)^2 + (dz/dt)^2 = 9e^{4t}$ ,  $L = \int_0^{\ln 2} 3e^{2t} dt = \left[\frac{3}{2}e^{2t}\right]_0^{\ln 2} = 9/2$

(b)  $(dr/dt)^2 + r^2(d\theta/dt)^2 + (dz/dt)^2 = 5t^2 + t^4 = t^2(5 + t^2)$ ,  
 $L = \int_1^2 t(5 + t^2)^{1/2} dt = 9 - 2\sqrt{6}$

34.  $\frac{dx}{dt} = \sin \phi \cos \theta \frac{d\rho}{dt} + \rho \cos \phi \cos \theta \frac{d\phi}{dt} - \rho \sin \phi \sin \theta \frac{d\theta}{dt}$ ,  
 $\frac{dy}{dt} = \sin \phi \sin \theta \frac{d\rho}{dt} + \rho \cos \phi \sin \theta \frac{d\phi}{dt} + \rho \sin \phi \cos \theta \frac{d\theta}{dt}$ ,  $\frac{dz}{dt} = \cos \phi \frac{d\rho}{dt} - \rho \sin \phi \frac{d\phi}{dt}$ ,  
 $\left(\frac{dx}{dt}\right)^2 + \left(\frac{dy}{dt}\right)^2 + \left(\frac{dz}{dt}\right)^2 = \left(\frac{d\rho}{dt}\right)^2 + \rho^2 \sin^2 \phi \left(\frac{d\theta}{dt}\right)^2 + \rho^2 \left(\frac{d\phi}{dt}\right)^2$

35. (a)  $(d\rho/dt)^2 + \rho^2 \sin^2 \phi (d\theta/dt)^2 + \rho^2 (d\phi/dt)^2 = 3e^{-2t}$ ,  $L = \int_0^2 \sqrt{3}e^{-t} dt = \sqrt{3}(1 - e^{-2})$   
 (b)  $(d\rho/dt)^2 + \rho^2 \sin^2 \phi (d\theta/dt)^2 + \rho^2 (d\phi/dt)^2 = 5$ ,  $L = \int_1^5 \sqrt{5} dt = 4\sqrt{5}$
36. (a)  $\frac{d}{dt} \mathbf{r}(t) = \mathbf{i} + 2t\mathbf{j}$  is never zero, but  $\frac{d}{d\tau} \mathbf{r}^3(\tau) = \frac{d}{d\tau} (\tau^3 \mathbf{i} + \tau^6 \mathbf{j}) = 3\tau^2 \mathbf{i} + 6\tau^5 \mathbf{j}$  is zero at  $\tau = 0$ .  
 (b)  $\frac{d\mathbf{r}}{d\tau} = \frac{d\mathbf{r}}{dt} \frac{dt}{d\tau}$ , and since  $t = \tau^3$ ,  $\frac{dt}{d\tau} = 0$  when  $\tau = 0$ .

37. (a)  $g(\tau) = \pi\tau$       (b)  $g(\tau) = \pi(1 - \tau)$       38.  $t = 1 - \tau$

39. Represent the helix by  $x = a \cos t$ ,  $y = a \sin t$ ,  $z = ct$  with  $a = 6.25$  and  $c = 10/\pi$ , so that the radius of the helix is the distance from the axis of the cylinder to the center of the copper cable, and the helix makes one turn in a distance of 20 in. ( $t = 2\pi$ ). From Exercise 29 the length of the helix is  $2\pi\sqrt{6.25^2 + (10/\pi)^2} \approx 44$  in.

40.  $\mathbf{r}(t) = \cos t \mathbf{i} + \sin t \mathbf{j} + t^{3/2} \mathbf{k}$ ,  $\mathbf{r}'(t) = -\sin t \mathbf{i} + \cos t \mathbf{j} + \frac{3}{2} t^{1/2} \mathbf{k}$   
 (a)  $\|\mathbf{r}'(t)\| = \sqrt{\sin^2 t + \cos^2 t + 9t/4} = \frac{1}{2}\sqrt{4 + 9t}$   
 (b)  $\frac{ds}{dt} = \frac{1}{2}\sqrt{4 + 9t}$       (c)  $\int_0^2 \frac{1}{2}\sqrt{4 + 9t} dt = \frac{2}{27}(11\sqrt{22} - 4)$

41.  $\mathbf{r}'(t) = (1/t)\mathbf{i} + 2\mathbf{j} + 2t\mathbf{k}$   
 (a)  $\|\mathbf{r}'(t)\| = \sqrt{1/t^2 + 4 + 4t^2} = \sqrt{(2t + 1/t)^2} = 2t + 1/t$   
 (b)  $\frac{ds}{dt} = 2t + 1/t$       (c)  $\int_1^3 (2t + 1/t) dt = 8 + \ln 3$

42. If  $\mathbf{r}(t) = x(t)\mathbf{i} + y(t)\mathbf{j} + z(t)\mathbf{k}$  is smooth, then  $\|\mathbf{r}'(t)\|$  is continuous and nonzero. Thus the angle between  $\mathbf{r}'(t)$  and  $\mathbf{i}$ , given by  $\cos^{-1}(x'(t)/\|\mathbf{r}'(t)\|)$ , is a continuous function of  $t$ . Similarly, the angles between  $\mathbf{r}'(t)$  and the vectors  $\mathbf{j}$  and  $\mathbf{k}$  are continuous functions of  $t$ .

43. Let  $\mathbf{r}(t) = x(t)\mathbf{i} + y(t)\mathbf{j}$  and use the chain rule.

**EXERCISE SET 14.4**

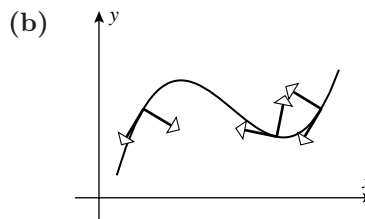
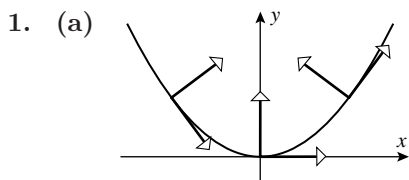

2.

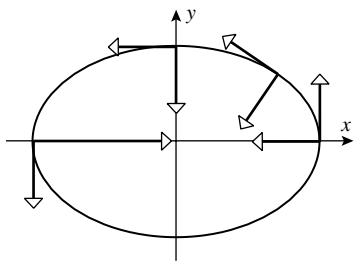

3.  $\mathbf{r}'(t) = 2t\mathbf{i} + \mathbf{j}$ ,  $\|\mathbf{r}'(t)\| = \sqrt{4t^2 + 1}$ ,  $\mathbf{T}(t) = (4t^2 + 1)^{-1/2}(2t\mathbf{i} + \mathbf{j})$ ,  
 $\mathbf{T}'(t) = (4t^2 + 1)^{-1/2}(2\mathbf{i}) - 4t(4t^2 + 1)^{-3/2}(2t\mathbf{i} + \mathbf{j})$ ;  
 $\mathbf{T}(1) = \frac{2}{\sqrt{5}}\mathbf{i} + \frac{1}{\sqrt{5}}\mathbf{j}$ ,  $\mathbf{T}'(1) = \frac{2}{5\sqrt{5}}(\mathbf{i} - 2\mathbf{j})$ ,  $\mathbf{N}(1) = \frac{1}{\sqrt{5}}\mathbf{i} - \frac{2}{\sqrt{5}}\mathbf{j}$ .
4.  $\mathbf{r}'(t) = t\mathbf{i} + t^2\mathbf{j}$ ,  $\mathbf{T}(t) = (t^2 + t^4)^{-1/2}(t\mathbf{i} + t^2\mathbf{j})$ ,  
 $\mathbf{T}'(t) = (t^2 + t^4)^{-1/2}(\mathbf{i} + 2t\mathbf{j}) - (t + 2t^3)(t^2 + t^4)^{-3/2}(t\mathbf{i} + t^2\mathbf{j})$ ;  
 $\mathbf{T}(1) = \frac{1}{\sqrt{2}}\mathbf{i} + \frac{1}{\sqrt{2}}\mathbf{j}$ ,  $\mathbf{T}'(1) = \frac{1}{2\sqrt{2}}(-\mathbf{i} + \mathbf{j})$ ,  $\mathbf{N}(1) = -\frac{1}{\sqrt{2}}\mathbf{i} + \frac{1}{\sqrt{2}}\mathbf{j}$
5.  $\mathbf{r}'(t) = -5\sin t\mathbf{i} + 5\cos t\mathbf{j}$ ,  $\|\mathbf{r}'(t)\| = 5$ ,  $\mathbf{T}(t) = -\sin t\mathbf{i} + \cos t\mathbf{j}$ ,  $\mathbf{T}'(t) = -\cos t\mathbf{i} - \sin t\mathbf{j}$ ;  
 $\mathbf{T}(\pi/3) = -\frac{\sqrt{3}}{2}\mathbf{i} + \frac{1}{2}\mathbf{j}$ ,  $\mathbf{T}'(\pi/3) = -\frac{1}{2}\mathbf{i} - \frac{\sqrt{3}}{2}\mathbf{j}$ ,  $\mathbf{N}(\pi/3) = -\frac{1}{2}\mathbf{i} - \frac{\sqrt{3}}{2}\mathbf{j}$
6.  $\mathbf{r}'(t) = \frac{1}{t}\mathbf{i} + \mathbf{j}$ ,  $\|\mathbf{r}'(t)\| = \frac{\sqrt{1+t^2}}{t}$ ,  $\mathbf{T}(t) = (1+t^2)^{-1/2}(\mathbf{i} + t\mathbf{j})$ ,  
 $\mathbf{T}'(t) = (1+t^2)^{-1/2}(\mathbf{j}) - t(1+t^2)^{-3/2}(\mathbf{i} + t\mathbf{j})$ ;  $\mathbf{T}(e) = \frac{1}{\sqrt{1+e^2}}\mathbf{i} + \frac{e}{\sqrt{1+e^2}}\mathbf{j}$ ,  
 $\mathbf{T}'(e) = \frac{1}{(1+e^2)^{3/2}}(-e\mathbf{i} + \mathbf{j})$ ,  $\mathbf{N}(e) = -\frac{e}{\sqrt{1+e^2}}\mathbf{i} + \frac{1}{\sqrt{1+e^2}}\mathbf{j}$
7.  $\mathbf{r}'(t) = -4\sin t\mathbf{i} + 4\cos t\mathbf{j} + \mathbf{k}$ ,  $\mathbf{T}(t) = \frac{1}{\sqrt{17}}(-4\sin t\mathbf{i} + 4\cos t\mathbf{j} + \mathbf{k})$ ,  
 $\mathbf{T}'(t) = \frac{1}{\sqrt{17}}(-4\cos t\mathbf{i} - 4\sin t\mathbf{j})$ ,  $\mathbf{T}(\pi/2) = -\frac{4}{\sqrt{17}}\mathbf{i} + \frac{1}{\sqrt{17}}\mathbf{k}$   
 $\mathbf{T}'(\pi/2) = -\frac{4}{\sqrt{17}}\mathbf{j}$ ,  $\mathbf{N}(\pi/2) = -\mathbf{j}$
8.  $\mathbf{r}'(t) = \mathbf{i} + t\mathbf{j} + t^2\mathbf{k}$ ,  $\mathbf{T}(t) = (1+t^2+t^4)^{-1/2}(\mathbf{i} + t\mathbf{j} + t^2\mathbf{k})$ ,  
 $\mathbf{T}'(t) = (1+t^2+t^4)^{-1/2}(\mathbf{j} + 2t\mathbf{k}) - (t+2t^3)(1+t^2+t^4)^{-3/2}(\mathbf{i} + t\mathbf{j} + t^2\mathbf{k})$ ,  
 $\mathbf{T}(0) = \mathbf{i}$ ,  $\mathbf{T}'(0) = \mathbf{j} = \mathbf{N}(0)$
9.  $\mathbf{r}'(t) = e^t[(\cos t - \sin t)\mathbf{i} + (\cos t + \sin t)\mathbf{j} + \mathbf{k}]$ ,  $\mathbf{T}(t) = \frac{1}{\sqrt{3}}[(\cos t - \sin t)\mathbf{i} + (\cos t + \sin t)\mathbf{j} + \mathbf{k}]$ ,  
 $\mathbf{T}'(t) = \frac{1}{\sqrt{3}}[(-\sin t - \cos t)\mathbf{i} + (-\sin t + \cos t)\mathbf{j}]$ ,  
 $\mathbf{T}(0) = \frac{1}{\sqrt{3}}\mathbf{i} + \frac{1}{\sqrt{3}}\mathbf{j} + \frac{1}{\sqrt{3}}\mathbf{k}$ ,  $\mathbf{T}'(0) = \frac{1}{\sqrt{3}}(-\mathbf{i} + \mathbf{j})$ ,  $\mathbf{N}(0) = -\frac{1}{\sqrt{2}}\mathbf{i} + \frac{1}{\sqrt{2}}\mathbf{j}$



10.  $\mathbf{r}'(t) = \sinh t \mathbf{i} + \cosh t \mathbf{j} + \mathbf{k}$ ,  $\|\mathbf{r}'(t)\| = \sqrt{\sinh^2 t + \cosh^2 t + 1} = \sqrt{2} \cosh t$ ,  
 $\mathbf{T}(t) = \frac{1}{\sqrt{2}}(\tanh t \mathbf{i} + \mathbf{j} + \operatorname{sech} t \mathbf{k})$ ,  $\mathbf{T}'(t) = \frac{1}{\sqrt{2}}(\operatorname{sech}^2 t \mathbf{i} - \operatorname{sech} t \tanh t \mathbf{k})$ , at  $t = \ln 2$ ,  
 $\tanh(\ln 2) = \frac{3}{5}$  and  $\operatorname{sech}(\ln 2) = \frac{4}{5}$  so  $\mathbf{T}(\ln 2) = \frac{3}{5\sqrt{2}}\mathbf{i} + \frac{1}{\sqrt{2}}\mathbf{j} + \frac{4}{5\sqrt{2}}\mathbf{k}$ ,  
 $\mathbf{T}'(\ln 2) = \frac{4}{25\sqrt{2}}(4\mathbf{i} - 3\mathbf{k})$ ,  $\mathbf{N}(\ln 2) = \frac{4}{5}\mathbf{i} - \frac{3}{5}\mathbf{k}$
11. From the remark, the line is parametrized by normalizing  $\mathbf{v}$ , but  $\mathbf{T}(t_0) = \mathbf{v}/\|\mathbf{v}\|$ , so  $\mathbf{r} = \mathbf{r}(t_0) + t\mathbf{v}$  becomes  $\mathbf{r} = \mathbf{r}(t_0) + s\mathbf{T}(t_0)$ .
12.  $\mathbf{r}'(t)\Big|_{t=1} = \langle 1, 2t \rangle\Big|_{t=1} = \langle 1, 2 \rangle$ , and  $\mathbf{T}(1) = \langle \frac{1}{\sqrt{5}}, \frac{2}{\sqrt{5}} \rangle$ , so the tangent line can be parametrized as  
 $\mathbf{r} = \langle 1, 1 \rangle + s \left\langle \frac{1}{\sqrt{5}}, \frac{2}{\sqrt{5}} \right\rangle$ , so  $x = 1 + \frac{s}{\sqrt{5}}$ ,  $y = 1 + \frac{2s}{\sqrt{5}}$ .
13.  $\mathbf{r}'(t) = \cos t \mathbf{i} - \sin t \mathbf{j} + t \mathbf{k}$ ,  $\mathbf{r}'(0) = \mathbf{i}$ ,  $\mathbf{r}(0) = \mathbf{j}$ ,  $\mathbf{T}(0) = \mathbf{i}$ , so the tangent line has the parametrization  $x = s, y = 1$ .
14.  $\mathbf{r}(1) = \mathbf{i} + \mathbf{j} + \sqrt{8}\mathbf{k}$ ,  $\mathbf{r}'(t) = \mathbf{i} + \mathbf{j} - \frac{t}{\sqrt{9-t^2}}\mathbf{k}$ ,  $\mathbf{r}'(1) = \mathbf{i} + \mathbf{j} - \frac{1}{\sqrt{8}}\mathbf{k}$ ,  $\|\mathbf{r}'(1)\| = \frac{\sqrt{17}}{\sqrt{8}}$ , so the tangent line has parametrizations  $\mathbf{r} = \mathbf{i} + \mathbf{j} + \sqrt{8}\mathbf{k} + t \left( \mathbf{i} + \mathbf{j} - \frac{1}{\sqrt{8}}\mathbf{k} \right) = \mathbf{i} + \mathbf{j} + \sqrt{8}\mathbf{k} + \frac{s\sqrt{8}}{\sqrt{17}} \left( \mathbf{i} + \mathbf{j} - \frac{1}{\sqrt{8}}\mathbf{k} \right)$ .
15.  $\mathbf{T} = \frac{3}{5} \cos t \mathbf{i} - \frac{3}{5} \sin t \mathbf{j} + \frac{4}{5} \mathbf{k}$ ,  $\mathbf{N} = -\sin t \mathbf{i} - \cos t \mathbf{j}$ ,  $\mathbf{B} = \mathbf{T} \times \mathbf{N} = \frac{4}{5} \cos t \mathbf{i} - \frac{4}{5} \sin t \mathbf{j} - \frac{3}{5} \mathbf{k}$
16.  $\mathbf{T}'(t) = \frac{1}{\sqrt{2}}[(\cos t + \sin t)\mathbf{i} + (-\sin t + \cos t)\mathbf{j}]$ ,  $\mathbf{N} = \frac{1}{\sqrt{2}}[(-\sin t + \cos t)\mathbf{i} - (\cos t + \sin t)\mathbf{j}]$ ,  
 $\mathbf{B} = \mathbf{T} \times \mathbf{N} = -\mathbf{k}$
17.  $\mathbf{r}'(t) = t \sin t \mathbf{i} + t \cos t \mathbf{j}$ ,  $\|\mathbf{r}'\| = t$ ,  $\mathbf{T} = \sin t \mathbf{i} + \cos t \mathbf{j}$ ,  $\mathbf{N} = \cos t \mathbf{i} - \sin t \mathbf{j}$ ,  $\mathbf{B} = \mathbf{T} \times \mathbf{N} = -\mathbf{k}$
18.  $\mathbf{T} = (-a \sin t \mathbf{i} + a \cos t \mathbf{j} + b \mathbf{k})/\sqrt{a^2 + b^2}$ ,  $\mathbf{N} = -\cos t \mathbf{i} - \sin t \mathbf{j}$ ,  
 $\mathbf{B} = \mathbf{T} \times \mathbf{N} = (b \sin t \mathbf{i} - b \cos t \mathbf{j} + a \mathbf{k})/\sqrt{a^2 + b^2}$
19.  $\mathbf{r}(\pi/4) = \frac{\sqrt{2}}{2}\mathbf{i} + \frac{\sqrt{2}}{2}\mathbf{j} + \mathbf{k}$ ,  $\mathbf{T} = -\sin t \mathbf{i} + \cos t \mathbf{j} = \frac{\sqrt{2}}{2}(-\mathbf{i} + \mathbf{j})$ ,  $\mathbf{N} = -(\cos t \mathbf{i} + \sin t \mathbf{j}) = -\frac{\sqrt{2}}{2}(\mathbf{i} + \mathbf{j})$ ,  
 $\mathbf{B} = \mathbf{k}$ ; the rectifying, osculating, and normal planes are given (respectively) by  $x + y = \sqrt{2}$ ,  $z = 1$ ,  $-x + y = 0$ .
20.  $\mathbf{r}(0) = \mathbf{i} + \mathbf{j}$ ,  $\mathbf{T} = \frac{1}{\sqrt{3}}(\mathbf{i} + \mathbf{j} + \mathbf{k})$ ,  $\mathbf{N} = \frac{1}{\sqrt{2}}(-\mathbf{j} + \mathbf{k})$ ,  $\mathbf{B} = \frac{1}{\sqrt{6}}(2\mathbf{i} - \mathbf{j} - \mathbf{k})$ ; the rectifying, osculating, and normal planes are given (respectively) by  $-y + z = -1$ ,  $2x - y - z = 1$ ,  $x + y + z = 2$ .
21. (a) By formulae (1) and (11),  $\mathbf{N}(t) = \mathbf{B}(t) \times \mathbf{T}(t) = \frac{\mathbf{r}'(t) \times \mathbf{r}''(t)}{\|\mathbf{r}'(t) \times \mathbf{r}''(t)\|} \times \frac{\mathbf{r}'(t)}{\|\mathbf{r}'(t)\|}$ .
- (b) Since  $\mathbf{r}'$  is perpendicular to  $\mathbf{r}' \times \mathbf{r}''$  it follows from Lagrange's Identity (Exercise 32 of Section 13.4) that  $\|(\mathbf{r}'(t) \times \mathbf{r}''(t)) \times \mathbf{r}'(t)\| = \|\mathbf{r}'(t) \times \mathbf{r}''(t)\| \|\mathbf{r}'(t)\|$ , and the result follows.
- (c) From Exercise 39 of Section 13.4,  $(\mathbf{r}'(t) \times \mathbf{r}''(t)) \times \mathbf{r}'(t) = \|\mathbf{r}'(t)\|^2 \mathbf{r}''(t) - (\mathbf{r}'(t) \cdot \mathbf{r}''(t))\mathbf{r}'(t) = \mathbf{u}(t)$ , so  $\mathbf{N}(t) = \mathbf{u}(t)/\|\mathbf{u}(t)\|$

22. (a)  $\mathbf{r}'(t) = 2t\mathbf{i} + \mathbf{j}$ ,  $\mathbf{r}'(1) = 2\mathbf{i} + \mathbf{j}$ ,  $\mathbf{r}''(t) = 2\mathbf{i}$ ,  $\mathbf{u} = 2\mathbf{i} - 4\mathbf{j}$ ,  $\mathbf{N} = \frac{1}{\sqrt{5}}\mathbf{i} - \frac{2}{\sqrt{5}}\mathbf{j}$
- (b)  $\mathbf{r}'(t) = -4\sin t\mathbf{i} + 4\cos t\mathbf{j} + \mathbf{k}$ ,  $\mathbf{r}'(\frac{\pi}{2}) = -4\mathbf{i} + \mathbf{k}$ ,  $\mathbf{r}''(t) = -4\cos t\mathbf{i} - 4\sin t\mathbf{j}$ ,  
 $\mathbf{r}''(\frac{\pi}{2}) = -4\mathbf{j}$ ,  $\mathbf{u} = 17(-4\mathbf{j})$ ,  $\mathbf{N} = -\mathbf{j}$
23.  $\mathbf{r}'(t) = \cos t\mathbf{i} - \sin t\mathbf{j} + \mathbf{k}$ ,  $\mathbf{r}''(t) = -\sin t\mathbf{i} - \cos t\mathbf{j}$ ,  $\mathbf{u} = -2(\sin t\mathbf{i} + \cos t\mathbf{j})$ ,  $\|\mathbf{u}\| = 2$ ,  $\mathbf{N} = -\sin t\mathbf{i} - \cos t\mathbf{j}$
24.  $\mathbf{r}'(t) = \mathbf{i} + 2t\mathbf{j} + 3t^2\mathbf{k}$ ,  $\mathbf{r}''(t) = 2\mathbf{j} + 6t\mathbf{k}$ ,  $\mathbf{u}(t) = -(4t + 18t^3)\mathbf{i} + (2 - 18t^4)\mathbf{j} + (6t + 12t^3)\mathbf{k}$ ,  
 $\mathbf{N} = \frac{1}{2\sqrt{81t^8 + 117t^6 + 54t^4 + 13t^2 + 1}} (-(4t + 18t^3)\mathbf{i} + (2 - 18t^4)\mathbf{j} + (6t + 12t^3)\mathbf{k})$

## EXERCISE SET 14.5

1.  $\kappa \approx \frac{1}{0.5} = 2$
2.  $\kappa \approx \frac{1}{4/3} = \frac{3}{4}$
3.  $\mathbf{r}'(t) = 2t\mathbf{i} + 3t^2\mathbf{j}$ ,  $\mathbf{r}''(t) = 2\mathbf{i} + 6t\mathbf{j}$ ,  $\kappa = \frac{\|\mathbf{r}'(t) \times \mathbf{r}''(t)\|}{\|\mathbf{r}'(t)\|^3} = \frac{6}{t(4 + 9t^2)^{3/2}}$
4.  $\mathbf{r}'(t) = -4\sin t\mathbf{i} + \cos t\mathbf{j}$ ,  $\mathbf{r}''(t) = -4\cos t\mathbf{i} - \sin t\mathbf{j}$ ,  $\kappa = \frac{\|\mathbf{r}'(t) \times \mathbf{r}''(t)\|}{\|\mathbf{r}'(t)\|^3} = \frac{4}{(16\sin^2 t + \cos^2 t)^{3/2}}$
5.  $\mathbf{r}'(t) = 3e^{3t}\mathbf{i} - e^{-t}\mathbf{j}$ ,  $\mathbf{r}''(t) = 9e^{3t}\mathbf{i} + e^{-t}\mathbf{j}$ ,  $\kappa = \frac{\|\mathbf{r}'(t) \times \mathbf{r}''(t)\|}{\|\mathbf{r}'(t)\|^3} = \frac{12e^{2t}}{(9e^{6t} + e^{-2t})^{3/2}}$
6.  $\mathbf{r}'(t) = -3t^2\mathbf{i} + (1 - 2t)\mathbf{j}$ ,  $\mathbf{r}''(t) = -6t\mathbf{i} - 2\mathbf{j}$ ,  $\kappa = \frac{\|\mathbf{r}'(t) \times \mathbf{r}''(t)\|}{\|\mathbf{r}'(t)\|^3} = \frac{6\sqrt{t^2(t-1)^2}}{(9t^4 + 4t^2 - 4t + 1)^{3/2}}$
7.  $\mathbf{r}'(t) = -4\sin t\mathbf{i} + 4\cos t\mathbf{j} + \mathbf{k}$ ,  $\mathbf{r}''(t) = -4\cos t\mathbf{i} - 4\sin t\mathbf{j}$ ,  
 $\kappa = \frac{\|\mathbf{r}'(t) \times \mathbf{r}''(t)\|}{\|\mathbf{r}'(t)\|^3} = 4/17$
8.  $\mathbf{r}'(t) = \mathbf{i} + t\mathbf{j} + t^2\mathbf{k}$ ,  $\mathbf{r}''(t) = \mathbf{j} + 2t\mathbf{k}$ ,  $\kappa = \frac{\|\mathbf{r}'(t) \times \mathbf{r}''(t)\|}{\|\mathbf{r}'(t)\|^3} = \frac{\sqrt{t^4 + 4t^2 + 1}}{(t^4 + t^2 + 1)^{3/2}}$
9.  $\mathbf{r}'(t) = \sinh t\mathbf{i} + \cosh t\mathbf{j} + \mathbf{k}$ ,  $\mathbf{r}''(t) = \cosh t\mathbf{i} + \sinh t\mathbf{j}$ ,  $\kappa = \frac{\|\mathbf{r}'(t) \times \mathbf{r}''(t)\|}{\|\mathbf{r}'(t)\|^3} = \frac{1}{2\cosh^2 t}$
10.  $\mathbf{r}'(t) = \mathbf{j} + 2t\mathbf{k}$ ,  $\mathbf{r}''(t) = 2\mathbf{k}$ ,  $\kappa = \frac{\|\mathbf{r}'(t) \times \mathbf{r}''(t)\|}{\|\mathbf{r}'(t)\|^3} = \frac{2}{(4t^2 + 1)^{3/2}}$
11.  $\mathbf{r}'(t) = -3\sin t\mathbf{i} + 4\cos t\mathbf{j} + \mathbf{k}$ ,  $\mathbf{r}''(t) = -3\cos t\mathbf{i} - 4\sin t\mathbf{j}$ ,  
 $\mathbf{r}'(\pi/2) = -3\mathbf{i} + \mathbf{k}$ ,  $\mathbf{r}''(\pi/2) = -4\mathbf{j}$ ;  $\kappa = \frac{\|4\mathbf{i} + 12\mathbf{k}\|}{\|-3\mathbf{i} + \mathbf{k}\|^3} = 2/5$ ,  $\rho = 5/2$
12.  $\mathbf{r}'(t) = e^t\mathbf{i} - e^{-t}\mathbf{j} + \mathbf{k}$ ,  $\mathbf{r}''(t) = e^t\mathbf{i} + e^{-t}\mathbf{j}$ ,  
 $\mathbf{r}'(0) = \mathbf{i} - \mathbf{j} + \mathbf{k}$ ,  $\mathbf{r}''(0) = \mathbf{i} + \mathbf{j}$ ;  $\kappa = \frac{\|-\mathbf{i} + \mathbf{j} + 2\mathbf{k}\|}{\|\mathbf{i} - \mathbf{j} + \mathbf{k}\|^3} = \sqrt{2}/3$ ,  $\rho = 3/\sqrt{2}$
13.  $\mathbf{r}'(t) = e^t(\cos t - \sin t)\mathbf{i} + e^t(\cos t + \sin t)\mathbf{j} + e^t\mathbf{k}$ ,  
 $\mathbf{r}''(t) = -2e^t \sin t\mathbf{i} + 2e^t \cos t\mathbf{j} + e^t\mathbf{k}$ ,  $\mathbf{r}'(0) = \mathbf{i} + \mathbf{j} + \mathbf{k}$ ,  
 $\mathbf{r}''(0) = 2\mathbf{j} + \mathbf{k}$ ;  $\kappa = \frac{\|-\mathbf{i} - \mathbf{j} + 2\mathbf{k}\|}{\|\mathbf{i} + \mathbf{j} + \mathbf{k}\|^3} = \sqrt{2}/3$ ,  $\rho = 3\sqrt{2}/2$

14.  $\mathbf{r}'(t) = \cos t \mathbf{i} - \sin t \mathbf{j} + t \mathbf{k}$ ,  $\mathbf{r}''(t) = -\sin t \mathbf{i} - \cos t \mathbf{j} + \mathbf{k}$ ,  
 $\mathbf{r}'(0) = \mathbf{i}$ ,  $\mathbf{r}''(0) = -\mathbf{j} + \mathbf{k}$ ;  $\kappa = \frac{\|\mathbf{j} - \mathbf{k}\|}{\|\mathbf{i}\|^3} = \sqrt{2}$ ,  $\rho = \sqrt{2}/2$
15.  $\mathbf{r}'(s) = \frac{1}{2} \cos\left(1 + \frac{s}{2}\right) \mathbf{i} - \frac{1}{2} \sin\left(1 + \frac{s}{2}\right) \mathbf{j} + \frac{\sqrt{3}}{2} \mathbf{k}$ ,  $\|\mathbf{r}'(s)\| = 1$ , so  
 $\frac{d\mathbf{T}}{ds} = -\frac{1}{4} \sin\left(1 + \frac{s}{2}\right) \mathbf{i} - \frac{1}{4} \cos\left(1 + \frac{s}{2}\right) \mathbf{j}$ ,  $\kappa = \left\| \frac{d\mathbf{T}}{ds} \right\| = \frac{1}{16}$
16.  $\mathbf{r}'(s) = -\sqrt{\frac{3-2s}{3}} \mathbf{i} + \sqrt{\frac{2s}{3}} \mathbf{j}$ ,  $\|\mathbf{r}'(s)\| = 1$ , so  
 $\frac{d\mathbf{T}}{ds} = \frac{1}{\sqrt{9-6s}} \mathbf{i} + \frac{1}{\sqrt{6s}} \mathbf{j}$ ,  $\kappa = \left\| \frac{d\mathbf{T}}{ds} \right\| = \sqrt{\frac{1}{9-6s} + \frac{1}{6s}} = \sqrt{\frac{3}{2s(9-6s)}}$
17. (a)  $\mathbf{r}' = x' \mathbf{i} + y' \mathbf{j}$ ,  $\mathbf{r}'' = x'' \mathbf{i} + y'' \mathbf{j}$ ,  $\|\mathbf{r}' \times \mathbf{r}''\| = |x' y'' - x'' y'|$ ,  $\kappa = \frac{|x' y'' - y' x''|}{(x'^2 + y'^2)^{3/2}}$   
 (b)  $\mathbf{r} = x \mathbf{i} + y(x) \mathbf{j}$ ,  $\mathbf{r}'(x) = \mathbf{i} + (dy/dx) \mathbf{j}$ ,  $\mathbf{r}''(x) = (d^2 y/dx^2) \mathbf{j}$ , so  
 $\kappa(x) = \|(d^2 y/dx^2) \mathbf{j}\| / \|\mathbf{i} + (dy/dx) \mathbf{j}\|^3 = |d^2 y/dx^2| / [1 + (dy/dx)^2]^{3/2}$ .
18.  $\frac{dy}{dx} = \tan \phi$ ,  $(1 + \tan^2 \phi)^{3/2} = (\sec^2 \phi)^{3/2} = |\sec \phi|^3$ ,  $\kappa(x) = \frac{|y''|}{|\sec \phi|^3} = |y'' \cos^3 \phi|$
19.  $\kappa(x) = \frac{|\sin x|}{(1 + \cos^2 x)^{3/2}}$ ,  $\kappa(\pi/2) = 1$
20.  $\kappa(x) = \frac{2|x|}{(1 + x^4)^{3/2}}$ ,  $\kappa(0) = 0$
21.  $\kappa(x) = \frac{2|x|^3}{(x^4 + 1)^{3/2}}$ ,  $\kappa(1) = 1/\sqrt{2}$
22.  $\kappa(x) = \frac{e^{-x}}{(1 + e^{-2x})^{3/2}}$ ,  $\kappa(1) = \frac{e^{-1}}{(1 + e^{-2})^{3/2}}$
23.  $\kappa(x) = \frac{2 \sec^2 x |\tan x|}{(1 + \sec^4 x)^{3/2}}$ ,  $\kappa(\pi/4) = 4/(5\sqrt{5})$
24. By implicit differentiation,  $dy/dx = 4x/y$ ,  $d^2 y/dx^2 = 36/y^3$  so  $\kappa = \frac{36/|y|^3}{(1 + 16x^2/y^2)^{3/2}}$ ;  
 if  $(x, y) = (2, 5)$  then  $\kappa = \frac{36/125}{(1 + 64/25)^{3/2}} = \frac{36}{89\sqrt{89}}$
25.  $x'(t) = 2t$ ,  $y'(t) = 3t^2$ ,  $x''(t) = 2$ ,  $y''(t) = 6t$ ,  
 $x'(1/2) = 1$ ,  $y'(1/2) = 3/4$ ,  $x''(1/2) = 2$ ,  $y''(1/2) = 3$ ;  $\kappa = 96/125$
26.  $x'(t) = -4 \sin t$ ,  $y'(t) = \cos t$ ,  $x''(t) = -4 \cos t$ ,  $y''(t) = -\sin t$ ,  
 $x'(\pi/2) = -4$ ,  $y'(\pi/2) = 0$ ,  $x''(\pi/2) = 0$ ,  $y''(\pi/2) = -1$ ;  $\kappa = 1/16$
27.  $x'(t) = 3e^{3t}$ ,  $y'(t) = -e^{-t}$ ,  $x''(t) = 9e^{3t}$ ,  $y''(t) = e^{-t}$ ,  
 $x'(0) = 3$ ,  $y'(0) = -1$ ,  $x''(0) = 9$ ,  $y''(0) = 1$ ;  $\kappa = 6/(5\sqrt{10})$
28.  $x'(t) = -3t^2$ ,  $y'(t) = 1 - 2t$ ,  $x''(t) = -6t$ ,  $y''(t) = -2$ ,  
 $x'(1) = -3$ ,  $y'(1) = -1$ ,  $x''(1) = -6$ ,  $y''(1) = -2$ ;  $\kappa = 0$

29.  $x'(t) = 1, y'(t) = -1/t^2, x''(t) = 0, y''(t) = 2/t^3$   
 $x'(1) = 1, y'(1) = -1, x''(1) = 0, y''(1) = 2; \kappa = 1/\sqrt{2}$

30.  $x'(t) = 4 \cos 2t, y'(t) = 3 \cos t, x''(t) = -8 \sin 2t, y''(t) = -3 \sin t$ ,  
 $x'(\pi/2) = -4, y'(\pi/2) = 0, x''(\pi/2) = 0, y''(\pi/2) = -3, \kappa = 12/4^{3/2} = 3/2$

31. (a)  $\kappa(x) = \frac{|\cos x|}{(1 + \sin^2 x)^{3/2}}$ ,

$$\rho(x) = \frac{(1 + \sin^2 x)^{3/2}}{|\cos x|}$$

$$\rho(0) = \rho(\pi) = 1.$$

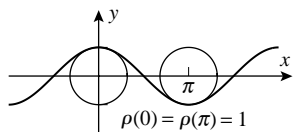

(b)  $\kappa(t) = \frac{2}{(4 \sin^2 t + \cos^2 t)^{3/2}}$ ,

$$\rho(t) = \frac{1}{2}(4 \sin^2 t + \cos^2 t)^{3/2},$$

$$\rho(0) = 1/2, \rho(\pi/2) = 4$$

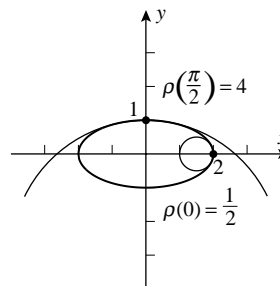

32.  $x'(t) = -e^{-t}(\cos t + \sin t)$ ,  
 $y'(t) = e^{-t}(\cos t - \sin t)$ ,  
 $x''(t) = 2e^{-t} \sin t$ ,  
 $y''(t) = -2e^{-t} \cos t$ ;  
 using the formula of Exercise 17(a),  
 $\kappa = \frac{1}{\sqrt{2}}e^t$ .

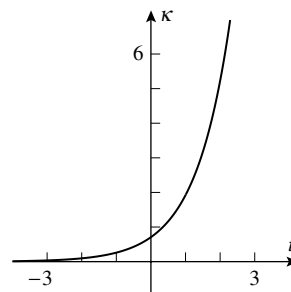

33. (a) At  $x = 0$  the curvature of I has a large value, yet the value of II there is zero, so II is not the curvature of I; hence I is the curvature of II.

(b) I has points of inflection where the curvature is zero, but II is not zero there, and hence is not the curvature of I; so I is the curvature of II.

34. (a) II takes the value zero at  $x = 0$ , yet the curvature of I is large there; hence I is the curvature of II.

(b) I has constant zero curvature; II has constant, positive curvature; hence I is the curvature of II.

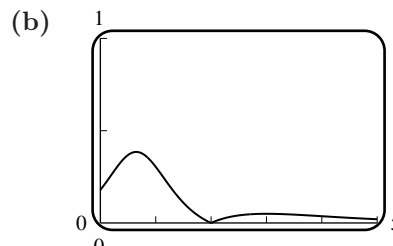
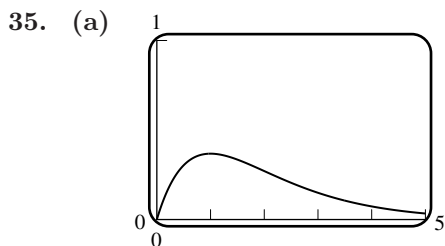

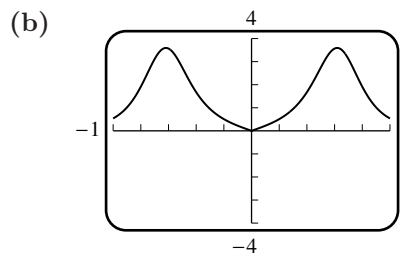
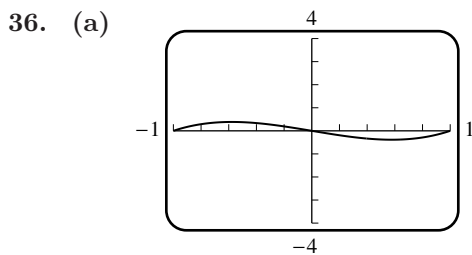

37. (a)  $\kappa = \frac{|12x^2 - 4|}{(1 + (4x^3 - 4x)^2)^{3/2}}$

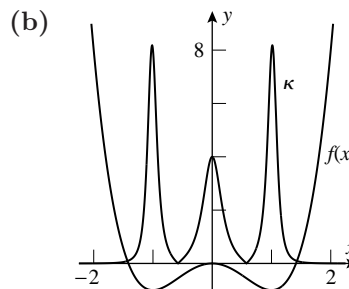

(c)  $f'(x) = 4x^3 - 4x = 0$  at  $x = 0, \pm 1$ ,  $f''(x) = 12x^2 - 4$ , so extrema at  $x = 0, \pm 1$ , and  $\rho = 1/4$  for  $x = 0$  and  $\rho = 1/8$  when  $x = \pm 1$ .

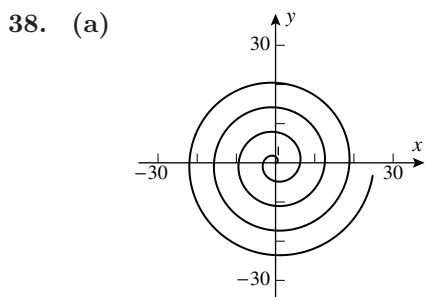

(c)  $\kappa(t) = \frac{t^2 + 2}{(t^2 + 1)^{3/2}}$

(d)  $\lim_{t \rightarrow +\infty} \kappa(t) = 0$

39.  $\mathbf{r}'(\theta) = \left(-r \sin \theta + \cos \theta \frac{dr}{d\theta}\right) \mathbf{i} + \left(r \cos \theta + \sin \theta \frac{dr}{d\theta}\right) \mathbf{j};$

$\mathbf{r}''(\theta) = \left(-r \cos \theta - 2 \sin \theta \frac{dr}{d\theta} + \cos \theta \frac{d^2r}{d\theta^2}\right) \mathbf{i} + \left(-r \sin \theta + 2 \cos \theta \frac{dr}{d\theta} + \sin \theta \frac{d^2r}{d\theta^2}\right) \mathbf{j};$

$$\kappa = \frac{\left| r^2 + 2 \left(\frac{dr}{d\theta}\right)^2 - r \frac{d^2r}{d\theta^2} \right|}{\left[ r^2 + \left(\frac{dr}{d\theta}\right)^2 \right]^{3/2}}.$$

40. Let  $r = a$  be the circle, so that  $dr/d\theta = 0$ , and  $\kappa(\theta) = \frac{1}{r} = \frac{1}{a}$

41.  $\kappa(\theta) = \frac{3}{2\sqrt{2}(1 + \cos \theta)^{1/2}}, \kappa(\pi/2) = \frac{3}{2\sqrt{2}}$

42.  $\kappa(\theta) = \frac{1}{\sqrt{5}e^{2\theta}}, \kappa(1) = \frac{1}{\sqrt{5}e^2}$

43.  $\kappa(\theta) = \frac{10 + 8 \cos^2 3\theta}{(1 + 8 \cos^2 \theta)^{3/2}}, \kappa(0) = \frac{2}{3}$

44.  $\kappa(\theta) = \frac{\theta^2 + 2}{(\theta^2 + 1)^{3/2}}, \kappa(1) = \frac{3}{2\sqrt{2}}$

45. The radius of curvature is zero when  $\theta = \pi$ , so there is a cusp there.

$$46. \frac{dr}{d\theta} = -\sin \theta, \frac{d^2r}{d\theta^2} = -\cos \theta, \kappa(\theta) = \frac{3}{2^{3/2}\sqrt{1+\cos \theta}}$$

$$47. \text{ Let } y = t, \text{ then } x = \frac{t^2}{4p} \text{ and } \kappa(t) = \frac{1/|2p|}{[t^2/(4p^2) + 1]^{3/2}};$$

$t = 0$  when  $(x, y) = (0, 0)$  so  $\kappa(0) = 1/|2p|$ ,  $\rho = 2|p|$ .

$$48. \kappa(x) = \frac{e^x}{(1+e^{2x})^{3/2}}, \kappa'(x) = \frac{e^x(1-2e^{2x})}{(1+e^{2x})^{5/2}}; \kappa'(x) = 0 \text{ when } e^{2x} = 1/2, x = -(\ln 2)/2. \text{ By the first derivative test, } \kappa(-\frac{1}{2}\ln 2) \text{ is maximum so the point is } (-\frac{1}{2}\ln 2, 1/\sqrt{2}).$$

$$49. \text{ Let } x = 3 \cos t, y = 2 \sin t \text{ for } 0 \leq t < 2\pi, \kappa(t) = \frac{6}{(9 \sin^2 t + 4 \cos^2 t)^{3/2}} \text{ so}$$

$$\rho(t) = \frac{1}{6}(9 \sin^2 t + 4 \cos^2 t)^{3/2} = \frac{1}{6}(5 \sin^2 t + 4)^{3/2} \text{ which, by inspection, is minimum when } t = 0 \text{ or } \pi. \text{ The radius of curvature is minimum at } (3, 0) \text{ and } (-3, 0).$$

$$50. \kappa(x) = \frac{6x}{(1+9x^4)^{3/2}} \text{ for } x > 0, \kappa'(x) = \frac{6(1-45x^4)}{(1+9x^4)^{5/2}}; \kappa'(x) = 0 \text{ when } x = 45^{-1/4} \text{ which, by the first derivative test, yields the maximum.}$$

$$51. \mathbf{r}'(t) = -\sin t \mathbf{i} + \cos t \mathbf{j} - \sin t \mathbf{k}, \mathbf{r}''(t) = -\cos t \mathbf{i} - \sin t \mathbf{j} - \cos t \mathbf{k},$$

$$\|\mathbf{r}'(t) \times \mathbf{r}''(t)\| = \|\mathbf{i} + \mathbf{k}\| = \sqrt{2}, \|\mathbf{r}'(t)\| = (1 + \sin^2 t)^{1/2}; \kappa(t) = \sqrt{2}/(1 + \sin^2 t)^{3/2},$$

$$\rho(t) = (1 + \sin^2 t)^{3/2}/\sqrt{2}. \text{ The minimum value of } \rho \text{ is } 1/\sqrt{2}; \text{ the maximum value is } 2.$$

$$52. \mathbf{r}'(t) = e^t \mathbf{i} - e^{-t} \mathbf{j} + \sqrt{2} \mathbf{k}, \mathbf{r}''(t) = e^t \mathbf{i} + e^{-t} \mathbf{j};$$

$$\kappa(t) = \frac{\sqrt{2}}{e^{2t} + e^{-2t} + 2}, \rho(t) = \frac{1}{\sqrt{2}}(e^t + e^{-t})^2 = 2\sqrt{2} \cosh^2 t. \text{ The minimum value of } \rho \text{ is } 2\sqrt{2}.$$

$$53. \text{ From Exercise 39: } dr/d\theta = ae^{a\theta} = ar, d^2r/d\theta^2 = a^2e^{a\theta} = a^2r; \kappa = 1/[\sqrt{1+a^2}r].$$

$$54. \text{ Use implicit differentiation on } r^2 = a^2 \cos 2\theta \text{ to get } 2r \frac{dr}{d\theta} = -2a^2 \sin 2\theta, r \frac{dr}{d\theta} = -a^2 \sin 2\theta, \text{ and}$$

again to get  $r \frac{d^2r}{d\theta^2} + \left(\frac{dr}{d\theta}\right)^2 = -2a^2 \cos 2\theta$  so  $r \frac{d^2r}{d\theta^2} = -\left(\frac{dr}{d\theta}\right)^2 - 2a^2 \cos 2\theta = -\left(\frac{dr}{d\theta}\right)^2 - 2r^2$ , thus

$$\left| r^2 + 2 \left(\frac{dr}{d\theta}\right)^2 - r \frac{d^2r}{d\theta^2} \right| = 3 \left[ r^2 + \left(\frac{dr}{d\theta}\right)^2 \right], \kappa = \frac{3}{[r^2 + (dr/d\theta)^2]^{1/2}}; \frac{dr}{d\theta} = -\frac{a^2 \sin 2\theta}{r} \text{ so}$$

$$r^2 + \left(\frac{dr}{d\theta}\right)^2 = r^2 + \frac{a^4 \sin^2 2\theta}{r^2} = \frac{r^4 + a^4 \sin^2 2\theta}{r^2} = \frac{a^4 \cos^2 2\theta + a^4 \sin^2 2\theta}{r^2} = \frac{a^4}{r^2}, \text{ hence } \kappa = \frac{3r}{a^2}.$$

55. (a)  $d^2y/dx^2 = 2$ ,  $\kappa(\phi) = |2 \cos^3 \phi|$

(b)  $dy/dx = \tan \phi = 1$ ,  $\phi = \pi/4$ ,  $\kappa(\pi/4) = |2 \cos^3(\pi/4)| = 1/\sqrt{2}$ ,  $\rho = \sqrt{2}$

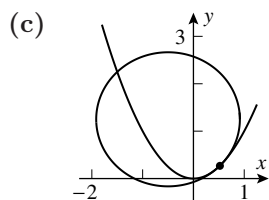

56. (a)  $(\frac{5}{3}, 0)$ ,  $(0, -\frac{5}{2})$  (b) clockwise (c) it is a point, namely the center of the circle

57.  $\kappa = 0$  along  $y = 0$ ; along  $y = x^2$ ,  $\kappa(x) = 2/(1 + 4x^2)^{3/2}$ ,  $\kappa(0) = 2$ . Along  $y = x^3$ ,  $\kappa(x) = 6|x|/(1 + 9x^4)^{3/2}$ ,  $\kappa(0) = 0$ .

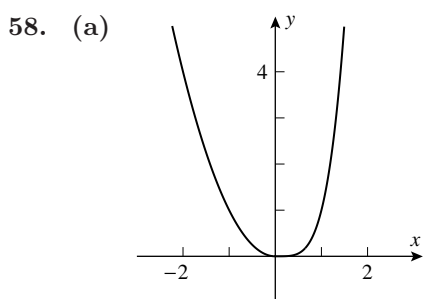

(b) For  $y = x^2$ ,  $\kappa(x) = \frac{2}{(1 + 4x^2)^{3/2}}$   
 so  $\kappa(0) = 2$ ; for  $y = x^4$ ,  
 $\kappa(x) = \frac{12x^2}{(1 + 16x^6)^{3/2}}$  so  $\kappa(0) = 0$ .  
 $\kappa$  is not continuous at  $x = 0$ .

59.  $\kappa = 1/r$  along the circle; along  $y = ax^2$ ,  $\kappa(x) = 2a/(1 + 4a^2x^2)^{3/2}$ ,  $\kappa(0) = 2a$  so  $2a = 1/r$ ,  $a = 1/(2r)$ .

60.  $\kappa(x) = \frac{|y''|}{(1 + y'^2)^{3/2}}$  so the transition will be smooth if the values of  $y$  are equal, the values of  $y'$  are equal, and the values of  $y''$  are equal at  $x = 0$ . If  $y = e^x$ , then  $y' = y'' = e^x$ ; if  $y = ax^2 + bx + c$ , then  $y' = 2ax + b$  and  $y'' = 2a$ . Equate  $y$ ,  $y'$ , and  $y''$  at  $x = 0$  to get  $c = 1$ ,  $b = 1$ , and  $a = 1/2$ .

61. The result follows from the definitions  $\mathbf{N} = \frac{\mathbf{T}'(s)}{\|\mathbf{T}'(s)\|}$  and  $\kappa = \|\mathbf{T}'(s)\|$ .

62. (a)  $\mathbf{B} \cdot \frac{d\mathbf{B}}{ds} = 0$  because  $\|\mathbf{B}(s)\| = 1$  so  $\frac{d\mathbf{B}}{ds}$  is perpendicular to  $\mathbf{B}(s)$ .

(b)  $\mathbf{B}(s) \cdot \mathbf{T}(s) = 0$ ,  $\mathbf{B}(s) \cdot \frac{d\mathbf{T}}{ds} + \frac{d\mathbf{B}}{ds} \cdot \mathbf{T}(s) = 0$ , but  $\frac{d\mathbf{T}}{ds} = \kappa\mathbf{N}(s)$  so  $\kappa\mathbf{B}(s) \cdot \mathbf{N}(s) + \frac{d\mathbf{B}}{ds} \cdot \mathbf{T}(s) = 0$ ,  $\frac{d\mathbf{B}}{ds} \cdot \mathbf{T}(s) = 0$  because  $\mathbf{B}(s) \cdot \mathbf{N}(s) = 0$ ; thus  $\frac{d\mathbf{B}}{ds}$  is perpendicular to  $\mathbf{T}(s)$ .

(c)  $\frac{d\mathbf{B}}{ds}$  is perpendicular to both  $\mathbf{B}(s)$  and  $\mathbf{T}(s)$  but so is  $\mathbf{N}(s)$ , thus  $\frac{d\mathbf{B}}{ds}$  is parallel to  $\mathbf{N}(s)$  and hence a scalar multiple of  $\mathbf{N}(s)$ .

(d) If  $C$  lies in a plane, then  $\mathbf{T}(s)$  and  $\mathbf{N}(s)$  also lie in the plane;  $\mathbf{B}(s) = \mathbf{T}(s) \times \mathbf{N}(s)$  so  $\mathbf{B}(s)$  is always perpendicular to the plane and hence  $d\mathbf{B}/ds = \mathbf{0}$ , thus  $\tau = 0$ .

63.  $\frac{d\mathbf{N}}{ds} = \mathbf{B} \times \frac{d\mathbf{T}}{ds} + \frac{d\mathbf{B}}{ds} \times \mathbf{T} = \mathbf{B} \times (\kappa\mathbf{N}) + (-\tau\mathbf{N}) \times \mathbf{T} = \kappa\mathbf{B} \times \mathbf{N} - \tau\mathbf{N} \times \mathbf{T}$ , but  $\mathbf{B} \times \mathbf{N} = -\mathbf{T}$  and  $\mathbf{N} \times \mathbf{T} = -\mathbf{B}$  so  $\frac{d\mathbf{N}}{ds} = -\kappa\mathbf{T} + \tau\mathbf{B}$

64.  $\mathbf{r}''(s) = d\mathbf{T}/ds = \kappa\mathbf{N}$  so  $\mathbf{r}'''(s) = \kappa d\mathbf{N}/ds + (d\kappa/ds)\mathbf{N}$  but  $d\mathbf{N}/ds = -\kappa\mathbf{T} + \tau\mathbf{B}$  so  
 $\mathbf{r}'''(s) = -\kappa^2\mathbf{T} + (d\kappa/ds)\mathbf{N} + \kappa\tau\mathbf{B}$ ,  $\mathbf{r}'(s) \times \mathbf{r}''(s) = \mathbf{T} \times (\kappa\mathbf{N}) = \kappa\mathbf{T} \times \mathbf{N} = \kappa\mathbf{B}$ ,  
 $[\mathbf{r}'(s) \times \mathbf{r}''(s)] \cdot \mathbf{r}'''(s) = -\kappa^3\mathbf{B} \cdot \mathbf{T} + \kappa(d\kappa/ds)\mathbf{B} \cdot \mathbf{N} + \kappa^2\tau\mathbf{B} \cdot \mathbf{B} = \kappa^2\tau$ ,  
 $\tau = [\mathbf{r}'(s) \times \mathbf{r}''(s)] \cdot \mathbf{r}'''(s)/\kappa^2 = [\mathbf{r}'(s) \times \mathbf{r}''(s)] \cdot \mathbf{r}'''(s)/\|\mathbf{r}''(s)\|^2$  and  
 $\mathbf{B} = \mathbf{T} \times \mathbf{N} = [\mathbf{r}'(s) \times \mathbf{r}''(s)]/\|\mathbf{r}'(s)\|$

65.  $\mathbf{r} = a \cos(s/w)\mathbf{i} + a \sin(s/w)\mathbf{j} + (cs/w)\mathbf{k}$ ,  $\mathbf{r}' = -(a/w)\sin(s/w)\mathbf{i} + (a/w)\cos(s/w)\mathbf{j} + (c/w)\mathbf{k}$ ,  
 $\mathbf{r}'' = -(a/w^2)\cos(s/w)\mathbf{i} - (a/w^2)\sin(s/w)\mathbf{j}$ ,  $\mathbf{r}''' = (a/w^3)\sin(s/w)\mathbf{i} - (a/w^3)\cos(s/w)\mathbf{j}$ ,  
 $\mathbf{r}' \times \mathbf{r}'' = (ac/w^3)\sin(s/w)\mathbf{i} - (ac/w^3)\cos(s/w)\mathbf{j} + (a^2/w^3)\mathbf{k}$ ,  $(\mathbf{r}' \times \mathbf{r}'') \cdot \mathbf{r}''' = a^2c/w^6$ ,  
 $\|\mathbf{r}''(s)\| = a/w^2$ , so  $\tau = c/w^2$  and  $\mathbf{B} = (c/w)\sin(s/w)\mathbf{i} - (c/w)\cos(s/w)\mathbf{j} + (a/w)\mathbf{k}$

66. (a)  $\mathbf{T}' = \frac{d\mathbf{T}}{dt} = \frac{d\mathbf{T}}{ds} \frac{ds}{dt} = (\kappa\mathbf{N})s' = \kappa s'\mathbf{N}$ ,

$$\mathbf{N}' = \frac{d\mathbf{N}}{dt} = \frac{d\mathbf{N}}{ds} \frac{ds}{dt} = (-\kappa\mathbf{T} + \tau\mathbf{B})s' = -\kappa s'\mathbf{T} + \tau s'\mathbf{B}.$$

(b)  $\|\mathbf{r}'(t)\| = s'$  so  $\mathbf{r}'(t) = s'\mathbf{T}$  and  $\mathbf{r}''(t) = s''\mathbf{T} + s'\mathbf{T}' = s''\mathbf{T} + s'(\kappa s'\mathbf{N}) = s''\mathbf{T} + \kappa(s')^2\mathbf{N}$ .

(c)  $\mathbf{r}'''(t) = s''\mathbf{T}' + s'''\mathbf{T} + \kappa(s')^2\mathbf{N}' + [2\kappa s's'' + \kappa'(s')^2]\mathbf{N}$   
 $= s''(\kappa s'\mathbf{N}) + s'''\mathbf{T} + \kappa(s')^2(-\kappa s'\mathbf{T} + \tau s'\mathbf{B}) + [2\kappa s's'' + \kappa'(s')^2]\mathbf{N}$   
 $= [s''' - \kappa^2(s')^3]\mathbf{T} + [3\kappa s's'' + \kappa'(s')^2]\mathbf{N} + \kappa\tau(s')^3\mathbf{B}.$

(d)  $\mathbf{r}'(t) \times \mathbf{r}''(t) = s's''\mathbf{T} \times \mathbf{T} + \kappa(s')^3\mathbf{T} \times \mathbf{N} = \kappa(s')^3\mathbf{B}$ ,  $[\mathbf{r}'(t) \times \mathbf{r}''(t)] \cdot \mathbf{r}'''(t) = \kappa^2\tau(s')^6$  so  
 $\tau = \frac{[\mathbf{r}'(t) \times \mathbf{r}''(t)] \cdot \mathbf{r}'''(t)}{\kappa^2(s')^6} = \frac{[\mathbf{r}'(t) \times \mathbf{r}''(t)] \cdot \mathbf{r}'''(t)}{\|\mathbf{r}'(t) \times \mathbf{r}''(t)\|^2}$

67.  $\mathbf{r}' = 2\mathbf{i} + 2t\mathbf{j} + t^2\mathbf{k}$ ,  $\mathbf{r}'' = 2\mathbf{j} + 2t\mathbf{k}$ ,  $\mathbf{r}''' = 2\mathbf{k}$ ,  $\mathbf{r}' \times \mathbf{r}'' = 2t^2\mathbf{i} - 4t\mathbf{j} + 4\mathbf{k}$ ,  $\|\mathbf{r}' \times \mathbf{r}''\| = 2(t^2 + 2)$ ,  
 $\tau = 8/[2(t^2 + 2)]^2 = 2/(t^2 + 2)^2$

68.  $\mathbf{r}' = -a \sin t\mathbf{i} + a \cos t\mathbf{j} + b\mathbf{k}$ ,  $\mathbf{r}'' = -a \cos t\mathbf{i} - a \sin t\mathbf{j}$ ,  $\mathbf{r}''' = a \sin t\mathbf{i} - a \cos t\mathbf{j}$ ,  
 $\mathbf{r}' \times \mathbf{r}'' = ab \sin t\mathbf{i} - ab \cos t\mathbf{j} + a^2\mathbf{k}$ ,  $\|\mathbf{r}' \times \mathbf{r}''\| = \sqrt{a^2(a^2 + b^2)}$ ,  
 $\tau = a^2b/[a^2(a^2 + b^2)] = b/(a^2 + b^2)$

69.  $\mathbf{r}' = e^t\mathbf{i} - e^{-t}\mathbf{j} + \sqrt{2}\mathbf{k}$ ,  $\mathbf{r}'' = e^t\mathbf{i} + e^{-t}\mathbf{j}$ ,  $\mathbf{r}''' = e^t\mathbf{i} - e^{-t}\mathbf{j}$ ,  $\mathbf{r}' \times \mathbf{r}'' = -\sqrt{2}e^{-t}\mathbf{i} + \sqrt{2}e^t\mathbf{j} + 2\mathbf{k}$ ,  
 $\|\mathbf{r}' \times \mathbf{r}''\| = \sqrt{2}(e^t + e^{-t})$ ,  $\tau = (-2\sqrt{2})/[2(e^t + e^{-t})^2] = -\sqrt{2}/(e^t + e^{-t})^2$

70.  $\mathbf{r}' = (1 - \cos t)\mathbf{i} + \sin t\mathbf{j} + \mathbf{k}$ ,  $\mathbf{r}'' = \sin t\mathbf{i} + \cos t\mathbf{j}$ ,  $\mathbf{r}''' = \cos t\mathbf{i} - \sin t\mathbf{j}$ ,  
 $\mathbf{r}' \times \mathbf{r}'' = -\cos t\mathbf{i} + \sin t\mathbf{j} + (\cos t - 1)\mathbf{k}$ ,  
 $\|\mathbf{r}' \times \mathbf{r}''\| = \sqrt{\cos^2 t + \sin^2 t + (\cos t - 1)^2} = \sqrt{1 + 4 \sin^4(t/2)}$ ,  $\tau = -1/[1 + 4 \sin^4(t/2)]$



**EXERCISE SET 14.6**

- $\mathbf{v}(t) = -3 \sin t \mathbf{i} + 3 \cos t \mathbf{j}$   
 $\mathbf{a}(t) = -3 \cos t \mathbf{i} - 3 \sin t \mathbf{j}$   
 $\|\mathbf{v}(t)\| = \sqrt{9 \sin^2 t + 9 \cos^2 t} = 3$   
 $\mathbf{r}(\pi/3) = (3/2)\mathbf{i} + (3\sqrt{3}/2)\mathbf{j}$   
 $\mathbf{v}(\pi/3) = -(3\sqrt{3}/2)\mathbf{i} + (3/2)\mathbf{j}$   
 $\mathbf{a}(\pi/3) = -(3/2)\mathbf{i} - (3\sqrt{3}/2)\mathbf{j}$

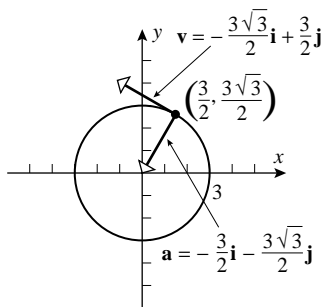

- $\mathbf{v}(t) = \mathbf{i} + 2t\mathbf{j}$   
 $\mathbf{a}(t) = 2\mathbf{j}$   
 $\|\mathbf{v}(t)\| = \sqrt{1 + 4t^2}$   
 $\mathbf{r}(2) = 2\mathbf{i} + 4\mathbf{j}$   
 $\mathbf{v}(2) = \mathbf{i} + 4\mathbf{j}$   
 $\mathbf{a}(2) = 2\mathbf{j}$

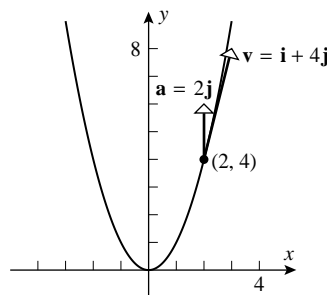

- $\mathbf{v}(t) = e^t \mathbf{i} - e^{-t} \mathbf{j}$   
 $\mathbf{a}(t) = e^t \mathbf{i} + e^{-t} \mathbf{j}$   
 $\|\mathbf{v}(t)\| = \sqrt{e^{2t} + e^{-2t}}$   
 $\mathbf{r}(0) = \mathbf{i} + \mathbf{j}$   
 $\mathbf{v}(0) = \mathbf{i} - \mathbf{j}$   
 $\mathbf{a}(0) = \mathbf{i} + \mathbf{j}$

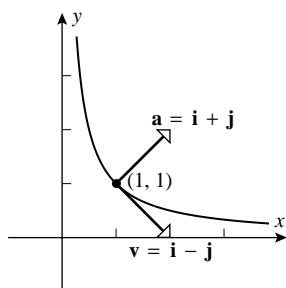

- $\mathbf{v}(t) = 4\mathbf{i} - \mathbf{j}$   
 $\mathbf{a}(t) = \mathbf{0}$   
 $\|\mathbf{v}(t)\| = \sqrt{17}$   
 $\mathbf{r}(1) = 6\mathbf{i}$   
 $\mathbf{v}(1) = 4\mathbf{i} - \mathbf{j}$   
 $\mathbf{a}(1) = \mathbf{0}$

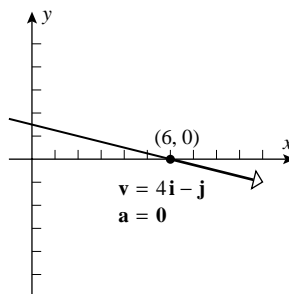

- $\mathbf{v} = \mathbf{i} + t\mathbf{j} + t^2\mathbf{k}, \mathbf{a} = \mathbf{j} + 2t\mathbf{k};$  at  $t = 1, \mathbf{v} = \mathbf{i} + \mathbf{j} + \mathbf{k}, \|\mathbf{v}\| = \sqrt{3}, \mathbf{a} = \mathbf{j} + 2\mathbf{k}$
- $\mathbf{r} = (1 + 3t)\mathbf{i} + (2 - 4t)\mathbf{j} + (7 + t)\mathbf{k}, \mathbf{v} = 3\mathbf{i} - 4\mathbf{j} + \mathbf{k},$   
 $\mathbf{a} = \mathbf{0};$  at  $t = 2, \mathbf{v} = 3\mathbf{i} - 4\mathbf{j} + \mathbf{k}, \|\mathbf{v}\| = \sqrt{26}, \mathbf{a} = \mathbf{0}$
- $\mathbf{v} = -2 \sin t \mathbf{i} + 2 \cos t \mathbf{j} + \mathbf{k}, \mathbf{a} = -2 \cos t \mathbf{i} - 2 \sin t \mathbf{j};$   
at  $t = \pi/4, \mathbf{v} = -\sqrt{2}\mathbf{i} + \sqrt{2}\mathbf{j} + \mathbf{k}, \|\mathbf{v}\| = \sqrt{5}, \mathbf{a} = -\sqrt{2}\mathbf{i} - \sqrt{2}\mathbf{j}$
- $\mathbf{v} = e^t(\cos t + \sin t)\mathbf{i} + e^t(\cos t - \sin t)\mathbf{j} + \mathbf{k}, \mathbf{a} = 2e^t \cos t \mathbf{i} - 2e^t \sin t \mathbf{j};$  at  $t = \pi/2,$   
 $\mathbf{v} = e^{\pi/2}\mathbf{i} - e^{\pi/2}\mathbf{j} + \mathbf{k}, \|\mathbf{v}\| = (1 + 2e^\pi)^{1/2}, \mathbf{a} = -2e^{\pi/2}\mathbf{j}$

9. (a)  $\mathbf{v} = -a\omega \sin \omega t \mathbf{i} + b\omega \cos \omega t \mathbf{j}$ ,  $\mathbf{a} = -a\omega^2 \cos \omega t \mathbf{i} - b\omega^2 \sin \omega t \mathbf{j} = -\omega^2 \mathbf{r}$   
 (b) From Part (a),  $\|\mathbf{a}\| = \omega^2 \|\mathbf{r}\|$
10. (a)  $\mathbf{v} = 16\pi \cos \pi t \mathbf{i} - 8\pi \sin 2\pi t \mathbf{j}$ ,  $\mathbf{a} = -16\pi^2 \sin \pi t \mathbf{i} - 16\pi^2 \cos 2\pi t \mathbf{j}$ ;  
 at  $t = 1$ ,  $\mathbf{v} = -16\pi \mathbf{i}$ ,  $\|\mathbf{v}\| = 16\pi$ ,  $\mathbf{a} = -16\pi^2 \mathbf{j}$   
 (b)  $x = 16 \sin \pi t$ ,  $y = 4 \cos 2\pi t = 4 \cos^2 \pi t - 4 \sin^2 \pi t = 4 - 8 \sin^2 \pi t$ ,  $y = 4 - x^2/32$   
 (c) Both  $x(t)$  and  $y(t)$  are periodic and have period 2, so after 2 s the particle retraces its path.
11.  $\mathbf{v} = (6/\sqrt{t})\mathbf{i} + (3/2)t^{1/2}\mathbf{j}$ ,  $\|\mathbf{v}\| = \sqrt{36/t + 9t/4}$ ,  $d\|\mathbf{v}\|/dt = (-36/t^2 + 9/4)/(2\sqrt{36/t + 9t/4}) = 0$  if  $t = 4$  which yields a minimum by the first derivative test. The minimum speed is  $3\sqrt{2}$  when  $\mathbf{r} = 24\mathbf{i} + 8\mathbf{j}$ .
12.  $\mathbf{v} = (1 - 2t)\mathbf{i} - 2t\mathbf{j}$ ,  $\|\mathbf{v}\| = \sqrt{(1 - 2t)^2 + 4t^2} = \sqrt{8t^2 - 4t + 1}$ ,  
 $\frac{d}{dt}\|\mathbf{v}\| = \frac{8t - 2}{\sqrt{8t^2 - 4t + 1}} = 0$  if  $t = \frac{1}{4}$  which yields a minimum by the first derivative test. The minimum speed is  $1/\sqrt{2}$  when the particle is at  $\mathbf{r} = \frac{3}{16}\mathbf{i} - \frac{1}{16}\mathbf{j}$ .

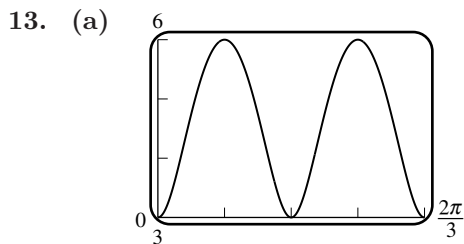

- (b)  $\mathbf{v} = 3 \cos 3t \mathbf{i} + 6 \sin 3t \mathbf{j}$ ,  $\|\mathbf{v}\| = \sqrt{9 \cos^2 3t + 36 \sin^2 3t} = 3\sqrt{1 + 3 \sin^2 3t}$ ; by inspection, maximum speed is 6 and minimum speed is 4  
 (d)  $\frac{d}{dt}\|\mathbf{v}\| = \frac{9 \sin 6t}{2\sqrt{1 + 3 \sin^2 3t}} = 0$  when  $t = 0, \pi/6, \pi/3, \pi/2, 2\pi/3$ ; the maximum speed is 6 which occurs first when  $\sin 3t = 1$ ,  $t = \pi/6$ .

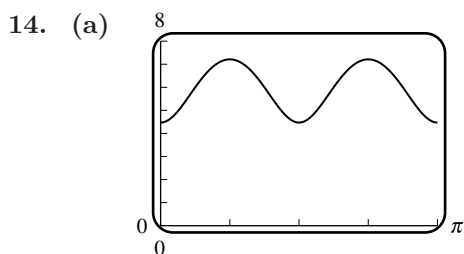

- (d)  $\mathbf{v} = -6 \sin 2t \mathbf{i} + 2 \cos 2t \mathbf{j} + 4\mathbf{k}$ ,  $\|\mathbf{v}\| = \sqrt{36 \sin^2 2t + 4 \cos^2 2t + 16} = 2\sqrt{8 \sin^2 t + 5}$ ; by inspection the maximum speed is  $2\sqrt{13}$  when  $t = \pi$ , the minimum speed is  $2\sqrt{5}$  when  $t = \pi/2$ .
15.  $\mathbf{v}(t) = -\sin t \mathbf{i} + \cos t \mathbf{j} + \mathbf{C}_1$ ,  $\mathbf{v}(0) = \mathbf{j} + \mathbf{C}_1 = \mathbf{i}$ ,  $\mathbf{C}_1 = \mathbf{i} - \mathbf{j}$ ,  $\mathbf{v}(t) = (1 - \sin t)\mathbf{i} + (\cos t - 1)\mathbf{j}$ ;  
 $\mathbf{r}(t) = (t + \cos t)\mathbf{i} + (\sin t - t)\mathbf{j} + \mathbf{C}_2$ ,  $\mathbf{r}(0) = \mathbf{i} + \mathbf{C}_2 = \mathbf{j}$ ,  
 $\mathbf{C}_2 = -\mathbf{i} + \mathbf{j}$  so  $\mathbf{r}(t) = (t + \cos t - 1)\mathbf{i} + (\sin t - t + 1)\mathbf{j}$

16.  $\mathbf{v}(t) = t\mathbf{i} - e^{-t}\mathbf{j} + \mathbf{C}_1$ ,  $\mathbf{v}(0) = -\mathbf{j} + \mathbf{C}_1 = 2\mathbf{i} + \mathbf{j}$ ;  $\mathbf{C}_1 = 2\mathbf{i} + 2\mathbf{j}$  so  
 $\mathbf{v}(t) = (t+2)\mathbf{i} + (2 - e^{-t})\mathbf{j}$ ;  $\mathbf{r}(t) = (t^2/2 + 2t)\mathbf{i} + (2t + e^{-t})\mathbf{j} + \mathbf{C}_2$   
 $\mathbf{r}(0) = \mathbf{j} + \mathbf{C}_2 = \mathbf{i} - \mathbf{j}$ ,  $\mathbf{C}_2 = \mathbf{i} - 2\mathbf{j}$  so  $\mathbf{r}(t) = (t^2/2 + 2t + 1)\mathbf{i} + (2t + e^{-t} - 2)\mathbf{j}$
17.  $\mathbf{v}(t) = -\cos t\mathbf{i} + \sin t\mathbf{j} + e^t\mathbf{k} + \mathbf{C}_1$ ,  $\mathbf{v}(0) = -\mathbf{i} + \mathbf{k} + \mathbf{C}_1 = \mathbf{k}$  so  
 $\mathbf{C}_1 = \mathbf{i}$ ,  $\mathbf{v}(t) = (1 - \cos t)\mathbf{i} + \sin t\mathbf{j} + e^t\mathbf{k}$ ;  $\mathbf{r}(t) = (t - \sin t)\mathbf{i} - \cos t\mathbf{j} + e^t\mathbf{k} + \mathbf{C}_2$ ,  
 $\mathbf{r}(0) = -\mathbf{j} + \mathbf{k} + \mathbf{C}_2 = -\mathbf{i} + \mathbf{k}$  so  $\mathbf{C}_2 = -\mathbf{i} + \mathbf{j}$ ,  $\mathbf{r}(t) = (t - \sin t - 1)\mathbf{i} + (1 - \cos t)\mathbf{j} + e^t\mathbf{k}$ .
18.  $\mathbf{v}(t) = -\frac{1}{t+1}\mathbf{j} + \frac{1}{2}e^{-2t}\mathbf{k} + \mathbf{C}_1$ ,  $\mathbf{v}(0) = -\mathbf{j} + \frac{1}{2}\mathbf{k} + \mathbf{C}_1 = 3\mathbf{i} - \mathbf{j}$  so  
 $\mathbf{C}_1 = 3\mathbf{i} - \frac{1}{2}\mathbf{k}$ ,  $\mathbf{v}(t) = 3\mathbf{i} - \frac{1}{t+1}\mathbf{j} + \left(\frac{1}{2}e^{-2t} - \frac{1}{2}\right)\mathbf{k}$ ;  
 $\mathbf{r}(t) = 3t\mathbf{i} - \ln(t+1)\mathbf{j} - \left(\frac{1}{4}e^{-2t} + \frac{1}{2}t\right)\mathbf{k} + \mathbf{C}_2$ ,  
 $\mathbf{r}(0) = -\frac{1}{4}\mathbf{k} + \mathbf{C}_2 = 2\mathbf{k}$  so  $\mathbf{C}_2 = \frac{9}{4}\mathbf{k}$ ,  $\mathbf{r}(t) = 3t\mathbf{i} - \ln(t+1)\mathbf{j} + \left(\frac{9}{4} - \frac{1}{4}e^{-2t} - \frac{1}{2}t\right)\mathbf{k}$ .
19. If  $\mathbf{a} = \mathbf{0}$  then  $x''(t) = y''(t) = z''(t) = 0$ , so  $x(t) = x_1t + x_0$ ,  $y(t) = y_1t + y_0$ ,  $z(t) = z_1t + z_0$ , the motion is along a straight line and has constant speed.
20. (a) If  $\|\mathbf{r}\|$  is constant then so is  $\|\mathbf{r}\|^2$ , but then  $x^2 + y^2 = c^2$  (2-space) or  $x^2 + y^2 + z^2 = c^2$  (3-space), so the motion is along a circle or a sphere of radius  $c$  centered at the origin, and the velocity vector is always perpendicular to the locating vector.  
 (b) If  $\|\mathbf{v}\|$  is constant then by the Theorem,  $\mathbf{v}(t) \cdot \mathbf{a}(t) = 0$ , so the velocity is always perpendicular to the acceleration.
21.  $\mathbf{v} = 3t^2\mathbf{i} + 2t\mathbf{j}$ ,  $\mathbf{a} = 6t\mathbf{i} + 2\mathbf{j}$ ;  $\mathbf{v} = 3\mathbf{i} + 2\mathbf{j}$  and  $\mathbf{a} = 6\mathbf{i} + 2\mathbf{j}$  when  $t = 1$  so  
 $\cos \theta = (\mathbf{v} \cdot \mathbf{a})/(\|\mathbf{v}\| \|\mathbf{a}\|) = 11/\sqrt{130}$ ,  $\theta \approx 15^\circ$ .
22.  $\mathbf{v} = e^t(\cos t - \sin t)\mathbf{i} + e^t(\cos t + \sin t)\mathbf{j}$ ,  $\mathbf{a} = -2e^t \sin t\mathbf{i} + 2e^t \cos t\mathbf{j}$ ,  $\mathbf{v} \cdot \mathbf{a} = 2e^{2t}$ ,  $\|\mathbf{v}\| = \sqrt{2}e^t$ ,  
 $\|\mathbf{a}\| = 2e^t$ ,  $\cos \theta = (\mathbf{v} \cdot \mathbf{a})/(\|\mathbf{v}\| \|\mathbf{a}\|) = 1/\sqrt{2}$ ,  $\theta = 45^\circ$ .
23. (a) displacement =  $\mathbf{r}_1 - \mathbf{r}_0 = 0.7\mathbf{i} + 2.7\mathbf{j} - 3.4\mathbf{k}$   
 (b)  $\Delta\mathbf{r} = \mathbf{r}_1 - \mathbf{r}_0$ , so  $\mathbf{r}_0 = \mathbf{r}_1 - \Delta\mathbf{r} = -0.7\mathbf{i} - 2.9\mathbf{j} + 4.8\mathbf{k}$ .

24. (a)  (b) distance =  $\sqrt{50(1 - \cos 2\pi t)}$

25.  $\Delta\mathbf{r} = \mathbf{r}(3) - \mathbf{r}(1) = 8\mathbf{i} + 26/3\mathbf{j}$ ;  $\mathbf{v} = 2t\mathbf{i} + t^2\mathbf{j}$ ,  $s = \int_1^3 t\sqrt{4+t^2} dt = (13\sqrt{13} - 5\sqrt{5})/3$ .

26.  $\Delta\mathbf{r} = \mathbf{r}(3\pi/2) - \mathbf{r}(0) = 3\mathbf{i} - 3\mathbf{j}$ ;  $\mathbf{v} = 3\cos t\mathbf{i} - 3\sin t\mathbf{j}$ ,  $s = \int_0^{3\pi/2} 3 dt = 9\pi/2$ .

27.  $\Delta \mathbf{r} = \mathbf{r}(\ln 3) - \mathbf{r}(0) = 2\mathbf{i} - 2/3\mathbf{j} + \sqrt{2} \ln 3\mathbf{k}$ ;  $\mathbf{v} = e^t\mathbf{i} - e^{-t}\mathbf{j} + \sqrt{2}\mathbf{k}$ ,  $s = \int_0^{\ln 3} (e^t + e^{-t})dt = 8/3$ .
28.  $\Delta \mathbf{r} = \mathbf{r}(\pi) - \mathbf{r}(0) = \mathbf{0}$ ;  $\mathbf{v} = -2 \sin 2t\mathbf{i} + 2 \sin 2t\mathbf{j} - \sin 2t\mathbf{k}$ ,  
 $\|\mathbf{v}\| = 3|\sin 2t|$ ,  $s = \int_0^\pi 3|\sin 2t|dt = 6 \int_0^{\pi/2} \sin 2t dt = 6$ .
29. In both cases, the equation of the path in rectangular coordinates is  $x^2 + y^2 = 4$ , the particles move counterclockwise around this circle;  $\mathbf{v}_1 = -6 \sin 3t\mathbf{i} + 6 \cos 3t\mathbf{j}$  and  $\mathbf{v}_2 = -4t \sin(t^2)\mathbf{i} + 4t \cos(t^2)\mathbf{j}$  so  $\|\mathbf{v}_1\| = 6$  and  $\|\mathbf{v}_2\| = 4t$ .
30. Let  $u = 1 - t^3$  in  $\mathbf{r}_2$  to get  $\mathbf{r}_2(u) = (3 + 2u)\mathbf{i} + u\mathbf{j} + (1 - u)\mathbf{k}$  so both particles move along the same line;  $\mathbf{v}_1 = 2\mathbf{i} + \mathbf{j} - \mathbf{k}$  and  $\mathbf{v}_2 = -6t^2\mathbf{i} - 3t^2\mathbf{j} + 3t^2\mathbf{k}$  so  $\|\mathbf{v}_1\| = \sqrt{6}$  and  $\|\mathbf{v}_2\| = 3\sqrt{6}t^2$ .
31. (a)  $\mathbf{v} = -e^{-t}\mathbf{i} + e^t\mathbf{j}$ ,  $\mathbf{a} = e^{-t}\mathbf{i} + e^t\mathbf{j}$ ; when  $t = 0$ ,  $\mathbf{v} = -\mathbf{i} + \mathbf{j}$ ,  $\mathbf{a} = \mathbf{i} + \mathbf{j}$ ,  $\|\mathbf{v}\| = \sqrt{2}$ ,  $\mathbf{v} \cdot \mathbf{a} = 0$ ,  $\mathbf{v} \times \mathbf{a} = -2\mathbf{k}$  so  $a_T = 0$ ,  $a_N = \sqrt{2}$ .  
 (b)  $a_T\mathbf{T} = \mathbf{0}$ ,  $a_N\mathbf{N} = \mathbf{a} - a_T\mathbf{T} = \mathbf{i} + \mathbf{j}$  (c)  $\kappa = 1/\sqrt{2}$
32. (a)  $\mathbf{v} = -2t \sin(t^2)\mathbf{i} + 2t \cos(t^2)\mathbf{j}$ ,  $\mathbf{a} = [-4t^2 \cos(t^2) - 2 \sin(t^2)]\mathbf{i} + [-4t^2 \sin(t^2) + 2 \cos(t^2)]\mathbf{j}$ ; when  $t = \sqrt{\pi}/2$ ,  $\mathbf{v} = -\sqrt{\pi/2}\mathbf{i} + \sqrt{\pi/2}\mathbf{j}$ ,  $\mathbf{a} = (-\pi/\sqrt{2} - \sqrt{2})\mathbf{i} + (-\pi/\sqrt{2} + \sqrt{2})\mathbf{j}$ ,  $\|\mathbf{v}\| = \sqrt{\pi}$ ,  $\mathbf{v} \cdot \mathbf{a} = 2\sqrt{\pi}$ ,  $\mathbf{v} \times \mathbf{a} = \pi^{3/2}\mathbf{k}$  so  $a_T = 2$ ,  $a_N = \pi$   
 (b)  $a_T\mathbf{T} = -\sqrt{2}(\mathbf{i} - \mathbf{j})$ ,  $a_N\mathbf{N} = \mathbf{a} - a_T\mathbf{T} = -(\pi/\sqrt{2})(\mathbf{i} + \mathbf{j})$   
 (c)  $\kappa = 1$
33. (a)  $\mathbf{v} = (3t^2 - 2)\mathbf{i} + 2t\mathbf{j}$ ,  $\mathbf{a} = 6t\mathbf{i} + 2\mathbf{j}$ ; when  $t = 1$ ,  $\mathbf{v} = \mathbf{i} + 2\mathbf{j}$ ,  $\mathbf{a} = 6\mathbf{i} + 2\mathbf{j}$ ,  $\|\mathbf{v}\| = \sqrt{5}$ ,  $\mathbf{v} \cdot \mathbf{a} = 10$ ,  $\mathbf{v} \times \mathbf{a} = -10\mathbf{k}$  so  $a_T = 2\sqrt{5}$ ,  $a_N = 2\sqrt{5}$   
 (b)  $a_T\mathbf{T} = \frac{2\sqrt{5}}{\sqrt{5}}(\mathbf{i} + 2\mathbf{j}) = 2\mathbf{i} + 4\mathbf{j}$ ,  $a_N\mathbf{N} = \mathbf{a} - a_T\mathbf{T} = 4\mathbf{i} - 2\mathbf{j}$   
 (c)  $\kappa = 2/\sqrt{5}$
34. (a)  $\mathbf{v} = e^t(-\sin t + \cos t)\mathbf{i} + e^t(\cos t + \sin t)\mathbf{j}$ ,  $\mathbf{a} = -2e^t \sin t\mathbf{i} + 2e^t \cos t\mathbf{j}$ ; when  $t = \pi/4$ ,  $\mathbf{v} = \sqrt{2}e^{\pi/4}\mathbf{j}$ ,  $\mathbf{a} = -\sqrt{2}e^{\pi/4}\mathbf{i} + \sqrt{2}e^{\pi/4}\mathbf{j}$ ,  $\|\mathbf{v}\| = \sqrt{2}e^{\pi/4}$ ,  $\mathbf{v} \cdot \mathbf{a} = 2e^{\pi/2}$ ,  $\mathbf{v} \times \mathbf{a} = 2e^{\pi/2}\mathbf{k}$  so  $a_T = \sqrt{2}e^{\pi/4}$ ,  $a_N = \sqrt{2}e^{\pi/4}$   
 (b)  $a_T\mathbf{T} = \sqrt{2}e^{\pi/4}\mathbf{j}$ ,  $a_N\mathbf{N} = \mathbf{a} - a_T\mathbf{T} = -\sqrt{2}e^{\pi/4}\mathbf{i}$   
 (c)  $\kappa = \frac{1}{\sqrt{2}e^{\pi/4}}$
35. (a)  $\mathbf{v} = \mathbf{i} + 2t\mathbf{j} + 3t^2\mathbf{k}$ ,  $\mathbf{a} = 2\mathbf{j} + 6t\mathbf{k}$ ; when  $t = 1$ ,  $\mathbf{v} = \mathbf{i} + 2\mathbf{j} + 3\mathbf{k}$ ,  $\mathbf{a} = 2\mathbf{j} + 6\mathbf{k}$ ,  $\|\mathbf{v}\| = \sqrt{14}$ ,  $\mathbf{v} \cdot \mathbf{a} = 22$ ,  $\mathbf{v} \times \mathbf{a} = 6\mathbf{i} - 6\mathbf{j} + 2\mathbf{k}$  so  $a_T = 22/\sqrt{14}$ ,  $a_N = \sqrt{76}/\sqrt{14} = \sqrt{38/7}$   
 (b)  $a_T\mathbf{T} = \frac{11}{7}\mathbf{i} + \frac{22}{7}\mathbf{j} + \frac{33}{7}\mathbf{k}$ ,  $a_N\mathbf{N} = \mathbf{a} - a_T\mathbf{T} = -\frac{11}{7}\mathbf{i} - \frac{8}{7}\mathbf{j} + \frac{9}{7}\mathbf{k}$   
 (c)  $\kappa = \frac{\sqrt{19}}{7\sqrt{14}}$
36. (a)  $\mathbf{v} = e^t\mathbf{i} - 2e^{-2t}\mathbf{j} + \mathbf{k}$ ,  $\mathbf{a} = e^t\mathbf{i} + 4e^{-2t}\mathbf{j}$ ; when  $t = 0$ ,  $\mathbf{v} = \mathbf{i} - 2\mathbf{j} + \mathbf{k}$ ,  $\mathbf{a} = \mathbf{i} + 4\mathbf{j}$ ,  $\|\mathbf{v}\| = \sqrt{6}$ ,  $\mathbf{v} \cdot \mathbf{a} = -7$ ,  $\mathbf{v} \times \mathbf{a} = -4\mathbf{i} + \mathbf{j} + 6\mathbf{k}$  so  $a_T = -7/\sqrt{6}$ ,  $a_N = \sqrt{53/6}$

- (b)  $a_T \mathbf{T} = -\frac{7}{6}(\mathbf{i} - 2\mathbf{j} + \mathbf{k}), a_N \mathbf{N} = \mathbf{a} - a_T \mathbf{T} = \frac{13}{6}\mathbf{i} + \frac{19}{3}\mathbf{j} + \frac{7}{6}\mathbf{k}$
- (c)  $\kappa = \frac{\sqrt{53}}{6\sqrt{6}}$
37. (a)  $\mathbf{v} = 3 \cos t \mathbf{i} - 2 \sin t \mathbf{j} - 2 \cos 2t \mathbf{k}, \mathbf{a} = -3 \sin t \mathbf{i} - 2 \cos t \mathbf{j} + 4 \sin 2t \mathbf{k}$ ; when  $t = \pi/2, \mathbf{v} = -2\mathbf{j} + 2\mathbf{k}, \mathbf{a} = -3\mathbf{i}, \|\mathbf{v}\| = 2\sqrt{2}, \mathbf{v} \cdot \mathbf{a} = 0, \mathbf{v} \times \mathbf{a} = -6\mathbf{j} - 6\mathbf{k}$  so  $a_T = 0, a_N = 3$
- (b)  $a_T \mathbf{T} = 0, a_N \mathbf{N} = \mathbf{a} = -3\mathbf{i}$
- (c)  $\kappa = \frac{3}{8}$
38. (a)  $\mathbf{v} = 3t^2 \mathbf{j} - (16/t)\mathbf{k}, \mathbf{a} = 6t \mathbf{j} + (16/t^2)\mathbf{k}$ ; when  $t = 1, \mathbf{v} = 3\mathbf{j} - 16\mathbf{k}, \mathbf{a} = 6\mathbf{j} + 16\mathbf{k}, \|\mathbf{v}\| = \sqrt{265}, \mathbf{v} \cdot \mathbf{a} = -238, \mathbf{v} \times \mathbf{a} = 144\mathbf{i}$  so  $a_T = -238/\sqrt{265}, a_N = 144/\sqrt{265}$
- (b)  $a_T \mathbf{T} = -\frac{714}{265}\mathbf{j} + \frac{3808}{265}\mathbf{k}, a_N \mathbf{N} = \mathbf{a} - a_T \mathbf{T} = \frac{2304}{265}\mathbf{j} + \frac{432}{265}\mathbf{k}$
- (c)  $\kappa = \frac{144}{265^{3/2}}$
39.  $\|\mathbf{v}\| = 4, \mathbf{v} \cdot \mathbf{a} = -12, \mathbf{v} \times \mathbf{a} = 8\mathbf{k}$  so  $a_T = -3, a_N = 2, \mathbf{T} = -\mathbf{j}, \mathbf{N} = (\mathbf{a} - a_T \mathbf{T})/a_N = \mathbf{i}$
40.  $\|\mathbf{v}\| = \sqrt{5}, \mathbf{v} \cdot \mathbf{a} = 3, \mathbf{v} \times \mathbf{a} = -6\mathbf{k}$  so  $a_T = 3/\sqrt{5}, a_N = 6/\sqrt{5}, \mathbf{T} = (1/\sqrt{5})(\mathbf{i} + 2\mathbf{j}), \mathbf{N} = (\mathbf{a} - a_T \mathbf{T})/a_N = (1/\sqrt{5})(2\mathbf{i} - \mathbf{j})$
41.  $\|\mathbf{v}\| = 3, \mathbf{v} \cdot \mathbf{a} = 4, \mathbf{v} \times \mathbf{a} = 4\mathbf{i} - 3\mathbf{j} - 2\mathbf{k}$  so  $a_T = 4/3, a_N = \sqrt{29}/3, \mathbf{T} = (1/3)(2\mathbf{i} + 2\mathbf{j} + \mathbf{k}), \mathbf{N} = (\mathbf{a} - a_T \mathbf{T})/a_N = (\mathbf{i} - 8\mathbf{j} + 14\mathbf{k})/(3\sqrt{29})$
42.  $\|\mathbf{v}\| = 5, \mathbf{v} \cdot \mathbf{a} = -5, \mathbf{v} \times \mathbf{a} = -4\mathbf{i} - 10\mathbf{j} - 3\mathbf{k}$  so  $a_T = -1, a_N = \sqrt{5}, \mathbf{T} = (1/5)(3\mathbf{i} - 4\mathbf{k}), \mathbf{N} = (\mathbf{a} - a_T \mathbf{T})/a_N = (8\mathbf{i} - 5\mathbf{j} + 6\mathbf{k})/(5\sqrt{5})$
43.  $a_T = \frac{d^2 s}{dt^2} = \frac{d}{dt} \sqrt{3t^2 + 4} = 3t/\sqrt{3t^2 + 4}$  so when  $t = 2, a_T = 3/2$ .
44.  $a_T = \frac{d^2 s}{dt^2} = \frac{d}{dt} \sqrt{t^2 + e^{-3t}} = (2t - 3e^{-3t})/[2\sqrt{t^2 + e^{-3t}}]$  so when  $t = 0, a_T = -3/2$ .
45.  $a_T = \frac{d^2 s}{dt^2} = \frac{d}{dt} \sqrt{(4t - 1)^2 + \cos^2 \pi t} = [4t - 1 - \pi \cos \pi t \sin \pi t]/\sqrt{(4t - 1)^2 + \cos^2 \pi t}$  so when  $t = 1/4, a_T = -\pi/\sqrt{2}$ .
46.  $a_T = \frac{d^2 s}{dt^2} = \frac{d}{dt} \sqrt{t^4 + 5t^2 + 3} = (2t^3 + 5t)/\sqrt{t^4 + 5t^2 + 3}$  so when  $t = 1, a_T = 7/3$ .
47.  $a_N = \kappa(ds/dt)^2 = (1/\rho)(ds/dt)^2 = (1/1)(2.9 \times 10^5)^2 = 8.41 \times 10^{10} \text{ km/s}^2$
48.  $\mathbf{a} = (d^2 s/dt^2)\mathbf{T} + \kappa(ds/dt)^2\mathbf{N}$  where  $\kappa = \frac{|d^2 y/dx^2|}{[1 + (dy/dx)^2]^{3/2}}$ . If  $d^2 y/dx^2 = 0$ , then  $\kappa = 0$  and  $\mathbf{a} = (d^2 s/dt^2)\mathbf{T}$  so  $\mathbf{a}$  is tangent to the curve.
49.  $a_N = \kappa(ds/dt)^2 = [2/(1 + 4x^2)^{3/2}](3)^2 = 18/(1 + 4x^2)^{3/2}$
50.  $y = e^x, a_N = \kappa(ds/dt)^2 = [e^x/(1 + e^{2x})^{3/2}](2)^2 = 4e^x/(1 + e^{2x})^{3/2}$

51.  $\mathbf{a} = a_T \mathbf{T} + a_N \mathbf{N}$ ; by the Pythagorean Theorem  $a_N = \sqrt{\|\mathbf{a}\|^2 - a_T^2} = \sqrt{9 - 9} = 0$
52. As in Exercise 51,  $\|\mathbf{a}\|^2 = a_T^2 + a_N^2$ ,  $81 = 9 + a_N^2$ ,  $a_N = \sqrt{72} = 6\sqrt{2}$ .
53. Let  $c = ds/dt$ ,  $a_N = \kappa \left(\frac{ds}{dt}\right)^2$ ,  $a_N = \frac{1}{1000}c^2$ , so  $c^2 = 1000a_N$ ,  $c \leq 10\sqrt{10}\sqrt{1.5} \approx 38.73$  m/s.
54. 10 km/h is the same as  $\frac{100}{36}$  m/s, so  $\|\mathbf{F}\| = 500 \frac{1}{15} \left(\frac{100}{36}\right)^2 \approx 257.20$  N.
55. (a)  $v_0 = 320$ ,  $\alpha = 60^\circ$ ,  $s_0 = 0$  so  $x = 160t$ ,  $y = 160\sqrt{3}t - 16t^2$ .  
 (b)  $dy/dt = 160\sqrt{3} - 32t$ ,  $dy/dt = 0$  when  $t = 5\sqrt{3}$  so  
 $y_{\max} = 160\sqrt{3}(5\sqrt{3}) - 16(5\sqrt{3})^2 = 1200$  ft.  
 (c)  $y = 16t(10\sqrt{3} - t)$ ,  $y = 0$  when  $t = 0$  or  $10\sqrt{3}$  so  $x_{\max} = 160(10\sqrt{3}) = 1600\sqrt{3}$  ft.  
 (d)  $\mathbf{v}(t) = 160\mathbf{i} + (160\sqrt{3} - 32t)\mathbf{j}$ ,  $\mathbf{v}(10\sqrt{3}) = 160(\mathbf{i} - \sqrt{3}\mathbf{j})$ ,  $\|\mathbf{v}(10\sqrt{3})\| = 320$  ft/s.
56. (a)  $v_0 = 980$ ,  $\alpha = 45^\circ$ ,  $s_0 = 0$  so  $x = 490\sqrt{2}t$ ,  $y = 490\sqrt{2}t - 4.9t^2$   
 (b)  $dy/dt = 490\sqrt{2} - 9.8t$ ,  $dy/dt = 0$  when  $t = 50\sqrt{2}$  so  
 $y_{\max} = 490\sqrt{2}(50\sqrt{2}) - 4.9(50\sqrt{2})^2 = 24,500$  m.  
 (c)  $y = 4.9t(100\sqrt{2} - t)$ ,  $y = 0$  when  $t = 0$  or  $100\sqrt{2}$  so  
 $x_{\max} = 490\sqrt{2}(100\sqrt{2}) = 98,000$  m.  
 (d)  $\mathbf{v}(t) = 490\sqrt{2}\mathbf{i} + (490\sqrt{2} - 9.8t)\mathbf{j}$ ,  $\mathbf{v}(100\sqrt{2}) = 490\sqrt{2}(\mathbf{i} - \mathbf{j})$ ,  $\|\mathbf{v}(100\sqrt{2})\| = 980$  m/s.
57.  $v_0 = 80$ ,  $\alpha = -60^\circ$ ,  $s_0 = 168$  so  $x = 40t$ ,  $y = 168 - 40\sqrt{3}t - 16t^2$ ;  $y = 0$  when  
 $t = -7\sqrt{3}/2$  (invalid) or  $t = \sqrt{3}$  so  $x(\sqrt{3}) = 40\sqrt{3}$  ft.
58.  $v_0 = 80$ ,  $\alpha = 0^\circ$ ,  $s_0 = 168$  so  $x = 80t$ ,  $y = 168 - 16t^2$ ;  $y = 0$  when  $t = -\sqrt{42}/2$  (invalid) or  
 $t = \sqrt{42}/2$  so  $x(\sqrt{42}/2) = 40\sqrt{42}$  ft.
59.  $\alpha = 30^\circ$ ,  $s_0 = 0$  so  $x = \sqrt{3}v_0t/2$ ,  $y = v_0t/2 - 16t^2$ ;  $dy/dt = v_0/2 - 32t$ ,  $dy/dt = 0$  when  $t = v_0/64$   
 so  $y_{\max} = v_0^2/256 = 2500$ ,  $v_0 = 800$  ft/s.
60.  $\alpha = 45^\circ$ ,  $s_0 = 0$  so  $x = \sqrt{2}v_0t/2$ ,  $y = \sqrt{2}v_0t/2 - 4.9t^2$ ;  $y = 0$  when  $t = 0$  or  $\sqrt{2}v_0/9.8$  so  
 $x_{\max} = v_0^2/9.8 = 24,500$ ,  $v_0 = 490$  m/s.
61.  $v_0 = 800$ ,  $s_0 = 0$  so  $x = (800 \cos \alpha)t$ ,  $y = (800 \sin \alpha)t - 16t^2 = 16t(50 \sin \alpha - t)$ ;  $y = 0$  when  $t = 0$   
 or  $50 \sin \alpha$  so  $x_{\max} = 40,000 \sin \alpha \cos \alpha = 20,000 \sin 2\alpha = 10,000$ ,  $2\alpha = 30^\circ$  or  $150^\circ$ ,  $\alpha = 15^\circ$   
 or  $75^\circ$ .
62. (a)  $v_0 = 5$ ,  $\alpha = 0^\circ$ ,  $s_0 = 4$  so  $x = 5t$ ,  $y = 4 - 16t^2$ ;  $y = 0$  when  $t = -1/2$  (invalid) or  $1/2$  so it  
 takes the ball  $1/2$  s to hit the floor.  
 (b)  $\mathbf{v}(t) = 5\mathbf{i} - 32t\mathbf{j}$ ,  $\mathbf{v}(1/2) = 5\mathbf{i} - 16\mathbf{j}$ ,  $\|\mathbf{v}(1/2)\| = \sqrt{281}$  so the ball hits the floor with a speed  
 of  $\sqrt{281}$  ft/s.  
 (c)  $v_0 = 0$ ,  $\alpha = -90^\circ$ ,  $s_0 = 4$  so  $x = 0$ ,  $y = 4 - 16t^2$ ;  $y = 0$  when  $t = 1/2$  so both balls would hit  
 the ground at the same instant.

63. (a)  $v_0 = 40, \alpha = 60, s_0 = 4$ , so  $x = 20t, y = 4 + 20\sqrt{3}t - 16t^2$ ; when  $x = 15, t = \frac{3}{4}$ ,  
 $y = 4 + 20\sqrt{3}\frac{3}{4} - 16\left(\frac{3}{4}\right)^2 \approx 20.98$  ft, so the water clears the corner point  $A$  with 0.98 ft to spare.
- (b)  $y = 20$  when  $-16t^2 + 25\sqrt{3}t - 16 = 0, t = 0.668$  (reject) or 1.500,  $x(1.500) \approx 30$  ft, so the water hits the roof.
- (c) about 15 ft
64.  $x = (v_0/2)t, y = 4 + (v_0\sqrt{3}/2)t - 16t^2$ , solve  $x = 15, y = 20$  simultaneously for  $v_0$  and  $t$ ,  
 $v_0/2 = 15/t, t^2 = \frac{15}{16}\sqrt{3} - 1, t \approx 0.7898, v_0 \approx 30/0.7898 \approx 37.98$  ft/s.
65. (a)  $x = (35\sqrt{2}/2)t, y = (35\sqrt{2}/2)t - 4.9t^2$ , from Exercise 17a in Section 14.5  
 $\kappa = \frac{|x'y'' - x''y'|}{[(x')^2 + (y')^2]^{3/2}}, \kappa(0) = \frac{9.8}{35^2\sqrt{2}} = 0.004\sqrt{2} \approx 0.00566$
- (b)  $y'(t) = 0$  when  $t = \frac{25}{14}\sqrt{2}, y = \frac{125}{4}$  m
66. (a)  $\mathbf{a} = a_T\mathbf{T} + a_N\mathbf{N}, a_T = \frac{d^2s}{dt^2} = -7.5$  ft/s<sup>2</sup>,  $a_N = \kappa\left(\frac{ds}{dt}\right)^2 = \frac{1}{\rho}(132)^2 = \frac{132^2}{3000}$  ft/s<sup>2</sup>,  
 $\|\mathbf{a}\| = \sqrt{a_T^2 + a_N^2} = \sqrt{(7.5)^2 + \left(\frac{132^2}{3000}\right)^2} \approx 9.49$  ft/s<sup>2</sup>
- (b)  $\cos\theta = \frac{\mathbf{a} \cdot \mathbf{T}}{\|\mathbf{a}\|\|\mathbf{T}\|} = \frac{a_T}{\|\mathbf{a}\|} \approx -\frac{7.5}{9.49} \approx -0.79, \theta \approx 2.48$  radians  $\approx 142^\circ$
67.  $s_0 = 0$  so  $x = (v_0 \cos \alpha)t, y = (v_0 \sin \alpha)t - gt^2/2$
- (a)  $dy/dt = v_0 \sin \alpha - gt$  so  $dy/dt = 0$  when  $t = (v_0 \sin \alpha)/g, y_{\max} = (v_0 \sin \alpha)^2/(2g)$
- (b)  $y = 0$  when  $t = 0$  or  $(2v_0 \sin \alpha)/g$ , so  $x = R = (2v_0^2 \sin \alpha \cos \alpha)/g = (v_0^2 \sin 2\alpha)/g$  when  $t = (2v_0 \sin \alpha)/g$ ;  $R$  is maximum when  $2\alpha = 90^\circ, \alpha = 45^\circ$ , and the maximum value of  $R$  is  $v_0^2/g$ .
68. The range is  $(v_0^2 \sin 2\alpha)/g$  and the maximum range is  $v_0^2/g$  so  $(v_0^2 \sin 2\alpha)/g = (3/4)v_0^2/g$ ,  
 $\sin 2\alpha = 3/4, \alpha = (1/2)\sin^{-1}(3/4) \approx 24.3^\circ$  or  $\alpha = (1/2)[180^\circ - \sin^{-1}(3/4)] \approx 65.7^\circ$ .
69.  $v_0 = 80, \alpha = 30^\circ, s_0 = 5$  so  $x = 40\sqrt{3}t, y = 5 + 40t - 16t^2$
- (a)  $y = 0$  when  $t = (-40 \pm \sqrt{(40)^2 - 4(-16)(5)})/(-32) = (5 \pm \sqrt{30})/4$ , reject  $(5 - \sqrt{30})/4$  to get  
 $t = (5 + \sqrt{30})/4 \approx 2.62$  s.
- (b)  $x \approx 40\sqrt{3}(2.62) \approx 181.5$  ft.
70. (a)  $v_0 = v, s_0 = h$  so  $x = (v \cos \alpha)t, y = h + (v \sin \alpha)t - \frac{1}{2}gt^2$ . If  $x = R$ , then  $(v \cos \alpha)t = R$ ,  
 $t = \frac{R}{v \cos \alpha}$  but  $y = 0$  for this value of  $t$  so  $h + (v \sin \alpha)[R/(v \cos \alpha)] - \frac{1}{2}g[R/(v \cos \alpha)]^2 = 0$ ,  
 $h + (\tan \alpha)R - g(\sec^2 \alpha)R^2/(2v^2) = 0, g(\sec^2 \alpha)R^2 - 2v^2(\tan \alpha)R - 2v^2h = 0$ .

- (b)  $2g \sec^2 \alpha \tan \alpha R^2 + 2g \sec^2 \alpha R \frac{dR}{d\alpha} - 2v^2 \sec^2 \alpha R - 2v^2 \tan \alpha \frac{dR}{d\alpha} = 0$ ; if  $\frac{dR}{d\alpha} = 0$  and  $\alpha = \alpha_0$  when  $R = R_0$ , then  $2g \sec^2 \alpha_0 \tan \alpha_0 R_0^2 - 2v^2 \sec^2 \alpha_0 R_0 = 0$ ,  $g \tan \alpha_0 R_0 - v^2 = 0$ ,  $\tan \alpha_0 = v^2/(gR_0)$ .
- (c) If  $\alpha = \alpha_0$  and  $R = R_0$ , then from part (a)  $g(\sec^2 \alpha_0)R_0^2 - 2v^2(\tan \alpha_0)R_0 - 2v^2h = 0$ , but from part (b)  $\tan \alpha_0 = v^2/(gR_0)$  so  $\sec^2 \alpha_0 = 1 + \tan^2 \alpha_0 = 1 + v^4/(gR_0)^2$  thus  $g[1 + v^4/(gR_0)^2]R_0^2 - 2v^2[v^2/(gR_0)]R_0 - 2v^2h = 0$ ,  $gR_0^2 - v^4/g - 2v^2h = 0$ ,  $R_0^2 = v^2(v^2 + 2gh)/g^2$ ,  $R_0 = (v/g)\sqrt{v^2 + 2gh}$  and  $\tan \alpha_0 = v^2/(v\sqrt{v^2 + 2gh}) = v/\sqrt{v^2 + 2gh}$ ,  $\alpha_0 = \tan^{-1}(v/\sqrt{v^2 + 2gh})$ .
71. (a)  $v_0(\cos \alpha)(2.9) = 259 \cos 23^\circ$  so  $v_0 \cos \alpha \approx 82.21061$ ,  $v_0(\sin \alpha)(2.9) - 16(2.9)^2 = -259 \sin 23^\circ$  so  $v_0 \sin \alpha \approx 11.50367$ ; divide  $v_0 \sin \alpha$  by  $v_0 \cos \alpha$  to get  $\tan \alpha \approx 0.139929$ , thus  $\alpha \approx 8^\circ$  and  $v_0 \approx 82.21061/\cos 8^\circ \approx 83$  ft/s.
- (b) From part (a),  $x \approx 82.21061t$  and  $y \approx 11.50367t - 16t^2$  for  $0 \leq t \leq 2.9$ ; the distance traveled is  $\int_0^{2.9} \sqrt{(dx/dt)^2 + (dy/dt)^2} dt \approx 268.76$  ft.

## EXERCISE SET 14.7

- The results follow from formulae (1) and (7) of Section 12.5.
- (a)  $(r_{\max} - r_{\min})/(r_{\max} + r_{\min}) = 2ae/(2a) = e$   
 (b)  $r_{\max}/r_{\min} = (1 + e)/(1 - e)$ , and the result follows.
- (a) From (15) and (6), at  $t = 0$ ,  
 $\mathbf{C} = \mathbf{v}_0 \times \mathbf{b}_0 - GM\mathbf{u} = v_0\mathbf{j} \times r_0v_0\mathbf{k} - GM\mathbf{u} = r_0v_0^2\mathbf{i} - GM\mathbf{i} = (r_0v_0^2 - GM)\mathbf{i}$   
 (b) From (22),  $r_0v_0^2 - GM = GM e$ , so from (7) and (17),  $\mathbf{v} \times \mathbf{b} = GM(\cos \theta \mathbf{i} + \sin \theta \mathbf{j}) + GM e \mathbf{i}$ , and the result follows.  
 (c) From (10) it follows that  $\mathbf{b}$  is perpendicular to  $\mathbf{v}$ , and the result follows.  
 (d) From Part (c) and (10),  $\|\mathbf{v} \times \mathbf{b}\| = \|\mathbf{v}\|\|\mathbf{b}\| = vr_0v_0$ . From Part (b),  
 $\|\mathbf{v} \times \mathbf{b}\| = GM\sqrt{(e + \cos \theta)^2 + \sin^2 \theta} = GM\sqrt{e^2 + 2e \cos \theta + 1}$ . By (10) and Part (d),  $\|\mathbf{v} \times \mathbf{b}\| = \|\mathbf{v}\|\|\mathbf{b}\| = v(r_0v_0)$  thus  $v = \frac{GM}{r_0v_0}\sqrt{e^2 + 2e \cos \theta + 1}$ . From (22),  
 $r_0v_0^2/(GM) = 1 + e$ ,  $GM/(r_0v_0) = v_0/(1 + e)$  so  $v = \frac{v_0}{1 + e}\sqrt{e^2 + 2e \cos \theta + 1}$ .
- At the end of the minor axis,  $\cos \theta = -c/a = -e$  so  
 $v = \frac{v_0}{1 + e}\sqrt{e^2 + 2e(-e) + 1} = \frac{v_0}{1 + e}\sqrt{1 - e^2} = v_0\sqrt{\frac{1 - e}{1 + e}}$ .
- $v_{\max}$  occurs when  $\theta = 0$  so  $v_{\max} = v_0$ ;  $v_{\min}$  occurs when  $\theta = \pi$  so  
 $v_{\min} = \frac{v_0}{1 + e}\sqrt{e^2 - 2e + 1} = v_{\max}\frac{1 - e}{1 + e}$ , thus  $v_{\max} = v_{\min}\frac{1 + e}{1 - e}$ .
- If the orbit is a circle then  $e = 0$  so from Part (e) of Exercise 3,  $v = v_0$  at all points on the orbit. Use (22) with  $e = 0$  to get  $v_0 = \sqrt{GM/r_0}$  so  $v = \sqrt{GM/r_0}$ .



7.  $r_0 = 6440 + 200 = 6640$  km so  $v = \sqrt{3.99 \times 10^5 / 6640} \approx 7.75$  km/s.
8. From Example 1, the orbit is 22,352 mi above the Earth, thus  $v \approx \sqrt{\frac{1.24 \times 10^{12}}{26,352}} \approx 6859.68$  mi/h.
9. From (23) with  $r_0 = 6440 + 300 = 6740$  km,  $v_{\text{esc}} = \sqrt{\frac{2(3.99) \times 10^5}{6740}} \approx 10.88$  km/s.
10. From (29),  $T = \frac{2\pi}{\sqrt{GM}} a^{3/2}$ . But  $T = 1$  yr  $= 365 \cdot 24 \cdot 3600$  s, thus  $M = \frac{4\pi^2 a^3}{GT^2} \approx 1.99 \times 10^{30}$  kg.
11. (a) At perigee,  $r = r_{\min} = a(1 - e) = 238,900(1 - 0.055) \approx 225,760$  mi; at apogee,  $r = r_{\max} = a(1 + e) = 238,900(1 + 0.055) \approx 252,040$  mi. Subtract the sum of the radius of the moon and the radius of the Earth to get  
 minimum distance  $= 225,760 - 5080 = 220,680$  mi,  
 and maximum distance  $= 252,040 - 5080 = 246,960$  mi.
- (b)  $T = 2\pi\sqrt{a^3/(GM)} = 2\pi\sqrt{(238,900)^3/(1.24 \times 10^{12})} \approx 659$  hr  $\approx 27.5$  days.
12. (a)  $r_{\min} = 6440 + 649 = 7,089$  km,  $r_{\max} = 6440 + 4,340 = 10,780$  km so  
 $a = (r_{\min} + r_{\max})/2 = 8934.5$  km.
- (b)  $e = (10,780 - 7,089)/(10,780 + 7,089) \approx 0.207$ .
- (c)  $T = 2\pi\sqrt{a^3/(GM)} = 2\pi\sqrt{(8934.5)^3/(3.99 \times 10^5)} \approx 8400$  s  $\approx 140$  min
13. (a)  $r_0 = 4000 + 180 = 4180$  mi,  $v = \sqrt{1.24 \times 10^{12}/4180} \approx 17,224$  mph
- (b)  $r_0 = 4180$  mi,  $v_0 = 17,224 + 600 = 17,824$  mi/h;  $e = \frac{r_0 v_0^2}{GM} - 1 = \frac{(4180)(17,824)^2}{1.24 \times 10^{12}} - 1 \approx 0.07094$ .  
 $r_{\max} = 4180(1 + 0.07094)/(1 - 0.07094) \approx 4818$  mi; the apogee altitude  
 is  $4818 - 4000 = 818$  mi.
14. By equation (20),  $r = \frac{k}{1 + e \cos \theta}$ , where  $k > 0$ . By assumption,  $r$  is minimal when  $\theta = 0$ , hence  $e \geq 0$ .

## CHAPTER 14 SUPPLEMENTARY EXERCISES

2. (a) the line through the tips of  $\mathbf{r}_0$  and  $\mathbf{r}_1$   
 (b) the line segment connecting the tips of  $\mathbf{r}_0$  and  $\mathbf{r}_1$   
 (c) the line through the tip of  $\mathbf{r}_0$  which is parallel to  $\mathbf{r}'(t_0)$
4. (a) speed      (b) distance traveled      (c) distance of the particle from the origin
7. (a)  $\mathbf{r}(t) = \int_0^t \cos\left(\frac{\pi u^2}{2}\right) du \mathbf{i} + \int_0^t \sin\left(\frac{\pi u^2}{2}\right) du \mathbf{j}$ ;  
 $\left\| \frac{d\mathbf{r}}{dt} \right\|^2 = x'(t)^2 + y'(t)^2 = \cos^2\left(\frac{\pi t^2}{2}\right) + \sin^2\left(\frac{\pi t^2}{2}\right) = 1$  and  $\mathbf{r}(0) = \mathbf{0}$

(b)  $\mathbf{r}'(s) = \cos\left(\frac{\pi s^2}{2}\right)\mathbf{i} + \sin\left(\frac{\pi s^2}{2}\right)\mathbf{j}$ ,  $\mathbf{r}''(s) = -\pi s \sin\left(\frac{\pi s^2}{2}\right)\mathbf{i} + \pi s \cos\left(\frac{\pi s^2}{2}\right)\mathbf{j}$ ,  
 $\kappa = \|\mathbf{r}''(s)\| = \pi|s|$

(c)  $\kappa(s) \rightarrow +\infty$ , so the spiral winds ever tighter.

8. (a) The tangent vector to the curve is always tangent to the sphere.

(b)  $\|\mathbf{v}\| = \text{const}$ , so  $\mathbf{v} \cdot \mathbf{a} = 0$ ; the acceleration vector is always perpendicular to the velocity vector

(c)  $\|\mathbf{r}(t)\|^2 = \left(1 - \frac{1}{4}\cos^2 t\right)(\cos^2 t + \sin^2 t) + \frac{1}{4}\cos^2 t = 1$

9. (a)  $\|\mathbf{r}(t)\| = 1$ , so by Theorem 14.2.7,  $\mathbf{r}'(t)$  is always perpendicular to the vector  $\mathbf{r}(t)$ . Then  $\mathbf{v}(t) = R\omega(-\sin\omega t\mathbf{i} + \cos\omega t\mathbf{j})$ ,  $v = \|\mathbf{v}(t)\| = R\omega$

(b)  $\mathbf{a} = -R\omega^2(\cos\omega t\mathbf{i} + \sin\omega t\mathbf{j})$ ,  $a = \|\mathbf{a}\| = R\omega^2$ , and  $\mathbf{a} = -\omega^2\mathbf{r}$  is directed toward the origin.

(c) The smallest value of  $t$  for which  $\mathbf{r}(t) = \mathbf{r}(0)$  satisfies  $\omega t = 2\pi$ , so  $T = t = \frac{2\pi}{\omega}$ .

10. (a)  $F = \|\mathbf{F}\| = m\|\mathbf{a}\| = mR\omega^2 = mR\frac{v^2}{R^2} = \frac{mv^2}{R}$

(b)  $R = 6440 + 3200 = 9600$  km,  $6.5 = v = R\omega = 9600\omega$ ,  $\omega = \frac{6.5}{9600} = \frac{13}{19,200}$ ,

$$\mathbf{a} = -a\frac{\mathbf{r}}{\|\mathbf{r}\|} = -R\omega^2\frac{\mathbf{r}}{R} = -R\omega^2(\cos\omega t\mathbf{i} + \sin\omega t\mathbf{j}) = -\frac{13}{2}\left(\cos\left(\frac{13t}{19,200}\right)\mathbf{i} + \sin\left(\frac{13t}{19,200}\right)\mathbf{j}\right)$$

(c)  $F = ma = 70\frac{2}{13} \text{ kg} \cdot \text{km/s}^2 \approx 10.77 \text{ N}$

11. (a) Let  $\mathbf{r} = x\mathbf{i} + y\mathbf{j} + z\mathbf{k}$ , then  $x^2 + z^2 = t^2(\sin^2\pi t + \cos^2\pi t) = t^2 = y^2$

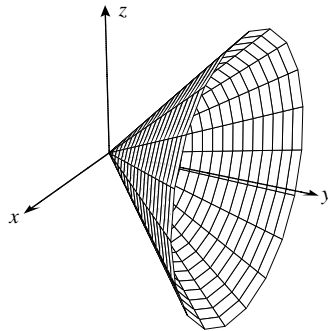

(b) Let  $x = t$ , then  $y = t^2$ ,  $z = \pm\sqrt{4 - t^2/3 - t^4/6}$

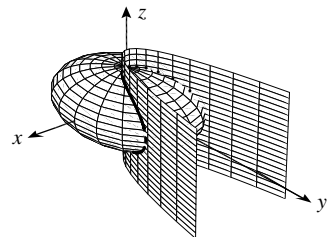

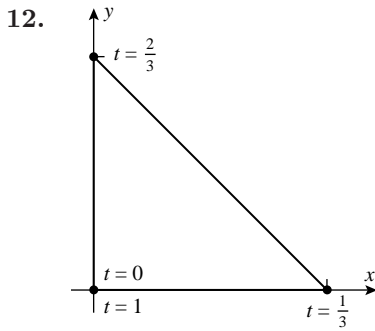

13. (a)  $\|\mathbf{e}_r(t)\|^2 = \cos^2 \theta + \sin^2 \theta = 1$ , so  $\mathbf{e}_r(t)$  is a unit vector;  $\mathbf{r}(t) = r(t)\mathbf{e}_r(t)$ , so they have the same direction if  $r(t) > 0$ , opposite if  $r(t) < 0$ .  $\mathbf{e}_\theta(t)$  is perpendicular to  $\mathbf{e}_r(t)$  since  $\mathbf{e}_r(t) \cdot \mathbf{e}_\theta(t) = 0$ , and it will result from a counterclockwise rotation of  $\mathbf{e}_r(t)$  provided  $\mathbf{e}_r(t) \times \mathbf{e}_\theta(t) = \mathbf{k}$ , which is true.

(b)  $\frac{d}{dt}\mathbf{e}_r(t) = \frac{d\theta}{dt}(-\sin \theta \mathbf{i} + \cos \theta \mathbf{j}) = \frac{d\theta}{dt}\mathbf{e}_\theta(t)$  and  $\frac{d}{dt}\mathbf{e}_\theta(t) = -\frac{d\theta}{dt}(\cos \theta \mathbf{i} + \sin \theta \mathbf{j}) = -\frac{d\theta}{dt}\mathbf{e}_r(t)$ , so

$$\mathbf{v}(t) = \frac{d}{dt}\mathbf{r}(t) = \frac{d}{dt}(r(t)\mathbf{e}_r(t)) = r'(t)\mathbf{e}_r(t) + r(t)\frac{d\theta}{dt}\mathbf{e}_\theta(t)$$

(c) From Part (b),  $\mathbf{a} = \frac{d}{dt}\mathbf{v}(t)$

$$\begin{aligned} &= r''(t)\mathbf{e}_r(t) + r'(t)\frac{d\theta}{dt}\mathbf{e}_\theta(t) + r'(t)\frac{d\theta}{dt}\mathbf{e}_\theta(t) + r(t)\frac{d^2\theta}{dt^2}\mathbf{e}_\theta(t) - r(t)\left(\frac{d\theta}{dt}\right)^2\mathbf{e}_r(t) \\ &= \left[\frac{d^2r}{dt^2} - r\left(\frac{d\theta}{dt}\right)^2\right]\mathbf{e}_r(t) + \left[r\frac{d^2\theta}{dt^2} + 2\frac{dr}{dt}\frac{d\theta}{dt}\right]\mathbf{e}_\theta(t) \end{aligned}$$

14. The height  $y(t)$  of the rocket satisfies  $\tan \theta = y/b$ ,  $y = b \tan \theta$ ,  $v = \frac{dy}{dt} = \frac{dy}{d\theta} \frac{d\theta}{dt} = b \sec^2 \theta \frac{d\theta}{dt}$ .

15.  $\mathbf{r} = \mathbf{r}_0 + t \overrightarrow{PQ} = (t-1)\mathbf{i} + (4-2t)\mathbf{j} + (3+2t)\mathbf{k}$ ;  $\left\|\frac{d\mathbf{r}}{dt}\right\| = 3$ ,  $\mathbf{r}(s) = \frac{s-3}{3}\mathbf{i} + \frac{12-2s}{3}\mathbf{j} + \frac{9+2s}{3}\mathbf{k}$

16. By equation (26) of Section 14.6,  $\mathbf{r}(t) = (60 \cos \alpha)t\mathbf{i} + ((60 \sin \alpha)t - 16t^2 + 4)\mathbf{j}$ , and the maximum height of the baseball occurs when  $y'(t) = 0$ ,  $60 \sin \alpha = 32t$ ,  $t = \frac{15}{8} \sin \alpha$ , so the ball clears the

ceiling if  $y_{\max} = (60 \sin \alpha) \frac{15}{8} \sin \alpha - 16 \frac{15^2}{8^2} \sin^2 \alpha + 4 \leq 25$ ,  $\frac{15^2 \sin^2 \alpha}{4} \leq 21$ ,  $\sin^2 \alpha \leq \frac{28}{75}$ . The ball

hits the wall when  $x = 60$ ,  $t = \sec \alpha$ , and  $y(\sec \alpha) = 60 \sin \alpha \sec \alpha - 16 \sec^2 \alpha + 4$ . Maximize the height  $h(\alpha) = y(\sec \alpha) = 60 \tan \alpha - 16 \sec^2 \alpha + 4$ , subject to the constraint  $\sin^2 \alpha \leq \frac{28}{75}$ . Then

$$h'(\alpha) = 60 \sec^2 \alpha - 32 \sec^2 \alpha \tan \alpha = 0, \tan \alpha = \frac{60}{32} = \frac{15}{8}, \text{ so } \sin \alpha = \frac{15}{\sqrt{8^2 + 15^2}} = \frac{15}{17}, \text{ but for}$$

this value of  $\alpha$  the constraint is not satisfied (the ball hits the ceiling). Hence the maximum value of  $h$  occurs at one of the endpoints of the  $\alpha$ -interval on which the ball clears the ceiling, i.e.  $\left[0, \sin^{-1} \sqrt{28/75}\right]$ . Since  $h'(0) = 60$ , it follows that  $h$  is increasing throughout the interval, since

$$h' > 0 \text{ inside the interval. Thus } h_{\max} \text{ occurs when } \sin^2 \alpha = \frac{28}{75}, h_{\max} = 60 \tan \alpha - 16 \sec^2 \alpha + 4 =$$

$$60 \frac{\sqrt{28}}{\sqrt{47}} - 16 \frac{75}{47} + 4 = \frac{120\sqrt{329} - 1012}{47} \approx 24.78 \text{ ft. Note: the possibility that the baseball keeps}$$

climbing until it hits the wall can be rejected as follows: if so, then  $y'(t) = 0$  after the ball hits the wall, i.e.  $t = \frac{15}{8} \sin \alpha$  occurs after  $t = \sec \alpha$ , hence  $\frac{15}{8} \sin \alpha \geq \sec \alpha$ ,  $15 \sin \alpha \cos \alpha \geq 8$ ,  $15 \sin 2\alpha \geq 16$ , impossible.

17.  $\mathbf{r}'(1) = 3\mathbf{i} + 10\mathbf{j} + 10\mathbf{k}$ , so if  $\mathbf{r}'(t) = 3t^2\mathbf{i} + 10\mathbf{j} + 10t\mathbf{k}$  is perpendicular to  $\mathbf{r}'(1)$ , then  $9t^2 + 100 + 100t = 0$ ,  $t = -10, -10/9$ ,  
so  $\mathbf{r} = -1000\mathbf{i} - 100\mathbf{j} + 500\mathbf{k}, -(1000/729)\mathbf{i} - (100/9)\mathbf{j} + (500/81)\mathbf{k}$ .
18. Let  $\mathbf{r}(t) = x(t)\mathbf{i} + y(t)\mathbf{j}$ , then  $\frac{dx}{dt} = x(t), \frac{dy}{dt} = y(t), x(0) = x_0, y(0) = y_0$ , so  
 $x(t) = x_0e^t, y(t) = y_0e^t, \mathbf{r}(t) = e^t\mathbf{r}_0$
19. (a)  $\frac{d\mathbf{v}}{dt} = 2t^2\mathbf{i} + \mathbf{j} + \cos 2t\mathbf{k}, \mathbf{v}_0 = \mathbf{i} + 2\mathbf{j} - \mathbf{k}$ , so  $x'(t) = \frac{2}{3}t^3 + 1, y'(t) = t + 2, z'(t) = \frac{1}{2}\sin 2t - 1$ ,  
 $x(t) = \frac{1}{6}t^4 + t, y(t) = \frac{1}{2}t^2 + 2t, z(t) = -\frac{1}{4}\cos 2t - t + \frac{1}{4}$ , since  $\mathbf{r}(0) = \mathbf{0}$ . Hence  
 $\mathbf{r}(t) = \left(\frac{1}{6}t^4 + t\right)\mathbf{i} + \left(\frac{1}{2}t^2 + 2t\right)\mathbf{j} - \left(\frac{1}{4}\cos 2t + t - \frac{1}{4}\right)\mathbf{k}$
- (b)  $\left.\frac{ds}{dt}\right|_{t=1} = \|\mathbf{r}'(t)\|_{t=1} = \sqrt{(5/3)^2 + 9 + (1 - (\sin 2)/2)^2} \approx 3.475$
20.  $\|\mathbf{v}\|^2 = \mathbf{v}(t) \cdot \mathbf{v}(t), 2\|\mathbf{v}\|\frac{d}{dt}\|\mathbf{v}\| = 2\mathbf{v} \cdot \mathbf{a}, \frac{d}{dt}(\|\mathbf{v}\|) = \frac{1}{\|\mathbf{v}\|}(\mathbf{v} \cdot \mathbf{a})$

# CHAPTER 15

## Partial Derivatives

### EXERCISE SET 15.1

1. (a)  $f(2, 1) = (2)^2(1) + 1 = 5$                       (b)  $f(1, 2) = (1)^2(2) + 1 = 3$   
 (c)  $f(0, 0) = (0)^2(0) + 1 = 1$                       (d)  $f(1, -3) = (1)^2(-3) + 1 = -2$   
 (e)  $f(3a, a) = (3a)^2(a) + 1 = 9a^3 + 1$             (f)  $f(ab, a - b) = (ab)^2(a - b) + 1 = a^3b^2 - a^2b^3 + 1$
2. (a)  $2t$     (b)  $2x$     (c)  $2y^2 + 2y$
3. (a)  $f(x + y, x - y) = (x + y)(x - y) + 3 = x^2 - y^2 + 3$   
 (b)  $f(xy, 3x^2y^3) = (xy)(3x^2y^3) + 3 = 3x^3y^4 + 3$
4. (a)  $(x/y) \sin(x/y)$                                       (b)  $xy \sin(xy)$                                       (c)  $(x - y) \sin(x - y)$
5.  $F(g(x), h(y)) = F(x^3, 3y + 1) = x^3e^{x^3(3y+1)}$
6.  $g(u(x, y), v(x, y)) = g(x^2y^3, \pi xy) = \pi xy \sin \left[ (x^2y^3)^2 (\pi xy) \right] = \pi xy \sin(\pi x^5y^7)$
7. (a)  $t^2 + 3t^{10}$     (b)  $0$     (c)  $3076$
8.  $\sqrt{t}e^{-3 \ln(t^2+1)} = \frac{\sqrt{t}}{(t^2 + 1)^3}$
9. (a)  $19$     (b)  $-9$     (c)  $3$   
 (d)  $a^6 + 3$     (e)  $-t^8 + 3$     (f)  $(a + b)(a - b)^2b^3 + 3$
10. (a)  $x^2(x + y)(x - y) + (x + y) = x^2(x^2 - y^2) + (x + y) = x^4 - x^2y^2 + x + y$   
 (b)  $(xz)(xy)(y/x) + xy = xy^2z + xy$
11.  $F(x^2, y + 1, z^2) = (y + 1)e^{x^2(y+1)z^2}$
12.  $g(x^2z^3, \pi xyz, xy/z) = (xy/z) \sin(\pi x^3yz^4)$
13. (a)  $f(\sqrt{5}, 2, \pi, -3\pi) = 80\sqrt{\pi}$                       (b)  $f(1, 1, \dots, 1) = \sum_{k=1}^n k = n(n + 1)/2$
14. (a)  $f(-2, 2, 0, \pi/4) = 1$   
 (b)  $f(1, 2, \dots, n) = n(n + 1)(2n + 1)/6$ , see (Theorem 2(b), Section 7.4)

15.

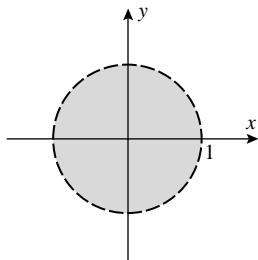

16.

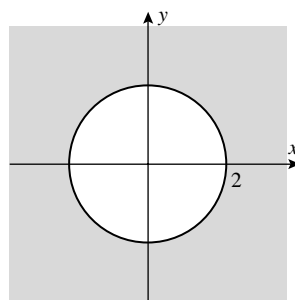

17.

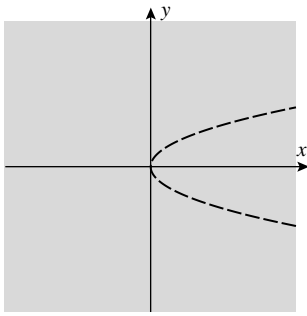

18.

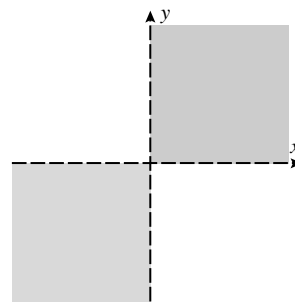

19. (a) all points above or on the line  $y = -2$   
 (b) all points on or within the sphere  $x^2 + y^2 + z^2 = 25$   
 (c) all points in 3-space
20. (a) all points on or between the vertical lines  $x = \pm 2$ .  
 (b) all points above the line  $y = 2x$   
 (c) all points not on the plane  $x + y + z = 0$

21.

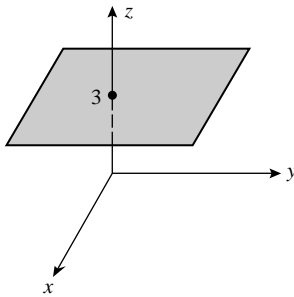

22.

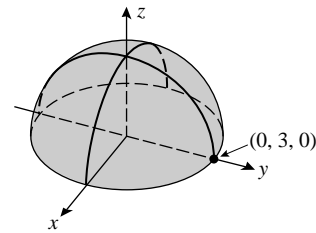

23.

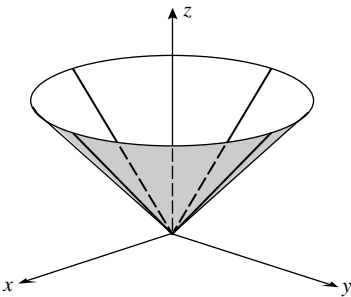

24.

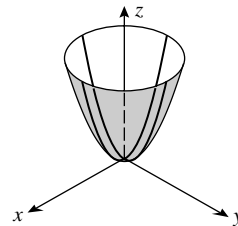

25.

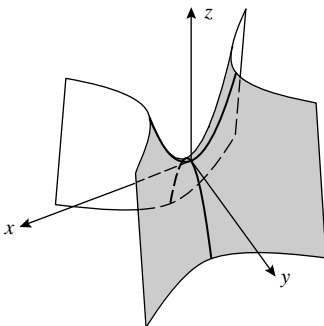

26.

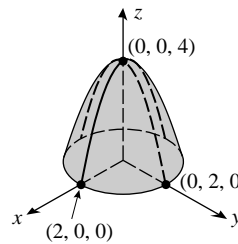

27.

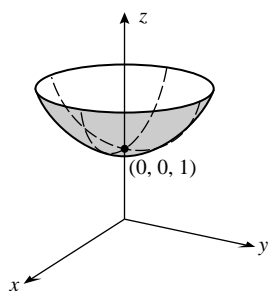

28.

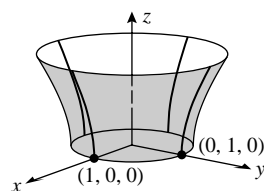

29.

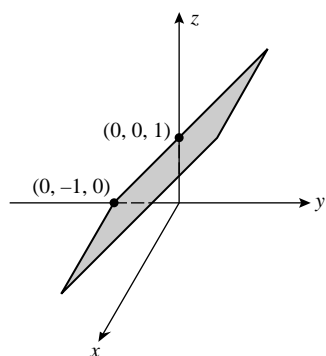

30.

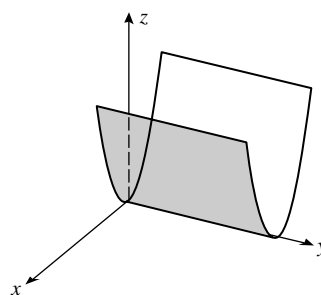

31.

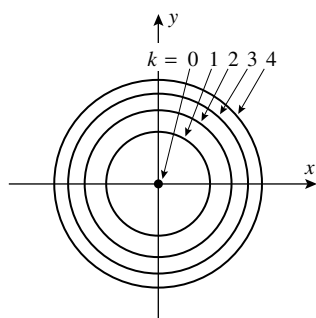

32.

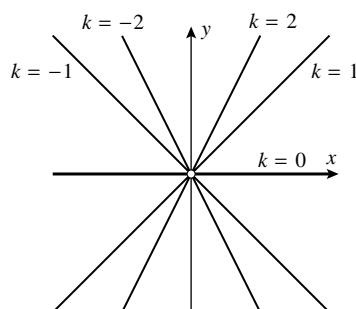

33.

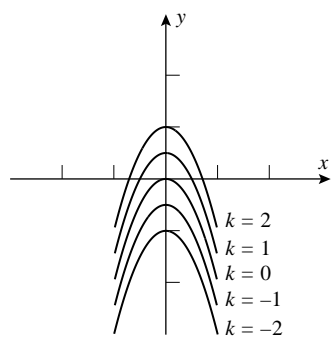

34.

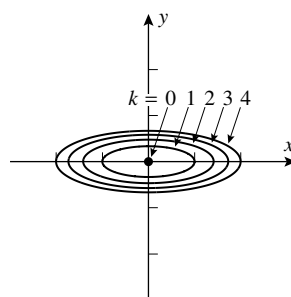

35.

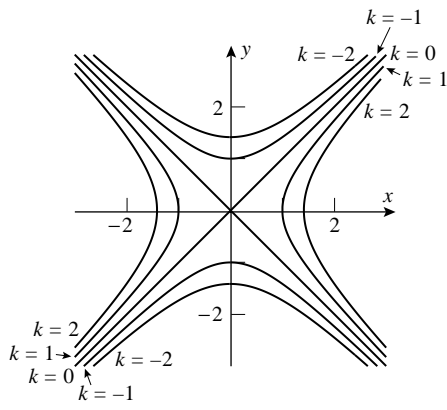

36.

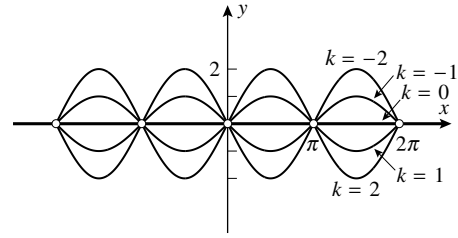

37.

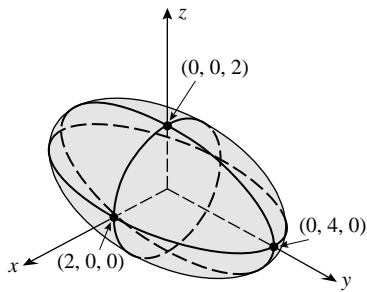

38.

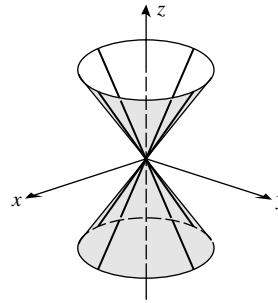

39.

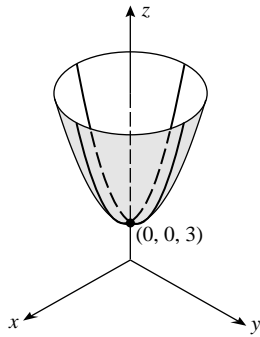

40.

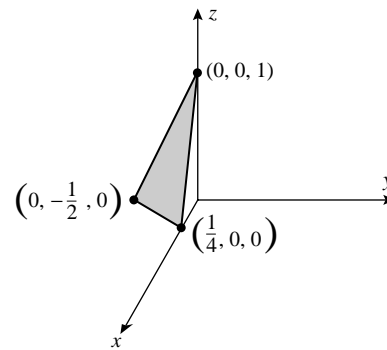

41. concentric spheres, common center at  $(2,0,0)$

42. parallel planes, common normal  $3\mathbf{i} - \mathbf{j} + 2\mathbf{k}$

43. concentric cylinders, common axis the  $y$ -axis

44. circular paraboloids, common axis the  $z$ -axis, all the same shape but with different vertices along  $z$ -axis.

45. (a)  $f(-1, 1) = 0; x^2 - 2x^3 + 3xy = 0$

(b)  $f(0, 0) = 0; x^2 - 2x^3 + 3xy = 0$

(c)  $f(2, -1) = -18; x^2 - 2x^3 + 3xy = -18$



46. (a)  $f(\ln 2, 1) = 2; ye^x = 2$   
 (c)  $f(1, -2) = -2e; ye^x = -2e$

(b)  $f(0, 3) = 3; ye^x = 3$

47. (a)  $f(1, -2, 0) = 5; x^2 + y^2 - z = 5$   
 (c)  $f(0, 0, 0) = 0; x^2 + y^2 - z = 0$

(b)  $f(1, 0, 3) = -2; x^2 + y^2 - z = -2$

48. (a)  $f(1, 0, 2) = 3; xyz + 3 = 3, xyz = 0$   
 (c)  $f(0, 0, 0) = 3; xyz = 0$

(b)  $f(-2, 4, 1) = -5; xyz + 3 = -5, xyz = -8$

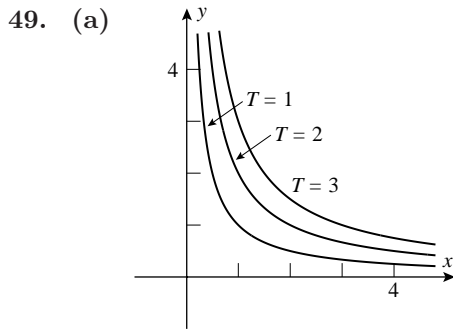

(b) At  $(1, 4)$  the temperature is  $T(1, 4) = 4$  so the temperature will remain constant along the path  $xy = 4$ .

50.  $V = 8/\sqrt{16 + x^2 + y^2} \Rightarrow \sqrt{16 + x^2 + y^2} = 8/V$   
 $= 8/V \Rightarrow x^2 + y^2 = 64/V^2 - 16$   
 the equipotential curves are circles.

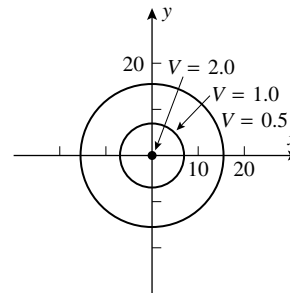

51. (a)  $f(x, y) = 1 - x^2 - y^2$ , because  $f = c$  is a circle of radius  $\sqrt{1 - c}$  (provided  $c \leq 1$ ), and the radii in (a) decrease as  $c$  increases.  
 (b)  $f(x, y) = \sqrt{x^2 + y^2}$  because  $f = c$  is a circle of radius  $c$ , and the radii increase uniformly.  
 (a) is the contour plot of  $f(x, y) = 1 - x^2 - y^2$ , because  $f = c$  is a circle of radius  $\sqrt{1 - c}$  (provided  $c \leq 1$ ), and the radii in (a) decrease as  $c$  increases.  
 (c)  $f(x, y) = x^2 + y^2$  because  $f = c$  is a circle of radius  $\sqrt{c}$  and the radii in the plot grow like the square root function.

52. (a) III                                      (b) IV                                      (c) I                                      (d) II

53. (a) A                                      (b) B                                      (c) increase  
 (d) decrease                                      (e) increase                                      (f) decrease

54. (a) Calgary, since the contour lines are closer together near Calgary than they are near Chicago.  
 (b) The change in atmospheric pressure is about  $\Delta p \approx 1012 - 999 = 13$ , so the average rate of change is  $\Delta p/1600 \approx 0.0081$ .

55. (a)

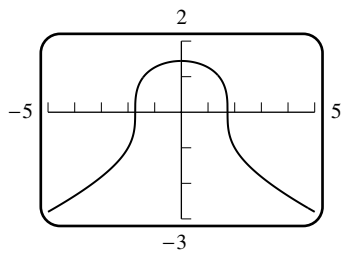

(b)

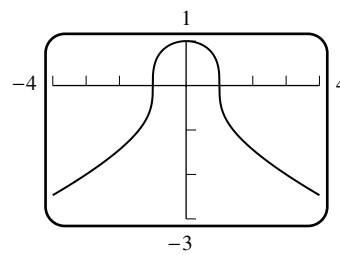

56. (a)

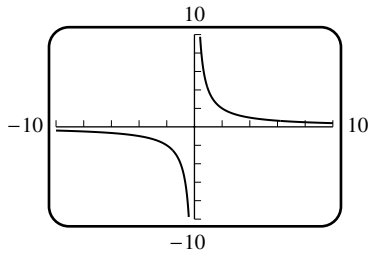

(b)

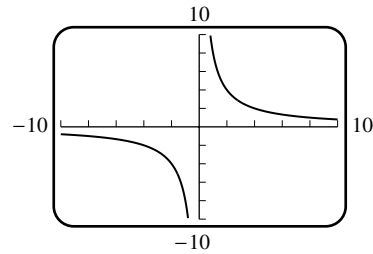

57. (a)

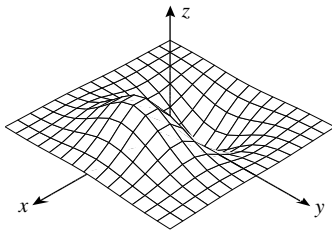

(b)

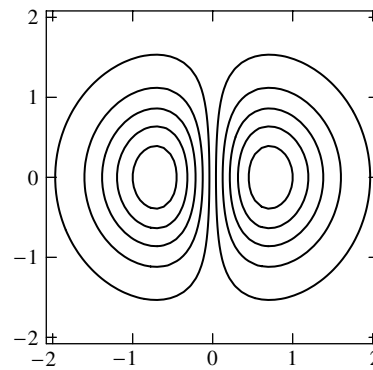

58. (a)

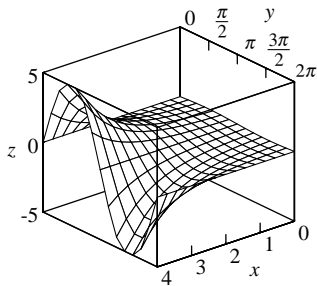

(b)

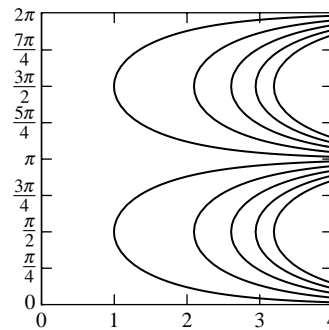

59. (a) The graph of  $g$  is the graph of  $f$  shifted one unit in the positive  $x$ -direction.  
 (b) The graph of  $g$  is the graph of  $f$  shifted one unit up the  $z$ -axis.  
 (c) The graph of  $g$  is the graph of  $f$  shifted one unit down the  $y$ -axis and then inverted with respect to the plane  $z = 0$ .

60. (a)

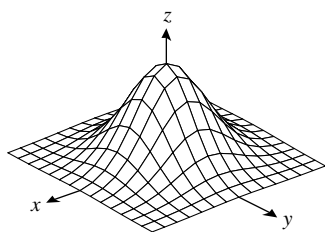

(b) If  $a$  is positive and increasing then the graph of  $g$  is more pointed, and in the limit as  $a \rightarrow +\infty$  the graph approaches a 'spike' on the  $z$ -axis of height 1. As  $a$  decreases to zero the graph of  $g$  gets flatter until it finally approaches the plane  $z = 1$ .

**EXERCISE SET 15.2**

1.

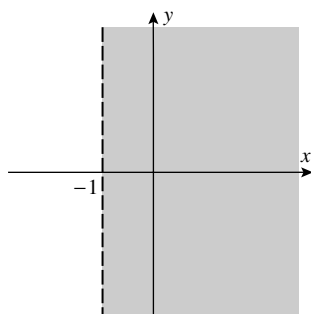

2.

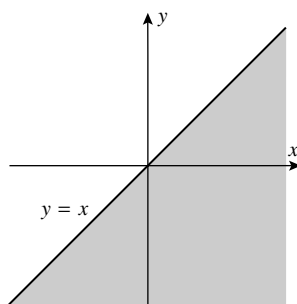

3.

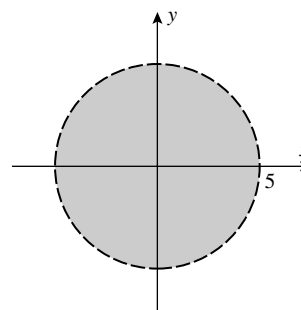

4.

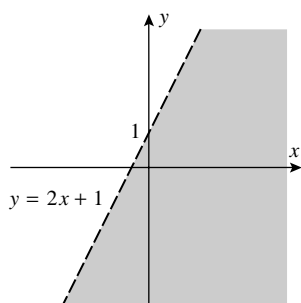

5.

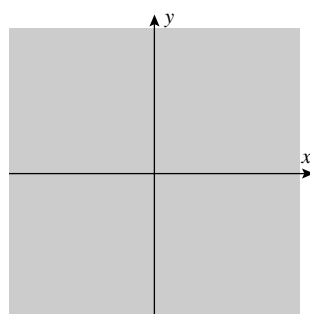

6.

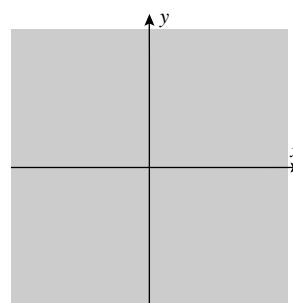

7.

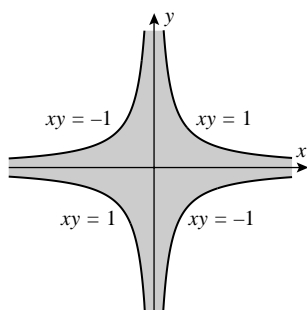

8.

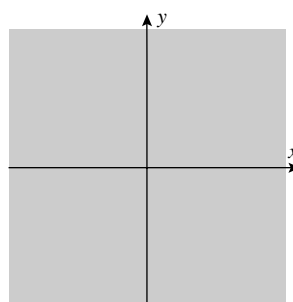

9. all of 3-space

10. all points inside the sphere with radius 2 and center at the origin
11. all points not on the cylinder  $x^2 + z^2 = 1$  12. all of 3-space
13. 35 14.  $\pi^2/2$  15. -8
16.  $e^{-7}$  17. 0 18. 0
19. (a) Along  $x = 0$   $\lim_{(x,y) \rightarrow (0,0)} \frac{3}{x^2 + 2y^2} = \lim_{y \rightarrow 0} \frac{3}{2y^2}$  does not exist.  
 (b) Along  $x = 0$ ,  $\lim_{(x,y) \rightarrow (0,0)} \frac{x+y}{x+y^2} = \lim_{y \rightarrow 0} \frac{1}{y}$  does not exist.
20. (a) Along  $y = 0$ :  $\lim_{x \rightarrow 0} \frac{x}{x^2} = \lim_{x \rightarrow 0} \frac{1}{x}$  does not exist because  $\left| \frac{1}{x} \right| \rightarrow +\infty$  as  $x \rightarrow 0$  so the original limit does not exist.  
 (b) Along  $y = 0$ :  $\lim_{x \rightarrow 0} \frac{1}{x}$  does not exist, so the original limit does not exist.
21. Let  $z = x^2 + y^2$ , then  $\lim_{(x,y) \rightarrow (0,0)} \frac{\sin(x^2 + y^2)}{x^2 + y^2} = \lim_{z \rightarrow 0^+} \frac{\sin z}{z} = 1$
22. Let  $z = x^2 + y^2$ , then  $\lim_{(x,y) \rightarrow (0,0)} \frac{1 - \cos(x^2 + y^2)}{x^2 + y^2} = \lim_{z \rightarrow 0^+} \frac{1 - \cos z}{z} = \lim_{z \rightarrow 0^+} \frac{\sin z}{1} = 0$
23. Let  $z = x^2 + y^2$ , then  $\lim_{(x,y) \rightarrow (0,0)} e^{-1/(x^2+y^2)} = \lim_{z \rightarrow 0^+} e^{-1/z} = 0$
24. With  $z = \frac{1}{x^2 + y^2}$ ,  $\lim_{z \rightarrow +\infty} \frac{1}{\sqrt{z}} e^{-1/\sqrt{z}}$ ; let  $w = \frac{1}{\sqrt{z}}$ ,  $\lim_{w \rightarrow +\infty} \frac{w}{e^w} = 0$
25.  $\lim_{(x,y) \rightarrow (0,0)} \frac{(x^2 + y^2)(x^2 - y^2)}{x^2 + y^2} = \lim_{(x,y) \rightarrow (0,0)} (x^2 - y^2) = 0$
26.  $\lim_{(x,y) \rightarrow (0,0)} \frac{(x^2 + 4y^2)(x^2 - 4y^2)}{x^2 + 4y^2} = \lim_{(x,y) \rightarrow (0,0)} (x^2 - 4y^2) = 0$
27. along  $y = 0$ :  $\lim_{x \rightarrow 0} \frac{0}{3x^2} = \lim_{x \rightarrow 0} 0 = 0$ ; along  $y = x$ :  $\lim_{x \rightarrow 0} \frac{x^2}{5x^2} = \lim_{x \rightarrow 0} 1/5 = 1/5$   
 so the limit does not exist.
28. Let  $z = x^2 + y^2$ , then  $\lim_{(x,y) \rightarrow (0,0)} \frac{1 - x^2 - y^2}{x^2 + y^2} = \lim_{z \rightarrow 0^+} \frac{1 - z^2}{z^2} = +\infty$  so the limit does not exist.
29.  $8/3$  30.  $\ln 5$
31. Let  $t = \sqrt{x^2 + y^2 + z^2}$ , then  $\lim_{(x,y,z) \rightarrow (0,0,0)} \frac{\sin(x^2 + y^2 + z^2)}{\sqrt{x^2 + y^2 + z^2}} = \lim_{t \rightarrow 0^+} \frac{\sin(t^2)}{t} = 0$

32. With  $t = \sqrt{x^2 + y^2 + z^2}$ ,  $\lim_{t \rightarrow 0^+} \frac{\sin t}{t^2} = \lim_{t \rightarrow 0^+} \frac{\cos t}{2t} = +\infty$  so the limit does not exist.
33.  $y \ln(x^2 + y^2) = r \sin \theta \ln r^2 = 2r(\ln r) \sin \theta$ , so  $\lim_{(x,y) \rightarrow (0,0)} y \ln(x^2 + y^2) = \lim_{r \rightarrow 0^+} 2r(\ln r) \sin \theta = 0$
34.  $\frac{x^2 y^2}{\sqrt{x^2 + y^2}} = \frac{(r^2 \cos^2 \theta)(r^2 \sin^2 \theta)}{r} = r^3 \cos^2 \theta \sin^2 \theta$ , so  $\lim_{(x,y) \rightarrow (0,0)} \frac{x^2 y^2}{\sqrt{x^2 + y^2}} = 0$
35.  $\frac{e^{\sqrt{x^2 + y^2 + z^2}}}{\sqrt{x^2 + y^2 + z^2}} = \frac{e^\rho}{\rho}$ , so  $\lim_{(x,y,z) \rightarrow (0,0,0)} \frac{e^{\sqrt{x^2 + y^2 + z^2}}}{\sqrt{x^2 + y^2 + z^2}} = \lim_{\rho \rightarrow 0^+} \frac{e^\rho}{\rho}$  does not exist.
36.  $\lim_{(x,y,z) \rightarrow (0,0,0)} \tan^{-1} \left[ \frac{1}{x^2 + y^2 + z^2} \right] = \lim_{\rho \rightarrow 0^+} \tan^{-1} \frac{1}{\rho^2} = \frac{\pi}{2}$
37. (a) No, since there seem to be points near  $(0,0)$  with  $z = 0$  and other points near  $(0,0)$  with  $z \approx 1/2$ .
- (b)  $\lim_{x \rightarrow 0} \frac{mx^3}{x^4 + m^2 x^2} = \lim_{x \rightarrow 0} \frac{mx}{x^2 + m^2} = 0$       (c)  $\lim_{x \rightarrow 0} \frac{x^4}{2x^4} = \lim_{x \rightarrow 0} 1/2 = 1/2$
- (d) A limit must be unique if it exists, so  $f(x, y)$  cannot have a limit as  $(x, y) \rightarrow (0, 0)$ .
38. (a) Along  $y = mx$ :  $\lim_{x \rightarrow 0} \frac{mx^4}{2x^6 + m^2 x^2} = \lim_{x \rightarrow 0} \frac{mx^2}{2x^4 + m^2} = 0$ ;  
 along  $y = kx^2$ :  $\lim_{x \rightarrow 0} \frac{kx^5}{2x^6 + k^2 x^4} = \lim_{x \rightarrow 0} \frac{kx}{2x^2 + k^2} = 0$ .
- (b)  $\lim_{x \rightarrow 0} \frac{x^6}{2x^6 + x^6} = \lim_{x \rightarrow 0} \frac{1}{3} = \frac{1}{3} \neq 0$
39. (a)  $\lim_{t \rightarrow 0} \frac{abct^3}{a^2 t^2 + b^4 t^4 + c^4 t^4} = \lim_{t \rightarrow 0} \frac{abct}{a^2 + b^4 t^2 + c^4 t^2} = 0$
- (b)  $\lim_{t \rightarrow 0} \frac{t^4}{t^4 + t^4 + t^4} = \lim_{t \rightarrow 0} 1/3 = 1/3$
40.  $\pi/2$  because  $\frac{x^2 + 1}{x^2 + (y - 1)^2} \rightarrow +\infty$  as  $(x, y) \rightarrow (0, 1)$
41.  $-\pi/2$  because  $\frac{x^2 - 1}{x^2 + (y - 1)^2} \rightarrow -\infty$  as  $(x, y) \rightarrow (0, 1)$
42. with  $z = x^2 + y^2$ ,  $\lim_{z \rightarrow 0^+} \frac{\sin z}{z} = 1 = f(0, 0)$
43. No, because  $\lim_{(x,y) \rightarrow (0,0)} \frac{x^2}{x^2 + y^2}$  does not exist.  
 Along  $x = 0$ :  $\lim_{y \rightarrow 0} (0/y^2) = \lim_{y \rightarrow 0} 0 = 0$ ; along  $y = 0$ :  $\lim_{x \rightarrow 0} (x^2/x^2) = \lim_{x \rightarrow 0} 1 = 1$ .
44. Using polar coordinates with  $r > 0$ ,  $xy = r^2 \sin \theta \cos \theta$  and  $x^2 + y^2 = r^2$  so  
 $|xy \ln(x^2 + y^2)| = |r^2 \sin \theta \cos \theta \ln r^2| \leq |2r^2 \ln r|$ , but  $\lim_{r \rightarrow 0^+} 2r^2 \ln r = 0$  thus  
 $\lim_{(x,y) \rightarrow (0,0)} xy \ln(x^2 + y^2) = 0$ ;  $f(x, y)$  will be continuous at  $(0,0)$  if we define  $f(0, 0) = 0$ .

## EXERCISE SET 15.3

1. (a)  $9x^2y^2$  (b)  $6x^3y$  (c)  $9y^2$  (d)  $9x^2$   
(e)  $6y$  (f)  $6x^3$  (g)  $36$  (h)  $12$
2. (a)  $2e^{2x} \sin y$  (b)  $e^{2x} \cos y$  (c)  $2 \sin y$  (d)  $0$   
(e)  $\cos y$  (f)  $e^{2x}$  (g)  $0$  (h)  $4$
3. (a)  $-\frac{1}{4x^{3/2}} \cos y$  (b)  $-\sqrt{x} \cos y$  (c)  $-\frac{\sin y}{2\sqrt{x}}$  (d)  $-\frac{\sin y}{2\sqrt{x}}$
4. (a)  $8 + 84x^2y^5$  (b)  $140x^4y^3$  (c)  $140x^3y^4$  (d)  $140x^3y^4$
5. (a)  $\frac{\partial z}{\partial x} = \frac{3}{2\sqrt{3x+2y}}$ ; slope =  $\frac{3}{8}$  (b)  $\frac{\partial z}{\partial y} = \frac{1}{\sqrt{3x+2y}}$ ; slope =  $\frac{1}{4}$
6. (a)  $\frac{\partial z}{\partial x} = e^{-y}$ ; slope =  $1$  (b)  $\frac{\partial z}{\partial y} = -xe^{-y} + 5$ ; slope =  $2$
7. (a)  $\frac{\partial z}{\partial x} = -4 \cos(y^2 - 4x)$ ; rate of change =  $-4 \cos 7$   
(b)  $\frac{\partial z}{\partial y} = 2y \cos(y^2 - 4x)$ ; rate of change =  $2 \cos 7$
8. (a)  $\frac{\partial z}{\partial x} = -\frac{1}{(x+y)^2}$ ; rate of change =  $-\frac{1}{4}$  (b)  $\frac{\partial z}{\partial y} = -\frac{1}{(x+y)^2}$ ; rate of change =  $-\frac{1}{4}$
9.  $\partial z/\partial x =$  slope of line parallel to  $xz$ -plane =  $-4$ ;  $\partial z/\partial y =$  slope of line parallel to  $yz$ -plane =  $1/2$
10. The slope at  $P$  in the positive  $x$ -direction is negative, the slope in the positive  $y$ -direction is negative, thus  $\partial z/\partial x < 0, \partial z/\partial y < 0$ ; the curve through  $P$  which is parallel to the  $x$ -axis is concave down, so  $\partial^2 z/\partial x^2 < 0$ ; the curve parallel to the  $y$ -axis is concave down, so  $\partial^2 z/\partial y^2 < 0$ .
11.  $\partial z/\partial x = 8xy^3e^{x^2y^3}, \partial z/\partial y = 12x^2y^2e^{x^2y^3}$
12.  $\partial z/\partial x = -5x^4y^4 \sin(x^5y^4), \partial z/\partial y = -4x^5y^3 \sin(x^5y^4)$
13.  $\partial z/\partial x = x^3/(y^{3/5} + x) + 3x^2 \ln(1 + xy^{-3/5}), \partial z/\partial y = -(3/5)x^4/(y^{8/5} + xy)$
14.  $\partial z/\partial x = ye^{xy} \sin(4y^2), \partial z/\partial y = 8ye^{xy} \cos(4y^2) + xe^{xy} \sin(4y^2)$
15.  $\frac{\partial z}{\partial x} = -\frac{y(x^2 - y^2)}{(x^2 + y^2)^2}, \frac{\partial z}{\partial y} = \frac{x(x^2 - y^2)}{(x^2 + y^2)^2}$  16.  $\frac{\partial z}{\partial x} = \frac{xy^3(3x + 4y)}{2(x + y)^{3/2}}, \frac{\partial z}{\partial y} = \frac{x^2y^2(6x + 5y)}{2(x + y)^{3/2}}$
17.  $f_x(x, y) = (3/2)x^2y(5x^2 - 7)(3x^5y - 7x^3y)^{-1/2}$   
 $f_y(x, y) = (1/2)x^3(3x^2 - 7)(3x^5y - 7x^3y)^{-1/2}$
18.  $f_x(x, y) = -2y/(x - y)^2, f_y(x, y) = 2x/(x - y)^2$
19.  $f_x(x, y) = \frac{y^{-1/2}}{y^2 + x^2}, f_y(x, y) = -\frac{xy^{-3/2}}{y^2 + x^2} - \frac{3}{2}y^{-5/2} \tan^{-1}(x/y)$

20.  $f_x(x, y) = 3x^2e^{-y} + (1/2)x^{-1/2}y^3 \sec \sqrt{x} \tan \sqrt{x}$ ,  $f_y(x, y) = -x^3e^{-y} + 3y^2 \sec \sqrt{x}$
21.  $f_x(x, y) = -(4/3)y^2 \sec^2 x (y^2 \tan x)^{-7/3}$ ,  $f_y(x, y) = -(8/3)y \tan x (y^2 \tan x)^{-7/3}$
22.  $f_x(x, y) = 2y^2 \cosh \sqrt{x} \sinh(xy^2) \cosh(xy^2) + \frac{1}{2}x^{-1/2} \sinh \sqrt{x} \sinh^2(xy^2)$   
 $f_y(x, y) = 4xy \cosh \sqrt{x} \sinh(xy^2) \cosh(xy^2)$
23.  $f_x(x, y) = -2x$ ,  $f_x(3, 1) = -6$ ;  $f_y(x, y) = -21y^2$ ,  $f_y(3, 1) = -21$
24.  $\partial f/\partial x = x^2y^2e^{xy} + 2xye^{xy}$ ,  $\partial f/\partial x|_{(1,1)} = 3e$ ;  $\partial f/\partial y = x^3ye^{xy} + x^2e^{xy}$ ,  $\partial f/\partial y|_{(1,1)} = 2e$
25.  $\partial z/\partial x = x(x^2 + 4y^2)^{-1/2}$ ,  $\partial z/\partial x|_{(1,2)} = 1/\sqrt{17}$ ;  $\partial z/\partial y = 4y(x^2 + 4y^2)^{-1/2}$ ,  $\partial z/\partial y|_{(1,2)} = 8/\sqrt{17}$
26.  $\partial w/\partial x = -x^2y \sin xy + 2x \cos xy$ ,  $\frac{\partial w}{\partial x}(1/2, \pi) = -\pi/4$ ;  $\partial w/\partial y = -x^3 \sin x$ ,  $\frac{\partial w}{\partial y}(1/2, \pi) = -1/8$
27.  $f_x = 8x - 8y^4$ ,  $f_y = -32xy^3 + 35y^4$ ,  $f_{xy} = f_{yx} = -32y^3$
28.  $f_x = x/\sqrt{x^2 + y^2}$ ,  $f_y = y/\sqrt{x^2 + y^2}$ ,  $f_{xy} = f_{yx} = -xy(x^2 + y^2)^{-3/2}$
29.  $f_x = e^x \cos y$ ,  $f_y = -e^x \sin y$ ,  $f_{xy} = f_{yx} = -e^x \sin y$
30.  $f_x = e^{x-y^2}$ ,  $f_y = -2ye^{x-y^2}$ ,  $f_{xy} = f_{yx} = -2ye^{x-y^2}$
31.  $f_x = 4/(4x - 5y)$ ,  $f_y = -5/(4x - 5y)$ ,  $f_{xy} = f_{yx} = 20/(4x - 5y)^2$
32.  $f_x = 4xy^2/(x^2 + y^2)^2$ ,  $f_y = -4x^2y/(x^2 + y^2)^2$ ,  $f_{xy} = f_{yx} = 8xy(x^2 - y^2)/(x^2 + y^2)^3$
35. (a)  $2x - 2z(\partial z/\partial x) = 0$ ,  $\partial z/\partial x = x/z = \pm 3/(2\sqrt{6}) = \pm\sqrt{6}/4$ ,  $\partial z/\partial x = \pm\sqrt{6}/4$   
 (b)  $z = \pm\sqrt{x^2 + y^2 - 1}$ ,  $\partial z/\partial x = \pm x/\sqrt{x^2 + y^2 - 1} = \pm\sqrt{6}/4$
36. (a)  $2y - 2z(\partial z/\partial y) = 0$ ,  $\partial z/\partial y = y/z = \pm 4/(2\sqrt{6}) = \pm\sqrt{6}/3$   
 (b)  $z = \pm\sqrt{x^2 + y^2 - 1}$ ,  $\partial z/\partial y = \pm y/\sqrt{x^2 + y^2 - 1} = \pm\sqrt{6}/3$
37.  $\frac{3}{2}(x^2 + y^2 + z^2)^{1/2} \left(2x + 2z \frac{\partial z}{\partial x}\right) = 0$ ,  $\partial z/\partial x = -x/z$ ; similarly,  $\partial z/\partial y = -y/z$
38.  $\frac{4x - 3z^2(\partial z/\partial x)}{2x^2 + y - z^3} = 1$ ,  $\frac{\partial z}{\partial x} = \frac{4x - 2x^2 - y + z^3}{3z^2}$ ;  $\frac{1 - 3z^2(\partial z/\partial y)}{2x^2 + y - z^3} = 1$ ,  $\frac{\partial z}{\partial y} = \frac{1 - 2x^2 - y + z^3}{3z^2}$
39.  $2x + z \left(xy \frac{\partial z}{\partial x} + yz\right) \cos xyz + \frac{\partial z}{\partial x} \sin xyz = 0$ ,  $\frac{\partial z}{\partial x} = -\frac{2x + yz^2 \cos xyz}{xyz \cos xyz + \sin xyz}$ ;  
 $z \left(xy \frac{\partial z}{\partial y} + xz\right) \cos xyz + \frac{\partial z}{\partial y} \sin xyz = 0$ ,  $\frac{\partial z}{\partial y} = -\frac{xz^2 \cos xyz}{xyz \cos xyz + \sin xyz}$
40.  $e^{xy}(\cosh z) \frac{\partial z}{\partial x} + ye^{xy} \sinh z - z^2 - 2xz \frac{\partial z}{\partial x} = 0$ ,  $\frac{\partial z}{\partial x} = \frac{z^2 - ye^{xy} \sinh z}{e^{xy} \cosh z - 2xz}$ ;  
 $e^{xy}(\cosh z) \frac{\partial z}{\partial y} + xe^{xy} \sinh z - 2xz \frac{\partial z}{\partial y} = 0$ ,  $\frac{\partial z}{\partial y} = -\frac{xe^{xy} \sinh z}{e^{xy} \cosh z - 2xz}$

41. III is a plane, and its partial derivatives are constants, so III cannot be  $f(x, y)$ . If I is the graph of  $z = f(x, y)$  then (by inspection)  $f_y$  is constant as  $y$  varies, but neither II nor III is constant as  $y$  varies. Hence  $z = f(x, y)$  has II as its graph, and as II seems to be an odd function of  $x$  and an even function of  $y$ ,  $f_x$  has I as its graph and  $f_y$  has III as its graph.
42. Moving to the right from  $(x_0, y_0)$  decreases  $f(x, y)$ , so  $f_x < 0$ ; moving up increases  $f$ , so  $f_y > 0$ .
43. (a)  $30xy^4 - 4$  (b)  $60x^2y^3$  (c)  $60x^3y^2$
44. (a)  $120(2x - y)^2$  (b)  $-240(2x - y)^2$  (c)  $480(2x - y)$
45. (a)  $f_{xyy}(0, 1) = -30$  (b)  $f_{xxx}(0, 1) = -125$  (c)  $f_{yyxx}(0, 1) = 150$
46. (a)  $\frac{\partial^3 w}{\partial y^2 \partial x} = -e^y \sin x$ ,  $\left. \frac{\partial^3 w}{\partial y^2 \partial x} \right|_{(\pi/4, 0)} = -1/\sqrt{2}$   
 (b)  $\frac{\partial^3 w}{\partial x^2 \partial y} = -e^y \cos x$ ,  $\left. \frac{\partial^3 w}{\partial x^2 \partial y} \right|_{(\pi/4, 0)} = -1/\sqrt{2}$
47. (a)  $\frac{\partial^3 f}{\partial x^3}$  (b)  $\frac{\partial^3 f}{\partial y^2 \partial x}$  (c)  $\frac{\partial^4 f}{\partial x^2 \partial y^2}$  (d)  $\frac{\partial^4 f}{\partial y^3 \partial x}$
48. (a)  $f_{xyy}$  (b)  $f_{xxx}$  (c)  $f_{xyy}$  (d)  $f_{yyyx}$
49. (a)  $2xy^4z^3 + y$  (b)  $4x^2y^3z^3 + x$  (c)  $3x^2y^4z^2 + 2z$   
 (d)  $2y^4z^3 + y$  (e)  $32z^3 + 1$  (f) 438
50. (a)  $2xy \cos z$  (b)  $x^2 \cos z$  (c)  $-x^2y \sin z$   
 (d)  $4y \cos z$  (e)  $4 \cos z$  (f) 0
51.  $f_x = 2z/x$ ,  $f_y = z/y$ ,  $f_z = \ln(x^2y \cos z) - z \tan z$
52.  $f_x = y^{-5/2}z \sec(xz/y) \tan(xz/y)$ ,  $f_y = -xy^{-7/2}z \sec(xz/y) \tan(xz/y) - (3/2)y^{-5/2} \sec(xz/y)$ ,  
 $f_z = xy^{-5/2} \sec(xz/y) \tan(xz/y)$
53.  $f_x = -y^2z^3/(1 + x^2y^4z^6)$ ,  $f_y = -2xyz^3/(1 + x^2y^4z^6)$ ,  $f_z = -3xy^2z^2/(1 + x^2y^4z^6)$
54.  $f_x = 4xyz \cosh \sqrt{z} \sinh(x^2yz) \cosh(x^2yz)$ ,  $f_y = 2x^2z \cosh \sqrt{z} \sinh(x^2yz) \cosh(x^2yz)$ ,  
 $f_z = 2x^2y \cosh \sqrt{z} \sinh(x^2yz) \cosh(x^2yz) + (1/2)z^{-1/2} \sinh \sqrt{z} \sinh^2(x^2yz)$
55.  $\partial w/\partial x = yze^z \cos xz$ ,  $\partial w/\partial y = e^z \sin xz$ ,  $\partial w/\partial z = ye^z(\sin xz + x \cos xz)$
56.  $\partial w/\partial x = 2x/(y^2 + z^2)$ ,  $\partial w/\partial y = -2y(x^2 + z^2)/(y^2 + z^2)^2$ ,  $\partial w/\partial z = 2z(y^2 - x^2)/(y^2 + z^2)^2$
57.  $\partial w/\partial x = x/\sqrt{x^2 + y^2 + z^2}$ ,  $\partial w/\partial y = y/\sqrt{x^2 + y^2 + z^2}$ ,  $\partial w/\partial z = z/\sqrt{x^2 + y^2 + z^2}$
58.  $\partial w/\partial x = 2y^3e^{2x+3z}$ ,  $\partial w/\partial y = 3y^2e^{2x+3z}$ ,  $\partial w/\partial z = 3y^3e^{2x+3z}$
59. (a)  $e$  (b)  $2e$  (c)  $e$



60. (a)  $2/\sqrt{7}$  (b)  $4/\sqrt{7}$  (c)  $1/\sqrt{7}$

62.

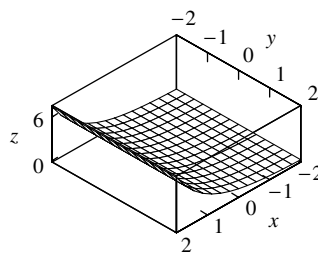
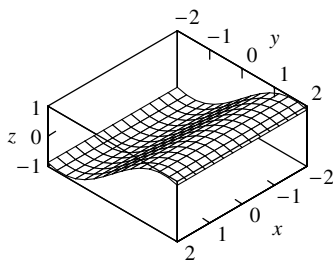

63.  $(3/2)(x^2 + y^2 + z^2 + w^2)^{1/2} \left( 2x + 2w \frac{\partial w}{\partial x} \right) = 0$ ,  $\partial w / \partial x = -x/w$ ; similarly,  $\partial w / \partial y = -y/w$  and  $\partial w / \partial z = -z/w$

64.  $\partial w / \partial x = -4x/3$ ,  $\partial w / \partial y = -1/3$ ,  $\partial w / \partial z = (2x^2 + y - z^3 + 3z^2 + 3w)/3$

65.  $\frac{\partial w}{\partial x} = -\frac{yzw \cos xyz}{2w + \sin xyz}$ ,  $\frac{\partial w}{\partial y} = -\frac{xzw \cos xyz}{2w + \sin xyz}$ ,  $\frac{\partial w}{\partial z} = -\frac{xyw \cos xyz}{2w + \sin xyz}$

66.  $\frac{\partial w}{\partial x} = \frac{ye^{xy} \sinh w}{z^2 - e^{xy} \cosh w}$ ,  $\frac{\partial w}{\partial y} = \frac{xe^{xy} \sinh w}{z^2 - e^{xy} \cosh w}$ ,  $\frac{\partial w}{\partial z} = \frac{2zw}{e^{xy} \cosh w - z^2}$

67. (a)  $f_{xy} = 15x^2y^4z^7 + 2y$  (b)  $f_{yz} = 35x^3y^4z^6 + 3y^2$   
 (c)  $f_{xz} = 21x^2y^5z^6$  (d)  $f_{zz} = 42x^3y^5z^5$   
 (e)  $f_{zyy} = 140x^3y^3z^6 + 6y$  (f)  $f_{xxy} = 30xy^4z^7$   
 (g)  $f_{zyx} = 105x^2y^4z^6$  (h)  $f_{xxyz} = 210xy^4z^6$

68. (a)  $160(4x - 3y + 2z)^3$  (b)  $-1440(4x - 3y + 2z)^2$  (c)  $-5760(4x - 3y + 2z)$

69.  $f_x = e^{x^2}$ ,  $f_y = -e^{y^2}$  70.  $f_x = ye^{x^2y^2}$ ,  $f_y = xe^{x^2y^2}$

71.  $\partial w / \partial x_i = -i \sin(x_1 + 2x_2 + \dots + nx_n)$  72.  $\partial w / \partial x_i = \frac{1}{n} \left( \sum_{k=1}^n x_k \right)^{(1/n)-1}$

73. (a)  $f_x = 2x + 2y$ ,  $f_{xx} = 2$ ,  $f_y = -2y + 2x$ ,  $f_{yy} = -2$ ;  $f_{xx} + f_{yy} = 2 - 2 = 0$

(b)  $z_x = e^x \sin y - e^y \sin x$ ,  $z_{xx} = e^x \sin y - e^y \cos x$ ,  $z_y = e^x \cos y + e^y \cos x$ ,  
 $z_{yy} = -e^x \sin y + e^y \cos x$ ;  $z_{xx} + z_{yy} = e^x \sin y - e^y \cos x - e^x \sin y + e^y \cos x = 0$

(c)  $z_x = \frac{2x}{x^2 + y^2} - 2 \frac{y}{x^2} \frac{1}{1 + (y/x)^2} = \frac{2x - 2y}{x^2 + y^2}$ ,  $z_{xx} = -2 \frac{x^2 - y^2 - 2xy}{(x^2 + y^2)^2}$ ,

$z_y = \frac{2y}{x^2 + y^2} + 2 \frac{1}{x} \frac{1}{1 + (y/x)^2} = \frac{2y + 2x}{x^2 + y^2}$ ,  $z_{yy} = -2 \frac{y^2 - x^2 + 2xy}{(x^2 + y^2)^2}$ ;

$z_{xx} + z_{yy} = -2 \frac{x^2 - y^2 - 2xy}{(x^2 + y^2)^2} - 2 \frac{y^2 - x^2 + 2xy}{(x^2 + y^2)^2} = 0$

74. (a)  $z_t = -e^{-t} \sin(x/c)$ ,  $z_x = (1/c)e^{-t} \cos(x/c)$ ,  $z_{xx} = -(1/c^2)e^{-t} \sin(x/c)$ ;  
 $z_t - c^2 z_{xx} = -e^{-t} \sin(x/c) - c^2(-(1/c^2)e^{-t} \sin(x/c)) = 0$
- (b)  $z_t = -e^{-t} \cos(x/c)$ ,  $z_x = -(1/c)e^{-t} \sin(x/c)$ ,  $z_{xx} = -(1/c^2)e^{-t} \cos(x/c)$ ;  
 $z_t - c^2 z_{xx} = -e^{-t} \cos(x/c) - c^2(-(1/c^2)e^{-t} \cos(x/c)) = 0$
75.  $u_x = \omega \sin c\omega t \cos \omega x$ ,  $u_{xx} = -\omega^2 \sin c\omega t \sin \omega x$ ,  $u_t = c\omega \cos c\omega t \sin \omega x$ ,  $u_{tt} = -c^2\omega^2 \sin c\omega t \sin \omega x$ ;  
 $u_{xx} - \frac{1}{c^2}u_{tt} = -\omega^2 \sin c\omega t \sin \omega x - \frac{1}{c^2}(-c^2)\omega^2 \sin c\omega t \sin \omega x = 0$
76. (a)  $\partial u/\partial x = \partial v/\partial y = 2x$ ,  $\partial u/\partial y = -\partial v/\partial x = -2y$
- (b)  $\partial u/\partial x = \partial v/\partial y = e^x \cos y$ ,  $\partial u/\partial y = -\partial v/\partial x = -e^x \sin y$
- (c)  $\partial u/\partial x = \partial v/\partial y = 2x/(x^2 + y^2)$ ,  $\partial u/\partial y = -\partial v/\partial x = 2y/(x^2 + y^2)$
77.  $\partial u/\partial x = \partial v/\partial y$  and  $\partial u/\partial y = -\partial v/\partial x$  so  $\partial^2 u/\partial x^2 = \partial^2 v/\partial x\partial y$ , and  $\partial^2 u/\partial y^2 = -\partial^2 v/\partial y\partial x$ ,  
 $\partial^2 u/\partial x^2 + \partial^2 u/\partial y^2 = \partial^2 v/\partial x\partial y - \partial^2 v/\partial y\partial x$ , if  $\partial^2 v/\partial x\partial y = \partial^2 v/\partial y\partial x$  then  
 $\partial^2 u/\partial x^2 + \partial^2 u/\partial y^2 = 0$ ; thus  $u$  satisfies Laplace's equation. The proof that  $v$  satisfies Laplace's  
equation is similar. Adding Laplace's equations for  $u$  and  $v$  gives Laplace's equation for  $u + v$ .
78.  $\partial z/\partial y = 6y$ ,  $\partial z/\partial y|_{(2,1)} = 6$
79.  $\partial z/\partial x = -x(29 - x^2 - y^2)^{-1/2}$ ,  $\partial z/\partial x|_{(4,3)} = -2$
80. (a)  $\partial z/\partial y = 8y$ ,  $\partial z/\partial y|_{(-1,1)} = 8$
- (b)  $\partial z/\partial x = 2x$ ,  $\partial z/\partial x|_{(-1,1)} = -2$
81. (a)  $\partial V/\partial r = 2\pi r h$
- (b)  $\partial V/\partial h = \pi r^2$
- (c)  $\partial V/\partial r|_{r=6, h=4} = 48\pi$
- (d)  $\partial V/\partial h|_{r=8, h=10} = 64\pi$
82. (a)  $\partial V/\partial s = \frac{\pi s d^2}{6\sqrt{4s^2 - d^2}}$
- (b)  $\partial V/\partial d = \frac{\pi d(8s^2 - 3d^2)}{24\sqrt{4s^2 - d^2}}$
- (c)  $\partial V/\partial s|_{s=10, d=16} = 320\pi/9$
- (d)  $\partial V/\partial d|_{s=10, d=16} = 16\pi/9$
83. (a)  $P = 10T/V$ ,  $\partial P/\partial T = 10/V$ ,  $\partial P/\partial T|_{T=80, V=50} = 1/5$  lb/(in<sup>2</sup>K)
- (b)  $V = 10T/P$ ,  $\partial V/\partial P = -10T/P^2$ , if  $V = 50$  and  $T = 80$  then  
 $P = 10(80)/(50) = 16$ ,  $\partial V/\partial P|_{T=80, P=16} = -25/8$ (in<sup>5</sup>/lb<sup>3</sup>)
84. (a)  $\partial z/\partial y = x^2$ ,  $\partial z/\partial y|_{(1,3)} = 1$ ,  $\mathbf{j} + \mathbf{k}$  is parallel to the tangent line so  $x = 1$ ,  $y = 3 + t$ ,  
 $z = 3 + t$
- (b)  $\partial z/\partial x = 2xy$ ,  $\partial z/\partial x|_{(1,3)} = 6$ ,  $6\mathbf{i} + 6\mathbf{k}$  is parallel to the tangent line so  $x = 1 + t$ ,  $y = 3$ ,  
 $z = 3 + 6t$
85.  $\left(1 + \frac{\partial z}{\partial x}\right) \cos(x+z) + \cos(x-y) = 0$ ,  $\frac{\partial z}{\partial x} = -1 - \frac{\cos(x-y)}{\cos(x+z)}$ ;  $\frac{\partial z}{\partial y} \cos(x+z) - \cos(x-y) = 0$ ,  
 $\frac{\partial z}{\partial y} = \frac{\cos(x-y)}{\cos(x+z)}$ ;  $\frac{\partial^2 z}{\partial x\partial y} = \frac{-\cos(x+z) \sin(x-y) + \cos(x-y) \sin(x+z)(1 + \partial z/\partial x)}{\cos^2(x+z)}$ ,  
substitute for  $\partial z/\partial x$  and simplify to get  $\frac{\partial^2 z}{\partial x\partial y} = -\frac{\cos^2(x+z) \sin(x-y) + \cos^2(x-y) \sin(x+z)}{\cos^3(x+z)}$ .

$$86. \quad \partial V/\partial r = \frac{2}{3}\pi r h = \frac{2}{r}\left(\frac{1}{3}\pi r^2 h\right) = 2V/r$$

$$87. \quad (\mathbf{a}) \quad \partial T/\partial x = 3x^2 + 1, \quad \partial T/\partial x|_{(1,2)} = 4 \qquad (\mathbf{b}) \quad \partial T/\partial y = 4y, \quad \partial T/\partial y|_{(1,2)} = 8$$

$$88. \quad \partial^2 R/\partial R_1^2 = -2R_2^2/(R_1 + R_2)^3, \quad \partial^2 R/\partial R_2^2 = -2R_1^2/(R_1 + R_2)^3, \\ (\partial^2 R/\partial R_1^2) (\partial^2 R/\partial R_2^2) = 4R_1^2 R_2^2 / (R_1 + R_2)^6 = \left[4/(R_1 + R_2)^4\right] [R_1 R_2 / (R_1 + R_2)]^2 \\ = 4R^2 / (R_1 + R_2)^4$$

$$89. \quad \frac{f(x + \Delta x, y) - f(x, y)}{\Delta x} = \frac{2(x + \Delta x)^2 - 3(x + \Delta x)y + y^2 - (2x^2 - 3xy + y^2)}{\Delta x} = 4x + 2\Delta x - 3y,$$

$$f_x = \lim_{\Delta x \rightarrow 0} \frac{f(x + \Delta x, y) - f(x, y)}{\Delta x} = \lim_{\Delta x \rightarrow 0} (4x + 2\Delta x - 3y) = 4x - 3y; \quad f_x(2, -1) = 11$$

$$\frac{f(x, y + \Delta y) - f(x, y)}{\Delta y} = \frac{2x^2 - 3x(y + \Delta y) + (y + \Delta y)^2 - (2x^2 - 3xy + y^2)}{\Delta y} = -3x + 2y + \Delta y,$$

$$f_y = \lim_{\Delta y \rightarrow 0} \frac{f(x, y + \Delta y) - f(x, y)}{\Delta y} = -3x + 2y; \quad f_y(2, -1) = -8$$

$$90. \quad f_x(x, y) = \frac{2}{3}(x^2 + y^2)^{-1/3}(2x) = \frac{4x}{3(x^2 + y^2)^{1/3}}, \quad (x, y) \neq (0, 0);$$

$$f_x(0, 0) = \left. \frac{d}{dx}[f(x, 0)] \right|_{x=0} = \left. \frac{d}{dx}[x^{4/3}] \right|_{x=0} = \left. \frac{4}{3}x^{1/3} \right|_{x=0} = 0.$$

$$91. \quad (\mathbf{a}) \quad f_y(0, 0) = \left. \frac{d}{dy}[f(0, y)] \right|_{y=0} = \left. \frac{d}{dy}[y] \right|_{y=0} = 1$$

$$(\mathbf{b}) \quad \text{If } (x, y) \neq (0, 0), \text{ then } f_y(x, y) = \frac{1}{3}(x^3 + y^3)^{-2/3}(3y^2) = \frac{y^2}{(x^3 + y^3)^{2/3}}; \\ f_y(x, y) \text{ does not exist where } y = -x, x \neq 0.$$

### EXERCISE SET 15.4

$$1. \quad 42t^{13}$$

$$2. \quad \frac{2(3 + t^{-1/3})}{3(2t + t^{2/3})}$$

$$3. \quad 3t^{-2} \sin(1/t)$$

$$4. \quad \frac{1 - 2t^4 - 8t^4 \ln t}{2t\sqrt{1 + \ln t} - 2t^4 \ln t}$$

$$5. \quad -\frac{10}{3}t^{7/3}e^{1-t^{10/3}}$$

$$6. \quad (1 + t)e^t \cosh(te^t/2) \sinh(te^t/2)$$

$$7. \quad \partial z/\partial u = 24u^2v^2 - 16uv^3 - 2v + 3, \quad \partial z/\partial v = 16u^3v - 24u^2v^2 - 2u - 3$$

$$8. \quad \partial z/\partial u = 2u/v^2 - u^2v \sec^2(u/v) - 2uv^2 \tan(u/v) \\ \partial z/\partial v = -2u^2/v^3 + u^3 \sec^2(u/v) - 2u^2v \tan(u/v)$$

$$9. \quad \partial z/\partial u = -\frac{2 \sin u}{3 \sin v}, \quad \partial z/\partial v = -\frac{2 \cos u \cos v}{3 \sin^2 v}$$

$$10. \quad \partial z/\partial u = 3 + 3v/u - 4u, \quad \partial z/\partial v = 2 + 3 \ln u + 2 \ln v$$

11.  $\partial z/\partial u = e^u$ ,  $\partial z/\partial v = 0$

12.  $\partial z/\partial u = -\sin(u-v)\sin(u^2+v^2) + 2u\cos(u-v)\cos(u^2+v^2)$   
 $\partial z/\partial v = \sin(u-v)\sin(u^2+v^2) + 2v\cos(u-v)\cos(u^2+v^2)$

13.  $\partial T/\partial r = 3r^2\sin\theta\cos^2\theta - 4r^3\sin^3\theta\cos\theta$   
 $\partial T/\partial\theta = -2r^3\sin^2\theta\cos\theta + r^4\sin^4\theta + r^3\cos^3\theta - 3r^4\sin^2\theta\cos^2\theta$

14.  $dR/d\phi = 5e^{5\phi}$

15.  $\partial t/\partial x = (x^2 + y^2)/(4x^2y^3)$ ,  $\partial t/\partial y = (y^2 - 3x^2)/(4xy^4)$

16.  $\partial w/\partial u = \frac{2v^2[u^2v^2 - (u-2v)^2]}{[u^2v^2 + (u-2v)^2]^2}$ ,  $\partial w/\partial v = \frac{u^2[(u-2v)^2 - u^2v^2]}{[u^2v^2 + (u-2v)^2]^2}$

17.  $-\pi$

18.  $351/2, -168$

19.  $\sqrt{3}e^{\sqrt{3}}, (2-4\sqrt{3})e^{\sqrt{3}}$

20. 1161

21.  $F(x, y) = x^2y^3 + \cos y$ ,  $\frac{dy}{dx} = -\frac{2xy^3}{3x^2y^2 - \sin y}$

22.  $F(x, y) = x^3 - 3xy^2 + y^3 - 5$ ,  $\frac{dy}{dx} = -\frac{3x^2 - 3y^2}{-6xy + 3y^2} = \frac{x^2 - y^2}{2xy - y^2}$

23.  $F(x, y) = e^{xy} + ye^y - 1$ ,  $\frac{dy}{dx} = -\frac{ye^{xy}}{xe^{xy} + ye^y + e^y}$

24.  $F(x, y) = x - (xy)^{1/2} + 3y - 4$ ,  $\frac{dy}{dx} = -\frac{1 - (1/2)(xy)^{-1/2}y}{-(1/2)(xy)^{-1/2}x + 3} = \frac{2\sqrt{xy} - y}{x - 6\sqrt{xy}}$

25.  $D = (x^2 + y^2)^{1/2}$  where  $x$  and  $y$  are the distances of cars A and B, respectively, from the intersection and  $D$  is the distance between them.

$$dD/dt = \left[ x/(x^2 + y^2)^{1/2} \right] (dx/dt) + \left[ y/(x^2 + y^2)^{1/2} \right] (dy/dt), \quad dx/dt = -25 \text{ and } dy/dt = -30$$

when  $x = 0.3$  and  $y = 0.4$  so  $dD/dt = (0.3/0.5)(-25) + (0.4/0.5)(-30) = -39$  mph.

26.  $T = (1/10)PV$ ,  $dT/dt = (V/10)(dP/dt) + (P/10)(dV/dt)$ ,  $dV/dt = 4$  and  $dP/dt = -1$  when  $V = 200$  and  $P = 5$  so  $dT/dt = (20)(-1) + (1/2)(4) = -18$  K/s.

27.  $A = \frac{1}{2}ab\sin\theta$  but  $\theta = \pi/6$  when  $a = 4$  and  $b = 3$  so  $A = \frac{1}{2}(4)(3)\sin(\pi/6) = 3$ .

Solve  $\frac{1}{2}ab\sin\theta = 3$  for  $\theta$  to get  $\theta = \sin^{-1}\left(\frac{6}{ab}\right)$ ,  $0 \leq \theta \leq \pi/2$ .

$$\begin{aligned} \frac{d\theta}{dt} &= \frac{\partial\theta}{\partial a} \frac{da}{dt} + \frac{\partial\theta}{\partial b} \frac{db}{dt} = \frac{1}{\sqrt{1 - \frac{36}{a^2b^2}}} \left( -\frac{6}{a^2b} \right) \frac{da}{dt} + \frac{1}{\sqrt{1 - \frac{36}{a^2b^2}}} \left( -\frac{6}{ab^2} \right) \frac{db}{dt} \\ &= -\frac{6}{\sqrt{a^2b^2 - 36}} \left( \frac{1}{a} \frac{da}{dt} + \frac{1}{b} \frac{db}{dt} \right), \quad \frac{da}{dt} = 1 \text{ and } \frac{db}{dt} = 1 \end{aligned}$$

when  $a = 4$  and  $b = 3$  so  $\frac{d\theta}{dt} = -\frac{6}{\sqrt{144 - 36}} \left( \frac{1}{4} + \frac{1}{3} \right) = -\frac{7}{12\sqrt{3}} = -\frac{7}{36}\sqrt{3}$  radians/s

28. From the law of cosines,  $c = \sqrt{a^2 + b^2 - 2ab \cos \theta}$  where  $c$  is the length of the third side.

$$\theta = \pi/3 \text{ so } c = \sqrt{a^2 + b^2 - ab},$$

$$\begin{aligned} \frac{dc}{dt} &= \frac{\partial c}{\partial a} \frac{da}{dt} + \frac{\partial c}{\partial b} \frac{db}{dt} = \frac{1}{2}(a^2 + b^2 - ab)^{-1/2}(2a - b) \frac{da}{dt} + \frac{1}{2}(a^2 + b^2 - ab)^{-1/2}(2b - a) \frac{db}{dt} \\ &= \frac{1}{2\sqrt{a^2 + b^2 - ab}} \left[ (2a - b) \frac{da}{dt} + (2b - a) \frac{db}{dt} \right], \frac{da}{dt} = 2 \text{ and } \frac{db}{dt} = 1 \text{ when } a = 5 \text{ and } b = 10 \end{aligned}$$

$$\text{so } \frac{dc}{dt} = \frac{1}{2\sqrt{75}} [(0)(2) + (15)(1)] = \sqrt{3}/2 \text{ cm/s. The third side is increasing.}$$

29.  $V = (\pi/4)D^2h$  where  $D$  is the diameter and  $h$  is the height, both measured in inches,  
 $dV/dt = (\pi/2)Dh(dD/dt) + (\pi/4)D^2(dh/dt)$ ,  $dD/dt = 3$  and  $dh/dt = 24$  when  $D = 30$  and  $h = 240$ , so  $dV/dt = (\pi/2)(30)(240)(3) + (\pi/4)(30)^2(24) = 16,200\pi \text{ in}^3/\text{year}$ .

30.  $\frac{dT}{dt} = \frac{\partial T}{\partial x} \frac{dx}{dt} + \frac{\partial T}{\partial y} \frac{dy}{dt} = \frac{y^2}{x} \frac{dx}{dt} + 2y \ln x \frac{dy}{dt}$ ,  $dx/dt = 1$  and  $dy/dt = -4$  at  $(3,2)$  so

$$dT/dt = (4/3)(1) + (4 \ln 3)(-4) = 4/3 - 16 \ln 3^\circ \text{ C/s.}$$

31. (a)  $xy$ -plane,  $f_x = 12x^2y + 6xy$ ,  $f_y = 4x^3 + 3x^2$ ,  $f_{xy} = f_{yx} = 12x^2 + 6x$

(b)  $y \neq 0$ ,  $f_x = 3x^2/y$ ,  $f_y = -x^3/y^2$ ,  $f_{xy} = f_{yx} = -3x^2/y^2$

32. (a)  $x^2 + y^2 > 1$ , (the exterior of the circle of radius 1 about the origin);

$$f_x = x/\sqrt{x^2 + y^2 - 1}, f_y = y/\sqrt{x^2 + y^2 - 1}, f_{xy} = f_{yx} = -xy(x^2 + y^2 - 1)^{-3/2}$$

(b)  $xy$ -plane,  $f_x = 2x \cos(x^2 + y^3)$ ,  $f_y = 3y^2 \cos(x^2 + y^3)$ ,  $f_{xy} = f_{yx} = -6xy^2 \sin(x^2 + y^3)$

33. (a) 4:  $f_{xxx}, f_{xxy} = f_{xyx}, f_{xyx}, f_{xyy} = f_{yxy} = f_{yyx}, f_{yyy}$

(b) 5:  $f_{xxxx}, f_{xxxxy} = f_{xxxyx} = f_{xyxxx} = f_{yxxxx},$   
 $f_{xxyyy} = f_{xyyyx} = f_{xyyyx} = f_{yxyyx} = f_{yyyx} = f_{yyxy},$   
 $f_{xyyyy} = f_{yxyyy} = f_{yyxyy} = f_{yyyyx}, f_{yyyyy}$

34. (a) Since  $e^w$  has infinitely many continuous derivatives, as does  $xy^2$ , by the Chain Rule the function  $e^{xy^2}$  has infinitely many continuous derivatives, hence by Theorem 15.4.6,

$$f_{xyx} = f_{xxy}; \text{ since } f_{xy} = f_{yx} \text{ it follows that } f_{xyx} = f_{yxx}.$$

(b)  $f_{xyx} = f_{xxy} = f_{yxx} = 2xy^5e^{xy^2} + 4y^3e^{xy^2}$

35. (a)  $f(tx, ty) = 3t^2x^2 + t^2y^2 = t^2f(x, y)$ ;  $n = 2$

(b)  $f(tx, ty) = \sqrt{t^2x^2 + t^2y^2} = tf(x, y)$ ;  $n = 1$

(c)  $f(tx, ty) = t^3x^2y - 2t^3y^3 = t^3f(x, y)$ ;  $n = 3$

(d)  $f(tx, ty) = 5/(t^2x^2 + 2t^2y^2)^2 = t^{-4}f(x, y)$ ;  $n = -4$

36. (a) If  $f(u, v) = t^n f(x, y)$ , then  $\frac{\partial f}{\partial u} \frac{du}{dt} + \frac{\partial f}{\partial v} \frac{dv}{dt} = nt^{n-1}f(x, y)$ ,  $x \frac{\partial f}{\partial u} + y \frac{\partial f}{\partial v} = nt^{n-1}f(x, y)$ ;

$$\text{let } t = 1 \text{ to get } x \frac{\partial f}{\partial x} + y \frac{\partial f}{\partial y} = nf(x, y).$$

- (b) If  $f(x, y) = 3x^2 + y^2$  then  $xf_x + yf_y = 6x^2 + 2y^2 = 2f(x, y)$ ;  
 If  $f(x, y) = \sqrt{x^2 + y^2}$  then  $xf_x + yf_y = x^2/\sqrt{x^2 + y^2} + y^2/\sqrt{x^2 + y^2} = \sqrt{x^2 + y^2} = f(x, y)$ ;  
 If  $f(x, y) = x^2y - 2y^3$  then  $xf_x + yf_y = 3x^2y - 6y^3 = 3f(x, y)$ ;  
 If  $f(x, y) = \frac{5}{(x^2 + 2y^2)^2}$  then  $xf_x + yf_y = x \frac{5(-2)2x}{(x^2 + 2y^2)^3} + y \frac{5(-2)4y}{(x^2 + 2y^2)^3} = -4f(x, y)$

37. (a)  $\frac{\partial z}{\partial x} = \frac{dz}{du} \frac{\partial u}{\partial x}, \frac{\partial z}{\partial y} = \frac{dz}{du} \frac{\partial u}{\partial y}$

(b)  $\frac{\partial^2 z}{\partial x^2} = \frac{dz}{du} \frac{\partial^2 u}{\partial x^2} + \frac{\partial}{\partial x} \left( \frac{dz}{du} \right) \frac{\partial u}{\partial x} = \frac{dz}{du} \frac{\partial^2 u}{\partial x^2} + \frac{d^2 z}{du^2} \left( \frac{\partial u}{\partial x} \right)^2$ ;

$$\frac{\partial^2 z}{\partial y \partial x} = \frac{dz}{du} \frac{\partial^2 u}{\partial y \partial x} + \frac{\partial}{\partial y} \left( \frac{dz}{du} \right) \frac{\partial u}{\partial x} = \frac{dz}{du} \frac{\partial^2 u}{\partial y \partial x} + \frac{d^2 z}{du^2} \frac{\partial u}{\partial x} \frac{\partial u}{\partial y}$$

$$\frac{\partial^2 z}{\partial y^2} = \frac{dz}{du} \frac{\partial^2 u}{\partial y^2} + \frac{\partial}{\partial y} \left( \frac{dz}{du} \right) \frac{\partial u}{\partial y} = \frac{dz}{du} \frac{\partial^2 u}{\partial y^2} + \frac{d^2 z}{du^2} \left( \frac{\partial u}{\partial y} \right)^2$$

38. (a)  $z = f(u), u = x^2 - y^2; \partial z/\partial x = (dz/du)(\partial u/\partial x) = 2xdz/du$

$$\partial z/\partial y = (dz/du)(\partial u/\partial y) = -2ydz/du, y\partial z/\partial x + x\partial z/\partial y = 2xydz/du - 2xydz/du = 0$$

(b)  $z = f(u), u = xy; \frac{\partial z}{\partial x} = \frac{dz}{du} \frac{\partial u}{\partial x} = y \frac{dz}{du}, \frac{\partial z}{\partial y} = \frac{dz}{du} \frac{\partial u}{\partial y} = x \frac{dz}{du}$ ,

$$x \frac{\partial z}{\partial x} - y \frac{\partial z}{\partial y} = xy \frac{dz}{du} - xy \frac{dz}{du} = 0.$$

(c)  $yz_x + xz_y = y(2x \cos(x^2 - y^2)) - x(2y \cos(x^2 - y^2)) = 0$

(d)  $xz_x - yz_y = xye^{xy} - yxe^{xy} = 0$

39. (a)  $1 = -r \sin \theta \frac{\partial \theta}{\partial x} + \cos \theta \frac{\partial r}{\partial x}$  and  $0 = r \cos \theta \frac{\partial \theta}{\partial x} + \sin \theta \frac{\partial r}{\partial x}$ ; solve for  $\partial r/\partial x$  and  $\partial \theta/\partial x$ .

(b)  $0 = -r \sin \theta \frac{\partial \theta}{\partial y} + \cos \theta \frac{\partial r}{\partial y}$  and  $1 = r \cos \theta \frac{\partial \theta}{\partial y} + \sin \theta \frac{\partial r}{\partial y}$ ; solve for  $\partial r/\partial y$  and  $\partial \theta/\partial y$ .

(c)  $\frac{\partial z}{\partial x} = \frac{\partial z}{\partial r} \frac{\partial r}{\partial x} + \frac{\partial z}{\partial \theta} \frac{\partial \theta}{\partial x} = \frac{\partial z}{\partial r} \cos \theta - \frac{1}{r} \frac{\partial z}{\partial \theta} \sin \theta$ .

$$\frac{\partial z}{\partial y} = \frac{\partial z}{\partial r} \frac{\partial r}{\partial y} + \frac{\partial z}{\partial \theta} \frac{\partial \theta}{\partial y} = \frac{\partial z}{\partial r} \sin \theta + \frac{1}{r} \frac{\partial z}{\partial \theta} \cos \theta.$$

(d) Square and add the results of parts (a) and (b).

(e) From Part (c),

$$\begin{aligned} \frac{\partial^2 z}{\partial x^2} &= \frac{\partial}{\partial r} \left( \frac{\partial z}{\partial r} \cos \theta - \frac{1}{r} \frac{\partial z}{\partial \theta} \sin \theta \right) \frac{\partial r}{\partial x} + \frac{\partial}{\partial \theta} \left( \frac{\partial z}{\partial r} \cos \theta - \frac{1}{r} \frac{\partial z}{\partial \theta} \sin \theta \right) \frac{\partial \theta}{\partial x} \\ &= \left( \frac{\partial^2 z}{\partial r^2} \cos \theta + \frac{1}{r^2} \frac{\partial z}{\partial \theta} \sin \theta - \frac{1}{r} \frac{\partial^2 z}{\partial r \partial \theta} \sin \theta \right) \cos \theta \\ &\quad + \left( \frac{\partial^2 z}{\partial \theta \partial r} \cos \theta - \frac{\partial z}{\partial r} \sin \theta - \frac{1}{r} \frac{\partial^2 z}{\partial \theta^2} \sin \theta - \frac{1}{r} \frac{\partial z}{\partial \theta} \cos \theta \right) \left( -\frac{\sin \theta}{r} \right) \\ &= \frac{\partial^2 z}{\partial r^2} \cos^2 \theta + \frac{2}{r^2} \frac{\partial z}{\partial \theta} \sin \theta \cos \theta - \frac{2}{r} \frac{\partial^2 z}{\partial \theta \partial r} \sin \theta \cos \theta + \frac{1}{r^2} \frac{\partial^2 z}{\partial \theta^2} \sin^2 \theta + \frac{1}{r} \frac{\partial z}{\partial r} \sin^2 \theta. \end{aligned}$$

Similarly, from Part (c),

$$\frac{\partial^2 z}{\partial y^2} = \frac{\partial^2 z}{\partial r^2} \sin^2 \theta - \frac{2}{r^2} \frac{\partial z}{\partial \theta} \sin \theta \cos \theta + \frac{2}{r} \frac{\partial^2 z}{\partial \theta \partial r} \sin \theta \cos \theta + \frac{1}{r^2} \frac{\partial^2 z}{\partial \theta^2} \cos^2 \theta + \frac{1}{r} \frac{\partial z}{\partial r} \cos^2 \theta.$$

$$\text{Add to get } \frac{\partial^2 z}{\partial x^2} + \frac{\partial^2 z}{\partial y^2} = \frac{\partial^2 z}{\partial r^2} + \frac{1}{r^2} \frac{\partial^2 z}{\partial \theta^2} + \frac{1}{r} \frac{\partial z}{\partial r}.$$

$$40. \quad z_x = \frac{-2y}{x^2 + y^2}, z_{xx} = \frac{4xy}{(x^2 + y^2)^2}, z_y = \frac{2x}{x^2 + y^2}, z_{yy} = -\frac{4xy}{(x^2 + y^2)^2}, z_{xx} + z_{yy} = 0;$$

$$z = \tan^{-1} \frac{2r^2 \cos \theta \sin \theta}{r^2(\cos^2 \theta - \sin^2 \theta)} = \tan^{-1} \tan 2\theta = 2\theta, z_r = 0, z_{\theta\theta} = 0$$

$$41. \quad (\text{a}) \quad \text{By the chain rule, } \frac{\partial u}{\partial r} = \frac{\partial u}{\partial x} \cos \theta + \frac{\partial u}{\partial y} \sin \theta \text{ and } \frac{\partial v}{\partial \theta} = -\frac{\partial v}{\partial x} r \sin \theta + \frac{\partial v}{\partial y} r \cos \theta, \text{ use the}$$

Cauchy-Riemann conditions  $\frac{\partial u}{\partial x} = \frac{\partial v}{\partial y}$  and  $\frac{\partial u}{\partial y} = -\frac{\partial v}{\partial x}$  in the equation for  $\frac{\partial u}{\partial r}$  to get

$$\frac{\partial u}{\partial r} = \frac{\partial v}{\partial y} \cos \theta - \frac{\partial v}{\partial x} \sin \theta \text{ and compare to } \frac{\partial v}{\partial \theta} \text{ to see that } \frac{\partial u}{\partial r} = \frac{1}{r} \frac{\partial v}{\partial \theta}. \text{ The result } \frac{\partial v}{\partial r} = -\frac{1}{r} \frac{\partial u}{\partial \theta}$$

can be obtained by considering  $\frac{\partial v}{\partial r}$  and  $\frac{\partial u}{\partial \theta}$ .

$$(b) \quad u_x = \frac{2x}{x^2 + y^2}, v_y = 2 \frac{1}{x} \frac{1}{1 + (y/x)^2} = \frac{2x}{x^2 + y^2} = u_x;$$

$$u_y = \frac{2y}{x^2 + y^2}, v_x = -2 \frac{y}{x^2} \frac{1}{1 + (y/x)^2} = -\frac{2y}{x^2 + y^2} = -u_y;$$

$$u = \ln r^2, v = 2\theta, u_r = 2/r, v_\theta = 2, \text{ so } u_r = \frac{1}{r} v_\theta, u_\theta = 0, v_r = 0, \text{ so } v_r = -\frac{1}{r} u_\theta$$

$$42. \quad z = f(u, v) \text{ where } u = x - y \text{ and } v = y - x,$$

$$\frac{\partial z}{\partial x} = \frac{\partial z}{\partial u} \frac{\partial u}{\partial x} + \frac{\partial z}{\partial v} \frac{\partial v}{\partial x} = \frac{\partial z}{\partial u} - \frac{\partial z}{\partial v} \text{ and } \frac{\partial z}{\partial y} = \frac{\partial z}{\partial u} \frac{\partial u}{\partial y} + \frac{\partial z}{\partial v} \frac{\partial v}{\partial y} = -\frac{\partial z}{\partial u} + \frac{\partial z}{\partial v} \text{ so } \frac{\partial z}{\partial x} + \frac{\partial z}{\partial y} = 0$$

$$43. \quad (\text{a}) \quad u_x = f'(x + ct), u_{xx} = f''(x + ct), u_t = cf'(x + ct), u_{tt} = c^2 f''(x + ct); u_{tt} = c^2 u_{xx}$$

(b) Substitute  $g$  for  $f$  and  $-c$  for  $c$  in Part (a).

(c) Since the sum of derivatives equals the derivative of the sum, the result follows from Parts (a) and (b).

$$(d) \quad \sin t \sin x = \frac{1}{2}(-\cos(x + t) + \cos(x - t))$$

$$44. \quad f_x(x_0, y_0) = y_0, f_y(x_0, y_0) = x_0,$$

$$\begin{aligned} \Delta f &= (x_0 + \Delta x)(y_0 + \Delta y) - x_0 y_0 = y_0 \Delta x + x_0 \Delta y + \Delta x \Delta y \\ &= f_x(x_0, y_0) \Delta x + f_y(x_0, y_0) \Delta y + (0) \Delta x + (\Delta x) \Delta y \text{ where } \epsilon_1 = 0 \text{ and } \epsilon_2 = \Delta x. \end{aligned}$$

$$45. \quad f_x(x_0, y_0) = 2x_0, f_y(x_0, y_0) = 2y_0,$$

$$\begin{aligned} \Delta f &= (x_0 + \Delta x)^2 + (y_0 + \Delta y)^2 - (x_0^2 + y_0^2) = 2x_0 \Delta x + (\Delta x)^2 + 2y_0 \Delta y + (\Delta y)^2 \\ &= f_x(x_0, y_0) \Delta x + f_y(x_0, y_0) \Delta y + (\Delta x) \Delta x + (\Delta y) \Delta y \text{ where } \epsilon_1 = \Delta x \text{ and } \epsilon_2 = \Delta y. \end{aligned}$$

46.  $f_x(x_0, y_0) = 2x_0y_0$ ,  $f_y(x_0, y_0) = x_0^2$ ,  
 $\Delta f = (x_0 + \Delta x)^2(y_0 + \Delta y) - x_0^2y_0 = 2x_0y_0\Delta x + x_0^2\Delta y + y_0(\Delta x)^2 + (\Delta x)^2\Delta y + 2x_0\Delta x\Delta y$   
 $= f_x(x_0, y_0)\Delta x + f_y(x_0, y_0)\Delta y + (y_0\Delta x + \Delta x\Delta y)\Delta x + (2x_0\Delta x)\Delta y$   
 where  $\epsilon_1 = y_0\Delta x + \Delta x\Delta y$  and  $\epsilon_2 = 2x_0\Delta x$ .
47.  $f_x(x_0, y_0) = 3$ ,  $f_y(x_0, y_0) = 2y_0$ ,  
 $\Delta f = 3(x_0 + \Delta x) + (y_0 + \Delta y)^2 - (3x_0 + y_0^2) = 3\Delta x + 2y_0\Delta y + (\Delta y)^2$   
 $= f_x(x_0, y_0)\Delta x + f_y(x_0, y_0)\Delta y + (0)\Delta x + (\Delta y)\Delta y$  where  $\epsilon_1 = 0$  and  $\epsilon_2 = \Delta y$ .
48. (a)  $\lim_{(x,y) \rightarrow (0,0)} f(x, y) = 0 = f(0, 0)$   
 (b)  $\lim_{\Delta x \rightarrow 0} \frac{f(0 + \Delta x, 0) - f(0, 0)}{\Delta x} = \lim_{\Delta x \rightarrow 0} \frac{f(\Delta x, 0)}{\Delta x} = \lim_{\Delta x \rightarrow 0} \frac{|\Delta x|}{\Delta x}$ , which does not exist because  
 $\lim_{\Delta x \rightarrow 0^+} |\Delta x|/\Delta x = 1$  and  $\lim_{\Delta x \rightarrow 0^-} |\Delta x|/\Delta x = -1$ .
49.  $f_x(0, 0) = \lim_{\Delta x \rightarrow 0} \frac{f(\Delta x, 0) - f(0, 0)}{\Delta x} = \lim_{\Delta x \rightarrow 0} \frac{-3\Delta x}{\Delta x} = -3$ ,  
 $f_y(0, 0) = \lim_{\Delta y \rightarrow 0} \frac{f(0, \Delta y) - f(0, 0)}{\Delta y} = \lim_{\Delta y \rightarrow 0} \frac{-2\Delta y}{\Delta y} = -2$ ;  
 $\lim_{(x,y) \rightarrow (0,0)} f(x, y)$  does not exist because  $f(x, y) \rightarrow 5$  if  $(x, y) \rightarrow (0, 0)$  where  $x \geq 0$  or  $y \geq 0$ , but  
 $f(x, y) \rightarrow 0$  if  $(x, y) \rightarrow (0, 0)$  where  $x < 0$  and  $y < 0$ , so  $f$  is not continuous at  $(0, 0)$ .
50.  $f_x(0, 0) = \lim_{\Delta x \rightarrow 0} \frac{f(\Delta x, 0) - f(0, 0)}{\Delta x} = \lim_{\Delta x \rightarrow 0} \frac{0 - 0}{\Delta x} = \lim_{\Delta x \rightarrow 0} 0 = 0$   
 $f_y(0, 0) = \lim_{\Delta y \rightarrow 0} \frac{f(0, \Delta y) - f(0, 0)}{\Delta y} = \lim_{\Delta y \rightarrow 0} \frac{0 - 0}{\Delta y} = 0$ ; along  $y = 0$ ,  $\lim_{x \rightarrow 0} \frac{0}{x^2} = \lim_{x \rightarrow 0} 0 = 0$ ,  
 along  $y = x$ ,  $\lim_{x \rightarrow 0} \frac{x^2}{2x^2} = \lim_{x \rightarrow 0} 1/2 = 1/2$  so  $\lim_{(x,y) \rightarrow (0,0)} f(x, y)$  does not exist.
51. (a)  $f_x(0, 0) = \lim_{\Delta x \rightarrow 0} \frac{f(\Delta x, 0) - f(0, 0)}{\Delta x} = 0$ ; similarly,  $f_y(0, 0) = 0$   
 (b)  $f_x(0, y) = \lim_{\Delta x \rightarrow 0} \frac{f(\Delta x, y) - f(0, y)}{\Delta x} = \lim_{\Delta x \rightarrow 0} \frac{y(\Delta x^2 - y^2)}{\Delta x^2 + y^2} = -y$   
 $f_y(x, 0) = \lim_{\Delta y \rightarrow 0} \frac{f(x, \Delta y) - f(x, 0)}{\Delta y} = \lim_{\Delta y \rightarrow 0} \frac{x(x^2 - \Delta y^2)}{x^2 + \Delta y^2} = x$   
 (c)  $f_{xy}(0, 0) = \lim_{\Delta y \rightarrow 0} \frac{f_x(0, \Delta y) - f_x(0, 0)}{\Delta y} = \lim_{\Delta y \rightarrow 0} \frac{-\Delta y}{\Delta y} = -1$   
 $f_{yx}(0, 0) = \lim_{\Delta x \rightarrow 0} \frac{f_y(\Delta x, 0) - f_y(0, 0)}{\Delta x} = \lim_{\Delta x \rightarrow 0} \frac{\Delta x}{\Delta x} = 1$   
 (d) No, since  $f_{xy}$  and  $f_{yx}$  are not continuous.
52. Represent the line segment  $C$  that joins  $A$  and  $B$  by  $x = x_0 + (x_1 - x_0)t$ ,  $y = y_0 + (y_1 - y_0)t$  for  $0 \leq t \leq 1$ . Let  $F(t) = f(x_0 + (x_1 - x_0)t, y_0 + (y_1 - y_0)t)$  for  $0 \leq t \leq 1$ ; then  
 $f(x_1, y_1) - f(x_0, y_0) = F(1) - F(0)$ . Apply the Mean Value Theorem to  $F(t)$  on the interval  $[0, 1]$  to get  $[F(1) - F(0)]/(1 - 0) = F'(t^*)$ ,  $F(1) - F(0) = F'(t^*)$  for some  $t^*$  in  $(0, 1)$  so  
 $f(x_1, y_1) - f(x_0, y_0) = F'(t^*)$ . By the chain rule,  $F'(t) = f_x(x, y)(dx/dt) + f_y(x, y)(dy/dt) =$   
 $f_x(x, y)(x_1 - x_0) + f_y(x, y)(y_1 - y_0)$ . Let  $(x^*, y^*)$  be the point on  $C$  for  $t = t^*$  then  
 $f(x_1, y_1) - f(x_0, y_0) = F'(t^*) = f_x(x^*, y^*)(x_1 - x_0) + f_y(x^*, y^*)(y_1 - y_0)$ .



53. Let  $(a, b)$  be any point in the region, if  $(x, y)$  is in the region then by the result of Exercise 52  $f(x, y) - f(a, b) = f_x(x^*, y^*)(x - a) + f_y(x^*, y^*)(y - b)$  where  $(x^*, y^*)$  is on the line segment joining  $(a, b)$  and  $(x, y)$ . If  $f_x(x, y) = f_y(x, y) = 0$  throughout the region then  $f(x, y) - f(a, b) = (0)(x - a) + (0)(y - b) = 0$ ,  $f(x, y) = f(a, b)$  so  $f(x, y)$  is constant on the region.

## EXERCISE SET 15.5

- At  $P$ ,  $\partial z/\partial x = 48$  and  $\partial z/\partial y = -14$ , tangent plane  $48x - 14y - z = 64$ , normal line  $x = 1 + 48t$ ,  $y = -2 - 14t$ ,  $z = 12 - t$ .
- At  $P$ ,  $\partial z/\partial x = 14$  and  $\partial z/\partial y = -2$ , tangent plane  $14x - 2y - z = 16$ , normal line  $x = 2 + 14t$ ,  $y = 4 - 2t$ ,  $z = 4 - t$ .
- At  $P$ ,  $\partial z/\partial x = 1$  and  $\partial z/\partial y = -1$ , tangent plane  $x - y - z = 0$ , normal line  $x = 1 + t$ ,  $y = -t$ ,  $z = 1 - t$ .
- At  $P$ ,  $\partial z/\partial x = -1$  and  $\partial z/\partial y = 0$ , tangent plane  $x + z = -1$ , normal line  $x = -1 - t$ ,  $y = 0$ ,  $z = -t$ .
- At  $P$ ,  $\partial z/\partial x = 0$  and  $\partial z/\partial y = 3$ , tangent plane  $3y - z = -1$ , normal line  $x = \pi/6$ ,  $y = 3t$ ,  $z = 1 - t$ .
- At  $P$ ,  $\partial z/\partial x = 1/4$  and  $\partial z/\partial y = 1/6$ , tangent plane  $3x + 2y - 12z = -30$ , normal line  $x = 4 + t/4$ ,  $y = 9 + t/6$ ,  $z = 5 - t$ .
- By implicit differentiation  $\partial z/\partial x = -x/z$ ,  $\partial z/\partial y = -y/z$  so at  $P$ ,  $\partial z/\partial x = 3/4$  and  $\partial z/\partial y = 0$ , tangent plane  $3x - 4z = -25$ , normal line  $x = -3 + 3t/4$ ,  $y = 0$ ,  $z = 4 - t$ .
- By implicit differentiation  $\partial z/\partial x = (xy)/(4z)$ ,  $\partial z/\partial y = x^2/(8z)$  so at  $P$ ,  $\partial z/\partial x = 3/8$  and  $\partial z/\partial y = -9/16$ , tangent plane  $6x - 9y - 16z = 5$ , normal line  $x = -3 + 3t/8$ ,  $y = 1 - 9t/16$ ,  $z = -2 - t$ .
- The tangent plane is horizontal if the normal  $\partial z/\partial x \mathbf{i} + \partial z/\partial y \mathbf{j} - \mathbf{k}$  is parallel to  $\mathbf{k}$  which occurs when  $\partial z/\partial x = \partial z/\partial y = 0$ .
  - $\partial z/\partial x = 3x^2y^2$ ,  $\partial z/\partial y = 2x^3y$ ;  $3x^2y^2 = 0$  and  $2x^3y = 0$  for all  $(x, y)$  on the  $x$ -axis or  $y$ -axis, and  $z = 0$  for these points, the tangent plane is horizontal at all points on the  $x$ -axis or  $y$ -axis.
  - $\partial z/\partial x = 2x - y - 2$ ,  $\partial z/\partial y = -x + 2y + 4$ ; solve the system  $2x - y - 2 = 0$ ,  $-x + 2y + 4 = 0$ , to get  $x = 0$ ,  $y = -2$ .  $z = -4$  at  $(0, -2)$ , the tangent plane is horizontal at  $(0, -2, -4)$ .
- $\partial z/\partial x = 6x$ ,  $\partial z/\partial y = -2y$ , so  $6x_0 \mathbf{i} - 2y_0 \mathbf{j} - \mathbf{k}$  is normal to the surface at a point  $(x_0, y_0, z_0)$  on the surface.  $6\mathbf{i} + 4\mathbf{j} - \mathbf{k}$  is normal to the given plane. The tangent plane and the given plane are parallel if their normals are parallel so  $6x_0 = 6$ ,  $x_0 = 1$  and  $-2y_0 = 4$ ,  $y_0 = -2$ .  $z = -1$  at  $(1, -2)$ , the point on the surface is  $(1, -2, -1)$ .
- $\partial z/\partial x = -6x$ ,  $\partial z/\partial y = -4y$  so  $-6x_0 \mathbf{i} - 4y_0 \mathbf{j} - \mathbf{k}$  is normal to the surface at a point  $(x_0, y_0, z_0)$  on the surface. This normal must be parallel to the given line and hence to the vector  $-3\mathbf{i} + 8\mathbf{j} - \mathbf{k}$  which is parallel to the line so  $-6x_0 = -3$ ,  $x_0 = 1/2$  and  $-4y_0 = 8$ ,  $y_0 = -2$ .  $z = -3/4$  at  $(1/2, -2)$ . The point on the surface is  $(1/2, -2, -3/4)$ .
- $(3, 4, 5)$  is a point of intersection because it satisfies both equations. Both surfaces have  $(3/5)\mathbf{i} + (4/5)\mathbf{j} - \mathbf{k}$  as a normal so they have a common tangent plane at  $(3, 4, 5)$ .

13.  $df = 2xydx + x^2dy = 0.6 + 0.2 = 0.8$ ,  $\Delta f = (x + \Delta x)^2(y + \Delta y) - x^2y = (1.1)^2(3.2) - 1^2 \cdot 3 = 0.872$
14.  $dz = 6xdx - 2dy = -12(0.02) - 2(-0.03) = -0.18$ ,  
 $\Delta z = 3(-2 + 0.02)^2 - 2(4 - 0.03) - (3(-2)^2 - 2(4)) = -0.1788$
15.  $3/1 - (-1)/2 = 7/2$
16.  $2(4)(-2) - (-2)^3 - (0 - 1^3) = -7$
17.  $dz = 3x^2y^2dx + 2x^3ydy$ ,  $\Delta z = (x + \Delta x)^3(y + \Delta y)^2 - x^3y^2$
18.  $dz = ye^{xy}dx + xe^{xy}dy$ ,  $\Delta z = e^{(x+\Delta x)(y+\Delta y)} - e^{xy}$
19.  $dz = 7dx - 2dy$
20.  $dz = (10xy^5 - 2)dx + (25x^2y^4 + 4)dy$
21.  $dz = [y/(1 + x^2y^2)]dx + [x/(1 + x^2y^2)]dy$
22.  $dz = 2\sec^2(x - 3y)\tan(x - 3y)dx - 6\sec^2(x - 3y)\tan(x - 3y)dy$
23. (a) Let  $f(x, y) = e^x \sin y$ ;  $f(0, 0) = 0$ ,  $f_x(0, 0) = 0$ ,  $f_y(0, 0) = 1$ , so  $e^x \sin y \approx y$   
 (b) Let  $f(x, y) = \frac{2x + 1}{y + 1}$ ;  $f(0, 0) = 1$ ,  $f_x(0, 0) = 2$ ,  $f_y(0, 0) = -1$ , so  $\frac{2x + 1}{y + 1} \approx 1 + 2x - y$
24.  $f(1, 1) = 1$ ,  $f_x(x, y) = \alpha x^{\alpha-1}y^\beta$ ,  $f_x(1, 1) = \alpha$ ,  $f_y(x, y) = \beta x^\alpha y^{\beta-1}$ ,  $f_y(1, 1) = \beta$ , so  
 $x^\alpha y^\beta \approx 1 + \alpha(x - 1) + \beta(y - 1)$
25.  $dT = T_x dx + T_y dy \approx 2(-0.02) - (0.02) = -0.06$ ,  $T \approx T(1, 3) + dT \approx 93 - 0.06 = 92.94^\circ$
26.  $p(104, 103) \approx p(100, 98) - p_x(100, 98)(104 - 100) - p_y(100, 98)(103 - 98)$   
 $= 1008 + (-2)4 + (1)5 = 1005$  mb
27.  $f(x, y) = (x^2 + y^2)^{-1/2}$ ,  $f_x(4, 3) = \frac{-x}{(x^2 + y^2)^{3/2}} = -\frac{4}{125}$ ,  $f_y(4, 3) = \frac{-y}{(x^2 + y^2)^{3/2}} = -\frac{3}{125}$ ,  
 $\frac{1}{\sqrt{(3.92)^2 + (3.01)^2}} \approx \frac{1}{\sqrt{4^2 + 3^2}} - \frac{4}{125}(-0.08) - \frac{3}{125}(0.01) = 0.20232$ ; actual value  $\approx 0.202334$ .
28. From Exercise 24,  $x^{0.5}y^{0.3} \approx 1 + 0.5(x - 1) + 0.3(y - 1)$ , so  
 $(1.05)^{0.5}(0.97)^{0.3} \approx 1 + 0.5(0.05) + 0.3(-0.03) = 1.016$ , actual value  $\approx 1.01537$
29.  $df = (2x + 2y - 4)dx + 2xdy$ ;  $x = 1$ ,  $y = 2$ ,  $dx = 0.01$ ,  $dy = 0.04$  so  $df = 0.10$
30.  $df = (1/3)x^{-2/3}y^{1/2}dx + (1/2)x^{1/3}y^{-1/2}dy$ ;  $x = 8$ ,  $y = 9$ ,  $dx = -0.02$ ,  $dy = 0.03$  so  $df = 0.005$
31.  $df = -x^{-2}dx - y^{-2}dy$ ;  $x = -1$ ,  $y = -2$ ,  $dx = -0.02$ ,  $dy = -0.04$  so  $df = 0.03$
32.  $df = \frac{y}{2(1 + xy)}dx + \frac{x}{2(1 + xy)}dy$ ;  $x = 0$ ,  $y = 2$ ,  $dx = -0.09$ ,  $dy = -0.02$  so  $df = -0.09$
33.  $z = \sqrt{x^2 + y^2}$ ,  $dz = x(x^2 + y^2)^{-1/2}dx + y(x^2 + y^2)^{-1/2}dy$ ;  $x = 3$ ,  $y = 4$ ,  $dx = 0.2$ ,  
 $dy = -0.04$  so  $dz = 0.088$  cm.
34.  $dV = (2/3)\pi r^2 dh + (1/3)\pi r^2 dh$ ;  $r = 4$ ,  $h = 20$ ,  $dr = 0.05$ ,  $dh = -0.05$  so  $dV = 2.4\pi \approx 7.54$  in<sup>3</sup>.

35.  $A = xy$ ,  $dA = ydx + xdy$ ,  $dA/A = dx/x + dy/y$ ,  $|dx/x| \leq 0.03$  and  $|dy/y| \leq 0.05$ ,  
 $|dA/A| \leq |dx/x| + |dy/y| \leq 0.08 = 8\%$
36.  $V = (1/3)\pi r^2 h$ ,  $dV = (2/3)\pi r h dr + (1/3)\pi r^2 dh$ ,  $dV/V = 2(dr/r) + dh/h$ ,  $|dr/r| \leq 0.01$  and  
 $|dh/h| \leq 0.04$ ,  $|dV/V| \leq 2|dr/r| + |dh/h| \leq 0.06 = 6\%$ .
37.  $z = \sqrt{x^2 + y^2}$ ,  $dz = \frac{x}{\sqrt{x^2 + y^2}} dx + \frac{y}{\sqrt{x^2 + y^2}} dy$ ,  
 $\frac{dz}{z} = \frac{x}{x^2 + y^2} dx + \frac{y}{x^2 + y^2} dy = \frac{x^2}{x^2 + y^2} \left(\frac{dx}{x}\right) + \frac{y^2}{x^2 + y^2} \left(\frac{dy}{y}\right)$ ,  
 $\left|\frac{dz}{z}\right| \leq \frac{x^2}{x^2 + y^2} \left|\frac{dx}{x}\right| + \frac{y^2}{x^2 + y^2} \left|\frac{dy}{y}\right|$ , if  $\left|\frac{dx}{x}\right| \leq r/100$  and  $\left|\frac{dy}{y}\right| \leq r/100$  then  
 $\left|\frac{dz}{z}\right| \leq \frac{x^2}{x^2 + y^2} (r/100) + \frac{y^2}{x^2 + y^2} (r/100) = \frac{r}{100}$  so the percentage error in  $z$  is at most about  $r\%$ .
38. (a)  $z = \sqrt{x^2 + y^2}$ ,  $dz = x(x^2 + y^2)^{-1/2} dx + y(x^2 + y^2)^{-1/2} dy$ ,  
 $|dz| \leq x(x^2 + y^2)^{-1/2} |dx| + y(x^2 + y^2)^{-1/2} |dy|$ ; if  $x = 3$ ,  $y = 4$ ,  $|dx| \leq 0.05$ , and  
 $|dy| \leq 0.05$  then  $|dz| \leq (3/5)(0.05) + (4/5)(0.05) = 0.07$  cm
- (b)  $A = (1/2)xy$ ,  $dA = (1/2)ydx + (1/2)x dy$ ,  
 $|dA| \leq (1/2)y|dx| + (1/2)x|dy| \leq 2(0.05) + (3/2)(0.05) = 0.175$  cm<sup>2</sup>.
39.  $dR = \frac{R_2^2}{(R_1 + R_2)^2} dR_1 + \frac{R_1^2}{(R_1 + R_2)^2} dR_2$ ,  $\frac{dR}{R} = \frac{R_2}{R_1 + R_2} \left(\frac{dR_1}{R_1}\right) + \frac{R_1}{R_1 + R_2} \left(\frac{dR_2}{R_2}\right)$ ,  
 $\left|\frac{dR}{R}\right| \leq \frac{R_2}{R_1 + R_2} \left|\frac{dR_1}{R_1}\right| + \frac{R_1}{R_1 + R_2} \left|\frac{dR_2}{R_2}\right|$ ; if  $R_1 = 200$ ,  $R_2 = 400$ ,  $|dR_1/R_1| \leq 0.02$ , and  
 $|dR_2/R_2| \leq 0.02$  then  $|dR/R| \leq (400/600)(0.02) + (200/600)(0.02) = 0.02 = 2\%$ .
40.  $dP = (k/V)dT - (kT/V^2)dV$ ,  $dP/P = dT/T - dV/V$ ; if  $dT/T = 0.03$  and  $dV/V = 0.05$  then  
 $dP/P = -0.02$  so there is about a 2% decrease in pressure.
41.  $d\theta = \frac{1}{\sqrt{c^2 - a^2}} da - \frac{a}{c\sqrt{c^2 - a^2}} dc$ ; if  $a = 3$ ,  $c = 5$ ,  $|da| \leq 0.01$ , and  $|dc| \leq 0.01$  then  
 $|d\theta| \leq (1/4)(0.01) + (3/20)(0.01) = 0.004$  radians.
42.  $V = \pi r^2 h$ ,  $dV = 2\pi r h dr + \pi r^2 dh$ ;  $r = 2$ ,  $h = 5$ ,  $dr = 0.01$ , and  $dh = 0.01$  so  
 $dV = (20\pi)(0.01) + (4\pi)(0.01) = 0.24\pi$ , or about  $0.754$  cm<sup>3</sup>.
43.  $dT = \frac{\pi}{g\sqrt{L/g}} dL - \frac{\pi L}{g^2\sqrt{L/g}} dg$ ,  $\frac{dT}{T} = \frac{1}{2} \frac{dL}{L} - \frac{1}{2} \frac{dg}{g}$ ;  $|dL/L| \leq 0.005$  and  $|dg/g| \leq 0.001$  so  
 $|dT/T| \leq (1/2)(0.005) + (1/2)(0.001) = 0.003 = 0.3\%$
44. Let  $h$  be the height of the building,  $x$  the distance to the building, and  $\theta$  the angle of elevation,  
then  $h = x \tan \theta$ ,  $dh = \tan \theta dx + x \sec^2 \theta d\theta$ ; if  $x = 100$ ,  $\theta = 60^\circ$ ,  $|dx| \leq 1/6$  ft, and  
 $|d\theta| \leq (0.2)(\pi/180) = \pi/900$  radians, then  $|dh| \leq (\sqrt{3})(1/6) + (100)(4)(\pi/900) < 1.7$  ft.
45. (a)  $z = xy$ ,  $dz = ydx + xdy$ ,  $dz/z = dx/x + dy/y$ ;  $(r + s)\%$ .  
(b)  $z = x/y$ ,  $dz = dx/y - xdy/y^2$ ,  $dz/z = dx/x - dy/y$ ;  $(r + s)\%$ .

(c)  $z = x^2y^3$ ,  $dz = 2xy^3dx + 3x^2y^2dy$ ,  $dz/z = 2dx/x + 3dy/y$ ;  $(2r + 3s)\%$ .

(d)  $z = x^3y^{1/2}$ ,  $dz = 3x^2y^{1/2}dx + x^3dy/(2y^{1/2})$ ,  $dz/z = 3dx/x + (1/2)dy/y$ ;  $(3r + s/2)\%$ .

46.  $z = \frac{k}{xy}$ ; at a point  $\left(a, b, \frac{k}{ab}\right)$  on the surface,  $\left\langle -\frac{k}{a^2b}, -\frac{k}{ab^2}, -1 \right\rangle$  and hence  $\langle bk, ak, a^2b^2 \rangle$  is normal to the surface so the tangent plane is  $bkx + ak y + a^2b^2z = 3abk$ . The plane cuts the  $x$ ,  $y$ , and  $z$ -axes at the points  $3a$ ,  $3b$ , and  $\frac{3k}{ab}$ , respectively, so the volume of the tetrahedron that is formed is  $V = \frac{1}{3} \left(\frac{3k}{ab}\right) \left[\frac{1}{2}(3a)(3b)\right] = \frac{9}{2}k$ , which does not depend on  $a$  and  $b$ .

47. (a)  $2t + 7 = (-1 + t)^2 + (2 + t)^2$ ,  $t^2 = 1$ ,  $t = \pm 1$  so the points of intersection are  $(-2, 1, 5)$  and  $(0, 3, 9)$ .

- (b)  $\partial z/\partial x = 2x$ ,  $\partial z/\partial y = 2y$  so at  $(-2, 1, 5)$  the vector  $\mathbf{n} = -4\mathbf{i} + 2\mathbf{j} - \mathbf{k}$  is normal to the surface.  $\mathbf{v} = \mathbf{i} + \mathbf{j} + 2\mathbf{k}$  is parallel to the line;  $\mathbf{n} \cdot \mathbf{v} = -4$  so the cosine of the acute angle is  $|\mathbf{n} \cdot (-\mathbf{v})| / (\|\mathbf{n}\| \|\mathbf{v}\|) = 4 / (\sqrt{21}\sqrt{6}) = 4 / (3\sqrt{14})$ . Similarly, at  $(0, 3, 9)$  the vector  $\mathbf{n} = 6\mathbf{j} - \mathbf{k}$  is normal to the surface,  $\mathbf{n} \cdot \mathbf{v} = 4$  so the cosine of the acute angle is  $4 / (\sqrt{37}\sqrt{6}) = 4 / \sqrt{222}$ .

48.  $z = xf(u)$  where  $u = x/y$ ,  $\partial z/\partial x = xf'(u)\partial u/\partial x + f(u) = (x/y)f'(u) + f(u) = uf'(u) + f(u)$ ,  $\partial z/\partial y = xf'(u)\partial u/\partial y = -(x^2/y^2)f'(u) = -u^2f'(u)$ . If  $(x_0, y_0, z_0)$  is on the surface then, with  $u_0 = x_0/y_0$ ,  $[u_0f'(u_0) + f(u_0)]\mathbf{i} - u_0^2f'(u_0)\mathbf{j} - \mathbf{k}$  is normal to the surface so the tangent plane is  $[u_0f'(u_0) + f(u_0)]x - u_0^2f'(u_0)y - z = [u_0f'(u_0) + f(u_0)]x_0 - u_0^2f'(u_0)y_0 - z_0$

$$= \left[ \frac{x_0}{y_0} f'(u_0) + f(u_0) \right] x_0 - \frac{x_0^2}{y_0^2} f'(u_0) y_0 - z_0$$

$$= x_0 f(u_0) - z_0 = 0$$

so all tangent planes pass through the origin.

49. Use implicit differentiation to get  $\partial z/\partial x = -c^2x/(a^2z)$ ,  $\partial z/\partial y = -c^2y/(b^2z)$ . At  $(x_0, y_0, z_0)$ ,  $z_0 \neq 0$ , a normal to the surface is  $-[c^2x_0/(a^2z_0)]\mathbf{i} - [c^2y_0/(b^2z_0)]\mathbf{j} - \mathbf{k}$  so the tangent plane is

$$-\frac{c^2x_0}{a^2z_0}x - \frac{c^2y_0}{b^2z_0}y - z = -\frac{c^2x_0^2}{a^2z_0} - \frac{c^2y_0^2}{b^2z_0} - z_0, \quad \frac{x_0x}{a^2} + \frac{y_0y}{b^2} + \frac{z_0z}{c^2} = \frac{x_0^2}{a^2} + \frac{y_0^2}{b^2} + \frac{z_0^2}{c^2} = 1$$

50.  $\partial z/\partial x = 2x/a^2$ ,  $\partial z/\partial y = 2y/b^2$ . At  $(x_0, y_0, z_0)$  the vector  $(2x_0/a^2)\mathbf{i} + (2y_0/b^2)\mathbf{j} - \mathbf{k}$  is normal to the surface so the tangent plane is  $(2x_0/a^2)x + (2y_0/b^2)y - z = 2x_0^2/a^2 + 2y_0^2/b^2 - z_0$ , but  $z_0 = x_0^2/a^2 + y_0^2/b^2$  so  $(2x_0/a^2)x + (2y_0/b^2)y - z = 2z_0 - z_0 = z_0$ ,  $2x_0x/a^2 + 2y_0y/b^2 = z + z_0$

51.  $\mathbf{n}_1 = f_x(x_0, y_0)\mathbf{i} + f_y(x_0, y_0)\mathbf{j} - \mathbf{k}$  and  $\mathbf{n}_2 = g_x(x_0, y_0)\mathbf{i} + g_y(x_0, y_0)\mathbf{j} - \mathbf{k}$  are normal, respectively, to  $z = f(x, y)$  and  $z = g(x, y)$  at  $P$ ;  $\mathbf{n}_1$  and  $\mathbf{n}_2$  are perpendicular if and only if  $\mathbf{n}_1 \cdot \mathbf{n}_2 = 0$ ,  $f_x(x_0, y_0)g_x(x_0, y_0) + f_y(x_0, y_0)g_y(x_0, y_0) + 1 = 0$ ,  $f_x(x_0, y_0)g_x(x_0, y_0) + f_y(x_0, y_0)g_y(x_0, y_0) = -1$ .

52.  $\mathbf{n}_1 = f_x\mathbf{i} + f_y\mathbf{j} - \mathbf{k} = \frac{x_0}{\sqrt{x_0^2 + y_0^2}}\mathbf{i} + \frac{y_0}{\sqrt{x_0^2 + y_0^2}}\mathbf{j} - \mathbf{k}$ ; similarly  $\mathbf{n}_2 = -\frac{x_0}{\sqrt{x_0^2 + y_0^2}}\mathbf{i} - \frac{y_0}{\sqrt{x_0^2 + y_0^2}}\mathbf{j} - \mathbf{k}$ ;

since a normal to the sphere is  $\mathbf{N} = x_0\mathbf{i} + y_0\mathbf{j} + z_0\mathbf{k}$ , and  $\mathbf{n}_1 \cdot \mathbf{N} = \sqrt{x_0^2 + y_0^2} - z_0 = 0$ ,

$\mathbf{n}_2 \cdot \mathbf{N} = -\sqrt{x_0^2 + y_0^2} - z_0 = 0$ , the result follows.

## EXERCISE SET 15.6

1.  $f$  increases the most in the direction of III.
2. The contour lines are closer at  $P$ , so the function is increasing more rapidly there, hence  $\nabla f$  is larger at  $P$ .
3.  $\nabla z = 4\mathbf{i} - 8\mathbf{j}$
4.  $\nabla z = -4e^{-3y} \sin 4x\mathbf{i} - 3e^{-3y} \cos 4x\mathbf{j}$
5.  $\nabla z = \frac{x}{x^2 + y^2}\mathbf{i} + \frac{y}{x^2 + y^2}\mathbf{j}$
6.  $\nabla z = e^{-5x} \sec x^2 y [(2xy \tan x^2 y - 5)\mathbf{i} + x^2 \tan x^2 y\mathbf{j}]$
7.  $\nabla f(x, y) = 3(2x + y)(x^2 + xy)^2\mathbf{i} + 3x(x^2 + xy)^2\mathbf{j}$ ,  $\nabla f(-1, -1) = -36\mathbf{i} - 12\mathbf{j}$
8.  $\nabla f(x, y) = -x(x^2 + y^2)^{-3/2}\mathbf{i} - y(x^2 + y^2)^{-3/2}\mathbf{j}$ ,  $\nabla f(3, 4) = -(3/125)\mathbf{i} - (4/125)\mathbf{j}$
9.  $\nabla f(x, y) = [y/(x + y)]\mathbf{i} + [y/(x + y) + \ln(x + y)]\mathbf{j}$ ,  $\nabla f(-3, 4) = 4\mathbf{i} + 4\mathbf{j}$
10.  $\nabla f(x, y) = 3y^2 \tan^2 x \sec^2 x\mathbf{i} + 2y \tan^3 x\mathbf{j}$ ,  $\nabla f(\pi/4, -3) = 54\mathbf{i} - 6\mathbf{j}$
11.  $\nabla f(x, y) = (3y/2)(1 + xy)^{1/2}\mathbf{i} + (3x/2)(1 + xy)^{1/2}\mathbf{j}$ ,  $\nabla f(3, 1) = 3\mathbf{i} + 9\mathbf{j}$ ,  
 $D_{\mathbf{u}}f = \nabla f \cdot \mathbf{u} = 12/\sqrt{2} = 6\sqrt{2}$
12.  $\nabla f(x, y) = 2ye^{2xy}\mathbf{i} + 2xe^{2xy}\mathbf{j}$ ,  $\nabla f(4, 0) = 8\mathbf{j}$ ,  $D_{\mathbf{u}}f = \nabla f \cdot \mathbf{u} = 32/5$
13.  $\nabla f(x, y) = [2x/(1 + x^2 + y)]\mathbf{i} + [1/(1 + x^2 + y)]\mathbf{j}$ ,  $\nabla f(0, 0) = \mathbf{j}$ ,  $D_{\mathbf{u}}f = -3/\sqrt{10}$
14.  $\nabla f(x, y) = -[(c + d)y/(x - y)^2]\mathbf{i} + [(c + d)x/(x - y)^2]\mathbf{j}$ ,  
 $\nabla f(3, 4) = -4(c + d)\mathbf{i} + 3(c + d)\mathbf{j}$ ,  $D_{\mathbf{u}}f = -(7/5)(c + d)$
15.  $\nabla f(x, y) = 12x^2y^2\mathbf{i} + 8x^3y\mathbf{j}$ ,  $\nabla f(2, 1) = 48\mathbf{i} + 64\mathbf{j}$ ,  $\mathbf{u} = (4/5)\mathbf{i} - (3/5)\mathbf{j}$ ,  $D_{\mathbf{u}}f = \nabla f \cdot \mathbf{u} = 0$
16.  $\nabla f(x, y) = (2x - 3y)\mathbf{i} + (-3x + 12y^2)\mathbf{j}$ ,  $\nabla f(-2, 0) = -4\mathbf{i} + 6\mathbf{j}$ ,  $\mathbf{u} = (\mathbf{i} + 2\mathbf{j})/\sqrt{5}$ ,  $D_{\mathbf{u}}f = 8/\sqrt{5}$
17.  $\nabla f(x, y) = (y^2/x)\mathbf{i} + 2y \ln x\mathbf{j}$ ,  $\nabla f(1, 4) = 16\mathbf{i}$ ,  $\mathbf{u} = (-\mathbf{i} + \mathbf{j})/\sqrt{2}$ ,  $D_{\mathbf{u}}f = -8\sqrt{2}$
18.  $\nabla f(x, y) = e^x \cos y\mathbf{i} - e^x \sin y\mathbf{j}$ ,  $\nabla f(0, \pi/4) = (\mathbf{i} - \mathbf{j})/\sqrt{2}$ ,  $\mathbf{u} = (5\mathbf{i} - 2\mathbf{j})/\sqrt{29}$ ,  $D_{\mathbf{u}}f = 7/\sqrt{58}$
19.  $\nabla f(x, y) = -[y/(x^2 + y^2)]\mathbf{i} + [x/(x^2 + y^2)]\mathbf{j}$ ,  
 $\nabla f(-2, 2) = -(\mathbf{i} + \mathbf{j})/4$ ,  $\mathbf{u} = -(\mathbf{i} + \mathbf{j})/\sqrt{2}$ ,  $D_{\mathbf{u}}f = \sqrt{2}/4$
20.  $\nabla f(x, y) = (e^y - ye^x)\mathbf{i} + (xe^y - e^x)\mathbf{j}$ ,  $\nabla f(0, 0) = \mathbf{i} - \mathbf{j}$ ,  $\mathbf{u} = (5\mathbf{i} - 2\mathbf{j})/\sqrt{29}$ ,  $D_{\mathbf{u}}f = 7/\sqrt{29}$
21.  $\nabla f(x, y) = (y/2)(xy)^{-1/2}\mathbf{i} + (x/2)(xy)^{-1/2}\mathbf{j}$ ,  $\nabla f(1, 4) = \mathbf{i} + (1/4)\mathbf{j}$ ,  
 $\mathbf{u} = \cos \theta\mathbf{i} + \sin \theta\mathbf{j} = (1/2)\mathbf{i} + (\sqrt{3}/2)\mathbf{j}$ ,  $D_{\mathbf{u}}f = 1/2 + \sqrt{3}/8$
22.  $\nabla f(x, y) = [2y/(x + y)^2]\mathbf{i} - [2x/(x + y)^2]\mathbf{j}$ ,  $\nabla f(-1, -2) = -(4/9)\mathbf{i} + (2/9)\mathbf{j}$ ,  $\mathbf{u} = \mathbf{j}$ ,  $D_{\mathbf{u}}f = 2/9$

23.  $\nabla f(x, y) = 2 \sec^2(2x + y)\mathbf{i} + \sec^2(2x + y)\mathbf{j}$ ,  $\nabla f(\pi/6, \pi/3) = 8\mathbf{i} + 4\mathbf{j}$ ,  $\mathbf{u} = (\mathbf{i} - \mathbf{j})/\sqrt{2}$ ,  $D_{\mathbf{u}}f = 2\sqrt{2}$

24.  $\nabla f(x, y) = \cosh x \cosh y\mathbf{i} + \sinh x \sinh y\mathbf{j}$ ,  $\nabla f(0, 0) = \mathbf{i}$ ,  $\mathbf{u} = -\mathbf{i}$ ,  $D_{\mathbf{u}}f = -1$

25.  $f(1, 2) = 3$ , level curve  $4x - 2y + 3 = 3$ ,  $2x - y = 0$ ;

$$\nabla f(x, y) = 4\mathbf{i} - 2\mathbf{j}$$

$$\nabla f(1, 2) = 4\mathbf{i} - 2\mathbf{j}$$

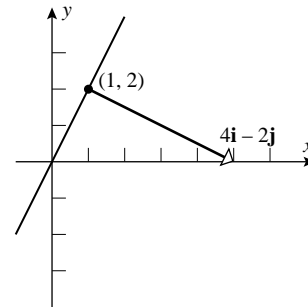

26.  $f(-2, 2) = 1/2$ , level curve  $y/x^2 = 1/2$ ,  $y = x^2/2$  for  $x \neq 0$ .

$$\nabla f(x, y) = -(2y/x^3)\mathbf{i} + (1/x^2)\mathbf{j}$$

$$\nabla f(-2, 2) = (1/2)\mathbf{i} + (1/4)\mathbf{j}$$

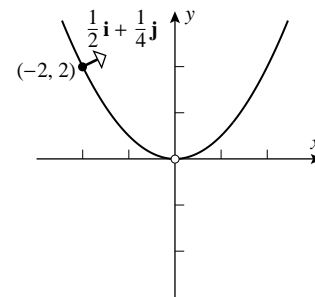

27.  $f(-2, 0) = 4$ , level curve  $x^2 + 4y^2 = 4$ ,  $x^2/4 + y^2 = 1$ .

$$\nabla f(x, y) = 2x\mathbf{i} + 8y\mathbf{j}$$

$$\nabla f(-2, 0) = -4\mathbf{i}$$

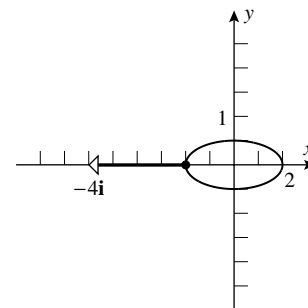

28.  $f(2, -1) = 3$ , level curve  $x^2 - y^2 = 3$ .

$$\nabla f(x, y) = 2x\mathbf{i} - 2y\mathbf{j}$$

$$\nabla f(2, -1) = 4\mathbf{i} + 2\mathbf{j}$$

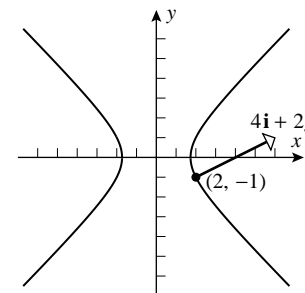

29.  $\nabla f(x, y) = 12x^2y^2\mathbf{i} + 8x^3y\mathbf{j}$ ,  $\nabla f(-1, 1) = 12\mathbf{i} - 8\mathbf{j}$ ,  $\mathbf{u} = (3\mathbf{i} - 2\mathbf{j})/\sqrt{13}$ ,  $\|\nabla f(-1, 1)\| = 4\sqrt{13}$

30.  $\nabla f(x, y) = 3\mathbf{i} - (1/y)\mathbf{j}$ ,  $\nabla f(2, 4) = 3\mathbf{i} - (1/4)\mathbf{j}$ ,  $\mathbf{u} = (12\mathbf{i} - \mathbf{j})/\sqrt{145}$ ,  $\|\nabla f(2, 4)\| = \sqrt{145}/4$
31.  $\nabla f(x, y) = x(x^2 + y^2)^{-1/2}\mathbf{i} + y(x^2 + y^2)^{-1/2}\mathbf{j}$ ,  
 $\nabla f(4, -3) = (4\mathbf{i} - 3\mathbf{j})/5$ ,  $\mathbf{u} = (4\mathbf{i} - 3\mathbf{j})/5$ ,  $\|\nabla f(4, -3)\| = 1$
32.  $\nabla f(x, y) = y(x + y)^{-2}\mathbf{i} - x(x + y)^{-2}\mathbf{j}$ ,  $\nabla f(0, 2) = (1/2)\mathbf{i}$ ,  $\mathbf{u} = \mathbf{i}$ ,  $\|\nabla f(0, 2)\| = 1/2$
33.  $\nabla f(x, y) = -2x\mathbf{i} - 2y\mathbf{j}$ ,  $\nabla f(-1, -3) = 2\mathbf{i} + 6\mathbf{j}$ ,  $\mathbf{u} = -(\mathbf{i} + 3\mathbf{j})/\sqrt{10}$ ,  $-\|\nabla f(-1, -3)\| = -2\sqrt{10}$
34.  $\nabla f(x, y) = ye^{xy}\mathbf{i} + xe^{xy}\mathbf{j}$ ;  $\nabla f(2, 3) = e^6(3\mathbf{i} + 2\mathbf{j})$ ,  $\mathbf{u} = -(3\mathbf{i} + 2\mathbf{j})/\sqrt{13}$ ,  $-\|\nabla f(2, 3)\| = -\sqrt{13}e^6$
35.  $\nabla f(x, y) = -3\sin(3x - y)\mathbf{i} + \sin(3x - y)\mathbf{j}$ ,  
 $\nabla f(\pi/6, \pi/4) = (-3\mathbf{i} + \mathbf{j})/\sqrt{2}$ ,  $\mathbf{u} = (3\mathbf{i} - \mathbf{j})/\sqrt{10}$ ,  $-\|\nabla f(\pi/6, \pi/4)\| = -\sqrt{5}$
36.  $\nabla f(x, y) = \frac{y}{(x + y)^2} \sqrt{\frac{x + y}{x - y}}\mathbf{i} - \frac{x}{(x + y)^2} \sqrt{\frac{x + y}{x - y}}\mathbf{j}$ ,  $\nabla f(3, 1) = (\sqrt{2}/16)(\mathbf{i} - 3\mathbf{j})$ ,  
 $\mathbf{u} = -(\mathbf{i} - 3\mathbf{j})/\sqrt{10}$ ,  $-\|\nabla f(3, 1)\| = -\sqrt{5}/8$
37.  $\nabla f(x, y) = y(x + y)^{-2}\mathbf{i} - x(x + y)^{-2}\mathbf{j}$ ,  $\nabla f(1, 0) = -\mathbf{j}$ ,  $\overrightarrow{PQ} = -2\mathbf{i} - \mathbf{j}$ ,  $\mathbf{u} = (-2\mathbf{i} - \mathbf{j})/\sqrt{5}$ ,  
 $D_{\mathbf{u}}f = 1/\sqrt{5}$
38.  $\nabla f(x, y) = -e^{-x} \sec y\mathbf{i} + e^{-x} \sec y \tan y\mathbf{j}$ ,  
 $\nabla f(0, \pi/4) = \sqrt{2}(-\mathbf{i} + \mathbf{j})$ ,  $\overrightarrow{PO} = -(\pi/4)\mathbf{j}$ ,  $\mathbf{u} = -\mathbf{j}$ ,  $D_{\mathbf{u}}f = -\sqrt{2}$
39.  $\nabla f(x, y) = \frac{ye^y}{2\sqrt{xy}}\mathbf{i} + \left(\sqrt{xy}e^y + \frac{xe^y}{2\sqrt{xy}}\right)\mathbf{j}$ ,  $\nabla f(1, 1) = (e/2)(\mathbf{i} + 3\mathbf{j})$ ,  $\mathbf{u} = -\mathbf{j}$ ,  $D_{\mathbf{u}}f = -3e/2$
40.  $\nabla f(x, y) = -y(x + y)^{-2}\mathbf{i} + x(x + y)^{-2}\mathbf{j}$ ,  $\nabla f(2, 3) = (-3\mathbf{i} + 2\mathbf{j})/25$ , if  $D_{\mathbf{u}}f = 0$  then  $\mathbf{u}$  and  $\nabla f$  are orthogonal, by inspection  $2\mathbf{i} + 3\mathbf{j}$  is orthogonal to  $\nabla f(2, 3)$  so  $\mathbf{u} = \pm(2\mathbf{i} + 3\mathbf{j})/\sqrt{13}$ .
41.  $\nabla f(x, y) = 8xy\mathbf{i} + 4x^2\mathbf{j}$ ,  $\nabla f(1, -2) = -16\mathbf{i} + 4\mathbf{j}$  is normal to the level curve through  $P$  so  
 $\mathbf{u} = \pm(-4\mathbf{i} + \mathbf{j})/\sqrt{17}$ .
42.  $\nabla f(x, y) = (6xy - y)\mathbf{i} + (3x^2 - x)\mathbf{j}$ ,  $\nabla f(2, -3) = -33\mathbf{i} + 10\mathbf{j}$  is normal to the level curve through  $P$  so  $\mathbf{u} = \pm(-33\mathbf{i} + 10\mathbf{j})/\sqrt{1189}$ .
43. Solve the system  $(3/5)f_x(1, 2) - (4/5)f_y(1, 2) = -5$ ,  $(4/5)f_x(1, 2) + (3/5)f_y(1, 2) = 10$  for  $f_x(1, 2)$  and  $f_y(1, 2)$  to get  $f_x(1, 2) = 5$ ,  $f_y(1, 2) = 10$ . For (c),  $\nabla f(1, 2) = 5\mathbf{i} + 10\mathbf{j}$ ,  
 $\mathbf{u} = (-\mathbf{i} - 2\mathbf{j})/\sqrt{5}$ ,  $D_{\mathbf{u}}f = -5\sqrt{5}$ .
44.  $\nabla f(-5, 1) = -3\mathbf{i} + 2\mathbf{j}$ ,  $\overrightarrow{PQ} = \mathbf{i} + 2\mathbf{j}$ ,  $\mathbf{u} = (\mathbf{i} + 2\mathbf{j})/\sqrt{5}$ ,  $D_{\mathbf{u}}f = 1/\sqrt{5}$
45.  $\nabla f(4, -5) = 2\mathbf{i} - \mathbf{j}$ ,  $\mathbf{u} = (5\mathbf{i} + 2\mathbf{j})/\sqrt{29}$ ,  $D_{\mathbf{u}}f = 8/\sqrt{29}$
46. Let  $\mathbf{u} = u_1\mathbf{i} + u_2\mathbf{j}$  where  $u_1^2 + u_2^2 = 1$ , but  $D_{\mathbf{u}}f = \nabla f \cdot \mathbf{u} = u_1 - 2u_2 = -2$  so  $u_1 = 2u_2 - 2$ ,  
 $(2u_2 - 2)^2 + u_2^2 = 1$ ,  $5u_2^2 - 8u_2 + 3 = 0$ ,  $u_2 = 1$  or  $u_2 = 3/5$  thus  $u_1 = 0$  or  $u_1 = -4/5$ ;  $\mathbf{u} = \mathbf{j}$  or  
 $\mathbf{u} = -\frac{4}{5}\mathbf{i} + \frac{3}{5}\mathbf{j}$ .

47. (a) At  $(1, 2)$  the steepest ascent seems to be in the direction  $\mathbf{i} + \mathbf{j}$  and the slope in that direction seems to be  $0.5/(\sqrt{2}/2) = 1/\sqrt{2}$ , so  $\nabla f \approx \frac{1}{2}\mathbf{i} + \frac{1}{2}\mathbf{j}$ , which has the required direction and magnitude.

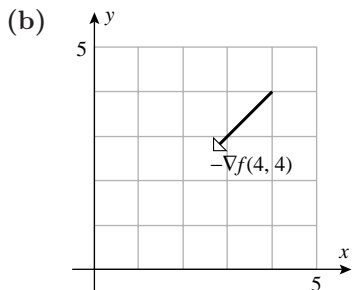

48. (a)

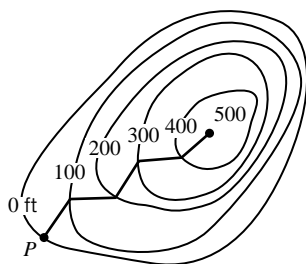

Depart from each contour line in a direction orthogonal to that contour line, as an approximation to the optimal path.

- (b)

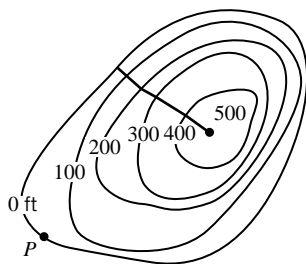

At the top there is no contour line, so head for the nearest contour line. From then on depart from each contour line in a direction orthogonal to that contour line, as in Part (a).

49.  $\nabla z = 6x\mathbf{i} - 2y\mathbf{j}$ ,  $\|\nabla z\| = \sqrt{36x^2 + 4y^2} = 6$  if  $36x^2 + 4y^2 = 36$ ; all points on the ellipse  $9x^2 + y^2 = 9$ .

50.  $\nabla z = 3\mathbf{i} + 2y\mathbf{j}$ ,  $\|\nabla z\| = \sqrt{9 + 4y^2}$ , so  $\nabla\|\nabla z\| = \frac{4y}{\sqrt{9 + 4y^2}} = \frac{8}{\sqrt{9 + 16}} = \frac{8}{5}$

51.  $\mathbf{r} = t\mathbf{i} - t^2\mathbf{j}$ ,  $d\mathbf{r}/dt = \mathbf{i} - 2t\mathbf{j} = \mathbf{i} - 4\mathbf{j}$  at the point  $(2, -4)$ ,  $\mathbf{u} = (\mathbf{i} - 4\mathbf{j})/\sqrt{17}$ ;  
 $\nabla z = 2x\mathbf{i} + 2y\mathbf{j} = 4\mathbf{i} - 8\mathbf{j}$  at  $(2, -4)$ , hence  $dz/ds = D_{\mathbf{u}}z = \nabla z \cdot \mathbf{u} = 36/\sqrt{17}$ .

52. (a)  $\nabla T(x, y) = \frac{y(1 - x^2 + y^2)}{(1 + x^2 + y^2)^2}\mathbf{i} + \frac{x(1 + x^2 - y^2)}{(1 + x^2 + y^2)^2}\mathbf{j}$ ,  $\nabla T(1, 1) = (\mathbf{i} + \mathbf{j})/9$ ,  $\mathbf{u} = (2\mathbf{i} - \mathbf{j})/\sqrt{5}$ ,  
 $D_{\mathbf{u}}T = 1/(9\sqrt{5})$

- (b)  $\mathbf{u} = -(\mathbf{i} + \mathbf{j})/\sqrt{2}$ , opposite to  $\nabla T(1, 1)$



53. (a)  $\nabla V(x, y) = -2e^{-2x} \cos 2y\mathbf{i} - 2e^{-2x} \sin 2y\mathbf{j}$ ,  $\mathbf{E} = -\nabla V(\pi/4, 0) = 2e^{-\pi/2}\mathbf{i}$   
 (b)  $V(x, y)$  decreases most rapidly in the direction of  $-\nabla V(x, y)$  which is  $\mathbf{E}$ .
54.  $\nabla z = -4x\mathbf{i} - 8y\mathbf{j}$ , if  $x = -20$  and  $y = 5$  then  $\nabla z = 80\mathbf{i} - 40\mathbf{j}$ .
- (a)  $\mathbf{u} = -\mathbf{i}$  points due west,  $D_{\mathbf{u}}z = -80$ , the climber will descend because  $z$  is decreasing.  
 (b)  $\mathbf{u} = (\mathbf{i} + \mathbf{j})/\sqrt{2}$  points northeast,  $D_{\mathbf{u}}z = 20\sqrt{2}$ , the climber will ascend at the rate of  $20\sqrt{2}$  ft per ft of travel in the  $xy$ -plane.  
 (c) The climber will travel a level path in a direction perpendicular to  $\nabla z = 80\mathbf{i} - 40\mathbf{j}$ , by inspection  $\pm(\mathbf{i} + 2\mathbf{j})/\sqrt{5}$  are unit vectors in these directions;  $(\mathbf{i} + 2\mathbf{j})/\sqrt{5}$  makes an angle of  $\tan^{-1}(1/2) \approx 27^\circ$  with the positive  $y$ -axis so  $-(\mathbf{i} + 2\mathbf{j})/\sqrt{5}$  makes the same angle with the negative  $y$ -axis. The compass direction should be N  $27^\circ$  E or S  $27^\circ$  W.
55. (a)  $\nabla r = \frac{x}{\sqrt{x^2 + y^2}}\mathbf{i} + \frac{y}{\sqrt{x^2 + y^2}}\mathbf{j} = \mathbf{r}/r$   
 (b)  $\nabla f(r) = \frac{\partial f(r)}{\partial x}\mathbf{i} + \frac{\partial f(r)}{\partial y}\mathbf{j} = f'(r)\frac{\partial r}{\partial x}\mathbf{i} + f'(r)\frac{\partial r}{\partial y}\mathbf{j} = f'(r)\nabla r$
56. (a)  $\nabla(re^{-3r}) = \frac{(1-3r)}{r}e^{-3r}\mathbf{r}$   
 (b)  $3r^2\mathbf{r} = \frac{f'(r)}{r}\mathbf{r}$  so  $f'(r) = 3r^3$ ,  $f(r) = \frac{3}{4}r^4 + C$ ,  $f(2) = 12 + C = 1$ ,  $C = -11$ ;  $f(r) = \frac{3}{4}r^4 - 11$
57.  $\mathbf{u}_r = \cos \theta\mathbf{i} + \sin \theta\mathbf{j}$ ,  $\mathbf{u}_\theta = -\sin \theta\mathbf{i} + \cos \theta\mathbf{j}$ ,  

$$\nabla z = \frac{\partial z}{\partial x}\mathbf{i} + \frac{\partial z}{\partial y}\mathbf{j} = \left(\frac{\partial z}{\partial r} \cos \theta - \frac{1}{r} \frac{\partial z}{\partial \theta} \sin \theta\right)\mathbf{i} + \left(\frac{\partial z}{\partial r} \sin \theta + \frac{1}{r} \frac{\partial z}{\partial \theta} \cos \theta\right)\mathbf{j}$$

$$= \frac{\partial z}{\partial r}(\cos \theta\mathbf{i} + \sin \theta\mathbf{j}) + \frac{1}{r} \frac{\partial z}{\partial \theta}(-\sin \theta\mathbf{i} + \cos \theta\mathbf{j}) = \frac{\partial z}{\partial r}\mathbf{u}_r + \frac{1}{r} \frac{\partial z}{\partial \theta}\mathbf{u}_\theta$$
58. (a)  $\nabla(f + g) = (f_x + g_x)\mathbf{i} + (f_y + g_y)\mathbf{j} = (f_x\mathbf{i} + f_y\mathbf{j}) + (g_x\mathbf{i} + g_y\mathbf{j}) = \nabla f + \nabla g$   
 (b)  $\nabla(cf) = (cf_x)\mathbf{i} + (cf_y)\mathbf{j} = c(f_x\mathbf{i} + f_y\mathbf{j}) = c\nabla f$   
 (c)  $\nabla(fg) = (fg_x + g f_x)\mathbf{i} + (fg_y + g f_y)\mathbf{j} = f(g_x\mathbf{i} + g_y\mathbf{j}) + g(f_x\mathbf{i} + f_y\mathbf{j}) = f\nabla g + g\nabla f$   
 (d)  $\nabla(f/g) = \frac{gf_x - fg_x}{g^2}\mathbf{i} + \frac{gf_y - fg_y}{g^2}\mathbf{j} = \frac{g(f_x\mathbf{i} + f_y\mathbf{j}) - f(g_x\mathbf{i} + g_y\mathbf{j})}{g^2} = \frac{g\nabla f - f\nabla g}{g^2}$   
 (e)  $\nabla(f^n) = (nf^{n-1}f_x)\mathbf{i} + (nf^{n-1}f_y)\mathbf{j} = nf^{n-1}(f_x\mathbf{i} + f_y\mathbf{j}) = nf^{n-1}\nabla f$
59.  $\mathbf{r}'(t) = \mathbf{v}(t) = k(x, y)\nabla \mathbf{T} = -8k(x, y)x\mathbf{i} - 2k(x, y)y\mathbf{j}$ ;  $\frac{dx}{dt} = -8kx$ ,  $\frac{dy}{dt} = -2ky$ . Divide and solve to get  $y^4 = 256x$ ; one parametrization is  $x(t) = e^{-8t}$ ,  $y(t) = 4e^{-2t}$ .
60.  $\mathbf{r}'(t) = \mathbf{v}(t) = k\nabla \mathbf{T} = -2k(x, y)x\mathbf{i} - 4k(x, y)y\mathbf{j}$ . Divide and solve to get  $y = \frac{3}{25}x^2$ ; one parametrization is  $x(t) = 5e^{-2t}$ ,  $y(t) = 3e^{-4t}$ .

61.

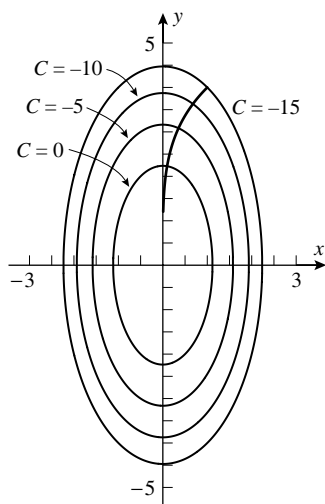

62.

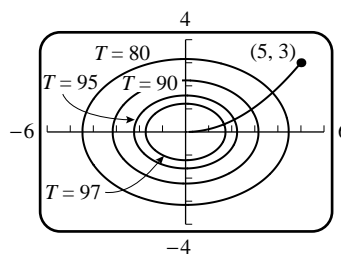

63. (a)

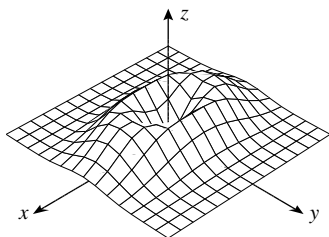

$$(c) \quad \nabla f = [2x - 2x(x^2 + 3y^2)]e^{-(x^2+y^2)}\mathbf{i} + [6y - 2y(x^2 + 3y^2)]e^{-(x^2+y^2)}\mathbf{j}$$

$$(d) \quad \nabla f = \mathbf{0} \text{ if } x = y = 0 \text{ or } x = 0, y = \pm 1 \text{ or } x = \pm 1, y = 0.$$

$$64. \quad dz/dt = (\partial z/\partial x)(dx/dt) + (\partial z/\partial y)(dy/dt)$$

$$= (\partial z/\partial x\mathbf{i} + \partial z/\partial y\mathbf{j}) \cdot (dx/dt\mathbf{i} + dy/dt\mathbf{j}) = \nabla z \cdot \mathbf{r}'(t)$$

$$65. \quad \nabla f(x, y) = f_x(x, y)\mathbf{i} + f_y(x, y)\mathbf{j}, \text{ if } \nabla f(x, y) = \mathbf{0} \text{ throughout the region then}$$

$$f_x(x, y) = f_y(x, y) = 0 \text{ throughout the region, the result follows from Exercise 51, Section 15.4.}$$

66. Let  $\mathbf{u}_1$  and  $\mathbf{u}_2$  be nonparallel unit vectors for which the directional derivative is zero. Let  $\mathbf{u}$  be any other unit vector, then  $\mathbf{u} = c_1\mathbf{u}_1 + c_2\mathbf{u}_2$  for some choice of scalars  $c_1$  and  $c_2$ ,

$$\begin{aligned} D_{\mathbf{u}}f(x, y) &= \nabla f(x, y) \cdot \mathbf{u} = c_1\nabla f(x, y) \cdot \mathbf{u}_1 + c_2\nabla f(x, y) \cdot \mathbf{u}_2 \\ &= c_1D_{\mathbf{u}_1}f(x, y) + c_2D_{\mathbf{u}_2}f(x, y) = 0. \end{aligned}$$

### EXERCISE SET 15.7

1.  $165t^{32}$

2.  $\frac{3 - (4/3)t^{-1/3} - 24t^{-7}}{3t - 2t^{2/3} + 4t^{-6}}$

3.  $-2t \cos(t^2)$

4.  $\frac{1 - 512t^5 - 2560t^5 \ln t}{2t\sqrt{1 + \ln t} - 512t^5 \ln t}$

5. 3264

6. 0

7.  $\nabla f(x, y, z) = 20x^4y^2z^3\mathbf{i} + 8x^5yz^3\mathbf{j} + 12x^5y^2z^2\mathbf{k}$ ,  $\nabla f(2, -1, 1) = 320\mathbf{i} - 256\mathbf{j} + 384\mathbf{k}$ ,  $D_{\mathbf{u}}f = -320$

8.  $\nabla f(x, y, z) = yze^{xz}\mathbf{i} + e^{xz}\mathbf{j} + (xye^{xz} + 2z)\mathbf{k}$ ,  $\nabla f(0, 2, 3) = 6\mathbf{i} + \mathbf{j} + 6\mathbf{k}$ ,  $D_{\mathbf{u}}f = 45/7$
9.  $\nabla f(x, y, z) = \frac{2x}{x^2 + 2y^2 + 3z^2}\mathbf{i} + \frac{4y}{x^2 + 2y^2 + 3z^2}\mathbf{j} + \frac{6z}{x^2 + 2y^2 + 3z^2}\mathbf{k}$ ,  
 $\nabla f(-1, 2, 4) = (-2/57)\mathbf{i} + (8/57)\mathbf{j} + (24/57)\mathbf{k}$ ,  $D_{\mathbf{u}}f = -314/741$
10.  $\nabla f(x, y, z) = yz \cos xyz\mathbf{i} + xz \cos xyz\mathbf{j} + xy \cos xyz\mathbf{k}$ ,  
 $\nabla f(1/2, 1/3, \pi) = (\pi\sqrt{3}/6)\mathbf{i} + (\pi\sqrt{3}/4)\mathbf{j} + (\sqrt{3}/12)\mathbf{k}$ ,  $D_{\mathbf{u}}f = (1 - \pi)/12$
11.  $\nabla f(x, y, z) = (3x^2z - 2xy)\mathbf{i} - x^2\mathbf{j} + (x^3 + 2z)\mathbf{k}$ ,  $\nabla f(2, -1, 1) = 16\mathbf{i} - 4\mathbf{j} + 10\mathbf{k}$ ,  
 $\mathbf{u} = (3\mathbf{i} - \mathbf{j} + 2\mathbf{k})/\sqrt{14}$ ,  $D_{\mathbf{u}}f = 72/\sqrt{14}$
12.  $\nabla f(x, y, z) = -x(x^2 + z^2)^{-1/2}\mathbf{i} + \mathbf{j} - z(x^2 + z^2)^{-1/2}\mathbf{k}$ ,  $\nabla f(-3, 1, 4) = (3/5)\mathbf{i} + \mathbf{j} - (4/5)\mathbf{k}$ ,  
 $\mathbf{u} = (2\mathbf{i} - 2\mathbf{j} - \mathbf{k})/3$ ,  $D_{\mathbf{u}}f = 0$
13.  $\nabla f(x, y, z) = -\frac{1}{z+y}\mathbf{i} - \frac{z-x}{(z+y)^2}\mathbf{j} + \frac{y+x}{(z+y)^2}\mathbf{k}$ ,  $\nabla f(1, 0, -3) = (1/3)\mathbf{i} + (4/9)\mathbf{j} + (1/9)\mathbf{k}$ ,  
 $\mathbf{u} = (-6\mathbf{i} + 3\mathbf{j} - 2\mathbf{k})/7$ ,  $D_{\mathbf{u}}f = -8/63$
14.  $\nabla f(x, y, z) = e^{x+y+3z}(\mathbf{i} + \mathbf{j} + 3\mathbf{k})$ ,  $\nabla f(-2, 2, -1) = e^{-3}(\mathbf{i} + \mathbf{j} + 3\mathbf{k})$ ,  $\mathbf{u} = (20\mathbf{i} - 4\mathbf{j} + 5\mathbf{k})/21$ ,  
 $D_{\mathbf{u}}f = (31/21)e^{-3}$
15.  $\nabla f(1, 1, -1) = 3\mathbf{i} - 3\mathbf{j}$ ,  $\mathbf{u} = (\mathbf{i} - \mathbf{j})/\sqrt{2}$ ,  $\|\nabla f(1, 1, -1)\| = 3\sqrt{2}$
16.  $\nabla f(0, -3, 0) = (\mathbf{i} - 3\mathbf{j} + 4\mathbf{k})/6$ ,  $\mathbf{u} = (\mathbf{i} - 3\mathbf{j} + 4\mathbf{k})/\sqrt{26}$ ,  $\|\nabla f(0, -3, 0)\| = \sqrt{26}/6$
17.  $\nabla f(1, 2, -2) = (-\mathbf{i} + \mathbf{j})/2$ ,  $\mathbf{u} = (-\mathbf{i} + \mathbf{j})/\sqrt{2}$ ,  $\|\nabla f(1, 2, -2)\| = 1/\sqrt{2}$
18.  $\nabla f(4, 2, 2) = (\mathbf{i} - \mathbf{j} - \mathbf{k})/8$ ,  $\mathbf{u} = (\mathbf{i} - \mathbf{j} - \mathbf{k})/\sqrt{3}$ ,  $\|\nabla f(4, 2, 2)\| = \sqrt{3}/8$
19.  $\nabla f(5, 7, 6) = -\mathbf{i} + 11\mathbf{j} - 12\mathbf{k}$ ,  $\mathbf{u} = (\mathbf{i} - 11\mathbf{j} + 12\mathbf{k})/\sqrt{266}$ ,  $-\|\nabla f(5, 7, 6)\| = -\sqrt{266}$
20.  $\nabla f(0, 1, \pi/4) = 2\sqrt{2}(\mathbf{i} - \mathbf{k})$ ,  $\mathbf{u} = -(\mathbf{i} - \mathbf{k})/\sqrt{2}$ ,  $-\|\nabla f(0, 1, \pi/4)\| = -4$
21.  $\nabla f(2, 1, -1) = -\mathbf{i} + \mathbf{j} - \mathbf{k}$ .  $\overrightarrow{PQ} = -3\mathbf{i} + \mathbf{j} + \mathbf{k}$ ,  $\mathbf{u} = (-3\mathbf{i} + \mathbf{j} + \mathbf{k})/\sqrt{11}$ ,  $D_{\mathbf{u}}f = 3/\sqrt{11}$
22.  $\nabla f(-1, -2, 1) = 13\mathbf{i} + 5\mathbf{j} - 20\mathbf{k}$ ,  $\mathbf{u} = -\mathbf{k}$ ,  $D_{\mathbf{u}}f = 20$
23. Let  $\mathbf{u}$  be the unit vector in the direction of  $\mathbf{a}$ , then  
 $D_{\mathbf{u}}f(3, -2, 1) = \nabla f(3, -2, 1) \cdot \mathbf{u} = \|\nabla f(3, -2, 1)\| \cos \theta = 5 \cos \theta = -5$ ,  $\cos \theta = -1$ ,  $\theta = \pi$  so  
 $\nabla f(3, -2, 1)$  is oppositely directed to  $\mathbf{u}$ ;  $\nabla f(3, -2, 1) = -5\mathbf{u} = -10/3\mathbf{i} + 5/3\mathbf{j} + 10/3\mathbf{k}$ .
24. (a)  $\nabla T(1, 1, 1) = (\mathbf{i} + \mathbf{j} + \mathbf{k})/8$ ,  $\mathbf{u} = -(\mathbf{i} + \mathbf{j} + \mathbf{k})/\sqrt{3}$ ,  $D_{\mathbf{u}}T = -\sqrt{3}/8$   
 (b)  $(\mathbf{i} + \mathbf{j} + \mathbf{k})/\sqrt{3}$  (c)  $\sqrt{3}/8$
25. (a)  $f(x, y, z) = x^2 + y^2 + 4z^2$ ,  $\nabla f = 2x\mathbf{i} + 2y\mathbf{j} + 8z\mathbf{k}$ ,  $\nabla f(2, 2, 1) = 4\mathbf{i} + 4\mathbf{j} + 8\mathbf{k}$ ,  
 $\mathbf{n} = \mathbf{i} + \mathbf{j} + 2\mathbf{k}$ ,  $x + y + 2z = 6$   
 (b)  $\mathbf{r}(t) = 2\mathbf{i} + 2\mathbf{j} + \mathbf{k} + t(\mathbf{i} + \mathbf{j} + 2\mathbf{k})$ ,  $x(t) = 2 + t$ ,  $y(t) = 2 + t$ ,  $z(t) = 1 + 2t$   
 (c)  $\cos \theta = \frac{\mathbf{n} \cdot \mathbf{k}}{\|\mathbf{n}\|} = \frac{\sqrt{2}}{\sqrt{3}}$ ,  $\theta \approx 35.26^\circ$

26. (a)  $f(x, y, z) = xz - yz^3 + yz^2$ ,  $\mathbf{n} = \nabla f(2, -1, 1) = \mathbf{i} + 3\mathbf{k}$ ; tangent plane  $x + 3z = 5$   
 (b) normal line  $x = 2 + t$ ,  $y = -1$ ,  $z = 1 + 3t$   
 (c)  $\cos \theta = \frac{\mathbf{n} \cdot \mathbf{k}}{\|\mathbf{n}\|} = \frac{3}{\sqrt{10}}$ ,  $\theta \approx 18.43^\circ$
27. Set  $f(x, y) = z + x - z^4(y - 1)$ , then  $f(x, y, z) = 0$ ,  $\mathbf{n} = \pm \nabla f(3, 5, 1) = \pm(\mathbf{i} - \mathbf{j} - 19\mathbf{k})$ ,  
 unit vectors  $\pm \frac{1}{363}(\mathbf{i} - \mathbf{j} - 19\mathbf{k})$
28.  $f(x, y, z) = \sin xz - 4 \cos yz$ ,  $\nabla f(\pi, \pi, 1) = -\mathbf{i} - \pi\mathbf{k}$ ; unit vectors  $\pm \frac{1}{\sqrt{1 + \pi^2}}(\mathbf{i} + \pi\mathbf{k})$
29.  $f(x, y, z) = x^2 + y^2 + z^2$ , if  $(x_0, y_0, z_0)$  is on the sphere then  $\nabla f(x_0, y_0, z_0) = 2(x_0\mathbf{i} + y_0\mathbf{j} + z_0\mathbf{k})$  is normal to the sphere at  $(x_0, y_0, z_0)$ , the normal line is  $x = x_0 + x_0t$ ,  $y = y_0 + y_0t$ ,  $z = z_0 + z_0t$  which passes through the origin when  $t = -1$ .
30.  $f(x, y, z) = 2x^2 + 3y^2 + 4z^2$ , if  $(x_0, y_0, z_0)$  is on the ellipsoid then  
 $\nabla f(x_0, y_0, z_0) = 2(2x_0\mathbf{i} + 3y_0\mathbf{j} + 4z_0\mathbf{k})$  is normal there and hence so is  $\mathbf{n}_1 = 2x_0\mathbf{i} + 3y_0\mathbf{j} + 4z_0\mathbf{k}$ ;  $\mathbf{n}_1$  must be parallel to  $\mathbf{n}_2 = \mathbf{i} - 2\mathbf{j} + 3\mathbf{k}$  which is normal to the given plane so  $\mathbf{n}_1 = c\mathbf{n}_2$  for some constant  $c$ . Equate corresponding components to get  $x_0 = c/2$ ,  $y_0 = -2c/3$ , and  $z_0 = 3c/4$ ; substitute into the equation of the ellipsoid yields  $2(c^2/4) + 3(4c^2/9) + 4(9c^2/16) = 9$ ,  $c^2 = 108/49$ ,  $c = \pm 6\sqrt{3}/7$ . The points on the ellipsoid are  $(3\sqrt{3}/7, -4\sqrt{3}/7, 9\sqrt{3}/14)$  and  $(-3\sqrt{3}/7, 4\sqrt{3}/7, -9\sqrt{3}/14)$ .
31.  $f(x, y, z) = x^2 + y^2 - z^2$ , if  $(x_0, y_0, z_0)$  is on the surface then  $\nabla f(x_0, y_0, z_0) = 2(x_0\mathbf{i} + y_0\mathbf{j} - z_0\mathbf{k})$  is normal there and hence so is  $\mathbf{n}_1 = x_0\mathbf{i} + y_0\mathbf{j} - z_0\mathbf{k}$ ;  $\mathbf{n}_1$  must be parallel to  $\overrightarrow{PQ} = 3\mathbf{i} + 2\mathbf{j} - 2\mathbf{k}$  so  $\mathbf{n}_1 = c\overrightarrow{PQ}$  for some constant  $c$ . Equate components to get  $x_0 = 3c$ ,  $y_0 = 2c$  and  $z_0 = 2c$  which when substituted into the equation of the surface yields  $9c^2 + 4c^2 - 4c^2 = 1$ ,  $c^2 = 1/9$ ,  $c = \pm 1/3$  so the points are  $(1, 2/3, 2/3)$  and  $(-1, -2/3, -2/3)$ .
32.  $f_1(x, y, z) = 2x^2 + 3y^2 + z^2$ ,  $f_2(x, y, z) = x^2 + y^2 + z^2 - 6x - 8y - 8z + 24$ ,  
 $\mathbf{n}_1 = \nabla f_1(1, 1, 2) = 4\mathbf{i} + 6\mathbf{j} + 4\mathbf{k}$ ,  $\mathbf{n}_2 = \nabla f_2(1, 1, 2) = -4\mathbf{i} - 6\mathbf{j} - 4\mathbf{k}$ ,  $\mathbf{n}_1 = -\mathbf{n}_2$  so  $\mathbf{n}_1$  and  $\mathbf{n}_2$  are parallel.
33.  $\mathbf{n}_1 = 2\mathbf{i} - 2\mathbf{j} - \mathbf{k}$ ,  $\mathbf{n}_2 = 2\mathbf{i} - 8\mathbf{j} + 4\mathbf{k}$ ,  $\mathbf{n}_1 \times \mathbf{n}_2 = 16\mathbf{i} - 10\mathbf{j} - 12\mathbf{k}$  is tangent to the line, so  
 $x(t) = 1 + 8t$ ,  $y(t) = -1 + 5t$ ,  $z(t) = 2 + 6t$
34.  $f(x, y, z) = \sqrt{x^2 + y^2} - z$ ,  $\mathbf{n}_1 = \nabla f(4, 3, 5) = \frac{4}{5}\mathbf{i} + \frac{3}{5}\mathbf{j} - \mathbf{k}$ ,  $\mathbf{n}_2 = \mathbf{i} + 2\mathbf{j} + 2\mathbf{k}$ ,  $\mathbf{n}_1 \times \mathbf{n}_2 = (16\mathbf{i} - 13\mathbf{j} + 5\mathbf{k})/5$   
 is tangent to the line,  $x(t) = 4 + 16t$ ,  $y(t) = 3 - 13t$ ,  $z(t) = 5 + 5t$
35.  $f(x, y, z) = x^2 + z^2 - 25$ ,  $g(x, y, z) = y^2 + z^2 - 25$ ,  $\mathbf{n}_1 = \nabla f(3, -3, 4) = 6\mathbf{i} + 8\mathbf{k}$ ,  
 $\mathbf{n}_2 = \nabla g(3, -3, 4) = -6\mathbf{j} + 8\mathbf{k}$ ,  $\mathbf{n}_1 \times \mathbf{n}_2 = 48\mathbf{i} - 48\mathbf{j} - 36\mathbf{k}$  is tangent to the line,  
 $x(t) = 3 + 4t$ ,  $y(t) = -3 - 4t$ ,  $z(t) = 4 - 3t$
36. (a)  $f(x, y, z) = z - 8 + x^2 + y^2$ ,  $g(x, y, z) = 4x + 2y - z$ ,  $\mathbf{n}_1 = 4\mathbf{j} + \mathbf{k}$ ,  $\mathbf{n}_2 = 4\mathbf{i} + 2\mathbf{j} - \mathbf{k}$ ,  
 $\mathbf{n}_1 \times \mathbf{n}_2 = -6\mathbf{i} + 4\mathbf{j} - 16\mathbf{k}$  is tangent to the line,  $x(t) = 3t$ ,  $y(t) = 2 - 2t$ ,  $z(t) = 4 + 8t$
37.  $dw = 3x^2y^2zdx + 2x^3yzdy + x^3y^2dz$ ,  $\Delta w = (x + \Delta x)^3(y + \Delta y)^2(z + \Delta z) - x^3y^2z$
38.  $dw = yze^{xyz}dx + xze^{xyz}dy + xye^{xyz}dz$ ,  $\Delta w = e^{(x+\Delta x)(y+\Delta y)(z+\Delta z)} - e^{xyz}$

39.  $dw = 8dx - 3dy + 4dz$

40.  $dw = (8xy^3z^7 - 3y) dx + (12x^2y^2z^7 - 3x) dy + (28x^2y^3z^6 + 1) dz$

41.  $dw = \frac{yz}{1+x^2y^2z^2} dx + \frac{xz}{1+x^2y^2z^2} dy + \frac{xy}{1+x^2y^2z^2} dz$

42.  $dw = \frac{1}{2\sqrt{x}} dx + \frac{1}{2\sqrt{y}} dy + \frac{1}{2\sqrt{z}} dz$

43.  $df = 2y^2z^3dx + 4xyz^3dy + 6xy^2z^2dz$   
 $= 2(-1)^2(2)^3(-0.01) + 4(1)(-1)(2)^3(-0.02) + 6(1)(-1)^2(2)^2(0.02) = 0.96$

44.  $df = \frac{yz(y+z)}{(x+y+z)^2} dx + \frac{xz(x+z)}{(x+y+z)^2} dy + \frac{xy(x+y)}{(x+y+z)^2} dz$   
 $= (-16)(-0.04) + (-12)(0.02) + (-6)(-0.03) = 0.58$

45.  $V = \ell wh$ ,  $dV = wh d\ell + \ell h dw + \ell w dh$ ,  
 $|dV| \leq wh|d\ell| + \ell h|dw| + \ell w|dh| \leq (4)(5)(0.05) + (3)(5)(0.05) + (3)(4)(0.05) = 2.35 \text{ cm}^3$

46.  $R = 1/(1/R_1 + 1/R_2 + 1/R_3)$ ,  $\partial R/\partial R_1 = \frac{1}{R_1^2(1/R_1 + 1/R_2 + 1/R_3)^2} = R^2/R_1^2$ , similarly  
 $\partial R/\partial R_2 = R^2/R_2^2$  and  $\partial R/\partial R_3 = R^2/R_3^2$  so  $\frac{dR}{R} = (R/R_1) \frac{dR_1}{R_1} + (R/R_2) \frac{dR_2}{R_2} + (R/R_3) \frac{dR_3}{R_3}$ ,  
 $\left| \frac{dR}{R} \right| \leq (R/R_1) \left| \frac{dR_1}{R_1} \right| + (R/R_2) \left| \frac{dR_2}{R_2} \right| + (R/R_3) \left| \frac{dR_3}{R_3} \right|$   
 $\leq (R/R_1)(0.10) + (R/R_2)(0.10) + (R/R_3)(0.10)$   
 $= R(1/R_1 + 1/R_2 + 1/R_3)(0.10) = (1)(0.10) = 0.10 = 10\%$

47.  $dA = \frac{1}{2}b \sin \theta da + \frac{1}{2}a \sin \theta db + \frac{1}{2}ab \cos \theta d\theta$ ,  
 $|dA| \leq \frac{1}{2}b \sin \theta |da| + \frac{1}{2}a \sin \theta |db| + \frac{1}{2}ab \cos \theta |d\theta|$   
 $\leq \frac{1}{2}(50)(1/2)(1/2) + \frac{1}{2}(40)(1/2)(1/4) + \frac{1}{2}(40)(50) \left( \frac{\sqrt{3}}{2} \right) (\pi/90)$   
 $= 35/4 + 50\pi\sqrt{3}/9 \approx 39 \text{ ft}^2$

48.  $V = \ell wh$ ,  $dV = whd\ell + \ell h dw + \ell w dh$ ,  $|dV/V| \leq |d\ell/\ell| + |dw/w| + |dh/h| \leq 3(r/100) = 3r\%$

49.  $\partial f/\partial v = 8vw^3x^4y^5$ ,  $\partial f/\partial w = 12v^2w^2x^4y^5$ ,  $\partial f/\partial x = 16v^2w^3x^3y^5$ ,  $\partial f/\partial y = 20v^2w^3x^4y^4$

50.  $\partial w/\partial r = \cos st + ue^u \cos ur$ ,  $\partial w/\partial s = -rt \sin st$ ,  
 $\partial w/\partial t = -rs \sin st$ ,  $\partial w/\partial u = re^u \cos ur + e^u \sin ur$

51.  $\partial f/\partial v_1 = 2v_1/(v_3^2 + v_4^2)$ ,  $\partial f/\partial v_2 = -2v_2/(v_3^2 + v_4^2)$ ,  $\partial f/\partial v_3 = -2v_3(v_1^2 - v_2^2)/(v_3^2 + v_4^2)^2$ ,  
 $\partial f/\partial v_4 = -2v_4(v_1^2 - v_2^2)/(v_3^2 + v_4^2)^2$

52.  $\frac{\partial V}{\partial x} = 2xe^{2x-y} + e^{2x-y}$ ,  $\frac{\partial V}{\partial y} = -xe^{2x-y} + w$ ,  $\frac{\partial V}{\partial z} = w^2e^{zw}$ ,  $\frac{\partial V}{\partial w} = we^{zw} + e^{zw} + y$

53. (a) 0 (b) 0 (c) 0 (d) 0  
 (e)  $2(yw + 1)e^{yw} \sin z \cos z$  (f)  $2xw(yw + 2)e^{yw} \sin z \cos z$
54. 128, -512, 32,  $64/3$
55.  $\partial z/\partial r = (dz/dx)(\partial x/\partial r) = 2r \cos^2 \theta / (r^2 \cos^2 \theta + 1)$ ,  
 $\partial z/\partial \theta = (dz/dx)(\partial x/\partial \theta) = -2r^2 \sin \theta \cos \theta / (r^2 \cos^2 \theta + 1)$
56.  $\partial u/\partial x = (\partial u/\partial r)(dr/dx) + (\partial u/\partial t)(\partial t/\partial x)$   
 $= (s^2 \ln t)(2x) + (rs^2/t)(y^3) = x(4y + 1)^2(1 + 2 \ln xy^3)$   
 $\partial u/\partial y = (\partial u/\partial s)(ds/dy) + (\partial u/\partial t)(\partial t/\partial y)$   
 $= (2rs \ln t)(4) + (rs^2/t)(3xy^2) = 8x^2(4y + 1) \ln xy^3 + 3x^2(4y + 1)^2/y$
57.  $\partial w/\partial \rho = 2\rho(4 \sin^2 \phi + \cos^2 \phi)$ ,  $\partial w/\partial \phi = 6\rho^2 \sin \phi \cos \phi$ ,  $\partial w/\partial \theta = 0$
58.  $\frac{dw}{dx} = \frac{\partial w}{\partial x} + \frac{\partial w}{\partial y} \frac{dy}{dx} + \frac{\partial w}{\partial z} \frac{dz}{dx} = 3y^2 z^3 + (6xyz^3)(6x) + 9xy^2 z^2 \frac{1}{2\sqrt{x-1}}$   
 $= 3(3x^2 + 2)^2(x-1)^{3/2} + 36x^2(3x^2 + 2)(x-1)^{3/2} + \frac{9}{2}x(3x^2 + 2)^2\sqrt{x-1}$   
 $= \frac{3}{2}(3x^2 + 2)(39x^3 - 30x^2 + 10x - 4)\sqrt{x-1}$
59. (a)  $V = \ell wh$ ,  $\frac{dV}{dt} = \frac{\partial V}{\partial \ell} \frac{d\ell}{dt} + \frac{\partial V}{\partial w} \frac{dw}{dt} + \frac{\partial V}{\partial h} \frac{dh}{dt} = wh \frac{d\ell}{dt} + \ell h \frac{dw}{dt} + \ell w \frac{dh}{dt}$   
 $= (3)(6)(1) + (2)(6)(2) + (2)(3)(3) = 60 \text{ in}^3/\text{s}$   
 (b)  $D = \sqrt{\ell^2 + w^2 + h^2}$ ;  $dD/dt = (\ell/D)d\ell/dt + (w/D)dw/dt + (h/D)dh/dt$   
 $= (2/7)(1) + (3/7)(2) + (6/7)(3) = 26/7 \text{ in/s}$
60. (a)  $\partial A/\partial a = (1/2)b \sin \theta = (1/2)(10)(\sqrt{3}/2) = 5\sqrt{3}/2$   
 (b)  $\partial A/\partial \theta = (1/2)ab \cos \theta = (1/2)(5)(10)(1/2) = 25/2$   
 (c)  $b = (2A \csc \theta)/a$ ,  $\partial b/\partial a = -(2A \csc \theta)/a^2 = -b/a = -2$
61. Let  $z = f(u)$  where  $u = x + 2y$ ; then  $\partial z/\partial x = (dz/du)(\partial u/\partial x) = dz/du$ ,  
 $\partial z/\partial y = (dz/du)(\partial u/\partial y) = 2dz/du$  so  $2\partial z/\partial x - \partial z/\partial y = 2dz/du - 2dz/du = 0$
62. Let  $z = f(u)$  where  $u = x^2 + y^2$ ; then  $\partial z/\partial x = (dz/du)(\partial u/\partial x) = 2x dz/du$ ,  
 $\partial z/\partial y = (dz/du)(\partial u/\partial y) = 2y dz/du$  so  $y \partial z/\partial x - x \partial z/\partial y = 2xy dz/du - 2xy dz/du = 0$
63.  $\partial w/\partial x = (dw/d\rho)(\partial \rho/\partial x) = (x/\rho)dw/d\rho$ , similarly  $\partial w/\partial y = (y/\rho)dw/d\rho$  and  
 $\partial w/\partial z = (z/\rho)dw/d\rho$  so  $(\partial w/\partial x)^2 + (\partial w/\partial y)^2 + (\partial w/\partial z)^2 = (dw/d\rho)^2$
64. Let  $w = f(r, s, t)$  where  $r = x - y$ ,  $s = y - z$ ,  $t = z - x$ ;  
 $\partial w/\partial x = (\partial w/\partial r)(\partial r/\partial x) + (\partial w/\partial t)(\partial t/\partial x) = \partial w/\partial r - \partial w/\partial t$ , similarly  
 $\partial w/\partial y = -\partial w/\partial r + \partial w/\partial s$  and  $\partial w/\partial z = -\partial w/\partial s + \partial w/\partial t$  so  $\partial w/\partial x + \partial w/\partial y + \partial w/\partial z = 0$
65.  $\partial w/\partial \rho = \sin \phi \cos \theta \partial w/\partial x + \sin \phi \sin \theta \partial w/\partial y + \cos \phi \partial w/\partial z$   
 $\partial w/\partial \phi = \rho \cos \phi \cos \theta \partial w/\partial x + \rho \cos \phi \sin \theta \partial w/\partial y - \rho \sin \phi \partial w/\partial z$   
 $\partial w/\partial \theta = -\rho \sin \phi \sin \theta \partial w/\partial x + \rho \sin \phi \cos \theta \partial w/\partial y$

$$66. \quad \frac{\partial F}{\partial x} + \frac{\partial F}{\partial z} \frac{\partial z}{\partial x} = 0 \text{ so } \frac{\partial z}{\partial x} = -\frac{\partial F/\partial x}{\partial F/\partial z}, \quad \frac{\partial F}{\partial y} + \frac{\partial F}{\partial z} \frac{\partial z}{\partial y} = 0 \text{ so } \frac{\partial z}{\partial y} = -\frac{\partial F/\partial y}{\partial F/\partial z}.$$

$$67. \quad \frac{\partial z}{\partial x} = \frac{2x + yz}{6yz - xy}, \quad \frac{\partial z}{\partial y} = \frac{xz - 3z^2}{6yz - xy}$$

$$68. \quad \ln(1+z) + xy^2 + z - 1 = 0; \quad \frac{\partial z}{\partial x} = -\frac{y^2(1+z)}{2+z}, \quad \frac{\partial z}{\partial y} = -\frac{2xy(1+z)}{2+z}$$

$$69. \quad ye^x - 5 \sin 3z - 3z = 0; \quad \frac{\partial z}{\partial x} = -\frac{ye^x}{-15 \cos 3z - 3} = \frac{ye^x}{15 \cos 3z + 3}, \quad \frac{\partial z}{\partial y} = \frac{e^x}{15 \cos 3z + 3}$$

$$70. \quad \frac{\partial z}{\partial x} = -\frac{ze^{yz} \cos xz - ye^{xy} \cos yz}{ye^{xy} \sin yz + xe^{yz} \cos xz + ye^{yz} \sin xz}, \quad \frac{\partial z}{\partial y} = -\frac{ze^{xy} \sin yz - xe^{xy} \cos yz + ze^{yz} \sin xz}{ye^{xy} \sin yz + xe^{yz} \cos xz + ye^{yz} \sin xz}$$

$$71. \quad \nabla f(u, v, w) = \frac{\partial f}{\partial x} \mathbf{i} + \frac{\partial f}{\partial y} \mathbf{j} + \frac{\partial f}{\partial z} \mathbf{k}$$

$$= \left( \frac{\partial f}{\partial u} \frac{\partial u}{\partial x} + \frac{\partial f}{\partial v} \frac{\partial v}{\partial x} + \frac{\partial f}{\partial w} \frac{\partial w}{\partial x} \right) \mathbf{i} + \left( \frac{\partial f}{\partial u} \frac{\partial u}{\partial y} + \frac{\partial f}{\partial v} \frac{\partial v}{\partial y} + \frac{\partial f}{\partial w} \frac{\partial w}{\partial y} \right) \mathbf{j}$$

$$+ \left( \frac{\partial f}{\partial u} \frac{\partial u}{\partial z} + \frac{\partial f}{\partial v} \frac{\partial v}{\partial z} + \frac{\partial f}{\partial w} \frac{\partial w}{\partial z} \right) \mathbf{k} = \frac{\partial f}{\partial u} \nabla u + \frac{\partial f}{\partial v} \nabla v + \frac{\partial f}{\partial w} \nabla w$$

$$72. \quad \text{(a) } \frac{\partial w}{\partial x} = \frac{\partial f}{\partial x} + \frac{\partial f}{\partial z} \frac{\partial z}{\partial x} \qquad \text{(b) } \frac{\partial w}{\partial y} = \frac{\partial f}{\partial y} + \frac{\partial f}{\partial z} \frac{\partial z}{\partial y}$$

$$73. \quad w_r = e^r / (e^r + e^s + e^t + e^u), \quad w_{rs} = -e^r e^s / (e^r + e^s + e^t + e^u)^2,$$

$$w_{rst} = 2e^r e^s e^t / (e^r + e^s + e^t + e^u)^3,$$

$$w_{rstu} = -6e^r e^s e^t e^u / (e^r + e^s + e^t + e^u)^4 = -6e^{r+s+t+u} / e^{4u} = -6e^{r+s+t+u-4u}$$

$$74. \quad \partial w / \partial y_1 = a_1 \partial w / \partial x_1 + a_2 \partial w / \partial x_2 + a_3 \partial w / \partial x_3,$$

$$\partial w / \partial y_2 = b_1 \partial w / \partial x_1 + b_2 \partial w / \partial x_2 + b_3 \partial w / \partial x_3$$

$$75. \quad \text{(a) } dw/dt = \sum_{i=1}^4 (\partial w / \partial x_i) (dx_i / dt)$$

$$\text{(b) } \partial w / \partial v_j = \sum_{i=1}^4 (\partial w / \partial x_i) (\partial x_i / \partial v_j) \text{ for } j = 1, 2, 3$$

$$76. \quad \text{Let } u = x_1^2 + x_2^2 + \dots + x_n^2; \text{ then } w = u^k, \quad \partial w / \partial x_i = k u^{k-1} (2x_i) = 2k x_i u^{k-1},$$

$$\partial^2 w / \partial x_i^2 = 2k(k-1)x_i u^{k-2} (2x_i) + 2k u^{k-1} = 4k(k-1)x_i^2 u^{k-2} + 2k u^{k-1} \text{ for } i = 1, 2, \dots, n$$

$$\text{so } \sum_{i=1}^n \partial^2 w / \partial x_i^2 = 4k(k-1) u^{k-2} \sum_{i=1}^n x_i^2 + 2kn u^{k-1}$$

$$= 4k(k-1)u^{k-2}u + 2kn u^{k-1} = 2ku^{k-1}[2(k-1) + n]$$

which is 0 if  $k = 0$  or if  $2(k-1) + n = 0$ ,  $k = 1 - n/2$ .

$$77. \quad dF/dx = (\partial F / \partial u)(du/dx) + (\partial F / \partial v)(dv/dx)$$

$$= f(u)g'(x) - f(v)h'(x) = f(g(x))g'(x) - f(h(x))h'(x)$$

78.  $\nabla f = f_x \mathbf{i} + f_y \mathbf{j} + f_z \mathbf{k}$  and  $\nabla g = g_x \mathbf{i} + g_y \mathbf{j} + g_z \mathbf{k}$  evaluated at  $(x_0, y_0, z_0)$  are normal, respectively, to the surfaces  $f(x, y, z) = 0$  and  $g(x, y, z) = 0$  at  $(x_0, y_0, z_0)$ . The surfaces are orthogonal at  $(x_0, y_0, z_0)$  if and only if  $\nabla f \cdot \nabla g = 0$  so  $f_x g_x + f_y g_y + f_z g_z = 0$ .
79.  $f(x, y, z) = x^2 + y^2 + z^2 - a^2 = 0$ ,  $g(x, y, z) = z^2 - x^2 - y^2 = 0$ ,  
 $f_x g_x + f_y g_y + f_z g_z = -4x^2 - 4y^2 + 4z^2 = 4g(x, y, z) = 0$

### EXERCISE SET 15.8

1. (a) minimum at  $(2, -1)$ , no maxima (b) maximum at  $(0, 0)$ , no minima  
 (c) no maxima or minima
2. (a) maximum at  $(-1, 5)$ , no minima (b) no maxima or minima  
 (c) no maxima or minima
3.  $f(x, y) = (x - 3)^2 + (y + 2)^2$ , minimum at  $(3, -2)$ , no maxima
4.  $f(x, y) = -(x + 1)^2 - 2(y - 1)^2 + 4$ , maximum at  $(-1, 1)$ , no minima
5.  $f_x = 6x + 2y = 0$ ,  $f_y = 2x + 2y = 0$ ; critical point  $(0, 0)$ ;  $D = 8 > 0$  and  $f_{xx} = 6 > 0$  at  $(0, 0)$ , relative minimum.
6.  $f_x = 3x^2 - 3y = 0$ ,  $f_y = -3x - 3y^2 = 0$ ; critical points  $(0, 0)$  and  $(-1, 1)$ ;  $D = -9 < 0$  at  $(0, 0)$ , saddle point;  $D = 27 > 0$  and  $f_{xx} = -6 < 0$  at  $(-1, 1)$ , relative maximum.
7.  $f_x = 2x - 2xy = 0$ ,  $f_y = 4y - x^2 = 0$ ; critical points  $(0, 0)$  and  $(\pm 2, 1)$ ;  $D = 8 > 0$  and  $f_{xx} = 2 > 0$  at  $(0, 0)$ , relative minimum;  $D = -16 < 0$  at  $(\pm 2, 1)$ , saddle points.
8.  $f_x = 3x^2 - 3 = 0$ ,  $f_y = 3y^2 - 3 = 0$ ; critical points  $(-1, \pm 1)$  and  $(1, \pm 1)$ ;  $D = -36 < 0$  at  $(-1, 1)$  and  $(1, -1)$ , saddle points;  $D = 36 > 0$  and  $f_{xx} = 6 > 0$  at  $(1, 1)$ , relative minimum;  $D = 36 > 0$  and  $f_{xx} = -36 < 0$  at  $(-1, -1)$ , relative maximum.
9.  $f_x = y + 2 = 0$ ,  $f_y = 2y + x + 3 = 0$ ; critical point  $(1, -2)$ ;  $D = -1 < 0$  at  $(1, -2)$ , saddle point.
10.  $f_x = 2x + y - 2 = 0$ ,  $f_y = x - 2 = 0$ ; critical point  $(2, -2)$ ;  $D = -1 < 0$  at  $(2, -2)$ , saddle point.
11.  $f_x = 2x + y - 3 = 0$ ,  $f_y = x + 2y = 0$ ; critical point  $(2, -1)$ ;  $D = 3 > 0$  and  $f_{xx} = 2 > 0$  at  $(2, -1)$ , relative minimum.
12.  $f_x = y - 3x^2 = 0$ ,  $f_y = x - 2y = 0$ ; critical points  $(0, 0)$  and  $(1/6, 1/12)$ ;  $D = -1 < 0$  at  $(0, 0)$ , saddle point;  $D = 1 > 0$  and  $f_{xx} = -1 < 0$  at  $(1/6, 1/12)$ , relative maximum.
13.  $f_x = 2x - 2/(x^2 y) = 0$ ,  $f_y = 2y - 2/(xy^2) = 0$ ; critical points  $(-1, -1)$  and  $(1, 1)$ ;  $D = 32 > 0$  and  $f_{xx} = 6 > 0$  at  $(-1, -1)$  and  $(1, 1)$ , relative minima.
14.  $f_x = e^y = 0$  is impossible, no critical points.
15.  $f_x = 2x = 0$ ,  $f_y = 1 - e^y = 0$ ; critical point  $(0, 0)$ ;  $D = -2 < 0$  at  $(0, 0)$ , saddle point.
16.  $f_x = y - 2/x^2 = 0$ ,  $f_y = x - 4/y^2 = 0$ ; critical point  $(1, 2)$ ;  $D = 3 > 0$  and  $f_{xx} = -4 > 0$  at  $(1, 2)$ , relative minimum.



17.  $f_x = e^x \sin y = 0$ ,  $f_y = e^x \cos y = 0$ ,  $\sin y = \cos y = 0$  is impossible, no critical points.
18.  $f_x = y \cos x = 0$ ,  $f_y = \sin x = 0$ ;  $\sin x = 0$  if  $x = n\pi$  for  $n = 0, \pm 1, \pm 2, \dots$  and  $\cos x \neq 0$  for these values of  $x$  so  $y = 0$ ; critical points  $(n\pi, 0)$  for  $n = 0, \pm 1, \pm 2, \dots$ ;  $D = -1 < 0$  at  $(n\pi, 0)$ , saddle points.
19.  $f_x = -2(x+1)e^{-(x^2+y^2+2x)} = 0$ ,  $f_y = -2ye^{-(x^2+y^2+2x)} = 0$ ; critical point  $(-1, 0)$ ;  $D = 4e^2 > 0$  and  $f_{xx} = -2e < 0$  at  $(-1, 0)$ , relative maximum.
20.  $f_x = y - a^3/x^2 = 0$ ,  $f_y = x - b^3/y^2 = 0$ ; critical point  $(a^2/b, b^2/a)$ ; if  $ab > 0$  then  $D = 3 > 0$  and  $f_{xx} = 2b^3/a^3 > 0$  at  $(a^2/b, b^2/a)$ , relative minimum; if  $ab < 0$  then  $D = 3 > 0$  and  $f_{xx} = 2b^3/a^3 < 0$  at  $(a^2/b, b^2/a)$ , relative maximum.

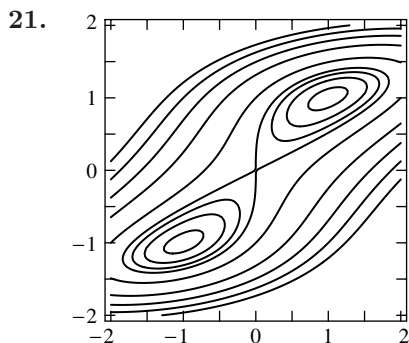

$\nabla f = (4x - 4y)\mathbf{i} - (4x - 4y^3)\mathbf{j} = \mathbf{0}$  when  $x = y, x = y^3$ , so  $x = y = 0$  or  $x = y = \pm 1$ . At  $(0, 0)$ ,  $D = -16$ , a saddle point; at  $(1, 1)$  and  $(-1, -1)$ ,  $D = 32 > 0$ ,  $f_{xx} = 4$ , a relative minimum.

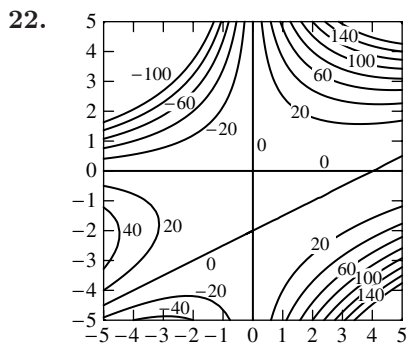

$\nabla f = (2y^2 - 2xy + 4y)\mathbf{i} + (4xy - x^2 + 4x)\mathbf{j} = \mathbf{0}$  when  $2y^2 - 2xy + 4y = 0$ ,  $4xy - x^2 + 4x = 0$ , with solutions  $(0, 0)$ ,  $(0, -2)$ ,  $(4, 0)$ ,  $(4/3, -2/3)$ . At  $(0, 0)$ ,  $D = -16$ , a saddle point. At  $(0, -2)$ ,  $D = -16$ , a saddle point. At  $(4, 0)$ ,  $D = -16$ , a saddle point. At  $(4/3, -2/3)$ ,  $D = 16/3$ ,  $f_{xx} = 4/3 > 0$ , a relative minimum.

23. (a) critical point  $(0,0)$ ;  $D = 0$   
 (b)  $f(0,0) = 0$ ,  $x^4 + y^4 \geq 0$  so  $f(x,y) \geq f(0,0)$ , relative minimum.
24. (a) critical point  $(0,0)$ ;  $D = 0$   
 (b)  $f(0,0) = 0$ , inside any circle centered at  $(0,0)$  there are points where  $f(x,y) > 0$  (along the  $x$ -axis) and points where  $f(x,y) < 0$  (along the  $y$ -axis) so  $(0,0)$  is a saddle point.

25. (a)  $f_x = 3e^y - 3x^2 = 3(e^y - x^2) = 0$ ,  $f_y = 3xe^y - 3e^{3y} = 3e^y(x - e^{2y}) = 0$ ,  $e^y = x^2$  and  $e^{2y} = x$ ,  $x^4 = x$ ,  $x(x^3 - 1) = 0$  so  $x = 0, 1$ ; critical point  $(1, 0)$ ;  $D = 27 > 0$  and  $f_{xx} = -6 < 0$  at  $(1, 0)$ , relative maximum.

(b)  $\lim_{x \rightarrow -\infty} f(x, 0) = \lim_{x \rightarrow -\infty} (3x - x^3 - 1) = +\infty$  so no absolute maximum.

26.  $f_x = 8xe^y - 8x^3 = 8x(e^y - x^2) = 0$ ,  $f_y = 4x^2e^y - 4e^{4y} = 4e^y(x^2 - e^{3y}) = 0$ ,  $x^2 = e^y$  and  $x^2 = e^{3y}$ ,  $e^{3y} = e^y$ ,  $e^{2y} = 1$ , so  $y = 0$  and  $x = \pm 1$ ; critical points  $(1, 0)$  and  $(-1, 0)$ .  $D = 128 > 0$  and  $f_{xx} = -16 < 0$  at both points so a relative maximum occurs at each one.

27.  $f_x = y - 1 = 0$ ,  $f_y = x - 3 = 0$ ; critical point  $(3, 1)$ .

Along  $y = 0$ :  $u(x) = -x$ ; no critical points,

along  $x = 0$ :  $v(y) = -3y$ ; no critical points,

along  $y = -\frac{4}{5}x + 4$ :  $w(x) = -\frac{4}{5}x^2 + \frac{27}{5}x - 12$ ; critical point  $(27/8, 13/10)$ .

$(x, y)$	$(3, 1)$	$(0, 0)$	$(5, 0)$	$(0, 4)$	$(27/8, 13/10)$
$f(x, y)$	$-3$	$0$	$-5$	$-12$	$-231/80$

Absolute maximum value is 0, absolute minimum value is  $-12$ .

28.  $f_x = y - 2 = 0$ ,  $f_y = x = 0$ ; critical point  $(0, 2)$ , but  $(0, 2)$  is not in the interior of  $R$ .

Along  $y = 0$ :  $u(x) = -2x$ ; no critical points,

along  $x = 0$ :  $v(y) = 0$ ; no critical points,

along  $y = 4 - x$ :  $w(x) = 2x - x^2$ ; critical point  $(1, 3)$ .

$(x, y)$	$(0, 0)$	$(0, 4)$	$(4, 0)$	$(1, 3)$
$f(x, y)$	$0$	$0$	$-8$	$1$

Absolute maximum value is 1, absolute minimum value is  $-8$ .

29.  $f_x = 2x - 2 = 0$ ,  $f_y = -6y + 6 = 0$ ; critical point  $(1, 1)$ .

Along  $y = 0$ :  $u_1(x) = x^2 - 2x$ ; critical point  $(1, 0)$ ,

along  $y = 2$ :  $u_2(x) = x^2 - 2x$ ; critical point  $(1, 2)$

along  $x = 0$ :  $v_1(y) = -3y^2 + 6y$ ; critical point  $(0, 1)$ ,

along  $x = 2$ :  $v_2(y) = -3y^2 + 6y$ ; critical point  $(2, 1)$

$(x, y)$	$(1, 1)$	$(1, 0)$	$(1, 2)$	$(0, 1)$	$(2, 1)$	$(0, 0)$	$(0, 2)$	$(2, 0)$	$(2, 2)$
$f(x, y)$	$2$	$-1$	$-1$	$3$	$3$	$0$	$0$	$0$	$0$

Absolute maximum value is 3, absolute minimum value is  $-1$ .

30.  $f_x = e^y - 2x = 0$ ,  $f_y = xe^y - e^y = e^y(x - 1) = 0$ ; critical point  $(1, \ln 2)$ .

Along  $y = 0$ :  $u_1(x) = x - x^2 - 1$ ; critical point  $(1/2, 0)$ ,

along  $y = 1$ :  $u_2(x) = ex - x^2 - e$ ; critical point  $(e/2, 1)$ ,

along  $x = 0$ :  $v_1(y) = -e^y$ ; no critical points,

along  $x = 2$ :  $v_2(y) = e^y - 4$ ; no critical points (for  $0 < y < 1$ ).

$(x, y)$	$(0, 0)$	$(0, 1)$	$(2, 1)$	$(2, 0)$	$(1, \ln 2)$	$(1/2, 0)$	$(e/2, 1)$
$f(x, y)$	$-1$	$-e$	$e - 4$	$-3$	$-1$	$-3/4$	$e(e - 4)/4 \approx -0.87$

Absolute maximum value is  $-3/4$ , absolute minimum value is  $-3$ .

31.  $f_x = 2x - 1 = 0$ ,  $f_y = 4y = 0$ ; critical point  $(1/2, 0)$ .

Along  $x^2 + y^2 = 4$ :  $y^2 = 4 - x^2$ ,  $u(x) = 8 - x - x^2$  for  $-2 \leq x \leq 2$ ; critical points  $(-1/2, \pm\sqrt{15}/2)$ .

$(x, y)$	$(1/2, 0)$	$(-1/2, \sqrt{15}/2)$	$(-1/2, -\sqrt{15}/2)$	$(-2, 0)$	$(2, 0)$
$f(x, y)$	$-1/4$	$33/4$	$33/4$	$6$	$2$

Absolute maximum value is  $33/4$ , absolute minimum value is  $-1/4$ .

32.  $f_x = y^2 = 0$ ,  $f_y = 2xy = 0$ ; no critical points in the interior of  $R$ .

Along  $y = 0$ :  $u(x) = 0$ ; no critical points,

along  $x = 0$ :  $v(y) = 0$ ; no critical points

along  $x^2 + y^2 = 1$ :  $w(x) = x - x^3$  for  $0 \leq x \leq 1$ ; critical point  $(1/\sqrt{3}, \sqrt{2/3})$ .

$(x, y)$	$(0, 0)$	$(0, 1)$	$(1, 0)$	$(1/\sqrt{3}, \sqrt{2/3})$
$f(x, y)$	$0$	$0$	$0$	$2\sqrt{3}/9$

Absolute maximum value is  $\frac{2}{9}\sqrt{3}$ , absolute minimum value is  $0$ .

33. Maximize  $P = xyz$  subject to  $x + y + z = 48$ ,  $x > 0$ ,  $y > 0$ ,  $z > 0$ .  $z = 48 - x - y$  so  $P = xy(48 - x - y) = 48xy - x^2y - xy^2$ ,  $P_x = 48y - 2xy - y^2 = 0$ ,  $P_y = 48x - x^2 - 2xy = 0$ . But  $x \neq 0$  and  $y \neq 0$  so  $48 - 2x - y = 0$  and  $48 - x - 2y = 0$ ; critical point  $(16, 16)$ .  $P_{xx}P_{yy} - P_{xy}^2 > 0$  and  $P_{xx} < 0$  at  $(16, 16)$ , relative maximum.  $z = 16$  when  $x = y = 16$ , the product is maximum for the numbers  $16, 16, 16$ .

34. Minimize  $S = x^2 + y^2 + z^2$  subject to  $x + y + z = 27$ ,  $x > 0$ ,  $y > 0$ ,  $z > 0$ .  $z = 27 - x - y$  so  $S = x^2 + y^2 + (27 - x - y)^2$ ,  $S_x = 4x + 2y - 54 = 0$ ,  $S_y = 2x + 4y - 54 = 0$ ; critical point  $(9, 9)$ ;  $S_{xx}S_{yy} - S_{xy}^2 = 12 > 0$  and  $S_{xx} = 4 > 0$  at  $(9, 9)$ , relative minimum.  $z = 9$  when  $x = y = 9$ , the sum of the squares is minimum for the numbers  $9, 9, 9$ .

35. Maximize  $w = xy^2z^2$  subject to  $x + y + z = 5$ ,  $x > 0$ ,  $y > 0$ ,  $z > 0$ .  $x = 5 - y - z$  so  $w = (5 - y - z)y^2z^2 = 5y^2z^2 - y^3z^2 - y^2z^3$ ,  $w_y = 10yz^2 - 3y^2z^2 - 2yz^3 = yz^2(10 - 3y - 2z) = 0$ ,  $w_z = 10y^2z - 2y^3z - 3y^2z^2 = y^2z(10 - 2y - 3z) = 0$ ,  $10 - 3y - 2z = 0$  and  $10 - 2y - 3z = 0$ ; critical point when  $y = z = 2$ ;  $w_{yy}w_{zz} - w_{yz}^2 = 320 > 0$  and  $w_{yy} = -24 < 0$  when  $y = z = 2$ , relative maximum.  $x = 1$  when  $y = z = 2$ ,  $xy^2z^2$  is maximum at  $(1, 2, 2)$ .

36. Minimize  $w = D^2 = x^2 + y^2 + z^2$  subject to  $x^2 - yz = 5$ .  $x^2 = 5 + yz$  so  $w = 5 + yz + y^2 + z^2$ ,  $w_y = z + 2y = 0$ ,  $w_z = y + 2z = 0$ ; critical point when  $y = z = 0$ ;  $w_{yy}w_{zz} - w_{yz}^2 = 3 > 0$  and  $w_{yy} = 2 > 0$  when  $y = z = 0$ , relative minimum.  $x^2 = 5$ ,  $x = \pm\sqrt{5}$  when  $y = z = 0$ . The points  $(\pm\sqrt{5}, 0, 0)$  are closest to the origin.

37. The diagonal of the box must equal the diameter of the sphere, thus we maximize  $V = xyz$  or, for convenience,  $w = V^2 = x^2y^2z^2$  subject to  $x^2 + y^2 + z^2 = 4a^2$ ,  $x > 0$ ,  $y > 0$ ,  $z > 0$ ;  $z^2 = 4a^2 - x^2 - y^2$  hence  $w = 4a^2x^2y^2 - x^4y^2 - x^2y^4$ ,  $w_x = 2xy^2(4a^2 - 2x^2 - y^2) = 0$ ,  $w_y = 2x^2y(4a^2 - x^2 - 2y^2) = 0$ ,  $4a^2 - 2x^2 - y^2 = 0$  and  $4a^2 - x^2 - 2y^2 = 0$ ; critical point  $(2a/\sqrt{3}, 2a/\sqrt{3})$ ;

$w_{xx}w_{yy} - w_{xy}^2 = \frac{4096}{27}a^8 > 0$  and  $w_{xx} = -\frac{128}{9}a^4 < 0$  at  $(2a/\sqrt{3}, 2a/\sqrt{3})$ , relative maximum.

$z = 2a/\sqrt{3}$  when  $x = y = 2a/\sqrt{3}$ , the dimensions of the box of maximum volume are  $2a/\sqrt{3}, 2a/\sqrt{3}, 2a/\sqrt{3}$ .

38. Maximize  $V = xyz$  subject to  $x + y + z = 1$ ,  $x > 0$ ,  $y > 0$ ,  $z > 0$ .  $z = 1 - x - y$  so  $V = xy - x^2y - xy^2$ ,  $V_x = y(1 - 2x - y) = 0$ ,  $V_y = x(1 - x - 2y) = 0$ ,  $1 - 2x - y = 0$  and  $1 - x - 2y = 0$ ; critical point  $(1/3, 1/3)$ ;  $V_{xx}V_{yy} - V_{xy}^2 = 1/3 > 0$  and  $V_{xx} = -2/3 < 0$  at  $(1/3, 1/3)$ , relative maximum. The maximum volume is  $V = (1/3)(1/3)(1/3) = 1/27$ .

- 39.** Let  $x$ ,  $y$ , and  $z$  be, respectively, the length, width, and height of the box. Minimize  $C = 10(2xy) + 5(2xz + 2yz) = 10(2xy + xz + yz)$  subject to  $xyz = 16$ .  $z = 16/(xy)$  so  $C = 20(xy + 8/y + 8/x)$ ,  $C_x = 20(y - 8/x^2) = 0$ ,  $C_y = 20(x - 8/y^2) = 0$ ; critical point  $(2,2)$ ;  $C_{xx}C_{yy} - C_{xy}^2 = 1200 > 0$  and  $C_{xx} = 40 > 0$  at  $(2,2)$ , relative minimum.  $z = 4$  when  $x = y = 2$ . The cost of materials is minimum if the length and width are 2 ft and the height is 4 ft.
- 40.** Maximize the profit  $P = 500(y - x)(x - 40) + [45,000 + 500(x - 2y)](y - 60)$   
 $= 500(-x^2 - 2y^2 + 2xy - 20x + 170y - 5400)$ .  
 $P_x = 1000(-x + y - 10) = 0$ ,  $P_y = 1000(-2y + x + 85) = 0$ ; critical point  $(65,75)$ ;  
 $P_{xx}P_{yy} - P_{xy}^2 = 1,000,000 > 0$  and  $P_{xx} = -1000 < 0$  at  $(65,75)$ , relative maximum. The profit will be maximum when  $x = 65$  and  $y = 75$ .
- 41.** (a)  $x = 0 : f(0, y) = -3y^2$ , minimum  $-3$ , maximum  $0$ ;  
 $x = 1, f(1, y) = 4 - 3y^2 + 2y, \frac{\partial f}{\partial y}(1, y) = -6y + 2 = 0$  at  $y = 1/3$ , minimum  $3$ ,  
maximum  $13/3$ ;  
 $y = 0, f(x, 0) = 4x^2$ , minimum  $0$ , maximum  $4$ ;  
 $y = 1, f(x, 1) = 4x^2 + 2x - 3, \frac{\partial f}{\partial x}(x, 1) = 8x + 2 \neq 0$  for  $0 < x < 1$ , minimum  $-3$ , maximum  $3$
- (b)  $f(x, x) = 3x^2$ , minimum  $0$ , maximum  $3$ ;  $f(x, 1-x) = -x^2 + 8x - 3, \frac{d}{dx}f(x, 1-x) = -2x + 8 \neq 0$  for  $0 < x < 1$ , maximum  $4$ , minimum  $-3$
- (c)  $f_x(x, y) = 8x + 2y = 0, f_y(x, y) = -3y + 2x = 0$ , solution is  $(0, 0)$ , which is not an interior point of the square, so check the sides: minimum  $-3$ , maximum  $14/3$ .
- 42.** Maximize  $A = ab \sin \alpha$  subject to  $2a + 2b = \ell, a > 0, b > 0, 0 < \alpha < \pi$ .  $b = (\ell - 2a)/2$  so  $A = (1/2)(\ell a - 2a^2) \sin \alpha, A_a = (1/2)(\ell - 4a) \sin \alpha, A_\alpha = (a/2)(\ell - 2a) \cos \alpha$ ;  $\sin \alpha \neq 0$  so from  $A_a = 0$  we get  $a = \ell/4$  and then from  $A_\alpha = 0$  we get  $\cos \alpha = 0, \alpha = \pi/2$ .  $A_{aa}A_{\alpha\alpha} - A_{a\alpha}^2 = \ell^2/8 > 0$  and  $A_{aa} = -2 < 0$  when  $a = \ell/4$  and  $\alpha = \pi/2$ , the area is maximum.
- 43.** Minimize  $S = xy + 2xz + 2yz$  subject to  $xyz = V, x > 0, y > 0, z > 0$  where  $x, y$ , and  $z$  are, respectively, the length, width, and height of the box.  $z = V/(xy)$  so  $S = xy + 2V/y + 2V/x, S_x = y - 2V/x^2 = 0, S_y = x - 2V/y^2 = 0$ ; critical point  $(\sqrt[3]{2V}, \sqrt[3]{2V})$ ;  $S_{xx}S_{yy} - S_{xy}^2 = 3 > 0$  and  $S_{xx} = 2 > 0$  at this point so there is a relative minimum there. The length and width are each  $\sqrt[3]{2V}$ , the height is  $z = \sqrt[3]{2V}/2$ .
- 44.** The altitude of the trapezoid is  $x \sin \phi$  and the lengths of the lower and upper bases are, respectively,  $27 - 2x$  and  $27 - 2x + 2x \cos \phi$  so we want to maximize  
 $A = (1/2)(x \sin \phi)[(27 - 2x) + (27 - 2x + 2x \cos \phi)] = 27x \sin \phi - 2x^2 \sin \phi + x^2 \sin \phi \cos \phi$ .  
 $A_x = \sin \phi(27 - 4x + 2x \cos \phi)$ ,  
 $A_\phi = x(27 \cos \phi - 2x \cos \phi - x \sin^2 \phi + x \cos^2 \phi) = x(27 \cos \phi - 2x \cos \phi + 2x \cos^2 \phi - x)$ .  
 $\sin \phi \neq 0$  so from  $A_x = 0$  we get  $\cos \phi = (4x - 27)/(2x), x \neq 0$  so from  $A_\phi = 0$  we get  
 $(27 - 2x + 2x \cos \phi) \cos \phi - x = 0$  which, for  $\cos \phi = (4x - 27)/(2x)$ , yields  $4x - 27 - x = 0$ ,  
 $x = 9$ . If  $x = 9$  then  $\cos \phi = 1/2, \phi = \pi/3$ . The critical point occurs when  $x = 9$  and  $\phi = \pi/3$ ;  
 $A_{xx}A_{\phi\phi} - A_{x\phi}^2 = 729/2 > 0$  and  $A_{xx} = -3\sqrt{3}/2 < 0$  there, the area is maximum when  $x = 9$  and  
 $\phi = \pi/3$ .

$$45. \quad (a) \quad \frac{\partial g}{\partial m} = \sum_{i=1}^n 2(mx_i + b - y_i)x_i = 2 \left( m \sum_{i=1}^n x_i^2 + b \sum_{i=1}^n x_i - \sum_{i=1}^n x_i y_i \right) = 0 \text{ if}$$

$$\left( \sum_{i=1}^n x_i^2 \right) m + \left( \sum_{i=1}^n x_i \right) b = \sum_{i=1}^n x_i y_i,$$

$$\frac{\partial g}{\partial b} = \sum_{i=1}^n 2(mx_i + b - y_i) = 2 \left( m \sum_{i=1}^n x_i + bn - \sum_{i=1}^n y_i \right) = 0 \text{ if } \left( \sum_{i=1}^n x_i \right) m + nb = \sum_{i=1}^n y_i$$

(b) The function  $z = g(m, b)$ , as a function of  $m$  and  $b$ , has only one critical point, found in part (a), and tends to  $+\infty$  as either  $|m|$  or  $|b|$  tends to infinity. Thus the only critical point must be a minimum.

$$46. \quad (a) \quad \sum_{i=1}^n (x_i - \bar{x})^2 = \sum_{i=1}^n (x_i^2 - 2\bar{x}x_i + \bar{x}^2) = \sum_{i=1}^n x_i^2 - 2\bar{x} \sum_{i=1}^n x_i + n\bar{x}^2$$

$$= \sum_{i=1}^n x_i^2 - \frac{2}{n} \left( \sum_{i=1}^n x_i \right)^2 + \frac{1}{n} \left( \sum_{i=1}^n x_i \right)^2$$

$$= \sum_{i=1}^n x_i^2 - \frac{1}{n} \left( \sum_{i=1}^n x_i \right)^2 > 0 \text{ so } n \sum_{i=1}^n x_i^2 - \left( \sum_{i=1}^n x_i \right)^2 > 0$$

$$(b) \quad g_{mm} = 2 \sum_{i=1}^n x_i^2, \quad g_{bb} = 2n, \quad g_{mb} = 2 \sum_{i=1}^n x_i,$$

$$D = g_{mm}g_{bb} - g_{mb}^2 = 4 \left[ n \sum_{i=1}^n x_i^2 - \left( \sum_{i=1}^n x_i \right)^2 \right] > 0 \text{ and } g_{mm} > 0$$

(c)  $g(m, b)$  is of the second-degree in  $m$  and  $b$  so the graph of  $z = g(m, b)$  is a quadric surface.

(d) The only quadric surface of this form having a relative minimum is a paraboloid that opens upward where the relative minimum is also the absolute minimum.

$$47. \quad n = 3, \sum_{i=1}^3 x_i = 3, \sum_{i=1}^3 y_i = 7, \sum_{i=1}^3 x_i y_i = 13, \sum_{i=1}^3 x_i^2 = 11, y = \frac{3}{4}x + \frac{19}{12}$$

$$48. \quad n = 4, \sum_{i=1}^4 x_i = 7, \sum_{i=1}^4 y_i = 4, \sum_{i=1}^4 x_i^2 = 21, \sum_{i=1}^4 x_i y_i = -2, y = -\frac{36}{35}x + \frac{14}{5}$$

$$49. \quad \sum_{i=1}^4 x_i = 10, \sum_{i=1}^4 y_i = 8.2, \sum_{i=1}^4 x_i^2 = 30, \sum_{i=1}^4 x_i y_i = 23, n = 4; m = 0.5, b = 0.8, y = 0.5x + 0.8.$$

$$50. \quad \sum_{i=1}^5 x_i = 15, \sum_{i=1}^5 y_i = 15.1, \sum_{i=1}^5 x_i^2 = 55, \sum_{i=1}^5 x_i y_i = 39.8, n = 5; m = -0.55, b = 4.67, y = 4.67 - 0.55x$$

51. (a)  $y = \frac{8843}{140} + \frac{57}{200}t \approx 63.1643 + 0.285t$

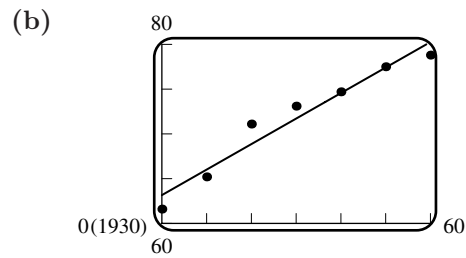

(c)  $y = \frac{2909}{35} \approx 83.1143$

52. (a)  $y \approx 119.84 - 1.13x$

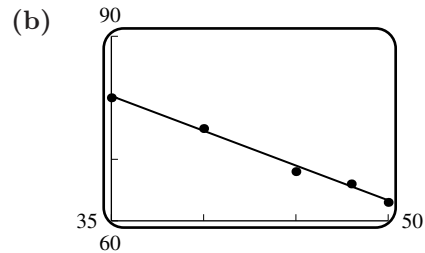

(c) about 52 units

53. (a)  $P = \frac{2798}{21} + \frac{171}{350}T \approx 133.2381 + 0.4886T$

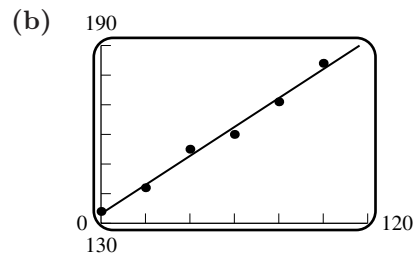

(c)  $T \approx -\frac{139,900}{513} \approx -272.7096^\circ \text{ C}$

54. (a) for example,  $z = y$

(b) For example, on  $0 \leq x \leq 1, 0 \leq y \leq 1$  let  $z = \begin{cases} y & \text{if } 0 < x < 1, 0 < y < 1 \\ 1/2 & \text{if } x = 0, 1 \text{ or } y = 0, 1 \end{cases}$

55.  $f(x_0, y_0) \geq f(x, y)$  for all  $(x, y)$  inside a circle centered at  $(x_0, y_0)$  by virtue of Definition 15.8.1. If  $r$  is the radius of the circle, then in particular  $f(x_0, y_0) \geq f(x, y_0)$  for all  $x$  satisfying  $|x - x_0| < r$  so  $f(x, y_0)$  has a relative maximum at  $x_0$ . The proof is similar for the function  $f(x_0, y)$ .

## EXERCISE SET 15.9

- (a)  $xy = 4$  is tangent to the line, so the maximum value of  $f$  is 4.

(b)  $xy = 2$  intersects the curve and so gives a smaller value of  $f$ .

(c) Maximize  $f(x, y) = xy$  subject to the constraint  $g(x, y) = x + y - 4 = 0, \nabla f = \lambda \nabla g,$   
 $y\mathbf{i} + x\mathbf{j} = \lambda(\mathbf{i} + \mathbf{j}),$  so solve the equations  $y = \lambda, x = \lambda$  with solution  $x = y = \lambda,$  but  $x + y = 4,$   
so  $x = y = 2,$  and the maximum value of  $f$  is  $f = xy = 4.$

2. (a)  $x^2 + y^2 = 25$  is tangent to the line at  $(3, 4)$ , so the minimum value of  $f$  is 25.  
 (b) A smaller value of  $f$  yields a circle of a smaller radius, and hence does not intersect the line.  
 (c) Minimize  $f(x, y) = x^2 + y^2$  subject to the constraint  $g(x, y) = 3x + 4y - 25 = 0$ ,  $\nabla f = \lambda \nabla g$ ,  $2x\mathbf{i} + 2y\mathbf{j} = 3\lambda\mathbf{i} + 4\lambda\mathbf{j}$ , so solve  $2x = 3\lambda$ ,  $2y = 4\lambda$ ; solution is  $x = 3$ ,  $y = 4$ , minimum = 25.
3.  $y = 8x\lambda$ ,  $x = 16y\lambda$ ;  $y/(8x) = x/(16y)$ ,  $x^2 = 2y^2$  so  $4(2y^2) + 8y^2 = 16$ ,  $y^2 = 1$ ,  $y = \pm 1$ . Test  $(\pm\sqrt{2}, -1)$  and  $(\pm\sqrt{2}, 1)$ .  $f(-\sqrt{2}, -1) = f(\sqrt{2}, 1) = \sqrt{2}$ ,  $f(-\sqrt{2}, 1) = f(\sqrt{2}, -1) = -\sqrt{2}$ . Maximum  $\sqrt{2}$  at  $(-\sqrt{2}, -1)$  and  $(\sqrt{2}, 1)$ , minimum  $-\sqrt{2}$  at  $(-\sqrt{2}, 1)$  and  $(\sqrt{2}, -1)$ .
4.  $2x = 2x\lambda$ ,  $-1 = 2y\lambda$ . If  $x \neq 0$  then  $\lambda = 1$  and  $y = -1/2$  so  $x^2 + (-1/2)^2 = 25$ ,  $x^2 = 99/4$ ,  $x = \pm 3\sqrt{11}/2$ . If  $x = 0$  then  $0^2 + y^2 = 25$ ,  $y = \pm 5$ . Test  $(\pm 3\sqrt{11}/2, -1/2)$  and  $(0, \pm 5)$ .  $f(\pm 3\sqrt{11}/2, -1/2) = 101/4$ ,  $f(0, -5) = 5$ ,  $f(0, 5) = -5$ . Maximum  $101/4$  at  $(\pm 3\sqrt{11}/2, -1/2)$ , minimum  $-5$  at  $(0, 5)$ .
5.  $12x^2 = 4x\lambda$ ,  $2y = 2y\lambda$ . If  $y \neq 0$  then  $\lambda = 1$  and  $12x^2 = 4x$ ,  $12x(x - 1/3) = 0$ ,  $x = 0$  or  $x = 1/3$  so from  $2x^2 + y^2 = 1$  we find that  $y = \pm 1$  when  $x = 0$ ,  $y = \pm\sqrt{7}/3$  when  $x = 1/3$ . If  $y = 0$  then  $2x^2 + (0)^2 = 1$ ,  $x = \pm 1/\sqrt{2}$ . Test  $(0, \pm 1)$ ,  $(1/3, \pm\sqrt{7}/3)$ , and  $(\pm 1/\sqrt{2}, 0)$ .  $f(0, \pm 1) = 1$ ,  $f(1/3, \pm\sqrt{7}/3) = 25/27$ ,  $f(1/\sqrt{2}, 0) = \sqrt{2}$ ,  $f(-1/\sqrt{2}, 0) = -\sqrt{2}$ . Maximum  $\sqrt{2}$  at  $(1/\sqrt{2}, 0)$ , minimum  $-\sqrt{2}$  at  $(-1/\sqrt{2}, 0)$ .
6.  $1 = 2x\lambda$ ,  $-3 = 6y\lambda$ ;  $1/(2x) = -1/(2y)$ ,  $y = -x$  so  $x^2 + 3(-x)^2 = 16$ ,  $x = \pm 2$ . Test  $(-2, 2)$  and  $(2, -2)$ .  $f(-2, 2) = -9$ ,  $f(2, -2) = 7$ . Maximum 7 at  $(2, -2)$ , minimum  $-9$  at  $(-2, 2)$ .
7.  $2 = 2x\lambda$ ,  $1 = 2y\lambda$ ,  $-2 = 2z\lambda$ ;  $1/x = 1/(2y) = -1/z$  thus  $x = 2y$ ,  $z = -2y$  so  $(2y)^2 + y^2 + (-2y)^2 = 4$ ,  $y^2 = 4/9$ ,  $y = \pm 2/3$ . Test  $(-4/3, -2/3, 4/3)$  and  $(4/3, 2/3, -4/3)$ .  $f(-4/3, -2/3, 4/3) = -6$ ,  $f(4/3, 2/3, -4/3) = 6$ . Maximum 6 at  $(4/3, 2/3, -4/3)$ , minimum  $-6$  at  $(-4/3, -2/3, 4/3)$ .
8.  $3 = 4x\lambda$ ,  $6 = 8y\lambda$ ,  $2 = 2z\lambda$ ;  $3/(4x) = 3/(4y) = 1/z$  thus  $y = x$ ,  $z = 4x/3$ , so  $2x^2 + 4(x)^2 + (4x/3)^2 = 70$ ,  $x^2 = 9$ ,  $x = \pm 3$ . Test  $(-3, -3, -4)$  and  $(3, 3, 4)$ .  $f(-3, -3, -4) = -35$ ,  $f(3, 3, 4) = 35$ . Maximum 35 at  $(3, 3, 4)$ , minimum  $-35$  at  $(-3, -3, -4)$ .
9.  $yz = 2x\lambda$ ,  $xz = 2y\lambda$ ,  $xy = 2z\lambda$ ;  $yz/(2x) = xz/(2y) = xy/(2z)$  thus  $y^2 = x^2$ ,  $z^2 = x^2$  so  $x^2 + x^2 + x^2 = 1$ ,  $x = \pm 1/\sqrt{3}$ . Test the eight possibilities with  $x = \pm 1/\sqrt{3}$ ,  $y = \pm 1/\sqrt{3}$ , and  $z = \pm 1/\sqrt{3}$  to find the maximum is  $1/(3\sqrt{3})$  at  $(1/\sqrt{3}, 1/\sqrt{3}, 1/\sqrt{3})$ ,  $(1/\sqrt{3}, -1/\sqrt{3}, -1/\sqrt{3})$ ,  $(-1/\sqrt{3}, 1/\sqrt{3}, -1/\sqrt{3})$ , and  $(-1/\sqrt{3}, -1/\sqrt{3}, 1/\sqrt{3})$ ; the minimum is  $-1/(3\sqrt{3})$  at  $(1/\sqrt{3}, 1/\sqrt{3}, -1/\sqrt{3})$ ,  $(1/\sqrt{3}, -1/\sqrt{3}, 1/\sqrt{3})$ ,  $(-1/\sqrt{3}, 1/\sqrt{3}, 1/\sqrt{3})$ , and  $(-1/\sqrt{3}, -1/\sqrt{3}, -1/\sqrt{3})$ .
10.  $4x^3 = \lambda$ ,  $4y^3 = \lambda$ ,  $4z^3 = \lambda$ , so  $x = y = z$ ;  $x + y + z = 3x = 1$ ,  $x = y = z = 1/3$ , minimum value  $1/27$ , no maximum
11.  $f(x, y) = x^2 + y^2$ ;  $2x = 2\lambda$ ,  $2y = -4\lambda$ ;  $y = -2x$  so  $2x - 4(-2x) = 3$ ,  $x = 3/10$ . The point is  $(3/10, -3/5)$ .
12.  $f(x, y) = (x - 4)^2 + (y - 2)^2$ ,  $g(x, y) = y - 2x - 3$ ;  $2(x - 4) = -2\lambda$ ,  $2(y - 2) = \lambda$ ;  $x - 4 = -2(y - 2)$ ,  $x = -2y + 8$  so  $y = 2(-2y + 8) + 3$ ,  $y = 19/5$ . The point is  $(2/5, 19/5)$ .
13.  $f(x, y, z) = x^2 + y^2 + z^2$ ;  $2x = \lambda$ ,  $2y = 2\lambda$ ,  $2z = \lambda$ ;  $y = 2x$ ,  $z = x$  so  $x + 2(2x) + x = 1$ ,  $x = 1/6$ . The point is  $(1/6, 1/3, 1/6)$ .
14.  $f(x, y, z) = (x - 1)^2 + (y + 1)^2 + (z - 1)^2$ ;  $2(x - 1) = 4\lambda$ ,  $2(y + 1) = 3\lambda$ ,  $2(z - 1) = \lambda$ ;  $x = 4z - 3$ ,  $y = 3z - 4$  so  $4(4z - 3) + 3(3z - 4) + z = 2$ ,  $z = 1$ . The point is  $(1, -1, 1)$ .

15.  $f(x, y) = (x - 1)^2 + (y - 2)^2$ ;  $2(x - 1) = 2x\lambda$ ,  $2(y - 2) = 2y\lambda$ ;  $(x - 1)/x = (y - 2)/y$ ,  $y = 2x$  so  $x^2 + (2x)^2 = 45$ ,  $x = \pm 3$ .  $f(-3, -6) = 80$  and  $f(3, 6) = 20$  so  $(3, 6)$  is closest and  $(-3, -6)$  is farthest.
16.  $f(x, y, z) = x^2 + y^2 + z^2$ ;  $2x = y\lambda$ ,  $2y = x\lambda$ ,  $2z = -2z\lambda$ . If  $z \neq 0$  then  $\lambda = -1$  so  $2x = -y$  and  $2y = -x$ ,  $x = y = 0$ ; substitute into  $xy - z^2 = 1$  to get  $z^2 = -1$  which has no real solution. If  $z = 0$  then  $xy - (0)^2 = 1$ ,  $y = 1/x$ , and also (from  $2x = y\lambda$  and  $2y = x\lambda$ ),  $2x/y = 2y/x$ ,  $y^2 = x^2$  so  $(1/x)^2 = x^2$ ,  $x^4 = 1$ ,  $x = \pm 1$ . Test  $(1, 1, 0)$  and  $(-1, -1, 0)$  to see that they are both closest to the origin.
17.  $f(x, y, z) = x + y + z$ ,  $x^2 + y^2 + z^2 = 25$  where  $x$ ,  $y$ , and  $z$  are the components of the vector;  $1 = 2x\lambda$ ,  $1 = 2y\lambda$ ,  $1 = 2z\lambda$ ;  $1/(2x) = 1/(2y) = 1/(2z)$ ;  $y = x$ ,  $z = x$  so  $x^2 + x^2 + x^2 = 25$ ,  $x = \pm 5/\sqrt{3}$ .  $f(-5/\sqrt{3}, -5/\sqrt{3}, -5/\sqrt{3}) = -5\sqrt{3}$  and  $f(5/\sqrt{3}, 5/\sqrt{3}, 5/\sqrt{3}) = 5\sqrt{3}$  so the vector is  $5(\mathbf{i} + \mathbf{j} + \mathbf{k})/\sqrt{3}$ .
18.  $x^2 + y^2 = 25$  is the constraint;  $8x - 4y = 2x\lambda$ ,  $-4x + 2y = 2y\lambda$ ;  $(4x - 2y)/x = (-2x + y)/y$ ,  $2x^2 + 3xy - 2y^2 = 0$ ,  $(2x - y)(x + 2y) = 0$ ,  $y = 2x$  or  $x = -2y$ . If  $y = 2x$  then  $x^2 + (2x)^2 = 25$ ,  $x = \pm\sqrt{5}$ . If  $x = -2y$  then  $(-2y^2) + y^2 = 25$ ,  $y = \pm\sqrt{5}$ .  $T(-\sqrt{5}, -2\sqrt{5}) = T(\sqrt{5}, 2\sqrt{5}) = 0$  and  $T(2\sqrt{5}, -\sqrt{5}) = T(-2\sqrt{5}, \sqrt{5}) = 125$ . The highest temperature is 125 and the lowest is 0.

19. (a)

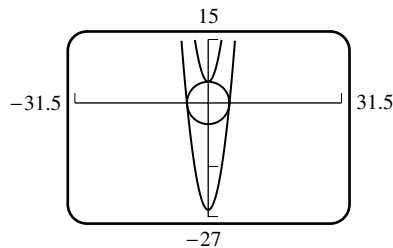
(b) minimum value  $-5$ ,  
maximum value  $101/4$ 

- (c) Find the minimum and maximum values of  $f(x, y) = x^2 - y$  subject to the constraint  $g(x, y) = x^2 + y^2 - 25 = 0$ ,  $\nabla f = \lambda \nabla g$ ,  $2x\mathbf{i} - \mathbf{j} = 2\lambda x\mathbf{i} + 2\lambda y\mathbf{j}$ , so solve  $2x = 2\lambda x$ ,  $-1 = 2\lambda y$ . If  $x = 0$  then  $y = \pm 5$ ,  $f = \mp 5$ , and if  $x \neq 0$  then  $\lambda = 1$ ,  $y = -1/2$ ,  $x^2 = 25 - 1/4 = 99/4$ ,  $f = 99/4 + 1/2 = 101/4$ , so the maximum value of  $f$  is  $101/4$  at  $(\pm 3\sqrt{11}/2, -1/2)$  and the minimum value of  $f$  is  $-5$  at  $(0, 5)$ .

20. (a)

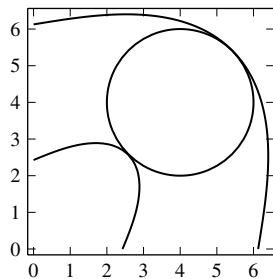
(b)  $f \approx 15$ 

- (d) Set  $f(x, y) = x^3 + y^3 - 3xy$ ,  $g(x, y) = (x - 4)^2 + (y - 4)^2 - 25$ ; minimize  $f$  subject to the constraint  $g = 0$ :  $\nabla f = \lambda \nabla g$ ,  $(3x^2 - 3y)\mathbf{i} + (3y^2 - 3x)\mathbf{j} = 2\lambda(x - 4)\mathbf{i} + 2\lambda(y - 4)\mathbf{j}$ , so solve (use a CAS)  $3x^2 - 3y = 2\lambda(x - 4)$ ,  $3y^2 - 3x = 2\lambda(y - 4)$ ; minimum value  $f = 14.52$  at  $(2.5858, 2.5858)$

21. Minimize  $f = x^2 + y^2 + z^2$  subject to  $g(x, y, z) = x + y + z - 27 = 0$ .  $\nabla f = \lambda \nabla g$ ,  $2x\mathbf{i} + 2y\mathbf{j} + 2z\mathbf{k} = \lambda\mathbf{i} + \lambda\mathbf{j} + \lambda\mathbf{k}$ , solution  $x = y = z = 9$ , minimum value 243



22. Maximize  $f(x, y, z) = xy^2z^2$  subject to  $g(x, y, z) = x + y + z - 5 = 0, \nabla f = \lambda \nabla g = \lambda(\mathbf{i} + \mathbf{j} + \mathbf{k}), \lambda = y^2z^2 = 2xy^2z = 2xy^2z, \lambda = 0$  is impossible, hence  $x, y, z \neq 0$ , and  $z = y = 2x, 5x - 5 = 0, x = 1, y = z = 2$ , maximum value 8 at  $(1, 2, 2)$
23. Minimize  $f = x^2 + y^2 + z^2$  subject to  $x^2 - yz = 5, \nabla f = \lambda \nabla g, 2x = 2x\lambda, 2y = -z\lambda, 2z = -y\lambda$ . If  $\lambda \neq \pm 2$ , then  $y = z = 0, x = \pm\sqrt{5}, f = 5$ ; if  $\lambda = \pm 2$  then  $x = 0$ , and since  $-yz = 5, y = -z = \pm\sqrt{5}, f = 10$ , thus the minimum value is 5 at  $(\pm\sqrt{5}, 0, 0)$ .
24. The diagonal of the box must equal the diameter of the sphere so maximize  $V = xyz$  or, for convenience, maximize  $f = V^2 = x^2y^2z^2$  subject to  $g(x, y, z) = x^2 + y^2 + z^2 - 4a^2 = 0, \nabla f = \lambda \nabla g, 2xy^2z^2 = 2\lambda x, 2x^2yz^2 = 2\lambda y, 2x^2y^2z = 2\lambda z$ . Since  $V \neq 0$  it follows that  $x, y, z \neq 0$ , hence  $x = \pm y = \pm z, 3x^2 = 4a^2, x = \pm 2a/\sqrt{3}$ , maximum volume  $8a^3/(3\sqrt{3})$ .
25. Let  $x, y$ , and  $z$  be, respectively, the length, width, and height of the box. Minimize  $f(x, y, z) = 10(2xy) + 5(2xz + 2yz) = 10(2xy + xz + yz)$  subject to  $g(x, y, z) = xyz - 16 = 0, \nabla f = \lambda \nabla g, 20y + 10z = \lambda yz, 20x + 10z = \lambda xz, 10x + 10y = \lambda z$ . Since  $V = xyz = 16, x, y, z \neq 0$ , thus  $\lambda z = 20 + 10(z/y) = 20 + 10(z/x) = 10x + 10y$ , so  $x = y$ . Then  $z = 16/x^2$ , thus  $20 + 10(16/x^3) = 20x, x^3 + 8 = x^4$ , the only real solution of which is  $x = 2$ , thus  $x = y = 2, z = 4$ , minimum value 240.
26. Minimize  $f(p, q, r) = 2pq + 2pr + 2qr$ , subject to  $g(p, q, r) = p + q + r - 1 = 0, \nabla_{(p,q,r)} f = \lambda \nabla_{(p,q,r)} g, 2(q + r) = \lambda, 2(p + r) = \lambda, 2(p + q) = \lambda$ , solution  $p = q = r = 1/3$ , minimum value  $2/3$ .
27. Maximize  $A(a, b, \alpha) = ab \sin \alpha$  subject to  $g(a, b, \alpha) = 2a + 2b - \ell = 0, \nabla_{(a,b,\alpha)} f = \lambda \nabla_{(a,b,\alpha)} g, b \sin \alpha = 2\lambda, a \sin \alpha = 2\lambda, ab \cos \alpha = 0$  with solution  $a = b, \alpha = \pi/2$  maximum value if parallelogram is a square.
28. Minimize  $f(x, y, z) = xy + 2xz + 2yz$  subject to  $g(x, y, z) = xyz - V = 0, \nabla f = \lambda \nabla g, y + 2z = \lambda yz, x + 2z = \lambda xz, 2x + 2y = \lambda xy; \lambda = 0$  leads to  $x = y = z = 0$ , impossible, so solve for  $\lambda = 1/z + 2/x = 1/z + 2/y = 2/y + 2/x$ , so  $x = y = 2z, x^3 = 2V$ , minimum value  $3(2V)^{2/3}$
29. (a) Maximize  $f(\alpha, \beta, \gamma) = \cos \alpha \cos \beta \cos \gamma$  subject to  $g(\alpha, \beta, \gamma) = \alpha + \beta + \gamma - \pi = 0, \nabla f = \lambda \nabla g, -\sin \alpha \cos \beta \cos \gamma = \lambda, -\cos \alpha \sin \beta \cos \gamma = \lambda, -\cos \alpha \cos \beta \sin \gamma = \lambda$  with solution  $\alpha = \beta = \gamma = \pi/3$ , maximum value  $3\sqrt{3}/8$
- (b) for example,  $f(\alpha, \beta) = \cos \alpha \cos \beta \cos(\pi - \alpha - \beta)$

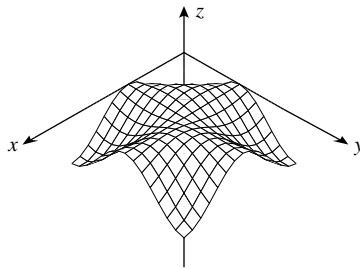

30. Find maxima and minima  $z = x^2 + 4y^2$  subject to the constraint  $g(x, y) = x^2 + y^2 - 1 = 0, \nabla z = \lambda \nabla g, 2x\mathbf{i} + 8y\mathbf{j} = 2\lambda x\mathbf{i} + 2\lambda y\mathbf{j}$ , solve  $2x = 2\lambda x, 8y = 2\lambda y$ . If  $y \neq 0$  then  $\lambda = 4, x = 0, y^2 = 1$  and  $z = x^2 + 4y^2 = 4$ . If  $y = 0$  then  $x^2 = 1$  and  $z = 1$ , so the maximum height is obtained for  $(x, y) = (0, \pm 1), z = 4$  and the minimum height is  $z = 1$  at  $(\pm 1, 0)$ .

## CHAPTER 15 SUPPLEMENTARY EXERCISES

1. (a) They approximate the profit per unit of any additional sales of the standard or high-resolution monitors, respectively.  
 (b) The rates of change with respect to the two directions  $x$  and  $y$ , and with respect to time.
3.  $z = \sqrt{x^2 + y^2} = c$  implies  $x^2 + y^2 = c^2$ , which is the equation of a circle;  $x^2 + y^2 = c$  is also the equation of a circle (for  $c > 0$ ).

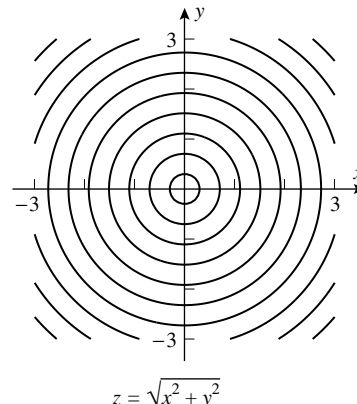
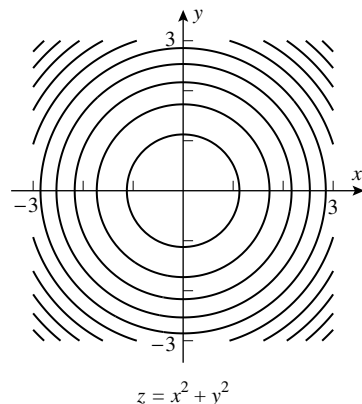

5. (b)  $f(x, y, z) = z - x^2 - y^2$

7. (a)  $f(\ln y, e^x) = e^{\ln y} \ln e^x = xy$

(b)  $e^{r+s} \ln rs$

8. (a)

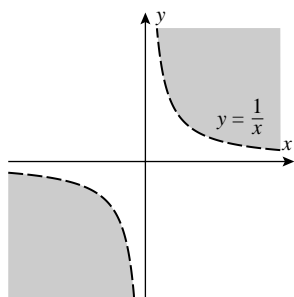

(b)

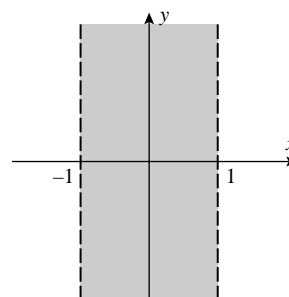

9.  $w_x = 2x \sec^2(x^2 + y^2) + \sqrt{y}$ ,  $w_{xy} = 8xy \sec^2(x^2 + y^2) \tan(x^2 + y^2) + \frac{1}{2}y^{-1/2}$ ,  
 $w_y = 2y \sec^2(x^2 + y^2) + \frac{1}{2}xy^{-1/2}$ ,  $w_{yx} = 8xy \sec^2(x^2 + y^2) \tan(x^2 + y^2) + \frac{1}{2}y^{-1/2}$
10.  $\partial w / \partial x = \frac{1}{x - y} - \sin(x + y)$ ,  $\partial^2 w / \partial x^2 = -\frac{1}{(x - y)^2} - \cos(x + y)$ ,  
 $\partial w / \partial y = -\frac{1}{x - y} - \sin(x + y)$ ,  $\partial^2 w / \partial y^2 = -\frac{1}{(x - y)^2} - \cos(x + y) = \partial^2 w / \partial x^2$
11.  $F_x = -6xz$ ,  $F_{xx} = -6z$ ,  $F_y = -6yz$ ,  $F_{yy} = -6z$ ,  $F_z = 6z^2 - 3x^2 - 3y^2$ ,  
 $F_{zz} = 12z$ ,  $F_{xx} + F_{yy} + F_{zz} = -6z - 6z + 12z = 0$
12.  $f_x = yz + 2x$ ,  $f_{xy} = z$ ,  $f_{xyz} = 1$ ,  $f_{xyzx} = 0$ ;  $f_z = xy - (1/z)$ ,  $f_{zx} = y$ ,  $f_{zxx} = 0$ ,  $f_{zxxy} = 0$

13. (a)  $P = \frac{10T}{V}$ ,  $\frac{dP}{dT} = \frac{10}{V} \frac{dT}{dT} = 12 \text{ K}/(\text{m}^2\text{min})$       (b)  $\frac{dP}{dt} = -10 \frac{P}{V^2} \frac{dV}{dt} = 240 \text{ K}/(\text{m}^2\text{min})$
14. (a)  $z = 1 - y^2$ , slope  $= \frac{\partial z}{\partial y} = -2y = 4$       (b)  $z = 1 - 4x^2$ ,  $\frac{\partial z}{\partial x} = -8x = -8$
15.  $x^4 - x + y - x^3y = (x^3 - 1)(x - y)$ , limit  $= -1$ , continuous
16.  $\frac{x^4 - y^4}{x^2 + y^2} = x^2 - y^2$ , limit  $= \lim_{(x,y) \rightarrow (0,0)} (x^2 - y^2) = 0$ , continuous
17. Use the unit vectors  $\mathbf{u} = \langle \frac{1}{\sqrt{2}}, \frac{1}{\sqrt{2}} \rangle$ ,  $\mathbf{v} = \langle 0, -1 \rangle$ ,  $\mathbf{w} = \langle -\frac{1}{\sqrt{5}}, -\frac{2}{\sqrt{5}} \rangle = -\frac{\sqrt{2}}{\sqrt{5}}\mathbf{u} + \frac{1}{\sqrt{5}}\mathbf{v}$ , so that  
 $D_{\mathbf{w}}f = -\frac{\sqrt{2}}{\sqrt{5}}D_{\mathbf{u}}f + \frac{1}{\sqrt{5}}D_{\mathbf{v}}f = -\frac{\sqrt{2}}{\sqrt{5}}2\sqrt{2} + \frac{1}{\sqrt{5}}(-3) = -\frac{7}{\sqrt{5}}$
18. (a)  $\mathbf{n} = z_x\mathbf{i} + z_y\mathbf{j} - \mathbf{k} = 8\mathbf{i} + 8\mathbf{j} - \mathbf{k}$ , tangent plane  $8x + 8y - z = 4 + 8 \ln 2$ , normal line  
 $x(t) = 1 + 8t$ ,  $y(t) = \ln 2 + 8t$ ,  $z(t) = 4 - t$
- (b)  $\mathbf{n} = 3\mathbf{i} + 10\mathbf{j} - 14\mathbf{k}$ , tangent plane  $3x + 10y - 14z = 30$ , normal line  
 $x(t) = 2 + 3t$ ,  $y(t) = 1 + 10t$ ,  $z(t) = -1 - 14t$
19. The origin is not such a point, so assume that the normal line at  $(x_0, y_0, z_0) \neq (0, 0, 0)$  passes through the origin, then  $\mathbf{n} = z_x\mathbf{i} + z_y\mathbf{j} - \mathbf{k} = -y_0\mathbf{i} - x_0\mathbf{j} - \mathbf{k}$ ; the line passes through the origin and is normal to the surface if it has the form  $\mathbf{r}(t) = -y_0t\mathbf{i} - x_0t\mathbf{j} - t\mathbf{k}$  and  $(x_0, y_0, z_0) = (x_0, y_0, 2 - x_0y_0)$  lies on the line if  $-y_0t = x_0$ ,  $-x_0t = y_0$ ,  $-t = 2 - x_0y_0$ , with solutions  $x_0 = y_0 = -1$ ,  $x_0 = y_0 = 1$ ,  $x_0 = y_0 = 0$ ; thus the points are  $(0, 0, 2)$ ,  $(1, 1, 1)$ ,  $(-1, -1, 1)$ .
20.  $\mathbf{n} = \frac{2}{3}x_0^{-1/3}\mathbf{i} + \frac{2}{3}y_0^{-1/3}\mathbf{j} + \frac{2}{3}z_0^{-1/3}\mathbf{k}$ , tangent plane  $x_0^{-1/3}x + y_0^{-1/3}y + z_0^{-1/3}z = x_0^{2/3} + y_0^{2/3} + z_0^{2/3} = 1$ ; intercepts are  $x = x_0^{1/3}$ ,  $y = y_0^{1/3}$ ,  $z = z_0^{1/3}$ , sum of squares of intercepts is  $x_0^{2/3} + y_0^{2/3} + z_0^{2/3} = 1$ .
21. A tangent to the line is  $6\mathbf{i} + 4\mathbf{j} + \mathbf{k}$ , a normal to the surface is  $\mathbf{n} = 18x\mathbf{i} + 8y\mathbf{j} - \mathbf{k}$ , so solve  
 $18x = 6k$ ,  $8y = 4k$ ,  $-1 = k$ ;  $k = -1$ ,  $x = -1/3$ ,  $y = -1/2$ ,  $z = 2$
22.  $\Delta w = (1.1)^2(-0.1) - 2(1.1)(-0.1) + (-0.1)^2(1.1) - 0 = 0.11$ ,  
 $dw = (2xy - 2y + y^2)dx + (x^2 - 2x + 2yx)dy = -(-0.1) = 0.1$
23.  $dV = \frac{2}{3}xhdx + \frac{1}{3}x^2dh = \frac{2}{3}2(-0.1) + \frac{1}{3}(0.2) = -0.06667 \text{ m}^3$ ;  $\Delta V = -0.07267 \text{ m}^3$
24.  $\nabla f = (2x + 3y - 6)\mathbf{i} + (3x + 6y + 3)\mathbf{j} = \mathbf{0}$  if  $2x + 3y = 6$ ,  $x + 2y = -1$ ,  $x = 15$ ,  $y = -8$ ,  $D = 3 > 0$ ,  $f_{xx} = 2 > 0$ , so  $f$  has a relative minimum at  $(15, -8)$ .
25.  $\nabla f = (2xy - 6x)\mathbf{i} + (x^2 - 12y)\mathbf{j} = \mathbf{0}$  if  $2xy - 6x = 0$ ,  $x^2 - 12y = 0$ ; if  $x = 0$  then  $y = 0$ , and if  $x \neq 0$  then  $y = 3$ ,  $x = \pm 6$ , thus the gradient vanishes at  $(0, 0)$ ,  $(-6, 3)$ ,  $(6, 3)$ ;  $f_{xx} = 0$  at all three points,  $f_{yy} = -12 < 0$ ,  $D = -4x^2$ , so  $(\pm 6, 3)$  are saddle points, and near the origin we write  $f(x, y) = (y - 3)x^2 - 6y^2$ ; since  $y - 3 < 0$  when  $|y| < 3$ ,  $f$  has a maximum by inspection.
26.  $\nabla f = (3x^2 - 3y)\mathbf{i} - (3x - y)\mathbf{j} = \mathbf{0}$  if  $y = x^2$ ,  $3x = y$ , so  $x = y = 0$  or  $x = 3$ ,  $y = 9$ ; at  $x = y = 0$ ,  $D = -9$ , saddle point; at  $x = 3$ ,  $y = 9$ ,  $D = 9$ ,  $f_{xx} = 18 > 0$ , relative minimum

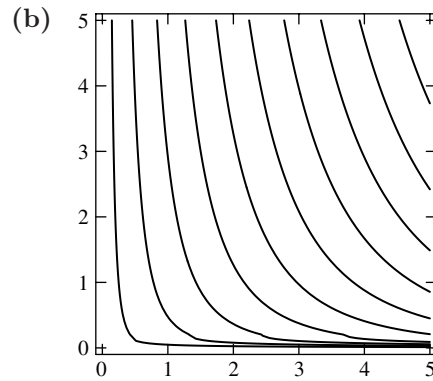
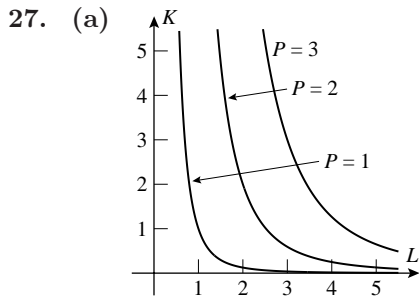

28. (a)  $\partial P/\partial L = c\alpha L^{\alpha-1}K^\beta$ ,  $\partial P/\partial K = c\beta L^\alpha K^{\beta-1}$   
 (b) the rates of change of output with respect to labor and capital equipment, respectively  
 (c)  $K(\partial P/\partial K) + L(\partial P/\partial L) = c\beta L^\alpha K^\beta + c\alpha L^\alpha K^\beta = (\alpha + \beta)P = P$
29. (a)  $L + K = 200,000$ ,  $P = 1000L^{0.6}(200,000 - L)^{0.4}$ ,  

$$dP/dL = 600 \frac{(200,000 - L)^{0.4}}{L^4} - 400 \frac{L^6}{(200,000 - L)^{0.6}} = 0 \text{ when } L = 120,000,$$
 $P = 102,033,960.1$ , which is a maximum because  $P = 0$  at  $L = 0, 200,000$ ,  $P > 0$  in between, and  $dP/dL = 0$  has only the one solution.  
 (b) Since  $L + K = 200,000$  and  $L = 120,000$ ,  $K = 80,000$
30. (a)  $y^2 = 8 - 4x^2$ , find extrema of  $f(x) = x^2(8 - 4x^2) = -4x^4 + 8x^2$  defined for  $-\sqrt{2} \leq x \leq \sqrt{2}$ . Then  $f'(x) = -16x^3 + 16x = 0$  when  $x = 0, \pm 1$ ,  $f''(x) = -48x^2 + 16$ , so  $f$  has a relative maximum at  $x = \pm 1, y = \pm 2$  and a relative minimum at  $x = 0, y = \pm 2\sqrt{2}$ . At the endpoints  $x = \pm\sqrt{2}, y = 0$  we obtain the minimum  $f = 0$  again.  
 (b)  $f(x, y) = x^2y^2, g(x, y) = 4x^2 + y^2 - 8 = 0, \nabla f = 2xy^2\mathbf{i} + 2x^2y\mathbf{j} = \lambda\nabla g = 8\lambda x\mathbf{i} + 2\lambda y\mathbf{j}$ , so solve  $2xy^2 = 8\lambda x, 2x^2y = 2\lambda y$ . If  $x = 0$  then  $y = \pm 2\sqrt{2}$ , and if  $y = 0$  then  $x = \pm\sqrt{2}$ . In either case  $f$  has a relative and absolute minimum. Assume  $x, y \neq 0$ , then  $y^2 = 4\lambda, x^2 = \lambda$ , use  $g = 0$  to obtain  $x^2 = 1, x = \pm 1, y = \pm 2$ , and  $f = 4$  is a relative and absolute maximum at  $(\pm 1, \pm 2)$ .
31. Let a corner of the box be at  $(x, y, z)$ , so that  $(x/a)^2 + (y/b)^2 + (z/c)^2 = 1$ . Maximize  $V = xyz$  subject to  $g(x, y, z) = (x/a)^2 + (y/b)^2 + (z/c)^2 = 1$ , solve  $\nabla V = \lambda\nabla g$ , or  $yz\mathbf{i} + xz\mathbf{j} + xy\mathbf{k} = (2\lambda x/a^2)\mathbf{i} + (2\lambda y/b^2)\mathbf{j} + (2\lambda z/c^2)\mathbf{k}$ ,  $a^2yz = 2\lambda x, b^2xz = 2\lambda y, c^2xy = 2\lambda z$ . For the maximum volume,  $x, y, z \neq 0$ ; divide the first and second equations to obtain  $a^2y^2 = b^2x^2$ ; the first and third to obtain  $a^2z^2 = c^2x^2$ , and finally  $b^2z^2 = c^2y^2$ . From  $g = 0$  get  $3(x/a)^2 = 1, x = \pm a/\sqrt{3}$ , and then  $y = \pm b/\sqrt{3}, z = \pm c/\sqrt{3}$ . The dimensions of the box are  $\frac{2a}{\sqrt{3}} \times \frac{2b}{\sqrt{3}} \times \frac{2c}{\sqrt{3}}$ , and the maximum volume is  $8abc/(3\sqrt{3})$ .
32. (a) Let  $f(x, y) = 3x^2 - 5xy + \tan xy = 0$ . Then  $\frac{df}{dx} = 6x - 5y + y \sec^2 xy + (-5x + x \sec^2 xy) \frac{dy}{dx} = 0$ , so  $\frac{dy}{dx} = \frac{6x - 5y + y \sec^2 xy}{5x - x \sec^2 xy}$ .  
 (b) Let  $g(x, y) = x \ln y + \sin(x - y) = \pi$ ,  $\frac{dg}{dx} = \ln y + \cos(x - y) + \left(\frac{x}{y} - \cos(x - y)\right) \frac{dy}{dx} = 0$ ,  

$$\frac{dy}{dx} = \frac{\ln y + \cos(x - y)}{-x/y + \cos(x - y)}$$

33.  $F(x, y) = 0, F_x + F_y \frac{dy}{dx} = 0, F_{xx} + F_{xy} \frac{dy}{dx} + F_{yx} \frac{dy}{dx} + F_y \frac{d^2y}{dx^2} = 0$ , thus

$$\frac{dy}{dx} = -\frac{F_x}{F_y}, \frac{d^2y}{dx^2} = -\frac{F_{xx} + 2F_{xy}(dy/dx)}{F_y} = -\frac{F_{xx}F_y - 2F_xF_{xy}}{F_y^2}$$

34. Denote the currents  $I_1, I_2, I_3$  by  $x, y, z$  respectively. Then minimize  $F(x, y, z) = x^2R_1 + y^2R_2 + z^2R_3$  subject to  $g(x, y, z) = x + y + z - I = 0$ , so solve  $\nabla F = \lambda \nabla g, 2xR_1\mathbf{i} + 2yR_2\mathbf{j} + 2zR_3\mathbf{k} = \lambda(\mathbf{i} + \mathbf{j} + \mathbf{k})$ ,  $\lambda = 2xR_1 = 2yR_2 = 2zR_3$ , so the minimum value of  $F$  occurs when  $I_1 : I_2 : I_3 = \frac{1}{R_1} : \frac{1}{R_2} : \frac{1}{R_3}$ .

35. Solve  $(t-1)^2/4 + 16e^{-2t} + (2-\sqrt{t})^2 = 1$  for  $t$  to get  $t = 1.8332, 2.83984$ ; the particle strikes the surface at the points  $P_1(0.8332, 0.63959, 0.64603), P_2(1.83984, 0.23374, 0.31482)$ . The velocity vectors are given by  $\mathbf{v} = \frac{dx}{dt}\mathbf{i} + \frac{dy}{dt}\mathbf{j} + \frac{dz}{dt}\mathbf{k} = \mathbf{i} - 4e^{-t}\mathbf{j} - 1/(2\sqrt{t})\mathbf{k}$ , and a normal to the surface is  $\mathbf{n} = \nabla(x^2/4 + y^2 + z^2) = x/2\mathbf{i} + 2y\mathbf{j} + 2z\mathbf{k}$ . At the points  $P_i$  these are  $\mathbf{v}_1 = \mathbf{i} - 0.639589\mathbf{j} - 0.369286\mathbf{k}, \mathbf{v}_2 = \mathbf{i} - 0.23374\mathbf{j} + 0.29670\mathbf{k}$ ;  $\mathbf{n}_1 = 0.41661\mathbf{i} + 1.27918\mathbf{j} + 1.29207\mathbf{k}$  and  $\mathbf{n}_2 = 0.91992\mathbf{i} + 0.46748\mathbf{j} + 0.62963\mathbf{k}$  so  $\cos^{-1}[(\mathbf{v}_i \cdot \mathbf{n}_i)/(\|\mathbf{v}_i\| \|\mathbf{n}_i\|)] = 112.3^\circ, 61.1^\circ$ ; the acute angles are  $67.7^\circ, 61.1^\circ$ .

36. (a)  $F'(x) = \int_0^1 e^y \cos(xe^y) dy = \frac{\sin(ex) - \sin x}{x}$

(b) Use a CAS to get  $x = \frac{\pi}{e+1}$  so the maximum value of  $F(x)$  is

$$F\left(\frac{\pi}{e+1}\right) = \int_0^1 \sin\left(\frac{\pi}{e+1}e^y\right) dy \approx 0.909026.$$

37. Let  $x, y, z$  be the lengths of the sides opposite angles  $\alpha, \beta, \gamma$ , located at  $A, B, C$  respectively. Then  $x^2 = y^2 + z^2 - 2yz \cos \alpha$  and  $x^2 = 100 + 400 - 2(10)(20)/2 = 300, x = 10\sqrt{3}$  and

$$\begin{aligned} 2x \frac{dx}{dt} &= 2y \frac{dy}{dt} + 2z \frac{dz}{dt} - 2 \left( y \frac{dz}{dt} \cos \alpha + z \frac{dy}{dt} \cos \alpha - yz(\sin \alpha) \frac{d\alpha}{dt} \right) \\ &= 2(10)(4) + 2(20)(2) - 2 \left( 10(2) \frac{1}{2} + 20(4) \frac{1}{2} - 10(20) \frac{\sqrt{3}}{2} \frac{\pi}{60} \right) = 60 + \frac{10\pi}{\sqrt{3}} \end{aligned}$$

so  $\frac{dx}{dt} = \sqrt{3} + \frac{\pi}{6}$ , the length of  $BC$  is increasing.

38. (a)  $\frac{d}{dt} \left( \frac{\partial z}{\partial x} \right) = \frac{\partial}{\partial x} \left( \frac{\partial z}{\partial x} \right) \frac{dx}{dt} + \frac{\partial}{\partial y} \left( \frac{\partial z}{\partial x} \right) \frac{dy}{dt} = \frac{\partial^2 z}{\partial x^2} \frac{dx}{dt} + \frac{\partial^2 z}{\partial y \partial x} \frac{dy}{dt}$  by the Chain Rule, and

$$\frac{d}{dt} \left( \frac{\partial z}{\partial y} \right) = \frac{\partial}{\partial x} \left( \frac{\partial z}{\partial y} \right) \frac{dx}{dt} + \frac{\partial}{\partial y} \left( \frac{\partial z}{\partial y} \right) \frac{dy}{dt} = \frac{\partial^2 z}{\partial x \partial y} \frac{dx}{dt} + \frac{\partial^2 z}{\partial y^2} \frac{dy}{dt}$$

(b)  $\frac{dz}{dt} = \frac{\partial z}{\partial x} \frac{dx}{dt} + \frac{\partial z}{\partial y} \frac{dy}{dt}$ ,

$$\frac{d^2z}{dt^2} = \frac{dx}{dt} \left( \frac{\partial^2 z}{\partial x^2} \frac{dx}{dt} + \frac{\partial^2 z}{\partial y \partial x} \frac{dy}{dt} \right) + \frac{\partial z}{\partial x} \frac{d^2x}{dt^2} + \frac{dy}{dt} \left( \frac{\partial^2 z}{\partial x \partial y} \frac{dx}{dt} + \frac{\partial^2 z}{\partial y^2} \frac{dy}{dt} \right) + \frac{\partial z}{\partial y} \frac{d^2y}{dt^2}$$

# CHAPTER 16

## Multiple Integrals

### EXERCISE SET 16.1

- $\int_0^1 \int_0^2 (x+3) dy dx = \int_0^1 (2x+6) dx = 7$
- $\int_1^3 \int_{-1}^1 (2x-4y) dy dx = \int_1^3 4x dx = 16$
- $\int_2^4 \int_0^1 x^2 y dx dy = \int_2^4 \frac{1}{3} y dy = 2$
- $\int_{-2}^0 \int_{-1}^2 (x^2 + y^2) dx dy = \int_{-2}^0 (3 + 3y^2) dy = 14$
- $\int_0^{\ln 3} \int_0^{\ln 2} e^{x+y} dy dx = \int_0^{\ln 3} e^x dx = 2$
- $\int_0^2 \int_0^1 y \sin x dy dx = \int_0^2 \frac{1}{2} \sin x dx = (1 - \cos 2)/2$
- $\int_{-1}^0 \int_2^5 dx dy = \int_{-1}^0 3 dy = 3$
- $\int_4^6 \int_{-3}^7 dy dx = \int_4^6 10 dx = 20$
- $\int_0^1 \int_0^1 \frac{x}{(xy+1)^2} dy dx = \int_0^1 \left(1 - \frac{1}{x+1}\right) dx = 1 - \ln 2$
- $\int_{\pi/2}^{\pi} \int_1^2 x \cos xy dy dx = \int_{\pi/2}^{\pi} (\sin 2x - \sin x) dx = -2$
- $\int_0^{\ln 2} \int_0^1 xy e^{y^2 x} dy dx = \int_0^{\ln 2} \frac{1}{2} (e^x - 1) dx = (1 - \ln 2)/2$
- $\int_3^4 \int_1^2 \frac{1}{(x+y)^2} dy dx = \int_3^4 \left(\frac{1}{x+1} - \frac{1}{x+2}\right) dx = \ln(25/24)$
- $\int_{-1}^1 \int_{-2}^2 4xy^3 dy dx = \int_{-1}^1 0 dx = 0$
- $\int_0^1 \int_0^1 \frac{xy}{\sqrt{x^2 + y^2 + 1}} dy dx = \int_0^1 [x(x^2 + 2)^{1/2} - x(x^2 + 1)^{1/2}] dx = (3\sqrt{3} - 4\sqrt{2} + 1)/3$
- $\int_0^1 \int_2^3 x \sqrt{1-x^2} dy dx = \int_0^1 x(1-x^2)^{1/2} dx = 1/3$
- $\int_0^{\pi/2} \int_0^{\pi/3} (x \sin y - y \sin x) dy dx = \int_0^{\pi/2} \left(\frac{x}{2} - \frac{\pi^2}{18} \sin x\right) dx = \pi^2/144$
- $V = \int_3^5 \int_1^2 (2x+y) dy dx = \int_3^5 (2x+3/2) dx = 19$
- $V = \int_1^3 \int_0^2 (3x^3 + 3x^2 y) dy dx = \int_1^3 (6x^3 + 6x^2) dx = 172$

21.  $V = \int_0^2 \int_0^3 x^2 dy dx = \int_0^2 3x^2 dx = 8$

22.  $V = \int_0^3 \int_0^4 5(1 - x/3) dy dx = \int_0^3 5(4 - 4x/3) dx = 30$

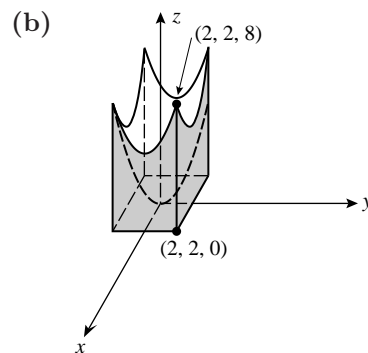
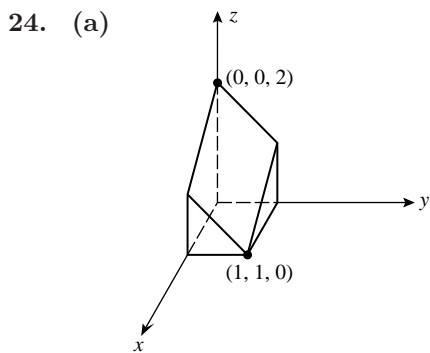
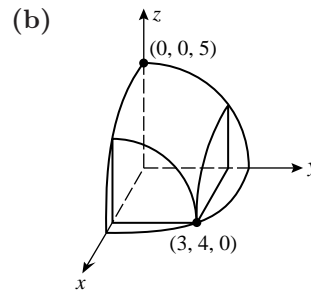
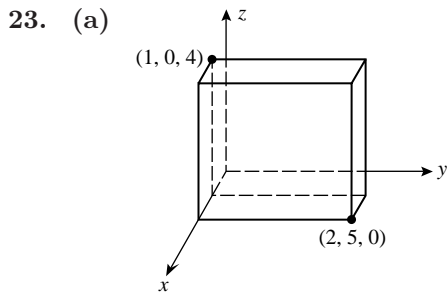

25. 
$$\int_0^{1/2} \int_0^\pi x \cos(xy) \cos^2 \pi x dy dx = \int_0^{1/2} \cos^2 \pi x \sin(xy) \Big|_0^\pi dx$$

$$= \int_0^{1/2} \cos^2 \pi x \sin \pi x dx = -\frac{1}{3} \cos^3 \pi x \Big|_0^{1/2} = \frac{1}{3\pi}$$

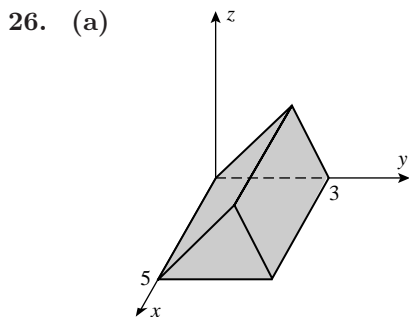

(b) The projection onto the  $xy$ -plane consists of  $R_1 : [0, 5] \times [0, 1]$ , over which lie each of the two skew planes, and  $R_2 : [0, 5] \times [1, 3]$ , over which is only the plane  $z = -2y + 6$ , so

$$V = \int_0^5 \int_0^1 ((-2y + 6) - y) dy dx + \int_0^5 \int_1^3 (-2y + 6) dy dx = \frac{45}{2} + 20 = \frac{85}{2}$$

27.  $f_{\text{ave}} = \frac{2}{\pi} \int_0^{\pi/2} \int_0^1 y \sin xy dy dx = \frac{2}{\pi} \int_0^{\pi/2} (-\cos xy) \Big|_0^1 dx = \frac{2}{\pi} \int_0^{\pi/2} (1 - \cos x) dx = 1 - \frac{2}{\pi}$

$$28. \text{ average} = \frac{1}{3} \int_0^3 \int_0^1 x(x^2 + y)^{1/2} dx dy = \int_0^3 \frac{1}{9} [(1+y)^{3/2} - y^{3/2}] dy = 2(31 - 9\sqrt{3})/45$$

$$29. T_{\text{ave}} = \frac{1}{2} \int_0^1 \int_0^2 (10 - 8x^2 - 2y^2) dy dx = \frac{1}{2} \int_0^1 \left( \frac{44}{3} - 16x^2 \right) dx = \left( \frac{14}{3} \right)^\circ$$

$$30. f_{\text{ave}} = \frac{1}{A(R)} \int_a^b \int_c^d k dy dx = \frac{1}{A(R)} (b-a)(d-c)k = k$$

$$31. 0.6211310829$$

$$32. 2.230985141$$

$$33. \iint_R f(x, y) dA = \int_a^b \left[ \int_c^d g(x)h(y) dy \right] dx = \int_a^b g(x) \left[ \int_c^d h(y) dy \right] dx \\ = \left[ \int_a^b g(x) dx \right] \left[ \int_c^d h(y) dy \right]$$

34. The integral of  $\tan x$  (an odd function) over the interval  $[-1, 1]$  is zero.

35. The first integral equals  $1/2$ , the second equals  $-1/2$ . No, because the integrand is not continuous.

$$36. \text{ (a) } \sum_{k=1}^{16} f(x_k^*, y_k^*) \Delta A_k^* = \sum_{i=1}^4 \sum_{j=1}^4 \left[ \left( \frac{i}{2} - \frac{1}{4} \right) - 2 \left( \frac{j}{2} - \frac{1}{4} \right) \right] \left( \frac{1}{2} \right)^2 = -4$$

$$\text{ (b) } \int_0^2 \int_0^2 (x - 2y) dy dx = \int_0^2 (2x - 4) dx = -4$$

## EXERCISE SET 16.2

$$1. \int_0^1 \int_{x^2}^x xy^2 dy dx = \int_0^1 \frac{1}{3} (x^4 - x^7) dx = 1/40$$

$$2. \int_1^{3/2} \int_y^{3-y} y dx dy = \int_1^{3/2} (3y - 2y^2) dy = 7/24$$

$$3. \int_0^3 \int_0^{\sqrt{9-y^2}} y dx dy = \int_0^3 y \sqrt{9-y^2} dy = 9$$

$$4. \int_{1/4}^1 \int_{x^2}^x \sqrt{x/y} dy dx = \int_{1/4}^1 \int_{x^2}^x x^{1/2} y^{-1/2} dy dx = \int_{1/4}^1 2(x - x^{3/2}) dx = 13/80$$

$$5. \int_{\sqrt{\pi}}^{\sqrt{2\pi}} \int_0^{x^3} \sin(y/x) dy dx = \int_{\sqrt{\pi}}^{\sqrt{2\pi}} [-x \cos(x^2) + x] dx = \pi/2$$

$$6. \int_{-1}^1 \int_{-x^2}^{x^2} (x^2 - y) dy dx = \int_{-1}^1 2x^4 dx = 4/5 \quad 7. \int_{\pi/2}^{\pi} \int_0^{x^2} \frac{1}{x} \cos(y/x) dy dx = \int_{\pi/2}^{\pi} \sin x dx = 1$$



8.  $\int_0^1 \int_0^x e^{x^2} dy dx = \int_0^1 x e^{x^2} dx = (e - 1)/2$       9.  $\int_0^1 \int_0^x y \sqrt{x^2 - y^2} dy dx = \int_0^1 \frac{1}{3} x^3 dx = 1/12$
10.  $\int_1^2 \int_0^{y^2} e^{x/y^2} dx dy = \int_1^2 (e - 1)y^2 dy = 7(e - 1)/3$
11. (a)  $\int_0^2 \int_0^{x^2} xy dy dx = \int_0^2 \frac{1}{2} x^5 dx = \frac{16}{3}$   
 (b)  $\int_1^3 \int_{-(y-5)/2}^{(y+7)/2} xy dx dy = \int_1^3 (3y^2 + 3y) dy = 38$
12. (a)  $\int_0^1 \int_{x^2}^{\sqrt{x}} (x + y) dy dx = \int_0^1 (x^{3/2} + x/2 - x^3 - x^4/2) dx = 3/10$   
 (b)  $\int_{-1}^1 \int_{-\sqrt{1-x^2}}^{\sqrt{1-x^2}} x dy dx + \int_{-1}^1 \int_{-\sqrt{1-x^2}}^{\sqrt{1-x^2}} y dy dx = \int_{-1}^1 2x\sqrt{1-x^2} dx + 0 = 0$
13.  $\int_4^8 \int_{16/x}^x x^2 dy dx = \int_4^8 (x^3 - 16x) dx = 576$       14.  $\int_1^2 \int_0^y xy^2 dx dy = \int_1^2 \frac{1}{2} y^4 dy = 31/10$
15.  $\int_0^4 \int_0^{\sqrt{y}} x(1 + y^2)^{-1/2} dx dy = \int_0^4 \frac{1}{2} y(1 + y^2)^{-1/2} dy = (\sqrt{17} - 1)/2$
16.  $\int_0^\pi \int_0^x x \cos y dy dx = \int_0^\pi x \sin x dx = \pi$
17.  $\int_{-1}^1 \int_{-\sqrt{1-x^2}}^{\sqrt{1-x^2}} (3x - 2y) dy dx = \int_{-1}^1 6x\sqrt{1-x^2} dx = 0$
18.  $\int_0^5 \int_{5-x}^{\sqrt{25-x^2}} y dy dx = \int_0^5 (5x - x^2) dx = 125/6$
19.  $\int_0^2 \int_{y^2}^{6-y} xy dx dy = \int_0^2 \frac{1}{2} (36y - 12y^2 + y^3 - y^5) dy = 50/3$
20.  $\int_0^{\pi/4} \int_{\sin y}^{1/\sqrt{2}} x dx dy = \int_0^{\pi/4} \frac{1}{4} \cos 2y dy = 1/8$
21.  $\int_{-1}^0 \int_x^{x^3} (x - 1) dy dx + \int_0^1 \int_{x^3}^x (x - 1) dy dx$   
 $= \int_{-1}^0 (x^4 - x^3 - x^2 + x) dx + \int_0^1 (-x^4 + x^3 + x^2 - x) dx = -1/2$
22.  $\int_0^{1/\sqrt{2}} \int_x^{2x} x^2 dy dx + \int_{1/\sqrt{2}}^1 \int_x^{1/x} x^2 dy dx = \int_0^{1/\sqrt{2}} x^3 dx + \int_{1/\sqrt{2}}^1 (x - x^3) dx = 1/8$

24. (a)  (b)  $(1, 3), (3, 27)$

$$(c) \int_1^3 \int_{3-4x+4x^2}^{4x^3-x^4} x \, dy \, dx = \int_1^3 x[(4x^3 - x^4) - (3 - 4x + 4x^2)] \, dx = \frac{224}{15}$$

$$25. A = \int_0^{\pi/4} \int_{\sin x}^{\cos x} dy \, dx = \int_0^{\pi/4} (\cos x - \sin x) \, dx = \sqrt{2} - 1$$

$$26. A = \int_{-4}^1 \int_{3y-4}^{-y^2} dx \, dy = \int_{-4}^1 (-y^2 - 3y + 4) \, dy = 125/6$$

$$27. A = \int_{-3}^3 \int_{1-y^2/9}^{9-y^2} dx \, dy = \int_{-3}^3 8(1 - y^2/9) \, dy = 32$$

$$28. A = \int_0^1 \int_{\sinh x}^{\cosh x} dy \, dx = \int_0^1 (\cosh x - \sinh x) \, dx = 1 - e^{-1}$$

$$29. \int_0^4 \int_0^{6-3x/2} (3 - 3x/4 - y/2) \, dy \, dx = \int_0^4 [(3 - 3x/4)(6 - 3x/2) - (6 - 3x/2)^2/4] \, dx = 12$$

$$30. \int_0^2 \int_0^{\sqrt{4-x^2}} \sqrt{4-x^2} \, dy \, dx = \int_0^2 (4-x^2) \, dx = 16/3$$

$$31. V = \int_{-3}^3 \int_{-\sqrt{9-x^2}}^{\sqrt{9-x^2}} (3-x) \, dy \, dx = \int_{-3}^3 (6\sqrt{9-x^2} - 2x\sqrt{9-x^2}) \, dx = 27\pi$$

$$32. V = \int_0^1 \int_{x^2}^x (x^2 + 3y^2) \, dy \, dx = \int_0^1 (2x^3 - x^4 - x^6) \, dx = 11/70$$

$$33. V = \int_0^3 \int_0^2 (9x^2 + y^2) \, dy \, dx = \int_0^3 (18x^2 + 8/3) \, dx = 170$$

$$34. V = \int_{-1}^1 \int_{y^2}^1 (1-x) \, dx \, dy = \int_{-1}^1 (1/2 - y^2 + y^4/2) \, dy = 8/15$$

$$35. V = \int_{-3/2}^{3/2} \int_{-\sqrt{9-4x^2}}^{\sqrt{9-4x^2}} (y+3) \, dy \, dx = \int_{-3/2}^{3/2} 6\sqrt{9-4x^2} \, dx = 27\pi/2$$

$$36. V = \int_0^3 \int_{y^2/3}^3 (9-x^2) \, dx \, dy = \int_0^3 (18 - 3y^2 + y^6/81) \, dy = 216/7$$

$$37. V = 8 \int_0^5 \int_0^{\sqrt{25-x^2}} \sqrt{25-x^2} dy dx = 8 \int_0^5 (25-x^2) dx = 2000/3$$

$$38. V = 2 \int_0^2 \int_0^{\sqrt{1-(y-1)^2}} (x^2 + y^2) dx dy = 2 \int_0^2 \left( \frac{1}{3} [1 - (y-1)^2]^{3/2} + y^2 [1 - (y-1)^2]^{1/2} \right) dy,$$

let  $y - 1 = \sin \theta$  to get  $V = 2 \int_{-\pi/2}^{\pi/2} \left[ \frac{1}{3} \cos^3 \theta + (1 + \sin \theta)^2 \cos \theta \right] \cos \theta d\theta$  which eventually yields  
 $V = 3\pi/2$

$$39. V = 4 \int_0^1 \int_0^{\sqrt{1-x^2}} (1-x^2-y^2) dy dx = \frac{8}{3} \int_0^1 (1-x^2)^{3/2} dx = \pi/2$$

$$40. V = \int_0^2 \int_0^{\sqrt{4-x^2}} (x^2 + y^2) dy dx = \int_0^2 \left[ x^2 \sqrt{4-x^2} + \frac{1}{3} (4-x^2)^{3/2} \right] dx = 2\pi$$

$$41. \int_0^{\sqrt{2}} \int_{y^2}^2 f(x, y) dx dy \quad 42. \int_0^8 \int_0^{x/2} f(x, y) dy dx \quad 43. \int_1^{e^2} \int_{\ln x}^2 f(x, y) dy dx$$

$$44. \int_0^1 \int_{e^y}^e f(x, y) dx dy \quad 45. \int_0^{\pi/2} \int_0^{\sin x} f(x, y) dy dx \quad 46. \int_0^1 \int_{x^2}^{\sqrt{x}} f(x, y) dy dx$$

$$47. \int_0^4 \int_0^{y/4} e^{-y^2} dx dy = \int_0^4 \frac{1}{4} y e^{-y^2} dy = (1 - e^{-16})/8$$

$$48. \int_0^1 \int_0^{2x} \cos(x^2) dy dx = \int_0^1 2x \cos(x^2) dx = \sin 1$$

$$49. \int_0^2 \int_0^{x^2} e^{x^3} dy dx = \int_0^2 x^2 e^{x^3} dx = (e^8 - 1)/3$$

$$50. \int_0^{\ln 3} \int_{e^y}^3 x dx dy = \frac{1}{2} \int_0^{\ln 3} (9 - e^{2y}) dy = \frac{1}{2} (9 \ln 3 - 4)$$

$$51. \int_0^2 \int_0^{y^2} \sin(y^3) dx dy = \int_0^2 y^2 \sin(y^3) dy = (1 - \cos 8)/3$$

$$52. \int_0^1 \int_{e^x}^e x dy dx = \int_0^1 (ex - xe^x) dx = e/2 - 1$$

53. (a)  $\int_0^4 \int_{\sqrt{x}}^2 \sin \pi y^3 dy dx$ ; the inner integral is non-elementary.

$$\int_0^2 \int_0^{y^2} \sin(\pi y^3) dx dy = \int_0^2 y^2 \sin(\pi y^3) dy = \left[ -\frac{1}{3\pi} \cos(\pi y^3) \right]_0^2 = 0$$

(b)  $\int_0^1 \int_{\sin^{-1} y}^{\pi/2} \sec^2(\cos x) dx dy$ ; the inner integral is non-elementary.  
 $\int_0^{\pi/2} \int_0^{\sin x} \sec^2(\cos x) dy dx = \int_0^{\pi/2} \sec^2(\cos x) \sin x dx = \tan 1$

54.  $V = 4 \int_0^2 \int_0^{\sqrt{4-x^2}} (x^2 + y^2) dy dx = 4 \int_0^2 \left( x^2 \sqrt{4-x^2} + \frac{1}{3}(4-x^2)^{3/2} \right) dx \quad (x = 2 \sin \theta)$   
 $= \int_0^{\pi/2} \left( \frac{64}{3} + \frac{64}{3} \sin^2 \theta - \frac{128}{3} \sin^4 \theta \right) d\theta = \frac{64}{3} \frac{\pi}{2} + \frac{64}{3} \frac{\pi}{4} - \frac{128}{3} \frac{\pi}{2} \cdot \frac{1}{4} = 8\pi$

55.  $\int_{-2}^{-1} \int_0^2 xy^2 dy dx + \int_{-1}^1 \int_1^2 xy^2 dy dx + \int_1^2 \int_0^2 xy^2 dy dx$   
 $= \int_{-2}^{-1} \frac{8}{3} x dx + \int_{-1}^1 \frac{7}{3} x dx + \int_1^2 \frac{8}{3} x dx = 0$

56. This is the volume in the first octant under the surface  $z = \sqrt{1-x^2-y^2}$ , so 1/8 of the volume of the sphere of radius 1, thus  $\frac{\pi}{6}$ .

57. Area of triangle is 1/2, so  $\bar{f} = 2 \int_0^1 \int_x^1 \frac{1}{1+x^2} dy dx = 2 \int_0^1 \left[ \frac{1}{1+x^2} - \frac{x}{1+x^2} \right] dx = \frac{\pi}{2} - \ln 2$

58. Area  $= \int_0^2 (3x - x^2 - x) dx = 4/3$ , so

$$\bar{f} = \frac{3}{4} \int_0^2 \int_x^{3x-x^2} (x^2 - xy) dy dx = \frac{3}{4} \int_0^2 (-2x^3 + 2x^4 - x^5/2) dx = -\frac{3}{4} \frac{8}{15} = -\frac{2}{5}$$

59.  $y = \sin x$  and  $y = x/2$  intersect at  $x = 0$  and  $x = a = 1.895494$ , so

$$V = \int_0^a \int_{x/2}^{\sin x} \sqrt{1+x+y} dy dx = 0.676089$$

### EXERCISE SET 16.3

1.  $\int_0^{\pi/2} \int_0^{\sin \theta} r \cos \theta dr d\theta = \int_0^{\pi/2} \frac{1}{2} \sin^2 \theta \cos \theta d\theta = 1/6$

2.  $\int_0^{\pi} \int_0^{1+\cos \theta} r dr d\theta = \int_0^{\pi} \frac{1}{2} (1+\cos \theta)^2 d\theta = 3\pi/4$

3.  $\int_0^{\pi/2} \int_0^{a \sin \theta} r^2 dr d\theta = \int_0^{\pi/2} \frac{a^3}{3} \sin^3 \theta d\theta = \frac{2}{9} a^3$

4.  $\int_0^{\pi/3} \int_0^{\cos 3\theta} r dr d\theta = \int_0^{\pi/3} \frac{1}{2} \cos^2 3\theta d\theta = \pi/12$

5.  $\int_0^{\pi} \int_0^{1-\sin \theta} r^2 \cos \theta dr d\theta = \int_0^{\pi} \frac{1}{3} (1-\sin \theta)^3 \cos \theta d\theta = 0$

6.  $\int_0^\pi \int_0^{\cos \theta} r^3 dr d\theta = \int_0^\pi \frac{1}{4} \cos^4 \theta d\theta = 3\pi/32$
7.  $A = \int_0^{2\pi} \int_0^{1-\cos \theta} r dr d\theta = \int_0^{2\pi} \frac{1}{2} (1 - \cos \theta)^2 d\theta = 3\pi/2$
8.  $A = 4 \int_0^{\pi/2} \int_0^{\sin 2\theta} r dr d\theta = 2 \int_0^{\pi/2} \sin^2 2\theta d\theta = \pi/2$
9.  $A = \int_{\pi/4}^{\pi/2} \int_{\sin 2\theta}^1 r dr d\theta = \int_{\pi/4}^{\pi/2} \frac{1}{2} (1 - \sin^2 2\theta) d\theta = \pi/16$
10.  $A = 2 \int_0^{\pi/3} \int_{\sec \theta}^2 r dr d\theta = \int_0^{\pi/3} (4 - \sec^2 \theta) d\theta = 4\pi/3 - \sqrt{3}$
11.  $A = 2 \int_{\pi/6}^{\pi/2} \int_2^{4 \sin \theta} r dr d\theta = \int_{\pi/6}^{\pi/2} (16 \sin^2 \theta - 4) d\theta = 4\pi/3 + 2\sqrt{3}$
12.  $A = 2 \int_{\pi/2}^\pi \int_{1+\cos \theta}^1 r dr d\theta = \int_{\pi/2}^\pi (-2 \cos \theta - \cos^2 \theta) d\theta = 2 - \pi/4$
13.  $V = 8 \int_0^{\pi/2} \int_1^3 r \sqrt{9-r^2} dr d\theta = \frac{128}{3} \sqrt{2} \int_0^{\pi/2} d\theta = \frac{64}{3} \sqrt{2} \pi$
14.  $V = 2 \int_0^{\pi/2} \int_0^{2 \sin \theta} r^2 dr d\theta = \frac{16}{3} \int_0^{\pi/2} \sin^3 \theta d\theta = 32/9$
15.  $V = 2 \int_0^{\pi/2} \int_0^{\cos \theta} (1-r^2)r dr d\theta = \frac{1}{2} \int_0^{\pi/2} (1 - \sin^4 \theta) d\theta = 5\pi/32$
16.  $V = 4 \int_0^{\pi/2} \int_1^3 dr d\theta = 8 \int_0^{\pi/2} d\theta = 4\pi$
17.  $V = \int_0^{\pi/2} \int_0^{3 \sin \theta} r^2 \sin \theta dr d\theta = 9 \int_0^{\pi/2} \sin^4 \theta d\theta = 27\pi/16$
18.  $V = 4 \int_0^{\pi/2} \int_0^{2 \cos \theta} r \sqrt{4-r^2} dr d\theta = \frac{32}{3} \int_0^{\pi/2} (1 - \sin^3 \theta) d\theta = \frac{16}{9} (3\pi - 4)$
19.  $\int_0^{2\pi} \int_0^1 e^{-r^2} r dr d\theta = \frac{1}{2} (1 - e^{-1}) \int_0^{2\pi} d\theta = (1 - e^{-1})\pi$
20.  $\int_0^{\pi/2} \int_0^3 r \sqrt{9-r^2} dr d\theta = 9 \int_0^{\pi/2} d\theta = 9\pi/2$
21.  $\int_0^{\pi/4} \int_0^2 \frac{1}{1+r^2} r dr d\theta = \frac{1}{2} \ln 5 \int_0^{\pi/4} d\theta = \frac{\pi}{8} \ln 5$
22.  $\int_{\pi/4}^{\pi/2} \int_0^{2 \cos \theta} 2r^2 \sin \theta dr d\theta = \frac{16}{3} \int_{\pi/4}^{\pi/2} \cos^3 \theta \sin \theta d\theta = 1/3$

23.  $\int_0^{\pi/2} \int_0^1 r^3 dr d\theta = \frac{1}{4} \int_0^{\pi/2} d\theta = \pi/8$
24.  $\int_0^{2\pi} \int_0^2 e^{-r^2} r dr d\theta = \frac{1}{2}(1 - e^{-4}) \int_0^{2\pi} d\theta = (1 - e^{-4})\pi$
25.  $\int_0^{\pi/2} \int_0^{2\cos\theta} r^2 dr d\theta = \frac{8}{3} \int_0^{\pi/2} \cos^3 \theta d\theta = 16/9$
26.  $\int_0^{\pi/2} \int_0^1 \cos(r^2)r dr d\theta = \frac{1}{2} \sin 1 \int_0^{\pi/2} d\theta = \frac{\pi}{4} \sin 1$
27.  $\int_0^{\pi/2} \int_0^a \frac{r}{(1+r^2)^{3/2}} dr d\theta = \frac{\pi}{2} \left(1 - 1/\sqrt{1+a^2}\right)$
28.  $\int_0^{\pi/4} \int_0^{\sec\theta \tan\theta} r^2 dr d\theta = \frac{1}{3} \int_0^{\pi/4} \sec^3 \theta \tan^3 \theta d\theta = 2(\sqrt{2} + 1)/45$
29.  $\int_0^{\pi/4} \int_0^2 \frac{r}{\sqrt{1+r^2}} dr d\theta = \frac{\pi}{4}(\sqrt{5} - 1)$
30.  $\int_{\tan^{-1}(3/4)}^{\pi/2} \int_{3\csc\theta}^5 r dr d\theta = \frac{1}{2} \int_{\tan^{-1}(3/4)}^{\pi/2} (25 - 9\csc^2 \theta) d\theta$   
 $= \frac{25}{2} \left[\frac{\pi}{2} - \tan^{-1}(3/4)\right] - 6 = \frac{25}{2} \tan^{-1}(4/3) - 6$
31.  $V = \int_0^{2\pi} \int_0^a hr dr d\theta = \int_0^{2\pi} h \frac{a^2}{2} d\theta = \pi a^2 h$
32. (a)  $V = 8 \int_0^{\pi/2} \int_0^a \frac{c}{a}(a^2 - r^2)^{1/2} r dr d\theta = -\frac{4c}{3a} \pi (a^2 - r^2)^{3/2} \Big|_0^a = \frac{4}{3} \pi a^2 c$   
 (b)  $V \approx \frac{4}{3} \pi (6378.1370)^2 6356.5231 \approx 1,083,168,200,000 \text{ km}^3$
33.  $V = 2 \int_0^{\pi/2} \int_0^{a\sin\theta} \frac{c}{a}(a^2 - r^2)^{1/2} r dr d\theta = \frac{2}{3} a^2 c \int_0^{\pi/2} (1 - \cos^3 \theta) d\theta = (3\pi - 4)a^2 c/9$
34.  $A = 4 \int_0^{\pi/4} \int_0^{a\sqrt{2\cos 2\theta}} r dr d\theta = 4a^2 \int_0^{\pi/4} \cos 2\theta d\theta = 2a^2$
35.  $A = \int_{\pi/6}^{\pi/4} \int_{\sqrt{8\cos 2\theta}}^{4\sin\theta} r dr d\theta + \int_{\pi/4}^{\pi/2} \int_0^{4\sin\theta} r dr d\theta$   
 $= \int_{\pi/6}^{\pi/4} (8\sin^2 \theta - 4\cos 2\theta) d\theta + \int_{\pi/4}^{\pi/2} 8\sin^2 \theta d\theta = 4\pi/3 + 2\sqrt{3} - 2$
36.  $A = \int_0^\phi \int_0^{2a\sin\theta} r dr d\theta = 2a^2 \int_0^\phi \sin^2 \theta d\theta = a^2 \phi - \frac{1}{2} a^2 \sin 2\phi$

37. (a) 
$$I^2 = \left[ \int_0^{+\infty} e^{-x^2} dx \right] \left[ \int_0^{+\infty} e^{-y^2} dy \right] = \int_0^{+\infty} \left[ \int_0^{+\infty} e^{-x^2} dx \right] e^{-y^2} dy$$

$$= \int_0^{+\infty} \int_0^{+\infty} e^{-x^2} e^{-y^2} dx dy = \int_0^{+\infty} \int_0^{+\infty} e^{-(x^2+y^2)} dx dy$$

(b) 
$$I^2 = \int_0^{\pi/2} \int_0^{+\infty} e^{-r^2} r dr d\theta = \frac{1}{2} \int_0^{\pi/2} d\theta = \pi/4$$
      (c) 
$$I = \sqrt{\pi}/2$$

38. (a) 1.173108605      (b) 
$$\int_0^{\pi} \int_0^1 r e^{-r^4} dr d\theta = \pi \int_0^1 r e^{-r^4} dr \approx 1.173108605$$

39. 
$$V = \int_0^{2\pi} \int_0^R D(r)r dr d\theta = \int_0^{2\pi} \int_0^R k e^{-r} r dr d\theta = -2\pi k(1+r)e^{-r} \Big|_0^R = 2\pi k[1 - (R+1)e^{-R}]$$

40. 
$$\int_{\tan^{-1}(1/3)}^{\tan^{-1}(2)} \int_0^2 r^3 \cos^2 \theta dr d\theta = 4 \int_{\tan^{-1}(1/3)}^{\tan^{-1}(2)} \cos^2 \theta d\theta = \frac{1}{5} + 2[\tan^{-1}(2) - \tan^{-1}(1/3)] = \frac{1}{5} + \frac{\pi}{2}$$

**EXERCISE SET 16.4**

1. (a)

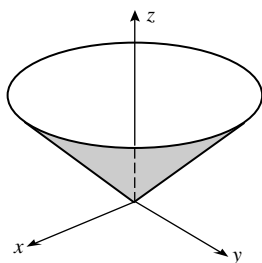

(b)

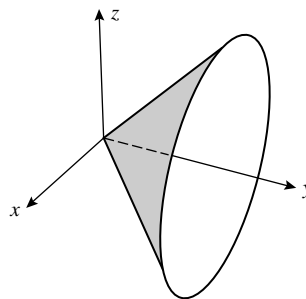

(c)

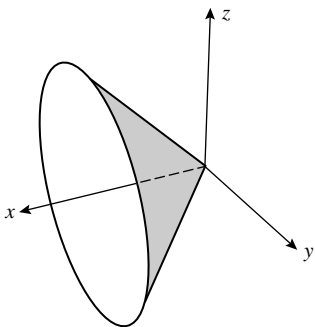

2. (a)

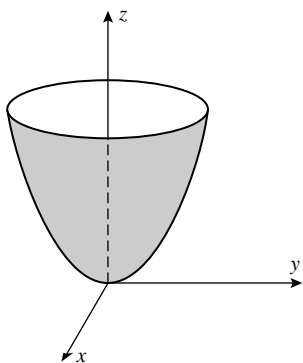

(b)

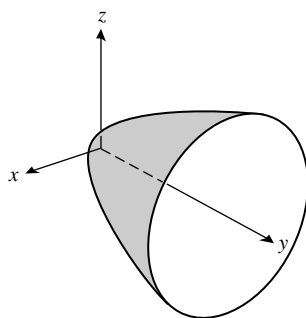

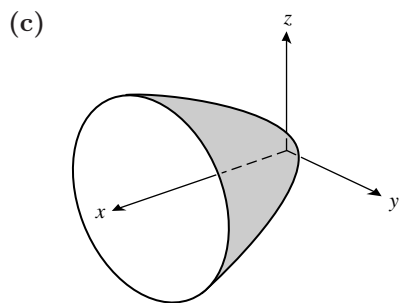

3. (a)  $x = u, y = v, z = \frac{5}{2} + \frac{3}{2}u - 2v$  (b)  $x = u, y = v, z = u^2$
4. (a)  $x = u, y = v, z = \frac{v}{1 + u^2}$  (b)  $x = u, y = v, z = \frac{1}{3}v^2 - \frac{5}{3}$
5. (a)  $x = 5 \cos u, y = 5 \sin u, z = v; 0 \leq u \leq 2\pi, 0 \leq v \leq 1$   
 (b)  $x = 2 \cos u, y = v, z = 2 \sin u; 0 \leq u \leq 2\pi, 1 \leq v \leq 3$
6. (a)  $x = u, y = 1 - u, z = v; -1 \leq v \leq 1$  (b)  $x = u, y = 5 + 2v, z = v; 0 \leq u \leq 3$
7.  $x = u, y = \sin u \cos v, z = \sin u \sin v$  8.  $x = u, y = e^u \cos v, z = e^u \sin v$
9.  $x = r \cos \theta, y = r \sin \theta, z = \frac{1}{1 + r^2}$  10.  $x = r \cos \theta, y = r \sin \theta, z = e^{-r^2}$
11.  $x = r \cos \theta, y = r \sin \theta, z = 2r^2 \cos \theta \sin \theta$
12.  $x = r \cos \theta, y = r \sin \theta, z = r^2(\cos^2 \theta - \sin^2 \theta)$
13.  $x = r \cos \theta, y = r \sin \theta, z = \sqrt{9 - r^2}; r \leq \sqrt{5}$
14.  $x = r \cos \theta, y = r \sin \theta, z = r; r \leq 3$  15.  $x = \frac{1}{2}\rho \cos \theta, y = \frac{1}{2}\rho \sin \theta, z = \frac{\sqrt{3}}{2}\rho$
16.  $x = 3 \cos \theta, y = 3 \sin \theta, z = 3 \cot \phi$  17.  $z = x - 2y$ ; a plane
18.  $y = x^2 + z^2, 0 \leq y \leq 4$ ; part of a circular paraboloid
19.  $(x/3)^2 + (y/2)^2 = 1; 2 \leq z \leq 4$ ; part of an elliptic cylinder
20.  $z = x^2 + y^2; 0 \leq z \leq 4$ ; part of a circular paraboloid
21.  $(x/3)^2 + (y/4)^2 = z^2; 0 \leq z \leq 1$ ; part of an elliptic cone
22.  $x^2 + (y/2)^2 + (z/3)^2 = 1$ ; part of an ellipsoid
23. (a)  $x = r \cos \theta, y = r \sin \theta, z = r; x = u, y = v, z = \sqrt{u^2 + v^2}; 0 \leq z \leq 2$
24. (a) I:  $x = r \cos \theta, y = r \sin \theta, z = r^2$ ; II:  $x = u, y = v, z = u^2 + v^2; u^2 + v^2 \leq 2$
25. (a)  $0 \leq u \leq 3, 0 \leq v \leq \pi$  (b)  $0 \leq u \leq 4, -\pi/2 \leq v \leq \pi/2$



26. (a)  $0 \leq u \leq 6, -\pi \leq v \leq 0$  (b)  $0 \leq u \leq 5, \pi/2 \leq v \leq 3\pi/2$
27. (a)  $0 \leq \phi \leq \pi/2, 0 \leq \theta \leq 2\pi$  (b)  $0 \leq \phi \leq \pi, 0 \leq \theta \leq \pi$
28. (a)  $\pi/2 \leq \phi \leq \pi$  (b)  $0 \leq \theta \leq \pi/2, 0 \leq \phi \leq \pi/2$
29.  $u = 1, v = 2, \mathbf{r}_u \times \mathbf{r}_v = -2\mathbf{i} - 4\mathbf{j} + \mathbf{k}; 2x + 4y - z = 5$
30.  $u = 1, v = 2, \mathbf{r}_u \times \mathbf{r}_v = -4\mathbf{i} - 2\mathbf{j} + 8\mathbf{k}; 2x + y - 4z = -6$
31.  $u = 0, v = 1, \mathbf{r}_u \times \mathbf{r}_v = 6\mathbf{k}; z = 0$  32.  $\mathbf{r}_u \times \mathbf{r}_v = 2\mathbf{i} - \mathbf{j} - 3\mathbf{k}; 2x - y - 3z = -4$
33.  $\mathbf{r}_u \times \mathbf{r}_v = (\sqrt{2}/2)\mathbf{i} - (\sqrt{2}/2)\mathbf{j} + (1/2)\mathbf{k}; x - y + \frac{\sqrt{2}}{2}z = \frac{\pi\sqrt{2}}{8}$
34.  $\mathbf{r}_u \times \mathbf{r}_v = 2\mathbf{i} - \ln 2\mathbf{k}; 2x - (\ln 2)z = 0$
35.  $z = \sqrt{9 - y^2}, z_x = 0, z_y = -y/\sqrt{9 - y^2}, z_x^2 + z_y^2 + 1 = 9/(9 - y^2),$   
 $S = \int_0^2 \int_{-3}^3 \frac{3}{\sqrt{9 - y^2}} dy dx = \int_0^2 3\pi dx = 6\pi$
36.  $z = 8 - 2x - 2y, z_x^2 + z_y^2 + 1 = 4 + 4 + 1 = 9, S = \int_0^4 \int_0^{4-x} 3 dy dx = \int_0^4 3(4 - x) dx = 24$
37.  $z^2 = 4x^2 + 4y^2, 2zz_x = 8x$  so  $z_x = 4x/z$ , similarly  $z_y = 4y/z$  thus  
 $z_x^2 + z_y^2 + 1 = (16x^2 + 16y^2)/z^2 + 1 = 5, S = \int_0^1 \int_{x^2}^x \sqrt{5} dy dx = \sqrt{5} \int_0^1 (x - x^2) dx = \sqrt{5}/6$
38.  $z^2 = x^2 + y^2, z_x = x/z, z_y = y/z, z_x^2 + z_y^2 + 1 = (z^2 + y^2)/z^2 + 1 = 2,$   
 $S = \iint_R \sqrt{2} dA = 2 \int_0^{\pi/2} \int_0^{2\cos\theta} \sqrt{2} r dr d\theta = 4\sqrt{2} \int_0^{\pi/2} \cos^2 \theta d\theta = \sqrt{2}\pi$
39.  $z_x = -2x, z_y = -2y, z_x^2 + z_y^2 + 1 = 4x^2 + 4y^2 + 1,$   
 $S = \iint_R \sqrt{4x^2 + 4y^2 + 1} dA = \int_0^{2\pi} \int_0^1 r \sqrt{4r^2 + 1} dr d\theta$   
 $= \frac{1}{12}(5\sqrt{5} - 1) \int_0^{2\pi} d\theta = (5\sqrt{5} - 1)\pi/6$
40.  $z_x = 2, z_y = 2y, z_x^2 + z_y^2 + 1 = 5 + 4y^2,$   
 $S = \int_0^1 \int_0^y \sqrt{5 + 4y^2} dx dy = \int_0^1 y \sqrt{5 + 4y^2} dy = (27 - 5\sqrt{5})/12$
41.  $\partial \mathbf{r} / \partial u = \cos v \mathbf{i} + \sin v \mathbf{j} + 2u \mathbf{k}, \partial \mathbf{r} / \partial v = -u \sin v \mathbf{i} + u \cos v \mathbf{j},$   
 $\|\partial \mathbf{r} / \partial u \times \partial \mathbf{r} / \partial v\| = u \sqrt{4u^2 + 1}; S = \int_0^{2\pi} \int_1^2 u \sqrt{4u^2 + 1} du dv = (17\sqrt{17} - 5\sqrt{5})\pi/6$
42.  $\partial \mathbf{r} / \partial u = \cos v \mathbf{i} + \sin v \mathbf{j} + \mathbf{k}, \partial \mathbf{r} / \partial v = -u \sin v \mathbf{i} + u \cos v \mathbf{j},$   
 $\|\partial \mathbf{r} / \partial u \times \partial \mathbf{r} / \partial v\| = \sqrt{2}u; S = \int_0^{\pi/2} \int_0^{2v} \sqrt{2} u du dv = \frac{\sqrt{2}}{12} \pi^3$

43.  $z_x = y, z_y = x, z_x^2 + z_y^2 + 1 = x^2 + y^2 + 1,$

$$S = \iint_R \sqrt{x^2 + y^2 + 1} dA = \int_0^{\pi/6} \int_0^3 r\sqrt{r^2 + 1} dr d\theta = \frac{1}{3}(10\sqrt{10} - 1) \int_0^{\pi/6} d\theta = (10\sqrt{10} - 1)\pi/18$$

44.  $z_x = x, z_y = y, z_x^2 + z_y^2 + 1 = x^2 + y^2 + 1,$

$$S = \iint_R \sqrt{x^2 + y^2 + 1} dA = \int_0^{2\pi} \int_0^{\sqrt{8}} r\sqrt{r^2 + 1} dr d\theta = \frac{26}{3} \int_0^{2\pi} d\theta = 52\pi/3$$

45. On the sphere,  $z_x = -x/z$  and  $z_y = -y/z$  so  $z_x^2 + z_y^2 + 1 = (x^2 + y^2 + z^2)/z^2 = 16/(16 - x^2 - y^2)$ ; the planes  $z = 1$  and  $z = 2$  intersect the sphere along the circles  $x^2 + y^2 = 15$  and  $x^2 + y^2 = 12$ ;

$$S = \iint_R \frac{4}{\sqrt{16 - x^2 - y^2}} dA = \int_0^{2\pi} \int_{\sqrt{12}}^{\sqrt{15}} \frac{4r}{\sqrt{16 - r^2}} dr d\theta = 4 \int_0^{2\pi} d\theta = 8\pi$$

46. On the sphere,  $z_x = -x/z$  and  $z_y = -y/z$  so  $z_x^2 + z_y^2 + 1 = (x^2 + y^2 + z^2)/z^2 = 8/(8 - x^2 - y^2)$ ; the cone cuts the sphere in the circle  $x^2 + y^2 = 4$ ;

$$S = \int_0^{2\pi} \int_0^2 \frac{2\sqrt{2}r}{\sqrt{8 - r^2}} dr d\theta = (8 - 4\sqrt{2}) \int_0^{2\pi} d\theta = 8(2 - \sqrt{2})\pi$$

47.  $\mathbf{r}(u, v) = a \cos u \sin v \mathbf{i} + a \sin u \sin v \mathbf{j} + a \cos v \mathbf{k}, \|\mathbf{r}_u \times \mathbf{r}_v\| = a^2 \sin v,$

$$S = \int_0^\pi \int_0^{2\pi} a^2 \sin v du dv = 2\pi a^2 \int_0^\pi \sin v dv = 4\pi a^2$$

48.  $\mathbf{r} = r \cos u \mathbf{i} + r \sin u \mathbf{j} + v \mathbf{k}, \|\mathbf{r}_u \times \mathbf{r}_v\| = r; S = \int_0^h \int_0^{2\pi} r du dv = 2\pi r h$

49.  $z_x = \frac{h}{a} \frac{x}{\sqrt{x^2 + y^2}}, z_y = \frac{h}{a} \frac{y}{\sqrt{x^2 + y^2}}, z_x^2 + z_y^2 + 1 = \frac{h^2 x^2 + h^2 y^2}{a^2(x^2 + y^2)} + 1 = (a^2 + h^2)/a^2,$

$$S = \int_0^{2\pi} \int_0^a \frac{\sqrt{a^2 + h^2}}{a} r dr d\theta = \frac{1}{2} a \sqrt{a^2 + h^2} \int_0^{2\pi} d\theta = \pi a \sqrt{a^2 + h^2}$$

50. Revolving a point  $(a_0, 0, b_0)$  of the  $xz$ -plane around the  $z$ -axis generates a circle, an equation of which is  $\mathbf{r} = a_0 \cos u \mathbf{i} + a_0 \sin u \mathbf{j} + b_0 \mathbf{k}, 0 \leq u \leq 2\pi$ . A point on the circle  $(x - a)^2 + z^2 = b^2$  which generates the torus can be written  $\mathbf{r} = (a + b \cos v) \mathbf{i} + b \sin v \mathbf{k}, 0 \leq v \leq 2\pi$ . Set  $a_0 = a + b \cos v$  and  $b_0 = a + b \sin v$  and use the first result: any point on the torus can thus be written in the form  $\mathbf{r} = (a + b \cos v) \cos u \mathbf{i} + (a + b \cos v) \sin u \mathbf{j} + b \sin v \mathbf{k}$ , which yields the result.

51.  $\partial \mathbf{r} / \partial u = -(a + b \cos v) \sin u \mathbf{i} + (a + b \cos v) \cos u \mathbf{j},$

$$\partial \mathbf{r} / \partial v = -b \sin v \cos u \mathbf{i} - b \sin v \sin u \mathbf{j} + b \cos v \mathbf{k}, \|\partial \mathbf{r} / \partial u \times \partial \mathbf{r} / \partial v\| = b(a + b \cos v);$$

$$S = \int_0^{2\pi} \int_0^{2\pi} b(a + b \cos v) du dv = 4\pi^2 ab$$

52.  $\|\mathbf{r}_u \times \mathbf{r}_v\| = \sqrt{u^2 + 1}; S = \int_0^{4\pi} \int_0^5 \sqrt{u^2 + 1} du dv = 4\pi \int_0^5 \sqrt{u^2 + 1} du = 174.7199011$

53.  $z = -1$  when  $v \approx 0.27955, z = 1$  when  $v \approx 2.86204, \|\mathbf{r}_u \times \mathbf{r}_v\| = |\cos v|;$

$$S = \int_0^{2\pi} \int_{0.27955}^{2.86204} |\cos v| dv du \approx 9.099$$

54. (a)  $x = v \cos u, y = v \sin u, z = f(v)$ , for example

(b)  $x = v \cos u, y = v \sin u, z = 1/v^2$

(c)

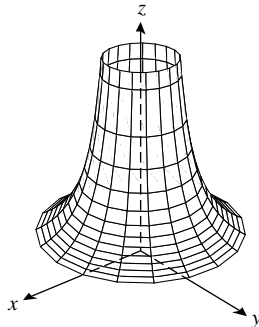

55.  $(x/a)^2 + (y/b)^2 + (z/c)^2 = \cos^2 v(\cos^2 u + \sin^2 u) + \sin^2 v = 1$ , ellipsoid

56.  $(x/a)^2 + (y/b)^2 - (z/c)^2 = \cos^2 u \cosh^2 v + \sin^2 u \cosh^2 v - \sinh^2 v = 1$ , hyperboloid of one sheet

57.  $(x/a)^2 + (y/b)^2 - (z/c)^2 = \sinh^2 v + \cosh^2 v(\sinh^2 u - \cosh^2 u) = -1$ , hyperboloid of two sheets

**EXERCISE SET 16.5**

1. 
$$\int_{-1}^1 \int_0^2 \int_0^1 (x^2 + y^2 + z^2) dx dy dz = \int_{-1}^1 \int_0^2 (1/3 + y^2 + z^2) dy dz = \int_{-1}^1 (10/3 + 2z^2) dz = 8$$

2. 
$$\int_{1/3}^{1/2} \int_0^\pi \int_0^1 z x \sin xy dz dy dx = \int_{1/3}^{1/2} \int_0^\pi \frac{1}{2} x \sin xy dy dx = \int_{1/3}^{1/2} \frac{1}{2} (1 - \cos \pi x) dx = \frac{1}{12} + \frac{\sqrt{3} - 2}{4\pi}$$

3. 
$$\int_0^2 \int_{-1}^{y^2} \int_{-1}^z yz dx dz dy = \int_0^2 \int_{-1}^{y^2} (yz^2 + yz) dz dy = \int_0^2 \left( \frac{1}{3} y^7 + \frac{1}{2} y^5 - \frac{1}{6} y \right) dy = \frac{47}{3}$$

4. 
$$\int_0^{\pi/4} \int_0^1 \int_0^{x^2} x \cos y dz dx dy = \int_0^{\pi/4} \int_0^1 x^3 \cos y dx dy = \int_0^{\pi/4} \frac{1}{4} \cos y dy = \sqrt{2}/8$$

5. 
$$\int_0^3 \int_0^{\sqrt{9-z^2}} \int_0^x xy dy dx dz = \int_0^3 \int_0^{\sqrt{9-z^2}} \frac{1}{2} x^3 dx dz = \int_0^3 \frac{1}{8} (81 - 18z^2 + z^4) dz = 81/5$$

6. 
$$\int_1^3 \int_x^{x^2} \int_0^{\ln z} x e^y dy dz dx = \int_1^3 \int_x^{x^2} (xz - x) dz dx = \int_1^3 \left( \frac{1}{2} x^5 - \frac{3}{2} x^3 + x^2 \right) dx = 118/3$$

7. 
$$\begin{aligned} \int_0^2 \int_0^{\sqrt{4-x^2}} \int_{-5+x^2+y^2}^{3-x^2-y^2} x dz dy dx &= \int_0^2 \int_0^{\sqrt{4-x^2}} [2x(4-x^2) - 2xy^2] dy dx \\ &= \int_0^2 \frac{4}{3} x(4-x^2)^{3/2} dx = 128/15 \end{aligned}$$

8. 
$$\int_1^2 \int_z^2 \int_0^{\sqrt{3y}} \frac{y}{x^2 + y^2} dx dy dz = \int_1^2 \int_z^2 \frac{\pi}{3} dy dz = \int_1^2 \frac{\pi}{3} (2-z) dz = \pi/6$$

9. 
$$\int_0^\pi \int_0^1 \int_0^{\pi/6} xy \sin yz \, dz \, dy \, dx = \int_0^\pi \int_0^1 x[1 - \cos(\pi y/6)] \, dy \, dx = \int_0^\pi (1 - 3/\pi)x \, dx = \pi(\pi - 3)/2$$
10. 
$$\int_{-1}^1 \int_0^{1-x^2} \int_0^y y \, dz \, dy \, dx = \int_{-1}^1 \int_0^{1-x^2} y^2 \, dy \, dx = \int_{-1}^1 \frac{1}{3}(1-x^2)^3 \, dx = 32/105$$
11. 
$$\int_0^{\sqrt{2}} \int_0^x \int_0^{2-x^2} xyz \, dz \, dy \, dx = \int_0^{\sqrt{2}} \int_0^x \frac{1}{2}xy(2-x^2)^2 \, dy \, dx = \int_0^{\sqrt{2}} \frac{1}{4}x^3(2-x^2)^2 \, dx = 1/6$$
12. 
$$\int_{\pi/6}^{\pi/2} \int_y^{\pi/2} \int_0^{xy} \cos(z/y) \, dz \, dx \, dy = \int_{\pi/6}^{\pi/2} \int_y^{\pi/2} y \sin x \, dx \, dy = \int_{\pi/6}^{\pi/2} y \cos y \, dy = (5\pi - 6\sqrt{3})/12$$
14. 
$$8 \int_0^1 \int_0^{\sqrt{1-x^2}} \int_0^{\sqrt{1-x^2-y^2}} e^{-x^2-y^2-z^2} \, dz \, dy \, dx \approx 2.381$$
15. 
$$\begin{aligned} V &= \int_0^4 \int_0^{(4-x)/2} \int_0^{(12-3x-6y)/4} dz \, dy \, dx = \int_0^4 \int_0^{(4-x)/2} \frac{1}{4}(12-3x-6y) \, dy \, dx \\ &= \int_0^4 \frac{3}{16}(4-x)^2 \, dx = 4 \end{aligned}$$
16. 
$$V = \int_0^1 \int_0^{1-x} \int_0^{\sqrt{y}} dz \, dy \, dx = \int_0^1 \int_0^{1-x} \sqrt{y} \, dy \, dx = \int_0^1 \frac{2}{3}(1-x)^{3/2} \, dx = 4/15$$
17. 
$$V = 2 \int_0^2 \int_{x^2}^4 \int_0^{4-y} dz \, dy \, dx = 2 \int_0^2 \int_{x^2}^4 (4-y) \, dy \, dx = 2 \int_0^2 \left(8 - 4x^2 + \frac{1}{2}x^4\right) \, dx = 256/15$$
18. 
$$V = \int_0^1 \int_0^y \int_0^{\sqrt{1-y^2}} dz \, dx \, dy = \int_0^1 \int_0^y \sqrt{1-y^2} \, dx \, dy = \int_0^1 y\sqrt{1-y^2} \, dy = 1/3$$
19. The projection of the curve of intersection onto the  $xy$ -plane is  $x^2 + y^2 = 1$ ,  

$$V = 4 \int_0^1 \int_0^{\sqrt{1-x^2}} \int_{4x^2+y^2}^{4-3y^2} dz \, dy \, dx$$
20. The projection of the curve of intersection onto the  $xy$ -plane is  $2x^2 + y^2 = 4$ ,  

$$V = 4 \int_0^{\sqrt{2}} \int_0^{\sqrt{4-2x^2}} \int_{3x^2+y^2}^{8-x^2-y^2} dz \, dy \, dx$$
21. 
$$V = 2 \int_{-3}^3 \int_0^{\sqrt{9-x^2}/3} \int_0^{x+3} dz \, dy \, dx$$
22. 
$$V = 8 \int_0^1 \int_0^{\sqrt{1-x^2}} \int_0^{\sqrt{1-x^2}} dz \, dy \, dx$$

23. (a)

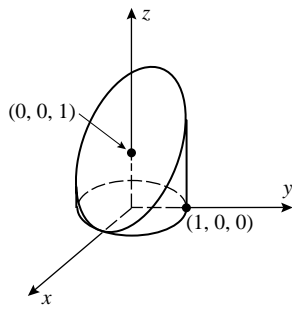

(b)

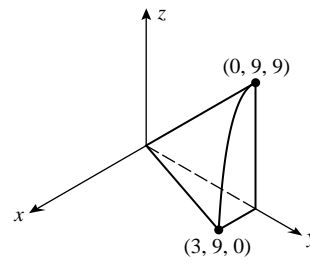

(c)

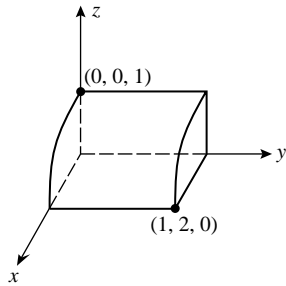

24. (a)

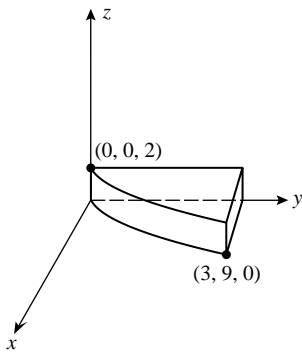

(b)

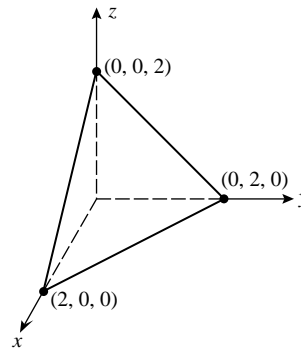

(c)

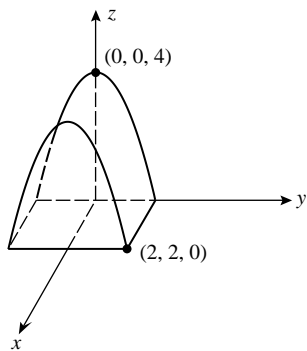

25.  $V = \int_0^1 \int_0^{1-x} \int_0^{1-x-y} dz dy dx = 1/6, f_{ave} = 6 \int_0^1 \int_0^{1-x} \int_0^{1-x-y} (x+y+z) dz dy dx = \frac{3}{4}$

26. The integrand is an odd function of each of  $x, y,$  and  $z,$  so the answer is zero.

$$27. \quad \text{(a)} \quad \int_0^a \int_0^{b(1-x/a)} \int_0^{c(1-x/a-y/b)} dz \, dy \, dx, \quad \int_0^b \int_0^{a(1-y/b)} \int_0^{c(1-x/a-y/b)} dz \, dx \, dy,$$

$$\int_0^c \int_0^{a(1-z/c)} \int_0^{b(1-x/a-z/c)} dy \, dx \, dz, \quad \int_0^a \int_0^{c(1-x/a)} \int_0^{b(1-x/a-z/c)} dy \, dz \, dx,$$

$$\int_0^c \int_0^{b(1-z/c)} \int_0^{a(1-y/b-z/c)} dx \, dy \, dz, \quad \int_0^b \int_0^{c(1-y/b)} \int_0^{a(1-y/b-z/c)} dx \, dz \, dy$$

(b) Use the first integral in part (a) to get

$$\int_0^a \int_0^{b(1-x/a)} c \left(1 - \frac{x}{a} - \frac{y}{b}\right) dy \, dx = \int_0^a \frac{1}{2} bc \left(1 - \frac{x}{a}\right)^2 dx = \frac{1}{6} abc$$

$$28. \quad \text{(a)} \quad \int_0^3 \int_0^{\sqrt{9-x^2}} \int_0^{\sqrt{9-x^2-y^2}} f(x, y, z) dz \, dy \, dx$$

$$\text{(b)} \quad \int_0^4 \int_0^{x/2} \int_0^2 f(x, y, z) dz \, dy \, dx \qquad \text{(c)} \quad \int_0^2 \int_0^{4-x^2} \int_{x^2}^{4-y} f(x, y, z) dz \, dy \, dx$$

$$29. \quad V = 8 \int_0^a \int_0^{b\sqrt{1-x^2/a^2}} \int_0^{c\sqrt{1-x^2/a^2-y^2/b^2}} dz \, dy \, dx$$

$$30. \quad \int_a^b \int_c^d \int_k^\ell f(x)g(y)h(z) dz \, dy \, dx = \int_a^b \int_c^d f(x)g(y) \left[ \int_k^\ell h(z) dz \right] dy \, dx$$

$$= \left[ \int_a^b f(x) \left[ \int_c^d g(y) dy \right] dx \right] \left[ \int_k^\ell h(z) dz \right]$$

$$= \left[ \int_a^b f(x) dx \right] \left[ \int_c^d g(y) dy \right] \left[ \int_k^\ell h(z) dz \right]$$

$$31. \quad \text{(a)} \quad \left[ \int_{-1}^1 x \, dx \right] \left[ \int_0^1 y^2 \, dy \right] \left[ \int_0^{\pi/2} \sin z \, dz \right] = (0)(1/3)(1) = 0$$

$$\text{(b)} \quad \left[ \int_0^1 e^{2x} \, dx \right] \left[ \int_0^{\ln 3} e^y \, dy \right] \left[ \int_0^{\ln 2} e^{-z} \, dz \right] = [(e^2 - 1)/2](2)(1/2) = (e^2 - 1)/2$$

32. (a) At any point outside the closed sphere  $\{x^2 + y^2 + z^2 \leq 1\}$  the integrand is negative, so to maximize the integral it suffices to include all points inside the sphere; hence the maximum value is taken on the region  $G = \{x^2 + y^2 + z^2 \leq 1\}$ .

$$\text{(b)} \quad \frac{8\pi}{15}$$

## EXERCISE SET 16.6

- Let  $a$  be the unknown coordinate of the fulcrum; then the total moment about the fulcrum is  $5(0 - a) + 10(5 - a) + 20(10 - a) = 0$  for equilibrium, so  $250 - 35a = 0$ ,  $a = 50/7$ . The fulcrum should be placed  $50/7$  ft to the right of  $m_1$ .

2. At equilibrium,  $10(0 - 4) + 3(2 - 4) + 4(3 - 4) + m(6 - 4) = 0$ ,  $m = 25$

3.  $A = 1$ ,  $\bar{x} = \int_0^1 \int_0^1 x \, dy \, dx = \frac{1}{2}$ ,  $\bar{y} = \int_0^1 \int_0^1 y \, dy \, dx = \frac{1}{2}$

4.  $A = 2$ ,  $\bar{x} = \frac{1}{2} \int_{-1}^0 \int_{-1-x}^{1+x} x \, dy \, dx + \int_0^1 \int_{-1+x}^{1-x} x \, dy \, dx = 0$ , similarly  $\bar{y} = 0$ .

5.  $A = 1/2$ ,  $\iint_R x \, dA = \int_0^1 \int_0^x x \, dy \, dx = 1/3$ ,  $\iint_R y \, dA = \int_0^1 \int_0^x y \, dy \, dx = 1/6$ ;  
centroid  $(2/3, 1/3)$

6.  $A = \int_0^1 \int_0^{x^2} dy \, dx = 1/3$ ,  $\iint_R x \, dA = \int_0^1 \int_0^{x^2} x \, dy \, dx = 1/4$ ,  
 $\iint_R y \, dA = \int_0^1 \int_0^{x^2} y \, dy \, dx = 1/10$ ; centroid  $(3/4, 3/10)$

7.  $A = \int_0^1 \int_x^{2-x^2} dy \, dx = 7/6$ ,  $\iint_R x \, dA = \int_0^1 \int_x^{2-x^2} x \, dy \, dx = 5/12$ ,  
 $\iint_R y \, dA = \int_0^1 \int_x^{2-x^2} y \, dy \, dx = 19/15$ ; centroid  $(5/14, 38/35)$

8.  $A = \frac{\pi}{4}$ ,  $\iint_R x \, dA = \int_0^1 \int_0^{\sqrt{1-x^2}} x \, dy \, dx = \frac{1}{3}$ ,  $\bar{x} = \frac{4}{3\pi}$ ,  $\bar{y} = \frac{4}{3\pi}$  by symmetry

9.  $\bar{x} = 0$  from the symmetry of the region,

$$A = \frac{1}{2}\pi(b^2 - a^2), \quad \iint_R y \, dA = \int_0^\pi \int_a^b r^2 \sin \theta \, dr \, d\theta = \frac{2}{3}(b^3 - a^3); \quad \text{centroid } \bar{x} = 0, \bar{y} = \frac{4(b^3 - a^3)}{3\pi(b^2 - a^2)}.$$

10.  $\bar{y} = 0$  from the symmetry of the region,  $A = \pi a^2/2$ ,

$$\iint_R x \, dA = \int_{-\pi/2}^{\pi/2} \int_0^a r^2 \cos \theta \, dr \, d\theta = 2a^3/3; \quad \text{centroid } \left(\frac{4a}{3\pi}, 0\right)$$

11.  $M = \int_0^1 \int_0^{\sqrt{x}} (x + y) \, dy \, dx = 13/20$ ,  $M_x = \int_0^1 \int_0^{\sqrt{x}} (x + y)y \, dy \, dx = 3/10$ ,

$$M_y = \int_0^1 \int_0^{\sqrt{x}} (x + y)x \, dy \, dx = 19/42, \quad \bar{x} = M_y/M = 190/273, \quad \bar{y} = M_x/M = 6/13;$$

the mass is  $13/20$  and the center of gravity is at  $(190/273, 6/13)$ .

12.  $M = \int_0^\pi \int_0^{\sin x} y \, dy \, dx = \pi/4$ ,  $\bar{x} = \pi/2$  from the symmetry of the density and the region,

$$M_x = \int_0^\pi \int_0^{\sin x} y^2 \, dy \, dx = 4/9, \quad \bar{y} = M_x/M = \frac{16}{9\pi}; \quad \text{mass } \pi/4, \quad \text{center of gravity } \left(\frac{\pi}{2}, \frac{16}{9\pi}\right).$$

13.  $M = \int_0^{\pi/2} \int_0^a r^3 \sin \theta \cos \theta \, dr \, d\theta = a^4/8$ ,  $\bar{x} = \bar{y}$  from the symmetry of the density and the region,  $M_y = \int_0^{\pi/2} \int_0^a r^4 \sin \theta \cos^2 \theta \, dr \, d\theta = a^5/15$ ,  $\bar{x} = 8a/15$ ; mass  $a^4/8$ , center of gravity  $(8a/15, 8a/15)$ .
14.  $M = \int_0^\pi \int_0^1 r^3 \, dr \, d\theta = \pi/4$ ,  $\bar{x} = 0$  from the symmetry of density and region,  
 $M_x = \int_0^\pi \int_0^1 r^4 \sin \theta \, dr \, d\theta = 2/5$ ,  $\bar{y} = \frac{8}{5\pi}$ ; mass  $\pi/4$ , center of gravity  $(0, \frac{8}{5\pi})$ .
15.  $V = 1$ ,  $\bar{x} = \int_0^1 \int_0^1 \int_0^1 x \, dz \, dy \, dx = \frac{1}{2}$ , similarly  $\bar{y} = \bar{z} = \frac{1}{2}$ ; centroid  $(\frac{1}{2}, \frac{1}{2}, \frac{1}{2})$
16.  $V = \pi r^2 h = 2\pi$ ,  $\bar{x} = \bar{y} = 0$  by symmetry,  $\iiint_G z \, dz \, dy \, dx = \int_0^2 \int_0^{2\pi} \int_0^1 r z \, dr \, d\theta \, dz = 2\pi$ ,  
 centroid =  $(0, 0, 1)$
17.  $\bar{x} = \bar{y} = \bar{z}$  from the symmetry of the region,  $V = 1/6$ ,  
 $\bar{x} = \frac{1}{V} \int_0^1 \int_0^{1-x} \int_0^{1-x-y} x \, dz \, dy \, dx = (6)(1/24) = 1/4$ ; centroid  $(1/4, 1/4, 1/4)$
18. The solid is described by  $-1 \leq y \leq 1, 0 \leq z \leq 1 - y^2, 0 \leq x \leq 1 - z$ ;  
 $V = \int_{-1}^1 \int_0^{1-y^2} \int_0^{1-z} dx \, dz \, dy = \frac{4}{5}$ ,  $\bar{x} = \frac{1}{V} \int_{-1}^1 \int_0^{1-y^2} \int_0^{1-z} x \, dx \, dz \, dy = \frac{5}{14}$ ,  $\bar{y} = 0$  by symmetry,  
 $\bar{z} = \frac{1}{V} \int_{-1}^1 \int_0^{1-y^2} \int_0^{1-z} z \, dx \, dz \, dy = \frac{2}{7}$ ; the centroid is  $(\frac{5}{14}, 0, \frac{2}{7})$ .
19.  $\bar{x} = 1/2$  and  $\bar{y} = 0$  from the symmetry of the region,  
 $V = \int_0^1 \int_{-1}^1 \int_{y^2}^1 dz \, dy \, dx = 4/3$ ,  $\bar{z} = \frac{1}{V} \iiint_G z \, dV = (3/4)(4/5) = 3/5$ ; centroid  $(1/2, 0, 3/5)$
20.  $\bar{x} = \bar{y}$  from the symmetry of the region,  
 $V = \int_0^2 \int_0^2 \int_0^{xy} dz \, dy \, dx = 4$ ,  $\bar{x} = \frac{1}{V} \iiint_G x \, dV = (1/4)(16/3) = 4/3$ ,  
 $\bar{z} = \frac{1}{V} \iiint_G z \, dV = (1/4)(32/9) = 8/9$ ; centroid  $(4/3, 4/3, 8/9)$
21.  $\bar{x} = \bar{y} = \bar{z}$  from the symmetry of the region,  $V = \pi a^3/6$ ,  
 $\bar{x} = \frac{1}{V} \int_0^a \int_0^{\sqrt{a^2-x^2}} \int_0^{\sqrt{a^2-x^2-y^2}} x \, dz \, dy \, dx = \frac{1}{V} \int_0^a \int_0^{\sqrt{a^2-x^2}} x \sqrt{a^2-x^2-y^2} \, dy \, dx$   
 $= \frac{1}{V} \int_0^{\pi/2} \int_0^a r^2 \sqrt{a^2-r^2} \cos \theta \, dr \, d\theta = \frac{6}{\pi a^3} (\pi a^4/16) = 3a/8$ ; centroid  $(3a/8, 3a/8, 3a/8)$



22.  $\bar{x} = \bar{y} = 0$  from the symmetry of the region,  $V = 2\pi a^3/3$

$$\begin{aligned}\bar{z} &= \frac{1}{V} \int_{-a}^a \int_{-\sqrt{a^2-x^2}}^{\sqrt{a^2-x^2}} \int_0^{\sqrt{a^2-x^2-y^2}} z \, dz \, dy \, dx = \frac{1}{V} \int_{-a}^a \int_{-\sqrt{a^2-x^2}}^{\sqrt{a^2-x^2}} \frac{1}{2}(a^2 - x^2 - y^2) \, dy \, dx \\ &= \frac{1}{V} \int_0^{2\pi} \int_0^a \frac{1}{2}(a^2 - r^2)r \, dr \, d\theta = \frac{3}{2\pi a^3}(\pi a^4/4) = 3a/8; \text{ centroid } (0, 0, 3a/8)\end{aligned}$$

23.  $M = \int_0^a \int_0^a \int_0^a (a-x) \, dz \, dy \, dx = a^4/2$ ,  $\bar{y} = \bar{z} = a/2$  from the symmetry of density and

$$\text{region, } \bar{x} = \frac{1}{M} \int_0^a \int_0^a \int_0^a x(a-x) \, dz \, dy \, dx = (2/a^4)(a^5/6) = a/3;$$

mass  $a^4/2$ , center of gravity  $(a/3, a/2, a/2)$

24.  $M = \int_{-a}^a \int_{-\sqrt{a^2-x^2}}^{\sqrt{a^2-x^2}} \int_0^h (h-z) \, dz \, dy \, dx = \frac{1}{2}\pi a^2 h^2$ ,  $\bar{x} = \bar{y} = 0$  from the symmetry of density

$$\text{and region, } \bar{z} = \frac{1}{M} \iiint_G z(h-z) \, dV = \frac{2}{\pi a^2 h^2}(\pi a^2 h^3/6) = h/3;$$

mass  $\pi a^2 h^2/2$ , center of gravity  $(0, 0, h/3)$

25.  $M = \int_{-1}^1 \int_0^1 \int_0^{1-y^2} yz \, dz \, dy \, dx = 1/6$ ,  $\bar{x} = 0$  by the symmetry of density and region,

$$\bar{y} = \frac{1}{M} \iiint_G y^2 z \, dV = (6)(8/105) = 16/35, \quad \bar{z} = \frac{1}{M} \iiint_G yz^2 \, dV = (6)(1/12) = 1/2;$$

mass  $1/6$ , center of gravity  $(0, 16/35, 1/2)$

26.  $M = \int_0^3 \int_0^{9-x^2} \int_0^1 xz \, dz \, dy \, dx = 81/8$ ,  $\bar{x} = \frac{1}{M} \iiint_G x^2 z \, dV = (8/81)(81/5) = 8/5$ ,

$$\bar{y} = \frac{1}{M} \iiint_G xyz \, dV = (8/81)(243/8) = 3, \quad \bar{z} = \frac{1}{M} \iiint_G xz^2 \, dV = (8/81)(27/4) = 2/3;$$

mass  $81/8$ , center of gravity  $(8/5, 3, 2/3)$

27. (a)  $M = \int_0^1 \int_0^1 k(x^2 + y^2) \, dy \, dx = 2k/3$ ,  $\bar{x} = \bar{y}$  from the symmetry of density and region,

$$\bar{x} = \frac{1}{M} \iint_R kx(x^2 + y^2) \, dA = \frac{3}{2k}(5k/12) = 5/8; \text{ center of gravity } (5/8, 5/8)$$

- (b)  $\bar{y} = 1/2$  from the symmetry of density and region,

$$M = \int_0^1 \int_0^1 kx \, dy \, dx = k/2, \quad \bar{x} = \frac{1}{M} \iint_R kx^2 \, dA = (2/k)(k/3) = 2/3,$$

center of gravity  $(2/3, 1/2)$

28. (a)  $\bar{x} = \bar{y} = \bar{z}$  from the symmetry of density and region,

$$M = \int_0^1 \int_0^1 \int_0^1 k(x^2 + y^2 + z^2) dz dy dx = k,$$

$$\bar{x} = \frac{1}{M} \iiint_G kx(x^2 + y^2 + z^2) dV = (1/k)(7k/12) = 7/12; \text{ center of gravity } (7/12, 7/12, 7/12)$$

- (b)  $\bar{x} = \bar{y} = \bar{z}$  from the symmetry of density and region,

$$M = \int_0^1 \int_0^1 \int_0^1 k(x + y + z) dz dy dx = 3k/2,$$

$$\bar{x} = \frac{1}{M} \iiint_G kx(x + y + z) dV = \frac{2}{3k}(5k/6) = 5/9; \text{ center of gravity } (5/9, 5/9, 5/9)$$

29.  $V = \iiint_G dV = \int_0^\pi \int_0^{\sin x} \int_0^{1/(1+x^2+y^2)} dz dy dx = 0.666633,$

$$\bar{x} = \frac{1}{V} \iiint_G x dV = 1.177406, \bar{y} = \frac{1}{V} \iiint_G y dV = 0.353554, \bar{z} = \frac{1}{V} \iiint_G z dV = 0.231557$$

30. (b) Use cylindrical coordinates to get

$$V = \iiint_G dV = \int_0^{2\pi} \int_0^a \int_0^{1/(1+r^2)} r dz dr d\theta = \pi \ln(1 + a^2),$$

$$\bar{z} = \frac{1}{V} \iiint_G z dV = \frac{a^2}{2(1 + a^2) \ln(1 + a^2)}$$

- (c)  $\lim_{a \rightarrow 0^+} \bar{z} = \frac{1}{2}; \lim_{a \rightarrow +\infty} \bar{z} = 0;$  solve  $\bar{z} = 1/4$  for  $a$  to obtain  $a \approx 1.980291$ .

31. Let  $x = r \cos \theta$ ,  $y = r \sin \theta$ , and  $dA = r dr d\theta$  in formulas (10) and (11).

32.  $\bar{x} = 0$  from the symmetry of the region,  $A = \int_0^{2\pi} \int_0^{a(1+\sin \theta)} r dr d\theta = 3\pi a^2/2,$

$$\bar{y} = \frac{1}{A} \int_0^{2\pi} \int_0^{a(1+\sin \theta)} r^2 \sin \theta dr d\theta = \frac{2}{3\pi a^2} (5\pi a^3/4) = 5a/6; \text{ centroid } (0, 5a/6)$$

33.  $\bar{x} = \bar{y}$  from the symmetry of the region,  $A = \int_0^{\pi/2} \int_0^{\sin 2\theta} r dr d\theta = \pi/8,$

$$\bar{x} = \frac{1}{A} \int_0^{\pi/2} \int_0^{\sin 2\theta} r^2 \cos \theta dr d\theta = (8/\pi)(16/105) = \frac{128}{105\pi}; \text{ centroid } \left( \frac{128}{105\pi}, \frac{128}{105\pi} \right)$$

34.  $\bar{x} = 3/2$  and  $\bar{y} = 1$  from the symmetry of the region,

$$\iint_R x dA = \bar{x}A = (3/2)(6) = 9, \iint_R y dA = \bar{y}A = (1)(6) = 6$$

35.  $\bar{x} = 0$  from the symmetry of the region,  $\pi a^2/2$  is the area of the semicircle,  $2\pi\bar{y}$  is the distance traveled by the centroid to generate the sphere so  $4\pi a^3/3 = (\pi a^2/2)(2\pi\bar{y})$ ,  $\bar{y} = 4a/(3\pi)$

$$36. \quad (\text{a}) \quad V = \left[ \frac{1}{2} \pi a^2 \right] \left[ 2\pi \left( a + \frac{4a}{3\pi} \right) \right] = \frac{1}{3} \pi (3\pi + 4) a^3$$

(b) the distance between the centroid and the line is  $\frac{\sqrt{2}}{2} \left( a + \frac{4a}{3\pi} \right)$  so

$$V = \left[ \frac{1}{2} \pi a^2 \right] \left[ 2\pi \frac{\sqrt{2}}{2} \left( a + \frac{4a}{3\pi} \right) \right] = \frac{1}{6} \sqrt{2} \pi (3\pi + 4) a^3$$

$$37. \quad \bar{x} = k \text{ so } V = (\pi ab)(2\pi k) = 2\pi^2 abk$$

38.  $\bar{y} = 4$  from the symmetry of the region,

$$A = \int_{-2}^2 \int_{x^2}^{8-x^2} dy dx = 64/3 \text{ so } V = (64/3)[2\pi(4)] = 512\pi/3$$

39. The region generates a cone of volume  $\frac{1}{3} \pi ab^2$  when it is revolved about the  $x$ -axis, the area of the region is  $\frac{1}{2} ab$  so  $\frac{1}{3} \pi ab^2 = \left( \frac{1}{2} ab \right) (2\pi \bar{y})$ ,  $\bar{y} = b/3$ . A cone of volume  $\frac{1}{3} \pi a^2 b$  is generated when the region is revolved about the  $y$ -axis so  $\frac{1}{3} \pi a^2 b = \left( \frac{1}{2} ab \right) (2\pi \bar{x})$ ,  $\bar{x} = a/3$ . The centroid is  $(a/3, b/3)$ .

$$40. \quad I_x = \int_0^a \int_0^b y^2 \delta dy dx = \frac{1}{3} \delta ab^3, \quad I_y = \int_0^a \int_0^b x^2 \delta dy dx = \frac{1}{3} \delta a^3 b,$$

$$I_z = \int_0^a \int_0^b (x^2 + y^2) \delta dy dx = \frac{1}{3} \delta ab(a^2 + b^2)$$

$$41. \quad I_x = \int_0^{2\pi} \int_0^a r^3 \sin^2 \theta \delta dr d\theta = \delta \pi a^4 / 4; \quad I_y = \int_0^{2\pi} \int_0^a r^3 \cos^2 \theta \delta dr d\theta = \delta \pi a^4 / 4 = I_x;$$

$$I_z = I_x + I_y = \delta \pi a^4 / 2$$

## EXERCISE SET 16.7

$$1. \quad \int_0^{2\pi} \int_0^1 \int_0^{\sqrt{1-r^2}} zr dz dr d\theta = \int_0^{2\pi} \int_0^1 \frac{1}{2} (1-r^2) r dr d\theta = \int_0^{2\pi} \frac{1}{8} d\theta = \pi/4$$

$$2. \quad \int_0^{\pi/2} \int_0^{\cos \theta} \int_0^{r^2} r \sin \theta dz dr d\theta = \int_0^{\pi/2} \int_0^{\cos \theta} r^3 \sin \theta dr d\theta = \int_0^{\pi/2} \frac{1}{4} \cos^4 \theta \sin \theta d\theta = 1/20$$

$$3. \quad \int_0^{\pi/2} \int_0^{\pi/2} \int_0^1 \rho^3 \sin \phi \cos \phi d\rho d\phi d\theta = \int_0^{\pi/2} \int_0^{\pi/2} \frac{1}{4} \sin \phi \cos \phi d\phi d\theta = \int_0^{\pi/2} \frac{1}{8} d\theta = \pi/16$$

$$4. \quad \int_0^{2\pi} \int_0^{\pi/4} \int_0^{a \sec \phi} \rho^2 \sin \phi d\rho d\phi d\theta = \int_0^{2\pi} \int_0^{\pi/4} \frac{1}{3} a^3 \sec^3 \phi \sin \phi d\phi d\theta = \int_0^{2\pi} \frac{1}{6} a^3 d\theta = \pi a^3 / 3$$

$$5. \quad V = \int_0^{2\pi} \int_0^3 \int_{r^2}^9 r dz dr d\theta = \int_0^{2\pi} \int_0^3 r(9-r^2) dr d\theta = \int_0^{2\pi} \frac{81}{4} d\theta = 81\pi/2$$

$$\begin{aligned}
 6. \quad V &= 2 \int_0^{2\pi} \int_0^2 \int_0^{\sqrt{9-r^2}} r \, dz \, dr \, d\theta = 2 \int_0^{2\pi} \int_0^2 r \sqrt{9-r^2} \, dr \, d\theta \\
 &= \frac{2}{3} (27 - 5\sqrt{5}) \int_0^{2\pi} d\theta = 4(27 - 5\sqrt{5})\pi/3
 \end{aligned}$$

7.  $r^2 + z^2 = 20$  intersects  $z = r^2$  in a circle of radius 2,

$$\begin{aligned}
 V &= \int_0^{2\pi} \int_0^2 \int_{r^2}^{\sqrt{20-r^2}} r \, dz \, dr \, d\theta = \int_0^{2\pi} \int_0^2 (r\sqrt{20-r^2} - r^3) \, dr \, d\theta \\
 &= \frac{4}{3} (10\sqrt{5} - 19) \int_0^{2\pi} d\theta = 8(10\sqrt{5} - 19)\pi/3
 \end{aligned}$$

8.  $z = hr/a$  intersects  $z = h$  in a circle of radius  $a$ ,

$$V = \int_0^{2\pi} \int_0^a \int_{hr/a}^h r \, dz \, dr \, d\theta = \int_0^{2\pi} \int_0^a \frac{h}{a} (ar - r^2) \, dr \, d\theta = \int_0^{2\pi} \frac{1}{6} a^2 h \, d\theta = \pi a^2 h/3$$

$$9. \quad V = \int_0^{2\pi} \int_0^{\pi/3} \int_0^4 \rho^2 \sin \phi \, d\rho \, d\phi \, d\theta = \int_0^{2\pi} \int_0^{\pi/3} \frac{64}{3} \sin \phi \, d\phi \, d\theta = \frac{32}{3} \int_0^{2\pi} d\theta = 64\pi/3$$

$$10. \quad V = \int_0^{2\pi} \int_0^{\pi/4} \int_1^2 \rho^2 \sin \phi \, d\rho \, d\phi \, d\theta = \int_0^{2\pi} \int_0^{\pi/4} \frac{7}{3} \sin \phi \, d\phi \, d\theta = \frac{7}{6} (2 - \sqrt{2}) \int_0^{2\pi} d\theta = 7(2 - \sqrt{2})\pi/3$$

11. In spherical coordinates the sphere and the plane  $z = a$  are  $\rho = 2a$  and  $\rho = a \sec \phi$ , respectively. They intersect at  $\phi = \pi/3$ ,

$$\begin{aligned}
 V &= \int_0^{2\pi} \int_0^{\pi/3} \int_0^{a \sec \phi} \rho^2 \sin \phi \, d\rho \, d\phi \, d\theta + \int_0^{2\pi} \int_{\pi/3}^{\pi/2} \int_0^{2a} \rho^2 \sin \phi \, d\rho \, d\phi \, d\theta \\
 &= \int_0^{2\pi} \int_0^{\pi/3} \frac{1}{3} a^3 \sec^3 \phi \sin \phi \, d\phi \, d\theta + \int_0^{2\pi} \int_{\pi/3}^{\pi/2} \frac{8}{3} a^3 \sin \phi \, d\phi \, d\theta \\
 &= \frac{1}{2} a^3 \int_0^{2\pi} d\theta + \frac{4}{3} a^3 \int_0^{2\pi} d\theta = 11\pi a^3/3
 \end{aligned}$$

$$12. \quad V = \int_0^{2\pi} \int_{\pi/4}^{\pi/2} \int_0^3 \rho^2 \sin \phi \, d\rho \, d\phi \, d\theta = \int_0^{2\pi} \int_{\pi/4}^{\pi/2} 9 \sin \phi \, d\phi \, d\theta = \frac{9\sqrt{2}}{2} \int_0^{2\pi} d\theta = 9\sqrt{2}\pi$$

$$\begin{aligned}
 13. \quad \int_0^{\pi/2} \int_0^a \int_0^{a^2-r^2} r^3 \cos^2 \theta \, dz \, dr \, d\theta &= \int_0^{\pi/2} \int_0^a (a^2 r^3 - r^5) \cos^2 \theta \, dr \, d\theta \\
 &= \frac{1}{12} a^6 \int_0^{\pi/2} \cos^2 \theta \, d\theta = \pi a^6/48
 \end{aligned}$$

$$14. \quad \int_0^\pi \int_0^{\pi/2} \int_0^1 e^{-\rho^3} \rho^2 \sin \phi \, d\rho \, d\phi \, d\theta = \frac{1}{3} (1 - e^{-1}) \int_0^\pi \int_0^{\pi/2} \sin \phi \, d\phi \, d\theta = (1 - e^{-1})\pi/3$$

$$15. \quad \int_0^{\pi/2} \int_0^{\pi/4} \int_0^{\sqrt{8}} \rho^4 \cos^2 \phi \sin \phi \, d\rho \, d\phi \, d\theta = 32(2\sqrt{2} - 1)\pi/15$$

$$16. \quad \int_0^{2\pi} \int_0^\pi \int_0^3 \rho^3 \sin \phi \, d\rho \, d\phi \, d\theta = 81\pi$$

$$18. \int_0^{\pi/2} \int_0^{\pi/4} \frac{1}{18} \cos^{37} \theta \cos \phi \, d\phi \, d\theta = \frac{\sqrt{2}}{36} \int_0^{\pi/2} \cos^{37} \theta \, d\theta = \frac{4,294,967,296}{755,505,013,725} \sqrt{2} \approx 0.008040$$

$$19. \text{ (a) } V = 2 \int_0^{2\pi} \int_0^a \int_0^{\sqrt{a^2-r^2}} r \, dz \, dr \, d\theta = 4\pi a^3/3$$

$$\text{ (b) } V = \int_0^{2\pi} \int_0^\pi \int_0^a \rho^2 \sin \phi \, d\rho \, d\phi \, d\theta = 4\pi a^3/3$$

$$20. \text{ (a) } \int_0^2 \int_0^{\sqrt{4-x^2}} \int_0^{\sqrt{4-x^2-y^2}} xyz \, dz \, dy \, dx \\ = \int_0^2 \int_0^{\sqrt{4-x^2}} \frac{1}{2} xy(4-x^2-y^2) \, dy \, dx = \frac{1}{8} \int_0^2 x(4-x^2)^2 \, dx = 4/3$$

$$\text{ (b) } \int_0^{\pi/2} \int_0^2 \int_0^{\sqrt{4-r^2}} r^3 z \sin \theta \cos \theta \, dz \, dr \, d\theta \\ = \int_0^{\pi/2} \int_0^2 \frac{1}{2} (4r^3 - r^5) \sin \theta \cos \theta \, dr \, d\theta = \frac{8}{3} \int_0^{\pi/2} \sin \theta \cos \theta \, d\theta = 4/3$$

$$\text{ (c) } \int_0^{\pi/2} \int_0^{\pi/2} \int_0^2 \rho^5 \sin^3 \phi \cos \phi \sin \theta \cos \theta \, d\rho \, d\phi \, d\theta \\ = \int_0^{\pi/2} \int_0^{\pi/2} \frac{32}{3} \sin^3 \phi \cos \phi \sin \theta \cos \theta \, d\phi \, d\theta = \frac{8}{3} \int_0^{\pi/2} \sin \theta \cos \theta \, d\theta = 4/3$$

$$21. M = \int_0^{2\pi} \int_0^3 \int_r^3 (3-z)r \, dz \, dr \, d\theta = \int_0^{2\pi} \int_0^3 \frac{1}{2} r(3-r)^2 \, dr \, d\theta = \frac{27}{8} \int_0^{2\pi} d\theta = 27\pi/4$$

$$22. M = \int_0^{2\pi} \int_0^a \int_0^h k z r \, dz \, dr \, d\theta = \int_0^{2\pi} \int_0^a \frac{1}{2} k h^2 r \, dr \, d\theta = \frac{1}{4} k a^2 h^2 \int_0^{2\pi} d\theta = \pi k a^2 h^2 / 2$$

$$23. M = \int_0^{2\pi} \int_0^\pi \int_0^a k \rho^3 \sin \phi \, d\rho \, d\phi \, d\theta = \int_0^{2\pi} \int_0^\pi \frac{1}{4} k a^4 \sin \phi \, d\phi \, d\theta = \frac{1}{2} k a^4 \int_0^{2\pi} d\theta = \pi k a^4$$

$$24. M = \int_0^{2\pi} \int_0^\pi \int_1^2 \rho \sin \phi \, d\rho \, d\phi \, d\theta = \int_0^{2\pi} \int_0^\pi \frac{3}{2} \sin \phi \, d\phi \, d\theta = 3 \int_0^{2\pi} d\theta = 6\pi$$

25.  $\bar{x} = \bar{y} = 0$  from the symmetry of the region,

$$V = \int_0^{2\pi} \int_0^1 \int_{r^2}^{\sqrt{2-r^2}} r \, dz \, dr \, d\theta = \int_0^{2\pi} \int_0^1 (r\sqrt{2-r^2} - r^3) \, dr \, d\theta = (8\sqrt{2} - 7)\pi/6,$$

$$\bar{z} = \frac{1}{V} \int_0^{2\pi} \int_0^1 \int_{r^2}^{\sqrt{2-r^2}} z r \, dz \, dr \, d\theta = \frac{6}{(8\sqrt{2} - 7)\pi} (7\pi/12) = 7/(16\sqrt{2} - 14);$$

$$\text{centroid} \left( 0, 0, \frac{7}{16\sqrt{2} - 14} \right)$$

26.  $\bar{x} = \bar{y} = 0$  from the symmetry of the region,  $V = 8\pi/3$ ,

$$\bar{z} = \frac{1}{V} \int_0^{2\pi} \int_0^2 \int_r^2 z r \, dz \, dr \, d\theta = \frac{3}{8\pi} (4\pi) = 3/2; \text{ centroid } (0, 0, 3/2)$$

27.  $\bar{x} = \bar{y} = \bar{z}$  from the symmetry of the region,  $V = \pi a^3/6$ ,

$$\bar{z} = \frac{1}{V} \int_0^{\pi/2} \int_0^{\pi/2} \int_0^a \rho^3 \cos \phi \sin \phi \, d\rho \, d\phi \, d\theta = \frac{6}{\pi a^3} (\pi a^4/16) = 3a/8;$$

centroid  $(3a/8, 3a/8, 3a/8)$

28.  $\bar{x} = \bar{y} = 0$  from the symmetry of the region,  $V = \int_0^{2\pi} \int_0^{\pi/3} \int_0^4 \rho^2 \sin \phi \, d\rho \, d\phi \, d\theta = 64\pi/3$ ,

$$\bar{z} = \frac{1}{V} \int_0^{2\pi} \int_0^{\pi/3} \int_0^4 \rho^3 \cos \phi \sin \phi \, d\rho \, d\phi \, d\theta = \frac{3}{64\pi} (48\pi) = 9/4; \text{ centroid } (0, 0, 9/4)$$

29.  $\bar{y} = 0$  from the symmetry of the region,  $V = 2 \int_0^{\pi/2} \int_0^{2 \cos \theta} \int_0^{r^2} r \, dz \, dr \, d\theta = 3\pi/2$ ,

$$\bar{x} = \frac{2}{V} \int_0^{\pi/2} \int_0^{2 \cos \theta} \int_0^{r^2} r^2 \cos \theta \, dz \, dr \, d\theta = \frac{4}{3\pi} (\pi) = 4/3,$$

$$\bar{z} = \frac{2}{V} \int_0^{\pi/2} \int_0^{2 \cos \theta} \int_0^{r^2} r z \, dz \, dr \, d\theta = \frac{4}{3\pi} (5\pi/6) = 10/9; \text{ centroid } (4/3, 0, 10/9)$$

$$\begin{aligned} 30. \quad M &= \int_0^{\pi/2} \int_0^{2 \cos \theta} \int_0^{4-r^2} z r \, dz \, dr \, d\theta = \int_0^{\pi/2} \int_0^{2 \cos \theta} \frac{1}{2} r (4-r^2)^2 \, dr \, d\theta \\ &= \frac{16}{3} \int_0^{\pi/2} (1 - \sin^6 \theta) \, d\theta = (16/3)(11\pi/32) = 11\pi/6 \end{aligned}$$

$$\begin{aligned} 31. \quad V &= \int_0^{\pi/2} \int_{\pi/6}^{\pi/3} \int_0^2 \rho^2 \sin \phi \, d\rho \, d\phi \, d\theta = \int_0^{\pi/2} \int_{\pi/6}^{\pi/3} \frac{8}{3} \sin \phi \, d\phi \, d\theta = \frac{4}{3} (\sqrt{3} - 1) \int_0^{\pi/2} d\theta \\ &= 2(\sqrt{3} - 1)\pi/3 \end{aligned}$$

$$32. \quad M = \int_0^{2\pi} \int_0^{\pi/4} \int_0^1 \rho^3 \sin \phi \, d\rho \, d\phi \, d\theta = \int_0^{2\pi} \int_0^{\pi/4} \frac{1}{4} \sin \phi \, d\phi \, d\theta = \frac{1}{8} (2 - \sqrt{2}) \int_0^{2\pi} d\theta = (2 - \sqrt{2})\pi/4$$

33.  $\bar{x} = \bar{y} = 0$  from the symmetry of density and region,

$$M = \int_0^{2\pi} \int_0^1 \int_0^{1-r^2} (r^2 + z^2) r \, dz \, dr \, d\theta = \pi/4,$$

$$\bar{z} = \frac{1}{M} \int_0^{2\pi} \int_0^1 \int_0^{1-r^2} z(r^2 + z^2) r \, dz \, dr \, d\theta = (4/\pi)(11\pi/120) = 11/30; \text{ center of gravity } (0, 0, 11/30)$$

34.  $\bar{x} = \bar{y} = 0$  from the symmetry of density and region,  $M = \int_0^{2\pi} \int_0^1 \int_0^r z r \, dz \, dr \, d\theta = \pi/4$ ,

$$\bar{z} = \frac{1}{M} \int_0^{2\pi} \int_0^1 \int_0^r z^2 r \, dz \, dr \, d\theta = (4/\pi)(2\pi/15) = 8/15; \text{ center of gravity } (0, 0, 8/15)$$

35.  $\bar{x} = \bar{y} = 0$  from the symmetry of density and region,

$$M = \int_0^{2\pi} \int_0^{\pi/2} \int_0^a k\rho^3 \sin \phi \, d\rho \, d\phi \, d\theta = \pi k a^4/2,$$

$$\bar{z} = \frac{1}{M} \int_0^{2\pi} \int_0^{\pi/2} \int_0^a k\rho^4 \sin \phi \cos \phi \, d\rho \, d\phi \, d\theta = \frac{2}{\pi k a^4} (\pi k a^5/5) = 2a/5; \text{ center of gravity } (0, 0, 2a/5)$$

36.  $\bar{x} = \bar{z} = 0$  from the symmetry of the region,  $V = 54\pi/3 - 16\pi/3 = 38\pi/3$ ,

$$\begin{aligned}\bar{y} &= \frac{1}{V} \int_0^\pi \int_0^\pi \int_2^3 \rho^3 \sin^2 \phi \sin \theta \, d\rho \, d\phi \, d\theta = \frac{1}{V} \int_0^\pi \int_0^\pi \frac{65}{4} \sin^2 \phi \sin \theta \, d\phi \, d\theta \\ &= \frac{1}{V} \int_0^\pi \frac{65\pi}{8} \sin \theta \, d\theta = \frac{3}{38\pi} (65\pi/4) = 195/152; \text{ centroid } (0, 195/152, 0)\end{aligned}$$

37.  $M = \int_0^{2\pi} \int_0^\pi \int_0^R \delta_0 e^{(\rho/R)^3} \rho^2 \sin \phi \, d\rho \, d\phi \, d\theta = \int_0^{2\pi} \int_0^\pi \frac{1}{3} (e-1) R^3 \delta_0 \sin \phi \, d\phi \, d\theta = \frac{4}{3} \pi (e-1) \delta_0 R^3$

38. (a) The sphere and cone intersect in a circle of radius  $\rho_0 \sin \phi_0$ ,

$$\begin{aligned}V &= \int_{\theta_1}^{\theta_2} \int_0^{\rho_0 \sin \phi_0} \int_{r \cot \phi_0}^{\sqrt{\rho_0^2 - r^2}} r \, dz \, dr \, d\theta = \int_{\theta_1}^{\theta_2} \int_0^{\rho_0 \sin \phi_0} \left( r \sqrt{\rho_0^2 - r^2} - r^2 \cot \phi_0 \right) dr \, d\theta \\ &= \int_{\theta_1}^{\theta_2} \frac{1}{3} \rho_0^3 (1 - \cos^3 \phi_0 - \sin^3 \phi_0 \cot \phi_0) d\theta = \frac{1}{3} \rho_0^3 (1 - \cos^3 \phi_0 - \sin^2 \phi_0 \cos \phi_0) (\theta_2 - \theta_1) \\ &= \frac{1}{3} \rho_0^3 (1 - \cos \phi_0) (\theta_2 - \theta_1).\end{aligned}$$

(b) From part (a), the volume of the solid bounded by  $\theta = \theta_1$ ,  $\theta = \theta_2$ ,  $\phi = \phi_1$ ,  $\phi = \phi_2$ , and  $\rho = \rho_0$  is  $\frac{1}{3} \rho_0^3 (1 - \cos \phi_2) (\theta_2 - \theta_1) - \frac{1}{3} \rho_0^3 (1 - \cos \phi_1) (\theta_2 - \theta_1) = \frac{1}{3} \rho_0^3 (\cos \phi_1 - \cos \phi_2) (\theta_2 - \theta_1)$  so the volume of the spherical wedge between  $\rho = \rho_1$  and  $\rho = \rho_2$  is

$$\begin{aligned}\Delta V &= \frac{1}{3} \rho_2^3 (\cos \phi_1 - \cos \phi_2) (\theta_2 - \theta_1) - \frac{1}{3} \rho_1^3 (\cos \phi_1 - \cos \phi_2) (\theta_2 - \theta_1) \\ &= \frac{1}{3} (\rho_2^3 - \rho_1^3) (\cos \phi_1 - \cos \phi_2) (\theta_2 - \theta_1)\end{aligned}$$

(c)  $\frac{d}{d\phi} \cos \phi = -\sin \phi$  so from the Mean-Value Theorem  $\cos \phi_2 - \cos \phi_1 = -(\phi_2 - \phi_1) \sin \phi^*$  where  $\phi^*$  is between  $\phi_1$  and  $\phi_2$ . Similarly  $\frac{d}{d\rho} \rho^3 = 3\rho^2$  so  $\rho_2^3 - \rho_1^3 = 3\rho^{*2} (\rho_2 - \rho_1)$  where  $\rho^*$  is between  $\rho_1$  and  $\rho_2$ . Thus  $\cos \phi_1 - \cos \phi_2 = \sin \phi^* \Delta \phi$  and  $\rho_2^3 - \rho_1^3 = 3\rho^{*2} \Delta \rho$  so  $\Delta V = \rho^{*2} \sin \phi^* \Delta \rho \Delta \phi \Delta \theta$ .

39.  $I_z = \int_0^{2\pi} \int_0^a \int_0^h r^2 \delta r \, dz \, dr \, d\theta = \delta \int_0^{2\pi} \int_0^a \int_0^h r^3 \, dz \, dr \, d\theta = \frac{1}{2} \delta \pi a^4 h$

40.  $I_y = \int_0^{2\pi} \int_0^a \int_0^h (r^2 \cos^2 \theta + z^2) \delta r \, dz \, dr \, d\theta = \delta \int_0^{2\pi} \int_0^a (hr^3 \cos^2 \theta + \frac{1}{3} h^3 r) \, dr \, d\theta$   
 $= \delta \int_0^{2\pi} \left( \frac{1}{4} a^4 h \cos^2 \theta + \frac{1}{6} a^2 h^3 \right) d\theta = \delta \left( \frac{\pi}{4} a^4 h + \frac{\pi}{3} a^2 h^3 \right)$

41.  $I_z = \int_0^{2\pi} \int_{a_1}^{a_2} \int_0^h r^2 \delta r \, dz \, dr \, d\theta = \delta \int_0^{2\pi} \int_{a_1}^{a_2} \int_0^h r^3 \, dz \, dr \, d\theta = \frac{1}{2} \delta \pi h (a_2^4 - a_1^4)$

42.  $I_z = \int_0^{2\pi} \int_0^\pi \int_0^a (\rho^2 \sin^2 \phi) \delta \rho^2 \sin \phi \, d\rho \, d\phi \, d\theta = \delta \int_0^{2\pi} \int_0^\pi \int_0^a \rho^4 \sin^3 \phi \, d\rho \, d\phi \, d\theta = \frac{8}{15} \delta \pi a^5$

## EXERCISE SET 16.8

$$1. \frac{\partial(x, y)}{\partial(u, v)} = \begin{vmatrix} 1 & 4 \\ 3 & -5 \end{vmatrix} = -17$$

$$2. \frac{\partial(x, y)}{\partial(u, v)} = \begin{vmatrix} 1 & 4v \\ 4u & -1 \end{vmatrix} = -1 - 16uv$$

$$3. \frac{\partial(x, y)}{\partial(u, v)} = \begin{vmatrix} \cos u & -\sin v \\ \sin u & \cos v \end{vmatrix} = \cos u \cos v + \sin u \sin v = \cos(u - v)$$

$$4. \frac{\partial(x, y)}{\partial(u, v)} = \begin{vmatrix} \frac{2(v^2 - u^2)}{(u^2 + v^2)^2} & -\frac{4uv}{(u^2 + v^2)^2} \\ \frac{4uv}{(u^2 + v^2)^2} & \frac{2(v^2 - u^2)}{(u^2 + v^2)^2} \end{vmatrix} = 4/(u^2 + v^2)^2$$

$$5. x = \frac{2}{9}u + \frac{5}{9}v, y = -\frac{1}{9}u + \frac{2}{9}v; \frac{\partial(x, y)}{\partial(u, v)} = \begin{vmatrix} 2/9 & 5/9 \\ -1/9 & 2/9 \end{vmatrix} = \frac{1}{9}$$

$$6. x = \ln u, y = uv; \frac{\partial(x, y)}{\partial(u, v)} = \begin{vmatrix} 1/u & 0 \\ v & u \end{vmatrix} = 1$$

$$7. x = \sqrt{u+v}/\sqrt{2}, y = \sqrt{v-u}/\sqrt{2}; \frac{\partial(x, y)}{\partial(u, v)} = \begin{vmatrix} \frac{1}{2\sqrt{2}\sqrt{u+v}} & \frac{1}{2\sqrt{2}\sqrt{u+v}} \\ -\frac{1}{2\sqrt{2}\sqrt{v-u}} & \frac{1}{2\sqrt{2}\sqrt{v-u}} \end{vmatrix} = \frac{1}{4\sqrt{v^2 - u^2}}$$

$$8. x = u^{3/2}/v^{1/2}, y = v^{1/2}/u^{1/2}; \frac{\partial(x, y)}{\partial(u, v)} = \begin{vmatrix} \frac{3u^{1/2}}{2v^{1/2}} & -\frac{u^{3/2}}{2v^{3/2}} \\ v^{1/2} & 1 \\ -\frac{1}{2u^{3/2}} & \frac{1}{2u^{1/2}v^{1/2}} \end{vmatrix} = \frac{1}{2v}$$

$$9. \frac{\partial(x, y, z)}{\partial(u, v, w)} = \begin{vmatrix} 3 & 1 & 0 \\ 1 & 0 & -2 \\ 0 & 1 & 1 \end{vmatrix} = 5$$

$$10. \frac{\partial(x, y, z)}{\partial(u, v, w)} = \begin{vmatrix} 1-v & -u & 0 \\ v-vw & u-uw & -uw \\ vw & uw & uv \end{vmatrix} = u^2v$$

$$11. y = v, x = u/y = u/v, z = w - x = w - u/v; \frac{\partial(x, y, z)}{\partial(u, v, w)} = \begin{vmatrix} 1/v & -u/v^2 & 0 \\ 0 & 1 & 0 \\ -1/v & u/v^2 & 1 \end{vmatrix} = 1/v$$

$$12. x = (v+w)/2, y = (u-w)/2, z = (u-v)/2; \frac{\partial(x, y, z)}{\partial(u, v, w)} = \begin{vmatrix} 0 & 1/2 & 1/2 \\ 1/2 & 0 & -1/2 \\ 1/2 & -1/2 & 0 \end{vmatrix} = -\frac{1}{4}$$



13.

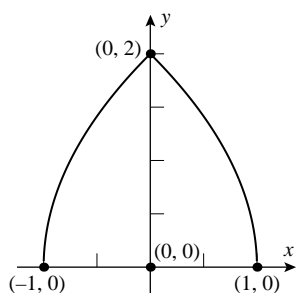

14.

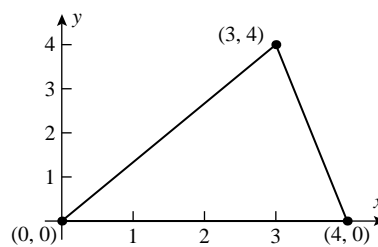

15.

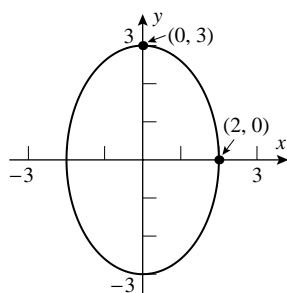

16.

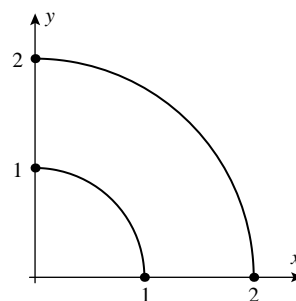

17.  $x = \frac{1}{5}u + \frac{2}{5}v, y = -\frac{2}{5}u + \frac{1}{5}v, \frac{\partial(x, y)}{\partial(u, v)} = \frac{1}{5}; \frac{1}{5} \iint_S \frac{u}{v} dA_{uv} = \frac{1}{5} \int_1^3 \int_1^4 \frac{u}{v} du dv = \frac{3}{2} \ln 3$

18.  $x = \frac{1}{2}u + \frac{1}{2}v, y = \frac{1}{2}u - \frac{1}{2}v, \frac{\partial(x, y)}{\partial(u, v)} = -\frac{1}{2}; \frac{1}{2} \iint_S ve^{uv} dA_{uv} = \frac{1}{2} \int_1^4 \int_0^1 ve^{uv} du dv = \frac{1}{2}(e^4 - e - 3)$

19.  $x = u + v, y = u - v, \frac{\partial(x, y)}{\partial(u, v)} = -2$ ; the boundary curves of the region  $S$  in the  $uv$ -plane are  $v = 0, v = u$ , and  $u = 1$  so  $2 \iint_S \sin u \cos v dA_{uv} = 2 \int_0^1 \int_0^u \sin u \cos v dv du = 1 - \frac{1}{2} \sin 2$

20.  $x = \sqrt{v/u}, y = \sqrt{uv}$  so, from Example 3,  $\frac{\partial(x, y)}{\partial(u, v)} = -\frac{1}{2u}$ ; the boundary curves of the region  $S$  in the  $uv$ -plane are  $u = 1, u = 3, v = 1$ , and  $v = 4$  so  $\iint_S uv^2 \left(\frac{1}{2u}\right) dA_{uv} = \frac{1}{2} \int_1^4 \int_1^3 v^2 du dv = 21$

21.  $x = 3u, y = 4v, \frac{\partial(x, y)}{\partial(u, v)} = 12$ ;  $S$  is the region in the  $uv$ -plane enclosed by the circle  $u^2 + v^2 = 1$ . Use polar coordinates to obtain  $\iint_S 12\sqrt{u^2 + v^2}(12) dA_{uv} = 144 \int_0^{2\pi} \int_0^1 r^2 dr d\theta = 96\pi$

22.  $x = 2u, y = v, \frac{\partial(x, y)}{\partial(u, v)} = 2$ ;  $S$  is the region in the  $uv$ -plane enclosed by the circle  $u^2 + v^2 = 1$ . Use polar coordinates to obtain  $\iint_S e^{-(4u^2 + 4v^2)}(2) dA_{uv} = 2 \int_0^{2\pi} \int_0^1 re^{-4r^2} dr d\theta = (1 - e^{-4})\pi/2$

23. Let  $S$  be the region in the  $uv$ -plane bounded by  $u^2 + v^2 = 1$ , so  $u = 2x, v = 3y$ ,

$$x = u/2, y = v/3, \frac{\partial(x, y)}{\partial(u, v)} = \begin{vmatrix} 1/2 & 0 \\ 0 & 1/3 \end{vmatrix} = 1/6, \text{ use polar coordinates to get}$$

$$\frac{1}{6} \iint_S \sin(u^2 + v^2) du dv = \frac{1}{6} \int_0^{\pi/2} \int_0^1 r \sin r^2 dr d\theta = \frac{\pi}{24} (-\cos r^2) \Big|_0^1 = \frac{\pi}{24} (1 - \cos 1)$$

24.  $u = x/a, v = y/b, x = au, y = bv; \frac{\partial(x, y)}{\partial(u, v)} = ab; A = ab \int_0^{2\pi} \int_0^1 r dr d\theta = \pi ab$

25.  $x = u/3, y = v/2, z = w, \frac{\partial(x, y, z)}{\partial(u, v, w)} = 1/6; S$  is the region in  $uvw$ -space enclosed by the sphere  $u^2 + v^2 + w^2 = 36$  so

$$\begin{aligned} \iiint_S \frac{u^2}{9} \frac{1}{6} dV_{uvw} &= \frac{1}{54} \int_0^{2\pi} \int_0^\pi \int_0^6 (\rho \sin \phi \cos \theta)^2 \rho^2 \sin \phi d\rho d\phi d\theta \\ &= \frac{1}{54} \int_0^{2\pi} \int_0^\pi \int_0^6 \rho^4 \sin^3 \phi \cos^2 \theta d\rho d\phi d\theta = \frac{192}{5} \pi \end{aligned}$$

26. Let  $G_1$  be the region  $u^2 + v^2 + w^2 \leq 1$ , let  $x = au, y = bv, z = cw, \frac{\partial(x, y, z)}{\partial(u, v, w)} = abc;$

$$\begin{aligned} I_x &= \iiint_G (y^2 + z^2) dx dy dz = \iiint_{G_1} (b^2 v^2 + c^2 w^2) du dv dw \\ &= \int_0^{2\pi} \int_0^\pi \int_0^1 abc (b^2 \sin^2 \phi \sin^2 \theta + c^2 \cos^2 \phi) \rho^4 \sin \phi d\rho d\phi d\theta \\ &= \int_0^{2\pi} \frac{abc}{15} (4b^2 \sin^2 \theta + 2c^2) d\theta = \frac{4}{15} \pi abc (b^2 + c^2) \end{aligned}$$

27. Let  $u = y - 4x, v = y + 4x$ , then  $x = \frac{1}{8}(v - u), y = \frac{1}{2}(v + u)$  so  $\frac{\partial(x, y)}{\partial(u, v)} = -\frac{1}{8};$

$$\frac{1}{8} \iint_S \frac{u}{v} dA_{uv} = \frac{1}{8} \int_2^5 \int_0^2 \frac{u}{v} du dv = \frac{1}{4} \ln \frac{5}{2}$$

28. Let  $u = y + x, v = y - x$ , then  $x = \frac{1}{2}(u - v), y = \frac{1}{2}(u + v)$  so  $\frac{\partial(x, y)}{\partial(u, v)} = \frac{1}{2};$

$$-\frac{1}{2} \iint_S uv dA_{uv} = -\frac{1}{2} \int_0^2 \int_0^1 uv du dv = -\frac{1}{2}$$

29. Let  $u = x - y, v = x + y$ , then  $x = \frac{1}{2}(v + u), y = \frac{1}{2}(v - u)$  so  $\frac{\partial(x, y)}{\partial(u, v)} = \frac{1}{2};$  the boundary curves of the region  $S$  in the  $uv$ -plane are  $u = 0, v = u$ , and  $v = \pi/4$ ; thus

$$\frac{1}{2} \iint_S \frac{\sin u}{\cos v} dA_{uv} = \frac{1}{2} \int_0^{\pi/4} \int_0^v \frac{\sin u}{\cos v} du dv = \frac{1}{2} [\ln(\sqrt{2} + 1) - \pi/4]$$

30. Let  $u = y - x, v = y + x$ , then  $x = \frac{1}{2}(v - u), y = \frac{1}{2}(u + v)$  so  $\frac{\partial(x, y)}{\partial(u, v)} = -\frac{1}{2}$ ; the boundary curves of the region  $S$  in the  $uv$ -plane are  $v = -u, v = u, v = 1$ , and  $v = 4$ ; thus

$$\frac{1}{2} \iint_S e^{u/v} dA_{uv} = \frac{1}{2} \int_1^4 \int_{-v}^v e^{u/v} du dv = \frac{15}{4}(e - e^{-1})$$

31. Let  $u = y/x, v = x/y^2$ , then  $x = 1/(u^2v), y = 1/(uv)$  so  $\frac{\partial(x, y)}{\partial(u, v)} = \frac{1}{u^4v^3}$ ;

$$\iint_S \frac{1}{u^4v^3} dA_{uv} = \int_1^4 \int_1^2 \frac{1}{u^4v^3} du dv = 35/256$$

32. Let  $x = 3u, y = 2v, \frac{\partial(x, y)}{\partial(u, v)} = 6$ ;  $S$  is the region in the  $uv$ -plane enclosed by the circle  $u^2 + v^2 = 1$

$$\text{so } \iint_R (9 - x - y) dA = \iint_S 6(9 - 3u - 2v) dA_{uv} = 6 \int_0^{2\pi} \int_0^1 (9 - 3r \cos \theta - 2r \sin \theta) r dr d\theta = 54\pi$$

33.  $x = u, y = w/u, z = v + w/u, \frac{\partial(x, y, z)}{\partial(u, v, w)} = -\frac{1}{u}$ ;

$$\iiint_S \frac{v^2w}{u} dV_{uvw} = \int_2^4 \int_0^1 \int_1^3 \frac{v^2w}{u} du dv dw = 2 \ln 3$$

34.  $u = xy, v = yz, w = xz, 1 \leq u \leq 2, 1 \leq v \leq 3, 1 \leq w \leq 4$ ,

$$x = \sqrt{uw/v}, y = \sqrt{uv/w}, z = \sqrt{vw/u}, \frac{\partial(x, y, z)}{\partial(u, v, w)} = \frac{1}{2\sqrt{uvw}}$$

$$V = \iiint_G dV = \int_1^2 \int_1^3 \int_1^4 \frac{1}{2\sqrt{uvw}} dw dv du = 4(\sqrt{2} - 1)(\sqrt{3} - 1)$$

35. (b) If  $x = x(u, v), y = y(u, v)$  where  $u = u(x, y), v = v(x, y)$ , then by the chain rule

$$\frac{\partial x}{\partial u} \frac{\partial u}{\partial x} + \frac{\partial x}{\partial v} \frac{\partial v}{\partial x} = \frac{\partial x}{\partial x} = 1, \frac{\partial x}{\partial u} \frac{\partial u}{\partial y} + \frac{\partial x}{\partial v} \frac{\partial v}{\partial y} = \frac{\partial x}{\partial y} = 0$$

$$\frac{\partial y}{\partial u} \frac{\partial u}{\partial x} + \frac{\partial y}{\partial v} \frac{\partial v}{\partial x} = \frac{\partial y}{\partial x} = 0, \frac{\partial y}{\partial u} \frac{\partial u}{\partial y} + \frac{\partial y}{\partial v} \frac{\partial v}{\partial y} = \frac{\partial y}{\partial y} = 1$$

36. (a)  $\frac{\partial(x, y)}{\partial(u, v)} = \begin{vmatrix} 1-v & -u \\ v & u \end{vmatrix} = u; \quad u = x + y, v = \frac{y}{x + y},$

$$\frac{\partial(u, v)}{\partial(x, y)} = \begin{vmatrix} 1 & 1 \\ -y/(x+y)^2 & x/(x+y)^2 \end{vmatrix} = \frac{x}{(x+y)^2} + \frac{y}{(x+y)^2} = \frac{1}{x+y} = \frac{1}{u};$$

$$\frac{\partial(u, v)}{\partial(x, y)} \frac{\partial(x, y)}{\partial(u, v)} = 1$$

- (b)  $\frac{\partial(x, y)}{\partial(u, v)} = \begin{vmatrix} v & u \\ 0 & 2v \end{vmatrix} = 2v^2; \quad u = x/\sqrt{y}, v = \sqrt{y},$

$$\frac{\partial(u, v)}{\partial(x, y)} = \begin{vmatrix} 1/\sqrt{y} & -x/(2y^{-3/2}) \\ 0 & 1/(2\sqrt{y}) \end{vmatrix} = \frac{1}{2y} = \frac{1}{2v^2}; \quad \frac{\partial(u, v)}{\partial(x, y)} \frac{\partial(x, y)}{\partial(u, v)} = 1$$

$$(c) \quad \frac{\partial(x, y)}{\partial(u, v)} = \begin{vmatrix} u & v \\ u & -v \end{vmatrix} = -2uv; \quad u = \sqrt{x+y}, v = \sqrt{x-y},$$

$$\frac{\partial(u, v)}{\partial(x, y)} = \begin{vmatrix} 1/(2\sqrt{x+y}) & 1/(2\sqrt{x+y}) \\ 1/(2\sqrt{x-y}) & -1/(2\sqrt{x-y}) \end{vmatrix} = -\frac{1}{2\sqrt{x^2-y^2}} = -\frac{1}{2uv}; \quad \frac{\partial(u, v)}{\partial(x, y)} \frac{\partial(x, y)}{\partial(u, v)} = 1$$

$$37. \quad \frac{\partial(u, v)}{\partial(x, y)} = 3xy^4 = 3v \text{ so } \frac{\partial(x, y)}{\partial(u, v)} = \frac{1}{3v}; \quad \frac{1}{3} \iint_S \frac{\sin u}{v} dA_{uv} = \frac{1}{3} \int_1^2 \int_\pi^{2\pi} \frac{\sin u}{v} du dv = -\frac{2}{3} \ln 2$$

$$38. \quad \frac{\partial(u, v)}{\partial(x, y)} = 8xy \text{ so } \frac{\partial(x, y)}{\partial(u, v)} = \frac{1}{8xy}; \quad xy \left| \frac{\partial(x, y)}{\partial(u, v)} \right| = xy \left( \frac{1}{8xy} \right) = \frac{1}{8} \text{ so}$$

$$\frac{1}{8} \iint_S dA_{uv} = \frac{1}{8} \int_9^{16} \int_1^4 du dv = 21/8$$

$$39. \quad \frac{\partial(u, v)}{\partial(x, y)} = -2(x^2 + y^2) \text{ so } \frac{\partial(x, y)}{\partial(u, v)} = -\frac{1}{2(x^2 + y^2)};$$

$$(x^4 - y^4)e^{xy} \left| \frac{\partial(x, y)}{\partial(u, v)} \right| = \frac{x^4 - y^4}{2(x^2 + y^2)} e^{xy} = \frac{1}{2}(x^2 - y^2)e^{xy} = \frac{1}{2}ve^u \text{ so}$$

$$\frac{1}{2} \iint_S ve^u dA_{uv} = \frac{1}{2} \int_3^4 \int_1^3 ve^u du dv = \frac{7}{4}(e^3 - e)$$

$$40. \quad \text{Set } u = x + y + 2z, v = x - 2y + z, w = 4x + y + z, \text{ then } \frac{\partial(u, v, w)}{\partial(x, y, z)} = \begin{vmatrix} 1 & 1 & 2 \\ 1 & -2 & 1 \\ 4 & 1 & 1 \end{vmatrix} = 18, \text{ and}$$

$$V = \iiint_R dx dy dz = \int_{-6}^6 \int_{-2}^2 \int_{-3}^3 \frac{\partial(x, y, z)}{\partial(u, v, w)} du dv dw = 6(4)(12) \frac{1}{18} = 16$$

41. (a) Let  $u = x + y, v = y$ , then the triangle  $R$  with vertices  $(0, 0), (1, 0)$  and  $(0, 1)$  becomes the triangle in the  $uv$ -plane with vertices  $(0, 0), (1, 0), (1, 1)$ , and

$$\iint_R f(x + y) dA = \int_0^1 \int_0^u f(u) \frac{\partial(x, y)}{\partial(u, v)} dv du = \int_0^1 uf(u) du$$

$$(b) \quad \int_0^1 ue^u du = (u - 1)e^u \Big|_0^1 = 1$$

$$42. \quad (a) \quad \frac{\partial(x, y)}{\partial(r, \theta)} = \begin{vmatrix} \cos \theta & -r \sin \theta \\ \sin \theta & r \cos \theta \end{vmatrix} = r, \quad \left| \frac{\partial(x, y)}{\partial(r, \theta)} \right| = r$$

$$(b) \quad \frac{\partial(x, y, z)}{\partial(\rho, \theta, \phi)} = \begin{vmatrix} \sin \phi \cos \theta & -\rho \sin \phi \sin \theta & \rho \cos \phi \cos \theta \\ \sin \phi \sin \theta & \rho \sin \phi \cos \theta & \rho \cos \phi \sin \theta \\ \cos \phi & 0 & -\rho \sin \phi \end{vmatrix} = -\rho^2 \sin \phi; \quad \left| \frac{\partial(x, y, z)}{\partial(\rho, \theta, \phi)} \right| = \rho^2 \sin \phi$$

## CHAPTER 16 SUPPLEMENTARY EXERCISES

$$3. \quad \text{(a)} \quad \iint_R dA \qquad \text{(b)} \quad \iiint_G dV \qquad \text{(c)} \quad \iint_R \sqrt{\left(\frac{\partial z}{\partial x}\right)^2 + \left(\frac{\partial z}{\partial y}\right)^2} dA$$

$$4. \quad \text{(a)} \quad x = a \sin \phi \cos \theta, y = a \sin \phi \sin \theta, z = \rho \cos \phi, 0 \leq \theta \leq 2\pi, 0 \leq \phi \leq \pi$$

$$\text{(b)} \quad x = a \cos \theta, y = a \sin \theta, z = z, 0 \leq \theta \leq 2\pi, 0 \leq z \leq h$$

$$7. \quad \int_0^1 \int_{1-\sqrt{1-y^2}}^{1+\sqrt{1-y^2}} f(x, y) dx dy \qquad 8. \quad \int_0^2 \int_x^{2x} f(x, y) dy dx + \int_2^3 \int_x^{6-x} f(x, y) dy dx$$

$$9. \quad \text{(a)} \quad (1, 2) = (b, d), (2, 1) = (a, c), \text{ so } a = 2, b = 1, c = 1, d = 2$$

$$\text{(b)} \quad \iint_R dA = \int_0^1 \int_0^1 \frac{\partial(x, y)}{\partial(u, v)} du dv = \int_0^1 \int_0^1 3 du dv = 3$$

$$10. \quad 0 < \sin \sqrt{xy} < 1 \text{ for } 0 < x, y < \pi, \text{ so}$$

$$0 = \int_0^\pi \int_0^\pi 0 dy dx < \int_0^\pi \int_0^\pi \sin \sqrt{xy} dy dx < \int_0^\pi \int_0^\pi 1 dy dx = \pi^2$$

$$11. \quad \int_{1/2}^1 2x \cos(\pi x^2) dx = \frac{1}{\pi} \sin(\pi x^2) \Big|_{1/2}^1 = -1/(\sqrt{2}\pi)$$

$$12. \quad \int_0^2 \frac{x^2}{2} e^{y^3} \Big|_{x=-y}^{x=2y} dy = \frac{3}{2} \int_0^2 y^2 e^{y^3} dy = \frac{1}{2} e^{y^3} \Big|_0^2 = \frac{1}{2} (e^8 - 1)$$

$$13. \quad \int_0^1 \int_{2y}^2 e^x e^y dx dy$$

$$14. \quad \int_0^\pi \int_0^x \frac{\sin x}{x} dy dx$$

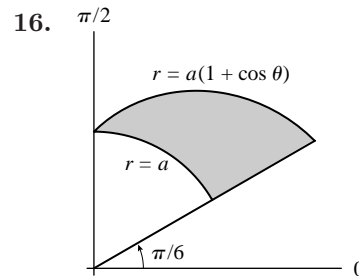
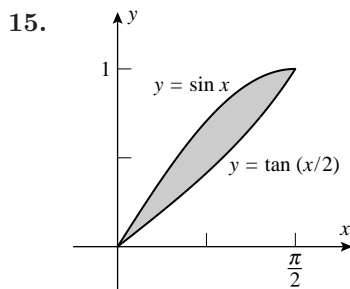

$$17. \quad 2 \int_0^8 \int_0^{y^{1/3}} x^2 \sin y^2 dx dy = \frac{2}{3} \int_0^8 y \sin y^2 dy = -\frac{1}{3} \cos y^2 \Big|_0^8 = \frac{1}{3} (1 - \cos 64) \approx 0.20271$$

$$18. \quad \int_0^{\pi/2} \int_0^2 (4 - r^2) r dr d\theta = 2\pi$$

19.  $\sin 2\theta = 2 \sin \theta \cos \theta = \frac{2xy}{x^2 + y^2}$ , and  $r = 2a \sin \theta$  is the circle  $x^2 + (y - a)^2 = a^2$ , so

$$\int_0^a \int_{a-\sqrt{a^2-x^2}}^{a+\sqrt{a^2-x^2}} \frac{2xy}{x^2 + y^2} dy dx = \int_0^a x \left[ \ln \left( a + \sqrt{a^2 - x^2} \right) - \ln \left( a - \sqrt{a^2 - x^2} \right) \right] dx = a^2$$

20.  $\int_{\pi/4}^{\pi/2} \int_0^2 4r^2 (\cos \theta \sin \theta) r dr d\theta = -4 \cos 2\theta \Big|_{\pi/4}^{\pi/2} = 4$

21.  $\int_0^{2\pi} \int_0^2 \int_{r^4}^{16} r^2 \cos^2 \theta r dz dr d\theta = \int_0^{2\pi} \cos^2 \theta d\theta \int_0^2 r^3 (16 - r^4) dr = 32\pi$

22.  $\int_0^{\pi/2} \int_0^{\pi/2} \int_0^1 \frac{1}{1 + \rho^2} \rho^2 \sin \phi d\rho d\phi d\theta = \left(1 - \frac{\pi}{4}\right) \frac{\pi}{2} \int_0^{\pi/2} \sin \phi d\phi$   
 $= \left(1 - \frac{\pi}{4}\right) \frac{\pi}{2} (-\cos \phi) \Big|_0^{\pi/2} = \left(1 - \frac{\pi}{4}\right) \frac{\pi}{2}$

23. (a)  $\int_0^{2\pi} \int_0^{\pi/3} \int_0^a (\rho^2 \sin^2 \phi) \rho^2 \sin \phi d\rho d\phi d\theta = \int_0^{2\pi} \int_0^{\pi/3} \int_0^a \rho^4 \sin^3 \phi d\rho d\phi d\theta$

(b)  $\int_0^{2\pi} \int_0^{\sqrt{3}a/2} \int_{r/\sqrt{3}}^{\sqrt{a^2-r^2}} r^2 dz r dr d\theta = \int_0^{2\pi} \int_0^{\sqrt{3}a/2} \int_{r/\sqrt{3}}^{\sqrt{a^2-r^2}} r^3 dz dr d\theta$

(c)  $\int_{-\sqrt{3}a/2}^{\sqrt{3}a/2} \int_{-\sqrt{(3a^2/4)-x^2}}^{\sqrt{(3a^2/4)-x^2}} \int_{\sqrt{x^2+y^2}/\sqrt{3}}^{\sqrt{a^2-x^2-y^2}} (x^2 + y^2) dz dy dx$

24. (a)  $\int_0^4 \int_{-\sqrt{4x-x^2}}^{\sqrt{4x-x^2}} \int_{x^2+y^2}^{4x} dz dy dx$

(b)  $\int_{-\pi/2}^{\pi/2} \int_0^{4 \cos \theta} \int_{r^2}^{4r \cos \theta} r dz dr d\theta$

25.  $\int_0^2 \int_{(y/2)^{1/3}}^{2-y/2} dx dy = \int_0^2 \left( 2 - \frac{y}{2} - \left(\frac{y}{2}\right)^{1/3} \right) dy = \left( 2y - \frac{y^2}{4} - \frac{3}{2} \left(\frac{y}{2}\right)^{4/3} \right) \Big|_0^2 = \frac{3}{2}$

26.  $A = 6 \int_0^{\pi/6} \int_0^{\cos 3\theta} r dr d\theta = 3 \int_0^{\pi/6} \cos^2 3\theta = \pi/4$

27.  $V = \int_0^{2\pi} \int_0^{a/\sqrt{3}} \int_{\sqrt{3}r}^a r dz dr d\theta = 2\pi \int_0^{a/\sqrt{3}} r(a - \sqrt{3}r) dr = \frac{\pi a^3}{9}$

28. The intersection of the two surfaces projects onto the  $yz$ -plane as  $2y^2 + z^2 = 1$ , so

$$V = 4 \int_0^{1/\sqrt{2}} \int_0^{\sqrt{1-2y^2}} \int_{y^2+z^2}^{1-y^2} dx dz dy$$

$$= 4 \int_0^{1/\sqrt{2}} \int_0^{\sqrt{1-2y^2}} (1 - 2y^2 - z^2) dz dy = 4 \int_0^{1/\sqrt{2}} \frac{8}{3} (1 - 2x^2)^{3/2} dx = \frac{\sqrt{2}\pi}{4}$$

29.  $\|\mathbf{r}_u \times \mathbf{r}_v\| = \sqrt{2u^2 + 2v^2 + 4}$ ,

$$S = \iint_{u^2+v^2 \leq 4} \sqrt{2u^2 + 2v^2 + 4} dA = \int_0^{2\pi} \int_0^2 \sqrt{2}\sqrt{r^2 + 2} r dr d\theta = \frac{8\pi}{3}(3\sqrt{3} - 1)$$

$$30. \quad \|\mathbf{r}_u \times \mathbf{r}_v\| = \sqrt{1+u^2}, \quad S = \int_0^2 \int_0^{3u} \sqrt{1+u^2} dv du = \int_0^2 3u\sqrt{1+u^2} du = 5^{3/2} - 1$$

$$31. \quad (\mathbf{r}_u \times \mathbf{r}_v) \Big|_{\substack{u=1 \\ v=2}} = \langle -2, -4, 1 \rangle, \text{ tangent plane } 2x + 4y - z = 5$$

$$32. \quad u = -3, v = 0, (\mathbf{r}_u \times \mathbf{r}_v) \Big|_{\substack{u=-3 \\ v=0}} = \langle -18, 0, -3 \rangle, \text{ tangent plane } 6x + z = -9$$

$$33. \quad A = \int_{-4}^4 \int_{y^2/4}^{2+y^2/8} dx dy = \int_{-4}^4 \left(2 - \frac{y^2}{8}\right) dy = \frac{32}{3}; \bar{y} = 0 \text{ by symmetry;}$$

$$\int_{-4}^4 \int_{y^2/4}^{2+y^2/8} x dx dy = \int_{-4}^4 \left(2 + \frac{1}{4}y^2 - \frac{3}{128}y^4\right) dy = \frac{256}{15}, \quad \bar{x} = \frac{3}{32} \frac{256}{15} = \frac{8}{5}; \text{ centroid } \left(\frac{8}{5}, 0\right)$$

$$34. \quad A = \pi ab/2, \bar{x} = 0 \text{ by symmetry,}$$

$$\int_{-a}^a \int_0^{b\sqrt{1-x^2/a^2}} y dy dx = \frac{1}{2} \int_{-a}^a b^2(1-x^2/a^2) dx = 2ab^2/3, \text{ centroid } \left(0, \frac{4b}{3\pi}\right)$$

$$35. \quad V = \frac{1}{3}\pi a^2 h, \bar{x} = \bar{y} = 0 \text{ by symmetry,}$$

$$\int_0^{2\pi} \int_0^a \int_0^{h-rh/a} rz dz dr d\theta = \pi \int_0^a rh^2 \left(1 - \frac{r}{a}\right)^2 dr = \pi a^2 h^2/12, \text{ centroid } (0, 0, h/4)$$

$$36. \quad V = \int_{-2}^2 \int_{x^2}^4 \int_0^{4-y} dz dy dx = \int_{-2}^2 \int_{x^2}^4 (4-y) dy dx = \int_{-2}^2 \left(8 - 4x^2 + \frac{1}{2}x^4\right) dx = \frac{256}{15},$$

$$\int_{-2}^2 \int_{x^2}^4 \int_0^{4-y} y dz dy dx = \int_{-2}^2 \int_{x^2}^4 (4y - y^2) dy dx = \int_{-2}^2 \left(\frac{1}{3}x^6 - 2x^4 + \frac{32}{3}\right) dx = \frac{1024}{35}$$

$$\int_{-2}^2 \int_{x^2}^4 \int_0^{4-y} z dz dy dx = \int_{-2}^2 \int_{x^2}^4 \frac{1}{2}(4-y)^2 dy dx = \int_{-2}^2 \left(-\frac{x^6}{6} + 2x^4 - 8x^2 + \frac{32}{3}\right) dx = \frac{2048}{105}$$

$$\bar{x} = 0 \text{ by symmetry, centroid } \left(0, \frac{8}{7}, 4\right)$$

37. The two quarter-circles with center at the origin and of radius  $A$  and  $\sqrt{2}A$  lie inside and outside of the square with corners  $(0, 0)$ ,  $(A, 0)$ ,  $(A, A)$ ,  $(0, A)$ , so the following inequalities hold:

$$\int_0^{\pi/2} \int_0^A \frac{1}{(1+r^2)^2} r dr d\theta \leq \int_0^A \int_0^A \frac{1}{(1+x^2+y^2)^2} dx dy \leq \int_0^{\pi/2} \int_0^{\sqrt{2}A} \frac{1}{(1+r^2)^2} r dr d\theta$$

The integral on the left can be evaluated as  $\frac{\pi A^2}{4(1+A^2)}$  and the integral on the right equals

$\frac{2\pi A^2}{4(1+2A^2)}$ . Since both of these quantities tend to  $\frac{\pi}{4}$ , it follows by sandwiching that

$$\int_0^{+\infty} \int_0^{+\infty} \frac{1}{(1+x^2+y^2)^2} dx dy = \frac{\pi}{4}.$$

38. The centroid of the circle which generates the tube travels a distance

$$s = \int_0^{4\pi} \sqrt{\sin^2 t + \cos^2 t + 1/16} dt = \sqrt{17}\pi, \text{ so } V = \pi(1/2)^2 \sqrt{17}\pi = \sqrt{17}\pi^2/4.$$

39. (a) The values of  $x$  in the formula of the astroidal sphere lie between  $-a$  and  $a$ ; and the same is true for  $x = (a \cos u \cos v)^3$ ; similarly for  $y$  and  $z$ . Moreover,
- $$\begin{aligned} x^{2/3} + y^{2/3} + z^{2/3} &= a^{2/3} \cos^2 u \cos^2 v + a^{2/3} \sin^2 u \cos^2 v + a^{2/3} \sin^2 v \\ &= a^{2/3} \cos^2 v + a^{2/3} \sin^2 v = a^{2/3} \end{aligned}$$

(b) 
$$\begin{aligned} S &= 8 \int_0^{\pi/2} \int_0^{\pi/2} \|\mathbf{r}_u \times \mathbf{r}_v\| du dv \\ &= 72 \int_0^{\pi/2} \int_0^{\pi/2} \sin u \cos u \sin v \cos^4 v \sqrt{\sin^2 v + \sin^2 u \cos^2 u \cos^2 v} du dv \approx 4.451 \end{aligned}$$

(c) 
$$8 \int_0^{(1-x^{2/3})^{3/2}} \int_0^1 \sqrt{1-x^{2/3}-y^{2/3}} dy dx \approx 0.3590$$

- (d) Let  $x = t \cos^3 u$ ,  $y = t \sin^3 u$ ,  $0 \leq t \leq 1$ ,  $0 \leq u \leq \pi/2$ , then  $J = \frac{\partial(x, y)}{\partial(t, u)} = 3t \sin^2 u \cos^2 u$ ,

$$V = 8 \int_0^1 \int_0^{\pi/2} (1-t^{2/3})^{3/2} 3t \sin^2 u \cos^2 u du dt = \frac{3\pi}{2} \int_0^1 t(1-t^{2/3})^{3/2} dt = \frac{4\pi}{35}$$

40. 
$$V = \frac{4}{3}\pi a^3, \bar{d} = \frac{3}{4\pi a^3} \iiint_{\rho \leq a} \rho dV = \frac{3}{4\pi a^3} \int_0^\pi \int_0^{2\pi} \int_0^a \rho^3 \sin \phi d\rho d\theta d\phi = \frac{3}{4\pi a^3} 2\pi(2) \frac{a^4}{4} = \frac{3}{4}a$$

41. (a)  $(x/a)^2 + (y/b)^2 + (z/c)^2 = \sin^2 \phi \cos^2 \theta + \sin^2 \phi \sin^2 \theta + \cos^2 \phi = \sin^2 \phi + \cos^2 \phi = 1$ , an ellipsoid

- (b)  $\mathbf{r}(\phi, \theta) = \langle 2 \sin \phi \cos \theta, 3 \sin \phi \sin \theta, 4 \cos \phi \rangle$ ;  $\mathbf{r}_\phi \times \mathbf{r}_\theta = 2 \langle 6 \sin^2 \phi \cos \theta, 4 \sin^2 \phi \sin \theta, 3 \cos \phi \sin \phi \rangle$ ,

$$\|\mathbf{r}_\phi \times \mathbf{r}_\theta\| = 2\sqrt{16 \sin^4 \phi + 20 \sin^4 \phi \cos^2 \theta + 9 \sin^2 \phi \cos^2 \phi},$$

$$S = \int_0^{2\pi} \int_0^\pi 2\sqrt{16 \sin^4 \phi + 20 \sin^4 \phi \cos^2 \theta + 9 \sin^2 \phi \cos^2 \phi} d\phi d\theta \approx 111.5457699$$





13.  $\operatorname{div} \mathbf{F} = 2x + y$ ,  $\operatorname{curl} \mathbf{F} = z\mathbf{i}$

14.  $\operatorname{div} \mathbf{F} = z^3 + 8y^3x^2 + 10zy$ ,  $\operatorname{curl} \mathbf{F} = 5z^2\mathbf{i} + 3xz^2\mathbf{j} + 4xy^4\mathbf{k}$

15.  $\operatorname{div} \mathbf{F} = 0$ ,  $\operatorname{curl} \mathbf{F} = (40x^2z^4 - 12xy^3)\mathbf{i} + (14y^3z + 3y^4)\mathbf{j} - (16xz^5 + 21y^2z^2)\mathbf{k}$

16.  $\operatorname{div} \mathbf{F} = ye^{xy} + \sin y + 2 \sin z \cos z$ ,  $\operatorname{curl} \mathbf{F} = -xe^{xy}\mathbf{k}$

17.  $\operatorname{div} \mathbf{F} = \frac{2}{\sqrt{x^2 + y^2 + z^2}}$ ,  $\operatorname{curl} \mathbf{F} = \mathbf{0}$

18.  $\operatorname{div} \mathbf{F} = \frac{1}{x} + xze^{xyz} + \frac{x}{x^2 + z^2}$ ,  $\operatorname{curl} \mathbf{F} = -xye^{xyz}\mathbf{i} + \frac{z}{x^2 + z^2}\mathbf{j} + yze^{xyz}\mathbf{k}$

19.  $\nabla \cdot (\mathbf{F} \times \mathbf{G}) = \nabla \cdot (-(z + 4y^2)\mathbf{i} + (4xy + 2xz)\mathbf{j} + (2xy - x)\mathbf{k}) = 4x$

20.  $\nabla \cdot (\mathbf{F} \times \mathbf{G}) = \nabla \cdot ((x^2yz^2 - x^2y^2)\mathbf{i} - xy^2z^2\mathbf{j} + xy^2z\mathbf{k}) = -xy^2$

21.  $\nabla \cdot (\nabla \times \mathbf{F}) = \nabla \cdot (-\sin(x - y)\mathbf{k}) = 0$

22.  $\nabla \cdot (\nabla \times \mathbf{F}) = \nabla \cdot (-ze^{yz}\mathbf{i} + xe^{xz}\mathbf{j} + 3e^y\mathbf{k}) = 0$

23.  $\nabla \times (\nabla \times \mathbf{F}) = \nabla \times (xz\mathbf{i} - yz\mathbf{j} + y\mathbf{k}) = (1 + y)\mathbf{i} + x\mathbf{j}$

24.  $\nabla \times (\nabla \times \mathbf{F}) = \nabla \times ((x + 3y)\mathbf{i} - y\mathbf{j} - 2xy\mathbf{k}) = -2x\mathbf{i} + 2y\mathbf{j} - 3\mathbf{k}$

25.  $\operatorname{div} (k\mathbf{F}) = k \frac{\partial f}{\partial x} + k \frac{\partial g}{\partial y} + k \frac{\partial h}{\partial z} = k \operatorname{div} \mathbf{F}$

26.  $\operatorname{curl} (k\mathbf{F}) = k \left( \frac{\partial h}{\partial y} - \frac{\partial g}{\partial z} \right) \mathbf{i} + k \left( \frac{\partial f}{\partial z} - \frac{\partial h}{\partial x} \right) \mathbf{j} + k \left( \frac{\partial g}{\partial x} - \frac{\partial f}{\partial y} \right) \mathbf{k} = k \operatorname{curl} \mathbf{F}$

27. Let  $\mathbf{F} = f(x, y, z)\mathbf{i} + g(x, y, z)\mathbf{j} + h(x, y, z)\mathbf{k}$  and  $\mathbf{G} = P(x, y, z)\mathbf{i} + Q(x, y, z)\mathbf{j} + R(x, y, z)\mathbf{k}$ , then

$$\begin{aligned} \operatorname{div} (\mathbf{F} + \mathbf{G}) &= \left( \frac{\partial f}{\partial x} + \frac{\partial P}{\partial x} \right) + \left( \frac{\partial g}{\partial y} + \frac{\partial Q}{\partial y} \right) + \left( \frac{\partial h}{\partial z} + \frac{\partial R}{\partial z} \right) \\ &= \left( \frac{\partial f}{\partial x} + \frac{\partial g}{\partial y} + \frac{\partial h}{\partial z} \right) + \left( \frac{\partial P}{\partial x} + \frac{\partial Q}{\partial y} + \frac{\partial R}{\partial z} \right) = \operatorname{div} \mathbf{F} + \operatorname{div} \mathbf{G} \end{aligned}$$

28. Let  $\mathbf{F} = f(x, y, z)\mathbf{i} + g(x, y, z)\mathbf{j} + h(x, y, z)\mathbf{k}$  and  $\mathbf{G} = P(x, y, z)\mathbf{i} + Q(x, y, z)\mathbf{j} + R(x, y, z)\mathbf{k}$ , then

$$\begin{aligned} \operatorname{curl} (\mathbf{F} + \mathbf{G}) &= \left[ \frac{\partial}{\partial y}(h + R) - \frac{\partial}{\partial z}(g + Q) \right] \mathbf{i} + \left[ \frac{\partial}{\partial z}(f + P) - \frac{\partial}{\partial x}(h + R) \right] \mathbf{j} \\ &\quad + \left[ \frac{\partial}{\partial x}(g + Q) - \frac{\partial}{\partial y}(f + P) \right] \mathbf{k}; \end{aligned}$$

expand and rearrange terms to get  $\operatorname{curl} \mathbf{F} + \operatorname{curl} \mathbf{G}$ .

29. 
$$\begin{aligned} \operatorname{div} (\phi\mathbf{F}) &= \left( \phi \frac{\partial f}{\partial x} + \frac{\partial \phi}{\partial x} f \right) + \left( \phi \frac{\partial g}{\partial y} + \frac{\partial \phi}{\partial y} g \right) + \left( \phi \frac{\partial h}{\partial z} + \frac{\partial \phi}{\partial z} h \right) \\ &= \phi \left( \frac{\partial f}{\partial x} + \frac{\partial g}{\partial y} + \frac{\partial h}{\partial z} \right) + \left( \frac{\partial \phi}{\partial x} f + \frac{\partial \phi}{\partial y} g + \frac{\partial \phi}{\partial z} h \right) \\ &= \phi \operatorname{div} \mathbf{F} + \nabla \phi \cdot \mathbf{F} \end{aligned}$$

30.  $\text{curl}(\phi\mathbf{F}) = \left[ \frac{\partial}{\partial y}(\phi h) - \frac{\partial}{\partial z}(\phi g) \right] \mathbf{i} + \left[ \frac{\partial}{\partial z}(\phi f) - \frac{\partial}{\partial x}(\phi h) \right] \mathbf{j} + \left[ \frac{\partial}{\partial x}(\phi g) - \frac{\partial}{\partial y}(\phi f) \right] \mathbf{k}$ ; use the product rule to expand each of the partial derivatives, rearrange to get  $\phi \text{curl } \mathbf{F} + \nabla\phi \times \mathbf{F}$

31.  $\text{div}(\text{curl } \mathbf{F}) = \frac{\partial}{\partial x} \left( \frac{\partial h}{\partial y} - \frac{\partial g}{\partial z} \right) + \frac{\partial}{\partial y} \left( \frac{\partial f}{\partial z} - \frac{\partial h}{\partial x} \right) + \frac{\partial}{\partial z} \left( \frac{\partial g}{\partial x} - \frac{\partial f}{\partial y} \right)$   
 $= \frac{\partial^2 h}{\partial x \partial y} - \frac{\partial^2 g}{\partial x \partial z} + \frac{\partial^2 f}{\partial y \partial z} - \frac{\partial^2 h}{\partial y \partial x} + \frac{\partial^2 g}{\partial z \partial x} - \frac{\partial^2 f}{\partial z \partial y} = 0$ ,  
 assuming equality of mixed second partial derivatives

32.  $\text{curl}(\nabla\phi) = \left( \frac{\partial^2 \phi}{\partial y \partial z} - \frac{\partial^2 \phi}{\partial z \partial y} \right) \mathbf{i} + \left( \frac{\partial^2 \phi}{\partial z \partial x} - \frac{\partial^2 \phi}{\partial x \partial z} \right) \mathbf{j} + \left( \frac{\partial^2 \phi}{\partial x \partial y} - \frac{\partial^2 \phi}{\partial y \partial x} \right) \mathbf{k} = \mathbf{0}$ , assuming equality of mixed second partial derivatives

33.  $\nabla \cdot (k\mathbf{F}) = k\nabla \cdot \mathbf{F}$ ,  $\nabla \cdot (\mathbf{F} + \mathbf{G}) = \nabla \cdot \mathbf{F} + \nabla \cdot \mathbf{G}$ ,  $\nabla \cdot (\phi\mathbf{F}) = \phi\nabla \cdot \mathbf{F} + \nabla\phi \cdot \mathbf{F}$ ,  $\nabla \cdot (\nabla \times \mathbf{F}) = 0$

34.  $\nabla \times (k\mathbf{F}) = k\nabla \times \mathbf{F}$ ,  $\nabla \times (\mathbf{F} + \mathbf{G}) = \nabla \times \mathbf{F} + \nabla \times \mathbf{G}$ ,  $\nabla \times (\phi\mathbf{F}) = \phi\nabla \times \mathbf{F} + \nabla\phi \times \mathbf{F}$ ,  $\nabla \times (\nabla\phi) = \mathbf{0}$

37. (a)  $\text{curl } \mathbf{r} = 0\mathbf{i} + 0\mathbf{j} + 0\mathbf{k} = \mathbf{0}$

(b)  $\nabla\|\mathbf{r}\| = \nabla\sqrt{x^2 + y^2 + z^2} = \frac{x}{\sqrt{x^2 + y^2 + z^2}}\mathbf{i} + \frac{y}{\sqrt{x^2 + y^2 + z^2}}\mathbf{j} + \frac{z}{\sqrt{x^2 + y^2 + z^2}}\mathbf{k} = \frac{\mathbf{r}}{\|\mathbf{r}\|}$

38. (a)  $\text{div } \mathbf{r} = 1 + 1 + 1 = 3$

(b)  $\nabla \frac{1}{\|\mathbf{r}\|} = \nabla(x^2 + y^2 + z^2)^{-1/2} = -\frac{x\mathbf{i} + y\mathbf{j} + z\mathbf{k}}{(x^2 + y^2 + z^2)^{3/2}} = -\frac{\mathbf{r}}{\|\mathbf{r}\|^3}$

39. (a)  $\nabla f(r) = f'(r)\frac{\partial r}{\partial x}\mathbf{i} + f'(r)\frac{\partial r}{\partial y}\mathbf{j} + f'(r)\frac{\partial r}{\partial z}\mathbf{k} = f'(r)\nabla r = \frac{f'(r)}{r}\mathbf{r}$

(b)  $\text{div}[f(r)\mathbf{r}] = f(r)\text{div } \mathbf{r} + \nabla f(r) \cdot \mathbf{r} = 3f(r) + \frac{f'(r)}{r}\mathbf{r} \cdot \mathbf{r} = 3f(r) + rf'(r)$

40. (a)  $\text{curl}[f(r)\mathbf{r}] = f(r)\text{curl } \mathbf{r} + \nabla f(r) \times \mathbf{r} = f(r)\mathbf{0} + \frac{f'(r)}{r}\mathbf{r} \times \mathbf{r} = \mathbf{0} + \mathbf{0} = \mathbf{0}$

(b)  $\nabla^2 f(r) = \text{div}[\nabla f(r)] = \text{div} \left[ \frac{f'(r)}{r}\mathbf{r} \right] = \frac{f'(r)}{r}\text{div } \mathbf{r} + \nabla \frac{f'(r)}{r} \cdot \mathbf{r}$   
 $= 3\frac{f'(r)}{r} + \frac{rf''(r) - f'(r)}{r^3}\mathbf{r} \cdot \mathbf{r} = 2\frac{f'(r)}{r} + f''(r)$

41.  $f(r) = 1/r^3$ ,  $f'(r) = -3/r^4$ ,  $\text{div}(\mathbf{r}/r^3) = 3(1/r^3) + r(-3/r^4) = 0$

42. Multiply  $3f(r) + rf'(r) = 0$  through by  $r^2$  to obtain  $3r^2f(r) + r^3f'(r) = 0$ ,  
 $d[r^3f(r)]/dr = 0$ ,  $r^3f(r) = C$ ,  $f(r) = C/r^3$ , so  $\mathbf{F} = C\mathbf{r}/r^3$  (an inverse-square field).

43. (a) At the point  $(x, y)$  the slope of the line along which the vector  $-y\mathbf{i} + x\mathbf{j}$  lies is  $-x/y$ ; the slope of the tangent line to  $C$  at  $(x, y)$  is  $dy/dx$ , so  $dy/dx = -x/y$ .

(b)  $ydy = -xdx$ ,  $y^2/2 = -x^2/2 + K_1$ ,  $x^2 + y^2 = K$

44.  $dy/dx = x, y = x^2/2 + K$

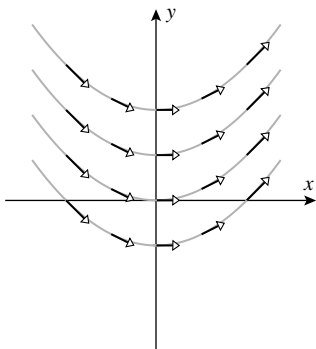

45.  $dy/dx = 1/x, y = \ln x + K$

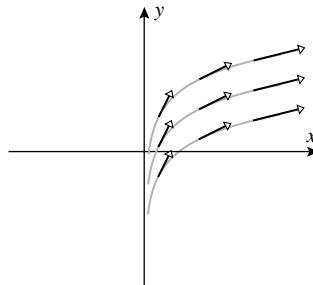

46.  $dy/dx = -y/x, (1/y)dy = (-1/x)dx, \ln y = -\ln x + K_1,$   
 $y = e^{K_1} e^{-\ln x} = K/x$

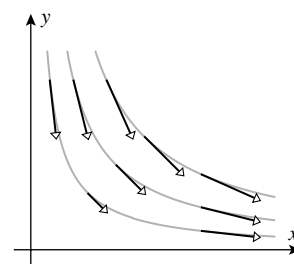

## EXERCISE SET 17.2

1. (a)  $\int_0^1 dy = 1$  because  $s = y$  is arclength measured from  $(0, 0)$

(b) 0, because  $\sin xy = 0$  along  $C$

2. (a)  $\int_C ds = \text{length of line segment} = 2$

(b) 0, because  $x$  is constant and  $dx = 0$

3. (a)  $ds = \sqrt{\left(\frac{dx}{dt}\right)^2 + \left(\frac{dy}{dt}\right)^2} dt$ , so  $\int_0^1 (2t - 3t^2)\sqrt{4 + 36t^2} dt = -\frac{11}{108}\sqrt{10} - \frac{1}{36}\ln(\sqrt{10} - 3) - \frac{4}{27}$

(b)  $\int_0^1 (2t - 3t^2)2 dt = 0$

(c)  $\int_0^1 (2t - 3t^2)6t dt = -\frac{1}{2}$

4. (a)  $\int_0^1 t(3t^2)(6t^3)^2\sqrt{1 + 36t^2 + 324t^4} dt = \frac{864}{5}$

(b)  $\int_0^1 t(3t^2)(6t^3)^2 dt = \frac{54}{5}$

(c)  $\int_0^1 t(3t^2)(6t^3)^2 6t dt = \frac{648}{11}$

(d)  $\int_0^1 t(3t^2)(6t^3)^2 18t^2 dt = 162$

5. (a)  $C: x = t, y = t, 0 \leq t \leq 1; \int_0^1 6t dt = 3$

(b)  $C: x = t, y = t^2, 0 \leq t \leq 1; \int_0^1 (3t + 6t^2 - 2t^3) dt = 3$

- (c)  $C : x = t, y = \sin(\pi t/2), 0 \leq t \leq 1;$   
 $\int_0^1 [3t + 2 \sin(\pi t/2) + \pi t \cos(\pi t/2) - (\pi/2) \sin(\pi t/2) \cos(\pi t/2)] dt = 3$
- (d)  $C : x = t^3, y = t, 0 \leq t \leq 1; \int_0^1 (9t^5 + 8t^3 - t) dt = 3$
6. (a)  $C : x = t, y = t, z = t, 0 \leq t \leq 1; \int_0^1 (t + t - t) dt = \frac{1}{2}$
- (b)  $C : x = t, y = t^2, z = t^3, 0 \leq t \leq 1; \int_0^1 (t^2 + t^3(2t) - t(3t^2)) dt = -\frac{1}{60}$
- (c)  $C : x = \cos \pi t, y = \sin \pi t, z = t, 0 \leq t \leq 1; \int_0^1 (-\pi \sin^2 \pi t + \pi t \cos \pi t - \cos \pi t) dt = -\frac{\pi}{2} - \frac{2}{\pi}$
7.  $\int_0^3 \frac{\sqrt{1+t}}{1+t} dt = \int_0^3 (1+t)^{-1/2} dt = 2$       8.  $\sqrt{5} \int_0^1 \frac{1+2t}{1+t^2} dt = \sqrt{5}(\pi/4 + \ln 2)$
9.  $\int_0^1 3(t^2)(t^2)(2t^3/3)(1+2t^2) dt = 2 \int_0^1 t^7(1+2t^2) dt = 13/20$
10.  $\frac{\sqrt{5}}{4} \int_0^{2\pi} e^{-t} dt = \sqrt{5}(1 - e^{-2\pi})/4$       11.  $\int_0^{\pi/4} (8 \cos^2 t - 16 \sin^2 t - 20 \sin t \cos t) dt = 1 - \pi$
12.  $\int_{-1}^1 \left( \frac{2}{3}t - \frac{2}{3}t^{5/3} + t^{2/3} \right) dt = 6/5$
13.  $C : x = (3-t)^2/3, y = 3-t, 0 \leq t \leq 3; \int_0^3 \frac{1}{3}(3-t)^2 dt = 3$
14.  $C : x = t^{2/3}, y = t, -1 \leq t \leq 1; \int_{-1}^1 \left( \frac{2}{3}t^{2/3} - \frac{2}{3}t^{1/3} + t^{7/3} \right) dt = 4/5$
15.  $C : x = \cos t, y = \sin t, 0 \leq t \leq \pi/2; \int_0^{\pi/2} (-\sin t - \cos^2 t) dt = -1 - \pi/4$
16.  $C : x = 3-t, y = 4-3t, 0 \leq t \leq 1; \int_0^1 (-37 + 41t - 9t^2) dt = -39/2$
17.  $\int_0^1 (-3)e^{3t} dt = 1 - e^3$
18.  $\int_0^{\pi/2} (\sin^2 t \cos t - \sin^2 t \cos t + t^4(2t)) dt = \frac{\pi^6}{192}$
20. (a)  $\int_0^{\pi/2} \cos^{21} t \sin^9 t \sqrt{(-3 \cos^2 t \sin t)^2 + (3 \sin^2 t \cos t)^2} dt$   
 $= 3 \int_0^{\pi/2} \cos^{22} t \sin^{10} t dt = \frac{61,047}{4,294,967,296} \pi$
- (b)  $\int_1^e \left( t^5 \ln t + 7t^2(2t) + t^4(\ln t) \frac{1}{t} \right) dt = \frac{5}{36}e^6 + \frac{59}{16}e^4 - \frac{491}{144}$

21. (a)  $C_1 : (0, 0)$  to  $(1, 0); x = t, y = 0, 0 \leq t \leq 1$   
 $C_2 : (1, 0)$  to  $(0, 1); x = 1 - t, y = t, 0 \leq t \leq 1$   
 $C_3 : (0, 1)$  to  $(0, 0); x = 0, y = 1 - t, 0 \leq t \leq 1$

$$\int_0^1 (0)dt + \int_0^1 (-1)dt + \int_0^1 (0)dt = -1$$

- (b)  $C_1 : (0, 0)$  to  $(1, 0); x = t, y = 0, 0 \leq t \leq 1$   
 $C_2 : (1, 0)$  to  $(1, 1); x = 1, y = t, 0 \leq t \leq 1$   
 $C_3 : (1, 1)$  to  $(0, 1); x = 1 - t, y = 1, 0 \leq t \leq 1$   
 $C_4 : (0, 1)$  to  $(0, 0); x = 0, y = 1 - t, 0 \leq t \leq 1$

$$\int_0^1 (0)dt + \int_0^1 (-1)dt + \int_0^1 (-1)dt + \int_0^1 (0)dt = -2$$

22. (a)  $C_1 : (0, 0)$  to  $(1, 1); x = t, y = t, 0 \leq t \leq 1$   
 $C_2 : (1, 1)$  to  $(2, 0); x = 1 + t, y = 1 - t, 0 \leq t \leq 1$   
 $C_3 : (2, 0)$  to  $(0, 0); x = 2 - 2t, y = 0, 0 \leq t \leq 1$

$$\int_0^1 (0)dt + \int_0^1 2dt + \int_0^1 (0)dt = 2$$

- (b)  $C_1 : (-5, 0)$  to  $(5, 0); x = t, y = 0, -5 \leq t \leq 5$   
 $C_2 : x = 5 \cos t, y = 5 \sin t, 0 \leq t \leq \pi$

$$\int_{-5}^5 (0)dt + \int_0^\pi (-25)dt = -25\pi$$

23.  $C_1 : x = t, y = z = 0, 0 \leq t \leq 1, \int_0^1 0 dt = 0; C_2 : x = 1, y = t, z = 0, 0 \leq t \leq 1, \int_0^1 (-t) dt = -\frac{1}{2}$

$$C_3 : x = 1, y = 1, z = t, 0 \leq t \leq 1, \int_0^1 3 dt = 3; \int_C x^2 z dx - yx^2 dy + 3 dz = 0 - \frac{1}{2} + 3 = \frac{5}{2}$$

24.  $C_1 : (0, 0, 0)$  to  $(1, 1, 0); x = t, y = t, z = 0, 0 \leq t \leq 1$   
 $C_2 : (1, 1, 0)$  to  $(1, 1, 1); x = 1, y = 1, z = t, 0 \leq t \leq 1$   
 $C_3 : (1, 1, 1)$  to  $(0, 0, 0); x = 1 - t, y = 1 - t, z = 1 - t, 0 \leq t \leq 1$

$$\int_0^1 (-t^3)dt + \int_0^1 3 dt + \int_0^1 -3dt = -1/4$$

25.  $\int_0^\pi (0)dt = 0$

26.  $\int_0^1 (e^{2t} - 4e^{-t})dt = e^2/2 + 4e^{-1} - 9/2$

27.  $\int_0^1 e^{-t} dt = 1 - e^{-1}$

28.  $\int_0^{\pi/2} (7 \sin^2 t \cos t + 3 \sin t \cos t) dt = 23/6$

29. Represent the circular arc by  $x = 3 \cos t, y = 3 \sin t, 0 \leq t \leq \pi/2$ .

$$\int_C x\sqrt{y} ds = 9\sqrt{3} \int_0^{\pi/2} \sqrt{\sin t} \cos t dt = 6\sqrt{3}$$

30.  $\delta(x, y) = k\sqrt{x^2 + y^2}$  where  $k$  is the constant of proportionality,

$$\int_C k\sqrt{x^2 + y^2} ds = k \int_0^1 e^t (\sqrt{2}e^t) dt = \sqrt{2}k \int_0^1 e^{2t} dt = (e^2 - 1)k/\sqrt{2}$$

$$31. \int_C \frac{kx}{1+y^2} ds = 15k \int_0^{\pi/2} \frac{\cos t}{1+9\sin^2 t} dt = 5k \tan^{-1} 3$$

$$32. \delta(x, y, z) = kz \text{ where } k \text{ is the constant of proportionality,}$$

$$\int_C kz ds = \int_1^4 k(4\sqrt{t})(2+1/t) dt = 136k/3$$

$$33. C : x = t^2, y = t, 0 \leq t \leq 1; W = \int_0^1 3t^4 dt = 3/5$$

$$34. W = \int_1^3 (t^2 + 1 - 1/t^3 + 1/t) dt = 92/9 + \ln 3$$

$$35. W = \int_0^1 (t^3 + 5t^6) dt = 27/28$$

$$36. C_1 : (0, 0, 0) \text{ to } (1, 3, 1); x = t, y = 3t, z = t, 0 \leq t \leq 1$$

$$C_2 : (1, 3, 1) \text{ to } (2, -1, 4); x = 1 + t, y = 3 - 4t, z = 1 + 3t, 0 \leq t \leq 1$$

$$W = \int_0^1 (4t + 8t^2) dt + \int_0^1 (-11 - 17t - 11t^2) dt = -37/2$$

37. Since  $\mathbf{F}$  and  $\mathbf{r}$  are parallel,  $\mathbf{F} \cdot \mathbf{r} = \|\mathbf{F}\| \|\mathbf{r}\|$ , and since  $\mathbf{F}$  is constant,

$$\int_C \mathbf{F} \cdot d\mathbf{r} = \int_C d(\mathbf{F} \cdot \mathbf{r}) = \int_C d(\|\mathbf{F}\| \|\mathbf{r}\|) = \sqrt{2} \int_{-4}^4 \sqrt{2} dt = 16$$

$$\int_C \mathbf{F} \cdot \mathbf{r} = \sqrt{2}(4\sqrt{2})$$

$$38. \int_C \mathbf{F} \cdot \mathbf{r} = 0, \text{ since } \mathbf{F} \text{ is perpendicular to the curve}$$

39.  $C : x = 4 \cos t, y = 4 \sin t, 0 \leq t \leq \pi/2$

$$\int_0^{\pi/2} \left( -\frac{1}{4} \sin t + \cos t \right) dt = 3/4$$

40.  $C_1 : (0, 3) \text{ to } (6, 3); x = 6t, y = 3, 0 \leq t \leq 1$

$C_2 : (6, 3) \text{ to } (6, 0); x = 6, y = 3 - 3t, 0 \leq t \leq 1$

$$\int_0^1 \frac{6}{36t^2 + 9} dt + \int_0^1 \frac{-12}{36 + 9(1-t)^2} dt = \frac{1}{3} \tan^{-1} 2 - \frac{2}{3} \tan^{-1}(1/2)$$

41. Represent the parabola by  $x = t, y = t^2, 0 \leq t \leq 2$ .

$$\int_C 3x ds = \int_0^2 3t \sqrt{1+4t^2} dt = (17\sqrt{17} - 1)/4$$

42. Represent the semicircle by  $x = 2 \cos t, y = 2 \sin t, 0 \leq t \leq \pi$ .

$$\int_C x^2 y ds = \int_0^\pi 16 \cos^2 t \sin t dt = 32/3$$

$$43. \text{(a) } 2\pi rh = 2\pi(1)2 = 4\pi \qquad \text{(b) } S = \int_C z(t) dt$$

$$\text{(c) } C : x = \cos t, y = \sin t, 0 \leq t \leq 2\pi; S = \int_0^{2\pi} (2 + (1/2) \sin 3t) dt = 4\pi$$

44.  $C : x = a \cos t, y = a \sin t, 0 \leq t \leq 2\pi, \int_{-C} dt = - \int_C dt = - \int_0^{2\pi} dt = -2\pi$
45.  $W = \int_0^1 \lambda[(1 - \lambda)t + (3\lambda - 1)t^2 - (1 + 2\lambda)t^3] dt = -\lambda/12, W = 1$  when  $\lambda = -12$
46. The force exerted by the farmer is  $\mathbf{F} = \left(150 + 20 - \frac{1}{10}z\right) \mathbf{k} = \left(170 - \frac{3}{4\pi}t\right) \mathbf{k}$ , so  
 $\mathbf{F} \cdot d\mathbf{r} = \left(170 - \frac{1}{10}z\right) dz$ , and  $W = \int_0^{60} \left(170 - \frac{1}{10}z\right) dz = 10,020$ . Note that the functions  $x(z), y(z)$  are irrelevant.

### EXERCISE SET 17.3

- $\partial x/\partial y = 0 = \partial y/\partial x$ , conservative so  $\partial\phi/\partial x = x$  and  $\partial\phi/\partial y = y$ ,  $\phi = x^2/2 + k(y)$ ,  $k'(y) = y$ ,  $k(y) = y^2/2 + K$ ,  $\phi = x^2/2 + y^2/2 + K$
- $\partial(3y^2)/\partial y = 6y = \partial(6xy)/\partial x$ , conservative so  $\partial\phi/\partial x = 3y^2$  and  $\partial\phi/\partial y = 6xy$ ,  $\phi = 3xy^2 + k(y)$ ,  $6xy + k'(y) = 6xy$ ,  $k'(y) = 0$ ,  $k(y) = K$ ,  $\phi = 3xy^2 + K$
- $\partial(x^2y)/\partial y = x^2$  and  $\partial(5xy^2)/\partial x = 5y^2$ , not conservative
- $\partial(e^x \cos y)/\partial y = -e^x \sin y = \partial(-e^x \sin y)/\partial x$ , conservative so  $\partial\phi/\partial x = e^x \cos y$  and  $\partial\phi/\partial y = -e^x \sin y$ ,  $\phi = e^x \cos y + k(y)$ ,  $-e^x \sin y + k'(y) = -e^x \sin y$ ,  $k'(y) = 0$ ,  $k(y) = K$ ,  $\phi = e^x \cos y + K$
- $\partial(\cos y + y \cos x)/\partial y = -\sin y + \cos x = \partial(\sin x - x \sin y)/\partial x$ , conservative so  $\partial\phi/\partial x = \cos y + y \cos x$  and  $\partial\phi/\partial y = \sin x - x \sin y$ ,  $\phi = x \cos y + y \sin x + k(y)$ ,  $-x \sin y + \sin x + k'(y) = \sin x - x \sin y$ ,  $k'(y) = 0$ ,  $k(y) = K$ ,  $\phi = x \cos y + y \sin x + K$
- $\partial(x \ln y)/\partial y = x/y$  and  $\partial(y \ln x)/\partial x = y/x$ , not conservative
- (a)  $\partial(y^2)/\partial y = 2y = \partial(2xy)/\partial x$ , independent of path  
 (b)  $C : x = -1 + 2t, y = 2 + t, 0 \leq t \leq 1; \int_0^1 (4 + 14t + 6t^2) dt = 13$   
 (c)  $\partial\phi/\partial x = y^2$  and  $\partial\phi/\partial y = 2xy$ ,  $\phi = xy^2 + k(y)$ ,  $2xy + k'(y) = 2xy$ ,  $k'(y) = 0$ ,  $k(y) = K$ ,  $\phi = xy^2 + K$ . Let  $K = 0$  to get  $\phi(1, 3) - \phi(-1, 2) = 9 - (-4) = 13$
- (a)  $\partial(y \sin x)/\partial y = \sin x = \partial(-\cos x)/\partial x$ , independent of path  
 (b)  $C_1 : x = \pi t, y = 1 - 2t, 0 \leq t \leq 1; \int_0^1 (\pi \sin \pi t - 2\pi t \sin \pi t + 2 \cos \pi t) dt = 0$   
 (c)  $\partial\phi/\partial x = y \sin x$  and  $\partial\phi/\partial y = -\cos x$ ,  $\phi = -y \cos x + k(y)$ ,  $-\cos x + k'(y) = -\cos x$ ,  $k'(y) = 0$ ,  $k(y) = K$ ,  $\phi = -y \cos x + K$ . Let  $K = 0$  to get  $\phi(\pi, -1) - \phi(0, 1) = (-1) - (-1) = 0$
- $\partial(3y)/\partial y = 3 = \partial(3x)/\partial x$ ,  $\phi = 3xy$ ,  $\phi(4, 0) - \phi(1, 2) = -6$
- $\partial(e^x \sin y)/\partial y = e^x \cos y = \partial(e^x \cos y)/\partial x$ ,  $\phi = e^x \sin y$ ,  $\phi(1, \pi/2) - \phi(0, 0) = e$
- $\partial(2xe^y)/\partial y = 2xe^y = \partial(x^2e^y)/\partial x$ ,  $\phi = x^2e^y$ ,  $\phi(3, 2) - \phi(0, 0) = 9e^2$



12.  $\partial(3x - y + 1)/\partial y = -1 = \partial[-(x + 4y + 2)]/\partial x$ ,  
 $\phi = 3x^2/2 - xy + x - 2y^2 - 2y$ ,  $\phi(0, 1) - \phi(-1, 2) = 11/2$
13.  $\partial(2xy^3)/\partial y = 6xy^2 = \partial(3x^2y^2)/\partial x$ ,  $\phi = x^2y^3$ ,  $\phi(-1, 0) - \phi(2, -2) = 32$
14.  $\partial(e^x \ln y - e^y/x)/\partial y = e^x/y - e^y/x = \partial(e^x/y - e^y \ln x)/\partial x$ ,  
 $\phi = e^x \ln y - e^y \ln x$ ,  $\phi(3, 3) - \phi(1, 1) = 0$
15.  $\phi = x^2y^2/2$ ,  $W = \phi(0, 0) - \phi(1, 1) = -1/2$     16.  $\phi = x^2y^3$ ,  $W = \phi(4, 1) - \phi(-3, 0) = 16$
17.  $\phi = e^{xy}$ ,  $W = \phi(2, 0) - \phi(-1, 1) = 1 - e^{-1}$
18.  $\phi = e^{-y} \sin x$ ,  $W = \phi(-\pi/2, 0) - \phi(\pi/2, 1) = -1 - 1/e$
19.  $\partial(e^y + ye^x)/\partial y = e^y + e^x = \partial(xe^y + e^x)/\partial x$  so  $\mathbf{F}$  is conservative,  $\phi(x, y) = xe^y + ye^x$  so  
 $\int_C \mathbf{F} \cdot d\mathbf{r} = \phi(0, \ln 2) - \phi(1, 0) = \ln 2 - 1$
20.  $\partial(2xy)/\partial y = 2x = \partial(x^2 + \cos y)/\partial x$  so  $\mathbf{F}$  is conservative,  $\phi(x, y) = x^2y + \sin y$  so  
 $\int_C \mathbf{F} \cdot d\mathbf{r} = \phi(\pi, \pi/2) - \phi(0, 0) = \pi^3/2 + 1$
21.  $\mathbf{F} \cdot d\mathbf{r} = [(e^y + ye^x)\mathbf{i} + (xe^y + e^x)\mathbf{j}] \cdot [(\pi/2) \cos(\pi t/2)\mathbf{i} + (1/t)\mathbf{j}] dt$   
 $= \left( \frac{\pi}{2} \cos(\pi t/2)(e^y + ye^x) + (xe^y + e^x)/t \right) dt$ ,  
so  $\int_C \mathbf{F} \cdot d\mathbf{r} = \int_1^2 \left( \frac{\pi}{2} \cos(\pi t/2) \left( e^{\ln t} + (\ln t)e^{\sin(\pi t/2)} \right) + \left( \sin(\pi t/2)e^{\ln t} + e^{\sin(\pi t/2)} \right) \right) dt \approx -0.307$
22.  $\mathbf{F} \cdot d\mathbf{r} = (2t^2 \cos(t/3) + [t^2 + \cos(t \cos(t/3))](\cos(t/3) - (t/3) \sin(t/3))) dt$ , so  
 $\int_C \mathbf{F} \cdot d\mathbf{r} = \int_0^\pi (2t^2 \cos(t/3) + [t^2 + \cos(t \cos(t/3))](\cos(t/3) - (t/3) \sin(t/3))) dt \approx 16.503$
23. No; a closed loop can be found whose tangent everywhere makes an angle  $< \pi$  with the vector field, so the line integral  $\int_C \mathbf{F} \cdot d\mathbf{r} > 0$ , and by Theorem 17.3.2 the vector field is not conservative.
24. The vector field is constant, say  $\mathbf{F} = a\mathbf{i} + b\mathbf{j}$ , so let  $\phi(x, y) = ax + by$  and  $\mathbf{F}$  is conservative.
25. If  $\mathbf{F}$  is conservative, then  $\mathbf{F} = \nabla\phi = \frac{\partial\phi}{\partial x}\mathbf{i} + \frac{\partial\phi}{\partial y}\mathbf{j} + \frac{\partial\phi}{\partial z}\mathbf{k}$  and hence  $f = \frac{\partial\phi}{\partial x}$ ,  $g = \frac{\partial\phi}{\partial y}$ , and  $h = \frac{\partial\phi}{\partial z}$ .  
Thus  $\frac{\partial f}{\partial y} = \frac{\partial^2\phi}{\partial y\partial x}$  and  $\frac{\partial g}{\partial x} = \frac{\partial^2\phi}{\partial x\partial y}$ ,  $\frac{\partial f}{\partial z} = \frac{\partial^2\phi}{\partial z\partial x}$  and  $\frac{\partial h}{\partial x} = \frac{\partial^2\phi}{\partial x\partial z}$ ,  $\frac{\partial g}{\partial z} = \frac{\partial^2\phi}{\partial z\partial y}$  and  $\frac{\partial h}{\partial y} = \frac{\partial^2\phi}{\partial y\partial z}$ .  
The result follows from the equality of mixed second partial derivatives.
26. Let  $f(x, y, z) = yz$ ,  $g(x, y, z) = xz$ ,  $h(x, y, z) = yx^2$ , then  $\partial f/\partial z = y$ ,  $\partial h/\partial x = 2xy \neq \partial f/\partial z$ , thus by Exercise 25,  $\mathbf{F} = f\mathbf{i} + g\mathbf{j} + h\mathbf{k}$  is not conservative, and by Theorem 17.3.2,  $\int_C yz dx + xz dy + yx^2 dz$  is not independent of the path.

$$27. \quad \frac{\partial}{\partial y}(h(x)[x \sin y + y \cos y]) = h(x)[x \cos y - y \sin y + \cos y]$$

$$\frac{\partial}{\partial x}(h(x)[x \cos y - y \sin y]) = h(x) \cos y + h'(x)[x \cos y - y \sin y],$$

equate these two partial derivatives to get  $(x \cos y - y \sin y)(h'(x) - h(x)) = 0$  which holds for all  $x$  and  $y$  if  $h'(x) = h(x)$ ,  $h(x) = Ce^x$  where  $C$  is an arbitrary constant.

$$28. \quad (a) \quad \frac{\partial}{\partial y} \frac{cx}{(x^2 + y^2)^{3/2}} = -\frac{3cxy}{(x^2 + y^2)^{-5/2}} = \frac{\partial}{\partial x} \frac{cy}{(x^2 + y^2)^{3/2}} \text{ when } (x, y) \neq (0, 0),$$

so by Theorem 17.3.3,  $\mathbf{F}$  is conservative. Set  $\partial\phi/\partial x = cx/(x^2 + y^2)^{-3/2}$ ,

then  $\phi(x, y) = -c(x^2 + y^2)^{-1/2} + k(y)$ ,  $\partial\phi/\partial y = cy/(x^2 + y^2)^{-3/2} + k'(y)$ , so  $k'(y) = 0$ .

Thus  $\phi(x, y) = -\frac{c}{(x^2 + y^2)^{1/2}}$  is a potential function.

(b) curl  $\mathbf{F} = \mathbf{0}$  is similar to part (a), so  $\mathbf{F}$  is conservative. Let

$$\phi(x, y, z) = \int \frac{cx}{(x^2 + y^2 + z^2)^{3/2}} dx = -c(x^2 + y^2 + z^2)^{-1/2} + k(y, z). \text{ As in part (a),}$$

$\partial k/\partial y = \partial k/\partial z = 0$ , so  $\phi(x, y, z) = -c/(x^2 + y^2 + z^2)^{1/2}$  is a potential function for  $\mathbf{F}$ .

$$29. \quad (a) \quad \text{See Exercise 28, } c = 1; W = \int_P^Q \mathbf{F} \cdot d\mathbf{r} = \phi(3, 2, 1) - \phi(1, 1, 2) = -\frac{1}{\sqrt{14}} + \frac{1}{\sqrt{6}}$$

$$(b) \quad C \text{ begins at } P(1, 1, 2) \text{ and ends at } Q(3, 2, 1) \text{ so the answer is again } W = -\frac{1}{\sqrt{14}} + \frac{1}{\sqrt{6}}.$$

(c)  $C$  begins at, say,  $(3, 0)$  and ends at the same point so  $W = 0$ .

$$30. \quad (a) \quad \mathbf{F} \cdot d\mathbf{r} = \left( y \frac{dx}{dt} - x \frac{dy}{dt} \right) dt \text{ for points on the circle } x^2 + y^2 = 1, \text{ so}$$

$$C_1 : x = \cos t, y = \sin t, 0 \leq t \leq \pi, \int_{C_1} \mathbf{F} \cdot d\mathbf{r} = \int_0^\pi (-\sin^2 t - \cos^2 t) dt = -\pi$$

$$C_2 : x = \cos t, y = -\sin t, 0 \leq t \leq \pi, \int_{C_2} \mathbf{F} \cdot d\mathbf{r} = \int_0^\pi (\sin^2 t + \cos^2 t) dt = \pi$$

$$(b) \quad \frac{\partial f}{\partial y} = \frac{x^2 - y^2}{(x^2 + y^2)^2}, \quad \frac{\partial g}{\partial x} = -\frac{y^2 - x^2}{(x^2 + y^2)^2} = \frac{\partial f}{\partial y}$$

(c) The circle about the origin of radius 1, which is formed by traversing  $C_1$  and then traversing  $C_2$  in the reverse direction, does not lie in an open simply connected region inside which  $\mathbf{F}$  is continuous, since  $\mathbf{F}$  is not defined at the origin, nor can it be defined there in such a way as to make the resulting function continuous there.

31. If  $C$  is composed of smooth curves  $C_1, C_2, \dots, C_n$  and curve  $C_i$  extends from  $(x_{i-1}, y_{i-1})$  to  $(x_i, y_i)$

$$\text{then } \int_C \mathbf{F} \cdot d\mathbf{r} = \sum_{i=1}^n \int_{C_i} \mathbf{F} \cdot d\mathbf{r} = \sum_{i=1}^n [\phi(x_i, y_i) - \phi(x_{i-1}, y_{i-1})] = \phi(x_n, y_n) - \phi(x_0, y_0)$$

where  $(x_0, y_0)$  and  $(x_n, y_n)$  are the endpoints of  $C$ .

$$32. \quad \int_{C_1} \mathbf{F} \cdot d\mathbf{r} + \int_{-C_2} \mathbf{F} \cdot d\mathbf{r} = 0, \text{ but } \int_{-C_2} \mathbf{F} \cdot d\mathbf{r} = -\int_{C_2} \mathbf{F} \cdot d\mathbf{r} \text{ so } \int_{C_1} \mathbf{F} \cdot d\mathbf{r} = \int_{C_2} \mathbf{F} \cdot d\mathbf{r}, \text{ thus}$$

$$\int_C \mathbf{F} \cdot d\mathbf{r} \text{ is independent of path.}$$

33. Let  $C_1$  be an arbitrary piecewise smooth curve from  $(a, b)$  to a point  $(x, y_1)$  in the disk, and  $C_2$  the vertical line segment from  $(x, y_1)$  to  $(x, y)$ . Then

$$\phi(x, y) = \int_{C_1} \mathbf{F} \cdot d\mathbf{r} + \int_{C_2} \mathbf{F} \cdot d\mathbf{r} = \int_{(a,b)}^{(x,y_1)} \mathbf{F} \cdot d\mathbf{r} + \int_{C_2} \mathbf{F} \cdot d\mathbf{r}.$$

The first term does not depend on  $y$ ;

$$\text{hence } \frac{\partial \phi}{\partial y} = \frac{\partial}{\partial y} \int_{C_2} \mathbf{F} \cdot d\mathbf{r} = \frac{\partial}{\partial y} \int_{C_2} f(x, y) dx + g(x, y) dy.$$

However, the line integral with respect to  $x$  is zero along  $C_2$ , so  $\frac{\partial \phi}{\partial y} = \frac{\partial}{\partial y} \int_{C_2} g(x, y) dy$ .

Express  $C_2$  as  $x = x, y = t$  where  $t$  varies from  $y_1$  to  $y$ , then  $\frac{\partial \phi}{\partial y} = \frac{\partial}{\partial y} \int_{y_1}^y g(x, t) dt = g(x, y)$ .

### EXERCISE SET 17.4

- $$\iint_R (2x - 2y) dA = \int_0^1 \int_0^1 (2x - 2y) dy dx = 0;$$
 for the line integral, on  $x = 0, y^2 dx = 0, x^2 dy = 0$ ;  
 on  $y = 0, y^2 dx = x^2 dy = 0$ ; on  $x = 1, y^2 dx + x^2 dy = dy$ ; and on  $y = 1, y^2 dx + x^2 dy = dx$ ,  
 hence  $\oint_C y^2 dx + x^2 dy = \int_0^1 dy + \int_1^0 dx = 1 - 1 = 0$
- $$\iint_R (1 - 1) dA = 0;$$
 for the line integral let  $x = \cos t, y = \sin t$ ,  

$$\oint_C y dx + x dy = \int_0^{2\pi} (-\sin^2 t + \cos^2 t) dt = 0$$
- $$\int_{-2}^4 \int_1^2 (2y - 3x) dy dx = 0$$
- $$\int_0^{2\pi} \int_0^3 (1 + 2r \sin \theta) r dr d\theta = 9\pi$$
- $$\int_0^{\pi/2} \int_0^{\pi/2} (-y \cos x + x \sin y) dy dx = 0$$
- $$\iint_R (\sec^2 x - \tan^2 x) dA = \iint_R dA = \pi$$
- $$\iint_R [1 - (-1)] dA = 2 \iint_R dA = 8\pi$$
- $$\int_0^1 \int_{x^2}^x (2x - 2y) dy dx = 1/30$$
- $$\iint_R \left( -\frac{y}{1+y} - \frac{1}{1+y} \right) dA = - \iint_R dA = -4$$
- $$\int_0^{\pi/2} \int_0^4 (-r^2) r dr d\theta = -32\pi$$
- $$\iint_R \left( -\frac{y^2}{1+y^2} - \frac{1}{1+y^2} \right) dA = - \iint_R dA = -1$$

$$12. \iint_R (\cos x \cos y - \cos x \sin y) dA = 0 \qquad 13. \int_0^1 \int_{x^2}^{\sqrt{x}} (y^2 - x^2) dy dx = 0$$

$$15. \text{(a)} \quad C : x = \cos t, y = \sin t, 0 \leq t \leq 2\pi;$$

$$\oint_C = \int_0^{2\pi} (e^{\sin t}(-\sin t) + \sin t \cos t e^{\cos t}) dt \approx -3.550999378;$$

$$\iint_R \left[ \frac{\partial}{\partial x}(ye^x) - \frac{\partial}{\partial y}e^y \right] dA = \iint_R [ye^x - e^y] dA$$

$$= \int_0^{2\pi} \int_0^1 [r \sin \theta e^{r \cos \theta} - e^{r \sin \theta}] r dr d\theta \approx -3.550999378$$

$$\text{(b)} \quad C_1 : x = t, y = t^2, 0 \leq t \leq 1; \int_{C_1} [e^y dx + ye^x dy] = \int_0^1 [e^{t^2} + 2t^3 e^t] dt \approx 2.589524432$$

$$C_2 : x = t^2, y = t, 0 \leq t \leq 1; \int_{C_2} [e^y dx + ye^x dy] = \int_0^1 [2te^t + te^{t^2}] dt = \frac{e+3}{2} \approx 2.859140914$$

$$\int_{C_1} - \int_{C_2} \approx -0.269616482; \iint_R = \int_0^1 \int_{x^2}^{\sqrt{x}} [ye^x - e^y] dy dx \approx -0.269616482$$

$$16. \text{(a)} \quad \oint_C x dy = \int_0^{2\pi} ab \cos^2 t dt = \pi ab \qquad \text{(b)} \quad \oint_C -y dx = \int_0^{2\pi} ab \sin^2 t dt = \pi ab$$

$$17. \quad A = \frac{1}{2} \oint_C -y dx + x dy = \frac{1}{2} \int_0^{2\pi} (3a^2 \sin^4 \phi \cos^2 \phi + 3a^2 \cos^4 \phi \sin^2 \phi) d\phi$$

$$= \frac{3}{2} a^2 \int_0^{2\pi} \sin^2 \phi \cos^2 \phi d\phi = \frac{3}{8} a^2 \int_0^{2\pi} \sin^2 2\phi d\phi = 3\pi a^2 / 8$$

$$18. \quad C_1 : (0, 0) \text{ to } (a, 0); x = at, \quad y = 0, \quad 0 \leq t \leq 1$$

$$C_2 : (a, 0) \text{ to } (0, b); x = a - at, y = bt, \quad 0 \leq t \leq 1$$

$$C_3 : (0, b) \text{ to } (0, 0); x = 0, \quad y = b - bt, 0 \leq t \leq 1$$

$$A = \oint_C x dy = \int_0^1 (0) dt + \int_0^1 ab(1-t) dt + \int_0^1 (0) dt = \frac{1}{2} ab$$

$$19. \quad C_1 : (0, 0) \text{ to } (a, 0); x = at, y = 0, 0 \leq t \leq 1$$

$$C_2 : (a, 0) \text{ to } (a \cos t_0, b \sin t_0); x = a \cos t, y = b \sin t, 0 \leq t \leq t_0$$

$$C_3 : (a \cos t_0, b \sin t_0) \text{ to } (0, 0); x = -a(\cos t_0)t, y = -b(\sin t_0)t, -1 \leq t \leq 0$$

$$A = \frac{1}{2} \oint_C -y dx + x dy = \frac{1}{2} \int_0^1 (0) dt + \frac{1}{2} \int_0^{t_0} ab dt + \frac{1}{2} \int_{-1}^0 (0) dt = \frac{1}{2} ab t_0$$

$$20. \quad C_1 : (0, 0) \text{ to } (a, 0); x = at, y = 0, 0 \leq t \leq 1$$

$$C_2 : (a, 0) \text{ to } (a \cosh t_0, b \sinh t_0); x = a \cosh t, y = b \sinh t, 0 \leq t \leq t_0$$

$$C_3 : (a \cosh t_0, b \sinh t_0) \text{ to } (0, 0); x = -a(\cosh t_0)t, y = -b(\sinh t_0)t, -1 \leq t \leq 0$$

$$A = \frac{1}{2} \oint_C -y dx + x dy = \frac{1}{2} \int_0^1 (0) dt + \frac{1}{2} \int_0^{t_0} ab dt + \frac{1}{2} \int_{-1}^0 (0) dt = \frac{1}{2} ab t_0$$

$$21. \quad W = \iint_R y \, dA = \int_0^\pi \int_0^5 r^2 \sin \theta \, dr \, d\theta = 250/3$$

22. We cannot apply Green's Theorem on the region enclosed by the closed curve  $C$ , since  $\mathbf{F}$  does not have first order partial derivatives at the origin. However, the curve  $C_\epsilon$ , consisting of  $y = x_0^3/4$ ,  $x_0 \leq x \leq 2$ ;  $x = 2$ ,  $x_0 \leq y \leq 2$ ; and  $y = x^3/4$ ,  $x_0 \leq x \leq 2$  encloses a region  $R_\epsilon$  in which Green's Theorem does hold, and

$$\begin{aligned} W &= \oint_C \mathbf{F} \cdot d\mathbf{r} = \lim_{\epsilon \rightarrow 0^+} \oint_{C_\epsilon} \mathbf{F} \cdot d\mathbf{r} = \lim_{\epsilon \rightarrow 0^+} \iint_{R_\epsilon} \nabla \cdot \mathbf{F} \, dA = \int_{x_0}^2 \int_{x_0^3/4}^{x^3/4} \left( \frac{1}{2}x^{-1/2} - \frac{1}{2}y^{-1/2} \right) dy \, dx \\ &= \lim_{\epsilon \rightarrow 0^+} \left( -\frac{18}{35}\sqrt{2} - \frac{\sqrt{2}}{4}x_0^3 + x_0^{3/2} + \frac{3}{14}x_0^{7/2} - \frac{3}{10}x_0^{5/2} \right) = -\frac{18}{35}\sqrt{2} \end{aligned}$$

$$23. \quad \oint_C y \, dx - x \, dy = \iint_R (-2) \, dA = -2 \int_0^{2\pi} \int_0^{a(1+\cos \theta)} r \, dr \, d\theta = -3\pi a^2$$

$$24. \quad \bar{x} = \frac{1}{A} \iint_R x \, dA, \text{ but } \oint_C \frac{1}{2}x^2 dy = \iint_R x \, dA \text{ from Green's Theorem so}$$

$$\bar{x} = \frac{1}{A} \oint_C \frac{1}{2}x^2 dy = \frac{1}{2A} \oint_C x^2 dy. \text{ Similarly, } \bar{y} = -\frac{1}{2A} \oint_C y^2 dx.$$

$$25. \quad A = \int_0^1 \int_{x^3}^x dy \, dx = \frac{1}{4}; \quad C_1 : x = t, y = t^3, 0 \leq t \leq 1, \int_{C_1} x^2 dy = \int_0^1 t^2(3t^2) dt = \frac{3}{5}$$

$$C_2 : x = t, y = t, 0 \leq t \leq 1; \int_{C_2} x^2 dy = \int_0^1 t^2 dt = \frac{1}{3}, \oint_C x^2 dy = \int_{C_1} - \int_{C_2} = \frac{3}{5} - \frac{1}{3} = \frac{4}{15}, \bar{x} = \frac{8}{15}$$

$$\int_C y^2 dx = \int_0^1 t^6 dt - \int_0^1 t^2 dt = \frac{1}{7} - \frac{1}{3} = -\frac{4}{21}, \bar{y} = \frac{8}{21}, \text{ centroid } \left( \frac{8}{15}, \frac{8}{21} \right)$$

$$26. \quad A = \frac{a^2}{2}; \quad C_1 : x = t, y = 0, 0 \leq t \leq a, \quad C_2 : x = a - t, y = t, 0 \leq t \leq a; \quad C_3 : x = 0, y = a - t, 0 \leq t \leq a;$$

$$\int_{C_1} x^2 dy = 0, \int_{C_2} x^2 dy = \int_0^a (a-t)^2 dt = \frac{a^3}{3}, \int_{C_3} x^2 dy = 0, \oint_C x^2 dy = \int_{C_1} + \int_{C_2} + \int_{C_3} = \frac{a^3}{3}, \bar{x} = \frac{a}{3};$$

$$\int_C y^2 dx = 0 - \int_0^a t^2 dt + 0 = -\frac{a^3}{3}, \bar{y} = \frac{a}{3}, \text{ centroid } \left( \frac{a}{3}, \frac{a}{3} \right)$$

27.  $\bar{x} = 0$  from the symmetry of the region,

$$C_1 : (a, 0) \text{ to } (-a, 0) \text{ along } y = \sqrt{a^2 - x^2}; \quad x = a \cos t, \quad y = a \sin t, \quad 0 \leq t \leq \pi$$

$$C_2 : (-a, 0) \text{ to } (a, 0); \quad x = t, \quad y = 0, \quad -a \leq t \leq a$$

$$A = \pi a^2/2, \quad \bar{y} = -\frac{1}{2A} \left[ \int_0^\pi -a^3 \sin^3 t \, dt + \int_{-a}^a (0) dt \right]$$

$$= -\frac{1}{\pi a^2} \left( -\frac{4a^3}{3} \right) = \frac{4a}{3\pi}; \text{ centroid } \left( 0, \frac{4a}{3\pi} \right)$$

28.  $A = \frac{ab}{2}$ ;  $C_1 : x = t, y = 0, 0 \leq t \leq a$ ,  $C_2 : x = a, y = t, 0 \leq t \leq b$ ;

$C_3 : x = a - t, y = b - bt/a, 0 \leq t \leq a$ ;

$$\int_{C_1} x^2 dy = 0, \int_{C_2} x^2 dy = \int_0^b a^2 dt = ba^2, \int_{C_3} x^2 dy = \int_0^a (a-t)^2(-b/a) dt = -\frac{ba^2}{3},$$

$$\oint_C x^2 dy = \int_{C_1} + \int_{C_2} + \int_{C_3} = \frac{2ba^2}{3}, \bar{x} = \frac{2a}{3};$$

$$\int_C y^2 dx = 0 + 0 - \int_0^a b^2 \left(a - \frac{t}{a}\right) dt = -\frac{ab^2}{3}, \bar{y} = \frac{b}{3}, \text{ centroid } \left(\frac{2a}{3}, \frac{b}{3}\right)$$

29. From Green's Theorem, the given integral equals  $\iint_R (1-x^2-y^2)dA$  where  $R$  is the region enclosed

by  $C$ . The value of this integral is maximum if the integration extends over the largest region for which the integrand  $1-x^2-y^2$  is nonnegative so we want  $1-x^2-y^2 \geq 0$ ,  $x^2+y^2 \leq 1$ . The largest region is that bounded by the circle  $x^2+y^2=1$  which is the desired curve  $C$ .

30. (a)  $C : x = a + (c-a)t, y = b + (d-b)t, 0 \leq t \leq 1$

$$\int_C -y dx + x dy = \int_0^1 (ad - bc)dt = ad - bc$$

(b) Let  $C_1, C_2$ , and  $C_3$  be the line segments from  $(x_1, y_1)$  to  $(x_2, y_2)$ ,  $(x_2, y_2)$  to  $(x_3, y_3)$ , and  $(x_3, y_3)$  to  $(x_1, y_1)$ , then if  $C$  is the entire boundary consisting of  $C_1, C_2$ , and  $C_3$

$$\begin{aligned} A &= \frac{1}{2} \int_C -y dx + x dy = \frac{1}{2} \sum_{i=1}^3 \int_{C_i} -y dx + x dy \\ &= \frac{1}{2} [(x_1 y_2 - x_2 y_1) + (x_2 y_3 - x_3 y_2) + (x_3 y_1 - x_1 y_3)] \end{aligned}$$

(c)  $A = \frac{1}{2} [(x_1 y_2 - x_2 y_1) + (x_2 y_3 - x_3 y_2) + \cdots + (x_n y_1 - x_1 y_n)]$

(d)  $A = \frac{1}{2} [(0-0) + (6+8) + (0+2) + (0-0)] = 8$

31.  $\int_C \mathbf{F} \cdot d\mathbf{r} = \int_C (x^2 + y) dx + (4x - \cos y) dy = 3 \iint_R dA = 3(25 - 2) = 69$

32.  $\int_C \mathbf{F} \cdot d\mathbf{r} = \int_C (e^{-x} + 3y) dx + x dy = -2 \iint_R dA = -2[\pi(4)^2 - \pi(2)^2] = -24\pi$

## EXERCISE SET 17.5

1.  $R$  is the annular region between  $x^2 + y^2 = 1$  and  $x^2 + y^2 = 4$ ;

$$\begin{aligned} \iint_{\sigma} z^2 dS &= \iint_R (x^2 + y^2) \sqrt{\frac{x^2}{x^2 + y^2} + \frac{y^2}{x^2 + y^2} + 1} dA \\ &= \sqrt{2} \iint_R (x^2 + y^2) dA = \sqrt{2} \int_0^{2\pi} \int_1^2 r^3 dr d\theta = \frac{15}{2} \pi \sqrt{2}. \end{aligned}$$

2.  $z = 1 - x - y$ ,  $R$  is the triangular region enclosed by  $x + y = 1$ ,  $x = 0$  and  $y = 0$ ;

$$\iint_{\sigma} xy \, dS = \iint_R xy\sqrt{3} \, dA = \sqrt{3} \int_0^1 \int_0^{1-x} xy \, dy \, dx = \frac{\sqrt{3}}{24}.$$

3. Let  $\mathbf{r}(u, v) = \cos u \mathbf{i} + v \mathbf{j} + \sin u \mathbf{k}$ ,  $0 \leq u \leq \pi$ ,  $0 \leq v \leq 1$ . Then  $\mathbf{r}_u = -\sin u \mathbf{i} + \cos u \mathbf{k}$ ,  $\mathbf{r}_v = \mathbf{j}$ ,

$$\mathbf{r}_u \times \mathbf{r}_v = -\cos u \mathbf{i} + \sin u \mathbf{k}, \|\mathbf{r}_u \times \mathbf{r}_v\| = 1, \iint_{\sigma} x^2 y \, dS = \int_0^1 \int_0^{\pi} v \cos^2 u \, du \, dv = \pi/4$$

4.  $z = \sqrt{4 - x^2 - y^2}$ ,  $R$  is the circular region enclosed by  $x^2 + y^2 = 3$ ;

$$\begin{aligned} \iint_{\sigma} (x^2 + y^2)z \, dS &= \iint_R (x^2 + y^2)\sqrt{4 - x^2 - y^2} \sqrt{\frac{x^2}{4 - x^2 - y^2} + \frac{y^2}{4 - x^2 - y^2} + 1} \, dA \\ &= \iint_R 2(x^2 + y^2) \, dA = 2 \int_0^{2\pi} \int_0^{\sqrt{3}} r^3 \, dr \, d\theta = 9\pi. \end{aligned}$$

5. If we use the projection of  $\sigma$  onto the  $xz$ -plane then  $y = 1 - x$  and  $R$  is the rectangular region in the  $xz$ -plane enclosed by  $x = 0$ ,  $x = 1$ ,  $z = 0$  and  $z = 1$ ;

$$\iint_{\sigma} (x - y - z) \, dS = \iint_R (2x - 1 - z)\sqrt{2} \, dA = \sqrt{2} \int_0^1 \int_0^1 (2x - 1 - z) \, dz \, dx = -\sqrt{2}/2$$

6.  $R$  is the triangular region enclosed by  $2x + 3y = 6$ ,  $x = 0$ , and  $y = 0$ ;

$$\iint_{\sigma} (x + y) \, dS = \iint_R (x + y)\sqrt{14} \, dA = \sqrt{14} \int_0^3 \int_0^{(6-2x)/3} (x + y) \, dy \, dx = 5\sqrt{14}.$$

7. There are six surfaces, parametrized by projecting onto planes:

$\sigma_1 : z = 0; 0 \leq x \leq 1, 0 \leq y \leq 1$  (onto  $xy$ -plane),  $\sigma_2 : x = 0; 0 \leq y \leq 1, 0 \leq z \leq 1$  (onto  $yz$ -plane),  
 $\sigma_3 : y = 0; 0 \leq x \leq 1, 0 \leq z \leq 1$  (onto  $xz$ -plane),  $\sigma_4 : z = 1; 0 \leq x \leq 1, 0 \leq y \leq 1$  (onto  $xy$ -plane),  
 $\sigma_5 : x = 1; 0 \leq y \leq 1, 0 \leq z \leq 1$  (onto  $yz$ -plane),  $\sigma_6 : y = 1; 0 \leq x \leq 1, 0 \leq z \leq 1$  (onto  $xz$ -plane).

By symmetry the integrals over  $\sigma_1, \sigma_2$  and  $\sigma_3$  are equal, as are those over  $\sigma_4, \sigma_5$  and  $\sigma_6$ , and

$$\iint_{\sigma_1} (x + y + z) \, dS = \int_0^1 \int_0^1 (x + y) \, dx \, dy = 1; \quad \iint_{\sigma_4} (x + y + z) \, dS = \int_0^1 \int_0^1 (x + y + 1) \, dx \, dy = 2,$$

thus,  $\iint_{\sigma} (x + y + z) \, dS = 3 \cdot 1 + 3 \cdot 2 = 9.$

8. Let  $\mathbf{r}(\phi, \theta) = \sin \phi \cos \theta \mathbf{i} + \sin \phi \sin \theta \mathbf{j} + \cos \phi \mathbf{k}$ ,

$$0 \leq \theta \leq 2\pi, 0 \leq \phi \leq \pi/2; \|\mathbf{r}_{\phi} \times \mathbf{r}_{\theta}\| = \sqrt{1 - \cos^2 \phi} = \sin \phi,$$

$$\begin{aligned} \iint_{\sigma} (1 + \sqrt{1 - x^2 - y^2}) \, dS &= \int_0^{2\pi} \int_0^{\pi/2} (1 + \sqrt{1 - \sin^2 \phi}) \sin \phi \, d\phi \, d\theta \\ &= 2\pi \int_0^{\pi/2} (1 + \cos \phi) \sin \phi \, d\phi = 3\pi \end{aligned}$$

9.  $R$  is the circular region enclosed by  $x^2 + y^2 = 1$ ;

$$\begin{aligned} \iint_{\sigma} \sqrt{x^2 + y^2 + z^2} dS &= \iint_R \sqrt{2(x^2 + y^2)} \sqrt{\frac{x^2}{x^2 + y^2} + \frac{y^2}{x^2 + y^2} + 1} dA \\ &= \lim_{r_0 \rightarrow 0^+} 2 \iint_{R'} \sqrt{x^2 + y^2} dA \end{aligned}$$

where  $R'$  is the annular region enclosed by  $x^2 + y^2 = 1$  and  $x^2 + y^2 = r_0^2$  with  $r_0$  slightly larger

than 0 because  $\sqrt{\frac{x^2}{x^2 + y^2} + \frac{y^2}{x^2 + y^2} + 1}$  is not defined for  $x^2 + y^2 = 0$ , so

$$\iint_{\sigma} \sqrt{x^2 + y^2 + z^2} dS = \lim_{r_0 \rightarrow 0^+} 2 \int_0^{2\pi} \int_{r_0}^1 r^2 dr d\theta = \lim_{r_0 \rightarrow 0^+} \frac{4\pi}{3} (1 - r_0^3) = \frac{4\pi}{3}.$$

10. Let  $\mathbf{r}(\phi, \theta) = a \sin \phi \cos \theta \mathbf{i} + a \sin \phi \sin \theta \mathbf{j} + a \cos \phi \mathbf{k}$ ,

$$0 \leq \theta \leq 2\pi, 0 \leq \phi \leq \pi/2; \|\mathbf{r}_{\phi} \times \mathbf{r}_{\theta}\| = a^2 \sqrt{1 - \cos^2 \phi},$$

$$\iint_{\sigma} f(x, y, z) = a^2 \int_0^{2\pi} \int_0^{\pi} a^2 \sin^2 \phi \sqrt{1 - \cos^2 \phi} d\phi d\theta = \frac{8}{3} \pi a^4$$

11. (a)  $\frac{\sqrt{29}}{16} \int_0^6 \int_0^{(12-2x)/3} xy(12 - 2x - 3y) dy dx$

(b)  $\frac{\sqrt{29}}{4} \int_0^3 \int_0^{(12-4z)/3} yz(12 - 3y - 4z) dy dz$

(c)  $\frac{\sqrt{29}}{9} \int_0^3 \int_0^{6-2z} xz(12 - 2x - 4z) dx dz$

12. (a)  $a \int_0^a \int_0^{\sqrt{a^2-x^2}} x dy dx$

(b)  $a \int_0^a \int_0^{\sqrt{a^2-z^2}} z dy dz$

(c)  $a \int_0^a \int_0^{\sqrt{a^2-z^2}} \frac{xz}{\sqrt{a^2-x^2-z^2}} dx dz$

13.  $18\sqrt{29}/5$

14.  $a^4/3$

15.  $\int_0^4 \int_1^2 y^3 z \sqrt{4y^2 + 1} dy dz; \frac{1}{2} \int_0^4 \int_1^4 xz \sqrt{1 + 4x} dx dz$

16.  $a \int_0^9 \int_{a/\sqrt{5}}^{a/\sqrt{2}} \frac{x^2 y}{\sqrt{a^2 - y^2}} dy dx, a \int_{a/\sqrt{2}}^{2a/\sqrt{5}} \int_0^9 x^2 dx dz$

17.  $391\sqrt{17}/15 - 5\sqrt{5}/3$

18. The region  $R: 3x^2 + 2y^2 = 5$  is symmetric in  $y$ . The integrand is

$$x^2 y z dS = x^2 y (5 - 3x^2 - 2y^2) \sqrt{1 + 36x^2 + 16y^2} dy dx, \text{ which is odd in } y, \text{ hence } \iiint_{\sigma} x^2 y z dS = 0.$$



19.  $z = \sqrt{4 - x^2}$ ,  $\frac{\partial z}{\partial x} = -\frac{x}{\sqrt{4 - x^2}}$ ,  $\frac{\partial z}{\partial y} = 0$ ;

$$\iint_{\sigma} \delta_0 dS = \delta_0 \iint_R \sqrt{\frac{x^2}{4 - x^2} + 1} dA = 2\delta_0 \int_0^4 \int_0^1 \frac{1}{\sqrt{4 - x^2}} dx dy = \frac{4}{3}\pi\delta_0.$$

20.  $z = \frac{1}{2}(x^2 + y^2)$ ,  $R$  is the circular region enclosed by  $x^2 + y^2 = 8$ ;

$$\iint_{\sigma} \delta_0 dS = \delta_0 \iint_R \sqrt{x^2 + y^2 + 1} dA = \delta_0 \int_0^{2\pi} \int_0^{\sqrt{8}} \sqrt{r^2 + 1} r dr d\theta = \frac{52}{3}\pi\delta_0.$$

21.  $z = 4 - y^2$ ,  $R$  is the rectangular region enclosed by  $x = 0$ ,  $x = 3$ ,  $y = 0$  and  $y = 3$ ;

$$\iint_{\sigma} y dS = \iint_R y\sqrt{4y^2 + 1} dA = \int_0^3 \int_0^3 y\sqrt{4y^2 + 1} dy dx = \frac{1}{4}(37\sqrt{37} - 1).$$

22.  $R$  is the annular region enclosed by  $x^2 + y^2 = 1$  and  $x^2 + y^2 = 16$ ;

$$\begin{aligned} \iint_{\sigma} x^2 z dS &= \iint_R x^2 \sqrt{x^2 + y^2} \sqrt{\frac{x^2}{x^2 + y^2} + \frac{y^2}{x^2 + y^2} + 1} dA \\ &= \sqrt{2} \iint_R x^2 \sqrt{x^2 + y^2} dA = \sqrt{2} \int_0^{2\pi} \int_1^4 r^4 \cos^2 \theta dr d\theta = \frac{1023\sqrt{2}}{5}\pi. \end{aligned}$$

23.  $M = \iint_{\sigma} \delta(x, y, z) dS = \iint_{\sigma} \delta_0 dS = \delta_0 \iint_{\sigma} dS = \delta_0 S$

24.  $\delta(x, y, z) = |z|$ ; use  $z = \sqrt{a^2 - x^2 - y^2}$ , let  $R$  be the circular region enclosed by  $x^2 + y^2 = a^2$ , and  $\sigma$  the hemisphere above  $R$ . By the symmetry of both the surface and the density function with respect to the  $xy$ -plane we have

$$M = 2 \iint_{\sigma} z dS = 2 \iint_R \sqrt{a^2 - x^2 - y^2} \sqrt{\frac{x^2}{a^2 - x^2 - y^2} + \frac{y^2}{a^2 - x^2 - y^2} + 1} dA = \lim_{r_0 \rightarrow a^-} 2a \iint_{R_{r_0}} dA$$

where  $R_{r_0}$  is the circular region with radius  $r_0$  that is slightly less than  $a$ . But  $\iint_{R_{r_0}} dA$  is simply

the area of the circle with radius  $r_0$  so  $M = \lim_{r_0 \rightarrow a^-} 2a(\pi r_0^2) = 2\pi a^3$ .

25. By symmetry  $\bar{x} = \bar{y} = 0$ .

$$\iint_{\sigma} dS = \iint_R \sqrt{x^2 + y^2 + 1} dA = \int_0^{2\pi} \int_0^{\sqrt{8}} \sqrt{r^2 + 1} r dr d\theta = \frac{52\pi}{3},$$

$$\begin{aligned} \iint_{\sigma} z dS &= \iint_R z\sqrt{x^2 + y^2 + 1} dA = \frac{1}{2} \iint_R (x^2 + y^2)\sqrt{x^2 + y^2 + 1} dA \\ &= \frac{1}{2} \int_0^{2\pi} \int_0^{\sqrt{8}} r^3 \sqrt{r^2 + 1} dr d\theta = \frac{596\pi}{15} \end{aligned}$$

so  $\bar{z} = \frac{596\pi/15}{52\pi/3} = \frac{149}{65}$ . The centroid is  $(\bar{x}, \bar{y}, \bar{z}) = (0, 0, 149/65)$ .

26. By symmetry  $\bar{x} = \bar{y} = 0$ .

$$\iint_{\sigma} dS = \iint_R \frac{2}{\sqrt{4-x^2-y^2}} dA = 2 \int_0^{2\pi} \int_0^{\sqrt{3}} \frac{r}{\sqrt{4-r^2}} dr d\theta = 4\pi,$$

$$\iint_{\sigma} z dS = \iint_R 2 dA = (2)(\text{area of circle of radius } \sqrt{3}) = 6\pi$$

so  $\bar{z} = \frac{6\pi}{4\pi} = \frac{3}{2}$ . The centroid is  $(\bar{x}, \bar{y}, \bar{z}) = (0, 0, 3/2)$ .

27.  $\partial\mathbf{r}/\partial u = \cos v\mathbf{i} + \sin v\mathbf{j} + 3\mathbf{k}$ ,  $\partial\mathbf{r}/\partial v = -u \sin v\mathbf{i} + u \cos v\mathbf{j}$ ,  $\|\partial\mathbf{r}/\partial u \times \partial\mathbf{r}/\partial v\| = \sqrt{10}u$ ;

$$3\sqrt{10} \iint_R u^4 \sin v \cos v dA = 3\sqrt{10} \int_0^{\pi/2} \int_1^2 u^4 \sin v \cos v du dv = 93/\sqrt{10}$$

28.  $\partial\mathbf{r}/\partial u = \mathbf{j}$ ,  $\partial\mathbf{r}/\partial v = -2 \sin v\mathbf{i} + 2 \cos v\mathbf{k}$ ,  $\|\partial\mathbf{r}/\partial u \times \partial\mathbf{r}/\partial v\| = 2$ ;

$$8 \iint_R \frac{1}{u} dA = 8 \int_0^{2\pi} \int_1^3 \frac{1}{u} du dv = 16\pi \ln 3$$

29.  $\partial\mathbf{r}/\partial u = \cos v\mathbf{i} + \sin v\mathbf{j} + 2u\mathbf{k}$ ,  $\partial\mathbf{r}/\partial v = -u \sin v\mathbf{i} + u \cos v\mathbf{j}$ ,  $\|\partial\mathbf{r}/\partial u \times \partial\mathbf{r}/\partial v\| = u\sqrt{4u^2+1}$ ;

$$\iint_R u dA = \int_0^{\pi} \int_0^{\sin v} u du dv = \pi/4$$

30.  $\partial\mathbf{r}/\partial u = 2 \cos u \cos v\mathbf{i} + 2 \cos u \sin v\mathbf{j} - 2 \sin u\mathbf{k}$ ,  $\partial\mathbf{r}/\partial v = -2 \sin u \sin v\mathbf{i} + 2 \sin u \cos v\mathbf{j}$ ;

$$\|\partial\mathbf{r}/\partial u \times \partial\mathbf{r}/\partial v\| = 4 \sin u;$$

$$4 \iint_R e^{-2 \cos u} \sin u dA = 4 \int_0^{2\pi} \int_0^{\pi/2} e^{-2 \cos u} \sin u du dv = 4\pi(1 - e^{-2})$$

31.  $\partial z/\partial x = -2xe^{-x^2-y^2}$ ,  $\partial z/\partial y = -2ye^{-x^2-y^2}$ ,

$$(\partial z/\partial x)^2 + (\partial z/\partial y)^2 + 1 = 4(x^2 + y^2)e^{-2(x^2+y^2)} + 1; \text{ use polar coordinates to get}$$

$$M = \int_0^{2\pi} \int_0^3 r^2 \sqrt{4r^2 e^{-2r^2} + 1} dr d\theta \approx 57.895751$$

32. (b)  $A = \iint_{\sigma} dS = \int_0^{2\pi} \int_{-1}^1 \frac{1}{2} \sqrt{40u \cos(v/2) + u^2 + 4u^2 \cos^2(v/2) + 100} du dv \approx 62.93768644$ ;

$$\bar{x} \approx 0.01663836266; \bar{y} = \bar{z} = 0 \text{ by symmetry}$$

## EXERCISE SET 17.6

- |                 |              |              |
|-----------------|--------------|--------------|
| 1. (a) zero     | (b) zero     | (c) positive |
| (d) negative    | (e) zero     | (f) zero     |
| 2. (a) positive | (b) zero     | (c) zero     |
| (d) zero        | (e) negative | (f) zero     |

3. (a) positive (b) zero (c) positive  
 (d) zero (e) positive (f) zero

4. 0; the flux is zero on the faces  $y = 0, 1$  and  $z = 0, 1$ ; it is 1 on  $x = 1$  and  $-1$  on  $x = 0$

5. (a)  $\mathbf{n} = -\cos \theta \mathbf{i} - \sin \theta \mathbf{j}$  (b) inward, by inspection

6. (a)  $-r \cos \theta \mathbf{i} - r \sin \theta \mathbf{j} + r \mathbf{k}$  (b) inward, by inspection

7.  $\mathbf{n} = -z_x \mathbf{i} - z_y \mathbf{j} + \mathbf{k}$ ,  $\iint_R \mathbf{F} \cdot \mathbf{n} dS = \iint_R (2x^2 + 2y^2 + 2(1 - x^2 - y^2)) dS = \int_0^{2\pi} \int_0^1 2r dr d\theta = 2\pi$

8. With  $z = 1 - x - y$ ,  $R$  is the triangular region enclosed by  $x + y = 1$ ,  $x = 0$  and  $y = 0$ ; use upward normals to get

$$\iint_{\sigma} \mathbf{F} \cdot \mathbf{n} dS = 2 \iint_R (x + y + z) dA = 2 \iint_R dA = (2)(\text{area of } R) = 1.$$

9.  $R$  is the annular region enclosed by  $x^2 + y^2 = 1$  and  $x^2 + y^2 = 4$ ;

$$\begin{aligned} \iint_{\sigma} \mathbf{F} \cdot \mathbf{n} dS &= \iint_R \left( -\frac{x^2}{\sqrt{x^2 + y^2}} - \frac{y^2}{\sqrt{x^2 + y^2}} + 2z \right) dA \\ &= \iint_R \sqrt{x^2 + y^2} dA = \int_0^{2\pi} \int_1^2 r^2 dr d\theta = \frac{14\pi}{3}. \end{aligned}$$

10.  $R$  is the circular region enclosed by  $x^2 + y^2 = 4$ ;

$$\iint_{\sigma} \mathbf{F} \cdot \mathbf{n} dS = \iint_R (2y^2 - 1) dA = \int_0^{2\pi} \int_0^2 (2r^2 \sin^2 \theta - 1) r dr d\theta = 4\pi.$$

11.  $R$  is the circular region enclosed by  $x^2 + y^2 - y = 0$ ;  $\iint_{\sigma} \mathbf{F} \cdot \mathbf{n} dS = \iint_R (-x) dA = 0$  since the region  $R$  is symmetric across the  $y$ -axis.

12. With  $z = \frac{1}{2}(6 - 6x - 3y)$ ,  $R$  is the triangular region enclosed by  $2x + y = 2$ ,  $x = 0$ , and  $y = 0$ ;

$$\iint_{\sigma} \mathbf{F} \cdot \mathbf{n} dS = \iint_R \left( 3x^2 + \frac{3}{2}yx + zx \right) dA = 3 \iint_R x dA = 3 \int_0^1 \int_0^{2-2x} x dy dx = 1.$$

13.  $\partial \mathbf{r} / \partial u = \cos v \mathbf{i} + \sin v \mathbf{j} - 2u \mathbf{k}$ ,  $\partial \mathbf{r} / \partial v = -u \sin v \mathbf{i} + u \cos v \mathbf{j}$ ,

$$\partial \mathbf{r} / \partial u \times \partial \mathbf{r} / \partial v = 2u^2 \cos v \mathbf{i} + 2u^2 \sin v \mathbf{j} + u \mathbf{k};$$

$$\iint_R (2u^3 + u) dA = \int_0^{2\pi} \int_1^2 (2u^3 + u) du dv = 18\pi$$

14.  $\partial \mathbf{r} / \partial u = \mathbf{k}$ ,  $\partial \mathbf{r} / \partial v = -2 \sin v \mathbf{i} + \cos v \mathbf{j}$ ,  $\partial \mathbf{r} / \partial u \times \partial \mathbf{r} / \partial v = -\cos v \mathbf{i} - 2 \sin v \mathbf{j}$ ;

$$\iint_R (2 \sin^2 v - e^{-\sin v} \cos v) dA = \int_0^{2\pi} \int_0^5 (2 \sin^2 v - e^{-\sin v} \cos v) du dv = 10\pi$$

15.  $\partial \mathbf{r} / \partial u = \cos v \mathbf{i} + \sin v \mathbf{j} + 2\mathbf{k}$ ,  $\partial \mathbf{r} / \partial v = -u \sin v \mathbf{i} + u \cos v \mathbf{j}$ ,

$$\partial \mathbf{r} / \partial u \times \partial \mathbf{r} / \partial v = -2u \cos v \mathbf{i} - 2u \sin v \mathbf{j} + u\mathbf{k};$$

$$\iint_R u^2 dA = \int_0^\pi \int_0^{\sin v} u^2 du dv = 4/9$$

16.  $\partial \mathbf{r} / \partial u = 2 \cos u \cos v \mathbf{i} + 2 \cos u \sin v \mathbf{j} - 2 \sin u \mathbf{k}$ ,  $\partial \mathbf{r} / \partial v = -2 \sin u \sin v \mathbf{i} + 2 \sin u \cos v \mathbf{j}$ ;

$$\partial \mathbf{r} / \partial u \times \partial \mathbf{r} / \partial v = 4 \sin^2 u \cos v \mathbf{i} + 4 \sin^2 u \sin v \mathbf{j} + 4 \sin u \cos u \mathbf{k};$$

$$\iint_R 8 \sin u dA = 8 \int_0^{2\pi} \int_0^{\pi/3} \sin u du dv = 8\pi$$

17. In each part, divide  $\sigma$  into the six surfaces

$$\sigma_1 : x = -1 \text{ with } |y| \leq 1, |z| \leq 1, \text{ and } \mathbf{n} = -\mathbf{i}, \sigma_2 : x = 1 \text{ with } |y| \leq 1, |z| \leq 1, \text{ and } \mathbf{n} = \mathbf{i},$$

$$\sigma_3 : y = -1 \text{ with } |x| \leq 1, |z| \leq 1, \text{ and } \mathbf{n} = -\mathbf{j}, \sigma_4 : y = 1 \text{ with } |x| \leq 1, |z| \leq 1, \text{ and } \mathbf{n} = \mathbf{j},$$

$$\sigma_5 : z = -1 \text{ with } |x| \leq 1, |y| \leq 1, \text{ and } \mathbf{n} = -\mathbf{k}, \sigma_6 : z = 1 \text{ with } |x| \leq 1, |y| \leq 1, \text{ and } \mathbf{n} = \mathbf{k},$$

(a)  $\iint_{\sigma_1} \mathbf{F} \cdot \mathbf{n} dS = \iint_{\sigma_1} dS = 4$ ,  $\iint_{\sigma_2} \mathbf{F} \cdot \mathbf{n} dS = \iint_{\sigma_2} dS = 4$ , and  $\iint_{\sigma_i} \mathbf{F} \cdot \mathbf{n} dS = 0$  for

$$i = 3, 4, 5, 6 \text{ so } \iint_{\sigma} \mathbf{F} \cdot \mathbf{n} dS = 4 + 4 + 0 + 0 + 0 + 0 = 8.$$

(b)  $\iint_{\sigma_1} \mathbf{F} \cdot \mathbf{n} dS = \iint_{\sigma_1} dS = 4$ , similarly  $\iint_{\sigma_i} \mathbf{F} \cdot \mathbf{n} dS = 4$  for  $i = 2, 3, 4, 5, 6$  so

$$\iint_{\sigma} \mathbf{F} \cdot \mathbf{n} dS = 4 + 4 + 4 + 4 + 4 + 4 = 24.$$

(c)  $\iint_{\sigma_1} \mathbf{F} \cdot \mathbf{n} dS = -\iint_{\sigma_1} dS = -4$ ,  $\iint_{\sigma_2} \mathbf{F} \cdot \mathbf{n} dS = 4$ , similarly  $\iint_{\sigma_i} \mathbf{F} \cdot \mathbf{n} dS = -4$  for  $i = 3, 5$

$$\text{and } \iint_{\sigma_i} \mathbf{F} \cdot \mathbf{n} dS = 4 \text{ for } i = 4, 6 \text{ so } \iint_{\sigma} \mathbf{F} \cdot \mathbf{n} dS = -4 + 4 - 4 + 4 - 4 + 4 = 0.$$

18. Decompose  $\sigma$  into a top  $\sigma_1$  (the disk) and a bottom  $\sigma_2$  (the portion of the paraboloid). Then

$$\mathbf{n}_1 = \mathbf{k}, \iint_{\sigma_1} \mathbf{F} \cdot \mathbf{n}_1 dS = -\iint_{\sigma_1} y dS = -\int_0^{2\pi} \int_0^1 r^2 \sin \theta dr d\theta = 0,$$

$$\mathbf{n}_2 = (2x\mathbf{i} + 2y\mathbf{j} - \mathbf{k}) / \sqrt{1 + 4x^2 + 4y^2}, \iint_{\sigma_2} \mathbf{F} \cdot \mathbf{n}_2 dS = \iint_{\sigma_2} \frac{y(2x^2 + 2y^2 + 1)}{\sqrt{1 + 4x^2 + 4y^2}} dS = 0,$$

because the surface  $\sigma_2$  is symmetric with respect to the  $xy$ -plane and the integrand is an odd function of  $y$ . Thus the flux is 0.

19.  $R$  is the circular region enclosed by  $x^2 + y^2 = 1$ ;

$$\iint_{\sigma} \mathbf{F} \cdot \mathbf{n} dS = \iint_R \left( \frac{x}{\sqrt{x^2 + y^2}} + \frac{y}{\sqrt{x^2 + y^2}} - 1 \right) dA = \iint_R \frac{x + y - \sqrt{x^2 + y^2}}{\sqrt{x^2 + y^2}} dA$$

$$= \lim_{r_0 \rightarrow 0^+} \int_0^{2\pi} \int_{r_0}^1 (r \cos \theta + r \sin \theta - r) dr d\theta = \lim_{r_0 \rightarrow 0^+} \pi(r_0^2 - 1) = -\pi.$$

20. Let  $\mathbf{r} = \cos v \mathbf{i} + u \mathbf{j} + \sin v \mathbf{k}$ ,  $-2 \leq u \leq 1$ ,  $0 \leq v \leq 2\pi$ ;  $\mathbf{r}_u \times \mathbf{r}_v = \cos v \mathbf{i} + \sin v \mathbf{k}$ ,

$$\iint_{\sigma} \mathbf{F} \cdot \mathbf{n} dS = \iint_R (\cos^2 v + \sin^2 v) dA = \text{area of } R = 3 \cdot 2\pi = 6\pi$$

21. (a)  $\iint_{\sigma} \mathbf{F} \cdot \mathbf{n} dS = \iint_R \mathbf{F} \cdot \left( \mathbf{i} - \frac{\partial x}{\partial y} \mathbf{j} - \frac{\partial x}{\partial z} \mathbf{k} \right) dA$ , if  $\sigma$  is oriented by front normals, and

$$\iint_{\sigma} \mathbf{F} \cdot \mathbf{n} dS = \iint_R \mathbf{F} \cdot \left( -\mathbf{i} + \frac{\partial x}{\partial y} \mathbf{j} + \frac{\partial x}{\partial z} \mathbf{k} \right) dA, \text{ if } \sigma \text{ is oriented by back normals,}$$

where  $R$  is the projection of  $\sigma$  onto the  $yz$ -plane.

- (b)  $R$  is the semicircular region in the  $yz$ -plane enclosed by  $z = \sqrt{1-y^2}$  and  $z = 0$ ;

$$\iint_{\sigma} \mathbf{F} \cdot \mathbf{n} dS = \iint_R (-y - 2yz + 16z) dA = \int_{-1}^1 \int_0^{\sqrt{1-y^2}} (-y - 2yz + 16z) dz dy = \frac{32}{3}.$$

22. (a)  $\iint_R \mathbf{F} \cdot \left( \frac{\partial y}{\partial x} \mathbf{i} - \mathbf{j} + \frac{\partial y}{\partial z} \mathbf{k} \right) dA$ ,  $\sigma$  oriented by right normals,

$$\text{and } \iint_R \mathbf{F} \cdot \left( -\frac{\partial y}{\partial x} \mathbf{i} + \mathbf{j} - \frac{\partial y}{\partial z} \mathbf{k} \right) dA, \sigma \text{ oriented by left normals,}$$

where  $R$  is the projection of  $\sigma$  onto the  $xz$ -plane.

- (b)  $R$  is the semicircular region in the  $xz$ -plane enclosed by  $z = \sqrt{1-x^2}$  and  $z = 0$ ;

$$\iint_{\sigma} \mathbf{F} \cdot \mathbf{n} dS = \iint_R (2x^2 - (x^2 + z^2) + z^2) dA = \int_{-1}^1 \int_0^{\sqrt{1-x^2}} (x^2 + z^2) dz dx = \frac{\pi}{4}.$$

23. (a) On the sphere,  $\|\mathbf{r}\| = a$  so  $\mathbf{F} = a^k \mathbf{r}$  and  $\mathbf{F} \cdot \mathbf{n} = a^k \mathbf{r} \cdot (\mathbf{r}/a) = a^{k-1} \|\mathbf{r}\|^2 = a^{k-1} a^2 = a^{k+1}$ ,  
hence  $\iint_{\sigma} \mathbf{F} \cdot \mathbf{n} dS = a^{k+1} \iint_{\sigma} dS = a^{k+1} (4\pi a^2) = 4\pi a^{k+3}$ .

- (b) If  $k = -3$ , then  $\iint_{\sigma} \mathbf{F} \cdot \mathbf{n} dS = 4\pi$ .

24. Let  $\mathbf{r} = \sin u \cos v \mathbf{i} + \sin u \sin v \mathbf{j} + \cos u \mathbf{k}$ ,  $\mathbf{r}_u \times \mathbf{r}_v = \sin^2 u \cos v \mathbf{i} + \sin^2 u \sin v \mathbf{j} + \sin u \cos u \mathbf{k}$ ,

$$\mathbf{F} \cdot (\mathbf{r}_u \times \mathbf{r}_v) = a^2 \sin^3 u \cos^2 v + \frac{1}{9} \sin^3 u \sin^2 v + a \sin u \cos^3 u,$$

$$\begin{aligned} \iint_{\sigma} \mathbf{F} \cdot \mathbf{n} dS &= \int_0^{2\pi} \int_0^{\pi} (a^2 \sin^3 u \cos^2 v + \frac{1}{9} \sin^3 u \sin^2 v + a \sin u \cos^3 u) du dv \\ &= a^2 \int_0^{\pi} \sin^3 u du \int_0^{2\pi} \cos^2 v dv + \frac{1}{9} \int_0^{\pi} \sin^3 u du \\ &\quad + \int_0^{2\pi} \sin^2 v dv + 2\pi a \int_0^{\pi} \sin u \cos^3 u du \\ &= \frac{4\pi}{3} \left( a^2 + \frac{1}{a} \right) = 10 \text{ if } a \approx -1.722730, 0.459525, 1.263205 \end{aligned}$$

## EXERCISE SET 17.7

$$1. \quad \sigma_1 : x = 0, \mathbf{F} \cdot \mathbf{n} = -x = 0, \iint_{\sigma_1} (0) dA = 0 \qquad \sigma_2 : x = 1, \mathbf{F} \cdot \mathbf{n} = x = 1, \iint_{\sigma_2} (1) dA = 1$$

$$\sigma_3 : y = 0, \mathbf{F} \cdot \mathbf{n} = -y = 0, \iint_{\sigma_3} (0) dA = 0 \qquad \sigma_4 : y = 1, \mathbf{F} \cdot \mathbf{n} = y = 1, \iint_{\sigma_4} (1) dA = 1$$

$$\sigma_5 : z = 0, \mathbf{F} \cdot \mathbf{n} = -z = 0, \iint_{\sigma_5} (0) dA = 0 \qquad \sigma_6 : z = 1, \mathbf{F} \cdot \mathbf{n} = z = 1, \iint_{\sigma_6} (1) dA = 1$$

$$\iint_{\sigma} \mathbf{F} \cdot \mathbf{n} = 3; \quad \iiint_G \operatorname{div} \mathbf{F} dV = \iiint_G 3 dV = 3$$

2. For any point  $\mathbf{r} = x\mathbf{i} + y\mathbf{j} + z\mathbf{k}$  on  $\sigma$  let  $\mathbf{n} = x\mathbf{i} + y\mathbf{j} + z\mathbf{k}$ ; then  $\mathbf{F} \cdot \mathbf{n} = x^2 + y^2 + z^2 = 1$ , so

$$\iint_{\sigma} \mathbf{F} \cdot \mathbf{n} dS = \iint_{\sigma} dS = 4\pi; \quad \text{also} \quad \iiint_G \operatorname{div} \mathbf{F} dV = \iiint_G 3 dV = 3(4\pi/3) = 4\pi$$

3.  $\sigma_1 : z = 1, \mathbf{n} = \mathbf{k}, \mathbf{F} \cdot \mathbf{n} = z^2 = 1, \iint_{\sigma_1} (1) dS = \pi,$

$$\sigma_2 : \mathbf{n} = 2x\mathbf{i} + 2y\mathbf{j} - \mathbf{k}, \mathbf{F} \cdot \mathbf{n} = 4x^2 - 4x^2y^2 - x^4 - 3y^4,$$

$$\iint_{\sigma_2} \mathbf{F} \cdot \mathbf{n} dS = \int_0^{2\pi} \int_0^1 [4r^2 \cos^2 \theta - 4r^4 \cos^2 \theta \sin^2 \theta - r^4 \cos^4 \theta - 3r^4 \sin^4 \theta] r dr d\theta = \frac{\pi}{3};$$

$$\iint_{\sigma} = \frac{4\pi}{3}$$

$$\iiint_G \operatorname{div} \mathbf{F} dV = \iiint_G (2 + z) dV = \int_0^{2\pi} \int_0^1 \int_{r^2}^1 (2 + z) dz r dr d\theta = 4\pi/3$$

$$4. \quad \sigma_1 : x = 0, \mathbf{F} \cdot \mathbf{n} = -xy = 0, \iint_{\sigma_1} (0) dA = 0 \qquad \sigma_2 : x = 2, \mathbf{F} \cdot \mathbf{n} = xy = 2y, \iint_{\sigma_2} (2y) dA = 8$$

$$\sigma_3 : y = 0, \mathbf{F} \cdot \mathbf{n} = -yz = 0, \iint_{\sigma_3} (0) dA = 0 \qquad \sigma_4 : y = 2, \mathbf{F} \cdot \mathbf{n} = yz = 2z, \iint_{\sigma_4} (2z) dA = 8$$

$$\sigma_5 : z = 0, \mathbf{F} \cdot \mathbf{n} = -xz = 0, \iint_{\sigma_5} (0) dA = 0 \qquad \sigma_6 : z = 2, \mathbf{F} \cdot \mathbf{n} = xz = 2x, \iint_{\sigma_6} (2x) dA = 8$$

$$\iint_{\sigma} \mathbf{F} \cdot \mathbf{n} = 24; \quad \text{also} \quad \iiint_G \operatorname{div} \mathbf{F} dV = \iiint_G (y + z + x) dV = 24$$

5.  $G$  is the rectangular solid;  $\iiint_G \operatorname{div} \mathbf{F} dV = \int_0^2 \int_0^1 \int_0^3 (2x - 1) dx dy dz = 12.$

6.  $G$  is the spherical solid enclosed by  $\sigma$ ;  $\iiint_G \operatorname{div} \mathbf{F} dV = \iiint_G 0 dV = 0 \quad \iint_{\sigma} dV = 0.$

- 7.
- $G$
- is the cylindrical solid;

$$\iiint_G \operatorname{div} \mathbf{F} dV = 3 \iiint_G dV = (3)(\text{volume of cylinder}) = (3)[\pi a^2(1)] = 3\pi a^2.$$

- 8.
- $G$
- is the solid bounded by
- $z = 1 - x^2 - y^2$
- and the
- $xy$
- plane;

$$\iiint_G \operatorname{div} \mathbf{F} dV = 3 \iiint_G dV = 3 \int_0^{2\pi} \int_0^1 \int_0^{1-r^2} r dz dr d\theta = \frac{3\pi}{2}.$$

- 9.
- $G$
- is the cylindrical solid;

$$\iiint_G \operatorname{div} \mathbf{F} dV = 3 \iiint_G (x^2 + y^2 + z^2) dV = 3 \int_0^{2\pi} \int_0^2 \int_0^3 (r^2 + z^2) r dz dr d\theta = 180\pi.$$

- 10.
- $G$
- is the tetrahedron;
- $\iiint_G \operatorname{div} \mathbf{F} dV = \iiint_G x dV = \int_0^1 \int_0^{1-x} \int_0^{1-x-y} x dz dy dx = \frac{1}{24}.$

- 11.
- $G$
- is the hemispherical solid bounded by
- $z = \sqrt{4 - x^2 - y^2}$
- and the
- $xy$
- plane;

$$\iiint_G \operatorname{div} \mathbf{F} dV = 3 \iiint_G (x^2 + y^2 + z^2) dV = 3 \int_0^{2\pi} \int_0^{\pi/2} \int_0^2 \rho^4 \sin \phi d\rho d\phi d\theta = \frac{192\pi}{5}.$$

- 12.
- $G$
- is the hemispherical solid;

$$\iiint_G \operatorname{div} \mathbf{F} dV = 5 \iiint_G z dV = 5 \int_0^{2\pi} \int_0^{\pi/2} \int_0^a \rho^3 \sin \phi \cos \phi d\rho d\phi d\theta = \frac{5\pi a^4}{4}.$$

- 13.
- $G$
- is the conical solid;

$$\iiint_G \operatorname{div} \mathbf{F} dV = 2 \iiint_G (x + y + z) dV = 2 \int_0^{2\pi} \int_0^1 \int_r^1 (r \cos \theta + r \sin \theta + z) r dz dr d\theta = \frac{\pi}{2}.$$

- 14.
- $G$
- is the solid bounded by
- $z = 2x$
- and
- $z = x^2 + y^2$
- ;

$$\iiint_G \operatorname{div} \mathbf{F} dV = \iiint_G dV = 2 \int_0^{\pi/2} \int_0^{2\cos\theta} \int_{r^2}^{2r\cos\theta} r dz dr d\theta = \frac{\pi}{2}.$$

- 15.
- $G$
- is the solid bounded by
- $z = 4 - x^2$
- ,
- $y + z = 5$
- , and the coordinate planes;

$$\iiint_G \operatorname{div} \mathbf{F} dV = 4 \iiint_G x^2 dV = 4 \int_{-2}^2 \int_0^{4-x^2} \int_0^{5-z} x^2 dy dz dx = \frac{4608}{35}.$$

- 16.
- $\iint_{\sigma} \mathbf{F} \cdot \mathbf{n} dS = \iiint_G \operatorname{div} \mathbf{F} dV = \iiint_G 0 dV = 0;$

since the vector field is constant, the same amount enters as leaves.

- 17.
- $\iint_{\sigma} \mathbf{r} \cdot \mathbf{n} dS = \iiint_G \operatorname{div} \mathbf{r} dV = 3 \iiint_G dV = 3\operatorname{vol}(G)$

$$18. \iint_{\sigma} \mathbf{F} \cdot \mathbf{n} \, dS = 3[\pi(3^2)(5)] = 135\pi$$

$$19. \iint_{\sigma} \operatorname{curl} \mathbf{F} \cdot \mathbf{n} \, dS = \iiint_G \operatorname{div}(\operatorname{curl} \mathbf{F}) \, dV = \iiint_G (0) \, dV = 0$$

$$20. \iint_{\sigma} \nabla f \cdot \mathbf{n} \, dS = \iiint_G \operatorname{div}(\nabla f) \, dV = \iiint_G \nabla^2 f \, dV$$

$$21. \iint_{\sigma} (f\nabla g) \cdot \mathbf{n} \, dS = \iiint_G \operatorname{div}(f\nabla g) \, dV = \iiint_G (f\nabla^2 g + \nabla f \cdot \nabla g) \, dV \text{ by Exercise 29, Section 17.1.}$$

$$22. \iint_{\sigma} (f\nabla g) \cdot \mathbf{n} \, dS = \iiint_G (f\nabla^2 g + \nabla f \cdot \nabla g) \, dV \text{ by Exercise 29, Section 17.1;}$$

$$\iint_{\sigma} (g\nabla f) \cdot \mathbf{n} \, dS = \iiint_G (g\nabla^2 f + \nabla g \cdot \nabla f) \, dV \text{ by interchanging } f \text{ and } g;$$

subtract to obtain the result.

23. Let the normal  $\mathbf{n} = n_1\mathbf{i} + n_2\mathbf{j} + n_3\mathbf{k}$ , then we have to show that

$$\iint_{\sigma} (fn_1\mathbf{i} + fn_2\mathbf{j} + fn_3\mathbf{k}) \, dS = \iiint_G (f_x\mathbf{i} + f_y\mathbf{j} + f_z\mathbf{k}) \, dV. \text{ We shall show that}$$

$\iint_{\sigma} fn_1\mathbf{i} \, dS = \iiint_G f_x\mathbf{i} \, dV$ , i.e. that  $\iint_{\sigma} fn_1 \, dS = \iiint_G f_x \, dV$ ; the other parts will follow in a similar manner. Let  $\mathbf{F}(x, y, z) = f(x, y, z)\mathbf{i}$ , then by the Divergence Theorem

$$\iint_{\sigma} fn_1 \, dS = \iint_{\sigma} \mathbf{F} \cdot \mathbf{n} \, dS = \iiint_G \nabla \cdot \mathbf{F} \, dV = \iiint_G f_x \, dV.$$

$$24. \operatorname{div} \mathbf{r} = c \left[ \frac{\partial}{\partial x} \frac{x}{(x^2 + y^2 + z^2)^{3/2}} + \frac{\partial}{\partial y} \frac{y}{(x^2 + y^2 + z^2)^{3/2}} + \frac{\partial}{\partial z} \frac{z}{(x^2 + y^2 + z^2)^{3/2}} \right]$$

$$= c \left[ \frac{(-2x^2 + y^2 + z^2) + (-2y^2 + x^2 + z^2) + (-2z^2 + x^2 + y^2)}{(x^2 + y^2 + z^2)^{5/2}} \right] = 0$$

25. (a) The flux through any cylinder whose axis is the  $z$ -axis is positive by inspection; by the Divergence Theorem, this says that the divergence cannot be negative at the origin, else the flux through a small enough cylinder would also be negative (impossible), hence the divergence at the origin must be  $\geq 0$ .

(b) Similar to Part (a),  $\leq 0$ .

26. (a)  $\mathbf{F} = x\mathbf{i} + y\mathbf{j} + z\mathbf{k}$ ,  $\operatorname{div} \mathbf{F} = 3$

(b)  $\mathbf{F} = -x\mathbf{i} - y\mathbf{j} - z\mathbf{k}$ ,  $\operatorname{div} \mathbf{F} = -3$

27.  $\operatorname{div} \mathbf{F} = 0$ ; no sources or sinks.

28.  $\operatorname{div} \mathbf{F} = y - x$ ; sources where  $y > x$ , sinks where  $y < x$ .

29.  $\operatorname{div} \mathbf{F} = 3x^2 + 3y^2 + 3z^2$ ; sources at all points except the origin, no sinks.



30.  $\operatorname{div} \mathbf{F} = 3(x^2 + y^2 + z^2 - 1)$ ; sources outside the sphere  $x^2 + y^2 + z^2 = 1$ , sinks inside the sphere  $x^2 + y^2 + z^2 = 1$ .
31. Let  $\sigma_1$  be the portion of the paraboloid  $z = 1 - x^2 - y^2$  for  $z \geq 0$ , and  $\sigma_2$  the portion of the plane  $z = 0$  for  $x^2 + y^2 \leq 1$ . Then

$$\begin{aligned} \iint_{\sigma_1} \mathbf{F} \cdot \mathbf{n} \, dS &= \iint_R \mathbf{F} \cdot (2x\mathbf{i} + 2y\mathbf{j} + \mathbf{k}) \, dA \\ &= \int_{-1}^1 \int_{-\sqrt{1-x^2}}^{\sqrt{1-x^2}} (2x[x^2y - (1 - x^2 - y^2)^2] + 2y(y^3 - x) + (2x + 2 - 3x^2 - 3y^2)) \, dy \, dx \\ &= 3\pi/4; \end{aligned}$$

$z = 0$  and  $\mathbf{n} = -\mathbf{k}$  on  $\sigma_2$  so  $\mathbf{F} \cdot \mathbf{n} = 1 - 2x$ ,  $\iint_{\sigma_2} \mathbf{F} \cdot \mathbf{n} \, dS = \iint_{\sigma_2} (1 - 2x) \, dS = \pi$ . Thus

$$\iint_{\sigma} \mathbf{F} \cdot \mathbf{n} \, dS = 3\pi/4 + \pi = 7\pi/4. \text{ But } \operatorname{div} \mathbf{F} = 2xy + 3y^2 + 3 \text{ so}$$

$$\iiint_G \operatorname{div} \mathbf{F} \, dV = \int_{-1}^1 \int_{-\sqrt{1-x^2}}^{\sqrt{1-x^2}} \int_0^{1-x^2-y^2} (2xy + 3y^2 + 3) \, dz \, dy \, dx = 7\pi/4.$$

### EXERCISE SET 17.8

- (a) The flow is independent of  $z$  and has no component in the direction of  $\mathbf{k}$ , and so by inspection the only nonzero component of the curl is in the direction of  $\mathbf{k}$ . However both sides of (9) are zero, as the flow is orthogonal to the curve  $C_a$ . Thus the curl is zero.

(b) Since the flow appears to be tangential to the curve  $C_a$ , it seems that the right hand side of (9) is nonzero, and thus the curl is nonzero, and points in the positive  $z$ -direction.
- (a) The only nonzero vector component of the vector field is in the direction of  $\mathbf{i}$ , and it increases with  $y$  and is independent of  $x$ . Thus the curl of  $F$  is nonzero, and points in the negative  $z$ -direction.

(b) By inspection the vector field is constant, and thus its curl is zero.

3. If  $\sigma$  is oriented with upward normals then  $C$  consists of three parts parametrized as

$$C_1 : \mathbf{r}(t) = (1-t)\mathbf{i} + t\mathbf{j} \text{ for } 0 \leq t \leq 1, \quad C_2 : \mathbf{r}(t) = (1-t)\mathbf{j} + t\mathbf{k} \text{ for } 0 \leq t \leq 1,$$

$$C_3 : \mathbf{r}(t) = t\mathbf{i} + (1-t)\mathbf{k} \text{ for } 0 \leq t \leq 1.$$

$$\int_{C_1} \mathbf{F} \cdot d\mathbf{r} = \int_{C_2} \mathbf{F} \cdot d\mathbf{r} = \int_{C_3} \mathbf{F} \cdot d\mathbf{r} = \int_0^1 (3t-1)dt = \frac{1}{2} \text{ so}$$

$$\oint_C \mathbf{F} \cdot d\mathbf{r} = \frac{1}{2} + \frac{1}{2} + \frac{1}{2} = \frac{3}{2}. \quad \operatorname{curl} \mathbf{F} = \mathbf{i} + \mathbf{j} + \mathbf{k}, \quad z = 1 - x - y, \quad R \text{ is the triangular region in}$$

the  $xy$ -plane enclosed by  $x + y = 1$ ,  $x = 0$ , and  $y = 0$ ;

$$\iint_{\sigma} (\operatorname{curl} \mathbf{F}) \cdot \mathbf{n} \, dS = 3 \iint_R dA = (3)(\text{area of } R) = (3) \left[ \frac{1}{2}(1)(1) \right] = \frac{3}{2}.$$

4. If  $\sigma$  is oriented with upward normals then  $C$  can be parametrized as  $\mathbf{r}(t) = \cos t \mathbf{i} + \sin t \mathbf{j} + \mathbf{k}$  for  $0 \leq t \leq 2\pi$ .

$$\oint_C \mathbf{F} \cdot d\mathbf{r} = \int_0^{2\pi} (\sin^2 t \cos t - \cos^2 t \sin t) dt = 0;$$

$$\text{curl } \mathbf{F} = \mathbf{0} \text{ so } \iint_{\sigma} (\text{curl } \mathbf{F}) \cdot \mathbf{n} dS = \iint_{\sigma} 0 dS = 0.$$

5. If  $\sigma$  is oriented with upward normals then  $C$  can be parametrized as  $\mathbf{r}(t) = a \cos t \mathbf{i} + a \sin t \mathbf{j}$  for  $0 \leq t \leq 2\pi$ .

$$\oint_C \mathbf{F} \cdot d\mathbf{r} = \int_0^{2\pi} 0 dt = 0; \text{ curl } \mathbf{F} = \mathbf{0} \text{ so } \iint_{\sigma} (\text{curl } \mathbf{F}) \cdot \mathbf{n} dS = \iint_{\sigma} 0 dS = 0.$$

6. If  $\sigma$  is oriented with upward normals then  $C$  can be parametrized as  $\mathbf{r}(t) = 3 \cos t \mathbf{i} + 3 \sin t \mathbf{j}$  for  $0 \leq t \leq 2\pi$ .

$$\oint_C \mathbf{F} \cdot d\mathbf{r} = \int_0^{2\pi} (9 \sin^2 t + 9 \cos^2 t) dt = 9 \int_0^{2\pi} dt = 18\pi.$$

$\text{curl } \mathbf{F} = -2\mathbf{i} + 2\mathbf{j} + 2\mathbf{k}$ ,  $R$  is the circular region in the  $xy$ -plane enclosed by  $x^2 + y^2 = 9$ ;

$$\iint_{\sigma} (\text{curl } \mathbf{F}) \cdot \mathbf{n} dS = \iint_R (-4x + 4y + 2) dA = \int_0^{2\pi} \int_0^3 (-4r \cos \theta + 4r \sin \theta + 2)r dr d\theta = 18\pi.$$

7. Take  $\sigma$  as the part of the plane  $z = 0$  for  $x^2 + y^2 \leq 1$  with  $\mathbf{n} = \mathbf{k}$ ;  $\text{curl } \mathbf{F} = -3y^2 \mathbf{i} + 2z \mathbf{j} + 2\mathbf{k}$ ,

$$\iint_{\sigma} (\text{curl } \mathbf{F}) \cdot \mathbf{n} dS = 2 \iint_{\sigma} dS = (2)(\text{area of circle}) = (2)[\pi(1)^2] = 2\pi.$$

8.  $\text{curl } \mathbf{F} = x\mathbf{i} + (x - y)\mathbf{j} + 6xy^2\mathbf{k}$ ;

$$\iint_{\sigma} (\text{curl } \mathbf{F}) \cdot \mathbf{n} dS = \iint_R (x - y - 6xy^2) dA = \int_0^1 \int_0^3 (x - y - 6xy^2) dy dx = -30.$$

9.  $C$  is the boundary of  $R$  and  $\text{curl } \mathbf{F} = 2\mathbf{i} + 3\mathbf{j} + 4\mathbf{k}$ , so

$$\oint_C \mathbf{F} \cdot \mathbf{r} = \iint_R \text{curl } \mathbf{F} \cdot \mathbf{n} dS = \iint_R 4 dA = 4(\text{area of } R) = 16\pi$$

10.  $\text{curl } \mathbf{F} = -4\mathbf{i} - 6\mathbf{j} + 6y\mathbf{k}$ ,  $z = y/2$  oriented with upward normals,  $R$  is the triangular region in the  $xy$ -plane enclosed by  $x + y = 2$ ,  $x = 0$ , and  $y = 0$ ;

$$\iint_{\sigma} (\text{curl } \mathbf{F}) \cdot \mathbf{n} dS = \iint_R (3 + 6y) dA = \int_0^2 \int_0^{2-x} (3 + 6y) dy dx = 14.$$

11.  $\text{curl } \mathbf{F} = x\mathbf{k}$ , take  $\sigma$  as part of the plane  $z = y$  oriented with upward normals,  $R$  is the circular region in the  $xy$ -plane enclosed by  $x^2 + y^2 - y = 0$ ;

$$\iint_{\sigma} (\text{curl } \mathbf{F}) \cdot \mathbf{n} dS = \iint_R x dA = \int_0^{\pi} \int_0^{\sin \theta} r^2 \cos \theta dr d\theta = 0.$$

12.  $\text{curl } \mathbf{F} = -y\mathbf{i} - z\mathbf{j} - x\mathbf{k}$ ,  $z = 1 - x - y$  oriented with upward normals,  $R$  is the triangular region in the  $xy$ -plane enclosed by  $x + y = 1$ ,  $x = 0$  and  $y = 0$ ;

$$\iint_{\sigma} (\text{curl } \mathbf{F}) \cdot \mathbf{n} dS = \iint_R (-y - z - x) dA = - \iint_R dA = -\frac{1}{2}(1)(1) = -\frac{1}{2}.$$

13.  $\text{curl } \mathbf{F} = \mathbf{i} + \mathbf{j} + \mathbf{k}$ , take  $\sigma$  as the part of the plane  $z = 0$  with  $x^2 + y^2 \leq a^2$  and  $\mathbf{n} = \mathbf{k}$ ;

$$\iint_{\sigma} (\text{curl } \mathbf{F}) \cdot \mathbf{n} \, dS = \iint_{\sigma} dS = \text{area of circle} = \pi a^2.$$

14.  $\text{curl } \mathbf{F} = \mathbf{i} + \mathbf{j} + \mathbf{k}$ , take  $\sigma$  as the part of the plane  $z = 1/\sqrt{2}$  with  $x^2 + y^2 \leq 1/2$  and  $\mathbf{n} = \mathbf{k}$ .

$$\iint_{\sigma} (\text{curl } \mathbf{F}) \cdot \mathbf{n} \, dS = \iint_{\sigma} dS = \text{area of circle} = \frac{\pi}{2}.$$

15. (a) Take  $\sigma$  as the part of the plane  $2x + y + 2z = 2$  in the first octant, oriented with downward normals;  $\text{curl } \mathbf{F} = -x\mathbf{i} + (y-1)\mathbf{j} - \mathbf{k}$ ,

$$\begin{aligned} \oint_C \mathbf{F} \cdot \mathbf{T} \, ds &= \iint_{\sigma} (\text{curl } \mathbf{F}) \cdot \mathbf{n} \, dS \\ &= \iint_R \left( x - \frac{1}{2}y + \frac{3}{2} \right) dA = \int_0^1 \int_0^{2-2x} \left( x - \frac{1}{2}y + \frac{3}{2} \right) dy \, dx = \frac{3}{2}. \end{aligned}$$

- (b) At the origin  $\text{curl } \mathbf{F} = -\mathbf{j} - \mathbf{k}$  and with  $\mathbf{n} = \mathbf{k}$ ,  $\text{curl } \mathbf{F}(0, 0, 0) \cdot \mathbf{n} = (-\mathbf{j} - \mathbf{k}) \cdot \mathbf{k} = -1$ .

- (c) The rotation of  $\mathbf{F}$  has its maximum value at the origin about the unit vector in the same direction as  $\text{curl } \mathbf{F}(0, 0, 0)$  so  $\mathbf{n} = -\frac{1}{\sqrt{2}}\mathbf{j} - \frac{1}{\sqrt{2}}\mathbf{k}$ .

16. (a) 
$$\begin{aligned} \text{div}(\text{curl } \mathbf{F}) &= \frac{\partial}{\partial x} \left( \frac{\partial h}{\partial y} - \frac{\partial g}{\partial z} \right) + \frac{\partial}{\partial y} \left( \frac{\partial f}{\partial z} - \frac{\partial h}{\partial x} \right) + \frac{\partial}{\partial z} \left( \frac{\partial g}{\partial x} - \frac{\partial f}{\partial y} \right) \\ &= \frac{\partial^2 h}{\partial x \partial y} - \frac{\partial^2 g}{\partial x \partial z} + \frac{\partial^2 f}{\partial y \partial z} - \frac{\partial^2 h}{\partial y \partial x} + \frac{\partial^2 g}{\partial z \partial x} - \frac{\partial^2 f}{\partial z \partial y} = 0, \end{aligned}$$

assuming equality of mixed second partial derivatives

- (b) By the Divergence Theorem

$$\iint_{\sigma} (\text{curl } \mathbf{F}) \cdot \mathbf{n} \, dS = \iiint_G \text{div}(\text{curl } \mathbf{F}) \, dV = \iiint_G 0 \, dV = 0.$$

- (c) The flux of the curl field through the boundary of a solid is zero.

17. Since  $\oint_C \mathbf{E} \cdot \mathbf{r} \, d\mathbf{r} = \iint_{\sigma} \text{curl } \mathbf{E} \cdot \mathbf{n} \, dS$ , it follows that  $\iint_{\sigma} \text{curl } \mathbf{E} \cdot \mathbf{n} \, dS = - \iint_{\sigma} \frac{\partial \mathbf{B}}{\partial t} \cdot \mathbf{n} \, dS$ . This relationship holds for any volume  $\sigma$ , hence  $\text{curl } \mathbf{E} = -\frac{\partial \mathbf{B}}{\partial t}$ .

18. Parametrize  $C$  by  $x = \cos t, y = \sin t, 0 \leq t \leq 2\pi$ . But  $\mathbf{F} = x^2y\mathbf{i} + (y^3 - x)\mathbf{j} + (2x - 1)\mathbf{k}$  along  $C$  so  $\oint_C \mathbf{F} \cdot d\mathbf{r} = -5\pi/4$ . Since  $\text{curl } \mathbf{F} = (-2z - 2)\mathbf{j} + (-1 - x^2)\mathbf{k}$ ,

$$\begin{aligned} \iint_{\sigma} (\text{curl } \mathbf{F}) \cdot \mathbf{n} \, dS &= \iint_R (\text{curl } \mathbf{F}) \cdot (2x\mathbf{i} + 2y\mathbf{j} + \mathbf{k}) \, dA \\ &= \int_{-1}^1 \int_{-\sqrt{1-x^2}}^{\sqrt{1-x^2}} [2y(2x^2 + 2y^2 - 4) - 1 - x^2] \, dy \, dx = -5\pi/4 \end{aligned}$$

## CHAPTER 17 SUPPLEMENTARY EXERCISES

$$2. \quad (\text{b}) \quad \frac{c}{\|\mathbf{r} - \mathbf{r}_0\|^3}(\mathbf{r} - \mathbf{r}_0) \qquad (\text{c}) \quad c \frac{x\mathbf{i} + y\mathbf{j} + z\mathbf{k}}{\sqrt{x^2 + y^2 + z^2}}$$

$$3. \quad (\text{a}) \quad \int_a^b \left[ f(x(t), y(t)) \frac{dx}{dt} + g(x(t), y(t)) \frac{dy}{dt} \right] dt$$

$$(\text{b}) \quad \int_a^b f(x(t), y(t)) \sqrt{x'(t)^2 + y'(t)^2} dt$$

$$4. \quad (\text{a}) \quad M = \int_C \delta(x, y, z) ds \qquad (\text{b}) \quad L = \int_C ds \qquad (\text{c}) \quad S = \iint_{\sigma} dS$$

$$(\text{d}) \quad A = \oint_C x dy = - \oint_C y dx = \frac{1}{2} \oint_C -y dx + x dy$$

$$11. \quad \iint_{\sigma} f(x, y, z) dS = \iint_R f(x(u, v), y(u, v), z(u, v)) \|\mathbf{r}_u \times \mathbf{r}_v\| du dv$$

$$13. \quad C_1 : (0, 0) \text{ to } (1, 0); x = t, y = 0, 0 \leq t \leq 1$$

$$C_2 : (1, 0) \text{ to } (\cosh t_0, \sinh t_0); x = \cosh t, y = \sinh t, 0 \leq t \leq t_0$$

$$C_3 : (\cosh t_0, \sinh t_0) \text{ to } (0, 0); x = -(\cosh t_0)t, y = -(\sinh t_0)t, -1 \leq t \leq 0$$

$$A = \frac{1}{2} \oint_C -y dx + x dy = \frac{1}{2} \int_0^1 (0) dt + \frac{1}{2} \int_0^{t_0} dt + \frac{1}{2} \int_{-1}^0 (0) dt = \frac{1}{2} t_0$$

$$14. \quad (\text{a}) \quad \mathbf{F}(x, y, z) = \frac{qQ(x\mathbf{i} + y\mathbf{j} + z\mathbf{k})}{4\pi\epsilon_0(x^2 + y^2 + z^2)^{3/2}}$$

$$(\text{b}) \quad \mathbf{F} = \nabla\phi, \text{ where } \phi = -\frac{qQ}{4\pi\epsilon_0(x^2 + y^2 + z^2)^{1/2}}, \text{ so } W = \phi(3, 1, 5) - \phi(3, 0, 0) = \frac{qQ}{4\pi\epsilon_0} \left( \frac{1}{3} - \frac{1}{\sqrt{35}} \right).$$

$$C : x = 3, y = t, z = 5t, 0 \leq t \leq 1; \mathbf{F} \cdot d\mathbf{r} = \frac{qQ[0 + t + 25t] dt}{4\pi\epsilon_0(9 + t^2 + 25t^2)^{3/2}}$$

$$W = \int_0^1 \frac{26qQt dt}{4\pi\epsilon_0(26t^2 + 9)^{3/2}} = \frac{qQ}{4\pi\epsilon_0} \left( \frac{1}{\sqrt{35}} - \frac{1}{3} \right)$$

$$15. \quad (\text{a}) \quad \text{Assume the mass } M \text{ is located at the origin and the mass } m \text{ at } (x, y, z), \text{ then}$$

$$\mathbf{r} = x\mathbf{i} + y\mathbf{j} + z\mathbf{k}, \mathbf{F}(x, y, z) = -\frac{GmM}{(x^2 + y^2 + z^2)^{3/2}}\mathbf{r},$$

$$\begin{aligned} W &= - \int_{t_1}^{t_2} \frac{GmM}{(x^2 + y^2 + z^2)^{3/2}} \left( x \frac{dx}{dt} + y \frac{dy}{dt} + z \frac{dz}{dt} \right) dt \\ &= GmM(x^2 + y^2 + z^2)^{-1/2} \Big|_{t_1}^{t_2} = GmM \left( \frac{1}{r_2} - \frac{1}{r_1} \right) \end{aligned}$$

$$(\text{b}) \quad W = 3.99 \times 10^5 \times 10^3 \left[ \frac{1}{7200} - \frac{1}{7000} \right] \approx -1.597 \times 10^9 \text{ J}$$

16. Let  $g(x, y) = x^2$ , then  $\int_C g \, dy = \iint_R 2x \, dA$ , so  $\bar{x} = \frac{1}{A} \iint_R x \, dA = \frac{1}{2A} \int_C g \, dy = \frac{1}{2A} \int_C x^2 \, dy$ ,

similarly for  $\bar{y}$ .

17.  $\bar{x} = 0$  by symmetry; by Exercise 16,  $\bar{y} = \frac{1}{2A} \int_C y^2 \, dx$ ;  $C_1 : y = 0, -a \leq x \leq a, y^2 \, dx = 0$ ;

$C_2 : x = a \cos \theta, y = a \sin \theta, 0 \leq \theta \leq \pi$ , so

$$\bar{y} = -\frac{1}{2(\pi a^2/2)} \int_0^\pi a^2 \sin^2 \theta (-a \sin \theta) \, d\theta = \frac{4a}{3\pi}$$

18.  $\bar{y} = \bar{x}$  by symmetry; by Exercise 16,  $\bar{x} = \frac{1}{2A} \int_C x^2 \, dy$ ;  $C_1 : y = 0, 0 \leq x \leq a, x^2 \, dy = 0$ ;

$C_2 : x = a \cos \theta, y = a \sin \theta, 0 \leq \theta \leq \pi/2$ ;  $C_3 : x = 0, x^2 \, dy = 0$ ;

$$\bar{x} = \frac{1}{2(\pi a^2/4)} \int_0^{\pi/2} a^2 (\cos^2 \theta) a \cos \theta \, d\theta = \frac{4a}{3\pi}$$

19.  $\bar{y} = 0$  by symmetry;  $\bar{x} = \frac{1}{2A} \int_C x^2 \, dy$ ;  $A = \alpha a^2$ ;  $C_1 : x = t \cos \alpha, y = -t \sin \alpha, 0 \leq t \leq a$ ;

$C_2 : x = a \cos \theta, y = a \sin \theta, -\alpha \leq \theta \leq \alpha$ ;  $C_3 : x = t \cos \alpha$ ,

$y = t \sin \alpha, 0 \leq t \leq a$  (reverse orientation);

$$\begin{aligned} 2A\bar{x} &= -\int_0^a t^2 \cos^2 \alpha \sin \alpha \, dt + \int_{-\alpha}^\alpha a^3 \cos^3 \theta \, d\theta - \int_0^a t^2 \cos^2 \alpha \sin \alpha \, dt, \\ &= -\frac{2a^3}{3} \cos^2 \alpha \sin \alpha + 2a^3 \int_0^\alpha \cos^3 \theta \, d\theta = -\frac{2a^3}{3} \cos^2 \alpha \sin \alpha + \frac{2a^3}{3} \cos^2 \alpha \sin \alpha = \frac{4}{3} a^3 \sin \alpha; \end{aligned}$$

$$\bar{x} = \frac{2a \sin \alpha}{3 \alpha}$$

20.  $A = \int_0^a \left( b - \frac{b}{a^2} x^2 \right) dx = \frac{2ab}{3}$ ,  $C_1 : x = t, y = bt^2/a^2, 0 \leq t \leq a$ ;

$C_2 : x = a - t, y = b, 0 \leq t \leq a, x^2 \, dy = 0$ ;  $C_3 : x = 0, y = b - t, 0 \leq t \leq b, x^2 \, dy = y^2 \, dx = 0$ ;

$$2A\bar{x} = \int_0^a t^2 (2bt/a^2) \, dt = \frac{a^2 b}{2}, \bar{x} = \frac{3a}{8};$$

$$2A\bar{y} = -\int_0^a (bt^2/a^2)^2 \, dt + \int_0^a b^2 \, dt = -\frac{ab^2}{5} + ab^2 = \frac{4ab^2}{5}, \bar{y} = \frac{3b}{5}$$

21. (a)  $\int_C f(x) \, dx + g(y) \, dy = \iint_R \left( \frac{\partial}{\partial x} g(y) - \frac{\partial}{\partial y} f(x) \right) dA = 0$

(b)  $W = \int_C \mathbf{F} \cdot d\mathbf{r} = \int_C f(x) \, dx + g(y) \, dy = 0$ , so the work done by the vector field around any

simple closed curve is zero. The field is conservative.

22. (a) Let  $\mathbf{r} = d \cos \theta \mathbf{i} + d \sin \theta \mathbf{j} + z \mathbf{k}$  in cylindrical coordinates, so

$$\frac{d\mathbf{r}}{dt} = \frac{d\mathbf{r}}{d\theta} \frac{d\theta}{dt} = \omega(-d \sin \theta \mathbf{i} + d \cos \theta \mathbf{j}), \mathbf{v} = \frac{d\mathbf{r}}{dt} = \omega \mathbf{k} \times \mathbf{r} = \boldsymbol{\omega} \times \mathbf{r}.$$

- (b) From Part (a),  $\mathbf{v} = \omega d(-\sin \theta \mathbf{i} + \cos \theta \mathbf{j}) = -\omega y \mathbf{i} + \omega x \mathbf{j}$

- (c) From Part (b),  $\text{curl } \mathbf{v} = 2\omega \mathbf{k} = 2\boldsymbol{\omega}$

- (d) No; from Exercise 32 in Section 17.1, if  $\phi$  were a potential function for  $\mathbf{v}$ , then  $\text{curl } (\nabla \phi) = \text{curl } \mathbf{v} = 0$ , contradicting Part (c) above.

23. Yes; by imagining a normal vector sliding around the surface it is evident that the surface has two sides.

$$\begin{aligned} 24. \quad D_{\mathbf{n}}\phi &= \mathbf{n} \cdot \nabla \phi, \text{ so } \iint_{\sigma} D_{\mathbf{n}}\phi \, dS = \iint_{\sigma} \mathbf{n} \cdot \nabla \phi \, dS = \iiint_G \nabla \cdot (\nabla \phi) \, dV \\ &= \iiint_G \left[ \frac{\partial^2 \phi}{\partial x^2} + \frac{\partial^2 \phi}{\partial y^2} + \frac{\partial^2 \phi}{\partial z^2} \right] \, dV \end{aligned}$$

$$25. \quad \text{By Exercise 24, } \iint_{\sigma} D_{\mathbf{n}}f \, dS = - \iiint_G [f_{xx} + f_{yy} + f_{zz}] \, dV = -6 \iiint_G dV = -6 \text{vol}(G) = -8\pi$$

26. (a)  $f_y - g_x = e^{xy} + xy e^{xy} - e^{xy} - xy e^{xy} = 0$  so the vector field is conservative.

- (b)  $\phi_x = ye^{xy} - 1, \phi = e^{xy} - x + k(x), \phi_y = xe^{xy}$ , let  $k(x) = 0; \phi(x, y) = e^{xy} - x$

$$(c) \quad W = \int_C \mathbf{F} \cdot d\mathbf{r} = \phi(x(8\pi), y(8\pi)) - \phi(x(0), y(0)) = \phi(8\pi, 0) - \phi(0, 0) = -8\pi$$

27. (a) If  $h(x)\mathbf{F}$  is conservative, then  $\frac{\partial}{\partial y}(yh(x)) = \frac{\partial}{\partial x}(-2xh(x))$ , or  $h(x) = -2h(x) - 2xh'(x)$  which has the general solution  $x^3 h(x)^2 = C_1, h(x) = Cx^{-3/2}$ , so  $C \frac{y}{x^{3/2}} \mathbf{i} - C \frac{2}{x^{1/2}} \mathbf{j}$  is conservative, with potential function  $\phi = -2Cy/\sqrt{x}$ .

- (b) If  $g(y)\mathbf{F}(x, y)$  is conservative then  $\frac{\partial}{\partial y}(yg(y)) = \frac{\partial}{\partial x}(-2xg(y))$ , or  $g(y) + yg'(y) = -2g(y)$ , with general solution  $g(y) = C/y^3$ , so  $\mathbf{F} = C \frac{1}{y^2} \mathbf{i} - C \frac{2x}{y^3} \mathbf{j}$  is conservative, with potential function  $Cx/y^2$ .

28. A computation of  $\text{curl } \mathbf{F}$  shows that  $\text{curl } \mathbf{F} = \mathbf{0}$  if and only if the three given equations hold. Moreover the equations hold if  $\mathbf{F}$  is conservative, so it remains to show that  $\mathbf{F}$  is conservative if  $\text{curl } \mathbf{F} = \mathbf{0}$ . Let  $C$  be any simple closed curve in the region. Since the region is simply connected, there is a piecewise smooth, oriented surface  $\sigma$  in the region with boundary  $C$ . By Stokes' Theorem,

$$\oint_C \mathbf{F} \cdot d\mathbf{r} = \iint_{\sigma} (\text{curl } \mathbf{F}) \cdot \mathbf{n} \, dS = \iint_{\sigma} \mathbf{0} \, dS = 0.$$

By the 3-space analog of Theorem 17.3.2,  $\mathbf{F}$  is conservative.

29. (a) conservative,  $\phi(x, y, z) = xz^2 - e^{-y}$       (b) not conservative,  $f_y \neq g_x$  (for example)

30. (a) conservative,  $\phi(x, y, z) = -\cos x + yz$       (b) not conservative,  $f_z \neq h_x$

## CHAPTER 17 HORIZON MODULE

1. (a) If  $\mathbf{r} = x\mathbf{i} + y\mathbf{j}$  denotes the position vector, then  $\mathbf{F}_1 \cdot \mathbf{r} = 0$  by inspection, so the velocity field is tangent to the circle. The relationship  $\mathbf{F}_1 \times \mathbf{r} = -\frac{k}{2\pi}\mathbf{k}$  indicates that  $\mathbf{r}, \mathbf{F}_1, \mathbf{k}$  is a right-handed system, so the flow is counterclockwise. The polar form  $\mathbf{F}_1 = -\frac{k}{2\pi r}(\sin\theta\mathbf{i} - \cos\theta\mathbf{j})$  shows that the speed is the constant  $\frac{k}{2\pi r}$  on a circle of radius  $r$ ; and it also shows that the speed is proportional to  $\frac{1}{r}$  with constant of proportionality  $2k\pi$ .
- (b) Since  $\|\mathbf{F}_1\| = \frac{k}{2\pi r}$ , when  $r = 1$  we get  $k = 2\pi\|\mathbf{F}_1\|$

2.

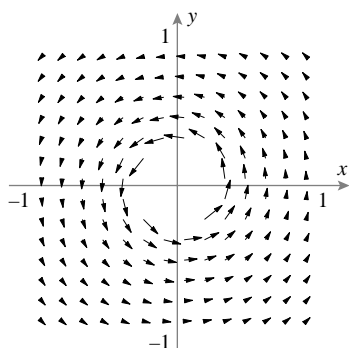

3. (a)  $\mathbf{F}_2 = -\frac{q}{2\pi\|\mathbf{r}\|^2}\mathbf{r}$  so  $\mathbf{F}_2$  is directed toward the origin, and  $\|\mathbf{F}_2\| = \frac{q}{2\pi r}$  is constant for constant  $r$ , and the speed is proportional to the distance from the origin (constant of proportionality  $\frac{q}{2\pi}$ ). Since the velocity vector is directed toward the origin, the fluid flows towards the origin, which must therefore be a sink.
- (b) From Part (a) when  $r = 1$ ,  $q = 2\pi\|\mathbf{F}_2\|$ .

4.

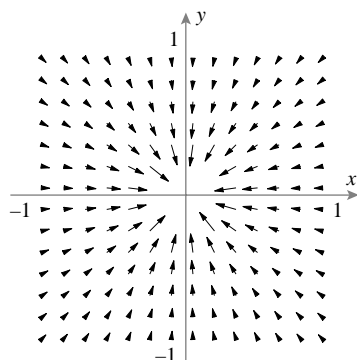

5. (b) The magnitudes of the field vectors increase, and their directions become more tangent to circles about the origin.
- (c) The magnitudes of the field vectors increase, and their directions tend more towards the origin.

6. (a) The inward component is  $\mathbf{F}_2$ , so at  $r = 20$ ,  $15 = \|\mathbf{F}_2\| = \frac{q}{2\pi(20)}$ , so  $q = 600\pi$ ; the tangential component is  $\mathbf{F}_1$ , so at  $r = 20$ ,  $45 = \|\mathbf{F}_1\| = \frac{k}{2\pi(20)}$ , so  $k = 1800\pi$ .

(b)  $\mathbf{F} = -\frac{1}{x^2 + y^2} [(300x + 900y)\mathbf{i} + (300y - 900x)\mathbf{j}]$

(c)  $\|\mathbf{F}\| = \frac{300\sqrt{10}}{r} \leq 5 \text{ km/hr if } r \geq 60\sqrt{10} \approx 189.7 \text{ km.}$

7.  $\mathbf{F} = -\frac{1}{2\pi r} [(q \cos \theta + k \sin \theta)\mathbf{i} + (q \sin \theta - k \cos \theta)\mathbf{j}] = -\frac{q}{2\pi r} \mathbf{u}_r + \frac{k}{2\pi r} \mathbf{u}_\theta = -\frac{1}{2\pi r} (q\mathbf{u}_r - k\mathbf{u}_\theta)$

8.  $\mathbf{F} \cdot \nabla \psi = -\frac{1}{2\pi r} (q\mathbf{u}_r - k\mathbf{u}_\theta) \cdot (-\frac{1}{2\pi} (k\mathbf{u}_r + q\mathbf{u}_\theta)) = \frac{1}{(2\pi r)^2} (qk - kq) = 0$ , since  $\mathbf{u}_r$  and  $\mathbf{u}_\theta$  are unit orthogonal vectors.

9. From the hypotheses of Exercise 8,  $\psi = -\frac{1}{2\pi} k \ln r + \alpha(\theta)$ ,  $\frac{\partial}{\partial \theta} \psi = \alpha'(\theta) = -\frac{q}{2\pi}$ ,

$$\alpha = -\frac{q}{2\pi} \theta, \psi = -\frac{1}{2\pi} (k \ln r + q\theta)$$

10. The streamline  $\psi = c$  becomes  $k \ln r + q\theta = -2\pi c$ ,  $\ln r = -q\theta/k - 2\pi c/k$ ,  
 $r = e^{-q\theta/k} e^{-2\pi c/k} = \kappa e^{-q\theta}$ , where  $\kappa > 0$ .

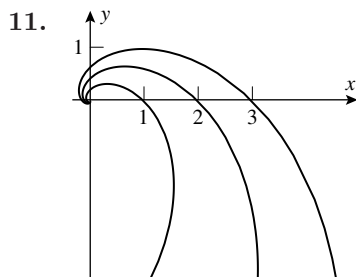

12.  $q = 600\pi$ ,  $k = 1800\pi$ ,  $r = \kappa e^{-\theta/3}$ ; at  $r = 20$ ,  $\theta = \pi/4$ ,  $\kappa = r e^{\theta/3} = 20 e^{\pi/12} \approx 25.985$ ; the desired streamline has the polar equation  $r = 25.985 e^{-\theta/3}$ .

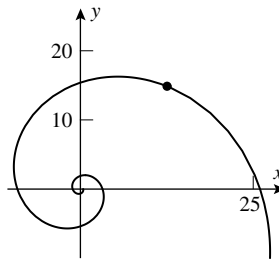



## APPENDIX A

# Real Numbers, Intervals, and Inequalities

### EXERCISE SET A

1. (a) rational (b) integer, rational (c) integer, rational  
 (d) rational (e) integer, rational (f) irrational  
 (g) rational (h) integer, rational
2. (a) irrational (b) rational (c) rational (d) rational
3. (a)  $x = 0.123123123\dots$ ,  $1000x = 123 + x$ ,  $x = 123/999 = 41/333$   
 (b)  $x = 12.7777\dots$ ,  $10(x - 12) = 7 + (x - 12)$ ,  $9x = 115$ ,  $x = 115/9$   
 (c)  $x = 38.07818181\dots$ ,  $100x = 3807.81818181\dots$ ,  $99x = 100x - x = 3769.74$ ,  
 $x = \frac{3769.74}{99} = \frac{376974}{9900} = \frac{20943}{550}$   
 (d)  $\frac{4296}{10000}$
4.  $x = 0.99999\dots$ ,  $10x = 9 + x$ ,  $9x = 9$ ,  $x = 1$
5. (a) If  $r$  is the radius, then  $D = 2r$  so  $\left(\frac{8}{9}D\right)^2 = \left(\frac{16}{9}r\right)^2 = \frac{256}{81}r^2$ . The area of a circle of radius  $r$  is  $\pi r^2$  so  $256/81$  was the approximation used for  $\pi$ .  
 (b)  $22/7 \approx 3.1429$  is better than  $256/81 \approx 3.1605$ .
6. (a)  $\frac{223}{71} < \frac{333}{106} < \frac{63}{25} \left(\frac{17 + 15\sqrt{5}}{7 + 15\sqrt{5}}\right) < \frac{355}{113} < \frac{22}{7}$   
 (b) Ramanujan's (c) Athoniszoon's (d) Ramanujan's
7. 

Line	2	3	4	5	6	7
Blocks	3, 4	1, 2	3, 4	2, 4, 5	1, 2	3, 4
8. 

Line	1	2	3	4	5
Blocks	all blocks	none	2, 4	2	2, 3
9. (a) always correct (add  $-3$  to both sides of  $a \leq b$ )  
 (b) not always correct (correct only if  $a = b$ )  
 (c) not always correct (correct only if  $a = b$ )  
 (d) always correct (multiply both sides of  $a \leq b$  by  $6$ )  
 (e) not always correct (correct only if  $a \geq 0$ )  
 (f) always correct (multiply both sides of  $a \leq b$  by the nonnegative quantity  $a^2$ )
10. (a) always correct  
 (b) not always correct (for example let  $a = b = 0$ ,  $c = 1$ ,  $d = 2$ )  
 (c) not always correct (for example let  $a = 1$ ,  $b = 2$ ,  $c = d = 0$ )
11. (a) all values because  $a = a$  is always valid (b) none
12.  $a = b$ , because if  $a \neq b$  then  $a < b$  and  $b < a$  are contradictory

13. (a) yes, because  $a \leq b$  is true if  $a < b$  (b) no, because  $a < b$  is false if  $a = b$  is true
14. (a)  $x^2 - 5x = 0$ ,  $x(x - 5) = 0$  so  $x = 0$  or  $x = 5$   
 (b)  $-1, 0, 1, 2$  are the only integers that satisfy  $-2 < x < 3$
15. (a)  $\{x : x \text{ is a positive odd integer}\}$  (b)  $\{x : x \text{ is an even integer}\}$   
 (c)  $\{x : x \text{ is irrational}\}$  (d)  $\{x : x \text{ is an integer and } 7 \leq x \leq 10\}$
16. (a) not equal to  $A$  because  $0$  is not in  $A$  (b) equal to  $A$   
 (c) equal to  $A$  because  $(x - 3)(x^2 - 3x + 2) = 0$ ,  $(x - 3)(x - 2)(x - 1) = 0$  so  $x = 1, 2$ , or  $3$
17. (a) false, there are points inside the triangle that are not inside the circle  
 (b) true, all points inside the triangle are also inside the square  
 (c) true (d) false (e) true  
 (f) true,  $a$  is inside the circle (g) true

18. (a)  $\emptyset, \{a_1\}, \{a_2\}, \{a_3\}, \{a_1, a_2\}, \{a_1, a_3\}, \{a_2, a_3\}, \{a_1, a_2, a_3\}$  (b)  $\emptyset$

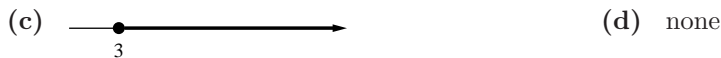
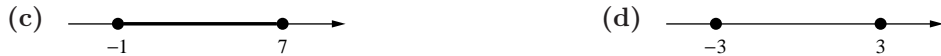

21. (a)  $[-2, 2]$  (b)  $(-\infty, -2) \cup (2, +\infty)$



23.  $3x < 10; (-\infty, 10/3)$

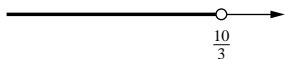

24.  $\frac{1}{5}x \geq 8; [40, +\infty)$

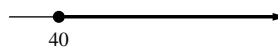

25.  $2x \leq -11; (-\infty, -11/2]$

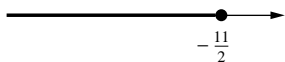

26.  $9x < -10; (-\infty, -10/9)$

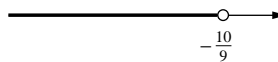

27.  $2x \leq 1$  and  $2x > -3; (-3/2, 1/2]$

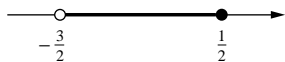

28.  $8x \geq 5$  and  $8x \leq 14; [5/8, 7/4]$

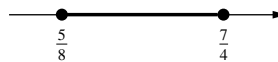

29.  $\frac{x}{x-3} - 4 < 0, \frac{12-3x}{x-3} < 0, \frac{4-x}{x-3} < 0;$   
 $(-\infty, 3) \cup (4, +\infty)$

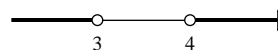
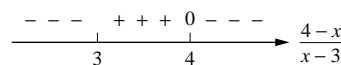
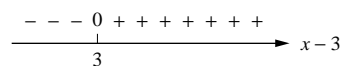
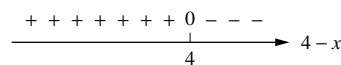

30.  $\frac{x}{8-x} + 2 = \frac{16-x}{8-x} \geq 0;$   
 $(-\infty, 8) \cup [16, +\infty)$

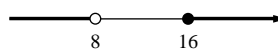
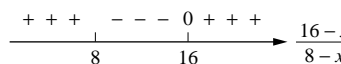
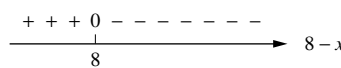
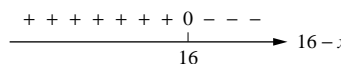

31.  $\frac{3x+1}{x-2} - 1 = \frac{2x+3}{x-2} < 0, \frac{x+3/2}{x-2} < 0;$   
 $(-\frac{3}{2}, 2)$

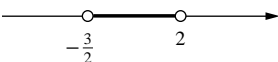
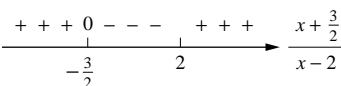
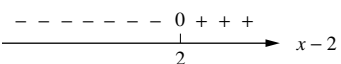
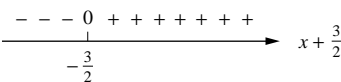

32.  $\frac{x/2 - 3}{4 + x} - 1 > 0, \frac{x - 6}{4 + x} - 2 > 0, \frac{x + 14}{x + 4} < 0;$   
 $(-14, -4)$

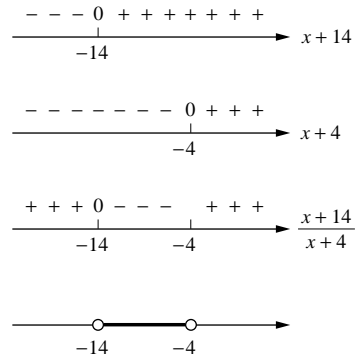

33.  $\frac{4}{2 - x} - 1 = \frac{x + 2}{2 - x} \leq 0; (-\infty, -2] \cup (2, +\infty)$

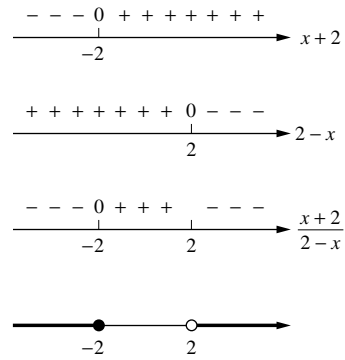

34.  $\frac{3}{x - 5} - 2 = \frac{13 - 2x}{x - 5} \leq 0, \frac{13/2 - x}{x - 5} \leq 0;$   
 $(-\infty, 5) \cup [\frac{13}{2}, +\infty)$

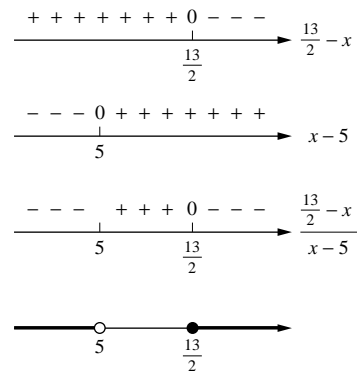

35.  $x^2 - 9 = (x + 3)(x - 3) > 0;$   
 $(-\infty, -3) \cup (3, +\infty)$

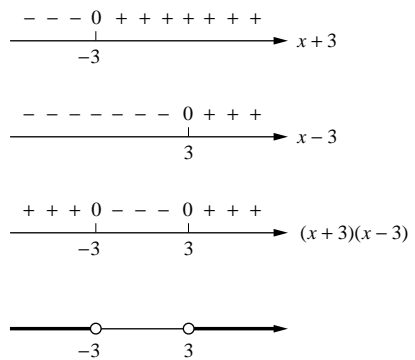

36.  $x^2 - 5 = (x - \sqrt{5})(x + \sqrt{5}) \leq 0; [-\sqrt{5}, \sqrt{5}]$

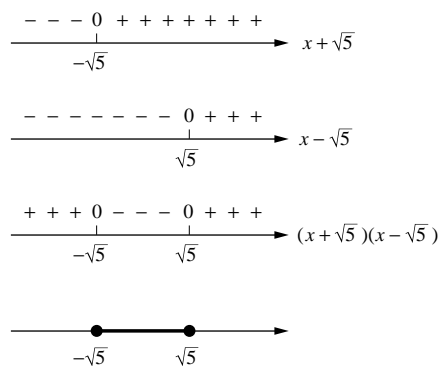

37.  $(x - 4)(x + 2) > 0; (-\infty, -2) \cup (4, +\infty)$

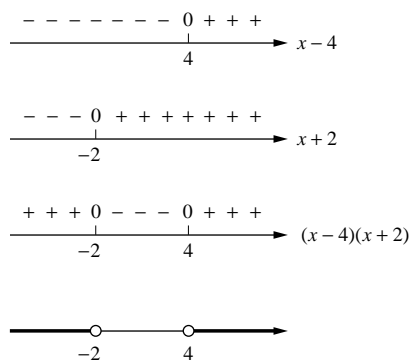

38.  $(x - 3)(x + 4) < 0; (-4, 3)$

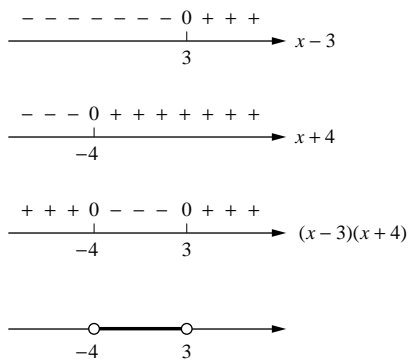

39.  $(x - 4)(x - 5) \leq 0; [4, 5]$

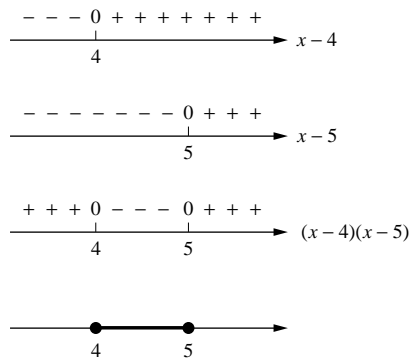

40.  $(x - 2)(x - 1) \geq 0; (-\infty, 1] \cup [2, +\infty)$

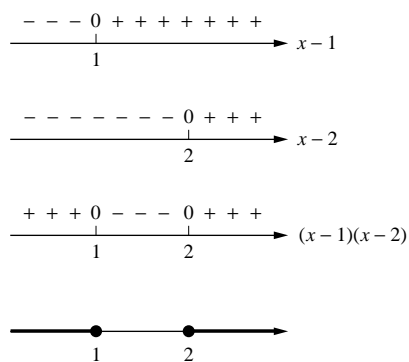

$$41. \frac{3}{x-4} - \frac{2}{x} = \frac{x+8}{x(x-4)} > 0; (-8, 0) \cup (4, +\infty)$$

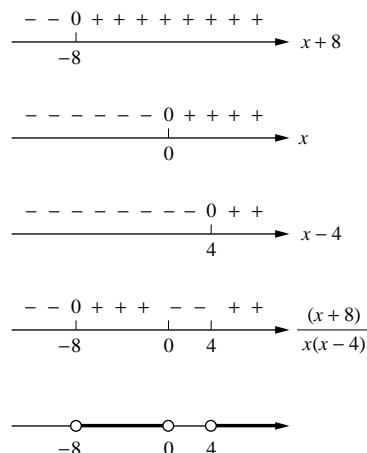

$$42. \frac{1}{x+1} - \frac{3}{x-2} = \frac{-2x-5}{(x+1)(x-2)} \geq 0,$$

$$\frac{x+5/2}{(x+1)(x-2)} \leq 0;$$

$$(-\infty, -\frac{5}{2}] \cup (-1, 2)$$

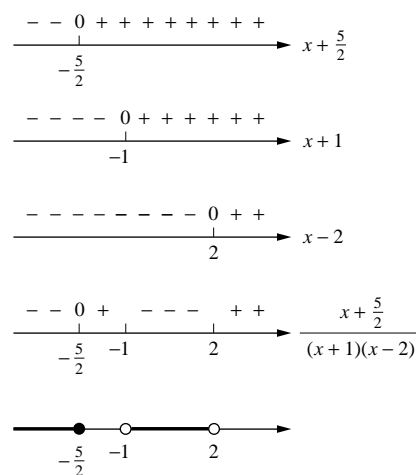

43. By trial-and-error we find that  $x = 2$  is a root of the equation  $x^3 - x^2 - x - 2 = 0$  so  $x - 2$  is a factor of  $x^3 - x^2 - x - 2$ . By long division we find that  $x^2 + x + 1$  is another factor so  $x^3 - x^2 - x - 2 = (x - 2)(x^2 + x + 1)$ . The linear factors of  $x^2 + x + 1$  can be determined by first finding the roots of  $x^2 + x + 1 = 0$  by the quadratic formula. These roots are complex numbers so  $x^2 + x + 1 \neq 0$  for all real  $x$ ; thus  $x^2 + x + 1$  must be always positive or always negative. Since  $x^2 + x + 1$  is positive when  $x = 0$ , it follows that  $x^2 + x + 1 > 0$  for all real  $x$ . Hence  $x^3 - x^2 - x - 2 > 0$ ,  $(x - 2)(x^2 + x + 1) > 0$ ,  $x - 2 > 0$ ,  $x > 2$ , so  $S = (2, +\infty)$ .

44. By trial-and-error we find that  $x = 1$  is a root of the equation  $x^3 - 3x + 2 = 0$  so  $x - 1$  is a factor of  $x^3 - 3x + 2$ . By long division we find that  $x^2 + x - 2$  is another factor so  $x^3 - 3x + 2 = (x - 1)(x^2 + x - 2) = (x - 1)(x - 1)(x + 2) = (x - 1)^2(x + 2)$ . Therefore we want to solve  $(x - 1)^2(x + 2) \leq 0$ . Now if  $x \neq 1$ , then  $(x - 1)^2 > 0$  and so  $x + 2 \leq 0$ ,  $x \leq -2$ . By inspection,  $x = 1$  is also a solution so  $S = (-\infty, -2] \cup \{1\}$ .

45.  $\sqrt{x^2 + x - 6}$  is real if  $x^2 + x - 6 \geq 0$ . Factor to get  $(x + 3)(x - 2) \geq 0$  which has as its solution  $x \leq -3$  or  $x \geq 2$ .

$$46. \frac{x+2}{x-1} \geq 0; (-\infty, -2] \cup (1, +\infty)$$

$$47. 25 \leq \frac{5}{9}(F - 32) \leq 40, 45 \leq F - 32 \leq 72, 77 \leq F \leq 104$$

48. (a)  $n = 2k$ ,  $n^2 = 4k^2 = 2(2k^2)$  where  $2k^2$  is an integer.

(b)  $n = 2k + 1$ ,  $n^2 = 4k^2 + 4k + 1 = 2(2k^2 + 2k) + 1$  where  $2k^2 + 2k$  is an integer.

49. (a) Assume  $m$  and  $n$  are rational, then  $m = \frac{p}{q}$  and  $n = \frac{r}{s}$  where  $p, q, r,$  and  $s$  are integers so  $m + n = \frac{p}{q} + \frac{r}{s} = \frac{ps + rq}{qs}$  which is rational because  $ps + rq$  and  $qs$  are integers.
- (b) (proof by contradiction) Assume  $m$  is rational and  $n$  is irrational, then  $m = \frac{p}{q}$  where  $p$  and  $q$  are integers. Suppose that  $m + n$  is rational, then  $m + n = \frac{r}{s}$  where  $r$  and  $s$  are integers so  $n = \frac{r}{s} - m = \frac{r}{s} - \frac{p}{q} = \frac{rq - ps}{sq}$ . But  $rq - ps$  and  $sq$  are integers, so  $n$  is rational which contradicts the assumption that  $n$  is irrational.
50. (a) Assume  $m$  and  $n$  are rational, then  $m = \frac{p}{q}$  and  $n = \frac{r}{s}$  where  $p, q, r,$  and  $s$  are integers so  $mn = \frac{p}{q} \cdot \frac{r}{s} = \frac{pr}{qs}$  which is rational because  $pr$  and  $qs$  are integers.
- (b) (proof by contradiction) Assume  $m$  is rational and nonzero and that  $n$  is irrational, then  $m = \frac{p}{q}$  where  $p$  and  $q$  are integers and  $p \neq 0$ . Suppose that  $mn$  is rational, then  $mn = \frac{r}{s}$  where  $r$  and  $s$  are integers so  $n = \frac{r/s}{m} = \frac{r/s}{p/q} = \frac{rq}{ps}$ . But  $rq$  and  $ps$  are integers, so  $n$  is rational which contradicts the assumption that  $n$  is irrational.
51.  $a = \sqrt{2}, b = \sqrt{3}, c = \sqrt{6}, d = -\sqrt{2}$  are irrational, and  $a + d = 0$ , a rational;  $a + a = 2\sqrt{2}$ , an irrational;  $ad = -2$ , a rational; and  $ab = c$ , an irrational.
52. (a) irrational (Exercise 49(b)) (b) irrational (Exercise 50(b))  
 (c) rational by inspection; Exercise 51 gives no information  
 (d)  $\sqrt{\pi}$  must be irrational, for if it were rational, then so would be  $\pi = (\sqrt{\pi})^2$  by Exercise 50(a); but  $\pi$  is known to be irrational.
53. The average of  $a$  and  $b$  is  $\frac{1}{2}(a + b)$ ; if  $a$  and  $b$  are rational then so is the average, by Exercise 49(a) and Exercise 50(a). On the other hand if  $a = b = \sqrt{2}$  then the average of  $a$  and  $b$  is irrational, but the average of  $a$  and  $-b$  is rational.
54. If  $10^x = 3$ , then  $x > 0$  because  $10^x \leq 1$  for  $x \leq 0$ . If  $10^{p/q} = 3$  with  $p, q$  integers, then  $10^p = 3^q$ , so  $3^q$  must be even (as well as  $10^p$  odd), a contradiction to Exercise 48(b).
55.  $8x^3 - 4x^2 - 2x + 1$  can be factored by grouping terms:  
 $(8x^3 - 4x^2) - (2x - 1) = 4x^2(2x - 1) - (2x - 1) = (2x - 1)(4x^2 - 1) = (2x - 1)^2(2x + 1)$ . The problem, then, is to solve  $(2x - 1)^2(2x + 1) < 0$ . By inspection,  $x = 1/2$  is not a solution. If  $x \neq 1/2$ , then  $(2x - 1)^2 > 0$  and it follows that  $2x + 1 < 0$ ,  $2x < -1$ ,  $x < -1/2$ , so  $S = (-\infty, -1/2)$ .
56. First, rewrite the inequality as  $12x^3 - 20x^2 + 11x - 2 \geq 0$ . Now, if a polynomial in  $x$  with integer coefficients has a rational zero  $\frac{p}{q}$ , then  $p$  will be a factor of the constant term and  $q$  will be a factor of the coefficient of the highest power of  $x$ . By trial-and-error we find that  $x = 1/2$  is a zero, thus  $(x - 1/2)$  is a factor so
- $$\begin{aligned} 12x^3 - 20x^2 + 11x - 2 &= (x - 1/2)(12x^2 - 14x + 4) \\ &= 2(x - 1/2)(6x^2 - 7x + 2) \\ &= 2(x - 1/2)(2x - 1)(3x - 2) = (2x - 1)^2(3x - 2). \end{aligned}$$
- Now to solve  $(2x - 1)^2(3x - 2) \geq 0$  we first note that  $x = 1/2$  is a solution. If  $x \neq 1/2$  then  $(2x - 1)^2 > 0$  and  $3x - 2 \geq 0$ ,  $3x \geq 2$ ,  $x \geq 2/3$  so  $S = [2/3, +\infty) \cup \{1/2\}$ .
57. If  $a < b$ , then  $ac < bc$  because  $c$  is positive; if  $c < d$ , then  $bc < bd$  because  $b$  is positive, so  $ac < bd$  (Theorem A.1(a)).
58. no, since the decimal representation is not repeating (the string of zeros does not have constant length)





21.  $|9x| - 11 = x$

Case 2:

$$\begin{array}{ll} 9x - 11 = x & -9x - 11 = x \\ 8x = 11 & -10x = 11 \\ x = 11/8 & x = -11/10 \end{array}$$

23.  $\left| \frac{x+5}{2-x} \right| = 6$

Case 1:

$$\frac{x+5}{2-x} = 6$$

$$x+5 = 12 - 6x$$

$$7x = 7$$

$$x = 1$$

Case 2:

$$\frac{x+5}{2-x} = -6$$

$$x+5 = -12 + 6x$$

$$-5x = -17$$

$$x = 17/5$$

25.  $|x+6| < 3$

$$-3 < x+6 < 3$$

$$-9 < x < -3$$

$$S = (-9, -3)$$

27.  $|2x-3| \leq 6$

$$-6 \leq 2x-3 \leq 6$$

$$-3 \leq 2x \leq 9$$

$$-3/2 \leq x \leq 9/2$$

$$S = [-3/2, 9/2]$$

29.  $|x+2| > 1$

Case 1:

$$x+2 > 1$$

$$x > -1$$

$$S = (-\infty, -3) \cup (-1, +\infty)$$

Case 2:

$$x+2 < -1$$

$$x < -3$$

22.  $2x-7 = |x+1|$

Case 1:

$$2x-7 = x+1$$

$$x = 8$$

Case 2:

$$2x-7 = -(x+1)$$

$$3x = 6$$

$$x = 2; \text{ not a solution}$$

because  $x$  must also satisfy  $x < -1$

24.  $\left| \frac{x-3}{x+4} \right| = 5$

Case 1:

$$\frac{x-3}{x+4} = 5$$

$$x-3 = 5x+20$$

$$-4x = 23$$

$$x = -23/4$$

Case 2:

$$\frac{x-3}{x+4} = -5$$

$$x-3 = -5x-20$$

$$6x = -17$$

$$x = -17/6$$

26.  $|7-x| \leq 5$

$$-5 \leq 7-x \leq 5$$

$$-12 \leq -x \leq -2$$

$$12 \geq x \geq 2$$

$$S = [2, 12]$$

28.  $|3x+1| < 4$

$$-4 < 3x+1 < 4$$

$$-5 < 3x < 3$$

$$-5/3 < x < 1$$

$$S = (-5/3, 1)$$

30.  $\left| \frac{1}{2}x - 1 \right| \geq 2$

Case 1:

$$\frac{1}{2}x - 1 \geq 2$$

$$\frac{1}{2}x \geq 3$$

$$x \geq 6$$

Case 2:

$$\frac{1}{2}x - 1 \leq -2$$

$$\frac{1}{2}x \leq -1$$

$$x \leq -2$$

$$S = (-\infty, -2] \cup [6, +\infty)$$

31.  $|5-2x| \geq 4$

Case 1:

$$5-2x \geq 4$$

$$-2x \geq -1$$

$$x \leq 1/2$$

$$S = (-\infty, 1/2] \cup [9/2, +\infty)$$

Case 2:

$$5-2x \leq -4$$

$$-2x \leq -9$$

$$x \geq 9/2$$

32.  $|7x+1| > 3$

Case 1:

$$7x+1 > 3$$

$$7x > 2$$

$$x > 2/7$$

Case 2:

$$7x+1 < -3$$

$$7x < -4$$

$$x < -4/7$$

$$S = (-\infty, -4/7) \cup (2/7, +\infty)$$

$$33. \quad \frac{1}{|x-1|} < 2, x \neq 1$$

$$|x-1| > 1/2$$

Case 1:      Case 2:

$$x-1 > 1/2 \quad x-1 < -1/2$$

$$x > 3/2 \quad x < 1/2$$

$$S = (-\infty, 1/2) \cup (3/2, +\infty)$$

$$34. \quad \frac{1}{|3x+1|} \geq 5, x \neq -1/3$$

$$|3x+1| \leq 1/5$$

$$-1/5 \leq 3x+1 \leq 1/5$$

$$-6/5 \leq 3x \leq -4/5$$

$$-2/5 \leq x \leq -4/15$$

$$S = [-2/5, -1/3) \cup (-1/3, -4/15]$$

$$35. \quad \frac{3}{|2x-1|} \geq 4, x \neq 1/2$$

$$\frac{|2x-1|}{3} \leq \frac{1}{4}$$

$$|2x-1| \leq 3/4$$

$$-3/4 \leq 2x-1 \leq 3/4$$

$$1/4 \leq 2x \leq 7/4$$

$$1/8 \leq x \leq 7/8$$

$$S = [1/8, 1/2) \cup (1/2, 7/8]$$

$$36. \quad \frac{2}{|x+3|} < 1, x \neq -3$$

$$\frac{|x+3|}{2} > 1$$

$$|x+3| > 2$$

Case 1:      Case 2:

$$x+3 > 2 \quad x+3 < -2$$

$$x > -1 \quad x < -5$$

$$S = (-\infty, -5) \cup (-1, +\infty)$$

37.  $\sqrt{(x^2 - 5x + 6)^2} = x^2 - 5x + 6$  if  $x^2 - 5x + 6 \geq 0$  or, equivalently, if  $(x-2)(x-3) \geq 0$ ;  
 $x \in (-\infty, 2] \cup [3, +\infty)$ .

38. If  $x \geq 2$  then  $3 \leq x-2 \leq 7$  so  $5 \leq x \leq 9$ ; if  $x < 2$  then  $3 \leq 2-x \leq 7$  so  $-5 \leq x \leq -1$ .  
 $S = [-5, -1] \cup [5, 9]$ .

39. If  $u = |x-3|$  then  $u^2 - 4u = 12$ ,  $u^2 - 4u - 12 = 0$ ,  $(u-6)(u+2) = 0$ , so  $u = 6$  or  $u = -2$ . If  $u = 6$  then  $|x-3| = 6$ , so  $x = 9$  or  $x = -3$ . If  $u = -2$  then  $|x-3| = -2$  which is impossible. The solutions are  $-3$  and  $9$ .

41.  $|a-b| = |a+(-b)|$   
 $\leq |a| + |-b|$  (triangle inequality)  
 $= |a| + |b|$ .

42.  $a = (a-b) + b$   
 $|a| = |(a-b) + b|$   
 $|a| \leq |a-b| + |b|$  (triangle inequality)  
 $|a| - |b| \leq |a-b|$ .

43. From Exercise 42

(i)  $|a| - |b| \leq |a-b|$ ; but  $|b| - |a| \leq |b-a| = |a-b|$ , so (ii)  $|a| - |b| \geq -|a-b|$ .

Combining (i) and (ii):  $-|a-b| \leq |a| - |b| \leq |a-b|$ , so  $||a| - |b|| \leq |a-b|$ .

# APPENDIX C

## Coordinate Planes and Lines

### EXERCISE SET C

1.

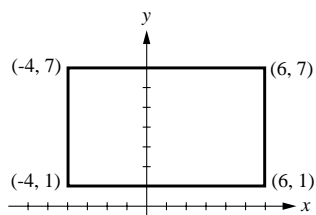

2.  $\text{area} = \frac{1}{2}bh = \frac{1}{2}(5 - (-3))(1) = 4$

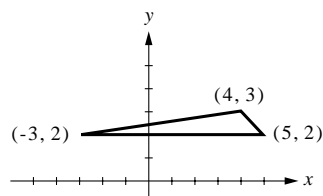

3. (a)  $x = 2$

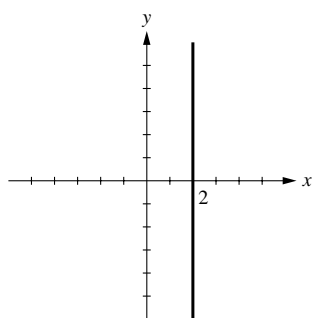

(b)  $y = -3$

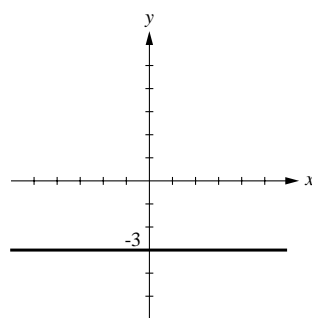

(c)  $x \geq 0$

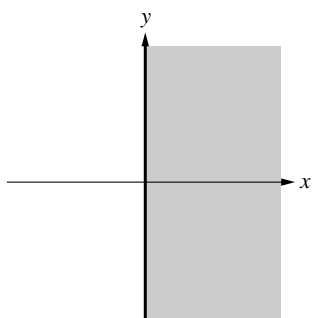

(d)  $y = x$

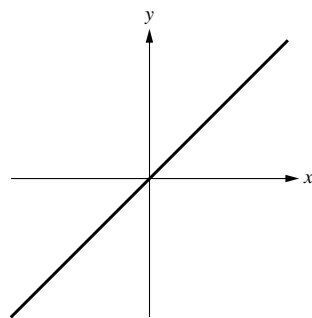

(e)  $y \geq x$

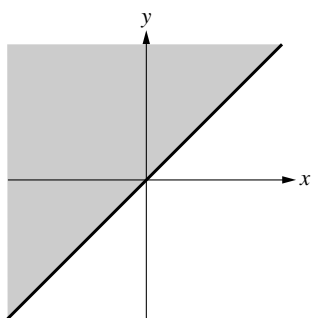

(f)  $|x| \geq 1$

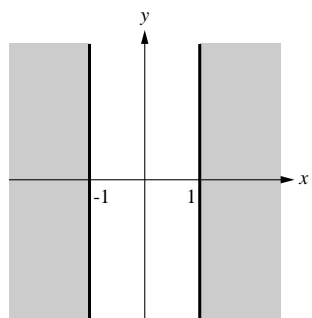

4. (a)  $x = 0$

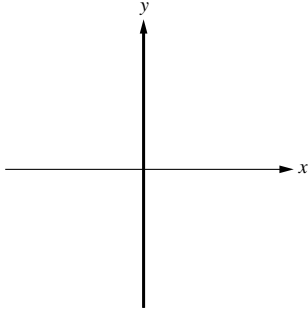

(b)  $y = 0$

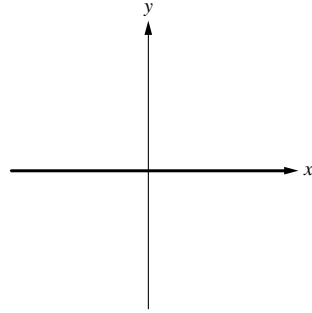

(c)  $y < 0$

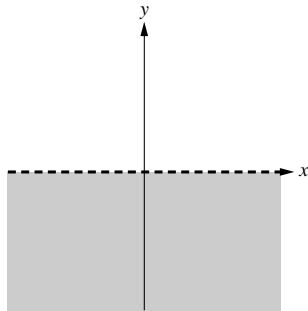

(d)  $x \geq 1$  and  $y \leq 2$

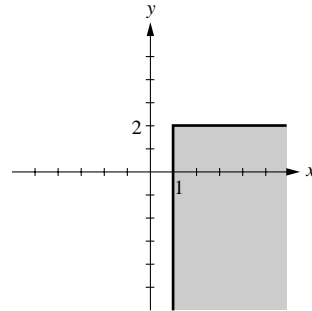

(e)  $x = 3$

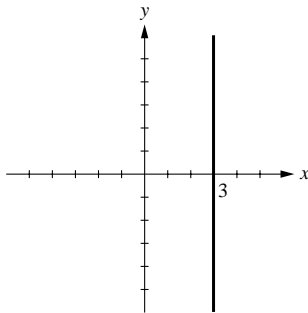

(f)  $|x| = 5$

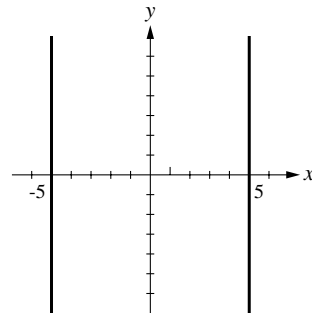

5.  $y = 4 - x^2$

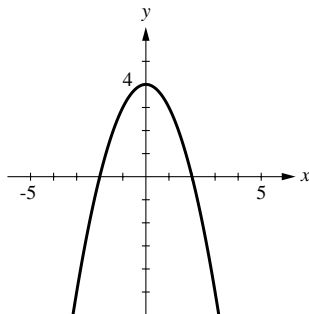

6.  $y = 1 + x^2$

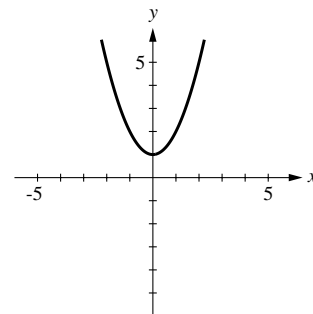

7.  $y = \sqrt{x-4}$

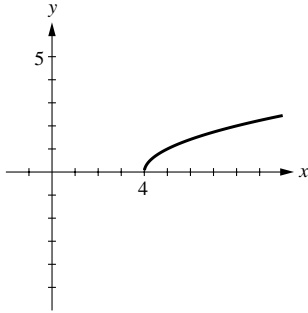

8.  $y = -\sqrt{x+1}$

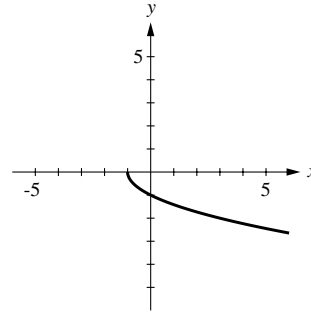

9.  $x^2 - x + y = 0$

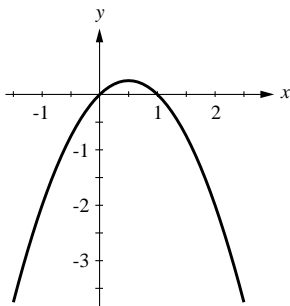

10.  $x = y^3 - y^2$

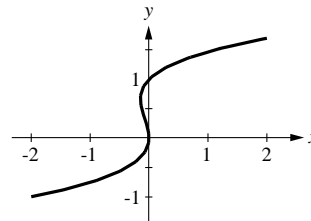

11.  $x^2y = 2$

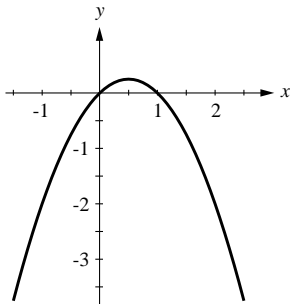

12.  $xy = -1$

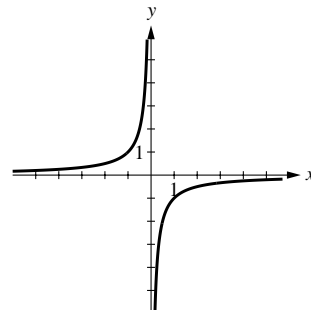

13. (a)  $m = \frac{4-2}{3-(-1)} = \frac{1}{2}$

(b)  $m = \frac{1-3}{7-5} = -1$

(c)  $m = \frac{\sqrt{2}-\sqrt{2}}{-3-4} = 0$

(d)  $m = \frac{12-(-6)}{-2-(-2)} = \frac{18}{0}$ , not defined

14.  $m_1 = \frac{5-2}{6-(-1)} = \frac{3}{7}$ ,  $m_2 = \frac{7-2}{2-(-1)} = \frac{5}{3}$ ,  $m_3 = \frac{7-5}{2-6} = -\frac{1}{2}$

15. (a) The line through (1, 1) and (-2, -5) has slope  $m_1 = \frac{-5-1}{-2-1} = 2$ , the line through (1, 1) and (0, -1) has slope  $m_2 = \frac{-1-1}{0-1} = 2$ . The given points lie on a line because  $m_1 = m_2$ .

- (b) The line through  $(-2, 4)$  and  $(0, 2)$  has slope  $m_1 = \frac{2-4}{0+2} = -1$ , the line through  $(-2, 4)$  and  $(1, 5)$  has slope  $m_2 = \frac{5-4}{1+2} = \frac{1}{3}$ . The given points do not lie on a line because  $m_1 \neq m_2$ .

16.

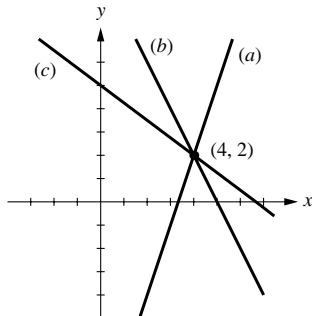

17.

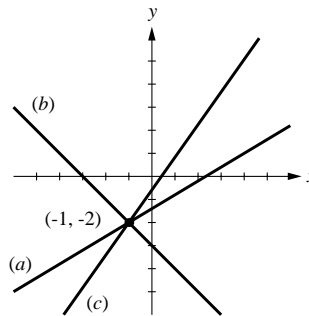

18. The triangle is equiangular because it is equilateral. The angles of inclination of the sides are  $0^\circ$ ,  $60^\circ$ , and  $120^\circ$  (see figure), thus the slopes of its sides are  $\tan 0^\circ = 0$ ,  $\tan 60^\circ = \sqrt{3}$ , and  $\tan 120^\circ = -\sqrt{3}$ .

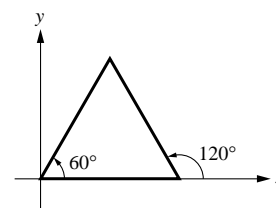

19. III &lt; II &lt; IV &lt; I

20. III &lt; IV &lt; I &lt; II

21. Use the points  $(1, 2)$  and  $(x, y)$  to calculate the slope:  $(y - 2)/(x - 1) = 3$

(a) if  $x = 5$ , then  $(y - 2)/(5 - 1) = 3$ ,  $y - 2 = 12$ ,  $y = 14$

(b) if  $y = -2$ , then  $(-2 - 2)/(x - 1) = 3$ ,  $x - 1 = -4/3$ ,  $x = -1/3$

22. Use  $(7, 5)$  and  $(x, y)$  to calculate the slope:  $(y - 5)/(x - 7) = -2$

(a) if  $x = 9$ , then  $(y - 5)/(9 - 7) = -2$ ,  $y - 5 = -4$ ,  $y = 1$

(b) if  $y = 12$ , then  $(12 - 5)/(x - 7) = -2$ ,  $x - 7 = -7/2$ ,  $x = 7/2$

23. Using  $(3, k)$  and  $(-2, 4)$  to calculate the slope, we find  $\frac{k-4}{3-(-2)} = 5$ ,  $k - 4 = 25$ ,  $k = 29$ .

24. The slope obtained by using the points  $(1, 5)$  and  $(k, 4)$  must be the same as that obtained from the points  $(1, 5)$  and  $(2, -3)$  so  $\frac{4-5}{k-1} = \frac{-3-5}{2-1}$ ,  $-\frac{1}{k-1} = -8$ ,  $k - 1 = 1/8$ ,  $k = 9/8$ .

25.  $\frac{0-2}{x-1} = -\frac{0-5}{x-4}$ ,  $-2x + 8 = 5x - 5$ ,  $7x = 13$ ,  $x = 13/7$

26. Use  $(0, 0)$  and  $(x, y)$  to get  $\frac{y-0}{x-0} = \frac{1}{2}$ ,  $y = \frac{1}{2}x$ . Use  $(7, 5)$  and  $(x, y)$  to get  $\frac{y-5}{x-7} = 2$ ,  $y - 5 = 2(x - 7)$ ,  $y = 2x - 9$ . Solve the system of equations  $y = \frac{1}{2}x$  and  $y = 2x - 9$  to get  $x = 6$ ,  $y = 3$ .

27. Show that opposite sides are parallel by showing that they have the same slope: using  $(3, -1)$  and  $(6, 4)$ ,  $m_1 = 5/3$ ; using  $(6, 4)$  and  $(-3, 2)$ ,  $m_2 = 2/9$ ; using  $(-3, 2)$  and  $(-6, -3)$ ,  $m_3 = 5/3$ ; using  $(-6, -3)$  and  $(3, -1)$ ,  $m_4 = 2/9$ . Opposite sides are parallel because  $m_1 = m_3$  and  $m_2 = m_4$ .

28. The line through  $(3, 1)$  and  $(6, 3)$  has slope  $m_1 = 2/3$ , the line through  $(3, 1)$  and  $(2, 9)$  has slope  $m_2 = -8$ , the line through  $(6, 3)$  and  $(2, 9)$  has slope  $m_3 = -3/2$ . Because  $m_1 m_3 = -1$ , the corresponding lines are perpendicular so the given points are vertices of a right triangle.

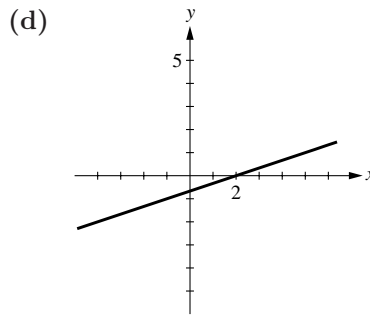
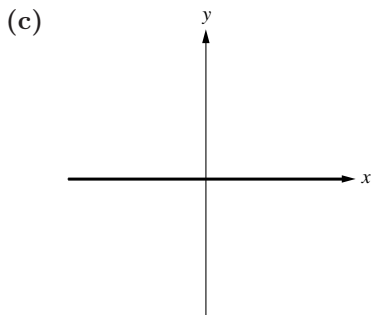
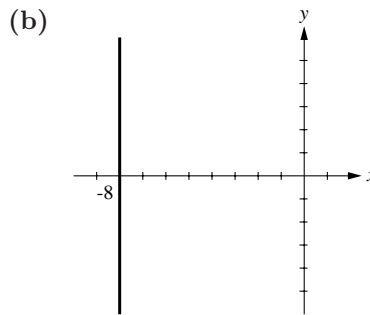
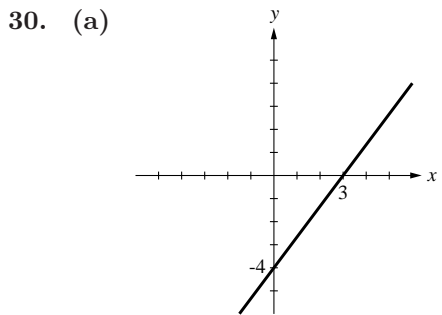
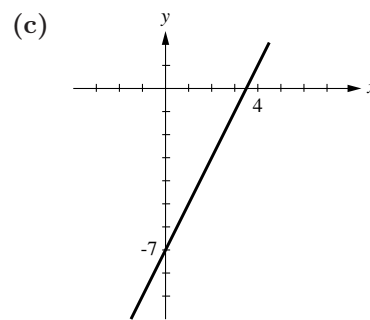
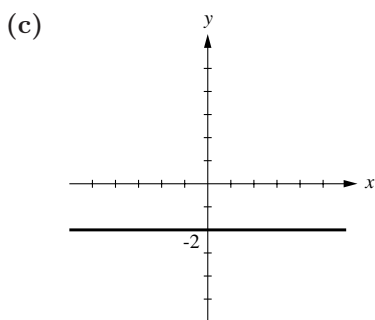
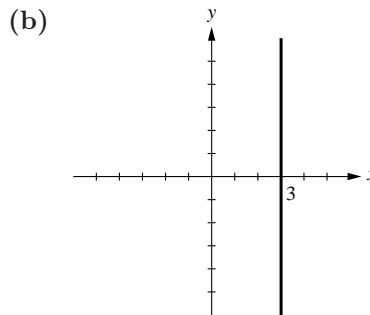
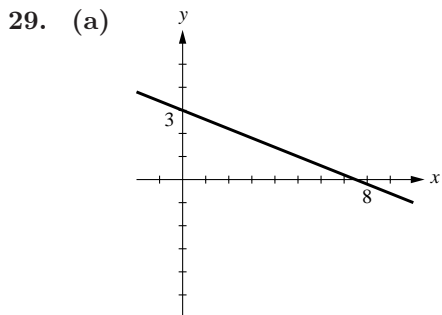

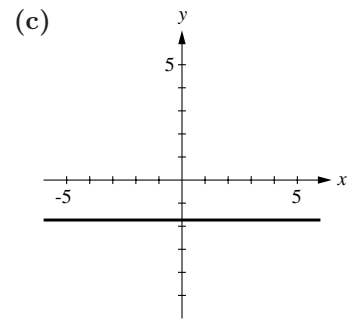
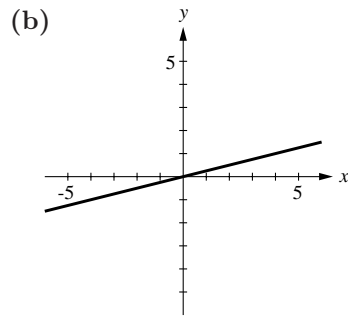
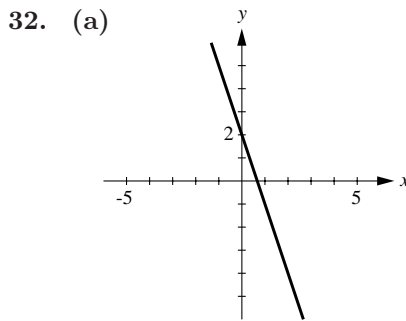
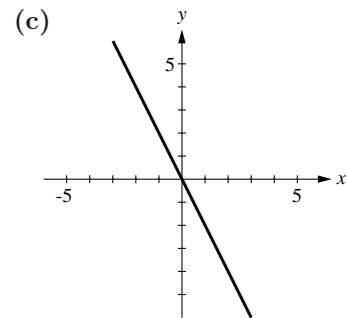
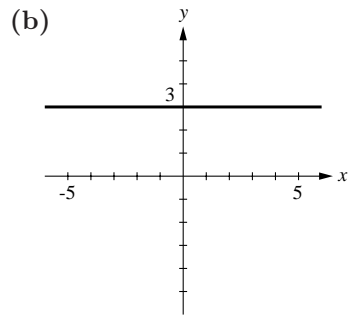
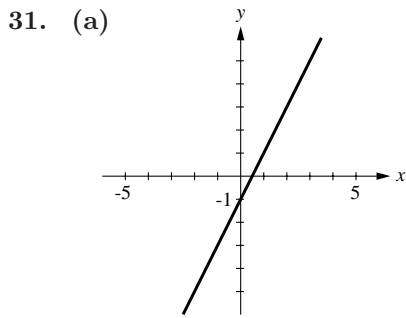

33. (a)  $m = 3, b = 2$

(b)  $m = -\frac{1}{4}, b = 3$

(c)  $y = -\frac{3}{5}x + \frac{8}{5}$  so  $m = -\frac{3}{5}, b = \frac{8}{5}$

(d)  $m = 0, b = 1$

(e)  $y = -\frac{b}{a}x + b$  so  $m = -\frac{b}{a}$ ,  $y$ -intercept  $b$

34. (a)  $m = -4, b = 2$

(b)  $y = \frac{1}{3}x - \frac{2}{3}$  so  $m = \frac{1}{3}, b = -\frac{2}{3}$

(c)  $y = -\frac{3}{2}x + 3$  so  $m = -\frac{3}{2}, b = 3$

(d)  $y = 3$  so  $m = 0, b = 3$

(e)  $y = -\frac{a_0}{a_1}x$  so  $m = -\frac{a_0}{a_1}, b = 0$

35. (a)  $m = (0 - (-3))/(2 - 0) = 3/2$  so  $y = 3x/2 - 3$

(b)  $m = (-3 - 0)/(4 - 0) = -3/4$  so  $y = -3x/4$

36. (a)  $m = (0 - 2)/(2 - 0) = -1$  so  $y = -x + 2$

(b)  $m = (2 - 0)/(3 - 0) = 2/3$  so  $y = 2x/3$

37.  $y = -2x + 4$

38.  $y = 5x - 3$

39. The slope  $m$  of the line must equal the slope of  $y = 4x - 2$ , thus  $m = 4$  so the equation is  $y = 4x + 7$ .

40. The slope of the line  $3x + 2y = 5$  is  $-3/2$  so the line through  $(-1, 2)$  with this slope is  $y - 2 = -\frac{3}{2}(x + 1)$ ;  $y = -\frac{3}{2}x + \frac{1}{2}$ .

41. The slope  $m$  of the line must be the negative reciprocal of the slope of  $y = 5x + 9$ , thus  $m = -1/5$  and the equation is  $y = -x/5 + 6$ .



42. The slope of the line  $x - 4y = 7$  is  $1/4$  so a line perpendicular to it must have a slope of  $-4$ ;  $y + 4 = -4(x - 3)$ ;  $y = -4x + 8$ .
43.  $y - 4 = \frac{-7 - 4}{1 - 2}(x - 2) = 11(x - 2)$ ,  $y = 11x - 18$ .
44.  $y - 6 = \frac{1 - 6}{-2 - (-3)}(x - (-3))$ ,  $y - 6 = -5(x + 3)$ ,  $y = -5x - 9$ .
45. The line passes through  $(0, 2)$  and  $(-4, 0)$ , thus  $m = \frac{0 - 2}{-4 - 0} = \frac{1}{2}$  so  $y = \frac{1}{2}x + 2$ .
46. The line passes through  $(0, b)$  and  $(a, 0)$ , thus  $m = \frac{0 - b}{a - 0} = -\frac{b}{a}$ , so the equation is  $y = -\frac{b}{a}x + b$ .
47.  $y = 1$
48.  $y = -8$
49. (a)  $m_1 = 4, m_2 = 4$ ; parallel because  $m_1 = m_2$   
 (b)  $m_1 = 2, m_2 = -1/2$ ; perpendicular because  $m_1 m_2 = -1$   
 (c)  $m_1 = 5/3, m_2 = 5/3$ ; parallel because  $m_1 = m_2$   
 (d) If  $A \neq 0$  and  $B \neq 0$ , then  $m_1 = -A/B, m_2 = B/A$  and the lines are perpendicular because  $m_1 m_2 = -1$ . If either  $A$  or  $B$  (but not both) is zero, then the lines are perpendicular because one is horizontal and the other is vertical.  
 (e)  $m_1 = 4, m_2 = 1/4$ ; neither
50. (a)  $m_1 = -5, m_2 = -5$ ; parallel because  $m_1 = m_2$   
 (b)  $m_1 = 2, m_2 = -1/2$ ; perpendicular because  $m_1 m_2 = -1$ .  
 (c)  $m_1 = -4/5, m_2 = 5/4$ ; perpendicular because  $m_1 m_2 = -1$ .  
 (d) If  $B \neq 0$ , then  $m_1 = m_2 = -A/B$  and the lines are parallel because  $m_1 = m_2$ . If  $B = 0$  (and  $A \neq 0$ ), then the lines are parallel because they are both perpendicular to the  $x$ -axis.  
 (e)  $m_1 = 1/2, m_2 = 2$ ; neither
51.  $y = (-3/k)x + 4/k, k \neq 0$   
 (a)  $-3/k = 2, k = -3/2$   
 (b)  $4/k = 5, k = 4/5$   
 (c)  $3(-2) + k(4) = 4, k = 5/2$   
 (d) The slope of  $2x - 5y = 1$  is  $2/5$  so  $-3/k = 2/5, k = -15/2$ .  
 (e) The slope of  $4x + 3y = 2$  is  $-4/3$  so the slope of the line perpendicular to it is  $3/4$ ;  $-3/k = 3/4, k = -4$ .
52.  $y^2 = 3x$ : the union of the graphs of  $y = \sqrt{3x}$  and  $y = -\sqrt{3x}$

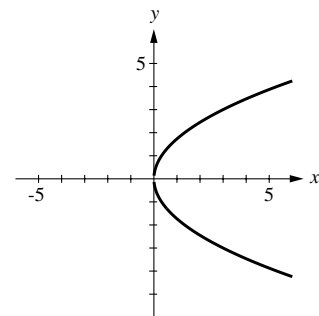

53.  $(x - y)(x + y) = 0$ : the union of the graphs of  $x - y = 0$  and  $x + y = 0$

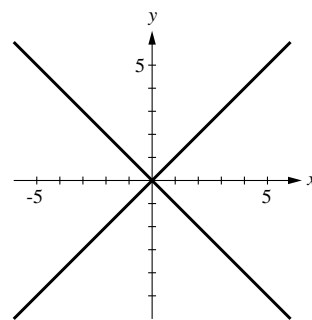

54.  $F = \frac{9}{5}C + 32$

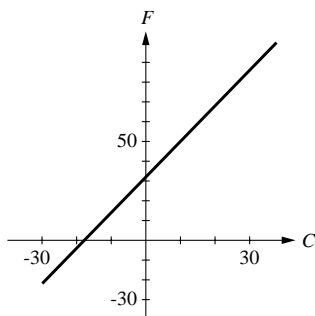

55.  $u = 3v^2$

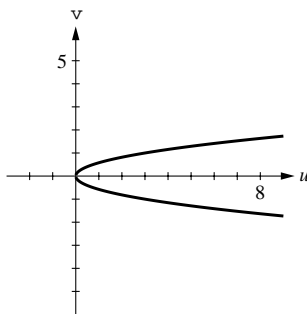

56.  $Y = 4X + 5$

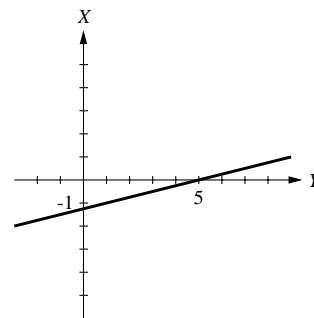

57. Solve  $x = 5t + 2$  for  $t$  to get  $t = \frac{1}{5}x - \frac{2}{5}$ , so  $y = \left(\frac{1}{5}x - \frac{2}{5}\right) - 3 = \frac{1}{5}x - \frac{17}{5}$ , which is a line.

58. Solve  $x = 1 + 3t^2$  for  $t^2$  to get  $t^2 = \frac{1}{3}x - \frac{1}{3}$ , so  $y = 2 - \left(\frac{1}{3}x - \frac{1}{3}\right) = -\frac{1}{3}x + \frac{7}{3}$ , which is a line;  $1 + 3t^2 \geq 1$  for all  $t$  so  $x \geq 1$ .

59. An equation of the line through  $(1, 4)$  and  $(2, 1)$  is  $y = -3x + 7$ . It crosses the  $y$ -axis at  $y = 7$ , and the  $x$ -axis at  $x = 7/3$ , so the area of the triangle is  $\frac{1}{2}(7)(7/3) = 49/6$ .

60.  $(2x - 3y)(2x + 3y) = 0$ , so  $2x - 3y = 0$ ,  $y = \frac{2}{3}x$  or  $2x + 3y = 0$ ,  $y = -\frac{2}{3}x$ . The graph consists of the lines  $y = \pm \frac{2}{3}x$ .

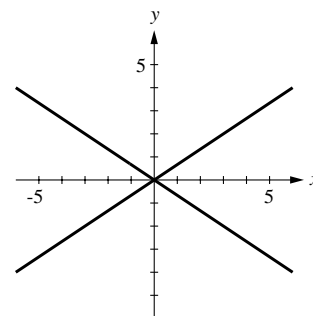

61. (a) yes (b) yes (c) no (d) yes (e) yes (f) yes (g) no

## APPENDIX D

# Distance, Circles, and Quadratic Equations

### EXERCISE SET D

1. in the proof of Theorem D.1
2. (a)  $d = \sqrt{(-1-2)^2 + (1-5)^2} = \sqrt{9+16} = \sqrt{25} = 5$   
 (b)  $\left(\frac{2+(-1)}{2}, \frac{5+1}{2}\right) = (1/2, 3)$
3. (a)  $d = \sqrt{(1-7)^2 + (9-1)^2} = \sqrt{36+64} = \sqrt{100} = 10$   
 (b)  $\left(\frac{7+1}{2}, \frac{1+9}{2}\right) = (4, 5)$
4. (a)  $d = \sqrt{(-3-2)^2 + (6-0)^2} = \sqrt{25+36} = \sqrt{61}$   
 (b)  $\left(\frac{2+(-3)}{2}, \frac{0+6}{2}\right) = (-1/2, 3)$
5. (a)  $d = \sqrt{[-7-(-2)]^2 + [-4-(-6)]^2} = \sqrt{25+4} = \sqrt{29}$   
 (b)  $\left(\frac{-2+(-7)}{2}, \frac{-6+(-4)}{2}\right) = (-9/2, -5)$

6. Let  $A(1, 1)$ ,  $B(-2, -8)$ , and  $C(4, 10)$  be the given points (see diagram).  $A$ ,  $B$ , and  $C$  lie on a straight line if and only if  $d_1 + d_2 = d_3$ , where  $d_1$ ,  $d_2$ , and  $d_3$  are the lengths of the line segments  $AB$ ,  $AC$ , and  $BC$ . But

$$d_1 = \sqrt{(-2-1)^2 + (-8-1)^2} = 3\sqrt{10},$$

$$d_2 = \sqrt{(4-1)^2 + (10-1)^2} = 3\sqrt{10},$$

$$d_3 = \sqrt{(4+2)^2 + (10+8)^2} = 6\sqrt{10}; \text{ because } d_1 + d_2 = d_3,$$

it follows that  $A$ ,  $B$ , and  $C$  lie on a straight line.

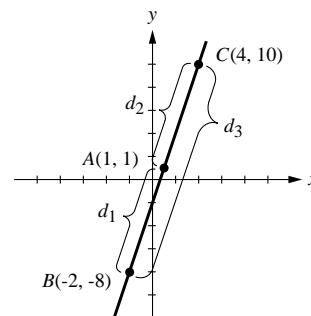

7. Let  $A(5, -2)$ ,  $B(6, 5)$ , and  $C(2, 2)$  be the given vertices and  $a$ ,  $b$ , and  $c$  the lengths of the sides opposite these vertices; then  
 $a = \sqrt{(2-6)^2 + (2-5)^2} = \sqrt{25} = 5$  and  $b = \sqrt{(2-5)^2 + (2+2)^2} = \sqrt{25} = 5$ .  
 Triangle  $ABC$  is isosceles because it has two equal sides ( $a = b$ ).
8. A triangle is a right triangle if and only if the square of the longest side is equal to the sum of the squares of the other two sides (Pythagorean theorem). With  $A(1, 3)$ ,  $B(4, 2)$ , and  $C(-2, -6)$  as vertices and  $s_1$ ,  $s_2$ , and  $s_3$  the lengths of the sides opposite these vertices we find that  $s_1^2 = (-2-4)^2 + (-6-2)^2 = 100$ ,  $s_2^2 = (-2-1)^2 + (-6-3)^2 = 90$ ,  $s_3^2 = (4-1)^2 + (2-3)^2 = 10$ , and that  $s_1^2 = s_2^2 + s_3^2$ , so  $ABC$  is a right triangle.
9.  $P_1(0, -2)$ ,  $P_2(-4, 8)$ , and  $P_3(3, 1)$  all lie on a circle whose center is  $C(-2, 3)$  if the points  $P_1$ ,  $P_2$  and  $P_3$  are equidistant from  $C$ . Denoting the distances between  $P_1$ ,  $P_2$ ,  $P_3$  and  $C$  by  $d_1$ ,  $d_2$  and  $d_3$  we find that  $d_1 = \sqrt{(0+2)^2 + (-2-3)^2} = \sqrt{29}$ ,  $d_2 = \sqrt{(-4+2)^2 + (8-3)^2} = \sqrt{29}$ , and  $d_3 = \sqrt{(3+2)^2 + (1-3)^2} = \sqrt{29}$ , so  $P_1$ ,  $P_2$  and  $P_3$  lie on a circle whose center is  $C(-2, 3)$  because  $d_1 = d_2 = d_3$ .

10. The distance between  $(t, 2t - 6)$  and  $(0, 4)$  is

$$\sqrt{(t-0)^2 + (2t-6-4)^2} = \sqrt{t^2 + (2t-10)^2} = \sqrt{5t^2 - 40t + 100};$$

the distance between  $(t, 2t - 6)$  and  $(8, 0)$  is  $\sqrt{(t-8)^2 + (2t-6)^2} = \sqrt{5t^2 - 40t + 100}$ ,  
so  $(t, 2t - 6)$  is equidistant from  $(0, 4)$  and  $(8, 0)$ .

11. If  $(2, k)$  is equidistant from  $(3, 7)$  and  $(9, 1)$ , then

$$\sqrt{(2-3)^2 + (k-7)^2} = \sqrt{(2-9)^2 + (k-1)^2}, \quad 1 + (k-7)^2 = 49 + (k-1)^2,$$

$$1 + k^2 - 14k + 49 = 49 + k^2 - 2k + 1, \quad -12k = 0, \quad k = 0.$$

12.  $(x-3)/2 = 4$  and  $(y+2)/2 = -5$  so  $x = 11$  and  $y = -12$ .

13. The slope of the line segment joining  $(2, 8)$  and  $(-4, 6)$  is  $\frac{6-8}{-4-2} = \frac{1}{3}$  so the slope of the perpendicular bisector is  $-3$ . The midpoint of the line segment is  $(-1, 7)$  so an equation of the bisector is  $y - 7 = -3(x + 1)$ ;  $y = -3x + 4$ .

14. The slope of the line segment joining  $(5, -1)$  and  $(4, 8)$  is  $\frac{8-(-1)}{4-5} = -9$  so the slope of the perpendicular bisector is  $\frac{1}{9}$ . The midpoint of the line segment is  $(9/2, 7/2)$  so an equation of the bisector is  $y - \frac{7}{2} = \frac{1}{9}\left(x - \frac{9}{2}\right)$ ;  $y = \frac{1}{9}x + 3$ .

15. Method (see figure): Find an equation of the perpendicular bisector of the line segment joining  $A(3, 3)$  and  $B(7, -3)$ . All points on this perpendicular bisector are equidistant from  $A$  and  $B$ , thus find where it intersects the given line.

The midpoint of  $AB$  is  $(5, 0)$ , the slope of  $AB$  is  $-3/2$  thus the slope of the perpendicular bisector is  $2/3$  so an equation is

$$y - 0 = \frac{2}{3}(x - 5)$$

$$3y = 2x - 10$$

$$2x - 3y - 10 = 0.$$

The solution of the system

$$\begin{cases} 4x - 2y + 3 = 0 \\ 2x - 3y - 10 = 0 \end{cases}$$

gives the point  $(-29/8, -23/4)$ .

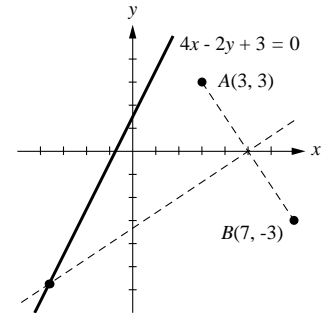

16. (a)  $y = 4$  is a horizontal line, so the vertical distance is  $|4 - (-2)| = |6| = 6$ .  
(b)  $x = -1$  is a vertical line, so the horizontal distance is  $|-1 - 3| = |-4| = 4$ .

17. Method (see figure): write an equation of the line that goes through the given point and that is perpendicular to the given line; find the point  $P$  where this line intersects the given line; find the distance between  $P$  and the given point.

The slope of the given line is  $4/3$ , so the slope of a line perpendicular to it is  $-3/4$ .

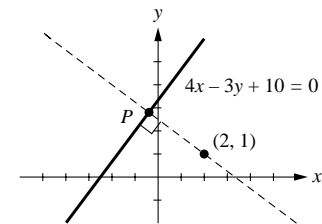

The line through  $(2, 1)$  having a slope of  $-3/4$  is  $y - 1 = -\frac{3}{4}(x - 2)$  or, after simplification,  $3x + 4y = 10$  which when solved simultaneously with  $4x - 3y + 10 = 0$  yields  $(-2/5, 14/5)$  as the point of intersection. The distance  $d$  between  $(-2/5, 14/5)$  and  $(2, 1)$  is

$$d = \sqrt{(2 + 2/5)^2 + (1 - 14/5)^2} = 3.$$

18. (See the solution to Exercise 17 for a description of the method.) The slope of the line  $5x + 12y - 36 = 0$  is  $-5/12$ . The line through  $(8, 4)$  and perpendicular to the given line is  $y - 4 = \frac{12}{5}(x - 8)$  or, after simplification,  $12x - 5y = 76$ . The point of intersection of this line with the given line is found to be  $(\frac{84}{13}, \frac{4}{13})$  and the distance between it and  $(8, 4)$  is 4.

19. If  $B = 0$ , then the line  $Ax + C = 0$  is vertical and  $x = -C/A$  for each point on the line. The line through  $(x_0, y_0)$  and perpendicular to the given line is horizontal and intersects the given line at the point  $(-C/A, y_0)$ . The distance  $d$  between  $(-C/A, y_0)$  and  $(x_0, y_0)$  is

$$d = \sqrt{(x_0 + C/A)^2 + (y_0 - y_0)^2} = \sqrt{\frac{(Ax_0 + C)^2}{A^2}} = \frac{|Ax_0 + C|}{\sqrt{A^2}}$$

which is the value of  $\frac{|Ax_0 + By_0 + C|}{\sqrt{A^2 + B^2}}$  for  $B = 0$ .

If  $B \neq 0$ , then the slope of the given line is  $-A/B$  and the line through  $(x_0, y_0)$  and perpendicular to the given line is

$$y - y_0 = \frac{B}{A}(x - x_0), \quad Ay - Ay_0 = Bx - Bx_0, \quad Bx - Ay = Bx_0 - Ay_0.$$

The point of intersection of this line and the given line is obtained by solving  $Ax + By = -C$  and  $Bx - Ay = Bx_0 - Ay_0$ .

Multiply the first equation through by  $A$  and the second by  $B$  and add the results to get

$$(A^2 + B^2)x = B^2x_0 - AB y_0 - AC \quad \text{so } x = \frac{B^2x_0 - AB y_0 - AC}{A^2 + B^2}$$

$$\text{Similarly, by multiplying by } B \text{ and } -A, \text{ we get } y = \frac{-ABx_0 + A^2y_0 - BC}{A^2 + B^2}.$$

The square of the distance  $d$  between  $(x, y)$  and  $(x_0, y_0)$  is

$$\begin{aligned} d^2 &= \left[ x_0 - \frac{B^2x_0 - AB y_0 - AC}{A^2 + B^2} \right]^2 + \left[ y_0 - \frac{-ABx_0 + A^2y_0 - BC}{A^2 + B^2} \right]^2 \\ &= \frac{(A^2x_0 + AB y_0 + AC)^2}{(A^2 + B^2)^2} + \frac{(ABx_0 + B^2y_0 + BC)^2}{(A^2 + B^2)^2} \\ &= \frac{A^2(Ax_0 + By_0 + C)^2 + B^2(Ax_0 + By_0 + C)^2}{(A^2 + B^2)^2} \\ &= \frac{(Ax_0 + By_0 + C)^2(A^2 + B^2)}{(A^2 + B^2)^2} = \frac{(Ax_0 + By_0 + C)^2}{A^2 + B^2} \end{aligned}$$

$$\text{so } d = \frac{|Ax_0 + By_0 + C|}{\sqrt{A^2 + B^2}}.$$

20.  $d = \frac{|4(2) - 3(1) + 10|}{\sqrt{4^2 + (-3)^2}} = \frac{|15|}{\sqrt{25}} = \frac{15}{5} = 3.$       21.  $d = \frac{|5(8) + 12(4) - 36|}{\sqrt{5^2 + 12^2}} = \frac{|52|}{\sqrt{169}} = \frac{52}{13} = 4.$

22. Method (see figure): Let  $A(0, a)$ ,  $B(b, 0)$ , and  $C(c, 0)$  be the given vertices; find equations for the perpendicular bisectors  $L_1$ ,  $L_2$ , and  $L_3$  and show that they all intersect at the same point.

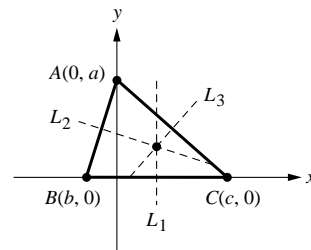

line  $L_1$ : The midpoint of  $BC$  is  $\left(\frac{b+c}{2}, 0\right)$  and since  $L_1$  is vertical, an equation for  $L_1$  is  $x = \frac{b+c}{2}$ ;

line  $L_2$ : The midpoint of  $AB$  is  $\left(\frac{b}{2}, \frac{a}{2}\right)$ ; the slope of  $AB$  is  $-\frac{a}{b}$  (if  $b \neq 0$ ) so the slope of

$L_2$  is  $\frac{b}{a}$  (even if  $b = 0$ ) and an equation of  $L_2$  is  $y - \frac{a}{2} = \frac{b}{a} \left(x - \frac{b}{2}\right)$ ;

line  $L_3$ : The midpoint of  $AC$  is  $\left(\frac{c}{2}, \frac{a}{2}\right)$ ; the slope of  $AC$  is  $-\frac{a}{c}$  (if  $c \neq 0$ ) so the slope of

$L_3$  is  $\frac{c}{a}$  (even if  $c = 0$ ) and an equation of  $L_3$  is  $y - \frac{a}{2} = \frac{c}{a} \left(x - \frac{c}{2}\right)$ .

For the point of intersection of  $L_1$  and  $L_2$ , solve  $x = \frac{b+c}{2}$  and  $y - \frac{a}{2} = \frac{b}{a} \left(x - \frac{b}{2}\right)$ .

The point is found to be  $\left(\frac{b+c}{2}, \frac{a^2+bc}{2}\right)$ . The point of intersection of  $L_1$  and  $L_3$  is obtained by

solving the system  $x = \frac{b+c}{2}$  and  $y - \frac{a}{2} = \frac{c}{a} \left(x - \frac{c}{2}\right)$ , its solution yields the point  $\left(\frac{b+c}{2}, \frac{a^2+bc}{2}\right)$ .

So  $L_1L_2$ , and  $L_3$  all intersect at the same point.

23. (a) center  $(0,0)$ , radius 5 (b) center  $(1,4)$ , radius 4  
 (c) center  $(-1,-3)$ , radius  $\sqrt{5}$  (d) center  $(0,-2)$ , radius 1
24. (a) center  $(0,0)$ , radius 3 (b) center  $(3,5)$ , radius 6  
 (c) center  $(-4,-1)$ , radius  $\sqrt{8}$  (d) center  $(-1,0)$ , radius 1
25.  $(x-3)^2 + (y-(-2))^2 = 4^2$ ,  $(x-3)^2 + (y+2)^2 = 16$
26.  $(x-1)^2 + (y-0)^2 = (\sqrt{8}/2)^2$ ,  $(x-1)^2 + y^2 = 2$
27.  $r = 8$  because the circle is tangent to the  $x$ -axis, so  $(x+4)^2 + (y-8)^2 = 64$ .
28.  $r = 5$  because the circle is tangent to the  $y$ -axis, so  $(x-5)^2 + (y-8)^2 = 25$ .
29.  $(0,0)$  is on the circle, so  $r = \sqrt{(-3-0)^2 + (-4-0)^2} = 5$ ;  $(x+3)^2 + (y+4)^2 = 25$ .
30.  $r = \sqrt{(4-1)^2 + (-5-3)^2} = \sqrt{73}$ ;  $(x-4)^2 + (y+5)^2 = 73$ .
31. The center is the midpoint of the line segment joining  $(2,0)$  and  $(0,2)$  so the center is at  $(1,1)$ . The radius is  $r = \sqrt{(2-1)^2 + (0-1)^2} = \sqrt{2}$ , so  $(x-1)^2 + (y-1)^2 = 2$ .
32. The center is the midpoint of the line segment joining  $(6,1)$  and  $(-2,3)$ , so the center is at  $(2,2)$ . The radius is  $r = \sqrt{(6-2)^2 + (1-2)^2} = \sqrt{17}$ , so  $(x-2)^2 + (y-2)^2 = 17$ .
33.  $(x^2 - 2x) + (y^2 - 4y) = 11$ ,  $(x^2 - 2x + 1) + (y^2 - 4y + 4) = 11 + 1 + 4$ ,  $(x-1)^2 + (y-2)^2 = 16$ ; center  $(1,2)$  and radius 4

34.  $(x^2 + 8x) + y^2 = -8$ ,  $(x^2 + 8x + 16) + y^2 = -8 + 16$ ,  $(x + 4)^2 + y^2 = 8$ ; center  $(-4, 0)$  and radius  $2\sqrt{2}$
35.  $2(x^2 + 2x) + 2(y^2 - 2y) = 0$ ,  $2(x^2 + 2x + 1) + 2(y^2 - 2y + 1) = 2 + 2$ ,  $(x + 1)^2 + (y - 1)^2 = 2$ ; center  $(-1, 1)$  and radius  $\sqrt{2}$
36.  $6(x^2 - x) + 6(y^2 + y) = 3$ ,  $6(x^2 - x + 1/4) + 6(y^2 + y + 1/4) = 3 + 6/4 + 6/4$ ,  $(x - 1/2)^2 + (y + 1/2)^2 = 1$ ; center  $(1/2, -1/2)$  and radius 1
37.  $(x^2 + 2x) + (y^2 + 2y) = -2$ ,  $(x^2 + 2x + 1) + (y^2 + 2y + 1) = -2 + 1 + 1$ ,  $(x + 1)^2 + (y + 1)^2 = 0$ ; the point  $(-1, -1)$
38.  $(x^2 - 4x) + (y^2 - 6y) = -13$ ,  $(x^2 - 4x + 4) + (y^2 - 6y + 9) = -13 + 4 + 9$ ,  $(x - 2)^2 + (y - 3)^2 = 0$ ; the point  $(2, 3)$
39.  $x^2 + y^2 = 1/9$ ; center  $(0, 0)$  and radius  $1/3$
40.  $x^2 + y^2 = 4$ ; center  $(0, 0)$  and radius 2
41.  $x^2 + (y^2 + 10y) = -26$ ,  $x^2 + (y^2 + 10y + 25) = -26 + 25$ ,  $x^2 + (y + 5)^2 = -1$ ; no graph
42.  $(x^2 - 10x) + (y^2 - 2y) = -29$ ,  $(x^2 - 10x + 25) + (y^2 - 2y + 1) = -29 + 25 + 1$ ,  $(x - 5)^2 + (y - 1)^2 = -3$ ; no graph
43.  $16\left(x^2 + \frac{5}{2}x\right) + 16(y^2 + y) = 7$ ,  $16\left(x^2 + \frac{5}{2}x + \frac{25}{16}\right) + 16\left(y^2 + y + \frac{1}{4}\right) = 7 + 25 + 4$ ,  $(x + 5/4)^2 + (y + 1/2)^2 = 9/4$ ; center  $(-5/4, -1/2)$  and radius  $3/2$
44.  $4(x^2 - 4x) + 4(y^2 - 6y) = 9$ ,  $4(x^2 - 4x + 4) + 4(y^2 - 6y + 9) = 9 + 16 + 36$ ,  $(x - 2)^2 + (y - 3)^2 = 61/4$ ; center  $(2, 3)$  and radius  $\sqrt{61}/2$
45. (a)  $y^2 = 16 - x^2$ , so  $y = \pm\sqrt{16 - x^2}$ . The bottom half is  $y = -\sqrt{16 - x^2}$ .  
 (b) Complete the square in  $y$  to get  $(y - 2)^2 = 3 - 2x - x^2$ , so  $y - 2 = \pm\sqrt{3 - 2x - x^2}$ , or  $y = 2 \pm \sqrt{3 - 2x - x^2}$ . The top half is  $y = 2 + \sqrt{3 - 2x - x^2}$ .
46. (a)  $x^2 = 9 - y^2$  so  $x = \pm\sqrt{9 - y^2}$ . The right half is  $x = \sqrt{9 - y^2}$ .  
 (b) Complete the square in  $x$  to get  $(x - 2)^2 = 1 - y^2$  so  $x - 2 = \pm\sqrt{1 - y^2}$ ,  $x = 2 \pm \sqrt{1 - y^2}$ . The left half is  $x = 2 - \sqrt{1 - y^2}$ .

47. (a)

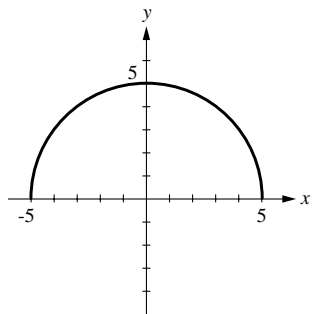

(b)

$$\begin{aligned}
 y &= \sqrt{5 + 4x - x^2} \\
 &= \sqrt{5 - (x^2 - 4x)} \\
 &= \sqrt{5 + 4 - (x^2 - 4x + 4)} \\
 &= \sqrt{9 - (x - 2)^2}
 \end{aligned}$$

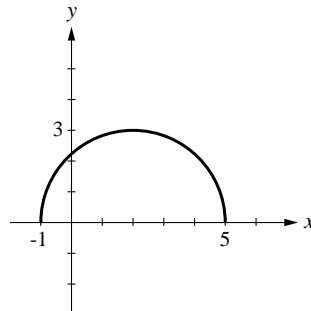

48. (a)

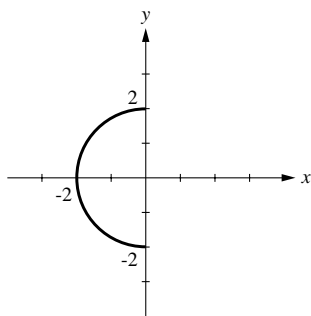

(b)

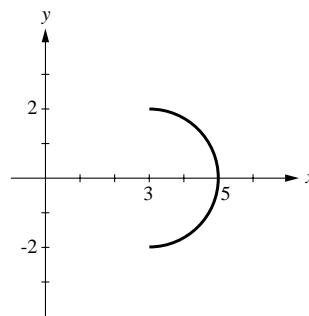

49. The tangent line is perpendicular to the radius at the point. The slope of the radius is  $4/3$ , so the slope of the perpendicular is  $-3/4$ . An equation of the tangent line is  $y - 4 = -\frac{3}{4}(x - 3)$ , or

$$y = -\frac{3}{4}x + \frac{25}{4}.$$

50. (a)  $(x + 1)^2 + y^2 = 10$ , center at  $C(-1, 0)$ . The slope of  $CP$  is  $-1/3$  so the slope of the tangent is 3;  $y + 1 = 3(x - 2)$ ,  $y = 3x - 7$ .

(b)  $(x - 3)^2 + (y + 2)^2 = 26$ , center at  $C(3, -2)$ . The slope of  $CP$  is 5 so the slope of the tangent is  $-1/5$ ;  $y - 3 = -\frac{1}{5}(x - 4)$ ,  $y = -\frac{1}{5}x + \frac{19}{5}$ .

51. (a) The center of the circle is at  $(0, 0)$  and its radius is  $\sqrt{20} = 2\sqrt{5}$ . The distance between  $P$  and the center is  $\sqrt{(-1)^2 + (2)^2} = \sqrt{5}$  which is less than  $2\sqrt{5}$ , so  $P$  is inside the circle.

(b) Draw the diameter of the circle that passes through  $P$ , then the shorter segment of the diameter is the shortest line that can be drawn from  $P$  to the circle, and the longer segment is the longest line that can be drawn from  $P$  to the circle (can you prove it?). Thus, the smallest distance is  $2\sqrt{5} - \sqrt{5} = \sqrt{5}$ , and the largest is  $2\sqrt{5} + \sqrt{5} = 3\sqrt{5}$ .

52. (a)  $x^2 + (y - 1)^2 = 5$ , center at  $C(0, 1)$  and radius  $\sqrt{5}$ . The distance between  $P$  and  $C$  is  $3\sqrt{5}/2$  so  $P$  is outside the circle.

(b) The smallest distance is  $\frac{3}{2}\sqrt{5} - \sqrt{5} = \frac{1}{2}\sqrt{5}$ , the largest distance is  $\frac{3}{2}\sqrt{5} + \sqrt{5} = \frac{5}{2}\sqrt{5}$ .

53. Let  $(a, b)$  be the coordinates of  $T$  (or  $T'$ ). The radius from  $(0, 0)$  to  $T$  (or  $T'$ ) will be perpendicular to  $L$  (or  $L'$ ) so, using slopes,  $b/a = -(a - 3)/b$ ,  $a^2 + b^2 = 3a$ . But  $(a, b)$  is on the circle so  $a^2 + b^2 = 1$ , thus  $3a = 1$ ,  $a = 1/3$ . Let  $a = 1/3$  in  $a^2 + b^2 = 1$  to get  $b^2 = 8/9$ ,  $b = \pm\sqrt{8}/3$ . The coordinates of  $T$  and  $T'$  are  $(1/3, \sqrt{8}/3)$  and  $(1/3, -\sqrt{8}/3)$ .

54. (a)  $\sqrt{(x - 2)^2 + (y - 0)^2} = \sqrt{2}\sqrt{(x - 0)^2 + (y - 1)^2}$ ; square both sides and expand to get  $x^2 - 4x + 4 + y^2 = 2(x^2 + y^2 - 2y + 1)$ ,  $x^2 + y^2 + 4x - 4y - 2 = 0$ , which is a circle.

(b)  $(x^2 + 4x) + (y^2 - 4y) = 2$ ,  $(x^2 + 4x + 4) + (y^2 - 4y + 4) = 2 + 4 + 4$ ,  $(x + 2)^2 + (y - 2)^2 = 10$ ; center  $(-2, 2)$ , radius  $\sqrt{10}$ .

55. (a)  $[(x - 4)^2 + (y - 1)^2] + [(x - 2)^2 + (y + 5)^2] = 45$   
 $x^2 - 8x + 16 + y^2 - 2y + 1 + x^2 - 4x + 4 + y^2 + 10y + 25 = 45$   
 $2x^2 + 2y^2 - 12x + 8y + 1 = 0$ , which is a circle.

(b)  $2(x^2 - 6x) + 2(y^2 + 4y) = -1$ ,  $2(x^2 - 6x + 9) + 2(y^2 + 4y + 4) = -1 + 18 + 8$ ,  
 $(x - 3)^2 + (y + 2)^2 = 25/2$ ; center  $(3, -2)$ , radius  $5/\sqrt{2}$ .



56. If  $x^2 - y^2 = 0$ , then  $y^2 = x^2$  so  $y = x$  or  $y = -x$ . The graph of  $x^2 - y^2 = 0$  consists of the graphs of the two lines  $y = \pm x$ . The graph of  $(x - c)^2 + y^2 = 1$  is a circle of radius 1 with center at  $(c, 0)$ . Examine the figure to see that the system cannot have just one solution, and has 0 solutions if  $|c| > \sqrt{2}$ , 2 solutions if  $|c| = \sqrt{2}$ , 3 solutions if  $|c| = 1$ , and 4 solutions if  $|c| < \sqrt{2}$ ,  $|c| \neq 1$ .

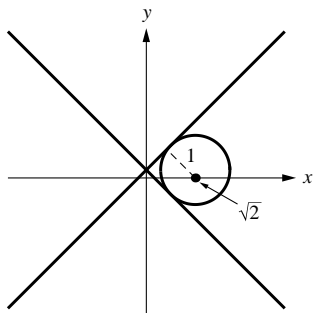

2 solutions

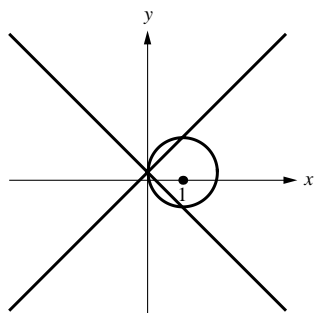

3 solutions

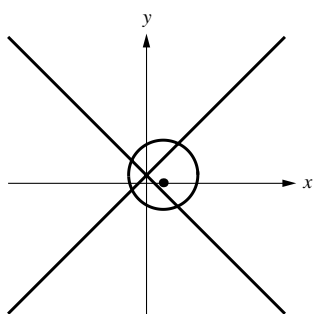

4 solutions

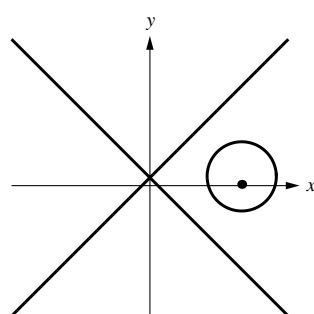

0 solutions

57.  $y = x^2 + 2$

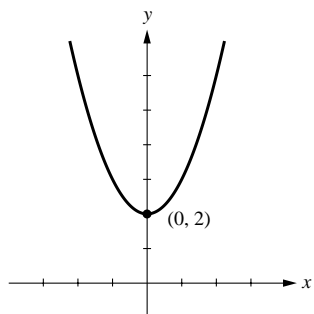

58.  $y = x^2 - 3$

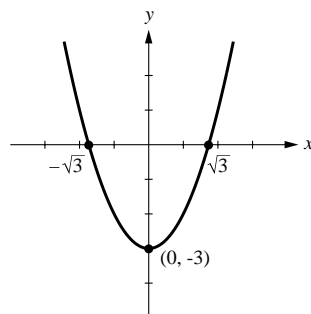

59.  $y = x^2 + 2x - 3$

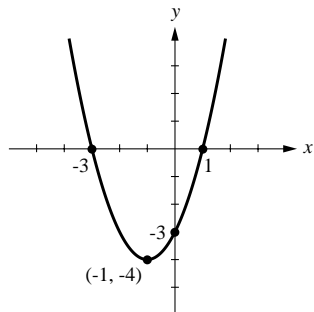

60.  $y = x^2 - 3x - 4$

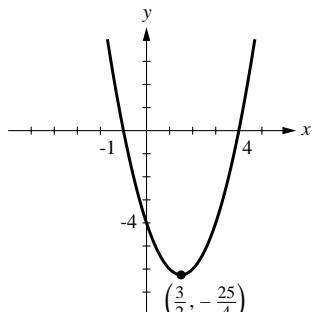

61.  $y = -x^2 + 4x + 5$

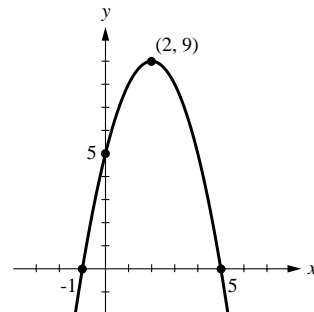

62.  $y = -x^2 + x$

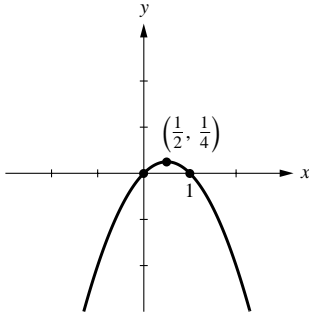

63.  $y = (x - 2)^2$

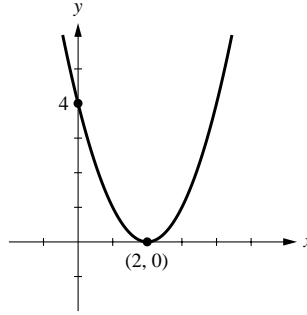

64.  $y = (3 + x)^2$

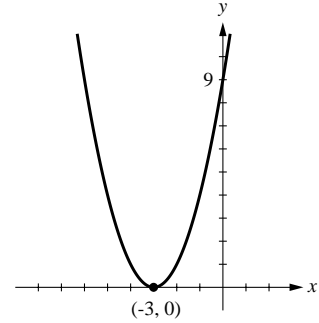

65.  $x^2 - 2x + y = 0$

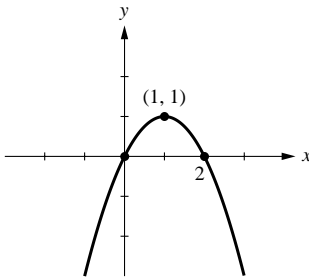

66.  $x^2 + 8x + 8y = 0$

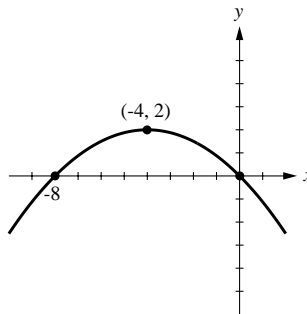

67.  $y = 3x^2 - 2x + 1$

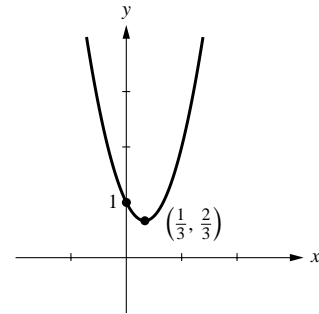

68.  $y = x^2 + x + 2$

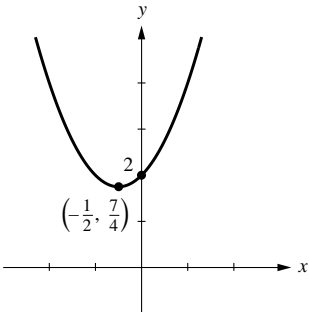

69.  $x = -y^2 + 2y + 2$

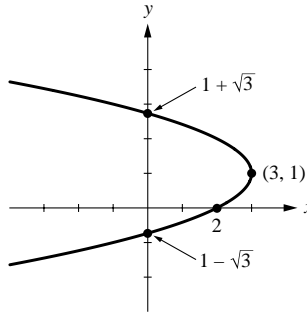

70.  $x = y^2 - 4y + 5$

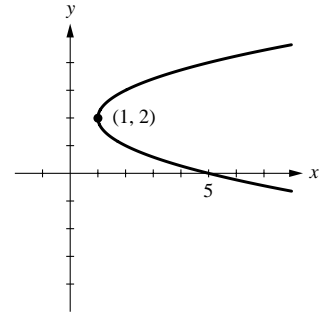

71. (a)  $x^2 = 3 - y$ ,  $x = \pm\sqrt{3 - y}$ . The right half is  $x = \sqrt{3 - y}$ .

(b) Complete the square in  $x$  to get  $(x-1)^2 = y+1$ ,  $x = 1 \pm \sqrt{y+1}$ . The left half is  $x = 1 - \sqrt{y+1}$ .

72. (a)  $y^2 = x + 5$ ,  $y = \pm\sqrt{x+5}$ . The upper half is  $y = \sqrt{x+5}$ .

(b) Complete the square in  $y$  to get  $(y - 1/2)^2 = x + 9/4$ ,  $y - 1/2 = \pm\sqrt{x + 9/4}$ ,  $y = 1/2 \pm \sqrt{x + 9/4}$ . The lower half is  $y = 1/2 - \sqrt{x + 9/4}$ .

73. (a)

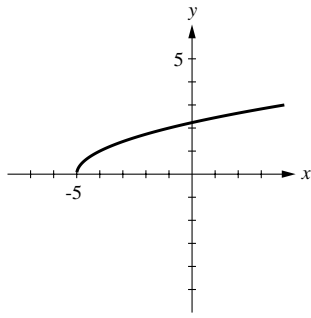

(b)

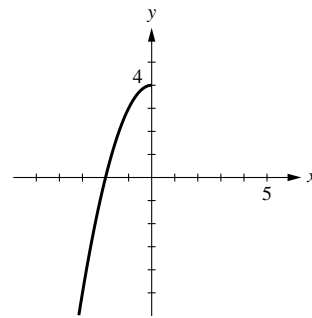

74. (a)

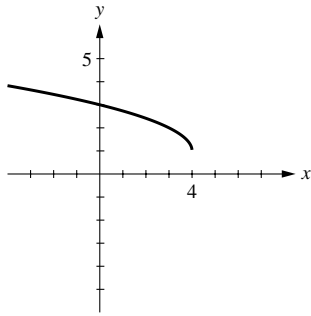

(b)

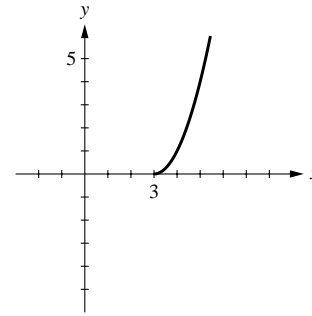

75. (a)

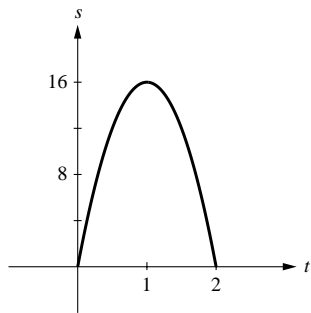

(b) The ball will be at its highest point when  $t = 1$  sec; it will rise 16 ft.

76. (a)  $2x + y = 500$ ,  $y = 500 - 2x$ .

(b)  $A = xy = x(500 - 2x) = 500x - 2x^2$ .

(c) The graph of  $A$  versus  $x$  is a parabola with its vertex (high point) at  $x = -b/(2a) = -500/(-4) = 125$ , so the maximum value of  $A$  is  $A = 500(125) - 2(125)^2 = 31,250 \text{ ft}^2$ .

77. (a)  $(3)(2x) + (2)(2y) = 600$ ,  $6x + 4y = 600$ ,  $y = 150 - 3x/2$

(b)  $A = xy = x(150 - 3x/2) = 150x - 3x^2/2$

(c) The graph of  $A$  versus  $x$  is a parabola with its vertex (high point) at  $x = -b/(2a) = -150/(-3) = 50$ , so the maximum value of  $A$  is  $A = 150(50) - 3(50)^2/2 = 3,750 \text{ ft}^2$ .

78. (a)  $y = ax^2 + bx + c = a\left(x^2 + \frac{b}{a}x\right) + c$   
 $= a\left(x^2 + \frac{b}{a}x + \frac{b^2}{4a^2}\right) + c - \frac{b^2}{4a} = a\left(x + \frac{b}{2a}\right)^2 + \left(c - \frac{b^2}{4a}\right)$
- (b) If  $a < 0$  then  $y$  is always less than  $c - \frac{b^2}{4a}$  except when  $x = -\frac{b}{2a}$ , so the graph has its high point there. If  $a > 0$  then  $y$  is always greater than  $c - \frac{b^2}{4a}$  except when  $x = -\frac{b}{2a}$ , so the graph has its low point there.
79. (a) The parabola  $y = 2x^2 + 5x - 1$  opens upward and has  $x$ -intercepts of  $x = (-5 \pm \sqrt{33})/4$ , so  $2x^2 + 5x - 1 < 0$  if  $(-5 - \sqrt{33})/4 < x < (-5 + \sqrt{33})/4$ .
- (b) The parabola  $y = x^2 - 2x + 3$  opens upward and has no  $x$ -intercepts, so  $x^2 - 2x + 3 > 0$  if  $-\infty < x < +\infty$ .
80. (a) The parabola  $y = x^2 + x - 1$  opens upward and has  $x$ -intercepts of  $x = (-1 \pm \sqrt{5})/2$ , so  $x^2 + x - 1 > 0$  if  $x < (-1 - \sqrt{5})/2$  or  $x > (-1 + \sqrt{5})/2$ .
- (b) The parabola  $y = x^2 - 4x + 6$  opens upward and has no  $x$ -intercepts, so  $x^2 - 4x + 6 < 0$  has no solution.
81. (a) The  $t$ -coordinate of the vertex is  $t = -40/[(2)(-16)] = 5/4$ , so the maximum height is  $s = 5 + 40(5/4) - 16(5/4)^2 = 30$  ft.
- (b)  $s = 5 + 40t - 16t^2 = 0$  if  $t \approx 2.6$  s
- (c)  $s = 5 + 40t - 16t^2 > 12$  if  $16t^2 - 40t + 7 < 0$ , which is true if  $(5 - 3\sqrt{2})/4 < t < (5 + 3\sqrt{2})/4$ . The length of this interval is  $(5 + 3\sqrt{2})/4 - (5 - 3\sqrt{2})/4 = 3\sqrt{2}/2 \approx 2.1$  s.
82.  $x + 3 - x^2 > 0$ ,  $x^2 - x - 3 < 0$ ,  $(1 - \sqrt{13})/2 < x < (1 + \sqrt{13})/2$

# APPENDIX E

## Trigonometry Review

### EXERCISE SET E

1. (a)  $5\pi/12$                       (b)  $13\pi/6$                       (c)  $\pi/9$                       (d)  $23\pi/30$
2. (a)  $7\pi/3$                       (b)  $\pi/12$                       (c)  $5\pi/4$                       (d)  $11\pi/12$
3. (a)  $12^\circ$                       (b)  $(270/\pi)^\circ$                       (c)  $288^\circ$                       (d)  $540^\circ$
4. (a)  $18^\circ$                       (b)  $(360/\pi)^\circ$                       (c)  $72^\circ$                       (d)  $210^\circ$

5.

	$\sin \theta$	$\cos \theta$	$\tan \theta$	$\csc \theta$	$\sec \theta$	$\cot \theta$
(a)	$\sqrt{21}/5$	$2/5$	$\sqrt{21}/2$	$5/\sqrt{21}$	$5/2$	$2/\sqrt{21}$
(b)	$3/4$	$\sqrt{7}/4$	$3/\sqrt{7}$	$4/3$	$4/\sqrt{7}$	$\sqrt{7}/3$
(c)	$3/\sqrt{10}$	$1/\sqrt{10}$	$3$	$\sqrt{10}/3$	$\sqrt{10}$	$1/3$

6.

	$\sin \theta$	$\cos \theta$	$\tan \theta$	$\csc \theta$	$\sec \theta$	$\cot \theta$
(a)	$1/\sqrt{2}$	$1/\sqrt{2}$	$1$	$\sqrt{2}$	$\sqrt{2}$	$1$
(b)	$3/5$	$4/5$	$3/4$	$5/3$	$5/4$	$4/3$
(c)	$1/4$	$\sqrt{15}/4$	$1/\sqrt{15}$	$4$	$4/\sqrt{15}$	$\sqrt{15}$

7.  $\sin \theta = 3/\sqrt{10}$ ,  $\cos \theta = 1/\sqrt{10}$                       8.  $\sin \theta = \sqrt{5}/3$ ,  $\tan \theta = \sqrt{5}/2$
9.  $\tan \theta = \sqrt{21}/2$ ,  $\csc \theta = 5/\sqrt{21}$                       10.  $\cot \theta = \sqrt{15}$ ,  $\sec \theta = 4/\sqrt{15}$
11. Let  $x$  be the length of the side adjacent to  $\theta$ , then  $\cos \theta = x/6 = 0.3$ ,  $x = 1.8$ .
12. Let  $x$  be the length of the hypotenuse, then  $\sin \theta = 2.4/x = 0.8$ ,  $x = 2.4/0.8 = 3$ .

13.

	$\theta$	$\sin \theta$	$\cos \theta$	$\tan \theta$	$\csc \theta$	$\sec \theta$	$\cot \theta$
(a)	$225^\circ$	$-1/\sqrt{2}$	$-1/\sqrt{2}$	$1$	$-\sqrt{2}$	$-\sqrt{2}$	$1$
(b)	$-210^\circ$	$1/2$	$-\sqrt{3}/2$	$-1/\sqrt{3}$	$2$	$-2/\sqrt{3}$	$-\sqrt{3}$
(c)	$5\pi/3$	$-\sqrt{3}/2$	$1/2$	$-\sqrt{3}$	$-2/\sqrt{3}$	$2$	$-1/\sqrt{3}$
(d)	$-3\pi/2$	$1$	$0$	$—$	$1$	$—$	$0$

14.

	$\theta$	$\sin \theta$	$\cos \theta$	$\tan \theta$	$\csc \theta$	$\sec \theta$	$\cot \theta$
(a)	$330^\circ$	$-1/2$	$\sqrt{3}/2$	$-1/\sqrt{3}$	$-2$	$2/\sqrt{3}$	$-\sqrt{3}$
(b)	$-120^\circ$	$-\sqrt{3}/2$	$-1/2$	$\sqrt{3}$	$-2/\sqrt{3}$	$-2$	$1/\sqrt{3}$
(c)	$9\pi/4$	$1/\sqrt{2}$	$1/\sqrt{2}$	$1$	$\sqrt{2}$	$\sqrt{2}$	$1$
(d)	$-3\pi$	$0$	$-1$	$0$	$—$	$-1$	$—$

15.

	$\sin \theta$	$\cos \theta$	$\tan \theta$	$\csc \theta$	$\sec \theta$	$\cot \theta$
(a)	4/5	3/5	4/3	5/4	5/3	3/4
(b)	-4/5	3/5	-4/3	-5/4	5/3	-3/4
(c)	1/2	$-\sqrt{3}/2$	$-1/\sqrt{3}$	2	$-2\sqrt{3}$	$-\sqrt{3}$
(d)	-1/2	$\sqrt{3}/2$	$-1/\sqrt{3}$	-2	$2/\sqrt{3}$	$-\sqrt{3}$
(e)	$1/\sqrt{2}$	$1/\sqrt{2}$	1	$\sqrt{2}$	$\sqrt{2}$	1
(f)	$1/\sqrt{2}$	$-1/\sqrt{2}$	-1	$\sqrt{2}$	$-\sqrt{2}$	-1

16.

	$\sin \theta$	$\cos \theta$	$\tan \theta$	$\csc \theta$	$\sec \theta$	$\cot \theta$
(a)	1/4	$\sqrt{15}/4$	$1/\sqrt{15}$	4	$4/\sqrt{15}$	$\sqrt{15}$
(b)	1/4	$-\sqrt{15}/4$	$-1/\sqrt{15}$	4	$-4/\sqrt{15}$	$-\sqrt{15}$
(c)	$3/\sqrt{10}$	$1/\sqrt{10}$	3	$\sqrt{10}/3$	$\sqrt{10}$	1/3
(d)	$-3/\sqrt{10}$	$-1/\sqrt{10}$	3	$-\sqrt{10}/3$	$-\sqrt{10}$	1/3
(e)	$\sqrt{21}/5$	-2/5	$-\sqrt{21}/2$	$5/\sqrt{21}$	-5/2	$-2/\sqrt{21}$
(f)	$-\sqrt{21}/5$	-2/5	$\sqrt{21}/2$	$-5/\sqrt{21}$	-5/2	$2/\sqrt{21}$

17. (a)  $x = 3 \sin 25^\circ \approx 1.2679$  (b)  $x = 3 / \tan(2\pi/9) \approx 3.5753$

18. (a)  $x = 2 / \sin 20^\circ \approx 5.8476$  (b)  $x = 3 / \cos(3\pi/11) \approx 4.5811$

19.

	$\sin \theta$	$\cos \theta$	$\tan \theta$	$\csc \theta$	$\sec \theta$	$\cot \theta$
(a)	$a/3$	$\sqrt{9 - a^2}/3$	$a/\sqrt{9 - a^2}$	$3/a$	$3/\sqrt{9 - a^2}$	$\sqrt{9 - a^2}/a$
(b)	$a/\sqrt{a^2 + 25}$	$5/\sqrt{a^2 + 25}$	$a/5$	$\sqrt{a^2 + 25}/a$	$\sqrt{a^2 + 25}/5$	$5/a$
(c)	$\sqrt{a^2 - 1}/a$	$1/a$	$\sqrt{a^2 - 1}$	$a/\sqrt{a^2 - 1}$	$a$	$1/\sqrt{a^2 - 1}$

20. (a)  $\theta = 3\pi/4 \pm 2n\pi$  and  $\theta = 5\pi/4 \pm 2n\pi$ ,  $n = 0, 1, 2, \dots$

(b)  $\theta = 5\pi/4 \pm 2n\pi$  and  $\theta = 7\pi/4 \pm 2n\pi$ ,  $n = 0, 1, 2, \dots$

21. (a)  $\theta = 3\pi/4 \pm n\pi$ ,  $n = 0, 1, 2, \dots$

(b)  $\theta = \pi/3 \pm 2n\pi$  and  $\theta = 5\pi/3 \pm 2n\pi$ ,  $n = 0, 1, 2, \dots$

22. (a)  $\theta = 7\pi/6 \pm 2n\pi$  and  $\theta = 11\pi/6 \pm 2n\pi$ ,  $n = 0, 1, 2, \dots$

(b)  $\theta = \pi/3 \pm n\pi$ ,  $n = 0, 1, 2, \dots$

23. (a)  $\theta = \pi/6 \pm n\pi$ ,  $n = 0, 1, 2, \dots$

(b)  $\theta = 4\pi/3 \pm 2n\pi$  and  $\theta = 5\pi/3 \pm 2n\pi$ ,  $n = 0, 1, 2, \dots$

24. (a)  $\theta = 3\pi/2 \pm n\pi$ ,  $n = 0, 1, 2, \dots$

(b)  $\theta = \pi \pm 2n\pi$ ,  $n = 0, 1, 2, \dots$

25. (a)  $\theta = 3\pi/4 \pm n\pi$ ,  $n = 0, 1, 2, \dots$

(b)  $\theta = \pi/6 \pm n\pi$ ,  $n = 0, 1, 2, \dots$

26. (a)  $\theta = 2\pi/3 \pm 2n\pi$  and  $\theta = 4\pi/3 \pm 2n\pi$ ,  $n = 0, 1, 2, \dots$

(b)  $\theta = 7\pi/6 \pm 2n\pi$  and  $\theta = 11\pi/6 \pm 2n\pi$ ,  $n = 0, 1, 2, \dots$

27. (a)  $\theta = \pi/3 \pm 2n\pi$  and  $\theta = 2\pi/3 \pm 2n\pi$ ,  $n = 0, 1, 2, \dots$   
 (b)  $\theta = \pi/6 \pm 2n\pi$  and  $\theta = 11\pi/6 \pm 2n\pi$ ,  $n = 0, 1, 2, \dots$
28.  $\sin \theta = -3/5$ ,  $\cos \theta = -4/5$ ,  $\tan \theta = 3/4$ ,  $\csc \theta = -5/3$ ,  $\sec \theta = -5/4$ ,  $\cot \theta = 4/3$
29.  $\sin \theta = 2/5$ ,  $\cos \theta = -\sqrt{21}/5$ ,  $\tan \theta = -2/\sqrt{21}$ ,  $\csc \theta = 5/2$ ,  $\sec \theta = -5/\sqrt{21}$ ,  $\cot \theta = -\sqrt{21}/2$
30. (a)  $\theta = \pi/2 \pm 2n\pi$ ,  $n = 0, 1, 2, \dots$  (b)  $\theta = \pm 2n\pi$ ,  $n = 0, 1, 2, \dots$   
 (c)  $\theta = \pi/4 \pm n\pi$ ,  $n = 0, 1, 2, \dots$  (d)  $\theta = \pi/2 \pm 2n\pi$ ,  $n = 0, 1, 2, \dots$   
 (e)  $\theta = \pm 2n\pi$ ,  $n = 0, 1, 2, \dots$  (f)  $\theta = \pi/4 \pm n\pi$ ,  $n = 0, 1, 2, \dots$
31. (a)  $\theta = \pm n\pi$ ,  $n = 0, 1, 2, \dots$  (b)  $\theta = \pi/2 \pm n\pi$ ,  $n = 0, 1, 2, \dots$   
 (c)  $\theta = \pm n\pi$ ,  $n = 0, 1, 2, \dots$  (d)  $\theta = \pm n\pi$ ,  $n = 0, 1, 2, \dots$   
 (e)  $\theta = \pi/2 \pm n\pi$ ,  $n = 0, 1, 2, \dots$  (f)  $\theta = \pm n\pi$ ,  $n = 0, 1, 2, \dots$
32. Construct a right triangle with one angle equal to  $17^\circ$ , measure the lengths of the sides and hypotenuse and use formula (6) for  $\sin \theta$  and  $\cos \theta$  to approximate  $\sin 17^\circ$  and  $\cos 17^\circ$ .

33. (a)  $s = r\theta = 4(\pi/6) = 2\pi/3$  cm (b)  $s = r\theta = 4(5\pi/6) = 10\pi/3$  cm
34.  $r = s/\theta = 7/(\pi/3) = 21/\pi$  35.  $\theta = s/r = 2/5$

36.  $\theta = s/r$  so  $A = \frac{1}{2}r^2\theta = \frac{1}{2}r^2(s/r) = \frac{1}{2}rs$

37. (a)  $2\pi r = R(2\pi - \theta)$ ,  $r = \frac{2\pi - \theta}{2\pi}R$   
 (b)  $h = \sqrt{R^2 - r^2} = \sqrt{R^2 - (2\pi - \theta)^2 R^2 / (4\pi^2)} = \frac{\sqrt{4\pi\theta - \theta^2}}{2\pi}R$

38. The circumference of the circular base is  $2\pi r$ . When cut and flattened, the cone becomes a circular sector of radius  $L$ . If  $\theta$  is the central angle that subtends the arc of length  $2\pi r$ , then  $\theta = (2\pi r)/L$  so the area  $S$  of the sector is  $S = (1/2)L^2(2\pi r/L) = \pi rL$  which is the lateral surface area of the cone.

39. Let  $h$  be the altitude as shown in the figure, then  
 $h = 3 \sin 60^\circ = 3\sqrt{3}/2$  so  $A = \frac{1}{2}(3\sqrt{3}/2)(7) = 21\sqrt{3}/4$ .

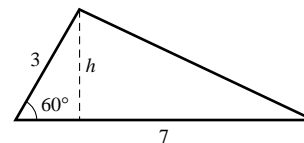

40. Draw the perpendicular from vertex  $C$  as shown in the figure, then  
 $h = 9 \sin 30^\circ = 9/2$ ,  $a = h/\sin 45^\circ = 9\sqrt{2}/2$ ,  
 $c_1 = 9 \cos 30^\circ = 9\sqrt{3}/2$ ,  $c_2 = a \cos 45^\circ = 9/2$ ,  
 $c_1 + c_2 = 9(\sqrt{3} + 1)/2$ , angle  $C = 180^\circ - (30^\circ + 45^\circ) = 105^\circ$

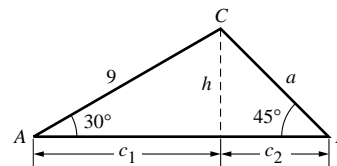

41. Let  $x$  be the distance above the ground, then  $x = 10 \sin 67^\circ \approx 9.2$  ft.  
 42. Let  $x$  be the height of the building, then  $x = 120 \tan 76^\circ \approx 481$  ft.

43. From the figure,  $h = x - y$  but  $x = d \tan \beta$ ,  
 $y = d \tan \alpha$  so  $h = d(\tan \beta - \tan \alpha)$ .

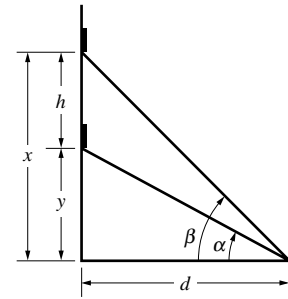

44. From the figure,  $d = x - y$  but  $x = h \cot \alpha$ ,  
 $y = h \cot \beta$  so  $d = h(\cot \alpha - \cot \beta)$ ,

$$h = \frac{d}{\cot \alpha - \cot \beta}.$$

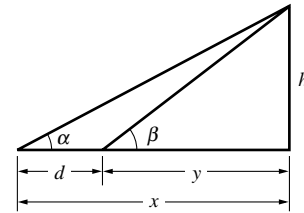

45. (a)  $\sin 2\theta = 2 \sin \theta \cos \theta = 2(\sqrt{5}/3)(2/3) = 4\sqrt{5}/9$

(b)  $\cos 2\theta = 2 \cos^2 \theta - 1 = 2(2/3)^2 - 1 = -1/9$

46. (a)  $\sin(\alpha - \beta) = \sin \alpha \cos \beta - \cos \alpha \sin \beta = (3/5)(1/\sqrt{5}) - (4/5)(2/\sqrt{5}) = -1/\sqrt{5}$

(b)  $\cos(\alpha + \beta) = \cos \alpha \cos \beta - \sin \alpha \sin \beta = (4/5)(1/\sqrt{5}) - (3/5)(2/\sqrt{5}) = -2/(5\sqrt{5})$

47.  $\sin 3\theta = \sin(2\theta + \theta) = \sin 2\theta \cos \theta + \cos 2\theta \sin \theta = (2 \sin \theta \cos \theta) \cos \theta + (\cos^2 \theta - \sin^2 \theta) \sin \theta$   
 $= 2 \sin \theta \cos^2 \theta + \sin \theta \cos^2 \theta - \sin^3 \theta = 3 \sin \theta \cos^2 \theta - \sin^3 \theta$ ; similarly,  $\cos 3\theta = \cos^3 \theta - 3 \sin^2 \theta \cos \theta$

48.  $\frac{\cos \theta \sec \theta}{1 + \tan^2 \theta} = \frac{\cos \theta \sec \theta}{\sec^2 \theta} = \frac{\cos \theta}{\sec \theta} = \frac{\cos \theta}{(1/\cos \theta)} = \cos^2 \theta$

49.  $\frac{\cos \theta \tan \theta + \sin \theta}{\tan \theta} = \frac{\cos \theta(\sin \theta / \cos \theta) + \sin \theta}{\sin \theta / \cos \theta} = 2 \cos \theta$

50.  $2 \csc 2\theta = \frac{2}{\sin 2\theta} = \frac{2}{2 \sin \theta \cos \theta} = \left(\frac{1}{\sin \theta}\right) \left(\frac{1}{\cos \theta}\right) = \csc \theta \sec \theta$

51.  $\tan \theta + \cot \theta = \frac{\sin \theta}{\cos \theta} + \frac{\cos \theta}{\sin \theta} = \frac{\sin^2 \theta + \cos^2 \theta}{\sin \theta \cos \theta} = \frac{1}{\sin \theta \cos \theta} = \frac{2}{2 \sin \theta \cos \theta} = \frac{2}{\sin 2\theta} = 2 \csc 2\theta$

52.  $\frac{\sin 2\theta}{\sin \theta} - \frac{\cos 2\theta}{\cos \theta} = \frac{\sin 2\theta \cos \theta - \cos 2\theta \sin \theta}{\sin \theta \cos \theta} = \frac{\sin \theta}{\sin \theta \cos \theta} = \sec \theta$

53.  $\frac{\sin \theta + \cos 2\theta - 1}{\cos \theta - \sin 2\theta} = \frac{\sin \theta + (1 - 2 \sin^2 \theta) - 1}{\cos \theta - 2 \sin \theta \cos \theta} = \frac{\sin \theta(1 - 2 \sin \theta)}{\cos \theta(1 - 2 \sin \theta)} = \tan \theta$

54. Using (47),  $2 \sin 2\theta \cos \theta = 2(1/2)(\sin \theta + \sin 3\theta) = \sin \theta + \sin 3\theta$

55. Using (47),  $2 \cos 2\theta \sin \theta = 2(1/2)[\sin(-\theta) + \sin 3\theta] = \sin 3\theta - \sin \theta$



56.  $\tan(\theta/2) = \frac{\sin(\theta/2)}{\cos(\theta/2)} = \frac{2 \sin^2(\theta/2)}{2 \sin(\theta/2) \cos(\theta/2)} = \frac{1 - \cos \theta}{\sin \theta}$

57.  $\tan(\theta/2) = \frac{\sin(\theta/2)}{\cos(\theta/2)} = \frac{2 \sin(\theta/2) \cos(\theta/2)}{2 \cos^2(\theta/2)} = \frac{\sin \theta}{1 + \cos \theta}$

58. From (52),  $\cos(\pi/3 + \theta) + \cos(\pi/3 - \theta) = 2 \cos(\pi/3) \cos \theta = 2(1/2) \cos \theta = \cos \theta$

59. From the figure, area =  $\frac{1}{2}hc$  but  $h = b \sin A$   
 so area =  $\frac{1}{2}bc \sin A$ . The formulas

area =  $\frac{1}{2}ac \sin B$  and area =  $\frac{1}{2}ab \sin C$

follow by drawing altitudes from vertices  $B$  and  $C$ , respectively.

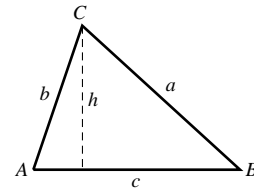

60. From right triangles  $ADC$  and  $BDC$ ,  
 $h_1 = b \sin A = a \sin B$  so  $a/\sin A = b/\sin B$ .  
 From right triangles  $AEB$  and  $CEB$ ,  
 $h_2 = c \sin A = a \sin C$  so  $a/\sin A = c/\sin C$   
 thus  $a/\sin A = b/\sin B = c/\sin C$ .

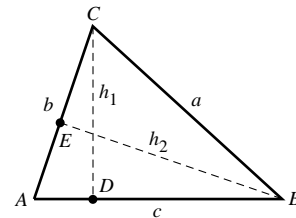

61. (a)  $\sin(\pi/2 + \theta) = \sin(\pi/2) \cos \theta + \cos(\pi/2) \sin \theta = (1) \cos \theta + (0) \sin \theta = \cos \theta$   
 (b)  $\cos(\pi/2 + \theta) = \cos(\pi/2) \cos \theta - \sin(\pi/2) \sin \theta = (0) \cos \theta - (1) \sin \theta = -\sin \theta$   
 (c)  $\sin(3\pi/2 - \theta) = \sin(3\pi/2) \cos \theta - \cos(3\pi/2) \sin \theta = (-1) \cos \theta - (0) \sin \theta = -\cos \theta$   
 (d)  $\cos(3\pi/2 + \theta) = \cos(3\pi/2) \cos \theta - \sin(3\pi/2) \sin \theta = (0) \cos \theta - (-1) \sin \theta = \sin \theta$

62.  $\tan(\alpha + \beta) = \frac{\sin(\alpha + \beta)}{\cos(\alpha + \beta)} = \frac{\sin \alpha \cos \beta + \cos \alpha \sin \beta}{\cos \alpha \cos \beta - \sin \alpha \sin \beta}$ , divide numerator and denominator by  $\cos \alpha \cos \beta$  and use  $\tan \alpha = \frac{\sin \alpha}{\cos \alpha}$  and  $\tan \beta = \frac{\sin \beta}{\cos \beta}$  to get (38);  
 $\tan(\alpha - \beta) = \tan(\alpha + (-\beta)) = \frac{\tan \alpha + \tan(-\beta)}{1 - \tan \alpha \tan(-\beta)} = \frac{\tan \alpha - \tan \beta}{1 + \tan \alpha \tan \beta}$  because  
 $\tan(-\beta) = -\tan \beta$ .

63. (a) Add (34) and (36) to get  $\sin(\alpha - \beta) + \sin(\alpha + \beta) = 2 \sin \alpha \cos \beta$  so  
 $\sin \alpha \cos \beta = (1/2)[\sin(\alpha - \beta) + \sin(\alpha + \beta)]$ .  
 (b) Subtract (35) from (37).  
 (c) Add (35) and (37).

64. (a) From (47),  $\sin \frac{A+B}{2} \cos \frac{A-B}{2} = \frac{1}{2}(\sin B + \sin A)$  so  
 $\sin A + \sin B = 2 \sin \frac{A+B}{2} \cos \frac{A-B}{2}$ .

(b) Use (49)

(c) Use (48)

65.  $\sin \alpha + \sin(-\beta) = 2 \sin \frac{\alpha - \beta}{2} \cos \frac{\alpha + \beta}{2}$ , but  $\sin(-\beta) = -\sin \beta$  so
- $$\sin \alpha - \sin \beta = 2 \cos \frac{\alpha + \beta}{2} \sin \frac{\alpha - \beta}{2}.$$
66. (a) From (34),  $C \sin(\alpha + \phi) = C \sin \alpha \cos \phi + C \cos \alpha \sin \phi$  so  $C \cos \phi = 3$  and  $C \sin \phi = 5$ , square and add to get  $C^2(\cos^2 \phi + \sin^2 \phi) = 9 + 25$ ,  $C^2 = 34$ . If  $C = \sqrt{34}$  then  $\cos \phi = 3/\sqrt{34}$  and  $\sin \phi = 5/\sqrt{34}$  so  $\phi$  is the first-quadrant angle for which  $\tan \phi = 5/3$ .  
 $3 \sin \alpha + 5 \cos \alpha = \sqrt{34} \sin(\alpha + \phi)$ .
- (b) Follow the procedure of part (a) to get  $C \cos \phi = A$  and  $C \sin \phi = B$ ,  $C = \sqrt{A^2 + B^2}$ ,  $\tan \phi = B/A$  where the quadrant in which  $\phi$  lies is determined by the signs of  $A$  and  $B$  because  $\cos \phi = A/C$  and  $\sin \phi = B/C$ , so  $A \sin \alpha + B \cos \alpha = \sqrt{A^2 + B^2} \sin(\alpha + \phi)$ .
67. Consider the triangle having  $a$ ,  $b$ , and  $d$  as sides. The angle formed by sides  $a$  and  $b$  is  $\pi - \theta$  so from the law of cosines,  $d^2 = a^2 + b^2 - 2ab \cos(\pi - \theta) = a^2 + b^2 + 2ab \cos \theta$ ,  $d = \sqrt{a^2 + b^2 + 2ab \cos \theta}$ .

# APPENDIX F

## Solving Polynomial Equations

### EXERCISE SET F

1. (a)  $q(x) = x^2 + 4x + 2, r(x) = -11x + 6$  (b)  $q(x) = 2x^2 + 4, r(x) = 9$   
 (c)  $q(x) = x^3 - x^2 + 2x - 2, r(x) = 2x + 1$
2. (a)  $q(x) = 2x^2 - x + 2, r(x) = 5x + 5$  (b)  $q(x) = x^3 + 3x^2 - x + 2, r(x) = 3x - 1$   
 (c)  $q(x) = 5x^3 - 5, r(x) = 4x^2 + 10$
3. (a)  $q(x) = 3x^2 + 6x + 8, r(x) = 15$  (b)  $q(x) = x^3 - 5x^2 + 20x - 100, r(x) = 504$   
 (c)  $q(x) = x^4 + x^3 + x^2 + x + 1, r(x) = 0$
4. (a)  $q(x) = 2x^2 + x - 1, r(x) = 0$  (b)  $q(x) = 2x^3 - 5x^2 + 3x - 39, r(x) = 147$   
 (c)  $q(x) = x^6 + x^5 + x^4 + x^3 + x^2 + x + 1, r(x) = 2$

5. 

$x$	0	1	-3	7
$p(x)$	-4	-3	101	5001

6. 

$x$	1	-1	3	-3	7	-7	21	-21
$p(x)$	-24	-12	12	0	420	-168	10416	-7812

7. (a)  $q(x) = x^2 + 6x + 13, r = 20$  (b)  $q(x) = x^2 + 3x - 2, r = -4$
8. (a)  $q(x) = x^4 - x^3 + x^2 - x + 1, r = -2$  (b)  $q(x) = x^4 + x^3 + x^2 + x + 1, r = 0$
9. Assume  $r = a/b$   $a$  and  $b$  integers with  $a > 0$ :  
 (a)  $b$  divides 1,  $b = \pm 1$ ;  $a$  divides 24,  $a = 1, 2, 3, 4, 6, 8, 12, 24$ ;  
 the possible candidates are  $\{\pm 1, \pm 2, \pm 3, \pm 4, \pm 6, \pm 8, \pm 12, \pm 24\}$   
 (b)  $b$  divides 3 so  $b = \pm 1, \pm 3$ ;  $a$  divides  $-10$  so  $a = 1, 2, 5, 10$ ;  
 the possible candidates are  $\{\pm 1, \pm 2, \pm 5, \pm 10, \pm 1/3, \pm 2/3, \pm 5/3, \pm 10/3\}$   
 (c)  $b$  divides 1 so  $b = \pm 1$ ;  $a$  divides 17 so  $a = 1, 17$ ;  
 the possible candidates are  $\{\pm 1, \pm 17\}$
10. An integer zero  $c$  divides  $-21$ , so  $c = \pm 1, \pm 3, \pm 7, \pm 21$  are the only possibilities; substitution of these candidates shows that the integer zeros are  $-7, -1, 3$
11.  $(x + 1)(x - 1)(x - 2)$                       12.  $(x + 2)(3x + 1)(x - 2)$
13.  $(x + 3)^3(x + 1)$                               14.  $2x^4 + x^3 - 19x^2 + 9$
15.  $(x + 3)(x + 2)(x + 1)^2(x - 3)$                       17.  $-3$  is the only real root.
18.  $x = -3/2$  is the only real root.                      19.  $x = -2, -2/3$  are the only real roots.

20.  $-2, -1, 1/2, 3$
21.  $-2, 2, 3$  are the only real roots.
23. If  $x - 1$  is a factor then  $p(1) = 0$ , so  $k^2 - 7k + 10 = 0$ ,  $k^2 - 7k + 10 = (k - 2)(k - 5)$ , so  $k = 2, 5$ .
24.  $(-3)^7 = -2187$ , so  $-3$  is a root and thus by Theorem F.4(a),  $x + 3$  is a factor of  $x^7 + 2187$ .
25. If the side of the cube is  $x$  then  $x^2(x - 3) = 196$ ; the only real root of this equation is  $x = 7$  cm.
26. (a) Try to solve  $\frac{a}{b} > \left(\frac{a}{b}\right)^3 + 1$ . The polynomial  $p(x) = x^3 - x + 1$  has only one real root  $c \approx -1.325$ , and  $p(0) = 1$  so  $p(x) > 0$  for all  $x > c$ ; hence there is no positive rational solution of  $\frac{a}{b} > \left(\frac{a}{b}\right)^3 + 1$ .
- (b) From part (a), any real  $x < c$  is a solution.
27. Use the Factor Theorem with  $x$  as the variable and  $y$  as the constant  $c$ .
- (a) For any positive integer  $n$  the polynomial  $x^n - y^n$  has  $x = y$  as a root.
- (b) For any positive even integer  $n$  the polynomial  $x^n - y^n$  has  $x = -y$  as a root.
- (c) For any positive odd integer  $n$  the polynomial  $x^n + y^n$  has  $x = -y$  as a root.