

Lovejoy Hydraulics
Water-Oil Coolers

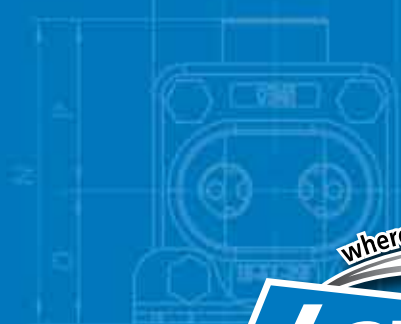
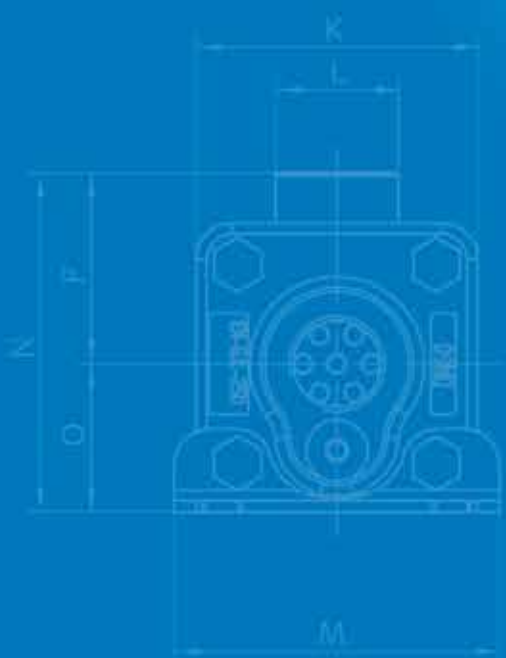

where the world turns for

Lovejoy

Hydraulics



Water-Oil Coolers

Table of Contents

	Page No.
Overview.....	4
BNZ Cooler Construction > Overview / Technical Data.....	5
BNZ Cooler Cartridges > Overview / Maximum Flow Rates	6
Selection Process.....	7
Oil Viscosity Correction Multipliers > Selection Process	8
1:1 Oil to Water Ratio > BNZ 60-131 to 920 and BNZ 80-208 to 920 / 1 Pass	9
1:1 Oil to Water Ratio > BNZ 125-310 to 920 and BNZ 125-1225 / 1 Pass	10
2:1 Oil to Water Ratio > BNZ 60-131 to 920 and BNZ 80-208 to 920 / 2 Pass	11
2:1 Oil to Water Ratio > BNZ 125-310 to 920 and BNZ 125-1225 / 2 Pass	12
4:1 Oil to Water Ratio > BNZ 60-208 to 463 and BNZ 80-208 to 920 / 2 Pass	13
4:1 Oil to Water Ratio > BNZ 80-208 to 920 / 4 Pass and BNZ 125-310 to 615 / 2 Pass	14
4:1 Oil to Water Ratio > BNZ 125-920 to 1225 / 2 Pass.....	15
7:1 Oil to Water Ratio > BNZ 60-310 to 463 and BNZ 80-208 to 615 / 2 Pass	16
7:1 Oil to Water Ratio > BNZ 80-208 to 920 / 4 Pass and BNZ 125-310 to 615 / 2 Pass	17
7:1 Oil to Water Ratio > BNZ 125-920 to 1225 / 2 Pass.....	18
10:1 Oil to Water Ratio > BNZ 60-310 / 2 Pass and BNZ 80-208 to 920 / 4 Pass	19
10:1 Oil to Water Ratio > BNZ 125-310 to 920 and BNZ 125-910 to 1225 / 4 Pass	20
Application Guidelines.....	21
1 Pass Models > Dimensional Data	22-23
2 Pass Models > Dimensional Data	24-25
4 Pass Models > Dimensional Data	26-27
1 Pass Models > Series Number - Product Code Breakdown / Item Selection.....	28
2 and 4 Pass Models > Item Selection	29
Product Warranty.....	31

Lovejoy, Inc has made every effort to assure the accuracy of the information contained in this catalog. However, Lovejoy, Inc expressly disclaims any and all liability for the contents of this catalog including, but not limited to, errors, inaccuracies, misstatements, omissions and any incidental or consequential damages which may occur as the result of relying on this information. Lovejoy reserves the right to change specifications and information without notice.

The BNZ Series of water - oil coolers provide an efficient way to cool hydraulic fluid utilizing shell and tube technology. The design consists of an outer housing shell and a tube / fin bundle known as a "cartridge", which fits inside the shell. Hydraulic fluid to be cooled is circulated through the housing shell and passes across the cooling fins, which transfers the heat to the cooling tubes in the cartridge. Cooling fluid, being typically water or water-glycol, flows through the cooling tubes that pass through the cartridge, carries the absorbed heat away. This rugged design offers high heat removal in a compact package. A large variety of cooling capacity sizes, port options and material choices are available to tailor the optimum cooler to meet specific application needs. For more application information, refer to the "Application Guidelines" section.

Features

- Compact size – "Shell and Tube Design"
- Extended cooling surface
- Low pressure drop – high efficiency
- Heat removal up to 400 hp [295 kW]
- Oil flow rates up to 105 GPM [400 l/min]
 [For higher flow rates, consult Lovejoy Hydraulics Technical Engineering]
- Removable end caps for easy cleaning
- Close-tolerance port face locations
- Interchangeable with Thermal Transfer EK series
- 100% pressure tested, leak-free performance
- Design flexibility
 - Three frame sizes to choose (BNZ 60, 80 and 125)
 - Customized lengths available
 - NPT, SAE O-Ring, BSPP and SAE Flange port options
 - Mounting may be rotated in 90 degree increments
 - Optional materials for increased corrosion protection

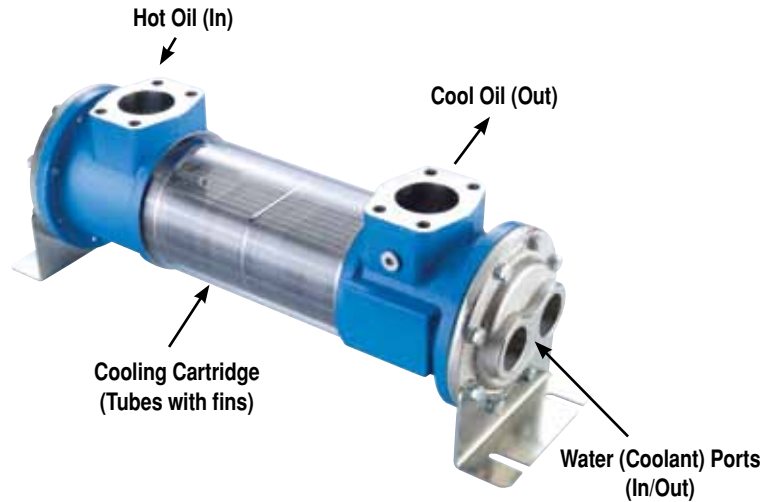

Materials

Component	Standard-Cooler	Sea water-Cooler	Optional Materials
Tubes	Cu	CuNi 90/10	—
Shell, guide plate, brackets, bypass valve	Steel	Steel	—
End cover	Cast Iron GG25	Electroless nickel-plated	Stainless Steel 1.4408 (AISI316)
Fins	Aluminum	Aluminum	Copper/Stainless Steel 1.4304 (AISI304)
Tube sheet	Steel	Steel with CuNi end plate 90/10	Stainless Steel
Gaskets	Flat Gaskets C4400	—	—

Ratings

Maximum Operating Pressure/Shell side..... 580 psi [40 bar]
 Maximum Operating Pressure/Tube side..... 230 psi [16 bar]
 Maximum Flow Rate Volumes..... 105 GPM [400 l/min]
 Maximum Operating Temperature..... 250° F [121°C] (higher temperatures on request)

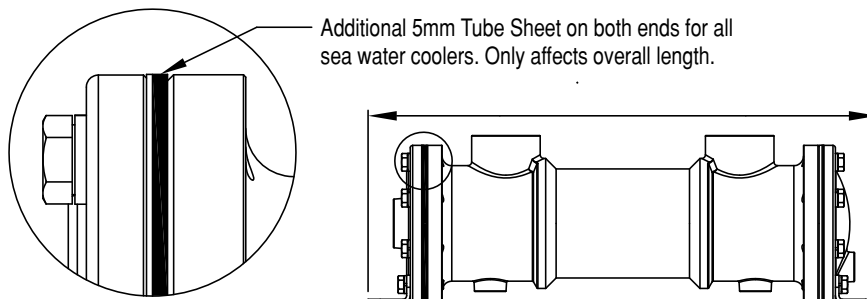

BNZ Cooler Construction

Materials

- Cast iron end caps
 - Stainless Steel optional
- Cast iron port housings
- Steel mounting brackets
 - May be rotated in 90 degree increments
- Welded steel shell tube
- C440 gaskets (compatible with fluids)
- Steel drain plug



Port Options Include

- NPT
- SAE O-Ring
- BSPP
- SAE Flange

Technical Data

Series	Surface Area		Oil Ports				Water Coolant Ports						Drain Plug	Test Port	Flange Bolt ¹	
			NPT	SAE O-Ring	BSPP	SAE Flange	1 Pass		2 Pass		4 Pass					
	m2	ft2	in	in	in	in	NPT	BSPP	NPT	BSPP	NPT	BSPP	in	in	mm	
BNZ 60-131	0.34	3.6	1/2 NPT	3/4-16 SAE O-Ring (-8)	G 1/2	—										
BNZ 60-208	0.60	6.4	3/4 NPT	1-1/16 - 12 SAE O-Ring (-12)	G 3/4	—	3/4 NPT	G 3/4	1/2 NPT	G 3/8	—	—	1/8-27 NPT	—	—	
BNZ 60-259	0.84	9.0														
BNZ 60-310	0.93	10.0														
BNZ 60-361	1.09	11.7														
BNZ 60-463	1.43	15.3														
BNZ 60-615	1.90	20.5														
BNZ 60-920	2.90	31.2														
BNZ 80-208	1.17	12.6	1-1/2 NPT	1-7/8 - 12 SAE O-Ring (-24)	G 1 1/2	—										
BNZ 80-310	1.78	19.1				SAE 1-1/2	1-1/2 NPT	G 1-1/4	1 NPT	G 1	1/2 NPT	G 1/2	1/4-18 NPT	1/4-18 NPT	M12	
BNZ 80-361	2.12	22.8														
BNZ 80-463	2.76	29.7														
BNZ 80-615	3.67	39.5														
BNZ 80-920	5.55	59.7														
BNZ 125-310	3.68	39.6	2 NPT	1-7/8 - 12 SAE O-Ring (-24)	G 1 1/2	SAE 2	1-1/2 NPT	G 1-1/2	1-1/4 NPT	G 1-1/4	3/4 NPT	G 3/4	1/4-18 NPT	1/4-18 NPT	M12	
BNZ 125-361	4.40	47.3														
BNZ 125-463	5.64	60.7														
BNZ 125-615	7.68	82.6														
BNZ 125-920	13.15	141.5														
BNZ 125-1225	15.27	164.3														

Note: ■ 1 indicates: Unified Thread Standard (UTS) [controlled by ANSI] standard machine thread bolt holes on flanges are available at no additional charge upon request.

BNZ Cooler Cartridges

- Tubes with aluminum fins provide extended cooler surface for additional cooler capacity in a compact package
- Aluminum fins are mechanically bonded to the tubes using a tube expansion process proprietary to Lovejoy, Inc.
- Each cartridge has a minimum of 1 baffle plate with longer designs having additional baffle plates to provide flow restriction and routing hot oil through the proper number of cooling passes
- Copper tubes are standard
 - Copper Nickel is available

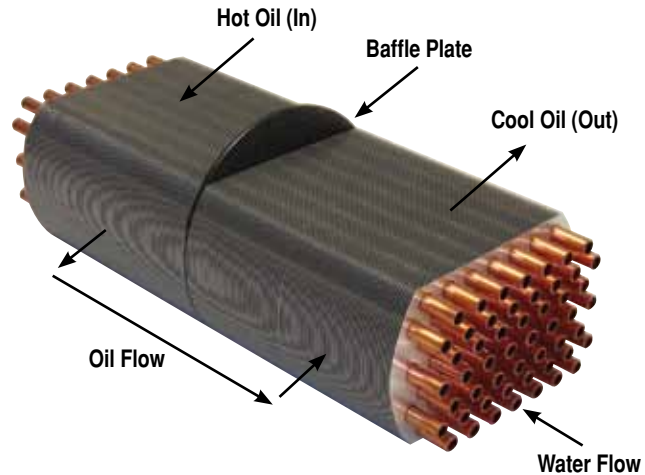

Maximum Flow Rate Volumes

Series	Shell Side (Oil)		Tube Side (Water)					
			1 Pass Copper		2 Pass Copper		4 Pass Copper	
	GPM	l/min	GPM	l/min	GPM	l/min	GPM	l/min
BNZ 60	20	75	12.4	47	6.1	23	—	—
BNZ 80 G*/F*	59	225	23.8	90	11.9	45	5.8	22
BNZ 125 - G*	87	330	54.4	206	27.2	103	13.5	51
BNZ 125 - F*	105	400	54.4	206	27.2	103	13.5	51

- Notes:
- G* indicates: Cooler with SAE O-Ring ports or metric BSPP ports.
 - F* indicates: Cooler with SAE Flange ports.
 - Copper Nickel tube material available for corrosive fluids. For more information please contact your Lovejoy Sales Representative.
 - For sea water application: water volume should be reduced. Please contact Lovejoy Hydraulic Technical Engineering.



Steps In Selecting a BNZ Cooler:

Note: Performance Curves are based on 100 SSU oil leaving the cooler 40°F higher than the incoming water temperature (40°F approach temperature).

Step 1: Determine how much heat that needs to be removed from the system (the Heat Load).

This will vary from system to system, but typically coolers are sized to remove 25 to 50% of the input nameplate horsepower, with 30% being an average number. (For Example: 100 HP Power Unit x .30 = 30HP Heat load.)

If BTU/Hr. is known: $HP = \frac{BTU/Hr}{2545}$

Step 2: Determine the Approach Temperature.

The desired oil leaving cooler (°F) minus the water inlet temperature (°F) = Actual Approach

Step 3: Determine Curve Horsepower Heat Load.

Enter the information from above:

HP heat load x $\frac{40}{\text{Actual Approach}}$ x Viscosity Correction from graph line A* = Graph Horsepower

*From the Oil Viscosity Corrections Multipliers graph on page 8, use "A" line on graph (Example: if oil is 500 SSU, then viscosity correction is 1.5)

Step 4: Enter Graph at oil flow through cooler (X-Axis) and Graph horsepower (Y-Axis). Graphs on pages 9-20.

Where the two lines intersect is your horsepower heat load at the stated oil flow.

Any curve above the intersecting point will work.

Step 5: Determine the Oil Pressure Drop from cooler performance curves.

Review the Oil Viscosity Corrections Multipliers graph on page 8 for selected water usage ratio (1:1, 2:1, 4:1, etc); 5psi pressure drop will be at lower left end of graph line, and 20psi will be toward upper right end of cooler graph line
Multiply pressure drop from cooler performance graph by correction factor B* found on oil viscosity correction graph.

*From the Oil Viscosity Corrections Multipliers graph on page 8, use "B" line on graph (Example: if the oil being used is 150 SSU, then viscosity correction is 1.5; actual pressure drop of cooler will be 1.5 times the pressure drop shown on the graph.)

● = 5 PSI; ■ = 10 PSI; ▲ = 20 PSI

Oil Temperature

Oil coolers can be selected by using entering or leaving oil temperatures.

Typical operating temperature ranges are:

Hydraulic Motor Oil	110°F – 130°F
Hydrostatic Drive Oil	130°F – 180°F
Lube Oil Circuits	110°F – 130°F
Automatic Transmission Fluid	200°F – 300°F



Water-Oil Coolers

Oil Viscosity Correction Multipliers

Selection Process

Desired Reservoir Temperature

- Return Line Cooling: Desired temperature is the oil temperature leaving the cooler. This will be the same temperature that will be found in the reservoir.
- Off-Line Recirculation Cooling Loop: Desired temperature is the temperature entering the cooler. In this case, the oil temperature change must be determined so that the actual oil leaving temperature can be found.

Calculate the oil temperature change (Oil ΔT) with this formula:

$$\text{Oil } \Delta T = (\text{BTU's/Hr.}) / (\text{GPM Oil Flow} \times 210)$$

- To calculate the oil leaving temperature from the cooler, use this formula:

$$\text{Oil Leaving Temperature} = \text{Oil Entering Temperature} - \text{Oil } \Delta T$$

Note: This formula may also be used in any application where the only temperature available is the entering oil temperature.

- Oil Pressure Drop: Most systems can tolerate a pressure drop through the heat exchanger of 20 to 30 PSI. Excessive pressure drop should be avoided.

Care should be taken to limit pressure drop to 5 PSI or less for case drain applications where high back pressure may damage the pump shaft seals.

Oil Viscosity Correction Multipliers

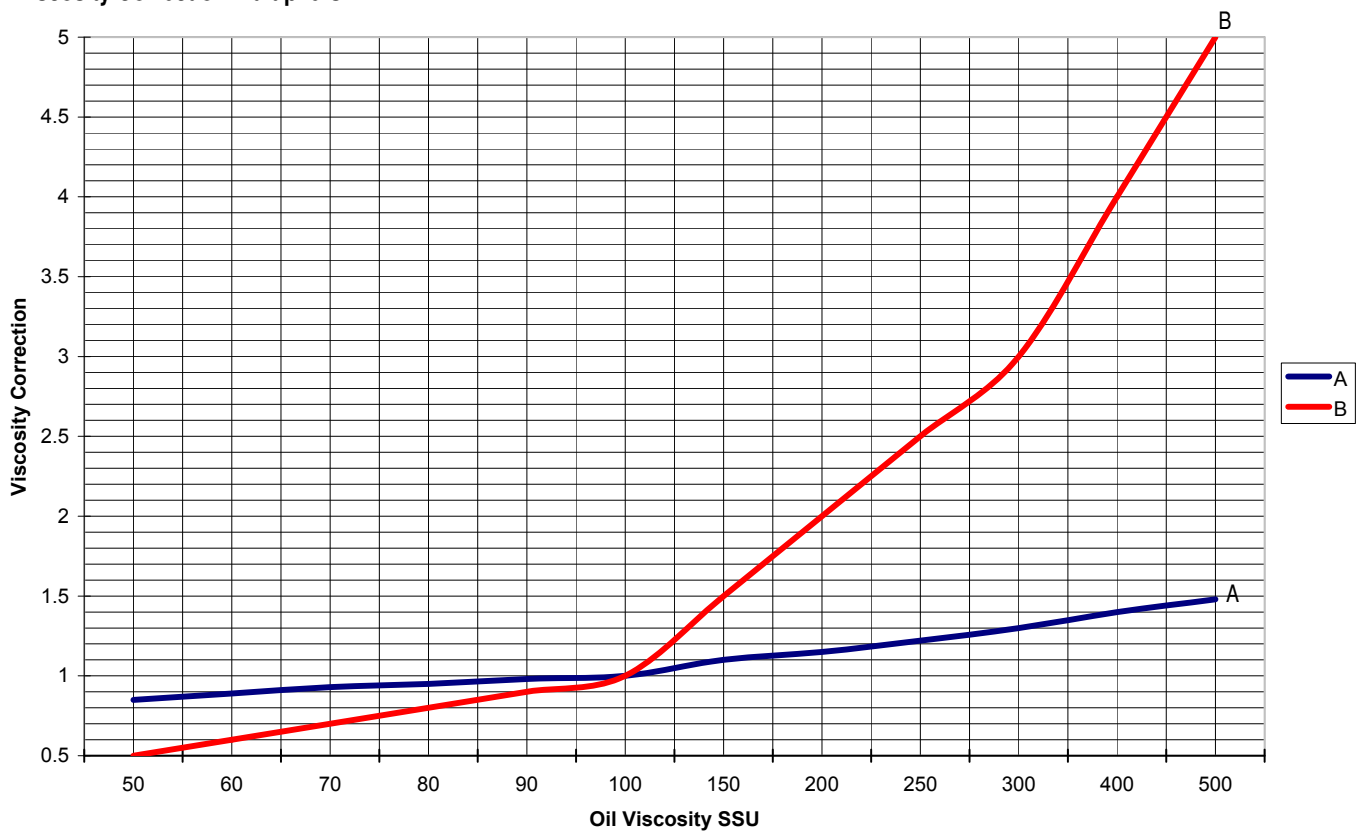



Water-Oil Coolers

1:1 Oil to Water Ratio

BNZ 60-131 to 920 and BNZ 80-208 to 920 / 1 Pass

BNZ 60-131 to 920, 1 Pass, 1:1 Oil to Water Ratio

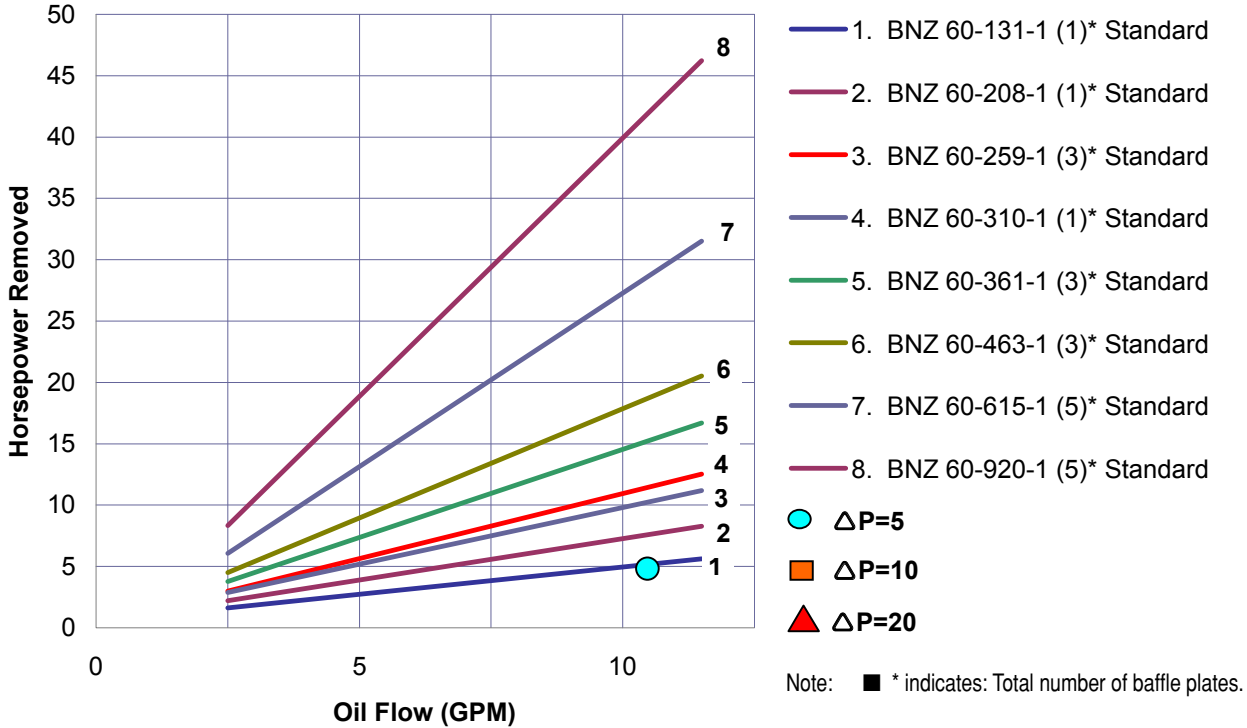

BNZ 80-208 to 920, 1 Pass, 1:1 Oil to Water Ratio

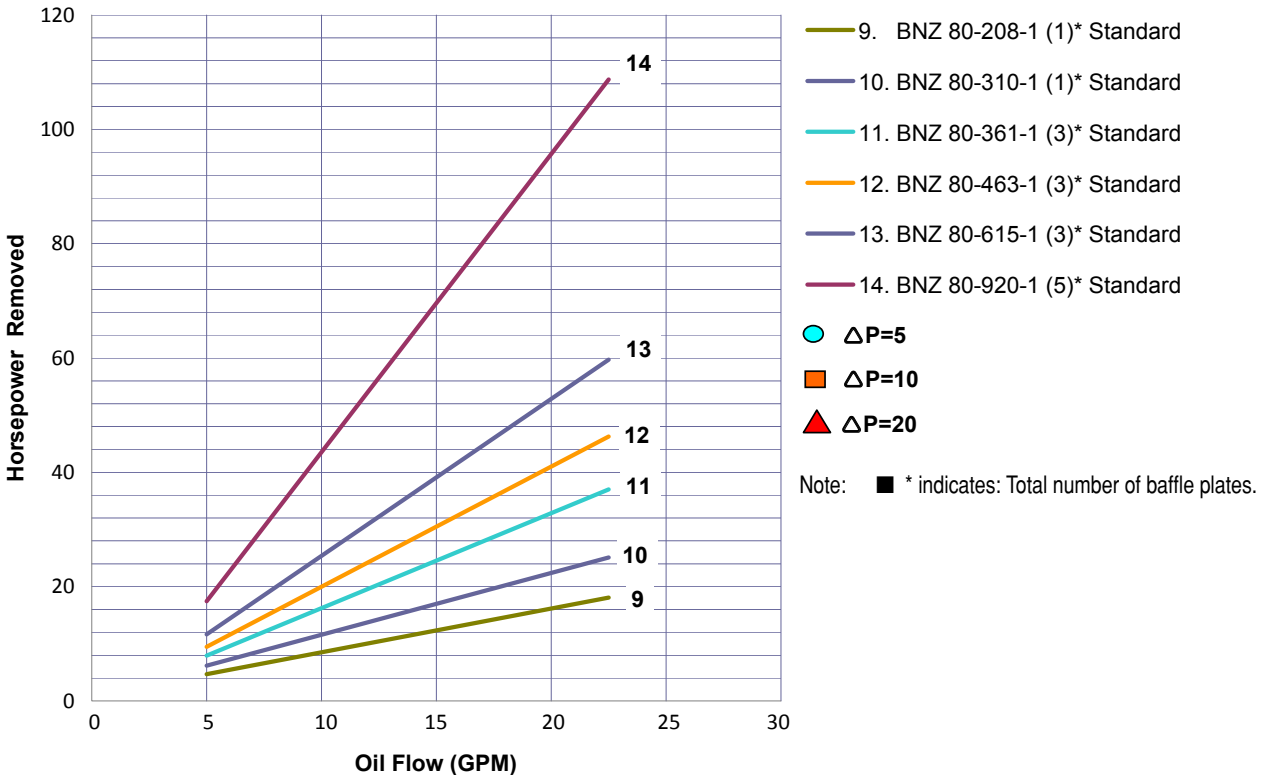



Water-Oil Coolers

1:1 Oil to Water Ratio

BNZ 125-310 to 920 and BNZ 125-1225 / 1 Pass

BNZ 125-310 to 920, 1 Pass, 1:1 Oil to Water Ratio

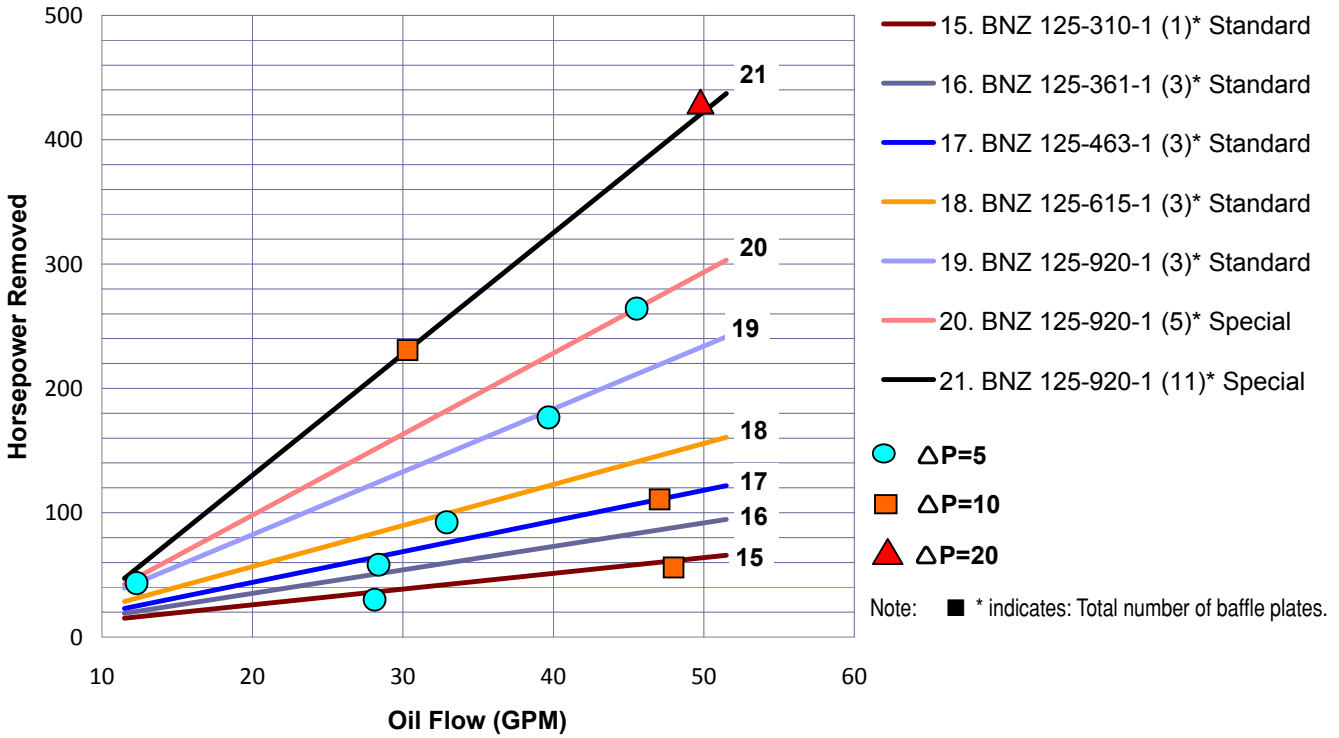

BNZ 125-1225, 1 Pass, 1:1 Oil to Water Ratio

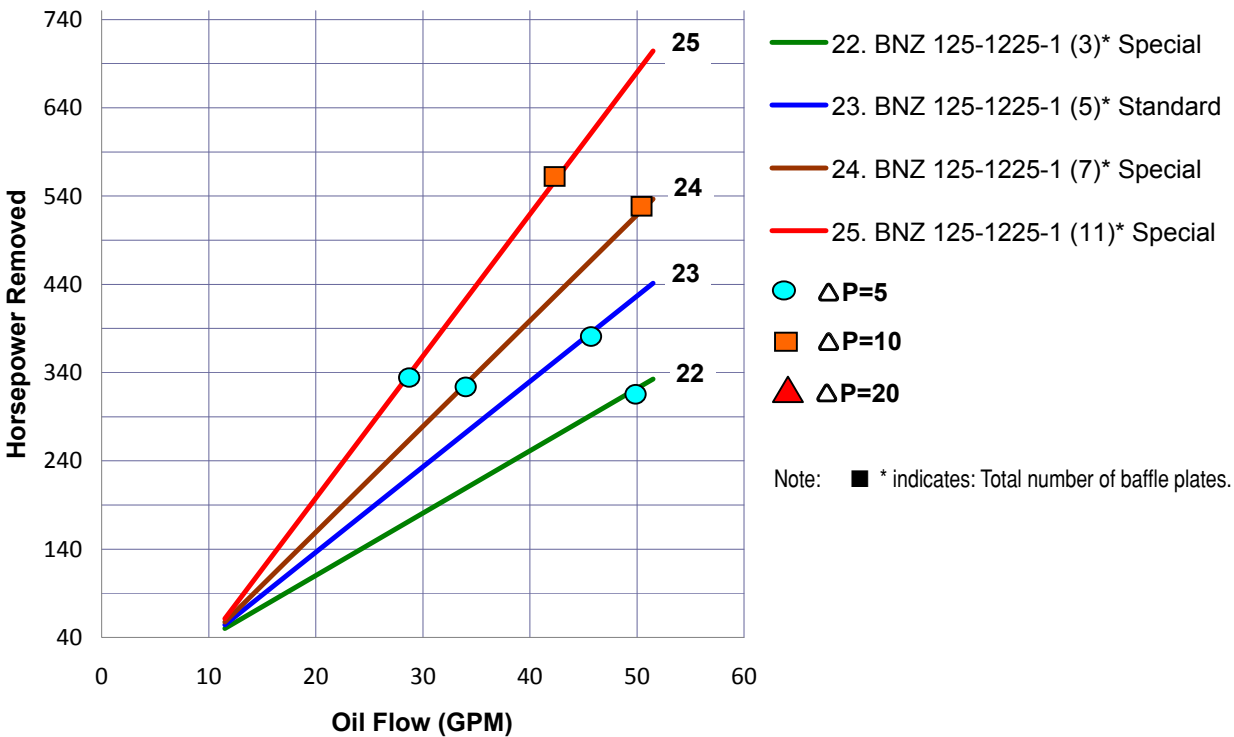



Water-Oil Coolers

2:1 Oil to Water Ratio

BNZ 60-131 to 920 and BNZ 80-208 to 920 / 2 Pass

BNZ 60-131 to 920, 2 Pass, 2:1 Oil to Water Ratio

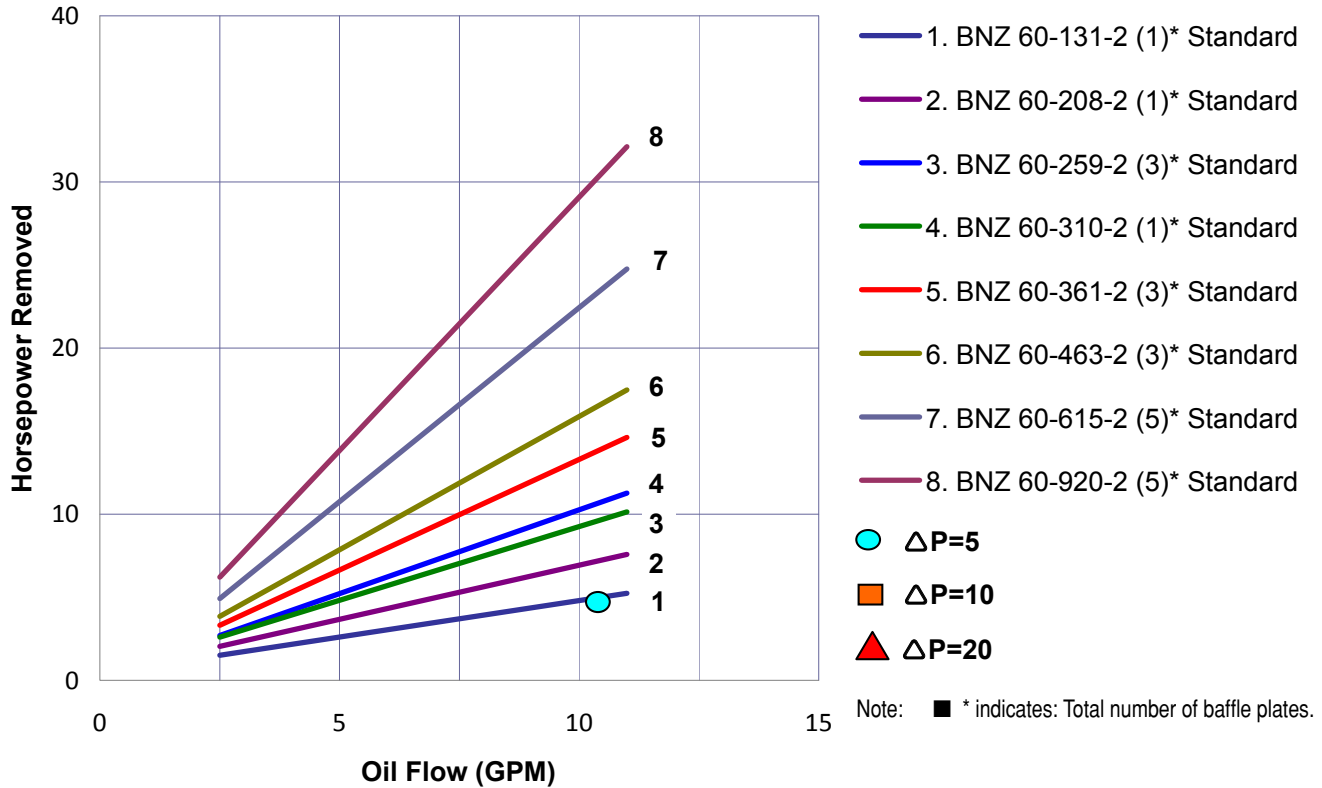

BNZ 80-208 to 920, 2 Pass, 2:1 Oil to Water Ratio

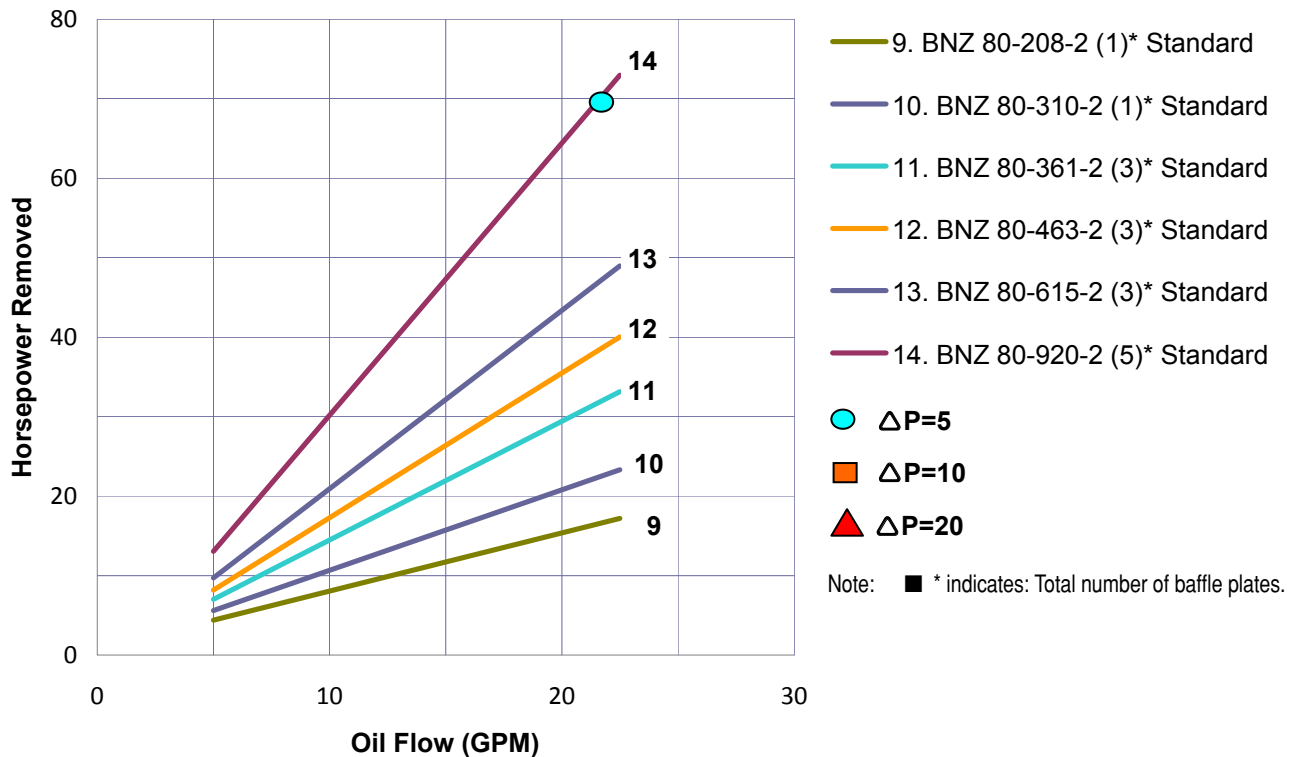



Water-Oil Coolers

2:1 Oil to Water Ratio

BNZ 125-310 to 920 and BNZ 125-1225 / 2 Pass

BNZ 125-310 to 920, 2 Pass, 2:1 Oil to Water Ratio

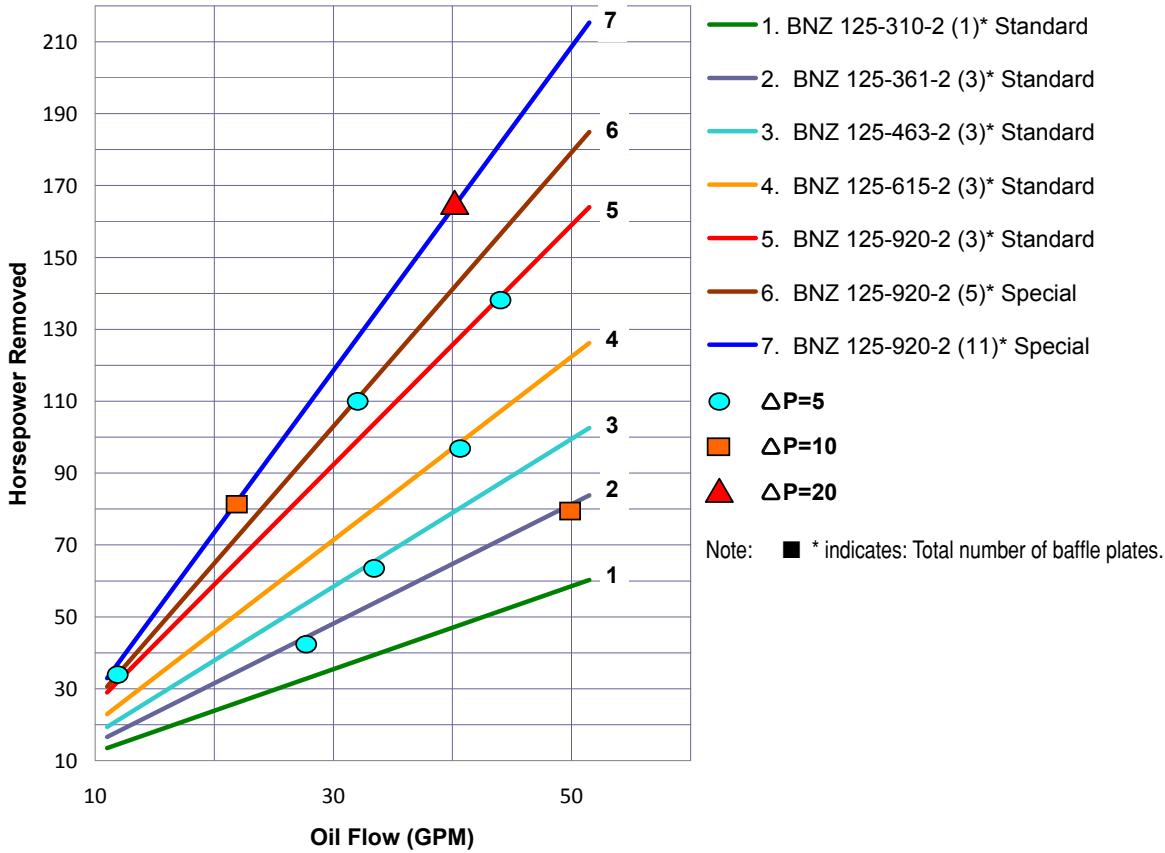

BNZ 125-1225, 2 Pass, 2:1 Oil to Water Ratio

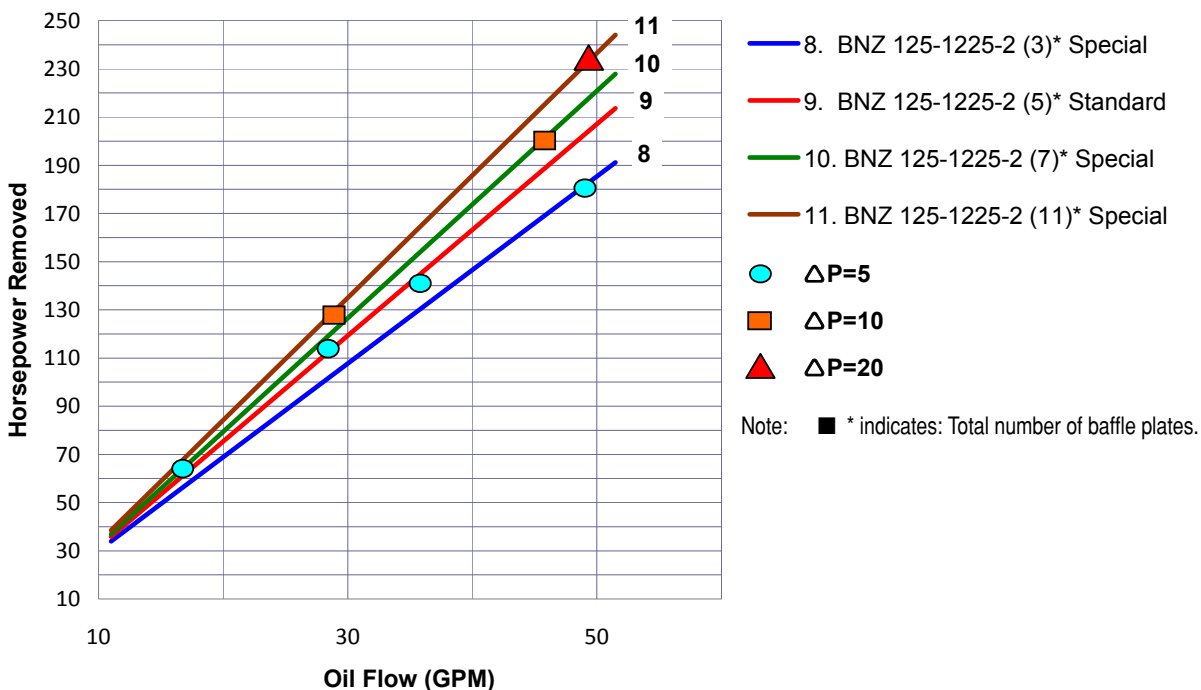



Water-Oil Coolers

4:1 Oil to Water Ratio

BNZ 60-208 to 463 and BNZ 80-208 to 920 / 2 Pass

BNZ 60-208 to 463, 2 Pass, 4:1 Oil to Water Ratio

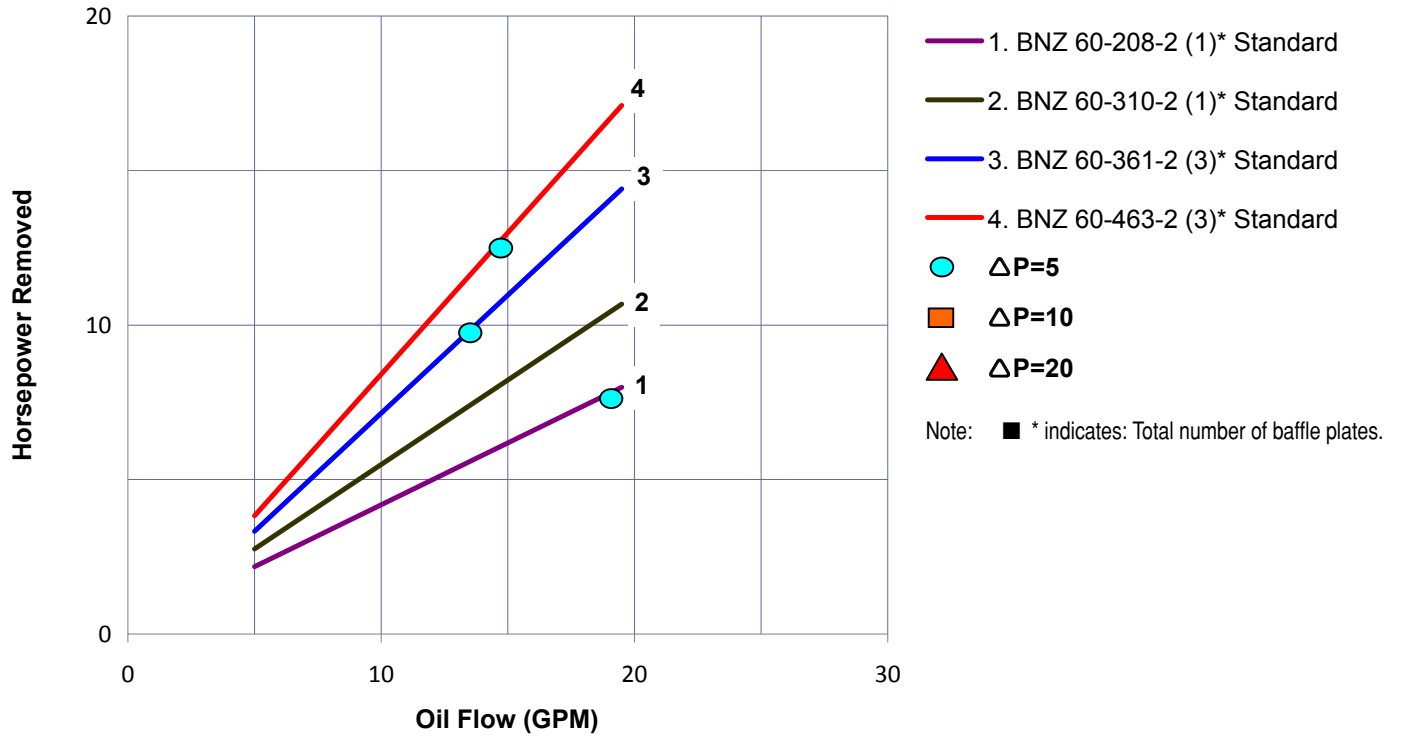

BNZ 80-208 to 920, 2 Pass, 4:1 Oil to Water Ratio

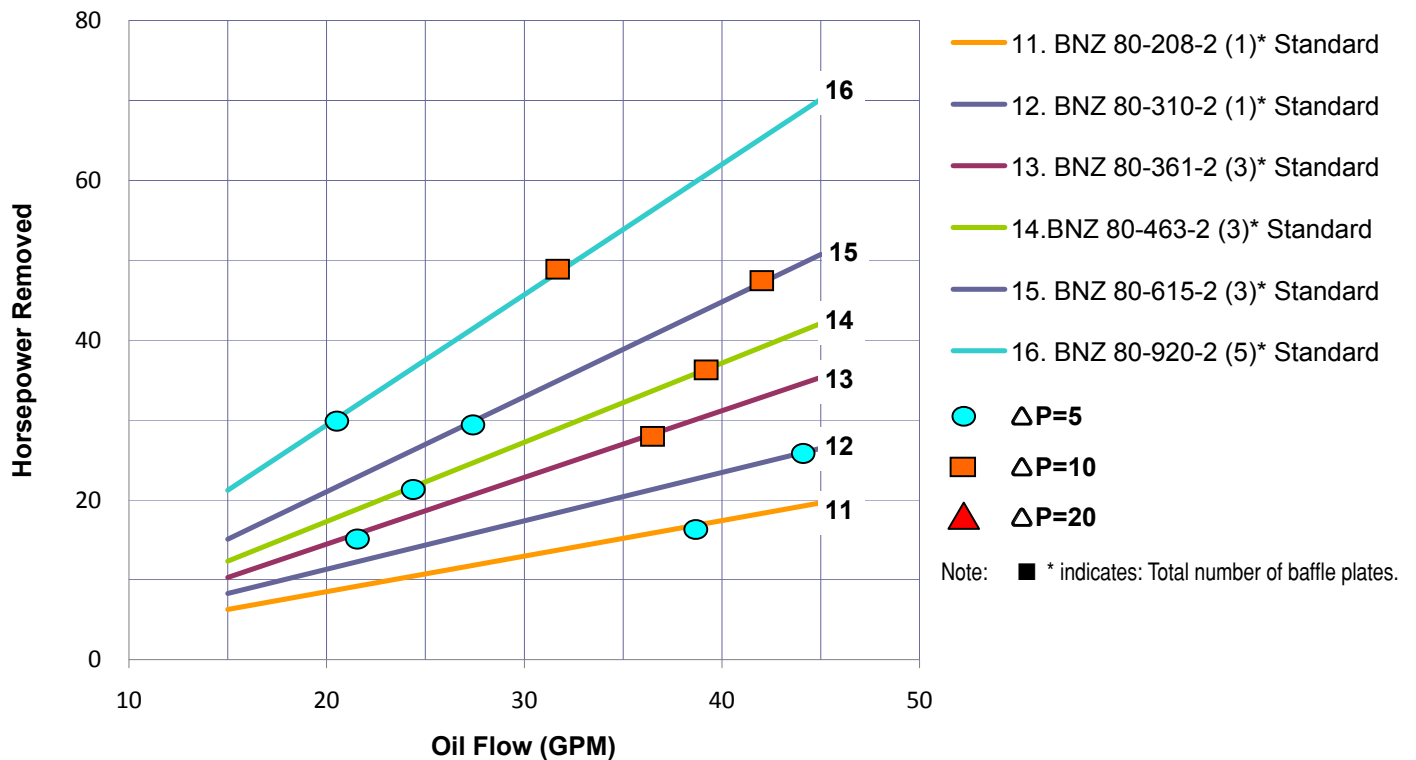



Water-Oil Coolers

4:1 Oil to Water Ratio

BNZ 80-208 to 920 / 4 Pass and BNZ 125-310 to 615 / 2 Pass

BNZ 80-208 to 920, 4 Pass, 4:1 Oil to Water Ratio

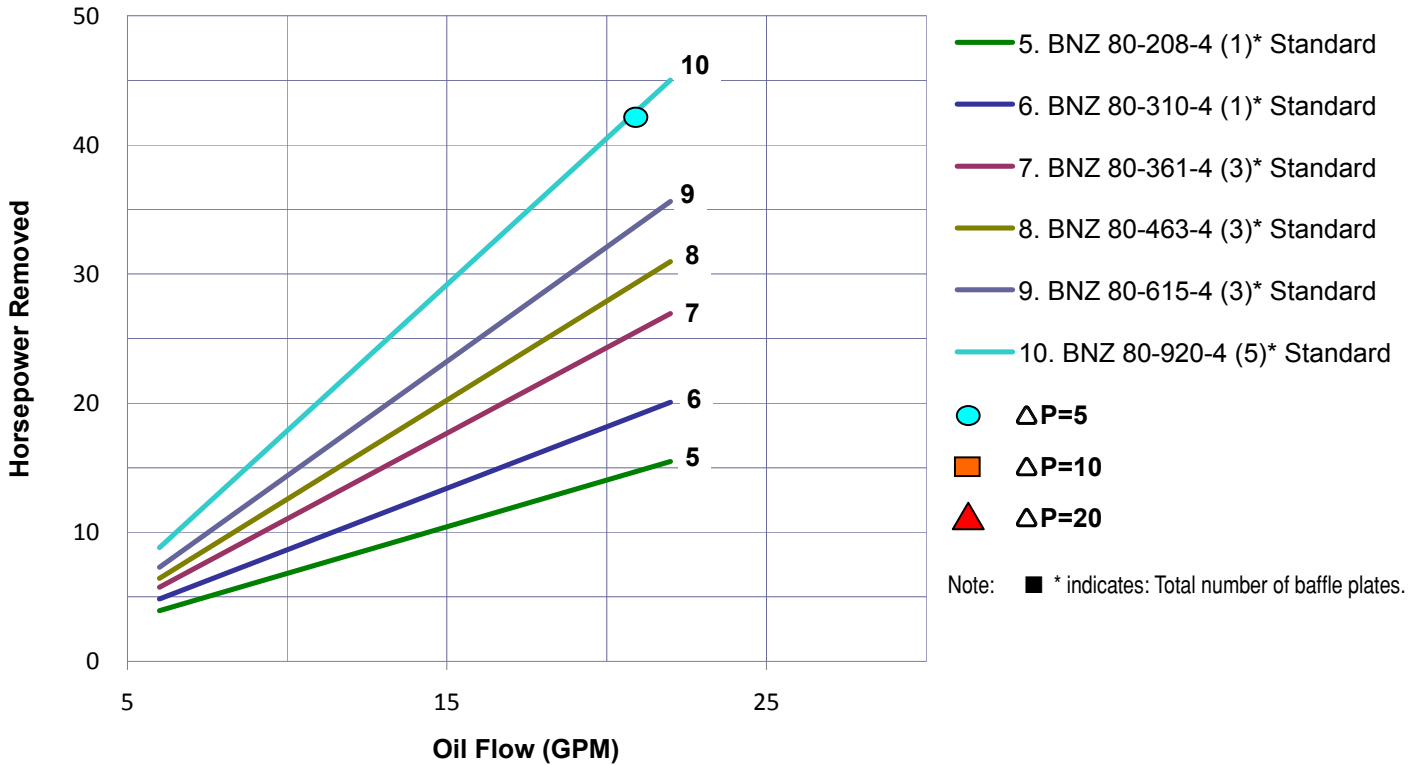

BNZ 125-310 to 615, 2 Pass, 4:1 Oil to Water Ratio

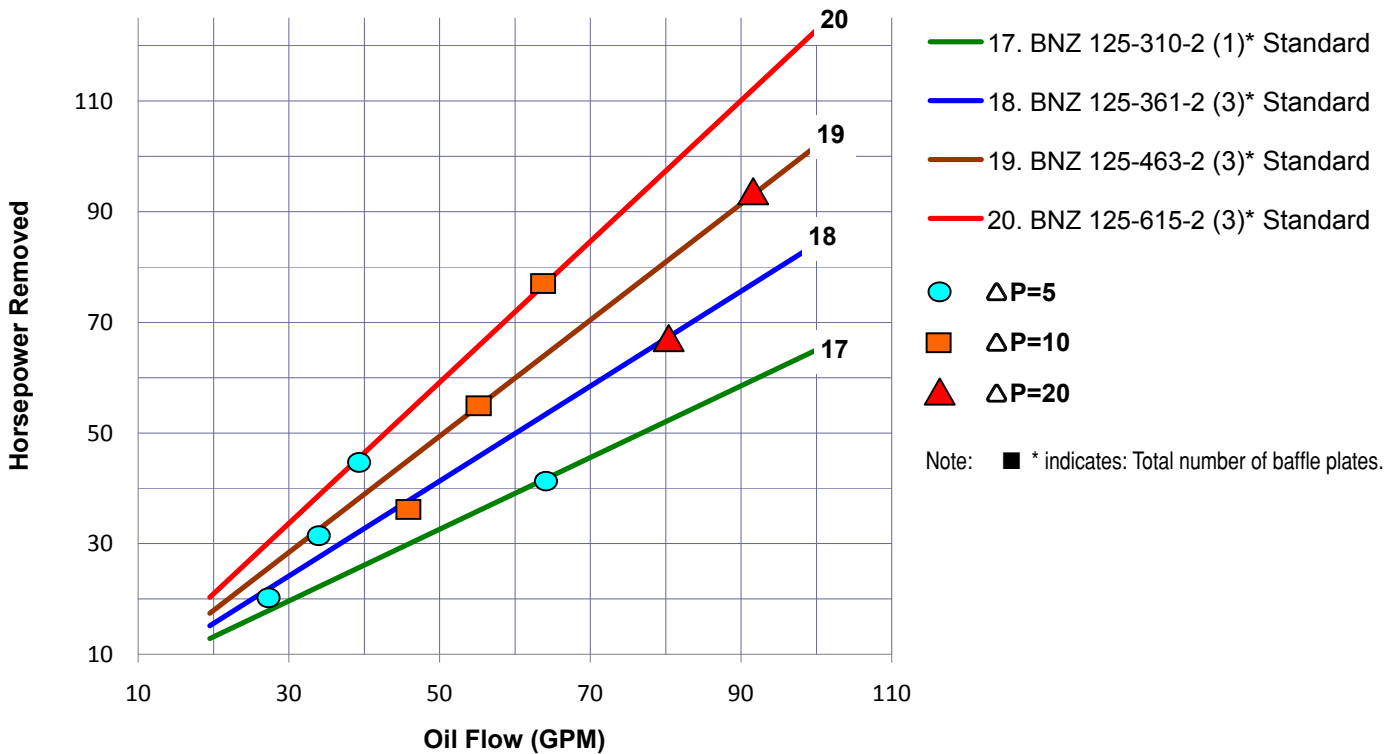

BNZ 125-920 to 1225, 2 Pass, 4:1 Oil to Water Ratio

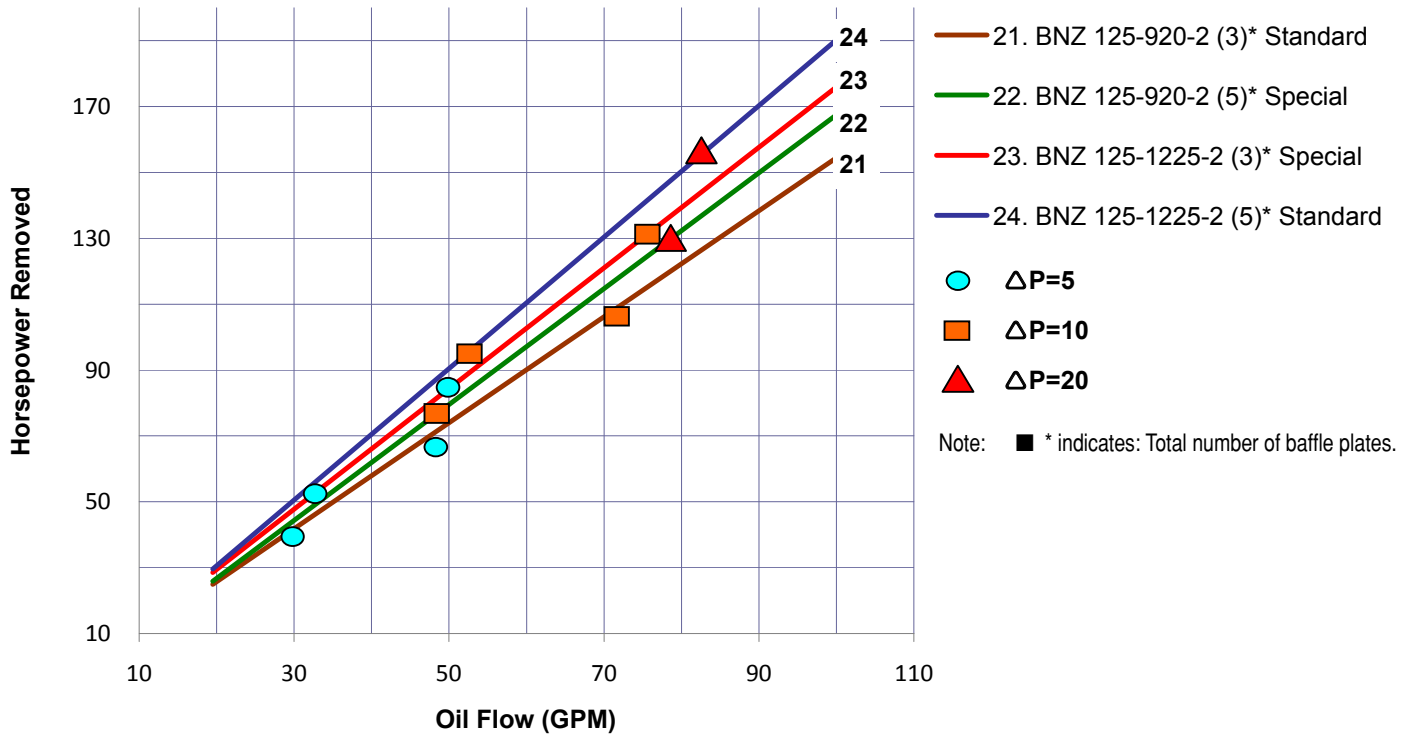



Water-Oil Coolers

7:1 Oil to Water Ratio

BNZ 60-310 to 463 and BNZ 80-208 to 615 / 2 Pass

BNZ 60-310 to 463, 2 Pass, 7:1 Oil to Water Ratio

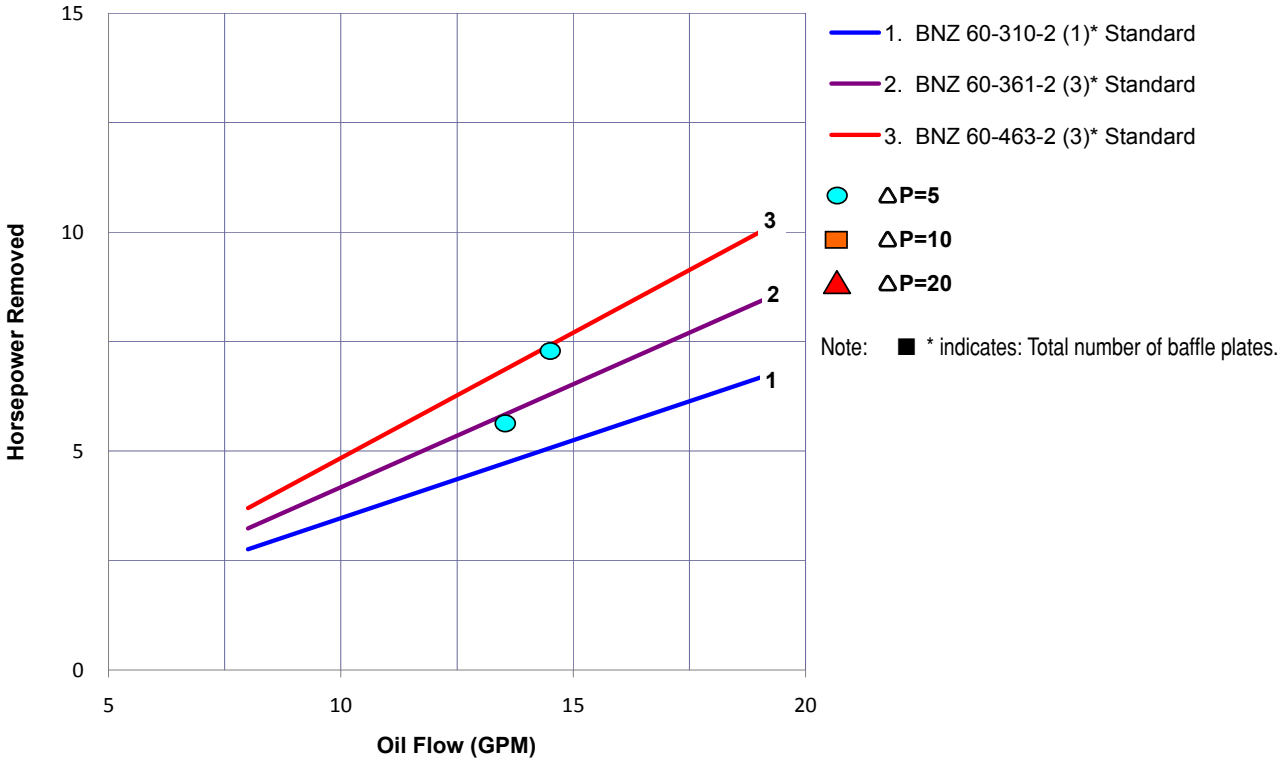

BNZ 80-208 to 615, 2 Pass, 7:1 Oil to Water Ratio

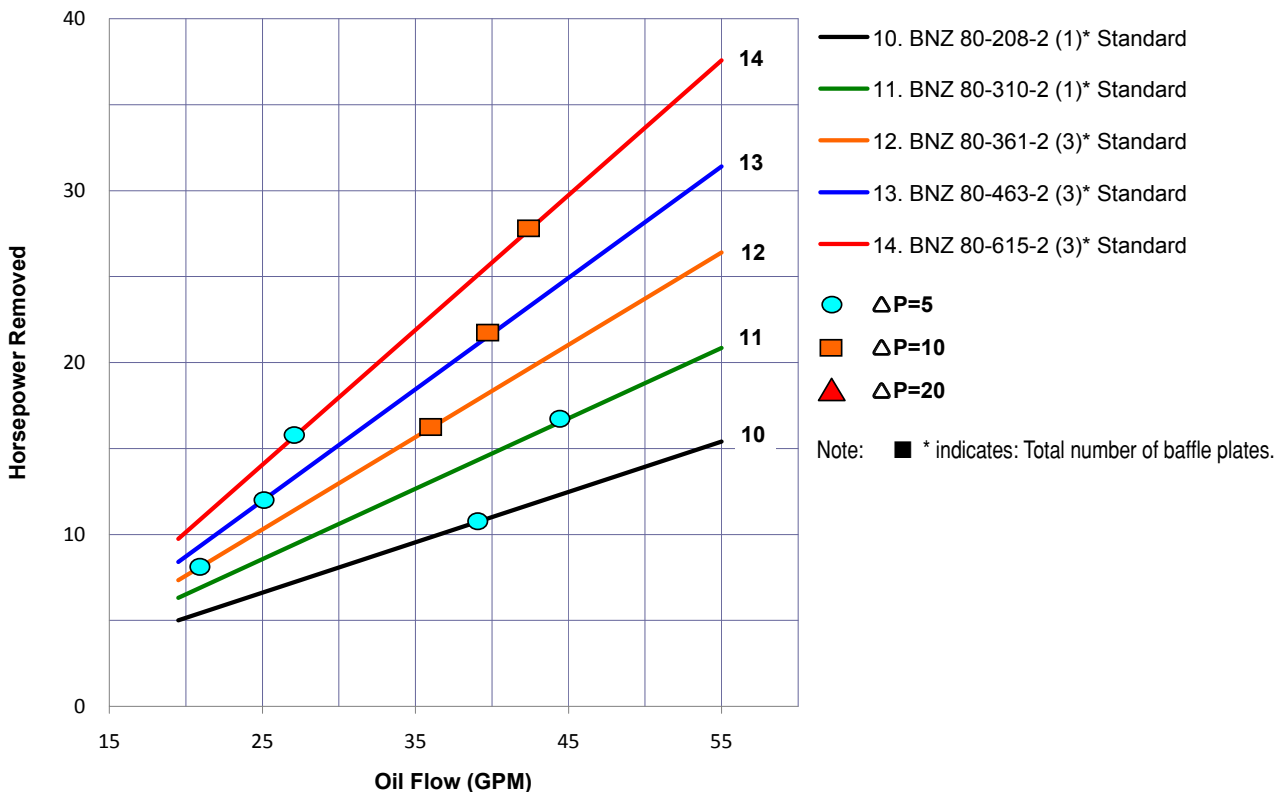



Water-Oil Coolers

7:1 Oil to Water Ratio

BNZ 80-208 to 920 / 4 Pass and BNZ 125-310 to 615 / 2 Pass

BNZ 80-208 to 920, 4 Pass, 7:1 Oil to Water Ratio

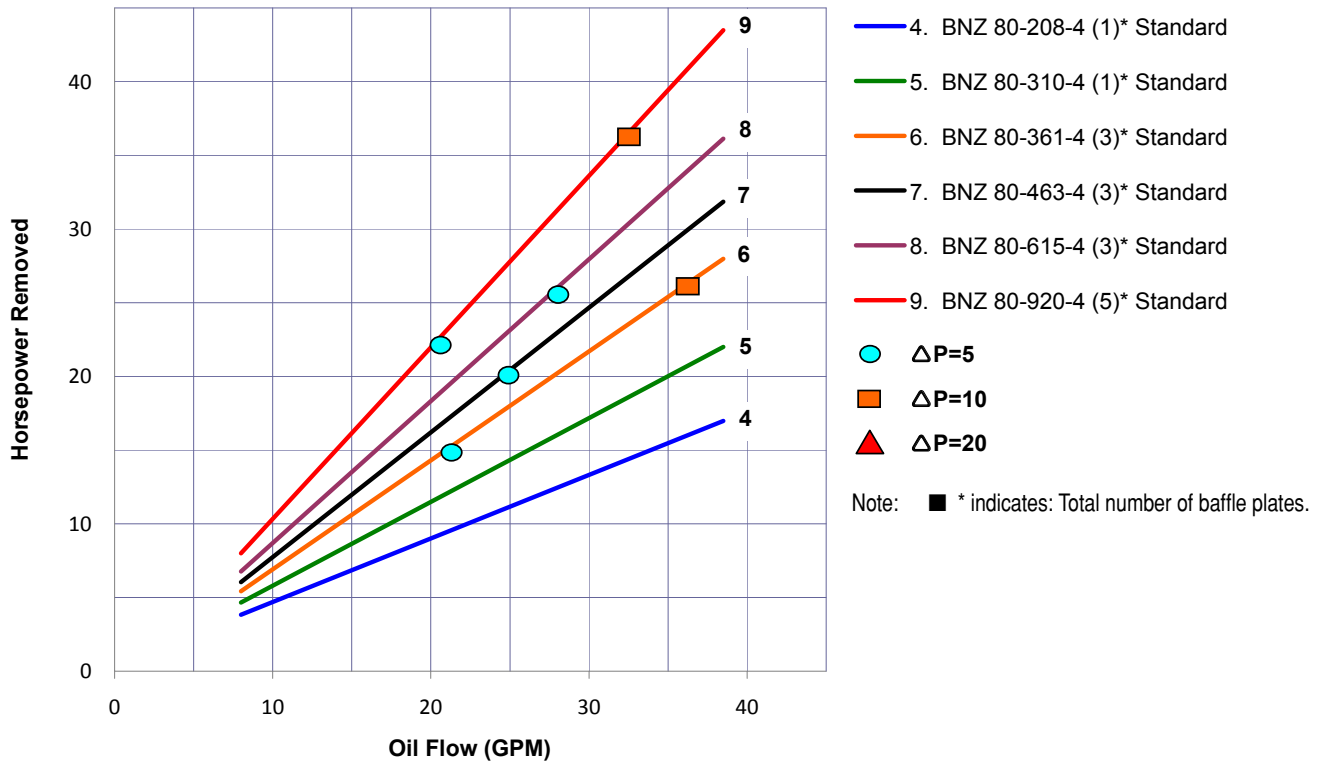

BNZ 125-310 to 615, 2 Pass, 7:1 Oil to Water Ratio

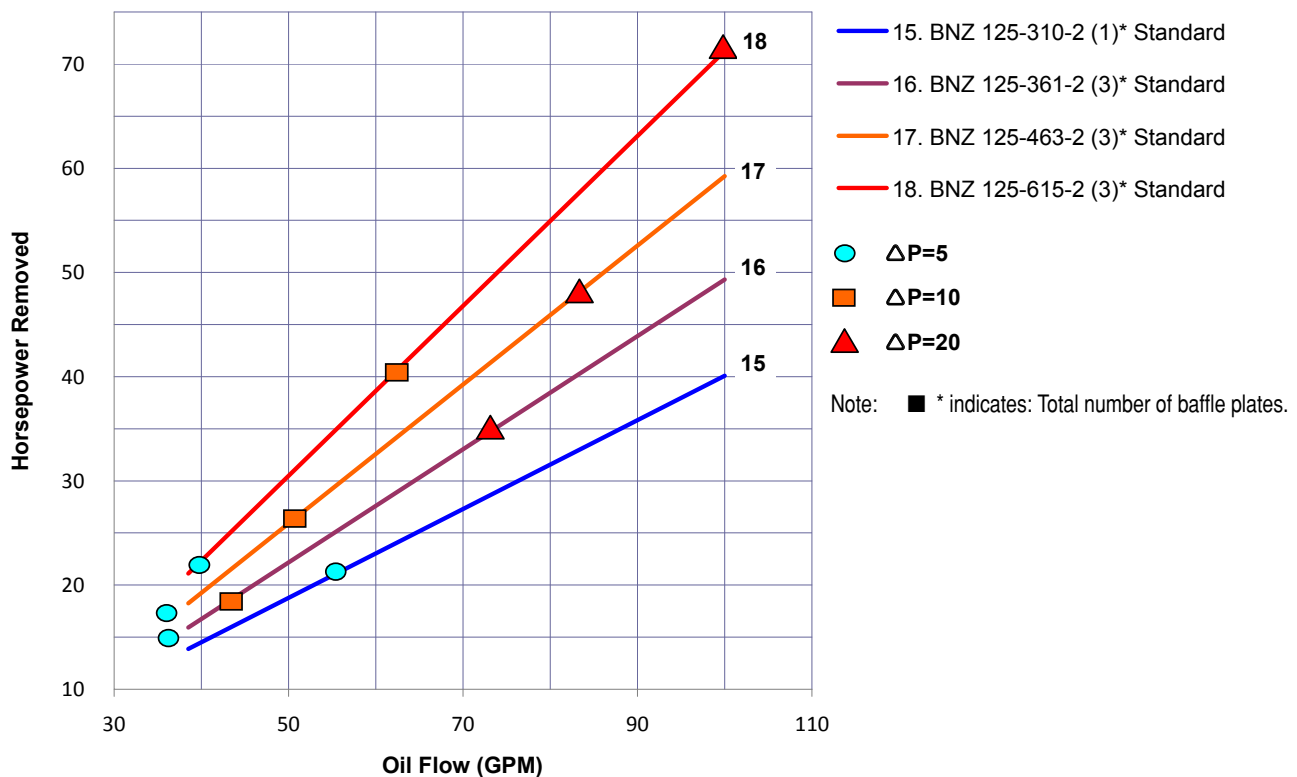



Water-Oil Coolers

7:1 Oil to Water Ratio

BNZ 125-920 to 1225 / 2 Pass

BNZ 125-920 to 1225, 2 Pass, 7:1 Oil to Water Ratio

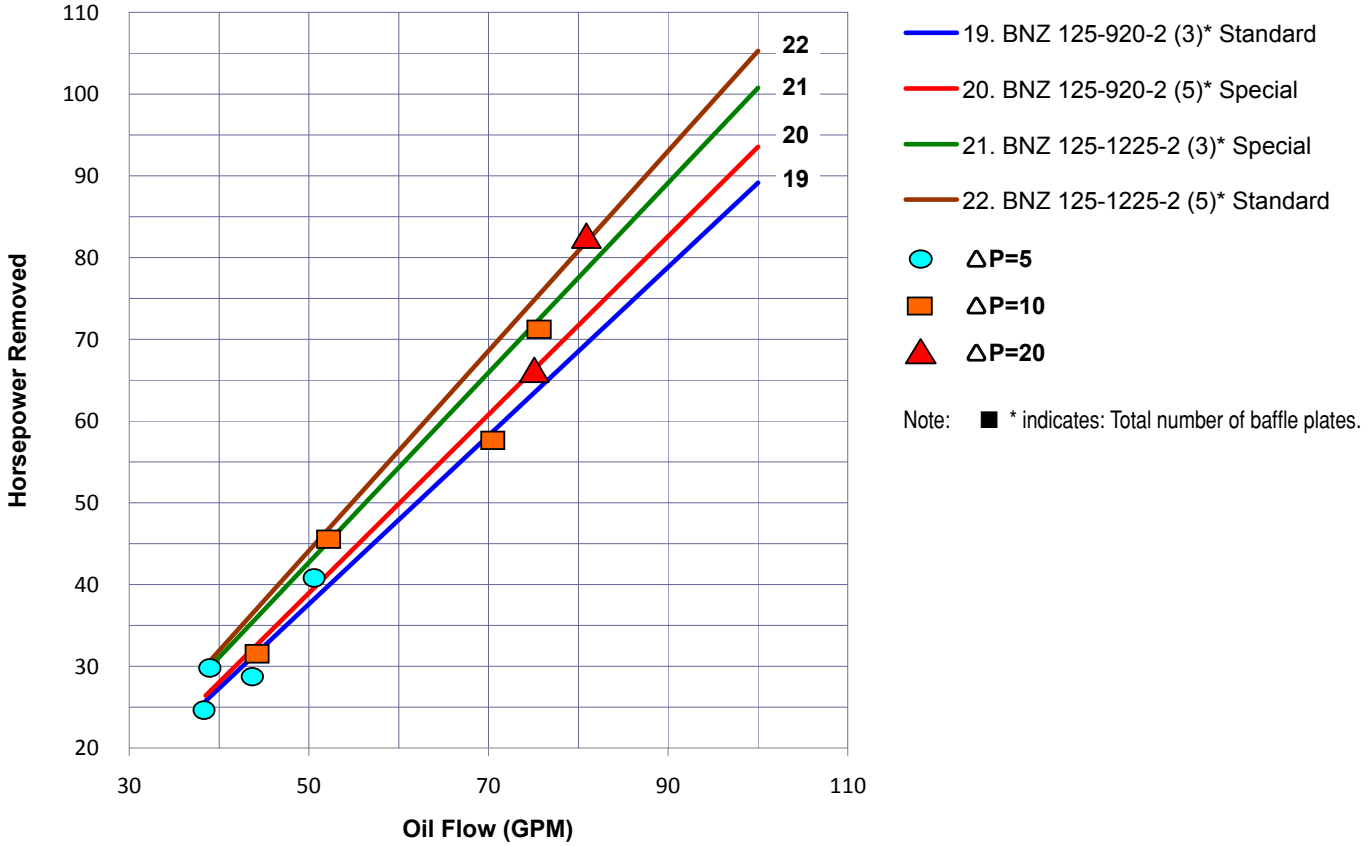



Water-Oil Coolers

10:1 Oil to Water Ratio

BNZ 60-310 / 2 Pass and BNZ 80-208 to 920 / 4 Pass

BNZ 60-310, 2 Pass, 10:1 Oil to Water Ratio

BNZ 80-208 to 920, 4 Pass, 10:1 Oil to Water Ratio

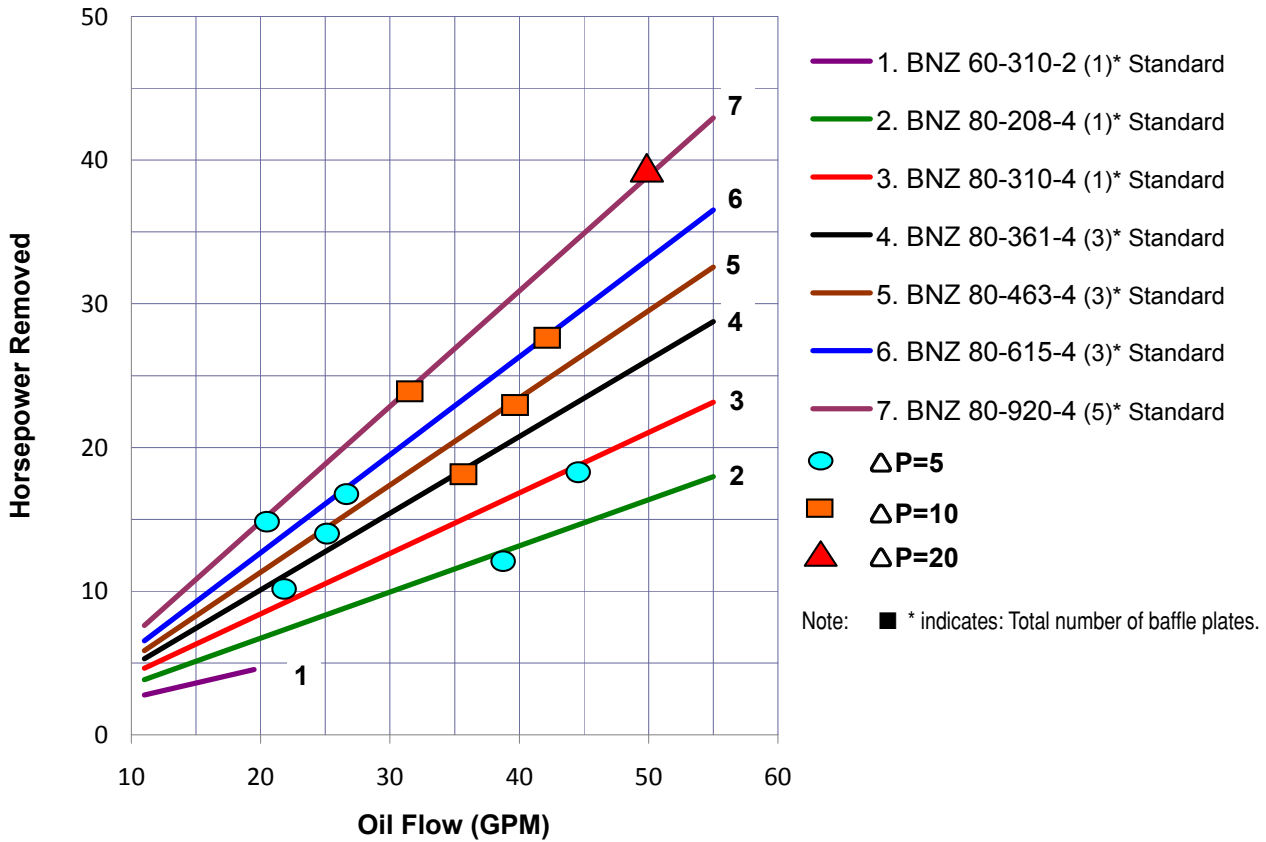



Water-Oil Coolers

10:1 Oil to Water Ratio

BNZ 125-310 to 920 and BNZ 125-910 to 1225 / 4 Pass

BNZ 125-310 to 920, 4 Pass, 10:1 Oil to Water Ratio

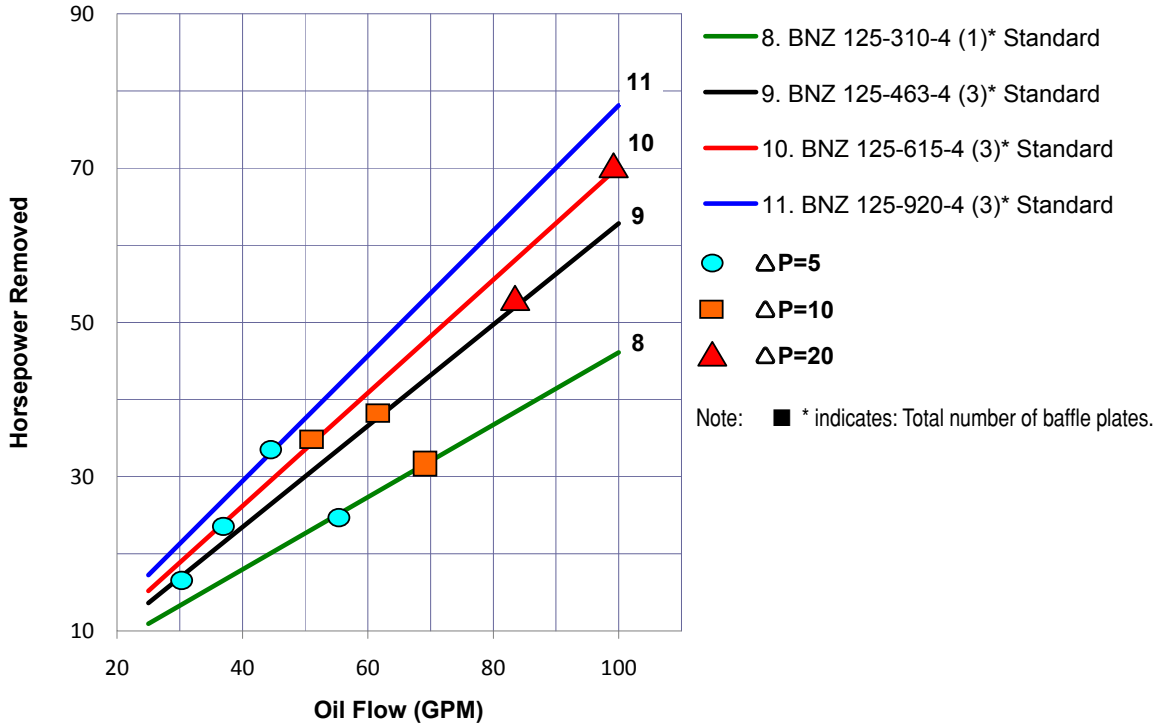

BNZ 125-920 to 1225, 4 Pass, 10:1 Oil to Water Ratio

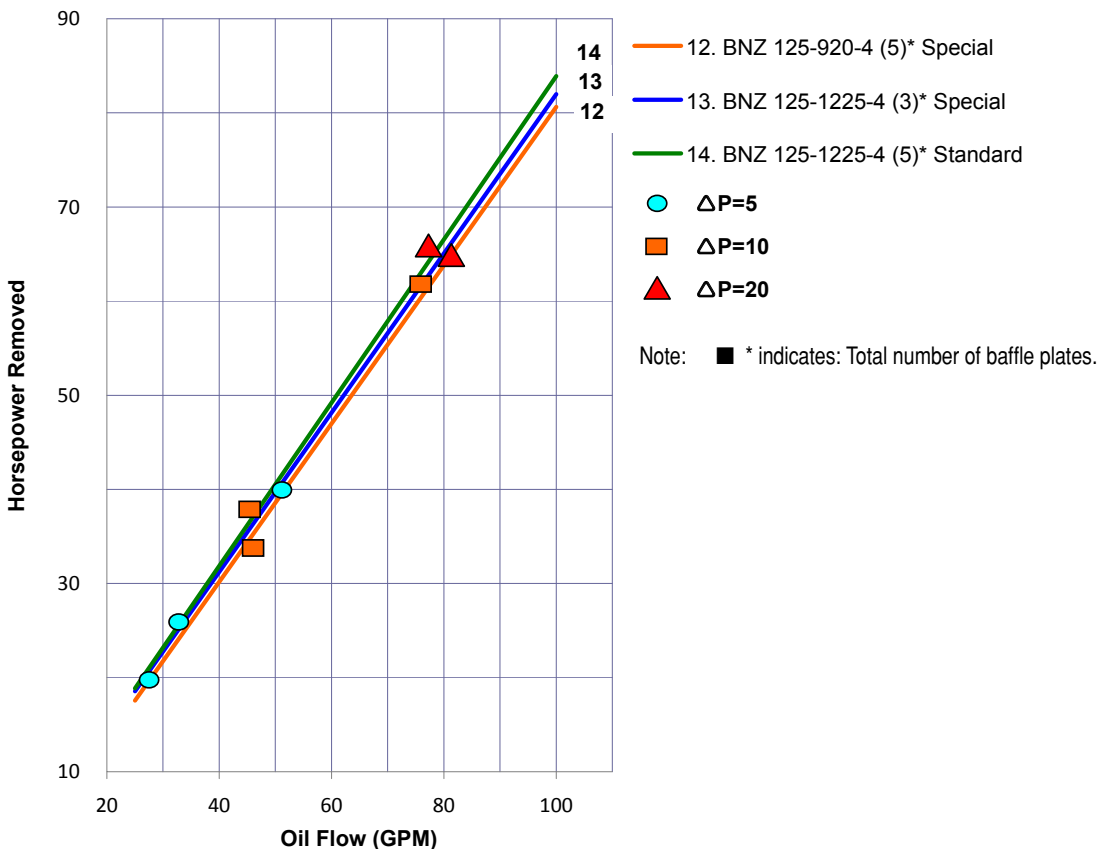



Application Guidelines:

All Lovejoy BNZ Series coolers are **cleaned and pressure tested** at the factory and should require no further special treatment prior to installation. It is advised the cooler be inspected with care to be sure the ports are free from dirt and or debris. The cooler should be installed firmly in place to fully support the cooler with line connections properly routed and tightened to prevent strain on the cooler ports. If excessive vibration is present, the use of shock absorbing mounts and flexible lines are recommended. Product performance and satisfactory use is dependent upon precautions which should be taken at the time of system design and installation. Special attention should be given for corrosive environments and sizing selection.

1. Connect and circulate the hot fluid in the shell side and the cooling water in the tube side.
2. Normally, there are no restrictions as to how the BNZ Series cooler may be mounted. However, consideration should be given to proper draining access and exit flow paths for service (draining of either oil or water paths). Fluid drain plugs are ideally located on the bottom of the cooler to accomplish draining of the fluids.
3. It is recommended to protect the cooler from high pressure surges of hot fluid by installing a fast-acting relief valve with sufficient flow capacity on the inlet line to the cooler. Pressure ratings should not be exceeded.
4. Water strainers installed upstream of the cooler are highly recommended when the source of cooling water is other than from a municipal water supply. Dirt and debris may plug water passages, robbing cooling performance.
5. If an automatic water regulating valve is used, it should be placed on the inlet connection of the cooler. The water outlet connections should be arranged so the exchanger remains flooded, but with little or no back pressure. The water regulating valve temperature probe should be placed in the hydraulic system reservoir to sense hydraulic system temperature change.
6. The BNZ cooler is a "fixed bundle" design and is generally not recommended for steam applications.
7. When using sealing tape on pipe threads, be careful to not over-tighten. Excessive tightening of tapered pipe threads has been known to result in cracking of housing and end cap castings.
8. During storage, be sure to keep the oil and water ports sealed. If storing in ambient temperatures below freezing, the water chamber must be drained to prevent damage from freezing.
9. Performance data should be collected and recorded on newly installed units so that a benchmark set of data can be used to detect reduction in effectiveness over time. Shell and tube coolers may suffer from "fouling" (accumulation of oil sludge, water scale and contamination) which results in loss of cooling performance over time.
10. The oil chamber of the cooler may become filled with sludge and require cleaning. It is recommended the unit be flooded with a commercial solvent and left to soak for one-half hour. Back-flowing the solvent or regular oil will help in removing most sludge. Repeated cleaning may be needed depending on the level of sludge buildup. If cleaning of the inside cooling tubes/fins is desired, a recommended 50/50 solution of inhibited muriatic acid and water may be used. Be sure to thoroughly remove all cleaning chemicals and flush with clean water before placing the cooler back into service.
11. End covers may be removed for servicing and end cover gaskets should be replaced when removing end covers. End cap bolts should be tightened to 10 Nm [88 inch lbs].
12. Salt water, brackish water or other corrosive fluids require special materials (stainless steel, copper-nickel, nickel-plate) for end covers, tubes and/or fins.

Best Practices Recommendation

For maximum performance: Install and pipe the cooler so that the water flow is the opposite direction of the oil flow.

1 Pass Models

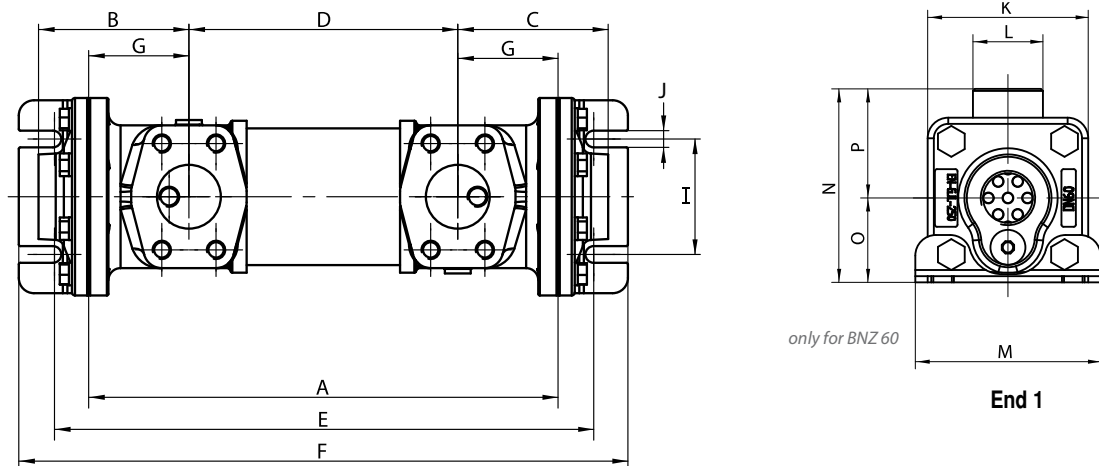

1 Pass Dimensional Data

Series	A		B = C		D		E		F		G		H		I		J	
	in	mm	in	mm	in	mm	in	mm	in	mm	in	mm	in	mm	in	mm	in	mm
BNZ 60-131	5.16	131	2.56	65.0	2.17	55	7.13	181	8.39	213	1.50	38.0						
BNZ 60-208	8.19	208	3.25	82.5	3.82	97	10.20	259	11.42	290	2.19	55.5	—	—	2.50	63.5	0.35	9
BNZ 60-259	10.20	259			5.83	148	12.20	310	13.43	341								
BNZ 60-310	12.20	310			7.48	199	14.21	361	15.43	392								
BNZ 60-361	14.21	361			9.84	250	16.22	412	17.44	443								
BNZ 60-463	18.22	463			13.86	352	20.24	514	21.46	545								
BNZ 60-615	24.21	615			19.84	504	26.22	666	28.44	697								
BNZ 60-920	36.22	920			31.85	809	38.23	971	39.44	1002								
BNZ 80-208	8.19	208			3.90	99.0	2.99	76	10.04	255								
BNZ 80-310	12.20	310	7.01	178			14.06	357	15.83	402								
BNZ 80-361	14.21	361	9.02	229			16.06	408	17.83	453								
BNZ 80-463	18.23	463	13.03	331			20.08	510	21.85	555								
BNZ 80-615	24.21	615	19.02	483			26.06	662	27.83	707								
BNZ 80-920	36.22	920	31.02	788			38.07	967	39.84	1012								
BNZ 125-310	12.20	310	4.31	109.5	6.18	157	14.76	375	17.17	436	3.01	76.5	0.83	21	4.02	102.0	0.43	11
BNZ 125-361	14.21	361			8.19	208	16.77	426	19.17	487								
BNZ 125-463	18.23	463			12.20	310	20.79	528	23.19	589								
BNZ 125-615	24.21	615			18.19	462	26.77	680	29.17	741								
BNZ 125-920	36.22	920			30.20	767	38.78	985	41.18	1046								
BNZ 125-1225	48.22	1225			42.20	1072	50.79	1290	53.19	1351								

Notes: ■ For sea water coolers - overall length increases a total of .394 (10mm) to accommodate the .197 (5mm) "tube sheets" required on both ends. This does not affect the oil ports center distance "D" dimension.
 ■ Production tolerances for above dimensions above may vary by up to +/- .079 in (2mm).
 ■ For Oil and Water Port specification, see page 5.

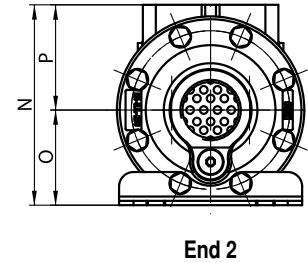
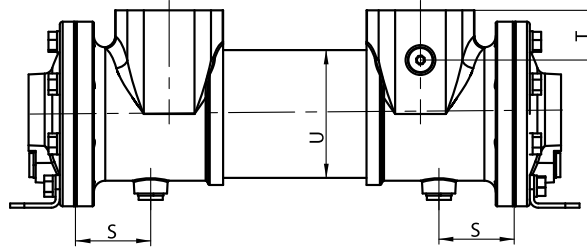
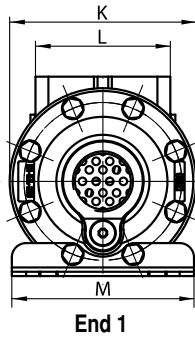

1 Pass Dimensional Data

Continued

Series	K		L		M		N		O		P		S		T		U	
	in	mm	in	mm	in	mm	in	mm	in	mm	in	mm	in	mm	in	mm	in	mm
BNZ 60-131	3.08	78	1.34	34	3.54	90	3.86	98	1.77	45	2.09	53	—	—	—	—	2.56	65
BNZ 60-208																		
BNZ 60-259																		
BNZ 60-310																		
BNZ 60-361																		
BNZ 60-463																		
BNZ 60-615																		
BNZ 60-920																		
BNZ 80-208	5.12	130	3.70	94	5.00	127	5.47	139	2.60	66	2.87	73	2.09	53	1.38	35	3.54	90
BNZ 80-310																		
BNZ 80-361																		
BNZ 80-463																		
BNZ 80-615																		
BNZ 80-920																		
BNZ 125-310	6.50	165	4.06	103	6.50	165	7.64	194	2.60	66	3.62	92	2.44	62	1.38	35	5.04	128
BNZ 125-361																		
BNZ 125-463																		
BNZ 125-615																		
BNZ 125-920																		
BNZ 125-1225																		

Notes: ■ For sea water coolers - overall length increases a total of .394 (10mm) to accommodate the .197 (5mm) "tube sheets" required on both ends. This does not affect the oil ports center distance "D" dimension.
 ■ Production tolerances for above dimensions above may vary by up to +/- .079 in (2mm).
 ■ For Oil and Water Port specification, see page 5.

2 Pass Models

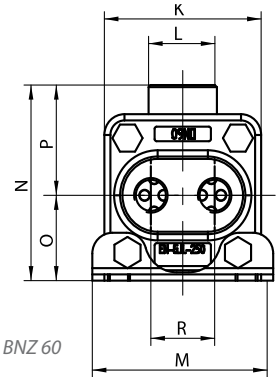
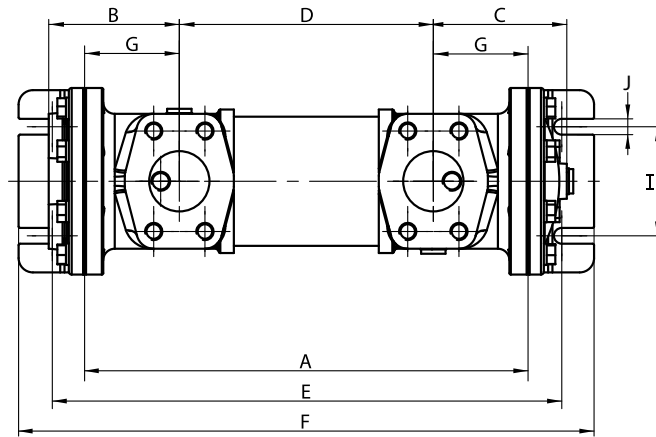

only for BNZ 60

End 1

2 Pass Dimensional Data

Series	A		B		C		D		E		F		G		H		I		J	
	in	mm	in	mm	in	mm	in	mm	in	mm	in	mm	in	mm	in	mm	in	mm	in	mm
BNZ 60-131	5.16	131	2.56	65	2.56	65.0	2.17	55	7.13	181	8.39	213	1.50	38.0						
BNZ 60-208	8.19	208					3.82	97	10.20	259	11.42	290								
BNZ 60-259	10.20	259					5.83	148	12.20	310	13.43	341								
BNZ 60-310	12.20	310					7.48	199	14.21	361	15.43	392								
BNZ 60-361	14.21	361	3.25	82.5	3.25	82.5	9.84	250	16.22	412	17.44	443	2.19	55.5	—	—	2.50	63.5	0.35	9
BNZ 60-463	18.22	463					13.86	352	20.24	514	21.46	545								
BNZ 60-615	24.21	615					19.84	504	26.22	666	28.44	697								
BNZ 60-920	36.22	920					31.85	809	38.23	971	39.44	1002								
BNZ 80-208	8.19	208					2.99	76	10.04	255	11.81	300								
BNZ 80-310	12.20	310					7.01	178	14.06	357	15.83	402								
BNZ 80-361	14.21	361	3.58	91.0	3.66	93.0	9.02	229	16.06	408	17.83	453	2.60	66.0	0.71	18	2.99	76.0	0.43	11
BNZ 80-463	18.23	463					13.03	331	20.08	510	21.85	555								
BNZ 80-615	24.21	615					19.02	483	26.06	662	27.83	707								
BNZ 80-920	36.22	920					31.02	788	38.07	967	39.84	1012								
BNZ 125-310	12.20	310					6.18	157	14.76	375	17.17	436								
BNZ 125-361	14.21	361					8.19	208	16.77	426	19.17	487								
BNZ 125-463	18.23	463	4.31	109.5	4.00	101.5	12.20	310	20.79	528	23.19	589	3.01	76.5	0.83	21	4.02	102.0	0.43	11
BNZ 125-615	24.21	615					18.19	462	26.77	680	29.17	741								
BNZ 125-920	36.22	920					30.20	767	38.78	985	41.18	1046								
BNZ 125-1225	48.22	1225					42.20	1072	50.79	1290	53.19	1351								

- Notes:
- For sea water coolers - overall length increases a total of .394 (10mm) to accommodate the .197 (5mm) "tube sheets" required on both ends. This does not affect the oil ports center distance "D" dimension.
 - Production tolerances for above dimensions above may vary by up to +/- .079 in (2mm).
 - For Oil and Water Port specification, see page 5.

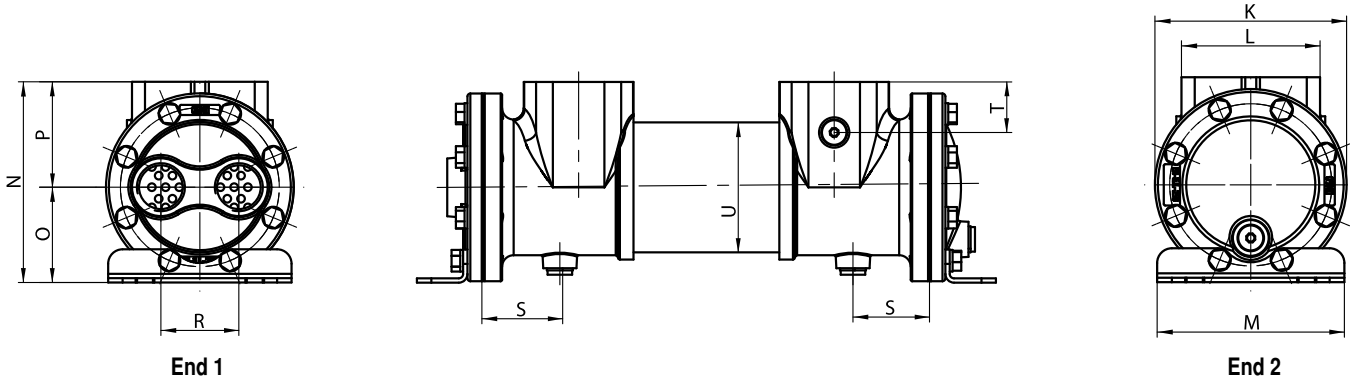

2 Pass Dimensional Data

Continued

Series	K		L		M		N		O		P		R		S		T		U	
	in	mm	in	mm	in	mm	in	mm	in	mm	in	mm	in	mm	mm	mm	in	mm	in	mm
BNZ 60-131	3.08	78	1.34	34	3.54	90	3.86	98	1.77	45	2.09	53	1.25	31.75	—	—	—	—	2.56	65
BNZ 60-208																				
BNZ 60-259																				
BNZ 60-310																				
BNZ 60-361																				
BNZ 60-463																				
BNZ 60-615																				
BNZ 60-920																				
BNZ 80-208	5.12	130	3.70	94	5.00	127	5.47	139	2.60	66	2.87	73	2.13	54.00	2.09	53	1.38	35	3.54	90
BNZ 80-310																				
BNZ 80-361																				
BNZ 80-463																				
BNZ 80-615																				
BNZ 80-920																				
BNZ 125-310	6.50	165	4.06	103	6.50	165	7.64	194	4.02	102	3.62	92	2.36	60.00	2.44	62	1.38	35	5.04	128
BNZ 125-361																				
BNZ 125-463																				
BNZ 125-615																				
BNZ 125-920																				
BNZ 125-1225																				

Notes: ■ For sea water coolers - overall length increases a total of .394 (10mm) to accommodate the .197 (5mm) "tube sheets" required on both ends. This does not affect the oil ports center distance "D" dimension.
 ■ Production tolerances for above dimensions above may vary by up to +/- .079 in (2mm).
 ■ For Oil and Water Port specification, see page 5.

4 Pass Models

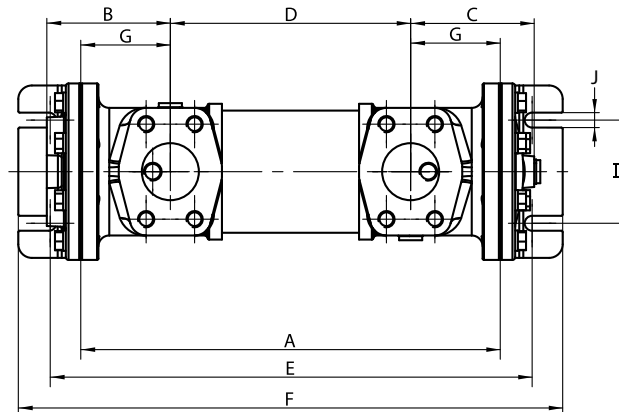

4 Pass Dimensional Data

Series	A		B		C		D		E		F		G		H		I		J	
	in	mm	in	mm	in	mm	in	mm	in	mm	in	mm	in	mm	in	mm	in	mm	in	mm
BNZ 80-208	8.19	208	3.58	91.0	3.58	91.0	2.99	76	10.04	255	11.81	300	2.60	66.0	0.71	18	2.99	76.0	0.43	11
BNZ 80-310	12.20	310					7.01	178	14.06	357	15.83	402								
BNZ 80-361	14.21	361					9.02	229	16.06	408	17.83	453								
BNZ 80-463	18.23	463					13.03	331	20.08	510	21.85	555								
BNZ 80-615	24.21	615					19.02	483	26.06	662	27.83	707								
BNZ 80-920	36.22	920					31.02	788	38.07	967	39.84	1012								
BNZ 125-310	12.20	310	4.31	109.5	4.00	101.5	6.18	157	14.76	375	17.17	436	3.01	76.5	0.83	21	4.02	102.0	0.43	11
BNZ 125-361	14.21	361					8.19	208	16.77	426	19.17	487								
BNZ 125-463	18.23	463					12.20	310	20.79	528	23.19	589								
BNZ 125-615	24.21	615					18.19	462	26.77	680	29.17	741								
BNZ 125-920	36.22	920					30.20	767	38.78	985	41.18	1046								
BNZ 125-1225	48.22	1225					42.20	1072	50.79	1290	53.19	1351								

Notes: ■ For sea water coolers - overall length increases a total of .394 (10mm) to accommodate the .197 (5mm) "tube sheets" required on both ends. This does not affect the oil ports center distance "D" dimension.

■ BNZ 60 Series is not available with the 4-pass option.

■ Production tolerances for above dimensions above may vary by up to +/- .079 in (2mm).

■ For Oil and Water Port specification, see page 5.

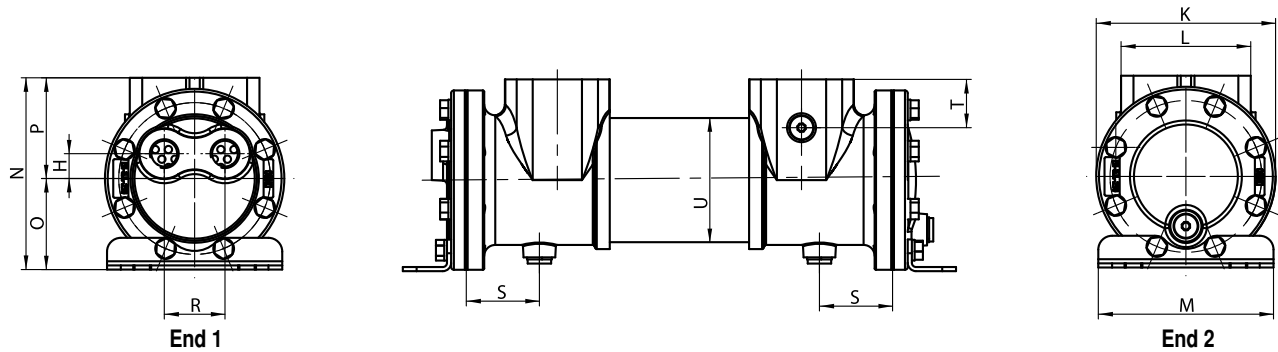

4 Pass Dimensional Data

Continued

Series	K		L		M		N		O		P		R		S		T		U	
	in	mm	in	mm	in	mm	in	mm	in	mm	in	mm	in	mm	mm	mm	in	mm	in	mm
BNZ 80-208	5.12	130	3.70	94	5.00	127	5.47	139	2.60	66	2.87	73	1.73	44	2.09	53	1.38	35	3.54	90
BNZ 80-310																				
BNZ 80-361																				
BNZ 80-463																				
BNZ 80-615																				
BNZ 80-920																				
BNZ 125-310	6.50	165	4.06	103	6.50	165	7.64	194	4.02	102	3.62	92	2.20	56	2.44	62	1.38	35	5.04	128
BNZ 125-361																				
BNZ 125-463																				
BNZ 125-615																				
BNZ 125-920																				
BNZ 125-1225																				

- Notes:
- For sea water coolers - overall length increases a total of .394 (10mm) to accommodate the .197 (5mm) "tube sheets" required on both ends. This does not affect the oil ports center distance "D" dimension.
 - BNZ 60 Series is not available with the 4-pass option.
 - Production tolerances for above dimensions above may vary by up to +/- .079 in (2mm).
 - For Oil and Water Port specification, see page 5.



Water-Oil Coolers

1 Pass Models

Series Number - Product Code Breakdown / Item Selection

Series Number - Product Code Breakdown

BNZ 60-208-1-N (example)

BNZ	---	-----	--	--	----
Series	Size	Length	Pass	Oil Port	Coolant Tube Material
	60 80 125	Listed in catalog	1 2 4	N = National Pipe Thread (NPT) S = SAE O-Ring B = British Standard Pipe Parallel F = SAE Flange	Cu = Copper (standard) CuNi = Copper Nickel (available)

1 Pass BNZ Water-Oil Cooler UPC Number Selection Tables

1 Pass	
NPT	
Series Number	UPC Number
BNZ 60-131-1-N	3131
BNZ 60-208-1-N	3132
BNZ 60-259-1-N	3133
BNZ 60-310-1-N	3134
BNZ 60-361-1-N	3135
BNZ 60-463-1-N	3136
BNZ 60-615-1-N	3137
BNZ 60-920-1-N	3138
BNZ 80-208-1-N	3232
BNZ 80-310-1-N	3206
BNZ 80-361-1-N	3210
BNZ 80-463-1-N	3233
BNZ 80-615-1-N	3234
BNZ 80-920-1-N	3235
BNZ 125-310-1-N	3330
BNZ 125-361-1-N	3331
BNZ 125-463-1-N	3332
BNZ 125-615-1-N	3333
BNZ 125-920-1-N	3334
BNZ 125-1225-1-N	3335

1 Pass	
SAE O-Ring	
Series Number	UPC Number
BNZ 60-131-1-S	3121
BNZ 60-208-1-S	3122
BNZ 60-259-1-S	3123
BNZ 60-310-1-S	3124
BNZ 60-361-1-S	3125
BNZ 60-463-1-S	3126
BNZ 60-615-1-S	3127
BNZ 60-920-1-S	3128
BNZ 80-208-1-S	3222
BNZ 80-310-1-S	3201
BNZ 80-361-1-S	3209
BNZ 80-463-1-S	3223
BNZ 80-615-1-S	3224
BNZ 80-920-1-S	3225
BNZ 125-310-1-S	3320
BNZ 125-361-1-S	3321
BNZ 125-463-1-S	3322
BNZ 125-615-1-S	3323
BNZ 125-920-1-S	3324
BNZ 125-1225-1-S	3325

1 Pass	
BSPP Oil Port	
Series Number	UPC Number
BNZ 60-131-1-B	3111
BNZ 60-208-1-B	3112
BNZ 60-259-1-B	3113
BNZ 60-310-1-B	3114
BNZ 60-361-1-B	3115
BNZ 60-463-1-B	3116
BNZ 60-615-1-B	3117
BNZ 60-920-1-B	3118
BNZ 80-208-1-B	3226
BNZ 80-310-1-B	3200
BNZ 80-361-1-B	3208
BNZ 80-463-1-B	3227
BNZ 80-615-1-B	3228
BNZ 80-920-1-B	3229
BNZ 125-310-1-B	3326
BNZ 125-361-1-B	3327
BNZ 125-463-1-B	3328
BNZ 125-615-1-B	3329
BNZ 125-920-1-B	3336
BNZ 125-1225-1-B	3337

1 Pass	
SAE Flange	
Series Number	UPC Number
BNZ 80-310-1-F	3207
BNZ 80-361-1-F	3211
BNZ 80-463-1-F	3243
BNZ 80-615-1-F	3244
BNZ 80-920-1-F	3245
BNZ 125-310-1-F	3340
BNZ 125-361-1-F	3341
BNZ 125-463-1-F	3342
BNZ 125-615-1-F	3343
BNZ 125-920-1-F	3344
BNZ 125-1225-1-F	3345

- Notes:
- BSPP Oil Ports only available with BSPP Coolant Ports.
 - SAE O-Ring, NPT and SAE Flange Oil Ports only available with NPT Coolant Ports.
 - Above models are with standard copper tubes, aluminum fins, standard black paint, and individually boxed.
 - Each cooler has been designed with a specific number of baffle plates as standard.
 - Copper Nickel tubes available, please contact your Lovejoy Sales Representative.
 - Bypass Plates (surge protection) available.
 - When referenceneing the Lovejoy Hydraulics UPC number in this table, include 8452710 as a prefix to the number shown.



Water-Oil Coolers

2 and 4 Pass Models

Item Selection

2 Pass BNZ Water-Oil Cooler UPC Number Selection Tables

2 Pass	
NPT	
Series Number	UPC Number
BNZ 60-131-2-N	3161
BNZ 60-208-2-N	3162
BNZ 60-259-2-N	3163
BNZ 60-310-2-N	3164
BNZ 60-361-2-N	3165
BNZ 60-463-2-N	3166
BNZ 60-615-2-N	3167
BNZ 60-920-2-N	3168
BNZ 80-208-2-N	3262
BNZ 80-310-2-N	3216
BNZ 80-361-2-N	3220
BNZ 80-463-2-N	3263
BNZ 80-615-2-N	3264
BNZ 80-920-2-N	3265
BNZ 125-310-2-N	3360
BNZ 125-361-2-N	3361
BNZ 125-463-2-N	3362
BNZ 125-615-2-N	3363
BNZ 125-920-2-N	3364
BNZ 125-1225-2-N	3365

2 Pass	
SAE O-Ring	
Series Number	UPC Number
BNZ 60-131-2-S	3151
BNZ 60-208-2-S	3152
BNZ 60-259-2-S	3153
BNZ 60-310-2-S	3154
BNZ 60-361-2-S	3155
BNZ 60-463-2-S	3156
BNZ 60-615-2-S	3157
BNZ 60-920-2-S	3158
BNZ 80-208-2-S	3252
BNZ 80-310-2-S	3215
BNZ 80-361-2-S	3219
BNZ 80-463-2-S	3253
BNZ 80-615-2-S	3254
BNZ 80-920-2-S	3255
BNZ 125-310-2-S	3350
BNZ 125-361-2-S	3351
BNZ 125-463-2-S	3352
BNZ 125-615-2-S	3353
BNZ 125-920-2-S	3354
BNZ 125-1225-2-S	3355

2 Pass	
BSPP Oil Port	
Series Number	UPC Number
BNZ 60-131-2-B	3141
BNZ 60-208-2-B	3142
BNZ 60-259-2-B	3143
BNZ 60-310-2-B	3144
BNZ 60-361-2-B	3145
BNZ 60-463-2-B	3146
BNZ 60-615-2-B	3147
BNZ 60-920-2-B	3148
BNZ 80-208-2-B	3236
BNZ 80-310-2-B	3214
BNZ 80-361-2-B	3218
BNZ 80-463-2-B	3237
BNZ 80-615-2-B	3238
BNZ 80-920-2-B	3239
BNZ 125-310-2-B	3338
BNZ 125-361-2-B	3339
BNZ 125-463-2-B	3346
BNZ 125-615-2-B	3347
BNZ 125-920-2-B	3348
BNZ 125-1225-2-B	3349

2 Pass	
SAE Flange	
Series Number	UPC Number
BNZ 80-310-2-F	3217
BNZ 80-361-2-F	3221
BNZ 80-463-2-F	3273
BNZ 80-615-2-F	3274
BNZ 80-920-2-F	3275
BNZ 125-310-2-F	3370
BNZ 125-361-2-F	3371
BNZ 125-463-2-F	3372
BNZ 125-615-2-F	3373
BNZ 125-920-2-F	3374
BNZ 125-1225-2-F	3375

4 Pass BNZ Water-Oil Cooler UPC Number Selection Tables

4 Pass	
NPT	
Series Number	UPC Number
BNZ 80-208-4-N	3292
BNZ 80-310-4-N	3240
BNZ 80-361-4-N	3256
BNZ 80-463-4-N	3293
BNZ 80-615-4-N	3294
BNZ 80-920-4-N	3295
BNZ 125-310-4-N	3390
BNZ 125-361-4-N	3391
BNZ 125-463-4-N	3392
BNZ 125-615-4-N	3393
BNZ 125-920-4-N	3394
BNZ 125-1225-4-N	3395

4 Pass	
SAE O-Ring	
Series Number	UPC Number
BNZ 80-208-4-S	3280
BNZ 80-310-4-S	3231
BNZ 80-361-4-S	3251
BNZ 80-463-4-S	3283
BNZ 80-615-4-S	3284
BNZ 80-920-4-S	3285
BNZ 125-310-4-S	3380
BNZ 125-361-4-S	3381
BNZ 125-463-4-S	3382
BNZ 125-615-4-S	3383
BNZ 125-920-4-S	3384
BNZ 125-1225-4-S	3385

4 Pass	
BSPP Oil Port	
Series Number	UPC Number
BNZ 80-208-4-B	3246
BNZ 80-310-4-B	3230
BNZ 80-361-4-B	3250
BNZ 80-463-4-B	3247
BNZ 80-615-4-B	3248
BNZ 80-920-4-B	3249
BNZ 125-310-4-B	3356
BNZ 125-361-4-B	3357
BNZ 125-463-4-B	3358
BNZ 125-615-4-B	3359
BNZ 125-920-4-B	3366
BNZ 125-1225-4-B	3367

4 Pass	
SAE Flange	
Series Number	UPC Number
BNZ 80-310-4-F	3241
BNZ 80-361-4-F	3257
BNZ 80-463-4-F	3203
BNZ 80-615-4-F	3204
BNZ 80-920-4-F	3205
BNZ 125-310-4-F	3300
BNZ 125-361-4-F	3301
BNZ 125-463-4-F	3302
BNZ 125-615-4-F	3303
BNZ 125-920-4-F	3304
BNZ 125-1225-4-F	3305

- Notes:
- BSPP Oil Ports only available with BSPP Coolant Ports.
 - SAE O-Ring, NPT and SAE Flange Oil Ports only available with NPT Coolant Ports.
 - Above models are with standard copper tubes, aluminum fins, standard black paint, and individually boxed.
 - Each cooler has been designed with a specific number of baffle plates as standard.
 - Copper Nickel tubes available, please contact your Lovejoy Sales Representative.
 - Bypass Plates (surge protection) available.
 - When referencing the Lovejoy Hydraulics UPC number in this table, include 8452710 as a prefix to the number shown.



Product Warranty

Lovejoy, Inc. warrants all products it manufactures to be free from defects in material and workmanship at the time of delivery to the purchaser. Defective products may be returned to Lovejoy after inspection by the purchaser and upon receipt from Lovejoy of shipping instructions specific to the defective products authorized by Lovejoy to be returned. Products returned in accordance with the foregoing procedure will be replaced or repaired, at the option of Lovejoy, without charge and returned to the purchaser F.O.B. Downers Grove, Illinois or South Haven, Michigan, depending upon origin of manufacture. In all cases, transportation costs and charges for returned products shall be paid by the purchaser and Lovejoy hereby disclaims all responsibility for any and all such transportation costs and charges.

This warranty is subject to the following LIMITATIONS:

The purchaser's exclusive remedy under this warranty is limited to the repair or replacement of defective products supplied by Lovejoy, as set forth above. LOVEJOY IS NOT RESPONSIBLE FOR ANY SPECIAL, INCIDENTAL OR CONSEQUENTIAL DAMAGES RESULTING FROM THE BREACH OF THIS OR ANY OTHER EXPRESS OR IMPLIED WARRANTY WITH RESPECT TO THE PRODUCTS, WHETHER ARISING IN TORT OR BY CONTRACT. LOVEJOY FURTHER DISCLAIMS ALL LIABILITY FROM PERSONAL INJURY RELATING TO ITS PRODUCTS TO THE EXTENT PERMITTED BY LAW. BY ACCEPTANCE OF ANY OF LOVEJOY'S PRODUCTS, THE PURCHASER ASSUMES ALL LIABILITY FOR THE CONSEQUENCES ARISING FROM THEIR USE OR MISUSE.

This express warranty is the only warranty applicable to this transaction. *IT EXCLUDES ALL OTHER EXPRESS ORAL OR WRITTEN WARRANTIES AND ALL WARRANTIES IMPLIED BY LAW WITH RESPECT TO THE PRODUCTS, INCLUDING ANY WARRANTIES OF MERCHANTABILITY OR FITNESS FOR A PARTICULAR PURPOSE.*

Every claim under this warranty shall be deemed waived by the purchaser unless made in writing within one (1) year of the receipt of the products to which such claim relates. This warranty is void in the event that repairs are made by anyone other than Lovejoy without prior authorization from Lovejoy. No person, firm or corporation is authorized to assume for Lovejoy any other liability in connection with the sale of its products. No person, firm or corporation is authorized to modify or waive the terms of this Warranty unless done in writing and signed by a duly authorized agent of Lovejoy.

Note: Specifications are subject to change without notice, and without liability therefor.

Lovejoy's Hydraulic Products



Aluminum Tanks /
Reservoirs and Accessories



Water-Oil Coolers



Pump / Motor Mounts



Couplings for Hydraulics



THE FPDA
MOTION & CONTROL NETWORK
MEMBER

Member of
Hydraulic
INDUSTRY



ISO 9001:2008 Certified

Lovejoy, Inc. World Headquarters

2655 Wisconsin Avenue
Downers Grove, IL 60515 U.S.A.
Phone: 630-852-0500
Fax: 630-852-2120
hydraulicsinfo@lovejoy-inc.com

R+L Hydraulics GmbH

Friedrichstrasse 6
D-58791 Werdohl
Germany
Phone +49 (0) 23 39 / 5 09-0
Fax +49 (0) 23 92 / 5 09-509
info@rl-hydraulics.com
www.rl-hydraulics.com

Lovejoy Canada

171 Superior Boulevard
Mississauga, Ontario
Canada L5T 2L6
Phone: 905-670-9421
Fax: 905-670-4594
lovejoycanada@lovejoy-inc.com

Other Lovejoy Affiliates:

Lovejoy Sintered Solutions LLC

Manufacturer of made-to-order powder metal components
www.lovejoy-LSS.com

www.lovejoyhydraulics.com

Lovejoy® is a registered trademark of Lovejoy, Inc. All other trademarks, brands, and names mentioned in this publication are property of their respective owners.