

Product Manual



ICC2-ATSC+

HDTV Tuner/Controller

March 21, 2017

S12 Control Version 6.5
HD Processor Version 5.10



Table of Contents

Overview	3
Specifications	4
Physical	4
Front Panel	4
Rear Panel	4
Tuning	5
Includes	5
Options.....	5
Trademarks	5
Troubleshooting	6
RF Wiring Options	8
Setup Guide	9
IR Remote Operation	9
Front Panel Setup	10
On-Screen Menus (IC Mode)	11
RS-232 Control Library	12
Input Selects	12
Input Command.....	12
n-Screen Menus	14
Main Menu	14
Channel Menus	14
Caption Menus.....	15
V-Chip Settings Menus.....	15
Setup Menu	16
IC-Net Control Protocol	18
Overview	18
Command String Structure.....	18
IC-Net Commands	19
Control	19
Tuning	20
Tuning	21
Text	21
HD2-RC Remote Emulation	22
Rack Mounting	23
iC-Net Zones, Units and Device Addresses	24
Safety Instructions	25
Limited Warranty and Disclaimer	25

Overview



The ICC2-ATSC+ HDTV Tuner includes all the proven performance of the previous ICC2-ATSC, plus new features requested by AV integrators:

- Lower profile enclosure - four tuners can fit into a 3RU space using Space Saver rack kits
- Simpler setup - all on-screen and front-panel menus can be accessed from the front panel - no IR remote needed
- SmartScan technology eliminates encrypted channels during the scanning process
- More energy efficient - draws almost a third less power
- Compatible - includes all firmware options of the 232-ATSC, no change in control commands

The ICC2-ATSC+ HDTV Tuner is an integrated HDTV tuner/controller that networks HD display monitors and projectors in a Display Express control system. As a universal TV tuner, the ICC2-ATSC+ can receive ATSC, NTSC, and clear QAM cable channels from an MATV antenna or CATV cable RF system.

The tuner displays broadcasts through simultaneous HDMI and NTSC composite ports and switched HD RGBHV or Component outputs. Full-time audio is available from digital Dolby 5.1/PCM/Variable PCM HDMI, optical, and coax ports, as well as variable-level analog stereo audio outputs.

- **Integrated Display Control** - Employs RS-232 control port for integrated display or video projector control, includes onboard database of display control command
- **Through-the-RF Coax Networking** - Communicates with Display Express Web software, and custom control systems via iC-Net RF protocol
- **Universal Tuning** – Handles a mix of ATSC, clear QAM and NTSC channels, cable or off-air tuning
- **Pro Integration** - Features 2-way RS-232 control and feedback with simple ASCII commands, as well as discrete IR and wired IR - AMX and Crestron modules available
- **Fast Tuning** - Changes analog and digital channels instantly with improved RF reception
- **Total Video** - Simultaneous HDMI and composite video, switchable RGBHV or Component HD video
- **Total Audio** - Simultaneous digital Dolby 5.1/PCM/Variable PCM HDMI, coax, and optical outputs, as well as variable-level analog stereo
- **HD Scaling** - Upscales NTSC broadcasts for HD output
- **Easy Set-up** - Front-panel programming supported by LCD display, on-screen menus using HD2-RC IR remote (included), and RS-232 control commands
- **Closed Captioning** - Displays analog and digital captioning text
- **On-Screen Menus** - Setup, Electronic Program Guide, Channel, Favorites, and Program Information menus
- **Compact Rack Mounting** - Mounts in 2RU single RK1-HD or dual RK2-HD 19" rack kits
- **Includes** - 12 VDC switching power supply
- **Options** – HD2-RC wireless remote, RK1-HD and RK2-HD rack kits, CC-232 or CC-COM RS-232 control cables, IR-RXC External IR Receiver
- **Green Machine** - Meets RoHS safety and California energy standards
- **Field Updatable** – download new control and HD processor firmware from CR website

Specifications

Physical

- Size (HWD):** 8.5" [216mm] wide x 2.0" [51mm] height (1.5 RU) x 8.0" [203mm] deep
- Weight:** 1.94 lbs [890 g]
- Enclosure:** Steel with black powder coat paint
- Mounting:** 2/1.5RU Rack mounting for one or two units side-by-side optional (RK1/2-HD+, RK1S/RK2S-HD+)

Front Panel

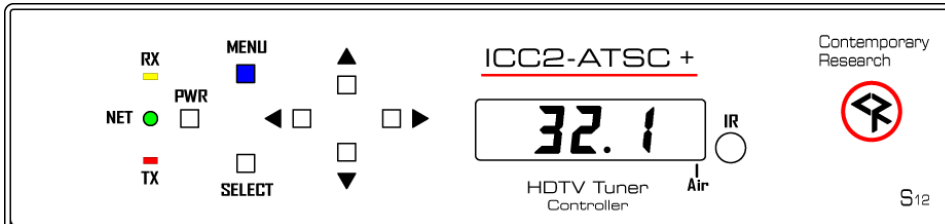

- Display:** Red LED Channel Display, dot separated major and minor channel numbers, dot at end indicates Off-Air tuning
- IR:** IR sensor
- Control:** Power, Menu, and Select buttons, navigation using Up and Down (Channel Up and Down) buttons Left and Right (Volume Down and Up) buttons
- LEDs:** RS-232 RX (Yellow), RS-232 TX (Red), Net (Green – flashes every second to confirm iC-Net control signal)

Rear Panel

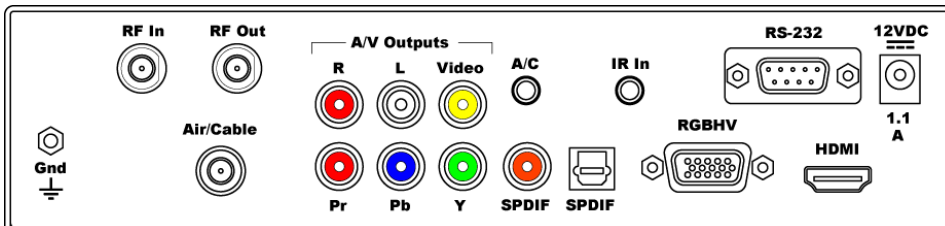

- RF In:** Air/Cable, 'F', female, 75 ohm impedance, -10 to 15 dBmV typical, receives RF control channel
- RF Out:** 'F', female, Passes RF channels to Air/Cable input, cable included
- Air/Cable:** 'F', female, 75 ohm impedance, -10 to 15 dBmV typical
- A/C Jack:** 3.5mm jack for RF-AB Air/Cable Switch
- Video Output:** Simultaneous HDM and NTSC video, switch between RGB and Component
 - Video Out:** RCA composite video output, 1V p-p at 75 ohm impedance, 480i
 - Component Out:** 3 RCA Y, Pr, Pb outputs (1080i/720p/480p/480i)
 - RGB Out:** RGBHV DB-15 female (1080i/720p/480p, 59.95 Hz)
 - HDMI:** HDMI receptacle, Type A, HD video and digital audio, version 1.3 (1080i/720p/480p), HDCP
Use PCM mode if HDMI audio connection is used to most displays (not all have Dolby)
- Audio Output:** Simultaneous HDMI, Coax, Optical, and Stereo
 - Digital Audio SPDIF:** Coax and Toslink optical output, Dolby 5.1 AC3/PCM/Variable PCM
 - Analog Audio Out:** Stereo RCA audio, Mono, Stereo, or SAP, variable level
- RS-232 Control:** DB-9 male, RS-232 data link to control system or PC, up to 9 tuners, 300-19,200 baud
- IR In:** 3.5mm stereo jack for optional IR-RXC IR Receiver
 - Sleeve= DC power+ from power jack input, limited to less than 100mA
 - Ring=DC power- (GND)
 - Tip= IR data signal
- Power In:** 2.1mm coaxial jack (inside center conductor positive)
1.1 A maximum, 11.5 to 15 VDC, 12 VDC typical

Tuning

Frequency Range: ATSC and Clear QAM (cable) television 55.25 to 801.25 MHz

TV System: ATSC, NTSC, Cable, and Clear QAM (1080i/720p/480p/480i)

Tuning: Off-air 14-69 (NTSC and 8-VSB) and CATV 1-135 (Analog, 64QAM, 256QAM, 8-VSB)

Aspect Ratio: 4:3, 16:9 (Digital), 4:3, 16:9, Zoom (Analog channels)

Captioning: DTV and analog, set by program or customized for size, font and display attributes

Captioning Data: HDMI, RGB, and Component ports don't have the ability to carry captioning data.

The composite video port will carry Line 21 data, but only when tuned to an analog channel

Lock: Parental option for channels and/or rating

Includes

Compact Power Supply, 1.5A maximum, 12 VDC

RF Loop Cable for connection of RF Out to Air/Cable input

Options

RK1-HD+ Single Rack Kit, 2RU

RK2-HD+ Dual Rack Kit, 2RU

RK1S-HD+ Single Space-Saver Rack, 1.5RU (reverse mount to stack)

RK2S-HD+ Dual Space-Saver Rack, 1.5RU (reverse mount to stack)

PMT-2+ Pole Mount Bracket

RF-AB RF A-B Switch, self-terminating, closure controlled (if system has dual Air and Cable feeds)

IR-RXC External IR Receiver

CC-COM or CC-232 RS-232 Control Cable

Firmware

HD V3.05 Provides Line captioning data on Composite video from analog and digital channels, tuner stays on sub-channel with program data is lost, does not change to default N.1 channel.

SF V5.1 This adapts commands to operate with a new series tuner board.

Trademarks

- VGA and XGA are trademarks of International Business Machines
- SVGA is a trademark of the Video Electronics Standard Association
- HDMI, the HDMI logo and High-Definition Multimedia Interface are trademarks or registered trademarks of HDMI Licensing LLC.



Manufactured under license from Dolby Laboratories, Dolby and the double-D symbol are trademarks of Laboratories

Troubleshooting

TUNING CABLE CHANNELS

Tip: The 232-ATSC+ will skip encrypted channels automatically when you activate a channel scan

Tip: You can skip scanning analog channels by pressing **Select** after you start the scan.

Symptom: *Channel ID is in XX-XX form, not cable box Guide form*

- Cable boxes translate the actual channel #s into a virtual Channel Guide, using channels 2 – 900, or more.
- The actual (physical) channels have IDs in XXX-XX form, just like off-air channels. Non-cable HDTV tuners like the ATSC or LCD TVs don't provide Guide features, so the channels will be displayed in their native, physical major-minor channel form.
- Some cable franchisees have a listing by physical channel, many do not. You can press the INFO button on the HD2-RC remote to view the channel name.

POWER/VIDEO OUTPUT

Symptom: *Tuner appears to be on, channel display is lit, but unresponsive, no video/audio out*

- This often occurs when a 232-ATSC+ is used to replace an old 232-series analog tuner.
- The solution is to not use the old 500 Ma power supply, and use the 1.5 Amp power supply that comes with the ATSC. The old supply has enough juice to light up the front panel LEDs, but nothing else.

Symptom: *No video on Component Out*

- The RGB and Component outputs are switchable, and the tuner ships set to RGB. Use Front Panel Mode, next section to switch the HD analog video to Component.

HDMI

Symptom: *No Video or Signal*

- Most monitors accept HDMI in the RGB and Component color space, but there are exceptions. Try switching from RGB to Component (Front panel mode 48).
- Switch between 720p and 1080i, or down to 480P or 480i for old DVI sets. (Front panel mode 49)
- If you're connecting via a Cat5 interface, HDMI receiver, or switcher, some delay the HDCP signal slightly out of range. Call CR Support on how to extend the delay on HDMI.

Symptom: *No audio or fluttering sound in display speakers connected via HDMI*

Change ATSC digital audio to PCM or PCM variable (most displays do not use Dolby 5.1)

RGB/Component

Symptom: *No RGB or Component Video output*

Check the RGB or Component output setting in Front Panel mode 48 (48.0 is RGB, 48.2 is Component).

Symptom: *No output display on VGA input*

Some monitors or projectors do not support 1080i or 720P operation on the RGB port. Set resolution in Front Panel mode 49 (49.2 for 480P).

Composite Video

Symptom: *Composite video out has small image in 16:9 setting, analog channels*

- For a 4:3 set, tune to an analog channel and press RATIO on the remote to set to 16:9. Image will fill left to right, you'll always have a black band top and bottom.
- Set to 4:3 if you're only feeding video to 4:3 TVs.
- Set output ratio on a digital channel as well - this a different setting than for analog channels.
- If the tuner is used for 16:9 displays and analog TVs, choose the best setting for the widescreen, and the NTSC will have to be a compromise. Most of the time, setting the RATIO while tuned to an analog channel and again for a digital channel will provide the best result.

IR Control

Symptom: IR remote won't control tuner

Hold down IR remote **Select**, press **9**, and release both. Front-panel setting should be **15.9**. In addition, check if the remote works when the lights are off. Some energy-saving fluorescent lights produce interference at our IR frequency (57 Hz). Try to cover the IR sensor so the lights don't affect operation, or add the IR-RXC External IR Sensor. It's easier to hide and tilt the sensor to help with reception, and you can try Select and 4 to use the lower IR frequency (the RXC has both types of sensors).

Line 21 (analog) Captioning on Video Output

Symptom: Video out does not include captioning

The 232-ATSC+ does not carry forward closed captioning codes when tuned to an analog channel. However, all captioning from digital TV channels is converted to analog captioning on the video output.

RF Wiring Options

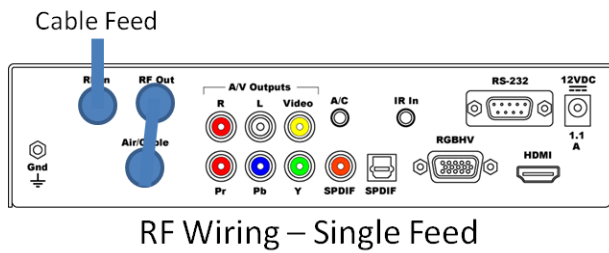

RF Wiring – Single Feed

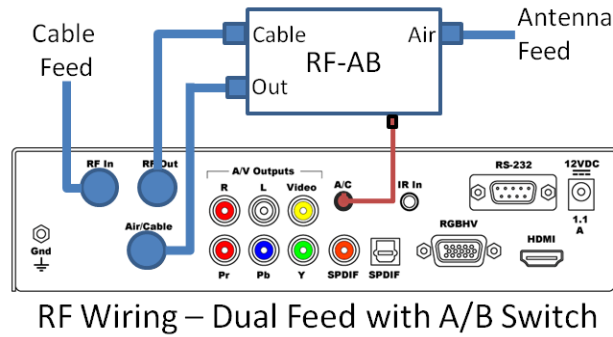

RF Wiring – Dual Feed with A/B Switch

There are two ways to wire RF feeds to the ICC2-ATSC+.

Single RF Feed

Most applications will use a single RF feed, either Cable or Air (Antenna).

- Connect the RF feed to RF In on the top of the tuner. This allows the tuner to receive the iC-Net control signal.
- Connect the included short RF cable from RF Out to the Air/Cable RF input. A low-loss tap feeds the RF feed the ATSC+ tuner.

Dual RF Feed

Other applications will use both Cable and Air (Antenna) feeds. The ICC2-ATSC+ can switch between both, maintaining separate channels lists for each. You'll need the optional RF-AB switch, which has a mini 3.5mm cable that connects to the A/C control output on the back of the tuner. The placement of RF connections on the RF-AB is different than shown – the RF ports above are arranged for clarity.

- Wire the Cable feed to the RF input of the ATSC+. Note that the Cable feed needs to go through the RF In on the ATSC+ first, so the tuner can receive the iC-Net control channel.
- Connect the ATSC+ RF Out to the Cable input of the RF-AB.
- Connect the Air/Antenna feed to the Air input of the RF-AB.
- Connect the included short RF cable to the RF-AB switch RF Out, then to the Air/Cable RF input on the ATSC+.
- Connect the 3.5mm mini plug to the ATSC+ A/C control output.

Setup Guide

The ICC2-ATSC+ supports a mix of setup tools, including:

- HD2-RC Remote Mode (accesses On-Screen Graphic Menus and special HD functions)
- IC-RC Remote Mode (accesses Text Menus and special media functions)
- Front-Panel Setup
- IC-Net commands from system or iC Send

The reason for the options is that the ICC2-ATSC+ is designed to offer advanced analog/digital tuning, yet be compatible with existing iC-Net systems.

IR Remote Operation

The IC-RC Remote is used with analog tuners as well as media and text menu control functions when used in iC-Net control systems. The HD2-RC IR Remote is designed for control and setup of ATSC-series HDTV tuners. Both remotes send the same IR codes, the difference is in how the tuner responds.

In most cases, IC-Net systems, especially for schools and other applications that access on-screen text menus and interactive media control, will continue to use the traditional IC-RC remote and mode.

System integrators can switch the ICC2-ATSC+ to the HD2-RC mode to access HD features, such as channel scans and set up of 16:9 or 4:3 display modes. Then switch to IC mode to test iC-net operation and IC-Net device number.

Front-Panel Setup

The Front Panel modes are useful for setting tune mode, HD output and resolution, and switching between IC and HD2 remote modes.

IC Send Control

You'll find the free IC Send program to be a great tool for system setup and testing, especially if the site is using the ICE-HE Head End and your laptop is configured for the site's network. You can also use a PC or laptop via RS-232 with the ICC-HE Head End. Key functions include:

- **On, Off and Tune** commands to test operation to one or all ICC2-ATSC+ units.
- **IR Mode.** Switch all tuners to IC or HD2 modes.
- **Channel Setup.** Use the T^ Command to force all units to scan channels, then use the XA and XD commands to add and remove channels from the list. If you're using RS-232 control at the head end, have an ICC2-ATSC+ at that location to check your setup.
- **Tuner Setup.** Use LM and TM commands to configure general tuner operation.
- **Default Input.** Use the ER command to set the default input.

Device Address Settings

Use the front-panel setting 2 and 3 to set the address. Menu 3 sets the Zone address, and Menu 2 sets the individual number in the zone. For example the system address for a controller is 257, set Menu 2 to 2.1 (1), and Menu 3 to 3.1 (Zone 1, which is address 256), $1 + 256 = 257$ system address. The controller will act by itself when you send the unique 257 code, as a zone group when you send 256, or with all with address 4095.

Zone	1	2	3	4	5	6	7	8
	256	512	768	1024	1280	1536	1792	2048
Zone	9	10	11	12	13	14	15	
	2304	2560	2816	3072	3328	3584	3840	

Front Panel Setup

To Enter a Front Panel Programming Mode:

1. Press **and hold** the Power button, then press the Volume Up button
2. Release all buttons, the ICC2-ATSC+ will now be in the front-panel programming mode. The Air LED will flash, indicating programming mode.
3. The first two digits show the mode, the second show the option.
4. Changes are saved in non-volatile memory as they are entered.
5. The Volume up/down buttons scroll through programming modes, forward and reverse.
6. The Channel up/down buttons scroll through possible options for each mode.

To Exit the Front Panel Mode - Push and release the Power button.

Mode	0-9	Parameters
RF Tune	0.0	0=CATV (Default) 1=Off-Air 2=IRC 3=HRC 4=Cable Auto
Baud Rate	1.1 1.2 1.3 1.4 1.5 1.6 1.7 1.8 1.9 1.10	300 600 1200 2400 4800 9600 19200 38.4K 57.6K 115.2K
Unit Number	2.1	1-99 (The LCD can't show a number higher number. It
Zone Number	3.0	1-15 System device number is (Unit + (Zone * 256))
Panel Lockout	4.0	Reserved (performed by LM command)
Power-up Volume	5.0 5.X	Restore previous level (default) 1 – 63 sets volume level
Firmware Version	6.20	Ex: Version 2.0 – When at this menu: Press and hold Channel Up, then Power to restore tuner to default settings Press and hold Channel Up and Down, then Power to scan channels
Captions	10.0 10.1	Captioning off (default) Captioning on
Caption Mode	11.1 11.2 11.3 11.4 11.X	1=Caption 1 (default) 2=Caption 2 3=Caption 3 4=Caption 4 5-8= Text 1-4 (rarely used)
Video Detect	12.3	No AV mute (fixed)
AV Status	13.0	No AV status (default)
Label Mode	14.2	Numeric (fixed)
IR Receive	15.9	0= Off, 9=Receive IR
Digital Captions	17.1	1-6, Default is 1
IR Remote	18.1	0=IC-RC 1=HD2-RC
Tune Control	19.0	0=Tune all channels 1= Only tune channels in List
Digital Audio	47.0 47.1 47.2	0=AC-3– Dolby 5.1 1=PCM (set to this for audio through HDMI) 2=PCM Variable (default)
HD Output	48.0 48.2	RGB (Default) Component
HD Format	49.0 49.1 49.2 49.3 49.4	0=1080i (Default) 1=720p 2=480p 3=480i 4=1080p
Control Type	50.n	Current Control type. Refer to next page for a list of types. Use Up/Down to change.

On-Screen Menus (IC Mode)

The remaining installation steps use the IR remote and the built-in character generator of the ICC2-ATSC+.

1. Change the IR Remote mode in front-panel menu 18 to **IC-RC (18.0)**. This will enable the character generator to display the menus below.
2. Touch **Menu**, then **999**, then **Enter**.
3. The text **CR MENU>** should appear on the screen.
4. Key in one of the commands shown below, then press **Enter** to activate.
5. Note that, in Menu mode, the **Channel Down** key acts as a backspace/delete key.

CR Menu Number	Function
Unit Setup	
45678	Display firmware version
45679	Display the unit's device #. At this point, you can use the Channel Down key as a Delete key, then enter a new device # with the remote's numeric keypad, then hit Enter to save the new number.
45700	Display current make/model control type, listed on the previous page. You can use the Channel Down key as a Delete key, then enter a new device # with the remote's numeric keypad, then hit Enter to save the new number. The setting will use the default baud rate, which can be changed using front-panel menus.
45720	Set Display/Projector Input Enter code 1-19. See page 15 in the ER section for input codes
45718	IR Remote Type – if you are done using the IC-RC mode, change this setting back to HD2-RC operation. 0=IC-RC 1=HD2-RC
Special Menus	
65478	Reset controller, similar to disconnecting power then restarting.
65487	Initialize to factory default settings: Power on, unlocked, display channel 11, channel ring set to 4, 5, and 11, Group 0. Note that this command works even if TV power is off or control is locked out.
65480	Enable constant Net transmit to the Head-End. This is used for measuring the signal strength of the unit's RF output. Press Enter to stop transmit or the unit will automatically stop after 50 seconds.
65481	Display DA transmitter frequency control voltage – should be 2000 - 3150.
65482	Display iCC-Net RF receive signal strength. Shows Net RX if receiving the iC-HE's "heartbeat" pulse once per second, !NET RX if not.
65483	Display DF transmitter frequency deviation – should be 245 - 300

RS-232 Control Library

The ICC2-ATSC 4 includes a full library of make/model codes, noted by the **Type** number. The tuner is shipped pre-set to the type required for the order. The integrator can change the types from the front panel or IC-RC mode with an IR remote, or from a T0 command send to the tuner over RF.

Type	Make	Display	Baud	Notes
0	CR Test		9600	
1	Sharp	Projector	9600	
3	Sanyo	Projector	19.2K	PLC-WK2500
4	NEC	Monitor	9600	Legacy models with early input commands; not plasma
5	Olevia	Monitor	19.2K	323V
6	Panasonic	Monitor	9600	
9	Mitsubishi	Projector	9600	XD560U
10	Samsung EX	Monitor	9600	Ex-Link
11	Samsung	Monitor	9600	400CXn, 460CXn, ME40A, ME46A, ME55A, MD55B
14	NEC	TV	9600	E-series TVs (redundant, this series has onboard tuners)
22	Hitachi	Projector	19.2K	Hitachi CP-S317, CP-S318, CP-X327, CP-X328 , Christie projector LW650, LW750, LS+700, DWDL95, DHD951, LWU501i, LWU502
24	Epson	Projector	9600	VP 595wi, 1925W Projector
27	Samsung	Monitor	9600	LCD 323T and 403T
28	Samsung	Plasma	9600	
29	LG	Monitor	9600	M32/4201, 42PMIM
32	NEC	Plasma	9600	Odd parity
33	Sharp	Monitor	9600	LC46LE820UN
44	Projection Design	Projector	9600	
45	Extron	Wall Panel	9600	Emulates buttons on Pole Vault wall panel
46	Sharp	Monitor	9600	PN-L702B, PN-V601
47	Sharp	Monitor	9600	LC70LE745U, same as 33, but slightly different input selects - Use for all new Sharp monitors
48	NEC	Monitor	9600	M-,P-, V-, X- series monitors
49	Christie	Projector	19.2K	DHD800
50	NEC	Projector	9600	NP-M402H File I2AT57NEC50.S19 (NEC default is 38.4K, user needs to change baud on projector)
51	Barco	Projector	115.2K	Barco RLS-W12
54	LG	Monitor	9600	
55	Christie 2	Projector	115.1K	DHD850 – different codes than DHD800

Input Selects

Inputs can be selected as well, using a 0-NNN channel command, or example 0-211 selects HDMI 1. Some makes will need a 0-200 command to return to the tuner channel, others will switch back to the tuner automatically. Some input number may shift, depending on the model.

200=TV/Tuner	206=Component1	211=HDMI1
201=Video1	207=Component2	212=HDMI2
202=Video2	208=RGB1	213=HDMI3
203=Video3	209=RGB2	214=HDMI4
204=S-Video1	210=RGB3	215=HDMI5
205=S-Video2		

Input Command

You will need to specify the default input for the ICC1-ATSC 4S, so that the unit will return to the correct input. Use IC-Send or Display Express to send the EI command on page 17 to the tuner once it's on the IC-Net RF network.

HD2-RC IR Remote

The HD2-RC IR Remote can be used to setup the tuner and for daily operation. The IC-RC remote will work as well, the image below shows the function of the keys when the tuner is in the HD2-RC mode.

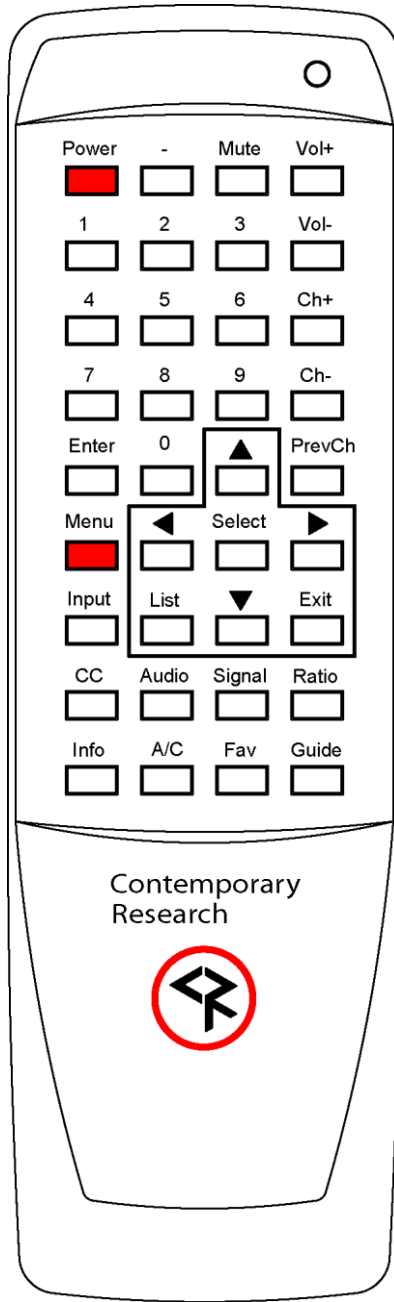

Power

Turns tuner on and off. Discrete on and off IR commands are available as well.

Volume Control

Use the **Vol+**, **Vol-** and **Mute** buttons.

Channel Selection

The key change in digital tuning is the need to add a dash (-) and number after the traditional channel number. Analog channels are accessed using XX-0, digital channels using XX-1 (or -2, -3, etc).

Ch+, **Ch-** and **PrevCh** can be used to access and recall channels.

Menu Operation

Press Menu to access the on-screen menus.





- Use the directional **Arrows**, **Select** and **Exit** to navigate the menus.
- **List** displays the list of all channels, arrow keys add/remove channels, set Favorite Channel list
- **Exit** steps backwards out of menus
- **Enter** selects menu choice





Special Functions





- **CC** steps through available closed-captioning options
- **Audio** selects audio and SAP modes
- **Signal** displays channel signal level
- **Ratio** steps through aspect ratios, options depend on channel and output types
- **Info** launches on-screen information window
- **A/C** selects Air or Cable tuning
- **Fav** Displays list of favorite channels
- **Guide** displays on-screen Guide



Features of many of the Special Function commands depend on whether the current channel is analog or digital.

On-Screen Menus

<h3>Main Menu</h3> 	<p>Selects sub-menus.</p> <ul style="list-style-type: none"> • Arrow keys highlight option • Select (or Enter) chooses option • Menu steps back or exits menu • Exit exits all menus • Some options are only available if you are currently tuned to an analog or digital channel
<h3>Channel Menus</h3> 	<p>Sub-Menu for Channels offers options for:</p> <ul style="list-style-type: none"> • Channel Auto-Scan • Favorite Channel Selection • Add/Delete Channels • Fine Tune (If tuned to an analog channel) • Signal Strength Meter
<h3>Auto-Scan</h3> 	<p>Starts scan of analog and digital channels for:</p> <ul style="list-style-type: none"> • Air – looks for NTSC and ATSC channels • Cable Auto – looks for analog and digital QAM cable channels, as well as all frequency plans • Cable STD - standard cable spacing • Cable HRC – HRC cable spacing • Cable IRC – IRC cable spacing <p>Tip: Normally, use Auto. Most cable channels will be in standard frequencies. If all the channels tune in STD but channels 5 and 6, scan for IRC. If few channels can be found, scan for HRC.</p>
<h3>Favorite Channels</h3> 	<p>Menu is also displayed from the List command, selects channels advanced by the FAV favorite channel command.</p> <p>Use the Up, Down arrows to move through the list, press Select to add a channel to Favorites.</p>

<p>Channel Add/Delete</p> 	<p>This menu can add or delete a channel accessed from Channel Up and Down.</p> <p>You can tune to a channel you want to delete, then press Menu/Channel/Add-Delete. Press Select to delete the channel. You can also keep the page on screen as you step through channels, adding and deleting as desired. If the channel has a good signal, it will be displayed in the background.</p> <p>Note that HDTV channels are broadcast on UHF frequencies. The Add/Delete will show the name of the digital channel, as well as the actual UHF channel used for broadcasting.</p> <p>You can delete one of a digital channel's sub-channels without affecting the others.</p>
<p>Signal Strength</p> 	<p>This page also displays from the Signal remote command. The graphic shows the current signal strength, and changes in real time. This allows you to monitor the strength of a channel as you adjust the antenna for best reception.</p>
<p>Caption Menus</p>	
<p>Caption Menus</p> 	<p>This menu accesses captioning features:</p> <ul style="list-style-type: none"> • On/Off – turn captions on/off – <i>other options are not available if captions are off.</i> • Analog Mode - CC 1-4 and Text 1-4 • Digital Mode – Service 1-6 • Digital Font Options <ul style="list-style-type: none"> • Size – Standard (15 pixels), Large (21 pixels), or Small (11 pixels) • Style – 1-6 • Color – 8 shade of background, foreground and edge colors • Opacity – foreground and background • Edge – 6 style options <p>Version displays current version of tuner firmware</p>
<p>V-Chip Settings Menus</p>	
<p>V-Chip Settings Menus</p> 	<p>Manages access to programming for US and Canadian standards.</p> <p>The default PIN number for access is 0000 (four zeros).</p>

<p>Change PIN</p> 	<p>Enter and confirm new PIN for access.</p>																																																	
<p>US Rating</p>  <table border="1" data-bbox="219 577 527 745"> <thead> <tr> <th>MOVIE</th> <th>TV</th> <th>FV</th> <th>D</th> <th>L</th> <th>S</th> <th>V</th> </tr> </thead> <tbody> <tr> <td>G</td> <td>TV-Y</td> <td></td> <td></td> <td></td> <td></td> <td></td> </tr> <tr> <td>PG</td> <td>TV-Y7</td> <td></td> <td></td> <td></td> <td></td> <td></td> </tr> <tr> <td>PG13</td> <td>TV-G</td> <td></td> <td></td> <td></td> <td></td> <td></td> </tr> <tr> <td>R</td> <td>TV-PG</td> <td></td> <td></td> <td></td> <td></td> <td></td> </tr> <tr> <td>NC17</td> <td>TV-14</td> <td></td> <td></td> <td></td> <td></td> <td></td> </tr> <tr> <td>X</td> <td>TV-MA</td> <td></td> <td></td> <td></td> <td></td> <td></td> </tr> </tbody> </table>	MOVIE	TV	FV	D	L	S	V	G	TV-Y						PG	TV-Y7						PG13	TV-G						R	TV-PG						NC17	TV-14						X	TV-MA						<p>Use arrows and Select functions to select level of Movie and TV rating allowed.</p>
MOVIE	TV	FV	D	L	S	V																																												
G	TV-Y																																																	
PG	TV-Y7																																																	
PG13	TV-G																																																	
R	TV-PG																																																	
NC17	TV-14																																																	
X	TV-MA																																																	
<p>Canada Rating</p>  <table border="1" data-bbox="219 903 527 1092"> <thead> <tr> <th></th> <th>English</th> <th>French</th> </tr> </thead> <tbody> <tr> <td>Allow All</td> <td>E</td> <td>E</td> </tr> <tr> <td>Block All</td> <td>C</td> <td>G</td> </tr> <tr> <td></td> <td>C8+</td> <td>8+</td> </tr> <tr> <td></td> <td>G</td> <td>13+</td> </tr> <tr> <td></td> <td>PG</td> <td>16+</td> </tr> <tr> <td></td> <td>14+</td> <td>18+</td> </tr> <tr> <td></td> <td>18+</td> <td></td> </tr> </tbody> </table>		English	French	Allow All	E	E	Block All	C	G		C8+	8+		G	13+		PG	16+		14+	18+		18+		<p>Use arrows and Select functions to select level of Movie and TV rating allowed.</p>																									
	English	French																																																
Allow All	E	E																																																
Block All	C	G																																																
	C8+	8+																																																
	G	13+																																																
	PG	16+																																																
	14+	18+																																																
	18+																																																	
<p>Setup Menus</p>																																																		
	<p>This series of menus select the options for tuner operation:</p> <ul style="list-style-type: none"> • Screen Format – 16:9 or 4:3 NOTE: Set when tuned to a digital channel, again when tuned to an analog channel – these are two different settings! You can use RATIO on the remote – does the same setting. • Time • Sound Settings • Video Noise Reduction - On/Off (if tuned to analog) Set to On – helps to clean up analog channels • Menu Language – English, Spanish, French 																																																	

<p>Screen Format</p> 	<p>Selects between 4:3 and 16:9 aspect ratios. The Ratio command can also adjust the settings.</p> <ul style="list-style-type: none"> • 4:3 Display offers three options for 16:9 video: 16:9, 4:3 (stretched vertically), and Zoom (cropped sides) • 16:9 Display offers three options for 4:3 video: 4:3 (small centered), 16:9 (stretched horizontally), and Zoom (stretched vertically and horizontally) – or 4:3 and 16:9 if the video is 16:9
<p>Time</p> 	<p>Sets time settings for:</p> <ul style="list-style-type: none"> • Daylight Saving – Select and choose on or off Note – The DST trigger comes from the broadcast stations, and may not be in sync with the new US standards. Use On/Off or time zone to offset time • Time Zone – Select local time Zone
<p>Time Zone</p> 	<p>Use left-right cursors to select the time zone, Select enters the current zone.</p>
<p>Sound</p> 	<p>Selects a variety of options, each is only active when you are currently tuned into an analog or digital channel:</p> <ul style="list-style-type: none"> • Analog MTS – Mono, Stereo, SAP (same as Audio) • Multi-Track – English, French, Spanish • Digital Out – AC-3 (Dolby 5.1), PCM, or variable-level PCM. Set to PCM when using audio through the HDMI connection – most displays cannot decode AC-3 (Dolby 5.1). • Auto Volume – On or off
<p>Pop-Up Menus</p>	 <p style="text-align: center;">Info Guide</p>

IC-Net Control Protocol

Overview

Control for over 4000 TV Controllers is provided through an ICE-HE Head-End Network Controller or ICE-HE DXL Display Control Center that inserts a micro control channel through RF coax. The ICE-HE receives control commands via RS-232 and Telnet, and the ICE-HE-DXL adds a USB port.

Each TV Controller is assigned a unique device number from 257 to 4094. The devices are organized into 16 zones of 255 devices to handle large-scale TV installations. All the devices in each zone will respond to a single “virtual device number” — one device number that represents all devices in each zone. There is also a global device number, 4095, that will command all devices in the system. This feature dramatically speeds up system operation and programming, because one command can affect an entire group of devices—or all. To take advantages of this feature, review the section **iC-Net Zones** following this section.

In Display Express, we reserve the first group of devices, 1-255 (for which there is no Zone), for components in special applications. Zones 1-15 are used for CR TV Controllers.

The RS-232 port can communicate from 1200 to 38.4K baud. The factory default setting is 19.2K baud, 8 data bits, no parity, and 1 stop bit. IP commands can be sent via Telnet to IP port 2728. The USB port is typically used to provide RS-232 control from a PC with Display Express software.

Command String Structure

Characters in command strings are expressed in a combination of hex and ASCII characters. For clarity, the following protocol examples use the following conventions:

- Single-byte hex numbers are preceded by the ‘\$’ symbol
- ASCII characters or strings are enclosed in single quotes
- Numbers not marked as hex or ASCII are a single decimal byte
- Parameters shown in < > brackets are single byte
- A series of multiple commands or parameters are set apart by [] brackets
- Commas separate the bytes, but are not part of the protocol
- Double quotes enclose the command string, but are not part of the protocol

Command format:

"\$A5,<dh>,<dl>,<ncb>,<cmd1>,<parameter> [<cmdN>]"

\$A5	Starts the command
<dh>	The zone or high order byte of the device*
<dl>	The unit or low order byte of the device (0 for global zone)
<ncb>	The number of command bytes to follow
<cmd1>	The first command byte
<parameter>	Command parameters (not used by all commands)
[<cmdN>]	Multiple commands can be concatenated, with byte count added to <ncb>

* iC-Net devices are arranged with a zone mindset. For example, a command sent to Device 256, which triggers all the units in Zone 1, would be expressed as \$A5, 1, 0 (first zone, device zero). A command sent to 257 would be \$A5, 1, 1 (first zone, device 1 in the zone). See iC-Net SmartZones toward the end of this manual.

IC-Net Commands

Command	Description	
Control		
Power Off	P0	"\$A5,<dh>,<dl>,2,'P0' " (6 bytes)
Power On	P1	"\$A5,<dh>,<dl>,2,'P1' " (6 bytes)
Power Toggle	PT	"\$A5,<dh>,<dl>,2,'PT' " (6 bytes)
Volume	VL	"\$A5,<dh>,<dl>,3,'VL',<vol level>" (7 bytes) Sets TV volume level 0 = Mute 1 – 63 = Minimum level (1) to maximum volume (63)
RS-232 Control	T0	"\$A5,<dh>,<dl>,3,'T0'<type>" (7 bytes) – Sets RS-232 control codes, see page 10
IR Remote	Q8=	"\$A5,<dh>,<dl>,3,'Q8',<IR Remote>" (7 bytes) 0=IC-RC 1=HD2-RC
Control Lock	LM	"\$A5,<dh>,<dl>,3,'LM',<control>" (7 bytes) Locks out front panel and IR remote control functions. Bit 7 Selects IR remote control operation (0=enabled, 1=disabled) Bit 6 Selects volume control operation (0=enabled, 1=disabled) Bit 5 - 1 Always 0 Bit 0 Selects front panel buttons operation (0=enabled, 1=disabled)
Operating Parameters	TM	"\$A5,<dh>,<dl>,3,'TM',<setting>" (7 bytes) Sets up key functions in the unit Bit 0 – Alpha channel labels 0=alpha labels off 1=alpha labels on Bit 1 – Numeric channel labels, 0=num labels off 1=num labels on Bit 2 – Channel up/down operation, 0=Tune Ring, 1=Send IR Keypad response Bit 3-7 = 0
Control String	UX	"\$A5,<dh>,<dl>,2+string length>,'UX'<string>" (variable bytes) Sends an RS-232 string (ASCII, decimal, or hex) directly to the TV display. Ex: "\$A5,1,2,6,'UX', 13" Sends PON, followed by carriage return (device 258)

Command	Description	
Tuning		
Tuning Format	S0=	<p>“\$A5,<dh>,<dl>,3,'S0',<format>” (7 bytes)</p> <p>0=CATV 1=Off-Air 2=IRC 3=HRC 4=Cable Auto</p>
Tuning Style	H1=	NA
TC Response	H2=	NA – When the ICC2-ATSC+ receives an analog channel command, it will attempt to tune the digital equivalent first. If there is not a matching virtual channel, the unit will tune the analog channel.
Channel Up	TU	“\$A5,<dh>,<dl>,2,'TU' ” (6 bytes) – Tunes to next channel up
Channel Dwn	TD	“\$A5,<dh>,<dl>,2,'TD' ” (6 bytes) – Tunes to next channel down
Prev Channel	TP	“\$A5,<dh>,<dl>,2,'TP' ” (6 bytes) – Tunes to previous channel
Tune Analog Channel	TC	“\$A5,<dh>,<dl>,3,'TC', <channel>” (7 bytes) – Tunes to a specific channel 2-127
Scan Mode	D0=	<p>“\$A5,<dh>,<dl>,3, 'D0',<mode>” (7 bytes) – Scan Mode</p> <p>Sets scan mode for digital and analog channels from the T^ or front panel scan command.</p> <p>0= Scans for analog and digital channels scan (default) 1= Scans for digital only, deletes analog channels 2= Scans for digital only, keeps analog channels 3= Scans for analog only, deletes digital channels 4= Scans for analog only, keeps digital channels</p>
Channel Scan	T^	“\$A5,<dh>,<dl>,2,'T^' ” (6 bytes) – Initiates channel scan
Tune HD Channel	TH=	<p>“\$A5,<dh>,<dl>,5,'TH',<H1>,<Major>,<Minor>” (9 bytes)</p> <p>The tuner will ignore the first bit (H1), and tune the major (virtual) and minor channels. Values may be in hex or decimal.</p> <p>Ex: “\$A5,1,4,5,'TH',0,2,3” Device 260, virtual channel 2-3</p> <p>See page 12 on how to use TH to select inputs</p>
Add Channel	XA=	“\$A5,<dh>,<dl>,5, 'XA',<chan Major>,<chan Minor>,<RF physical channel>” (9 bytes) – adds channel to tune ring/list
Delete Channel	XD=	“\$A5,<dh>,<dl>,4, 'XD',<chan Major>,<chan Minor>” (8 bytes) – Deletes channel from tune ring/list
Tune Control	Q9=	<p>“\$A5,<dh>,<dl>,3, 'Q9',<control>” (7 bytes)</p> <p>0= Tune any channel 1= Only tune channels from the tune ring/list</p>
Captions	Q0=	<p>“\$A5,<dh>,<dl>,3, 'Q0',<on-off>” (7 bytes)</p> <p>0=Captioning off (default) 1=Captioning on</p>
Caption Mode	Q1=	<p>“\$A5,<dh>,<dl>,3, 'Q1',<mode>” (7 bytes)</p> <p>1=Caption 1 (normal setting for most captioning) 2=Caption 2 3=Caption 3 4=Caption 4 5-8= Text 1-4 (rarely used)</p>

Command	Description																					
Tuning																						
Input	EI	<p>"\$A5,<dh>,<dl>,3,'EI',<Input>" (7 bytes)</p> <p>Sets the input for controlled projector or display. See Input list in ER.</p>																				
Input Ring	ER	<p>"\$A5,<dh>,<dl>,<ncb>,'ER', [<input 1>, <input N>]" (variable bytes)</p> <p>Sets a list of inputs that are cycled by the Input command on the IC-IR remote or KK command. Follow the standard list of inputs below, check with CR Support on which are available for your make and model of video display.</p> <table border="0"> <tr> <td>1 Video1</td> <td>11 DVI/HDMI1</td> </tr> <tr> <td>2 Video2</td> <td>12 DVI/HDMI2</td> </tr> <tr> <td>3 Video3</td> <td>13 DVI/HDMI3</td> </tr> <tr> <td>4 S-Video1</td> <td>14 DVI/HDMI4</td> </tr> <tr> <td>5 S-Video2</td> <td>15 DVI/HDMI5</td> </tr> <tr> <td>6 Component1</td> <td>16 TV</td> </tr> <tr> <td>7 Component2</td> <td>17 TV2</td> </tr> <tr> <td>8 RGB1</td> <td>18 1394</td> </tr> <tr> <td>9 RGB2</td> <td>19 Memory stick</td> </tr> <tr> <td>10 RGB3/DTV</td> <td></td> </tr> </table> <p>Ex: "\$A5,<dh>,<dl>,6,'ER', 1,4,8,11" sets ring to Inputs 1, 4, 8 and 11.</p>	1 Video1	11 DVI/HDMI1	2 Video2	12 DVI/HDMI2	3 Video3	13 DVI/HDMI3	4 S-Video1	14 DVI/HDMI4	5 S-Video2	15 DVI/HDMI5	6 Component1	16 TV	7 Component2	17 TV2	8 RGB1	18 1394	9 RGB2	19 Memory stick	10 RGB3/DTV	
1 Video1	11 DVI/HDMI1																					
2 Video2	12 DVI/HDMI2																					
3 Video3	13 DVI/HDMI3																					
4 S-Video1	14 DVI/HDMI4																					
5 S-Video2	15 DVI/HDMI5																					
6 Component1	16 TV																					
7 Component2	17 TV2																					
8 RGB1	18 1394																					
9 RGB2	19 Memory stick																					
10 RGB3/DTV																						
Text																						
Write Text	DM	<p>"\$A5,<dh>,<dl>,<ncb>,'DM', <start line>,<text color>,<text background color>, <screen background>,<size and shadow>,<timeout>,<message bytes>" (variable bytes)</p> <p>Clears current text, displays text message over video (default) or blank background. The built-in character generator can accept up to 40 characters of text (including carriage returns), 28 characters per line. Use a hex \$0D or decimal 13 in the text as a carriage return, which will advance CG to the next line, first space on the right.</p> <p>Start Line - 1-9 Text Color - 1-7= White Text Background Color – 0-7=Transparent (no background) Full screen background – 0=normal insert over video Size and Shadow – 0-3=small text with drop shadow Time-Out – 0=15-second display, 1=persistent</p> <p>Persistent text stays on screen until the next DM, or new Menu or channel.</p> <p>Ex1: "\$A5,<dh>,<dl>,10,'DM', 2,7,0,0,1,0,'TEST' " displays the word TEST on the second line, white text, inserted over video, small size with drop shadow, and timing out after 15 seconds.</p> <p>Ex2: "\$A5,<dh>,<dl>,2,'DM' " clears on-screen display, also clears persistent text</p> <p>The ATSC uses white text and clear backgrounds when it receives a Text or Background Color parameter between 1 and 7, and accepts values 0-3 for text size and shadow. This allows compatibility with Smart TVs mixed in the same system that can display other colors and fonts.</p>																				
Return	EB	<p>"\$A5,<dh>,<dl>,2,'EB' " (6 bytes)</p> <p>Moves cursor down to the first column of the next row.</p>																				
Text Timeout	DQ	<p>"\$A5,<dh>,<dl>,3,'DQ', <time>" (7 bytes)</p> <p>Sets screen timeout to specified time in seconds (1-254). If time is 0 or 255, any text on the screen will persist indefinitely, or until cleared.</p>																				

HD2-RC Remote Emulation

You can also emulate IR commands sent from the CR HD2-RC Wireless Remote. If you are using the numeric keys to select a channel, the user or program will need to follow the numeric command with an Enter.

KK=<key>	"\$A5,<dh>,<dl>,3,'KK',<control>" (7 bytes)	
	* = Reserved for future products/applications	
0=*		88=Favorite
1=*		95=List
2=*		96=Add/Delete Channel
3=*		98=Air/Cable
4=*		99=Dash -
5=*		100=Info
6=*		101=Prev Chan
7=*		105=Menu
8=*		106=Cur Rt
9=Power (tog)		107=Cur Lt
10=0		108=Cur Up
11=1		109=Cur Dn
12=2		110=Select
13=3		111=Exit
14=4		115=CC
15=5		141=Format 1080i
16=6		142=Format 720p
17=7		143=Format 480p
18=8		144=Format 480i
19=9		149=Output RGB
20=		151=Output YPbPr
21=Enter		153=Air
22=Ch Up		154=Cable
23=Ch Dn		155=Aspect ratio pillar/letter box
24=Vol Up		156=Aspect ratio full/wide
25=Vol Dn		157=Aspect ratio zoom
26=Vol Mute (tog)		158=AC-3(Dolby 5.1)
27=Power On		159=PCM
28=Power Off		160=PCM Variable
29=Menu		161=16:9
63=Guide		162=4:3
80=Freeze		
81=Signal		
82=Ratio		
85=Audio		

Rack Mounting

Three options are available for rack-mounting tuners.

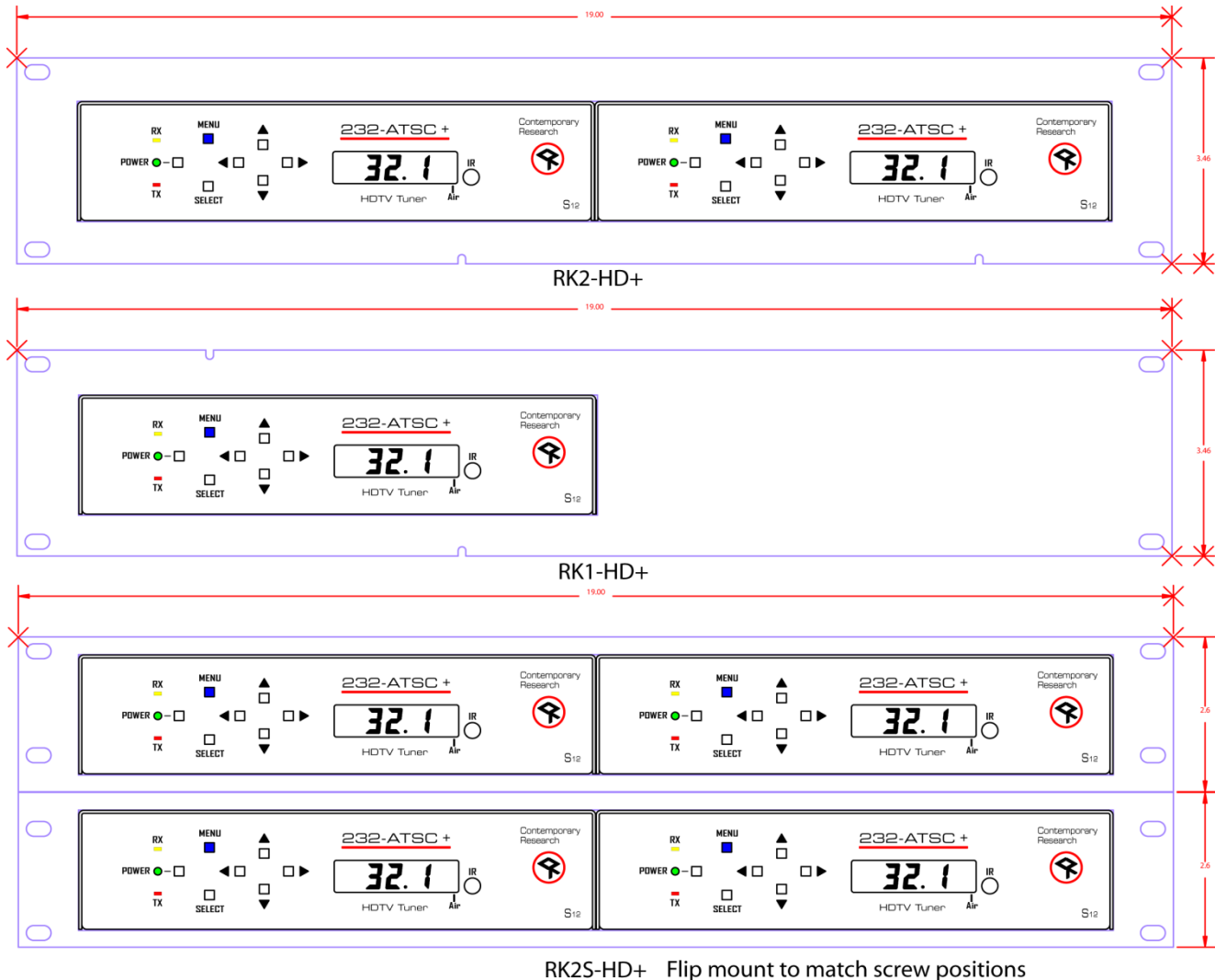

RK1-HD+

- Insert 232-ATSC+ into RK1-HD frame.
- Use screws included with kit to attach tuner to the side flanges.

RK2-HD+

- Use supplied screws to attach left tuner to left and top flanges
- Use supplied screws to attach right tuner to right and top flanges

RK2S-HD+ Space-Saver Rack Kit

- Use supplied screws to attach left tuner to left and top flanges
- Use supplied screws to attach right tuner to right and top flanges
- Mount the first rack, then flip the next rack upside down, add tuners and mount
- With this method, you can mount 4 tuners in 3 rack spaces

iC-Net Zones, Units and Device Addresses

In the front-panel setup instructions, you set the Unit # (1-255), then the Zone # (1-15). This refers to the iC-Net address structure that includes device number 256 – 4095 that is divided up into 15 Zones.

To simplify controlling groups of devices, iC-Net is divided into 15 zones of 255 devices, called SmartZones. All the devices within each zone can be controlled simultaneously by sending a command to a single virtual device number.

For example, noting the zone chart below, if we send a Power On command to device #256, all iC-Net controllers in Zone 1 will turn off at the same time.

This is an immensely powerful feature, because most systems can only address one device at time. If you need to turn off all 50 TV in a zone, you would need to send 50 commands. In addition to the hassles of creating multiple commands, there would be a long delay between the first and last command. One command, instant response is easier.

The Zone number plus the Unit number equals the actual device address.

Zone	Device #	Unit	Total Device #
1	256	1-255	257-511
2	512	1-255	512-767
3	768	1-255	769-1023
4	1024	1-255	1025-1279
5	1280	1-255	1281-1535
6	1536	1-255	1537-1791
7	1792	1-255	1793-2047
8	2048	1-255	2049-2303
9	2304	1-255	2305-2559
10	2560	1-255	2561-2815
11	2816	1-255	2817-3071
12	3072	1-255	3073-3327
13	3328	1-255	3329-3583
14	3584	1-255	3585-3839
15	3840	1-255	3841-4000
All Zones	4095		

Tip: While many applications can use just the Zone number, it's a good practice to assign a unique Unit number to each controller in the zone. This allows the system software to address individual controllers if necessary.

Safety Instructions

Read before operating equipment.

- **Cleaning** - Unplug this product from the wall outlet before cleaning. Do not use liquid cleaners or aerosol cleaners. Use a damp cloth for cleaning.
- **Power Sources** - Use supplied or equivalent UL/CSA approved low voltage DC plug-in transformer.
- **Outdoor Antenna Grounding** - If you connect an outside antenna or cable system to the product, be sure the antenna or cable system is grounded so as to provide some protection against voltage surges and built-up static charges. Section 810 of the National Electrical Code, ANSI/NFPA No. 70, provides information with respect to proper grounding of the mast and supporting structure, grounding of the lead-in wire to an antenna discharge unit, size of grounding conductors, location of antenna discharge unit, connection to grounding electrodes, and requirements for the grounding electrode.
- **Lightning** - Avoid installation or reconfiguration of wiring during lightning activity.

Power Lines - Do not locate an outside antenna system near overhead power lines or other electric light or power circuits or where it can fall into such power lines or circuits. When installing an outside antenna system, refrain from touching such power lines or circuits, as contact with them might be fatal.

- **Overloading** - Do not overload wall outlets and extension cords as this can result in a risk of fire or electric shock.
- **Object and Liquid Entry** - Never push objects of any kind into this product through openings as they may touch dangerous voltage points or short out parts, resulting in a fire or electric shock. Never spill liquid of any kind on the product.
- **Servicing** - Do not attempt to service this product yourself as opening or removing covers may expose you to dangerous voltage or other hazards. Refer all servicing to qualified service personnel.
- **Damage Requiring Service** - Unplug this product from the wall outlet and refer servicing to qualified service personnel under the following conditions:
 - When the power supply cord or plug is damaged.
 - If liquid spills or objects fall into the product.
 - If the product is exposed to rain or water.
 - If the product does not operate normally by following the operating instructions. Adjust only those controls that are covered by the operating instructions. An improper adjustment of other controls may result in damage and will often require extensive work by a qualified technician to restore the product to its normal operation.
 - If the video product is dropped or the cabinet is damaged.
 - When the video product exhibits a distinct change in performance, this indicates a need for service.

* Note to CATV system installer: This reminder is provided to call CATV system installer's attention to Article 820-40 of the National Electrical Code (Section 54 of Canadian Electrical Code, Part I), that provides guidelines for proper grounding and, in particular, specifies that the cable ground shall be connected to the grounding system of the building as close to the point of cable entry as possible.

Limited Warranty and Disclaimer

Warranty: Three (3) year limited warranty on all parts and labor for Contemporary Research manufactured products from the day of purchase by authorized dealer. Manufactured products are warranted against defects in materials and workmanship. If Contemporary Research receives notice of such defects during the warranty period, Contemporary Research will repair or replace, at its option, products that prove to be defective.

Exclusions: The above warranty shall not apply to defects resulting from improper or inadequate maintenance by the customer, customers applied software or interfacing, unauthorized modifications or misuse, mishandling, operation outside the normal environmental specifications for the product, use of the incorrect, modified or extended power supply, or improper site operation and maintenance. *Please note Contemporary Research SSV-DX Display Express PC product carries a six month limited warranty.*