

Small Packaged Products Accessory Crankcase Heaters

Cancels: IIK 582A-18-12 IIK 582A-18-16
6-04

Installation Instructions

P/N: CPCRKHTR003A00, CPCRKHTR004A00
CPCRKHTR005A00, CPCRKHTR007A00, CPCRKHTR008A00

NOTE: Read the entire instruction manual before starting the installation.

This symbol → indicates a change since the last issue.

SAFETY CONSIDERATIONS

Installing and servicing air conditioning equipment can be hazardous due to system pressures, electrical components, and fuel gases. Only trained and qualified personnel should install, service, or repair air conditioning equipment.

Untrained personnel can perform basic maintenance functions such as cleaning coils, or cleaning and replacing filters. All other operations should be performed by trained service personnel. When working on air conditioning equipment, observe precautions in the literature, on tags, and on labels attached to the unit.

Recognize safety information. This is the safety-alert symbol . When you see this symbol on the unit and in instructions or manuals, be alert to the potential for personal injury.

Understand the signal words DANGER, WARNING, and CAUTION. These words are used with the safety-alert symbol. DANGER identifies the most serious hazards which **will** result in severe personal injury or death. WARNING signifies a hazard which **could** result in personal injury or death. CAUTION is used to identify unsafe practices which **would** result in minor personal injury or product and property damage. NOTE is used to highlight suggestions which **will** result in enhanced installation, reliability, or operation.

Follow all safety codes. Wear safety glasses and work gloves. Have a fire extinguisher available.

INTRODUCTION

These instructions cover the installation of an Accessory Crankcase Heater on Electric Cooling, Heat Pump and Electric Cooling/Gas Heating units.

DESCRIPTION AND USAGE

The accessory crankcase heater warms the compressor crankcase oil to reduce refrigerant migration in the crankcase and ensure proper compressor lubrication. Refer to Tables 1, 2, 3 and 4.

INSTALLATION

WARNING

ELECTRICAL SHOCK HAZARD

Electrical shock or explosion could cause serious injury or death.

Before performing service or maintenance operations on unit, turn off the main power switch to unit. TAG DISCONNECT SWITCH WITH SUITABLE WARNING LABEL.

1. Turn off gas supply (if applicable) first, then disconnect electric power supply.
2. Install Lockout Tag.

→ **Table 1—Accessory Crankcase Heater Usage
See Below for Units Applicable**

48GX/583A/PY2P-B 50GX/702A/PA2P-B 50JX/602A/PH2P-B		
UNIT SIZE	240 V	460 V
024	CPCRKHTR008A00	NA
030	CPCRKHTR004A00	NA
036	CPCRKHTR004A00	CPCRKHTR005A00
042	CPCRKHTR004A00	CPCRKHTR005A00
048	CPCRKHTR004A00	CPCRKHTR005A00
060	CPCRKHTR004A00	CPCRKHTR005A00

→ **Table 2—Accessory Crankcase Heater Usage
See Below for Units Applicable**

48GP/583B, 50GL/702B 50JZ/602B, 48JZ/683B (FACTORY INSTALLED ON 042-060) ‡50XP/704B, ‡50XZ/604B (FACTORY INSTALLED ON 042-060) ‡48XP/574B, ‡48XZ/674B (FACTORY INSTALLED ON 042-060)		
UNIT SIZE	240 V	460 V
024	CPCRKHTR004A00	NA
030	CPCRKHTR004A00	NA
036	CPCRKHTR004A00	CPCRKHTR005A00
042	CPCRKHTR004A00	CPCRKHTR005A00
048	CPCRKHTR004A00	CPCRKHTR005A00
060	CPCRKHTR004A00	CPCRKHTR005A00

‡ Units only available in 240 V

**Table 3—Accessory Crankcase Heater Usage
See Below for Units Applicable**

48GS/582A/PY1P-B 50GS/701A/PA1P-B		
UNIT SIZE	240 V	460 V
018	CPCRKHTR007A00	NA
024	CPCRKHTR007A00	NA
030	CPCRKHTR007A00	NA
036	CPCRKHTR007A00	CPCRKHTR003A00
042	CPCRKHTR007A00	CPCRKHTR003A00
048	CPCRKHTR004A00	CPCRKHTR005A00
060	CPCRKHTR007A00	CPCRKHTR003A00

3. Remove access panel for compressor and control box (See Fig. 1).
4. Spread crankcase heater arms and wrap heater around compressor base approximately 2-in. above compressor mounting plate (See Fig. 1).

Manufacturer reserves the right to discontinue, or change at any time, specifications or designs without notice and without incurring obligations.

Table 4—Accessory Crankcase Heater Usage
See Below for Units Applicable

50JS/601A/PH1P-B (FACTORY INSTALLED ON 036)		
UNIT SIZE	240 V	460V
018	CPCRKHTR007A00	NA
024	CPCRKHTR007A00	NA
030	CPCRKHTR007A00	NA
036	CPCRKHTR007A00	CPCRKHTR003A00
042	CPCRKHTR004A00	CPCRKHTR005A00
048	CPCRKHTR004A00	CPCRKHTR005A00
060	CPCRKHTR004A00	CPCRKHTR005A00

5. Fasten heater firmly in place with fastening clip provided with the crankcase heater (See Fig. 1).

- Route crankcase heater leads into unit control box, following the path of the compressor leads (See Fig. 1).
- Connect one black lead to the compressor contactor terminal 11, and connect other black lead to compressor contactor terminal 21 (See Fig. 2).
- Attach green crankcase heater ground lead to ground screw in control box.
- Replace access panel.
- Turn on main power, then (if applicable) gas supply.

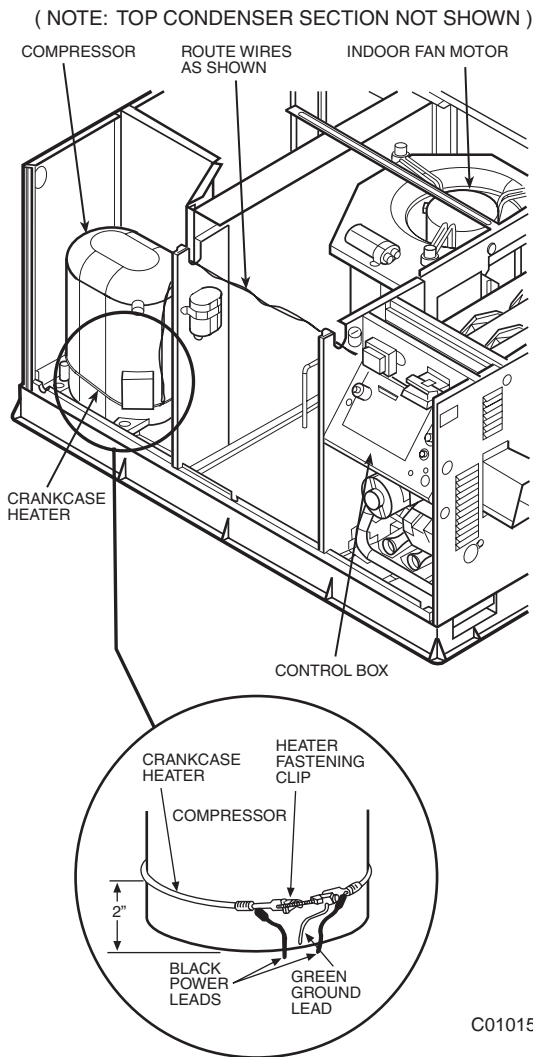

Fig. 1 — Typical Crankcase Heater Installation

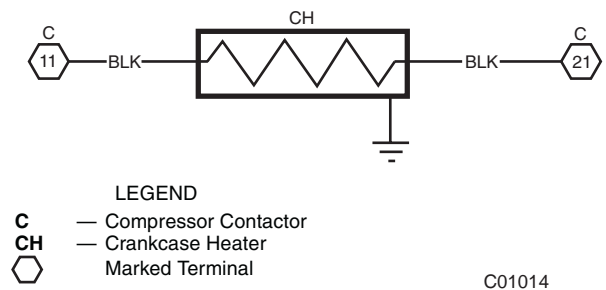

Fig. 2 —Crankcase Heater Wiring