



**INSTRUCTION MANUAL IM-251**  
**For Gas Turbine Tensioned**  
**Studs and Nuts**

**Note: This manual is written specifically for connections that employ the use of Load Coupling Spacers placed under the nuts. If spacers are not used, consult manual IM-327**

Applicable Bolting Connections –

Fr. 7FA.05 Gas Turbine to 7FH2B Generator  
 Fr. 7FA.05 Gas Turbine to Load Coupling  
 Load Coupling to 7FH2B Generator

Applicable GE Ordering Sheet Part Numbers

110T2635P0001  
 110T2635P0002  
 110T2635P0003  
 110T2635P0004  
 110T2635P0005  
 110T2635P0006  
 110T2635P0007

	<b>GE Power Generation</b>	GENERAL ELECTRIC COMPANY	
<b><u>VENDOR SUPPLIED</u></b>			
GE NOT TO REVISE. GE REVISION LEVEL IS SHOWN ON THIS APPLIQUE. THIS DOCUMENT IS FILED UNDER THE GE DRAWING NUMBER.  THIS DOCUMENT SHALL BE REVISED IN ITS ENTIRETY. ALL SHEETS OF THIS DOCUMENT ARE THE SAME REVISION LEVEL AS INDICATED IN THIS VENDOR SUPPLIED DRAWING APPLIQUE.			
MLI:		___ OF ___	
GE SIGNATURES	DATE	GE DRAWING NUMBER	REV
CHECKED:		<b>373A4040</b>	<b>E</b>
ISSUED:			

The Riverhawk Company reserves the right to update this document without dissemination or notice. The latest revision may be obtained by contacting Riverhawk Company or thru [www.riverhawk.com](http://www.riverhawk.com).

215 Clinton Road  
 New Hartford, NY 13413  
 Tel: +1 315 768 4855  
 Fax: +1 315 768 4941  
 Email: [info@riverhawk.com](mailto:info@riverhawk.com)

**Table of Contents**

Section	Description	Page Number
1.0	Cautions and Safety Warnings	3
2.0	Scope and GE Part Number Cross Reference	4
3.0	Quick Checklist	6
4.0	General Preparations	11
5.0	Hardware Set Preparations	14
6.0	Stud, Nut, and Load Coupling Spacer Assembly	17
7.0	Hydraulic Tensioner Equipment Assembly	20
8.0	Assembly of Tensioner on Stud	23
9.0	Stud Tensioning	27
10.0	Thread Locking	30
11.0	Stud, Nut, and Load Coupling Spacer Removal	30
12.0	Storage Instructions	34
13.0	Frequently Asked Questions	35
14.0	Revision History	38
Appendix A1	18-Bolt Tensioning Pattern (GT-LC) Record Sheet	39
Appendix A2	16-Bolt Tensioning Pattern (LC-GEN) Record Sheet	40



215 Clinton Road  
 New Hartford, NY 13413  
 Tel: +1 315 768 4855  
 Fax: +1 315 768 4941  
 Email: info@riverhawk.com

GE DRAWING NUMBER	REV
373A4040	E

## 1.0 Cautions and Safety Warnings

### WARNING

**Improper tool use and the failure to follow the correct procedures are the primary root causes of tool failures and personal injuries. A lack of training or experience can lead to incorrect hardware installation or incorrect tool use. Only trained operators with careful, deliberate actions should use hydraulic tensioners.**

### CAUTION

Personal injury and equipment damage can occur if the proper health and safety codes and procedures are not followed. Contact the site's health and safety office to determine all applicable safety rules and regulations.

### WARNING

The proper personal protective equipment must be worn at all times.

### CAUTION

It is especially important to check the condition of the conical thread used to tension the stud. Thread damage from previous abuse can lead to failure of the stud or tensioning equipment

### CAUTION

Riverhawk recommends that the tensioner should be returned to Riverhawk for periodic inspections. Replacement of obsolete tensioners is recommended. Functional upgrades are also recommended. The Riverhawk Service Returns Coordinator should be notified 3-6 months prior to a planned outage to schedule an inspection service.

### WARNING

A damaged burst disc must be replaced with a burst disc of the same design and pressure rating. Do not substitute a damaged burst disc with a different disc type, a different pressure rating, or a foreign object.

### WARNING

To avoid failure, ensure safety, and proper operation, the tensioner assembly must be installed on a stud in the flange before bleeding and pressurizing the tensioner. Do not use the tensioner at any pressure unless the tool is installed on a stud in a flange.

### CAUTION

Personal injury and equipment damage can occur if the puller screw is not securely engaged with the tapered threads of the stud. Proper engagement is achieved when the puller screw is tight in the stud and the tensioner assembly is free to turn.



215 Clinton Road  
New Hartford, NY 13413  
Tel: +1 315 768 4855  
Fax: +1 315 768 4941  
Email: info@riverhawk.com

GE DRAWING NUMBER	REV
373A4040	E

**WARNING**

The safety cage must be in place at all times. When the tensioner is pressurized hands must be kept out of designated areas to avoid any potential for personal injury.

**CAUTION**

Before threading the puller screw into the stud, carefully check the cleanliness of both the stud's and the puller screw's conical threads. Apply a light coat of clean turbine oil or a spray lubricant to the puller screw. This procedure will ease assembly and assure positive mating of the threads before tightening. Do not use "Never Seize" on the conical threads.

**CAUTION**

Do not tighten the nut while the tool is coming up to pressure; wait until pressure is achieved before attempting to tighten the nut with the spanner ring. If the tool is not properly installed, the tool could jump off the stud while coming up to pressure.

**CAUTION**

Do not exceed the maximum pressure marked on the tensioner. Excessive pressure can damage the stud and puller screw.

**WARNING**

**FIRE HAZARD:** DO NOT heat when puller assembly is in place. Personal injury or equipment damage may occur. Use of an Oxy-Acetylene torch is not recommended

**WARNING**

Do not use a hydraulic tensioner to remove a stud with damaged conical threads.

**2.0 Scope and GE Part Number Cross Reference**

This document describes the procedure to be used to install the stud and nut sets supplied by the Riverhawk Company in the flanges at the Gas Turbine/Load Coupling and Load Coupling/Generator connections.

The various frame configurations covered in this manual are listed in Sections 2.1 through 2.4 with differences as related to connective hardware defined. Listed also are the pertinent hardware drawings (HF-xxxx). These drawings as well as tooling drawings (HT-xxxx) form part of this manual.



215 Clinton Road  
New Hartford, NY 13413  
Tel: +1 315 768 4855  
Fax: +1 315 768 4941  
Email: info@riverhawk.com

GE DRAWING NUMBER	REV
373A4040	E

**2.1 Frame 7FA.05 Gas Turbine to 7FH2B Generator**

GE Part Number	Riverhawk P/N	GE VENDOC P/N
110T2635P0001	HF-5117	GE 269B8710
110T2635P0002	HF-5117	GE 269B8710

The hydraulic tooling used for installation and removal is Riverhawk HT-5144 and HT-6285 for the gas turbine side of the load coupling and HT-6019 for the generator side of the load coupling.

These hardware drawings depict the stud and nut set for the Gas Turbine to Load Coupling (2-1/4" size, Qty 18) as well as the Load Coupling to 7FH2B Generator (2-3/4" size, Qty 16). The Gas Turbine to Load Coupling stud and nut set is used with a set of load coupling spacers that are supplied separately.

**2.2 Frame 7FA.05 Gas Turbine to Load Coupling**

GE Part Number	Riverhawk P/N	GE VENDOC P/N
110T2635P0004	HF-5411	GE 269B8711

The hydraulic tooling used for installation and removal is Riverhawk HT-5144 and HT-6285.

These hardware drawings depict the stud and nut set for the Gas Turbine to Load Coupling (2-1/4" size, Qty 18). The Gas Turbine to Load Coupling stud and nut set is used with a set of load coupling spacers that are supplied separately.

**2.3 Load Coupling to 7FH2B Generator**

GE Part Number	Riverhawk P/N	GE VENDOC P/N
110T2635P0005	HF-5412	GE 269B8712

The hydraulic tooling used for installation and removal is Riverhawk HT-6019.

These hardware drawings depict the stud and nut set for the Load Coupling to 7FH2B Generator (2-3/4" size, Qty 16).



215 Clinton Road  
 New Hartford, NY 13413  
 Tel: +1 315 768 4855  
 Fax: +1 315 768 4941  
 Email: info@riverhawk.com

GE DRAWING NUMBER	REV
373A4040	E

## 2.4 Hydraulic Tooling

GE Part Number	Riverhawk P/N	GE VENDOC P/N
110T2635P0003	HT-5144	GE 269B8713
	HT-6019	GE 269B8762
	GT-6030	GE 269B8763
	AP-0532	GE 359B2502
110T2635P0006	HT-6285	GE 373A4069
110T2635P0007	HT-5144	GE 269B8713
	HT-6019	GE 269B8762
	GT-6030	GE 269B8763
	AP-0532	GE 359B2502
	HT-6285	GE 373A4069

## 3.0 Quick Checklist

The following checklist is intended as a summary of the steps needed to use the Riverhawk-supplied equipment. New personnel or those experienced personnel who have not used the Riverhawk equipment recently are encouraged to read the entire manual.

### EQUIPMENT INSPECTION

- Check oil level in hydraulic pump.
- Check air pressure at 80psi [5.5 bar] minimum. (For air-driven pumps)
- Check hydraulic hose for damage.
- Test pump.
- Inspect tensioner for any damage.

### NUT AND STUD PREPARATION

- Inspect studs and nuts for any damage.
- Clean the studs, nuts, and load coupling spacers (**Load Coupling Spacers on gas turbine to load coupling flange only**)



215 Clinton Road  
 New Hartford, NY 13413  
 Tel: +1 315 768 4855  
 Fax: +1 315 768 4941  
 Email: info@riverhawk.com

GE DRAWING NUMBER	REV
373A4040	E

- Measure stud lengths. (VERY IMPORTANT)
- Lubricate the stud's threads with clean turbine oil or spray lubricant. Lubricate the nut's threads and nut face with clean turbine oil or spray lubricant.
- Install studs, nuts, and load coupling spacers (off-center) into the flange (**Load Coupling Spacers are placed on the load coupling side of the gas turbine to load coupling flange only**)
- Set stick-out dimension on the load coupling side of the flange.
- With Allen wrench in backside of stud, firmly seat backside nut using spanner ring and pin wrench.
- Verify stick-out measurement (**VERY IMPORTANT**)
- Measure and record starting stud installation gage readings. (**Generator Side Only**)

**TENSIONING (Bolt Installation)**

- Check tensioner drawing for correct parts and part numbers.
- Apply a light coat of clean turbine oil or spray lubricant to the puller screw. **DO NOT USE "NEVER SEIZE" ON THE CONICAL THREADS.**
- Install the retention screws into the adjacent studs on either side of the stud to be tensioned. (**Generator Side Only**)
- Install the spanner ring onto the nut.
- Thread the puller screw into the stud.
- Insert an Allen wrench into the back side of the stud.
- Insert another Allen wrench into the puller screw. While holding the stud still, tighten the puller screw until hand tight and then loosen the puller screw 1/2 of a turn.
- Retighten the puller screw and leave tight. **DO NOT BACK OFF PULLER SCREW.**



215 Clinton Road  
 New Hartford, NY 13413  
 Tel: +1 315 768 4855  
 Fax: +1 315 768 4941  
 Email: info@riverhawk.com

GE DRAWING NUMBER	REV
373A4040	E

- Slide the foot over the puller stud and orientate the foot into position.
- Place Foot Extension blocks on either side of the nut. **(Gas Turbine Side Only)**
- Thread the tensioner onto puller screw until it stops. There should be a 1/16" to 3/16" gap between the foot and tensioner.
- Place the guard over the tensioner and position guide pin into the hole in the backside of the stud. **(Gas Turbine Side Only)**
- Place the guard over tensioner and position the guard's pocketed slots into retention screws. **(Generator Side Only)**
- Tighten the guard's knurled interlock fitting by hand until it presses firmly against tensioner (no gap).
- The retention screws must be inside the guard's pocketed slots. **(Generator Side Only)**
- Push the center of the interlock fitting towards the tensioner while pulling back on the fitting's pull tabs until it locks onto the tensioner and release the pull tabs.
- Install the backside guard to cover stud to be tensioned. **(Generator Side Only)**
- Connect the hydraulic pump to the tensioner and tension to 50%. Consult manual for correct pressure.
- Use the pin wrench to turn the spanner ring to firmly tighten nut with 20 ft·lbs [27 N·m] of torque.
- Release pressure and allow the tensioner to fully retract.
- Disconnect the hose and release the interlock fitting by pushing the center of the interlock fitting towards the tensioner while pulling back on the fitting's pull tabs.
- Remove the backside guard. **(Generator Side Only)**
- Loosen the knurled interlock fitting and remove the guard.
- Unscrew the tensioner from the puller screw.



215 Clinton Road  
 New Hartford, NY 13413  
 Tel: +1 315 768 4855  
 Fax: +1 315 768 4941  
 Email: info@riverhawk.com

GE DRAWING NUMBER	REV
373A4040	E

- Remove the foot, foot extensions (**Gas Turbine Side Only**) , puller screw, spanner ring, and in the case of the generator side the retention screws.
- Move to the next stud in the pattern. Tension all studs to 50% before proceeding to final pressure.
- Repeat above steps at final pressure.
- Measure final stud length and record on stretch datasheets. Calculate final stretch measurement. The generator side must use GT-6030 gauge to verify installation.
- Torque the nuts' set screws.

**DETENSIONING (Stud Removal)**

- Loosen nuts' set screws
- Inspect and clean studs' conical threads. **Do not continue until ALL debris is removed from the threads!** See instruction manual IM-220. **Do not try to use the tensioner to remove a damaged stud!**
- Apply a light coat of clean turbine oil or spray lubricant to the puller screw. **DO NOT USE “NEVER SEIZE” ON THE CONICAL THREADS.**
- Install the retention screws into the adjacent studs on either side of the stud to be tensioned. (**Generator Side Only**)
- Install the spanner ring onto the nut.
- Thread the puller screw into the stud.
- Insert an Allen wrench into the back side of the stud.
- Insert another Allen wrench into the puller screw. While holding the stud still, tighten the puller screw until hand tight and then loosen the puller screw 1/2 of a turn.
- Retighten the puller screw and leave tight. **DO NOT BACK OFF PULLER SCREW.**
- Place the foot extension blocks on either side of the nut. (**Gas Turbine Side Only**)
- Slide the foot over the puller stud and orientate the foot into position.



215 Clinton Road  
 New Hartford, NY 13413  
 Tel: +1 315 768 4855  
 Fax: +1 315 768 4941  
 Email: info@riverhawk.com

GE DRAWING NUMBER	REV
373A4040	E

- Thread the tensioner onto puller screw until it stops. There should be a 1/16" to 3/16" gap between the foot and tensioner.
- Place the guard over the tensioner and position guide pin into the hole in the backside of the stud. **(Gas Turbine Side Only)**
- Place the guard over tensioner and position the guard's pocketed slots into retention screws. **(Generator Side Only)**
- Tighten the guard's knurled interlock fitting by hand until it presses firmly against tensioner (no gap).
- The retention screws must be inside the guard's pocketed slots. **(Generator Side Only)**
- Push the center of the interlock fitting towards the tensioner while pulling back on the fitting's pull tabs until it locks onto the tensioner and release the pull tabs.
- Install the backside guard to cover stud to be tensioned. **(Generator Side Only)**
- Connect the hydraulic pump to the tensioner and tension to final pressure. Consult manual for correct pressure.
- Loosen nut with the spanner ring and pin wrench.
- Release pressure and allow the tensioner to fully retract.
- Disconnect the hose and release the interlock fitting by pushing the center of the interlock fitting towards the tensioner while pulling back on the fitting's pull tabs.
- Remove the backside guard. **(Generator Side Only)**
- Loosen the knurled interlock fitting and remove the guard.
- Unscrew the tensioner from the puller screw.
- Remove the foot, foot extensions **(Gas Turbine Side Only)**, puller screw, spanner ring, and in the case of the generator side the retention screws. It may be necessary to insert an Allen wrench into the backside of the stud to remove the puller screw.
- Move to next stud in pattern



215 Clinton Road  
 New Hartford, NY 13413  
 Tel: +1 315 768 4855  
 Fax: +1 315 768 4941  
 Email: info@riverhawk.com

GE DRAWING NUMBER	REV
373A4040	E

## 4.0 General Preparations

Read and understand all instructions before installing and tensioning studs.

Operators should be trained or have previous experience using Riverhawk tensioning equipment. Training will minimize the chance of improper use of the equipment.

The hydraulic tooling including the hydraulic hoses should be inspected prior to use. Inspection guidelines are listed in the following sub-sections.

This equipment produces very high hydraulic pressures and very high forces. Operators must exercise caution and wear the appropriate personal protective equipment when handling and operating the hydraulic tooling.

High-pressure oil from the hydraulic pump pressurizes the tensioner which generates a very large force that actually stretches the stud. As the stud is stretched the nut lifts off the flange. The nut is then turned by hand using the supplied spanner ring. Once the nut is tight against the flange, the pressure in the tensioner is released. The hardware is now clamping the flange together.

### 4.1 Machine Preparation

The flange to be tensioned must be fully closed prior to positioning of studs in the flanges. Turning the turbine shafts is not required, but may be useful. Also, it will be advantageous to remove as many obstructions as possible from the flange area, such as speed probes, shipping plates, and conduit.

### 4.2 Hardware – Balance

The studs are supplied in component balanced sets. A stud can be exchanged with another stud in its set without affected the overall balance of the equipment. Do not exchange a stud from one set with another stud from a different set. When shipped from Riverhawk, the studs are not assigned to any specific hole in the load coupling flange; this is optional and can be done at the installation site. The set size is determined by the relevant GE order drawing (see section 2.0).

The nuts are supplied in component balanced sets. A nut can be exchanged with another in its set without affecting the overall balance of the equipment. Do not exchange a nut from one set with another nut from a different set. When shipped from Riverhawk, the nuts are not assigned to any specific hole in the load coupling flange; this is optional and can be done at the installation site. The set size is determined by the relevant GE order drawing (see section 2.0).



215 Clinton Road  
New Hartford, NY 13413  
Tel: +1 315 768 4855  
Fax: +1 315 768 4941  
Email: info@riverhawk.com

GE DRAWING NUMBER	REV
373A4040	E

A weight balance certification is supplied with each order. Store this certification in an appropriate location as it will be needed for the purchase of replacement equipment.

The load coupling spacers are supplied separately. Load coupling spacers supplied by Riverhawk are in component balanced sets. A Riverhawk-supplied load coupling spacer can be exchanged with another in its set without affecting the overall balance of the equipment. Do not exchange a load coupling spacer from one set with another spacer from a different set. When shipped from Riverhawk, the load coupling spacers are not assigned to any specific hole in the load coupling flange; this is optional and can be done at the installation site. The set size is determined by the relevant GE order drawing (see section 2.0).

#### 4.3 Tensioner – Care and Handling

When not in use, the tensioner shall be maintained in a clean environment and all caps and plugs for hydraulic openings and fittings must be in place.

When in use, the tensioner shall be protected from sand and grit.

See section 12 for long term storage requirements.

#### 4.4 Hand Tools

Several hand wrenches and micrometers may be required to perform installation and measurement of the studs:

5/8" Wrench

3/4" Wrench

A set of Allen Wrenches

3' to 4' Breaker Bar

10" to 11" Micrometer or Caliper



215 Clinton Road  
New Hartford, NY 13413  
Tel: +1 315 768 4855  
Fax: +1 315 768 4941  
Email: info@riverhawk.com

GE DRAWING NUMBER	REV
373A4040	E

## 4.5 Special Tools

Hydraulic Tensioner Kit: HT-5144 Hydraulic Tensioner, 2-1/4"  
**(Gas Turbine Side Only)**  
(reference GE VENDOC 269B8713)

HT-6285 Tensioner Foot Extensions  
**(Gas Turbine Side Only)**  
(reference GE VENDOC 373A4069)

HT-6019 Hydraulic Tensioner, 2-3/4"  
**(Generator Side Only)**  
(reference GE VENDOC 269B8762)

Stud Stretch Measuring Gauge: GT-6030 Stretch Gauge  
**(Generator Side Only)**  
(reference GE VENDOC 269B8763)

Hydraulic Pump Kit: AP-0532 Air-Operated Hydraulic Pump  
(recommended)  
(reference GE VENDOC 359B2502)

MP-0130 Manual Hand-Operated Hydraulic Pump  
(reference GE VENDOC 359B2506)

### CAUTION

**Riverhawk recommends that the tensioners be returned to Riverhawk for periodic inspections. Replacement of obsolete tensioners is recommended. Functional upgrades are also recommended. The Riverhawk Service Returns Coordinator should be notified 3-6 months prior to a planned outage to schedule an inspection service.**



215 Clinton Road  
New Hartford, NY 13413  
Tel: +1 315 768 4855  
Fax: +1 315 768 4941  
Email: info@riverhawk.com

GE DRAWING NUMBER	REV
373A4040	E

## 5.0 Hardware Set Preparations

### 5.1 Nut and Load Coupling Spacer Preparation

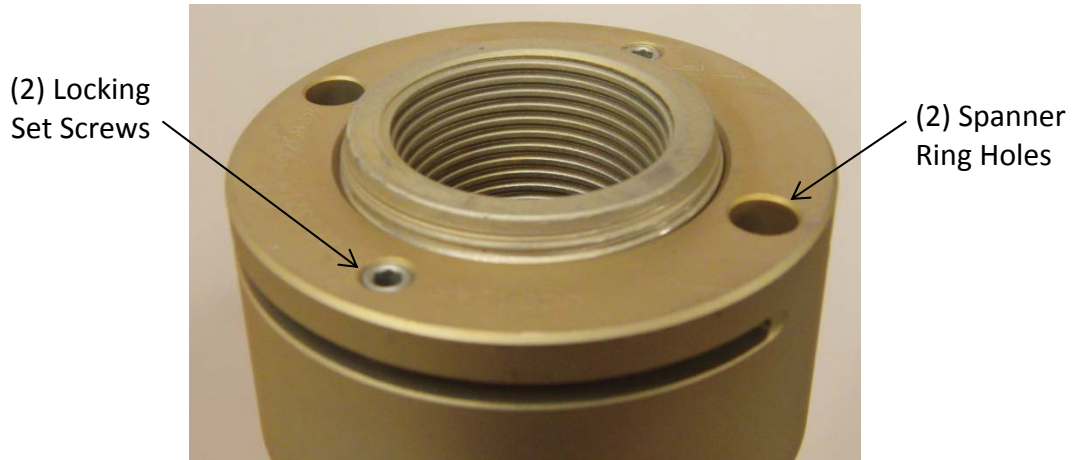

**Picture 5A** - Riverhawk Locknut

If there is any visible damage on a nut or load coupling spacer, do not use the part and contact the General Electric or Riverhawk Company for a replacement part. Please be prepared to supply the turbine number, weight certification, and digital photographs for evaluation.

#### 5.1.1 Nut and Load Coupling Spacer Cleaning - New Installations

For new installations, the nuts should come sealed from the factory and will need no cleaning.

#### 5.1.2 Nut and Load Coupling Spacer Cleaning - Old Installations

Previously installed nuts require cleaning as follows: Wire brush using a petroleum-based solvent to remove any foreign material on the threads. Clean mating faces with a petroleum based solvent to remove any foreign material.

## 5.2 Stud Preparation

Check the stud for any visible damage. If there is any visible damage, do not use the stud and contact the Riverhawk Company for a replacement stud. Please be prepared to supply the turbine number, weight certification, and digital photographs for evaluation.



215 Clinton Road  
 New Hartford, NY 13413  
 Tel: +1 315 768 4855  
 Fax: +1 315 768 4941  
 Email: info@riverhawk.com

GE DRAWING NUMBER	REV
373A4040	E

**CAUTION**

**It is especially important to check the condition of the conical thread used to tension the stud. Thread damage from previous abuse can lead to failure of the stud or tensioning equipment.**

The conical threads of each stud must be clean of grit and dirt before installation or removal. This ensures the proper seating of the puller screw.

**5.2.1 Stud Cleaning - New Installations**

For new installations, the studs should come sealed from the factory and will need no cleaning.

**5.2.2 Stud Cleaning - Old Installations**

Previously installed studs may require cleaning. Clean internal conical threads should have a bright and shiny appearance.

If cleaning is required, follow these steps:

1. Blow out the threads with compressed air to remove loose debris and dry conical threads. Do not apply a solvent or other cleaning solution to the threads as this may chemically attack the stud.
2. Use Stud Cleaning Kit, GT-4253 or a similar 1" diameter Brass power brush.



**Picture 5B - Brass Power Brush**

3. Insert the brush into an electric drill and set drill to run in a counterclockwise direction at high speed.
4. Work the drill in a circular motion while moving the brush in and out to clean all of the threads. Try not to hold the brush in one place too long, so as not to remove the stud's protective coating.
5. Blow out the threads with compressed air to remove loosened debris.
6. Visually inspect threads for cleanliness. Threads should be bright and shiny.
7. Repeat if any dirt can be seen in the threads.



215 Clinton Road  
New Hartford, NY 13413  
Tel: +1 315 768 4855  
Fax: +1 315 768 4941  
Email: info@riverhawk.com

GE DRAWING NUMBER	REV
373A4040	E

8. Verify threads are clean by using a dental pick to lightly scrape the root of the thread. If additional material comes loose, repeat cleaning process.
9. Inspect threads for any damage that may have been caused by previous installation.
10. Do **not** apply “Never Seize” to the stud’s threads.
11. Finish the cleaning process by rinsing in a volatile solvent such as acetone and allow the stud to dry.

### 5.3 Stud Length Measurement

#### 5.3.1 Gas Turbine Flange 2-1/4” [58mm] Studs

Measure and record the initial lengths of the studs. The following suggestions will improve your results.

- **Plan to start and finish any flange in the same day.**
- **Studs and flange must be at the same temperature.**
- **Number each stud with a marker for later stretch measurement tracking.**
- **Mark the location of measurement on stud end with a permanent marker.**
- **Measure each stud to nearest 0.001 inch (.01 mm).**
- **Record each measurement on the supplied record sheets.**
- **Do not allow the measuring instruments to sit in the sun.**
- **The same person should make all measurements.**



215 Clinton Road  
New Hartford, NY 13413  
Tel: +1 315 768 4855  
Fax: +1 315 768 4941  
Email: info@riverhawk.com

GE DRAWING NUMBER	REV
373A4040	E

### 5.3.2 Generator Flange Stud 2-3/4" [71mm] Studs

The generator flange studs require the use of a special stud installation gauge. This gauge measures the relative distance from the end of the stud to the flange face.

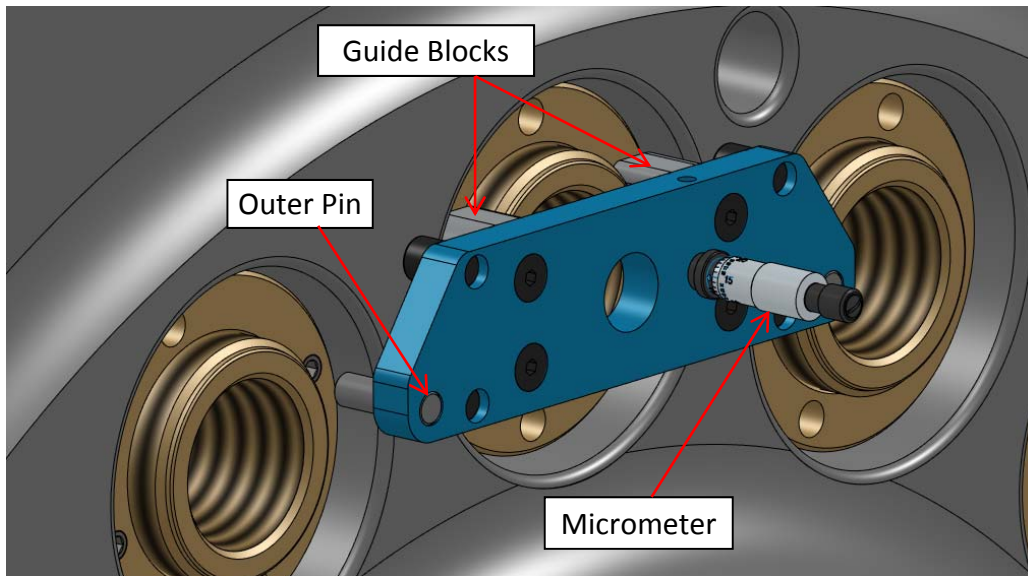

Picture 5C – Stud Installation Gauge

Refer to the GT-6030 Stud Installation Gauge instruction manual, IM-309. The latest revision may be obtained by contacting Riverhawk Company or thru [www.riverhawk.com](http://www.riverhawk.com).

### 6.0 Stud, Nut, and Load Coupling Spacer Assembly

Refer to the hardware assembly drawing (HF-xxxx) listed in Section 2.0 of the manual.

1. Assemble the cylindrical nut to the internal, conical thread end of the stud.
2. Lubricate the stud's threads with clean turbine oil or spray lubricant.
3. Lubricate the nut's threads and nut face with clean turbine oil or spray lubricant.
4. **On the gas turbine side only**, slide the load coupling spacer over the stud until it contacts with the nut.
5. Slide the stud, nut, and spacer into the flange as shown in Figures 6A and 6B.



215 Clinton Road  
 New Hartford, NY 13413  
 Tel: +1 315 768 4855  
 Fax: +1 315 768 4941  
 Email: [info@riverhawk.com](mailto:info@riverhawk.com)

GE DRAWING NUMBER	REV
373A4040	E

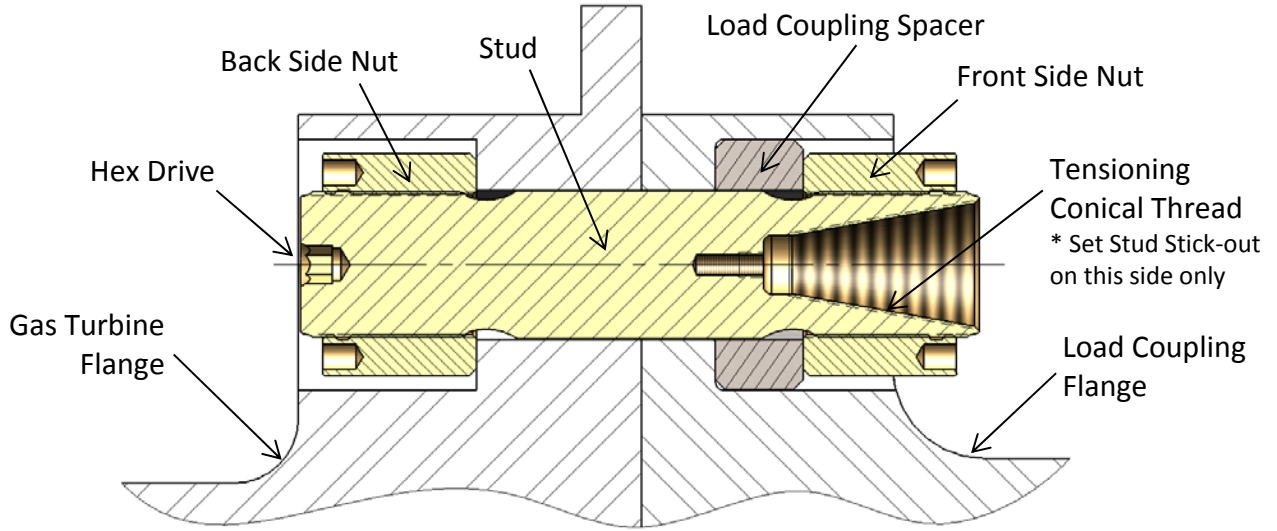

**Figure 6A** – Cross-section View of Gas Turbine to Load Coupling Bolted Flange Connection

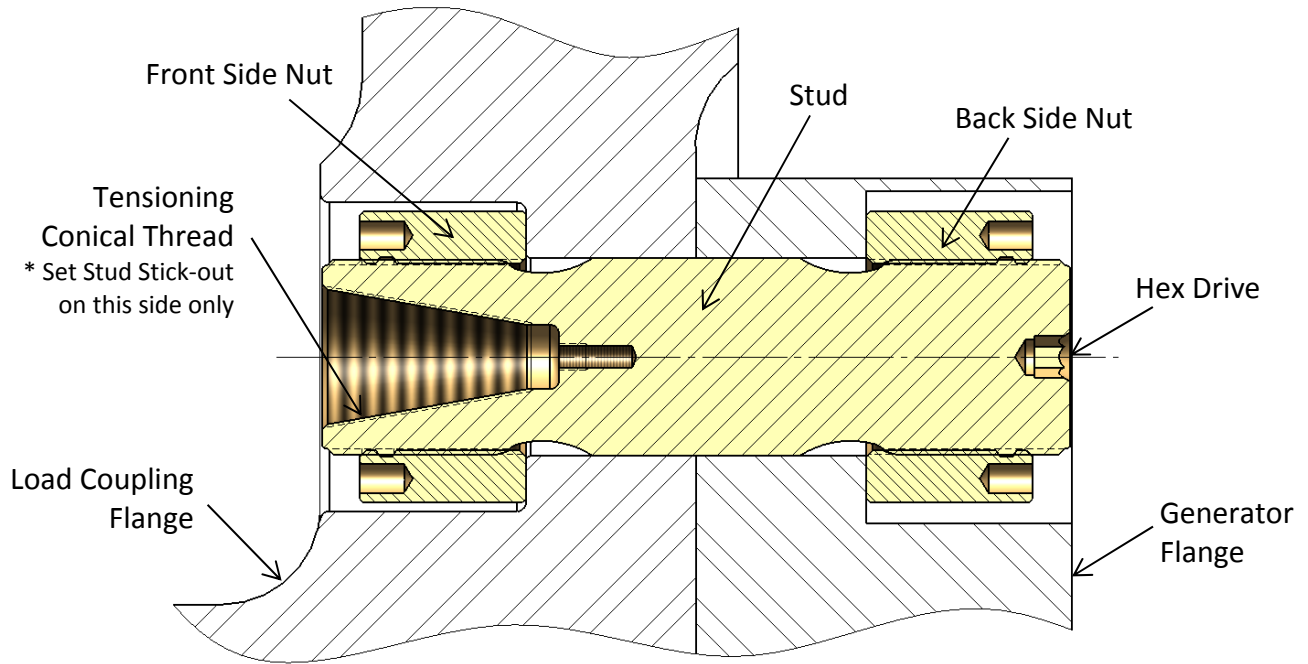

**Figure 6B** – Cross-section View of Load Coupling to Generator Bolted Flange Connection



215 Clinton Road  
 New Hartford, NY 13413  
 Tel: +1 315 768 4855  
 Fax: +1 315 768 4941  
 Email: info@riverhawk.com

GE DRAWING NUMBER	REV
373A4040	E

6. Install the other nut on the backside.
7. Adjust the nut/stud assembly so that the stud protrudes (or sticks out) from the face of the cylindrical nut the distance specified on the hardware drawing (HF-xxxx). **SETTING THIS PROTRUSION OF STUD TO NUT IS CRITICAL FOR PROPER TENSIONER OPERATION.** A metal stick-out gage is provided with the tensioner to assist the operator in setting the protrusion dimension.



**Picture 6C** – Use of Stick-Out Gage on the Gas Turbine side of the Flange Joint

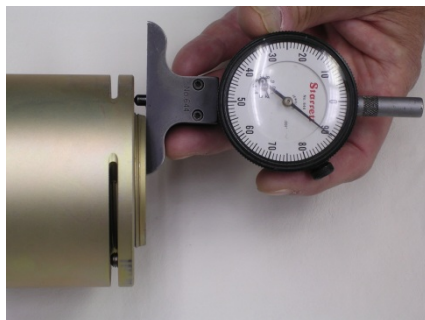

**Picture 6D** – Use of Drop Gage to measure stick-out

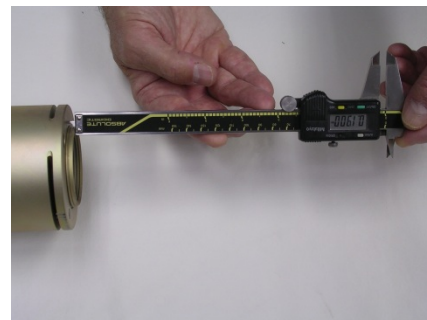

**Picture 6E** – Use of Calipers to measure stick-out

8. With Allen wrench in backside of stud, firmly seat backside nut using spanner ring and pin wrench.
9. Recheck the stud stick-out length. If the stick-out length does not match the hardware drawing, adjust the nuts as necessary.
10. Measure and record starting stud installation gage readings. **(Generator Side Only)**



215 Clinton Road  
 New Hartford, NY 13413  
 Tel: +1 315 768 4855  
 Fax: +1 315 768 4941  
 Email: info@riverhawk.com

GE DRAWING NUMBER	REV
373A4040	E

## 7.0 Hydraulic Tensioner Equipment Assembly

### 7.1 Hydraulic Equipment Inspection

#### 7.1.1 Hydraulic Tensioner Inspection

##### CAUTION

**Riverhawk recommends that the tensioner be returned to Riverhawk for periodic inspections. Replacement of obsolete tensioners is recommended. Functional upgrades are also recommended. The Riverhawk Service Returns Coordinator should be notified 3-6 months prior to a planned outage to schedule an inspection service.**

This tensioner does not require bleeding. See section 8.3

##### WARNING

**To avoid failure, ensure safety, and proper operation, the tensioner assembly must be installed on a stud in the flange before pressurizing the tensioner. Do not use the tensioner at any pressure unless the tool is installed on a stud in a flange.**

Clean puller screw and check for any debris and dents.

Inspect the tensioner guard for any signs of damage including cracked welds. Any guards modified in the field should be replaced. Bent guards should be replaced. Also, be sure the rubber pad is in place on the back side guard, if missing, replace.

Inspect the outside of the tensioner for discoloration patterns that may indicate submersion and internal damage.

Perform an inventory of the loose equipment supplied with the tensioner. An inventory list is provided on the tensioner's technical drawing (Riverhawk HT-xxxx listed in section 2.0 and 4.5). Replacement parts are available from Riverhawk.

##### 7.1.1.1 Hydraulic Tensioner's Burst Disc Replacement

The hydraulic tensioner's burst disc is a key element in the overall safe use of the hydraulic tensioner. The burst disc's location is shown on the tensioner's technical drawing (Riverhawk HT-xxxx listed in section 2.0 and 4.5).

Each tensioner is shipped from our factory with one burst disc already installed in the tensioner and with another spare disc for field replacement. Extra burst discs are available from Riverhawk for replacement purposes.



215 Clinton Road  
New Hartford, NY 13413  
Tel: +1 315 768 4855  
Fax: +1 315 768 4941  
Email: info@riverhawk.com

GE DRAWING NUMBER	REV
373A4040	E

To replace a damaged burst disc:

1. Remove the hydraulic port's dispersion nut, compression ring, and damaged burst disc.
2. Discard the damaged burst disc.
3. Clean the dispersion nut, compression ring, new burst disc, and the hydraulic port with a solvent to ensure a dirt-free installation.
4. Reassemble new burst disc, compression ring, and dispersion nut into the same hydraulic port.

**Warning**

**A damaged burst disc must be replaced with a burst disc of the same design and pressure rating. Do not substitute a damaged burst disc with a different disc type, a different pressure rating, or a foreign object.**

**7.1.2 Hydraulic Pump Kit Inspection**

Refer to the Hydraulic Pump Kit Instruction Manual, IM-293 (GE VENDOC 373A4058). The latest revision may be obtained by contacting Riverhawk Company or thru [www.riverhawk.com](http://www.riverhawk.com).



215 Clinton Road  
New Hartford, NY 13413  
Tel: +1 315 768 4855  
Fax: +1 315 768 4941  
Email: [info@riverhawk.com](mailto:info@riverhawk.com)

GE DRAWING NUMBER	REV
373A4040	E

## 7.2 Hydraulic Fittings

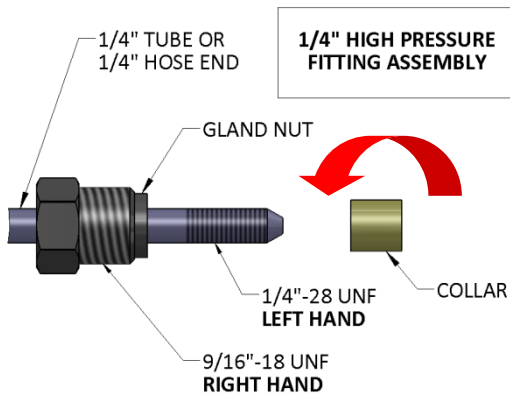

Illustration 1

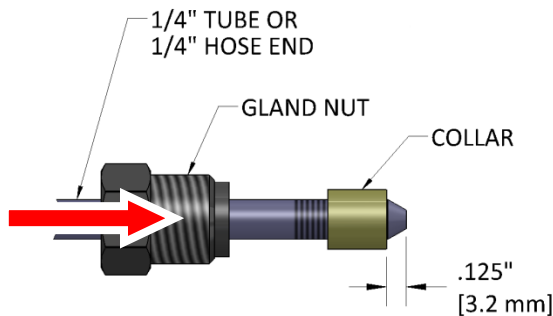

Illustration 2

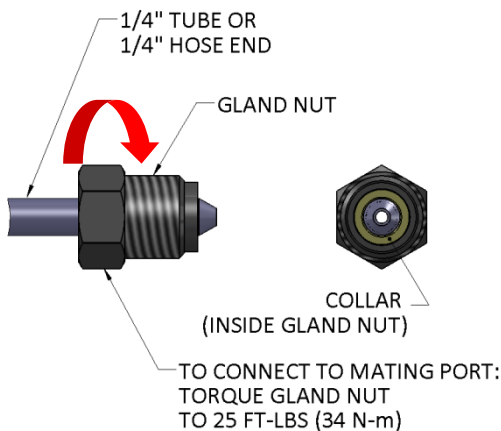

Illustration 3

Riverhawk hydraulic pumps use a 1/4" High Pressure port to connect its hydraulic hoses. The hose connector is made from a three piece assembly: a gland nut, a collar, and a 1/4" tube or 1/4" hose end. (See Illustration 1)

To assembly the fitting, slide the gland nut over the 1/4" tube or 1/4" hose end. Turn the collar counter-clockwise (**left hand** thread) on to the tube or hose end as shown in Illustration 1.

The collar should be placed .125" (3.2 mm) from the tip of the cone. (See Illustration 2) It may be necessary to adjust this collar with a set of vise-grip pliers. Be careful to not strip the threads off the tube or hose end.

Slide the gland nut down over the collar. (See Illustration 3) Insert the 1/4" tube or 1/4" hose end into the tensioner's quick coupler. While firmly holding the tube or hose end to stop it from rotating, turn the gland nut clockwise (**right hand** thread) and torque the gland nut to 25 FT-LBS (34 N-m).

### Tips:

- Make sure all parts are clean and free from debris.
- Protect the cone on the end of the 1/4" tube or 1/4" hose end from scratches as this is the sealing surface.
- Replace red plastic caps when finished to protect the threads and cone.



215 Clinton Road  
New Hartford, NY 13413  
Tel: +1 315 768 4855  
Fax: +1 315 768 4941  
Email: info@riverhawk.com

GE DRAWING NUMBER	REV
373A4040	E

## 8.0 Assembly of Tensioner on a Stud

The tensioner used in this application can be identified by its ORANGE safety guard. If the tensioner's safety guard is YELLOW, a different set of instructions are required. Consult the Riverhawk factory for assistance.

### 8.1 Handling of the Tensioner

The tensioner used in this application is designed to require no special lifting instructions. Do not drop any part of the tensioner on the operator or other nearby personnel.

### 8.2 Kit Assembly

Connect the hydraulic hose from the hydraulic pump to the tensioner.

Refer to the hardware assembly drawing (HF-xxxx) listed in Section 2.0 of this manual and the tensioner assembly drawing (HT-xxxx) listed in Section 4.5 of this manual to determine how the tensioner must be assembled on the load coupling for its correct operation.

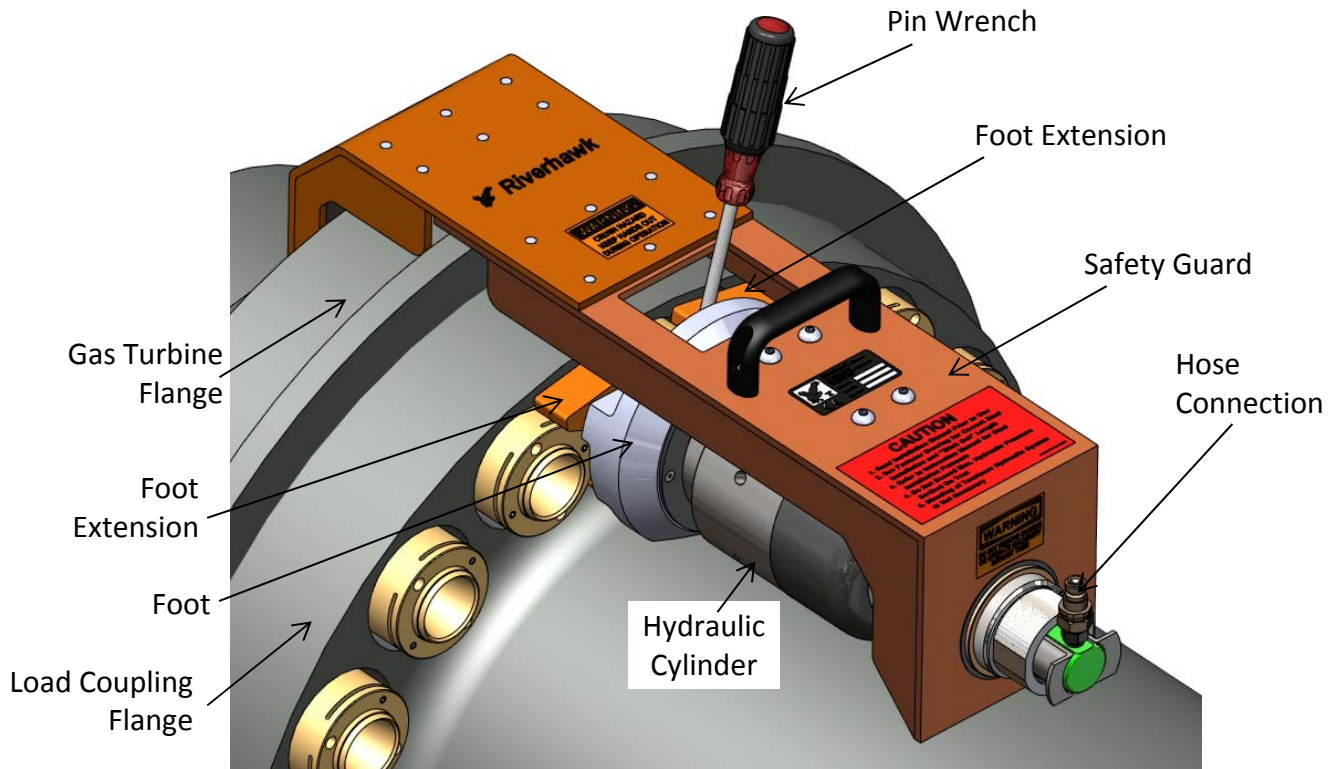

Picture 8A – Features of the Hydraulic Tensioner HT-5144



215 Clinton Road  
 New Hartford, NY 13413  
 Tel: +1 315 768 4855  
 Fax: +1 315 768 4941  
 Email: info@riverhawk.com

GE DRAWING NUMBER	REV
373A4040	E

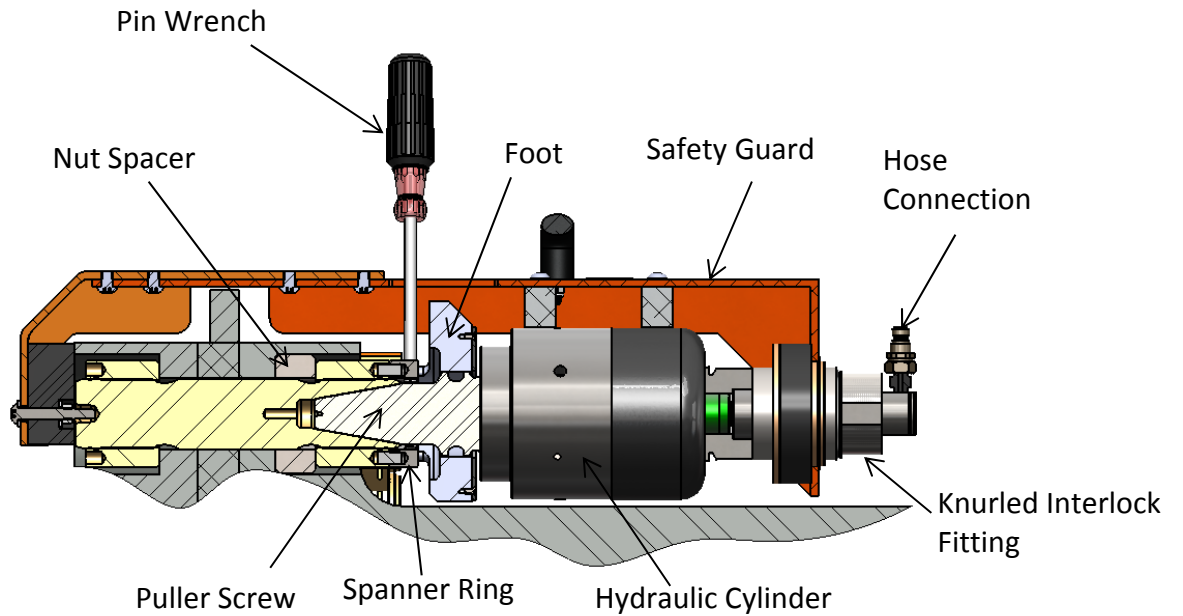
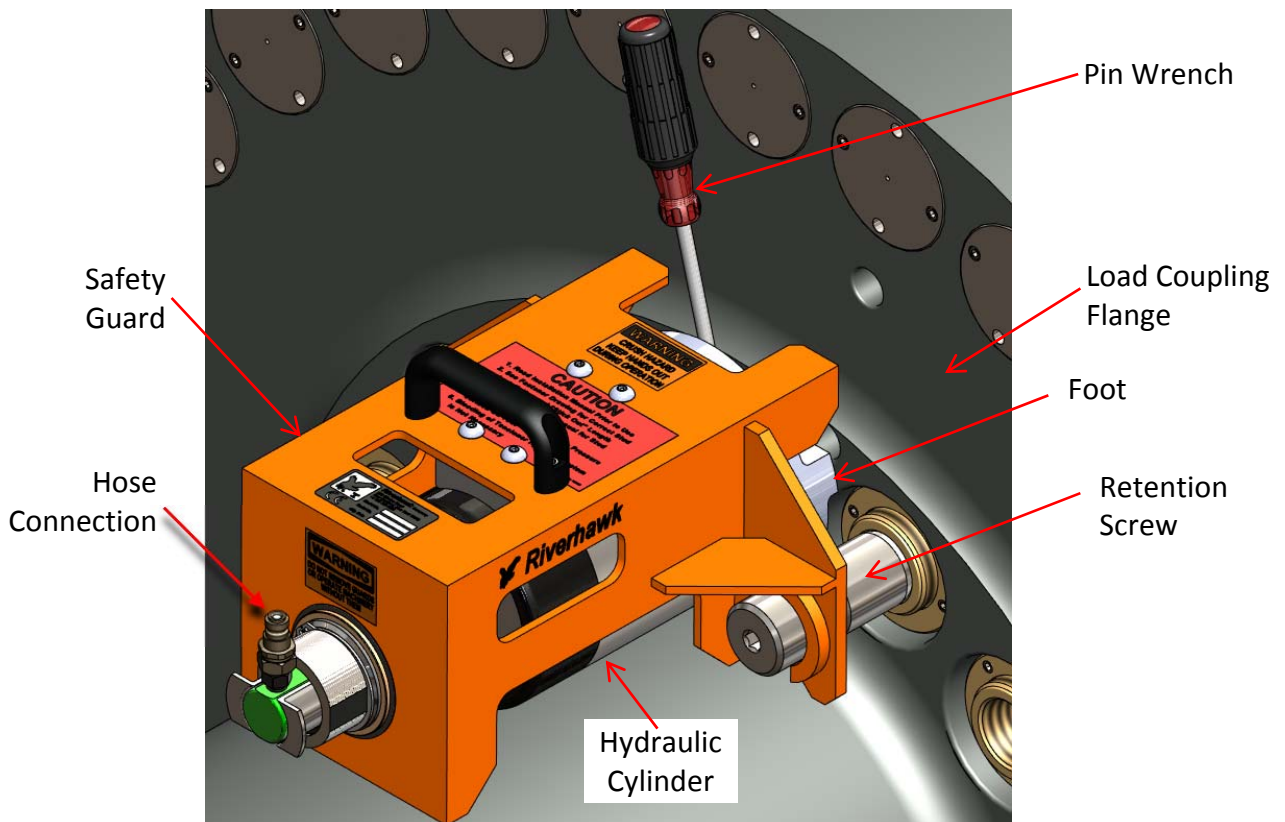

Figure 8B – Cutaway view of Hydraulic Tensioner HT-5144



Picture 8C – Features of the Hydraulic Tensioner HT-6019



215 Clinton Road  
 New Hartford, NY 13413  
 Tel: +1 315 768 4855  
 Fax: +1 315 768 4941  
 Email: info@riverhawk.com

GE DRAWING NUMBER	REV
373A4040	E

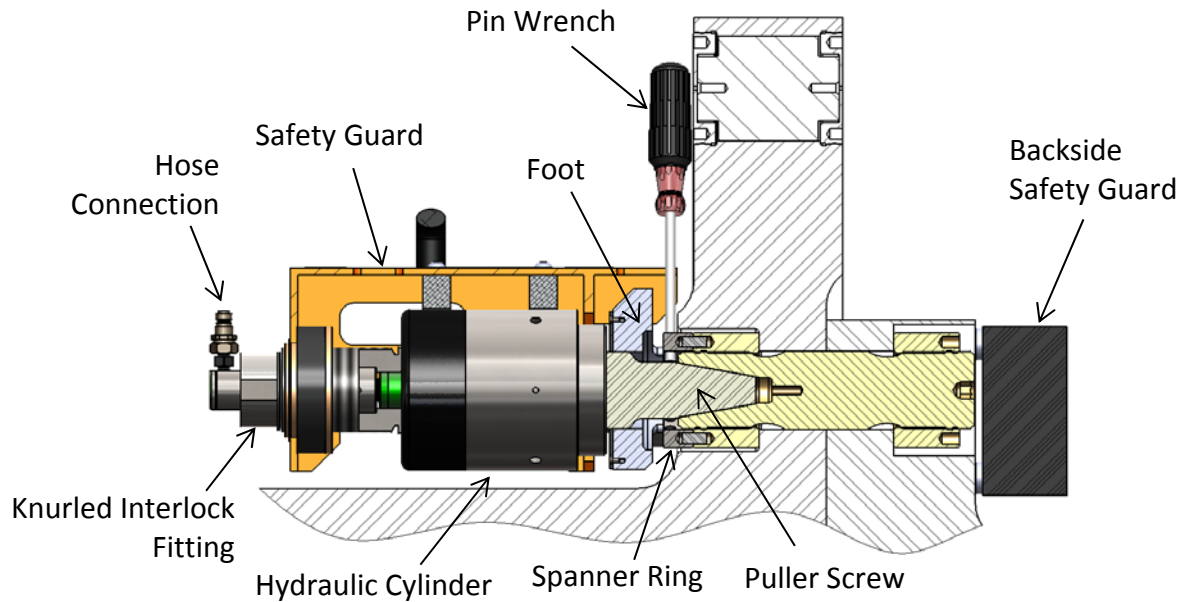

Figure 8D – Cutaway view of Hydraulic Tensioner HT-6019

**Note:** Before threading the puller screw into the stud, carefully check the cleanliness of both the stud's and the puller screw's conical threads. Apply a light coat of clean turbine oil or a spray lubricant to the puller screw. Do not use "Never Seize" on the conical threads. This procedure will ease assembly and assure positive mating of the threads before tightening.

Assembly sequence is as follows:

1. Open the hydraulic return valve on the pump to allow hydraulic fluid to be pushed back from the puller tool into the pump reservoir. (This is automatic on the air-operated hydraulic pump)
2. Thread the retention screws into the adjacent studs on either side of the stud to be tensioned until hand tight. **(Generator Side Tensioner Only)**
3. Place the spanner ring on the nut.
4. Insert the puller screw into the tapered thread of the stud and hand tighten. **Be sure not to cross-thread the puller screw.**
5. Place the two foot extensions on either side of the nut **(Gas Turbine Side Only)**
6. Using an Allen wrench, tighten the puller screw and then back off the puller screw 1/2 a turn.
7. Retighten the puller screw by hand until it is fully inserted. **DO NOT BACK OFF THE PULLER SCREW.**
8. Place the foot over the puller screw and orientate it into position.



215 Clinton Road  
 New Hartford, NY 13413  
 Tel: +1 315 768 4855  
 Fax: +1 315 768 4941  
 Email: info@riverhawk.com

GE DRAWING NUMBER	REV
373A4040	E

9. Thread the tensioner onto the puller screw until it stops. Please note that the internal stop inside the tensioner will cause a gap in between the foot and tensioner. The gap should be 1/16" [1.6mm] to 3/16" [4.8mm]. **DO NOT ATTEMPT TO TIGHTEN THE TENSIONER AGAINST THE FOOT.**
- 9A. Place the guard over the tensioner and position the guide pin into the hole in the backside of the stud. **(Gas Turbine Side Tensioner Only)**
- 9B. Place the orange guard over the tensioner and position the pocketed slots into the retention screws. **(Generator Side Tensioner Only)**
10. Tighten the knurled interlock fitting by hand until it firmly presses against the tensioner. There should be no gap between the tensioner the interlock fitting.
11. The retention screws must be inside the guard's pocketed slots. **(Generator Side Tensioner Only)**
12. Activate the custom connector from the rear of guard by pushing on the center with your thumb and pulling the tabs with your fore finger and middle finger. Push the assembly forward until it locks into the tensioner. Release fingers from the tabs and then remove thumb, Ensure connection is firmly engaged or else the tensioner will not be connected to the pump.

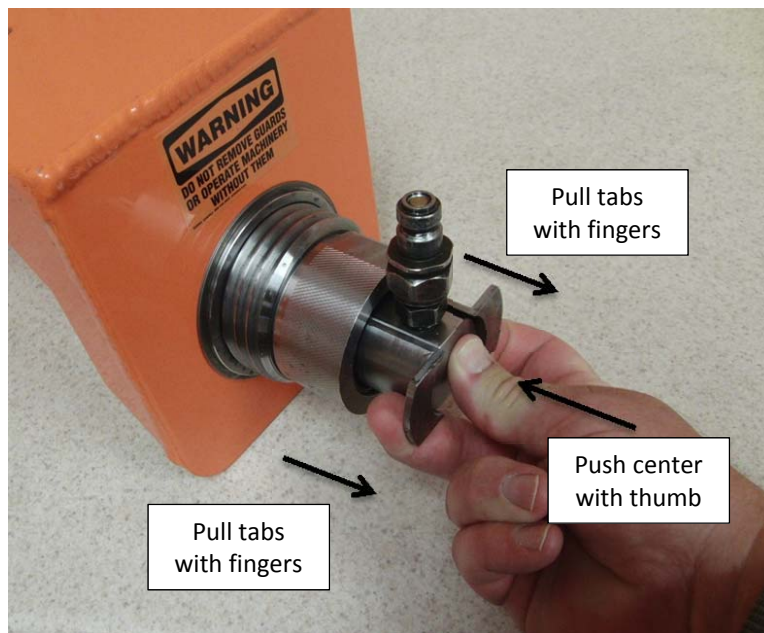

**Picture 8E** - Activation of the safety interlock

13. Install the backside guard and center the guard over the stud to be tensioned. Thread the backside guard into the adjacent studs until it stops. **(Generator Side Tensioner Only)**
14. Connect the hydraulic pump to the tensioner. The tensioner should now be completely assembled and ready for use.



215 Clinton Road  
 New Hartford, NY 13413  
 Tel: +1 315 768 4855  
 Fax: +1 315 768 4941  
 Email: info@riverhawk.com

GE DRAWING NUMBER	REV
373A4040	E

### 8.3 Bleeding Hydraulic System

Bleeding of the hydraulic system is not necessary with this tensioner design.

### 9.0 Stud Tensioning

The studs will be tensioned in two steps, at 50% pressure and at final pressure. Follow the tensioning sequence for each flange joint as defined on the record sheets found at the end of this manual.

#### 9.1 Tensioning at 50% pressure

After the tensioner is properly installed apply hydraulic pressure to the tool. Bring the pressure to the 50% level in accordance with the following table.

#### **WARNING**

**The safety cage must be in place at all times. Keep hands out of designated areas at all times when the tensioner is pressurized otherwise personal injury can occur.**

#### **CAUTION**

**Before threading the puller screw into the stud, carefully check the cleanliness of both the stud's and the puller screw's conical threads. Apply a light coat of clean turbine oil or a spray lubricant to the puller screw. This procedure will ease assembly and assure positive mating of the threads before tightening. Do not use "Never Seize" on the conical threads.**

#### **CAUTION**

**Do not exceed the maximum pressure marked on the tensioner. Excessive pressure can damage the stud and puller screw.**

#### **CAUTION**

**Do not tighten the nut while the tool is coming up to pressure; wait until pressure is achieved before attempting to tighten the nut with the spanner ring. If the tool is not properly installed, the tool could jump off the stud while coming up to pressure.**



215 Clinton Road  
New Hartford, NY 13413  
Tel: +1 315 768 4855  
Fax: +1 315 768 4941  
Email: info@riverhawk.com

GE DRAWING NUMBER	REV
373A4040	E

<u>Flange Position</u>	<u>Stud Size</u>	<u>50% Pressure</u>	<u>50% Stretch</u>
Gas Turbine to Load Coupling	2-1/4" [58 mm]	9000 psi [620 bar]	Do not measure Do not use
Load Coupling to Generator	2-3/4" [71 mm]	10000 psi [690 bar]	Do not measure Do not use

Firmly tighten the cylindrical nuts with approximately 20 ft·lbs [27 N·m] of torque using the pin wrench and spanner ring. Turn the nut until it bottoms on the flange.

### 9.2 Removing the Tensioner from an Installed Stud

The tensioner removal is accomplished by the follows steps:

1. Release the hydraulic pressure by either releasing the hand switch on the AP-0532 Pump Kit or by opening the valve on the MP-0130 Manual Pump Kit and leave the valve open.
2. Remove the backside guard. **(Generator Side Tensioner Only)**
3. Unscrew the knurled interlock fitting at the end of the guard and remove the guard from the tensioner.
4. Unscrew the tensioner from puller screw.
5. Remove the foot and the two foot extensions from around the puller screw.
6. Unscrew the puller screw using an Allen wrench. Tapping the Allen wrench with a hammer or the use of a 3-4' breaker bar may be necessary to loosen the puller screw. Do not use an impact wrench as this can damage the puller screw.
7. Remove the spanner ring from the nut.
8. In the case of the generator side of the load coupling flange, unscrew the retention screws using an Allen wrench. It may be necessary to tap the Allen wrench with a hammer or use a 3-4' breaker bar to loosen the retention screws. Do not use an impact wrench as this can damage the retention screws.
9. Move the tool to the next bolt hole following the tensioning pattern from the stretched record sheets at the end of this manual.

### 9.3 Tensioning at Final Pressure

Repeat the pulling and tightening procedure stated above at full pressure. After all of the studs have been tensioned, measure the final stud length. The final pressure and required stretch values are listed in the following table.



215 Clinton Road  
New Hartford, NY 13413  
Tel: +1 315 768 4855  
Fax: +1 315 768 4941  
Email: info@riverhawk.com

GE DRAWING NUMBER	REV
373A4040	E

**WARNING**

The safety cage must be in place at all times. Keep hands out of designated areas at all times when the tensioner is pressurized otherwise personal injury can occur.

**CAUTION**

Before threading the puller screw into the stud, carefully check the cleanliness of both the stud's and the puller screw's conical threads. Apply a light coat of clean turbine oil or a spray lubricant to the puller screw. This procedure will ease assembly and assure positive mating of the threads before tightening. Do not use "Never Seize" on the conical threads.

**CAUTION**

Do not exceed the maximum pressure marked on the tensioner. Excessive pressure can damage the stud and puller screw.

**CAUTION**

Do not tighten the nut while the tool is coming up to pressure; wait until pressure is achieved before attempting to tighten the nut with the spanner ring. If the tool is not properly installed, the tool could jump off the stud while coming up to pressure.

<u>Flange Position</u>	<u>Stud Size</u>	<u>Final Pressure</u>	<u>Final Stretch</u>	<u>Gauge Reading</u>
Gas Turbine to Load Coupling	2-1/4" [58 mm]	18000 psi [1240 bar]	0.018" - 0.020" [0.51 mm - 0.56 mm]	-----
Load Coupling to Generator	2-3/4" [71 mm]	19000 psi [1310 bar]	0.014" - 0.016" [0.36 mm - 0.41 mm]	0.025"-0.030" [0.63mm-0.76mm]

Firmly tighten the cylindrical nuts with approximately 20 ft-lbs [27 N·m] of torque using the pin wrench and spanner ring. Turn the nut until it bottoms on the flange.

Failure to achieve the correct final stretch values will result in an incorrectly tensioned stud.

Incorrect stretch values can be corrected by uninstalling some or all of the selected studs. Re-measure the initial length of the studs and repeat the installation instructions studs. Excessive stretch variations can also be corrected by the same method.

Have final stretch values approved by the supervisor responsible for the installation.



215 Clinton Road  
New Hartford, NY 13413  
Tel: +1 315 768 4855  
Fax: +1 315 768 4941  
Email: info@riverhawk.com

GE DRAWING NUMBER	REV
373A4040	E

## 10.0 Thread Locking

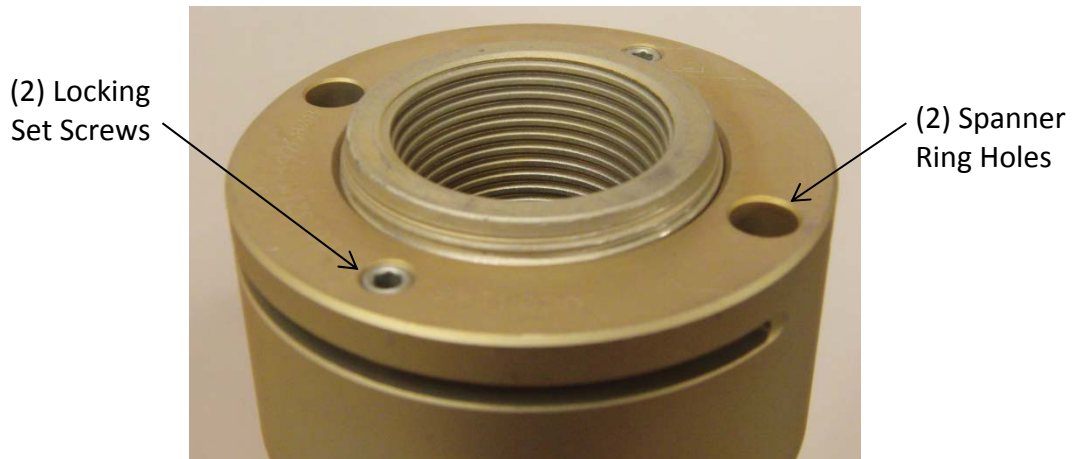

**Picture 10A** - Riverhawk Locknut

Mechanical lock nuts have two set screws located in the top face. Before threading the nut onto the stud, check to be certain the set screws are free to turn. Once the nut is seated torque the set screws to the values specified in the following table. When seated and torqued to the values specified, the load created by the set screw displaces the thread of the nut in the area of the web thereby creating the desired locking action.

<u>Flange Position</u>	<u>Stud Size</u>	<u>Set Screw Size</u>	<u>Torque</u>
Gas Turbine to Load Coupling	2-1/4" [58 mm]	1/4"-28 UN	70 in·lbs - 80 in·lbs [7.9 N·m – 9.0 N·m]
Load Coupling to Generator	2-3/4" [71 mm]	3/8"-24 UN	200 in·lbs - 250 in·lbs [22.6 N·m – 28.2 N·m]

## 11.0 Stud, Nut, and Load Coupling Spacer Removal

### 11.1 Handling of the Tensioner

The tensioner used in this application is designed for no special lifting instructions. Do not drop any part of the tensioner on the operator or other nearby personnel.



215 Clinton Road  
New Hartford, NY 13413  
Tel: +1 315 768 4855  
Fax: +1 315 768 4941  
Email: info@riverhawk.com

GE DRAWING NUMBER	REV
373A4040	E

## 11.2 Stud, Nut, and Load Coupling Spacer Removal

### WARNING

The safety cage must be in place at all times. Keep hands out of designated areas at all times when the tensioner is pressurized otherwise personal injury can occur.

### CAUTION

Before threading the puller screw into the stud, carefully check the cleanliness of both the stud's and the puller screw's conical threads. Apply a light coat of clean turbine oil or a spray lubricant to the puller screw. This procedure will ease assembly and assure positive mating of the threads before tightening. Do not use "Never Seize" on the conical threads.

### CAUTION

Do not exceed the maximum pressure marked on the tensioner. Excessive pressure can damage the stud and puller screw.

### CAUTION

Do not tighten the nut while the tool is coming up to pressure; wait until pressure is achieved before attempting to tighten the nut with the spanner ring. If the tool is not properly installed, the tool could jump off the stud while coming up to pressure.

Refer to the hardware assembly drawing (HF-xxxx) listed in Section 2.0 of this manual and the tensioner assembly drawing (HT-xxxx) listed in Section 4.5 of this manual to determine how the tensioner must be assembled on the load coupling for its correct operation.

Section 8.0 contains diagrams of the tensioner equipment.

**Note:** Before threading the puller screw into the stud, carefully check the cleanliness of both the stud's and the puller screw's conical threads. Apply a light coat of clean turbine oil or a spray lubricant to the puller screw. Do not use "Never Seize" on the conical threads. This procedure will ease assembly and assure positive mating of the threads before tightening.

Disassembly sequence is as follows:

1. Using a wire brush (GT-4253) and shop air, clean the internal tapered thread of the stud to remove any debris/deposits which may have accumulated during service as described in section 5.2.2. Do not continue until ALL debris is removed from the threads.

### WARNING

Do not use a hydraulic tensioner to remove a stud with damaged conical threads.

2. With an Allen-wrench loosen the two locking set screws but do not remove from the nut.



215 Clinton Road  
New Hartford, NY 13413  
Tel: +1 315 768 4855  
Fax: +1 315 768 4941  
Email: info@riverhawk.com

GE DRAWING NUMBER	REV
373A4040	E



**Picture 11A** - Loosening of a nut's set screws

3. Connect the hydraulic hose from the hydraulic pump to the tensioner.
4. Open the hydraulic return valve on the pump to allow hydraulic fluid to be pushed back from the puller tool into the pump reservoir. (This is automatic on the air-operated hydraulic pump)
5. Thread the retention screws into the adjacent studs on either side of the stud to be tensioned until hand tight. **(Generator Side Tensioner Only)**
6. Place the spanner ring on the nut.
7. Insert the puller screw into the tapered thread of the stud and hand tighten. **Be sure not to cross-thread the puller screw.**
8. Using an Allen wrench, tighten the puller screw and then back off the puller screw 1/2 a turn.
9. Retighten the puller screw by hand until it is fully inserted. **DO NOT BACK OFF THE PULLER SCREW.**
10. Place the two foot extensions on either side of the nut **(Gas Turbine Side Only)**
11. Place the foot over the puller screw and orientate it into position.
12. Thread the tensioner onto the puller screw until it stops. Please note that the internal stop inside the tensioner will cause a gap in between the foot and tensioner. The gap should be 1/16" [1.6mm] to 3/16" [4.8mm]. **DO NOT ATTEMPT TO TIGHTEN THE TENSIONER AGAINST THE FOOT.**
- 12A. Place the guard over the tensioner and position the guide pin into the hole in the backside of the stud. **(Gas Turbine Side Tensioner Only)**
- 12B. Place the orange guard over the tensioner and position the pocketed slots into the retention screws. **(Generator Side Tensioner Only)**
13. Tighten the knurled interlock fitting by hand until it firmly presses against the tensioner. There should be no gap between the tensioner the interlock fitting.



215 Clinton Road  
 New Hartford, NY 13413  
 Tel: +1 315 768 4855  
 Fax: +1 315 768 4941  
 Email: info@riverhawk.com

GE DRAWING NUMBER	REV
373A4040	E

14. The retention screws must be inside the guard's pocketed slots. **(Generator Side Tensioner Only)**
15. Activate the custom connector from the rear of guard by pushing on the center with your thumb and pulling the tabs with your fore finger and middle finger. Push the assembly forward until it locks into the tensioner. Release fingers from the tabs and then remove thumb, Ensure connection is firmly engaged or else the tensioner will not be connected to the pump.



**Picture 11B** - Activation of the safety interlock

16. Install the backside guard and center the guard over the stud to be tensioned. Thread the backside guard into the adjacent studs until it stops. **(Generator Side Tensioner Only)**
17. Connect the hydraulic pump to the tensioner and apply the appropriate hydraulic pressure per this table.

<u>Flange Position</u>	<u>Stud Size</u>	<u>Final Pressure</u>
Gas Turbine to Load Coupling	2-1/4" [58 mm]	18000 psi [1240 bar]
Load Coupling to Generator	2-3/4" [71 mm]	19000 psi [1310 bar]



215 Clinton Road  
New Hartford, NY 13413  
Tel: +1 315 768 4855  
Fax: +1 315 768 4941  
Email: info@riverhawk.com

GE DRAWING NUMBER	REV
373A4040	E

18. Turn the spanner ring with the pin wrench. Loosen and turn the nut approximately 3/4 of a turn.
19. Release the hydraulic pressure.

### 11.3.1 Removing the Tensioner from a Stud

The tensioner removal is accomplished by the follows steps:

1. Release the hydraulic pressure by either releasing the hand switch on the AP-0532 Pump Kit or by opening the valve on the MP-0130 Manual Pump Kit and leave the valve open.
2. Remove the backside guard. **(Generator Side Tensioner Only)**
3. Unscrew the knurled interlock fitting at the end of the guard and remove the guard from the tensioner.
4. Unscrew the tensioner from puller screw.
5. Remove the foot and the two foot extensions from around the puller screw.
6. Unscrew the puller screw using an Allen wrench. Tapping the Allen wrench with a hammer or the use of a 3-4' breaker bar may be necessary to loosen the puller screw. Do not use an impact wrench as this can damage the puller screw.
7. Remove the spanner ring from the nut.
8. In the case of the generator side of the load coupling flange, unscrew the retention screws using an Allen wrench. It may be necessary to tap the Allen wrench with a hammer or use a 3-4' breaker bar to loosen the retention screws. Do not use an impact wrench as this can damage the retention screws.
9. Move the tool to the next bolt hole following the tensioning pattern from the stretched record sheets at the end of this manual.

## 12.0 Storage Instructions

Follow these directions to properly store your hydraulic tensioner and hydraulic pump kit for long term storage and shipment.

If any damage is observed, contact the Riverhawk Company to schedule a maintenance inspection.

### 12.1 Hydraulic Pump Kit Storage

Refer to the Hydraulic Pump Kit Instruction Manual, IM-293 (GE VENDOC 373A4058). The latest revision may be obtained by contacting Riverhawk Company or thru [www.riverhawk.com](http://www.riverhawk.com).



215 Clinton Road  
 New Hartford, NY 13413  
 Tel: +1 315 768 4855  
 Fax: +1 315 768 4941  
 Email: [info@riverhawk.com](mailto:info@riverhawk.com)

GE DRAWING NUMBER	REV
373A4040	E

## 12.2 Hydraulic Tensioner Storage

Check the tensioner for any damage

1. Clean puller screw and check for any debris and dents.
2. Knurled interlock fitting should be clean and free to rotate.
3. Inspect the tensioner guard for any signs of damage. Bent guards must be replaced.

If any damage is observed, contact the Riverhawk Company to schedule a maintenance inspection.

Place the protective plastic cap on the guard's knurled interlock fitting.

Coat the hydraulic tensioner with a light coat of oil and place the tensioner into the original shipping container.

## 12.3 Store shipping container

Secure the hydraulic pump and hydraulic tensioner into the original shipping containers using the supplied wood braces.

Seal the original shipping container and store under shelter and protected from moisture, sand, and grit.

## 13.0 Frequently Asked Questions

This section contains some frequently asked questions and problems. If the steps listed here do not solve your problem, contact the Riverhawk Company thru our website, email, or phone call.

**Q:** Can I rent a hydraulic tensioner kit?

**A:** Yes, Riverhawk has rental tensioner kits available for most of our hydraulic tensioners.

**Q:** A tensioner has pulled itself out of the stud's conical threads. Can I continue using a tensioner on this stud?

**A:** No. Both the tensioner and the stud may have been damaged and must be removed from the work area. If the stud is tensioned, a Nut Buster repair kit, from Riverhawk, must be used to remove the damaged stud by drilling out the nut. Leaving a damaged stud in place will lead to a safety hazard on future outages.



215 Clinton Road  
New Hartford, NY 13413  
Tel: +1 315 768 4855  
Fax: +1 315 768 4941  
Email: info@riverhawk.com

GE DRAWING NUMBER	REV
373A4040	E

Riverhawk can supply a replacement stud and nut based on the initial weight certification supplied with the hardware set (see section 4.2). The damaged tensioner should also be returned to Riverhawk for inspection and repair.

If a stud must be left in place, paint the damaged stud with a generous amount of indelible, bright-colored paint. Notify the appropriate GE Safety and Service personnel. Note the location of the damaged stud in the services notes for the machine.

**Q:** The hydraulic tensioner has been taken up to its final pressure. The final stretch length is short of the final stretch target. What is the next step?

**A:** Do not increase the hydraulic pressure. Check if the hydraulic pump is set to the right pressure. Install the tensioner and re-pressurize the tensioner to the final pressure then recheck the stretch measurement. If the stretch value is still short, remove the stud from the hole and re-measure the stud's initial length then try to install the stud again.

**Q:** The hydraulic tensioner has been taken up to its final pressure. The final stretch length is larger than the final stretch target. What is the next step?

**A:** Remove the stud from the bolt hole. Check if the hydraulic pump is set to the right pressure. Re-measure the stud's initial length then try to install the stud again.

**Q:** The tensioner is at its final pressure, but the nut cannot be loosened.

**A:** If the nuts cannot be loosened at the final pressure, continually increasing the pressure will not help and can be dangerous and in some cases make it harder to remove the nut. Check the nut to see if its set screws have been loosened. Check for and remove any corrosion around the nut's threads. Apply penetrating oil between the stud and the nut.

**Q:** How do I clean the conical threads on a stud?

**A:** The conical threads are best cleaned using a spiral wound brass brush in a drill as described in section 5.2.2



215 Clinton Road  
New Hartford, NY 13413  
Tel: +1 315 768 4855  
Fax: +1 315 768 4941  
Email: info@riverhawk.com

GE DRAWING NUMBER	REV
373A4040	E

**Q:** During the initial steps of removing a tensioned stud, the stick-out length is found to be wrong.

**A:** Do not proceed. Contact Riverhawk for assistance. With the wrong stick-out length, the hydraulic tensioner has a limited stroke and may not work properly and can be damaged.

**Q:** The hydraulic pump appears to be leaking.

**A:** Check the hose connection to the hydraulic pump. If the 1/4" high pressure fitting is not assembled correctly as shown in section 7.2, it may look like the pump is leaking. If the problem continues, it may be necessary to open the pump kit. Contact Riverhawk for guidance.

**Q:** The hydraulic hose has a collar on it that can't be moved by hand

**A:** The hydraulic fitting is shown in section 7.2. The collar is sometimes held in place with a thread locking compound. This prevents the collar from moving too easily. It may be necessary to adjust this collar with a set of vise-grip pliers. Be careful to not strip the threads off the tube or hose end.



215 Clinton Road  
New Hartford, NY 13413  
Tel: +1 315 768 4855  
Fax: +1 315 768 4941  
Email: info@riverhawk.com

GE DRAWING NUMBER	REV
373A4040	E

**14.0 Revision History**

Revision Letter	Effective Date	Description
E	Feb 16, 2014	Section 3.0 & 6.0 Removed hand tighten, added tighten with spanner ring, Section 3.0 & 6.0 added measure and record starting gage readings (generator side), Section 5.3.2 revised stud stretch measurement gauge to read stud installation gauge, Section 9.3 added gage reading column to final installation chart (generator side), Appendix 2 renamed final stretch to final gauge reading
D	12/19/13	Updated GE part number from 106T1751P003 to 110T2635P0003 page 6, section 2.4. RS.
C	12/11/13	Added note to title page and changed stretch from .020/.022 to .018/.020 on the turbine end. RJD.
B	Oct 25, 2013	Removed GE 106T1751 from the title page and section 2.0 and replaced it with GE 110T2635, Added references to load coupling spacers to sections 3, 4.2, 5.0, and 6.0, Added references to foot extensions to sections 3, 4.5, 8.2, 9.2, and 11.2
A	Mar 25, 2013	Corrected typo in rupture disc warning in sections 1.0 and 7.1.1.1, Corrected arrow location in Figure 6A, Added reference to tensioner list to sections 7.1.1 and 7.1.1.1, Added retention screw arrow/text to Picture 8C, Corrected type in section 8.2 step 12 and section 11.2 step 15, added "approximately" to sections 9.1 and 9.3
-	Mar 20, 2013	Released



215 Clinton Road  
 New Hartford, NY 13413  
 Tel: +1 315 768 4855  
 Fax: +1 315 768 4941  
 Email: info@riverhawk.com

GE DRAWING NUMBER	REV
373A4040	E

**Appendix A1**

STRETCH RECORD SHEET FOR  
THE GAS TURBINE TO LOAD COUPLING

TURBINE NUMBER:

DATE:

TECHNICIAN:

SUPERVISOR:

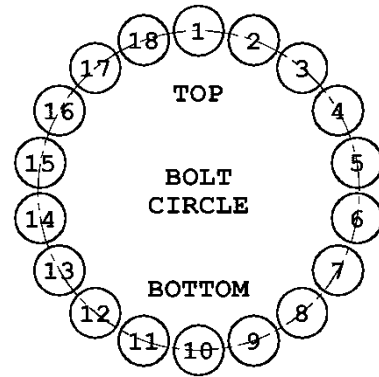

HOLE NUMBER	STARTING LENGTH	FINAL LENGTH	FINAL STRETCH
1			
10			
2			
11			
3			
12			
4			
13			
5			
14			
6			
15			
7			
16			
8			
17			
9			
18			



215 Clinton Road  
New Hartford, NY 13413  
Tel: +1 315 768 4855  
Fax: +1 315 768 4941  
Email: info@riverhawk.com

GE DRAWING NUMBER	REV
373A4040	E

**Appendix A2**

STRETCH RECORD SHEET FOR  
THE LOAD COUPLING TO GENERATOR

TURBINE NUMBER:

DATE:

TECHNICIAN:

SUPERVISOR:

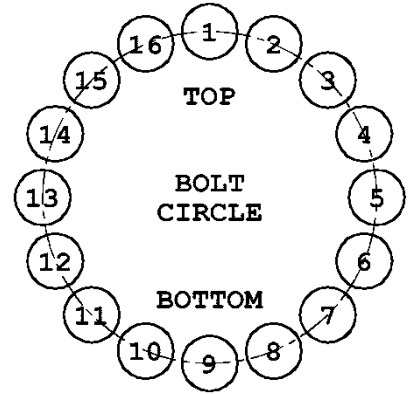

HOLE NUMBER	STARTING MEASUREMENT	FINAL MEASUREMENT	FINAL GAUGE READING
1			
9			
5			
13			
15			
7			
3			
11			
8			
16			
12			
4			
10			
2			
6			
14			



215 Clinton Road  
New Hartford, NY 13413  
Tel: +1 315 768 4855  
Fax: +1 315 768 4941  
Email: info@riverhawk.com

GE DRAWING NUMBER	REV
373A4040	E