

For use with machines Code 11212

Safety Depends on You

Lincoln arc welding and cutting equipment is designed and built with safety in mind. However, your overall safety can be increased by proper installation ... and thoughtful operation on your part. **DO NOT INSTALL, OPERATE OR REPAIR THIS EQUIPMENT WITHOUT READING THIS MANUAL AND THE SAFETY PRECAUTIONS CONTAINED THROUGHOUT.** And, most importantly, think before you act and be careful.

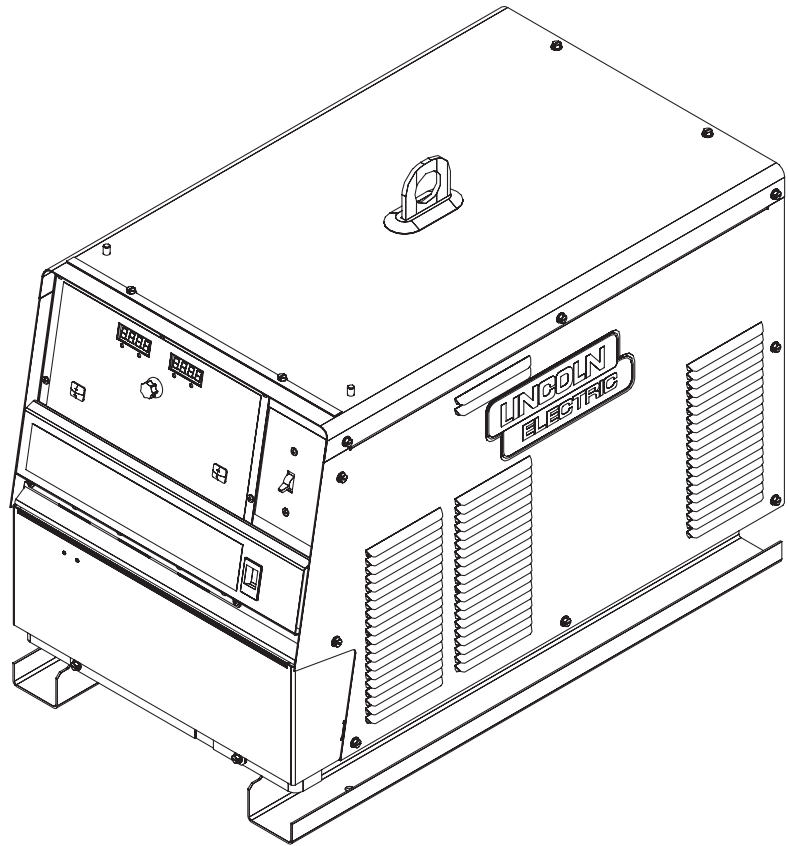

OPERATOR'S MANUAL



Copyright © Lincoln Global Inc.

• World's Leader in Welding and Cutting Products •

• Sales and Service through Subsidiaries and Distributors Worldwide •

Cleveland, Ohio 44117-1199 U.S.A. TEL: 216.481.8100 FAX: 216.486.1751 WEB SITE: www.lincolnelectric.com

⚠ WARNING

⚠ CALIFORNIA PROPOSITION 65 WARNINGS ⚠

Diesel engine exhaust and some of its constituents are known to the State of California to cause cancer, birth defects, and other reproductive harm.

The Above For Diesel Engines

The engine exhaust from this product contains chemicals known to the State of California to cause cancer, birth defects, or other reproductive harm.

The Above For Gasoline Engines

ARC WELDING CAN BE HAZARDOUS. PROTECT YOURSELF AND OTHERS FROM POSSIBLE SERIOUS INJURY OR DEATH. KEEP CHILDREN AWAY. PACEMAKER WEARERS SHOULD CONSULT WITH THEIR DOCTOR BEFORE OPERATING.

Read and understand the following safety highlights. For additional safety information, it is strongly recommended that you purchase a copy of "Safety in Welding & Cutting - ANSI Standard Z49.1" from the American Welding Society, P.O. Box 351040, Miami, Florida 33135 or CSA Standard W117.2-1974. A Free copy of "Arc Welding Safety" booklet E205 is available from the Lincoln Electric Company, 22801 St. Clair Avenue, Cleveland, Ohio 44117-1199.

BE SURE THAT ALL INSTALLATION, OPERATION, MAINTENANCE AND REPAIR PROCEDURES ARE PERFORMED ONLY BY QUALIFIED INDIVIDUALS.



FOR ENGINE powered equipment.

1.a. Turn the engine off before troubleshooting and maintenance work unless the maintenance work requires it to be running.



1.b. Operate engines in open, well-ventilated areas or vent the engine exhaust fumes outdoors.



1.c. Do not add the fuel near an open flame welding arc or when the engine is running. Stop the engine and allow it to cool before refueling to prevent spilled fuel from vaporizing on contact with hot engine parts and igniting. Do not spill fuel when filling tank. If fuel is spilled, wipe it up and do not start engine until fumes have been eliminated.

1.d. Keep all equipment safety guards, covers and devices in position and in good repair. Keep hands, hair, clothing and tools away from V-belts, gears, fans and all other moving parts when starting, operating or repairing equipment.

1.e. In some cases it may be necessary to remove safety guards to perform required maintenance. Remove guards only when necessary and replace them when the maintenance requiring their removal is complete. Always use the greatest care when working near moving parts.



1.f. Do not put your hands near the engine fan. Do not attempt to override the governor or idler by pushing on the throttle control rods while the engine is running.

1.g. To prevent accidentally starting gasoline engines while turning the engine or welding generator during maintenance work, disconnect the spark plug wires, distributor cap or magneto wire as appropriate.



1.h. To avoid scalding, do not remove the radiator pressure cap when the engine is hot.



ELECTRIC AND MAGNETIC FIELDS may be dangerous

2.a. Electric current flowing through any conductor causes localized Electric and Magnetic Fields (EMF). Welding current creates EMF fields around welding cables and welding machines

2.b. EMF fields may interfere with some pacemakers, and welders having a pacemaker should consult their physician before welding.

2.c. Exposure to EMF fields in welding may have other health effects which are now not known.

2.d. All welders should use the following procedures in order to minimize exposure to EMF fields from the welding circuit:

2.d.1. Route the electrode and work cables together - Secure them with tape when possible.

2.d.2. Never coil the electrode lead around your body.

2.d.3. Do not place your body between the electrode and work cables. If the electrode cable is on your right side, the work cable should also be on your right side.

2.d.4. Connect the work cable to the workpiece as close as possible to the area being welded.

2.d.5. Do not work next to welding power source.

Mar '95



ELECTRIC SHOCK can kill.

- 3.a. The electrode and work (or ground) circuits are electrically “hot” when the welder is on. Do not touch these “hot” parts with your bare skin or wet clothing. Wear dry, hole-free gloves to insulate hands.
- 3.b. Insulate yourself from work and ground using dry insulation. Make certain the insulation is large enough to cover your full area of physical contact with work and ground.

In addition to the normal safety precautions, if welding must be performed under electrically hazardous conditions (in damp locations or while wearing wet clothing; on metal structures such as floors, gratings or scaffolds; when in cramped positions such as sitting, kneeling or lying, if there is a high risk of unavoidable or accidental contact with the workpiece or ground) use the following equipment:

- Semiautomatic DC Constant Voltage (Wire) Welder.
 - DC Manual (Stick) Welder.
 - AC Welder with Reduced Voltage Control.
- 3.c. In semiautomatic or automatic wire welding, the electrode, electrode reel, welding head, nozzle or semiautomatic welding gun are also electrically “hot”.
- 3.d. Always be sure the work cable makes a good electrical connection with the metal being welded. The connection should be as close as possible to the area being welded.
- 3.e. Ground the work or metal to be welded to a good electrical (earth) ground.
- 3.f. Maintain the electrode holder, work clamp, welding cable and welding machine in good, safe operating condition. Replace damaged insulation.
- 3.g. Never dip the electrode in water for cooling.
- 3.h. Never simultaneously touch electrically “hot” parts of electrode holders connected to two welders because voltage between the two can be the total of the open circuit voltage of both welders.
- 3.i. When working above floor level, use a safety belt to protect yourself from a fall should you get a shock.
- 3.j. Also see Items 6.c. and 8.



ARC RAYS can burn.

- 4.a. Use a shield with the proper filter and cover plates to protect your eyes from sparks and the rays of the arc when welding or observing open arc welding. Headshield and filter lens should conform to ANSI Z87.1 standards.
- 4.b. Use suitable clothing made from durable flame-resistant material to protect your skin and that of your helpers from the arc rays.
- 4.c. Protect other nearby personnel with suitable, non-flammable screening and/or warn them not to watch the arc nor expose themselves to the arc rays or to hot spatter or metal.



FUMES AND GASES can be dangerous.

- 5.a. Welding may produce fumes and gases hazardous to health. Avoid breathing these fumes and gases. When welding, keep your head out of the fume. Use enough ventilation and/or exhaust at the arc to keep fumes and gases away from the breathing zone. **When welding with electrodes which require special ventilation such as stainless or hard facing (see instructions on container or MSDS) or on lead or cadmium plated steel and other metals or coatings which produce highly toxic fumes, keep exposure as low as possible and within applicable OSHA PEL and ACGIH TLV limits using local exhaust or mechanical ventilation. In confined spaces or in some circumstances, outdoors, a respirator may be required. Additional precautions are also required when welding on galvanized steel.**
- 5.b. The operation of welding fume control equipment is affected by various factors including proper use and positioning of the equipment, maintenance of the equipment and the specific welding procedure and application involved. Worker exposure level should be checked upon installation and periodically thereafter to be certain it is within applicable OSHA PEL and ACGIH TLV limits.
- 5.c. Do not weld in locations near chlorinated hydrocarbon vapors coming from degreasing, cleaning or spraying operations. The heat and rays of the arc can react with solvent vapors to form phosgene, a highly toxic gas, and other irritating products.
- 5.d. Shielding gases used for arc welding can displace air and cause injury or death. Always use enough ventilation, especially in confined areas, to insure breathing air is safe.
- 5.e. Read and understand the manufacturer’s instructions for this equipment and the consumables to be used, including the material safety data sheet (MSDS) and follow your employer’s safety practices. MSDS forms are available from your welding distributor or from the manufacturer.
- 5.f. Also see item 1.b.

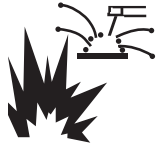

WELDING and CUTTING SPARKS can cause fire or explosion.

6.a. Remove fire hazards from the welding area. If this is not possible, cover them to prevent the welding sparks from starting a fire.

Remember that welding sparks and hot materials from welding can easily go through small cracks and openings to adjacent areas. Avoid welding near hydraulic lines. Have a fire extinguisher readily available.

6.b. Where compressed gases are to be used at the job site, special precautions should be used to prevent hazardous situations. Refer to "Safety in Welding and Cutting" (ANSI Standard Z49.1) and the operating information for the equipment being used.

6.c. When not welding, make certain no part of the electrode circuit is touching the work or ground. Accidental contact can cause overheating and create a fire hazard.

6.d. Do not heat, cut or weld tanks, drums or containers until the proper steps have been taken to insure that such procedures will not cause flammable or toxic vapors from substances inside. They can cause an explosion even though they have been "cleaned". For information, purchase "Recommended Safe Practices for the Preparation for Welding and Cutting of Containers and Piping That Have Held Hazardous Substances", AWS F4.1 from the American Welding Society (see address above).

6.e. Vent hollow castings or containers before heating, cutting or welding. They may explode.

6.f. Sparks and spatter are thrown from the welding arc. Wear oil free protective garments such as leather gloves, heavy shirt, cuffless trousers, high shoes and a cap over your hair. Wear ear plugs when welding out of position or in confined places. Always wear safety glasses with side shields when in a welding area.

6.g. Connect the work cable to the work as close to the welding area as practical. Work cables connected to the building framework or other locations away from the welding area increase the possibility of the welding current passing through lifting chains, crane cables or other alternate circuits. This can create fire hazards or overheat lifting chains or cables until they fail.

6.h. Also see item 1.c.

6.i. Read and follow NFPA 51B "Standard for Fire Prevention During Welding, Cutting and Other Hot Work", available from NFPA, 1 Batterymarch Park, PO box 9101, Quincy, Ma 022690-9101.

6.j. Do not use a welding power source for pipe thawing.



CYLINDER may explode if damaged.

7.a. Use only compressed gas cylinders containing the correct shielding gas for the process used and properly operating regulators designed for the gas and pressure used. All hoses, fittings, etc. should be suitable for the application and maintained in good condition.

7.b. Always keep cylinders in an upright position securely chained to an undercarriage or fixed support.

7.c. Cylinders should be located:

- Away from areas where they may be struck or subjected to physical damage.

- A safe distance from arc welding or cutting operations and any other source of heat, sparks, or flame.

7.d. Never allow the electrode, electrode holder or any other electrically "hot" parts to touch a cylinder.

7.e. Keep your head and face away from the cylinder valve outlet when opening the cylinder valve.

7.f. Valve protection caps should always be in place and hand tight except when the cylinder is in use or connected for use.

7.g. Read and follow the instructions on compressed gas cylinders, associated equipment, and CGA publication P-1, "Precautions for Safe Handling of Compressed Gases in Cylinders," available from the Compressed Gas Association 1235 Jefferson Davis Highway, Arlington, VA 22202.



FOR ELECTRICALLY powered equipment.

8.a. Turn off input power using the disconnect switch at the fuse box before working on the equipment.

8.b. Install equipment in accordance with the U.S. National Electrical Code, all local codes and the manufacturer's recommendations.

8.c. Ground the equipment in accordance with the U.S. National Electrical Code and the manufacturer's recommendations.

Refer to <http://www.lincolnelectric.com/safety> for additional safety information.

PRÉCAUTIONS DE SÛRETÉ

Pour votre propre protection lire et observer toutes les instructions et les précautions de sûreté spécifiques qui paraissent dans ce manuel aussi bien que les précautions de sûreté générales suivantes:

Sûreté Pour Soudage A L'Arc

1. Protégez-vous contre la secousse électrique:
 - a. Les circuits à l'électrode et à la pièce sont sous tension quand la machine à souder est en marche. Eviter toujours tout contact entre les parties sous tension et la peau nue ou les vêtements mouillés. Porter des gants secs et sans trous pour isoler les mains.
 - b. Faire très attention de bien s'isoler de la masse quand on soude dans des endroits humides, ou sur un plancher métallique ou des grilles métalliques, principalement dans les positions assis ou couché pour lesquelles une grande partie du corps peut être en contact avec la masse.
 - c. Maintenir le porte-électrode, la pince de masse, le câble de soudage et la machine à souder en bon et sûr état de fonctionnement.
 - d. Ne jamais plonger le porte-électrode dans l'eau pour le refroidir.
 - e. Ne jamais toucher simultanément les parties sous tension des porte-électrodes connectés à deux machines à souder parce que la tension entre les deux pinces peut être le total de la tension à vide des deux machines.
 - f. Si on utilise la machine à souder comme une source de courant pour soudage semi-automatique, ces précautions pour le porte-électrode s'appliquent aussi au pistolet de soudage.
2. Dans le cas de travail au dessus du niveau du sol, se protéger contre les chutes dans le cas où on recoit un choc. Ne jamais enrouler le câble-électrode autour de n'importe quelle partie du corps.
3. Un coup d'arc peut être plus sévère qu'un coup de soliel, donc:
 - a. Utiliser un bon masque avec un verre filtrant approprié ainsi qu'un verre blanc afin de se protéger les yeux du rayonnement de l'arc et des projections quand on soude ou quand on regarde l'arc.
 - b. Porter des vêtements convenables afin de protéger la peau de soudeur et des aides contre le rayonnement de l'arc.
 - c. Protéger l'autre personnel travaillant à proximité au soudage à l'aide d'écrans appropriés et non-inflammables.
4. Des gouttes de laitier en fusion sont émises de l'arc de soudage. Se protéger avec des vêtements de protection libres de l'huile, tels que les gants en cuir, chemise épaisse, pantalons sans revers, et chaussures montantes.
5. Toujours porter des lunettes de sécurité dans la zone de soudage. Utiliser des lunettes avec écrans latéraux dans les zones où l'on pique le laitier.

6. Eloigner les matériaux inflammables ou les recouvrir afin de prévenir tout risque d'incendie dû aux étincelles.
7. Quand on ne soude pas, poser la pince à un endroit isolé de la masse. Un court-circuit accidentel peut provoquer un échauffement et un risque d'incendie.
8. S'assurer que la masse est connectée le plus près possible de la zone de travail qu'il est pratique de le faire. Si on place la masse sur la charpente de la construction ou d'autres endroits éloignés de la zone de travail, on augmente le risque de voir passer le courant de soudage par les chaînes de levage, câbles de grue, ou autres circuits. Cela peut provoquer des risques d'incendie ou d'échauffement des chaînes et des câbles jusqu'à ce qu'ils se rompent.
9. Assurer une ventilation suffisante dans la zone de soudage. Ceci est particulièrement important pour le soudage de tôles galvanisées plombées, ou cadmiées ou tout autre métal qui produit des fumeés toxiques.
10. Ne pas souder en présence de vapeurs de chlore provenant d'opérations de dégraissage, nettoyage ou pistolage. La chaleur ou les rayons de l'arc peuvent réagir avec les vapeurs du solvant pour produire du phosgène (gas fortement toxique) ou autres produits irritants.
11. Pour obtenir de plus amples renseignements sur la sûreté, voir le code "Code for safety in welding and cutting" CSA Standard W 117.2-1974.

PRÉCAUTIONS DE SÛRETÉ POUR LES MACHINES À SOUDER À TRANSFORMATEUR ET À REDRESSEUR

1. Relier à la terre le chassis du poste conformément au code de l'électricité et aux recommandations du fabricant. Le dispositif de montage ou la pièce à souder doit être branché à une bonne mise à la terre.
2. Autant que possible, l'installation et l'entretien du poste seront effectués par un électricien qualifié.
3. Avant de faire des travaux à l'intérieur de poste, la débrancher à l'interrupteur à la boîte de fusibles.
4. Garder tous les couvercles et dispositifs de sûreté à leur place.

Thank You

for selecting a **QUALITY** product by Lincoln Electric. We want you to take pride in operating this Lincoln Electric Company product
••• as much pride as we have in bringing this product to you!

CUSTOMER ASSISTANCE POLICY

The business of The Lincoln Electric Company is manufacturing and selling high quality welding equipment, consumables, and cutting equipment. Our challenge is to meet the needs of our customers and to exceed their expectations. On occasion, purchasers may ask Lincoln Electric for advice or information about their use of our products. We respond to our customers based on the best information in our possession at that time. Lincoln Electric is not in a position to warrant or guarantee such advice, and assumes no liability, with respect to such information or advice. We expressly disclaim any warranty of any kind, including any warranty of fitness for any customer's particular purpose, with respect to such information or advice. As a matter of practical consideration, we also cannot assume any responsibility for updating or correcting any such information or advice once it has been given, nor does the provision of information or advice create, expand or alter any warranty with respect to the sale of our products.

Lincoln Electric is a responsive manufacturer, but the selection and use of specific products sold by Lincoln Electric is solely within the control of, and remains the sole responsibility of the customer. Many variables beyond the control of Lincoln Electric affect the results obtained in applying these types of fabrication methods and service requirements.

Subject to Change – This information is accurate to the best of our knowledge at the time of printing. Please refer to www.lincolnelectric.com for any updated information.

Please Examine Carton and Equipment For Damage Immediately

When this equipment is shipped, title passes to the purchaser upon receipt by the carrier. Consequently, Claims for material damaged in shipment must be made by the purchaser against the transportation company at the time the shipment is received.

Please record your equipment identification information below for future reference. This information can be found on your machine nameplate.

Product _____

Model Number _____

Code Number or Date Code _____

Serial Number _____

Date Purchased _____

Where Purchased _____

Whenever you request replacement parts or information on this equipment, always supply the information you have recorded above. The code number is especially important when identifying the correct replacement parts.

On-Line Product Registration

- Register your machine with Lincoln Electric either via fax or over the Internet.
- For faxing: Complete the form on the back of the warranty statement included in the literature packet accompanying this machine and fax the form per the instructions printed on it.
- For On-Line Registration: Go to our **WEB SITE at www.lincolnelectric.com**. Choose "Quick Links" and then "Product Registration". Please complete the form and submit your registration.

Read this Operators Manual completely before attempting to use this equipment. Save this manual and keep it handy for quick reference. Pay particular attention to the safety instructions we have provided for your protection. The level of seriousness to be applied to each is explained below:

WARNING

This statement appears where the information **must** be followed **exactly** to avoid **serious personal injury** or **loss of life**.

CAUTION

This statement appears where the information **must** be followed to avoid **minor personal injury** or **damage to this equipment**.

Installation	Section A
Technical Specifications	A-1
Safety Precautions	A-2
Select Suitable Location	A-2
Stacking	A-2
Machine Grounding	A-2
High Frequency Connections	A-2
Input Connections	A-2
Connection Diagram	A-3
Input Fuse and Supply	A-3
Input Voltage Change Over	A-3
Electrode and Work Cable	A-3
Cable Inductance and Its Effects on Pulse Welding	A-4
Negative Electrode Polarity	A-4
Connection of Wire Feeders	A-5, A-6
Parallel Operations	A-6
Operation	Section B
Safety Precautions	B-1
General Description	B-1
Duty Cycle	B-1
Operational Features and Controls	B-1
Upper Control Panel	B-1, B-2
Hidden Middle Control Panel and Advance Process Panel	B-2 thru B-5
Weld Mode Details and Pulse Programs	B-6, B-7
Middle and Lower Case Panel Controls, Connections	B-8
Remote Control Selection	B-8
Auxiliary Power	B-9
Limitations	B-9
Recommended Processes	B-9
Accessories	Section C
Options / Accessories	C-1
Field Installed Options	C-1
Maintenance	Section D
Safety Precautions	D-1
Capacitor Discharge Procedure	D-1
Visual Inspection	D-1
Routine Maintenance	D-1
Overload and Thermal Protection	D-1
Calibration Procedures	D-2 thru D-4
Section E	Troubleshooting
Safety Precautions	E-1
How to Use Troubleshooting Guide	E-1
Troubleshooting Guide	E-2 Thru E-4
Fault Codes	E-5
Displays and Description	E-6
Connection, Wiring Diagrams and Dimension Prints	Section F
Parts List	P525 Series

TECHNICAL SPECIFICATIONS - INVERTEC® V450-PRO

INPUT AT RATED OUTPUT - THREE PHASE ONLY					
INPUT VOLTS-FREQUENCY	OUTPUT CONDITIONS AMPS / VOLTS / DUTY CYCLE	INPUT CURRENT AMPS	IDLE POWER	POWER FACTOR @ RATED OUTPUT	EFFICIENCY @ RATED OUTPUT
208/230/460/575V - 60HZ.	450A@38V. 100% 570A@43V. 60%	58/53/25/22 82/78/37/31	400 Watts Max.	.95 MIN.	88%
200/220/440/575V - 50HZ.	400A@36V. 100% 500A@40V. 60%	49/45/23/18 67/61/31/25			
OUTPUT					
PULSE FREQUENCY	PULSE VOLTAGE RANGE	PULSE AND BACKGROUND TIME RANGE	AUXILIARY POWER (CIRCUIT BREAKER PROTECTED)		
0.15 - 1000 Hz	5 - 55 VDC	100 MICRO SEC. -3.3 SEC.	24VAC 42VAC AT 10 AMPS 115VAC AT 15* AMPS		
OPEN CIRCUIT VOLTAGE	PROCESS CURRENT RANGE (DC)		CURRENT		
30-76 76 76 18-76 76	MIG/MAG FCAW SMAW GTAW Pulse		50-570 Average Amps 40-570 Average Amps 55-570 Average Amps 5-570 Average Amps 5-750 Peak Amps		
RECOMMENDED INPUT WIRE AND FUSE SIZES FOR MAXIMUM RATED OUTPUT					
INPUT VOLTAGE / FREQUENCY	TYPE 75°C COPPER WIRE IN CONDUIT AWG(MM ²) SIZES	TYPE 75°C GROUND WIRE IN CONDUIT AWG(MM ²) SIZES	TYPE 75°C (SUPER LAG) OR BREAKER SIZE (AMPS)		
208/50/60HZ 230/50/60HZ 460/50/60HZ 575/50/60HZ	4(25) 4(25) 8(10) 10(6)	8(10) 8(10) 10(6) 10(6)	100 100 50 40		
PHYSICAL DIMENSIONS					
HEIGHT	WIDTH	DEPTH	WEIGHT		
26.10 in 663 mm	19.86 in 505 mm	32.88 in 835 mm	293 lbs. 133 kg.		
TEMPERATURE RANGES					
OPERATING TEMPERATURE RANGE			STORAGE TEMPERATURE RANGE		
-20°C to +40°C			-40°C to +40°C		

* Earlier models used 10 amps circuit breaker.

INVERTEC® V450-PRO



SAFETY PRECAUTIONS

Read this entire installation section before you start installation.



WARNING



ELECTRIC SHOCK can kill.

- Only qualified personnel should perform this installation.
- Turn the input power OFF at the disconnect switch or fuse box before working on this equipment.

Turn off the input power to any other equipment connected to the welding system at the disconnect switch or fuse box before working on the equipment.

- Do not touch electrically hot parts.
- Always connect the V450-PRO grounding lug (located inside the reconnect input access door) to a proper safety (Earth) ground.

SELECT SUITABLE LOCATION

Do not use the Invertec in outdoor environments without appropriate protection. The V450-PRO power source should not be subjected to falling water, nor should any parts of it be submerged in water. Doing so may cause improper operation as well as pose a safety hazard. The best practice is to keep the machine in a dry, sheltered area.



WARNING

Do not mount the V450-PRO over combustible surfaces. Where there is a combustible surface directly under stationary or fixed electrical equipment, that surface shall be covered with a steel plate at least .060" (1.6mm) thick, which shall extend not less than 5.90" (150mm) beyond the equipment on all sides.

Place the welder where clean cooling air can freely circulate in through the rear louvers and out through the case sides and bottom. Water, Dirt, dust, or any foreign material that can be drawn into the welder should be kept at a minimum. Failure to observe these precautions can result in excessive operating temperatures and nuisance shutdowns.

Machines are equipped with F.A.N. (fan as needed) circuitry. The fan runs whenever the output is enabled, whether under loaded or open circuit conditions. The fan also runs for a period of time (approximately 5 minutes) after the output is disabled, to ensure all components are properly cooled.

If desired, the F.A.N. feature can be disabled (causing the fan to run whenever the power source is on). To disable F.A.N., connect leads 444 and X3A together at the output of the solid state fan control relay, located on the back of the Control PC board enclosure. (See Wiring Diagram)

LIFTING

Lift the machine by the lift bail only. The lift bail is designed to lift the power source only. Do not attempt to lift the V450-PRO with accessories attached to it.

STACKING

V450-PRO machines can be stacked to a maximum of 3 high.



CAUTION

The bottom machine must always be placed on a firm, secure, level surface. There is a danger of machines toppling over if this precaution is not taken.

MACHINE GROUNDING

The frame of the welder must be grounded. A ground terminal marked with the symbol  is located inside the reconnect/input access door for this purpose. See your local and national electrical codes for proper grounding methods.

HIGH FREQUENCY PROTECTION

Locate the V450-PRO away from radio controlled machinery.



CAUTION

The normal operation of the V450-PRO may adversely affect the operation of RF controlled equipment, which may result in bodily injury or damage to the equipment.

INPUT CONNECTION



WARNING

Only a qualified electrician should connect the input leads to the V450-PRO. Connections should be made in accordance with all local and national electrical codes and the connection diagram located on the inside of the reconnect/input access door of the machine. Failure to do so may result in bodily injury or death.

Use a three-phase supply line. A 1.75 inch (45 mm) diameter access hole for the input supply is located on the upper left case back next to the input access door. Connect L1, L2, L3 and ground according to the Input Supply Connection Diagram decal located on the inside of the input access door or refer to Figure A.1 on the following page.

FIGURE A.1 - CONNECTION DIAGRAM ON CONNECTION/INPUT ACCESS DOOR

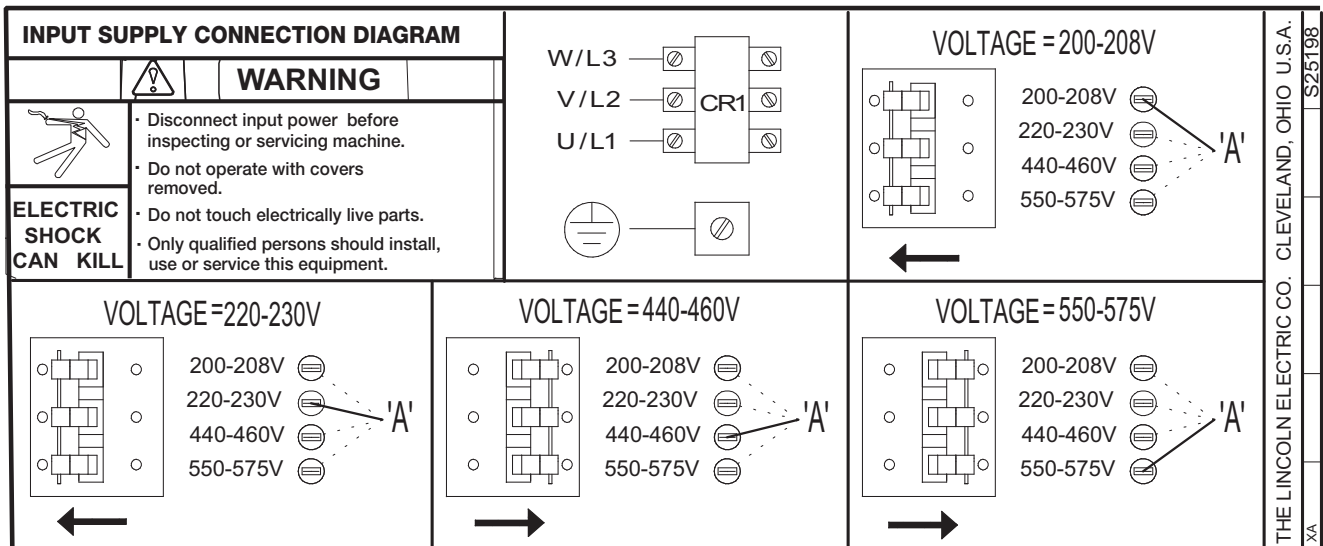

NOTE: Turn main input power to the machine OFF before performing connection procedure. Failure to do so will result in damage to the machine.

INPUT FUSE AND SUPPLY WIRE CONSIDERATIONS

Refer to the Technical Specifications at the beginning of this Installation section for recommended fuse and wire sizes. Fuse the input circuit with the recommended super lag fuse or delay type breakers (also called “inverse time” or “thermal/magnetic” circuit breakers). Choose an input and grounding wire size according to local or national electrical codes. Using fuses or circuit breakers smaller than recommended may result in “nuisance” shut-offs from welder inrush currents, even if the machine is not being used at high currents.

INPUT VOLTAGE CHANGE OVER (FOR MULTIPLE INPUT VOLTAGE MACHINES ONLY)

Welders are shipped connected for the highest input voltage listed on the rating plate. To move this connection to a different input voltage, see the diagram located on the inside of the input access door. If the main reconnect switch or link position is placed in the wrong position, the welder will not produce output power.

If the Auxiliary (A) lead is placed in the wrong position, there are two possible results. If the lead is placed in a position higher than the applied line voltage, the welder may not come on at all. If the Auxiliary (A) lead is placed in a position lower than the applied line voltage, the welder will not come on, and the two circuit breakers or fuses in the reconnect area will open. If this occurs, turn off the input voltage, properly connect the (A) lead, reset the breakers, and try again. For machines equipped with a fuse in the reconnect area, turn off the input voltage and replace the fuse with the spare fuse that is attached to the reconnect switch pin.

ELECTRODE AND WORK CABLE CONNECTIONS

Connect a work lead of sufficient size and length (Per Table 1) between the proper output terminal on the power source and the work. Be sure the connection to the work makes tight metal-to-metal electrical contact. To avoid interference problems with other equipment and to achieve the best possible operation, route all cables directly to the work and wire feeder. Avoid excessive lengths and do not coil excess cable.

Minimum work and electrode cable sizes are as follows:

TABLE A.1

(Current (60% Duty Cycle))	MINIMUM COPPER WORK CABLE SIZE AWG
	Up To-100 Ft. Length (30 m)
400 Amps	2/0 (67 mm ²)
500 Amps	3/0 (85 mm ²)
600 Amps	3/0 (85 mm ²)

NOTE: K1796 coaxial welding cable is recommended to reduce the cable inductance in long cable lengths. This is especially important when Pulse welding up to 350 amps.

CAUTION

When using inverter type power sources like the V450-PRO, use the largest welding (electrode and work) cables that are practical. At least 2/0 (67 mm²) copper wire - even if the average output current would not normally require it. When pulsing, the pulse current can reach very high levels. Voltage drops can become excessive, leading to poor welding characteristics, if undersized welding cables are used.

CABLE INDUCTANCE, AND ITS EFFECTS ON PULSE WELDING

For Pulse Welding processes, cable inductance will cause the welding performance to degrade. For the total welding loop length less than 50 ft.(15.24m), traditional welding cables may be used without any effects on welding performance. For the total welding loop length greater than 50 ft.(15.24m)), the K1796 Coaxial Welding Cables are recommended. The welding loop length is defined as the total of electrode cable length (A) + work cable length (B) + work length (C) (See Figure A.2).

FIGURE A.2

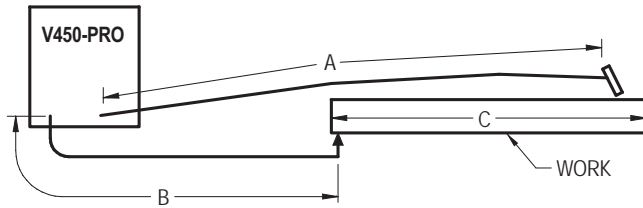

For long work piece lengths, a sliding ground should be considered to keep the total welding loop length less than 50 ft.(15.24m). (See Figure A.3.)

FIGURE A.3

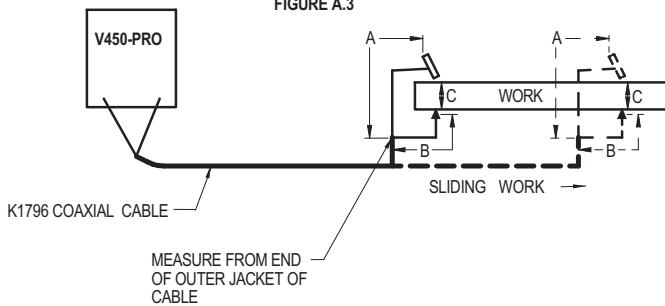

Output connections on some V450-PRO are made via 1/2-13 threaded output studs located beneath the spring loaded output cover at the bottom of the case front.

Most welding applications run with the electrode being positive (+). For those applications, connect the electrode cable between the wire feeder and the positive (+) output stud on the power source (located beneath the spring loaded output cover near the bottom of the case front). Connect the other end of the electrode cable to the wire drive feed plate. The electrode cable lug must be against the feed plate. Be sure the connection to the feed plate makes tight metal-to-metal electrical contact. The electrode cable should be sized according to the specifications given in the work cable connections section. Connect a work lead from the negative (-) power source output stud to the work piece. The work piece connection must be firm and secure, especially if pulse welding is planned.

For additional Safety information regarding the electrode and work cable set-up, See the standard "SAFETY INFORMATION" located in the front of the Instruction Manuals.



CAUTION

Excessive voltage drops caused by poor work piece connections often result in unsatisfactory welding performance.

NEGATIVE ELECTRODE POLARITY

When negative electrode polarity is required, such as in some Innershield applications, switch the output connections at the power source (electrode cable to the negative (-) stud, and work cable to the positive (+) stud).

CONNECTIONS OF WIRE FEEDERS TO V450-PRO

LF-72, 74 Connection Instructions

- Turn the Invertec power switch "off".
- Connect the K1797-[] control cable from the LF-72, 74 to the 14-pin MS-style connector.
- Connect the electrode cable to the output terminal of the polarity required by electrode. Connect the work lead to the other terminal.
- If a remote control such as K857 is to be used with the LF-72, 74 the remote can be connected directly to the 6-pin MS-style connector on the front of the Invertec or use a K864 adapter to connect the LF-72, 74 and the remote to the 14-pin MS-style connector.

LN-10, DH-10 Connection Instructions

- Turn the Invertec power switch "off"
- Connect the K1505 control cable from the LN-10 to the 14-pin MS-style connector.
- Connect the electrode cable to the output terminal of polarity required by the electrode. Connect the work lead to the other terminal.
- Set the meter polarity switch on the front of the Invertec to coincide with wire feeder polarity used.
- See the LN-10 manual for details on accessing Control DIP Switch. Dip Switches for the V350 and the same settings may be used for the V450.

LN-15 Connection Instructions

(See Figure A.4)

- Turn the Invertec power switch "off".
- Connect the electrode cable to the output terminal of polarity required by electrode. (See Figures below)
- Set the meter polarity switch on the front of the Invertec to coincide with wire feeder polarity used.

LN-25 Connection Instructions

- Turn the Invertec power switch "off".
- Connect the electrode cable to the output terminal of polarity required by electrode. Connect the work lead to the other terminal.
- LN-25 with Remote Control 6-Pin (K444-1) and 14-pin (K444-2) remotes can be connected directly to the 6-pin & 14-pin MS-style connectors. The 42 Volt Remote Voltage and Output Control (K624-1) Kit can be connected to the V450's 14-pin MS-style connector using Remote Control Cable assembly K627- []. LN-25s with a K431-1 remote kit can be connected to the V450's 14-pin MS-style connector using a K432 cable and K876 adapter. (See connection diagram S19899). Or the K432 cable could be modified with a K867 Universal Adapter Plug (See connection diagram S19405) to connect it to the V450's 14-pin MS-style connector.

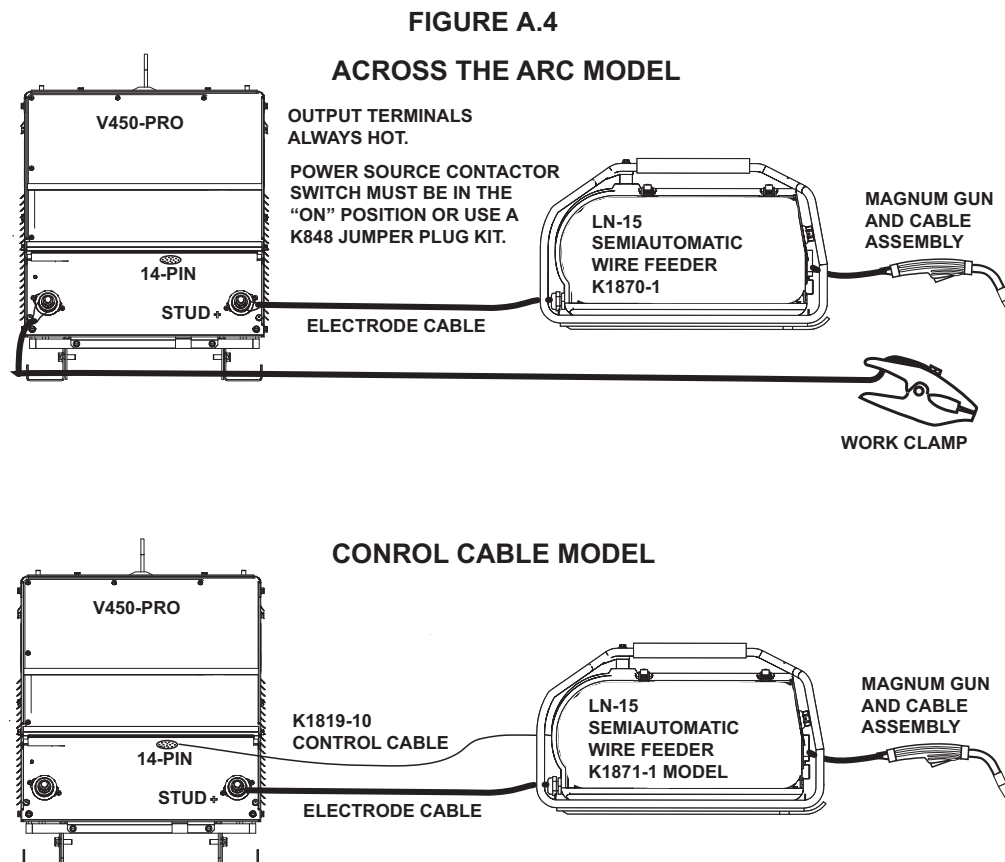

INVERTEC® V450-PRO



LN-742 Connection Instructions

- Turn the Invertec power switch "off"
- Either a K1819-1 Input cable assembly is required to connect the LN-742 to the Invertec.
- Connect the control cable from the LN-742 to the 14-pin MS-style connector.
- Connect the electrode cable to the output terminal of the polarity required by electrode. Connect the work lead to the other terminal.
- Set the meter polarity switch on the front of the Invertec to coincide with wire feeder polarity used. The wire feeder will now display the welding voltage.
- If a remote control such as K857 is to be used with the LN-742, the remote can be connected directly to the 6-pin MS-style connector on the front of the Invertec or use a K864 adapter to connect the LN-742 and the remote to the 14-pin MS-style connector.

Cobramatic Connection Instructions

- Turn the Invertec power switch "off"
- Connect the control cable from the Cobramatic to the 14-pin MS-style connector.
- Connect the electrode cable to the output terminal of the polarity required by electrode. Connect the work lead to the other terminal.
- Set the meter polarity switch on the front of the Invertec to coincide with wire feeder polarity used.
- If a remote control such as K857 is to be used with the Cobramatic, the remote can be connected directly to the 6-pin MS-style connector on the front of the Invertec or use a K864 adapter to connect the cobramatic and the remote to the 14-pin MS-style connector.

TIG Module K930-2

The TIG Module connects to the Factory and Advanced Process V450-Pro versions with a K936-1 (9-14 pin) control cable. Connect the K936-1 to the 14-Pin MS-style connector.

General Instructions for Connection of Wire Feeders to V450-Pro

Wire feeders other than those listed above may be used provided that the auxiliary power supply rating of the V450-Pro is not exceeded and the V450 PRO output is not actively controlled by the wire feeder. (Like an LN-9). K867 universal adapter plug is required. See connection diagram S24985 on page F-4.

REMOTE CONTROL OF INVERTEC

Remote Control K857, Hand Amptrol K963 and Foot Amptrol K870 may be used.

PARALLEL OPERATION

The V450-Pro are operable in parallel in CC mode. For best results, the currents of each machine should be reasonably equally balanced. As an example, with two machines set up in parallel for a 800 amps procedure, each machine should be set to deliver approximately 400 amps, not 450 amps from one and 350 amps from the other. This will minimize nuisance shutdown conditions. In general, more than two machines in parallel will not be effective due to the voltage requirements of procedures in that power range.

To set machine outputs, start with output control pots and arc control pots in identical positions. Use the output control pots to balance the currents and maintain the desired current. The arc control pots should be kept identical on the two machines.

SAFETY PRECAUTIONS

⚠ WARNING



ELECTRIC SHOCK can kill.

- Do not touch electrically live parts or electrode with skin or wet clothing.
- Insulate yourself from work and ground.
- Always wear dry insulating gloves.



FUMES AND GASES can be dangerous.

- Keep your head out of fumes.
- Use ventilation or exhaust to remove fumes from breathing zone.



WELDING SPARKS can cause fire or explosion.

- Keep flammable material away.
- Do not weld on closed containers.



ARC RAYS can burn eyes and skin.

- Wear eye, ear and body protection.

See additional warning information at front of this operator's manual.

GENERAL DESCRIPTION

The INVERTEC® V450-PRO offers multi-process CV, CC, and DC welding and is rated 570 amps, 43 volts at a 60% duty cycle.

DUTY CYCLE

The V450-Pro is rated at 570 amps, 60% duty cycle (based on a 10 minute cycle). It is also rated at 450 amps, 100% duty cycle.

OPERATIONAL FEATURES and CONTROLS:

UPPER CONTROL PANEL

1. ON, OFF- SWITCH

2. AMPS Meter

- Prior to STICK or TIG operation (current flow), the meter displays preset current value (either +/- 2 amps or +/- 3% (e.g. 3 amps on 100), whichever is greater).
- Prior to CV operation, the meter displays four dashes indicating non-presetable AMPS.
- During welding, this meter displays actual average amps.

- After welding, the meter holds the actual current value for 5 seconds. Output adjustment while in the "hold" period results in the "prior to operation" characteristics stated above. The displays blink indicating that the machine is in the "Hold" period.

3. VOLT METER

- Prior to CV operation (current flow), the meter displays desired preset voltage value (+/- .5V).
- Prior to STICK or TIG operation, the meter displays the Open Circuit Voltage of the Power Source or four dashes if the output has not been turned on.
- During welding, this meter displays actual average volts.
- After welding, the meter holds the actual voltage value for 5 seconds. The displays blink indicating that the machine is in the "Hold" period.
- Output adjustment while in the "hold" period results in the "prior to operation" characteristics stated above.

4. OUTPUT CONTROL

- Output control is conducted via a single turn potentiometer.
- Adjustment is indicated by the meters as stated above.
- When in TIG modes, this control sets the maximum welding current. Full depression of a foot or hand Amptrol results in the preset level of current.

5. WELD TERMINALS-REMOTE / ON

- Two status lights indicate the location of trigger control as determined by the "WELD TERMINALS" push button.
- If trigger control is local "weld terminals on", the ON display will be lit.
- If trigger control is remote "weld terminals remotely controlled", the REMOTE display will be lit.
- The unit will power up in "pre-determined preferred" trigger modes.

STICK = ON

CV = REMOTE

TIG = REMOTE if remote output controls are attached to the machine.

TIG = ON if remote output controls are not attached to the machine.

For all versions, these trigger modes can be over-ridden (switched) with the WELD TERMINALS push button. When changed, the unit will power up in the configuration it was in when it was last powered down.

6. THERMAL

- This status light indicates when the power source has been driven into thermal overload. If the output terminals were "ON", the "ON" light will blink indicating that the output will be turned back on once the unit cools down to an acceptable temperature level. If the unit was operating in the "REMOTE" mode, the trigger will need to be opened before or after the thermal has cleared and closed after the machine has cooled down to an acceptable temperature to establish output.

7. CONTROL-REMOTE / LOCAL

- Two status lights indicate the location of output control as pre-determined by the power sources auto-configure system.
- The LOCAL display will be lit when control is at the power source.
- The REMOTE display will be lit when a remote pot/control is detected.

These Output Control configurations can be overridden (switched) with the CONTROL push button. When changed, the unit will power up in the configuration it was in when it was last powered down.

Hidden Middle Control Panel – Process Set Up Panel

The middle control panel is removable to allow for upgrades (see Field Installed Options/Accessories). Additionally, this panel is hidden by an access door to provide protection to the controls.

8. WELD MODE SELECT - STANDARD (See Figure B.1)

The Mode Control button selects from the following welding modes.

CC-STICK SOFT: The Stick Soft process features continuous control ranging from 5 to 570 amps. This mode was intended for most SMAW applications, and Arc Gouging.

- Arc Gouging: Setting the output of the Stick Soft mode to 570 amps or setting the arc control to maximum will enable the arc-gouging mode. The actual output current will depend on the size of carbon used. The recommended maximum size carbon is 3/8"(9.5mm).
- The Hot Start control regulates the starting current at arc initiation. Hot Start can be adjusted from minimum (0), with no additional current added at arc start, to maximum (10), with double the preset current or 570 amps (max of machine) added for the first second after arc initiation.
- The Arc Control regulates the Arc Force to adjust the short circuit current. The minimum setting (-10) will produce a "soft" arc and will produce minimal spatter. The maximum setting (+10) will produce a "crisp" arc and will minimize electrode sticking.

CC-STICK CRISP:The Stick Crisp mode features continuous control from 5 to 570 amps with a crisp shorting response optimized for E6010 type electrodes.

- Arc Gouging: Setting the output of the Crisp mode to 570 amps or setting the arc control to maximum will enable the arc-gouging mode. The actual output current will depend on the size of carbon used. The recommended maximum size carbon is 3/8"(9.5mm).
- The Hot Start control regulates the starting current at arc initiation. Hot Start can adjust starting current up or down by 25% of the preset value. The recommended setting for Hot Start is 5 where the initial current is equal to the preset current.

FIGURE B.1

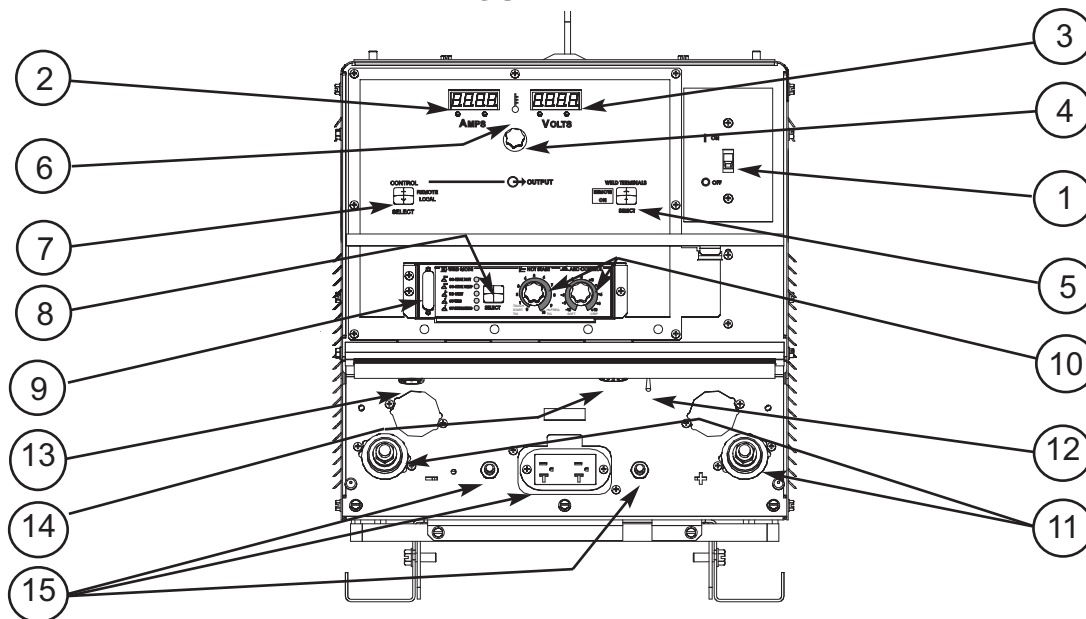

INVERTEC® V450-PRO



- The Arc Control regulates the Arc Force to adjust the short circuit current. The minimum setting (-10) will produce a "soft" arc and will produce minimal spatter. The maximum setting (+10) will produce a "crisp" arc and will minimize electrode sticking.
- The Arc Control regulates pinch effect. At the minimum setting (-10), minimizes pinch and results in a soft arc. At the maximum setting (+10), maximizes pinch effect and results in a crisp arc. Most self-shielded wires work well at an Arc Control setting of 5.

TIG GTAW: The TIG mode features continuous control from 5 to 570 amps. The TIG mode can be run in either the TIG touch start or high frequency (optional equipment required) assisted start mode.

- The Hot Start control selects the starting mode desired. A setting of less than 5, the TIG lift start mode is selected. The OCV is controlled below 10v and the short circuit "TIG touch" current is maintained at 25 amps independent of the preset current.

When the tungsten is lifted, an arc is initiated and the output is regulated at the preset value. Hot start settings between 0 and 5 regulate the arc initiation current. A setting of 5 results in the most positive arc initiation. A setting of 0 reduces hot start.

- Hot Start settings between 5 and 10, select high frequency assisted starting TIG mode. In this range, the OCV of the machine is controlled between 50 and 70 volts. If using the Lincoln K930-1 TIG Module, set the Hot start to 10 for maximum OCV.
- The Arc Control is not used in the TIG mode.

CV-WIRE: The CV-WIRE mode features continuous control from 10 to 40 volts. This mode was intended for most GMAW, FCAW, and MCAW applications.

- The Hot Start control is not used in the CV-WIRE mode.
- The Arc Control regulates pinch effect. At the minimum setting (-10), minimizes pinch and results in a soft arc. Low pinch settings are preferable for welding with gas mixes containing mostly inert gases. At the maximum setting (+10), maximizes pinch effect and results in a crisp arc. High pinch settings are preferable for welding FCAW and GMAW with CO₂.

CV-INNERSHIELD: The CV-INNERSHIELD mode features continuous control from 10 to 45 volts. This mode was designed for self-shielded flux cored wires that require tight voltage control.

- The Hot Start control is not used in the CV-INNERSHIELD mode.

8A. WELD MODE SELECT-FOR MACHINES EQUIPPED WITH OPTIONAL ADVANCED PROCESS PANEL

(See Figure B.2 UPPER AND MIDDLE SECTION)

See (WELD MODE DETAILS) in this section.

To program Welding modes. Select knob is used to Scroll through all Welding modes. The Memory button is used to store and access Welding modes into locations M1 thru M8.

Modes:

In addition to the 5 welding modes described in SECTION 7, the Advance Process Panel allows you to select the Following additional modes.

• Constant Power mode

In the Power Mode;

The work point will be in the Volts window. The Amp window will have **CP** displayed indicating Constant Power. Once current starts flowing and during the 5 second "Hold" feature the displays will show Volts and Amps respectively.

• Gouge Mode

The gouging mode is specifically designed for carbon arc gouging with electrodes up to 3/8".

• Pulsed Modes

In Pulse Modes;

The work point will be in the Amps window and should be set close to the wire feed speed of the wire feeder in inches per minute. The Volts window will have **SPd** displayed indicating Wire Feed Speed. Once current starts flowing and during the 5 second "Hold" feature the displays will show amps and volts.

Pulse Mode features that are displayed while selecting a Welding pulse mode are listed below;

Steel - .030", .035", .045", .052", 1/16" – Argon Blends
Stainless Steel - .030", .035", .045" – Argon Blends & Helium/Argon Blends

Aluminum - .035", 3/64", 1/16" – 4043 & 5356

Metal Core - .045", .052", 1/16" – Argon Blends

Nickel - .035", .045" – Argon/Helium blends

FIGURE B.2

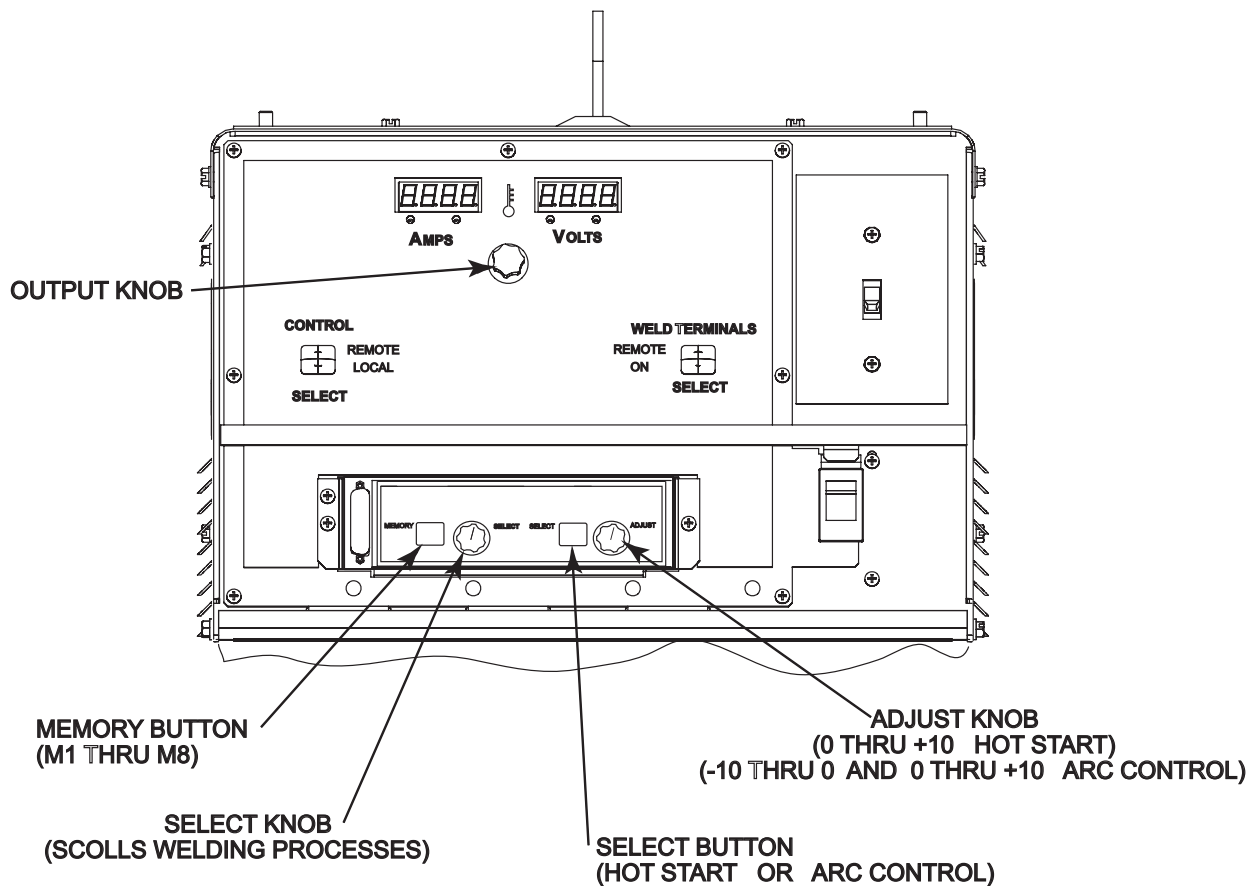

ADVANCE PROCESS PANEL- MIDDLE SECTION OF WELDER (OPTIONAL)

MEMORY SELECTIONS:

(See Figure B.2 for location of controls)

The **MEMORY button** and **SELECT knob** are used together to select a welding process and store it in memory (M1 thru M8). The **SELECT knob** scrolls through the, welding process modes and memory M1 thru M8. The **MEMORY button** stores the welding process in memory.

- **SELECT button**" (The right button) selects between the "Hot Start" or "Arc Control". The < will indicate the active feature shown below.

Right Digital Window
 "Hot Start" (-10 to 0 +10)
 "Arc Control" (0 to 10) <

- The **ADJUST knob** adjusts the desired settings for the Hot Start or Arc Control feature that is active.

WELDING PROCESS MODES AVAILABLE

Stick SMAW, TIG GTAW
 Gouge CAG, CV MIG GMAW
 CV Flux Core, Pulse MIG

ELECTRODE MATERIAL

Steel, Metal Core, Stainless, Aluminum, Nickel

EXAMPLE OF SAVING WELDING MODES TO MEMORY

The following example is how to select **Pulse MIG** using .035 steel and store it into memory.

1. Turn the **Select knob** until welding process is displayed.

RIGHT WINDOW	LEFT WINDOW
Pulse MIG	Argon Blends
Steel .035	

2. Wait two seconds and the right window will display Arc Control on the second line on the right side.

Pulse MIG	Argon Blends
Steel .035	Arc Cntrl ### <

3. **SPd** is displayed in the upper right **Volts** window. The left **Amps** window matches the desired wire feed speed that is set on the wire feeder. Adjust the **Output knob** until desired number is displayed.

4. Start welding. If the arc length is too short turn the **Output knob** up. If the arc length is too long turn the **Output knob** down.

The Arc Control which is displayed in the right digital window can be used to fine-tune the arc length and characteristics.

5. After all adjustments have been made press and hold the **Memory button** until the display changes. The right and the left window will display a memory position, lets say M1(or turn knob to select memory of your choice. To store in M1 push the **Memory button** again to save the Pulse Mig mode to memory M1.

6. The display in the digital windows read as follows:

M1	Pulse MIG	Argon Blends
Steel	.035	Arc Cntrl 1.2

7. To save a second welding mode to a memory position of your choice, turn the **Select knob** until the desired welding process mode is displayed in right digital window. Then follow steps 2 thru 6.

8. Adjust the output control to the correct wire feed setting and the V450-PRO is ready to weld again. (Note: The wire feed speed setting is not stored in memory and will need to be reset.)

9. Adjust the Arc Control and note that the M1 goes away indicating that the V450-PRO settings no longer match what is stored in memory. Going back to the original settings will not bring the M1 back. You will need to push the **Memory button** to recall the original settings in M1.

Note: After all memory's M1 thru M8 are used and the welder needs to store another welding process, a new welding process will overwrite what was originally in the memory and will read,

Save to MEM
M1 Overwrite

M1 which stored Pulse Mig is Overwritten with the new welding process.

WELD MODE DETAILS:

Mode	Range	Comments
Stick Soft	55 - 570 amps	The stick soft mode is the best selection for general stick applications. Arc Control = Arc Force Hot Start = Initial hot start current (min = start a match set amps, Max. = greatest hot start current) During hot start, arc force is set at high and is fast response. For gouging applications: Turn current up to 570 amps.
Stick Crisp	55 - 570 amps	The stick crisp mode features an aggressive arc force routine well suited for Exx10, Exx11 series electrodes. Arc Control = Arc Force Hot Start = Initial hot start current (Mid range = welding current and will vary up and down with knob control.) During hot start, arc force is set at high and is fast response. For gouging applications: Turn current up to 570 amps.
GTAW (Tig mode)	5 - 570 amps	The tig mode produces a soft, steady constant current waveform for either touch start or high frequency assisted start DC GTAW applications. Hot Start = Min to Mid range = Touch start with low OCV Mid to Max range = High frequency assisted starting with adjustable OCV up to 70 volts.
GMAW - CV	10 - 45 volts	The GMAW - CV mode is the best selection for general MIG welding, Metal core, and gas shielded applications. Arc Control = Pinch (Min = min pinch, softest arc), (Max = max pinch, crispest arc)
FCAW-SS	10 - 45 volts	The FCAW-SS mode is designed for Self Shielded Innershield products that require tight voltage control. For example; the NR 203 series or NR 207) Arc Control = Pinch (Min = min pinch, softest arc), (Max = max pinch, crispest arc,)
ADVANCED PULSE PANEL WELDING PROGRAMS		
Gouging	60 - 570 amps	The gouging mode is specifically designed for carbon arc gouging with electrodes up to 3/8".
GMAW - Power	0.1 - 20 KW	The GMAW - power mode is similar in operation to other GMAW modes. The power mode features a very stable short arc performance which is especially good when welding small diameter (.025 and .030 steel and stainless) wires for low procedures. The short arc steel and stainless applications, a fast response for spray applications, and a drooper type spray mode characteristic for Aluminum.

PULSE PROGRAMS:

MODE	IPM*	COMMENTS
.030 Steel	75 - 800	<p>The V450 pulse programs are non-synergic and allow independent control of the wire feed speed and the arc length. The Output Control Knob on the V450, adjusts an "SPD" value. Similar to trim, the "SPD" value indicates the relative arc length setting. The value of "SPD" is meant to be a starting point at which to set the arc length relative to the wire feed speed. Depending on the application, the "SPD" value can be adjusted to obtain the desired arc length.</p> <p>The "SPD" value displayed on the V450 may not match the actual wire feed speed!</p> <p>The operation of the Arc Control knob on the V450 is similar to the Power Wave series. As Arc Control is increased, the frequency is increased and the background reduced. Decreasing Arc Control will reduce frequency and increase background current. Arc Control acts to fine tune the arc plasma to the specific application. Preferred gas selections:</p> <p>Steel Argon Blends = Argon with CO₂ additions from 2 to 20 % or Oxygen additions from 2 to 5%.</p> <p>Stainless Argon Blends = Argon with Oxygen additions up to 2%.</p> <p>Stainless He Ar CO₂ = ~ 90% Helium, 7 1/2 % Argon 2 1/2 CO₂ Aluminum 100% Argon</p> <p>The Nickel Alloy pulse programs are non adaptive. The operator sets the output control knob to deliver the correct arc length at desired wire feed speed and stick out. While welding, the operator manipulates the stick out to maintain the correct arc length. This method of operation produces very stable arc performance considering the nature of nickel alloys.</p> <p>Preferred gas: Argon/Helium Blends = for the best results add helium to the argon base from 0-25%.</p>
.035 Steel	50 - 800	
.045 Steel	60 - 800	
.052 Steel	60 - 750	
1/16 Steel	60 - 600	
.045 Metal Core	60 - 700	
.052 Metal Core	60 - 500	
1/16 Metal Core	60 - 500	
.030 Stainless Ar Blends	100 - 800	
.030 Stainless He Ar CO ₂	100 - 800	
.035 Stainless Ar Blends	70 - 800	
.035 Stainless He Ar CO ₂	70 - 700	
.045 Stainless Ar Blends	50 - 700	
.045 Stainless He Ar CO ₂	60 - 700	
.035 Aluminum 4043	125 - 700	
.035 Aluminum 5356	130 - 750	
3/64 Aluminum 4043	85 - 600	
3/64 Aluminum 5356	85 - 700	
1/16 Aluminum 4043	55 - 300	
1/16 Aluminum 5356	65 - 400	
.035 Nickel Alloys (Non Adaptive)	60 - 700	
.045 Nickel Alloys (Non Adaptive)	60 - 600	
PULSE ON PULSE		
.035 4043 (4x Pulse on Pulse)	125 - 600	<p>Arc Control = Pulse on Pulse frequency. For faster travel speed welds, the arc control should be increased.</p> <p>For larger puddle, slower travel speeds, the arc control should be decreased.</p>
3/64 4043 (4x Pulse on Pulse)	85 - 400	
1/16 4043 (4x Pulse on Pulse)	65 - 315	
.035 5356 (5x Pulse on Pulse)	140 - 700	
3/64 5356 (5x Pulse on Pulse)	100 - 550	
1/16 5356 (5x Pulse on Pulse)	75 - 360	

*IPM (INCHES PER MINUTE)

LN-10/DH-10 Wire Feeder Compatibility Note:

The LN-10 and DH-10 feeders can be used to pulse weld and in the power mode with the panel. The displays on the LN-10 & DH-10 do not show the wire feed speed or power.

9. SERIAL PORT FOR SOFTWARE UPDATES

10. HOT START and ARC CONTROL features have different functions depending on the welding Mode that is active. Each feature is described under the welding mode heading. (See Item 8 or 8A for specified Mode Operations) (See Figure B.1 or B.2)

LOWER CASE PANEL (See Figure B.1)

The output studs, Meter Polarity switch and remote connector are located on the lower case front.

11. Both Output terminals are "STUD" connectors.

12. The **METER POLARITY** switch is located above the output connectors. The switch provides a work connection for wire feeder voltmeters. Place the switch in the position of the electrode polarity indicated by the decal. **The switch does not change the welding polarity.**

13. **6-pin** MS-style connector for remote control.

14. **14-PIN** MS-style connector for wire and remote control.

15. AUXILIARY POWER

- 115VAC, 42VAC and 24VAC power is available from the 14-pin MS-style connector.
- 42 VAC supply is rated at 10 amps.
- 24 VAC supply is rated at 10 amps.
- 115VAC outlet rated at 15* amps.

* Earlier models used a 10 amp circuit breaker.

REMOTE CONTROL SELECTION

The INVERTEC® V450-PRO has auto sensing of remote output controls. If after connecting or removing a remote, the INVERTEC® V450-PRO did not configure the way you would like the local or remote control settings can be changed by pushing the OUTPUT CONTROL or WELD TERMINAL button. (A user cannot select between the 6 and 14 pin MS-style connectors.)

CV modes

- The remote will default to the 14-pin MS-style connector if a remote is connected. If no remote is connected to the 14-pin MS-style connector then the remote will default to the 6-pin MS-style connector if a remote is connected to it.
- In all of the CV modes, the WELD TERMINAL control will default to REMOTE.

TIG mode

- The remote will default to the 6-pin MS-style if a remote control is connected to the 6-pin MS-style and to the 14-pin MS-style connector. If a remote is not connected to the 6-pin MS-style connector then the remote will default to the 14-pin MS-style connector if a remote is connected.
- If a remote control is connected to any of the MS-style connectors the WELD TERMINAL control will default to REMOTE. If there are not any remote control devices attached the WELD TERMINAL control will default to ON.

CC-Stick modes

- The remote will default to only the 6-pin MS-style connector if a remote is connected to it.
- The WELD TERMINAL control will default to ON with or without a remote connected.

Types of Remote OUTPUT CONTROL

- The INVERTEC® V450-PRO's Output Control can be controlled by either a potentiometer connected between 77 & 75 with the wiper connected to 76 or a 0V to 10V DC supply connected between 76 & 75. (76 needs to be positive)
- 14-Pin Ms-style connector lead 75 is pin G, lead 76 is pin F and lead 77 is pin E.
- 6-Pin Ms-style connector lead 75 is pin C, lead 76 is pin B and lead 77 is pin A.

Potentiometer Control

- The total resistance should be between 2000 ohms (2K) and 10,000 ohms (10K)
- The machine output will be at minimum when lead 76 (wiper) is at the end of the potentiometer that is connected to 75. The machine's output will increase as the wiper of the potentiometer is moved to the end that is connected to 77. (Note: In TIG mode, moving the lead 76 (wiper) to lead 77 would produce the current that has been set by the INVERTEC® V450-PRO's front panel Output Control.)
- Remotes of this type offered by Lincoln Electric are the K857, K812 and K870.

Voltage Control

- The supply should be an isolated supply. (Not referenced to earth ground, any auxiliary power from the INVERTEC® V450-PRO or the welding output) The supply should be capable of supplying at least 20mA.
- 0 volts supplied to 76 will set the INVERTEC® V450-PRO to minimum output for the mode that has been selected while 10 volts supplied to 76 will set the INVERTEC® V450-PRO to the maximum output for the mode. (Note: In TIG mode, 10 volts supplied to lead 76 would produce the current that has been set by the INVERTEC® V450-PRO's front panel

Output Control.)

Types of Remote WELD TERMINAL Control

- The INVERTEC® V450-PRO's Weld Terminals can be controlled from each of the MS-style connectors. The circuit has a nominal OCV of 15VDC and requires a dry contact closure (less than 100 ohms) to activate the output of the INVERTEC® V450-PRO.
- 14-Pin MS-style connector, the Weld Terminals are controlled from pin C (lead 2) and pin D (lead 4). Pin C is positive.
- 6-Pin MS-style connector, the Weld Terminals are controlled from pin D (lead 2) and pin E (lead 4). In the 6-pin MS-style connector pin D is positive.

LIMITATIONS

- The V450-Pro is not recommended for processes other than those listed.
- The V450-Pro can only be used with the recommended equipment and options.

RECOMMENDED PROCESSES

Properly equipped, the INVERTEC® V450-PRO supports GMAW-P, FCAW, SMAW, GTAW and CAC-A processes for a variety of materials, including mild steel, stainless steel, cored wires, and aluminum.

OPTIONS / ACCESSORIES

K857	Remote Output Control
K814	Arc Start Switch
K812	Hand Operated Amptrol
K870	Foot Operated Amptrol

Note: All of the above remote controls connect directly to the 6-pin MS-style connector, with either a K864 or K876 adapter and connect it to the 14 pin wire feeder MS-style connector. (See Diagram in Section F-1)

K930-[]	TIG Module
K428, K446, K449	LN-25 *
K617 (-1 or -2) K618 (-1 or -2)	LN-742
K2327-[]	LF-72
K2426-[]	LF-74
K1559-1, K1564-1	LN-10
K1499-1, K1521-1	DH-10
K1587-1	Cobramatic

*Not recommended for pulse welding

FIELD INSTALLED OPTION (ALL VERSIONS)

- **K1763-1** Advanced Process Panel

SAFETY PRECAUTIONS

⚠ WARNING



- ELECTRIC SHOCK can kill.**
- Do not touch electrically live parts or electrode with skin or wet clothing.
 - Insulate yourself from work and ground
 - Always wear dry insulating gloves.



EXPLODING PARTS can cause injury.

- Failed parts can explode or cause other parts to explode when power is applied.
- Always wear a face shield and long sleeves when servicing.

See additional warning information throughout this Operator's Manual

CAPACITOR DISCHARGE PROCEDURE

1. Obtain a power resistor (25 ohms, 25 watts).
2. Hold resistor body with electrically insulated glove. **DO NOT TOUCH TERMINALS.** Connect the resistor terminals across the two studs in the position shown. Hold in each position for 1 second. Repeat for all three capacitors.

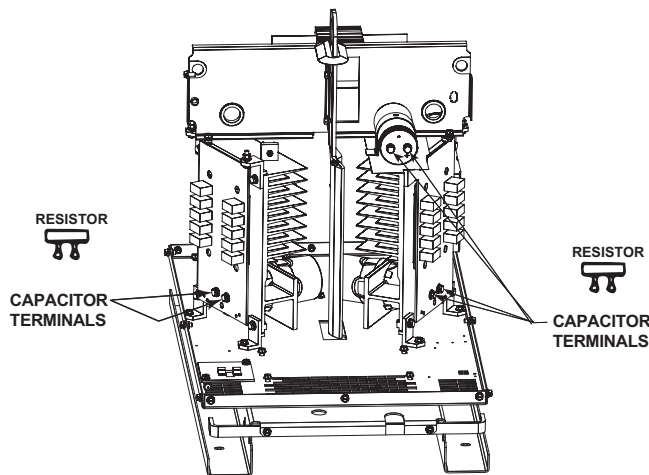

3. Use a DC voltmeter to check that voltage is not present across the terminals on three capacitors.

VISUAL INSPECTION

Clean interior of machine with a low pressure air stream. Make a thorough inspection of all components. Look for signs of overheating, broken leads or other obvious problems. Many problems can be uncovered with a good visual inspection.

ROUTINE MAINTENANCE

1. Every 6 months or so the machine should be cleaned with a low pressure airstream. Keeping the machine clean will result in cooler operation and higher reliability. Be sure to clean these areas:
 - All printed circuit boards
 - Power switch
 - Main transformer
 - Input rectifier
 - Auxiliary Transformer
 - Reconnect Switch Area
 - Fan (Blow air through the rear louvers)
2. Examine the sheet metal case for dents or breakage. Repair the case as required. Keep the case in good condition to insure that high voltage parts are protected and correct spacings are maintained. All external sheet metal screws must be in place to insure case strength and electrical ground continuity.

OVERLOAD PROTECTION

The machine is electrically protected from producing high output currents. Should the output current exceed 570A, an electronic protection circuit will reduce the current to approximately 100A. The machine will continue to produce this low current until the protection circuit is reset. Reset occurs when the output load is removed.

THERMAL PROTECTION

Thermostats protect the machine from excessive operating temperatures. Excessive temperatures may be caused by a lack of cooling air or operating the machine beyond the duty cycle and output rating. If excessive operating temperature should occur, the thermostat will prevent output voltage or current. The meter will remain energized during this time.

Thermostats are self-resetting once the machine cools sufficiently. If the thermostat shutdown was caused by excessive output or duty cycle and the fan is operating normally, the Power Switch may be left on and the reset should occur within a 15 minute period.

VOLTAGE AND CURRENT CALIBRATION PROCEDURE



WARNING

Service and repair should be performed by only Lincoln Electric factory trained personnel. Unauthorized repairs performed on this equipment may result in danger to the technician or machine operator and will invalidate your factory warranty. For your safety and to avoid electrical shock, please observe all safety notes and precautions detailed throughout this manual.

If for any reason you do not understand the test procedures or are unable to perform the test/repairs safely, contact the Lincoln Electric Service Department for electrical troubleshooting assistance before you proceed. Call 1-888-935-3877.

DESCRIPTION

This test will help determine if the machine is capable of producing welding output and to check and adjust, if necessary, the voltage and or current calibration.

MATERIALS NEEDED

- Resistive Load Bank
- Calibrated Test Voltmeter
- Calibrated Test Ammeter

This procedure takes approximately 20 minutes to perform.

VOLTAGE AND CURRENT CALIBRATION PROCEDURE *(continued)*

CALIBRATION CHECK

The calibration of the V450-PRO can be checked using a resistive load bank with the V450-PRO in mode 200. Mode 200 is a constant current test mode.

1. Press and hold in the Mode Select button.
2. Turn on the V450-PRO.
3. Rotate the output knob, while still holding the mode select button in, until the displays read "mode 200". **NOTE:** Machines with an Advanced Process Panels do not have a mode select button. Use the same procedure except hold in the Memory button on the advanced process panel instead of the mode select button.
4. Release the Mode Select/Memory button and the machine will be in mode 200.
5. With the machine in mode 200 apply a resistive load to the welding output terminals (approximately .087 ohms) set the machine output to 300 amps and enable the Weld Terminals. (Weld Terminals Select ON).
6. Using the test meters note the output voltage and current.
7. The V450-PRO voltmeter must match the test meter reading to within +/- 1 volt.
8. The V450-PRO ammeter must match the test meter within +/- 5 amps.
9. If the voltmeter does not meet the specification then proceed to the ***Voltage Calibration Procedure.***
10. If the ammeter does not meet the specification then proceed to the ***Current Calibration Procedure.***

NOTE: Before attempting to calibrate the voltage or current setting of the V450-PRO, be sure to read the entire voltage or current calibration section. If the steps are not completed quickly, the machine will automatically leave the calibration mode without changing the calibration settings. The voltage and current calibration settings of the V450-PRO are completely independent of each other. Adjusting one will not affect the other.

VOLTAGE CALIBRATION

1. Connect the resistive load band (approximately .087 ohms) and test voltmeter to the welding output terminals.
2. Press and hold in the Mode Select/Memory button.
3. Turn on the V450-PRO.
4. Rotate the Output Control knob until the display reads "vol cAL".
5. Release the Mode Select/Memory button.
6. Adjust the output control knob until the actual output voltage reading on the test volt meter is 20volts +/- .5 volts.
7. Wait for the machine's output to be automatically turned off and then back on.
8. Adjust the Output Control knob again if necessary to make the actual voltage output 20 volts +/- .5 volts.
9. Wait for the machine's output to be automatically turned off and then back on.
10. Repeat the above two steps if necessary.
11. Press and release the Mode Select/Memory button to save the calibration.

NOTE: If the Mode Select/Memory button is not pressed within 30 seconds after adjusting the Output Control knob the machine will leave the calibration mode and use the previous calibration settings.

VOLTAGE AND CURRENT CALIBRATION PROCEDURE *(continued)***CURRENT CALIBRATION PROCEDURE**

1. Connect the resistive load band (approximately .087 ohms) and test ammeter to the welding output terminals.
2. Press and hold in the Mode Select/Memory button.
3. Turn on the V450-PRO.
4. Rotate the Output Control knob until the display reads "cur cAL".
5. Release the Mode Select/Memory button.
6. The left display will change to "IcAL" to indicate that current calibration is in progress.
7. The right display will scroll the following message: Adj oCP SorEAL cur-300A.
8. Adjust the Output Control knob until the actual output current reading on the test ammeter is 300amps +/-2A.
9. Wait for the machines output to be automatically turned off and then back on.
10. Adjust the Output Control knob again if necessary to make the actual output current reading on the test ammeter 300 amps +/-2A.
11. Wait for the machines output to be automatically turned off and then back on.
12. Repeat the above two steps if necessary.
13. Press and release the Mode Select/Memory button to save the calibration.
14. The left display will scroll the message IcAL SAVEd.
15. The machine will reset to normal operation.

NOTE: If the Mode Select/Memory button is not pressed within 30 seconds after adjusting the Output Control knob the machine will leave the calibration mode and use the previous calibration settings.

HOW TO USE TROUBLESHOOTING GUIDE

WARNING

Service and Repair should only be performed by Lincoln Electric Factory Trained Personnel. Unauthorized repairs performed on this equipment may result in danger to the technician and machine operator and will invalidate your factory warranty. For your safety and to avoid Electrical Shock, please observe all safety notes and precautions detailed throughout this manual.

This Troubleshooting Guide is provided to help you locate and repair possible machine malfunctions. Simply follow the three-step procedure listed below.

Step 1. LOCATE PROBLEM (SYMPTOM).

Look under the column labeled "PROBLEM (SYMPTOMS)". This column describes possible symptoms that the machine may exhibit. Find the listing that best describes the symptom that the machine is exhibiting.

Step 2. POSSIBLE CAUSE.

The second column labeled "POSSIBLE CAUSE" lists the obvious external possibilities that may contribute to the machine symptom.

Step 3. RECOMMENDED COURSE OF ACTION

This column provides a course of action for the Possible Cause, generally it states to contact your local Lincoln Authorized Field Service Facility.

If you do not understand or are unable to perform the Recommended Course of Action safely, contact your local Lincoln Authorized Field Service Facility.

(For Calibration Procedures See Maintenance Section)

CAUTION

If for any reason you do not understand the test procedures or are unable to perform the tests/repairs safely, contact your **Local Lincoln Authorized Field Service Facility** for technical troubleshooting assistance before you proceed.

Observe all Safety Guidelines detailed throughout this manual

PROBLEMS (SYMPTOMS)	POSSIBLE CAUSE	RECOMMENDED COURSE OF ACTION
Major physical or electrical damage is evident when the sheet metal covers are removed.	1. Contact your local authorized Lincoln Electric Field Service facility for technical assistance.	1.If all recommended possible areas of misadjustment have been checked and the problem persists, Contact your local Lincoln Authorized Field Service Facility.
Input fuses keep blowing, or input breaker keeps tripping	<ol style="list-style-type: none"> 1. Make certain that the fuses or breakers are properly sized. See installation section of the manual for recommended fuse and breaker sizes. 2. Welding procedure is drawing too much output current, or duty cycle is too high. Reduce output current, duty cycle or both. 3. There is internal damage to the power source. Contact an authorized Lincoln Electric Service facility. 	
Machine will not power up (No lights)	<ol style="list-style-type: none"> 1. Make certain that the power switch is in the "ON" position. 2. The circuit breaker or fuse in the reconnect area may have opened. Reset. Check input voltage section below. 3. Input voltage selection made improperly. Power down, check input voltage reconnect according to diagram on reconnect cover. 4. The 10 amp breaker may have opened. Check for overload on 42VAC or 24VAC supply from the 14 pin MS-style connector. 	
Machine won't weld, can't get any output.	<ol style="list-style-type: none"> 1. If the displays show an Err ### see the fault section for corrective action. 2. If the displays are not lit refer to machine will not power up section. 3. If the thermal symbol is lit refer to the thermal section. 4. If the output terminals are in remote control switch to "ON" and check for output voltage. If output voltage is now present check for correct remote control connection and operation. 	

 **CAUTION**

If for any reason you do not understand the test procedures or are unable to perform the tests/repairs safely, contact your **Local Lincoln Authorized Field Service Facility** for technical troubleshooting assistance before you proceed.

INVERTEC® V450-PRO



Observe all Safety Guidelines detailed throughout this manual

PROBLEMS (SYMPTOMS)	POSSIBLE CAUSE	RECOMMENDED COURSE OF ACTION
Machine often “noodle welds” (output is limited to approximately 100 amps) when running a particular procedure, especially a procedure with high WFS.	<ol style="list-style-type: none"> 1. Secondary current limit has been exceeded, and the machine has phased back to protect itself. 2. Adjust procedure or reduce load to lower current draw from the machine. 3. A single phase input (loss of L2) will reduce the secondary current limit from 570 Amps to 325 Amps. 	<p>If all recommended possible areas of misadjustment have been checked and the problem persists, Contact your local Lincoln Authorized Field Service Facility.</p>
Machine won't produce full output.	<ol style="list-style-type: none"> 1. Input voltage may be too low, limiting output capability of the power source. Make certain that the input voltage is proper, according to the Rating Plate located on the rear of the machine. 2. Input may be “single phased”. Make certain the input voltage is proper on all three Input lines. 3. Secondary current or voltage not properly calibrated. Check values displayed on the Power Feed 10/11 verses readings on an external meter. 	
Auxiliary receptacle is “dead” no auxiliary voltage.	<ol style="list-style-type: none"> 1. Circuit breaker CB2 (on case front) may have opened. Reset. 2. Circuit breaker CB4 (in reconnect area) may have opened. Reset. 	
General degradation of the weld performance.	<ol style="list-style-type: none"> 1. Check for feeding problems, bad connections, excessive loops in cabling, etc. 2. Verify weld mode is correct for processes. 3. The power source may require calibration. 4. Check the actual current displayed vs. actual current measured via external meter. 5. Check the actual voltage displayed vs. actual voltage measured via external meter. 	

 **CAUTION**

If for any reason you do not understand the test procedures or are unable to perform the tests/repairs safely, contact your **Local Lincoln Authorized Field Service Facility** for technical troubleshooting assistance before you proceed.

INVERTEC® V450-PRO



Observe all Safety Guidelines detailed throughout this manual

PROBLEMS (SYMPTOMS)	POSSIBLE CAUSE	RECOMMENDED COURSE OF ACTION
Thermal symbol is lit	<ol style="list-style-type: none"> 1. Check for proper fan operation. 2. Check for material blocking intake or exhaust louvers. 3. Blow air in the rear louvers to clear dirt from the fan. 	<ol style="list-style-type: none"> 1. If all recommended possible areas of misadjustment have been checked and the problem persists, Contact your local Lincoln Authorized Field Service Facility.
Wire feeder won't work. Apparently no power to wire feeder	<ol style="list-style-type: none"> 1. Check circuit breakers by the wire feeder receptacles on the lower front panel. Reset 2. Check the control cable between the power source and the wire feeder for continuity. 	

 **CAUTION**

If for any reason you do not understand the test procedures or are unable to perform the tests/repairs safely, contact your **Local Lincoln Authorized Field Service Facility** for technical troubleshooting assistance before you proceed.

INVERTEC® V450-PRO



Observe all Safety Guidelines detailed throughout this manual

Fault Codes			
Code	Description		Corrective Action
31	Primary over current.	If condition persists contact an authorized Lincoln Field Service Shop.	The machine needs to be turned off and back on to reset the machine.
32	CAP bank A under voltage.	Check input power reconnect to make sure the machine is connected for the input power being supplied.	Self-clearing as condition ceases.
33	CAP bank B under voltage.		
34	CAP bank A over voltage.		
35	CAP bank B over voltage.		
37	Soft start Failed.		
39	Glitch on the primary over current fault interrupt; possibly caused by noise or a signal level (misc. hardware fault #1)	Check the machine ground. If problem persists contact an authorized Lincoln Field Service Shop.	Self-clearing as condition ceases.
43	CAP delta; CAP A and B are out of balance.	Check input power reconnect to make sure the machine is connected for the input power being supplied.	
44	Main CPU problem. The DSP has detected a problem with the CPU.	Check the machine ground.	
47	Possible erroneous electrical noise on Voltage/Frequency capacitor feed back circuit. (misc. hardware fault #2)	If problem persists contact an authorized Lincoln Field Service Shop.	
48	The main contactor opened unexpectedly. (misc. hardware fault #3)	If condition persist contact an authorized Lincoln Field Service Shop.	Self-clearing
"bad node' #####"	The selected weld mode does not exist in the weld table that is presently loaded in the machine.	If condition persists contact an authorized Lincoln Field Service Shop.	Press the Mode Select button to select a different mode

CAUTION

If for any reason you do not understand the test procedures or are unable to perform the tests/repairs safely, contact your **Local Lincoln Authorized Field Service Facility** for technical troubleshooting assistance before you proceed.

INVERTEC® V450-PRO



Observe all Safety Guidelines detailed throughout this manual

Displays	Description
Scrolling dash	Appears at power up while the machine is going through its self configuration
"Err" "####"	Fault code display. The first fault to occur will be displayed for three seconds. The display will cycle through fault codes for all faults that persist after the initial three-second period are displayed for 1 second each.
"----" "----"	Weld mode is changing
"----" "####"	A constant voltage weld mode is selected, machine output is off. The numeric value in the right display is the work point.
"####" "----"	A constant current weld mode is selected, machine output is off. The numeric value in the left display is either the work point or a work point limit, depending on the weld mode and remote configuration.
"####" "####"(on steady)	machine output is on. Left display is current, right display is voltage. If actively welding, the displays are arc current and arc voltage. If not actively welding, the display will show work point.
"####" "####" (blinking)	weld just finished – the average arc voltage and current will be blinked for 5 seconds following a weld. If the work point changes during this 5 second period, the display will revert to the above mode.

CAUTION

If for any reason you do not understand the test procedures or are unable to perform the tests/repairs safely, contact your **Local Lincoln Authorized Field Service Facility** for technical troubleshooting assistance before you proceed.

INVERTEC® V450-PRO



REMOTE CONTROL ADAPTERS

<p>▲ WARNING:</p>	<p>ELECTRIC SHOCK CAN KILL</p>
	<p>TURN THE POWER SWITCH OF THE WELDING POWER SOURCE "OFF" BEFORE INSTALLING PLUGS ON CABLES OR WHEN CONNECTING OR DISCONNECTING PLUGS TO WELDING POWER SOURCE.</p>

STRAIGHT PLUG (14 PIN)
TO POWER SOURCE

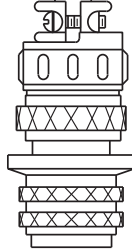

K864

CABLE RECEPTACLE (6 SOCKET)
TO: 1) K857 REMOTE CONTROL
2) K963 HAND AMPTRON
3) K870 FOOT AMPTRON

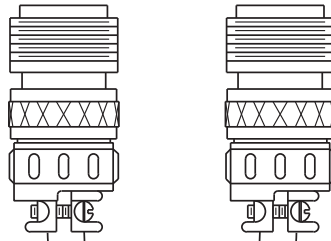

CABLE RECEPTACLE (14 SOCKET)
TO: 1) LN-7 WIRE FEEDERS

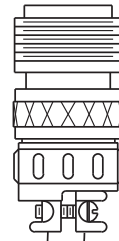

STRAIGHT PLUG (14 PIN)
TO POWER SOURCE

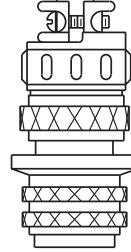

K876

CABLE RECEPTACLE (6 SOCKET)
TO: 1) LN-25 WIRE FEEDERS

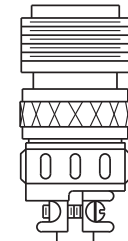

K867 PLUG TO LN-25 - CONNECTION DIAGRAM

 <p>WARNING</p> <p>ELECTRIC SHOCK CAN KILL</p>	<ul style="list-style-type: none"> • Turn off input power to the Welding Power Source using the disconnect switch at the fuse box Before connecting the wire feeder. • Only qualified persons should install, use or service this machine.
--	--

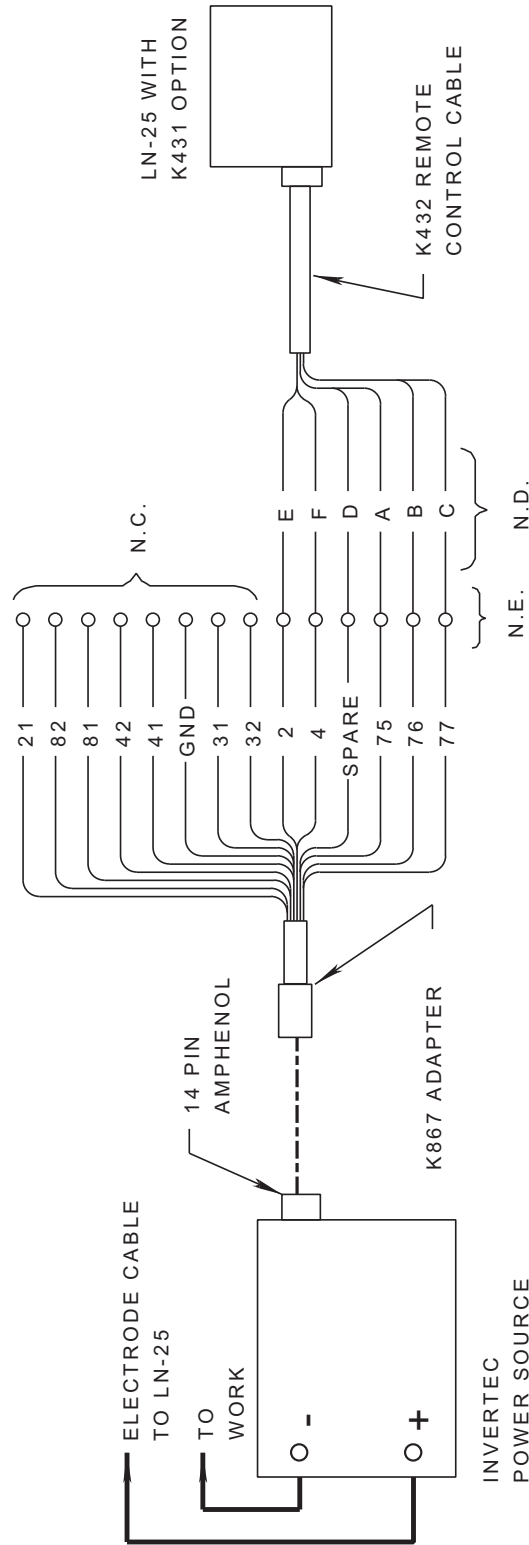

- INVERTEC POWER SOURCE
- N.A. WELDING CABLE MUST BE SIZED FOR CURRENT AND DUTY CYCLE OF APPLICATION.
 - N.B. DIAGRAM SHOWS ELECTRODE POSITIVE. TO CHANGE POLARITY, TURN POWER "OFF", REVERSE ELECTRODE AND WORK CABLE AT POWER SOURCE.
 - N.C. INSULATE EACH UNUSED LEAD INDIVIDUALLY.
 - N.D. REMOVE 6 PIN PLUG FROM K432 CABLE IN ORDER TO CONNECT K867 PLUG. LABEL EACH LEAD (A THRU F) AS THEY ARE REMOVED FROM 6 PIN PLUG.
 - N.E. SPLICE LEADS AND INSULATE.

1-25-91
S19405

K867 UNIVERSAL ADAPTER / INVERTEC - CONNECTION DIAGRAM

<p>WARNING</p>	<ul style="list-style-type: none"> Turn off input power to the Welding Power Source using the disconnect switch at the fuse box Before connecting the wire feeder. Only qualified persons should install, use or service this machine.
<p>ELECTRIC SHOCK CAN KILL</p>	

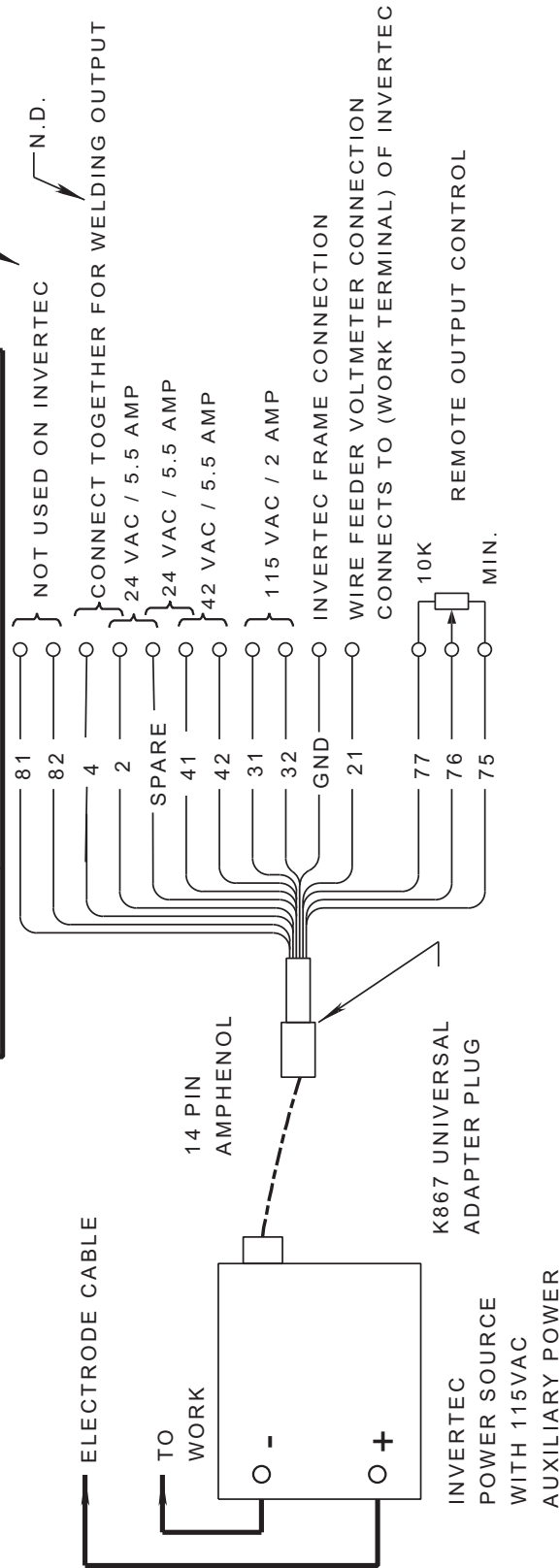

- N.A. WELDING CABLE MUST BE SIZED FOR CURRENT AND DUTY CYCLE OF APPLICATION.
- N.B. DIAGRAM SHOWS ELECTRODE POSITIVE. TO CHANGE POLARITY, TURN POWER "OFF", REVERSE ELECTRODE AND WORK CABLE AT POWER SOURCE.
- N.C. INSULATE EACH UNUSED LEAD INDIVIDUALLY.
- N.D. FOR WIRE FEEDERS THAT RETURN A SIGNAL FOR WELDING OUTPUT, USE ISOLATION RELAY TO CLOSE LEADS 2 & 4.

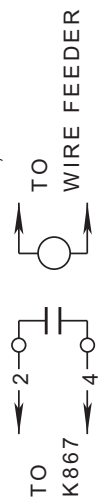

K876 ADAPTER TO LN-25 - CONNECTION DIAGRAM

<p>WARNING</p> 	<ul style="list-style-type: none"> • Turn off input power to the Welding Power Source using the disconnect switch at the fuse box Before connecting the wire feeder. • Only qualified persons should install, use or service this machine.
<p>ELECTRIC SHOCK CAN KILL</p>	

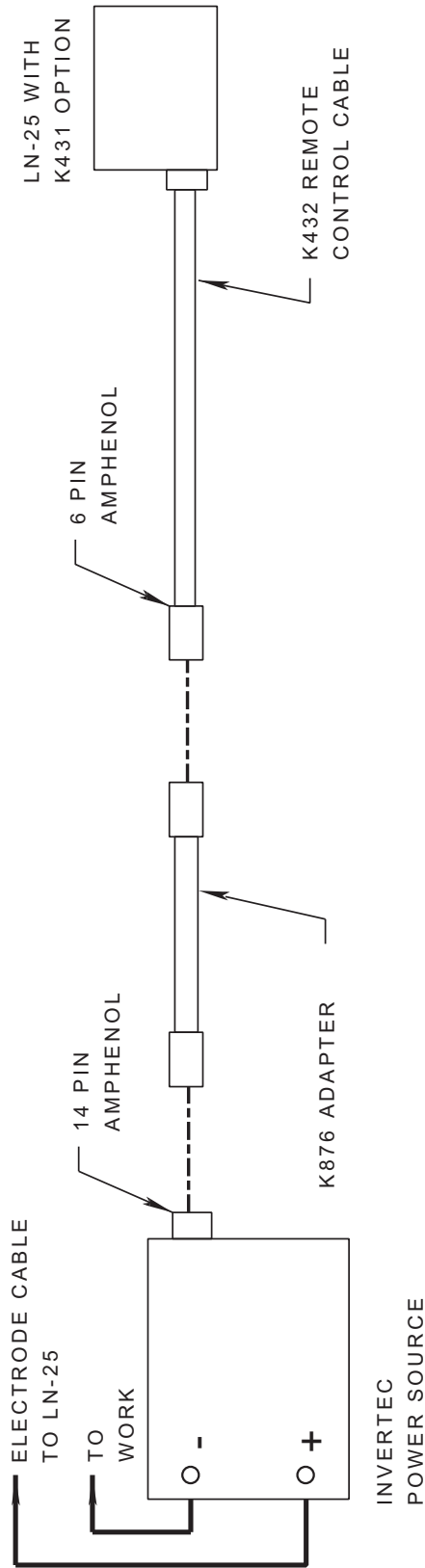

- N.A. WELDING CABLE MUST BE SIZED FOR CURRENT AND DUTY CYCLE OF APPLICATION.
- N.B. DIAGRAM SHOWS ELECTRODE POSITIVE. TO CHANGE POLARITY, TURN POWER "OFF", REVERSE ELECTRODE AND WORK CABLE AT POWER SOURCE.
- N.C. FOR INVERTECS WITH 6 PIN AMPHENOL, K432 CABLE CAN BE CONNECTED DIRECTLY.

1-25-91
S19889

INVERTEC V450-PRO™ WIRING DIAGRAM FOR CODE 11212

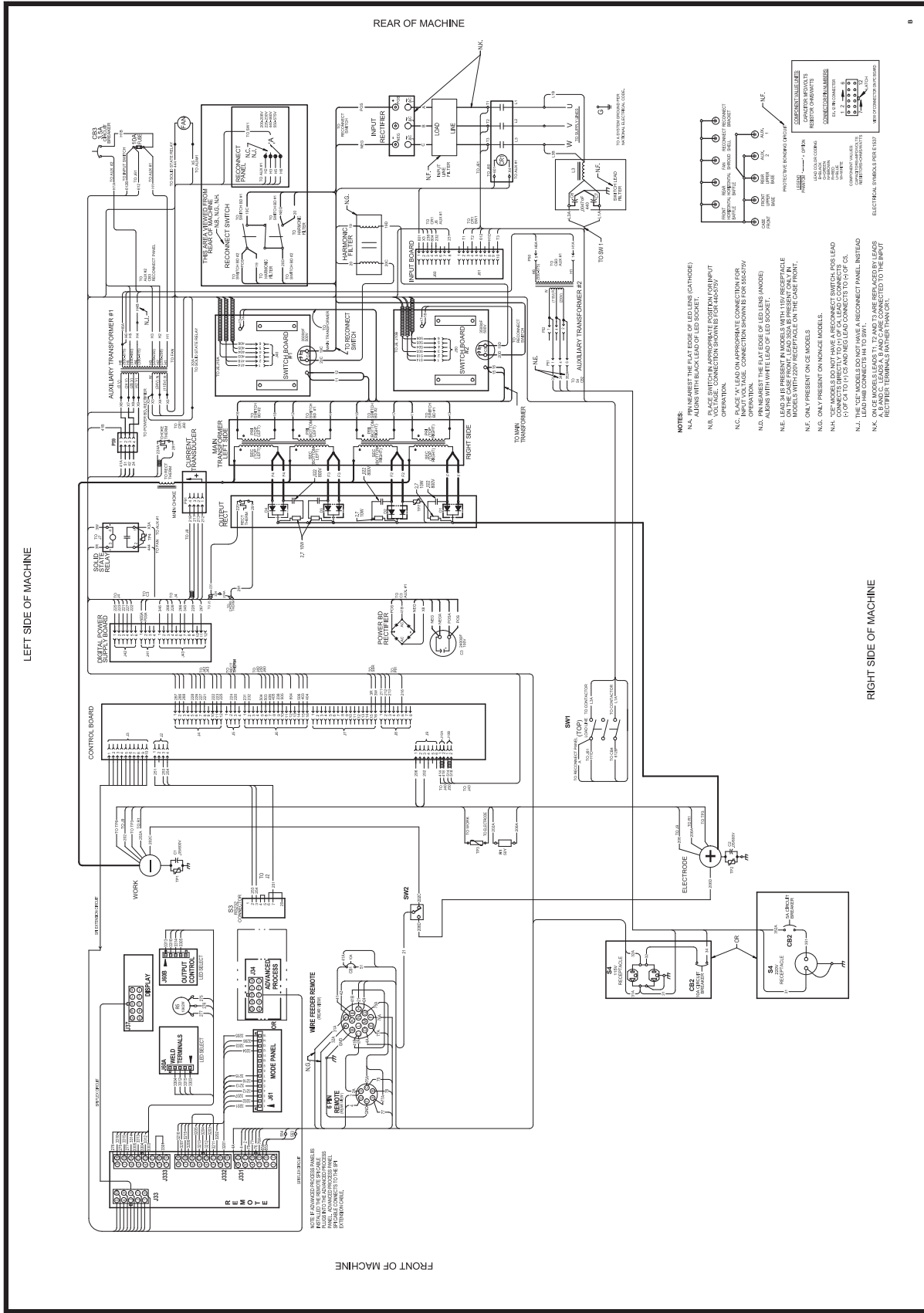

G4923

NOTE: This diagram is for reference only. It may not be accurate for all machines covered by this manual. The specific diagram for a particular code is pasted inside the machine on one of the enclosure panels. If the diagram is illegible, write to the Service Department for a replacement. Give the equipment code number.

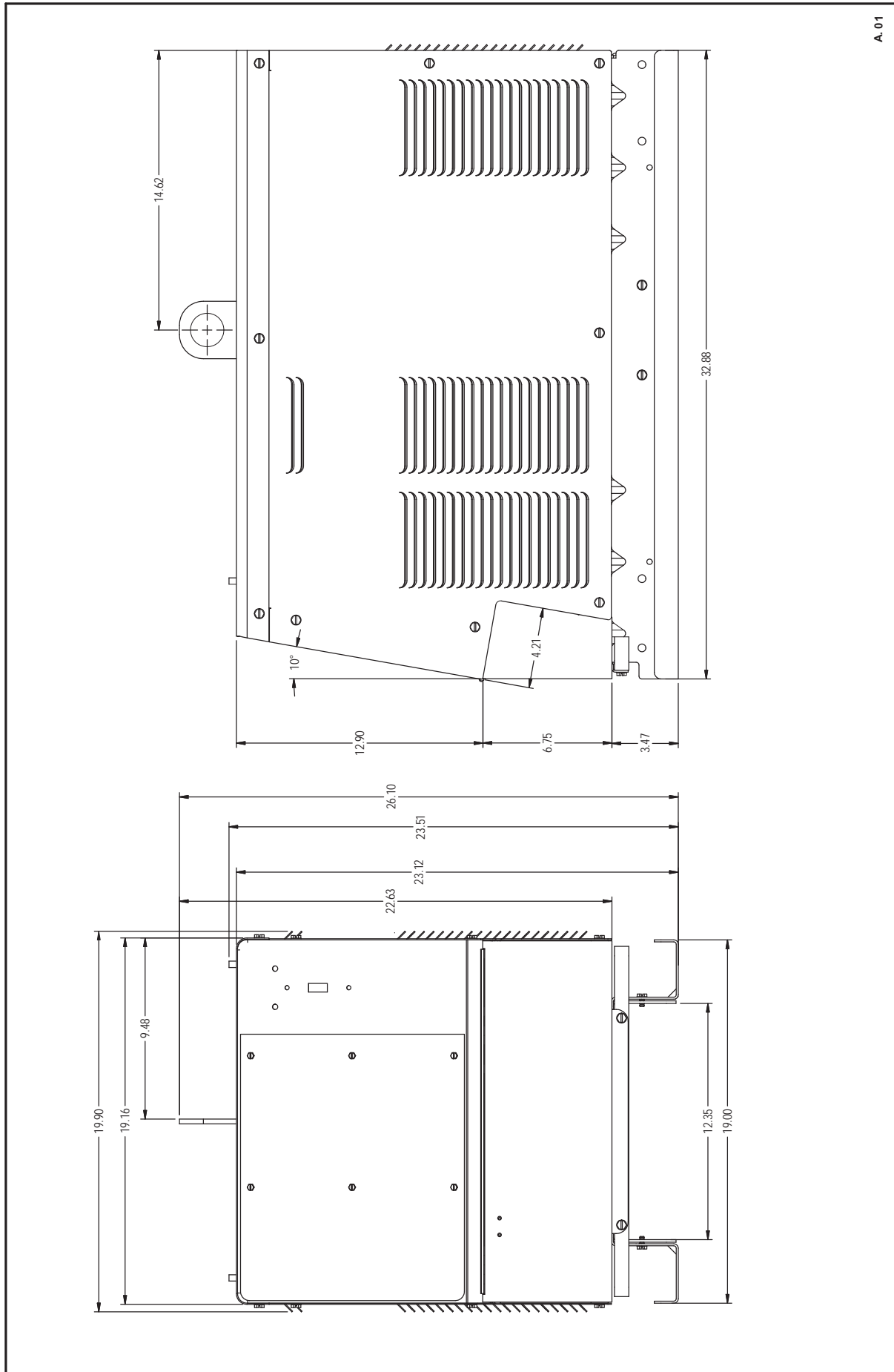

A.01

M18241

INVERTEC® V450-PRO



NOTES

INVERTEC® V450-PRO



NOTES

INVERTEC® V450-PRO



			
WARNING	<ul style="list-style-type: none"> Do not touch electrically live parts or electrode with skin or wet clothing. Insulate yourself from work and ground. 	<ul style="list-style-type: none"> Keep flammable materials away. 	<ul style="list-style-type: none"> Wear eye, ear and body protection.
Spanish AVISO DE PRECAUCION	<ul style="list-style-type: none"> No toque las partes o los electrodos bajo carga con la piel o ropa mojada. Aíslese del trabajo y de la tierra. 	<ul style="list-style-type: none"> Mantenga el material combustible fuera del área de trabajo. 	<ul style="list-style-type: none"> Protéjase los ojos, los oídos y el cuerpo.
French ATTENTION	<ul style="list-style-type: none"> Ne laissez ni la peau ni des vêtements mouillés entrer en contact avec des pièces sous tension. Isolez-vous du travail et de la terre. 	<ul style="list-style-type: none"> Gardez à l'écart de tout matériel inflammable. 	<ul style="list-style-type: none"> Protégez vos yeux, vos oreilles et votre corps.
German WARNUNG	<ul style="list-style-type: none"> Berühren Sie keine stromführenden Teile oder Elektroden mit Ihrem Körper oder feuchter Kleidung! Isolieren Sie sich von den Elektroden und dem Erdboden! 	<ul style="list-style-type: none"> Entfernen Sie brennbares Material! 	<ul style="list-style-type: none"> Tragen Sie Augen-, Ohren- und Körperschutz!
Portuguese ATENÇÃO	<ul style="list-style-type: none"> Não toque partes elétricas e electrodos com a pele ou roupa molhada. Isole-se da peça e terra. 	<ul style="list-style-type: none"> Mantenha inflamáveis bem guardados. 	<ul style="list-style-type: none"> Use proteção para a vista, ouvido e corpo.
Japanese 注意事項	<ul style="list-style-type: none"> 通電中の電気部品、又は溶材にヒブやぬれた布で触れないこと。 施工物やアースから身体が絶縁されている様にして下さい。 	<ul style="list-style-type: none"> 燃えやすいものの側での溶接作業は絶対にしてはなりません。 	<ul style="list-style-type: none"> 目、耳及び身体に保護具をして下さい。
Chinese 警告	<ul style="list-style-type: none"> 皮肤或湿衣物切勿接触带电部件及焊缝。 使你自己与地面和工件绝缘。 	<ul style="list-style-type: none"> 把一切易燃物品移离工作场所。 	<ul style="list-style-type: none"> 佩戴眼、耳及身体劳动保护用具。
Korean 위험	<ul style="list-style-type: none"> 전도체나 용접봉을 젖은 청킹 또는 피부로 절대 접촉치 마십시오. 모재와 접지를 접촉치 마십시오. 	<ul style="list-style-type: none"> 인화성 물질을 접근시키지 마십시오. 	<ul style="list-style-type: none"> 눈, 귀와 몸에 보호장구를 착용하십시오.
Arabic تحذير	<ul style="list-style-type: none"> لا تلمس الاجزاء التي يسري فيها التيار الكهربائي أو الألكترود بجك الجسم أو بالملابس المبللة بالماء. ضع عازل على جسمك خلال العمل. 	<ul style="list-style-type: none"> ضع المواد القابلة للاشتعال في مكان بعيد. 	<ul style="list-style-type: none"> ضع أدوات وملابس واقية على عينيك وأذنيك وجسمك.

READ AND UNDERSTAND THE MANUFACTURER'S INSTRUCTION FOR THIS EQUIPMENT AND THE CONSUMABLES TO BE USED AND FOLLOW YOUR EMPLOYER'S SAFETY PRACTICES.

SE RECOMIENDA LEER Y ENTENDER LAS INSTRUCCIONES DEL FABRICANTE PARA EL USO DE ESTE EQUIPO Y LOS CONSUMIBLES QUE VA A UTILIZAR, SIGA LAS MEDIDAS DE SEGURIDAD DE SU SUPERVISOR.

LISEZ ET COMPRENEZ LES INSTRUCTIONS DU FABRICANT EN CE QUI REGARDE CET EQUIPMENT ET LES PRODUITS A ETRE EMPLOYES ET SUIVEZ LES PROCEDURES DE SECURITE DE VOTRE EMPLOYEUR.

LESEN SIE UND BEFOLGEN SIE DIE BETRIEBSANLEITUNG DER ANLAGE UND DEN ELEKTRODENEINSATZ DES HERSTELLERS. DIE UNFALLVERHÜTUNGSVORSCHRIFTEN DES ARBEITGEBERS SIND EBENFALLS ZU BEACHTEN.

			
<ul style="list-style-type: none"> ● Keep your head out of fumes. ● Use ventilation or exhaust to remove fumes from breathing zone. 	<ul style="list-style-type: none"> ● Turn power off before servicing. 	<ul style="list-style-type: none"> ● Do not operate with panel open or guards off. 	WARNING
<ul style="list-style-type: none"> ● Los humos fuera de la zona de respiración. ● Mantenga la cabeza fuera de los humos. Utilice ventilación o aspiración para gases. 	<ul style="list-style-type: none"> ● Desconectar el cable de alimentación de poder de la máquina antes de iniciar cualquier servicio. 	<ul style="list-style-type: none"> ● No operar con panel abierto o guardas quitadas. 	Spanish AVISO DE PRECAUCION
<ul style="list-style-type: none"> ● Gardez la tête à l'écart des fumées. ● Utilisez un ventilateur ou un aspirateur pour ôter les fumées des zones de travail. 	<ul style="list-style-type: none"> ● Débranchez le courant avant l'entretien. 	<ul style="list-style-type: none"> ● N'opérez pas avec les panneaux ouverts ou avec les dispositifs de protection enlevés. 	French ATTENTION
<ul style="list-style-type: none"> ● Vermeiden Sie das Einatmen von Schweißrauch! ● Sorgen Sie für gute Be- und Entlüftung des Arbeitsplatzes! 	<ul style="list-style-type: none"> ● Strom vor Wartungsarbeiten abschalten! (Netzstrom völlig öffnen; Maschine anhalten!) 	<ul style="list-style-type: none"> ● Anlage nie ohne Schutzgehäuse oder Innenschutzverkleidung in Betrieb setzen! 	German WARNUNG
<ul style="list-style-type: none"> ● Mantenha seu rosto da fumaça. ● Use ventilação e exaustão para remover fumo da zona respiratória. 	<ul style="list-style-type: none"> ● Não opere com as tampas removidas. ● Desligue a corrente antes de fazer serviço. ● Não toque as partes elétricas nuas. 	<ul style="list-style-type: none"> ● Mantenha-se afastado das partes moventes. ● Não opere com os painéis abertos ou guardas removidas. 	Portuguese ATENÇÃO
<ul style="list-style-type: none"> ● ヒュームから頭を離すようにして下さい。 ● 換気や排煙に十分留意して下さい。 	<ul style="list-style-type: none"> ● メンテナンス・サービスに取りかかる際には、まず電源スイッチを必ず切って下さい。 	<ul style="list-style-type: none"> ● パネルやカバーを取り外したまま機械操作をしないで下さい。 	Japanese 注意事項
<ul style="list-style-type: none"> ● 頭部遠離煙霧。 ● 在呼吸區使用通風或排風器除煙。 	<ul style="list-style-type: none"> ● 維修前切斷電源。 	<ul style="list-style-type: none"> ● 儀表板打開或沒有安全罩時不準作業。 	Chinese 警告
<ul style="list-style-type: none"> ● 얼굴로부터 용접가스를 멀리하십시오. ● 호흡지역으로부터 용접가스를 제거하기 위해 가스제거기나 통풍기를 사용하십시오. 	<ul style="list-style-type: none"> ● 보수전에 전원을 차단하십시오. 	<ul style="list-style-type: none"> ● 관널이 열린 상태로 작동치 마십시오. 	Korean 위험
<ul style="list-style-type: none"> ● ابعد رأسك بعيداً عن الدخان. ● استعمل التهوية أو جهاز ضغط الدخان للخارج لكي تبعد الدخان عن المنطقة التي تتنفس فيها. 	<ul style="list-style-type: none"> ● اقطع التيار الكهربائي قبل القيام بأية صيانة. 	<ul style="list-style-type: none"> ● لا تشغيل هذا الجهاز اذا كانت الاغطية الحديدية الواقية ليست عليه. 	Arabic تحذير

LEIA E COMPREENDA AS INSTRUÇÕES DO FABRICANTE PARA ESTE EQUIPAMENTO E AS PARTES DE USO, E SIGA AS PRÁTICAS DE SEGURANÇA DO EMPREGADOR.

使う機械や溶材のメーカーの指示書をよく読み、まず理解して下さい。そして貴社の安全規定に従って下さい。

請詳細閱讀並理解製造廠提供的說明以及應該使用的銀焊材料，並請遵守貴方的有閣勞動保護規定。

이 제품에 동봉된 작업지침서를 숙지하시고 귀사의 작업자 안전수칙을 준수하시기 바랍니다.

اقرأ بتمعن وافهم تعليمات المصنع المنتج لهذه المعدات والمواد قبل استعمالها واتبع تعليمات الوقاية لصاحب العمل.



• World's Leader in Welding and Cutting Products •

• Sales and Service through Subsidiaries and Distributors Worldwide •

Cleveland, Ohio 44117-1199 U.S.A. TEL: 216.481.8100 FAX: 216.486.1751 WEB SITE: www.lincolnelectric.com