

# PIPELINER® LN-23P

IM867-A

November, 2006

## Portable Innershield® Semiautomatic Wire Feeder

For use with machines having Code Numbers 11171, 11363

### Safety Depends on You

Lincoln arc welding and cutting equipment is designed and built with safety in mind. However, your overall safety can be increased by proper installation ... and thoughtful operation on your part. **DO NOT INSTALL, OPERATE OR REPAIR THIS EQUIPMENT WITHOUT READING THIS MANUAL AND THE SAFETY PRECAUTIONS CONTAINED THROUGHOUT.** And, most importantly, think before you act and be careful.



## OPERATOR'S MANUAL



**LINCOLN®**  
**ELECTRIC**

Copyright © 2006 Lincoln Global Inc.

- World's Leader in Welding and Cutting Products •
- Sales and Service through Subsidiaries and Distributors Worldwide •

Cleveland, Ohio 44117-1199 U.S.A. TEL: 216.481.8100 FAX: 216.486.1751 WEB SITE: [www.lincolnelectric.com](http://www.lincolnelectric.com)

## ⚠ WARNING

### ⚠ CALIFORNIA PROPOSITION 65 WARNINGS ⚠

Diesel engine exhaust and some of its constituents are known to the State of California to cause cancer, birth defects, and other reproductive harm.

The Above For Diesel Engines

The engine exhaust from this product contains chemicals known to the State of California to cause cancer, birth defects, or other reproductive harm.

The Above For Gasoline Engines

**ARC WELDING CAN BE HAZARDOUS. PROTECT YOURSELF AND OTHERS FROM POSSIBLE SERIOUS INJURY OR DEATH. KEEP CHILDREN AWAY. PACEMAKER WEARERS SHOULD CONSULT WITH THEIR DOCTOR BEFORE OPERATING.**

Read and understand the following safety highlights. For additional safety information, it is strongly recommended that you purchase a copy of "Safety in Welding & Cutting - ANSI Standard Z49.1" from the American Welding Society, P.O. Box 351040, Miami, Florida 33135 or CSA Standard W117.2-1974. A Free copy of "Arc Welding Safety" booklet E205 is available from the Lincoln Electric Company, 22801 St. Clair Avenue, Cleveland, Ohio 44117-1199.

**BE SURE THAT ALL INSTALLATION, OPERATION, MAINTENANCE AND REPAIR PROCEDURES ARE PERFORMED ONLY BY QUALIFIED INDIVIDUALS.**



### FOR ENGINE powered equipment.

1.a. Turn the engine off before troubleshooting and maintenance work unless the maintenance work requires it to be running.



1.b. Operate engines in open, well-ventilated areas or vent the engine exhaust fumes outdoors.



1.c. Do not add the fuel near an open flame welding arc or when the engine is running. Stop the engine and allow it to cool before refueling to prevent spilled fuel from vaporizing on contact with hot engine parts and igniting. Do not spill fuel when filling tank. If fuel is spilled, wipe it up and do not start engine until fumes have been eliminated.

1.d. Keep all equipment safety guards, covers and devices in position and in good repair. Keep hands, hair, clothing and tools away from V-belts, gears, fans and all other moving parts when starting, operating or repairing equipment.

1.e. In some cases it may be necessary to remove safety guards to perform required maintenance. Remove guards only when necessary and replace them when the maintenance requiring their removal is complete. Always use the greatest care when working near moving parts.



1.f. Do not put your hands near the engine fan. Do not attempt to override the governor or idler by pushing on the throttle control rods while the engine is running.

1.g. To prevent accidentally starting gasoline engines while turning the engine or welding generator during maintenance work, disconnect the spark plug wires, distributor cap or magneto wire as appropriate.



1.h. To avoid scalding, do not remove the radiator pressure cap when the engine is hot.



### ELECTRIC AND MAGNETIC FIELDS may be dangerous

2.a. Electric current flowing through any conductor causes localized Electric and Magnetic Fields (EMF). Welding current creates EMF fields around welding cables and welding machines

2.b. EMF fields may interfere with some pacemakers, and welders having a pacemaker should consult their physician before welding.

2.c. Exposure to EMF fields in welding may have other health effects which are now not known.

2.d. All welders should use the following procedures in order to minimize exposure to EMF fields from the welding circuit:

2.d.1. Route the electrode and work cables together - Secure them with tape when possible.

2.d.2. Never coil the electrode lead around your body.

2.d.3. Do not place your body between the electrode and work cables. If the electrode cable is on your right side, the work cable should also be on your right side.

2.d.4. Connect the work cable to the workpiece as close as possible to the area being welded.

2.d.5. Do not work next to welding power source.

Mar '95



## ELECTRIC SHOCK can kill.

- 3.a. The electrode and work (or ground) circuits are electrically “hot” when the welder is on. Do not touch these “hot” parts with your bare skin or wet clothing. Wear dry, hole-free gloves to insulate hands.
- 3.b. Insulate yourself from work and ground using dry insulation. Make certain the insulation is large enough to cover your full area of physical contact with work and ground.
- In addition to the normal safety precautions, if welding must be performed under electrically hazardous conditions (in damp locations or while wearing wet clothing; on metal structures such as floors, gratings or scaffolds; when in cramped positions such as sitting, kneeling or lying, if there is a high risk of unavoidable or accidental contact with the workpiece or ground) use the following equipment:**
- Semiautomatic DC Constant Voltage (Wire) Welder.
  - DC Manual (Stick) Welder.
  - AC Welder with Reduced Voltage Control.
- 3.c. In semiautomatic or automatic wire welding, the electrode, electrode reel, welding head, nozzle or semiautomatic welding gun are also electrically “hot”.
- 3.d. Always be sure the work cable makes a good electrical connection with the metal being welded. The connection should be as close as possible to the area being welded.
- 3.e. Ground the work or metal to be welded to a good electrical (earth) ground.
- 3.f. Maintain the electrode holder, work clamp, welding cable and welding machine in good, safe operating condition. Replace damaged insulation.
- 3.g. Never dip the electrode in water for cooling.
- 3.h. Never simultaneously touch electrically “hot” parts of electrode holders connected to two welders because voltage between the two can be the total of the open circuit voltage of both welders.
- 3.i. When working above floor level, use a safety belt to protect yourself from a fall should you get a shock.
- 3.j. Also see Items 6.c. and 8.



## ARC RAYS can burn.

- 4.a. Use a shield with the proper filter and cover plates to protect your eyes from sparks and the rays of the arc when welding or observing open arc welding. Headshield and filter lens should conform to ANSI Z87.1 standards.
- 4.b. Use suitable clothing made from durable flame-resistant material to protect your skin and that of your helpers from the arc rays.
- 4.c. Protect other nearby personnel with suitable, non-flammable screening and/or warn them not to watch the arc nor expose themselves to the arc rays or to hot spatter or metal.



## FUMES AND GASES can be dangerous.

- 5.a. Welding may produce fumes and gases hazardous to health. Avoid breathing these fumes and gases. When welding, keep your head out of the fume. Use enough ventilation and/or exhaust at the arc to keep fumes and gases away from the breathing zone. **When welding with electrodes which require special ventilation such as stainless or hard facing (see instructions on container or MSDS) or on lead or cadmium plated steel and other metals or coatings which produce highly toxic fumes, keep exposure as low as possible and below Threshold Limit Values (TLV) using local exhaust or mechanical ventilation. In confined spaces or in some circumstances, outdoors, a respirator may be required. Additional precautions are also required when welding on galvanized steel.**
5. b. The operation of welding fume control equipment is affected by various factors including proper use and positioning of the equipment, maintenance of the equipment and the specific welding procedure and application involved. Worker exposure level should be checked upon installation and periodically thereafter to be certain it is within applicable OSHA PEL and ACGIH TLV limits.
- 5.c. Do not weld in locations near chlorinated hydrocarbon vapors coming from degreasing, cleaning or spraying operations. The heat and rays of the arc can react with solvent vapors to form phosgene, a highly toxic gas, and other irritating products.
- 5.d. Shielding gases used for arc welding can displace air and cause injury or death. Always use enough ventilation, especially in confined areas, to insure breathing air is safe.
- 5.e. Read and understand the manufacturer’s instructions for this equipment and the consumables to be used, including the material safety data sheet (MSDS) and follow your employer’s safety practices. MSDS forms are available from your welding distributor or from the manufacturer.
- 5.f. Also see item 1.b.

AUG 06

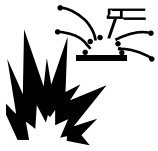

### WELDING SPARKS can cause fire or explosion.

6.a. Remove fire hazards from the welding area. If this is not possible, cover them to prevent the welding sparks from starting a fire.

Remember that welding sparks and hot materials from welding can easily go through small cracks and openings to adjacent areas. Avoid welding near hydraulic lines. Have a fire extinguisher readily available.

- 6.b. Where compressed gases are to be used at the job site, special precautions should be used to prevent hazardous situations. Refer to "Safety in Welding and Cutting" (ANSI Standard Z49.1) and the operating information for the equipment being used.
- 6.c. When not welding, make certain no part of the electrode circuit is touching the work or ground. Accidental contact can cause overheating and create a fire hazard.
- 6.d. Do not heat, cut or weld tanks, drums or containers until the proper steps have been taken to insure that such procedures will not cause flammable or toxic vapors from substances inside. They can cause an explosion even though they have been "cleaned". For information, purchase "Recommended Safe Practices for the Preparation for Welding and Cutting of Containers and Piping That Have Held Hazardous Substances", AWS F4.1 from the American Welding Society (see address above).
- 6.e. Vent hollow castings or containers before heating, cutting or welding. They may explode.
- 6.f. Sparks and spatter are thrown from the welding arc. Wear oil free protective garments such as leather gloves, heavy shirt, cuffless trousers, high shoes and a cap over your hair. Wear ear plugs when welding out of position or in confined places. Always wear safety glasses with side shields when in a welding area.
- 6.g. Connect the work cable to the work as close to the welding area as practical. Work cables connected to the building framework or other locations away from the welding area increase the possibility of the welding current passing through lifting chains, crane cables or other alternate circuits. This can create fire hazards or overheat lifting chains or cables until they fail.
- 6.h. Also see item 1.c.

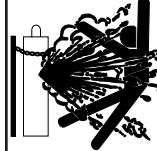

### CYLINDER may explode if damaged.

7.a. Use only compressed gas cylinders containing the correct shielding gas for the process used and properly operating regulators designed for the gas and pressure used. All hoses, fittings, etc. should be suitable for the application and maintained in good condition.

- 7.b. Always keep cylinders in an upright position securely chained to an undercarriage or fixed support.
- 7.c. Cylinders should be located:
  - Away from areas where they may be struck or subjected to physical damage.
  - A safe distance from arc welding or cutting operations and any other source of heat, sparks, or flame.
- 7.d. Never allow the electrode, electrode holder or any other electrically "hot" parts to touch a cylinder.
- 7.e. Keep your head and face away from the cylinder valve outlet when opening the cylinder valve.
- 7.f. Valve protection caps should always be in place and hand tight except when the cylinder is in use or connected for use.
- 7.g. Read and follow the instructions on compressed gas cylinders, associated equipment, and CGA publication P-1, "Precautions for Safe Handling of Compressed Gases in Cylinders," available from the Compressed Gas Association 1235 Jefferson Davis Highway, Arlington, VA 22202.



### FOR ELECTRICALLY powered equipment.

- 8.a. Turn off input power using the disconnect switch at the fuse box before working on the equipment.
- 8.b. Install equipment in accordance with the U.S. National Electrical Code, all local codes and the manufacturer's recommendations.
- 8.c. Ground the equipment in accordance with the U.S. National Electrical Code and the manufacturer's recommendations.

Mar '95

## PRÉCAUTIONS DE SÛRETÉ

Pour votre propre protection lire et observer toutes les instructions et les précautions de sûreté spécifiques qui paraissent dans ce manuel aussi bien que les précautions de sûreté générales suivantes:

### Sûreté Pour Soudage A L'Arc

1. Protégez-vous contre la secousse électrique:
  - a. Les circuits à l'électrode et à la pièce sont sous tension quand la machine à souder est en marche. Eviter toujours tout contact entre les parties sous tension et la peau nue ou les vêtements mouillés. Porter des gants secs et sans trous pour isoler les mains.
  - b. Faire très attention de bien s'isoler de la masse quand on soude dans des endroits humides, ou sur un plancher métallique ou des grilles métalliques, principalement dans les positions assis ou couché pour lesquelles une grande partie du corps peut être en contact avec la masse.
  - c. Maintenir le porte-électrode, la pince de masse, le câble de soudage et la machine à souder en bon et sûr état de fonctionnement.
  - d. Ne jamais plonger le porte-électrode dans l'eau pour le refroidir.
  - e. Ne jamais toucher simultanément les parties sous tension des porte-électrodes connectés à deux machines à souder parce que la tension entre les deux pinces peut être le total de la tension à vide des deux machines.
  - f. Si on utilise la machine à souder comme une source de courant pour soudage semi-automatique, ces précautions pour le porte-électrode s'appliquent aussi au pistolet de soudage.
2. Dans le cas de travail au dessus du niveau du sol, se protéger contre les chutes dans le cas où on recoit un choc. Ne jamais enrouler le câble-électrode autour de n'importe quelle partie du corps.
3. Un coup d'arc peut être plus sévère qu'un coup de soleil, donc:
  - a. Utiliser un bon masque avec un verre filtrant approprié ainsi qu'un verre blanc afin de se protéger les yeux du rayonnement de l'arc et des projections quand on soude ou quand on regarde l'arc.
  - b. Porter des vêtements convenables afin de protéger la peau de soudeur et des aides contre le rayonnement de l'arc.
  - c. Protéger l'autre personnel travaillant à proximité au soudage à l'aide d'écrans appropriés et non-inflammables.
4. Des gouttes de laitier en fusion sont émises de l'arc de soudage. Se protéger avec des vêtements de protection libres de l'huile, tels que les gants en cuir, chemise épaisse, pantalons sans revers, et chaussures montantes.
5. Toujours porter des lunettes de sécurité dans la zone de soudage. Utiliser des lunettes avec écrans latéraux dans les zones où l'on pique le laitier.

6. Eloigner les matériaux inflammables ou les recouvrir afin de prévenir tout risque d'incendie dû aux étincelles.
7. Quand on ne soude pas, poser la pince à un endroit isolé de la masse. Un court-circuit accidentel peut provoquer un échauffement et un risque d'incendie.
8. S'assurer que la masse est connectée le plus près possible de la zone de travail qu'il est pratique de le faire. Si on place la masse sur la charpente de la construction ou d'autres endroits éloignés de la zone de travail, on augmente le risque de voir passer le courant de soudage par les chaînes de levage, câbles de grue, ou autres circuits. Cela peut provoquer des risques d'incendie ou d'échauffement des chaînes et des câbles jusqu'à ce qu'ils se rompent.
9. Assurer une ventilation suffisante dans la zone de soudage. Ceci est particulièrement important pour le soudage de tôles galvanisées plombées, ou cadmiées ou tout autre métal qui produit des fumées toxiques.
10. Ne pas souder en présence de vapeurs de chlore provenant d'opérations de dégraissage, nettoyage ou pistelage. La chaleur ou les rayons de l'arc peuvent réagir avec les vapeurs du solvant pour produire du phosgène (gas fortement toxique) ou autres produits irritants.
11. Pour obtenir de plus amples renseignements sur la sûreté, voir le code "Code for safety in welding and cutting" CSA Standard W 117.2-1974.

## PRÉCAUTIONS DE SÛRETÉ POUR LES MACHINES À SOUDER À TRANSFORMATEUR ET À REDRESSEUR

1. Relier à la terre le châssis du poste conformément au code de l'électricité et aux recommandations du fabricant. Le dispositif de montage ou la pièce à souder doit être branché à une bonne mise à la terre.
2. Autant que possible, l'installation et l'entretien du poste seront effectués par un électricien qualifié.
3. Avant de faire des travaux à l'intérieur de poste, la débrancher à l'interrupteur à la boîte de fusibles.
4. Garder tous les couvercles et dispositifs de sûreté à leur place.

Mar. '93

# Thank You

for selecting a **QUALITY** product by Lincoln Electric. We want you to take pride in operating this Lincoln Electric Company product  
•• as much pride as we have in bringing this product to you!

### **Please Examine Carton and Equipment For Damage Immediately**

When this equipment is shipped, title passes to the purchaser upon receipt by the carrier. Consequently, Claims for material damaged in shipment must be made by the purchaser against the transportation company at the time the shipment is received.

Please record your equipment identification information below for future reference. This information can be found on your machine nameplate.

Product \_\_\_\_\_

Model Number \_\_\_\_\_

Code Number or Date Code \_\_\_\_\_

Serial Number \_\_\_\_\_

Date Purchased \_\_\_\_\_

Where Purchased \_\_\_\_\_

Whenever you request replacement parts or information on this equipment, always supply the information you have recorded above. The code number is especially important when identifying the correct replacement parts.

### **On-Line Product Registration**

- Register your machine with Lincoln Electric either via fax or over the Internet.
- For faxing: Complete the form on the back of the warranty statement included in the literature packet accompanying this machine and fax the form per the instructions printed on it.
- For On-Line Registration: Go to our **WEB SITE at [www.lincolnelectric.com](http://www.lincolnelectric.com)**. Choose "Quick Links" and then "Product Registration". Please complete the form and submit your registration.

**Read this Operators Manual completely** before attempting to use this equipment. Save this manual and keep it handy for quick reference. Pay particular attention to the safety instructions we have provided for your protection. The level of seriousness to be applied to each is explained below:

#### **⚠ WARNING**

This statement appears where the information **must** be followed **exactly** to avoid **serious personal injury** or **loss of life**.

#### **⚠ CAUTION**

This statement appears where the information **must** be followed to avoid **minor personal injury** or **damage to this equipment**.

<b>Installation</b> .....	<b>Section A</b>
Technical Specifications .....	A-1
Installation Instructions .....	A-2
Safety Precautions .....	A-2
Input Cable .....	A-2
Working Cable and Remote Voltage Sensing Work Lead .....	A-2
Wire Drive Rolls and Guide Tubes .....	A-3
Optional Features Installation .....	A-3
Innershield Gun and Cable .....	A-3
K-276 Enclosed 50 Lb Wire Reel Support. ....	A-3
<hr/>	
<b>Operation</b> .....	<b>Section B</b>
Safety Precautions .....	B-1
Product Description .....	B-1
Loading the Wire Reel.....	B-1
Drive Roll Pressure .....	B-1
Adjusting Wire Feed Speed and Voltage .....	B-2
Marking the Weld .....	B-2
<hr/>	
<b>Accessories</b> .....	<b>Section C</b>
Optional Equipment .....	C-1
Gun and Cable Assemblies .....	C-1
K-350 Adapter Kit.....	C-1
K-276 Enclosed Wire Reel Support.....	C-1
<hr/>	
<b>Maintenance</b> .....	<b>Section D</b>
Safety Precautions .....	D-1
Replacing or Reversing Drive Rolls.....	D-1
Removing Idle Roll Assembly.....	D-1
Gun and Cable .....	D-1
Wire Drive Assembly Maintenance.....	D-1
Circuit Protection .....	D-2
Nameplates .....	D-2
Power Source.....	D-2
<hr/>	
<b>Troubleshooting</b> .....	<b>Section E</b>
Safety Precautions.....	E-1
How to Use Troubleshooting Guide.....	E-1
Troubleshooting .....	E-2 to E-3
<hr/>	
<b>Connection and Wiring Diagrams</b> .....	<b>Section F</b>
<hr/>	
<b>Parts List</b> .....	<b>P513, P103, P107</b>

## TECHNICAL SPECIFICATIONS – PIPELINER<sup>®</sup> LN-23P (K316L-5)

### OPERATING ARC VOLTAGE

Constant Voltage (CV)

14-50VDC (90VDC Maximum OCV)

### RATED CURRENT

250-350 Amps 60% Duty Cycle

(Depending on Gun Used)

### WIRE SPEED RANGE

30-170 Inches Per Minute (IPM)

(1.18-6.70 mm)

### RECOMMENDED ELECTRODE WIRE SIZES

.068"

.072"

5/64"

INNERSHIELD

INNERSHIELD

INNERSHIELD

### PHYSICAL DIMENSIONS

HEIGHT20.5 Inches  
(520.7 mm)WIDTH9.0 Inches  
(228.6 mm)DEPTH19.0 Inches  
(482.6mm)WEIGHT27 lbs  
(12.3 kg)

### TEMPERATURE RANGE

OPERATION: - 30° C\* to +40° C (- 22° F to +104° F)

STORAGE: - 40° C to +40° C (- 40° F to +104° F)

### ENVIRONMENTAL RATING

\*At temperatures below 0°C, the gun cable may require a warm up operating time to improve flexibility.

## SAFETY PRECAUTIONS

### ⚠ WARNING



**ELECTRIC SHOCK can kill.**

- Only qualified personnel should perform this installation, maintenance and troubleshooting work.

- Turn off the input power at the fuse box before working on other equipment connected to the welding system at the disconnect switch or fuse box before working on this equipment.

- Do not touch electrically hot parts.

## INPUT CABLE

The standard input cable between the LN-23P and the power source consists of a control cable and an electrode cable. **With the power source turned off,** install the input cable per the following instructions:

- Connect the end of the control cable into the mating 14-pin receptacle on the power source. Connect the electrode cable to the negative output stud on the power source.
- Connect the input control cable polarized plug into the mating 8-pin receptacle on the rear of the control section of the LN-23P. Tighten the threaded locking collar until the connector is completely seated.
- Unclip the rubber retaining strap that holds the wire enclosure cover in place and remove the cover. Push the wire drive section door latch towards the rear of the LN-23P and open the door. Route the electrode cable through the large rubber grommet in the rear of the wire feed section and connect the lug to the brass conductor block at the front of motor-gearbox assembly using the bolt provided. Attach the control cable strain relief hook to bracket on the frame of the LN-23P.

## WORK CABLE AND REMOTE VOLTAGE SENSING WORK LEAD

- Connect a work cable of sufficient size and length, per the following table, between the proper output stud on the power source and the work. Be sure the connection to the work makes tight metal to metal contact.

Electrode Cable Length	Work Cable Length	Copper Electrode Cable Size	Copper Work Cable Size
0-25 ft.	0-75 ft.	1/0	1/0
0-25	76-125	1/0	2/0
26-75	26-75	2/0	2/0
26-75	76-125	2/0	4/0
76-100	76-125	3/0	4/0

Above cable sizes are based on a maximum voltage drop of 4.3 volts in the combined lengths of electrode and work cable at 350 amps.

- Connect a 12 AWG or larger rubber covered flexible lead physically suitable for the installation to the voltage sensing work lead coming out of the 8-pin receptacle on the control cable. Connect directly to the work or to the work cable connection on the work piece. This lead supplies the voltage to the voltmeter in the LN-23P and also supplies the power to the LN-23P drive motor.

## WIRE DRIVE ROLLS AND GUIDE TUBES

The LN-23P is shipped with the proper drive rolls and guide tubes factory installed. Do not adjust the idle roll tension adjusting screw. If the idle roll tension must be relieved temporarily, see “A” and “B” of Maintenance Section.

## OPTIONAL FEATURES INSTALLATION

### INNERSHIELD GUN AND CABLE

- Unclip the rubber retaining strap that holds the wire enclosure cover in place and remove the cover.
- Push the wire drive section door latch towards the rear of LN-23P and open door.
- Loosen the gun locking set screw in the conductor block on the front of the gear box with a 3/16 hex Allen wrench.
- Lay the cable out straight. Insert the connector on the conductor cable through the large grommet in the front of the wire drive section and into the brass block on the front of the gear box. Make sure it is all the way in and tighten the locking set screw with a 3/16 hex Allen wrench. Keep this connection clean and bright.
- Connect the 3-pin gun trigger connector to the lower receptacle.
- If the gun cable being used has a reduced speed switch, connect the 4-pin reduced speed switch connector to the upper receptacle. If the reduced speed switch is not used, install the protective cap on the upper receptacle.

### CAUTION

**K-276 ENCLOSED 50lb.WIRE REEL SUPPORT**  
Installation and loading instructions (M-13153) are supplied with the kit.

-----

## SAFETY PRECAUTIONS

### WARNING



**ELECTRIC SHOCK can kill.**

- Do not touch electrically live parts such as output terminals or internal wiring.

- When inching with gun trigger, electrode and drive mechanism are “hot” to work and ground and could remain energized several seconds after the gun trigger is released.
- Turn OFF input power at welding power source before installation or changing drive roll and/or guide tubes.
- Welding power source must be connected to system ground per the National Electrical Code or any applicable local codes.
- Only qualified personnel should perform this installation.

## PRODUCT DESCRIPTION

The K316L-5 / LN-23P is a lightweight, portable wire feed unit which includes calibrated wire speed control, voltage control, wire drive with enclosed 14 lb. wire reel, analog voltmeter and various input control and electrode cable lengths.

The feeder is designed for welding with 14 pound coils of .068 and 5/64 Innershield self-shielding electrodes using a constant voltage type DC power Source. When shipped, it is internally connected for welding with electrode negative polarity (DC-). Depending upon which gun and cable is used, its rating is either 350 amps or 250 amps at 60% duty cycle.

The wire speed control has a calibrated dial plate with a range of 30 to 170 inches per minute and allows quick and easy setting of the procedure wire feed speed. The wire speed is not affected by changes in the arc voltage setting even though the wire feed circuit is powered by arc voltage. A two-position switch, which is mounted on the gun and a reduced speed circuit, allows selection of the preset wire speed or 83% of the preset speed.

A low voltage gun trigger circuit turns both the power source output and wire feed on and off\*. The gun trigger circuit is interlocked by a weld current sensing reed switch so that while welding, the gun trigger switch does not have to be held closed. The welding process is stopped by pulling the gun away from the work. The electrode remains cold until the gun trigger is operated.

\* In an SAE-400 application, the power source output does not turn off - **the electrode remains hot even when the gun trigger is not being operated.**

The LN-23P includes a voltage control which controls the power source output. Also included is an analog voltmeter which allows easy setting of the procedure arc voltage at the LN-23P.

## LOADING THE WIRE REEL

- Lay the LN-23P flat with the wire reel cover up, unclip the rubber retaining strap, and remove the cover.
- Remove the center clamping nut and the cover plate from the wire reel.
- Unpack the 14-pound coil of wire. Be sure not to bend the side tangs of the coil liner and straighten any tangs that may have been bent.
- Place the coil on the wire reel so the coil will unwind when it rotates in a clockwise direction.
- Remove the start end of the coil from its holding slot in the coil liner, cut off the bent end, straighten the first few inches and thread it through the wire feed conduit connected to the wire enclosure until several inches of electrode are exposed. Be careful not to release the electrode until it is through the wire feed conduit; otherwise, it may unwind and tangle.
- Be sure all the lower tangs of the coil liner are flush against the back half of the wire reel and that none of the upper tangs are bent in against the coil.
- Replace the reel cover plate and the center clamping nut.
- Replace the cover of the wire reel enclosure and clip the retaining strap in place.
- Pull about 2 feet of the exposed end of the electrode through the wire feed conduit. Slide the insulator all the way up on the wire feed conduit. Make a single, free loop in the electrode and feed the end into the section of wire feed conduit connected to the gearbox. Press the gun trigger and push the electrode into the drive rolls. Release the electrode as soon as it is picked up by the drive rolls. Continue feeding electrode until the excess length is fed through the drive rolls. Watch the single loop and guide it if necessary to make certain it untwists without kinking. Do not feed electrode through cable at this time. Slide insulator down on wire feed conduit until it slips over section of conduit connected to gearbox.
- Set the unit upright on floor, straighten the gun cable, press the gun trigger, and feed electrode through the gun and cable assembly.

## DRIVE ROLL PRESSURE

- Do not adjust the drive roll pressure. If the idle roll tension must be relieved temporarily, see (Maintenance Section).

## ADJUSTING WIRE FEED SPEED AND VOLTAGE

Set the wire feed as specified in the procedures using the calibrated dial on the back of the LN-23P control box. When the reduced wire speed switch (mounted on the gun handle) is in Position No. 1, the wire feed speed will be that which is indicated on the dial. In Position No. 2, the wire feed speed will be 83% of the figure indicated on the dial.

Set the voltage by adjusting the voltage control while welding until the voltage specified in the procedures is indicated on the meter. The meter reading with the power source on but not welding is the open circuit voltage. With some power sources, this voltage may be significantly higher than welding voltage.

When establishing initial procedures, start with the voltage control set near minimum. Strike an arc on scrap steel. If the arc fails to start, increase the voltage settings until the arc can be established.

When inching wire (not welding) at open circuit voltages below 20 volts or above 25 volts, feeding may be unsteady or the wire speed may vary from that set on the dial. This condition does not exist while welding. Minimum usable arc voltage is 14 volts.

**NOTE:** For improved readability of the voltmeter in some applications, the voltmeter guard may be installed rotated end for end. This will result in the protective bars crossing the meter face in a different location.

## MAKING THE WELD

Be sure the proper contact tip for either .068" or 5/64" wire, as appropriate, is in the gun. The thread protector should cover the external threads on the nozzle.

Loosen the insulated screw on the side of the gun, rotate the gun nozzle to the position most convenient for the particular application, and retighten the insulated screw.

When welding, set the wire feeder on the floor or hang it near the work area as convenient. Place the LN-23P to minimize the amount of spatter falling onto it. **Always avoid sharp bends and keep the gun cable as straight as practical.**

Be sure the electrode cable, work cable, and control lead are connected and the power source is on.

Press the gun trigger to feed the electrode out of the gun. Use a visible stickout equal to the electrical stickout specified in the procedures for the wire being used.

Position the gun with the wire just off or **lightly** touching the work. Press the gun trigger to start the arc. Once the arc is established, the gun trigger can be released while welding. The gun trigger interlock circuit automatically keeps the welding process on. At the end of the weld, pull the gun away from the work.

When not welding, always store the gun in the insulated tube on the front of wire feeder.

## OPTIONAL EQUIPMENT

### GUN AND CABLE ASSEMBLIES

Type	K-355-10*	K-345-10*	K-264-8	K-361-10	K-406*
Length:	10 feet	10 feet	8 feet	10 feet	Linconditioner Gun 10 ft. (15 ft. Exhaust Hose)
Rated Welding Current:	250 Amps	350 Amps	250 Amps	350 Amps	350 Amps
Duty Cycle	60%	60%	60%	60%	60%
Electrode Sizes	.068, .072, 5/64	.068, .072, 5/64	068, .072, 5/64	068, .072, 5/64	068, .072, 5/64
Reduced Speed Switch	Std.	Std.	None	None	Std.
Sizes	5/64	5/64	5/64	5/64	5/64
Nozzle Angle	90E	90E	62E	62E	68E
Weight	7.0 lbs.	8.9 lbs.	5.2 lbs.	7.5 lbs.	16.0 lbs.

\* Recommended for pipe welding applications.

All guns include one each .068/.072 tip, 5/64 tip, and a thread protector\*\*. The K-264-8 also includes an insulated guide for 3/4" to 1-1/2" stickout. The K-361-10 also includes an insulated guide for 2" stickout.\*\* The K-406 includes an insulated guide for 2" to 1" stickout, but no thread protector.

#### K2393-1 25' INPUT CABLE ASSEMBLY.

8-pin to 14-pin control cable attached to 350A lug-to-lug electrode; 15' work sense lead included.

#### K2393-2 75' INPUT CABLE ASSEMBLY.

8-pin to 14-pin control cable attached to 350A lug-to-lug electrode; 15' work sense lead included.

#### K2379-1 50' INPUT CABLE and ADAPTER ASSEMBLY.

Required for SAE-400 installation. 8-pin to 14-pin control cable attached to 350A lug-to-lug electrode; 15' work sense lead included.

#### K-276 ENCLOSED WIRE REEL SUPPORT

Bolts to the LN-23P frame for feeding wire from standard 50 lb. Innershield coils. Includes enclosure and door to keep the dirt out; also includes wire reel brake assembly.

## SAFETY PRECAUTIONS

### ⚠ WARNING

Have qualified personnel do the maintenance work. Turn the engine off before working inside the machine. In some cases, it may be necessary to remove safety guards to perform required maintenance. Remove guards only when necessary and replace them when the maintenance requiring their removal is complete. Always use the greatest care when working near moving parts.



**ELECTRIC SHOCK can kill.**

- Do not touch electrically live parts or electrode with skin or wet clothing.
- Insulate yourself from work and ground
- Always wear dry insulating gloves.

See additional warning information throughout this operator's manual and the Engine manual as well.

**REPLACING OR REVERSING DRIVE ROLLS** (See drawing below.)

Loosen idle roll tension screw (Item 1) to release pressure between idle roll and drive rolls.

Remove hex head screw (Item 2) with a 1/2" wrench and remove the drive roll clamping collar (Item 3).

Remove drive rolls from shaft.

Wipe the drive roll surfaces clean. Then install drive rolls. If reversing drive rolls, turn drive rolls over so unworn teeth face each other.

Replace clamping collar and hex head screw.

Tighten the idle roll tension screw until it bottoms and then back it out two complete turns.

### REMOVING IDLE ROLL ASSEMBLY

Remove the idle roll tension screw (Item 1), tension spring retainer (Item 4), and tension spring (Item 5).

Pivot the idle roll assembly away from the gearbox and lift it off the pivot pin (Item 6).

To re-assemble, replace idle roll assembly, tension spring, retainer, and tension screw. Tighten the tension screw until it bottoms, and then back it out two complete turns.

## GUN AND CABLE MAINTENANCE

Remove spatter from tip after each ten minutes of arc time or as required.

Replace worn contact tips and thread protectors as required.

Replace worn spring liners in nozzles. The life of the spring can be doubled by rotating it 180°.

Clean cables after using approximately 300 pounds of electrode. Remove the cable from the wire feeder and lay it out straight on the floor. Remove the contact nozzle tip from the gun. Using an air hose and only partial pressure, gently blow out the cable from the gun end. (Too much pressure at the start will cause the dirt to form a plug.) Flex the cable over its entire length and again blow out the cable. Repeat this procedure until no further dirt comes out.

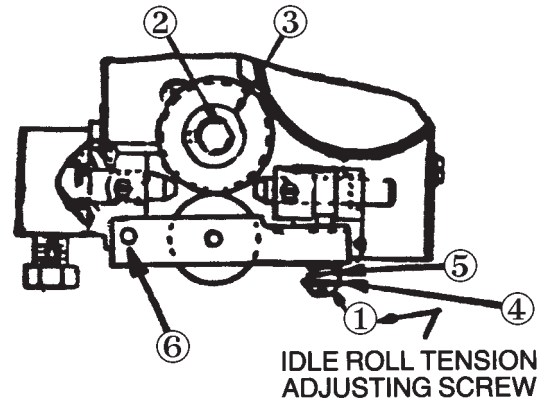

Before any gun is disassembled, remove unit from the wire feeder or shut off the power source.

### WIRE DRIVE ASSEMBLY MAINTENANCE

Every 500 pounds of electrode, the drive roll section should be inspected and cleaned out if necessary. Do not use a solvent for cleaning the idle roll as it may wash lubricant out of the bearing.

Replace drive rolls as required. Drive rolls should be worn on both sides before replacing. See "A" of this section.

Check the motor brushes every six months. Replace if they are less than 1/4" long.

Every year examine the gear box and paint the gear teeth with moly-disulfide filled grease.

**CIRCUIT PROTECTION**

**Circuit Breaker** – The 3.5 amp circuit breaker located on the rear of the unit normally trips only when an overload occurs because of excessive loading in the wire feed cable or a defective motor or control components. After allowing a few minutes for cooling, push the reset button and weld. If it trips again, be sure the gun cable is not being excessively bent, is clean, and is the proper size for the wire diameter being fed. If it still trips, look for a defective electrical component.

**NAMEPLATES**

Whenever routine maintenance is performed on this machine — or at least yearly — inspect all nameplates and labels for legibility. Replace those which are no longer clear. Refer to the parts list for the replacement item number.

Pipeliner®LN-23P Power Sources
<ul style="list-style-type: none"> <li>• Classic II, Classic 300G, Classic 300D. (With K623-1 Wire Feed Module)</li> <li>• Commander 300, Vantage 500.</li> <li>• Ranger 250, Ranger 305G, Ranger 305D.</li> <li>• CV-300, CV-400, V350-Pipe, V350-Pro, DC-400, DC-600, DC655.</li> <li>• Pipeliner 200G, Pipeliner 200D (With K623-1 Wire Feed Module)</li> <li>• SAE-400 or SAE-400 Weld 'N Air Requires K2379-1 and CV Adapter (K385-2).</li> </ul>

## HOW TO USE TROUBLESHOOTING GUIDE

### WARNING

Service and Repair should only be performed by Lincoln Electric Factory Trained Personnel. Unauthorized repairs performed on this equipment may result in danger to the technician and machine operator and will invalidate your factory warranty. For your safety and to avoid Electrical Shock, please observe all safety notes and precautions detailed throughout this manual.

This Troubleshooting Guide is provided to help you locate and repair possible machine malfunctions. Simply follow the three-step procedure listed below.

#### **Step 1. LOCATE PROBLEM (SYMPTOM).**

Look under the column labeled “PROBLEM (SYMPTOMS)”. This column describes possible symptoms that the machine may exhibit. Find the listing that best describes the symptom that the machine is exhibiting.

#### **Step 2. POSSIBLE CAUSE.**

The second column labeled “POSSIBLE CAUSE” lists the obvious external possibilities that may contribute to the machine symptom.

#### **Step 3. RECOMMENDED COURSE OF ACTION**

This column provides a course of action for the Possible Cause, generally it states to contact your local Lincoln Authorized Field Service Facility.

If you do not understand or are unable to perform the Recommended Course of Action safely, contact your local Lincoln Authorized Field Service Facility.

### CAUTION

If for any reason you do not understand the test procedures or are unable to perform the tests/repairs safely, contact your **Local Lincoln Authorized Field Service Facility** for technical troubleshooting assistance before you proceed.

Observe all Safety Guidelines detailed throughout this manual

PROBLEMS (SYMPTOMS)	POSSIBLE CAUSE	RECOMMENDED COURSE OF ACTION
Motor won't run.	<ol style="list-style-type: none"> <li>1. Circuit breaker tripped.</li> <li>2. OCV is above 100 volts.</li> <li>3. Wrong polarity – unit is shipped internally connected to operate on negative polarity only.</li> <li>4. Remote voltage sensing work lead not connected to work.</li> <li>5. Electrode lead not connected to LN-23P.</li> <li>6. Control cable not properly connected to Power Source.</li> <li>7. Faulty gun trigger or broken control wires.</li> <li>8. Faulty control circuit.</li> <li>9. Faulty CV Adapter, Wire Feed Module or Power Source.</li> </ol>	<p>If all recommended possible areas of misadjustment have been checked and the problem persists, <b>Contact your local Lincoln Authorized Field Service Facility.</b></p>
Wire will not feed, or erratic feeding.	<ol style="list-style-type: none"> <li>1. Gun cable being excessively bent.</li> <li>2. Dirty gun cable.</li> <li>3. Loop of wire caught on bent tang in wire reel.</li> <li>4. Worn drive rolls.</li> <li>5. Improper idle roll tension setting.</li> </ol>	
Erratic arc action.	<ol style="list-style-type: none"> <li>1. Worn tip.</li> <li>2. Incorrect wire feed speed or voltage.</li> <li>3. Poor work lead connection.</li> </ol>	

 **CAUTION**

If for any reason you do not understand the test procedures or are unable to perform the tests/repairs safely, contact your **Local Lincoln Authorized Field Service Facility** for technical troubleshooting assistance before you proceed.

PIPELINER® LN-23P



Observe all Safety Guidelines detailed throughout this manual

PROBLEMS (SYMPTOMS)	POSSIBLE CAUSE	RECOMMENDED COURSE OF ACTION
Improper wire speed control.	1. Faulty printed circuit board, faulty rheostat, or faulty motor.	If all recommended possible areas of misadjustment have been checked and the problem persists, <b>Contact your local Lincoln Authorized Field Service Facility.</b>
Can't obtain required voltage.	1. Defective power source CV Adapter or Wire Feed Module.  2. On SAM welders, constant voltage control must be adjusted to give required voltage and mode switch must be set to constant voltage position.  3. On DC-600 and R3S welders, fine voltage control switch must be set to remote position.  4. Broken lead(s) in 75-76-77 (A-B-C) control circuit.  5. Defective voltage control rheostat.	

 **CAUTION**

If for any reason you do not understand the test procedures or are unable to perform the tests/repairs safely, contact your **Local Lincoln Authorized Field Service Facility** for technical troubleshooting assistance before you proceed.

PIPELINER® LN-23P



LN-23P WIRING DIAGRAM

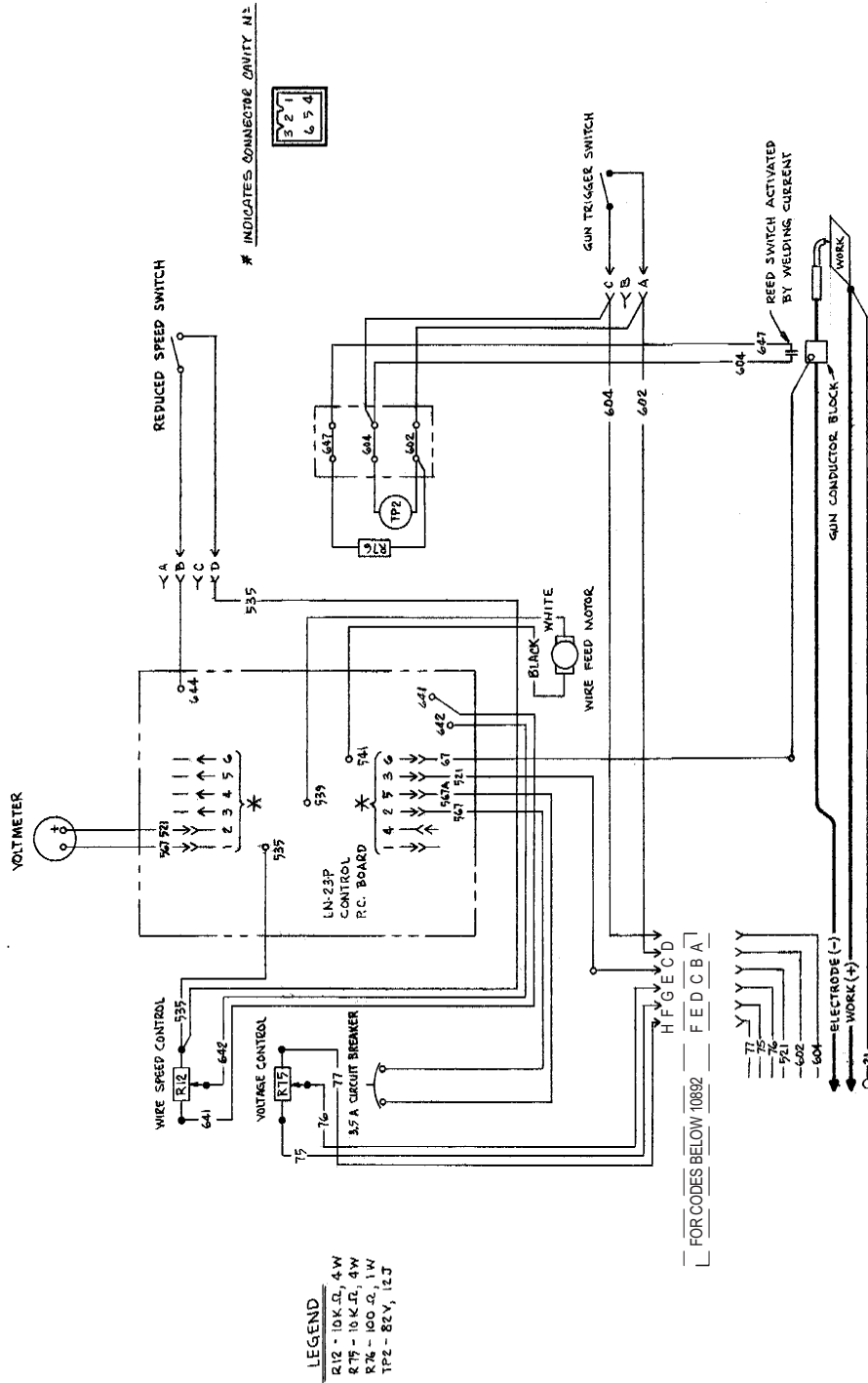

CRM33074 (8/01)  
**M14197**

NOTE: This diagram is for reference only. It may not be accurate for all machines covered by this manual. The specific diagram for a particular code is pasted inside the machine on one of the enclosure panels. If the diagram is illegible, write to the Service Department for a replacement. Give the equipment code number.

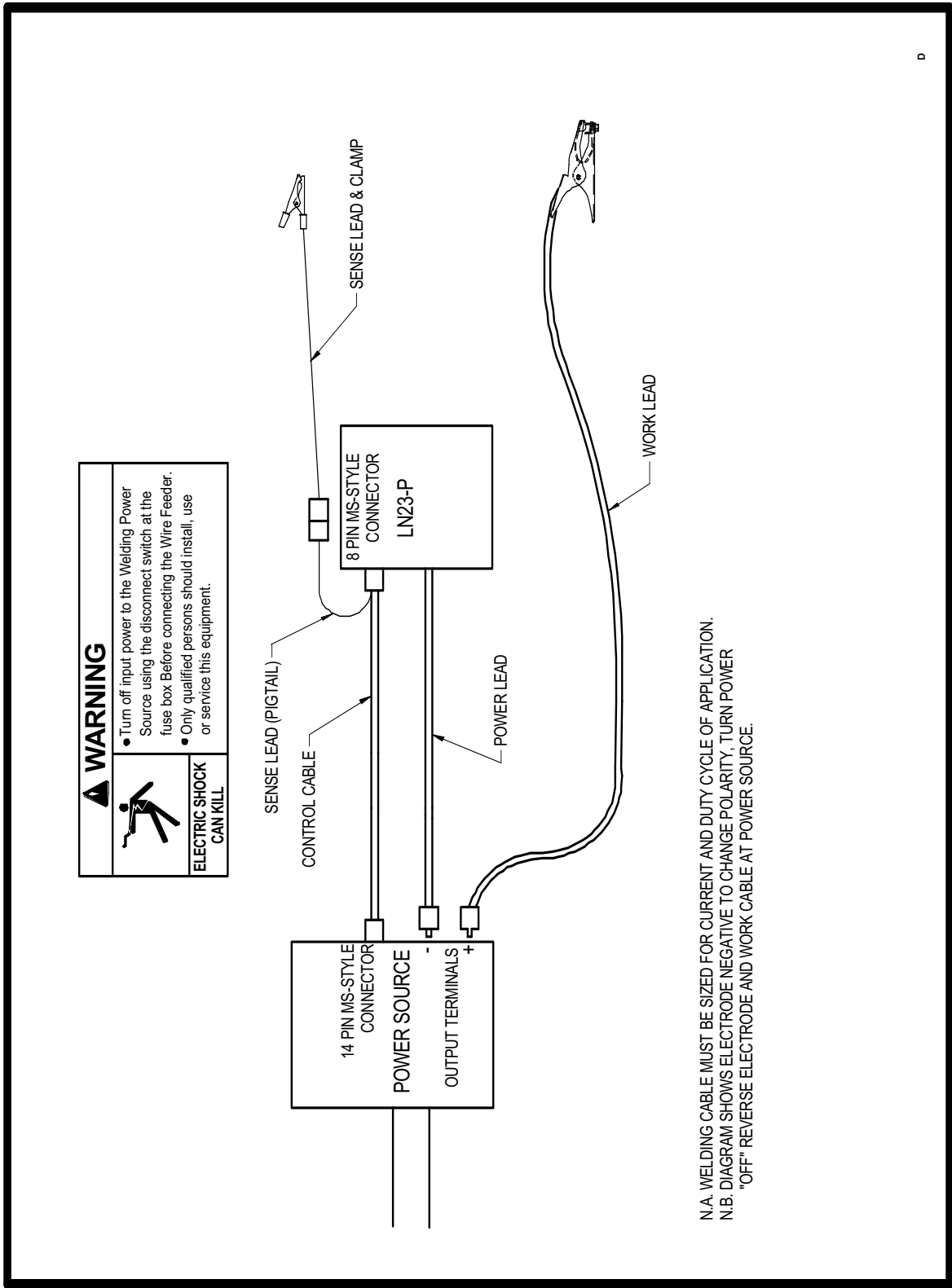

S25419

NOTE: This diagram is for reference only. It may not be accurate for all machines covered by this manual. The specific diagram for a particular code is pasted inside the machine on one of the enclosure panels. If the diagram is illegible, write to the Service Department for a replacement. Give the equipment code number.

CONNECTION DIAGRAM: SAE 400 ENGINE WELDERS COMPATIBLE WITH LN-23P AND K2379-1 INTERFACE KIT

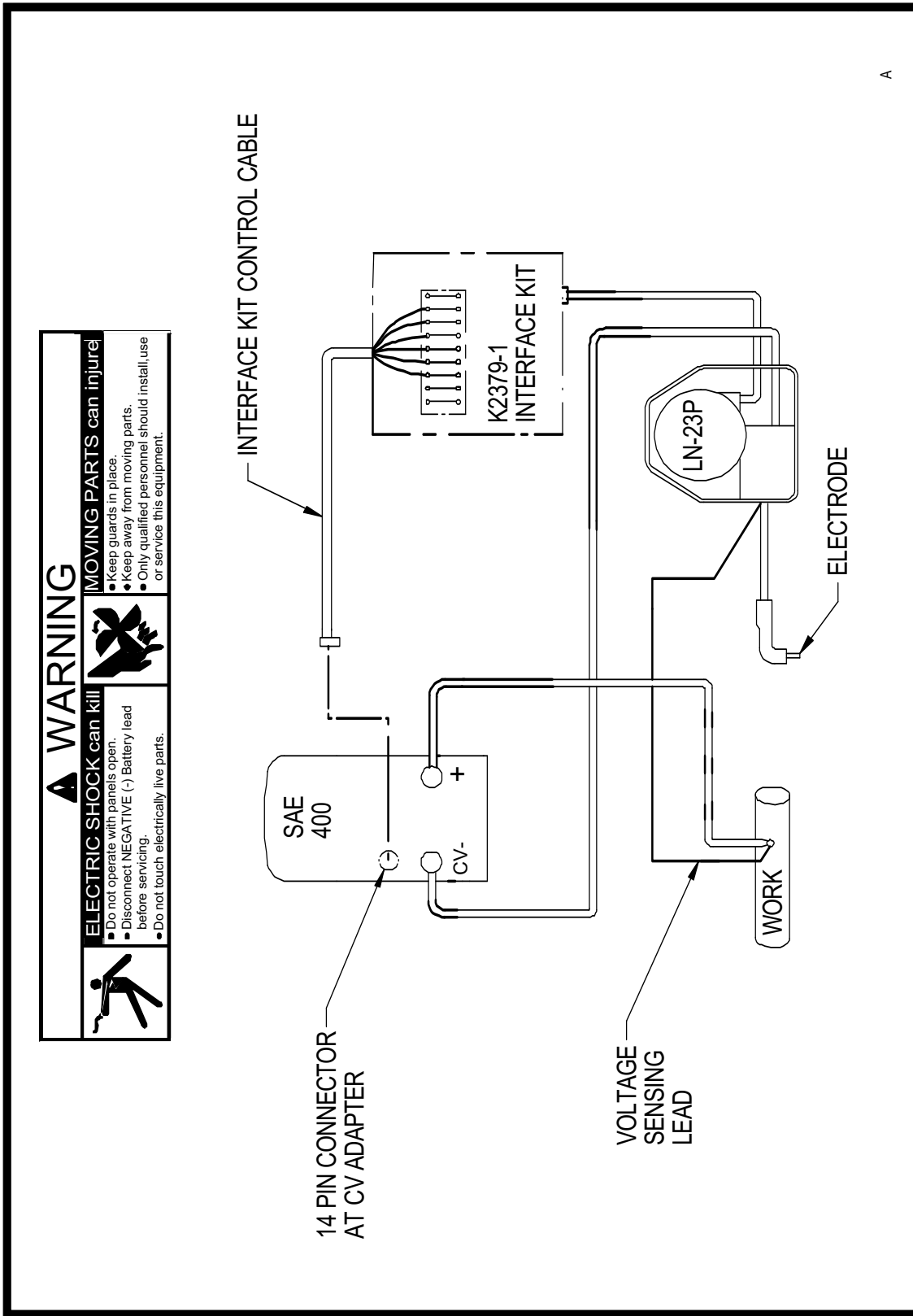

	<b>WARNING</b>		<b>MOVING PARTS can injure!</b>
<p><b>ELECTRIC SHOCK can kill!</b></p> <ul style="list-style-type: none"> <li>Do not operate with panels open.</li> <li>Disconnect NEGATIVE (-) Battery lead before servicing.</li> <li>Do not touch electrically live parts.</li> </ul>		<ul style="list-style-type: none"> <li>Keep guards in place.</li> <li>Keep away from moving parts.</li> <li>Only qualified personnel should install, use or service this equipment.</li> </ul>	

S25869

NOTE: This diagram is for reference only. It may not be accurate for all machines covered by this manual. The specific diagram for a particular code is pasted inside the machine on one of the enclosure panels. If the diagram is illegible, write to the Service Department for a replacement. Give the equipment code number.

K2379-1 SAE 400/LN 23P INTERFACE KIT

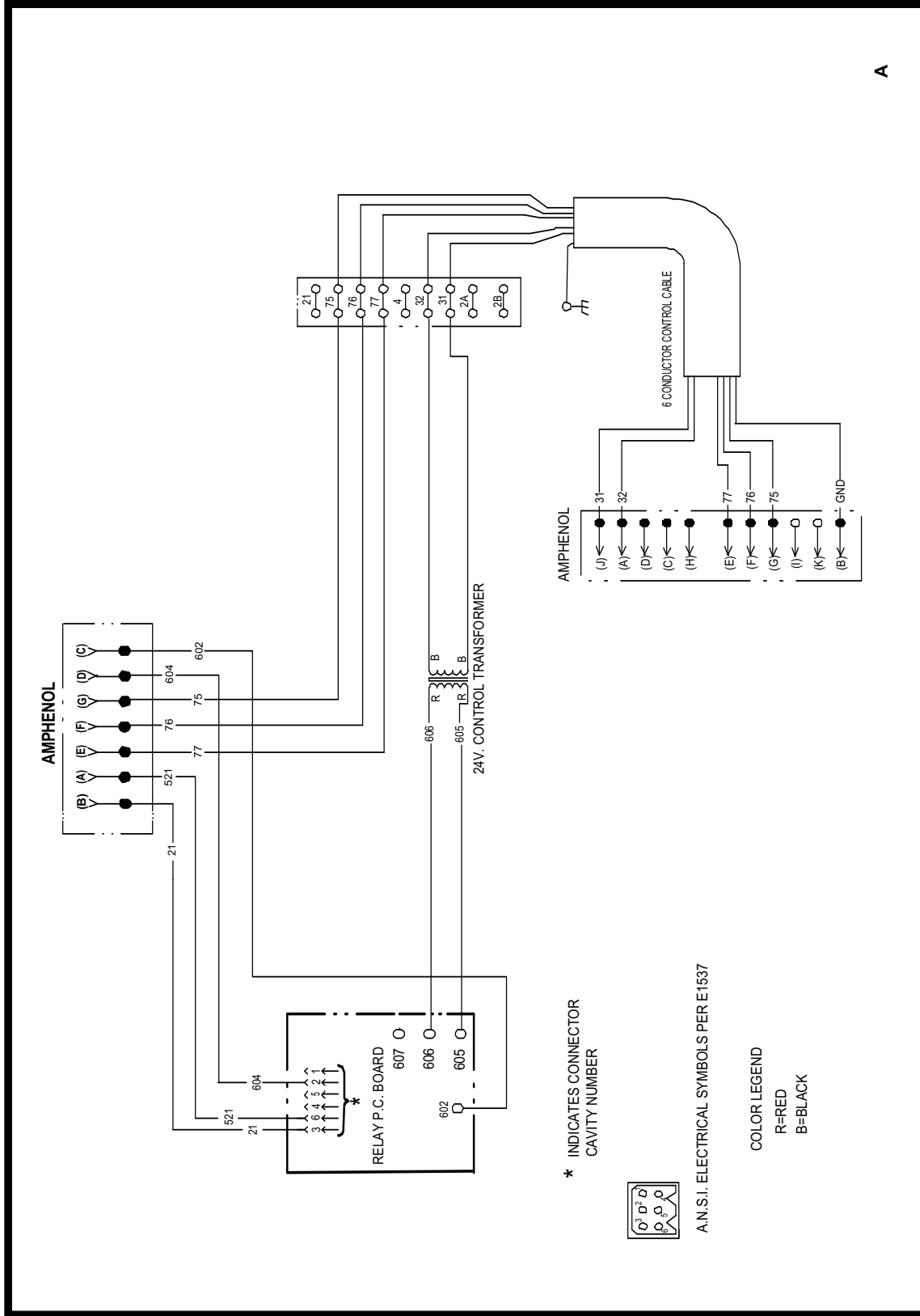

M20405

## FIELD CALIBRATION OF K-316 LN-23P P.C. BOARD

1. Calibration of the P.C. board for correct Wire Speed dial setting is necessary if any of the following changes are made:
  - a. Replacement of the P.C. board.
  - b. Replacement of the motor or motor-gearbox assembly.
2. Load the LN-23P with the type of electrode being used and set the power source as required for the process. Set the OCV of the power source at 22 to 24 volts.
3. Set the "Wire Speed" control to exactly 30 IPM on the dial plate and feed wire. CAUTION: The electrode is electrically "HOT" while feeding. Make certain that the reduced wire speed switch (mounted on the gun handle) is in Position No. 1.
4. Measure the actual wire feed speed with a portable digital wire speed meter or measure the length of wire fed out in 30 seconds and multiply by two to obtain inches per minute. If the latter method is used, while feeding wire, cut the wire off at the tip of nozzle and in the same instant start the 30 second timed interval. At precisely the end of 30 second interval, again while feeding wire, cut the wire at the tip of the nozzle. Measure the cut length of wire and multiply by two. Adjust control board trimmer R14 ("LO") in small increments until the actual wire feed speed obtained is exactly 30 IPM. (Clockwise rotation of trimmer increases wire speed.)
5. Set the "Wire Speed" control to exactly 170 IPM on the dial plate and feed wire.
6. Adjust control board trimmer R10 ("HI") so that the actual wire feed speed is exactly 170 IPM using the procedure in Step #4 above.
7. The setting of the trimmers *must* be done in this order. Do *not* adjust R14 after setting R10.

S-16902  
3-30-84M

# NOTES

---

PIPELINER® LN-23P



# NOTES

---

PIPELINER® LN-23P



<b>WARNING</b>	<ul style="list-style-type: none"> <li>● Do not touch electrically live parts or electrode with skin or wet clothing.</li> <li>● Insulate yourself from work and ground.</li> </ul>	<ul style="list-style-type: none"> <li>● Keep flammable materials away.</li> </ul>	<ul style="list-style-type: none"> <li>● Wear eye, ear and body protection.</li> </ul>
Spanish <b>AVISO DE PRECAUCION</b>	<ul style="list-style-type: none"> <li>● No toque las partes o los electrodos bajo carga con la piel o ropa mojada.</li> <li>● Aíslese del trabajo y de la tierra.</li> </ul>	<ul style="list-style-type: none"> <li>● Mantenga el material combustible fuera del área de trabajo.</li> </ul>	<ul style="list-style-type: none"> <li>● Protéjase los ojos, los oídos y el cuerpo.</li> </ul>
French <b>ATTENTION</b>	<ul style="list-style-type: none"> <li>● Ne laissez ni la peau ni des vêtements mouillés entrer en contact avec des pièces sous tension.</li> <li>● Isolez-vous du travail et de la terre.</li> </ul>	<ul style="list-style-type: none"> <li>● Gardez à l'écart de tout matériel inflammable.</li> </ul>	<ul style="list-style-type: none"> <li>● Protégez vos yeux, vos oreilles et votre corps.</li> </ul>
German <b>WARNUNG</b>	<ul style="list-style-type: none"> <li>● Berühren Sie keine stromführenden Teile oder Elektroden mit Ihrem Körper oder feuchter Kleidung!</li> <li>● Isolieren Sie sich von den Elektroden und dem Erdboden!</li> </ul>	<ul style="list-style-type: none"> <li>● Entfernen Sie brennbares Material!</li> </ul>	<ul style="list-style-type: none"> <li>● Tragen Sie Augen-, Ohren- und Körperschutz!</li> </ul>
Portuguese <b>ATENÇÃO</b>	<ul style="list-style-type: none"> <li>● Não toque partes elétricas e electrodos com a pele ou roupa molhada.</li> <li>● Isole-se da peça e terra.</li> </ul>	<ul style="list-style-type: none"> <li>● Mantenha inflamáveis bem guardados.</li> </ul>	<ul style="list-style-type: none"> <li>● Use proteção para a vista, ouvido e corpo.</li> </ul>
Japanese <b>注意事項</b>	<ul style="list-style-type: none"> <li>● 通電中の電気部品、又は溶材にヒフやぬれた布で触れないこと。</li> <li>● 施工物やアースから身体が絶縁されている様にして下さい。</li> </ul>	<ul style="list-style-type: none"> <li>● 燃えやすいものの側での溶接作業は絶対にしてはなりません。</li> </ul>	<ul style="list-style-type: none"> <li>● 目、耳及び身体に保護具をして下さい。</li> </ul>
Chinese <b>警告</b>	<ul style="list-style-type: none"> <li>● 皮膚或濕衣物切勿接觸帶電部件及鎢條。</li> <li>● 使你自己與地面和工件絕緣。</li> </ul>	<ul style="list-style-type: none"> <li>● 把一切易燃物品移離工作場所。</li> </ul>	<ul style="list-style-type: none"> <li>● 佩戴眼、耳及身體勞動保護用具。</li> </ul>
Korean <b>위험</b>	<ul style="list-style-type: none"> <li>● 전도체나 용접봉을 젖은 형갑 또는 피부로 절대 접촉치 마십시오.</li> <li>● 모재와 접지를 접촉치 마십시오.</li> </ul>	<ul style="list-style-type: none"> <li>● 인화성 물질을 접근시키지 마십시오.</li> </ul>	<ul style="list-style-type: none"> <li>● 눈, 귀와 몸에 보호장구를 착용하십시오.</li> </ul>
Arabic <b>تحذير</b>	<ul style="list-style-type: none"> <li>● لا تلمس الاجزاء التي يسري فيها التيار الكهربائي أو الألكترود بجسد الجسم أو بالملابس المبللة بالماء.</li> <li>● ضع عازلا على جسمك خلال العمل.</li> </ul>	<ul style="list-style-type: none"> <li>● ضع المواد القابلة للاشتعال في مكان بعيد.</li> </ul>	<ul style="list-style-type: none"> <li>● ضع أدوات وملابس واقية على عينيك وأذنيك وجسمك.</li> </ul>

**READ AND UNDERSTAND THE MANUFACTURER'S INSTRUCTION FOR THIS EQUIPMENT AND THE CONSUMABLES TO BE USED AND FOLLOW YOUR EMPLOYER'S SAFETY PRACTICES.**

**SE RECOMIENDA LEER Y ENTENDER LAS INSTRUCCIONES DEL FABRICANTE PARA EL USO DE ESTE EQUIPO Y LOS CONSUMIBLES QUE VA A UTILIZAR, SIGA LAS MEDIDAS DE SEGURIDAD DE SU SUPERVISOR.**

**LISEZ ET COMPRENEZ LES INSTRUCTIONS DU FABRICANT EN CE QUI REGARDE CET EQUIPMENT ET LES PRODUITS A ETRE EMPLOYES ET SUIVEZ LES PROCEDURES DE SECURITE DE VOTRE EMPLOYEUR.**

**LESEN SIE UND BEFOLGEN SIE DIE BETRIEBSANLEITUNG DER ANLAGE UND DEN ELEKTRODENEINSATZ DES HERSTELLERS. DIE UNFALLVERHÜTUNGSVORSCHRIFTEN DES ARBEITGEBERS SIND EBENFALLS ZU BEACHTEN.**

<ul style="list-style-type: none"> <li>● Keep your head out of fumes.</li> <li>● Use ventilation or exhaust to remove fumes from breathing zone.</li> </ul>	<ul style="list-style-type: none"> <li>● Turn power off before servicing.</li> </ul>	<ul style="list-style-type: none"> <li>● Do not operate with panel open or guards off.</li> </ul>	<b>WARNING</b>
<ul style="list-style-type: none"> <li>● Los humos fuera de la zona de respiración.</li> <li>● Mantenga la cabeza fuera de los humos. Utilice ventilación o aspiración para gases.</li> </ul>	<ul style="list-style-type: none"> <li>● Desconectar el cable de alimentación de poder de la máquina antes de iniciar cualquier servicio.</li> </ul>	<ul style="list-style-type: none"> <li>● No operar con panel abierto o guardas quitadas.</li> </ul>	Spanish <b>AVISO DE PRECAUCION</b>
<ul style="list-style-type: none"> <li>● Gardez la tête à l'écart des fumées.</li> <li>● Utilisez un ventilateur ou un aspirateur pour ôter les fumées des zones de travail.</li> </ul>	<ul style="list-style-type: none"> <li>● Débranchez le courant avant l'entretien.</li> </ul>	<ul style="list-style-type: none"> <li>● N'opérez pas avec les panneaux ouverts ou avec les dispositifs de protection enlevés.</li> </ul>	French <b>ATTENTION</b>
<ul style="list-style-type: none"> <li>● Vermeiden Sie das Einatmen von Schweißrauch!</li> <li>● Sorgen Sie für gute Be- und Entlüftung des Arbeitsplatzes!</li> </ul>	<ul style="list-style-type: none"> <li>● Strom vor Wartungsarbeiten abschalten! (Netzstrom völlig öffnen; Maschine anhalten!)</li> </ul>	<ul style="list-style-type: none"> <li>● Anlage nie ohne Schutzgehäuse oder Innenschutzverkleidung in Betrieb setzen!</li> </ul>	German <b>WARNUNG</b>
<ul style="list-style-type: none"> <li>● Mantenha seu rosto da fumaça.</li> <li>● Use ventilação e exaustão para remover fumo da zona respiratória.</li> </ul>	<ul style="list-style-type: none"> <li>● Não opere com as tampas removidas.</li> <li>● Desligue a corrente antes de fazer serviço.</li> <li>● Não toque as partes elétricas nuas.</li> </ul>	<ul style="list-style-type: none"> <li>● Mantenha-se afastado das partes moventes.</li> <li>● Não opere com os painéis abertos ou guardas removidas.</li> </ul>	Portuguese <b>ATENÇÃO</b>
<ul style="list-style-type: none"> <li>● ヒュームから頭を離すようにして下さい。</li> <li>● 換気や排煙に十分留意して下さい。</li> </ul>	<ul style="list-style-type: none"> <li>● メンテナンス・サービスに取りかかる際には、まず電源スイッチを必ず切して下さい。</li> </ul>	<ul style="list-style-type: none"> <li>● パネルやカバーを取り外したまま機械操作をしないで下さい。</li> </ul>	Japanese <b>注意事項</b>
<ul style="list-style-type: none"> <li>● 頭部遠離煙霧。</li> <li>● 在呼吸區使用通風或排風器除煙。</li> </ul>	<ul style="list-style-type: none"> <li>● 維修前切斷電源。</li> </ul>	<ul style="list-style-type: none"> <li>● 儀表板打開或沒有安全罩時不準作業。</li> </ul>	Chinese <b>警告</b>
<ul style="list-style-type: none"> <li>● 얼굴로부터 용접가스를 멀리하십시오.</li> <li>● 호흡지역으로부터 용접가스를 제거하기 위해 가스제거기나 통풍기를 사용하십시오.</li> </ul>	<ul style="list-style-type: none"> <li>● 보수전에 전원을 차단하십시오.</li> </ul>	<ul style="list-style-type: none"> <li>● 판넬이 열린 상태로 작동치 마십시오.</li> </ul>	Korean <b>위험</b>
<ul style="list-style-type: none"> <li>● ابعد رأسك بعيداً عن الدخان.</li> <li>● استعمل التهوية أو جهاز ضغط الدخان للخارج لكي تبعد الدخان عن المنطقة التي تتنفس فيها.</li> </ul>	<ul style="list-style-type: none"> <li>● أقطع التيار الكهربائي قبل القيام بأية صيانة.</li> </ul>	<ul style="list-style-type: none"> <li>● لا تشغيل هذا الجهاز اذا كانت الاغطية الحديدية الواقية ليست عليه.</li> </ul>	Arabic <b>تحذير</b>

**LEIA E COMPREENDA AS INSTRUÇÕES DO FABRICANTE PARA ESTE EQUIPAMENTO E AS PARTES DE USO, E SIGA AS PRÁTICAS DE SEGURANÇA DO EMPREGADOR.**

使う機械や溶材のメーカーの指示書をよく読み、まず理解して下さい。そして貴社の安全規定に従って下さい。

請詳細閱讀並理解製造廠提供的說明以及應該使用的銀焊材料，並請遵守貴方的有閣勞動保護規定。

이 제품에 동봉된 작업지침서를 숙지하시고 귀사의 작업자 안전수칙을 준수하시기 바랍니다.

اقرأ بتمعن وافهم تعليمات المصنع المنتج لهذه المعدات والمواد قبل استعمالها واتبع تعليمات الوقاية لصاحب العمل.



• World's Leader in Welding and Cutting Products •

• Sales and Service through Subsidiaries and Distributors Worldwide •

Cleveland, Ohio 44117-1199 U.S.A. TEL: 216.481.8100 FAX: 216.486.1751 WEB SITE: [www.lincolnelectric.com](http://www.lincolnelectric.com)