

INSTALLATION MANUAL

CONTENTS

GENERAL	5
SAFETY CONSIDERATIONS	5
INSPECTION	5
REFERENCE	6
RENEWAL PARTS	6
APPROVALS	6
NOMENCLATURE.....	7
INSTALLATION	8
OPERATION	60
START-UP (COOLING)	65
START-UP (GAS HEAT)	66
TROUBLESHOOTING	73

See following pages for a complete Table of Contents.

NOTES, CAUTIONS AND WARNINGS

The installer should pay particular attention to the words: *NOTE*, *CAUTION*, and *WARNING*. Notes are intended to clarify or make the installation easier. Cautions are given to prevent equipment damage. Warnings are given to alert installer that personal injury and/or equipment damage may result if installation procedure is not handled properly.

CAUTION: READ ALL SAFETY GUIDES BEFORE YOU BEGIN TO INSTALL YOUR UNIT.

SAVE THIS MANUAL

PREDATOR®

SINGLE PACKAGE AIR CONDITIONERS AND SINGLE PACKAGE GAS/ELECTRIC UNITS

DM/DH 078, 090, 102, 120 and 150

6-1/2 TO 12-1/2 TON

(9.0 TO 11.5 EER)



Tested in accordance with:



ARI Standard 340/360
Commercial and Industrial Unitary
Air Conditioning Equipment

TABLE OF CONTENTS

GENERAL	5	ECONOMIZER WITH POWER EXHAUST	61
SAFETY CONSIDERATIONS	5	MOTORIZED OUTDOOR AIR DAMPERS	61
INSPECTION	5	COOLING OPERATION ERRORS	61
REFERENCE	6	HIGH-PRESSURE LIMIT SWITCH	61
RENEWAL PARTS	6	LOW-PRESSURE LIMIT SWITCH	61
APPROVALS	6	FREEZESTAT	61
NOMENCLATURE	7	LOW AMBIENT COOLING	61
INSTALLATION	8	SAFETY CONTROLS	61
INSTALLATION SAFETY INFORMATION	8	COMPRESSOR PROTECTION	62
PRECEDING INSTALLATION	8	FLASH CODES	62
LIMITATIONS	9	RESET	62
LOCATION	10	ELECTRIC HEATING SEQUENCE	
RIGGING AND HANDLING	11	OF OPERATIONS	62
CLEARANCES	12	ELECTRIC HEAT OPERATION ERRORS	62
DUCTWORK	15	TEMPERATURE LIMIT	62
DUCT COVERS	15	SAFETY CONTROLS	62
CONDENSATE DRAIN	16	LIMIT SWITCH (LS)	62
COMPRESSORS	16	FLASH CODES	63
FILTERS	16	RESET	63
THERMOSTAT WIRING	17	ELECTRIC HEAT ANTICIPATOR SETPOINTS	63
POWER AND CONTROL WIRING	17	GAS HEATING SEQUENCE OF OPERATIONS	63
POWER WIRING DETAIL	17	IGNITION CONTROL BOARD	63
OPTIONAL ELECTRIC HEAT	31	FIRST STAGE OF HEATING	63
OPTIONAL GAS HEAT	31	SECOND STAGE OF HEATING	63
GAS PIPING	31	RETRY OPERATION	63
GAS CONNECTION	32	RECYCLE OPERATION	64
LP UNITS, TANKS AND PIPING	33	GAS HEATING OPERATION ERRORS	64
VENT AND COMBUSTION AIR	33	LOCK-OUT	64
OPTIONS/ACCESSORIES	33	TEMPERATURE LIMIT	64
ELECTRIC HEAT	33	FLAME SENSE	64
MOTORIZED OUTDOOR DAMPER	33	GAS VALVE	64
ECONOMIZER	33	SAFETY CONTROLS	64
POWER EXHAUST	33	LIMIT SWITCH (LS)	64
RAIN HOOD	34	AUXILIARY LIMIT SWITCH (ALS)	64
ECONOMIZER AND POWER EXHAUST SET		PRESSURE SWITCH (PS)	65
POINT ADJUSTMENTS AND INFORMATION	34	ROLLOUT SWITCH (ROS)	65
MINIMUM POSITION ADJUSTMENT	34	INTERNAL MICROPROCESSOR FAILURE	65
ENTHALPY SET POINT ADJUSTMENT	34	FLASH CODES	65
POWER EXHAUST DAMPER SET POINT (WITH OR		RESETS	65
WITHOUT POWER EXHAUST)	34	GAS HEAT ANTICIPATOR SETPOINTS	65
INDOOR AIR QUALITY AQ	34	START-UP (COOLING)	65
PHASING	36	PRESTART CHECK LIST	65
BLOWER ROTATION	36	OPERATING INSTRUCTIONS	65
BELT TENSION	36	POST START CHECK LIST	66
AIR BALANCE	56	START-UP (GAS HEAT)	66
CHECKING AIR QUANTITY	56	PRE-START CHECK LIST	66
METHOD ONE	56	OPERATING INSTRUCTIONS	66
METHOD TWO	56	LIGHTING THE MAIN BURNERS	66
SUPPLY AIR DRIVE ADJUSTMENT	58	POST START CHECKLIST	66
OPERATION	60	SHUT DOWN	66
SEQUENCE OF OPERATIONS OVERVIEW	60	MANIFOLD GAS PRESSURE ADJUSTMENT	66
COOLING SEQUENCE OF OPERATION	60	CHECKING GAS INPUT	67
CONTINUOUS BLOWER	60	NATURAL GAS	67
INTERMITTENT BLOWER	60	ADJUSTMENT OF TEMPERATURE RISE	68
NO OUTDOOR AIR OPTIONS	60	BURNERS/ORIFICES INSPECTION/SERVICING	68
ECONOMIZER WITH SINGLE ENTHALPY SENSOR	60	CHARGING THE UNIT	69
ECONOMIZER WITH DUAL ENTHALPY SENSORS	61	TROUBLESHOOTING	73
		PREDATOR® FLASH CODES	73
		COOLING TROUBLESHOOTING GUIDE	77
		GAS HEAT TROUBLESHOOTING GUIDE	80

LIST OF FIGURES

<u>Fig. #</u>	<u>Pg. #</u>	<u>Fig. #</u>	<u>Pg. #</u>
1	8	18	18
2	8	19	19
3	8	20	19
4	10	21	31
5	11	22	31
6	12	23	35
7	12	24	35
8	13	25	36
9	14	26	57
10	14	27	57
11	15	28	65
12	15	29	68
13	16	30	74
14	16	31	75
15	16	32	75
16	16	33	76
17	18		

LIST OF TABLES

<u>Tbl. #</u>	<u>Pg. #</u>	<u>Tbl. #</u>	<u>Pg. #</u>
1	10	17	24
2	10	18	24
3	11	19	25
4	11	20	25
5	12	21	26
6	13	22	26
7	13	23	27
8	17	24	27
9	20	25	28
10	20	26	28
11	21	27	29
12	21	28	29
13	22	29	30
14	22		
15	23		
16	23		

LIST OF TABLES (CONT'D)

<u>Tbl. #</u>	<u>Pg. #</u>	<u>Tbl. #</u>	<u>Pg. #</u>
30	30	55	53
31	31	56	53
32	31	57	54
33	32	58	54
34	36	59	55
35	37	60	55
36	37	61	59
37	38	62	59
38	39	63	60
39	40	64	62
40	41	65	63
41	42	66	63
42	43	67	64
43	44	68	65
44	44	69	67
45	45	70	67
46	45	71	69
47	46	72	69
48	46	73	70
49	47	74	70
50	48	75	71
51	49	76	71
52	50	77	72
53	51	78	72
54	52	79	72
		80	73
		81	74

GENERAL

YORK® Predator® units are single package air conditioners with optional gas heating designed for outdoor installation on a rooftop or slab and for non-residential use. These units can be equipped with factory or field installed electric heaters for heating applications.

These units are completely assembled on rigid, permanently attached base rails. All piping, refrigerant charge, and electrical wiring is factory installed and tested. The units require electric power, gas supply (where applicable), and duct connections. The electric heaters have nickel-chrome elements and utilize single-point power connection.

SAFETY CONSIDERATIONS

WARNING

Should overheating occur, or the gas supply fail to shut off, shut off the manual gas valve to the furnace before shutting off the electrical supply.

Do not use this furnace if any part has been under water. Immediately call a qualified service technician to inspect the furnace and to replace any part of the control system and any gas control which has been under water.

Due to system pressure, moving parts, and electrical components, installation and servicing of air conditioning equipment can be hazardous. Only qualified, trained service personnel should install, repair, or service this equipment. Untrained personnel can perform basic maintenance functions of cleaning coils and filters and replacing filters.

Observe all precautions in the literature, labels, and tags accompanying the equipment whenever working on air conditioning equipment. Be sure to follow all other applicable safety precautions and codes including ANSI Z223.1 or CSA-B149.1- latest edition.

Wear safety glasses and work gloves. Use quenching cloth and have a fire extinguisher available during brazing operations.

WARNING

If the information in this manual is not followed exactly, a fire or explosion may result causing property damage, personal injury or loss of life.

Do not store or use gasoline or other flammable vapors and liquids in the vicinity of this or any other appliance.

WHAT TO DO IF YOU SMELL GAS:

- a. Do not try to light any appliance.
- b. Do not touch any electrical switch; do not use any phone in your building.
- c. Immediately call your gas supplier from a neighbor's phone. Follow the gas supplier's instructions.
- d. If you cannot reach your gas supplier, call the fire department.

Installation and service must be performed by a qualified installer, service agency or the gas supplier.

INSPECTION

As soon as a unit is received, it should be inspected for possible damage during transit. If damage is evident, the extent of the damage should be noted on the carrier's freight bill. A separate request for inspection by the carrier's agent should be made in writing.

WARNING

This furnace is not to be used for temporary heating of buildings or structures under construction.

Before performing service or maintenance operations on unit, turn off main power switch to unit. Electrical shock could cause personal injury. Improper installation, adjustment, alteration, service or maintenance can cause injury or property damage. Refer to this manual. For assistance or additional information consult a qualified installer, service agency or the gas supplier.

REFERENCE

Additional information is available in the following reference forms:

- Technical Guide - DH078-150, 246646
- Technical Guide - DM078-150, 246645
- General Installation - DH/DM078-150, 264973
- Pre-start & Post-start Check List
- Economizer Accessory -
 - Downflow Factory Installed
 - Downflow Field Installed
 - Horizontal Field Installed
- Motorized Outdoor Air Damper
- Manual Outdoor Air Damper (0-100%)
- Manual Outdoor Air Damper (0-35%)
- Gas Heat Propane Conversion Kit
- Gas Heat High Altitude Kit (Natural Gas)
- Gas Heat High Altitude Kit (Propane)
- -60°F Gas Heat Kit
- Electric Heater Accessory 50" cabinet
- Electric Heater Accessory 42" cabinet

RENEWAL PARTS

Contact your local York® parts distribution center for authorized replacement parts.

APPROVALS

Design certified by CSA as follows:

1. For use as a cooling only unit, cooling unit with supplemental electric heat or a forced air furnace.
2. *For outdoor installation only.*
3. For installation on combustible material and may be installed directly on combustible flooring or, in the U.S., on wood flooring or Class A, Class B or Class C roof covering materials.
4. For use with natural gas (convertible to LP with kit).

CAUTION

This product must be installed in strict compliance with the enclosed installation instructions and any applicable local, state, and national codes including, but not limited to, building, electrical, and mechanical codes.

WARNING

Improper installation may create a condition where the operation of the product could cause personal injury or property damage.

The installer should pay particular attention to the words: NOTE, CAUTION, and WARNING. NOTES are intended to clarify or make the installation easier. CAUTIONS are given to prevent equipment damage. WARNINGS are given to alert installer that personal injury and/or equipment damage may result if installation procedure is not handled properly.

NOMENCLATURE

6.5-12.5 Ton York® Model Number Nomenclature

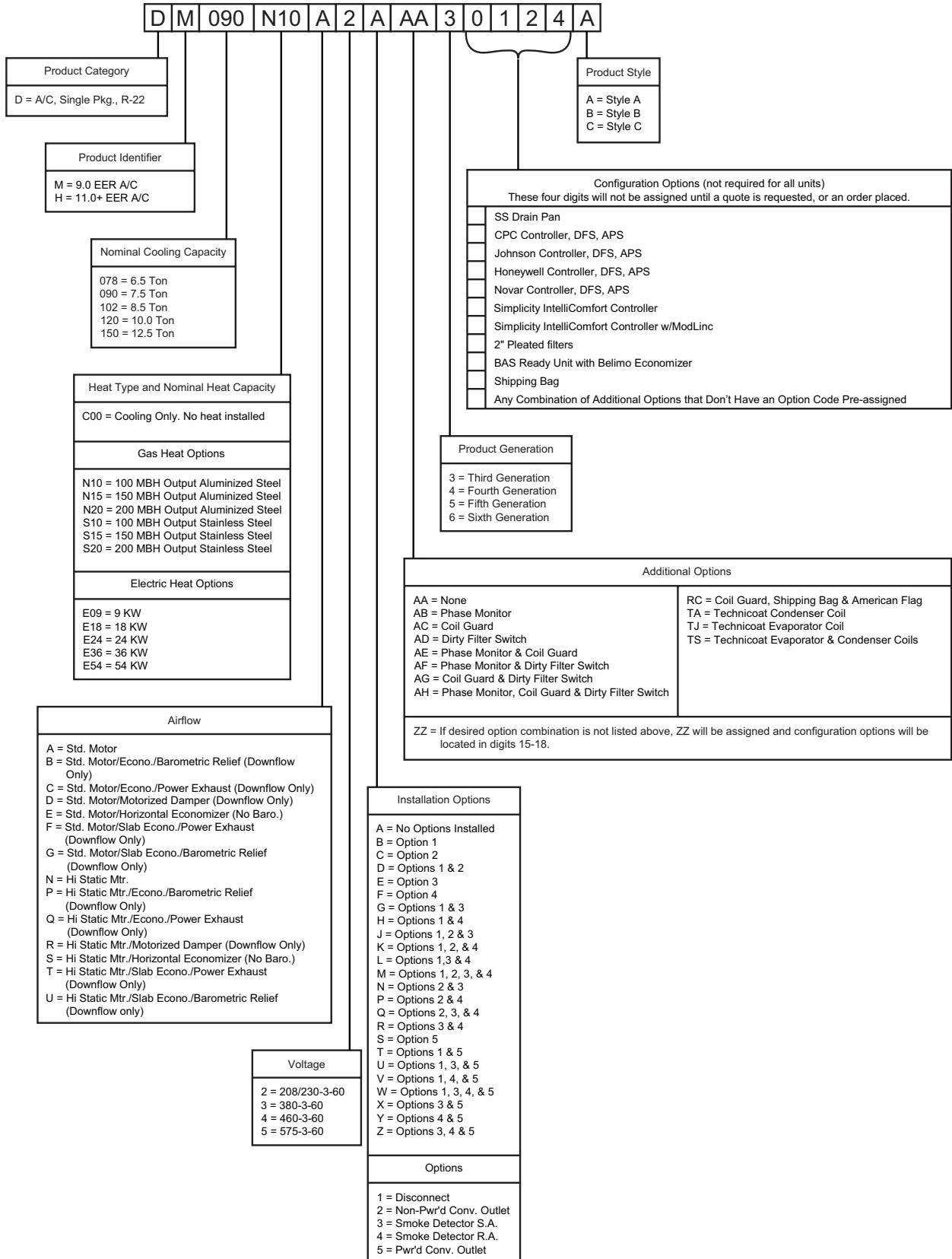

INSTALLATION

INSTALLATION SAFETY INFORMATION

Read these instructions before continuing this appliance installation. This is an outdoor combination heating and cooling unit. The installer must assure that these instructions are made available to the consumer and with instructions to retain them for future reference.

1. Refer to the furnace rating plate for the approved type of gas for this furnace.
2. Install this furnace only in a location and position as specified on Page 13 of these instructions.
3. Never test for gas leaks with an open flame. Use commercially available soap solution made specifically for the detection of leaks when checking all connections, as specified on Pages 8, 32, 33 and 66 of these instructions.
4. Always install furnace to operate within the furnace's intended temperature-rise range with the duct system and within the allowable external static pressure range, as specified on the unit name/rating plate, specified on Page 68 of these instructions.
5. This equipment is not to be used for temporary heating of buildings or structures under construction.

▲WARNING

FIRE OR EXPLOSION HAZARD

Failure to follow the safety warning exactly could result in serious injury, death or property damage.

Never test for gas leaks with an open flame. use a commercially available soap solution made specifically for the detection of leaks to check all connections. A fire or explosion may result causing property damage, personal injury or loss of life.

PRECEDING INSTALLATION

1. Remove the two screws holding the brackets in the front, rear and compressor side fork-lift slots.

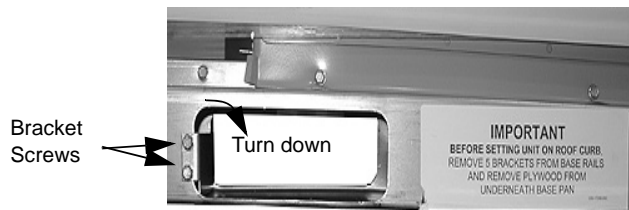

FIGURE 1 - UNIT SHIPPING BRACKET

2. Turn each bracket toward the ground and the protective plywood covering will drop to the ground.
3. Remove the condenser coil external protective covering prior to operation.
4. Remove the toolless doorknobs and instruction packet prior to installation.

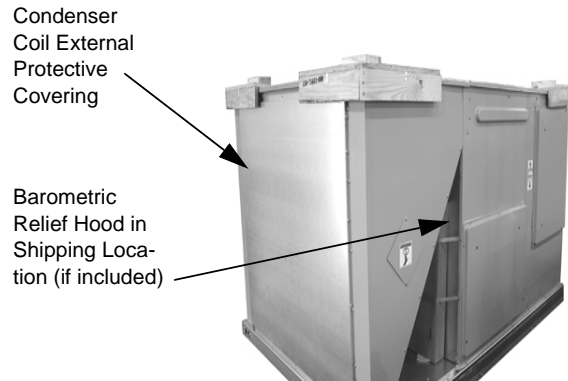

FIGURE 2 - CONDENSER COVERING

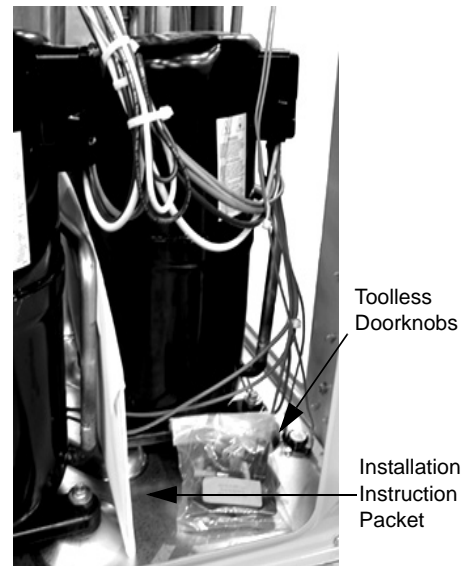

FIGURE 3 - COMPRESSOR SECTION

CAUTION

This product must be installed in strict compliance with the enclosed installation instructions and any applicable local, state and national codes including, but not limited to, building, electrical, and mechanical codes.

The furnace and its individual shut-off valve must be disconnected from the gas supply piping system during any pressure testing at pressures in excess of 1/2 PSIG.

Pressures greater than 1/2 PSIG will cause gas valve damage resulting in a hazardous condition. If it is subjected to a pressure greater than 1/2 PSIG, the gas valve must be replaced.

The furnace must be isolated from the gas supply piping system by closing its individual manual shut-off valve during any pressure testing of the gas supply piping system at test pressures equal to or less than 1/2 PSIG.

LIMITATIONS

These units must be installed in accordance with the following:

In U.S.A.:

1. National Electrical Code, ANSI/NFPA No. 70 - Latest Edition
2. National Fuel Gas Code, ANSI Z223.1 - Latest Edition

3. Gas-Fired Central Furnace Standard, ANSI Z21.47a. - Latest Edition
4. Local building codes, and
5. Local gas utility requirements

In Canada:

1. Canadian Electrical Code, CSA C22.1
2. Installation Codes, CSA - B149.1.
3. Local plumbing and waste water codes, and
4. Other applicable local codes.

Refer to Tables 1 & 2 for unit application data.

After installation, gas fired units must be adjusted to obtain a temperature rise within the range specified on the unit rating plate.

If components are to be added to a unit to meet local codes, they are to be installed at the dealer's and/or customer's expense.

Size of unit for proposed installation should be based on heat loss/heat gain calculation made according to the methods of Air Conditioning Contractors of America (ACCA).

This furnace is not to be used for temporary heating of buildings or structures under construction.

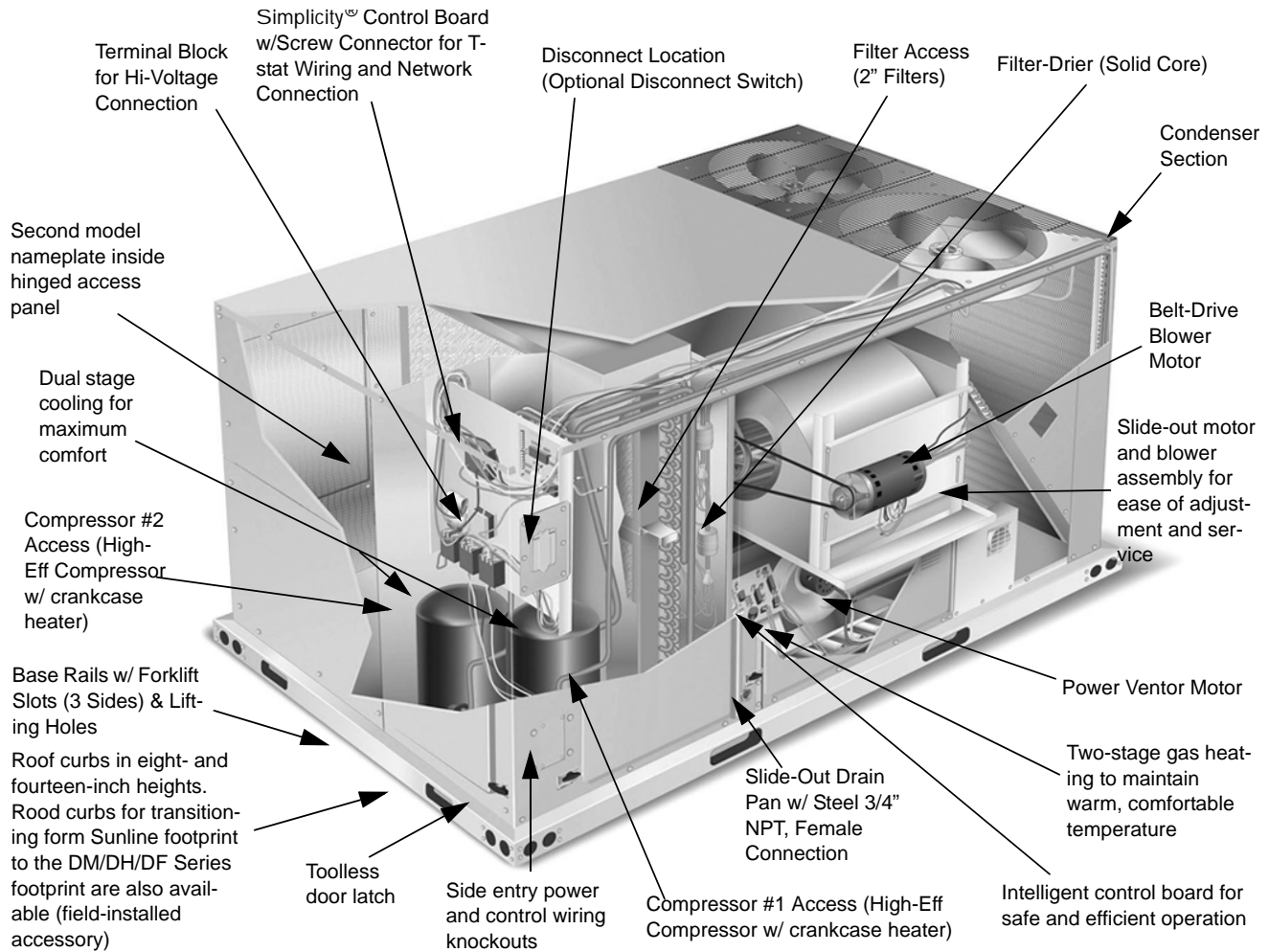

FIGURE 4 - PREDATOR® COMPONENT LOCATION (DM 120 SHOWN)

TABLE 1: UNIT VOLTAGE LIMITATIONS

Power Rating ¹	Minimum	Maximum
208/230-3-60	187	252
460-3-60	432	504
575-3-60	540	630

¹. Utilization range "A" in accordance with ARI Standard 110.

TABLE 2: UNIT TEMPERATURE LIMITATIONS

Temperature	Min.	Max.
Wet Bulb Temperature (°F) of Air on Evaporator Coil	57	72
Dry Bulb Temperature (°F) of Air on Condenser Coil	0 ¹	125

¹. A low ambient accessory is available for operation down to -20°F.

LOCATION

Use the following guidelines to select a suitable location for these units:

1. Unit is designed for *outdoor installation only*.
2. Condenser coils must have an unlimited supply of air. Where a choice of location is possible, position the unit on either north or east side of building.
3. Suitable for mounting on roof curb.
4. For ground level installation, use a level concrete slab with a minimum thickness of 4 inches. The length and width should be at least 6 inches greater than the unit base rails. Do not tie slab to the building foundation.
5. Roof structures must be able to support the weight of the unit and its options/accessories. Unit must be installed on a solid, level roof curb or appropriate angle iron frame.

- 6. Maintain level tolerance to 1/2" across the entire width and length of unit.

WARNING

Excessive exposure of this furnace to contaminated combustion air may result in equipment damage or personal injury. Typical contaminants include: permanent wave solution, chlorinated waxes and cleaners, chlorine based swimming pool chemicals, water softening chemicals, carbon tetrachloride, Halogen type refrigerants, cleaning solvents (e.g. perchloroethylene), printing inks, paint removers, varnishes, hydrochloric acid, cements and glues, antistatic fabric softeners for clothes dryers, masonry acid washing materials.

RIGGING AND HANDLING

Exercise care when moving the unit. Do not remove any packaging until the unit is near the place of installation. Rig the unit by attaching chain or cable slings to the lifting holes provided in the base rails. Spreader bars, whose length exceeds the largest dimension across the unit, **MUST** be used across the top of the unit.

CAUTION

If a unit is to be installed on a roof curb other than a YORK roof curb, gasketing must be applied to all surfaces that come in contact with the unit underside.

CAUTION

Before lifting, make sure the unit weight is distributed equally on the rigging cables so it will lift evenly.

Units may be moved or lifted with a forklift. Slotted openings in the base rails are provided for this purpose.

LENGTH OF FORKS MUST BE A MINIMUM OF 60 INCHES.

CAUTION

All panels must be secured in place when the unit is lifted.

The condenser coils should be protected from rigging cable damage with plywood or other suitable material.

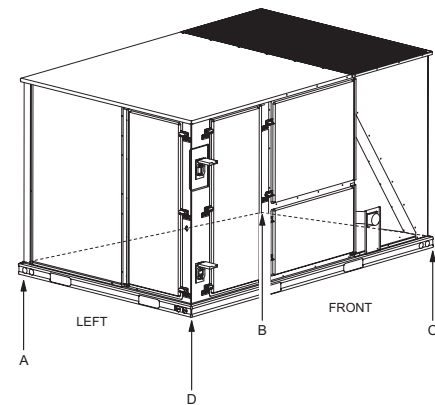

FIGURE 5 - UNIT 4 POINT LOAD

TABLE 3: UNIT WEIGHTS

Model	Shipping Weight ¹ (lb.)	Operating Weight ¹ (lb.)
DM078	1056	1041
DM090	865	860
DM102	880	875
DM120	1131	1116
DM150	1210	1195
DH078	888	883
DH090	895	890
DH102	905	900
DH120	1222	1207
DH150	1212	1197
w/Econ.	85	84
w/ PE	150	148
w/Elec. Heat	49	49
w/Gas Heat ²	110	110

1. 54 kW heater.
2. 8 Tube Heat Exchanger.

TABLE 4: 4 POINT LOAD WEIGHT

Model	Location (lbs.) ¹			
	A	B	C	D
DM078	228	195	285	333
DM090	192	143	224	301
DM102	195	146	228	306
DM120	245	209	305	357
DM150	262	224	327	382
DH078	197	147	230	309
DH090	199	148	232	311
DH102	201	150	234	315
DH120	265	226	330	386
DH150	263	224	327	383

¹. Weights include largest gas heat option.

TABLE 5: 6 POINT LOAD WEIGHT

Model	Location (lbs.) ¹					
	A	B	C	D	E	F
DM078	156	140	127	185	205	228
DM090	135	110	91	142	172	211
DM102	137	112	93	145	175	214
DM120	168	151	136	198	219	244
DM150	180	161	145	212	235	262
DH078	138	113	93	146	176	216
DH090	139	113	94	147	128	218
DH102	141	115	95	149	180	221
DH120	181	163	147	214	237	264
DH150	180	161	146	213	235	262

¹. Weights include largest gas heat option.

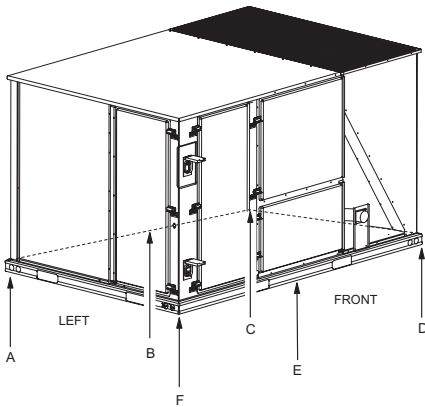
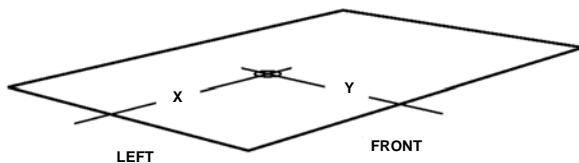
**FIGURE 6 - UNIT 6 POINT LOAD**

Unit Model Number	X	Y
DM078	47 1/2	25 1/2
DM090	38	23
DM102	38	23
DM120	47 1/2	25 1/2
DM150	47 1/2	25 1/2
DH078	38	23
DH090	38	23
DH102	38	23
DH120	47 1/2	25 1/2
DH150	47 1/2	25 1/2

FIGURE 7 - UNIT CENTER OF GRAVITY**CLEARANCES**

All units require particular clearances for proper operation and service. Installer must make provisions for adequate combustion and ventilation air in accordance with section 5.3 of Air for Combustion and Ventilation of the National Fuel Gas Code, ANSI Z223.1 – Latest Edition (in U.S.A.), or Sections 7.2, 7.3, or 7.4 of Gas Installation Codes, CSA-B149.1 (in Canada) - Latest Edition, and/or applicable provisions of the local building codes. Refer to Table 7 for clearances required for combustible construction, servicing, and proper unit operation.

WARNING

Do not permit overhanging structures or shrubs to obstruct condenser air discharge outlet, combustion air inlet or vent outlets.

WARNING

Excessive exposure to contaminated combustion air will result in safety and performance related problems. To maintain combustion air quality, the recommended source of combustion air is the outdoor air supply. The outdoor air supplied for combustion should be free from contaminants due to chemical exposure that may be present from the following sources.

- Commercial buildings
- Indoor pools
- Laundry rooms
- Hobby or craft rooms
- Chemical storage areas

The following substances should be avoided to maintain outdoor combustion air quality.

- Permanent wave solutions
- Chlorinated waxes and cleaners
- Chlorine based swimming pool cleaners
- Water softening chemicals
- De-icing salts or chemicals
- Carbon tetrachloride
- Halogen type refrigerants
- Cleaning solvents (such as perchloroethylene)
- Printing inks, paint removers, varnishes, etc.
- Hydrochloric acid
- Cements and glues
- Anti-static fabric softeners for clothes dryers
- Masonry acid washing materials

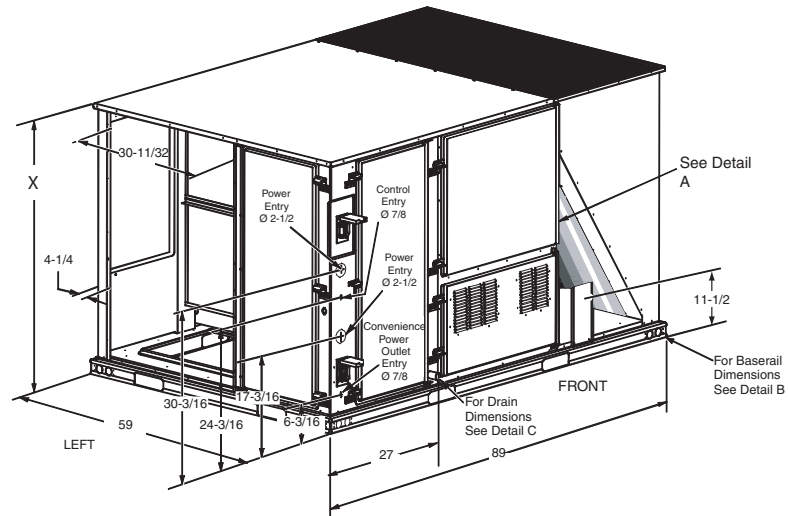

FIGURE 8 - UNIT DIMENSIONS

TABLE 6: UNIT HEIGHT

Unit Model Number	X
DM078	50 3/4
DM090	42
DM102	42
DM120	50 3/4
DM150	50 3/4
DH078	42
DH090	42
DH102	42
DH120	50 3/4
DH150	50 3/4

TABLE 7: UNIT CLEARANCES

Top ¹	72"	Right	12"
Front ²	36"	Left	36"
Rear ³	36"	Bottom ⁴	0"

- Units must be installed outdoors. Overhanging structure or shrubs should not obstruct condenser air discharge outlet.
- The products of combustion must not be allowed to accumulate within a confined space and re-circulate.
- To remove the slide-out drain pan, a rear clearance of sixty inches is required. If space is unavailable, the drain pan can be removed through the front by separating the corner wall.
- Units may be installed on combustible floors made from wood or class A, B or C roof covering materials.

DETAIL A

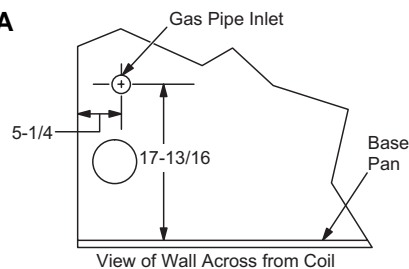

NOTE: A one-inch clearance must be provided between any combustible material and the supply ductwork for a distance of 3 feet from the unit.

DETAIL B

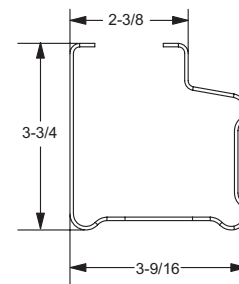

DETAIL C

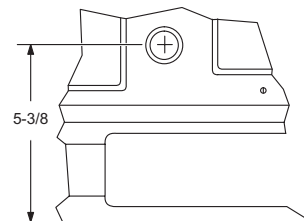

NOTE: If the unit includes gas heating, locate the unit so the flue exhaust is at least:

- Three (3) feet above any forced air inlet located within 10 horizontal feet (excluding those integral to the unit).
- Four (4) feet below, four (4) horizontal feet from, or one (1) foot above any door or gravity air inlet into the building.
- Four (4) feet from electric meters, gas meters, regulators, and relief equipment.

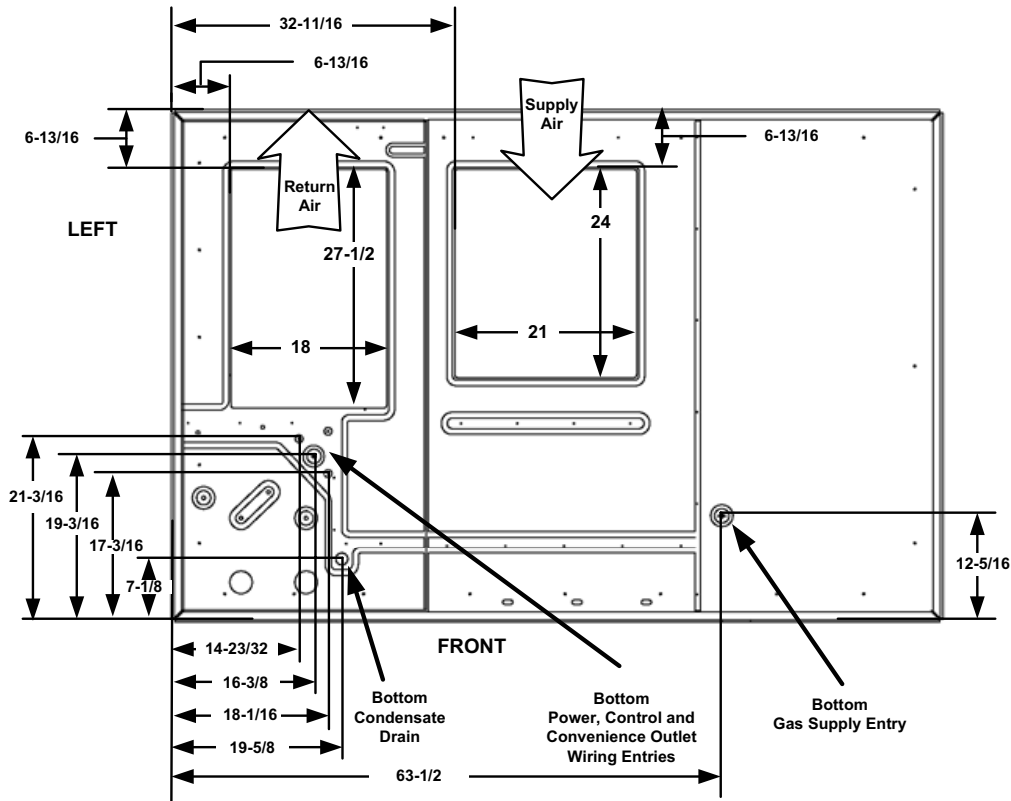

FIGURE 9 - BOTTOM DUCT OPENINGS (FROM ABOVE)

REAR DUCT DIMENSIONS

CABINET SIZE	DIMENSION		
	"A"	"B"	"C"
50 3/4"	28 1/4	18 1/16	28 1/4
42"	27 3/4	12 1/16	27 1/2

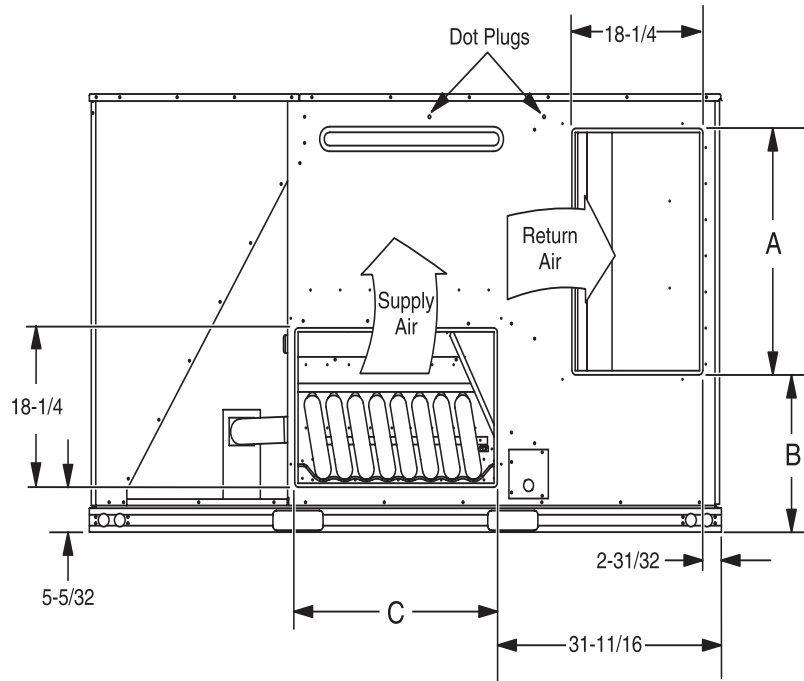

FIGURE 10 - REAR DUCT DIMENSIONS

DUCTWORK

Ductwork should be designed and sized according to the methods in Manual D of the Air Conditioning Contractors of America (ACCA) or as recommended by any other recognized authority such as ASHRAE or SMACNA.

A closed return duct system should be used. This will not preclude use of economizers or outdoor fresh air intake. The supply and return air duct connections at the unit should be made with flexible joints to minimize noise.

The supply and return air duct systems should be designed for the CFM and static pressure requirements of the job. They should NOT be sized to match the dimensions of the duct connections on the unit.

Refer to Figure 9 for bottom air duct openings. Refer to Figure 10 for rear air duct openings.

DUCT COVERS

Units are shipped with the side duct openings covered and a covering over the bottom of the unit. For bottom duct application, no duct cover changes are necessary. For side duct application, remove the side duct covers and install over the bottom duct openings. The panels removed from the side duct connections are designed to be reused by securing each panel to its respective downflow opening. But keep in mind that the supply panel is installed with the painted surface UP, facing the heat exchanger, while the return panel is installed with the painted surface DOWN, facing the downflow duct opening. The supply panel is secured with the bracket (already in place from the factory) and two screws. It's a snug fit for the panel when sliding it between the heat exchanger and unit bottom, but there is room. The return panel is secured with four screws.

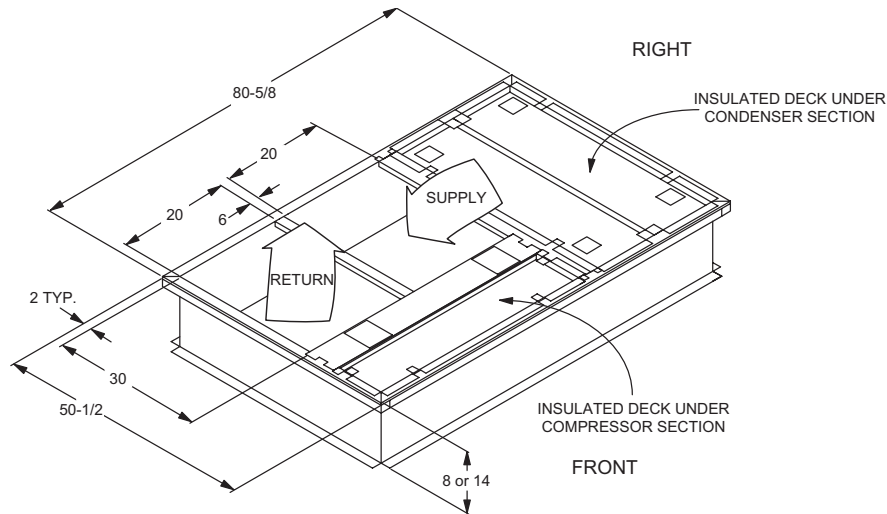

FIGURE 11 - PREDATOR® ROOF CURB DIMENSIONS

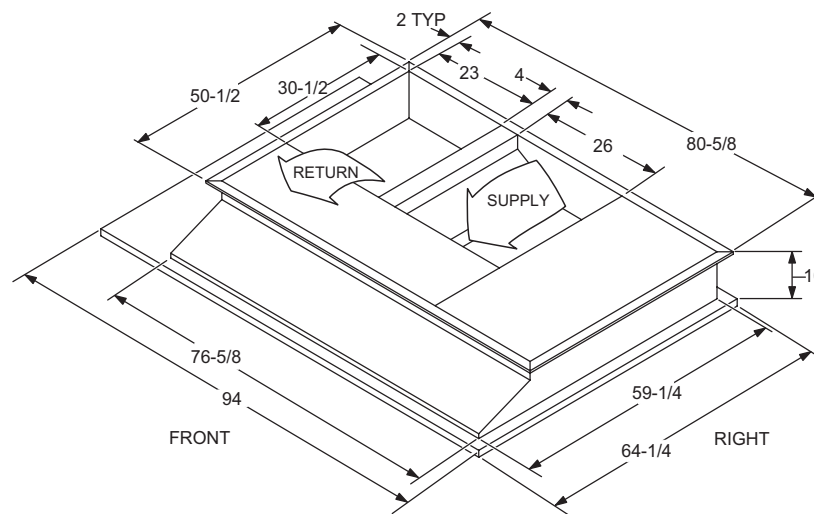

FIGURE 12 - SUNLINE™ TO PREDATOR® TRANSITION ROOF CURBS

CAUTION

When fastening ductwork to side duct flanges on unit, insert screws through duct flanges only. DO NOT insert screws through casing. Outdoor ductwork must be insulated and water-proofed.



FIGURE 13 - SIDE PANELS WITH HOLE PLUGS

Note orientation. Panel is “insulation” side up.



FIGURE 14 - RETURN DOWNFLOW PLENUM WITH PANEL



FIGURE 15 - DISCHARGE PANEL IN PLACE

CONDENSATE DRAIN

The side condensate drain is reversible and maybe re-oriented to the rear of the cabinet to facilitate condensate piping. A condensate drain connection is available through the base pan for piping inside the roof curb. Trap the connection per Figure 16. The trap and drain lines should be protected from freezing.

Plumbing must conform to local codes. Use a sealing compound on male pipe threads. Install condensate drain line from the 3/4 inch NPT female connection on the unit to an open drain.

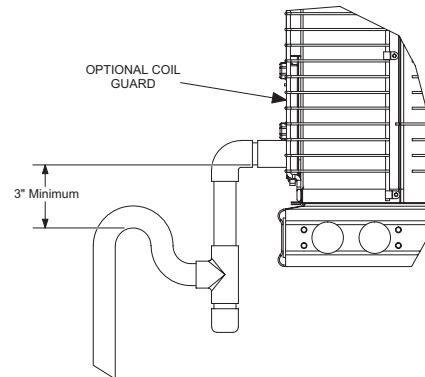

FIGURE 16 - CONDENSATE DRAIN

COMPRESSORS

The compressors are mounted on elastomer insulators. The mounting bolts have been fully tightened for shipping.

CAUTION

Do not loosen the compressor mounting bolts.

FILTERS

Two-inch filters are supplied with each unit. One-inch filters may be used with no modification to the filter racks. Filters must always be installed ahead of evaporator coil and must be kept clean or replaced with same size and type. Dirty filters reduce the capacity of the unit and result in frosted coils or safety shutdown. Refer to physical data tables, for the number and size of filters needed for the unit. The unit should not be operated without filters properly installed.

CAUTION

Make sure that panel latches are properly positioned on the unit to maintain an airtight seal.

THERMOSTAT WIRING

The thermostat should be located on an inside wall approximately 56 inch above the floor where it will not be subject to drafts, sun exposure or heat from electrical fixtures or appliances. Follow the manufacturer's instructions enclosed with thermostat for general installation procedure. Seven (7) color-coded, insulated wires should be used to connect the thermostat to the unit. Refer to Table 8 for control wire sizing and maximum length.

TABLE 8: CONTROL WIRE SIZES

Wire Size	Maximum Length ¹
18 AWG	150 Feet

¹. From the unit to the thermostat and back to the unit.

POWER AND CONTROL WIRING

Field wiring to the unit, fuses, and disconnects must conform to provisions of National Electrical Code (NEC), ANSI/NFPA No. 70 – Latest Edition (in U.S.A.), current Canadian Electrical Code C221, and/or local ordinances. The unit must be electrically grounded in accordance with NEC and CEC as specified above and/or local codes.

Voltage tolerances which must be maintained at the compressor terminals during starting and running conditions are indicated on the unit Rating Plate and Table 1.

The internal wiring harnesses furnished with this unit are an integral part of the design certified unit. Field alteration to comply with electrical codes should not be required. If any of the wire supplied with the unit must be replaced, replacement wire must be of the type shown on the wiring diagram and the same minimum gauge as the replaced wire.

A disconnect must be utilized for these units. Factory installed disconnects are available. If installing a disconnect (field supplied or York International[®] supplied accessory), refer to Figure 4 for the recommended mounting location.

CAUTION

Avoid damage to internal components if drilling holes for disconnect mounting.

NOTE: Since not all local codes allow the mounting of a disconnect on the unit, please confirm compliance with local code before mounting a disconnect on the unit.

Electrical line must be sized properly to carry the load. USE COPPER CONDUCTORS ONLY. Each unit must be wired with a separate branch circuit fed directly from the meter panel and properly fused.

Refer to Figures 17, 18 and 19 for typical field wiring and to the appropriate unit wiring diagram mounted inside control doors for control circuit and power wiring information.

CAUTION

When connecting electrical power and control wiring to the unit, water-proof connectors must be used so that water or moisture cannot be drawn into the unit during normal operation. The above water-proofing conditions will also apply when installing a field supplied disconnect switch.

POWER WIRING DETAIL

Units are factory wired for the voltage shown on the unit nameplate. Refer to Electrical Data Tables 9 to 28 to size power wiring, fuses, and disconnect switch.

Power wiring is brought into the unit through the side of the unit or the basepan inside the curb.

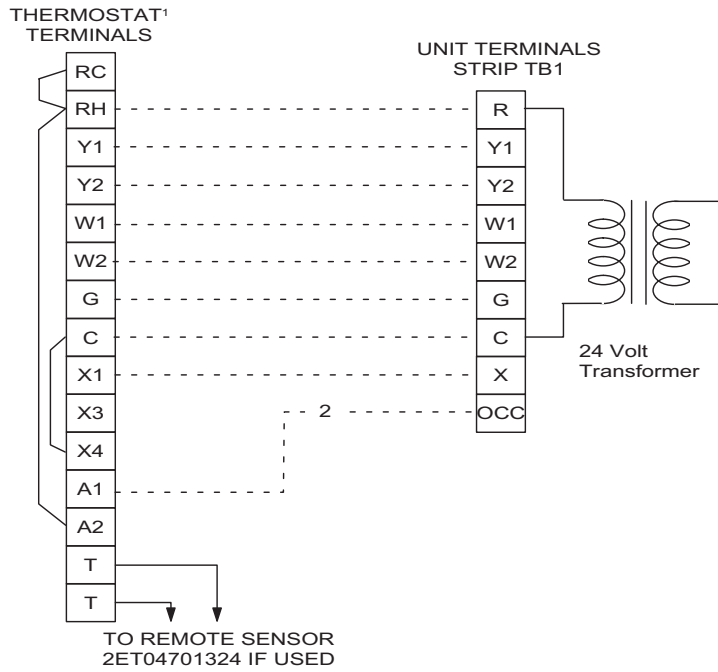

¹ Electronic programmable Thermostat 2ET0770010024 (includes subbase).
² Terminals A1 and A2 provide a relay output to close the outdoor economizer dampers when the thermostat switches to the set-back position.

FIGURE 17 - ELECTRONIC THERMOSTAT FIELD WIRING

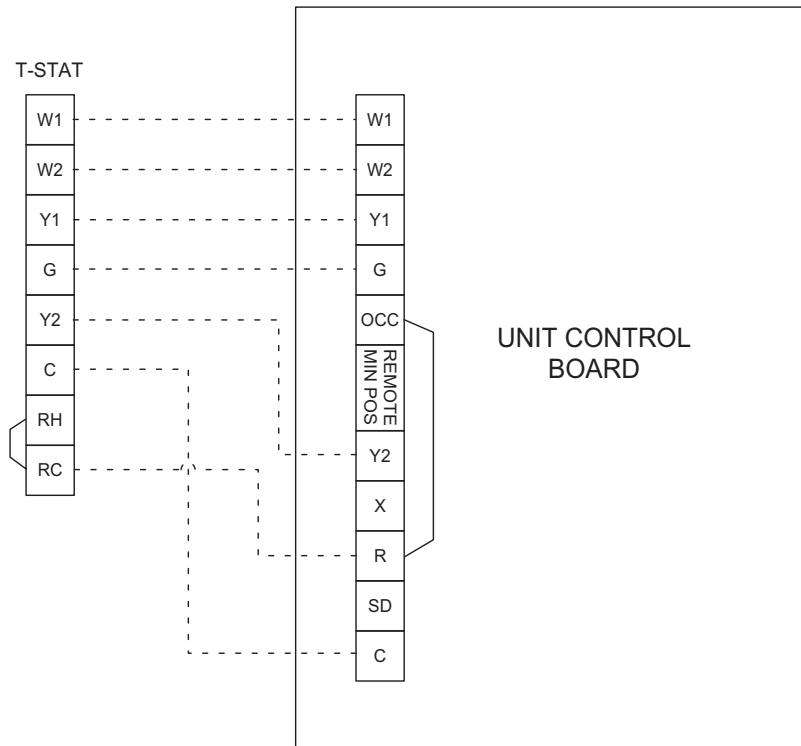

FIGURE 18 - FIELD WIRING 24 VOLT THERMOSTAT

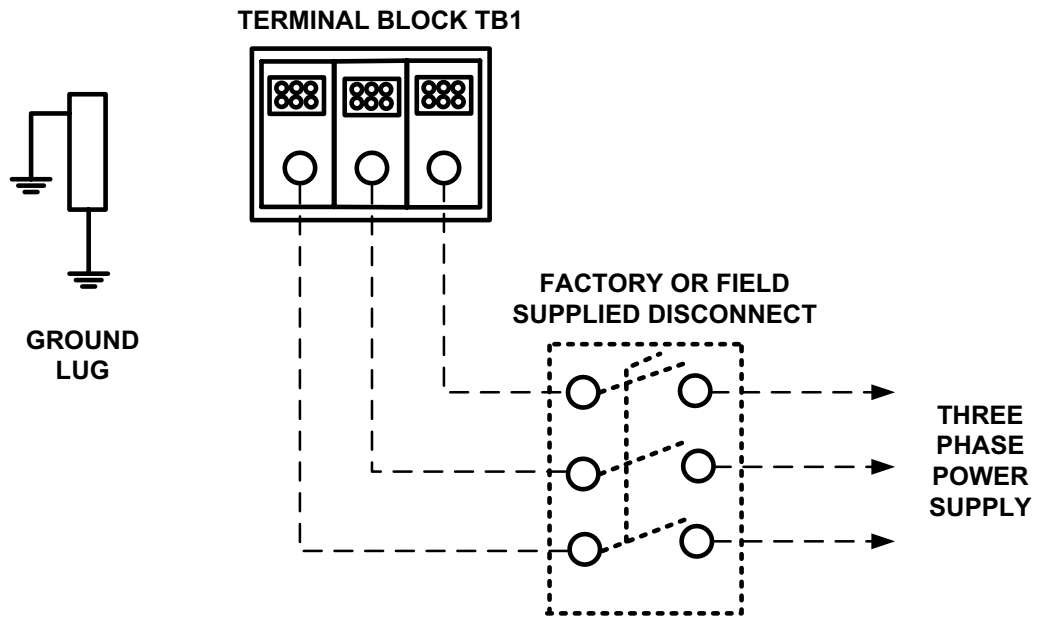

FIGURE 19 - FIELD WIRING DISCONNECT - COOLING UNIT WITH/WITHOUT ELECTRIC HEAT

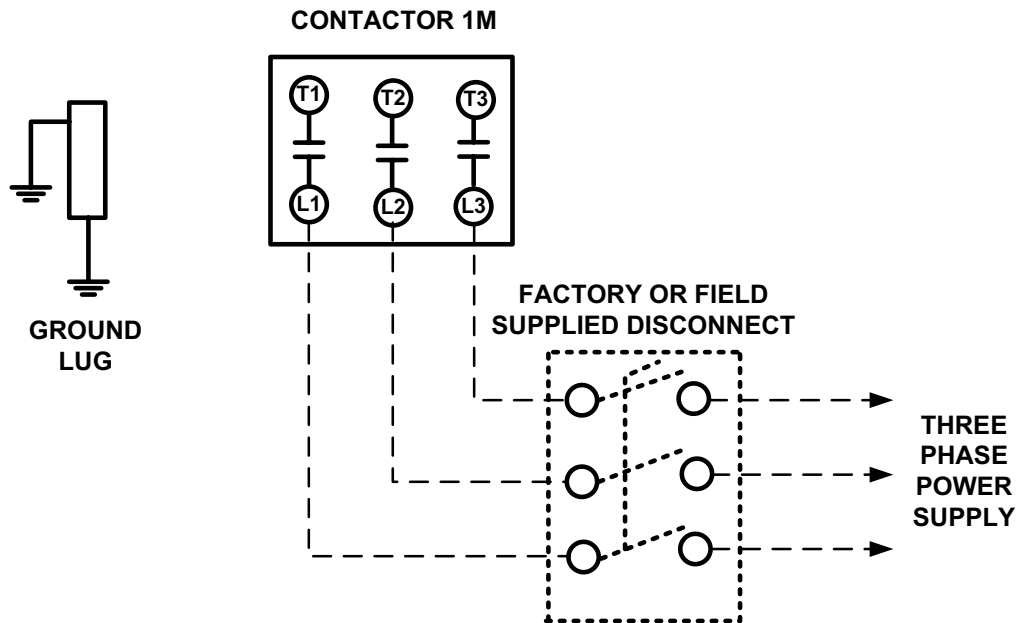

FIGURE 20 - FIELD WIRING DISCONNECT - COOLING UNIT WITH GAS HEAT

TABLE 9: ELECTRICAL DATA - DM078 (6-1/2 TON) STANDARD EFFICIENCY W/O PWRD CONV. OUTLET

Voltage	Compressors		OD Fan Motors	Supply Blower Motor FLA		Pwr Exh Motor	Pwr Conv Outlet	Electric Heater Model No.	Actual KW	Heater Amps	Min. Circuit Ampacity (Amps)		MCA w/Power Exhaust (Amps)		Max Fuse* Size (Amps)		Max Fuse* Size w/Power Exhaust (Amps)			
	RLA ea.	LRA ea.	FLA ea.	1.5 HP	2 HP	FLA	FLA				1.5 HP	2 HP	1.5 HP	2 HP	1.5 HP	2 HP	1.5 HP	2 HP		
208	12.8	110.0	1.5	6.2	8.2	5.5	0.0	None	--	--	38.0	40.0	43.5	45.5	50	50	50	50		
								2TP04520925	6.8	18.9	38.0	40.0	43.5	45.5	50	50	50	50	50	50
								2TP04521825	13.5	37.5	54.6	57.1	61.5	64.0	60	60	70	70	70	70
								2TP04522425	18	50.0	70.2	72.7	77.1	79.6	80	80	80	80	80	80
								2TP04523625	25.5	70.8	96.2	98.7	103.1	105.6	100	100	110	110	110	110
230	12.8	110.0	1.5	6.2	8.2	5.5	0.0	None	--	--	38.0	40.0	43.5	45.5	50	50	50	50		
								2TP04520925	9	21.7	38.0	40.0	43.5	45.5	50	50	50	50	50	
								2TP04521825	18	43.3	61.9	64.4	68.8	71.3	70	70	70	70	80	
								2TP04522425	24	57.7	79.9	82.4	86.8	89.3	80	90	90	90	90	
								2TP04523625	34	81.8	110.0	112.5	116.9	119.4	110	125	125	125	125	
460	7.1	54.0	0.8	3.1	4.1	2.2	0.0	None	--	--	20.7	21.7	22.9	23.9	25	25	25	30		
								2TP04520946	9	11.3	20.7	21.7	22.9	23.9	25	25	25	30	30	
								2TP04521846	18	22.6	30.9	32.2	33.7	34.9	35	35	35	35	35	
								2TP04522446	24	30.1	40	41.2	42.7	44	40	45	45	45	45	
								2TP04523646	34	42.7	55	56.2	57.7	59	60	60	60	60	60	
575	5.1	44.0	0.6	2.4	3.6	1.8	0.0	None	--	--	15.1	16.3	16.9	18.1	20	20	20	20		
								2TP04520958	9	9.0	15.1	16.3	16.9	18.1	20	20	20	20	20	
								2TP04521858	18	18.1	24.7	26.2	26.9	28.4	25	30	30	30	30	
								2TP04522458	24	24.1	31.9	33.4	34.1	35.6	35	35	35	40	40	
								2TP04523658	34	34.1	43.9	45.4	46.1	47.6	45	50	50	50	50	

* Maximum HACR breaker of the same AMP size is applicable.

TABLE 10: ELECTRICAL DATA - DM078 (6-1/2 TON) STANDARD EFFICIENCY W/PWRD CONV. OUTLET

Voltage	Compressors		OD Fan Motors	Supply Blower Motor FLA		Pwr Exh Motor	Pwr Conv Outlet	Electric Heater Model No.	Actual KW	Heater Amps	Min. Circuit Ampacity (Amps)		MCA w/Power Exhaust (Amps)		Max Fuse* Size (Amps)		Max Fuse* Size w/Power Exhaust (Amps)		
	RLA ea.	LRA ea.	FLA ea.	1.5 HP	2 HP	FLA	FLA				1.5 HP	2 HP	1.5 HP	2 HP	1.5 HP	2 HP	1.5 HP	2 HP	
208	12.8	110.0	1.5	6.2	8.2	5.5	10.0	None	--	--	48.0	50.0	53.5	55.5	60	60	60	60	
								2TP04520925	6.8	18.9	48.0	50.0	53.5	55.5	60	60	60	60	60
								2TP04521825	13.5	37.5	67.1	69.6	74.0	76.5	70	70	80	80	80
								2TP04522425	18	50.0	82.7	85.2	89.6	92.1	90	90	90	100	100
								2TP04523625	25.5	70.8	108.7	111.2	115.6	118.1	110	125	125	125	125
230	12.8	110.0	1.5	6.2	8.2	5.5	10.0	None	--	--	48.0	50.0	53.5	55.5	60	60	60	60	
								2TP04520925	9	21.7	48.0	50.0	54.2	56.7	60	60	60	60	
								2TP04521825	18	43.3	74.4	76.9	81.3	83.8	80	80	90	90	
								2TP04522425	24	57.7	92.4	94.9	99.3	101.8	100	100	100	110	
								2TP04523625	34	81.8	122.5	125.0	129.4	131.9	125	125	150	150	
460	7.1	54.0	0.8	3.1	4.1	2.2	5.0	None	--	--	25.7	26.7	27.9	28.9	30	30	30	35	
								2TP04520946	9	11.3	25.7	26.7	27.9	28.9	30	30	30	35	
								2TP04521846	18	22.6	37.2	38.4	39.9	41.2	40	40	40	45	
								2TP04522446	24	30.1	46.2	47.5	49	50.2	50	50	50	60	
								2TP04523646	34	42.7	61.2	62.5	64	65.2	70	70	70	70	
575	5.1	44.0	0.6	2.4	3.6	1.8	4.0	None	--	--	19.1	20.3	20.9	22.1	20	25	25	25	
								2TP04520958	9	9.0	19.1	20.3	21.1	22.6	20	25	25	25	
								2TP04521858	18	18.1	29.7	31.2	31.9	33.4	30	35	35	35	
								2TP04522458	24	24.1	36.9	38.4	39.1	40.6	40	40	40	45	
								2TP04523658	34	34.1	48.9	50.4	51.1	52.6	50	60	60	60	

* Maximum HACR breaker of the same AMP size is applicable.

TABLE 11: ELECTRICAL DATA - DH078 (6-1/2 TON) HIGH EFFICIENCY W/O PWRD CONV. OUTLET

Voltage	Compressors		OD Fan Motors	Supply Blower Motor FLA		Pwr Exh Motor	Pwr Conv Outlet	Electric Heater Model No.	Actual KW	Heater Amps	Min. Circuit Ampacity (Amps)		MCA w/Power Exhaust (Amps)		Max Fuse* Size (Amps)		Max Fuse Size w/Power Exhaust (Amps)			
	RLA	LRA	FLA	1.5	2	FLA	FLA				1.5	2	1.5	2	1.5	2	1.5	2	1.5	2
	ea.	ea.	ea.	HP	HP						HP	HP	HP	HP	HP	HP	HP	HP	HP	HP
208	9.0	72.0	1.5	6.2	8.2	5.5	0.0	None	--	--	29.5	31.5	35.0	37.0	35	40	40	45		
								2TP04540925	6.8	18.9	31.3	33.8	38.2	40.7	35	40	40	45		
								2TP04541825	13.5	37.5	54.6	57.1	61.5	64.0	60	60	70	70		
								2TP04542425	18	50.0	70.2	72.7	77.1	79.6	80	80	80	80		
								2TP04543625	25.5	70.8	96.2	98.7	103.1	105.6	100	100	110	110		
230	9.0	72.0	1.5	6.2	8.2	5.5	0.0	None	--	--	29.5	31.5	35.0	37.0	35	40	40	45		
								2TP04540925	9	21.7	34.8	37.3	41.7	44.2	35	40	45	45		
								2TP04541825	18	43.3	61.9	64.4	68.8	71.3	70	70	70	80		
								2TP04542425	24	57.7	79.9	82.4	86.8	89.3	80	90	90	90		
								2TP04543625	34	81.8	110.0	112.5	116.9	119.4	110	125	125	125		
460	5.8	45.0	0.8	3.1	4.1	2.2	0.0	None	--	--	17.8	18.8	20	21	20	20	25	25		
								2TP04540946	9	11.3	17.8	18.8	20.2	21.4	20	20	25	25		
								2TP04541846	18	22.6	30.9	32.2	33.7	34.9	35	35	35	35		
								2TP04542446	24	30.1	40	41.2	42.7	44	40	45	45	45		
								2TP04543646	34	42.7	55	56.2	57.7	59	60	60	60	60		
575	4.5	36.0	0.6	2.4	3.6	1.8	0.0	None	--	--	13.7	14.9	15.5	16.7	15	15	20	20		
								2TP04540958	9	9.0	13.8	15.3	16.1	17.6	15	20	20	20		
								2TP04541858	18	18.1	24.7	26.2	26.9	28.4	25	30	30	30		
								2TP04542458	24	24.1	31.9	33.4	34.1	35.6	35	35	35	40		
								2TP04543658	34	34.1	43.9	45.4	46.1	47.6	45	50	50	50		

TABLE 12: ELECTRICAL DATA - DH078 (6-1/2 TON) HIGH EFFICIENCY W/PWRD CONV. OUTLET

Voltage	Compressors		OD Fan Motors	Supply Blower Motor FLA		Pwr Exh Motor	Pwr Conv Outlet	Electric Heater Model No.	Actual KW	Heater Amps	Min. Circuit Ampacity (Amps)		MCA w/Power Exhaust (Amps)		Max Fuse* Size (Amps)		Max Fuse Size w/Power Exhaust (Amps)			
	RLA	LRA	FLA	1.5	2	FLA	FLA				1.5	2	1.5	2	1.5	2	1.5	2	1.5	2
	ea.	ea.	ea.	HP	HP						HP	HP	HP	HP	HP	HP	HP	HP	HP	HP
208	9.0	72.0	1.5	6.2	8.2	5.5	10.0	None	--	--	39.7	41.7	45.2	47.2	45	50	50	50		
								2TP04540925	6.8	18.9	43.8	46.3	50.7	53.2	45	50	60	60		
								2TP04541825	13.5	37.5	67.1	69.6	74.0	76.5	70	70	80	80		
								2TP04542425	18	50.0	82.7	85.2	89.6	92.1	90	90	90	100		
								2TP04543625	25.5	70.8	108.7	111.2	115.6	118.1	110	125	125	125		
230	9.0	72.0	1.5	6.2	8.2	5.5	10.0	None	--	--	39.7	41.7	45.2	47.2	45	50	50	50		
								2TP04540925	9	21.7	47.3	49.8	54.2	56.7	50	50	60	60		
								2TP04541825	18	43.3	74.4	76.9	81.3	83.8	80	80	90	90		
								2TP04542425	24	57.7	92.4	94.9	99.3	101.8	100	100	100	110		
								2TP04543625	34	81.8	122.5	125.0	129.4	131.9	125	125	150	150		
460	5.8	45.0	0.8	3.1	4.1	2.2	5.0	None	--	--	22.8	23.8	25	26	25	25	30	30		
								2TP04540946	9	11.3	23.7	24.9	26.4	27.7	25	25	30	30		
								2TP04541846	18	22.6	37.2	38.4	39.9	41.2	40	40	40	45		
								2TP04542446	24	30.1	46.2	47.5	49	50.2	50	50	50	60		
								2TP04543646	34	42.7	61.2	62.5	64	65.2	70	70	70	70		
575	4.5	36.0	0.6	2.4	3.6	1.8	4.0	None	--	--	17.7	18.9	19.5	20.7	20	20	20	25		
								2TP04540958	9	9.0	18.8	20.3	21.1	22.6	20	25	25	25		
								2TP04541858	18	18.1	29.7	31.2	31.9	33.4	30	35	35	35		
								2TP04542458	24	24.1	36.9	38.4	39.1	40.6	40	40	40	45		
								2TP04543658	34	34.1	48.9	50.4	51.1	52.6	50	60	60	60		

TABLE 13: ELECTRICAL DATA - DM090 (7-1/2 TON) STANDARD EFFICIENCY W/O PWRD CONV. OUTLET

Voltage	Compressors		OD Fan Motors	Supply Blower Motor FLA		Pwr Exh Motor	Pwr Conv Outlet	Electric Heater Model No.	Actual KW	Heater Amps	Min. Circuit Ampacity (Amps)		MCA w/Power Exhaust (Amps)		Max Fuse* Size (Amps)		Max Fuse Size w/Power Exhaust (Amps)			
	RLA	LRA	FLA	2 HP	3 HP	FLA	FLA				2 HP	3 HP	2 HP	3 HP	2 HP	3 HP	2 HP	3 HP		
	ea.	ea.	ea.																	
208	11.5	84.0	3.5	8.2	10.9	5.5	0.0	None	--	--	41.1	43.8	46.6	49.3	50	50	50	60		
								2TP04540925	6.8	18.9	41.1	43.8	46.6	49.3	50	50	50	50	60	60
								2TP04541825	13.5	37.5	57.1	60.5	64.0	67.3	60	70	70	70	70	70
								2TP04542425	18.0	50.0	72.7	76.1	79.6	83.0	80	80	80	80	90	90
								2TP04543625	25.5	70.8	98.7	102.1	105.6	109.0	100	110	110	110	110	110
230	11.5	84.0	3.5	8.2	10.9	5.5	0.0	None	--	--	41.1	43.8	46.6	49.3	50	50	50	60		
								2TP04540925	9.0	21.7	41.1	43.8	46.6	49.3	50	50	50	50	60	
								2TP04541825	18.0	43.3	64.4	67.8	71.3	74.6	70	70	80	80	80	
								2TP04542425	24.0	57.7	82.4	85.8	89.3	92.7	90	90	90	90	100	
								2TP04543625	34.0	81.8	112.5	115.9	119.4	122.7	125	125	125	125	125	
460	6.4	42.0	1.6	4.1	5.3	2.2	0.0	None	--	--	21.7	22.9	23.9	25.1	25	25	30	30		
								2TP04540946	9	11.3	21.7	22.9	23.9	25.1	25	25	30	30	30	
								2TP04541846	18	22.6	32.2	33.7	34.9	36.4	35	35	35	40	40	
								2TP04542446	24	30.1	41.2	42.7	44	45.5	45	45	45	50	50	
								2TP04543646	34	42.7	56.2	57.7	59	60.5	60	60	60	70	70	
575	5.1	34.0	1.3	3.6	4.1	1.8	0.0	None	--	--	17.7	18.2	19.5	20	20	20	20	25		
								2TP04540958	9	9.0	17.7	18.2	19.5	20	20	20	20	20	25	
								2TP04541858	18	18.1	26.2	26.8	28.4	29	30	30	30	30	30	
								2TP04542458	24	24.1	33.4	34	35.6	36.2	35	35	40	40	40	
								2TP04543658	34	34.1	45.4	46	47.6	48.3	50	50	50	50	50	

TABLE 14: ELECTRICAL DATA - DM090 (7-1/2 TON) STANDARD EFFICIENCY W/PWRD CONV. OUTLET

Voltage	Compressors		OD Fan Motors	Supply Blower Motor FLA		Pwr Exh Motor	Pwr Conv Outlet	Electric Heater Model No.	Actual KW	Heater Amps	Min. Circuit Ampacity (Amps)		MCA w/Power Exhaust (Amps)		Max Fuse* Size (Amps)		Max Fuse Size w/Power Exhaust (Amps)		
	RLA	LRA	FLA	2 HP	3 HP	FLA	FLA				2 HP	3 HP	2 HP	3 HP	2 HP	3 HP	2 HP	3 HP	
	ea.	ea.	ea.																
208	11.5	84.0	3.5	8.2	10.9	5.5	10.0	None	--	--	51.1	53.8	56.6	59.3	60	60	60	70	
								2TP04540925	6.8	18.9	51.1	53.8	56.6	59.3	60	60	60	60	70
								2TP04541825	13.5	37.5	69.6	73.0	76.5	79.8	70	80	80	80	80
								2TP04542425	18.0	50.0	85.2	88.6	92.1	95.5	90	90	100	100	100
								2TP04543625	25.5	70.8	111.2	114.6	118.1	121.5	125	125	125	125	125
230	11.5	84.0	3.5	8.2	10.9	5.5	10.0	None	--	--	51.1	53.8	56.6	59.3	60	60	60	70	
								2TP04540925	9.0	21.7	51.1	53.8	56.7	60.1	60	60	60	70	
								2TP04541825	18.0	43.3	76.9	80.3	83.8	87.1	80	90	90	90	90
								2TP04542425	24.0	57.7	94.9	98.3	101.8	105.2	100	100	110	110	110
								2TP04543625	34.0	81.8	125.0	128.4	131.9	135.2	125	150	150	150	150
460	6.4	42.0	1.6	4.1	5.3	2.2	5.0	None	--	--	26.7	27.9	28.9	30.1	30	30	35	35	
								2TP04540946	9	11.3	26.7	27.9	28.9	30.1	30	30	35	35	
								2TP04541846	18	22.6	38.4	39.9	41.2	42.7	40	40	45	45	
								2TP04542446	24	30.1	47.5	49	50.2	51.7	50	50	60	60	
								2TP04543646	34	42.7	62.5	64	65.2	66.7	70	70	70	70	
575	5.1	34.0	1.3	3.6	4.1	1.8	4.0	None	--	--	21.7	22.2	23.5	24	25	25	25	25	
								2TP04540958	9	9.0	21.7	22.2	23.5	24	25	25	25	25	
								2TP04541858	18	18.1	31.2	31.8	33.4	34	35	35	35	35	
								2TP04542458	24	24.1	38.4	39	40.6	41.2	40	40	45	45	
								2TP04543658	34	34.1	50.4	51	52.6	53.3	60	60	60	60	

TABLE 15: ELECTRICAL DATA - DH090 (7-1/2 TON) HIGH EFFICIENCY W/O PWRD CONV. OUTLET

Voltage	Compressors		OD Fan Motors	Supply Blower Motor FLA		Pwr Exh Motor	Pwr Conv Outlet	Electric Heater Model No.	Actual KW	Heater Amps	Min. Circuit Ampacity (Amps)		MCA w/Power Exhaust (Amps)		Max Fuse* Size (Amps)		Max Fuse Size w/Power Exhaust (Amps)		
	RLA	LRA	FLA	2 HP	3 HP	FLA	FLA				2 HP	3 HP	2 HP	3 HP	2 HP	3 HP	2 HP	3 HP	
	ea.	ea.	ea.																
208	11.5	84.0	1.5	8.2	10.9	5.5	0.0	None	--	--	37.1	39.8	42.6	45.3	45	50	50	50	
								2TP04540925	6.8	18.9	37.1	39.8	42.6	45.3	45	50	50	50	50
								2TP04541825	13.5	37.5	57.1	60.5	64.0	67.3	60	70	70	70	70
								2TP04542425	18.0	50.0	72.7	76.1	79.6	83.0	80	80	80	80	90
								2TP04543625	25.5	70.8	98.7	102.1	105.6	109.0	100	110	110	110	110
230	11.5	84.0	1.5	8.2	10.9	5.5	0.0	None	--	--	37.1	39.8	42.6	45.3	45	50	50	50	
								2TP04540925	9.0	21.7	37.3	40.7	44.2	47.6	45	50	50	50	50
								2TP04541825	18.0	43.3	64.4	67.8	71.3	74.6	70	70	80	80	80
								2TP04542425	24.0	57.7	82.4	85.8	89.3	92.7	90	90	90	100	100
								2TP04543625	34.0	81.8	112.5	115.9	119.4	122.7	125	125	125	125	125
460	5.8	42.0	0.8	4.1	5.3	2.2	0.0	None	--	--	18.8	20	21	22.2	20	25	25	25	
								2TP04540946	9	11.3	18.8	20.2	21.4	22.9	20	25	25	25	25
								2TP04541846	18	22.6	32.2	33.7	34.9	36.4	35	35	35	40	40
								2TP04542446	24	30.1	41.2	42.7	44	45.5	45	45	45	50	50
								2TP04543646	34	42.7	56.2	57.7	59	60.5	60	60	60	70	70
575	5.1	34.0	0.6	3.6	4.1	1.8	0.0	None	--	--	16.3	16.8	18.1	18.6	20	20	20	20	
								2TP04540958	9	9.0	16.3	16.8	18.1	18.6	20	20	20	20	20
								2TP04541858	18	18.1	26.2	26.8	28.4	29	30	30	30	30	30
								2TP04542458	24	24.1	33.4	34	35.6	36.2	35	35	40	40	40
								2TP04543658	34	34.1	45.4	46	47.6	48.3	50	50	50	50	50

TABLE 16: ELECTRICAL DATA - DH090 (7-1/2 TON) HIGH EFFICIENCY W/PWRD CONV. OUTLET

Voltage	Compressors		OD Fan Motors	Supply Blower Motor FLA		Pwr Exh Motor	Pwr Conv Outlet	Electric Heater Model No.	Actual KW	Heater Amps	Min. Circuit Ampacity (Amps)		MCA w/Power Exhaust (Amps)		Max Fuse* Size (Amps)		Max Fuse Size w/Power Exhaust (Amps)		
	RLA	LRA	FLA	2 HP	3 HP	FLA	FLA				2 HP	3 HP	2 HP	3 HP	2 HP	3 HP	2 HP	3 HP	
	ea.	ea.	ea.																
208	11.5	84.0	1.5	8.2	10.9	5.5	10.0	None	--	--	47.1	49.8	52.6	55.3	50	60	60	60	
								2TP04540925	6.8	18.9	47.1	49.8	53.2	56.6	50	60	60	60	60
								2TP04541825	13.5	37.5	69.6	73.0	76.5	79.8	70	80	80	80	80
								2TP04542425	18.0	50.0	85.2	88.6	92.1	95.5	90	90	100	100	100
								2TP04543625	25.5	70.8	111.2	114.6	118.1	121.5	125	125	125	125	125
230	11.5	84.0	1.5	8.2	10.9	5.5	10.0	None	--	--	47.1	49.8	52.6	55.3	50	60	60	60	
								2TP04540925	9.0	21.7	49.8	53.2	56.7	60.1	50	60	60	70	70
								2TP04541825	18.0	43.3	76.9	80.3	83.8	87.1	80	90	90	90	90
								2TP04542425	24.0	57.7	94.9	98.3	101.8	105.2	100	100	110	110	110
								2TP04543625	34.0	81.8	125.0	128.4	131.9	135.2	125	150	150	150	150
460	5.8	42.0	0.8	4.1	5.3	2.2	5.0	None	--	--	23.8	25	26	27.2	25	30	30	30	
								2TP04540946	9	11.3	24.9	26.4	27.7	29.2	25	30	30	30	30
								2TP04541846	18	22.6	38.4	39.9	41.2	42.7	40	40	45	45	45
								2TP04542446	24	30.1	47.5	49	50.2	51.7	50	50	60	60	60
								2TP04543646	34	42.7	62.5	64	65.2	66.7	70	70	70	70	70
575	5.1	34.0	0.6	3.6	4.1	1.8	4.0	None	--	--	20.3	20.8	22.1	22.6	25	25	25	25	
								2TP04540958	9	9.0	20.3	21	22.6	23.2	25	25	25	25	25
								2TP04541858	18	18.1	31.2	31.8	33.4	34	35	35	35	35	35
								2TP04542458	24	24.1	38.4	39	40.6	41.2	40	40	45	45	45
								2TP04543658	34	34.1	50.4	51	52.6	53.3	60	60	60	60	60

TABLE 17: ELECTRICAL DATA - DM102 (8-1/2 TON) STANDARD EFFICIENCY W/O PWRD CONV. OUTLET

Voltage	Compressors		OD Fan Motors	Supply Blower Motor FLA		Pwr Exh Motor	Pwr Conv Outlet	Electric Heater Model No.	Actual KW	Heater Amps	Min. Circuit Ampacity (Amps)		MCA w/Power Exhaust (Amps)		Max Fuse* Size (Amps)		Max Fuse Size w/Power Exhaust (Amps)			
	RLA ea.	LRA ea.	FLA ea.	3 HP	3 HP	FLA	FLA				3 HP	3 HP	3 HP	3 HP	3 HP	3 HP	3 HP	3 HP	3 HP	3 HP
208	11.7	88.0	3.5	10.9	10.9	5.5	0.0	None	--	--	44.2	44.2	49.7	49.7	50	50	60	60		
								2TP04540925	6.8	18.9	44.2	44.2	49.7	49.7	50	50	60	60	60	60
								2TP04541825	13.5	37.5	60.5	60.5	67.3	67.3	70	70	70	70	70	70
								2TP04542425	18	50.0	76.1	76.1	83.0	83.0	80	80	90	90	90	90
								2TP04543625	25.5	70.8	102.1	102.1	109.0	109.0	110	110	110	110	110	110
230	11.7	88.0	3.5	10.9	10.9	5.5	0.0	None	--	--	44.2	44.2	50.4	50.4	50	50	60	60		
								2TP04540925	9	21.7	44.2	44.2	50.4	50.4	50	50	60	60	60	60
								2TP04541825	18	43.3	67.8	67.8	74.6	74.6	70	70	80	80	80	80
								2TP04542425	24	57.7	85.8	85.8	92.7	92.7	90	90	100	100	100	100
								2TP04543625	34	81.8	115.9	115.9	122.7	122.7	125	125	125	125	125	125
460	6.4	42.0	1.6	5.3	5.3	2.2	0.0	None	--	--	22.9	22.9	25.1	25.1	25	25	30	30		
								2TP04540946	9	11.3	22.9	22.9	25.1	25.1	25	25	30	30	30	30
								2TP04541846	18	22.6	33.7	33.7	36.4	36.4	35	35	40	40	40	40
								2TP04542446	24	30.1	42.7	42.7	45.5	45.5	45	45	50	50	50	50
								2TP04543646	34	42.7	57.7	57.7	60.5	60.5	60	60	70	70	70	70
575	5.1	36.0	1.3	4.1	4.1	1.8	0.0	None	--	--	18.2	18.2	20	20	20	20	25	25		
								2TP04540958	9	9.0	18.2	18.2	20	20	20	20	25	25	25	25
								2TP04541858	18	18.1	26.8	26.8	29	29	30	30	30	30	30	30
								2TP04542458	24	24.1	34	34	36.2	36.2	35	35	40	40	40	40
								2TP04543658	34	34.1	46	46	48.3	48.3	50	50	50	50	50	50

TABLE 18: ELECTRICAL DATA - DM102 (8-1/2 TON) STANDARD EFFICIENCY W/PWRD CONV. OUTLET

Voltage	Compressors		OD Fan Motors	Supply Blower Motor FLA		Pwr Exh Motor	Pwr Conv Outlet	Electric Heater Model No.	Actual KW	Heater Amps	Min. Circuit Ampacity (Amps)		MCA w/Power Exhaust (Amps)		Max Fuse* Size (Amps)		Max Fuse Size w/Power Exhaust (Amps)			
	RLA ea.	LRA ea.	FLA ea.	3 HP	3 HP	FLA	FLA				3 HP	3 HP	3 HP	3 HP	3 HP	3 HP	3 HP	3 HP	3 HP	3 HP
208	11.7	88.0	3.5	10.9	10.9	5.5	10.0	None	--	--	54.2	54.2	59.7	59.7	60	60	70	70		
								2TP04540925	6.8	18.9	54.2	54.2	59.7	59.7	60	60	70	70	70	70
								2TP04541825	13.5	37.5	73.0	73.0	79.8	79.8	80	80	80	80	80	80
								2TP04542425	18	50.0	88.6	88.6	95.5	95.5	90	90	100	100	100	100
								2TP04543625	25.5	70.8	114.6	114.6	121.5	121.5	125	125	125	125	125	125
230	11.7	88.0	3.5	10.9	10.9	5.5	10.0	None	--	--	54.2	54.2	59.7	59.7	60	60	70	70		
								2TP04540925	9	21.7	54.2	54.2	59.7	59.7	60	60	70	70	70	70
								2TP04541825	18	43.3	80.3	80.3	87.1	87.1	90	90	90	90	90	90
								2TP04542425	24	57.7	98.3	98.3	105.2	105.2	100	100	110	110	110	110
								2TP04543625	34	81.8	128.4	128.4	135.2	135.2	150	150	150	150	150	150
460	6.4	42.0	1.6	5.3	5.3	2.2	10.0	None	--	--	27.9	27.9	30.1	30.1	30	30	35	35		
								2TP04540946	9	11.3	27.9	27.9	30.1	30.1	30	30	35	35	35	35
								2TP04541846	18	22.6	39.9	39.9	42.7	42.7	40	40	45	45	45	45
								2TP04542446	24	30.1	49	49	51.7	51.7	50	50	60	60	60	60
								2TP04543646	34	42.7	64	64	66.7	66.7	70	70	70	70	70	70
575	5.1	36.0	1.3	4.1	4.1	1.8	10.0	None	--	--	22.2	22.2	24	24	25	25	25	25		
								2TP04540958	9	9.0	22.2	22.2	24	24	25	25	25	25	25	25
								2TP04541858	18	18.1	31.8	31.8	34	34	35	35	35	35	35	35
								2TP04542458	24	24.1	39	39	41.2	41.2	40	40	45	45	45	45
								2TP04543658	34	34.1	51	51	53.3	53.3	60	60	60	60	60	60

TABLE 19: ELECTRICAL DATA - DH102 (8-1/2 TON) HIGH EFFICIENCY W/O PWRD CONV. OUTLET

Voltage	Compressors		OD Fan Motors	Supply Blower Motor FLA		Pwr Exh Motor	Pwr Conv Outlet	Electric Heater Model No.	Actual KW	Heater Amps	Min. Circuit Ampacity (Amps)		MCA w/Power Exhaust (Amps)		Max Fuse* Size (Amps)		Max Fuse Size w/Power Exhaust (Amps)			
	RLA ea.	LRA ea.	FLA ea.	3 HP	3 HP	FLA	FLA				3 HP	3 HP	3 HP	3 HP	3 HP	3 HP	3 HP	3 HP	3 HP	3 HP
208	11.7	88.0	3.5	10.9	10.9	5.5	0.0	None	--	--	44.2	44.2	49.7	49.7	50	50	60	60		
								2TP04540925	6.8	18.9	44.2	44.2	49.7	49.7	50	50	60	60	60	60
								2TP04541825	13.5	37.5	60.5	60.5	67.3	67.3	70	70	70	70	70	70
								2TP04542425	18	50.0	76.1	76.1	83.0	83.0	80	80	90	90	90	90
								2TP04543625	25.5	70.8	102.1	102.1	109.0	109.0	110	110	110	110	110	110
230	11.7	88.0	3.5	10.9	10.9	5.5	0.0	None	--	--	44.2	44.2	50.4	50.4	50	50	60	60		
								2TP04540925	9	21.7	44.2	44.2	50.4	50.4	50	50	60	60	60	
								2TP04541825	18	43.3	67.8	67.8	74.6	74.6	70	70	80	80	80	
								2TP04542425	24	57.7	85.8	85.8	92.7	92.7	90	90	100	100	100	
								2TP04543625	34	81.8	115.9	115.9	122.7	122.7	125	125	125	125	125	125
460	6.4	42.0	1.6	5.3	5.3	2.2	0.0	None	--	--	22.9	22.9	25.1	25.1	25	25	30	30		
								2TP04540946	9	11.3	22.9	22.9	25.1	25.1	25	25	30	30	30	
								2TP04541846	18	22.6	33.7	33.7	36.4	36.4	35	35	40	40	40	
								2TP04542446	24	30.1	42.7	42.7	45.5	45.5	45	45	50	50	50	
								2TP04543646	34	42.7	57.7	57.7	60.5	60.5	60	60	70	70	70	
575	5.1	36.0	1.3	4.1	4.1	1.8	0.0	None	--	--	18.2	18.2	20	20	20	20	25	25		
								2TP04540958	9	9.0	18.2	18.2	20	20	20	20	20	25	25	
								2TP04541858	18	18.1	26.8	26.8	29	29	30	30	30	30	30	
								2TP04542458	24	24.1	34	34	36.2	36.2	35	35	40	40	40	
								2TP04543658	34	34.1	46	46	48.3	48.3	50	50	50	50	50	

TABLE 20: ELECTRICAL DATA - DH102 (8-1/2 TON) HIGH EFFICIENCY W/PWRD CONV. OUTLET

Voltage	Compressors		OD Fan Motors	Supply Blower Motor FLA		Pwr Exh Motor	Pwr Conv Outlet	Electric Heater Model No.	Actual KW	Heater Amps	Min. Circuit Ampacity (Amps)		MCA w/Power Exhaust (Amps)		Max Fuse* Size (Amps)		Max Fuse Size w/Power Exhaust (Amps)		
	RLA ea.	LRA ea.	FLA ea.	3 HP	3 HP	FLA	FLA				3 HP	3 HP	3 HP	3 HP	3 HP	3 HP	3 HP	3 HP	3 HP
208	11.7	88.0	3.5	10.9	10.9	5.5	10.0	None	--	--	54.2	54.2	59.7	59.7	60	60	70	70	
								2TP04540925	6.8	18.9	54.2	54.2	59.7	59.7	60	60	70	70	70
								2TP04541825	13.5	37.5	73.0	73.0	79.8	79.8	80	80	80	80	80
								2TP04542425	18	50.0	88.6	88.6	95.5	95.5	90	90	100	100	100
								2TP04543625	25.5	70.8	114.6	114.6	121.5	121.5	125	125	125	125	125
230	11.7	88.0	3.5	10.9	10.9	5.5	10.0	None	--	--	54.2	54.2	59.7	59.7	60	60	70	70	
								2TP04540925	9	21.7	54.2	54.2	59.7	59.7	60	60	70	70	
								2TP04541825	18	43.3	80.3	80.3	87.1	87.1	90	90	90	90	90
								2TP04542425	24	57.7	98.3	98.3	105.2	105.2	100	100	110	110	110
								2TP04543625	34	81.8	128.4	128.4	135.2	135.2	150	150	150	150	150
460	6.4	42.0	1.6	5.3	5.3	2.2	10.0	None	--	--	27.9	27.9	30.1	30.1	30	30	35	35	
								2TP04540946	9	11.3	27.9	27.9	30.1	30.1	30	30	35	35	
								2TP04541846	18	22.6	39.9	39.9	42.7	42.7	40	40	45	45	
								2TP04542446	24	30.1	49	49	51.7	51.7	50	50	60	60	
								2TP04543646	34	42.7	64	64	66.7	66.7	70	70	70	70	
575	5.1	36.0	1.3	4.1	4.1	1.8	10.0	None	--	--	22.2	22.2	24	24	25	25	25	25	
								2TP04540958	9	9.0	22.2	22.2	24	24	25	25	25	25	
								2TP04541858	18	18.1	31.8	31.8	34	34	35	35	35	35	
								2TP04542458	24	24.1	39	39	41.2	41.2	40	40	45	45	
								2TP04543658	34	34.1	51	51	53.3	53.3	60	60	60	60	

TABLE 21: ELECTRICAL DATA - DM120 (10 TON) STANDARD EFFICIENCY W/O PWRD CONV. OUTLET

Voltage	Compressors		OD Fan Motors	Supply Blower Motor FLA		Pwr Exh Motor	Pwr Conv Outlet	Electric Heater Model No.	Actual KW	Heater Amps	Min. Circuit Ampacity (Amps)		MCA w/Power Exhaust (Amps)		Max Fuse* Size (Amps)		Max Fuse* Size w/Power Exhaust (Amps)			
	RLA ea.	LRA ea.	FLA ea.	2 HP	3 HP	FLA	FLA				2 HP	3 HP	2 HP	3 HP	2 HP	3 HP	2 HP	3 HP	2 HP	3 HP
	208	16.3	150.0	3.5	8.2	10.9	5.5				0.0	None	--	--	51.9	54.6	57.4	60.1	60	70
								2TP04521825	13.5	37.5	57.1	60.5	64.0	67.3	60	70	70	70		
								2TP04522425	18	50.0	72.7	76.1	79.6	83.0	80	80	80	90		
								2TP04523625	25.5	70.8	98.7	102.1	105.6	109.0	100	110	110	110		
								2TP04525425	40.6	112.7	151.1	154.5	158.0	161.4	175	175	175	175		
230	16.3	150.0	3.5	8.2	10.9	5.5	0.0	None	--	--	51.9	54.6	57.4	60.1	60	70	70	70		
								2TP04521825	18	43.3	64.4	67.8	71.3	74.6	70	70	80	80		
								2TP04522425	24	57.7	82.4	85.8	89.3	92.7	90	90	90	100		
								2TP04523625	34	81.8	112.5	115.9	119.4	122.7	125	125	125	125		
								2TP04525425	54	129.9	140.2	143.5	147.0	150.4	150	175	175	175		
460	11.5	75.0	1.6	4.1	5.3	2.2	0.0	None	--	--	33.2	34.4	35.4	36.6	40	45	45	45		
								2TP04521846	18	22.6	33.2	34.4	35.4	36.6	40	45	45	45		
								2TP04522446	24	30.1	41.2	42.7	44	45.5	45	45	45	50		
								2TP04523646	34	42.7	56.2	57.7	59	60.5	60	60	60	70		
								2TP04525446	54	67.8	70.1	71.6	72.8	74.3	80	80	80	80		
575	7.1	62.0	1.3	3.6	4.1	1.8	0.0	None	--	--	22.2	22.7	24	24.5	25	25	30	30		
								2TP04521858	18	18.1	26.2	26.8	28.4	29	30	30	30	30		
								2TP04522458	24	24.1	33.4	34	35.6	36.2	35	35	40	40		
								2TP04523658	34	34.1	45.4	46	47.6	48.3	50	50	50	50		
								2TP04525458	54	54.2	56.5	57.1	58.7	59.3	70	70	70	70		

* Maximum HACR breaker of the same AMP size is applicable.

TABLE 22: ELECTRICAL DATA - DM120 (10 TON) STANDARD EFFICIENCY W/PWRD CONV. OUTLET

Voltage	Compressors		OD Fan Motors	Supply Blower Motor FLA		Pwr Exh Motor	Pwr Conv Outlet	Electric Heater Model No.	Actual KW	Heater Amps	Min. Circuit Ampacity (Amps)		MCA w/Power Exhaust (Amps)		Max Fuse* Size (Amps)		Max Fuse* Size w/Power Exhaust (Amps)			
	RLA ea.	LRA ea.	FLA ea.	2 HP	3 HP	FLA	FLA				2 HP	3 HP	2 HP	3 HP	2 HP	3 HP	2 HP	3 HP	2 HP	3 HP
	208	16.3	150.0	3.5	8.2	10.9	5.5				10.0	None	--	--	61.9	64.6	67.4	70.1	70	80
								2TP04521825	13.5	37.5	69.6	73.0	76.5	79.8	70	80	80	80		
								2TP04522425	18	50.0	85.2	88.6	92.1	95.5	90	90	100	100		
								2TP04523625	25.5	70.8	111.2	114.6	118.1	121.5	125	125	125	125		
								2TP04525425	40.6	112.7	163.6	167.0	170.5	173.9	175	175	175	175		
230	16.3	150.0	3.5	8.2	10.9	5.5	10.0	None	--	--	61.9	64.6	67.4	70.1	70	80	80	80		
								2TP04521825	18	43.3	76.9	80.3	83.8	87.1	80	90	90	90		
								2TP04522425	24	57.7	94.9	98.3	101.8	105.2	100	100	110	110		
								2TP04523625	34	81.8	125.0	128.4	131.9	135.2	125	150	150	150		
								2TP04525425	54	129.9	152.7	156.0	159.5	162.9	175	175	175	175		
460	11.5	75.0	1.6	4.1	5.3	2.2	5.0	None	--	--	38.2	39.4	40.4	41.6	45	50	50	50		
								2TP04521846	18	22.6	38.4	39.9	41.2	42.7	45	50	50	50		
								2TP04522446	24	30.1	47.5	49	50.2	51.7	50	50	60	60		
								2TP04523646	34	42.7	62.5	64	65.2	66.7	70	70	70	70		
								2TP04525446	54	67.8	76.3	77.8	79.1	80.6	90	90	90	90		
575	7.1	62.0	1.3	3.6	4.1	1.8	4.0	None	--	--	26.2	26.7	28	28.5	30	30	35	35		
								2TP04521858	18	18.1	31.2	31.8	33.4	34	35	35	35	35		
								2TP04522458	24	24.1	38.4	39	40.6	41.2	40	40	45	45		
								2TP04523658	34	34.1	50.4	51	52.6	53.3	60	60	60	60		
								2TP04525458	54	54.2	61.5	62.1	63.7	64.3	70	70	70	70		

* Maximum HACR breaker of the same AMP size is applicable.

TABLE 23: ELECTRICAL DATA - DH120 (10 TON) HIGH EFFICIENCY W/O PWRD CONV. OUTLET

Voltage	Compressors		OD Fan Motors	Supply Blower Motor FLA		Pwr Exh Motor	Pwr Conv Outlet	Electric Heater Model No.	Actual KW	Heater Amps	Min. Circuit Ampacity (Amps)		MCA w/Power Exhaust (Amps)		Max Fuse* Size (Amps)		Max Fuse* Size w/Power Exhaust (Amps)	
	RLA ea.	LRA ea.	FLA ea.	2 HP	3 HP	FLA	FLA				2 HP	3 HP	2 HP	3 HP	2 HP	3 HP	2 HP	3 HP
208	16.0	137.0	3.5	8.2	10.9	5.5	0.0	None	--	--	51.2	53.9	56.7	59.4	60	60	70	70
								2TP04521825	13.5	37.5	57.1	60.5	64.0	67.3	60	70	70	70
								2TP04522425	18	50.0	72.7	76.1	79.6	83.0	80	80	80	90
								2TP04523625	25.5	70.8	98.7	102.1	105.6	109.0	100	110	110	110
								2TP04525425	40.6	112.7	151.1	154.5	158.0	161.4	175	175	175	175
230	16.0	137.0	3.5	8.2	10.9	5.5	0.0	None	--	--	51.2	53.9	56.7	59.4	60	60	70	70
								2TP04521825	18	43.3	64.4	67.8	71.3	74.6	70	70	80	80
								2TP04522425	24	57.7	82.4	85.8	89.3	92.7	90	90	90	100
								2TP04523625	34	81.8	112.5	115.9	119.4	122.7	125	125	125	125
								2TP04525425	54	129.9	140.2	143.5	147.0	150.4	150	175	175	175
460	8.3	69.0	1.6	4.1	5.3	2.2	0.0	None	--	--	26	27.2	28.2	29.4	30	35	35	35
								2TP04521846	18	22.6	32.2	33.7	34.9	36.4	35	35	35	40
								2TP04522446	24	30.1	41.2	42.7	44	45.5	45	45	45	50
								2TP04523646	34	42.7	56.2	57.7	59	60.5	60	60	60	70
								2TP04525446	54	67.8	70.1	71.6	72.8	74.3	80	80	80	80
575	6.4	58.0	1.3	3.6	4.1	1.8	0.0	None	--	--	20.6	21.1	22.4	22.9	25	25	25	25
								2TP04521858	18	18.1	26.2	26.8	28.4	29	30	30	30	30
								2TP04522458	24	24.1	33.4	34	35.6	36.2	35	35	40	40
								2TP04523658	34	34.1	45.4	46	47.6	48.3	50	50	50	50
								2TP04525458	54	54.2	56.5	57.1	58.7	59.3	70	70	70	70

* Maximum HACR breaker of the same AMP size is applicable.

TABLE 24: ELECTRICAL DATA - DH120 (10 TON) HIGH EFFICIENCY W/PWRD CONV. OUTLET

Voltage	Compressors		OD Fan Motors	Supply Blower Motor FLA		Pwr Exh Motor	Pwr Conv Outlet	Electric Heater Model No.	Actual KW	Heater Amps	Min. Circuit Ampacity (Amps)		MCA w/Power Exhaust (Amps)		Max Fuse* Size (Amps)		Max Fuse* Size w/Power Exhaust (Amps)	
	RLA ea.	LRA ea.	FLA ea.	2 HP	3 HP	FLA	FLA				2 HP	3 HP	2 HP	3 HP	2 HP	3 HP	2 HP	3 HP
208	16.0	137.0	3.5	8.2	10.9	5.5	10.0	None	--	--	61.2	63.9	66.7	69.4	70	70	80	80
								2TP04521825	13.5	37.5	69.6	73.0	76.5	79.8	70	80	80	80
								2TP04522425	18	50.0	85.2	88.6	92.1	95.5	90	90	100	100
								2TP04523625	25.5	70.8	111.2	114.6	118.1	121.5	125	125	125	125
								2TP04525425	40.6	112.7	163.6	167.0	170.5	173.9	175	175	175	175
230	16.0	137.0	3.5	8.2	10.9	5.5	10.0	None	--	--	61.2	63.9	66.7	69.4	70	70	80	80
								2TP04521825	18	43.3	76.9	80.3	83.8	87.1	80	90	90	90
								2TP04522425	24	57.7	94.9	98.3	101.8	105.2	100	100	110	110
								2TP04523625	34	81.8	125.0	128.4	131.9	135.2	125	150	150	150
								2TP04525425	54	129.9	152.7	156.0	159.5	162.9	175	175	175	175
460	8.3	69.0	1.6	4.1	5.3	2.2	5.0	None	--	--	31	32.2	33.2	34.4	35	40	40	40
								2TP04521846	18	22.6	38.4	39.9	41.2	42.7	40	40	45	45
								2TP04522446	24	30.1	47.5	49	50.2	51.7	50	50	60	60
								2TP04523646	34	42.7	62.5	64	65.2	66.7	70	70	70	70
								2TP04525446	54	67.8	76.3	77.8	79.1	80.6	90	90	90	90
575	6.4	58.0	1.3	3.6	4.1	1.8	4.0	None	--	--	24.6	25.1	26.4	26.9	30	30	30	30
								2TP04521858	18	18.1	31.2	31.8	33.4	34	35	35	35	35
								2TP04522458	24	24.1	38.4	39	40.6	41.2	40	40	45	45
								2TP04523658	34	34.1	50.4	51	52.6	53.3	60	60	60	60
								2TP04525458	54	54.2	61.5	62.1	63.7	64.3	70	70	70	70

* Maximum HACR breaker of the same AMP size is applicable.

TABLE 25: ELECTRICAL DATA - DM150 (12-1/2 TON) STANDARD EFFICIENCY W/O PWRD CONV. OUTLET

Voltage	Compressors		OD Fan Motors	Supply Blower Motor FLA		Pwr Exh Motor	Pwr Conv Outlet	Electric Heater Model No.	Actual KW	Heater Amps	Min. Circuit Ampacity (Amps)		MCA w/Power Exhaust (Amps)		Max Fuse* Size (Amps)		Max Fuse Size w/Power	
	RLA	LRA	FLA	3	5	FLA	FLA				3	5	3	5	3	5	3	5
	ea.	ea.	ea.	HP	HP						HP	HP	HP	HP	HP	HP	HP	HP
208	20.0	146.0	3.5	10.9	16.1	5.5	0.0	None	--	--	62.9	68.1	68.4	73.6	80	80	80	90
								2TP04521825	13.5	37.5	62.9	68.1	68.4	73.8	80	80	80	90
								2TP04522425	18	50.0	76.1	82.6	83.0	89.5	80	90	90	90
								2TP04523625	25.5	70.8	102.1	108.6	109.0	115.5	110	110	110	125
								2TP04525425	40.6	112.7	154.5	161.0	161.4	167.9	175	175	175	175
230	20.0	146.0	3.5	10.9	16.1	5.5	0.0	None	--	--	62.9	68.1	68.4	73.6	80	80	80	90
								2TP04521825	18	43.3	67.8	74.3	74.6	81.1	80	80	80	90
								2TP04522425	24	57.7	85.8	92.3	92.7	99.2	90	100	100	100
								2TP04523625	34	81.8	115.9	122.4	122.7	129.2	125	125	125	150
								2TP04525425	54	129.9	143.5	150.0	150.4	156.9	175	175	175	175
460	8.4	73.0	1.6	5.3	8.1	2.2	0.0	None	--	--	27.4	30.2	29.6	32.4	35	35	35	40
								2TP04521846	18	22.6	33.7	37.2	36.4	39.9	35	40	40	40
								2TP04522446	24	30.1	42.7	46.2	45.5	49	45	50	50	50
								2TP04523646	34	42.7	57.7	61.2	60.5	64	60	70	70	70
								2TP04525446	54	67.8	71.6	75.1	74.3	77.8	80	90	80	90
575	6.7	60.0	1.3	4.1	6.0	1.8	0.0	None	--	--	21.8	23.7	23.6	25.5	25	30	30	30
								2TP04521858	18	18.1	26.8	29.2	29	31.4	30	30	30	35
								2TP04522458	24	24.1	34	36.4	36.2	38.6	35	40	40	40
								2TP04523658	34	34.1	46	48.4	48.3	50.6	50	50	50	60
								2TP04525458	54	54.2	57.1	59.5	59.3	61.7	70	70	70	70

* Maximum HACR breaker of the same AMP size is applicable.

TABLE 26: ELECTRICAL DATA - DM150 (12-1/2 TON) STANDARD EFFICIENCY W/PWRD CONV. OUTLET

Voltage	Compressors		OD Fan Motors	Supply Blower Motor FLA		Pwr Exh Motor	Pwr Conv Outlet	Electric Heater Model No.	Actual KW	Heater Amps	Min. Circuit Ampacity (Amps)		MCA w/Power Exhaust (Amps)		Max Fuse* Size (Amps)		Max Fuse Size w/Power	
	RLA	LRA	FLA	3	5	FLA	FLA				3	5	3	5	3	5	3	5
	ea.	ea.	ea.	HP	HP						HP	HP	HP	HP	HP	HP	HP	HP
208	20.0	146.0	3.5	10.9	16.1	5.5	10.0	None	--	--	72.9	78.1	78.4	83.6	90	90	90	100
								2TP04521825	13.5	37.5	73.0	79.5	79.8	86.3	90	90	90	100
								2TP04522425	18	50.0	88.6	95.1	95.5	102.0	90	100	100	110
								2TP04523625	25.5	70.8	114.6	121.1	121.5	128.0	125	125	125	150
								2TP04525425	40.6	112.7	167.0	173.5	173.9	180.4	175	175	175	200
230	20.0	146.0	3.5	10.9	16.1	5.5	10.0	None	--	--	72.9	78.1	78.4	83.6	90	90	90	100
								2TP04521825	18	43.3	80.3	86.8	87.1	93.6	90	90	90	100
								2TP04522425	24	57.7	98.3	104.8	105.2	111.7	100	110	110	125
								2TP04523625	34	81.8	128.4	134.9	135.2	141.7	150	150	150	150
								2TP04525425	54	129.9	156.0	162.5	162.9	169.4	175	175	175	175
460	8.4	73.0	1.6	5.3	8.1	2.2	5.0	None	--	--	32.4	35.2	34.6	37.4	40	40	40	45
								2TP04521846	18	22.6	39.9	43.4	42.7	46.2	40	45	45	50
								2TP04522446	24	30.1	49	52.5	51.7	55.2	50	60	60	60
								2TP04523646	34	42.7	64	67.5	66.7	70.2	70	70	70	80
								2TP04525446	54	67.8	77.8	81.3	80.6	84.1	90	90	90	90
575	6.7	60.0	1.3	4.1	6.0	1.8	4.0	None	--	--	25.8	27.7	27.6	29.5	30	30	30	35
								2TP04521858	18	18.1	31.8	34.2	34	36.4	35	35	35	40
								2TP04522458	24	24.1	39	41.4	41.2	43.6	40	45	45	45
								2TP04523658	34	34.1	51	53.4	53.3	55.6	60	60	60	60
								2TP04525458	54	54.2	62.1	64.5	64.3	66.7	70	70	70	70

* Maximum HACR breaker of the same AMP size is applicable.

TABLE 27: ELECTRICAL DATA - DH150 (12-1/2 TON) HIGH EFFICIENCY W/O PWRD CONV. OUTLET

Voltage	Compressors		OD Fan Motors	Supply Blower Motor FLA		Pwr Exh Motor	Pwr Conv Outlet	Electric Heater Model No.	Actual KW	Heater Amps	Min. Circuit Ampacity (Amps)		MCA w/Power Exhaust (Amps)		Max Fuse* Size (Amps)		Max Fuse* Size w/Power Exhaust (Amps)			
	RLA ea.	LRA ea.	FLA ea.	3 HP	5 HP	FLA	FLA				3 HP	5 HP	3 HP	5 HP	3 HP	5 HP	3 HP	5 HP	3 HP	5 HP
	208	18.9	146.0	3.5	10.9	16.1	5.5				0.0	None	--	--	60.4	65.6	65.9	71.1	70	80
								2TP04521825	13.5	37.5	60.5	67.0	67.3	73.8	70	80	80	90		
								2TP04522425	18	50.0	76.1	82.6	83.0	89.5	80	90	90	90		
								2TP04523625	25.5	70.8	102.1	108.6	109.0	115.5	110	110	110	125		
								2TP04525425	40.6	112.7	154.5	161.0	161.4	167.9	175	175	175	175		
230	18.9	146.0	3.5	10.9	16.1	5.5	0.0	None	--	--	60.4	65.6	65.9	71.1	70	80	80	90		
								2TP04521825	18	43.3	67.8	74.3	74.6	81.1	70	80	80	90		
								2TP04522425	24	57.7	85.8	92.3	92.7	99.2	90	100	100	100		
								2TP04523625	34	81.8	115.9	122.4	122.7	129.2	125	125	125	150		
								2TP04525425	54	129.9	143.5	150.0	150.4	156.9	175	175	175	175		
460	9.5	73.0	1.6	5.3	8.1	2.2	0.0	None	--	--	29.9	32.7	32.1	34.9	35	40	40	40		
								2TP04521846	18	22.6	33.7	37.2	36.4	39.9	35	40	40	40		
								2TP04522446	24	30.1	42.7	46.2	45.5	49	45	50	50	50		
								2TP04523646	34	42.7	57.7	61.2	60.5	64	60	70	70	70		
								2TP04525446	54	67.8	71.6	75.1	74.3	77.8	80	90	80	90		
575	7.6	58.4	1.3	4.1	6.0	1.8	0.0	None	--	--	23.8	25.7	25.6	27.5	30	30	30	35		
								2TP04521858	18	18.1	26.8	29.2	29	31.4	30	30	30	35		
								2TP04522458	24	24.1	34	36.4	36.2	38.6	35	40	40	40		
								2TP04523658	34	34.1	46	48.4	48.3	50.6	50	50	50	60		
								2TP04525458	54	54.2	57.1	59.5	59.3	61.7	70	70	70	70		

* Maximum HACR breaker of the same AMP size is applicable.

TABLE 28: ELECTRICAL DATA - DH150 (12-1/2 TON) HIGH EFFICIENCY W/PWRD CONV. OUTLET

Voltage	Compressors		OD Fan Motors	Supply Blower Motor FLA		Pwr Exh Motor	Pwr Conv Outlet	Electric Heater Model No.	Actual KW	Heater Amps	Min. Circuit Ampacity (Amps)		MCA w/Power Exhaust (Amps)		Max Fuse* Size (Amps)		Max Fuse* Size w/Power Exhaust (Amps)			
	RLA ea.	LRA ea.	FLA ea.	3 HP	5 HP	FLA	FLA				3 HP	5 HP	3 HP	5 HP	3 HP	5 HP	3 HP	5 HP	3 HP	5 HP
	208	18.9	146.0	3.5	10.9	16.1	5.5				10.0	None	--	--	70.4	75.6	75.9	81.1	80	90
								2TP04521825	13.5	37.5	73.0	79.5	79.8	86.3	80	90	90	100		
								2TP04522425	18	50.0	88.6	95.1	95.5	102.0	90	100	100	110		
								2TP04523625	25.5	70.8	114.6	121.1	121.5	128.0	125	125	125	150		
								2TP04525425	40.6	112.7	167.0	173.5	173.9	180.4	175	175	175	200		
230	18.9	146.0	3.5	10.9	16.1	5.5	10.0	None	--	--	70.4	75.6	75.9	81.1	80	90	90	100		
								2TP04521825	18	43.3	80.3	86.8	87.1	93.6	90	90	90	100		
								2TP04522425	24	57.7	98.3	104.8	105.2	111.7	100	110	110	125		
								2TP04523625	34	81.8	128.4	134.9	135.2	141.7	150	150	150	150		
								2TP04525425	54	129.9	156.0	162.5	162.9	169.4	175	175	175	175		
460	9.5	73.0	1.6	5.3	8.1	2.2	5.0	None	--	--	34.9	37.7	37.1	39.9	40	45	45	45		
								2TP04521846	18	22.6	39.9	43.4	42.7	46.2	40	45	45	50		
								2TP04522446	24	30.1	49	52.5	51.7	55.2	50	60	60	60		
								2TP04523646	34	42.7	64	67.5	66.7	70.2	70	70	70	80		
								2TP04525446	54	67.8	77.8	81.3	80.6	84.1	90	90	90	90		
575	7.6	58.4	1.3	4.1	6.0	1.8	4.0	None	--	--	27.8	29.7	29.6	31.5	35	35	35	35		
								2TP04521858	18	18.1	31.8	34.2	34	36.4	35	35	35	40		
								2TP04522458	24	24.1	39	41.4	41.2	43.6	40	45	45	45		
								2TP04523658	34	34.1	51	53.4	53.3	55.6	60	60	60	60		
								2TP04525458	54	54.2	62.1	64.5	64.3	66.7	70	70	70	70		

* Maximum HACR breaker of the same AMP size is applicable.

TABLE 29: DM PHYSICAL DATA

Component		Models				
		078	090	102	120	150
Evaporator Blower	Blower, Centrifugal (Dia X Wd. In)	15 x 15	12 x 12	12 X 12	15 x 15	15 x 15
	Motor, Standard (HP)	1-1/2	2	3	2	3
	Motor, Optional (HP)	2	3	3	3	5
Evaporator Coil	Rows	2	2	3	2	3
	Fins per Inch	15	15	15	15	15
	Height (in.)	30	32	32	40	40
	Face Area (ft2)	9.9	10.67	10.67	13.2	13.2
Condenser Fan (2 per Unit)	Propeller Dia. (in.)	24	24	24	24	24
	Motor (HP each)	1/3	3/4	3/4	3/4	3/4
	CFM, Nominal (each)	3400	4400	4400	4400	4400
Condenser Coil (2 per unit)	Rows	1	1	1	1	2
	Fins per Inch	20	20	20	20	20
	Height (in.)	24	28	36	44	44
	Face Area (ft2)	7.9	9.33	12	14.5	14.5
Refrigerant Charge	System 1 (lb/oz)	4/6	4/10	5/8	6/12	10/12
	System 2 (lb/oz)	4/0	3/14	5/2	6/12	11/0
Compressors	Quantity	2	2	2	2	2
	Type	Recip	Recip	Recip.	Recip	Scroll
Air Filters	Size (Wd. X Ht. x Thickness in.)	25x20x2	25x16x2	25x16x2	25x20x2	25x20x2
	Number Per Unit	4	4	4	4	4

TABLE 30: DH PHYSICAL DATA

Component		Models				
		078	090	102	120	150
Evaporator Blower	Blower, Centrifugal (Dia. X Wd. in.)	12 x 12	12 x 12	12 X 12	15 x 15	15 x 15
	Motor, Standard (HP)	1-1/2	2	3	2	3
	Motor, Optional (HP)	2	3	3	3	5
Evaporator Coil	Rows	3	3	3	4	4
	Fins per Inch	15	15	15	15	15
	Height (in.)	32	32	32	40	40
	Face Area (ft. ² each)	10.67	10.67	10.67	13.2	13.2
Condenser Fan (2 per Unit)	Propeller Dia. (in., each)	24	24	24	24	24
	Motor (HP, each)	1/3	1/3	1/3	3/4	3/4
	CFM, Nominal (each)	3400	3400	3400	4400	4400
Condenser Coil (2 per unit)	Rows (each)	Sys 1: 2 Row Sys 2: 1 Row	2	2	2	2
	Fins per Inch	20	20	20	20	20
	Height (in., each)	36	36	36	44	44
	Face Area (ft. ² each)	12	12	12	14.5	14.5
Refrigerant Charge	System 1 (lb./oz.)	8/0	8/12	9/8	12/0	9/14
	System 2 (lb./oz.)	4/12	9/0	8/2	11/0	9/4
Compressors	Quantity	2	2	2	2	2
	Type	Recip.	Recip	Recip.	Recip	Scroll
Air Filters	Size (Wd. x Ht. x Thickness in.)	25x16x2	25x16x2	25x16x2	25x20x2	25x20x2

OPTIONAL ELECTRIC HEAT

The factory-installed heaters are wired for single point power supply. Power supply need only be brought into the single point terminal block.

These CSA approved heaters are located within the central compartment of the unit with the heater elements extending in to the supply air chamber.

Fuses are supplied, where required, by the factory. Some kW sizes require fuses and others do not. refer to Table 31 for minimum CFM limitations and to Tables 9 through 28 for electrical data.

TABLE 31: MINIMUM SUPPLY AIR CFM

Heater kW	Voltage	Unit Model Size (Nominal Tons)				
		078 (6.5)	090 (7.5)	102 (8.5)	120 (10)	150 (12.5)
Minimum Supply Air CFM						
9	208/ 230	1950	2250	2550	-	-
18		1950	2250	2550	3000	3750
24		1950	2250	2550	3000	3750
36		1950	2250	2550	3000	3750
54		-	-	-	3000	3750
9	480	1950	2250	2550	-	-
18		1950	2250	2550	3000	3750
24		1950	2250	2550	3000	3750
36		1950	2250	2550	3000	3750
54		-	-	-	3000	3750
9	600	1950	2250	2550	-	-
18		1950	2250	2550	3000	3750
24		1950	2250	2550	3000	3750
36		1950	2250	2550	3000	3750
54		-	-	-	3000	3750

OPTIONAL GAS HEAT

These gas-fired heaters have aluminized-steel or optional stainless steel, tubular heat exchangers with spark ignition.

TABLE 32: GAS APPLICATION DATA

Unit Size	Unit		Input (MBH)	Output (MBH)	Temp Rise (°F)
	Size	Opt.			
078	10		120	96	20-50
	15		180	144	35-65
090	10		120	96	15-45
	15		180	144	30-60
102	10		120	96	15-45
	15		180	144	30-60
120	15		180	144	20-50
	20		240	192	30-60
150	15		180	144	10-40
	20		240	192	20-50

GAS PIPING

Proper sizing of gas piping depends on the cubic feet per hour of gas flow required, specific gravity of the gas and the length of run. "National Fuel Gas Code" Z223.1 (in U.S.A.) or the current Gas Installation Codes CSA-B149.1 (in Canada) should be followed in all cases unless superseded by local codes or gas utility requirements. Refer to the Pipe Sizing Table 33. The heating value of the gas may differ with locality. The value should be checked with the local gas utility.

NOTE: There may be a local gas utility requirement specifying a minimum diameter for gas piping. All units require a one-inch pipe connection at the entrance fitting.

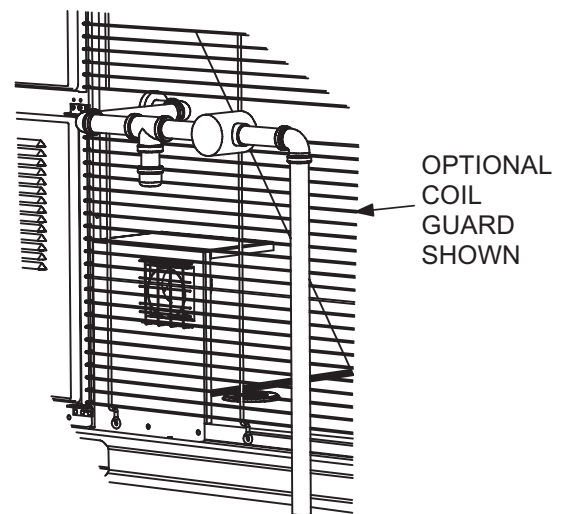

FIGURE 21 - SIDE ENTRY GAS PIPING

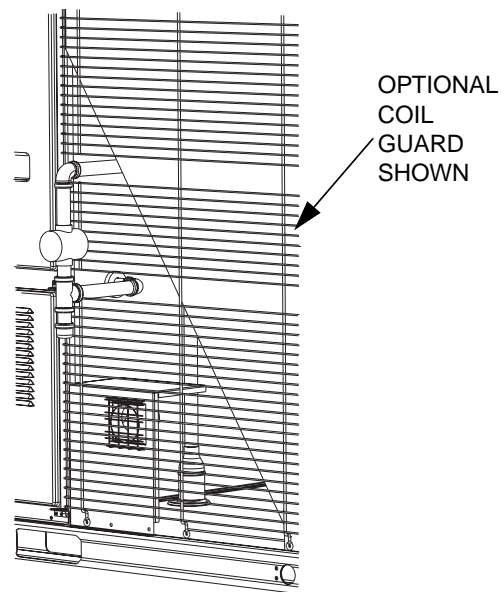

FIGURE 22 - BOTTOM ENTRY GAS PIPING

TABLE 33: GAS PIPE SIZING - CAPACITY OF PIPE

Length of Pipe (ft.)	Nominal Iron Pipe Size		
	3/4 in.	1 in.	1-1/4 in.
10	278	520	1050
20	190	350	730
30	152	285	590
40	130	245	500
50	115	215	440
60	105	195	400
70	96	180	370
80	90	170	350
90	84	160	320
100	79	150	305

NOTE: Maximum capacity of pipe in cubic feet of gas per hour based upon a pressure drop of 0.3 inch W.C. and 0.6 specific gravity gas.

NOTE: There may be a local gas utility requirement specifying a minimum diameter for gas piping. All units require a 3/4 inch pipe connection at the entrance fitting. Line should not be sized smaller than the entrance fitting size.

GAS CONNECTION

The gas supply line can be routed within the space and roof curb, exiting through the unit's basepan. Refer to Figure 9 for the gas piping inlet location. Typical supply piping arrangements are shown in Figures 21 and 22. All pipe nipples, fittings, and the gas cock are field supplied or may be purchased in UPG accessory kit #1GP0405.

Gas piping recommendations:

1. A drip leg and a ground joint union must be installed in the gas piping.
2. Where required by local codes, a manual shut-off valve must be installed outside of the unit.
3. Use wrought iron or steel pipe for all gas lines. Pipe dope should be applied sparingly to male threads only.

WARNING

Natural gas may contain some propane. Propane is an excellent solvent and will quickly dissolve white lead and most standard commercial compounds. A special pipe dope must be used when assembling wrought iron or steel pipe. Shellac based compounds such as Gaskolac or Stalastic, and compounds such as Rectorseal #5, Clydes's or John Crane may be used.

4. All piping should be cleaned of dirt and scale by hammering on the outside of the pipe and blowing out loose particles. Before initial start-up, be sure that all gas lines external to the unit have been purged of air.
5. The gas supply should be a separate line and installed in accordance with all safety codes as prescribed under "Limitations".
6. A 1/8-inch NPT plugged tapping, accessible for test gage connection, must be installed immediately upstream of the gas supply connection to the unit.
7. After the gas connections have been completed, open the main shut-off valve admitting *normal gas pressure* to the mains. *Check all joints for leaks with soap solution or other material suitable for the purpose. NEVER USE A FLAME.*

WARNING

FIRE OR EXPLOSION HAZARD

Failure to follow the safety warning exactly could result in serious injury, death or property damage.

Never test for gas leaks with an open flame. Use a commercially available soap solution made specifically for the detection of leaks to check all connections. A fire or explosion may result causing property damage, personal injury or loss of life.

CAUTION

The furnace and its individual shut-off valve must be disconnected from the gas supply piping system during any pressure testing at pressures in excess of 1/2 PSIG.

Pressures greater than 1/2 PSIG will cause gas valve damage resulting in a hazardous condition. If it is subjected to a pressure greater than 1/2 PSIG, the gas valve must be replaced.

The furnace must be isolated from the gas supply piping system by closing its individual manual shut-off valve during any pressure testing of the gas supply piping system at test pressures equal to or less than 1/2 PSIG.

WARNING

Threaded joints should be coated with a sealing compound that is resistant to the action of liquefied petroleum gases. **Do not use Teflon tape.**

LP UNITS, TANKS AND PIPING

All gas heat units are shipped from the factory equipped for natural gas use only. The unit may be converted in the field for use with LP gas with accessory kit model number 1NP0442.

All LP gas equipment must conform to the safety standards of the National Fire Protection Association.

For satisfactory operation, LP gas pressure must be 10.5 inch W.C. at the unit under full load. Maintaining proper gas pressure depends on three main factors:

1. The vaporization rate which depends on the temperature of the liquid and the “wetted surface” area of the container(s).
2. The proper pressure regulation. (Two-stage regulation is recommended).
3. The pressure drop in the lines between regulators and between the second stage regulator and the appliance. Pipe size required will depend on the length of the pipe run and the total load of all appliances.

Complete information regarding tank sizing for vaporization, recommended regulator settings, and pipe sizing is available from most regulator manufacturers and LP gas suppliers.

LP gas is an excellent solvent and will quickly dissolve white lead and most standard commercial compounds. A special pipe dope must be used when assembling wrought iron or steel pipe for LP. Shellac base compounds such as Gaskolac or Stalastic, and compounds such as Rectorseal #5, Clyde’s, or John Crane may be used.

Check all connections for leaks when piping is completed using a soap solution. **NEVER USE A FLAME.**

 WARNING
<p>FIRE OR EXPLOSION HAZARD</p> <p>Failure to follow the safety warning exactly could result in serious injury, death or property damage.</p> <p>Never test for gas leaks with an open flame. Use a commercially available soap solution made specifically for the detection of leaks to check all connections. A fire or explosion may result causing property damage, personal injury or loss of life.</p>

VENT AND COMBUSTION AIR

Venting slots in the heating compartment access panel remove the need for a combustion air hood. The gas heat

flue exhaust is routed through factory installed exhaust piping with screen. If necessary, a flue exhaust extension may be installed at the point of installation.

OPTIONS/ACCESSORIES

ELECTRIC HEAT

Electric heaters are available as factory-installed options or field-installed accessories. Refer to electric heat instructions for installation. These heaters mount in the heat compartment with the heating elements extending into the supply air chamber. All electric heaters are fused and intended for use with single point power supply.

MOTORIZED OUTDOOR DAMPER

The Motorized Outdoor Damper can be a factory installed option or a field installed accessory. If factory installed, refer to the instructions included with the outdoor air hood to complete the assembly. Field installed Motorized Outdoor Damper accessories include complete instructions for installation.

ECONOMIZER

The Economizer can be a factory installed option or a field installed accessory. If factory installed, refer to the instructions included with the outdoor air hood to complete the assembly. Field installed Economizer accessories include complete instructions for installation.

There are two Economizer options:

1. Down Flow application with barometric relief hood standard.
2. Horizontal Flow application that requires the purchase of a barometric relief hood.

POWER EXHAUST

The Power Exhaust can be a factory installed option or a field installed accessory. If factory installed, refer to the instructions included with the outdoor air hood to complete the assembly. Field installed Power Exhaust accessories include complete instructions for installation.

The Power Exhaust factory installed option is for Down Flow application only.

There are two field installed Power Exhaust accessories:

1. Down Flow application.
2. Horizontal Flow application that requires the purchase of a barometric relief hood.

RAIN HOOD

All of the hood components, including the filters, the gasketing and the hardware for assembling, are packaged and located between the condenser coil section and the main unit cabinet, if the unit has factory installed options. If field installed accessories are being installed all parts necessary for the installation comes in the accessory.

ECONOMIZER AND POWER EXHAUST SET POINT ADJUSTMENTS AND INFORMATION

Remove the top rear access panel from the unit. Locate the economizer control module, where the following adjustments will be made.

CAUTION

Extreme care must be exercised in turning all set point, maximum and minimum damper positioning adjustment screws to prevent twisting them off.

MINIMUM POSITION ADJUSTMENT

- Check that the damper blades move smoothly without binding; carefully turn the Minimum Position Adjust screw (found on the damper control module) fully clockwise and then set the thermostat indoor fan switch to the ON position and then OFF or energize and de-energize terminals "R" to "G".
- With the thermostat set to the indoor fan ON position or terminals "R" to "G" energized, turn the Minimum Position Adjusting screw (located on the damper control module) counterclockwise until the desired minimum damper position has been attained.

ENTHALPY SET POINT ADJUSTMENT

The enthalpy set point may now be set by selecting the desired set point shown in the Enthalpy Set Point Adjustment Figure 23. Adjust as follows:

- For a single enthalpy operation carefully turn the set point adjusting screw (found on the damper control module) to the "A", "B", "C" or "D" setting corresponding to the lettered curve of the Enthalpy Set Point Adjustment Figure 23.
- For a dual enthalpy operation, carefully turn the set point adjusting screw fully clockwise past the "D" setting.

POWER EXHAUST DAMPER SET POINT (WITH OR WITHOUT POWER EXHAUST)

- With no power exhaust option, adjust the Exhaust Air Adjustment Screw fully clockwise. This will allow 2nd stage cooling to operate.
- With power exhaust option, each building pressurization requirement will be different. The point at which the power exhaust comes on is determined by the economizer damper position (Percent Open). The Exhaust Air Adjustment Screw should be set at the Percent Open of the economizer damper at which the power exhaust is needed. It can be set from 0 to 100% damper open.

INDOOR AIR QUALITY AQ

Indoor Air Quality (indoor sensor input): Terminal AQ accepts a +2 to +10 Vdc signal with respect to the (AQ1) terminal. When the signal is below it's set point, the actuator is allowed to modulate normally in accordance with the enthalpy and mixed air sensor inputs. When the AQ signal exceeds it's set point setting and there is no call for free cooling, the actuator is proportionately modulated from the 2 to 10 Vdc signal, with 2 Vdc corresponding to full closed and 10 Vdc corresponding to full open. When there is no call for free cooling, the damper position is limited by the IAQ Max damper position setting. When the signal exceeds it's set point (Demand Control Ventilation Set Point) setting and there is a call for free cooling, the actuator modulates from the minimum position to the full open position based on the highest call from either the mixed air sensor input or the AQ voltage input.

- Optional CO₂ Space Sensor Kit Part # 2AQ04700324
- Optional CO₂ Sensor Kit Part # 2AQ04700424

Replace the top rear access panel on the unit.

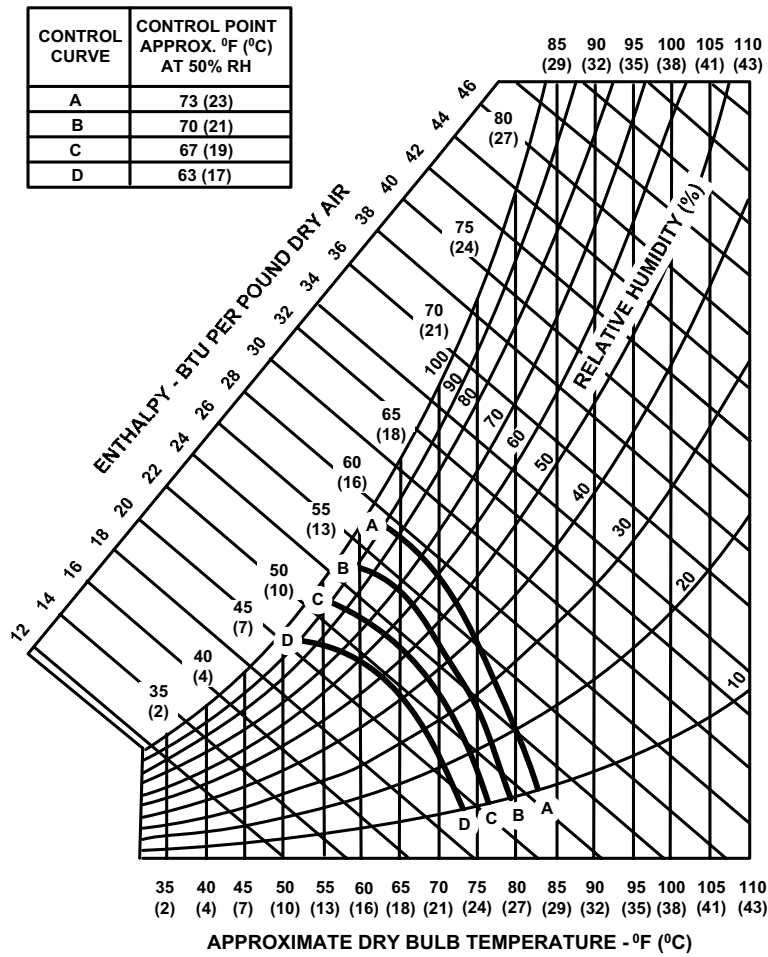

FIGURE 23 - ENTHALPY SET POINT CHART

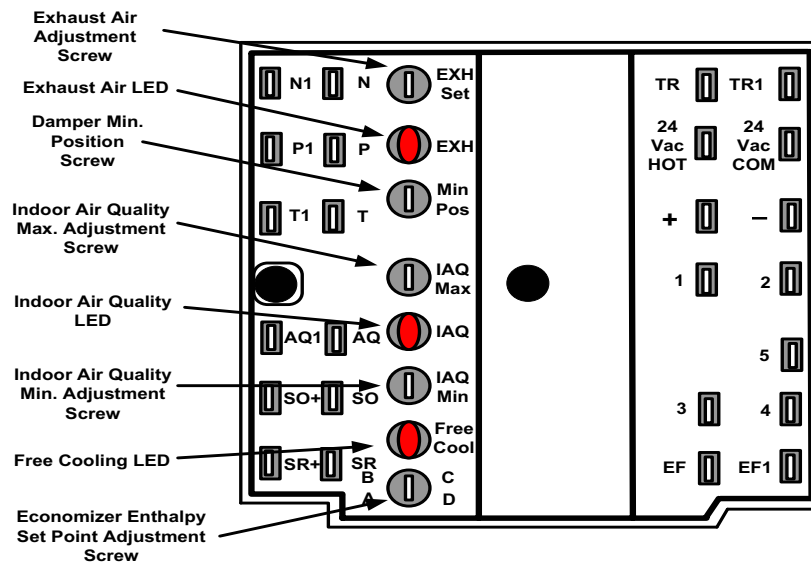

FIGURE 24 - HONEYWELL ECONOMIZER CONTROL W7212

PHASING

Predator® units are properly phased at the factory. Check for proper compressor rotation. If the blower or compressors rotate in the wrong direction at start-up, the electrical connection to the unit is misphased. Change the phasing of the **Field Line Connection at the factory or field supplied disconnect** to obtain proper rotation. (Scroll compressors operate in only one direction. If the scroll is drawing low amperage, has similar suction and discharge pressures, or producing a high noise level, the scroll is misphased.)

⚠ CAUTION

Scroll compressors require proper rotation to operate correctly. Units are properly phased at the factory. Do not change the internal wiring to make the blower condenser fans, or compressor rotate correctly.

BLOWER ROTATION

Check for proper supply air blower rotation. If the blower is rotating backwards, the line voltage at the unit point of power connection is misphased (See 'PHASING').

TABLE 34: SUPPLY AIR LIMITATIONS

Unit Size	Minimum	Maximum
078	1950	3250
090	2250	3750
102	2550	4250
120	3000	5000
150	3750	6250

BELT TENSION

The tension on the belt should be adjusted as shown in Figure 25.

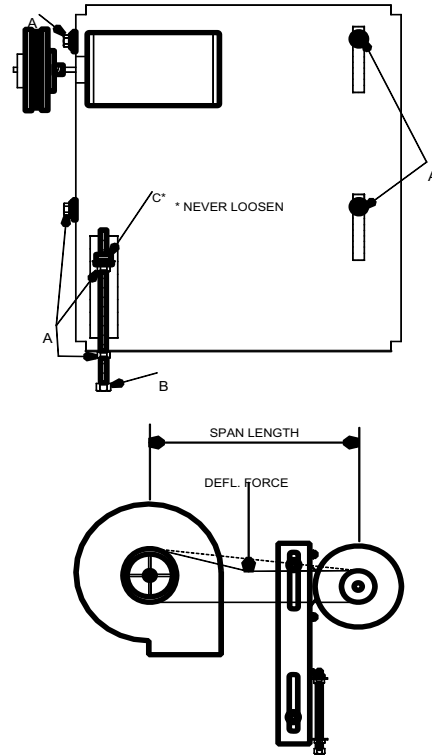

FIGURE 25 - BELT ADJUSTMENT

⚠ CAUTION

Procedure for adjusting belt tension:

1. Loosen six nuts (top and bottom) A.
2. Adjust by turning (B).
3. Never loosen nuts (C).
4. Use belt tension checker to apply a perpendicular force to one belt at the midpoint of the span as shown. Deflection distance of 4mm (5/32") is obtained.

To determine the deflection distance from normal position, use a straight edge from sheave to sheave as reference line. The recommended deflection force is as follows:

Tension new belts at the max. deflection force recommended for the belt section. Check the belt tension at least two times during the first 24 hours of operation. Any retensioning should fall between the min. and max. deflection force values.

5. After adjusting retighten nuts (A).

TABLE 35: DM078 (6-1/2 TON) STANDARD MOTOR DOWN SHOT BLOWER PERFORMANCE^{1 2}

ESP ³	TURNS OPEN ⁴																	
	0			1			2			3			4			5		
	CFM	W ⁵	BHP	CFM	W ⁵	BHP	CFM	W ⁵	BHP	CFM	W ⁵	BHP	CFM	W ⁵	BHP	CFM	W ⁵	BHP
0.2	-	-	-	-	-	-	3291	1191	1.28	3096	1059	1.14	2963	948	1.02	2757	831	0.89
0.4	-	-	-	3168	1225	1.31	2969	1085	1.16	2658	939	1.01	2535	834	0.89	2255	718	0.77
0.6	3223	1273	1.37	2732	1084	1.16	2500	947	1.02	2110	803	0.86	1923	699	0.75	1608	596	0.64
0.8	2541	1091	1.17	2168	925	0.99	1882	793	0.85	-	-	-	-	-	-	-	-	-
1.0	1859	908	0.97	-	-	-	-	-	-	-	-	-	-	-	-	-	-	-

1. Blower performance for gas heat includes maximum number of heat tubes available for each tonnage.
2. Blower performance includes two-inch throwaway filters.
3. ESP (External Static Pressure) given is that available for the supply and return air duct system. All internal resistances have been deducted from the total static pressure of the blower.
4. "Turns Open" refers to the setting of the variable pitch motor sheave, where "0 Turns Open" is fully closed.
5. W = Watts

TABLE 36: DM078 (6-1/2 TON) OPTIONAL MOTOR DOWN SHOT BLOWER PERFORMANCE^{1 2}

ESP ³	TURNS OPEN ⁴																	
	0			1			2			3			4			5		
	CFM	W ⁵	BHP	CFM	W ⁵	BHP	CFM	W ⁵	BHP	CFM	W ⁵	BHP	CFM	W ⁵	BHP	CFM	W ⁵	BHP
0.4	-	-	-	-	-	-	-	-	-	-	-	-	-	-	-	3489	1553	1.67
0.6	-	-	-	-	-	-	-	-	-	-	-	-	3394	1641	1.76	3101	1407	1.51
0.8	-	-	-	-	-	-	3623	2009	2.15	3323	1742	1.87	2971	1477	1.58	2607	1241	1.33
1.0	-	-	-	3643	2150	2.31	3224	1820	1.95	2889	1569	1.68	2466	1306	1.40	2009	1071	1.15
1.2	3613	2238	2.40	3143	1917	2.06	2748	1621	1.74	2369	1385	1.49	1879	1141	1.22	-	-	-
1.4	3099	2039	2.19	2636	1711	1.83	2195	1424	1.53	-	-	-	-	-	-	-	-	-
1.6	2586	1833	1.97	2124	1532	1.64	-	-	-	-	-	-	-	-	-	-	-	-
1.8	2073	1621	1.74	-	-	-	-	-	-	-	-	-	-	-	-	-	-	-

1. Blower performance for gas heat includes maximum number of heat tubes available for each tonnage.
2. Blower performance includes two-inch throwaway filters.
3. ESP (External Static Pressure) given is that available for the supply and return air duct system. All internal resistances have been deducted from the total static pressure of the blower.
4. "Turns Open" refers to the setting of the variable pitch motor sheave, where "0 Turns Open" is fully closed.
5. W = Watts

TABLE 37: DH078 (6-1/2 TON) STANDARD MOTOR DOWN SHOT BLOWER PERFORMANCE^{1,2}

ESP ³	TURNS OPEN ⁴																							
	0 Turns				1 Turn				2 Turns				3 Turns				4 Turns				5 Turns			
	CFM	RPM	W ⁵	BHP	CFM	RPM	W ⁵	BHP	CFM	RPM	W ⁵	BHP	CFM	RPM	W ⁵	BHP	CFM	RPM	W ⁵	BHP	CFM	RPM	W ⁵	BHP
0.2	—	—	—	—	3310	1079	1590	1.71	3190	1035	1410	1.51	3005	991	1230	1.32	2780	945	1070	1.15	2560	897	940	1.01
0.4	3320	1126	1650	1.77	3050	1082	1440	1.54	2850	1038	1290	1.38	2680	992	1100	1.18	2480	946	970	1.04	2200	899	840	0.90
0.6	3020	1129	1530	1.64	2780	1086	1320	1.42	2550	1040	1150	1.23	2320	996	980	1.05	2055	948	840	0.90	1925	902	720	0.77
0.8	2700	1132	1380	1.48	2450	1088	1180	1.27	2160	1043	1010	1.08	1879	998	840	0.90	1500	952	700	0.75	—	—	—	—
1.0	2300	1136	1230	1.32	2003	1091	1010	1.08	1570	1047	820	0.88	—	—	—	—	—	—	—	—	—	—	—	—
1.2	1781	1120	1010	1.08	—	—	—	—	—	—	—	—	—	—	—	—	—	—	—	—	—	—	—	—

1. Blower performance for gas heat includes maximum number of heat tubes available for each tonnage.
2. Blower performance includes two-inch throwaway filters.
3. ESP (External Static Pressure) given is that available for the supply and return air duct system. All internal resistances have been deducted from the total static pressure of the blower.
4. "Turns Open" refers to the setting of the variable pitch motor sheave, where "0 Turns Open" is fully closed.
5. W = Watts

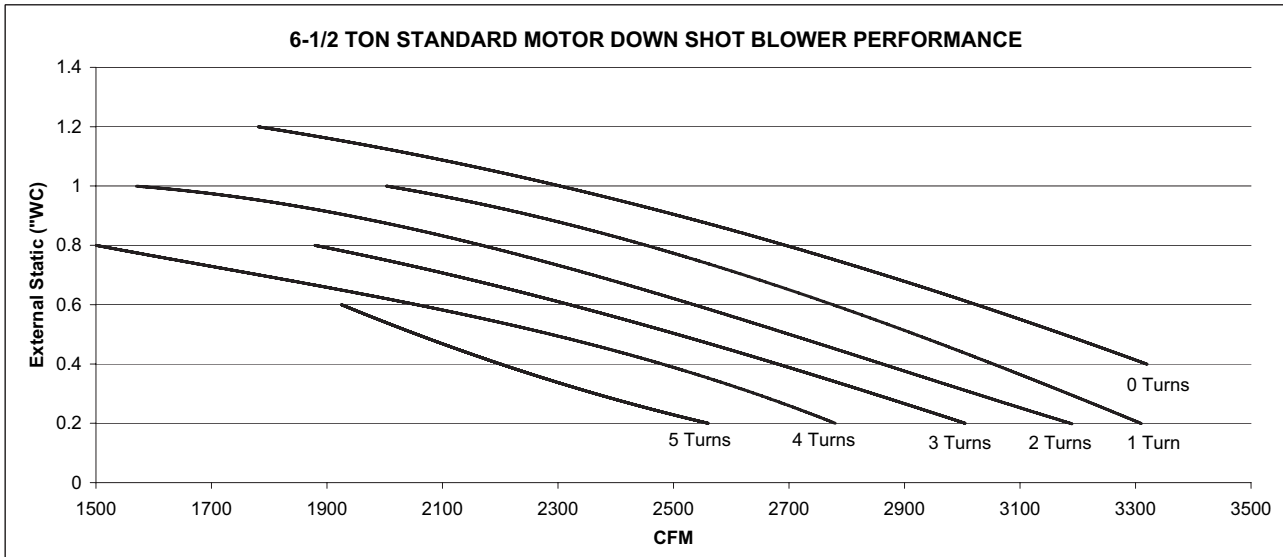

TABLE 38: DH078 (6-1/2 TON) OPTIONAL MOTOR DOWN SHOT BLOWER PERFORMANCE^{1,2}

ESP ³	TURNS OPEN ⁴																							
	0 Turns				1 Turn				2 Turns				3 Turns				4 Turns				5 Turns			
	CFM	RPM	W ⁵	BHP	CFM	RPM	W ⁵	BHP	CFM	RPM	W ⁵	BHP	CFM	RPM	W ⁵	BHP	CFM	RPM	W ⁵	BHP	CFM	RPM	W ⁵	BHP
0.2	-	-	-	-	-	-	-	-	3426	1156	1940	2.1	3300	1108	1700	1.8	3081	1057	1500	1.6	2889	1004	1300	1.4
0.4	-	-	-	-	3343	1207	2040	2.2	3155	1160	1780	1.9	3014	1111	1590	1.7	2800	1059	1380	1.5	2600	1007	1170	1.3
0.6	3281	1259	2140	2.3	3123	1212	1910	2.0	2912	1164	1650	1.8	2757	1114	1460	1.6	2514	1062	1240	1.3	2287	1008	1050	1.1
0.8	3031	1262	1970	2.1	2875	1215	1760	1.9	2651	1167	1500	1.6	2449	1116	1320	1.4	2148	1065	1090	1.2	1868	1012	900	1.0
1	2765	1268	1810	1.9	2595	1220	1630	1.7	2300	1171	1360	1.5	2051	1120	1170	1.2	1715	1069	950	1.0	-	-	-	-
1.2	2493	1273	1700	1.8	2228	1225	1420	1.5	1916	1176	1160	1.2	1323	1126	880	0.9	-	-	-	-	-	-	-	-
1.4	2284	1278	1520	1.6	1690	1231	1170	1.3	-	-	-	-	-	-	-	-	-	-	-	-	-	-	-	-

1. Blower performance for gas heat includes maximum number of heat tubes available for each tonnage.
2. Blower performance includes two-inch throwaway filters.
3. ESP (External Static Pressure) given is that available for the supply and return air duct system. All internal resistances have been deducted from the total static pressure of the blower.
4. "Turns Open" refers to the setting of the variable pitch motor sheave, where "0 Turns Open" is fully closed.
5. W = Watts

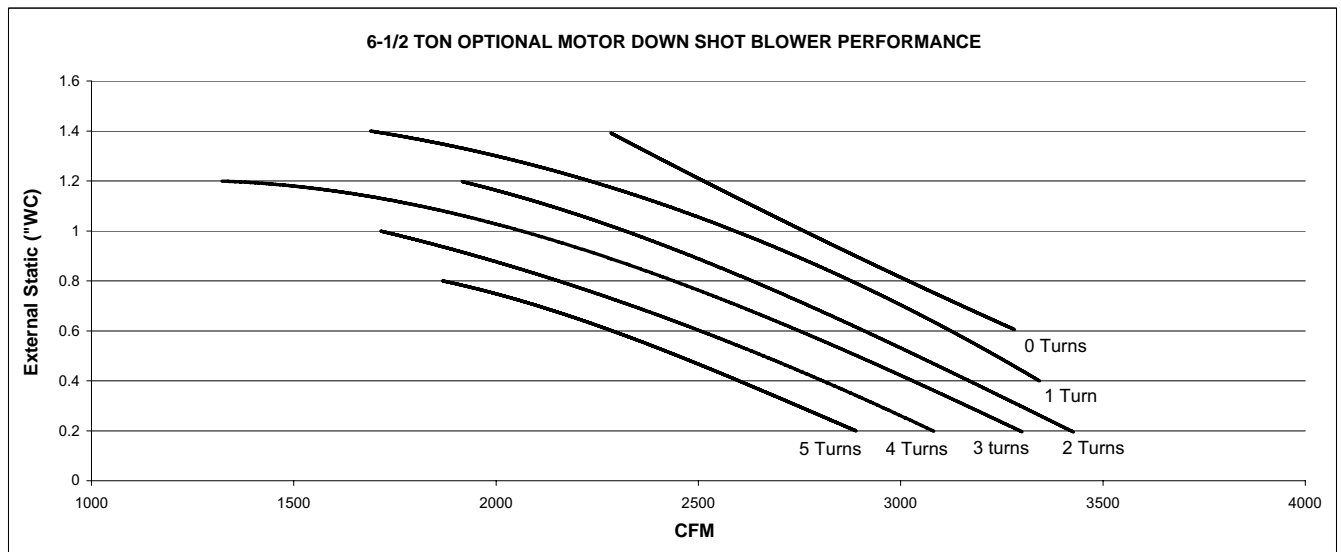

TABLE 39: DM, DH 090 (7-1/2 TON) STANDARD MOTOR DOWN SHOT BLOWER PERFORMANCE

ESP ³	TURNS OPEN ⁴																							
	0 Turns				1 Turn				2 Turns				3 Turns				4 Turns				5 Turns			
	CFM	RPM	W ⁵	BHP	CFM	RPM	W ⁵	BHP	CFM	RPM	W ⁵	BHP	CFM	RPM	W ⁵	BHP	CFM	RPM	W ⁵	BHP	CFM	RPM	W ⁵	BHP
0.2	3619	1203	2148	2.3	3452	1156	1913	2.1	3272	1110	1696	1.8	3085	1063	1503	1.6	2932	1013	1299	1.4	2742	963	1123	1.2
0.4	3343	1204	1988	2.1	3189	1159	1781	1.9	2995	1113	1547	1.7	2798	1065	1360	1.5	2640	1014	1190	1.3	2421	965	1024	1.1
0.6	3100	1205	1857	2.0	2944	1162	1676	1.8	2746	1116	1440	1.5	2512	1068	1246	1.3	2340	1017	1067	1.1	2084	967	918	1.0
0.8	2846	1205	1712	1.8	2675	1166	1534	1.6	2448	1118	1326	1.4	2162	1071	1098	1.2	1956	1020	934	1.0	1606	969	781	0.8
1	2559	1207	1574	1.7	2335	1169	1364	1.5	2084	1119	1174	1.3	1712	1074	941	1.0	-	-	-	-	-	-	-	-
1.2	2219	1209	1435	1.5	1935	1174	1039	1.1	-	-	-	-	-	-	-	-	-	-	-	-	-	-	-	-

1. Blower performance for gas heat includes maximum number of heat tubes available for each tonnage.
2. Blower performance includes two-inch throwaway filters.
3. ESP (External Static Pressure) given is that available for the supply and return air duct system. All internal resistances have been deducted from the total static pressure of the blower.
4. "Turns Open" refers to the setting of the variable pitch motor sheave, where "0 Turns Open" is fully closed.
5. W = Watts

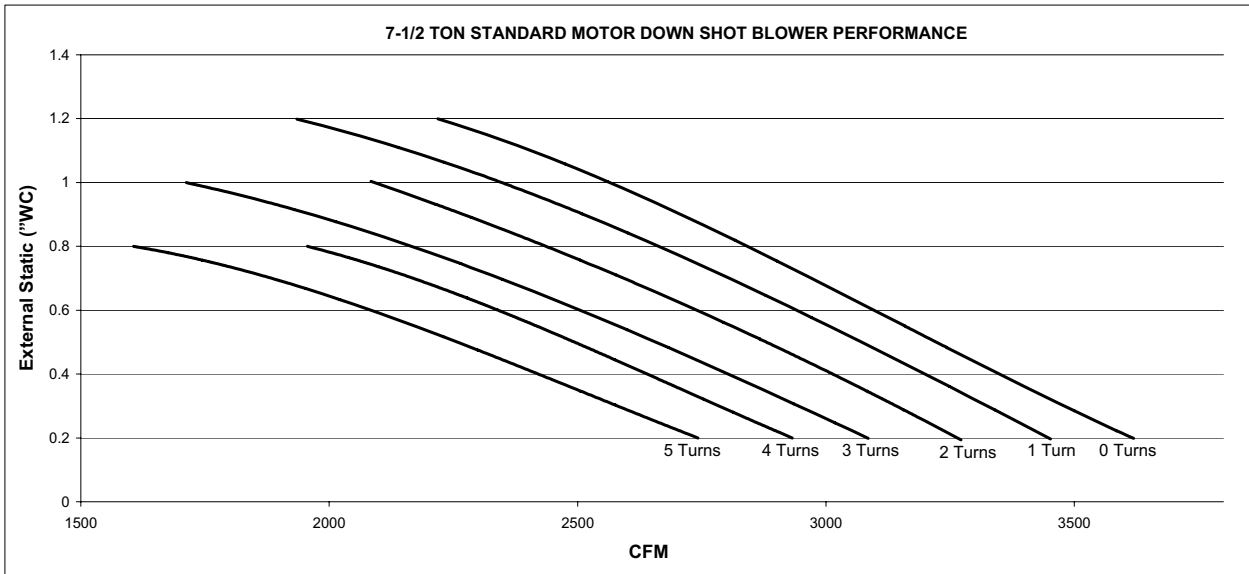

TABLE 40: DM, DH 090 (7-1/2 TON) OPTIONAL MOTOR DOWNSHOT BLOWER PERFORMANCE

ESP ³	TURNS OPEN ⁴																							
	0 Turns				1 Turn				2 Turns				3 Turns				4 Turns				5 Turns			
	CFM	RPM	W ⁵	BHP	CFM	RPM	W ⁵	BHP	CFM	RPM	W ⁵	BHP	CFM	RPM	W ⁵	BHP	CFM	RPM	W ⁵	BHP	CFM	RPM	W ⁵	BHP
0.2	3995	1299	2790	3.0	3765	1249	2420	2.6	3619	1198	2147	2.3	3399	1144	1849	2.0	3223	1092	1630	1.7	3002	1038	1421	1.5
0.4	3718	1303	2580	2.8	3508	1252	2290	2.5	3353	1201	2010	2.2	3131	1147	1715	1.8	2945	1094	1525	1.6	2715	1039	1328	1.4
0.6	3506	1305	2440	2.6	3288	1255	2117	2.3	3107	1203	1862	2.0	2876	1149	1603	1.7	2666	1096	1368	1.5	2418	1042	1206	1.3
0.8	3290	1308	2290	2.5	3053	1258	1982	2.1	2858	1206	1712	1.8	2594	1152	1487	1.6	2334	1099	1248	1.3	2049	1044	1037	1.1
1	3065	1312	2167	2.3	2795	1261	1844	2.0	2558	1209	1602	1.7	2259	1155	1318	1.4	1954	1101	1095	1.2	-	-	-	-
1.2	2799	1315	1977	2.1	2458	1264	1675	1.8	2223	1212	1408	1.5	1780	1159	1084	1.2	-	-	-	-	-	-	-	-
1.4	2401	1320	1775	1.9	2098	1269	1487	1.6	-	-	-	-	-	-	-	-	-	-	-	-	-	-	-	-
1.6	1940	1325	1514	1.6	-	-	-	-	-	-	-	-	-	-	-	-	-	-	-	-	-	-	-	-

1. Blower performance for gas heat includes maximum number of heat tubes available for each tonnage.
2. Blower performance includes two-inch throwaway filters.
3. ESP (External Static Pressure) given is that available for the supply and return air duct system. All internal resistances have been deducted from the total static pressure of the blower.
4. "Turns Open" refers to the setting of the variable pitch motor sheave, where "0 Turns Open" is fully closed.
5. W = Watts

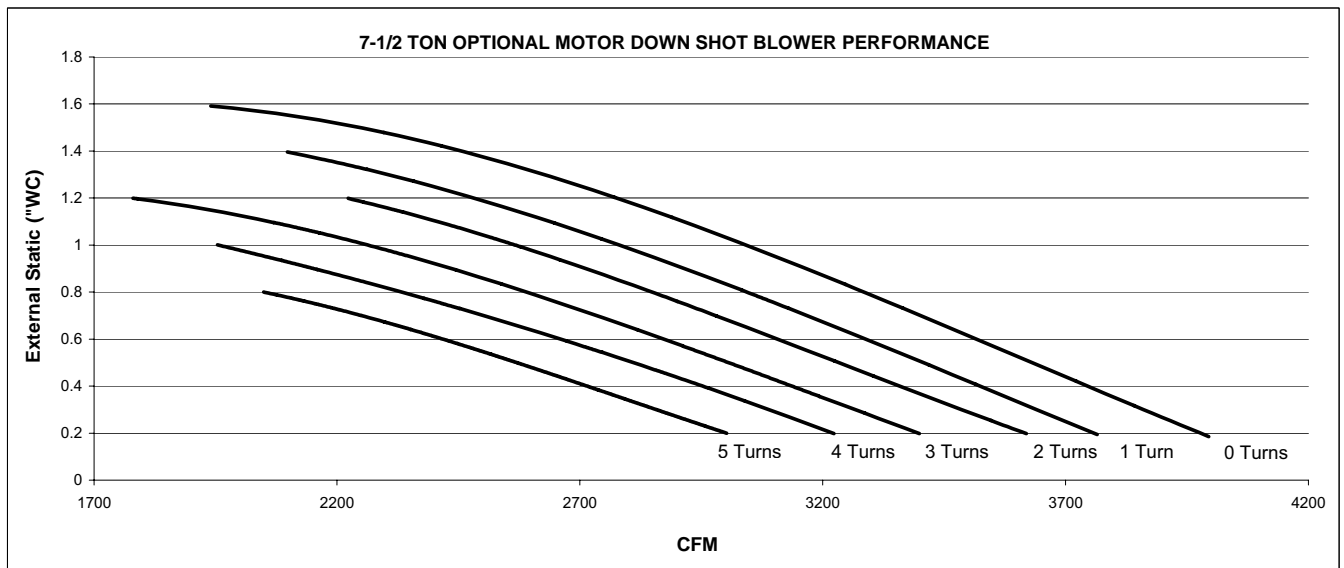

TABLE 41: DM, DH 102 (8-1/2 TON) STANDARD MOTOR DOWN SHOT BLOWER PERFORMANCE

ESP ³	TURNS OPEN ⁴																							
	0 Turns				1 Turn				2 Turns				3 Turns				4 Turns				5 Turns			
	CFM	RPM	W ⁵	BHP	CFM	RPM	W ⁵	BHP	CFM	RPM	W ⁵	BHP	CFM	RPM	W ⁵	BHP	CFM	RPM	W ⁵	BHP	CFM	RPM	W ⁵	BHP
0.2	3995	1299	2790	3.0	3765	1249	2420	2.6	3619	1198	2147	2.3	3399	1144	1849	2.0	3223	1092	1630	1.7	3002	1038	1421	1.5
0.4	3718	1303	2580	2.8	3508	1252	2290	2.5	3353	1201	2010	2.2	3131	1147	1715	1.8	2945	1094	1525	1.6	2715	1039	1328	1.4
0.6	3506	1305	2440	2.6	3288	1255	2117	2.3	3107	1203	1862	2.0	2876	1149	1603	1.7	2666	1096	1368	1.5	2418	1042	1206	1.3
0.8	3290	1308	2290	2.5	3053	1258	1982	2.1	2858	1206	1712	1.8	2594	1152	1487	1.6	2334	1099	1248	1.3	2049	1044	1037	1.1
1	3065	1312	2167	2.3	2795	1261	1844	2.0	2558	1209	1602	1.7	2259	1155	1318	1.4	1954	1101	1095	1.2	-	-	-	-
1.2	2799	1315	1977	2.1	2458	1264	1675	1.8	2223	1212	1408	1.5	1780	1159	1084	1.2	-	-	-	-	-	-	-	-
1.4	2401	1320	1775	1.9	2098	1269	1487	1.6	-	-	-	-	-	-	-	-	-	-	-	-	-	-	-	-
1.6	1940	1325	1514	1.6	-	-	-	-	-	-	-	-	-	-	-	-	-	-	-	-	-	-	-	-

1. Blower performance for gas heat includes maximum number of heat tubes available for each tonnage.
2. Blower performance includes two-inch throwaway filters.
3. ESP (External Static Pressure) given is that available for the supply and return air duct system. All internal resistances have been deducted from the total static pressure of the blower.
4. "Turns Open" refers to the setting of the variable pitch motor sheave, where "0 Turns Open" is fully closed.
5. W = Watts

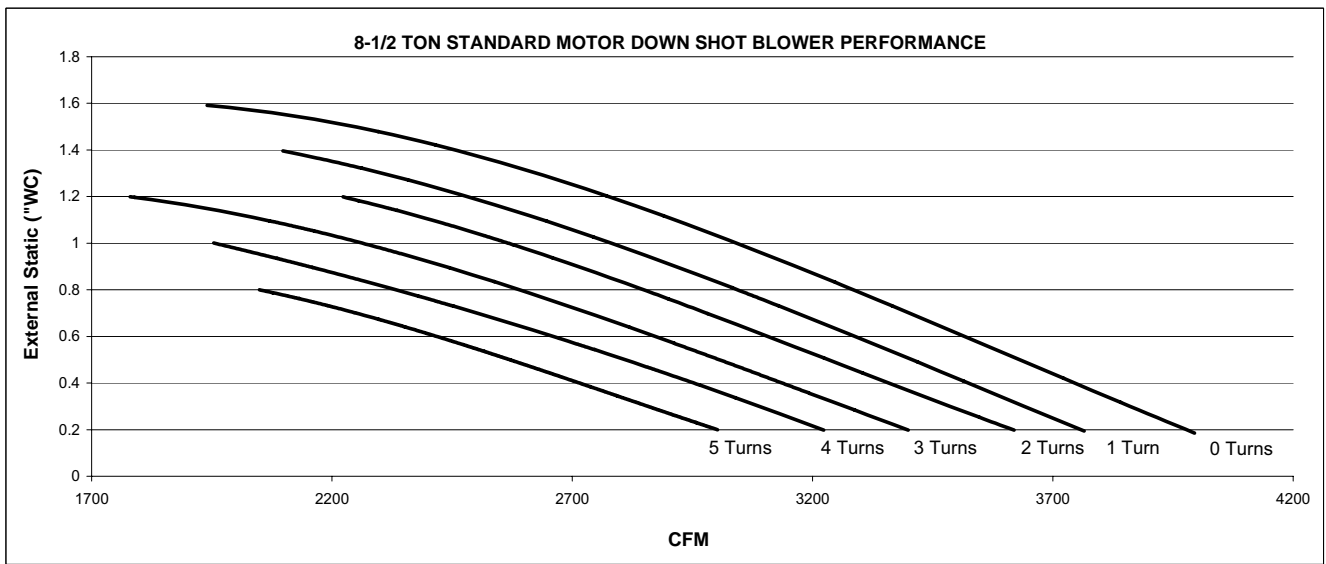

TABLE 42: DM, DH 102 (8-1/2 TON) OPTIONAL DRIVE DOWN SHOT BLOWER PERFORMANCE

ESP ⁵	TURNS OPEN ⁴																							
	0 Turns				1 Turn				2 Turns				3 Turns				4 Turns				5 Turns			
	CFM	RPM	W ⁵	BHP	CFM	RPM	W ⁵	BHP	CFM	RPM	W ⁵	BHP	CFM	RPM	W ⁵	BHP	CFM	RPM	W ⁵	BHP	CFM	RPM	W ⁵	BHP
0.2	4073	1346	2930	3.1	3897	1296	2700	2.9	3732	1245	2390	2.6	3598	1191	2100	2.2	3445	1136	1800	2.0	3209	1078	1600	1.8
0.4	3841	1351	2910	3.1	3632	1301	2470	2.6	3460	1248	2270	2.4	3324	1194	1930	2.1	3168	1138	1680	1.8	2922	1081	1470	1.6
0.6	3627	1354	2800	3.0	3425	1304	2360	2.4	3267	1251	2090	2.2	3085	1197	1800	1.9	2904	1141	1550	1.7	2638	1082	1370	1.5
0.8	3404	1358	2570	2.8	3226	1308	2230	2.4	3047	1254	2000	2.1	2820	1200	1670	1.8	2585	1144	1490	1.6	2258	1085	1260	1.4
1	3182	1362	2540	2.7	2975	1312	2030	2.2	2778	1257	1790	1.9	2478	1203	1550	1.7	2241	1147	1270	1.4	1811	1088	1110	1.2
1.2	2935	1367	2290	2.5	2685	1317	2000	2.1	2462	1261	1630	1.7	2160	1206	1380	1.5	1729	1151	1040	1.1	-	-	-	-
1.4	2615	1371	2150	2.3	2409	1319	1690	1.8	2106	1265	1470	1.6	1407	1213	1000	1.0	-	-	-	-	-	-	-	-
1.6	2294	1375	2010	2.2	1970	1325	1430	1.5	-	-	-	-	-	-	-	-	-	-	-	-	-	-	-	-
1.8	1808	1382	1390	1.5	-	-	-	-	-	-	-	-	-	-	-	-	-	-	-	-	-	-	-	-

1. Blower performance for gas heat includes maximum number of heat tubes available for each tonnage.
2. Blower performance includes two-inch throwaway filters.
3. ESP (External Static Pressure) given is that available for the supply and return air duct system. All internal resistances have been deducted from the total static pressure of the blower.
4. "Turns Open" refers to the setting of the variable pitch motor sheave, where "0 Turns Open" is fully closed.
5. W = Watts

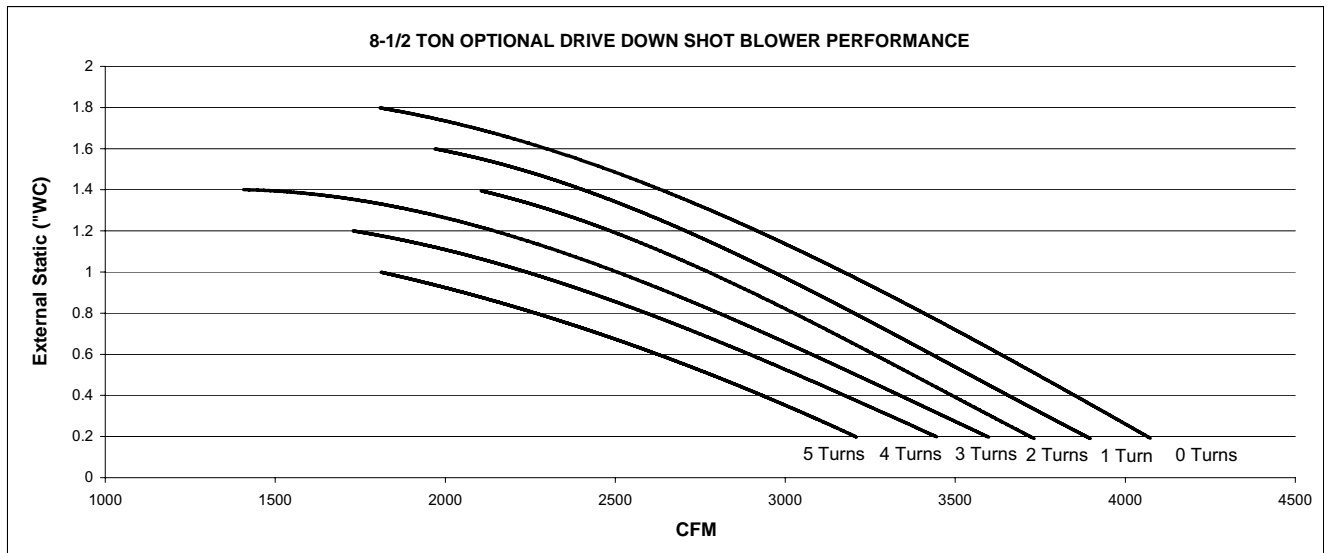

TABLE 43: DM, DH 120 (10 TON) STANDARD MOTOR DOWN SHOT BLOWER PERFORMANCE^{1 2}

ESP ³	TURNS OPEN ⁴																	
	0			1			2			3			4			5		
	CFM	W ⁵	BHP	CFM	W ⁵	BHP	CFM	W ⁵	BHP	CFM	W ⁵	BHP	CFM	W ⁵	BHP	CFM	W ⁵	BHP
0.2	-	-	-	-	-	-	-	-	-	3896	1639	1.76	3688	1453	1.56	3447	1268	1.36
0.4	4040	2076	2.23	4005	1934	2.07	3790	1698	1.82	3569	1508	1.62	3333	1330	1.43	3057	1147	1.23
0.6	3890	2006	2.15	3697	1790	1.92	3427	1550	1.66	3152	1356	1.45	-	-	-	-	-	-
0.8	3620	1882	2.02	3324	1629	1.75	2972	1380	1.48	-	-	-	-	-	-	-	-	-
1.0	3227	1708	1.83	-	-	-	-	-	-	-	-	-	-	-	-	-	-	-

1. Blower performance for gas heat includes maximum number of heat tubes available for each tonnage.
2. Blower performance includes two-inch throwaway filters.
3. ESP (External Static Pressure) given is that available for the supply and return air duct system. All internal resistances have been deducted from the total static pressure of the blower.
4. "Turns Open" refers to the setting of the variable pitch motor sheave, where "0 Turns Open" is fully closed.
5. W = Watts

TABLE 44: DM, DH 120 (10 TON) OPTIONAL MOTOR DOWN SHOT BLOWER PERFORMANCE^{1 2}

ESP ³	TURNS OPEN ⁴																	
	0			1			2			3			4			5		
	CFM	W ⁵	BHP	CFM	W ⁵	BHP	CFM	W ⁵	BHP	CFM	W ⁵	BHP	CFM	W ⁵	BHP	CFM	W ⁵	BHP
0.4	4965	3485	3.74	4875	3150	3.38	4613	2739	2.94	4322	2374	2.55	4156	2106	2.26	3907	1860	1.99
0.6	4876	3416	3.66	4651	2997	3.21	4359	2582	2.77	4038	2220	2.38	3860	1966	2.11	3590	1724	1.85
0.8	4713	3291	3.53	4387	2823	3.03	4077	2417	2.59	3719	2059	2.21	3541	1827	1.96	3242	1584	1.70
1.0	4476	3116	3.34	4084	2632	2.82	3768	2245	2.41	3365	1892	2.03	3197	1691	1.81	-	-	-
1.2	4165	2898	3.11	3741	2427	2.60	3432	2070	2.22	-	-	-	-	-	-	-	-	-
1.4	3779	2646	2.84	3359	2212	2.37	3069	1895	2.03	-	-	-	-	-	-	-	-	-
1.6	3319	2372	2.54	-	-	-	-	-	-	-	-	-	-	-	-	-	-	-

1. Blower performance for gas heat includes maximum number of heat tubes available for each tonnage.
2. Blower performance includes two-inch throwaway filters.
3. ESP (External Static Pressure) given is that available for the supply and return air duct system. All internal resistances have been deducted from the total static pressure of the blower.
4. "Turns Open" refers to the setting of the variable pitch motor sheave, where "0 Turns Open" is fully closed.
5. W = Watts

TABLE 45: DM, DH 150 (12-1/2 TON) STANDARD MOTOR DOWN SHOT BLOWER PERFORMANCE^{1 2}

ESP ³	TURNS OPEN ⁴																	
	0			1			2			3			4			5		
	CFM	W ⁵	BHP	CFM	W ⁵	BHP	CFM	W ⁵	BHP	CFM	W ⁵	BHP	CFM	W ⁵	BHP	CFM	W ⁵	BHP
0.4	5078	3630	3.89	4809	3103	3.33	4594	3053	3.27	4360	2478	2.66	4090	2093	2.24	3812	1798	1.93
0.6	4865	3456	3.71	4584	2961	3.17	4349	2912	3.12	4106	2318	2.49	3814	1964	2.11	-	-	-
0.8	4642	3284	3.52	4356	2828	3.03	4089	2776	2.98	3840	2137	2.29	-	-	-	-	-	-
1.0	4408	3114	3.34	4124	2705	2.90	3815	2647	2.84	-	-	-	-	-	-	-	-	-
1.2	4164	2947	3.16	3889	2592	2.78	-	-	-	-	-	-	-	-	-	-	-	-
1.4	3910	2787	2.99	-	-	-	-	-	-	-	-	-	-	-	-	-	-	-

1. Blower performance for gas heat includes maximum number of heat tubes available for each tonnage.
2. Blower performance includes two-inch throwaway filters.
3. ESP (External Static Pressure) given is that available for the supply and return air duct system. All internal resistances have been deducted from the total static pressure of the blower.
4. "Turns Open" refers to the setting of the variable pitch motor sheave, where "0 Turns Open" is fully closed.
5. W = Watts

TABLE 46: DM, DH 150 (12-1/2 TON) OPTIONAL MOTOR DOWN SHOT BLOWER PERFORMANCE^{1 2}

ESP ³	TURNS OPEN ⁴																	
	0			1			2			3			4			5		
	CFM	W ⁵	BHP	CFM	W ⁵	BHP	CFM	W ⁵	BHP	CFM	W ⁵	BHP	CFM	W ⁵	BHP	CFM	W ⁵	BHP
0.4	5994	5400	5.79	5565	4369	4.69	5488	4169	4.47	5264	3599	3.86	4990	3085	3.31	4738	2812	3.02
0.6	5824	5216	5.59	5368	4186	4.49	5289	3991	4.28	5049	3437	3.69	4763	2937	3.15	4491	2655	2.85
0.8	5641	5022	5.39	5170	4012	4.30	5076	3807	4.08	4822	3272	3.51	4528	2790	2.99	4235	2497	2.68
1.0	5444	4819	5.17	4971	3846	4.12	4847	3618	3.88	4584	3103	3.33	4286	2644	2.83	3969	2340	2.51
1.2	5233	4609	4.94	4771	3687	3.95	4604	3426	3.67	4335	2933	3.15	4035	2499	2.68	-	-	-
1.4	5009	4394	4.71	4571	3537	3.79	4346	3233	3.47	4074	2762	2.96	3777	2356	2.53	-	-	-
1.6	4771	4174	4.48	4370	3395	3.64	4074	3040	3.26	3802	2590	2.78	-	-	-	-	-	-
1.8	4520	3951	4.24	4169	3262	3.50	3786	2850	3.06	-	-	-	-	-	-	-	-	-
2.0	4255	3728	4.00	3966	3137	3.36	-	-	-	-	-	-	-	-	-	-	-	-
2.2	3976	3505	3.76	3763	3020	3.24	-	-	-	-	-	-	-	-	-	-	-	-

1. Blower performance for gas heat includes maximum number of heat tubes available for each tonnage.
2. Blower performance includes two-inch throwaway filters.
3. ESP (External Static Pressure) given is that available for the supply and return air duct system. All internal resistances have been deducted from the total static pressure of the blower.
4. "Turns Open" refers to the setting of the variable pitch motor sheave, where "0 Turns Open" is fully closed.
5. W = Watts

TABLE 47: DM078 (6-1/2 TON) STANDARD MOTOR SIDE SHOT BLOWER PERFORMANCE^{1 2}

ESP ³	TURNS OPEN ⁴																	
	0			1			2			3			4			5		
	CFM	W ⁵	BHP	CFM	W ⁵	BHP	CFM	W ⁵	BHP	CFM	W ⁵	BHP	CFM	W ⁵	BHP	CFM	W ⁵	BHP
0.4	-	-	-	-	-	-	3367	1216	1.30	3133	1067	1.14	2954	944	1.01	2701	819	0.88
0.6	-	-	-	3208	1239	1.33	2913	1068	1.15	2466	913	0.98	2350	789	0.85	1750	621	0.67
0.8	-	-	-	2651	1058	1.13	2317	894	0.96	1656	700	0.75	-	-	-	-	-	-
1.0	2186	998	1.07	1774	830	0.89	-	-	-	-	-	-	-	-	-	-	-	-

1. Blower performance for gas heat includes maximum number of heat tubes available for each tonnage.
2. Blower performance includes two-inch throwaway filters.
3. ESP (External Static Pressure) given is that available for the supply and return air duct system. All internal resistances have been deducted from the total static pressure of the blower.
4. "Turns Open" refers to the setting of the variable pitch motor sheave, where "0 Turns Open" is fully closed.
5. W = Watts

TABLE 48: DM078 (6-1/2 TON) OPTIONAL MOTOR SIDE SHOT BLOWER PERFORMANCE^{1 2}

ESP ³	TURNS OPEN ⁴																	
	0			1			2			3			4			5		
	CFM	W ⁵	BHP	CFM	W ⁵	BHP	CFM	W ⁵	BHP	CFM	W ⁵	BHP	CFM	W ⁵	BHP	CFM	W ⁵	BHP
0.6	-	-	-	-	-	-	-	-	-	-	-	-	-	-	-	3597	1598	1.71
0.8	-	-	-	-	-	-	-	-	-	-	-	-	3503	1689	1.81	3172	1430	1.53
1.0	-	-	-	-	-	-	-	-	-	3406	1778	1.91	3032	1497	1.61	2248	1143	1.23
1.2	-	-	-	-	-	-	3327	1866	2.00	2926	1578	1.69	2160	1217	1.31	-	-	-
1.4	-	-	-	3270	1971	2.11	2537	1544	1.66	2043	1296	1.39	-	-	-	-	-	-
1.6	3196	2077	2.23	2460	1651	1.77	1858	1318	1.41	-	-	-	-	-	-	-	-	-
1.8	2426	1768	1.90	-	-	-	-	-	-	-	-	-	-	-	-	-	-	-

1. Blower performance for gas heat includes maximum number of heat tubes available for each tonnage.
2. Blower performance includes two-inch throwaway filters.
3. ESP (External Static Pressure) given is that available for the supply and return air duct system. All internal resistances have been deducted from the total static pressure of the blower.
4. "Turns Open" refers to the setting of the variable pitch motor sheave, where "0 Turns Open" is fully closed.
5. W = Watts

TABLE 49: DH078 (6-1/2 TON) STANDARD MOTOR SIDE SHOT BLOWER PERFORMANCE

ESP ³	TURNS OPEN ⁴																							
	0 Turns				1 Turn				2 Turns				3 Turns				4 Turns				5 Turns			
	CFM	RPM	W ⁵	BHP	CFM	RPM	W ⁵	BHP	CFM	RPM	W ⁵	BHP	CFM	RPM	W ⁵	BHP	CFM	RPM	W ⁵	BHP	CFM	RPM	W ⁵	BHP
0.2	-	-	-	-	-	-	-	-	3278	1021	1540	1.7	3146	980	1370	1.5	2963	936	1200	1.3	2792	892	1040	1.1
0.4	-	-	-	-	-	-	-	-	3007	1025	1430	1.5	2865	982	1280	1.4	2673	939	1100	1.2	2483	893	940	1.0
0.6	-	-	-	-	2974	1071	1530	1.6	2749	1029	1320	1.4	2585	986	1170	1.3	2371	941	980	1.1	2154	894	850	0.9
0.8	2866	1117	1600	1.7	2724	1075	1420	1.5	2465	1032	1220	1.3	2278	989	1050	1.1	2020	944	890	1.0	1745	896	750	0.8
1	2611	1122	1470	1.6	2417	1079	1300	1.4	2133	1036	1100	1.2	1907	992	940	1.0	1542	947	760	0.8	-	-	-	-
1.2	2300	1126	1340	1.4	2070	1083	1160	1.2	1702	1040	950	1.0	-	-	-	-	-	-	-	-	-	-	-	-
1.4	1918	1131	1180	1.3	-	-	-	-	-	-	-	-	-	-	-	-	-	-	-	-	-	-	-	-

1. Blower performance for gas heat includes maximum number of heat tubes available for each tonnage.
2. Blower performance includes two-inch throwaway filters.
3. ESP (External Static Pressure) given is that available for the supply and return air duct system. All internal resistances have been deducted from the total static pressure of the blower.
4. "Turns Open" refers to the setting of the variable pitch motor sheave, where "0 Turns Open" is fully closed.
5. W = Watts

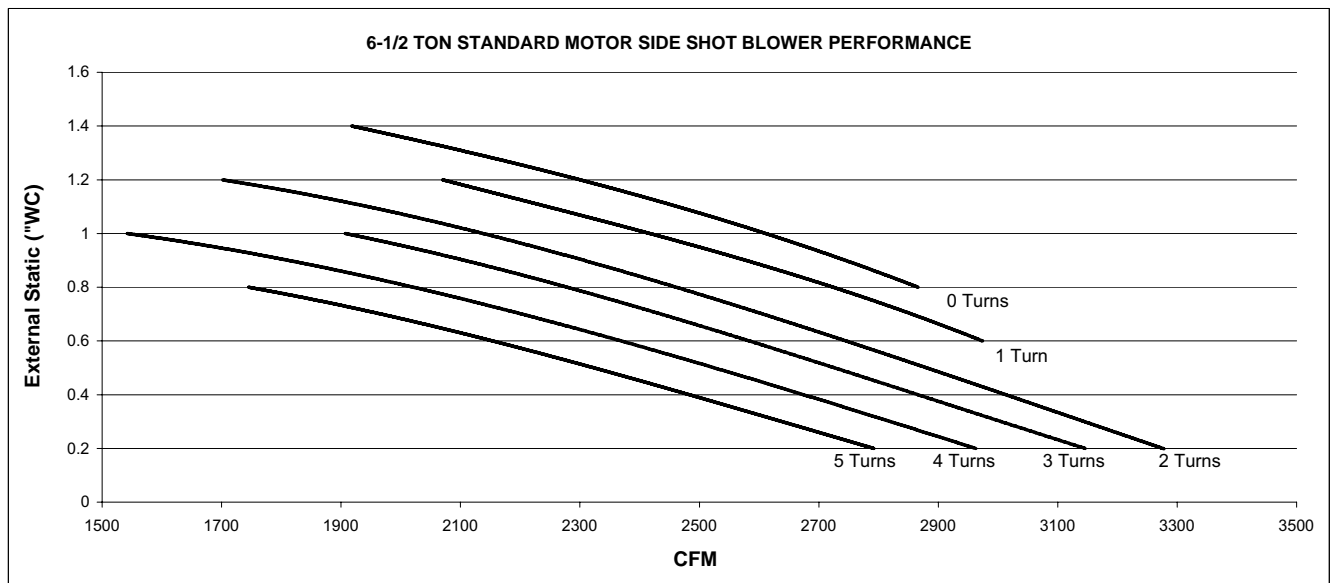

TABLE 50: DH078 (6-1/2 TON) OPTIONAL MOTOR SIDE SHOT BLOWER PERFORMANCE

ESP ³	TURNS OPEN ⁴																							
	0 Turns				1 Turn				2 Turns				3 Turns				4 Turns				5 Turns			
	CFM	RPM	W ⁵	BHP	CFM	RPM	W ⁵	BHP	CFM	RPM	W ⁵	BHP	CFM	RPM	W ⁵	BHP	CFM	RPM	W ⁵	BHP	CFM	RPM	W ⁵	BHP
0.2	-	-	-	-	-	-	-	-	-	-	-	-	-	-	-	-	-	-	-	-	-	-	-	-
0.4	-	-	-	-	-	-	-	-	3626	1152	2100	2.3	3406	1137	1830	2.0	3134	1046	1510	1.6	3020	1003	1390	1.5
0.6	-	-	-	-	-	-	-	-	3397	1156	1970	2.1	3160	1107	1680	1.8	2879	1048	1380	1.5	2734	1005	1260	1.4
0.8	-	-	-	-	3368	1206	2130	2.3	3148	1159	1830	2.0	2909	1110	1560	1.7	2596	1050	1270	1.4	2428	1008	1150	1.2
1	-	-	-	-	3139	1211	1990	2.1	2891	1162	1690	1.8	2642	1113	1450	1.6	2288	1053	1140	1.2	2073	1010	1030	1.1
1.2	3204	1259	2190	2.3	2892	1213	1840	2.0	2619	1167	1560	1.7	2316	1116	1320	1.4	1871	1056	1020	1.1	-	-	-	-
1.4	2966	1264	2070	2.2	2621	1217	1700	1.8	2289	1170	1420	1.5	1930	1120	1160	1.2	-	-	-	-	-	-	-	-
1.6	2594	1270	1890	2.0	2286	1221	1550	1.7	1844	1175	1240	1.3	-	-	-	-	-	-	-	-	-	-	-	-
1.8	2391	1273	1740	1.9	1909	1226	1370	1.5	-	-	-	-	-	-	-	-	-	-	-	-	-	-	-	-
2	1912	1279	1510	1.6	-	-	-	-	-	-	-	-	-	-	-	-	-	-	-	-	-	-	-	-

1. Blower performance for gas heat includes maximum number of heat tubes available for each tonnage.
2. Blower performance includes two-inch throwaway filters.
3. ESP (External Static Pressure) given is that available for the supply and return air duct system. All internal resistances have been deducted from the total static pressure of the blower.
4. "Turns Open" refers to the setting of the variable pitch motor sheave, where "0 Turns Open" is fully closed.
5. W = Watts

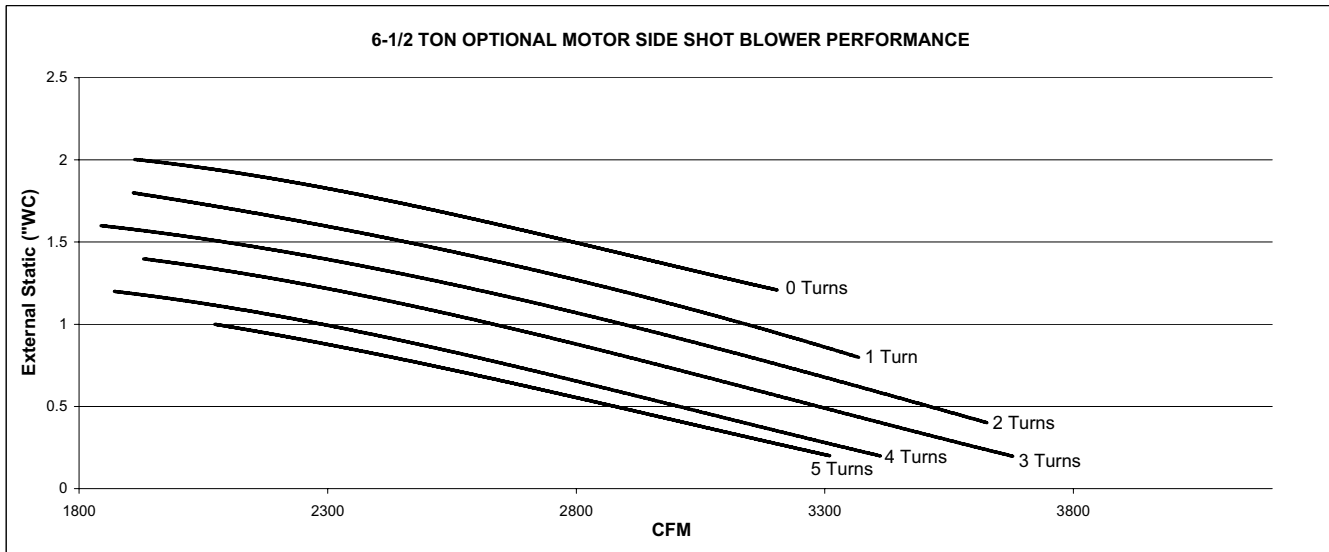

TABLE 51: DM, DH 090 (7-1/2 TON) STANDARD MOTOR SIDE SHOT BLOWER PERFORMANCE

ESP ³	TURNS OPEN ⁴																							
	0 Turns				1 Turn				2 Turns				3 Turns				4 Turns				5 Turns			
	CFM	RPM	W ⁵	BHP	CFM	RPM	W ⁵	BHP	CFM	RPM	W ⁵	BHP	CFM	RPM	W ⁵	BHP	CFM	RPM	W ⁵	BHP	CFM	RPM	W ⁵	BHP
0.2	-	-	-	-	-	-	-	-	3721	1108	1951	2.1	3495	1053	1684	1.8	3377	1006	1520	1.6	3124	957	1309	1.4
0.4	-	-	-	-	-	-	-	-	3446	1104	1831	2.0	3239	1055	1408	1.5	3058	1008	1388	1.5	2825	959	1182	1.3
0.6	-	-	-	-	3439	1152	1996	2.1	3198	1106	1697	1.8	2964	1057	1456	1.6	2772	1010	1268	1.4	2523	960	1090	1.2
0.8	3309	1202	2058	2.2	3178	1156	1847	2.0	2922	1109	1591	1.7	2688	1060	1336	1.4	2469	1012	1177	1.3	2177	963	975	1.0
1	3058	1206	1899	2.0	2918	1159	1714	1.8	2649	1111	1453	1.6	2385	1063	1241	1.3	2108	1015	1035	1.1	1746	965	851	0.9
1.2	2809	1209	1793	1.9	2645	1162	1595	1.7	2333	1115	1325	1.4	2002	1066	1114	1.2	1624	1017	886.2	1.0	-	-	-	-
1.4	2580	1212	1701	1.8	2340	1165	1455	1.6	1951	1118	1176	1.3	-	-	-	-	-	-	-	-	-	-	-	-

1. Blower performance for gas heat includes maximum number of heat tubes available for each tonnage.
2. Blower performance includes two-inch throwaway filters.
3. ESP (External Static Pressure) given is that available for the supply and return air duct system. All internal resistances have been deducted from the total static pressure of the blower.
4. "Turns Open" refers to the setting of the variable pitch motor sheave, where "0 Turns Open" is fully closed.
5. W = Watts

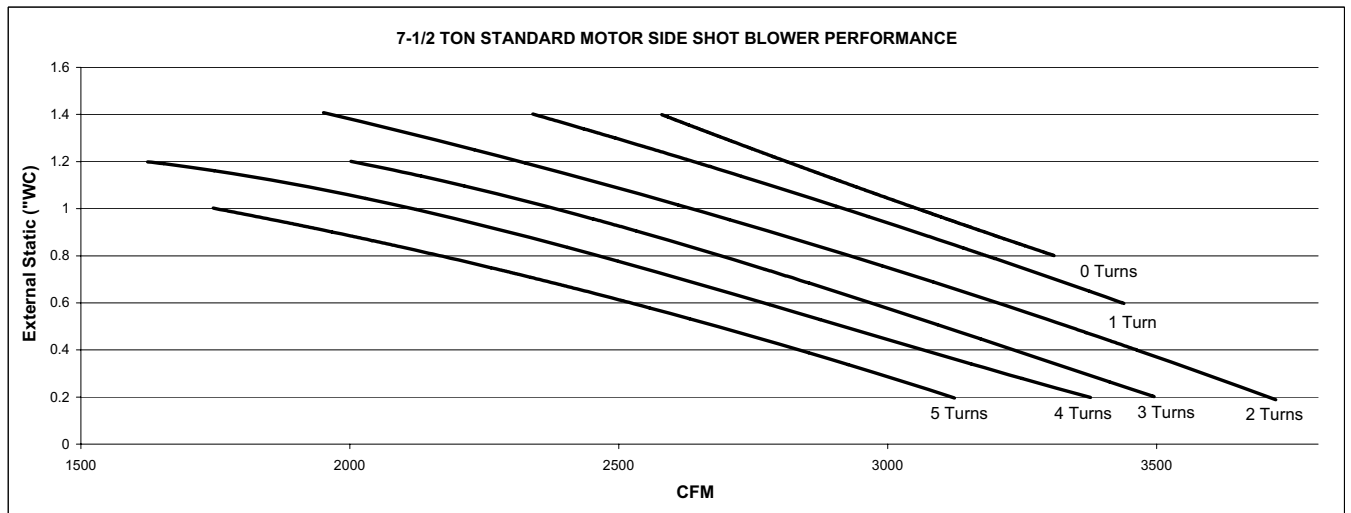

TABLE 52: DM, DH 090 (7-1/2 TON) OPTIONAL SIDE SHOT BLOWER PERFORMANCE

ESP ³	TURNS OPEN ⁴																							
	0 Turns				1 Turn				2 Turns				3 Turns				4 Turns				5 Turns			
	CFM	RPM	W ⁵	BHP	CFM	RPM	W ⁵	BHP	CFM	RPM	W ⁵	BHP	CFM	RPM	W ⁵	BHP	CFM	RPM	W ⁵	BHP	CFM	RPM	W ⁵	BHP
0.2	4467	1295	3131	3.4	4316	1246	2800	3.0	4139	1195	2476	2.7	3886	1146	2178	2.3	3622	1092	1894	2.0	3413	1037	1644	1.8
0.4	4216	1299	3018	3.2	4058	1248	2708	2.9	3882	1199	2391	2.6	3612	1147	2048	2.2	3351	1095	1775	1.9	3139	1039	1550	1.7
0.6	4001	1301	2861	3.1	3825	1252	2534	2.7	3664	1201	2290	2.5	3369	1149	1915	2.1	3100	1097	1643	1.8	2869	1041	1408	1.5
0.8	3804	1304	2729	2.9	3652	1254	2426	2.6	3436	1204	2097	2.3	3118	1151	1816	1.9	2827	1099	1552	1.7	2583	1042	1307	1.4
1	3603	1308	2598	2.8	3442	1256	2306	2.5	3153	1207	2000	2.1	2840	1153	1644	1.8	2539	1100	1398	1.5	2259	1045	1173	1.3
1.2	3370	1310	2435	2.6	3225	1259	2173	2.3	2898	1209	1858	2.0	2560	1155	1554	1.7	2215	1103	1294	1.4	1828	1047	1027	1.1
1.4	3185	1312	2327	2.5	2970	1262	2049	2.2	2617	1212	1719	1.8	2216	1158	1417	1.5	1758	1105	1116	1.2	-	-	-	-
1.6	2928	1315	2173	2.3	2742	1266	1944	2.1	2251	1214	1555	1.7	-	-	-	-	-	-	-	-	-	-	-	-
1.8	2678	1319	2055	2.2	2294	1268	1687	1.8	-	-	-	-	-	-	-	-	-	-	-	-	-	-	-	-
2	2326	1354	1844	2.0	-	-	-	-	-	-	-	-	-	-	-	-	-	-	-	-	-	-	-	-

1. Blower performance for gas heat includes maximum number of heat tubes available for each tonnage.
2. Blower performance includes two-inch throwaway filters.
3. ESP (External Static Pressure) given is that available for the supply and return air duct system. All internal resistances have been deducted from the total static pressure of the blower.
4. "Turns Open" refers to the setting of the variable pitch motor sheave, where "0 Turns Open" is fully closed.
5. W = Watts

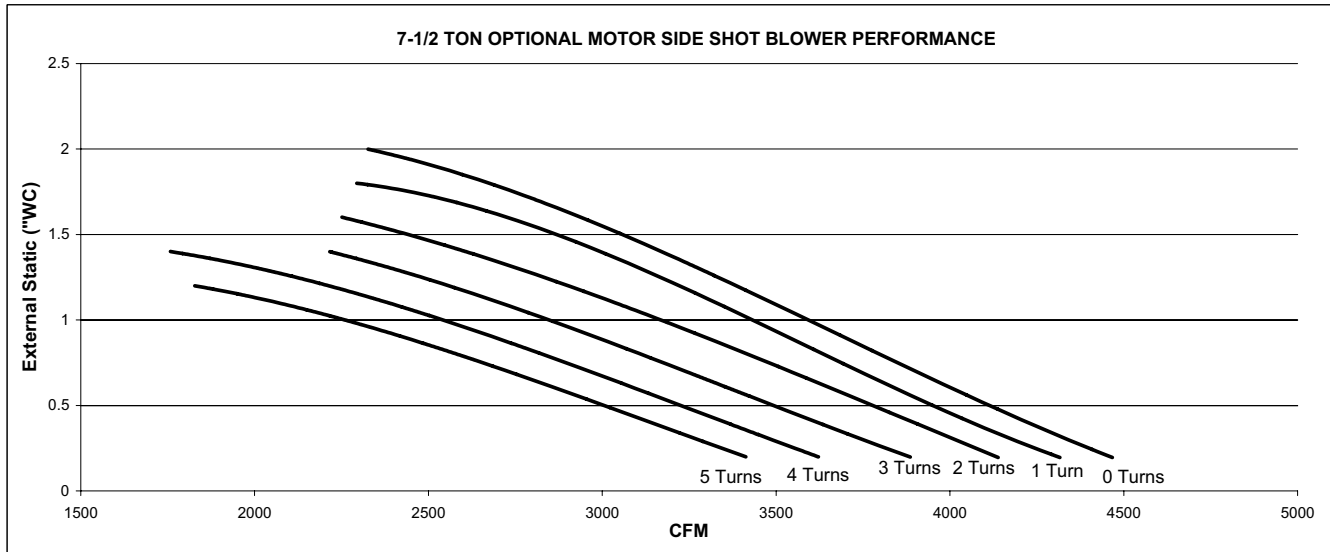

TABLE 53: DM, DH 102 (8-1/2 TON) STANDARD MOTOR SIDE SHOT BLOWER PERFORMANCE

ESP ³	TURNS OPEN ⁴																							
	0 Turns				1 Turn				2 Turns				3 Turns				4 Turns				5 Turns			
	CFM	RPM	W ⁵	BHP	CFM	RPM	W ⁵	BHP	CFM	RPM	W ⁵	BHP	CFM	RPM	W ⁵	BHP	CFM	RPM	W ⁵	BHP	CFM	RPM	W ⁵	BHP
0.2	4467	1295	3131	3.4	4316	1246	2800	3.0	4139	1195	2476	2.7	3886	1146	2178	2.3	3622	1092	1894	2.0	3413	1037	1644	1.8
0.4	4216	1299	3018	3.2	4058	1248	2708	2.9	3882	1199	2391	2.6	3612	1147	2048	2.2	3351	1095	1775	1.9	3139	1039	1550	1.7
0.6	4001	1301	2861	3.1	3825	1252	2534	2.7	3664	1201	2290	2.5	3369	1149	1915	2.1	3100	1097	1643	1.8	2869	1041	1408	1.5
0.8	3804	1304	2729	2.9	3652	1254	2426	2.6	3436	1204	2097	2.3	3118	1151	1816	1.9	2827	1099	1552	1.7	2583	1042	1307	1.4
1	3603	1308	2598	2.8	3442	1256	2306	2.5	3153	1207	2000	2.1	2840	1153	1644	1.8	2539	1100	1398	1.5	2259	1045	1173	1.3
1.2	3370	1310	2435	2.6	3225	1259	2173	2.3	2898	1209	1858	2.0	2560	1155	1554	1.7	2215	1103	1294	1.4	1828	1047	1027	1.1
1.4	3185	1312	2327	2.5	2970	1262	2049	2.2	2617	1212	1719	1.8	2216	1158	1417	1.5	1758	1105	1116	1.2	-	-	-	-
1.6	2928	1315	2173	2.3	2742	1266	1944	2.1	2251	1214	1555	1.7	-	-	-	-	-	-	-	-	-	-	-	
1.8	2678	1319	2055	2.2	2294	1268	1687	1.8	-	-	-	-	-	-	-	-	-	-	-	-	-	-	-	
2	2326	1354	1844	2.0	-	-	-	-	-	-	-	-	-	-	-	-	-	-	-	-	-	-	-	

1. Blower performance for gas heat includes maximum number of heat tubes available for each tonnage.
2. Blower performance includes two-inch throwaway filters.
3. ESP (External Static Pressure) given is that available for the supply and return air duct system. All internal resistances have been deducted from the total static pressure of the blower.
4. "Turns Open" refers to the setting of the variable pitch motor sheave, where "0 Turns Open" is fully closed.
5. W = Watts

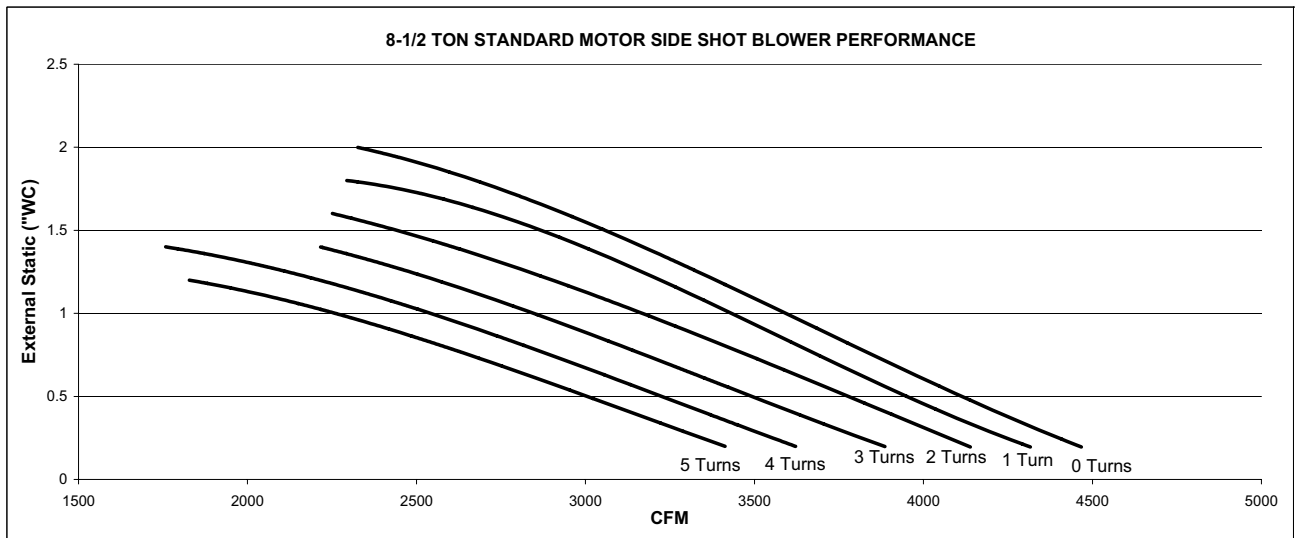

TABLE 54: DM, DH 102 (8-1/2 TON) OPTIONAL DRIVE SIDE SHOT BLOWER PERFORMANCE

ESP ³	TURNS OPEN ⁴																							
	0 Turns				1 Turn				2 Turns				3 Turns				4 Turns				5 Turns			
	CFM	RPM	W ⁵	BHP	CFM	RPM	W ⁵	BHP	CFM	RPM	W ⁵	BHP	CFM	RPM	W ⁵	BHP	CFM	RPM	W ⁵	BHP	CFM	RPM	W ⁵	BHP
0.2	-	-	-	-	4478	1289	3150	3.4	4375	1265	2890	3.1	4092	1203	2460	2.6	3967	1142	2250	2.4	3677	1086	1880	2.0
0.4	-	-	-	-	4243	1293	3020	3.2	4116	1266	2740	2.9	3831	1204	2330	2.5	3691	1144	2100	2.2	3402	1088	1790	1.9
0.6	-	-	-	-	4037	1294	2920	3.1	3900	1266	2600	2.8	3615	1205	2200	2.4	3460	1147	1960	2.1	3199	1091	1670	1.8
0.8	4085	1354	3160	3.4	3848	1295	2770	3.0	3691	1267	2500	2.7	3393	1206	2090	2.2	3195	1149	1828	1.9	2900	1093	1540	1.6
1	3900	1362	3050	3.3	3678	1309	2650	2.8	3469	1267	2340	2.5	3161	1206	1960	2.1	2931	1150	1700	1.8	2609	1094	1410	1.5
1.2	3708	1366	2910	3.1	3456	1313	2490	2.7	3239	1268	2200	2.4	2910	1207	1840	2.0	2655	1151	1500	1.7	2302	1096	1300	1.4
1.4	3500	1369	2750	3.0	3238	1315	2370	2.5	2994	1269	2070	2.2	2633	1208	1700	1.8	2313	1151	1400	1.5	1801	1099	1100	1.2
1.6	3273	1372	2600	2.8	3012	1317	2230	2.4	2752	1269	1910	2.0	2282	1210	1540	1.7	1833	1152	1200	1.3	-	-	-	-
1.8	3050	1376	2450	2.6	2848	1320	2140	2.3	2373	1273	1730	1.9	-	-	-	-	-	-	-	-	-	-	-	-

1. Blower performance for gas heat includes maximum number of heat tubes available for each tonnage.
2. Blower performance includes two-inch throwaway filters.
3. ESP (External Static Pressure) given is that available for the supply and return air duct system. All internal resistances have been deducted from the total static pressure of the blower.
4. "Turns Open" refers to the setting of the variable pitch motor sheave, where "0 Turns Open" is fully closed.
5. W = Watts

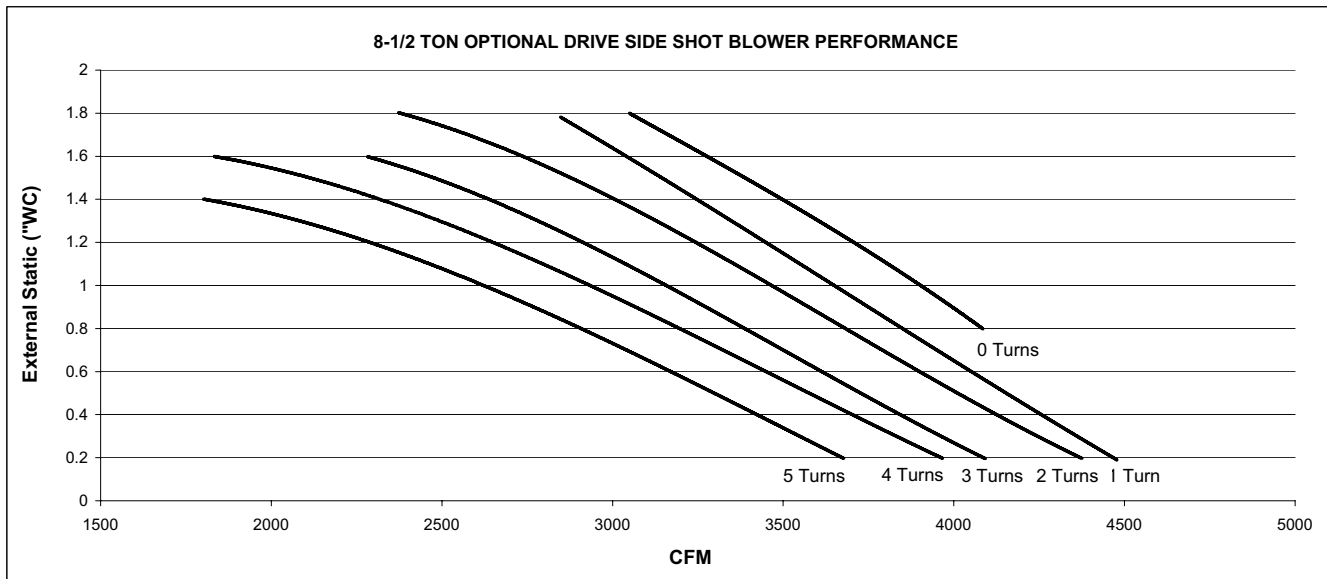

TABLE 55: DM, DH 120 (10 TON) STANDARD MOTOR SIDE SHOT BLOWER PERFORMANCE^{1 2}

ESP ³	TURNS OPEN ⁴																	
	0			1			2			3			4			5		
	CFM	W ⁵	BHP	CFM	W ⁵	BHP	CFM	W ⁵	BHP	CFM	W ⁵	BHP	CFM	W ⁵	BHP	CFM	W ⁵	BHP
0.2	-	-	-	-	-	-	-	-	-	4368	1843	1.98	4132	1624	1.74	3870	1423	1.53
0.4	-	-	-	4515	2192	2.35	4213	1885	2.02	4020	1692	1.81	3791	1491	1.60	3499	1283	1.38
0.6	-	-	-	4192	2027	2.17	3905	1741	1.87	3657	1537	1.65	3383	1345	1.44	3062	1149	1.23
0.8	-	-	-	3838	1858	1.99	3534	1591	1.71	3236	1386	1.49	2934	1202	1.29	-	-	-
1.0	3755	1942	2.08	3489	1695	1.82	3081	1425	1.53	-	-	-	-	-	-	-	-	-
1.2	3337	1757	1.88	2918	1475	1.58	-	-	-	-	-	-	-	-	-	-	-	-

1. Blower performance for gas heat includes maximum number of heat tubes available for each tonnage.
2. Blower performance includes two-inch throwaway filters.
3. ESP (External Static Pressure) given is that available for the supply and return air duct system. All internal resistances have been deducted from the total static pressure of the blower.
4. "Turns Open" refers to the setting of the variable pitch motor sheave, where "0 Turns Open" is fully closed.
5. W = Watts

TABLE 56: DM, DH 120 (10 TON) OPTIONAL MOTOR SIDE SHOT BLOWER PERFORMANCE^{1 2}

ESP ³	TURNS OPEN ⁴																	
	0			1			2			3			4			5		
	CFM	W ⁵	BHP	CFM	W ⁵	BHP	CFM	W ⁵	BHP	CFM	W ⁵	BHP	CFM	W ⁵	BHP	CFM	W ⁵	BHP
0.2	-	-	-	-	-	-	-	-	-	-	-	-	5067	2614	2.80	4809	2290	2.46
0.4	-	-	-	-	-	-	5179	3112	3.34	4884	2703	2.90	4729	2401	2.57	4459	2113	2.27
0.6	-	-	-	-	-	-	4925	2943	3.16	4585	2521	2.70	4429	2244	2.41	4137	1964	2.11
0.8	-	-	-	4974	3220	3.45	4607	2727	2.92	4267	2342	2.51	4099	2080	2.23	3783	1809	1.94
1.0	4975	3453	3.70	4657	2995	3.21	4305	2550	2.73	3941	2171	2.33	3751	1919	2.06	3371	1630	1.75
1.2	4679	3423	3.67	4366	2808	3.01	4022	2373	2.54	3545	1978	2.12	3305	1741	1.87	-	-	-
1.4	4429	3065	3.29	4040	2607	2.80	3669	2673	2.87	2918	1700	1.82	-	-	-	-	-	-
1.6	4107	2845	3.05	3620	2357	2.53	2931	1830	1.96	-	-	-	-	-	-	-	-	-
1.8	3553	2500	2.68	2756	1899	2.04	-	-	-	-	-	-	-	-	-	-	-	-
2.0	2439	1939	2.08	-	-	-	-	-	-	-	-	-	-	-	-	-	-	-

1. Blower performance for gas heat includes maximum number of heat tubes available for each tonnage.
2. Blower performance includes two-inch throwaway filters.
3. ESP (External Static Pressure) given is that available for the supply and return air duct system. All internal resistances have been deducted from the total static pressure of the blower.
4. "Turns Open" refers to the setting of the variable pitch motor sheave, where "0 Turns Open" is fully closed.
5. W = Watts

TABLE 57: DM, DH 150 (12-1/2 TON) STANDARD MOTOR SIDE SHOT BLOWER PERFORMANCE^{1 2}

ESP ³	TURNS OPEN ⁴																	
	0			1			2			3			4			5		
	CFM	W ⁵	BHP	CFM	W ⁵	BHP	CFM	W ⁵	BHP	CFM	W ⁵	BHP	CFM	W ⁵	BHP	CFM	W ⁵	BHP
0.4	-	-	-	-	-	-	5201	3162	3.39	4966	2796	3.00	4681	2405	2.58	4355	2054	2.20
0.6	-	-	-	5220	3395	3.64	4942	2980	3.20	4657	2608	2.80	4358	2230	2.39	4007	1890	2.03
0.8	-	-	-	4944	3194	3.43	4661	2806	3.01	4378	2572	2.76	4016	2057	2.21	-	-	-
1.0	5003	3490	3.74	4647	2988	3.20	4380	2636	2.83	4030	2257	2.42	-	-	-	-	-	-
1.2	4724	3290	3.53	4363	2875	3.08	4012	2505	2.69	-	-	-	-	-	-	-	-	-
1.4	4428	3040	3.26	-	-	-	-	-	-	-	-	-	-	-	-	-	-	-

1. Blower performance for gas heat includes maximum number of heat tubes available for each tonnage.
2. Blower performance includes two-inch throwaway filters.
3. ESP (External Static Pressure) given is that available for the supply and return air duct system. All internal resistances have been deducted from the total static pressure of the blower.
4. "Turns Open" refers to the setting of the variable pitch motor sheave, where "0 Turns Open" is fully closed.
5. W = Watts

TABLE 58: DM, DH 150 (12-1/2 TON) OPTIONAL MOTOR SIDE SHOT BLOWER PERFORMANCE^{1 2}

ESP ³	TURNS OPEN ⁴																	
	0			1			2			3			4			5		
	CFM	W ⁵	BHP	CFM	W ⁵	BHP	CFM	W ⁵	BHP	CFM	W ⁵	BHP	CFM	W ⁵	BHP	CFM	W ⁵	BHP
0.4	-	-	-	6447	5315	5.70	6207	4760	5.1046	5966	4205	4.51	5717	3716	3.98	5470	3307	3.55
0.6	-	-	-	6110	4917	5.27	5965	4464	4.79	5740	4023	4.31	5430	3501	3.75	5126	3054	3.28
0.8	-	-	-	5772	4519	4.85	5741	4274	4.58	5503	3821	4.10	5162	3294	3.53	4849	2870	3.08
1.0	6235	5521	5.92	5628	4407	4.73	5474	4048	4.34	5244	3611	3.87	4882	3101	3.33	4530	2667	2.86
1.2	5881	5137	5.51	5384	4205	4.51	5248	3854	4.13	4941	3387	3.63	4589	2906	3.12	4225	2502	2.68
1.4	5695	4950	5.31	5123	3996	4.29	5014	3670	3.94	4651	3178	3.41	4284	2716	2.91	3858	2280	2.45
1.6	5471	4728	5.07	4919	3828	4.11	4732	3460	3.71	4365	2983	3.20	3951	2516	2.70	3491	2058	2.21
1.8	5242	4514	4.84	4656	3611	3.87	4438	3240	3.47	3998	2740	2.94	3618	2316	2.48	-	-	-
2.0	4954	4231	4.54	4339	3380	3.62	3905	2861	3.07	3631	2497	2.68	-	-	-	-	-	-
2.2	4585	3934	4.22	4022	3149	3.38	-	-	-	-	-	-	-	-	-	-	-	-
2.4	4217	3637	3.90	-	-	-	-	-	-	-	-	-	-	-	-	-	-	-
2.6	3848	3340	3.58	-	-	-	-	-	-	-	-	-	-	-	-	-	-	-

1. Blower performance for gas heat includes maximum number of heat tubes available for each tonnage.
2. Blower performance includes two-inch throwaway filters.
3. ESP (External Static Pressure) given is that available for the supply and return air duct system. All internal resistances have been deducted from the total static pressure of the blower.
4. "Turns Open" refers to the setting of the variable pitch motor sheave, where "0 Turns Open" is fully closed.
5. W = Watts

NOTES FOR TABLE 35 THROUGH TABLE 58:

- Blower performance includes dry coil and two-inch filters.
- Blower performance for gas heat includes the maximum number of heat tubes available for each tonnage.
- ESP (External Static Pressure) given is that available for the supply and return air duct system. All internal resistances have been deducted from the total static pressure of the blower.

TABLE 59: INDOOR BLOWER SPECIFICATIONS

MODEL	MOTOR					MOTOR SHEAVE			BLOWER SHEAVE			BELT
	HP	RPM	Eff.	SF	Frame	Datum Dia. (in.)	Bore (in.)	Model	Datum Dia. (in.)	Bore (in.)	Model	
DM078	1-1/2	1725	80%	1.15	56	3.4 - 4.4	7/8	1VM50	9.5	1	AK99	A58
	2	1725	80%	1.15	56	3.4 - 4.4	7/8	1VM50	7.5	1	AK79	A55
DH078	1-1/2	1725	80%	1.15	56	3.4 - 4.4	7/8	1VM50	7.0	1	AK74	A49
	2	1725	80%	1.15	56	3.4 - 4.4	7/8	1VM50	6.2	1	AK66	A49
DM090	2	1725	80%	1.15	56	3.4 - 4.4	7/8	1VM50	6.5	1	AK69	A49
	3	1725	80%	1.15	56	3.4 - 4.4	7/8	1VM50	6.0	1	AK64	A49
DH090	2	1725	80%	1.15	56	3.4 - 4.4	7/8	1VM50	6.5	1	AK69	A49
	3	1725	80%	1.15	56	3.4 - 4.4	7/8	1VM50	6.0	1	AK64	A49
DM102	3	1725	80%	1.15	56	3.4 - 4.4	7/8	1VM50	6.0	1	AK64	A49
	3	1725	80%	1.15	56	3.4 - 4.4	7/8	1VM50	5.7	1	AK61	A49
DH102	3	1725	80%	1.15	56	3.4 - 4.4	7/8	1VM50	6.0	1	AK64	A49
	3	1725	80%	1.15	56	3.4 - 4.4	7/8	1VM50	5.7	1	AK61	A49
DM120	2	1725	80%	1.15	56	3.4 - 4.4	7/8	1VM50	8.5	1	AK89	A56
	3	1725	80%	1.15	56	3.4 - 4.4	7/8	1VM50	7.0	1	AK74	A54
DH120	2	1725	80%	1.15	56	3.4 - 4.4	7/8	1VM50	8.5	1	AK89	A56
	3	1725	80%	1.15	56	3.4 - 4.4	7/8	1VM50	7.0	1	AK74	A54
DM150	3	1725	80%	1.15	56	3.4 - 4.4	7/8	1VM50	7.0	1	AK74	A54
	5	1725	87%	1.15	184T	4.3 - 5.3	1 1/8	1VP56	6.7	1	BK77	BX55
DH150	3	1725	80%	1.15	56	3.4 - 4.4	7/8	1VM50	7.0	1	AK74	A54
	5	1725	87%	1.15	184T	4.3 - 5.3	1 1/8	1VP56	6.7	1	BK77	BX55

TABLE 60: POWER EXHAUST SPECIFICATIONS

POWER EXHAUST MODEL	VOLT	PHASE	MOTOR			ELECTRICAL			FUSE SIZE	CFM@ 0.1 ESP
			HP	RPM ¹	QTY	LRA	FLA	MCA		
2PE0473225	208/230	1	0.75	1075	1	24.9	5.0	6.3	10	3,800
2PE0473246	460	1				-	2.2	2.8	5	
2PE0473258	575	1				-	1.5	1.9	4	

¹. Motors are multi-tapped and factory wired for high speed.

AIR BALANCE

Start the supply air blower motor. Adjust the resistances in both the supply and the return air duct systems to balance the air distribution throughout the conditioned space. The job specifications may require that this balancing be done by someone other than the equipment installer.

CHECKING AIR QUANTITY

METHOD ONE

1. Remove the dot plugs from the duct panel (for location of the dot plugs see Figure 10).
2. Insert eight-inches of 1/4 inch metal tubing into the airflow on both sides of the indoor coil.

NOTE: The tubes must be inserted and held in a position perpendicular to the air flow so that velocity pressure will not affect the static pressure readings.

3. Use an Inclined Manometer or Magnehelic to determine the pressure drop across a dry evaporator coil. Since the moisture on an evaporator coil can vary greatly, measuring the pressure drop across a wet coil under field conditions could be inaccurate. To assure a dry coil, the compressors should be de-activated while the test is being run.

NOTE: De-energize the compressors before taking any test measurements to assure a dry evaporator coil.

4. The CFM through the unit can be determined from the pressure drop indicated by the manometer by referring to Figure 26. In order to obtain an accurate measurement, be certain that the air filters are clean.
5. To adjust Measured CFM to Required CFM, see 'SUPPLY AIR DRIVE ADJUSTMENT'.
6. After readings have been obtained, remove the tubes and replace the dot plugs.

WARNING

Failure to properly adjust the total system air quantity can result in extensive blower damage.

METHOD TWO

1. Drill two 5/16 inch holes, one in the return air duct as close to the inlet of the unit as possible, and another in the supply air duct as close to the outlet of the unit as possible.
2. Using the whole drilled in step 1, insert eight inches of 1/4 inch metal tubing into the airflow of the return and supply air ducts of the unit.

NOTE: The tubes must be inserted and held in position perpendicular to the airflow so that velocity pressure will not affect the static pressure readings.

3. Use an Inclined Manometer or Magnehelic to determine the pressure drop across the unit. This is the External Static Pressure (ESP). In order to obtain an accurate measurement, be certain that the air filters are clean.
4. Determine the number of turns the variable motor sheave is open.
5. Select the correct blower performance table for the unit from Tables 35 - 46. Tables are presented for horizontal and downflow configuration.
6. Determine the unit Measured CFM from the Blower Performance Table, External Static Pressure and the number of turns the variable motor sheave is open.
7. To adjust Measured CFM to Required CFM, see 'SUPPLY AIR DRIVE ADJUSTMENT'.
8. After reading has been obtained, remove the tubes and seal holes.

NOTE: With the addition of field installed accessories repeat this procedure.

WARNING

Failure to properly adjust the total system air quantity can result in extensive blower damage.

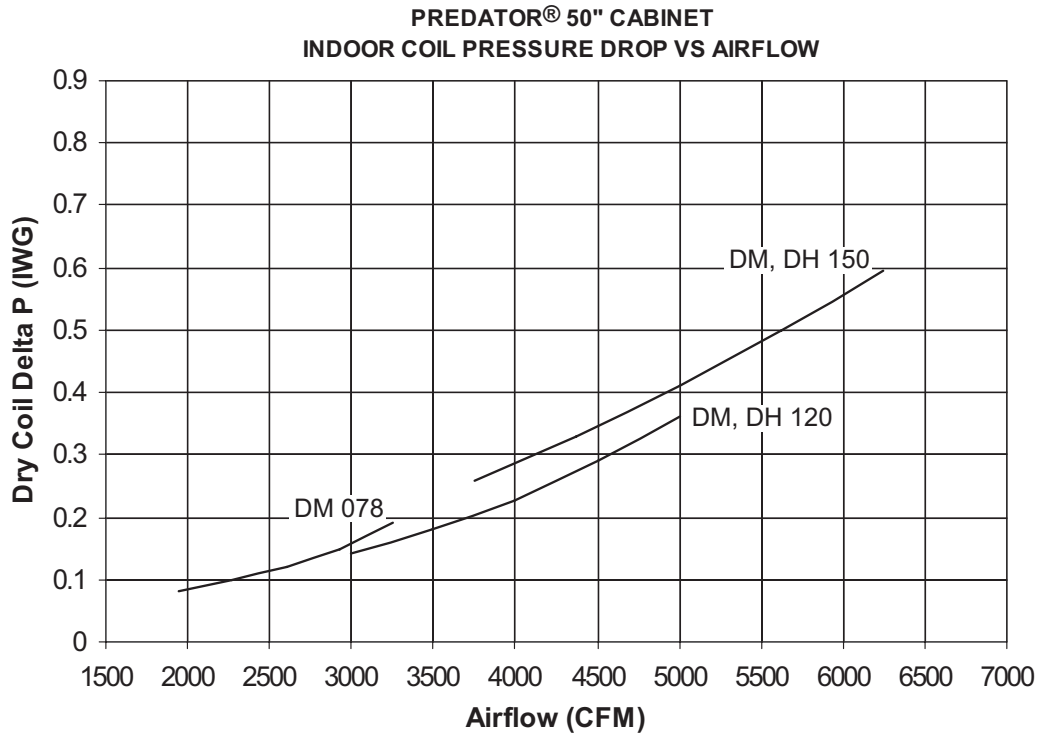

FIGURE 26 - DRY COIL DELTA P 50" CABINET

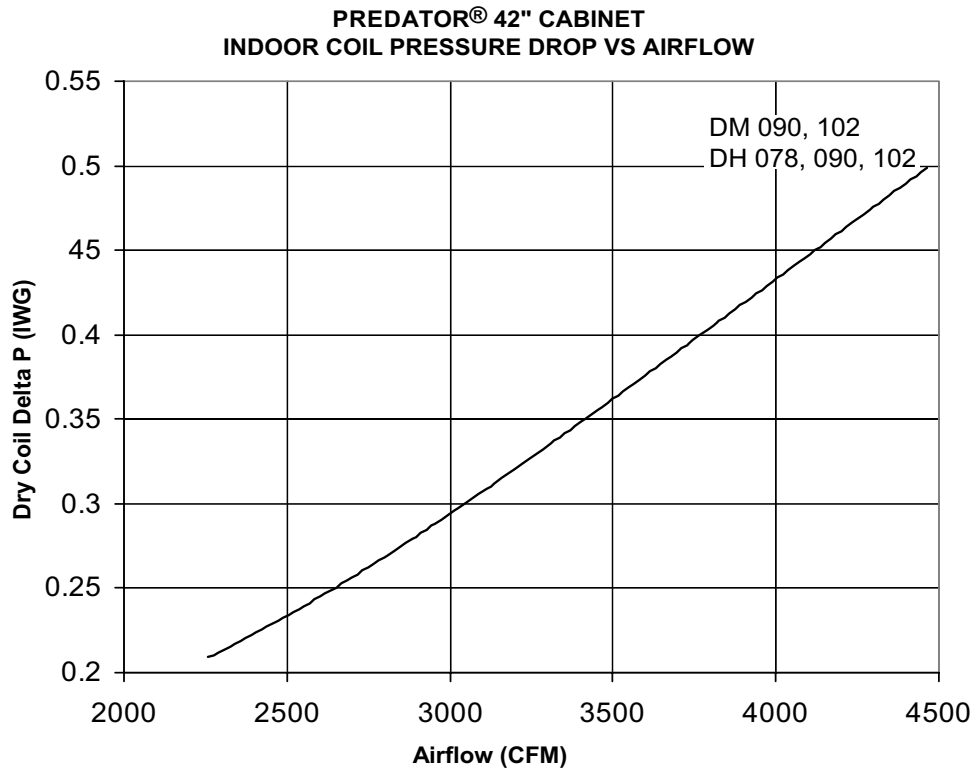

FIGURE 27 - DRY COIL DELTA P 42" CABINET

SUPPLY AIR DRIVE ADJUSTMENT

CAUTION

Before making any blower speed changes review the installation for any installation errors, leaks or undesirable systems effects that can result in loss of airflow.

Even small changes in blower speed can result in substantial changes in static pressure and BHP. BHP and AMP draw of the blower motor will increase by the cube of the blower speed. Static pressure will increase by the square of the blower speed. Only qualified personnel should make blower speed changes, strictly adhering to the fan laws.

At unit start-up, the measured CFM may be higher or lower than the required CFM. To achieve the required CFM, the speed of the drive may have adjusted by changing the datum diameter (DD) of the variable pitch motor sheave as described below:

$$\left(\frac{\text{Required CFM}}{\text{Measured CFM}} \right) \cdot \text{Existing DD} = \text{New DD}$$

Use the following tables and the DD calculated per the above equation to adjust the motor variable pitch sheave.

EXAMPLE

A 12.5 ton unit was selected to deliver 4,000 CFM with a 3 HP motor, but the unit is delivering 3,800 CFM. The variable pitch motor sheave is set at 2 turns open.

Use the equation to determine the required DD for the new motor sheave,

$$\left(\frac{4,000 \text{ CFM}}{3,800 \text{ CFM}} \right) \cdot 4.0 \text{ in.} = 4.21 \text{ in.}$$

Use Table 63 to locate the DD nearest to 4.21 in. Close the sheave to 1 turn open.

New BHP

$$= (\text{Speed increase})^3 \cdot \text{BHP at 3,800 CFM}$$

$$= (\text{Speed increase})^3 \cdot \text{Original BHP}$$

$$= \text{New BHP}$$

New motor Amps

$$= (\text{Speed increase})^3 \cdot \text{Amps at 3,800 CFM}$$

$$= (\text{Speed increase})^3 \cdot \text{Original Amps}$$

$$= \text{New Amps}$$

TABLE 61: ADDITIONAL STATIC RESISTANCE DM 078, 120, 150 AND DH 120, 150

CFM	Cooling Only ¹	Economizer ^{2 3}	Electric Heat KW ²				
			9	18	24	36	54
1900	0.06	0.02	0.05	0.06	0.07	0.08	0.10
2100	0.07	0.02	0.06	0.07	0.08	0.09	0.11
2300	0.08	0.02	0.07	0.08	0.09	0.10	0.13
2500	0.09	0.02	0.08	0.09	0.10	0.11	0.14
2700	0.11	0.03	0.09	0.10	0.12	0.13	0.16
2900	0.12	0.03	0.10	0.11	0.13	0.14	0.18
3100	0.14	0.03	0.12	0.13	0.15	0.16	0.20
3300	0.16	0.03	0.13	0.14	0.17	0.18	0.22
3500	0.18	0.04	0.15	0.16	0.19	0.20	0.24
3700	0.20	0.04	0.17	0.18	0.21	0.22	0.26
3900	0.23	0.04	0.19	0.20	0.23	0.24	0.28
4100	0.25	0.04	0.21	0.22	0.25	0.26	0.31
4300	0.28	0.05	0.23	0.24	0.28	0.29	0.34
4500	0.30	0.05	0.25	0.26	0.30	0.31	0.37
4700	0.33	0.05	0.28	0.29	0.33	0.34	0.40
4900	0.36	0.05	0.30	0.31	0.35	0.37	0.43
5100	0.39	0.06	0.33	0.34	0.38	0.40	0.46
5300	0.42	0.06	0.35	0.37	0.41	0.43	0.49
5500	0.45	0.06	0.38	0.40	0.44	0.46	0.53
5700	0.48	0.06	0.41	0.43	0.47	0.49	0.56
5900	0.52	0.07	0.44	0.46	0.50	0.53	0.59
6100	0.56	0.07	0.47	0.49	0.53	0.56	0.62
6300	0.60	0.07	0.50	0.53	0.56	0.59	0.65

1. Add these resistance values to the available static resistance in the respective Blower Performance Tables.
2. Deduct these resistance values from the available external static pressure shown in the respective Blower Performance Table.
3. The pressure drop through the economizer is greater for 100% outdoor air than for 100% return air. If the resistance of the return air duct system is less than 0.25 IWG, the unit will deliver less CFM during full economizer operation.

TABLE 62: ADDITIONAL STATIC RESISTANCE DM 090, 102 AND DH 078, 090, 102

CFM	Cooling Only ¹	Economizer ^{2 3}	Electric Heat KW ²				
			9	18	24	36	54
1900	-0.004	0.07	0.05	0.06	0.07	0.08	0.1
2100	0.01	0.09	0.06	0.07	0.08	0.09	0.11
2300	0.01	0.11	0.07	0.08	0.09	0.1	0.13
2500	0.02	0.13	0.08	0.09	0.1	0.11	0.14
2700	0.03	0.16	0.09	0.1	0.12	0.13	0.16
2900	0.04	0.18	0.1	0.11	0.13	0.14	0.18
3100	0.05	0.20	0.12	0.13	0.15	0.16	0.2
3300	0.06	0.22	0.13	0.14	0.17	0.18	0.22
3500	0.07	0.24	0.15	0.16	0.19	0.2	0.24
3700	0.08	0.27	0.17	0.18	0.21	0.22	0.26
3900	0.09	0.29	0.19	0.2	0.23	0.24	0.28
4100	0.09	0.31	0.21	0.22	0.25	0.26	0.31
4300	0.10	0.33	0.23	0.24	0.28	0.29	0.34

1. Deduct these resistance values to the available static resistance in the respective Blower Performance Tables.
2. Deduct these resistance values from the available external static pressure shown in the respective Blower Performance Table.
3. The pressure drop through the economizer is greater for 100% outdoor air than for 100% return air. If the resistance of the return air duct system is less than 0.25 IWG, the unit will deliver less CFM during full economizer operation.

TABLE 63: MOTOR SHEAVE DATUM DIAMETERS

1VM50x7/8 (1-1/2, 2 & 3 HP Motor)		1VP56x1-1/8 (5 HP Motor)	
Turns Open	Datum Diameter	Turns Open	Datum Diameter
0	4.4	1	5.3
1/2	4.3	1-1/2	5.2
1	4.2	2	5.1
1-1/2	4.1	2-1/2	5.0
2	4.0	3	4.9
2-1/2	3.9	3-1/2	4.8
3	3.8	4	4.7
3-1/2	3.7	4-1/2	4.6
4	3.6	5	4.5
4-1/2	3.5	5-1/2	4.4
5	3.4	6	4.3

OPERATION

SEQUENCE OF OPERATIONS OVERVIEW

For the Predator[®] series of units, the thermostat makes a circuit between "R" and "Y1" for the first stage of cooling.

The call is passed to the **Unit Control Board (UCB)**, which then determines whether the requested operation is available and, if so, which components to energize.

For gas heating, the UCB monitors the "W1" call but does not handle the operation of the gas furnace. An ignition control board controls the gas heater operation. For electric heat units, the UCB passes the call to the electric heater. In both cases, when the "W1" call is sensed, the indoor air blower is energized following a specified heating delay.

If at any time a call for both heating and cooling are present, the heating operation will be performed. If operating, the cooling system is halted as with a completion of a call for cooling. Heating always takes priority.

COOLING SEQUENCE OF OPERATION

CONTINUOUS BLOWER

By setting the room thermostat fan switch to "ON," the supply air blower will operate continuously.

INTERMITTENT BLOWER

With the room thermostat fan switch set to "AUTO" and the system switch set to either the "AUTO" or "HEAT" settings, the blower is energized whenever a cooling or heating operation is requested. The blower is energized after any specified delay associated with the operation.

When energized, the indoor blower has a minimum run time of 30 seconds. Additionally, the indoor blower has a delay of 10 seconds between operations.

NO OUTDOOR AIR OPTIONS

When the thermostat calls for the first stage of cooling, the low-voltage control circuit from "R" to "Y1" and "G" is completed. The UCB energizes the economizer (if installed and free cooling is available) or the first available compressor* and the condenser fans. For first stage cooling, compressor #1 is energized. If compressor #1 is unavailable, compressor #2 is energized. After completing the specified fan on delay for cooling, the UCB will energize the blower motor.

When the thermostat calls for the second stage of cooling, the low-voltage control circuit from "R" to "Y2" is completed. The control board energizes the first available compressor. If free cooling is being used for the first stage of cooling, compressor #1 is energized. If compressor #1 is active for first stage cooling or the first compressor is locked-out, compressor #2 is energized. In free-cooling mode, if the call for the second stage of cooling continues for 20 minutes, compressor #2 is energized, provided it has not been locked-out.

If there is an initial call for both stages of cooling, the UCB will delay energizing compressor #2 by 30 seconds in order to avoid a power rush.

Once the thermostat has been satisfied, it will de-energize Y1 and Y2. If the compressors have satisfied their minimum run times, the compressors and condenser fans are de-energized. Otherwise, the unit operates each cooling system until the minimum run times for the compressors have been completed. Upon the final compressor de-energizing, the blower is stopped following the elapse of the fan off delay for cooling.

* To be available, a compressor must not be locked-out due to a high or low-pressure switch or freezestat trip and the **Anti-Short Cycle Delay (ASCD)** must have elapsed.

ECONOMIZER WITH SINGLE ENTHALPY SENSOR -

When the room thermostat calls for "first-stage" cooling, the low voltage control circuit from "R" to "G" and "Y1" is completed. The UCB energizes the blower motor (if the fan switch on the room thermostat is set in the "AUTO" position) and drives the economizer dampers from fully closed to their minimum position. If the enthalpy of the outdoor air is below the set point of the enthalpy controller (previously determined), "Y1" energizes the economizer. The dampers will modulate to maintain a constant supply air temperature as monitored by the discharge air sensor. If the outdoor air enthalpy is above the set point, "Y1" energizes compressor #1.

When the thermostat calls for "second-stage" cooling, the low voltage control circuit from "R" to "Y2" is completed. The UCB energizes the first available compressor. If the enthalpy of the outdoor air is below the set point of the enthalpy controller (i.e. first stage has energized the economizer), "Y2" will energize compressor #1. If the outdoor air is above the set point, "Y2" will energize compressor #2.

Once the thermostat has been satisfied, it will de-energize "Y1" and "Y2". If the compressors have satisfied their minimum run times, the compressors and condenser fans are de-energized. Otherwise, the unit operates each cooling system until the minimum run times for the compressors have been

completed. Upon the final compressor de-energizing, the blower is stopped following the elapse of the fan off delay for cooling, and the economizer damper goes to the closed position. If the unit is in continuous fan operation, the economizer damper goes to the minimum position.

ECONOMIZER WITH DUAL ENTHALPY SENSORS -

The operation with the dual enthalpy sensors is identical to the single sensor except that a second enthalpy sensor is mounted in the return air. This return air sensor allows the economizer to choose between outdoor air and return air, whichever has the lowest enthalpy value, to provide maximum operating efficiency.

ECONOMIZER WITH POWER EXHAUST -

A unit equipped with an economizer (single or dual enthalpy) and a power exhaust operates as specified above with one addition. The power exhaust motor is energized 45 seconds after the actuator position exceeds the exhaust fan set point on the economizer control. When the power exhaust is operating, the second stage of mechanical cooling will not operate. As always, the "R" to "G" connection provides minimum position but does not provide power exhaust operation.

MOTORIZED OUTDOOR AIR DAMPERS -

This system operation is the same as the units with no outdoor air options with one exception. When the "R" to "G" circuit is complete, the motorized damper drives open to a position set by the thumbwheel on the damper motor. When the "R" to "G" circuit is opened, the damper spring returns fully closed.

COOLING OPERATION ERRORS

Each cooling system is monitored for operation outside of the intended parameters. Errors are handled as described below. All system errors override minimum run times for compressors.

HIGH-PRESSURE LIMIT SWITCH

During cooling operation, if a high-pressure limit switch opens, the UCB will de-energize the associated compressor, initiate the ASCD (Anti-short cycle delay), and, if the other compressor is idle, stop the condenser fans. If the call for cooling is still present at the conclusion of the ASCD, the UCB will re-energize the halted compressor.

Should a high-pressure switch open three times within two hours of operation, the UCB will lock-out the associated compressor and flash a code (see Table 80). If the other compressor is inactive, the condenser fans will be de-energized.

LOW-PRESSURE LIMIT SWITCH

The low-pressure limit switch is not monitored during the initial 30 seconds of a cooling system's operation. For the following 30 seconds, the UCB will monitor the low-pressure switch to ensure it closes. If the low-pressure switch fails to close after the 30-second monitoring phase, the UCB will de-energize the associated compressor, initiate the ASCD, and, if the other compressor is idle, stop the condenser fans.

Once the low-pressure switch has been proven (closed during the 30-second monitor period described above), the UCB will monitor the low-pressure limit switch for any openings. If the low-pressure switch opens for greater than 5 seconds, the UCB will de-energize the associated compressor, initiate the ASCD, and, if the other compressor is idle, stop the condenser fans.

If the call for cooling is still present at the conclusion of the ASCD, the UCB will re-energize the halted compressor.

Should a low-pressure switch open three times within one hour of operation, the UCB will lock-out the associated compressor and flash a code (Table 80). If the other compressor is inactive, the condenser fans will be de-energized.

FREEZESTAT

During cooling operation, if a freezestat opens, the UCB will de-energize the associated compressor, initiate the ASCD, and, if the other compressor is idle, stop the condenser fans. If the call for cooling is still present at the conclusion of the ASCD, the UCB will re-energize the halted compressor.

Should a freezestat open three times within two hours of operation, the UCB will lock-out the associated compressor and flash a code (Table 80). If the other compressor is inactive, the condenser fans will be de-energized.

LOW AMBIENT COOLING

To determine when to operate in low ambient mode, the UCB has a pair of terminals connected to a temperature-activated switch set at 45°F. When the low ambient switch is closed and the thermostat is calling for cooling, the UCB will operate in the low ambient mode.

Low ambient mode operates the compressors in this manner: 10 minutes on, 5 minutes off. The indoor blower is operated throughout the cycle. The 5-minute off period is necessary to defrost the indoor coil.

Low ambient mode always begins with compressor operation. Compressor minimum run time may extend the minutes of compressor operation. The defrost cycle will begin immediately following the elapse of the minimum run time.

When operating in low ambient mode, the UCB will not lock-out the compressors due to a freezestat trip. However, a freezestat trip will de-energize the associated compressor. If the call for cooling is still present at the end of the ASCD and the freezestat has closed, the unit will resume operation.

SAFETY CONTROLS

The unit control board monitors the following inputs for each cooling system:

1. A suction line freezestat to protect against low evaporator temperatures due to a low airflow or a low return air temperature, (opens at 26 ± 5 °F and resets at 38 ± 5 °F).
2. A high-pressure switch to protect against excessive discharge pressures due to a blocked condenser coil or a

condenser motor failure, (opens at 405 ± 10 psig or 440 ± 10 psig depending on unit model).

3. A low-pressure switch to protect against loss of refrigerant charge, (opens at 22 ± 5 psig or 45 ± 5 psig).

The above pressure switches are hard-soldered to the unit. The refrigeration systems are independently monitored and controlled. On any fault, only the associated system will be affected by any safety/preventive action. The other refrigerant system will continue in operation unless it is affected by the fault as well.

The unit control board monitors the temperature limit switch of electric heat units and the temperature limit switch and the gas valve of gas furnace units.

COMPRESSOR PROTECTION

In addition to the external pressure switches, the compressors also have inherent (internal) protection. If there is an abnormal temperature rise in a compressor, the protector will open to shut down the compressor. The UCB incorporates features to minimize compressor wear and damage. An **Anti-Short Cycle Delay (ASCD)** is utilized to prevent operation of a compressor too soon after its previous run. Additionally, a minimum run time is imposed any time a compressor is energized.

The ASCD is initiated on unit start-up and on any compressor reset or lock-out.

FLASH CODES

The UCB will initiate a flash code associated with errors within the system. Refer to UNIT CONTROL BOARD FLASH CODES Table 80.

RESET

Remove the call for cooling, by raising thermostat setting higher than the conditioned space temperature. This resets any pressure or freezestat flash codes.

ELECTRIC HEATING SEQUENCE OF OPERATIONS

The following sequence describes the operation of the electric heat section.

Two-stage heating:

- a. Upon a call for first stage heat by the thermostat, the heater relay (RA) will be energized. After completing the specified fan on delay for heating, the UCB will energize the blower motor. If the second stage of heat is required, heater relay (RB) will be energized. After completing the specified fan on delay for heating, the UCB will energize the blower motor.
- b. The thermostat will cycle the electric heat to satisfy the heating requirements of the conditioned space.

ELECTRIC HEAT OPERATION ERRORS

TEMPERATURE LIMIT

If the UCB senses zero volts from the high temperature limit, the indoor blower motor is immediately energized.

This limit is monitored regardless of unit operation status, i.e. the limit is monitored at all times.

If the temperature limit opens three times within one hour, it will lock-on the indoor blower motor and a flash code is initiated (See Table 80).

SAFETY CONTROLS

The UCB monitors the temperature limit switch of electric heat units.

The control circuit includes the following safety controls:

LIMIT SWITCH (LS)

This control is located inside the heater compartment and is set to open at the temperature indicated in the Electric Heat Limit Setting Table 64. It resets automatically. The limit switch operates when a high temperature condition, caused by inadequate supply air flow occurs, thus shutting down the heater and energizing the blower.

**TABLE 64: ELECTRIC HEAT LIMIT SETTING
50" CABINET**

UNIT (TONS)	VOLTAGE	HEATER kW	LIMIT SWITCH OPENS °F
DM 078 (6.5)	208/230	9	150
DM 078,120,150 (6.5, 10, 12.5) DH 120, 150 (10, 12.5)		18	150
DM 078,120,150 (6.5, 10, 12.5) DH 120, 150 (10, 12.5)		24	150
DM 078,120,150 (6.5, 10, 12.5) DH 120, 150 (10, 12.5)		34	150
DM, DH 120, 150 (10, 12.5)		54	130
DM 078 (6.5)	480	9	150
DM 078,120,150 (6.5, 10, 12.5) DH 120, 150 (10, 12.5)		18	150
DM 078,120,150 (6.5, 10, 12.5) DH 120, 150 (10, 12.5)		24	150
DM 078,120,150 (6.5, 10, 12.5) DH 120, 150 (10, 12.5)		34	150
DM, DH 120, 150 (10, 12.5)		54	130
DM 078 (6.5)	600	9	150
DM 078,120,150 (6.5, 10, 12.5) DH 120, 150 (10, 12.5)		18	150
DM 078,120,150 (6.5, 10, 12.5) DH 120, 150 (10, 12.5)		24	150
DM 078,120,150 (6.5, 10, 12.5) DH 120, 150 (10, 12.5)		34	150
DM, DH 120, 150 (10, 12.5)		54	130

TABLE 65: ELECTRIC HEAT LIMIT SETTING 42” CABINET

UNIT (TONS)	VOLTAGE	HEATER kW	LIMIT SWITCH OPENS °F
DM 090, 102 (7.5, 8.5) DH 078, 090, 102 (6.5, 7.5, 8.5)	208/230	9	135
		18	150
		24	165
		34	190
DM 090, 102(7.5, 8.5) DH 078, 090, 102 (6.5, 7.5, 8.5)	480	9	135
		18	150
		24	165
		34	185
DM 090, 102 (7.5, 8.5) DH 078, 090, 102 (6.5, 7.5, 8.5)	600	9	135
		18	150
		24	150
		34	185

FLASH CODES

The UCB will initiate a flash code associated with errors within the system. Refer to UNIT CONTROL BOARD FLASH CODES Table 80.

RESET

Remove the call for heating by lowering the thermostat setting lower than the conditioned space temperature. This resets any flash codes.

ELECTRIC HEAT ANTICIPATOR SETPOINTS

It is important that the anticipator setpoint be correct. Too high of a setting will result in longer heat cycles and a greater temperature swing in the conditioned space. Reducing the value below the correct setpoint will give shorter “ON” cycles and may result in the lowering of the temperature within the conditioned space. Refer to Table 66 for the required electric heat anticipator setting.

TABLE 66: ELECTRIC HEAT ANTICIPATOR SETPOINTS

SETTING, AMPS	
W1	W2
0.13	0.1

GAS HEATING SEQUENCE OF OPERATIONS

When the thermostat calls for the first stage of heating, the low-voltage control circuit from “R” to “W1” is completed. A call for heat passes through the UCB to the **Ignition Control Board (ICB)**. The UCB monitors the “W1” call and acts upon any call for heat by monitoring the **Gas Valve (GV)**. Once voltage has been sensed at the GV, the UCB will initiate the

fan on delay for heating, energizing the indoor blower the specified delay has elapsed.

When the thermostat has been satisfied, heating calls are ceased. The GV is immediately closed. The blower is de-energized after the fan off delay for heating has elapsed. The draft motor performs a 30-second post purge.

IGNITION CONTROL BOARD**FIRST STAGE OF HEATING**

When the ICB receives a call for first stage of heating, “W1,” the draft motor is energized. Once the draft motor has been proven, a 30-second purge is initiated. At the end of the purge, the GV is opened, and the spark ignitor is energized for 10 seconds. The ICB then checks for the presence of flame. If flame is detected, the ICB enters a flame stabilization period. If flame was not detected, the GV closes, and a retry operation begins.

During the flame stabilization period, a loss of the flame for 2 seconds will cause the GV to close and the retry operation to begin. After the flame stabilization period, a loss of flame for 3/4 second will cause the GV to close and the retry operation to begin.

At the conclusion of the flame stabilization period, the ICB will operate the gas heat in high fire for an additional 60 seconds (for a total for 120 seconds of high fire operation). After this 60 seconds, the ICB will then use the call for the second stage of heat to control second stage operation of the GV.

When “W1” is satisfied, both valves are closed.

SECOND STAGE OF HEATING

When the ICB receives a call for the second stage of heating, “W2,” the ICB conducts a complete first stage ignition sequence. If this sequence is satisfied, the second main valve of the GV is opened.

When “W2” is satisfied, the second main valve is closed.

RETRY OPERATION

When a flame is lost or is not detected during an attempt to achieve ignition, a retry operation occurs. A 30-second purge is performed between ignition attempts.

If the unit fails after three ignition attempts, the furnace is locked-out for one hour. The furnace is monitored during this one-hour period for unsafe conditions.

RECYCLE OPERATION

When a flame is lost after the flame stabilization period, a recycle operation occurs. If the unit fails after five recycle attempts, the furnace is locked-out for one hour.

GAS HEATING OPERATION ERRORS

LOCK-OUT

A one-hour lockout occurs following three retries or five recycles. During the one-hour lockout, flame detection, limit conditions, and main valves are tested. Any improper results will cause the appropriate action to occur. Recycling the low voltage power cancels the lock-out.

TEMPERATURE LIMIT

If the UCB senses zero volts from the high temperature limit, the indoor blower motor is immediately energized. When the UCB again senses 24 volts from the temperature limit, the draft motor will perform a 15-second post-purge and the indoor blower will be de-energized following the elapse of the fan off delay for heating.

This limit is monitored regardless of unit operation status, i.e. this limit is monitored at all times.

If the temperature limit opens three times within one hour, it will lock-on the indoor blower motor and flash code is initiated (See Table 80).

FLAME SENSE

Flame sensing occurs at all times. If “W1” is not present and a flame is sensed for 2 seconds, the draft motor is energized and the GV is kept off. The ICB halts any operation until a flame is not detected. Once the flame detection is lost, the ICB performs a post-purge. Normal operation is allowed concurrently with the purge (i.e. this purge can be considered the purge associated with a call for “W1”).

If “W1” is present, a flame is sensed, but the GV is not energized, the draft motor is energized until the flame detection is lost. Normal operation is now allowed.

The flame detection circuitry continually tests itself. If the ICB finds the flame detection circuitry to be faulty, the ICB will not permit an ignition sequence and the draft motor is energized. If this failure should occur during an ignition cycle the failure is counted as a recycle.

GAS VALVE

The UCB and ICB continuously monitor the GV.

If the ICB senses voltage at the GV when not requested, the ICB will energize the draft motor. The ICB will not operate the furnace until voltage is no longer sensed at the GV. The draft motor is stopped when voltage is not sensed at the GV.

Any time the UCB senses voltage at the GV without a call for heat for a continuous five-minute period, the UCB will lock-on the indoor blower and a flash code is initiated (Table 80). When voltage is no longer sensed at the GV, the UCB will de-energize the indoor blower following the elapse of the fan off delay for heating.

If voltage has been sensed at the GV for at least 15 seconds during the fan on delay for heating and GV voltage or “W1” is lost, the indoor blower is forced on for the length of the fan off delay for heating.

During a call for heat, if the UCB does not sense voltage at the GV for a continuous five-minute period the UCB will initiate a flash code (Table 80). The indoor blower motor will not be locked-on while there is no GV voltage.

SAFETY CONTROLS

The UCB monitors the temperature limit switch of gas heat units.

The control circuit includes the following safety controls:

LIMIT SWITCH (LS)

This control is located inside the gas heat compartment and is set to open at the temperature indicated in the Gas Heat Limit Control Settings Table 67. It resets automatically. The limit switch operates when a high temperature condition, caused by inadequate supply air flow occurs, thus shutting down the heater and energizing the blower.

AUXILIARY LIMIT SWITCH (ALS)

This control is located inside the supply air compartment and is set to open at the temperature indicated in the Gas Heat Limit Control Settings Table 67. It resets manually. The limit switch operates when a high temperature condition, caused by inadequate supply air flow occurs, thus shutting down the heater and energizing the blower.

The auxiliary limit switch is wired in series with the limit switch. As such, the UCB cannot distinguish the auxiliary limit and the gas heat limit switch operation except the auxiliary is manual reset. Consequently, the control will respond in the same manner as outlined above under “Limit Switch”.

TABLE 67: GAS HEAT LIMIT CONTROL SETTINGS¹

Size	Unit		Main Limit Setting °F
		Opt.	
DM 078		10	215
		15	195
DM 090		10	165
		15	165
DM 102		10	165
		15	165
DM 120		15	195
		20	160
DM 150		15	195
		20	160
DH 078		10	165
		15	165
DH 090		10	165
		15	165
DH 102		10	165
		15	165
DH 120		15	195
		20	160
DH 150		15	195
		20	160

¹. Rollout = 300°F, Auxiliary Limit = 200°F.

The ICB monitors the Pressure and Rollout switches of gas heat units.

The control circuit includes the following safety controls:

PRESSURE SWITCH (PS)

Once the draft motor has reached full speed and closes the pressure switch during a normal ignition sequence, if the pressure sw opens for 2 seconds, the GV will be de-energized, the ignition cycle is aborted, and the ICB flashes the appropriate code. See Table 81 Ignition Control Flash Codes. The draft motor is energized until the pressure switch closes or "W1" is lost.

ROLLOUT SWITCH (ROS)

The rollout switch is wired in series with the pressure switch. As such, the ICB cannot distinguish the rollout switch operation from that of the pressure switch.

Consequently, the control will only respond in the same manner as outlined above under "Pressure Switch". An open rollout will inhibit the gas valve from actuating.

INTERNAL MICROPROCESSOR FAILURE

If the ICB detects an internal failure, it will cease all outputs, ignore inputs, and display the proper flash code for control replacement. The ICB remains in this condition until replaced.

FLASH CODES

The UCB will initiate a flash code associated with errors within the system. Refer to UNIT CONTROL BOARD FLASH CODES Table 80.

RESETS

Remove the call for heating by lowering the thermostat setting lower than the conditioned space temperature. This resets any flash codes.

GAS HEAT ANTICIPATOR SETPOINTS

It is important that the anticipator setpoint be correct. Too high of a setting will result in longer heat cycles and a greater temperature swing in the conditioned space. Reducing the value below the correct setpoint will give shorter "ON cycles and may result in the lowering of the temperature within the conditioned space. Refer to Table 68 for the required gas heat anticipator setting.

TABLE 68: GAS HEAT ANTICIPATOR SETPOINTS

SETTING, AMPS	
W1	W2
0.65	0.1

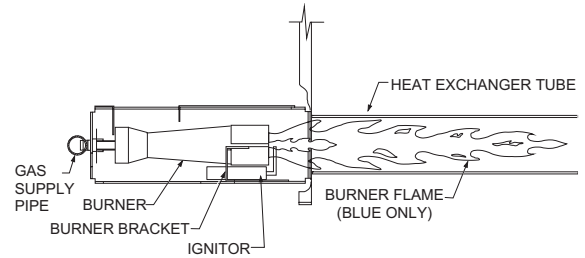

FIGURE 28 : TYPICAL FLAME

START-UP (COOLING)

PRESTART CHECK LIST

After installation has been completed:

1. Check the electrical supply voltage being supplied. Be sure that it is the same as listed on the unit nameplate.
2. Set the room thermostat to the off position.
3. Turn unit electrical power on.
4. Set the room thermostat fan switch to on.
5. Check indoor blower rotation.
 - If blower rotation is in the wrong direction. Refer to Phasing Section in general information section.
 - Check blower drive belt tension.
6. Check the unit supply air (CFM).
7. Measure evaporator fan motor's amp draw.
8. Set the room thermostat fan switch to off.
9. Turn unit electrical power off.

OPERATING INSTRUCTIONS

1. Turn unit electrical power on.

NOTE: Prior to each cooling season, the crankcase heaters must be energized at least 10 hours before the system is put into operation.

2. Set the room thermostat setting to lower than the room temperature.
3. First stage compressors will energize after the built-in time delay (five minutes).
4. The second stage of the thermostat will energize second stage compressor if needed.

POST START CHECK LIST

1. Verify proper system pressures for both circuits.
2. Measure the temperature drop across the evaporator coil.

START-UP (GAS HEAT)

PRE-START CHECK LIST

Complete the following checks before starting the unit.

1. Check the type of gas being supplied. Be sure that it is the same as listed on the unit nameplate.
2. Make sure that the vent outlet and combustion air inlet are free of any debris or obstruction.

OPERATING INSTRUCTIONS

CAUTION

This furnace is equipped with an automatic re-ignition system. DO NOT attempt to manually light the pilot.

LIGHTING THE MAIN BURNERS

1. Turn "OFF" electric power to unit.
2. Turn room thermostat to lowest setting.
3. Turn gas valve counter-clockwise to "ON" position (see Figure 29).
4. Turn "ON" electric power to unit.
5. If thermostat set temperature is above room temperature, the main burners will ignite. If a second stage of heat is called for, the main burners for second stage heat will ignite for the second stage heat.

POST START CHECKLIST

After the entire control circuit has been energized and the heating section is operating, make the following checks:

1. Check for gas leaks in the unit piping as well as the supply piping.

WARNING

FIRE OR EXPLOSION HAZARD

Failure to follow the safety warning exactly could result in serious injury, death or property damage.

Never test for gas leaks with an open flame. Use a commercially available soap solution made specifically for the detection of leaks to check all connections. A fire or explosion may result causing property damage, personal injury or loss of life.

2. Check for correct manifold gas pressures. (See 'CHECKING GAS INPUT'.)
3. Check the supply gas pressure. It must be within the limits shown on the rating nameplate. Supply pressure should be checked with all gas appliances in the building at full fire. At no time should the standby gas pressure exceed 10.5 in. or the operating pressure drop below 4.5 in. for natural gas units. If gas pressure is outside these limits, contact the local gas utility or propane supplier for corrective action.

SHUT DOWN

1. Set the thermostat to the lowest temperature setting.
2. Turn "OFF" all electric power to unit.
3. Open gas heat access panel.
4. Turn gas valve clockwise to "OFF" position (See Figure 29).

MANIFOLD GAS PRESSURE ADJUSTMENT

This gas furnace has two heat stages. Therefore, the gas valve has two adjustment screws located under a plastic protective cover. The second stage (100% input) adjustment screw is adjacent to the "HI" marking on the valve and the first stage (60% input) adjustment screw is located adjacent to the "LO" marking on the valve (See Figure 29).

Manifold pressure adjustment procedure.

Adjust second stage (100% input) pressure first, then adjust first stage (60% input) pressure.

1. Turn off all power to the unit.
2. Using the outlet pressure port on the gas valve, connect a manometer to monitor the manifold pressure.
3. Remove plastic cap covering HI and LO pressure adjustment screws.
4. Turn on power to the unit.
5. Set thermostat to call for second stage heat and start furnace.
6. If necessary, using a screwdriver, turn the second stage adjustment screw (adjacent to the "HI" marking on the valve) clockwise to increase manifold pressure or counterclockwise to decrease manifold pressure. **Be sure not to over-fire the unit on second stage.**
7. After the high manifold pressure has been checked, adjust the thermostat to call for first stage heat.
8. If necessary, using a screwdriver, turn the first stage adjustment screw (adjacent to the "LO" marking on the

valve) clockwise to increase manifold pressure or counterclockwise to decrease manifold pressure. **Be sure not to under-fire the unit on first stage.**

- Once pressure has been checked, replace the plastic cap covering the HI and LO pressure adjustment screws.

NOTE: When using natural gas, the manifold pressure for second stage (100% input) should be 3.5 IWG \pm 0.3. The manifold pressure for first stage (60% input) when using natural gas should be 1.5 IWG \pm 0.3.

TABLE 69: GAS HEAT STAGES

# of Burner Tubes	2nd Stage Input (100% Btuh)	1st Stage Input (60% Btuh)
4	120,000	72,000
6	180,000	108,000
8	240,000	144,000

CHECKING GAS INPUT

NATURAL GAS

This unit has two stages of gas heat. The first stage is 60% of the full fire input and is considered the minimum input for the furnace. The intended input for each furnace is shown in the table below. The following Table applies to units operating on 60 Hz power only.

To determine the rate of gas flow (Second Stage).

- Turn off all other gas appliances connected to the gas meter.
- Turn on the furnace and make sure the thermostat is calling for Second stage (100% input) heat.
- Measure the time needed for one revolution of the hand on the smallest dial on the meter. A typical gas meter has a 1/2 or a 1 cubic foot test dial.
- Using the number of seconds it takes for one revolution of the dial, calculate the cubic feet of gas consumed per hour. (See example below).
- If necessary, adjust the high pressure regulator as discussed in the section "Manifold Gas Pressure Adjustment". **Be sure not to over-fire** the furnace on Second stage. If in doubt, it is better to leave the Second stage of the furnace slightly under-fired. Repeat Steps 1-5.

To determine the rate of gas flow (First Stage)

- Turn off all other gas appliances connected to the gas meter.
- Turn on the furnace and make sure the thermostat is calling for first stage (60% input) heat.

- Even when the thermostat is calling for first stage heat, the unit will light on second stage and will run on Second stage for 1 minute. Allow this one-minute time period to expire and be certain the unit is running on first stage.
- Measure the time needed for one revolution of the hand on the smallest dial on the meter. A typical gas meter has a 1/2 or a 1 cubic foot test dial.
- Using the number of seconds it takes for one revolution of the dial, calculate the cubic feet of gas consumed per hour (See example below).
- If necessary, adjust the low pressure regulator as discussed in the section "Manifold Gas Pressure Adjustment". **Be sure not to under-fire** the furnace on first stage. If in doubt, it is better to leave the first stage of the furnace slightly over-fired (greater than 60% input). Repeat Steps 1-6.

TABLE 70: GAS RATE CUBIC FEET PER HOUR

Seconds for One Rev.	Size of Test Dial	
	1/2 cu. ft.	1 cu. ft.
10	180	360
12	150	300
14	129	257
16	113	225
18	100	200
20	90	180
22	82	164
24	75	150
26	69	138
28	64	129
30	60	120
32	56	113
34	53	106
36	50	100
38	47	95
40	45	90
42	43	86
44	41	82
46	39	78
48	37	75
50	36	72
52	35	69
54	34	67
56	32	64
58	31	62
60	30	60

NOTE: To find the Btu input, multiply the number of cubic feet of gas consumed per hour by the Btu content of the gas in your particular locality (contact your gas company for this information as it varies widely from area to area).

EXAMPLE:

By actual measurement, it takes 19 seconds for the hand on a 1 cubic foot dial to make a revolution with a 192,000 Btuh furnace running. To determine rotations per minute, divide 60 by 19 = 3.16. To calculate rotations per hour, multiply 3.16 • 60 = 189.6. Multiply 189.6 • 1 (0.5 if using a 1/2 cubic foot dial) = 189.6. Multiply 189.6 • (the Btu rating of the gas). For this example, assume the gas has a Btu rating of 1050 Btu/ft.³. The result of 199,000 Btuh is within 5% of the 192,000 Btuh rating of the furnace.

ADJUSTMENT OF TEMPERATURE RISE

The temperature rise (the difference of temperature between the return air and the heated air from the furnace) must lie within the range shown on the CSA rating plate and the data in Table 32.

After the temperature rise has been determined, the CFM can be calculated as follows:

$$\text{CFM} = \text{Btu Input} \cdot \frac{0.8}{(1.08 \cdot \Delta^{\circ}\text{F})}$$

After about 20 minutes of operation, determine the furnace temperature rise. Take readings of both the return air and the heated air in the ducts (about 6 feet from the furnace) where they will not be affected by radiant heat. Increase the blower CFM to decrease the temperature rise; decrease the blower CFM to increase the rise (See 'SUPPLY AIR DRIVE ADJUSTMENT').

NOTE: Each gas heat exchanger size has a minimum allowable CFM. Below this CFM, the limit will open.

BURNERS/ORIFICES INSPECTION/SERVICING

Before checking or changing burners, pilot or orifices, CLOSE MAIN MANUAL SHUT-OFF VALVE AND SHUT OFF ALL POWER TO THE UNIT.

1. Open the union fitting just upstream of the unit gas valve and downstream from the main manual shut-off valve in the gas supply line.

2. Remove the screws holding each end of the manifold to the manifold supports.
3. Disconnect wiring to the gas valves and spark igniter(s). Remove the manifold & gas valve assembly. Orifices can now be inspected and/or replaced.

To service burners, complete step 4.

4. Remove the heat shield on top of the manifold supports. Burners are now accessible for inspection and/or replacement.

NOTE: Reverse the above procedure to replace the assemblies.

Make sure that burners are level and seat at the rear of the gas orifice.

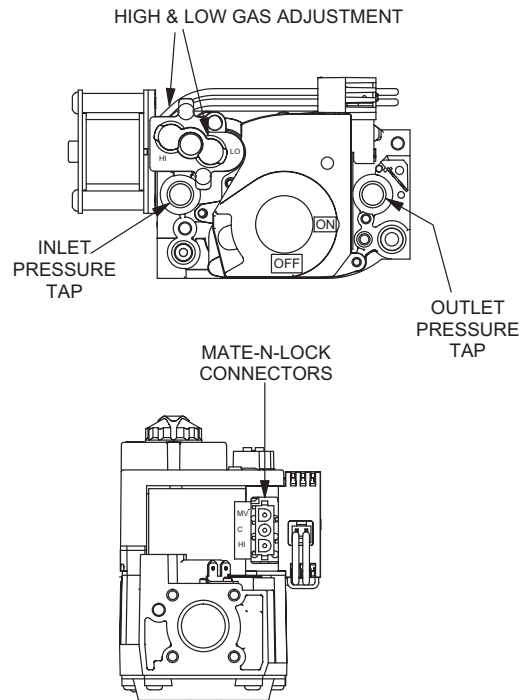

FIGURE 29 : TYPICAL GAS VALVE

CHARGING THE UNIT

These units should be charged using the superheat method. Super heat charging data is shown in Tables 71 thru 79.

When charging each system, superheat data should be taken at the compressor inlet.

TABLE 71: DM078 (6.5 TON) STANDARD EFFICIENCY SUPERHEAT CHARGING

Outdoor Temp (°F)	Superheat at Compressor Suction (°F)										
	Airflow = 2500 CFM										
	Indoor WB Temp (°F)										
	55	57	59	61	63	65	67	69	71	73	75
65	21.9	22.6	23.2	23.9	24.6	25.3	26.0	27.4	28.9	30.4	31.9
70	18.1	19.1	20.0	21.0	22.0	22.9	23.9	25.5	27.2	28.9	30.5
75	14.4	15.6	16.8	18.1	19.3	20.6	21.8	23.7	25.5	27.3	29.1
80	10.6	12.1	13.7	15.2	16.7	18.2	19.8	21.8	23.8	25.8	27.8
85	6.8	8.7	10.5	12.3	14.1	15.9	17.7	19.9	22.1	24.2	26.4
90	-	6.2	8.0	9.8	11.6	13.4	15.3	17.8	20.4	23.0	25.5
95	-	-	5.6	7.4	9.2	11.0	12.8	15.8	18.7	21.7	24.6
100	-	-	5.1	6.5	7.8	9.2	10.5	13.2	16.0	18.7	21.4
105	-	-	-	5.6	6.5	7.4	8.3	10.7	13.2	15.7	18.2
110	-	-	-	-	5.2	5.6	6.0	8.2	10.5	12.7	14.9
115	-	-	-	-	-	-	-	5.7	7.7	9.7	11.7

TABLE 72: DM090 (7.5 TON) STANDARD EFFICIENCY SUPERHEAT CHARGING

Outdoor Temp (°F)	Superheat at Compressor Suction (°F)										
	Airflow = 3000 CFM										
	Indoor WB Temp (°F)										
	55	57	59	61	63	65	67	69	71	73	75
65	-	6.4	8.7	10.9	13.2	15.4	17.7	19.8	21.9	24.1	26.2
70	-	6.3	8.5	10.7	12.9	15.1	17.3	19.2	21.1	23.0	24.9
75	-	6.1	8.3	10.4	12.6	14.7	16.9	18.6	20.2	21.9	23.5
80	-	6.0	8.1	10.2	12.3	14.4	16.5	17.9	19.4	20.8	22.2
85	-	5.8	7.9	9.9	12.0	14.0	16.1	17.3	18.5	19.7	20.9
90	-	5.7	7.7	9.7	11.7	13.7	15.7	16.3	16.9	17.5	18.1
95	-	5.5	7.5	9.4	11.4	13.3	15.3	15.3	15.3	15.3	15.3
100	-	-	6.2	7.8	9.3	10.8	12.4	12.4	12.4	12.5	12.5
105	-	-	-	6.1	7.2	8.3	9.4	9.5	9.6	9.6	9.7
110	-	-	-	-	5.1	5.8	6.5	6.6	6.7	6.8	6.9
115	-	-	-	-	-	-	-	-	-	-	-

TABLE 73: DM102 (8.5 TON) STANDARD EFFICIENCY SUPERHEAT CHARGING

Outdoor Temp (°F)	Superheat at Compressor Suction (°F) Airflow = 3400 CFM										
	Indoor WB Temp (°F)										
	55	57	59	61	63	65	67	69	71	73	75
65	17.0	19.1	21.2	23.3	25.4	27.5	29.6	31.4	33.1	34.9	36.6
70	14.6	16.6	18.6	20.6	22.6	24.6	26.7	28.4	30.1	31.8	33.6
75	12.1	14.1	16.0	17.9	19.8	21.8	23.7	25.4	27.1	28.8	30.5
80	9.7	11.5	13.4	15.2	17.1	18.9	20.8	22.4	24.1	25.8	27.4
85	7.2	9.0	10.8	12.5	14.3	16.0	17.8	19.4	21.1	22.7	24.4
90	-	-	6.6	8.7	10.7	12.7	14.8	16.7	18.7	20.7	22.7
95	-	-	-	-	7.1	9.4	11.7	14.0	16.3	18.7	21.0
100	-	-	-	-	5.3	7.0	8.8	11.0	13.2	15.5	17.7
105	-	-	-	-	-	-	5.8	8.0	10.1	12.3	14.4
110	-	-	-	-	-	-	-	-	7.0	9.1	11.1
115	-	-	-	-	-	-	-	-	-	5.9	7.8

TABLE 74: DM 120 (10 TON) STANDARD EFFICIENCY SUPERHEAT CHARGING

Outdoor Temp (°F)	Superheat at Compressor Suction (°F) Airflow = 4000 CFM										
	Indoor WB Temp (°F)										
	55	57	59	61	63	65	67	69	71	73	75
65	19.6	20.8	22.0	23.2	24.4	25.6	26.9	28.4	29.9	31.4	32.9
70	14.4	16.0	17.5	19.0	20.5	22.0	23.5	25.4	27.3	29.2	31.0
75	9.3	11.1	12.9	14.7	16.6	18.4	20.2	22.4	24.7	26.9	29.1
80	-	6.3	8.4	10.5	12.6	14.8	16.9	19.5	22.0	24.6	27.2
85	-	-	-	6.3	8.7	11.1	13.6	16.5	19.4	22.4	25.3
90	-	-	-	5.6	7.8	9.9	12.0	15.0	17.9	20.8	23.7
95	-	-	-	-	6.8	8.7	10.5	13.4	16.3	19.3	22.2
100	-	-	-	-	5.3	6.7	8.1	10.8	13.5	16.2	18.9
105	-	-	-	-	-	-	5.7	8.1	10.6	13.1	15.5
110	-	-	-	-	-	-	-	5.5	7.7	10.0	12.2
115	-	-	-	-	-	-	-	-	-	6.9	8.9

TABLE 75: DM150 (12.5 TON) STANDARD EFFICIENCY SUPERHEAT CHARGING

Outdoor Temp (°F)	Superheat at Compressor Suction (°F) Airflow = 5000 CFM										
	Indoor WB Temp (°F)										
	55	57	59	61	63	65	67	69	71	73	75
65	33.9	34.5	35.1	35.7	36.3	36.9	37.5	38.1	38.7	39.3	39.9
70	30.2	31.0	31.8	32.7	33.5	34.3	35.2	36.0	36.8	37.7	38.5
75	26.4	27.5	28.6	29.6	30.7	31.8	32.8	33.9	35.0	36.0	37.1
80	23.5	24.7	26.0	27.2	28.4	29.7	30.9	32.1	33.4	34.6	35.8
85	20.6	22.0	23.4	24.8	26.2	27.6	29.0	30.4	31.8	33.2	34.6
90	17.2	18.8	20.3	21.9	23.5	25.0	26.6	28.2	29.7	31.3	32.9
95	13.8	15.5	17.2	19.0	20.7	22.4	24.2	25.9	27.6	29.4	31.1
100	9.9	11.8	13.6	15.5	17.4	19.2	21.1	23.0	24.8	26.7	28.6
105	6.0	8.0	10.0	12.0	14.0	16.0	18.0	20.0	22.0	24.0	26.0
110	4.8	6.5	8.2	9.8	11.5	13.2	14.8	16.5	18.2	19.8	21.5
115	3.7	5.0	6.3	7.7	9.0	10.3	11.7	13.0	14.3	15.7	17.0

TABLE 76: DH078 (6.5 TON) HIGH EFFICIENCY SUPERHEAT CHARGING

Outdoor Temp (°F)	Superheat at Compressor Suction (°F) Airflow = 2500 CFM										
	Indoor WB Temp (°F)										
	55	57	59	61	63	65	67	69	71	73	75
65	12.0	15.8	19.6	23.4	27.2	31.0	34.8	38.1	41.4	44.8	48.1
70	11.6	14.9	18.3	21.6	24.9	28.2	31.6	34.3	37.1	39.9	42.7
75	11.2	14.1	16.9	19.8	22.6	25.5	28.3	30.5	32.8	35.0	37.3
80	10.8	13.2	15.6	17.9	20.3	22.7	25.1	26.8	28.5	30.2	31.9
85	10.4	12.3	14.2	16.1	18.0	19.9	21.8	23.0	24.1	25.3	26.4
90	-	6.1	8.3	10.4	12.5	14.7	16.8	19.0	21.2	23.4	25.6
95	-	-	-	-	7.1	9.4	11.8	15.0	18.3	21.5	24.8
100	-	-	-	-	5.3	7.1	8.9	11.3	13.7	16.1	18.6
105	-	-	-	-	-	-	5.9	7.5	9.1	10.8	12.4
110	-	-	-	-	-	-	-	-	-	5.4	6.2
115	-	-	-	-	-	-	-	-	-	-	-

TABLE 77: DH090 (7.5 TON) HIGH EFFICIENCY SUPERHEAT CHARGING

Outdoor Temp (°F)	Superheat at Compressor Suction (°F)										
	Airflow = 3000 CFM										
	Indoor WB Temp (°F)										
	55	57	59	61	63	65	67	69	71	73	75
65	37.1	37.6	38.1	38.5	39.0	39.4	39.9	40.0	40.1	40.2	40.3
70	32.1	32.8	33.4	34.1	34.8	35.5	36.2	36.4	36.7	37.0	37.3
75	27.0	27.9	28.8	29.7	30.6	31.5	32.4	32.9	33.4	33.9	34.4
80	21.9	23.1	24.2	25.3	26.4	27.5	28.7	29.3	30.0	30.7	31.4
85	16.9	18.2	19.5	20.9	22.2	23.6	24.9	25.8	26.7	27.5	28.4
90	7.3	9.6	11.8	14.0	16.2	18.4	20.6	22.3	24.1	25.8	27.6
95	-	-	-	7.0	10.1	13.1	16.2	18.8	21.5	24.1	26.8
100	-	-	-	5.4	7.8	10.2	12.6	15.3	18.0	20.7	23.4
105	-	-	-	-	5.5	7.2	8.9	11.7	14.5	17.3	20.1
110	-	-	-	-	-	-	5.3	8.1	11.0	13.9	16.8
115	-	-	-	-	-	-	-	-	7.5	10.5	13.4

TABLE 78: DH102 (8.5 TON) HIGH EFFICIENCY SUPERHEAT CHARGING

Outdoor Temp (°F)	Superheat at Compressor Suction (°F)										
	Airflow = 3000 CFM										
	Indoor WB Temp (°F)										
	55	57	59	61	63	65	67	69	71	73	75
65	29.9	31.4	32.9	34.4	35.8	37.3	38.8	39.9	41.0	42.2	43.3
70	27.5	29.0	30.5	32.0	33.5	35.0	36.5	37.4	38.4	39.3	40.3
75	25.1	26.7	28.2	29.7	31.2	32.7	34.2	35.0	35.7	36.5	37.2
80	22.8	24.3	25.8	27.3	28.9	30.4	31.9	32.5	33.1	33.6	34.2
85	20.4	21.9	23.4	25.0	26.5	28.1	29.6	30.0	30.4	30.8	31.2
90	12.1	14.4	16.6	18.9	21.2	23.5	25.8	26.9	28.0	29.1	30.2
95	-	6.8	9.8	12.9	15.9	19.0	22.0	23.8	25.6	27.4	29.2
100	-	5.3	7.6	9.8	12.1	14.3	16.6	19.1	21.7	24.3	26.9
105	-	-	5.3	6.7	8.2	9.6	11.1	14.5	17.8	21.2	24.5
110	-	-	-	-	-	-	5.7	9.8	13.9	18.1	22.2
115	-	-	-	-	-	-	-	5.1	10.0	15.0	19.9

DH120 (10 ton) high efficiency unit uses TXV. Charge the unit to 10° subcooling.

TABLE 79: DH150 (12.5 TON) HIGH EFFICIENCY SUPERHEAT CHARGING

Outdoor Temp (°F)	Superheat at Compressor Suction (°F)										
	Airflow = 5000 CFM										
	Indoor WB Temp (°F)										
	55	57	59	61	63	65	67	69	71	73	75
65	7.9	10.7	13.6	16.4	19.3	22.2	25.0	26.9	28.7	30.5	32.4
70	7.3	9.7	12.2	14.6	17.1	19.5	22.0	24.2	26.5	28.8	31.0
75	6.7	8.7	10.8	12.8	14.8	16.9	18.9	21.6	24.3	27.0	29.7
80	6.1	7.7	9.3	11.0	12.6	14.3	15.9	19.0	22.1	25.2	28.3
85	5.5	6.7	7.9	9.2	10.4	11.6	12.9	16.4	19.9	23.5	27.0
90	5.6	6.5	7.4	8.4	9.3	10.2	11.2	14.9	18.7	22.5	26.2
95	5.6	6.3	6.9	7.6	8.2	8.8	9.5	13.5	17.5	21.5	25.5
100	5.2	5.8	6.5	7.1	7.8	8.4	9.0	12.3	15.6	18.8	22.1
105	-	5.4	6.0	6.7	7.3	8.0	8.6	11.1	13.7	16.2	18.7
110	-	-	5.6	6.2	6.9	7.5	8.2	10.0	11.8	13.6	15.4
115	-	-	5.1	5.8	6.4	7.1	7.7	8.8	9.9	10.9	12.0

TROUBLESHOOTING

WARNING

Troubleshooting of components may require opening the electrical control box with the power connected to the unit. **Use extreme care when working with live circuits!** Check the unit nameplate for the correct line voltage and set the voltmeter to the correct range before making any connections with line terminals.

When not necessary, shut off all electric power to the unit prior to any of the following maintenance procedures so as to prevent personal injury.

CAUTION

Label all wires prior to disconnection when servicing controls. Wiring errors can cause improper and dangerous operation which could cause injury to person and/or damage unit components. Verify proper operation after servicing.

PREDATOR® FLASH CODES

Various flash codes are utilized by the unit control board (UCB) to aid in troubleshooting. Flash codes are distinguished by the short on and off cycle used (approximately 200ms on and 200ms off). To show normal operation, the control board flashes a 1 second on, 1 second off "heartbeat" during normal operation. This is to verify that the UCB is functioning correctly. Do not confuse this with an error flash code. To prevent confusion, a 1-flash, flash code is not used.

Alarm condition codes are flashed on the UCB lower left Red LED, See Figure 30. While the alarm code is being flashed, it will also be shown by the other LEDs: lit continuously while the alarm is being flashed. The total of the continuously lit LEDs equates to the number of flashes, and is shown in the table. Pressing and releasing the LAST ERROR button on the UCB can check the alarm history. The UCB will cycle through the last five (5) alarms, most recent to oldest, separating each alarm flash code by approximately 2 seconds. In all cases, a flashing Green LED will be used to indicate non-alarm condition.

In some cases, it may be necessary to "zero" the ASCD for the compressors in order to perform troubleshooting. To reset all ASCDs for one cycle, press and release the UCB TEST/RESET button once.

Flash codes that do and do not represent alarms are listed in Table 80.

TABLE 80: UNIT CONTROL BOARD FLASH CODES

FLASH CODE	DESCRIPTION	GREEN LED 16	RED LED 8	RED LED 4	RED LED 2	RED LED 1
On Steady	This is a Control Failure	-	-	-	-	-
1 Flash	Not Applicable	-	-	-	-	-
2 Flashes	Control waiting ASCD ¹	Flashing	Off	Off	On	Off
3 Flashes	HPS1 Compressor Lockout	Off	Off	Off	On	On
4 Flashes	HPS2 Compressor Lockout	Off	Off	On	Off	Off
5 Flashes	LPS1 Compressor Lockout	Off	Off	On	Off	On
6 Flashes	LPS2 Compressor Lockout	Off	Off	On	On	Off
7 Flashes	FS1 Compressor Lockout	Off	Off	On	On	On
8 Flashes	FS2 Compressor Lockout	Off	On	Off	Off	Off
9 Flashes	Ignition Control Locked Out / Ignition Control Failure	Off	On	Off	Off	On
10 Flashes	Compressors Locked Out on Low Outdoor Air Temperature ¹	Flashing	On	Off	On	Off
11 Flashes	Compressors locked out because the Economizer is using free Cooling ¹	Flashing	On	Off	On	On
12 Flashes	Unit Locked Out due to Fan Overload Switch Failure	Off	On	On	Off	Off
13 Flashes	Compressor Held Off due to Low Voltage ¹	Flashing	On	On	Off	On
14 Flashes	EEPROM Storage Failure	Off	On	On	On	Off
OFF	No Power or Control Failure	Off	Off	Off	Off	Off

¹. Non-alarm condition.

TABLE 81: IGNITION CONTROL FLASH CODES

FLASHES	FAULT CONDITIONS	CHECK
STEADY ON	Control Failure	Control
HEARTBEAT	Normal Operation	
1	Not Applicable	
2	Pressure Switch Stuck Closed	Pressure Switch
3	Pressure Switch Failed To Close	Venter Pressure Switch Vent Blocked
4	Limit Switch Open	Main Limit AUX Limit
5	Flame Present With Gas Off First Stage Gas Valve Energized With W1 Off Second Stage Gas Valve Energized With First Stage Gas Valve Off	Gas Valve
6	Ignition Lockout	Gas Flow Gas Pressure Gas Valve Flame Sensor
STEADY OFF	No Power Or Control Failure	24VAC or Control

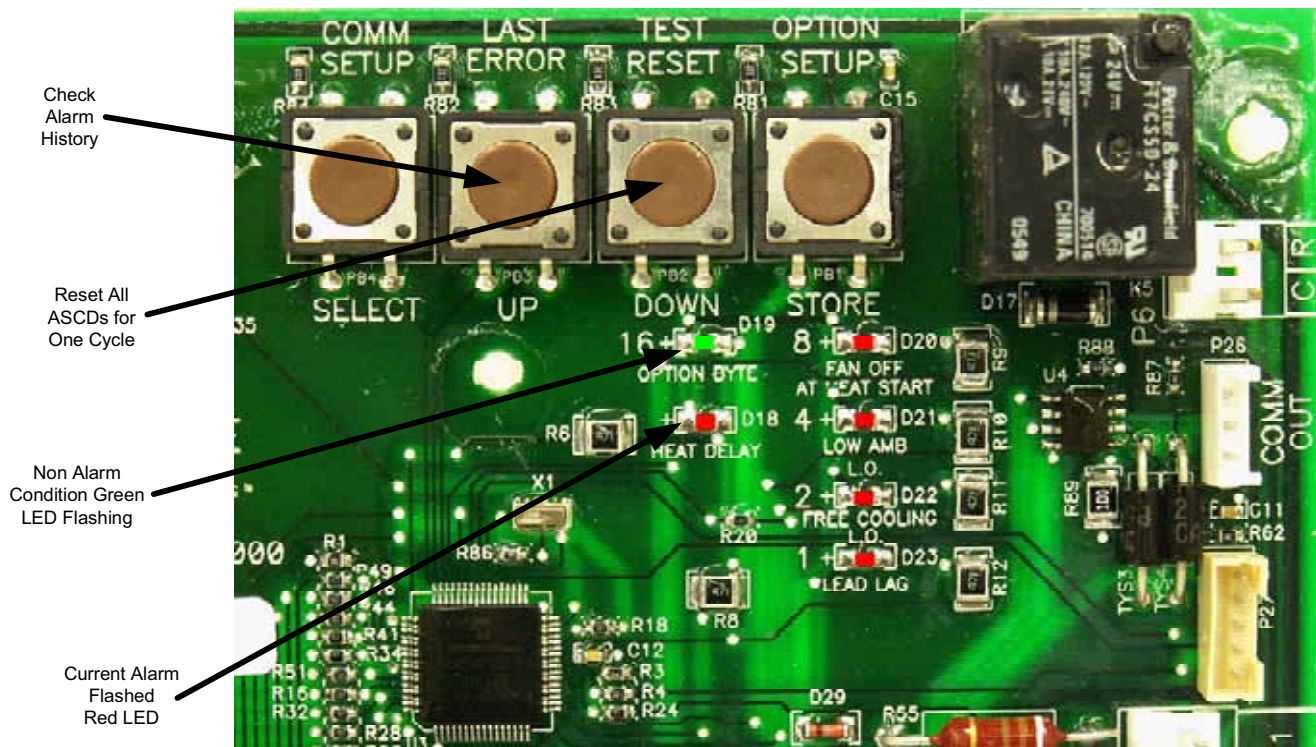

FIGURE 30: UNIT CONTROL BOARD

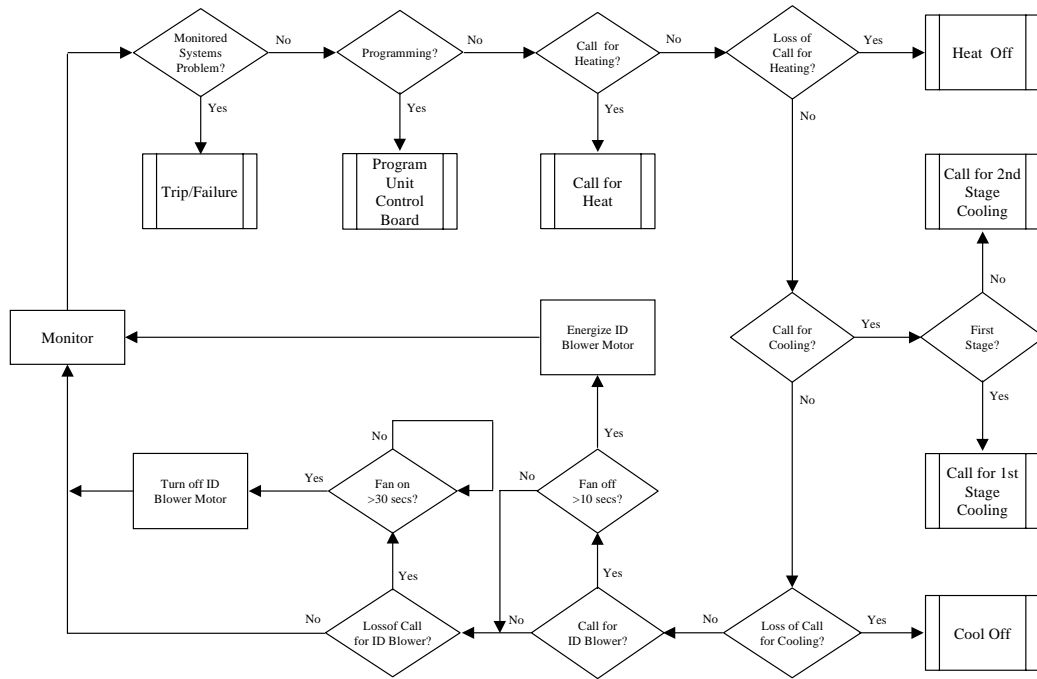

FIGURE 31 - BASIC TROUBLESHOOTING FLOWCHART

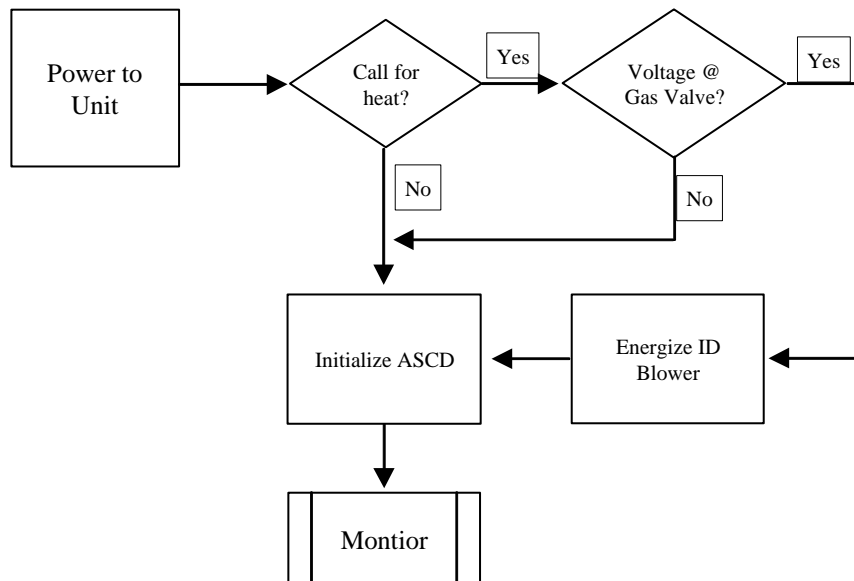
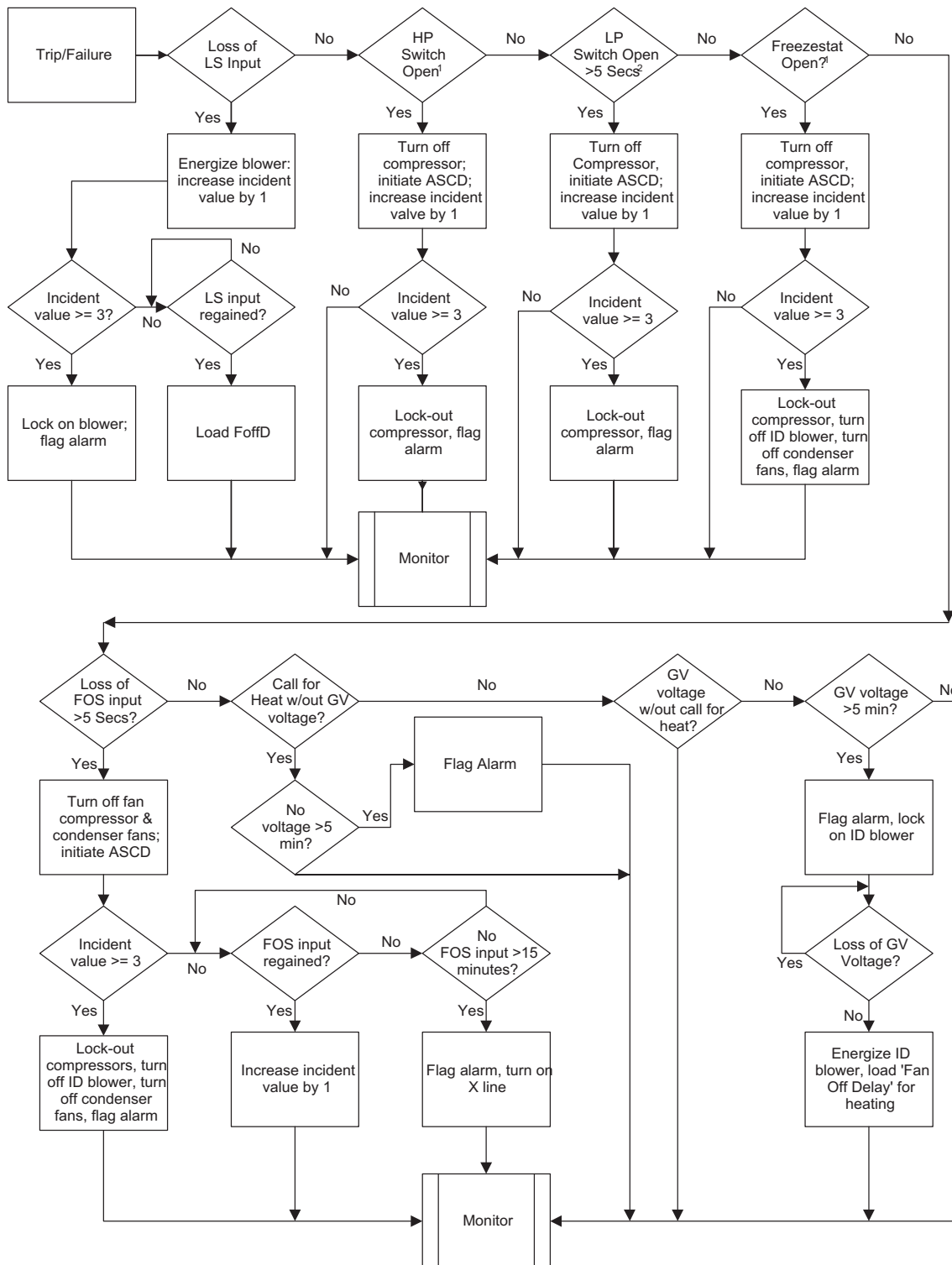

FIGURE 32 - POWER ON FLOW CHART



1 The control board only monitors the input when the compressor really is energized.
 2 The low-pressure switch is not monitored for the first 30 seconds of compressor activity. The control board then monitors the switch to ensure it closes. If the switch remains open and additional 30 seconds, the control board turns off the associated compressor and initiates the ASCD. Once it has closed during the start up period, the control board no longer handles the low-pressure switch differently than other inputs.

FIGURE 33 - TRIP FAILURE FLOW CHART

COOLING TROUBLESHOOTING GUIDE

On calls for cooling, if the compressors are operating but the supply air blower motor does not energize after a short delay (the room thermostat fan switch is in the "AUTO" position):

1. Turn the thermostat fan switch to the ON position. If the supply air blower motor does not energize, go to Step 3.
 2. If the blower motor runs with the fan switch in the ON position but will not run after the first compressor has energized when the fan switch is in the AUTO position, check the room thermostat for contact between R and G in the AUTO position during calls for cooling.
 3. If the supply air blower motor does not energize when the fan switch is set to ON, check that line voltage is being supplied to the contacts of the M3, contactor, and that the contactor is pulled in. Check for loose wiring between the contactor and the supply air blower motor.
 4. If M3 is pulled in and voltage is supplied to M3, lightly touch the supply air blower motor housing. If it is hot, the motor may be off on internal protection. Cancel any thermostat calls and set the fan switch to AUTO. Wait for the internal overload to reset. Test again when cool.
 5. If M3 is not pulled in, check for 24 volts at the M3 coil. If 24 volts are present at M3 but M3 is not pulled in, replace the contactor.
 6. Failing the above, if there is line voltage supplied at M3, M3 is pulled in, and the supply air blower motor still does not operate, replace the motor.
 7. If 24 volts is not present at M3, check that 24 volts is present at the UCB supply air blower motor terminal, "FAN". If 24 volts is present at the FAN, check for loose wiring between the UCB and M3.
 8. If 24 volts is not present at the "FAN" terminal, check for 24 volts from the room thermostat. If 24 volts are not present from the room thermostat, check for the following:
 - a. Proper operation of the room thermostat (contact between R and G with the fan switch in the ON position and in the AUTO position during operation calls).
 - b. Proper wiring between the room thermostat and the UCB, and
 - c. Loose wiring from the room thermostat to the UCB
 9. If 24 volts is present at the room thermostat but not at the UCB, check for proper wiring between the thermostat and the UCB, i.e. that the thermostat G terminal is connected to the G terminal of the UCB, and for loose wiring.
 10. If the thermostat and UCB are properly wired, replace the UCB.
- On calls for cooling, the supply air blower motor is operating but compressor #1 is not (the room thermostat fan switch is in the "AUTO" position):
1. If installed, check the position of the economizer blades. If the blades are open, the economizer is providing free cooling and the compressors will not immediately operate. If both stages of cooling are requested simultaneously and the economizer provides free cooling, following a short delay compressor #1 will be energized unless it is locked out. If compressor #1 is locked out, compressor #2 is energized. Compressor #2 is always energized in place of compressor #1 when compressor #1 is requested but locked out.
 2. If no economizer is installed or the economizer is not opening to provide free cooling and compressor #1 does not energize on a call for cooling, check for line voltage at the compressor contactor, M1, and that the contactor is pulled in. Check for loose wiring between the contactor and the compressor.
 3. If M1 is pulled in and voltage is supplied at M1, lightly touch the compressor housing. If it is hot, the compressor may be off on inherent protection. Cancel any calls for cooling and wait for the internal overload to reset. Test again when cool.
 4. If M1 is not pulled in, check for 24 volts at the M1 coil. If 24 volts are present and M1 is not pulled in, replace the contactor.
 5. Failing the above, if voltage is supplied at M1, M1 is pulled in, and the compressor still does not operate, replace the compressor.
 6. If 24 volts is not present at M1, check for 24 volts at the UCB terminal, C1. If 24 volts is present, check for loose wiring between C1 and the compressor contactor.
 7. If 24 volts is not present at the C1 terminal, check for 24 volts from the room thermostat at the UCB Y1 terminal. If 24 volts is not present from the room thermostat, check for the following:
 - a. 24 volts at the thermostat Y1 terminal
 - b. Proper wiring between the room thermostat and the UCB, i.e. Y1 to Y1, Y2 to Y2, and
 - c. Loose wiring from the room thermostat to the UCB
 8. If 24 volts is present at the UCB Y1 terminal, the compressor may be out due to an open high-pressure switch, low-pressure switch, or freestat. Check for 24 volts at the HPS1, LPS1, and FS1 terminals of the UCB. If a switch has opened, there should be a voltage potential between the UCB terminals, e.g. if LPS1 has opened, there will be a 24-volt potential between the LPS1 terminals.
 9. If 24 volts is present at the UCB Y1 terminal and none of the protection switches have opened, the UCB may have

locked out the compressor for repeat trips. The UCB should be flashing an alarm code. If not, press and release the ALARMS button on the UCB. The UCB will flash the last five alarms on the LED. If the compressor is locked out, cancel any call for cooling. This will reset any compressor lock outs.

NOTE: While the above step will reset any lockouts, compressor #1 may be held off for the ASCD. See the next step.

10. If 24 volts is present at the UCB Y1 terminal and none of the switches are open and the compressor is not locked out, the UCB may have the compressor in an ASCD. Check the LED for an indication of an ASCD cycle. The ASCD should time out within 5 minutes. Press and release the TEST button to reset all ASCDs.
11. If 24 volts is present at the UCB Y1 terminal and the compressor is not out due to a protective switch trip, repeat trip lock out, or ASCD, the economizer terminals of the UCB may be improperly wired. Check for 24 volts at the Y1 "OUT" terminal of the UCB. If 24 volts is present, trace the wiring from Y1 "OUT" for incorrect wiring. If 24 volts is not present at the Y1 "OUT" terminal, the UCB must be replaced.
12. *For units without economizers:* If 24 volts is present at the Y1 OUT terminal, check for 24 volts at the Y1 "ECON" terminal. If 24 volts is not present, check for loose wiring from the Y1 "OUT" terminal to the Mate-N-Lock plug, the jumper in the Mate-N-Lock plug, and in the wiring from the Mate-N-Lock plug to the Y1 "ECON" terminal.
13. *For units with economizers:* If 24 volts is present at the Y1 "OUT" terminal, check for 24 volts at the Y1 "ECON" terminal. If 24 volts is not present, check for loose wiring from the Y1 "OUT" terminal to the Mate-N-Lock plug, a poor connection between the UCB and economizer Mate-N-Lock plugs, loose wiring from the Mate-N-Lock plug to the economizer, back to the Mate-N-Lock plug, and from the Mate-N-Lock plug to the Y1 "ECON" terminal. If nothing is found, the economizer control may have faulted and is failing to return the 24-volt "call" to the Y1 "ECON" terminal even though the economizer is not providing free cooling. To test, disconnect the Mate-N-Locks and jumper between the WHITE and YELLOW wires of the UCB's Mate-N-Lock plug. If compressor #1 energizes, there is a fault in the economizer wiring or the economizer control.
14. The UCB can be programmed to lock out compressor operation during free cooling and in low ambient conditions. These options are not enabled by default. Local distributors can test the UCB for this programming.

For units with factory installed economizers, the UCB is programmed to lock out compressor operation when the LAS set point is reached.

For units without factory installed or with field installed economizers, the UCB allows compressor operation all the time. This programming can be checked or changed by the local distributor.

15. If none of the above corrected the error, test the integrity of the UCB. Disconnect the C1 terminal wire and jumper it to the Y1 terminal. DO NOT jump the Y1 to C1 terminals. If the compressor engages, the UCB has faulted.
16. If none of the above correct the error, replace the UCB.

On calls for the second stage of cooling, the supply air blower motor and compressor #1 are operating but compressor #2 is not (the room thermostat fan switch is in the "AUTO" position):

1. If installed, check the position of the economizer blades. If the blades are open, the economizer is providing free cooling. If the second stage of cooling is requested, following a short delay, compressor #1 will be energized unless it is locked out. Typically, compressor #2 is energized only during free cooling if the call for the second stage of cooling persists for 20 minutes.
2. Compressor #2 will not energize simultaneously with compressor #1 if a call for both stages of cooling is received. The UCB delays compressor #2 by 30 seconds to prevent a power surge. If after the delay compressor #2 does not energize on a second stage call for cooling, check for line voltage at the compressor contactor, M2, and that the contactor is pulled in. Check for loose wiring between the contactor and the compressor.
3. If M2 is pulled in and voltage is supplied at M2, lightly touch the compressor housing. If it is hot, the compressor may be off on inherent protection. Cancel any calls for cooling and wait for the internal overload to reset. Test again when cool.
4. If M2 is not pulled in, check for 24 volts at the M2 coil. If 24 volts is present and M2 is not pulled in, replace the contactor.
5. Failing the above, if voltage is supplied at M2, M2 is pulled in, and the compressor still does not operate, replace the compressor.
6. If 24 volts is not present at M2, check for 24 volts at the UCB terminal, C2. If 24 volts are present, check for loose wiring between C2 and the compressor contactor.
7. If 24 volts is not present at the C2 terminal, check for 24 volts from the room thermostat at the UCB Y2 terminal. If 24 volts is not present from the room thermostat, check for the following:
 - a. 24 volts at the thermostat Y2 terminal
 - b. Proper wiring between the room thermostat and the UCB, i.e. Y1 to Y1, Y2 to Y2, and
 - c. Loose wiring from the room thermostat to the UCB

8. If 24 volts is present at the UCB Y2 terminal, the compressor may be out due to an open high-pressure switch, low-pressure switch, or freezestat. Check for 24 volts at the HPS2, LPS2, and FS2 terminals of the UCB. If a switch has opened, there should be a voltage potential between the UCB terminals, e.g. if LPS2 has opened, there will be 24 volts of potential between the LPS2 terminals.
9. If 24 volts is present at the UCB Y2 terminal and none of the protection switches have opened, the UCB may have locked out the compressor for repeat trips. The UCB should be flashing a code. If not, press and release the ALARMS button on the UCB. The UCB will flash the last five alarms on the LED. If the compressor is locked out, remove any call for cooling at the thermostat or by disconnecting the thermostat wiring at the Y2 UCB terminal. This will reset any compressor lock outs.

NOTE: While the above step will reset any lock outs, compressor #1 will be held off for the ASCD, and compressor #2 may be held off for a portion of the ASCD. See the next step.

10. If 24 volts is present at the UCB Y2 terminal and none of the switches are open and the compressor is not locked out, the UCB may have the compressor in an ASCD. Check the LED for an indication of an ASCD cycle. The ASCD should time out within 5 minutes. Press and release the TEST button to reset all ASCDs.
11. The UCB can be programmed to lock out compressor operation during free cooling and in low ambient conditions. These options are not enabled by default. Local distributors can test the UCB for this programming.

For units with factory installed economizers, the UCB is programmed to lock out compressor operation when the LAS set point is reached.

For units without factory installed or with field installed economizers, the UCB allows compressor operation all the time. This programming can be checked or changed by the local distributor.
12. If none of the above corrected the error, test the integrity of the UCB. Disconnect the C2 terminal wire and jumper it to the Y2 terminal. DO NOT jump the Y2 to C2 terminals. If the compressor engages, the UCB has faulted.
13. If none of the above correct the error, replace the UCB.

On a call for cooling, the supply air blower motor and compressor #2 are operating but compressor #1 is not (the room thermostat fan switch is in the "AUTO" position):

1. Compressor #2 is energized in place of compressor #1 when compressor #1 is unavailable for cooling calls. Check the UCB for alarms indicating that compressor #1 is locked out. Press and release the ALARMS button if the LED is not flashing an alarm.

2. Check for line voltage at the compressor contactor, M1, and that the contactor is pulled in. Check for loose wiring between the contactor and the compressor.
3. If M1 is pulled in and voltage is supplied at M1, lightly touch the compressor housing. If it is hot, the compressor may be off on inherent protection. Cancel any calls for cooling and wait for the internal overload to reset. Test again when cool.
4. If M1 is not pulled in, check for 24 volts at the M1 coil. If 24 volts is present and M1 is not pulled in, replace the contactor.
5. Failing the above, if voltage is supplied at M1, M1 is pulled in, and the compressor still does not operate, replace the compressor.
6. If 24 volts is not present at M1, check for 24 volts at the UCB terminal, C1. If 24 volts is present, check for loose wiring between C1 and the compressor contactor.
7. If 24 volts is not present at the C1 terminal, check for 24 volts from the room thermostat at the UCB Y1 terminal. If 24 volts are not present at the UCB Y1 terminal, the UCB may have faulted. Check for 24 volts at the Y1 "ECON" terminal. If 24 volts is not present at Y1 "ECON", the UCB has faulted. The UCB should de-energize all compressors on a loss of call for the first stage of cooling, i.e. a loss if 24 volts at the Y1 terminal.
8. If 24 volts are present at the UCB Y1 terminal, the compressor may be out due to an open high-pressure switch, low-pressure switch, or freezestat. Check for 24 volts at the HPS1, LPS1, and FS1 terminals of the UCB. If a switch has opened, there should be a voltage potential between the UCB terminals, e.g. if LPS1 has opened, there will be a 24-volt potential between the LPS1 terminals.
9. If 24 volts is present at the UCB Y1 terminal and none of the protection switches have opened, the UCB may have locked out the compressor for repeat trips. The UCB should be flashing a code. If not, press and release the ALARMS button on the UCB. The UCB will flash the last five alarms on the LED. If the compressor is locked out, remove any call for cooling. This will reset any compressor lock outs.

NOTE: While the above step will reset any lock outs, compressor #2 will be held off for the ASCD, and compressor #1 may be held off for a portion of the ASCD. See the next step.

10. If 24 volts is present at the UCB Y1 terminal and none of the switches are open and the compressor is not locked out, the UCB may have the compressor in an ASCD. Check the LED for an indication of an ASCD cycle. The ASCD should time out within 5 minutes. Press and release the TEST button to reset all ASCDs.

11. If 24 volts is present at the UCB Y1 terminal and the compressor is not out due to a protective switch trip, repeat trip lock out, or ASCD, the economizer terminals of the UCB may be improperly wired. Check for 24 volts at the Y1 "OUT" terminal of the UCB. If 24 volts is present, trace the wiring from Y1 "OUT" for incorrect wiring. If 24 volts is not present at the Y1 "OUT" terminal, the UCB must be replaced.

12. *For units without economizers:* If 24 volts is present at the Y1 "OUT" terminal, check for 24 volts at the Y1 "ECON" terminal. If 24 volts is not present, check for loose wiring from the Y1 "OUT" terminal to the Mate-N-Lock plug, the jumper in the Mate-N-Lock plug, and in the wiring from the Mate-N-Lock plug to the Y1 "ECON" terminal.

For units with economizers: If 24 volts is present at the Y1 "OUT" terminal, check for 24 volts at the Y1 "ECON" terminal. If 24 volts is not present, check for loose wiring from the Y1 "OUT" terminal to the Mate-N-Lock plug, a poor connection between the UCB and economizer Mate-N-Lock plugs, loose wiring from the Mate-N-Lock plug to the economizer, back to the Mate-N-Lock plug, and from the Mate-N-Lock plug to the Y1 "ECON" terminal. The economizer control may have faulted and is not returning the 24 volts to the Y1 "ECON" terminal even though the economizer is not providing free cooling. To test the economizer control, disconnect the Mate-N-Locks and jumper between the WHITE and YELLOW wires of the UCB's Mate-N-Lock plug.

13. The UCB can be programmed to lock out compressor operation during free cooling and in low ambient conditions. These options are not enabled by default. They can be checked by local distributors.

For units with factory installed economizers, the UCB is programmed to lock out compressor operation when the LAS set point is reached.

For units without factory installed or with field installed economizers, the UCB allows compressor operation all the time. This programming can be checked or changed by the local distributor.

14. If none of the above corrected the error, test the integrity of the UCB. Disconnect the C1 terminal wire and jumper it to the Y1 terminal. DO NOT jump the Y1 to C1 terminals. If the compressor engages, the UCB has faulted.

15. If none of the above correct the error, replace the UCB.

GAS HEAT TROUBLESHOOTING GUIDE

On calls for heating, the draft motor operates and the furnace lights but the supply air blower motor does not energize after a short delay (the room thermostat fan switch is in "AUTO" position).

WARNING

The furnace may shut down on a high temperature condition during the procedure. If this occurs, the UCB energize the supply air blower motor until the high temperature limit has reset. Caution should be used at all times as the supply air blower may energize regardless of the room thermostat fan switch position.

1. Place the thermostat fan switch in the "ON" position. If the supply air blower motor energizes, go to Step 9.
2. If the supply air blower motor does not energize when the fan switch is set to "ON," check that line voltage is being supplied to the contacts of the M3 contactor, and that the contactor is pulled in. Check for loose wiring between the contactor and the supply air blower motor.
3. If M3 is pulled in and voltage is supplied at M3, lightly touch the supply air blower motor housing. If it is hot, the motor may be off on inherent protection. Cancel any thermostat calls and set the fan switch to "AUTO", wait for the internal overload to reset. Test again when cool.
4. If M3 is not pulled in, check for 24 volts at the M3 coil. If 24 volts is present at M3 but M3 is not pulled in, replace the contactor.
5. Failing the above, if there is line voltage supplied at M3, M3 is pulled in, and the supply air blower motor still does not operate, replace the motor.
6. If 24 volts is not present at M3, check that 24 volts is present at the supply air blower motor terminal on the UCB. If 24 volts is present at the UCB terminal, check for loose wiring between the UCB and M3.
 - a. If 24 volts is not present at the UCB supply air blower motor terminal, check for 24 volts from the room thermostat. If 24 volts is not present from the room thermostat, check for the following:
 - i. Proper operation of the room thermostat (contact between R and G with the fan switch in the "ON" position and in the "AUTO" position during operation calls)
 - ii. Proper wiring between the room thermostat and the UCB, and
 - iii. Loose wiring from the room thermostat to the UCB
7. If 24 volts is present at the room thermostat but not at the UCB, check for proper wiring between the thermostat and the UCB, i.e. that the thermostat G terminal is connected to the G terminal of the UCB, and for loose wiring.
8. If the thermostat and UCB are properly wired, replace the UCB.

9. If the blower motor runs with the fan switch in the "ON" position but does not run shortly after the furnace has ignited when the fan switch is in the "AUTO" position, check the room thermostat for contact between R and G during "W1" calls.

On calls for heating, the supply air blower operates but the draft motor does not (the room thermostat fan switch is in the "AUTO" position).

1. The draft motor has inherent protection. If the motor shell is hot to the touch, wait for the internal overload to reset.
2. If the motor shell is cold with the room thermostat calling for heat, check for line voltage at the motor leads. If line voltage is present, replace the draft motor.
3. If line voltage is not present, check for line voltage on the ignition control at the "inducer" terminal draft motor relay (DMR or DMC) contacts in the main control box and check to see if the (DMR or DMC) is pulled in.

The draft motor runs but the furnace does not light and the spark ignitor does not spark.

1. Check for 24 volts at the spark ignitor from the ignition control board (ICB). Check the 24-volt wiring from the ICB to the spark ignitor. Check for 24 volts at the ICB spark ignitor terminal.
2. Check the ground wiring for the ICB and the gas valve is intact and making good electrical connection. Check the ceramic insulator on the spark ignitor for breaks or cracks. Replace the spark ignitor if damaged.
3. With the draft motor running, check for 24 volts at the pressure switch terminal on the ICB. If not present, check for 24 volts on the terminal from the pressure switch. If present, go to step 4. If 24 volts is not present,

the either pressure or rollout switch is not closed. Or the draft motor is not sufficiently evacuating the heat exchanger tubes or the pressure switch has failed. Check the operation of the pressure switch. Check the line voltage to the unit; if line voltage is low, call the local power company. If the problem persists, the draft motor may need replacement.

4. If the furnace is hot, it may be out on a high temperature limit open; wait for limit reset.
5. If all are intact replace the ICB.

The draft motor runs and the spark ignitor sparks at the burner, but the burner does not ignite and a gas odor is not detected at the draft motor outlet.

1. Check to ensure gas is being supplied to the unit. Confirm that the gas pressure to the unit is within the proper limits as described in the "POST START CHECKLIST".
2. Check the voltage at the gas valve and at the gas valve terminals on the ICB. Check all wiring between the ICB and the gas valve. Check to make sure the ground connections are intact.
3. If 24 volts is present, remove the pilot burner and the orifice. The removal procedure is described in "BURNER/ORIFICE INSPECTION/SERVICING." Inspect the orifice for obstruction. If it is clear, replace the gas valve.

Main burners light but exhibit erratic flame characteristics.

1. Check the main burner orifices for obstruction and alignment. The removal procedure is described in "BURNER/ORIFICE INSPECTION/SERVICING". Clean or replace burner orifices and burners as needed.

