

Bosch Integrus

Data Brochure



BOSCH
Invented for life



Table of Contents

Introduction	1
System Description and Planning	5
System Specification	15
Transmitters and Interface Modules	17
INT-TX Transmitters	17
INT-TXK Transmitter Upgrade Kits	19
LBB 3422/20 Symmetrical Audio Input and Interpreter Module	20
DCN-FCCCU Flight Case for 2 Central Control Units	21
Infra-red Radiators	23
LBB 451x/00 Infra-red Radiators	23
INT-FCRAD Flight Case for Radiator	25
LBB 3414/00 Wall Mounting Bracket	25
LBC 1259/00 Universal Floorstand	26
LBB 3410/05 Infra-red Radiator	28
Infra-red Receivers, Charging Units and Accessories	29
LBB 4540 Pocket Receivers	29
LBB 4550/00 NiMH Battery Pack	30
LBB 4560 Charging Units	31
INT-FCRX Storage Case	32
Headphones	33
LBB 3441/10 Under the Chin Headphones	33
LBB 3442/00 Single Earphone	33
LBB 3443 Lightweight Headphones	34
LBB 3015/04 High Quality Dynamic Headphones	35
HDP-ILN Induction Loop Neckband	35
Interpreter Desk and Accessories	37
LBB 3222/04 Interpreter Desk	37
LBB 3306 Extension Cables	38
LBB 9095/30 Interpreter Headphones	38

Introduction



Simultaneous Interpretation

For international conferences with multiple languages, it is obviously of utmost importance that all participants can understand what is being said. That is why a system which enables interpreters to simultaneously interpret the speaker's language is almost indispensable. The interpretations created are then distributed throughout the conference venue, so delegates can select their language of choice and listen to it through headphones.

Infra-Red Distribution

The most effective method of distributing the interpretations is by using an infra-red language distribution system. Infra-red means wireless, so delegates have total freedom of movement. It means information integrity, because distributed signals cannot pass beyond the conference hall. And now, with the Bosch Integrus system, it means better than ever audio quality, with no interference from hall lighting.

In simple terms, an infra-red distribution system consists of a transmitter, one or more radiators and a number of receivers. Various accessories are also available, such as headphones, cables and battery chargers.

The transmitter is the central element in the Integrus system. It accepts inputs from either analog or digital sources, modulates these signals on to carrier waves, then transmits the waves to infra-red radiators located elsewhere in the room. The transmitter accommodates special interface modules to ensure compatibility with these external signal sources. Depending on the transmitter model, up to 32 separate channels can be transmitted simultaneously.

The output of the infra-red radiators is intensity-modulated infra-red radiation. Each delegate is supplied with a pocket receiver, which has a lens to collect the infra-red signal and direct it to a sensor. These signals are then decoded back into interpretation languages, which are chosen by delegates using a channel selector and passed to the delegate's headphones.

Advanced Digital Technology

The Integrus language distribution system incorporates unique, specially-developed Bosch Ir-Digital technology that is characterized by a number of features:

- The Integrus conforms to IEC 61603, part 7. This is the industry standard for digital infra-red transmission for language distribution

- The use of the 2-8 MHz frequency band eliminates disturbance from all types of lighting systems
- Error correction by means of a Reed Solomon coder, plus the bit error rate threshold, ensures a high audio quality
- The digital transmission protocol used allows additional information to be sent (e.g. synchronization of the number of channels in use)
- The application of digital technology results in a very high sound quality with a signal/noise ratio of 80 dB

Some of the advantages of this new technology are described in more detail below.

Characteristics of Infra-red Distribution

Infra-red radiation is an ideal medium for audio distribution. It is invisible to the human eye and can carry multiple channels, each with a separate language, over relatively large distances. And, above all, it is a wireless distribution system, so conference participants can receive interpretations without being physically connected to the system.

Freedom of Movement for Delegates

With an infra-red system, delegates have great freedom in movement throughout the conference room. As the interpretations are transmitted through the air, there is no physical connection to the system, so the only limitations are the walls of the venue itself. The receivers used by delegates to pick up interpretations are lightweight, portable and unobtrusive, and can be easily slipped into a shirt or jacket pocket.



Conference Hall Privacy

Conferences can often involve discussion of sensitive information, where it is important that any audio distribution does not compromise security. As infra-red radiation is unable to pass through opaque structures such as walls, the congress venue itself acts as a barrier to infra-red radiation escaping and being overheard.



Language Distribution in Adjacent Halls

Infra-red systems are ideally-suited for conference centers with a number of separate halls. Since walls are opaque to infra-red radiation, there is no interference between separate conferences.

No Interference from Lighting Systems

One of the limitations of traditional infra-red language distribution systems was interference from lighting. The problem was particularly acute with newer (fluorescent) lighting systems, which operate at higher frequencies and therefore cause more interference. The Integrus system has completely solved this problem by using a much higher frequency band – 2 to 8 MHz – for audio distribution.

Freedom from interference from all types of venue lighting brings two major advantages: audio quality is greatly improved, and systems can be used much more easily on a rental basis, because they will be compatible with all types of venue lighting.



Distorted reception (left) with other language distribution systems, and perfect reception (right) with Bosch Integrus system

Audio Quality

The Integrus system offers greatly improved audio quality. Better compression techniques and a higher signal-to-noise ratio means that the received signal is much clearer, and, as mentioned above, there is no interference from lighting systems. Greater intelligibility makes the system less tiring to use over extended periods. Delegates can therefore maintain their concentration more easily during a long conference session.

Number of Channels

The Integrus gives the user real flexibility in choosing the number of required channels. By using a much higher frequency band (2 to 8 MHz) it offers four quality modes:

- Standard-quality mono (for interpretations). Four channels of this quality can be incorporated in a single carrier signal
- Standard quality stereo (for reproduction of music or presentations). Two channels of this quality can be incorporated in a single carrier signal
- Premium-quality mono (with double the bandwidth). Two channels of this quality can be incorporated in a single carrier signal
- Premium-quality stereo (for excellent reproduction of music or presentations). One channel of this quality can be incorporated in a single carrier signal

The Integrus can therefore provide a maximum of 32 standard-quality audio channels (which means up to 31 different interpretations + the floor), more than enough to accommodate even the largest international conferences. It can also be configured for high quality stereo sound, with up to eight different channels available for applications like multimedia presentations or music distribution. Combinations of standard- and premium-quality configuration are also possible.

User-Friendly Channel Selection

The Integrus receivers offer the user the exact amount of channels available. This eliminates having to scroll through unused channels before reaching the required signal. All receivers in the system automatically update themselves if the number of available channels changes.

Installation and Maintenance of the System

The Integrus system is easy to install (installation time is largely determined by the time required to position and align the radiators.) Connection of the transmitters is straightforward and quick. The transmitter has slots for modules that enable interfacing with digital or analogue conference systems. All information regarding installation, configuration and system status is given on the transmitter front-panel display. The display also shows the menu, which allows all system parameters to be set or altered. One easy-to-use button is all that is required to select all menu options.

Circuitry in the transmitter and matching circuitry in the radiators allows effective monitoring of the infra-red radiator function. The status of the radiators is indicated on the transmitter display and by LEDs on each radiator. The system is also easy to maintain. Maintenance of the receivers generally involves recharging or replacing the batteries they use.

Once installed, the system can easily be extended to accommodate more conference delegates, simply by adding the required number of extra receivers. The basic system structure will remain the same.

Testing Coverage

The Integrus receivers have an ingenious feature, which allows installers to test the coverage of infra-red radiators without the need for measuring equipment. Simply by walking throughout the venue holding a receiver in measuring mode, it is possible to check the coverage at every point. This makes it easy to see whether extra radiators are required or if the positioning of existing ones should be altered.

Integrated Charging Electronics

A breakthrough in technology has made receiver charging more reliable than ever. The process is regulated from the Integrus system IC, although each receiver now has integrated electronics to allow it to manage its own charging process. This ensures optimum charging performance and maximum battery lifetime.

Room Coupling

For distributing interpretations to multiple rooms, the Integrus transmitter has a master/slave operation mode. This means that separate (slave) transmitters can be located in the other rooms, providing exactly the same functionality as the master transmitter and providing local outputs for radiators. This removes the need to connect the radiators required for the additional rooms to one transmitter, which cuts the amount of wiring required and eliminates the risk of capacity overload.

Emergency or Auxiliary Input

To provide delegates with an additional degree of safety and security, the infra-red transmitter unit includes an additional auxiliary input which overrides all active audio channels. This auxiliary input allows the immediate distribution of emergency messages to all active channels. The auxiliary input may also be used for the distribution of music or other information.

Complete Integration

Integrus integrates seamlessly with the DCN Next Generation and DCN Wireless using an optical network for a maximum 31 different languages, plus floor. Use Integrus with CCS 800 Ultro and the analog 6-channel interpreter desk for perfect reception at smaller meetings. Or easily interface with virtually any other brand of congress system.

For more information, see the relevant data brochures.



Music Distribution and Hearing Assistance

The Integrus offers more than just language (interpretation) distribution. Its flexibility and high audio quality also make it suitable for:

- Music distribution. In places as diverse as fitness centers and factories, it can provide a choice of music for listeners in locations throughout the premises
- High-quality audio distribution. Multi-lingual cinemas can offer different language soundtracks in the same hall
- Hearing assistance. Helps the hard-of-hearing in places like theatres and other public buildings
- Concert halls and live theaters can distribute the amplified sound in high quality to the musicians on stage without interference or risk of feedback
- Distribution of instructions. TV studios can use the system to distribute instructions from the control gallery to the camera men without RF interference
- Tour guide. Canal boats and museums can offer their customers the tour information in their own language with high audio quality
- Provides musicians on stage the audio they require for their performance
- Interpretation schools. Distribution of the floor and the interpretation on respectively the left and right channel for simultaneous listening to the floor and the selected interpretation

System Description and Planning

System overview

Integrus is a system for wireless distribution of audio signals via infra-red radiation. It can be used in a simultaneous interpretation system for international conferences where multiple languages are used. To enable all participants to understand the proceedings, interpreters simultaneously translate the speaker's language as required. These interpretations are distributed throughout the conference venue, and delegates select the language of their choice and listen to it through headphones.

The Integrus system can also be used for music distribution (mono as well as stereo).

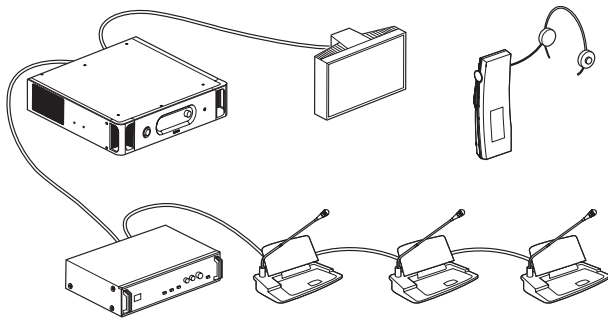

Figure 1: Integrus system overview (with DCN system as input)

The Integrus Digital Infra-red Language Distribution System comprises one or more of the following:

Infra-red transmitter

The transmitter is the core of the Integrus system. Four types are available:

- INT-TX04 with inputs for 4 audio channels
- INT-TX08 with inputs for 8 audio channels
- INT-TX16 with inputs for 16 audio channels
- INT-TX32 with inputs for 32 audio channels

Interface module

An LBB 3422/20 Symmetrical Audio Input and Interpreter Module to connect to analogue discussion and conference systems (such as CCS 800), or to LBB 3222/04 6-channel interpreters desks.

Infra-red radiators

Three types of radiators available:

- LBB 3410/05 wide beam radiator for small conference venues
- LBB 4511/00 medium-power radiator for small / medium conference venues
- LBB 4512/00 high-power radiator for medium/large conference venues

All three types can be switched between full and half power use. They can be mounted on walls, ceilings or floor stands.

Infra-red receivers

Three multi-channel infra-red receivers are available:

- LBB 4540/04 for 4 audio channels
- LBB 4540/08 for 8 audio channels
- LBB 4540/32 for 32 audio channels

They can operate with a rechargeable NiMH battery pack or with disposable batteries. Charging circuitry is incorporated in the receiver.

Charging equipment

Equipment is available for charging and storing 56 infra-red receivers. It is available for portable or fixed-installation applications.

System technology

IR radiation

The Integrus system is based on transmission by modulated infra-red radiation. Infra-red radiation forms part of the electro-magnetic spectrum, which is composed of visible light, radio waves and other types of radiation. It has a wavelength just above that of visible light. Like visible light, it is reflected from hard surfaces, yet passes through translucent materials such as glass. The infra-red radiation in relation to other relevant spectra is shown in figure 2

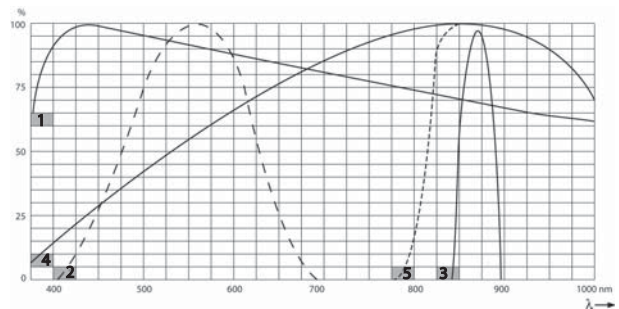

Figure 2: Infra-red radiation spectrum in relation to other spectra

(1) Daylight spectrum

(2) Sensitivity of the human eye

(3) IR radiator

(4) Sensitivity of the IR sensor

(5) Sensitivity of the IR sensor with daylight filter

Signal Processing

The Integrus system uses high frequency carrier signals (typically 2 to 8 MHz) to prevent interference problems with modern light sources (see section 'Ambient Lighting'). The digital audio processing guarantees a constant high audio quality.

The signal processing in the transmitter consists of the following main steps (see figure 3):

1. **A/D conversion** - Each analogue audio channel is converted to a digital signal.
2. **Compression** - The digital signals are compressed to increase the amount of information that can be distributed on each carrier. The compression factor is also related to the required audio quality.

3. **Protocol Creation** - Groups of up to four digital signals are combined into a digital information stream. Extra fault algorithm information is added. This information is used by the receivers for fault detection and correction.
4. **Modulation** - A high frequency carrier signal is phase modulated with the digital information stream.
5. **Radiation** - Up to 8 modulated carrier signals are combined and sent to the IR radiators, which convert the carrier signals to modulated infra-red light.

In the IR receivers a reverse processing is used to convert the modulated infra-red light to separate analogue audio channels.

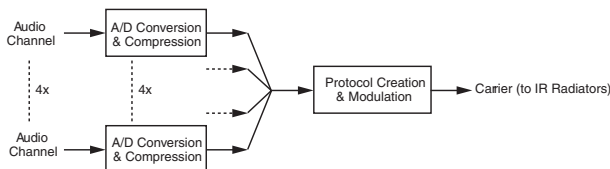

Figure 3: Overview of the signal processing (for one carrier)

Quality modes

The Integrus system can transmit audio in four different quality modes:

- Mono, standard quality, maximum 32 channels
- Mono, premium quality, maximum 16 channels
- Stereo, standard quality, maximum 16 channels
- Stereo, premium quality, maximum 8 channels

The standard quality mode uses less bandwidth and can be used for transmitting speech. For music the premium quality mode gives near CD quality.

Carriers and channels

The Integrus system can transmit up to 8 different carrier signals (depending on the transmitter type). Each carrier can contain up to 4 different audio channels. The maximum number of channels per carrier is dependent on the selected quality modes. Stereo signals use twice as much bandwidth as a mono signals, premium quality uses twice as much bandwidth as standard quality.

Per carrier a mix of channels with different quality modes is possible, as long as the total available bandwidth is not exceeded. The table below lists all possible channel combinations per carrier:

Channel Quality				
Mono Standard	Mono Premium	Stereo Standard	Stereo Premium	Bandwidth
4				4 x 10 kHz
2	1			2 x 10 kHz and 1 x 10 kHz
2		1		2 x 10 kHz and 1 x 10 kHz (left) and 1 x 10 kHz (right)
	1	1		1 x 20 kHz and 1 x 10 kHz (left) and 1 x 10 kHz (right)
		2		2 x 20 kHz (left) and 2 x 10 kHz (right)
	2			2 x 20 kHz
			1	1 x 20 kHz (left) and 1 x 10 kHz (right)

Aspects of infra-red distribution systems

A good infra-red distribution system ensures that all delegates in a conference venue receive the distributed signals without disturbance. This is achieved by using enough radiators, placed at well planned positions, so that the conference venue is covered with uniform IR-radiation of adequate strength.

There are several aspects that influence the uniformity and quality of the infra-red signal, which must be considered when planning an infra-red radiation distribution system. These are discussed in the next sections.

Directional sensitivity of the receiver

The sensitivity of a receiver is at its best when it is aimed directly towards a radiator. The axis of maximum sensitivity is tilted upwards at an angle of 45 degrees (see figure 4). Rotating the receiver will decrease the sensitivity.

For rotations of less than +/- 45 degrees this effect is not large, but for larger rotations the sensitivity will decrease rapidly.

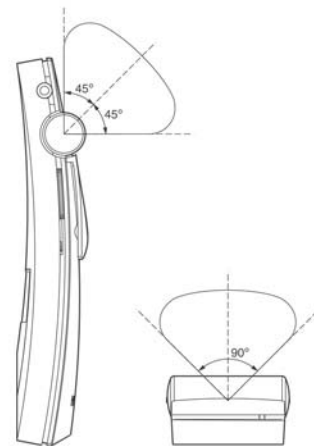

Figure 4: Directional characteristics of the receivers

The footprint of the radiator

The coverage area of a radiator depends on the number of transmitted carriers and the output power of the radiator. The coverage area of the LBB 4512/00 radiator is twice as large as the coverage area of the LBB 4511/00. The coverage area can also be doubled by mounting two radiators side by side. The total radiation energy of a radiator is distributed over the transmitted carriers.

When more carriers are used, the coverage area gets proportionally smaller. The receiver requires a strength of the IR signal of 4 mW/m2 per carrier to work without errors (resulting in a 80 dB S/N ratio for the audio channels).

The effect of the number of carriers on the coverage area can be seen in figure 5 and figure 6. The radiation pattern is the area within which the radiation intensity is at least the minimum required signal strength.

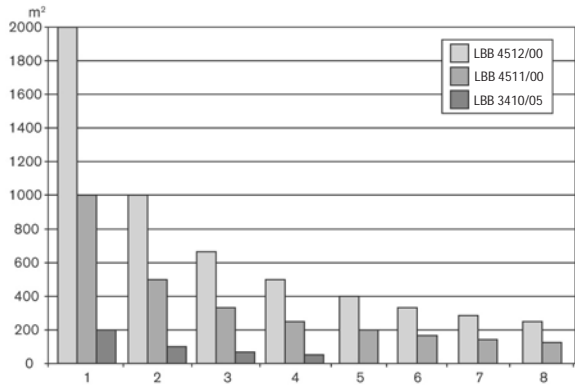

Figure 5: Total coverage area of LBB 4511/00, LBB 4512/00 and LBB 3410/05 for 1 to 8 carriers

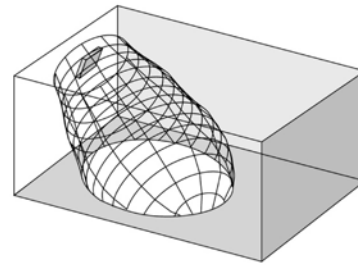

Figure 8: The radiator mounted at 45° to the ceiling

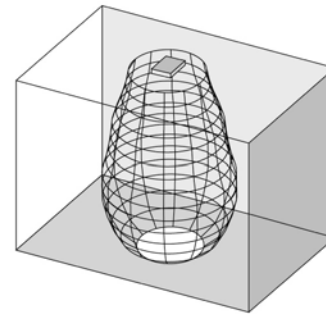

Figure 9: The radiator mounted perpendicular (at 90°) to the ceiling

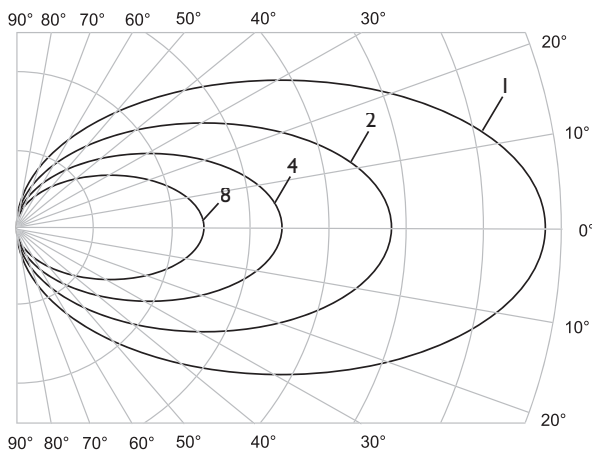

Figure 6: Polar diagram of the radiation pattern for 1, 2, 4 and 8 carriers

The cross section of the 3-dimensional radiation pattern with the floor of the conference venue is known as the footprint (the white area in figure 7 to figure 9). This is the floor area in which the direct signal is strong enough to ensure proper reception, when the receiver is directed towards the radiator. As shown, the size and position of the footprint depends on the mounting height and angle of the radiator.

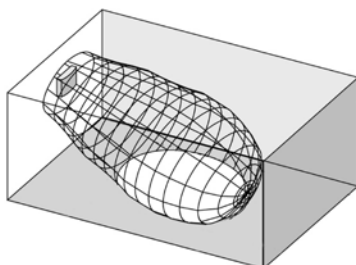

Figure 7: The radiator mounted at 15° to the ceiling

Ambient lighting

The Integrus system is practically immune for the effect of ambient lighting. Fluorescent lamps (with or without electronic ballast or dimming facility), such as TL lamps or energy saving lamps give no problems with the Integrus system. Also sunlight and artificial lighting with incandescent or halogen lamps up to 1000 lux give no problems with the Integrus system. When high levels of artificial lighting with incandescent or halogen lamps, such as spotlights or stage lighting are applied, you should directly point a radiator at the receivers in order to ensure reliable transmission. For venues containing large, unscreened windows, you must plan on using additional radiators. For events taking place in the open air a site test will be required in order to determine the required amount of radiators. With sufficient radiators installed, the receivers will work without errors, even in bright sunlight.

Objects, surfaces and reflections

The presence of objects in a conference venue can influence the distribution of infra-red light. The texture and color of the objects, walls and ceilings also plays an important role.

Infra-red radiation is reflected from almost all surfaces. As is the case with visible light, smooth, bright or shiny surfaces reflect well. Dark or rough surfaces absorb large proportions of the infra-red signal (see figure 10). With few exceptions it cannot pass through materials that are opaque to visible light.

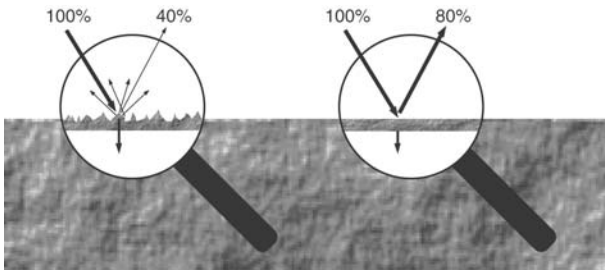

Figure 10: The texture of the material determines how much light is reflected and how much is absorbed

Problems caused by shadows from walls or furniture can be solved by ensuring that there are sufficient radiators and that they are well positioned, so that a strong enough infra-red field is produced over the whole conference area. Care should be taken not to direct radiators towards uncovered windows, as most of this radiation will subsequently be lost.

Positioning the radiators

Since infra-red radiation can reach a receiver directly and/or via diffused reflections, it is important to take this into account when considering the positioning of the radiators. Though it is best if receivers pick up direct path infra-red radiation, reflections improve the signal reception and should therefore not be minimized. Radiators should be positioned high enough not to be blocked by people in the hall (see figures 11 and 12).

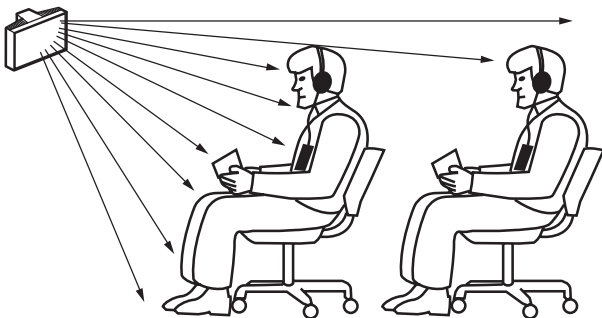

Figure 11: Infra-red signal blocked by a person in front of the participant

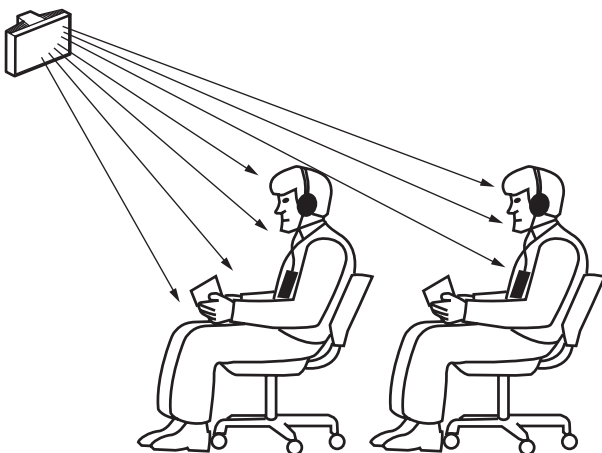

Figure 12: Infra-red signal not blocked by a person in front of the participant

The figures below illustrate how infra-red radiation can be directed to conference participants. In figure 13, the participant is situated clear from obstacles and walls, so a combination of direct and diffused radiation can be received. Figure 14 shows the signal being reflected from a number of surfaces to the participant.

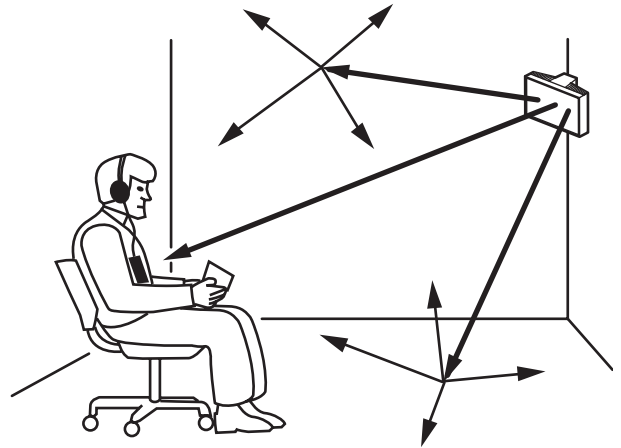

Figure 13: Combination of direct and reflected radiation

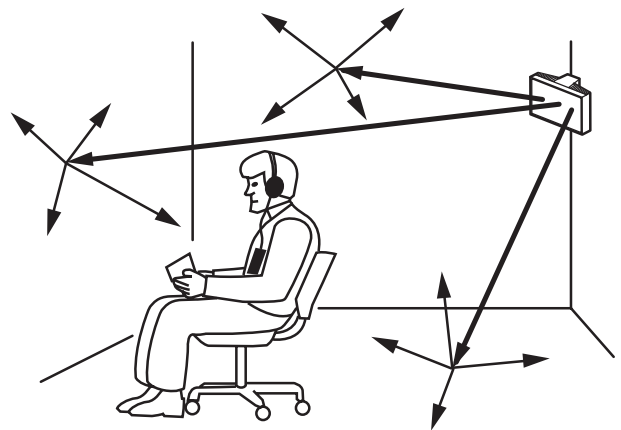

Figure 14: Combination of several reflected signals

For concentrically arranged conference rooms, centrally placed, angled radiators located high up can cover the area very efficiently. In rooms with few or no reflecting surfaces, such as a darkened film-projection room, the audience should be covered by direct path infra-red radiation from radiators positioned in front. When the direction of the receiver changes, e.g. with varying seat arrangements, mount the radiators in the corners of the room (see figure 15).

If the audience is always directed towards the radiators, you do not need radiators at the back (see figure 16). If the path of the infra-red signals is partially blocked, e.g. under balconies, you should cover the 'shaded' area with an additional radiator (see figure 17).

The figures below illustrate the most effective positioning of the radiators:

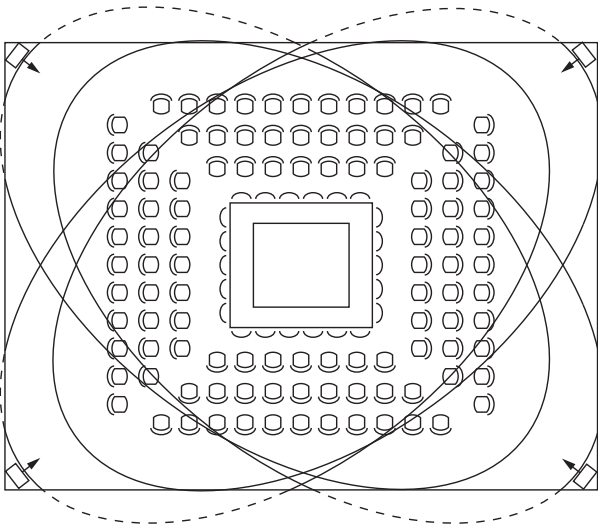

Figure 15: Radiators covering seats arranged in a square

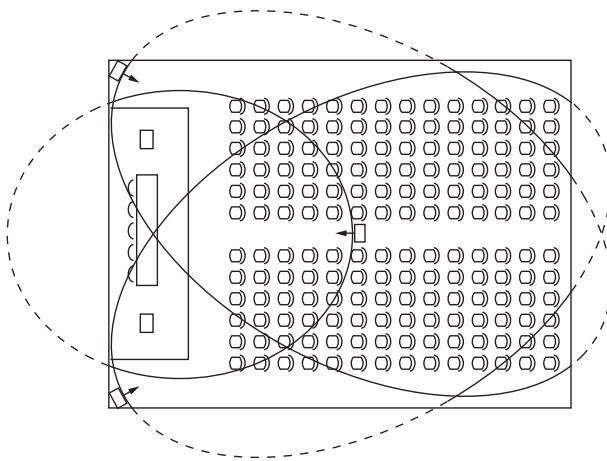

Figure 16: Radiator position in a conference hall with auditorium seating and podium

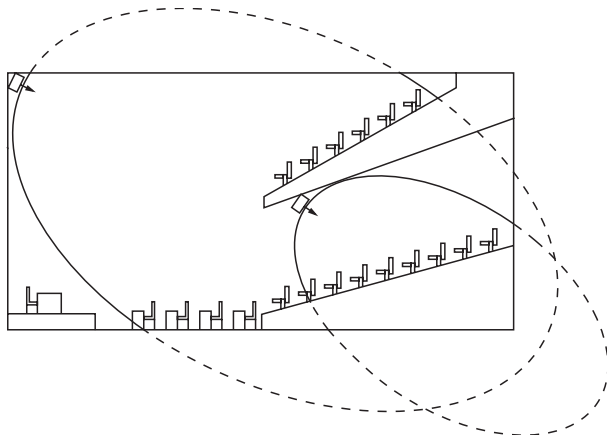

Figure 17: Radiators covering seats beneath a balcony

Overlapping footprints and multipath effects

When the footprints of two radiators partly overlap, the total coverage area can be larger than the sum of the two separate footprints. In the overlap area the signal radiation power of two radiators are added, which increases the area where the radiation intensity is larger than the required intensity.

However, differences in the delays of the signals picked up by the receiver from two or more radiators can cause the signals to cancel each other out (multi path effect). In worst-case situations this can lead to a loss of reception at such positions (black spots). Figures 18 and 19 show the effect of overlapping footprints and differences in signal delays.

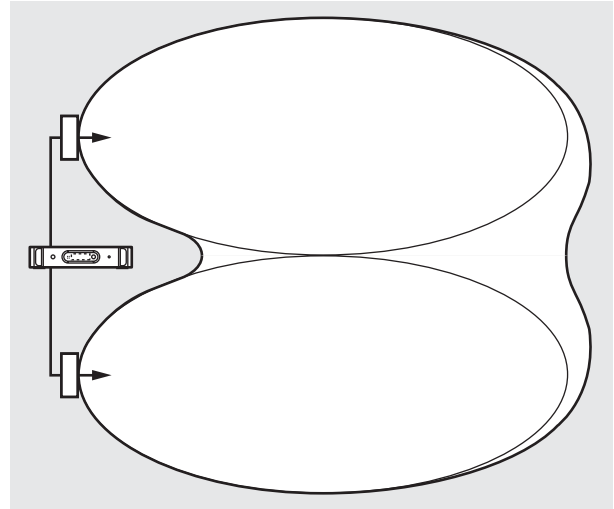

Figure 18: Increased coverage from added radiation power

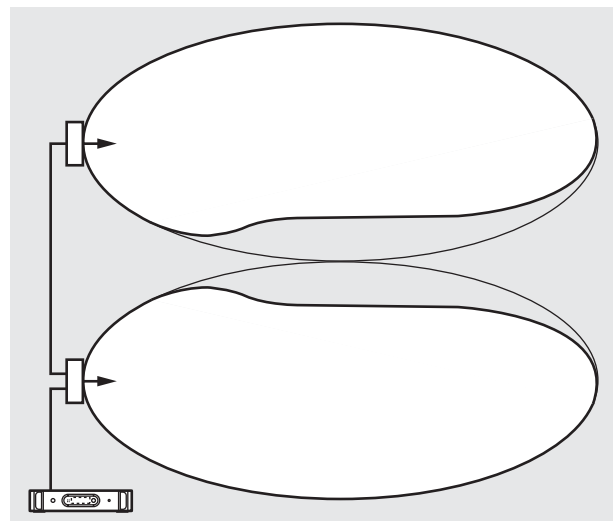

Figure 19: Reduced coverage caused by cable signal delay differences

The lower the carrier frequency, the less susceptible the receiver is for differences in signal delays.

The signal delays can be compensated by using the delay compensation switches on the radiators (see manual).

Planning an Integrus infra-red radiation system

Rectangular footprints

Determining the optimal number of infra-red radiators required to give 100% coverage of a hall can normally only be done by performing a site test. However, a good estimation can be made by using 'guaranteed rectangular footprints'. Figures 20 and 21 show what is meant by a rectangular footprint. As can be seen, the rectangular footprint is smaller than the total footprint. Note that in figure 21 the 'offset' X is negative because the radiator is actually mounted beyond the horizontal point at which the rectangular footprint starts.

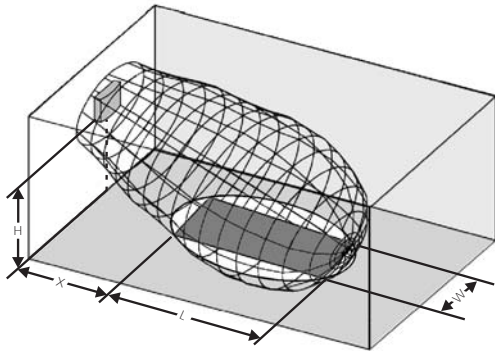

Figure 20: Typical rectangular footprint for a 15° mounting angle

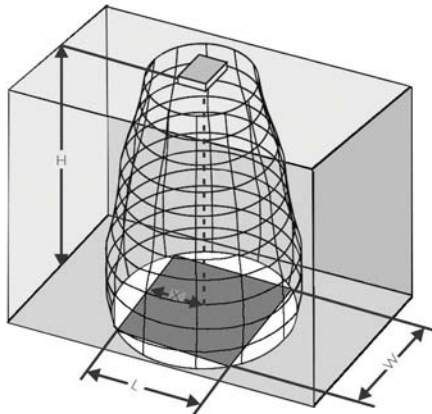

Figure 21: Typical rectangular footprint for a 90° mounting angle

The guaranteed rectangular footprints for various numbers of carriers, mounting heights and mounting angles can be found in the section 'Guaranteed rectangular footprints'. The height is the distance from the reception plane and not from the floor.

Guaranteed rectangular footprints can also be calculated with the footprint calculation tool (available on the documentation CD-ROM). The given values are for one radiator only, and therefore do not take into consideration the beneficial effects of overlapping footprints. The beneficial effects of reflections are also not included.

Generally (for systems with up to 4 carriers) if the receiver can pick up the signal of two adjacent radiators, the distance between these radiators can be increased approximately by a factor 2.4 (see figure 22).

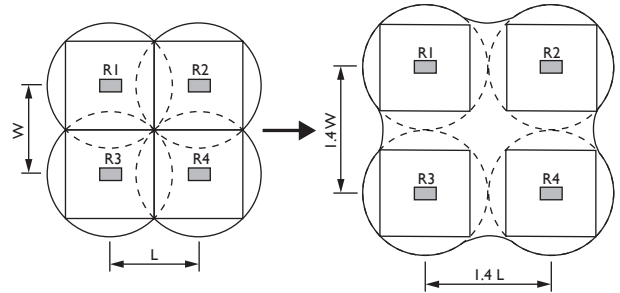

Figure 22: The effect of overlapping footprints

Planning radiators

Use the following procedure to plan the radiators:

1. Follow the recommendations in section 'Aspects of infra-red distribution systems' to determine the radiator positions.
2. Look up (in the table) or calculate (with the footprint calculation tool) the applicable rectangular footprints.
3. Draw the rectangular footprints in the room lay-out.
4. If the receiver can pick up the signal of two adjacent radiators in some areas, determine the overlap effect and draw the footprint enlargement(s) in the room lay-out.
5. Check if you have sufficient coverage with the radiators at the intended positions. If not, add additional radiators to the room.

See figures 15, 16 and 17 for examples of a radiator lay-out.

Cabling

Signal delay differences can occur due to differences in the cable length from the transmitter to each radiator. To minimize the risk of black spots use equal cable length from transmitter to radiator if possible (see figure 23).

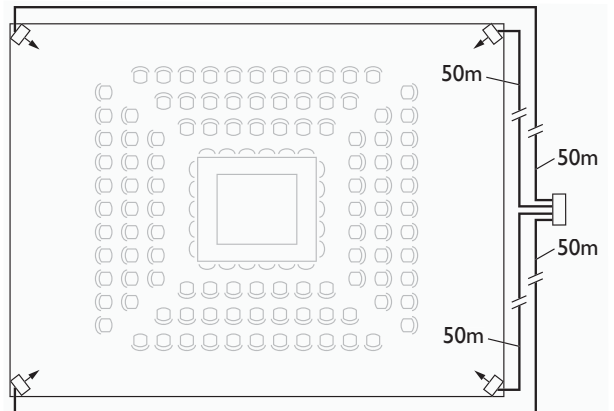

Figure 23: Radiators with equal cable length

When radiators are loop-through connected, the cabling between each radiator and the transmitter should be as symmetrical as possible (see figures 24 and 25). The differences in cable signal delays can be compensated with the signal delay compensation switches on the radiators.

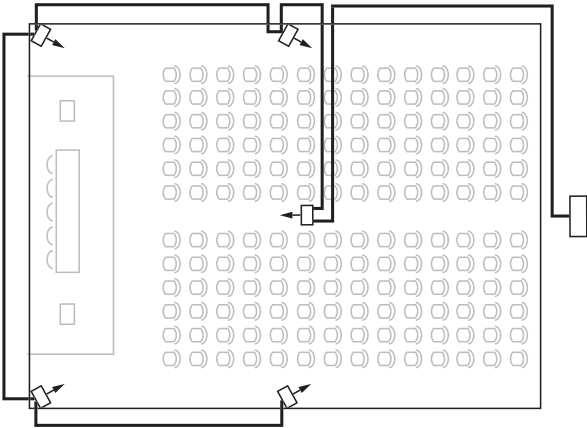

Figure 24: Asymmetrical radiator cabling (to be avoided)

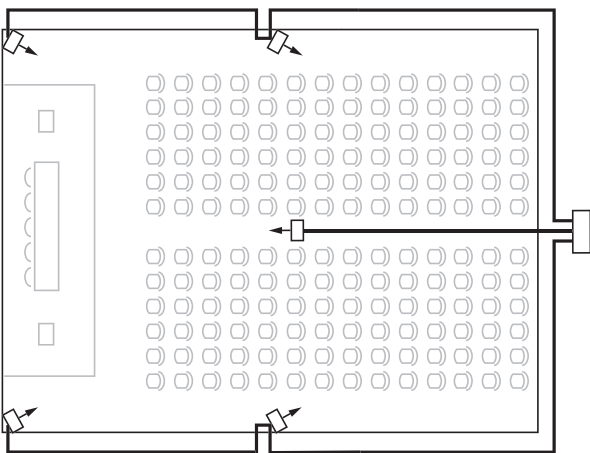

Figure 25: Symmetrical radiator cabling (recommended)

number of carriers	mounting height [m]	mounting angle [degrees]	LBB 3410/05 at full power				LBB 4511/00 at full power				LBB 4512/00 at full power				
			area A [m ²]	length L [m]	width W [m]	offset X [m]	area A [m ²]	length L [m]	width W [m]	offset X [m]	area A [m ²]	length L [m]	width W [m]	offset X [m]	
1	2.5	0	130	13	10	4	627	33	19	7	1269	47	27	10	
	5	15	130	13	10	4	620	31	20	7	1196	46	26	8	
		30	140	14	10	3	468	26	18	4	816	34	24	6	
		45	120	12	10	3	288	18	16	2	480	24	20	2	
		60	100	10	10	1	196	14	14	0	324	18	18	0	
		90	56	7	8	-4	144	12	12	-6	196	14	14	-7	
	10	15	72	9	8	7	589	31	19	9	1288	46	28	10	
		30	90	9	10	4	551	29	19	5	988	38	26	6	
		45	90	9	10	4	414	23	18	2	672	28	24	2	
		60	108	12	9	0	306	18	17	-1	506	23	22	-1	
		90	80	8	10	-5	256	16	16	-8	400	20	20	-10	
	20	30					408	24	17	13	1080	40	27	11	
		45					368	23	16	7	945	35	27	4	
		60					418	22	19	1	754	29	26	-1	
		90					324	18	18	-9	676	26	26	-13	
2	2.5	15	63	9	7	2	308	22	14	4	576	32	18	6	
	5	15	63	9	7	3	322	23	14	5	620	31	20	7	
		30	56	8	7	3	247	19	13	3	468	26	18	4	
		45	49	7	7	1	168	14	12	1	288	18	16	2	
		60	49	7	7	0	132	12	11	-1	196	14	14	0	
		90	42	6	7	-3	100	10	10	-5	144	12	12	-6	
	10	30					266	19	14	6	551	29	19	5	
		45					234	18	13	2	414	23	18	2	
		60	30	5	6	2	195	15	13	-1	306	18	17	-1	
		90	42	6	7	-3	144	12	12	-6	256	16	16	-8	
	20	60					195	15	13	3	418	22	19	1	
		90					196	14	14	-7	324	18	18	-9	
	4	2.5	15	20	5	4	2	160	16	10	3	308	22	14	4
		5	15					144	16	9	4	322	23	14	5
			30					140	14	10	3	247	19	13	3
45							99	11	9	1	168	14	12	1	
60							90	10	9	-1	132	12	11	-1	
90							64	8	8	-4	100	10	10	-5	
10		45					120	12	10	3	234	18	13	2	
		60					108	12	9	0	195	15	13	-1	
		90					100	10	10	-5	144	12	12	-6	
20		90					64	8	8	-4	196	14	14	-7	
8		2.5	15					84	12	7	2	160	16	10	3
		5	15					60	10	6	4	144	16	9	4
			30					70	10	7	3	140	14	10	3
			45					63	9	7	1	99	11	9	1
			60					49	7	7	0	90	10	9	-1
	90						36	6	6	-3	64	8	8	-4	
	10	60					49	7	7	2	108	12	9	0	
		90					49	7	7	-3.5	100	10	10	-5	

Guaranteed rectangular footprints (shown in metric units)

Note: The mounting height is the distance from the reception plane and not from the floor

number of carriers	mounting height [ft]	mounting angle [degrees]	LBB 3410/05 at full power				LBB 4511/00 at full power				LBB 4512/00 at full power				
			area	length	width	offset	area	length	width	offset	area	length	width	offset	
			A [ft ²]	L [ft]	W [ft]	X [ft]	A [ft ²]	L [ft]	W [ft]	X [ft]	A [ft ²]	L [ft]	W [ft]	X [ft]	
1	8	0	1419	43	33	13	6696	108	62	23	13706	154	89	33	
		15	1419	43	33	13	6732	102	66	23	12835	151	85	26	
	16	30	1518	46	33	10	5015	85	59	13	8848	112	79	20	
		45	1287	39	33	10	3068	59	52	7	5214	79	66	7	
		60	1089	33	33	3	2116	46	46	0	3481	59	59	0	
		90	598	23	26	-13	1521	39	39	-20	2116	46	46	-23	
	33	15					6324	102	62	30	13892	151	92	33	
		30	780	30	26	23	5890	95	62	16	10625	125	85	20	
		45	990	30	33	13	4425	75	59	7	7268	92	79	7	
		60	1170	39	30	0	3304	59	56	-3	5400	75	72	-3	
	66	90	858	26	33	-16	2704	52	52	-26	4356	66	66	-33	
		30					4424	79	56	43	11659	131	89	36	
45						3900	75	52	23	10235	115	89	13		
60						4464	72	62	3	8075	95	85	-3		
2	8	15	690	30	23	7	3312	72	46	13	6195	105	59	20	
		30	690	30	23	10	3450	75	46	16	6732	102	66	23	
		45	598	26	23	10	2666	62	43	10	5015	85	59	13	
		60	529	23	23	3	1794	46	39	3	3068	59	52	7	
33	16	90	529	23	23	0	1404	39	36	-3	2116	46	46	0	
		30	460	20	23	-10	1089	33	33	-16	1521	39	39	-20	
		45					2852	62	46	20	5890	95	62	16	
		60					2537	59	43	7	4425	75	59	7	
66	33	90	320	16	20	7	2107	49	43	-3	3304	59	56	-3	
		30	460	20	23	-10	1521	39	39	-20	2704	52	52	-26	
		45					2107	49	43	10	4464	72	62	3	
		60					2116	46	46	-23	3481	59	59	-30	
4	8	15	208	16	13	7	1716	52	33	10	3312	72	46	13	
		30					1560	52	30	13	3450	75	46	16	
		45					1518	46	33	10	2666	62	43	10	
		60					1080	36	30	3	1794	46	39	3	
	33	16	90					990	33	30	-3	1404	39	36	-3
			30					676	26	26	-13	1089	33	33	-16
			45					1287	39	33	10	2537	59	43	7
			60					1170	39	30	0	2107	49	43	-3
	66	33	90					1089	33	33	-16	1521	39	39	-20
			30					676	26	26	-13	2116	46	46	-23
			45					897	39	23	7	1716	52	33	10
			60					660	33	20	13	1560	52	30	13
8	16	15					759	33	23	10	1518	46	33	10	
		30					690	30	23	3	1080	36	30	3	
		45					529	23	23	0	990	33	30	-3	
		60					400	20	20	-10	676	26	26	-13	
33	33	60					529	23	23	7	1170	39	30	0	
		90					529	23	23	-11	1089	33	33	-16	

Guaranteed rectangular footprints (shown in imperial units)

Note: The mounting height is the distance from the reception plane and not from the floor

System Specification



Features

- ▶ Up to 32 digital audio channels
- ▶ Wireless transmission gives participants freedom of movement
- ▶ Digitized audio ensures very high audio quality
- ▶ Powerful compression techniques enable efficient, low-loss transmission
- ▶ Comprehensive error correction ensures error-free transmission
- ▶ Mono standard quality mode for efficient language distribution
- ▶ Stereo standard quality mode for efficient music distribution

Functions

- Conference hall privacy; the congress venue itself acts as a barrier to infra-red signals escaping and being overheard (infra-red cannot pass through opaque structures such as walls)
- No interference between separate conference rooms makes it possible to use an unlimited number of systems in adjacent rooms
- Synchronization with the number of channels in use means the user does not have to scroll through unused channels
- Quality levels are programmable per channel, giving maximum flexibility for optimizing transmission
- Premium quality modes for distribution of very high quality sound
- Transmission in 2-8 MHz frequency band eliminates disturbance from all types of lighting systems

Certifications and Approvals

CE marking	Conforms to IEC 60914, the international standard for conference systems. Conforms to IEC 61603 part 7, the international standard for digital infra-red transmission of audio signals for conference and similar applications
Safety:	According to EN 60065, CAN/CSA-E65 (Canada and US) and UL 6500 or UL1419 (for LBB 4511/00 and LBB 4512/00)
EMC emission	According to harmonized standard EN 55103-1 and FCC rules part 15, complying with the limits for a class A digital device
EMC immunity	According to harmonized standard EN 55103-2
EMC approvals	Affixed with the CE mark
ESD	According to harmonized standard EN 55103-2
Mains harmonics	According to harmonized standard EN 55103-1
Environmental requirements	Contains no banned substances as specified in UAT-0480/100 (e.g. no cadmium or asbestos)

Technical Specifications

Transmission Characteristics

IR transmission wavelength	870 nm
Modulation frequency	
Carriers 0 to 5	2 to 6 MHz
Carriers 6 and 7	up to 8 MHz
Protocol and modulation technique	DQPSK

System Audio Performance

Measured from the audio input of an INT-TX transmitter to the headphone output of an LBB 4540 receiver

Audio frequency response	
at Standard Quality	20 Hz to 10 kHz (-3 dB)
at Premium Quality	20 Hz to 20 kHz (-3 dB)
Total harmonic distortion at 1 kHz	< 0.05%
Crosstalk attenuation at 1 kHz	> 80 dB
Dynamic range	> 80 dB
Weighted signal-to-noise ratio	> 80 dB(A)

Cabling and System Limits

Cable type	75 ohm RG59
Maximum number of radiators	30 per HF output
Maximum cable length	900 m per HF output

System Environmental Conditions

Working conditions	Fixed / stationary / portable
Temperature range	
transport	-40 to +70 °C (-40 to 158 °F)
operating	+5 to +45 °C (41 to 122 °F)
for LBB 4560	+5 to +35 °C (41 to 113 °F)
for INT-TX	+5 to +55 °C (41 to 131 °F)
Maximum relative humidity	< 93%

INT-TX Transmitters



Features

- ▶ Can distribute a maximum of 4, 8, 16 or 32 audio channels
- ▶ Can be used with DCN Next Generation, or analogue systems like the CCS 800
- ▶ Flexible configuration of channels and channel quality modes for efficient distribution
- ▶ Configuration of transmitter and system via a display and one single rotary push button

The transmitter is the central element in the Integrus system. It accepts analogue or digital input, modulates these signals onto carrier waves and transmits these carrier waves to radiators located in the room.

Functions

- Auxiliary mode for distribution of music to all channels during a break
- Slave mode for distribution of signals from another transmitter allows multiple rooms to be used
- Test mode which produces a different frequency tone for each input/channel, with the tone gradually rising as the channels are stepped through
- Adjustable sensitivity for each input to enable fine tuning of audio levels
- Built-in mini infra-red radiator for audio monitoring
- Radiator and system status indication via display
- Each transmitter can be assigned a unique name by the installer for easy identification in a multi-transmitter system
- Each audio channel can also be assigned a unique name by the installer. These names can be selected from a list of options or entered manually
- Automatic distribution of emergency messages to all channels
- Automatic standby/on function
- Automatic synchronization to the number of channels in use in a DCN system

- Universal mains power facility allows use worldwide
- Stylish 19" (2U) housing for tabletop use or rack mounting
- Handgrips for easy transportation

Controls and Indicators

- 2 x 16 character LCD display for status information and transmitter configuration
- Rotary push button for navigation through menus and configuration
- Power on/off switch on front panel

Interconnections



Interconnections (at rear of transmitter)

- Male Euro socket for mains connection
- Slot with audio data bus connector (H 15, female) for accepting LBB 3422/20 Symmetrical Audio Input and Interpreters Module
- 4, 8, 16 or 32 cinch connectors for input of asymmetrical audio signals
- Two XLR sockets for input of symmetrical signals of floor, emergency messages or music
- One terminal block socket for distribution of emergency messages to all channels
- 3.5 mm (0.14 in) stereo headphone socket for monitoring inputs and channels
- One BNC connector for accepting an HF signal from another transmitter
- Six BNC connectors for output of HF signal to up to 30 radiators
- Two Optical Network Connectors for connection within a DCN Next Generation system*

* LBB 4416/xx Optical Network Cables required

Parts Included

Quantity	Component
1	INT-TX transmitter
1	19" rack mounting brackets, detachable feet and mounting accessories for modules included
1	System installation and operating manual on CD-ROM
1	Mains cable

Technical Specifications

Electrical

Mains voltage	90 to 260 V, 50 to 60 Hz
Power consumption operating, maximum	55 W
standby	29 W
Asymmetrical audio inputs	+3 dBV nominal, +6 dBV maximum (± 6 dB) +15 dBV nominal, +18 dBV maximum (± 6 dB)
Symmetrical audio inputs	+6 to +18 dBV nominal
Emergency switch connector	emergency control input
Headphone output	32 ohm to 2 kohm
HF input	nominal 1 Vpp, minimum 10 mVpp, 75 ohm
HF output	1 Vpp, 6 VDC, 75 ohm

Mechanical

Dimensions (H x W x D) for tabletop use, with feet	92 x 440 x 410 mm (3.6 x 17.3 x 16.1 in)
for 19" rack use, with brackets in front of brackets behind brackets	88 x 483 x 410 mm (3.5 x 19 x 16.1 in) 40 mm (1.6 in) 370 mm (14.6 in)
Weight without brackets, with feet	6.8 kg (15.0 lb)
Mounting	brackets for 19" rack mounting or fixing to a tabletop Detachable feet for free-standing on a ta- bletop
Color	charcoal (PH 10736) with silver

Ordering Information

INT-TX04 4-Channel Transmitter	INT-TX04
INT-TX08 8-Channel Transmitter	INT-TX08
INT-TX16 16-Channel Transmitter	INT-TX16
INT-TX32 32-Channel Transmitter	INT-TX32
Accessories	
LBB 3422/20 Symmetrical Audio Input and Interpreter Module	LBB3422/20
LBB 3423/20 DCN Interface Module	LBB3423/20

INT-TXK Transmitter Upgrade Kits

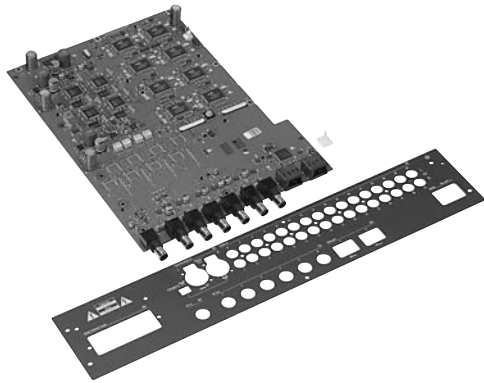

To upgrade a transmitter without an optical network connection (LBB 4502 range) to a transmitter with an optical network connection (INT-TX range) a Transmitter Upgrade Kit (INT-TXK) is required. The upgrade kit comprises the main PCB of the transmitter, a rear panel, a glue stud and a screw for mounting the main PCB in the housing of the LBB 4502 transmitter.

Ordering Information

INT-TXK04 Transmitter Upgrade Kit 4 channel	INT-TXK04
INT-TXK08 Transmitter Upgrade Kit 8 channel	INT-TXK08
INT-TXK16 Transmitter Upgrade Kit 16 channel	INT-TXK16
INT-TXK32 Transmitter Upgrade Kit 32 channel	INT-TXK32

LBB 3422/20 Symmetrical Audio Input and Interpreter Module

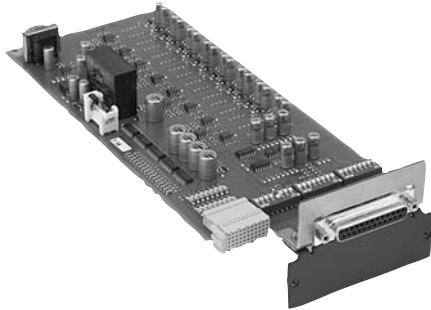

Features

- ▶ Direct connection of up to 12 LBB 3222/04 Interpreter Desks for six languages
- ▶ Routing of floor signal (for instance from a CCS 800 discussion system) to interpreter desks
- ▶ Eight symmetrical inputs
- ▶ Facility for mounting input transformers for galvanic isolation between audio source and the transmitter

The LBB 3422/20 Symmetrical Audio Input and Interpreters Module is used for interfacing the transmitter with the CCS 800 discussion systems and the LBB 3222/04 6-Channel Interpreter Desk with Loudspeaker. Different connections and switch settings are possible to also allow the module to be used with non-Bosch systems.

Functions

Controls and Indicators

- On-board switches can be set for directly connecting interpreter desks (LBB 3222/04) or other audio sources
- An on-board switch can be used to match the amplification of floor signals from CCS 800 or from other analogue conference systems
- An on-board switch can be used to replace the interpretation signal with the floor signal for distribution to the listeners when an interpreter channel is not in use

Interconnection

- Symmetrical analogue audio input; 25-pole female sub-D connector
- Audio and data bus connector; H 15 male connector

Technical Specifications

Electrical

Audio input level with AGC	-16.5 dBV (150 mVeff) to +3.5 dBV (1500 mVeff)
Audio input level without AGC	-4.4 dBV (600 mVeff)
Asymmetric input impedance	≥ 10kohm
DC input impedance	≥ 200kohm

Mechanical

Mounting	Front panel is removed when used with INT-TX Transmitter
Dimensions (H x W x D) without front panel	100 x 26 x 231 mm (39 x 10 x 91 in)
Weight without front panel	132 g (0.29 lb)

Ordering Information

LBB 3422/20 Symmetrical Audio Input and Interpreter Module	LBB3422/20
---	------------

DCN-FCCCU Flight Case for 2 Central Control Units



Features

- ▶ Robust construction with reinforced corners
- ▶ Easy to carry and store
- ▶ Shaped interior
- ▶ Holds up to two 19" units

The DCN-FCCCU flight case accommodates two 19" units, e.g. 1 central control unit (CCU) + 1 transmitter or 1 audio expander unit.

Technical Specifications

Mechanical

Dimensions (H x W x D)	510 x 460 x 290 mm (20.1 x 18.1 x 11.4 in)
Weight	6 kg (13.2 lb)
Color	Light grey

Ordering Information

DCN-FCCCU Flight Case for 2 Central Control Units	DCN-FCCCU
--	-----------

holds two 19" units (CCU, audio expander, transmitter)

LBB 451x/00 Infra-red Radiators



Features

- ▶ LBB 4511/00 covers up to 1000 m² (one carrier, 4 standard quality channels)
- ▶ LBB 4512/00 covers up to 2000 m² (one carrier, 4 standard quality channels)
- ▶ Automatic gain control ensures the IREDs (infra-red emitting diodes) function with maximum efficiency
- ▶ Power output selection for efficiency and economy

These radiators are used to distribute infra-red signals throughout the conference venue, enabling delegates to listen to the proceedings by means of personal receivers.

Functions

- Universal mains power facility allows use worldwide
- No fan - cooled by convection - resulting in quieter operation and less moving parts to wear out
- LED indicators for radiator status checking
- Communication between radiator and transmitter for easy checking by the operator
- Automatically switches on when transmitter is switched on and vice versa
- Automatic cable equalization ensures maximum transmission efficiency with different quality of cables
- Automatic cable termination simplifies installation
- Temperature protection circuitry automatically switches radiator from full- to half- power if the temperature becomes too high
- Adjustable radiator angle ensures maximum coverage
- IREDs protected by a cover plate, making the units easy to maintain and clean
- Attractive and stylish design

Controls and Indicators

- Two yellow LEDs: one on each radiator panel to indicate that this panel is switched on and is receiving carrier waves from the transmitter
- Two red LEDs: one on each radiator panel to indicate that this panel is in standby mode
- Red and yellow LEDs simultaneously illuminated to indicate the radiator panel is malfunctioning
- Red LED flashing and yellow LEDs to indicate the radiator panel is in temperature protection mode
- Power reduction switch to reduce the output of the radiator to half-power
- Two delay compensation switches to compensate for differences in cable lengths between transmitter and radiators

Interconnection

- Male Euro socket for mains connection
- HF input and output connectors (2 x BNC) for connection to transmitter and loop-through to other radiators

Parts Included

Quantity	Component
1	LBB 451x/00 Infra-red Radiator
1	Mains cable
1	Bracket for mounting unit on ceiling
2	Plates for mounting unit on floor stand

Technical Specifications

Electrical

Mains voltage	90 to 260 V, 50 to 60 Hz
Power consumption	
LBB 4511, operating	100 W
LBB 4511, standby	8 W
LBB 4512, operating	180 W
LBB 4512, standby	10 W
Number of IREDs	
LBB 4511	260
LBB 4512	480
Total optical peak intensity	
LBB 4511	9 W/sr
LBB 4512	18 W/sr
Angle of half intensity	± 22°

HF input	nominal 1 Vpp, minimum 10 mVpp
----------	--------------------------------

Mechanical

Mounting	Suspension bracket for direct ceiling mounting Mounting plates for floor stands with M10 and 1/2 in Whitworth thread Optional wall mounting bracket (LBB 3414/00) available
----------	---

Mechanical

Dimensions (H x W x D)

LBB 4511 without bracket 200 x 500 x 175 mm
(7.9 x 19.7 x 6.9 in)

LBB 4512 without bracket 300 x 500 x 175 mm
(11.0 x 19.7 x 6.9 in)

Radiator angle

floor-stand mounting 0, 15, and 30°

wall/ceiling mounting 0, 15, 30, 45, 60, 75 and 90°

Weight

LBB 4511 without bracket 6.8 kg (15 lb)

LBB 4511 with bracket 7.6 kg (17 lb)

LBB 4512 without bracket 9.5 kg (21 lb)

LBB 4512 with bracket 10.3 kg (23 lb)

Color bronze

Ordering Information

LBB 4511/00 Infra-red Radiator LBB4511/00

medium-power, covers up to 1000 m²
(21528 ft²)

LBB 4512/00 Infra-red Radiator LBB4512/00

high-power, covers up to 2000 m² (10764 ft²)

Accessories

LBB 3414/00 Wall Mounting Bracket LBB3414/00

INT-FCRAD Flight Case for Radiator



Features

- ▶ Robust construction with reinforced corners
- ▶ Easy to carry and store
- ▶ Shaped interior
- ▶ Holds one radiator

Storage suitcase for LBB 4511/00 or LBB 4512/00 Radiator.

Technical Specifications

Mechanical

Dimensions (H x W x D)	250 x 540 x 400 mm (10 x 21 x 16 in)
Weight	7.0 kg (15 lb)
Color	grey

Ordering Information

INT-FCRAD Flight Case for Radiator	INT-FCRAD
flight case for 1 radiator	

LBB 3414/00 Wall Mounting Bracket



Bracket to wall mount the LBB 4511/00 and LBB 4512/00 Radiators.

Technical Specifications

Mechanical

Dimensions (H x W x D)	200 x 280 x 160 mm (7.9 x 11.0 x 6.3 in)
Weight	1.8 kg (4.0 lb)
Color	quartz grey

Ordering Information

LBB 3414/00 Wall Mounting Bracket	LBB3414/00
--	------------

LBC 1259/00 Universal Floorstand



Features

- ▶ Multi-purpose, lightweight aluminum stand
- ▶ For mounting a loudspeaker, wireless access point or Integrus radiator
- ▶ Double-braced folding base
- ▶ Reducer flange for different mountings
- ▶ Hand-adjustable
- ▶ Carrier bag for two pieces as optional accessory

This universal floorstand provides effective mounting solutions for loudspeaker installations, a Wireless Access Point of the DCN-Wireless system, or a radiator of the Integrus digital language distribution system. They are manufactured and finished to the same high standards as all Bosch products, assuring excellent quality and guaranteed compatibility throughout the range. The LBC 1259/00 is suited to a wide range of applications where a secure yet transportable mounting solution is required.

Functions

Adjustable and safe

The LBC 1259/00 floorstand is hand-adjustable using a spring-loaded locking screw for heights between 1.4 and 2.2 m (4.6 and 7.2 ft). An extra safety bolt on the support can be tightened to ensure the stand remains extended.

This lightweight stand has a double-braced folding base for extra strength, and a wide leg span to ensure stability.

Adaptable

The floorstand is standard supplied with a 36 mm (1.42 in) reducer flange with an M10 x 12 threaded pin to mount different sized equipment, and with an M10 knob to fix the Wireless Access Point mounting bracket.

Accessories

For storage and ease of transport, a carrier bag is available with two inside compartments with separate zippers for holding two universal floorstands (LBC 1259/00). The bag, with Bosch logo, is made from sturdy black weather-proof nylon. Two handles are fitted for carrying the bag by hand or over the shoulder.



LM1-CB Carrier Bag (optional)

Installation/Configuration Notes



LBC 1259/00 with DCN Wireless Access Point, LBB 451x/00 Infra-red Radiator and XLA 3200 Line Array Loudspeaker

Parts Included

Quantity	Component
1	LBC 1259/00 Universal Floorstand
1	36 mm (1.42 in) reducer flange with (M10 x 12) threaded pin
1	M10 securing knob for WAP mounting bracket

Technical Specifications

Mechanical

Length

standing	1.375 to 2.185 m (54 to 86 in)
folded	1.20 m (47 in)

Width

legs extended	980 mm (38.6 in)
legs folded	130 mm (5.1 in)

Weight 3.5 kg (7.7 lb)

Max. load 50 kg (110.2 lb)

Material Aluminum

Tube diameter 36 mm (1.42 in)

Thread 1/2" Whitworth

Mechanical

Carrier bag accessory

Dimensions (L x D)	1.25 m x 27 mm (49 x 1.06 in)
Weight	750 g (1.65 lb)
Color	Black with light grey handles
Material	Nylon

Ordering Information

LBC 1259/00 Universal Floorstand lightweight aluminum construction, foldable, M10 x 12 reducer flange	LBC1259/00
LM1-CB Carrier Bag for two floorstands LBC 1259/00	LM1-CB

LBB 3410/05 Infra-red Radiator



Features

- ▶ Economic solution for small conference venues
- ▶ Covers up to 200 m² (2150 ft²) with one carrier, 4 standard quality channels
- ▶ Automatic gain control ensures the IREDs (infra-red emitting diodes) function with maximum efficiency
- ▶ Power output selection for efficiency and economy

The LBB 3410/05 low power wide beam radiator is used to distribute infra-red signals throughout a small conference venue, enabling delegates to listen to the proceedings by means of personal receivers.

Functions

- Attractive and stylish design
- Built in power supply
- Automatically switches on when transmitter is switched on and vice versa
- LED indicators for radiator status checking
- Adjustable radiator angle ensures maximum coverage
- IREDs protected by a front cover, making the units easy to maintain and clean

Limitations

- Only the first 4 carriers can be transmitted
- Not more than 100 m (328 ft) cable length from transmitter to last radiator
- Direct connection of the radiators to the transmitter with equal cable length. In loop-through connection, the total cable length from the first to the last radiator may not exceed 5 meters.
Reason: there are no facilities on this radiator for compensating the cable signal delay
- Don't use this radiator in combination with LBB 4511/00 and LBB 4512/00 radiators in one system, as the internal signal delay of these radiators is different
- No automatic cable termination: the termination plug has to be connected to the last radiator in a trunk

- No communication of the radiator status to the transmitter
- Using this radiator at 105 to 125 V requires internal adjustments

Controls and Indicators

- Green LED to indicate the radiator is switched on and is receiving carrier waves from the transmitter
- Red LED, which illuminates when the infra-red output power of the radiator is reduced to 70% or less of normal output level
- Power reduction switch to reduce the output of the radiator to half-power

Interconnections

- Male mains socket for mains connection
- HF input and output connectors (2 x BNC) for connection to transmitter and loop-through to other radiators

Parts Included

Quantity	Component
1	LBB 3410/05 Infra-red Radiator
1	Bracket for mounting on ceiling, wall and floors stands
1	Termination plug and mains cable

Technical Specifications

Electrical

Mains voltage	105 to 125 V or 220 to 240 V internally selectable, 50 to 60 Hz
Power consumption operating	25 VA
standby	5 VA
Number of IREDs	88
Total IR output	1.8 Wrms 3.0 Wpp
Total optical peak intensity	2.0 W/sr
Angle of half intensity	± 24° vertical, ± 48° horizontal

Mechanical

Mounting	Bracket for ceiling, wall and floor stand mounting with 3/8 in Whitworth thread
Dimensions (H x W x D)	176 x 300 x 125 mm (7 x 12 x 5 in)
Radiator angle	0 to 90° (without steps)
Weight	1.5 kg (3.3 lb)
Color	Black

Ordering Information

LBB 3410/05 Infra-red Radiator	LBB3410/05
low-power, wide-beam, covers up to 200 m ² (2150 ft ²), not available in EU countries, Norway & Switzerland	

LBB 4540 Pocket Receivers



Features

- ▶ Specially-designed IC for maximum performance and a long battery life time
- ▶ Recharging electronics integrated in the chip, ensuring optimum charging performance
- ▶ 2-digit LCD display with battery and reception status indication
- ▶ Number of available channels is always the same as the number of channels in use by the system, eliminating the need to scroll through unused channels

These ergonomically designed receivers incorporate the latest electronics technology - including a specially designed IC - to ensure maximum performance and a long battery lifetime. The receivers can be used for both language and music distribution.

Functions

- Audio signal automatically muted when signal is too low, ensuring that the user receives only high quality audio
- Can be used with disposable batteries (2x AA alkaline batteries, not included) or environmentally-friendly NiMH rechargeable battery pack LBB 4550/00, (not included)
- No power used when headphone is disconnected
- Clip for easy wearing
- Measurement mode for easy checking of radiator coverage
- Attractive and stylish design
- Up to 200 hours operation with alkaline batteries
- Up to 75 hours operation with battery pack
- Recharges from empty to full capacity within 1 hour and 45 minutes

Controls and Indicators

- 2-digit LCD display with channel number, battery and reception status indication
- On/off button
- Volume control slide adjuster
- Channel selection up/down buttons
- Charging indicator LED

Interconnections

- 3.5 mm (0.14 in) stereo jack output socket for headphones
- Battery contacts for use with AA alkaline batteries
- Connector for use with LBB 4550/00 battery packs
- Charging contacts on the left-hand side of the receiver for compatibility with LBB 4560 charging units*

* LBB 3406, 3407, 3408 and 3409 charging units are electronically incompatible with LBB 4540 Pocket Receivers, and can actually damage them. The charging contacts on LBB 4540 Pocket Receivers and LBB 4560 Charging Units have deliberately been located on the left-hand side, which is a different position than found on the mentioned charging units. The battery pack and disposable batteries are not included.

Technical Specifications

Electrical

IR irradiance level	4 mW/m ² per carrier
Angle of half sensitivity	± 50°
Headphone output level at 2.4 V	450 mVrms (speech at maximum volume, 32 ohm headphone)
Headphone output frequency range	20 Hz to 20 kHz
Headphone output impedance	32 ohm to 2 kohm
Max. signal-to-noise ratio	80 dB(A)
Supply voltage	1.8 to 3.6 V, nominal 2.4 V
Power consumption at 2.4 V (battery voltage)	15 mA (speech at maximum volume, 32 ohm headphone)
Power consumption (standby)	< 1 mA

Mechanical

Dimensions (H x W x D)	155 x 45 x 30 mm (6.1 x 1.8 x 1.2 in)
Weight	
excluding battery	75 g (0.16 lb)
including battery	125 g (0.27 lb)
Color	charcoal with silver

Ordering Information

LBB 4540/04 Pocket Receiver 4-channel	LBB4540/04
LBB 4540/08 Pocket Receivers 8-channel	LBB4540/08
LBB 4540/32 Pocket Receiver 32-channel	LBB4540/32

LBB 4550/00 NiMH Battery Pack

Ordering Information

Accessories

INT-FCRX Storage Case for 100 LBB 4540 Pocket Receivers	INT-FCRX
LBB 4550/00 NiMH Battery Pack	LBB4550/00
LBB 4560/00 Charging Case for portable use	LBB4560/00
LBB 4560/50 Charging Cabinet for fixed installation	LBB4650/50



Features

- Temperature sensor for optimal charging process

NiMH battery pack for use with LBB 4540 Pocket Receivers.

Technical Specifications

Electrical

Voltage	2.4 V
Capacity	1100 mAh

Mechanical

Dimensions (H x W x D)	14 x 28 x 49 mm (0.6 x 1.1 x 1.9 in)
Weight	50 g (0.11 lb)

Ordering Information

LBB 4550/00 NiMH Battery Pack	LBB4550/00
--------------------------------------	------------

LBB 4560 Charging Units



Features

- ▶ Can accommodate 56 receivers
- ▶ Universal mains power facility allows use worldwide
- ▶ Rapid recharging: within 1 hour and 45 minutes

The charging units are used for charging and storing the LBB 4540 Pocket Receivers.

Functions

Controls and Indicators

- On/off switch
- Charging status indication on the receivers

Interconnection

- Mains input with loop-through facility; male and female Euro mains socket
- 56 charging contacts. Compatible with LBB 4540 receivers

Parts Included

Quantity	Component
1	LBB 4560 Charging Unit
1	Mains cable

Technical Specifications

Electrical

Mains voltage	90 to 260 V, 50 to 60 Hz
Power consumption	270 W (56 receivers charging)
Power consumption (standby)	17 W (no receivers in the charging unit)

Mechanical

Mounting	
LBB 4560/50	Screws and plugs for wall mounting included
Dimensions (H x W x D)	
LBB 4560/00	230 x 690 x 530 mm (9 x 27 x 21 in)
LBB 4560/50	130 x 680 x 520 mm (5 x 27 x 20 in)
Weight excl. receivers	
LBB 4560/00	15.5 kg (34 lb)
LBB 4560/50	11.2 kg (25 lb)
Weight incl. 56 receivers	
LBB 4560/00	22.3 kg (49 lb)
LBB 4560/50	18.0 kg (40 lb)
Color	Charcoal with grey

Ordering Information

LBB 4560/00 Charging Case for portable use	LBB4560/00
LBB 4560/50 Charging Cabinet for fixed installation	LBB4650/50

INT-FCRX Storage Case



Features

- ▶ Robust construction with reinforced corners
- ▶ Easy to carry and store
- ▶ Shaped foam interior
- ▶ Holds up to 100 receivers

This storage case can hold up to 100 LBB 4540 Pocket Receivers.

Technical Specifications

Mechanical

Dimensions (H x W x D)	207 x 690 x 530 mm (8 x 27 x 21 in)
------------------------	--

Weight	7.5 kg (16.5 lb)
--------	------------------

Color	grey
-------	------

Ordering Information

INT-FCRX Storage Case for 100 LBB 4540 Pocket Receivers	INT-FCRX
---	----------

LBB 3441/10 Under the Chin Headphones



Features

- ▶ Lightweight stereo headphones
- ▶ Ergonomic design for use under the chin
- ▶ Replaceable ear tips
- ▶ Right-angled, gold-plated jack plug

Functions

Interconnections

- 1.2 m (4 ft) cable terminated with 3.5 mm (0.14 in) right-angled stereo jack plug

Technical Specifications

Electrical

Impedance	150 ohm per earpiece
Audio frequency response	50 Hz – 5 kHz (-10 dB)
Power handling capacity	60 mW
Sensitivity (1 kHz)	107 dB SPL/earpiece at 1 mW/earpiece

Mechanical

Weight	33 g (0.07 lb)
Color	Black

Ordering Information

LBB 3441/10 Under the Chin Headphones	LBB3441/10
LBB 3441/50 Ear Tips for LBB 3441 (500 pairs)	LBB3441/50

LBB 3442/00 Single Earphone



Features

- ▶ Lightweight single earphone
- ▶ Left or right ear use

Functions

Interconnections

- 1.2 m (4 ft) cable terminated with 3.5 mm (0.14 in) jack plug

Technical Specifications

Electrical

Impedance	32 ohm
Audio frequency response	100 Hz - 5 kHz (-10 dB)
Power handling capacity	5 mW
Sensitivity (1 kHz)	114 dB SPL/earpiece at 1 mW/earpiece

Mechanical

Weight	25 g (0.06 lb)
Color	Dark grey

Ordering Information

LBB 3442/00 Single Earphone	LBB3442/00
------------------------------------	------------

LBB 3443 Lightweight Headphones



Features

- ▶ Lightweight with high quality sound reproduction
- ▶ Replaceable ear pads
- ▶ Available with normal or durable cable
- ▶ Separate available solid washable ear pads

Functions

These headphones can be fitted with an optional set of washable ear pads.



Washable ear pads

Interconnections

- 1.3 m (4.25 ft) cable terminated with gold-plated 3.5 mm (0.14 in) angled stereo jack plug

Technical Specifications

Electrical

Impedance	32 ohm per earpiece
Audio frequency response	50 Hz - 20 kHz (-10 dB)
Power handling capacity	50 mW
Sensitivity (1 kHz)	98 dB SPL/earpiece at 1 mW/earpiece

Mechanical

Weight	70 g (0.16 lb)
Finish	Charcoal (PH 10736) with silver

Ordering Information

LBB 3443/00 Lightweight Headphones	LBB3443/00
LBB 3443/10 Lightweight Headphones Durable Cable	LBB3443/10

Accessories

LBB 3443/50 Foam Ear Pads for LBB 3443 (50 pairs) replacement foam ear pads	LBB3443/50
HDP-LWSP Solid Ear Pads for LBB 3443 (50 pairs) washable replacement ear pads	HDP-LWSP

LBB 3015/04 High Quality Dynamic Headphones



Features

- ▶ Durable dynamic headphones
- ▶ Replaceable ear pads
- ▶ High-quality sound reproduction
- ▶ Gold-plated stereo jack plug

Functions

Interconnections

- 1.5 m (5 ft) cable terminated with a 3.5 mm (0.14 in) stereo jack plug

Technical Specifications

Electrical

Impedance	720 ohm per earpiece
Audio frequency response	250 Hz - 13 kHz (-10 dB)
Power handling capacity	200 mW
Sensitivity (1 kHz)	97 dB SPL/earpiece at 0 dBV/system 96 dB SPL/earpiece at 1 mW/earpiece

Mechanical

Weight	110 g (0.24 lb)
Color	Dark grey

Ordering Information

LBB 3015/04 High Quality Dynamic Headphones	LBB3015/04
LBB 9095/50 Ear pads for LBB 3015	LBB9095/50
LBB 9095 (25 pairs)	

HDP-ILN Induction Loop Neckband



Features

- ▶ Lightweight
- ▶ Used with 'T-coil' hearing aids

Functions

This induction loop neckband can be used with:

- Integrus receivers
- CCS800 unit
- DCN unit

The neckband magnetically couples the sound signal from the headphone output to a 'T-coil' hearing aid.

Interconnections

- 0.9 m (3ft) cable terminated with a 3.5 mm (0.14 in) gold-plated plug

Technical Specifications

Mechanical

Weight	45 g (0.10 lb)
Color	Charcoal with silver

Ordering Information

HDP-ILN Induction Loop Neckband	HDP-ILN
--	---------

LBB 3222/04 Interpreter Desk



Features

- ▶ Accommodates 6 different language channels plus the original floor language
- ▶ Incoming channel pre-selector key eliminates the need to manually search through all available language channels
- ▶ Quick switching between the floor language and the channel set on the channel selector reduces the chance of operator errors
- ▶ Electronic channel interlock function prevents interpreters in different booths from using the same output channel

Functions

- Built-in loudspeaker
- 12 interpreter desks can be loop-through connected within and/or between interpreter booths
- Up to three interpreter desks can be present per booth
- Auto relay enable function allows the interpreter to provide the auto relay language (OR2) for relay interpretation
- The channel B disable function allows the interpreter to disable channel B while ensuring that the desk remains connected to channel A

Controls and Indicators

- Microphone mounted on a flexible stem, complete with a light ring which illuminates when the microphone is on
- Headphone volume, treble and bass controls
- A-B channel selector key with channel select indicators
- Six outgoing B-channel select keys with channel select indicators
- Outgoing 'OR2' (auto relay) indicator
- 'Channel engaged' indicators to show which channels are in use by other interpreters
- Microphone 'mute' key
- Microphone activating key with LED status indicator

- Select key with LED indicators for fast switching between the original floor language and the channel set on the channel selector
- Incoming channel 'OR2' (auto relay) indicator to show that the original floor language has been replaced by a transfer interpretation channel, when the auto-relay facility is in operation
- Incoming language channel selector for headphone monitoring
- Call key (voice) to provide two-way communication between interpreter and chairman/operator
- Outgoing message key
- Incoming message indicator
- Rotary switch to preset the outgoing channel via the A output

Interconnections

- 3 m (10 ft) cable terminated with a 25-pin sub D-type connector
- 25-pin sub D-type socket for loop-through connections
- 6.3 mm (0.25 in) stereo jack headphone connectors
- 15-pole 180° DIN-type socket for connection of interpreter's headset with microphone, plus switch to mute the built-in microphone
- Auxiliary socket (message) for the desk's message function

Technical Specifications

Electrical

Frequency response 125 Hz (-10 dB) to 12.5 kHz (-2 dB)

Rated equivalent sound pressure due to inherent noise < 32 dB

Total harmonic distortion at overload < 5%

Crosstalk attenuation > 66 dB

Mechanical

Mounting tabletop or flush mounting

Dimensions (H x W x D) 20-58 x 250 x 189 mm
(0.79-2.28 x 9.84 x 7.44 in)

Weight 1.75 kg (3.85 lb)

Color light grey

Ordering Information

LBB 3222/04 Interpreter Desk

LBB3222/04

LBB 3306 Extension Cables



Extension cables to interconnect 6-channel interpreter desks when the standard cable is too short.

Functions

Connectors

- 25-pole sub-D type plug with sliding lock mechanism
- 25-pole sub-D type socket with pin lock mechanism

Ordering Information

LBB 3306/00 Installation Cable 100 m, without connectors	LBB3306/00
LBB 3306/05 Extension Cable 5 m, 25-pole sub-D type plug and socket	LBB3306/05
LBB 3306/20 Extension Cable 20 m, 25-pole sub-D type plug and socket	LBB3306/20

LBB 9095/30 Interpreter Headphones



Features

- ▶ Durable and dynamic
- ▶ Replaceable ear pads
- ▶ High-quality sound reproduction

Lightweight, dynamic headphones for direct connection to DCN-IDEK Interpreter's Desk.

Functions

Interconnections

- 2.2 m (7 ft) cable terminated with a 6.3 mm (0.25 in) stereo jack plug

Technical Specifications

Electrical

Impedance	720 ohm per earpiece
Audio frequency response	250 Hz - 13 kHz (-10 dB)
Power handling capacity	200 mW
Sensitivity (1 kHz)	97 dB SPL/earpiece at 0 dBV/system 96 dB SPL/earpiece at 1 mW/earpiece

Mechanical

Weight	125 g (0.28 lb)
Color	Black/grey

Ordering Information

LBB 9095/30 Interpreter Headphones	LBB9095/30
---	------------

D

DCN-FCCCU Flight Case for 2 Central Control Units . . 21

H

HDP-ILN Induction Loop Neckband 35

I

INT-FCRAD Flight Case for Radiator 25

INT-FCRX Storage Case 32

Introduction 1

INT-TX Transmitters 17

INT-TXK Transmitter Upgrade Kits 19

L

LBB 3015/04 High Quality Dynamic Headphones 35

LBB 3222/04 Interpreter Desk 37

LBB 3306 Extension Cables 38

LBB 3410/05 Infra-red Radiator 28

LBB 3414/00 Wall Mounting Bracket 25

LBB 3422/20 Symmetrical Audio Input and
Interpreter Module 20

LBB 3441/10 Under the Chin Headphones 33

LBB 3442/00 Single Earphone 33

LBB 3443 Lightweight Headphones 34

LBB 451x/00 Infra-red Radiators 23

LBB 4540 Pocket Receivers 29

LBB 4550/00 NiMH Battery Pack 30

LBB 4560 Charging Units 31

LBB 9095/30 Interpreter Headphones 38

LBC 1259/00 Universal Floorstand 26

S

System Description and Planning 5

System Specification 15

Tradition of quality and innovation

For over 100 years, the Bosch name has stood for quality and reliability. Bosch Security Systems proudly offers a wide range of fire, intrusion, social alarm, CCTV, management and communication systems and components to help you find the solution for any application. We are the global supplier of choice for innovative technology backed by the highest level of service and support. When you need solutions you can rely on, choose Bosch.



Bosch Security Systems

For more information please visit
www.boschsecurity.com
or send an e-mail to
emea.securitysystems@bosch.com

© Bosch Security Systems, 2007
Printed in The Netherlands
Modifications reserved
CO-EH-en-05_F01U517922_04