

Model T104P201 with Plastic enclosure
 Model T104R201 with Metal enclosure
 24 Hour Dial Time switch with Fireman switch

240Volt timer with heater protection that turns off gas-fired pool heater 15-20 minutes before turning off filter pump. This eliminates knocking due to overheated water, reduces scale and lime, and extends service life of heater

DOUBLE POLE SINGLE THROW (DPST)
40 AMP. RESISTIVE EACH POLE 120-480 VOLT AC;
40 AMP.INDUCTIVE OR TUNGSTEN OR 1000 VA
PILOT DUTY EACH POLE 120V-277V AC;
2 HP (24 FLA)-120V AC; 5 HP (28 FLA)-240V AC.

Heater protection circuit: 10A 240V max.

WG1573 clock motor/ 156T1978A Tripper / 9-3/8" H x 5-1/2" W x 3-5/8" D/ 1/2" and 3/4" KO on back and side



CLOCK MOTOR: 208-277 VOLTS - 60 HZ.

CLOCK MOTOR VOLTAGE AND CYCLE MUST BE AS SPECIFIED. TO ORDER REPLACEMENT, INDICATE PART NO. (WG--) ON MOTOR COVER.

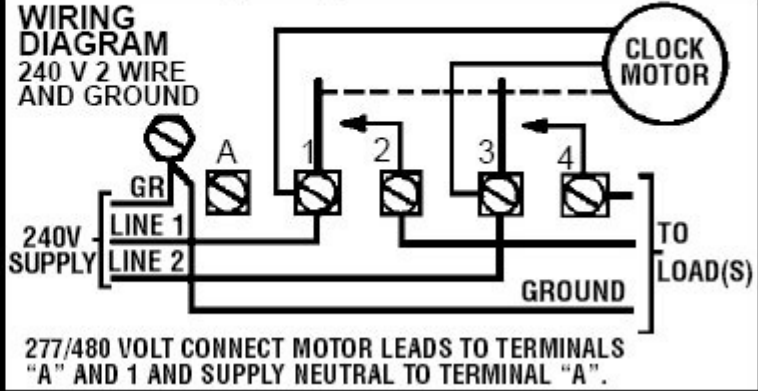
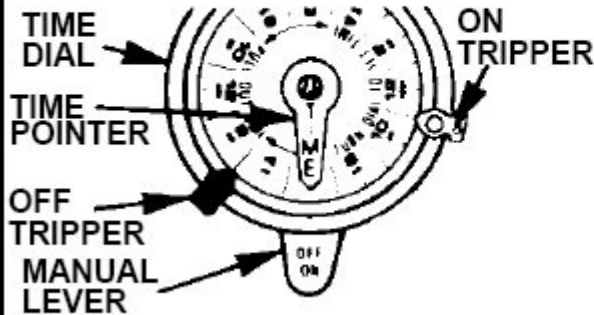

PROGRAMMING INSTRUCTIONS

- 1. TO SET "ON" AND "OFF" TIMES:** Hold trippers against edge of **CLOCK-DIAL**, pointing to time (AM or PM) when **ON** and **OFF** operations are desired, tighten tripper screws firmly. For additional tripper pairs on **CLOCK-DIAL** order 156T1978A.
- 2. TO SET TIME-OF-DAY:** Pull **CLOCK-DIAL** outward. Turn in either direction and align the exact time-of-day on the **CLOCK-DIAL** (the time now, when switch is being put into operation) to the pointer. **DO NOT MOVE POINTER.**

OPERATING INSTRUCTIONS

- TO OPERATE SWITCH MANUALLY:** Move **MANUAL LEVER** below **CLOCK-DIAL** left or right as indicated by arrows. This will not effect next operation.
- IN CASE OF POWER FAILURE,** reset **CLOCK-DIAL** to proper time-of-day. See programming instructions.

WIRING INSTRUCTIONS: To wire switch follow diagram above. Use solid or stranded COPPER **only** wire with insulation to suit installation. See gauge selection table for normal service applications. To make power connections remove 1/2 inch of insulation from wire ends. Insert bare ends of wire under the pressure plate of terminals. Use 3/16 or larger screwdriver to tighten terminal screws firmly. (25 lb-in minimum).

Typical T104P201 and T104R201 wiring

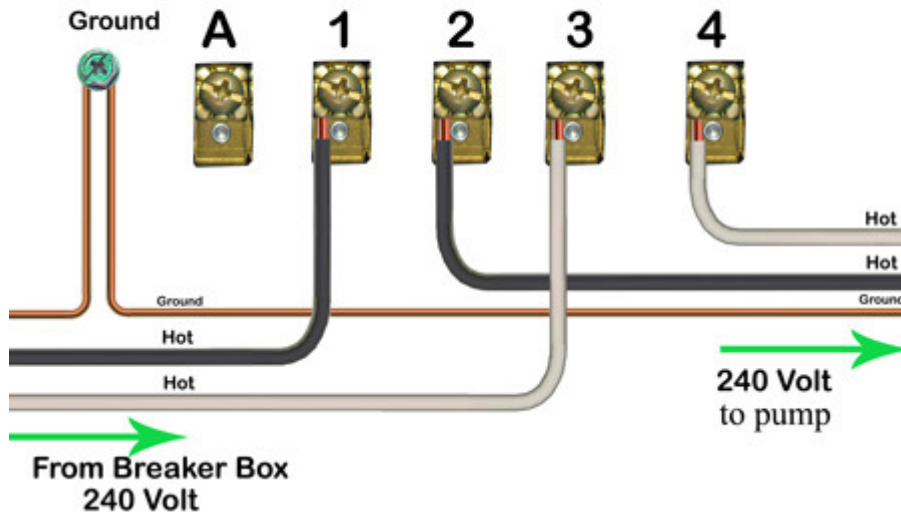

Typical wiring for timer

Fireman switch installation

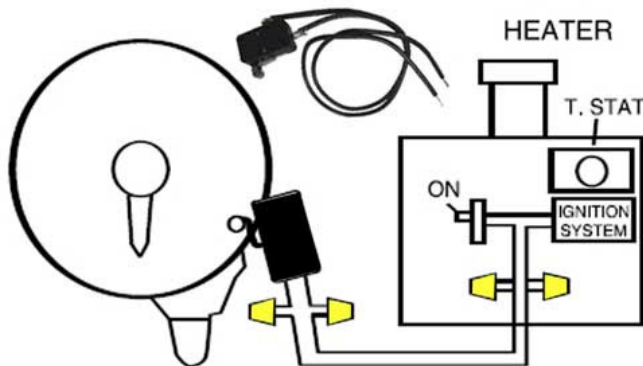

WARNING: Do not disconnect high limit or pressure switches

REPLACE INSULATOR BEFORE TURNING ON ELECTRICITY.

MINIMUM COPPER WIRE SIZE (AWG)	MAX. LOAD (AMP)	MIN. INSULATION TEMP(°C)	75°C INSULATION MAX. MOTOR LOAD (HP)			
			SINGLE PHASE		3 PHASE	
			120 V.	240 V.	208 V.	240 V.
14	15	60	1/2	2		
12	20	60	1			
10	30	60	2			
8	40	75	-			



PRESSURE PLATE

TERMINAL SCREW

MAKE SURE WIRE INSULATION CLEARS PRESSURE PLATE

INTERMATIC INCORPORATED
 SPRING GROVE, ILLINOIS 60081-9698