



An Oshkosh Corporation Company

---

# Service and Maintenance Manual

## ***Model*** ***600S*** ***660SJ***

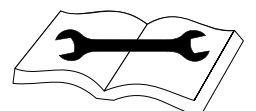
*S/N 0300171769*  
to Present

***P/N - 3121298***

February 26, 2014

***ANSI***

**CE**





## SECTION A. INTRODUCTION - MAINTENANCE SAFETY PRECAUTIONS

### A GENERAL

This section contains the general safety precautions which must be observed during maintenance of the aerial platform. It is of utmost importance that maintenance personnel pay strict attention to these warnings and precautions to avoid possible injury to themselves or others, or damage to the equipment. A maintenance program must be followed to ensure that the machine is safe to operate.

#### WARNING

**MODIFICATION OR ALTERATION OF AN AERIAL WORK PLATFORM SHALL BE MADE ONLY WITH WRITTEN PERMISSION FROM THE MANUFACTURER.**

The specific precautions to be observed during maintenance are inserted at the appropriate point in the manual. These precautions are, for the most part, those that apply when servicing hydraulic and larger machine component parts.

Your safety, and that of others, is the first consideration when engaging in the maintenance of equipment. Always be conscious of weight. Never attempt to move heavy parts without the aid of a mechanical device. Do not allow heavy objects to rest in an unstable position. When raising a portion of the equipment, ensure that adequate support is provided.

#### WARNING

**SINCE THE MACHINE MANUFACTURER HAS NO DIRECT CONTROL OVER THE FIELD INSPECTION AND MAINTENANCE, SAFETY IN THIS AREA RESPONSIBILITY OF THE OWNER/OPERATOR.**

### B HYDRAULIC SYSTEM SAFETY

It should be noted that the machines hydraulic systems operate at extremely high potentially dangerous pressures. Every effort should be made to relieve any system pressure prior to disconnecting or removing any portion of the system.

### C MAINTENANCE

#### WARNING

**FAILURE TO COMPLY WITH SAFETY PRECAUTIONS LISTED IN THIS SECTION COULD RESULT IN MACHINE DAMAGE, PERSONNEL INJURY OR DEATH AND IS A SAFETY VIOLATION.**

- ENSURE REPLACEMENT PARTS OR COMPONENTS ARE IDENTICAL OR EQUIVALENT TO ORIGINAL PARTS OR COMPONENTS.
- NO SMOKING IS MANDATORY. NEVER REFUEL DURING ELECTRICAL STORMS. ENSURE THAT FUEL CAP IS CLOSED AND SECURE AT ALL OTHER TIMES.
- REMOVE ALL RINGS, WATCHES AND JEWELRY WHEN PERFORMING ANY MAINTENANCE.
- DO NOT WEAR LONG HAIR UNRESTRAINED, OR LOOSE-FITTING CLOTHING AND NECKTIES WHICH ARE APT TO BECOME CAUGHT ON OR ENTANGLED IN EQUIPMENT.
- OBSERVE AND OBEY ALL WARNINGS AND CAUTIONS ON MACHINE AND IN SERVICE MANUAL.
- KEEP OIL, GREASE, WATER, ETC. WIPED FROM STANDING SURFACES AND HAND HOLDS.
- USE CAUTION WHEN CHECKING A HOT, PRESSURIZED COOLANT SYSTEM.
- NEVER WORK UNDER AN ELEVATED BOOM UNTIL BOOM HAS BEEN SAFELY RESTRAINED FROM ANY MOVEMENT BY BLOCKING OR OVERHEAD SLING, OR BOOM SAFETY PROP HAS BEEN ENGAGED.
- BEFORE MAKING ADJUSTMENTS, LUBRICATING OR PERFORMING ANY OTHER MAINTENANCE, SHUT OFF ALL POWER CONTROLS.
- BATTERY SHOULD ALWAYS BE DISCONNECTED DURING REPLACEMENT OF ELECTRICAL COMPONENTS.
- KEEP ALL SUPPORT EQUIPMENT AND ATTACHMENTS STOWED IN THEIR PROPER PLACE.
- USE ONLY APPROVED, NONFLAMMABLE CLEANING SOLVENTS.

**REVISION LOG**

Original Issue	- August 7, 2013
Revised	- October 10, 2013
Revised	- November 25, 2013
Revised	- February 26, 2014

<b>SECTION NO.</b>	<b>TITLE</b>	<b>PAGE NO.</b>
<b>SECTION A - INTRODUCTION - MAINTENANCE SAFETY PRECAUTIONS</b>		
A	General .....	A-1
B	Hydraulic System Safety .....	A-1
C	Maintenance .....	A-1
<b>SECTION 1 - SPECIFICATIONS</b>		
1.1	Operating Specifications .....	1-1
1.2	Dimensional Data .....	1-1
1.3	Capacities .....	1-2
1.4	Tires .....	1-2
1.5	Engine Data .....	1-2
1.6	Function Speeds .....	1-3
	Machine Orientation When Doing Speed Tests .....	1-3
	Test Notes .....	1-3
1.7	Torque Requirements .....	1-3
1.8	Hydraulic Oil .....	1-4
1.9	Major Component Weights .....	1-5
1.10	Operator Maintenance .....	1-6
<b>SECTION 2 - GENERAL</b>		
2.1	Machine Preparation, Inspection, and Maintenance .....	2-1
	General .....	2-1
	Preparation, Inspection, and Maintenance .....	2-1
	Pre-Start Inspection .....	2-1
	Pre-Delivery Inspection and Frequent Inspection .....	2-1
	Annual Machine Inspection .....	2-1
	Preventive Maintenance .....	2-1
2.2	Service and Guidelines .....	2-2
	General .....	2-2
	Safety and Workmanship .....	2-2
	Cleanliness .....	2-2
	Components Removal and Installation .....	2-2
	Component Disassembly and Reassembly .....	2-3
	Pressure-Fit Parts .....	2-3
	Bearings .....	2-3
	Gaskets .....	2-3
	Bolt Usage and Torque Application .....	2-3
	Hydraulic Lines and Electrical Wiring .....	2-3
	Hydraulic System .....	2-3
	Lubrication .....	2-3
	Battery .....	2-3
	Lubrication and Servicing .....	2-3
2.3	Lubrication and Information .....	2-4
	Hydraulic System .....	2-4
	Hydraulic Oil .....	2-4
	Changing Hydraulic Oil .....	2-4
	Lubrication Specifications .....	2-4
2.4	Cylinder Drift Test .....	2-4
	Platform Drift .....	2-4
	Cylinder Drift .....	2-4
2.5	Pins and Composite Bearing Repair Guidelines .....	2-5
2.6	Welding on JLG Equipment .....	2-5
	Do the Following When Welding on JLG Equipment: .....	2-5
	Do NOT Do the Following When Welding on JLG Equipment: .....	2-5

<b>SECTION NO.</b>	<b>TITLE</b>	<b>PAGE NO.</b>
<b>SECTION 3</b>	<b>- CHASSIS &amp; TURNTABLE</b>	
3.1	Tires & Wheels.....	3-1
	Tire Inflation.....	3-1
	Tire Damage.....	3-1
	Tire Replacement.....	3-1
	Wheel Replacement.....	3-1
	Wheel Installation.....	3-1
3.2	Torque Hub.....	3-2
	Oil Information.....	3-2
	Roll and Leak Testing.....	3-2
	Tightening and Torquing Bolts.....	3-2
	Main Disassembly.....	3-4
	Output Carrier Disassembly.....	3-5
	Input Carrier Disassembly.....	3-5
	Hub-Spindle Disassembly.....	3-6
	Spindle-Brake Disassembly.....	3-7
	Cover Disassembly.....	3-8
	Cover Assembly.....	3-8
	Input Carrier Assembly.....	3-9
	Spindle - Brake Assembly.....	3-10
	Hub-Spindle Assembly.....	3-11
	Output Planet Gear Assembly.....	3-12
	Main Assembly.....	3-13
	Integral Brake Check.....	3-13
3.3	Free Wheeling Option.....	3-17
	Disengage Drive Motors & Brakes for Towing, etc. (Free Wheel).....	3-17
	Engage Drive Motors & Brakes (Normal Operation).....	3-17
3.4	Drive Motor.....	3-17
	Description.....	3-17
	Shaft Seal Replacement.....	3-18
	Loop Flushing Valve.....	3-19
	Troubleshooting.....	3-20
	Disassembly.....	3-21
	Inspection.....	3-25
	Assembly.....	3-27
	Initial Start-up Procedures.....	3-32
3.5	Oscillating Axle Bleed Procedure and Lockout Test.....	3-32
	Lockout Cylinder Bleeding.....	3-32
	Oscillating Axle Lockout Test.....	3-33
3.6	Steer Adjustments.....	3-33
3.7	Swing Drive.....	3-34
	Gear Backlash.....	3-36
	Swing Drive Lubrication.....	3-36
	Motor Control Valve Disassembly.....	3-37
	Motor and Brake Disassembly.....	3-37
	Main Disassembly.....	3-38
	Hub-Shaft Disassembly.....	3-38
	Carrier Disassembly.....	3-39
	Hub-Shaft Subassembly.....	3-40
	Carrier Subassembly.....	3-41
	Main Assembly.....	3-42
	Motor and Brake Assembly.....	3-43
	Motor Control Valve Assembly.....	3-43

<b>SECTION NO.</b>	<b>TITLE</b>	<b>PAGE NO.</b>
3.8	Swing Bearing .....	3-44
	Turntable Bearing Mounting Bolt Condition Check .....	3-44
	Wear Tolerance .....	3-44
	Swing Bearing Replacement .....	3-46
	Swing Bearing Torque Values .....	3-47
3.9	Rotary Coupling .....	3-48
3.10	Generator .....	3-52
	Every 250 hours .....	3-52
	Every 500 hours .....	3-52
	Overload Protection .....	3-53
	Inspecting Brushes, Replacing Brushes, and Cleaning Slip Rings .....	3-53
3.11	Deutz D2.9 L4 Engine .....	3-55
	Check Oil Level .....	3-57
	Change Engine Oil .....	3-57
	Change Oil Filter .....	3-58
	Change Fuel Filters .....	3-58
3.12	Deutz D2011 Engine .....	3-59
	Checking Oil Level .....	3-61
	Changing Engine Oil .....	3-61
	Changing Oil Filter .....	3-62
	Replace Fuel Filter .....	3-62
	Clean Fuel Strainer .....	3-63
3.13	Spark Arrester Cleaning Instructions .....	3-63
3.14	Glow Plugs .....	3-63
3.15	Deutz EMR 2 .....	3-64
3.16	Bio Fuel in Deutz Engines .....	3-76
	General .....	3-76
	Bio Fuel .....	3-76
	Biological Contamination In Fuels .....	3-77
3.17	GM Engine General Maintenance .....	3-78
	Drive Belt Maintenance .....	3-78
	Engine Electrical System Maintenance .....	3-78
	Checking/Filling Engine Oil Level .....	3-78
	Changing Engine Oil .....	3-79
	Coolant Fill Procedure - Dual Fuel Engine .....	3-79
3.18	GM Engine Dual Fuel System .....	3-80
	Fuel Filter .....	3-80
	Direct Electronic Pressure Regulator (DEPR) .....	3-82
	Air Fuel Mixer .....	3-82
	Electronic Throttle Control (ETC) .....	3-83
	Electric Lock Off .....	3-83
	Engine Control Module (ECM) .....	3-83
	Heated Exhaust Gas Oxygen Sensor .....	3-84
	Gasoline Multi Point Fuel Injection System (MPFI) .....	3-84
	Gasoline Fuel Pump .....	3-84
	Gasoline Pressure And Temperature Sensor Manifold .....	3-84
	Fuel Filter .....	3-85
	Fuel Injector Rail .....	3-85
	Fuel Injector .....	3-85
3.19	GM Engine Fuel System Repair .....	3-85
	Propane Fuel System Pressure Relief .....	3-85
	Propane Fuel System Leak Test .....	3-85
	Propane Fuel Filter Replacement .....	3-86
	Direct Electronic Pressure Regulator (DEPR) Maintenance And Inspection .....	3-86
	Check/Drain Oil Build-Up In 2-Stage Vaporizer .....	3-87
	Air Fuel Mixer/Throttle Control Device Maintenance And Inspection .....	3-87
	Exhaust System And Catalytic Converter Inspection And Maintenance .....	3-88
	Temperature Manifold Absolute Pressure (TMAP) Sensor .....	3-88

## TABLE OF CONTENTS

<b>SECTION NO.</b>	<b>TITLE</b>	<b>PAGE NO.</b>
	Throttle Body (ETC) Replacement .....	3-88
	Mixer Replacement .....	3-88
	Electronic Pressure Regulator (EPR) Replacement .....	3-89
	Regulator Replacement .....	3-89
	Coolant Hose Replacement .....	3-89
	Vapor Hose Replacement .....	3-89
	Engine Control Module Replacement .....	3-90
	Heated Exhaust Gas Oxygen Sensor Replacement .....	3-90
3.20	GM Engine LPG Fuel System Diagnosis .....	3-91
	Fuel System Description .....	3-91
	Diagnostic Aids.....	3-91
<b>SECTION 4</b>	<b>- BOOM &amp; PLATFORM</b>	
4.1	Boom Systems .....	4-1
	Removal .....	4-1
4.2	Wear Pads.....	4-2
4.3	Boom Disassembly/Assembly & Cable Replacement .....	4-3
	Boom Section Disassembly .....	4-3
4.4	Wire Rope.....	4-4
	Inspection.....	4-4
	Three Month Inspection .....	4-4
	Eight Year Inspection .....	4-4
	Replacement Criteria .....	4-4
4.5	Wire Rope Tensioning Adjustment .....	4-5
	Wire Rope Tensioning Procedure .....	4-5
	Inspection.....	4-9
	Assembly .....	4-10
	Installation .....	4-13
4.6	Articulating Jib Boom.....	4-14
	Removal .....	4-14
	Disassembly.....	4-14
	Inspection.....	4-14
	Assembly .....	4-15
4.7	Limit Switches and Cam Valve Adjustment .....	4-15
4.8	Boom Cleanliness Guidelines .....	4-15
4.9	Rotary Actuator .....	4-18
	Theory of Operation .....	4-18
	Required Tools .....	4-18
	Disassembly.....	4-21
	Inspection.....	4-25
	Assembly .....	4-26
	Installing Counterbalance Valve.....	4-30
	Testing Actuator.....	4-31
	Testing Actuator for Internal Leaks.....	4-31
	Installation and Bleeding .....	4-31
	Troubleshooting .....	4-32
4.10	Foot Switch Adjustment .....	4-33
4.11	Platform .....	4-33
	Platform Support Torque Settings.....	4-33
	Replace Platform Sections .....	4-33
4.12	Powertrack Maintenance .....	4-34
	Remove Link .....	4-34
	Install New Link .....	4-37
	Replace Fixed End Brackets .....	4-40
	Replace Moving End Brackets.....	4-41



<b>SECTION NO.</b>	<b>TITLE</b>	<b>PAGE NO.</b>
<b>SECTION 5 - HYDRAULICS</b>		
5.1	O-Ring Lubrication .....	5-1
	Cup and Brush .....	5-1
	Dip .....	5-2
	Spray .....	5-2
	Brush-On .....	5-2
5.2	Cylinders - Theory of Operation.....	5-3
	Systems With Double Acting Cylinders.....	5-3
	Systems With Holding Valves .....	5-3
5.3	Cylinder Checking Procedure.....	5-3
	Cylinders Without Counterbalance Valves - Master Cylinder and Steer Cylinder.....	5-3
	Cylinders With Single Counterbalance Valve .....	5-4
	Cylinders With Dual Counterbalance Valves .....	5-4
5.4	Cylinder Removal and Installation .....	5-5
	Main Boom Telescope Cylinder Removal .....	5-5
	Main Boom Telescope Cylinder Installation .....	5-5
	Main Boom Lift Cylinder Removal.....	5-6
	Main Boom Lift Cylinder Installation .....	5-6
5.5	Cylinder Repair.....	5-6
	Disassembly .....	5-6
	Cylinder Locations .....	5-7
	Main Lift Cylinder .....	5-8
	Cleaning and Inspection.....	5-10
	Assembly .....	5-11
	Master Cylinder .....	5-13
	Cleaning and Inspection.....	5-15
	Assembly .....	5-16
	Telescope Cylinder .....	5-18
	Cleaning and Inspection.....	5-20
	Assembly .....	5-21
	Platform Level (Slave) Cylinder.....	5-23
	Cleaning and Inspection.....	5-25
	Assembly .....	5-26
	Jib Lift Cylinder (SJ Only) .....	5-28
	Cleaning and Inspection.....	5-30
	Assembly .....	5-31
	Steer Cylinder.....	5-33
	Cleaning and Inspection.....	5-35
	Assembly .....	5-36
	Axle Lockout Cylinder .....	5-37
5.6	Hydraulic Pump (Gear) .....	5-39
	Disassembly .....	5-39
	Inspect Parts For Wear.....	5-41
	General Information.....	5-42
	Reverse Shaft Rotation of Pump .....	5-42
	Assembly .....	5-42
	Placing Pump Back Into Service.....	5-45
5.7	Variable Pump .....	5-45
	Ports and Pressure Gauges .....	5-45
	NFPE Control.....	5-45
	Remove and Install FNR and NFPE Modules .....	5-46
	Remove and Install FNR and NFPE Control Orifices .....	5-46
	Charge Relief Valve.....	5-46
	Shaft Seal and Shaft Replacement .....	5-49
	Hydraulic Pump W/Hayes Pump Drive Coupling Lubrication .....	5-50
	Charge Pump .....	5-51

## TABLE OF CONTENTS

---

<b>SECTION NO.</b>	<b>TITLE</b>	<b>PAGE NO.</b>
5.8	Hydraulic Component Start-Up .....	5-52
5.9	Pressure Setting Procedures .....	5-53
	Main Relief, Steer, Swing, and Lift Down .....	5-53
	Platform Level .....	5-53
	Articulating Jib Boom (If Equipped) .....	5-53
	4 Wheel Steer (If Equipped) .....	5-53
<b>SECTION 6 - JLG CONTROL SYSTEM</b>		
6.1	Introduction .....	6-1
	Connect JLG Control System Analyzer .....	6-3
	Using Analyzer .....	6-3
	Changing Access Level .....	6-4
	Adjust Parameters .....	6-5
	Machine Setup .....	6-6
	Level Vehicle Description .....	6-6
6.2	Machine Personality Settings .....	6-15
6.3	Machine Orientation When Setting Function Speeds .....	6-37
	Test Notes .....	6-38
6.4	CANbus Communications .....	6-38
<b>SECTION 7 - BASIC ELECTRICAL INFORMATION &amp; SCHEMATICS</b>		
7.1	General .....	7-1
7.2	Multimeter Basics .....	7-1
	Grounding .....	7-1
	Backprobing .....	7-1
	Min/Max .....	7-1
	Polarity .....	7-1
	Scale .....	7-1
	Voltage Measurement .....	7-1
	Resistance Measurement .....	7-2
	Continuity Measurement .....	7-2
	Current Measurement .....	7-3
7.3	Applying Silicone Dielectric Compound to Electrical Connections .....	7-3
	Dielectric Grease Application .....	7-4
	Deutsch HD, DT, DTM, DRC Series .....	7-4
	AMP Seal .....	7-4
	AMP Mate-N-Lok .....	7-5
	DIN Connectors .....	7-5
	Exclusions .....	7-5
7.4	AMP Connector .....	7-6
	Contact Assembly .....	7-6
	Connector Assembly .....	7-6
	Disassembly .....	7-7
	Wedge Lock .....	7-7
	Service - Voltage Reading .....	7-7
7.5	Deutsch Connectors .....	7-8
	DT/DTP Series Assembly .....	7-8
	DT/DTP Series Disassembly .....	7-8
	HD30/HDP20 Series Assembly .....	7-9
	HD30/HDP20 Series Disassembly .....	7-9

<b>FIGURE NO.</b>	<b>TITLE</b>	<b>PAGE NO.</b>
1-1.	Operator Maintenance and Lubrication .....	1-6
1-2.	Torque Chart (SAE Fasteners - Sheet 1 of 7) .....	1-11
1-3.	Torque Chart (SAE Fasteners - Sheet 2 of 7) .....	1-12
1-4.	Torque Chart (SAE Fasteners - Sheet 3 of 7) .....	1-13
1-5.	Torque Chart (SAE Fasteners - Sheet 4 of 7) .....	1-14
1-6.	Torque Chart (METRIC Fasteners - Sheet 5 of 7) .....	1-15
1-7.	Torque Chart (METRIC Fasteners - Sheet 6 of 7) .....	1-16
1-8.	Torque Chart (METRIC Fasteners - Sheet 7 of 7) .....	1-17
2-1.	Deutz Engine and Hydraulic Operating Temperature Specifications .....	2-9
2-2.	GM Engine and Hydraulic Operating Temperature Specifications .....	2-10
3-1.	Wheel Lug Nut Tightening Sequence .....	3-1
3-2.	Bolt Tightening Sequence .....	3-2
3-3.	Torque Hub .....	3-3
3-4.	Torque Hub Main Disassembly .....	3-4
3-5.	Output Carrier Disassembly .....	3-5
3-6.	Input Carrier Disassembly .....	3-5
3-7.	Hub Spindle Disassembly .....	3-6
3-8.	Spindle Brake Disassembly .....	3-7
3-9.	Torque Hub Cover .....	3-8
3-10.	Input Carrier Assembly .....	3-9
3-11.	Spindle-Brake Assembly .....	3-10
3-12.	Hub Spindle Assembly .....	3-11
3-13.	Output Planet Gear Assembly .....	3-12
3-14.	Main Assembly .....	3-13
3-15.	Hub Assembly .....	3-14
3-16.	Bearing Cup Pressing Tool .....	3-15
3-17.	Seal Pressing Tool .....	3-15
3-18.	Bearing Cup Pressing Tool .....	3-16
3-19.	Drift Pin for Lining Up Thrust Washers with Output Planet Gear .....	3-16
3-20.	Disengaging Drive Hubs .....	3-17
3-21.	Drive Motor Cross Section .....	3-17
3-22.	Removing Shaft Seal .....	3-18
3-23.	Loop Flushing Spool .....	3-19
3-24.	Loop Flushing Spool .....	3-21
3-25.	Plugs, Fittings, and Speed Sensor .....	3-21
3-26.	End Cap .....	3-22
3-27.	Valve Plate & Rear Shaft Bearing .....	3-22
3-28.	Cylinder Kit .....	3-23
3-29.	Shaft Seal .....	3-23
3-30.	Shaft & Front Bearing .....	3-24
3-31.	Swash Plate & Servo Piston .....	3-24
3-32.	Cylinder Kit Disassembly .....	3-25
3-33.	Servo Piston .....	3-27
3-34.	Swash Plate and Journal Bearing .....	3-28
3-35.	Shaft and Front Bearing .....	3-29
3-36.	Cylinder Kit Installation .....	3-29
3-37.	Servo Spring and Minimum Angle Stop .....	3-29
3-38.	Valve Plate and Rear Bearing .....	3-30
3-39.	End Cap .....	3-30
3-40.	Shaft Seal .....	3-31
3-41.	Plugs and Fittings Installation .....	3-31
3-42.	Loop Flushing Spool .....	3-31
3-43.	Bleeder Valve Location .....	3-32
3-44.	Steer Adjustments .....	3-33
3-45.	Swing Drive Assembly .....	3-34
3-46.	Swing Motor and Brake Assembly .....	3-35
3-47.	Swing Drive Shim Placement .....	3-36
3-48.	Swing Drive Pivot and Mounting Bolts .....	3-36
3-49.	Swing Drive Jam Nut and Mounting Bolt .....	3-36
3-50.	Swing Drive Lubrication .....	3-36

<b>FIGURE NO.</b>	<b>TITLE</b>	<b>PAGE NO.</b>
3-51.	Main Control Valve Disassembly .....	3-37
3-52.	Motor and Brake Disassembly .....	3-37
3-53.	Main Disassembly .....	3-38
3-54.	Hub-Shaft Disassembly .....	3-38
3-55.	Carrier Disassembly .....	3-39
3-56.	Hub-Shaft Subassembly .....	3-40
3-57.	Carrier Subassembly .....	3-41
3-58.	Main Assembly .....	3-42
3-59.	Motor and Brake Assembly .....	3-43
3-60.	Motor Control Valve Assembly .....	3-43
3-61.	Swing Bearing Bolt Feeler Gauge Check .....	3-44
3-62.	Swing Bearing Tolerance Measuring Point .....	3-44
3-63.	Swing Bearing Tolerance Measurement Location & Boom Placement .....	3-45
3-64.	Swing Bearing Torque Sequence .....	3-47
3-65.	Rotary Coupling - Sheet 1 of 2 .....	3-48
3-66.	Rotary Coupling - Sheet 2 of 2 .....	3-49
3-67.	Rotary Coupling Port Location - 2WS .....	3-50
3-68.	Rotary Coupling Port Location - 4WS .....	3-51
3-69.	Generator Belt Tension .....	3-52
3-70.	Generator Brushes and Slip Rings .....	3-52
3-71.	Generator Cleaning .....	3-52
3-72.	Generator Circuit Breaker Location .....	3-53
3-73.	Inspecting Generator Brushes, Replacing Brushes, and Cleaning Slip Rings .....	3-54
3-74.	Deutz D2.9 L4 Engine Installation - Sheet 1 of 2 .....	3-55
3-75.	Deutz D2.9 L4 Engine Installation - Sheet 2 of 2 .....	3-56
3-76.	Deutz 2.9 T4F Dipstick Markings .....	3-57
3-77.	Engine Oil Viscosity .....	3-57
3-78.	Deutz D2011 Engine Installation - Sheet 1 of 2 .....	3-59
3-79.	Deutz D2011 Engine Installation - Sheet 2 of 2 .....	3-60
3-80.	Deutz Dipstick Markings .....	3-61
3-81.	Engine Oil Viscosity .....	3-61
3-82.	EMR 2 Engine Side Equipment .....	3-64
3-83.	Deutz EMR 2 Troubleshooting Flow Chart .....	3-65
3-84.	Deutz EMR 2 Vehicle Side Connection Diagram .....	3-66
3-85.	Deutz EMR 2 Engine Side Connection Diagram - Sheet 1 of 2 .....	3-67
3-86.	Deutz EMR 2 Engine Side Connection Diagram - Sheet 2 of 2 .....	3-68
3-87.	EMR 2 Engine Plug Pin Identification .....	3-69
3-88.	EMR 2 Vehicle Plug Pin Identification .....	3-70
3-89.	EMR2 Fault Codes - Sheet 1 of 5 .....	3-71
3-90.	EMR2 Fault Codes - Sheet 2 of 5 .....	3-72
3-91.	EMR2 Fault Codes - Sheet 3 of 5 .....	3-73
3-92.	EMR2 Fault Codes - Sheet 4 of 5 .....	3-74
3-93.	EMR2 Fault Codes - Sheet 5 of 5 .....	3-75
3-94.	GM Engine Oil Dip Stick .....	3-78
3-95.	GM 3.0 Dual Fuel System Components .....	3-81
3-96.	Direct Electronic Pressure Regulator .....	3-82
3-97.	Air Fuel Mixer .....	3-82
3-98.	Electronic Throttle Control Device .....	3-83
3-99.	Electric Lock Off Assembly .....	3-83
3-100.	ECM Assembly .....	3-83
3-101.	ECM Input-Output Diagram .....	3-83
3-102.	Heated Exhaust Gas Oxygen Sensor (HEGO) .....	3-84
3-103.	Gasoline Fuel Pressure and Temperature Manifold Assembly .....	3-84
3-104.	Filter Lock Assembly .....	3-86
3-105.	DEPR .....	3-91
4-1.	Location of Components - Platform Support .....	4-1
4-2.	Rotator and Leveling Cylinder Locations .....	4-1
4-3.	Boom Powertrack Components .....	4-2
4-4.	Location and Thickness of Wear Pads .....	4-2
4-5.	Clamping Wire Ropes .....	4-3

<b>FIGURE NO.</b>	<b>TITLE</b>	<b>PAGE NO.</b>
4-6.	Proximity Switch Assembly Disassembly .....	4-3
4-7.	Wire Rope Wire Breaks .....	4-4
4-8.	Wire Rope Kink .....	4-4
4-9.	Sheave Groove Wear .....	4-4
4-10.	Dimensions of Boom Sections .....	4-5
4-11.	Clamping Wire Ropes .....	4-5
4-12.	Boom Assembly Cutaway - Sheet 1 of 3 .....	4-6
4-13.	Boom Assembly Cutaway - Sheet 2 of 3 .....	4-7
4-14.	Boom Assembly Cutaway - Sheet 3 of 3 .....	4-8
4-15.	Disassembly of Sheave Assembly .....	4-8
4-16.	Wire Rope Routing Disassembly .....	4-9
4-17.	Dimension of Sheaves When New .....	4-9
4-18.	Routing Installation of Retract Wire Ropes .....	4-10
4-19.	Boom Powertrack Installation .....	4-11
4-20.	Proximity Switch Installation .....	4-12
4-21.	Boom Powertrack Assembly .....	4-13
4-22.	Articulating Jib Boom Components .....	4-14
4-23.	Horizontal Limit and Dual Capacity Limit Switches Adjustments .....	4-16
4-24.	Transport Switch Adjustments - CE Machines Only .....	4-17
4-25.	Rotary Actuator - Exploded View .....	4-19
4-26.	Rotary Actuator - Assembly Drawing .....	4-20
4-27.	Rotator Counterbalance Valve .....	4-30
4-28.	Actuator Bleed Ports .....	4-31
4-29.	Foot Switch Adjustment .....	4-33
4-30.	Platform Support Torque Values .....	4-33
4-31.	Platform Section Replacement .....	4-33
5-1.	Boom Positioning and Support, Cylinder Repair .....	5-3
5-2.	Hydraulic Cylinder Locations .....	5-7
5-3.	Cylinder Barrel Support .....	5-8
5-4.	Marking Cylinder for Alignment .....	5-8
5-5.	Cylinder Rod Support .....	5-8
5-6.	Main Lift Cylinder Assembly .....	5-9
5-7.	Tapered Bushing Removal .....	5-10
5-8.	Composite Bushing Installation .....	5-10
5-9.	Rod Seal Installation .....	5-11
5-10.	Poly-Pak Piston Seal Installation .....	5-11
5-11.	Wiper Seal Installation .....	5-11
5-12.	Head Seal Kit Installation .....	5-11
5-13.	Piston Seal Kit Installation .....	5-12
5-14.	Tapered Bushing Installation .....	5-12
5-15.	Rod Assembly Installation .....	5-12
5-16.	Cylinder Barrel Support .....	5-13
5-17.	Marking Cylinder for Alignment .....	5-13
5-18.	Cylinder Rod Support .....	5-13
5-19.	Master Cylinder Assembly .....	5-14
5-20.	Tapered Bushing Removal .....	5-15
5-21.	Composite Bushing Installation .....	5-15
5-22.	Rod Seal Installation .....	5-16
5-23.	Poly-Pak Piston Seal Installation .....	5-16
5-24.	Wiper Seal Installation .....	5-16
5-25.	Head Seal Kit Installation .....	5-16
5-26.	Piston Seal Kit Installation .....	5-17
5-27.	Tapered Bushing Installation .....	5-17
5-28.	Rod Assembly Installation .....	5-17
5-29.	Cylinder Barrel Support .....	5-18
5-30.	Marking Cylinder for Alignment .....	5-18
5-31.	Cylinder Rod Support .....	5-18
5-32.	Telescope Cylinder Assembly .....	5-19
5-33.	Tapered Bushing Removal .....	5-20
5-34.	Composite Bushing Installation .....	5-20

<b>FIGURE NO.</b>	<b>TITLE</b>	<b>PAGE NO.</b>
5-35.	Rod Seal Installation .....	5-21
5-36.	Poly-Pak Piston Seal Installation.....	5-21
5-37.	Wiper Seal Installation .....	5-21
5-38.	Head Seal Kit Installation .....	5-21
5-39.	Piston Seal Kit Installation.....	5-22
5-40.	Tapered Bushing Installation.....	5-22
5-41.	Rod Assembly Installation .....	5-22
5-42.	Cylinder Barrel Support .....	5-23
5-43.	Marking Cylinder for Alignment.....	5-23
5-44.	Cylinder Rod Support.....	5-23
5-45.	Platform Level (Slave) Cylinder Assembly.....	5-24
5-46.	Tapered Bushing Removal .....	5-25
5-47.	Composite Bushing Installation .....	5-25
5-48.	Rod Seal Installation .....	5-26
5-49.	Poly-Pak Piston Seal Installation.....	5-26
5-50.	Wiper Seal Installation .....	5-26
5-51.	Head Seal Kit Installation .....	5-26
5-52.	Piston Seal Kit Installation.....	5-27
5-53.	Tapered Bushing Installation.....	5-27
5-54.	Rod Assembly Installation .....	5-27
5-55.	Cylinder Barrel Support .....	5-28
5-56.	Marking Cylinder for Alignment.....	5-28
5-57.	Cylinder Rod Support.....	5-28
5-58.	Jib Lift Cylinder Assembly(600SJ).....	5-29
5-59.	Tapered Bushing Removal .....	5-30
5-60.	Composite Bushing Installation .....	5-30
5-61.	Rod Seal Installation .....	5-31
5-62.	Poly-Pak Piston Seal Installation.....	5-31
5-63.	Wiper Seal Installation .....	5-31
5-64.	Head Seal Kit Installation .....	5-31
5-65.	Piston Seal Kit Installation.....	5-32
5-66.	Tapered Bushing Installation.....	5-32
5-67.	Rod Assembly Installation .....	5-32
5-68.	Cylinder Barrel Support .....	5-33
5-69.	Removing Spanner Nut .....	5-33
5-70.	Cylinder Rod Support .....	5-33
5-71.	Steer Cylinder Assembly .....	5-34
5-72.	Piston Seal and Wear Ring .....	5-35
5-73.	Cylinder Head Disassembly .....	5-35
5-74.	Composite Bushing Installation .....	5-35
5-75.	Cylinder Head Assembly .....	5-36
5-76.	Piston Seal and Wear Ring .....	5-36
5-77.	Spanner Nut Torque .....	5-36
5-78.	Axle Lockout Cylinder .....	5-38
5-79.	Shim Adjustable Charge Relief Valve Components.....	5-46
5-80.	Gauge Port Locations.....	5-47
5-81.	Plugs/Fittings Size & Torque .....	5-48
5-82.	Screw Adjustable Charge Relief Valve Components.....	5-49
5-83.	Shaft Seal Components .....	5-49
5-84.	Installation of Shaft Seal .....	5-49
5-85.	Shaft Components .....	5-50
5-86.	Charge Pump Components .....	5-51
5-87.	Articulating Jib Boom Pressure Adjustment .....	5-53
5-88.	Main Control Valve - Sheet 1 of 2.....	5-54
5-89.	Main Control Valve - Sheet 1 of 2.....	5-55
5-90.	Location of Components - Main Control Valve.....	5-56
6-1.	Hand-Held Analyzer (WANALYZER Controls and Display Similar) .....	6-1
6-2.	Controller Block Diagram .....	6-2
6-3.	Analyzer Platform Connector .....	6-3
6-4.	Analyzer Ground Control Box Connector .....	6-3

<b>FIGURE NO.</b>	<b>TITLE</b>	<b>PAGE NO.</b>
6-5.	Analyzer Software Version 6.8 - Sheet 1 of 6 .....	6-9
6-6.	Analyzer Software Version 6.8 - Sheet 2 of 6 .....	6-10
6-7.	Analyzer Software Version 6.8 - Sheet 3 of 6 .....	6-11
6-8.	Analyzer Software Version 6.8 - Sheet 4 of 6 .....	6-12
6-9.	Analyzer Software Version 6.8 - Sheet 5 of 6 .....	6-13
6-10.	Analyzer Software Version 6.8 - Sheet 6 of 6 .....	6-14
6-11.	Control Module Locations .....	6-48
6-12.	Ground Control Module Pin Connections 1 of 3 .....	6-49
6-13.	Ground Control Module Pin Connections 2 of 3 .....	6-50
6-14.	Ground Control Module Pin Connections 3 of 3 .....	6-51
6-15.	Platform Control Module Pin Connections 1 of 2 .....	6-52
6-16.	Platform Control Module Pin Connections 2 of 2 .....	6-53
7-1.	Voltage Measurement (DC) .....	7-1
7-2.	Resistance Measurement .....	7-2
7-3.	Continuity Measurement .....	7-2
7-4.	Current Measurement (DC) .....	7-3
7-5.	Applying Dielectric Grease .....	7-4
7-6.	Deutsch Connector .....	7-4
7-7.	Dielectric Grease On Female Contacts .....	7-4
7-8.	Seal Plugs .....	7-4
7-9.	AMP Mate-N-Lok Connector .....	7-5
7-10.	DIN Connector .....	7-5
7-11.	Brad Harrison/Phoenix Connectors .....	7-5
7-12.	AMP Junior Timer .....	7-5
7-13.	AMP Connector .....	7-6
7-14.	AMP Contact Assembly .....	7-6
7-15.	AMP Connector Assembly .....	7-6
7-16.	AMP Contact Installation .....	7-6
7-17.	Close Wedge Lock .....	7-7
7-18.	Seating Wedge Lock .....	7-7
7-19.	AMP Connector Disassembly .....	7-7
7-20.	DT/DTP Contact Installation .....	7-8
7-21.	DT/DTP Contact Removal .....	7-8
7-22.	HD/HDP Contact Installation .....	7-9
7-23.	HD/HDP Locking Contacts Into Position .....	7-9
7-24.	HD/HDP Contact Removal .....	7-9
7-25.	HD/HDP Unlocking Contacts .....	7-9
7-26.	Electrical Components 1 of 2 .....	7-10
7-27.	Electrical Components 2 of 2 .....	7-11
7-28.	Platform and Ground Control Electrical Schematic - 1 of 2 .....	7-12
7-29.	Platform and Ground Control Electrical Schematic - 2 of 2 .....	7-13
7-30.	Generator Wiring Schematic 1 of 2 .....	7-14
7-31.	Generator Wiring Schematic 2 of 2 .....	7-15
7-32.	Deutz Engine Harness Electrical Schematic .....	7-16
7-33.	GM/PSI Engine Harness Electrical Schematic .....	7-17
7-34.	Deutz Tier 4 Final Engine Harness Electrical Schematic .....	7-18
7-35.	Deutz Tier 4 Final Engine Harness Electrical Schematic .....	7-19
7-36.	Hydraulic Schematic .....	7-20
7-37.	Hydraulic Schematic .....	7-21
7-38.	Hydraulic Schematic 2-Wheel Drive - 1 of 2 .....	7-22
7-39.	Hydraulic Schematic 2-Wheel Drive - 2 of 2 .....	7-23
7-40.	Hydraulic Schematic 4-Wheel Drive - 1 of 2 .....	7-24
7-41.	Hydraulic Schematic 4-Wheel Drive - 2 of 2 .....	7-25

<b>TABLE NO.</b>	<b>TITLE</b>	<b>PAGE NO.</b>
1-1	Operating Specifications . . . . .	1-1
1-2	Dimensional Data . . . . .	1-1
1-3	Capacities . . . . .	1-2
1-4	Tire Specifications . . . . .	1-2
1-5	Deutz TD 2.9 Specifications . . . . .	1-2
1-6	Deutz D2011L04 . . . . .	1-2
1-7	GM 3.0L . . . . .	1-2
1-8	Function Speeds (In Seconds) . . . . .	1-3
1-9	Torque Requirements . . . . .	1-3
1-10	Hydraulic Oil . . . . .	1-4
1-11	Mobilfluid 424 . . . . .	1-4
1-12	Mobil DTE 13M . . . . .	1-4
1-13	UCon Hydrolube HP-5046 . . . . .	1-4
1-14	Mobil EAL H 46 . . . . .	1-5
1-15	Exxon Univas HVI 26 . . . . .	1-5
1-16	Component Weights . . . . .	1-5
1-17	Lubrication Specifications. . . . .	1-6
2-1	Inspection and Maintenance. . . . .	2-2
2-2	Cylinder Drift . . . . .	2-4
2-3	Inspection and Preventive Maintenance Schedule . . . . .	2-6
3-1	Wheel Torque Chart . . . . .	3-2
3-2	Torque Hub Brake Release Pressure . . . . .	3-13
3-3	Excessive Noise and/or Vibration . . . . .	3-20
3-4	System Operating Hot. . . . .	3-20
3-5	Won't Shift or Slow to Start. . . . .	3-20
3-6	Displacement Identifiers . . . . .	3-23
3-7	Slipper Foot Thickness & End Play . . . . .	3-25
3-8	Cylinder Block Measurements . . . . .	3-26
3-9	Coupling Port Information Table - 2WS . . . . .	3-52
3-10	Coupling Port Information Table - 4WS . . . . .	3-52
3-11	LP Fuel System Diagnosis . . . . .	3-92
3-12	Symptom Diagnosis . . . . .	3-94
3-13	DTC to SPN/FMI Cross Reference Chart . . . . .	3-102
4-1	Troubleshooting . . . . .	4-32
5-1	Hydraulic Pump Bolt Torque Chart. . . . .	5-44
5-2	Recommended Gauge Size . . . . .	5-45
6-1	Analyzer Abbreviations . . . . .	6-7
6-2	Personality Ranges/Defaults . . . . .	6-15
6-3	Help Fault Codes, Displayed Faults, and Descriptions . . . . .	6-18
6-4	Help Message/Fault Listing. . . . .	6-27
6-5	Machine Configuration Programming Information . . . . .	6-33
6-6	Fault Code List . . . . .	6-39



## SECTION 1. SPECIFICATIONS

## 1.1 OPERATING SPECIFICATIONS

Table 1-1. Operating Specifications

Ground Bearing Pressure 600S 660SJ	67 psi (4.7 kg/cm <sup>2</sup> ) 75 psi (5.3 kg/cm <sup>2</sup> )
Maximum Drive Speed	4.25 MPH (6.8 Km/hr.)
Electrical System	12VDC
Gross Machine Weight (Approximate) 600S - 2WS 600S - 4WS 660SJ - 2WD 660SJ - 4WS	21,425 lbs. (9718 kg) 21,800 lbs. (9888 kg) 26,275 lbs. (11918 kg) 25,910 lbs. (12088 kg)
Ground Bearing Pressure 600S 660SJ	67 psi (4.7 kg/cm <sup>2</sup> ) 75 psi (5.3 kg/cm <sup>2</sup> )
Maximum Drive Speed	4.25 MPH (6.8 Km/hr.)
Electrical System	12VDC
Gross Machine Weight (Approximate) 600S - 2WS 600S - 4WS 660SJ - 2WD 660SJ - 4WS	21,425 lbs. (9718 kg) 21,800 lbs. (9888 kg) 26,275 lbs. (11918 kg) 25,910 lbs. (12088 kg)
Ground Bearing Pressure 600S 660SJ	67 psi (4.7 kg/cm <sup>2</sup> ) 75 psi (5.3 kg/cm <sup>2</sup> )
Maximum Drive Speed	4.25 MPH (6.8 Km/hr.)
Electrical System	12VDC

## 1.2 DIMENSIONAL DATA

Table 1-2. Dimensional Data

Machine Height (Stowed)	8ft. 5in. (2.57 m)
Machine Length (Stowed) 600S 660SJ	28ft. 4.6in. (8.65 m) 35ft. 8in. (10.88 m)
Machine Width (by tire size) 39x15 - 22.5 15x19.5 tire (non-marking) 41/18LLx22.5X625 (turf)	97in. (2.46 m) 98in. (2.49 m) 100in. (2.54 m)
Wheelbase	8ft. 1in. (2.46 m)
Ground Clearance	12in. (0.3 m)
Platform Height 600S 660SJ	60ft. 3in. (18.36 m) 66ft. 8in. (20.32 m)
Horizontal Reach 600S 660SJ	49ft. 6in. (15.08 m) 56ft. 9in. (17.30 m)
Tail Swing	3ft. 9in. (1.14 m)
Capacity (Unrestricted)	500 lbs (227 kg)

## SECTION 1 - SPECIFICATIONS

### 1.3 CAPACITIES

**Table 1-3. Capacities**

Fuel Tank	40 Gallons (151 L)
Hydraulic Oil Tank	32 Gallons (98.4 L)
Hydraulic System (Including Tank)	40 Gallons (121 L)
Torque Hub, Drive*	17 ounces (0.5 L)
Engine Crankcase Deutz D2011L04 GM	11 quarts (10.5 L) 4.5 qts. (4.25 L) w/Filter
*Fill torque hubs half (1/2) full of lubricant.	

### 1.4 TIRES

**Table 1-4. Tire Specifications**

Size	39 x 15-22.5
Load Range	G
Ply Rating	14
Foam Fill (Optional)	Foam/Crumb
Diameter	38.5
Width	15.5
Rim Size	11.75 x 22.5
Tire & Wheel Weight	128T, 262FF,
Max Tire Load	16,000 lb (7257 kg) @ 95 psi (6.5 bar)
Size	15 x 19.5 Non-Marking
Load Range	G
Ply Rating	14
Foam Fill	Foam/Crumb
Diameter	40
Width	15.3
Rim Size	11.75 x 19.5
Tire & Wheel Weight	585 lb
Max Tire Load	20,000 lb @ 95 psi (6.5 bar)
Size	41/18LL x 22.5 Turf/Sand
Load Range	H
Ply Rating	16
Foam Fill	Soft
Diameter	41
Width	18.4
Rim Size	14 x 22.5
Tire & Wheel Weight	724 lb (329 kg)
Max Tire Load	15,500 lb @ 70 psi/5 bar

### 1.5 ENGINE DATA

**Table 1-5. Deutz TD 2.9 Specifications**

Fuel	Ultra Low Sulfur Diesel (15 ppm)
Output	67 hp (50 kW)
Torque	173 ft.lbs. (234 Nm) @ 1800rpm
Oil Capacity (Crankcase)	2.4 gal (8.9 L) w/Filter
Cooling System	3.3 gal (12.5 L)
Low RPM	1200 ± 50 rpm
High RPM	2600 ± 50 rpm
Alternator	95 Amp
Fuel Consumption	0.65 GPH (2.48 lph)

**Table 1-6. Deutz D2011L04**

Fuel	Diesel
Oil Capacity	5 Quarts (4.5 L)
Cooling System	11 Quarts (10.5 L) w/Filter
Crankcase	16 Quarts (15 L)
Total Capacity	
Idle RPM	1000
Low RPM	1800
High RPM	2500
Alternator	60 Amp, belt drive
Battery	950 Cold Cranking Amps, 205 Minutes Reserve Capacity, 12 VDC
Fuel Consumption	0.65 GPH (2.46 lph)
Horsepower	49

**Table 1-7. GM 3.0L**

Fuel	Gasoline or Gasoline/LP Gas
No. of Cylinders	4
BHP	
Gasoline	83 hp @ 3000 rpm
LP	75 hp @ 3000 rpm
Bore	4.0 in. (101.6 mm)
Stroke	3.6 in. (91.44 mm)
Displacement	181 cu.in. (3.0 L, 2966 cc)
Oil Capacity w/filter	4.5 qts. (4.25 L)
Minimum Oil Pressure	
at idle	6 psi (0.4 Bar) @ 1000 rpm
Hot	18 psi (1.2 Bar) @ 2000 rpm
Compression Ratio	9.2:1
Firing Order	1-3-4-2
Max. RPM	2800
Fuel Consumption	N/A

**1.6 FUNCTION SPEEDS**

**Table 1-8. Function Speeds (In Seconds)**

Function	600S	600SJ
Lift Up	46 - 60	46 - 60
Lift Down	33 - 43	33 - 43
Swing Right & Left*	79 - 101	79 - 101
Telescope In	25 - 33	25 - 33
Telescope Out	50 - 67	50 - 67
Platform Rotate Right & Left**	16 - 25	25 - 32
Jib Up	N/A	22 - 34
Jib Down	N/A	16 - 26
Drive (2WD & 4WD GM Engine)	30-34 (4.25 MPH)	30-34 (4.25 MPH)
Drive (2WD & 4WD Deutz Engines)	34-38 (4.02 MPH)	34-38 (4.02 MPH)
Drive above Horizontal (50 ft.)	46-54 (0.68 MPH)	46-54 (0.68 MPH)
*Max 10% Difference Between Left & Right		
**Max 15% Difference Between Left & Right		

**Machine Orientation When Doing Speed Tests**

**Lift:** Boom retracted. Telescope retracted. Lift up, record time, Lift down, record time.

**Swing:** Boom at full elevation. Telescope retracted. Swing turntable off center and stop. Swing opposite direction and start test when centered. This eliminates controller ramp up and ramp down affecting times.

**Telescope:** Boom at full elevation; Telescope retracted; Telescope out, record time. Telescope In, record time.

**Drive:** Test to be done on a smooth level surface. Set Drive Select Switch to 2WD High Engine. Start approximately 25 ft (7.62 m) from starting point so unit is at maximum speed when starting test. Record results for a 200 ft. (60.96 m) course. Drive forward, record time. Drive reverse, record time.

**Drive (Above Horizontal):** Test should be done on a smooth level surface. Set Drive Select Switch to 2WD High Engine. Select Platform Speed Knob out of creep speed. This verifies switches are working when boom is above horizontal. Results should be recorded for a 50 ft course. Drive forward, record time. Drive reverse, record time.

**Platform Rotate:** Platform level and completely rotated one direction. Rotate opposite direction, record time. Rotate other direction, record time.

**Jib:** Platform level and centered with boom. Start with Jib down. Jib up, record time. Jib down, record time.

**Test Notes**

1. Start stop watch with function, not with controller or switch.
2. Drive test results reflect 12x16.5 or 33/1550x16.5 air or foam-filled tires.
3. All speed tests are run from platform. Speeds do not reflect ground control operation.
4. Platform speed knob control must be at full speed (turned clockwise completely).
5. Test with oil temperature above 100° F (38° C). Function speeds vary if hydraulic oil is cold and thick.
6. Some flow control functions may not work with speed knob clicked into creep position.

**1.7 TORQUE REQUIREMENTS**

**Table 1-9. Torque Requirements**

Description	Torque Value (Dry)	Interval Hours
Bearing To Chassis	190 ft. lbs. (258 Nm)	50/600*
Bearing To Turntable	190 ft. lbs. (258 Nm)	50/600*
Wire Rope	15 ft. lbs (20 Nm)	150
Wheel Lugs	170 ft. lbs (231 Nm)	150
Engine Mounting Bolts	165 ft. lbs. (231 Nm)	A/R
Engine Manifold Mounting Bolts	30 ft. lbs. (42 Nm)	A/R
*Check swing bearing bolts after first 50 hours of operation and every 600 hours thereafter. (See Swing Bearing in Section 3.)		

## SECTION 1 - SPECIFICATIONS

### 1.8 HYDRAULIC OIL

**Table 1-10. Hydraulic Oil**

Hydraulic System Operating Temperature Range	S.A.E. Viscosity Grade
+0° to +180° F (-18° to +83° C)	10W
+0° to +210° F (-18° to +99° C)	10W-20, 10W30
+50° to +210° F (+10° to +99° C)	20W-20

**NOTE:** Hydraulic oils require anti-wear qualities at least API Service Classification GL-3, and sufficient chemical stability for mobile hydraulic system service.

**NOTE:** Aside from JLG recommendations, it is not advisable to mix oils of different brands or types. They may not contain required additives or be of comparable viscosities. If hydraulic oil other than Mobil 424 is desired, contact JLG Industries for proper recommendations.

**Table 1-11. Mobilfluid 424**

SAE Grade	10W30
Gravity, API	29.0
Density, Lb/Gal. 60°F	7.35
Pour Point, Max	-46°F (-43°C)
Flash Point, Min.	442°F (228°C)
<b>Viscosity</b>	
Brookfield, cP at -18°C	2700
at 40° C	55 cSt
at 100° C	9.3 cSt
Viscosity Index	152

**Table 1-12. Mobil DTE 13M**

ISO Viscosity Grade	#32
Specific Gravity	0.877
Pour Point, Max	-40°F (-40°C)
Flash Point, Min.	330°F (166°C)
<b>Viscosity</b>	
at 40° C	33cSt
at 100° C	6.6 cSt
at 100° F	169 SUS
at 210° F	48 SUS
cp at -20° F	6,200
Viscosity Index	140

**Table 1-13. UCon Hydrolube HP-5046**

Type	Synthetic Biodegradable
Specific Gravity	1.082
Pour Point, Max	-58°F (-50°C)
pH	9.1
<b>Viscosity</b>	
at 0° C (32° F)	340 cSt (1600SUS)
at 40° C (104° F)	46 cSt (215SUS)
at 65° C (150° F)	22 cSt (106SUS)
Viscosity Index	170

**Table 1-14. Mobil EAL H 46**

Type	Synthetic Biodegradable
ISO Viscosity Grade	46
Specific Gravity	.910
Pour Point	-44°F (-42°C)
Flash Point	500°F (260°C)
Operating Temp.	0 to 180°F (-17 to 162°C)
Weight	7.64 lb. per gal. (0.9 kg per liter)
<b>Viscosity</b>	
at 40° C	45 cSt
at 100° C	8.0 cSt
Viscosity Index	153

**Table 1-15. Exxon Univis HVI 26**

Specific Gravity	32.1
Pour Point	-76°F (-60°C)
Flash Point	217°F (103°C)
<b>Viscosity</b>	
at 40° C	25.8 cSt
at 100° C	9.3 cSt
Viscosity Index	376
<b>NOTE:</b> ExxonMobil recommends checking oil viscosity yearly.	

## 1.9 MAJOR COMPONENT WEIGHTS

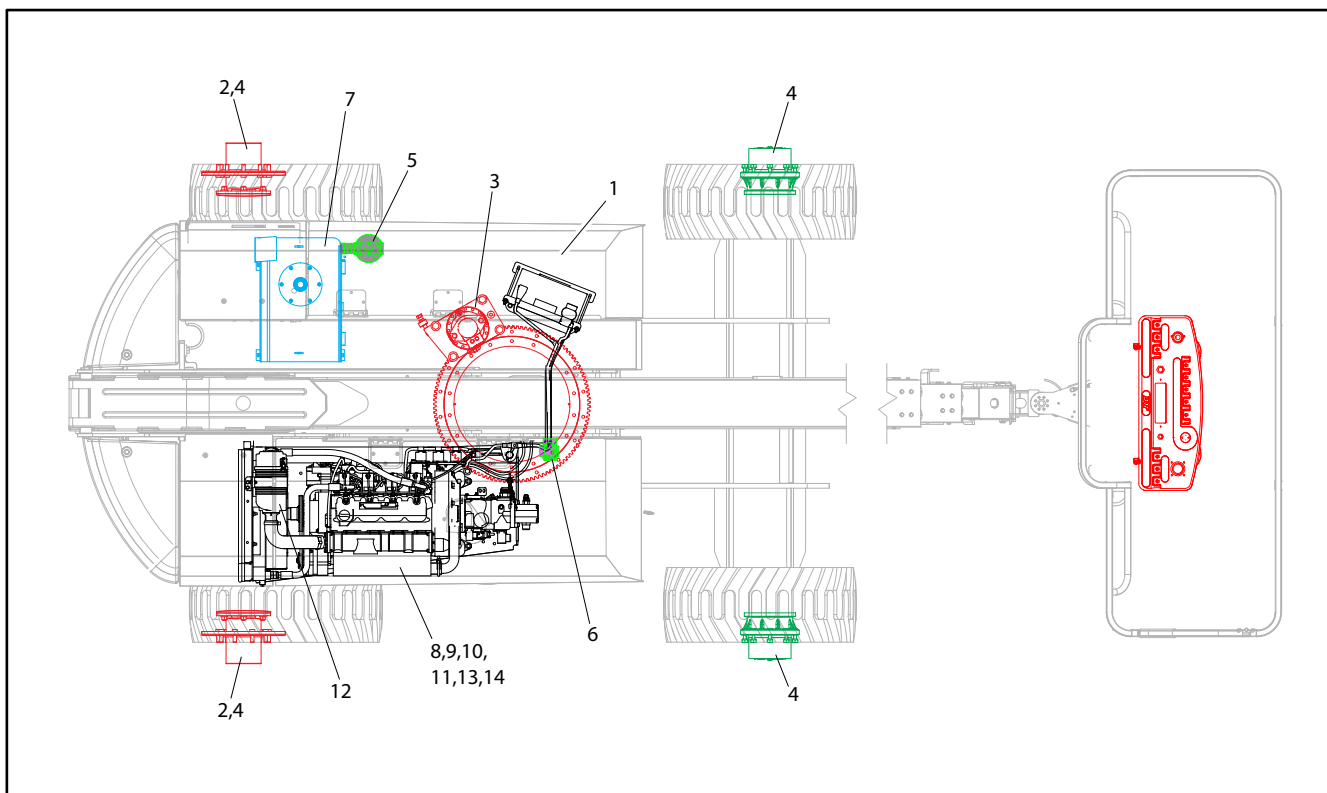
### **⚠ WARNING**

DO NOT REPLACE ITEMS CRITICAL TO STABILITY WITH ITEMS OF DIFFERENT WEIGHT OR SPECIFICATION (FOR EXAMPLE: BATTERIES, FILLED TIRES, PLATFORM) DO NOT MODIFY UNIT IN ANY WAY TO AFFECT STABILITY.

**Table 1-16. Component Weights**

600S Components	LBS.	KG.
Tire and Wheel (Ballasted Only) 15 - 19.5	253	115
Engine - Deutz	534	242
Counterweight	2900	1315
Platform - 6 ft. (1.83 M)	205	93
Platform - 8 ft. (2.44 M)	230	105

600SJ Components	LBS.	KG.
Tire and Wheel (Ballasted Only) 15 - 19.5	253	115
Engine - Deutz	534	242
Counterweight	4650	2109
Platform - 6 ft. (1.83 M)	205	93
Platform - 8 ft. (2.44 M)	230	105



**Figure 1-1. Operator Maintenance and Lubrication**

**1.10 OPERATOR MAINTENANCE**

**NOTE:** The following numbers correspond to those in Figure 1-1., Operator Maintenance and Lubrication.

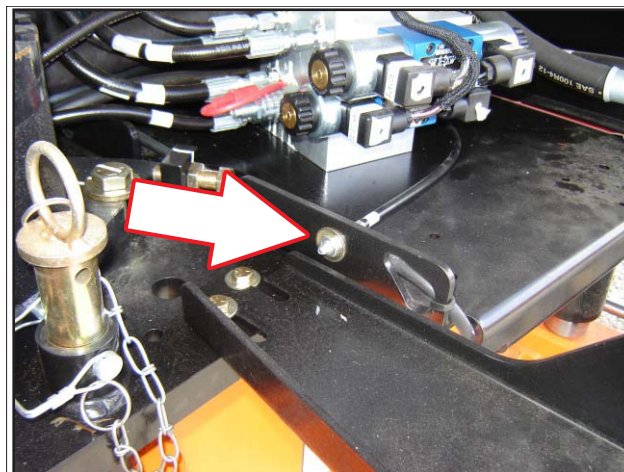
**Table 1-17. Lubrication Specifications.**

KEY	SPECIFICATIONS
MPG	Multipurpose Grease having a minimum dripping point of 350° F (177° C). Excellent water resistance and adhesive qualities, and being of extreme pressure type. (Timken OK 40 pounds minimum.)
EPGL	Extreme Pressure Gear Lube (oil) meeting API service classification GL-5 or MIL-Spec MIL-L-2105
HO	Hydraulic Oil. API service classification GL-3, e.g. Mobilfluid 424
EO	Engine (crankcase) Oil. Gas - API SF, SH, SG class, MIL-L-2104. Diesel - API CC/CD class, MIL-L-2104B/MIL-L-2104C

**NOTICE**

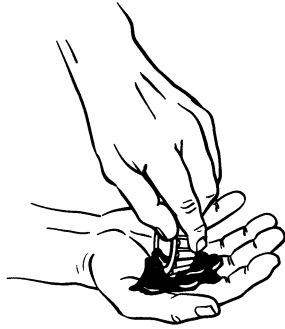
**LUBRICATION INTERVALS ARE BASED ON MACHINE OPERATION UNDER NORMAL CONDITIONS. FOR MACHINES USED IN MULTI-SHIFT OPERATIONS AND/OR EXPOSED TO HOSTILE ENVIRONMENTS OR CONDITIONS, LUBRICATION FREQUENCIES MUST BE INCREASED ACCORDINGLY.**

**1. Swing Bearing**



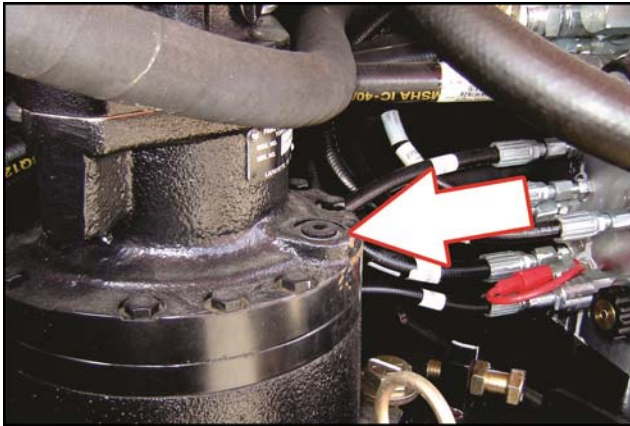
Lube Point(s) - 1 Grease Fittings  
 Capacity - A/R  
 Lube - MPG  
 Interval - Every 3 months or 150 hrs of operation  
 Comments - Remote Access. Apply grease and rotate in 90 degree intervals until bearing is completely lubricated.

**2. Wheel Bearings (If equipped)**



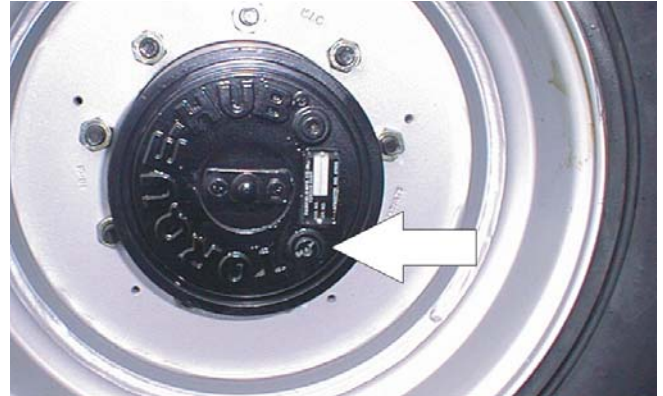
Lube Point(s) - Repack  
 Capacity - A/R  
 Lube - MPG  
 Interval - Every 2 years or 1200 hours of operation

**3. Swing Drive Hub**



**4. Lube Point(s) - Level/Fill Plug**  
 Capacity - 43 oz. (1.3 L)  
 Lube - 90w80 Gear Oil  
 Interval - Check level every 3 months or 150 hrs of operation; change every 2 years or 1200 hours of operation

**5. Wheel Drive Hub**



Lube Point(s) - Level/Fill Plug  
 Capacity - 17 oz. (1/2 Full)  
 Lube - EPGL  
 Interval - Check level every 3 months or 150 hrs of operation; change every 2 years or 1200 hours of operation

**6. Hydraulic Return Filter**



Interval - Change after first 50 hrs. and every 6 months or 300 hrs. thereafter or as shown by Condition Indicator.

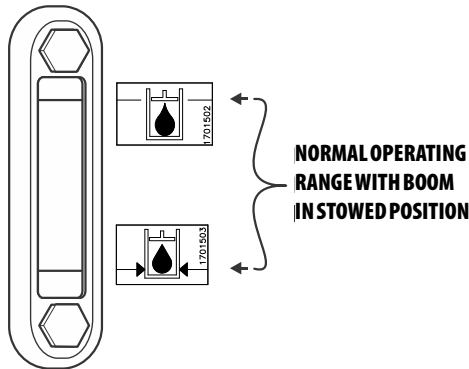
**SECTION 1 - SPECIFICATIONS**

**7. Hydraulic Charge Filter**



Interval - Change after first 50 hrs. and every 6 months or 300 hrs. thereafter, or as shown by Condition Indicator.

**8. Hydraulic Tank Lube Point(s) - Fill Cap**

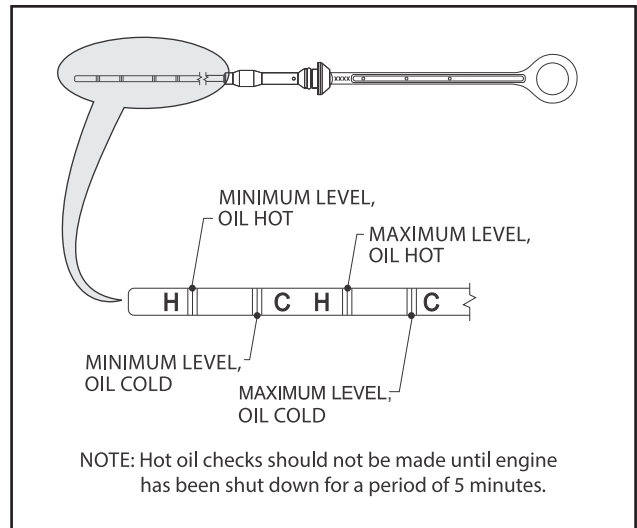


Capacity - 26 gal. Tank; 40 gal. System  
 Lube - HO  
 Interval - Check Level daily; Change every 2 years or 1200 hours of operation

**9. Oil Change w/Filter - Deutz D2011**

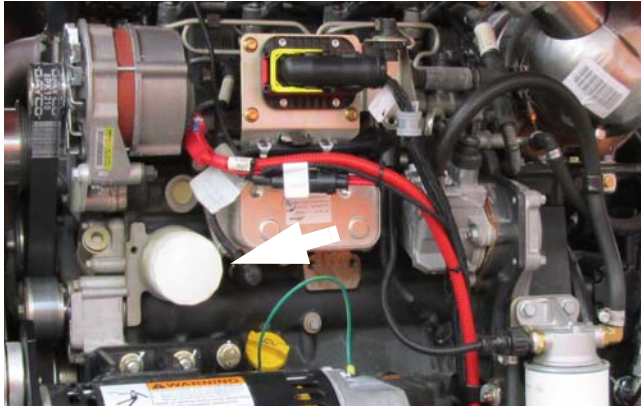


Lube Point(s) - Fill Cap/Spin-on Element  
 Capacity - 11 Quarts Crankcase; 5 Quarts Cooler  
 Lube - EO  
 Interval - Every Year or 1200 hours of operation  
 Comments - Check level daily/Change in accordance with engine manual..

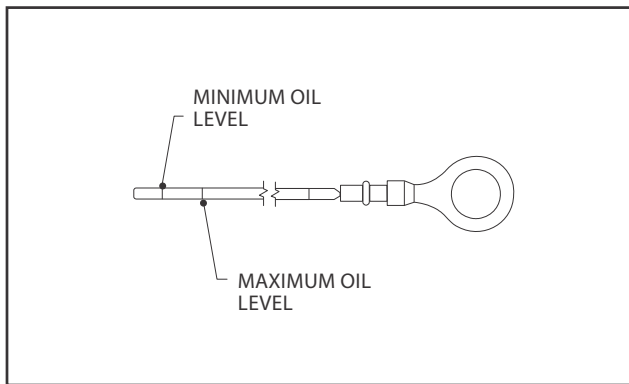




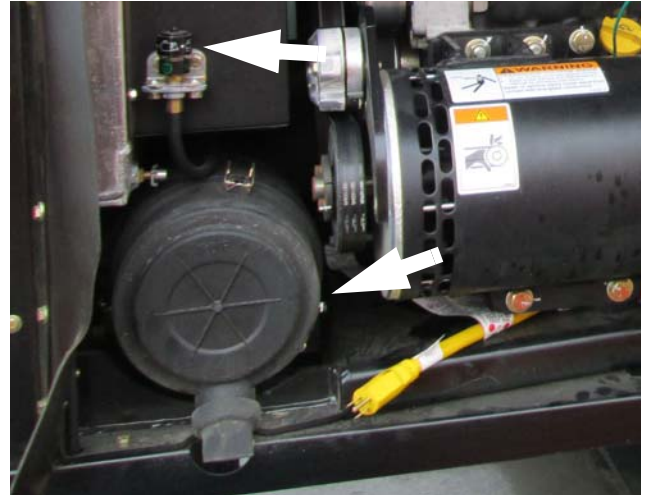
**10. Oil Change w/Filter - Deutz D2.9**



Lube Point(s) - Fill Cap/Spin-on Element  
Capacity - 8.45 Qt (8 L) Crankcase and Filter  
Interval - Every Year or 600 hours of operation  
Comments - Check level daily/Change in accordance with engine manual..



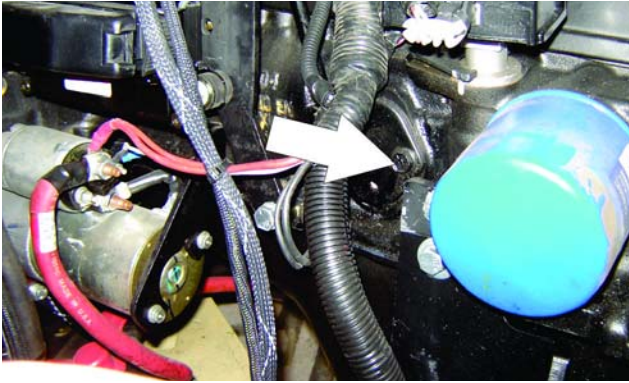
**11. Air Filter - Deutz D2.9**



Lube Point(s) - Replaceable Element  
Interval - Every 6 months or 300 hours of operation or as shown by condition indicator

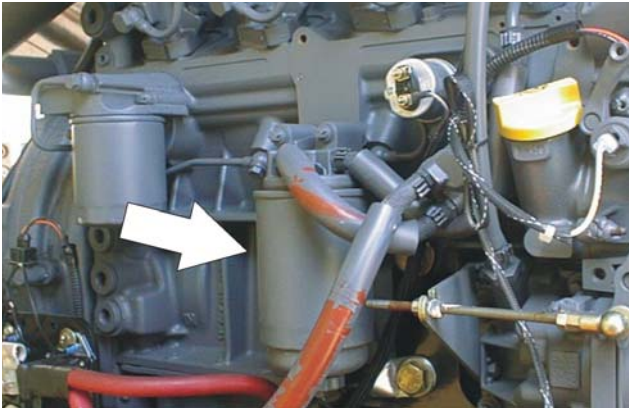
## SECTION 1 - SPECIFICATIONS

### 12. Oil Change w/Filter - GM



Lube Point(s) - Fill Cap/Spin-on Element  
(JLG P/N 7027965)  
Capacity - 4.5 qt. (4.25 L) w/filter  
Lube - EO  
Interval - 3 Months or 150 hours of operation  
Comments - Check level daily/Change in accordance with engine manual.

### 13. Fuel Filter - Deutz



Lube Point(s) - Replaceable Element  
Interval - Every Year or 600 hours of operation

### 14. Fuel Filter (Gasoline) - GM

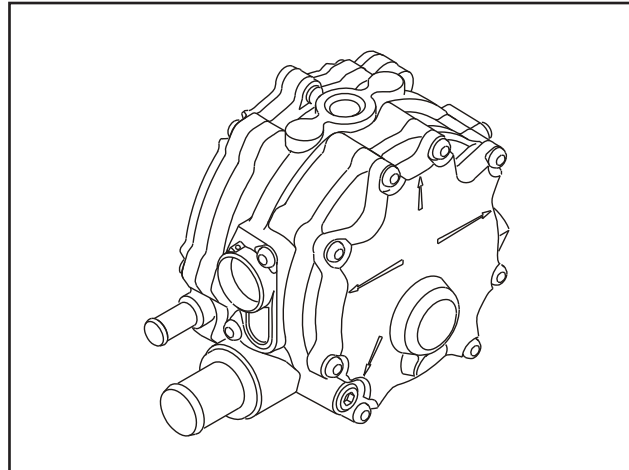
Lube Point(s) - Replaceable Element  
Interval - Every 6 months or 300 hours of operation

### 15. Air Filter



Lube Point(s) - Replaceable Element  
Interval - Every 6 months or 300 hours of operation or as indicated by the condition indicator

### 16. 2-Stage Vaporizer (LP only)



Interval - 3 Months or 150 hours of operation, or whenever fuel is contaminated.  
Comments - Drain oil build up or contamination.

### 17. Fuel Filter (Propane) - GM Engine



Interval - 3 Months or 150 hours of operation  
Comments - Replace filter.

Values for Zinc Yellow Chromate Fasteners (Ref 4150707)												
SAE GRADE 5 BOLTS & GRADE 2 NUTS												
Size	TPI	Bolt Dia	Tensile Stress Area	Clamp Load	Torque (Dry)		Torque Lubricated		Torque (Loctite® 242™ or 271™ OR Vibra-TITE™ 111 or 140)		Torque (Loctite® 262™ or Vibra-TITE™ 131)	
					IN-LB	[N.m]	IN-LB	[N.m]	IN-LB	[N.m]	IN-LB	[N.m]
		In	Sq In	LB								
4	40	0.1120	0.00604	380	8	0.9	6	0.7				
	48	0.1120	0.00661	420	9	1.0	7	0.8				
6	32	0.1380	0.00909	580	16	1.8	12	1.4				
	40	0.1380	0.01015	610	18	2.0	13	1.5				
8	32	0.1640	0.01400	900	30	3.4	22	2.5				
	36	0.1640	0.01474	940	31	3.5	23	2.6				
10	24	0.1900	0.01750	1120	43	4.8	32	3.5				
	32	0.1900	0.02000	1285	49	5.5	36	4				
1/4	20	0.2500	0.0318	2020	96	10.8	75	9	105	12		
	28	0.2500	0.0364	2320	120	13.5	86	10	135	15		
		In	Sq In	LB	FT-LB	[N.m]	FT-LB	[N.m]	FT-LB	[N.m]	FT-LB	[N.m]
5/16	18	0.3125	0.0524	3340	17	23	13	18	19	26	16	22
	24	0.3125	0.0580	3700	19	26	14	19	21	29	17	23
3/8	16	0.3750	0.0775	4940	30	41	23	31	35	48	28	38
	24	0.3750	0.0878	5600	35	47	25	34	40	54	32	43
7/16	14	0.4375	0.1063	6800	50	68	35	47	55	75	45	61
	20	0.4375	0.1187	7550	55	75	40	54	60	82	50	68
1/2	13	0.5000	0.1419	9050	75	102	55	75	85	116	68	92
	20	0.5000	0.1599	10700	90	122	65	88	100	136	80	108
9/16	12	0.5625	0.1820	11600	110	149	80	108	120	163	98	133
	18	0.5625	0.2030	12950	120	163	90	122	135	184	109	148
5/8	11	0.6250	0.2260	14400	150	203	110	149	165	224	135	183
	18	0.6250	0.2560	16300	170	230	130	176	190	258	153	207
3/4	10	0.7500	0.3340	21300	260	353	200	271	285	388	240	325
	16	0.7500	0.3730	23800	300	407	220	298	330	449	268	363
7/8	9	0.8750	0.4620	29400	430	583	320	434	475	646	386	523
	14	0.8750	0.5090	32400	470	637	350	475	520	707	425	576
1	8	1.0000	0.6060	38600	640	868	480	651	675	918	579	785
	12	1.0000	0.6630	42200	700	949	530	719	735	1000	633	858
1 1/8	7	1.1250	0.7630	42300	800	1085	600	813	840	1142	714	968
	12	1.1250	0.8560	47500	880	1193	660	895	925	1258	802	1087
1 1/4	7	1.2500	0.9690	53800	1120	1518	840	1139	1175	1598	1009	1368
	12	1.2500	1.0730	59600	1240	1681	920	1247	1300	1768	1118	1516
1 3/8	6	1.3750	1.1550	64100	1460	1979	1100	1491	1525	2074	1322	1792
	12	1.3750	1.3150	73000	1680	2278	1260	1708	1750	2380	1506	2042
1 1/2	6	1.5000	1.4050	78000	1940	2630	1460	1979	2025	2754	1755	2379
	12	1.5000	1.5800	87700	2200	2983	1640	2224	2300	3128	1974	2676

NO. 500059 REV. J

- NOTES: 1. THESE TORQUE VALUES DO NOT APPLY TO CADMIUM PLATED FASTENERS  
 2. ALL TORQUE VALUES ARE STATIC TORQUE MEASURED PER STANDARD AUDIT METHODS TOLERANCE = ±10%  
 3. \* ASSEMBLY USES HARDENED WASHER

REFERENCE JLG ANEROBIC THREAD LOCKING COMPOUND				
JLG P/N	Loctite® P/N		ND Industries P/N	Description
0100011	242™		Vibra-TITE™ 121	Medium Strength (Blue)
0100019	271™		Vibra-TITE™ 140	High Strength (Red)
0100071	262™		Vibra-TITE™ 131	Medium - High Strength (Red)

Figure 1-2. Torque Chart (SAE Fasteners - Sheet 1 of 7)

**SECTION 1 - SPECIFICATIONS**

Values for Zinc Yellow Chromate Fasteners (Ref 4150707)										
SAE GRADE 8 (HEX HD) BOLTS & GRADE 8 NUTS*										
Size	TPI	Bolt Dia	Tensile Stress Area	Clamp Load	Torque (Dry or Loctite® 263) K= 0.20		Torque (Loctite® 242™ or 271™ OR Vibra-TITE™ 111 or 140) K=.18		Torque (Loctite® 262™ or Vibra-TITE™ 131) K=0.15	
					IN-LB	[N.m]	IN-LB	[N.m]	IN-LB	[N.m]
		In	Sq In	LB	FT-LB	[N.m]	FT-LB	[N.m]	FT-LB	[N.m]
4	40	0.1120	0.00604							
	48	0.1120	0.00661							
6	32	0.1380	0.00909							
	40	0.1380	0.01015							
8	32	0.1640	0.01400							
	36	0.1640	0.01474	1320	43	5				
10	24	0.1900	0.01750	1580	60	7				
	32	0.1900	0.02000	1800	68	8				
1/4	20	0.2500	0.0318	2860	143	16	129	15		
	28	0.2500	0.0364	3280	164	19	148	17		
		In	Sq In	LB	FT-LB	[N.m]	FT-LB	[N.m]	FT-LB	[N.m]
5/16	18	0.3125	0.0524	4720	25	35	20	25	20	25
	24	0.3125	0.0580	5220	25	35	25	35	20	25
3/8	16	0.3750	0.0775	7000	45	60	40	55	35	50
	24	0.3750	0.0878	7900	50	70	45	60	35	50
7/16	14	0.4375	0.1063	9550	70	95	65	90	50	70
	20	0.4375	0.1187	10700	80	110	70	95	60	80
1/2	13	0.5000	0.1419	12750	105	145	95	130	80	110
	20	0.5000	0.1599	14400	120	165	110	150	90	120
9/16	12	0.5625	0.1820	16400	155	210	140	190	115	155
	18	0.5625	0.2030	18250	170	230	155	210	130	175
5/8	11	0.6250	0.2260	20350	210	285	190	260	160	220
	18	0.6250	0.2560	23000	240	325	215	290	180	245
3/4	10	0.7500	0.3340	30100	375	510	340	460	280	380
	16	0.7500	0.3730	33600	420	570	380	515	315	430
7/8	9	0.8750	0.4620	41600	605	825	545	740	455	620
	14	0.8750	0.5090	45800	670	910	600	815	500	680
1	8	1.0000	0.6060	51500	860	1170	770	1045	645	875
	12	1.0000	0.6630	59700	995	1355	895	1215	745	1015
1 1/8	7	1.1250	0.7630	68700	1290	1755	1160	1580	965	1310
	12	1.1250	0.8560	77000	1445	1965	1300	1770	1085	1475
1 1/4	7	1.2500	0.9690	87200	1815	2470	1635	2225	1365	1855
	12	1.2500	1.0730	96600	2015	2740	1810	2460	1510	2055
1 3/8	6	1.3750	1.1550	104000	2385	3245	2145	2915	1785	2430
	12	1.3750	1.3150	118100	2705	3680	2435	3310	2030	2760
1 1/2	6	1.5000	1.4050	126500	3165	4305	2845	3870	2370	3225
	12	1.5000	1.5800	142200	3555	4835	3200	4350	2665	3625

NOTES: 1. THESE TORQUE VALUES DO NOT APPLY TO CADMIUM PLATED FASTENERS  
 2. ALL TORQUE VALUES ARE STATIC TORQUE MEASURED PER STANDARD AUDIT METHODS TOLERANCE = ±10%  
 3. \* ASSEMBLY USES HARDENED WASHER

NO. 500059 REV. J

Figure 1-3. Torque Chart (SAE Fasteners - Sheet 2 of 7)

SOCKET HEAD CAP SCREWS										
Magni Coating (Ref 4150701)*										
Size	TPI	Bolt Dia	Tensile Stress Area	Clamp Load See Note 4	Torque (Dry) K = .17		Torque (Loctite® 242™ or 271™ OR Vibra-TITE™ 111 or 140 OR Precoat 85® K=0.16)		Torque (Loctite® 262™ or Vibra-TITE™ 131) K=0.15	
					IN-LB	[N.m]	IN-LB	[N.m]	IN-LB	[N.m]
		In	Sq In	LB						
4	40	0.1120	0.00604							
	48	0.1120	0.00661							
6	32	0.1380	0.00909							
	40	0.1380	0.01015							
8	32	0.1640	0.01400							
	36	0.1640	0.01474							
10	24	0.1900	0.01750							
	32	0.1900	0.02000							
1/4	20	0.2500	0.0318	2860	122	14	114	13		
	28	0.2500	0.0364	3280	139	16	131	15		
		In	Sq In	LB	FT-LB	[N.m]	FT-LB	[N.m]	FT-LB	[N.m]
5/16	18	0.3125	0.0524	4720	20	25	20	25	20	25
	24	0.3125	0.0580	5220	25	35	20	25	20	25
3/8	16	0.3750	0.0775	7000	35	50	35	50	35	50
	24	0.3750	0.0878	7900	40	55	40	55	35	50
7/16	14	0.4375	0.1063	9550	60	80	55	75	50	70
	20	0.4375	0.1187	10700	65	90	60	80	60	80
1/2	13	0.5000	0.1419	12750	90	120	85	115	80	110
	20	0.5000	0.1599	14400	100	135	95	130	90	120
9/16	12	0.5625	0.1820	16400	130	175	125	170	115	155
	18	0.5625	0.2030	18250	145	195	135	185	130	175
5/8	11	0.6250	0.2260	20350	180	245	170	230	160	220
	18	0.6250	0.2560	23000	205	280	190	260	180	245
3/4	10	0.7500	0.3340	30100	320	435	300	410	280	380
	16	0.7500	0.3730	33600	355	485	335	455	315	430
7/8	9	0.8750	0.4620	41600	515	700	485	660	455	620
	14	0.8750	0.5090	45800	570	775	535	730	500	680
1	8	1.0000	0.6060	51500	730	995	685	930	645	875
	12	1.0000	0.6630	59700	845	1150	795	1080	745	1015
1 1/8	7	1.1250	0.7630	68700	1095	1490	1030	1400	965	1310
	12	1.1250	0.8560	77000	1225	1665	1155	1570	1085	1475
1 1/4	7	1.2500	0.9690	87200	1545	2100	1455	1980	1365	1855
	12	1.2500	1.0730	96600	1710	2325	1610	2190	1510	2055
1 3/8	6	1.3750	1.1550	104000	2025	2755	1905	2590	1785	2430
	12	1.3750	1.3150	118100	2300	3130	2165	2945	2030	2760
1 1/2	6	1.5000	1.4050	126500	2690	3660	2530	3440	2370	3225
	12	1.5000	1.5800	142200	3020	4105	2845	3870	2665	3625

**NO. 500059 REV. J**

- NOTES: 1. THESE TORQUE VALUES DO NOT APPLY TO CADMIUM PLATED FASTENERS  
 2. ALL TORQUE VALUES ARE STATIC TORQUE MEASURED PER STANDARD AUDIT METHODS TOLERANCE = ±10%  
 \*3. ASSEMBLY USES HARDENED WASHER OR FASTENER IS PLACED AGAINST PLATED STEEL OR RAW ALUMINUM  
 4. CLAMP LOAD LISTED FOR SHCS IS SAME AS GRADE 8 OR CLASS 10.9 AND DOES NOT REPRESENT FULL STRENGTH CAPABILITY OF SHCS. IF HIGHER LOAD IS REQUIRED, ADDITIONAL TESTING IS REQUIRED.

**Figure 1-4. Torque Chart (SAE Fasteners - Sheet 3 of 7)**

**SECTION 1 - SPECIFICATIONS**

SOCKET HEAD CAP SCREWS										
Zinc Yellow Chromate Fasteners (Ref 4150707)*										
Size	TPI	Bolt Dia	Tensile Stress Area	Clamp Load See Note 4	Torque (Dry) K = .20		Torque (Loctite® 242™ or 271™ OR Vibra-TITE™ 111 or 140 OR Precoat 85® K=0.18		Torque (Loctite® 262™ or Vibra-TITE™ 131) K=0.15	
					IN-LB	[N.m]	IN-LB	[N.m]	IN-LB	[N.m]
		In	Sq In	LB						
4	40	0.1120	0.00604							
	48	0.1120	0.00661							
6	32	0.1380	0.00909							
	40	0.1380	0.01015							
8	32	0.1640	0.01400							
	36	0.1640	0.01474							
10	24	0.1900	0.01750							
	32	0.1900	0.02000							
1/4	20	0.2500	0.0318	2860	143	16	129	15		
	28	0.2500	0.0364	3280	164	19	148	17		
		In	Sq In	LB	FT-LB	[N.m]	FT-LB	[N.m]	FT-LB	[N.m]
5/16	18	0.3125	0.0524	4720	25	35	20	25	20	25
	24	0.3125	0.0580	5220	25	35	25	35	20	25
3/8	16	0.3750	0.0775	7000	45	60	40	55	35	50
	24	0.3750	0.0878	7900	50	70	45	60	35	50
7/16	14	0.4375	0.1063	9550	70	95	65	90	50	70
	20	0.4375	0.1187	10700	80	110	70	95	60	80
1/2	13	0.5000	0.1419	12750	105	145	95	130	80	110
	20	0.5000	0.1599	14400	120	165	110	150	90	120
9/16	12	0.5625	0.1820	16400	155	210	140	190	115	155
	18	0.5625	0.2030	18250	170	230	155	210	130	175
5/8	11	0.6250	0.2260	20350	210	285	190	260	160	220
	18	0.6250	0.2560	23000	240	325	215	290	180	245
3/4	10	0.7500	0.3340	30100	375	510	340	460	280	380
	16	0.7500	0.3730	33600	420	570	380	515	315	430
7/8	9	0.8750	0.4620	41600	605	825	545	740	455	620
	14	0.8750	0.5090	45800	670	910	600	815	500	680
1	8	1.0000	0.6060	51500	860	1170	775	1055	645	875
	12	1.0000	0.6630	59700	995	1355	895	1215	745	1015
1 1/8	7	1.1250	0.7630	68700	1290	1755	1160	1580	965	1310
	12	1.1250	0.8560	77000	1445	1965	1300	1770	1085	1475
1 1/4	7	1.2500	0.9690	87200	1815	2470	1635	2225	1365	1855
	12	1.2500	1.0730	96600	2015	2740	1810	2460	1510	2055
1 3/8	6	1.3750	1.1550	104000	2385	3245	2145	2915	1785	2430
	12	1.3750	1.3150	118100	2705	3680	2435	3310	2030	2760
1 1/2	6	1.5000	1.4050	126500	3165	4305	2845	3870	2370	3225
	12	1.5000	1.5800	142200	3555	4835	3200	4350	2665	3625

**NO. 500059 REV. J**

- NOTES: 1. THESE TORQUE VALUES DO NOT APPLY TO CADMIUM PLATED FASTENERS  
 2. ALL TORQUE VALUES ARE STATIC TORQUE MEASURED PER STANDARD AUDIT METHODS TOLERANCE = ±10%  
 \*3. ASSEMBLY USES HARDENED WASHER OR FASTENER IS PLACED AGAINST PLATED STEEL OR RAW ALUMINUM  
 4. CLAMP LOAD LISTED FOR SHCS IS SAME AS GRADE 8 OR CLASS 10.9 AND DOES NOT REPRESENT FULL STRENGTH CAPABILITY OF SHCS. IF HIGHER LOAD IS REQUIRED, ADDITIONAL TESTING IS REQUIRED.

**Figure 1-5. Torque Chart (SAE Fasteners - Sheet 4 of 7)**

Values for Zinc Yellow Chromate Fasteners (Ref 4150707)							
CLASS 8.8 METRIC BOLTS CLASS 8 METRIC NUTS							
Size	PITCH	Tensile Stress Area	Clamp Load	Torque (Dry or Loctite® 263™)	Torque (Lub)	Torque (Loctite® 262™ OR Vibra-TITE™ 131)	Torque (Loctite® 242™ or 271™ OR Vibra-TITE™ 111 or 140)
		Sq mm	KN	[N.m]	[N.m]	[N.m]	[N.m]
3	0.5	5.03	2.19	1.3	1.0	1.2	1.4
3.5	0.6	6.78	2.95	2.1	1.6	1.9	2.3
4	0.7	8.78	3.82	3.1	2.3	2.8	3.4
5	0.8	14.20	6.18	6.2	4.6	5.6	6.8
6	1	20.10	8.74	11	7.9	9.4	12
7	1	28.90	12.6	18	13	16	19
8	1.25	36.60	15.9	26	19	23	28
10	1.5	58.00	25.2	50	38	45	55
12	1.75	84.30	36.7	88	66	79	97
14	2	115	50.0	140	105	126	154
16	2	157	68.3	219	164	197	241
18	2.5	192	83.5	301	226	271	331
20	2.5	245	106.5	426	320	383	469
22	2.5	303	132.0	581	436	523	639
24	3	353	153.5	737	553	663	811
27	3	459	199.5	1080	810	970	1130
30	3.5	561	244.0	1460	1100	1320	1530
33	3.5	694	302.0	1990	1490	1790	2090
36	4	817	355.5	2560	1920	2300	2690
42	4.5	1120	487.0	4090	3070	3680	4290

**NO. 500059 REV. J**

- NOTES: 1. THESE TORQUE VALUES DO NOT APPLY TO CADMIUM PLATED FASTENERS  
 2. ALL TORQUE VALUES ARE STATIC TORQUE MEASURED PER STANDARD AUDIT METHODS TOLERANCE = ±10%  
 \*3. ASSEMBLY USES HARDENED WASHER OR FASTENER IS PLACED AGAINST PLATED STEEL OR RAW ALUMINUM  
 4. CLAMP LOAD LISTED FOR SHCS IS SAME AS GRADE 8 OR CLASS 10.9 AND DOES NOT REPRESENT FULL STRENGTH CAPABILITY OF SHCS. IF HIGHER LOAD IS REQUIRED, ADDITIONAL TESTING IS REQUIRED.

**Figure 1-6. Torque Chart (METRIC Fasteners - Sheet 5 of 7)**

**SECTION 1 - SPECIFICATIONS**

Values for Zinc Yellow Chromate Fasteners (Ref 4150707)						
CLASS 10.9 METRIC BOLTS CLASS 10 METRIC NUTS CLASS 12.9 SOCKET HEAD CAP SCREWS M3 - M5*						
Size	PITCH	Tensile Stress Area	Clamp Load	Torque (Dry or Loctite® 263™) K = 0.20	Torque (Lub OR Loctite® 242™ or 271™ OR Vibra-TITE™ 111 or 140) K= 0.18	Torque (Loctite® 262™ OR Vibra-TITE™ 131) K=0.15
		Sq mm	KN	[N.m]	[N.m]	[N.m]
3	0.5	5.03	3.13			
3.5	0.6	6.78	4.22			
4	0.7	8.78	5.47			
5	0.8	14.20	8.85			
6	1	20.10	12.5			
7	1	28.90	18.0	25.2	22.7	18.9
8	1.25	36.60	22.8	36.5	32.8	27.4
10	1.5	58.00	36.1	70	65	55
12	1.75	84.30	52.5	125	115	95
14	2	115	71.6	200	180	150
16	2	157	97.8	315	280	235
18	2.5	192	119.5	430	385	325
20	2.5	245	152.5	610	550	460
22	2.5	303	189.0	830	750	625
24	3	353	222.0	1065	960	800
27	3	459	286.0	1545	1390	1160
30	3.5	561	349.5	2095	1885	1575
33	3.5	694	432.5	2855	2570	2140
36	4	817	509.0	3665	3300	2750
42	4.5	1120	698.0	5865	5275	4395

NO. 500059 REV. J

- NOTES: 1. THESE TORQUE VALUES DO NOT APPLY TO CADMIUM PLATED FASTENERS  
 2. ALL TORQUE VALUES ARE STATIC TORQUE MEASURED PER STANDARD AUDIT METHODS TOLERANCE = ±10%  
 \*3. ASSEMBLY USES HARDENED WASHER OR FASTENER IS PLACED AGAINST PLATED STEEL OR RAW ALUMINUM  
 4. CLAMP LOAD LISTED FOR SHCS IS SAME AS GRADE 8 OR CLASS 10.9 AND DOES NOT REPRESENT FULL STRENGTH CAPABILITY OF SHCS. IF HIGHER LOAD IS REQUIRED, ADDITIONAL TESTING IS REQUIRED.

**Figure 1-7. Torque Chart (METRIC Fasteners - Sheet 6 of 7)**



Magni Coating (Ref 4150701)*						
CLASS 12.9 SOCKET HEAD CAP SCREWS M6 AND ABOVE*						
Size	PITCH	Tensile Stress Area	Clamp Load See Note 4	Torque (Dry or Loctite® 263™) K = .17	Torque (Lub OR Loctite® 242™ or 271™ OR Vibra-TITE™ 111 or 140) K = .16	Torque (Loctite® 262™ OR Vibra-TITE™ 131) K = .15
		Sq mm	kN	[N.m]	[N.m]	[N.m]
3	0.5	5.03				
3.5	0.6	6.78				
4	0.7	8.78				
5	0.8	14.20				
6	1	20.10	12.5	13	12	11
7	1	28.90	18.0	21	20	19
8	1.25	36.60	22.8	31	29	27
10	1.5	58.00	36.1	61	58	54
12	1.75	84.30	52.5	105	100	95
14	2	115	71.6	170	160	150
16	2	157	97.8	265	250	235
18	2.5	192	119.5	365	345	325
20	2.5	245	152.5	520	490	460
22	2.5	303	189.0	705	665	625
24	3	353	220.0	900	845	790
27	3	459	286.0	1315	1235	1160
30	3.5	561	349.5	1780	1680	1575
33	3.5	694	432.5	2425	2285	2140
36	4	817	509.0	3115	2930	2750
42	4.5	1120	698.0	4985	4690	4395

**NO. 500059 REV. J**

- NOTES: 1. THESE TORQUE VALUES DO NOT APPLY TO CADMIUM PLATED FASTENERS  
 2. ALL TORQUE VALUES ARE STATIC TORQUE MEASURED PER STANDARD AUDIT METHODS TOLERANCE = ±10%  
 \*3. ASSEMBLY USES HARDENED WASHER OR FASTENER IS PLACED AGAINST PLATED STEEL OR RAW ALUMINUM  
 4. CLAMP LOAD LISTED FOR SHCS IS SAME AS GRADE 8 OR CLASS 10.9 AND DOES NOT REPRESENT FULL STRENGTH CAPABILITY OF SHCS. IF HIGHER LOAD IS REQUIRED, ADDITIONAL TESTING IS REQUIRED.

**Figure 1-8. Torque Chart (METRIC Fasteners - Sheet 7 of 7)**



## SECTION 2. GENERAL

### 2.1 MACHINE PREPARATION, INSPECTION, AND MAINTENANCE

#### General

This section provides information needed by personnel responsible to place machine in operation readiness and maintain its safe operating condition. For maximum service life and safe operation, ensure all necessary inspections and maintenance have been completed before placing machine in service.

#### Preparation, Inspection, and Maintenance

It is important to establish and conform to a comprehensive inspection and preventive maintenance program. The following table outlines periodic machine inspections and maintenance recommended by JLG Industries, Inc. Consult your national, regional, or local regulations for further requirements for aerial work platforms. Frequency of inspections and maintenance must be increased as environment, severity and frequency of usage requires.

#### Pre-Start Inspection

It is the User's or Operator's primary responsibility to perform a Pre-Start Inspection of the machine before use daily or at each change of operator. Reference the Operator's and Safety Manual for Pre-Start Inspection procedures. The Operator and Safety Manual must be read and understood in its entirety before performing the Pre-Start Inspection.

#### Pre-Delivery Inspection and Frequent Inspection

The Pre-Delivery Inspection and Frequent Inspection shall be performed by a qualified JLG equipment mechanic. JLG Industries, Inc. recognizes a qualified JLG equipment mechanic as a person who, by possession of a recognized degree, certificate, extensive knowledge, training, or experience, has successfully demonstrated the ability and proficiency to service, repair, and maintain the subject JLG product model.

The Pre-Delivery Inspection and Frequent Inspection procedures are performed in the same manner, but at different times. The Pre-Delivery Inspection shall be performed prior to each sale, lease, or rental delivery. The Frequent Inspection shall be accomplished for each machine in service for 3 months or 150 hours (whichever comes first); out of service for a period of more than 3 months; or when purchased used. Frequency of this inspection must be increased as environment, severity and frequency of usage requires.

Reference the JLG Pre-Delivery and Frequent Inspection Form and Inspection and Preventive Maintenance Schedule for items requiring inspection. Reference appropriate areas of this manual for servicing and maintenance procedures.

#### Annual Machine Inspection

The Annual Machine Inspection must be performed on an annual basis, no later than thirteen (13) months from the date of the prior Annual Machine Inspection. JLG Industries recommends this task be performed by a Factory-Trained Service Technician. JLG Industries, Inc. recognizes a Factory-Trained Service Technician as a person who has successfully completed the JLG Service Training School for the subject JLG product model. Reference the machine Service and Maintenance Manual and appropriate JLG inspection form for performance of this inspection.

Reference the JLG Annual Machine Inspection Form and Inspection and Preventive Maintenance Schedule for items requiring inspection. Reference appropriate areas of this manual for servicing and maintenance procedures.

For the purpose of receiving safety-related bulletins, it is important that JLG Industries, Inc. has updated ownership information for each machine. When performing each Annual Machine Inspection, notify JLG Industries, Inc. of current machine ownership.

#### Preventive Maintenance

In conjunction with specified inspections, maintenance shall be performed by a qualified JLG equipment mechanic. JLG Industries, Inc. recognizes a qualified JLG equipment mechanic as a person who, by possession of a recognized degree, certificate, extensive knowledge, training, or experience, has successfully demonstrated the ability and proficiency to service, repair, and maintain the subject JLG product model.

Reference the Preventive Maintenance Schedule and appropriate areas of this manual for servicing and maintenance procedures. Frequency of service and maintenance must be increased as environment, severity and frequency of usage requires.

**Table 2-1. Inspection and Maintenance**

Type	Frequency	Primary Responsibility	Service Qualification	Reference
Pre-Start Inspection	Prior to use each day; or at each Operator change.	User or Operator	User or Operator	Operation and Safety Manual
Pre-Delivery Inspection	Prior to each sale, lease, or rental delivery.	Owner, Dealer, or User	Qualified JLG Mechanic	Service and Maintenance Manual and applicable JLG inspection form.
Frequent Inspection	In service for 3 months or 150 hours, whichever comes first; or out of service for a period of more than 3 months; or purchased used.	Owner, Dealer, or User	Qualified JLG Mechanic	Service and Maintenance Manual and applicable JLG inspection form.
Annual Machine Inspection	Annually, no later than 13 months from date of prior inspection.	Owner, Dealer, or User	Factory-Trained Service Technician (Recommended)	Service and Maintenance Manual and applicable JLG inspection form.
Preventive Maintenance	At intervals as specified in Service and Maintenance Manual.	Owner, Dealer, or User	Qualified JLG Mechanic	Service and Maintenance Manual

**2.2 SERVICE AND GUIDELINES**

**General**

Following information is provided to assist you in using servicing and maintenance procedures in this manual.

**Safety and Workmanship**

Your safety, and that of others, is the first consideration in maintenance of equipment. Always be conscious of weight. Never attempt to move heavy parts without aid of a mechanical device. Do not allow heavy objects to rest in an unstable position. Ensure adequate support is provided when raising a portion of the equipment.

**Cleanliness**

1. The most important single item in preserving the long service life of a machine is to keep dirt and contamination out of vital components. Shields, covers, seals, and filters are provided to keep air, fuel, and oil supplies clean; however, these items must be maintained on a schedule to function properly.
2. Any time air, fuel, or oil lines are disconnected, clean adjacent areas as well as the openings and fittings themselves. As soon as a line or component is disconnected, cap or cover all openings to prevent contamination.

3. Clean and inspect all parts during servicing or maintenance. Ensure all passages and openings are unobstructed. Cover all parts to keep them clean. Make sure all parts are clean before they are installed. New parts should remain in their containers until ready to be used.

**Components Removal and Installation**

1. Use adjustable lifting devices, whenever possible, if mechanical assistance is required. All slings (chains, cables, etc.) should be parallel to each other and as near perpendicular as possible to top of part being lifted.
2. Should it be necessary to remove a component on an angle, keep in mind the capacity of an eyebolt or similar bracket lessens, as the angle between the supporting structure and component becomes less than 90 degrees.
3. If a part resists removal, check to see if all nuts, bolts, cables, brackets, wiring, etc., have been removed and no adjacent parts are interfering.

## Component Disassembly and Reassembly

Complete procedural steps in sequence when disassembling or reassembling a component. Do not partially disassemble or assemble one part, then start on another. Always recheck your work to ensure nothing is overlooked. Do not make any adjustments, other than those recommended, without obtaining proper approval.

## Pressure-Fit Parts

When assembling pressure-fit parts, use a molybdenum disulfide base compound or equivalent to lubricate the mating surface.

## Bearings

1. When a bearing is removed, cover it to keep out dirt and abrasives. Clean bearings in nonflammable cleaning solvent and allow to drip dry. Compressed air can be used, but do not spin the bearing.
2. Discard bearings if races and balls (or rollers) are pitted, scored, or burned.
3. If bearing is found to be serviceable, apply a light coat of oil and wrap it in clean (waxed) paper. Do not unwrap reusable or new bearings until ready to install.
4. Lubricate new or used serviceable bearings before installation. Apply pressure to the outer race when pressing a bearing into a retainer or bore. Apply pressure to the inner race if bearing is installed on a shaft.

## Gaskets

Check holes in gaskets align with openings in mating parts. If it is necessary to hand-fabricate a gasket, use gasket material or stock of equivalent material and thickness. Be sure to cut holes in the correct location. Blank gaskets can cause serious system damage.

## Bolt Usage and Torque Application

### NOTICE

**SELF LOCKING FASTENERS, SUCH AS NYLON INSERT AND THREAD DEFORMING LOCKNUTS, ARE NOT INTENDED TO BE REINSTALLED AFTER REMOVAL.**

1. Always use new replacement hardware when installing locking fasteners. Use bolts of proper length. A bolt which is too long will bottom before the head is tight against its related part. If a bolt is too short, there will not be enough thread area to engage and hold the part properly. When replacing bolts, use only those having the same specifications of the original, or one which is equivalent.

2. Unless specific torque requirements are given within the text, use standard torque values on heat-treated bolts, studs, and steel nuts, in accordance with recommended shop practices. (See Torque Chart in Section 1.)

## Hydraulic Lines and Electrical Wiring

Clearly mark or tag hydraulic lines and electrical wiring, and their receptacles, when disconnecting or removing them from the unit. This ensures correct reinstallation.

## Hydraulic System

1. Keep the system clean. If evidence of metal or rubber particles are found in the hydraulic system, drain and flush the entire system.
2. Disassemble and reassemble parts on clean work surface. Clean all metal parts with non-flammable cleaning solvent. Lubricate components as needed to aid assembly.

## Lubrication

Service applicable components with the amount, type, and grade of lubricant recommended in this manual at the specified intervals. When recommended lubricants are not available, consult your local supplier for an equivalent that meets or exceeds the specifications listed.

## Battery

Clean battery using a non-metallic brush and a solution of baking soda and water. Rinse with clean water. After cleaning, thoroughly dry battery and coat terminals with an anti corrosion compound.

## Lubrication and Servicing

Components and assemblies requiring lubrication and servicing are shown in the Lubrication Chart in Section 1.

## 2.3 LUBRICATION AND INFORMATION

### Hydraulic System

1. The primary enemy of a hydraulic system is contamination. Contaminants can enter the system by using inadequate hydraulic oil; allowing moisture, grease, filings, sealing components, sand, etc., to enter when performing maintenance; or allowing the pump to cavitate due to insufficient system warm-up or leaks in pump supply (suction) lines.
2. Design and manufacturing tolerances of component working parts are very close. The smallest amount of dirt or other contamination entering a system can cause wear or damage to components and faulty operation. Take every precaution to keep hydraulic oil clean - including reserve oil in storage. Check, clean, and replace hydraulic system filters as at intervals specified in the Lubrication Chart in Section 1. Always examine filters for metal particles.
3. Cloudy oils indicate high moisture content which permits organic growth and causes oxidation or corrosion. If this condition occurs, the system must be drained, flushed, and refilled with clean oil.
4. It is not advisable to mix oils of different brands or types. They may not contain required additives or be of comparable viscosities. Good grade mineral oils, with viscosities suited to ambient temperatures in which the machine is operating, are recommended for use.

**NOTE:** Metal particles may appear in oil or filters of new machines due to wear-in of meshing components.

### Hydraulic Oil

1. Refer to Section 1 for viscosity ranges.

### Changing Hydraulic Oil

1. Filter elements must be changed after the first 50 hours of operation and every 300 hours (unless specified otherwise) thereafter. If it is necessary to change the oil, use only those oils meeting or exceeding specifications in this manual. If unable to obtain the same type of oil supplied with the machine, consult local supplier for assistance in selecting the proper equivalent. Avoid mixing petroleum and synthetic base oils.
2. Keep hydraulic oil clean. If oil must be poured from original container into another, clean all possible contaminants from the service container. Always clean filter mesh element and replace cartridge any time system oil is changed.
3. While the unit is shut down, a good preventive maintenance measure is to make a thorough inspection of all hydraulic components, lines, fittings, etc., as well as a

functional check of each system, before placing machine back in service.

### Lubrication Specifications

Specified lubricants, as recommended by component manufacturers, are always the best choice. However, multi-purpose greases usually have qualities which meet a variety of single purpose grease requirements. Should questions arise regarding use of greases in maintenance stock, consult your local supplier for evaluation. Refer to Section 1 for an explanation of lubricant key designations in the Lubrication Chart.

## 2.4 CYLINDER DRIFT TEST

Measure maximum acceptable cylinder drift using the following methods.

### Platform Drift

Measure platform drift to ground. Lower booms (if equipped) slightly elevated, main boom fully extended with rated load in platform and power off. Maximum allowable drift is 2 inches (5 cm) in 10 minutes. If machine does not pass this test, proceed with the following.

### Cylinder Drift

Table 2-2. Cylinder Drift

Cylinder Bore Diameter		Max. Acceptable Drift in 10 Minutes*	
inches	mm	inches	mm
3	76.2	0.026	0.66
3.5	89	0.019	0.48
4	101.6	0.015	0.38
5	127	0.009	0.22
6	152.4	0.006	0.15
7	177.8	0.005	0.13
8	203.2	0.0038	0.10
9	228.6	0.0030	0.08

\*Based on 6 drops per minute cylinder leakage.

Measure drift at cylinder rod with a calibrated dial indicator. Cylinder oil must be at stabilized ambient temperature.

Cylinder must have normal platform load applied.

Cylinder is acceptable if it passes this test.

## 2.5 PINS AND COMPOSITE BEARING REPAIR GUIDELINES

Filament wound bearings.

1. Pinned joints should be disassembled and inspected if the following occurs:
  - a. Excessive sloppiness in joints.
  - b. Noise originating from joint during operation.
2. Filament wound bearings should be replaced if any of the following is observed:
  - a. Frayed or separated fibers on the liner surface.
  - b. Cracked or damaged liner backing.
  - c. Bearings that have moved or spun in their housing.
  - d. Debris embedded in liner surface.
3. Pins should be replaced if any of the following is observed (Clean pin before inspection):
  - a. Detectable bearing area wear.
  - b. Flaking, peeling, scoring, or scratches on pin surface.
  - c. Rusting of pin in bearing area.
4. Re-assembly of pinned joints using filament wound bearings:
  - a. Blow out housing using compressed air to remove all dirt and debris. Bearings and bearing housings must be free of all contamination.
  - b. Clean bearings and pins with solvent to remove all grease and oil.

**NOTE:** *Filament wound bearings are a dry joint and should not be lubricated unless otherwise instructed (i.e. sheave pins).*

- c. Inspect pin to ensure it is free of burrs, nicks, and scratches which can damage bearing during installation and operation.

## 2.6 WELDING ON JLG EQUIPMENT

**NOTE:** *This instruction applies to repairs, or modifications to the machine and to welding performed from the machine on an external structure, or component,*

### **Do the Following When Welding on JLG Equipment:**

- Disconnect battery.
- Disconnect moment pin connection (where fitted)
- Ground only to structure being welded.

### **Do NOT Do the Following When Welding on JLG Equipment:**

#### **NOTICE**

**FAILURE TO COMPLY WITH THESE INSTRUCTIONS MAY RESULT IN COMPONENT DAMAGE (I.E. ELECTRONIC MODULES, SWING BEARING, COLLECTOR RING, BOOM WIRE ROPES ETC.)**

- Do NOT ground on frame and weld on any other area than chassis.
- Do NOT ground on turntable and weld on any other area than turntable.
- Do NOT ground on platform/support and weld on any other area than platform/support.
- Do NOT ground on a specific boom section and weld on any other area than that specific boom section.
- Do NOT allow pins, wear pads, wire ropes, bearings, gearing, seals, valves, electrical wiring, or hoses to be between grounding position and welded area.

**SECTION 2 - GENERAL**

**Table 2-3. Inspection and Preventive Maintenance Schedule**

AREA	INTERVAL				
	Weekly Preventive Maintenance	Monthly Preventive Maintenance	Pre-Delivery <sup>2</sup> or Frequent <sup>3</sup> Inspection	Annual <sup>4</sup> (Yearly) Inspection	Every 2 Years
<b>Boom Assembly</b>					
Boom Weldments			1,2,4	1,2,4	
Hose/Cable Carrier Installations			1,2,9,12	1,2,9,12	
Pivot Pins and Pin Retainers			1,2	1,2	
Sheaves, Sheave Pins			1,2	1,2	
Bearings			1,2	1,2	
Wear Pads			1,2	1,2	
Covers or Shields			1,2	1,2	
Extend/Retract Chain or Cable Systems			1,2,3	1,2,3	
Boom Assembly				14	
<b>Platform Assembly</b>					
Platform				1,2	
Railing			1	1,2	
Gate		5	1	1,5	
Floor			1	1,2	
Rotator	9,5		15		
Lanyard Anchorage Point			1,2,10	1,2,10	
<b>Turntable Assembly</b>					
Swing Bearing			1,2,14	1,2,3,13,14	
Oil Coupling	9				
Swing Drive System			11	11	
Turntable Lock			1,2,5	1,2,5	
Hood, Hood Props, Hood Latches			5	1,2,5	
<b>Chassis Assembly</b>					
Tires	16,17		16,17,18	16,17,18	
Wheel Nuts/Bolts	15		15	15	
Wheel Bearings					14,24
Oscillating Axle/Lockout Cylinder Systems				5,8	
Extendable Axle Systems			5,8	5,8	
Steer Components					
Spindle Thrust Bearing/Washers				1,2	
Drive Hubs			11	11	



Table 2-3. Inspection and Preventive Maintenance Schedule

AREA	INTERVAL				
	Weekly Preventive Maintenance	Monthly Preventive Maintenance	Pre-Delivery <sup>2</sup> or Frequent <sup>3</sup> Inspection	Annual <sup>4</sup> (Yearly) Inspection	Every 2 Years
<b>Functions/Controls</b>					
Platform Controls	5		6	6	
Ground Controls	5		6	6	
Function Control Locks, Guards, or Detents	1,5		5	5	
Footswitch			5	5	
Emergency Stop Switches (Ground & Platform)			5	5	
Function Limit or Cutout Switch Systems			5	5	
Drive Brakes			5		
Swing Brakes			5		
Auxiliary Power			5	5	
<b>Power System</b>					
Engine Idle, Throttle, and RPM			3	3	
Engine Fluids (Oil, Coolant, Fuel)	9,11		11	11	
Air/Fuel Filter	1,7		7	7	
Exhaust System		1,9	9	9	
Batteries	1,9			19	
Battery Fluid	11		11	11	
Battery Charger	5			5	
Fuel Reservoir, Cap, and Breather		2	1,5	1,5	
<b>Hydraulic/Electric System</b>					
Hydraulic Pumps	1,9		1,2,9		
Hydraulic Cylinders	1,9,7	2	1,2,9	1,2,9	
Cylinder Attachment Pins and Pin Retainers	1,9		1,2	1,2	
Hydraulic Hoses, Lines, and Fittings	1,9	12	1,2,9,12	1,2,9,12	
Hydraulic Reservoir, Cap, and Breather	1,9	2	1,5	1,5	24
Hydraulic Filter	1,9		7	7	
Hydraulic Fluid			7,11	7,11	
Electrical Connections	1		20	20	
Instruments, Gauges, Switches, Lights, Horn	1			5,23	
<b>General</b>					
Operation and Safety Manuals in Storage Box			21	21	
ANSI and AEM Manuals/Handbooks Installed (ANSI Markets Only)				21	
Capacity Decals Installed, Secure, Legible			21	21	
All Decals/Placards Installed, Secure, Legible			21	21	

**SECTION 2 - GENERAL**

**Table 2-3. Inspection and Preventive Maintenance Schedule**

AREA	INTERVAL				
	Weekly Preventive Maintenance	Monthly Preventive Maintenance	Pre-Delivery <sup>2</sup> or Frequent <sup>3</sup> Inspection	Annual <sup>4</sup> (Yearly) Inspection	Every 2 Years
Annual Machine Inspection Due			21		
No Unauthorized Modifications or Additions			21	21	
All Relevant Safety Publications Incorporated			21	21	
General Structural Condition and Welds			2,4	2,4	
All Fasteners, Pins, Shields, and Covers			1,2	1,2	
Grease and Lubricate to Specifications			22	22	
Function Test of All Systems			21	21,22	
Paint and Appearance			7	7	
Stamp Inspection Date on Frame				22	
Notify JLG of Machine Ownership				22	

Footnotes:

<sup>1</sup> Prior to use each day; or at each Operator change

<sup>2</sup> Prior to each sale, lease, or delivery

<sup>3</sup> In service for 3 months or 150 Hours; or Out of service for 3 months or more; or Purchased used

<sup>4</sup> Annually, no later than 13 months from the date of the prior inspection

Performance Codes:

- 1 - Check for proper and secure installation
- 2 - Visual inspection for damage, cracks, distortion or excessive wear
- 3 - Check for proper adjustment
- 4 - Check for cracked or broken welds
- 5 - Operates Properly
- 6 - Returns to neutral or "off" position when released
- 7 - Clean and free of debris
- 8 - Interlocks function properly
- 9 - Check for signs of leakage
- 10 - Decals installed and legible
- 11 - Check for proper fluid level
- 12 - Check for chafing and proper routing
- 13 - Check for proper tolerances
- 14 - Properly lubricated
- 15 - Torqued to proper specification
- 16 - No gouges, excessive wear, or cords showing
- 17 - Properly inflated and seated around rim
- 18 - Proper and authorized components
- 19 - Fully charged
- 20 - No loose connections, corrosion, or abrasions
- 21 - Verify
- 22 - Perform
- 23 - Sealed Properly
- 24 - Drain, Clean, Refill

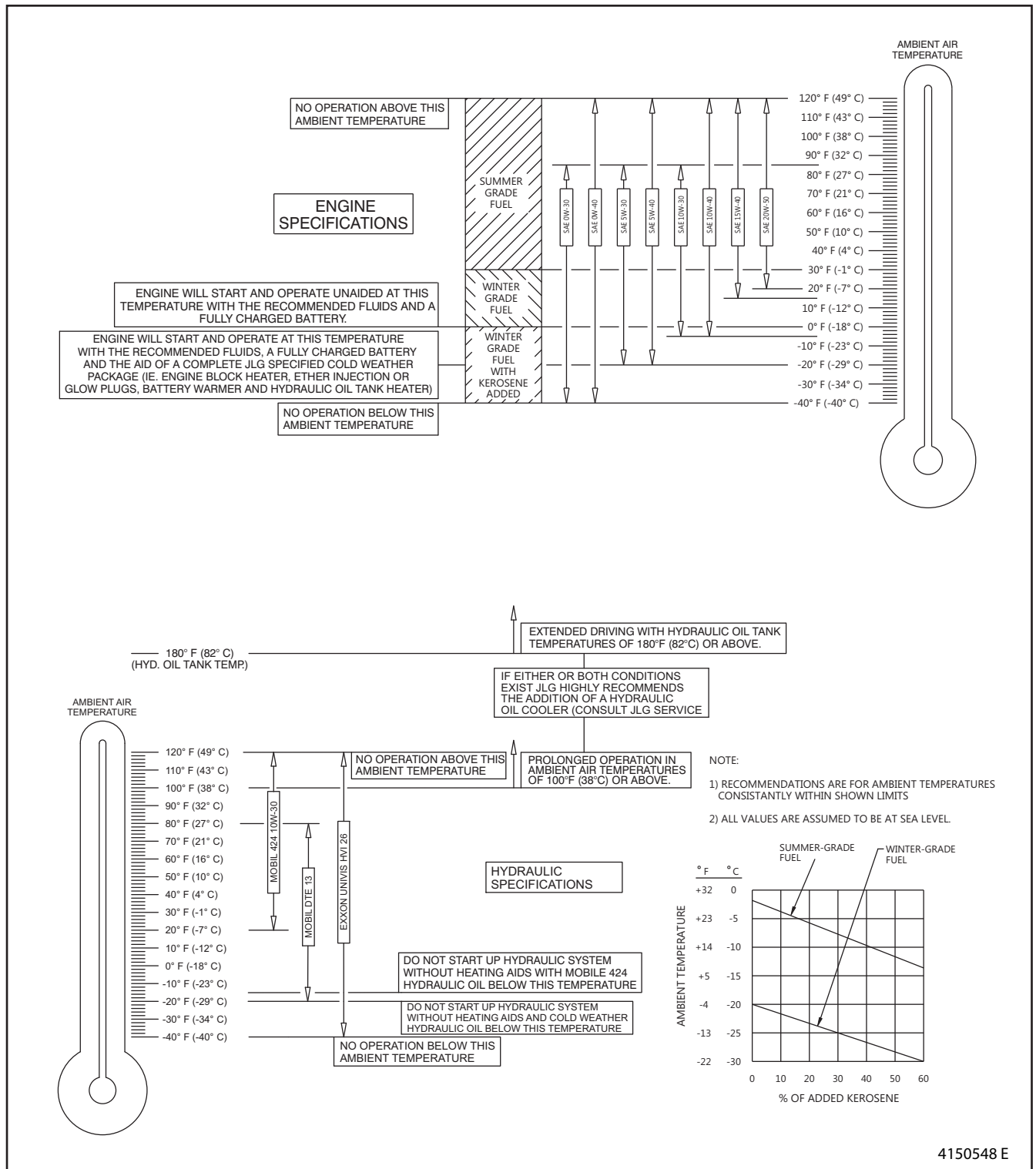


Figure 2-1. Deutz Engine and Hydraulic Operating Temperature Specifications

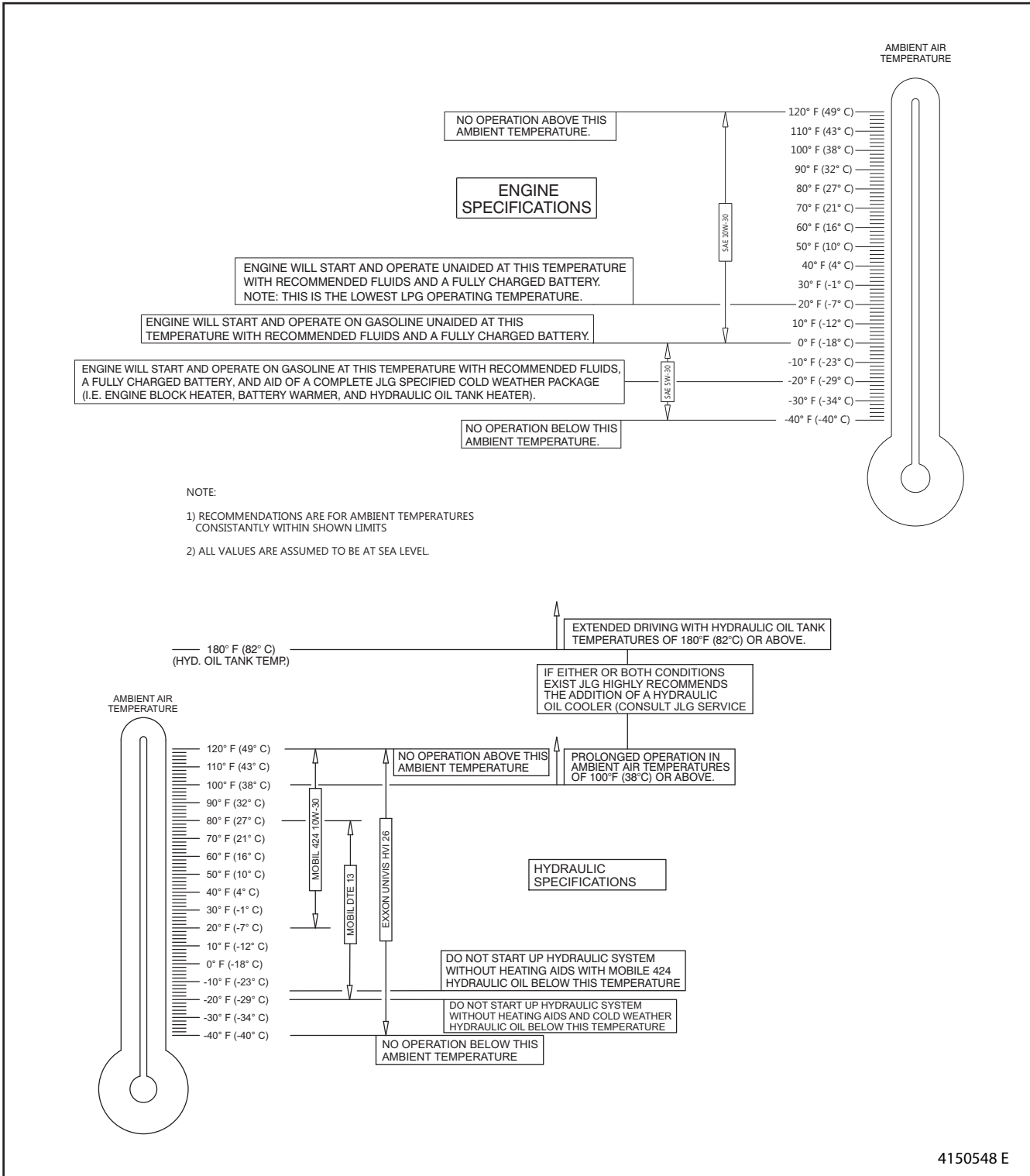


Figure 2-2. GM Engine and Hydraulic Operating Temperature Specifications

## SECTION 3. CHASSIS & TURNTABLE

### 3.1 TIRES & WHEELS

#### Tire Inflation

Pneumatic tire air pressure must be equal to air pressure stenciled on side of JLG product or rim decal for safe and proper machine operation.

#### Tire Damage

##### PNEUMATIC TIRES

JLG Industries, Inc. recommends when any cut, rip, or tear is discovered that exposes sidewall or tread area cords in the tire, measures must be taken to remove the JLG product from service immediately. Arrangements must be made for replacement of the tire or tire assembly.

##### POLYURETHANE FOAM FILLED TIRES

JLG Industries, Inc. recommends when any of the following are discovered, measures must be taken to remove the JLG product from service immediately and arrangements made for replacement of tire or tire assembly:

- Smooth, even cut through cord plies which exceeds 3" (7.5 cm) in total length.
- Tears or rips (ragged edges) in cord plies which exceeds 1" (2.5 cm) in any direction.
- Punctures which exceed 1" in diameter.
- Damage to bead area cords.

**NOTE:** *If a tire is damaged but within above criteria, it must be inspected daily to ensure damage does not exceed allowable criteria.*

#### Tire Replacement

JLG recommends a replacement tire be the same size, ply, and brand as originally installed on the machine. Please refer to the JLG Parts Manual for part number of approved tires for a particular machine model. If not using a JLG approved replacement tire, we recommend replacement tires have the following characteristics:

- Equal or greater ply/load rating and size of original
- Tire tread contact width equal or greater than original
- Wheel diameter, width, and offset dimensions equal to the original
- Approved for the application by the tire manufacturer (including inflation pressure and maximum tire load)

Unless specifically approved by JLG Industries Inc. do not replace a foam filled or ballast filled tire assembly with a pneumatic tire. When selecting and installing a replacement tire, ensure all tires are inflated to pressure recommended by JLG. Due to size variations between tire brands, both tires on the same axle should be identical.

#### Wheel Replacement

Rims installed on each product model are designed for stability requirements which consist of track width, tire pressure, and load capacity. Size changes such as rim width, center piece location, larger or smaller diameter, etc., without written factory recommendations, may result in unsafe stability conditions.

#### Wheel Installation

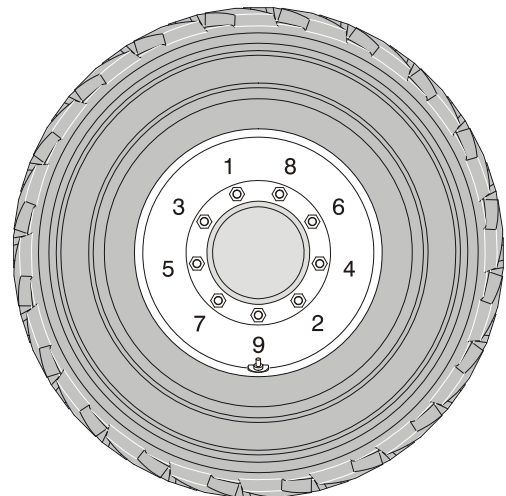
##### **⚠ WARNING**

**WHEEL NUTS MUST BE INSTALLED AND MAINTAINED AT PROPER TORQUE TO PREVENT LOOSE WHEELS, BROKEN STUDS, AND DANGEROUS SEPARATION OF WHEEL FROM AXLE. USE ONLY NUTS MATCHED TO CONE ANGLE OF WHEEL.**

Tighten lug nuts to proper torque to prevent wheels from coming loose. Use a torque wrench to tighten fasteners. If you do not have a torque wrench, tighten fasteners with a lug wrench, then immediately have a service garage or dealer tighten lug nuts to proper torque.

Over-tightening will break studs or permanently deform mounting stud holes in wheels.

1. Start all nuts by hand to prevent cross threading. DO NOT use a lubricant on threads or nuts.
2. Tighten nuts in the following sequence:



**Figure 3-1. Wheel Lug Nut Tightening Sequence**

- Torque to specifications shown in Table 3-1 below.

**Table 3-1. Wheel Torque Chart**

TORQUE SEQUENCE		
1st Stage	2nd Stage	3rd Stage
40 ft-lb (55 Nm)	100 ft-lb (130 Nm)	170 ft-lb (255 Nm)

- Torque wheel nuts after first 50 hours of operation and after each wheel removal. Check torque every 3 months or 150 hours of operation.

### 3.2 TORQUE HUB

#### Oil Information

1. TYPE – EP90  
Use EP90 for normal applications. For applications where lubricant must meet special requirements, the O.E.M can recommend a suitable substitute.
  2. OIL TEMPERATURE  
Continuous – 160° F (70° C) Intermittent – 200° F (95° C).
  3. OIL CHANGE  
Initial – After 50 hours or 50,000 revolutions of operation. Subsequent – After 1000 hours or (1) year, whichever comes first.
- NOTE:** Higher temperatures make it necessary to change oil more frequently.
4. OIL FILL LEVEL AND VOLUME  
Unit mounted horizontal – half full. (See Diagram A.)  
Approximate volume - 17 oz. (0.5 ltr).

#### Roll and Leak Testing

Always roll and leak test Torque-Hubs after assembly to make sure that the unit's gears and sealants are working properly. The following information briefly outlines what to look for when performing these tests.

##### ROLL TEST

The roll test determines if the unit's gears rotate freely and properly. You should be able to rotate gears by applying a constant force to the roll checker. If you feel more drag in gears only at certain points, gears are not rolling freely. Examine them for improper installation or defects.

Some gear packages roll with more difficulty than others. Do not be concerned if gears seem to roll hard as long as they roll with consistency.

##### LEAK TEST

The purpose of a leak test is to make sure unit is air tight. You can tell if your unit has a leak if pressure gauge test reading starts to fall once you have pressurized the unit.

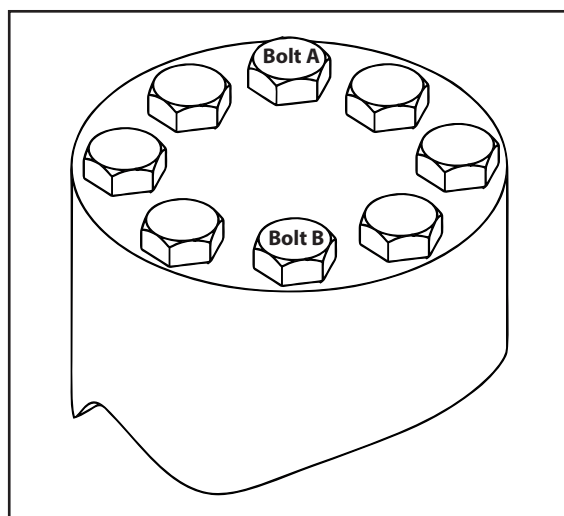
Leaks usually occur at the main seal or wherever O-rings or gaskets are located. You can usually detect location of a leak by brushing a soap and water solution around main seal and where O-rings or gaskets meet unit exterior, then checking for air bubbles. Replace part immediately if you detect a leak in a seal, O-ring, or gasket.

#### Tightening and Torquing Bolts

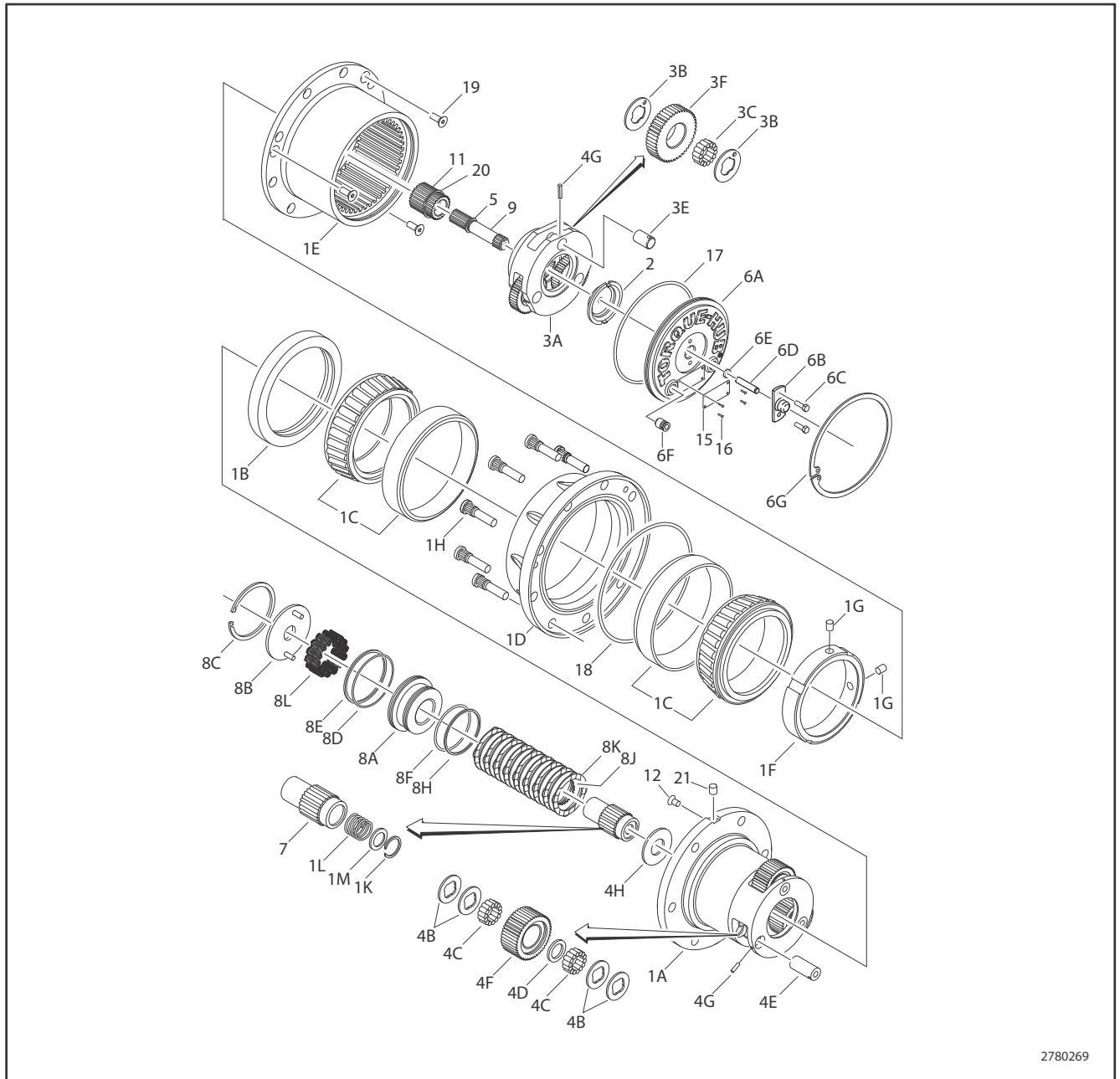
##### NOTICE

**USE EXTREME CARE WHEN USING AN AIR IMPACT WRENCH. DO NOT TIGHTEN BOLTS BEYOND THEIR TORQUE SPECIFICATION. NEVER USE AN IMPACT WRENCH TO TIGHTEN SHOULDER BOLTS. TIGHTEN ALL SHOULDER BOLTS BY HAND.**

1. Tighten (but do not torque) bolt "A" until snug.
2. Go to opposite side of bolt circle and tighten bolt "B" until equally snug.
3. Continue around bolt circle and tighten remaining bolts.
4. Use a torque wrench to apply specified torque to bolt "A".
5. Continue around bolt circle and apply equal torque to remaining bolts.



**Figure 3-2. Bolt Tightening Sequence**



2780269

- |                    |                    |                    |                    |                  |                       |
|--------------------|--------------------|--------------------|--------------------|------------------|-----------------------|
| 1A. Spindle        | 1L. Spring         | 4C. Needle Bearing | 6C. Bolt           | 8D. O-Ring       | 12. Plug              |
| 1B. Seal           | 1M. Thrustwasher   | 4D. Thrust Spacer  | 6D. Dowel Pin      | 8E. Back-up Ring | 15. I.D. Plate        |
| 1C. Bearing        | 2. Thrustwasher    | 4E. Planet Shaft   | 6E. O-Ring         | 8F. O-Ring       | 16. Drive Screw       |
| 1D. Housing        | 3A. Carrier        | 4F. Planet Gear    | 6F. Pipe Plug      | 8H. Back-up Ring | 17. O-Ring            |
| 1E. Ring Gear      | 3B. Thrustwasher   | 4G. Roll Pin       | 6G. Retaining Ring | 8J. Brake Rotor  | 18. O-Ring            |
| 1F. Bearing Nut    | 3C. Needle Bearing | 4H. Thrustwasher   | 7. Coupling        | 8K. Brake Stator | 19. Countersunk Screw |
| 1G. Setscrew       | 3E. Planet Shaft   | 5. Retaining Ring  | 8A. Brake Piston   | 8L. Brake Spring | 20. Retaining Ring    |
| 1H. Wheel Stud     | 3F. Planet Gear    | 6A. Cover Plate    | 8B. Pressure Plate | 9. Input Shaft   | 21. Plug              |
| 1K. Retaining Ring | 4B. Thrustwasher   | 6B. Disengage Cap  | 8C. Retaining Ring | 11. Sun Gear     |                       |

Figure 3-3. Torque Hub

## SECTION 3 - CHASSIS & TURNTABLE

### Main Disassembly

1. Perform Roll Check, Leak Check, and Brake Check if applicable before disassembly.
2. Drain oil from unit. Note condition and volume of oil.
3. Remove Retaining Ring (6G) by prying open end of Retaining Ring out of groove in Ring Gear (1E) with a screwdriver. Grasp loose end with pliers and pull out Retaining Ring.
4. Remove Cover Subassembly (6).
5. Remove Input Carrier Subassembly (3).
6. Remove Input Shaft (9).
7. Remove Second Stage Sun Gear (11).
8. Loosen and remove three Flat Head Bolts (19) that retain Ring Gear (1E) to Housing (1D).
9. Lift Ring Gear (1E) off Housing (1D).
10. Remove O-ring (18) from Housing (1D).

**NOTE:** Carefully pressurize unit with air to pop cover off.

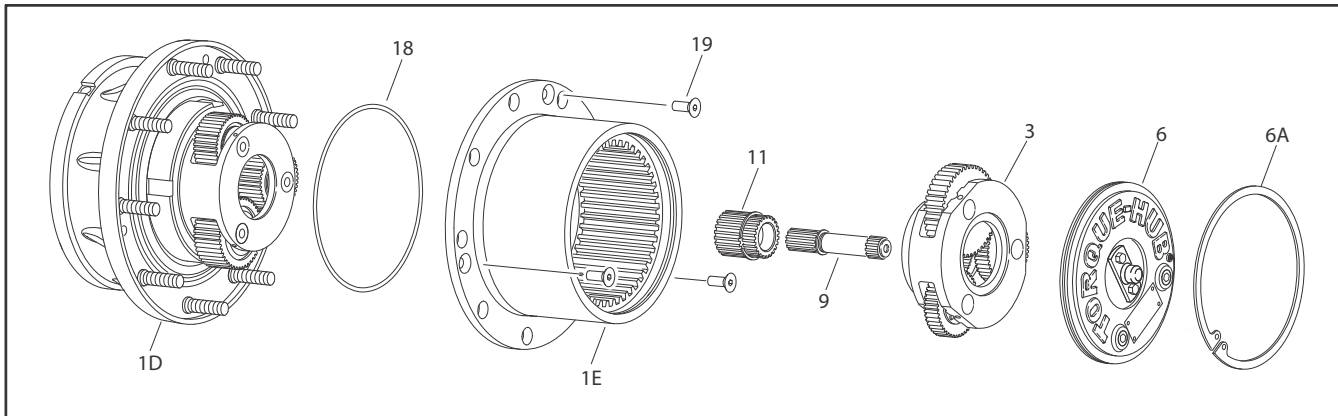


Figure 3-4. Torque Hub Main Disassembly



### Output Carrier Disassembly

1. Use a 1/8" diameter punch to drive Roll Pin (4G) in Planet Shaft (4E) until it bottoms against Spindle (1A).
2. Grasp Roll Pin (4G) with needle nosed pliers or a hooked tool and pull Planet Shaft (4E) out of Spindle (1A).
3. Drive Roll Pin (4G) out of Planet Shaft (4E). Discard roll pin.
4. Slide Planet Gear Subassembly (4) out of Spindle (1A). Do not drop Needle Bearings (4C).
5. Remove four Thrust Washers (4B), 28 Needle Rollers (4C), and Thrust Spacer (4D) from Second Stage Planet Gear (4F).
6. Repeat Steps 12-15 for remaining Planet Gears (4F).
7. Remove Thrust Washer (4H) from Spindle (1A) counter-bore.

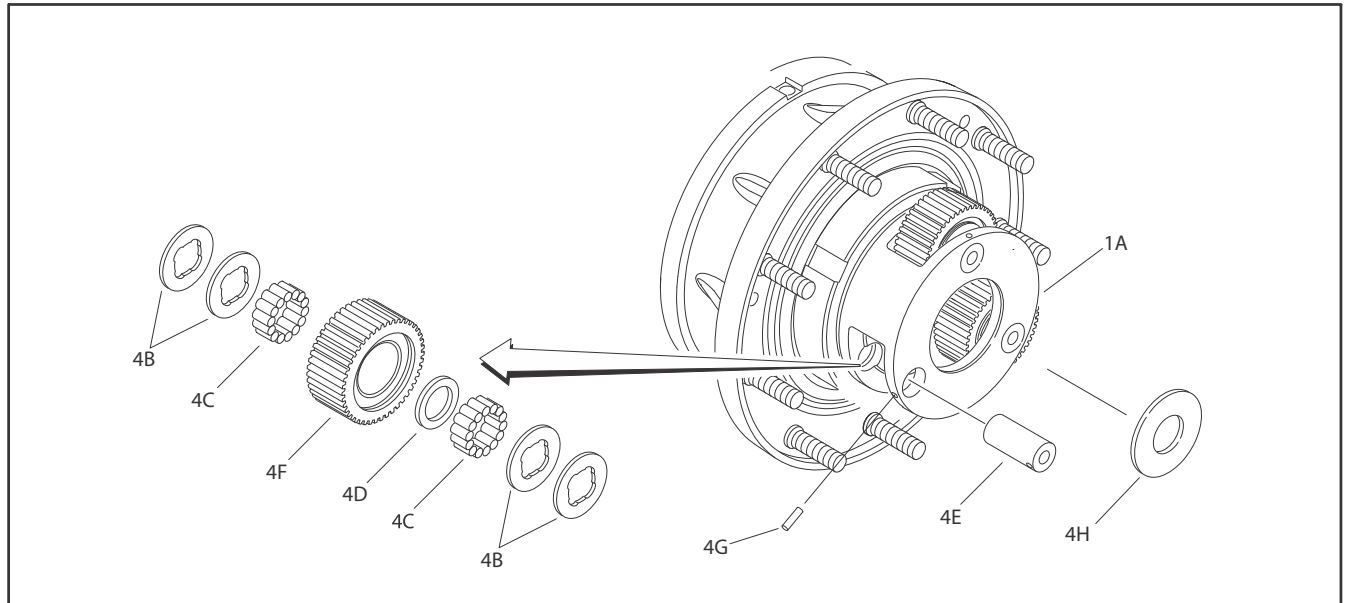


Figure 3-5. Output Carrier Disassembly

### Input Carrier Disassembly

1. Using a 1/8" diameter punch, drive Roll Pin (4G) in Planet Shaft (3E) until it bottoms against Carrier (3A).
2. Using a soft face hammer, tap Planet Shaft (3E) out of Carrier (3A).
3. Using a 1/8" diameter punch, drive Roll Pin (4G) out of Planet Shaft (3E). Discard roll pin.
4. Slide Planet Gear (3F) and two Thrust Washers (3B) out of Carrier (3A).
5. Remove 14 needle Bearings (3C) from bore of Planet Gear (3F).
6. Repeat steps 1 through 5 for remaining planet gears.

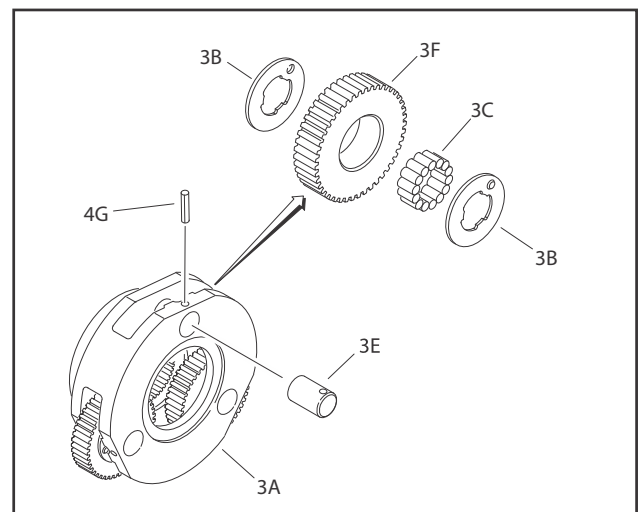


Figure 3-6. Input Carrier Disassembly

### Hub-Spindle Disassembly

1. Place unit on bench with Spindle (1A) end down.
  2. Remove 2 Set Screws (1G) and Bearing Nut (1F) using T-206569.
- NOTE:** Holes in Bearing Nut (1F) for Set Screws (1G) are staked for retention of Set Screws (1G). Clean holes before removing Set Screws.
3. Remove "A" position Bearing Cone (1C) from Bearing Cup (1C) in Hub (1D).
  4. While supporting unit on Hub (1D) flange, press Spindle (1A) out of Hub (1D).

5. Lift Hub (1D) off of Spindle (1A). Remove Boot Seal (1Q) from Hub (1D) if applicable.
6. If necessary, press nine Studs (1H) out of Hub (1D). Locate Hub (1D) on Seal (1B) end.
7. Remove Seal (1B) from Hub (1D). Discard seal.
8. Remove "B" position Bearing Cone (1C) from Bearing Cup (1C) in Hub (1D).
9. Remove "B" position Bearing Cone (1C) from Hub (1D).
10. Using a soft steel rod, knock both Bearing Cups (1C) out of Hub (1D).

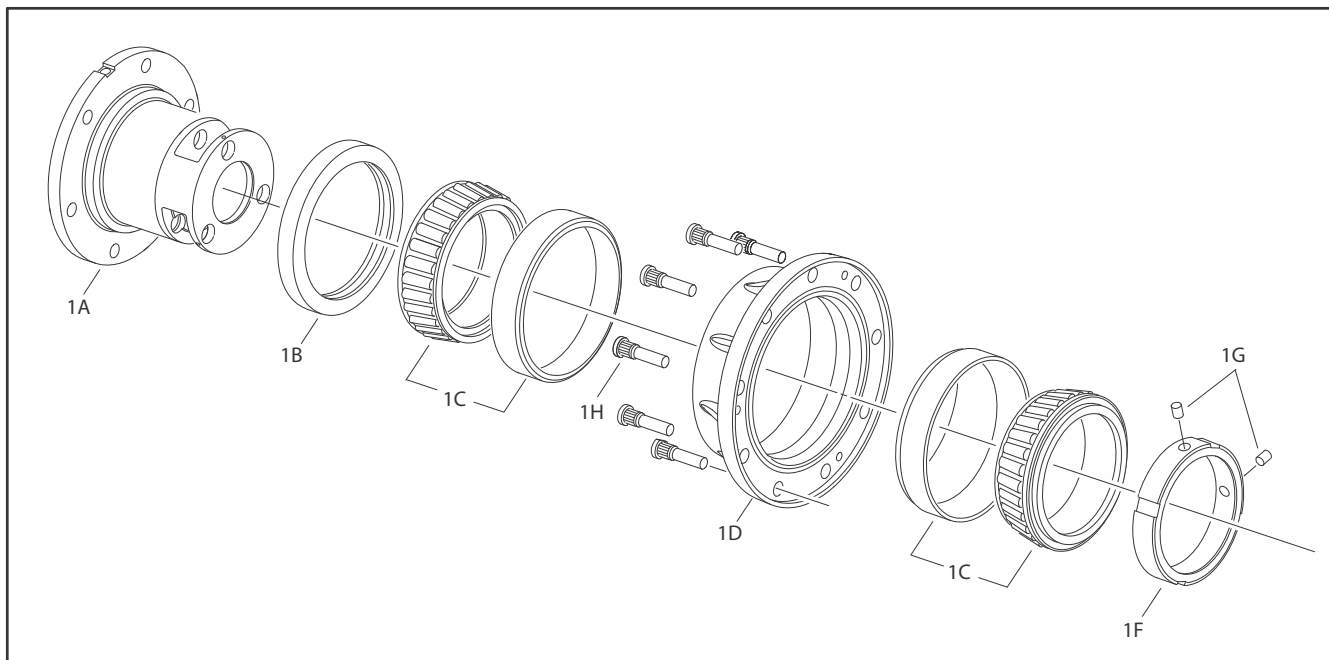


Figure 3-7. Hub Spindle Disassembly

## Spindle-Brake Disassembly

**NOTE:** Units with integral Input Brake (8) only.

### **CAUTION**

**COMPRESSED SPRINGS CAN FLY OUT AND CAUSE SEVERE EYE DAMAGE OR OTHER INJURIES. WEAR EYE PROTECTION WHEN PERFORMING THESE PROCEDURES.**

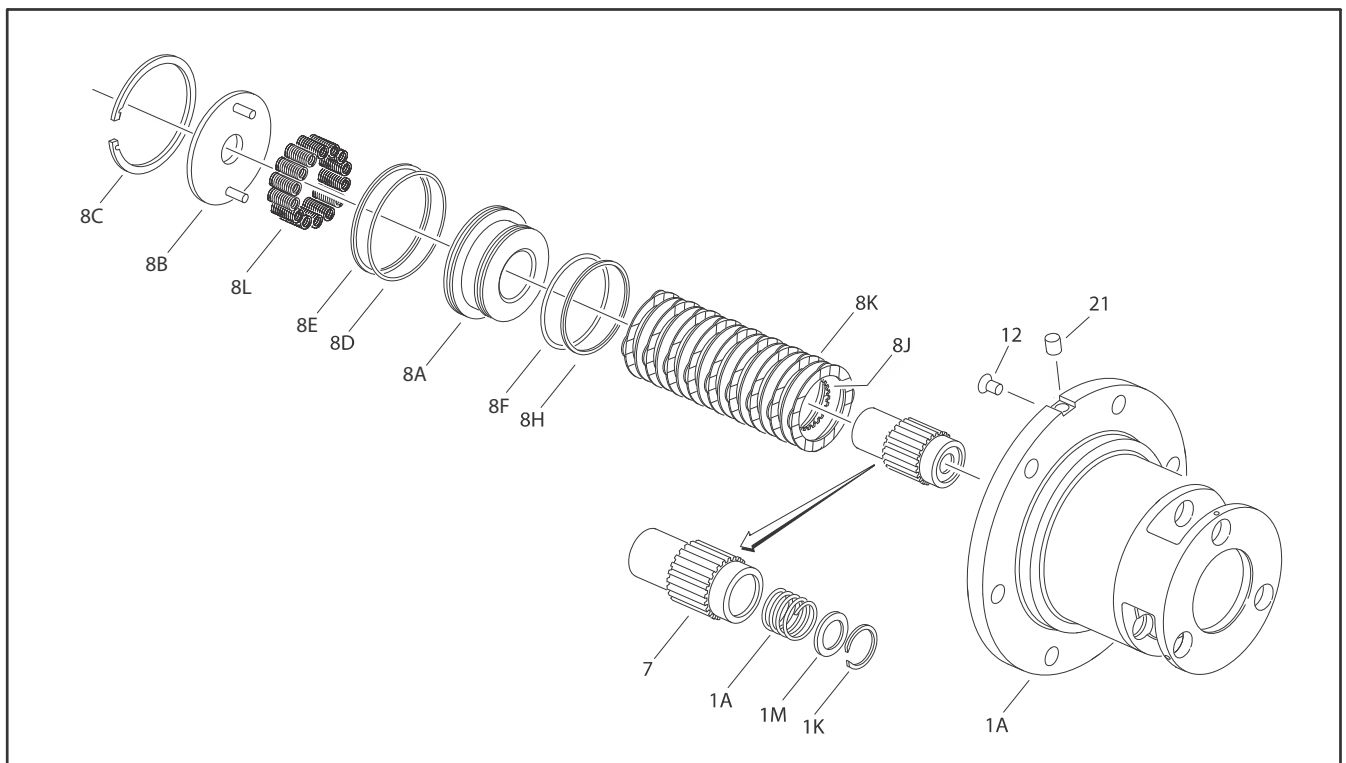
1. Install two 1/4"-20 x 5/8" Flat Head Cap Screws (22) through Pressure Plate (8B) into Piston (8A). Tighten incrementally until spring force is taken off Retaining Ring (8C).

**NOTE:** Flat Head Cap Screws (22) are for transit and service only and are removed before shipping new units. They are included in most brake repair kits.

2. Using retaining ring pliers, remove Retaining Ring (8C) from groove in Spindle (1A).
3. Back Flat Head Cap Screws (22) incrementally out of Piston (8A) until spring force is relieved from Pressure Plate

(8B). Remove Flat Head Cap Screws (22) and Pressure Plate (8B) from brake cavity in Spindle (1A).

4. Remove Compression Springs (8L) from Piston (8A).
5. Using an air hose, slowly and carefully pressurize brake port in Spindle (1A) until Piston (8A) comes out of piston bore of Spindle (1A). Pull Piston (8A) out of Spindle (1A) by hand.
6. Remove Backup Rings (8E and 8H) and O-rings (8D and 8F) from grooves in Piston (8A).
7. Remove Rotors (8J) and Stators (8K) from brake cavity in Spindle (1A).
8. Remove Coupling Subassembly (7) from brake cavity in Spindle (1A).
9. Remove Retaining Ring (1K) from internal groove using appropriate tool.
10. Remove Spacer (1M) and Spring (1L) from bore of Coupling (7).
11. Remove Plastic Plug (12) and Pipe Plug (21) from Spindle (1A) if applicable.



**Figure 3-8. Spindle Brake Disassembly**

### Cover Disassembly

1. Remove O-Ring (17) from groove in Cover (6A).
2. Remove Thrust Washer (2) from Cover (6A) pockets.
3. Unscrew two Hex Head Bolts (6C) and remove Disengage Cap (6B) from Cover (6A).
4. Pull Disengage Rod (6D) out from Cover (6A).
5. Use appropriate tool to remove O-ring (6E) from internal groove in Cover (6A).
6. Remove two O-Ring Pipe Plugs (6F) from Cover (6A).

### Cover Assembly

1. Grease O-Ring (6E) and insert in internal groove in Cover (6A).
2. Assemble Disengage Cap (6B) on Cover (6A) using two Hex Head Bolts (6C). Torque bolts to 70-80 in-lbs.
3. Insert Disengage Rod (6D) in hole in Cover (6A) until it touches inside of Disengage Cap (6B).

**NOTE:** Disengage Rod can be inserted either end first.

4. Grease face of Thrust Washer (2) and place in Cover (6A). Make sure tangs on washer seat into pockets in cover.
5. Install O-Ring Pipe Plugs (6F) in Cover (6A). Plugs should be hand tight.

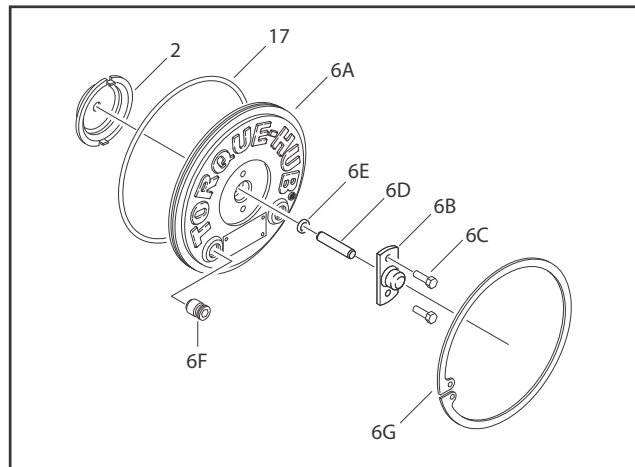


Figure 3-9. Torque Hub Cover

## Input Carrier Assembly

1. Apply a liberal coat of grease to bore of one Input Planet Gear (3F).
2. Line inside of Planet Gear (3F) with 14 Needle Rollers (3C).

**NOTE:** *The last roller installed must be installed end wise. That is, the end of the last roller must be placed in between ends of the two rollers which form the space, and then slid, parallel to the other rollers, into place.*

3. Set Carrier (3A) in an upright position.

### NOTICE

**INSERT END OF PLANET SHAFT THAT DOES NOT HAVE ROLL PIN HOLE IN CARRIER FIRST.**

4. Insert a Planet Shaft (3E) in planet shaft hole in end of Carrier (3A) opposite splined end.
5. Place one Thrust Washer (3B) on end of Planet Shaft (3E). Make sure the flat faces towards inside of carrier and make sure button fits in the pocket on inside of Carrier (3A) towards the OD.
6. Following the thrust washer, place Planet Gear (3F) with needle rollers, on Planet Shaft (3E).
7. Following the planet gear, place one more Thrust Washer (3B) onto Planet Shaft (3E). Align Thrust Washer (3B) in same manner described in Step 5.

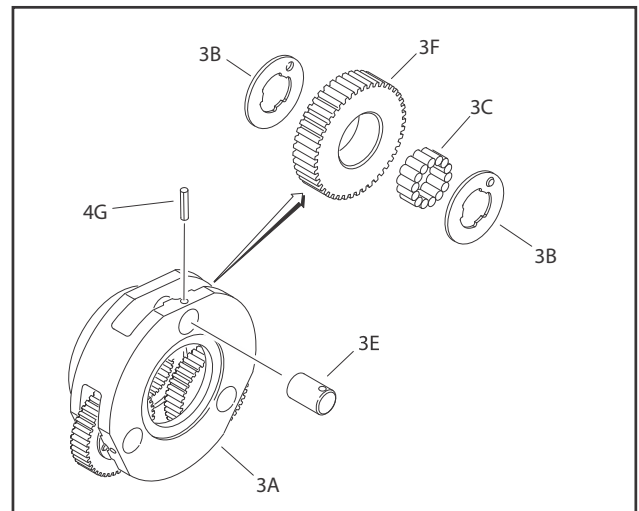
8. Now insert Planet Shaft (3E) through opposite planet shaft hole on Carrier (3A). Use an alignment punch or similar tool to align roll pin holes on Carrier (3A) and Planet Shaft (3E).

### NOTICE

**DO NOT TO HIT PLANET GEARS (3F) WHEN DRIVING IN ROLL PINS (4G).**

9. Drive Roll Pin (4G) down into aligned roll pin holes. Pin should be flush with flat of carrier.
10. Repeat Steps 1-9 for installation of two remaining Planet Gears (3F).

**NOTE:** *Some grease may need to be applied to Thrust Washers (3B) to hold them in place while installing planet gears.*

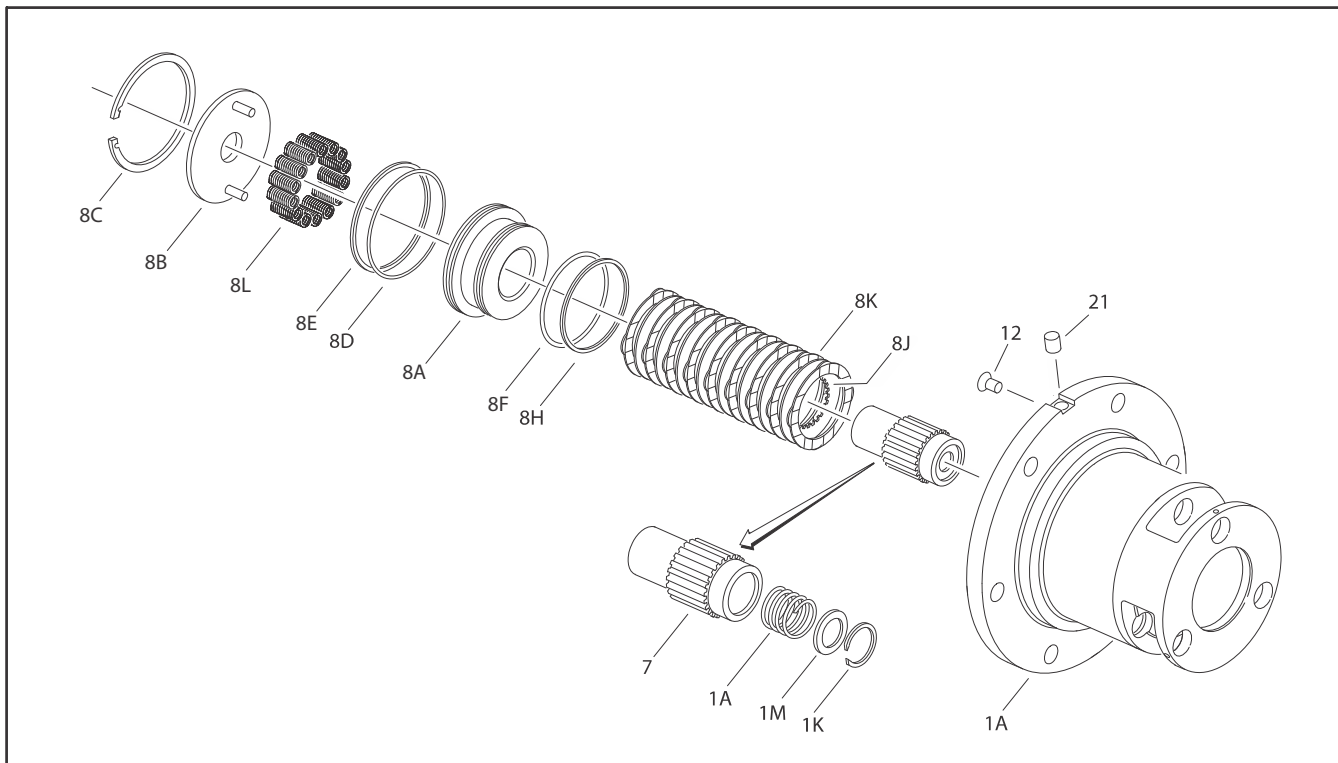


**Figure 3-10. Input Carrier Assembly**

**Spindle - Brake Assembly**

1. Place Spindle (1A) with flange side up.
2. Place Stator (8K) in Spindle (1A) scallop cuts.
3. Place Rotor (8J) on top of Stator (8K).
4. Repeat steps 2 & 3 until there are a total of 9 Stators (8K) and 8 Rotors (8J) installed.
5. Place Piston (8A) with smaller O.D. end facing up. Grease two O-Rings and two Backup Rings.
6. Install large Backup Ring (8E) in large-diameter groove at bottom of Piston (8A).
7. Install large O-Ring (8D) in large-diameter groove at bottom of Piston (8A), on top of large Backup Ring (8E).
8. Install small O-Ring (8F) in small-diameter groove near top of Piston (8A). Make sure O-Ring is seated on the bottom of the groove.
9. Install small Backup Ring (8H) in small-diameter groove near top of Piston (8A), on top of small O-Ring (8F).

10. Insert Piston (8A) in Spindle (1A) until it contacts Stator (8K).
  11. Insert appropriate number of Springs (8L), based on assembly print, into Piston (8A) counterbore.
  12. Place Spring (1L) in Coupling (7) counterbore. Place Pressure plate (1M) on top of Spring (1L).
  13. Use appropriate tool to install Retaining Ring (1K) in retaining ring groove in coupling (7) counterbore.
  14. Insert Coupling subassembly (7) through Rotors (8J).
  15. Place Pressure Plate (8B) on top of Springs (8L).
  16. Use two ¼ -20 x 0.625 Flat Head Cap Screws (22) by bolting Pressure Plate (8B) and Piston (8A) together or some other appropriate tools to install Retaining Ring on top of Pressure Plate (8B) until Retaining Ring (8C) is seated.
- NOTE:** Remove two screws from units when done or brake will not function.
17. Install Pipe Plug (21) if applicable.



**Figure 3-11. Spindle-Brake Assembly**

## Hub-Spindle Assembly

**NOTE:** Spray a light film of oil on all component parts during assembly. Spray a generous amount of oil on bearings during installation.

1. Press Bearing Cup of part (1C), position "A", into Hub using T-158422 pressing tool.
2. Turn hub over and press Bearing Cup of part (1C), position "B", into hub using T-158422 pressing tool.(T).
3. Place Bearing Cone of part (1C), into Bearing Cup of part (1C), position "B".
4. Grease Seal (1B) lip and press seal into Hub (1D) using appropriate tool until seal is flush with end of hub.(T).

### NOTICE

**DO NOT USE EXCESSIVELY HIGH PRESSURE TO PRESS IN STUDS OR HUB MAY CRACK.**

5. Place Hub (1D) into pressing base. Press nine Studs (1H) in Hub.

6. Set Spindle assembly (1A) on bench with flange down. Turn Hub (1D) over and lower onto Spindle (5). Install boot (21) if applicable.
7. Install Bearing Cone of part (1C) in Bearing Cup, position "A".
8. Apply Loctite 243 or equivalent on Bearing Nut (1F) thread. Screw Nut (1F) on top of Bearing Cone of part (1C). Leave 0.003-0.005 inches end play to check initial rolling torque with unit tied down. Torque Bearing Nut (1F) until rolling torque is 40 - 50 in-lb (4.5 - 5.6 Nm) greater than initial rolling torque. Using tool T-206569 for Bearing Nut.

**NOTE:** Final torque is initial rolling torque plus 40-50 in-lb E.g., if initial rolling torque is 30 in-lb, final rolling torque is between 70-80 in-lb. Be sure to rotate hub as torque is applied to properly seat bearing. Be sure torque wrench is tangent to the Hub (1D) OD.

9. Install two Set Screws (1G) in Bearing Nut (1F) threaded holes. Make sure Set Screw is driven in spindle thread. Tighten set screws to damage thread and stake edge of nut around Set Screws (1G) so nut will not loosen.

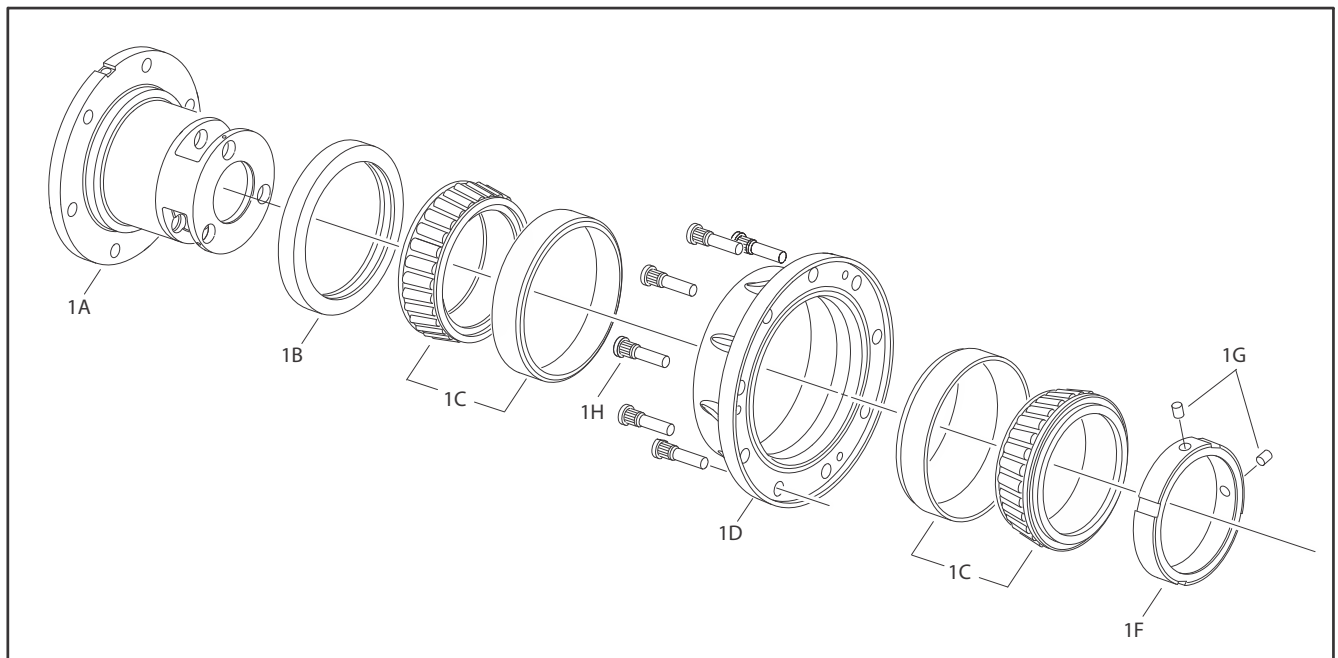


Figure 3-12. Hub Spindle Assembly

**Output Planet Gear Assembly**

1. Apply a liberal coat of grease to the bore of one Output Planet Gear (4F).
  2. Line inside of Planet Gear (4F) with 14 Needle Rollers (4C).
- NOTE:** Last roller installed must be installed end wise. That is, the end of the last roller must be placed in between the ends of the two rollers which form the space, and then slid, parallel to the other rollers, into place.
3. Place Spacer (4D) in bore of Output Planet (4F).
  4. Repeat Step 2 to put in second roll of Needle Rollers (4C).
  5. Apply grease to hold two Thrust Washers (4B) together and on Output Planet Gear (4F) counterbore. Repeat on other side.
  6. Repeat Steps 1-5 for remaining Output Planet Gears (4F).
  7. Place Thrust Washer (4H) in counterbore of Spindle (1A).

8. Place Planet Gear Subassembly (4) in Spindle (1A) through gap between two Studs (1H). Align planet gear bore with one of the planet shaft holes on spindle (1A) assembly using special tool T-209919.

**NOTICE**

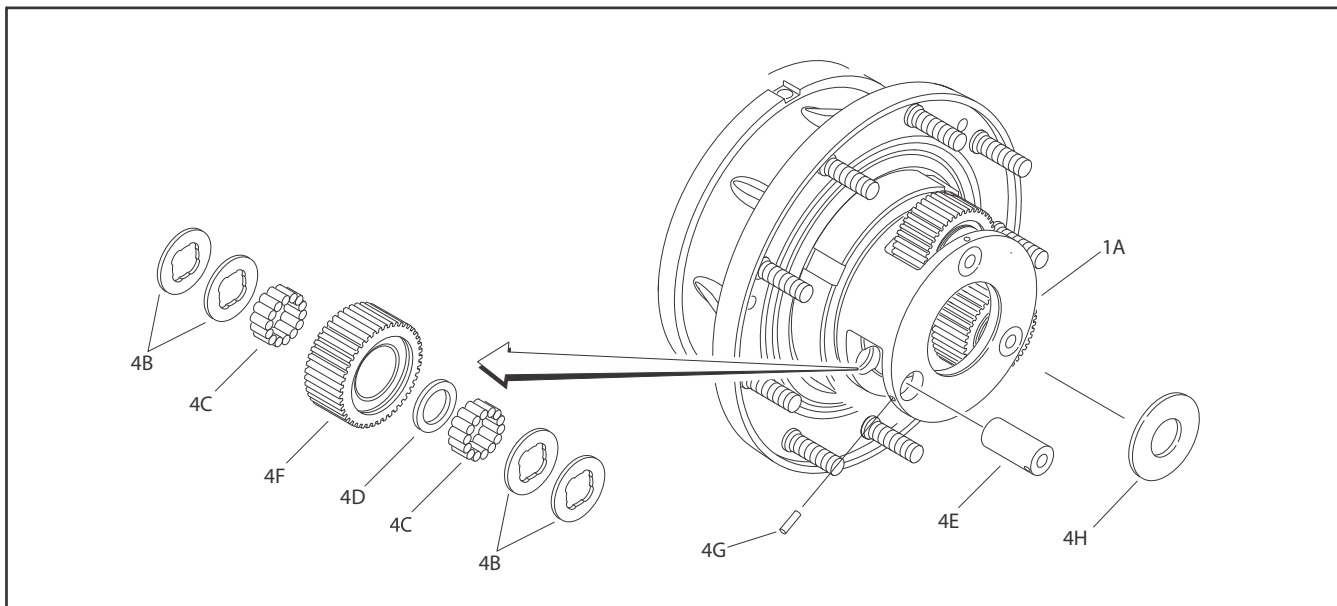
**INSERT END OF PLANET SHAFT THAT DOES NOT HAVE ROLL PIN HOLE IN SPINDLE FIRST.**

9. Insert Planet Shaft (4E) in Spindle (1A) through first set of Thrust Washers (4B), Planet gear, and second set of Washers (4B).
10. Use an alignment punch or similar tool to align roll pin holes on Spindle (1A) and Planet Shaft (4E).

**NOTICE**

**DO NOT HIT PLANET GEARS (4F) WHEN DRIVING IN ROLL PINS (4G).**

11. Drive new Roll Pin (4G) in aligned roll pin holes. Pin should be flush with OD of spindle.
12. Repeat Steps (11-14) for remaining Planet Gears (4F).



**Figure 3-13. Output Planet Gear Assembly**



### Main Assembly

**NOTE:** Coat all components with a generous amount of lubricant oil as they are being assembled.

1. Place Hub-Spindle Subassembly on bench.
2. Grease O-Ring (18) and place it in groove of Hub (1D).
3. Place Ring Gear (1E) on Hub (1D). Align three shipping Cap Screw Holes on Hub (1D) and Ring Gear (1E).
4. Install three shipping Cap Screws (19) in ring gear and hub. Torque to 15-20 ft-lb.
5. Place External Retaining Ring (5) over 13T spline to the retaining groove on Input Shaft (9).

**NOTE:** For ratio 48:1, assemble Output Sun Gear (11) over Input Shaft (9) first, then install External Retaining Ring (5).

6. Using appropriate tool to install Retaining Ring (20) in groove on Output Sun (11).
7. Place Input Shaft (9) spline end into mesh with Internal Coupling (7) splines.
8. With modified spline end facing up, place Output Gear (11) in mesh with planet gears from Hub-Spindle Subassembly.
9. Place Input Carrier Subassembly (3) on Output Sun Gear (11) splines.
10. Grease O-Ring (17) and insert in groove in Cover Subassembly (6).
11. Install Cover Subassembly (6) in Ring Gear (1E) counter-bore and install Retaining Ring (6G) in groove in Ring Gear (1E).
12. Check disconnect, roll and air check unit, leak check brake, and record release pressure.

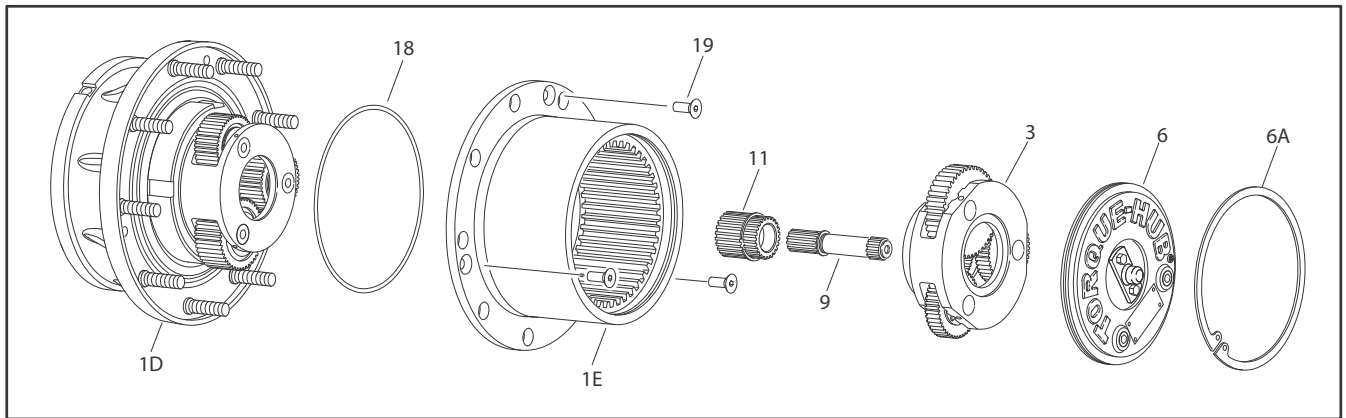


Figure 3-14. Main Assembly

### Integral Brake Check

1. Using appropriate fittings, connect hydraulic line from hand pump to brake port.
2. Check brake is set by trying to rotate Input Shaft (9). This can be accomplished by installing an appropriate tool (any tool that can locate on splines of Input Coupling (7), such as a mating splined shaft) into Input Coupling (7). Bleed brake.
3. Increase hydraulic pressure gradually while trying to rotate input until brake just starts to release. Note this pressure. Make sure pressure falls into appropriate range in Table 3-2.

Table 3-2. Torque Hub Brake Release Pressure

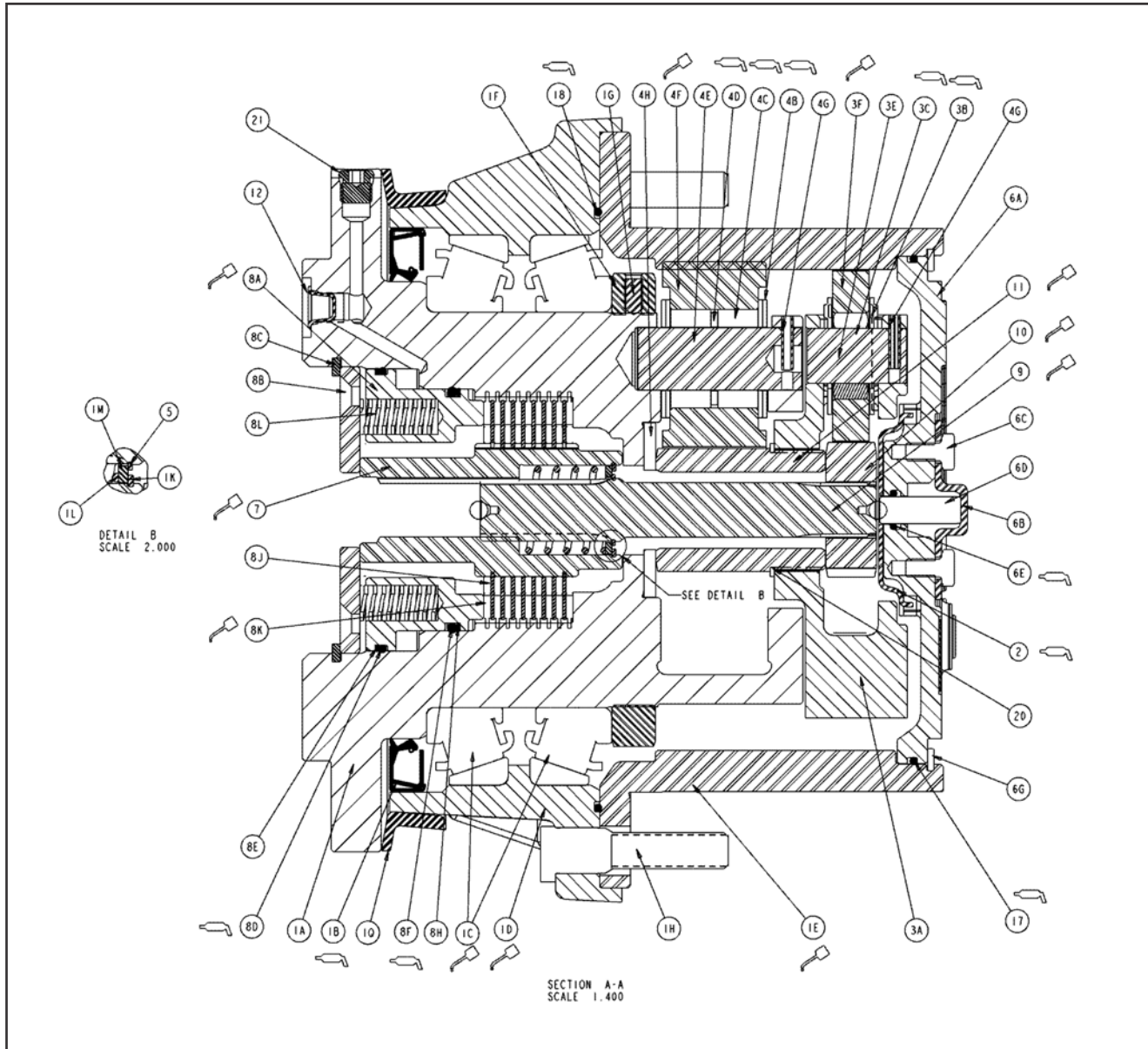
BRAKE CODE	JUST RELEASE PRESSURE RANGE	
	PSI	BAR
A	200-260	13.7-17.9
B	170-220	11.7-15.1
C	140-185	9.6-12.7
D	130-155	8.9-10.6
E	115-145	7.9-9.9

4. Increase pressure to 1,000 psi and hold for 30 seconds to check for leaks. Repair leaks if necessary.

**NOTE:** Make sure brake re-engages when pressure is released.

**NOTE:** When done, make sure Input Coupling (7) is centered in Spindle (1A) to make installation of motor possible without release of brake.

**SECTION 3 - CHASSIS & TURNTABLE**



- |                     |                    |                    |                    |                  |                    |
|---------------------|--------------------|--------------------|--------------------|------------------|--------------------|
| 1A. Spindle         | 1M. Thrust Washer  | 4C. Needle Bearing | 6C. Bolt           | 8D. O-Ring       | 11. Sun Gear       |
| 1B. Lip Seal        | 1Q. Seal Boot      | 4D. Thrust Spacer  | 6D. Dowel Pin      | 8E. Backup Ring  | 12. Plastic Plug   |
| 1C. Tapered Bearing | 2. Thrust Spacer   | 4E. Planet Shaft   | 6E. O-Ring         | 8F. O-Ring       | 15. ID Plate       |
| 1D. Housing         | 3A. Carrier        | 4F. Planet Gear    | 6F. Pipe Plug      | 8H. Backup Ring  | 16. Drive Screw    |
| 1E. Ring Gear       | 3B. Thrust Washer  | 4G. Roll Pin       | 6G. Retaining Ring | 8J. Brake Rotor  | 17. O-Ring         |
| 1F. Bearing Nut     | 3C. Needle Bearing | 4H. Thrust Washer  | 7. Coupling        | 8K. Brake Stator | 18. O-Ring         |
| 1G. Setscrew        | 3E. Planet Shaft   | 5. Retaining Ring  | 8A. Brake Piston   | 8L. Spring       | 19. Bolt           |
| 1H. Stud            | 3F. Planet Gear    | 6A. Cover          | 8B. Pressure Plate | 9. Input Shaft   | 20. Retaining Ring |
| 1K. Retaining Ring  | 4B. Thrust Washer  | 6B. Disengage Cap  | 8C. Retaining Ring | 10. Sun Gear     | 21. O-Ring Plug    |
| 1L. Spring          |                    |                    |                    |                  |                    |

**Figure 3-15. Hub Assembly**

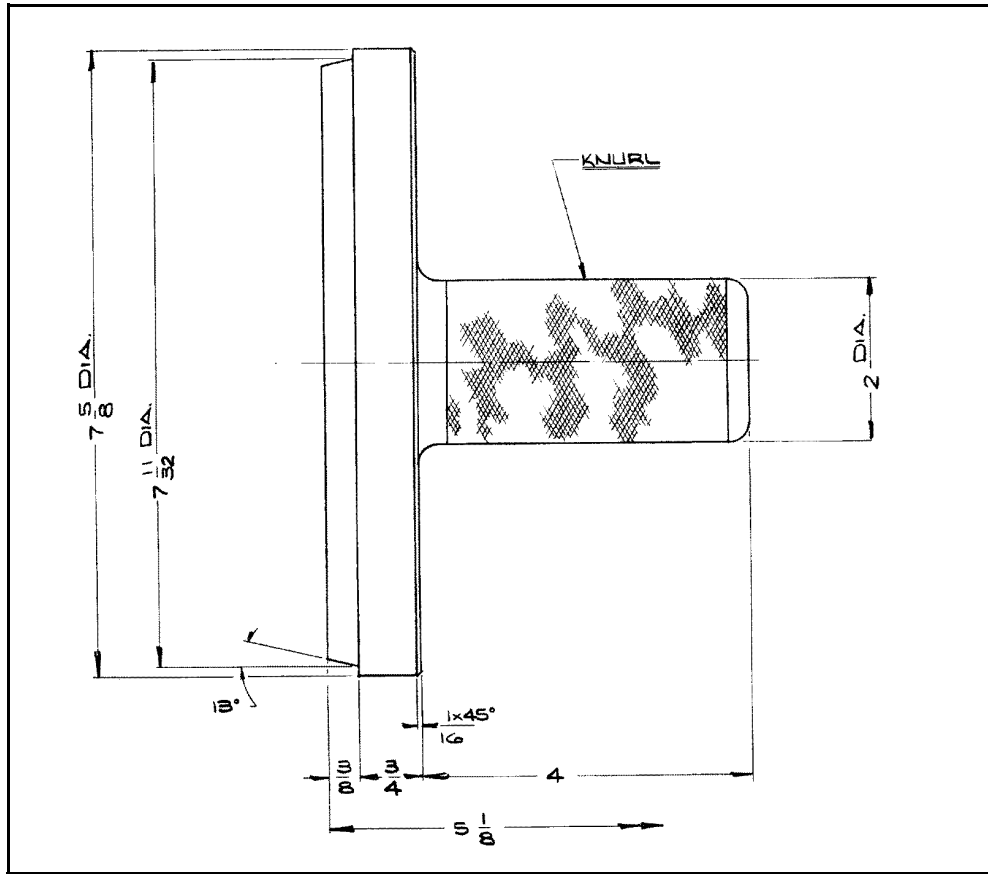


Figure 3-16. Bearing Cup Pressing Tool

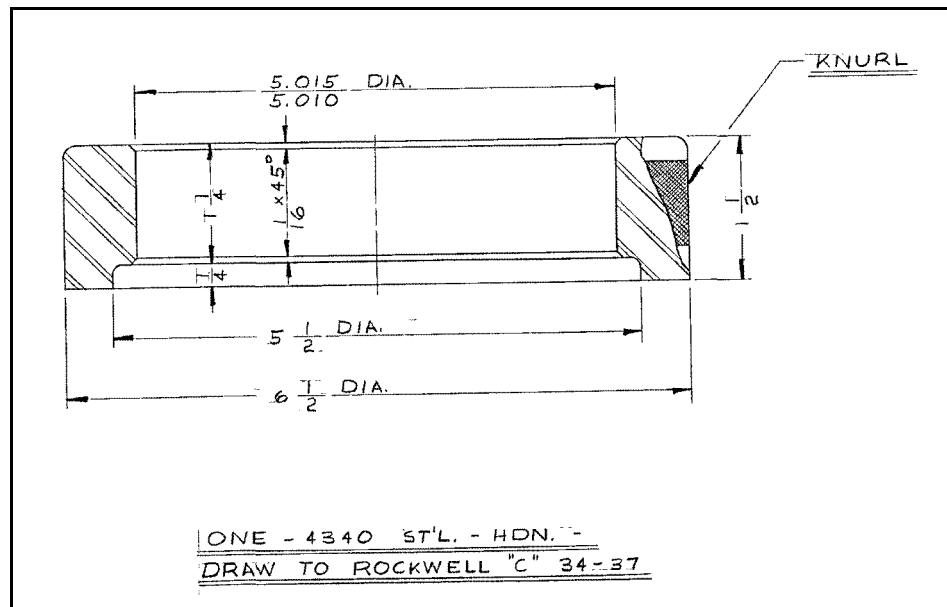


Figure 3-17. Seal Pressing Tool

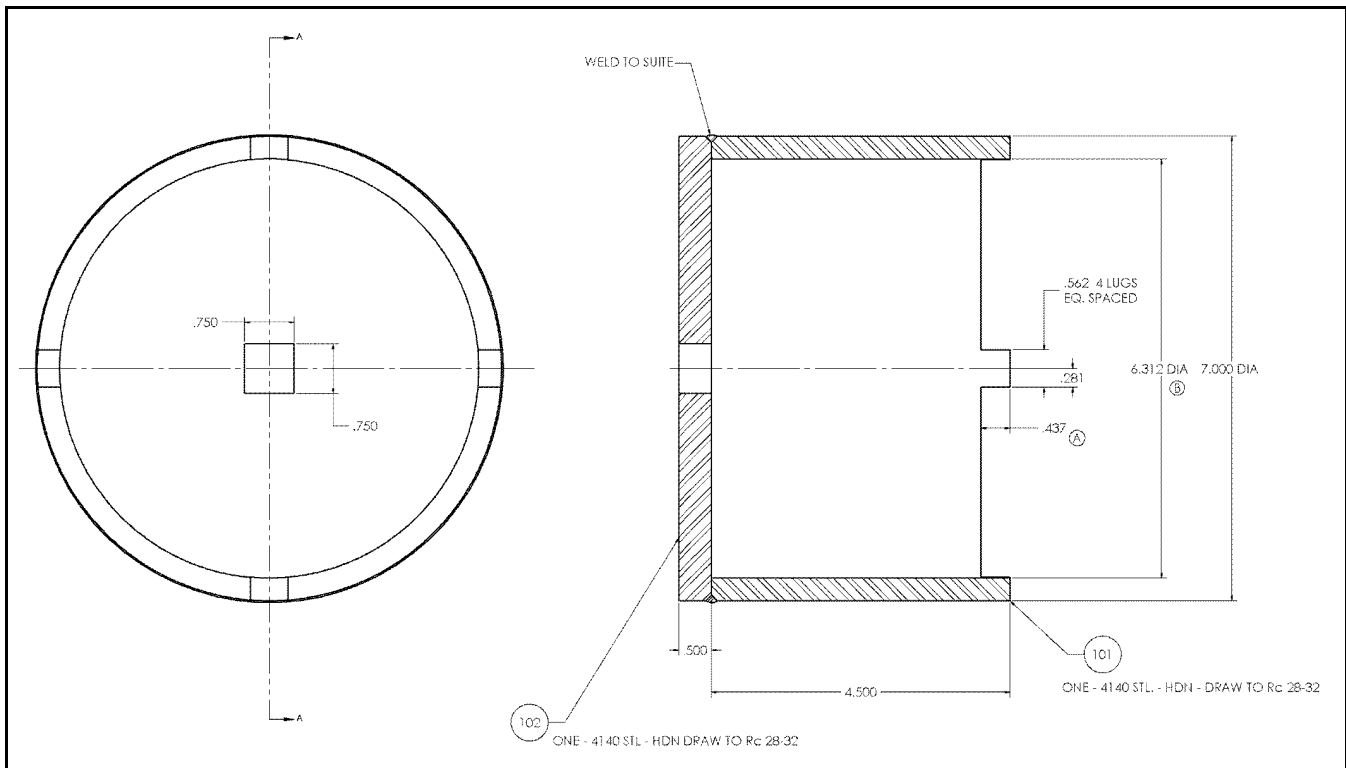


Figure 3-18. Bearing Cup Pressing Tool

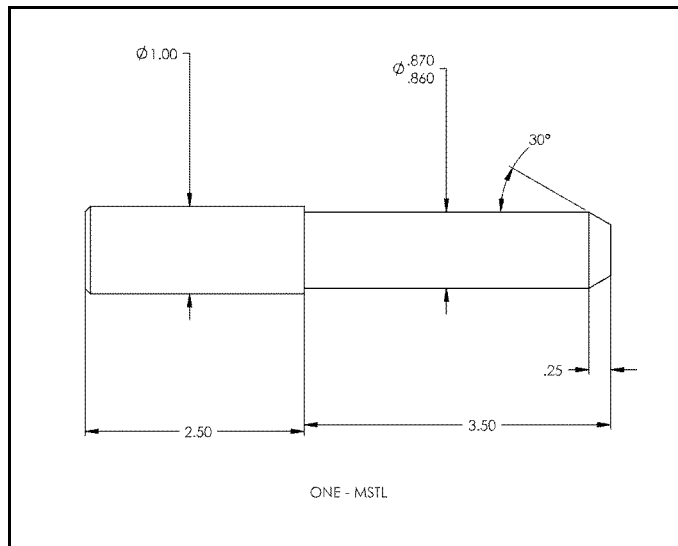


Figure 3-19. Drift Pin for Lining Up Thrust Washers with Output Planet Gear

### 3.3 FREE WHEELING OPTION

#### Disengage Drive Motors & Brakes for Towing, etc. (Free Wheel)

1. Chock wheels securely if not on flat level surface.
2. Disconnect both drive hubs by inverting disconnect caps in center of hubs.
3. If equipped, move steer/tow selector valve to float (tow) position by pulling valve knob out.

#### Engage Drive Motors & Brakes (Normal Operation)

1. If equipped, move steer/tow valve to steer position by pushing valve knob in.
2. Connect both drive hubs by inverting disconnect cap in center of hub.
3. Remove chocks from wheels as required.

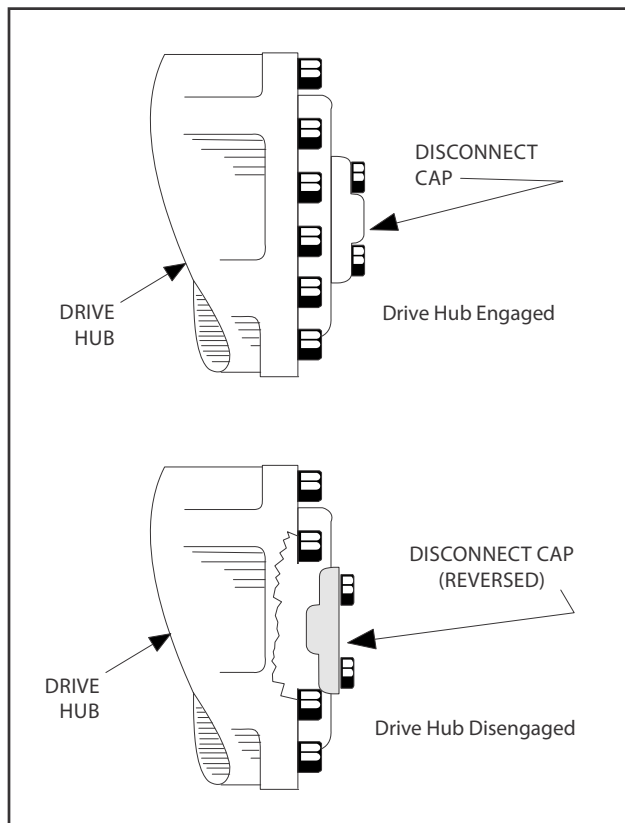


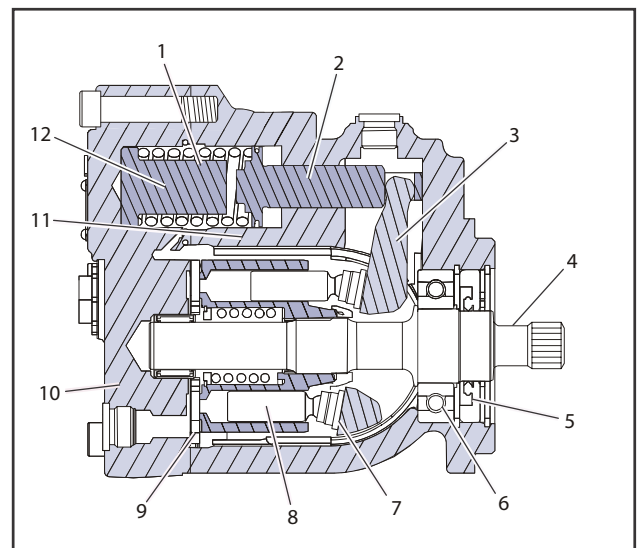
Figure 3-20. Disengaging Drive Hubs

### 3.4 DRIVE MOTOR

#### Description

Drive motors are low to medium power, two-position axial piston motors incorporating an integral servo piston. They are designed for operation in open and closed circuit applications. The standard control is a direct acting single line hydraulic control. The integral servo piston controls motor displacement.

Motors are spring biased to maximum displacement and hydraulically shifted to minimum displacement. Minimum and maximum displacement can be set with fixed internal stops. The large diameter servo piston allows smooth acceleration and deceleration with relatively large circuit orificing.



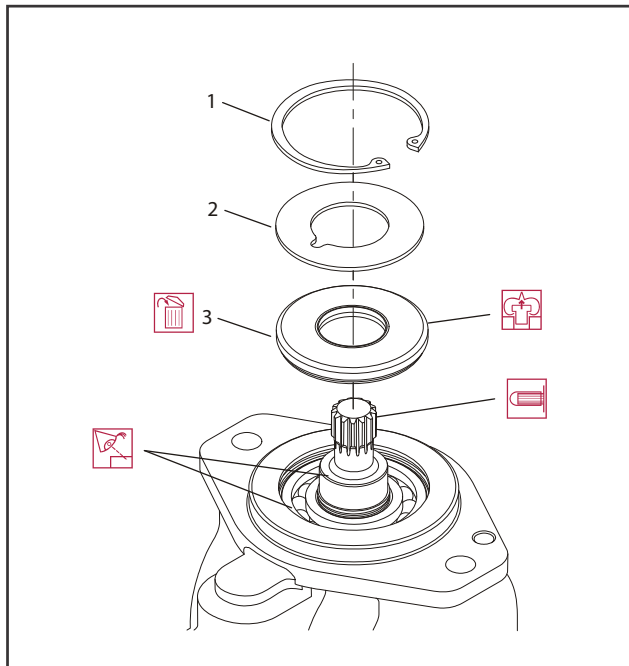
- |                 |               |                        |
|-----------------|---------------|------------------------|
| 1. Bias Spring  | 5. Shaft Seal | 9. Valve Plate         |
| 2. ServoPiston  | 6. Bearing    | 10. End Cap            |
| 3. Swashplate   | 7. Slipper    | 11. Cylinder Block     |
| 4. Output Shaft | 8. Piston     | 12. Minimum Angle Stop |

Figure 3-21. Drive Motor Cross Section

### Shaft Seal Replacement

#### REMOVAL

1. Remove snap ring (1) retaining shaft seal, and support washer.



1. Snap Ring
2. Support Washer
3. Shaft Seal

**Figure 3-22. Removing Shaft Seal**

2. Remove support washer (2).
3. Carefully pry out shaft seal (3).

**NOTE:** To avoid damaging shaft during removal, install a large sheet metal screw in chuck of a slide hammer. Drive screw in seal surface and use slide hammer to pull seal.

4. Discard seal.

#### INSPECTION

Inspect new seal, motor housing seal bore, and sealing area on shaft for rust, wear, and contamination. Polish shaft and clean housing if necessary.

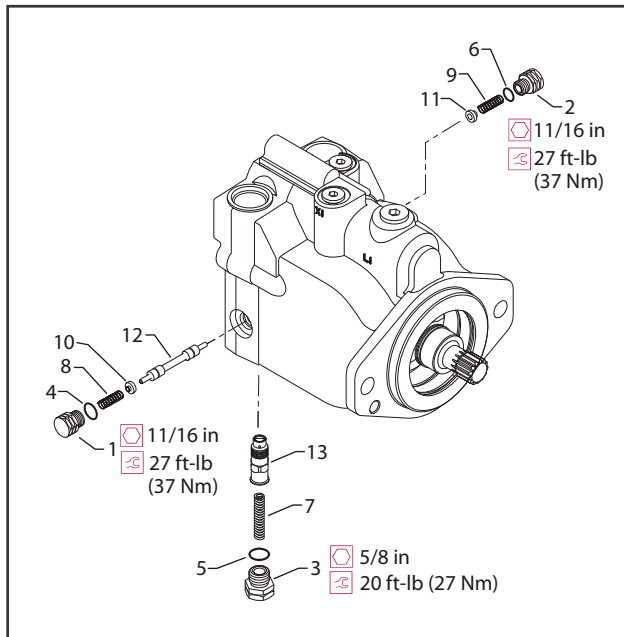
#### INSTALLATION

1. Cover shaft splines with an installation sleeve to protect shaft seal during installation.
2. Install new shaft seal with cupped side facing motor. Press seal into housing until it bottoms out. Press evenly to avoid binding and damaging the seal.
3. Install seal support washer.
4. Install snap ring.
5. Remove installation sleeve.

## Loop Flushing Valve

### REMOVAL

- Using a 11/16 in internal hex wrench remove plug (1) and (2).



- |           |            |                    |
|-----------|------------|--------------------|
| 1. Plug   | 6. O-ring  | 11. Washer         |
| 2. Plug   | 7. Spring  | 12. Shift Spool    |
| 3. Plug   | 8. Spring  | 13. Orifice Poppet |
| 4. O-ring | 9. Spring  |                    |
| 5. O-ring | 10. Washer |                    |

**Figure 3-23. Loop Flushing Spool**

- Using a 1/4 in hex wrench remove plug (3).
- Remove O-rings (4, 5, and 6).
- Using pliers, remove centering springs (7, 8, and 9).
- Remove spring retaining washers (10 and 11).
- Remove shift spool (12).
- Remove orifice poppet (13).

### INSPECTION

Inspect new O-rings and the sealing area for rust, wear, or contamination. Check springs and poppet for wear.

### INSTALLATION

- Install orifice poppet (13).
- Install shift spool (12).
- Install spring retaining washers on springs (10 and 11).
- Carefully install centering springs (7, 8, and 9).
- Install new O-rings (6, 4, and 5).
- Using a 1/4 in hex wrench torque plug (3) to 20 ft. lbs. (27 Nm).
- Using a 11/16 in internal hex, torque plugs (2 and 1) to 27 ft.lbs. (37 Nm).

## SECTION 3 - CHASSIS & TURNTABLE

### Troubleshooting

**Table 3-3. Excessive Noise and/or Vibration**

Item	Description	Action
Check oil level in reservoir and oil supply to motor.	Insufficient hydraulic fluid could lead to cavitation that would cause system noise.	Fill reservoir to proper level. Ensure oil supply to motor is adequate and lines are unobstructed.
Check for air in system.	Air trapped in system lines or motor could result in cavitation that would cause system noise.	Ensure all system lines and components are purged of air.
Inspect output shaft couplings.	A loose or incorrect shaft coupling will produce vibrations that could result in system noise.	Ensure correct coupling is used and that it fits properly on shaft.
Inspect output shaft alignment.	Misaligned shafts create excessive frictional vibration that could result in system noise.	Ensure shafts are properly aligned.
Hydraulic oil viscosity above limits.	Viscosity above acceptable limits will result in cavitation that would lead to system noise.	Replace hydraulic oil with appropriate fluid for operating conditions.

**Table 3-4. System Operating Hot**

Item	Description	Action
Check oil level in reservoir and oil supply to pump.	Insufficient amount of hydraulic fluid will not meet system cooling demands.	Fill reservoir to proper level.
Inspect heat exchanger, (if equipped).	If heat exchanger fails, or becomes obstructed, it may not meet system cooling demands.	Ensure heat exchanger is receiving adequate air flow and is in good operating condition. Repair or replace as necessary.
Check system relief valves.	If a system relief valve becomes unseated for an extended period of time or fails for any other reason, system could become overheated.	Repair or replace any malfunctioning relief valves as applicable and verify loads on machine are not excessive.

**Table 3-5. Won't Shift or Slow to Start**

Item	Description	Action
Check signal line to servo control port.	Obstructed or restricted flow through servo control signal lines could result in slow shift or no shift motor conditions.	Ensure signal lines are not obstructed or restricted and signal pressure is adequate to shift motor.
Check correct supply and drain orifices are properly installed and not obstructed.	Supply and drain orifices determine motor shift. The smaller the orifice, the longer the time it takes to shift the motor. Obstruction also increases shift times.	Ensure proper control orifices are installed in motor and not obstructed. Clean or replace as necessary.



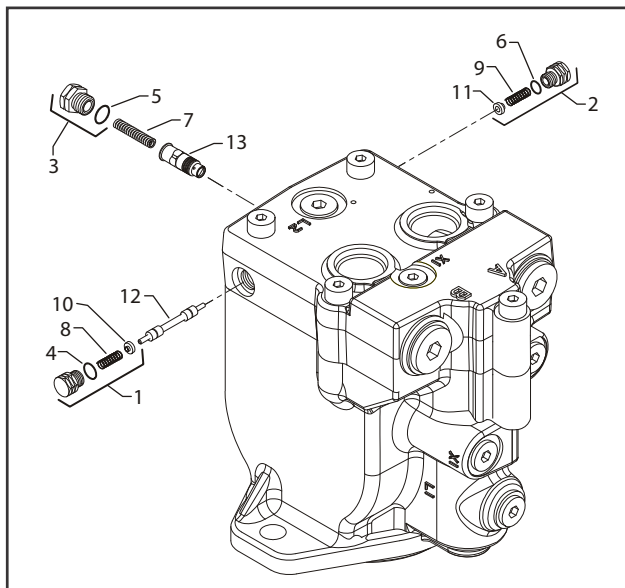
## Disassembly

**NOTE:** Removal of endcap voids warranty.

During assembly, coat all moving parts with a film of clean hydraulic oil. This ensures parts will be lubricated during start-up.

Replace all O-Rings and gaskets.

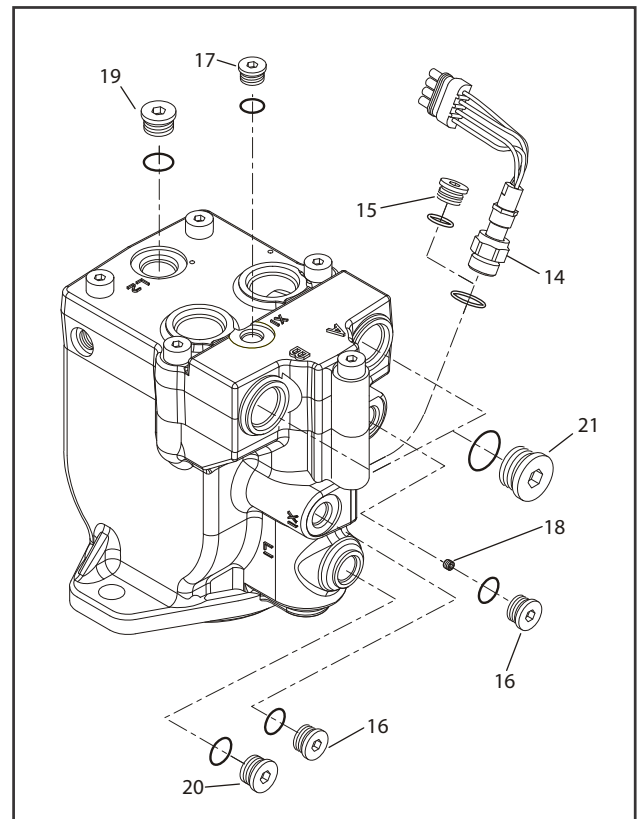
It is recommended that all O-rings be replaced. Lightly lubricate all O-rings with clean petroleum jelly prior to assembly.



- |           |           |            |                    |
|-----------|-----------|------------|--------------------|
| 1. Plug   | 5. O-ring | 9. Spring  | 12. Shift Spool    |
| 2. Plug   | 6. O-ring | 10. Washer | 13. Orifice Poppet |
| 3. Plug   | 7. Spring | 11. Washer |                    |
| 4. O-ring | 8. Spring |            |                    |

**Figure 3-24. Loop Flushing Spool**

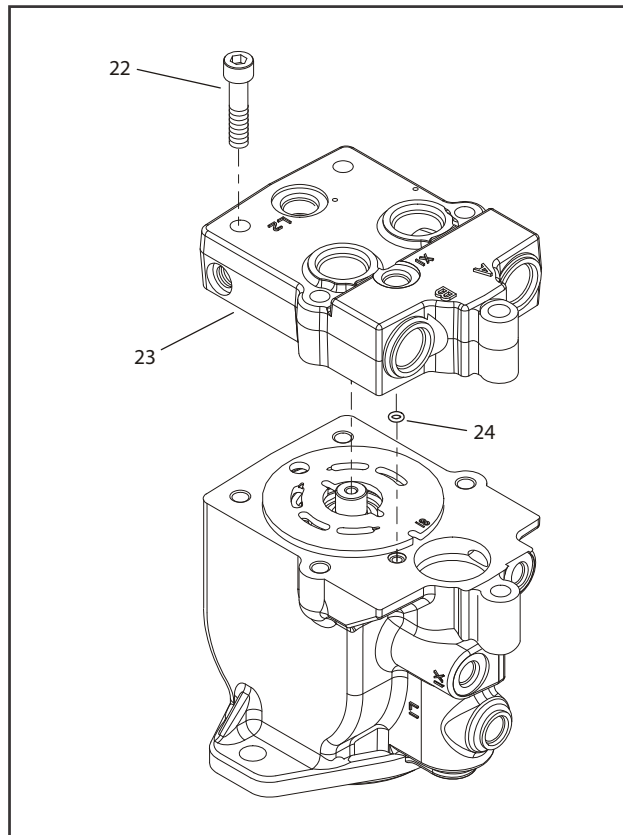
1. Using a 11/16 in wrench remove plug (1) and (2).
2. Using a 5/8 in hex wrench remove plug (3).
3. Remove O-rings (4, 5, and 6).
4. Using pliers, remove centering springs (7, 8, and 9).
5. Remove spring retaining washers (10 and 11).
6. Remove shift spool (12).
7. Remove orifice poppet (13).



- |                       |                    |
|-----------------------|--------------------|
| 14. Lock Nut          | 18. Cavity Plug    |
| 15. O-ring Plug       | 19. Drain Plug     |
| 16. Control Line Plug | 20. Drain Plug     |
| 17. Control Line Plug | 21. Work Port Plug |

**Figure 3-25. Plugs, Fittings, and Speed Sensor**

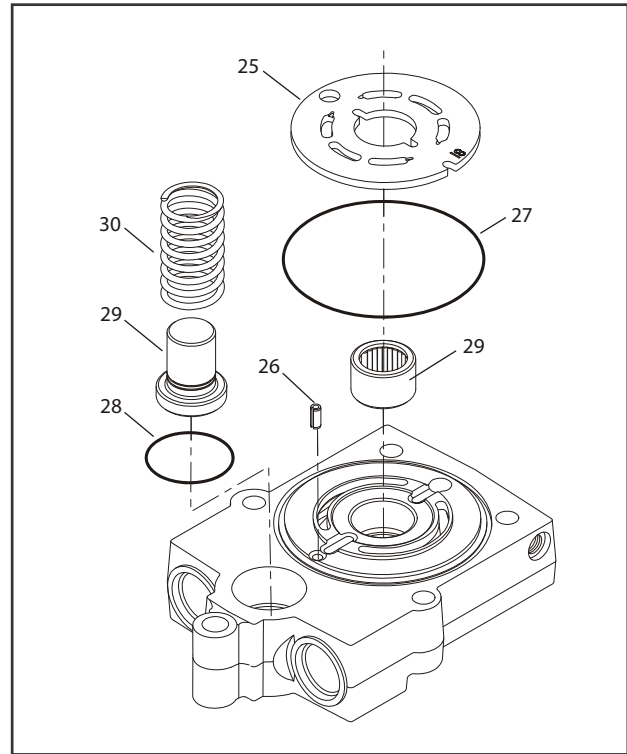
8. Remove all fittings from unit. Discard any O-rings on fittings.
9. Using an 11/16 inch hex wrench, loosen speed sensor lock nut (14) if equipped. Remove speed sensor using a 1/2 inch hex wrench. Units without speed sensor have an O-ring plug (15) installed in that location; remove it with a 3/8 inch internal hex wrench.
10. Using a 1/4 inch internal hex wrench, remove control line plugs (16, 17). Discard O-rings. Using a 3 mm hex wrench, remove cavity plug (18, if equipped with two-line control) from X2 cavity.
11. Using a 5/16 inch internal hex wrench, remove drain plugs (19, 20). Discard O-rings.
12. Using a 9/16 inch internal hex wrench, remove work port plugs (21, if equipped with axial ports). Discard O-rings.



- 22. Screw
- 23. End Cap
- 24. O-ring

**Figure 3-26. End Cap**

13. Using an 8 mm internal hex wrench, remove endcap screws (22).
14. Remove endcap (23). Remove O-ring (24) from housing or endcap. When endcap screws are removed, pressure from servo spring will cause endcap to bind on shaft. Press down on portion of endcap covering servo piston and hold endcap level while removing.



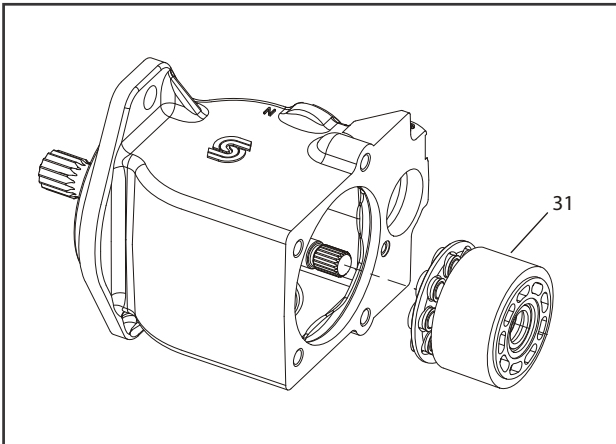
- |                 |                  |
|-----------------|------------------|
| 25. Valve Plate | 28. O-ring       |
| 26. End Cap     | 29. Angle Stop   |
| 27. O-ring      | 30. Servo Spring |

**Figure 3-27. Valve Plate & Rear Shaft Bearing**

**NOTICE**

**DO NOT SCRATCH VALVE PLATE SURFACE. DO NOT DRIVE BEARING PAST REAR SHAFT JOURNAL. BEARING MAY BECOME TRAPPED ON SHAFT AND DAMAGED.**

15. Remove valve plate (25) and timing pin (26) from endcap. Each displacement has a unique valve plate. For identification, the last two digits of the valve plate part number are stamped on its surface.
16. Remove and discard O-rings (27, 28).
17. Remove rear shaft bearing (29) from endcap with a bearing puller. Bearing may be difficult to remove with a puller. Try this as an alternative: Pack bearing cavity with heavy grease. After shaft is removed, insert it into bearing cavity and tap splined end lightly with a soft mallet. Grease will force the bearing out. Remove minimum angle stop (29) and servo spring (30) from housing.



31. Cylinder Kit Assembly

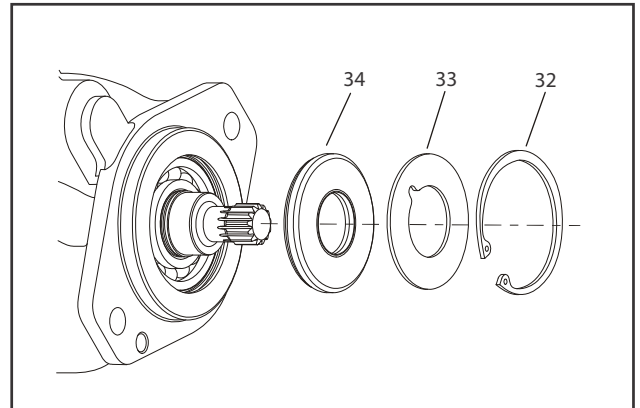
**Figure 3-28. Cylinder Kit**

18. Turn housing on its side and remove cylinder kit assembly (31). Set assembly aside. Do not scratch running surface.

**NOTE:** Grooves on surface of cylinder kit identify its displacement:

**Table 3-6. Displacement Identifiers**

# of Grooves	Frame L	Frame K
1	25	38
2	30	45
3	35	--



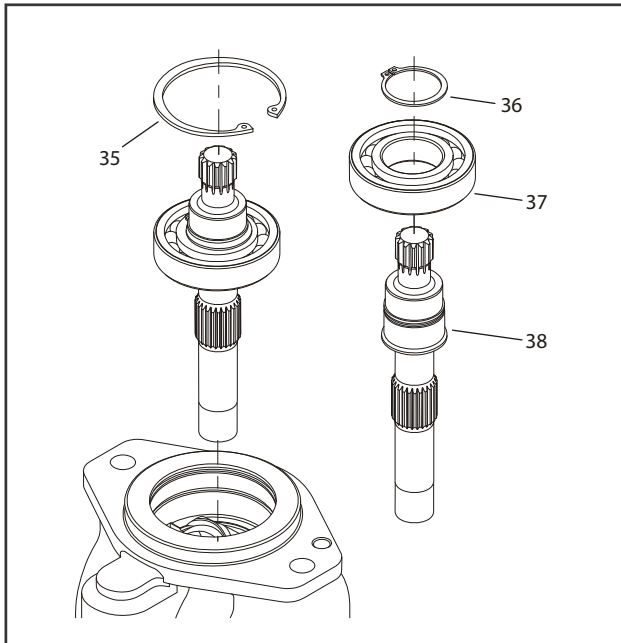
- 32. Snap Ring
- 33. Support Washer
- 34. Shaft Seal

**Figure 3-29. Shaft Seal**

**NOTICE**

**TO AVOID DAMAGING SHAFT DURING SEAL REMOVAL, INSTALL A LARGE SHEET METAL SCREW IN CHUCK OF SLIDE HAMMER. DRIVE SCREW INTO SEAL SURFACE AND USE SLIDE HAMMER TO PULL SEAL.**

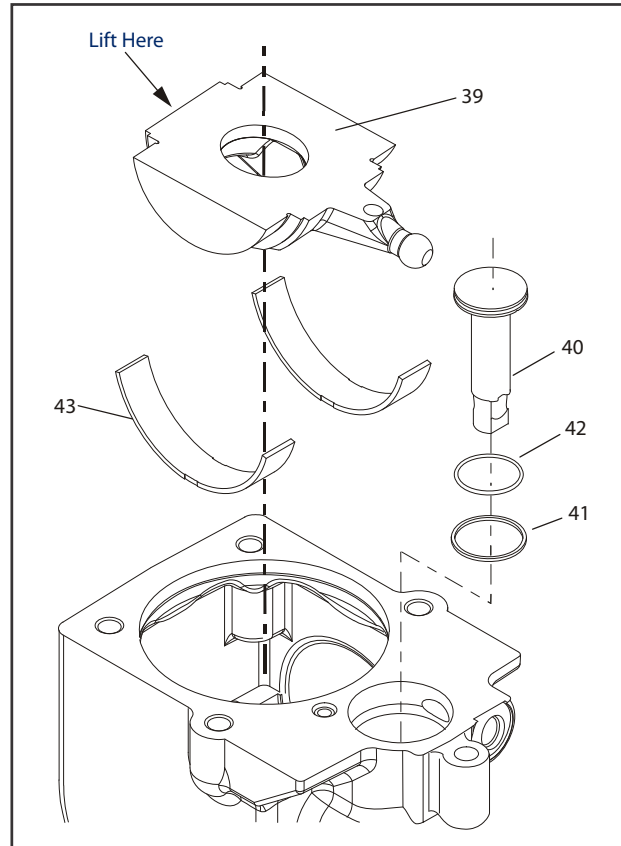
1. Turn housing over and remove snap ring (32) retaining shaft seal and support washer. Remove support washer (33) and carefully pry out shaft seal (34). Discard seal.



- |                    |             |
|--------------------|-------------|
| 35. InnerSnap Ring | 37. Bearing |
| 36. Snap Ring      | 38. Shaft   |

**Figure 3-30. Shaft & Front Bearing**

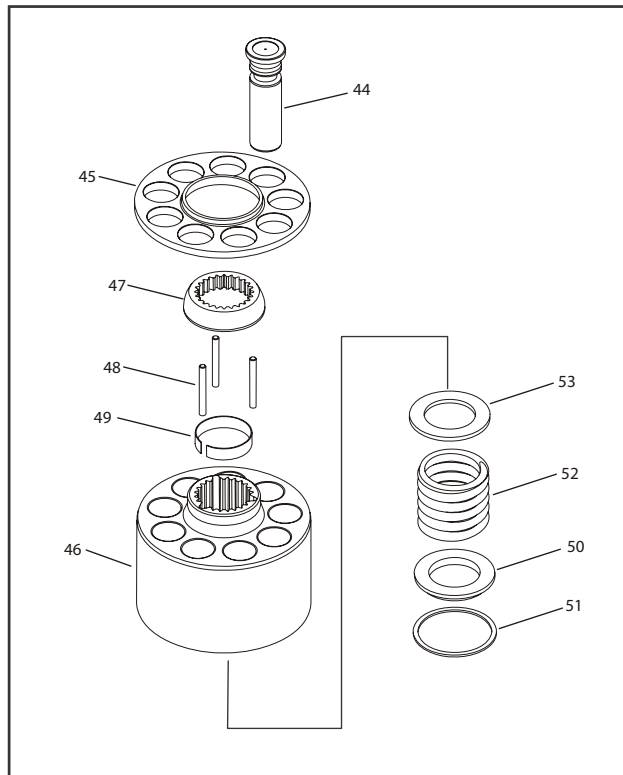
2. Remove inner snap ring (35) and shaft/bearing assembly.
3. Remove snap-ring (36) retaining shaft front bearing. Pull bearing (37) off shaft (38).



- |                  |                      |
|------------------|----------------------|
| 39. Swashplate   | 42. O-ring           |
| 40. Servo Piston | 43. Journal Bearings |
| 41. Piston Seal  |                      |

**Figure 3-31. Swash Plate & Servo Piston**

4. Turn housing over and remove swashplate (39) by lifting on end opposite servo lever.
5. Remove servo piston (40). Remove piston seal (41) and O-ring (42) from servo piston. Discard seal and O-ring.
6. Remove journal bearings (43) from housing. Note location and orientation of each bearing for reassembly.



- 44. Piston
- 45. Slipper Retainer
- 46. Cylinder Block
- 47. Ball Guide
- 48. Holddown Pins
- 49. Retaining Ring
- 50. Block Spring Washer
- 51. Spiral Retaining Ring
- 52. Block Spring
- 53. Inner Block Spring Washer

**Figure 3-32. Cylinder Kit Disassembly**

7. Remove pistons (44) and slipper retainer (45) from cylinder block (46).

**NOTE:** *Pistons are not selectively fitted. However, units with high hourly usage may develop wear patterns. Number pistons and bores for reassembly if they are to be reused.*

8. Remove ball guide (47), hold-down pins (48), and retaining ring (49) from cylinder block.

**NOTE:** *Most repairs do not require block spring removal. Perform this procedure only if you suspect problems with the block spring.*

**⚠ WARNING**

**RISK OF PERSONAL INJURY: COMPRESSING THE BLOCK SPRING REQUIRES FORCE OF ABOUT 80 TO 90 LBF (350 TO 400 N). USE A PRESS SUFFICIENT TO MAINTAIN THIS FORCE WITH REASONABLE EFFORT. ENSURE THE SPRING IS SECURE BEFORE ATTEMPTING TO REMOVE THE SPIRAL RETAINING RING. RELEASE THE PRESSURE SLOWLY AFTER THE RETAINING RING IS REMOVED.**

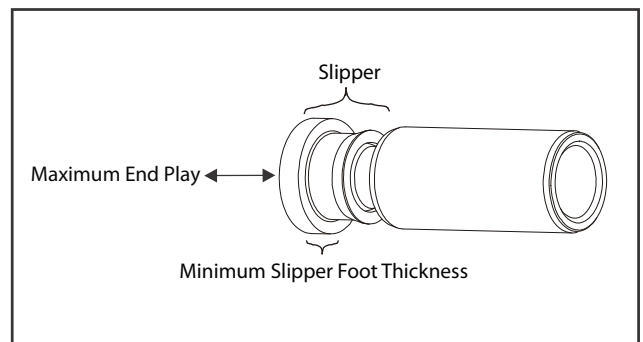
9. Turn block over. Using a press, apply pressure on block spring washer (50) to compress block spring. Compress spring enough to safely remove spiral retaining ring (51). While maintaining pressure, unwind spiral retaining ring (51). Carefully release pressure and remove outer block spring washer (50), block spring (52), and inner block spring washer (53) from cylinder block.

**Inspection**

After disassembly, wash all parts (including end-cap and housing) thoroughly with clean solvent and allow to air dry. Blow out oil passages in housing and endcap with compressed air. Conduct inspection in a clean area and keep all parts free from contamination. Clean and dry parts again after any rework or resurfacing.

**PISTON**

Inspect pistons for damage and discoloration. Discolored pistons may indicate excessive heat; do not reuse.



**SLIPPERS**

Inspect slipper running surfaces. Replace piston assemblies with scored or excessively rounded slipper edges. Measure slipper foot thickness. Replace piston assemblies with excessively worn slippers. Check slipper axial end-play. Replace piston assemblies with excessive end-play.

**Table 3-7. Slipper Foot Thickness & End Play**

Measurement	L Frame	K Frame
Slipper Foot Thickness	2.71 mm (0.11 in.)	4.07 mm (0.16 in.)
Piston/Slipper End Play	0.15 mm (0.006 in.)	

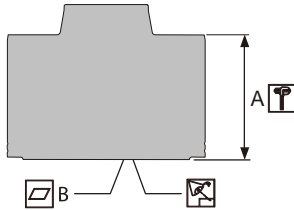
## SECTION 3 - CHASSIS & TURNTABLE

### CYLINDER BLOCK

Measure cylinder block height. Replace blocks worn beyond minimum height specification. Inspect cylinder block running surface. Replace or resurface worn or scratched blocks. Blocks may be resurfaced to specifications shown in the drawing, provided resurfacing will not reduce block height below minimum specification. Table 3-8, Cylinder Block Measurements.

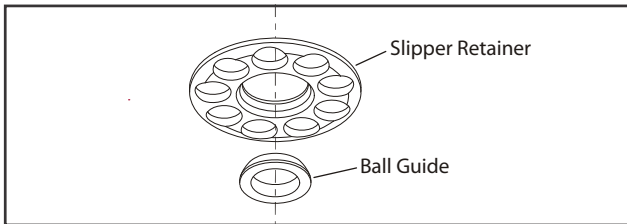
**Table 3-8. Cylinder Block Measurements**

Measurement	L25	L30	L35	K38	K45
Minimum Cylinder Block Height (A)	50.8 (2.00)	50.8 (2.00)	50.8 (2.00)	54.4 (2.14)	54.4 (2.14)
Cylinder Block Surface Flatness	0.002 (0.0000079)	0.002 (0.0000079)	0.002 (0.0000079)	0.002 (0.0000079)	0.002 (0.0000079)



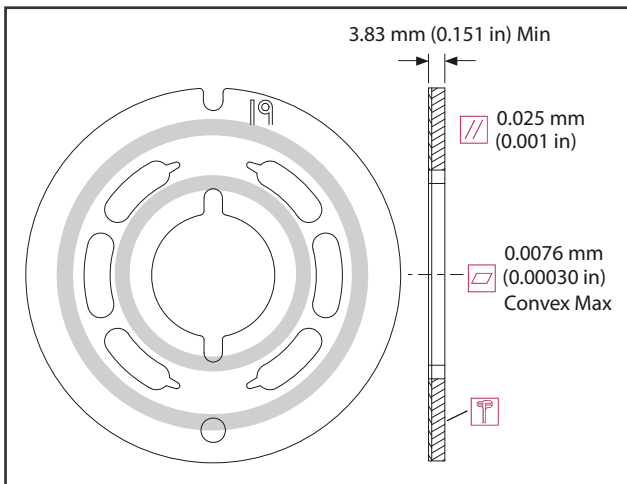
### BALL GUIDE AND SLIPPER RETAINER

Inspect ball guide and slipper retainer for damage, discoloration, or excessive wear. A discolored ball guide or slipper retainer indicates excessive heat. Do not reuse.



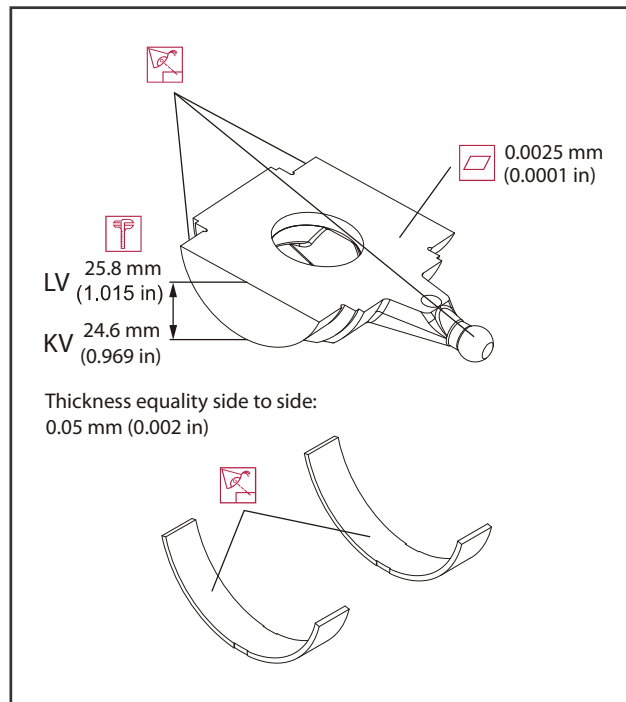
### VALVE PLATE

Valve Plate condition is critical to efficiency of the motor. Inspect valve plate surfaces carefully for excessive wear, grooves, or scratches. Replace or resurface grooved or scratched valve plates. Measure valve plate thickness and replace if worn beyond minimum specification. Valve plates may be resurfaced, provided resurfacing will not reduce thickness below minimum specification.



### SWASHPLATE AND JOURNAL BEARINGS

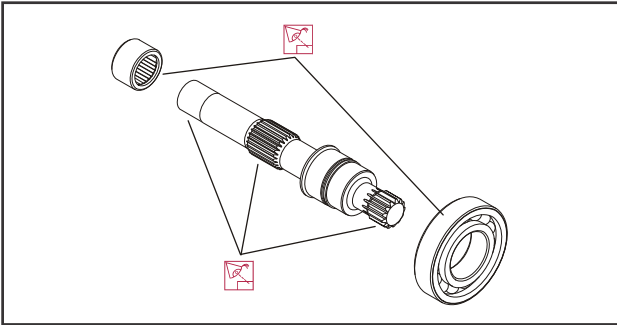
Inspect running face, servo ball-joint, and swashplate journal surfaces for damage or excessive wear. Some material transfer may appear on these surfaces and is acceptable if surface condition meets specifications shown. Measure swashplate thickness from journals running face. Replace swashplate if damaged or worn beyond minimum specification. Replace swashplate if difference in thickness from one side to the other exceeds specification.



Inspect journal bearings for damage or excessive wear. Replace journal bearings if scratched, warped, or excessively worn. Polymer wear layer must be smooth and intact.

**SHAFT BEARINGS**

Inspect bearings for excessive wear or contamination. Rotate bearings while feeling for uneven movement. Bearings should spin smoothly and freely. Replace bearings that appear worn or do not rotate smoothly.

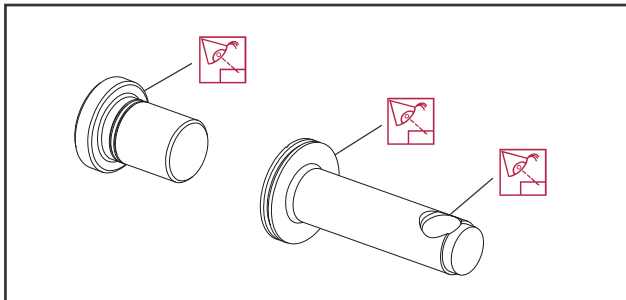


**SHAFT**

Inspect motor shaft for damage or excessive wear on output and block splines. Inspect bearing surfaces and sealing surface. Replace shafts with damaged or excessively worn splines, bearing surfaces, or sealing surfaces.

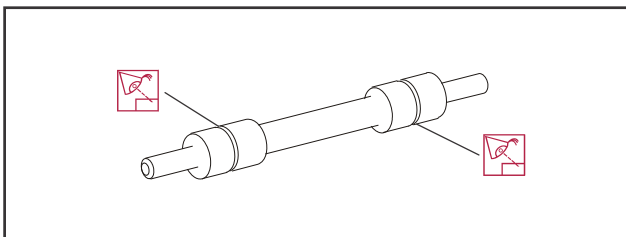
**SERVO PISTON AND MINIMUM ANGLE STOP**

Inspect minimum angle stop, servo piston head, and servo piston ball-socket for damage or excessive wear. Replace as required.



**LOOP FLUSHING SPOOL**

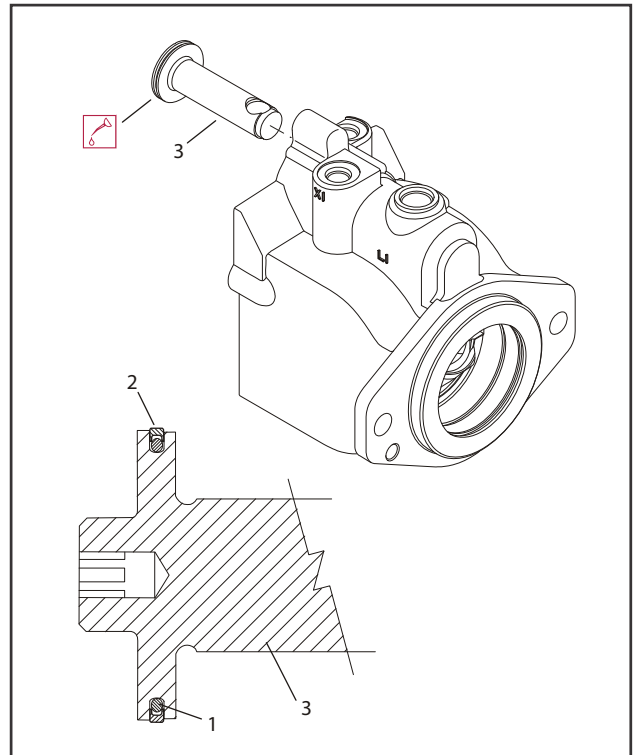
Inspect loop flushing spool for cracks or damage. Replace as required.



**Assembly**

1. Install new O-ring (1) and piston seal (2) to servo piston (3). Install piston seal over O-ring.

**NOTE:** Installing piston seal stretches it, making it difficult to install servo piston in its bore. Allow 30 minutes for seal to relax after installation. To speed up seal relaxation, compress seal by installing piston head in end-cap servo cavity and let it stand for at least five minutes.



1. O-ring
2. Piston Seal
3. Servo Piston

**Figure 3-33. Servo Piston**

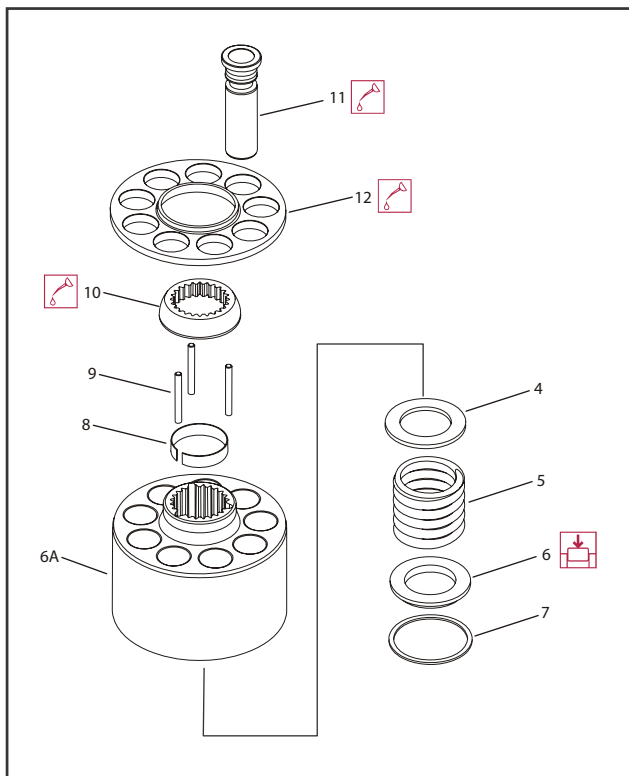
2. After piston seal has relaxed, lubricate and install servo piston in housing bore. Align piston with ball socket facing inside of housing.

## SECTION 3 - CHASSIS & TURNTABLE

### **⚠ CAUTION**

**RISK OF PERSONAL INJURY: COMPRESSING THE BLOCK SPRING REQUIRES ABOUT 80 TO 90 LBF (350 TO 400 N) OF FORCE. USE A PRESS SUFFICIENT TO MAINTAIN THIS FORCE WITH REASONABLE EFFORT. ENSURE SPRING IS SECURE BEFORE ATTEMPTING TO INSTALL THE SPIRAL RETAINING RING. RELEASE PRESSURE SLOWLY AFTER RETAINING RING IS INSTALLED.**

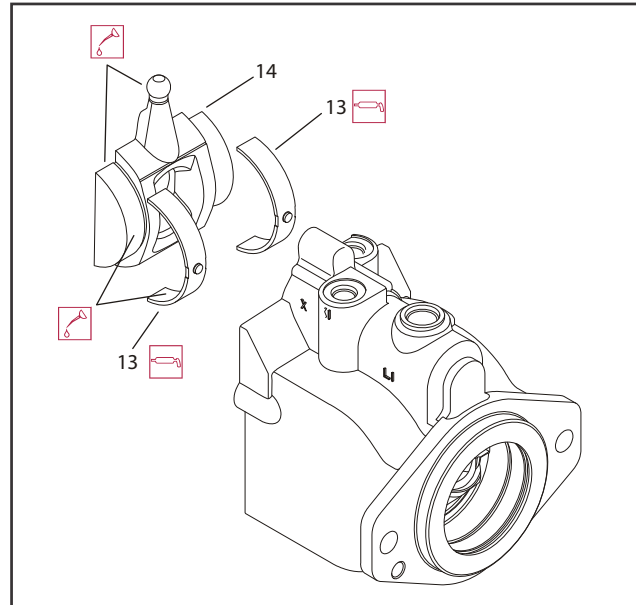
3. Install inner block spring washer (4), block spring (5), and outer washer (6) in cylinder block (6A). Using a press, compress block spring enough to expose retaining ring groove. Wind spiral retaining ring (7) in cylinder block groove.



- |                          |                      |
|--------------------------|----------------------|
| 4. Block Spring Washer   | 8. Retaining Ring    |
| 5. Block Spring          | 9. Hold-down Pins    |
| 6. Outer Washer          | 10. Ball Guide       |
| 6A. Cylinder Block       | 11. Piston           |
| 7. Spiral Retaining Ring | 12. Slipper Retainer |

4. Turn block over and install retaining ring (8), hold-down pins (9), and ball guide (10) to cylinder block.
5. Install pistons (11) to slipper retainer (12). Install piston/retainer assembly in cylinder block. Ensure concave surface of retainer seats on ball guide. If reusing pistons, install them in original block bores. Lubricate pistons, slippers, retainer, and ball guide before assembly. Set cylinder kit aside on a clean surface until needed.

6. Install journal bearings (13) in housing seats. Use assembly grease to keep bearings seated during assembly. Ensure locating nubs drop into seat cavities. If reusing bearings, install in original location and orientation. Lubricate journal bearings.



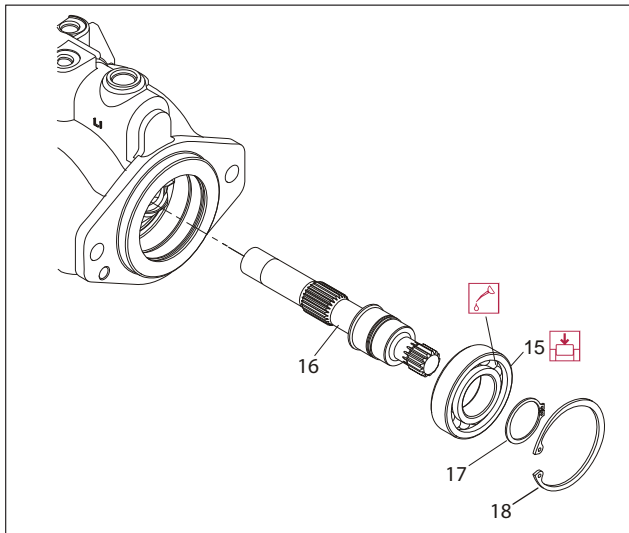
13. Journal Bearings  
14. Swash Plate

**Figure 3-34. Swash Plate and Journal Bearing**

7. Install swashplate (14) in housing. Tilt swashplate and guide servo lever ball into its socket in the servo piston rod. Ensure swashplate seats into journal bearings and moves freely. Lubricate running surface of swashplate.



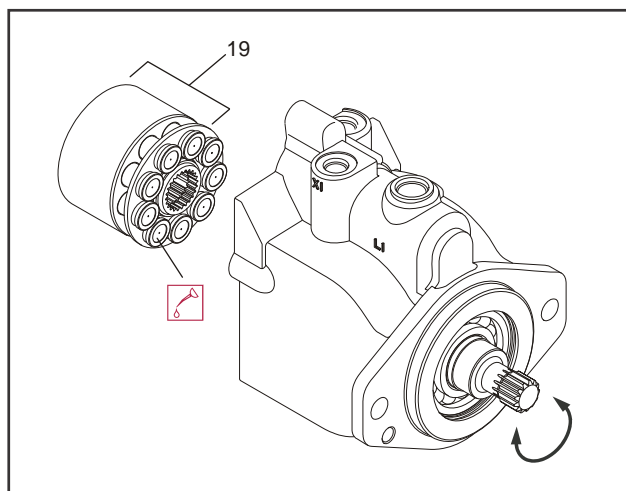
8. Press front shaft bearing (15) on shaft (16). Press bearing on shaft with lettering facing out. Lubricate bearing rollers. Install snap-ring (17) on shaft.



- |                         |               |
|-------------------------|---------------|
| 15. Front Shaft Bearing | 17. Snap Ring |
| 16. Shaft               | 18. Snap Ring |

**Figure 3-35. Shaft and Front Bearing**

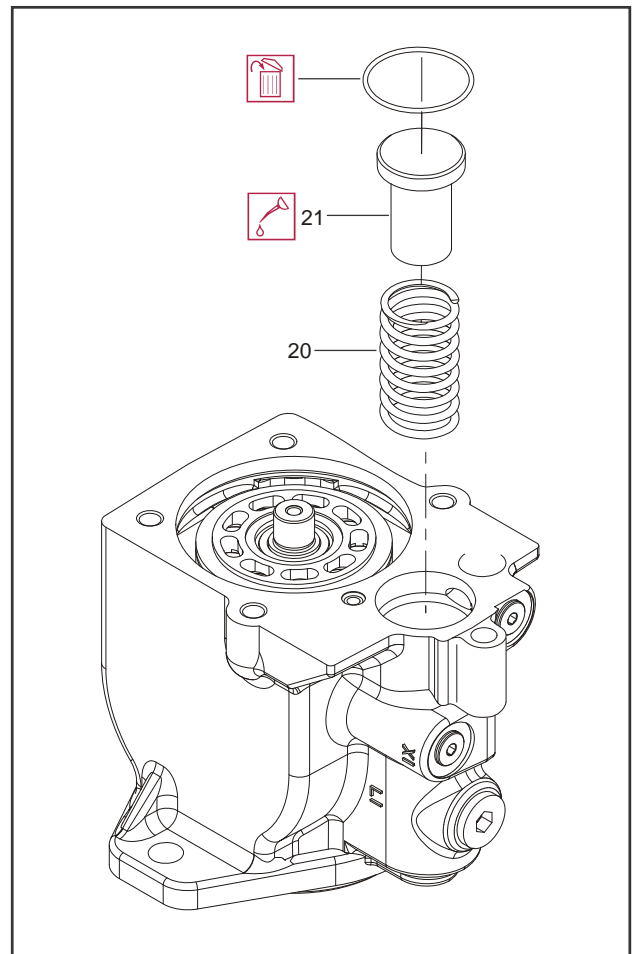
9. While holding swashplate in place, turn housing on its side. Install the install shaft/bearing assembly into housing from flange end. Install snap-ring (18).
10. Verify swashplate and bearings are properly seated. Install cylinder kit (19) on shaft. Install with slippers facing swashplate. Rock the shaft to align block splines and slide cylinder kit into place. Orient motor with shaft pointing downward and verify cylinder kit, swashplate, journal bearings, and servo piston are properly installed.



19. Cylinder Kit

**Figure 3-36. Cylinder Kit Installation**

11. Lubricate and install servo spring (20) and minimum angle stop (21) in housing bore.

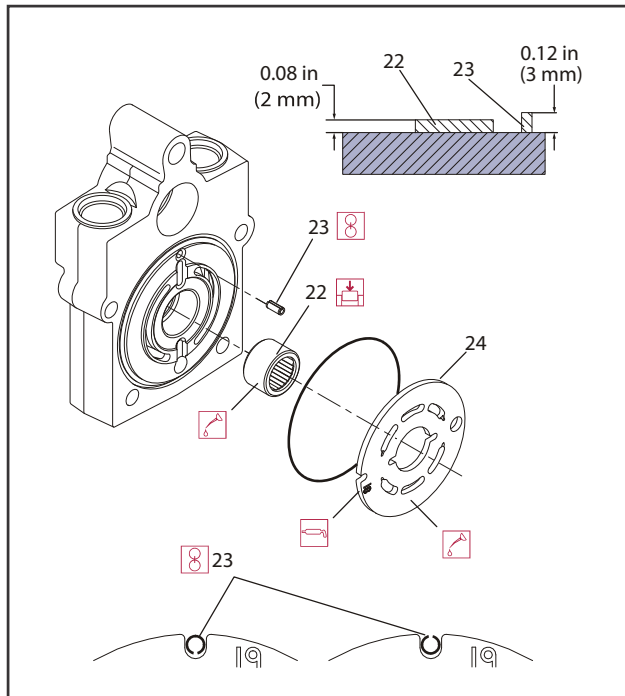


- |                        |
|------------------------|
| 20. Servo Spring       |
| 21. Minimum Angle Stop |

**Figure 3-37. Servo Spring and Minimum Angle Stop**

## SECTION 3 - CHASSIS & TURNTABLE

12. Press rear shaft bearing (22) in endcap. Install bearing with letters facing out. Press until bearing surface is  $0.08 \pm 0.01$  in ( $2 \pm 0.25$  mm) above endcap surface.

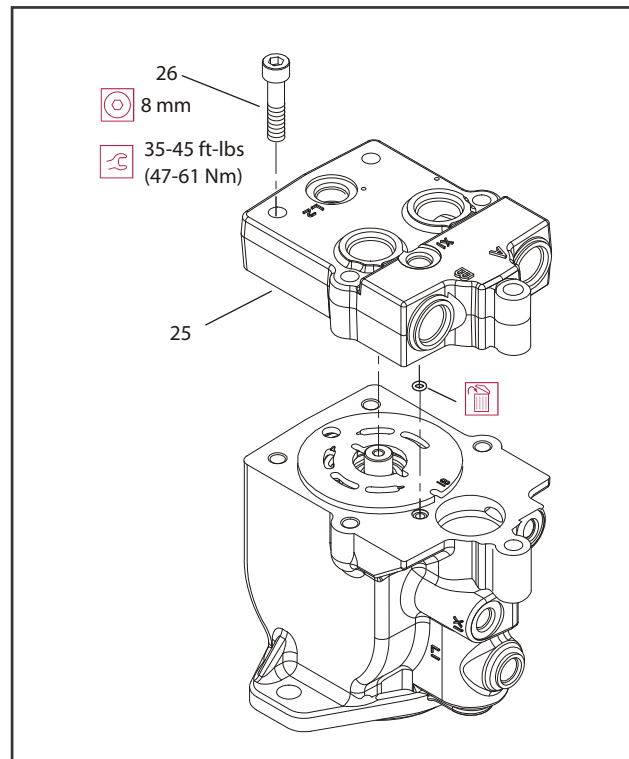


- 22. Rear Shaft Bearing
- 23. Timing Pin
- 24. Valve Plate

**Figure 3-38. Valve Plate and Rear Bearing**

13. Install timing pin (23) into its bore in the endcap. Install pin with groove facing toward or away from shaft. Press pin until end protrudes  $0.12 \pm 0.01$  in ( $3 \pm 0.25$  mm) above endcap surface.
14. Install valve plate (24) on endcap. Install valve plate with yellow surface toward cylinder block. Align slot in valve plate with timing pin. Apply a liberal coat of assembly grease to endcap side of valve plate to keep it in place during installation.

15. Install endcap (25) on housing with endcap screws (26). Ensure endcap will properly seat to housing without interference. Improper assembly of internal components may prevent endcap from seating properly. Ensure O-rings seat properly when installing endcap.

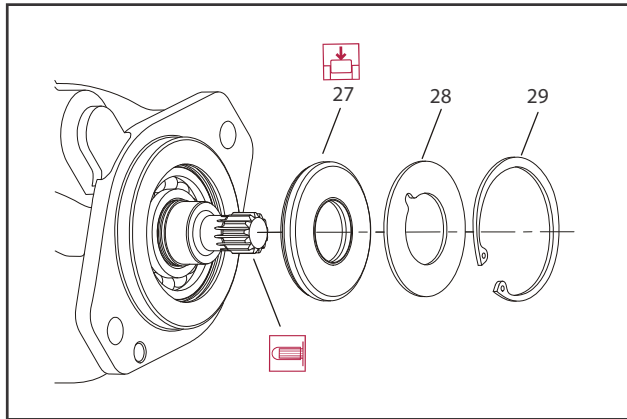


- 25. End Cap
- 26. Screw

**Figure 3-39. End Cap**

16. Using an 8 mm internal hex wrench, tighten endcap screws. Tighten screws in opposite corners slowly and evenly to compress the servo spring and properly seat the endcap. Torque endcap screws 35-45 ft-lb (47-61 Nm).
17. Before installing shaft seal, ensure shaft turns smoothly with less than 120 in-lb (13.5 Nm) of force. If shaft does not turn smoothly within specified maximum force, disassemble and check unit.

18. Cover shaft splines with an installation sleeve. Install a new shaft seal (27) with cup side facing motor. Press seal in housing until it bottoms out. Press evenly to avoid binding and damaging seal. Install seal support washer (28) and snap ring (29).



- 27. Shaft Seal
- 28. Seal Support Washer
- 29. Snap Ring

Figure 3-40. Shaft Seal

19. Install remaining plugs and fittings to housing. Refer to drawing below for wrench sizes and installation torques.

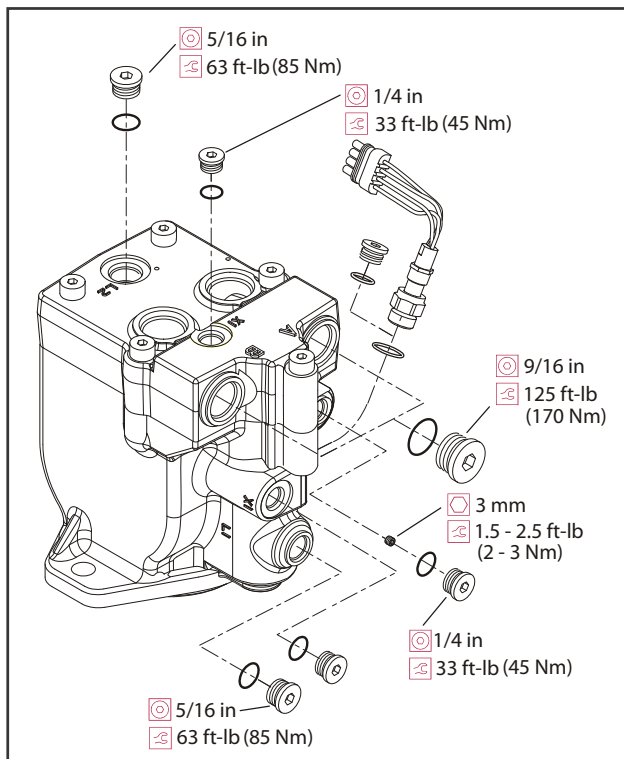
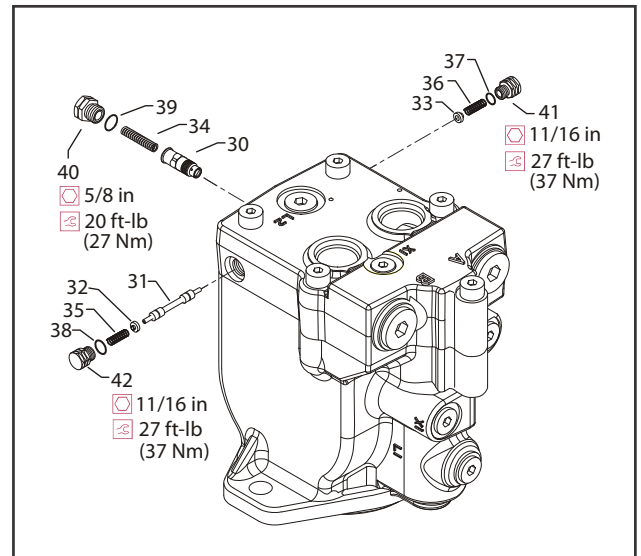


Figure 3-41. Plugs and Fittings Installation

20. Install orifice poppet (30).



- |                    |            |            |          |
|--------------------|------------|------------|----------|
| 30. Orifice Poppet | 34. Spring | 37. O-ring | 40. Plug |
| 31. Shift Spool    | 35. Spring | 38. O-ring | 41. Plug |
| 32. Spring         | 36. Spring | 39. O-ring | 42. Plug |
| 33. Spring         |            |            |          |

Figure 3-42. Loop Flushing Spool

21. Install shift spool (31).
22. Install spring retaining washers on springs (32 and 33).
23. Carefully install centering springs (34, 35, and 36).
24. Install new O-rings (37, 38, and 39).
25. Using a 5/8 in wrench torque plug (40) to 20 ft-lb (27 Nm).
26. Using a 11/16 in wrench, torque plugs (41 and 42) to 27 ft-lb (37 Nm).

### Initial Start-up Procedures

Follow this procedure when starting-up a new motor or when installing a motor that has been removed.

Prior to installing the motor, inspect for damage incurred during shipping. Make certain all system components (reservoir, hoses, valves, fittings, heat exchanger, etc.) are clean prior to filling with fluid.

1. Fill reservoir with recommended hydraulic fluid. Always filter fluid through a 10 micron filter when pouring into the reservoir. Never reuse hydraulic fluid.
2. Fill inlet line leading from pump to reservoir. Check inlet line for properly tightened fittings and be certain it is free of restrictions and air leaks.
3. Fill pump and motor housing with clean hydraulic fluid. Pour filtered oil directly in upper most case drain port.
4. To ensure pump and motor stay filled with oil, install case drain lines in upper most case drain ports.
5. Install a 0 to 500 psi (0 to 35 bar) gauge in charge pressure gauge port of pump to monitor system pressure during start up.
6. Watching pressure gauge and run engine at lowest possible speed until system pressure builds to normal levels (minimum 160 psi [11 bar]). Once system pressure is established, increase to full operating speed. If system pressure is not maintained, shut down engine, determine cause, and take corrective action.
7. Operate hydraulic system for at least fifteen minutes under light load conditions.
8. Check and adjust control settings as necessary after installation.
9. Shut down engine and remove pressure gauge. Replace plug at charge pressure gauge port.
10. Check fluid level in reservoir. Add clean filtered fluid if necessary. Motor is now ready for operation.

### 3.5 OSCILLATING AXLE BLEED PROCEDURE AND LOCKOUT TEST

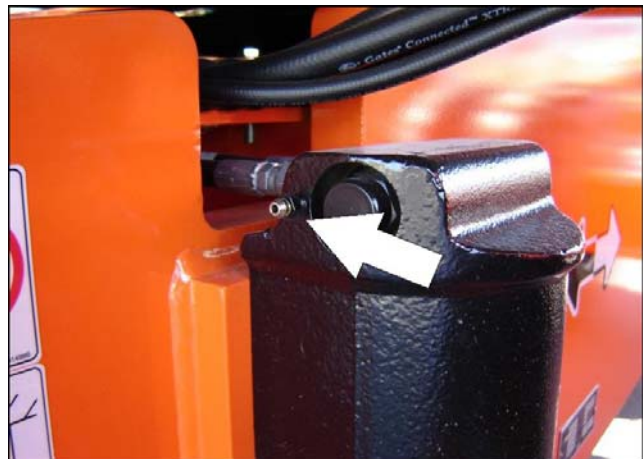
#### Lockout Cylinder Bleeding

#### **NOTICE**

**ENSURE MACHINE IS ON A LEVEL SURFACE, REAR WHEELS ARE BLOCKED, AND BRAKE WIRE IS DISCONNECTED. ENSURE PLATFORM IS FULLY LOWERED AND BOOM IS CENTERED OVER REAR AXLE BEFORE STARTING BLEED PROCEDURE.**

1. Park machine on a level surface and block rear wheels.
2. Center boom over rear axle to make sure oscillation valve in rotary coupling is activated.
3. Place suitable container under flow divider mounted on inside of frame to catch hydraulic fluid.
4. Remove Port 11 tee fitting from flow divider. Cap fitting and plug hose.
5. Place suitable containers under each lockout cylinder to catch hydraulic fluid.
6. Have helper start engine from platform. Turn function control knob speed fully counter-clockwise to Turtle position to set drive creep mode. Activate Low Drive In Reverse creep mode.
7. Open bleeder screw on one lockout cylinder.

**NOTE:** *Open bleeder valve enough to get a fast stream of oil. A fast stream of oil will exhaust air from hose and lockout cylinder better than a slow stream.*



**Figure 3-43. Bleeder Valve Location**

8. Close bleeder valve when no more air in hydraulic oil.
9. Repeat on opposite lockout cylinder.
10. Shut down engine.
11. Reconnect hose and tee fitting to Port 11 on flow divider.

## Oscillating Axle Lockout Test

### NOTICE

**LOCKOUT SYSTEM TEST MUST BE PERFORMED QUARTERLY, ANY TIME A SYSTEM COMPONENT IS REPLACED, OR WHEN IMPROPER SYSTEM OPERATION IS SUSPECTED.**

**NOTE:** Ensure boom is fully retracted, lowered, and centered between drive wheels before starting lockout cylinder test.

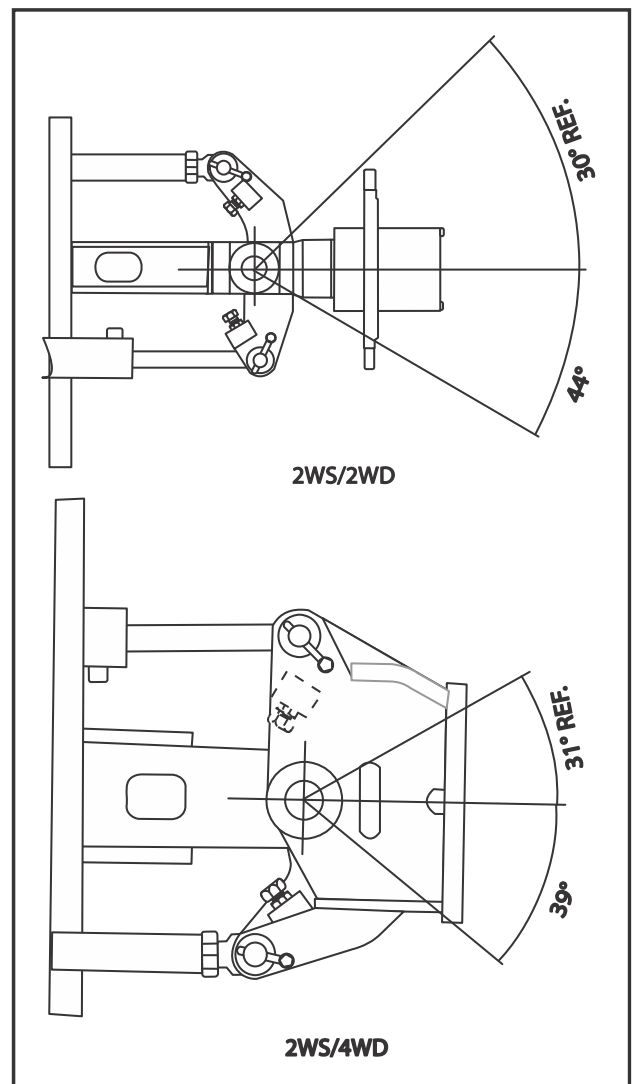
1. Place a 6 inch (15.2 cm) high block with ascension ramp in front of left front wheel.
2. From platform control station, activate machine hydraulic system.
3. Place FUNCTION SPEED CONTROL and DRIVE SPEED/TORQUE SELECT control switches to their respective LOW positions.
4. Place DRIVE control lever to FORWARD position and carefully drive machine up ascension ramp until left front wheel is on top of block.
5. Carefully activate SWING control lever and position boom over right side of machine.
6. With boom over right side of machine, place DRIVE control lever to REVERSE. Drive machine off block and ramp.
7. Have an assistant check if left front wheel remains locked in position off of ground.
8. Carefully activate SWING control lever and return boom to stowed position (centered between drive wheels). When boom reaches center, stowed position, lockout cylinders should release and allow wheel to rest on ground. It may be necessary activate DRIVE to release cylinders.
9. Place 6 inch (15.2 cm) high block with ascension ramp in front of right front wheel.
10. Place DRIVE control lever to FORWARD and carefully drive machine up ascension ramp until right front wheel is on top of block.
11. Carefully activate SWING control lever and position boom over left side of machine.
12. With boom over left side of machine, place DRIVE control lever to REVERSE. Drive machine off block and ramp.
13. Have an assistant check if right front wheel remains locked in position off of ground.
14. Carefully activate SWING control lever and return boom to stowed position (centered between drive wheels). When boom reaches center, stowed position, lockout cylinders should release and allow wheel to rest on ground. It may be necessary activate DRIVE to release cylinders.

15. If lockout cylinders do not function properly, have qualified personnel correct malfunction before further operation.

## 3.6 STEER ADJUSTMENTS

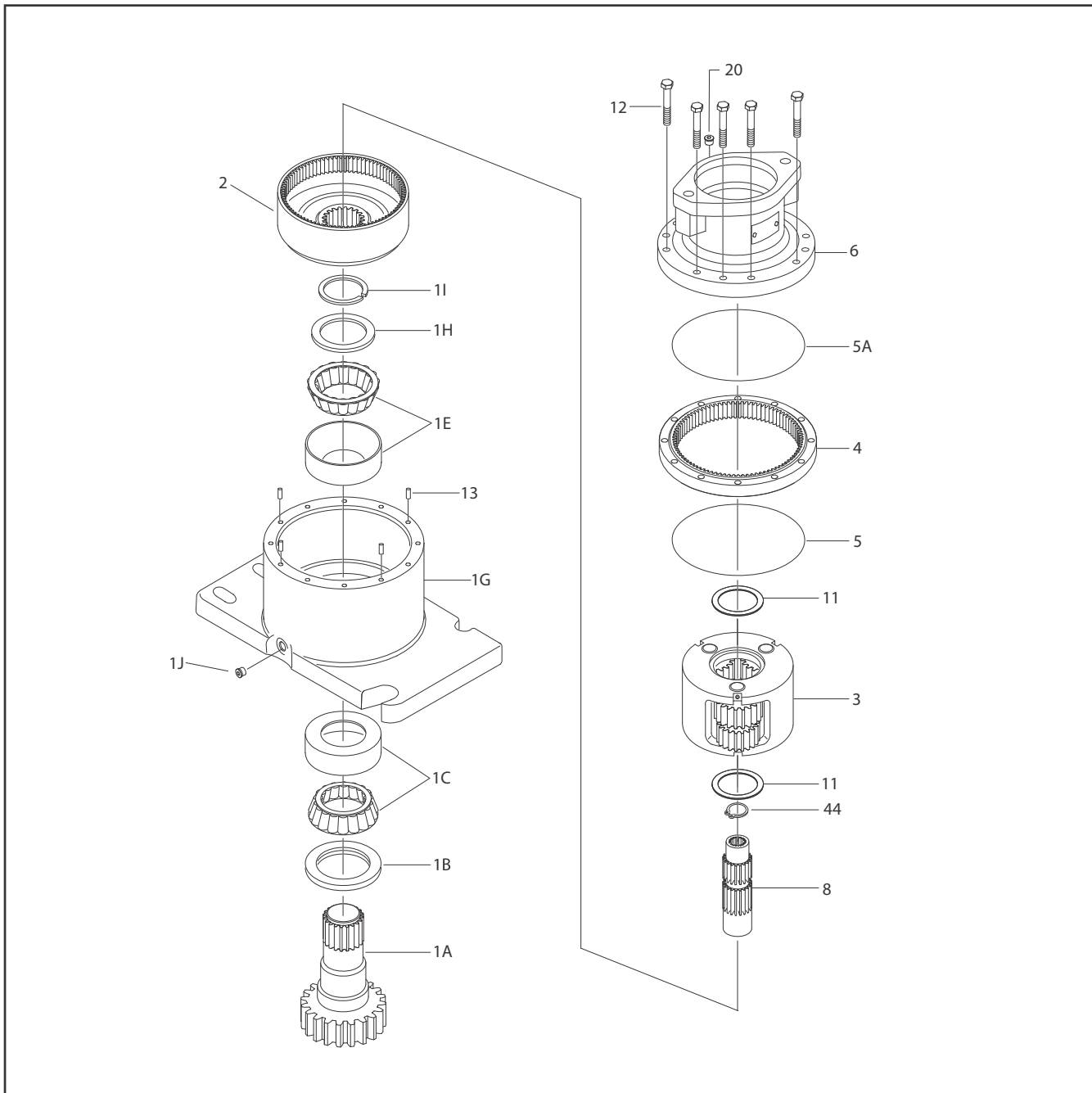
**NOTE:** 2 Wheel Steering/2 Wheel Drive: Spindles do not stop on cylinder stroke. Adjust steering stops as follows: Adjust item #1 to achieve 44° inside turn angles. Steer full left and adjust RH item #2 to contact axle. Steer full right and adjust LH item #2 to contact axle.

2 Wheel Steering/Four Wheel Drive: Spindles do not stop on cylinder stroke. Adjust steering stops as follows: Adjust item #1 to achieve 39° inside turn angles. Steer full left and adjust RH item #2 to contact axle. Steer full right and adjust LH item #2 to contact axle.



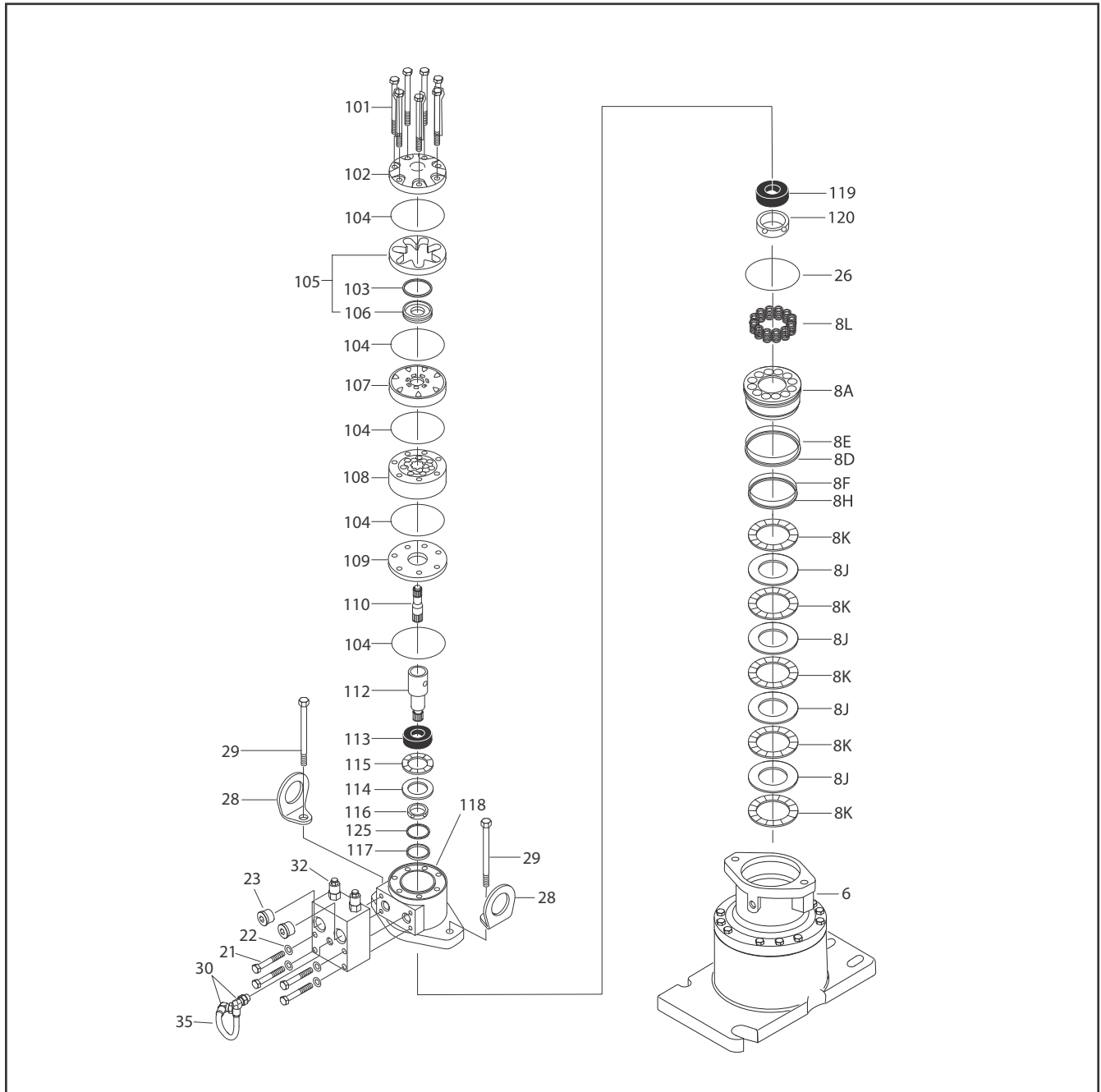
**Figure 3-44. Steer Adjustments**

3.7 SWING DRIVE



- |                  |                    |                     |                   |                             |
|------------------|--------------------|---------------------|-------------------|-----------------------------|
| 1A. Output Shaft | 1G. Housing        | 2. Internal Gear    | 5A. O-Ring        | 12. Bolt                    |
| 1B. Lip Seal     | 1H. Thrust Washer  | 3. Carrier Assembly | 6. Brake Housing  | 13. Dowel Pin               |
| 1C. Bearing      | 1I. Retaining Ring | 4. Ring Gear        | 8. Sun Gear       | 20. Pipe Plug               |
| 1E. Bearing      | 1J. Pipe Plug      | 5. O-Ring           | 11. Thrust Washer | 44. Internal Retaining Ring |

Figure 3-45. Swing Drive Assembly



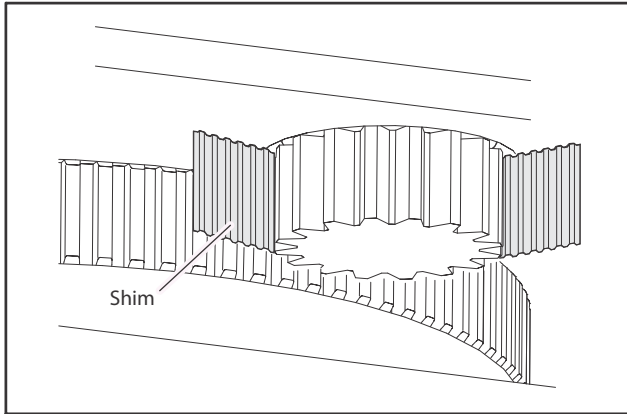
- |                  |                 |                               |                     |                     |
|------------------|-----------------|-------------------------------|---------------------|---------------------|
| 6. Brake Housing | 8L. Spring      | 35. Tube                      | 108. Rotor Set      | 117. Back-up Washer |
| 8A. Piston       | 21. Bolt        | 101. Bolt                     | 109. Wear Plate     | 118. Housing        |
| 8D. O-Ring       | 22. Lockwasher  | 102. End Cover                | 110. Drive Link     | 119. Outer Bearing  |
| 8E. Back-Up Ring | 23. Pipe Plug   | 103. Commutator Seal          | 112. Coupling Shaft | 120. Seal           |
| 8F. O-Ring       | 26. O-Ring      | 104. Ring Seal                | 113. Inner Bearing  | 125. Back-up Washer |
| 8H. Back-up Ring | 28. Lifting Lug | 105. Commutator and Ring Assy | 114. Thrust Washer  |                     |
| 8J. Rotor Disc   | 29. Bolt        | 106. Ring                     | 115. Thrust Bearing |                     |
| 8K. Stator Disc  | 30. Elbow       | 107. Manifold                 | 116. Inner Seal     |                     |

Figure 3-46. Swing Motor and Brake Assembly

**Gear Backlash**

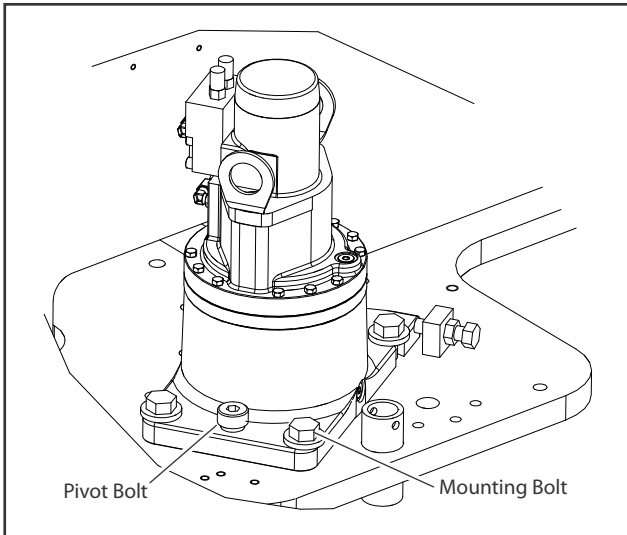
Set backlash to .010 - .015 in (0.254 to 0.381 mm).

1. Insert shim (JLG P/N 4071009) between pinion and bearing on the bearing high spot. The bearing high spot should be stamped with an "X" on the surface below the teeth and marked with yellow paint in the tooth space.



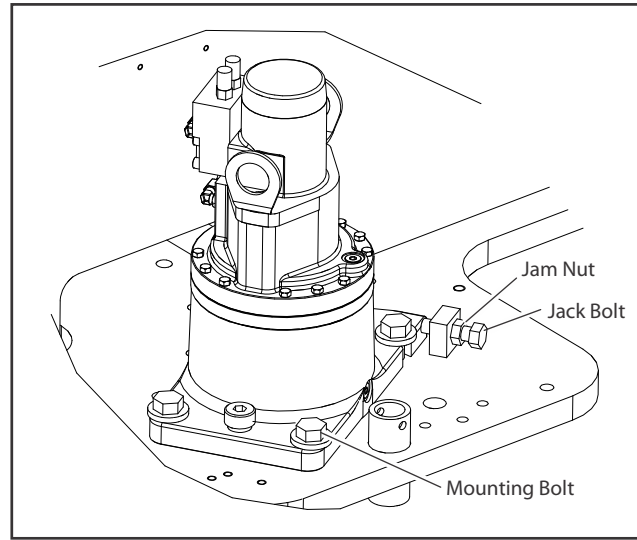
**Figure 3-47. Swing Drive Shim Placement**

2. Apply JLG Thread locking compound P/N 0100019 to pivot bolt. Torque pivot bolt to 205 ft-lb (280 Nm).
3. Remove turntable lock pin.
4. Apply JLG Thread locking compound P/N 0100019 to four mounting bolts. Torque mounting bolts to 30 ft-lb (40 Nm).



**Figure 3-48. Swing Drive Pivot and Mounting Bolts**

5. Loosen jam nut.
6. Tighten jack bolt until pinion is snug against shim and bearing, then loosen jack bolt.
7. Apply JLG Thread locking compound P/N 0100019 to jack bolt threads. Torque jack bolt to 50 ft-lb (68 Nm).
8. Tighten jam nut.
9. Torque four mounting bolts to 340 ft-lb (461 Nm).

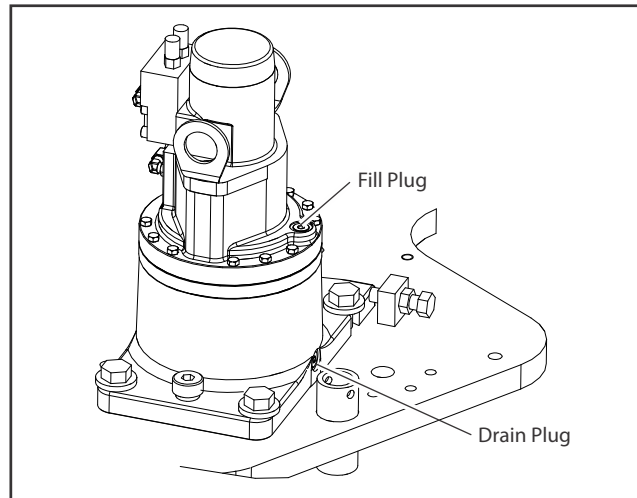


**Figure 3-49. Swing Drive Jam Nut and Mounting Bolt**

10. Remove and discard swing drive shim.

**Swing Drive Lubrication**

Fill Swing Drive Gearbox with 43 oz (1.27L) 90w80 gear oil with EP additives. Oil should cover the ring gear. Torque pipe plug 23 - 24 ft-lb (31 - 32.5 Nm).



**Figure 3-50. Swing Drive Lubrication**



### Motor Control Valve Disassembly

1. Place unit on bench with motor end up.
2. Remove Drain Plug (1P) and drain oil from gearbox.
3. Remove Hydraulic Tubing Assembly (35).
4. Loosen jam nuts on Elbow Fittings (30). Remove fittings from Brake (6) and Motor Control Valve (32).
5. Remove O-ring Plugs (23) from Motor Control Valve (32).
6. Remove four bolts (21), washers (22), and Motor Control Valve (32) from Motor (31).
7. Reinstall Drain Plug (1P). Torque to 23 - 24 ft-lb (31 - 32.5 Nm).

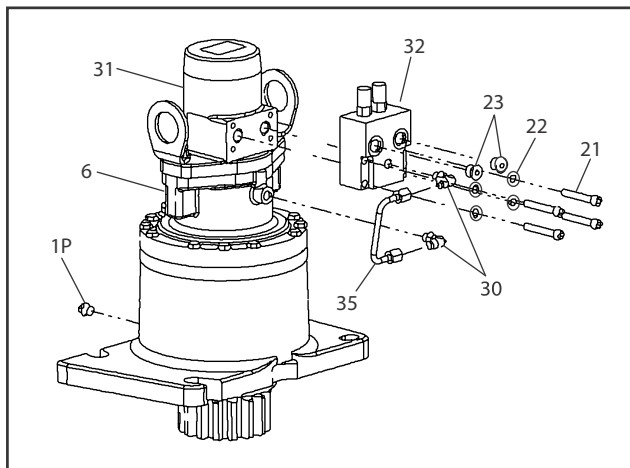


Figure 3-51. Main Control Valve Disassembly

### Motor and Brake Disassembly

1. With unit resting on bench with Motor (31) end up, remove Hex Bolts (29) and Lift Lugs (28) from Motor (31).
2. Pull Motor (31) straight up and remove Motor (31) from Brake Housing (6).
3. Remove O-ring (26) between Motor (31) and Brake Housing (6).
4. Remove Springs (8L) from piston.

#### **CAUTION**

**PISTON (8A) MAY MOVE QUICKLY. WEAR EYE PROTECTION.**

5. Apply less than 50 psi air to brake port to remove Brake Piston (8A).
6. Remove Rotors (8J) and Stators (8K) from Brake Housing (6).

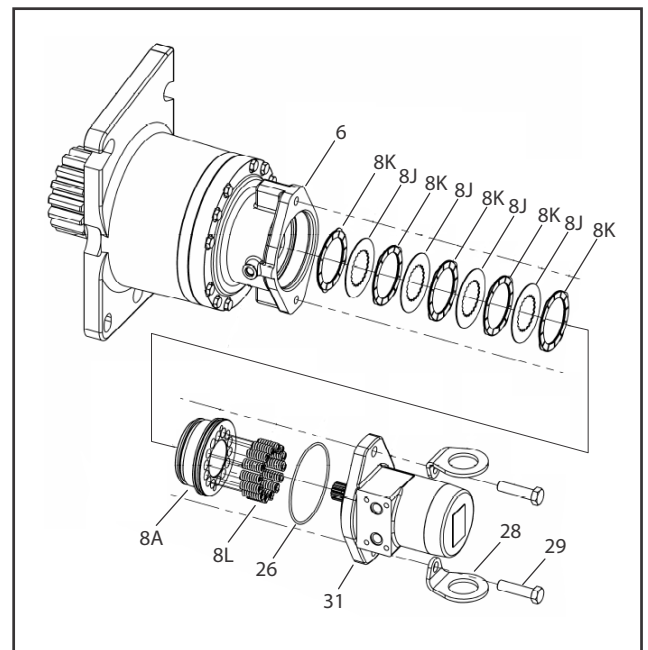


Figure 3-52. Motor and Brake Disassembly

### Main Disassembly

1. Remove Sun Gear (8) with Retaining Ring (44) inside.
2. With unit resting on Output Shaft (Pinion) (1A), remove Bolts (12) from Brake Housing (6).
3. Remove Brake Housing (6) from main assembly.
4. Remove O-ring (5A) from Brake Housing (6) and Ring Gear (4).
5. Remove Thrust Washer (11) from Brake Housing (6) and Carrier Subassembly.
6. Remove Ring Gear (4) from Housing (1G).
7. Remove O-ring (5) from Ring Gear (4) and Housing (1G).
8. Remove Carrier Subassembly.
9. Remove Thrust Washer (11) between Carrier Subassembly and Internal Gear (2).
10. Remove Internal Gear (2).

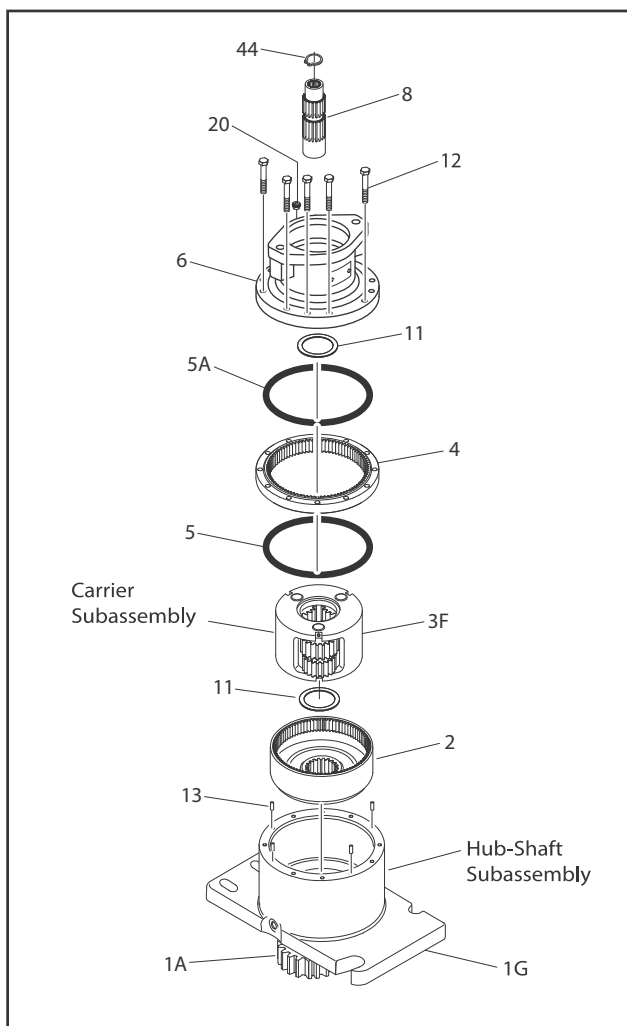


Figure 3-53. Main Disassembly

### Hub-Shaft Disassembly

**CAUTION**

WEAR EYE PROTECTION DURING THIS PROCEDURE.

11. Using retaining ring pliers, remove and discard Retaining Ring (11) from groove in Output Shaft (1A).
12. Remove Thrust Washer (1H).
13. Support Housing (1G) on Output Shaft (1A) end. Press Output Shaft (1A) out of Housing (1G).

**NOTE:** Lip Seal (1B) will be pressed out of Housing (1G) by Bearing Cone (1D) during this step.

14. Remove Bearing Cone (1E) from Housing (1G).
15. Use a bearing puller to remove Bearing Cone (1D) from Shaft (1A). Bearing Cups (1C & 1F) will remain in Housing (1G).

**NOTE:** If bearing replacement is necessary, Bearing Cups (1C & 1F) can be removed with a slide hammer puller or driven out with a punch.

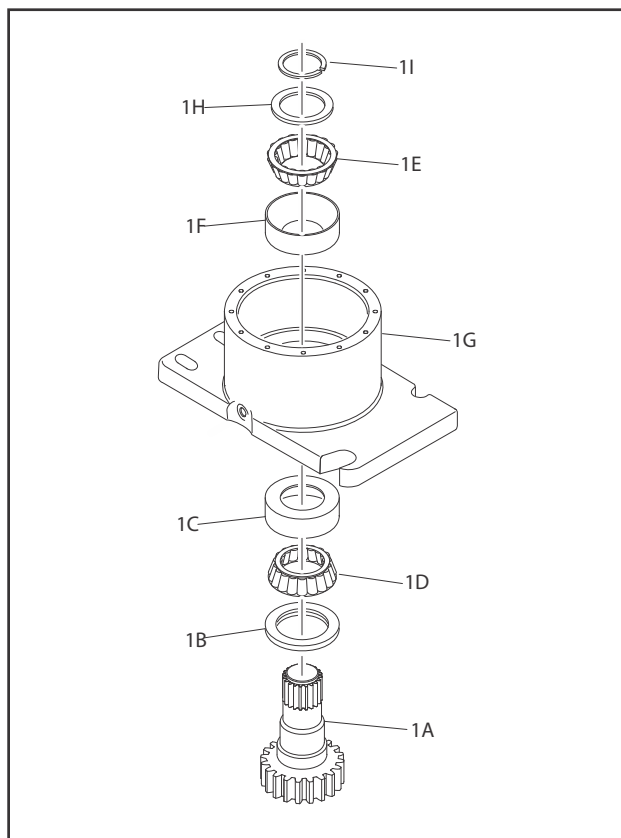


Figure 3-54. Hub-Shaft Disassembly

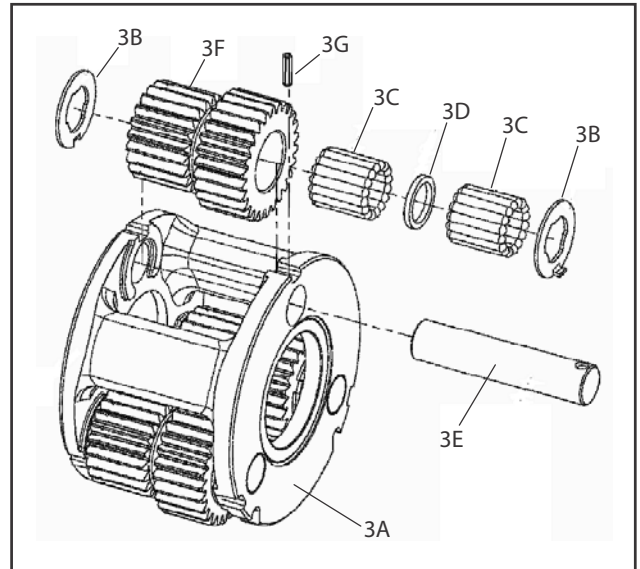
## Carrier Disassembly

1. Using a 3/16" punch drive Roll Pin (3G) holding Planet Shaft (3E) in Carrier (3A) in Planet Shaft (3E) until it bottoms.

### **NOTICE**

**MAKE SURE ROLL PIN HAS BOTTOMED OR CARRIER MAY BE DAMAGED WHEN PLANET SHAFT IS REMOVED.**

2. Remove Planet Shaft (3E) from Carrier (3A). Use a small punch to remove Roll Pin (3G) from Planet Shaft (3E).
3. Slide Planet Gear (3F) and two Thrust Washers (3B) out of Carrier (3A).
4. Remove both rows of Needle Bearings (3C) and Spacer (3D) from bore of Planet Gear (3F).
5. Repeat Steps 1 thru 4 for remaining Cluster Gears (3F).



**Figure 3-55. Carrier Disassembly**

**Hub-Shaft Subassembly**

1. Press Bearing Cup (1C) in Housing (1G). Make sure cup starts square with bore of Hub (1G).
2. Place Bearing Cone (1D) in Bearing Cup (1C) in Housing (1G).
3. Apply grease to rubber portion of Seal (1B). Press or tap Seal (1B) with smooth face up, in counterbore of Housing (1G) until it is flush with Housing (1G) face bore.
4. Invert Hub (1G) and press Bearing Cup (1E) in counterbore of Housing (1G).
5. Carefully lower Housing (1G) on Output Shaft (1A) until Bearing Cone (1D) contacts Output Shaft (1A).
6. Press on small end of Bearing Cone (1D), being careful not to contact the bearing cage, until Bearing Cone (1D) seats on Output Shaft (1A) shoulder.
7. Start Bearing Cone (1F) on Output Shaft (1A).
8. Press or tap Bearing Cone (1F) on Output Shaft (1A) until it is just seated in Bearing Cup (1E), while rotating the Housing (1G).
9. Install Bearing Spacer (1H) on Output Shaft (1A) against Bearing Cone (1F).

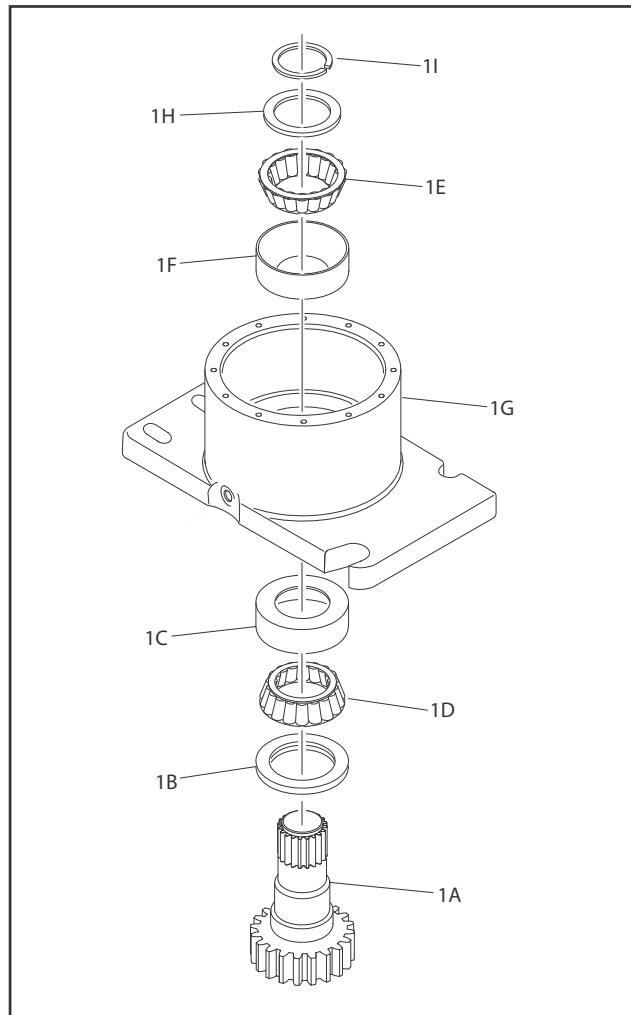
**CAUTION**

**RINGS UNDER TENSION CAN FLY OUT AND CAUSE SERIOUS INJURY. WEAR EYE PROTECTION WHEN INSTALLING RINGS.**

**NOTICE**

**NEVER REUSE A RETAINING RING IN REBUILD OR REPAIR.**

10. Install new Retaining Ring (1I) in groove of Output Shaft (1A).
11. Tap Retaining Ring (1I) with a soft metal punch to ensure it is completely seated in groove of Output Shaft (1A).



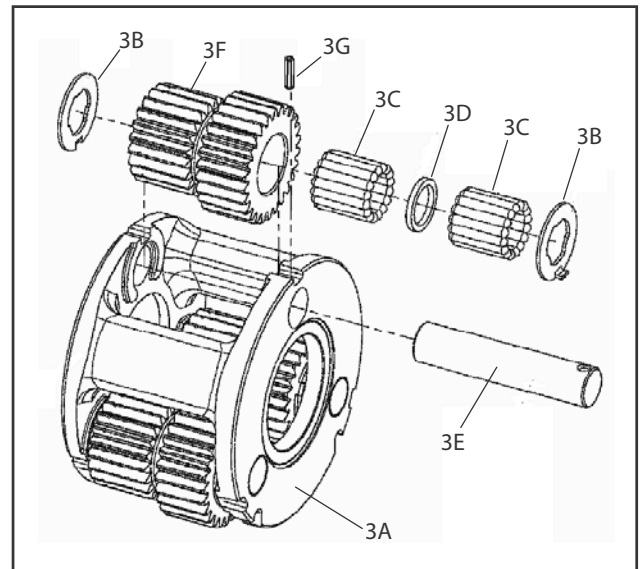
**Figure 3-56. Hub-Shaft Subassembly**

12. Reinstall Drain Plug if not already installed (1P from Fig. 3-45). Torque to 23 - 24 ft-lb (31 - 32 Nm).

### Carrier Subassembly

1. Apply a liberal coat of grease to bore of Cluster Gear (3F). This holds Needle Rollers (3C) in place during assembly.
2. Install first row of Needle Rollers (3C) in bore of Cluster Gear (3F).
3. Insert Spacer (3D) in bore of Cluster Gear (3F) on top of Needle Rollers (3C).
4. Place second row of Needle Rollers (3C) in bore of Cluster Gear (3F) against Spacer(3D).
5. Place Carrier (3A) with one roll pin hole straight up.
6. Start Planet Shaft (3E) through hole in Carrier (3A). Using ample grease to hold it in position, slide one Thrust Washer (3B) over Planet Shaft (3E) with tang resting in cast slot of Carrier (3A).
7. With large end of Cluster Gear (3F) facing roll pin hole in Carrier, place Cluster Gear in position in Carrier (3A). Push Planet Shaft (3E) through Cluster Gear (3F) without going all the way through.
8. Slide second Thrust Washer (3B) between Cluster Gear (3F) and Carrier (3A) with washer tang located in cast slot of Carrier (3A). Finish sliding Planet Shaft (3E) through Thrust Washer (3B) into Carrier (3A).
9. Position non-chamfered side on Planet Shaft (3E) Roll Pin hole in line with hole in Carrier (3A) using a 1/8 inch diameter punch.

10. Use a 3/16" punch to align two roll pin holes. Drive roll pin (3G) through Carrier (3A) and into Planet Shaft (3E) until Roll Pin (3G) is flush with bottom of cast slot in Carrier (3A) outside diameter at Thrust Washer (3B) tang. Use a 1/4" pin punch to make sure roll pin (3G) is flush in slot.
11. Repeat Steps 1 thru 10 for remaining Cluster Gears (3F).



**Figure 3-57. Carrier Subassembly**

### Main Assembly

1. With Hub Shaft Subassembly resting on Shaft (1A) install Internal Gear (2). The spline of Internal Gear (2) bore will mesh with spline of Output Shaft (1A). This will be a tight fit.
2. Inspect location of Internal Gear (2) on Output Shaft (1A). A portion of Output Shaft (1A) should protrude through Internal Gear (2) bore.
3. Install 4 Dowel Pins (13) into counter bore holes in Hub (1G).
4. Install Thrust Washer (11) in counter bore of Carrier Subassembly (Small Cluster-Gear end) Use grease to hold in place.
5. Place O-ring (5) into Hub counter-bore. Use grease to hold O-ring in place.

#### **CAUTION**

**SHARP EDGES OF COUNTER-BORE CAN CAUSE SERIOUS INJURY. BE CAREFUL WHEN SEATING O-RING.**

6. Place Carrier Subassembly on bench with large end of Cluster Gears (3F) facing up with one at 12 o'clock position. Find punch marked tooth on each gear at large end and locate at 12 o'clock (straight up) from each planet pin. Marked tooth will be located just under Carrier on upper two gears. Check timing through slots in carrier. (See Carrier Subassembly)
7. With longer shoulder side of Ring Gear (4) facing down, place Ring Gear (4) over (into mesh with) cluster gears (3F). Be sure cluster gear timing marks (punch marks) remain in correct location during Ring Gear (4) installation. Ring Gear (4) side with an "X" or punch mark stamped on it should be up.
8. While holding Ring Gear (4) and Cluster Gears (3F) in mesh, place small end of Cluster Gears (3F) into mesh with Internal Gear (2). On Ring Gear (4), locate hole marked "X" or punch marked over one of the marked counter-bored holes (Step 5) in Hub (1G). Check timing through slots in carrier. Rotate carrier in assembly to check freedom of rotation.

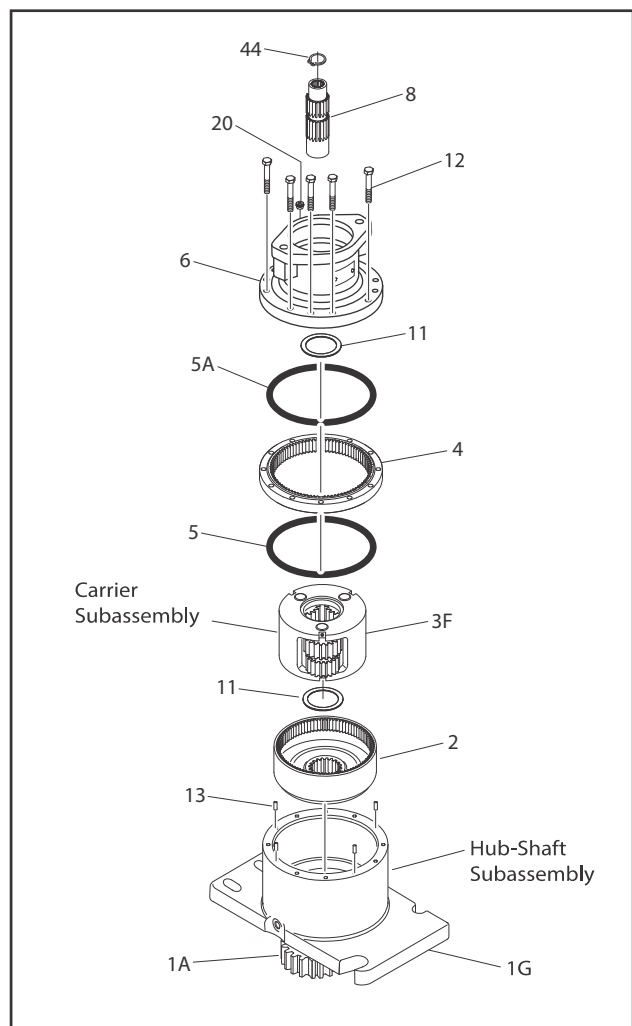
**NOTE:** *If gears do not mesh easily or Carrier Assembly does not rotate freely, remove Carrier and Ring Gear. Check Cluster Gear timing.*

9. Install Thrust Washer (11) in counter bore on face of carrier. Use grease to hold in place.
10. Place O-ring (5A) into counter bore of Brake Housing (6). Use grease to hold O-Ring in place.

#### **CAUTION**

**SHARP EDGES OF COUNTER-BORE CAN CAUSE SERIOUS INJURY. BE CAREFUL WHEN SEATING O-RING.**

11. Install Brake Housing (6). Align Pipe Plug hole (20) with those in the Hub (1G).
12. Install Bolts (12) through Brake Housing (6) into Hub (1G). Torque to 23 - 27 ft-lb (31-36 Nm).
13. With gearbox standing on pinion end, fill gearbox with 43 oz of ISO VG150 / VG220 gear oil.
14. Install Retaining Ring (44) in groove of Sun Gear (8).
15. Install Sun Gear (8) into mesh with Planet Gears (3F).
16. Install Pipe Plug (20) in Cover (6). Torque to 23 to 24 ft-lb (31 - 32 Nm).



**Figure 3-58. Main Assembly**

## Motor and Brake Assembly

1. Insert Stator (8K) (O.D. lobes) in bore of Brake Housing (6). Alternate Rotors (8J) (I.D. splines) and Stators, ending with a Stator (8K).
2. Grease O-rings (8F) & (8D) and Back-up rings (8H) & (8E). Place them in their respective grooves in Brake Housing (6) and Piston (8A). Make sure Back-up rings are correctly positioned.
3. Apply grease sparingly to Piston O.D. (8A) and bore of Brake Housing (6). Insert Piston (8A) in Brake Housing (6). Do not damage O-rings.
4. Install Springs (8L) in Piston (8A) spring pockets.
5. Test brake and perform roll test. Remove Brake Test Plate.
6. Install O-ring (26) on pilot of Motor (31). Use grease to keep O-ring in place.
7. Place Motor (31) in Brake pilot and line up holes. Check timing sheet.
8. Assemble Lift Lugs (28) on Hex Bolts (29). Assemble Hex Bolts (29) with Lift Lugs (28) through Motor (31) and Brake (6) against Motor flange. Torque to 80-100 ft-lb (108-135 Nm).

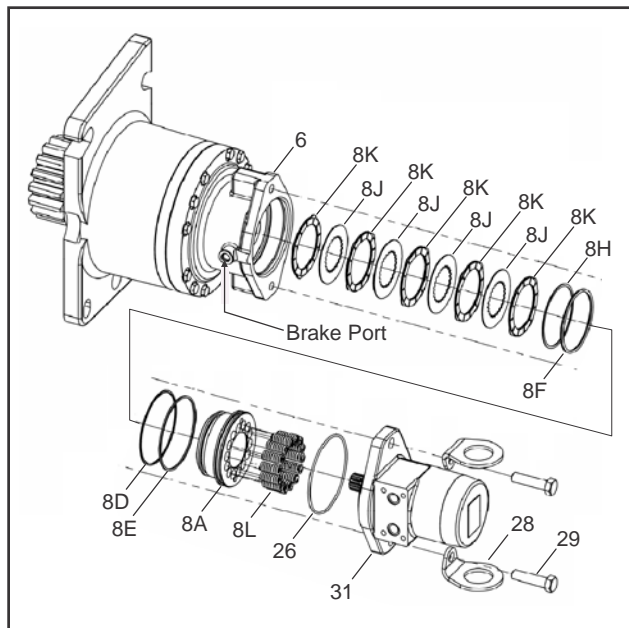


Figure 3-59. Motor and Brake Assembly

## Motor Control Valve Assembly

1. Lay assembly down with motor ports facing up. Remove two plastic plugs in the motor ports. Do not lose O-ring in each port. Assemble Motor control Valve (32) on Motor (31) with Bolt (21) and Lock Washers (22). Torque Bolts (21) to 23-27 ft-lb (31-36 Nm).

**NOTE:** Align holes in control valve with motor ports.

2. Install Elbow Fittings (30) in Brake (6). Do not tighten jam nuts.
3. Install Elbow Fittings (30) in Motor Control Valve (32). Do not tighten jam nuts.
4. Assemble Tube (35) in Elbow Fittings (30). Torque jam nuts to 13-15 ft-lb (17-20 Nm).
5. Install one O-ring Plug (23) in Motor Control Valve (32). Torque to 30-31 ft-lb (40-42 Nm).
6. Pressure test brake, tube, and control valve connections by applying 3000 psi (207 bar) pressure to open port in Motor Control Valve (32) and holding for one minute. Check for leaks at control-valve-motor interface and tube connections. Release pressure and install remaining O-ring Plug (23) in Motor Control Valve (32). Torque to 30-31 ft-lb (40-42 Nm).

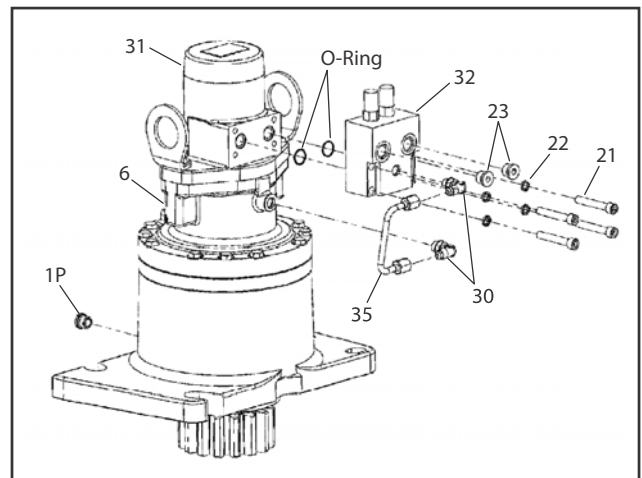


Figure 3-60. Motor Control Valve Assembly

### 3.8 SWING BEARING

#### Turntable Bearing Mounting Bolt Condition Check

**NOTE:** This check is designed to replace existing bearing bolt torque checks on JLG Lifts in service. This check must be performed after first 50 hours of machine operation and every 600 hours of machine operation thereafter. If any bolts are missing or loose, replace missing or loose bolts with new bolts and torque to value specified in torque chart after lubricating bolt threads with loctite #271. After replacing and retorquing bolt or bolts, recheck all bolts for looseness.

1. Check frame to bearing. Attach bolts as follows:
  - a. Elevate fully retracted boom to 70° (full elevation).
  - b. Try and insert a 0.0015" feeler gauge between bolt head and hardened washer at position shown in Figure 3-61.
  - c. Make sure 0.0015" feeler gauge will not fit under bolt head to bolt shank.
  - d. Swing turntable 90° and check some selected bolts at new position.
  - e. Continue rotating turntable at 90° intervals until a sampling of bolts are checked in all quadrants.
2. Check turntable to bearing. Attach bolts as follows:
  - a. Elevate fully retracted boom to 70° (full elevation).
  - b. try and insert a 0.0015" feeler gauge between bolt head and hardened washer at positions shown in Figure 3-61.
  - c. Lower boom to horizontal and fully extend boom.
  - d. Try and insert the 0.0015" feeler gauge between bolt head and hardened washer at position shown in Figure 3-61.

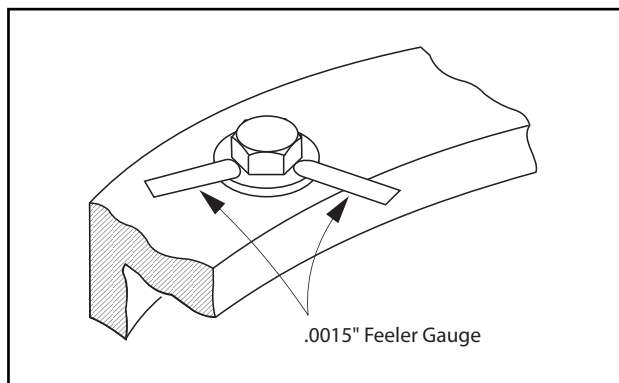


Figure 3-61. Swing Bearing Bolt Feeler Gauge Check

### Wear Tolerance

#### **⚠ WARNING**

**SWING BEARING IS ONE OF THE MOST CRITICAL POINTS ON AN AERIAL LIFT. IT IS HERE STRESSES OF LIFTING ARE CONCENTRATED, AT CENTER OF ROTATION. BECAUSE OF THIS, PROPER MAINTENANCE OF SWING BEARING BOLTS IS A MUST FOR SAFE OPERATION.**

1. From underside of machine, at rear center, with boom fully elevated and fully retracted, as shown in Figure 3-63., Swing Bearing Tolerance Measurement Location & Boom Placement A, using a magnetic base dial indicator, measure and record distance between swing bearing and turntable as shown in Figure 3-62., Swing Bearing Tolerance Measuring Point.
2. At the same point, with boom horizontal and fully extended, and tower boom fully elevated as shown in - Swing Bearing Tolerance Boom Placement B, using a magnetic base dial indicator, measure and record distance between swing bearing and turntable as shown in Figure 3-62., Swing Bearing Tolerance Measuring Point.
3. If difference is greater than 0.079 in. (2.00 mm), replace swing bearing.
4. If difference is less than 0.079 in. (2.00 mm) and any of the following conditions exist:
  - a. Metal particles in grease.
  - b. Increased drive power required.
  - c. Noise.
  - d. Rough rotation.
5. Remove, disassemble, and inspect bearing. If bearing inspection shows no defects, reassemble and return to service.

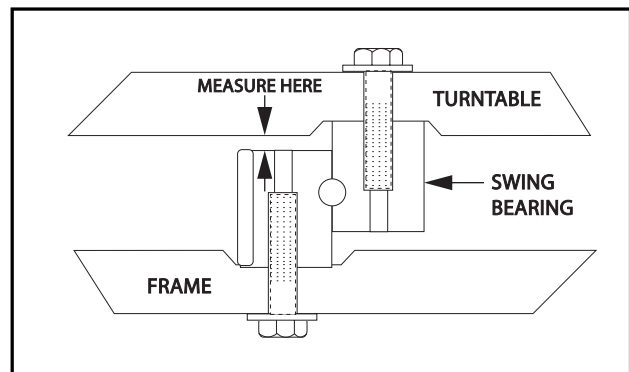


Figure 3-62. Swing Bearing Tolerance Measuring Point



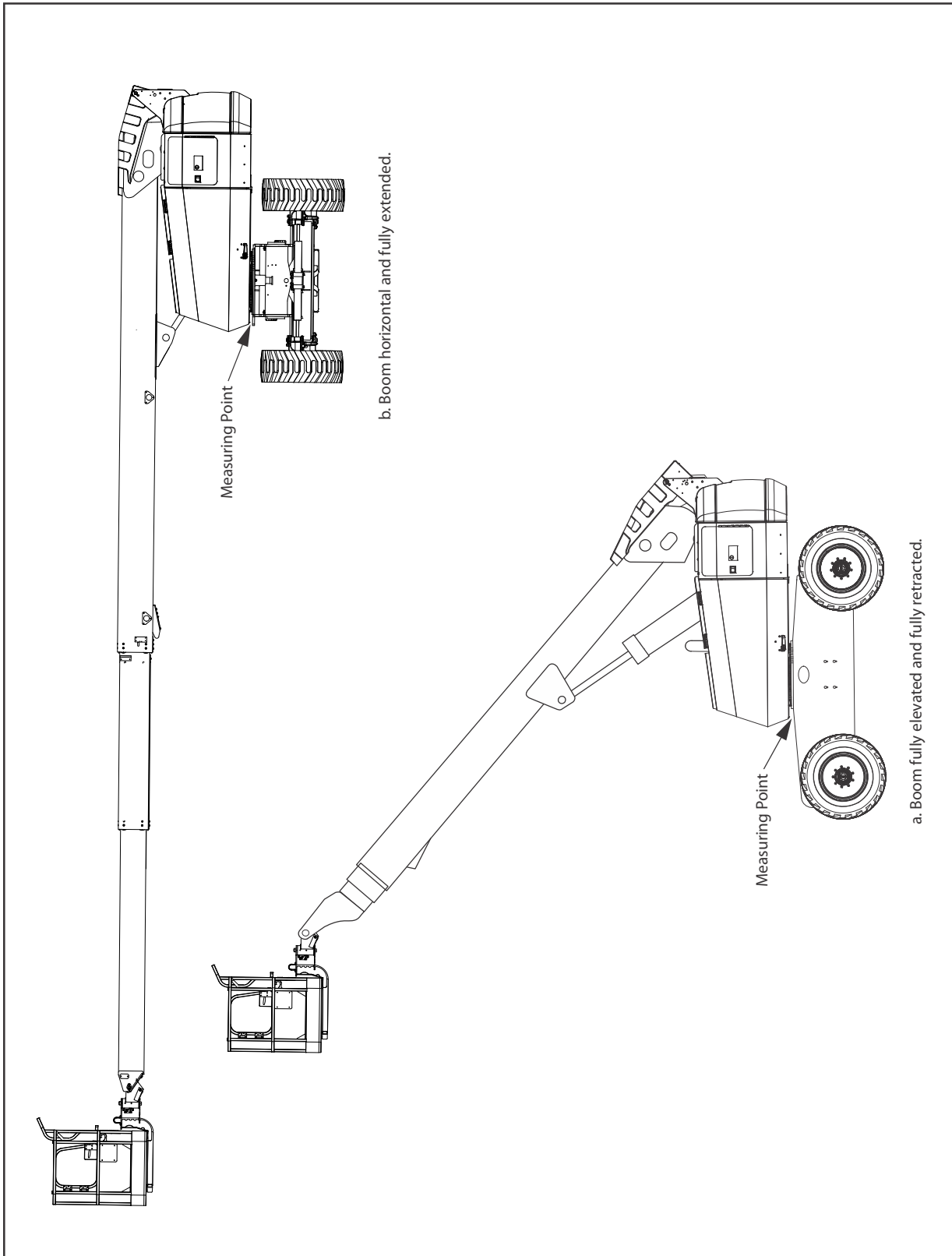


Figure 3-63. Swing Bearing Tolerance Measurement Location & Boom Placement

### Swing Bearing Replacement

#### REMOVAL

1. Operate boom from Ground Control station to provide access to frame opening or rotary coupling.

#### **⚠ WARNING**

**NEVER WORK BENEATH THE BOOM WITHOUT FIRST ENGAGING BOOM SAFETY PROP OR PROVIDING ADEQUATE OVERHEAD SLING SUPPORT AND/OR BLOCKING.**

2. Attach an adequate support sling to boom and draw all slack from sling. Prop or block boom if feasible.
3. From inside turntable, remove mounting hardware attaching rotary coupling retaining yoke brackets to turntable.

#### **NOTICE**

**HYDRAULIC LINES AND PORTS SHOULD BE CAPPED IMMEDIATELY AFTER DISCONNECTING LINES TO AVOID THE ENTRY OF CONTAMINANTS INTO THE SYSTEM.**

4. Tag and disconnect hydraulic lines from fittings on top of rotary coupling. Use a suitable container to retain any residual hydraulic fluid. Immediately cap lines and ports.
5. Attach suitable overhead lifting equipment to base of turntable weldment.
6. Use a suitable tool to scribe a line on swing bearing inner race an underside of turntable. This will aid in aligning bearing upon installation. Remove bolts and washers which attach turntable to bearing inner race. Discard bolts.
7. Use lifting equipment to carefully lift complete turntable assembly from bearing. Ensure no damage occurs to turntable, bearing, or frame-mounted components.
8. Carefully place turntable on a suitably supported trestle.
9. Use a suitable tool to scribe a line on outer swing bearing race and frame. This line will aid in aligning bearing upon installation. Remove bolts and washers which attach outer race of bearing to frame. Discard bolts. Use suitable lifting equipment to remove bearing from frame, then move bearing to a clean, suitably supported work area.

#### INSTALLATION

1. Using suitable lifting equipment, carefully lower swing bearing in position on frame. Ensure scribed line of outer bearing race aligns with scribed line on frame. If a new swing bearing is used, ensure filler plug fitting is 90° from fore and aft center line of frame.

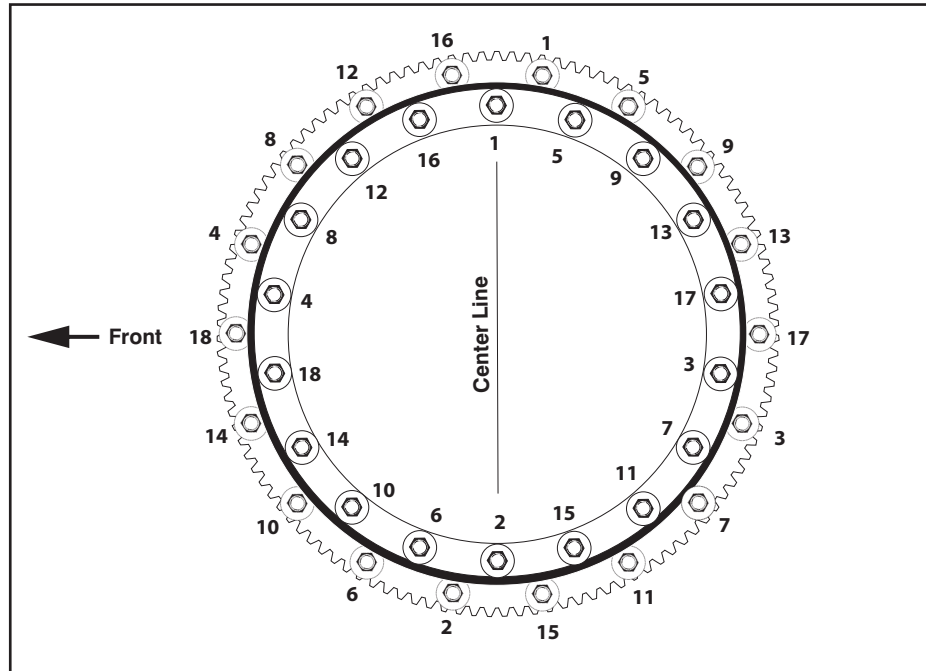
#### **⚠ CAUTION**

**JLG INDUSTRIES RECOMMENDS ALL REMOVED BEARING BOLTS BE DISCARDED AND REPLACED WITH NEW BOLTS. SINCE THE SWING BEARING IS THE ONLY STRUCTURAL LINK BETWEEN THE FRAME AND TURNTABLE, IT IS IMPERATIVE SUCH REPLACEMENT HARDWARE MEETS JLG SPECIFICATIONS. USE OF GENUINE JLG HARDWARE IS HIGHLY RECOMMENDED.**

#### **⚠ CAUTION**

**CHECK TORQUE SETTING ACCURACY OF TOOL IF COMPRESSED AIR OR ELECTRICALLY OPERATED IMPACT WRENCH IS USED TO TIGHTEN BEARING ATTACHMENT BOLTS.**

2. Refer to Torque Sequence diagram as shown in Figure 3-64., Swing Bearing Torque Sequence. Clean residue off new bearing bolts and apply a light coating of Thread Locking Compound JLG P/N 0100019. Install bolts and washers through frame and outer bearing race. Torque bolts to 190 ft-lb (258 Nm). Remove lifting equipment from bearing.
3. Using suitable lifting equipment, carefully position turntable assembly above machine frame.
4. Carefully lower turntable onto swing bearing. Ensure scribed line of inner bearing race aligns with scribed line on turntable. If a new swing bearing is used, ensure filler plug fitting is 90° fore and aft center line of turntable.
5. Clean residue off new bearing bolts and apply a light coating of Thread Locking Compound JLG P/N 0100019. Install bolts and washers through turntable and bearing inner race.



**Figure 3-64. Swing Bearing Torque Sequence**

6. Following Torque Sequence diagram shown in Figure 3-64., Swing Bearing Torque Sequence, torque bolts to 190 ft-lb (258 Nm) w/Loctite.
7. Remove lifting equipment.
8. Install rotary coupling retaining yoke brackets. Apply a light coating of Thread Locking Compound, JLG P/N 0100011 to attaching bolts. Secure yoke to turntable with mounting hardware.
9. Connect hydraulic lines to rotary coupling as tagged prior to removal.
10. At ground control station, use boom lift control to lower boom to stowed position.
11. Using all applicable safety precautions, activate hydraulic system and check swing system for proper and safe operation.

### Swing Bearing Torque Values

1. Outer Race - 190 ft-lb (258 Nm) w/Loctite.
2. Inner Race - 190 ft-lb (258 Nm) w/Loctite.
3. See Figure 3-64. Swing Bearing Torque Sequence.

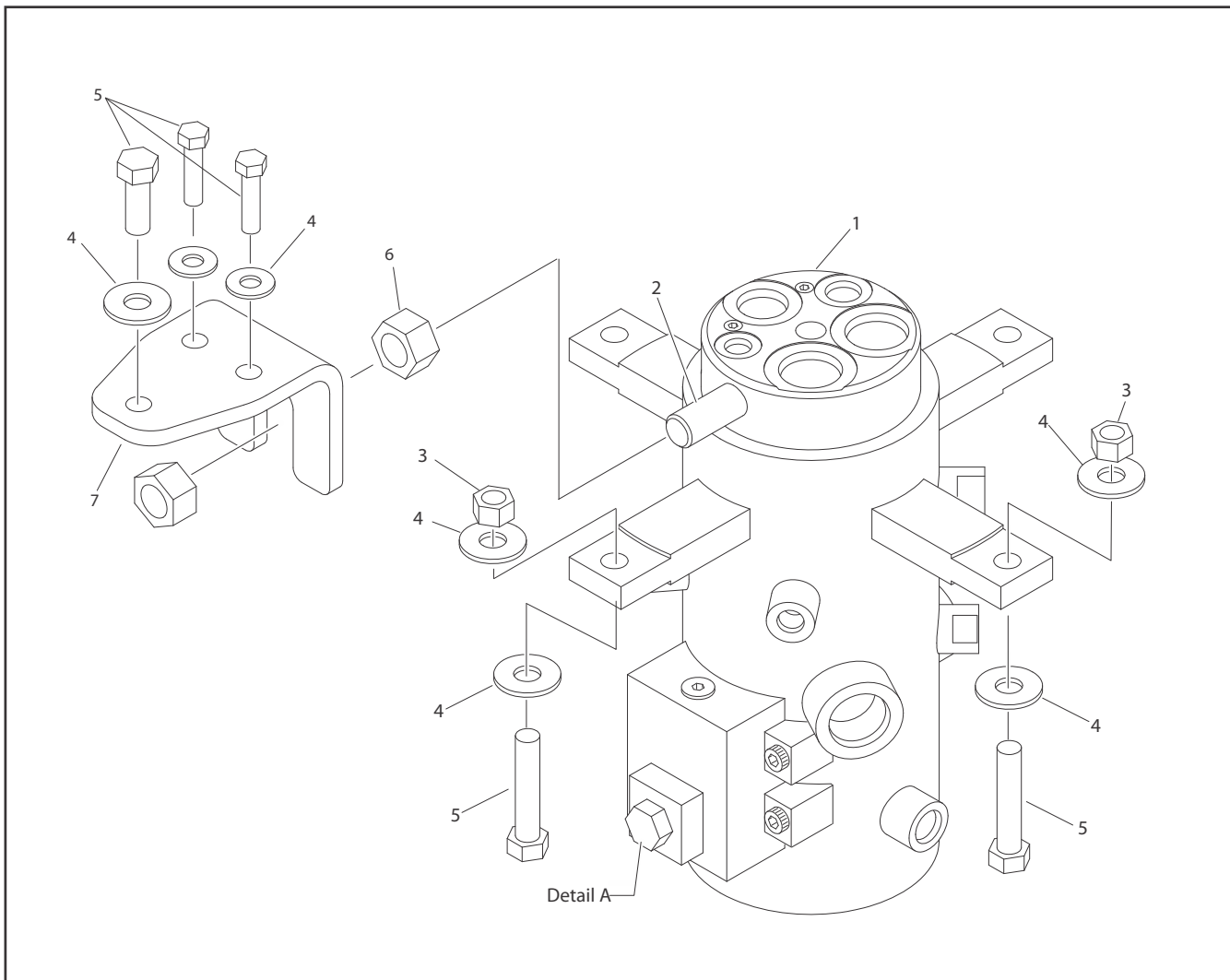
### **⚠ WARNING**

**CHECK OR MISSING OR LOOSE INNER AND OUTER SWING BEARING BOLTS AFTER FIRST 50 HOURS OF OPERATION AND EVERY 600 HOURS THEREAFTER.**

**3.9 ROTARY COUPLING**

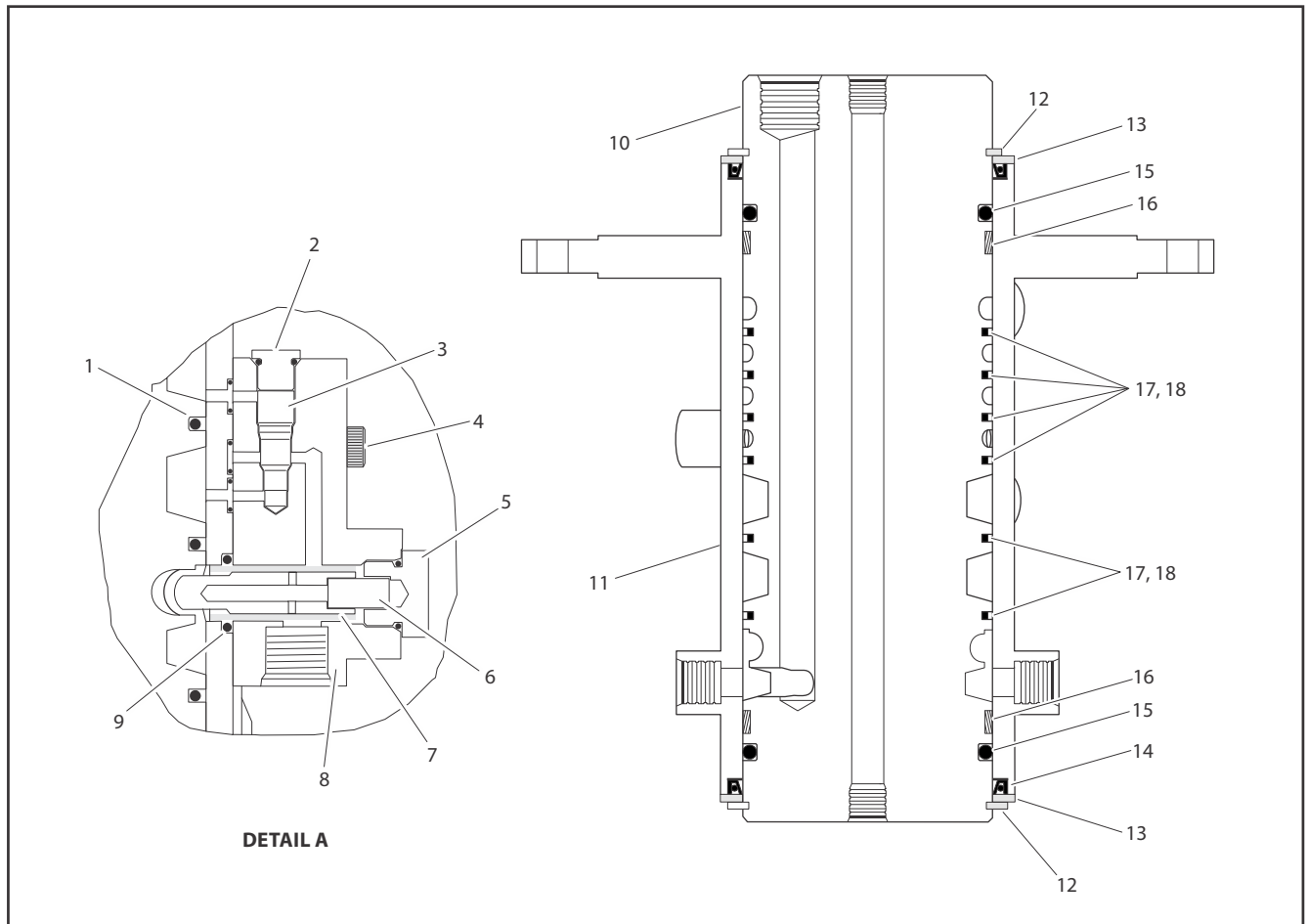
Use the following procedure to install the seal kit.

1. If not already removed, remove axle oscillation valve from cylinder barrel. The valve spool protrudes into the barrel and will damage spool and seals if left in place.
2. Remove snap ring (12) from end.
3. Remove thrust ring (13) from same end.
4. Remove center body (10) from housing (11).
5. Cut off old seals (14,15,17,18).
6. Assemble lip seals (14) in direction shown in Figure 3-66., Rotary Coupling - Sheet 2 of 2.
7. Reassemble O-ring (18).
8. Heat cap seals (17) in hydraulic oil for 5 minutes at 300° F (149° C).
9. Assemble cap seals over O-rings
10. Reinsert center body in housing (lube with hydraulic oil).
11. Replace thrust ring and snap ring.



- |                    |                |            |
|--------------------|----------------|------------|
| 1. Rotary Coupling | 3. Locknut     | 5. Bolt    |
| 2. Torque Lug      | 4. Flat Washer | 6. Nut     |
|                    |                | 7. Bracket |

**Figure 3-65. Rotary Coupling - Sheet 1 of 2**



DETAIL A

- |                |                        |                    |              |
|----------------|------------------------|--------------------|--------------|
| 1. O-ring      | 6. Spring              | 11. Housing        | 16. Bearing  |
| 2. Plug        | 7. Valve Block Plunger | 12. Retaining Ring | 17. Cap Seal |
| 3. Check Valve | 8. Valve Block         | 13. Ring           | 18. O-ring   |
| 4. Screw       | 9. O-ring              | 14. Oil Seal       |              |
| 5. Plug        | 10. Body               | 15. O-ring         |              |

Figure 3-66. Rotary Coupling - Sheet 2 of 2

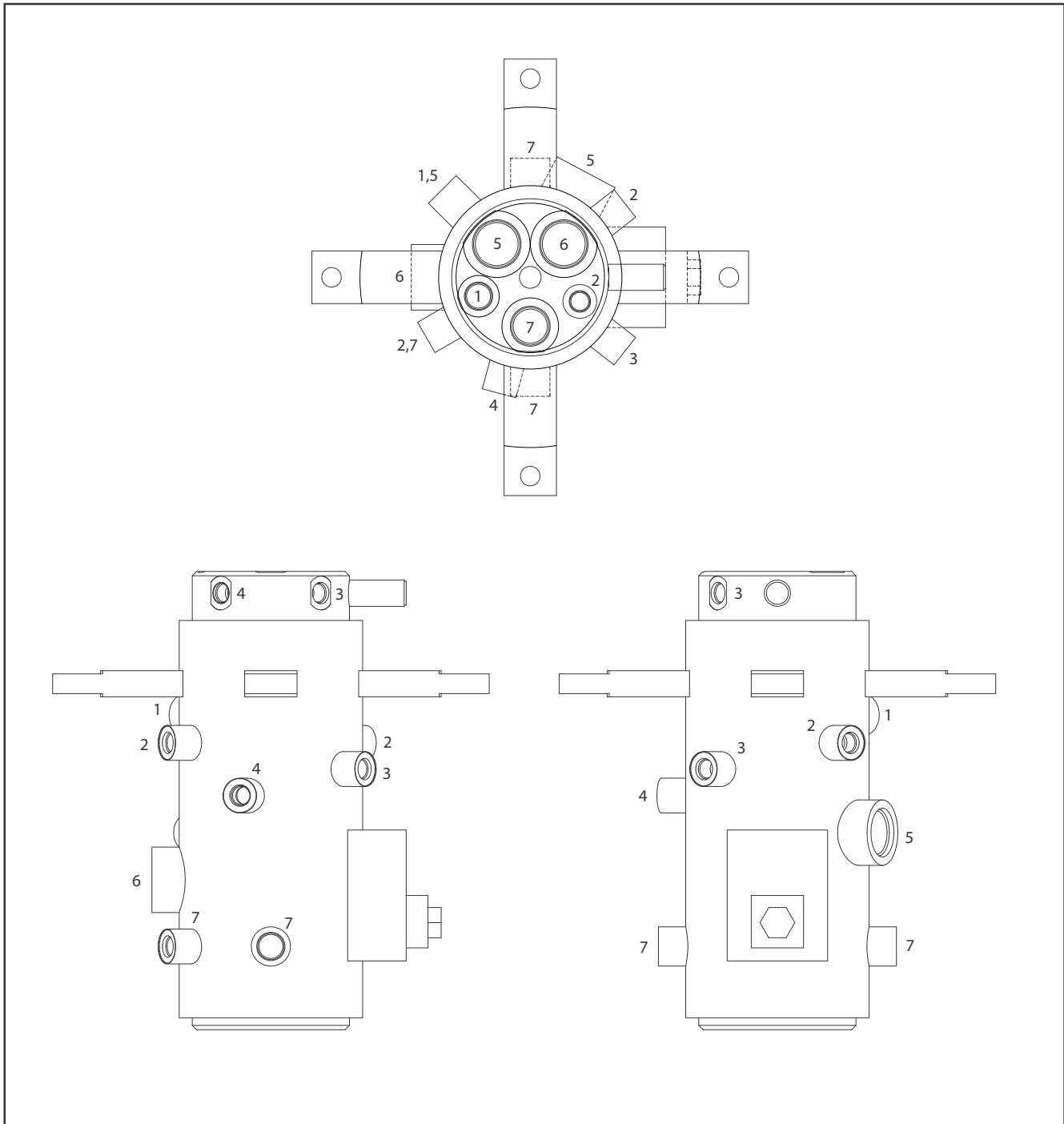


Figure 3-67. Rotary Coupling Port Location - 2WS

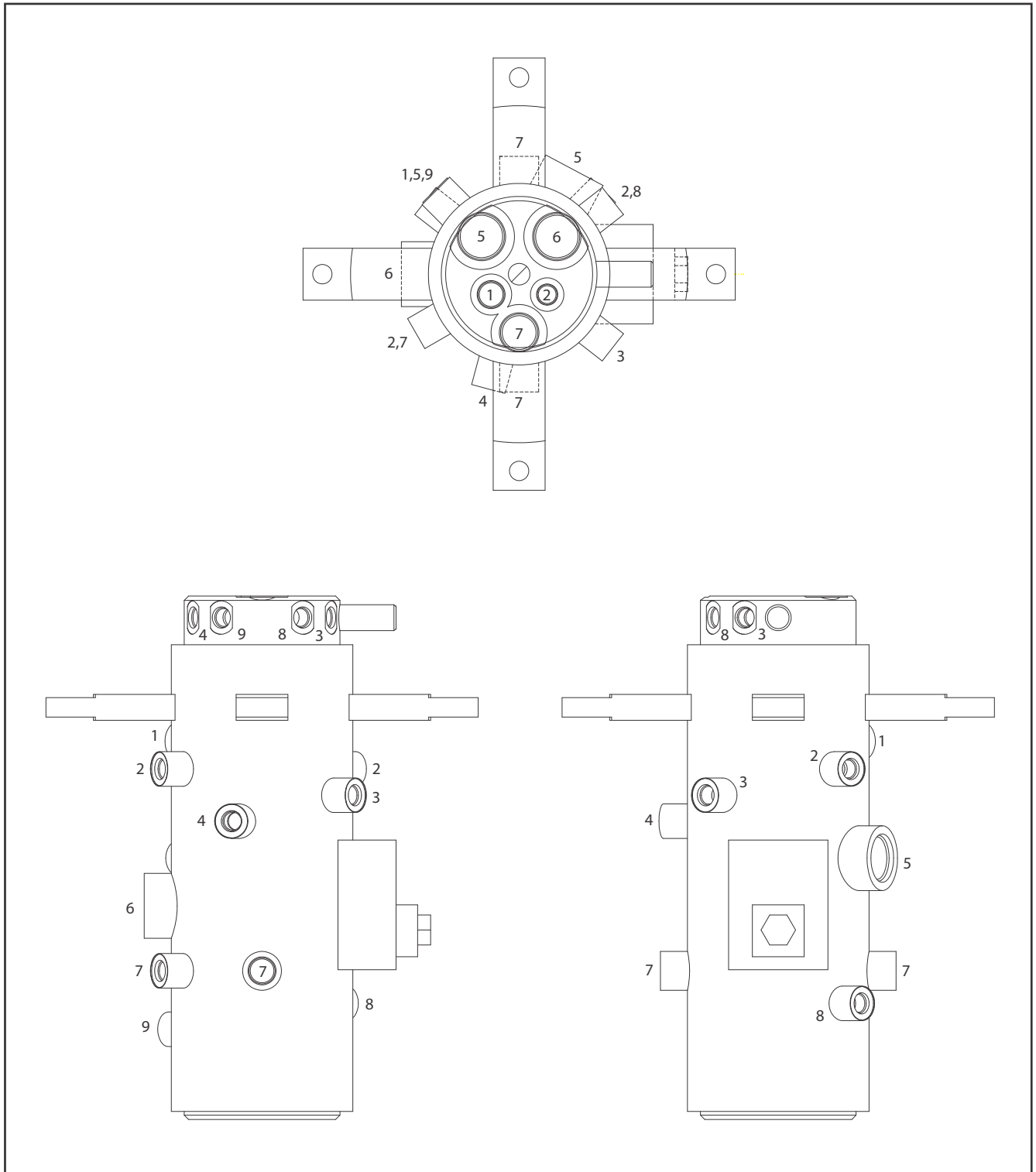


Figure 3-68. Rotary Coupling Port Location - 4WS

## SECTION 3 - CHASSIS & TURNTABLE

**Table 3-9. Coupling Port Information Table - 2WS**

Port No.	Outlet	Port Size	Description	Operating Pressure PSI (Bar)	Proof Pressure PSI (Bar)
1	1	-8	Brake	450 (31)	675 (47)
2	2	-6	2Speed	4500 (310)	6750 (465)
3	1	-6	Steer	2500 (172)	3750 (259)
4	1	-6	Steer	2500 (172)	3750 (259)
5	2	-6, -16	Drive Reverse	4500 (310)	6750 (465)
6	1	-16	Drive Forward	4500 (310)	6750 (465)
7	3	-8, -6	Case Drain	250 (17)	375 (26)

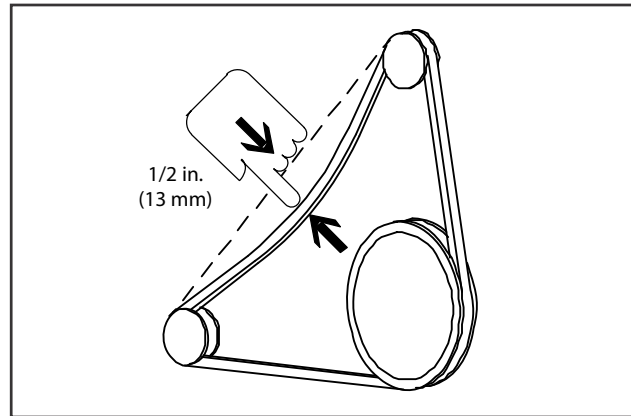
**Table 3-10. Coupling Port Information Table - 4WS**

Port No.	Outlet	Port Size	Description	Operating Pressure PSI (Bar)	Proof Pressure PSI (Bar)
1	1	-8	Brake	450 (31)	675 (47)
2	2	-6	2Speed	4500 (310)	6750 (465)
3	1	-6	Steer	2500 (172)	3750 (259)
4	1	-6	Steer	2500 (172)	3750 (259)
5	2	-6, -16	Drive Reverse	4500 (310)	6750 (465)
6	1	-16	Drive Forward	4500 (310)	6750 (465)
7	3	-8, -6	Case Drain	250 (17)	375 (26)
8	1	-6	Steer	2500 (172)	3750 (259)
9	1	-6	Steer	2500 (172)	3750 (259)

### 3.10 GENERATOR

#### Every 250 hours

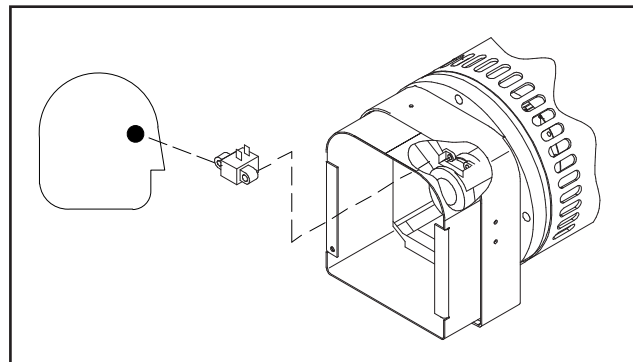
Check drive belt tension every 250 hours of operation,.



**Figure 3-69. Generator Belt Tension**

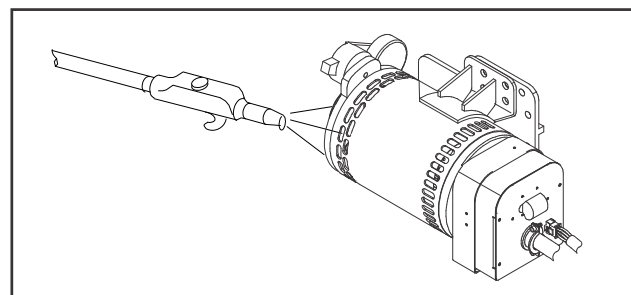
#### Every 500 hours

Service generator brushes and slip rings every 500 hours of operation. Hostile environments may require more frequent service.



**Figure 3-70. Generator Brushes and Slip Rings**

Blow out inside of generator every 500 hours of service. If operating in a hostile environment, clean monthly.



**Figure 3-71. Generator Cleaning**



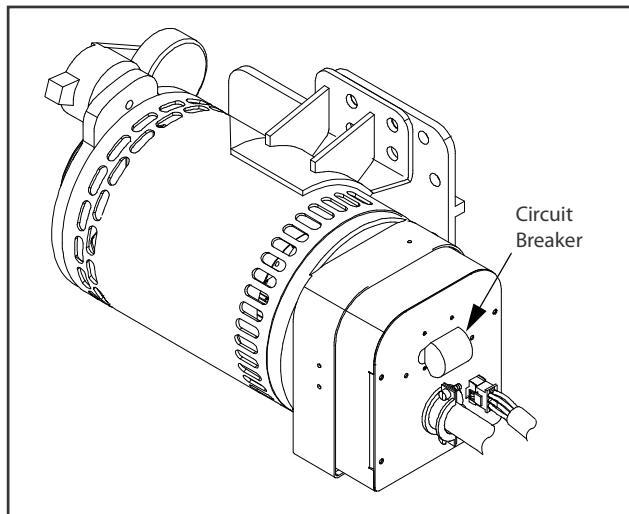
## Overload Protection

### **⚠ CAUTION**

**STOP ENGINE WHENEVER CHECKING OR INSPECTING CIRCUIT BREAKER.**

The circuit breaker protects generator windings from overload. Generator output stops if circuit breaker opens.

If circuit breaker continues to open, check for faulty equipment connected to platform receptacles.



**Figure 3-72. Generator Circuit Breaker Location**

## Inspecting Brushes, Replacing Brushes, and Cleaning Slip Rings

Refer to Figure 3-73., *Inspecting Generator Brushes, Replacing Brushes, and Cleaning Slip Rings.*

### INSPECTING BRUSH POSITION

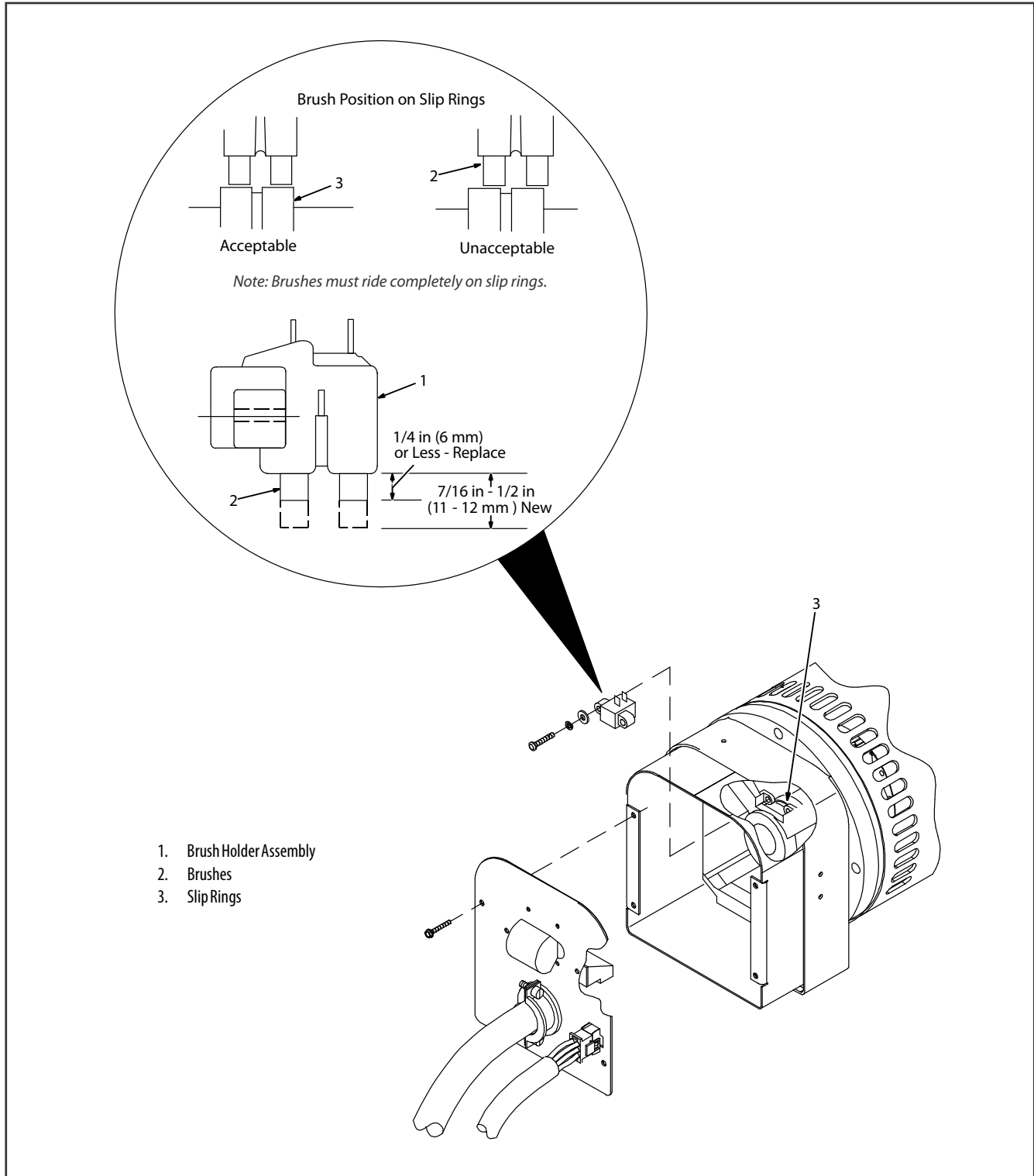
Inspect brush alignment with slip rings. View alignment through air vents in stator barrel. Brushes must ride completely on slip rings.

### INSPECTING BRUSHES

1. Remove end panel. Inspect wires.
2. Remove brush holder assembly. Pull brushes from holders.
3. Replace brushes if damaged, or if brush is at or near minimum length.

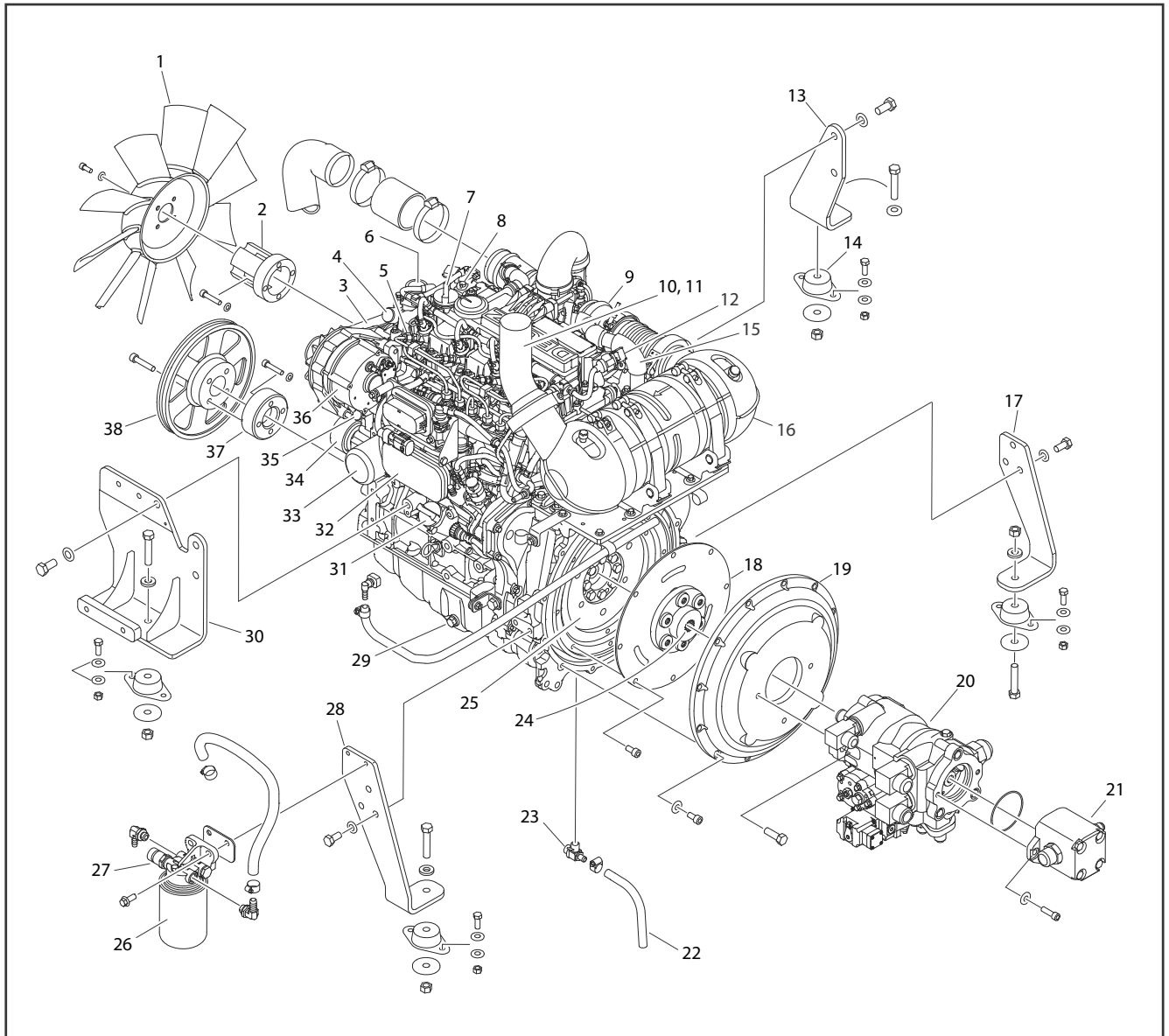
### CLEANING SLIP RINGS

1. Visually inspect the slip rings. Under normal use, the rings turn dark brown.
2. If slip rings are corroded or their surface is uneven, remove belt to turn shaft by hand for cleaning.
3. Clean rings with 220 grit emery paper. Remove as little material as possible. If rings are deeply pitted and do not clean up, consult generator factory service.
4. Reinstall belt, brush holder assembly, and end panel.



**Figure 3-73. Inspecting Generator Brushes, Replacing Brushes, and Cleaning Slip Rings**

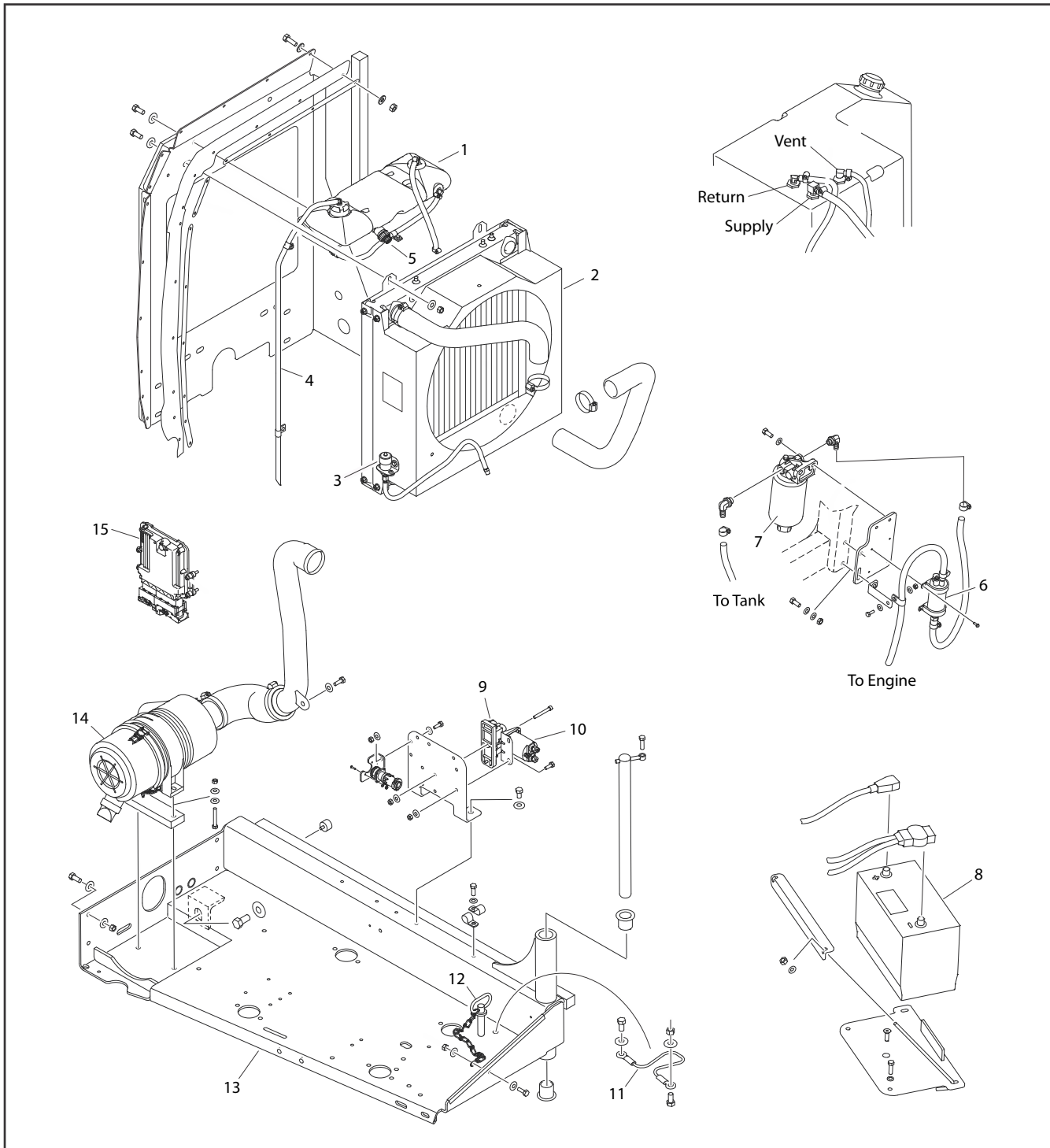
3.11 DEUTZ D2.9 L4 ENGINE



- |                       |                                 |                        |                                  |                    |
|-----------------------|---------------------------------|------------------------|----------------------------------|--------------------|
| 1. Fan                | 9. Turbocharger                 | 17. Rear Engine Mount  | 25. Flywheel                     | 33. Oil Filter     |
| 2. Adapter            | 10. Exhaust Pipe                | 18. Coupling           | 26. Fuel Filter                  | 34. Belt Tensioner |
| 3. Drive Belt         | 11. Spark Arrester              | 19. Pump Adapter Plate | 27. Pressure Sensor              | 35. Plug           |
| 4. Water Pump         | 12. Pressure Sensor             | 20. Pump Assembly      | 28. Rear Engine Mount            | 36. Alternator     |
| 5. Fuel Injector      | 13. Front Engine Mount          | 21. Gear Pump Assembly | 29. Oil Pan Drain Plug           | 37. Adapter        |
| 6. Thermostat         | 14. Motor Mount                 | 22. Oil Drain Hose     | 30. Front Engine/Generator Mount | 38. Pulley         |
| 7. Oil Fill Cap       | 15. Shuttle Valve               | 23. Oil Drain Valve    | 31. Oil Fill Cap                 |                    |
| 8. Temperature Sender | 16. Catalytic Converter/Muffler | 24. Pump Coupler       | 32. Oil Cooler                   |                    |

Figure 3-74. Deutz D2.9 L4 Engine Installation - Sheet 1 of 2

## SECTION 3 - CHASSIS & TURNTABLE



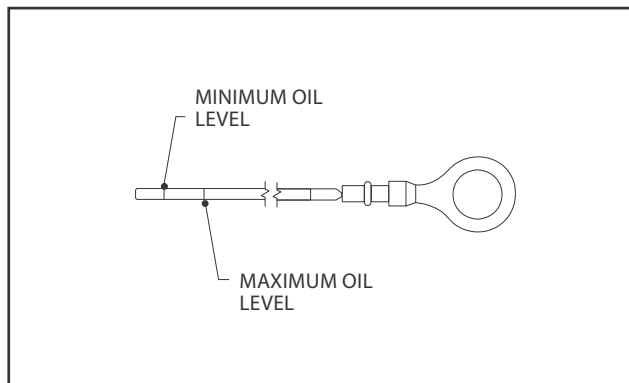
- |                                 |                          |                       |               |                               |
|---------------------------------|--------------------------|-----------------------|---------------|-------------------------------|
| 1. Coolant Recovery Tank        | 4. Coolant Overflow Hose | 7. Fuel Pre-Filter    | 10. Relay     | 13. Engine Tray               |
| 2. Radiator Assembly            | 5. Coolant Level Sensor  | 8. Battery            | 11. Lanyard   | 14. Air Filter Assembly       |
| 3. Air Filter Service Indicator | 6. Fuel Pump             | 9. Power Module Relay | 12. Hitch Pin | 15. Engine Control Unit (ECU) |

**Figure 3-75. Deutz D2.9 L4 Engine Installation - Sheet 2 of 2**

**NOTE:** Refer to engine manufacturer's manual for detailed operating and maintenance instructions.

### Check Oil Level

1. Make sure machine and engine are level and switch engine OFF before checking oil level.
2. Remove oil dipstick and wipe with clean cloth.
3. Insert dipstick to the stop and remove again.
4. Check oil level. Top oil level as shown in figure below with an approved grade and type of oil outlined in engine manufacturer's operator's manual.



**Figure 3-76. Deutz 2.9 T4F Dipstick Markings**

5. Replace dipstick until fully seated.

### Change Engine Oil

1. Allow engine to warm up. Engine oil should reach approximately 176° F (80° C).
2. Make sure machine and engine are level and switch off engine.
3. Place oil tray under engine.

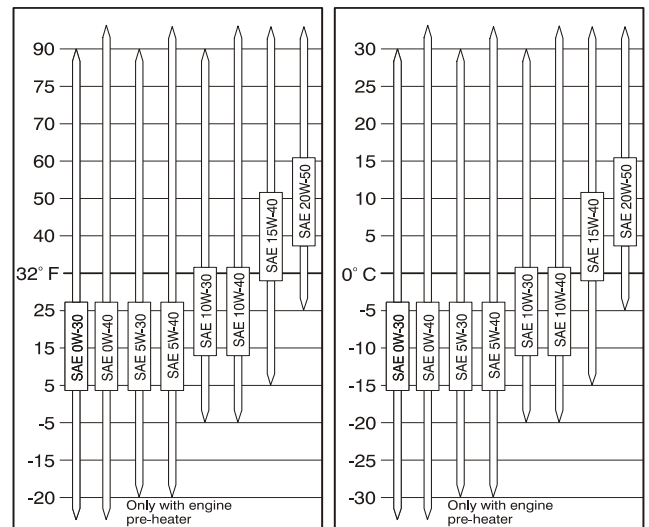
#### **CAUTION**

**HOT ENGINE OIL CAN CAUSE BURNS. AVOID CONTACT WITH HOT OIL WHEN DRAINING.**

#### **NOTICE**

**COLLECT USED OIL IN A CONTAINER SUITABLE FOR DISPOSAL OR RECYCLING. DISPOSE OF USED ENGINE OIL IN ACCORDANCE WITH ENVIRONMENTAL REGULATIONS.**

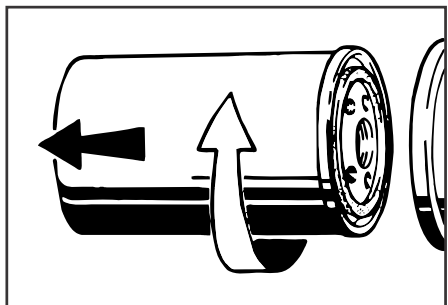
4. Open oil drain valve and drain oil.
5. Close oil drain valve.
6. Pour in new engine oil. Refer to Section 1 for capacity and Figure 3-81., Engine Oil Viscosity.



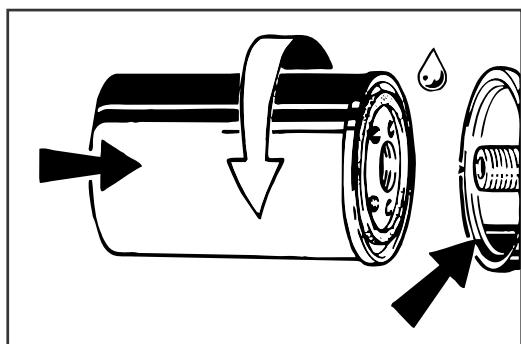
**Figure 3-77. Engine Oil Viscosity**

### Change Oil Filter

1. Wipe area around filter to clean any dirt from area.
2. Using a suitable oil filter removal tool, loosen lube oil filter cartridge and spin off.



3. Catch any escaping oil.
4. Clean any dirt from filter carrier sealing surface.
5. Lightly coat new oil filter rubber gasket with clean oil
6. Screw in new filter by hand until gasket is flush.
7. Hand-tighten filter another half-turn.



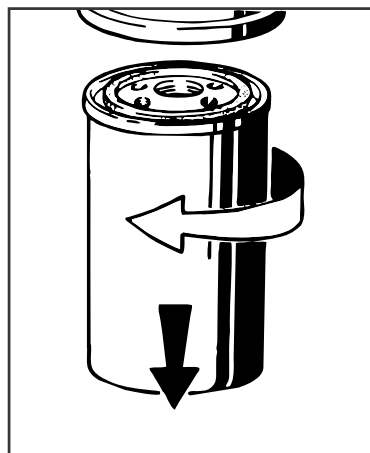
8. Check oil level.
9. Check oil pressure.
10. Check oil filter cartridge for leaks.

### Change Fuel Filters

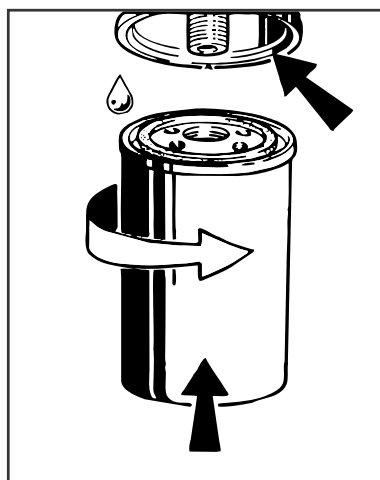
**⚠ WARNING**

**FUEL IS FLAMMABLE AND CAN CAUSE DEATH OR SERIOUS INJURY. MAKE SURE NO OPEN FLAMES OR SPARKS ARE IN THE AREA WHEN WORKING ON FUEL SYSTEM. DO NOT SMOKE WHEN WORKING ON FUEL SYSTEM.**

1. Wipe area around filter to clean any dirt from area.
2. Disconnect water sensor connector (Pre-filter Only).
3. Remove fuel filter cartridge. Catch any escaping fuel.

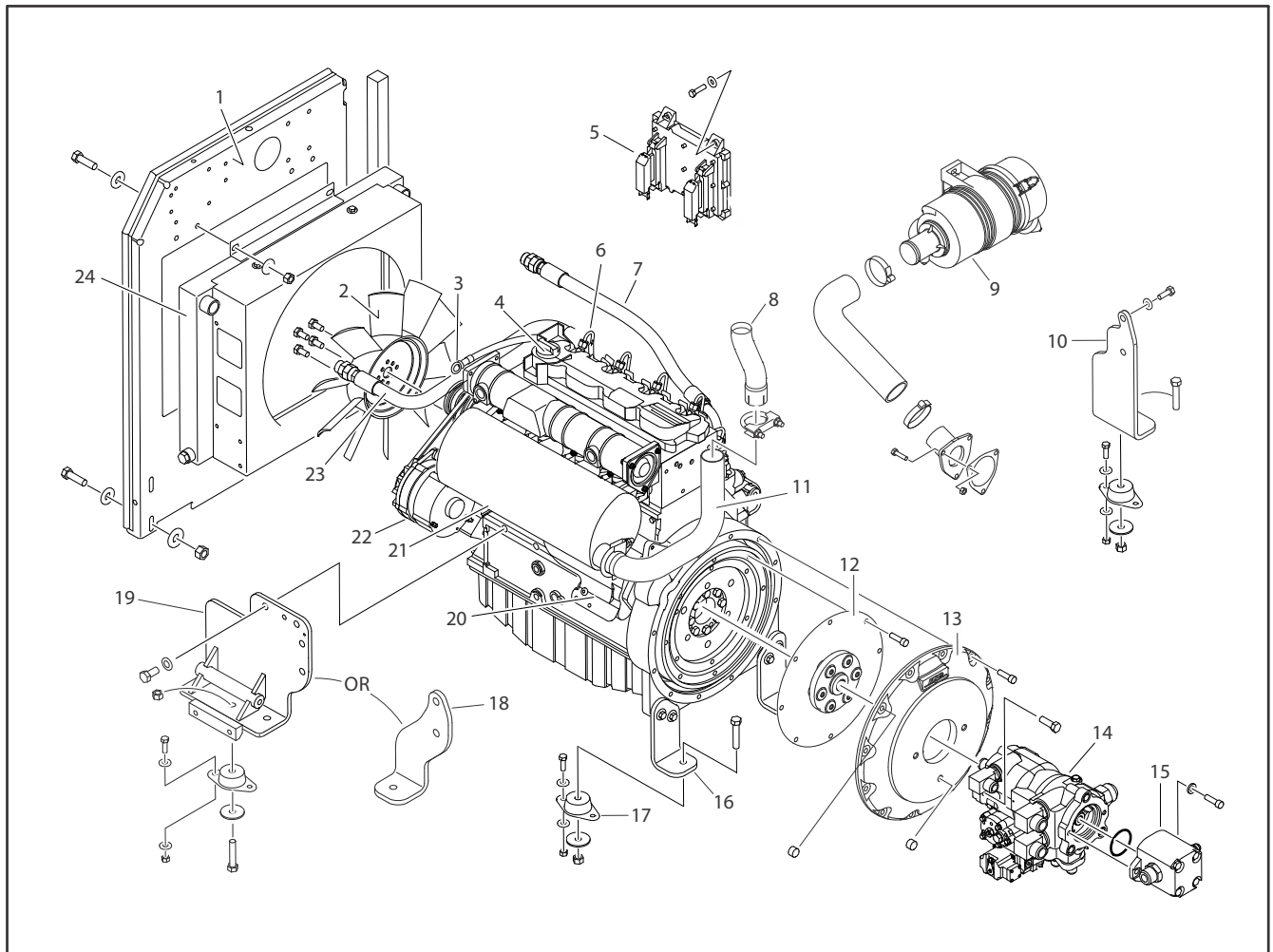


4. Clean dirt from filter carrier sealing surface.
5. Apply light film of oil or diesel fuel to rubber gasket of new filter cartridge.
6. Screw in new filter by hand until gasket is flush. Hand-tighten filter another half-turn.



7. Connect water sensor connector (Pre-filter Only).
8. Open fuel shut-off valve.
9. Check for leaks.

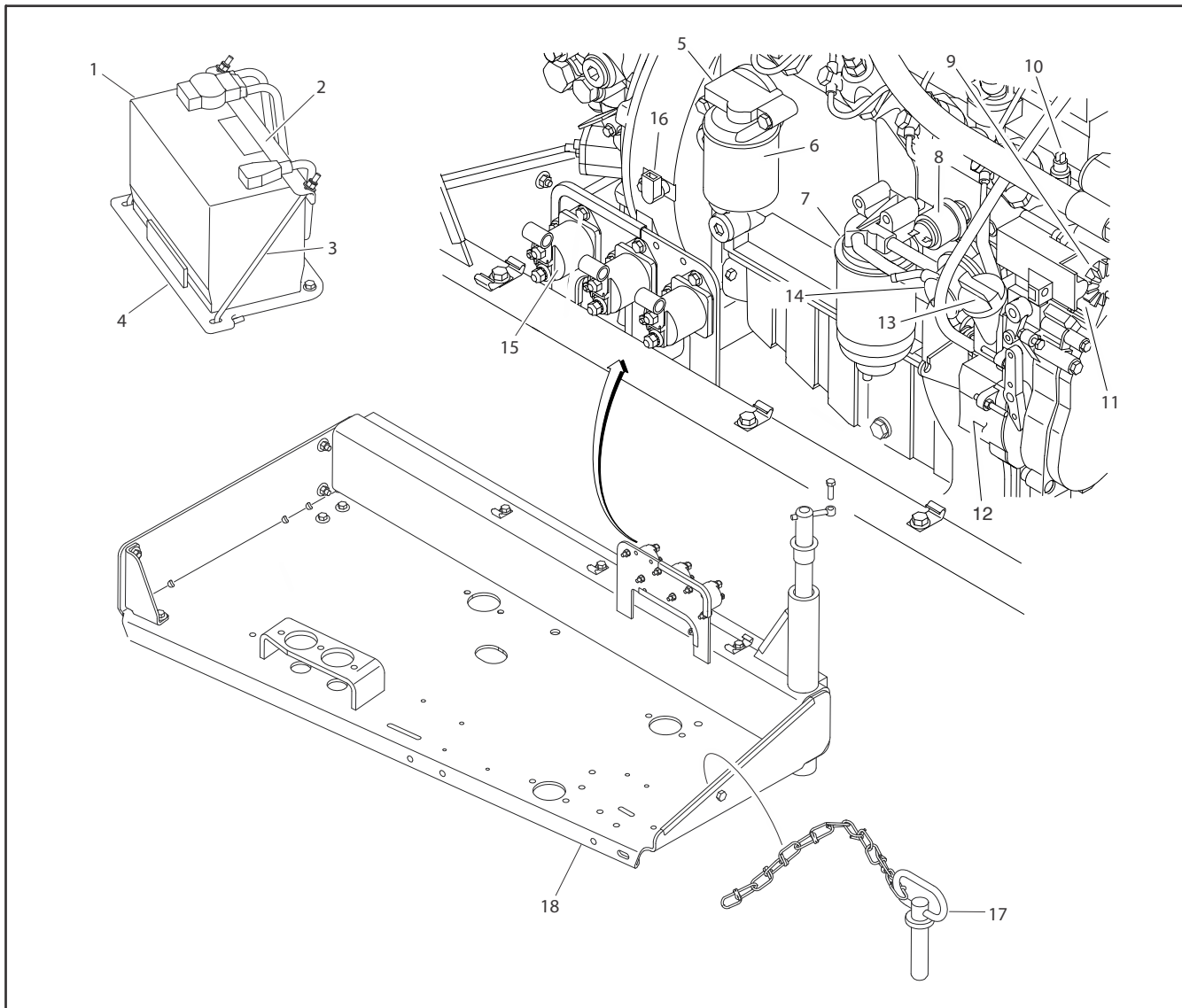
3.12 DEUTZ D2011 ENGINE



- |                            |                                      |                                     |   |
|----------------------------|--------------------------------------|-------------------------------------|---|
| 1. Radiator Mounting Plate | 7. Oil Cooler Hose                   | 13. Pump Adapter Plate              | 19. Left Front Engine/Generator Support |
| 2. Fan                     | 8. Exhaust Pipe Extension            | 14. Piston Pump                     | 20. Starter                             |
| 3. Dipstick                | 9. Air Cleaner                       | 15. Gear Pump                       | 21. Muffler                             |
| 4. Oil Filler Cap          | 10. Right Rear Engine Mounting Plate | 16. Left Rear Engine Mounting Plate | 22. Alternator                          |
| 5. Control Module          | 11. Exhaust Pipe                     | 17. Engine Mount                    | 23. Radiator Hose                       |
| 6. Fuel Injector           | 12. Coupling                         | 18. Left Front Engine Support       | 24. Radiator                            |

Figure 3-78. Deutz D2011 Engine Installation - Sheet 1 of 2

## SECTION 3 - CHASSIS & TURNTABLE



- |                            |                        |                        |                      |                  |
|----------------------------|------------------------|------------------------|----------------------|------------------|
| 1. Battery                 | 5. Temperature Sensor  | 9. Throttle Actuator   | 13. Oil Filler Cap   | 16. Speed Sensor |
| 2. Battery Hold-Down       | 6. Oil Filter          | 10. Temperature Sensor | 14. Fuel Supply Pump | 17. Hitch Pin    |
| 3. J-Bolt                  | 7. Fuel Filter         | 11. Starter            | 15. Relay            | 18. Engine Tray  |
| 4. Battery Hold-Down Plate | 8. Oil Pressure Sensor | 12. Oil Lube Pump      |                      |                  |

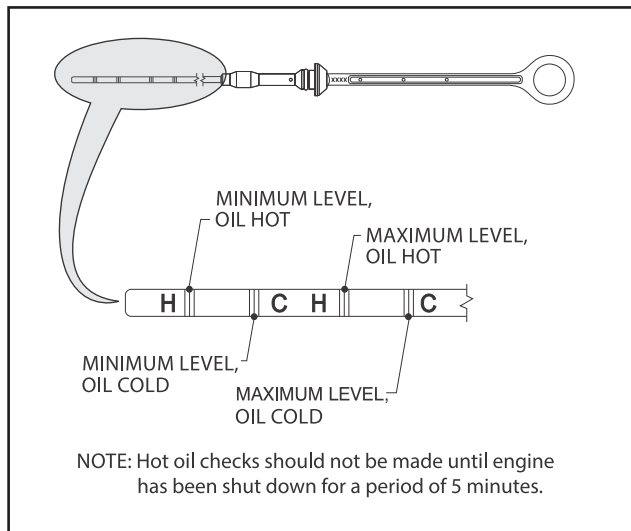
**Figure 3-79. Deutz D2011 Engine Installation - Sheet 2 of 2**



**NOTE:** Refer to engine manufacturer's manual for detailed operating and maintenance instructions.

### Checking Oil Level

1. Make sure machine and engine are level and switch engine OFF before checking oil level.
2. Remove oil dipstick and wipe with clean cloth.
3. Insert dipstick to the stop and remove again.
4. Check oil level. Top oil level as shown in figure below with an approved grade and type of oil outlined in engine manufacturer's operator's manual.



**Figure 3-80. Deutz Dipstick Markings**

5. Replace dipstick until fully seated.

### Changing Engine Oil

1. Allow engine to warm up. Engine oil should reach approximately 176° F (80° C).
2. Make sure machine and engine are level and switch off engine.
3. Place oil tray under engine.

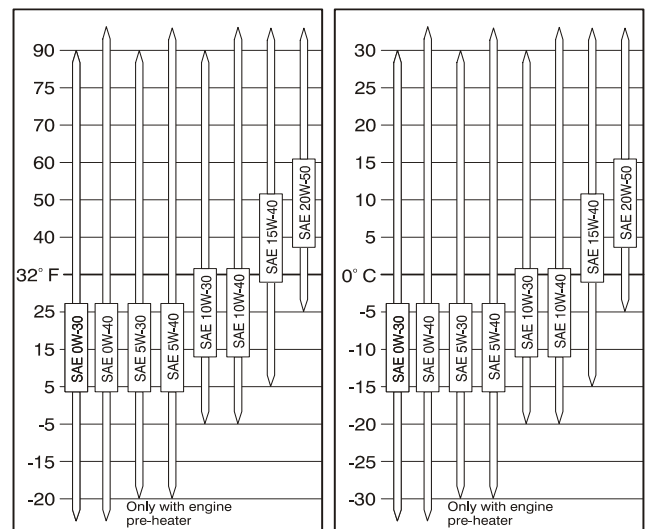
#### **CAUTION**

**HOT ENGINE OIL CAN CAUSE BURNS. AVOID CONTACT WITH HOT OIL WHEN DRAINING.**

#### **NOTICE**

**COLLECT USED OIL IN A CONTAINER SUITABLE FOR DISPOSAL OR RECYCLING. DISPOSE OF USED ENGINE OIL IN ACCORDANCE WITH ENVIRONMENTAL REGULATIONS.**

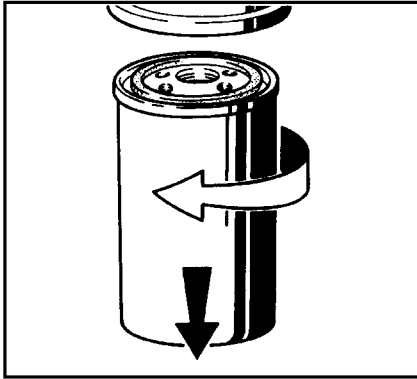
4. Open oil drain valve and drain oil.
5. Close oil drain valve.
6. Pour in new engine oil. Refer to Section 1 for capacity and Figure 3-81., Engine Oil Viscosity.



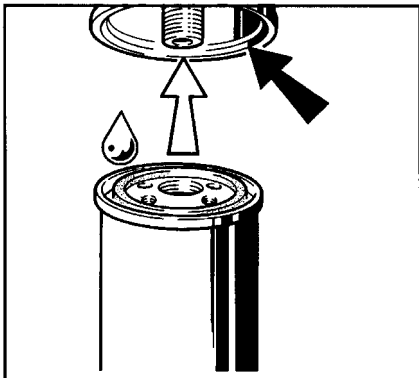
**Figure 3-81. Engine Oil Viscosity**

### Changing Oil Filter

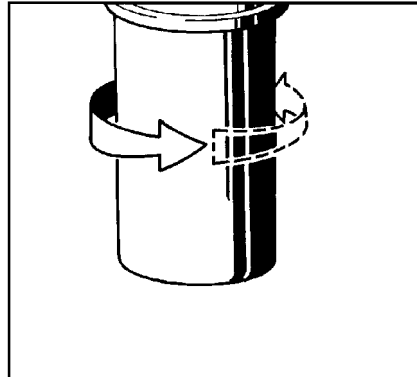
1. Wipe area around filter to clean any dirt from area.
2. Using a suitable oil filter removal tool, loosen lube oil filter cartridge and spin off.



3. Catch any escaping oil.
4. Clean any dirt from filter carrier sealing surface.
5. Lightly coat new oil filter rubber gasket with clean oil.



6. Screw in new filter by hand until gasket is flush.



7. Hand-tighten filter another half-turn.
8. Check oil level.
9. Check oil pressure.
10. Check oil filter cartridge for leaks.

### Replace Fuel Filter

**⚠ WARNING**

**FUEL IS FLAMMABLE AND CAN CAUSE DEATH OR SERIOUS INJURY. MAKE SURE NO OPEN FLAMES OR SPARKS ARE IN THE AREA WHEN WORKING ON FUEL SYSTEM. DO NOT SMOKE WHEN WORKING ON FUEL SYSTEM.**

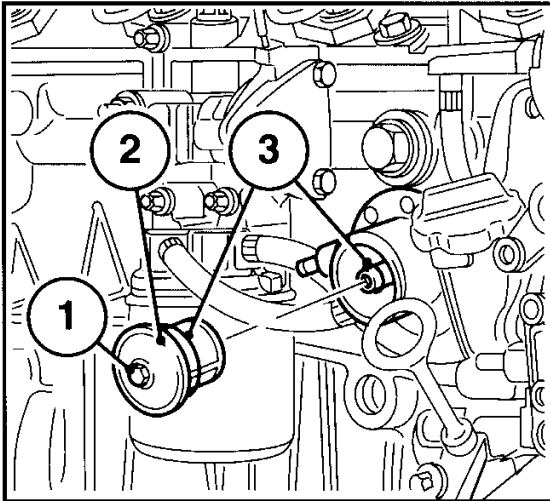
1. Wipe area around filter to clean any dirt from area.
2. Remove fuel filter cartridge. Catch any escaping fuel.
3. Clean dirt from filter carrier sealing surface.
4. Apply light film of oil or diesel fuel to rubber gasket of new filter cartridge.
5. Screw in new filter by hand until gasket is flush. Hand-tighten filter another half-turn.
6. Open fuel shut-off valve.
7. Check for leaks.

## Clean Fuel Strainer

### **⚠ WARNING**

**FUEL IS FLAMMABLE AND CAN CAUSE DEATH OR SERIOUS INJURY. MAKE SURE NO OPEN FLAMES OR SPARKS ARE IN THE AREA WHEN WORKING ON FUEL SYSTEM. DO NOT SMOKE WHEN WORKING ON FUEL SYSTEM.**

1. Unscrew hexagonal nut (1).



2. Remove fuel strainer cover (2).
3. Clean fuel strainer with diesel fuel and replace as needed.
4. Place seal (3) in position.
5. Install fuel strainer cover (2). Tighten screw (1).
6. Check for leaks.

## 3.13 SPARK ARRESTER CLEANING INSTRUCTIONS

1. Remove cleanout plug in bottom of spark arrester (muffler).
2. Without causing deformation (or any type of damage to spark arrester) repeatedly tap on arrester near cleanout plug. This may be enough to begin spark trap drainage.
3. An industrial vacuum cleaner can do a complete job at this point.
  - a. Or, IN A SAFE AREA, start engine. Alternate between low idle and high idle for two to three minutes.
  - b. Or, operate engine as required by application for two to three minutes.
4. Install cleanout plug.

## 3.14 GLOW PLUGS

If glow plug option is enabled in the JLG Control System, glow plug and indicator lamp will be energized when Power/Emergency Stop switch is pulled on if ambient air temperature is less than 50° F (10° C) and engine coolant temperature is less than 140° F (60° C).

This determination occurs one second after the Power/Emergency Stop switch has been pulled on. Lamp and glow plugs remain energized for period of time specified by setting in the JLG Control System. Engine start is disabled during this period.

On Deutz engines, glow plugs continue (post glow) after engine has started three times the machine digit setting.

**3.15 DEUTZ EMR 2**

The EMR2 consists of sensors, control unit, and actuator. Engine-side controls and the JLG Control System are connected by separate cable harnesses to the EMR control unit.

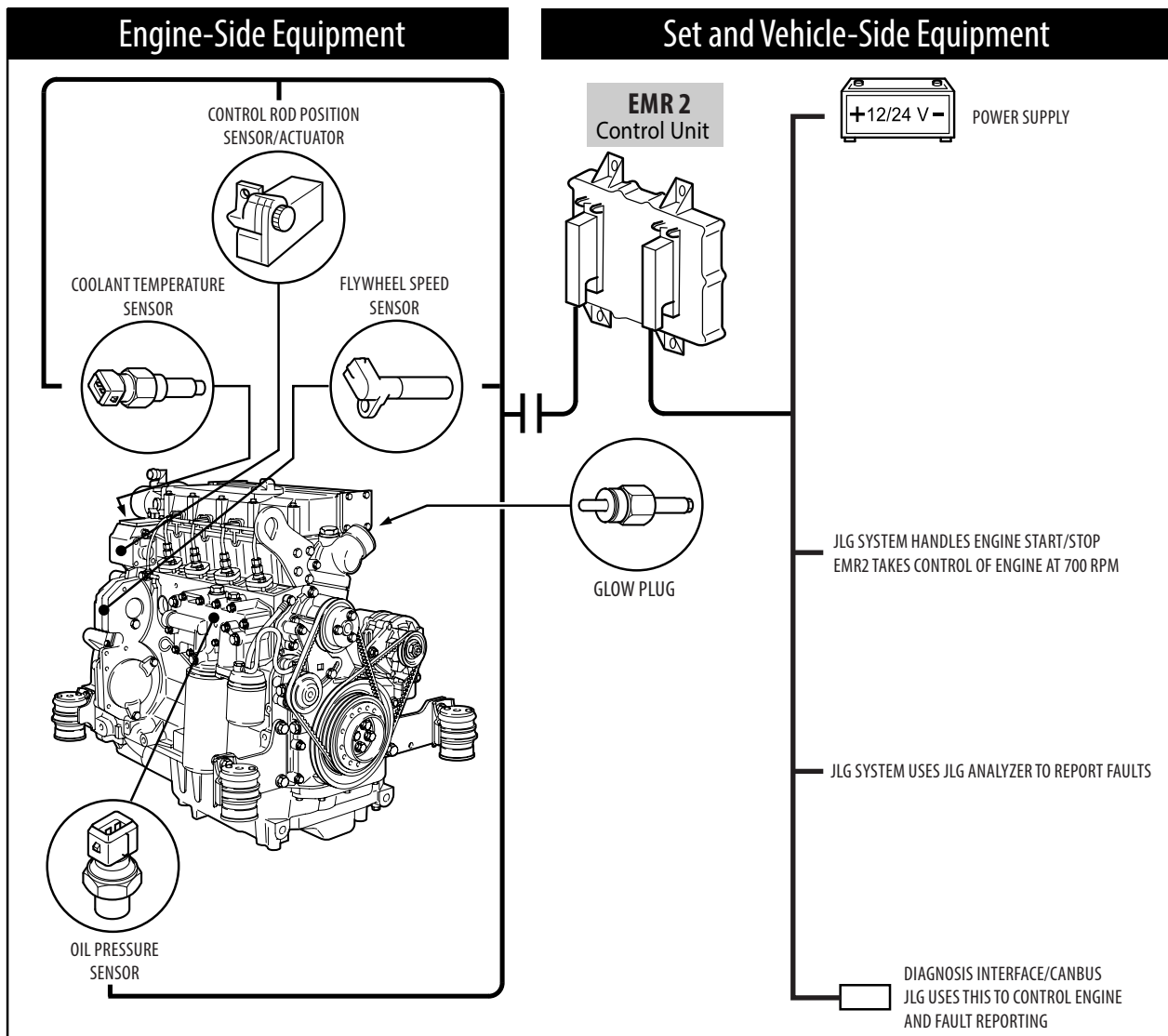
Sensors attached to the engine provide control unit electronics with all relevant physical parameters. In accordance with information of the current engine conditions and preconditions (throttle position etc.), the EMR2 controls an actuator that operates the control rod of the injection pump and thus doses the fuel quantity in accordance with the performance requirements.

Exact position of the regulating rod is reported back and, if necessary, is corrected, by means of the control rod travel sensor, situated together with the rotation magnets in a housing of the actuator.

The EMR2 is equipped with safety devices and measures in the hardware and software to ensure emergency running (Limp home) functions. In order to switch the engine off, the EMR2 is switched in a de-energized fashion over the ignition switch. A strong spring in the actuator presses the control rod in the de-energized condition into the zero position. As a redundancy measure, an additional solenoid serves for switching off and this, independently of the actuator, also moves the control rod in the de-energized condition into the zero position.

After programming over the ISO9141 interface, the EMR2 possesses a motor-specific data set which is permanently assigned to the engine. Included in this are the various application cases as well as the customer's wishes regarding a particular scope of function.

Each EMR2 module is matched by serial number to the engine. Modules cannot be swapped between engines.



**Figure 3-82. EMR 2 Engine Side Equipment**

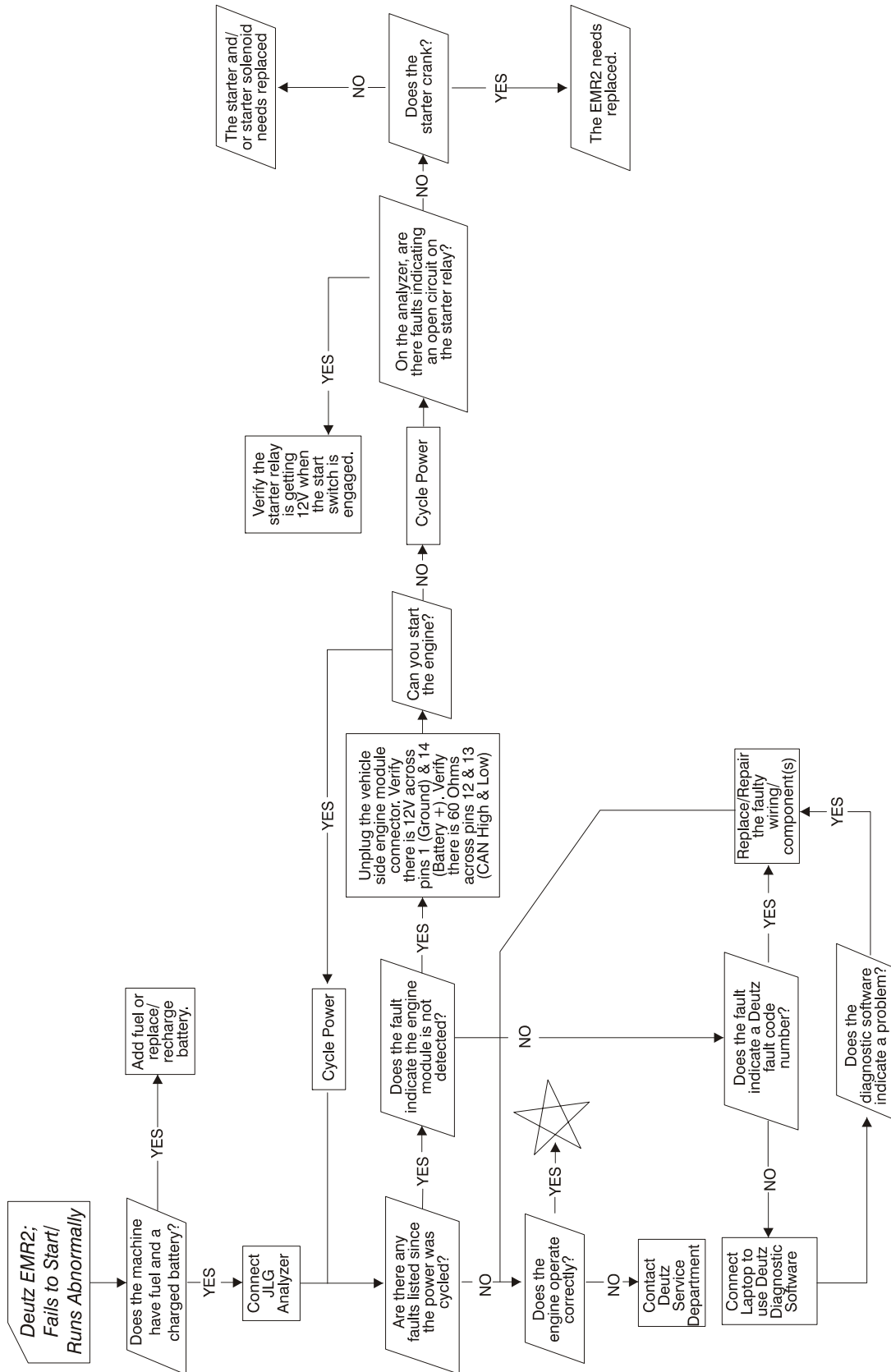


Figure 3-83. Deutz EMR 2 Troubleshooting Flow Chart

# SECTION 3 - CHASSIS & TURNTABLE

- Notes: (N ...)
- equipment designation according (X22) to H22986, part 1, e.g.
  - bus terminal resistance for CAN interfaces SAE J 1939 to be monitored externally, see page 043/307/10
  - cross-section of conducting lines: 1,5 mm<sup>2</sup>
  - control unit ECU → battery: 7 m  
control unit ECU → actuator: 5,5 m  
equipment plug → battery: 7 m  
equipment plug → actuator: 5,5 m  
Steuergerät ECU → Batterie: 7 m  
Steuergerät ECU → Aktuator: 5,5 m  
Geräteleider → Batterie und Aktor getrennt: 5 m
  - Max. zulässige Stromstärke: 30 mA
  - Kein BOUTZ-Lieferant
  - AND nicht mit Motormasse verbinden
  - Nach Sicherung
  - Keine zusätzlichen Verbraucher anschliessen
  - Anschlusspunkte nahe an Steuergerät montieren

- Notes: (N ...)
- equipment designation according (X22) to H22986, part 1, e.g.
  - bus terminal resistance for CAN interfaces SAE J 1939 to be monitored externally, see page 043/307/10
  - cross-section of conducting lines: 1,5 mm<sup>2</sup>
  - control unit ECU → battery: 7 m  
control unit ECU → actuator: 5,5 m  
equipment plug → battery: 7 m  
equipment plug → actuator: 5,5 m  
Steuergerät ECU → Batterie: 7 m  
Steuergerät ECU → Aktuator: 5,5 m  
Geräteleider → Batterie und Aktor getrennt: 5 m
  - Max. zulässige Stromstärke: 30 mA
  - Kein BOUTZ-Lieferant
  - AND nicht mit Motormasse verbinden
  - Nach Sicherung
  - Keine zusätzlichen Verbraucher anschliessen
  - Anschlusspunkte nahe an ECU

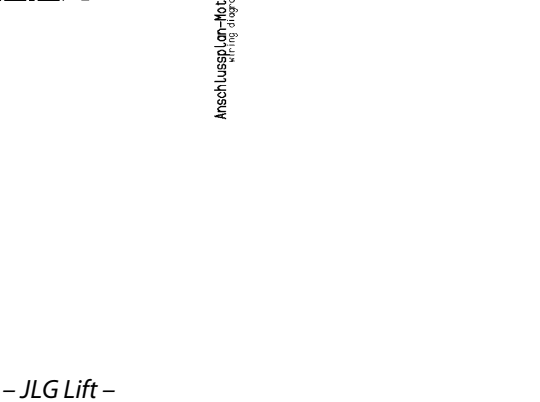
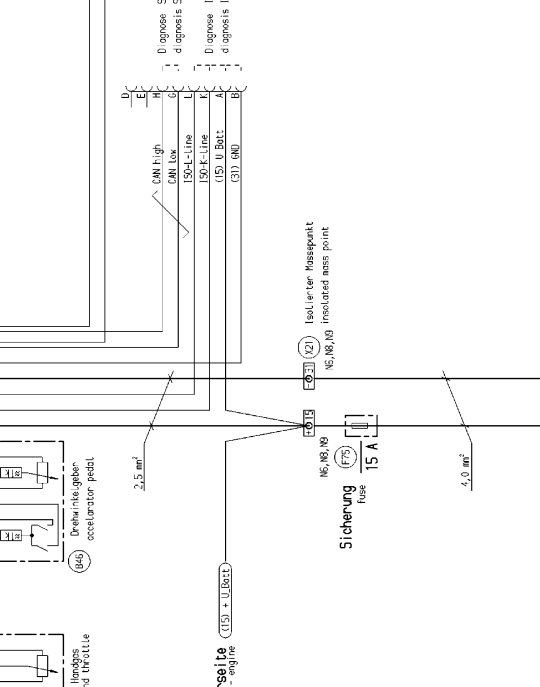
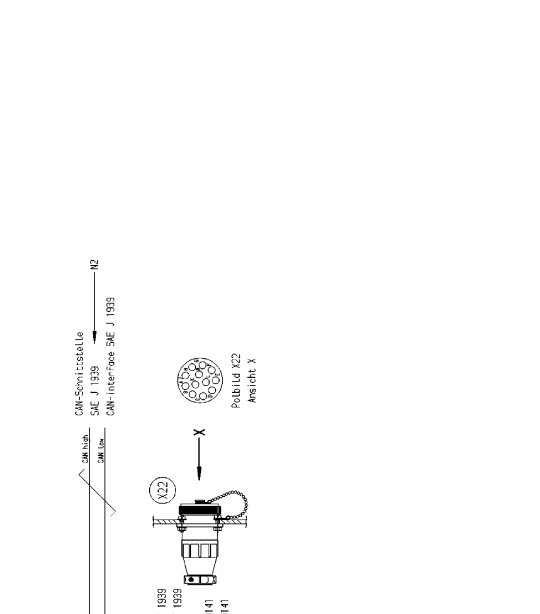
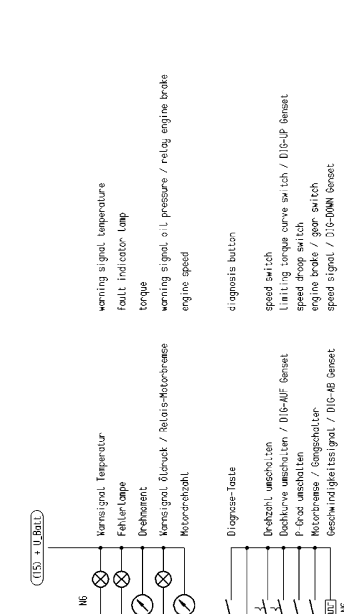
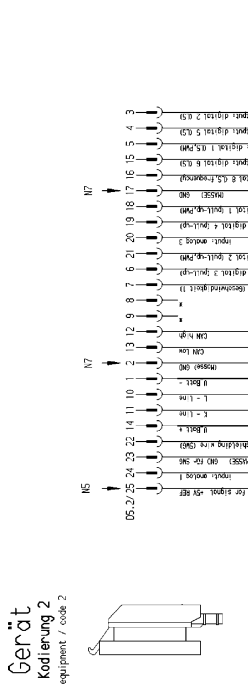


Figure 3-84. Deutz EMR 2 Vehicle Side Connection Diagram

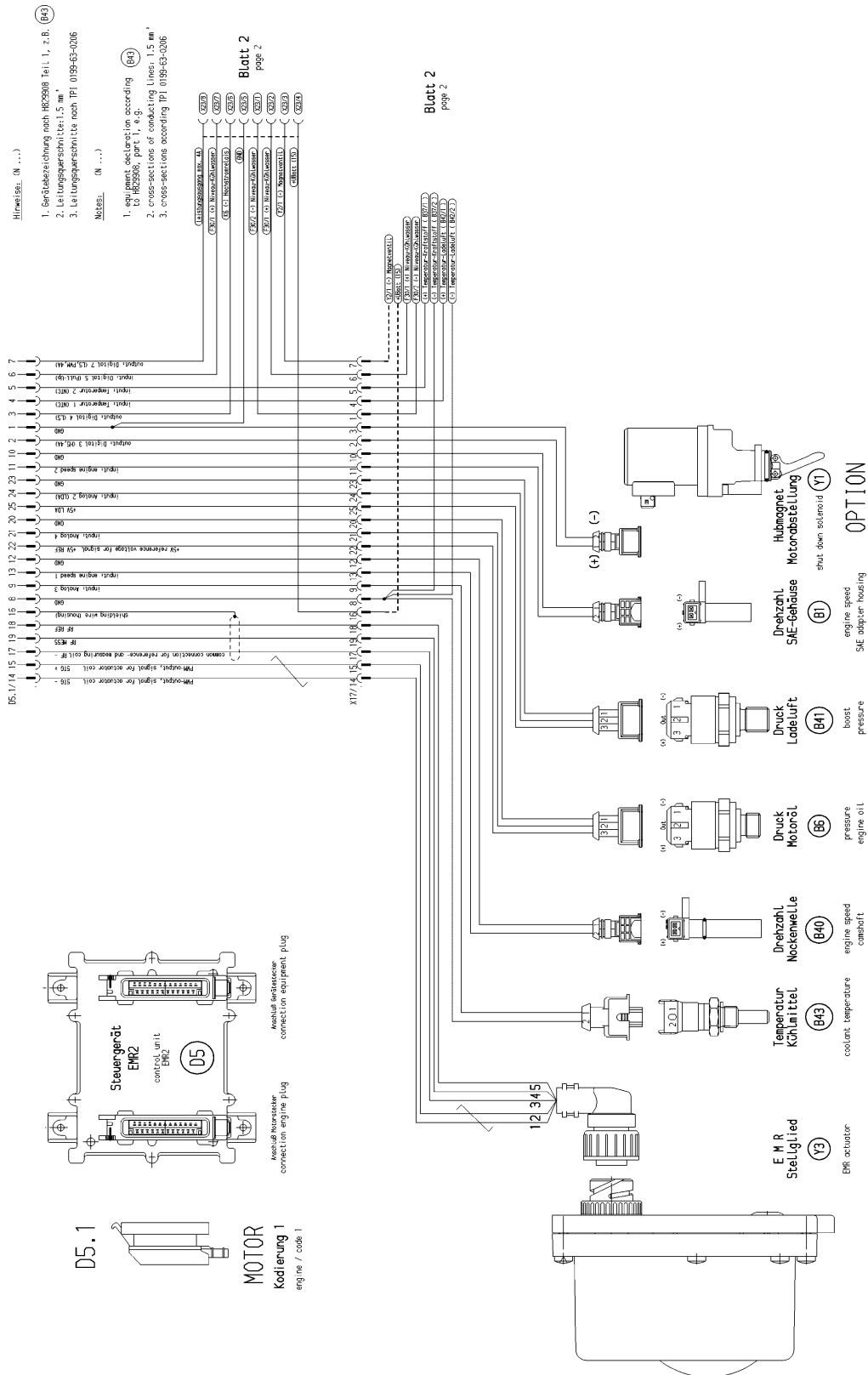


Figure 3-85. Deutz EMR 2 Engine Side Connection Diagram - Sheet 1 of 2

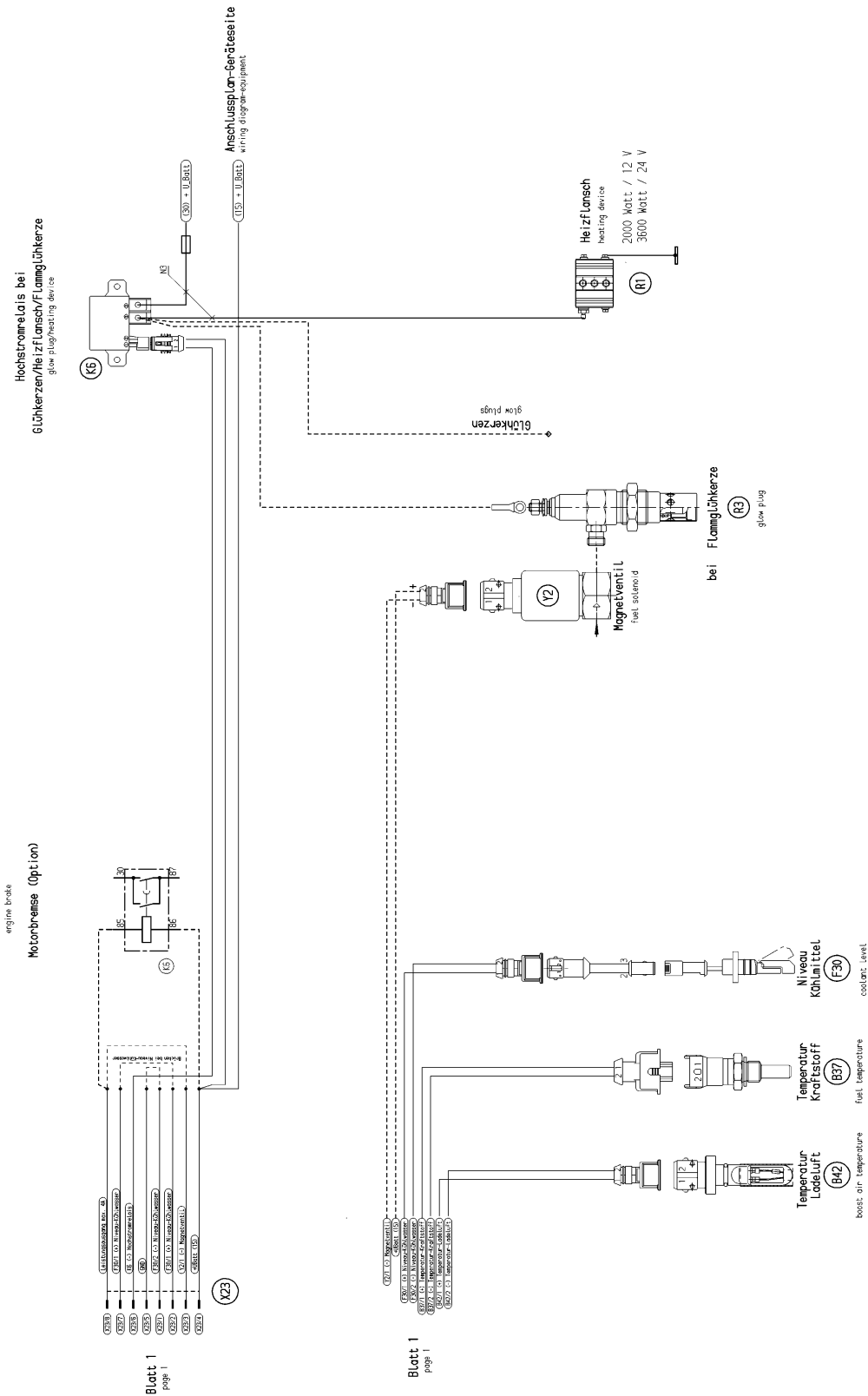
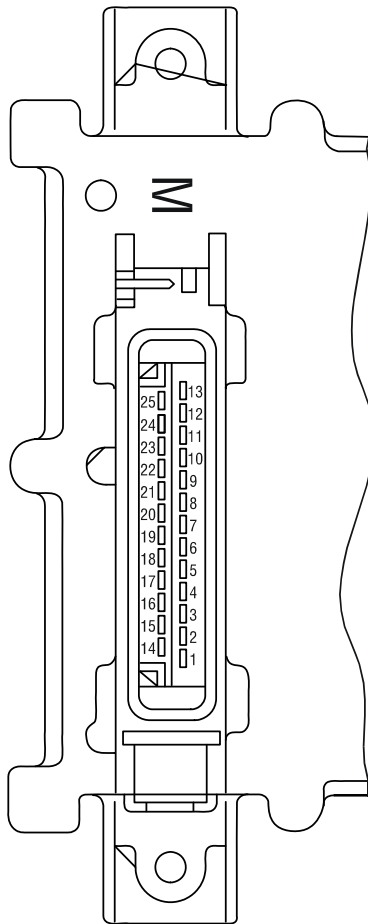


Figure 3-86. Deutz EMR 2 Engine Side Connection Diagram - Sheet 2 of 2





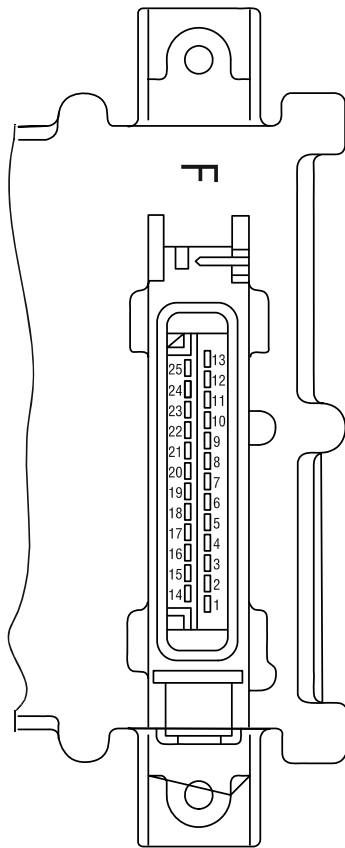
Pin No.	Designation	Description
1	Reserve	Reserve
2	Output: digital 3	Digital output for solenoid <sup>1)</sup>
3	Output: digital 4	For heating flange (optional)/ glow plug (optional)
4	Input (optional) Temp 1	Fuel temperature <sup>2)</sup>
5	Input (optional) Temp 2	Charge air temperature
6	Input (optional) DigIn 5	Coolant level / oil level
7	Output: PWM2/digital 6	
8	GND	Reference potential for analog signal at pin 9
9	Input: analog 7	Analog input for Coolant temperature sensor (NTC)
10	GND	Reference potential for analog signal at pin 11
11	Multi-function input: speed 2/DigIn 2	Digital input second engine speed (crankshaft) (optional) and speed signal (optional)
12	GND	Reference potential for analog signal at pin 13
13	Input: speed 1	Digital input first engine speed (camshaft)
14	STG -	PWM output, signal for actuator coil
15	STG +	PWM output, signal for actuator coil
16	Screen	Screening regulating rod travel sensor (for lines 17, 18, 19)
17	RF -	General connection for reference and measuring coil
18	RF REF	Analog input, reference signal of the reference coil
19	RF MESS	Analog input, measuring signal of the measuring coil
20	GND	Reference potential for signal at pin 21
21	Input: analog 4/digital 9	Analog input 4 (sensor signal oil pressure sensor) or digital input 9
22	+5 V REF	+5 V Reference voltage for signal at pin 21 (max. 15 mA)
23	GND	Reference potential for signal at pin 24
24	Input: analog 2/digital 7	Analog input 2 (sensor signal charge air) or digital input 7
25	+5 V LDA	+5 V Reference potential for signal at pin 24 (max. 15 mA)

1) For continuous power: < 4 A

2) Corresponds to special function "fuel temperature compensation at the EMR (0211 2571)

**Figure 3-87. EMR 2 Engine Plug Pin Identification**

## SECTION 3 - CHASSIS & TURNTABLE



Pin-No.	Designation	Description
1	U Batt -	Negative pole at battery (clamp 31)
2	GND	Reference potential for signal
3	Output: digital 2	PWM or digital output, various functions
4	Input / output: DigInOut	Fault lamp and diagnostic button
5	Output: PWM 1/Dig 1	PWM or digital output, various functions
6	Multi-function input: DigIn 3	Genset applications/gear shift/motor brake
7	Input: digital 10/velocity	Speed signal (tacho input)
8	NC	Not occupied
9	NC	Not occupied
10	L-line	Serial ISO 9141 interface
11	K-line	Serial ISO 9141 interface
12	CAN high	Interface for CAN-Bus
13	CAN low	Interface for CAN-Bus
14	U Batt +	Positive pole for battery (clamp 15)
15	Output: digital 5	Digital output, various functions
16	Output: digital 7/Frequency	Frequency, PWM or digital output, various functions
17	Ground	Reference potential for signal at pins 18, 19 and 21
18	Input: digital 1 / PWM 1	PWM 1 or digital input 1, various functions
19	Multi-function input: DigIn 4	Performance curve switching/genset applications
20	Multi-function input: digital 8 / analog 3	Hand hand throttle/genset applications, Digital (8) or analog input (3)
21	Input: digital 2 / PWM 2	PWM 2 or digital input 2, various functions
22	Screen	Screening (e.g. for lines hand throttle or PWG)
23	GND	Reference potential for signal at pin 24
24	Input: analog 1 / digital 6	Analog input 1 (pedal value sensor, PWG) or digital input 6
25	+5 V REF	+5 V Reference voltage for signal at pin 24

Figure 3-88. EMR 2 Vehicle Plug Pin Identification

Fault group	Fault no. (in SERDIA)	Fault locality/ Fault description	SPN	FMI	Cause	Remarks	Help
Zero error display	-	No faults	524287	31	No active faults present		
Revolutions / speed acquisition	01	Speed sensor 1	190	8	Sensor failure. Distance from gear too far. Additional fault impulses. Cable joint interrupted.	Governor in emergency operation (if sensor 2 available). Emergency switch-off (if sensor 2 not available or failed). Governor in emergency operation (with sensor 1). Emergency switch-off (if sensor 1 not available or failed).	Check distance. Check cable connection. Check sensor and replace if required.
	03	Speed sensor	84	8	Tacho failed. Additional fault impulses. Cable connection interrupted.	Governor in emergency operation.	Check cable connection and Tacho. Replace if required.
	04	Excess speed switch-off	190	0	Speed was/is in excess of limit.e. Check PID setting. Check rods. Check actuator and replace if required. Check cable to actuator (impulse on incorrect speed). Check No. of teeth. For vehicles check for possible thrust mode.	Engine stop.	Check parameter (21). Check speed settings.
Sensors	07	Charge air pressure	102	2			
	08	Oil pressure	100	2			
	09	Coolant temperature	110	2	Fault at corresponding sensor entry (e.g. short circuit or cable break).	With failure of the sensor, the associated monitoring function is de-activated.	Check sensor cable. Check sensor and replace if required. Check fault limits for sensor.
	10	Charge air temperature	105	2			
	11	Fuel temperature	174	2			

NOTE: SID is equal to 512. To get SPN #, add 512 + number. For example, SID 254 would be 512+254 or an SPN of 766.

Figure 3-89. EMR2 Fault Codes - Sheet 1 of 5

## SECTION 3 - CHASSIS & TURNTABLE

Fault group	Fault no. (in SERDIA)	Fault locality/ Fault description	SPN	FMI	Cause	Remarks	Help
Functional fault warning	30	Oil pressure warning	100	1	Oil pressure below speed-dependent warning line characteristic	Fault message (disappears when oil pressure is again above recovery limit). After a delay time - fill limitation.	Check engine (oil level, oil pump). Check oil pressure sensor and cable. Check oil pressure warning line characteristic.
	31	Coolant temperature warning	110	0	Coolant temperature has exceeded warning level.	Fault message (disappears when coolant temperature again drops below recovery level). After a delay time - fill limitation.	Check coolant. Check coolant temperature sensor and cable.
	32	Charge air temperature warning	105	0	Charge air temperature has exceeded warning level.	Fault message (disappears when charge air temperature gain drops below recovery level). After a delay time - fill limitation.	Check charge air. Check charge air-temperature sensor and cable.
	34	Coolant level warning	111	1	Switch input "Low coolant level" is active.	Fault message.	Check coolant level. Check coolant level sensor and cable.
	35	Speed warning (with thrust mode operation).	SID 190	14	revolutions was/is above (top) revolution speed limit. "Thrust mode" function is active.		Check parameters. Check speed settings.
	36	Fuel temperature warning	174	0	Fuel-temperature has exceeded warning level.	Fault message (disappears when fuel temperature again drops below recovery level).	Check fuel. Check fuel temperature sensor and cable.

NOTE: SID is equal to 512. To get SPN #, add 512 + number. For example, SID 254 would be 512+254 or an SPN of 766.

Figure 3-90. EMR2 Fault Codes - Sheet 2 of 5

Fault group	Fault no. (in SERDIA)	Fault locality/ Fault description	SPN	FMI	Cause	Remarks	Help
Functional fault, switch-off	42	Charge air temperature switch-off	105	0	Charge air temperature has exceeded switch-off limit.	Emergency stop	Check charge air. Check charge air-temperature sensor and cable. Check switch-off limit.
	44	Coolant level switch-off	111	1	Switch input "Low coolant level" is active.	Emergency stop. Start lock.	Check coolant level. Check coolant level sensor and cable.
Actuator	50	Feedback	SID 24	12	Actuator not connected. Fault in actuator confirmation.	Emergency switch-off. Actuator cannot be operated.	Check actuator, replace if required. Check cable, check fault limits for "Confirmation".
	52	Reference feedback	SID 24	13			Check actuator, replace if required. Check cable, check fault limits for "Rifeness confirmation".
	53	Control travel difference	SID 23	7	Injection pump/actuator jammed or not connected. Difference between nominal/actual control travel is > 10 % of the overall control path.	Fault message (disappears when difference is < 10 %).	Check actuator/actuator rods / injection pump, replace if required. Check actuator cable.
	59	Auto calibration BOSCH-EDC pumps faulty operation	SID 23	13	No automatic actuator equalization possible. Incorrect input of the actuator reference values.	Engine stop / start lock. Governor cannot be taken into use. EDC actuator calibration required.	Check actuator and replaced if required. Check feedback cable. Check fault limits and reference values of the feedback. Program the fault limits for feedback, save the fault limits for feedback, save values. Switch ignition off and on again. Check again, if faulty, inform DEUTZ-Service and carry out automatic equalization again. Set fault limits again.

NOTE: SID is equal to 512. To get SPN #, add 512 + number. For example, SID 254 would be 512+254 or an SPN of 766.

Figure 3-91. EMR2 Fault Codes - Sheet 3 of 5

**SECTION 3 - CHASSIS & TURNTABLE**

Fault group	Fault no. (in SERDIA)	Fault locality/ Fault description	SPN	FMI	Cause	Remarks	Help
Hardware inputs/outputs	60	Digital output 3 (Switch-off solenoid, pin M 2)	SID 51	2	Fault (short circuit / cable break) at digital output.	Driver level is switched off.	Check cable of digital output (cable break or short circuit).
	62	Digital output 6, pin M 7	SID 60	2		Fault message.	
	63	Excess voltage switch-off solenoid	SID 51	6			
	67	Error Hand Setp1	91	11			
	68	Error CAN Setp1	898	2			
	Communication	70	CAN-Bus controller	SID 231	12	CAN-controller for CAN-bus is faulty. Fault removal despite re-initialising continuously not possible	Application-dependent.
71		CAN interface SAE J 1939	SID 231	9	Overflow in input buffer or a transmission cannot be placed on the bus.		
74		Cable break, short circuit or bus-error	SID 231	14			Check CAN connection, cable connection. Check sensor and replace if required.
Memory	76	Parameter programming (write EEPROM)	SID 253	12	Fault in parameter programming in the governor fixed value memory.		Switch ignition off and on again. Check again, if faulty inform DEUTZ Service
	77	Cyclic program test	SID 240	12	Constant monitoring of program memory shows error (so-called "Flash-test").	Emergency switch-off, engine cannot be started.	
	78	Cyclic RAM test	SID 254	2	Constant monitoring of working memory shows error.		Note values of parameters (3895 and 3896). Switch ignition off and on again. Check again. If faulty inform DEUTZ Service.

NOTE: SID is equal to 512. To get SPN #, add 512 + number. For example, SID 254 would be 512+254 or an SPN of 766.

**Figure 3-92. EMR2 Fault Codes - Sheet 4 of 5**

Fault group	Fault no. (in SERDIA)	Fault locality/ Fault description	SPN	FMI	Cause	Remarks	Help
Control unit hardware	80	Power supply (Actuator)	SID 254	2	Power supply for actuator not in the permissible range.	Fault message (disappears when power again in the normal range).	Switch ignition off and on again. Check again. If faulty inform DEUTZ Service.
	83	Reference voltage 1	SID 254	2	Reference voltage for actuator not in the permissible range.	Fault message (disappears when power again in the normal range). Auxiliary value 5 V	Check voltage supply. Switch ignition off and on again. Check again. If faulty inform DEUTZ Service.
	84	Reference voltage 2	SID 254	2			
	85	Reference voltage 4	SID 254	2			
	86	Internal temperature	171	12	Internal temperature for control unit not in permissible range.	Fault message (disappears when power again in the normal range).	Switch ignition off and on again. Check again. If faulty inform DEUTZ Service.
87	Atmospheric pressure	108	12	Atmospheric pressure not in permissible range.	Fault message (disappears when power again in normal range). Atmospheric pressure monitoring function de-activated.	Switch ignition off and on again. Check again. If faulty inform DEUTZ Service.	
Program logic	90	Parameter fault (EEPROM retrieval or checksum faulty).	SID 253	2	No data found or checksum of data is faulty (note: fault only occurs during setting of parameter / saving or reset).	Engine cannot be started.	Check data for correct settings. Save parameters. Switch ignition off and on again. Check again. If faulty inform DEUTZ Service.
	93	Stack overflow	SID 240	2	Internal calculation fault (so-called "Stack overflow" fault).	Emergency switch-off. Engine cannot be started.	Note parameters (3897 and 3898). Switch ignition off and on again. Check again. If faulty inform DEUTZ Service.
	94	Internal fault	SID 254	2			

NOTE: SID is equal to 512. To get SPN #, add 512 + number. For example, SID 254 would be 512+254 or an SPN of 766.

Figure 3-93. EMR2 Fault Codes - Sheet 5 of 5

### 3.16 BIO FUEL IN DEUTZ ENGINES

#### General

Use of bio fuels is permitted for the compact engines made by DEUTZ.

Distillate fuels with residue oil percentages or mixed fuels may not be used in DEUTZ compact engines.

DEUTZ vehicle engines are designed for diesel fuels in accordance with EN 590 with a cetane number of at least 51. DEUTZ engines for mobile machinery are designed for a cetane number of at least 45. When using fuels of a low cetane number, disturbing white smoke and ignition misfires are to be expected under some circumstances.

A cetane number of at least 40 is permissible for the US market, therefore special engine models have been developed to avoid starting difficulties, extreme white smoke or increased hydrocarbon emissions (EPA specification - US EPA REGULATIONS FOR LARGE NONROAD COMPRESSION-IGNITION ENGINES).

If white smoke is unacceptable when using a very low cetane number, use of ignition improvers is to be recommended as a later remedial measure.

Certification measurements for compliance with legal emission limits are carried out with test fuels prescribed by law. These correspond to diesel fuels in accordance with EN 590 and ASTM D 975. No emission values are guaranteed with other fuels described. It is the obligation of the owner to check permission for use of fuels in accordance with regional regulations.

#### Bio Fuel

##### PERMITTED BIO-DIESEL FUELS

Originally only rape seed oil methylester (RME) was sold as a bio-diesel fuel in Europe but fatty acid methylester (FAME) based on other oils have come onto the market increasingly in recent years. However, with the latter there is a risk that the limit values of EN 14214 are not kept in the field. Anyone who uses bio-diesel fuel in DEUTZ engines must therefore choose his supplier very carefully and have him guarantee compliance with the EN 14214 limit values. Since experience has shown that rape seed oil methylester (RME) exceeds the limit values less often than other esters, it is expressly recommended to use only rape seed oil methylester. DEUTZ customers in Germany can additionally ensure the quality by buying bio-diesel fuel with an AGQM certificate (Arbeitsgemeinschaft Qualitäts-Management Biodiesel e.V.).

The use of US bio-diesel based on soy oil methylester is only permissible in mixtures with diesel fuel with a bio-diesel part of a max. 20 weight-%. The US bio-diesel used for the mixture must comply with the ASTM D6751-07a (B100) standard.

#### APPROVED ENGINES

912, 913, 914, 1011, 2011, 1012, 2012, 1013, 2013, 413 and 513 series are approved for bio-diesel from year of manufacture 1993 under compliance with basic conditions specified below.

#### BASIC CONDITIONS TO BE OBSERVED

- A power loss of 5-9% in relation to diesel fuel in accordance with EN 590 is possible due to the lower heating value. Blocking of fuel injector is not allowed.
- Lubricating oil quality must correspond to TR 0199-99-3002. Lubricating oil change interval must be halved in relation to operation with diesel fuel in accordance with EN 590.
- Standstills of longer than 4 to 6 weeks must be avoided with bio-diesel. Otherwise, engine must be started and stopped with diesel fuel.
- Bio-diesels can be mixed with normal diesel fuel but basic conditions described in this subsection apply for mixtures. Mixtures with up to 5% (m/m) bio-diesel (B5) which have recently been on sale at European fuel stations are excepted. These fuels must be treated like normal diesel fuels because EN 590 expressly permits adding up to 5% (m/m) bio-diesel in accordance with EN 14214.
- Approximately 30-50 hours after changing from diesel fuel to bio-diesel, the fuel filter should be changed as a preventive measure to avoid a drop in performance due to clogged fuel filters. Deposited fuel ageing products are dissolved by bio-diesel and transported into the fuel filter. They should not be changed immediately, but after 30 to 50 hours because that is the time it takes for most dirt to be dissolved.

#### PLANT OIL

##### **NOTICE**

**PURE PLANT OILS (E.G. RAPE SEED OIL, SOY OIL, PALM OIL) ARE NOT CLASSIFIED AS BIO-DIESEL AND EXHIBIT PROBLEMATIC PROPERTIES FOR DIESEL ENGINE OPERATION (STRONG TENDENCY TO COKE, RISK OF PISTON SEIZURE, EXTREMELY HIGH VISCOSITY, AND POOR EVAPORATION BEHAVIOR).**

The conversion of DEUTZ engines to rape seed oil fuel operation with conversion kits and modified tanks systems of various manufacturers is not allowed and leads to loss of warranty rights.



## **Biological Contamination In Fuels**

### **SYMPTOMS**

The following symptoms may indicate a fuel tank is contaminated by micro-organisms:

- Internal tank corrosion,
- Filter blockage and associated loss of power due to gel-like deposits on the fuel filter (especially after long standstills)

### **CAUSE**

Micro-organisms (bacteria, yeasts, fungi) can form bio-sludge under unfavorable conditions (favoured particularly by heat and water).

Penetration by water is usually caused by condensation of water in the air. Water does not dissolve in fuel so penetrating water collects at bottom of the tank. Bacteria and fungi grow in the watery phase, at phase boundary to the fuel phase, from which they draw their nutrition. There is an increased risk especially with bio-diesel (FAME).

### **PREVENTIVE MEASURES**

- Keep storage tank clean. Perform regular cleaning of the tank by specialist companies
- Installation of fuel pre-filters with water traps, especially in countries with frequently fluctuating fuel qualities and high percentage of water.

If the fuel system and storage tank have already been attacked by micro-organisms. Biocide must be dosed according to the manufacturer's specifications.

- Avoid direct exposure of the storage tank to sunlight
- Use smaller storage tanks with corresponding low dwell times of the stored fuel

### **FUEL ADDITIVES**

The use of fuel additives is not permitted. The flow improvers mentioned above are an exception. Use of unsuitable additives will result in loss of warranty.

### 3.17 GM ENGINE GENERAL MAINTENANCE

#### Drive Belt Maintenance

The serpentine drive belt utilizes a spring loaded tensioner which keeps the belt properly adjusted. The drive belt is an integral part of the cooling and charging systems and should be inspected frequently.

When inspecting belts check for:

- Cracks or breaks
- Chunking of the belt
- Splits
- Material hanging from belt
- Glazing and hardening
- Damaged or improperly aligned pulleys
- Improperly performing tensioner

Check belt tensioner by pressing down on the midway point of the longest stretch between pulleys. The belt should not depress beyond 1/2 inch (13mm). If depression is more than allowable, adjust tension.

#### **NOTICE**

**ENGINE MANUFACTURER DOES NOT RECOMMEND USE OF "BELT DRESSING" OR "ANTI SLIPPING AGENTS" ON DRIVE BELT.**

#### Engine Electrical System Maintenance

The engine electrical system incorporates computers and microprocessors to control engine ignition, fuel control, and emissions. Periodic inspection of electrical wiring is necessary due to sensitivity of computers to good electrical connections. When inspecting the electrical system use the following:

- Check and clean battery terminal connections and ensure connections are tight
- Check battery for any cracks or damage to case
- Check Positive and Negative battery cables for corrosion build up, or rubbing and chafing. Check connections on chassis are tight.
- Check entire engine wire harness for rubbing chafing, cuts or damaged connections. Repair as needed.
- Check all wire harness connectors to ensure they are fully seated and locked.
- Check ignition coil and spark plug cables for hardening, cracking, chafing, separation, split boot covers, and fit
- Replace spark plugs at the proper intervals as prescribed in the engine manufacturer's manual
- Make sure all electrical components are fitted securely.
- Check ground and platform control stations to ensure all warning indicator lights are functioning.

#### Checking/Filling Engine Oil Level

#### **NOTICE**

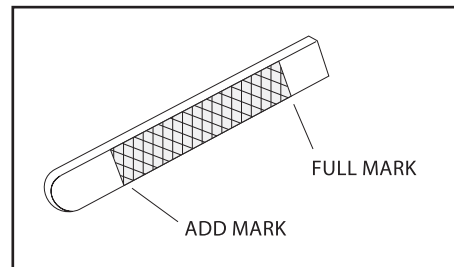
**AN OVERFILLED CRANKCASE (OIL LEVEL OVER THE SPECIFIED FULL MARK) CAN CAUSE AN OIL LEAK, FLUCTUATION OR DROP IN OIL PRESSURE, AND ROCKER ARM "CLATTER".**

#### **NOTICE**

**CARE MUST BE TAKEN WHEN CHECKING ENGINE OIL LEVEL. OIL LEVEL MUST BE MAINTAINED BETWEEN "ADD" MARK AND "FULL" MARK ON DIPSTICK.**

To ensure you are not getting a false reading, make sure the following steps are taken before checking oil level.

1. Stop engine if in use.
2. Allow sufficient time (approximately 5 minutes) for oil to drain back into oil pan.
3. Remove dipstick. Wipe with a clean cloth or paper towel and reinstall. Push dipstick all the way in dipstick tube.
4. Remove dipstick and note oil level.
5. Oil level must be between "FULL" and "ADD" marks.



**Figure 3-94. GM Engine Oil Dip Stick**

6. If oil level is below "ADD" mark, proceed to Step 7 and 8 and reinstall dipstick in dipstick tube.
7. Remove oil filter cap from valve rocker arm cover.
8. Add required amount of oil to bring level up to, but not over, "FULL" mark on dipstick.
9. Reinstall oil fill cap to valve rocker cover and wipe away any excess oil.

## Changing Engine Oil

### NOTICE

ALWAYS CHANGE OIL FILTER WHEN CHANGING OIL. CHANGE OIL WHEN ENGINE IS WARM FROM OPERATION. OILS WILL FLOW FREELY AND CARRY AWAY MORE IMPURITIES.

To change oil use the following steps:

1. Start engine and run until it reaches normal operating temperature.
2. Stop engine.
3. Remove drain plug and allow oil to drain.
4. Remove and discard oil filter and sealing ring.
5. Coat sealing ring on new filter with clean engine oil and wipe engine filter mounting surface to remove contamination. Tighten filter securely (follow filter manufacturer's instructions). Do not over tighten.
6. Check sealing ring on drain plug for damage. Replace if necessary. Pipe plug and oil pan sealing surface with a clean rag. Reinstall plug. Do not over tighten.
7. Fill crankcase with oil.
8. Start engine and check for oil leaks.
9. Stop engine and check oil level is at "FULL".
10. Dispose of oil and filter in a safe manner as required by local regulations.

## Coolant Fill Procedure - Dual Fuel Engine

### CAUTION

HOT ENGINE AND COMPONENTS CAN CAUSE SEVERE BURNS. MAKE SURE ENGINE IS COOL BEFORE PERFORMING MAINTENANCE.

### NOTICE

DAMAGE TO ENGINE CAN OCCUR IF NOT PROPERLY FILLED WITH COOLANT. LPG FUELED ENGINES ARE MOST PRONE TO CREATING AN AIR LOCK DURING A COOLANT FILL OPERATION DUE TO ELECTRONIC PRESSURE REGULATOR (EPR) BEING THE HIGHEST POINT IN THE COOLING SYSTEM. AN EPR THAT APPEARS TO HAVE FROST FORMING ON IT IS A SIGN THE ENGINE COOLING SYSTEM CONTAINS AIR. APPEARANCE AND TEMPERATURE OF THE EPR SHOULD BE MONITORED DURING COOLANT FILL OPERATION. A WARM EPR IS AN INDICATION THAT THE COOLING SYSTEM IS PROPERLY FILLED AND FUNCTIONING.

1. Loosen worm gear clamp on coolant line running to EPR as shown below. Remove hose from EPR. Place a rag under hose to prevent coolant from running onto engine/machine.



2. Remove radiator cap. Fill radiator with coolant until coolant starts to appear from previously removed hose at the EPR. Reinstall hose back on EPR and continue to fill radiator with coolant.



3. With radiator cap still removed, start engine and run until thermostat opens at 170° F (77° C), which can be checked using the JLG handheld analyzer.

### NOTICE

WHILE ENGINE IS RUNNING, AIR AND/OR STEAM MAY BE PRESENT COMING FROM THE RADIATOR. THIS IS NORMAL.

4. Run engine for five minutes after it has reached operating temperature. Shut off engine and continue to step 5.

### **⚠ CAUTION**

WITH ENGINE RUNNING OR WHEN SHUTTING OFF ENGINE, SOME HEATED COOLANT MAY SPILL OUT DUE TO AIR "BURPING" OUT OF THE SYSTEM WITH RADIATOR CAP OFF.

5. Verify the two coolant hoses on the EPR are warm. If they are not warm repeat step 3 and 4, otherwise continue to step 6.

### **NOTICE**

A PROPERLY PURGED COOLING SYSTEM WILL YIELD A WARM UPPER RADIATOR HOSE AND A WARM EPR HOSE. IF UPPER RADIATOR AND EPR HOSES ARE NOT WARM TO THE TOUCH AFTER ENGINE HAS RUN FOR 5-8 MINUTES AFTER REACHING OPERATING TEMPERATURE, THE SYSTEM MAY STILL CONTAIN AIR. IT MAY BE NECESSARY TO REPEAT ABOVE STEPS.

6. Fill radiator with coolant as needed and install radiator cap.
7. Remove coolant recovery bottle cap and fill to just below HOT FULL line. Reinstall cap.



### 3.18 GM ENGINE DUAL FUEL SYSTEM

The fuel system installed on this engine is designed to meet mobile engine emission standards applicable for 2010 and later model years. The Dual Fuel system allows the vehicle to operate on gasoline or LPG by positioning a selector switch in the operator's platform. When the operator places the selector switch in gasoline mode, the gasoline fuel pump is energized. In gasoline mode the LPG fuel lock-off is isolated and will not energize. In addition, the gasoline injector circuit is enabled and injector pulses are provided to each injector. ECM calibration for gasoline is also enabled.

When LPG mode is selected the Low Pressure LPG lock-off is energized and fuel from the LPG tank flows to the Electronic Pressure Regulator (EPR). The EPR receives an electronic signal to position the secondary lever for start or run positions. When the engine begins to crank, the mixer air valve will rise and fuel begins flowing to engine. During this mode the gasoline fuel pump is isolated and is not activated.

Primary components of the gasoline dual fuel system are the gasoline tank, electric fuel pump and filter, fuel supply line, injector rail and injectors and the fuel pressure regulator.

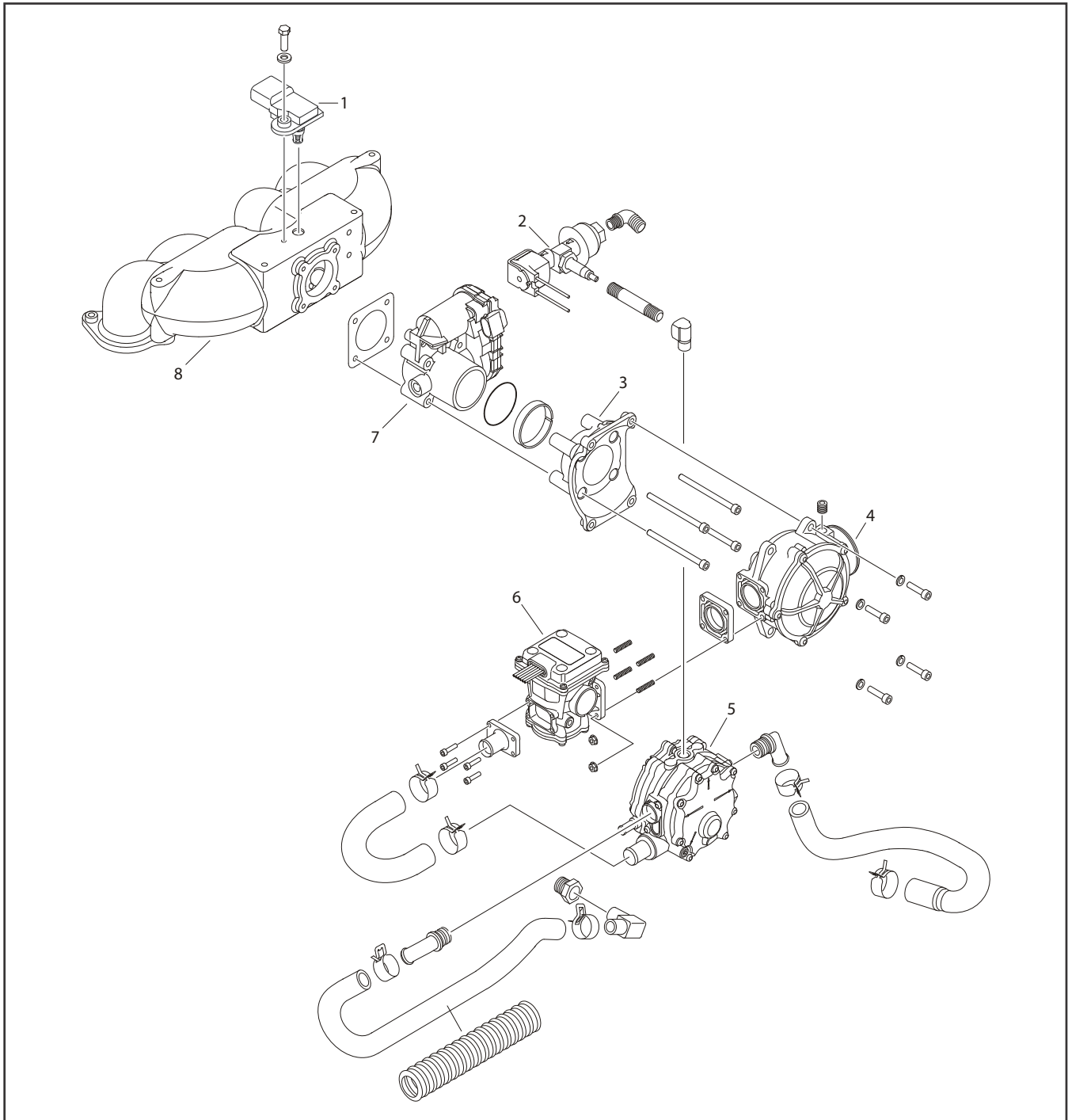
Primary components of the LPG dual fuel system are the LPG fuel tank, in-fuel filter, LPG Low Pressure lock-off, Electronic Pressure Regulator (EPR) and the fuel mixer module. The LPG fuel system operates at pressures which range from 14.0 inches (355.60 mm) of water column up to 312 psi (21.5 BAR).

Components shared by both systems include the Electronic Throttle Control and ECM. The ECM contains a dual calibration; one controls the gasoline fuel system during gasoline operation and one controls the LPG fuel system during LPG operation.

#### Fuel Filter

Propane fuel, like all other motor fuels, is subject to contamination from outside sources. Refueling and removal of the tank from the equipment can contaminate the fuel system. It is necessary to filter fuel before it enters fuel system components downstream of the tank.

An in-line fuel filter is installed in the fuel system to remove fuel contamination. The in-line filter is replaceable as a unit only. Filter maintenance is critical to proper operation of the fuel system and should be replaced as listed in Section 1. More frequent replacement of the filter may be necessary in severe operating conditions.



- |                   |            |  |                    |
|-------------------|------------|--|--------------------|
| 1. T-MAP Sensor   | 3. Mixer   | 5. Regulator                                   | 7. Throttle Body   |
| 2. Lock-Off Valve | 4. Adapter | 6. Direct Electronic Pressure Regulator (DEPR) | 8. Intake Manifold |

**Figure 3-95. GM 3.0 Dual Fuel System Components**

## Direct Electronic Pressure Regulator (DEPR)

### NOTICE

THE DEPR IS AN EMISSION CONTROL DEVICE AND SHOULD ONLY BE SERVICED BY QUALIFIED TECHNICIANS.

The ECI engine management system uses the DEPR to control fuel delivery for precise fuel metering needed for optimum combustion, fuel economy, and transient response.

The DEPR is a single-stage microprocessor based electromechanical fuel pressure regulator that incorporates a high speed/fast acting actuator. It communicates with the Engine Control Module (ECM) over a Controller Area Network (CAN) link, receiving fuel pressure commands and broadcasting DEPR operating parameters back to the ECM.

The DEPR can regulate fuel pressure from -18 to +13 inches of water column above the Mixer air inlet pressure, providing sufficient control authority to stall an engine either rich or lean.

When the DEPR receives an output pressure command from the ECM, the valve is internally driven to attain targeted fuel pressure, the DEPR then closes the loop internally using a built in fuel pressure sensor to maintain target fuel pressure/fuel flow rate, until another external command from the ECM is received (intervals < 10 ms).

The DEPR has an integral fuel temperature sensor that is used by the ECM to correct for variations in fuel density. This provides an extremely accurate method for open loop fuel control. Then with the addition of the pre- and post-cat oxygen sensors, the pressure command transmitted from the ECM can be further adjusted using closed loop feedback.

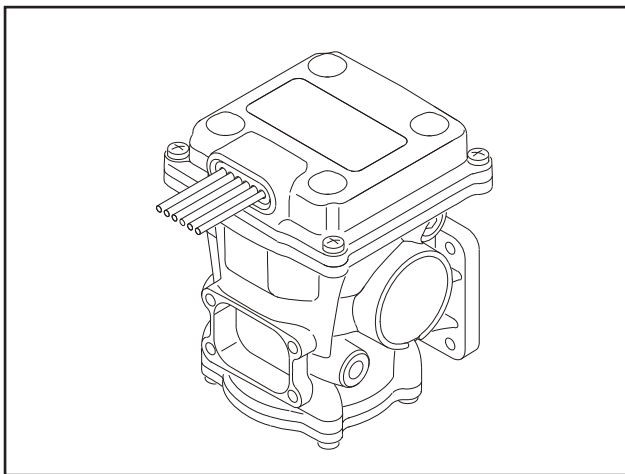


Figure 3-96. Direct Electronic Pressure Regulator

## Air Fuel Mixer

### NOTICE

THE AIR/FUEL MIXER IS AN EMISSION CONTROL DEVICE. COMPONENTS INSIDE THE MIXER ARE SPECIFICALLY CALIBRATED TO MEET THE ENGINE'S EMISSIONS REQUIREMENTS AND SHOULD NEVER BE DISASSEMBLED OR REBUILT. IF THE MIXER FAILS TO FUNCTION CORRECTLY, REPLACE WITH AN OEM REPLACEMENT PART.

The air valve mixer is a self-contained air-fuel metering device. The mixer is an air valve design, utilizing a relatively constant pressure drop to draw fuel into the mixer from cranking speeds to full load.

The mixer is mounted in the air stream ahead of the throttle control device. When the engine begins to crank it draws in air with the air valve covering the inlet, and negative pressure begins to build. This negative pressure signal is communicated to the top of the air valve chamber through vacuum ports in the air valve assembly. A pressure/force imbalance begins to build across the air valve diaphragm between the air valve vacuum chamber and the atmospheric pressure below the diaphragm.

The vacuum being created is referred to as Air Valve Vacuum (AVV). As the air valve vacuum reaches the imbalance point, the air valve begins to lift against the air valve spring. The amount of AVV generated is a direct result of throttle position. At low engine speed the air valve vacuum and the air valve position is low, creating a small venturi for the fuel to flow. As engine speed increases, AVV increases and the air valve is lifted higher creating a much larger venturi. Air valve vacuum is communicated from the mixer venturi to the IEPV via the fuel supply hose.

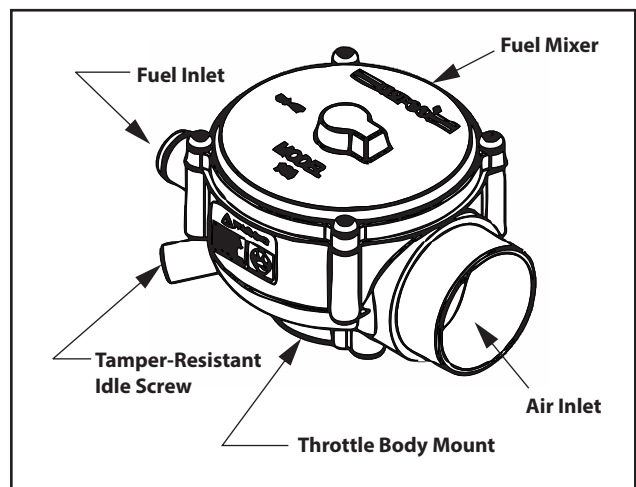


Figure 3-97. Air Fuel Mixer

### Electronic Throttle Control (ETC)

The Electronic Throttle Control device or "Throttle Body Assembly" is connected to the intake manifold of the engine. The electronic throttle control device utilizes an electric motor connected to the throttle shaft.

When the engine is running, electrical signals are sent from equipment controls to the engine ECM. The ECM then sends an electrical signal to the motor on the electronic throttle control to increase or decrease the angle of the throttle blade thus increasing or decreasing the air/fuel flow to the engine.

Two internal Throttle Position Sensors (TPS) provide throttle shaft and blade position output signals to the ECM. TPS information is used by the ECM to correct speed and load control, as well as emission control.

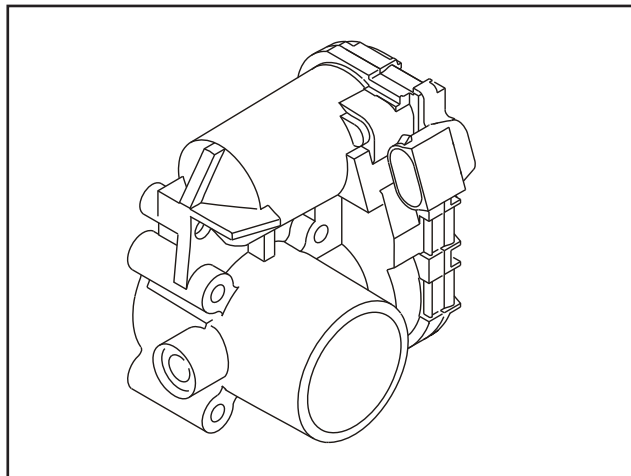


Figure 3-98. Electronic Throttle Control Device

### Electric Lock Off

The Electric Lock Off device is an integrated assembly consisting of a 12 volt solenoid and normally closed valve. When energized, the solenoid opens the valve and allows propane fuel to flow through the device. The valve opens during engine cranking and run cycles. Lock Off supply voltage is controlled by the Engine Control Module (ECM).

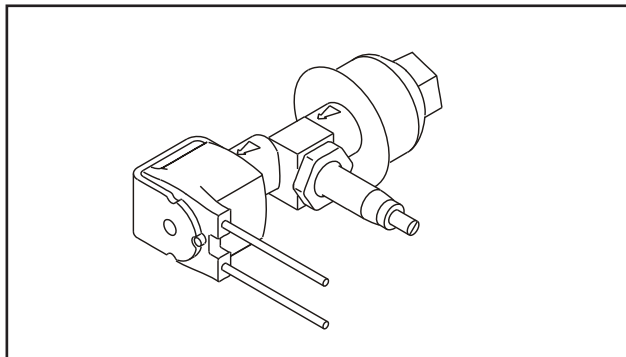


Figure 3-99. Electric Lock Off Assembly

### Engine Control Module (ECM)

**NOTE:** The ECM may also be referred to as the Engine Control Unit (ECU) in some applications.

To obtain maximum effect from the catalyst and accurate control of air fuel ratio, the emission certified engine is equipped with an onboard computer or Engine Control Module (ECM). The ECM is a 32 bit controller which receives input data from sensors fitted to the engine and fuel system and then outputs various signals to control engine operation.

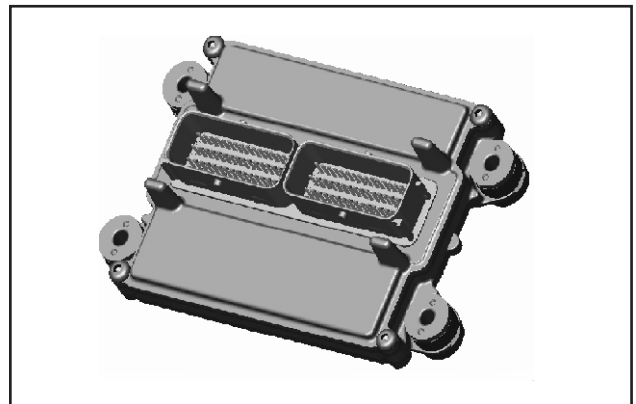


Figure 3-100. ECM Assembly

One specific function of the controller is to maintain "closed loop fuel control". Closed loop fuel control is accomplished when the exhaust gas oxygen sensor (HEGO) mounted in the exhaust system sends a voltage signal to the controller. The controller calculates corrections for the air fuel ratio, and outputs signals to the DEPR to correct the amount of fuel supplied to the mixer. At the same time the ECM may correct throttle blade position to correct engine speed and load.

The controller also performs fuel system diagnostic functions and notifies the operator of malfunctions by turning on a Malfunction Indicator Light (MIL) mounted in the Ground Control Station and Platform Control Station. System malfunctions are identified by a Diagnostic Code number. In addition to notifying the operator of the system malfunction, the controller also stores information about the malfunction in its memory.

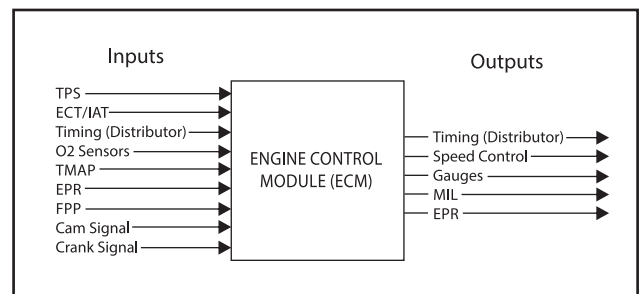


Figure 3-101. ECM Input-Output Diagram

### Heated Exhaust Gas Oxygen Sensor

There are two Heated Exhaust Gas Oxygen Sensors (HEGO). The first HEGO is mounted in the exhaust system downstream of the engine. It is used to measure the amount of oxygen present in the exhaust stream and communicate that to the ECM via an electrical signal. The amount of oxygen present in the exhaust stream indicates whether the fuel/air ratio is too rich or too lean. If the HEGO sensor signal indicates exhaust stream is too rich, the ECM will decrease or lean the fuel mixture during engine operation. If mixture is too lean the ECM will richen the mixture. The ECM continuously monitors the HEGO sensor output. If a rich or lean condition is present for an extended period of time, and the ECM cannot correct the condition, the ECM sets a diagnostic code and turns on the MIL light in control box.

The second HEGO is mounted in the exhaust system after the muffler. It measures the amount of oxygen in the exhaust system after the catalyst treatment has been completed in the muffler. If the ECM detects that the catalytic action in the muffler is not sufficient and fuel correction cannot correct the malfunction the MIL light is illuminated in the control box and a DTC code will stored in the computer.

**NOTICE**

**THE HEATED EXHAUST GAS OXYGEN SENSOR IS AN EMISSION CONTROL DEVICE. IF THE HEGO FAILS TO OPERATE, REPLACE IT WITH AN OEM REPLACEMENT PART. THE HEGO SENSOR IS SENSITIVE TO SILICONE OR SILICONE BASED PRODUCTS AND CAN BECOME CONTAMINATED. AVOID USING SILICONE SEALERS OR HOSES TREATED WITH SILICONE LUBRICANTS IN THE AIR STREAM OR FUEL LINES.**



Figure 3-102. Heated Exhaust Gas Oxygen Sensor

### Gasoline Multi Point Fuel Injection System (MPFI)

The primary components of the Gasoline Multi Point Fuel Injection (MPFI) fuel system are the fuel tank, electric fuel pump, fuel pressure and temperature sensor manifold, fuel filter, and fuel rail.

### Gasoline Fuel Pump

Gasoline is stored as a liquid in the fuel tank and is drawn into the fuel system by an electric fuel pump. The fuel pump receives a signal from the ECM to prime the fuel system for approximately two seconds before start. Priming the fuel system provides for a quicker start when engine begins to crank.

### Gasoline Pressure And Temperature Sensor Manifold

This engine is equipped with a fuel injector rail that does not have a pressure regulator or a return circuit to the fuel tank. Fuel pressure for this engine is regulated by the engine's ECM. The ECM receive fuel pressure and temperature feedback from the gasoline fuel sensor manifold and uses this information to control the ground side of the fuel pump. Fuel pressure is regulated by the ECM pulse width modulating (PWM) the fuel pump. The fuel pressure and temperature sensor manifold has a return or "bleed" circuit that connects back to the fuel tank. This circuit is used to bleed off any vapor that develops in the line and return a small amount of fuel to the tank.

Fuel comes from the fuel tank and passes through the fuel pump. Fuel exits the fuel pump, passes through the filter and then enters the fuel pressure and temperature manifold assembly. Fuel flows through the feed circuit and is delivered to the fuel injector rail. Fuel that enters the bleed circuits through the bypass valve in the manifold is returned to the fuel tank.

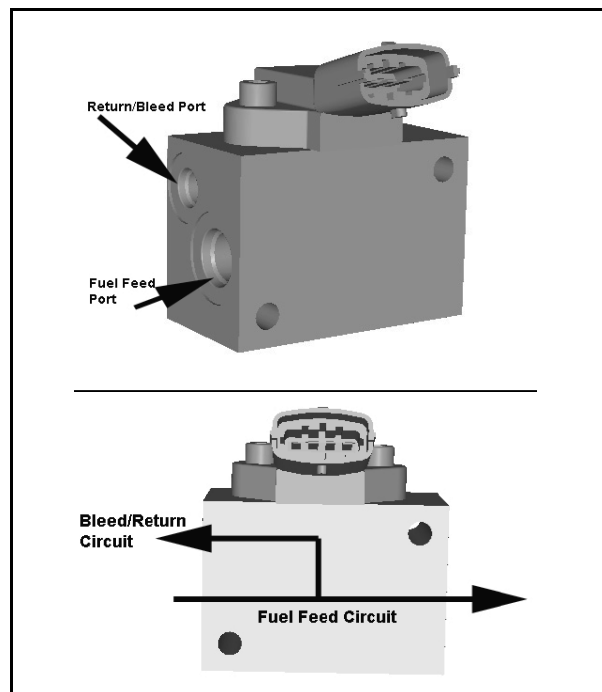


Figure 3-103. Gasoline Fuel Pressure and Temperature Manifold Assembly



## Fuel Filter

After fuel is drawn into the fuel pump, the fuel flows through the gasoline fuel filter. The fuel filter traps small particles as fuel passes through the filter to remove debris and prevents fuel pressure and temperature manifold and fuel injectors from becoming damaged. Fuel filter maintenance is required as shown in Section 1.

## Fuel Injector Rail

Fuel flows from the fuel pressure and temperature manifold assembly to the fuel rails where fuel is delivered to the fuel injectors. The fuel rail also contains a Schrader valve which is used to test regulated pressure of the fuel system.

## Fuel Injector

The fuel supply is maintained on the top of the injector from the injector rail. The injector is fed a "pulse" signal through the wire harness which causes the injector to open. During regular operating conditions the ECM controls the opening and duration of opening of the injector. During lower RPM operation the injector signals or "pulses" are less frequent than when the engine is operating at higher RPMs. The engine has been calibrated to deliver the precise amount of fuel for optimum performance and emission control.

## 3.19 GM ENGINE FUEL SYSTEM REPAIR

### Propane Fuel System Pressure Relief

#### **⚠ CAUTION**

**THE PROPANE FUEL SYSTEM OPERATES AT PRESSURES UP TO 312 PSI (21.5 BAR). TO MINIMIZE THE RISK OF FIRE AND PERSONAL INJURY, RELIEVE THE PROPANE FUEL SYSTEM PRESSURE (WHERE APPLICABLE) BEFORE SERVICING THE PROPANE FUEL SYSTEM COMPONENTS.**

To relieve propane fuel system pressure:

1. Close manual shut-off valve on propane fuel tank.
2. Start and run vehicle until engine stalls.
3. Turn ignition switch OFF.

#### **NOTICE**

**RESIDUAL VAPOR PRESSURE WILL BE PRESENT IN THE FUEL SYSTEM. ENSURE WORK AREA IS WELL VENTILATED BEFORE DISCONNECTING ANY FUEL LINE.**

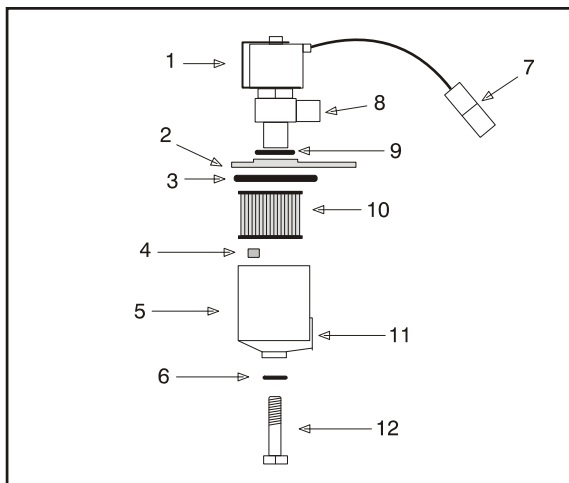
### Propane Fuel System Leak Test

#### **⚠ CAUTION**

**PROPANE IS HIGHLY FLAMMABLE AND CAN EASILY IGNITE AND CAUSE BURNS AND SERIOUS INJURIES. NEVER USE AN OPEN FLAME OF ANY TYPE TO CHECK FOR PROPANE FUEL SYSTEM LEAKS.**

Always inspect propane fuel system for leaks after performing service. Check for leaks at fittings of the serviced or replaced component. Use a commercially available liquid leak detector or an electronic leak detector. When using both methods, use electronic leak detector first to avoid contamination by liquid leak detector.

## Propane Fuel Filter Replacement



- |                               |                         |
|-------------------------------|-------------------------|
| 1. Electric Lock Off Solenoid | 7. Electrical Connector |
| 2. Mounting Plate             | 8. Fuel Outlet          |
| 3. Housing Seal               | 9. O-ring               |
| 4. Filter Magnet              | 10. Filter              |
| 5. Filter Housing             | 11. Fuel Inlet          |
| 6. Seal                       | 12. Retaining Bolt      |

Figure 3-104. Filter Lock Assembly

### REMOVAL

1. Relieve propane fuel system pressure. Refer to Propane Fuel System Pressure Relief.
2. Disconnect the negative battery cable.
3. Slowly loosen the filter housing retaining bolt and remove it.
4. Pull filter housing from electric lock off assembly.
5. Locate and remove filter magnet.
6. Remove the filter from housing.
7. Remove and discard housing seal.
8. Remove and discard retaining bolt seal.
9. Remove and discard mounting plate to lock off O-ring seal.

### INSTALLATION

#### NOTICE

REINSTALL FILTER MAGNET IN HOUSING BEFORE INSTALLING NEW SEAL.

1. Install mounting plate to lock off O-ring seal.
2. Install retaining bolt seal.
3. Install housing seal.
4. Drop magnet in bottom of filter housing.
5. Install filter in housing.
6. Install retaining bolt in filter housing.
7. Install filter up to bottom of electric lock off.
8. Tighten filter retaining bolt to 106 in-lb (12 Nm).
9. Open manual shut-off valve. Start vehicle and leak check propane fuel system at each serviced fitting. Refer to Propane Fuel System Leak Test.

## Direct Electronic Pressure Regulator (DEPR) Maintenance And Inspection

Refer to Figure 3-95. GM 3.0 Dual Fuel System Components.

#### NOTICE

DEPR COMPONENTS ARE SPECIFICALLY DESIGNED AND CALIBRATED TO MEET FUEL SYSTEM REQUIREMENTS OF THE EMISSION CERTIFIED ENGINE. IF THE DEPR FAILS TO OPERATE OR DEVELOPS A LEAK, IT SHOULD BE REPAIRED OR REPLACED WITH OEM RECOMMENDED REPLACEMENT PARTS.

1. Check for any fuel leaks at inlet and outlet fittings.
2. Check for any fuel leaks in DEPR body.
3. Check inlet and outlet fittings of coolant supply lines for water leaks if applicable.
4. Check DEPR is securely mounted and mounting bolts are tight.
5. Check DEPR for external damage.
6. Check DEPR electrical connections are seated and locked.

## Check/Drain Oil Build-Up In 2-Stage Vaporizer

Refer to Figure 3-95. GM 3.0 Dual Fuel System Components.

During normal operation for LPG engines oil or "heavy ends" may build inside the Vaporizer secondary chamber. These oil and heavy ends may be a result of poor fuel quality, fuel contamination, or regional variation of the fuel make up. A significant build up of oil can affect performance of the secondary diaphragm response.

### NOTICE

**FAILURE TO FOLLOW THIS RECOMMENDATION MAY BE USED TO DENY A WARRANTY CLAIM.**

Drain oil periodically to maintain emission warranty. More frequent draining of the Vaporizer Regulator is recommended where substandard fuel may be a problem. Drain Vaporizer Regulator at every engine oil change if contaminated or substandard fuel is suspected or known to be have been used with the emission compliant fuel system.

**NOTE:** *Draining regulator when engine is warm will help oils to flow freely from the regulator.*

1. Move equipment well ventilated area and ensure no external ignition sources are present.
2. Start engine.
3. With engine running, close manual valve.
4. When engine runs out of fuel and stops, turn key OFF.
5. Disconnect negative battery cable.

### ⚠ CAUTION

**A SMALL AMOUNT OF FUEL MAY STILL BE PRESENT IN THE FUEL LINE. USE GLOVES TO PREVENT BURNS AND WEAR PROPER EYE PROTECTION.**

**NOTE:** *If fuel continues to flow from connections when loosened, check manual valve is fully closed.*

6. Loosen hose clamps at inlet and outlet hoses. Remove hoses.
7. Remove regulator mounting bolts.
8. Place a small receptacle in the engine compartment.
9. Rotate regulator to 90° so outlet fitting is pointing down into receptacle. Drain regulator.
10. Inspect secondary chamber for any large dried particles and remove.
11. Remove receptacle and reinstall regulator retaining bolts. Torque to specifications.
12. Reinstall fuel hoses. Reconnect any other hoses removed during this procedure.
13. Slowly open manual service valve.

### NOTICE

**FUEL CYLINDER MANUAL VALVE CONTAINS AN "EXCESS FLOW CHECK VALVE". OPEN MANUAL VALVE SLOWLY TO PREVENT ACTIVATING THE "EXCESS FLOW CHECK VALVE."**

14. Check for leaks at the inlet and outlet fittings using a soapy solution or an electronic leak detector.
15. Check coolant line connections for leaks.
16. Start engine. Recheck regulator for leaks.
17. Dispose of any drained material in safe and proper manner according to applicable regulations.

## Air Fuel Mixer/Throttle Control Device Maintenance And Inspection

Refer to Figure 3-95. GM 3.0 Dual Fuel System Components.

### NOTICE

**AIR FUEL MIXER COMPONENTS HAVE BEEN SPECIFICALLY DESIGNED AND CALIBRATED TO MEET FUEL SYSTEM REQUIREMENTS OF THE EMISSION CERTIFIED ENGINE. THE MIXER SHOULD NOT BE DISASSEMBLED OR REBUILT. IF MIXER FAILS TO OPERATE OR DEVELOPS A LEAK, IT SHOULD BE REPLACED WITH OEM RECOMMENDED REPLACEMENT PARTS.**

1. Check for leaks at the inlet fitting.
2. Inspect fuel inlet hose for cracking, splitting, or chaffing. Replace if any of these condition exist.
3. Ensure mixer is securely mounted and not leaking vacuum at the mounting gasket or surface.
4. Inspect air inlet hose connection and clamp. Inspect inlet hose for cracking, splitting, or chafing. Replace if any of these conditions exist.
5. Inspect air cleaner element.
6. Check fuel lines for cracking, splitting, or chafing. Replace if any of these conditions exist.
7. Check for leaks at the throttle body and intake manifold.

### Exhaust System And Catalytic Converter Inspection And Maintenance

#### NOTICE

EXHAUST SYSTEM ON THIS EMISSION CERTIFIED ENGINE CONTAINS A HEATED EXHAUST GAS OXYGEN SENSOR (HEGO) WHICH PROVIDES FEEDBACK TO THE ECM ON AMOUNT OF OXYGEN PRESENT IN THE EXHAUST STREAM AFTER COMBUSTION. OXYGEN IN THE EXHAUST STREAM IS MEASURED IN VOLTAGE AND SENT TO THE ECM. THE ECM THEN MAKES CORRECTIONS TO THE FUEL AIR RATIO TO ENSURE PROPER FUEL CHARGE AND OPTIMUM CATALYTIC PERFORMANCE. EXHAUST CONNECTIONS MUST REMAIN SECURE AND AIR TIGHT.

#### NOTICE

THE HEGO SENSOR IS SENSITIVE TO SILICONE BASED PRODUCTS. DO NOT USE SILICONE SPRAYS OR HOSES WHICH ARE ASSEMBLED USING SILICONE LUBRICANTS. SILICONE CONTAMINATION CAN CAUSE SEVERE DAMAGE TO THE HEGO.

1. Check exhaust manifold at cylinder head for leaks and all retaining bolts and shields (if used) are in place.
2. Check manifold to exhaust pipe fasteners are tight and there are no exhaust leaks. Repair if necessary.
3. Inspect HEGO electrical connector is seated and locked. Check wires for cracking, splits, chafing or "burn through." Repair if necessary.
4. Check exhaust pipe extension connector for leaks. Tighten if necessary.
5. Check catalyst muffler is securely mounted. Check for leaks at inlet and outlet.

### Temperature Manifold Absolute Pressure (TMAP) Sensor

Refer to Figure 3-95. GM 3.0 Dual Fuel System Components.

#### REMOVAL

1. Disconnect TMAP (402) electrical connector.
2. Remove retaining bolt (403), washer (404), and TMAP (402).

#### INSTALLATION

**NOTE:** Apply a small amount of O-ring lubricant before installation.

1. Install TMAP (402). Secure with washer (404) and bolt (403).
2. Torque retaining bolt to 62 in-lb (7 Nm).
3. Start vehicle and check for proper operation.

### Throttle Body (ETC) Replacement

Refer to Figure 3-95. GM 3.0 Dual Fuel System Components.

#### REMOVAL

1. Disconnect negative battery cable.
2. Remove Mixer (See "Mixer Replacement" on page 88).
3. Disconnect TMAP electrical connector.
4. Disconnect electronic throttle control connector.
5. Remove bolts (208), adapter (204), and throttle body (201) from manifold.
6. Remove spacer (205).
7. Remove and discard gasket (202) and O-ring (203).

#### INSTALLATION

**NOTE:** Lightly lubricate O-ring.

1. Install O-ring (203) and spacer (205) on throttle body (201).
2. Align new gasket (202) and throttle body on manifold.
3. Slide adapter (204) on throttle body and secure with four bolts (208).
4. Reinstall Mixer (See "Mixer Replacement" on page 88).

### Mixer Replacement

Refer to Figure 3-95. GM 3.0 Dual Fuel System Components.

#### REMOVAL

1. Remove EPR. (See Electronic Pressure Regulator Replacement on next page).
2. Remove Air Intake hose from Mixer.
3. Remove four bolts (206) and washers (207) securing mixer (104) to adapter (204). Remove Mixer.

#### INSTALLATION

#### NOTICE

**COVER THROTTLE BODY ADAPTER OPENING TO PREVENT DEBRIS FROM ENTERING ENGINE.**

1. Install Mixer (104) to Adapter (204). Secure with four washers (207) and bolts (206). Torque to 80 in-lb (9 Nm)
2. Install EPR (See Electronic Pressure Regulator Replacement on next page).
3. Reinstall Air Intake Hose.
4. Start engine and leak check all fittings and connections.

## Electronic Pressure Regulator (EPR) Replacement

### REMOVAL

Refer to Figure 3-95. GM 3.0 Dual Fuel System Components.

1. Unplug EPR (102) electrical connector.
2. Remove hoses from EPR.
3. Remove four flange nuts (107) and EPR from Mixer (104).
4. If new EPR is being installed, remove and retain hose adapter (103) and four bolts (105).

### INSTALLATION

1. If new EPR is being installed, install adapter (103) and four bolts (105) to EPR.
2. Install EPR (102) on Mixer (104). Secure with four flange nuts (107).
3. Reattach all hoses.
4. Start engine and leak check all fittings and connections.

## Regulator Replacement

Refer to Figure 3-95. GM 3.0 Dual Fuel System Components.

### REMOVAL

1. Disconnect and remove Lock-Off Valve (12) from Regulator (16).
2. Remove hoses from regulator.
3. Remove regulator from engine.

### INSTALLATION

1. Install Regulator (16) on engine.
2. Install hoses on regulator.
3. Install Lock-Off Valve (12) to Regulator. Reconnect Lock-Off Valve.
4. Start engine and leak check all fittings and connections.

## Coolant Hose Replacement

### REMOVAL

1. Drain coolant.
2. Using hose clamp pliers, disconnect both hose clamps on each hose.
3. Remove hose from fittings.

### INSTALLATION

**NOTE:** Use hose material and lengths specified by JLG.

1. Install hose clamps to each hose and set clamp back on each hose to make installation easier.
2. Fit hose to fittings.
3. Secure by positioning each of the clamps.

## Vapor Hose Replacement

### REMOVAL

1. Disconnect both hose clamps using hose clamp pliers.
2. Remove vapor hose from each fitting.

### INSTALLATION

#### **NOTICE**

**VAPOR SUPPLY HOSE IS SPECIFICALLY DESIGNED FOR THIS EQUIPMENT. DO NOT USE HOSE MATERIAL OR LENGTH OTHER THAN JLG SPECIFIED PARTS.**

1. Install hose clamps and set back on each hose.
2. Reinstall vapor hose to each fitting.
3. Reset clamps.
4. Start engine and check for leaks.

### Engine Control Module Replacement

#### REMOVAL

1. Disconnect Negative battery cable.
2. Remove controller from mounting bracket.
3. Push connector lock back to unlock connector.
4. Unplug and remove controller.

#### INSTALLATION

#### **NOTICE**

**CONTROLLER IS CALIBRATED FOR EACH ENGINE. VERIFY YOU HAVE CORRECT CONTROLLER.**

1. Plug connector into controller.
2. Push lock into place.
3. Mount controller into mounting bracket.
4. Reconnect the battery cable.
5. Start engine.
6. Check and clear any DTC codes.
7. Verify engine is in closed loop and no warning lights are illuminated.

### Heated Exhaust Gas Oxygen Sensor Replacement

#### REMOVAL

1. Disconnect negative (-) battery cable.
2. Disconnect O2 sensor electrical connector.
3. Using an O2 Sensor socket, remove and discard Sensor.

#### INSTALLATION

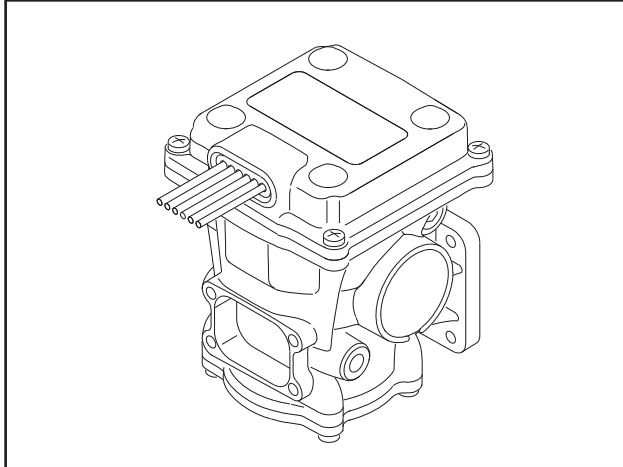
#### **NOTICE**

**LUBRICATE O2 SENSOR THREADS WITH ANTI-SEIZE COMPOUND GM P/N 5613695 OR EQUIVALENT BEFORE INSTALLATION. DO NOT GET COMPOUND ON SENSOR TIP.**

1. Install O2 sensor. Tighten to 30 lb-ft (41 Nm).
2. Start engine.
3. Check and clear any DTC codes.
4. Verify engine is in closed loop and no warning lights are illuminated.

## 3.20 GM ENGINE LPG FUEL SYSTEM DIAGNOSIS

### Fuel System Description



**Figure 3-105. DEPR**

The Engine Control Module (ECM) receives information from various engine sensors to control the Direct Electronic Pressure Regulator (DEPR) and lock-off Valve.

The lock-off Valve solenoid prevents fuel flow unless the engine is cranking or running.

At Key ON, the DEPR valve receives a two (2) second prime pulse from the ECM, allowing time for the fuel to flow through the fuel filter and fuel lines to the DEPR.

Fuel travels from the lock-off to the light duty 2- stage regulator into the DEPR.

Engine cranking generates vacuum which provided lift for the mixer air valve and is commonly referred to as air valve vacuum. Once in the mixer, fuel is combined with air and drawn into the engine for combustion.

### Diagnostic Aids

This procedure is intended to diagnose a vehicle operating on LPG. If vehicle will not continue to run on LPG, refer to Hard Start for preliminary checks.

**NOTE:** Before proceeding with this procedure, verify vehicle has a sufficient quantity of fuel and that liquid fuel is being delivered to the LPR. Ensure the LPG tank manual shut off valve is fully opened and excess flow valve has not been activated.

#### Tools Required:

- 7/16 Open end wrench (for test port plugs)
- DVOM (GM J 39200, Fluke 88 or equivalent).
- 12 volt test light

#### Diagnostic Scan Tool

- Diagnostic Display tool.

#### Pressure Gauges

- IMPCO ITK-2 Test kit
- Water Column Gauge / Manometer (GM 7333-6 or equivalent).
- 0-10 PSI Gauge

#### Test Description

Numbers below refer to step numbers on the diagnostic table.

5. This step determines if the LPR requires replacement
6. This step determines if the problems are in the mechanical side of the Pressure Regulator or the Electronic Voice Coil
10. This step determines if the Mixer requires replacement
14. This step determines if the Lock Off requires replacement
17. This step determines if the Fuel Filter requires replacement.

## SECTION 3 - CHASSIS & TURNTABLE

**Table 3-11. LP Fuel System Diagnosis**

STEP	ACTION	VALUE(S)	YES	NO
1	Were you referred to this procedure by a DTC diagnostic chart?	--	Go to Step 3	Go to Step 2
2	Perform the On Board Diagnostic (OBD) System Check. Are any DTCs present in the ECM?	--	Go to the applicable DTC Table	Go to Step 3
3	Verify that the LPG fuel tank has a minimum of 1/4 tank of fuel, that the manual valve is open and the tank quick connect is fully engaged Does the vehicle have fuel?	--	Go to Step 4	--
4	1. Connect a water column gauge or a manometer to the secondary test port of the low pressure regulator (LPR). 2. Start the engine and allow it to reach operating temperature. Does the engine start and run?	--	Go to Step 5	Go to Step 8
5	With the engine idling, observe the pressure reading for the LPR secondary pressure. Does the fuel pressure fluctuate rhythmically OUTSIDE the specified range?	-1.0" to -2.0" w.c	Go to Step 25	Go to Step 6
6	1. Disconnect the LPR electrical connectors. NOTE: This action will cause a DTC to be set by the ECM 2. With the engine idling observe the pressure reading on the secondary test port. Is the fuel pressure WITHIN the specified range?	-1.0" to -2.0" w.c	Go to Fuel Control System Diagnosis	Go to Step 7
7	1. Inspect the air intake stream between the mixer assembly and the throttle body for leaks. 2. Inspect the fuel hose connection between the LPR and mixer assembly for damage or leakage. 3. Inspect any vacuum hoses for leaks Was a problem found and corrected?	--	Go to Step 26	Go to Step 22
8	1. Connect a water column gauge or a manometer to the secondary test port of the low pressure regulator (LPR). 2. Crank the engine and observe the pressure reading for the LPR secondary pressure. Does the fuel pressure indicate a vacuum is present?	--	Go to Step 12	Go to Step 9
9	1. Remove Air induction hose to the mixer 2. Observe the air valve for movement while the engine is cranking. Note: Movement of the air valve will be minimal at cranking speeds. Does the air valve move when the engine is cranked?	--	Go to Step 11	Go to Step 10
10	1. Inspect the air intake stream to the mixer assembly and the throttle body for vacuum leaks. 2. Inspect the vacuum hoses from the mixer for proper connection and condition. Was a problem found and repaired?	--	Go to Step 26	Go to Step 24
11	Inspect the fuel hose connection between the LPR and the mixer assembly for damage or leakage. Was a problem found and repaired?	--	Go to Step 26	Go to Step 12
12	1. Connect a 0-10 psi gauge to the primary test port of the low pressure regulator (LPR). 2. Crank the engine and observe the pressure reading for the LPR primary pressure. Is the fuel pressure ABOVE the specified value?	1-3 PSI	Go to Step 22	Go to Step 13
13	1. Turn OFF the ignition. 2. Disconnect the LPL connector. 3. Install a test light between the pins of the LPL connector. 4. Crank the engine. The test light should illuminate. Does the test light illuminate?	--	Go to Step 14	Go to Step 16
14	Using a DVOM, check the resistance of the low pressure lock-off (LPL). Is the resistance within the specified range?	12W - 16W	Go to Step 15	Go to Step 23



Table 3-11. LP Fuel System Diagnosis

STEP	ACTION	VALUE(S)	YES	NO
15	1. Turn the ignition OFF. 2. Close the manual shut-off valve on the LPG tank. CAUTION: When disconnecting LPG fuel lines, liquid LPG may be present. Perform this step in a well ventilated area. 3. Loosen the fuel inlet hose fitting at the inlet of the LPL. Was fuel present when the fitting was loosened?	--	Go to Step 23	Go to Step 17
16	1. Turn OFF the ignition. 2. Connect the test light to chassis ground and probe pin A of the LPL connector. 3. Crank the engine. The test light should illuminate. Does the test light illuminate?	--	Go to Step 20	Go to Step 21
17	1. Remove the LPG fuel filter /LPL. 2. Remove the filter from the LPL. 3. Empty the contents of the inlet side of the LPG fuel filter onto a clean surface. 4. Inspect the contents of the LPG fuel filter for an excessive amount of foreign material or water. If necessary, locate and repair the source of contamination. 5. Verify the LPG fuel filter is not restricted or plugged. Was a problem found?	--	Go to Step 19	Go to Step 18
18	The fuel supply system or hoses are plugged or restricted, locate and repair the problem. Is the action complete?	--	Go to Step 26	--
19	Replace the fuel filter. Refer to Fuel Filter Replacement. Is the action complete?	--	Go to Step 26	--
20	Repair the open in the lock-off ground circuit. Is the action complete?	--	Go to Step 26	--
21	Repair the open in the lock-off power circuit. Is the action complete?	--	Go to Step 26	--
22	Replace the low pressure regulator (LPR). Refer to Low Pressure Regulator Replacement. Is the action complete?	--	Go to Step 26	--
23	Replace the lock-off. Refer to Lock-off Replacement. Is the action complete?	--	Go to Step 26	--
24	Replace the mixer assembly. Refer to Fuel Mixer Replacement. Is the action complete?	--	Go to Step 26	--
25	The fuel supply system is operating normally, if a failure of the control solenoids is suspected. Refer to Fuel Control System Diagnosis.  1. Install the test plug in the LPR secondary chamber. 2. If you were sent to this routine by another diagnostic chart, return to the previous diagnostic procedure. Is the action complete?	--	System OK	--
26	1. Disconnect all test equipment 2. Install the primary and secondary test port plugs. 3. Start the engine. 4. Using SNOOP or equivalent, leak check the test port plugs. Is the action complete?	--	System OK	--

## SECTION 3 - CHASSIS & TURNTABLE

**Table 3-12. Symptom Diagnosis**

Checks	Action
<b>Important Preliminary Checks</b>	
Before Using This Section	<p>Before using this section, you should have performed On Board Diagnostic Check and determined that:</p> <ol style="list-style-type: none"> <li>1. The Control Module and MIL (Malfunction Indicator Lamp) are operating correctly.</li> <li>2. There are no Diagnostic Trouble Codes (DTCs) stored, or a DTC exists but without a MIL.</li> </ol> <p>Several of the following symptom procedures call for a careful visual and physical check. The visual and physical checks are very important. The checks can lead to correcting a problem without further checks that may save valuable time.</p>
LPG Fuel System Check	<ol style="list-style-type: none"> <li>1. Verify the customer complaint.</li> <li>2. Locate the correct symptom table.</li> <li>3. Check the items indicated under that symptom.</li> <li>4. Operate the vehicle under the conditions the symptom occurs. Verify HEGO switching between lean and rich.</li> </ol> <p><b>IMPORTANT! Normal HEGO switching indicates the LPG fuel system is in closed loop and operating correctly at that time.</b></p>
Visual and Physical Checks	<ol style="list-style-type: none"> <li><sup>2</sup> Check all ECM system fuses and circuit breakers.</li> <li><sup>2</sup> Check the ECM ground for being clean, tight and in its proper location.</li> <li><sup>2</sup> Check the vacuum hoses for splits, kinks and proper connections.</li> <li><sup>2</sup> Check thoroughly for any type of leak or restriction.</li> <li><sup>2</sup> Check for air leaks at all the mounting areas of the intake manifold sealing surfaces.</li> <li><sup>2</sup> Check for proper installation of the mixer module assembly.</li> <li><sup>2</sup> Check for air leaks at the mixer assembly.</li> <li><sup>2</sup> Check the ignition wires for the following conditions: <ul style="list-style-type: none"> <li>- Cracking</li> <li>- Hardness</li> <li>- Proper routing</li> <li>- Carbon tracking</li> </ul> </li> <li><sup>2</sup> Check the wiring for the following items: <ul style="list-style-type: none"> <li>- Proper connections, pinches or cuts.</li> </ul> </li> <li><sup>2</sup> The following symptom tables contain groups of possible causes for each symptom. The order of these procedures is not important. If the scan tool readings do not indicate the problems, then proceed in a logical order, easiest to check or most likely to cause first.</li> </ol>
<b>Intermittent</b>	
DEFINITION: The problem may or may not turn ON the Malfunction Indicator Lamp (MIL) or store a Diagnostic Trouble Code (DTC).	
Preliminary Checks	<ol style="list-style-type: none"> <li><sup>2</sup> Refer to Important Preliminary Checks.</li> <li><sup>2</sup> Do not use the DTC tables. If a fault is an intermittent, the use of the DTC tables may result in the replacement of good parts.</li> </ol>
Faulty Electrical Connections or Wiring	<ol style="list-style-type: none"> <li><sup>2</sup> Faulty electrical connections or wiring can cause most intermittent problems.</li> <li><sup>2</sup> Check the suspected circuit for the following conditions: <ul style="list-style-type: none"> <li>- Faulty fuse or circuit breaker</li> <li>- Connectors poorly mated</li> <li>- Terminals not fully seated in the connector (backed out)</li> <li>- Terminals not properly formed or damaged</li> <li>- Terminal to wires poorly connected</li> <li>- Terminal tension insufficient.</li> </ul> </li> <li><sup>2</sup> Carefully remove all the connector terminals in the problem circuit in order to ensure the proper contact tension. If necessary, replace all the connector terminals in the problem circuit in order to ensure the proper contact tension.</li> <li><sup>2</sup> Checking for poor terminal to wire connections requires removing the terminal from the connector body.</li> </ol>
Operational Test	If a visual and physical check does not locate the cause of the problem, drive the vehicle with a scan tool. When the problem occurs, an abnormal voltage or scan reading indicates the problem may be in that circuit.

Table 3-12. Symptom Diagnosis

Checks	Action
Intermittent Malfunction Indicator Lamp (MIL)	The following components can cause intermittent MIL and no DTC(s): <sup>2</sup> A defective relay, Control Module driven solenoid, or a switch that can cause electrical system interference. Normally, the problem will occur when the faulty component is operating. <sup>2</sup> The improper installation of electrical devices, such as lights, 2-way radios, electric motors, etc. <sup>2</sup> The ignition secondary voltage shorted to a ground. <sup>2</sup> The Malfunction Indicator Lamp (MIL) circuit or the Diagnostic Test Terminal intermittently shorted to ground. <sup>2</sup> The Control Module grounds.
Loss of DTC Memory	To check for the loss of the DTC Memory: 1. Disconnect the TMAP sensor. 2. Idle the engine until the Malfunction Indicator Lamp illuminates.  The ECM should store a TMAP DTC. The TMAP DTC should remain in the memory when the ignition is turned OFF. If the TMAP DTC does not store and remain, the ECM is faulty
Additional Checks	
No Start	
DEFINITION: The engine cranks OK <sup>22</sup> but does not start.	
Preliminary Checks	Refer to Important Preliminary Checks.
Control Module Checks	If a scan tool is available: <sup>2</sup> Check for proper communication with both the ECM <sup>2</sup> Check the fuse in the ECM battery power circuit. Refer to Engine Controls Schematics. <sup>2</sup> Check battery power, ignition power and ground circuits to the ECM. Refer to Engine Control Schematics. Verify voltage and/or continuity for each circuit.
Sensor Checks	<sup>2</sup> Check the TMAP sensor. <sup>2</sup> Check the Magnetic pickup sensor (RPM).
Fuel System Checks	<b>Important:</b> A closed LPG manual fuel shut off valve will create a no start condition. <sup>2</sup> Check for air intake system leakage between the mixer and the throttle body. <sup>2</sup> Verify proper operation of the low pressure lock-off solenoids. <sup>2</sup> Check the fuel system pressures. Refer to the LPG Fuel System Diagnosis. <sup>2</sup> Check for proper mixer air valve operation.
Ignition System Checks	Note: LPG being a gaseous fuel requires higher secondary ignition system voltages for the equivalent gasoline operating conditions. <sup>2</sup> Check for the proper ignition voltage output with J 26792 or the equivalent. <sup>2</sup> Verify that the spark plugs are correct for use with LPG (R42LTS) <sup>2</sup> Check the spark plugs for the following conditions: - Wet plugs - Cracks - Wear - Improper gap - Burned electrodes - Heavy deposits <sup>2</sup> Check for bare or shorted ignition wires. <sup>2</sup> Check for loose ignition coil connections at the coil.
Engine Mechanical Checks	<b>Important:</b> The LPG Fuel system works on a fumigation principle of fuel introduction and is more sensitive to intake manifold leakage than the gasoline fuel supply system. <sup>2</sup> Check for the following: - Vacuum leaks - Improper valve timing - Low compression - Bent pushrods - Worn rocker arms - Broken or weak valve springs - Worn camshaft lobes.

## SECTION 3 - CHASSIS & TURNTABLE

**Table 3-12. Symptom Diagnosis**

Checks	Action
Exhaust System Checks	<sup>2</sup> Check the exhaust system for a possible restriction: <ul style="list-style-type: none"> <li>- Inspect the exhaust system for damaged or collapsed pipes</li> <li>- Inspect the muffler for signs of heat distress or for possible internal failure.</li> </ul> <sup>2</sup> Check for possible plugged catalytic converter. Refer to Restricted Exhaust System Diagnosis
<b>Hard Start</b>	
DEFINITION: The engine cranks OK, but does not start for a long time. The engine does eventually run, or may start but immediately dies.	
Preliminary Checks	<sup>2</sup> Refer to Important Preliminary Checks. <sup>2</sup> Make sure the vehicle's operator is using the correct starting procedure.
Sensor Checks	<sup>2</sup> Check the Engine Coolant Temperature sensor with the scan tool. Compare the engine coolant temperature with the ambient air temperature on a cold engine. IF the coolant temperature reading is more than 5 degrees greater or less than the ambient air temperature on a cold engine, check for high resistance in the coolant sensor circuit. Refer to DTC 111 <sup>2</sup> Check the Crankshaft Position (CKP) sensor. <sup>2</sup> Check the Throttle position (TPS) sensor.
Fuel System Checks	Important: A closed LPG manual fuel shut off valve will create an extended crank OR no start condition. <sup>2</sup> Verify the excess flow valve in the LPG manual shut-off valve is not tripped. <sup>2</sup> Check mixer module assembly for proper installation and leakage. <sup>2</sup> Verify proper operation of the low pressure lock-off solenoids. <sup>2</sup> Verify proper operation of the EPR <sup>2</sup> Check for air intake system leakage between the mixer and the throttle body. <sup>2</sup> Check the fuel system pressures. Refer to the Fuel System Diagnosis.
Ignition System Checks	Note: LPG being a gaseous fuel requires higher secondary ignition system voltages for the equivalent gasoline operating conditions. <sup>2</sup> Check for the proper ignition voltage output with J 26792 or the equivalent. <sup>2</sup> Verify that the spark plugs are correct for use with LPG (R42LTS) <sup>2</sup> Check the spark plugs for the following conditions: <ul style="list-style-type: none"> <li>- Wet plugs</li> <li>- Cracks</li> <li>- Wear</li> <li>- Improper gap</li> <li>- Burned electrodes</li> <li>- Heavy deposits</li> </ul> <sup>2</sup> Check for bare or shorted ignition wires. <sup>2</sup> Check for moisture in the distributor cap if applicable. <sup>2</sup> Check for loose ignition coil connections. <b>Important:</b> 1. If the engine starts but then immediately stalls, Check the Crankshaft Position (CKP). 2. Check for improper gap, debris or faulty connections.
Engine Mechanical Checks	Important: The LPG Fuel system works on a fumigation principle of fuel introduction and is more sensitive to intake manifold leakage than the gasoline fuel supply system. <sup>2</sup> Check for the following: <ul style="list-style-type: none"> <li>- Vacuum leaks               <ul style="list-style-type: none"> <li>- Improper valve timing</li> <li>- Low compression</li> <li>- Bent pushrods</li> <li>- Worn rocker arms</li> <li>- Broken or weak valve springs</li> <li>- Worn camshaft lobes.</li> </ul> </li> </ul> <sup>2</sup> Check the intake and exhaust manifolds for casting flash.
Exhaust System Checks	<sup>2</sup> Check the exhaust system for a possible restriction: <ul style="list-style-type: none"> <li>- Inspect the exhaust system for damaged or collapsed pipes</li> <li>- Inspect the muffler for signs of heat distress or for possible internal failure.</li> </ul> <sup>2</sup> Check for possible plugged catalytic converter. Refer to Restricted Exhaust System Diagnosis or Exhaust System in the GM Base Engine Service Manual

Table 3-12. Symptom Diagnosis

Checks	Action
Additional Checks	<sup>2</sup>
Cuts Out, Misses	
DEFINITION: A surging or jerking that follows engine speed, usually more pronounced as the engine load increases which is not normally felt above 1500 RPM. The exhaust has a steady spitting sound at idle, low speed, or hard acceleration for the fuel starvation that can cause the engine to cut-out.	
Preliminary Checks	<sup>2</sup> Refer to Important Preliminary Checks.
Ignition System Checks	<sup>2</sup> Start the engine. <sup>2</sup> Wet down the secondary ignition system with water from a spray bottle, and look/listen for arcing or misfiring as you apply water. <sup>2</sup> Check for proper ignition output voltage with spark tester J 26792. <sup>2</sup> Check for a cylinder misfire. <sup>2</sup> Verify that the spark plugs are correct for use with LPG (R42LTS) <sup>2</sup> Remove the spark plugs in these cylinders and check for the following conditions: <sup>2</sup> Insulation cracks <sup>2</sup> Wear <sup>2</sup> Improper gap <sup>2</sup> Burned electrodes <sup>2</sup> Heavy deposits <sup>2</sup> Visually/Physically inspect the secondary ignition for the following: <sup>2</sup> Ignition wires for arcing, cross-firing and proper routing <sup>2</sup> Ignition coils for cracks or carbon tracking
Engine Mechanical Checks	<sup>2</sup> Perform a cylinder compression check. <sup>2</sup> Check the engine for the following: <ul style="list-style-type: none"> <li>- Improper valve timing</li> <li>- Bent pushrods</li> <li>- Worn rocker arms</li> <li>- Worn camshaft lobes.</li> <li>- Broken or weak valve springs.</li> </ul> <sup>2</sup> Check the intake and exhaust manifold passages for casting flash.
Fuel System Checks	<sup>2</sup> Check the fuel system - plugged fuel filter, low fuel pressure, etc. Refer to LPG Fuel System Diagnosis. <sup>2</sup> Check the condition of the wiring to the low pressure lock-off solenoid.
Additional Check	Check for Electromagnetic Interference (EMI). <sup>2</sup> EMI on the reference circuit can cause a missing condition. <sup>2</sup> Monitoring the engine RPM with a scan tool can detect an EMI. <sup>2</sup> A sudden increase in the RPM with little change in the actual engine RPM, indicates EMI is present. <sup>2</sup> If the problem exists, check the routing of the secondary wires and the ground circuit.
Hesitation, Sag, Stumble	
DEFINITION: The vehicle has a momentary lack of response when depressing the accelerator. The condition can occur at any vehicle speed. The condition may cause the engine to stall if it's severe enough.	
Preliminary Checks	Refer to Important Preliminary Checks.
Fuel System Checks	<sup>2</sup> Check the fuel pressure. Refer to LPG Fuel System Diagnosis. <sup>2</sup> Check for low fuel pressure during a moderate or full throttle acceleration. If the fuel pressure drops below specification, there is possibly a faulty low pressure regulator or a restriction in the fuel system. <sup>2</sup> Check the Manifold Absolute Pressure (MAP) sensor response and accuracy. <sup>2</sup> Check LPL electrical connection <sup>2</sup> Check the mixer air valve for sticking or binding. <sup>2</sup> Check the mixer module assembly for proper installation and leakage. <sup>2</sup> Check the EPR electrical connections.

## SECTION 3 - CHASSIS & TURNTABLE

**Table 3-12. Symptom Diagnosis**

Checks	Action
Ignition System Checks	Note: LPG being a gaseous fuel requires higher secondary ignition system voltages for the equivalent gasoline operating conditions. If a problem is reported on LPG and not gasoline, do not discount the possibility of a LPG only ignition system failure and test the system accordingly. <sup>2</sup> Check for the proper ignition voltage output with J 26792 or the equivalent. <sup>2</sup> Verify that the spark plugs are correct for use with LPG (R42LTS) <sup>2</sup> Check for faulty spark plug wires <sup>2</sup> Check for fouled spark plugs.
Additional Check	<sup>2</sup> Check for manifold vacuum or air induction system leaks <sup>2</sup> Check the generator output voltage.
<b>Backfire</b>	
DEFINITION: The fuel ignites in the intake manifold, or in the exhaust system, making a loud popping noise.	
Preliminary Check	<sup>2</sup> Refer to Important Preliminary Checks.
Ignition System Checks	<b>Important! LPG, being a gaseous fuel, requires higher secondary ignition system voltages for the equivalent gasoline operating conditions. The ignition system must be maintained in peak condition to prevent backfire.</b> <sup>2</sup> Check for the proper ignition coil output voltage using the spark tester J26792 or the equivalent. <sup>2</sup> Check the spark plug wires by connecting an ohmmeter to the ends of each wire in question. If the meter reads over 30,000 ohms, replace the wires. <sup>2</sup> Check the connection at each ignition coil. <sup>2</sup> Check for deteriorated spark plug wire insulation. <sup>2</sup> Check the spark plugs. The correct spark plugs for LPG are (R42LTS) <sup>2</sup> Remove the plugs and inspect them for the following conditions: <ul style="list-style-type: none"> <li>- Wet plugs</li> <li>- Cracks</li> <li>- Wear</li> <li>- Improper gap</li> <li>- Burned electrodes</li> <li>- Heavy deposits</li> </ul>
Engine Mechanical Check	Important! The LPG Fuel system works on a fumigation principle of fuel introduction and is more sensitive to intake manifold leakage than a gasoline fuel supply system. <sup>2</sup> Check the engine for the following: <ul style="list-style-type: none"> <li>- Improper valve timing</li> <li>- Engine compression</li> <li>- Manifold vacuum leaks</li> <li>- Intake manifold gaskets</li> <li>- Sticking or leaking valves</li> <li>- Exhaust system leakage</li> </ul> <sup>2</sup> Check the intake and exhaust system for casting flash or other restrictions.
Fuel System Checks	<sup>2</sup> Perform a fuel system diagnosis. Refer to LPG Fuel System Diagnosis.
<b>Lack of Power, Sluggishness, or Sponginess</b>	
DEFINITION: The engine delivers less than expected power. There is little or no increase in speed when partially applying the accelerator pedal.	
Preliminary Checks	<sup>2</sup> Refer to Important Preliminary Checks. <sup>2</sup> Refer to the LPG Fuel system OBD System Check <sup>2</sup> Compare the customer's vehicle with a similar unit. Make sure the customer has an actual problem. Do not compare the power output of the vehicle operating on LPG to a vehicle operating on gasoline as the fuels do have different drive feel characteristics <sup>2</sup> Remove the air filter and check for dirt or restriction. <sup>2</sup> Check the vehicle transmission Refer to the OEM transmission diagnostics.

Table 3-12. Symptom Diagnosis

Checks	Action
Fuel System Checks	<sup>2</sup> Check for a restricted fuel filter, contaminated fuel, or improper fuel pressure. Refer to LPG Fuel System Diagnosis. <sup>2</sup> Check for the proper ignition output voltage with the spark tester J 26792 or the equivalent. <sup>2</sup> Check for proper installation of the mixer module assembly. <sup>2</sup> Check all air inlet ducts for condition and proper installation. <sup>2</sup> Check for fuel leaks between the LPR and the mixer. <sup>2</sup> Verify that the LPG tank manual shut-off valve is fully open. <sup>2</sup> Verify that liquid fuel (not vapor) is being delivered to the LPR.
Sensor Checks	<sup>2</sup> Check the Heated Exhaust Gas Oxygen Sensor (HEGO) for contamination and performance. Check for proper operation of the MAP sensor. <sup>2</sup> Check for proper operation of the TPS sensor.
Exhaust System Checks	<sup>2</sup> Check the exhaust system for a possible restriction: - Inspect the exhaust system for damaged or collapsed pipes - Inspect the muffler for signs of heat distress or for possible internal failure. - Check for possible plugged catalytic converter.
Engine Mechanical Check	Check the engine for the following: <sup>2</sup> Engine compression <sup>2</sup> Valve timing <sup>2</sup> Improper or worn camshaft. Refer to Engine Mechanical in the Service Manual.
Additional Check	<sup>2</sup> Check the ECM grounds for being clean, tight, and in their proper locations. <sup>2</sup> Check the generator output voltage. <sup>2</sup> If all procedures have been completed and no malfunction has been found, review and inspect the following items: <sup>2</sup> Visually and physically, inspect all electrical connections within the suspected circuit and/or systems. <sup>2</sup> Check the scan tool data.
<b>Poor Fuel Economy</b>	
<b>DEFINITION:</b> Fuel economy, as measured by refueling records, is noticeably lower than expected. Also, the economy is noticeably lower than it was on this vehicle at one time, as previously shown by an by refueling records.	
Preliminary Checks	<sup>2</sup> Refer to Important Preliminary Checks. <sup>2</sup> Check the air cleaner element (filter) for dirt or being plugged. <sup>2</sup> Visually (Physically) check the vacuum hoses for splits, kinks, and proper connections. <sup>2</sup> Check the operators driving habits for the following items: - Is there excessive idling or stop and go driving? - Are the tires at the correct air pressure? - Are excessively heavy loads being carried? - Is their often rapid acceleration? <sup>2</sup> Suggest to the owner to fill the fuel tank and to recheck the fuel economy. <sup>2</sup> Suggest that a different operator use the equipment and record the results.
Fuel System Checks	<sup>2</sup> Check the LPR fuel pressure. Refer to LPG Fuel System Diagnosis. <sup>2</sup> Check the fuel system for leakage.
Sensor Checks	<sup>2</sup> Check the Temperature Manifold Absolute Pressure (TMAP) sensor.
Ignition System Checks	<sup>2</sup> Verify that the spark plugs are correct for use with LPG (R42LTS) <sup>2</sup> Check the spark plugs. Remove the plugs and inspect them for the following conditions: - Wet plugs - Cracks - Wear - Improper gap - Burned electrodes - Heavy deposits <sup>2</sup> Check the ignition wires for the following items: - Cracking - Hardness - Proper connections
Cooling System Checks	<sup>2</sup> Check the engine thermostat for always being open or for the wrong heat range

## SECTION 3 - CHASSIS & TURNTABLE

**Table 3-12. Symptom Diagnosis**

Checks	Action
Additional Check	<sup>2</sup> Check the transmission shift pattern. Refer to the OEM Transmission Controls section the Service Manual. <sup>2</sup> Check for dragging brakes.
<b>Rough, Unstable, or Incorrect Idle, Stalling</b>	
DEFINITION: The engine runs unevenly at idle. If severe enough, the engine or vehicle may shake. The engine idle speed may vary in RPM. Either condition may be severe enough to stall the engine.	
Preliminary Check	Refer to Important Preliminary Checks.
Sensor Checks	<sup>2</sup> Check for silicon contamination from fuel or improperly used sealant. The sensor will have a white powdery coating. The sensor will result in a high but false signal voltage (rich exhaust indication). The ECM will reduce the amount of fuel delivered to the engine causing a severe drive-ability problem. <sup>2</sup> Check the Heated Exhaust Gas Oxygen Sensor (HEGO) performance: <sup>2</sup> Check the Temperature Manifold Absolute Pressure (TMAP) sensor response and accuracy.
Fuel System Checks	<sup>2</sup> Check for rich or lean symptom that causes the condition. Drive the vehicle at the speed of the complaint. Monitoring the oxygen sensors will help identify the problem. <sup>2</sup> Check for a sticking mixer air valve. <sup>2</sup> Verify proper operation of the EPR. <sup>2</sup> Perform a cylinder compression test. Refer to Engine Mechanical in the Service Manual. <sup>2</sup> Check the LPR fuel pressure. Refer to the LPG Fuel System Diagnosis. <sup>2</sup> Check mixer module assembly for proper installation and connection.
Ignition System Checks	<sup>2</sup> Check for the proper ignition output voltage using the spark tester J26792 or the equivalent. <sup>2</sup> Verify that the spark plugs are correct for use with LPG (R42LTS) <sup>2</sup> Check the spark plugs. Remove the plugs and inspect them for the following conditions: - Wet plugs - Cracks - Wear - Improper gap - Burned electrodes - Blistered insulators - Heavy deposits <sup>2</sup> Check the spark plug wires by connecting an ohmmeter to the ends of each wire in question. If the meter reads over 30,000 ohms, replace the wires.
Additional Checks	<b>Important:</b> The LPG Fuel system works on a fumigation principle of fuel introduction and is more sensitive to intake manifold leakage than the gasoline fuel supply system. <sup>2</sup> Check for vacuum leaks. Vacuum leaks can cause a higher than normal idle and low throttle angle control command. <sup>2</sup> Check the ECM grounds for being clean, tight, and in their proper locations. <sup>2</sup> Check the battery cables and ground straps. They should be clean and secure. Erratic voltage may cause all sensor readings to be skewed resulting in poor idle quality.
Engine Mechanical Check	<sup>2</sup> Check the engine for the following: - Broken motor mounts - Improper valve timing - Low compression - Bent pushrods - Worn rocker arms - Broken or weak valves springs - Worn camshaft lobes
<b>Surges/Chuggles</b>	
DEFINITION: The engine has a power variation under a steady throttle or cruise. The vehicle feels as if it speeds up and slows down with no change in the accelerator pedal.	
Preliminary Checks	Refer to Important Preliminary Checks.
Sensor Checks	<sup>2</sup> Check Heated Exhaust Gas Oxygen Sensor (HEGO) performance.



Table 3-12. Symptom Diagnosis

Checks	Action
Fuel System Checks	<sup>2</sup> Check for Rich or Lean symptom that causes the condition. Drive the vehicle at the speed of the complaint. Monitoring the oxygen sensors will help identify the problem. <sup>2</sup> Check the fuel pressure while the condition exists. Refer to LPG Fuel System Diagnosis. <sup>2</sup> Verify proper fuel control solenoid operation. <sup>2</sup> Verify that the LPG manual shut-off valve is fully open. <sup>2</sup> Check the in-line fuel filter for restrictions.
Ignition System Checks	<sup>2</sup> Check for the proper ignition output voltage using the spark tester J26792 or the equivalent. <sup>2</sup> Verify that the spark plugs are correct for use with LPG (R42LTS) <sup>2</sup> Check the spark plugs. Remove the plugs and inspect them for the following conditions: <ul style="list-style-type: none"> <li>- Wet plugs</li> <li>- Cracks</li> <li>- Wear</li> <li>- Improper gap</li> <li>- Burned electrodes</li> <li>- Heavy deposits</li> <li>- Check the Crankshaft Position (CKP) sensor.</li> </ul>
Additional Check	<sup>2</sup> Check the ECM grounds for being clean, tight, and in their proper locations. <sup>2</sup> Check the generator output voltage. <sup>2</sup> Check the vacuum hoses for kinks or leaks. <sup>2</sup> Check Transmission

## SECTION 3 - CHASSIS & TURNTABLE

**Table 3-13. DTC to SPN/FMI Cross Reference Chart**

DTC	Description	SPN Code	FMI Code
16	Crank Never Synced at Start	636	8
91	Fuel Pump Low Voltage	94	4
92	Fuel Pump High Voltage	94	3
107	MAP Low Voltage	106	4
108	MAP High Pressure	106	16
111	IAT Higher Than Expected 1	105	15
112	IAT Low Voltage	105	4
113	IAT High Voltage	105	3
116	ECT Higher Than Expected 1	110	15
117	ECT Low Voltage	110	4
118	ECT High Voltage	110	3
121	TPS 1 Lower Than TPS 2	51	1
122	TPS 1 Signal Voltage Low	51	4
123	TPS 1 Signal Voltage High	51	3
127	IAT Higher Than Expected 2	105	0
129	BP Low Pressure	108	1
134	EGO 1 Open/Inactive	724	10
154	EGO 2 Open/Inactive	520208	10
171	Adaptive Learn High Gasoline	520200	0
172	Adaptive Learn Low Gasoline	520200	1
182	Fuel Temp Gasoline Low Voltage	174	4
183	Fuel Temp Gasoline High Voltage	174	3
187	Fuel Temp LPG Low Voltage	520240	4
188	Fuel Temp LPG High Voltage	520240	3
217	ECT Higher Than Expected 2	110	0
219	Max Govern Speed Override	515	15
221	TPS 2 Signal Voltage Low	51	0
222	TPS 2 Signal Low Voltage	520251	4
223	TPS 2 Signal High Voltage	520251	3
261	Injector Driver 1 Open	651	5
262	Injector Driver 1 Shorted	651	6
264	Injector Driver 2 Open	652	5
265	Injector Driver 2 Shorted	652	6
267	Injector Driver 3 Open	653	5
268	Injector Driver 3 Shorted	653	6
270	Injector Driver 4 Open	654	5
271	Injector Driver 4 Shorted	654	6
336	Crank Sync Noise	636	2
337	Crank Loss	636	4
341	Cam Sync Noise	723	2
342	Cam Sensor Loss	723	4
420	Gasoline Cat Monitor	520211	10
524	Oil Pressure Low	100	1

Table 3-13. DTC to SPN/FMI Cross Reference Chart

DTC	Description	SPN Code	FMI Code
562	System Voltage Low	168	17
563	System Voltage High	168	15
601	Flash Checksum Invalid	628	13
604	RAM Failure	630	12
606	COP Failure	629	31
642	External 5V Reference Low	1079	4
643	External 5V Reference High	1079	3
685	Power Relay Open	1485	5
686	Power Relay Shorted	1485	4
687	Power Relay Short to Power	1485	3
1111	Fuel Rev Limit	515	16
1112	Spark Rev Limit	515	0
1151	Closed Loop Multiplier High LPG	520206	0
1152	Closed Loop Multiplier Low LPG	520206	1
1155	Closed Loop Multiplier High Gasoline	520204	0
1156	Closed Loop Multiplier Low Gasoline	520204	1
1161	Adaptive Learn High LPG	520202	0
1162	Adaptive Learn Low LPG	520202	1
1165	LPG Cat Monitor	520213	10
1171	LPG Pressure Higher Than Expected	520260	0
1172	LPG Pressure Lower Than Expected	520260	1
1173	EPR Comm Lost	520260	31
1174	EPR Voltage Supply High	520260	3
1175	EPR Voltage Supply Low	520260	4
1176	EPR Internal Actuator Fault	520260	12
1177	EPR Internal Circuitry Fault	520260	12
1178	EPR Internal Comm Fault	520260	12
1612	RTI 1 loss	629	31
1613	RTI 2 Loss	629	31
1614	RTI 3 Loss	629	31
1615	A/D Loss	629	31
1616	Invalid Interrupt	629	31
1625	Shutdown Request	1384	31
1626	CAN Tx Failure	639	12
1627	CAN Rx Failure	639	12
1628	CAN Address Conflict Failure	639	13
1629	Loss of TSC 1	639	31
2111	Unable to Reach Lower TPS	51	7
2112	Unable to Reach Higher TPS	51	
2135	TPS 1/2 Simultaneous Voltages	51	31
2229	BP Pressure High	108	0



## SECTION 4. BOOM &amp; PLATFORM

## 4.1 BOOM SYSTEMS

## Removal

1. Remove platform/support as follows:
  - a. Disconnect electrical cable from control console.
  - b. Remove eight bolts securing platform to platform support and remove the platform.
  - c. Using an overhead crane or suitable lifting device, strap support platform support.
  - d. Remove six bolts and locknuts securing support to rotator.
  - e. Using a suitable brass drift and hammer, remove rotator shaft, then remove support from rotator.

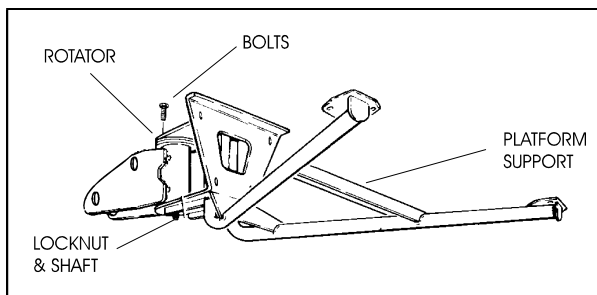


Figure 4-1. Location of Components - Platform Support

2. Remove rotator and slave level cylinder from fly boom as follows:
  - a. Tag and disconnect hydraulic lines to rotator. Use suitable container for residual hydraulic fluid. Cap hydraulic lines and ports.
  - b. Remove hardware from pin #1. Remove pin #1 from fly boom with a suitable brass drift and hammer.
  - c. Support rotator. Remove hardware from pin #2. Remove pin #2 from fly boom with a suitable brass drift and hammer. Remove rotator.
  - d. Telescope fly section out approximately 20 inches (50.8 cm) to access slave leveling cylinder.
  - e. Support slave cylinder. Remove hardware from pin #3. Remove pin #3 from fly boom with a suitable brass drift and hammer.

- f. Tag and disconnect hydraulic lines to slave leveling cylinder. Use a suitable container for residual hydraulic fluid. Cap hydraulic lines and ports. Remove slave cylinder.

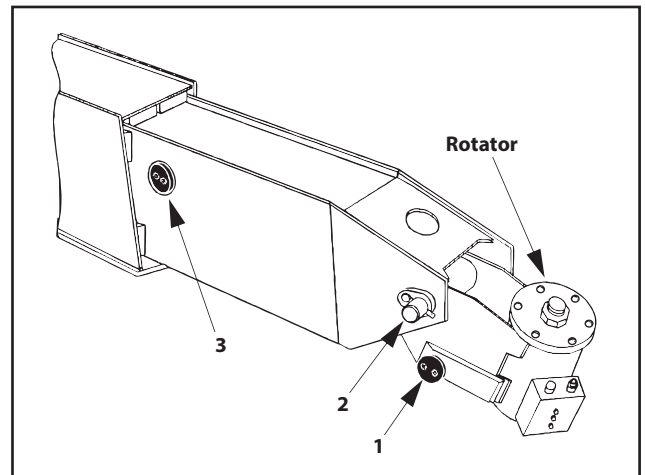


Figure 4-2. Rotator and Leveling Cylinder Locations

3. Remove powertrack from boom as follows:
  - a. Disconnect wiring harness from ground control box.

**NOTICE**

**HYDRAULIC LINES AND PORTS SHOULD BE CAPPED IMMEDIATELY AFTER DISCONNECTING LINES TO AVOID ENTRY OF CONTAMINANTS INTO SYSTEM.**

- b. Tag and disconnect hydraulic lines from boom to control valve. Use a suitable container for residual hydraulic fluid. Cap hydraulic lines and ports.
- c. Disconnect dual capacity indicator limit switch from side of boom section.
- d. Remove hydraulic lines and electrical cables from powertrack.
- e. Using a suitable lifting equipment, adequately support powertrack weight along entire length.
- f. Remove bolts #1 securing push tube on fly boom section.
- g. Remove bolts #2 securing push tube on mid boom section.

- h. With powertrack support and using all applicable safety precautions, remove bolts #3 and #4 securing rail to the base boom section. Remove powertrack from boom section.

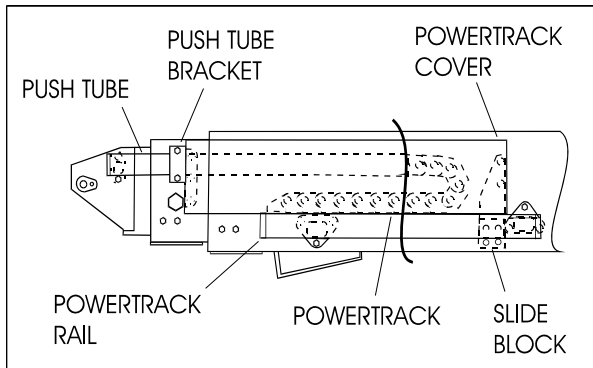


Figure 4-3. Boom Powertrack Components

4. Remove boom assembly from machine as follows:
  - a. Using suitable lifting equipment, adequately support boom assembly weight along entire length.

**NOTICE**

**CAP HYDRAULIC LINES AND PORTS IMMEDIATELY AFTER DISCONNECTING LINES TO PREVENT ENTRY OF CONTAMINANTS INTO SYSTEM.**

- b. Tag and disconnect hydraulic lines from telescope cylinder. Use a suitable container for residual hydraulic fluid. Cap hydraulic lines and ports.
- c. Remove hardware securing lift cylinder rod end to base boom section.
- d. Using a suitable brass drift and hammer, remove lift cylinder pin from base boom.
- e. Remove hardware securing master cylinder rod end to base boom section.
- f. Using a suitable brass drift and hammer, remove the master cylinder pin from the base boom.
- g. Remove hardware securing push bar to turntable upright.

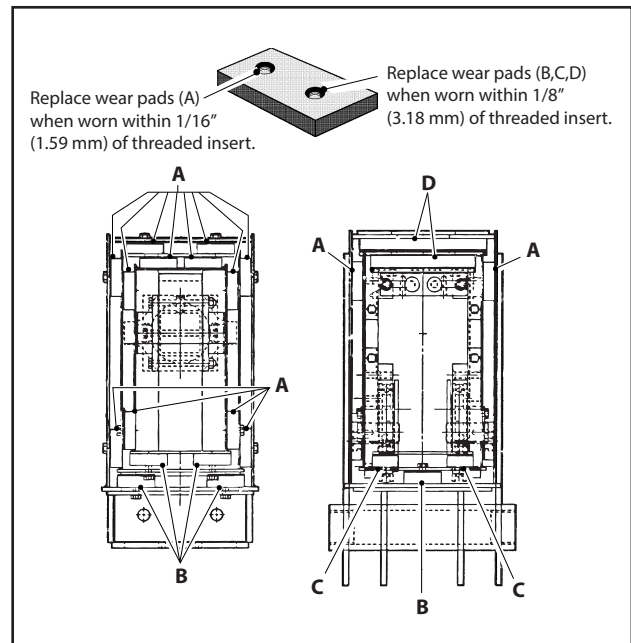
**NOTICE**

**WHEN REMOVING PIN FROM PUSHBAR DO NOT DROP PUSHBAR ON WIRE ROPE ADJUSTMENT THREADS. FAILURE TO DO SO WILL DAMAGE THREADS.**

- h. Using a suitable brass drift and hammer, remove push bar pin from turntable upright.
- i. Remove hardware securing boom pivot pin to turntable upright.
- j. Using a suitable brass drift and hammer, remove pivot pin from turntable upright.
- k. Using all applicable safety precautions, carefully lift boom assembly clear of turntable and lower to ground or suitably supported work surface.

**4.2 WEAR PADS**

Wear pads are made of polyethylene. Pads move on polyurethane painted surfaces. No paint is removed and no lubrication is applied.



PAD	THICKNESS OF NEW PAD	REPLACE WHEN WORN TO:
A	5/8"	9/16"
B,C,D	3/4"	5/8"

Figure 4-4. Location and Thickness of Wear Pads

1. Shim wear pads to within 1/32 inch (.79 mm) tolerance between wear pad and adjacent surface.
2. Replace wear pads when worn within 1/16 inch (1.59 mm) and 1/8 inch (3.18 mm) - B, C, D of threaded insert. See Location and Thickness Of Wear Pads.
3. Bolt length must be changed when adjusting wear pads and removing or adding shims.
  - a. Longer bolts must be used when adding shims to ensure proper thread engagement in insert.
  - b. Shorter bolts must be used when shims are removed so bolt does not protrude from insert and contact boom surface.

### 4.3 BOOM DISASSEMBLY/ASSEMBLY & CABLE REPLACEMENT

#### Boom Section Disassembly

1. Remove hardware securing push bar to aft end of telescope cylinder. Remove pin from cylinder.
2. Remove hardware securing cover plate on bottom front of base boom section.

#### NOTICE

DO NOT ALLOW WIRE ROPE TO ROTATE. THIS MAY DAMAGE THE WIRE ROPE.

3. Clamp both threaded ends of wire rope to prevent rotation. Note: Do not clamp on threads. Remove jam nuts and nuts which secure wire rope adjustments to bottom front of base boom section.

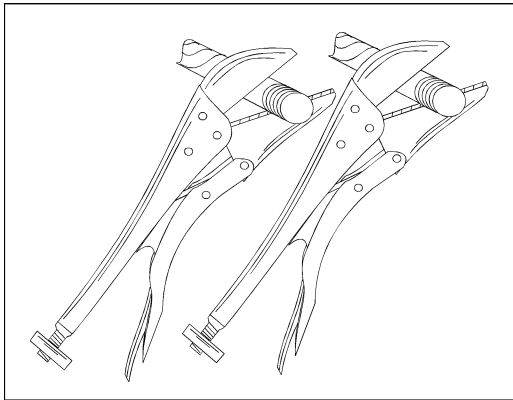


Figure 4-5. Clamping Wire Ropes

**NOTE:** CE specification machines go to Step 4. All other machines go to Step 5.

4. Remove spring mounting plate, spring, and proximity switch from aft end of base section.

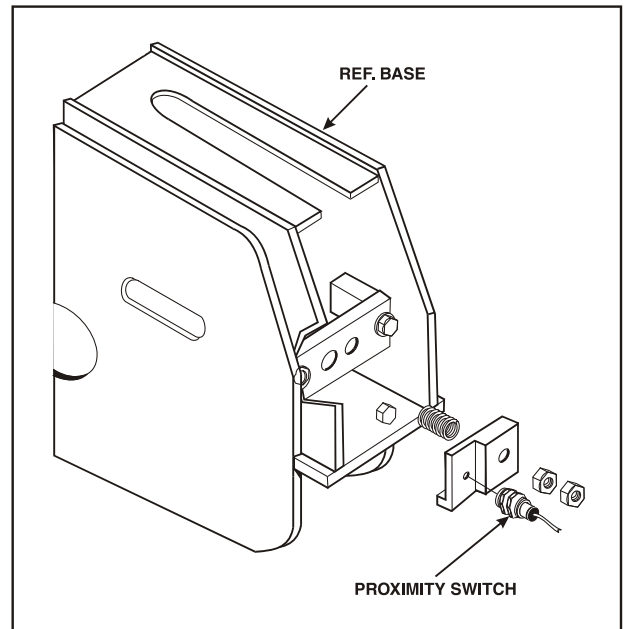


Figure 4-6. Proximity Switch Assembly Disassembly

5. Remove hardware securing wire rope adjustment block to aft end of base boom section and remove block.
6. Remove hardware securing telescope cylinder to aft end of mid boom section.

#### NOTICE

WHEN REMOVING TELESCOPE CYLINDER FROM BOOM, IT MAY BE NECESSARY TO TURN CYLINDER SLIGHTLY TO CLEAR ASSEMBLIES MOUNTED IN BOOM. MOVE CYLINDER SLOWLY OUT OF POSITION. DAMAGE TO COMPONENTS MAY RESULT FROM FORCIBLE IMPACT WITH ASSEMBLIES.

7. Remove bolts securing wire rope attach bar to top of fly boom section.
8. Pull telescope cylinder and wire ropes partially from aft end of base boom section. Secure cylinder with a suitable sling and lifting device at center of gravity.

## 4.4 WIRE ROPE

### CAUTION

WIRE ROPE CAN HAVE SHARP EDGES AND CAUSE SERIOUS INJURY. NEVER HANDLE WIRE ROPE WITH BARE HANDS.

Each day before using machine:

1. Raise main boom approximately horizontal.
2. Extend and retract the boom sections.
3. Check for delayed movement of fly section which indicates loose wire ropes.

### Inspection

**NOTE:** Pictures in this paragraph are samples to show rope replacement criteria.

1. Inspect ropes for broken wires, particularly valley wire breaks and breaks at end terminations.

**NOTE:** Flexing a wire rope can often expose broken wires hidden in valleys between strands.

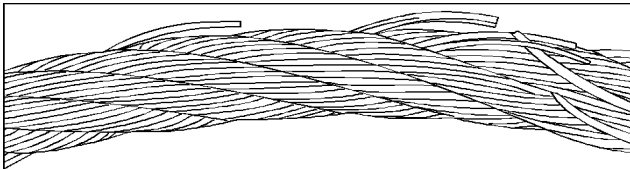


Figure 4-7. Wire Rope Wire Breaks

2. Inspect ropes for corrosion.
3. Inspect ropes for kinks or abuse.

**NOTE:** A kink is caused by pulling down a loop in a slack line during improper handling, installation, or operation.

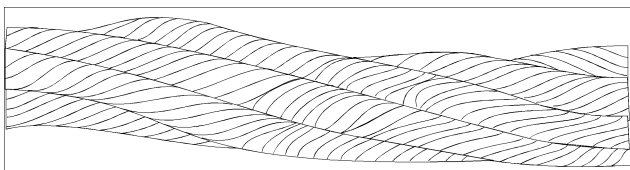


Figure 4-8. Wire Rope Kink

4. Inspect sheaves for condition of bearings/pins. (See Dimension Of Sheaves for proper dimension.) Inspect sheaves for condition of flanges. (See Dimension Of Sheaves for proper dimension.)
5. Inspect sheaves with a groove wearout gauge for excessive wear.

**NOTE:** Check groove so that it may be clearly seen if gauge contour matches sheave groove contour.

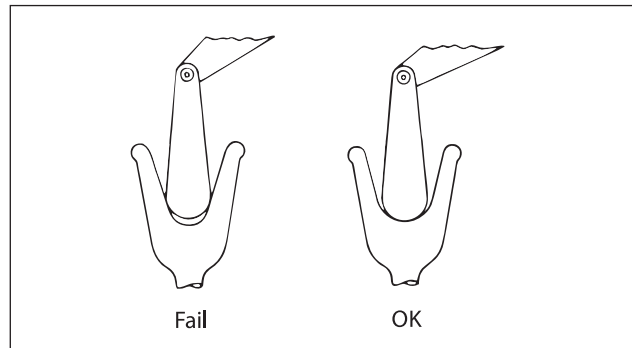


Figure 4-9. Sheave Groove Wear

7. Ropes passing inspection should be lubricated with wire rope lubricant before reassembly.

### Three Month Inspection

1. Remove boom covers and visually (with flashlight) inspect the ropes for rust, broken wires, frays, abuse, or any signs of abnormalities.
2. Check wire rope tension by deflecting wire ropes by hand. Properly tensioned ropes should have little or no movement.

### Eight Year Inspection

1. Mandatory wire rope and sheave replacement.

Additional inspection required if:

- a. Machine is exposed to hostile environment or conditions.
- b. Erratic boom operation or unusual noise exists.
- c. Machine is idle for an extended period.
- d. Boom is overloaded or sustained a shock load.
- e. Boom exposed to electrical arc. Wires may be fused internally.

### Replacement Criteria

**NOTE:** Sheaves and wire rope must be replaced as sets.

1. Rusted or corroded wire ropes.
2. Kinked, "bird caged", or crushed ropes.
3. Ropes at end of adjustment range.
4. Sheaves failing wearout gage inspection.
5. Ropes with 6 total broken wires in one rope lay, 3 in one strand in one rope lay, 1 valley break, or 1 break at any end termination.



## 4.5 WIRE ROPE TENSIONING ADJUSTMENT

### Wire Rope Tensioning Procedure

1. Position boom in fully down and retracted position.

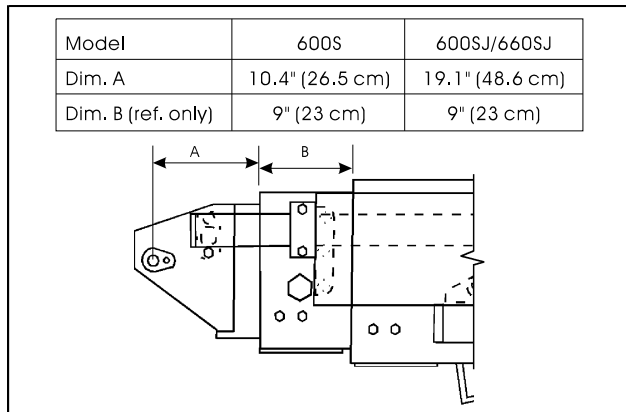


Figure 4-10. Dimensions of Boom Sections

### NOTICE

DO NOT CLAMP ON THREADS OR THREADS MAY BE DAMAGED.

DO NOT ALLOW WIRE ROPE TO ROTATE OR WIRE ROPE MAY BE DAMAGED.  
CLAMP THREADED ENDS OF WIRE ROPE TO PREVENT ROTATION.

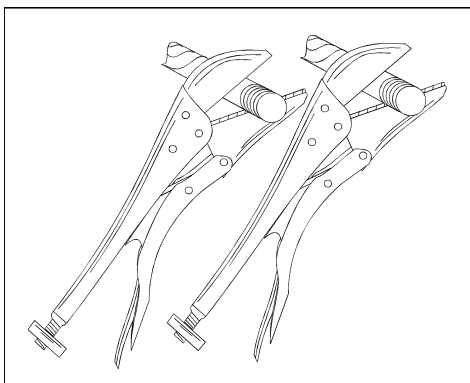


Figure 4-11. Clamping Wire Ropes

2. Install adjusting nuts (or remove nylon collar locknuts if re-adjusting) to both retract and extend wire ropes.
  3. Torque retract adjusting nuts (platform end) to 15 ft-lb (20 Nm) alternating between the two wire ropes and keeping approximately the same amount of thread beyond the adjusting nut.
  4. Repeat torque procedure in step #4 to extend wire ropes (turntable end).
  5. Extend boom 2 - 3 feet using telescope function. Repeat step #4.
  6. Retract boom 1 - 2 feet using telescope function. Do not bottom out telescope cylinder. Repeat step #5.
  7. Extend boom approximately 2 - 3 feet again and check torque on retract wire ropes.
  8. Retract boom without bottoming out telescope cylinder. Check torque on extend wire ropes.
- NOTE:** Step #8 and #9 may need to be repeated to equalize the torque on all 4 wire ropes.
9. After all wire ropes are properly torqued, install nylon collar locknuts. Remove all clamping devices and install all covers and guards. Check boom for proper function.

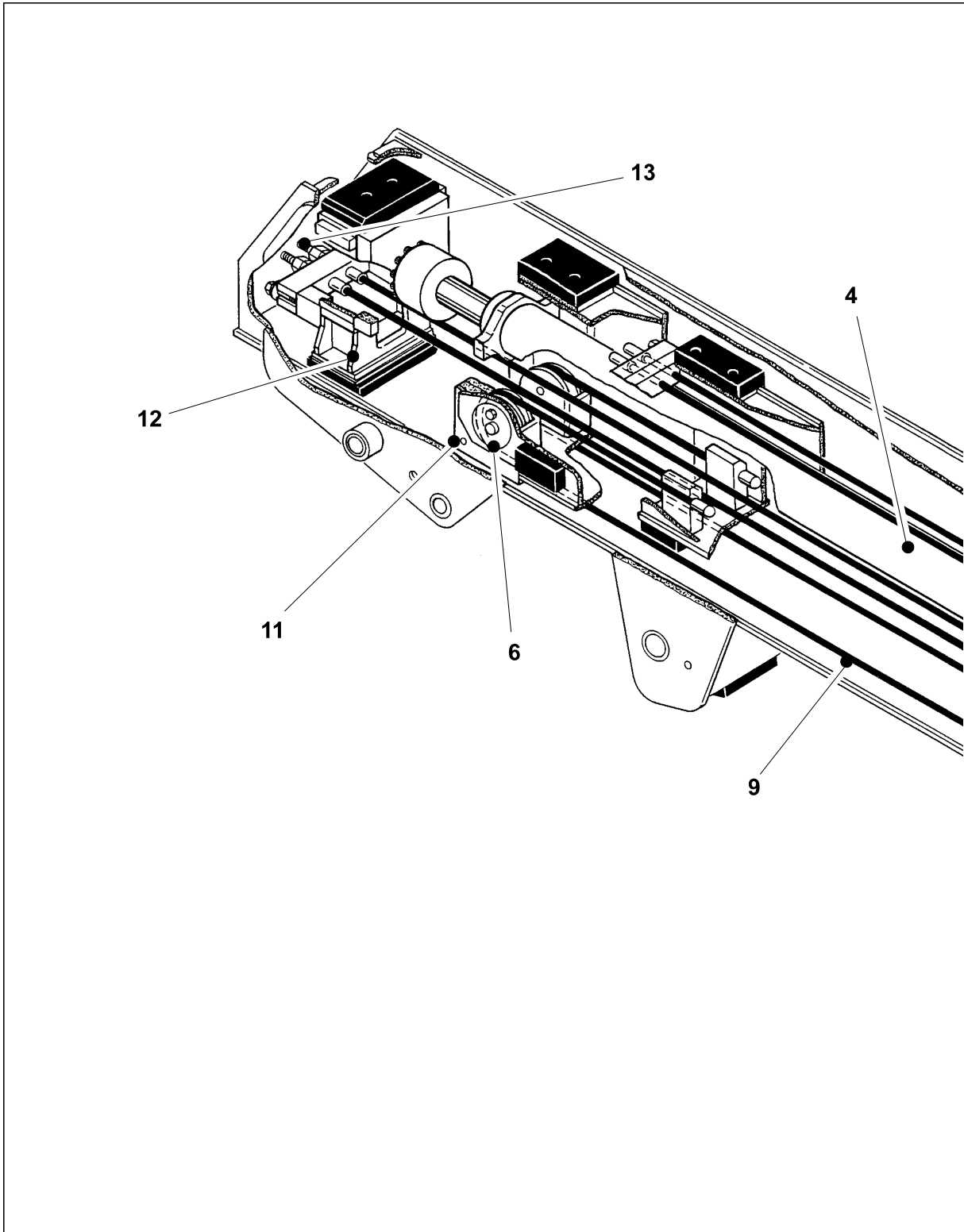


Figure 4-12. Boom Assembly Cutaway - Sheet 1 of 3

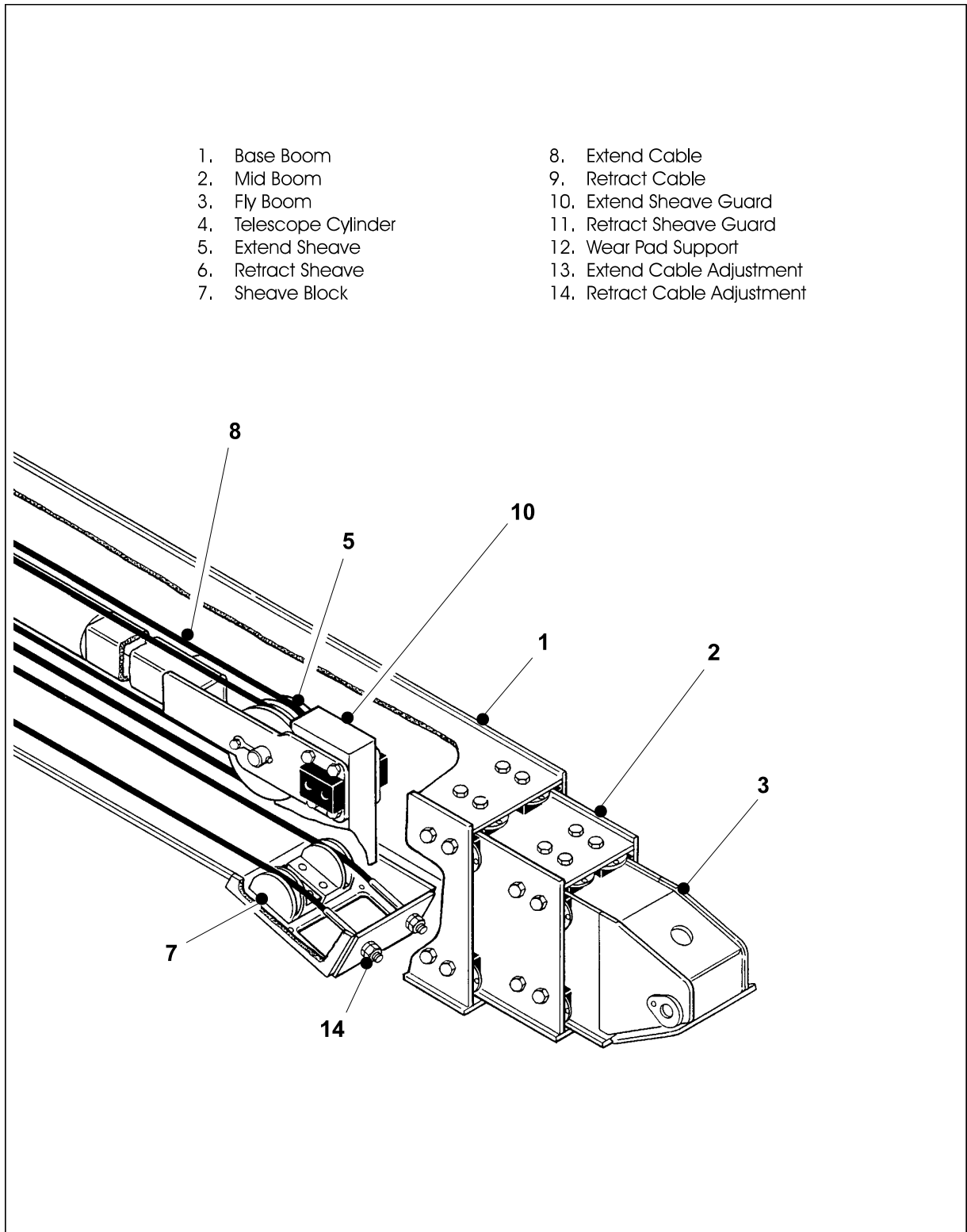
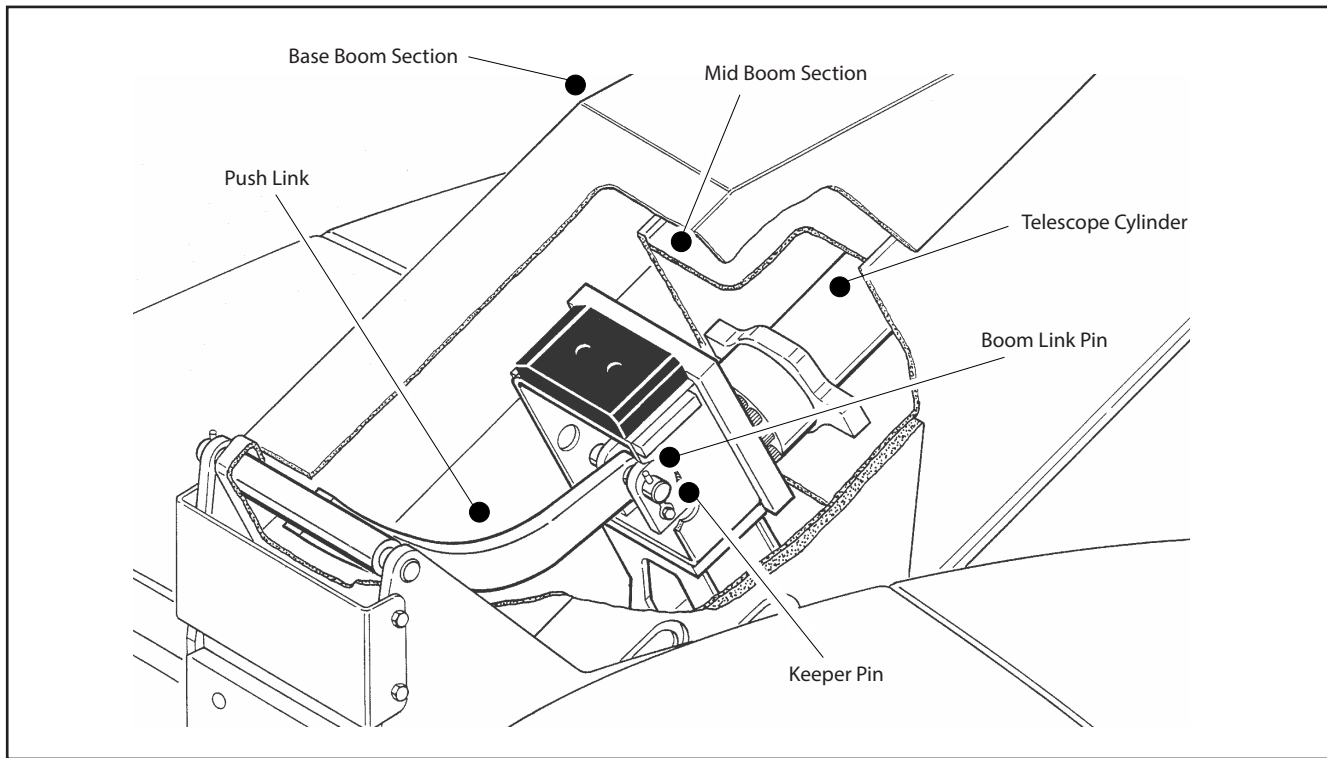


Figure 4-13. Boom Assembly Cutaway - Sheet 2 of 3

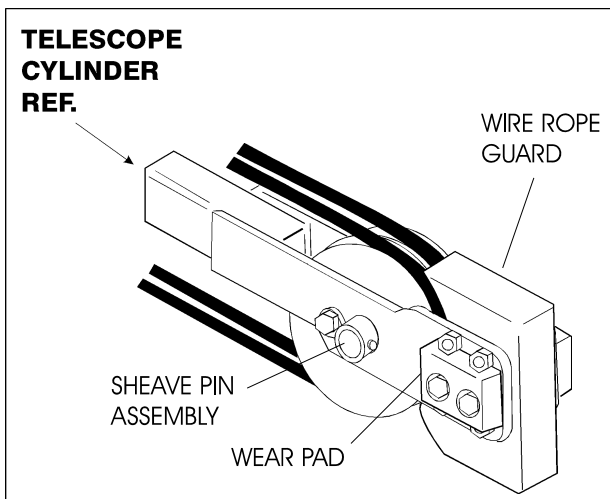


**Figure 4-14. Boom Assembly Cutaway - Sheet 3 of 3**

10. Carefully remove telescope cylinder and sheave assembly. Place telescope cylinder on a suitable trestle.
  - a. Remove hardware from wear pads. Remove wear pads from cylinder.
  - b. Remove hardware from wire rope guard. Remove guard from cylinder.
  - c. Remove hardware from sheave pin. Remove pin and sheave from cylinder.

**Figure 4-15. Disassembly of Sheave Assembly**

11. Remove hardware securing wear pads to front of base boom section. Remove wear pads from top, sides, and bottom of base boom section.
12. Using an overhead crane or suitable lifting device, remove mid and fly boom sections from base section. Note: When removing mid and fly boom sections from base boom section, retract wire rope must be dragged along with boom sections.
13. Remove hardware which secures wear pads to aft end of mid boom section. Remove wear pads from top, sides, and bottom of mid boom section.
14. Remove hardware which secures sheave guards and sheave assemblies to mid boom section. Remove sheave assemblies from mid boom section.
15. Remove hardware which secures wear pads to front of mid boom section. Remove wear pads from top, sides, and bottom of the mid boom section.



- Remove fly boom section from mid section using an overhead crane or suitable lifting device.

**NOTE:** When removing fly boom section from mid boom section, retract wire rope must be dragged along with fly boom section.

- Remove hardware which secures wear pads to aft end of fly boom section. Remove wear pads from top, sides, and bottom of fly boom section.
- When removing wire rope from fly boom section, push cable into fly boom. Route wire rope back through holes in side of fly boom section.

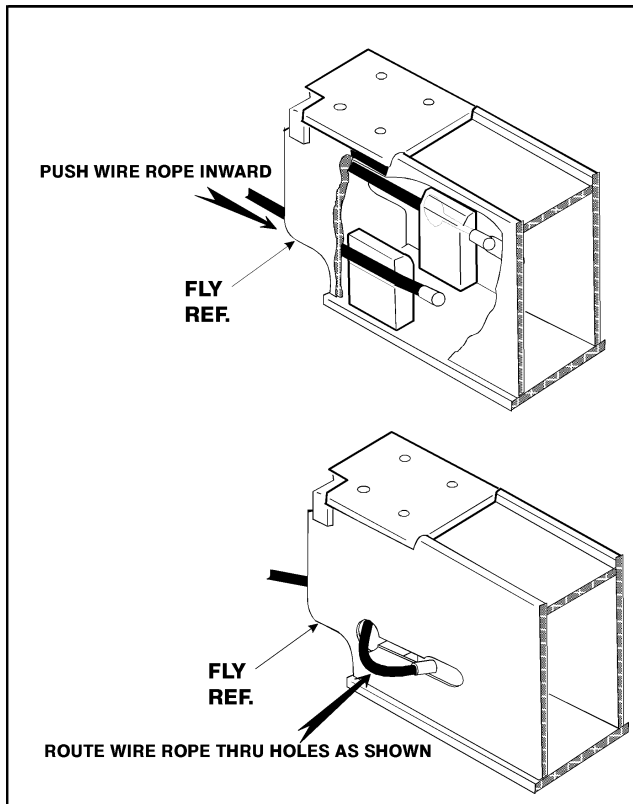


Figure 4-16. Wire Rope Routing Disassembly

### Inspection

**NOTE:** Refer to guidelines established in Section 2 - General when inspecting pins and bearings.

- Inspect all sheaves (extend and retract wire ropes and telescope cylinder) for excessive groove wear, burrs, or other damage. Replace sheaves as necessary.

**NOTE:** Use a groove gauge to check size, contour, and amount of wear. Replace sheave if worn as shown in the following drawing.

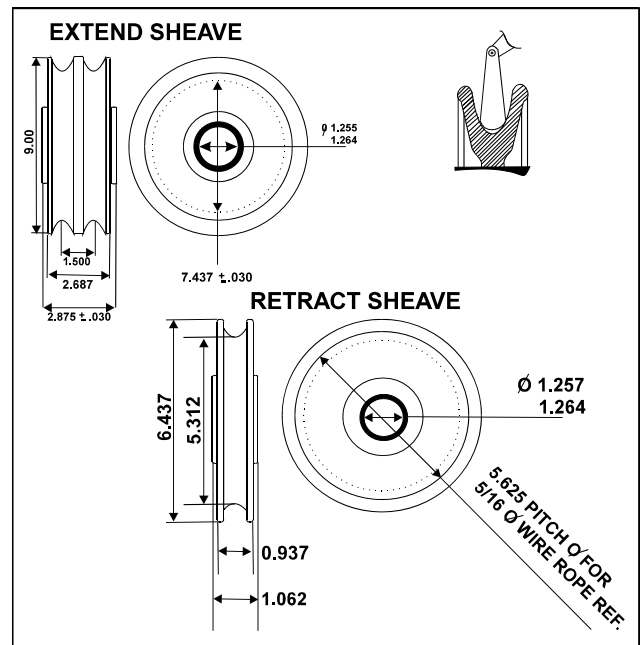


Figure 4-17. Dimension of Sheaves When New

## SECTION 4 - BOOM & PLATFORM

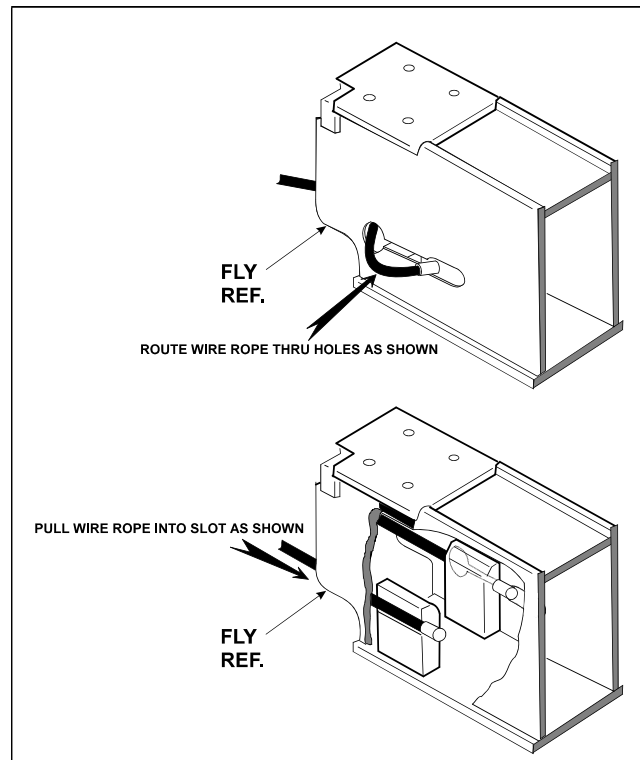
2. Inspect extend and retract wire rope sheave bearings for wear, scoring or other damage, and ovality.
3. Inspect extend wire rope and retract wire rope sheave pins for scoring, tapering and ovality. Replace pins as necessary.
4. Inspect telescope cylinder sheave pin for scoring, tapering and ovality. Replace pins as necessary.
5. Inspect boom pivot pin for wear, scoring, tapering and ovality, or other damage. Replace pins as necessary.
6. Inspect telescope cylinder attach point for scoring, tapering and ovality. Replace pins as necessary.
7. Inspect upper lift cylinder attach pin for wear, scoring, tapering and ovality, or other damage. Ensure pin surfaces are protected prior to installation. Replace pins as necessary.
8. Inspect inner diameter of boom pivot bushing for scoring, distortion, wear, or other damage. Replace bearing as necessary.
9. Inspect all wear pads for excessive wear or other damage. Replace pads when worn to within 1/8 inch (3.2 mm) of threaded insert.
10. Inspect extend and retract wire rope attach point components for cracks, stretching, distortion, or other damage. Replace components as necessary.
11. Inspect all threaded components for damage such as stretching, thread deformation, or twisting. Replace as necessary.
12. Inspect structural units of boom assembly for bending, cracking, separation of welds, or other damage. Replace boom sections as necessary.

### Assembly

**NOTE:** Install same number and thickness of shims removed during disassembly when installing fly section wear pads.

1. Measure inside dimensions of base and mid sections to determine number of shims required for proper lift.

2. Measure inside dimensions of mid section to determine number of shims required for proper lift.
3. Install side, top, and bottom wear pads to aft end of fly section. Shim evenly to inside measurements of mid section.
4. Install retract wire ropes in aft end of fly section. Route wire ropes through holes in side of fly boom section and pull into slot.



**Figure 4-18. Routing Installation of Retract Wire Ropes**

5. Install side, top, and bottom wear pads to aft end of mid section. Shim evenly to mid section inside measurements.

### NOTICE

**WHEN ASSEMBLING BOOM SECTIONS, ENSURE BOOM SLIDING TRAJECTORIES ARE CLEAR OF CHAINS, TOOLS, AND OTHER OBSTRUCTIONS.**

6. Shim insides of boom sections for a total of 1/16 inch (0.062) clearance (if action is centered, there will be 1/32 inch clearance on each side).

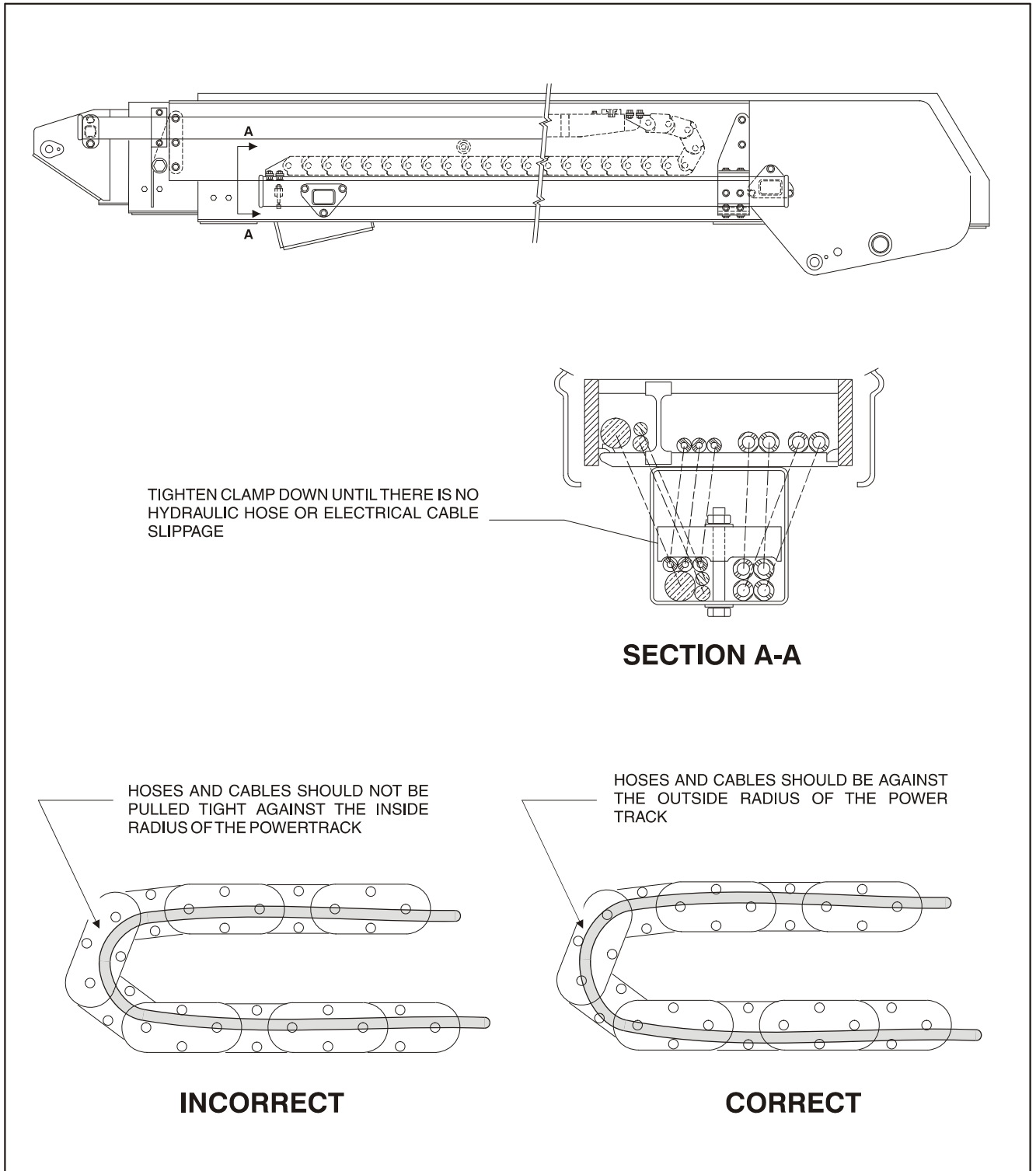


Figure 4-19. Boom Powertrack Installation

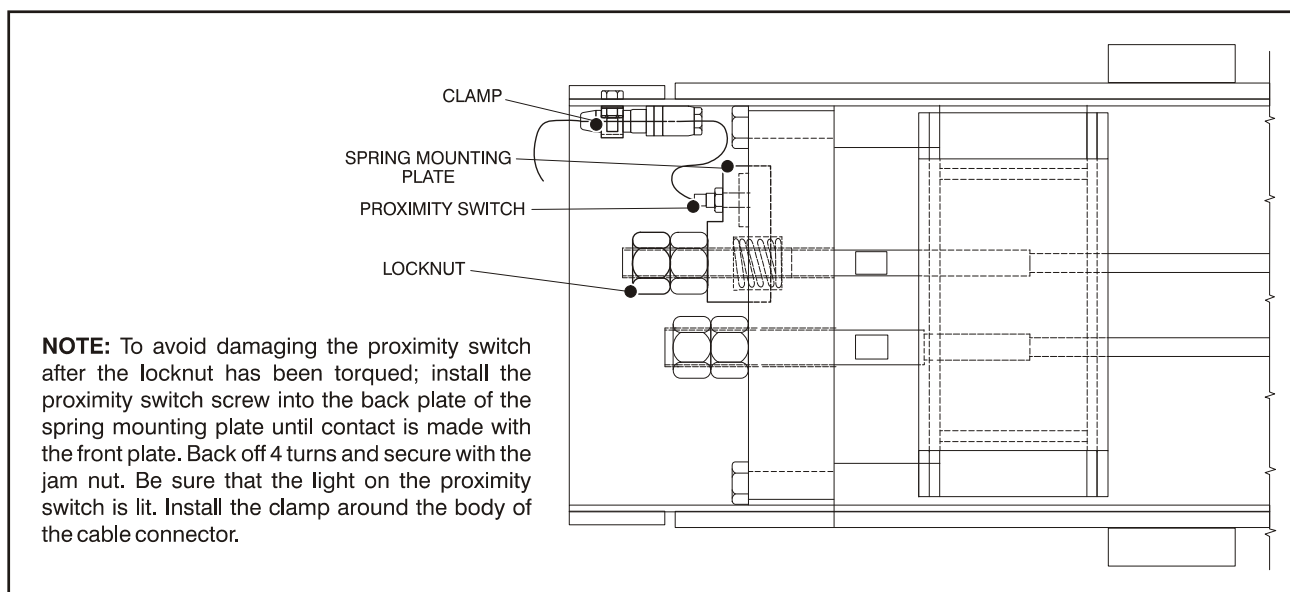
## SECTION 4 - BOOM & PLATFORM

7. Slide fly boom section into mid boom section. Shim boom, if necessary, for a total of 1/16 inch (0.062) clearance.
  8. Install wear pads in forward position of the mid boom section. Shim boom, if necessary, for a total of 2/10 inch (0.20) clearance.
  9. Properly position retraction wire rope sheaves assemblies at aft end of mid boom section. Ensure all sheave-to-mounting block attachment holes align. Install sheave pins and secure them with mounting hardware. Position retract wire ropes onto sheaves.
  10. Install sheave guards to aft end of mid boom section and secure with mounting hardware.
  11. Slide mid boom section into base boom section. Allow retraction wire ropes to trail between bottom surfaces of boom sections. Shim boom, if necessary, for a total of 1/16 inch (0.062) clearance.
  12. Install wear pads into the forward position of base boom section. Shim boom, if necessary, for a total of 2/10 inch (0.20) clearance.
  13. Install sheave block to bottom of base boom section and adjust block so that retract wire ropes do not come into contact with boom surfaces.
  14. Install wire rope threaded ends thru attachment holes in bottom of base boom section. Loosely install nuts and jam nuts on threaded ends of wire ropes.
  15. Align telescope cylinder barrel-to-sheave attachment point. Install extend sheave pin through telescope cylinder barrel and sheave assembly; secure pin with mounting hardware.
  16. Route extend wire ropes around extend sheave and secure wire ropes to the telescope cylinder.
  17. Install extend wire rope mounting blocks to threaded ends of wire ropes. Loosely install nuts and jam nuts on threaded ends of wire ropes.
- NOTE:** Do not twist or cross wire ropes during installation.
- NOTE:** For non CE specification machines, skip step 18 and proceed to step 19.
18. Install extend wire rope mounting blocks, proximity mounting plate and spring to threaded ends of wire ropes. Loosely install nuts and jam nuts on threaded ends of wire ropes. Refer to Figure 4-20., Proximity Switch Installation.
  19. Secure sling and lifting device at telescope cylinder's approximate center of gravity, and lift cylinder to aft end of boom assembly.

### NOTICE

**WHEN INSERTING TELESCOPE CYLINDER IN BOOM, IT MAY BE NECESSARY TO TURN CYLINDER SLIGHTLY TO CLEAR ASSEMBLIES MOUNTED IN BOOM. CARE MUST BE TAKEN TO MOVE CYLINDER SLOWLY INTO POSITION. DAMAGE TO COMPONENTS MAY RESULT FROM FORCIBLE IMPACT WITH ASSEMBLIES.**

20. Align cylinder with slots at aft end of mid boom section, then secure cylinder with mounting hardware.
21. Align holes in aft end of fly boom section with holes in wire rope mounting block. Secure with mounting hardware.



**Figure 4-20. Proximity Switch Installation**



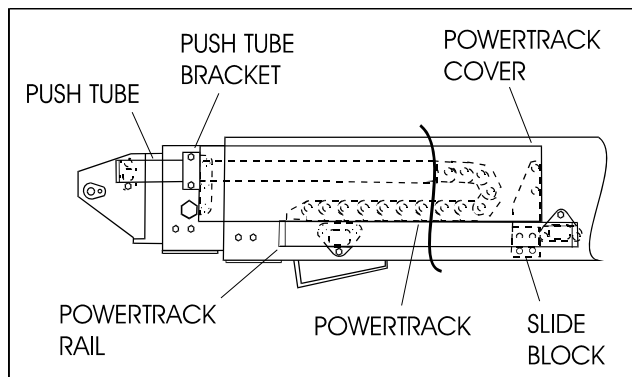
22. Align holes in aft end of mid boom section with holes in wire rope mounting block. Secure with mounting hardware.

**NOTE:** Boom wire ropes must be torqued after installation of boom assembly.

23. Align holes in rod end of telescope cylinder with holes in push bar. Install push bar pin and secure with mounting hardware.
23. Install hydraulic lines and electrical cables, and harnessing powertrack components as follows:
  - a. Align holes in powertrack rail with attachment holes in side of base boom section. Secure rail with mounting hardware.
  - b. Install powertrack to rail with mounting hardware.
  - c. Attach push tube bracket to side of mid boom section with mounting hardware.

**NOTE:** Do not over tighten attach bolt on push tube bracket. It should pivot freely.

- d. Install slide block and wear pads to powertrack rail with mounting hardware.
- e. Install powertrack to push tube with mounting hardware.
- f. Carefully feed hoses and electrical cables through aft end of powertrack rail, powertrack, and push tube.
- g. Ensure all hoses and cables are properly routed through powertrack rail, powertrack, and push tube. Tighten or install all clamping or securing apparatus to hoses or cables, as necessary.
- h. Install powertrack cover and push tube rods with mounting hardware.



**Figure 4-21. Boom Powertrack Assembly**

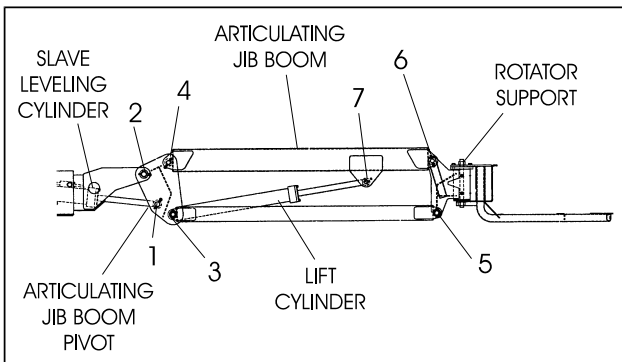
## Installation

1. Using a suitable lifting device, position boom assembly on turntable so pivot holes in both boom and turntable are aligned.
2. Install boom pivot pin. Ensure location of hole in pin is aligned with attach point on turntable.
3. If necessary, gently tap pin into position with soft headed mallet. Secure pin mounting hardware.
4. Align push bar pivot hole with pivot holes in turntable. Install push bar pivot pin, Ensure location of hole in pin is aligned with attach point on turntable.
5. If necessary, gently tap pin into position with soft headed mallet. Secure pin mounting hardware.
6. Connect all wiring to ground control box.
7. Connect all hydraulic lines running along side of boom assembly.
8. Using all applicable safety precautions, operate lifting device to position boom lift cylinder so holes in cylinder rod end and boom structure are aligned. Insert lift cylinder pin. Ensure location of hole in pin is aligned with attach point on boom.
9. Align holes in boom structure with hole in master cylinder. Insert master cylinder pin. Ensuring hole in pin is aligned with attach point on boom.
10. Adjust retract and extend cables to proper torque. Refer to paragraph 2-6, boom cable torque procedures.
11. Using all applicable safety precautions, operate machine systems and raise and extend boom fully. Note extension cycle performance.
12. Retract and lower boom. Note retraction cycle performance.

## 4.6 ARTICULATING JIB BOOM

### Removal

1. For platform/support removal see platform/support removal diagram. See Section 4-1., Location of Components - Platform Support.
2. Position articulating jib boom level with ground.
3. Remove mounting hardware from slave leveling cylinder pin #1. Using a suitable brass drift and hammer, remove cylinder pin from articulating jib boom.



**Figure 4-22. Articulating Jib Boom Components**

4. Remove mounting hardware from articulating jib boom pivot pin #2. Using a suitable brass drift and hammer, remove pivot pin from boom assembly.

### Disassembly

1. Remove mounting hardware from articulating jib boom pivot pins #3 and #4. Using a suitable brass drift and hammer, remove the pins from articulating jib boom pivot weldment.
2. Remove mounting hardware from rotator support pins #5 and #6. Using a suitable brass drift and hammer, remove pins from rotator support.
3. Remove mounting hardware from lift cylinder pin #7. Using a suitable brass drift and hammer, remove the cylinder pin from articulating jib boom.

### Inspection

**NOTE:** Refer to Section 2 - General, when inspecting pins and bearings.

1. Inspect articulating fly boom pivot pin for wear, scoring, tapering and ovality, or other damage. Replace pins as necessary.
2. Inspect articulating fly boom pivot attach points for scoring, tapering and ovality, or other damage. Replace pins as necessary.
3. Inspect inner diameter of articulating fly boom pivot bearings for scoring, distortion, wear, or other damage. Replace bearings as necessary.
4. Inspect lift cylinder attach pin for wear, scoring, tapering and ovality, or other damage. Ensure pin surfaces are protected prior to installation. Replace pins as necessary.
5. Inspect inner diameter of rotator attach point bearings for scoring, distortion, wear, or other damage. Replace bearing as necessary.
6. Inspect all threaded components for damage such as stretching, thread deformation, or twisting. Replace as necessary.
7. Inspect structural units of articulating jib boom assembly for bending, cracking, separation of welds, or other damage. Replace boom sections as necessary.

## Assembly

**NOTE:** For location of components See Section 4-22., Articulating Jib Boom Components.

1. Align lift cylinder with attach holes in articulating jib boom. Using a soft head mallet, install cylinder pin #7 into articulating jib boom and secure with mounting hardware.
2. Align rotator support with attach hole in articulating jib boom. Using a soft head mallet, install rotator support pin #6 into articulating jib boom and secure with mounting hardware.
3. Align bottom tubes with attach holes in rotator support. Using a soft head mallet, install rotator support pin #5 into articulating jib boom and secure with mounting hardware.
4. Align articulating jib boom with attach hole in articulating jib boom pivot weldment. Using a soft head mallet, install rotator support pin #4 into articulating jib boom and secure with mounting hardware.
5. Align bottom tubes with attach holes in articulating jib boom pivot weldment. Using a soft head mallet, install rotator support pin #3 into articulating jib boom pivot weldment. Secure with mounting hardware.
6. Align articulating jib boom pivot weldment with attach holes in fly boom assembly. Using a soft head mallet, install pivot pin #2 into fly boom assembly. Secure with mounting hardware.
7. Align slave leveling cylinder with attach holes in articulating jib boom pivot weldment. Using a soft head mallet, install slave leveling cylinder pin #1 into articulating jib boom pivot weldment. Secure with mounting hardware.

## 4.7 LIMIT SWITCHES AND CAM VALVE ADJUSTMENT

Adjust switches and cam valve as shown in Figure 4-23., Horizontal Limit and Dual Capacity Limit Switches Adjustments and Figure 4-24., Transport Switch Adjustments - CE Machines Only.

## 4.8 BOOM CLEANLINESS GUIDELINES

The following are guidelines for internal boom cleanliness for machines used in excessively dirty environments.

1. JLG recommends use of JLG Hostile Environment Package to keep internal portions of a boom cleaner and help prevent dirt and debris from entering the boom. This package reduces the amount of contamination which can enter the boom, but does not eliminate the need for more frequent inspections and maintenance when used in these types of environments.
2. JLG recommends you follow all guidelines for servicing your equipment in accordance with instruction in the JLG Service & Maintenance Manual for your machine. Periodic maintenance and inspection is vital to proper operation of the machine. Frequency of service and maintenance must be increased as environment, severity, and frequency of usage requires.
3. Debris and contamination inside the boom can cause premature failure of components and should be removed. Methods to remove debris should always be done using all applicable safety precautions outlined in the JLG Operation & Safety Manual and the JLG Service & Maintenance Manuals.
4. The first attempt to remove debris from inside the boom must be to utilize pressurized air to blow the debris toward the nearest exiting point from the boom. Make sure that all debris is removed before operating the machine.
5. If pressurized air cannot dislodge debris, then water with mild solvents applied with a pressure washer can be used. Wash debris toward the nearest exiting point from the boom. Make sure all debris is removed, no "puddling" of water has occurred, and boom internal components are dry before operating machine. Make sure you comply with all federal and local laws for disposing of wash water and debris.
6. If pressurized air or washing boom does not dislodge and remove debris, disassemble boom following instructions outlined in the JLG Service & Maintenance Manual to remove debris.

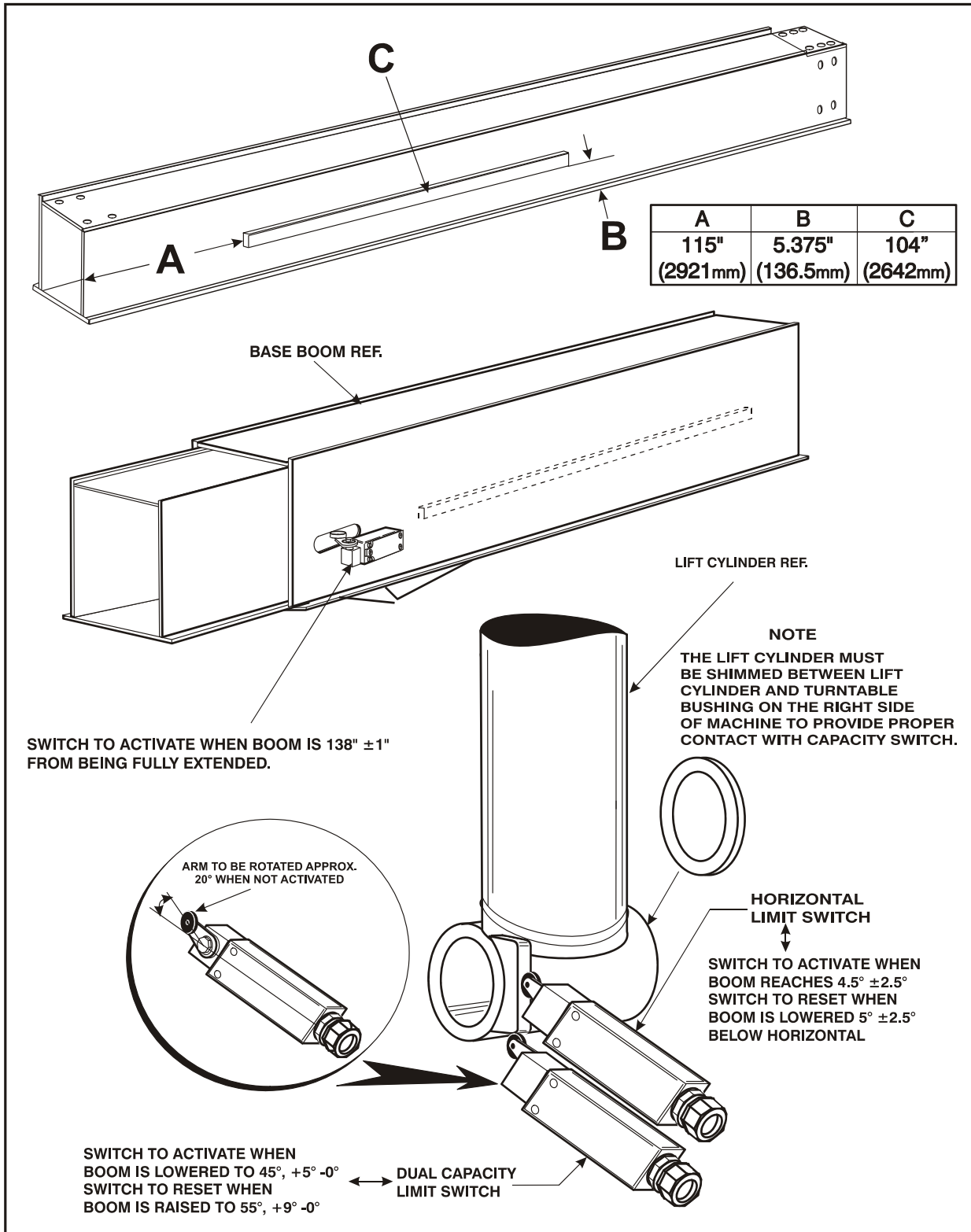


Figure 4-23. Horizontal Limit and Dual Capacity Limit Switches Adjustments

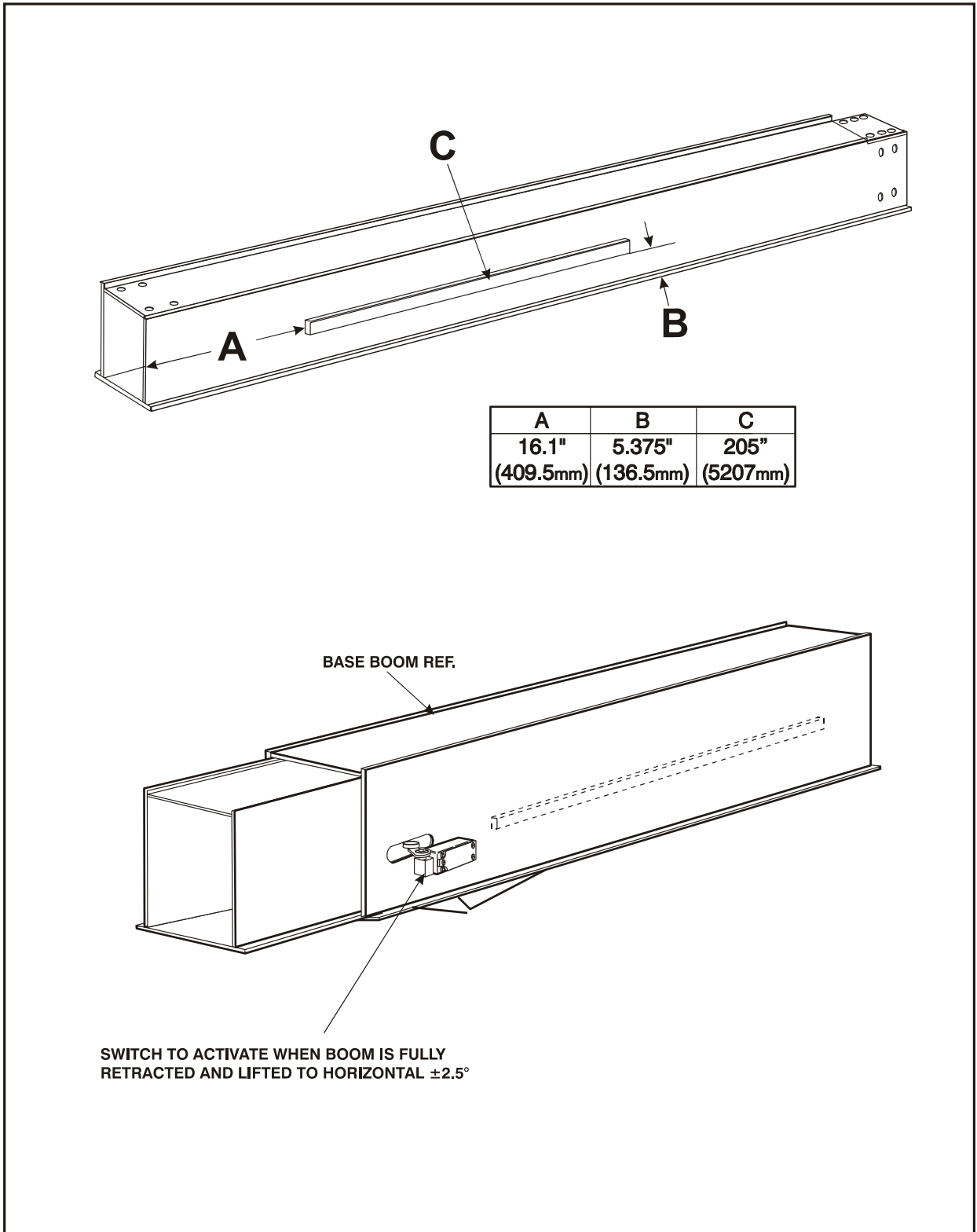


Figure 4-24. Transport Switch Adjustments - CE Machines Only

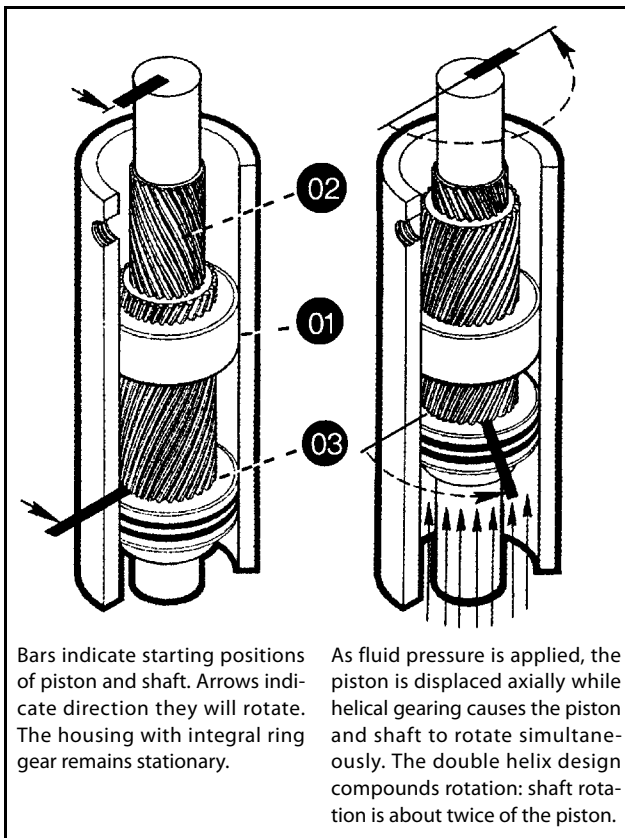
## 4.9 ROTARY ACTUATOR

### Theory of Operation

The L20 Series rotary actuator is a simple mechanism that uses the sliding spline operating concept to convert linear piston motion into powerful shaft rotation.

Each actuator is composed of a housing with integrated gear teeth (01) and only two moving parts: the central shaft with integrated bearing tube and mounting flange (02), and the annular piston sleeve (03). Helical spline teeth machined on the shaft engage matching splines on the piston inside diameter. The piston outside diameter carries a second set of opposite direction splines which engage with matching splines in the housing.

As hydraulic pressure is applied, piston is displaced axially within the housing - similar to operation of a hydraulic cylinder - while splines cause shaft to rotate. When control valve is closed, oil is trapped inside the actuator, preventing piston movement and locking the shaft in position. The shaft is sup-



Bars indicate starting positions of piston and shaft. Arrows indicate direction they will rotate. The housing with integral ring gear remains stationary.

As fluid pressure is applied, the piston is displaced axially while helical gearing causes the piston and shaft to rotate simultaneously. The double helix design compounds rotation: shaft rotation is about twice of the piston.

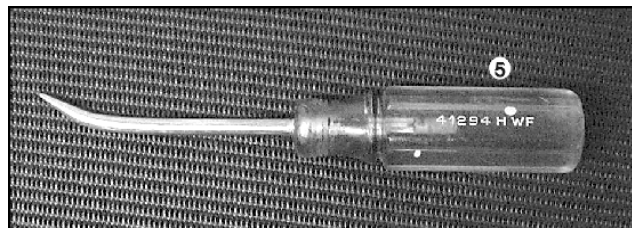
ported radially by the large upper radial bearing and lower radial bearing. Axially, the shaft is separated from the housing by upper and lower thrust washers. End cap is adjusted for axial clearance and locked in position by set screws or pins.

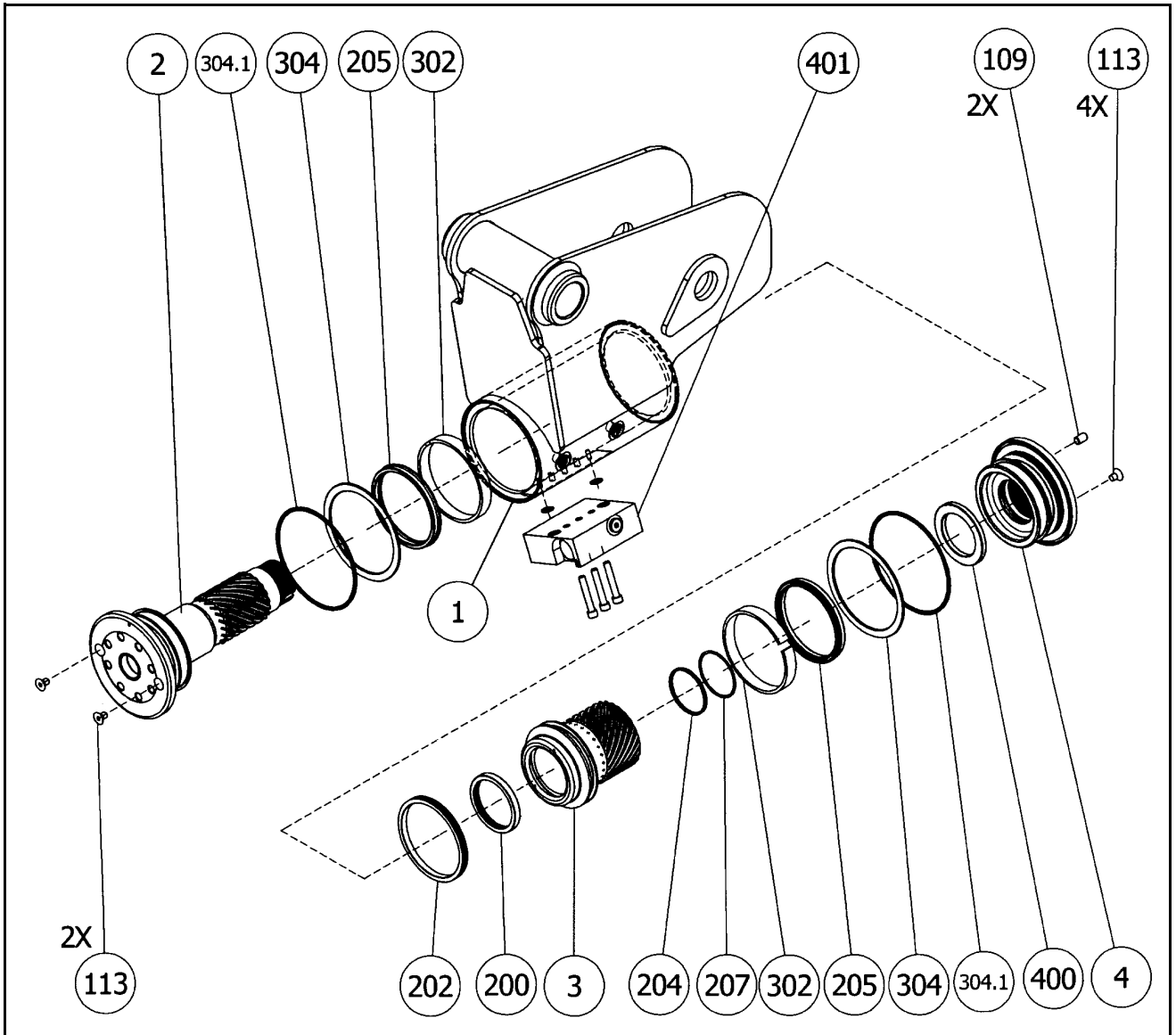
### Required Tools



1. Flashlight - Examine timing marks, component failure, and overall condition.
2. Felt Marker - Match mark timing marks and outline troubled areas.
3. Allen wrench - Remove port plugs and set screws.
4. Box knife - removal of seals.
5. Seal tool - assembly and disassembly of seals and wear guides.
6. Pry bar - End cap removal and manual rotation of shaft.
7. Rubber mallet- Removal and installation of shaft and piston sleeve assembly.
8. Nylon drift - Piston sleeve installation.
9. End cap dowel pins - removal and installation of end cap (sold with Helac seal kit).

The seal tool is a customized standard flat head screwdriver. To make this tool, heat flat end with a torch. Secure heated end of screwdriver in a vice and bend to a slight radius. Once radius is achieved, round off all sharp edges using a grinder. There may be some slight modifications for your personal preference.





PARTS

- 1. Housing
- 2. Shaft
- 3. Piston Sleeve
- 4. End Cap

HARDWARE

- 103.1. Screw
- 103.2. Washer
- 106.1. Port Plug
- 106.2. Port Plug
- 109. Lock Pin
- 113. Capscrew

SEALS

- 200. T-Seal
- 202. T-Seal
- 204. O-ring
- 205. Cup Seal
- 207. Backup Ring
- 304.1. Wiper Seal

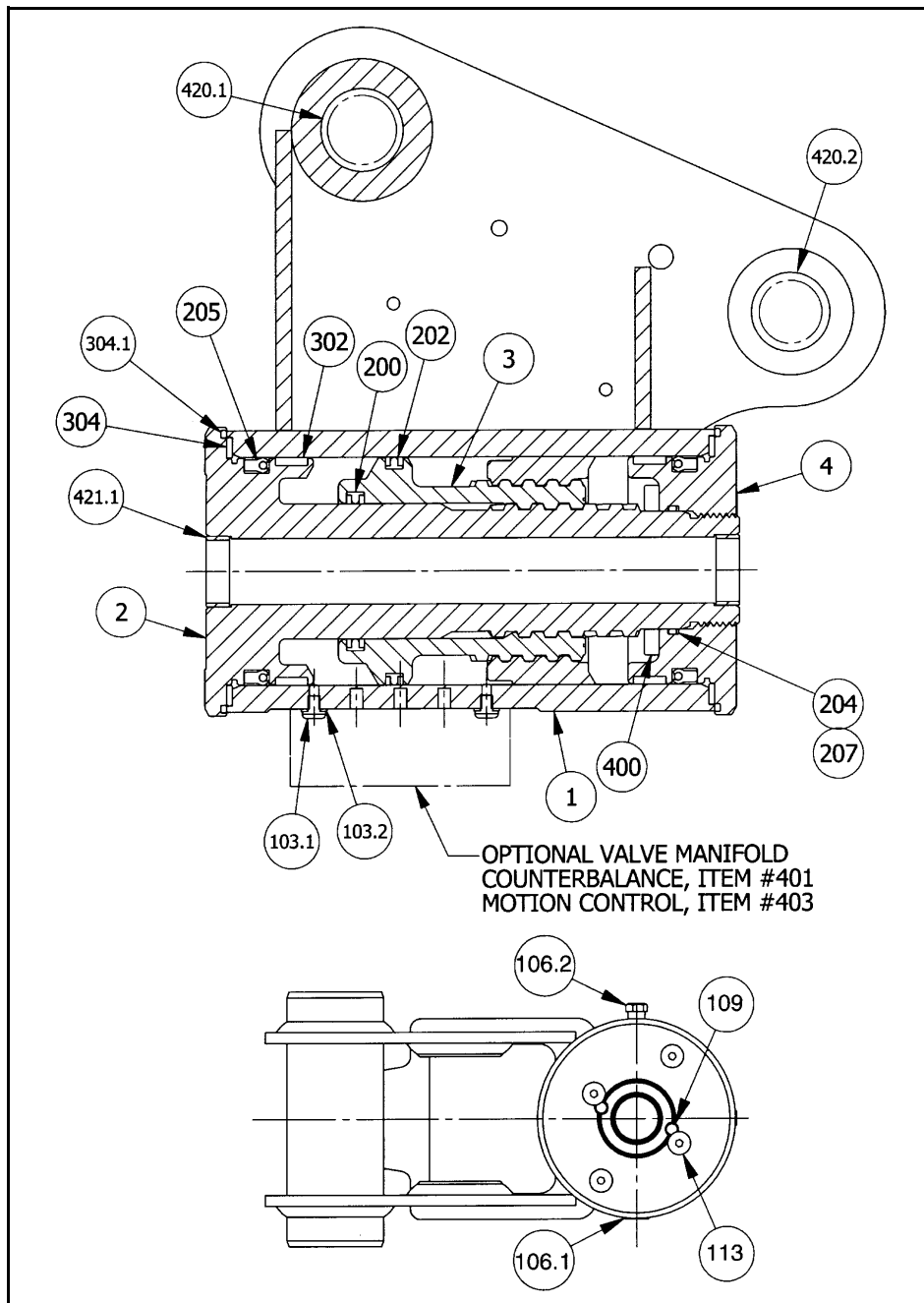
BEARINGS

- 302. Wear Guide
- 304. Thrust Washer

ACCESSORIES

- 400. Stop Tube
- 420.1 Bushing
- 420.2 Bushing
- 421.1 Bushing

Figure 4-25. Rotary Actuator - Exploded View



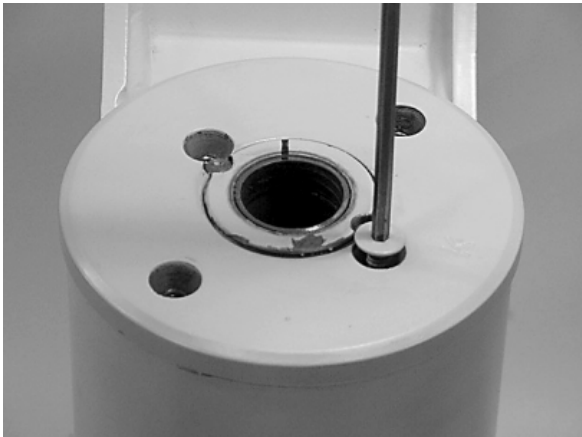
PARTS	HARDWARE	SEALS	BEARINGS	ACCESSORIES
1. Housing	103.1. Screw	200. T-Seal	302. Wear Guide	400. Stop Tube
2. Shaft	103.2. Washer	202. T-Seal	304. Thrust Washer	420.1 Bushing
3. Piston Sleeve	106.1. Port Plug	204. O-ring		420.2 Bushing
4. End Cap	106.2. Port Plug	205. Cup Seal		421.1 Bushing
	109. Lock Pin	207. Backup Ring		
	113. Capscrew	304.1. Wiper Seal		

**Figure 4-26. Rotary Actuator - Assembly Drawing**



**Disassembly**

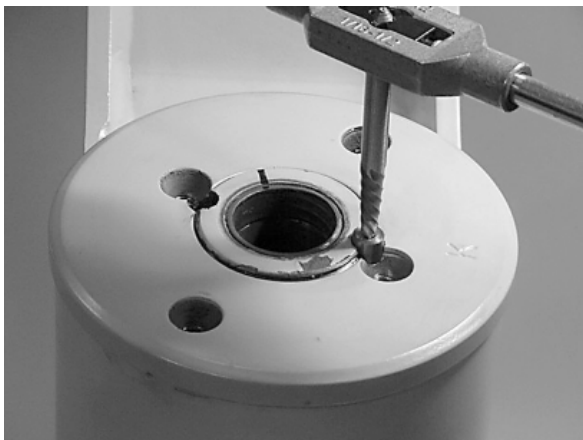
1. Remove capscrews (113) over end cap lock pins (109).



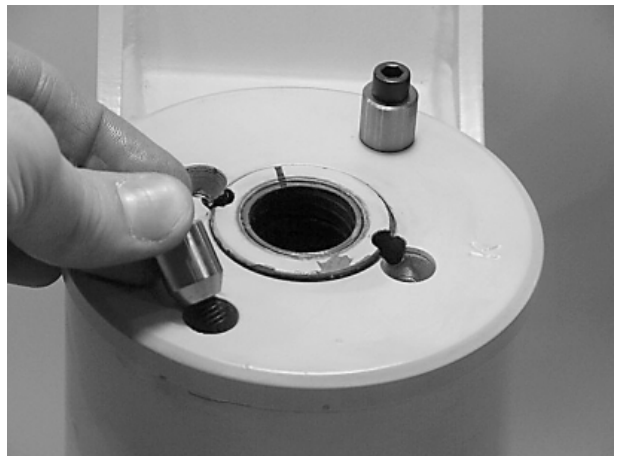
2. Using a 1/8" (3.18mm) drill bit, drill a hole in center of each lock pin approximately 3/16" (4.76mm) deep.



3. Remove lock pins using an "Easy Out" (Size #2 shown. If pin will not come out, use 5/16" drill bit 1/2" (12.7mm) deep to drill out entire pin.



4. Remove end cap (4) using tools provided with Helac seal kit.



5. Using a metal bar or similar tool, unscrew end cap (4) by turning it counter clockwise.



6. Remove end cap (4) and set aside for later inspection.

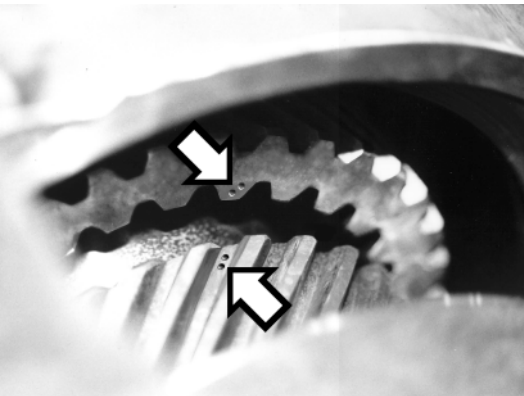


## SECTION 4 - BOOM & PLATFORM

7. Remove stop tube if installed.



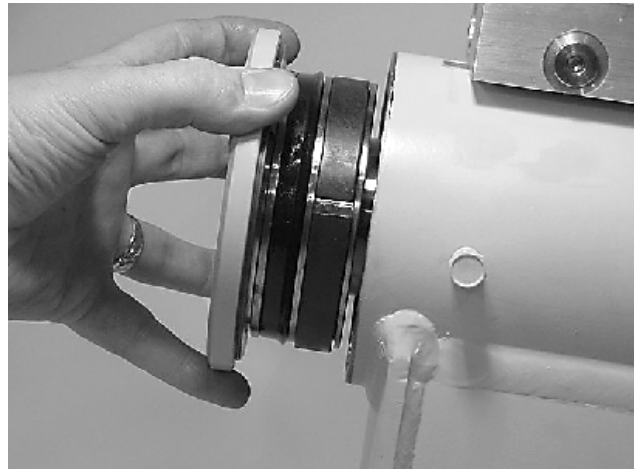
8. Actuator has timing marks for proper engagement.



9. Before removing shaft, (2), use a felt marker to clearly indicate timing marks between shaft and piston. This simplifies timing during assembly.



10. Remove shaft (2). It may be necessary to strike threaded end of shaft with a rubber mallet.



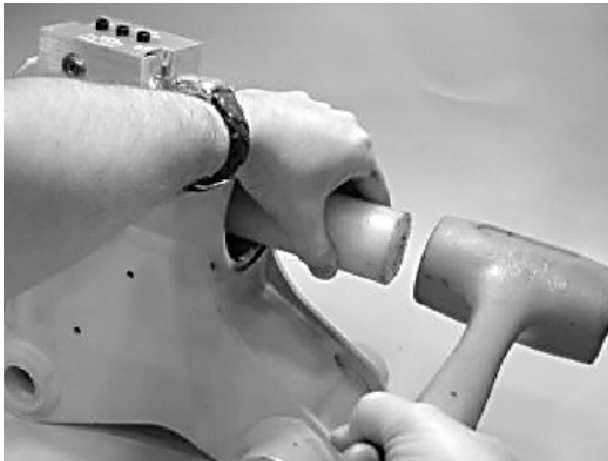
11. Before removing piston (3), mark housing (1) ring gear in relation to piston O.D. gear. There should be timing marks on housing (1) ring gear, piston (3), and shaft (2).



13. At the point when piston gear teeth come out of engagement with housing gear teeth, mark piston and housing with a marker as shown.



12. To remove piston (3), use a rubber mallet and plastic mandrel so piston is not damaged.



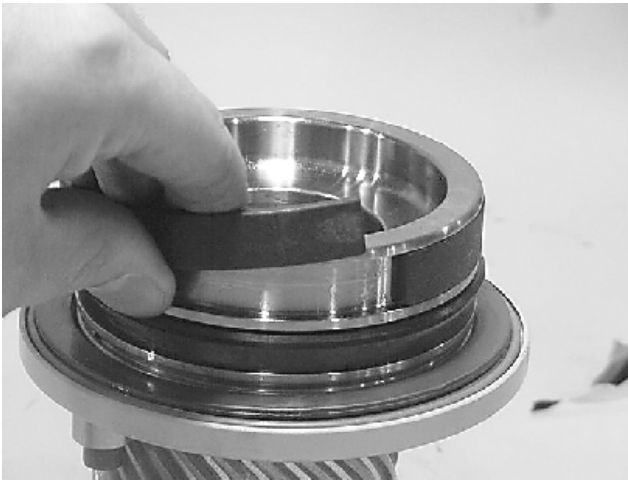
14. Remove O-ring (204) and backup ring (207) from end cap (4) and set aside for inspection.



## SECTION 4 - BOOM & PLATFORM

---

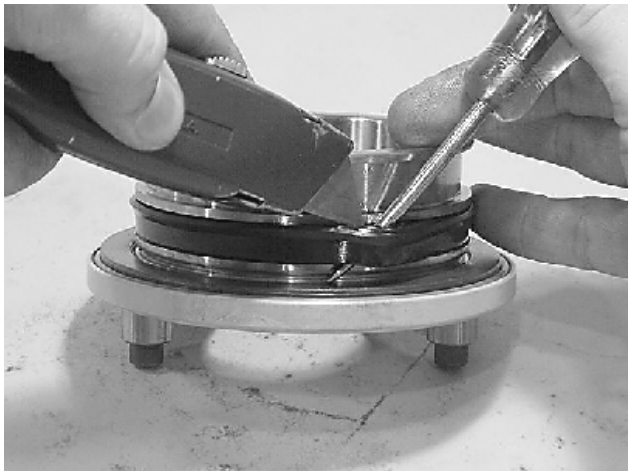
15. Remove wear guides (302) from end cap (4) and shaft (2).



17. Remove thrust washers (304) from end cap (4) and shaft (2).



16. To remove main pressure seals (205), cut them with a sharp razor blade. Do not to damage seal groove.



18. Remove wiper seal (304.1) from end cap (4) and shaft (2).



19. Remove piston O.D. seal (202).



20. Remove piston I.D. seal (200).

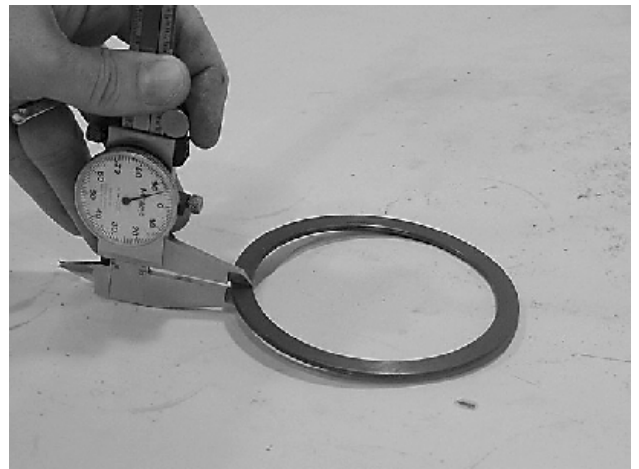


**Inspection**

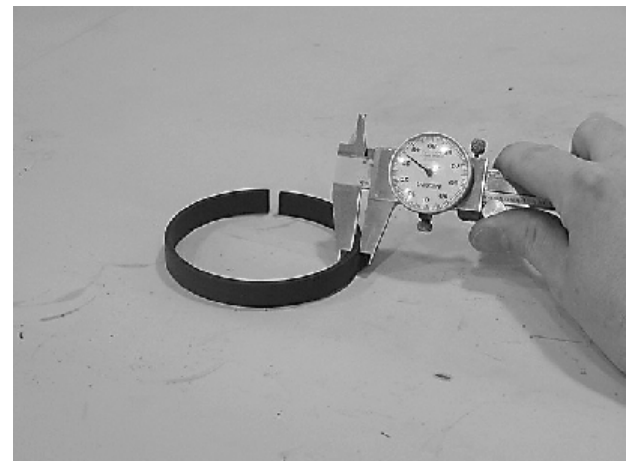
1. Clean all parts in a solvent tank and dry with compressed air before inspecting. Carefully inspect all critical areas for any surface finish abnormalities: Seal grooves, bearing grooves, thrust surfaces, rod surface, housing bore, and gear teeth.



2. Inspect thrust washers (304) for rough or worn edges and surfaces. Measure thickness is within specifications (Not less than 0.092" or 2.34 mm).

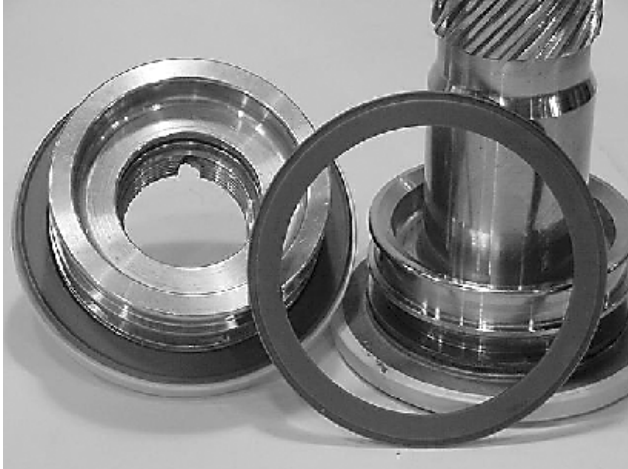


3. Inspect wear guide condition and measure thickness (not less than 0.123" or 3.12 mm).



**Assembly**

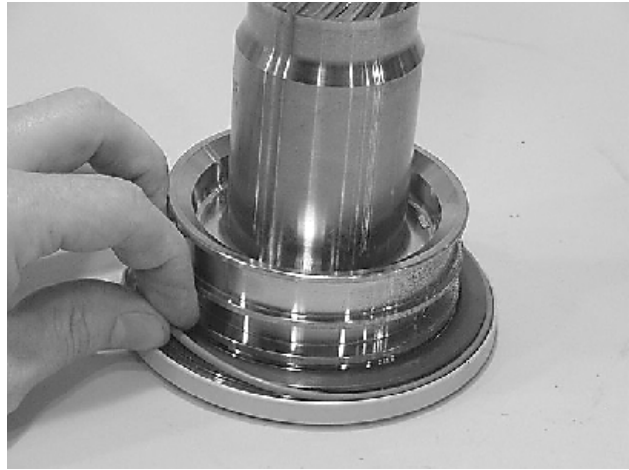
1. Gather all components and tools to one location. Use cut away drawing to reference seal orientations.



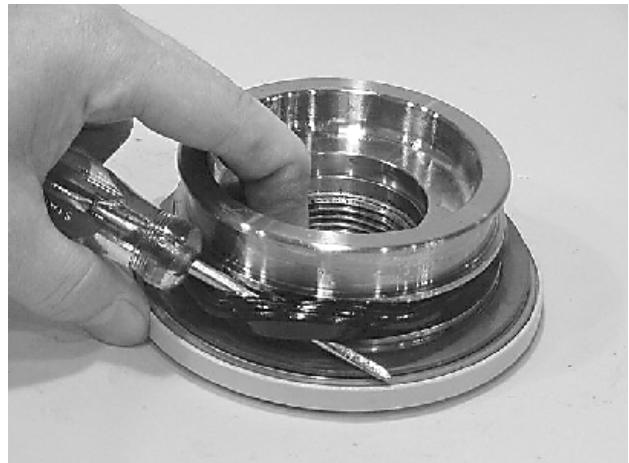
2. Install thrust washer (304) on shaft (2) and end cap (4).



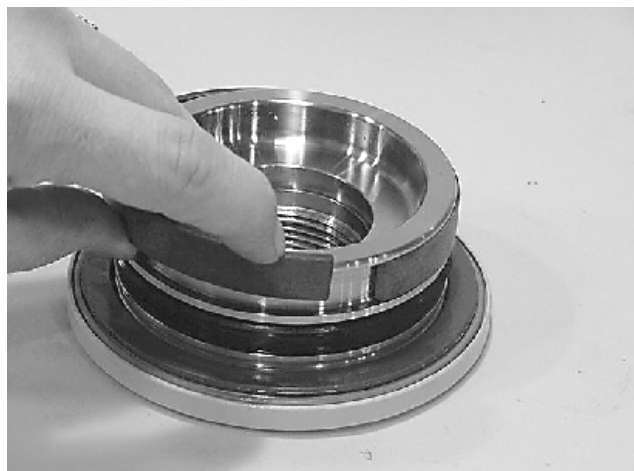
3. Install wiper seal (304.1/green O-ring) in groove on shaft (2) and end cap (4) - around outside edge of thrust washer (304).



4. Use a seal tool install main pressure seal (205) on shaft (2) and end cap (4). Use seal tool in a circular motion.



5. Install wear guide (302) on end cap (4) and shaft (2).



6. Install inner T-seal (200) in piston (3) using a circular motion. Install outer T-seal (202) by stretching it around the groove in a circular motion. Each T-seal has two back-up rings (see drawing for orientation).

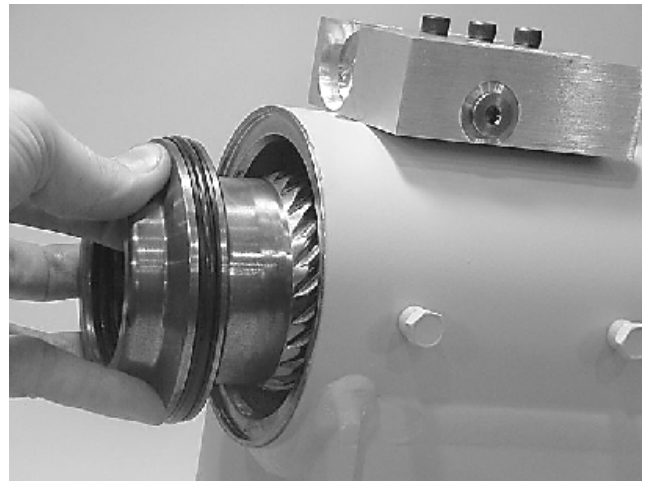


7. Beginning with inner seal (200) insert one end of b/u ring in lower groove and feed the rest in using a circular motion. Make sure wedged ends overlap correctly.

Repeat for outer seal (202).



8. Insert piston (3) in housing (1) as shown, until outer piston seal (202) touches inside housing bore.

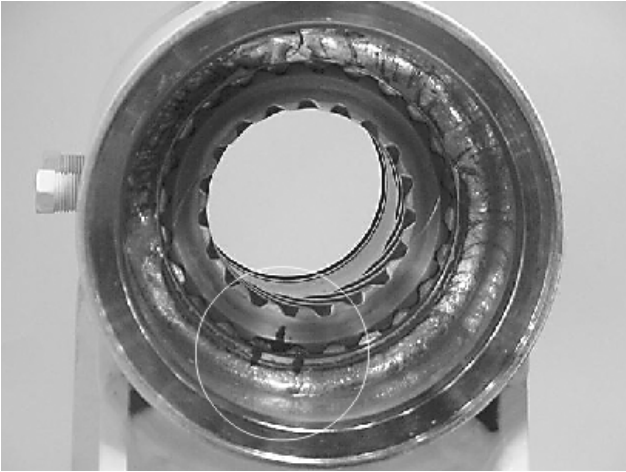


9. Looking from angle shown, rotate piston (3) until marks you put on piston and housing (1) during disassembly line up as shown. Using a rubber mallet, tap piston in housing to point where gear teeth meet.

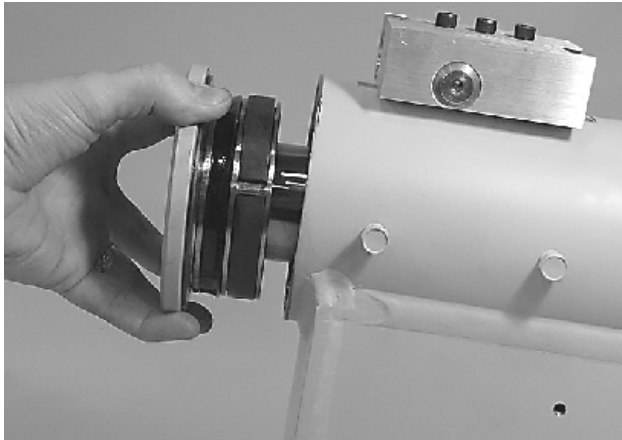


## SECTION 4 - BOOM & PLATFORM

10. Looking from opposite end of housing (1) when timing marks line up, tap piston (3) in until gear teeth mesh together. Tap piston in housing until it bottoms out.



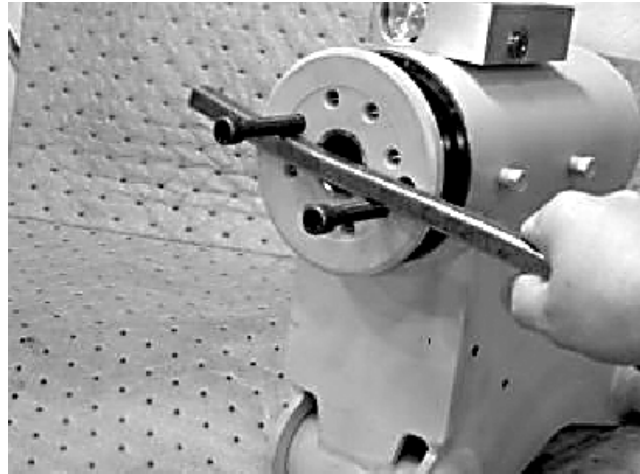
11. Install shaft (2) in piston (3). Do not damage seals. Do not engage piston gear teeth.



12. Looking from view shown, use existing timing marks to line up gear teeth on shaft (2) with gear teeth on inside of piston (3). Tap flange end of shaft with rubber mallet until gear teeth engage.

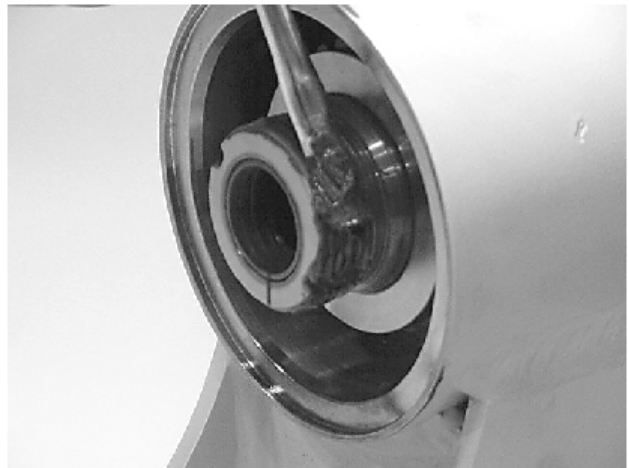


13. Install 2 bolts in threaded holes in flange. Using a bar, rotate shaft clockwise until wear guides are seated in housing bore.



14. Install stop tube on shaft end. Stop tube is an available option to limit actuator rotation.

15. Coat threads on end of shaft with anti-seize grease to prevent galling.

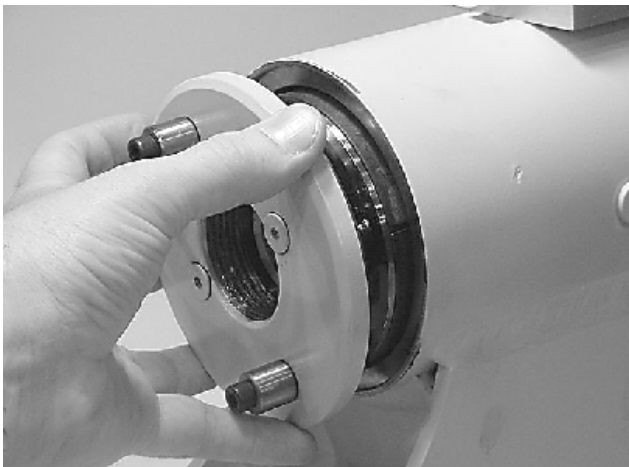




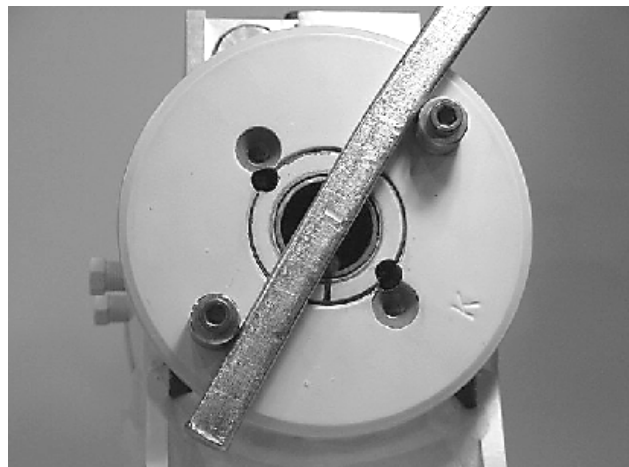
16. Install O-ring (204) and back-up ring (207) in inner seal groove on end cap (4).



17. Thread end cap (4) on shaft (2) end. Ensure wear guide stays in place on end cap as it is threaded in housing (1).



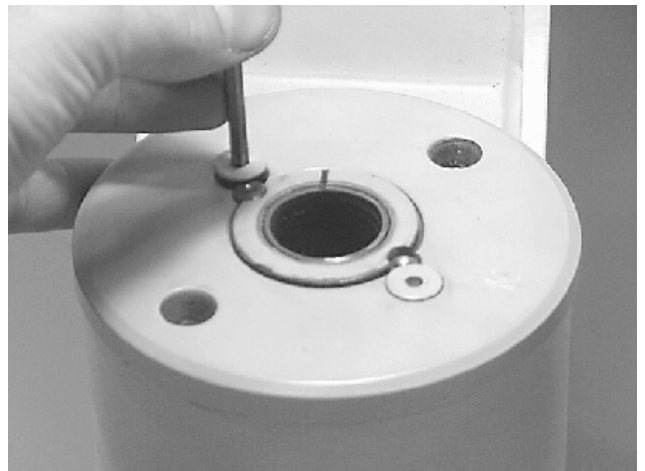
18. Tighten end cap (4). Ensure holes for lock pins line up.



19. Place lock pins (109) provided in Helac seal kit in holes with dimple side up. Using a punch, tap lock pins to bottom of hole.



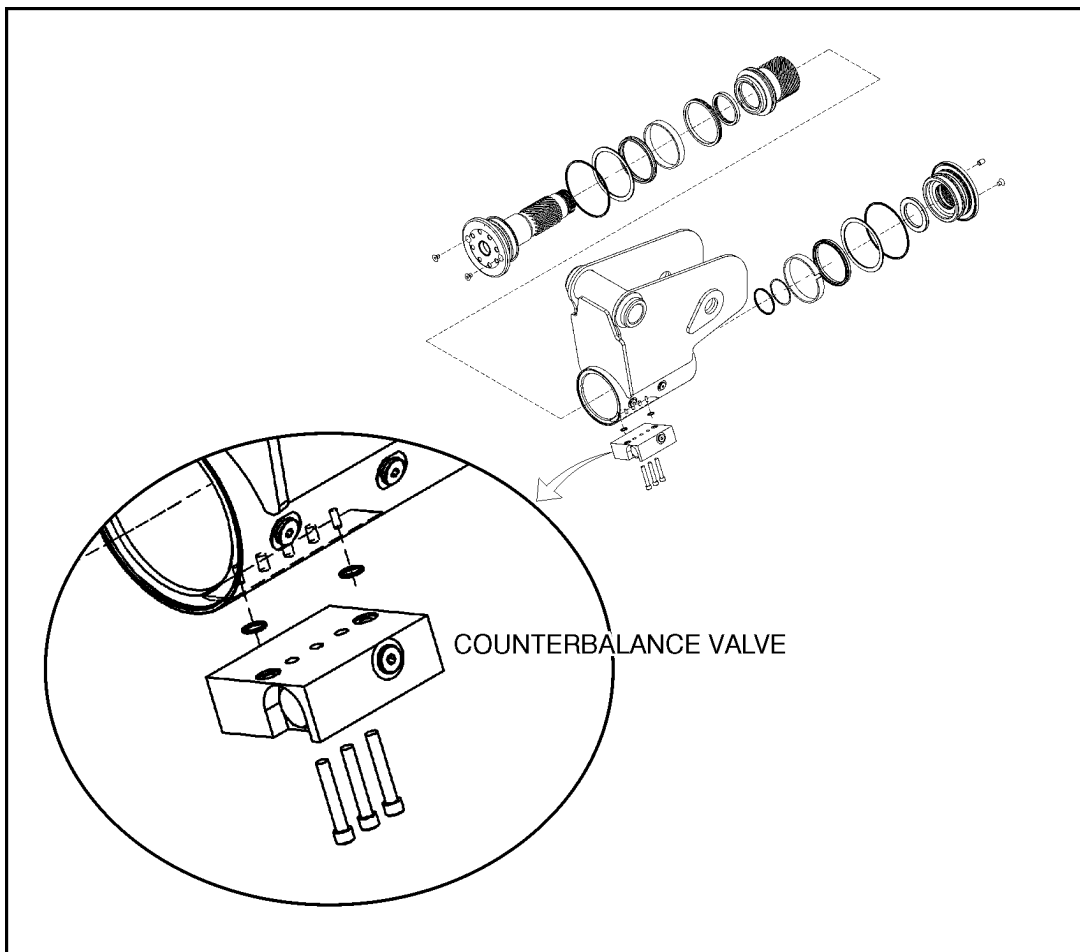
20. Insert set screws (113) over lock pins. Tighten to 25 in-lb (2.825 Nm).



**Installing Counterbalance Valve**

Refer to Figure 4-27., Rotator Counterbalance Valve.

1. Make sure surface of actuator is clean and free of any contamination and debris, including old Loctite.
2. Make sure new valve has the O-rings in counterbores of valve to seal it to the actuator housing.
3. Bolts that come with valve are Grade 8 bolts. Install new bolts with a new valve. Apply Loctite #242 to shanks of the three bolts at time of installation.
4. Torque 1/4-inch bolts 110-120 in-lb (12.4-13.5 Nm). Do not torque over 125 in-lb (14.1 Nm). Torque 5/16-inch bolts to 140 in-lb (15.8 Nm). Do not torque over 145 in-lb (16.3 Nm).



**Figure 4-27. Rotator Counterbalance Valve**

## Testing Actuator

If equipment is available, test actuator on a hydraulic test bench. Breakaway pressure — the pressure at which the shaft begins to rotate — should be approximately 400 psi (28 bar). Cycle actuator at least 25 times at 3000 psi (210 bar) pressure. After 25 rotations, increase pressure to 4500 psi (315 bar). Check for leaks and cracks. Perform test again at end of rotation in the opposite direction.

## Testing Actuator for Internal Leaks

If actuator is equipped with a counterbalance valve, plug valve ports, connect hydraulic lines to housing ports. Bleed all air from actuator (see Installation and Bleeding). Rotate shaft to end of rotation at 3000 psi (210 bar) and maintain pressure. Remove hydraulic line from non-pressurized side.

Continuous oil flow from open housing port indicates internal leakage across the piston. Replace line and rotate shaft to end of rotation in opposite direction. Repeat test procedure outlined above for other port. If there is an internal leak, disassemble, inspect, and repair.

## Installation and Bleeding

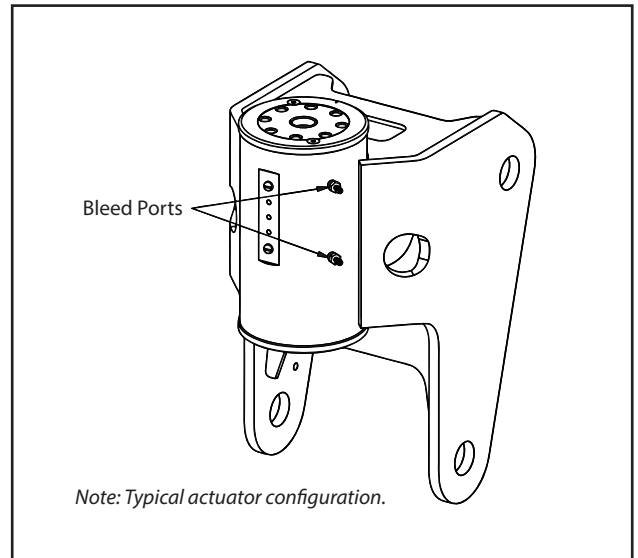
### **⚠ WARNING**

**AFTER INSTALLING ACTUATOR, IT IS IMPORTANT THAT ALL SAFETY DEVICES SUCH AS TIE RODS OR SAFETY CABLES ARE PROPERLY REATTACHED.**

To purge air from hydraulic lines, connect them together to create a closed loop and pump hydraulic fluid through them. Review hydraulic schematic to determine which hydraulic lines to connect. The linear feet and inside diameter of hydraulic supply lines together with pump capacity determine amount of pumping time required to fully purge the hydraulic system.

Bleeding may be necessary if excessive backlash is exhibited after actuator is connected to hydraulic system. The following steps are recommended when a minimum of two gal (8L) is purged.

1. Connect a 3/16" inside diameter x 5/16" outside diameter x 5 foot clear, vinyl drain tube to each of the two bleed nipples. Secure with hose clamps. Place vinyl tubes in a clean 5-gallon container to collect purged oil.
2. Oil can be returned to reservoir after procedure is completed.



**Figure 4-28. Actuator Bleed Ports**

3. With an operator in the platform, open both bleed nipples 1/4 turn. Hydraulically rotate platform to end of rotation (clockwise or counterclockwise), and maintain hydraulic pressure. Oil with small air bubbles will be seen flowing through the tubes. Allow 1/2 gallon of fluid to be purged from actuator.
4. Keep fittings open and rotate platform in opposite direction to end position. Maintain hydraulic pressure until an additional 1/4 gallon of fluid is pumped into the container.
5. Repeat steps 2 & 3. After last 1/2 gallon is purged, close both bleed nipples before rotating away from end position.

**Table 4-1. Troubleshooting**

Problem	Cause	Solution
1. Shaft rotates slowly or not at all	a. Insufficient torque output  b. Low rate of fluid flow  c. Control or counterbalance valve has internal leak  d. Piston and/or shaft seal leak  e. Corrosion build-up on the thrust surfaces  f. Swollen seals and composite bearings caused by incompatible hydraulic fluid	a. Verify correct operating pressure. Do not exceed OEM's pressure specifications. Load may be above maximum capacity of the actuator.  b. Inspect ports for obstructions and hydraulic lines for restrictions and leaks.  c. Disconnect hydraulic lines and bypass valve. Leave valve ports open and operate actuator through housing ports (do not exceed OEM's operating pressure). Valve must be replaced if a steady flow of fluid is seen coming from valve ports.  d. Remove plug and housing's valve ports. Operate actuator through housing ports. Conduct internal leakage test.  e. Rebuild actuator. Remove all rust then polish. Replacement parts may be needed.  f. Rebuild actuator. Use fluid compatible with all seals and bearings.
2. Operation is erratic or not responsive	a. Air in actuator	a. Purge air from actuator. See bleeding procedures.
3. Shaft will not fully rotate	a. Twisted or chipped gear teeth  b. Port fittings are obstructing the piston	a. Check for gear binding. Actuator may not be able to be rebuilt and may need to be replaced. Damage could be a result of overload or shock.  b. Check thread length of port fittings. Fittings should during stroke not reach inside housing bore.
4. Selected position cannot be maintained	a. Control or counterbalance valve has internal leak  b. Piston and/or shaft seal leak  c. Air in actuator	a. Disconnect hydraulic lines and bypass valve. Leave valve ports open and operate actuator through housing ports (do not exceed OEM's operating pressure). Valve must be replaced if a steady flow of fluid is seen coming from valve ports.  b. Remove plug and housing's valve ports. Operate actuator through housing ports. Conduct internal leakage test.  c. Purge air from actuator. See bleeding procedures

## 4.10 FOOT SWITCH ADJUSTMENT

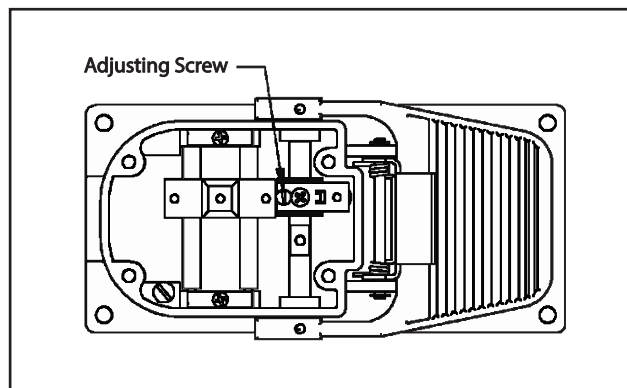
Adjust foot switch to operate functions when pedal is at center of travel. Adjust if switch operates within last 1/2 in. (6.35 mm) of top or bottom travel.

### **⚠ WARNING**

**ELECTRIC SHOCK OR UNCONTROLLED MACHINE MOVEMENT CAN CAUSE DEATH OR SERIOUS INJURY. DISCONNECT INPUT POWER BEFORE PERFORMING INSTALLATION OR MAINTENANCE.**

**NOTE:** For models with two switches, both switches can be independently adjusted.

1. Remove four socket head cap screws and cover from foot switch assembly.
2. To increase travel before switch is activated, turn Adjustment Screw clockwise.
3. To decrease travel before switch is activated, turn Adjustment Screw counter-clockwise.



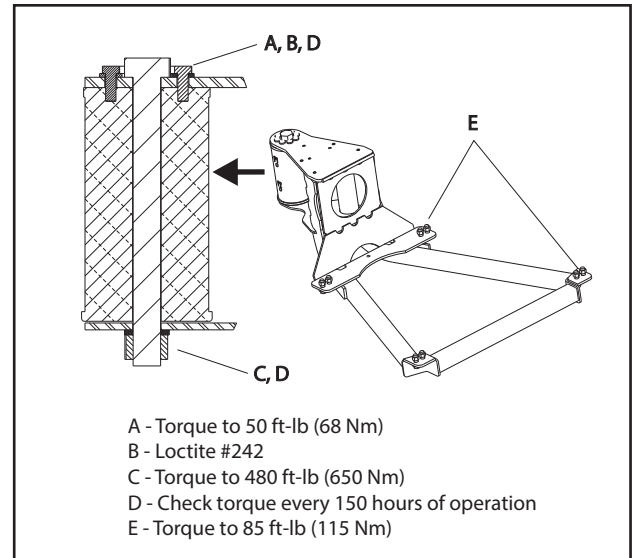
**Figure 4-29. Foot Switch Adjustment**

4. Install cover and secure with four socket head cap screws. Torque to 18-22 in-lb (2-3 Nm).

## 4.11 PLATFORM

### Platform Support Torque Settings

**NOTE:** If any rotator bolts are replaced, re-torque all rotator bolts.

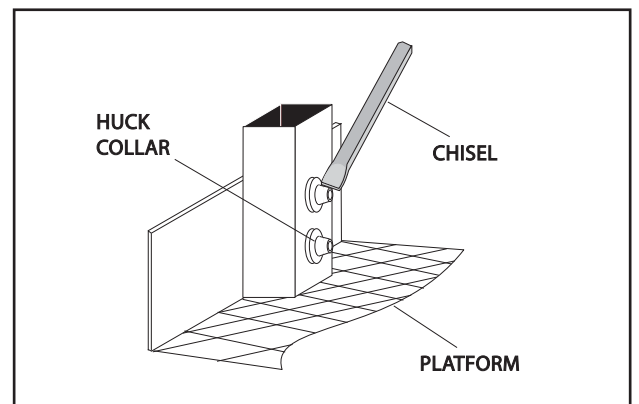


**Figure 4-30. Platform Support Torque Values**

### Replace Platform Sections

The platform is made up of five sections: floor, right side, left side, back (console box mounting.), and gate. Sections are secured with Huck magna grip fastener and collars.

1. Support Huck collar with a suitable support.
2. Using a hammer and chisel, remove collar from fastener.



**Figure 4-31. Platform Section Replacement**

3. Replace Huck fasteners with 1/4 x 20 NC x 2 1/4" grade 5 bolts, flat washers, and locknuts when installing new section of platform.
4. Replace rivets with 1/4 x 20 NC x 2 "grade 5 bolts, flat washers, and locknuts when installing a new gate to platform.

## 4.12 POWERTRACK MAINTENANCE

### Remove Link

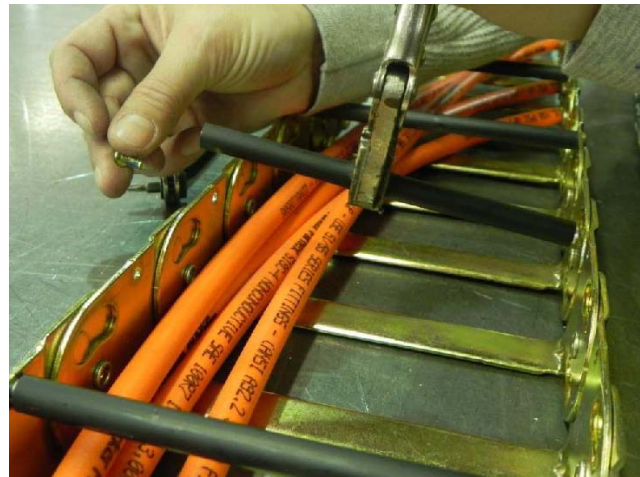
**NOTE:** Hoses shown in powertrack are for example only. Actual hose and cable arrangements are different.



1. Clamp bar and poly roller tightly so they do not spin when removing screw. With a small 1/4" ratchet and a T-20 Torx bit, remove 8-32 x 0.500 screw from one side.



2. Repeat step 1 and remove screw from other side of track. Remove bar/poly roller from powertrack.



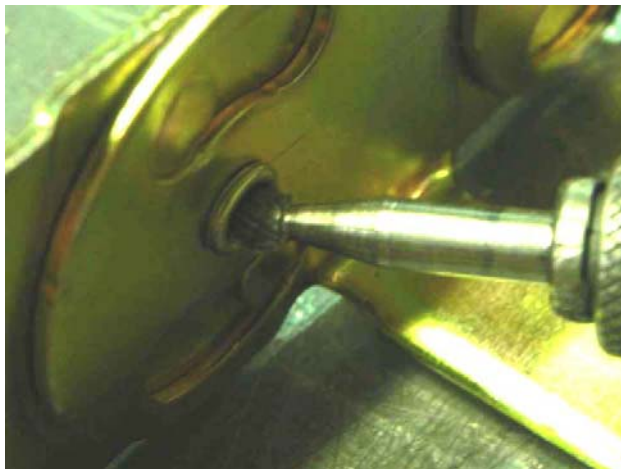
**NOTICE**

**REPOSITION CABLES/HOSES. KEEP COVERED DURING GRINDING TO PREVENT DAMAGE.**

3. To remove a link, rivets holding links together must be removed. Use a right-angle pneumatic die grinder with a 1/4" ball double cut bur attachment.

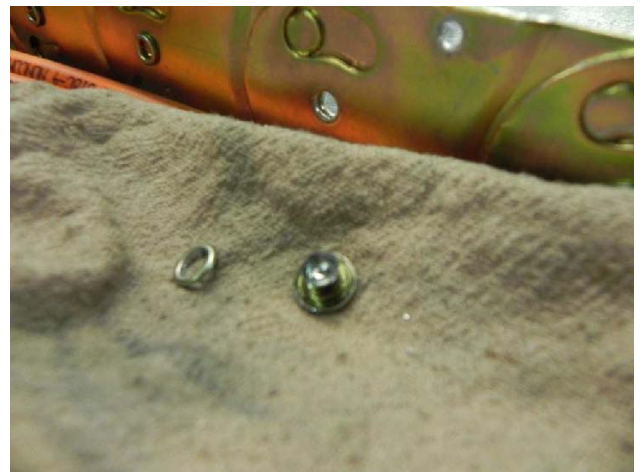


4. insert tool into rolled over end of rivet. Grind out middle of rivet until rolled over part of rivet falls off. Repeat for all rivets to be removed.



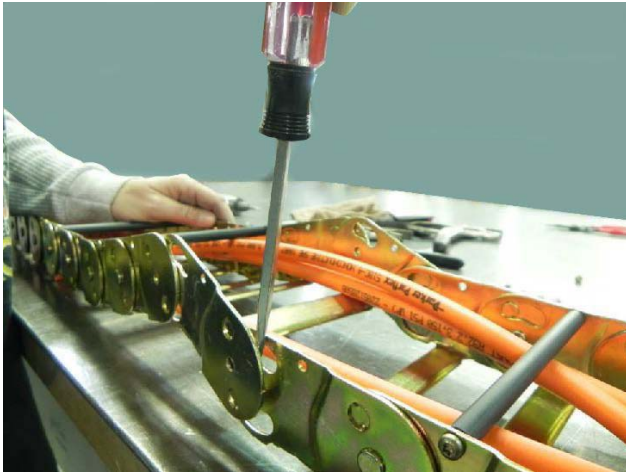
5. After grinding it may be necessary to use a center punch with a hammer to remove rivet.

**NOTE:** It may be necessary to loosen fixed end brackets from machine to move track section enough to disconnect links.

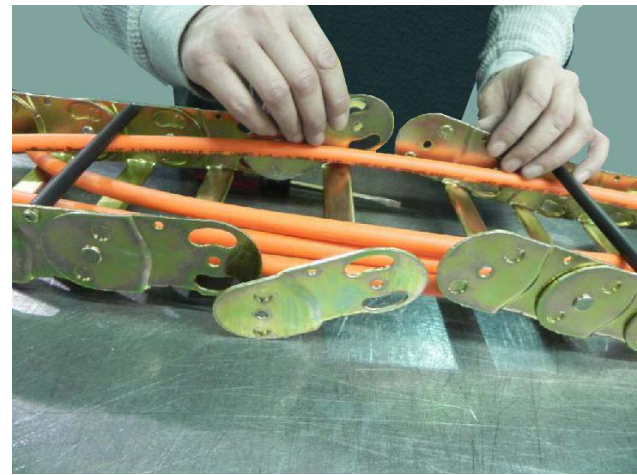


## SECTION 4 - BOOM & PLATFORM

6. Insert flat head screwdriver between links. Twist and pull links apart.



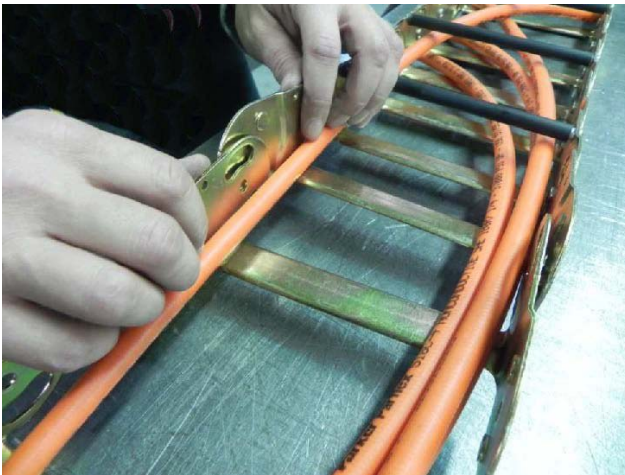
7. Remove link from other section of powertrack using screwdriver.



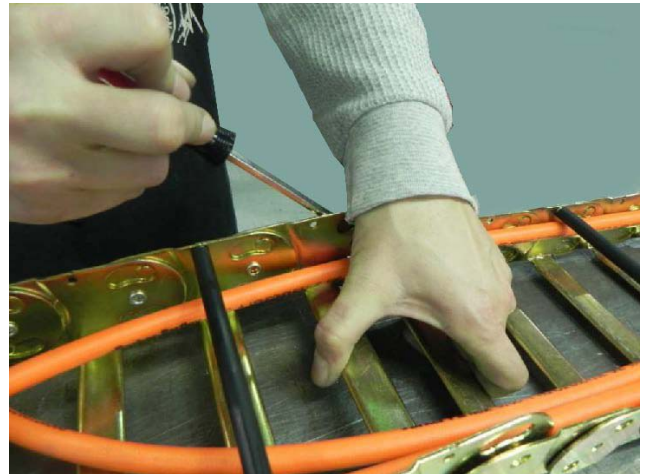
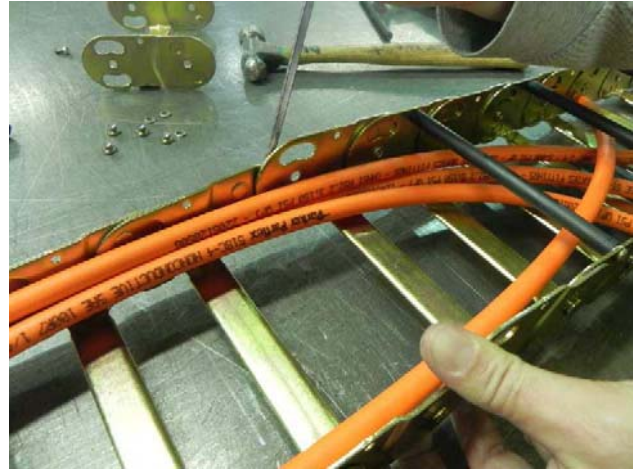


### Install New Link

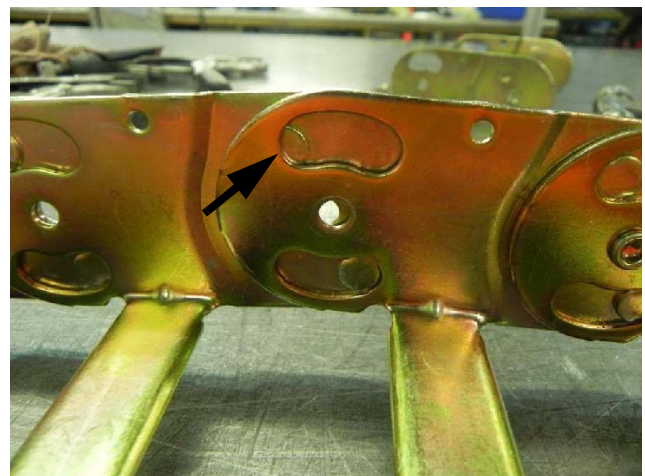
1. Squeeze cut-out end of new link into half-shear (female) end of track section.



2. Spread half-shear (female) end of new link and slide cut-out end of track section into it. Use screwdriver if necessary.

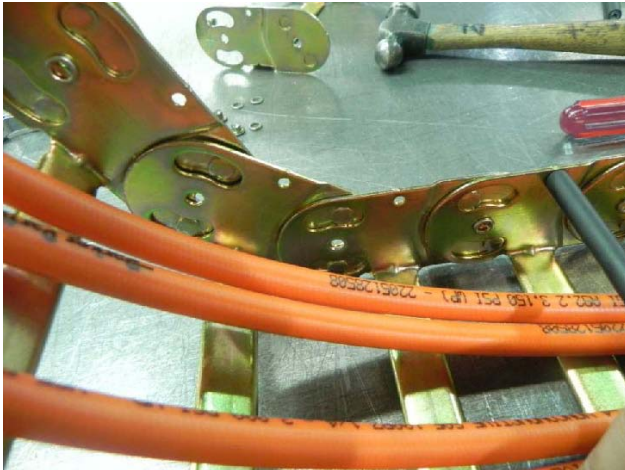


3. Round half-shears will not fit properly in cut-outs after new link is installed .

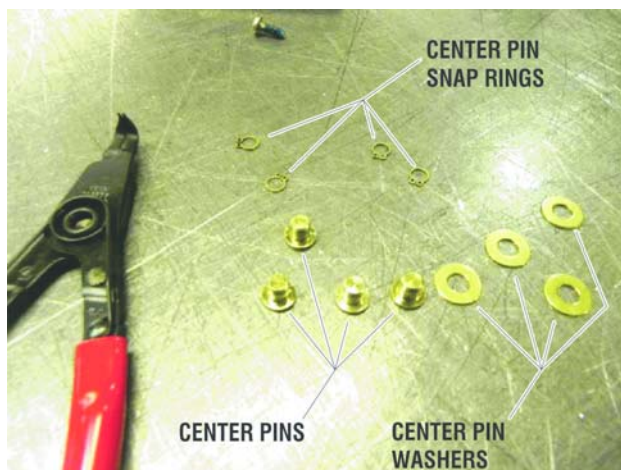


## SECTION 4 - BOOM & PLATFORM

4. Pull moving end over track so new connection is positioned in curve of powertrack. Round half-shears will rotate into cut-outs.



5. Parts shown below connect new link to powertrack.



6. Push pin through center hole. Slide washer on pin.



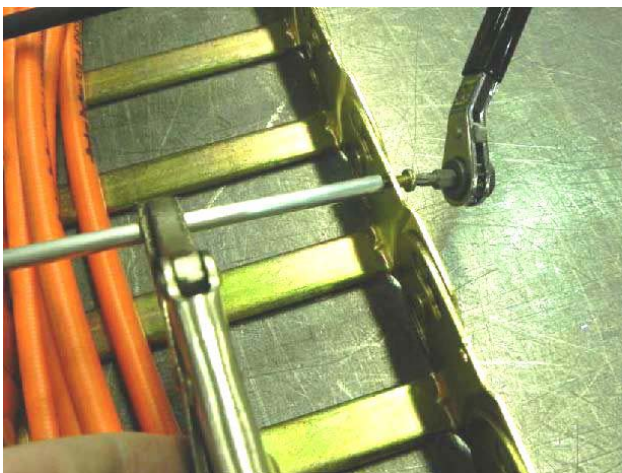
7. Install snap ring in groove on pin. Repeat pin installation steps for all center holes with rivets removed.



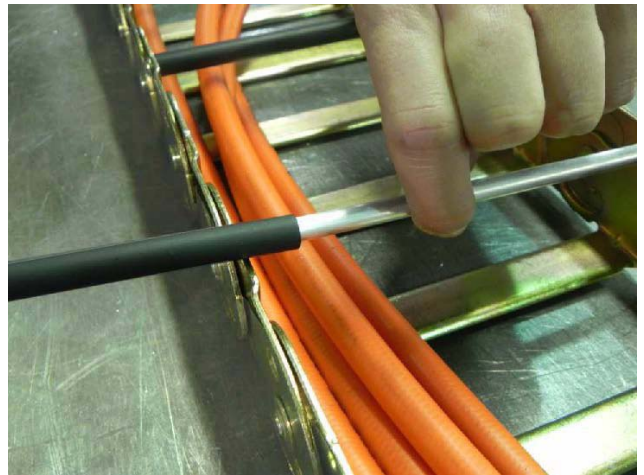
**NOTE:** Make sure snap rings are seated in pin groove and closed properly.



1. Install new 8-32 x 0.500 self-threading Torx head screw in end of new aluminum round bar. Torque to 18-20 in-lb (2-2.25 Nm).

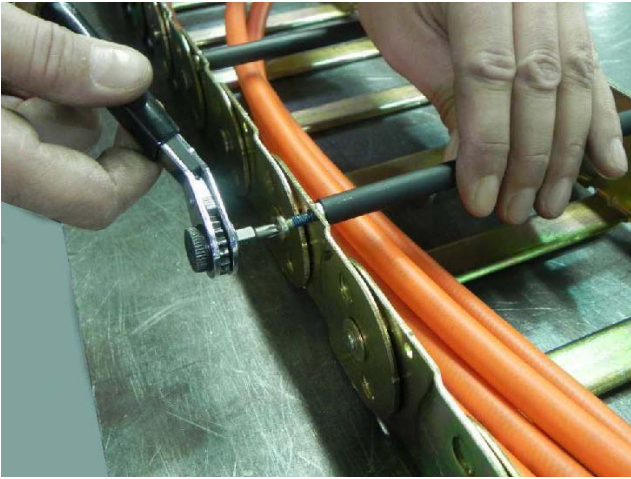


2. Pull up on other end of round bar. Slide new poly roller on bar.

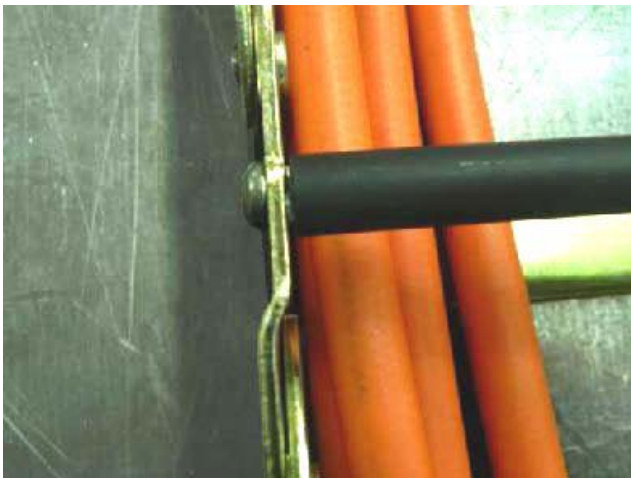


## SECTION 4 - BOOM & PLATFORM

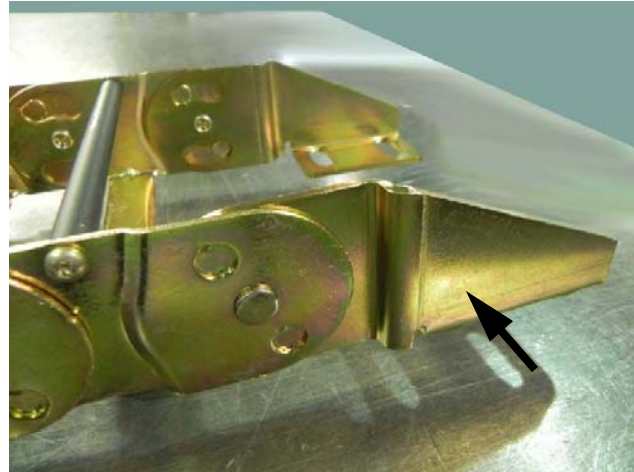
3. Install new 8-32 x 0.500 self threading screw on other side. Torque to 18-20 in-lb (2-2.25 Nm).



**NOTE:** When tightening screws make sure screw head is seated against link with no space in between link and underside of screw head.



## Replace Fixed End Brackets



### NOTICE

REPOSITION CABLES/HOSES. KEEP COVERED DURING GRINDING TO PREVENT DAMAGE.

1. Remove rivets as shown in link removal instructions..



2. Parts used: Bracket Center Pin and Center Pin Snap Ring.



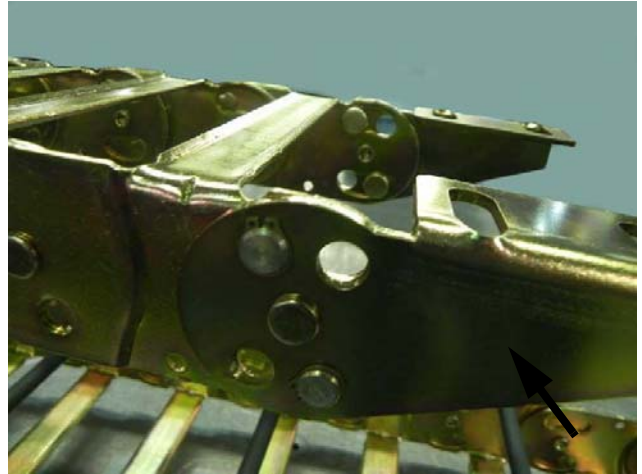
3. Take new bracket and install bracket center pin and snap ring. Repeat on other bracket if replacing it.



**NOTE:** Ensure snap rings are seated in pin groove and closed properly.



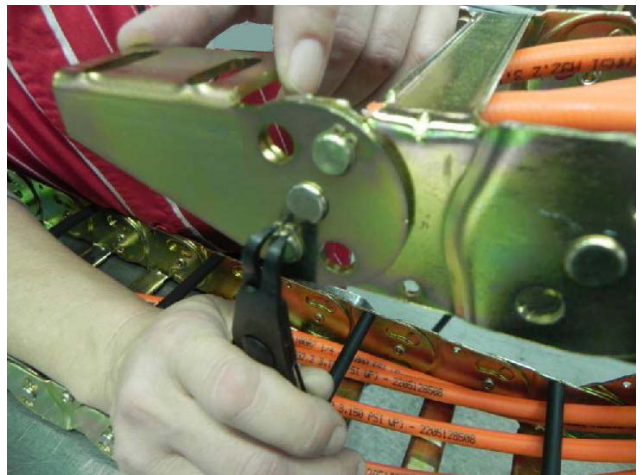
## Replace Moving End Brackets



### NOTICE

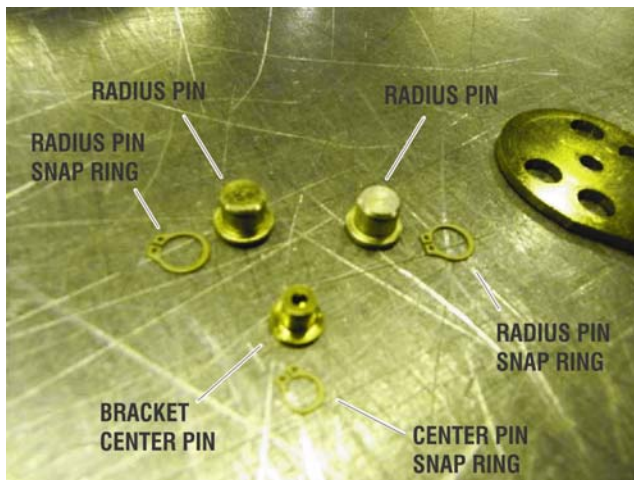
**REPOSITION CABLES AND HOSES. KEEP COVERED DURING GRINDING TO PREVENT DAMAGE.**

1. Remove existing pins and center rivet. Remove rivet as shown in link removal instructions on page 4-20. Repeat on other bracket if replaced.

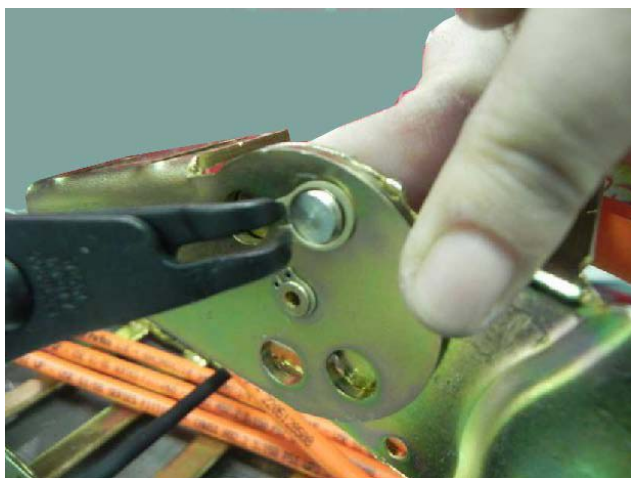


## SECTION 4 - BOOM & PLATFORM

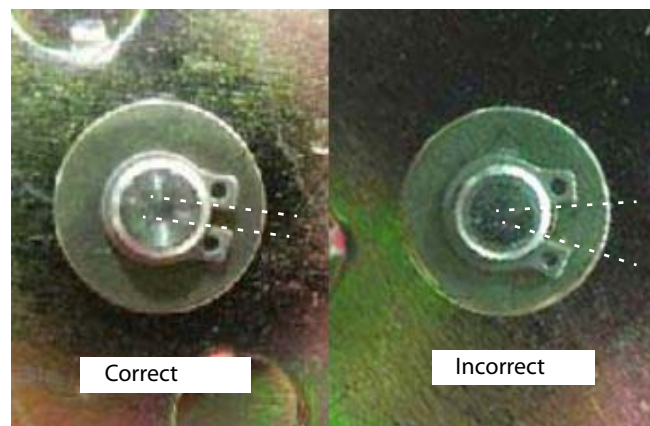
2. Install center pin with snap ring in new bracket.



3. Install radius pins and snap rings in original locations. Repeat with other moving end if replaced.



**NOTE:** Ensure snap rings are seated in pin groove and closed properly.



1. Make sure both brackets rotate correctly.



## SECTION 5. HYDRAULICS

### 5.1 O-RING LUBRICATION

When assembling connectors, all fittings with O-rings must be lubricated with hydraulic oil before assembly. There are four methods of lubricating O-rings:

1. Cup and Brush
2. Dip
3. Spray
4. Brush-On

#### Cup and Brush

Tools needed:

- Small container for hydraulic oil
- Small paint brush



1. Hold fitting in one hand and dip brush into container with other hand. Remove excess hydraulic oil from brush so an even film of oil is applied to O-ring.



2. Hold fitting over hydraulic oil container and brush an even film of oil around entire O-ring in fitting. Make sure O-ring is completely saturated.



3. Turn fitting over and repeat previous step to O-ring on other side of fitting. Make sure entire O-ring is coated with hydraulic oil.



### Dip

**NOTE:** This method works best with Face Seal O-rings, but will work for all O-ring fitting types.

Tools needed:

- Small leak proof container
  - Sponge cut to fit inside container
  - Small amount of hydraulic oil to saturate sponge.
1. Place sponge inside container and add hydraulic oil to sponge until fully saturated.
  2. Dip fitting into sponge using firm pressure.



3. After lifting fitting, a small droplet should form and drip from bottom of fitting. This indicates an even coating of oil.



**NOTE:** O-ring boss-type fittings require more pressure to immerse more of fitting into saturated sponge. This also causes more oil to be dispersed from sponge.

### Spray

This method requires a pump or trigger spray bottle.

1. Fill spray bottle with hydraulic oil.
2. Hold fitting over suitable catch can.
3. Spray entire O-ring surface with medium coat of oil.



### Brush-On

This method requires a sealed bottle brush.

1. Fill bottle with hydraulic oil.
2. Using slight pressure to body of spray bottle, invert bottle so brush end faces down.
3. Brush an even coat of hydraulic oil on entire O-ring.





## 5.2 CYLINDERS - THEORY OF OPERATION

### Systems With Double Acting Cylinders

Systems with double acting cylinders are the Slave Level, Master Level, Lift, Telescope, Articulating Jib Boom Lift, Axle Lockout, and Steer. A double acting cylinder is one that requires oil flow to operate the cylinder rod in both directions. Directing oil (by actuating the corresponding control valve to piston side of cylinder) forces the piston to travel toward the rod end of the barrel, extending the cylinder rod (piston attached to rod). When oil flow is stopped, movement of rod stops. By directing oil to the rod side of the cylinder, the piston is forced in the opposite direction and the cylinder rod retracts.

### Systems With Holding Valves

Holding valves are used in the Lift, Telescope, Lockout, Slave Level, and Articulating Jib Boom Lift circuits to prevent retraction of the cylinder rod should a hydraulic line rupture or a leak develop between the cylinder and its control valve.

## 5.3 CYLINDER CHECKING PROCEDURE

**NOTE:** Cylinder check must be performed anytime a system component is replaced or when improper system operation is suspected.

### Cylinders Without Counterbalance Valves - Master Cylinder and Steer Cylinder

1. Using all applicable safety precautions, activate engine and fully extend cylinder to be checked. Shut down engine.
2. Carefully disconnect hydraulic hoses from retract port of cylinder. There will be some initial weeping of hydraulic fluid which can be caught in a suitable container. After initial discharge, there should be no further drainage from the retract port.
3. Activate engine and extend cylinder.
4. If cylinder retract port leakage is less than 6-8 drops per minute, carefully reconnect hose to port and retract cylinder. If leakage continues at a rate of 6-8 drops per minute or more, repair cylinder.
5. With cylinder fully retracted, shut down engine and carefully disconnect hydraulic hose from cylinder extend port.
6. Activate engine and retract cylinder. Check extend port for leakage.
7. If extend port leakage is less than 6-8 drops per minute, carefully reconnect hose to extend port, then activate cylinder through one complete cycle and check for leaks. If leakage continues at a rate of 6-8 drops per minute or more, repair cylinder.

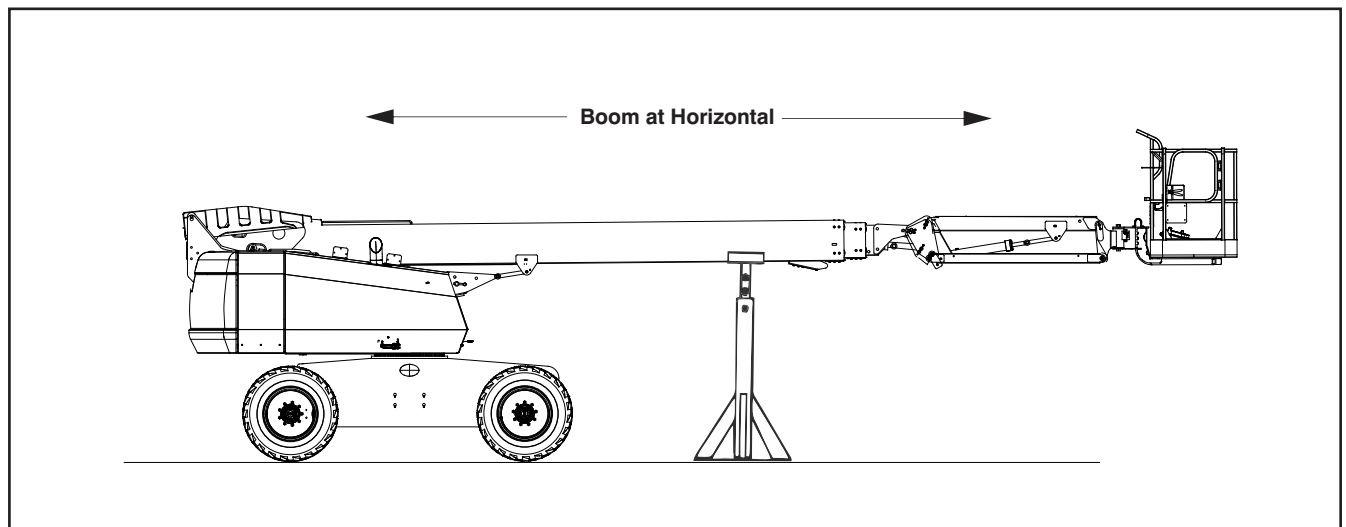


Figure 5-1. Boom Positioning and Support, Cylinder Repair

## Cylinders With Single Counterbalance Valve

(Upper Lift Cylinder)

### **⚠ WARNING**

**OPERATE ALL FUNCTIONS FROM GROUND CONTROL STATION ONLY.**

1. Using all applicable safety precautions, activate hydraulic system.

### **⚠ WARNING**

**WHEN WORKING ON MAIN LIFT CYLINDER, RAISE BOOM TO HORIZONTAL AND PLACE A BOOM PROP APPROXIMATELY 1 INCH (2.54 CM) BELOW THE MAIN BOOM. DO NOT WORK ON CYLINDER WITHOUT A SUITABLE PROP IN PLACE.**

2. Shut down hydraulic system and allow machine to sit for 10-15 minutes. If machine is equipped with proportional control valves, turn IGNITION SWITCH to ON, move control switch or lever for applicable cylinder in each direction, then turn IGNITION SWITCH to OFF. If machine is equipped with hydraulic control valves, move control lever for applicable cylinder in each direction. This is done to relieve hydraulic line pressure. Carefully remove hydraulic hoses from appropriate cylinder port block.
3. There will be initial weeping of hydraulic fluid, which can be caught in a suitable container. After initial discharge, there should be no further leakage from the ports. If leakage continues at a rate of 6-8 drops per minute or more, counterbalance valve is defective and must be replaced.
4. To check piston seals, carefully remove counterbalance valve from the retract port. After initial discharge, there should be no further leakage from the ports. If leakage occurs at a rate of 6-8 drops per minute or more, piston seals are defective and must be replaced.
5. If no repairs are necessary or when repairs have been made, replace counterbalance valve and connect hydraulic hoses to cylinder port block.
6. If used, remove lifting device from upright or remove prop from below main boom. Activate hydraulic system and run cylinder through one complete cycle to check for leaks.

## Cylinders With Dual Counterbalance Valves

(Articulating Jib Boom Lift, and Slave), Slave Level, Lower Lift, Upright level, Main Telescope and Tower Telescope)

### **⚠ WARNING**

**OPERATE ALL FUNCTIONS FROM GROUND CONTROL STATION ONLY.**

1. Using all applicable safety precautions, activate hydraulic system.

### **⚠ WARNING**

**IF WORKING ON TOWER BOOM LIFT CYLINDER, RAISE TOWER BOOM HALF-WAY, FULLY ELEVATE MAIN BOOM WITH TELESCOPE CYLINDER FULLY RETRACTED. ATTACH AN OVERHEAD CRANE TO THE UPRIGHT FOR SUPPORT, LEAVING APPROXIMATELY 1 INCH (2.54 CM) OF SLACK IN CHAIN OR SLING FOR TEST PURPOSES. IF WORKING ON THE UPRIGHT LEVEL, RAISE TOWER BOOM HALF-WAY, THEN RAISE MAIN BOOM TO HORIZONTAL AND POSITION A SUITABLE BOOM PROP APPROXIMATELY 1 INCH (2.54 CM) BELOW MAIN BOOM. IF WORKING ON PLATFORM LEVEL CYLINDER, STROKE PLATFORM LEVEL CYLINDER FORWARD UNTIL PLATFORM SITS AT A 45 DEGREES ANGLE.**

2. Shut down hydraulic system and allow machine to sit for 10-15 minutes. If machine is equipped with proportional control valves, turn IGNITION SWITCH to ON, move control switch or lever for applicable cylinder in each direction, then turn IGNITION SWITCH to OFF. If machine is equipped with hydraulic control valves, move control lever for applicable cylinder in each direction. This is done to relieve hydraulic line pressure. Carefully remove hydraulic hoses from appropriate cylinder port block.
3. There will be initial weeping of hydraulic fluid, which can be caught in a suitable container. After initial discharge, there should be no further leakage from the ports. If leakage continues at a rate of 6-8 drops per minute or more, counterbalance valve is defective and must be replaced.
4. To check piston seals, carefully remove the counterbalance valve from the retract port. After initial discharge, there should be no further leakage from the ports. If leakage occurs at a rate of 6-8 drops per minute or more, the piston seals are defective and must be replaced.
5. If no repairs are necessary or when repairs have been made, replace counterbalance valve and carefully connect hydraulic hoses to cylinder port block.
6. Remove lifting device from upright or remove prop from below main boom. Activate hydraulic system and run cylinder through one complete cycle to check for leaks.

## 5.4 CYLINDER REMOVAL AND INSTALLATION

### Main Boom Telescope Cylinder Removal

1. Place machine on a flat and level surface, with main boom in the horizontal position.
2. Shut down engine. Support main boom basket end with a prop. (See Figure 5-1., Boom Positioning and Support, Cylinder Repair).

#### **NOTICE**

**CAP HYDRAULIC LINES AND PORTS IMMEDIATELY AFTER DISCONNECTING LINES TO PREVENT ENTRY OF CONTAMINANTS INTO THE SYSTEM.**

3. Tag and disconnect hydraulic lines to telescope cylinder. Use a suitable container to retain residual hydraulic fluid. Cap hydraulic lines and ports.
4. Remove hardware securing cover plate on bottom of base boom section and remove cover.

#### **NOTICE**

**DO NOT ALLOW CABLE TO ROTATE. THIS MAY DAMAGE THE CABLE.**

5. Clamp both threaded ends of cable to prevent rotation. Note: Do not clamp on threads. Remove jam nuts and loosen adjustment nuts so there is slack in the cables. (See Section 4 - Boom & Platform).
6. Remove hardware securing push bar to turntable and telescope cylinder.
7. Using a suitable brass drift, carefully drive push bar pins from telescope cylinder rod and turntable.
8. Remove hardware securing cable adjustment block to aft end of the base boom section and remove block.
9. Remove hardware securing telescope cylinder to aft end of mid boom section.

#### **NOTICE**

**WHEN REMOVING TELESCOPE CYLINDER FROM BOOM, IT MAY BE NECESSARY AT SOME POINT TO TURN CYLINDER SLIGHTLY IN ORDER TO CLEAR ASSEMBLIES MOUNTED IN THE BOOM. MOVE CYLINDER SLOWLY INTO POSITION OR DAMAGE TO COMPONENTS MAY RESULT FROM FORCIBLE IMPACT WITH THESE ASSEMBLIES.**

10. Remove bolts securing cable attach bar to top of fly boom section.
11. Pull telescope cylinder and cables partially from aft end of base boom section. Secure cylinder with a suitable sling and lifting device at center of gravity.
12. Carefully remove telescope cylinder and sheave assembly. Place telescope cylinder on a suitable trestle.

### Main Boom Telescope Cylinder Installation

1. Route extend cables around extend sheave and secure cables to the telescope cylinder.
2. Install extend cables mounting blocks to threaded ends of cables. Loosely install nuts and jam nuts on threaded end of cables.

#### **NOTICE**

**DO NOT TO TWIST OR CROSS CABLES DURING INSTALLATION.**

3. Secure sling and lifting device at telescope cylinder's center of gravity. Lift cylinder to aft end of boom assembly.
4. Install extend cable mounting blocks to threaded ends of cables. Loosely install nuts and jam nuts on threaded ends of cables.

#### **NOTICE**

**WHEN INSERTING TELESCOPE CYLINDER INTO BOOM, IT MAY BE NECESSARY TO TURN CYLINDER SLIGHTLY TO CLEAR ASSEMBLIES MOUNTED IN THE BOOM. MOVE CYLINDER SLOWLY INTO POSITION OR DAMAGE TO COMPONENTS MAY RESULT FROM FORCIBLE IMPACT WITH THESE ASSEMBLIES.**

5. Carefully install telescope cylinder barrel end support into slots in mid boom and secure with blocks and bolts. Use Loctite #242 on bolts.
6. Align holes in aft end of fly boom section with holes in cable mounting block. Secure with mounting hardware.
7. Align holes in aft end of base boom section with holes in cable mounting block. Secure with mounting hardware.
8. Remove cylinder port plugs and hydraulic line caps. Correctly attach lines to cylinder ports.
9. Align holes in rod end of telescope cylinder with holes in push bar. Install push bar pin and secure with mounting hardware.
10. Align holes in push bar with holes in turntable. Install push bar pin and secure with mounting hardware.

**NOTE:** *Boom cables must be torqued after telescope cylinder installation. (See Section 4.1, Boom Rope Torquing Procedures)*

### Main Boom Lift Cylinder Removal

1. Place machine on a flat and level surface. Start engine and place main boom in horizontal position. Shut down engine and prop boom. (See Figure 5-1., Boom Positioning and Support, Cylinder Repair)
2. Remove hardware retaining cylinder rod attach pin to boom. Using a suitable brass drift, drive out cylinder rod pin.
3. Using auxiliary power, retract the lift cylinder rod completely.
4. Disconnect, cap and tag the main boom lift cylinder hydraulic lines and ports.
5. Remove barrel end attach pin retaining hardware. Using a suitable brass drift drive out the barrel end attach pin from the turntable.
6. Remove the cylinder from the turntable and place in a suitable work area.

### Main Boom Lift Cylinder Installation

1. Install lift cylinder in place using suitable slings or supports, aligning attach pin mounting holes on the turntable.
2. Using a suitable drift, drive barrel end attach pin through mounting holes in lift cylinder and turntable. Secure in place with pin retaining hardware.
3. Remove cylinder port plugs and hydraulic line caps and correctly attach lines to cylinder ports.
4. Using auxiliary power, extend cylinder rod until attach pin hole aligns with those in the boom. Using a suitable soft mallet, drive cylinder rod attach pin through the boom and lift cylinder. Secure pin in place with attaching hardware.
5. Remove boom prop and overhead crane. Activate hydraulic system.
6. Using all applicable safety precautions, operate boom functions. Check for correct operation and hydraulic leaks. Secure as necessary.
7. Check fluid level of hydraulic tank. Adjust as necessary.

## 5.5 CYLINDER REPAIR

**NOTE:** *Following are general procedures that apply to all cylinders on this machine. Procedures that apply to a specific cylinder are noted.*

### Disassembly

#### **NOTICE**

**CYLINDER DISASSEMBLY SHOULD BE PERFORMED ON A CLEAN WORK SURFACE IN A DIRT FREE WORK AREA TO PREVENT CONTAMINATION.**

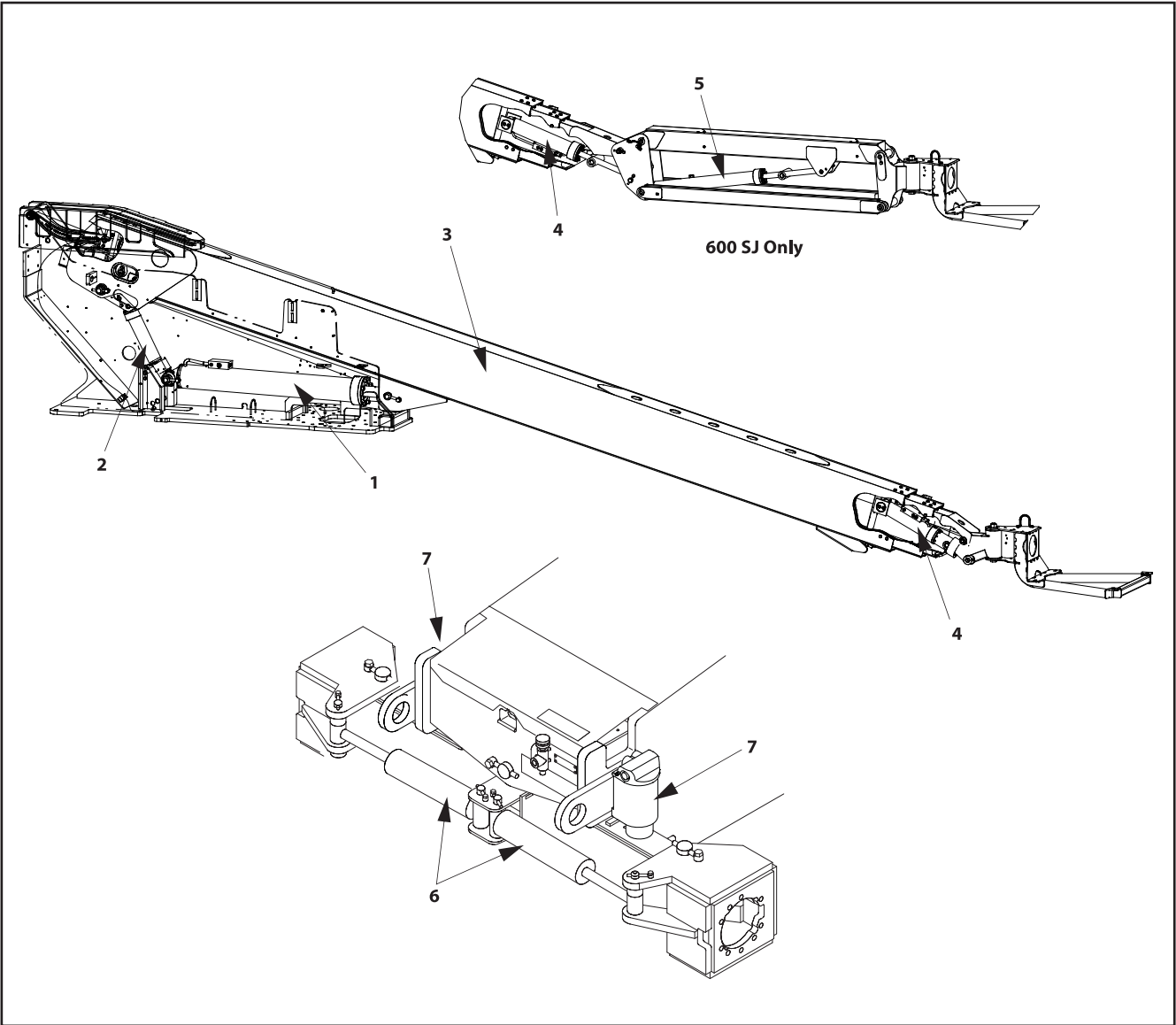
1. Connect a suitable auxiliary hydraulic power source to cylinder port block fitting.

#### **⚠ WARNING**

**DO NOT FULLY EXTEND CYLINDER TO END OF STROKE. RETRACT CYLINDER SLIGHTLY TO AVOID TRAPPING PRESSURE.**

2. Operate hydraulic power source and extend the cylinder. Shut down and disconnect power source. Adequately support cylinder rod, if applicable.
3. If applicable, remove cartridge-type holding valve and fittings from cylinder port block. Discard O-rings.

Cylinder Locations



Item	Cylinder
1	Main Lift
2	Master
3	Telescope
4	Slave (Platform Level)
5	Jib Lift
6	Steer
7	Axle Lockout

Figure 5-2. Hydraulic Cylinder Locations

## Main Lift Cylinder

### DISASSEMBLY

**NOTE:** Refer to Figure 5-6.

#### NOTICE

**CONTAMINATION MAY DAMAGE EQUIPMENT. DISASSEMBLE CYLINDER ON A CLEAN WORK SURFACE IN A DIRT FREE WORK AREA.**

1. Connect a suitable auxiliary hydraulic power source to cylinder port block fitting.

#### WARNING

**DO NOT FULLY EXTEND CYLINDER TO THE END OF STROKE. RETRACT CYLINDER SLIGHTLY TO AVOID TRAPPING PRESSURE.**

2. Operate hydraulic power source and extend cylinder. Shut down and disconnect power source. Adequately support cylinder rod, if applicable.
3. If applicable, remove cartridge-type counterbalance valve and fittings from cylinder port block. Discard O-rings.
4. Place cylinder barrel in a suitable holding fixture. Tap around outside of cylinder head retainer with a suitable hammer to break thread-locking compound.

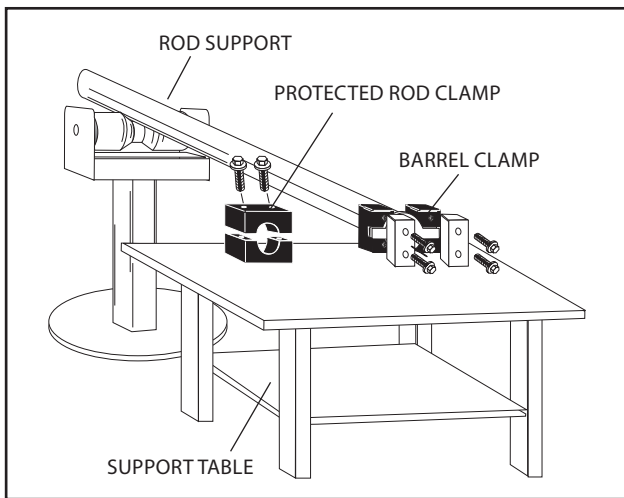


Figure 5-3. Cylinder Barrel Support

5. Mark cylinder head (1) and barrel (2) with center punch marks (3) for later realignment. Remove eight cylinder head cap screws (4).

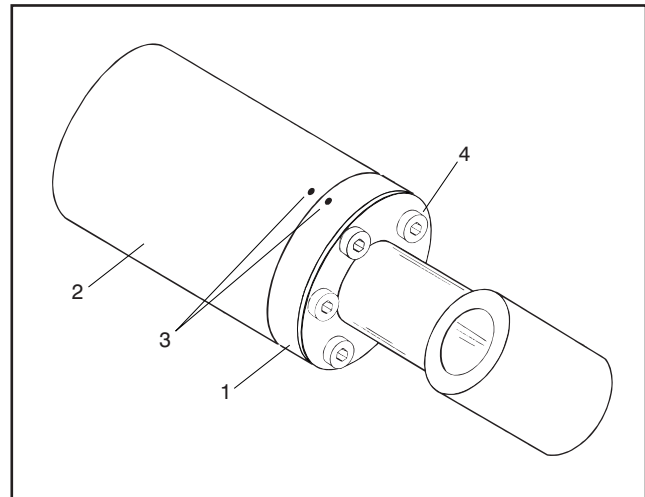


Figure 5-4. Marking Cylinder for Alignment

#### NOTICE

**PULLING ROD OFF-CENTER CAN DAMAGE PISTON AND CYLINDER BARREL SURFACES. USE EXTREME CARE WHEN REMOVING CYLINDER ROD, HEAD, AND PISTON.**

6. Clamp barrel securely. Pull rod assembly and cylinder head from barrel.
7. Protect cylinder rod from damage and clamp in a vise or holding fixture as close to piston as possible.

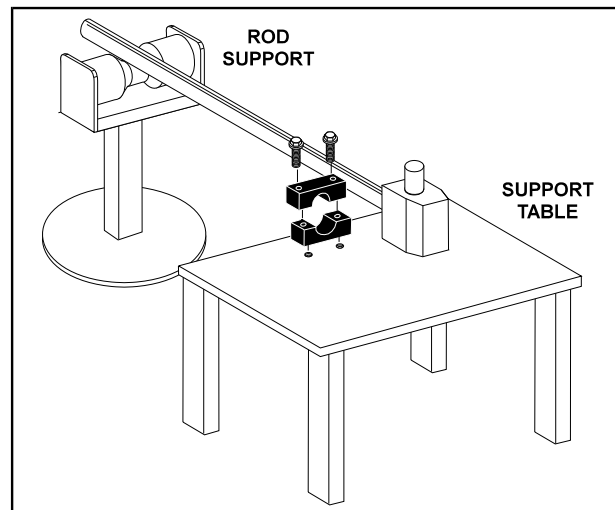
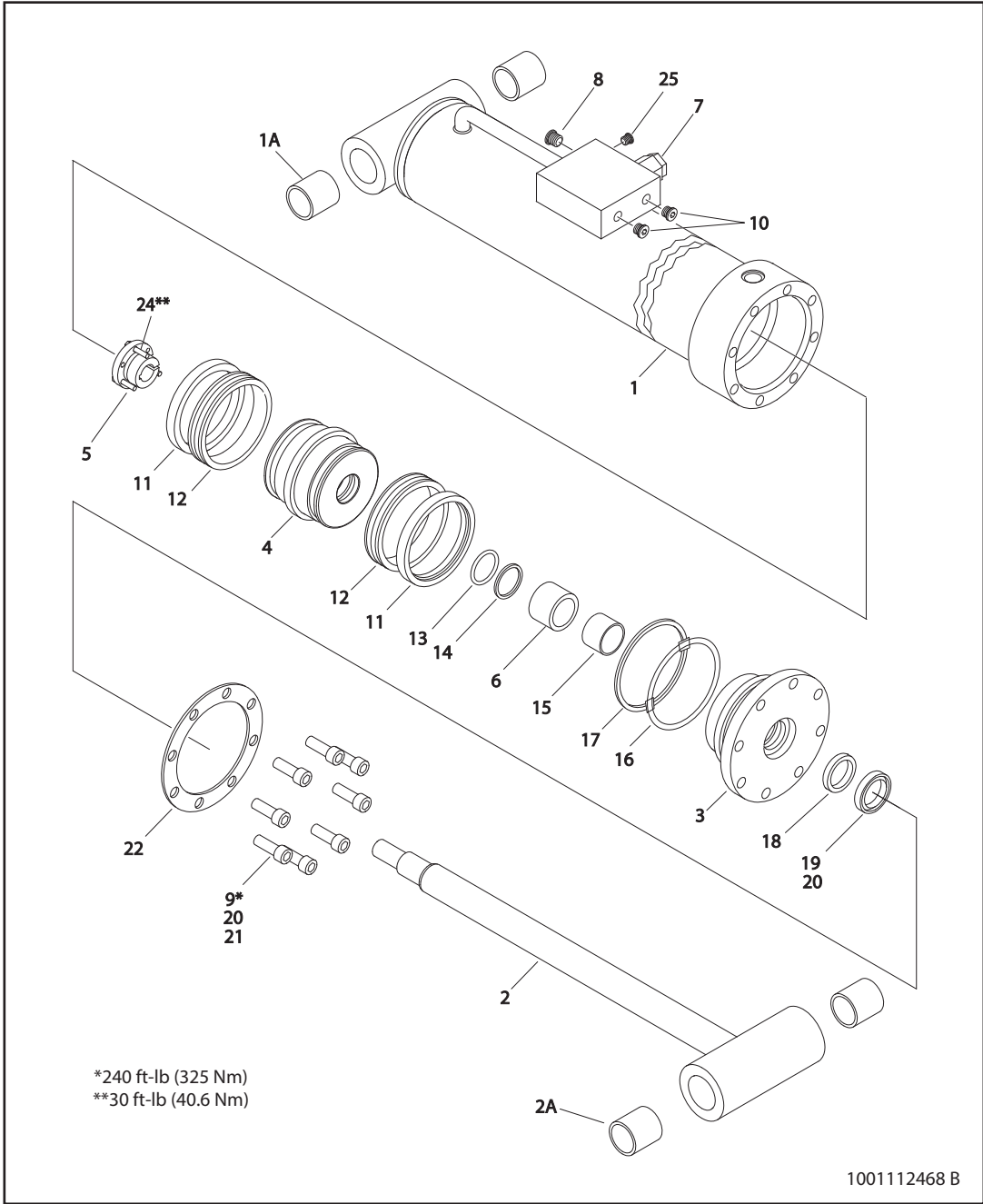


Figure 5-5. Cylinder Rod Support

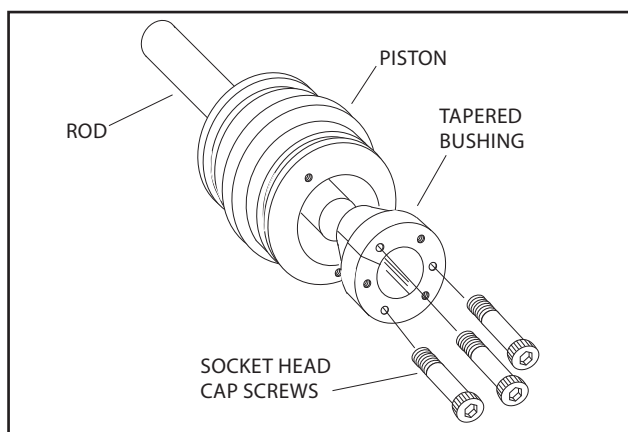


- |                       |                    |                    |                      |                       |
|-----------------------|--------------------|--------------------|----------------------|-----------------------|
| 1. Barrel             | 5. Tapered Bushing | 11. Lock Ring      | 17. Back-Up Ring     | 23. Not Used          |
| 1a. Composite Bushing | 6. Spacer          | 12. Hydrolock Seal | 18. Rod Seal         | 24. Socket Head Screw |
| 2. Rod                | 7. Cartridge Valve | 13. O-Ring         | 19. Wiper            | 25. O-Ring Plug       |
| 2a. Composite Bushing | 8. O-Ring Plug     | 14. Back-Up Ring   | 20. Locking Compound |                       |
| 3. Head               | 9. 5/16"-11x2 Bolt | 15. Wear Ring      | 21. Locking Primer   |                       |
| 4. Piston             | 10. O-Ring Plug    | 16. O-Ring         | 22. Ring Washer      |                       |

Figure 5-6. Main Lift Cylinder Assembly

## SECTION 5 - HYDRAULICS

- Using suitable protection, clamp cylinder rod in a vise or similar holding fixture as close to piston as possible.
- Loosen and remove nut attaching piston to rod. Remove piston.
- Loosen and remove cap screw(s), if applicable, attaching tapered bushing to piston.
- Insert cap screw(s) in threaded holes in outer piece of tapered bushing. Progressively tighten cap screw(s) until bushing is loose on piston.
- Remove tapered bushing from piston.
- Screw piston counter-clockwise by hand and remove from cylinder rod.



**Figure 5-7. Tapered Bushing Removal**

- Remove and discard piston O-rings, seal rings, and backup rings.
- Remove piston spacer, if applicable, from rod.
- Remove rod from holding fixture. Remove cylinder head gland and retainer plate, if applicable. Discard O-rings, back-up rings, rod seals, and wiper seals.

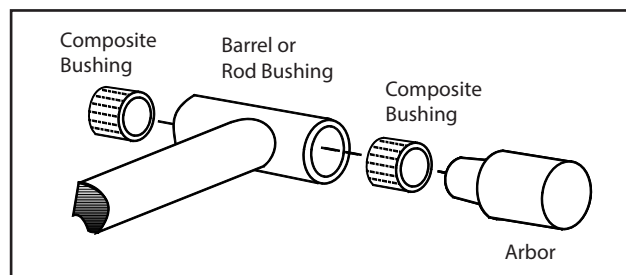
### Cleaning and Inspection

- Clean parts thoroughly with approved cleaning solvent.
- Inspect cylinder rod for scoring, tapering, ovality, or other damage. If necessary, dress rod with Scotch Brite or equivalent. Replace rod if necessary.
- Inspect threaded portion of rod for excessive damage. Dress threads as necessary.
- Inspect inner surface of cylinder barrel tube for scoring or other damage. Check inside diameter for tapering or ovality. Replace if necessary.
- Inspect threaded portion of barrel for damage. Dress threads as necessary.
- Inspect piston surface for damage, scoring, or distortion. Dress piston surface or replace piston as necessary.

- Inspect threaded portion of piston for damage. Dress threads as necessary.
- Inspect seal and O-ring grooves in piston for burrs and sharp edges. Dress surfaces as necessary.
- Inspect cylinder head inside diameter for scoring or other damage, and for ovality and tapering. Replace as necessary.
- Inspect threaded portion of head for damage. Dress threads as necessary.
- Inspect seal and O-ring grooves in head for burrs and sharp edges. Dress applicable surfaces as necessary.
- Inspect cylinder head outside diameter for scoring, damage, ovality, and tapering. Replace as necessary.
- If applicable, inspect rod and barrel bearings for signs of correct excessive wear or damage. Replace as necessary.
  - Thoroughly clean hole, (steel bushing) of burrs, dirt etc. to facilitate bearing installation.
  - Inspect steel bushing for wear or other damage. If steel bushing is worn or damaged, rod/barrel must be replaced.
  - Lubricate inside of the steel bushing with WD40 prior to bearing installation.

**NOTE:** Lubrication is not required with nickel plated pins and bearings. Install pin in composite bushing dry.

- Press composite bushing into barrel or rod bushing with correct size arbor.



**Figure 5-8. Composite Bushing Installation**

- Inspect travel limiting collar or spacer for burrs and sharp edges. If necessary, dress inside diameter surface with Scotch Brite or equivalent.
- If applicable, inspect port block fittings and holding valve. Replace as necessary.
- Inspect oil ports for blockage or presence of dirt or other foreign material. Repair as necessary.
- If applicable, inspect piston rings for cracks or other damage. Replace as necessary.



**Assembly**

**NOTE:** Use proper cylinder seal kit for cylinder assembly. See your JLG Parts Manual.

Apply a light film of hydraulic oil to all components before assembly.

1. Use seal tool to install new rod seal into applicable cylinder head gland groove.

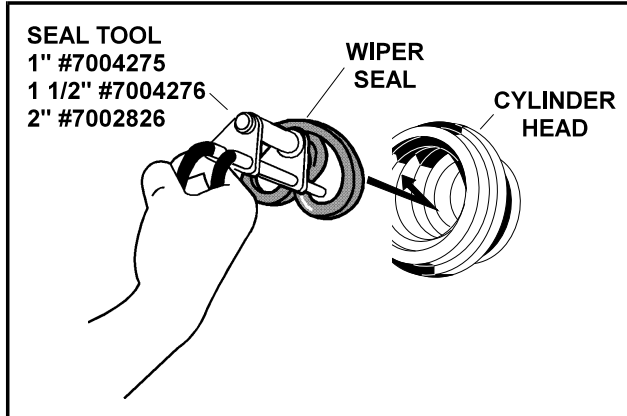


Figure 5-9. Rod Seal Installation

**NOTICE**

IMPROPER SEAL INSTALLATION CAN CAUSE CYLINDER LEAKS AND IMPROPER CYLINDER OPERATION. ENSURE 'POLY-PAK' PISTON SEALS ARE PROPERLY INSTALLED. REFER TO WIPER SEAL INSTALLATION FOR CORRECT SEAL ORIENTATION.

2. Use a soft mallet to tap new wiper seal into applicable cylinder head gland groove. Install new wear ring in applicable cylinder head gland groove.

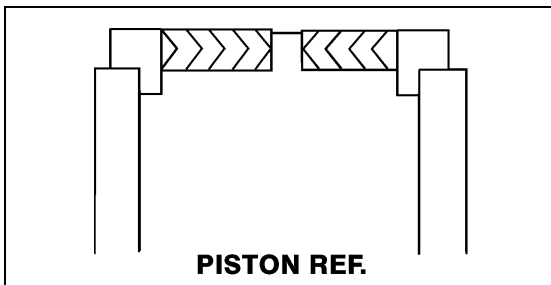


Figure 5-10. Poly-Pak Piston Seal Installation

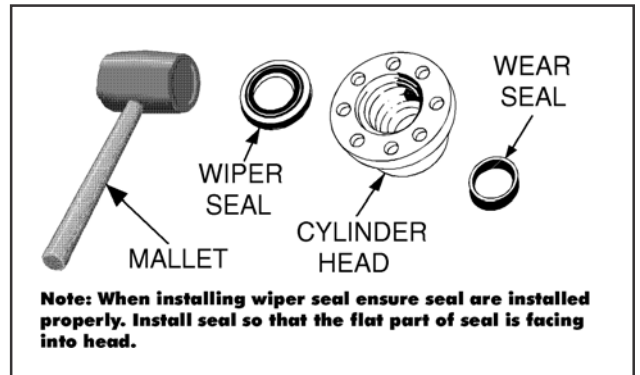


Figure 5-11. Wiper Seal Installation

3. Place new O-ring and back-up seal in applicable outside diameter groove of cylinder head.

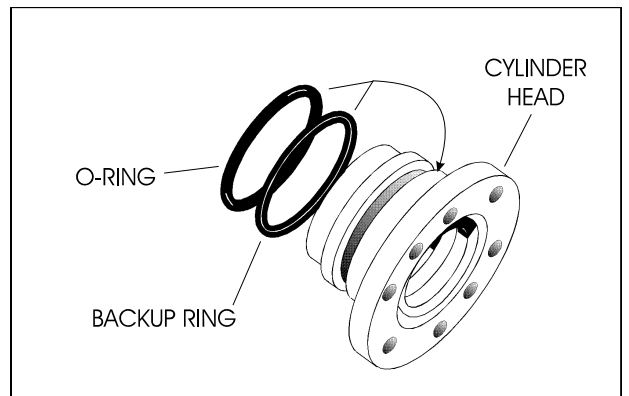


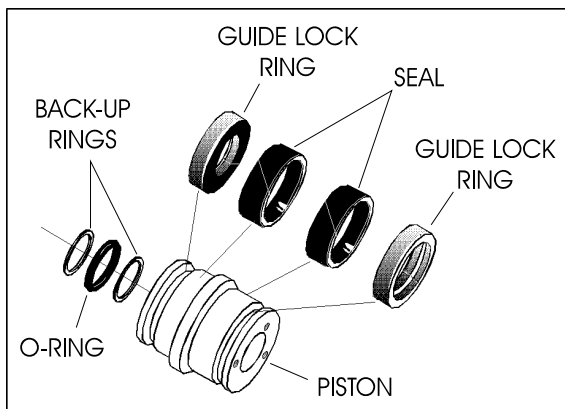
Figure 5-12. Head Seal Kit Installation

4. Install washer ring on rod. Carefully install head gland on rod. Do not damage or dislodge wiper and rod seals. Push head along rod to rod end, as applicable.
5. Carefully slide piston spacer on rod.

**NOTE:** Upper telescope cylinder piston has an O-ring installed inside spacer.

## SECTION 5 - HYDRAULICS

- If applicable, place new O-ring and back-up rings in inner piston diameter groove.



**Figure 5-13. Piston Seal Kit Installation**

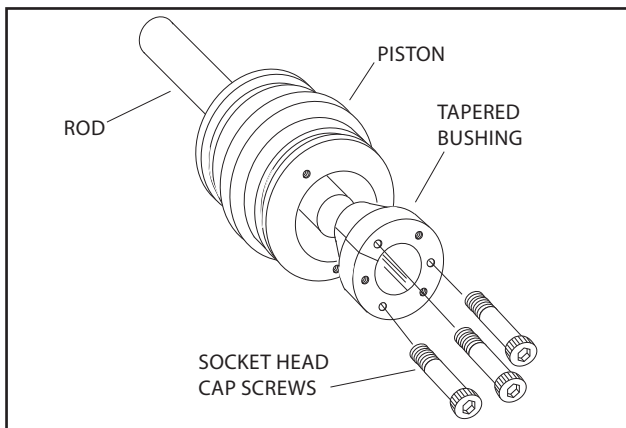
- Using suitable protection, clamp cylinder rod in a vise or similar holding fixture as close to piston as possible.
- Carefully thread piston on cylinder rod hand tight, Ensure O-ring and back-up rings are not damaged or dislodged.

**NOTE:** Piston and mating end of rod must be free of oil when installing tapered bushing.

- Thread piston onto rod until it aligns with spacer end and install tapered bushing.

**NOTE:** Apply LOCTITE #242 or equivalent to tapered bushing bolts when rebuilding master, slave, lift, and telescope cylinders.

- Install bolts in tapered bushing using loctite #242



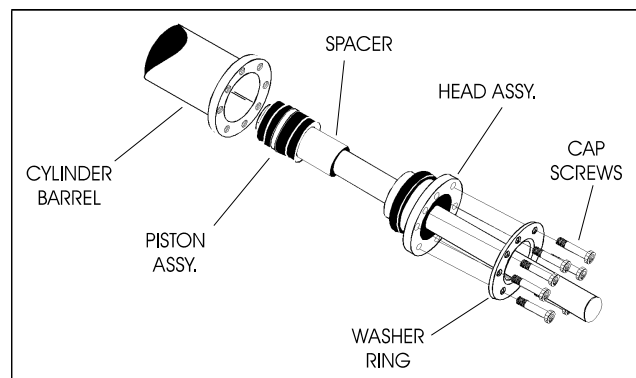
**Figure 5-14. Tapered Bushing Installation**

- Remove cylinder rod from holding fixture.
- Place new guide locks and seals in applicable outside diameter grooves of cylinder piston. (See Figure 2-28. Piston Seal Kit Installation.)
- Position cylinder barrel in a suitable holding fixture.

### NOTICE

**INSERTING ROD OFF-CENTER CAN DAMAGE PISTON AND CYLINDER BARREL SURFACES. USE EXTREME CARE WHEN INSTALLING CYLINDER ROD, HEAD, AND PISTON.**

- Clamp barrel clamped securely and support rod. Insert piston end into barrel cylinder. Do not damage or dislodge piston loading O-ring and seal ring.
- Continue pushing rod into barrel until cylinder head gland can be inserted into barrel cylinder.
- Secure cylinder head gland using washer ring and socket head bolts.



**Figure 5-15. Rod Assembly Installation**

## Master Cylinder

### DISASSEMBLY

**NOTE:** Refer to Figure 5-19. Master Cylinder.

#### NOTICE

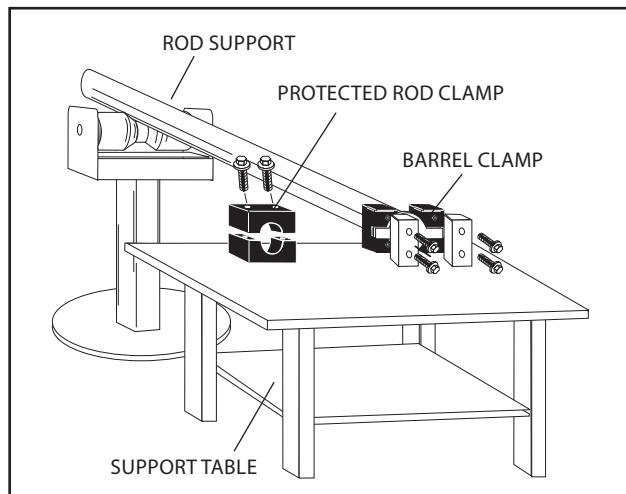
**CONTAMINATION MAY DAMAGE EQUIPMENT. DISASSEMBLE CYLINDER ON A CLEAN WORK SURFACE IN A DIRT FREE WORK AREA.**

1. Connect a suitable auxiliary hydraulic power source to cylinder port block fitting.

#### WARNING

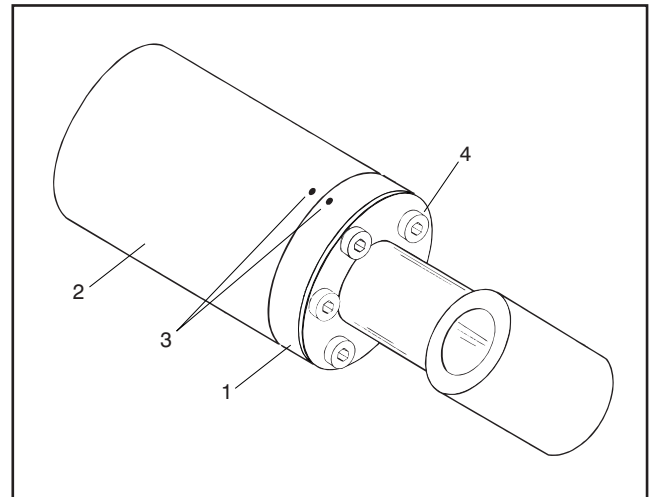
**DO NOT FULLY EXTEND CYLINDER TO THE END OF STROKE. RETRACT CYLINDER SLIGHTLY TO AVOID TRAPPING PRESSURE.**

2. Operate hydraulic power source and extend cylinder. Shut down and disconnect power source. Adequately support cylinder rod, if applicable.
3. If applicable, remove cartridge-type counterbalance valve and fittings from cylinder port block. Discard O-rings.
4. Place cylinder barrel in a suitable holding fixture. Tap around outside of cylinder head retainer with a suitable hammer to break thread-locking compound.



**Figure 5-16. Cylinder Barrel Support**

5. Mark cylinder head (1) and barrel (2) with center punch marks (3) for later realignment. Remove eight cylinder head cap screws (4).

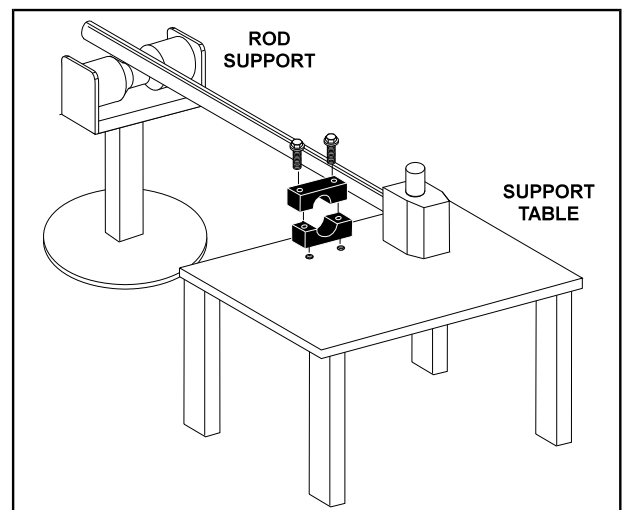


**Figure 5-17. Marking Cylinder for Alignment**

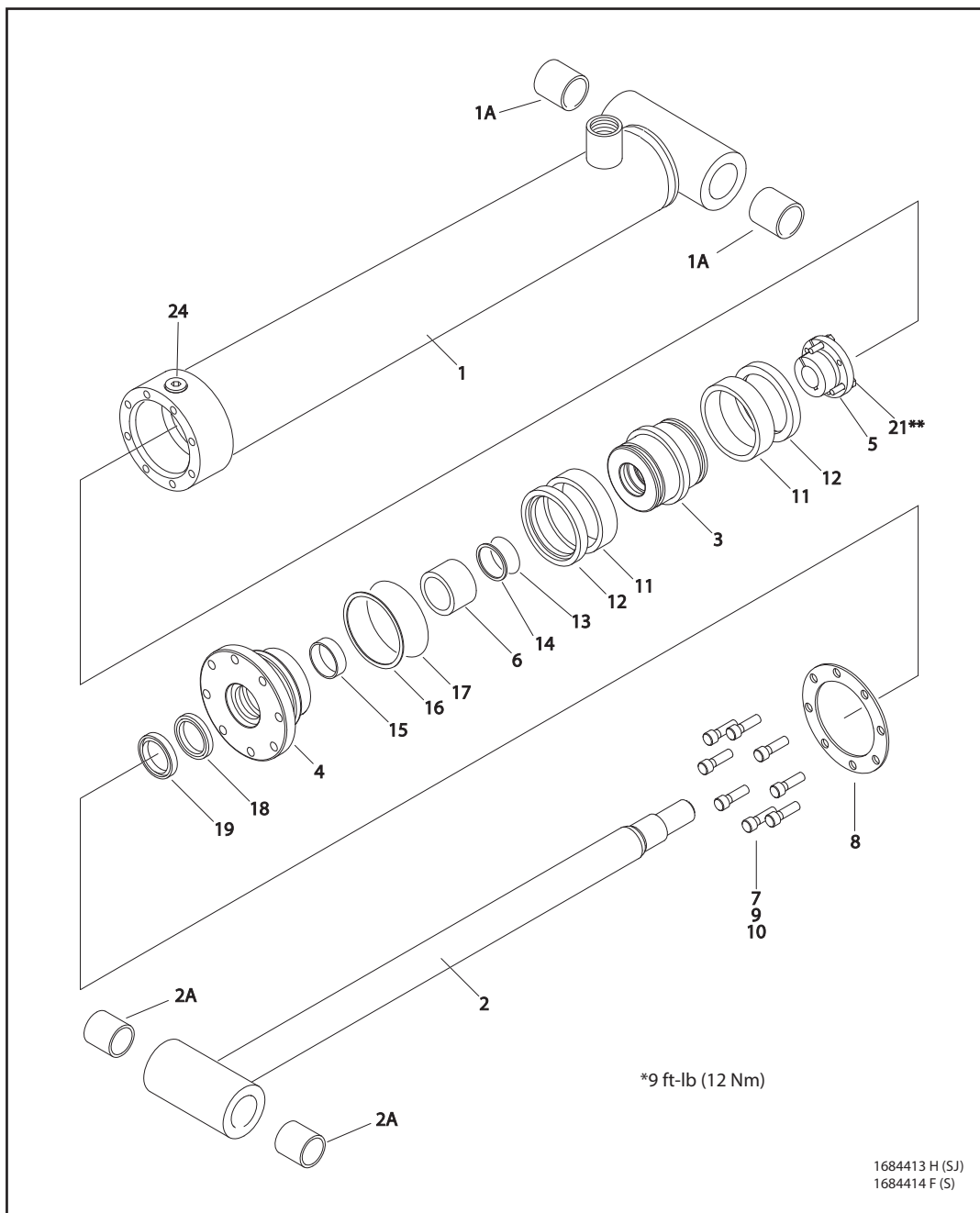
#### NOTICE

**PULLING ROD OFF-CENTER CAN DAMAGE PISTON AND CYLINDER BARREL SURFACES. USE EXTREME CARE WHEN REMOVING CYLINDER ROD, HEAD, AND PISTON.**

6. Clamp barrel securely. Pull rod assembly and cylinder head from barrel.
7. Protect cylinder rod from damage and clamp in a vise or holding fixture as close to piston as possible.



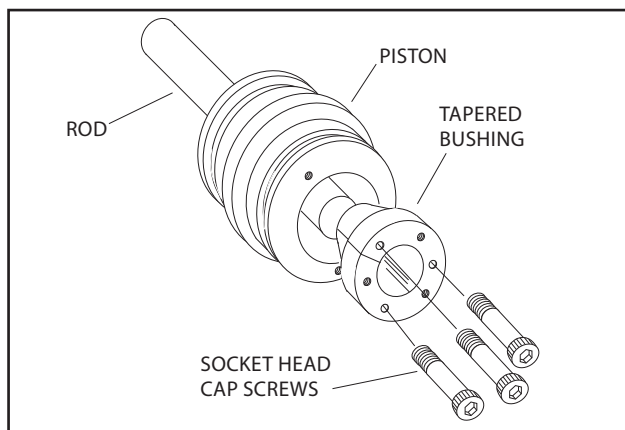
**Figure 5-18. Cylinder Rod Support**



- |                       |                    |                     |                  |              |
|-----------------------|--------------------|---------------------|------------------|--------------|
| 1. Barrel             | 4. Head            | 9. Locking Compound | 14. Back-Up Ring | 19. Wiper    |
| 1a. Composite Bushing | 5. Tapered Bushing | 10. Locking Primer  | 15. Wear Ring    | 20. Not Used |
| 2. Rod                | 6. Spacer          | 11. Seal            | 16. O-Ring       | 21. Capscrew |
| 2a. Composite Bushing | 7. Capscrew        | 12. Lock Ring       | 17. Back-Up Ring |              |
| 3. Piston             | 8. Ring Washer     | 13. O-Ring          | 18. Rod Seal     |              |

Figure 5-19. Master Cylinder Assembly

8. Using suitable protection, clamp cylinder rod in a vise or similar holding fixture as close to piston as possible.
9. Loosen and remove nut attaching piston to rod. Remove piston.
10. Loosen and remove cap screw(s), if applicable, attaching tapered bushing to piston.
11. Insert cap screw(s) in threaded holes in outer piece of tapered bushing. Progressively tighten cap screw(s) until bushing is loose on piston.
12. Remove tapered bushing from piston.
13. Screw piston counter-clockwise by hand and remove from cylinder rod.



**Figure 5-20. Tapered Bushing Removal**

14. Remove and discard piston O-rings, seal rings, and backup rings.
15. Remove piston spacer, if applicable, from rod.
16. Remove rod from holding fixture. Remove cylinder head gland and retainer plate, if applicable. Discard O-rings, back-up rings, rod seals, and wiper seals.

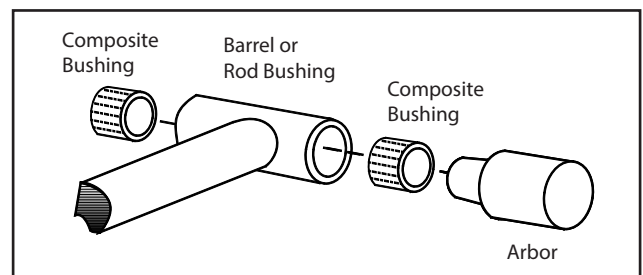
## Cleaning and Inspection

1. Clean parts thoroughly with approved cleaning solvent.
2. Inspect cylinder rod for scoring, tapering, ovality, or other damage. If necessary, dress rod with Scotch Brite or equivalent. Replace rod if necessary.
3. Inspect threaded portion of rod for excessive damage. Dress threads as necessary.
4. Inspect inner surface of cylinder barrel tube for scoring or other damage. Check inside diameter for tapering or ovality. Replace if necessary.
5. Inspect threaded portion of barrel for damage. Dress threads as necessary.
6. Inspect piston surface for damage, scoring, or distortion. Dress piston surface or replace piston as necessary.

7. Inspect threaded portion of piston for damage. Dress threads as necessary.
8. Inspect seal and O-ring grooves in piston for burrs and sharp edges. Dress surfaces as necessary.
9. Inspect cylinder head inside diameter for scoring or other damage, and for ovality and tapering. Replace as necessary.
10. Inspect threaded portion of head for damage. Dress threads as necessary.
11. Inspect seal and O-ring grooves in head for burrs and sharp edges. Dress applicable surfaces as necessary.
12. Inspect cylinder head outside diameter for scoring, damage, ovality, and tapering. Replace as necessary.
13. If applicable, inspect rod and barrel bearings for signs of correct excessive wear or damage. Replace as necessary.
  - a. Thoroughly clean hole, (steel bushing) of burrs, dirt etc. to facilitate bearing installation.
  - b. Inspect steel bushing for wear or other damage. If steel bushing is worn or damaged, rod/barrel must be replaced.
  - c. Lubricate inside of the steel bushing with WD40 prior to bearing installation.

**NOTE:** Lubrication is not required with nickel plated pins and bearings. Install pin in composite bushing dry.

- d. Press composite bushing into barrel or rod bushing with correct size arbor.



**Figure 5-21. Composite Bushing Installation**

14. Inspect travel limiting collar or spacer for burrs and sharp edges. If necessary, dress inside diameter surface with Scotch Brite or equivalent.
15. If applicable, inspect port block fittings and holding valve. Replace as necessary.
16. Inspect oil ports for blockage or presence of dirt or other foreign material. Repair as necessary.
17. If applicable, inspect piston rings for cracks or other damage. Replace as necessary.

**Assembly**

**NOTE:** Use proper cylinder seal kit for cylinder assembly. See your JLG Parts Manual.

Apply a light film of hydraulic oil to all components before assembly.

1. Use seal tool to install new rod seal into applicable cylinder head gland groove.

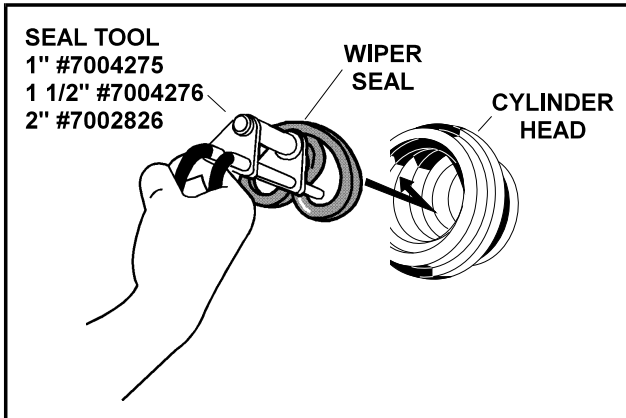


Figure 5-22. Rod Seal Installation

**NOTICE**

IMPROPER SEAL INSTALLATION CAN CAUSE CYLINDER LEAKS AND IMPROPER CYLINDER OPERATION. ENSURE 'POLY-PAK' PISTON SEALS ARE PROPERLY INSTALLED. REFER TO WIPER SEAL INSTALLATION FOR CORRECT SEAL ORIENTATION.

2. Use a soft mallet to tap new wiper seal into applicable cylinder head gland groove. Install new wear ring in applicable cylinder head gland groove.

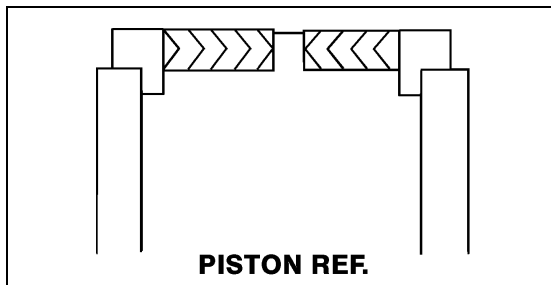


Figure 5-23. Poly-Pak Piston Seal Installation

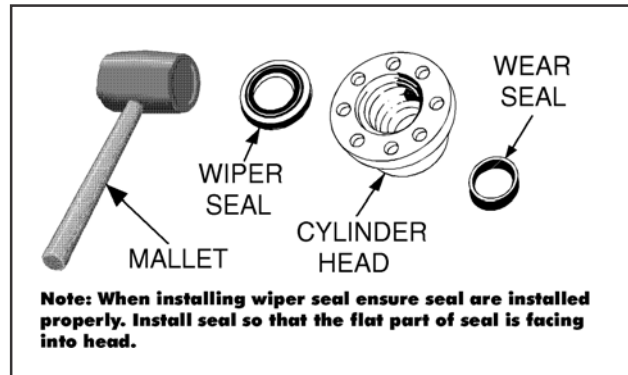


Figure 5-24. Wiper Seal Installation

3. Place new O-ring and back-up seal in applicable outside diameter groove of cylinder head.

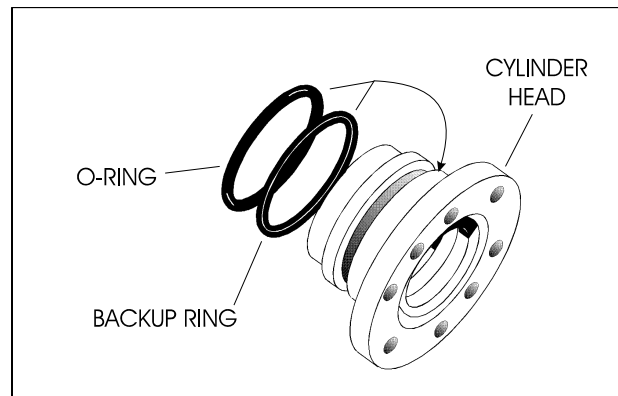
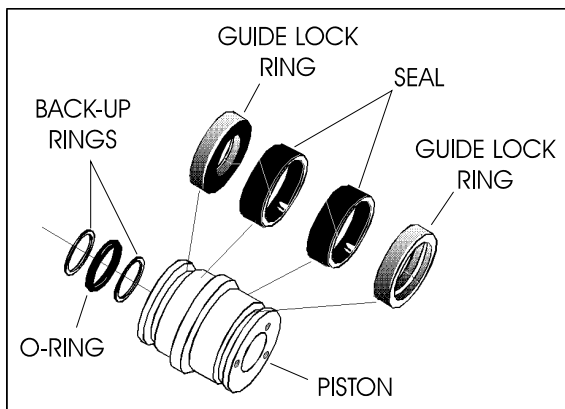


Figure 5-25. Head Seal Kit Installation

4. Install washer ring on rod. Carefully install head gland on rod. Do not damage or dislodge wiper and rod seals. Push head along rod to rod end, as applicable.
5. Carefully slide piston spacer on rod.

**NOTE:** Upper telescope cylinder piston has an O-ring installed inside spacer.

6. If applicable, place new O-ring and back-up rings in inner piston diameter groove.



**Figure 5-26. Piston Seal Kit Installation**

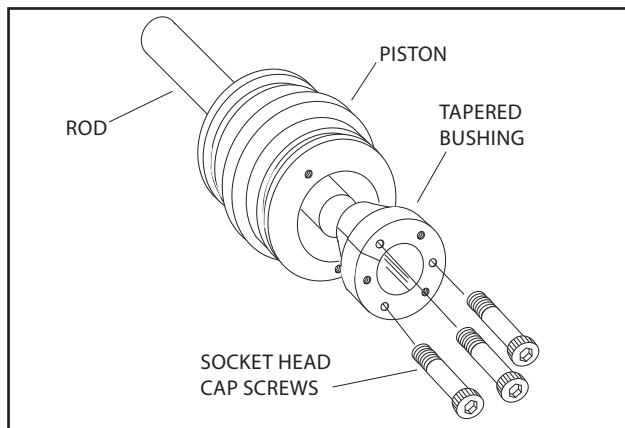
7. Using suitable protection, clamp cylinder rod in a vise or similar holding fixture as close to piston as possible.
8. Carefully thread piston on cylinder rod hand tight, Ensure O-ring and back-up rings are not damaged or dislodged.

**NOTE:** Piston and mating end of rod must be free of oil when installing tapered bushing.

9. Thread piston onto rod until it aligns with spacer end and install tapered bushing.

**NOTE:** Apply LOCTITE #242 or equivalent to tapered bushing bolts when rebuilding master, slave, lift, and telescope cylinders.

10. Install bolts in tapered bushing using loctite #242



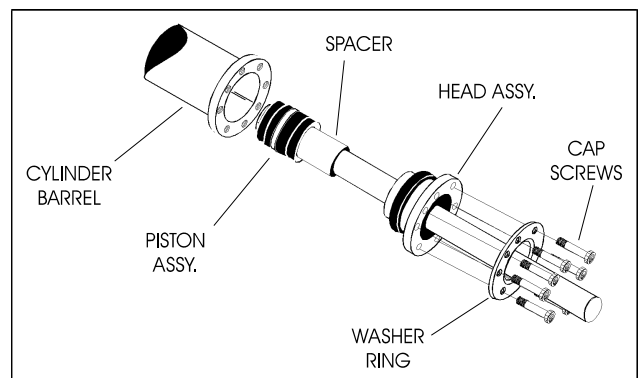
**Figure 5-27. Tapered Bushing Installation**

11. Remove cylinder rod from holding fixture.
12. Place new guide locks and seals in applicable outside diameter grooves of cylinder piston. (See Figure 2-28. Piston Seal Kit Installation.)
13. Position cylinder barrel in a suitable holding fixture.

**NOTICE**

**INSERTING ROD OFF-CENTER CAN DAMAGE PISTON AND CYLINDER BARREL SURFACES. USE EXTREME CARE WHEN INSTALLING CYLINDER ROD, HEAD, AND PISTON.**

14. Clamp barrel clamped securely and support rod. Insert piston end into barrel cylinder. Do not damage or dislodge piston loading O-ring and seal ring.
15. Continue pushing rod into barrel until cylinder head gland can be inserted into barrel cylinder.
16. Secure cylinder head gland using washer ring and socket head bolts.



**Figure 5-28. Rod Assembly Installation**

## Telescope Cylinder

### DISASSEMBLY

#### NOTICE

CONTAMINATION MAY DAMAGE EQUIPMENT. DISASSEMBLE CYLINDER ON A CLEAN WORK SURFACE IN A DIRT FREE WORK AREA.

1. Connect a suitable auxiliary hydraulic power source to cylinder port block fitting.

#### WARNING

DO NOT FULLY EXTEND CYLINDER TO THE END OF STROKE. RETRACT CYLINDER SLIGHTLY TO AVOID TRAPPING PRESSURE.

2. Operate hydraulic power source and extend cylinder. Shut down and disconnect power source. Adequately support cylinder rod, if applicable.
3. If applicable, remove cartridge-type counterbalance valve and fittings from cylinder port block. Discard O-rings.
4. Place cylinder barrel in a suitable holding fixture. Tap around outside of cylinder head retainer with a suitable hammer to break thread-locking compound.

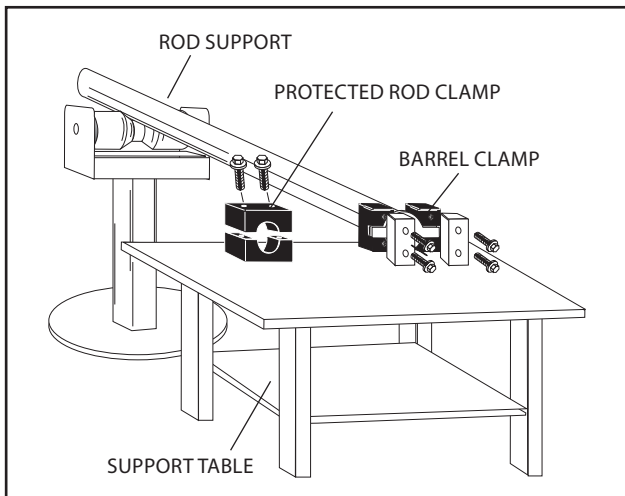


Figure 5-29. Cylinder Barrel Support

5. Mark cylinder head (1) and barrel (2) with center punch marks (3) for later realignment. Remove eight cylinder head cap screws (4).

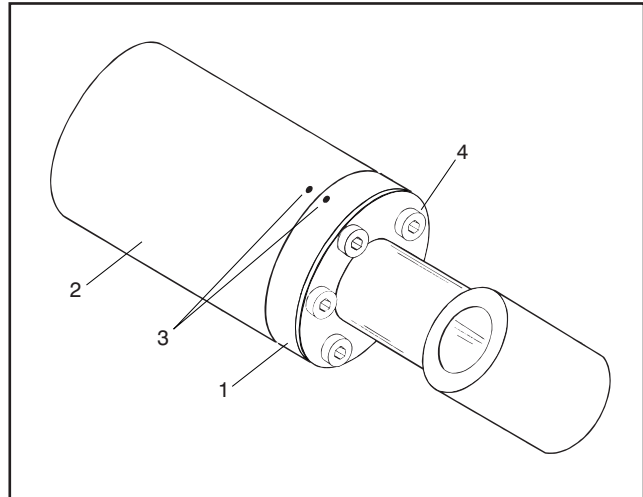


Figure 5-30. Marking Cylinder for Alignment

#### NOTICE

PULLING ROD OFF-CENTER CAN DAMAGE PISTON AND CYLINDER BARREL SURFACES. USE EXTREME CARE WHEN REMOVING CYLINDER ROD, HEAD, AND PISTON.

6. Clamp barrel securely. Pull rod assembly and cylinder head from barrel.
7. Protect cylinder rod from damage and clamp in a vise or holding fixture as close to piston as possible.

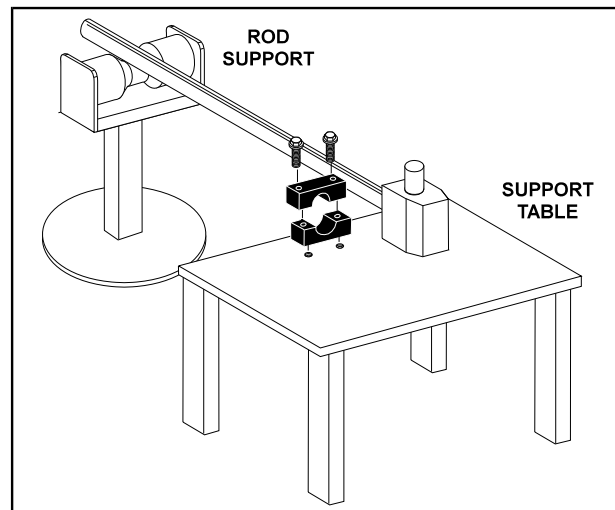
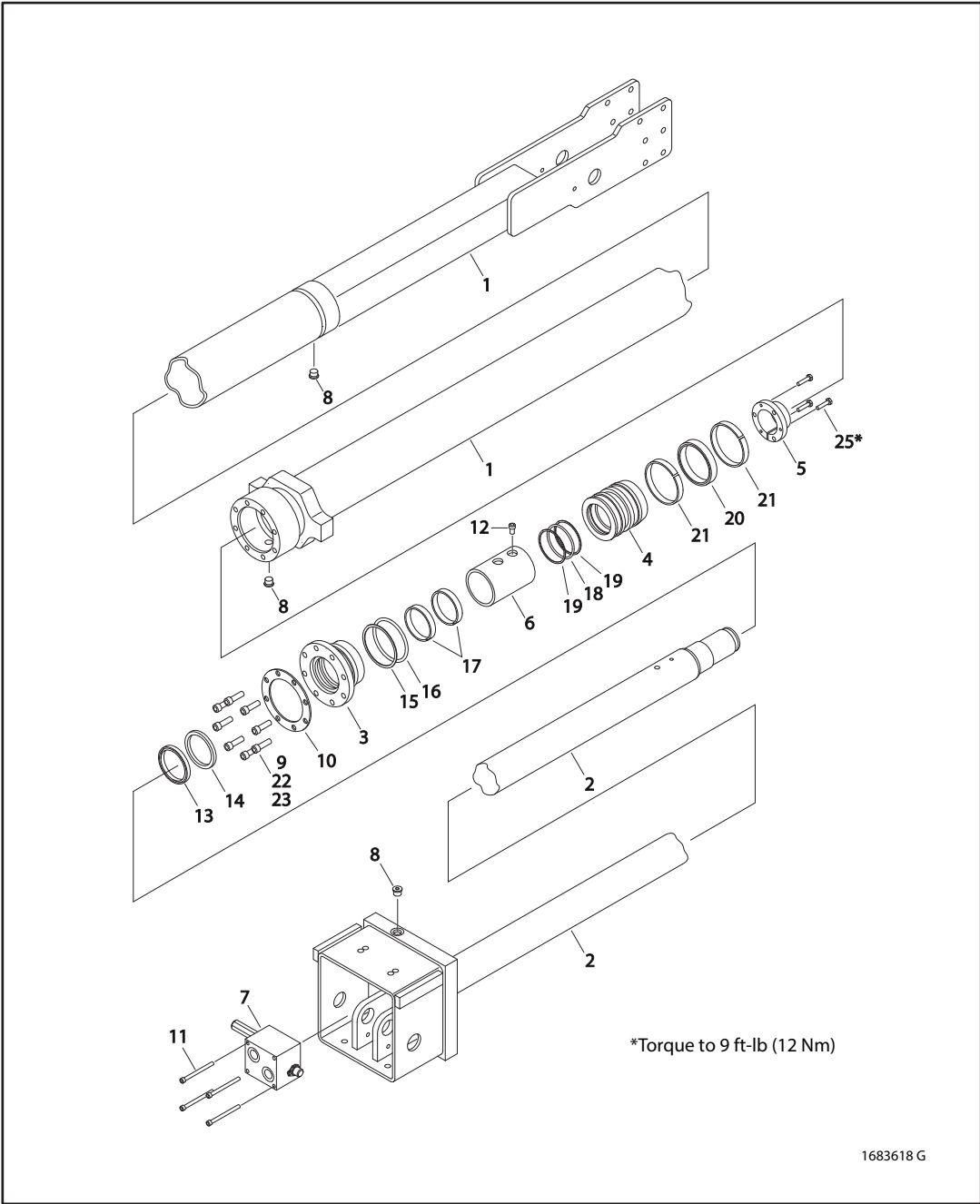


Figure 5-31. Cylinder Rod Support



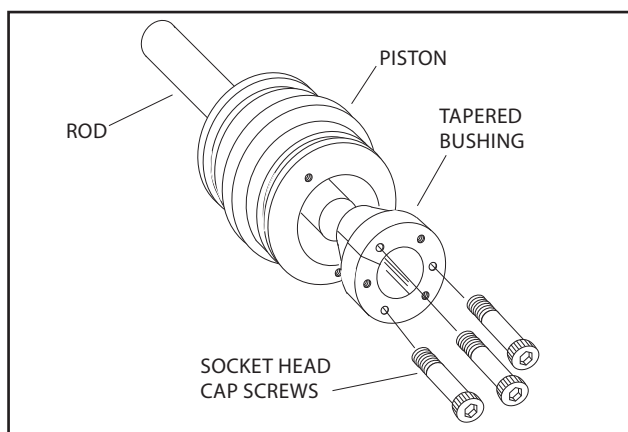


- |                    |                   |              |                  |                      |
|--------------------|-------------------|--------------|------------------|----------------------|
| 1. Barrel          | 6. Spacer         | 11. Capscrew | 16. Back-Up Ring | 21. Wear Ring        |
| 2. Rod             | 7. Valve Assembly | 12. Capscrew | 17. Wear Ring    | 22. Locking Compound |
| 3. Head            | 8. O-Ring Plug    | 13. Wiper    | 18. O-Ring       | 23. Locking primer   |
| 4. Piston          | 9. Capscrew       | 14. Rod Seal | 19. Back-Up Ring | 24. Not Used         |
| 5. Tapered Bushing | 10. Ring Washer   | 15. O-Ring   | 20. T-Seal       | 25. Bolt             |

Figure 5-32. Telescope Cylinder Assembly

## SECTION 5 - HYDRAULICS

8. Using suitable protection, clamp cylinder rod in a vise or similar holding fixture as close to piston as possible.
9. Loosen and remove nut attaching piston to rod. Remove piston.
10. Loosen and remove cap screw(s), if applicable, attaching tapered bushing to piston.
11. Insert cap screw(s) in threaded holes in outer piece of tapered bushing. Progressively tighten cap screw(s) until bushing is loose on piston.
12. Remove tapered bushing from piston.
13. Screw piston counter-clockwise by hand and remove from cylinder rod.



**Figure 5-33. Tapered Bushing Removal**

14. Remove and discard piston O-rings, seal rings, and backup rings.
15. Remove piston spacer, if applicable, from rod.
16. Remove rod from holding fixture. Remove cylinder head gland and retainer plate, if applicable. Discard O-rings, back-up rings, rod seals, and wiper seals.

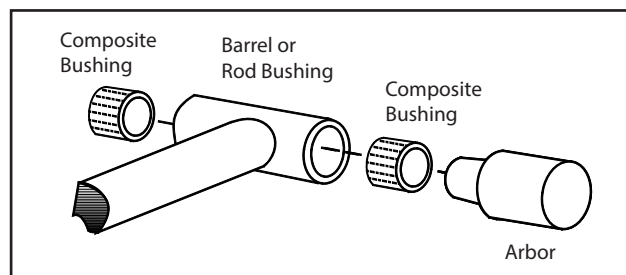
### Cleaning and Inspection

1. Clean parts thoroughly with approved cleaning solvent.
2. Inspect cylinder rod for scoring, tapering, ovality, or other damage. If necessary, dress rod with Scotch Brite or equivalent. Replace rod if necessary.
3. Inspect threaded portion of rod for excessive damage. Dress threads as necessary.
4. Inspect inner surface of cylinder barrel tube for scoring or other damage. Check inside diameter for tapering or ovality. Replace if necessary.
5. Inspect threaded portion of barrel for damage. Dress threads as necessary.
6. Inspect piston surface for damage, scoring, or distortion. Dress piston surface or replace piston as necessary.

7. Inspect threaded portion of piston for damage. Dress threads as necessary.
8. Inspect seal and O-ring grooves in piston for burrs and sharp edges. Dress surfaces as necessary.
9. Inspect cylinder head inside diameter for scoring or other damage, and for ovality and tapering. Replace as necessary.
10. Inspect threaded portion of head for damage. Dress threads as necessary.
11. Inspect seal and O-ring grooves in head for burrs and sharp edges. Dress applicable surfaces as necessary.
12. Inspect cylinder head outside diameter for scoring, damage, ovality, and tapering. Replace as necessary.
13. If applicable, inspect rod and barrel bearings for signs of correct excessive wear or damage. Replace as necessary.
  - a. Thoroughly clean hole, (steel bushing) of burrs, dirt etc. to facilitate bearing installation.
  - b. Inspect steel bushing for wear or other damage. If steel bushing is worn or damaged, rod/barrel must be replaced.
  - c. Lubricate inside of the steel bushing with WD40 prior to bearing installation.

**NOTE:** Lubrication is not required with nickel plated pins and bearings. Install pin in composite bushing dry.

- d. Press composite bushing into barrel or rod bushing with correct size arbor.



**Figure 5-34. Composite Bushing Installation**

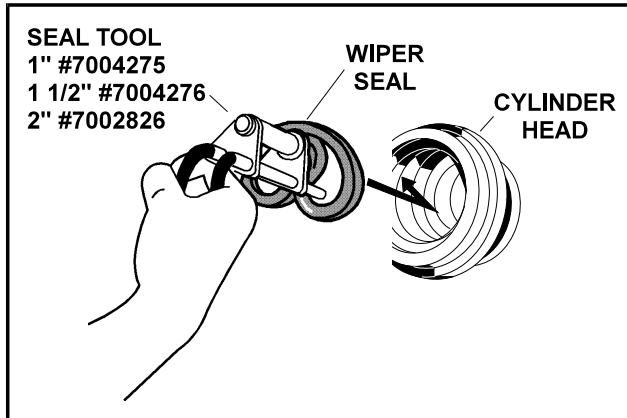
14. Inspect travel limiting collar or spacer for burrs and sharp edges. If necessary, dress inside diameter surface with Scotch Brite or equivalent.
15. If applicable, inspect port block fittings and holding valve. Replace as necessary.
16. Inspect oil ports for blockage or presence of dirt or other foreign material. Repair as necessary.
17. If applicable, inspect piston rings for cracks or other damage. Replace as necessary.

**Assembly**

**NOTE:** Use proper cylinder seal kit for cylinder assembly. See your JLG Parts Manual.

Apply a light film of hydraulic oil to all components before assembly.

1. Use seal tool to install new rod seal into applicable cylinder head gland groove.

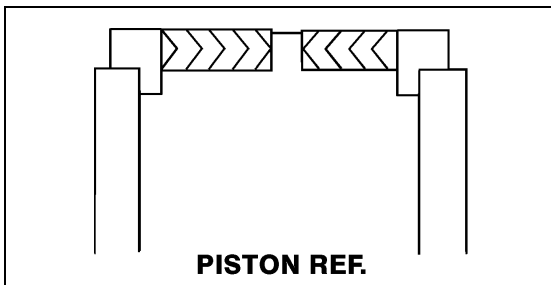


**Figure 5-35. Rod Seal Installation**

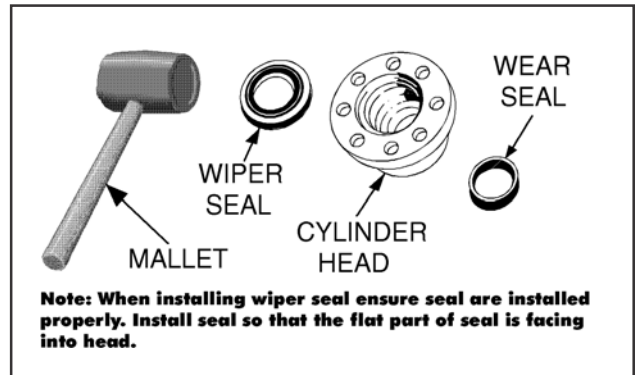
**NOTICE**

IMPROPER SEAL INSTALLATION CAN CAUSE CYLINDER LEAKS AND IMPROPER CYLINDER OPERATION. ENSURE 'POLY-PAK' PISTON SEALS ARE PROPERLY INSTALLED. REFER TO WIPER SEAL INSTALLATION FOR CORRECT SEAL ORIENTATION.

2. Use a soft mallet to tap new wiper seal into applicable cylinder head gland groove. Install new wear ring in applicable cylinder head gland groove.

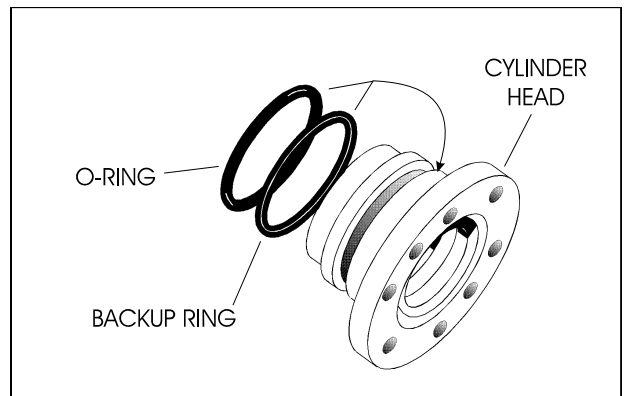


**Figure 5-36. Poly-Pak Piston Seal Installation**



**Figure 5-37. Wiper Seal Installation**

3. Place new O-ring and back-up seal in applicable outside diameter groove of cylinder head.



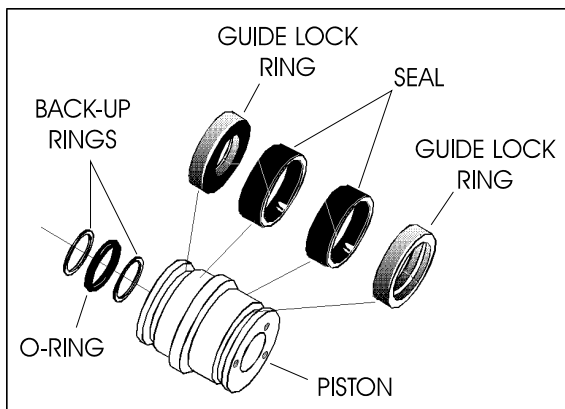
**Figure 5-38. Head Seal Kit Installation**

4. Install washer ring on rod. Carefully install head gland on rod. Do not damage or dislodge wiper and rod seals. Push head along rod to rod end, as applicable.
5. Carefully slide piston spacer on rod.

**NOTE:** Upper telescope cylinder piston has an O-ring installed inside spacer.

## SECTION 5 - HYDRAULICS

- If applicable, place new O-ring and back-up rings in inner piston diameter groove.



**Figure 5-39. Piston Seal Kit Installation**

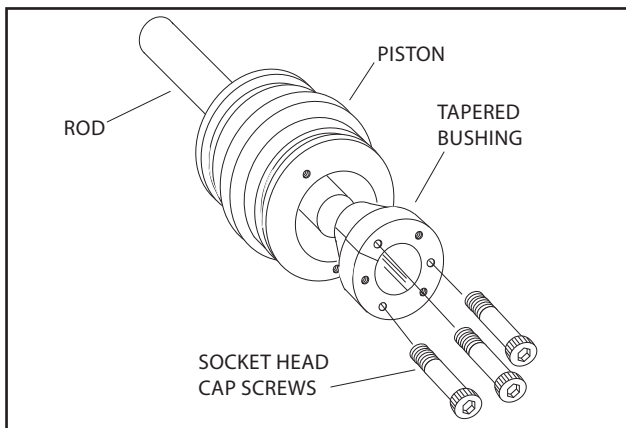
- Using suitable protection, clamp cylinder rod in a vise or similar holding fixture as close to piston as possible.
- Carefully thread piston on cylinder rod hand tight, Ensure O-ring and back-up rings are not damaged or dislodged.

**NOTE:** Piston and mating end of rod must be free of oil when installing tapered bushing.

- Thread piston onto rod until it aligns with spacer end and install tapered bushing.

**NOTE:** Apply LOCTITE #242 or equivalent to tapered bushing bolts when rebuilding master, slave, lift, and telescope cylinders.

- Install bolts in tapered bushing using loctite #242



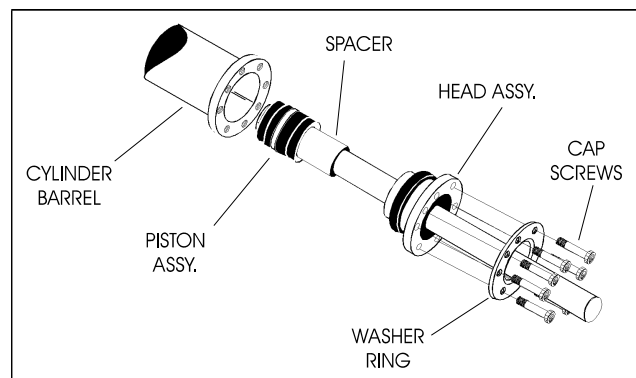
**Figure 5-40. Tapered Bushing Installation**

- Remove cylinder rod from holding fixture.
- Place new guide locks and seals in applicable outside diameter grooves of cylinder piston. (See Figure 2-28. Piston Seal Kit Installation.)
- Position cylinder barrel in a suitable holding fixture.

### NOTICE

**INSERTING ROD OFF-CENTER CAN DAMAGE PISTON AND CYLINDER BARREL SURFACES. USE EXTREME CARE WHEN INSTALLING CYLINDER ROD, HEAD, AND PISTON.**

- Clamp barrel clamped securely and support rod. Insert piston end into barrel cylinder. Do not damage or dislodge piston loading O-ring and seal ring.
- Continue pushing rod into barrel until cylinder head gland can be inserted into barrel cylinder.
- Secure cylinder head gland using washer ring and socket head bolts.



**Figure 5-41. Rod Assembly Installation**

## Platform Level (Slave) Cylinder

### DISASSEMBLY

#### NOTICE

CONTAMINATION MAY DAMAGE EQUIPMENT. DISASSEMBLE CYLINDER ON A CLEAN WORK SURFACE IN A DIRT FREE WORK AREA.

1. Connect a suitable auxiliary hydraulic power source to cylinder port block fitting.

#### WARNING

DO NOT FULLY EXTEND CYLINDER TO THE END OF STROKE. RETRACT CYLINDER SLIGHTLY TO AVOID TRAPPING PRESSURE.

2. Operate hydraulic power source and extend cylinder. Shut down and disconnect power source. Adequately support cylinder rod, if applicable.
3. If applicable, remove cartridge-type counterbalance valve and fittings from cylinder port block. Discard O-rings.
4. Place cylinder barrel in a suitable holding fixture. Tap around outside of cylinder head retainer with a suitable hammer to break thread-locking compound.

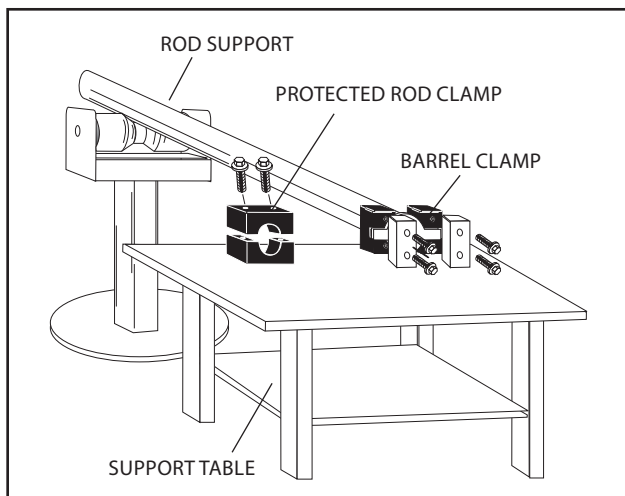


Figure 5-42. Cylinder Barrel Support

5. Mark cylinder head (1) and barrel (2) with center punch marks (3) for later realignment. Remove eight cylinder head cap screws (4).

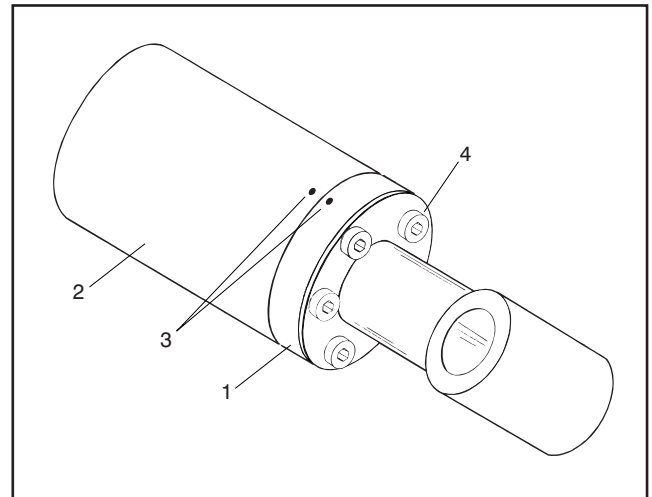


Figure 5-43. Marking Cylinder for Alignment

#### NOTICE

PULLING ROD OFF-CENTER CAN DAMAGE PISTON AND CYLINDER BARREL SURFACES. USE EXTREME CARE WHEN REMOVING CYLINDER ROD, HEAD, AND PISTON.

6. Clamp barrel securely. Pull rod assembly and cylinder head from barrel.
7. Protect cylinder rod from damage and clamp in a vise or holding fixture as close to piston as possible.

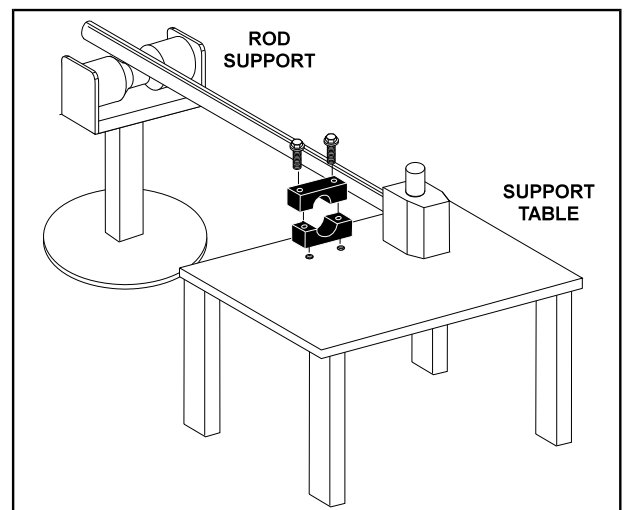
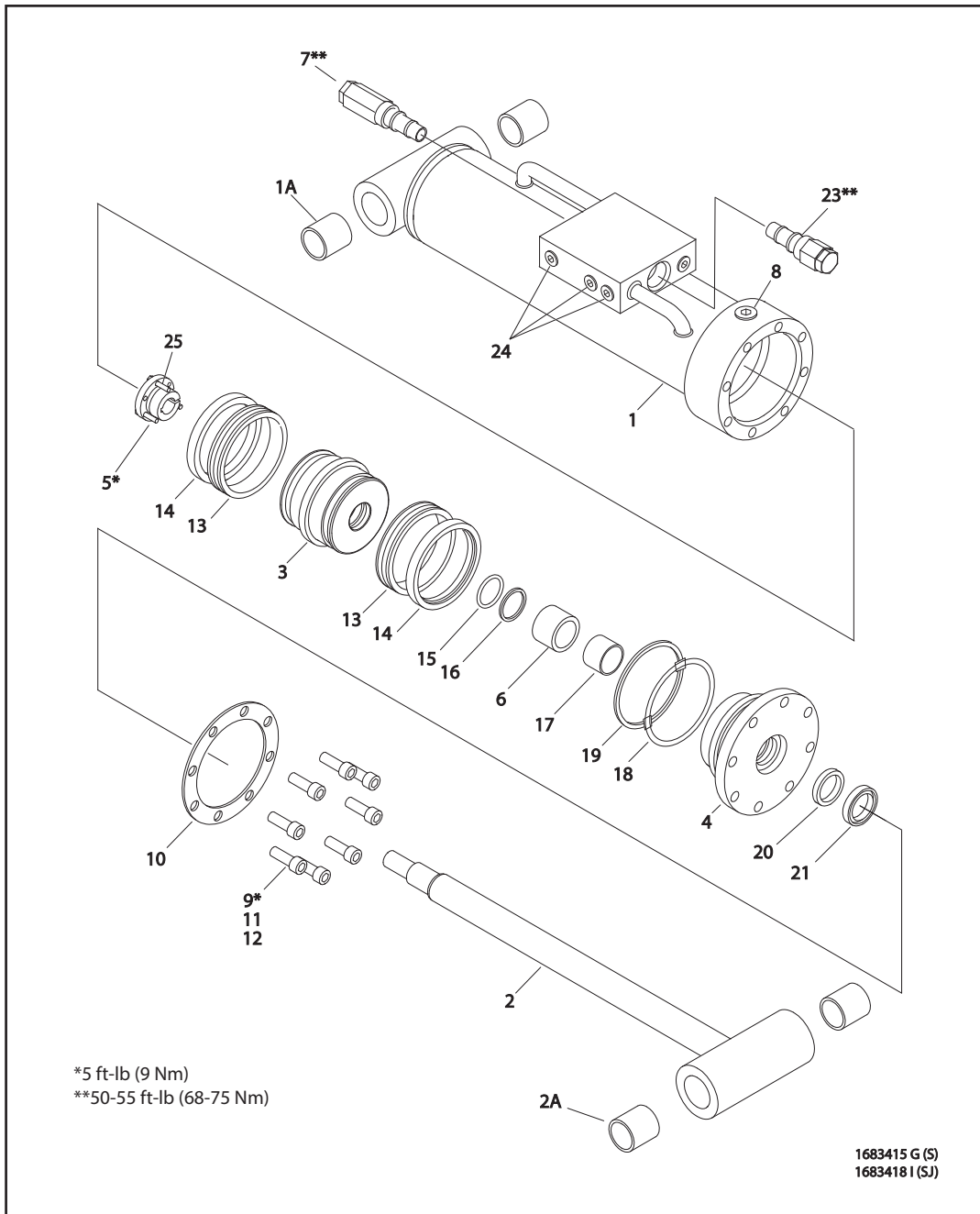


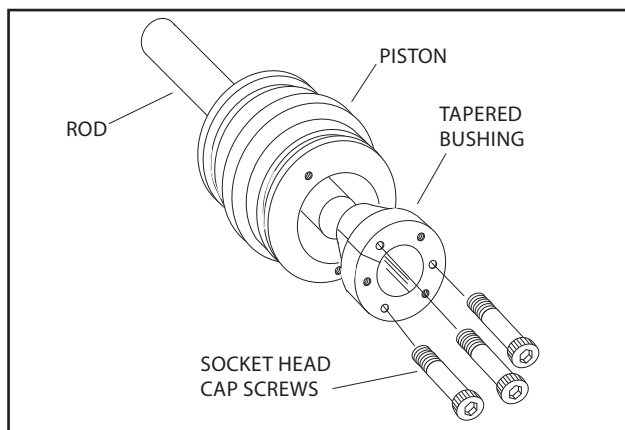
Figure 5-44. Cylinder Rod Support



- |                       |                    |                      |                  |                     |
|-----------------------|--------------------|----------------------|------------------|---------------------|
| 1. Barrel             | 5. Tapered Bushing | 11. Locking Compound | 17. Wear Ring    | 22. Not Used        |
| 1a. Composite Bushing | 6. Spacer          | 12. Locking Primer   | 18. O-Ring       | 23. Cartridge Valve |
| 2. Rod                | 7. Cartridge Valve | 13. Seal             | 19. Back-Up Ring | 24. O-Ring Plug     |
| 2a. Composite Bushing | 8. O-Ring Plug     | 14. Ring Lock        | 20. Rod Seal     | 25. Bolt            |
| 3. Piston             | 9. Capscrew        | 15. O-Ring           | 21. Wiper        |                     |
| 4. Head               | 10. Ring Washer    | 16. Back-Up Ring     |                  |                     |

Figure 5-45. Platform Level (Slave) Cylinder Assembly

8. Using suitable protection, clamp cylinder rod in a vise or similar holding fixture as close to piston as possible.
9. Loosen and remove nut attaching piston to rod. Remove piston.
10. Loosen and remove cap screw(s), if applicable, attaching tapered bushing to piston.
11. Insert cap screw(s) in threaded holes in outer piece of tapered bushing. Progressively tighten cap screw(s) until bushing is loose on piston.
12. Remove tapered bushing from piston.
13. Screw piston counter-clockwise by hand and remove from cylinder rod.



**Figure 5-46. Tapered Bushing Removal**

14. Remove and discard piston O-rings, seal rings, and backup rings.
15. Remove piston spacer, if applicable, from rod.
16. Remove rod from holding fixture. Remove cylinder head gland and retainer plate, if applicable. Discard O-rings, back-up rings, rod seals, and wiper seals.

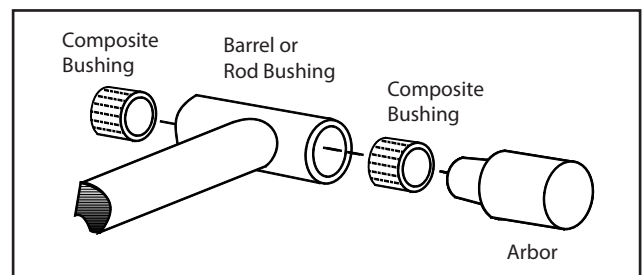
## Cleaning and Inspection

1. Clean parts thoroughly with approved cleaning solvent.
2. Inspect cylinder rod for scoring, tapering, ovality, or other damage. If necessary, dress rod with Scotch Brite or equivalent. Replace rod if necessary.
3. Inspect threaded portion of rod for excessive damage. Dress threads as necessary.
4. Inspect inner surface of cylinder barrel tube for scoring or other damage. Check inside diameter for tapering or ovality. Replace if necessary.
5. Inspect threaded portion of barrel for damage. Dress threads as necessary.
6. Inspect piston surface for damage, scoring, or distortion. Dress piston surface or replace piston as necessary.

7. Inspect threaded portion of piston for damage. Dress threads as necessary.
8. Inspect seal and O-ring grooves in piston for burrs and sharp edges. Dress surfaces as necessary.
9. Inspect cylinder head inside diameter for scoring or other damage, and for ovality and tapering. Replace as necessary.
10. Inspect threaded portion of head for damage. Dress threads as necessary.
11. Inspect seal and O-ring grooves in head for burrs and sharp edges. Dress applicable surfaces as necessary.
12. Inspect cylinder head outside diameter for scoring, damage, ovality, and tapering. Replace as necessary.
13. If applicable, inspect rod and barrel bearings for signs of correct excessive wear or damage. Replace as necessary.
  - a. Thoroughly clean hole, (steel bushing) of burrs, dirt etc. to facilitate bearing installation.
  - b. Inspect steel bushing for wear or other damage. If steel bushing is worn or damaged, rod/barrel must be replaced.
  - c. Lubricate inside of the steel bushing with WD40 prior to bearing installation.

**NOTE:** Lubrication is not required with nickel plated pins and bearings. Install pin in composite bushing dry.

- d. Press composite bushing into barrel or rod bushing with correct size arbor.



**Figure 5-47. Composite Bushing Installation**

14. Inspect travel limiting collar or spacer for burrs and sharp edges. If necessary, dress inside diameter surface with Scotch Brite or equivalent.
15. If applicable, inspect port block fittings and holding valve. Replace as necessary.
16. Inspect oil ports for blockage or presence of dirt or other foreign material. Repair as necessary.
17. If applicable, inspect piston rings for cracks or other damage. Replace as necessary.

**Assembly**

**NOTE:** Use proper cylinder seal kit for cylinder assembly. See your JLG Parts Manual.

Apply a light film of hydraulic oil to all components before assembly.

1. Use seal tool to install new rod seal into applicable cylinder head gland groove.

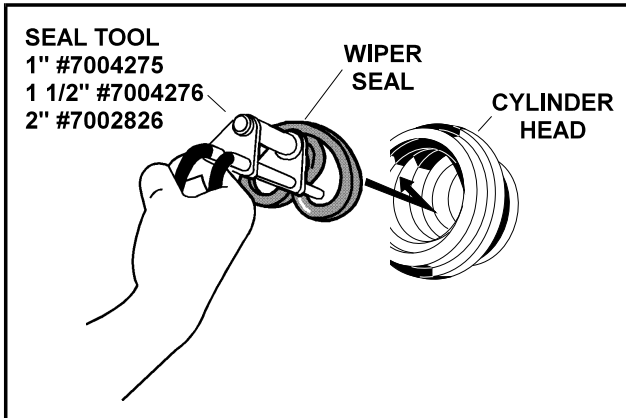


Figure 5-48. Rod Seal Installation

**NOTICE**

IMPROPER SEAL INSTALLATION CAN CAUSE CYLINDER LEAKS AND IMPROPER CYLINDER OPERATION. ENSURE 'POLY-PAK' PISTON SEALS ARE PROPERLY INSTALLED. REFER TO WIPER SEAL INSTALLATION FOR CORRECT SEAL ORIENTATION.

2. Use a soft mallet to tap new wiper seal into applicable cylinder head gland groove. Install new wear ring in applicable cylinder head gland groove.

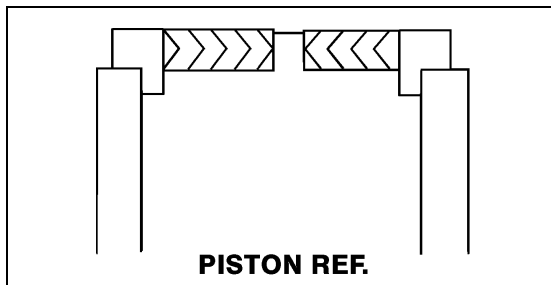


Figure 5-49. Poly-Pak Piston Seal Installation

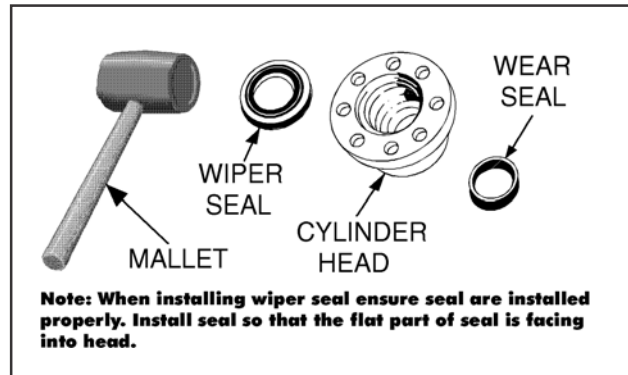


Figure 5-50. Wiper Seal Installation

3. Place new O-ring and back-up seal in applicable outside diameter groove of cylinder head.

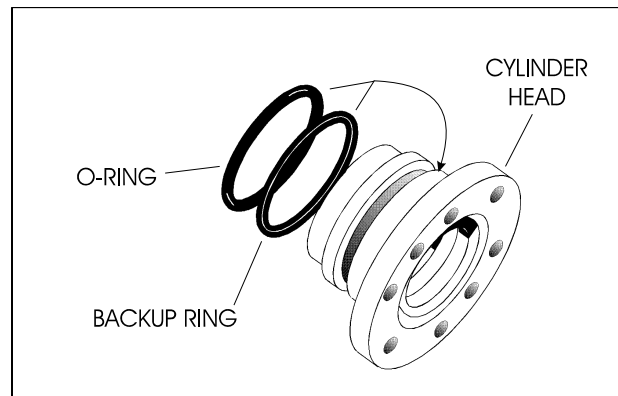


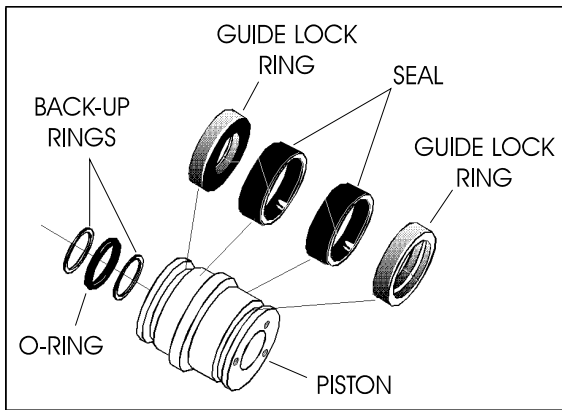
Figure 5-51. Head Seal Kit Installation

4. Install washer ring on rod. Carefully install head gland on rod. Do not damage or dislodge wiper and rod seals. Push head along rod to rod end, as applicable.
5. Carefully slide piston spacer on rod.

**NOTE:** Upper telescope cylinder piston has an O-ring installed inside spacer.



6. If applicable, place new O-ring and back-up rings in inner piston diameter groove.



**Figure 5-52. Piston Seal Kit Installation**

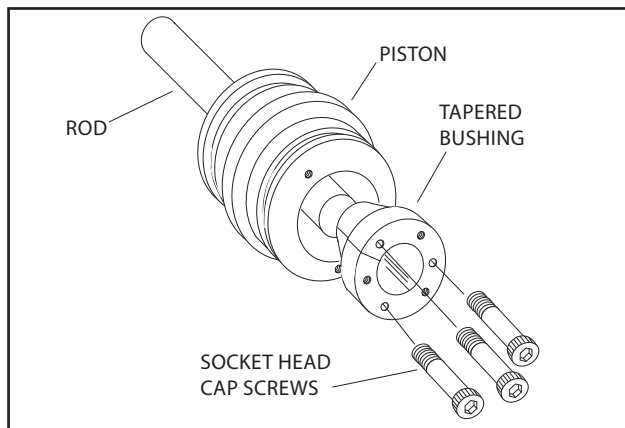
7. Using suitable protection, clamp cylinder rod in a vise or similar holding fixture as close to piston as possible.
8. Carefully thread piston on cylinder rod hand tight, Ensure O-ring and back-up rings are not damaged or dislodged.

**NOTE:** Piston and mating end of rod must be free of oil when installing tapered bushing.

9. Thread piston onto rod until it aligns with spacer end and install tapered bushing.

**NOTE:** Apply LOCTITE #242 or equivalent to tapered bushing bolts when rebuilding master, slave, lift, and telescope cylinders.

10. Install bolts in tapered bushing using loctite #242



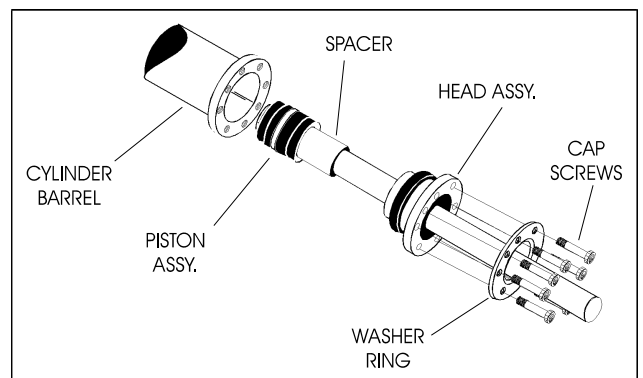
**Figure 5-53. Tapered Bushing Installation**

11. Remove cylinder rod from holding fixture.
12. Place new guide locks and seals in applicable outside diameter grooves of cylinder piston. (See Figure 2-28. Piston Seal Kit Installation.)
13. Position cylinder barrel in a suitable holding fixture.

**NOTICE**

**INSERTING ROD OFF-CENTER CAN DAMAGE PISTON AND CYLINDER BARREL SURFACES. USE EXTREME CARE WHEN INSTALLING CYLINDER ROD, HEAD, AND PISTON.**

14. Clamp barrel clamped securely and support rod. Insert piston end into barrel cylinder. Do not damage or dislodge piston loading O-ring and seal ring.
15. Continue pushing rod into barrel until cylinder head gland can be inserted into barrel cylinder.
16. Secure cylinder head gland using washer ring and socket head bolts.



**Figure 5-54. Rod Assembly Installation**

**Jib Lift Cylinder (SJ Only)**

**DISASSEMBLY**

**NOTICE**

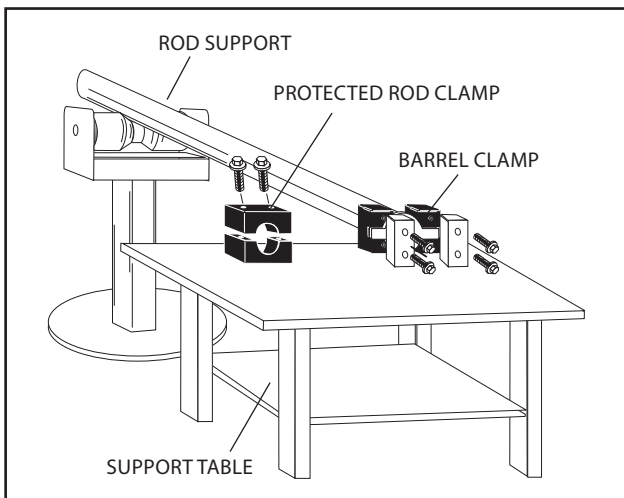
CONTAMINATION MAY DAMAGE EQUIPMENT. DISASSEMBLE CYLINDER ON A CLEAN WORK SURFACE IN A DIRT FREE WORK AREA.

1. Connect a suitable auxiliary hydraulic power source to cylinder port block fitting.

**WARNING**

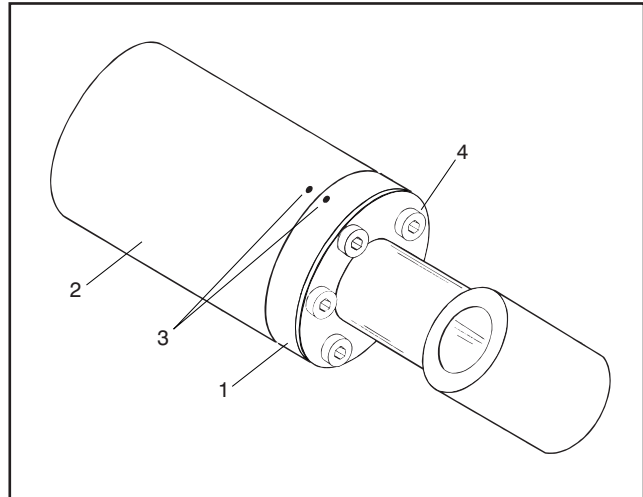
DO NOT FULLY EXTEND CYLINDER TO THE END OF STROKE. RETRACT CYLINDER SLIGHTLY TO AVOID TRAPPING PRESSURE.

2. Operate hydraulic power source and extend cylinder. Shut down and disconnect power source. Adequately support cylinder rod, if applicable.
3. If applicable, remove cartridge-type counterbalance valve and fittings from cylinder port block. Discard O-rings.
4. Place cylinder barrel in a suitable holding fixture. Tap around outside of cylinder head retainer with a suitable hammer to break thread-locking compound.



**Figure 5-55. Cylinder Barrel Support**

5. Mark cylinder head (1) and barrel (2) with center punch marks (3) for later realignment. Remove eight cylinder head cap screws (4).

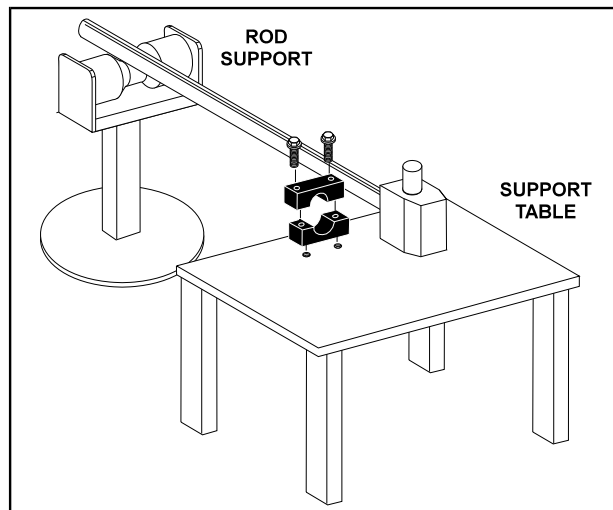


**Figure 5-56. Marking Cylinder for Alignment**

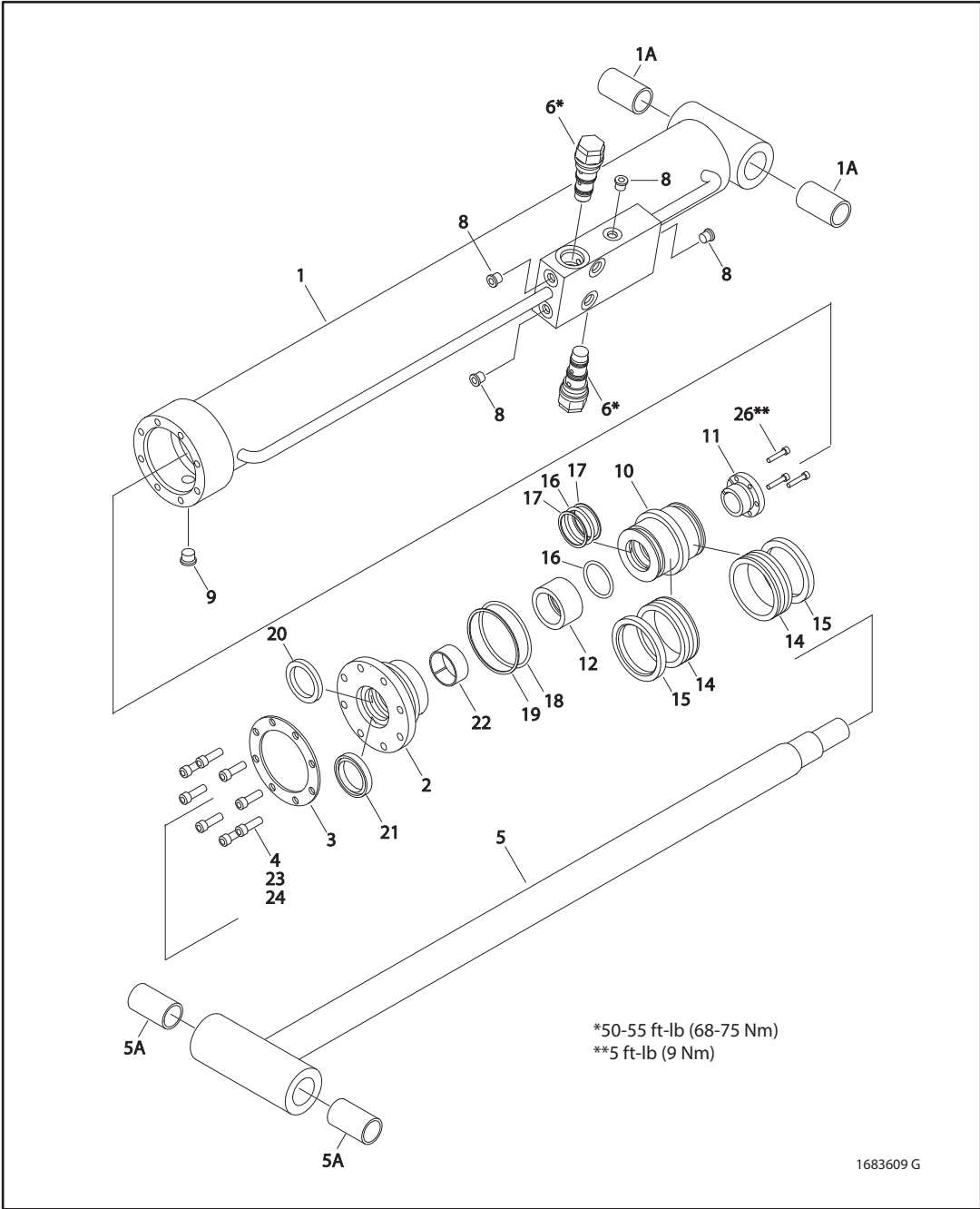
**NOTICE**

PULLING ROD OFF-CENTER CAN DAMAGE PISTON AND CYLINDER BARREL SURFACES. USE EXTREME CARE WHEN REMOVING CYLINDER ROD, HEAD, AND PISTON.

6. Clamp barrel securely. Pull rod assembly and cylinder head from barrel.
7. Protect cylinder rod from damage and clamp in a vise or holding fixture as close to piston as possible.



**Figure 5-57. Cylinder Rod Support**

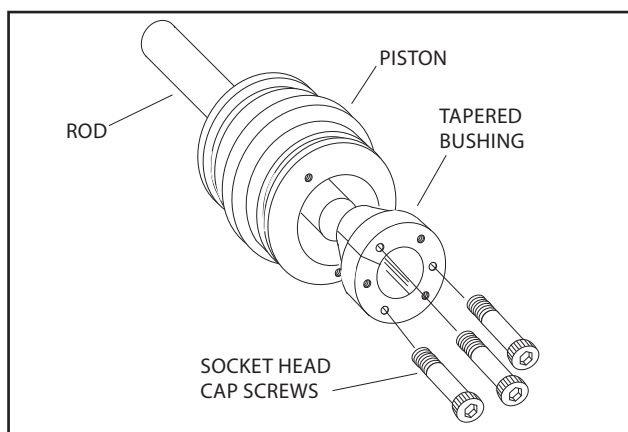


- |                |                    |                     |                  |                      |                    |
|----------------|--------------------|---------------------|------------------|----------------------|--------------------|
| 1. Barrel      | 5. Rod             | 9. O-Ring Plug      | 14. Seal         | 19. Wiper            | 24. Locking Primer |
| 1a. Bushing    | 5a. Bushing        | 10. Piston          | 15. Lock Ring    | 20. Wear Ring        | 25. Not Used       |
| 2. Head        | 6. Cartridge Valve | 11. Tapered Bushing | 16. O-Ring       | 21. Wiper            | 26. Bolt           |
| 3. Ring Washer | 7. Not Used        | 12. Spacer          | 17. Back-Up Ring | 22. Wear Ring        |                    |
| 4. Capscrew    | 8. O-Ring Plug     | 13. Not Used        | 18. Rod Seal     | 23. Locking Compound |                    |

Figure 5-58. Jib Lift Cylinder Assembly(600SJ)

## SECTION 5 - HYDRAULICS

8. Using suitable protection, clamp cylinder rod in a vise or similar holding fixture as close to piston as possible.
9. Loosen and remove nut attaching piston to rod. Remove piston.
10. Loosen and remove cap screw(s), if applicable, attaching tapered bushing to piston.
11. Insert cap screw(s) in threaded holes in outer piece of tapered bushing. Progressively tighten cap screw(s) until bushing is loose on piston.
12. Remove tapered bushing from piston.
13. Screw piston counter-clockwise by hand and remove from cylinder rod.



**Figure 5-59. Tapered Bushing Removal**

14. Remove and discard piston O-rings, seal rings, and backup rings.
15. Remove piston spacer, if applicable, from rod.
16. Remove rod from holding fixture. Remove cylinder head gland and retainer plate, if applicable. Discard O-rings, back-up rings, rod seals, and wiper seals.

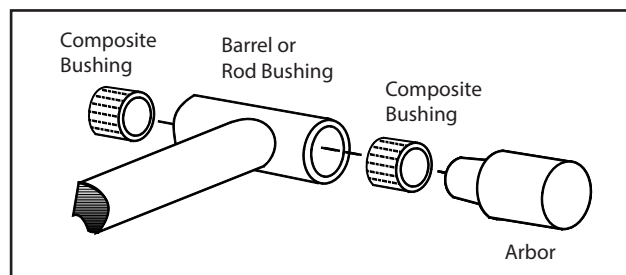
### Cleaning and Inspection

1. Clean parts thoroughly with approved cleaning solvent.
2. Inspect cylinder rod for scoring, tapering, ovality, or other damage. If necessary, dress rod with Scotch Brite or equivalent. Replace rod if necessary.
3. Inspect threaded portion of rod for excessive damage. Dress threads as necessary.
4. Inspect inner surface of cylinder barrel tube for scoring or other damage. Check inside diameter for tapering or ovality. Replace if necessary.
5. Inspect threaded portion of barrel for damage. Dress threads as necessary.
6. Inspect piston surface for damage, scoring, or distortion. Dress piston surface or replace piston as necessary.

7. Inspect threaded portion of piston for damage. Dress threads as necessary.
8. Inspect seal and O-ring grooves in piston for burrs and sharp edges. Dress surfaces as necessary.
9. Inspect cylinder head inside diameter for scoring or other damage, and for ovality and tapering. Replace as necessary.
10. Inspect threaded portion of head for damage. Dress threads as necessary.
11. Inspect seal and O-ring grooves in head for burrs and sharp edges. Dress applicable surfaces as necessary.
12. Inspect cylinder head outside diameter for scoring, damage, ovality, and tapering. Replace as necessary.
13. If applicable, inspect rod and barrel bearings for signs of correct excessive wear or damage. Replace as necessary.
  - a. Thoroughly clean hole, (steel bushing) of burrs, dirt etc. to facilitate bearing installation.
  - b. Inspect steel bushing for wear or other damage. If steel bushing is worn or damaged, rod/barrel must be replaced.
  - c. Lubricate inside of the steel bushing with WD40 prior to bearing installation.

**NOTE:** Lubrication is not required with nickel plated pins and bearings. Install pin in composite bushing dry.

- d. Press composite bushing into barrel or rod bushing with correct size arbor.



**Figure 5-60. Composite Bushing Installation**

14. Inspect travel limiting collar or spacer for burrs and sharp edges. If necessary, dress inside diameter surface with Scotch Brite or equivalent.
15. If applicable, inspect port block fittings and holding valve. Replace as necessary.
16. Inspect oil ports for blockage or presence of dirt or other foreign material. Repair as necessary.
17. If applicable, inspect piston rings for cracks or other damage. Replace as necessary.

## Assembly

**NOTE:** Use proper cylinder seal kit for cylinder assembly. See your JLG Parts Manual.

Apply a light film of hydraulic oil to all components before assembly.

1. Use seal tool to install new rod seal into applicable cylinder head gland groove.

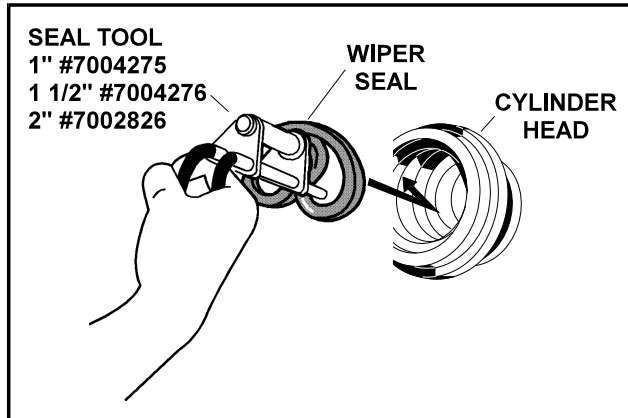


Figure 5-61. Rod Seal Installation

### NOTICE

IMPROPER SEAL INSTALLATION CAN CAUSE CYLINDER LEAKS AND IMPROPER CYLINDER OPERATION. ENSURE 'POLY-PAK' PISTON SEALS ARE PROPERLY INSTALLED. REFER TO WIPER SEAL INSTALLATION FOR CORRECT SEAL ORIENTATION.

2. Use a soft mallet to tap new wiper seal into applicable cylinder head gland groove. Install new wear ring in applicable cylinder head gland groove.

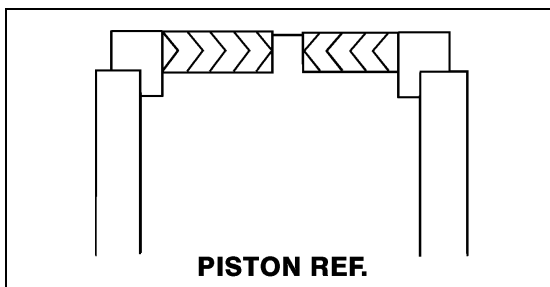


Figure 5-62. Poly-Pak Piston Seal Installation

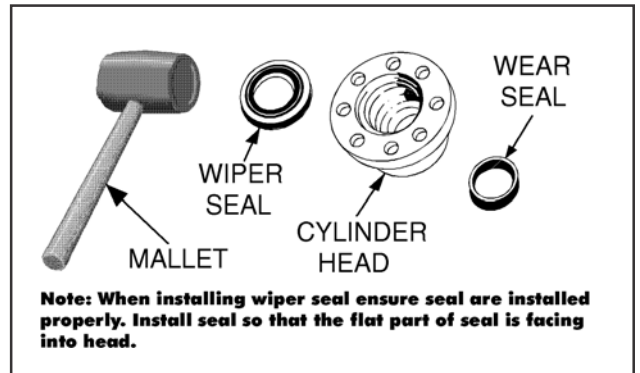


Figure 5-63. Wiper Seal Installation

3. Place new O-ring and back-up seal in applicable outside diameter groove of cylinder head.

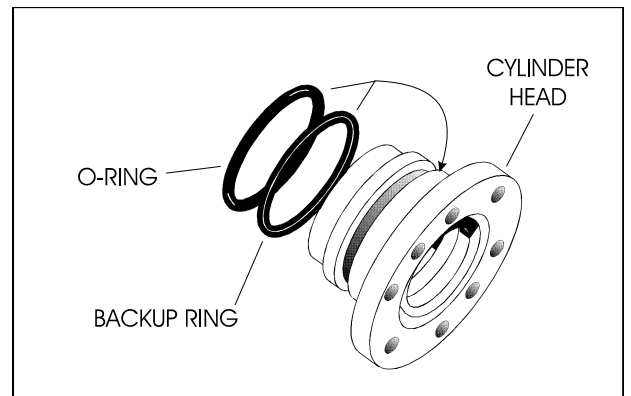


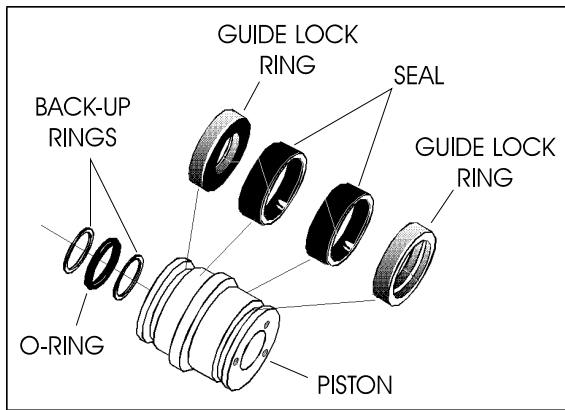
Figure 5-64. Head Seal Kit Installation

4. Install washer ring on rod. Carefully install head gland on rod. Do not damage or dislodge wiper and rod seals. Push head along rod to rod end, as applicable.
5. Carefully slide piston spacer on rod.

**NOTE:** Upper telescope cylinder piston has an O-ring installed inside spacer.

## SECTION 5 - HYDRAULICS

- If applicable, place new O-ring and back-up rings in inner piston diameter groove.



**Figure 5-65. Piston Seal Kit Installation**

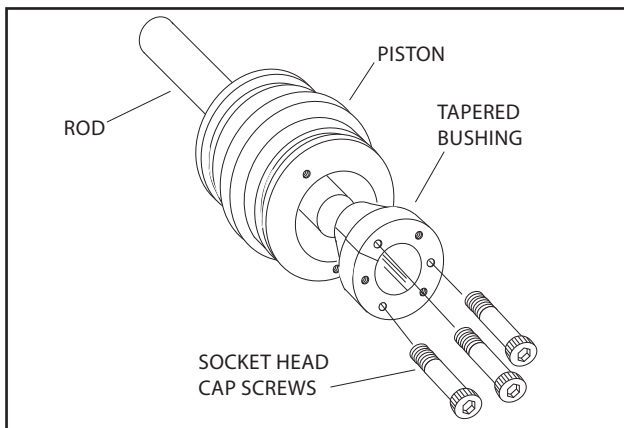
- Using suitable protection, clamp cylinder rod in a vise or similar holding fixture as close to piston as possible.
- Carefully thread piston on cylinder rod hand tight, Ensure O-ring and back-up rings are not damaged or dislodged.

**NOTE:** Piston and mating end of rod must be free of oil when installing tapered bushing.

- Thread piston onto rod until it aligns with spacer end and install tapered bushing.

**NOTE:** Apply LOCTITE #242 or equivalent to tapered bushing bolts when rebuilding master, slave, lift, and telescope cylinders.

- Install bolts in tapered bushing using loctite #242



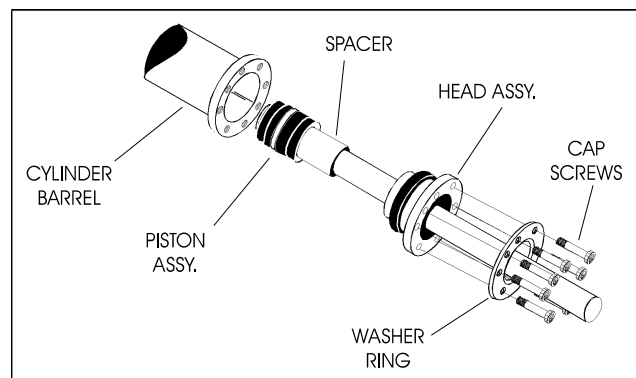
**Figure 5-66. Tapered Bushing Installation**

- Remove cylinder rod from holding fixture.
- Place new guide locks and seals in applicable outside diameter grooves of cylinder piston. (See Figure 2-28. Piston Seal Kit Installation.)
- Position cylinder barrel in a suitable holding fixture.

### NOTICE

**INSERTING ROD OFF-CENTER CAN DAMAGE PISTON AND CYLINDER BARREL SURFACES. USE EXTREME CARE WHEN INSTALLING CYLINDER ROD, HEAD, AND PISTON.**

- Clamp barrel clamped securely and support rod. Insert piston end into barrel cylinder. Do not damage or dislodge piston loading O-ring and seal ring.
- Continue pushing rod into barrel until cylinder head gland can be inserted into barrel cylinder.
- Secure cylinder head gland using washer ring and socket head bolts.



**Figure 5-67. Rod Assembly Installation**

## Steer Cylinder

### DISASSEMBLY

**NOTE:** Refer to Figure 5-71.

#### NOTICE

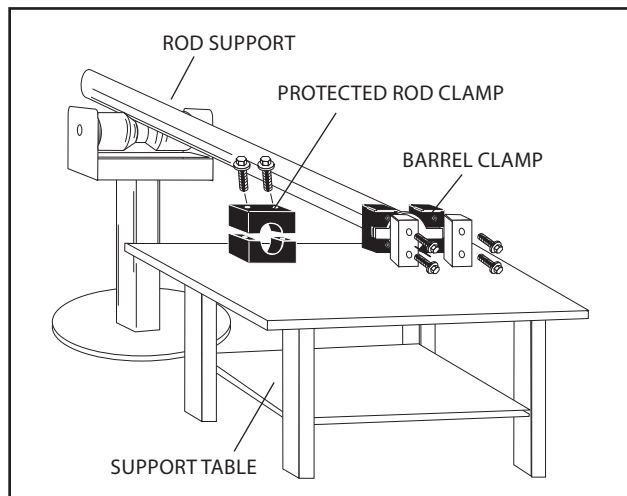
CONTAMINATION MAY DAMAGE EQUIPMENT. DISASSEMBLE CYLINDER ON A CLEAN WORK SURFACE IN A DIRT FREE WORK AREA.

1. Connect a suitable auxiliary hydraulic power source to cylinder port block fitting.

#### WARNING

DO NOT FULLY EXTEND CYLINDER TO THE END OF STROKE. RETRACT CYLINDER SLIGHTLY TO AVOID TRAPPING PRESSURE.

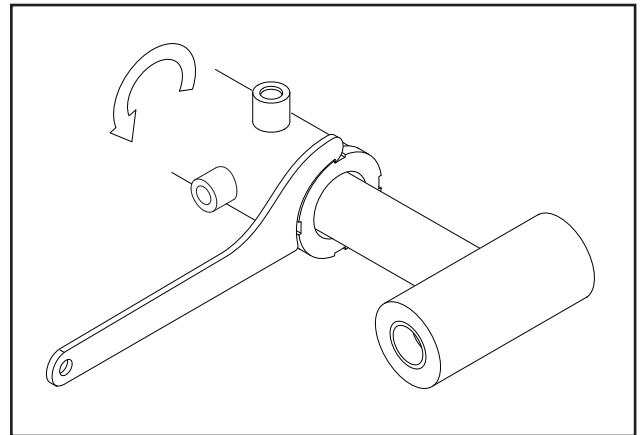
2. Operate hydraulic power source and extend cylinder. Shut down and disconnect power source. Adequately support cylinder rod, if applicable.
3. Place cylinder barrel in a suitable holding fixture. Tap around outside of cylinder head retainer with a suitable hammer to break thread-locking compound.



**Figure 5-68. Cylinder Barrel Support**

4. Remove burrs and contamination from cylinder before disassembly.

5. Unscrew Spanner Nut (13) with hook spanner.

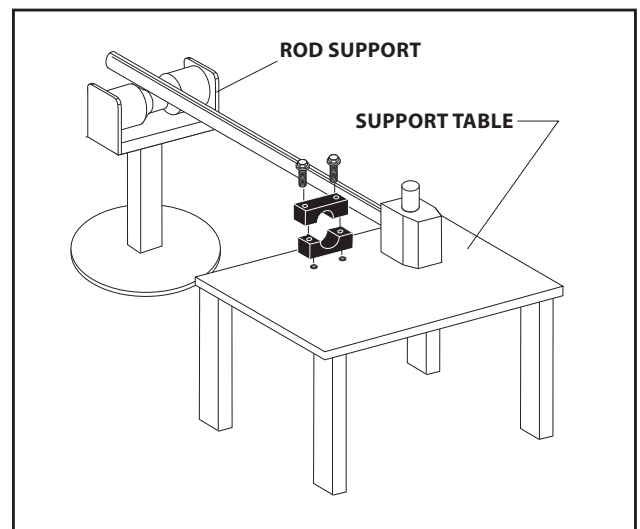


**Figure 5-69. Removing Spanner Nut**

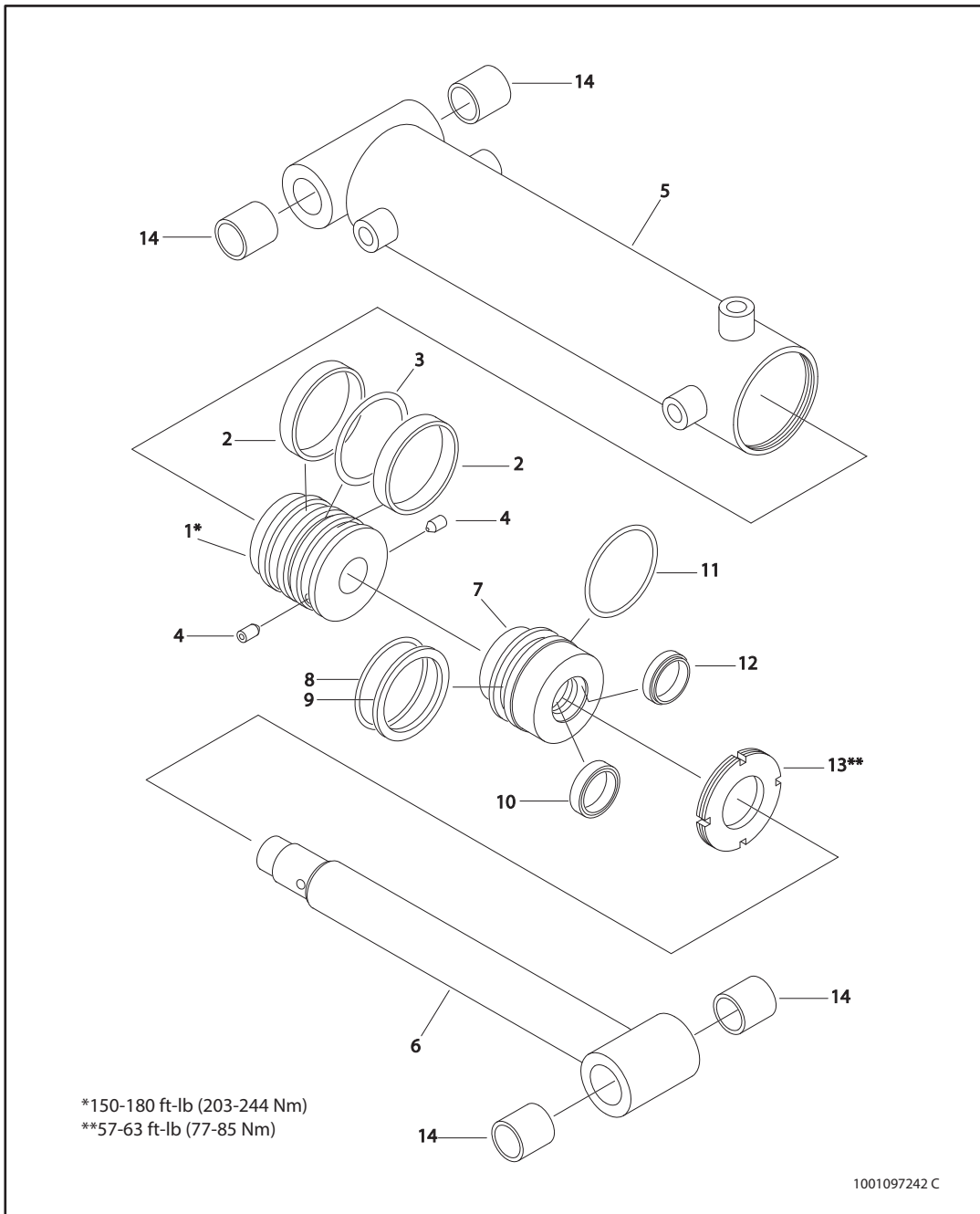
#### NOTICE

PULLING ROD OFF-CENTER CAN DAMAGE PISTON AND CYLINDER BARREL SURFACES. USE EXTREME CARE WHEN REMOVING CYLINDER ROD AND PISTON.

6. Clamp barrel securely. Apply pressure to rod pulling device and carefully withdraw complete rod assembly from cylinder barrel.



**Figure 5-70. Cylinder Rod Support**

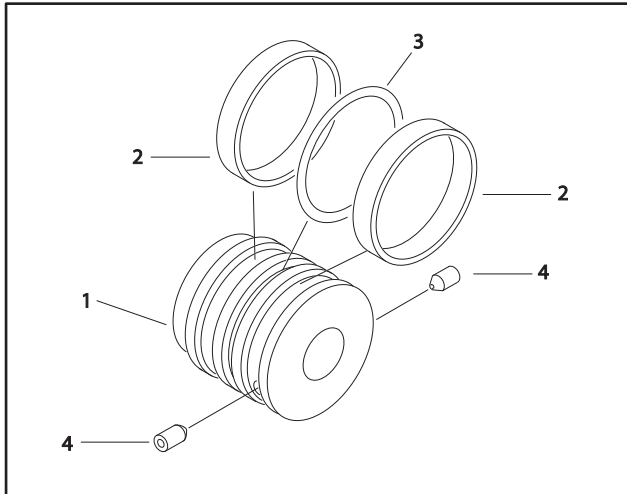


- |             |           |                 |                       |
|-------------|-----------|-----------------|-----------------------|
| 1. Piston   | 5. Barrel | 9. Back-Up Ring | 12. Wiper             |
| 2. Seal     | 6. Rod    | 10. Seal        | 13. Spanner Nut       |
| 3. O-Ring   | 7. Head   | 11. O-Ring      | 14. Composite Bushing |
| 4. Setscrew | 8. O-Ring |                 |                       |

Figure 5-71. Steer Cylinder Assembly

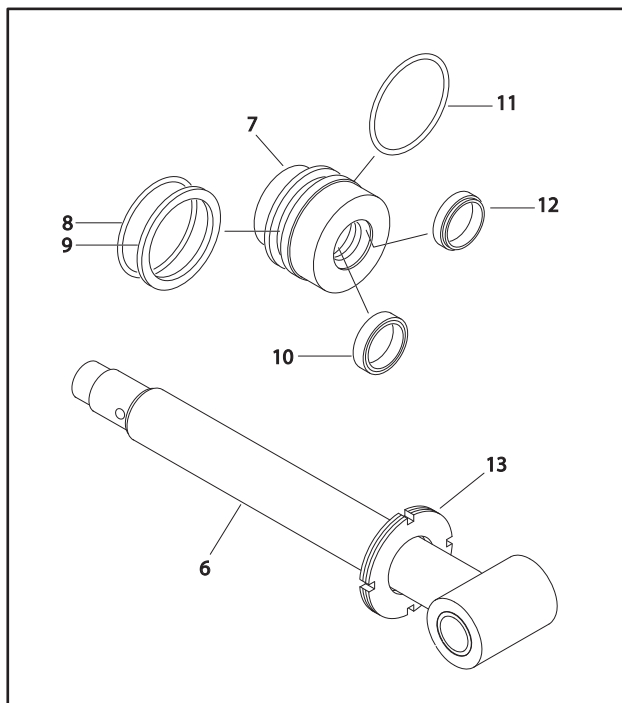


7. Remove two Seals (2) and O-Ring (3) from Piston (1).
8. Loosen two Setscrews (4) in Piston (1). Unscrew and remove Piston (1) from Rod (6) with strap wrench.



**Figure 5-72. Piston Seal and Wear Ring**

9. Remove Cylinder Head (7) from Rod (6).
10. Remove O-Ring (11), O-Ring (9), and Backup Ring (8) from Cylinder Head (7).
11. Remove Wiper (12) and Rod Seal (10). Do not damage cylinder head groove.
12. Remove Spanner Nut (13) from Rod (6).

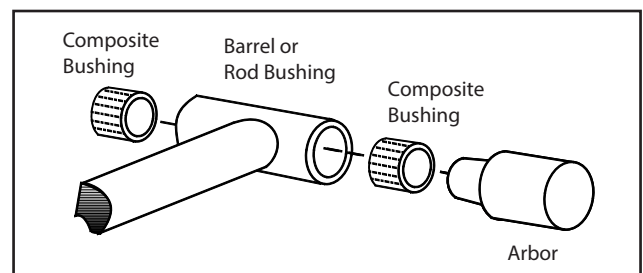


**Figure 5-73. Cylinder Head Disassembly**

## Cleaning and Inspection

1. Clean all parts in an approved cleaning solvent.
2. Inspect cylinder rod for scoring, tapering, ovality, or other damage. If necessary, dress rod with Scotch Brite™ or equivalent. Replace rod if necessary.
3. Inspect inner surface of cylinder barrel tube for scoring, tapering, ovality, or other damage. Replace if necessary.
4. Inspect threaded portion of barrel for damage. Dress threads as necessary.
5. Inspect piston surface for damage and scoring and for distortion. Inspect seal and O-ring grooves in piston for burrs and sharp edges. Dress piston surfaces or replace rod assembly as necessary.
6. Inspect rod bushings for excessive wear or damage. Replace as necessary.
  - a. Thoroughly clean rod bushing of burrs, dirt, etc.
  - b. Inspect rod bushing for wear or other damage. If rod bushing is worn or damaged, rod must be replaced.
  - c. Lubricate inside of rod bushing with WD40 before installing composite bushing.
  - d. Press composite bushing in rod bushing using correct size arbor.

**NOTE:** Pin is installed in composite bushing dry. Lubrication is not required with nickel plated pins and bearings.



**Figure 5-74. Composite Bushing Installation**

7. Inspect cylinder head inside diameter for scoring, tapering, ovality, or other damage. Replace as necessary.
8. Inspect threads, and seal and O-Ring grooves in head for burrs, sharp edges, and other damage. Dress surfaces as necessary.
9. Inspect oil ports for blockage or contamination. Repair as necessary.

## Assembly

**NOTE:** Apply a light film of hydraulic oil to all components before assembly.

1. Position cylinder barrel in a suitable holding fixture.

### NOTICE

**IMPROPER SEAL INSTALLATION CAN CAUSE CYLINDER LEAKS AND IMPROPER CYLINDER OPERATION.**

2. Install Spanner Nut (3) on Rod (6).
3. Install Rod Seal (5) and Wiper ( ) in Cylinder Head (3).
4. Install O-Ring (7), Backup Ring (8), and O-Ring (9).

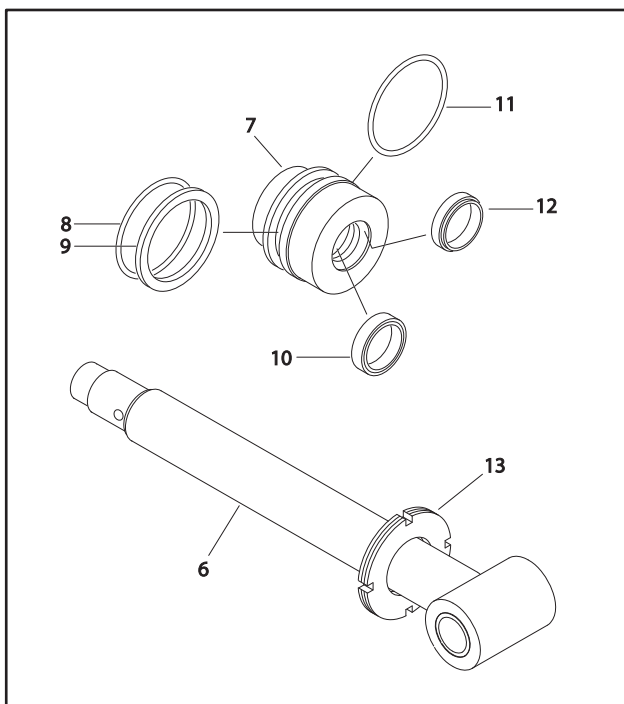


Figure 5-75. Cylinder Head Assembly

5. Install wear ring (11) in piston groove.
6. Install seal (10) in piston groove.

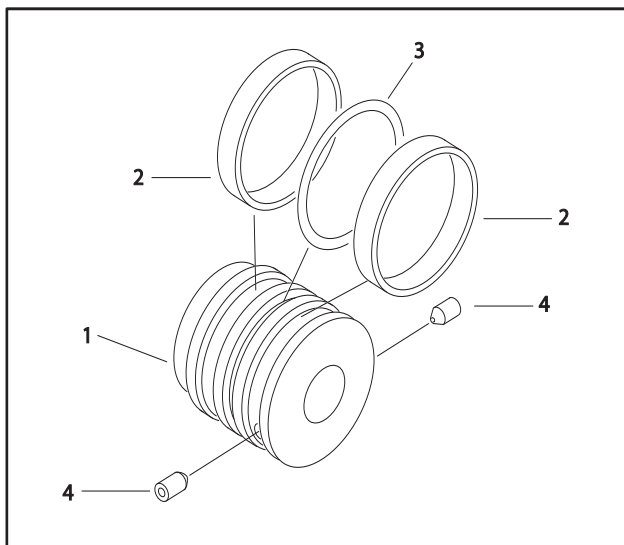


Figure 5-76. Piston Seal and Wear Ring

### NOTICE

**INSERTING ROD OFF-CENTER CAN DAMAGE PISTON AND CYLINDER BARREL SURFACES. USE EXTREME CARE INSTALLING CYLINDER ROD AND PISTON.**

7. Insert Rod Assembly in Barrel (1).
8. Apply Locking Primer and Loctite 242 (or equivalent) to threads of Spanner Nut (3). Tighten spanner nut (3) with hook spanner to 57-63 ft-lb (77-85 Nm).

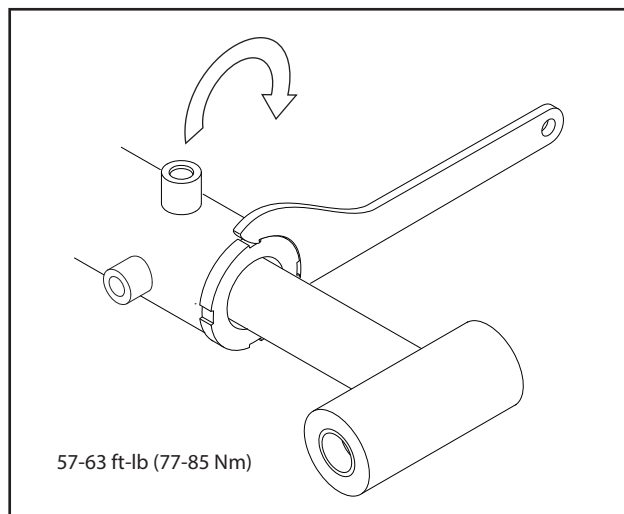


Figure 5-77. Spanner Nut Torque

## Axle Lockout Cylinder

**NOTE:** Refer to Figure 5-78., Axle Lockout Cylinder.

### DISASSEMBLY

#### **NOTICE**

CONTAMINATION MAY DAMAGE EQUIPMENT. DISASSEMBLE CYLINDER ON A CLEAN WORK SURFACE IN A DIRT FREE WORK AREA.

#### **CAUTION**

PISTON CAN FALL OUT OF HOUSING AND CAUSE INJURY OR DAMAGE TO EQUIPMENT. BE CAREFUL WHEN REMOVING AXLE CYLINDER. OPENING BLEED VALVE CAN CAUSE PISTON TO FALL OUT OF HOUSING.

1. Open bleed valve (8). Rotate piston (2) and remove from housing (1).
2. Remove wiper (6). Do not scratch housing bore.
3. Remove two wear rings (5) and rod seal (7) from grooves in piston bore. Do not scratch housing bore.
4. Remove check valve (9), if required.
5. Inspect bore and piston for scoring, pitting, or excessive wear.
6. Remove minor surface blemishes with wet 2000-grit sandpaper. Pitting requires replacement of housing or piston.
7. Clean all parts with approved solvent and dry with compressed air.

### ASSEMBLY

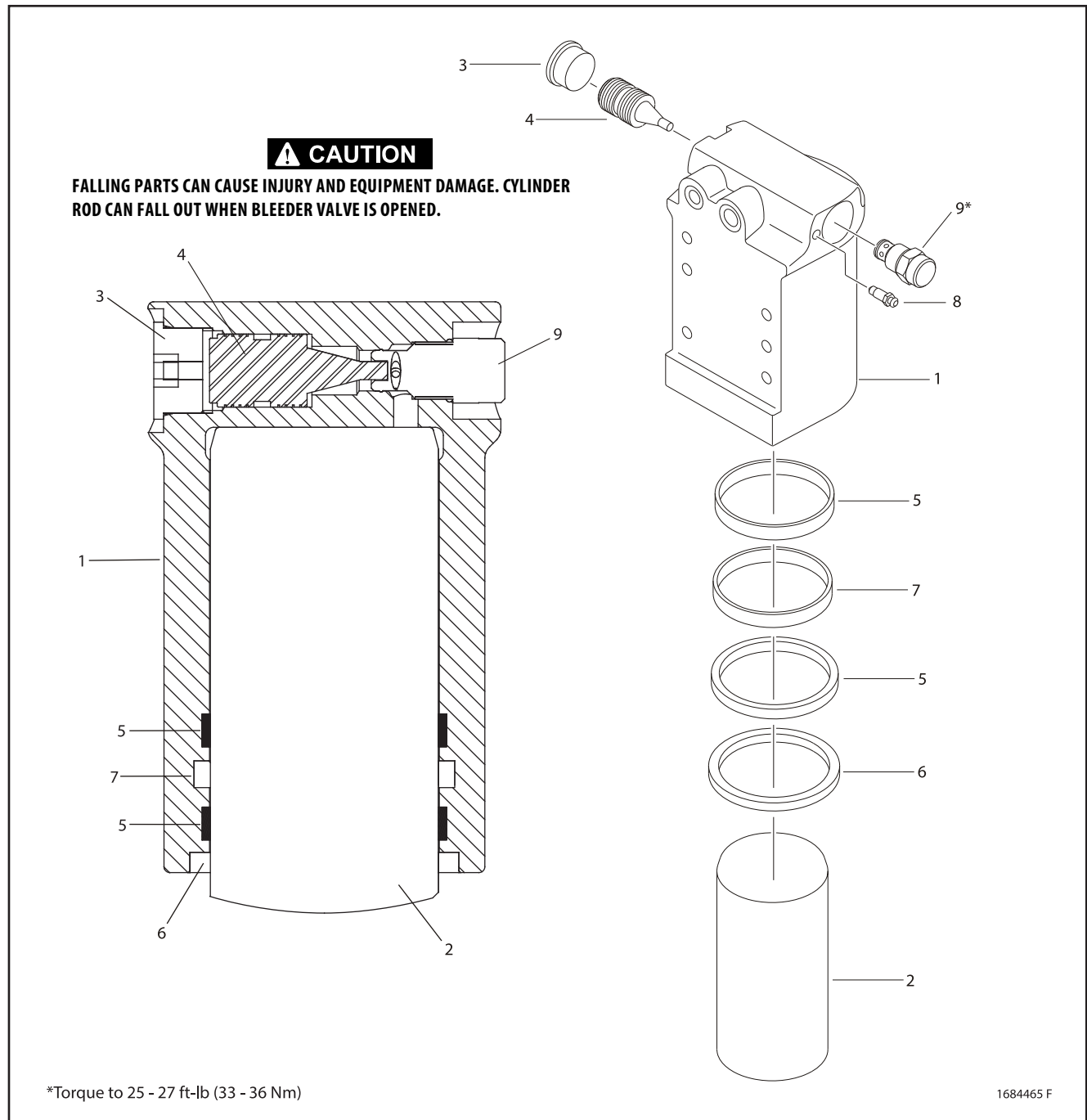
Refer to Figure 5-78., Axle Lockout Cylinder.

1. Install two new wear rings (5) and rod seal (7) in piston bore grooves. Make sure they are not twisted.
2. Install new wiper (6) in housing.
3. Lubricate piston bore with clean hydraulic fluid.

#### **NOTICE**

INSERTING PISTON OFF-CENTER CAN DAMAGE PISTON AND PISTON BORE SURFACES. USE EXTREME CARE WHEN INSTALLING PISTON.

4. Install piston (2) in bore and push to top of bore.
5. Install check valve (9). Torque to 25 - 27 ft-lb (33 - 36 Nm).
6. Bleed system.



- |                 |                    |
|-----------------|--------------------|
| 1. Barrel       | 6. Wiper           |
| 2. Rod          | 7. Rod Seal        |
| 3. Plug         | 8. Bleeder         |
| 4. Pilot Piston | 9. Cartridge Valve |
| 5. Wear Ring    |                    |

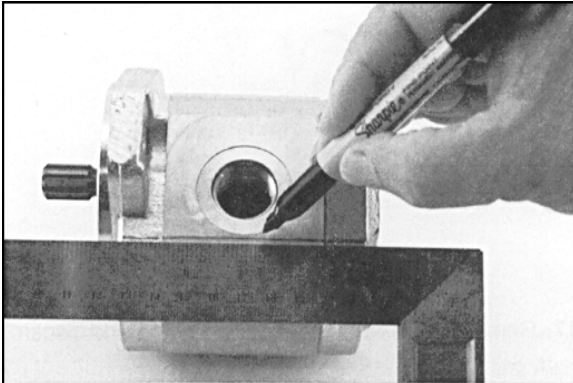
Figure 5-78. Axle Lockout Cylinder

## 5.6 HYDRAULIC PUMP (GEAR)

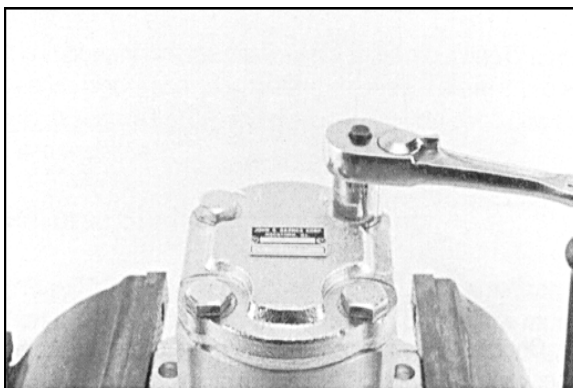
### Disassembly

**NOTE:** The following general instructions also apply to multiple section gear pumps. The only extra parts are the coupling between drive shafts and center distance plate which divides the two pump sections. This repair procedure also applies to "W" series Gear Motors.

1. Always work in a clean work area when repairing hydraulic products. Plug ports and wash exterior of pump with approved cleaning solvent.
2. Remove port plugs and drain oil from pump.

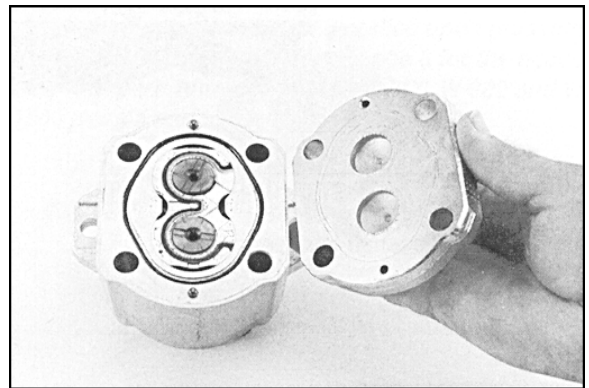


3. Use a permanent marker pen to mark a line across mounting flange, gear housing and end cover. This will assure proper reassembly and rotation of pump.
4. Remove key from drive shaft if applicable.

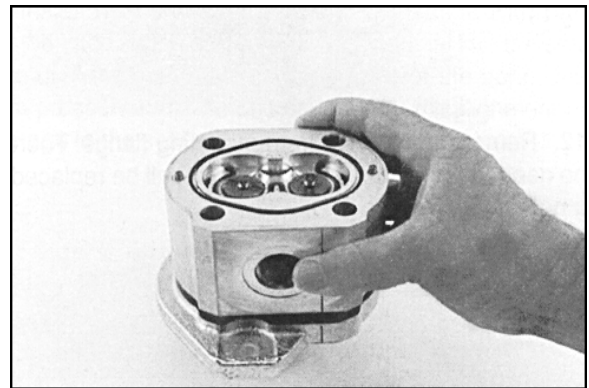


5. Clamp mounting flange in a protected jaw vise with pump shaft facing down.
6. Loosen four metric hex head bolts.

7. Remove pump from vise and place on clean work bench. Remove four hex head bolts and spacers if applicable.



8. Lift and remove end cover.

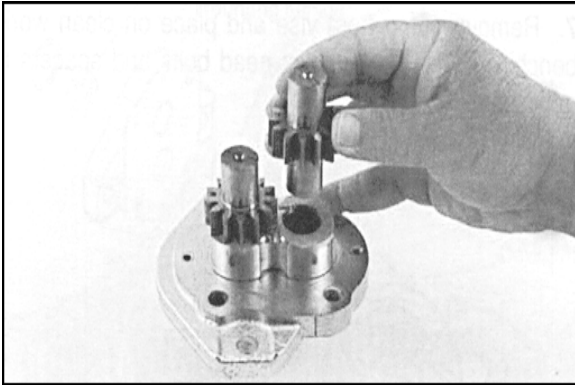


9. Carefully remove gear housing and place on work bench. Make sure rear bearing block remains on drive and idler shafts.

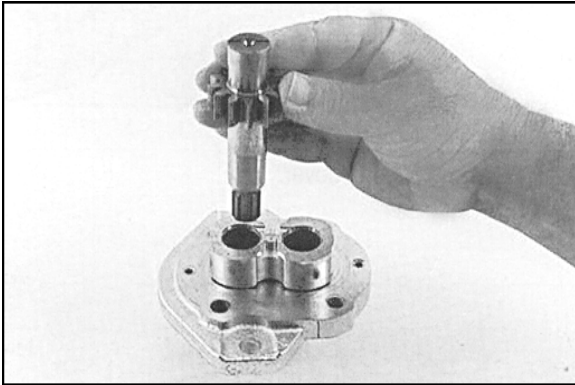


## SECTION 5 - HYDRAULICS

10. Remove rear bearing block from drive and idler shafts.

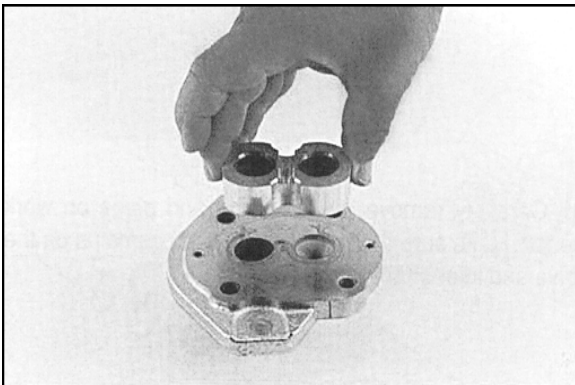


11. Remove idler shaft from bearing block.

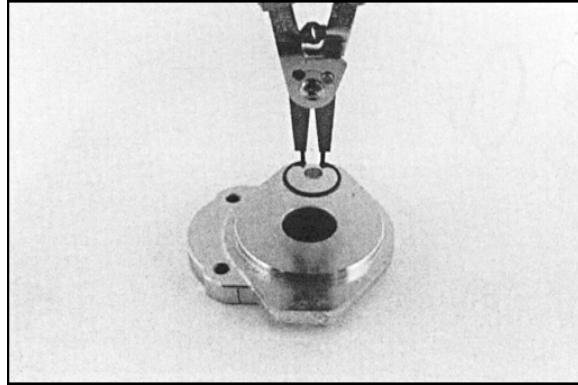


12. Remove drive shaft from mounting flange.

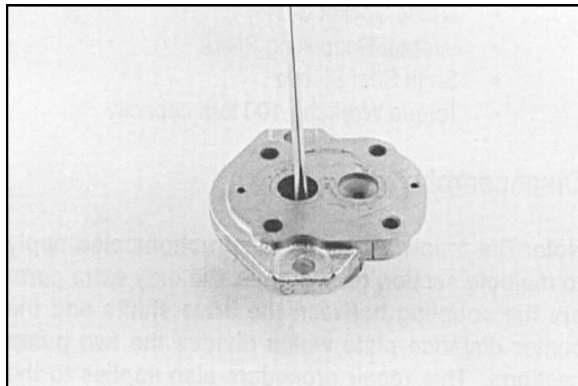
**NOTE:** Shaft seal will be replaced.



13. Remove front bearing block.

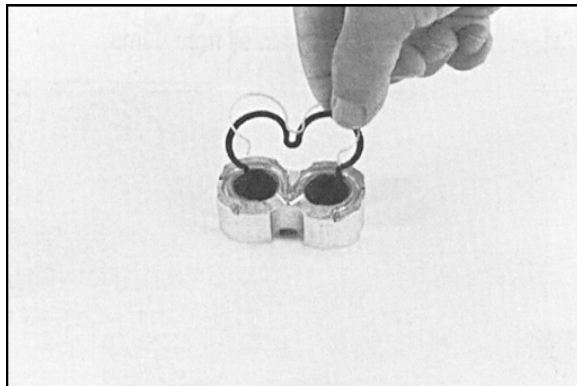


14. Turn mounting flange over, with shaft seal up. Remove retaining ring with snap ring pliers.



15. Remove oil seal from mounting flange. Do not mar or scratch seal bore.

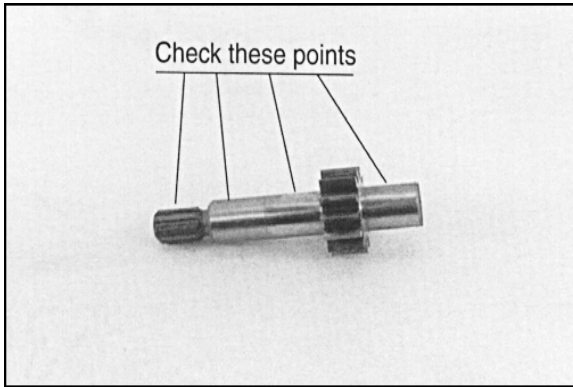
16. Remove dowel pins from gear housing. Do not lose pins.



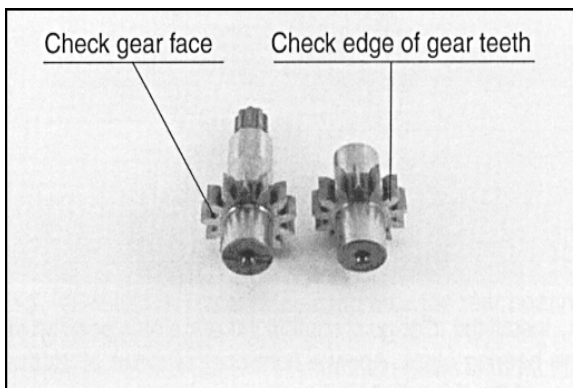
17. Remove and discard seals from both bearing blocks.

## Inspect Parts For Wear

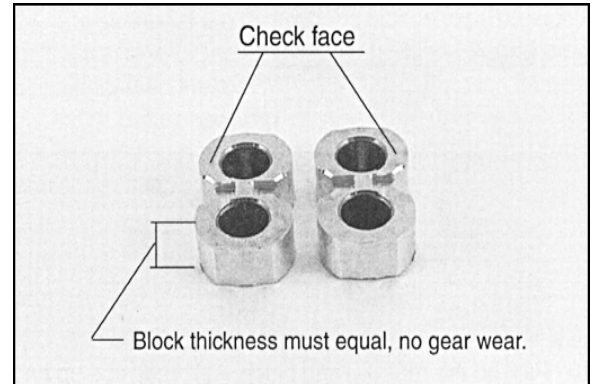
1. Clean and dry all parts thoroughly before inspection. It is not necessary to inspect seals. They will be placed as new items.



2. Check drive shaft spine for twisted or broken teeth, check keyed drive shaft for broken or chipped keyway. No marks or grooves on shaft in seal area, some discoloration of shaft is allowable.
3. Inspect drive gear shaft and idler gear shafts at bearing points and seal area for rough surfaces and excessive wear.



4. Inspect gear face for scoring or excessive wear. If face edge of gear teeth are sharp, they will mill into the bearing blocks. If wear has occurred, parts are unusable.



5. Inspect bearing blocks for excessive wear or scoring on surfaces in contact with gears. Inspect bearings for excessive wear or scoring.
6. Inspect area inside gear housing. A clean "wipe" on inside surface of intake side is normal. There should not be excessive wear, deep scratches, or gouges.

## General Information

### NOTICE

FAILURE TO PROPERLY ASSEMBLE THIS PUMP WILL RESULT WITH LITTLE OR NO FLOW AT RATED PRESSURE. RELATIONSHIP OF MOUNTING FLANGE, BEARING BLOCKS, AND GEAR HOUSING MUST BE CORRECT.

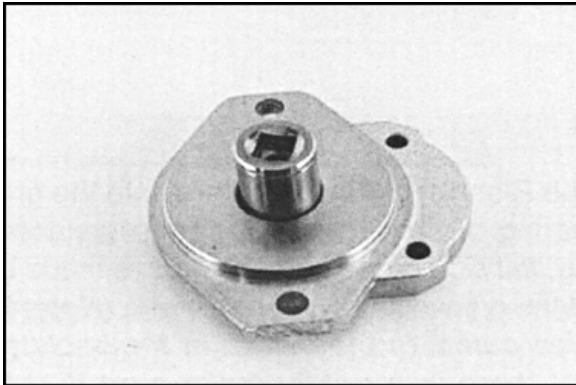
## Reverse Shaft Rotation of Pump

**NOTE:** Pump is not bi-rotational. Use the following procedure if shaft rotation direction is changed.

Reverse shaft rotation of "W" series gear pump by rotating, as a group, two bearing blocks and gear housing 180° in relationship to remaining parts of pump. This places pressure port opposite from original position.

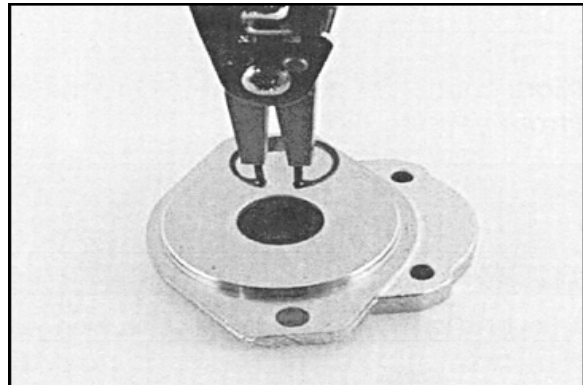
## Assembly

**NOTE:** Install new seals when reassembling pump or motor. Go to page 8 for kit part numbers for W-600, W-900, and W-1500 pumps and motors.

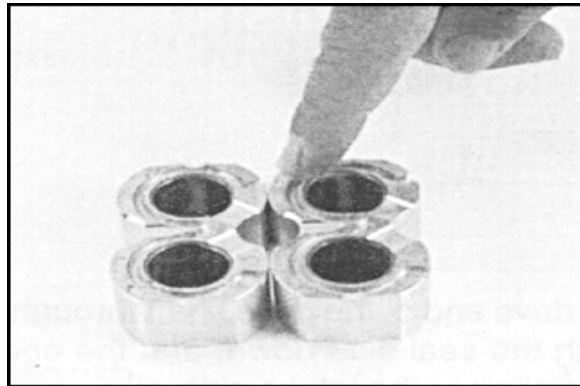


1. Install new shaft seal in mounting flange with part number side facing out. Press seal into seal bore until seal reaches bottom of bore. Use uniform pressure to prevent seal misalignment or damage.

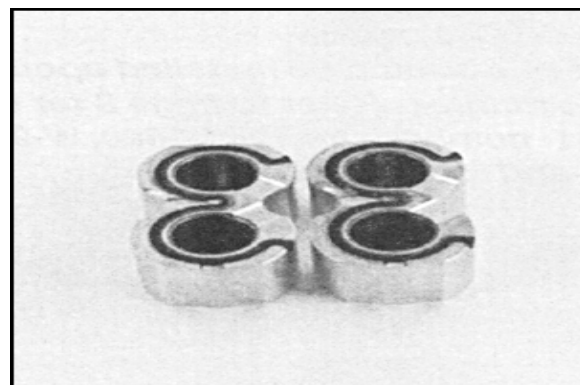
2. Install retaining ring in groove in seal bore of mounting flange.



3. Place front and back bearing blocks on a clean surface with E-seal grooves facing up. Apply a light coating of petroleum jelly in the grooves. Coat E-seal and backup with petroleum jelly. This helps keep seals in place during reassembly

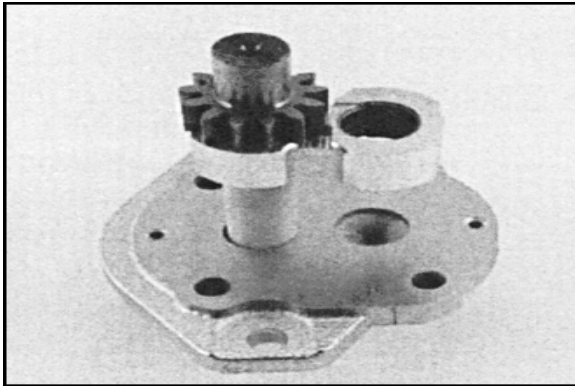


4. Place E-seals, flat side out, into grooves in both bearing blocks. Carefully place backup ring, flat side out, in groove made by E-seal and groove in bearing block. (Note: W900 series pump - In center of backup ring and E-seal there is a notch. Make sure notches line up so backup ring will set flush with E-seal). Backup ring in W1500 pump is symmetrical.

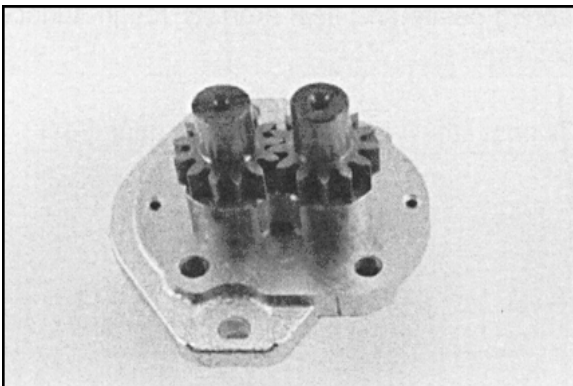




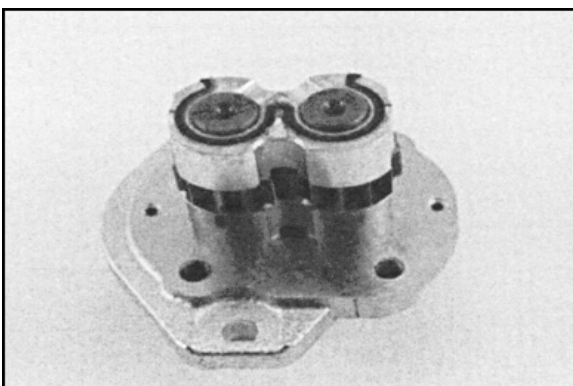
5. Place mounting flange, with shaft seal side down, on a clean flat surface.
6. Apply a light coating of petroleum jelly to exposed face of front bearing block.



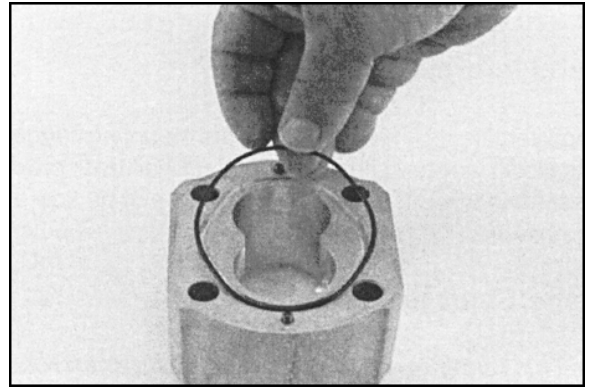
7. Insert drive end of drive shaft through bearing block with seal side down and open side of E-seal pointing to intake side of pump.
8. Install seal sleeve over drive shaft. Carefully slide drive shaft through shaft seal. Remove seal sleeve from shaft.



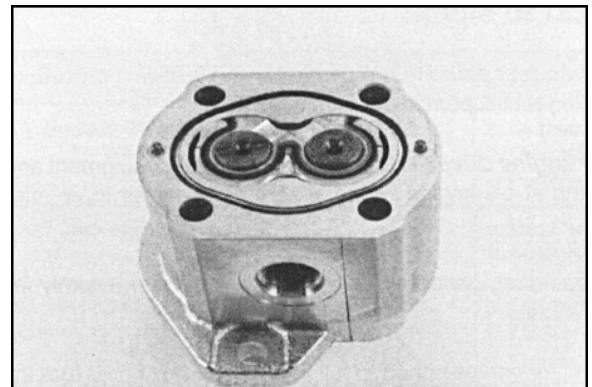
9. Install idler gear shaft in remaining position in bearing block. Apply a light coat of clean oil to face of drive and idler gears.



10. Place rear bearing block over drive and idler gear shafts with seal side up and open end of E-seal facing intake side of pump.
11. Install two dowel pins in mounting flange holes or two long dowel pins through gear housing if pump is a multiple section pump.



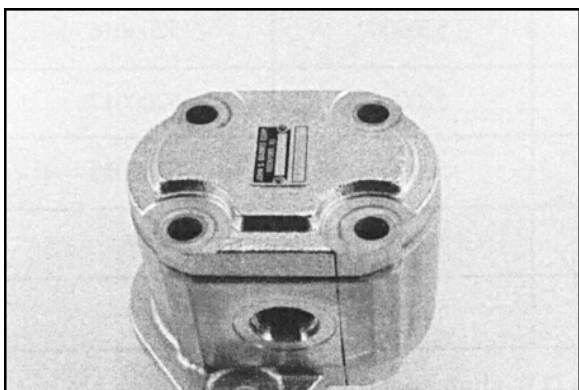
12. Apply a light coating of petroleum jelly in grooves on both sides of gear housing. Coat new O-rings and install in grooves.



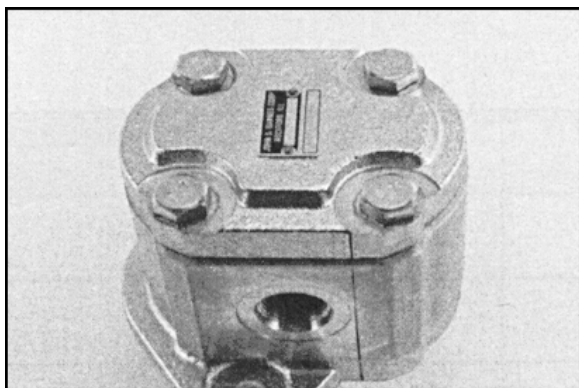
## SECTION 5 - HYDRAULICS

13. Gently slide gear housing over rear bearing block assembly. Slide housing down until it engages dowel pins. Press firmly in place with hands, do not force or use any tool. Check intake port in housing is on same side as open end of E-seal, and marked lines on mounting flange and gear housing are aligned.

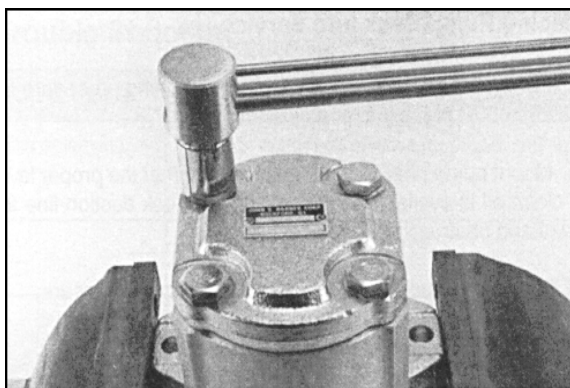
**NOTE:** Rear bearing block surface should be slightly below gear housing face. If bearing block is higher than rear face of gear housing, E-seal or O-ring have shifted out of groove. Remove gear housing and check for proper seal installation.



14. Install two remaining dowel pins in rear of gear housing, if applicable. Place end cover over back of pump.



15. Install four spacers (if applicable) and hex head bolts through bolt holes in end cover. Hand tighten.



16. Place mounting flange of pump in protected jawed vise and alternately torque bolts to torque chart specifications. All torque figures are for "dry torque" bolts.

**Table 5-1. Hydraulic Pump Bolt Torque Chart**

Pump Series	Thread Size	Torque Values, Black Oxide End Cover	Torque Values, Zinc Plated End Cover
W-600	M 8 x 1.25	18-21 ft.lb. 24-30 Nm	16-18 ft.lb. 21.7-24.4 Nm
W-900	M 10 x 1.5	50-55 ft.lb. 68-75 Nm	38-43 ft.lb. 51.5-58.3 Nm
W-1500	M 12 x 1.75	80-85 ft.lb. 108-115 Nm	68-73 ft.lb. 92.2-99 Nm

17. Remove pump from vise.
18. Place a small amount of clean oil in pump inlet and rotate drive shaft away from inlet one revolution. If drive shaft binds, disassemble pump and check for assembly problems. Reassemble pump.

## Placing Pump Back Into Service

1. *If shop test stand is available, use the following procedure for testing rebuilt pumps:*
  - a. Mount pump on test stand. Make sure proper level of clean oil is available in reservoir. Check suction line for leaks and obstructions.
  - b. Start pump and run for three minutes at zero pressure.
  - c. Intermittently load pump to 500 P.S.I. for three minutes.
  - d. Intermittently load pump to 1000 P.S.I. for three minutes.
  - e. Intermittently load pump to 2000 P.S.I. for three minutes.
  - f. Remove pump from test stand and check for freeness of drive shaft. Check pump for signs of external leakage.
2. *If shop test stand is not available, use the following procedure for testing rebuilt pumps:*
  - a. *For engine driven pumps,* mount pump on equipment and run pump at 1/2 engine speed at zero pressure for three minutes.
  - b. Operate control valve and build pressure intermittently for three minutes.
  - c. Increase engine speed to full throttle and build pressure intermittently for three minutes.
  - d. Stop engine and check pump for external leaks.

## 5.7 VARIABLE PUMP

### Ports and Pressure Gauges

Proper servicing of pumps and motors requires pressure measured and monitored at various hydraulic circuit points. The Series 42 pump has several locations at which to take these measurements. The following outlines show gauge port locations, and gauge and fitting size for each port.

**Table 5-2. Recommended Gauge Size**

Gauge Port Name	Pressure Measured	Recommended Gauge Size		Fitting
		PSI	Bar	
M1&M2	System Pressure Ports A & B	10000	600	9/16-18ORF
M3	Charge	1000	60	3/4-16ORF
M4&M5	Servo	1000	60	9/16-18ORF
L1&L2	Case	500	35	1-1/16-12ORF
S	Charge Pump Inlet Vacuum	30 in. Hg Vac.	1	1-1/16-12ORF

### NFPE Control

The 3-position FNR control, and electric and hydraulic non-feedback proportional (NFPE and NFPH) controls are non-feedback type controls. FNR and NFPE controls consist of pump housing mounted modules. Hydraulic input for NFPH is received through ports on top of pump [9/16-18 SAE O-ring fitting].

Non-feedback controls are factory set. Control modules can be removed to clean ports and change O-rings.

FNR and NFPE orifice plugs are located inside the servo piston covers. NFPH orifice plugs are located in the NFPH ports. Orifice plugs may be cleaned or replaced.

### Remove and Install FNR and NFPE Modules

1. Clean pump and module housings.
2. Remove four screws retaining module to pump housing (4 mm Int. Hex). Remove module from housing.
3. Remove O-rings from the control ports. Examine ports for cleanliness.
4. Clean sealing surfaces.
5. Replace locator pin.
6. Install new O-rings.
7. Replace screws. Torque to 3.5 - 4.5 ft-lb (4.7-6.1 Nm).

### Remove and Install FNR and NFPE Control Orifices

**NOTE:** Future models may contain an orifice plate between module and pump housing. This will take the place of the orifice plugs beneath the servo piston cover.

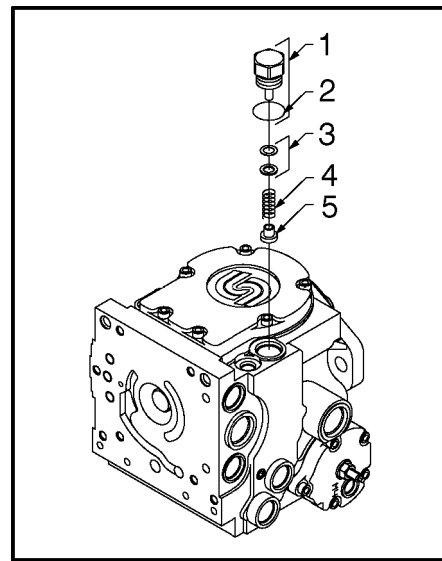
1. Remove servo piston cover.
2. Remove orifice plug (1/8" Int. Hex).
3. Examine orifice and port for cleanliness.
4. Install orifice plug. Torque to 1.5 - 2.5 ft-lb (2.0-3.4 Nm).

### Charge Relief Valve

Charge relief valve may be removed for cleaning and installation of new O-rings. Pressure setting may be changed for different charge flows depending on charge pump size and pump speed.

Factory setting is set relative to case pressure at 1800 rpm. Actual charge pressure varies at different speeds.

### SHIM ADJUSTABLE STYLE

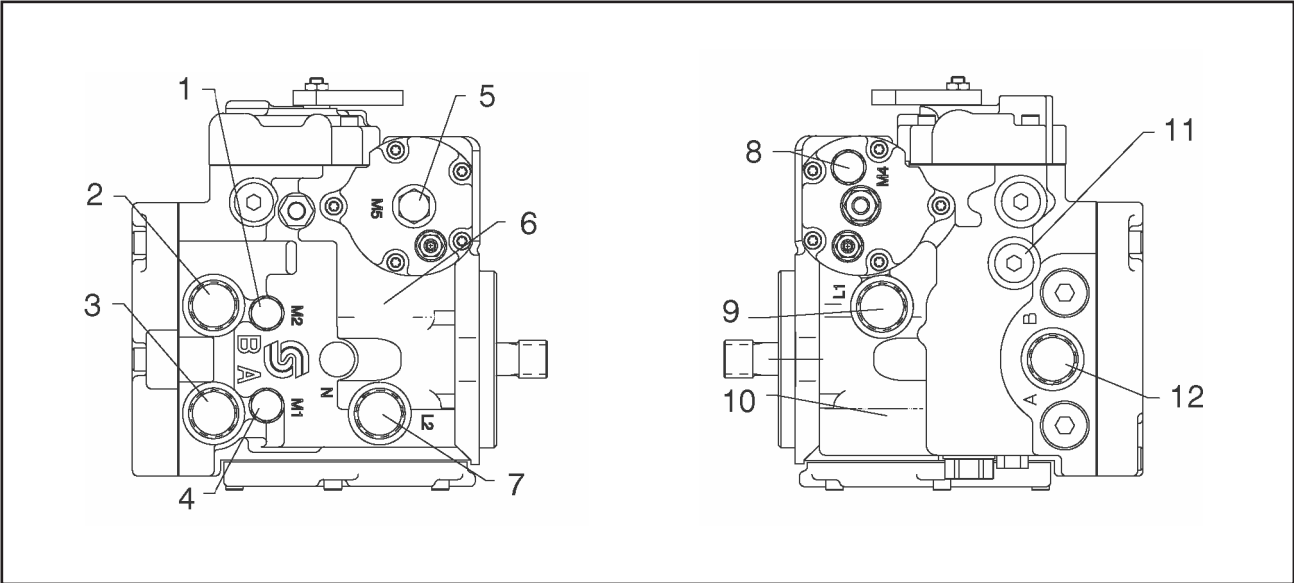


- |           |                  |
|-----------|------------------|
| 1. Plug   | 4. Spring T-Seal |
| 2. O-Ring | 5. Poppet        |
| 3. Shims  |                  |

**Figure 5-79. Shim Adjustable Charge Relief Valve Components**

1. Remove shim adjustable charge relief valve plug (1" Hex) from pump housing. Remove O-ring from plug.
2. Remove spring and poppet from housing.
3. Do not alter shims which may be installed between spring and valve plug, or interchange parts with another valve. Inspect poppet and mating seat in housing for damage or foreign material.
4. If desired, change charge relief valve setting. An approximate rule of thumb is 4 bar / 1.25 mm (58 psi / 0.050 in). Effective setting will vary.

To confirm charge relief valve setting, measure charge pressure (port M3) with pump in stroke. Charge pressure should level off when relief setting is reached.



- |                                      |                                       |
|--------------------------------------|---------------------------------------|
| 1. System Pressure Gauge Port M2     | 7. Case Drain Port L2                 |
| 2. System Pressure Port B            | 8. Servo Pressure Gauge Port L4       |
| 3. System Pressure Port A            | 9. Case Drain Port L1                 |
| 4. System Pressure Gauge Port M1     | 10. Case Drain Port L1 (non-feedback) |
| 5. Servo Pressure Gauge Port M5      | 11. Charge Pressure Gauge             |
| 6. Case Drain Port L2 (non-feedback) | 12. Charge Pump Inlet Port S          |

Figure 5-80. Gauge Port Locations

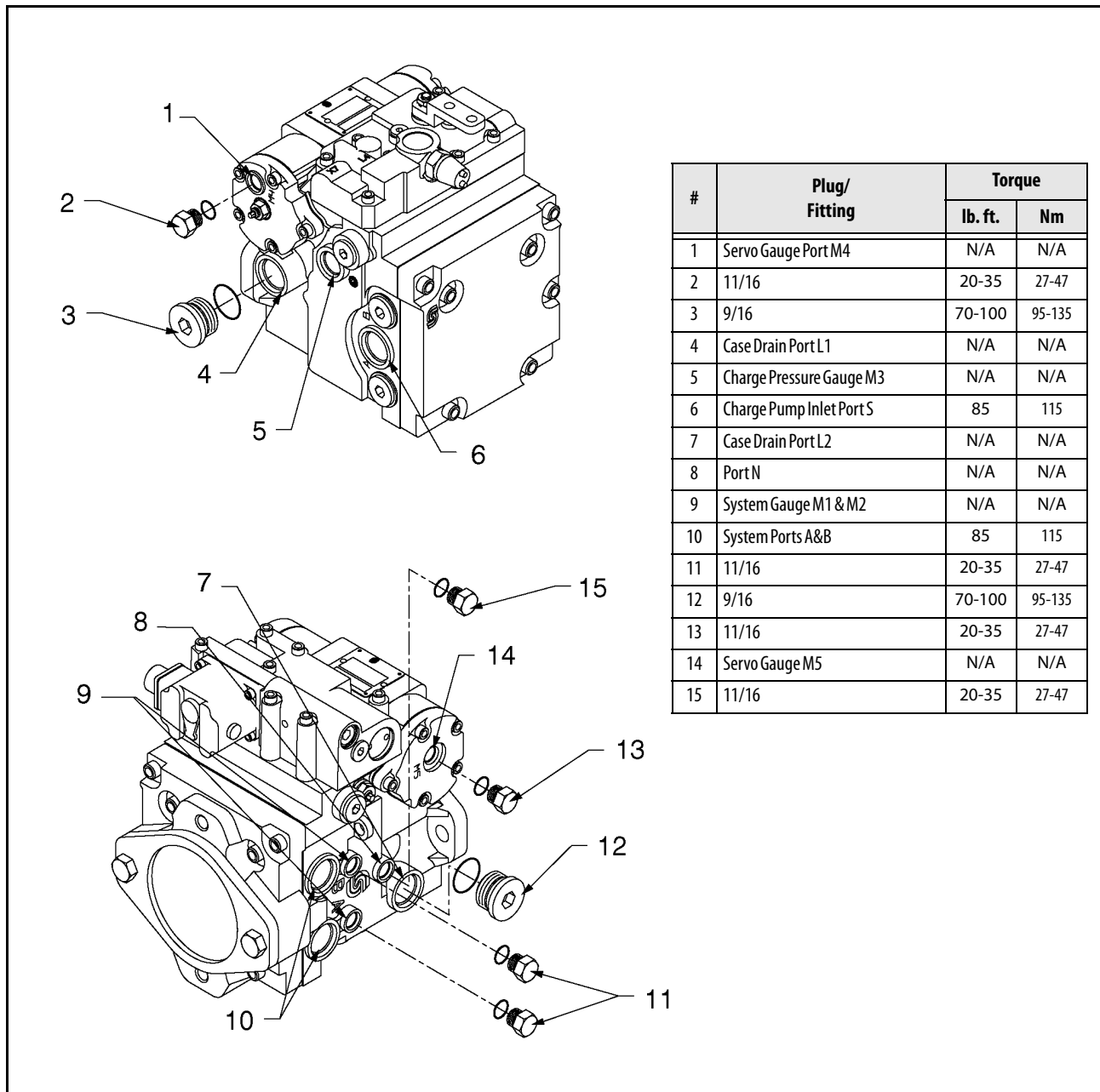
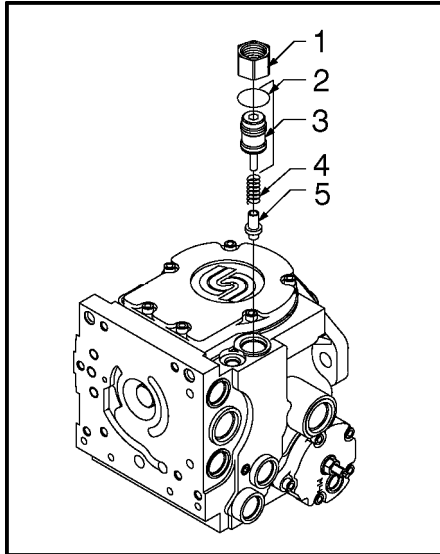


Figure 5-81. Plugs/Fittings Size & Torque

5. Install new O-ring on valve plug. Reinstall poppet, spring, and plug (with shims and O-ring) into pump housing. Torque to 40-100 ft-lb (55-135 Nm).

**SCREW ADJUSTABLE STYLE**

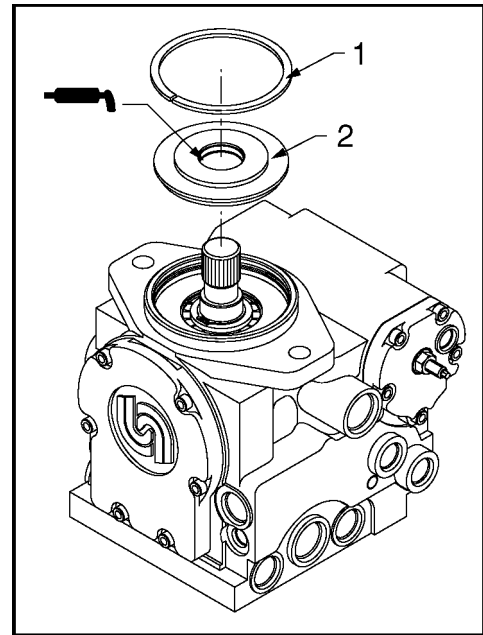


- |             |                  |
|-------------|------------------|
| 1. Lock Nut | 4. Spring-T-Seal |
| 2. O-Ring   | 5. Poppet        |
| 3. Plug     |                  |

**Figure 5-82. Screw Adjustable Charge Relief Valve Components**

1. Mark plug, lock nut, and housing to maintain original adjustment before removing screw adjustable relief valve plug. Loosen lock nut (1-1/16" Hex) and remove plug (8 mm Int. Hex). Remove O-ring from plug.
2. Remove spring and poppet from housing.
3. Inspect poppet and mating seat in housing for damage or foreign material.
4. Install new O-ring on valve plug. Reinstall poppet and spring. Reinstall plug and lock nut. Torque to 34 - 42 ft-lb (47-57 Nm), aligning marks made at disassembly.
5. Check and adjust charge pressure if necessary. For screw adjustable "anti-stall" charge relief valves, an approximate rule of thumb is 2.8 bar/quarter turn (40 psi/quarter turn).
6. Measure charge pressure (port M3) with pump in stroke. Charge pressure should level off when relief setting is reached.

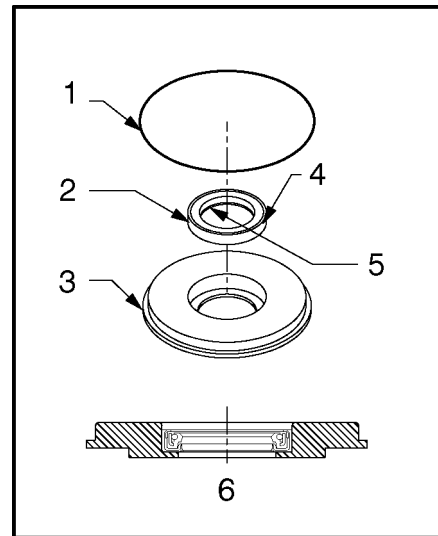
**Shaft Seal and Shaft Replacement**



- |                   |                          |
|-------------------|--------------------------|
| 1. Retaining Ring | 2. Seal Carrier Assembly |
|-------------------|--------------------------|

**Figure 5-83. Shaft Seal Components**

A lip type shaft seal is used in Series 42 pumps. Seal and shaft can be replaced without major unit disassembly. Replacement generally requires removing pump from machine.



- |                 |  |
|-----------------|--|
| 1. O-Ring       | 4. Sealant may be used on outside diameter |
| 2. Seal         | 5. Inside Lip (face down)                  |
| 3. Seal Carrier | 6. Press Seal to Bottom of Seal Carrier    |

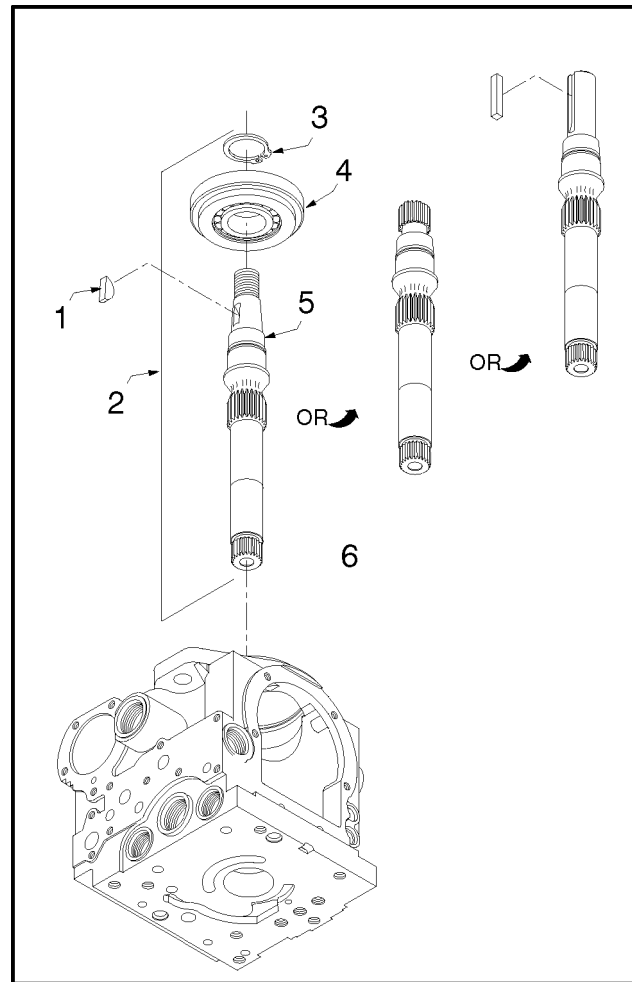
**Figure 5-84. Installation of Shaft Seal**

## SECTION 5 - HYDRAULICS

1. Position pump with shaft facing up.

**NOTE:** If unit is positioned horizontally when shaft is removed, cylinder block could move out of place, making shaft installation difficult.

2. Remove retaining ring from housing.
3. Pull out seal carrier assembly.
4. Remove O-ring from seal carrier. To install a new shaft only, go to step 8.
5. Place seal carrier in an arbor press with shaft bearing side down and press out old seal. An appropriately sized pipe spacer or socket wrench can be used as a press tool. Seal is not reusable.
6. Inspect seal carrier and new seal for damage. Inspect sealing area on shaft for rust, wear, or contamination. Polish sealing area on shaft if necessary.
7. Press new seal in shaft bearing side of seal carrier. Seal lip must face outside of pump. Do not damage seal. Outside diameter of seal may be coated with a sealant (e.g. Loctite High Performance Sealant #59231) before installation. This helps prevent leaks caused by damage to seal bore in seal carrier. If shaft is not being replaced go to step 11.
8. Remove shaft and roller bearing assembly from pump or motor.
9. Remove retaining ring from roller bearing assembly with snap ring pliers. Remove roller bearing assembly.
10. Place roller bearing assembly on new shaft and secure with retaining ring.
11. Wrap spline or key end of shaft with thin plastic to prevent damage to seal lip during installation. Lubricate inside diameter of shaft seal with petroleum jelly.
12. Place O-ring on shaft bearing and lubricate with petroleum jelly.
13. Slide seal carrier assembly over shaft and into housing bore. Press against O-ring. Hold inward pressure against shaft to compress cylinder block spring while pressing seal carrier into place.
14. Install retaining ring.



1. Key  
2. Shaft Assembly  
3. Retaining Ring  
4. Roller Bearing  
5. Shaft  
6. Seal

**Figure 5-85. Shaft Components**

### Hydraulic Pump W/Hayes Pump Drive Coupling Lubrication

Coat pump and drive coupling splines with Lithium Soap Base Grease (TEXACO CODE 1912 OR EQUIVALENT) whenever pump or pump drive coupling is removed. Coupling is greased prior to assembly.



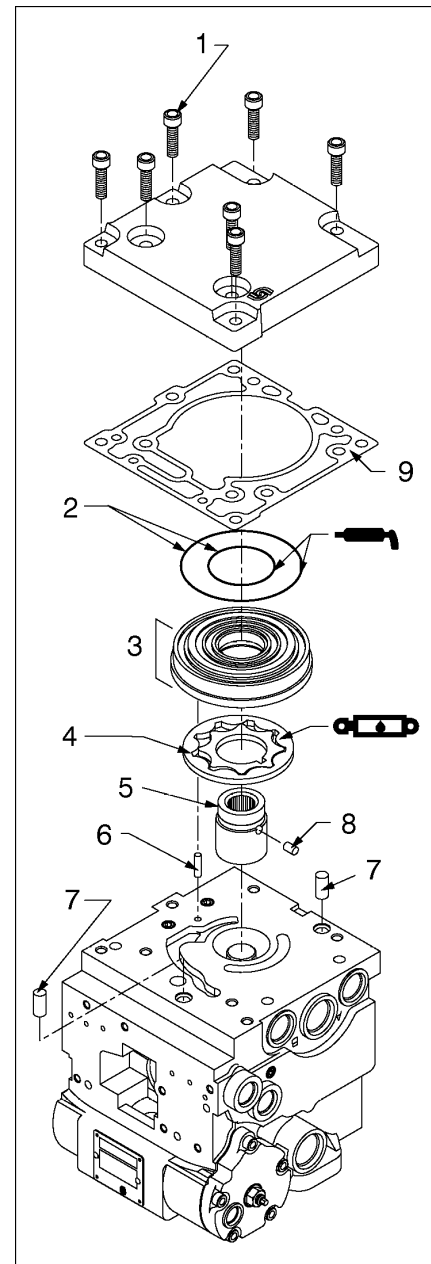
## Charge Pump

**NOTE:** *Disassemble charge pump to inspect and clean, or change auxiliary shaft drive coupling.*

1. Remove auxiliary pump if necessary.
2. Remove screws retaining charge pump cover to pump housing (Torx T). Seven screws are used with "no pad" or SAE "A" auxiliary mounting pad charge pump cover, and six screws are used with SAE "B" auxiliary mounting pad charge pump cover. Remove charge pump cover, gasket, and cover locating pins.
3. Remove gerotor cover assembly from charge pump cover or back of pump housing. Remove gerotor cover O-rings. Two O-rings are used on gerotor cover of all pumps.
4. Remove gerotor assembly from gerotor cover or pump housing.
5. Remove gerotor drive pin and drive coupling. Remove gerotor cover locating pin from pump housing.
6. Inspect each part if they are to be reused. If either gerotor assembly parts needs to be replaced, they must both be replaced. Always replace O-rings and charge pump cover gasket. Inspect journal bearing in gerotor cover for excessive wear.
7. Lubricate gerotor assembly with clean hydraulic oil before assembly.
8. Install gerotor drive pin into hole in drive coupling. Apply grease or petroleum jelly to keep in place.
9. Install drive coupling on pump shaft with smaller outside diameter facing away from shaft.
10. Install gerotor assembly onto coupling.
11. Install gerotor cover locating pin into pump housing. Install gerotor cover assembly over gerotor. Locating pin must engage slot in gerotor cover.

**NOTE:** *Charge pump rotation is determined by location of gerotor recess and pressure balance hole in gerotor cover. Different gerotor covers are used for clockwise and counterclockwise rotation pumps.*

12. Install new pressure balance O-rings to gerotor cover and retain with petroleum jelly or grease.
13. Install charge pump cover locating pins and new charge pump cover gasket.
14. Install charge pump cover. Cover must engage gerotor cover and locating pins. Install charge pump cover screws. Torque evenly to 26 - 32 ft-lb (36-43 Nm).
15. Reinstall auxiliary pump if necessary.



- |                          |                                   |
|--------------------------|-----------------------------------|
| 1. Cover Retaining Screw | 6. Gerotor Cover Locating Pin     |
| 2. O-Ring                | 7. Charge Pump Cover Locating Pin |
| 3. Gerotor Cover         | 8. Gerotor Drive Pin              |
| 4. Gerotor Assembly      | 9. Gasket                         |
| 5. Drive Coupling        |                                   |

**Figure 5-86. Charge Pump Components**

### 5.8 HYDRAULIC COMPONENT START-UP

The goal at hydrostatic system start up is to preserve the designed life span of the system. Use the following start-up procedure when a new pump or motor is installed or a system is restarted after a pump or motor has been removed and reinstalled.

#### **⚠ WARNING**

**THE FOLLOWING PROCEDURE MAY REQUIRE MACHINE TO BE DISABLED (WHEELS RAISED OFF THE GROUND, WORK FUNCTIONS DISCONNECTED, ETC.) WHILE PERFORMING PROCEDURE. TO PREVENT INJURY. TAKE NECESSARY SAFETY PRECAUTIONS BEFORE MOVING VEHICLE/MACHINE.**

Inspect pumps or motors for damage that may have been incurred during shipping and handling before installation. Make sure all system components (reservoir, hoses, valves, fittings, heat exchanger, etc.) are clean before filling with fluid.

Fill reservoir with recommended hydraulic fluid. This fluid should be passed through a 10 micron (nominal, no bypass) filter before entering reservoir. Using contaminated fluid can damage components and may cause unexpected vehicle/machine movement.

#### **NOTICE**

**INSPECT ALL PUMPS OR MOTORS FOR DAMAGE AND CONTAMINATION IF ANY PUMP OR MOTOR IS REPLACED DUE TO INTERNAL DAMAGE. FLUSH AND REPLACE ALL HYDRAULIC SYSTEM FLUID OR DAMAGE TO ENTIRE SYSTEM MAY RESULT.**

Inlet line from reservoir to pump must be filled prior to start-up. Check inlet line for properly tightened fittings, restrictions, and air leaks.

**NOTE:** *Reservoir is usually above pump inlet. Pressure head created by higher oil level helps keep inlet pressures within acceptable range and prevent high vacuum levels. However, air may be trapped due to hose routing or low reservoir locations. Bleed air by loosening hose at fitting closest to pump. When oil begins to flow, line is full and air has been purged. Tighten fitting to specified torque. If tank needs to be pressurized to start oil flow, take a vacuum reading at pump inlet during operation to verify pump is not trying to draw an inlet vacuum higher than its capability.*

Fill pump and motor housing with clean hydraulic fluid before start up. Fill housing by pouring filtered oil in upper case drain port.

**NOTE:** *Use highest possible case drain port. This ensures housing contains as much oil as possible and offers the greatest amount of lubrication to internal components.*

**NOTE:** *It may be easier to fill housing before installing the case drain line. Component (especially motor) location may prevent case drain port access after installation.*

**NOTE:** *Oil used to fill component housing must be clean. Store fill container properly to prevent contamination.*

Install 1000 psi (60 bar) pressure gauge in charge pressure gauge port to monitor charge pressure during start-up.

It is recommended external control input signal, (electrical connections for EDC), be disconnected at pump control until after initial start-up. This ensures pump remains in its neutral position.

#### **⚠ WARNING**

**DO NOT START ENGINE UNLESS PUMP IS IN NEUTRAL POSITION (0° SWASH-PLATE ANGLE). TAKE PRECAUTIONS TO PREVENT MACHINE MOVEMENT IN CASE PUMP IS ACTUATED DURING INITIAL START-UP.**

"Jog" or slowly rotate engine until charge pressure starts to rise. Start engine and run at lowest possible RPM until charge pressure is established. Excess air should be bled from system lines as close to motors as possible.

**NOTE:** *With engine on low idle loosen, do not remove, system lines at motor(s). Continue to run engine at low idle and tighten system lines as soon as oil is observed to leak from them. When oil is observed to "leak" at motor, line is full and air is purged. Tighten system hoses to specified torque.*

Once charge pressure is established, increase speed to normal operating RPM. Charge pressure should be as indicated in the pump model code. If charge pressure is inadequate, shut down and determine cause.

#### **⚠ WARNING**

**INADEQUATE CHARGE PRESSURE WILL AFFECT OPERATOR'S ABILITY TO CONTROL MACHINE.**

Shut down engine and connect external control input signal. Reconnect machine function(s), if disconnected earlier. Start engine, checking pump remains in neutral. With engine at normal operating RPM, slowly check forward and reverse machine operation.

Charge pressure may slightly decrease during forward or reverse operation. Continue to cycle slowly between forward and reverse for at least five minutes.

Shut down engine, remove gauges, and plug ports. Check reservoir level and add filtered fluid if needed.

Machine is ready for operation.

## 5.9 PRESSURE SETTING PROCEDURES

### NOTICE

COLD TEMPERATURES HAVE A SIGNIFICANT IMPACT ON PRESSURE READINGS. JLG INDUSTRIES, INC. RECOMMENDS OPERATING THE MACHINE UNTIL THE HYDRAULIC SYSTEM HAS WARMED TO NORMAL OPERATING TEMPERATURES PRIOR TO CHECKING PRESSURES. JLG ALSO RECOMMENDS USING A CALIBRATED GAUGE. PRESSURE READINGS ARE ACCEPTABLE IF WITHIN +/- 5% OF SPECIFIED PRESSURES.

### Main Relief, Steer, Swing, and Lift Down

1. Install pressure gauge at quick disconnect on port MP on main valve.
2. With aid of an assistant, activate telescope in.
3. Monitor pressure gauge and adjust main relief valve to 3000 PSI (206.85 Bar).
4. With the aid of an assistant, activate steer left.
5. Monitoring pressure gauge and adjust steer left relief valve to 1800 PSI (124.1 Bar).
6. With aid of an assistant, activate steer right.
7. Monitor pressure gauge and adjust steer right relief valve to 1800 PSI (124.1 Bar).
8. With aid of an assistant, activate swing left or right.
9. Monitor pressure gauge and adjust swing relief valve to 1700 PSI (117.2 Bar).
10. With aid of an assistant, activate lift down.
11. Monitoring pressure gauge and adjust lift down relief valve to 1500 PSI (103.4 Bar).

### Platform Level

1. Install pressure gauge at quick disconnect on port M3 on main valve.
2. With aid of an assistant, activate platform level forward.
3. While monitoring pressure gauge, adjust platform level relief to 2800 PSI (193.06 Bar).
4. Install pressure gauge at quick disconnect on port M4 on main valve.
5. With aid of an assistant, activate platform level backward.
6. Monitor pressure gauge and adjust platform level relief valve to 1800 PSI (124.11 Bar).

### Articulating Jib Boom (If Equipped)

1. Install pressure gauge at quick disconnect on articulating valve.
2. With aid of an assistant, activate articulating jib up.
3. Monitor pressure gauge and adjust articulating jib up relief valve to 1500 PSI (103 Bar).
4. With aid of an assistant, activate articulating jib down.
5. Monitor pressure gauge and adjust activate articulating jib down relief valve to 1200 PSI (83 Bar).

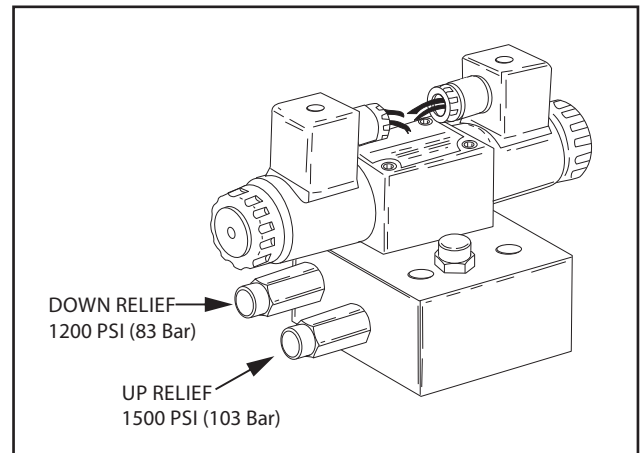


Figure 5-87. Articulating Jib Boom Pressure Adjustment

### 4 Wheel Steer (If Equipped)

1. Activate "2 wheel steer" at platform console using steer select switch.
2. Install pressure gauge in port MP on main control valve.
3. With aid of an assistant, activate steer left and right. Adjust front steer relief valve to 2500 PSI (172.4 Bar). This pressure only affects the front axle.
4. Activate "crab" or "coordinated" steer at platform console using steer select switch
5. Disconnect wire DIN connectors on front steer valve at main control valve block. When steer is activated only rear steer will work.
6. Install pressure gauge in port MP on main control valve.
7. With aid of an assistant, activate steer left and right. Adjust rear steer relief valve to 2500 PSI (172.4 Bar). 2500 PSI (172.4 Bar) at valve bank will give 2000PSI (137.9 Bar) at cylinders.
8. Reconnect front steer DIN connectors at valve bank.

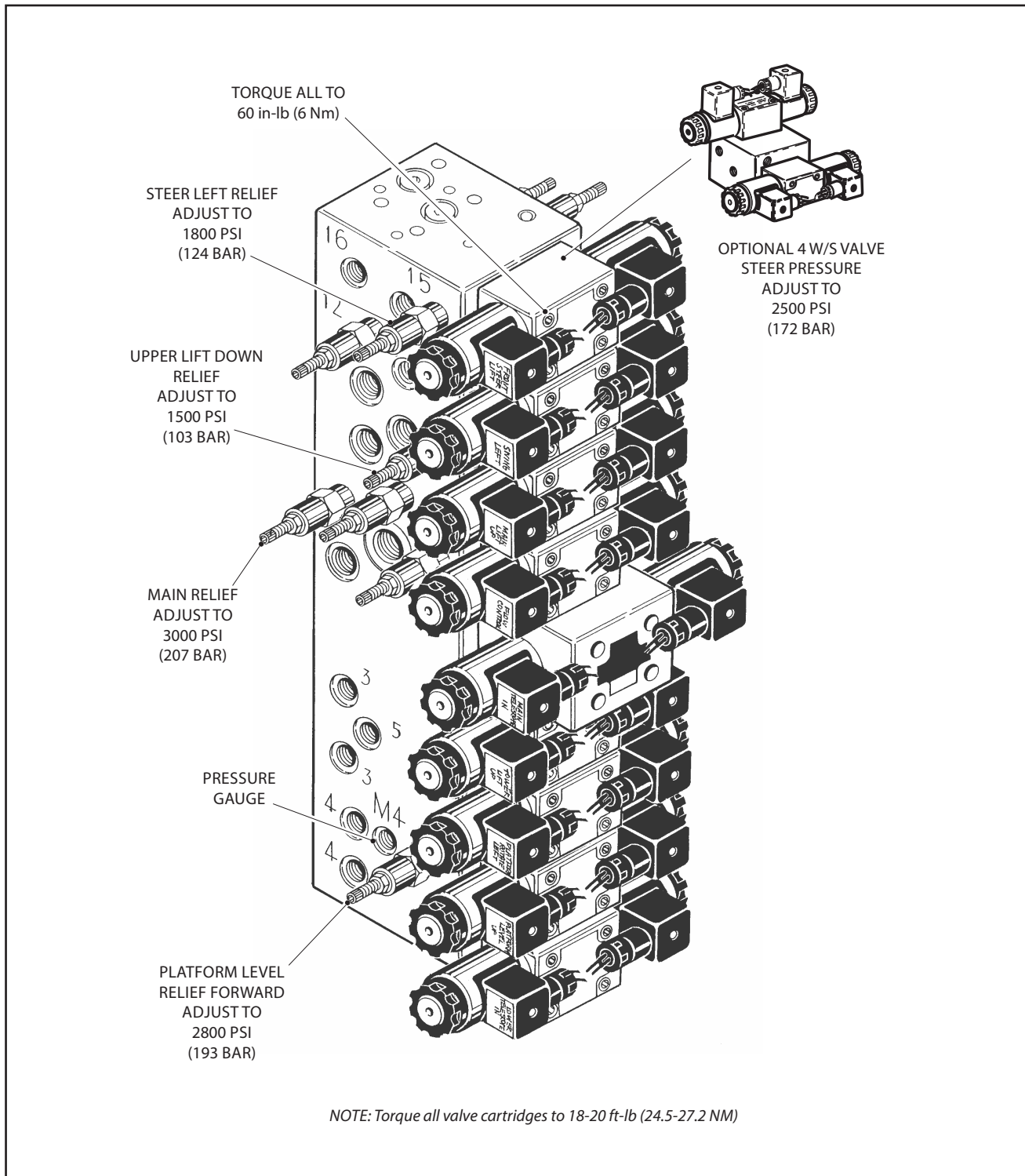


Figure 5-88. Main Control Valve - Sheet 1 of 2

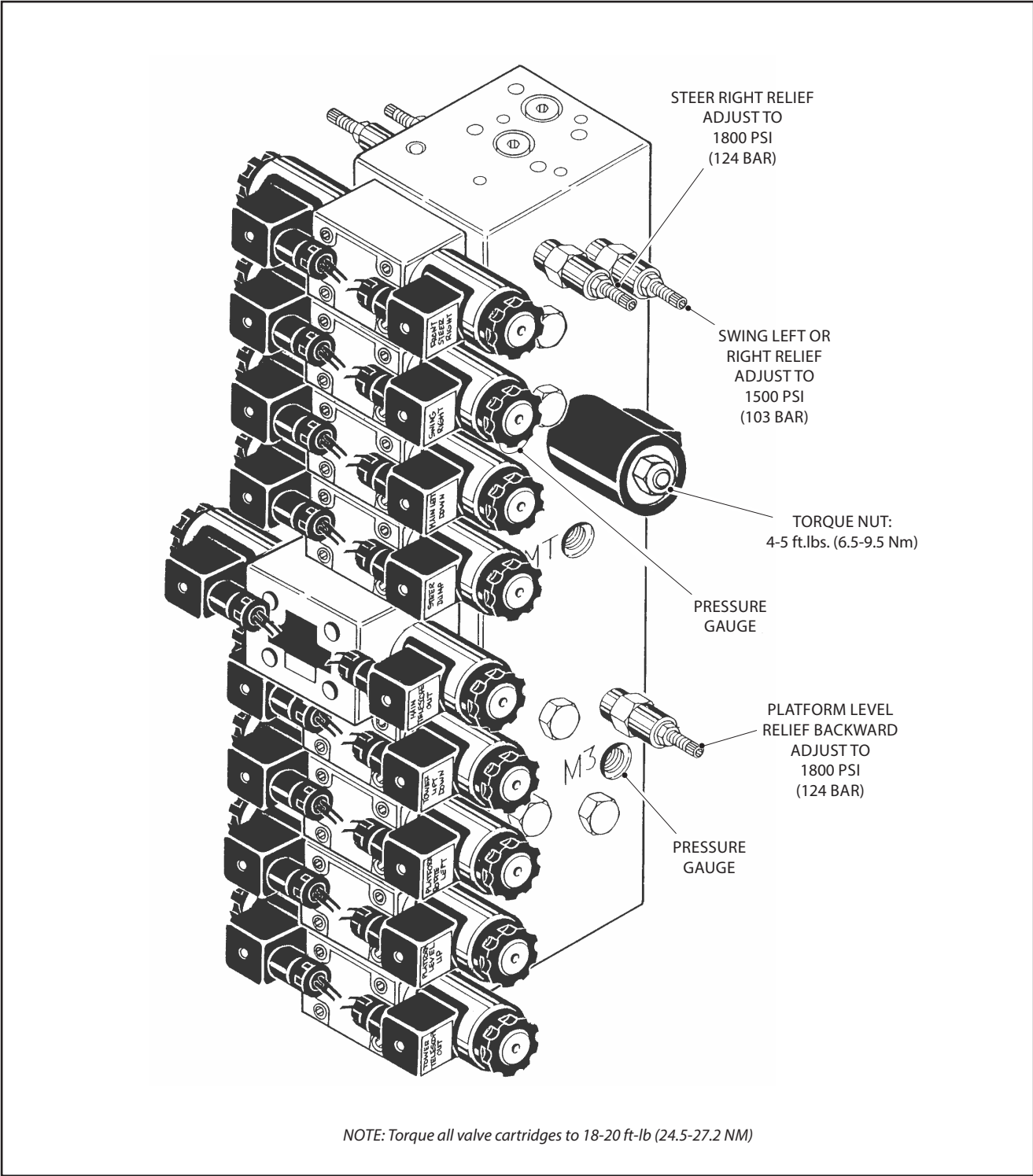
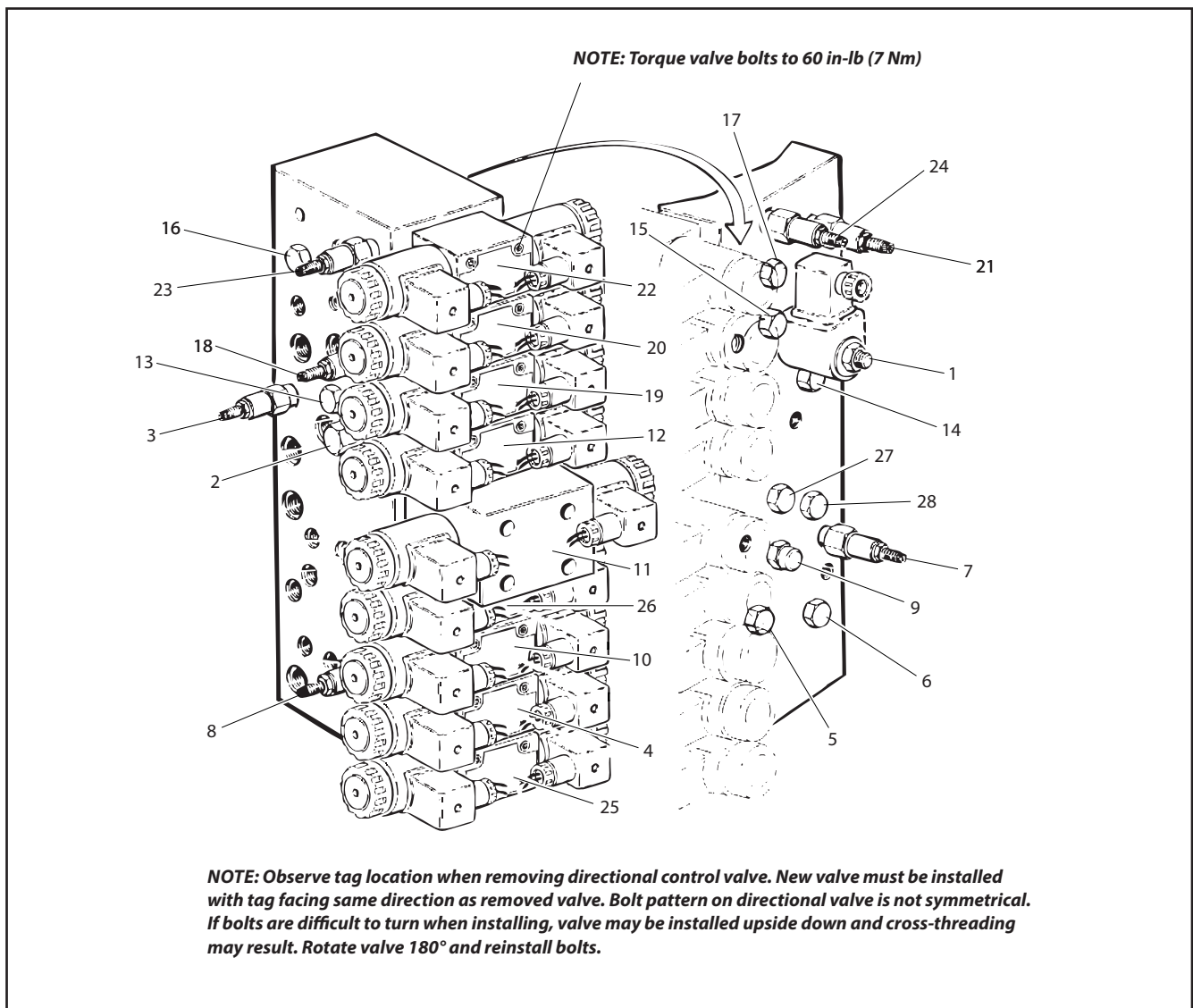


Figure 5-89. Main Control Valve - Sheet 1 of 2



- |  |  |   |
|--|--|---|
| 1. Solenoid Operated 2-Way valve                     | 10. Directional Control Valve (Platform Rotator) | 19. Directional Control Valve (Upper Lift)      |
| 2. Pressure Control Load Sense Cartridge             | 11. Directional Control Valve (Upper Telescope)  | 20. Directional Control Valve (Swing)           |
| 3. Direct Operated Relief Valve (Main Relief)        | 12. Directional Control Valve (Flow Control)     | 21. Direct Operated Relief Valve                |
| 4. Directional Control Valve (Platform Level)        | 13. Load Shuttle Valve                           | 22. Directional Control Valve (Steer)           |
| 5. Pilot Operated Check Valve                        | 14. Load Shuttle Valve                           | 23. Direct Operated Relief Valve                |
| 6. Pilot Operated Check Valve                        | 15. Load Shuttle Valve                           | 24. Direct Operated Relief Valve                |
| 7. Direct Operated Relief Valve                      | 16. Load Shuttle Valve                           | 25. Directional Control Valve (Lower Telescope) |
| 8. Direct Operated Relief Valve                      | 17. Load Shuttle Valve                           | 26. Directional Control Valve (Lower Lift)      |
| 9. Pressure Compensated Flow Control (Fixed 0.2 GPM) | 18. Direct Operated Relief Valve                 | 27. Check Valve                                 |

Figure 5-90. Location of Components - Main Control Valve

1.

## SECTION 6. JLG CONTROL SYSTEM

## 6.1 INTRODUCTION

**NOTICE**

WHEN INSTALLING A NEW GROUND MODULE CONTROLLER IT IS NECESSARY TO PROGRAM THE CONTROLLER FOR PROPER MACHINE CONFIGURATION, INCLUDING OPTIONS.

**NOTICE**

AVOID PRESSURE-WASHING ELECTRICAL/ELECTRONIC COMPONENTS. IF PRESSURE-WASHING IS USED TO WASH AREAS CONTAINING ELECTRICAL/ELECTRONIC COMPONENTS, JLG INDUSTRIES, INC. RECOMMENDS A MAXIMUM PRESSURE OF 750 PSI (52 BAR) AT A MINIMUM DISTANCE OF 12 INCHES (30.5 CM) FROM THESE COMPONENTS. IF ELECTRICAL/ELECTRONIC COMPONENTS ARE SPRAYED, SPRAYING MUST NOT BE DIRECT AND FOR BRIEF TIME PERIODS TO AVOID HEAVY SATURATION.

The JLG designed Control System is a 12 volt based motor control unit installed on the boom lift.

The JLG Control System has reduced the need for exposed terminal strips, diodes and trimpots and provides simplicity in viewing and adjusting the various personality settings for smooth control of: acceleration, deceleration, creep, min

speed, and max.-speed for all boom, drive, and steering functions.

Upper lift, swing, and drive are controlled by individual joysticks. Steering is controlled by a rocker switch built in the top of the drive joystick. To activate Drive, Lift, and Swing; pull up the slide lock on the joystick and move the handle in the desired direction.

The control system provides voltage output to the valves and pump, as programmed, for smooth operation and maximum cycle time. Ground control speeds for all boom functions can also be programmed in the control system.

The JLG Control System controller has a built in LED to indicate any faults. The system stores recent faults which may be accessed for troubleshooting. Optional equipment includes a soft touch system, head and tail lights, and ground alarm. These options may be added later but must be programmed into the control system when installed.

The Control System may be accessed with a custom designed, direct connect hand held analyzer or wireless adapter using an app on your Android or iPhone/iPad device. The analyzer or wireless output displays two lines of information at a time, by scrolling through the program.

Each module has a label with JLG part number and a serial number containing a date code.

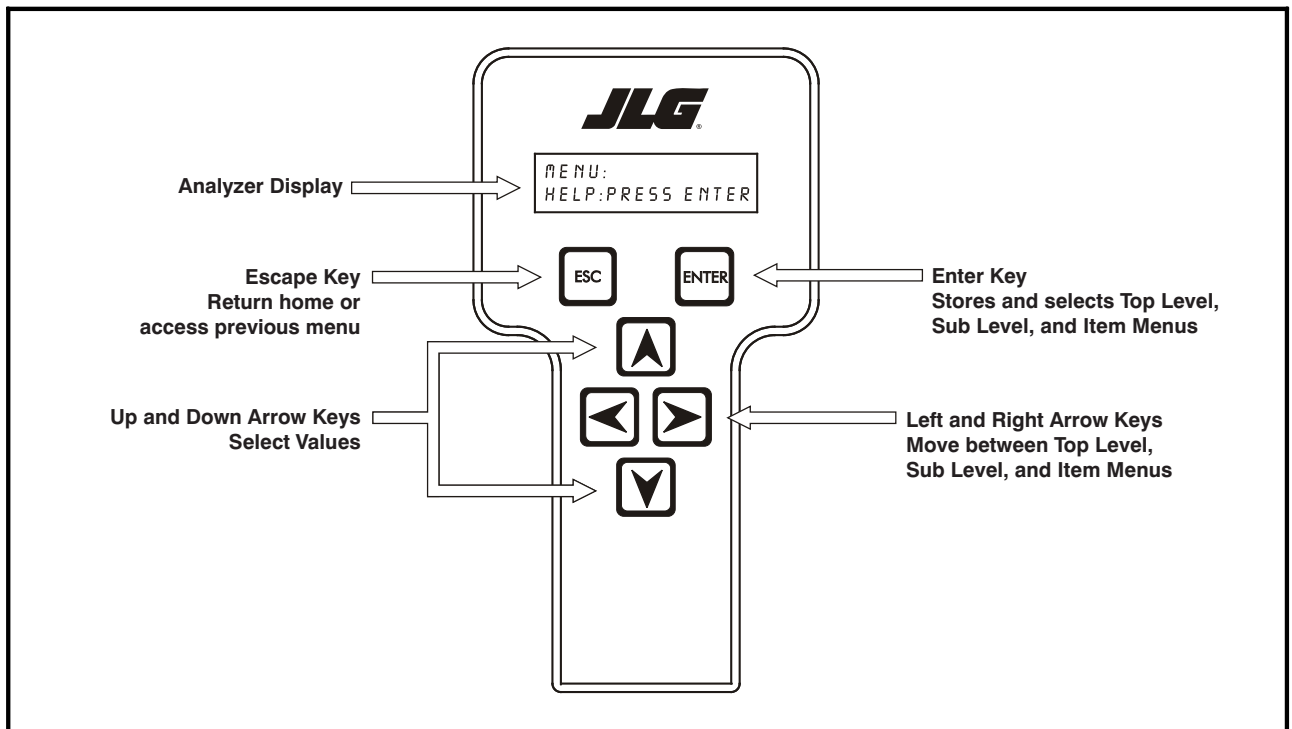
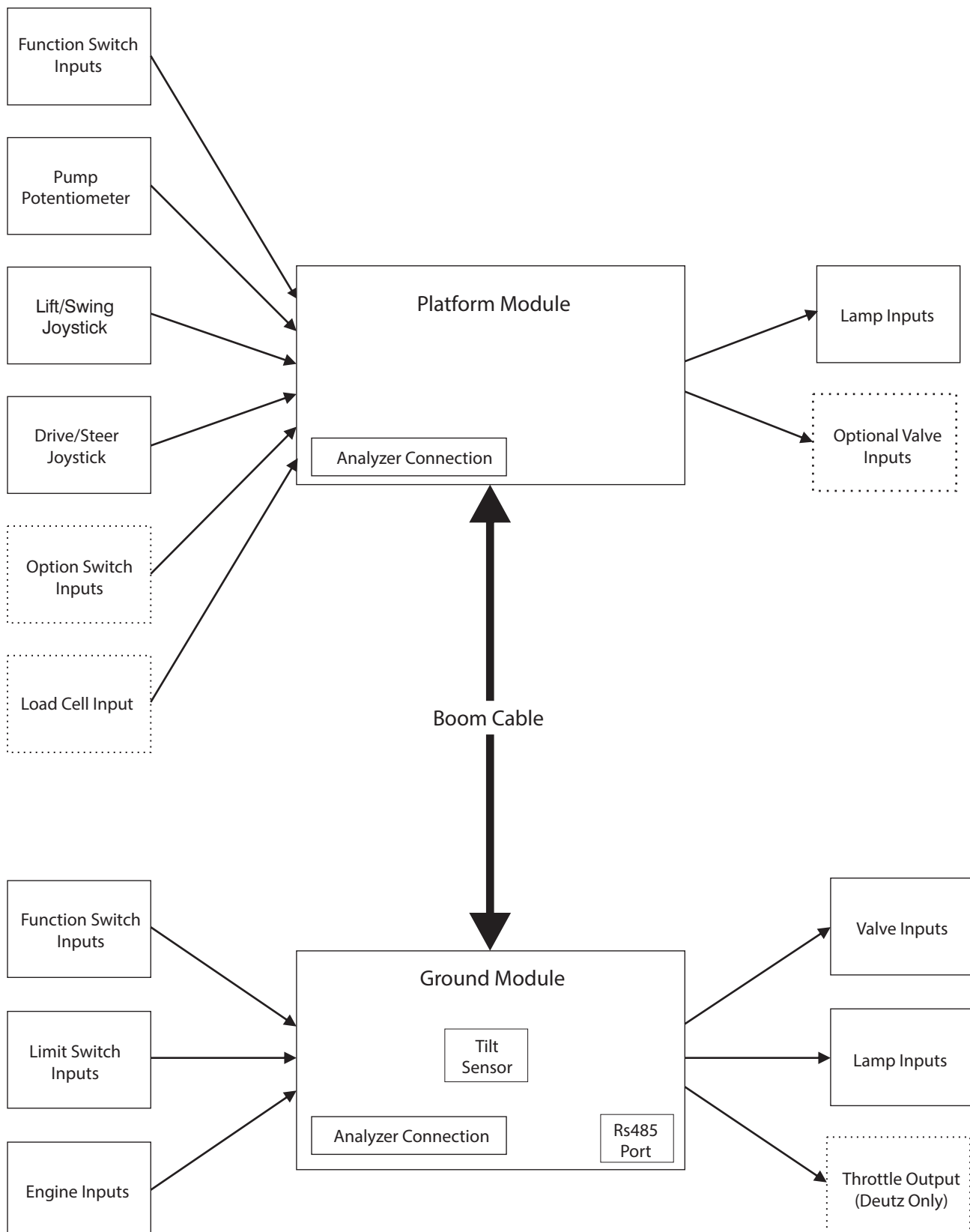


Figure 6-1. Hand-Held Analyzer (WANALYZER Controls and Display Similar)



**Figure 6-2. Controller Block Diagram**



### Connect JLG Control System Analyzer

1. Connect four pin end of cable supplied with hand-held or wireless analyzer to controller module on platform box or at controller module inside ground control box. Connect other end of cable to analyzer.

**NOTE:** Cable has a keyed four pin connector at each end. It cannot be connected backwards.



Figure 6-3. Analyzer Platform Connector

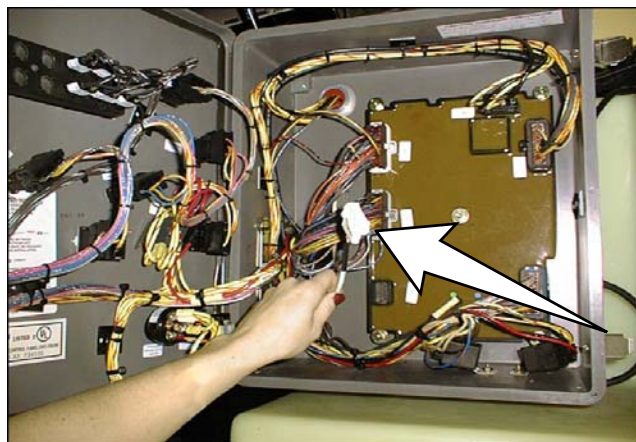


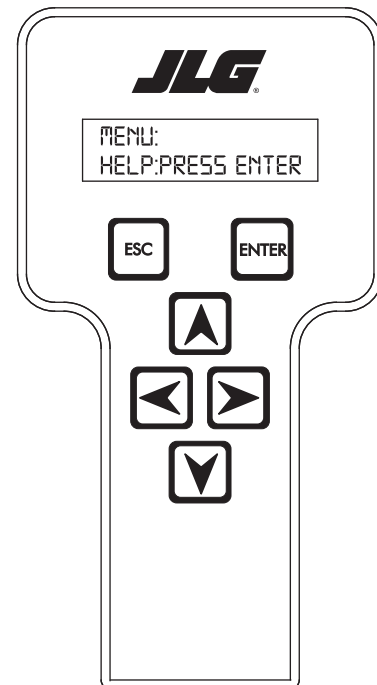
Figure 6-4. Analyzer Ground Control Box Connector

**NOTE:** Follow instructions provided with Wireless Analyzer (WANALYZER) kit. JLG Analyzer application must be downloaded and installed to your smartphone or tablet device.

### Using Analyzer

1. Power up Control System by turning lower key to platform or ground position and pulling both emergency stop buttons out.

Analyzer displays the following with machine power on and analyzer connected properly:



**MENU:**  
**HELP:PRESS ENTER**

Move between top level menu items using


**RIGHT**  and **LEFT**  arrow keys. To select a displayed menu item, press **ENTER** .


To cancel a selected menu item press **ESC** .

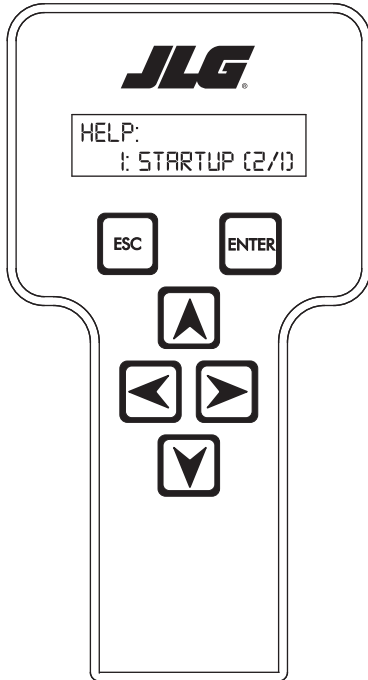
Scroll using right and left arrow keys to select a different menu item.

Top level menus:

- HELP**
- DIAGNOSTICS**
- SYSTEM TEST**
- ACCESS LEVEL**
- PERSONALITIES**
- MACHINE SETUP**
- CALIBRATIONS (view only)**


If **ENTER**  is selected at the **HELP: PRESS ENTER** display, and a fault is present, the analyzer display scrolls the fault across the screen. If no fault is detected, the display shows: **HELP: EVERYTHING OK**. If powered up at the ground station, the display shows: **GROUND OK**.

If **ENTER**  is pressed again, display shows the following:




**LOGGED HELP  
1: POWER CYCLE (0/0)**


Analyzer displays last system fault if any are present. Use right and left arrow keys to scroll through fault logs and view last 25

faults. Press **ESC**  two times to return to MENU screen. **POWER CYCLE (0/0)** indicates a power up.

When a top level menu is selected, a new set of menu items may be offered: for example:

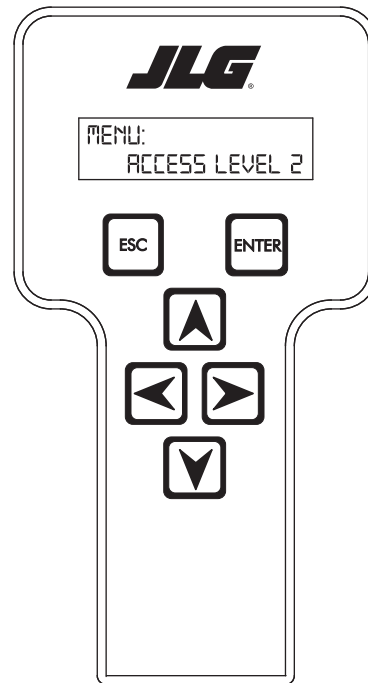
- DRIVE**
- BOOM**
- SYSTEM**
- DATALOG**
- VERSIONS**

Pressing **ENTER**  with any of the above displayed menus, displays additional sub-menus within the selected menu. In some cases, such as **DRIVE**, the next level is the parameter or information to be changed. Refer to the flow chart for what menus are available within the top level menus. You may only view the personality settings for selected menus while in access level 2. Remember, you may always cancel a selected


menu item by pressing the **ESCAPE**  key.

**Changing Access Level**

When analyzer is first connected, you will be in access level 2 which enables you to only view most settings which cannot be changed until you enter a password to advance to a lower level. This ensures that a setting cannot be accidentally altered. To change access level, the correct password must be entered. To enter password, scroll to **ACCESS LEVEL** menu. For example:




**ACCESS LEVEL:  
CODE 00000**

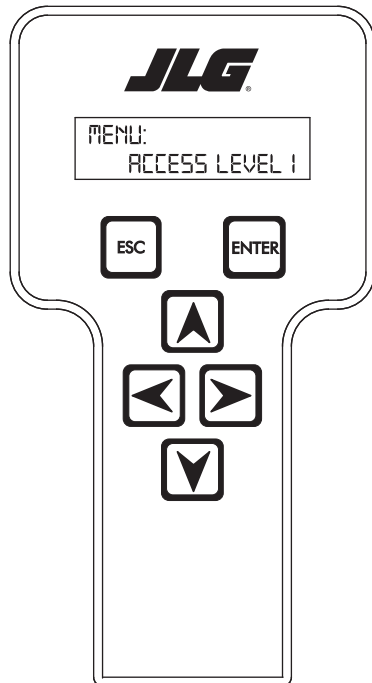
Press **ENTER**  to select the **ACCESS LEVEL** menu.

Using the **UP**  or **DOWN**  arrow keys, enter first digit of the password, 3.

Then using the **RIGHT**  arrow key, position cursor right one space to enter the second digit of the password.

Use the **UP**  or **DOWN**  arrow key to enter the second digit of the password which is 33271.



When correct password is displayed, press **ENTER** . The access level displays the following if password was entered correctly:

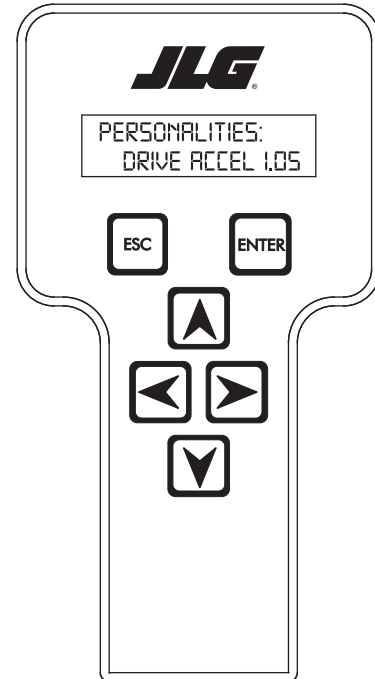


**MENU:  
ACCESS LEVEL 1**



Repeat above steps if correct access level is not displayed or you can not adjust personality settings.

## Adjust Parameters



Once you have gained access to level 1, and a personality item is selected, press the **UP**  or **DOWN**  arrow keys to adjust its value, for example:

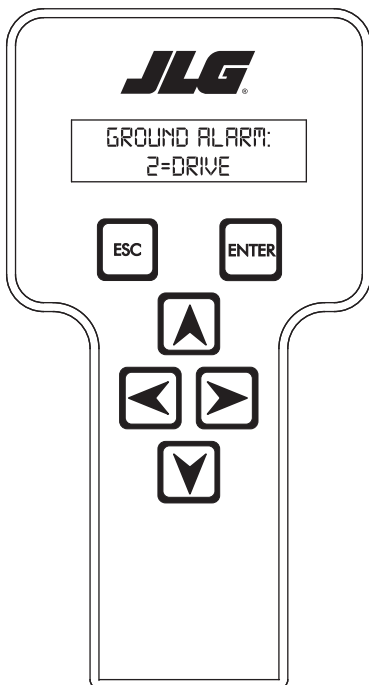


**DRIVE:  
ACCEL 1.05**

There will be a minimum and maximum for the value to ensure efficient operation. The Value will not increase if the **UP**  arrow is pressed at maximum value or decrease if the **DOWN**  arrow is pressed at minimum value for any personality. If value does not change when pressing up and down arrows, check access level is at access level 1.

**Machine Setup**

When a machine digit item is selected, press **UP**  or **DOWN**  arrow keys to adjust its value, for example:



**GROUND ALARM:  
2 = DRIVE**

The effect of the machine digit value is displayed along with its value. The above display would be selected if the machine was equipped with a ground alarm and you wanted it to sound when driving. There are certain settings allowed to install optional features or select the machine model.

When selection the machine model to match the size of the machine, the personality settings will all default to the factory recommended setting.

**NOTE:** Refer to Personality Ranges/Defaults for the recommended factory settings.

**NOTE:** Password 33271 allows access to level 1 to change machine personality settings.

There is a setting that JLG strongly recommends that you do not change. This setting is so noted below:

**ELEVATION CUTBACK**

**⚠ WARNING**

**CHANGING ELEVATION CUTBACK SETTING MAY ADVERSELY AFFECT PERFORMANCE OF YOUR MACHINE.**

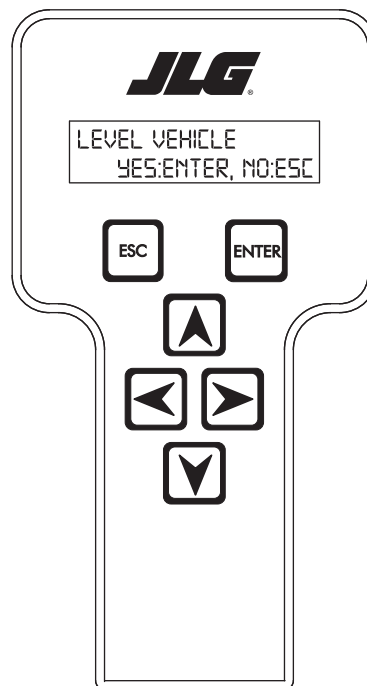
**NOTICE**

**AVOID PRESSURE-WASHING ELECTRICAL/ELECTRONIC COMPONENTS. IF PRESSURE-WASHING IS USED TO WASH AREAS CONTAINING ELECTRICAL/ELECTRONIC COMPONENTS, JLG INDUSTRIES INC. RECOMMENDS A MAXIMUM PRESSURE OF 750 PSI (52 BAR) AT A MINIMUM DISTANCE OF 12 INCHES (30.5CM) FROM THESE COMPONENTS. IF ELECTRICAL/ELECTRONIC COMPONENTS ARE SPRAYED, SPRAYING MUST NOT BE DIRECT AND FOR BRIEF TIME PERIODS TO AVOID HEAVY SATURATION.**


**Level Vehicle Description**

**⚠ WARNING**

**DO NOT LEVEL VEHICLE EXCEPT ON A LEVEL SURFACE.**



**LEVEL VEHICLE  
YES:ENTER, NO:ESC**

Not available at password level 2. **ENTER**  confirms vehicle is current.

**Table 6-1. Analyzer Abbreviations**

ABBREVIATION	MEANING
ACCEL	ACCELERATE
ACT	ACTIVE
A/D	ANALOG DIGITAL CONVERTER COUNT
AMB.	AMBIENT
ANG	ANGLE
AUX	AUXILIARY
BCS	BOOM CONTROL SYSTEM
BM	BOOM LENGTH ANGLE MODULE
BLAM	BOOM LENGTH ANGLE MODULE
BR	BROKEN
BSK	BASKET
CAL	CALIBRATION
CL	CLOSED
CM	CHASSIS MODULE
CNTL	CONTROL
CNTRL	CONTROL
C/O	CUTOUT
CONT(S)	CONTRACTOR(S)
COOR	COORDINATED
CRKPT	CRACK POINT
CRP	CREEP
CUT	CUTOUT
CYL	CYLINDER
DECEL	DECELERATE
D	DOWN
DN	DOWN
DWN	DOWN
DEG.	DEGREE
DOS	DRIVE ORIENTATION SYSTEM
DRV	DRIVE
E	ERROR
E&T	ELEVATED & TILTED
ELEV	ELEVATION
ENG	ENGINE
EXT	EXTEND
F	FRONT
FL	FLOW
FNT	FRONT
FOR	FORWARD
FWD	FORWARD
FSW	FOOT SWITCH
FUNC	FUNCTION
G	GROUND

**Table 6-1. Analyzer Abbreviations**

ABBREVIATION	MEANING
GND	GROUND
GRN	GREEN
GM	GROUND MODULE
H	HOURS
HW	HARDWARE
HWFS	HARDWARE FAILSAFE
I	IN or CURRENT
JOY	JOYSTICK
L	LEFT
LB	POUND
LEN	LENGTH
LIM	LIMIT
LT	LEFT
LVL	LEVEL
M	MINUTES
MIN	MINIMUM
MAX	MAXIMUM
M	MAIN
MN	MAIN
NO	NORMALLY OPEN or NO
NC	NORMALLY CLOSED
O	OUT
O/C	OPEN CIRCUIT
OP	OPEN
O/R	OVERRIDE or OUTRIGGER
O//R	OVERRIDE
OSC	OSCILLATING
OVRD	OVERRIDE
P	PLATFORM
P	PRESSURE
PCV	PROPORTIONAL CONTROL VALVE
PLAT	PLATFORM
PLT	PLATFORM
PM	PLATFORM MODULE
POT	POTENTIOMETER
PRES	PRESSURE
PRS	PRESSURE
PT	POINT
R	REAR or RIGHT
REV	REVERSE or REVISION
RET	RETRACT
ROT.	ROTATE
RT	RIGHT

## SECTION 6 - JLG CONTROL SYSTEM

---

**Table 6-1. Analyzer Abbreviations**

<b>ABBREVIATION</b>	<b>MEANING</b>
S/C	SHORT CIRCUIT
SEL	SELECTOR
SN	SERIAL NUMBER
SPD	SPEED
STOW	STOWED
STOWD	STOWED
SW	SWITCH or SOFTWARE
TELE	TELESCOPE
TEMP	TEMPERATURE
TORQ.	TORQUE
TRN	TRANSPORT
T/T	TURNTABLE
T	TOWER
TURNTBL	TURNTABLE
TWR	TOWER
U	UPPER or UP
V	VOLT
VER	VERSION
VLV	VALVE
WIT	WITNESS
YEL	YELLOW

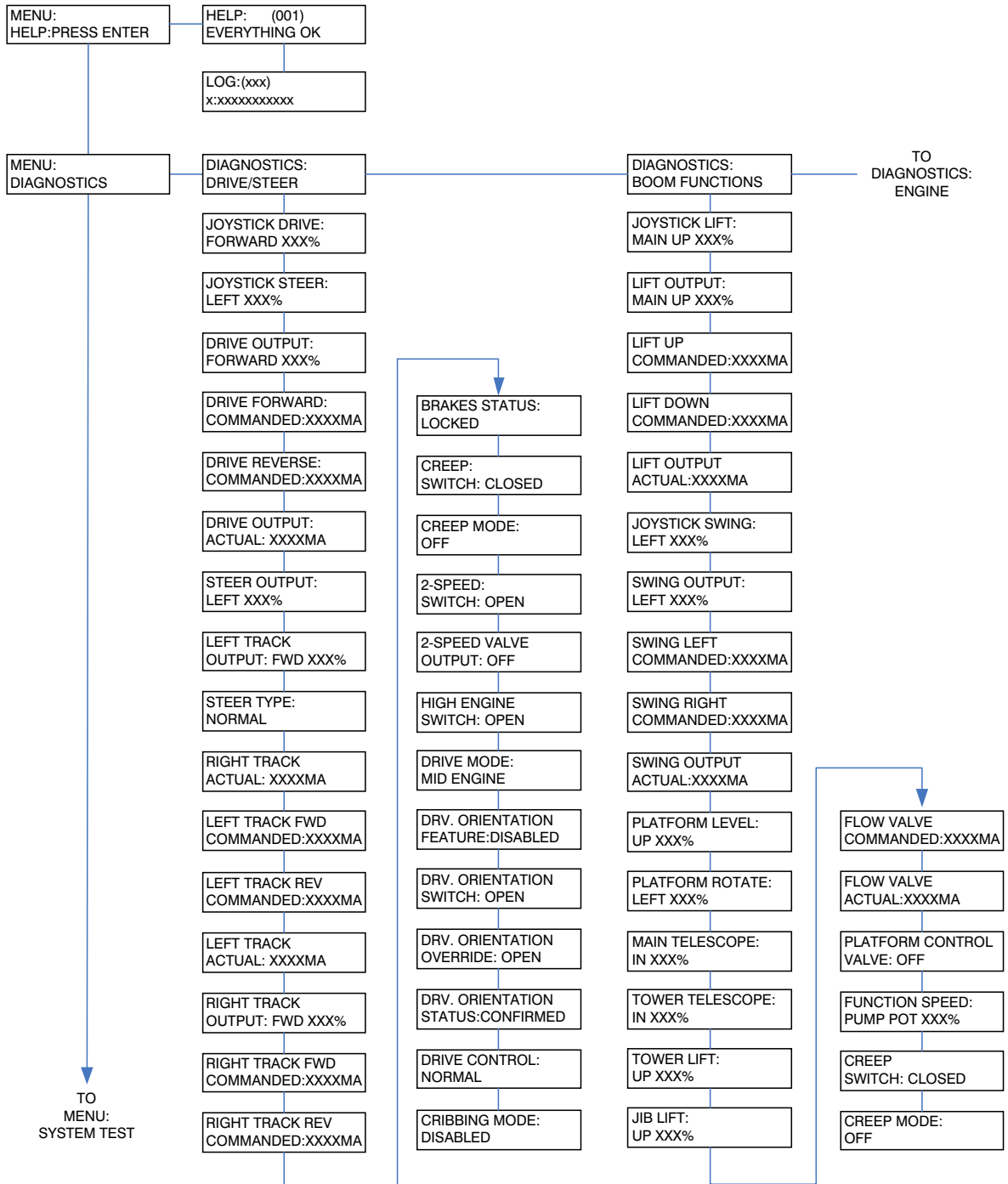


Figure 6-5. Analyzer Software Version 6.8 - Sheet 1 of 6

## SECTION 6 - JLG CONTROL SYSTEM

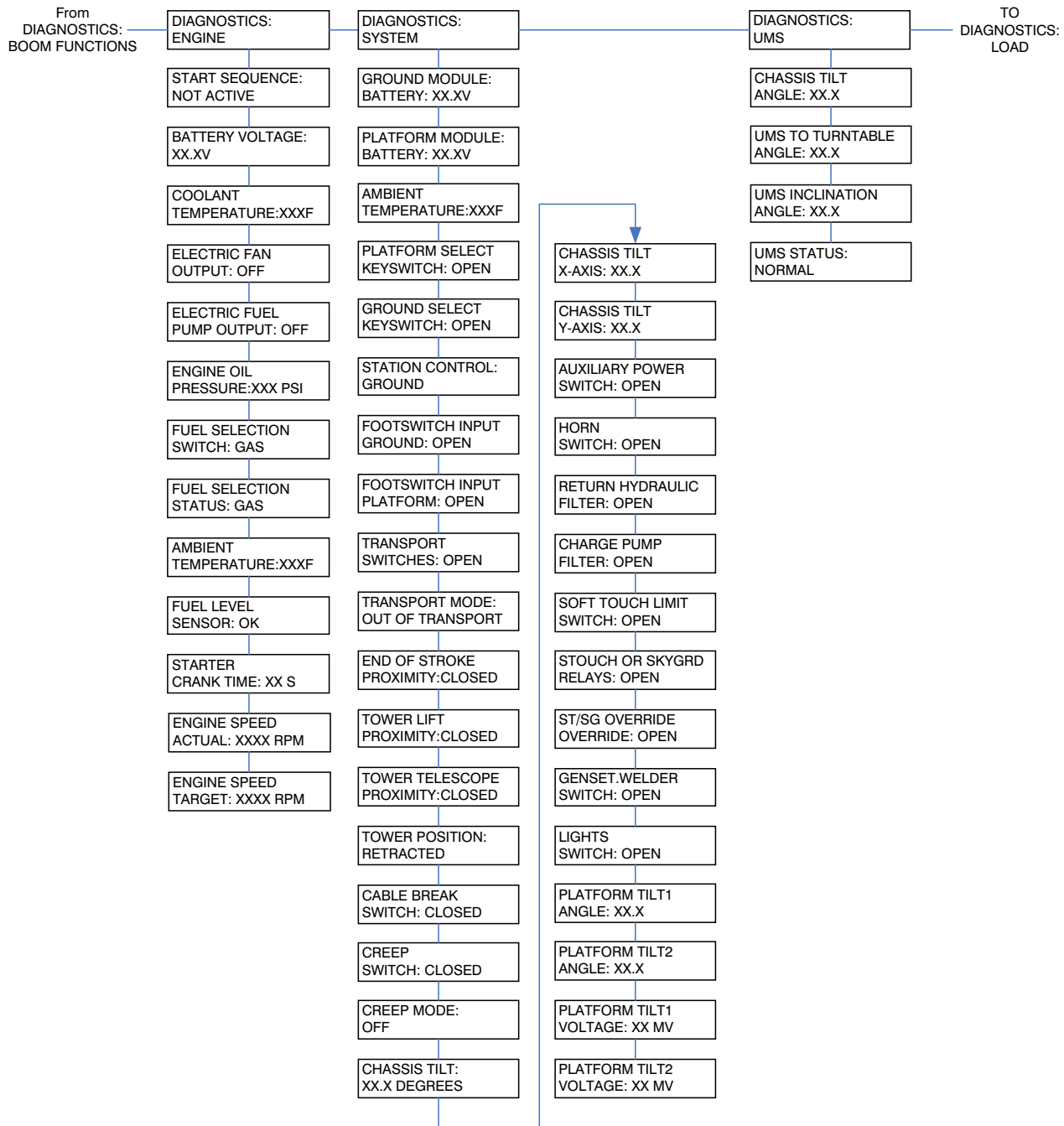


Figure 6-6. Analyzer Software Version 6.8 - Sheet 2 of 6



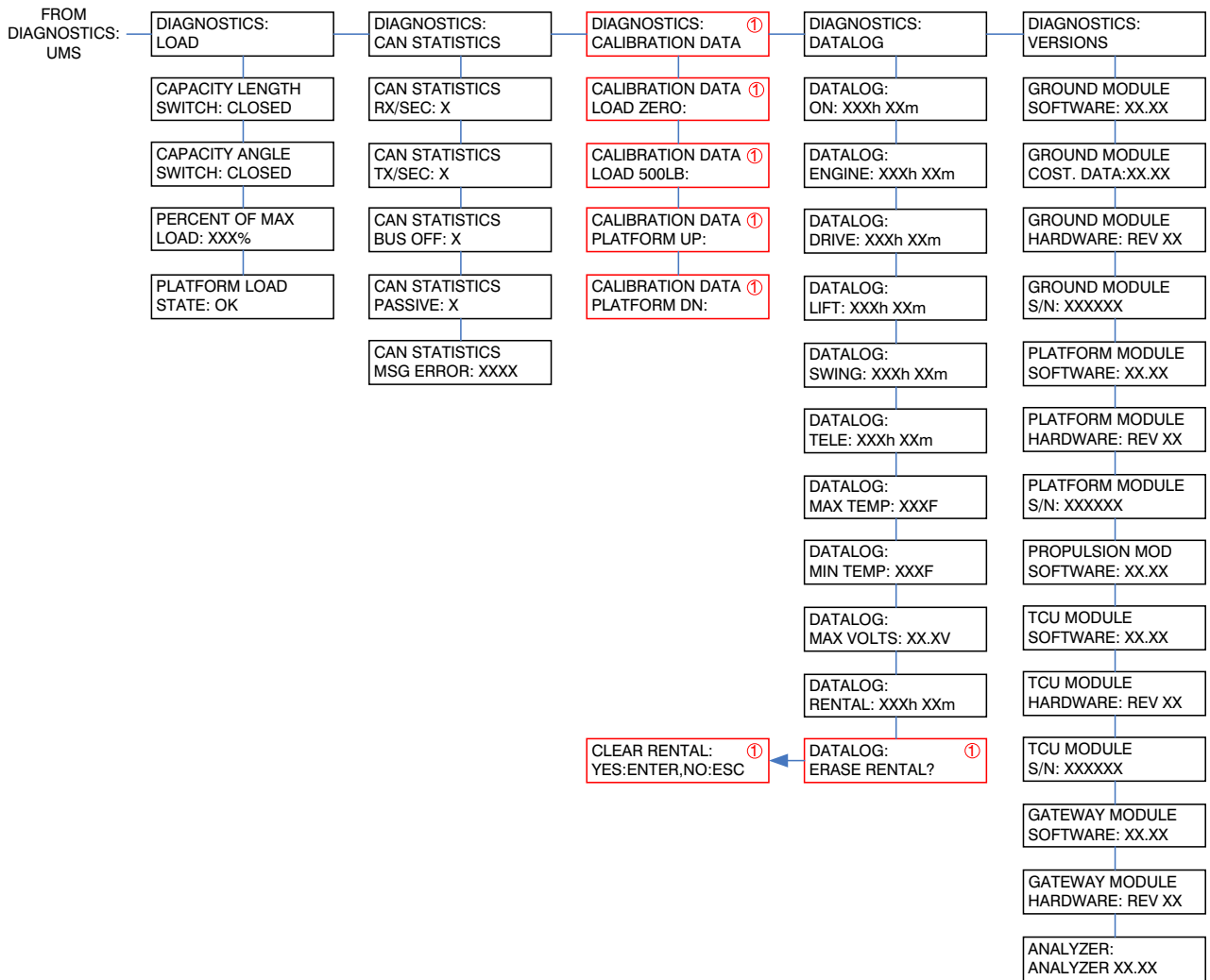
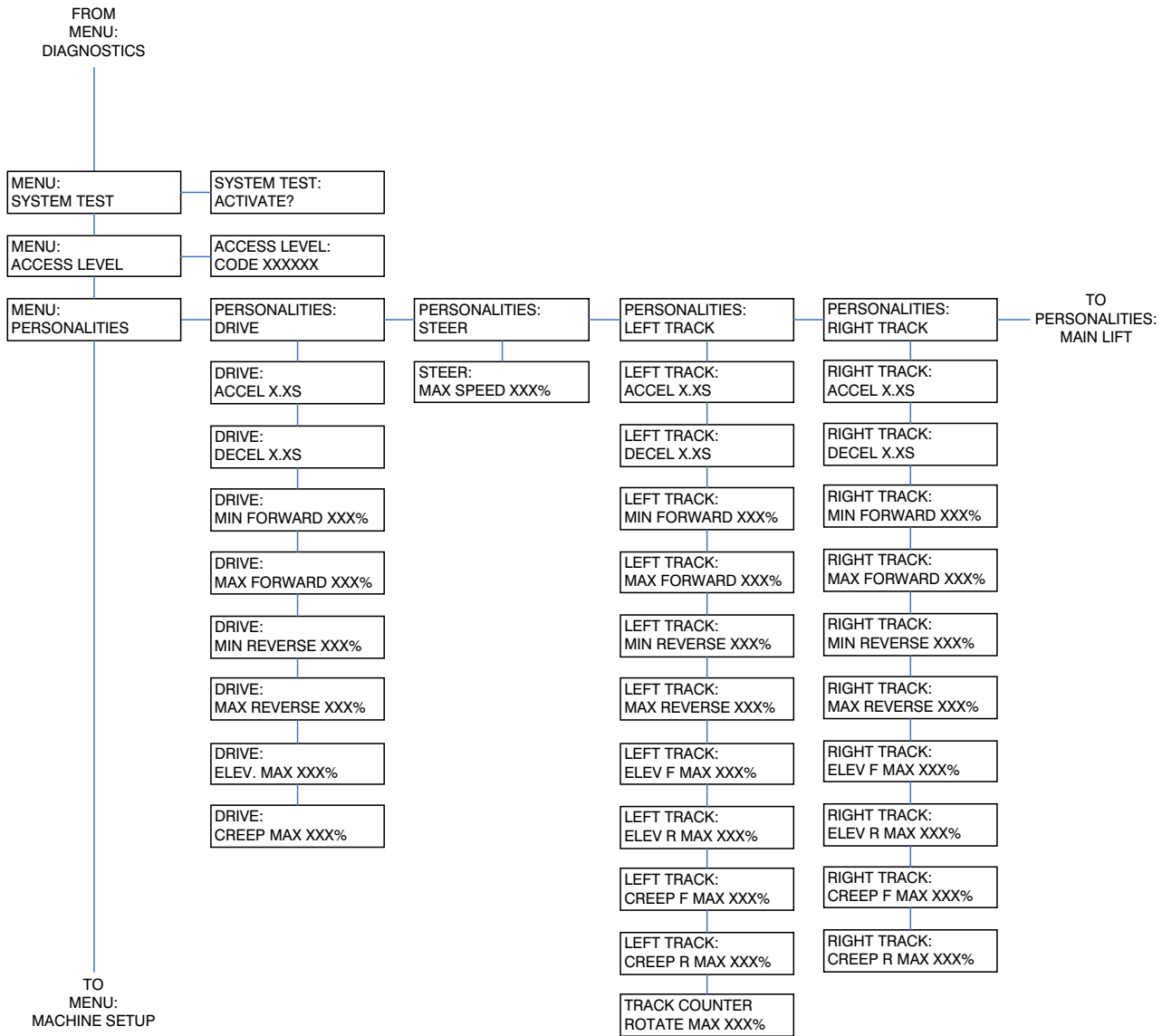


Figure 6-7. Analyzer Software Version 6.8 - Sheet 3 of 6

**SECTION 6 - JLG CONTROL SYSTEM**



**Figure 6-8. Analyzer Software Version 6.8 - Sheet 4 of 6**

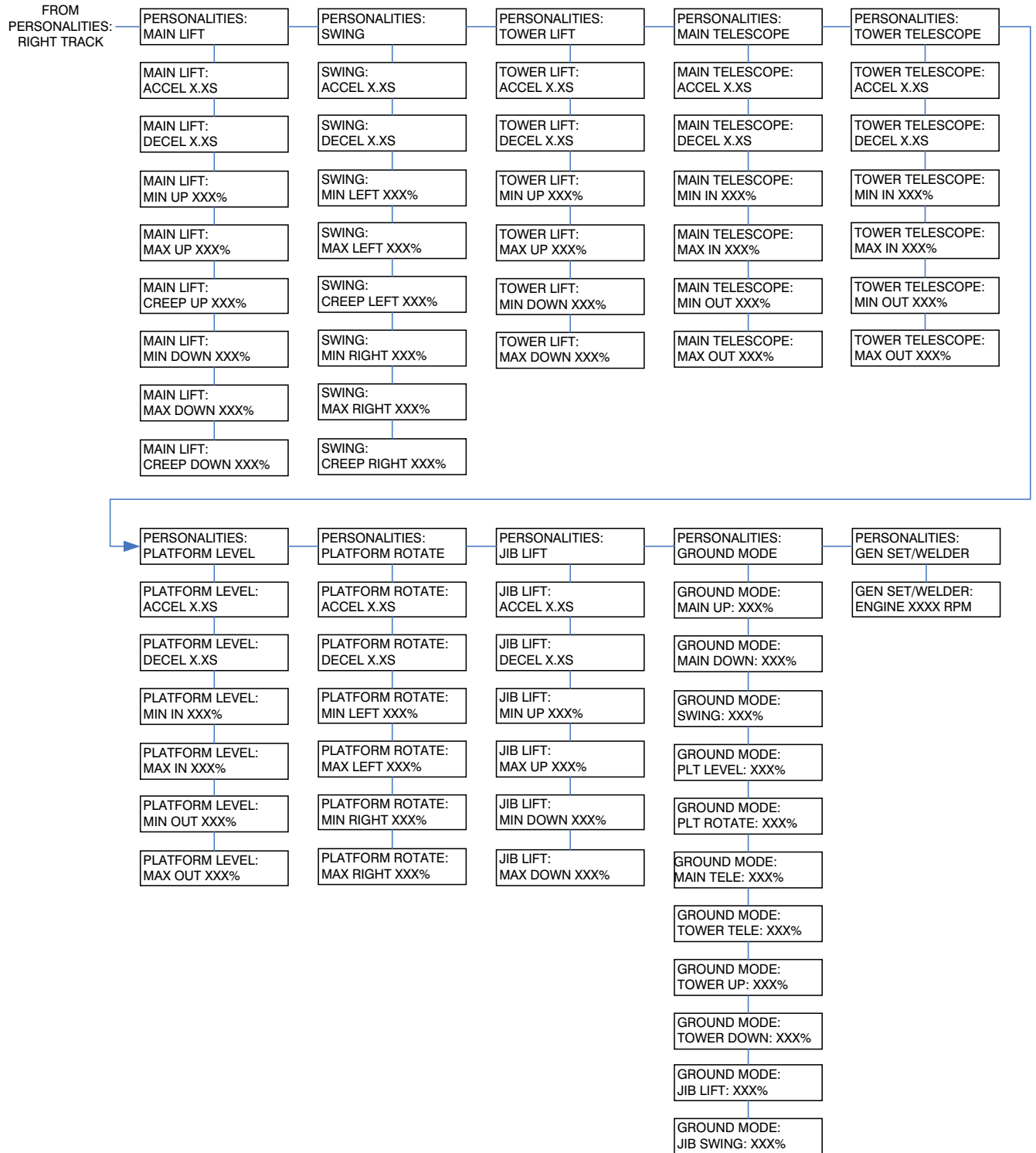


Figure 6-9. Analyzer Software Version 6.8 - Sheet 5 of 6

# SECTION 6 - JLG CONTROL SYSTEM

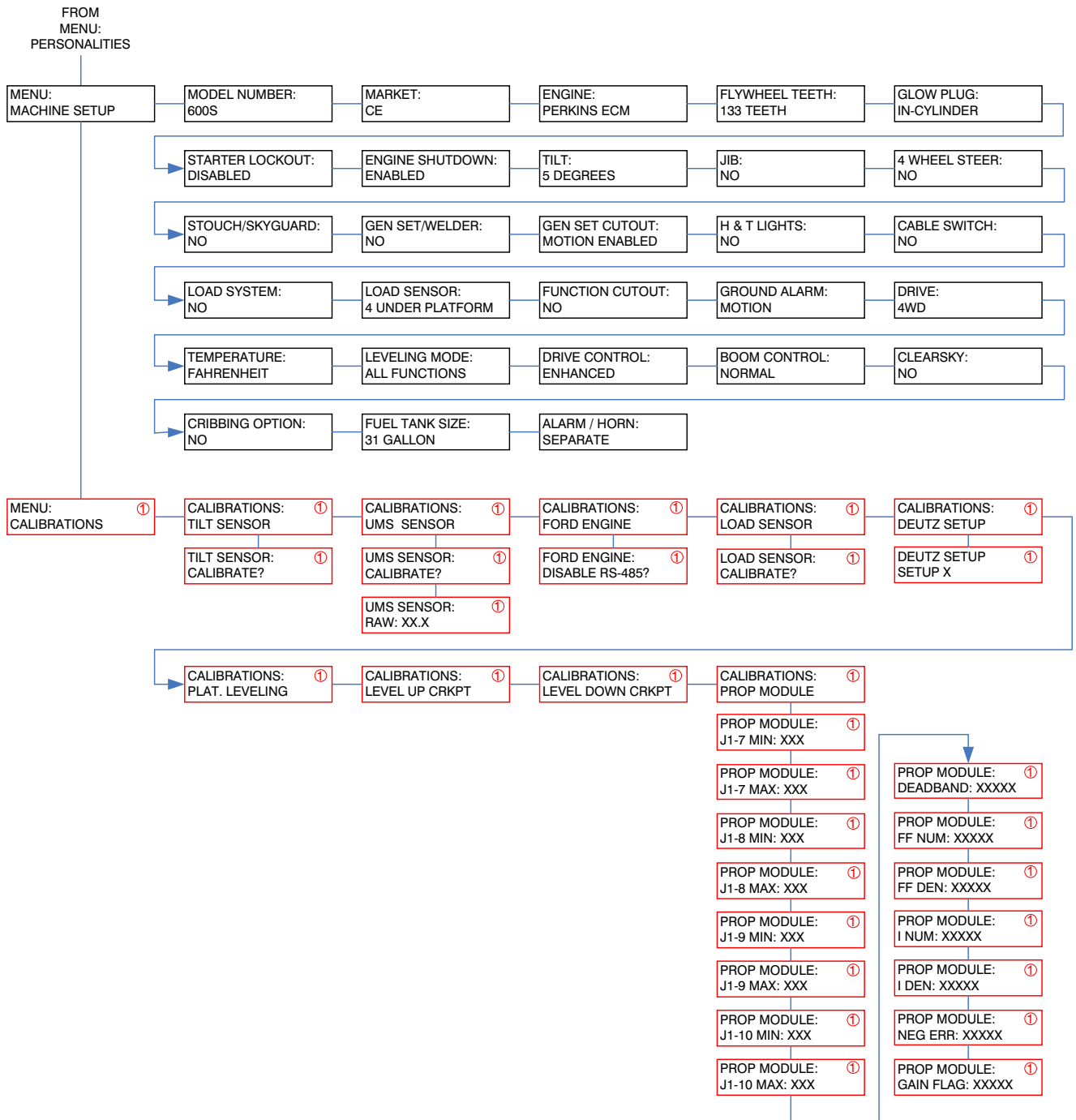


Figure 6-10. Analyzer Software Version 6.8 - Sheet 6 of 6

## 6.2 MACHINE PERSONALITY SETTINGS

**NOTE:** Personality settings can be adjusted within the adjustment range for optimum machine performance.

**Table 6-2. Personality Ranges/Defaults**

FUNCTION	PERSONALITY	RANGE	DEFAULTS - 600S
DRIVE	ACCEleration	0.1sto 5.0s	2.0
	DECEleration	0.1sto 3.0s	2.0
	Forward MINimum speed	0 to 35%	4
	Forward MAXimum speed	0 to 100%	35
	REVerse MINimum speed	0 to 35%	4
	REVerse MAXimum speed	0 to 100%	35
	ELEVATED MAXimum speed	0 to 50%	15
	CREEP MAXimum speed	0 to 50%	25
	Engine RPM	800 to 2900	1800
TOWER LIFT	ACCEleration	0.1 to 5.0	N/A
	DECEleration	0.1 to 3.0	N/A
	MINimum UP speed	0 to 60%	N/A
	MAXimum UP speed	0 to 100%	N/A
	MINimum DOWN speed	0 to 60%	N/A
	MAXimum DOWN speed	0 to 100%	N/A
	Engine RPM	800 to 2900	N/A
UPPER LIFT	ACCEleration	0.1 to 5.0	2.0
	DECEleration	0.1 to 3.0	0.7
	MINimum UP speed	0 to 60%	40
	MAXimum UP speed	0 to 100%	80
	CREEP Maximum UP speed	0 to 65%	55
	MINimum DOWN speed	0 to 60%	40
	MAXimum DOWN speed	0 to 100%	70
	CREEP maximum DOWN speed	0 to 75%	55
	Engine RPM	800 to 2900	1800

## SECTION 6 - JLG CONTROL SYSTEM

**Table 6-2. Personality Ranges/Defaults**

<b>FUNCTION</b>	<b>PERSONALITY</b>	<b>RANGE</b>	<b>DEFAULTS - 600S</b>
SWING	ACCEleration	0.1 to 5.0s	2.0
	DECEleration	0.1 to 3.0s	1.8
	MINimum LEFT speed	0 to 50%	30
	MAXimum LEFT speed	0 to 100%	65
	CREEP maximum LEFT speed	0 to 65%	45
	MINimum RIGHT speed	0 to 50%	30
	MAXimum RIGHT speed	0 to 100%	65
	CREEP maximum RIGHT speed	0 to 65%	45
	Engine RPM	800 to 2900	1400
TELESCOPE UPPER	ACCEleration	0.1 to 5.0	3.5
	DECEleration	0.1 to 3.0	0.8
	MINimum IN speed	0 to 65%	45
	MAXimum IN speed	0 to 100%	75
	MINimum OUT speed	0 to 65%	45
	MAXimum OUT speed	0 to 100%	70
	Engine RPM	800 to 2900	1800
TELESCOPE TOWER	ACCEleration	0.1 to 5.0	N/A
	DECEleration	0.1 to 3.0	N/A
	MINimum IN speed	0 to 65%	N/A
	MAXimum IN speed	0 to 100%	N/A
	MINimum OUT speed	0 to 65%	N/A
	MAXimum OUT speed	0 to 100%	N/A
	Engine RPM	800 to 2900	N/A
BASKET LEVEL	ACCEleration	0.1 to 5.0	2.5
	DECEleration	0.1 to 3.0	0.5
	MINimum UP speed	0 to 65%	48
	MAXimum UP speed	0 to 100%	52
	MINimum DOWN speed	0 to 65%	45
	MAXimum DOWN speed	0 to 100%	50
	Engine RPM	800 to 2900	1500

Table 6-2. Personality Ranges/Defaults

FUNCTION	PERSONALITY	RANGE	DEFAULTS - 600S
BASKET ROTATE	ACCEleration	0.1 to 5.0	1.8
	DECEleration	0.1 to 3.0	0.7
	MINimum LEFT speed	0 to 65%	46
	MAXimum LEFT speed	0 to 100%	50
	MINimum RIGHT speed	0 to 65%	46
	MAXimum RIGHT speed	0 to 100%	50
	Engine RPM	800 to 2900	1500
JIB LIFT	ACCEleration	0.1 to 5.0	5.0
	DECEleration	0.1 to 3.0	1.0
	MINimum UP speed	0 to 65%	46
	MAXimum UP speed	0 to 100%	52
	MINimum DOWN speed	0 to 65%	45
	MAXimum DOWN speed	0 to 100%	52
	Engine RPM	800 to 2900	1800
STEER	MAXimum speed	0 to 100%	100
	Engine RPM	800 to 2900	1800
GROUND MODE	Tower LIFT UP speed	0 to 100%	N/A
	Tower LIFT DOWN speed	0 to 100%	N/A
	Upper LIFT UP	0 to 100%	60
	Upper LIFT DOWN	0 to 100%	60
	SWING speed	0 to 100%	60
	Upper TELEscope speed	0 to 100%	70
	Tower TELEscope speed	0 to 100%	N/A
	BASKET ROTATE speed	0 to 100%	50
	BASKET LEVEL speed	0 to 100%	50
	JIB LIFT speed	0 to 100%	50

**NOTE:** Personality settings can be adjusted anywhere within the adjustment range for optimum machine performance.

4150365B

## SECTION 6 - JLG CONTROL SYSTEM

**Table 6-3. Help Fault Codes, Displayed Faults, and Descriptions**

Fault Flash Code	Communicated (Displayed on Analyzer) Fault	Description	Priority
<b>None</b>		No flash code is indicated for the following help messages. They are intended to hint at a possible problem if vehicle is not behaving as expected.	1
	EVERYTHING OK	The “normal” help message in platform mode	
	GROUND MODE OK	The “normal” help message in ground mode	
	FSW OPEN	A drive or boom function has been selected but footswitch is open.	
	RUNNING AT CREEP – CREEP SWITCH OPEN	All function speeds are limited to creep because creep switch is open.	
	RUNNING AT CREEP – TILTED AND ABOVE ELEVATION	All boom function speeds are limited to creep because vehicle is tilted and above elevation.	
	RUNNING AT CUTBACK – ABOVE ELEVATION	Drive speed is limited to “ELEVATED MAX” because vehicle is above elevation.	
	TILT SENSOR OUT OF RANGE	The tilt sensor has indicated a tilt angle greater than 19 degrees for more than 4 seconds. Not reported during 2 second power-up.	
	LOAD SENSOR READING UNDER WEIGHT	The load sensor is reading 20% or more under the calibrated zero point. This fault may occur if platform is resting on the ground. Not reported during 2 second power-up.	
<b>1/1</b>		Flash code 1/1 indicates a “sleep” mode. NOT REQUIRED	
<b>2/1</b>		Flash code 2/1 indicates problems with footswitch.	2
	FSW FAULTY	The two footswitch inputs have read the same state for more than one second.	
	KEYSWITCH FAULTY	Both platform and ground modes are selected simultaneously	
<b>2/2</b>		Flash code 2/2 indicates problems with drive & steer selection. Except where noted, these faults are not reported during 2 second power-up sequence.	3
	DRIVE LOCKED – JOYSTICK MOVED BEFORE FOOTSWITCH	Drive was selected before and during footswitch closure. Can be reported during power-up sequence.	
	FSW INTERLOCK TRIPPED	Footswitch was closed for seven seconds with no function selected. Can be reported during power-up sequence.	
	STEER LOCKED – SELECTED BEFORE FOOTSWITCH	Steer was selected before and during footswitch closure.	
	STEER SWITCHES FAULTY	Both steer switches are active together.	
	DRIVE / STEER WITH NO QPROX	This fault only occurs with inductive joysticks. It occurs if the joystick is moved out of the neutral position with no Qprox sensors active.	
	D/S JOY. QPROX BAD	These faults only occur with inductive joysticks. They indicate that the Q-Prox sensor is reading above 3.18 volts.	
	D/S JOY. OUT OF RANGE LOW	Resistive joysticks: These faults do not occur. Inductive joysticks: The trigger points for these faults are dependent on the centertap voltage reading. These faults will be triggered when the voltage is less than the centertap voltage minus half the center tap voltage minus 0.3 volts. If the centertap is at the high end of the range, these faults will be triggered below 1.05 volts. If the centertap is at the low end of the range, these faults will be triggered below 0.79 volts.	



Table 6-3. Help Fault Codes, Displayed Faults, and Descriptions

Fault Flash Code	Communicated (Displayed on Analyzer) Fault	Description	Priority
	D/S JOY. OUT OF RANGE HIGH	Resistive joysticks: These faults do not occur if the Vref voltage is below 8.1 volts. If Vref is above 7.7 volts, Vref is operating out of tolerance or a short to battery has occurred. Inductive joysticks: The trigger points for these faults are dependent on the centertap voltage reading. These faults will be triggered when the voltage is more than the centertap voltage plus half the centertap voltage plus 0.3 volts. If the centertap is at the high end of the range, these faults will be triggered above 4.35 volts. If the centertap is at the low end of the range, these faults will be triggered above 3.8 volts.	
	D/S JOY. CENTER TAP BAD	Resistive joysticks: These faults occur when the center tap voltage is not between 3.08 volts and 3.83 volts. Due to resistor tolerances there is a +/- .1 volt range around these values where the fault may be indicated. Inductive joysticks: These faults occur when the center tap voltage is not between 2.18 volts and 2.70 volts. Due to resistor tolerances there is a +/- .1 volt range around these values where the fault may be indicated.	
	WAITING FOR FSW TO BE OPEN	Footswitch was closed when platform mode was selected. Can be reported during power-up sequence.	
<b>2/3</b>		Flash code 2/3 indicates problems with boom function selection.	3
	LIFT/SWING LOCKED – JOYSTICK MOVED BEFORE FOOTSWITCH	Platform upper lift or swing was selected before and during footswitch closure.	
	PUMP SWITCHES FAULTY – CHECK DIAGNOSTICS/BOOM	A boom function (lower lift, telescope, basket level, basket rotate, jib) has both directions selected together.	
	PUMP SWITCHES LOCKED – SELECTED BEFORE FOOTSWITCH	A platform boom function (lower lift, telescope, basket level, basket rotate, jib) was selected before key switch or footswitch closure.	
	PUMP SWITCHES LOCKED – SELECTED BEFORE AUX POWER	A ground boom function (lower lift, telescope, basket level, basket rotate, jib) was selected before aux power.	
	LIFT / SWING WITH NO QPROX	This fault only occurs with inductive joysticks. It occurs if the joystick is moved out of the neutral position with no Qprox sensors active.	
	I/S JOY. QPROX BAD	These faults only occur with inductive joysticks. They indicate the Q-Prox sensor is reading above 3.18 volts.	
	I/S JOY. OUT OF RANGE LOW	Resistive joysticks: These faults do not occur. Inductive joysticks: The trigger points for these faults are dependent on the centertap voltage reading. These faults will be triggered when voltage is less than centertap voltage minus half the center tap voltage minus 0.3 volts. If centertap is at high end of the range, these faults will be triggered below 1.05 volts. If centertap is at low end of the range, these faults will be triggered below 0.79 volts.	
	I/S JOY. OUT OF RANGE HIGH	Resistive joysticks: These faults do not occur if Vref voltage is below 8.1 volts. If Vref is above 7.7 volts, Vref is operating out of tolerance or a short to battery has occurred. Inductive joysticks: The trigger points for these faults are dependent on the centertap voltage reading. These faults will be triggered when voltage is more than centertap voltage plus half the centertap voltage plus 0.3 volts. If centertap is at high end of the range, these faults will be triggered above 4.35 volts. If centertap is at low end of the range, these faults will be triggered above 3.8 volts.	

## SECTION 6 - JLG CONTROL SYSTEM

**Table 6-3. Help Fault Codes, Displayed Faults, and Descriptions**

Fault Flash Code	Communicated (Displayed on Analyzer) Fault	Description	Priority
	I/S JOY. CENTER TAP BAD	Resistive joysticks: These faults occur when center tap voltage is not between 3.08 volts and 3.83 volts. Due to resistor tolerances there is a +/- .1 volt range around these values where the fault may be indicated. Inductive joysticks: These faults occur when center tap voltage is not between 2.18 volts and 2.70 volts. Due to resistor tolerances there is a +/- .1 volt range around these values where the fault may be indicated.	
	PUMP SWITCHES LOCKED – SELECTED BEFORE START SWITCH	This fault occurs when a hydraulic function switch is closed before start switch is closed.	
	FOOTSWITCH SELECTED BEFORE START	User attempted to start machine with footswitch engaged.	
<b>2/4</b>		Flash code 2/4 indicates steering digital inputs are faulty. NOT REQUIRED	
<b>2/5</b>		Flash code 2/5 indicates a function is prevented due to a cutout.	4
	BOOM PREVENTED – DRIVE SELECTED	A boom function is selected while a drive function is selected and drive cutout is configured to prevent simultaneous drive & boom operation.	
	DRIVE PREVENTED – ABOVE ELEVATION	Drive is selected while above elevation and drive cutout is configured to prevent drive.	
	DRIVE PREVENTED – BOOM SELECTED	Drive is selected while a boom function is selected and drive cutout is configured to prevent simultaneous drive & boom operation.	
	DRIVE PREVENTED – TILTED & ABOVE ELEVATION	Drive is selected while tilted and above elevation and tilt is configured to cutout drive.	
	MODEL CHANGED – HYDRAULICS SUSPENDED – CYCLE EMS	User changed model number using the analyzer. User must cycle power before hydraulics system will be active again.	11
<b>2/7</b>		Flash code 2/7 indicates accelerator input is faulty. NOT REQUIRED	
<b>2/8</b>		Flash code 2/8 indicates a problem with a hydraulic filter. Not reported during 2 second power-up.	5
	RETURN FILTER BYPASSED	Hydraulic return filter clogged	
	CHARGE PUMP FILTER BYPASSED	Charge pump filter clogged	
<b>3/1</b>		Flash code 3/1 indicates a contactor did not close when energized. NOT REQUIRED	
<b>3/2</b>		Flash code 3/2 indicates a contactor did not open when energized. NOT REQUIRED	
<b>3/3</b>		Flash code 3/3 indicates a driver problem. All driver faults are detected in a similar manner. Open circuit faults are detected when analog feedback reads too high and the output is commanded off. Short to ground is detected when analog feedback reads low and the output is commanded on. Short to battery is detected when analog feedback reads Vbat and the output is commanded off. Not reported during 2 second power-up.	6
	ALTERNATOR/ECM POWER SHORT TO GROUND		
	HOUR METER SHORT TO GROUND		
	HOUR METER SHORT TO BATTERY		
	HORN SHORT TO GROUND		
	HORN OPEN CIRCUIT		

Table 6-3. Help Fault Codes, Displayed Faults, and Descriptions

Fault Flash Code	Communicated (Displayed on Analyzer) Fault	Description	Priority
	HORN SHORT TO BATTERY		
	AUX POWER SHORT TO GROUND		
	AUX POWER OPEN CIRCUIT		
	AUX POWER SHORT TO BATTERY		
	GLOW PLUG SHORT TO GROUND		
	GLOW PLUG OPEN CIRCUIT		
	GLOW PLUG SHORT TO BATTERY		
	LP LOCK SHORT TO GROUND		
	LP LOCK OPEN CIRCUIT		
	LP LOCK SHORT TO BATTERY		
	LP START ASSIST SHORT TO GROUND		
	LP START ASSIST OPEN CIRCUIT		
	LP START ASSIST SHORT TO BATTERY		
	MAIN DUMP SHORT TO GROUND		
	MAIN DUMP OPEN CIRCUIT		
	MAIN DUMP SHORT TO BATTERY		
	PARKING BRAKE SHORT TO GROUND		
	PARKING BRAKE OPEN CIRCUIT		
	PARKING BRAKE SHORT TO BATTERY		
	START SOLENOID SHORT TO GROUND		
	START SOLENOID OPEN CIRCUIT		
	START SOLENOID SHORT TO BATTERY		
	STEER DUMP SHORT TO GROUND		
	STEER DUMP OPEN CIRCUIT		
	STEER DUMP SHORT TO BATTERY		
	TWO SPEED SHORT TO GROUND		
	TWO SPEED OPEN CIRCUIT		
	TWO SPEED SHORT TO BATTERY		
	GROUND ALARM SHORT TO GROUND		

## SECTION 6 - JLG CONTROL SYSTEM

**Table 6-3. Help Fault Codes, Displayed Faults, and Descriptions**

<b>Fault Flash Code</b>	<b>Communicated (Displayed on Analyzer) Fault</b>	<b>Description</b>	<b>Priority</b>
	GROUND ALARM OPEN CIRCUIT		
	GROUND ALARM SHORT TO BATTERY		
	GENERATOR SHORT TO GROUND		
	GENERATOR OPEN CIRCUIT		
	GENERATOR SHORT TO BATTERY		
	WELDER SHORT TO GROUND		
	WELDER OPEN CIRCUIT		
	WELDER SHORT TO BATTERY		
	HEAD TAIL LIGHT SHORT TO GROUND		
	HEAD TAIL LIGHT OPEN CIRCUIT		
	HEAD TAIL LIGHT SHORT TO BATTERY		
	BASKET UP OVERRIDE SHORT TO GROUND	Only occurs on machines with electronic leveling systems.	
	BASKET UP OVERRIDE OPEN CIRCUIT	Only occurs on machines with electronic leveling systems.	
	BASKET UP OVERRIDE SHORT TO BATTERY	Only occurs on machines with electronic leveling systems.	
	BASKET UP SHORT TO GROUND		
	BASKET UP OPEN CIRCUIT		
	BASKET UP SHORT TO BATTERY		
	BASKET DOWN SHORT TO GROUND		
	BASKET DOWN OPEN CIRCUIT		
	BASKET DOWN SHORT TO BATTERY		
	BASKET DOWN OVERRIDE SHORT TO GROUND	Only occurs on machines with electronic leveling systems.	
	BASKET DOWN OVERRIDE OPEN CIRCUIT	Only occurs on machines with electronic leveling systems.	
	BASKET DOWN OVERRIDE SHORT TO BATTERY	Only occurs on machines with electronic leveling systems.	
	BASKET LEFT OPEN CIRCUIT		
	BASKET LEFT SHORT TO BATTERY		
	BASKET LEFT SHORT TO GROUND		
	BASKET RIGHT SHORT TO GROUND		

**Table 6-3. Help Fault Codes, Displayed Faults, and Descriptions**

<b>Fault Flash Code</b>	<b>Communicated (Displayed on Analyzer) Fault</b>	<b>Description</b>	<b>Priority</b>
	BASKET RIGHT OPEN CIRCUIT		
	BASKET RIGHT SHORT TO BATTERY		
	JIB UP SHORT TO GROUND		
	JIB UP OPEN CIRCUIT		
	JIB UP SHORT TO BATTERY		
	JIB DOWN SHORT TO GROUND		
	JIB DOWN OPEN CIRCUIT		
	JIB DOWN SHORT TO BATTERY		
	JIB LEFT SHORT TO GROUND		
	JIB LEFT OPEN CIRCUIT		
	JIB LEFT SHORT TO BATTERY		
	JIB RIGHT SHORT TO GROUND		
	JIB RIGHT OPEN CIRCUIT		
	JIB RIGHT SHORT TO BATTERY		
	TOWER UP SHORT TO GROUND		
	TOWER UP OPEN CIRCUIT		
	TOWER UP SHORT TO BATTERY		
	TOWER DOWN SHORT TO GROUND		
	TOWER DOWN OPEN CIRCUIT		
	TOWER DOWN SHORT TO BATTERY		
	TOWER IN SHORT TO GROUND		
	TOWER IN OPEN CIRCUIT		
	TOWER IN SHORT TO BATTERY		
	TOWER OUT SHORT TO GROUND		
	TOWER OUT OPEN CIRCUIT		
	TOWER OUT SHORT TO BATTERY		
	UPPER IN SHORT TO GROUND		
	UPPER IN OPEN CIRCUIT		
	UPPER IN SHORT TO BATTERY		
	UPPER OUT SHORT TO GROUND		
	UPPER OUT OPEN CIRCUIT		
	UPPER OUT SHORT TO BATTERY		
	LIFT UP DUMP SHORT TO GROUND		
	LIFT UP DUMP OPEN CIRCUIT		

## SECTION 6 - JLG CONTROL SYSTEM

**Table 6-3. Help Fault Codes, Displayed Faults, and Descriptions**

<b>Fault Flash Code</b>	<b>Communicated (Displayed on Analyzer) Fault</b>	<b>Description</b>	<b>Priority</b>
	LIFT UP DUMP SHORT TO BATTERY		
	LIFT DOWN HOLDING SHORT TO GROUND		
	LIFT DOWN HOLDING OPEN CIRCUIT		
	LIFT DOWN SHORT TO BATTERY		
	HOUR METER OPEN CIRCUIT	This fault cannot be detected during normal operation. It may be reported during self test.	
	FORD ECM POWER OPEN CIRCUIT	This fault cannot be detected during normal operation. It may be reported during self test.	
	FORD ECM POWER SHORT TO BATTERY	This fault cannot be detected during normal operation. It may be reported during self test.	
<b>3/4</b>		Flash code 3/4 indicates a driver problem on a platform valve block valve driver. All driver faults are detected in a similar manner. Open circuit faults are detected when analog feedback reads too high and the output is commanded off. Short to ground is detected when analog feedback reads low and the output is commanded on. Short to battery is detected when analog feedback reads Vbat and the output is commanded off. Not reported during 2 second power-up.	<b>6</b>
	BASKET UP SHORT TO BATTERY		
	BASKET UP SHORT TO GROUND		
	BASKET UP OPEN CIRCUIT		
	BASKET UP SHORT TO BATTERY OR OPEN CIRCUIT	Only occurs on machines with electronic basket leveling	
	BASKET DOWN SHORT TO BATTERY		
	BASKET DOWN SHORT TO GROUND		
	BASKET DOWN OPEN CIRCUIT		
	BASKET DOWN SHORT TO BATTERY OR OPEN CIRCUIT	Only occurs on machines with electronic basket leveling.	
	BASKET LEFT SHORT TO BATTERY		
	BASKER LEFT SHORT TO GROUND		
	BASKET LEFT OPEN CIRCUIT		
	BASKET RIGHT SHORT TO BATTERY		
	BASKET RIGHT SHORT TO GROUND		
	BASKET RIGHT OPEN CIRCUIT		
	JIB UP SHORT TO BATTERY		
	JIB UP SHORT TO GROUND		
	JIB UP OPEN CIRCUIT		

Table 6-3. Help Fault Codes, Displayed Faults, and Descriptions

Fault Flash Code	Communicated (Displayed on Analyzer) Fault	Description	Priority
	JIB DOWN SHORT TO BATTERY		
	JIB DOWN SHORT TO GROUND		
	JIB DOWN OPEN CIRCUIT		
	JIB LEFT SHORT TO BATTERY		
	JIB LEFT SHORT TO GROUND		
	JIB LEFT OPEN CIRCUIT		
	JIB RIGHT SHORT TO BATTERY		
	JIB RIGHT SHORT TO GROUND		
	JIB RIGHT OPEN CIRCUIT		
	PLATFORM CONTROL VALVE SHORT TO BATTERY	Only occurs on machines with electronic basket leveling	
	PLATFORM CONTROL VALVE SHORT TO GROUND	Only occurs on machines with electronic basket leveling	
	PLATFORM CONTROL VALVE OPEN CIRCUIT	Only occurs on machines with electronic basket leveling	
<b>3/5</b>		Flash code 3/5 indicates a brake pressure problem. NOT REQUIRED	
<b>4/2</b>		Flash code 4/2 indicates engine is over temperature. NOT REQUIRED	
<b>4/3</b>		Flash code 4/3 indicates problems with the engine. Except where noted, these faults are not reported during 2 second power-up sequence.	9
	HIGH ENGINE TEMP	Occurs when engine temperature is above 117° Celsius for Ford engines, and above 130° Celsius for Deutz engines.	
	AIR FILTER BYPASSED	Air filter clogged	
	NO ALTERNATOR OUTPUT	Engine has been running for 15 seconds or more and battery voltage is still below 12.5 volts.	
	LOW OIL PRESSURE	If a Deutz engine is installed, oil pressure is below 8 PSI and the engine has been running for at least 10 seconds. If a Ford engine is installed, the Ford ECM has reported a low oil pressure fault.	
	OIL PRESSURE SHORT TO BATTERY	If a Deutz engine is installed, this indicates oil pressure sensor is reading above 6.6 volts.	
	OIL PRESSURE SHORT TO GROUND	If a Deutz engine is installed, this indicates oil pressure sensor is reading below 0.1 volts for more than 5 seconds. This fault is not detected during crank.	
	COOLANT TEMPERATURE SHORT TO GROUND	If a Deutz engine is installed, this indicates coolant temperature is reading below 0.1 volts.	
	FORD FAULT CODE ##	All Ford fault codes except 63 are simply passed through from the FORDECM. They only occur if a Ford engine is selected in machine configuration digits. Can be reported during power-up sequence.	
	FORD FAULT CODE UNKNOWN	An unrecognized Ford ECM fault code has been received. Can be reported during power-up sequence.	
	485 COMMUNICATIONS LOST	This fault only occurs with a Ford engine. It occurs when no responses are received from the ECM for 2.5 seconds. Can be reported during power-up sequence.	
	FUEL SENSOR SHORT TO BATTERY	Indicates fuel sensor is reading above 4.3 volts.	

## SECTION 6 - JLG CONTROL SYSTEM

**Table 6-3. Help Fault Codes, Displayed Faults, and Descriptions**

<b>Fault Flash Code</b>	<b>Communicated (Displayed on Analyzer) Fault</b>	<b>Description</b>	<b>Priority</b>
	FUEL SENSOR SHORT TO GROUND	Indicates fuel sensor is reading below 0.2 volts.	
<b>4/4</b>		Flash code 4/4 indicates problems with the battery supply. Not reported during 2 second power-up.	7
	BATTERY LOW	Battery voltage is below 11V for more than 5 seconds. This fault is not detected during crank. This is a warning – controller does not shut down.	
	BATTERY TOO HIGH – SYSTEM SHUT DOWN	Battery voltage is above 16V. EMS recycle required.	
	BATTERY TOO LOW – SYSTEM SHUT DOWN	Battery voltage is below 9V.	
<b>5/5</b>		Flash code 5/5 indicates problems with vehicle engine RPM or the encoder. Not reported during 2 second power-up.	8
	SPEED SENSOR READING INVALID SPEED	This fault is detected with diesel engines only. The RPM pickup is indicating a speed that greater than 4000 RPM or approximately 8875 Hz.	
	SPEED INPUT LOST	This fault is detected with diesel engines only. It occurs if there is no RPM detected and the oil pressure input is reading above 8 PSI for more than three seconds. This is probably due to wiring problems at the ground module or a faulty speed sensor.	
<b>6/6</b>		Flash code 6/6 indicates problems with the CAN bus.	10
	CAN BUS FAILURE:	Ground module or platform module is not receiving CAN messages. This is probably due to wiring problems between the platform and ground modules.	
<b>7/7</b>		Flash code 7/7 indicates problems with a motor. NOT REQUIRED	
<b>9/9</b>		Flash code 9/9 indicates problems with the controller.	11
	PLATFORM MODULE SOFTWARE UPDATE REQUIRED	Platform module code is too old to support the EIM or BPE load sensor and the machine is configured to use one of these two sensors. The PM code must be updated to a newer version.	
	HIGH RESOLUTION A2D FAILURE –INTERRUPT LOST	The ADS1213 chip in the platform module has stopped asserting its interrupt (DRDY) line for some reason. An EMS cycle is required.	
	HIGH RESOLUTION A2D FAILURE-REINIT LIMIT	The ADS1213 has needed to be reset 3 or more times.	
	PLATFORM MODULE FAILURE: HWFS CODE 1	Platform module V(Low) FET has failed	
	GROUND MODULE FAILURE: HWFS CODE 1	Ground module V(Low) FET has failed	
	GROUND SENSOR REF VOLTAGE OUT OF RANGE	These faults occur when the seven volt reference voltage used for joysticks, sensors, etc. goes out of range. Not reported during 2 second power-up.	
	PLATFORM SENSOR REF VOLTAGE OUT OF RANGE	These faults occur when the seven volt reference voltage used for the joysticks, sensors, etc. goes out of range. Not reported during 2 second power-up.	
	EEPROM FAILURE – CHECK ALL SETTINGS	A critical failure occurred with the EEPROM. Personalities, machine configuration digits, etc. may be reset to default values and should be checked.	
	CHASSIS TILT SENSOR NOT GAIN CALIBRATED	Indicates that chassis tilt sensor calibration information has been lost. Machine will indicate it is tilted at all times. This calibration data is programmed into the unit at the factory.	
	CHASSIS TILT SENSOR GAIN OUT OF RANGE	Indicates chassis tilt sensor calibration is corrupted.	



Table 6-4. Help Message/Fault Listing

HELP MESSAGE	FAULT	FAULT REMOVAL
OK	0 0	CLEAR WHEN FAULT IS REMOVED
DRIVING AT CREEP - TILTED	0 0	CLEAR WHEN FAULT IS REMOVED
FSW OPEN	0 0	CLEAR WHEN FAULT IS REMOVED
RUNNING AT CREEP - CREEP SWITCH OPEN	0 0	CLEAR WHEN FAULT IS REMOVED
RUNNING AT CREEP - TILTED AND ABOVE ELEVATION	0 0	CLEAR WHEN FAULT IS REMOVED
RUNNING AT CUTBACK - ABOVE ELEVATION	0 0	CLEAR WHEN FAULT IS REMOVED
TILT SENSOR OUT OF RANGE	0 0	CLEAR WHEN FAULT IS REMOVED
LOAD SENSOR READING UNDER WEIGHT	0 0	CLEAR WHEN FAULT IS REMOVED
FSW FAULTY	2 1	REQUIRES EMS TO BE RECYCLED TO CLEAR FAULT
KEYSWITCH FAULTY	2 1	CLEAR WHEN FAULT IS REMOVED
DRIVE LOCKED - JOYSTICK MOVED BEFORE FOOTSWITCH	2 2	CLEAR WHEN FAULT IS REMOVED
FSW INTERLOCK TRIPPED	2 2	CLEAR WHEN FAULT IS REMOVED
STEER LOCKED - SELECTED BEFORE FOOTSWITCH	2 2	CLEAR WHEN FAULT IS REMOVED
STEER SWITCHES FAULTY	2 2	CLEAR WHEN FAULT IS REMOVED
D/S JOY. QPROX BAD	2 2	CLEAR WHEN FAULT IS REMOVED
L/S JOY. QPROX BAD	2 3	CLEAR WHEN FAULT IS REMOVED
D/S JOY. OUT OF RANGE LOW	2 2	CLEAR WHEN FAULT IS REMOVED
D/S JOY. OUT OF RANGE HIGH	2 2	CLEAR WHEN FAULT IS REMOVED
L/S JOY. OUT OF RANGE LOW	2 3	CLEAR WHEN FAULT IS REMOVED
L/S JOY. OUT OF RANGE HIGH	2 3	CLEAR WHEN FAULT IS REMOVED
D/S JOY. CENTER TAP BAD	2 2	CLEAR WHEN FAULT IS REMOVED
L/S JOY. CENTER TAP BAD	2 3	CLEAR WHEN FAULT IS REMOVED
WAITING FOR FSW TO BE OPEN	2 2	CLEAR WHEN FAULT IS REMOVED
PUMP POT FAULTY	2 3	CLEAR WHEN FAULT IS REMOVED
PUMP SWITCHES FAULTY - CHECK DIAGNOSTICS/BOOM	2 3	CLEAR WHEN FAULT IS REMOVED
PUMP SWITCHES LOCKED - SELECTED BEFORE FOOTSWITCH	2 3	CLEAR WHEN FAULT IS REMOVED
PUMP SWITCHES LOCKED - SELECTED BEFORE START SWITCH	2 3	CLEAR WHEN FAULT IS REMOVED
FOOTSWITCH SELECTED BEFORE START	2 3	CLEAR WHEN FAULT IS REMOVED
BOOM PREVENTED - DRIVE SELECTED	2 5	CLEAR WHEN FAULT IS REMOVED
DRIVE PREVENTED - ABOVE ELEVATION	2 5	CLEAR WHEN FAULT IS REMOVED
DRIVE PREVENTED - TILTED & ABOVE ELEVATION	2 5	CLEAR WHEN FAULT IS REMOVED
DRIVE PREVENTED - BOOM SELECTED	2 5	CLEAR WHEN FAULT IS REMOVED

## SECTION 6 - JLG CONTROL SYSTEM

Table 6-4. Help Message/Fault Listing

HELP MESSAGE	FAULT	FAULT REMOVAL
FORDECM POWER SHORT TO GROUND	3 3	REQUIRES EMS TO BE RECYCLED TO CLEAR FAULT
HORN SHORT TO GROUND	3 3	REQUIRES EMS TO BE RECYCLED TO CLEAR FAULT
HORN OPEN CIRCUIT	3 3	REQUIRES EMS TO BE RECYCLED TO CLEAR FAULT
HORN SHORT TO BATTERY	3 3	REQUIRES EMS TO BE RECYCLED TO CLEAR FAULT
AUX POWER SHORT TO GROUND	3 3	REQUIRES EMS TO BE RECYCLED TO CLEAR FAULT
AUX POWER OPEN CIRCUIT	3 3	REQUIRES EMS TO BE RECYCLED TO CLEAR FAULT
AUX POWER SHORT TO BATTERY	3 3	REQUIRES EMS TO BE RECYCLED TO CLEAR FAULT
GLOW PLUG SHORT TO GROUND	3 3	REQUIRES EMS TO BE RECYCLED TO CLEAR FAULT
GLOW PLUG OPEN CIRCUIT	3 3	REQUIRES EMS TO BE RECYCLED TO CLEAR FAULT
GLOW PLUG SHORT TO BATTERY	3 3	REQUIRES EMS TO BE RECYCLED TO CLEAR FAULT
LP LOCK SHORT TO GROUND	3 3	REQUIRES EMS TO BE RECYCLED TO CLEAR FAULT
LP LOCK OPEN CIRCUIT	3 3	REQUIRES EMS TO BE RECYCLED TO CLEAR FAULT
LP LOCK SHORT TO BATTERY	3 3	REQUIRES EMS TO BE RECYCLED TO CLEAR FAULT
LP START ASSIST SHORT TO GROUND	3 3	REQUIRES EMS TO BE RECYCLED TO CLEAR FAULT
LP START ASSIST OPEN CIRCUIT	3 3	REQUIRES EMS TO BE RECYCLED TO CLEAR FAULT
LP START ASSIST SHORT TO BATTERY	3 3	REQUIRES EMS TO BE RECYCLED TO CLEAR FAULT
MAIN DUMP SHORT TO GROUND	3 3	REQUIRES EMS TO BE RECYCLED TO CLEAR FAULT
MAIN DUMP OPEN CIRCUIT	3 3	REQUIRES EMS TO BE RECYCLED TO CLEAR FAULT
MAIN DUMP SHORT TO BATTERY	3 3	REQUIRES EMS TO BE RECYCLED TO CLEAR FAULT
PARKING BRAKE SHORT TO GROUND	3 3	REQUIRES EMS TO BE RECYCLED TO CLEAR FAULT
PARKING BRAKE OPEN CIRCUIT	3 3	REQUIRES EMS TO BE RECYCLED TO CLEAR FAULT
PARKING BRAKE SHORT TO BATTERY	3 3	REQUIRES EMS TO BE RECYCLED TO CLEAR FAULT
START SOLENOID SHORT TO GROUND	3 3	REQUIRES EMS TO BE RECYCLED TO CLEAR FAULT
START SOLENOID OPEN CIRCUIT	3 3	REQUIRES EMS TO BE RECYCLED TO CLEAR FAULT
START SOLENOID SHORT TO BATTERY	3 3	REQUIRES EMS TO BE RECYCLED TO CLEAR FAULT
STEER DUMP SHORT TO GROUND	3 3	REQUIRES EMS TO BE RECYCLED TO CLEAR FAULT
STEER DUMP OPEN CIRCUIT	3 3	REQUIRES EMS TO BE RECYCLED TO CLEAR FAULT
STEER DUMP SHORT TO BATTERY	3 3	REQUIRES EMS TO BE RECYCLED TO CLEAR FAULT
TWO SPEED SHORT TO GROUND	3 3	REQUIRES EMS TO BE RECYCLED TO CLEAR FAULT
TWO SPEED OPEN CIRCUIT	3 3	REQUIRES EMS TO BE RECYCLED TO CLEAR FAULT
TWO SPEED SHORT TO BATTERY	3 3	REQUIRES EMS TO BE RECYCLED TO CLEAR FAULT
ALARM SHORT TO GROUND	3 3	REQUIRES EMS TO BE RECYCLED TO CLEAR FAULT
ALARM OPEN CIRCUIT	3 3	REQUIRES EMS TO BE RECYCLED TO CLEAR FAULT

Table 6-4. Help Message/Fault Listing

HELP MESSAGE	FAULT		FAULT REMOVAL
ALARM SHORT TO BATTERY	3	3	REQUIRES EMS TO BE RECYCLED TO CLEAR FAULT
GENERATOR SHORT TO GROUND	3	3	REQUIRES EMS TO BE RECYCLED TO CLEAR FAULT
GENERATOR OPEN CIRCUIT	3	3	REQUIRES EMS TO BE RECYCLED TO CLEAR FAULT
GENERATOR SHORT TO BATTERY	3	3	REQUIRES EMS TO BE RECYCLED TO CLEAR FAULT
HEAD TAIL LIGHT SHORT TO GROUND	3	3	REQUIRES EMS TO BE RECYCLED TO CLEAR FAULT
HEAD TAIL LIGHT OPEN CIRCUIT	3	3	REQUIRES EMS TO BE RECYCLED TO CLEAR FAULT
HEAD TAIL LIGHT SHORT TO BATTERY	3	3	REQUIRES EMS TO BE RECYCLED TO CLEAR FAULT
HOURMETER SHORT TO GROUND	3	3	REQUIRES EMS TO BE RECYCLED TO CLEAR FAULT
HOURMETER SHORT TO BATTERY	3	3	REQUIRES EMS TO BE RECYCLED TO CLEAR FAULT
BASKET UP SHORT TO GROUND	3	3	REQUIRES EMS TO BE RECYCLED TO CLEAR FAULT
BASKET UP OPEN CIRCUIT	3	3	REQUIRES EMS TO BE RECYCLED TO CLEAR FAULT
BASKET UP SHORT TO BATTERY	3	3	REQUIRES EMS TO BE RECYCLED TO CLEAR FAULT
BASKET DOWN SHORT TO GROUND	3	3	REQUIRES EMS TO BE RECYCLED TO CLEAR FAULT
BASKET DOWN OPEN CIRCUIT	3	3	REQUIRES EMS TO BE RECYCLED TO CLEAR FAULT
BASKET DOWN SHORT TO BATTERY	3	3	REQUIRES EMS TO BE RECYCLED TO CLEAR FAULT
BASKET LEFT SHORT TO GROUND	3	3	REQUIRES EMS TO BE RECYCLED TO CLEAR FAULT
BASKET LEFT OPEN CIRCUIT	3	3	REQUIRES EMS TO BE RECYCLED TO CLEAR FAULT
BASKET LEFT SHORT TO BATTERY	3	3	REQUIRES EMS TO BE RECYCLED TO CLEAR FAULT
BASKET RIGHT SHORT TO GROUND	3	3	REQUIRES EMS TO BE RECYCLED TO CLEAR FAULT
BASKET RIGHT OPEN CIRCUIT	3	3	REQUIRES EMS TO BE RECYCLED TO CLEAR FAULT
BASKET RIGHT SHORT TO BATTERY	3	3	REQUIRES EMS TO BE RECYCLED TO CLEAR FAULT
JIB UP SHORT TO GROUND	3	3	REQUIRES EMS TO BE RECYCLED TO CLEAR FAULT
JIB UP OPEN CIRCUIT	3	3	REQUIRES EMS TO BE RECYCLED TO CLEAR FAULT
JIB UP SHORT TO BATTERY	3	3	REQUIRES EMS TO BE RECYCLED TO CLEAR FAULT
JIB DOWN SHORT TO GROUND	3	3	REQUIRES EMS TO BE RECYCLED TO CLEAR FAULT
JIB DOWN OPEN CIRCUIT	3	3	REQUIRES EMS TO BE RECYCLED TO CLEAR FAULT
JIB DOWN SHORT TO BATTERY	3	3	REQUIRES EMS TO BE RECYCLED TO CLEAR FAULT
JIB LEFT SHORT TO GROUND	3	3	REQUIRES EMS TO BE RECYCLED TO CLEAR FAULT
JIB LEFT OPEN CIRCUIT	3	3	REQUIRES EMS TO BE RECYCLED TO CLEAR FAULT
JIB LEFT SHORT TO BATTERY	3	3	REQUIRES EMS TO BE RECYCLED TO CLEAR FAULT
JIB RIGHT SHORT TO GROUND	3	3	REQUIRES EMS TO BE RECYCLED TO CLEAR FAULT
JIB RIGHT OPEN CIRCUIT	3	3	REQUIRES EMS TO BE RECYCLED TO CLEAR FAULT
JIB RIGHT SHORT TO BATTERY	3	3	REQUIRES EMS TO BE RECYCLED TO CLEAR FAULT

## SECTION 6 - JLG CONTROL SYSTEM

Table 6-4. Help Message/Fault Listing

HELP MESSAGE	FAULT		FAULT REMOVAL
TOWER UP SHORT TO GROUND	3	3	REQUIRES EMS TO BE RECYCLED TO CLEAR FAULT
TOWER UP OPEN CIRCUIT	3	3	REQUIRES EMS TO BE RECYCLED TO CLEAR FAULT
TOWER UP SHORT TO BATTERY	3	3	REQUIRES EMS TO BE RECYCLED TO CLEAR FAULT
TOWER DOWN SHORT TO GROUND	3	3	REQUIRES EMS TO BE RECYCLED TO CLEAR FAULT
TOWER DOWN OPEN CIRCUIT	3	3	REQUIRES EMS TO BE RECYCLED TO CLEAR FAULT
TOWER DOWN SHORT TO BATTERY	3	3	REQUIRES EMS TO BE RECYCLED TO CLEAR FAULT
TOWER IN SHORT TO GROUND	3	3	REQUIRES EMS TO BE RECYCLED TO CLEAR FAULT
TOWER IN OPEN CIRCUIT	3	3	REQUIRES EMS TO BE RECYCLED TO CLEAR FAULT
TOWER IN SHORT TO BATTERY	3	3	REQUIRES EMS TO BE RECYCLED TO CLEAR FAULT
TOWER OUT SHORT TO GROUND	3	3	REQUIRES EMS TO BE RECYCLED TO CLEAR FAULT
TOWER OUT OPEN CIRCUIT	3	3	REQUIRES EMS TO BE RECYCLED TO CLEAR FAULT
TOWER OUT SHORT TO BATTERY	3	3	REQUIRES EMS TO BE RECYCLED TO CLEAR FAULT
UPPER IN SHORT TO GROUND	3	3	REQUIRES EMS TO BE RECYCLED TO CLEAR FAULT
UPPER IN OPEN CIRCUIT	3	3	REQUIRES EMS TO BE RECYCLED TO CLEAR FAULT
UPPER IN SHORT TO BATTERY	3	3	REQUIRES EMS TO BE RECYCLED TO CLEAR FAULT
UPPER OUT SHORT TO GROUND	3	3	REQUIRES EMS TO BE RECYCLED TO CLEAR FAULT
UPPER OUT OPEN CIRCUIT	3	3	REQUIRES EMS TO BE RECYCLED TO CLEAR FAULT
UPPER OUT SHORT TO BATTERY	3	3	REQUIRES EMS TO BE RECYCLED TO CLEAR FAULT
FUEL SENSOR SHORT TO BATTERY	3	3	CLEAR WHEN FAULT IS REMOVED
FUEL SENSOR SHORT TO GROUND	3	3	CLEAR WHEN FAULT IS REMOVED
OIL PRESSURE SHORT TO BATTERY	4	3	CLEAR WHEN FAULT IS REMOVED
OIL PRESSURE SHORT TO GROUND	4	3	CLEAR WHEN FAULT IS REMOVED
COOLANT TEMPERATURE SHORT TO GROUND	4	3	CLEAR WHEN FAULT IS REMOVED
FORD FAULT CODE 12	4	3	CLEAR WHEN FAULT IS REMOVED
FORD FAULT CODE 13	4	3	CLEAR WHEN FAULT IS REMOVED
FORD FAULT CODE 14	4	3	CLEAR WHEN FAULT IS REMOVED
FORD FAULT CODE 15	4	3	CLEAR WHEN FAULT IS REMOVED
FORD FAULT CODE 21	4	3	CLEAR WHEN FAULT IS REMOVED
FORD FAULT CODE 22	4	3	CLEAR WHEN FAULT IS REMOVED
FORD FAULT CODE 23	4	3	CLEAR WHEN FAULT IS REMOVED
FORD FAULT CODE 24	4	3	CLEAR WHEN FAULT IS REMOVED
FORD FAULT CODE 25	4	3	CLEAR WHEN FAULT IS REMOVED
FORD FAULT CODE 26	4	3	CLEAR WHEN FAULT IS REMOVED

Table 6-4. Help Message/Fault Listing

HELP MESSAGE	FAULT	FAULT REMOVAL
FORD FAULT CODE 31	4 3	CLEARs WHEN FAULT IS REMOVED
FORD FAULT CODE 32	4 3	CLEARs WHEN FAULT IS REMOVED
FORD FAULT CODE 33	4 3	CLEARs WHEN FAULT IS REMOVED
FORD FAULT CODE 34	4 3	CLEARs WHEN FAULT IS REMOVED
FORD FAULT CODE 35	4 3	CLEARs WHEN FAULT IS REMOVED
FORD FAULT CODE 36	4 3	CLEARs WHEN FAULT IS REMOVED
FORD FAULT CODE 41	4 3	CLEARs WHEN FAULT IS REMOVED
FORD FAULT CODE 42	4 3	CLEARs WHEN FAULT IS REMOVED
FORD FAULT CODE 43	4 3	CLEARs WHEN FAULT IS REMOVED
FORD FAULT CODE 44	4 3	CLEARs WHEN FAULT IS REMOVED
FORD FAULT CODE 45	4 3	CLEARs WHEN FAULT IS REMOVED
FORD FAULT CODE 46	4 3	CLEARs WHEN FAULT IS REMOVED
FORD FAULT CODE 51	4 3	CLEARs WHEN FAULT IS REMOVED
FORD FAULT CODE 52	4 3	CLEARs WHEN FAULT IS REMOVED
FORD FAULT CODE 53	4 3	CLEARs WHEN FAULT IS REMOVED
FORD FAULT CODE 54	4 3	CLEARs WHEN FAULT IS REMOVED
FORD FAULT CODE 55	4 3	CLEARs WHEN FAULT IS REMOVED
FORD FAULT CODE 56	4 3	CLEARs WHEN FAULT IS REMOVED
FORD FAULT CODE 57	4 3	CLEARs WHEN FAULT IS REMOVED
FORD FAULT CODE 61	4 3	CLEARs WHEN FAULT IS REMOVED
FORD FAULT CODE 62	4 3	CLEARs WHEN FAULT IS REMOVED
FORD FAULT CODE 63	4 3	CLEARs WHEN FAULT IS REMOVED
FORD FAULT CODE 64	4 3	CLEARs WHEN FAULT IS REMOVED
FORD FAULT CODE UNKNOWN	4 3	CLEARs WHEN FAULT IS REMOVED
RETURN FILTER BYPASSED	2 8	CLEARs WHEN FAULT IS REMOVED
CHARGE PUMP FILTER BYPASSED	2 8	CLEARs WHEN FAULT IS REMOVED
BATTERY LOW	4 4	CLEARs WHEN FAULT IS REMOVED
BATTERY TOO HIGH - SYSTEM SHUT DOWN	4 4	REQUIRES EMS TO BE RECYCLED TO CLEAR FAULT
BATTERY TOO LOW - SYSTEM SHUT DOWN	4 4	CLEARs WHEN FAULT IS REMOVED
SPEED SENSOR READING INVALID SPEED	5 5	CLEARs WHEN FAULT IS REMOVED
SPEED INPUT LOST	5 5	CLEARs WHEN FAULT IS REMOVED
ENGINE TEMP HIGH	4 3	CLEARs WHEN FAULT IS REMOVED
AIR FILTER BYPASSED	4 3	CLEARs WHEN FAULT IS REMOVED

## SECTION 6 - JLG CONTROL SYSTEM

---

**Table 6-4. Help Message/Fault Listing**

<b>HELP MESSAGE</b>	<b>FAULT</b>		<b>FAULT REMOVAL</b>
NO ALTERNATOR OUTPUT	4	3	CLEAR WHEN FAULT IS REMOVED
OIL PRESSURE LOW	4	3	CLEAR WHEN FAULT IS REMOVED
485 COMMUNICATIONS LOST	4	3	CLEAR WHEN FAULT IS REMOVED
CAN BUS FAILURE	6	6	CLEAR WHEN FAULT IS REMOVED
LOAD SENSOR NOT CALIBRATED	9	9	CLEAR WHEN FAULT IS REMOVED
TILT SENSOR NOT CALIBRATED	9	9	CLEAR WHEN FAULT IS REMOVED
EEPROM FAILURE - CHECK ALL SETTINGS	9	9	REQUIRES EMS TO BE RECYCLED TO CLEAR FAULT
PLATFORM MODULE FAILURE: HWFS CODE 1	9	9	CLEAR WHEN FAULT IS REMOVED
GROUND MODULE FAILURE: HWFS CODE 1	9	9	CLEAR WHEN FAULT IS REMOVED

Table 6-5. Machine Configuration Programming Information

Configuration Digit	Number	Description	Default Number
<b>NOTE:</b> Machine configuration must be completed before any personality settings can be changed. Changing personality settings first and then changing the model number of the machine configuration will cause personality settings to return to default			
MODEL NUMBER: 1	0	No Model	0
	4	600S	1
MARKET: 2	0	ANSI USA	0
	1	ANSI EXPORT	
	2	CSA	
	3	CE	
	4	AUSTRALIA	
	5	JAPAN	
ENGINE: 3	8	DEUTZ F4 TIER1: Deutz BF4M1011 Diesel (Tier 1)	14
	9	DEUTZ F4 TIER2: Deutz BF4M2011 Diesel (Tier 2)	
	12	DEUTZ ECM: Engine Control Module	
	13	CAT Engine	
FLYWHEEL TEETH: 4	0	133 TEETH: 133 flywheel teeth.	1
	1	110 TEETH: 110 flywheel teeth.	
GLOW PLUG: 5	0	NO GLOW PLUGS: No glow plugs installed.	2
	1	AIR INTAKE: Glow plugs installed in the air intake on the manifold.	
	2	IN-CYLINDER: Glow plugs installed in each cylinder.	
STARTER LOCKOUT: 6	0	DISABLED: Automatic pre-glow time determined by ambient air temperature; engine start can be attempted at any time during pre-glow.	0
	1	ENABLED: Automatic pre-glow time determined by ambient air temperature; engine start is NOT permitted until pre-glow is finished.	
ENGINE SHUT-DOWN: 7	0	DISABLED: No engine shutdown.	1
	1	ENABLED: Shutdown engine when coolant temperature is greater than 110°C or oil pressure is less than 8 PSI.	

## SECTION 6 - JLG CONTROL SYSTEM

**Table 6-5. Machine Configuration Programming Information**

Configuration Digit	Number	Description	Default Number
TILT: 8	1	5 DEGREES: Reduces the maximum speed of all boom functions to creep when tilted more than 5 degrees and above elevation; also reduces drive speed to creep.	1
	2	4 DEGREES: Reduces the maximum speed of all boom functions to creep when tilted more than 4 degrees and above elevation; also reduces drive speed to creep.	
	3	3 DEGREES: Reduces the maximum speed of all boom functions to creep when tilted more than 3 degrees and above elevation; also reduces drive speed to creep.	
	4	4 DEGREES + CUT: Reduces the maximum speed of all boom functions to creep when tilted more than 4 degrees and above elevation; also disallows tower lift up, tower telescope out, drive, main telescope out and main lift up.	
	5	3 DEGREES + CUT: Reduces the maximum speed of all boom functions to creep when tilted more than 3 degrees and above elevation; also disallows tower lift up, tower telescope out, drive, main telescope out and main lift up.	
Note: Any of the selections above will light the tilt lamp when a tilted condition occurs and will sound the platform alarm when the machine is also above elevation.			
JIB: 9	0 1	NO: No Jib installed. YES: Jib installed which has up and down movements only.	0
4 WHEEL STEER: 10	0 1	NO: No four-wheel steer installed. YES: Four wheel steer installed	0
STOUCH/SKY-GUARD: 11	0 1 2 3	NO: No soft touch or SkyGuard system installed. SOFT TOUCH: Soft touch only installed. SKYGUARD: SkyGuard only installed. BOTH (CUTOUT) - Soft touch and SkyGuard installed.	0
GEN SET/WELDER: 12	0 1	NO: No generator installed. BELT DRIVE: Belt driven setup	0
GEN SET CUTOUT: 13*	0 1	MOTION ENABLED: Motion enabled when generator is ON. MOTION CUTOUT: Motion cutout in platform mode only.	0
* Only visible if Gen Set / Welder Menu selection is not 0.			



Table 6-5. Machine Configuration Programming Information

Configuration Digit	Number	Description	Default Number
H & T LIGHTS: 14	0 1	NO: No head and tail lights installed. YES: Head and tail lights installed.	0
CABLE SWITCH: 15*	0 1	NO: No broken cable switch installed. YES: Broken cable switch installed.	0
* Certain market selections will alter default setting.			
LOAD SYSTEM: 16*	0 1 2 3 4	NO: No load sensor installed.  WARN ONLY: Functions in creep, overload lamp lit, platform alarm beeps (5 sec ON, 2 sec OFF).  CUTOFF PLATFORM: All functions cutout, overload lamp lit, platform alarm beeps (5 sec ON, 2 sec OFF).  CUTOFF ALL: All functions cutout, flash overload light (500mS on, 500mS off), platform alarm beeps (5 sec ON, 2 sec OFF).  SPECIAL 1: Functions in creep, overload lamp lit, disables main telescope out & main lift up, platform alarm beeps (5 sec ON, 2 sec OFF).	0
* Only visible under certain market selections.			
* Certain market selections will limit load system options or alter default setting.			
LOAD SENSOR: 17*	0 1	1 ON ROTATOR: Use the on-board load sensor for all models except those which use the Leveling Platform Module.  4 UNDER PLATFORM: Use the EIM for load sensing.	1
* Only visible under certain market selections.			
* Certain market selections will limit load system options or alter default setting.			

## SECTION 6 - JLG CONTROL SYSTEM

**Table 6-5. Machine Configuration Programming Information**

Configuration Digit	Number	Description	Default Number
FUNCTION CUT-OUT: 18*	0	NO: No drive cutout.	0
	1	BOOM CUTOFF: Boom function cutout while driving above elevation.	
	2	DRIVE CUTOFF: Drive cutout above elevation.	
	3	DRIVE CUT E&T: Drive cutout above elevation and tilted.	
* Only visible under certain market selections.			
* Certain market selections will limit function cutout options or alter default setting.			
GROUND ALARM: 19*	0	NO: No ground alarm installed.	3
	1	DRIVE: Travel alarm sounds when the drive function is active (Option).	
	2	DESCENT: Descent alarm sounds when lift down is active (Option).	
	3	MOTION: Motion alarm sounds when any function is active (Option).	
* Certain market selections will alter default setting.			
DRIVE: 20*	0	4 WD: Four wheel drive.	0
	1	2WD: Two wheel drive.	
	2	2WD W/2-SPEED: Two wheel drive with two-speed valve.	
* Only visible under certain market selections.			
DISPLAY UNITS: 21*	0	IMPERIAL: DEG F, PSI, LBS	0
	1	METRIC: DEG C, KPA, KGS.	
* Certain market selections will alter default setting.			
LEVELING MODE: 22*	0	ALL: Platform level with all functions.	0
	1	LEVEL LIFT /TELESCOPE: Platform level on lift and telescope only.	
* Only visible on 800S models.			
DRIVE CONTROL: 23	0	NORMAL: Drive coils are energized from the Ground Module.	2
	1	PROPULSION: Drive coils are energized from the Propulsion Module.	
	2	ENHANCED: Drive coils are energized from the Ground Module and the ground side of the drive coils are brought back to current feedback returns.	
BOOM CONTROL: 24	0	NORMAL: Boom control coils are energized from the Ground Module.	0
	1	ENHANCED: Boom control coils are energized from the Ground Module and the ground side of the drive coils are brought back to current feedback returns.	

Table 6-5. Machine Configuration Programming Information

Configuration Digit	Number	Description	Default Number
CLEARSKY: 25	0 1	NO: ClearSky Telematics system not installed. YES: ClearSky Telematics system installed.	0
CRIBBING OPTION: 26	0 1	NO: Cribbing Option is disabled. YES: Cribbing Option is enabled.	0
FUEL TANK SIZE: 27	0 1	31 Gallon tank. 52 Gallon tank.	0
ALARM/HORN: 28	0 1	SEPERATE: Separate alarm and horn. COMBINED: combination alarm/horn.	0

4150364F

### 6.3 MACHINE ORIENTATION WHEN SETTING FUNCTION SPEEDS

**LIFT UP:** from platform control, lowest elevation up to maximum elevation, boom retracted, jib retracted.

**LIFT DOWN:** from platform control, maximum elevation down to minimum elevation, boom retracted, jib retracted.

**JIB LIFT UP:** from platform control, lowest jib elevation up to maximum jib elevation, boom retracted, jib retracted.

**JIB LIFT DOWN:** from platform control, maximum jib elevation down to minimum jib elevation, boom retracted, jib retracted.

**SWING RIGHT(Max):** 360°, from platform control, boom approximately 45° elevation, boom retracted, jib retracted.

**SWING LEFT(Max):** 360°, from platform control, boom approximately 45° elevation, boom retracted, jib retracted.

**TELESCOPE OUT:** from platform control, boom 20°, 500 lb (226 kg) capacity selected.

**TELESCOPE IN:** from platform control, boom 20°, 500 lb (226 kg) capacity selected.

**JIB TELESCOPE IN:** from platform control, boom horizontal, jib horizontal, 500 lb (226 kg) capacity selected.

**JIB TELESCOPE OUT:** from platform control, boom horizontal, jib horizontal, 500 lb (226 kg) capacity selected.

**DRIVE FORWARD (Max):** high speed - low torque setting, drive 200 ft (61 m) front wheels to front wheels. Timed after machine has obtained maximum speed.

**DRIVE REVERSE (Max):** high speed - low torque setting, drive 200 ft (61 m) front wheels to front wheels Timed after machine has obtained maximum speed.

**DRIVE FORWARD (Creep Max):** high torque - low speed setting, platform speed knob at full creep

**DRIVE REVERSE (Creep Max):** high torque - low speed setting, platform speed knob at full creep

**DRIVE FORWARD (Elevated Max - Boom Beyond Transport):** high speed - low torque setting, platform speed knob out of creep, Lift boom above transport, drive forward 50 ft (15 m).

**DRIVE REVERSE (Elevated Max - Boom Beyond Transport):** high speed - low torque setting, platform speed knob out of creep, Lift boom above transport, drive backward 50 ft (15 m).

### Test Notes

1. Personality settings can be adjusted anywhere within the adjustment range for optimum machine performance.
2. Stop watch should start when function is activated - not controller or switch.
3. Unless noted, measure function speeds from platform.
4. Platform speed knob must be at full speed (fully clockwise).
5. Perform all tests with oil temperature above 100° F (38° C).

### 6.4 CANBUS COMMUNICATIONS

CANbus: CAN (Control Area Network) is a two wire differential serial link between the Platform and Ground Modules providing bi-directional communications.

Two-wire: One wire (red) is driven high (5v) and the other low (black) (0v) to send a signal. Both wires "float" (2.5v) when no signal is being sent.

Differential: Any electrical line noise can affect the high or the low wires but never both, so communications is not corrupted.

Serial Link: Messages are being sent bit by bit along the wires; the high bus speed allow all modules to be constantly updated around 20 times per second. Typical traffic is 300 - 500 messages per second.

A complete CANbus circuit is approximately 60 ohms, which can be verified at the "T" fitting inside the ground station. Individual circuits are approximately 120 ohms.

The GROUND MODULE (UGM) is the master system controller. Most functions are dispatched and coordinated from this module. The PLATFORM MODULE handles sub-tasks. All characterized information (values) are stored in the ground module (i.e., Personalities or Calibrations).

**Interlocks:** Any device that sends an electrical input. (For an example a limit switch, proximity switch, etc;)

**Platform Level:** The GROUND MODULE stores default values and handles interlocks. The PLATFORM MODULE reads sensors mounted on the platform assembly and controls Level Up / Down valves to maintain setpoint sent from the GROUND MODULE.

**Steer:** The GROUND MODULE stores crack points, and sends desired drive direction, steering mode, and axle extend/retract commands. The PLATFORM MODULE reports steering switch position to the GROUND MODULE.

**Drive:** The GROUND MODULE stores crack points and sends commands for each drive pump. (Command is computed from drive joystick input, interlocks, wheel angle, etc).

**Lift, Tele, & Swing:** The GROUND MODULE stores default values, and handles interlocks and calibration information. Lift, Telescope, and Swing commands depend on interlocks through out the machine. Boom angle, length, and swing are controlled by the GROUND MODULE

Table 6-6. Fault Code List

DTC	Text
001	EVERYTHING OK
0010	RUNNING AT CUTBACK - OUT OF TRANSPORT POSITION
0011	FSW OPEN
0012	RUNNING AT CREEP - CREEP SWITCH OPEN
0013	RUNNING AT CREEP - TILTED AND ABOVE ELEVATION
0014	CHASSIS TILT SENSOR OUT OF RANGE
0030	RUNNING AT CREEP - PLATFORM STOWED
0031	FUEL LEVEL LOW - ENGINE SHUTDOWN
211	POWER CYCLE
212	KEYSWITCH FAULTY
213	FSW FAULTY
224	FUNCTION PROBLEM - STEER LEFT PERMANENTLY SELECTED
225	FUNCTION PROBLEM - STEER RIGHT PERMANENTLY SELECTED
227	STEER SWITCHES FAULTY
2211	FSW INTERLOCK TRIPPED
2212	DRIVE LOCKED - JOYSTICK MOVED BEFORE FOOTSWITCH
2213	STEER LOCKED - SELECTED BEFORE FOOTSWITCH
2216	D/S JOY. OUT OF RANGE HIGH
2217	D/S JOY. CENTER TAP BAD
2219	L/S JOY. OUT OF RANGE HIGH
2220	L/S JOY. CENTER TAP BAD
2221	LIFT/SWING LOCKED - JOYSTICK MOVED BEFORE FOOTSWITCH
2222	WAITING FOR FSW TO BE OPEN
2223	FUNCTION SWITCHES LOCKED - SELECTED BEFORE ENABLE
2224	FOOTSWITCH SELECTED BEFORE START
2247	FUNCTION PROBLEM - PLATFORM ROTATE LEFT PERMANENTLY SELECTED
2248	FUNCTION PROBLEM - PLATFORM ROTATE RIGHT PERMANENTLY SELECTED
2249	FUNCTION PROBLEM - JIB LIFT UP PERMANENTLY SELECTED
2250	FUNCTION PROBLEM - JIB LIFT DOWN PERMANENTLY SELECTED
2251	FUNCTION PROBLEM - TELESCOPE IN PERMANENTLY SELECTED
2252	FUNCTION PROBLEM - TELESCOPE OUT PERMANENTLY SELECTED
2257	FUNCTION PROBLEM - TOWER LIFT UP PERMANENTLY SELECTED
2258	FUNCTION PROBLEM - TOWER LIFT DOWN PERMANENTLY SELECTED
2262	FUNCTION PROBLEM - PLATFORM LEVEL UP PERMANENTLY SELECTED
2263	FUNCTION PROBLEM - PLATFORM LEVEL DOWN PERMANENTLY SELECTED
234	FUNCTION SWITCHES FAULTY - CHECK DIAGNOSTICS/BOOM
235	FUNCTION SWITCHES LOCKED - SELECTED BEFORE AUX POWER
236	FUNCTION SWITCHES LOCKED - SELECTED BEFORE START SWITCH
237	START SWITCH LOCKED - SELECTED BEFORE KEYSWITCH
2310	FUNCTION PROBLEM - GROUND ENABLE PERMANENTLY SELECTED
2370	FUNCTION PROBLEM - JIB LIFT UP PERMANENTLY SELECTED

## SECTION 6 - JLG CONTROL SYSTEM

**Table 6-6. Fault Code List**

DTC	Text
2371	FUNCTION PROBLEM - JIB LIFT DOWN PERMANENTLY SELECTED
2372	FUNCTION PROBLEM - SWING LEFT PERMANENTLY SELECTED
2373	FUNCTION PROBLEM - SWING RIGHT PERMANENTLY SELECTED
23104	BOOM TRANSPORT SWITCH DISAGREEMENT
23105	FUNCTION PROBLEM - TOWER LIFT UP PERMANENTLY SELECTED
23106	FUNCTION PROBLEM - TOWER LIFT DOWN PERMANENTLY SELECTED
23107	FUNCTION PROBLEM - LIFT UP PERMANENTLY SELECTED
23108	FUNCTION PROBLEM - LIFT DOWN PERMANENTLY SELECTED
23109	FUNCTION PROBLEM - TELESCOPE IN PERMANENTLY SELECTED
23110	FUNCTION PROBLEM - TELESCOPE OUT PERMANENTLY SELECTED
23111	FUNCTION PROBLEM - PLATFORM LEVEL UP PERMANENTLY SELECTED
23112	FUNCTION PROBLEM - PLATFORM LEVEL DOWN PERMANENTLY SELECTED
23113	FUNCTION PROBLEM - PLATFORM ROTATE LEFT PERMANENTLY SELECTED
23114	FUNCTION PROBLEM - PLATFORM ROTATE RIGHT PERMANENTLY SELECTED
259	MODEL CHANGED - HYDRAULICS SUSPENDED - CYCLE EMS
2513	GENERATOR MOTION CUTOFF ACTIVE
2514	BOOM PREVENTED - DRIVE SELECTED
2516	DRIVE PREVENTED - ABOVE ELEVATION
2517	DRIVE PREVENTED - TILTED & ABOVE ELEVATION
2518	DRIVE PREVENTED - BOOM SELECTED
331	BRAKE - SHORT TO BATTERY
332	BRAKE - OPEN CIRCUIT
334	LIFT UP VALVE - OPEN CIRCUIT
335	LIFT DOWN VALVE - SHORT TO BATTERY
336	LIFT DOWN VALVE - OPEN CIRCUIT
3311	GROUND ALARM - SHORT TO BATTERY
3352	LP LOCK - SHORT TO GROUND
3353	LP LOCK - OPEN CIRCUIT
3354	LP LOCK - SHORT TO BATTERY
3355	LP START ASSIST - SHORT TO GROUND
3356	LP START ASSIST - OPEN CIRCUIT
3357	LP START ASSIST - SHORT TO BATTERY
3358	MAIN DUMP VALVE - SHORT TO GROUND
3359	MAIN DUMP VALVE - OPEN CIRCUIT
3360	MAIN DUMP VALVE - SHORT TO BATTERY
3361	BRAKE - SHORT TO GROUND
3362	START SOLENOID - SHORT TO GROUND
3363	START SOLENOID - OPEN CIRCUIT
3364	START SOLENOID - SHORT TO BATTERY
3365	STEER DUMP VALVE - SHORT TO GROUND
3366	STEER DUMP VALVE - OPEN CIRCUIT
3367	STEER DUMP VALVE - SHORT TO BATTERY
3373	GEN SET/WELDER - SHORT TO GROUND

Table 6-6. Fault Code List

DTC	Text
3374	GEN SET/WELDER - OPEN CIRCUIT
3375	GEN SET/WELDER - SHORT TO BATTERY
3376	HEAD TAIL LIGHT - SHORT TO GROUND
3377	HEAD TAIL LIGHT - OPEN CIRCUIT
3378	HEAD TAIL LIGHT - SHORT TO BATTERY
3379	HOUR METER - SHORT TO GROUND
3382	PLATFORM LEVEL UP VALVE - SHORT TO GROUND
3383	PLATFORM LEVEL UP VALVE - OPEN CIRCUIT
3384	PLATFORM LEVEL UP VALVE - SHORT TO BATTERY
3388	PLATFORM LEVEL DOWN VALVE - SHORT TO GROUND
3389	PLATFORM LEVEL DOWN VALVE - OPEN CIRCUIT
3390	PLATFORM LEVEL DOWN VALVE - SHORT TO BATTERY
3394	PLATFORM ROTATE LEFT VALVE - SHORT TO GROUND
3395	PLATFORM ROTATE LEFT VALVE - OPEN CIRCUIT
3396	PLATFORM ROTATE LEFT VALVE - SHORT TO BATTERY
3397	PLATFORM ROTATE RIGHT VALVE - SHORT TO GROUND
3398	PLATFORM ROTATE RIGHT VALVE - OPEN CIRCUIT
3399	PLATFORM ROTATE RIGHT VALVE - SHORT TO BATTERY
33100	JIB LIFT UP VALVE - SHORT TO GROUND
33101	JIB LIFT UP VALVE - OPEN CIRCUIT
33102	JIB LIFT UP VALVE - SHORT TO BATTERY
33103	JIB LIFT DOWN VALVE - SHORT TO GROUND
33104	JIB LIFT DOWN VALVE - OPEN CIRCUIT
33105	JIB LIFT DOWN VALVE - SHORT TO BATTERY
33106	TOWER LIFT UP VALVE - SHORT TO GROUND
33107	TOWER LIFT UP VALVE - OPEN CIRCUIT
33109	TOWER LIFT DOWN VALVE - SHORT TO GROUND
33110	TOWER LIFT DOWN VALVE - OPEN CIRCUIT
33118	SWING RIGHT VALVE - SHORT TO GROUND
33119	SWING RIGHT VALVE - OPEN CIRCUIT
33120	TELESCOPE IN VALVE - SHORT TO BATTERY
33122	SWING LEFT VALVE - SHORT TO GROUND
33123	TELESCOPE OUT VALVE - SHORT TO BATTERY
33130	THROTTLE ACTUATOR - SHORT TO GROUND
33131	THROTTLE ACTUATOR - OPEN CIRCUIT
33132	THROTTLE ACTUATOR - SHORT TO BATTERY
33182	LIFT VALVES - SHORT TO BATTERY
33186	TELESCOPE OUT VALVE - OPEN CIRCUIT
33188	TELESCOPE OUT VALVE - SHORT TO GROUND
33189	TELESCOPE IN VALVE - OPEN CIRCUIT
33190	TELESCOPE IN VALVE - SHORT TO GROUND
33279	GLOWPLUG - OPEN CIRCUIT
33280	GLOWPLUG - SHORT TO BATTERY

## SECTION 6 - JLG CONTROL SYSTEM

**Table 6-6. Fault Code List**

DTC	Text
33281	GLOWPLUG - SHORT TO GROUND
33287	LIFT - CURRENT FEEDBACK READING TOO LOW
33295	SWING LEFT VALVE - OPEN CIRCUIT
33314	FLOW CONTROL VALVE - OPEN CIRCUIT
33315	FLOW CONTROL VALVE - SHORT TO BATTERY
33316	FLOW CONTROL VALVE - SHORT TO GROUND
33317	DRIVE FORWARD VALVE - OPEN CIRCUIT
33318	DRIVE FORWARD VALVE - SHORT TO BATTERY
33319	DRIVE FORWARD VALVE - SHORT TO GROUND
33320	DRIVE REVERSE VALVE - OPEN CIRCUIT
33322	DRIVE REVERSE VALVE - SHORT TO GROUND
33331	DRIVE - CURRENT FEEDBACK READING TOO LOW
33406	LIFT UP VALVE - SHORT TO GROUND
33410	DRIVE - CURRENT FEEDBACK READING LOST
33412	SWING VALVES - SHORT TO BATTERY
33413	TOWER LIFT - CURRENT FEEDBACK READING TOO LOW
33414	SWING - CURRENT FEEDBACK READING TOO LOW
33415	FLOW CONTROL VALVE - CURRENT FEEDBACK READING TOO LOW
33416	TOWER LIFT - CURRENT FEEDBACK READING LOST
33417	LIFT - CURRENT FEEDBACK READING LOST
33418	SWING - CURRENT FEEDBACK READING LOST
33419	FLOW CONTROL VALVE - CURRENT FEEDBACK READING LOST
33420	TRACTION LOCK VALVE - SHORT TO BATTERY
33421	TRACTION LOCK VALVE - OPEN CIRCUIT
33422	TRACTION LOCK VALVE - SHORT TO GROUND
33423	OSCILLATING AXLE VALVES - SHORT TO BATTERY
33424	OSCILLATING AXLE VALVES - SHORT TO GROUND
33425	TOWER LIFT VALVES - SHORT TO BATTERY
342	PLATFORM LEVEL UP VALVE - SHORT TO BATTERY
343	PLATFORM LEVEL UP VALVE - SHORT TO GROUND
345	PLATFORM LEVEL DOWN VALVE - OPEN CIRCUIT
346	PLATFORM LEVEL DOWN VALVE - SHORT TO BATTERY
347	PLATFORM LEVEL DOWN VALVE - SHORT TO GROUND
349	PLATFORM ROTATE LEFT VALVE - OPEN CIRCUIT
3410	PLATFORM ROTATE LEFT VALVE - SHORT TO BATTERY
3411	PLATFORM ROTATE LEFT VALVE - SHORT TO GROUND
3412	PLATFORM ROTATE RIGHT VALVE - OPEN CIRCUIT
3413	PLATFORM ROTATE RIGHT VALVE - SHORT TO BATTERY
3414	PLATFORM ROTATE RIGHT VALVE - SHORT TO GROUND
3415	JIB LIFT UP VALVE - OPEN CIRCUIT
3416	JIB LIFT UP VALVE - SHORT TO BATTERY
3417	JIB LIFT UP VALVE - SHORT TO GROUND
3418	JIB LIFT DOWN VALVE - OPEN CIRCUIT



Table 6-6. Fault Code List

DTC	Text
3419	JIB LIFT DOWN VALVE - SHORT TO BATTERY
3420	JIB LIFT DOWN VALVE - SHORT TO GROUND
431	FUEL SENSOR - SHORT TO BATTERY
432	FUEL SENSOR - SHORT TO GROUND
433	OIL PRESSURE - SHORT TO BATTERY
434	OIL PRESSURE - SHORT TO GROUND
435	COOLANT TEMPERATURE - SHORT TO GROUND
437	ENGINE TROUBLE CODE
438	HIGH ENGINE TEMP
4310	NO ALTERNATOR OUTPUT
4311	LOW OIL PRESSURE
4313	THROTTLE ACTUATOR FAILURE
4314	WRONG ENGINE SELECTED - ECM DETECTED
4322	LOSS OF ENGINE SPEED SENSOR
4323	SPEED SENSOR READING INVALID SPEED
4326	FUEL ACTUATOR - SHORT TO GROUND
4327	FUEL ACTUATOR - OPEN CIRCUIT
4328	FUEL ACTUATOR - SHORT TO BATTERY
4329	FUEL ACTUATOR - CURRENT FEEDBACK READING TOO LOW
4330	FUEL ACTUATOR - CURRENT FEEDBACK READING LOST
441	BATTERY VOLTAGE TOO LOW - SYSTEM SHUTDOWN
442	BATTERY VOLTAGE TOO HIGH - SYSTEM SHUTDOWN
443	LSS BATTERY VOLTAGE TOO HIGH
444	LSS BATTERY VOLTAGE TOO LOW
445	BATTERY VOLTAGE LOW
662	CANBUS FAILURE - PLATFORM MODULE
663	CANBUS FAILURE - LOAD SENSING SYSTEM MODULE
666	CANBUS FAILURE - ENGINE CONTROLLER
6613	CANBUS FAILURE - EXCESSIVE CANBUS ERRORS
6622	CANBUS FAILURE - TCU MODULE
6629	CANBUS FAILURE - TELEMATICS CANBUS LOADING TOO HIGH
681	REMOTE CONTRACT MANAGEMENT OVERRIDE - ALL FUNCTIONS IN CREEP
813	CHASSIS TILT SENSOR NOT CALIBRATED
814	CHASSIS TILT SENSOR OUT OF RANGE
815	CHASSIS TILT SENSOR DISAGREEMENT
821	LSS CELL #1 ERROR
822	LSS CELL #2 ERROR
823	LSS CELL #3 ERROR
824	LSS CELL #4 ERROR
825	LSS HAS NOT BEEN CALIBRATED
826	RUNNING AT CREEP - PLATFORM OVERLOADED
827	DRIVE & BOOM PREVENTED - PLATFORM OVERLOADED
828	LIFT UP & TELE OUT PREVENTED - PLATFORM OVERLOADED

**Table 6-6. Fault Code List**

<b>DTC</b>	<b>Text</b>
8211	LSS READING UNDER WEIGHT
8639	FRONT LEFT STEER VALVE - OPEN CIRCUIT
8640	FRONT LEFT STEER VALVE - SHORT TO BATTERY
8641	FRONT LEFT STEER VALVE - SHORT TO GROUND
8642	FRONT RIGHT STEER VALVE - OPEN CIRCUIT
8643	FRONT RIGHT STEER VALVE - SHORT TO BATTERY
8644	FRONT RIGHT STEER VALVE - SHORT TO GROUND
8669	OSCILLATING AXLE SWITCH DISAGREEMENT
991	LSS WATCHDOG RESET
992	LSS EEPROM ERROR
993	LSS INTERNAL ERROR - PIN EXCITATION
994	LSS INTERNAL ERROR - DRDY MISSING FROM A/D
998	EEPROM FAILURE - CHECK ALL SETTINGS
9910	FUNCTIONS LOCKED OUT - PLATFORM MODULE SOFTWARE VERSION IMPROPER
9911	FUNCTIONS LOCKED OUT - LSS MODULE SOFTWARE VERSION IMPROPER
9915	CHASSIS TILT SENSOR NOT GAIN CALIBRATED
9919	GROUND SENSOR REF VOLTAGE OUT OF RANGE
9920	PLATFORM SENSOR REF VOLTAGE OUT OF RANGE
9921	GROUND MODULE FAILURE - HIGH SIDE DRIVER CUTOFF FAULTY
9922	PLATFORM MODULE FAILURE - HWFS CODE 1
9924	FUNCTIONS LOCKED OUT - MACHINE NOT CONFIGURED
9927	GROUND MODULE CONSTANT DATA UPDATE REQUIRED
9944	CURRENT FEEDBACK GAINS OUT OF RANGE
9945	CURRENT FEEDBACK CALIBRATION CHECKSUM INCORRECT
9949	MACHINE CONFIGURATION OUT OF RANGE - CHECK ALL SETTINGS
9977	LSS CORRUPT EEPROM
9979	FUNCTIONS LOCKED OUT - GROUND MODULE SOFTWARE VERSION IMPROPER
9986	GROUND MODULE VLOW FET FAILURE

**NOTE:** Bold Italic Numbers indicate the default setting. Plain text indicates another available selection. Bold, Italic underlined numbers indicate the default when the option is factory installed.

6005																														
	MODEL NUMBER		MARKET		ENGINE		FLYWHEEL TEETH		GLOW PLUG			STARTER LOCKOUT			ENGINE SHUTDOWN			TILT					JIB		4 WHEEL STEER			STOUC/CH/SKYGUARD		
	1	2	1	2	1	2	1	2	1	2	3	1	2	3	1	2	3	1	2	3	4	5	1	2	1	2	3	1	2	3
ANSI USA	<b><i>4</i></b>	<b><i>0</i></b>	<b><i>12</i></b>	0	<b><i>1</i></b>	0	1	<b><i>2</i></b>	<b><i>0</i></b>	1	0	<b><i>1</i></b>	<b><i>1</i></b>	2	3	4	5	<b><i>0</i></b>	<b><i>0</i></b>	<b><i>0</i></b>	1	2	3	1	2	3				
ANSI EXPORT	<b><i>4</i></b>	<b><i>1</i></b>	<b><i>12</i></b>	0	<b><i>1</i></b>	0	1	<b><i>2</i></b>	<b><i>0</i></b>	1	0	<b><i>1</i></b>	<b><i>1</i></b>	2	3	4	5	<b><i>0</i></b>	<b><i>0</i></b>	<b><i>0</i></b>	1	2	3	1	2	3				
CSA	<b><i>4</i></b>	<b><i>2</i></b>	<b><i>12</i></b>	0	<b><i>1</i></b>	0	1	<b><i>2</i></b>	<b><i>0</i></b>	1	0	<b><i>1</i></b>	<b><i>1</i></b>	2	3	4	5	<b><i>0</i></b>	<b><i>0</i></b>	<b><i>0</i></b>	1	2	3	1	2	3				
CE	<b><i>4</i></b>	<b><i>3</i></b>	<b><i>12</i></b>	0	<b><i>1</i></b>	0	1	<b><i>2</i></b>	<b><i>0</i></b>	1	0	<b><i>1</i></b>	<b><i>X</i></b>	<b><i>X</i></b>	<b><i>3</i></b>	<b><i>X</i></b>	5	<b><i>0</i></b>	<b><i>0</i></b>	<b><i>0</i></b>	1	2	3	1	2	3				
AUSTRALIA	<b><i>4</i></b>	<b><i>4</i></b>	<b><i>12</i></b>	0	<b><i>1</i></b>	0	1	<b><i>2</i></b>	<b><i>0</i></b>	1	0	<b><i>1</i></b>	<b><i>X</i></b>	<b><i>X</i></b>	<b><i>3</i></b>	<b><i>X</i></b>	5	<b><i>0</i></b>	<b><i>0</i></b>	<b><i>0</i></b>	1	2	3	1	2	3				
JAPAN	<b><i>4</i></b>	<b><i>5</i></b>	<b><i>12</i></b>	0	<b><i>1</i></b>	0	1	<b><i>2</i></b>	<b><i>0</i></b>	1	0	<b><i>1</i></b>	<b><i>1</i></b>	2	3	4	5	<b><i>0</i></b>	<b><i>0</i></b>	<b><i>0</i></b>	1	2	3	1	2	3				

6005																							
	GEN SET / WELDER		GEN SET CUTOUT		HEAD & TAIL LIGHTS		CABLE BREAK SWITCH		LOAD SYSTEM					LOAD SENSOR		FUNCTION CUTOUT			GROUND ALARM				
	1	2	1	2	1	2	1	2	1	2	3	4	5	1	2	1	2	3	1	2	3		
ANSI USA	<b><i>0</i></b>	1	<b><i>0</i></b>	1	<b><i>0</i></b>	1	<b><i>0</i></b>	1	<b><i>0</i></b>	<b><i>X</i></b>	<b><i>X</i></b>	<b><i>X</i></b>	<b><i>X</i></b>	0	<b><i>1</i></b>	<b><i>0</i></b>	<b><i>X</i></b>	2	<b><i>X</i></b>	0	1	2	<b><i>3</i></b>
ANSI EXPORT	<b><i>0</i></b>	1	<b><i>0</i></b>	1	<b><i>0</i></b>	1	<b><i>0</i></b>	1	<b><i>0</i></b>	<b><i>1</i></b>	2	3	4	0	<b><i>1</i></b>	<b><i>0</i></b>	1	2	3	0	1	2	<b><i>3</i></b>
CSA	<b><i>0</i></b>	1	<b><i>0</i></b>	1	<b><i>0</i></b>	1	<b><i>0</i></b>	1	<b><i>0</i></b>	<b><i>X</i></b>	<b><i>X</i></b>	<b><i>X</i></b>	<b><i>X</i></b>	0	<b><i>1</i></b>	<b><i>0</i></b>	1	2	3	0	1	2	<b><i>3</i></b>
CE	<b><i>0</i></b>	1	<b><i>0</i></b>	1	<b><i>0</i></b>	1	0	<b><i>1</i></b>	0	<b><i>X</i></b>	<b><i>2</i></b>	3	<b><i>X</i></b>	0	<b><i>1</i></b>	0	<b><i>1</i></b>	<b><i>X</i></b>	<b><i>X</i></b>	0	1	2	<b><i>3</i></b>
AUSTRALIA	<b><i>0</i></b>	1	<b><i>0</i></b>	1	<b><i>0</i></b>	1	0	<b><i>1</i></b>	0	<b><i>X</i></b>	<b><i>2</i></b>	<b><i>X</i></b>	<b><i>X</i></b>	0	<b><i>1</i></b>	<b><i>0</i></b>	1	2	3	0	1	2	<b><i>3</i></b>
JAPAN	<b><i>0</i></b>	1	<b><i>0</i></b>	1	<b><i>0</i></b>	1	<b><i>0</i></b>	1	0	<b><i>1</i></b>	2	3	4	0	<b><i>1</i></b>	<b><i>0</i></b>	1	2	3	0	1	2	<b><i>3</i></b>

## SECTION 6 - JLG CONTROL SYSTEM

**NOTE:** Bold Italic Numbers indicate the default setting. Plain text indicates another available selection. Bold, Italic underlined numbers indicate the default when the option is factory installed.

6005																				
	DRIVE TYPE			DISPLAY UNITS		LEVELING MODE		DRIVE CONTROL			BOOM CONTROL		CLEARSKY		CRIBBING OP		FUEL TANK SIZE		ALARM/HORN	
ANSI USA	<b>0</b>	1	2	<b>0</b>	1	<b>0</b>	1	<b>0</b>	1	2	<b>0</b>	1	<b>0</b>	1	<b>0</b>	1	<b>0</b>	1	<b>0</b>	1
ANSI EXPORT	<b>0</b>	1	2	<b>0</b>	1	<b>0</b>	1	<b>0</b>	1	2	<b>0</b>	1	<b>0</b>	1	<b>0</b>	1	<b>0</b>	1	<b>0</b>	1
CSA	<b>0</b>	1	2	0	<b>1</b>	<b>0</b>	1	<b>0</b>	1	2	<b>0</b>	1	<b>0</b>	1	<b>0</b>	1	<b>0</b>	1	<b>0</b>	1
CE	<b>0</b>	1	2	0	<b>1</b>	<b>0</b>	1	<b>0</b>	1	2	<b>0</b>	1	<b>0</b>	1	<b>0</b>	1	<b>0</b>	1	<b>0</b>	1
AUSTRALIA	<b>0</b>	1	2	0	<b>1</b>	<b>0</b>	1	<b>0</b>	1	2	<b>0</b>	1	<b>0</b>	1	<b>0</b>	1	<b>0</b>	1	<b>0</b>	1
JAPAN	<b>0</b>	1	2	0	<b>1</b>	<b>0</b>	1	<b>0</b>	1	2	<b>0</b>	1	<b>0</b>	1	<b>0</b>	1	<b>0</b>	1	<b>0</b>	1

**NOTE:** Bold Italic Numbers indicate the default setting. Plain text indicates another available selection. Bold, Italic underlined numbers indicate the default when the option is factory installed.

6005J																								
	MODEL NUMBER	MARKET	ENGINE	FLYWHEEL TEETH		GLOW PLUG			STARTER LOCKOUT		ENGINE SHUTDOWN		TILT					JIB		4 WHEEL STEER		STOUCH/SKYGUARD		
ANSI USA	<b>4</b>	<b>0</b>	<b>12</b>	0	<b>1</b>	0	1	<b>2</b>	<b>0</b>	1	0	<b>1</b>	<b>1</b>	2	3	4	5	<b>1</b>	<b>0</b>	<b>0</b>	1	2	3	
ANSI EXPORT	<b>4</b>	<b>1</b>	<b>12</b>	0	<b>1</b>	0	1	<b>2</b>	<b>0</b>	1	0	<b>1</b>	<b>1</b>	2	3	4	5	<b>1</b>	<b>0</b>	<b>0</b>	1	2	3	
CSA	<b>4</b>	<b>2</b>	<b>12</b>	0	<b>1</b>	0	1	<b>2</b>	<b>0</b>	1	0	<b>1</b>	<b>1</b>	2	3	4	5	<b>1</b>	<b>0</b>	<b>0</b>	1	2	3	
CE	<b>4</b>	<b>3</b>	<b>12</b>	0	<b>1</b>	0	1	<b>2</b>	<b>0</b>	1	0	<b>1</b>	<b>X</b>	<b>X</b>	<b>3</b>	<b>X</b>	5	<b>1</b>	<b>0</b>	<b>0</b>	1	2	3	
AUSTRALIA	<b>4</b>	<b>4</b>	<b>12</b>	0	<b>1</b>	0	1	<b>2</b>	<b>0</b>	1	0	<b>1</b>	<b>X</b>	<b>X</b>	<b>3</b>	<b>X</b>	5	<b>1</b>	<b>0</b>	<b>0</b>	1	2	3	
JAPAN	<b>4</b>	<b>5</b>	<b>12</b>	0	<b>1</b>	0	1	<b>2</b>	<b>0</b>	1	0	<b>1</b>	<b>1</b>	2	3	4	5	<b>1</b>	<b>0</b>	<b>0</b>	1	2	3	

**NOTE:** Bold Italic Numbers indicate the default setting. Plain text indicates another available selection. Bold, Italic underlined numbers indicate the default when the option is factory installed.

600SJ																							
	GEN SET / WELDER		GEN SET CUTOFF		HEAD & TAIL LIGHTS		CABLE BREAK SWITCH		LOAD SYSTEM					LOAD SENSOR		FUNCTION CUTOFF			GROUND ALARM				
ANSI USA	<i>0</i>	<i>1</i>	<i>0</i>	<i>1</i>	<i>0</i>	<i>1</i>	<i>0</i>	<i>1</i>	<i>0</i>	<i>X</i>	<i>X</i>	<i>X</i>	<i>X</i>	<i>0</i>	<i>1</i>	<i>0</i>	<i>X</i>	<i>2</i>	<i>X</i>	<i>0</i>	<i>1</i>	<i>2</i>	<i>3</i>
ANSI EXPORT	<i>0</i>	<i>1</i>	<i>0</i>	<i>1</i>	<i>0</i>	<i>1</i>	<i>0</i>	<i>1</i>	<i>0</i>	<i>1</i>	<i>2</i>	<i>3</i>	<i>4</i>	<i>0</i>	<i>1</i>	<i>0</i>	<i>1</i>	<i>2</i>	<i>3</i>	<i>0</i>	<i>1</i>	<i>2</i>	<i>3</i>
CSA	<i>0</i>	<i>1</i>	<i>0</i>	<i>1</i>	<i>0</i>	<i>1</i>	<i>0</i>	<i>1</i>	<i>0</i>	<i>X</i>	<i>X</i>	<i>X</i>	<i>X</i>	<i>0</i>	<i>1</i>	<i>0</i>	<i>1</i>	<i>2</i>	<i>3</i>	<i>0</i>	<i>1</i>	<i>2</i>	<i>3</i>
CE	<i>0</i>	<i>1</i>	<i>0</i>	<i>1</i>	<i>0</i>	<i>1</i>	<i>0</i>	<i>1</i>	<i>0</i>	<i>X</i>	<i>2</i>	<i>3</i>	<i>X</i>	<i>0</i>	<i>1</i>	<i>0</i>	<i>1</i>	<i>X</i>	<i>X</i>	<i>0</i>	<i>1</i>	<i>2</i>	<i>3</i>
AUSTRALIA	<i>0</i>	<i>1</i>	<i>0</i>	<i>1</i>	<i>0</i>	<i>1</i>	<i>0</i>	<i>1</i>	<i>0</i>	<i>X</i>	<i>2</i>	<i>X</i>	<i>X</i>	<i>0</i>	<i>1</i>	<i>0</i>	<i>1</i>	<i>2</i>	<i>3</i>	<i>0</i>	<i>1</i>	<i>2</i>	<i>3</i>
JAPAN	<i>0</i>	<i>1</i>	<i>0</i>	<i>1</i>	<i>0</i>	<i>1</i>	<i>0</i>	<i>1</i>	<i>0</i>	<i>1</i>	<i>2</i>	<i>3</i>	<i>4</i>	<i>0</i>	<i>1</i>	<i>0</i>	<i>1</i>	<i>2</i>	<i>3</i>	<i>0</i>	<i>1</i>	<i>2</i>	<i>3</i>

**NOTE:** Bold Italic Numbers indicate the default setting. Plain text indicates another available selection. Bold, Italic underlined numbers indicate the default when the option is factory installed.

600SJ																				
	DRIVE TYPE			DISPLAY UNITS		LEVELING MODE		DRIVE CONTROL			BOOM CONTROL		CLEARSKY		CRIBBING OP		FUEL TANK SIZE		ALARM/HORN	
ANSI USA	<i>0</i>	<i>1</i>	<i>2</i>	<i>0</i>	<i>1</i>	<i>0</i>	<i>1</i>	<i>0</i>	<i>1</i>	<i>2</i>	<i>0</i>	<i>1</i>	<i>0</i>	<i>1</i>	<i>0</i>	<i>1</i>	<i>0</i>	<i>1</i>	<i>0</i>	<i>1</i>
ANSI EXPORT	<i>0</i>	<i>1</i>	<i>2</i>	<i>0</i>	<i>1</i>	<i>0</i>	<i>1</i>	<i>0</i>	<i>1</i>	<i>2</i>	<i>0</i>	<i>1</i>	<i>0</i>	<i>1</i>	<i>0</i>	<i>1</i>	<i>0</i>	<i>1</i>	<i>0</i>	<i>1</i>
CSA	<i>0</i>	<i>1</i>	<i>2</i>	<i>0</i>	<i>1</i>	<i>0</i>	<i>1</i>	<i>0</i>	<i>1</i>	<i>2</i>	<i>0</i>	<i>1</i>	<i>0</i>	<i>1</i>	<i>0</i>	<i>1</i>	<i>0</i>	<i>1</i>	<i>0</i>	<i>1</i>
CE	<i>0</i>	<i>1</i>	<i>2</i>	<i>0</i>	<i>1</i>	<i>0</i>	<i>1</i>	<i>0</i>	<i>1</i>	<i>2</i>	<i>0</i>	<i>1</i>	<i>0</i>	<i>1</i>	<i>0</i>	<i>1</i>	<i>0</i>	<i>1</i>	<i>0</i>	<i>1</i>
AUSTRALIA	<i>0</i>	<i>1</i>	<i>2</i>	<i>0</i>	<i>1</i>	<i>0</i>	<i>1</i>	<i>0</i>	<i>1</i>	<i>2</i>	<i>0</i>	<i>1</i>	<i>0</i>	<i>1</i>	<i>0</i>	<i>1</i>	<i>0</i>	<i>1</i>	<i>0</i>	<i>1</i>
JAPAN	<i>0</i>	<i>1</i>	<i>2</i>	<i>0</i>	<i>1</i>	<i>0</i>	<i>1</i>	<i>0</i>	<i>1</i>	<i>2</i>	<i>0</i>	<i>1</i>	<i>0</i>	<i>1</i>	<i>0</i>	<i>1</i>	<i>0</i>	<i>1</i>	<i>0</i>	<i>1</i>

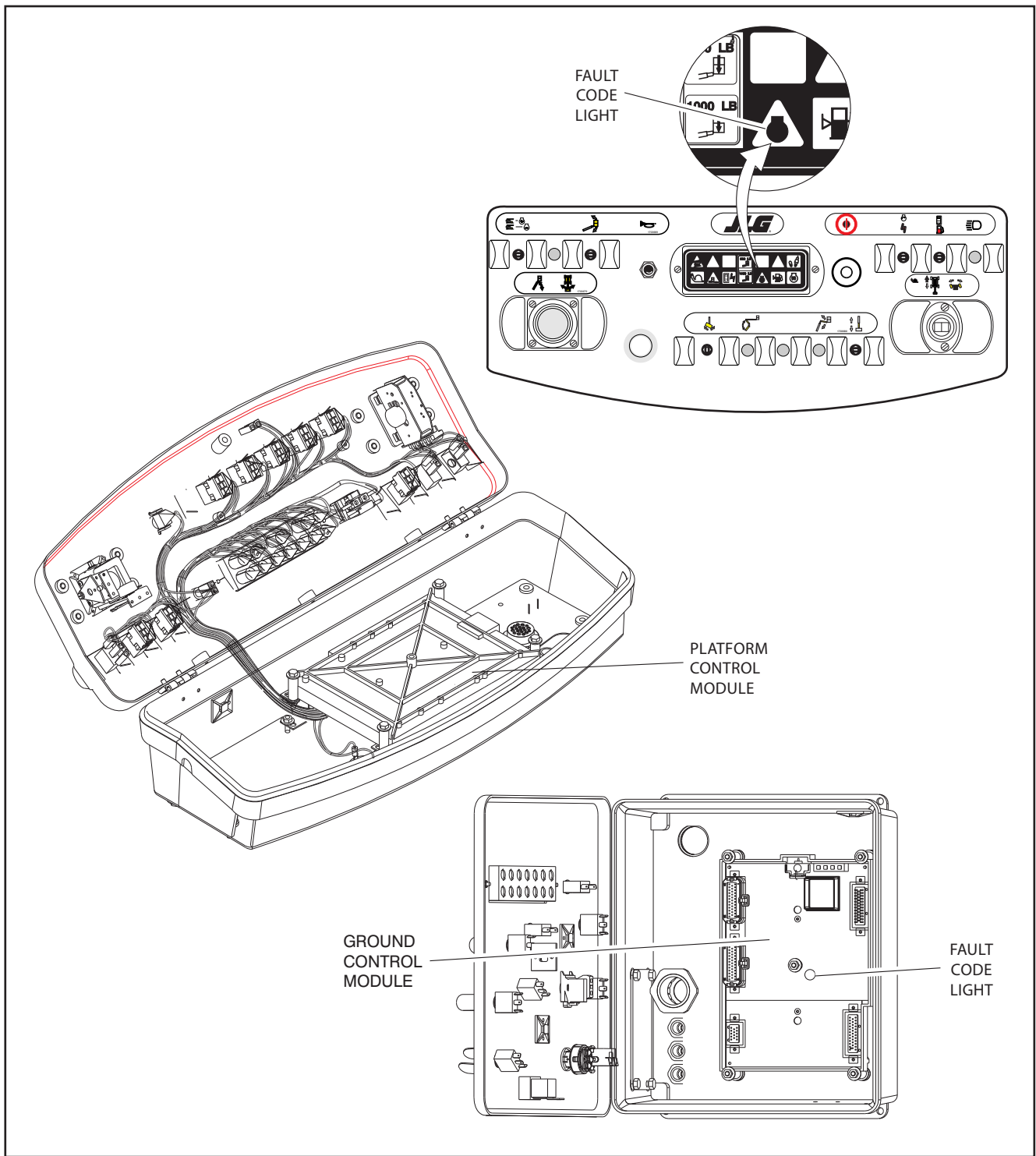
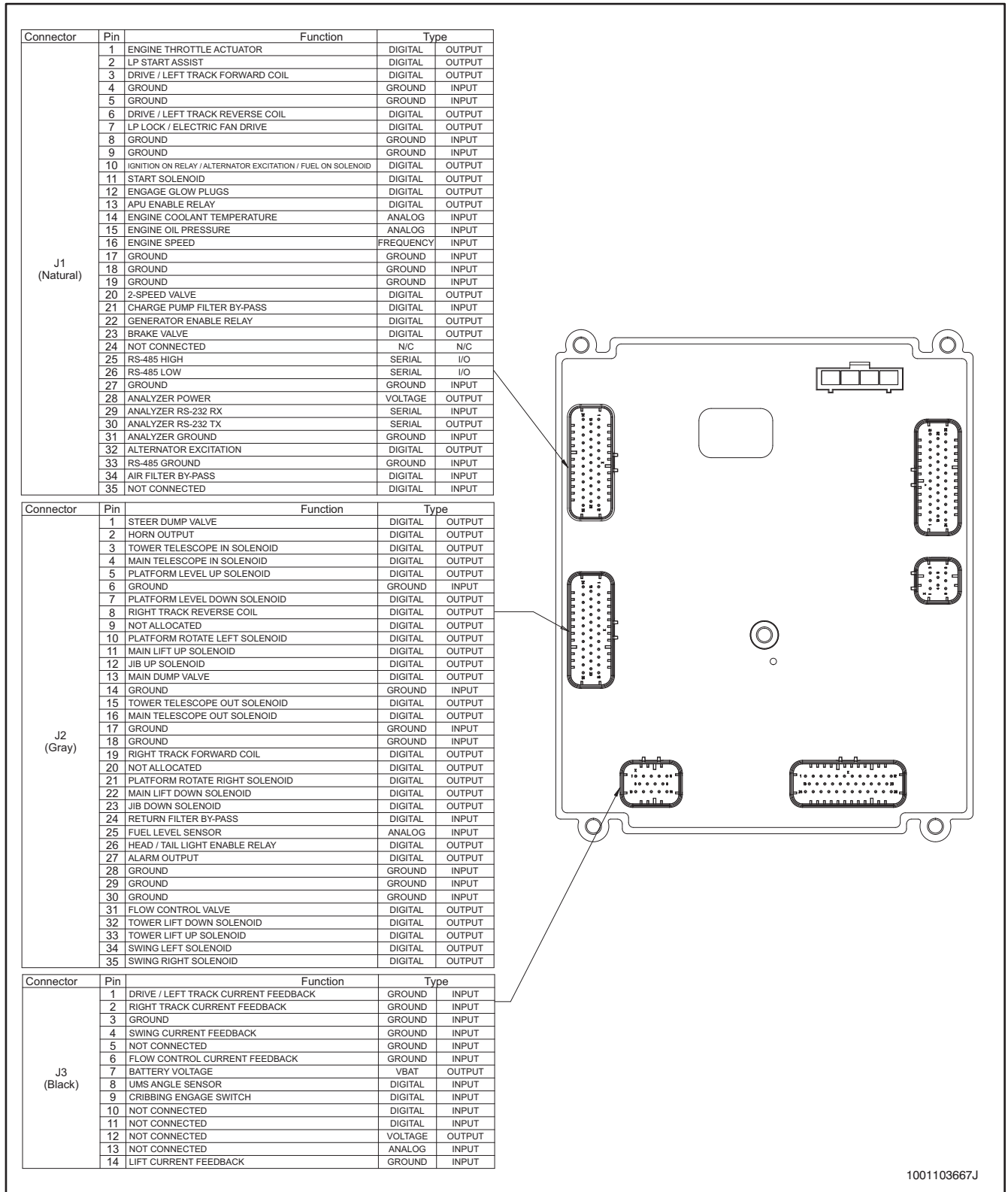


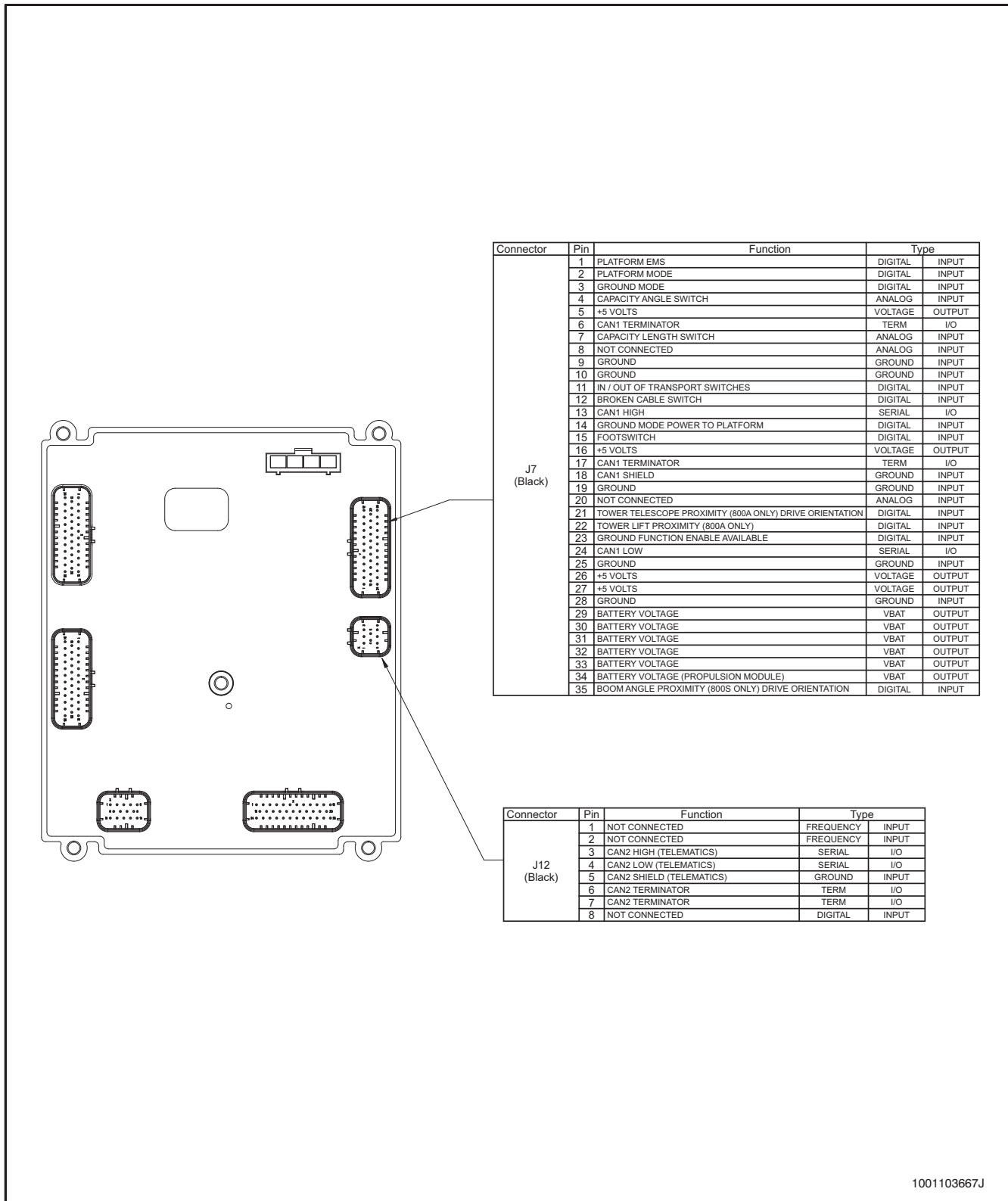
Figure 6-11. Control Module Locations



1001103667J

Figure 6-12. Ground Control Module Pin Connections 1 of 3

## SECTION 6 - JLG CONTROL SYSTEM



1001103667J

Figure 6-13. Ground Control Module Pin Connections 2 of 3



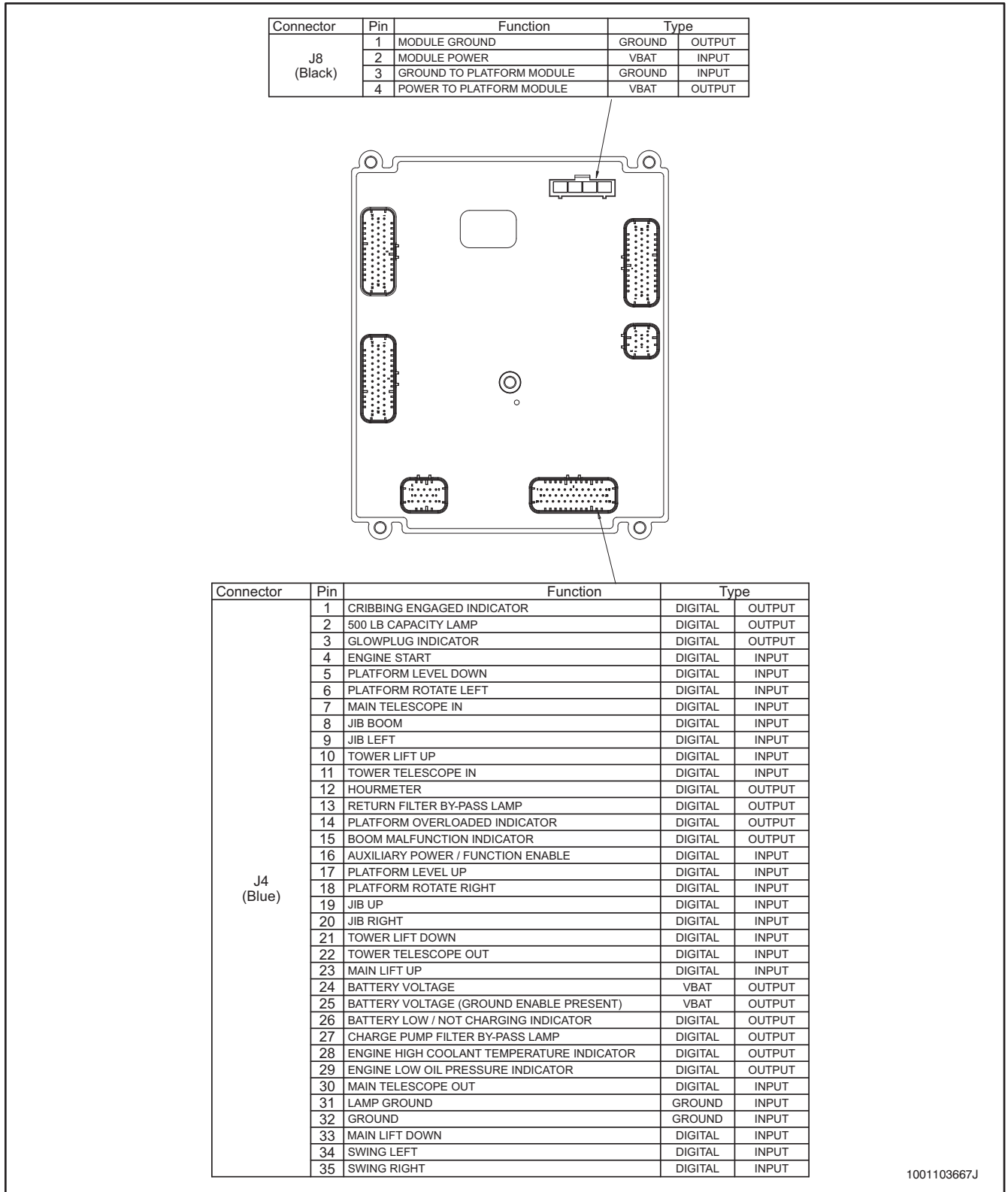
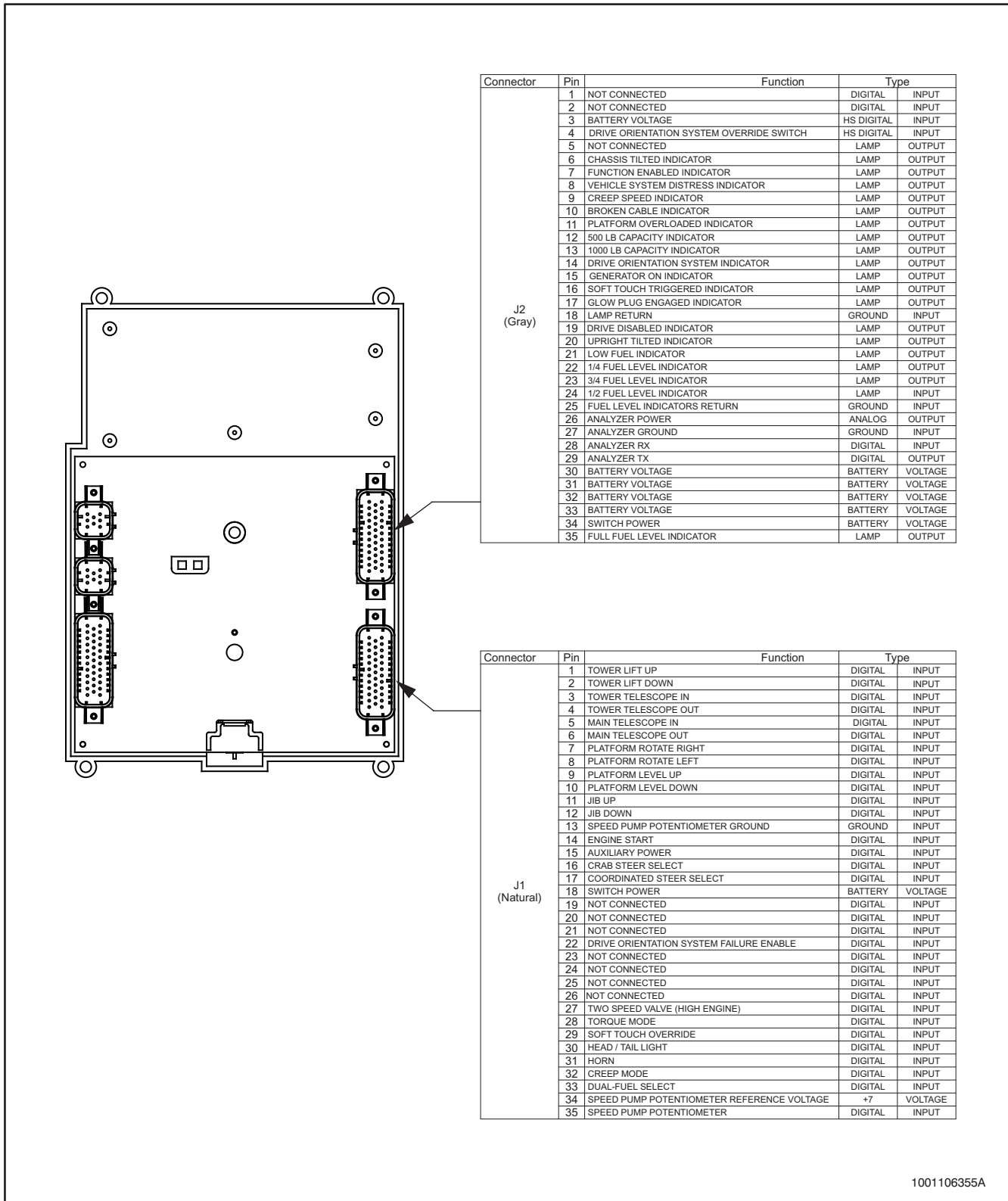


Figure 6-14. Ground Control Module Pin Connections 3 of 3

## SECTION 6 - JLG CONTROL SYSTEM



1001106355A

Figure 6-15. Platform Control Module Pin Connections 1 of 2

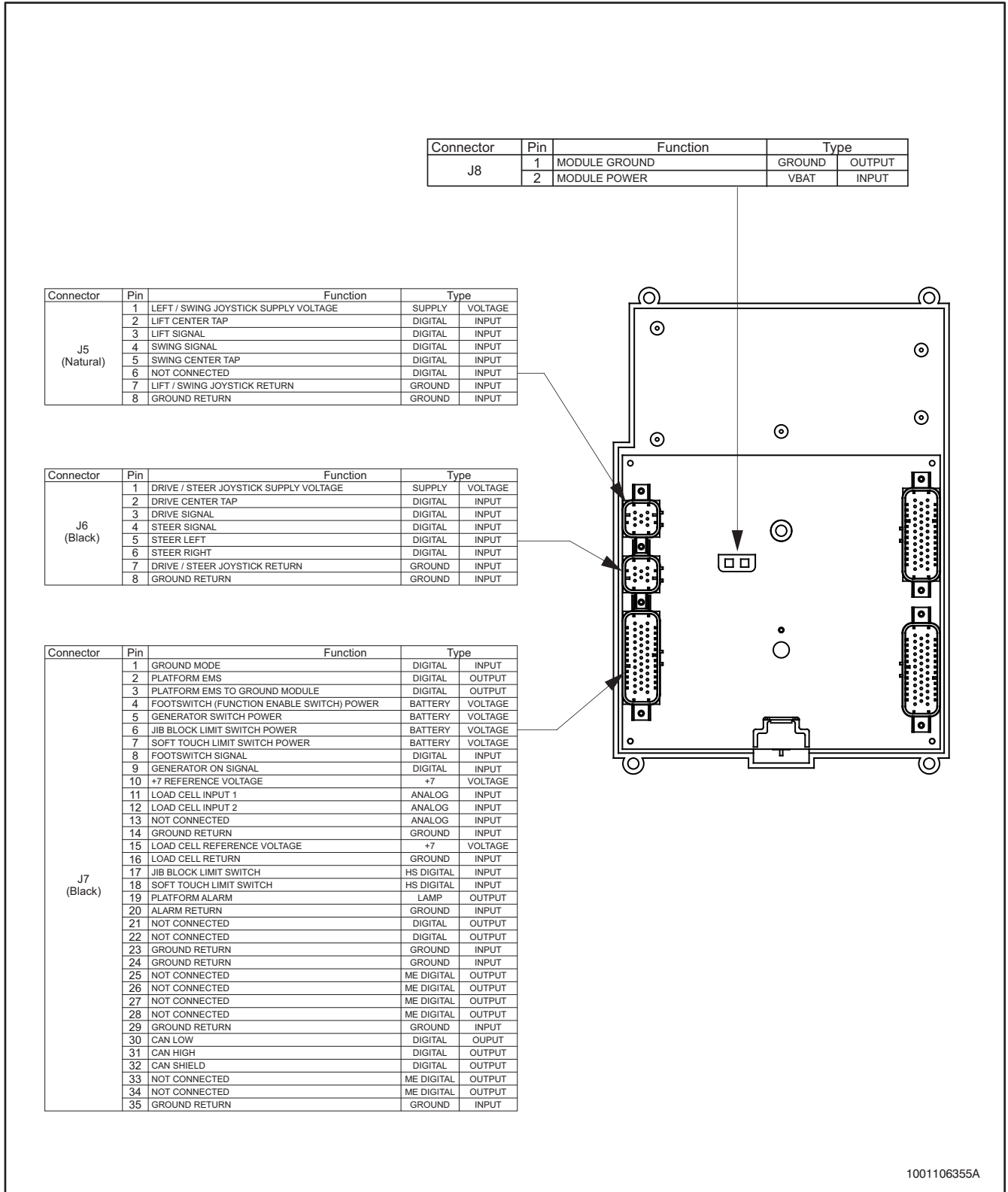


Figure 6-16. Platform Control Module Pin Connections 2 of 2

 **NOTES:**


## SECTION 7. BASIC ELECTRICAL INFORMATION & SCHEMATICS

### 7.1 GENERAL

This section contains basic electrical information and schematics for locating and correcting most electrical problems. If a problem develops which is not presented in this section or corrected by listed corrective actions, obtain technically qualified guidance before proceeding with any additional maintenance.

**NOTE:** Some procedures/connectors shown in this section may not apply to all models.

### 7.2 MULTIMETER BASICS

A wide variety of multimeters or Volt Ohm Meters (VOM) can be used for troubleshooting your equipment. This section shows diagrams of a common, digital VOM configured for several different circuit measurements. Instructions for your VOM may vary. Please consult the meter operator's manual for more information.

#### Grounding

"Grounding the meter" means to take the black lead (which is connected to the COM (common) or negative port) and touch it to a good path to the negative side of the Voltage source.

#### Backprobing

To "backprobe" means to take the measurement by accessing a connector's contact on the same side as the wires, the back of the connector. Readings can be done while maintaining circuit continuity this way. If the connector is the sealed type, great care must be taken to avoid damaging the seal around the wire. It is best to use probes or probe tips specifically designed for this technique, especially on sealed connectors. Whenever possible insert probes into the side of the connector such that the test also checks both terminals of the connection. It is possible to inspect a connection within a closed connector by backprobing both sides of a connector terminal and measuring resistance. Do this after giving each wire a gentle pull to ensure the wires are still attached to the contact and contacts are seated in the connector.

#### Min/Max

"Min/Max" recording feature of some meters can help when taking measurements of intermittent conditions while alone. For example, you can read voltage applied to a solenoid when it is only operational while a switch, far from the solenoid and meter, is held down.

#### Polarity

Getting a negative Voltage or current reading when expecting a positive reading frequently means the leads are reversed. Check what reading is expected, location of the signal and leads are correctly connected to the device under test. Also check the lead on the "COM" port goes to the ground or negative side of the signal and lead on the other port goes to the positive side of the signal.

#### Scale

M = Mega = 1,000,000 \* (Displayed Number)

k = kilo = 1,000 \* (Displayed Number)

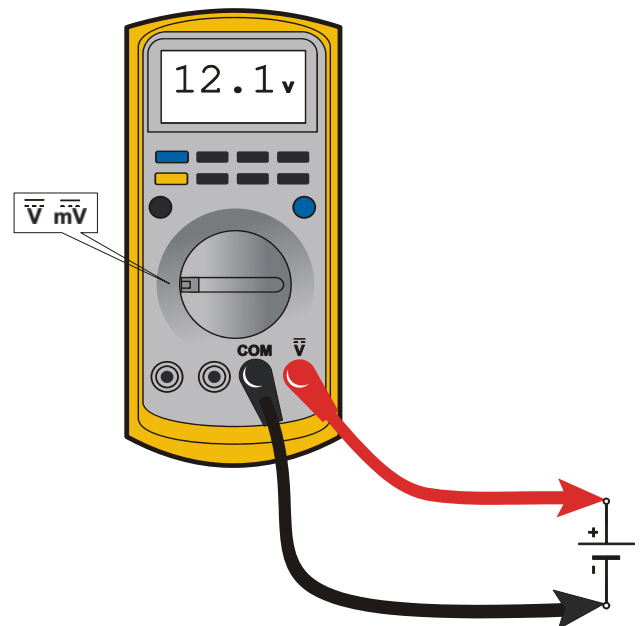
m = milli = (Displayed Number) / 1,000

$\mu$  = micro = (Displayed Number) / 1,000,000

Example: 1.2 k $\Omega$  = 1200  $\Omega$

Example: 50 mA = 0.05 A

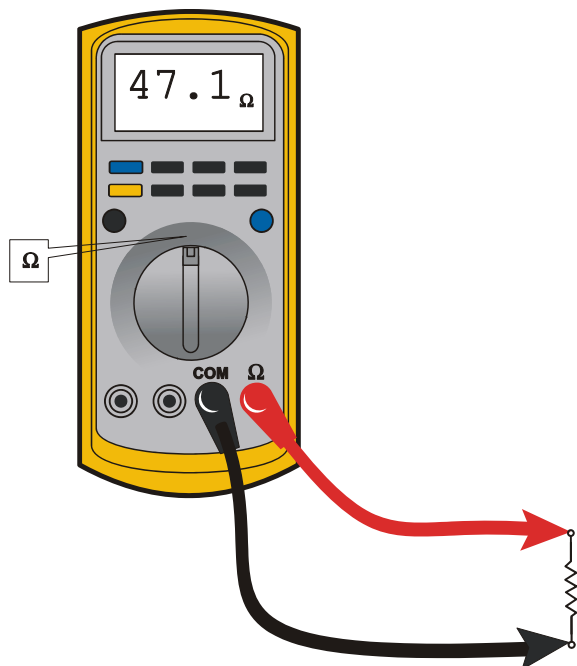
#### Voltage Measurement



**Figure 7-1. Voltage Measurement (DC)**

- If meter is not auto ranging, set it to the correct range (See multimeter's operation manual)
- Use firm contact with meter leads

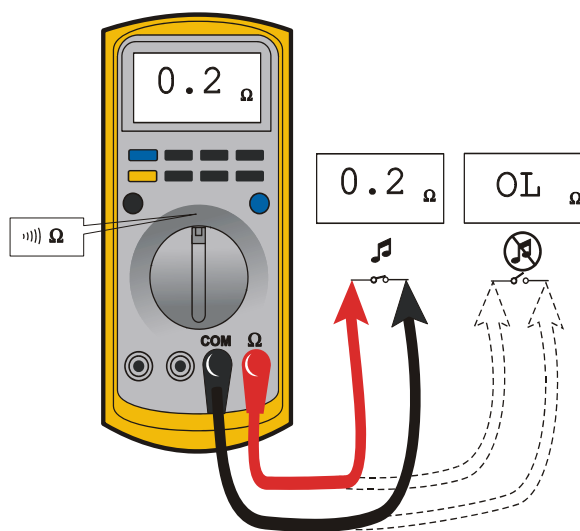
### Resistance Measurement



**Figure 7-2. Resistance Measurement**

- First test meter and leads by touching leads together. Resistance should read a short circuit (very low resistance)
- Circuit power must be turned OFF before testing resistance
- Disconnect component from circuit before testing
- If meter is not auto ranging, set it to the correct range (See multimeter's operation manual)
- Use firm contact with meter leads

### Continuity Measurement



**Figure 7-3. Continuity Measurement**

- Some meters require a separate button press to enable audible continuity testing
- Circuit power must be turned OFF before testing continuity
- Disconnect component from circuit before testing
- Use firm contact with meter leads
- First test meter and leads by touching leads together. Meter should produce an audible alarm, indicating continuity

## Current Measurement

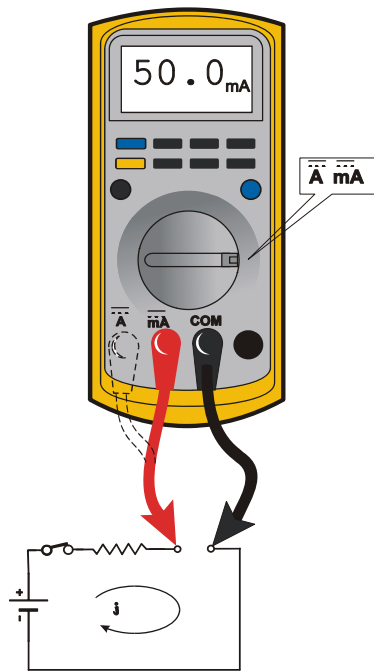


Figure 7-4. Current Measurement (DC)

- Set up meter for expected current range
- Be sure to connect meter leads to correct jacks for selected current range
- If meter is not auto ranging, set it to correct range (See multi meter's operation manual)
- Use firm contact with meter leads

## 7.3 APPLYING SILICONE DIELECTRIC COMPOUND TO ELECTRICAL CONNECTIONS

**NOTE:** This section is not applicable for battery terminals.

### NOTICE

JLG P/N 0100048 DIELECTRIC GREASE (NOVAGARD G661) IS THE ONLY MATERIAL APPROVED FOR USE AS A DIELECTRIC GREASE.

**NOTE:** Do NOT apply dielectric grease to the following connections:

- Main Boom Rotary sensor connections (on Celesco Sensor),
- LSS Modules connections,
- Deutz EMR 2 ECM connection.

Silicone Dielectric Compound must be used on all electrical connections except for those mentioned above for the following reasons:

- To prevent oxidation at mechanical joint between male and female pins.
- To prevent electrical malfunction caused by low level conductivity between pins when wet.

Use the following procedure to apply Silicone Dielectric Compound to the electrical connectors. This procedure applies to all plug connections not enclosed in a box. Silicone grease should not be applied to connectors with external seals.

1. To prevent oxidation, silicone grease must be packed completely around male and female pins on the inside of the connector prior to assembly. This is most easily achieved by using a syringe.

**NOTE:** Over a period of time, oxidation increases electrical resistance at the connection, eventually causing circuit failure.

2. To prevent shorting, silicone grease must be packed around each wire where they enter the outside of the connector housing. Also, silicone grease must be applied at the joint where the male and female connectors come together. Any other joints (around strain reliefs, etc.) where water could enter the connector should also be sealed.

**NOTE:** This condition is especially common when machines are pressure washed since the washing solution is much more conductive than water.

3. Anderson connectors for battery boxes and battery chargers should have silicone grease applied to contacts only.

**NOTE:** Curing-type sealants can also be used to prevent shorting and would be less messy, but make future pin removal difficult.

When applied to electrical connections, dielectric grease helps prevent corrosion of electrical contacts and improper conductivity between contacts from moisture intrusion. Open and sealed connectors benefit from application of dielectric grease.

Dielectric grease shall be applied to all electrical connectors at the time of connection (except those noted under Exclusions).

### Dielectric Grease Application

Before following these instructions, refer to excluded connector types (See Exclusions below).

1. Use dielectric grease in a tube for larger connection points or apply with a syringe for small connectors.
2. Apply dielectric grease to the female contact (fill it approximately 1/2 full; see example below)
3. Leave a thin layer of dielectric grease on connector face.
4. Assemble connector system immediately to prevent moisture or dust contamination
5. Pierce one of the unused wire seals before assembly if the connector system tends to trap air (i.e. AMP Seal) and then install a seal plug.

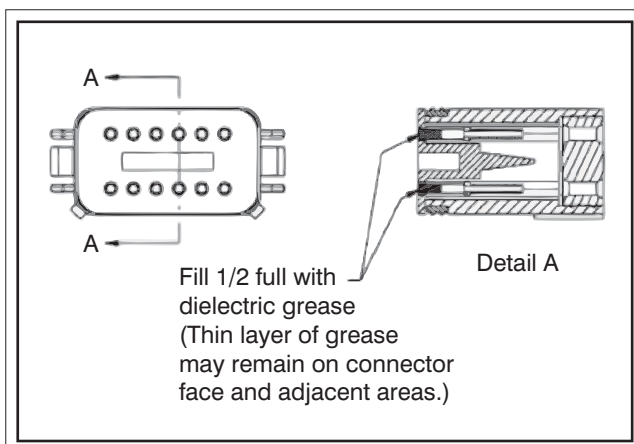


Figure 7-5. Applying Dielectric Grease

### Deutsch HD, DT, DTM, DRC Series

The Deutsch connector system is commonly used for harsh environments. Follow installation instructions.



Figure 7-6. Deutsch Connector

### AMP Seal

The AMP Seal connector system is used on Control ADE Platform and Ground Modules.

Apply dielectric grease to the female contact. If trapped air prevents connector from latching, pierce one of the unused wire seals.



Figure 7-7. Dielectric Grease On Female Contacts

After assembly, install a seal plug (JLG #4460905) to keep out moisture. Seal plugs may also be installed by the wire harness manufacturer if an unused wire seal was damaged during assembly.

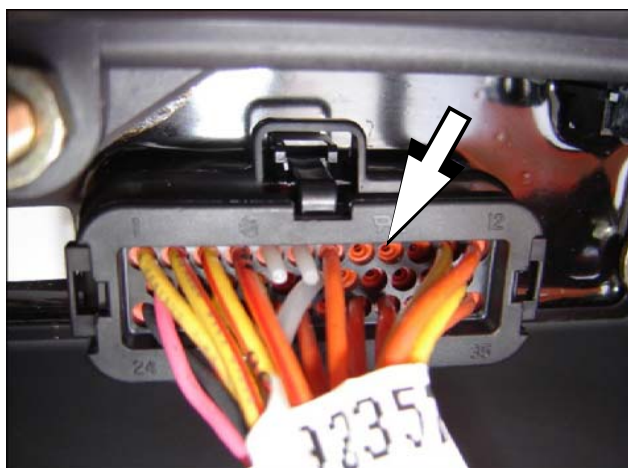


Figure 7-8. Seal Plugs



### AMP Mate-N-Lok

Follow manufacturer installation instructions.

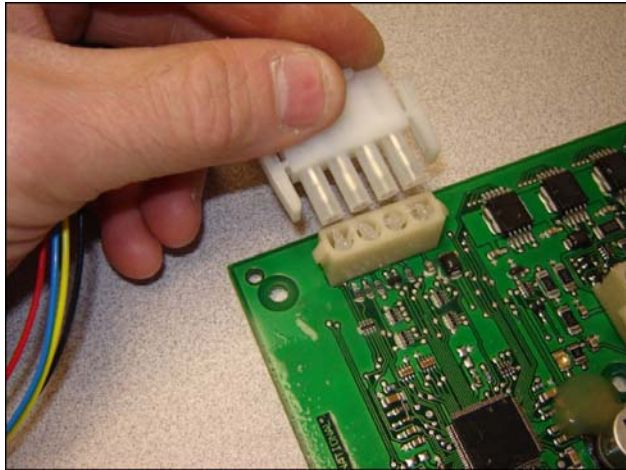


Figure 7-9. AMP Mate-N-Lok Connector

### DIN Connectors

This connector is typically used on hydraulic valves. Follow manufacturer installation instructions.



Figure 7-10. DIN Connector

### Exclusions

Some connectors do not require or may be permanently damaged by application of dielectric grease. Dielectric grease may not be required in properly sealed enclosures.

**NOTICE**

**DO NOT USE DIELECTRIC GREASE ON BRAD HARRISON/PHOENIX CONTACT M12 OR AMP JUNIOR TIMER CONNECTORS. LOW-FORCE CONTACTS CANNOT DISPLACE DIELECTRIC GREASE AND CREATE ELECTRICAL CONTACT.**

### BRAD HARRISON/PHOENIX CONTACT M12

This connector uses gold contact material to resist corrosion and an O-ring seal for moisture integrity. Low-force contacts cannot displace dielectric grease to achieve electrical contact. Once contaminated, replacement of female contacts is required. The JLG Load Sensing System and 1250AJP Rotary Angle Sensors are examples of components with the M12 connector system.



Figure 7-11. Brad Harrison/Phoenix Connectors

### AMP JUNIOR TIMER

This type of connector uses back-seals to keep out moisture. Low-force contacts cannot displace dielectric grease and create electrical contact. Use solvents (i.e. contact cleaner or mineral spirits) to remove dielectric grease. The Deutz EMR2 engine control module uses this connector.



Figure 7-12. AMP Junior Timer

## 7.4 AMP CONNECTOR

Plug and header assembly colors are mechanically keyed to mate only with identical colors.

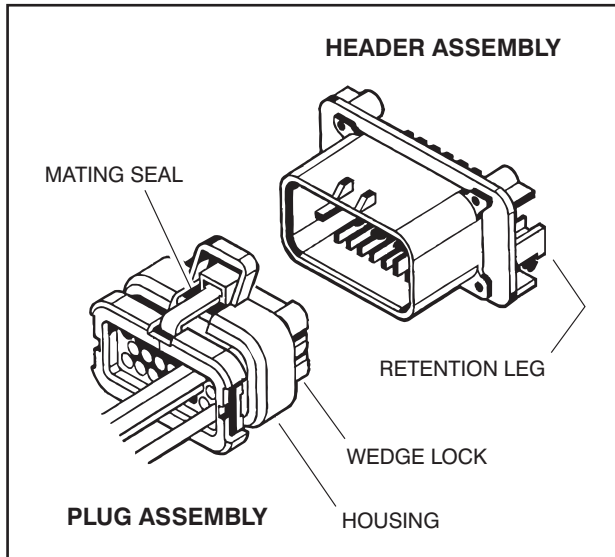


Figure 7-13. AMP Connector

### Contact Assembly

1. Strip wire and install in crimp end of connector as shown in Figure 7-14.
2. Crimp connector. Do not damage cutoff tab.

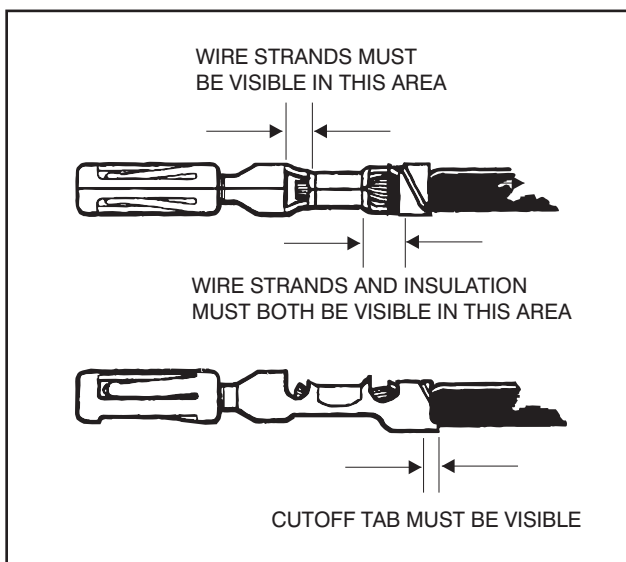


Figure 7-14. AMP Contact Assembly

### Connector Assembly

1. Check wedge lock is in the open, or as-shipped, position.

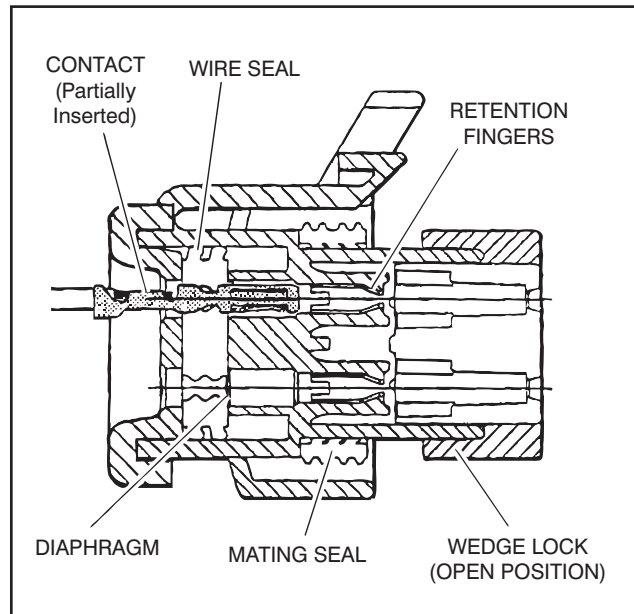


Figure 7-15. AMP Connector Assembly

2. Push contact straight into circuit cavity as far as it will go.
3. Pull on contact wire with a force of 1 - 2 lb to be sure retention fingers are holding contact.

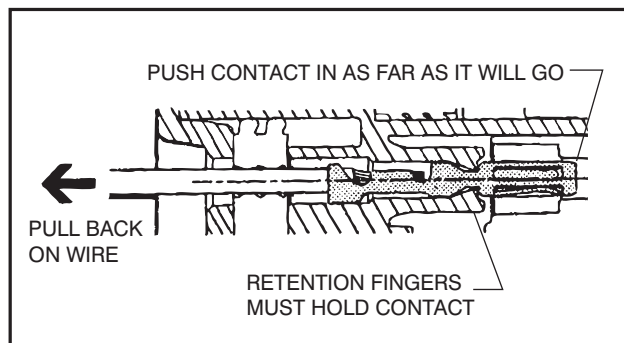


Figure 7-16. AMP Contact Installation

4. After all contacts are inserted, close wedge lock to its locked position. Release locking latches by squeezing them inward.

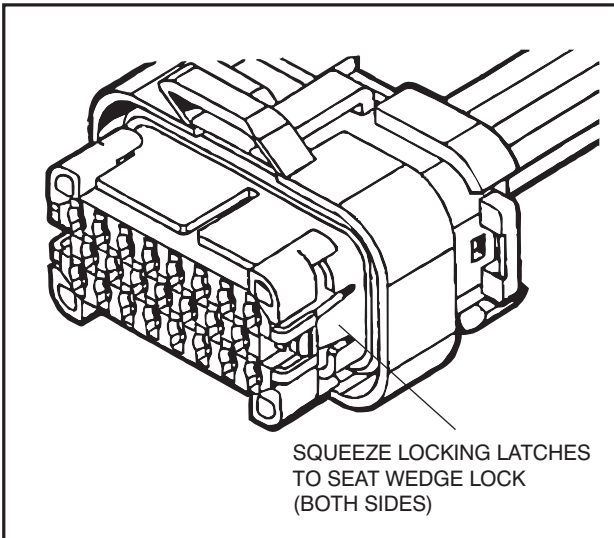


Figure 7-17. Close Wedge Lock

5. Slide wedge lock in housing until flush with housing.

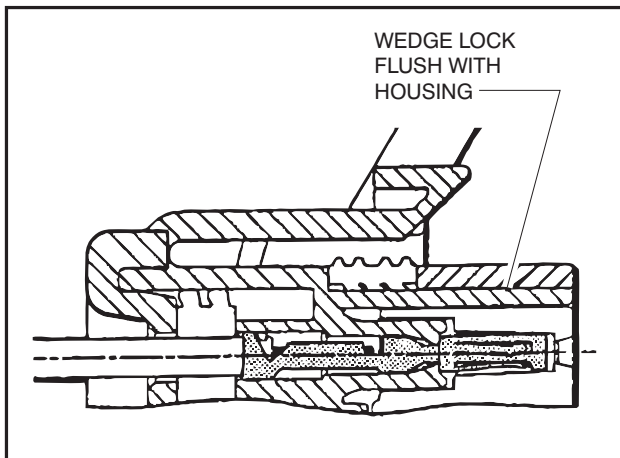


Figure 7-18. Seating Wedge Lock

### Disassembly

1. Insert a 4.8 mm (3/16") wide screwdriver blade between mating seal and one of red wedge lock tabs.
2. Pry wedge lock open.
3. While rotating wire back and forth over a half turn (1/4 turn in each direction), gently pull wire until contact is removed.

**NOTE:** Wedge lock should never be removed from housing for insertion or removal of contacts.

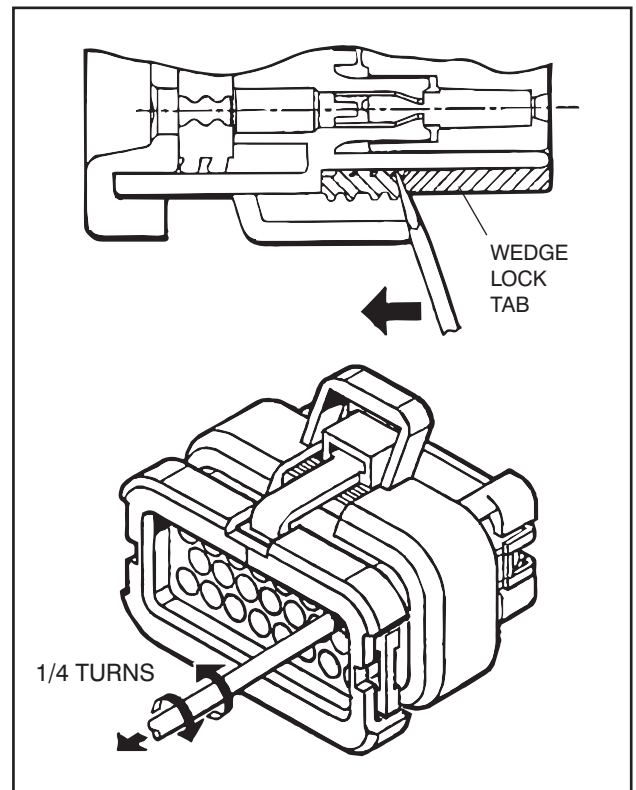


Figure 7-19. AMP Connector Disassembly

### Wedge Lock

The wedge lock has slotted openings in the forward, or mating end. These slots accommodate circuit testing in the field by using a flat probe such as a pocket knife. DO NOT use a sharp point such as an ice pick.

### Service - Voltage Reading

#### **NOTICE**

**HOLES IN WIRE INSULATION CAN LET IN MOISTURE AND CAUSE SYSTEM FAILURE. DO NOT PIERCE WIRE INSULATION TO TAKE VOLTAGE READINGS.**

It has been common practice in electrical troubleshooting to probe wires by piercing insulation with a sharp point. This practice should be discouraged when dealing with an AMPSEAL plug assembly or any other sealed connector system. Resulting pinholes in the insulation allows moisture to enter by traveling along wire strands and could result in system failure.

## 7.5 DEUTSCH CONNECTORS

### DT/DTP Series Assembly

1. Grasp crimped contact (1) about 25mm behind contact barrel.
2. Hold connector with rear grommet (2) facing you.
3. Push contact straight into connector grommet (3) until a click is felt. A slight tug confirms it is locked in place.
4. Once all contacts are in place, insert wedgelock (4) with arrow pointing toward exterior locking mechanism. The wedgelock will snap into place. Rectangular wedges are not oriented. They may go in either way.

**NOTE:** Receptacle shown - use same procedure for plug.

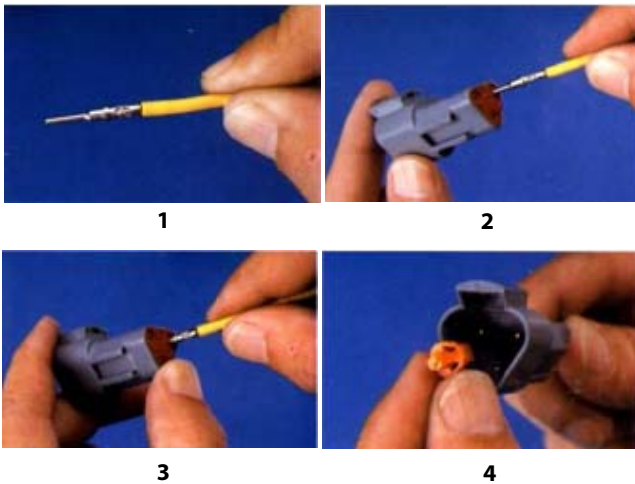


Figure 7-20. DT/DTP Contact Installation

### DT/DTP Series Disassembly

1. Remove wedgelock (1) using needle-nose pliers or a hook shaped wire to pull wedge straight out.
2. To remove contacts, gently pull wire backwards at the same time releasing the locking finger (2) by moving it away from contact with a screwdriver.
3. Hold rear seal (3) in place. Removing contact may displace seal.

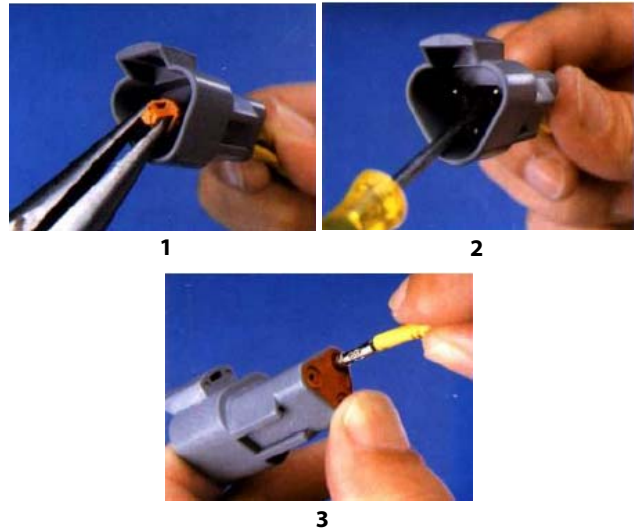


Figure 7-21. DT/DTP Contact Removal

### HD30/HDP20 Series Assembly

1. Grasp contact (1) about 25mm behind contact crimp barrel.
2. Hold connector with rear grommet (2) facing you.

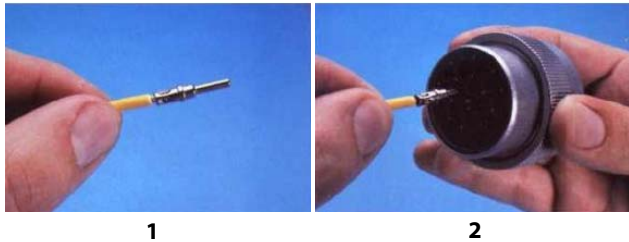


Figure 7-22. HD/HDP Contact Installation

3. Push contact straight into connector grommet until a positive stop is felt. A slight tug will confirm it is locked in place.

#### LOCKING FINGERS

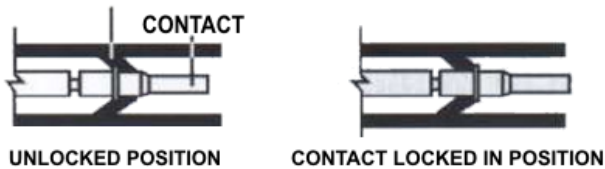


Figure 7-23. HD/HDP Locking Contacts Into Position

**NOTE:** Insert sealing plugs in unused wire cavities for full environmental sealing.

### HD30/HDP20 Series Disassembly

1. With rear insert toward you, snap appropriate size extractor tool (1) over wire of contact to be removed.
2. Push tool in the insert cavity (2) until it engages contact and resistance is felt.

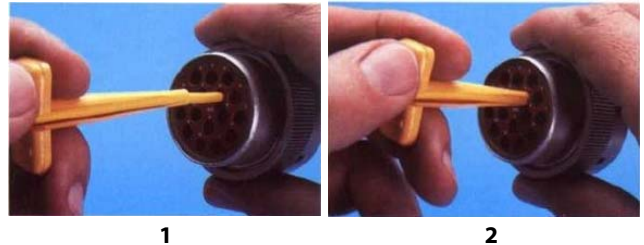


Figure 7-24. HD/HDP Contact Removal

3. Pull contact-wire assembly out of connector

**NOTE:** Do Not twist or insert tool at an angle.

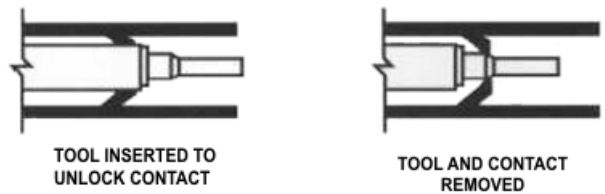
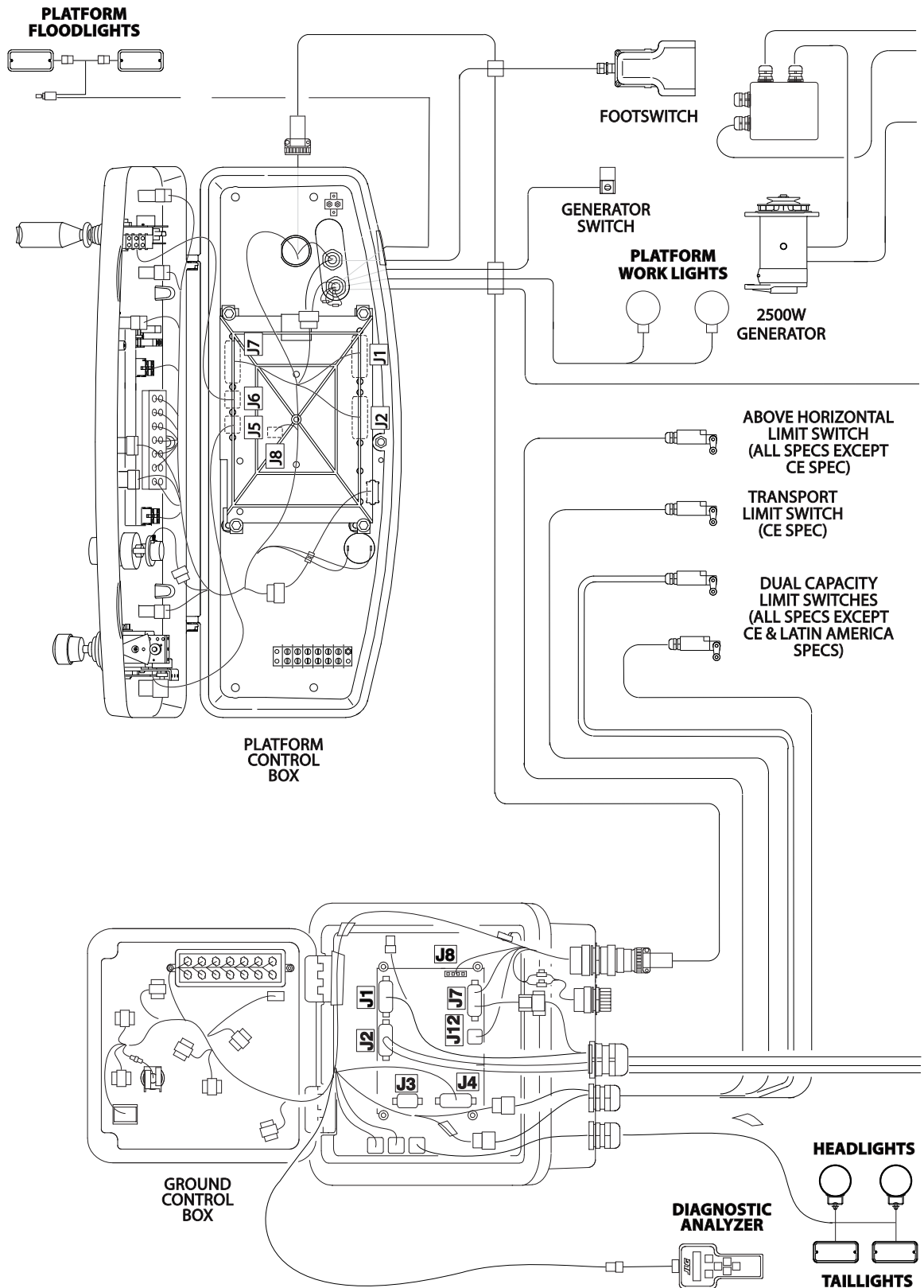


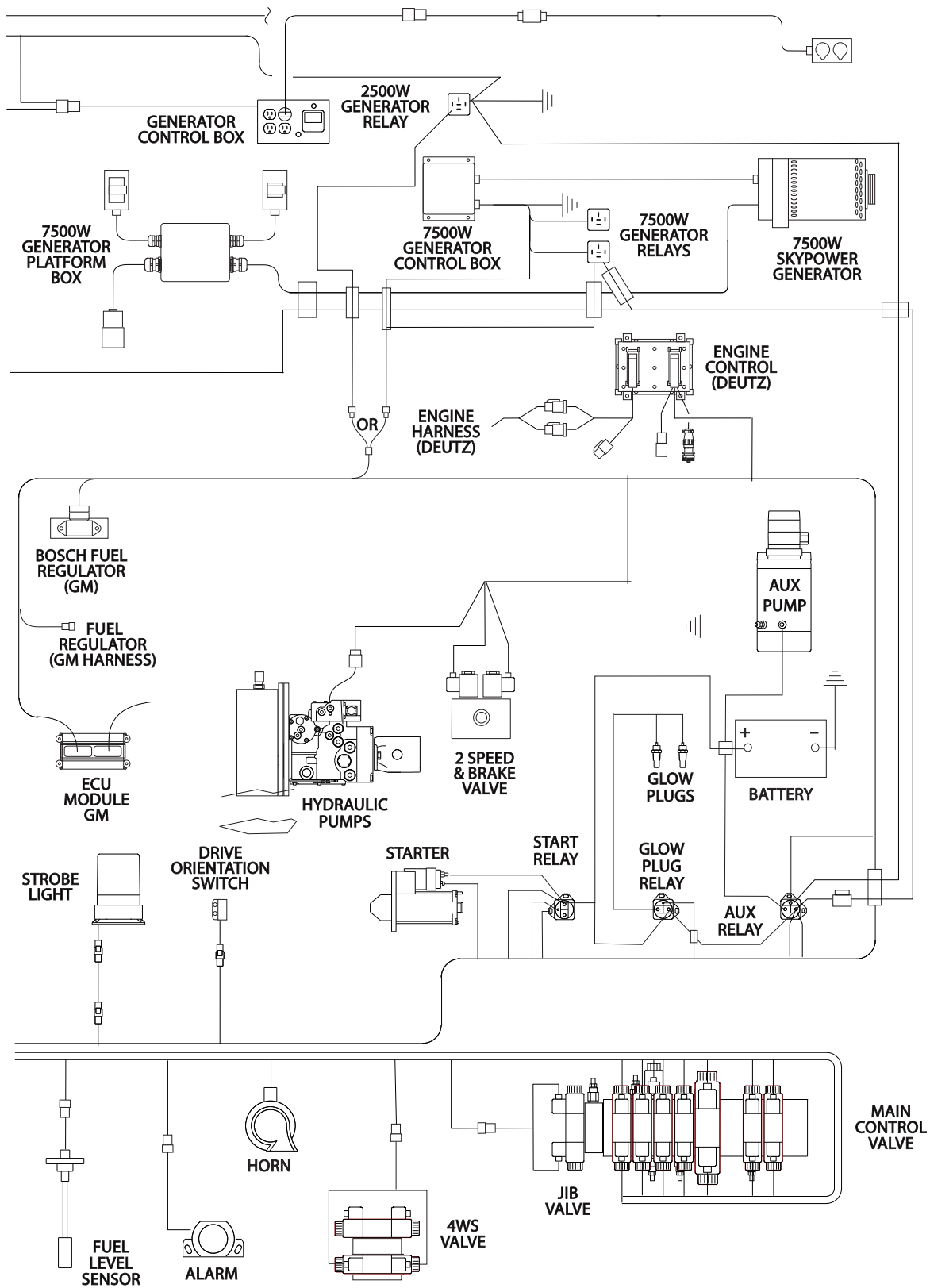
Figure 7-25. HD/HDP Unlocking Contacts

**SECTION 7 - BASIC ELECTRICAL INFORMATION & SCHEMATICS**



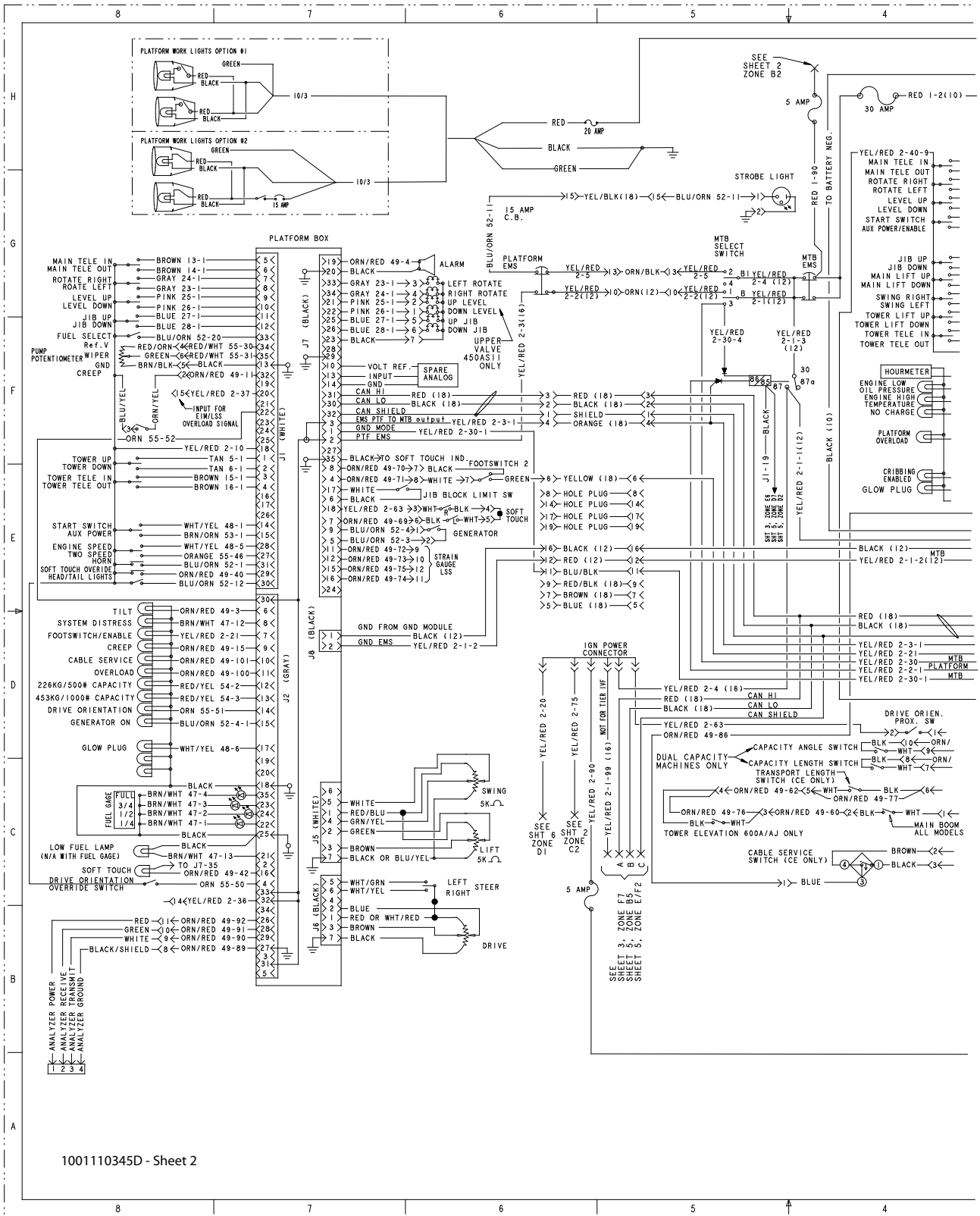
**Figure 7-26. Electrical Components 1 of 2**

**SECTION 7 - BASIC ELECTRICAL INFORMATION & SCHEMATICS**



**Figure 7-27. Electrical Components 2 of 2**

**SECTION 7 - BASIC ELECTRICAL INFORMATION & SCHEMATICS**



**Figure 7-28. Platform and Ground Control Electrical Schematic - 1 of 2**



SECTION 7 - BASIC ELECTRICAL INFORMATION & SCHEMATICS

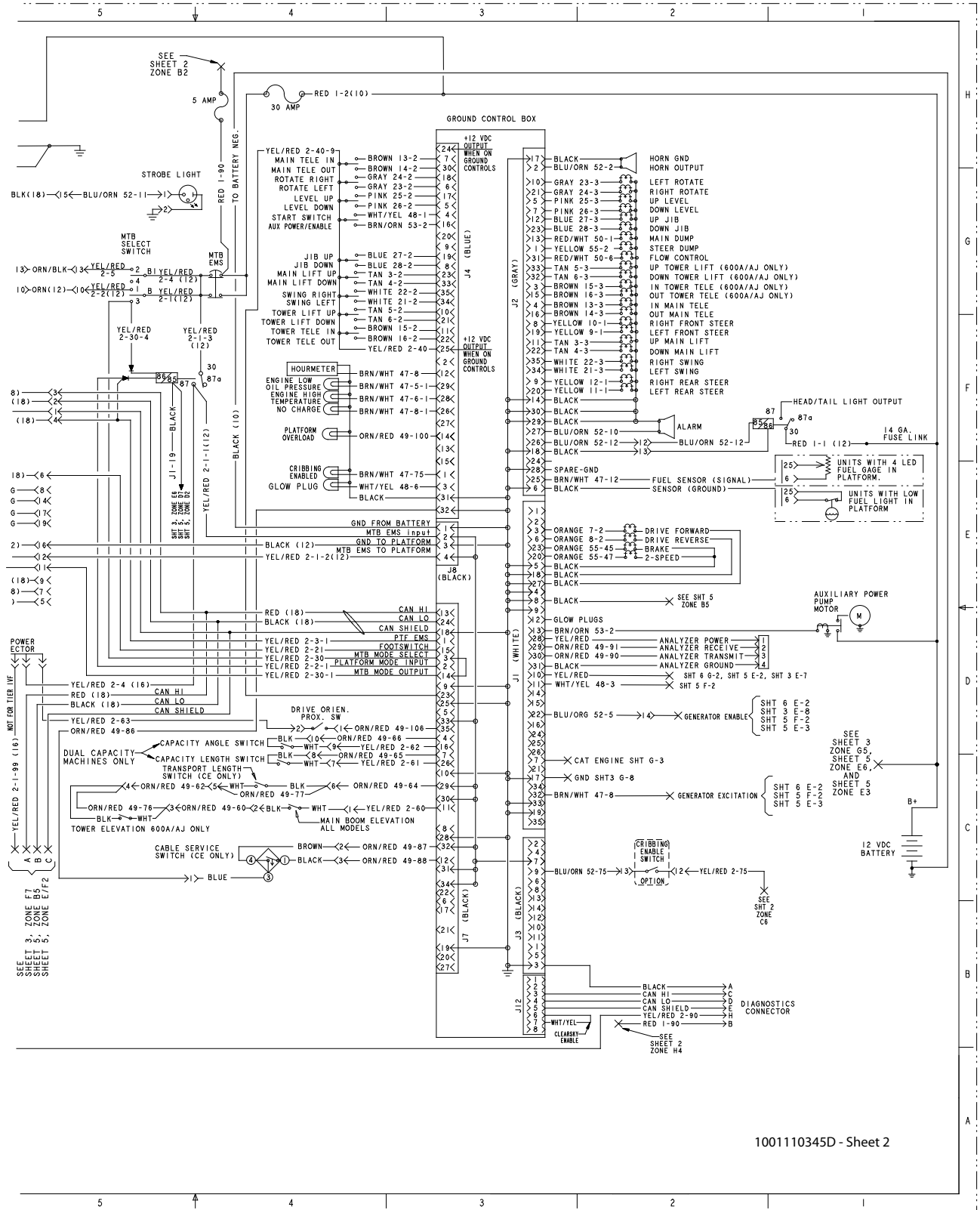
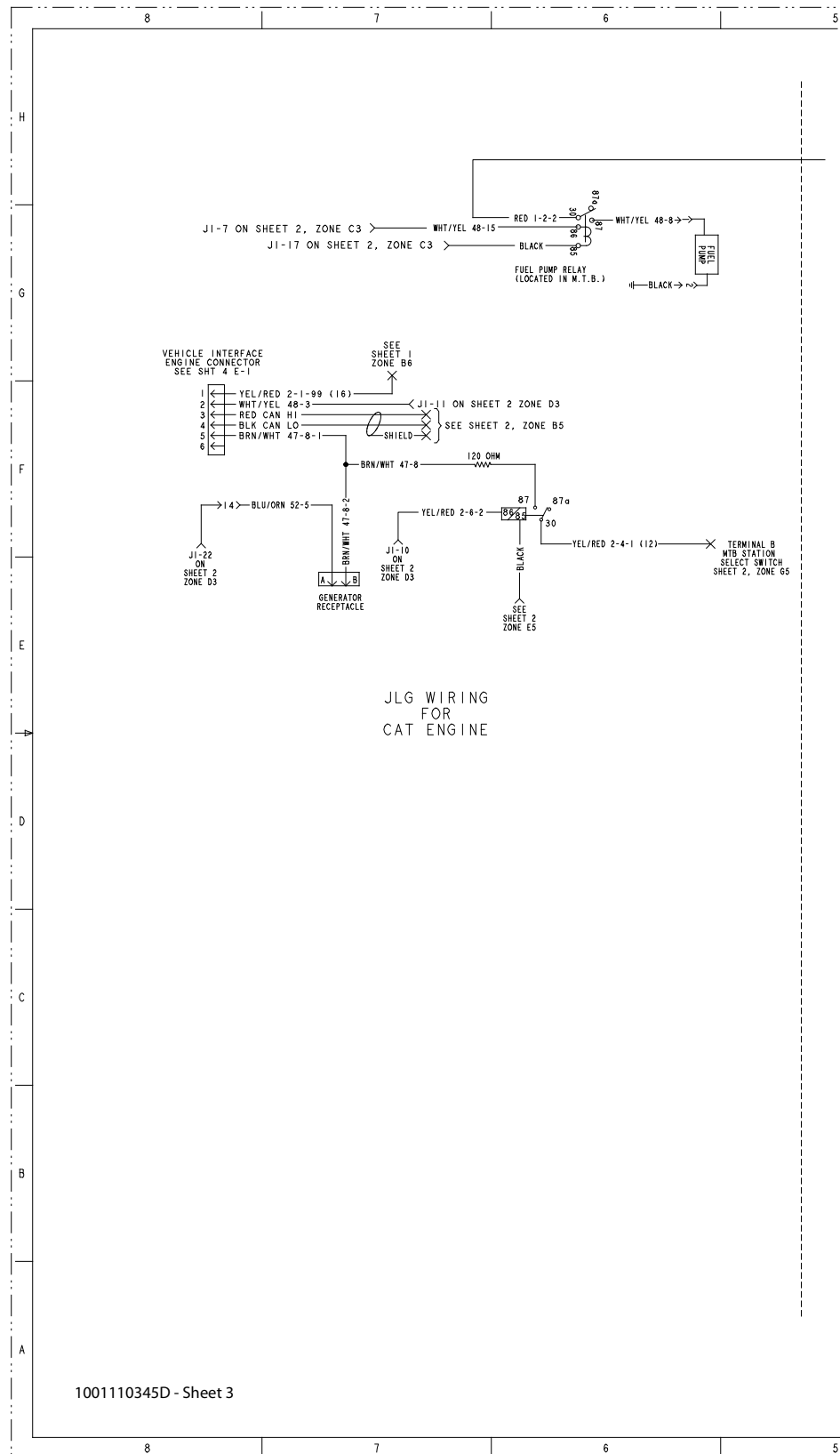


Figure 7-29. Platform and Ground Control Electrical Schematic - 2 of 2

1001110345D - Sheet 2

**SECTION 7 - BASIC ELECTRICAL INFORMATION & SCHEMATICS**



**Figure 7-30. Generator Wiring Schematic 1 of 2**

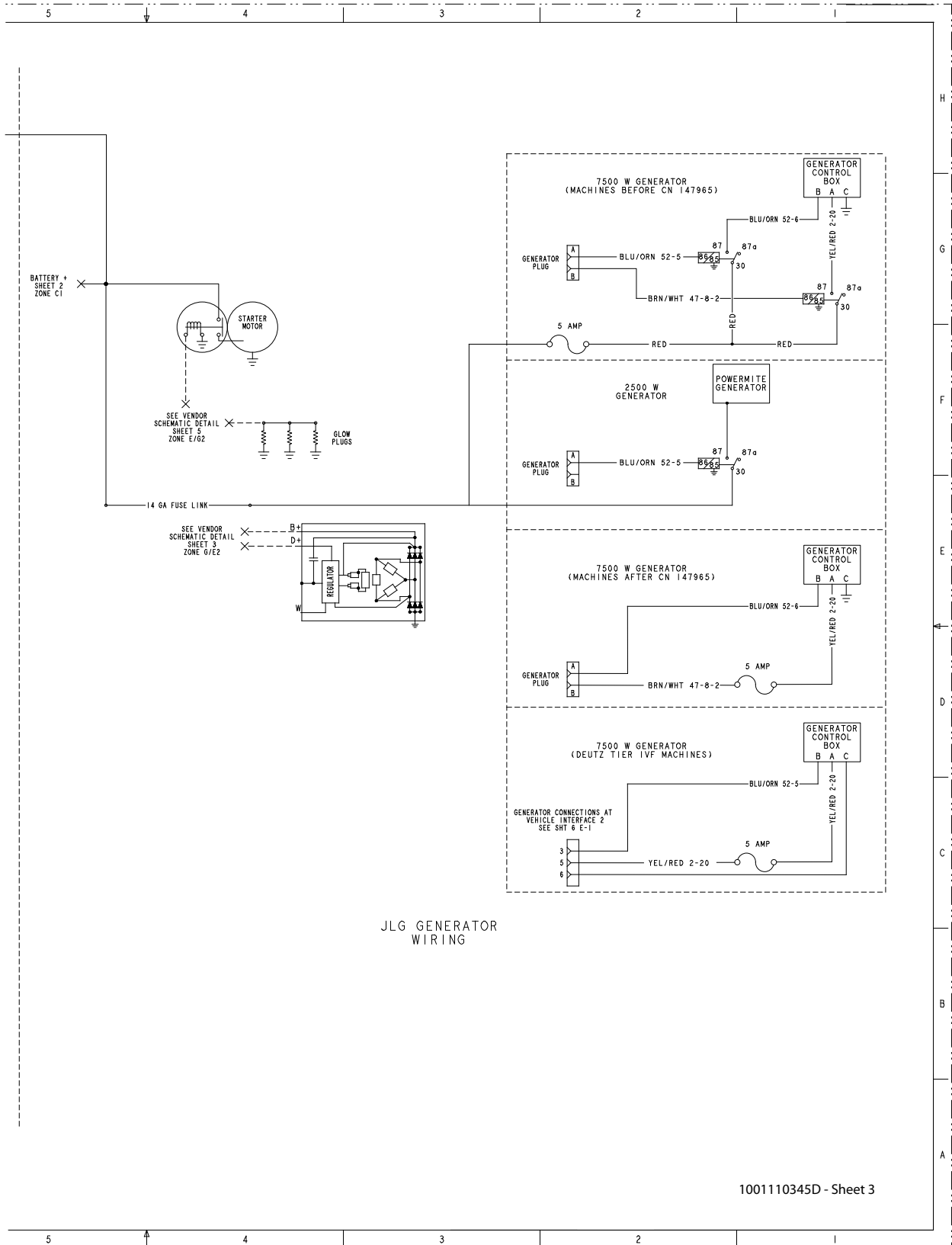


Figure 7-31. Generator Wiring Schematic 2 of 2

# SECTION 7 - BASIC ELECTRICAL INFORMATION & SCHEMATICS

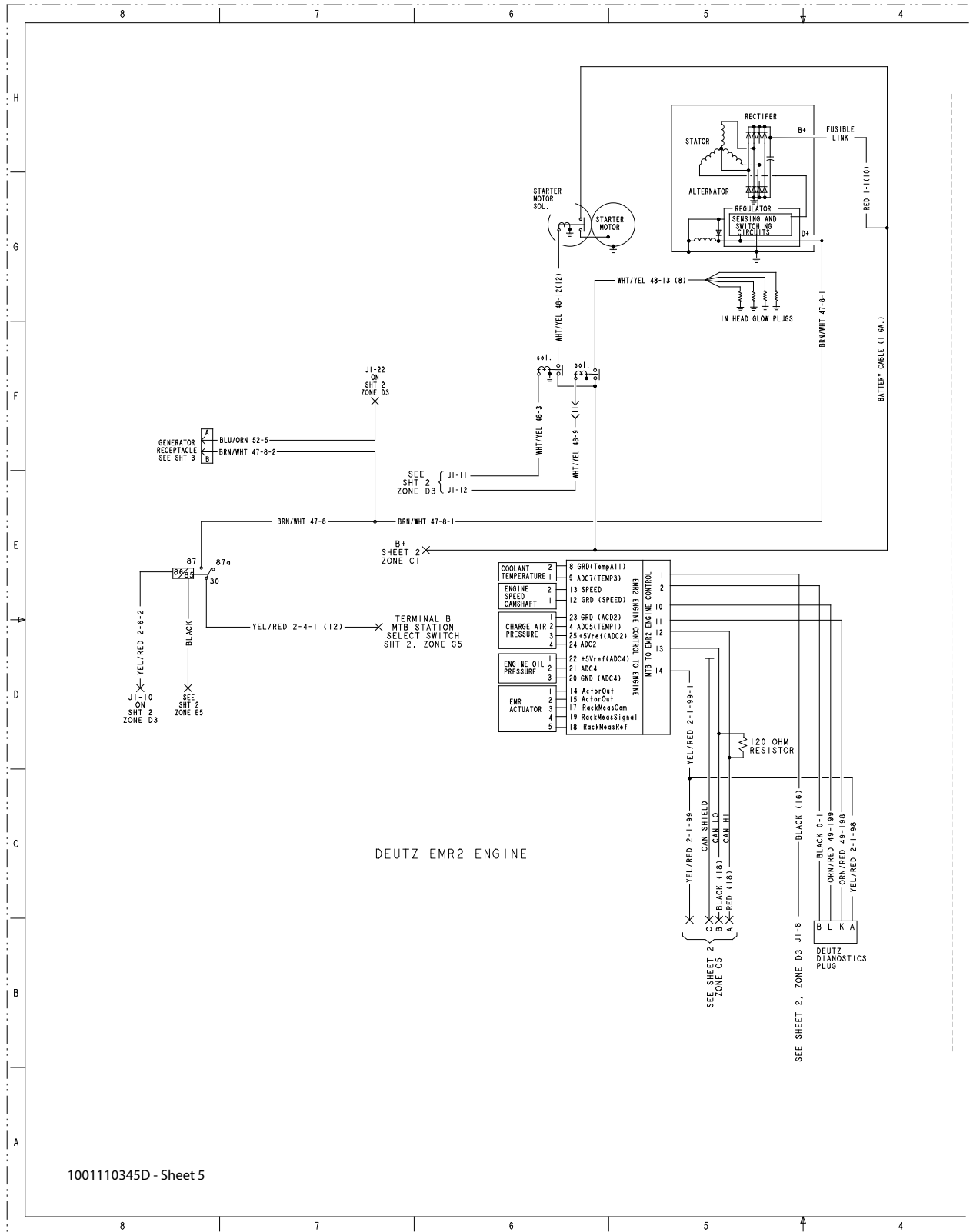


Figure 7-32. Deutz Engine Harness Electrical Schematic

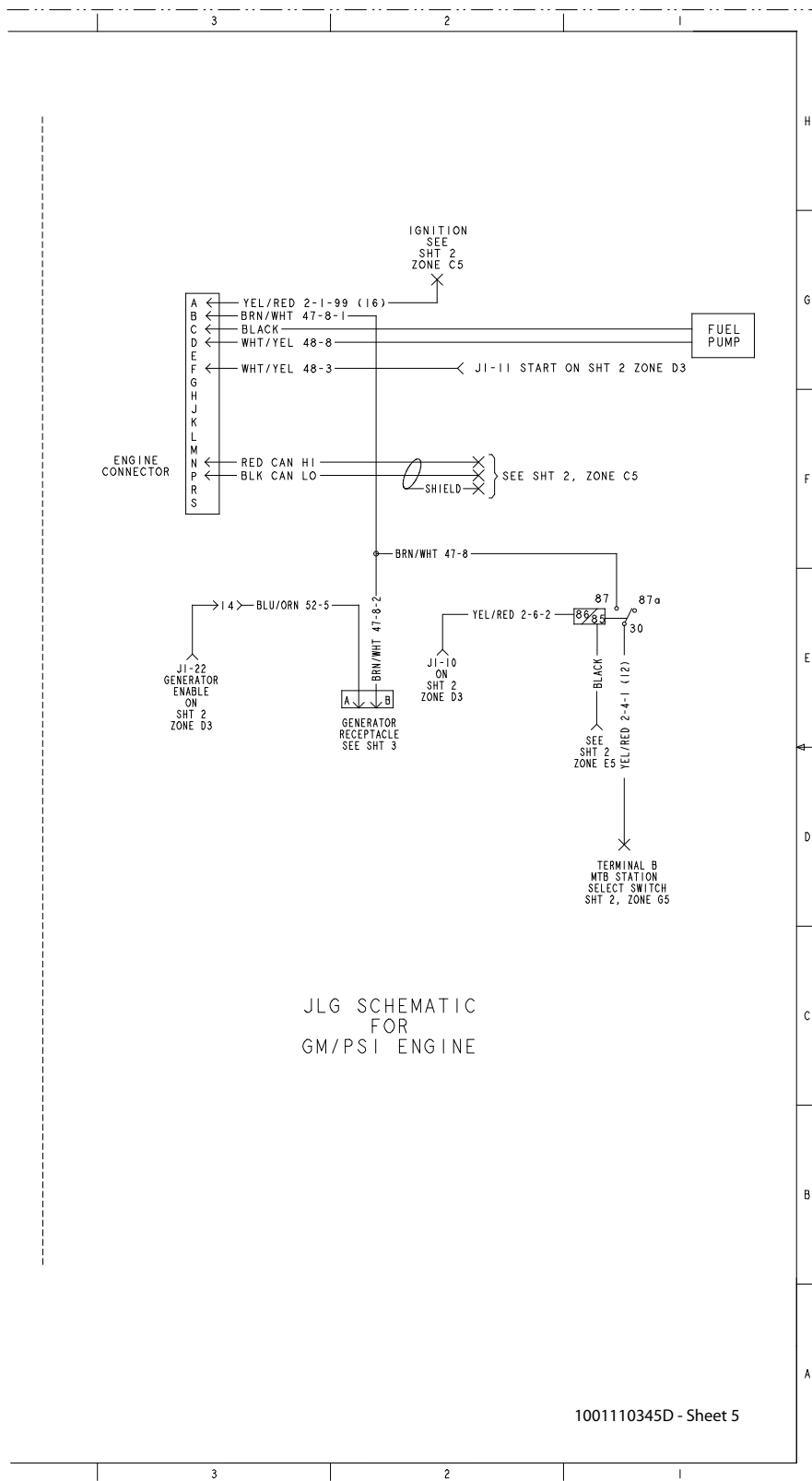


Figure 7-33. GM/PSI Engine Harness Electrical Schematic

# SECTION 7 - BASIC ELECTRICAL INFORMATION & SCHEMATICS

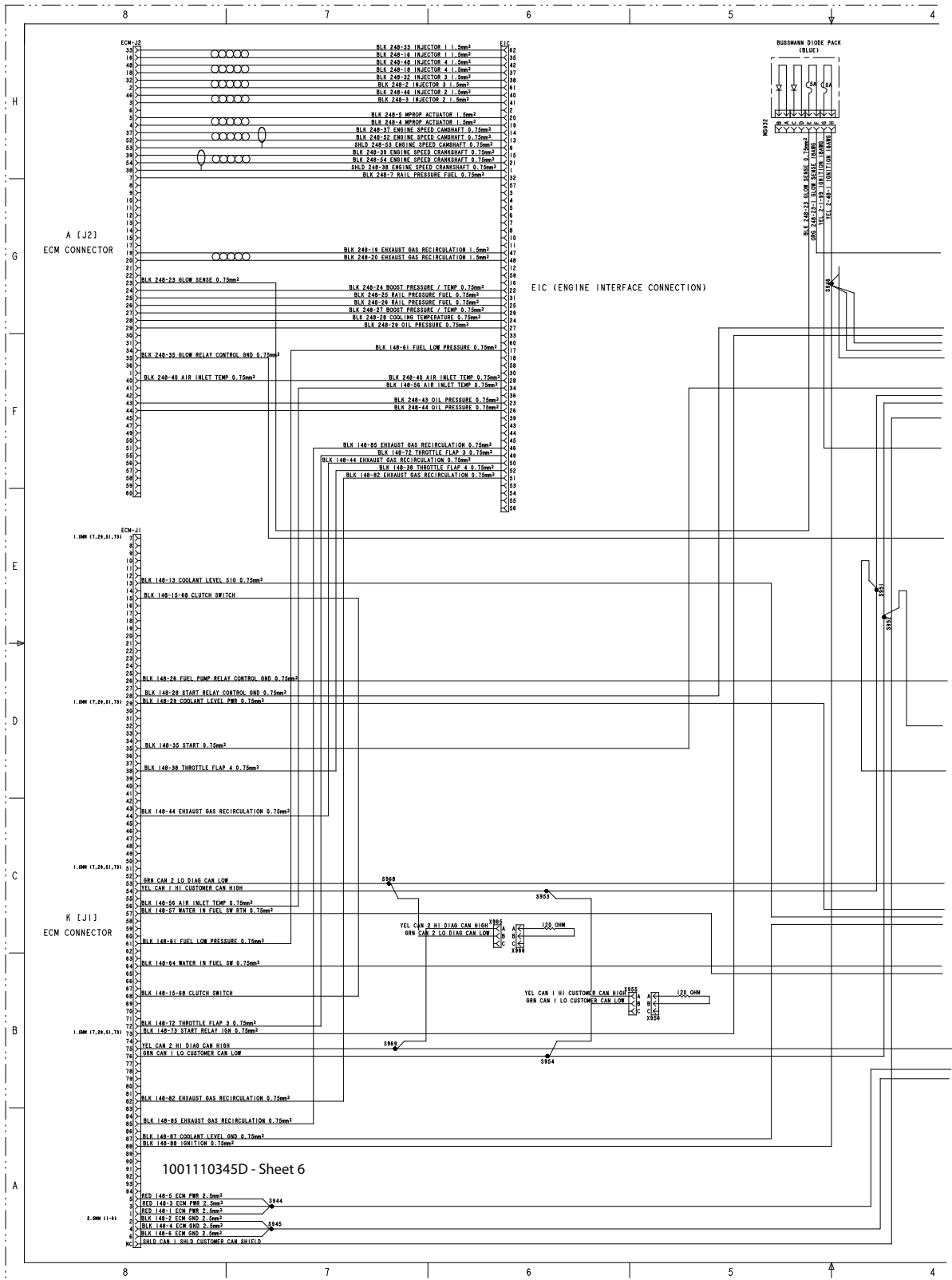


Figure 7-34. Deutz Tier 4 Final Engine Harness Electrical Schematic

SECTION 7 - BASIC ELECTRICAL INFORMATION & SCHEMATICS

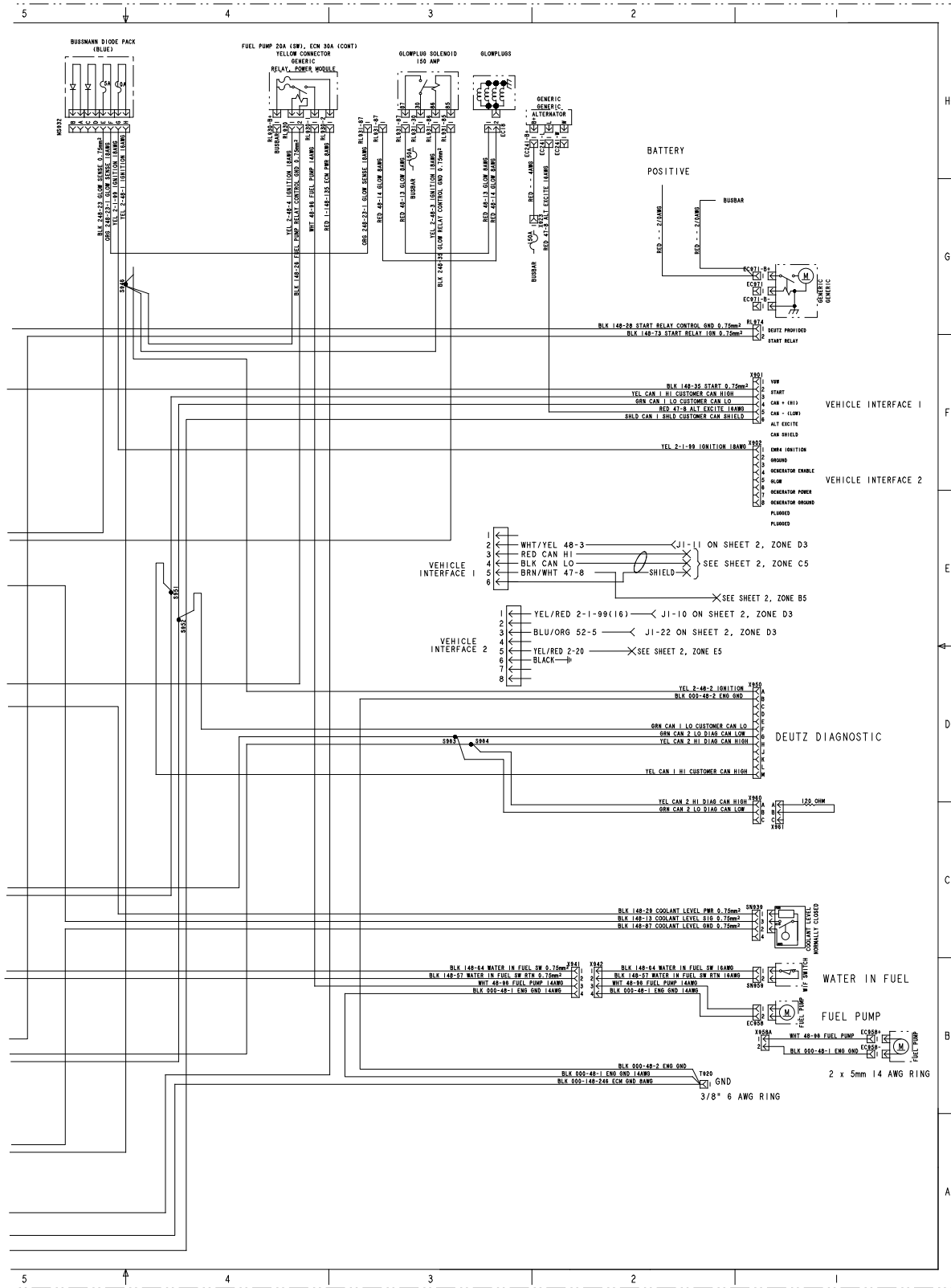
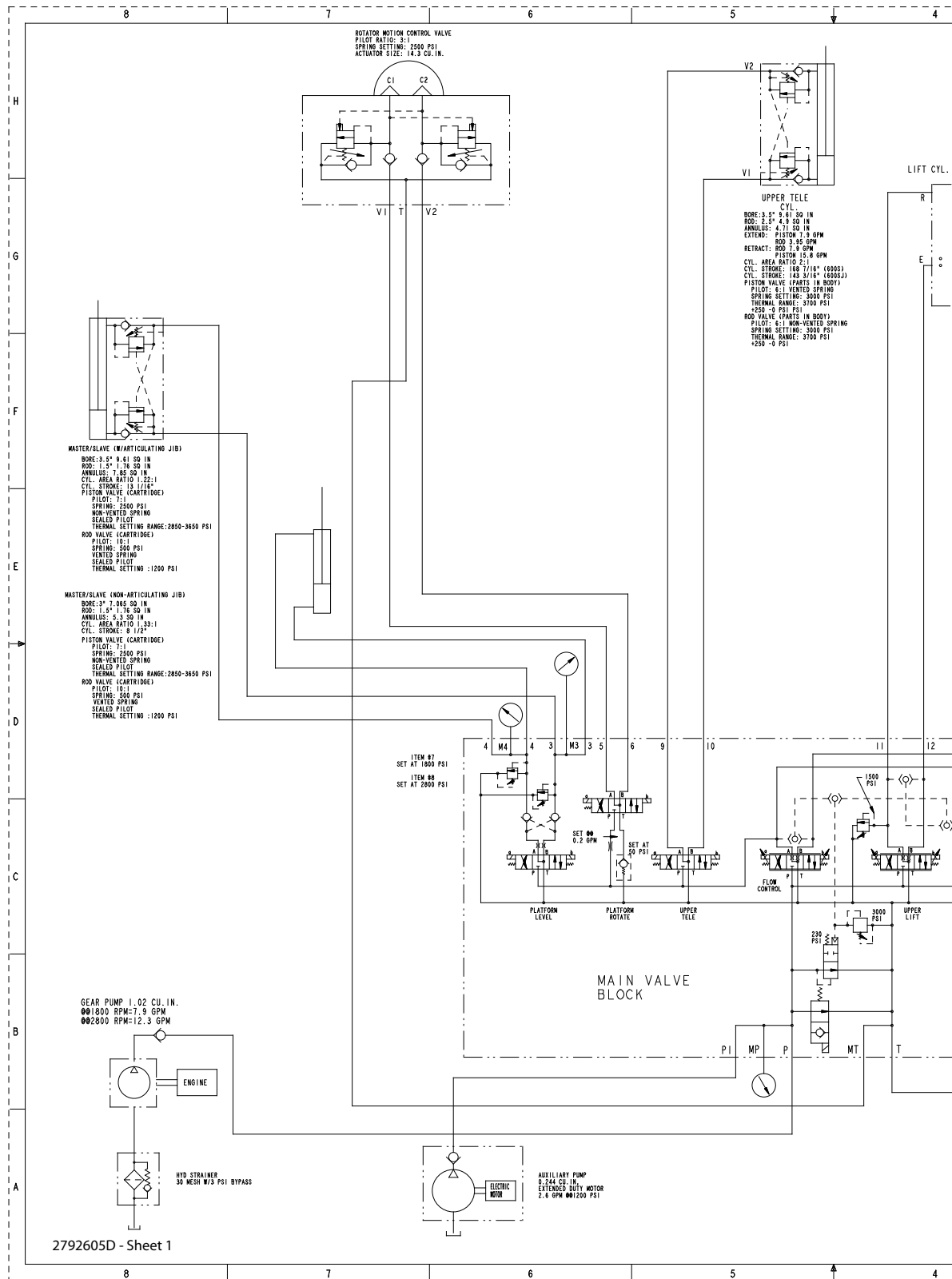


Figure 7-35. Deutz Tier 4 Final Engine Harness Electrical Schematic

**SECTION 7 - BASIC ELECTRICAL INFORMATION & SCHEMATICS**



**Figure 7-36. Hydraulic Schematic**



SECTION 7 - BASIC ELECTRICAL INFORMATION & SCHEMATICS

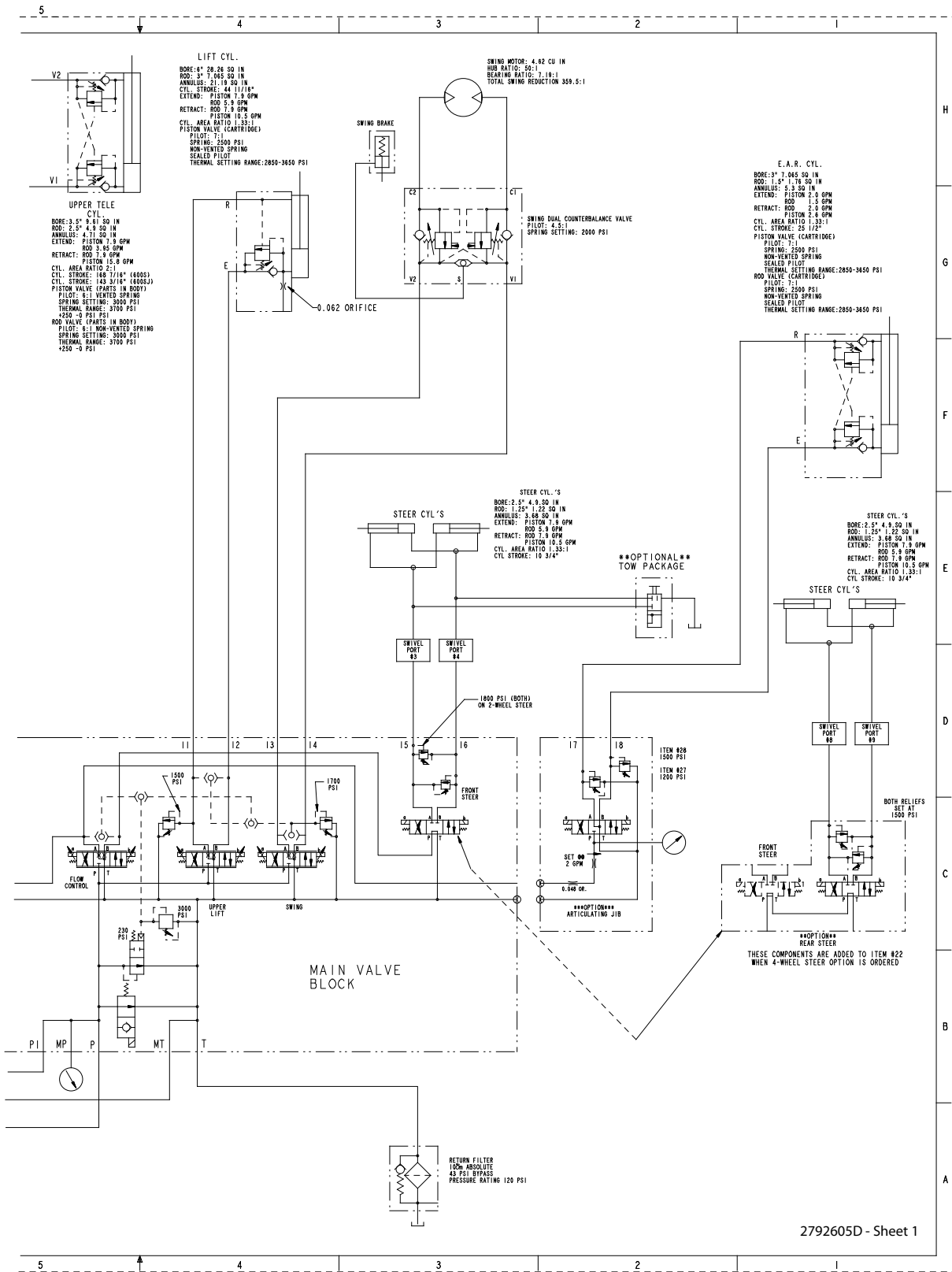
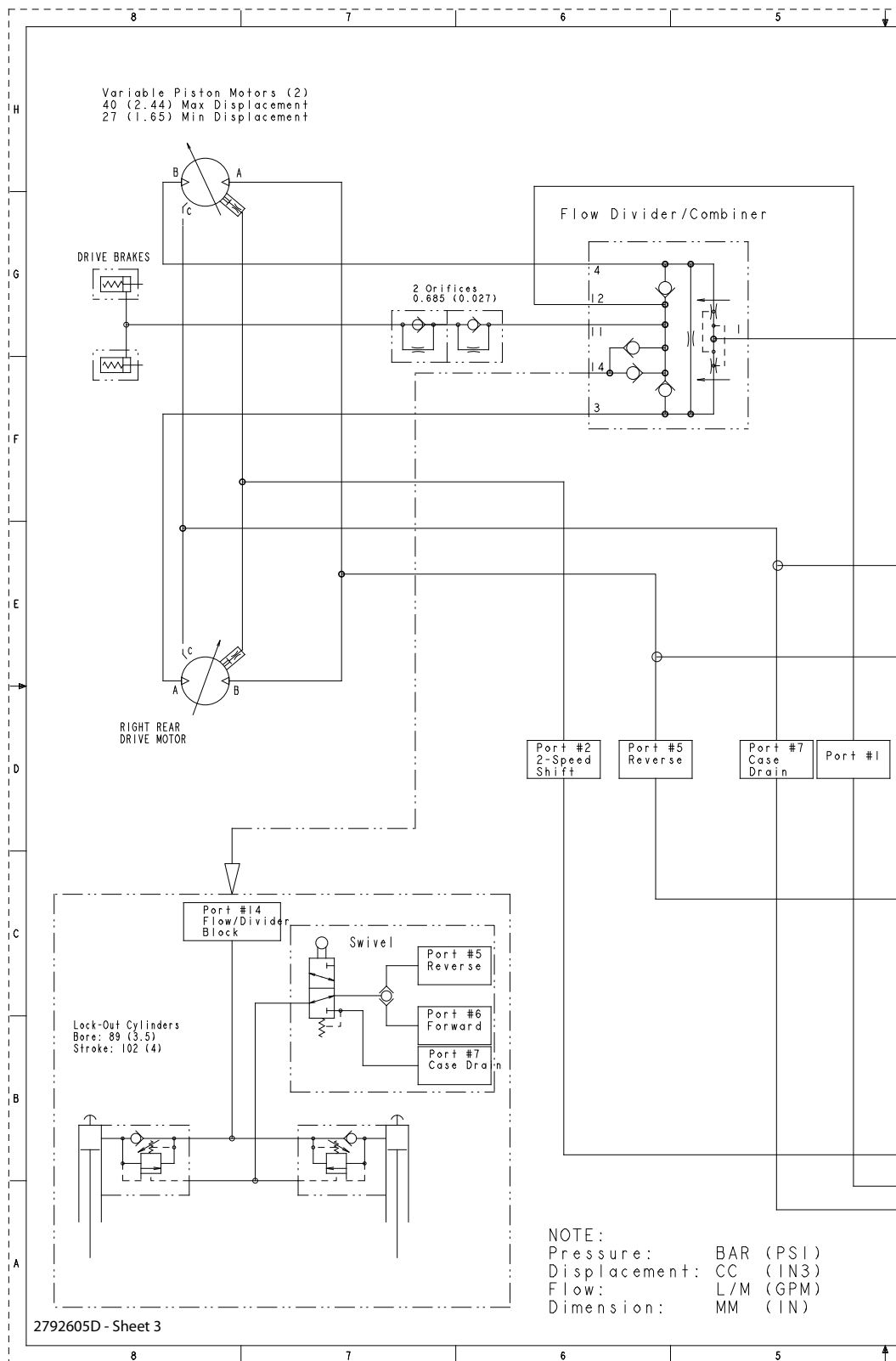


Figure 7-37. Hydraulic Schematic

**SECTION 7 - BASIC ELECTRICAL INFORMATION & SCHEMATICS**



**Figure 7-38. Hydraulic Schematic 2-Wheel Drive - 1 of 2**

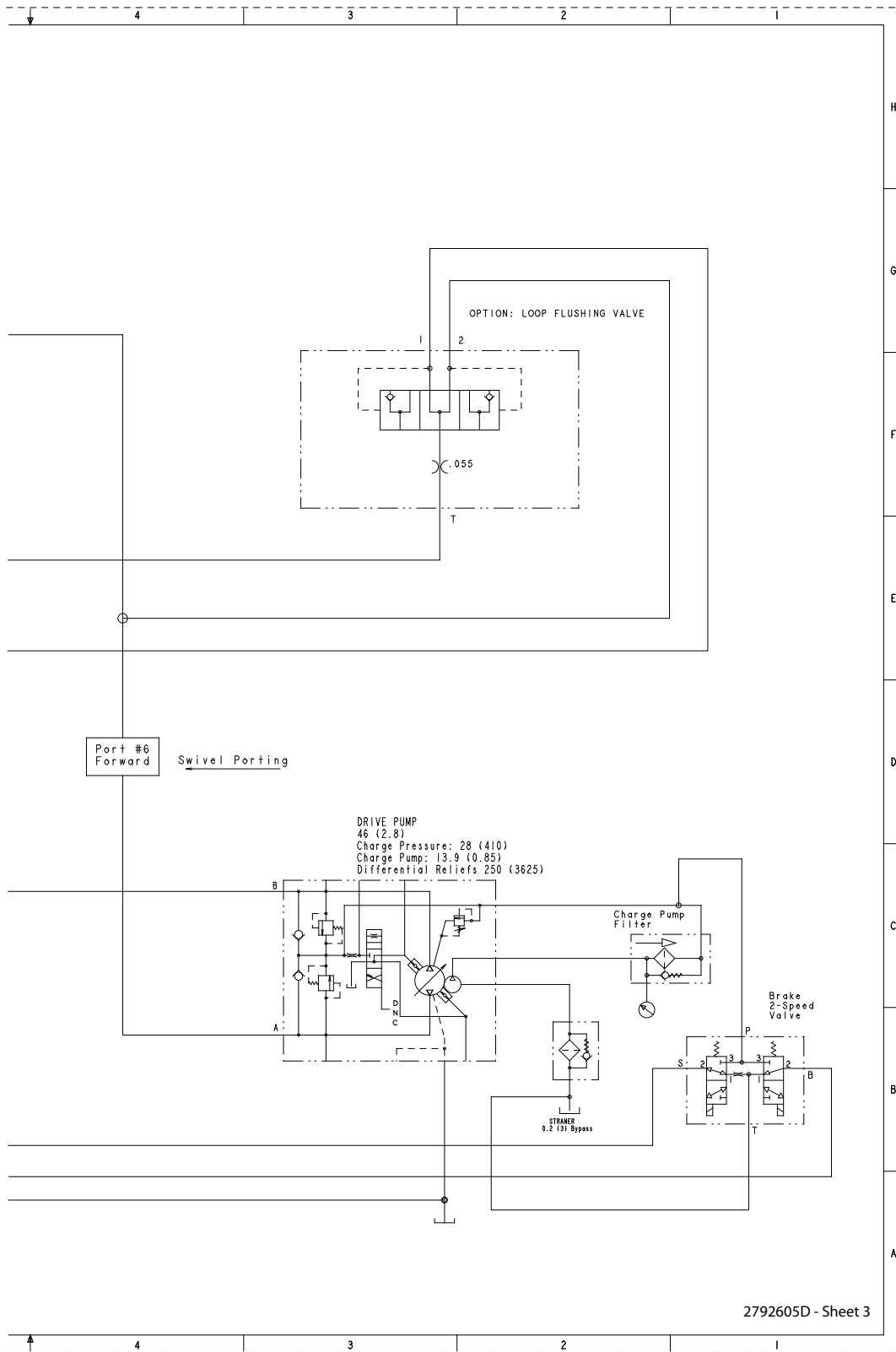
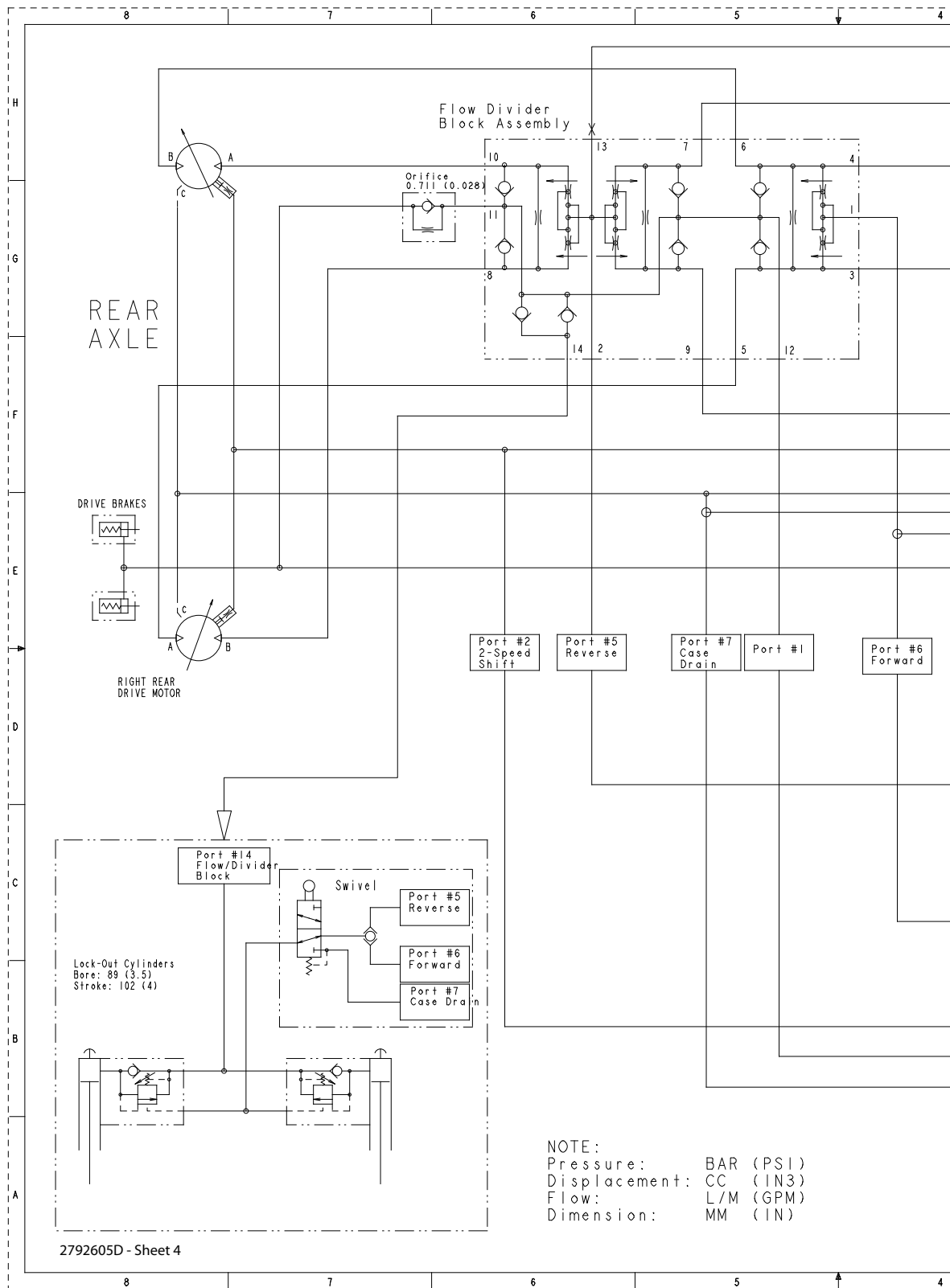


Figure 7-39. Hydraulic Schematic 2-Wheel Drive - 2 of 2

**SECTION 7 - BASIC ELECTRICAL INFORMATION & SCHEMATICS**



**Figure 7-40. Hydraulic Schematic 4-Wheel Drive - 1 of 2**

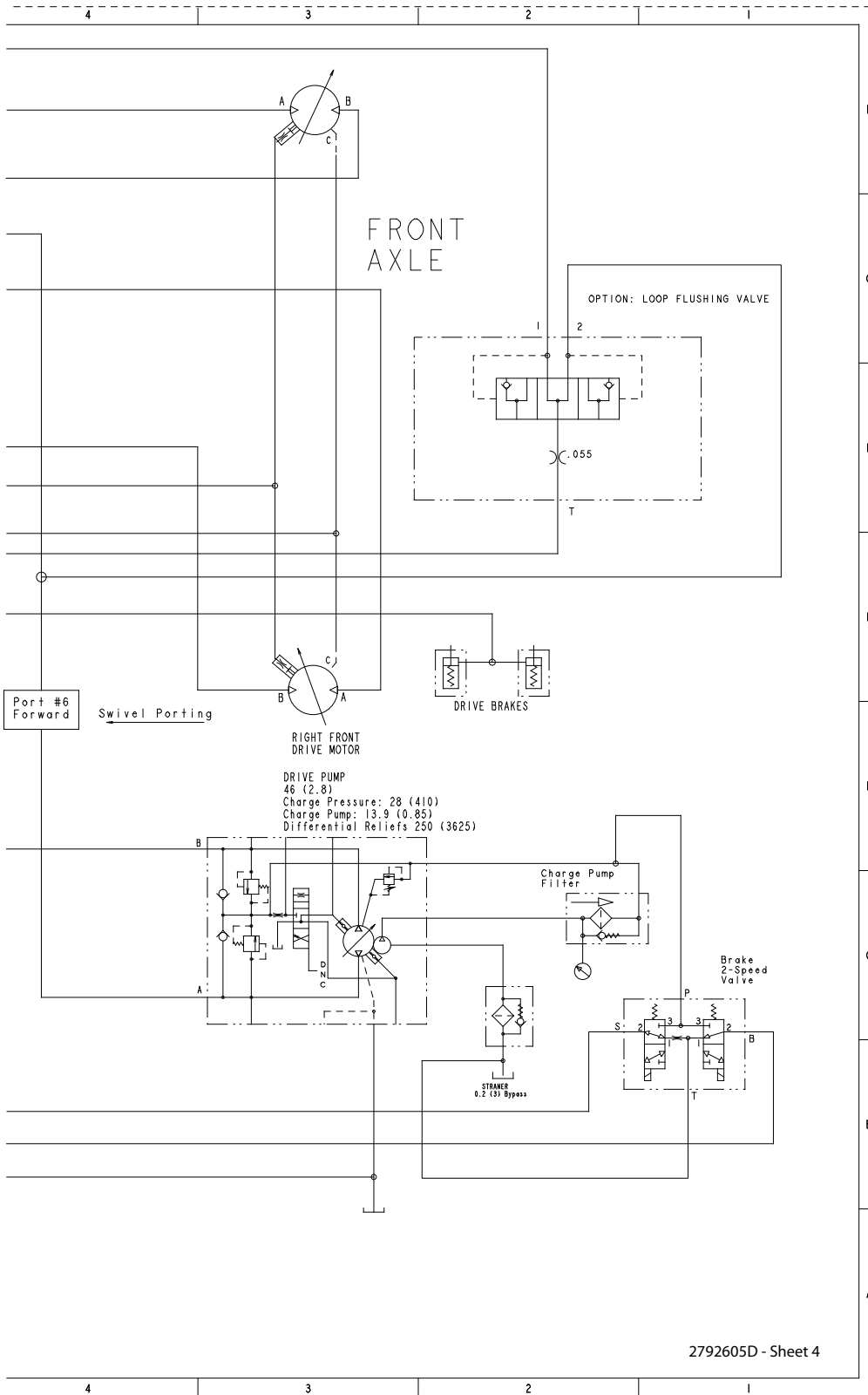


Figure 7-41. Hydraulic Schematic 4-Wheel Drive - 2 of 2



## **PROPOSITION 65 WARNING**

- **Battery posts, terminals and related accessories contain lead and lead compounds, chemicals known to the State of California to cause cancer and reproductive harm.**
- **Batteries also contain other chemicals known to the State of California to cause cancer.**
- **Wash hands after handling.**



**WARNING:**



**The engine exhaust from this product contains chemicals known to the State of California to cause cancer, birth defects, or other reproductive harm.**

1702961



3121298



An Oshkosh Corporation Company

Corporate Office  
JLG Industries, Inc.  
1 JLG Drive  
McConnellsburg PA. 17233-9533  
USA

☎ (717) 485-5161

📠 (717) 485-6417

## JLG Worldwide Locations

JLG Industries (Australia)  
P.O. Box 5119  
11 Bolwarra Road  
Port Macquarie  
N.S.W. 2444  
Australia  
☎ +61 2 65 811111  
📠 +61 2 65813058

JLG Latino Americana Ltda.  
Rua Eng. Carlos Stevenson,  
80-Suite 71  
13092-310 Campinas-SP  
Brazil  
☎ +55 19 3295 0407  
📠 +55 19 3295 1025

JLG Industries (UK) Ltd  
Bentley House  
Bentley Avenue  
Middleton  
Greater Manchester  
M24 2GP - England  
☎ +44 (0)161 654 1000  
📠 +44 (0)161 654 1001

JLG France SAS  
Z.I. de Baulieu  
47400 Fauillet  
France  
☎ +33 (0)5 53 88 31 70  
📠 +33 (0)5 53 88 31 79

JLG Deutschland GmbH  
Max-Planck-Str. 21  
D - 27721 Ritterhude - Ihlpohl  
Germany  
☎ +49 (0)421 69 350 20  
📠 +49 (0)421 69 350 45

JLG Equipment Services Ltd.  
Rm 1107 Landmark North  
39 Lung Sum Avenue  
Sheung Shui N. T.  
Hong Kong  
☎ (852) 2639 5783  
📠 (852) 2639 5797

JLG Industries (Italia) s.r.l.  
Via Po. 22  
20010 Pregnana Milanese - MI  
Italy  
☎ +39 029 359 5210  
📠 +39 029 359 5845

Oshkosh-JLG Singapore  
Technology Equipment Pte Ltd  
29 Tuas Ave 4,  
Jurong Industrial Estate  
Singapore, 639379  
☎ +65-6591 9030  
📠 +65-6591 9031

Plataformas Elevadoras  
JLG Iberica, S.L.  
Trapadella, 2  
Pl. Castellbisbal Sur  
08755 Castellbisbal, Barcelona  
Spain  
☎ +34 93 772 4700  
📠 +34 93 771 1762

JLG Sverige AB  
Enkopingsvagen 150  
Box 704  
SE - 176 27 Jarfalla  
Sweden  
☎ +46 (0)850 659 500  
📠 +46 (0)850 659 534

[www.jlg.com](http://www.jlg.com)