

# 2014 TL Navigation Manual (Unlinked)

This document may not contain hyperlinks and may be formatted for printing instead of web use. This is due to changes in content and specifications of the vehicle that happen throughout the model year. This manual will be replaced with a hyperlinked version at the end of the model year.

<b>Introduction</b> .....	<b>4</b>
Manual Overview .....	4
System Overview .....	4
Accessories Precautions .....	5
Important Safety Information .....	5
Map Overview .....	6
<i>Current Street</i> .....	6
<i>Verified/Unverified Street</i> .....	6
<b>User Agreement</b> .....	<b>8</b>
<b>Getting Started</b> .....	<b>10</b>
System Controls .....	10
Voice Control Basics .....	13
<i>Using the Voice Control System</i> .....	14
<i>Improving Voice Recognition</i> .....	14
Selecting an Item in a List .....	15
Entering Information .....	16
System Start-up .....	18
System Language Selection .....	18
<b>Bluetooth®</b> HandsFreeLink® .....	19
Map Screen Legend .....	20
Map Screen Description .....	21
<i>Zoom In/Out</i> .....	21
<i>Map Scrolling</i> .....	21
Displaying Current Location .....	21
System Function Diagram .....	22

<b>Entering a Destination</b> .....	<b>23</b>
By Address .....	24
<i>Selecting the Province or State</i> .....	24
<i>Selecting the ZIP Code</i> .....	25
<i>Selecting the City</i> .....	25
<i>Selecting the Street</i> .....	26
<i>Entering the Street Number</i> .....	28
By Address Book .....	28
<i>Adding Addresses to the Personal</i> <i>Address Book</i> .....	29
By Previous Destinations .....	29
By Place Name .....	30
By Place Category .....	31
<i>Subcategories</i> .....	32
<i>Finding a restaurant</i> .....	34
<i>Place Name</i> .....	35
<i>City Vicinity</i> .....	35
<i>Sort by Distance to Travel</i> .....	36
<i>Search by Keyword</i> .....	36
<i>Sort by Zagat Rating</i> .....	37
By Place Phone Number .....	37
By ZAGAT® 2012 .....	38
By Coordinate .....	39
By Intersection .....	40
By Map Input .....	41
<i>Showing the Map of Current</i> <i>Position</i> .....	41

<i>Showing the Map of City</i> .....	42
<i>Showing the Map of Provinces</i> .....	43
<i>Showing the Map of USA, Canada</i> <i>and Mexico</i> .....	45
By Go Home 1 or 2 .....	45
<b>Driving to Your Destination</b> .....	<b>47</b>
Driving to Your Destination .....	47
Calculate Route to Screen .....	47
<i>Changing the Routing Method</i> .....	48
<i>Viewing the Routes</i> .....	48
<i>Viewing the Destination Map</i> .....	49
Map Screen .....	50
<i>Route Line</i> .....	50
<i>Voice Guidance Prompts</i> .....	50
<i>Map Screen Legend</i> .....	52
Guidance Screen .....	53
<i>Guidance Screen Legend</i> .....	53
Distance and Time to Destination .....	54
Map Menu .....	54
Guidance Menu .....	55
<i>Directions</i> .....	55
<i>EXIT INFO (Highway Exit</i> <i>Information)</i> .....	56
<i>Guidance Mode</i> .....	56
Map Information .....	57
Showing Icons on the Map .....	57

# Table of Contents

Map Orientation .....	59	Voice Info .....	74	Phonetic Modification.....	91
<i>Current Location</i> .....	60	<i>Setup</i> .....	75	SET UP Screen (Other).....	92
<i>Map Legend</i> .....	60	INFO Screen (Other) .....	75	Basic Settings.....	92
Map Scale .....	61	<i>Calendar</i> .....	75	<i>Units (mile or km)</i> .....	93
Destination Icon .....	62	<i>Scenic Road Information</i> .....	77	<i>Voice Recognition Tutor</i> .....	93
Various Other Icons .....	62	<i>Calculator</i> .....	78	<i>Verbal Reminders</i> .....	93
<i>Landmark Icons</i> .....	62	<i>System/Device Information</i> .....	79	Routing & Guidance .....	93
Going Off the Route.....	64	<i>Map Update Status</i> .....	79	<i>Rerouting</i> .....	93
Off-road Tracking .....	64	<i>Roadside Assistance</i> .....	79	<i>Unverified Area Routing</i> .....	94
Viewing/Saving the Current		<i>Key to Zagat Ratings</i> .....	80	<i>Edit Avoid Area</i> .....	98
Location .....	65	<i>Show Wallpaper</i> .....	81	<i>Edit Waypoint Search Area</i> .....	100
Pop-ups and Disclaimers.....	66	<b>System Setup.....</b>	<b>82</b>	<i>Guidance Mode</i> .....	101
Changing the Route.....	67	SETUP Mode.....	82	Clock Adjustment.....	101
<i>DEST Screen (Route)</i> .....	67	SETUP Screen (Main Set up) .....	82	<i>Auto Daylight</i> .....	101
<i>Destination Lists</i> .....	70	<i>Brightness</i> .....	82	<i>Auto Time Zone</i> .....	102
Changing Your Destination.....	71	<i>Contrast</i> .....	82	<i>Time Adjustment</i> .....	102
<i>Find Nearest (Voice command)</i> ....	71	<i>Black Level</i> .....	82	Vehicle .....	102
<i>Go Home (Voice command)</i> .....	71	<i>Volume</i> .....	83	<i>Off-road Tracking</i> .....	102
<i>Using Interface Dial to Change</i>		<i>Interface Dial Feedback</i> .....	83	<i>Correct Vehicle Position</i> .....	103
<i>Destination</i> .....	71	Personal Information.....	83	Colour .....	104
<i>Entering a Destination from the</i>		<i>Address Book</i> .....	83	<i>Map Colour</i> .....	104
<i>DEST Screen (while en route)</i> ...	72	<i>Home Address</i> .....	87	<i>Menu Colour</i> .....	105
Continue Trip to Screen .....	72	<i>PIN</i> .....	88	<i>Switching Display Mode</i>	
<b>Information Features .....</b>	<b>73</b>	<i>Previous Destinations</i> .....	89	<i>Manually</i> .....	105
INFO Screen .....	73	Music Search.....	90	<i>Switching Display Mode</i>	
<i>Cellular Phone</i> .....	73	<i>Song By Voice™ (SBV)</i> .....	90	<i>Automatically</i> .....	106

Language.....	107	<i>PUERTO RICO</i> .....	125	On-Screen Commands.....	151
Wallpapers Setting .....	107	<i>Canada Detailed Coverage Areas</i> .....	126	On-Screen Spelling Assist .....	151
<i>Importing Pictures from USB</i> .....	108	<b>Frequently Asked Questions</b> ....	<b>132</b>	<b>INDEX</b> .....	<b>155</b>
<i>Selecting Wallpaper Pictures</i> .....	108	<b>Troubleshooting</b> .....	<b>139</b>	<b>Other</b> .....	<b>159</b>
<i>Delete pictures on HDD</i> .....	109	<b>Glossary</b> .....	<b>140</b>		
Reset Factory Default Settings....	109	Glossary .....	140		
Clear Personal Data .....	110	<b>Voice Command Index</b> .....	<b>143</b>		
Rearview Camera.....	111	Global Commands .....	143		
<i>Rearview Camera Brightness</i>		Navigation General Commands...	143		
<i>Adjustment</i> .....	111	Navigation Display Commands...	144		
<i>Rearview Camera Image</i> .....	111	Find Place Commands .....	145		
<b>System Initialization</b> .....	<b>112</b>	Climate Control Commands .....	146		
System Initialization .....	112	Radio Voice Commands .....	147		
Entering the Security Code.....	112	Disc Voice Commands .....	148		
GPS Initialization.....	113	HDD Voice Commands .....	148		
Map Matching .....	113	AUX Voice Commands .....	148		
<b>System Limitations</b> .....	<b>115</b>	USB Voice Commands .....	149		
<i>GPS Reception Issues</i> .....	115	iPod Voice Commands.....	149		
<b>Database Limitations</b> .....	<b>116</b>	<i>Bluetooth</i> <sup>®</sup> Audio Commands .....	149		
<b>Client Assistance</b> .....	<b>118</b>	Song By Voice™ Commands.....	150		
<b>Coverage Areas</b> .....	<b>120</b>	Cellular Phone Commands .....	150		
Map Coverage .....	120	SET UP Screen (Main Set up)			
<i>U.S. Detailed Coverage Areas</i> .....	120	Commands .....	150		

# Introduction

---

## Manual Overview

The manual is divided into the following sections:

- Getting Started - A basic introduction that discusses the controls and how to communicate with the system.
- Entering a Destination - How to enter an address or locate a point of interest (POI).
- Driving to Your Destination - An explanation of the map features, guidance, and cautions.
- Information Features - An explanation of the information features, voice command help, and other accessories.
- System Setup - How to set up and tailor the system for your personal use and use the Address Book.

The back of this manual contains:

- Map Coverage (page 120)
- Frequently Asked Questions (FAQs) (page 132)
- Troubleshooting Guide (page 139)
- Glossary of Terms (page 140)
- Voice Command List (page 143)

## System Overview

Your navigation system is a highly sophisticated location system with voice control that uses satellites and a map database to show you where you are and to help guide you to a desired destination.

The navigation system receives signals from the global positioning system (GPS), a network of 24 satellites in orbit around the earth. By receiving signals from several of these satellites, the navigation system can determine the latitude, longitude, and elevation of your vehicle. In addition, a gyroscopic yaw sensor and a vehicle speed sensor in your vehicle keep track of the direction and speed of travel at all times.

The navigation system applies location, direction, and speed information to the maps and calculates a route to the destination you enter. As you drive to that destination, the system provides map and voice guidance.

The navigation system is easy to use. The locations of many places of business and entertainment are already entered in the system. You can select any of them as a destination by using the Interface Dial or voice control.

There are several ways to enter a destination, such as by point of interest (POI), by address, by phone number, and by selecting it from the map. The last 50 destinations are saved for reuse at a later date. The system also allows you to store a home address to simplify returning home from your destination.

## Accessories Precautions

If you have rear window tinting installed, be aware that if the tint has metallic properties, it can seriously degrade or prevent GPS reception. This is because the GPS antenna is located behind the navigation display in the centre of the dashboard.

If you plan to install electronic components such as radar detectors, vehicle tracking devices, remote starters, additional amplifiers, or other audio components, ensure that they are not located near the navigation display in the centre of the dashboard, or near the GPS antenna behind the navigation display. Signal noise emanating from these devices can cause intermittent disruption of the navigation system.

## Important Safety Information

The navigation system can distract your attention from the road if you focus on the screen or operate the system's controls while driving.

Enter as much information as possible into the system before you begin driving, or when the vehicle is stopped. Then, as you drive, listen to the audio instructions and use voice commands when possible.

# Introduction

## WARNING

Using the navigation system while driving can take your attention away from the road, causing a crash in which you could be seriously injured or killed.

Only operate system controls when the conditions permit you to safely do so.

While driving, do not look at the screen or operate the system controls for more than a second or so at a time, and only after deciding you can do so safely. Pull to the side of the road if you need more time to look at the screen or operate the controls.

The navigation system is designed to provide route information to help you reach your destination. However, this route guidance may sometimes conflict with current road conditions such as street closures, road construction, detours, and out-of-date map data.

Additionally, the system itself has certain limitations (see page 115). Therefore, you must verify the audio and visual route information provided by the system by carefully observing the roadway, signs and signals, etc. If you are unsure, proceed with caution. Always use your own good judgment, and obey traffic laws while driving.

## Map Overview

### **Current Street**

The current street on which your vehicle is located appears at the bottom of the map screen (see page 20). A message saying “Not on a digitized road” may appear instead when you drive half a mile away from a mapped road. For more details, see *Off-road Tracking* on page 64.

### **Verified/Unverified Street**

Your navigation system has two kinds of streets: verified (red, gray and pink) and unverified (purple). The differences between the two types of streets are contrasted in the chart on page 7.

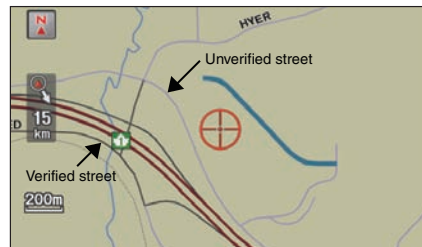

	Verified streets	Unverified streets
<b>When displayed</b>	These roads are found within metropolitan areas, and include interstate highways and major roads connecting cities.	These roads are found in rural areas, and typically include residential streets away from the centre of a town.
<b>Street colour</b>	Shown as red (highways), pink (state routes), or gray (verified streets) on the daytime map screen.	Shown on the daytime map screen as purple.
<b>Map quality</b>	The database vendor has verified these streets. Information like turn restrictions, average speed, and whether it is a one-way street have been gathered and used when creating your route to a destination.	These streets have not been verified by the database vendor. The system does not contain information on one-way streets, turn restrictions, or the road's average speed. They are shown on the map for reference and may have errors in map location, naming, and address range.
<b>Routing differences</b>	While driving to your destination, the displayed route line is solid blue. The system provides voice and map guidance to your destination.	Your route line is either a purple dotted "vector line," or a dashed pink/blue line. For information on selecting this option, and the routing differences, see <i>Unverified Area Routing</i> on page 94.
<b>Cautions</b>	There are no pop-up boxes urging extra caution during a route. However, because roads constantly change, you are urged to use common sense, and always obey posted traffic restrictions.	Regardless of whether the user chooses route guidance, there are cautionary screens before and during the route urging the user to be extra cautious, and obey all traffic restrictions. See <i>Unverified Area Routing</i> on page 94.
<b>Guidance voice</b>	Voice guidance issues instructions such as "In a 800 metres, make a right turn."	The phrase "if possible" is added to each guidance instruction. For example: "In a 800 metres, make a right turn, if possible."
<b>Time and distance "to go"</b>	The time and distance "to go," displayed while en route to a destination, is based on the average speed and distance for the roads used for your route.	The time and distance "to go," displayed while en route to a destination, is based on the average speed and distance for the roads used for your route.



# User Agreement

---

In using this HDD “Satellite Linked Navigation System” (the “HDD”), which includes HONDA MOTOR CO., LTD. software, PIONEER CORPORATION software, and NAVTEQ database contents (hereinafter referred to as “Licensers”), you are bound by the terms and conditions set forth below. By using your copy of the HDD, you have expressed your Agreement to the terms and conditions of this Agreement. You should, therefore, make sure that you read and understand the following provisions. If for any reason you do not wish to be bound by the terms of this Agreement, please return the HDD to your dealer.

- The HDD may not be copied, duplicated, or otherwise modified, in whole or in part, without the express written permission of the Licensers.
- The HDD may not be transferred or sublicensed to any third party for profit, rent or loan, or licenced for reuse in any manner.
- The HDD may not be decompiled, reverse engineered or otherwise disassembled, in whole or in part.
- The HDD may not be used in a network or by any other manner of simultaneous use in multiple systems.
- The HDD is intended solely for personal use (or internal use where the end-user is a business) by the consumer. The HDD is not to be used for commercial purposes.
- The Licensers do not guarantee to the client that the functions included in the HDD meet the specific objectives of the user.
- Licensor shall not be responsible for any damages caused by the use of the HDD to the actual user or to any third party.
- The warranty on the HDD shall not extend to an exchange or refund due to misspelling, omission of letters, or any other cosmetic discrepancy in the contents of the HDD.
- The right to use the HDD shall expire either when the user destroys the HDD or software, or when any of the terms of this Agreement are violated and the Licensers exercise the option to revoke the licence to use the HDD or software.

- The terms and conditions hereof apply to all subsequent users and owners as well as to the original purchaser.
- The logos of oil companies, hotels, convenience stores, and other businesses are displayed for your information and convenience, and in no way imply any sponsorship, approval or endorsement of these companies, or their products. The logos are trademarks of their respective owners.
- The marks of companies displayed by this product to indicate business locations are the marks of their respective owners. The use of such marks in this product does not imply any sponsorship, approval, or endorsement by such companies of this product.

The user shall indemnify and save harmless the Licensers, and their officers, employees and agents, from and against any claim, demand or action, irrespective of the nature of the cause of the claim, demand or action, alleging loss, costs, expense, damages or injuries (including injuries resulting in death) arising out of the use or possession of the HDD or software.

Use, duplication, or disclosure of this HDD by or on behalf of the United States government is subject to “Restricted Rights” as set forth at FAR 52.227-14, -19 or DFARS 252.227-7013, as applicable. Manufacturers are the Licensers, including HONDA MOTOR CO., LTD., 2-1-1 Minami Aoyama Minato-Ku Tokyo 107-8556 JAPAN., PIONEER CORPORATION, 1-4-1 Meguro Meguro-ku Tokyo 153-8654 Japan., NAVTEQ Corporation, 425 W Randolph St. Chicago, IL 60606, USA.

# Getting Started

## System Controls

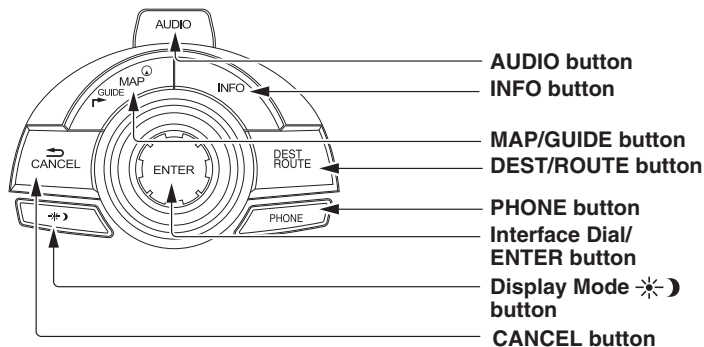
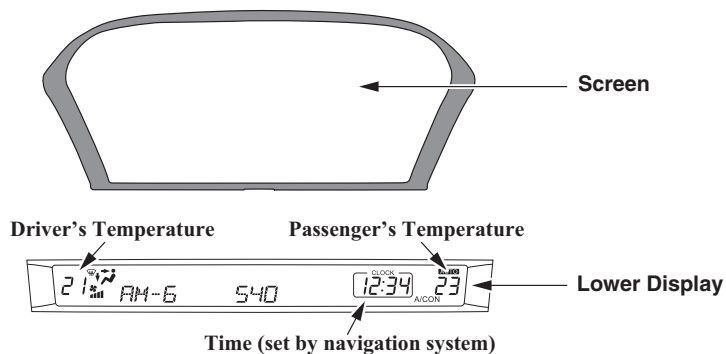

### AUDIO button

Press to display the audio screen. For more information on audio system features, see the Audio section of the your owner's manual.

### INFO button

Displays the "Main Info" options on the INFO screen. When selecting the "Other" tab, displays the "Other" options on the INFO screen. See page 73.

### MAP/GUIDE button

Displays the map. When en route, switches between the map and Directions screens. See page 20 or 52.

### DEST/ROUTE button

Displays the "Dest. MENU 1" options on the DEST screen. When en route, displays the "Route" options on the DEST screen. See page 23 or 67.

### Display Mode button

Adjusts the screen brightness for Day or Night mode, or turns the screen OFF. See page 105.

## PHONE button

Press to display the Cellular phone screen.

For more information, see the *Bluetooth® HandsFreeLink®* section of your owner's manual.

## CANCEL button

Cancels the current screen and returns to the previous screen display.

### NOTE:

The **BACK** button on the steering wheel performs the same basic function. See **BACK** button on page 13.

## Interface Dial/ENTER button

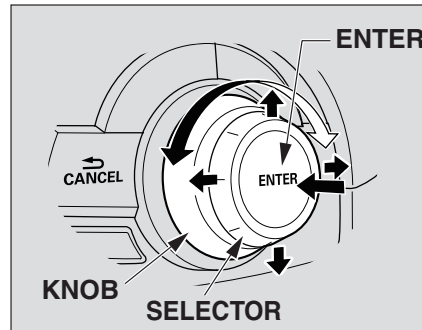

To see areas beyond the map that is displayed, you can move the **Interface Dial** left, right, up, or down. Rotating the **Interface Dial knob** allows you to change the scale. Rotating it clockwise reduces the scale, showing less area with greater detail. Rotating it counterclockwise increases the scale, showing more area with less detail.

You can also rotate the **Interface Dial knob** to scroll through a list or highlight items in a list to select. After making a selection in a menu or list, push in on the **Interface Dial (ENTER button)** to enter the selection into the system.

In almost all cases, you can enter a selection into the system by pushing in on the **Interface Dial**.

# Getting Started

---

## Screen

All selections and instructions are displayed on the screen. The display is not a “touch screen” - you enter information into the system either by voice or by using the **Interface Dial**.

Clean the screen with a soft, damp cloth. You may use a mild cleaner intended for use on computer screens.

### **NOTE:**

Whenever you shift to R (Reverse), the rear view behind the vehicle is shown on the navigation system screen. See page 111.

## Lower Display

Shows a summary of the audio and climate control information, as well as the time. This summary is helpful as a confirmation when adjusting audio or climate by voice.

The audio summary consists of the radio band, frequency, and volume. For XM radio, a brief description of the station and current music is displayed.

The climate status consists of the driver’s and passenger’s temperature, fan speed, ON/OFF (A/C), and vent setting. The time is automatically set by the navigation system. Settings can be adjusted in SETUP (see *Time Adjustment* on page 102).

## Voice Control Basics

Your vehicle has a voice control system that allows hands-free operation of most of the navigation system functions. You can also control the audio system and the climate control system. The voice control system uses the **TALK** and **BACK** buttons on the steering wheel and a microphone near the map lights on the ceiling.

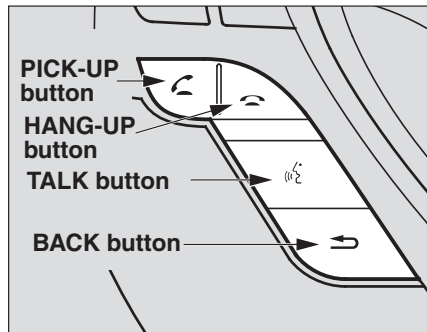

### NOTE:

While using the voice control system, all of the speakers are muted.

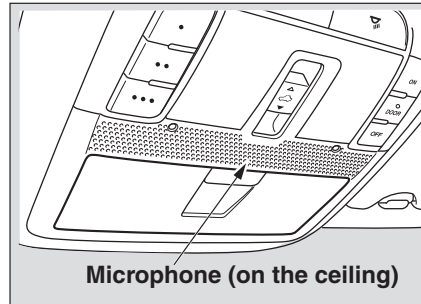

### TALK button

This button activates the voice control system. Press and release it when you want to give a voice command. See *Voice Command Index* on page 143 for a list of voice commands.

### BACK button

This button has the same function as the **CANCEL** button. When you press and release it, the display returns to the previous screen. When the previous screen appears, the system replays the last prompt.

When you press this button during voice recognition, voice recognition is ended. (The display does not return to the previous screen.)



# Getting Started

---

## **Using the Voice Control System**

You should use the voice control system as much as possible, and consider manual entry using the **Interface Dial** as a backup method.

Most of the system's functions can be controlled by voice commands activated with the **TALK** button. To control your navigation system by voice:

- Press and release the **TALK** button. On the map screen, a voice recognition screen and pop-up voice icon  are displayed. If you press and release the **TALK** button while on any other screen, only the pop-up voice icon  appears.
- Wait for the beep.
- Give a voice command. (Voice commands that the system recognizes are highlighted.)

Once the microphone picks up your command, the system changes the display in response to the command and prompts you for the next command. Using the **TALK** button, answer the prompts as required.

If the system does not understand a command or you wait too long to give a command, on the Voice Recognition Example Commands screen, it responds with “Pardon? No command was heard. Please press the **TALK** button and say a command. To return to the previous screen, press the **BACK** button.” On any other screen, it responds with “Pardon? No command was heard. Please press the **TALK** button and say a command.” If the system cannot perform a command or the command is not appropriate for the screen you are on, a beep will sound.

You can find out which voice commands are available for a particular screen by saying “Help.” The system will display and read the list of available commands to you. (When **Help** is grayed out, this feature cannot be used.)

When you speak a command, the system generally either repeats the command as a confirmation or asks you for further information. If you do not wish to hear this feedback, you can turn it off.

However, hearing the feedback will familiarize you with the way the system expects commands to be phrased. See the **Voice Recognition Tutor** setting in SET UP.

If you hear a prompt such as “Please use the **Interface Dial** to...” or “Please choose an area with the **Interface Dial**,” the system is asking for input that cannot be performed using the voice control system.

## **Improving Voice Recognition**

To achieve optimum voice recognition when using either the navigation or *Bluetooth*® HandsFreeLink® voice control system, the following guidelines should be followed:

### **NOTE:**

Make sure the correct screen is displayed for the voice command that you are using. See Voice Command Index on page 143.

- It is best if the windows and sunroof are closed. If they are open, speak a little louder to overcome the wind noise.

- The fan speed automatically lowers when the **TALK** button is pressed. Adjust the airflow from both the dashboard and side vents so air does not blow against the microphone on the ceiling.
- If more than one person is speaking at the same time, the system may misinterpret your command.
- After pressing and releasing the **TALK** button, wait for the beep, then give a voice command.
- Give a voice command in a clear, natural speaking voice without pausing between words.
- Try to reduce any background noise.
- If you are still having trouble with the voice control system, refer to **Voice Info** on the **INFO** screen (Main Info).

### **NOTE:**

The voice control system can only be used from the driver's position. The microphone does not recognize voice commands from anywhere else in the vehicle.

## Selecting an Item (Button) on the Screen

On most screens, there are items that can be selected (like buttons with titles such as **OK** or **Return**). To select an item on any screen, do one of the following:

- Use the voice control system and say the name of the desired item. Almost all selectable items on the screen, including some listed items, are recognized by the voice control system.
- Move the highlighting to the desired item with the **Interface Dial** or its **knob**, then push in on the **Interface Dial**.

### *Tip:*

If items are grayed out, this means that they cannot be selected.

## Selecting an Item in a List

To scroll through a list, do one of the following:

- Rotate the **Interface Dial knob** to scroll one item at a time.
- Use the voice control system to scroll page by page. For example, to scroll up, say “Up” or “Previous.” To scroll down, say “Next” or “Down.”

If you cannot find the desired name, or have made an error, return to the previous screen by pressing the **CANCEL** or the **BACK** button.

To select the desired item in the list, do one of the following:

- Use the voice control system, and say the item number of the desired item.
- Rotate the **Interface Dial knob** to move the highlighting to the item, then push in on the **Interface Dial**.



# Getting Started

---

## Entering Information

When the system needs input from you, the display changes to a screen similar to the one on the next page. You can then use the displayed letters, numbers, or symbols to enter information. You can enter your keyboard input in either of the following ways:

- Say the desired letter, number, or symbol on the screen if you are entering a city or street name.
- Move the highlighting to the desired letter, number, or symbol by rotating the **Interface Dial knob**, then push in on the **Interface Dial**.

Each entered letter will appear at the top of the display. To enter a space between words, say “Space” or move the **Interface Dial** to the right. To delete an entry, say “Delete” or move the **Interface Dial** to the left.

If a letter has options (such as accent marks or symbols), they will appear in gray next to the selected letter on the upper row. Move the **Interface Dial** up to select **OPTION**, and use the **Interface Dial knob** to select the letter.

To enter symbols, rotate the **Interface Dial Knob** and select # or @, then move the **Interface Dial** up to select **OPTION**.

When entering an address, the system searches the database for words that match the letters you are entering. As a result, you will notice that some letters are no longer available.

When the system finds only one entry that matches, it completes the name entry for you. If the system finds more than one entry that matches your input, a list of these matches is displayed.

### *Tip:*

When entering a name of a city, street, or place, or if you are unsure of the spelling of the name, enter the letters that you are sure of, then move the **Interface Dial** down to select **LIST**. The system will display a list of names that most closely match your input. For each letter that is entered, the number of corresponding choices is displayed on the right-hand side.

**NOTE:**

The voice command names that can be used for each letter are shown below. For additional keyboard symbols, see page 152.

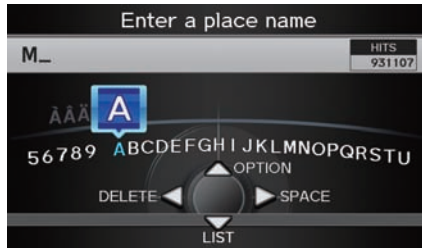

Say	Or say "..."	Say	Or say "..."	Say	Or say "..."	Say	Or say "..."
<b>A</b>	Alpha/Apple	<b>H</b>	Hotel/Henry	<b>O</b>	Oscar	<b>V</b>	Victor
<b>B</b>	Bravo/Boy	<b>I</b>	India/Igloo	<b>P</b>	Papa/Paul	<b>W</b>	Whiskey/William
<b>C</b>	Charlie	<b>J</b>	Juliet/John	<b>Q</b>	Quebec/Queen	<b>X</b>	X-ray
<b>D</b>	Delta/Dog	<b>K</b>	Kilo/King	<b>R</b>	Romeo/Robert	<b>Y</b>	Yankee/Yellow
<b>E</b>	Echo/Edward	<b>L</b>	Lima/Larry	<b>S</b>	Sierra/Sam	<b>Z</b>	Zulu/Zebra
<b>F</b>	Foxtrot/Frank	<b>M</b>	Mike/Mary	<b>T</b>	Tango/Tom	↵	Enter
<b>G</b>	Golf/George	<b>N</b>	November/Nancy	<b>U</b>	Uniform/Uncle		

# Getting Started

## System Start-up

When you change the power mode to the ON mode, it takes about 10 seconds for the navigation system to boot up.

The first screen to appear is the navigation system globe screen. The screen then changes to the Disclaimer screen:

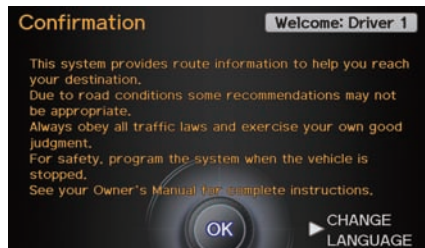

## System Language Selection

Move the **Interface Dial** to the right to select **CHANGE LANGUAGE**.

On the **Select a language** screen, you can select the language to be used by the entire system by choosing from the language choices that are displayed. After you have changed the language settings, you will be returned to the Disclaimer screen.



Read this disclaimer carefully so you understand it before continuing. Push in on the **Interface Dial** to select **OK**, and the map screen will appear on the display. The “OK” cannot be activated by voice.

If you do not push in on the **Interface Dial**, the screen will go dark after 30 seconds. (You can also display the **Wallpaper** screen. See page 107.) To return to the **Disclaimer** screen, press any navigation or voice control button.

If you have entered any Calendar reminders, they are displayed after you select **OK**. See *Calendar* on page 75.

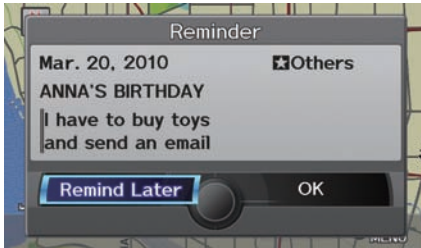

The Calendar reminder screen remains displayed until you select **OK** or **Remind Later** by rotating the **Interface Dial knob** and pushing in on the **Interface Dial**, or press the **CANCEL** button.

If you select **OK** and push in on the **Interface Dial**, the reminder will not show up again. (It will be deleted from the Calendar.)

If you select **Remind Later** and push in on the **Interface Dial**, the reminder will show up again the next time you start the vehicle. If there are several reminders, the next reminder will be displayed.

If you press the **CANCEL** button, the system will skip all the reminders. The reminders will show up again the next time you start the vehicle.

### **NOTE:**

The system will display the current message and any older or previously unread messages, with the newest message appearing first and the remaining messages appearing in date order.

If you turn off the engine during route guidance and then restart the vehicle, the **Continue Trip to** screen will be displayed. For more information, see on page 72.

## **Bluetooth® HandsFreeLink®**

If you have a Bluetooth-compatible cell phone that is paired with the system, then **CALL** on the Calculate route to screen is enabled.



When you select **CALL**, the system dials the number shown on the screen.

For more information on *Bluetooth®* *HandsFreeLink®*, see your owner's manual.

# Getting Started

## Map Screen Legend

**Vehicle Position** (see page 65)  
(Use voice command “Display current location” or use the **Interface Dial** to show current location.)



**Current Map Scale**  
(see page 61)

**Current Street**  
(see page 6)

**Map Scale Adjustment**  
(km or mile per half inch appears only when you zoom in or out by rotating the **Interface Dial knob**.)

 **No Entry Icon**

### GPS Signal Strength

 **GPS**: Best Reception  
 **GPS**: Good Reception  
(Missing): Poor/No Reception

### Map Orientation

(see page 59)

 “Heading Up”  “North Up”

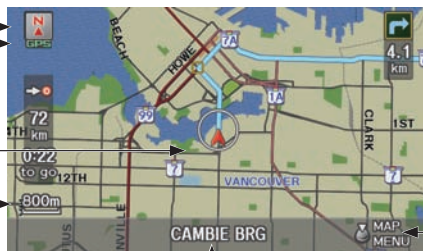

### Map Menu

(see page 54)

(Push in on the **Interface Dial** to view.)

### “Breadcrumbs”

(see *Off-road Tracking* on page 64)

















### Streets

(see Map Overview on page 6)

 : Highways (Red)  
 : Interstates (Pink)  
 : Verified Streets (Gray)  
 : Unverified Streets (Purple)  
 : One-Way Streets (see page 62)  
(80 metres scale only)

### Landmark Icon - Generic (see page 62)

 Honda Dealer (USA)	 Honda Dealer (Canada, Mexico)
 Hospital	 Acura Dealer
 Grocery Store	 School
 Gas Station	 Restaurant
 Hotel/Lodging	 ATM
 Parking Garage	 Parking Lot
 Highway Exit Information	 Post Office

### Map Features

 Park	 Airport/Business
 Hospital	 Body of Water
 Shopping Mall	 Cemetery
 Golf Course/ Stadium	 University

### NOTE:

If you move the **Interface Dial** over an area (map features shown above), the name is displayed at the top of the screen.

### NOTE:

See Map Legend in the **Map Information** on the **MAP MENU** screen for further explanation.

## Map Screen Description

### Zoom In/Out

Rotate the **Interface Dial knob** to change the map scale. Zooming in increases the detail, while zooming out gives you a wide area view. After changing the scale, give the system a few moments to update the display.

### Map Scrolling

To view other map areas, move the **Interface Dial** left, right, up, or down. The map will shift in that direction. To return the map to your current location, press either the **MAP/GUIDE**, the **CANCEL**, or the **BACK** button on the steering wheel.

## Displaying Current Location

You can see the current address, latitude, longitude, and elevation at any time by doing one of the following:

- Use the voice control system and say “Display the current location.”
- Push in on the **Interface Dial** while displaying the map of the current location, and select **Map Information**. Rotate the **Interface Dial knob** to select **CURRENT LOCATION**.

The Current location screen will appear on the display.



### NOTE:

The elevation will not appear when the system is temporarily lacking proper GPS information. The system elevation may not agree with elevations shown on roadside elevation signs, and may fluctuate plus or minus 30 metres or more.

You can save the current location in your Address Book by doing one of the following (if an Address Book PIN has been set, you need to enter your PIN.):

- Use the voice control system and say “Save.”
- Select **SAVE** by rotating the **Interface Dial knob** and push in on the **Interface Dial**.

Say “Register the current location” on the map screen, and you can register the current location without displaying the Current Location screen.

Select **Return** to return to the previous screen.



When you press the **DEST/ROUTE** button, the display changes to:



To display the “Dest. MENU 1” tab or the “Dest. MENU 2” tab, move the **Interface Dial** to the left or right.

**NOTE:**

*If you press the **DEST/ROUTE** button while en route, the **DEST** screen (Route) will be displayed. To enter the destination, select the “Dest. MENU 1” tab by moving the **Interface Dial** to the right.*

**Address** (see page 24)

You can enter the street, city, province or ZIP (postal) code to search for your destination.

**Address Book** (see page 28)

You can select locations stored in the **Address Book** as destinations. The addresses of these locations can also be saved. The system can store up to a combined total of 200 DRIVER 1 and DRIVER 2 addresses.

**Previous Destinations** (see page 29)

When you enter a destination with any of the available selections (except **Address Book**, **Go Home 1** and **Go Home 2**), the last 50 destinations are saved by the system. Use this selection to choose a destination again.

**NOTE:**

*If **Previous Destinations** is grayed out, there are no Previous Destinations entered.*

**Place Name** (see page 30)

You can input the names of the places to search for your destination.

**Place Category** (see page 31)

The system has been programmed with the locations of many businesses, parks, hospitals, etc. This selection lets you search these by category, name, or Zagat 2012 (for restaurant information).

**Go Home 1** (see page 45)

This selection allows you to select Home Address 1 as a destination.

**NOTE:**

*If you have no home address entered, the system prompts you for one.*



## Entering a Destination

### Place Phone No. (See page 37)

You can search for the destination by inputting a place's phone number.

### ZAGAT 2012 (See page 38)

This selection allows you to find a restaurant by the ZAGAT Rating information.

### Coordinate (See page 39)

You can search for the destination by inputting the latitude and longitude for the destination.

### Intersection (see page 40)

This selection allows you to enter the names of two intersecting streets in a city. This is useful if you know the general location of your destination, but not the exact address.

### Map Input (See page 41)

You can select a destination from the MAP screen.

### Go Home 2 (See page 45)

If you select this feature, you can select Home Address 2 as a destination.

## By Address

After you select **Address** from the DEST screen (Dest. MENU 1), the display changes to:



### Tip:

- *When entering an address by voice, it is more efficient to say the city name first, then the street name.*
- *When entering an address by the **Interface Dial**, it is usually easier to enter the street first. A city or cities that the street appears in will be displayed. For your convenience, you do not have to enter both city and street.*

### NOTE:

- *If you find that your city is not listed, it may be part of a larger metropolitan area. Try entering the street first.*

- *Prior to departure, you can set areas to avoid. The system then includes them in its calculations for the destination you have entered. See Edit Avoid Area on page 98.*

## Selecting the Province or State

The province you are in is displayed at top of the screen. If your desired destination is in another province, select **CHANGE PROVINCE** by moving the **Interface Dial** to the left or right.

The display then changes to the Select a province screen. Use the voice control system and say the name or corresponding number of the province, or rotate the **Interface Dial knob** to select the province.

You can select either of the **Canada/AK, USA,** or **Mexico** tab by moving the **Interface Dial** to the left or right. If you select **Canada/AK**, Canada and Alaska will be displayed. If you choose **USA**, the American mainland, Hawaii, and Puerto Rico will be displayed. If you select **Mexico**, the states of Mexico will be displayed.

### Selecting the ZIP Code

If you rotate the **Interface Dial knob** and select **ZIP code** while on the Find address by screen, the Enter ZIP Code screen will display.



Use the **Interface Dial** to input the Postal code. If the Postal code is found, the **Select a city** screen will appear, listing all cities with that Postal code.

If you only know the partial Postal code, input the first few digits, move the **Interface Dial** down, and select **List**.

### Tip:

*This system is enabled for both American and Canadian Postal codes.*

### Selecting the City

This is helpful if the street runs through several cities, and you know what city includes the street. The city you are in is displayed on the screen.

### By Voice Control:

Say “City” on the Find address by screen, and the display changes to the Enter city name screen.

Say the city name by saying individual letters, or words that represent the letters, one at a time.



The system has a talk back function.

If your spoken letter is not recognized, the system will talk back to you. For example, if you say “E” but the system does not recognize the command, it will ask you, “Please select the number of the input letter from the list,” and the following pop-up box will appear:

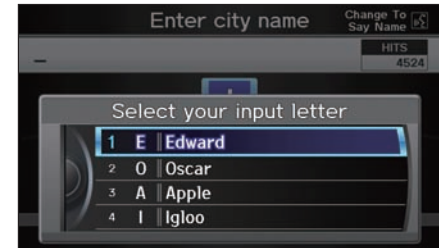

You should select a letter by saying the number.

Alternatively, to improve voice recognition, you can say “Echo” or “Edward” instead of “E.” See page 17 for a list of available words for each letter.

### By Interface Dial:

Select **City**, and the display then changes to the Enter city name screen.

## Entering a Destination

### Tip:

After the display has been changed to the Enter city name screen, the name of the city where your vehicle is currently located will be displayed.

Vehicle position may not be displayed when the automobile is travelling off road. You can select the **City** that is currently displayed and conduct a Street search by moving the **Interface Dial** down.

Use the **Interface Dial** to enter the name of the city.

The system will display a list of city names, with the closest match to the name you entered at the top of the list. Select the number (1-6) of the desired city from the list.

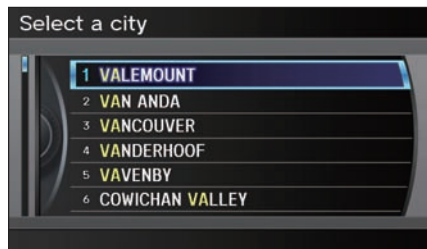

You can also enter part of the name and look for the name you want from the list that appears.

### Tip:

For name input, you don't need to enter spaces and symbols (&, -, %, etc.). The system is also enabled for partial match searches. For example, when you search "LOS ANGELES," it is on the list of search results if you input "LOS" or "ANGELES."

Listings of cities and towns in the non-detailed coverage area may have an asterisk "\*" next to their names. If you select one, a pop-up box is displayed saying, "No detailed street data...", and a street address cannot be entered (see *Map Coverage* on page 120). Try entering the street first, and then select the city if available.

Select **DESTINATION MAP** and use the **Interface Dial** to select an icon, approximate area, or street you wish to choose as your destination. Otherwise, a central location of the city will be selected. If you select a point of interest (POI) or road in an unverified area, you may or may not have routing in these areas. See *Map Overview* on page 6.

## Selecting the Street

### By Voice Control

After you have selected the city, or if you say "Street" on the Find address by screen, the display changes to the Enter street name screen.

Say the street name by saying individual letters or numbers, or words that represent the letters, one at a time.



The system has a talk back function. If your spoken letter is not recognized, the system will talk back to you. For example, if you say "E" but the system does not recognize the command, it will ask you, "Please select the number of the input letter from the list," and the following pop-up box will appear:

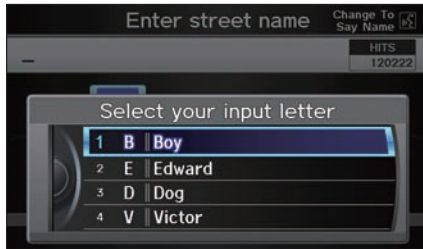

You should select a letter by saying the number.

Alternatively, to improve voice recognition, you can say “Echo” or “Edward” instead of “E.” See page 17 for a list of available words for each letter.

### By Interface Dial:

After you have selected the city, or if you selected **Street** in the beginning, the display changes to the **Enter street name** screen. Use the **Interface Dial** to enter the name of the street (e.g., ELM or 42ND) that is your destination.

When entering the names of major highways, it is possible to use the following abbreviations for names of the highways. For interstates, use an “I” (I-10). For U.S. freeways, use “US” (US-18). For state freeways, use the two character state designation (CA-101). For county roads, use the appropriate designation (G-2, for example). For Trans-Canada and Provincial highways, use “Hwy” (HWY-7). For County roads, use “CR” (CR-32). For Regional Roads, use “RR” (RR-5).

### Tip:

*When entering a street, you do not need to enter the direction (N, S, E, W) or the type (St, Ave, etc.). The system will automatically determine that for you, based on your entered city and street number.*

The system will display a list of street names, with the closest match to the name you entered at the top of the list. Select the number (1-6) of the desired street from the list.

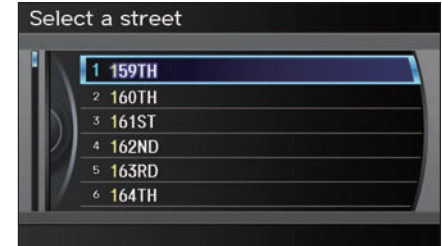

## Entering a Destination

### Entering the Street Number

After you have completed the street name, the display changes to the **Enter street number** screen. Use the voice control system and say the address number as a continuous string of numbers. For example, the address 1527 should be spoken as “One, five, two, seven.” You can also use the **Interface Dial** to enter the street number.

Some address numbers may not be available on the selected street. For example, let’s say the individual address ranges for a selected street name are 1 - 20 and 9,000 - 10,000, with an overall range shown on the display of 1 to 10,000. If you try to enter a number outside the individual address ranges such as 500, the system will show this number as unavailable (grayed out).

- When using the **Interface Dial**, the system only allows you to choose available address numbers.
- When using voice control, the system beeps if you try to select an unavailable (grayed out) address number.

If you did not select a city in the beginning, the street name you selected might appear in more than one city. The system will give you a list of cities that the street appears in. Select the desired city from the list. The system then displays the **Calculate route** to screen (see *Driving to Your Destination* on page 47).

### Tip:

*If the particular address you want cannot be found, select **Map Input** on the DEST screen (Dest. MENU 2) and use the **Interface Dial** to select the appropriate location on the map (see *By Map Input* on page 41).*

Select **DESTINATION MAP** and use the **Interface Dial** to select an icon, approximate area, or street you wish to choose as your destination. Otherwise, a central location of the street will be selected. If you select a point of interest (POI) or road in an unverified area, you may or may not have routing in these areas. See *Map Overview* on page 6.

### By Address Book

This selection allows you to choose a personal address entry for a destination. After you select **Address Book** from the DEST screen (Dest. MENU 1), the display changes to:

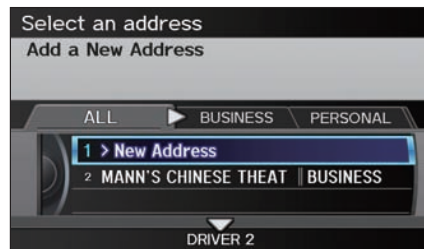

If an **Address Book PIN** has been set in SETUP, the system prompts you to enter your PIN. Say or enter your PIN.

If the PIN has not been entered, the system displays the list.

To switch the list between **Driver 1** or **Driver 2**, move the **Interface Dial** down.

### NOTE:

*When changing settings related to the PIN, please see **Address Book PIN** on page 88.*

The system then displays a list of the places entered in your personal Address Book. Using the **Interface Dial**, you can sort the displayed addresses by **ALL, BUSINESS, PERSONAL, UNFILED**, or by other categories you may create.



Scroll through the list to find your desired destination. After you select it, the system then displays the **Calculate route** to screen (see *Driving to Your Destination* on page 47).

### Tip:

If you select **New Address** in the list, you can store a new address in the personal Address Book. For information on inputting New Address, see Address Book on page 84.

### Adding Addresses to the Personal Address Book

There are three ways to enter addresses to the personal Address Book:

- Selecting **New Address** on the Select an address screen (see page 84).
- Entering them to the personal Address Book feature in SET UP (see page 84).
- Adding them to the Address Book directly from the Calculate route to screen (see page 47).

### NOTE:

- *Destinations chosen from the Address Book do not show up in Previous Destinations.*
- *Prior to departure, you can set areas to avoid. The system then includes them in its calculations for the destination you have entered. See Edit Avoid Area on page 98.*
- *For information on the available voice commands, see Voice Command Index on page 143.*

### By Previous Destinations

Every time you route to a destination, that destination is saved by the system. Up to 50 destinations can be stored. Select **Previous Destinations** from the DEST screen (Dest. MENU 1) to choose one of those destinations.

After you select **Previous Destinations**, the display lists the last 50 destinations entered, with the most recent appearing first.



### NOTE:

- *If Previous Destinations is grayed out, there are no Previous Destinations entered.*

## Entering a Destination

- *Neither your home address nor the personal Address Book is displayed on the Previous Destinations list.*

Scroll through the list and say the line number (1-6) of the destination, or select the desired destination you want.

Once you select the desired destination, the system then displays the **Calculate route** to screen (see *Driving to Your Destination* on page 47).

### NOTE:

- *Prior to departure, you can set areas to avoid. The system then includes them in its calculations for the destination you have entered. See Edit Avoid Area on page 98.*
- *For information on the available voice commands, see Voice Command Index on page 143.*

### By Place Name

If you select **Place Name** from the MENU screen (Dest. MENU 1), the display will switch to the **Enter a place name** screen. Use the **Interface Dial** to input the location name. You can input this place name by spelling out the word one letter at a time.

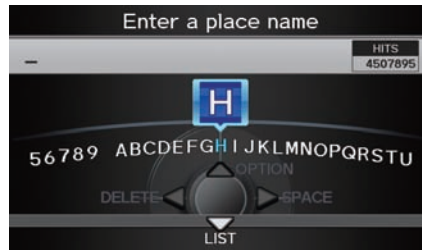

Well-known facilities and other businesses known by more than one name can be searched for by multiple name queries.

If you select a restaurant name with a **Z** icon next to it, move the **Interface Dial** to the right to view the Zagat information.

### NOTE:

- *Prior to departure, you can set areas to avoid. The system then includes them in its calculations for the destination you have entered. See Edit Avoid Area on page 98.*
- *ZAGAT information is not displayed by finding destination in Mexico.*

The place name closest to what you input will be displayed at the top of the list. If the place falls into multiple categories, the categories are listed after making a selection.

If you move the **Interface Dial** down while the list is displayed, the display will switch to **SORT BY DISTANCE** or **SORT BY NAME**.



### NOTE:

When there are more than 20,000 destinations, the ordering of the items in the list cannot be sorted by distance or name.

When you select a location, the system displays the Calculate route to screen. (See *Driving to Your Destination* on page 47.)

### By Place Category

After you select **Place Category** from the MENU screen (Dest. MENU 1), the display changes to:



If you select a category from the list, you can select even more detailed sub-categories.

Let's assume you want to find a coffee shop (restaurant) called "Bucks."

- If you know the phone number of the coffee shop, select **Place Phone No.**, then enter the 10-digit number with area code. This is the quickest way to find it. See *By Place Phone Number* on page 37.

- The second best method is to select **Place Category**, then **Restaurant**, then **CAFÉ/COFFEE SHOP**, and then enter the keyword "Bucks." The list will include all restaurants that have the letters "bucks" anywhere in the name.
- You can try to enter "Bucks" using **Place Name**, but you may have to search through a list that might include Bucks Welding, Bucks Surplus, etc.

### NOTE:

- Prior to departure, you can set areas to avoid. The system then includes them in its calculations for the destination you have entered. See *Edit Avoid Area* on page 98.
- You can enter the desired destination using the voice control system. For information on the available voice commands, see 143.



# Entering a Destination

## Subcategories

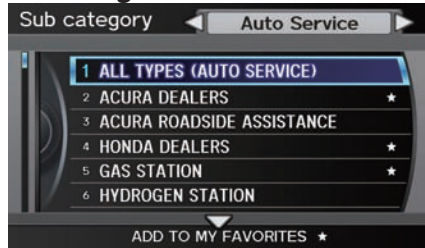

If you select a subcategory and move the **Interface Dial** down, the subcategory is stored to “**My Favorites.**” A maximum of 30 subcategories may be stored.

### *Tip:*

*If you are not sure of the spelling of a place, the best way to find it is to use the keyword search. Select **Place Category**, choose a category and subcategory from the menus, then select **Search by Keyword**, and enter the partial name.*



## Entering a Destination

### Finding a restaurant

The ZAGAT SURVEY for some restaurants is available in the system. See the INFO screen (Other), “Key to ZAGAT Rating” for an explanation of these ratings (see page 80).

#### NOTE:

*Restaurant information in Mexico cannot be searched with ZAGAT 2012.*

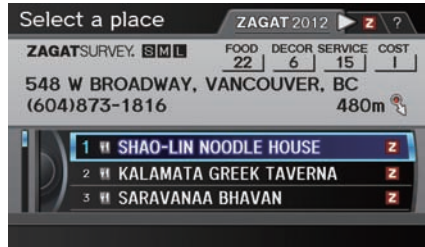

On the Select a place screen, restaurants with a Zagat Rating have a **Z** icon at the end of the line. To list only restaurants with Zagat Reviews, say “Zagat” or select **ZAGAT 2012**. You can view the complete Zagat Review for a selected restaurant by selecting the **Z** tab.

By voice, select the **Z** tab by saying “Zagat list number X” (where X is the line number 1-3). Alternatively, use the **Interface Dial** to first select the line item, and move the **Interface Dial** to the right to view the survey.

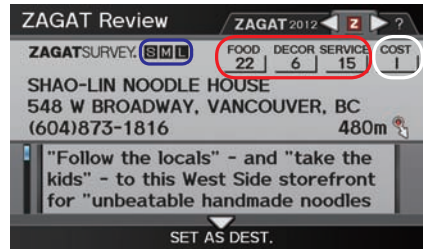

Say “Read List” or push in on the **Interface Dial**, and the review will be read to you. Move the **Interface Dial** down to display the Calculate route to screen.

#### NOTE:

*Scrolling through the Zagat Review is disabled when the vehicle is moving.*

“Food,” “Decor,” and “Service” categories (red frame) are rated using numbered values (e.g., 22, 21, 20 etc.)

“Cost” (white frame) is the average cost of a meal (including drink and tip). If unavailable then estimated cost symbols are shown:

“VE”: Very Expensive  
“E”: Expensive  
“M”: Moderate  
“I”: Inexpensive

The symbols, if displayed (blue frame), indicate the following information:

- S** open on Sunday
- M** open on Monday
- L** open for lunch
- 🕒 serving after 11 PM
- 🚫 no credit card accepted

After selecting a category, the system will give you the options of **Place Name**, **Sort by Distance to Travel**, **City Vicinity**, or **Search by Keyword** with the following screen:

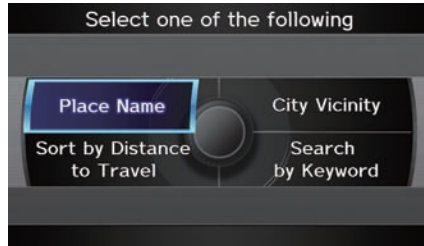

If you selected **Restaurant** as a category, **Sort by ZAGAT Rating** will be included as an option.

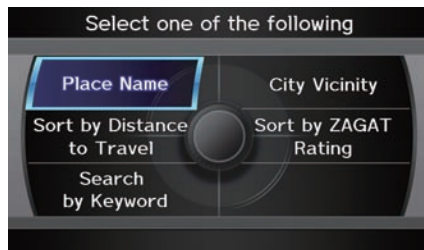

### Place Name

When you select this option, the display changes to **Enter a place name** screen. Enter the place name, using the **Interface Dial**. After entering the place name, if you move the **Interface Dial** down while the list is displayed, the display will switch to **SORT BY DISTANCE** or **SORT BY NAME**. Once you select a place, the system then displays the **Calculate route to** screen (see *Driving to Your Destination* on page 47).

### NOTE:

*When there are more than 20,000 destinations, the ordering of the items in the list cannot be changed to listing by order of distance or alphabetical order*

### City Vicinity

The system allows you to find points of interest in the vicinity of the city you entered. When you select this option, the display changes to **Enter city name** screen. Enter the name of the city using the **Interface Dial**. If the system does not find an exact match, select **LIST** when you finish entering the name of the city. Select a desired city from the list.

Once you have selected the city, the display changes to **Enter a place name** screen. Enter the name of the place using the **Interface Dial**.

The system searches within a 30 kilometres radius of the city centre. If more than 1000 POIs are located, only the first 1000 are displayed.

Once you select a place, the system then displays the **Calculate route to** screen (see *Driving to Your Destination* on page 47).

## Entering a Destination

### Sort by Distance to Travel

When you select this option, the system gives you a list of all the places in the subcategory. This list is arranged by distance from your current location, with the closest at the top of the list.



The distance and direction to the destination at the cursor position in the list are shown on the screen. The distance shown is straight line distance (as the crow flies), not driving distance. Say or select the number (1-4) of the desired destination from the list.

Once you select a place, the system then displays the **Calculate route to** screen (see *Driving to Your Destination* on page 47).

### Search by Keyword

If you do not know the exact name of the destination, you can find the place with a keyword. When you select this option, the display changes to:



You can find your destination with a keyword using the **Sort by Distance to Travel** option or **City Vicinity** option.

If you select the **Sort by Distance to Travel** option, the **Enter keyword for place** screen appears. Enter the keyword using the **Interface Dial**. If the system does not find an exact match, select **LIST** when you finish entering the keyword. The system starts searching for places that match the entered keyword. If you see your desired place, select it from the list. If not, scroll through the list to find the desired place.

If you move the **Interface Dial** down, the scope of the search can be increased. When there are a large number of search results, the number of locations will increase to 100, 200, and up to 1000 locations. When the number of locations is 100 or less, you can increase the scope to 800 kilometres, 1600 kilometres or the entire Canada by using **Search radius**.

If you select the **City Vicinity** option, the **Enter city name** screen appears. Enter the name of the city using the **Interface Dial**. The system will display a list of city names, with the closest match to the name you entered at the top of the list. Select your desired city name from the list. Once you have selected your desired city name, the **Enter keyword for place** screen appears. Enter the keyword using the **Interface Dial** to specify the desired place. Once you select a place, the system then displays the **Calculate route to** screen (see *Driving to Your Destination* on page 47).

### Sort by Zagat Rating

This item appears on the Select one of the Following screen only when “Restaurant” has been selected as the category.

When you use this option, you can search for restaurants using the Zagat Ratings information.



Food, Décor, Service - When you select **Food**, **Décor**, or **Service**, the restaurant will be listed by rating value.

Cost - When you select **Cost**, the restaurant will be listed by the average cost of a meal (including drink and tip).

When you select a sorting method, the list of restaurants will appear.



Copyright© 2012 Zagat Survey, LLC. All rights reserved.

### ZAGATSURVEY.

You can see the survey for a listed item by selecting the “Z” tab, or by saying “Zagat list number X” (where X is the number 1-3).

Once you select a restaurant, the system then displays the Calculate route to screen (see *Driving to Your Destination* on page 47).

### NOTE:

- *Selecting this sorting method will show you Zagat’s highest-rated restaurants by the options, and not necessarily by distance from your current location.*
- *For details on the ratings and symbols, say “Key to Zagat rating” or select the “?” tab using the **Interface Dial**.*
- *Restaurant information on Mexico cannot be searched with ZAGAT 2012.*

### By Place Phone Number

You can select a destination by phone number. Only phone numbers saved in the system are recognized. The phone numbers of private residences and numbers entered in your private address book are not in the system. If you select **Place Phone No.** on the DEST screen (Dest. MENU 2), the display will switch to the Enter Phone Number screen. Use the **Interface Dial** to enter the phone number.

## Entering a Destination



### NOTE:

Prior to departure, you can set areas to avoid. The system then includes them in its calculations for the destination you have entered. See Edit Avoid Area on page 98.

When you edit the phone number, continue pushing in on **Interface Dial** more than three seconds to display the Edit Mode screen. You can move the position of the cursor by rotating **Interface Dial knob**. To return the Enter phone number screen, move **Interface Dial** down.

After entering the number, move the **Interface Dial** down and select **OK**. Multiple listings for the same phone number may be shown.

### Tip:

*When using the voice control system, the entry should be spoken as a continuous string of numbers. For example, the telephone number (310) 555-4000 should be spoken as “Three, one, zero, five, five, five, four, zero, zero, zero.”*

## By ZAGAT® 2012

The **ZAGAT 2012** option allows you to find a restaurant by the ZAGAT Rating information. When you select **ZAGAT 2012** on the DEST screen (Dest. MENU 2), the system lets you select the metro area, neighborhood, and food type to search the restaurant you like. After you select the food type, the following display appears:

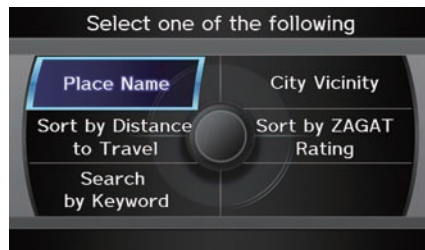

### By Coordinate

If you select **Coordinate** from the DEST screen (Dest. MENU 2), the display will change to the Enter Latitude screen. Use the **Interface Dial** to input the latitude.

#### NOTE:

*Latitude and longitude must be entered up to the seconds' value.*



#### NOTE:

*Prior to departure, you can set areas to avoid. The system then includes them in its calculations for the destination you have entered. See Edit Avoid Area on page 98.*

After entering the number, move the **Interface Dial** down and select **OK**. The display will change as indicated in the following paragraph.

On the Enter Longitude screen, use the **Interface Dial** to input the longitude.



With the selection of **Coordinate**, it is assumed that you are searching for the destination within the area that is in the closest proximity. The display will change as indicated on the next page.



Move the **Interface Dial** to find the desired destination. The map and target mark move in the same direction.

If so desired, you can also rotate the **Interface Dial knob** and change the scale of the map. When the target mark are on the desired icon, map location, or road, push in on the **Interface Dial**. The address for this location will be displayed at the very top of the screen.

The yellow box (shown in scales above 1 mile) denotes the area that can be viewed with the **Interface Dial** when the current map is clicked.



## Entering a Destination

### NOTE:

Information icons are displayed at scales from 1,6 kilometres to 400 metres, POI icons are displayed at 200 metres or less, and roads are displayed at 400 metres or less.

When you find the desired address, press on the **Interface Dial** again. If it is not the desired address, change the location of the target mark with the **Interface Dial**. Push in on the **Interface Dial** again to display a new address.

If you select a single icon or a section of road within the target mark, the following screen appears. Select **Set as Dest.** and calculate the route for the destination that you selected.

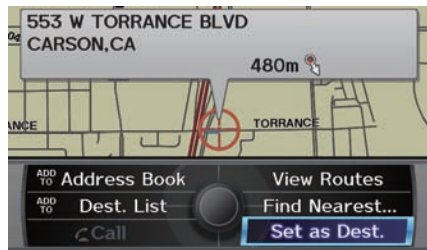

### By Intersection

After you select **Intersection** from the DEST screen (Dest. MENU 2), the display changes to:



To select an intersection outside the province you are currently in, select the province. For details of how to select a province, see *Selecting the Province or State* on page 24.

Next, select the city where the intersection is located. For details of how to select a city, see *Selecting the City* on page 25.

Last, select the two streets which intersect. For details of how to select a street, see *Selecting the Street* on page 26.

If the two streets that you have selected do not intersect, no intersection will appear.

### Tip:

When entering an address, it is usually easier to enter the street first. A city or cities that the street appears in will be displayed. For your convenience, you do not have to enter both city and street.

### NOTE

- If you find that your city is not listed, it may be part of a larger metropolitan area. Try entering the street first.
- Prior to departure, you can set areas to avoid. The system then includes them in its calculations for the destination you have entered. See *Edit Avoid Area* on page 98.

## By Map Input

After you select **Map Input** from the DEST screen (Dest. MENU 2), the display changes to:



Select **Current Position**, **City**, **Province**, or **USA, Canada and Mexico** to display the map.

### NOTE:

- *Prior to departure, you can set areas to avoid. The system then includes them in its calculations for the destination you have entered. See Edit Avoid Area on page 98.*
- *For information on the available voice commands, see Voice Command Index on page 143.*

## Showing the Map of Current Position

The **Current Position** selection assumes that you are looking for a destination in the immediate area. The display changes to:



The red arrow indicates your vehicle position. Find your desired destination by moving the **Interface Dial** up and down and to the left and right. The map and target mark will move in the same direction.

The yellow box indicates the area you will see when you click on the current map with the **Interface Dial**. The scale will decrease each time you push in the **Interface Dial**.

If desired, rotate the **Interface Dial knob** to change the map scale. When you have the target mark on the desired icon, polygon, or road, push in on the **Interface Dial**. The address of the location will appear at the top of the screen (at scales less than 1 mile).

### NOTE:

*Information icons are displayed at scales from 1,6 kilometres to 400 metres, POI icons are displayed at 200 metres mile or less, and roads are displayed at 400 metres or less.*

If this is the desired address, push in on the **Interface Dial** again. If not, use the **Interface Dial** to reposition the target mark, then push in on the **Interface Dial** again to display the new address.

## Entering a Destination

If you select a single icon or road segment within the target mark, the following screen appears. Select **Set as Dest.** to calculate a route to the selected destination.

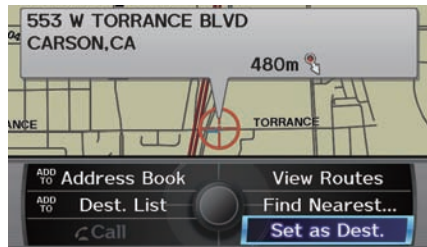

If you select multiple icons within the cursor radius, the following screen appears.

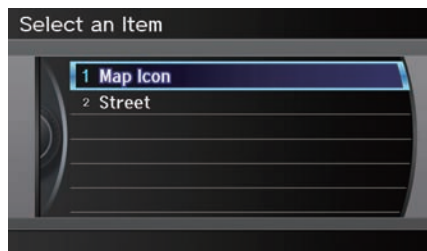

Select an item from the list. Then select **OK** to calculate a route to the selected destination.

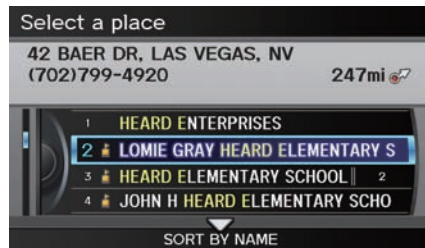

## Showing the Map of City

You can search for a city name in all coverage areas.

### By Voice Control:



Say the city name by saying individual letters, or words that represent the letters, one at a time.

The system has a talk back function. If your spoken letter is not recognized, the system will talk back to you. For example, if you say "E" but the system does not recognize the command, it will ask you "Please select the number of the input letter from the list" and the following pop-up box will appear:

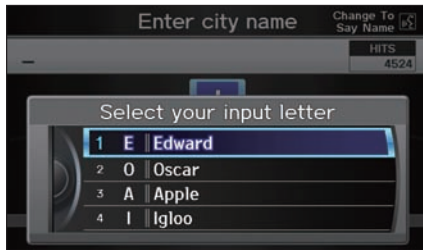

You should select a letter by saying the number.

Alternatively, to improve voice recognition, you can say “Echo” or “Edward” instead of “E.” See page 17 for a list of available words for each letter.

### By Interface Dial:

With the **City** selection, the display changes to the **Enter city name** screen. For instructions on entering the city name, see *Selecting the City* on page 25.

When you have entered the desired city, the display changes to a map. The starting location will be the central position in the selected city.

See *Showing the Map of Current Position* on page 41 for instructions on finding and entering your desired destination.

### Showing the Map of Provinces By Voice Control:

Say “Province” on the Show map of screen, and the display changes to the **Select a province** screen. Say the province name (e.g., British Columbia or BC) or the province number (1-7).

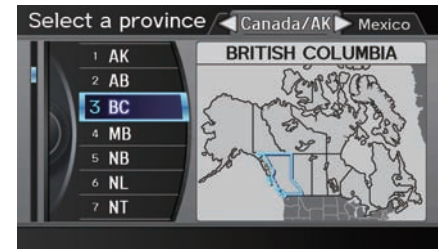

You can select either the **Canada/AK, USA**, or **Mexico** tab by moving the **Interface Dial** to the left and right.

If you select **Canada/AK**, Canada and Alaska will be displayed. If you choose **USA**, the American mainland, Hawaii, and Puerto Rico will be displayed. If you select **Mexico**, the states of Mexico will be displayed.

## Entering a Destination

Say the province name by saying individual letters, or words that represent the letters, one at a time.

### By Interface Dial:

With the **Province** selection, the display changes to the **Select a province** screen.

After you select the desired province, the display changes to a map of the province, with the target mark located near the middle.

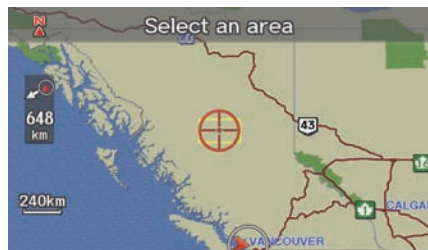

The yellow box indicates the area you will see when you click on the current map with the **Interface Dial**. The scale will decrease each time you push in on the **Interface Dial**.

Use the **Interface Dial** to move the target mark to the area of the province close to your intended destination. If desired, rotate the **Interface Dial knob** to change the map scale. When you have the target mark in the desired area, push in on the **Interface Dial**. The address of the location you have selected will appear at the top of the screen.

### NOTE:

*Information icons are displayed at scales from 1,6 kilometres to 400 metres, POI icons are displayed at 200 metres or less, and roads are displayed at 400 metres or less.*

If this is the desired address, push in on the **Interface Dial** again. If not, use the **Interface Dial** to reposition the target mark, then push in on the **Interface Dial** again to display the new address.

If you selected a single icon or road segment, select **Set as Dest.** to calculate a route to the selected destination. If you selected multiple icons within the cursor radius, select an item from the list. Then select **OK** to calculate a route to the selected destination.

### Showing the Map of USA, Canada and Mexico

With the **USA, Canada and Mexico** selection, the display changes to:

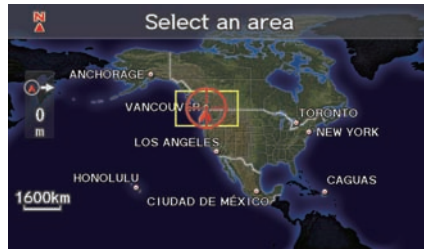

The yellow box indicates the area you will see when you click on the current map with the **Interface Dial**. The scale will decrease each time you push in on the **Interface Dial**.

Use the **Interface Dial** to move the target mark to the area of the country close to your intended destination. Then push in on the **Interface Dial**.

If desired, rotate the **Interface Dial knob** to change the map scale. When you have the target mark on the desired icon, polygon, or road, push in on the **Interface Dial**. The address of the location you have selected will appear at the top of the screen.

#### **NOTE:**

*Information icons are displayed at scales from 1,6 kilometres to 400 metres, POI icons are displayed at 200 metres or less, and roads are displayed at 400 metres or less.*

If this is the desired address, push in on the **Interface Dial** again. If not, use the **Interface Dial** to reposition the target mark, then push in on the **Interface Dial** again to display the new address.

If you selected a single icon or road segment, select **Set as Dest.** to calculate a route to the selected destination. If you selected multiple icons within the cursor radius, select an item from the list. Then select **OK** to calculate a route to the selected destination.

### By Go Home 1 or 2

Selecting **Go Home 1 or 2** from the **DEST** screen (**Dest. MENU 1 or 2**) takes you to the address you have set as “home.”

If a **Go Home 1 or 2 PIN** has been set, the system prompts you to enter your PIN.

Say or enter your PIN. The system will then display the **Calculate route** to screen (see *Driving to Your Destination* on page 47).

If a **Go Home 1 or 2 PIN** has not been set, the system displays the **Calculate route** to screen after you select **Go Home 1 or 2** (see *Driving to Your Destination* on page 47).

## Entering a Destination

---

### **NOTE:**

- *To edit Home Address, see Home Address on page 87.*
- *When no Home Address 1 or 2 has been set, the **SETUP** screen will be displayed. For details, see Home Address on page 87.*
- *Prior to departure, you can set areas to avoid. The system then includes them in its calculations for the destination you have entered. See Edit Avoid Area on page 98.*
- *PINs are optional. If you choose to use a PIN, make sure you remember it. If you forget your PIN, your dealer will have to reset it for you, and all PINs will be cleared.*
- *If a PIN is desired, enter it using the PIN feature in **SET UP**. See page 88 for information on entering your PIN.*

## Driving to Your Destination

A route typically has three phases.

- Initial route calculation (Calculate route to screen) (see page 47)
- Change the route while en route (see page 67).
- Resume the route when restarting the engine (see *Continue Trip to Screen* on page 72).

## Calculate Route to Screen



Say or select **OK**. The system calculates the route (see *Map Screen* on page 50).

### NOTE:

- Prior to departure, you can set areas to avoid. The system then includes them in its calculations for the destination you have entered. See *Edit Avoid Area* on page 98.
- For information on the available voice commands, see *Voice Command Index* on page 143.

Further selections from the Calculate route to screen include:

## ADD TO Address Book

Allows you to add the destination to your Address Book. See *By Address Book* on page 28.

### NOTE:

If **EDIT Address Book** is displayed, the destination is already stored in your Address Book. You can edit the address in your Address Book by selecting this button. For information on editing your Address Book, see *Address Book* on page 83.

## ADD TO Dest. Lists

Allows you to add a location to the **Destination Lists** as a destination or waypoint. While on the Calculate route to screen, rotate the **Interface Dial knob** and select **Calculate route to**. The Add to Dest. List screen appears and the destination is added.

## CALL

Dials the number on the screen when available. See *Bluetooth® HandsFreeLink®* on page 19.



# Driving to Your Destination

## Changing the Routing Method

The system lets you select the way you want to drive to your destination. Select **Route Pref.** on the Calculate route to screen by rotating the **Interface Dial knob**.



- You can choose **MAX** or **MIN** for three settings: **Use Highways**, **Use Toll Roads**, and **Use Ferries**. The route calculations for the current selection will be displayed in the upper right-hand corner of the screen.

The generated route may not be the route you would choose. For safety reasons, the system generally applies the following rules to your route:

- Shortcuts through residential areas are avoided.
- Right turns are favored over left turns or U-turns.
- Restricted turns (turns that cannot be made during or at certain times of the day) are not used.

## Viewing the Routes

If you select **View Routes** on the Calculate route to screen, you can view three possible routes to your destination. You can also use the **Interface Dial** to verify the areas peripheral to the map. If you select **View Routes**, the display changes to:



These different routes are shown and calculated based on the setup options in **Route Preference**.

You can select one of the three routes (1-3) by rotating the **Interface Dial knob**. The system will calculate the selected route and display the map screen.

### NOTE:

- *The driving distance and time estimated for the various routes is displayed.*
- *It is not unusual for the different methods to pick the same route. Voice commands cannot be used while the system is calculating.*
- *Zoom IN/OUT to view route details is not available on the View Routes screen. After moving the **Interface Dial** and scrolling through the map, you can then zoom in or out on the map screen to view your route in details.*

Based on the route data, you can change the routing method by rotating the **Interface Dial knob**.

Once you confirm your selection, say the number of the desired routing method or push in on the **Interface Dial**.

The calculated route will be highlighted as a blue line, and a voice prompt will tell you how to proceed along the highlighted route.

Push in on the **Interface Dial** and select **Voice** to have the guidance repeated.



### Viewing the Destination Map

If you move the **Interface Dial** down and select **DESTINATION MAP** while on the Calculate route to screen, a map of the destination vicinity is displayed. Press the **CANCEL** or **BACK** button, or select **Return** to return to the previous screen. You can view the destination map anytime while en route by saying “Display destination map.”

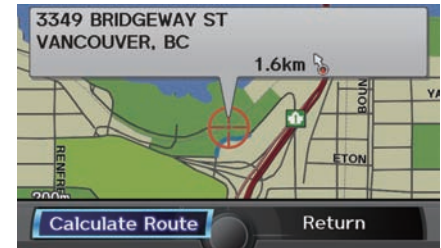

# Driving to Your Destination

## Map Screen

When you select **OK** on the Calculate route to screen, the map screen appears, showing your highlighted route (blue line) in real time.

## Route Line

When driving on unverified streets (purple), the route line changes to either a purple dotted “vector line” pointing to your destination, or a blue-pink line. See *Unverified Area Routing* on page 94 for a detailed explanation of how to enable unverified routing, and the related cautions and disclaimers.

### NOTE:

*You can always view the entire route by simply saying, “Display entire route.”*

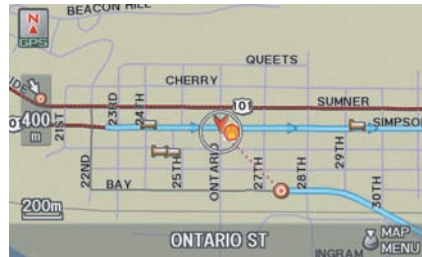

“Vector line” (unverified routing off)



Blue-pink unverified route line (unverified routing on)

## Voice Guidance Prompts

As you get near the guidance point, you will hear a voice reminder and see a pop-up window showing you the guidance point. You will typically hear three prompts:

- The first is about 800 metres from the guidance point if you are traveling on an ordinary road or street, or about 3 kilometres from the guidance point if you are traveling on a freeway.
- The next is about 400 metres from the guidance point if you are traveling on an ordinary road or street, or about 1,600 metres from the guidance point if you are traveling on a freeway.
- The final prompt is close to your actual turn.

If the distance between the next two guidance points is very small, both of them are displayed on the screen in a single window, and the voice will remind you of them at the same time.

**NOTE:**

- You can say “Voice” at any time, or select **Voice** after pushing in on the **Interface Dial** to be reminded of the next guidance point.
- Typically, a pop-up guidance window shows your next turn, and a voice guidance is heard. The timing of guidance varies depending on the type of road you are on and the distance to the next guidance point.

When the guidance in unverified areas, the phrase “if possible” is inserted before each guidance prompts. See Unverified Area Routing on page 94 for more detailed information on the unverified routing.

# Driving to Your Destination

## Map Screen Legend

### Map Orientation (see page 59)



### Streets (see Map Overview on page 6)

- : Highways (Red)
- : Interstates (Pink)
- : Verified Street (Gray)
- : Unverified Street (Purple)
- : One-Way Streets (see page 62)  
(80 metres scale only)

### Direction of Destination (when en route)

### Distance to Destination (see page 54)

### Vehicle Position (see page 65)

### Time to Destination (see page 54)

### Current Map Scale (see page 61)

### Map Scale Adjustment

(Mile or km per half-inch appears only when you zoom in or out by rotating the **Interface Dial knob**.) (see page 61)

### Waypoint (see page 68)



### Blue Line Calculated route (see page 50)

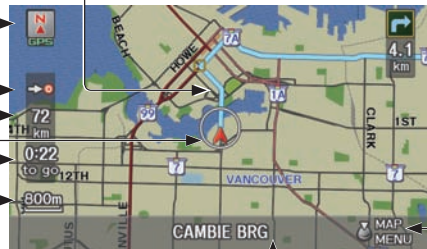

### Current Street (see page 65)



### Map Menu (see page 54) (Push in on the **Interface Dial** to view.)



### No Entry Icon

### "Breadcrumbs"

(see *Off-road Tracking* on page 64)



### Landmark Icon - Generic (see page 62)

- |                          |                               |
|--------------------------|-------------------------------|
| Honda Dealer (USA)       | Honda Dealer (Canada, Mexico) |
| Hospital                 | Acura Dealer                  |
| Grocery Store            | School                        |
| Gas Station              | Restaurant                    |
| Hotel/Lodging            | ATM                           |
| Parking Garage           | Parking Lot                   |
| Highway Exit Information | Post Office                   |

### Map Features

- |                         |                  |
|-------------------------|------------------|
| Park                    | Airport/Business |
| Hospital                | Body of Water    |
| Shopping Mall           | Cemetery         |
| Golf Course/<br>Stadium | University       |

### NOTE:

If you move the **Interface Dial** over an area (map features shown above), the name is displayed at the top of screen.

### NOTE:

See Map Legend in the **Map Information** on the **MAP MENU** screen for further explanation.

## Guidance Screen

The guidance screen offers an alternative way to view your route information. Many of the icons and screen features are similar to those on the **map** screen. While driving to your destination, press the **MAP/GUIDE** button to switch between the map and guidance screens. The guidance screen shows you:

**Milestone to Destination** - The position of the small circular icon shows your trip progress. As you get closer to your destination, the indicator will approach .

### NOTE:

- The map and voice guidance in unverified areas differ from those in verified areas.
- Current manoeuvres and those within 300 metres will show on the Countdown bar, indicating the distance until the next manoeuvre.
- Lane information is not displayed while driving on the road in Mexico.

## Guidance Screen Legend

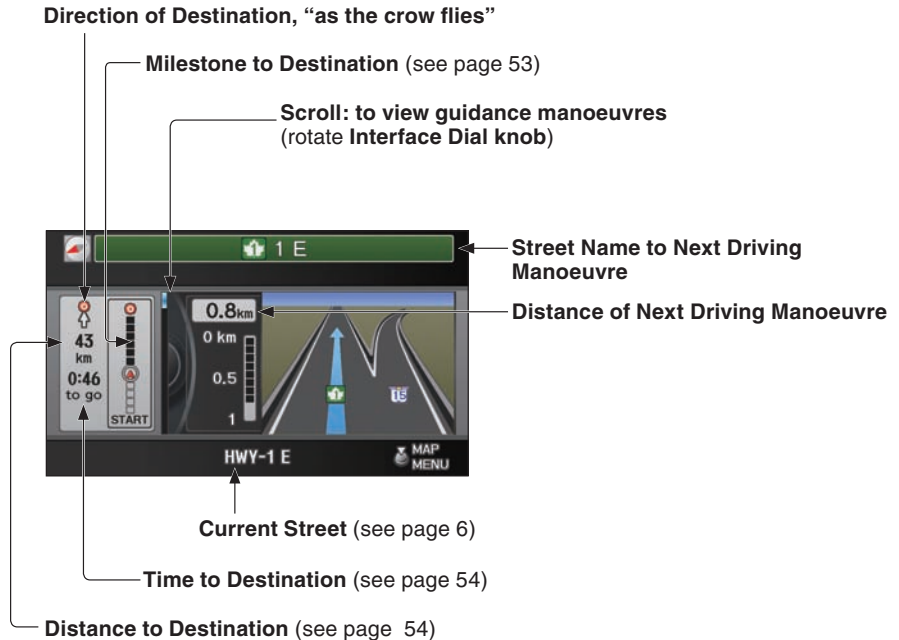

# Driving to Your Destination

## Distance and Time to Destination

When you select a destination, the distance to the destination is the actual road distance of the calculated route, and not “as the crow flies.” When viewing a list of destinations (points of interest), such as restaurants, the distance is “as the crow flies” (see *Sort by Distance to Travel* on page 36).

The displayed time to the destination may differ from the actual travel time because the time is calculated based on the posted road speed data and your current speed.

### NOTE:

*If you are en route and the **Interface Dial** is moved, the “Time to Destination” and “Distance to Destination” indications are replaced with an indicator showing distance from the current vehicle location.*

## Map Menu

When the map screen is displayed, pressing in on the **Interface Dial** displays the Map menu. If the map is scrolled, the Map menu will not appear. Press the **MAP/GUIDE** button, the **BACK** button, or the **CANCEL** button to return to the basic map screen.

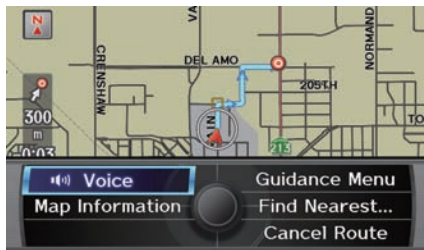

**Voice** - Shown if currently en route. Select to hear the next guidance manoeuvre.

**Guidance Menu** - Allows you to confirm Directions and Highway Exit information en route. You also can change Guidance Mode (single screen/ split screen). For detailed information on this feature, see *Directions* on page 55, *EXIT INFO* on page 56, or *Guidance Mode* on page 56.

**Find Nearest ...** - Selects a subcategory from the list to search the nearest POI from your current location. For detailed information on this feature, see *Subcategories* on page 32.

**Map Information** - Allows you to confirm information on the map or change the settings of displaying a map. For detailed information on this feature, see *Map Orientation* on page 59, *Showing Icons on the Map* on page 57, *Viewing/Saving the Current Location* on page 65 or *Map Legend* on page 60.

**Cancel Route** - Cancels your current route. The map screen will display your current position.

## Guidance Menu

When you select **Guidance Menu** from the Map menu, the Guidance menu screen appears.

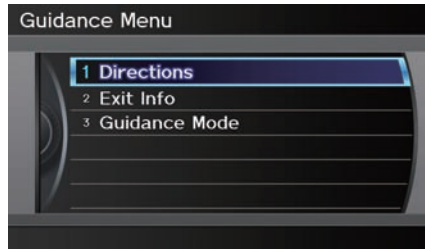

**Directions** - Select to confirm the directions (guidance points) to your destination (see page 55).

**Exit Info.** - Allows you to set a new destination or waypoint located near a highway exit when you are en route (see page 56).

**Guidance Mode** - Allows you to select the guidance mode (single screen or split screen) (see page 56).

## Directions

You can display a list of the manoeuvres on your route and confirm the distance between them. If you select **Guidance Menu** from the **Map menu** and then select **Directions**, the display changes to:

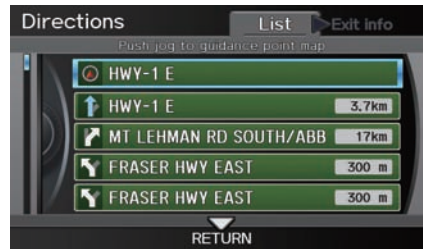

### NOTE:

- When you select a manoeuvre from the list, a map of the manoeuvre is shown.
- Manoeuvres that occur at highway exits or contain highway exit information will show the exit info icon (i).

Press the **CANCEL** button or the **BACK** button, or move the **Interface Dial** down to return to the previous screen.

You can scroll one manoeuvre at a time by rotating the **Interface Dial knob**.

The route guidance display disappears and guidance ends when you reach your destination. Press the **DEST/ROUTE** button to return to the **DEST** screen (Dest. MENU 1 or 2).



### **EXIT INFO (Highway Exit Information)**

#### **NOTE:**

*Currently, only available when travelling in the United States.*

You can search highway exit information (gas stations, restaurants, ATMs, etc.) and add new destinations or waypoints to the calculated route. Select the **Guidance Menu** from the **Map menu** screen. Select **Exit Info**, and a list of highway exits for the route is displayed.

If you select the freeway exit you plan on taking, a list of businesses in the area will be displayed. You can choose a listing to set as a new destination or waypoint, and say or select **OK**.

On the map screen, you can display Highway Exit information using the **Interface Dial**. The Exit Info icon will only be displayed on the **map** screen if there is any highway exit information available. Choose the 400 metres, 800 metres or 1,6 kilometres scale, then move the target mark to the desired Exit Info icon and push in on the **Interface Dial**. Choose a place from the list and set it as a new destination or waypoint.

#### **NOTE:**

- *To turn on “Highway exit information” on the map screen, display the icon bar and select the “” icon (see page 62).*
- *Exit Info, cannot be selected when the highway exit is in Mexico.*

### **Guidance Mode**

When en route to a destination, you have two display options: single-screen mode (the factory default) or split-screen mode.

If you select the **Guidance Menu** on the **Map menu** screen and then select **Guidance Mode**, the Selection screen will appear.

**Single-screen mode** - While the map screen is displayed, only the map is shown with occasional guidance pop-up windows as you approach a manoeuvre. When you press the **MAP/GUIDE** button and switch to the **Guidance** screen, only the **Directions** screen is displayed.

**Split-screen mode** - While the map screen is displayed, the map is displayed on the left of the screen, and the next manoeuvre is on the right side of the screen. You will see the same screen setup when you press the **MAP/GUIDE** button.

Guidance mode can be changed in **SET UP** (see *Guidance Mode* on page 101).

When you get near the manoeuvre, the map screen changes to:



On the map screen, the location of the manoeuvre is marked with a small yellow square. The guidance window is simply an enlargement of the next manoeuvre area. After you complete the manoeuvre, the display returns to a full map screen when single-screen mode is set, or to a map and direction list screen when split-screen mode is set.

## Map Information

When you select Map Information from the Map menu, the Map information screen appears.

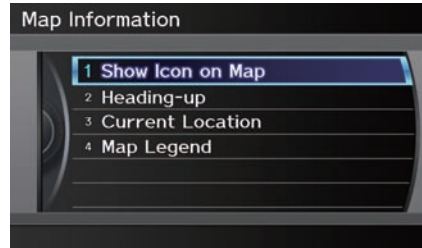

**Show Icon on Map** - Allows you to select the icons displayed on the map (see page 57).

**North-up/Heading-up** - Select **North-up** or **Heading-up** to change map orientation (see page 59). On scales greater than 1 mile, this button is grayed out (North-up only mode).

**Current Location** - Allows you to display and/or save your current location (see page 65).

**Map Legend** - Allows you to learn the meaning of map features (see page 60).

## Showing Icons on the Map

Selecting **Show Icon on Map** from **Map Information** on the **Map** menu (see page 54) displays the following screen:



The screen consists of the following items:

### Icon Bar

The icon bar allows you to manually select the icons that are displayed on the map (see page 63 for a list of these icons).

## Driving to Your Destination

In the screen shown, gas station and restaurants are selected. Rotate the **Interface Dial knob** and push in to select (blue with box checked) or remove them (black with box unchecked). You can also display or hide the same icons by using the “Display” or “Hide” voice commands on the map screen (see page 144).

### ICON OPTIONS

This feature allows you to “fine tune” some of the icons on the Icon bar.

If you move the **Interface Dial** down and select **ICON OPTIONS**, the following screen will be displayed:

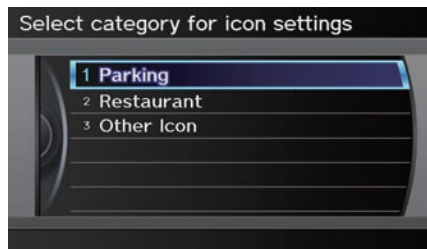

The three icon choices — **Parking**, **Restaurant**, and **Other Icon** — can each be tailored to your needs.

For instance, let’s assume that your hospital is not displayed on the map, and you want to make sure that your settings are correct. You would do the following:

- First, ensure that the **Other Icon** button on the Icon Bar is selected.
- Second, select **Other Icon** and verify that the hospital option is on (blue with box checked). This procedure is explained below.

If you select **Other Icon** from the Select category for icon settings screen, the other icon options are displayed:

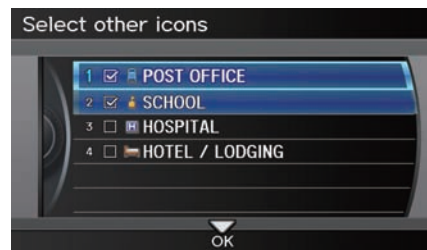

In the example shown, only **POST OFFICE** and **SCHOOL** are selected and will show up on the map. To also see **HOSPITAL** on the map, this would need to be turned on by first selecting it and then pushing in on the **Interface Dial** to select it so it appears as below.



Exit, and save your settings by moving the **Interface Dial** down (**OK**).

**NOTE:**

*When viewing the map screen, you can turn some icons on using voice control. See the Voice Command Index on page 143 for the available “Display” and “Hide” icon commands.*

### Map Orientation

The map can be orientated two ways:

- North-up: North pointing up as you would normally view a paper map.
- Heading-up: The map constantly rotates so the road you are driving on always points up (as you see the road through your front windshield).



“North Up”



“Heading Up”

**NOTE:**

*The red arrow in both heading symbols always shows the direction north.*

Push in on the **Interface Dial** when you are on the map screen, and select **Map Information**. Select **North-up** or **Heading-up**, or say “Display heading up” or “Display north up.”

In the larger map scales (above 2 mile or 3 kilometre), the map is always oriented with north facing upward. You cannot change the orientation.

**NOTE:**

*For information on the available voice commands, see Voice Command Index on page 143.*

# Driving to Your Destination

## Current Location

Whenever you are on a map screen, you can always obtain your current location either by pushing in on the **Interface Dial**, selecting **Current Location** from **Map Information**, or by using the voice control system and saying “Display current location.” A screen pops up which shows the address of your current location, as well as the latitude, longitude, and elevation.



## Map Legend

You can use the Map legend screens to learn the meaning of map features, icons, colours, etc. used in this system.

When you say or select **Map Legend**, the display changes to:

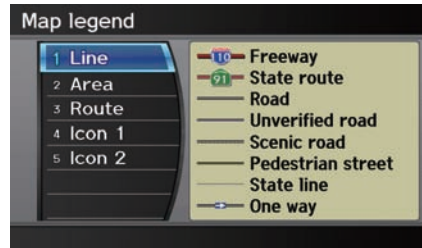

Say or select the desired item or item number to view each section of the map legend.

## Map Scale

Rotate the **Interface Dial knob** or a voice command such as “Display 800 metres scale” (see page 144) to change the scale of the map. Zooming in increases the detail, while zooming out gives you a view of a wider area. After changing the scale, give the system a few moments to update the display.

### Functions available at various map scales

Map Scale (English and Metric) For selecting units, see page 93.		1/20mi.	1/8 mi.	1/4 mi.	1/2 mi.	1 mi.	2 mi.	5 mi.	15 mi.	50 mi.	150 mi.	350 mi.	1000mi.
		80 m	200 m	400 m	800 m	1.6 km	3 km	8 km	24 km	80 km	240 km	560 km	1600 km
POI icon symbols (like ATM)	page 62	X	X										
Breadcrumbs (off-road tracking dots)	page 64	X	X	X	X								
Highway exit information icons	page 62			X	X	X							
One-way traffic icon	page 62	X											
Unverified road display (purple)	page 6	X	X	X	X	X	X	X	X				
Map orientation “Heading up”	page 59	X	X	X	X	X							
Map orientation “North up”	page 59	X	X	X	X	X	X	X	X	X	X	X	X
Map features (park, golf course)	page 52	X	X	X	X	X	X	X	X	X	X	X	
Avoid area shown on map	page 98	X	X	X									
Avoid area scales (when creating)	page 98	X	X	X									
Waypoint “flag” icons	page 68	X	X	X	X	X	X	X	X	X	X	X	X

### NOTE:

- You can change between miles or kilometres in **SETUP** (see Units on page 93).
- For information on the available voice commands, see Voice Command Index on page 143.

# Driving to Your Destination

## Destination Icon

The destination icon only shows the approximate location of the destination. This occurs because a city block can have as many as 100 possible addresses (for example, the 1400 block is followed by the 1500 block.) Since most cities use only a portion of the 100 possible addresses (for example, in the 1400 block, the addresses may only go up to 1425 before the 1500 block starts). Therefore, the address 1425 will be shown a quarter of the way down the block by the system instead of near the end of the block where the destination is actually located.















### Tip:

When en route, you can view a map showing your destination. Using voice control, say “Display destination map.”

## Various Other Icons

### Landmark Icons

Landmark icons are shown in the map screen on 1/20 and 1/8 mile scale, or 80 and 200 metre scale. The Highway exit information is displayed on the 400, 800 metres, and 1,6 kilometres scales. The icons are:

	Honda Dealer (Canada, Mexico)		
	Honda Dealer (USA)		
	Acura Dealer		
	Hospital		School
	Grocery Store		Restaurant
	Gas Station		ATM
	Hotel/Lodging		Parking Lot
	Parking Garage		Post Office
	Highway Exit Information		

## One-Way Traffic Icon

The one-way traffic icons (see *Map Screen Legend* on page 52) are only shown on the 80 metres scale.

Some icons can be turned on or off. To hide or display icons, use the **Interface Dial** to select **Map Information** from the Map menu, and select **Show Icon on Map** (see page 57). You can also hide or display icons by using voice commands (see page 144).

You can select most landmark icons with the **Interface Dial** to display the icon's information. See the table on page 63 for exceptions.

### NOTE:

- The same icon list can be viewed on the screen by selecting **Map Legend** from the Map Information screen in the Map menu.
- When there are overlapping landmark icons, a list of the points of interest (POIs) is displayed when selected.
- For information on the available voice commands, see Voice Command Index on page 143.

For some icons, you can choose to show or hide them on the map, while others like Honda Dealers are always shown. The table below shows the features for each icon type. Some Points of Interest (POIs) like Police Stations are not shown as an icon, but you can still locate the nearest one with the voice command, “Find nearest Police station.” See *Find Place Commands* on page 145.

## Landmark icon

POI type	Icon can be manually displayed	Icon can be manually hidden	Icon selection by voice	Icon can be selected as a destination on the map screen with the Interface Dial	POI can be found on the map screen using voice command “Find...”
Honda/Acura dealer	Yes, always	No	No	Yes	Yes
Hospital	Yes	Yes	Yes	Yes	Yes
School	Yes	Yes	Yes	Yes	Yes
ATM	Yes	Yes	Yes	Yes	Yes
Gas station*1	Yes	Yes	Yes	Yes	Yes
Restaurants*2	Yes	Yes	Yes	Yes	Yes
Post office	Yes	Yes	Yes	Yes	Yes
Grocery store*1	Yes	Yes	Yes	Yes	Yes
Hotel*1/ Lodging	Yes	Yes	Yes	Yes	Yes
Police station	No icon	No icon	No icon	No icon	No icon
Shopping, Tourist attraction, Bank	No icon	No icon	No	No	Yes
Parking garage	Yes	Yes	Yes	Yes	Yes
Parking lot	Yes	Yes	Yes	Yes	Yes
Highway exit information	Yes	Yes	Yes	Yes (choose POI)	No
One-way traffic icon	Yes	Yes	No	No	No

\*1. When these types are selected for view on the map, some icons are shown as “brand icons.”

\*2. When selecting **Restaurant** on the **Select category for icon settings** screen (see *ICON OPTIONS* on page 58), specialty types of restaurants, like Chinese or Italian, can be individually displayed or hidden. See *Showing Icons on the Map* on page 63. Also see the *Voice Command Index* on page 144 for the “Display,” “Hide,” and “Find” commands.



# Driving to Your Destination

## Going Off the Route

If you leave the calculated route, “Recalculating...” is displayed at the top of the screen. The system will recalculate the route from your current location and direction to the desired destination then give you a new route instruction. This is done automatically if you have set **Rerouting** to **AUTOMATIC** on the **SET UP** screen (Other) (see page 93).

If the **Rerouting** option in **SET UP** is set to **MANUAL**, “Off route” appears at the top of the screen when you leave the calculated route. Say “Recalculate,” or select **Recalculation** whenever you want the system to perform a recalculation.

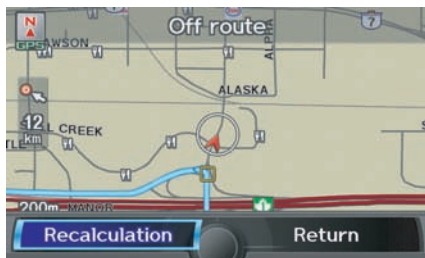

## Off-road Tracking

If you drive away from a mapped road, “Not on a digitized road” appears at the bottom of the screen.

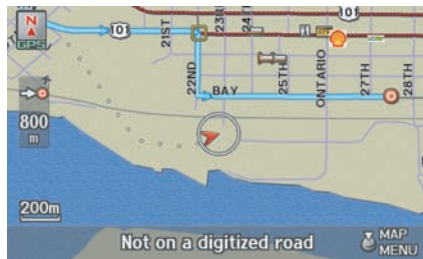

The map screen starts displaying a series of dots (breadcrumbs) to show the path you have taken if **Off-road Tracking** on the **SET UP** screen (Other) is set to **ON** (see page 102).

By following the dots, you can backtrack to the mapped road you originally left. “Breadcrumbs” may occasionally be displayed in urban areas, such as large parking lots in shopping malls, or in new subdivisions where the roads are not yet in the database. In other cases, you may see dots if the system temporarily goes off route, like in a parking garage where the GPS signal is unavailable. These dots appear only in the 80, 200, 400, and 800 metres map scales. Rotate the **Interface Dial knob** to change scales if necessary.

Off-road tracking continues for approximately 240 kilometres; dots at the beginning of the trail will start disappearing when you exceed that distance. When you reach a mapped road, the system stops displaying dots.

### Viewing/Saving the Current Location

Whenever you are on a map screen, you can always obtain your current location either by pushing in on the **Interface Dial**, selecting **Current Location** from **Map Information**, or by using the voice control system and saying “Display current location.” A screen pops up which shows the address of your current location, as well as the latitude, longitude, and elevation.



#### **NOTE:**

*The elevation will not appear when the system is temporarily lacking proper GPS information. The system elevation may not agree with elevations shown on roadside elevation signs, and may fluctuate plus or minus 30 metres or more.*

You can store the current location for later use. It does not change or cancel your current route.

For example, you are following the system's directions to get to a destination. While sitting at a stoplight you notice a store on the corner, but do not have time to visit it right now. You can save the location to select as a destination at a later date.

To save the location, say “Save current location” or select Save on the **Current location** screen. The **Edit address book** screen with the current location data will appear. You can edit the name, phone number, or category name to be saved in your personal Address Book.

Select **Return** and you will be returned to the **Map Information** screen. You can then use **Address Book** from the **DEST** screen (**Dest. MENU 1**) to select the saved location, and return to the same spot.

## Driving to Your Destination

### Pop-ups and Disclaimers

When you say “OK” in the Calculate Route to screen, or if you change your route, the system checks your route and provides you with pop-up messages for the following situations:

- Your route takes you into an area that you previously set as an “Avoid Area” (see *Edit Avoid Area* on page 98).

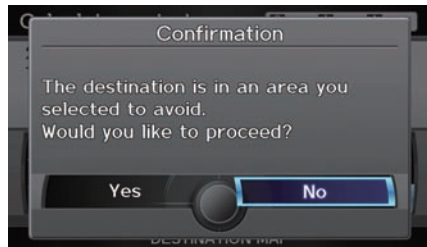

- Your route includes traffic restrictions in the vicinity of the departure point or destination.

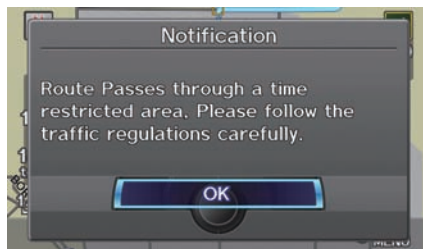

- Your route passes through unverified areas (see *Unverified Area Routing* on page 94).

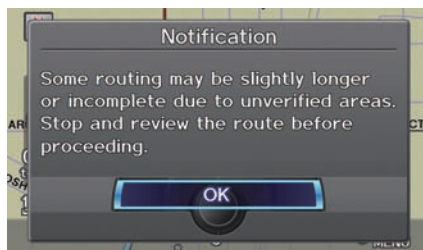

- Your route includes unverified areas (see *Unverified Area Routing* on page 94).

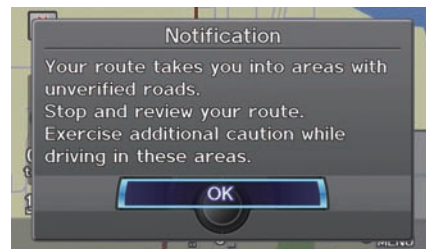

- You are about to enter an unverified area (see *Unverified Area Routing* on page 94).

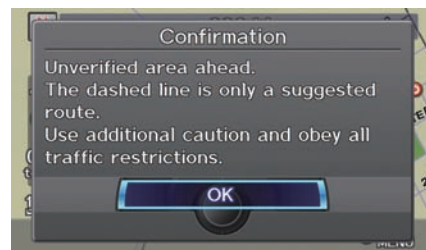

- You actually entered an unverified area (see *Unverified Area Routing* on page 94).



## Changing the Route

While en route, you may wish to alter your route, add an interim “Waypoint” (pit stop), choose a different destination, or cancel your current destination. To change your present route, you can do any of the following:

Say “Menu,” or press the **DEST/ROUTE** button to view the DEST screen (Route):

- Cancel Route (page 68)
- Detour (page 68)
- Avoid Streets (page 68)
- Change Route Preference (page 68)
- Waypoint (page 68)
- Destination Lists (page 70)

Choose a different destination (other methods) by:

- Saying, “Find Nearest...” to find a POI (page 71).
- Saying, “Go Home” (page 71).

- Using the **Interface Dial** to select a different POI or address on the map (page 71).
- Pressing the **DEST/ROUTE** button and selecting the “Dest. MENU 1 or 2” tab on the DEST screen (page 72).

## DEST Screen (Route)

Pressing the **DEST/ROUTE** button displays the DEST screen (Route):



### NOTE:

The “Route” tab can be selected only when you are en route.

# Driving to Your Destination

## Cancel Route

Cancels the current route (and any waypoints) and returns you to the map screen.

## Detour

Calculates a detour route for you if you encounter an unexpected obstacle such as a closed road or extremely heavy traffic congestion. If a detour is selected, the system will attempt to recalculate a new route, avoiding the next 8 kilometres (while on a highway) or 1,6 kilometres (while on a surface street).

## Avoid Streets

From the DEST screen (Route), if you say or select **Avoid Streets**, the system displays a list of streets that will get you to your destination. This feature allows you to avoid a street or streets along your route. This is helpful if you know of road construction, closures, or excessive traffic along the route. Simply select the street or streets you wish to avoid. You can store up to 10 streets to be avoided. You cannot avoid

your current street or the streets of your waypoint(s) or destination (system beeps if selected).

### NOTE:

*Although you can choose streets to avoid, you cannot choose specific streets you want to use.*

## Change Route Preference

From the DEST screen (Route), if you say or select **Change Route Pref.**, then the Route Preference screen is displayed. See *Changing the Routing Method* on page 48 for details.



## Waypoint

Waypoints allow you to add an interim “pit stop” while travelling to a destination. For instance, you may want to stop for gas or food, and then continue on to your destination. Although you can enter up to five places including the destination at a time, typically you may never use more than one at a time.

Waypoints are routed to in the order they were entered (number 1 first, etc.), with your final destination routed to last.

When you enter waypoints, they appear on the map screen as small red flags numbered 1-4.

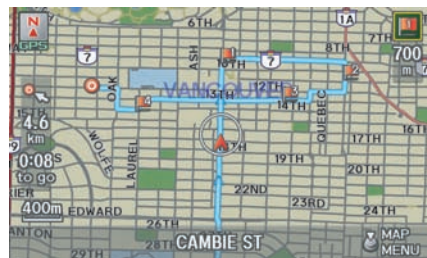

## Adding Waypoint

From the DEST screen (Route), if you say or select **Waypoint**, the Add Waypoint screen is displayed. Select either **SEARCH AROUND** or **SEARCH ALONG** by rotating Interface Dial knob.

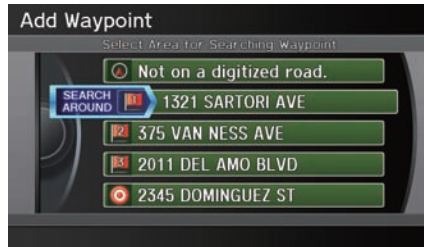
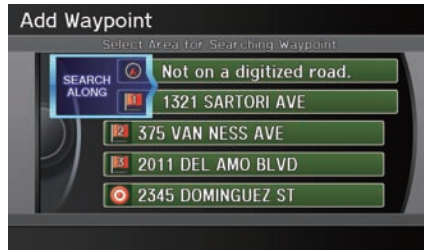

Next, select the categories from the “Originals” or “My Favorites” tab on the **Category** screen, then follow the menu prompts to select a destination.

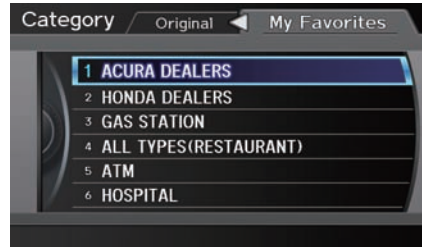

When the system performs a search from **SEARCH ALONG**, it displays matches that lie within a corridor on either side and in front of your route.

From **SEARCH AROUND**, the system displays matches that are a uniform distance from the departure point/waypoint/destination.

The search “corridor” distance value can be changed in **Edit Waypoint Search Area** in SET UP (see page 100).

If you add a waypoint, the Dest List screen will be displayed. If you move the **Interface Dial** down and select **OK**, the addition is completed and rerouting begins. Press the **MAP/GUIDE** button to return to the map screen without adding the waypoint.

To add another waypoint, press the **DEST/ROUTE** button and repeat the procedure.

If **Waypoint** is grayed out, the maximum of five places (including the destination) has been entered.

### NOTE:

*The system does not allow you to select the roads you want to use to get to a destination. However, after you enter a destination, you can select intersections or POI waypoints that the system will use to tailor your route.*

## Driving to Your Destination

### Destination Lists

If you select **Destination Lists** from the DEST screen (ROUTE), you can store four waypoints and one destination simultaneously. If you cancel the route, everything will be deleted.

### Verifying Destination Lists

If you select **Destination Lists** from the DEST screen (ROUTE), the display will change to the Dest. List screen.

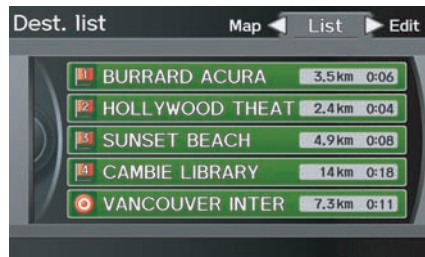

If you move the **Interface Dial** to the left to select **Map**, you will be able to see all the destinations on the map.

### NOTE:

*Prior to departure, you can set areas to avoid. The system then includes them in its calculations for the destination you have entered. See Edit Avoid Area on page 98.*

### Editing Destination Lists

If you rotate the **Interface Dial** to the right to select **Edit** on the Dest. List screen, the select an edit menu screen will appear. If you select **Delete**, you can select which items to delete. If you select **Edit Order**, you can change the order of items in the list.

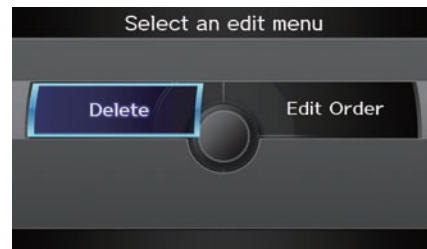



### Changing Your Destination

There are four methods by which you can change or add a waypoint to your route. These are:

#### ***Find Nearest (Voice command)***

From the map screen, say one of the “Find Nearest...” voice commands to locate the nearest gas station, ATM, restaurant or other point of interest. See the “*Find Nearest*” voice commands listing on page 145.

#### ***Go Home (Voice command)***

From the map screen, say “Go Home 1” or “Go Home 2.” If an address has been entered in both **Home Address 1** and **Home Address 2**, say “Go Home” and the system will give preference to **Home Address 1** and display the confirmation screen.

### ***Using Interface Dial to Change Destination***

While following a calculated route, you can select a new destination with the map screen and the **Interface Dial**.

With the map screen displayed, use the **Interface Dial** to move the cursor. It will change to target mark. Use the **Interface Dial** to position the target mark on your desired new destination, street, or icon, then push in on the **Interface Dial**. The Select an item screen or a pop-up menu may be displayed if there are multiple POIs in the vicinity.

#### ***NOTE:***

*The Select an item screen will be displayed when the target mark are positioned near multiple icons or locations. A pop-up menu will be displayed when the target mark are positioned on a particular street.*

If this is not your desired new destination, press the **CANCEL** button or the **BACK** button to return to the map screen. Reposition the target mark with the **Interface Dial**, then push in on the **Interface Dial** again to see the new address.

When the Select an item screen is displayed, select an item from the list, and the Calculate route to screen is displayed. Then select **OK** and push in on the **Interface Dial**.



## Driving to Your Destination

When the pop-up menu is displayed, select **New Dest.** to set your location as a replacement destination, or **Waypoint** to set as a waypoint.

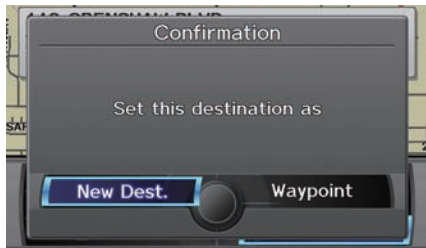

The system will return to the map screen and recalculate the route to your new destination or waypoint.

### *Entering a Destination from the DEST Screen (while en route)*

If you say "Menu", or press the **DEST/ROUTE** button and select the "Dest. MENU 1" or "Dest. MENU 2" tab, the system displays the DEST screen. Follow the procedure described in *Entering a Destination*, which begins on page 23.

When the Calculate route to screen is displayed, select **OK** and push in on the **Interface Dial**.

When the pop-up menu is displayed, select **New Dest.** to set your location as a replacement destination, or **Waypoint** to set as a waypoint.

The system will return to the map screen and recalculate the route to your specified new destination or waypoint.

### Continue Trip to Screen

If you restart the vehicle without having completed your prior trip, you will see the following screen:

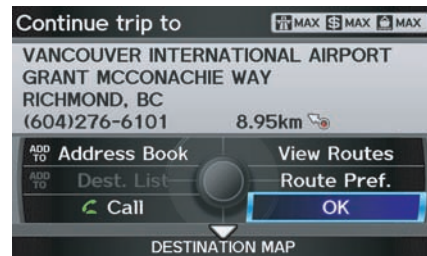

- To continue to your destination or other waypoints, say or select **OK**.
- To cancel your destination, press the **CANCEL** button or the **BACK** button on the steering wheel, or using the voice control system, say "Cancel" or "Back."
- If you wish to change the routing method, select **Route Pref.** by using the **Interface Dial**.
- For additional information on changing the routing method, see *Changing the Routing Method* on page 48.

The INFO function consists of two main screens. To display the INFO screen (**Main Info**), say “Information” or press the **INFO** button. To change it to the INFO screen (**Other**), select the “Other” tab. You can switch screens by selecting the tab.

You can use the voice control system to select any item on the INFO screen.

**NOTE:**

For information on the available voice commands, see Voice Command Index on page 143.

## INFO Screen

When you say “Information” or press the **INFO** button, the display changes to:

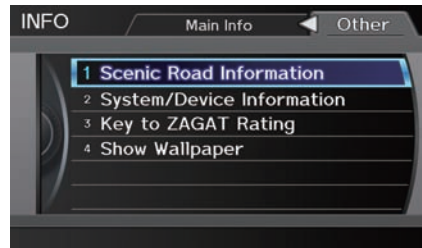

Move the **Interface Dial** to the left and right to display **Main Info** or **Other**.

## Cellular Phone

The **Cellular Phone** option (available on some phones) allows you to import up to 1,000 entries (up to 10 phone numbers per entry) to the phonebook of *Bluetooth*® HandsFreeLink® (HFL). Say or select **Cellular Phone** from the INFO screen (**Main Info**), and the display changes to:



**NOTE:**

- For more information on this feature, see your owner’s manual.

## Information Features

### Voice Info

When you say or select **Voice Info** on the INFO screen (Main Info), you will see the following screen:

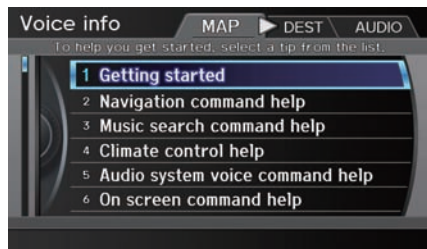

You can select the “MAP,” “MENU,” or “AUDIO” tab by moving the **Interface Dial** to the left or right.

#### NOTE:

*You can select an item by saying either the line number or the item name.*

There is a tutorial available for the voice command help. Say or select **Getting started**, and the display changes to:

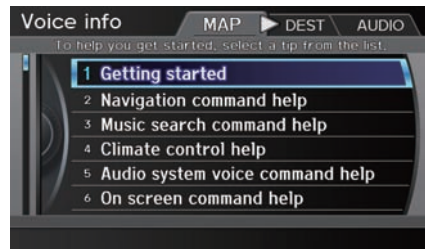

Select the line number of the desired tutorial you want to view, and the tutorial will automatically be read. To stop the reading, push in on the **Interface Dial** and select **STOP**. To resume the reading, push in on the **Interface Dial** again.

When you make a command help selection under any of the help screens, you will see the help commands that can be used with voice control. You can say “Read List” or push in on the **Interface Dial** to select **Using the talk button**, and the system will read the list to you.

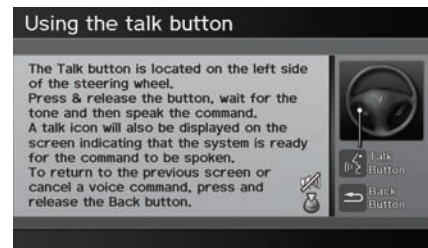

For a listing of all voice commands, see *Voice Command Index* on page 143.

## Setup

When you select **Setup**, you will see the following screen:



For detailed information on the SETUP screen, see System Setup on page 82.

## INFO Screen (Other)

Select the “Other” tab to view additional information, and the following screen appears:

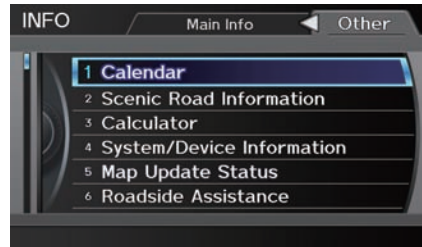
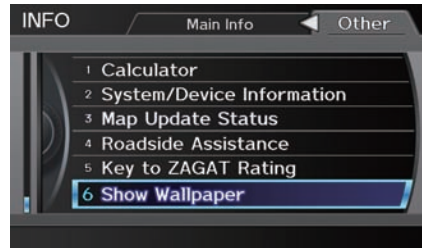

### NOTE:

**Map Data Update Status** can be selected only during the update of map data.

## Calendar

The Calendar option allows you to enter events and be reminded of them in the future. When you say or select **Calendar** from the INFO screen (Other), the system shows the calendar with the current calendar day highlighted.

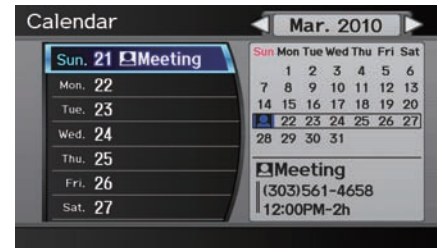

Dates with an icon indicate there is a scheduled entry for that date.

### NOTE:

Entries may be stored in the calendar for 10 years.

## Information Features

You can scroll through the calendar day by day by rotating the **Interface Dial knob**, or select the day by voice. When you move the **Interface Dial** up or down, you can also scroll through the calendar week by week. To change the month, say “Next month” or “Previous month,” or move the **Interface Dial** right or left.

### Entering Your Schedule

Set your schedule by selecting the day on the calendar, and the display changes to:

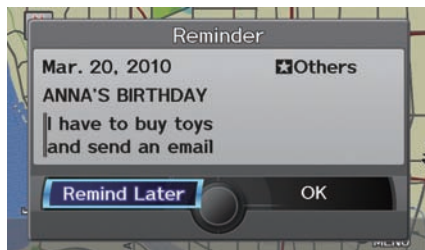
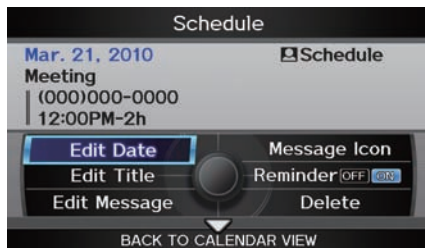

### Reminder

The default for Reminder is **ON**. This allows the system to remind you of the calendar item the next time you start the vehicle. See *System Start-up* on page 18.

### Edit Date

This allows you to move your calendar entry to a different date. If you say or select **Edit Date**, the **Edit Date** screen is displayed with existing entries grayed out. When you select a new date, the display will return to the **Schedule** screen.

### Edit Title

Say or select **Edit Title**, then enter the name of your title using the **Interface Dial**. Once you have entered the title, say or select **OK**. The title will be displayed on the specified date on the **Calendar** screen and the display will return to the **Schedule** screen.

### Edit Message

Say or select **Edit Message**, and the system will show the **Edit Message** screen. You can enter a message on two lines. Use **↵** to change the line.

Once you have entered the message, say or select **OK**. The message will be displayed on the specified date on the **Calendar** screen and the display will return to the **Schedule** screen.

### Message Icon

Say or select **Message Icon**, and the system displays a list of icons you can select to help identify the type of message you entered. The message icon you choose will be displayed alongside the specified date on the **Calendar** screen.

### Delete

Say or select **Delete** to display the confirmation screen. If you select **YES**, the entry that is displayed will be deleted.

### Back to Calendar View

Once you have finished entering the schedule, say or select **BACK TO CALENDAR VIEW** by moving the **Interface Dial** down. The **Calendar** screen will appear and display the scheduled entry.

#### NOTE:

- *Only one entry can be stored for each calendar day.*
- *A maximum of 50 entries can be stored in the calendar. After you reach 50 entries, a warning message will appear telling you that the limit has been reached. You can clear any older entries as needed.*
- *The system displays active calendar entries only after you answer **OK** on the Disclaimer screen.*
- *For more information, see System Start-up on page 18.*

### Scenic Road Information

Say or select **Scenic Road Information** while on the **INFO** screen (**Other**), and the display will change as indicated below.

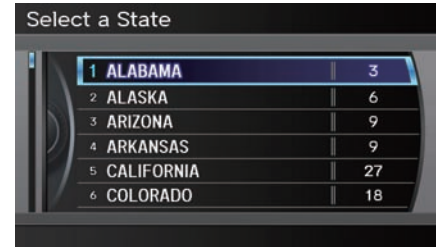

The number of scenic roads for each province will be listed.

Select a province and a list of the scenic roads in that province will be displayed. After making a selection, the scenic road will display on the **Map Click** screen at a scale, where its main portion is the focal point of the map. You can then set this as a destination or waypoint.

If you select a scenic road that runs through multiple provinces, only the portion of the road in the selected province will be displayed.

## Information Features

### NOTE:

You cannot select state that exists in Mexico on this screen.

### Calculator

When you say or select **Calculator** on the INFO screen (Other), the display changes to:

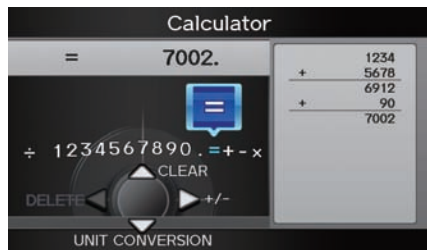

Use the **Interface Dial** and **Knob** to use the following features:

### Calculator

The calculator function operates like a standard handheld calculator.

### Unit Conversion

Values entered on the calculator can be converted from one unit to another (e.g., inches to millimetres).

To perform a conversion:

1. Enter a numeric value to be converted (for example, 100).
2. Move the **Interface Dial** down to select **UNIT CONVERSION**. The screen changes to:

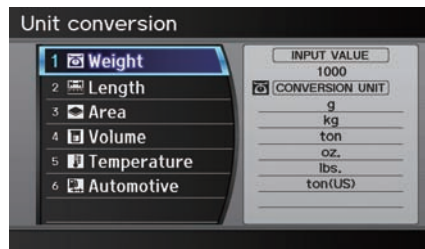

3. Rotate the **Interface Dial knob** to select the type of unit you want to convert (for example, weight) and push in on the **Interface Dial** to select. The screen for that conversion type appears (see illustration in step 4).

4. Select the base unit (e.g., pounds) that you wish to convert to some other unit. All other units will change automatically depending on the base unit value. In the example below, 1000 mm converts to 100 cm, 1 m (U.S.), etc.

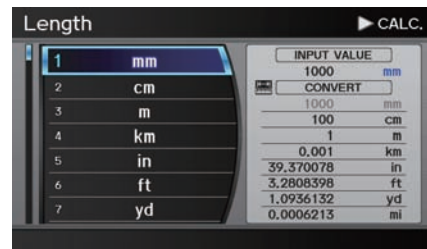

### NOTE:

- If you do not enter a value to be converted, only “Temperature” units are selectable.
- Conversions using negative values may produce meaningless or physically impossible values.
- To return the Calculator screen, select **CALC.** by moving the **Interface Dial** to the right.



## System/Device Information

Say or select **System/Device Information** while on the INFO screen (Other), and the display will change as indicated below.

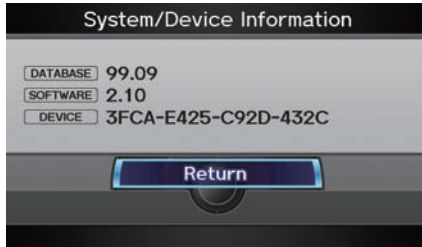

You will need this information when ordering an update DVD. See page 119 for more information.

## Map Update Status

During data updates, you can check the update status for map data for each province.

During the update of map data, say or select **Map Update Status** while on the INFO screen (Main Info), and the display will change as indicated below.



### NOTE:

- This operation can only be carried out during a disc update.
- You can check the data update status with the status bar that is displayed on the screen.
- If you say “Question” or select the ? tab, you can refer to the Map Update Status explanation.

## Roadside Assistance

Acura Roadside Assistance is provided as a service to Acura clients. When paired with a Bluetooth-enabled cell phone, the system can call for assistance as long as the setting is switched **ON**.

Say or select **Roadside Assistance** while on the INFO screen (Other), and the display will change as indicated below.

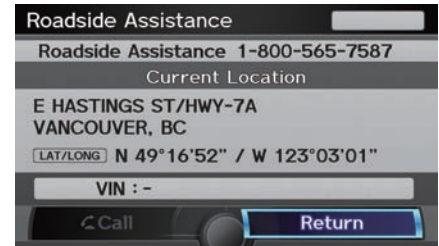

When you select the country, the phone number for Roadside Assistance and vehicle position information will be displayed.

Say “Call” or select **CALL** with the **Interface Dial**, and then select **Yes** from the confirmation screen.



# Information Features

## Key to Zagat Ratings

By saying or selecting **Key to Zagat Ratings** on the INFO screen (Other), you can see the explanation of the data displayed for the Zagat-surveyed restaurants.

### NOTE:

*Restaurant information on Mexico by Key to Zagat Ratings is not be displayed.*

- “Food,” “Décor,” and “Service” categories (red circle) are rated using numbered values (e.g., 0-9, 10-15, etc.)
- “Cost” (white circle) is the average cost of a meal (including drink and tip).

The code displayed has the following meaning:

“VE”: Very Expensive

“E”: Expensive

“M”: Moderate

“I”: Inexpensive

- The symbols, if displayed, indicate the following information:

- open on Sunday
- closed on Sunday
- open on Monday
- closed on Monday
- open for lunch
- lunch not served
- serving after 11 PM
- no credit card accepted

Use the **Interface Dial** to scroll through the **Key to Zagat Ratings** screens.

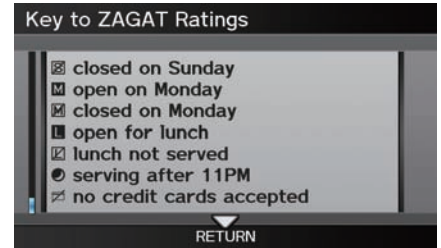
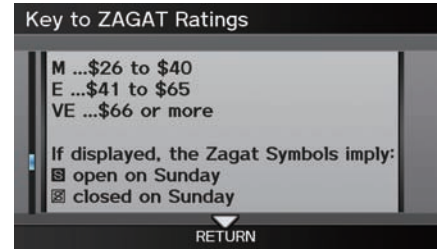
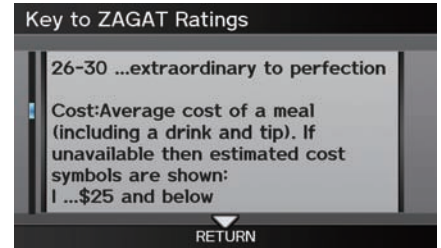

Copyright© 2012 Zagat Survey, LLC. All rights reserved.

**ZAGATSURVEY**

### **Show Wallpaper**

If you say or select **Show wallpaper** from the INFO screen (Other), the wallpaper that is currently selected will be displayed on the screen. If you push in on the **Interface Dial**, the original screen will return. For instructions on changing *Wallpapers Setting*, see page 107.

## System Setup

### SETUP Mode

The SET UP function consists of two main screens that allow you to change and update information in the system.

#### **NOTE:**

*For information on the available voice commands, see Voice Command Index on page 150.*

### SETUP Screen (Main Set up)

Select **Set up** from the INFO screen (Main info), and the following screen will display.



#### **Brightness**

The screen brightness has 11 settings. To change the brightness, use the voice control system and say “Brightness up” or “Brightness down.” You can also select **Brightness** and change the setting by rotating the **Interface Dial knob**.

#### **Tip:**

*If you are having trouble viewing the screen in bright lighting conditions, try increasing the brightness.*

#### **Contrast**

The screen contrast has 11 settings. To adjust the contrast, use the voice control system and say “Contrast up” or “Contrast down.” You can also select **Contrast** and change the setting by rotating the **Interface Dial knob**.

#### **Black Level**

The screen black level has 11 settings. To change the black level, use the voice control system and say “Black level up” or “Black level down.” You can also select **Black Level** and change the setting by rotating the **Interface Dial knob**.

#### **NOTE:**

*You can have separate daytime and night time settings for Brightness, Contrast, and Black Level. Adjust each setting when the display is in either daytime or night time mode. Use the **DisplayMode** button (page 10 and 105) to select Daytime or Night time mode.*

## Volume

The navigation voice volume has 11 settings and can be adjusted by:

- Using the voice control system and saying “Volume up” or “Volume down.”
- Selecting **Volume** and changing the setting by rotating the **Interface Dial knob**.
- Saying “Volume Off,” or selecting **Volume** and then **OFF**.

### NOTE:

*If you turn the volume off, you will not hear route guidance or voice command confirmations.*

If you then select **Voice** in the Map menu, you will hear route guidance at the default volume.

## Interface Dial Feedback

This setting allows you to control when (and if) the system will read the current selection you choose with the **Interface Dial**. The purpose of this feature is to minimise the need to look at the screen while operating the dial. You can set the one of the three settings explained in the following table. The factory default is **AUTO**.

Setting	Degree of assistance
<b>ON</b>	When selection is made, the system always reads what is selected.
<b>AUTO</b> (factory default)	The system reads selection only when moving
<b>OFF</b>	No voice assistance when selecting.

## Personal Information

From the SET UP screen (Main Set up), say or select **Personal Information** and the following screen appears:

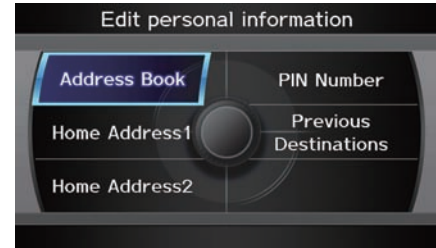

### Address Book

The Address Book allows up to a total of 200 address entries. After 200 entries, no more entries can be added. The 200 addresses are shared between DRIVER 1 and DRIVER 2. For example, if DRIVER 1 has 150 addresses, DRIVER 2 can only have 50. You can add, modify, and delete information in the personal Address Book list.

## System Setup

You may choose to use a Personal Identification Number (PIN) to protect your privacy. However, PINs are optional, and if you decide to use one, record it in case you forget the number (see page 88).

### **NOTE:**

*If you forget your PIN, your dealer will have to reset it for you, and all of your stored information will be cleared.*

You can do the following functions in the address book:

- Enter an address (see page 84)
- Edit an existing address (see page 85)
- Delete an existing address (see page 87)

### **Accessing the Address Book List**

After selecting the **Address Book**, move the **Interface Dial** down while on the **Select an address** screen to change to **DRIVER 1** or **DRIVER 2**.

If an Address Book PIN has been set, the system prompts you to enter your PIN. Verify that the correct user is displayed, then enter your PIN. After entering your PIN correctly by voice or by using the **Interface Dial**, the system displays your Address Book.

If no Address Book PIN has been set, the system displays your Address Book after selecting **DRIVER 1** or **DRIVER 2**.

### **NOTE:**

*Personal information cannot be backed up or moved to another navigation system.*

### **Entering an Address**

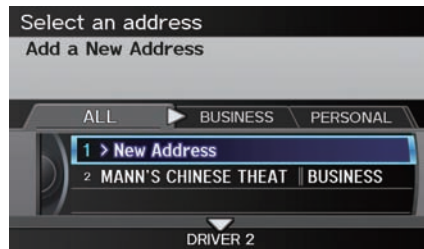

Select **New Address** by pushing in on the **Interface Dial** when beginning to build your Address Book list.

If you move the **Interface Dial** down, you can change to **DRIVER 1** or **DRIVER 2**.

## Edit Name

You may use the “Name” field to give the entry a name or title that you will recognize later, such as “Doctor Smith” or “Broadway Theatre.” If you do not give the address a name, the system will assign one (Address 001, etc.).



Say or select **Edit Name**. Then use the **Interface Dial** to enter the name. Select **OK** when finished.

### NOTE:

*You can always re-enter, edit, or make changes to any entry. “Address” is the only required field.*

## Edit Address

When you say or select **Edit Address**, the display changes to:



**Current Position** - Allows you to use your current position as the address.

**Address** - Requires you to enter the city and address you wish to store. The operation is the same as selecting **Address** from the DEST screen (Dest. MENU 1). See page 24.

**Previous Destinations** - Allows you to choose one of the locations in the Previous Destinations list for your Address Book list. This operation is the same as selecting **Previous Destinations** from the DEST screen (Dest. MENU 1). See page 29.

**Place Name** - Allows you to select one of the Point of Interest (POI) locations already stored in the system as one of your personal addresses. This is the same as selecting **Place Name** from the DEST screen (Dest. MENU 1). See page 30.

**Place Category** - Allows you to select a point of interest (POI) that has been saved in the system as one individual address. This is the same as selecting **Place Category** from the DEST screen (Dest. MENU 1). See page 31.

**Place Phone Number** - This feature is very convenient when you know the phone number of place or business that you want to save. This is the same as selecting **Place Phone No.** from the DEST screen (Dest. MENU 1). See page 37.

## System Setup

After you have used one of these six options to enter the address, the initial screen for entering the personal address is redisplayed, with the address shown in the “Address” field. If you have entered the address using **Place Name**, **Place Category**, or **Place Phone No.**, the phone number corresponding to the address also appears in the “Place Phone No.” field.

### Edit Phone Number

You can enter the phone number of the address. If the address was chosen with **Place Name**, **Place Category**, or **Place Phone No.**, and it has a phone number, that number is entered automatically.

Say or select **Edit Phone No.** to display the Enter phone number screen. Enter the phone number, including the area code, by using the voice control system (say the entire phone number one digit at a time) or by using the **Interface Dial**. Say or select **OK** when finished.

### Edit Category

If desired, you can specify the category of the address or the icon. Say or select **Edit Category** to display the Select a category screen.

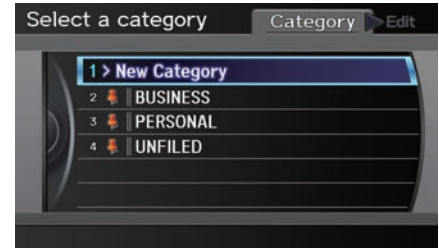

Scroll the screen and select a category by saying the number next to your choice, or by pushing in on the **Interface Dial**.

To add a new category, select **New Category** from the list. To edit or delete a category, select **Edit** by moving the **Interface Dial** to the right. The system will display the **Select an edit menu** screen. Follow the on-screen prompts to edit or delete a category. If you delete a category that was used to categorise addresses, the category for those addresses becomes “UNFILED.”

**NOTE:**

You can have 100 categories (including **UNFILED**). These are shared between **DRIVER 1** and **DRIVER 2**.

The system will then display everything that you have entered.

If all the information is correct, say or select **OK**. This will return you to the Address Book list.

If you want to enter another address, select **New Address** in the list, then repeat the procedures above. If not, press the **CANCEL** button.

**Delete an Address**

This feature allows you to select an address to delete. Once an address is selected, say “Delete” or push in on the **Interface Dial** to select **Delete**.

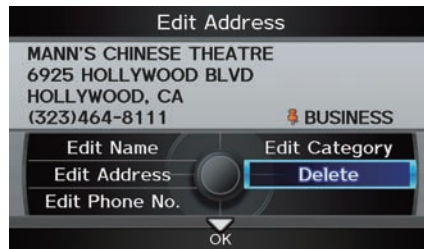
**Home Address**

This feature lets you return “Home” from any location simply by saying “Go home 1 or 2” at the map screen. Alternatively, you can select **Go home 1 or 2** on the DEST screen (Dest. MENU 1 or 2). See *By Go Home 1 or 2* on page 45.

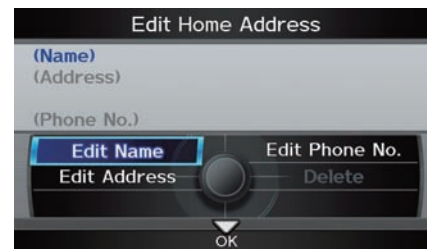

Select **Home Address 1** or **Home Address 2**.

Enter the name, address, and phone number in the same way as entering a personal address, then say or select **OK**. To leave the screen, press the **CANCEL** button.



## System Setup

### NOTE:

If your Home Address cannot be found in the system, then while located on the street close to your home, select “Current Position” when entering the “Edit Address” field.

### PIN

You can set a four-digit PIN (Personal Identification Number) for accessing and changing personal addresses and your home address if desired. Once you set the PIN on this screen, the system asks you to enter the PIN when you access a personal address or your home address.

### NOTE:

PINs are optional. If you choose to use a PIN, make sure you remember it. If you forget your PIN, the dealer will have to reset it for you, and all of your stored information will be cleared.

When you select **PIN Number**, the display changes to:

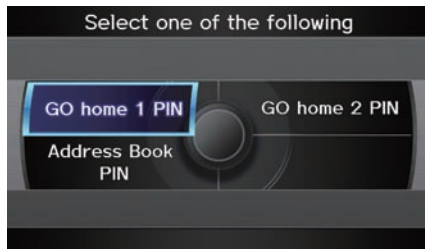

### Address Book PIN

If you choose to enter a PIN for the personal Address Book, you will have to enter it any time you edit your Address Book (see page 84) or select **Address Book** on the DEST screen (Dest. MENU 1) (see page 28).

1. Select **Address Book PIN**.
2. The display changes to:



3. Enter your new four-digit PIN. If you do not wish to use a PIN, select **DO NOT USE PIN**.

### NOTE:

The factory default is no PIN.

- When you have entered your PIN, the display changes to the **Please reenter new PIN** screen. Enter the same number to validate the number you have selected.
- If you have entered the same number both times, the display returns to the **Select one of the following** screen. If not, “INCORRECT PIN” appears. Enter your PIN again.

**NOTE:**

- If you wish to remove your PIN, return to the same screen and, after entering your PIN correctly, select **DO NOT USE PIN**.
- PINs are optional. If you choose to use a PIN, make sure you remember it. If you forget your PIN, your dealer will have to reset it for you, and all PINs will be cleared.

## Go home 1 or 2 PIN

- Select **Go home 1 or 2 PIN**, and the system displays the **Enter your new PIN** screen.
- Enter your PIN in the same way as entering the Address Book PIN.

**NOTE:**

- The factory default is no PIN. If you choose to use a PIN, you will have to enter it whenever you say “Go home 1 or 2” at the map screen or select **Go home 1 or 2** on the DEST screen (Dest. MENU 1 or 2).
- PINs are optional. If you choose to use a PIN, make sure you remember it. If you forget your PIN, your dealer will have to reset it for you, and all stored information will be cleared.

## Previous Destinations

Allows you to delete some or all of your previous destinations.

- Select this option, and the display changes to:



- Scroll through the list and find the address you want to delete.
- Select the address to delete by saying the line number, or by using the **Interface Dial**.

**NOTE:**

To cancel the deletion of *Previous Destinations*, select the address that was to have been deleted and push in on the **Interface Dial** before performing step 4.

- Say or select **OK** to perform the deletion, and the display returns to the previous screen.

# System Setup

## Music Search

On the iPod playback screen, push the interface selector down to display **AUDIO MENU**. Turn the interface knob to select Music Search Setup.

**Music Search Setup** screen appears.

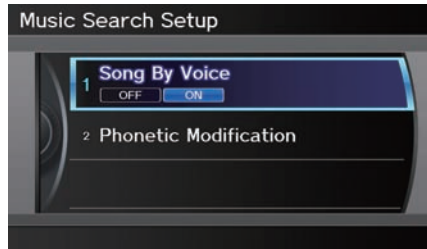

### Song By Voice™ (SBV)

Song By Voice™ allows you to search for and play music from your HDD or iPod using voice commands.

To activate this mode, press the **TALK** button on the steering wheel and say “Hard Disc Drive Search” or “iPod Search” depending on the media that you would like to access. From this mode, you can use the following voice commands to select songs or display a song list.

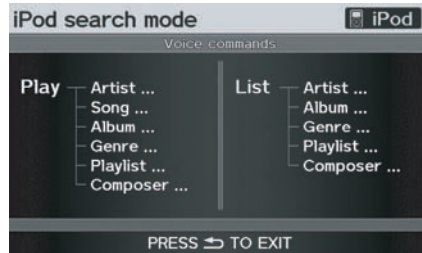

Say the desired voice command followed by the artist, song title, album, genre, playlist, or composer you wish to select. For example, when you say “Play artist A,” the system will provide voice feedback and start playing all songs of that artist.

#### NOTE:

- For information on the available voice commands in the Song By Voice™ mode, see Song By Voice™ Commands on page 150.
- Languages other than English may not be available for artist name, song title, album title, etc.
- You can turn this feature **ON** or **OFF**.

When you say “List artist A,” the system will provide the following song list for that artist.

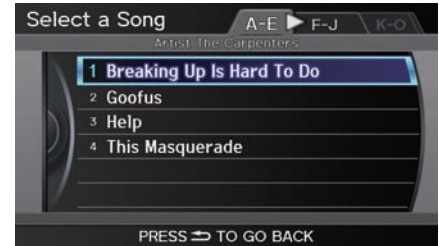

Select the desired song. The system will start playing the selected song and return back to the main Song By Voice™ screen.

To cancel the Song By Voice™ mode, press the **BACK** button on the steering wheel or any navigation button.

#### NOTE:

Once you have canceled this mode, you will need to say “Hard Disc Drive Search” or “iPod Search” again to reactivate this mode.

See your owner’s manual for more information on how to operate HDD and iPod audio features.

### Phonetic Modification

You can modify the phonetics for all artists, songs, albums, and composers on the HDD and connected iPod. The modified phonetics can be used for the voice commands in the Song By Voice™ mode.

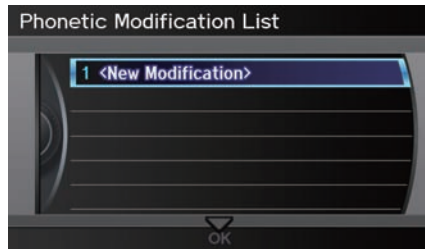

When you select **New Modification**, the following screen appears:

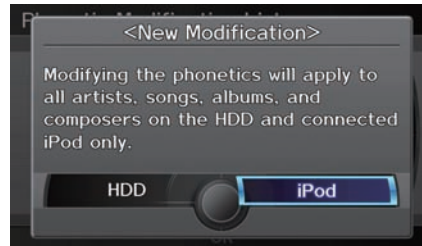

Select **HDD** or **iPod** depending on the media that you would like to access.

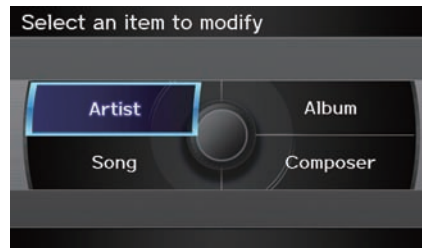

Select **Artist**, **Track**, **Album**, or **Composer** and then select an item to modify.



As in the example above, select the artist name stored as “No Name.” To play back the phonetic modification and check that it sounds right, select **Play**. Select **Edit** and enter the desired phonetic (e.g., “ABC”), and then select **OK**.

## System Setup

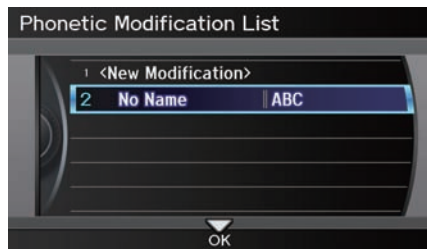

The artist “No Name” is modified to “ABC” and you can use the voice command “Play artist ABC” in the Song By Voice™ mode (see page 90).

If you add some other phonetics, repeat the procedure. When you finish modification, select **OK**.

### NOTE:

- When **Song By Voice** is set to **OFF**, **Phonetic Modification** will be grayed out.
- Up to 2,000 phonetic modification items can be stored.

## SET UP Screen (Other)

Select the “Other” tab by moving the **Interface Dial** to the right to view additional SET UP functions and the following screen appears:

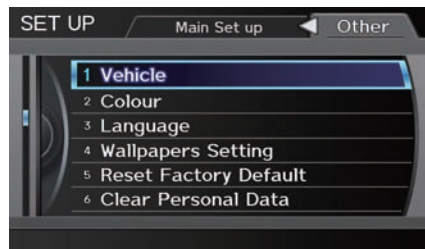
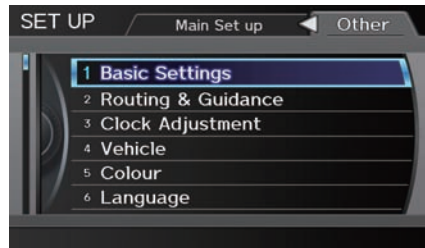

## Basic Settings

From the SET UP screen (Other), say or select **Basic Settings** and the following screen appears:



## Units (mile or km)

Allows you to select the units for the entire system (**mile** or **km**).

## Voice Recognition Tutor

Allows you to turn voice control system prompts **ON** or **OFF**. When **OFF**, you will not hear the voice control system confirmations or prompts.

## Verbal Reminders

If the parking brake has not been disengaged, or if either the driver or a passenger forgets to buckle his/her seat belt, an audio voice warning is given. This function can be toggled between **ON** and **OFF** at this time.

## Routing & Guidance

From the SET UP screen (Other), say or select **Routing & Guidance** and the following screen appears:

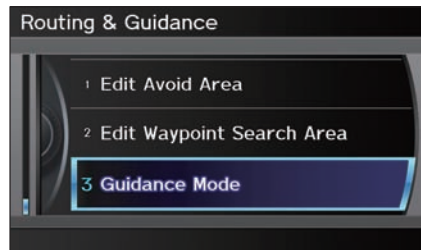
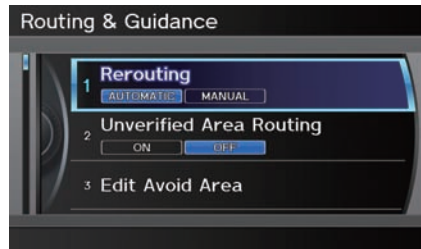

## Rerouting

If **Rerouting** is set to **AUTOMATIC** and you deviate from the route, you will see “Recalculating...” at the top of the screen for several seconds as the system calculates a new route. This is followed by new routing instructions.

If **Rerouting** is set to **MANUAL**, you will hear a tone when the “Off route” message is displayed. Say “Recalculate” or select **Recalculation** on the screen to make the system recalculate your new route.

### NOTE:

- *It is strongly recommended that you leave the system set to the factory default (Automatic).*
- *If you live in an area with poor mapping, you may wish to set **Rerouting** to **MANUAL** to avoid constant recalculation. However, you will have to manually select **Recalculation** on the screen to have the system plot a new route.*

# System Setup

## ***Unverified Area Routing***

Allows you to receive turn-by-turn map and voice guidance in unverified areas when en route to a destination (see *Manual Overview* on page 6). The chart below illustrates the routing differences with this setting **ON** or **OFF**.

	<b>Unverified Area Routing: OFF</b> (factory default)	<b>Unverified Area Routing: ON</b>
<b>Decision: Why choose ON or OFF?</b>	The driver wishes to navigate manually by using the navigation map and choosing the streets that lead to the destination. The driver understands that unverified roads may not be accurate, and can contain errors in location, naming, and address range.	The driver chooses to let the navigation system suggest possible routing. The driver understands that in some cases guidance may not be appropriate. Unverified roads may not be accurate, and can contain errors in location, naming, and address range.
<b>What you will see...</b>	A blue dotted vector line is displayed on the map that continually points to your destination. The driver should stop and then use the map to select streets that lead to the destination.	A blue-pink dashed route line highlights suggested unverified streets on the map while travelling to your destination. This is in sharp contrast to the normal blue route line displayed in verified areas.
<b>Cautionary messages</b>	There are cautionary pop-up screens and voice announcements, before and during the route. These serve as reminders that you should obey all traffic restrictions.	There are cautionary pop-up screens and voice announcements, before and during the route. These serve as reminders that you should exercise additional caution, and obey all traffic restrictions.
<b>Guidance (map/voice)</b>	There is no turn-by-turn map or voice guidance.	Voice guidance commands end with the words “if possible.” This is to remind the driver to verify all traffic restrictions before making a manoeuvre.
<b>Directions list</b>	A direction list is typically not available. However, depending on your route, directions are provided to help you reach the first available verified road.	A direction list is provided showing street names and turn symbols in pink.



## Unverified Area Routing

When driving to your destination, you have the choice of using or not using “unverified” roads. You make this choice in the SET UP screen. The next few pages contain an example of a route to a destination in an unverified area explaining the routing differences found in unverified areas.

With **Unverified Area Routing OFF**, the system tries to use verified roads whenever possible. In this example, since only verified streets are used, it created a longer route than necessary.

With **Unverified Area Routing ON**, the route is shorter, but consists of unverified (purple) streets that may not be accurate. Because the streets are unverified, there may be errors in street location, name, or address range. Additional caution is recommended in these areas. Always obey posted traffic restrictions.

Because both routes bypass or use unverified streets, it is recommended that you stop and review the map.

## Unverified Area Routing “OFF”

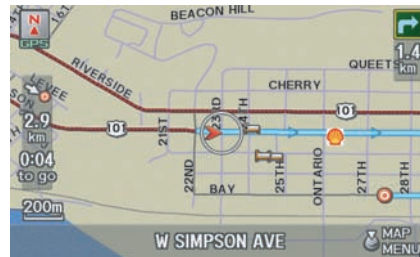
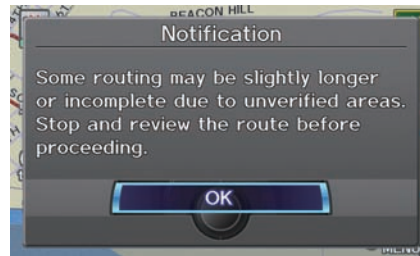

## Unverified Area Routing “ON”

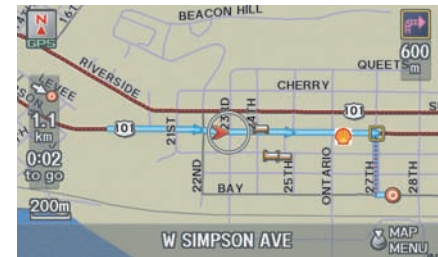
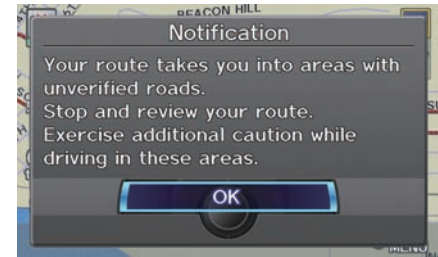

### NOTE:

Unverified roads are shown only when viewing the map in the 1/20, 1/8, 1/4 mile map scales, or the 80, 200, 400 metre map scales.



## System Setup

With **Unverified Area Routing OFF**, before you enter an unverified street, a caution box appears on the screen and a voice message is given. This lets you know that you are about to enter an unverified area and that you will be following a dotted “vector line” that points to your destination.

With **Unverified Area Routing ON**, a caution box appears on the screen and is read by the voice. In this case, you will be presented with a dashed blue/pink line instead of the regular blue route line. This is your signal to pay attention to posted traffic restrictions. You cannot assume that all guidance is appropriate.

In both cases, when you actually enter the unverified street, a short caution will remind you. You will see and hear this short caution message whenever you enter unverified areas.

If you regularly enter and leave unverified roads for short amounts of time, there may be cases where no guidance is provided.

### Unverified Area Routing “OFF”

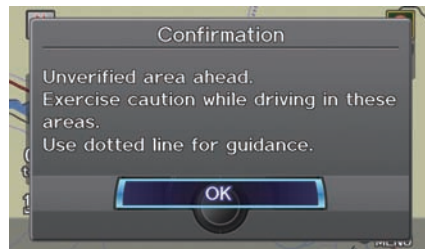

### Unverified Area Routing “ON”

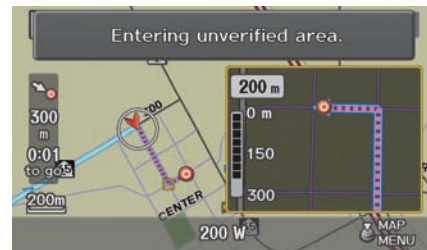
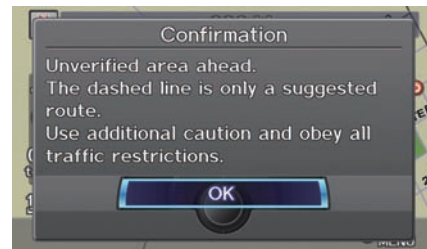

With **Unverified Area Routing OFF**, you are presented with a blue “vector line” that always points to the destination. You must manually choose streets from the map that will lead to your destination. No guidance is provided, and there are no directions to the destination.

With **Unverified Area Routing ON**, a blue/pink route line is shown for unverified segments. Voice guidance commands in unverified areas always end with “if possible.” This is your signal that you should use additional caution, and obey all traffic restrictions. The manoeuvre window “arrow” shows any portions of unverified turns in blue/pink dashes.

These guidance manoeuvres are only a suggestion. You should always confirm that the manoeuvre is possible. A directions list is also provided that shows any unverified roads in a blue colour, with pink arrows pointing to the next manoeuvre.

## Unverified Area Routing “OFF”



### NOTE:

*For the pop-up menu displayed when pushing in on the **Interface Dial** from the map screen, **Voice** is grayed out. With **Unverified Area Routing OFF**, no **Direction List** is provided.*

If you select **Directions** in the **Guidance Menu** on the Map Menu screen, you will receive guidance by **Directions** while you are driving.

## Unverified Area Routing “ON”

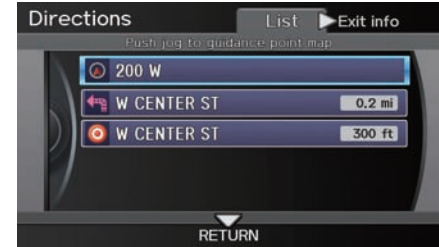

## System Setup

### **Edit Avoid Area**

This function allows you to select areas you wish to avoid when calculating a route to your destination. You can select up to five areas to avoid. You may wish to set up an “avoid area” to route around long-term road construction, closures, or any area you wish to avoid. If you enter a route that takes you through or into an “avoid area,” a pop-up box will warn you that your route takes you into one of these areas. However, you can still choose destinations in an avoided area.

When you select **Edit Avoid Area**, the following list screen is displayed.

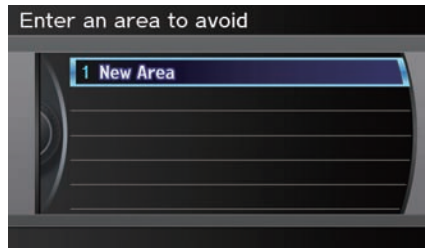

You can select **New Area**, or select one of your existing areas to modify. If you choose **New Area**, the following screen is displayed:



Say or select **Edit Name**, and use the **Interface Dial** to enter the name on the **Enter avoid area name screen** (25 characters max). Say or select **OK** to return to the previous screen.

Say or select **Edit Area** to create the area to be avoided. The following screen appears:



Either select **Address** or **Map Input** on the **Enter avoid area by** screen. Each choice provides a slightly different way to locate the approximate map display for drawing the area you wish to avoid.

After selecting the choice, a map screen will be displayed.



Rotate the **Interface Dial knob** to select the map scale (available scales are 80, 200 and 400 metres scales). Use the **Interface Dial** to move the target mark (red circle) to the desired start point and push in on the **Interface Dial** to “set” the start point. Then move the **Interface Dial** in a straight or diagonal direction to encompass the area to be avoided.



**NOTE:**

*The maximum size of the “Avoid area” is 800 metres in length or width.*

The selected area will be displayed as a shaded box with a yellow border. Push in on the **Interface Dial** to set the end point of the avoided area. To “redraw” the area, select **CANCEL** and repeat the area selection process.

Say or select **OK** to return to the Edit avoid area screen.

If your selected area contains a highway, the system will prompt you with a pop-up box saying “Do you want to avoid highways?” Answering “No” allows you to enter a route through an avoided area on a highway and skip the “Avoid area caution box” (see *Pop-ups and Disclaimers* on page 66).

When you return to the **Edit avoid area** screen, the “Vicinity” field is automatically filled in by the system. Re-edit the area “Name” if desired. Select **OK** on the Edit avoid area screen to finish editing. Your new avoided area will now appear on the “Avoid area” list and be viewable on the map screen.

**NOTE:**

*You can select areas to avoid, however you cannot select roads or areas that you want the system to use for routing.*

# System Setup

## Edit Waypoint Search Area

When driving en route to your destination, you can select a temporary destination waypoint (marked with a small flag on the map) along your route for gas, a restaurant, or other POI. When you resume your trip from the waypoint, the system continues the trip to your original destination. To use this feature, see on page 68.

This SET UP item allows you to select the distance from your highlighted route line (on either side of your route) that the system will search for a waypoint.

From the Routing & Guidance screen, select **Edit Waypoint Search Area**, and then choose the desired search distance for either “On Highways” or “On Surface Street.”



The diagram below shows how the system handles the search for “SEARCH ALONG” or “SEARCH AROUND the Destination” (see on page 69).

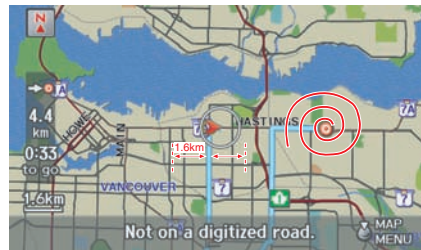

For “Places along the route,” the system looks in front of you within a corridor width specified by your values for “On Highways” or “On Surface Street.” The system checks the upcoming area, based on your input.

For “Places around the destination,” the system searches outwards in a spiral from the destination. In this case, specific search values are not needed; the matches are displayed in order of distance from destination.

### NOTE:

*These settings do not affect the search range used for the voice commands like “Find nearest gas station” that are also available when viewing the map screen.*

## Guidance Mode

Allows you to select the guidance display mode: **Single Screen** or **Split Screen**.

To get to Guidance Mode from the SET UP screen, select the “Other” tab, **Routing & Guidance**, and **Guidance Mode**.

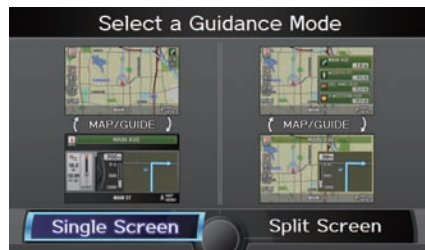

The factory default is **Single Screen**.

### NOTE:

The **Guidance Mode** on the Map Menu screen can also be selected. See *Driving to Your Destination* on page 56.

## Clock Adjustment

From the SET UP screen (Other), say or select **Clock Adjustment** and the following screen appears:



This screen allows you to set or adjust the following:

- Auto Daylight (Default = ON)
- Auto Time Zone (Default = ON)
- Adjust Time (adjust your clock)
- Reset (resets this screen’s settings to factory defaults)

## Auto Daylight

Sets automatic daylight saving time **ON** or **OFF**. If set to **ON**, the clock will automatically “spring ahead” or “fall behind” by one hour when a daylight saving time change occurs.

### NOTE:

Even if you have set Auto Daylight to **ON**, this function is not activated in areas that do not adopt daylight saving time.

## System Setup

### Auto Time Zone

Sets automatic time zone selection by GPS to **ON** or **OFF**. If you are driving across the country and passing through time zones, then this feature will automatically set the time to the time zone you are travelling through. However, if you live and work in two different time zones, you may want to turn this feature off.

#### **NOTE:**

*When driving near a time zone boundary, the displayed time zone may fluctuate between the two zone times.*

### Time Adjustment

Adjusts the current time in hours and minutes. Select the current time by moving the **Interface Dial** up, and then switch **HOUR** and **MINUTE** by moving the **Interface Dial** to the left and right and changing the value by rotating the **Interface Dial knob**. Selecting **OK** returns you to the previous screen. You can reset the adjustment by selecting **RESET**.

#### **NOTE:**

*Selecting **RESET** also clears any changes you made to “Auto Daylight,” or “Auto Time Zone” settings. Depending on your location, you may need to adjust these settings.*

### Vehicle

From the **SET UP** screen (Other), say or select **Vehicle** and the following screen appears:

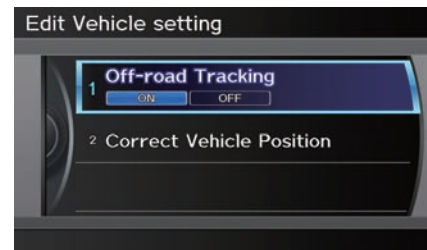

### Off-road Tracking

With this **ON**, the system will provide white off-road tracking dots (“breadcrumbs”) on the **map** screen whenever you drive into an area where the map does not show any roads. See *Map Screen Legend* on page 52.



After you have travelled approximately 800 metres away from a mapped road, the system will display a series of white dots on the **map** screen to show the path you have travelled. This is provided so you can follow the dots to backtrack to the mapped road you originally left. Tracking continues until you reach a mapped road. See *Off-road Tracking* on page 64.

Tracking is shown only in the 1/20, 1/8, 1/4, and 1/2 mile scales, or the 80, 200, 400, and 800 metre scales. Rotate the **Interface Dial knob** to change the scales if necessary.

**NOTE:**

*To clear existing dots, turn this feature **OFF** and exit SET UP. To re-enable this feature, return to SET UP and turn it on again.*

**Correct Vehicle Position**

The system relies on satellites for positioning information. Buildings, tunnels, and other objects can block or reflect these signals, requiring the system to use “dead reckoning” to determine your location and direction. This can sometimes lead to small errors in positioning, such as showing you on an adjacent street.

**NOTE:**

*Using this function to adjust vehicle position is not recommended. When the system acquires a GPS signal, it will automatically place the vehicle in the correct location.*

If you choose to do this, follow these steps:

1. Stop the vehicle.
2. Select **Correct Vehicle Position**, and the system will display a Correct vehicle position screen.



3. Use the **Interface Dial** to move the vehicle position arrowhead to the correct location, and push in on the **Interface Dial**. The display will change to:





## System Setup

4. Rotate the **Interface Dial knob** so the vehicle position arrowhead is pointing in the correct direction, and push in on the **Interface Dial**. The display will return to the previous screen.

### NOTE:

*If you continually have to do this, there are either problems in the database or GPS reception problems. See Accessories Precautions on page 5.*

5. As you drive, the current road will be displayed at the bottom of the screen.

## Colour

From the **SET UP** screen (**Other**), say or select **Colour** and the following screen appears:

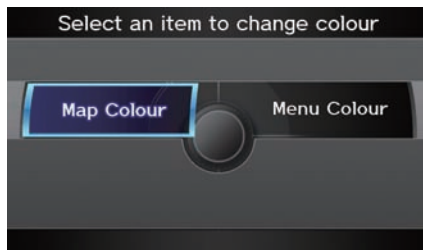

## Map Colour

Allows you to choose the map colour from one of five colours for the Day and Night mode.

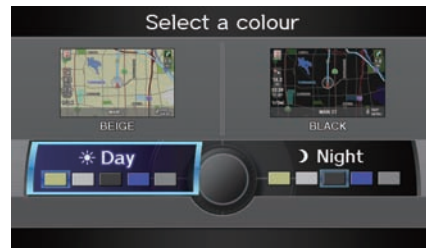

Press the **CANCEL** button to return to the previous screen.

### NOTE:

- Choose “White” (factory default is Beige) as the Day colour to obtain the best daytime display contrast.
- Choose “Black” (factory default) as the Night colour to obtain the best night time display contrast.

## Menu Colour

Allows you to choose the menu colour from one of five colours for the Day and Night modes.

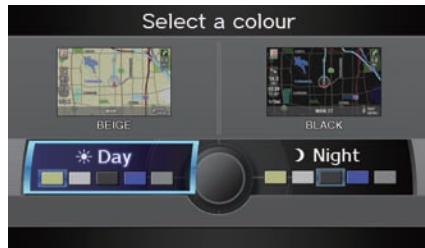

Press the **CANCEL** button to return to the previous screen.

### NOTE:

- Choose “White” (factory default) as the Day colour to obtain the best daytime display contrast.
- Choose “Black” (factory default) as the Night colour to obtain the best night time display contrast.

## Switching Display Mode

### Manually

Pressing the **Display Mode** button  allows you to toggle through the screen display modes: **Day**, **Night**, or **Off**. When selecting **Day** or **Night**, the Brightness bar will be displayed; rotate the **Interface Dial knob** and adjust the Brightness value. This button is the overriding control for the day/night display mode, and is the simplest way to control the display mode.

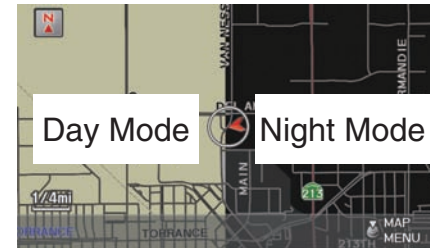

See the chart on page 106 for an explanation of other day/night display mode adjustments and how they interact with each other.



(Example of Day/Night Mode)

# System Setup

## Switching Display Mode Automatically

Illumination control	Operation	But remember
<b>Display Mode</b> button  (see page 10)	Allows selection of <b>Day</b> , <b>Night</b> or <b>Off</b> display mode. This button has the highest priority and overrides all other display control adjustments listed below.	When the car is restarted, the display mode previously selected by this button is canceled and is determined by one of the controls below.
Sunlight sensor (middle of dash near the windshield, see the vehicle Owner's manual for location)	If the sunlight sensor detects daylight and the headlights are turned on, the system automatically overrides (cancels) the <b>Night</b> display and displays the <b>Day</b> display mode.	If desired, use the <b>Display Mode</b> button  to override this automatic choice.
Dash illumination adjustment knob (see the vehicle Owner's manual for location)	When headlights are turned on, and you wish to have the <b>Day</b> display mode, then adjust the illumination to the full bright setting (beeps).	Remember to adjust the dash brightness back to mid-range to allow auto switching by sensing whether the headlights are on or off.
Headlights (Auto/On/Off)	When turned on, the display changes to <b>Night</b> display mode. The previous two controls listed above can cancel this function.	Use the <b>Display Mode</b> button,  or, with the headlights on, adjust the dash illumination to full bright to set the display to your desired choice.
Map <b>Day/Night</b> screen colour choice (see page 104 for the <b>Day</b> and <b>Night</b> colour choices)	The user can select the colour of the screen that will be displayed for the <b>Day</b> and <b>Night</b> display modes.	For best contrast, ensure that the map colour is white for <b>Day</b> and black for <b>Night</b> .

### Recommended Display Mode Day/Night settings:

- With the headlights on, select mid-range for the dash illumination (see the vehicle Owner's manual for location of knob).
- With the headlights off, select mid-range for the dash illumination (see the vehicle Owner's manual for location of knob).
- On the SET UP "Colour" adjustment screen, choose white for the map **Day** display and black for the map **Night** display (see page 104). Inappropriate adjustment of these colours can cause the Day/Night modes to appear inoperative.

### NOTE:

See the vehicle Owner's manual for additional information regarding the dash brightness adjustment.

## Language

Selects the language to be used on each screen that the system displays. From the SET UP screen (Other), say or select **Language** and the following screen will be displayed.



You can choose from three languages: **English**, **French**, or **Spanish**.

### NOTE:

- *If you select one language, and then select a different language immediately after, there are cases where the conversion will not be successful. In this case, conversion of all the voice data has not been completed (the system will display a message).*

- *Voice confirmation of cities and streets only occurs out when English has been selected.*
- *When French or Spanish is selected, messages will continue to be displayed in English.*

## Wallpapers Setting

From the SET UP screen (Other), say or select **Wallpapers Setting** and the following screen will be displayed.



With the factory default, two images are provided for the HDD.

## System Setup

### Importing Pictures from USB

To use a wallpaper image other than the factory defaults, you can import pictures from a USB thumb drive or similar device.

If you say or select **Import pictures from USB** and a USB thumb drive is properly connected, the following screen will display.

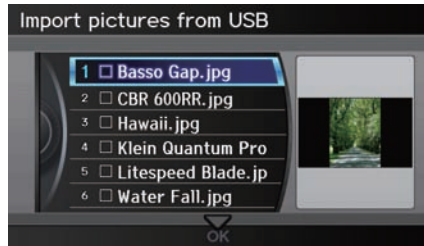

Rotate the **Interface Dial** knob and select the images to be uploaded to the HDD. Move the **Interface Dial** down and select **OK**.

#### NOTE:

- Depending on the USB thumb drive, pictures may not be imported.
- You can import images from the root directory. Images in folders cannot

be imported.

- The display image size is 800 x 480 pixels. Smaller images are displayed with the extra area appearing in black. Larger images are reduced to a displayable size without changing the aspect ratio.
- Ten uploaded images (in BMP or JPEG format) can be saved to the HDD for Driver 1 and Driver 2 each.
- Incompatible data formats or images greater than 6 MB cannot be saved.
- When the file name is longer than 221 characters, the image cannot be uploaded.
- If you attempt to upload an image with the same name as an existing image, a pop-up screen will appear, asking if you want to overwrite the existing image file.
- When music files that are saved within a USB thumb drive are being played, image files cannot be uploaded.
- You cannot import images while driving.

### Selecting Wallpaper Pictures

Establish the Wallpaper setting for those images that are within the HDD. If you say or select **Select wallpaper picture**, a list of the images in the HDD will appear.

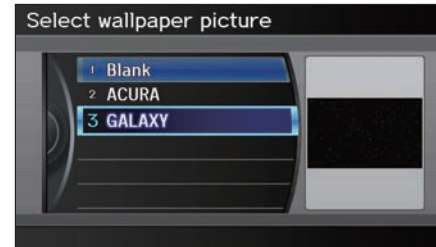

#### NOTE:

If Wallpaper has not been set up, “Blank” will be selected.

If you select an image, the image will appear in a pop-up screen. Select **OK** to complete the setup. The selected image will be highlighted on the list screen.

**Delete pictures on HDD**

If you say or select **Delete pictures on HDD**, a list of the images on the HDD will appear.



To delete the image, use the **Interface Dial** to select it, and the image will display. Select **OK** if you want to continue to delete the image, and the list of images will be displayed, with your selected image highlighted. Move the **Interface Dial** down to select **OK** to delete. A confirmation message will appear.

**NOTE:**

- If there are no images on the HDD, "No Entries Exist" will appear.
- You cannot delete images while driving.

Images that have not yet completed migration from a USB thumb drive, etc.) cannot be deleted.

**Reset Factory Default Settings**

The **Set up** settings and rear camera brightness value settings can be returned to the factory default settings. If you say or select **Reset Factory Default** from the **SET UP** screen (**Other**), the following screen will display.

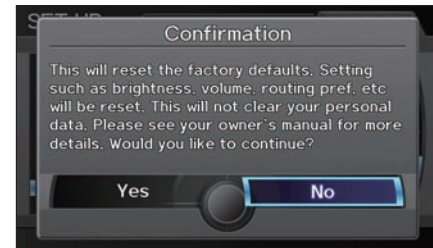

If you select **Yes**, the following Set up settings return to the factory default settings. If you select **No**, these settings will remain as they are currently set.

- Brightness, Contrast, Black Level, Volume, Interface Dial Feedback, Brightness (Rear Camera)

## System Setup

- Basic Settings: Units, Voice Recognition Tutor, Verbal Reminder
- Routing & Guidance: Rerouting, Unverified Area Rerouting, Traffic Rerouting, Edit Waypoint Search Area, Guidance Mode
- Clock Adjustment: Auto Daylight, Auto Time Zone, Time
- Vehicle: Off-road Tracking
- Colour: Map Colour, Menu Colour

### NOTE:

*Messages are not deleted.*

### Clear Personal Data

Any uploaded data, calendar entries, address books, stored destinations, or other settings can be cleared or returned to factory defaults. If you say or select **Clear Personal Data** from the SET UP screen (Other), the Select items to clear screen will display.

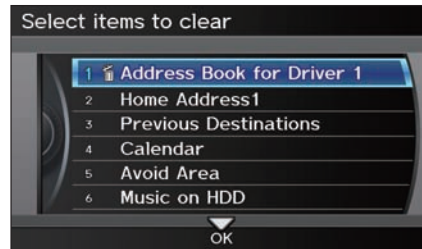

Rotate the **Interface Dial knob** and select the data to be deleted.

If a PIN number is set, the screen for entering the PIN code will be displayed. A pop-up screen verifying whether deletion is to be continued or not will be displayed, and then another deletion verification message will appear. Select **Yes** to commence the deletion; select **No** to suspend it.

### NOTE:

- When the **Address Book** is deleted, all contents (except the Categories) will be deleted.
- When Cellular Phone Information is deleted, Voice Tag information will also be deleted.
- If you select **Music on HDD** or **Music Search Phonetics**, the system will automatically be restarted after deletion.

## Rearview Camera

Your vehicle is equipped with a rearview camera as shown in the illustration.

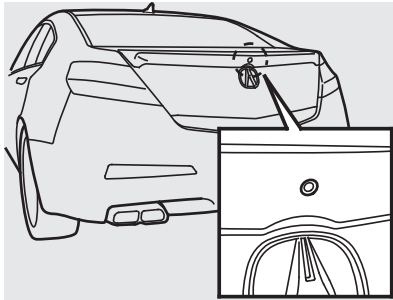

When you shift to R (Reverse) with the power mode in the ON mode, the rear view is shown on the navigation screen. Parking guidelines appear in the rear view. For the best image, always keep the rearview camera lens clean, and be sure it is not covered.

Since the rearview camera display area is limited, you should always back up slowly and carefully, and look behind you for obstacles.

## Rearview Camera Brightness Adjustment

When in reverse, the navigation “hard” buttons are locked out, except the rotating portion of the **Interface Dial knob**. Rotate the **Interface Dial knob** clockwise to make the camera image brighter, and counterclockwise to darken the image.

This brightness adjustment is independent of the screen brightness adjustment in SET UP.

### NOTE:

- The camera brightness cannot be adjusted by voice control.
- Slight delays can occur when switching to the camera image (especially when first starting your vehicle), or switching back to the map/menu screen. This is normal.

## Rearview Camera Image

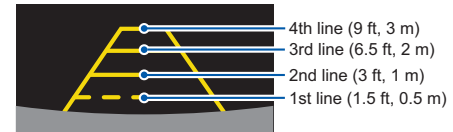

The rearview camera display has distance guidelines indicating distance from the back of the vehicle to one of the lines.

### NOTE:

- The rearview camera has a special lens that makes distances appear closer than they actually are.
- The rearview camera display has a limited range, and the size and position of objects around the area may appear different from reality. Make sure to check the surrounding area carefully.



# System Initialization

---

## System Initialization

If for any reason you lose power to the vehicle (e.g., the battery is disconnected), the navigation and audio system will require initialization. Once completed, your system will be ready to use.

This initialization requires the following:

- Entry of the 5-digit anti-theft security code to “unlock” the navigation and audio system.
- GPS initialization (may not be needed depending on the length of time the system was without power). (See *GPS Initialization* on page 113.)
- Map matching to align the GPS coordinates to a place on the map (displays current street at the bottom of the map). (See *Map Matching* on page 113.)

## Entering the Security Code

When you purchased the vehicle, you should have received one card containing a 5-digit anti-theft code used to activate both the navigation and audio system.

Enter the 5-digit security code in accordance with the instructions in your owner’s manual. If you do not enter the security code, navigation, audio, and voice recognition will not function.

If you lose the card or do not have access to it, you can retrieve it using one of the following methods:

- 1) Call Acura Client Services at 1-888-9-ACURA-9.
- 2) Visit your dealer.

You will need your radio serial number and vehicle VIN to retrieve the anti-theft code.

To retrieve the radio serial number, press and hold the audio preset 1 and 6 buttons. Continue to hold the buttons, then turn on the radio. Record the serial number shown on the radio display.

### **NOTE:**

*The anti-theft security code is unrelated to your optional navigation system PIN (for Address Book or Home Address).*

## GPS Initialization

Depending on the length of time the battery was disconnected, your system may require GPS initialization. If it does, the following screen appears:

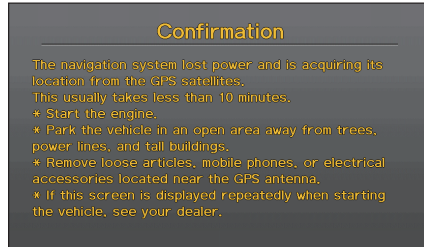

If this procedure is not necessary, the system proceeds directly to the Disclaimer screen (see page 18). During initialization, the system searches for all available GPS satellites and obtains their orbital information. During this procedure, the vehicle should be out in the open with a clear view of the sky.

If the navigation system finds the satellites properly, this box clears and the Disclaimer screen is shown. If within 10 minutes the system fails to locate a sufficient number of satellites to locate your position, the following screen appears:

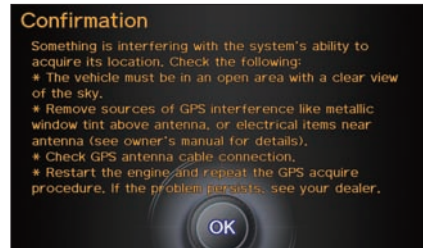

If the system is still unable to acquire a signal, follow the instructions on the screen, or contact your local dealer for assistance.

### **NOTE:**

*The average acquiring time is less than 10 minutes.*

## Map Matching

This part of the initialization matches the GPS coordinates found above with a road on the map screen. To perform this part of the procedure, ensure that the navigation system is displaying a map, and drive the vehicle on a mapped road (a road shown on the map screen). Do not enter a destination at this time. When the name of the current road you are driving on appears at the bottom of the screen, the entire procedure is complete. Your system is now ready to use.

## System Initialization

---

Although your navigation system is one of the most highly sophisticated pieces of equipment you will find in a modern automobile, you may find during its use that it has certain limitations.

The system uses GPS signals to aid in determining its current location. The GPS is operated by the U.S. Department of Defense. For security reasons, there are certain inaccuracies built into the GPS that the navigation system must constantly compensate for. This can cause occasional positioning errors of up to several hundred feet.

For example, in urban areas where streets are close together, this could cause the system to show that you are travelling on a street that parallels the street you are actually on. The system will, under most circumstances, correct itself while you drive.

Also, depending on your current view of the sky and the position of the satellites, the elevation may be shown incorrectly.

You may also notice some delay of the vehicle position icon at intersections; this is normal.

### **GPS Reception Issues**

The signals received from the GPS satellites are extremely weak (less than a millionth of the strength of a local FM station) and require an unobstructed view of sky. The signal can easily be interrupted or interfered with by the following:

- Aftermarket metallic window tint above or to the sides of the GPS antenna (located on the back of the navigation display)
- Cell phones, PDAs, or other electronic devices docked in a cradle or lying loose on the dashboard
- Remote starters or “hidden” vehicle location systems mounted near the navigation unit

- Other aftermarket audio electronic devices mounted near the navigation unit
- Trees, tall buildings, highway overpasses, tunnels, or overhead electrical power wires

Although the system will direct you to your desired destination, it may not always generate what you consider to be the most direct route. Try changing the method of routing. See *Changing the Routing Method* on page 48. You may also have Unverified Area Routing set to OFF. See *Unverified Area Routing* on page 94.

Additionally, the mapping database contains verified and unverified maps. See *Map Overview* on page 6. A **Disclaimer** screen will warn you if your route includes unverified streets. Unverified streets may be missing from the map, in the wrong location, or have an incorrect name or address range. Exercise additional caution when driving in these unverified areas.

The destination icon shows the approximate location of the destination. This occurs because a city block can have as many as 100 possible addresses (for example, the 1400 block is followed by the 1500 block) Since most cities use only a portion of the 100 possible addresses (for example, in the 1400 block, the addresses may only go up to 1425 before the 1500 block starts), the address 1425 will be shown a quarter of the way down the block by the system instead of at the end of the block where the destination is actually located.

You may find that the system occasionally reboots. This is indicated by the display returning to the globe screen. A reboot can be caused by a number of things, such as extreme temperatures or shock from bumpy roads. It does not necessarily indicate a problem that requires service. If this happens frequently, please see your dealer.

## Database Limitations

---

You will find that some points of interest (POI) may be missing when you search the database. This can be caused if at the time the database was gathered, the name was misspelled, the place was improperly categorised, or the POI change is not yet in the database. This means you may not find places listed that you know exist. This is also true for police agencies and hospitals. In outlying areas, facilities listed may not be the closest. Always check with local information sources if you need law enforcement or hospital services.

Every effort has been made to verify that the system's database was accurate at the time it was created. However, businesses do close or relocate, and new businesses start in the old locations. For this reason, you may occasionally find inaccurate information when you select and drive to a point of interest (for example, a restaurant is now a jewelry store). The number of these inaccuracies increases the longer you go without an update.

The digitized map database reflects conditions as they existed at various points in time before production. Accordingly, your database may contain inaccurate or incomplete data or information due to the passage of time, road construction, changing conditions, or other causes.

Due to ongoing software and database improvements, navigation software and mapping versions may change in the middle of a production year. The version shipped with your vehicle was the most recent available at the time of production and is considered standard equipment for that vehicle. There is no free programme to retrofit early production vehicles with the latest software and mapping versions. For update DVD ordering information, see page 119.

In addition, this database does not include, analyze, process, consider, or reflect any of the following categories of information:

- Neighborhood quality or safety
- Population density
- Availability or proximity of law enforcement
- Emergency, rescue, medical, or other assistance
- Construction work, zones, or hazards
- Road and lane closures
- Legal restrictions (such as vehicular type, weight, load, height, and speed restrictions)
- Road slope or grade
- Bridge height, width, weight, or other limits

- Traffic facilities safety
- Special events
- Pavement characteristics or conditions

We assume no liability for any incident that may result from an error in the programme, or from changed conditions not noted above.

### Copyrights

- Copyright © 2012 Zagat Survey, LLC. All rights reserved.  
**ZAGATSURVEY.**
- © 2012 NAVTEQ All Rights Reserved.
- Portions of the software in this product are copyright 2007 The FreeType Project ([www.freetype.org](http://www.freetype.org)). All rights reserved.  
Licenced under the FreeType Project LICENSER, 2006-Jan-27. (<http://www.freetype.org/FTL.TXT>)

# Client Assistance

---

## Reporting Errors

Occasionally, you may encounter database errors.

- If the error pertains to highways and main “verified” roads shown in black on the map, then report it either online at <http://update.navteq.com/>, or to Acura Client Services.
- If the error involves a purple “unverified” road, then do not report it. These areas have not been verified and are provided for reference only (see *Map Overview* on page 6).
- For errors in points of interest (POI), like a business that has changed its name, do not report them. Keep in mind that depending on when the data was collected, the database can be out of date. The business may have not reported the change(s), or not be in the database at all. Update Navigation DVDs are available for purchase, usually in the fall of each year. See *Obtaining a Navigation Update DVD* on page 119 regarding updates to the navigation system.

- If the error does not involve the database, such as vehicle position icon error, screen error messages, or other GPS related errors, see *Frequently Asked Questions* on page 132, *System Limitations* on page 115, or *Troubleshooting* on page 139.

## Acura Client Services

Telephone: 1-888-9-ACURA-9

Hours: 8:00 am to 7:30 pm Monday to Friday (Eastern time)

Mail:

### Acura Navi

Honda Canada Inc.  
Acura Client Services  
180 Honda Boulevard  
Markham, ON  
L6C 0H9

E-mail: [acura\\_cr@ch.honda.com](mailto:acura_cr@ch.honda.com)

## Visiting Your Dealer

We strive to make this manual as complete as possible and to answer all questions regarding operation of the system. Occasionally, you may run into a specific issue that you cannot find in the book. You may save yourself a trip to the dealer by first consulting the following resources:

- The Troubleshooting section (see page 139)
- The Frequently Asked Questions (FAQs) section (see page 132)
- The FAQs found on the online update DVD order site (see “Obtaining a Navigation Update DVD”)
- For detailed questions regarding HFL, audio, or other systems that interact with the navigation system, see your owner’s manual, or the Advanced Technology Guide.

- Call Acura Client Services (see *Acura Client Services* on page 118).
- For database or POI issues, follow the guidelines in the “Reporting Errors” section (see page 118).

If your question is still unanswered and you wish to visit the dealer, please be prepared to demonstrate the issue to the service consultant. That way, the service consultant can document the issue for the factory to allow more efficient troubleshooting. Some issues may at first seem random, but you may notice a pattern, like they only occur when you enter a specific address, when driving on a certain road, or just when it’s cold. This information is very useful to the service consultant. Be patient, the service consultant may be unfamiliar with your specific issue.

## Obtaining a Navigation Update DVD

Acura is continually expanding the scope of the navigation system. Upgraded software may be made available to navigation system owners periodically, usually in the fall of each year.

To purchase an updated DVD, you will need your vehicle’s VIN number and the System/Device Information from the INFO screen (Other). Order online by going to [www.acuranavi.ca](http://www.acuranavi.ca).

### **NOTE:**

- *Update DVDs are not available at your dealer. However, the dealer may order an update DVD for you out of courtesy. There is no programme for free DVD updates.*
- *The update DVD order line staff cannot answer technical questions regarding navigation operation, coverage, or POIs.*



## Coverage Areas

---

### Map Coverage

The system provides map coverage for the following U.S. states, as well as for Canada, Puerto Rico, and Mexico. The all map coverage consists of accurately mapped (verified) metropolitan areas (in the following list) and a less accurate (unverified) rural database. See *Map Overview* on page 6 for a discussion of map coverage.

The cities and metropolitan areas in the following list are fully mapped. Only major streets, roads, and highways have been verified outside these areas. If your route passes through these areas, routing may be limited, depending on your routing choices. See *Unverified Area Routing* on page 94.

If you desire additional map coverage information, contact Acura Client Services or go to [www.acura.ca](http://www.acura.ca). Enter your vehicle model and model year, and then select the province for which you want to verify map coverage.

### ***U.S. Detailed Coverage Areas***

#### ***Alabama***

Auburn-Opelika  
Birmingham/Tuscaloosa  
Huntsville  
Mobile  
Montgomery

#### ***Alaska***

Anchorage  
Fairbanks-Denali  
Juneau

#### ***Arizona***

Phoenix Metro  
Prescott  
Sedona  
Tucson  
Yuma

#### ***Arkansas***

Fayetteville  
Fort Smith  
Hot Springs  
Little Rock  
Pine Bluff

#### ***California***

Central Valley - including Fresno,  
Merced, Modesto, and Stockton  
Humboldt  
Los Angeles/San Diego Metro

Mammoth Lakes  
Redding  
Sacramento Metro  
San Francisco Bay (*approximately  
Monterey to Sonoma*) – including  
*Monterey County and Hollister*  
Southern California Area – including  
*Bakersfield and San Luis Obispo*  
Yuba

#### ***Colorado***

Denver/Boulder/Colorado Springs/  
Ski Resorts Metro area – including  
*Ft. Collins*  
Durango  
Grand Junction  
Telluride

#### ***Connecticut***

Bridgeport  
Danbury  
Hartford Metro  
New Haven Metro  
Norwalk  
Stamford

#### ***Delaware***

Entire state – including Dover,  
Wilmington Metro area, New  
Castle County

## Florida

Cape Canaveral/Cocoa Beach/  
Titusville  
Dixie County  
Florida Keys  
Fort Myers Metro area – *including  
Naples*  
Fort Pierce  
Gainesville  
Jacksonville Metro – *including St.  
Johns County*  
Miami/Fort Lauderdale/West Palm  
Beach Metro  
Orlando/Daytona Beach/Melbourne  
area – *including Osceola County  
Panama City*  
Pensacola  
Tallahassee  
Tampa Bay/St. Petersburg Metro  
– *including Pasco and Manatee  
Counties*  
Vero Beach

## Georgia

Athens  
Albany  
Atlanta Metro  
Augusta/Aiken Metro  
Columbus  
Dalton

Macon  
Rome  
Valdosta  
Warner Robbins

## Hawaii (all cities for the following islands)

Hawaii  
Kauai  
Lanai  
Maui  
Molokai  
Oahu

## Idaho

Boise  
Idaho Falls  
Pocatello  
Sun Valley Ski Resorts

## Illinois

Bloomington-Normal  
Carbondale  
Champaign  
Charleston  
Chicago Metro (to Wisconsin border)  
– *including Lake County, IN, and  
DeKalb County, IL*  
East St. Louis Metro  
Galesburg  
Moline  
Peoria

Quincy  
Rock Island  
Rockford  
Springfield  
Urbana-Danville

## Indiana

Bloomington  
Evansville  
Fort Wayne  
Gary/Hammond Metro  
Indianapolis Metro  
Kokomo Metro  
Lafayette  
Muncie  
Northwest Indiana  
South Bend/Elkhart/Goshen  
Terre Haute

## Iowa

Ames  
Cedar Rapids  
Davenport  
Des Moines  
Dubuque  
Iowa City  
Sioux City  
Waterloo-Cedar Falls

## Coverage Areas

---

### **Kansas**

Kansas City/Leavenworth Metro  
Topeka  
Wichita

### **Kentucky**

Bowling Green  
Lexington  
Louisville  
Owensboro

### **Louisiana**

Baton Rouge  
Lafayette  
New Orleans Metro  
Shreveport

### **Maine**

Bangor  
Bar Harbor/Acadia National Park  
Portland/Lewiston/Auburn  
Southern Maine

### **Maryland**

State of (partial) - Baltimore/  
Washington D.C. Metro – including  
*Charles and Carroll Counties*  
Cumberland  
Ocean City

### **Massachusetts**

Boston/Cape Cod Metro  
Cape Cod  
Springfield Metro area  
*Complete coverage of all cities in  
Barnstable, Berkshire, Bristol,  
Essex, Hampshire, Hampden,  
Middlesex, Norfolk, Plymouth,  
Suffolk, and Worcester Counties*

### **Michigan**

Detroit Metro area – including *Ann  
Arbor, Pontiac, Flint, Clinton,  
Eaton, and Monroe Counties*  
Kalamazoo  
Northern Michigan Resort Area  
– including *Traverse City, Elk  
Rapids, Petoskey, Charlevoix,  
Boyne City, and Harbor Springs*  
Saginaw-Midland  
Southeast Michigan – including  
*Detroit - Grand Rapids - Lansing*  
Southern Michigan

### **Minnesota**

Duluth  
Minneapolis/St. Paul Metro –  
*including cities in Anoka Scott and  
Carver Counties*  
Mankato  
Moorhead  
Rochester

### **Mississippi**

Alcorn County  
Biloxi/Gulfport  
Jackson  
Memphis  
Pascagoula  
Tupelo

### **Missouri**

Branson  
Columbia  
Jefferson City  
Joplin  
Kansas City (KS-MO) Metro  
– including *Platte County*  
Lake of the Ozarks  
Springfield  
St. Louis Metro (IL-MO) – including  
*additional cities in Jefferson  
County*

### **Montana**

Billings  
Helena  
Missoula

### **Nebraska**

Lincoln (Lancaster County)  
Omaha

### **Nevada**

Las Vegas Metro  
Reno/Lake Tahoe

### ***New Hampshire***

Lebanon  
Manchester  
Nashua  
The State of (partial) – *including Laconia , Keene, Lebanon, Manchester, Concord, Franklin, Portsmouth, Dover, Rochester, Somersworth*

### ***New Jersey***

Camden Metro  
Newark Metro  
Southern New Jersey – *including Atlantic City/Cape May/ Cumberland Metro*  
Trenton Metro – *including Ocean and Hunterdon Counties*

### ***New Mexico***

Albuquerque  
Las Cruces  
Santa Fe  
Taos Ski Resorts

### ***New York***

Binghamton  
Buffalo – *including Erie and Niagara Counties*  
Eastern New York – *including the Adirondack, Oneonta - Cooperstown, New York City Metro, Albany, Glen Falls, Schenectady, Troy*  
Elmira  
Ithaca  
Lake Placid  
Rochester – *including cities in Monroe County*  
Syracuse  
Utica  
Watertown

### ***North Carolina***

Asheville  
Charlotte Metro  
Greenville/New Bern  
Fayetteville  
Hickory  
Jacksonville  
Morgantown  
Outer Banks  
Raleigh-Durham Metro  
Wilmington  
Winston-Salem/Greensboro Metro

### ***North Dakota***

Fargo Metro  
Grand Forks

### ***Ohio***

Akron  
Columbus/Marysville Metro  
Cincinnati Metro – *including Butler County*  
Cleveland Metro – *including Geauga County*  
Dayton  
Lima  
Mansfield  
Parkersburg  
Portsmouth  
Steubenville  
Springfield  
Toledo (Lucas County)  
Youngstown

### ***Oklahoma***

Oklahoma City  
Tulsa

### ***Oregon***

Bend  
Corvallis  
Eugene  
Medford  
Portland/Salem Metro  
Seaside/Astoria/Cannon Beach

## Coverage Areas

---

### **Pennsylvania**

Allentown  
Eastern Pennsylvania  
Erie  
Gettysburg  
Harrisburg  
Lancaster  
Philadelphia Metro  
Reading  
Southeastern Pennsylvania  
Southwest Pennsylvania – *including  
Pittsburgh and Washington County*  
State College/University Park  
Wilkes-Barre/Scranton  
Williamsport  
York

### **Rhode Island**

Newport  
Providence Metro

### **South Carolina**

Beaufort  
Charleston  
Columbia  
Greenville/Spartanburg – *including  
additional cities in Greenville and  
Spartanburg Counties*  
Myrtle Beach Metro  
Rock Hill Metro  
Sumter/Florence

### **South Dakota**

Rapid City  
Sioux Falls

### **Tennessee**

Chattanooga  
Chester County  
Franklin County  
Johnson City/Kingsport/Bristol  
Knoxville/Farragut Metro  
Memphis Metro – *including Desoto  
and Tunica Counties*  
Nashville

### **Texas**

Abilene  
Amarillo  
Austin Metro  
Beaumont  
Big Bend  
Brownsville  
Bryan/College Station  
Corpus Christi  
Dallas/Fort Worth Metro – *including  
additional cities in Grayson  
County*  
El Paso  
Houston Metro – *including  
additional cities in Galveston  
County*  
Laredo

Lawton  
Longview  
Lubbock  
McAllen  
Midland/Odessa Metro  
Nacogdoches-Lufkin  
San Angelo  
San Antonio Metro  
South Padre Island  
Texarkana  
Wichita Falls

### **Utah**

Moab  
Ogden  
Park City  
Salt Lake City Metro  
St. George

### **Vermont**

Rutland  
State of (partial) – *including  
Burlington, Montpelier*

### **Virginia**

Washington D.C. detailed area  
– *including Alexandria, Arlington,  
Fairfax, Falls Church, Fauquier  
County, Fredericksburg City,  
Manassas, and additional cities  
in Loudon and Prince William  
Counties*

Bristol  
Charlottesville  
Danville  
Emporia  
Lynchburg  
Richmond Metro  
Roanoke  
Shenandoah National Park  
Staunton-Waynesboro-Harrisonburg  
Williamsburg/Norfolk/Virginia  
Beach Metro – *including Charles City, Hopewell, Kent, and Prince George Counties*  
Winchester

## **Washington**

Bellingham  
Portland/Salem/Eugene  
Seattle/Tacoma/Olympia Metro – *including Island County*  
Spokane  
Tri-Cities  
Whatcom  
*Point Roberts (community)*  
Yakima

## **West Virginia**

Charleston  
Harper's Ferry Metro  
Huntington  
Morgantown  
Parkersburg

## **Wisconsin**

Appleton  
Beloit  
Eau Claire  
Green Bay  
Janesville  
Kenosha County  
La Crosse  
Madison  
Manitowoc  
Lake Geneva  
Milwaukee Metro – *including Milwaukee, Ozaukee, Washington, and Waukesha Counties*

Neenah  
Oshkosh  
Racine  
Sheboygan  
Southeastern Wisconsin  
Wausau

## **Wyoming**

Cheyenne  
Grand Teton/Jackson  
Jackson Ski Resorts

## **PUERTO RICO**

Arecibo  
Bayamon  
Cabo Rojo  
Caguas  
Canovanas  
Carolina  
Ceiba  
Cidra  
Dorado  
Fajardo  
Guayama  
Guaynabo  
Humacao  
Juana Diaz  
Juncas  
Las Piedras  
Loiza  
Mayaguez  
Ponce  
Toa Alta  
Toa Baja  
Trujillo Alto  
Yubacoo

## **Catano**

Catano  
Fort Buchanan

## Coverage Areas

---

### *Gurabo*

Celada  
Gurabo

### *San Juan*

Hato Rey  
San Juan  
Santurce

### *Canada Detailed Coverage Areas*

#### *Alberta*

Airdrie  
Alberta  
Calgary  
Edmonton  
Grande Prairie  
Lethbridge  
Medicine Hat  
Parkland County  
Red Deer  
Red Deer County  
Rocky View No 44  
St Albert  
Strathcona County  
Sturgeon County  
Wood Buffalo

### *British Columbia*

Abbotsford  
Burnaby  
Campbell River  
Central Saanich  
Chilliwack  
Colwood  
Comox  
Coquitlam  
Courtenay  
Cranbrook  
Dawson Creek  
Delta  
Esquimalt  
Fort St John  
Kamloops  
Kelowna  
Langford  
Langley  
Langley Twp  
Maple Ridge  
Mission  
Nanaimo  
New Westminster  
North Cowichan  
North Saanich  
North Vancouver  
North Vancouver District  
Oak Bay  
Penticton

Pitt Meadows  
Port Alberni  
Port Coquitlam  
Port Moody  
Powell River  
Prince George  
Richmond  
Saanich  
Salmon Arm  
Sidney  
Squamish  
Summerland  
Surrey  
Terrace  
Vancouver  
Vernon  
Victoria  
West Vancouver  
White Rock  
Williams Lake

### ***Manitoba***

Brandon  
Winnipeg

### ***New Brunswick***

Bathurst  
Campbellton  
Dieppe  
Edmundston  
Fredericton  
Miramichi  
Moncton  
Moncton Parish  
Oromocto  
Quispamsis  
Riverview  
Rothesay  
Saint John  
Saumarez

### ***Newfoundland & Labrador***

Bay Roberts  
Conception Bay South  
Corner Brook  
Gander  
Grand Falls-Windsor  
Happy Valley-Goose Bay  
Labrador City  
Marystown  
Mt Pearl  
Paradise  
Portugal Cove-St Philip's  
St John's  
Stephenville  
Torbay

### ***Northwest Territories***

Hay River  
Yellowknife

### ***Nova Scotia***

Cape Breton  
East Hants  
Halifax  
Kings  
Lunenburg



## Coverage Areas

---

### *Ontario*

Ajax  
Amherstburg  
Aurora  
Barrie  
Belleville  
Bracebridge  
Bradford West Gwillimbury  
Brampton  
Brant  
Brantford  
Brockville  
Burlington  
Caledon  
Cambridge  
Centre Wellington  
Chatham-Kent  
Clarence-Rockland  
Clarington  
Clearview  
Cobourg  
Collingwood  
Cornwall  
East Gwillimbury  
Essa  
Essex  
Fort Erie  
Georgina  
Greater Napanee  
Greater Sudbury

Grimsby  
Guelph  
Haldimand  
Halton Hills  
Hamilton  
Huntsville  
Innisfil  
Kawartha Lakes  
Kenora  
King  
Kingston  
Kingsville  
Kitchener  
Lakeshore  
Lasalle  
Leamington  
Lincoln  
London  
Loyalist  
Markham  
Middlesex Centre  
Midland  
Milton  
Mississauga  
New Tecumseth  
Newmarket  
Niagara Falls  
Niagara-on-the-Lake  
Norfolk  
North Bay

North Grenville  
Oakville  
Orangeville  
Orillia  
Oro-Medonte  
Oshawa  
Ottawa  
Owen Sound  
Pelham  
Petawawa  
Peterborough  
Pickering  
Port Colborne  
Port Hope and Hope  
Prince Edward  
Quinte West  
Richmond Hill  
Sarnia  
Sault Ste Marie  
Scugog  
Smith-Ennismore-Lakefield  
South Frontenac  
Springwater  
St Catharines  
St Clair  
St Thomas  
Stratford  
Strathroy-Caradoc  
Tecumseh  
Thorold

Thunder Bay  
 Tillsonburg  
 Timmins  
 Toronto  
 Uxbridge  
 Vaughan  
 Waterloo  
 Welland  
 Whitby  
 Whitchurch-Stouffville  
 Wilmot  
 Windsor  
 Woodstock  
 Woolwich

***Prince Edward Island***

Charlottetown  
 Cornwall  
 Montague  
 Stratford  
 Summerside

***Québec***

Alma  
 Amos  
 Anjou  
 Aylmer  
 Baie-Comeau  
 Beaconsfield  
 Beauport  
 Bellefeuille  
 Beloeil  
 Blainville  
 Boisbriand  
 Boucherville  
 Brossard  
 Cap-De-La-Madelaine  
 Cap-Rouge  
 Chambly  
 Charlesbourg  
 Châteauguay  
 Chicoutimi  
 Côte-St-Luc  
 Deux-Montagnes  
 Dolbeau-Mistassini  
 Dollard-Des Ormeaux  
 Dorval  
 Drummondville  
 Fleurimont  
 Gaspé  
 Gatineau  
 Granby

Grand-Mère  
 Greenfield Park  
 Hull  
 Joliette  
 Jonquière  
 Kirkland  
 La Baie  
 La Plaine  
 La Prairie  
 La Salle  
 Lachenaie  
 Lachine  
 L'ancienne-Lorette  
 L'assomption  
 Laval  
 Le Gardeur  
 Lévis  
 L'île-Bizard  
 Longueuil  
 Loretteville  
 Magog  
 Mascouche  
 Mirabel  
 Montréal  
 Montréal-Nord  
 Mont-Royal  
 Mont-St-Hilaire  
 Outremont  
 Pierrefonds  
 Pointe-Claire

## Coverage Areas

---

Québec  
Repentigny  
Rimouski  
Rivière-Du-Loup  
Rock Forest  
Rosemère  
Rouyn-Noranda  
Salaberry-De-Valleyfield  
Sept-Îles  
Shawinigan  
Sherbrooke  
Sorel-Tracy  
St-Augustin-de-Desmaures  
St-Bruno-De-Montarville  
St-Constant  
Ste-Anne-Des-Plaines  
Ste-Catherine  
Ste-Foy  
Ste-Julie  
Ste-Thérèse  
St-Eustache  
St-Georges  
St-Hubert  
St-Hyacinthe  
St-Jean-Chrysostome  
St-Jean-Sur-Richelieu  
St-Jérôme  
St-Lambert  
St-Laurent  
St-Lazare

St-Léonard  
St-Luc  
St-Nicolas  
Terrebonne  
Thetford Mines  
Trois-Rivières  
Trois-Rivières-Ouest  
Val-Bélair  
Val-D'or  
Varenes  
Vaudreuil-Dorion  
Verdun  
Victoriaville  
Westmount

### *Saskatchewan*

Corman Park No 344  
Estevan  
Humboldt  
Lloydminster  
Meadow Lake  
Melfort  
Moose Jaw  
North Battleford  
Prince Albert  
Regina  
Saskatoon  
Swift Current  
Weyburn  
Yorkton

## CANADA CONNECTOR ROADS

The Cross-Canada Connector Road allows for travel between the provinces of British Columbia and Quebec in DCA 11. Major metropolitan city POIs are also included.

### Road Inclusion

#### *Roads in the province of British Columbia*

Hwy-1/Trans Canada Hwy from Alberta/BC boundary to Vancouver detailed city  
 Hwy-3/Crowsnest Hwy from Hwy-1/Trans Canada Hwy (Hope) to Hwy-5/Coquihalla Hwy (Hope)  
 Hwy-5/Coquihalla Hwy (in Hope) to Hwy-1/Trans Canada Hwy (in Kamloops)  
 Hwy-99 between Vancouver and Whistler

#### *Roads in the province of Alberta*

Hwy-1/Trans Canada Hwy across whole province  
 Hwy-1A from Cochrane to Canmore  
 Hwy-1X from Hwy-1A to Hwy-1/Trans Canada Hwy  
 Morley Road from Hwy-1/Trans Canada Hwy  
 Hwy-3/Crowsnest Hwy (at Medicine Hat) to Lethbridge  
 Hwy-4 (at Lethbridge) to 1-15 (U.S. border)  
 Hwy-36 between Hwy-3 (in Taber) and Hwy-4 (in Warner)  
 Hwy-3/Crowsnest Hwy (in Lethbridge) to Hwy-2 (in Fort Macleod)  
 Hwy-2 (in Fort Macleod) to Hwy-1/Trans Canada Hwy (in Calgary)

#### *Roads in the province of Saskatchewan*

Hwy-1/Trans Canada Hwy across whole province

#### *Roads in the province of Manitoba*

Hwy-1/Trans Canada Hwy across whole province  
 Hwy-100/Trans Canada Hwy in Winnipeg (partial beltway)  
 Hwy-75 from Hwy-100/Trans Canada Hwy (Winnipeg) south to link with 1-29 (U.S. border)

#### *Roads in the province of Ontario*

Hwy-69/Trans Canada Hwy from Muskoka district to Sudbury  
 Hwy-17/Trans Canada Hwy from Ottawa Detailed Area Coverage to Manitoba border  
 Hwy-17B at Sault Ste Marie to link with 1-75 (U.S. border)  
 Hwy-61 from Hwy-17 at Thunder Bay to link with US-61 (U.S. border)  
 Hwy-11 from Muskoka district to North Bay  
 Hwy-60 and Hwy-127 in Nipissing County

# Frequently Asked Questions

## Map and Features, Voice Operation, Entering Addresses

Problem	Solution
Why does the Disclaimer screen need to be displayed every time I start the car? I am the only driver.	The Disclaimer screen reminds you and your guest drivers to always operate the navigation system in a safe manner.
I tried entering an address, but the city or street could not be found. Is there any other way to route to the location?	Some cities are lumped in with a major metro area. Try entering the street first. In rural “unverified” areas or new subdivisions, streets may be missing, or only partially numbered. Try selecting the destination directly from the map. See <i>By Map Input</i> on page 41.
When I enter an address, some letters become grayed out. Is this normal?	Yes. As you enter each letter in an address or a point of interest (POI), the system looks in the database to see what letters are possible and “grays out” letters that do not apply.
How do I delete Personal Addresses, Previous Destinations, or the Home Address?	This is done in the SET UP screen (Main Set up), under “Personal Information.” See page 83.
I cannot hear the navigation system voice.	1) Ensure that <b>Volume</b> in the SET UP screen (Main Set up) is not <b>OFF</b> . See page 83. 2) Go to “Basic Settings” in the SET UP screen (Main Set up), and set <b>Voice Recognition Tutor</b> to <b>ON</b> . See page 93.
The voice control system is having difficulty recognizing my voice commands.	Ensure that the vents are not blowing on the microphone on the ceiling, the vehicle is as quiet as possible, and you are using the correct command when speaking (see <i>Improving Voice Recognition</i> on page 14). Say “Help” at any screen to see a list of the applicable voice commands. If the system cannot recognize your command because of background noise, speak louder.
When the system pronounces the street name in the guidance command or reads the destination address, it sounds strange. What causes this?	The basic guidance phrase uses a studio-recorded voice, but the street name is pronounced by the system using a machine-generated voice. Consequently, the name may be mispronounced or sound strange at times.

## Frequently Asked Questions

Problem	Solution
When I drive at night, the screen is bright and will not switch to the night display mode. Why?	Verify the following: The nighttime dash brightness control is not set to maximum, and <b>Map Colour</b> in SET UP is set to <b>Black</b> for Night. See <i>Switching Display Mode Manually</i> on page 105.
The daytime map screen is dark like the night display mode, and it is hard to see. Why?	Verify the following: The <b>Map Colour</b> in SET UP is set to <b>White</b> for Day. See <i>Switching Display Mode Manually</i> on page 105.
How do I change or remove my PIN?	Go to “Personal Information” in the SETUP screen (Other), and select <b>PIN Number</b> . Select <b>GO Home 1 PIN</b> or <b>GO Home 2 PIN</b> or <b>Address Book PIN</b> and enter your existing PIN. You then have the choice to change or remove the PIN. See page 88.
I forgot the PIN for Home, or the PIN for personal addresses (DRIVER 1 or DRIVER 2). How do I reset it?	PINs are optional. See information regarding PINs on page 88. Your dealer can reset the PIN for you.
<b>CALL</b> is not available on the Calculate route to screen. Why?	Your phone is not paired to HFL, or if your phone is paired, it is in use; press the <b>HANG-UP</b> button.

# Frequently Asked Questions

## Guidance, Routing

Problem	Solution
The navigation system does not route me the same way I would go, or the way some other mapping programme displays. Why is this?	The navigation system attempts to generate the optimum route. See <i>Changing the Routing Method</i> on page 48.
Why is the street I'm on not shown on the map? It has been here for more than a year.	The mapping database is constantly undergoing revision. See page 120 for ways to obtain the latest detailed coverage information.
The vehicle position icon is not following the road and the "GPS icon" text in the upper left hand corner of the screen is white or missing.	<ul style="list-style-type: none"><li>• The GPS antenna (located on the back of the navigation display) may be blocked by personal items. For best reception, remove items from the dashboard, such as radar detectors, cell phones, or loose articles.</li><li>• Metallic tinting or other aftermarket devices can interfere with the GPS reception. Please see your dealer. Also see <i>System Limitations</i> on page 115.</li></ul>
I entered a destination, but the blue highlighted route and voice guidance stopped, or turned into a blue/pink dashed line before I got to my destination. Why is this?	Your route has entered an unverified area. See <i>Unverified Area Routing</i> on page 94.
The map rotates while I make turns. How can I stop this?	Select the North-up map orientation by voice, or by selecting <b>North-up</b> from the Map menu. See <i>Map Orientation</i> on page 59.
Sometimes, I cannot select between the North-up and Heading-up map orientations. Why is this?	The Heading-up map orientation can only be shown in the lower scales (80 metres - 1,6 kilometres scales). See <i>Map Scale</i> on page 61.
While driving to my destination, the "time to go" display sometimes increases, even though I am getting closer.	The "Time to go" is based on actual road speeds. However if your speed slows down when you encounter slower traffic, the system updates the "Time to go" based of your actual speed to give you a better estimate of arrival time.
The vehicle position icon on the map "lags" a short distance behind, especially when I arrive at an intersection. Is there anything wrong?	No. When at an intersection, the system is unaware of the width of the intersecting road. Large differences in vehicle position can indicate a temporary loss of the GPS signal. See <i>GPS Reception Issues</i> on page 115.
While I drive, my screen shows white dots ("breadcrumbs") on it. What do they mean?	These are called "breadcrumbs." If you drive more than 800 metres from mapped roads, the off-road tracking feature begins to function. See <i>Off-road Tracking</i> on pages 64 and 102.

## Frequently Asked Questions

Problem	Solution
How can I get rid of the white dots (“breadcrumbs”) from my screen?	Go to “Vehicle” in the SET UP screen (Other), and set <b>Off-road Tracking</b> to <b>OFF</b> , then return to the map. See page 102.
A road that I selected to avoid is being used when routing. What is wrong?	When you “draw” your area to avoid, make sure to select sections of roads that include at least one intersection. See page 98.
My elevation (shown when I display the current position) seems to fluctuate even though my elevation has not changed.	This is normal and due to errors in satellite position. The elevation can vary +/- 30 metres. See <i>System Initialization</i> on page 112.
My elevation is missing on the “current position” screen. Why?	If the GPS antenna cannot receive signals from at least four satellites, the elevation is not displayed. Try moving the vehicle into an open area. If the elevation is zero, or below sea level, the elevation is also not displayed.



## Frequently Asked Questions

---

### Update DVD, Coverage, Map Errors, Limitations

Problem	Solution
When is my city going to become part of a fully verified detailed coverage area?	The mapping database vendor is constantly revising map coverage. See <i>Map Coverage</i> page 120 for ways to obtain the latest detailed coverage information.
Will the navigation system work outside North America?	The system contains maps for the 50 U.S. states, as well as for Canada, Puerto Rico, and Mexico. See <i>Map Coverage</i> on page 120.
Can I play video DVDs in my navigation system?	No. The navigation system is designed only to read music discs and the update DVD provided with your vehicle. The system cannot read other mapping databases or video DVDs. If you experience any problems that you cannot resolve, please contact your dealer.
I found some errors in the database. How do I report them?	Minor errors are bound to occur in a large database. If you encounter major errors, you can report them following the instructions on page 118.

### Display, Accessories

Problem	Solution
The display appears dim when starting the car in really cold weather. Is there a problem?	No. This is normal, and it will become brighter after a few minutes.

### Rear Camera

Problem	Solution
When I shift gears, the rear camera image is delayed.	When shifting into or out of reverse, you may experience delays when the screen image switches between the navigation screen and the rear camera image. This is normal.
The rear camera image is too dark or too bright. How do I adjust the brightness?	While the camera image is displayed, use the rotating portion of the <b>Interface Dial (knob)</b> to adjust the brightness. This adjustment does not affect the <b>Setup</b> screen brightness adjustments.

### Miscellaneous Other Questions

Problem	Solution
My clock frequently changes forward and backward by one hour. Why is this?	The clock is being automatically set based on your GPS location. If you live and work on the boundary between two time zones, you can turn off this feature. See page 102.
When driving near a time zone border, the time changes even though I am not near the time zone. Why is this?	The time zone borders are only approximated in the system. Depending on the geography of the time zone boundary, the switch to a different zone can be erratic. See page 102.
My province does not observe daylight saving time. How do I turn off this feature?	You can turn off this feature. See page 101.
Daylight saving time occurred, but the navigation system did not change time even though <b>SETUP</b> shows <b>Auto Daylight</b> is <b>ON</b> .	The automatic daylight saving time feature does not work in regions where the daylight saving time system is not adopted.

## Frequently Asked Questions

Problem	Solution
The navigation system automatic daylight time feature is not switching the navigation system clock on the correct dates. Why is this?	1) Go to the Clock adjustment screen in SETUP and ensure that <b>Auto Daylight</b> is <b>ON</b> . 2) The automatic daylight saving time feature does not work in regions where the daylight saving time system is not adopted. For more information, see <i>Clock Adjustment</i> on page 101.
The navigation system clock switched by one hour for no apparent reason. What can cause this?	You may be driving near a time zone boundary (see <i>Auto Daylight</i> on page 101). See page 101 for more information.
My battery was disconnected or went dead, and the navigation system is asking for a code. Where do I find this code?	There should be a card in the glove box with the anti-theft code for the navigation/audio system. This card contains the 5-digit security code and serial number. If you cannot find it, your dealer can help you out.
I speak a language other than English. Are there any other languages available for the system?	Besides English, you may select French or Spanish for your language setting. However, messages will continue to be in English.

Screen Error Message	Solution
The display temperature is too high! For protection, the display will shut down.	This message will appear briefly when the display temperature is too high, and then the display will turn off until the temperature cools down. The system will turn back on when the display cools down.
Cannot write to the HDD due to the low temperature. Please wait until the system warms up.	The temperature is below -30°C and the navigation system has difficulty reading the HDD. The system will start up when the temperature warms up.
Cannot access the HDD due to low atmospheric pressure. Navigation and HDD audio functions are disabled. The system will restart when atmospheric pressure is OK.	Navigation HDD audio functions are disabled. The system will restart when atmospheric pressure is OK.
Route has not been completed. Please try again from a different location.	This message will appear when you are routing to or from a place (new area) that is not in the database. Try planning a different route to or from a different location.*
No alternate route found. Original route will be followed.	No alternative route method was found. The original route method will be used.* Ensure that a road name is displayed at the bottom of the map.
This destination cannot be found in database.	The destination was not found in the database. Try another destination nearby, or select the destination with the <b>Interface Dial</b> .*

\* If the error persists, or is shown for a wide area, see your dealer.

# Glossary

---

## Glossary

The following is a glossary of terms pertaining to the voice recognition navigation system.

**Avoid Area** - Areas you wish to avoid can be entered into the system, and will be avoided while routing.

**Breadcrumbs** - Off-road tracking dots that can be followed on the map to retrace your route back to a mapped (digitized) road. This function can be turned on/off in the **SETUP** screen (Other).

**Database** - This consists of the map data, and the POI (Points of Interest) data stored on the HDD.

**DCA** - Detailed Coverage Area. U.S. states, as well as Canada, Puerto Rico, and Mexico, are mapped. See page 120 for a list of these areas.

**Digitized Road** - A road that appears on the navigation screen. The road name will appear at the bottom of the navigation screen. If the user drives “off road,” the navigation system will display “breadcrumbs,” depending on how far you drive from a mapped road.

**Disclaimer Screen** - Screen containing cautionary information. It is meant to be read carefully and acknowledged by the client when using the navigation system.

**FAQ** - Frequently Asked Questions. See page 132 for a list of the client FAQs and troubleshooting information.

**GPS** - Global Positioning System. A network of 24 satellites in orbit around the earth. The navigation system can simultaneously receive signals from up to 12 satellites to accurately position the vehicle on the map.

**GPS Antenna** - Located on the back of the navigation display, which is in the centre of the dashboard. Electronic items operating in this general location can interfere with the GPS signal.

**HDD** - Hard Disc Drive. The primary data storage device containing your vehicle’s navigation and map software and uploaded wallpaper images. The HDD can also store audio files. See the Audio section of your owner’s manual for more information.

**HFL** - *Bluetooth*® HandsFreeLink®. Your vehicle is equipped with this feature, which uses Bluetooth technology as a wireless link between the vehicle and your Bluetooth-compatible cell phone.

**Icon** - Symbol representing Points of Interest (POI) that can be displayed on the map.

**Initialization** - This refers to the period needed to reacquire the GPS satellite orbital information whenever the navigation system power has been disconnected. This can take 10 to 45 minutes with the vehicle out in an open area.

**LCD** - Liquid Crystal Display. The navigation screen.

**Map Matching** - The received GPS information allows the navigation system to position the vehicle on the map. Map matching has occurred if the map screen is displaying the current street name in the bottom-shaded area.

**Mic** - Abbreviation for the microphone used for receiving voice commands. It is located near the map lights in the ceiling.

**MW** - Manoeuvre Window. While en route to a destination, this window displays information about the next manoeuvre.

**Navi** - Abbreviation for the navigation system.

**North Pointer** - The map symbol showing the map orientation. See page 59.

**Off road** - This occurs when the user leaves mapped roads. Off-road tracking dots (“breadcrumbs”) are displayed if the option is enabled in the **SETUP** screen. The user can use them to return to a mapped road. The bottom of the navigation screen will say, “Not on a digitized road.”

**Outlying Areas** - These are rural areas that typically have only their main roads mapped. All other roads are shown in purple for reference only, since they have not been verified.

**PIN** - Personal Identification Number. A 4-digit number created by the client to protect personal information.

**POI** - Point of Interest. These are the businesses, schools, etc. found under **Place category** or **Place Name** on the **DEST** screen (**Dest. MENU 1**). See page 62.

**Polygon** - Coloured areas on the map screen denoting parks, schools, etc. See Map Screen “features” for a list of the assigned colours. See page 52.

**Reminder** - Automatic pop-up Calendar message. See *Calendar* on page 75.

**Security Code** - Code needed to activate the navigation system or audio system. See *Entering the Security Code* on page 112.

**Unverified Streets** - These streets have not been verified for turn restrictions, one-way, etc. They are shown in purple on the map. Unverified streets may be missing from the map, shown in the wrong location, or have an incorrect name or address range.

## Glossary

---

**USB** - Universal Serial Bus. A computer hardware interface used to store and play audio files from USB devices, such as thumb drives or iPods. Image files can also be stored to USB devices and uploaded to the HDD. See the Audio section in your owner's manual for more information.

**Vehicle Speed Sensor** - Provides speed signal to the navigation system for moving the VP icon on the map.

**Verified Streets** - These streets consist of the detailed metropolitan coverage areas and all other inter-town connection roads. These roads are shown in black, red, or pink on the map.

**Voice Control** - See VR.

**VP** - Vehicle Position. When in map mode, this circular icon shows the vehicle position on the map. Push in on the **Interface Dial**, select **Map Informaton** on the Map menu, and then rotate the **Interface Dial Knob** to select the **CURRENT LOCATION**. It shows the latitude, longitude, and elevation of your current position.

**VR** - Voice Recognition. This allows voice control of many of the navigation functions. The hardware consists of the microphone, voice control switch (**TALK/BACK** buttons), and the front speakers.

**Waypoint** - A temporary destination you may enter while en route (e.g., a gas station, ATM, etc.). See page 68.

**Yaw Rate Sensor** - Senses when the vehicle makes a turn, which makes the VP change direction on the map as you turn.

**Zagat Ratings** - Restaurant ratings information provided by Zagat Survey. See the **INFO** screen on page 80 for an explanation of the ratings.

### Global Commands

The system accepts these commands on any screen.

- Help (displays the list of commands for current displayed screen)
- Display map (displays the map screen)
- Display menu (displays the DEST screen (Dest. MENU 1 or 2))
- Display information (displays the INFO screen)
- Display audio screen (displays the Audio screen)
- Display phone screen (displays the Cellular Phone screen)
- Back (to previous screen, same as **CANCEL** or **BACK** button)
- Cancel (cancels current activity)
- What is today's date? (reads the current date)
- What time is it?

The "Voice Info" option on the INFO screen (Main Info) lists many of the following controls. To avoid distraction while you are driving, the system can read the commands for you.

The commands are accessible at any time while driving and can be read to you so that you do not need to memorize all of them.

### Navigation General Commands

The system accepts these commands on a map/guidance screen.

- Display menu (if en route, displays the DEST screen (Route))
- Display navigation (if en route, displays the DEST screen (Route))
- Display map
- Display map guide (when en route, shows the next manoeuvre)
- Display information (or just Information)
- Display audio screen
- Cancel
- Backward (or just Back)
- What time is it?
- Help (reads list of Navigation General and Navigation Display Commands at any screen)
- What is today's date? (reads the current date)



## Voice Command Index

---

How long to the destination?  
(when en route, tells the time to destination)\*

How far to the destination? (when en route, tells the distance to destination)\*

Display destination map (when en route, shows the map of the destination)

Display entire route (when en route, adjusts the map scale so that the entire route is displayed)

Register the current location (puts current location in the personal Address Book)

\* These commands are not available if you scroll the map while en route to a destination.

### Navigation Display Commands

The system accepts these commands on a map/guidance screen.

Display current location (shows current latitude, longitude, and elevation)

Display north up

Display heading up

Display zoom in

Display zoom out

Display: (the selected scale)

80 m (1/20 mile) scale

200 m (1/8 mile) scale

400 m (1/4 mile) scale

800 m (1/2 mile) scale

1600 m (1 mile) scale

3 km (2 mile) scale

8 km (5 mile) scale

24 km (15 mile) scale

80 km (50 mile) scale

240 km (150 mile) scale

560 km (350 mile) scale

1600 km (1000 mile) scale

Display: (display the selected icon on the screen)

ATM

gas station

restaurant

zagat restaurant

post office

grocery store

lodging (hotel, motel)

parking garage

parking lot

school

hospital

highway exit information

Hide: (hide the selected icon from the screen)

ATM

gas station

restaurant

zagat restaurant

post office

grocery store

lodging (hotel, motel)

parking garage

parking lot

school

hospital

one way

highway exit information

Max zoom in

Max zoom out

Go home 1

Go home 2

## Find Place Commands

The system accepts these commands on a map/guidance screen.

Find nearest: (find the nearest selection)

Auto Service centre

ACURA dealer

HONDA dealer

Gas station

Hydrogen station

Auto parts & electronics shop

Auto repair & maintenance shop

Car wash & detailing shop

Motorcycle dealer

Other car dealer

Parking garage

Parking lot

Rental car agency

Roadside assistance

Banking centre

ATM

Bank

Check cashing place

Community

Business place

City hall

Civic centre

Convention centre

Court house

University

Library

Post office

School

Emergency room

Hospital

Police station

Veterinarian

Lodging

Bed & breakfast

Hotel

Leisure centre

Amusement park

Golf course

Historical monument

Marina

Movie theater

Museum

Park

Performing arts centre

Sports complex

Restaurant

Zagat restaurant

American restaurant

Chain restaurant

Café/Coffee shop

## Voice Command Index

---

Californian restaurant  
Chinese restaurant  
Continental restaurant  
Fast food restaurant  
French restaurant  
German restaurant  
Greek restaurant  
Indian restaurant  
Italian restaurant  
Japanese restaurant  
Korean restaurant  
Mexican restaurant  
Seafood restaurant  
Thai restaurant  
Vegetarian restaurant  
Vietnamese restaurant  
Other restaurant  
Pizza restaurant  
Ice cream shop  
Shopping Area  
Accessory store  
Book store  
Clothing store  
Shoe store  
Furniture store  
Grocery store  
Home improvement store  
Mall  
Office supply store  
Pharmacy

Pet food store  
Sewing store  
Sporting goods store  
Toy store  
Travel Centre  
Airport  
Automobile club  
Bus station  
Camping site  
Commuter rail station  
Ferry terminal  
Named place  
Park & ride  
Rest area  
Ski area  
Tourist attraction  
Tourist information centre  
Train station  
Travel agency  
Truck stop

### Climate Control Commands

The system accepts these commands on most screens.

Climate control automatic (controls temperature to your selection)  
Passenger climate control automatic  
Climate control on  
Climate control off  
Climate control  
Air conditioner on\*  
Air conditioner off\*  
Air conditioner  
Climate control defrost on\*  
Climate control defrost off\*  
Climate control defrost  
Rear defrost on\*  
Rear defrost off\*  
Rear defrost  
Climate control fresh air  
Climate control recirculate  
Climate control vent  
Climate control sync on  
Climate control sync off  
Climate control sync  
Climate control bi-level (vent and floor)  
Climate control floor  
Climate control floor and defrost  
Passenger climate control vent

Passenger climate control bi-level  
Passenger climate control floor  
Fan speed up  
Fan speed down  
Fan speed # (#:1-7) (for best voice control, lower the fan speed)  
Driver temperature # degrees (#: 14 - 30 degrees C)  
Passenger temperature # degrees (#: 14 - 30 degrees C)  
Driver temperature up  
Driver temperature down  
Passenger temperature up  
Passenger temperature down  
Driver temperature max hot  
Driver temperature max cold  
Passenger temperature max hot  
Passenger temperature max cold

## Radio Voice Commands

The system accepts these commands on most screens.

Audio on\*  
Audio off\*  
Audio  
Radio on\*  
Radio off\*  
Radio  
Radio select FM1  
Radio select FM2  
Radio select AM  
Radio tune to # FM (#: frequency.  
    Example Radio 95.5 FM)  
Radio tune to # AM (#: frequency.  
    Example Radio 1020 AM)  
Radio seek up  
Radio seek down  
Radio next station  
Radio preset # (#: 1-6)  
Radio FM preset # (#: 1-6)  
Radio FM1 preset # (#: 1-6)  
Radio FM2 preset # (#: 1-6)  
Radio AM preset # (#: 1-6)  
Radio auto select\*  
Radio scan\*  
Radio select XM1  
Radio select XM2

XM channel # (#: 1-255)  
XM channel up  
XM channel down  
XM category up  
XM category down  
XM preset # (#: 1-6)  
XM1 preset # (#: 1-6)  
XM2 preset # (#: 1-6)  
XM scan\*  
XM category scan\*  
XM channel scan\*  
XM category mode  
XM channel mode

\* Repeating these commands switches (toggles) the function between On and Off, so the action that occurs may not match the command you speak.

### **NOTE:**

*Radio volume levels cannot be controlled using voice control. Use the buttons on your steering wheel. See your owner's manual for more information.*

# Voice Command Index

---

## Disc Voice Commands

The system accepts these commands on most screens.

DISC play  
DISC play track # (#: 1-30)  
DISC skip forward  
DISC skip back  
DISC track random\*  
DISC track repeat\*  
DISC track scan  
DISC folder up  
DISC folder down  
DISC folder random\*  
DISC folder repeat\*  
DISC folder scan\*  
DISC normal play (resumes “Play”  
from these commands: “DISC  
track random,” “DISC track  
repeat,” and “DISC track scan”)

\* Repeating these commands switches (toggles) the function between On and Off, so the action that occurs may not match the command you speak.

## HDD Voice Commands

The system accepts these commands on most screens.

HDD play  
HDD play track # (#:1-30)  
HDD skip forward  
HDD skip back  
HDD album up  
HDD album down  
HDD genre up  
HDD genre down  
HDD artist up  
HDD artist down  
HDD track up  
HDD track down  
HDD playlist up  
HDD playlist down  
HDD track repeat\*  
HDD track scan\*  
HDD track random\*  
HDD normal play (resumes “Play”  
from the random-, repeat-, or  
scanplay)

\* Repeating these commands switches (toggles) the function between On and Off, so the action that occurs may not match the command you speak.

## AUX Voice Commands

The system accepts these commands on most screens.

AUX play

\* Repeating these commands switches (toggles) the function between On and Off, so the action that occurs may not match the command you speak.

## USB Voice Commands

The system accepts these commands on most screens.

- USB play
- USB play track # (#:1-30)
- USB skip forward
- USB skip back
- USB track random\*
- USB track repeat\*
- USB track scan\*
- USB folder up
- USB folder down
- USB folder random\*
- USB folder repeat\*
- USB folder scan\*
- USB normal play

\* Repeating these commands switches (toggles) the function between On and Off, so the action that occurs may not match the command you speak.

## iPod Voice Commands

The system accepts these commands on most screens.

- iPod play
- iPod play track # (#:1-30)
- iPod skip forward
- iPod skip back
- iPod track shuffle\*
- iPod album shuffle\*
- iPod track repeat\*
- iPod normal play (resumes “Play”  
from the shuffle- or repeat-play)

\* Repeating these commands switches (toggles) the function between On and Off, so the action that occurs may not match the command you speak.

## Bluetooth® Audio Commands

The system accepts these commands on most screens.

- Bluetooth AUDIO play
- Bluetooth AUDIO skip forward
- Bluetooth AUDIO skip back
- Bluetooth AUDIO pause
- Bluetooth AUDIO resume
- Bluetooth AUDIO group up
- Bluetooth AUDIO group down

\* Repeating these commands switches (toggles) the function between On and Off, so the action that occurs may not match the command you speak.

# Voice Command Index

---

## Song By Voice™ Commands

The system accepts these commands on most screens.

- iPod Search (activates Song By Voice™)
- HDD Search (activates Song By Voice™)
- What/Who am I listening to?
- Who is this?
- What's playing?
- Who's playing?
- What album is this?
- List album (specify album)
- List artist (specify artist)
- List composer (specify composer)
- List genre (specify genre)
- List playlist (specify playlist)
- Play album (specify album)
- Play artist (specify artist)
- Play composer (specify composer)
- Play genre (specify genre)
- Play playlist (specify playlist)
- Play song (specify song)

### **NOTE:**

*Song By Voice™ commands are available for tracks stored in the HDD or iPod.*

## Cellular Phone Commands

The system accepts these commands on any screen.

- Dial/Call by number
- Dial/Call by voice tag

### **NOTE:**

*Voice tags can be recorded for each of your speed dial entries. Please see your owner's manual for storing speed dial and voice tags.*

## SET UP Screen (Main Set up) Commands

The system accepts these commands on SET UP screen (Main Set up). (For SET UP screen (Other), simply say what is written on the screen, and follow the voice prompts)

- Brightness up
- Brightness down
- Brightness minimum/min.
- Brightness maximum/max.
- Contrast up
- Contrast down
- Contrast minimum/min.
- Contrast maximum/max.
- Black level up
- Black level down
- Black level minimum/min.
- Black level maximum/max.
- Volume up
- Volume down
- Volume minimum/min.
- Volume maximum/max.
- Volume off
- Interface dial feedback off
- Interface dial feedback auto
- Interface dial feedback on

## On-Screen Commands

The system accepts these commands on any screen. There are over 100 on-screen commands. Just say what is written on the screen (this excludes listed items).

Next (or “Down”)  
Previous (or “Up”)  
Return  
OK (except at Disclaimer screen)  
Delete

## On-Screen Spelling Assist

When speaking the letters or using “spell mode,” you can substitute the name that represents each letter or symbol. This improves recognition. For example:

- To select the letter “A”:  
Say “A,” “Alpha,” or “Apple.”
- To select the letter “M”:  
Say “M,” “Mary,” or “Mike.”

The system will respond to the names shown in the following tables.

### NOTE:

- *The system will only respond to the names shown in the following tables.*
- *To select the letter “A,” you can also; select the “A” by using the **Interface Dial**.*
- *To select the number “1,” say “One” or “Number One,” or select the “1” by using the **Interface Dial**.*
- *To select the symbol “- (hyphen),” say “Hyphen” or “Symbol Hyphen,” or select the “-” by using the **Interface Dial**.*
- *When selecting letters using the voice control system, a confirmation box may pop up to confirm the letter.*



# Voice Command Index

## Letters Assist Definitions:

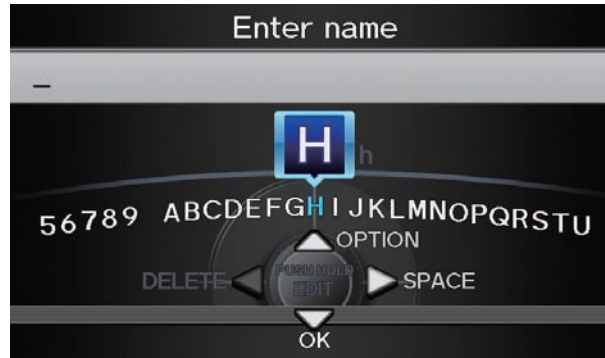

Say	Or say "..."	Say	Or say "..."	Say	Or say "..."	Say	Or say "..."
A	Apple/Alpha	<b>H</b>	Henry/Hotel	O	Oscar	V	Victor
B	Boy/Bravo	I	Igloo/India	P	Paul/Papa	W	William/Whiskey
C	Charlie	J	John/Juliet	Q	Queen/Québec	X	X-Ray
D	Dog/Delta	K	King/Kilo	R	Robert/Romeo	Y	Yellow/Yankee
E	Edward/Echo	L	Larry/Lima	S	Sam/Sierra	Z	Zebra/Zulu
F	Frank/Foxtrot	M	Mary/Mike	T	Tom/Tango	↵	Enter
G	George/Golf	N	Nancy/November	U	Uncle/Uniform		

## Symbol Assist Definitions:



Symbols	Say “...” or “Symbol ...”	Symbols	Say “...” or “Symbol ...”	Symbols	Say “...” or “Symbol ...”
À	A grave	î	I circumflex	_	Underscore
Â	A circumflex	ï	I umlaut	`	Back quote
Ä	A umlaut	Ô	O circumflex	,	Comma
Ç	C cedilla	Ù	U grave	.	Dot
È	E grave	Û	U circumflex	?	Question Mark
É	E acute	Ü	U umlaut	:	Colon
Ê	E circumflex	@	At sign	;	Semi colon
Ë	E umlaut	^	Caret	+	Plus
ì	I grave	*	Asterisk	↵	Enter

**NOTE:**

The term “grave” (used for symbols À, È, Ì, and Ù) is pronounced like “save.”

# Voice Command Index

## Numbers and Additional Symbol Assist Definitions:



Numbers	Say "...” or “Number ...”	Symbols	Say "...” or “Symbol ...”	Symbols	Say "...” or “Symbol ...”
1	One	-	Hyphen	~	Tilde
2	Two	!	Exclamation point	/	Slash
3	Three	”	Double quote	<	Less than
4	Four	#	Pound	>	Greater than
5	Five	\$	Dollar	{	Open brace
6	Six	%	Percent	}	Close brace
7	Seven	&	Ampersand	↵	Enter
8	Eight	'	Apostrophe		
9	Nine	(	Open parenthesis		
0	Zero	)	Close parenthesis		

## A

Accessing the Address Book List .....	84
Acura Client Services.....	118
Adding Destinations to the List .....	47
Adding Waypoint .....	69
Address .....	23, 24, 83
Address Book.....	24, 28, 83
Address Book PIN .....	88
Advanced .....	33
AUDIO button.....	10
Auto Daylight .....	101
Auto Service.....	33
Auto Time Zone .....	102
Avoid Streets .....	68

## B

BACK button.....	13
Banking.....	33
Basic Settings.....	92
Black Level.....	82
Bluetooth® Audio Commands.....	149
Bluetooth® HandsFreeLink® .....	19

Breadcrumbs .....	20, 64
Brightness.....	82
By Address.....	24
By Address Book .....	28
By Coordinate .....	39
By Go Home 1 or 2 .....	45
By Intersection .....	40
By Map Input .....	41
By Place Category.....	31
By Place Name.....	30
By Place Phone Number .....	37
By Previous Destinations .....	29

## C

Calculator .....	78
Calendar .....	19, 75
CALL .....	19
CANCEL button .....	11
Cancel Route .....	68
Category .....	23, 31, 85
Cellular Phone.....	73
Change Route Preference .....	67
Change Province .....	24, 44
Changing the Route.....	67

Changing the Routing Method.....	48
Changing Your Destination.....	71
City.....	25, 42
City Vicinity.....	35
Client Assistance.....	118
Climate Control Commands .....	146
Clock Adjustment.....	101
Colour.....	104
Community .....	33
Contrast .....	82
Convert (Unit) .....	78
Correct Vehicle Position.....	103
Coverage Areas .....	120
Current Location.....	21, 60
Current Position .....	41
Current Street.....	6

## D

Database Limitations .....	116
Destination .....	23, 29, 85
Destination Icon .....	62
Destination Map.....	49
DEST/ROUTE button .....	10
Detour .....	68

# INDEX

Directions.....	55
Disc Voice Commands.....	148
Display Mode button.....	10
Driving to Your Destination.....	47

## **E**

Edit Avoid Area.....	98
Edit Waypoint Search Area.....	100
Edit/Delete Address .....	85, 87
Emergency.....	33
Entering a Destination.....	23
Entering Address Book.....	84
Entering Security Code.....	112
Entering the Street Number .....	28
Entering Your Schedule .....	76
Error Message .....	139
Exit Info .....	56

## **F**

Find Place Commands .....	145
Frequently Asked Questions .....	132

## **G**

Getting Started.....	10
Global Commands .....	143
Glossary .....	140
Go Home 1 or 2.....	45
Go Home 1 or 2 PIN .....	89
Going Off the Route.....	64
GPS Initialization.....	113
Guidance Mode.....	101
Guidance Screen .....	53

## **H**

Home Address.....	87
Hotel/Motel (Lodging).....	33

## **I**

Icon Bar.....	57
INFO button .....	10, 73
INFO screen.....	73
Interface Dial .....	11
Interface Dial Feedback .....	83
Interface Dial knob .....	11
Intersection.....	24, 40

## **K**

Key to Zagat Ratings.....	80
---------------------------	----

## **L**

Landmark Icons .....	62
Leisure.....	33
Lodging.....	33
Lower Display .....	12

## **M**

Map Colour .....	104
Map Coverage .....	120
Map Input.....	24, 41
Map Legend .....	60
Map Matching.....	113
Map Orientation .....	59
Map Scale.....	61
Map Screen .....	20, 50
MAP/GUIDE button.....	10, 53
Menu Colour .....	105
Microphone .....	13
Music Search.....	90

## N

- Navigation Display Commands..... 144
- Navigation General Commands ..... 143

## O

- Off-road Tracking ..... 64, 102
- On-Screen Commands ..... 151
- On-Screen Spelling Assist ..... 151

## P

- Personal Information..... 83
- PHONE button ..... 11
- Phone Number..... 36
- PIN ..... 83
- Place Name ..... 23, 30, 35, 86
- Previous Destinations..... 23, 29, 89
- Province ..... 24, 41, 43

## R

- Radio Voice Commands..... 147
- Read List ..... 74
- Rearview Camera..... 111
- Recalculation..... 64, 93
- Reporting Errors ..... 118

- Rerouting..... 93
- Restaurant ..... 33
- Route ..... 46, 48, 67, 68
- Routing & Guidance ..... 93
- Routing Method ..... 48

## S

- Save Current Location..... 65
- Schedule ..... 76
- Screen..... 12
- Search by Keyword ..... 36
- Security Code..... 112
- Selecting the City ..... 25, 42
- Selecting the Province..... 24
- Selecting the Street..... 26
- SETUP Screen (Main Setup)
  - Commands ..... 150
- Shopping ..... 33
- Show Icon on Map ..... 62
- Single-screen Mode..... 57
- Song By Voice™ (SBV)..... 90
- Sort by Distance to Travel..... 36
- Split-screen Mode ..... 56
- State..... 24
- Street ..... 26, 52

- Switching Display Mode ..... 105, 106
- System Controls ..... 10
- System Function Diagram..... 22
- System Information..... 79
- System Initialization ..... 112
- System Limitations..... 115
- System Set up..... 82
- System Start-up ..... 18

## T

- TALK button..... 13
- Time Adjustment..... 102
- Travel..... 33
- Troubleshooting..... 139

## U

- Unit Conversion..... 78
- Units (mile or km)..... 93
- Unverified Area Routing ..... 94
- Unverified streets ..... 6
- Update DVD..... 119
- Use Ferries ..... 48
- Use Highways..... 48
- Use Toll Roads ..... 48
- Using the Voice Control System ..... 14

# INDEX

---

## V

Vehicle.....	102
Verified Streets.....	6
View Routes .....	48
Visiting Your Dealer .....	119
Voice Command Index.....	143
Voice Control Basics .....	13
Voice Info.....	74
Voice Recognition .....	14
Voice Recognition Tutor.....	93
Volume .....	83

## W

Waypoints.....	100
----------------	-----

## Z

Zagat 2012.....	38
-----------------	----

- 1) *This device complies with Part 15 of the FCC Rules and Canadian RSS-210/RSS-Gen. Operation is subject to the following two conditions: (1) this device may not cause harmful interference, and (2) this device must accept any interference received, including interference that may cause undesired operation.*
- 2) *The FCC requires the user to be notified that any changes or modifications made to this device that are not expressly approved by the party responsible for compliance may void the user's authority to operate the equipment.*
- 3) *This product emits radio frequency energy, but the radiated output power of this device is far below the FCC and IC radio frequency exposure limits. This equipment complies with FCC and IC RF radiation exposure limits for an uncontrolled environment. Nevertheless, the device should be used in such a manner that the potential for human contact with the antenna during normal operation is minimized.*