

SPECIFICATIONS

		Note
Power requirements	110 V AC, 60 Hz	
Power consumption (W)	Indicated on the rear of the TV	
Television system	M	
Color system	NTSC3.58, PAL*, PAL 60*, SECAM*, NTSC4.43* (*AV IN only)	
Stereo/Bilingual system	MTS	
Channel coverage	VHF: 2 to 13 / UHF: 14 to 69 / CATV: 1 to 125	
⌚ (Antenna)	75-ohm external terminal	
Audio output (Speaker)	15W + 15W	
Number of terminal		
Video	Input: 4 Output: 1	Phono jacks; 1 V _{p-p} , 75 ohms
Audio	Input: 4 Output: 1	Phono jacks; 500 mV _{rms}
S Video	Input: 2	Y : 1 V _{p-p} , 75 ohms, unbalanced, sync negative C : 0.286 V _{p-p} , 75 ohms
Component Video (DVD) IN	Input: 1	Phono jacks Y : 1 V _{p-p} , 75 ohms, sync negative CB : 0.7 V _{p-p} , 75 ohms CR : 0.7 V _{p-p} , 75 ohms Audio : 500 mV _{rms}
DIGITAL IN	Input: 1	Phono jack; 0.5 V _{p-p} , 75 ohms
Headphones	Output: 1	Stereo minijack
Picture tube	38 inch	
Diagonal tube size	970 mm	
Diagonal screen size	911 mm	
Dimension (w/h/d, mm)	962 x 728 x 615 mm	
Mass	112 kg	

Design and specifications are subject to change without notice.

CAUTION

SHORT CIRCUIT THE ANODE OF THE PICTURE TUBE AND THE ANODE CAP TO THE METAL CHASSIS, CRT SHIELD, OR CARBON PAINTED ON THE CRT, AFTER REMOVING THE ANODE.

SAFETY-RELATED COMPONENT WARNING!!

COMPONENTS IDENTIFIED BY SHADING AND MARK \triangle ON THE SCHEMATIC DIAGRAMS, EXPLODED VIEWS AND IN THE PARTS LIST ARE CRITICAL TO SAFE OPERATION. REPLACE THESE COMPONENTS WITH SONY PARTS WHOSE PART NUMBERS APPEAR AS SHOWN IN THIS MANUAL OR IN SUPPLEMENTS PUBLISHED BY SONY.

TABLE OF CONTENTS

<u>Section</u>	<u>Title</u>	<u>Page</u>	<u>Section</u>	<u>Title</u>	<u>Page</u>
SELF DIAGNOSTIC FUNCTION		4	6. CIRCUIT ADJUSTMENTS		
1. GENERAL		7	6-1. Adjustment with Commander		43
2. DISASSEMBLY			6-2. Adjustment Method		43
2-1. Rear Cover Removal		30	6-3. Picture Quality Adjustments		56
2-2. Speaker Box Removal		30	6-4. Deflection Adjustments		57
2-3. H2 Board Removal		30	6-5. A Board Adjustment After IC003 (Memory) Replacement		59
2-4. Chassis Assy Removal		31	6-6. Picture Distortion Adjustment (1)		60
2-5. Service Position		31	7. DIAGRAMS		
2-6. DH Board Removal		31	7-1. Block Diagram		61
2-7. J Board Removal		31	7-2. Schematic Diagram		72
2-8. B3, D1 and E Boards Removal		32	(1) Schematic Diagram of A Board		73
2-9. A and D Boards Removal		32	(2) Schematic Diagram of D Board		75
2-10. H1 Board Removal		32	(3) Schematic Diagram of D1 Board		77
2-11. F2 Board Removal		32	(4) Schematic Diagram of C Board		79
2-12. Demagnetization Coil Removal		33	(5) Schematic Diagram of E Board		81
2-13. Top Switch Removal (H3 Board Removal)		33	(6) Schematic Diagram of J Board		83
2-14. G2 Lead Removal		33	(7) Schematic Diagrams of VM and F1 Boards		85
2-15. Picture Tube Removal		34	(8) Schematic Diagrams of H1, H3, F2 and SP Boards		87
2-16. Frame Sub-Assy Disassembly		34	(9) Schematic Diagrams of DH and H2 Boards ...		89
3. SERVICE JIG			(10) Schematic Diagram of A1 Board		91
3-1. Jigs Required For Servicing		37	(11) Schematic Diagram of BC4 Board		93
4. CIRCUIT BOARDS LOCATION		37	(12) Schematic Diagram of B3 Board		95
5. SET-UP ADJUSTMENTS			7-3. Voltage Measurement		107
5-1. Beam Landing		38	7-4. Waveforms		119
5-2. Convergence Adjustment		39	7-5. Printed Wiring Board and Parts Location		123
5-3. Focus Adjustment		41	7-6. Semiconductors		139
5-4. Neck Assy Twist Adjustment		41	8. EXPLODED VIEWS		
5-5. G2 (Screen) and White Balance Adjustment		42	8-1. Speaker Bracket		142
			8-2. Chassis		143
			8-3. Picture tube		144
			9. ELECTRICAL PARTS LIST		145

SELF DIAGNOSTIC FUNCTION

The units in this manual contain a self-diagnostic function. If an error occurs, the STANDBY/TIMER lamp will automatically begin to flash.

The number of times the lamp flashes translates to a probable source of the problem. A definition of the STANDBY/TIMER lamp flash indicators is listed in the instruction manual for the user's knowledge and reference. If an error symptom cannot be reproduced, the remote commander can be used to review the failure occurrence data stored in memory to reveal past problems and how often these problems occur.

1. DIAGNOSTIC TEST INDICATORS

When an errors occurs, the STANDBY/TIMER lamp will flash a set number of times to indicate the possible cause of the problem. If there is more than one error, the lamp will identify the first of the problem areas.

Result for all of the following diagnostic items are displayed on screen. No error has occurred if the screen displays a "0".

Diagnostic Item Description	No. of times STANDBY/TIMER lamp flashes	Self-diagnostic display/ Diagnostic result	Probable Cause Location	Detected Symptoms
• Power does not turn on	Does not light	—	<ul style="list-style-type: none"> • Power cord is not plugged in. • Fuse is burned out F1601 (F1 Board) 	<ul style="list-style-type: none"> • Power does not come on. • No power is supplied to the TV. • AC power supply is faulty.
• +B overcurrent (OCP)	2 times	002:000 or 002:001~255	<ul style="list-style-type: none"> • H.OUT Q6807 is shorted. • H.IN Q6810 is shorted. 	<ul style="list-style-type: none"> • Power does not come on. • Load on power line is shorted.
• +B overvoltage (OVP)	3 times	003:000 or 003:001~255	<ul style="list-style-type: none"> • PH 6602 faulty. • 10.5V is not supplied. (D board) 	<ul style="list-style-type: none"> • Power does not come on.
• Vertical deflection failure	4 times	004:000 or 004:001~255	<ul style="list-style-type: none"> • V.OUT IC6800 faulty • D6816 faulty • D6817 faulty • D6824 faulty • R6852 open • R6851 open 	<ul style="list-style-type: none"> • Vertical deflection pulse is stopped. • Vertical size is too small. • Vertical deflection stopped.
• White balance failure (no PICTURE)	5 times	005:000 or 005:001~255	<ul style="list-style-type: none"> • G2 is improperly adjusted. (Note 2) • CRT problem. • Video OUT IC9001, 9002, 9003 are faulty. (C board) • IC8306 (J board) and IC4301 (E board) are faulty. • No connection E board to C board. 	<ul style="list-style-type: none"> • No raster is generated. • CRT cathode current detection reference pulse output is small.
• Horizontal deflection failure	6 times	006:000 or 006:001~225	<ul style="list-style-type: none"> • C6831 is open circuit. • CN6101 (D1 board) is disconnected. 	<ul style="list-style-type: none"> • H pulse output is too high.
• Audio Protection	7 times	007:000 or 007:001~225	<ul style="list-style-type: none"> • Power supply fails. • IC1203, IC1204 faulty 	<ul style="list-style-type: none"> • There is picture but speaker does not release sound.
• Micro reset	—	101:00 or 101:001~225	<ul style="list-style-type: none"> • Discharge CRT (C Board) • Static discharge • External noise 	<ul style="list-style-type: none"> • Power is shut down shortly, after this return back to normal. • Detect Micro latch up.

Note 1: Refer to screen (G2) Adjustment in section 4-5 of this manual.

2. DISPLAY OF STANDBY/TIMER LIGHT FLASH COUNT

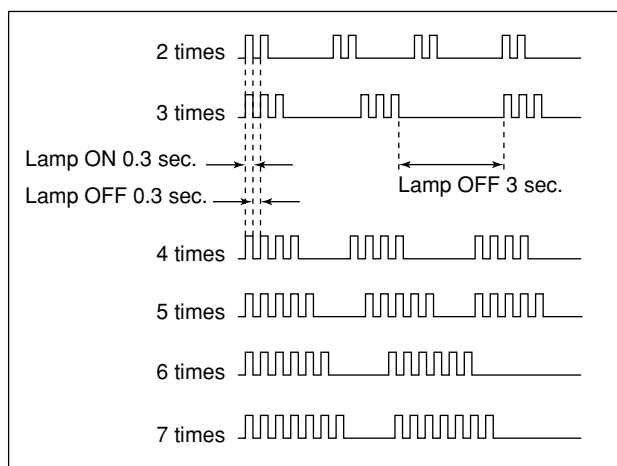

Diagnostic Item	Flash Count*
+B overcurrent	2 times
+B overvoltage	3 times
V deflection stop	4 times
White balance failure	5 times
High voltage protector	6 times
Audio Protection	7 times

* One flash count is not used for self-diagnostic.

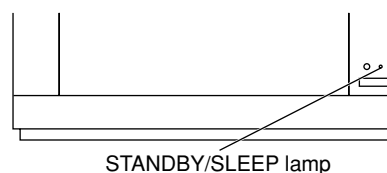

3. STOPPING THE STANDBY/TIMER FLASH

Turn off the power switch on the TV main unit or unplug the power cord from the outlet to stop the STANDBY/TIMER lamp from flashing.

4. SELF-DIAGNOSTIC SCREEN DISPLAY

For errors with symptoms such as "power sometimes shuts off" or "screen sometimes goes out" that cannot be confirmed, it is possible to bring up past occurrences of failure for confirmation on the screen:

[To Bring Up Screen Test]

In standby mode, press buttons on the remote commander sequentially in rapid succession as shown below:

Screen display → channel [5] → Sound volume [] → Power ON
↑

Note that this differs from entering the service mode (mode volume []).

Self-Diagnosis screen display

SELF DIAGNOSTIC	
002 : 000 ←	Numeral "0" means that no fault has been detected.
003 : 000	
004 : 000	
005 : 001 ←	Numeral "1" means a fault has been detected.
006 : 002 ←	Numeral "2" means two faults have been detected.
007 : 000	
101 : 000	

5. HANDLING OF SELF-DIAGNOSTIC SCREEN DISPLAY

Since the diagnostic results displayed on the screen are not automatically cleared, always check the self-diagnostic screen during repairs. When you have completed the repairs, clear the result display to "0".

Unless the result display is cleared to "0", the self-diagnostic function will not be able to detect subsequent faults after completion of the repairs.

[Clearing the result display]

To clear the result display to "0", press buttons on the remote commander sequentially as shown below when the diagnostic screen is being displayed.

Channel [8] → 0

[Quitting Self-diagnostic screen]

To quit the entire self-diagnostic screen, turn off the power switch on the remote commander or the main unit.

6. SELF-DIAGNOSTIC CIRCUIT

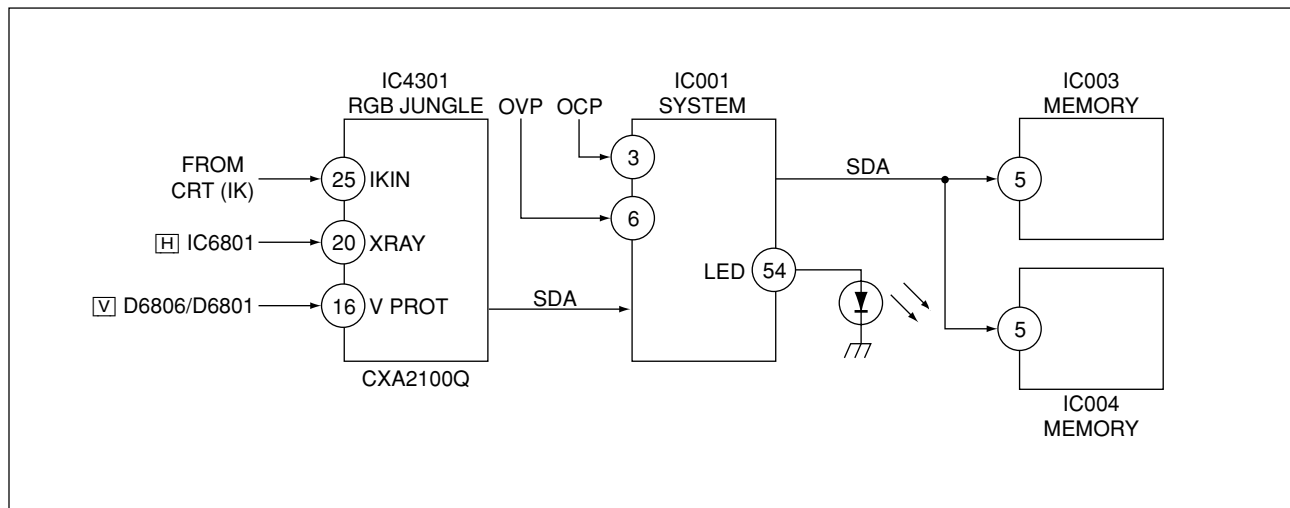

+B overcurrent (OCP)

Occurs when an overcurrent on the +B(135) line is detected by Q6610 and Q6609. If Q6610 and Q6609 go to ON, the voltage to the pin3 of IC001 go to UP. The unit will automatically turn off.

+B overvoltage (OVP)

Occurs when an overvoltage on the +B(135) line is detected by D6635, Q6611 and Q6612. If Q6611 and Q6612 go to ON, the voltage to pin6 of IC001 go to UP. The unit will automatically turn off.

Vertical deflection failure

Occurs when an absence of the vertical deflection pulse is detected by Q6811, Q6819, Q6820, Q6821 and D6801. Shut down the power supply.

White balance failure

If the RGB levels do not balance or become low level within 5 seconds. This error will be detected by IC4301. TV will stay on, but there will be no picture.



High voltage protector of Horizontal Deflection

Occurs when an overvoltage of horizontal pulse is detected by D6809 and IC6801. If the voltage of 7 pin of IC6801 goes to High, the voltage to pin20 of IC4301 go to UP. The unit will automatically turn off.

The operating instruction mentioned here are partial abstracts from the Operating Instruction Manual. The page numbers of the Operating Instruction Manual remain as in the manual.

警告

- 本電視機內存在危險性高電壓。
- 電視機的操作電壓：110 伏特交流電壓。

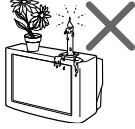
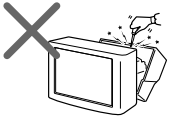
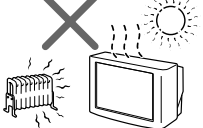
 <p>為了個人安全起見，雷雨期間，請勿觸摸電視機的任何部份，包括電源線和天線電纜。</p>	 <p>為了兒童安全起見，請勿讓他們獨自留在電視機旁。千萬別讓兒童攀爬本電視機。</p>
 <p>為防火災或觸電，請勿使本電視機被雨淋或受潮。</p>	 <p>若有任何液體流入或固體落入本電視機內時，請勿操作本電視機。應立即請合格的專業人員檢查。</p>
 <p>請勿堵塞本電視機的通風口。 請勿將本電視機放置於諸如書架或嵌入式壁櫥等封閉之處。</p>	 <p>請用乾的軟布清潔本電視機。 請勿使用汽油、稀釋劑或任何其它化學品清潔本電視機。請勿刮劃顯像管。</p>
 <p>請勿放置任何物體於電視機上。</p>	 <p>請勿在同一電源插座上插入太多的電器。請勿損壞電源線。</p>
 <p>請勿打開本電視機的機殼和後蓋，因電視機內存在高電壓和危險性部件。須由合格的專業人員對電視機進行檢修或棄置。</p>	 <p>本電視機只適於家庭使用。請勿將本電視機放置於任何交通工具內或多塵、高溫、潮濕或震動頻繁之處。</p>

SECTION 1 GENERAL

警告 (續)

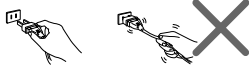
 <p>請將本電視機放置於所推荐的電視支架 (SU-ES38G) 或相同規格的電視支架上。請確認電視支架和地板是否穩定並足以支撐電視機的重量 (112 公斤)。</p>	 <p>捏住插頭將電源線拔開。請勿直接拉拔電源線。即使電視機已斷開電源，但只要電源線還在插座內，它仍接通至交流電源。若想移動本電視機或打算近期內不使用本電視機時，請將電源線拔開。</p>
---	--

使用您的新電視機

使用您的新電視機

準備工作

注意

- 若未完成所有連接程序，請勿插入電源線；否則極少量的電流可能經天線或其它端子外泄。
- 若打算近期內不使用遙控器，請將電池取出，以避免電池洩漏而損壞遙控器。若您不小心觸及電池所洩漏的液體，應立即用水洗淨。

步驟 1

連接天線

若您連接錄影機，則請參閱以下連接錄影機接線圖。

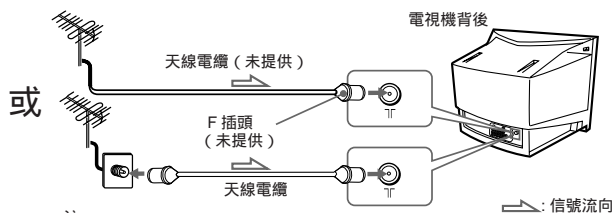

注

- 若輸入 T (天線) 的信號非常微弱，畫面可能會自動轉為暗淡，而“無信號”即顯示於螢幕上。這並不表示發生故障。

連接錄影機

要觀看影音輸入時，按壓 VIDEO (請參閱第 11 頁)。

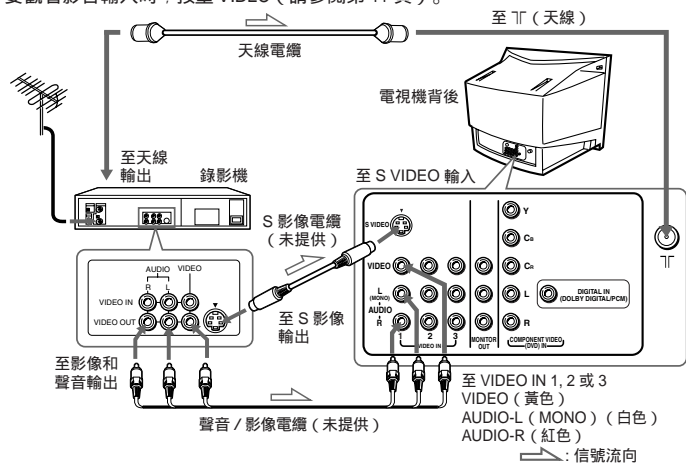

步驟 2

將電池裝入遙控器



注

- 請勿使用舊電池或同時使用不同類型的電池。

步驟 3

自動預設頻道

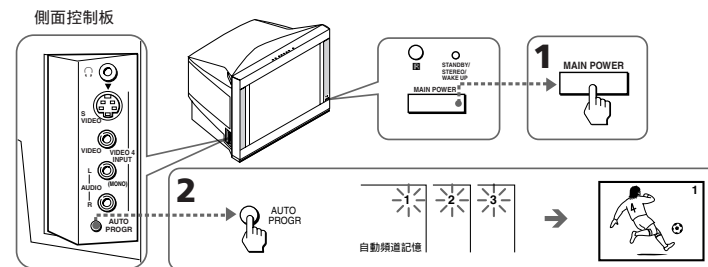

提示

- 要停止自動頻道預設時，按壓 MENU 鍵。
- 若您的電視已預設一個不想要的頻道或不能預設某一個頻道，您必須手動預設頻道 (請參閱第 40 頁)。
- 若要打開電視機的側面控制板，請輕按“PUSH”部直到您聽見滴答聲。

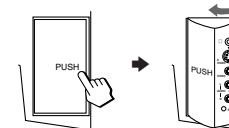

連接選購的裝置

本電視機可以與如錄影機、影碟機、攝影機、電視遊戲機或立體聲音響裝置等選購的聲音 / 影像裝置相連接。要觀看和操作所連接裝置的圖像時，請參閱第 11 頁和 24 頁。

用 VIDEO 4 INPUT 插口與攝影機 / 電視遊戲機相連接

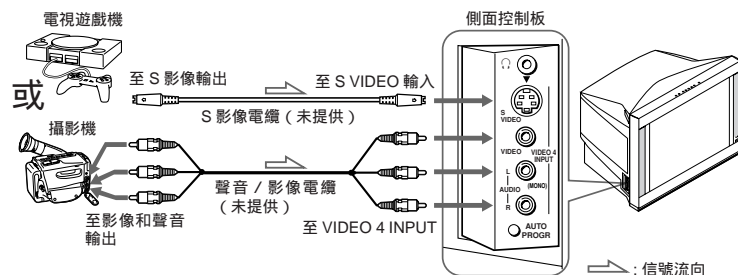

- 注
- 當連接電視遊戲機時，若您要調整適當的圖像設定以觀看電視遊戲節目，則顯示“功能選擇”選單，然後在“電玩模式”中選擇“開”（請參閱第 35 頁）。
 - 您也可將電視遊戲機連接至本電視機後面的 VIDEO IN 1, 2, 或 3 插口。
 - 當 S VIDEO 和 VIDEO 4 INPUT 兩者相連接時，S VIDEO 即自動被選定。要收看 VIDEO 4 INPUT 輸入的圖像，斷開 S 影像電纜即可。

用 MONITOR OUT 插口與聲音 / 影像裝置相連接

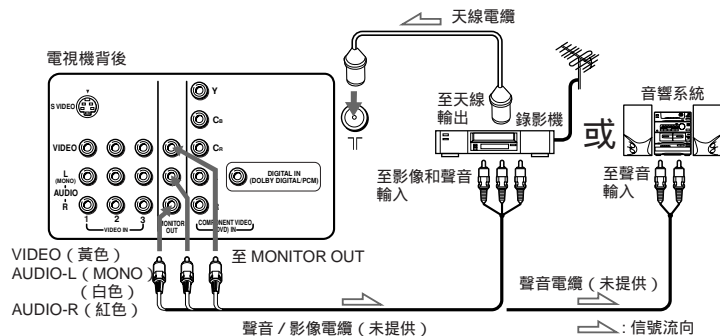

- 注
- 若您在電視螢幕上選擇“DVD”，MONITOR OUT 插口將不會輸出任何信號（請參閱第 11 頁）。

用 COMPONENT VIDEO (DVD) IN 插口與 DVD 播放機相連接

- 將電視機上的 COMPONENT VIDEO (DVD) IN 的 R (右) 和 L (左) 與 DVD 播放機上的 LINE OUT 的 AUDIO R (右) 和 L (左) 輸出插口連接起來。
- 用同軸數位信號線將電視機上的 COMPONENT VIDEO (DVD) IN 的 DIGITAL IN 插口連接至 DVD 播放機上的 DIGITAL OUT 的 COAXIAL 插口。
- 用 DVD 色差端子電纜將電視機上的 COMPONENT VIDEO (DVD) IN 的 Y, Cb 和 Cr 插口連接至 DVD 播放機上的 COMPONENT VIDEO OUT 的 Y, Cb 和 Cr 插口。
- 按壓遙控器或電視機上的 VIDEO 鍵直到“DVD”顯示在螢幕上。

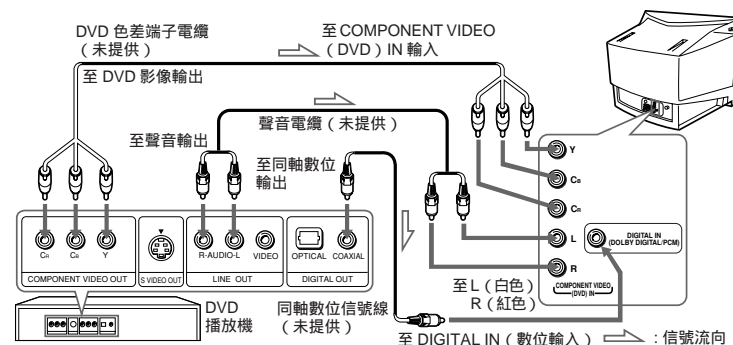

- 注
- 當連接 DVD 播放機至電視機上的 COMPONENT VIDEO (DVD) IN 時，若您的 DVD 播放機可輸出隔行和逐行的掃描模式信號，則請選擇隔行掃描輸出。您的電視機可接收 525i/60 赫茲或 625i/50 赫茲的隔行掃描信號。
 - 某些 DVD 播放機的插口可能標記不同：

連接	至 (DVD 播放機上的)
Y (綠色)	Y
Cb (藍色)	Cb, B-Y 或 Pb
Cr (紅色)	Cr, R-Y 或 Pr

- 您必須連接電視機上的 COMPONENT VIDEO (DVD) IN 的 Y, Cb 和 Cr 插口以接收影像信號。同時，您也必須連接 DIGITAL IN 插口以接收數位聲音信號或 L (左) 和 R (右) 插口以接收模擬聲音信號（請參閱第 31 頁）。
- 當連接電視機上的 COMPONENT VIDEO (DVD) IN 的 DIGITAL IN 插口時，確定“影音選擇”選單顯示“數位音訊輸入：開”。當連接完成後，必須設定“數位音訊輸入：開”。當您還未完成 DIGITAL IN 插口的連接而將“數位音訊輸入”設定為“開”時，揚聲器將會突然產生噪音。這將會影響您的聽覺和損壞揚聲器（請參閱第 31 頁）。

續

連接選購的裝置 (續)

用 VIDEO IN 1, 2 或 3 插口與 DVD 播放機相連接

將電視機上的 VIDEO IN 1、2 或 3 AUDIO/VIDEO 插口與 DVD 播放機上的 LINE OUT 插口相連接。

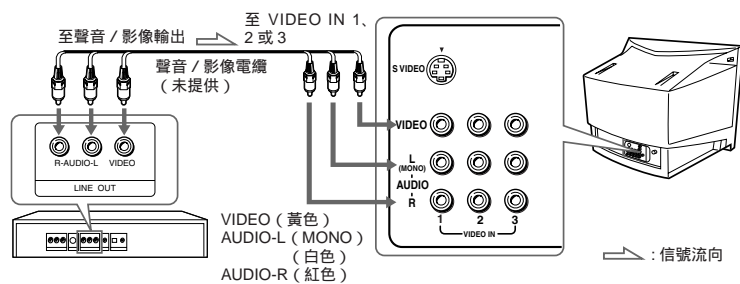

注

- 由於 DVD 碟片上的高質量螢幕包含許多信息，因此可能出現螢幕紊亂。在這種情形下，請調整“畫質模式”選單中的“調整”項目的“銳度”（請參閱第 30 頁）。
- 請將您的 DVD 播放機直接連接至您的電視機。若中間通過其它影像裝置連接 DVD 播放機，將導致不必要的螢幕紊亂。

固定電視機

為防止電視機摔落，請採用下述方法之一將電視機固定：

A 將固定用的帶條，用所提供的螺釘按帶條上的孔安裝在電視機和其支架上。

或

B 用一根繩索或鏈條穿過夾子將電視機固定在牆上或柱子上。

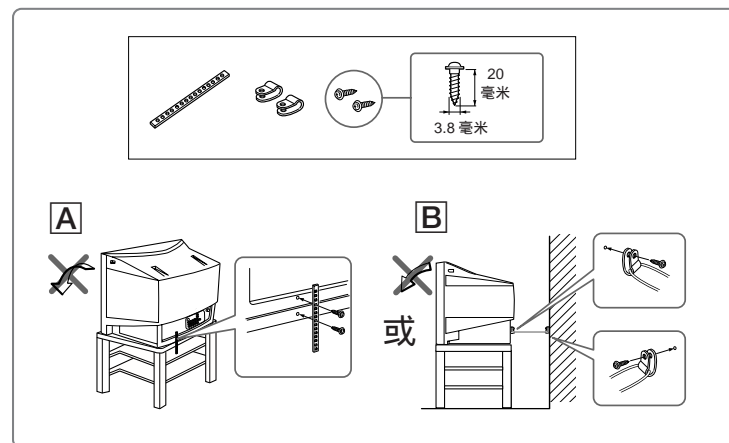

注

- 請僅使用提供的螺釘。使用其它螺釘可能會損壞本電視機。

使用您的新電視機

觀看電視

本節說明觀看電視時所使用的功能和操作。大多數操作都可以用遙控器進行。

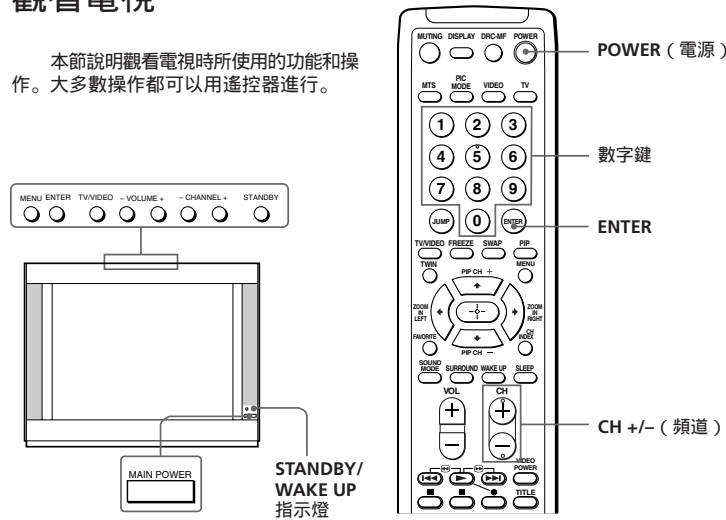

1 按壓 MAIN POWER 鍵以接通電視機電源。

當電視機處於待機狀態時（電視機上的 STANDBY 指示燈呈紅色亮光），按壓遙控器上的 POWER（電源）鍵或電視機上的 STANDBY 鍵。



2 要選擇頻道號碼時，按壓數字鍵後再按壓 ENTER 鍵，或直接按壓 CH +/-（頻道）鍵。

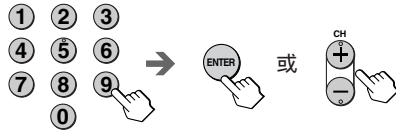

提示

- 當您打開電視機時，頻道號碼或影音輸入將被顯示在螢幕上大約 40 秒。與此同時，若您將“功能選擇”選單中的“省電模式”設定為“開”，省電模式符號（) 也將被顯示在螢幕上（請參閱第 35 頁）。

要快速選擇某一個頻道號碼時

- 持續按壓 CH +/-（頻道）鍵。
- 當您所要的頻道號碼顯示時，停止按壓 CH +/-（頻道）鍵。

注

- 當您快速選擇某一個頻道號碼時，圖像可能會失真。這並不表示發生故障。

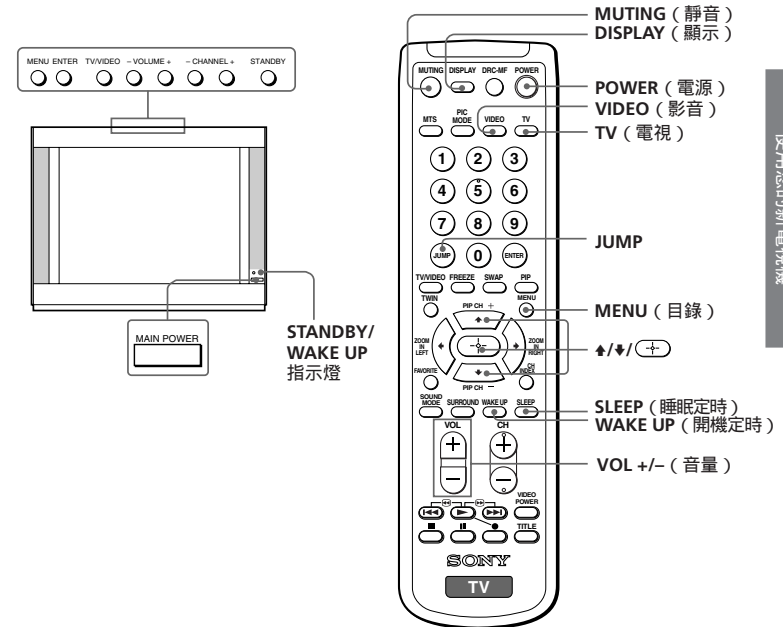

附加操作

要	按壓
暫時切斷電視機的電源	POWER (電源) 鍵。 電視機上的 STANDBY 指示燈呈紅色亮光。
完全切斷電視機的電源	電視機上的 MAIN POWER 鍵。
調整音量	VOL +/- (音量) 鍵。
消除聲音	MUTING (靜音) 鍵。
觀看影音輸入 (錄影機、攝影機等)	VIDEO (影音) 鍵 (或電視機上的 TV/VIDEO 鍵) 以選擇“影音輸入 1”、“影音輸入 2”、“影音輸入 3”、“影音輸入 4”或“DVD”。 要回到電視節目時，按壓 TV (電視) 鍵 (或電視機上的 TV/VIDEO 鍵)。
跳回到之前收看的頻道號碼	JUMP 鍵。
顯示螢幕上的信息*	DISPLAY (顯示) 鍵。

* 螢幕上即顯示圖像、聲音以及頻道號碼或影音輸入的信息。螢幕上的圖像和聲音設定在顯示約三秒後自動消失。

使用您的新電視機

觀看電視 (續)

改變選單語言

您可改變選單語言和螢幕語言。有關如何使用選單的詳細情況，請參閱第 26 頁的介紹選單系統。

1 按壓 MENU (目錄) 鍵。



2 按壓 ▲ 鍵或 ▼ 鍵以選擇“系統設定”符號 (⚙️)，然後按壓 (+) 鍵。



3 確認“語文顯示 / LANGUAGE”已被選擇，然後按壓 (+) 鍵。

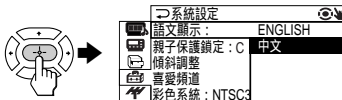

4 按壓 ▲ 鍵或 ▼ 鍵以選擇所要的語言 (例如，“ENGLISH”)，然後按壓 (+) 鍵。
被選擇的選單語言將顯示在螢幕上。



要回到普通螢幕顯示時

按壓 MENU (目錄) 鍵。

設定開機定時器

1 按壓 WAKE UP (開機定時) 鍵直到您所指定的時間顯示在螢幕上。

一旦時間被設定，開機定時器立即啟動。

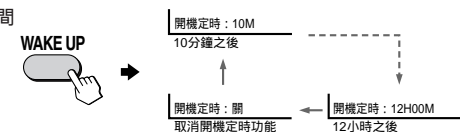

2 選擇當您醒來時所要觀看的頻道號碼或影音輸入。

3 若您要電視機自動切斷電源，請按壓 POWER (電源) 鍵或設定睡眠定時功能。電視機上的 WAKE UP 指示燈即發出橙色亮光。

要取消開機定時器時

按壓 WAKE UP (開機定時) 鍵直到“開機定時: 關”顯示在螢幕上，或切斷電視機的主電源。

注

- 用開機定時器接通電視機電源並超過兩小時後，若您不按壓電視機或遙控器上的任何一個按鍵或控制鍵，則電視機再進入待機狀態。要恢復觀看電視時，按壓電視機或遙控器上任何一個按鍵或控制鍵即可。

設定睡眠定時器

按壓 SLEEP (睡眠定時) 鍵直到您所指定的時間顯示在螢幕上。

一旦時間被設定，睡眠定時器立即啟動。

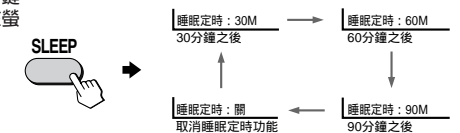

要取消睡眠定時器時

按壓 SLEEP (睡眠定時) 鍵直到“睡眠定時: 關”顯示在螢幕上，或切斷電視機電源。

使用您的新電視機

選擇畫質和音效模式

您可選擇畫質和音效模式並使用“使用者”模式來調整您所偏好的設定。

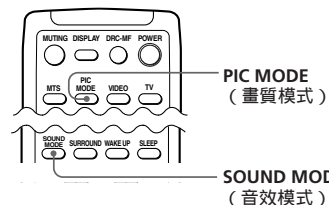

選擇畫質模式

重復按壓 PIC MODE (畫質模式) 鍵直到您所要的畫質模式被選定。



選擇	以
“動態”	觀看對比度強的圖像。
“標準”	觀看普通的圖像。
“高解析”	觀看更高的密度和柔和對比的圖像。
“使用者”	接收“影音選擇”選單中的“調整”項目所調整的最終圖像設定(請參閱第30頁)。

選擇音效模式

重復按壓 SOUND MODE (音效模式) 鍵直到您所要的音效模式被選定。

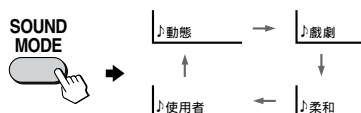

選擇	以
“動態”	收聽強調低和高音調的動態及清晰音響。
“戲劇”	收聽強調人聲和高音調的聲音。
“柔和”	收聽柔和的聲音。
“使用者”	接收在“影音選擇”選單中的“調整”項目所調整的最終音響設定(請參閱第30頁)。

提示

- 您也可使用選單設定畫質和音效模式(請參閱第29頁的改變“影音選擇”設定)。

觀看高素質圖像

— “DRC-MF”

“DRC-MF”功能可讓您享受高素質的電視圖像。您可選擇“DRC4倍密”以觀看超真實(更高的密度)圖像,或選擇“DRC PROGRESSIVE”以減少螢幕的跳動。

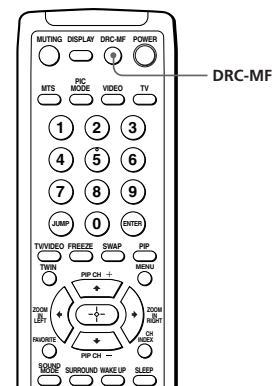

重復按壓 DRC-MF 鍵直到您收到滿意的圖像素質。



選擇	以
“DRC4倍密”	觀看更高的密度的圖像。
“DRC PROGRESSIVE”	減少螢幕上某些部份或掃描線條的跳動(例如,在字母或物體邊沿上)。

提示

- 您也可使用選單以選擇“DRC-MF”的項目(請參閱第29頁的改變“影音選擇”設定)。
- 當廣播信號微弱時,螢幕上也許會出現少許的圓點或會產生噪音。要減低干擾時,顯示“影音選擇”選單以在“畫質模式”中選擇“調整”,然後調整“銳度”以減低鮮明度(請參閱第30頁)。

注

- 您無法在“頻道索引”、“喜愛頻道”、“電玩模式”、“子母畫面”或“雙畫面”功能打開時選擇“DRC-MF”模式。

DRC-MF 的標識 () 和 “DRC-MF” 是 Sony Corporation 的註冊商標。

收看您的喜愛頻道

— “喜愛頻道”

您可簡易快速的在電視螢幕上顯示和選擇七個喜愛頻道。

用數字鍵最後選取的七個頻道以“自動設定”模式顯示在螢幕上，您可用“喜愛頻道”選單中的“手動設定”模式以設定您自己的喜愛頻道。（請參閱第 38 頁的輸入喜愛頻道。）

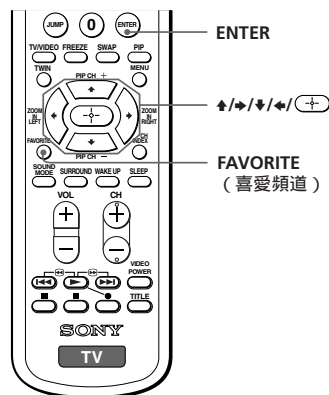

選擇喜愛頻道

- 1 按壓 FAVORITE (喜愛頻道) 鍵。



- 2 按壓 ↑, →, ↓ 或 ← 鍵以選擇所要的頻道號碼 (例如, 頻道號碼 8), 然後按壓 (+) 鍵。

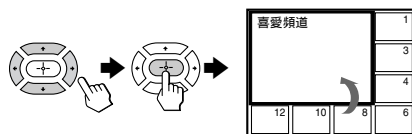

- 3 再次按壓 (+) 鍵。

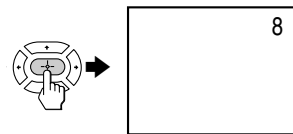

注
• 若您第一次使用喜愛頻道功能，七個已被預設的喜愛頻道將顯示在螢幕上。

同時觀看兩個節目

— “子母畫面”, “雙畫面”

用子母畫面或雙畫面功能，您可在一個主螢幕中或主螢幕旁邊顯示一個不同頻道號碼或影音輸入。

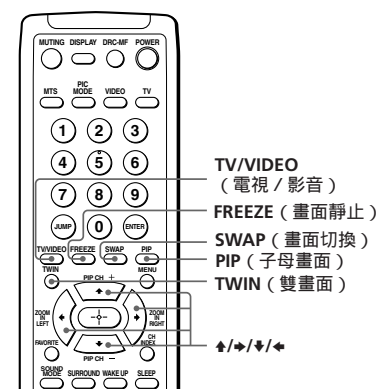

顯示子母畫面螢幕

按壓 PIP (子母畫面) 鍵。

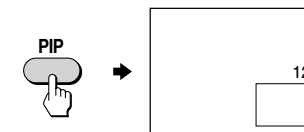

顯示雙畫面

按壓 TWIN (雙畫面) 鍵。

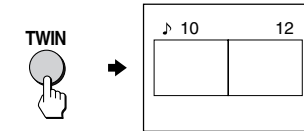



要回到普通螢幕顯示時

按壓 PIP (子母畫面) 鍵 (當顯示子母畫面螢幕時) 或 TWIN (雙畫面) 鍵 (當顯示雙畫面時)。

提示
• 您也可使用選單顯示子母畫面螢幕或雙畫面，以及操作選單中的部份功能 (請參閱第 32 頁的改變“複分格畫面”設定)。

同時觀看兩個節目 (續)

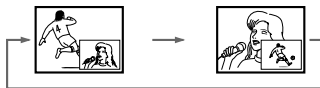
附加的子母畫面 / 雙畫面操作

要	按壓
改變子畫面螢幕中的頻道號碼或雙畫面右邊的頻道號碼	◀ 或 ▶ 鍵。
選擇子畫面螢幕中的影音輸入或雙畫面右邊的影音輸入	◀ 鍵。
切換主螢幕與子畫面螢幕的圖像	SWAP (畫面切換) 鍵。 
靜止子畫面螢幕	FREEZE (畫面靜止) 鍵。 要使螢幕活動起來，再次按壓此鍵。
切換雙畫面中的右螢幕和左螢幕	SWAP (畫面切換) 鍵。 

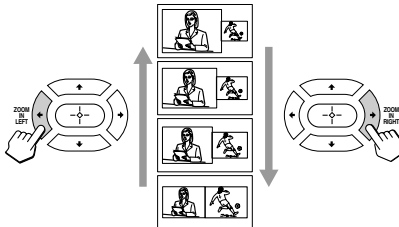
改變雙畫面的螢幕尺寸	<p>◀ 鍵 (左螢幕放大) 以增大左螢幕的尺寸。</p> <p>▶ 鍵 (右螢幕放大) 以增大右螢幕的尺寸。</p> 
------------	---

注

- 處於雙畫面模式時 FREEZE (畫面靜止) 鍵不起作用。
- 當您在子畫面螢幕上以快 / 慢速度顯示影音輸入圖像時，圖像可能會受干擾，這取決於錄影機的情況。
- 若您在主螢幕上和子畫面螢幕上顯示不同的彩色系統，則子畫面螢幕的尺寸可能會不同，而且子畫面螢幕的圖像可能會受干擾。這並不表示電視機發生故障。
- 在雙畫面螢幕中，您僅可操作和聽到左邊的主螢幕的聲音 (♪ 顯示在螢幕上)。
- 當按壓 TWIN (雙畫面) 鍵時，在雙畫面顯示之前，電視螢幕會閃爍或呈現空白約 1 秒。這並不表示電視機發生故障。

顯示多種節目

— “頻道索引”

頻道索引功能可顯示所有預設的頻道號碼，以及直接選擇顯示在十二個或七個小螢幕上的頻道號碼。

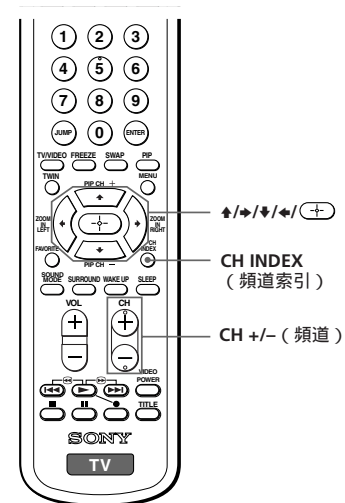

按壓 CH INDEX (頻道索引) 鍵。

最先預設的十二個頻道號碼即順著時針方向從左上角按照次序顯示在螢幕上。

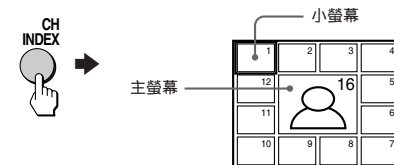

當預設的頻道號碼數量少過於八個時，最先預設的七個頻道號碼將順著時針方向從右上角按照次序顯示在螢幕上。

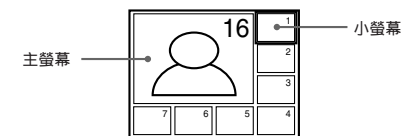

提示

- 當處於雙畫面模式時按壓 CH INDEX (頻道索引) 鍵，左螢幕將成為頻道索引模式的主螢幕。

續

顯示多種節目 (續)

要收看之後或之前的十二個預設頻道號碼時

當預設的頻道號碼數量超過十二個時，此功能才起作用。

按壓遙控器上的 CH +/- (頻道) 鍵或電視機上的 CHANNEL +/- 鍵。



要從小螢幕直接選擇想收看的頻道號碼時

1 按壓 ↑, →, ↓ 或 ← 鍵以選擇您所要收看的頻道號碼。

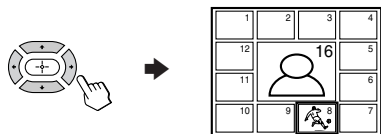

2 按壓 (+) 鍵。

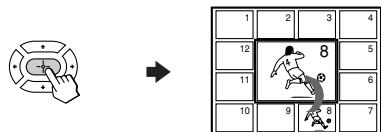

3 再次按壓 (+) 鍵。



提示

- 您可按壓數字鍵以直接顯示頻道號碼。

要回到普通螢幕顯示時

再次按壓 CH INDEX (頻道索引) 鍵，或：

- 1 從“複分格畫面”選單中選擇“頻道索引”。
- 2 按壓 (←) 鍵。

提示

- 您也可使用選單顯示多個頻道號碼 (請參閱第 32 頁的改變“複分格畫面”設定)。

注

- 當顯示多個頻道號碼時，僅可聽到主螢幕的聲音。

收聽環繞音效

環繞音效功能可使您欣賞音樂廳或電影院的音響效果。

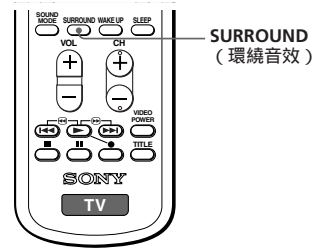

重復按壓 SURROUND (環繞音效) 鍵至收到您所想收聽的環繞音效。



選擇	要
“ 擬真音場 ”	收聽編碼杜比*環繞音效。
“ TruSurround ”	收聽傳遍整個房間的環繞音效。
“ 模擬立體音效 ”	收聽模擬立體聲的單聲道音響。
“ 關 ”	關閉環繞音效。

提示

- 您也可使用選單選擇環繞音效 (請參閱第 29 頁的改變 “ 影音選擇 ” 設定)。

注

- 這個型號的虛擬杜比環繞音效是由 Dolby Digital, Dolby Pro Logic 和 TruSurround 組成的。
- 當電視機背後的 COMPONENT VIDEO (DVD) IN 的 DIGITAL IN 插口接收到杜比數位信號時，而且 “ 影音選擇 ” 選單顯示 “ 數位音訊輸入：開 ” 您才可使用 “ 擬真音場 ” (請參閱第 7 和 29 頁)。
- 當使用電視機背後的 COMPONENT VIDEO (DVD) IN 的 DIGITAL IN 插口時，所接收的環繞音效模式將隨著數位信號類型而定。
- “ 模擬立體音效 ” 使用 SRS (單聲道)。

* 經杜比實驗證明公司授權製造。
杜比, DOLBY 雙 D 標章 及 PRO LOGIC 為杜比實驗證明公司之商標。

“ **TruSurround** ” 是 SRS Labs, Inc. 的註冊商標。SRS 及 SRS 的標識是 SRS Labs, Inc. 在美國及一些經特選的外國註冊登記過的商標。SRS 及 TruSurround 科技是登記在 SRS Labs, Inc. 特許證下，並受到美國專利號碼 4,748,669 和 4,841,572，以及許多補充發佈的和正待發佈的外國專利保護。

欣賞立體聲或雙語言節目

您可欣賞 MTS (音聲多重) 立體聲製式的立體聲音響或雙語言節目。

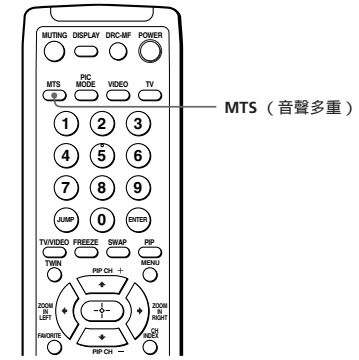
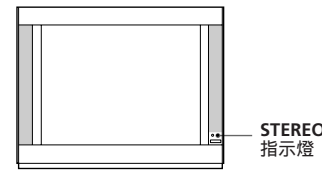

重復按壓 MTS (音聲多重) 鍵至收到您想收聽的音響。

屏幕顯示會變化以顯示所選擇的聲音。
當接收到任何立體聲節目時，電視機上的 STEREO 指示燈即呈紅色亮光。

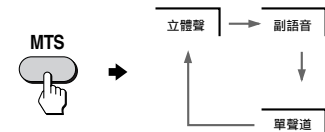

選擇	以
“ 立體聲 ”	收聽立體聲。
“ 副語言 ”	收聽雙語言節目。
“ 單聲道 ”	接收單聲道的聲音。

注

- 當選擇副語言時，非副語言節目的聲音將會與立體聲相似。
- 當信號微弱時，“副語言”或“立體聲”的聲音可能會不正常。要改善聲音，選擇“單聲道”。

使用選購的裝置

您可使用提供的遙控器操作 Sony 影像裝置如 Beta 錄影機、8mm 錄影機、VHS 錄影機、影碟機、鐳射唱機或 DVD 播放機等。

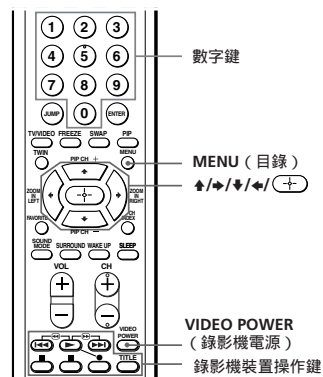

設定遙控器，使其能夠操作相連裝置

當按壓 VIDEO POWER (錄影機電源) 鍵的同時再按壓一個數字鍵以輸入該裝置的代碼號。(請參閱下表)

例如：要操作一台 Sony 8mm 盒式錄影機時：

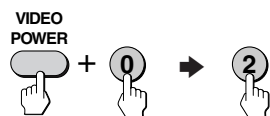

Sony 影像裝置代碼號

要操縱	按壓 VIDEO POWER 鍵並按壓
DVD	00
VTR1 (Beta)	01
VTR2 (8mm)	02
VTR3 (VHS)	03
MDP	04
CD	06
MD	07

注

- 若您的影像裝置配有 COMMAND MODE (命令模式) 選擇器，則請將該選擇器設定與設定代碼一樣的位置。
- 若影像裝置不具備這種功能，則遙控器上的相應按鍵將不起作用。

用遙控器操作錄影機

要	按壓
打開 / 關閉	VIDEO POWER (錄影機電源)
錄影	▶ 鍵的同時按壓 ● 鍵。
播放	▶ 鍵
停止	■ 鍵
快進 (▶▶)	▶▶ 鍵
倒帶 (◀◀)	◀◀ 鍵
暫停	鍵
向前 (▶▶) 或向後 (◀◀) 尋找圖像	再次按壓此鍵以恢復普通播放。 ▶▶ 鍵或 ◀◀ 鍵。 鬆開此鍵以恢復普通播放。

用遙控器操作 DVD 播放機

要	按壓
打開 / 關閉	VIDEO POWER (錄影機電源)
播放	▶ 鍵
停止	■ 鍵
暫停	鍵
搜索磁帶的不同片段	再次按壓此鍵以恢復普通播放。 ▶▶ 鍵向前搜索或 ◀◀ 鍵向後搜索。
顯示標題選單	TITLE (標題) 鍵
顯示選單	MENU (目錄) 鍵的同時按壓 ● 鍵。
選擇選單項目	▲/▼/▶/◀ 鍵的同時按壓 ● 鍵。

用遙控器操作鐳射影碟機

要	按壓
打開 / 關閉	VIDEO POWER (錄影機電源)
播放	▶ 鍵
停止	■ 鍵
暫停	鍵
搜索磁帶的不同片段	再次按壓此鍵以恢復普通播放。 ▶▶ 鍵向前搜索或 ◀◀ 鍵向後搜索。

用遙控器操作 CD/MD

要	按壓
打開 / 關閉	VIDEO POWER (錄影機電源)
播放	▶ 鍵
停止	■ 鍵
暫停	鍵
進入下一首 / 前一首樂曲	再次按壓此鍵以恢復普通播放。 ▶▶ 或 ◀◀ 鍵
在一首樂曲中快速向前 (▶▶) / 快速倒退 (◀◀)	▶▶ 或 ◀◀ 鍵的同時按壓 ▶ 鍵。

調整您的設定 (MENU)

介紹選單系統

MENU 按鍵可使您顯示選單和改變您電視機的設定。下面是選單系統的總概況。

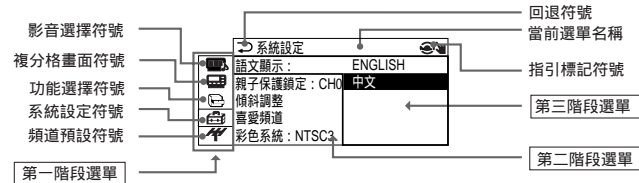

第一階段	第二階段	第三階段 / 功能
“影音選擇” 	“DRC-MF”	選擇 DRC-MF 模式： “DRC4倍密” → “PROGRESSIVE”
	“畫質模式”	選擇畫質模式： “動態” → “標準” → “高解析” → “使用者” → “調整”
	“調整”	調整“使用者”項目： “對比” → “彩色” → “亮度” → “色相” → “銳度”
	“音效模式”	選擇音效模式： “動態” → “戲劇” → “柔和” → “使用者” → “調整”
	“調整”	調整“使用者”項目： “低音” → “高音” → “平衡” → “BBE”*
	“環繞音效”	選擇環繞音效模式： “ <input type="checkbox"/> 擬真音場” → “TruSurround” → “模擬立體音效” → “關”
	“數位音訊輸入”	啟動或取消電視機背後的數位聲音輸入插口。
“複分格畫面” 	“子母畫面”	顯示主螢幕中的子畫面螢幕。
	“子畫面位置”	改變小螢幕的位置。
	“畫面切換”	切換主螢幕與子畫面螢幕的圖像。
	“雙畫面”	顯示主螢幕旁邊的頻道號碼或影音輸入。
	“頻道索引”	同時顯示所有預設的頻道號碼。
“功能選擇” 	“寬螢幕模式”	改變圖像的尺寸。
	“省電模式”	節省電能。
	“電玩模式”	調整圖像以觀看電視遊戲節目。

第一階段	第二階段	第三階段 / 功能
“系統設定” 	“語文顯示/ LANGUAGE”	改變選單語言： “ENGLISH” (英文) → “中文”
	“親子保護鎖定”	鎖定特定頻道號碼。
	“傾斜調整”	旋轉圖像。
	“喜愛頻道”	設定喜愛頻道。
	“彩色系統”	選擇彩色系統： “自動切換” → “PAL” → “SECAM” → “NTSC3.58” → “NTSC4.43” (僅於影音模式)
“頻道預設” 	“自動頻道記憶”	自動預設頻道。
	“有線電視”	選擇“開”以觀看有線電視。
	“記憶 / 刪除”	手動預設頻道。
	“ 敏感度”	調整電視接收敏感度。

* BBE 是 Sony 公司經 BBE 音響公司獲准後生產的並應用了美國專利號碼 No.4,638,258 和 No.4,482,866。“BBE”這詞與 BBE 這符號是 BBE 音響公司的商標。

調整您的設定 (MENU)

續

介紹選單系統 (續)

如何使用選單

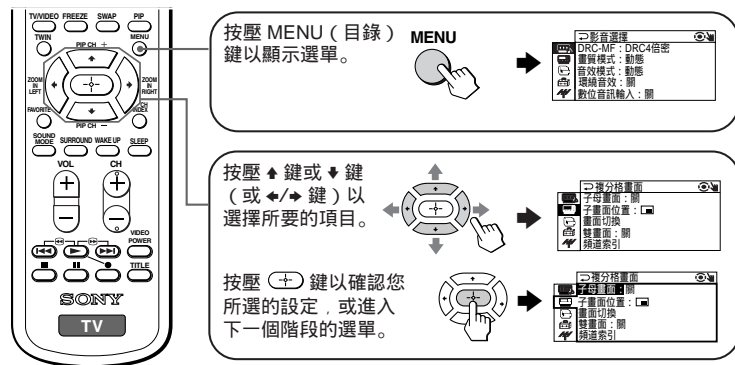

其它選單操作

要	按壓
調整設定值	\uparrow / \downarrow 鍵或 \leftarrow / \rightarrow 鍵。
回到之前或進入下一個階段的選單	\leftarrow 鍵或 \rightarrow 鍵。
取消選單	MENU (目錄) 鍵。

提示

- 要從第二階段選單回到第一階段選單時, 則按壓 \uparrow 鍵或 \downarrow 鍵直到回退符號 (◀) 被選中, 然後按壓 ENTER 鍵。
- 電視機上的 MENU 鍵、ENTER 鍵和 VOLUME +/- 鍵也可用作上述操作。

注

- 若兩次輸入之間的時間超過 60 秒則選單將會從螢幕上自動消失。

改變“影音選擇”設定

“影音選擇”選單可使您調整圖像和音響設定。

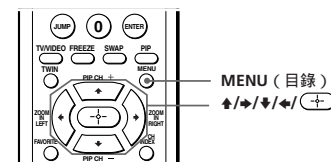

1 按壓 MENU (目錄) 鍵。

2 確認“影音選擇”符號 (☺) 已被選擇, 然後按壓 ENTER 鍵。

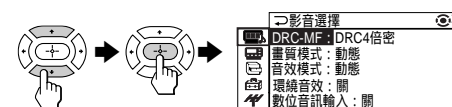

3 按壓 \uparrow 鍵或 \downarrow 鍵以選擇所要的項目 (例如, “DRC-MF”), 然後按壓 ENTER 鍵。

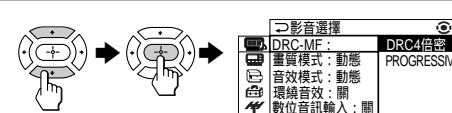

選擇	以
“DRC-MF”	選擇“DRC4倍密”或“PROGRESSIVE”。
“畫質模式”	選擇“動態”、“標準”、“高解析”、“使用者”*或“調整”。
“音效模式”	選擇“動態”、“戲劇”、“柔和”、“使用者”*或“調整”。
“環繞音效”	選擇“ <input type="checkbox"/> 擬真音場”、“TruSurround”、“模擬立體音效”或“關”。
“數位音訊輸入”	選擇“開”或“關”。

* 當選擇“使用者”模式時, 您可接收到最後一次在“調整”模式中所調整的圖像或聲音設定 (請參閱第 30 頁)。

提示

- 有關“DRC-MF”、“畫質模式”/“音效模式”、“環繞音效”和“數位音訊輸入”的選擇項目的詳情, 請分別參閱第 15、14、22 和 31 頁。

要回到普通螢幕顯示時

按壓 MENU (目錄) 鍵。

續

改變“影音選擇”(續)

調整“畫質模式”下的“調整”項目

- 1 按壓 \blacktriangle 鍵或 \blacktriangledown 鍵以選擇所要的項目(例如,“彩色”),然後按壓 \oplus 鍵。

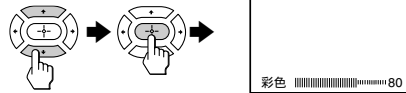

- 2 按照下表調整項目值,然後按壓 \oplus 鍵。

項目	按壓 $\blacktriangledown/\blacktriangle$ 鍵以	按壓 $\blacktriangle/\blacktriangledown$ 鍵以
“對比”	降低圖像對比度	提高圖像對比度
“彩色”	減低彩色濃度	增加彩色濃度
“亮度”	降低圖像亮度	提高圖像亮度
“色相”*	使圖像色調增強紅色	使圖像色調增強綠色
“銳度”	使圖像柔和	使圖像鮮明

* 只有 NTSC 彩色系統能讓您調整“色相”。

- 3 重復上述步驟操作以調整其它項目。

當您選擇“使用者”項目時,將接收調整好的設定。

調整“音效模式”下的“調整”項目

- 1 按壓 \blacktriangle 鍵或 \blacktriangledown 鍵以選擇所要的項目(例如,“平衡”),然後按壓 \oplus 鍵。

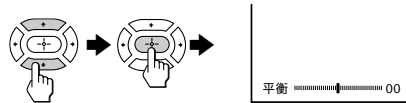

- 2 按照下表調整項目值,然後按壓 \oplus 鍵。

項目	按壓
“低音”	$\blacktriangledown/\blacktriangle$ 鍵以減弱低音, $\blacktriangle/\blacktriangledown$ 鍵以增強低音。
“高音”	$\blacktriangledown/\blacktriangle$ 鍵以減弱高音, $\blacktriangle/\blacktriangledown$ 鍵以增強高音。
“平衡”	$\blacktriangledown/\blacktriangle$ 鍵以提高左揚聲器的音量, $\blacktriangle/\blacktriangledown$ 鍵以提高右揚聲器的音量。
“BBE”	$\blacktriangle/\blacktriangledown$ 鍵以: 選擇“強”以強調較高的聲音清純度; 選擇“弱”以強調較低的聲音清純度; 選擇“關”以取消 BBE 功能。

- 3 重復上述步驟操作以調整其它項目。

當您選擇“使用者”項目時,將接收調整好的設定。

設定“數位音訊輸入”項目

- 1 當您進入“數位音訊輸入”選單時,按壓 \blacktriangle 鍵或 \blacktriangledown 鍵以選擇所要的項目(請參閱下表)。



選擇	以
“開”	通過 COMPONENT VIDEO (DVD) IN 的 DIGITAL IN 插口接收數位聲音信號。
“關”	通過 COMPONENT VIDEO (DVD) IN 的 L (左) 和 R (右) 插口接收模擬聲音信號。

- 2 按壓 \oplus 鍵以確認所選的項目。



注

- 您的電視機通過 COMPONENT VIDEO (DVD) IN 的 DIGITAL IN 插口只能夠接收到杜比數位或線性 PCM 格式數位的信號(請參閱第 7 頁)。接收其它格式的數位信號將可能造成揚聲器發出噪音或沒有聲音。

提示

- 有關選單系統和如何使用選單的詳細情況,請參閱第 26 頁的介紹選單系統。

改變“複分格畫面”設定

“複分格畫面”選單可使您使用子母畫面、雙畫面或頻道索引功能。

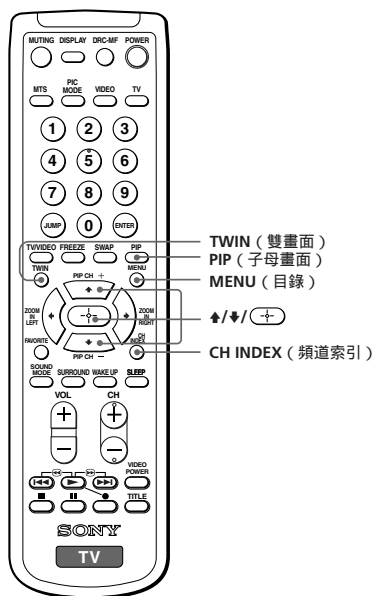

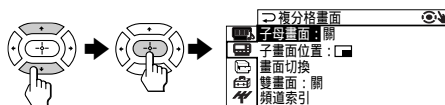

1 按壓 MENU (目錄) 鍵。

2 按壓 \uparrow 鍵或 \downarrow 鍵以選擇“複分格畫面”符號 (), 然後按壓 \rightarrow 鍵。

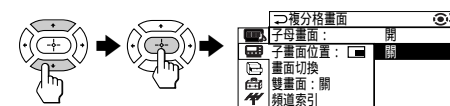

3 按壓 \uparrow 鍵或 \downarrow 鍵以選擇所要的項目 (例如“子母畫面”)，然後按壓 \rightarrow 鍵。



選擇	以
“子母畫面”	顯示主螢幕中的子畫面螢幕。 按壓 \uparrow 鍵或 \downarrow 鍵以選擇“開”，然後按壓 \rightarrow 鍵。 要取消時，按壓 PIP (子母畫面) 鍵或選擇“關”，然後按壓 \rightarrow 鍵。
“子畫面位置”	改變子畫面螢幕的位置。 按壓 \uparrow 鍵或 \downarrow 鍵以選擇所要的位置，然後按壓 \rightarrow 鍵。 
“畫面切換”	切換主螢幕和子畫面螢幕或雙畫面的右螢幕和左螢幕。
“雙畫面”	顯示主螢幕旁邊的不同頻道號碼或影音輸入。 按壓 \uparrow 鍵或 \downarrow 鍵以選擇“開”，然後按壓 \rightarrow 鍵。 要取消時，按壓 TWIN (雙畫面) 鍵或選擇“關”，然後按壓 \rightarrow 鍵。
“頻道索引”	收看小螢幕上的多個頻道號碼。 要取消時，按壓 CH INDEX (頻道索引) 鍵。

要回到普通螢幕顯示時

按壓 MENU (目錄) 鍵。

提示

- 有關選單系統和如何使用選單的詳細情況，請參閱第 26 頁的介紹選單系統。

改變“功能選擇”設定

當接收到 16 : 9 寬螢幕模式的圖像信號時，“功能選擇”選單可讓您改變螢幕圖像的尺寸。此外，這項功能也可讓您調整圖像設定以適於觀看電視遊戲節目和節省電能。

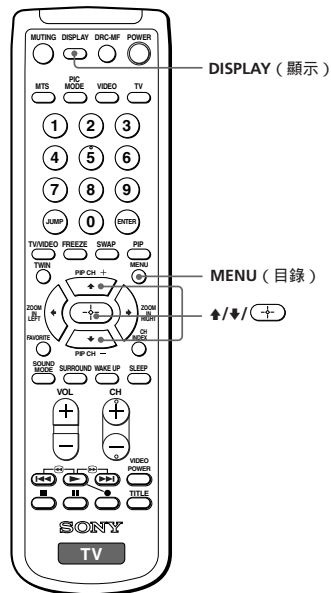

1 按壓 MENU (目錄) 鍵。

2 按壓 ↑ 鍵或 ↓ 鍵以選擇“功能選擇”符號 (⏏)，然後按壓 (+) 鍵。

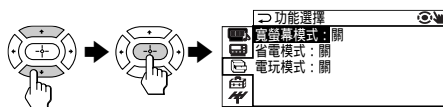

3 按壓 ↑ 鍵或 ↓ 鍵以選擇所要的項目 (例如，“寬螢幕模式”)，然後按壓 (+) 鍵。

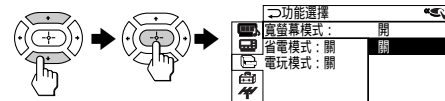

選擇 以

“寬螢幕模式” 改變 16 : 9 寬螢幕模式信號的圖像尺寸。

按壓 ↑ 鍵或 ↓ 鍵以選擇“開”，然後按壓 (+) 鍵。

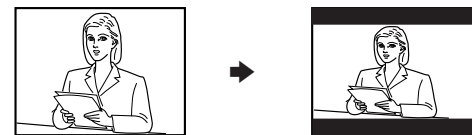

要回到普通圖像尺寸時，請選擇“關”，然後按壓 (+) 鍵。

“省電模式”

節省電能。

按壓 ↑ 鍵或 ↓ 鍵以選擇“開”，然後按壓 (+) 鍵。
要取消時，請選擇“關”，然後按壓 (+) 鍵。

“電玩模式”

調整圖像設定以適於觀看電視遊戲節目。

按壓 ↑ 鍵或 ↓ 鍵以選擇“開”，然後按壓 (+) 鍵。
要取消時，請選擇“關”，然後按壓 (+) 鍵。

注

- 當您打開“省電模式”時，圖像可能變得稍為暗淡。
- 您只可通過電視機側面或背后的 VIDEO IN 1、2 或 3、VIDEO 4 INPUT、S VIDEO 或 COMPONENT VIDEO (DVD) IN 插口所接收的信號使用“寬螢幕模式”和“電玩模式”。
- 當您打開電視機或按壓遙控器上的 DISPLAY (顯示) 鍵時，若“省電模式”被打開，省電模式符號 (⏏) 將被顯示在螢幕上的右下角 (請參閱第 10 和 11 頁)。

要回到普通螢幕顯示時

按壓 MENU (目錄) 鍵。

提示

- 有關選單系統和如何使用選單的詳細情況，請參閱第 26 頁的介紹選單系統。

改變“系統設定”內容

“系統設定”選單可使您：
自動改變選單語言，鎖定頻道號碼，調整螢幕位置，輸入喜愛頻道，以及更換彩色系統。

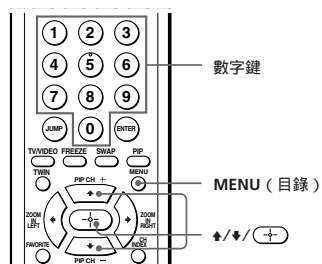

1 按壓 MENU (目錄) 鍵。

2 按壓 ↕ 鍵或 ↔ 鍵以選擇“系統設定”符號 ()，然後按壓 ⊕ 鍵。

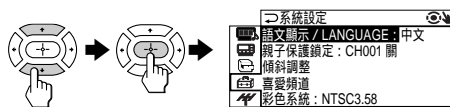

3 按壓 ↕ 鍵或 ↔ 鍵以選擇所要的項目 (例如，“親子保護鎖定”)，然後按壓 ⊕ 鍵。

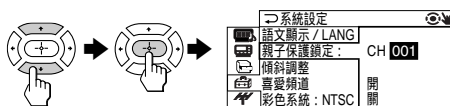

選擇	以
“語文顯示/LANGUAGE”	更換選單語言 (請參閱第 12 頁)。
“親子保護鎖定”	鎖定頻道號碼 (請參閱第 37 頁)。
“傾斜調整”	調整電視螢幕上傾斜的圖像。 按壓 ↕ 鍵或 ↔ 鍵順時針方向調整螢幕位置，然後按壓 ⊕ 鍵。 按壓 ↕ 鍵或 ↔ 鍵逆時針方向調整螢幕位置，然後按壓 ⊕ 鍵。
	傾斜調整
“喜愛頻道”	選擇您的喜愛頻道 (請參閱第 16 和 38 頁)。
“彩色系統”	更換彩色系統 (僅於影音模式)。 按壓 ↕ 鍵或 ↔ 鍵以選擇適當的彩色系統，然後按壓 ⊕ 鍵。 通常將此設定為“自動切換”。

要回到普通螢幕顯示時

按壓 MENU (目錄) 鍵。

鎖定頻道號碼 (“親子保護鎖定”)

1 選擇“親子保護鎖定”之後，按壓 ↕ 鍵或 ↔ 鍵或按壓數字鍵，【或 CH +/- (頻道) 鍵】以選擇所要的頻道號碼 (例如，頻道號碼 006)，然後按壓 ⊕ 鍵。

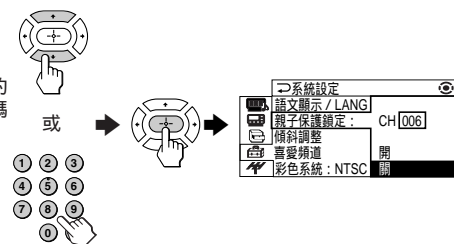

2 按壓 ↕ 鍵或 ↔ 鍵以選擇“開”，然後按壓 ⊕ 鍵。要取消時，選擇“關”。

當選擇“開”時，親子保護鎖定符號 () 即顯示在螢幕上。

若選擇了一個鎖定的頻道號碼，則親子保護鎖定符號即顯示在螢幕上。

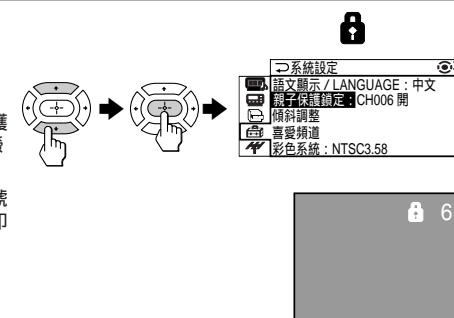

3 重復第 1 和第 2 步驟以鎖定其它頻道號碼。

要回到普通螢幕顯示時

按壓 MENU (目錄) 鍵。

注

- 若您自動預設鎖定的頻道號碼，則此頻道號碼將自動解鎖 (請參閱第 39 頁)。

改變 [Sat +] 內容 (續)

輸入喜愛頻道

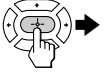
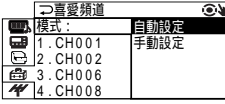
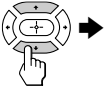
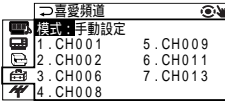
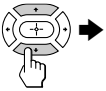
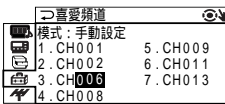
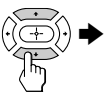
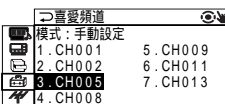
- 選擇“喜愛頻道”之後，確認“模式”已被選定，然後按壓 **+** 鍵。

- 按壓 **▲** 鍵或 **▼** 鍵以選擇“手動設定”，然後按壓 **+** 鍵。

- 按壓 **▲** 鍵或 **▼** 鍵以選擇您要輸入的喜愛頻道，然後按壓 **+** 鍵。

- 按壓 **▲** 鍵或 **▼** 鍵以改變頻道號碼，然後按壓 **+** 鍵。

- 重復第 3 和第 4 步驟以設定其它喜愛頻道。

要回到普通螢幕顯示時

按壓 MENU (目錄) 鍵。

注

- 若您在上述步驟 4 中按壓 CH +/- (頻道) 鍵或數字鍵，則電視將即刻顯示此頻道號碼。





提示

- 若要觀看所輸入的喜愛頻道，請參閱第 16 頁的收看您的喜愛頻道。

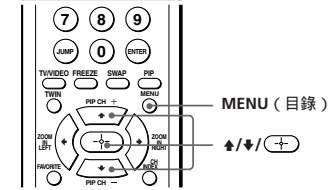
改變“頻道預設”設定

“頻道預設”選單可讓您調整電視機的設定，以接收有線電視、VHF 及 UHF 廣播。另外，您也可手動預設頻道來接收自動預設所不能接收到的信號微弱的頻道。

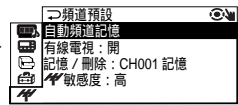

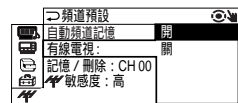
- 按壓 MENU (目錄) 鍵。

- 按壓 **▲** 鍵或 **▼** 鍵以選擇“頻道預設”符號 (📺)，然後按壓 **+** 鍵。

- 按壓 **▲** 鍵或 **▼** 鍵以選擇所要的項目 (例如，“有線電視”)，然後按壓 **+** 鍵。



選擇	以
“自動頻道記憶”	自動預設頻道。 若您自動預設任何一個鎖定頻道號碼，此頻道號碼將自動解鎖 (請參閱第 37 頁)。
“有線電視”	接收有線電視節目。 按壓 ▲ 鍵或 ▼ 鍵以選擇“開”，然後按壓 + 鍵。 若沒有有線電視，您將接收 VHF/UHF 廣播頻道。 若只想接收 VHF/UHF 廣播頻道，選擇“關”，然後按壓 + 鍵。
“記憶 / 刪除”	手動預設頻道 (參閱第 40 頁)。
“📺 敏感度”	調整電視接收敏感度。

要回到普通螢幕顯示時

按壓 MENU (目錄) 鍵。

提示

- 有關選單系統和如何使用選單的詳細情況，請參閱第 26 頁的介紹選單系統。

續

附加信息

自動檢測判斷功能

您的電視機設有自動檢測判斷功能。若您的電視機發生故障，STANDBY 指示燈會發出紅色亮光。STANDBY 指示燈所發出的亮光次數將表明可能存在的原因。

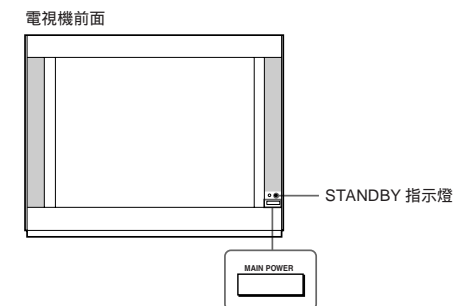

- 1 檢查 STANDBY 指示燈所發出的紅色亮光是否相隔三秒。
- 2 計算 STANDBY 指示燈的亮光次數。
- 3 按壓 MAIN POWER 鍵以關閉您的電視機。
- 4 通知您鄰近的 Sony 經銷商有關於 ⏻ 指示燈所發出的亮光次數。確定您將電視機背後所注明的機型和機身號記錄下來。

改變“頻道預設”設定 (續)

手動預設頻道

1 要記憶或刪除某一個頻道號碼時，您可手動預設頻道。

- (1) 按壓 \blacktriangle 鍵或 \blacktriangledown 鍵以選擇“記憶/刪除”，然後按壓 CH 鍵。



- (2) 按壓 \blacktriangle 鍵或 \blacktriangledown 鍵直到您要記憶或刪除的頻道號碼 (例如，頻道號碼 111) 出現在選單上，然後按壓 CH 鍵。

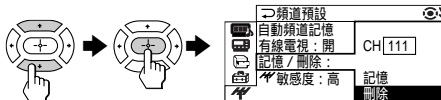

- (3) 按壓 \blacktriangle 鍵或 \blacktriangledown 鍵以選擇“記憶”或“刪除”，然後按壓 CH 鍵。

提示

- 您也可用 CH +/- (頻道) 鍵或數字鍵選擇頻道號碼。

2 若電視信號太強而且圖像失真，則您可調整電視接收敏感度。

- (1) 按壓 \blacktriangle 鍵或 \blacktriangledown 鍵以選擇“ ⚡ 敏感度”，然後按壓 CH 鍵。



- (2) 按壓 \blacktriangle 鍵或 \blacktriangledown 鍵以選擇“低”，然後按壓 CH 鍵。

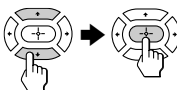

要回到普通螢幕顯示時

按壓 MENU (目錄) 鍵。





注

- 每個頻道號碼都記憶入電視接收敏感度 (“ ⚡ 敏感度”) 設定。
- 若您自動預設鎖定的頻道號碼，則該頻道號碼將自動解鎖 (請參閱第 37 頁)。

故障檢修

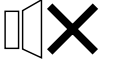
若您觀看電視時遇見任何問題，您可參考下列故障檢修指南。若問題仍然存在，請聯絡 Sony 經銷商。

癥狀	可能因素	解決方法	頁面
 圖像有雪花狀斑點	<ul style="list-style-type: none"> • 連接已鬆脫或電纜已損壞。 • 頻道預設不適當或不完整。 • 天線類型不合適。 	<ul style="list-style-type: none"> • 檢查天線電纜以及電視機、錄影機和牆上的天線連接是否正確。 • 再次預設頻道。 • 檢查天線類型 (VHF/UHF)。請尋求 Sony 經銷商的協助。 	4 40 -
 有噪聲 或 “無信號”顯示於螢幕上，而畫面轉為暗淡。	<ul style="list-style-type: none"> • 天線定位方向不正確。 • 傳送信號微弱。 	<ul style="list-style-type: none"> • 調整天線方向。請尋求 Sony 經銷商的協助。 • 嘗試使用信號增強器。 	- -
 圖像失真	<ul style="list-style-type: none"> • 廣播信號太強。 	<ul style="list-style-type: none"> • 顯示“頻道預設”選單，然後選擇“ 敏感度：低”。 • 切斷信號增強器的電源或拔掉插頭以終其操作。 	40 -
 有噪聲			
 圖像良好	<ul style="list-style-type: none"> • 數位聲音信號不正確。 	<ul style="list-style-type: none"> • 將“影音選擇”選單中的“數位音訊輸入”設定為“關”。同時也連接電視機上的 COMPONENT VIDEO (DVD) IN 的 L (左) 和 R (右) 插口以接收模擬聲音信號。 	7, 31
 有噪聲			
 沒有圖像	<ul style="list-style-type: none"> • 電源線、天線或錄影機沒有被連接。 • 電視機電源沒有被接通。 	<ul style="list-style-type: none"> • 檢查電源線、天線以及與錄影機的連接是否正確。 • 按壓 POWER (電源) 鍵。 • 按壓電視機上的 MAIN POWER 鍵以切斷電視機電源，五秒左右後再次接通電源。 	4 10 11
 沒有聲音			

癥狀	可能因素	解決方法	頁面
 圖像良好	<ul style="list-style-type: none"> • 音量水平過低。 • 聲音被消除。 • 數位聲音信號不正確。 	<ul style="list-style-type: none"> • 按壓 VOL + (音量) 鍵或 VOLUME + 鍵以提高音量水平。 • 按壓 MUTING (靜音) 鍵取消消音。 • 將“影音選擇”選單中的“數位音訊輸入”設定為“關”。同時也連接電視機上的 COMPONENT VIDEO (DVD) IN 的 L (左) 和 R (右) 插口以接收模擬聲音信號。 	11 11 7, 31
 沒有聲音	<ul style="list-style-type: none"> • “影音選擇”選單中的“數位音訊輸入”設定不正確。 	<ul style="list-style-type: none"> • 當連接電視機上的 COMPONENT VIDEO (DVD) IN 插口時，若要通過 COMPONENT VIDEO (DVD) IN 的 DIGITAL IN 插口接收數位聲音信號，請將“數位音訊輸入”設定為“開”。相反的，若通過 COMPONENT VIDEO (DVD) IN 的 L (左) 和 R (右) 插口接收模擬聲音信號，請將“數位音訊輸入”設定為“關”。 	31
 圖像有點線或條紋	<ul style="list-style-type: none"> • 受周圍環境 (如汽車、霓虹燈、吹風機、發電機等) 影響。 	<ul style="list-style-type: none"> • 不要在電視機旁使用吹風機或其它電器。 • 調整天線方向以減低干擾。請尋求 Sony 經銷商的協助。 	- -
 圖像出現雙重影像或疊像	<ul style="list-style-type: none"> • 廣播信號受周圍高山或大廈干擾。 • 天線定位方向不正確。 • 信號增強器的使用不適當。 	<ul style="list-style-type: none"> • 使用高定向天線。 • 調整天線方向。請尋求 Sony 經銷商的協助。 • 切斷信號增強器的電源或拔掉插頭以終其操作。 	— — —
 圖像無彩色	<ul style="list-style-type: none"> • 彩色水平設定過低。 • 彩色系統設定不正確。 • 天線定位方向不正確。 	<ul style="list-style-type: none"> • 顯示“影音選擇”選單，並選擇“畫質模式”中的“調整”，然後調整“彩色”濃度。 • 顯示“系統設定”選單，並檢查“彩色系統”設定 (通常將此設定為“自動切換”) (僅於影音模式)。 • 調整天線方向。請尋求 Sony 經銷商的協助。 	30 36 -
 圖像有不正常的彩色斑點	<ul style="list-style-type: none"> • 受外部揚聲器或其它電器電磁性的影響，或受地球磁場方向的影響。 	<ul style="list-style-type: none"> • 將電視機放置在遠離外部揚聲器或其它電器的地方。請別移動已被接通電源的電視機。按壓電視機上的 MAIN POWER 鍵以切斷電視機電源。約 15 分鐘後再接通電視機電源。 	-

續

故障檢修 (續)

癥狀	可能因素	解決方法	頁面
電視機無法接收立體聲廣播信號。	• 立體聲接收設定不適當。	• 按壓 MTS (音聲多重) 鍵直到 “立體聲” 顯示在螢幕上。	23
立體聲廣播聲音開關失常或聲音失真。	• 連接已鬆動或電纜已損壞。	• 檢查天線電纜以及電視機、錄影機和牆上的天線連接是否正確。	4
或	• 天線定位方向不正確。	• 調整天線方向。請尋求 Sony 經銷商的協助。	-
聲音頻繁地轉換於單聲道和立體聲之間。	• 廣播信號有傳送故障。	• 按壓 MTS (音聲多重) 鍵直到聲音正常為止。	23
圖像傾斜 	• 受外部揚聲器或其它電器電磁性的影響，或受地球磁場方向的影響。	• 將電視機放置在遠離外部揚聲器或其它電器的地方。 • 顯示 “系統設定” 選單並調整 “傾斜調整”，以使圖像位置調至最佳。	36
電視機上的 STANDBY 指示燈每隔三秒閃爍至少一次的紅色亮光。	• 您的電視機可能需要修理。	• 請尋求 Sony 經銷商的協助。	41
不能操作電視遊戲。	• 本電視機不能用於那些電子鎗或萊福鎗操縱的電視射擊遊戲的操作。詳細內容請參閱電視遊戲機軟件所附的說明書。	—	-
電視機外殼發出吱吱聲。	• 隨室內溫度的變化，電視機的外殼會膨脹或縮小而有時產生噪聲。這並不表示發生故障。	—	-
當您接通電視機電源時，聽到 “喇” 的聲音。	• 電視機自動消磁。這並不表示發生故障。	—	-
當您觸摸電視機外殼時，您將會感覺到靜電。	• 這種情況與您觸摸到金屬門柄或汽車門的靜電情況相似。這通常在空氣乾燥的時後發生，例如冬天。這並不表示發生故障。	—	-

控制鍵總概況

前面，頂部和側面控制板

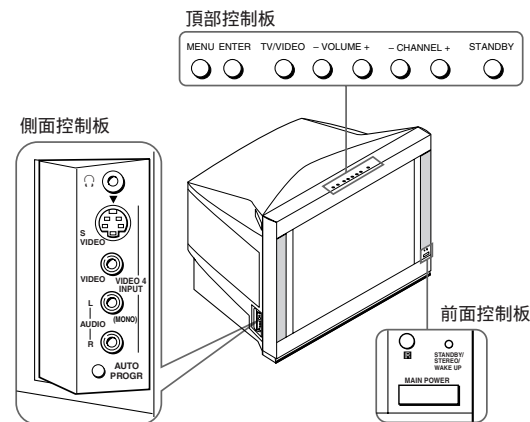

按鍵	功能	頁面
側面控制板		
	耳機插孔。	-
AUTO PROGR	自動預設頻道。	5
前面控制板		
MAIN POWER	接通或完全切斷電視機電源。	10
STANDBY	待機指示燈。	10
WAKE UP	開機定時指示燈。	13
STEREO	立體聲指示燈。	23
頂部控制板		
STANDBY	接通或暫時切斷電視機電源。	10
CHANNEL +/-	選擇頻道號碼。	10
VOLUME +/-	調整音量。	11
TV/VIDEO	選擇電視或影音輸入。	11
ENTER	確認被選項目。	28
MENU	顯示選單。	28

續

控制鍵總概況 (續)

遙控器

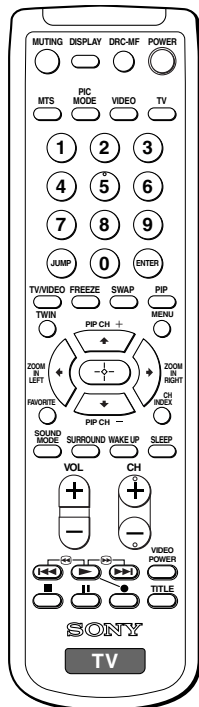

按鍵	功能	頁面
POWER (電源)	接通或暫時切斷電視機電源。	10
CH +/- (頻道)	選擇頻道號碼。	10
0 - 9	輸入號碼。	10
ENTER	確認所輸入的號碼。	10
DISPLAY (顯示)	顯示螢幕上的信息。	11
MUTING (靜音)	消除聲音。	11
TV (電視)	顯示電視節目。	11
VIDEO (影音)	選擇電視或影音輸入。	11
VOL +/- (音量)	調整音量。	11
JUMP	跳回到之前收看的頻道號碼。	11
定時器操作		
WAKE UP (開機定時)	設定電視自動打開。	13
SLEEP (睡眠定時)	設定電視自動關閉。	13
SOUND MODE (音效模式)	選擇音效模式。	14
PIC MODE (畫質模式)	選擇畫質模式。	14
DRC-MF	選擇 "DRC-MF" 模式。	15
喜愛頻道操作		
FAVORITE (喜愛頻道)	顯示喜愛頻道。	16
▲, ▼, ◀, ▶, (+)	選擇所要的喜愛頻道。	16
子母畫面和雙畫面操作		
PIP (子母畫面)	顯示子畫面的螢幕。	17
TWIN (雙畫面)	顯示雙畫面。	17
▶ (ZOOM IN RIGHT) (右螢幕放大)	調整雙畫面圖像的尺寸。	18
◀ (ZOOM IN LEFT) (左螢幕放大)		
▲ (PIP CH +) (子畫面頻道 +)	改變子畫面或雙畫面中的節目。	18
▼ (PIP CH -) (子畫面頻道 -)		
TV/VIDEO (電視 / 影音)	選擇子畫面或雙畫面中的影音輸入。	18
SWAP (畫面切換)	對換子畫面或雙畫面中的圖像。	18
FREEZE (畫面靜止)	靜止子畫面的圖像。	18

遙控器

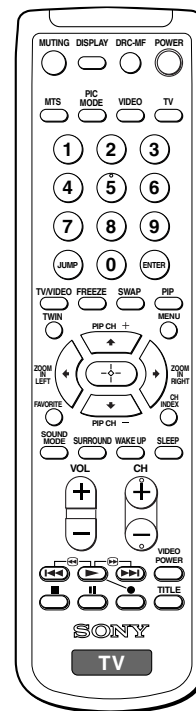

按鍵	功能	頁面
頻道搜索操作		
CH INDEX (頻道索引)	顯示全部預設的頻道號碼。	19
CH +/- (頻道)	觀看之後或之前的 12 個頻道號碼。	20
▲, ▼, ◀, ▶, (+)	選擇所要的頻道號碼。	20
SURROUND (環繞音效)	選擇環繞音效模式。	22
欣賞立體聲或雙語言節目		
MTS (音聲多重)	選擇立體聲或雙語言模式。	23
選購裝置操作		
VIDEO POWER (錄影機電源)	電源和設定遙控器。	24
0 - 9	設定遙控器。	24
TITLE (標題)	顯示標題選單。	25
▶	播放。	25
▶▶	快進、向前選擇。	25
◀◀	倒帶、向後選擇。	25
●	錄影。	25
■	停止。	25
	暫停。	25
選單操作		
MENU (目錄)	顯示選單。	28
▲, ▼, ◀, ▶, (+)	選擇、調整和確認被選項目。	28

SECTION 2 DISASSEMBLY

2-1. REAR COVER REMOVAL

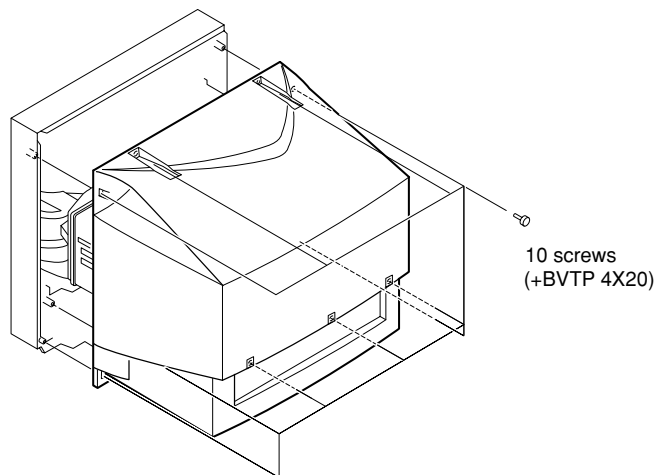

2-2. SPEAKER BOX REMOVAL

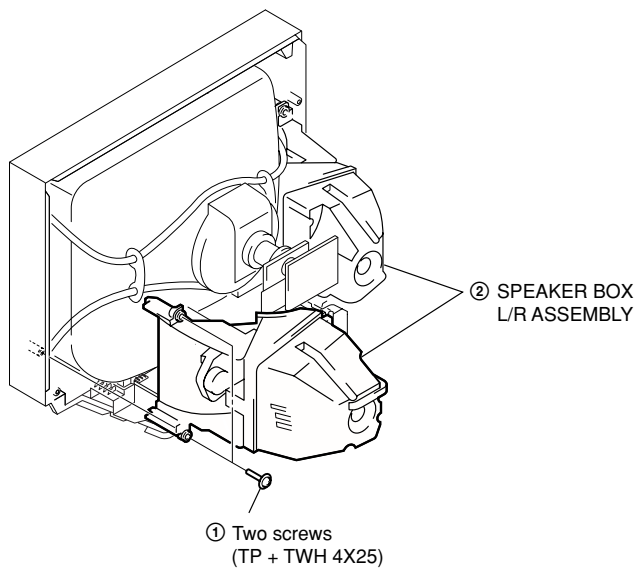

2-3. H2 BOARD REMOVAL

Caution: Please make sure that the red colour taped point is just placed with the purse lock when treating the leads to H2 board. If lead treatment is wrongly arranged, it will affect the door opening and closing malfunction.

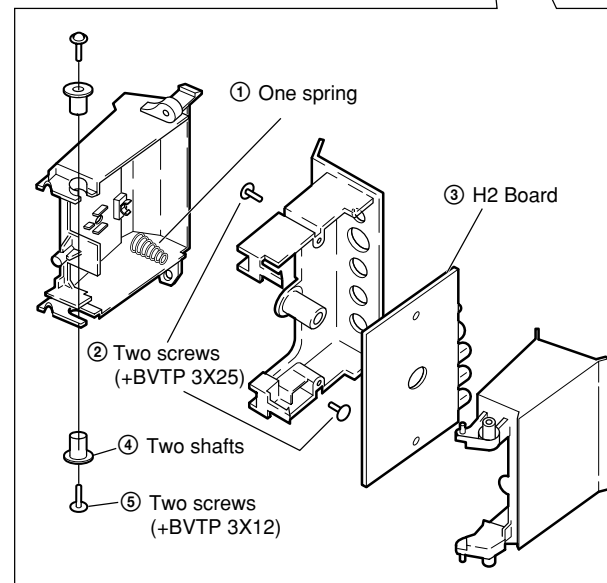
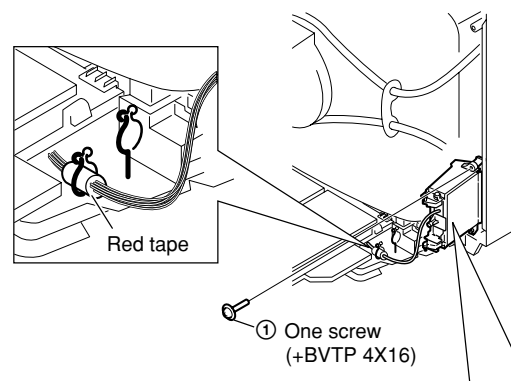

2-4. CHASSIS ASSY REMOVAL

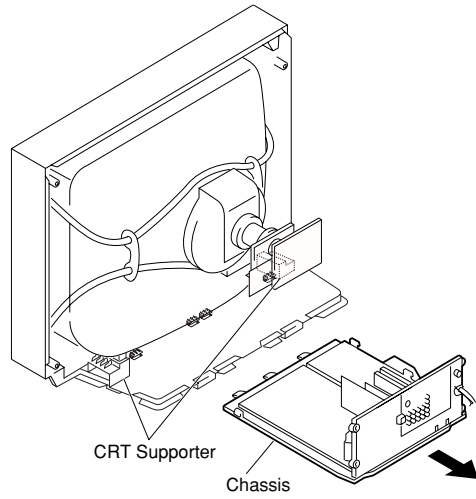

2-6. DH BOARD REMOVAL

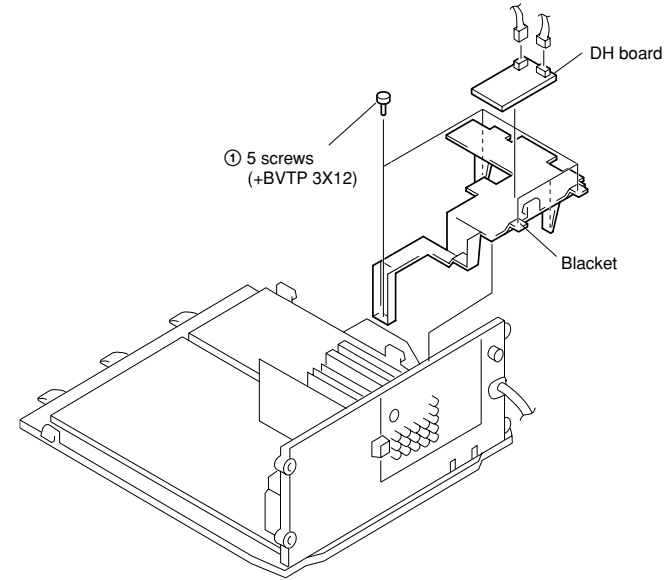

2-5. SERVICE POSITION

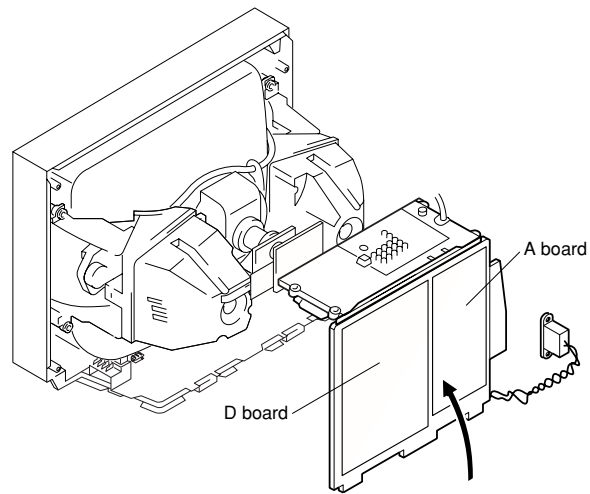

2-7. J BOARD REMOVAL

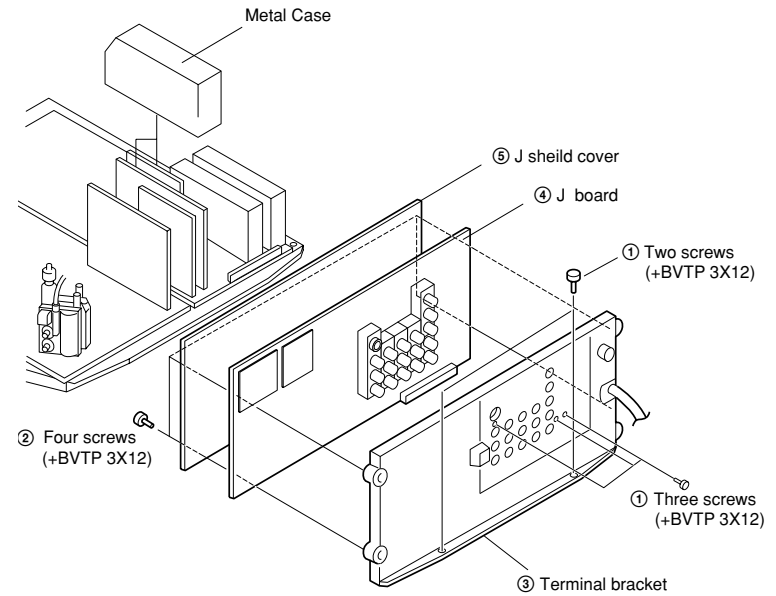

2-8. B3, D1 AND E BOARDS REMOVAL

NOTE : V Board is not used for this model.

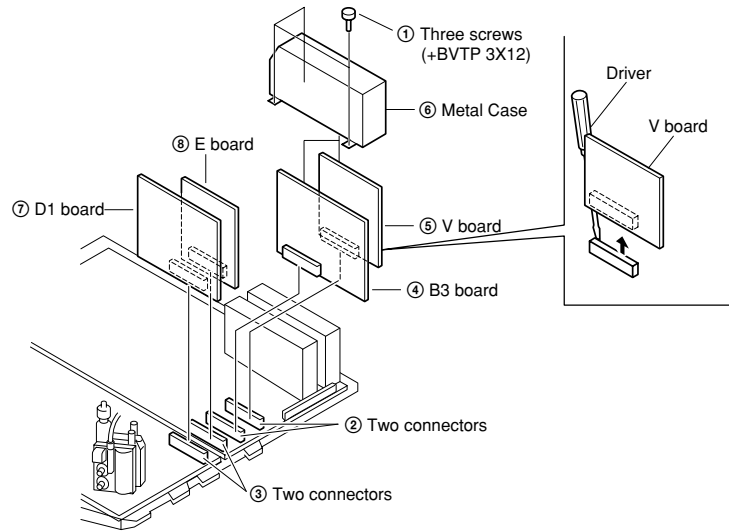

2-9. A AND D BOARDS REMOVAL

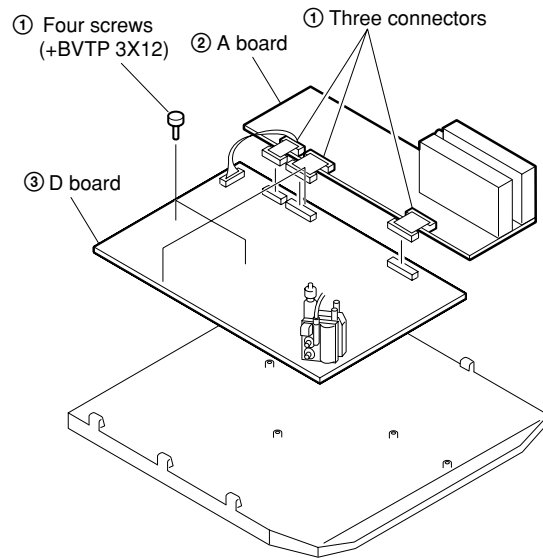

2-10. H1 BOARD REMOVAL

NOTE : Push the hook down using the tip of a screwdriver and at the same time pull the H1 bracket.

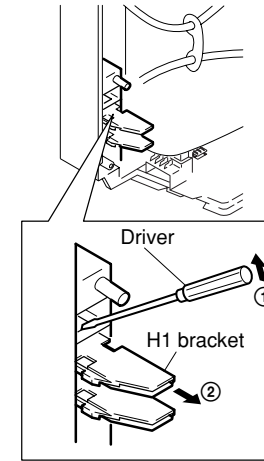

2-11. F2 BOARD REMOVAL

NOTE : To remove F2 board, firstly remove the H1 board. Then, push the hook down using the tip of a screwdriver and at the same time pull the F2 bracket.

Caution : When removing the F2 board, please turn off the main AC supply and disconnect the AC plug.

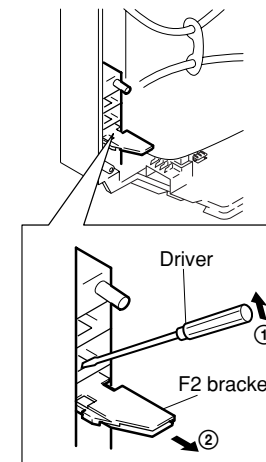

2-12. DEMAGNETIZATION COIL REMOVAL

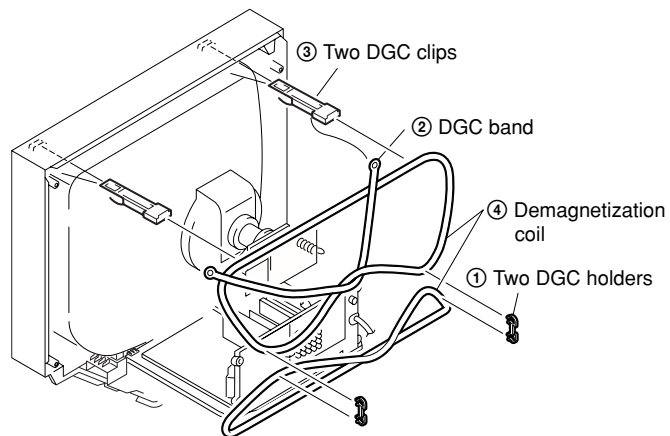

2-14. G2 LEAD REMOVAL

NOTE : Insert pin to both edge holes on socket and release the lock.

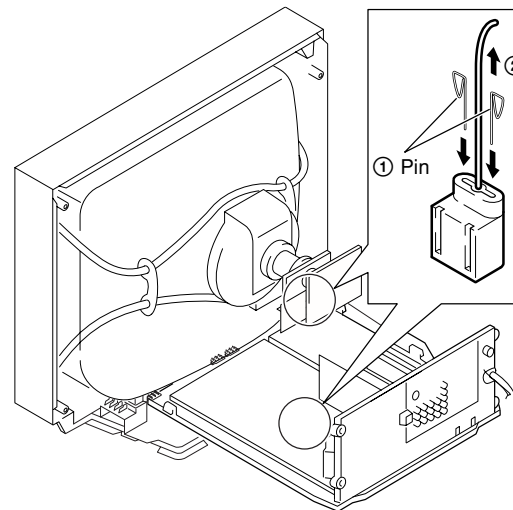

2-13. TOP SWITCH REMOVAL (H3 BOARD REMOVAL)

NOTE : To remove H3 board, the CRT has to be removed first.

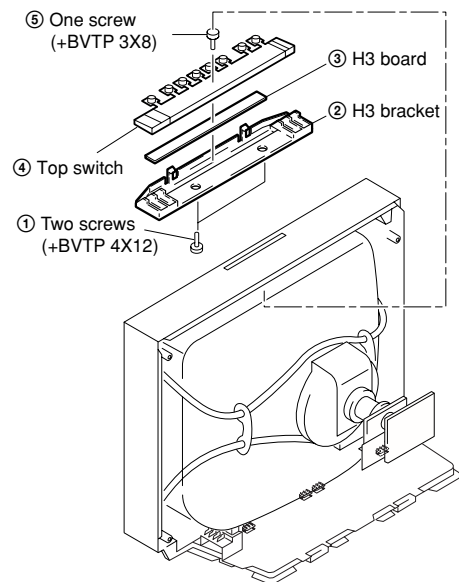

2-15. PICTURE TUBE REMOVAL

i) Prior to picture tube removal, please remove the front cover first.
 Caution : Aluminium frame is easily scratched if extra caution is not taken when handling it.

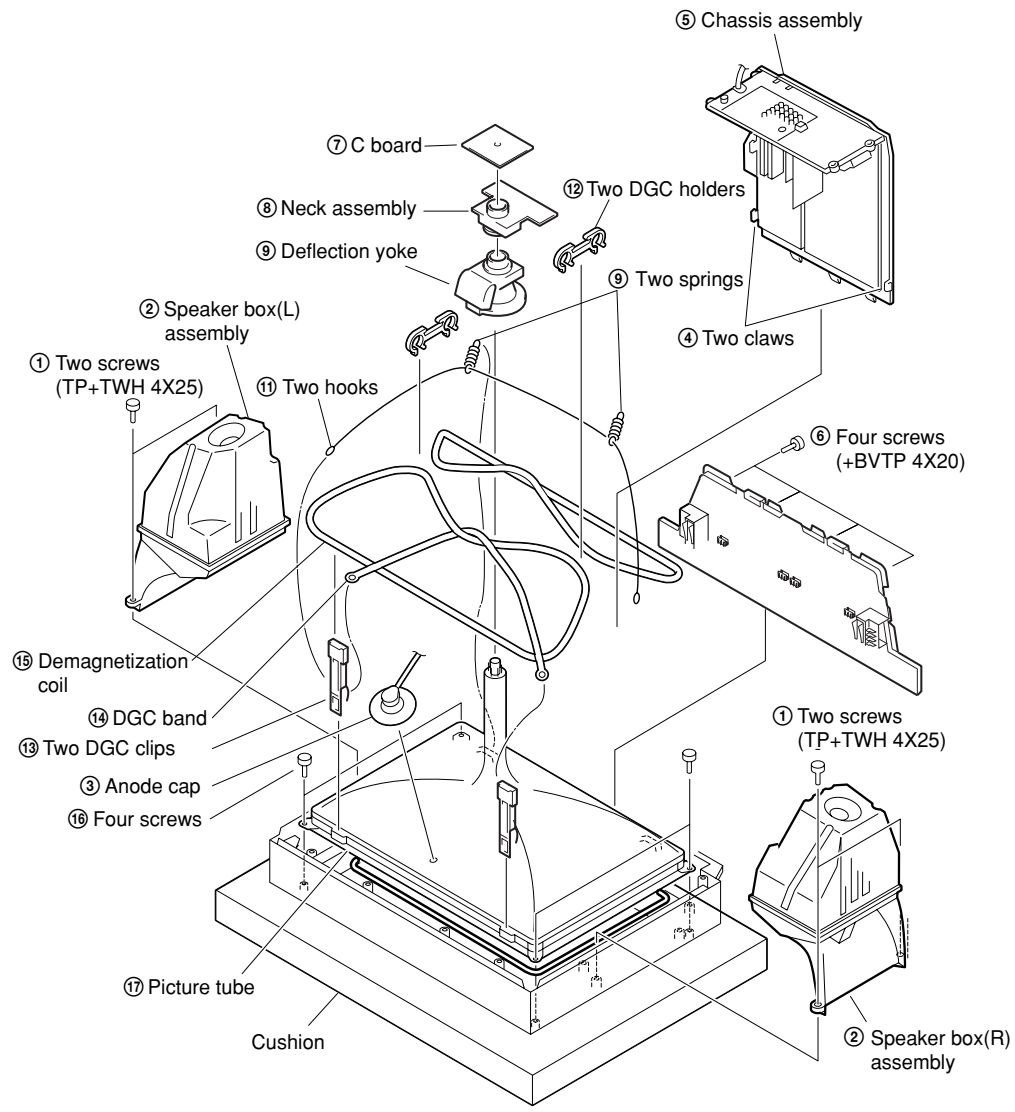

2-16. FRAME SUB-ASSY DISASSEMBLY

①

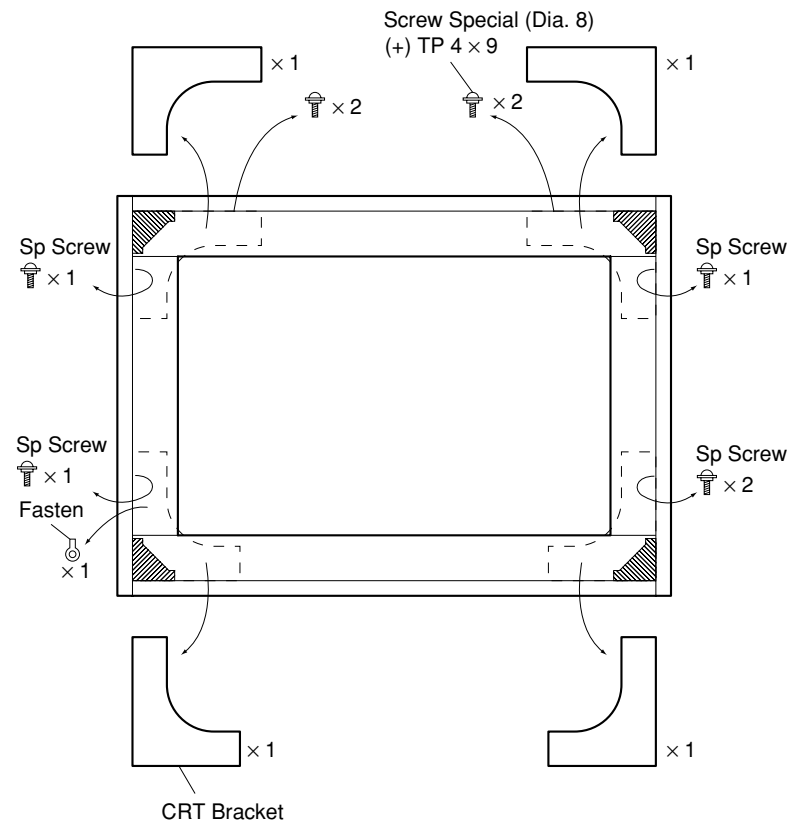

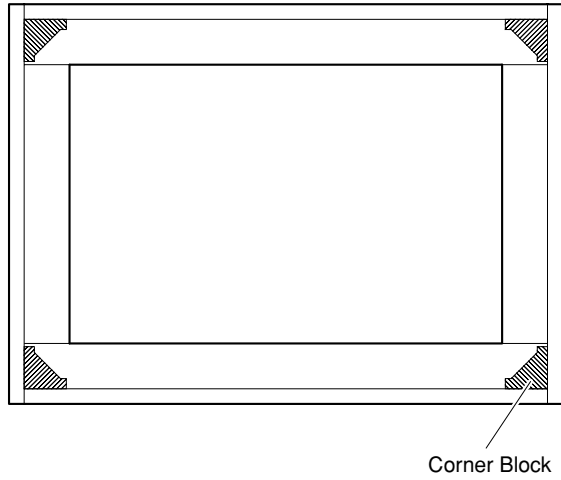

FRAME SUB ASSY, RIGHT REMOVAL

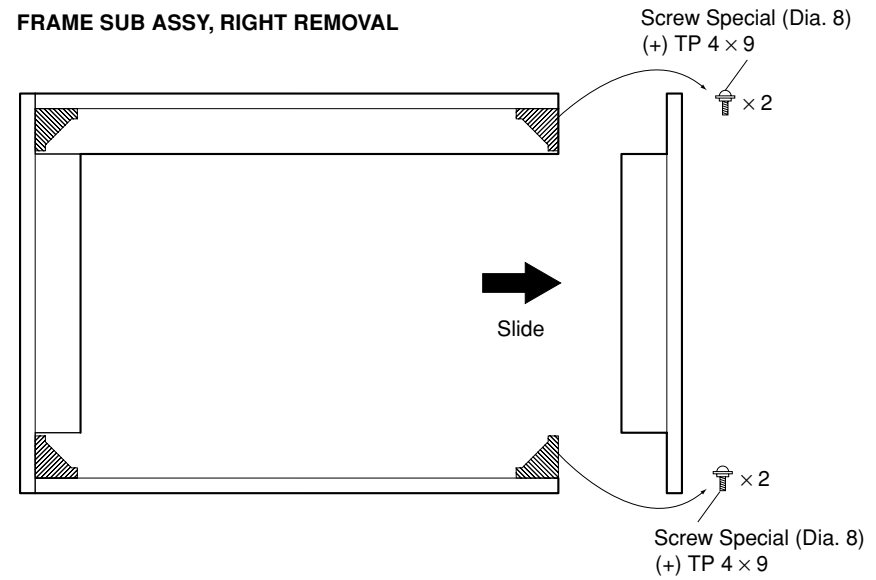

FRAME SUB ASSY, LEFT REMOVAL

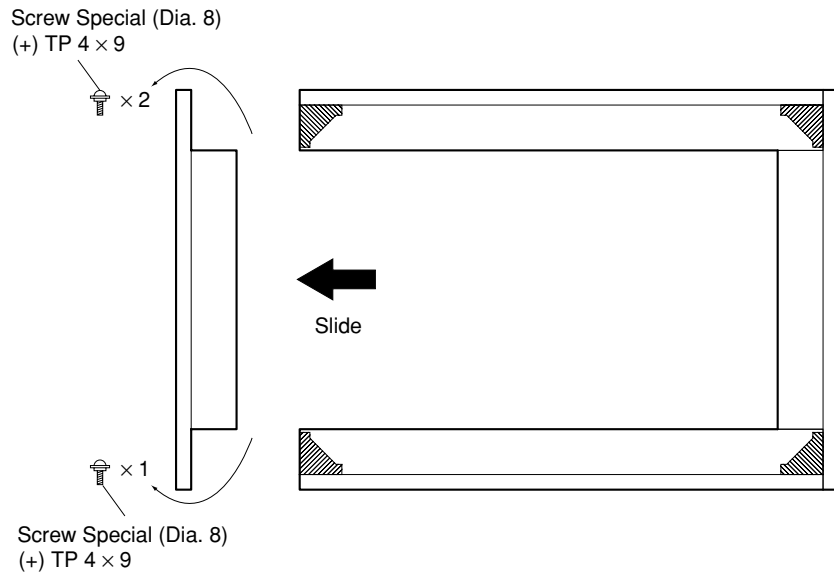

FRAME SUB ASSY, TOP REMOVAL

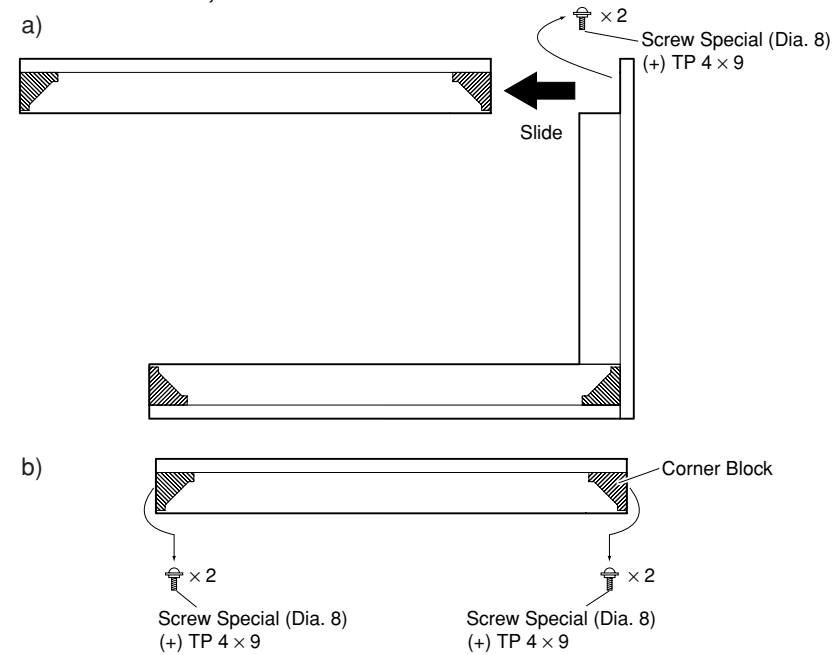

FRAME SUB ASSY, BOTTOM REMOVAL

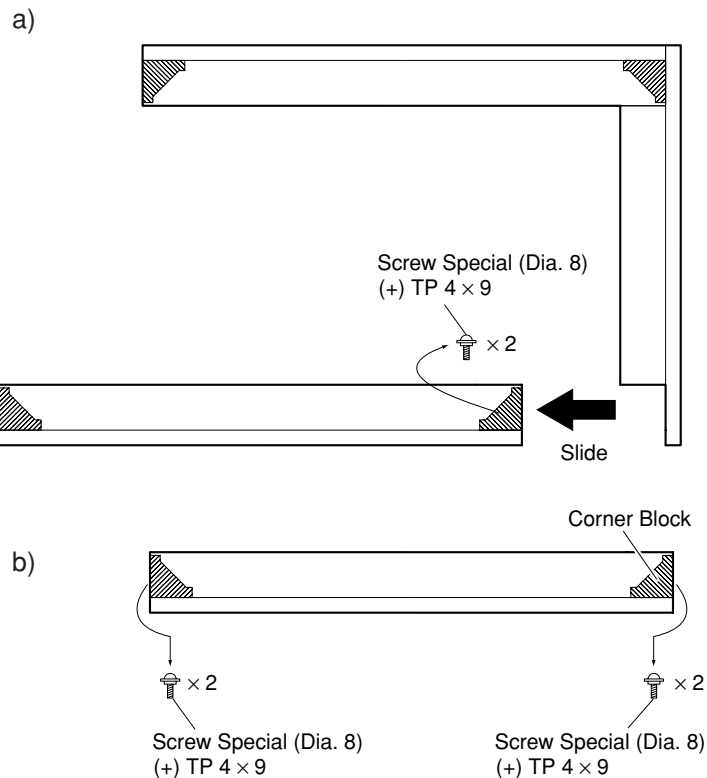

NOTE : When replacing the Frame Sub-Assy Top and Bottom, fix the original corner block to the new part.

•REMOVAL OF ANODE-CAP

NOTE : After removing the anode, short circuit the anode of the picture tube and the anode cap to the metal chassis, CRT shield or carbon paint on the CRT.

•REMOVING PROCEDURES

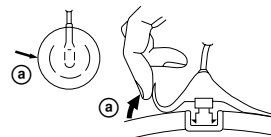

① Turn up one side of the rubber cap in the direction indicated by the arrow a).

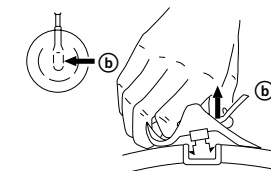

② Using a thumb pull up the rubber cap firmly in the direction indicated by the arrow b).

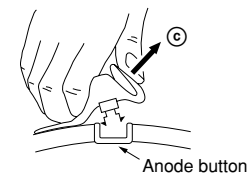

③ When one side of the rubber cap is separated from the anode button, the anode-cap can be removed by turning up the rubber cap and pulling it up in the direction of the arrow c).

• HOW TO HANDLE AN ANODE-CAP

- ① Do not damage the surface of anode-caps with sharp shaped objects.
- ② Do not press the rubber too hard so as not to damage the inside of anode-cap. A metal fitting called the shatter-hook terminal is built into the rubber.
- ③ Do not turn the foot of rubber over too hard. The shatter-hook terminal will stick out or damage the rubber.

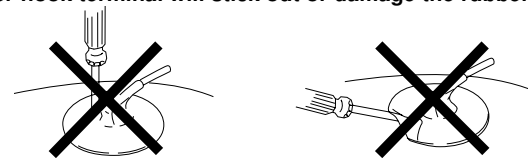

SECTION 3 SERVICE JIG

3-1. JIGS REQUIRED FOR SERVICING

REF NO.	DESCRIPTION	PART NO.	REMARK
J-1	TOOL (20P), SERVICE	3-702-763-01	For A to V board extension
J-2	TOOL (40P), SERVICE	3-702-764-01	For A to E board extension
J-3	TOOL (50P-A), SERVICE	3-702-765-01	For A to B3 board extension
J-4	TOOL (50P-J), SERVICE	3-702-766-01	For A to J board extension For D to D1 board extension

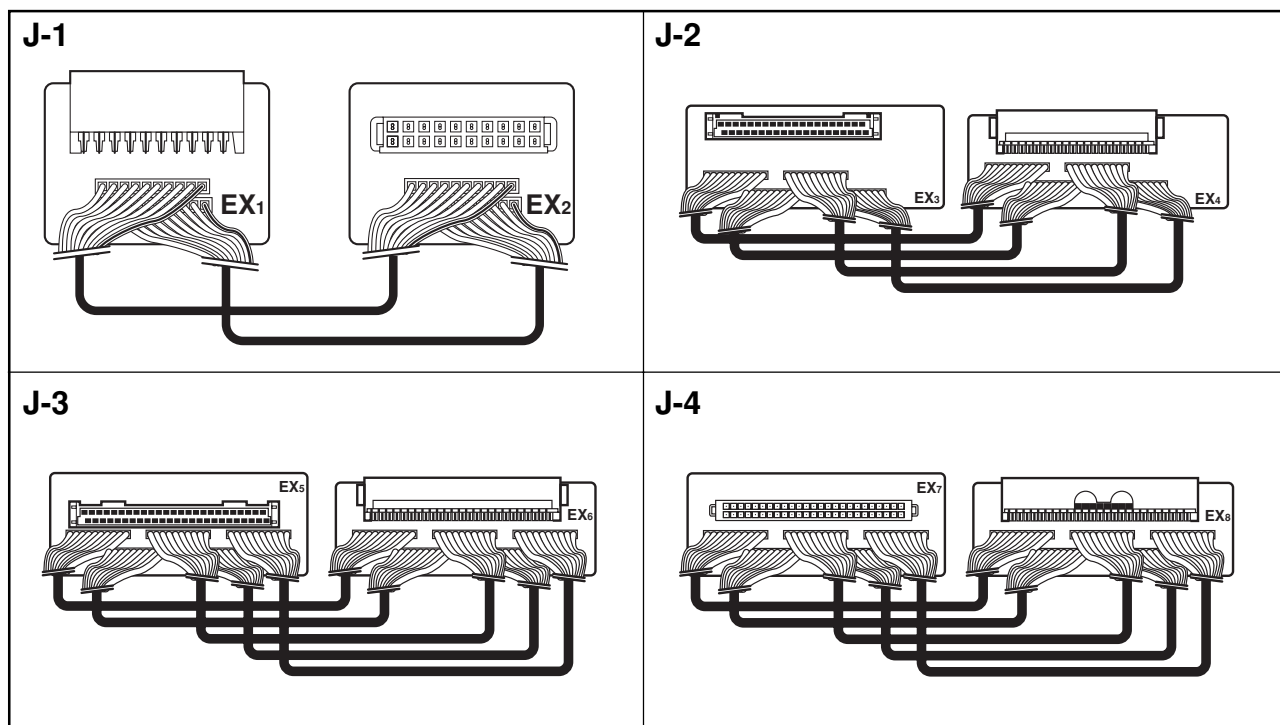

SECTION 4 CIRCUIT BOARDS LOCATION

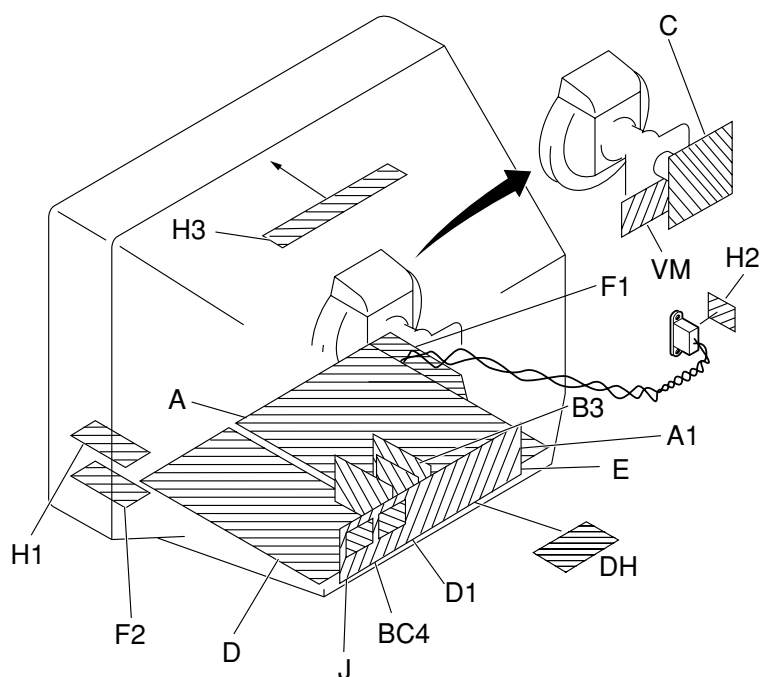

Note: SP Board is located at the Duct, speaker

SECTION 5 SET-UP ADJUSTMENTS

- The following adjustments should be made when a complete realignment is required or a new picture tube is installed.
- These adjustments should be performed with rated power supply voltage unless otherwise noted.

Controls and switches should be set as follows unless otherwise noted:

PICTURE control normal
BRIGHTNESS control normal

Perform the adjustments in the following order :

1. Beam Landing
2. Convergence
3. Focus
4. White Balance

Note : Test Equipment Required.

1. Color-bar/Pattern Generator
2. Degausser
3. Oscilloscope

Preparation :

- In order to reduce the influence of geomagnetism on the set's picture tube, face it east or west.
- Switch on the set's power and degauss with the degausser.

5-1. BEAM LANDING

1. Input a white signal with the pattern generator.

Contrast	}	normal
Brightness		
2. Position neck assy as shown in Fig 5-1.
3. Set the pattern generator raster signal to a green raster.
4. Move the deflection yoke to the rear and adjust with the purity control so that the green is at the center and the blue and the red take up equally sized areas on each side.
(See Figures 5-1 through 5-3.)
5. Move the deflection yoke forward and adjust so that the entire screen is green. (See Figure 5-2.)
6. Switch the raster signal to blue, then to green and verify the condition.
7. When the position of the deflection yoke has been decided, fasten the deflection yoke with the screws and DY spacers.
8. If the beam does not land correctly in all the corners, use a magnet to adjust it.
(See Figure 5-4.)

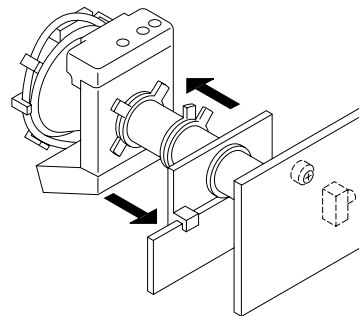

Fig. 5-2

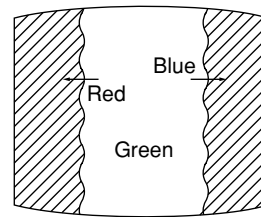

Fig. 5-3

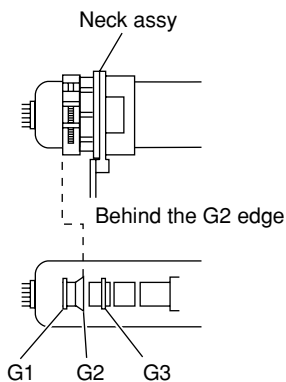

Fig. 5-1

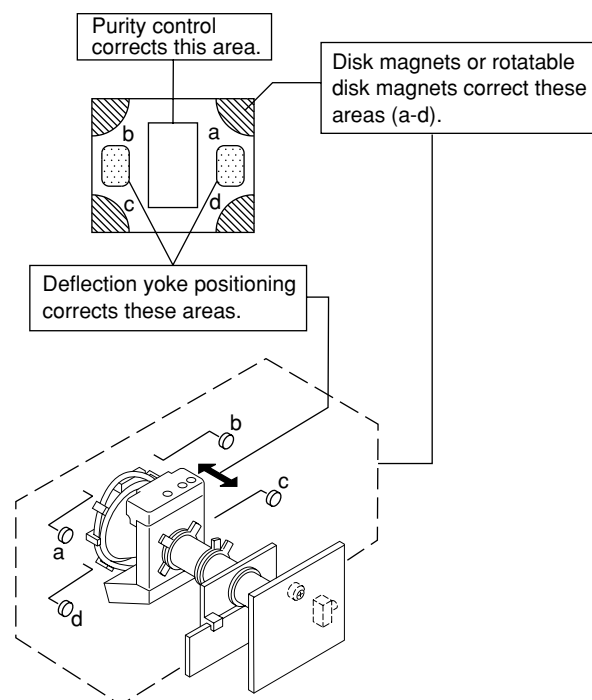

Fig. 5-4

5-2. CONVERGENCE ADJUSTMENT

Preparation :

- Before starting this adjustment, adjust the focus, horizontal size and vertical size.
- Set the Picture Mode to "STANDARD".
- Cross hatch / Dot pattern.

(1) Horizontal and Vertical Static Convergence

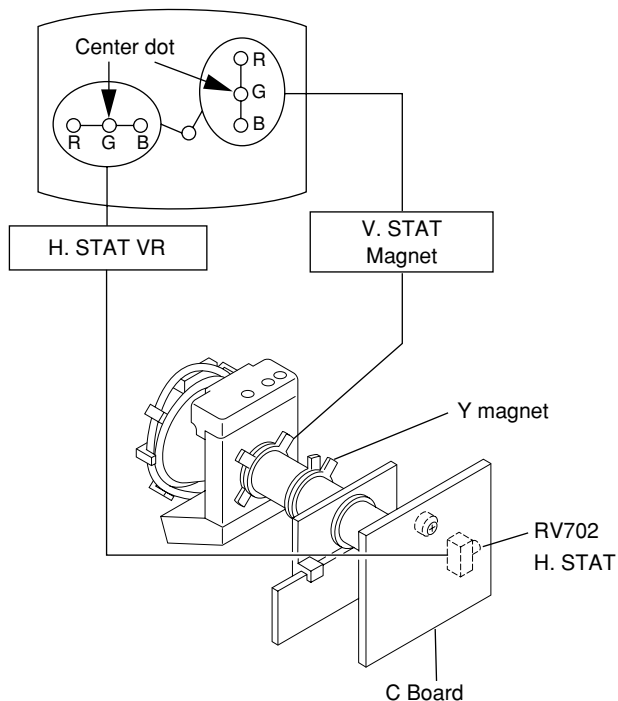

1. (Moving horizontally), adjust the H.STAT control so that the red, green and blue dots are on top of each other at the center of the screen.
2. (Moving vertically), adjust the V.STAT magnet so that the red, green and blue dots are on top of each other at the center of the screen.
3. Adjust Horizontal Trapezoid with "DAC 04 HTR" in Service Mode to make H-Trapezoid distortion best.
4. If the H.STAT variable resistor cannot bring the red, green and blue dots together at the center of the screen, adjust the horizontal convergence with the H.STAT variable resistor and the V.STAT magnet in the manner given below.
(In this case, the H.STAT variable resistor and the V.STAT magnet influence each other, so be sure to perform adjustments while tracking.)

① V. STAT

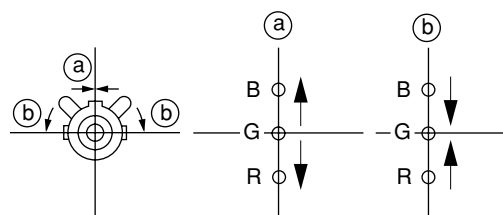

② H. STAT VR

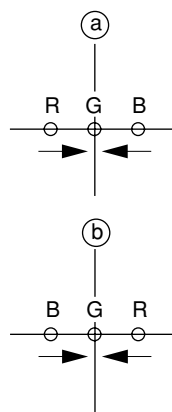

③

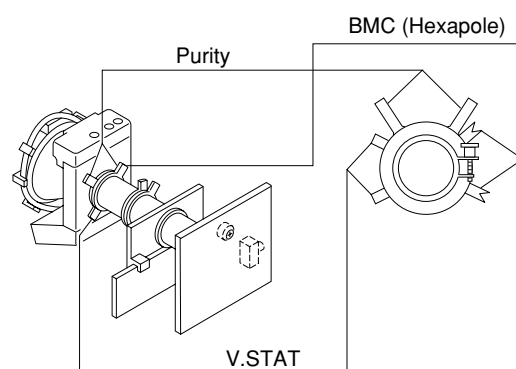
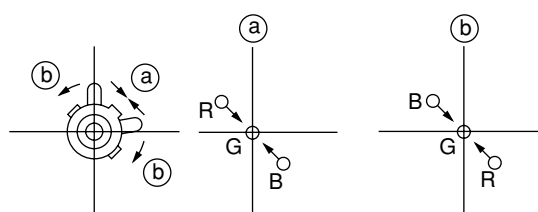

④ BMC (Hexapole) Magnet.

If the red, green and blue dots are not balanced or aligned, then use the BMC magnet to adjust in the manner described below.

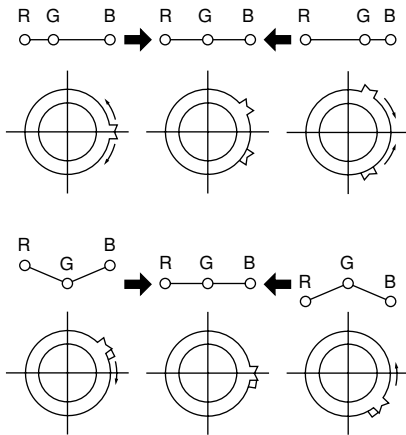

⑤ Y separation axis correction magnet adjustment.

1. Receive the cross-hatch signal and adjust [PICTURE] to [MIN] and [BRIGHTNESS] to [STANDARD] .
2. Adjust the Y separation axis correction magnet on the neck assembly so that the horizontal lines at the top and bottom of the screen are straight.

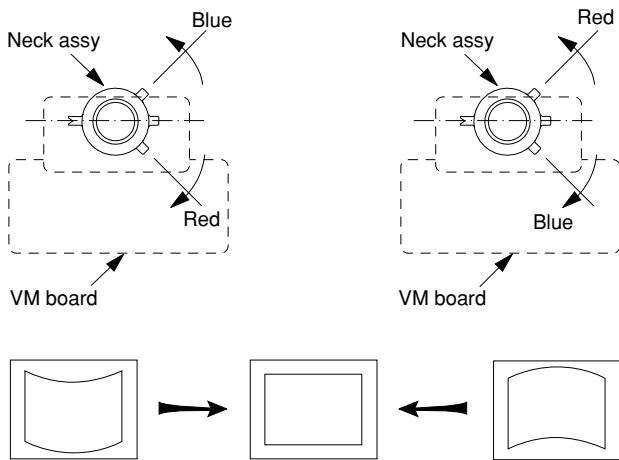

Note

1. The Red and Blue magnets should be equally far from the horizontal center line.
2. Do not separate the Red and Blue magnets too far. (Less than 8 mm)

(2) Dynamic Convergence Adjustment

Preparation:

- Before starting this adjustment, adjust the horizontal static convergence and the vertical static convergence
- Set the PICTURE and BRIGHTNESS to normal.

1. Adjust TLH. (TLH correction piece)

- ① Receive the dot/hatch pattern signal and adjust picture quality by the menu.
- ② Correct horizontal mis-convergence of red and blue of both sides on the X axis.

When red is outside insert BMC magnet to right side (TLH+) views from DY neck. And when blue is outside, insert it to left side (TLH-) and take both sides.

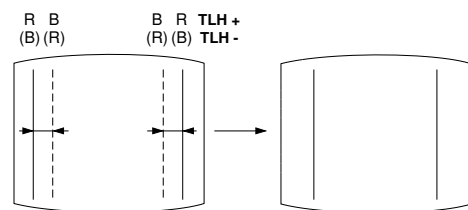

2. Adjust V-TILT-TLV.

Correct the vertical mis-convergence of red and blue of vertically sides on the Y axis.

3. Adjust YCH.

Adjust horizontal mis-convergence of red and blue of vertically sides on the Y axis. Mentioned above steps 2 to 4 are adjusting respectively perform minuteness tracking.

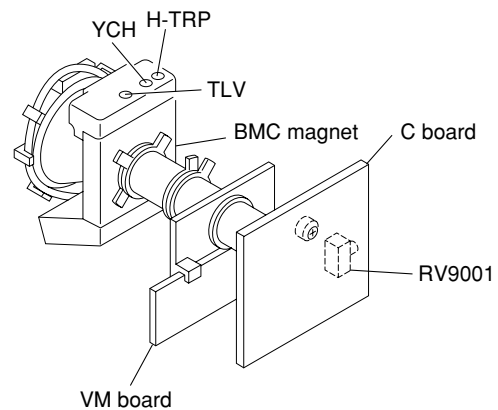

(3) Screen-corner Convergence

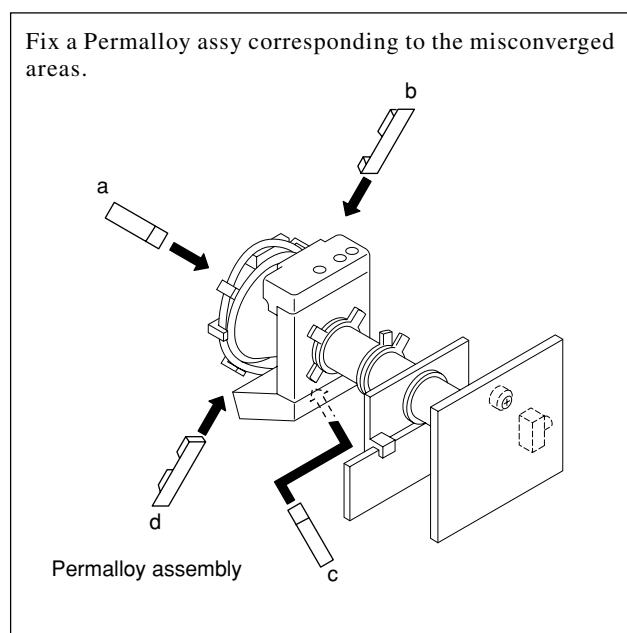
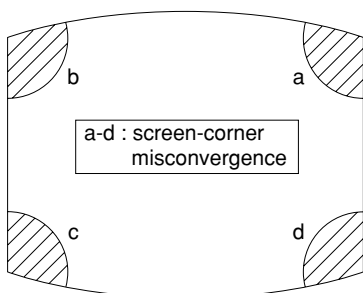

5-3. FOCUS ADJUSTMENT

Note

Focus adjustment should be completed before W/B adjustment.

- (1) Receive digital monoscope pattern.
- (2) Set "A/V CONTROL" to "STANDARD".
- (3) Adjust FOCUS VR so that the center of the screen becomes justfocus.
- (4) Change the receiving signal to white pattern and blue back.
- (5) Confirm MAGENTA RING should not be over the limit sample. In case MAGENTA RING is over the limit sample, adjust FOCUS VR to take tracking of MAGENTA RING and FOCUS.

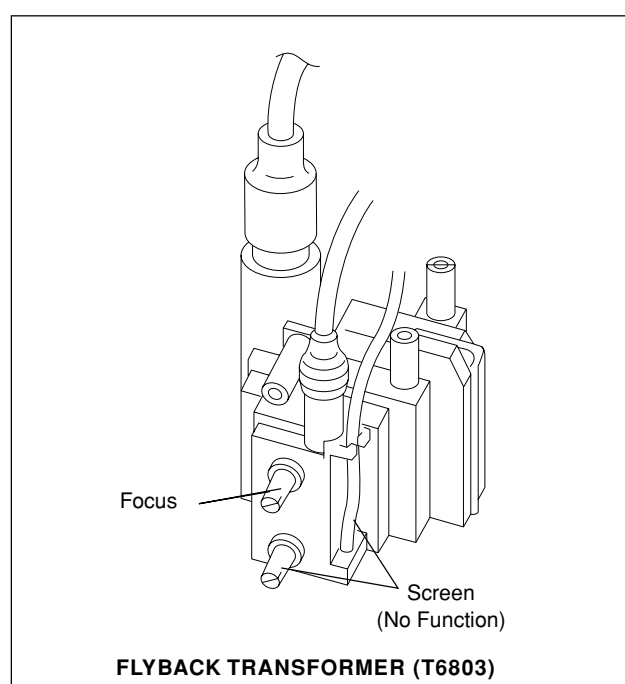

5-4. NECK ASSY TWIST ADJUSTMENT

- (1) Receive dot/hatch pattern.
- (2) Turn FOCUS VR fully counter-clockwise.
- (3) Confirm the dot shape at the screen center. (Fig. 5-4)
- (4) Resume FOCUS VR.

Note

In case of turning NECK ASSY, loosen the screw 3 turns. Do not move the position.

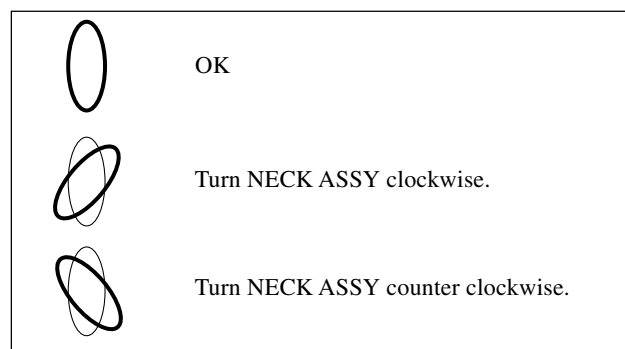
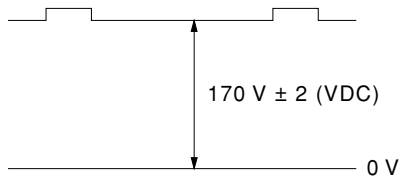

Fig. 5-4

5-5. G2 (SCREEN) AND WHITE BALANCE ADJUSTMENTS

1. G2 (SCREEN) ADJUSTMENT

- 1) Set the PICTURE and BRIGHTNESS to normal.
- 2) Put to VIDEO input mode without signals.
- 3) Connect R, G and B of the C board cathode to the oscilloscope.
- 4) Adjust BRIGHTNESS to obtain the cathode voltage to the value below.
- 5) Whilst watching the picture, adjust the screen VR (RV9002) located on the C board to the point just before the flyback return lines disappear (to the point before cut-off)



2. WHITE BALANCE ADJUSTMENT

- 1) Set to Service Mode (Refer Section 6-1: ADJUSTMENTS WITH COMMANDER).
- 2) Input white raster signal.
- 3) Set the following condition.
PICTURE minimum, BRIGHTNESS 50%
- 4) Select GCT (WHB 7) and BCT (WHB 8) with **[1]** and **[4]**, and adjust the level with **[3]** and **[6]** for the best white balance.
- 5) Set the PICTURE to maximum.
- 6) Select GDR (WHB 4) and BDR (WHB 5) with **[1]** and **[4]**, and adjust the level with **[3]** and **[6]** for the best white balance.
- 7) Write into the memory by pressing **[MUTING]** then **[0]**.

3. SUB PICTURE BRIGHTNESS ADJUSTMENT

- 1) Tune RF PAL white signal at program No. 1 and No. 2.
- 2) Select "TWIN PICTURE" mode.
- 3) Receive different RF PAL white signals in MAIN and Sub picture.
- 4) Adjust RV3300 on A PWB, so that the output from the 17 pin and 20 pin of the CN1180 becomes within the spec.

CVBS 1

17 pin

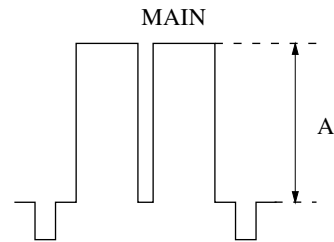

CVBS 2

20 pin

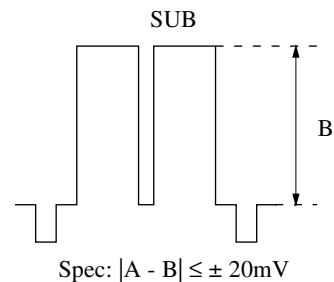

SECTION 6 CIRCUIT ADJUSTMENTS

6-1. ADJUSTMENTS WITH COMMANDER

Service adjustments are made with the RM-958 that comes with this unit.

a. ENTERING SERVICE MODE

This operation sequence puts the unit into service mode.

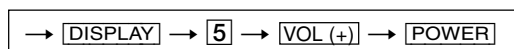

The screen display is :

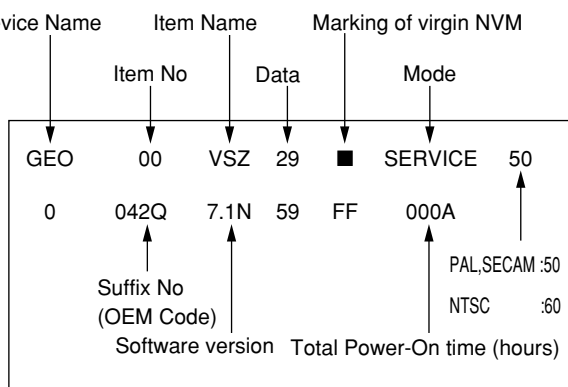

b. METHOD OF CANCELLATION FROM SERVICE MODE

Set the standby condition (Press [POWER] button on the commander), then press [POWER] button again, hereupon it becomes TV mode.

c. METHOD OF WRITE INTO MEMORY

- 1) Set to Service Mode.
- 2) Press [1] (UP) and [4] (DOWN), select an item of adjustment.
- 3) Press [MUTING] button and it will indicate WRITE on the screen.
- 4) Press [0] button to write into memory.

d. MEMORY WRITE CONFIRMATION METHOD

- 1) After adjustment, pull out the plug from AC outlet, and then plug into AC outlet again.
- 2) Turn the power switch ON and set to Service Mode.
- 3) Call the adjusted items again to confirm adjustments were made.

The screen display is :

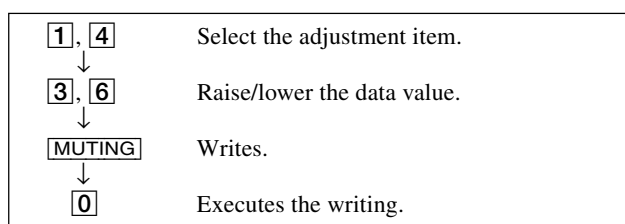

- [7], [0] All the data becomes the values in memory.
- [8], [0] All user control goes to the standard state.
- [5], [0] Service data initialization (Be sure not to use usually.)

[DISPLAY], [0] Write 50Hz adjustment data to 60Hz, or vice versa.

[2], [0] Write 50Hz adjustment data to 60Hz, or vice versa.

[Cursor +/-] Copy and write all data.

example:
GEO 00 VSZ
↑
DAC 00 HCT

6-2. ADJUSTMENT METHOD

Item Number 00 of device GEO

This explanation uses V-size as an example.

1. Select "GEO 00 VSZ" with the [1] and [4] buttons.
2. Raise/lower the data with the [3] and [6] buttons.
3. Select the optimum state. (The standard is 1F for PAL reception.)
4. Write with the [MUTING] button. (The display changes to WRITE.)
5. Execute the writing with the [0] button. (The WRITE display will be changed to red color while executing, and back to SERVICE.)

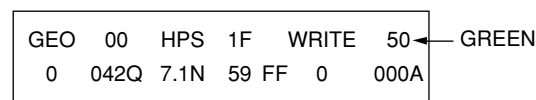
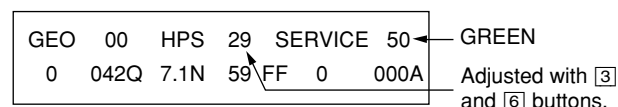

Write with [MUTING]

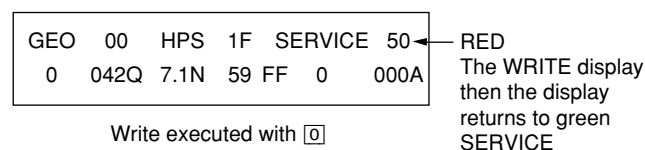

Write executed with [0]

Use the same method for all Items. Use [1] and [4] to select the adjustment item, use [3] and [6] to adjust, write with [MUTING], then execute the write with [0].

Note : 1. In [WRITE], the data for all items are written into memory together.

2. For adjustment items that have different standard data between 50Hz or 60Hz, be sure to use the respective input signal after adjustment.

3. Additional function to skip category (device) to category (device).

example:

GEO 00 VSZ
↑
DAC 00 XXX

The buttons for the function above should be ↑ and ↓.

Adjustment Item Table

TVG Category	Functionality		Initial	Range	Function	Table and Note	PAL 50				NTSC 60				Device Name				
	No.	Name					DRC 1250V	PinP	PinPV	INDEX	TWIN	DRC 1250	60 VC	PinP		PinPV	INDEX	TWIN	
GEO	00	VSZ	21	3F	V SIZE	FF/4P*50/60*VC/NC, TW/IX*50/60	1B	21	1B	21	20	20	1D	21	1D	21	20	23	
	01	VPS	27	3F	V POSITION	FF/4P*50/60*VC/NC, TW/IX*50/60	25	24	25	24	23	25	27	27	27	27	25	29	
	02	VLN	5	0F	V LINESRITY	FF/R4/PR*50/60*VC/NC	06	06	06	06	06	06	06	06	06	06	06	06	06
	03	SCO	0A	0F	S CORRECTION	FF/R4/PR*50/60*VC/NC	07	07	07	07	07	07	07	07	07	07	07	07	07
	04	HSZ	1E	3F	H SIZE	FF/4P*50/60*VC/NC, TW/IX*50/60	26	27	26	27	1E	1E	24	24	24	24	23	1F	
	05	HPS	2F	3F	H POSITION	FF/R4/PR*50/60*VC/NC, TW/IX*50/60	38	36	38	35	3B	3C	30	2F	30	30	31	36	
	06	DVH	5	0F	H POSITION OFFSET FOR DVD	50/60Hz (DVD)	06	06	06	06			07	07	07	07			
	07	PAP	28	3F	PIN AMP	FF/R4/PR*50/60*VC/NC	21	1F	21	1C	21	21	1F	20	1F	1F	1F	1F	
	08	UPN	25	3F	UPPER CONER PIN	FF/R4/PR*50/60*VC/NC, TW/IX*50/60	1E	1D	1E	1D	1D	1E	1C	23	1C	1E	1C	1C	
	09	LPN	23	3F	LOWER CONER PIN	FF/R4/PR*50/60*VC/NC, TW/IX*50/60	1C	16	1C	16	1B	1C	1B	1A	1B	1A	1B	1B	
	0A	TRZ	0C	0F	TRAPEZIUM	FF/R4/PR*50/60*VC/NC, TW/IX*50/60	08	08	08	07	07	09	08	08	08	08	07	09	
	0B	AGL	0A	0F	AFC ANGLE	FF/R4/PR*50/60*VC/NC	07	07	06	07	06	06	07	07	06	07	06	06	
	0C	BOW	6	0F	AFC BOW	FF/R4/PR*50/60*VC/NC	08	07	07	06	07	07	07	07	08	07	08	08	
	0D	LBL	12	3F	LEFT H BLANKING	FF/R4/PR*50/60*VC/NC, TW/IX*50/60	11	11	11	11	11	11	1C	1C	1C	1C	1C	1C	
	0E	RBL	2C	3F	RIGHT H BLANKING	FF/R4/PR*50/60*VC/NC, TW/IX*50/60	2C	2C	2C	2C	2C	2C	23	23	23	23	23	23	
	0F	MPN	0	3	MIDDLE PIN DISTORTION COMPENSATION	50/60*VC/NC	00	00	00	00	00	00	00	00	00	00	00	00	
	10	UVL	0	0F	UPPER LINEARITY	50/60Hz	00	00	00	00	00	00	00	00	00	00	00	00	
	11	LVL	0	0F	LOWER LINEARITY	50/60Hz	00	00	00	00	00	00	00	00	00	00	00	00	
	12	HCP	0	3	HORIZONTAL HIGH VOLTAGE COMPENSATION	50/60*VC/NC	00	00	00	00	00	00	00	00	00	00	00	00	
13	VCP	1	3	VERTICAL HIGH VOLTAGE COMPENSATION	50/60*VC/NC	00	00	00	00	00	00	00	00	00	00	00	00		
14	VAS	2F	3F	V ASPECT	FF/R4/PR*50/60*VC/NC, TW/IX*50/60	2F	2E	2F	2E	2F	30	2F	31	2F	31	2F	2E		
15	VSC	1F	3F	V SCROLL	FF/R4/PR*50/60*VC/NC, TW/IX*50/60	22	22	22	22	22	24	22	22	22	22	22	23		
16	USC	0	1	UNDER-SCAN MODE ON/OFF	50/60*VC/NC														
17	VBW	0	3	V BLANKING WIDTH CONTROL	FF/R4/PR*50/60*VC/NC	00	03	00	03	00	00	00	03	00	03	00	00		
18	AT1	2	3	AKB REFERENCE TIMING	FF/R4/PR*50/60*VC/NC	02	03	02	03	02	02	02	03	02	03	02	02		
19	CPY	0	1	COPY THE GEO DATA TO ALL 50/60HZ NVM AREA															

Adjustment Item Table

TVG Category	Functionality		Initial	Range	Function	Table and Note	PAL 50					Eco Mode					NTSC 60					Device Name			
	No.	Name					DRC 1250	DRC 1250V	PinP	PinPV	INDEX	TWIN	Eco On NC	Eco Off NC	Eco On VC	Eco Off VC	DRC 1250	60VC	PinP	PinPV	INDEX		TWIN		
DAC	00	HCT	33	FF	H CENTER	50/60Hz	30	30	30	30	30	30					6B	6B	6B	6B	6B	6B	6B	6B	MB88141
	01	HLN	27	3F	H LINEARITY	FF/4P*50/60	30	30	30	30	30	30					33	33	33	33	33	33	33	33	
	02	MDP	26	3F	MIDDLE PIN	FF/4P*50/60	1A	1A	1A	1A	1A	1A					1A	1A	1A	1A	1A	1A	1A	1A	
	03	CCP	37	3F	LOWER CONER PIN	FF/4P*50/60	1F	1F	1F	1F	1F	1F					1F	1F	1F	1F	1F	1F	1F	1F	
	04	HTR	26	3F	HORIZONTAL TRAPEZIUM	FF/4P*50/60	1F	1F	1F	1F	1F	1F					1F	1F	1F	1F	1F	1F	1F	1F	
	05	DF	01	1	DF ON/OFF SWITCH	FF/4P*50/60	01	01	01	01	01	01					01	01	01	01	01	01	01	01	
	06	DPH	1F	3F	DF PHASE	FF/4P*50/60	27	27	27	27	27	27					27	27	27	27	27	27	27	27	
	07	QPH	19	3F	QP PHASE	FF/4P*50/60	15	15	15	15	15	15					15	15	15	15	15	15	15	15	
	08	QAC	23	3F	QP AMPLITUDE	FF/4P*50/60	23	23	23	23	23	23					23	23	23	23	23	23	23	23	
	09	QDC	20	3F	QP DC LEVEL	FF/4P*50/60	20	20	20	20	20	20					20	20	20	20	20	20	20	20	
0A	QDV	1F	3F	QP V MODULATION	FF/4P*50/60	1D	1D	1D	1D	1D	1D					1E	1E	1E	1E	1E	1E	1E	1E		
0B	QAV	1A	3F	QP AMPLITUDE MODULATION	FF/4P*50/60	3F	3F	3F	3F	3F	3F					3F	3F	3F	3F	3F	3F	3F	3F		
0C	ABC	0	FF	ABL D/A CONTROL	ECO on/off*VC/NC											00	00	00	00	00	00	00	00		
0D	CPY	0	1	COPY THE GEO DATA TO ALL 50/60HZ NVM AREA																					

TVG Category	Functionality No.	Name	Initial	Range	Function	Table and Note	Common	Device Name
	01	CRO	7	0F	DC OFFSET CANCELLER FOR CR1	0A		
	02	SBR	18	3F	SUB BRIGHTNESS CONTROL	24		
	03	RDR	29	3F	R DRIVE	29		
	04	GDR	25	3F	G DRIVE	25		
	05	BDR	26	3F	B DRIVE	20		
	06	RCT	29	3F	R CUTOFF	24		
	07	GCT	12	3F	G CUTOFF	07		
	08	BCT	31	3F	B CUTOFF	2F		
	09	SBO	29	3F	SUB BRIGHTNESS OFFSET	1C		
	0A	RDO	1F	3F	R DRIVE OFFSET	1F		
	0B	GDO	1A	3F	G DRIVE OFFSET	1B		
	0C	BDO	1A	3F	B DRIVE OFFSET	1B		
	0D	RCO	1F	3F	R CUTOFF OFFSET	1F		
	0E	GCO	1E	3F	G CUTOFF OFFSET	1F		
	0F	BCO	15	3F	B CUTOFF OFFSET	1A		

Adjustment Item Table

TVG Category	Functionality		Initial	Range	Function	Table and Note	Common	COLOR MODE				60		60	Device Name
	No.	Name						S-Input	SECAM	NTSC	PAL	TV	Video		
SYC	00	TNT	1F	3F	TINT ADJUSTMENT FOR NTSC	TV/Video					21	21	21	21	CXA2123Q
	01	PNG	0	1	PAL/NTSC GATE WIDTH		01								
	02	PNI	0	1	PAL/NTSC SENSITIVITY SW		00								
	03	SCL	7	0F	SUB COLOR CONTROL	50/60*TV/Video					06	07	05	07	
	04	SCT	7	0F	SUB CONTRAST CONTROL	50/60*TV/Video					08	08	04	07	
	05	SF0	2	3	SHARPNESS CENTER FREQUENCY CHANGING		02								
	06	SEQ	3	3	SHARPNESS EQUALIZER CHARACTERISTIC		03								
	07	SHG	7	0F	SHARPNESS GAIN CONTROL		07								
	08	YOL	1F	3F	Y-OUTPUT LEVEL CONTROL		1E								
	09	BSP	0	3	BLACK STRETCH START POINT CHANGING		00								
	0A	COL	1F	3F	CB/CR OUTPUT LEVEL CONTROL		1D								
	0B	DCR	0	3	DC RESTORATION RATIO ADJUSTMENT		00								
	0C	BF0	1	3	BPF/TQF F0 ADJUSTMENT		01								
	0D	BFQ	2	3	BPF/TQF Q ADJUSTMENT		02								
	0E	FSW	1	1	BPF/TQF SWITCH		01								
	0F	SDT	1	1	SECAM DOUBLE TRAP SWITCH		01								
	10	LPF	1	1	Y/CB/CR LPF SWITCH		01								
	11	YDL	3	0F	Y-DL TIME ADJUSTMENT	PAL/NTSC/SECAM/S-Input		05	03	02	03				
	12	NCM	1	1	1-H ADDITION SWITCH		01								
	13	CMT	0	1	CB/CR OUTPUT MUTE SWITCH		00								
	14	BO1	7	0F	CB OFFSET1 ADJUSTMENT (MAIN ROUTE)		07								
	15	RO1	7	0F	CB OFFSET1 ADJUSTMENT		07								
	16	ODF	0	7	V COUNT DOWN FREQUENCY SWITCH		00								
17	CDM	0	3	V COUNT DOWN JUDGE SWITCH		00									
18	AFC	0	3	AFC SENSITIVITY SWITCH	(TV)/Video/DVD						00	00	00	00	
19	MVM	0	1	MACROVISION + AFC MASK		00									
1A	SRY	7	0F	SECAM R-Y BLACK ADJUSTMENT		07									
1B	SBY	1	0F	SECAM B-Y BLACK ADJUSTMENT		01									
1C	BEL	2	3	SECAM BELL/HPF SWITCHING		02									
1D	BLF	0	1	BELL F0 ADJUSTMENT		00									
1E	SVI	0	1	SECAM V-ID SWITCH		00									
1F	SGP	0	3	SECAM GATE POSITION ADJUSTMENT		00									
20	SID	1	1	SECAM SENSITIVITY SWITCH	except SECAM	01									
21	SIH	0	1	SECAM INHIBITION SWITCH		00									
22	STP	0	1	Y BLACK LEVEL SETUP FOR PAL PLUS		00									
23	HVC	2	3	H-VCO TEMPERATURE CHARACTER CANCELLING		02									

Adjustment Item Table

TVG Category	Functionality		Initial	Range	Function	Table and Note	Initial Value (Detailed)				Device Name
	No.	Name					Common	Dynamic	Standard/Drama	Hi-Fine/Soft	
AP	00	BAS	0A	0F	BASE CONTROL	EXCEPT PESONAL	0B	08	07		TDA7315
	01	TRE	0A	0F	TREBLE CONTROL	EXCEPT PESONAL	0B	09	07		
	02	LDN	1	1	LOUDNESS CONTROL					01	

TVG Category	Functionality		Initial	Range	Function	Common	Device Name
	No.	Name					
MSP	00	WST	15	FF	W/G STEREO THRESHOLD	15	MSP3415D
	01	WBT	EA	FF	W/G BILINGUAL THRESHOLD	EA	
	02	WLL	5	FF	W/G MONOAUURAL THRESHOLD	05	
	03	WAC	1	0F	W/G AGREEMENT COUNT	01	
	04	WDL	30	FF	W/G SEARCH DELAY	30	
	05	NDL	20	FF	NICAM SEARCH DELAY	20	
	06	SDL	10	FF	STEREO STATUS READ DELAY	10	
	07	AGC	1	1	AGC SWITCH AUTO/CONSTANT	01	
	08	REL	28	3F	AGC GAIN AT CONSTANT MODE	28	
	09	CRM	0	1	CARRIER MUTING ON/OFF	00	
	0A	ACO	1	1	AUDIO CLOCK ON/OFF	01	
	0B	FP	1B	7F	FM PRESCALE FOR NON-M SYSTEM	1B	
0C	FPM	32	7F	FM PRESCALE FOR M SYSTEM	32		
0D	FH	2D	7F	FM PRESCALE FOR HDEV	2D		
0E	FHM	65	7F	FM PRESCALE FOR HDEV AND M	65		
0F	WGP	2A	7F	W/G PRESCALE	2A		
10	NIP	6D	7F	NICAM PRESCALE	6D		
11	ERR	50	FF	AUTO FM SWITCH THRESHOLD	50		
12	VOL	6D	FF	LOUDSPEAKER GAIN 0700H TO 07FFH	6D		

Adjustment Item Table

TVG Category	Functionality		Initial	Range	Function	Table and Note	Common			Video			PICTURE MODE			Device Name
	No.	Name					Twin	TV	Dynamic	Standard/Drama	Hi-Fine/Soft	Personal				
LTI	00	LDH	1	1	HISTOGRAM SEGMENT SELECTION		01								TDA9178	
	01	CFS	1	1	COUNTER FILTER SELECTION		01									
	02	WLB	0	1	LETTERBOX WINDOW SWITCH		00									
	03	VDC	1	1	VIDEO DEPENDENT CORING	PICTURE MODE	00		01	01	01	01	01	01		
	04	DEM	0	1	DEMONSTRATION MODE		00									
	05	CDP	4	07	LUMINANCE DELAY		04									
	06	OSP	0	1	OVERRULE SMART PEAKING		00									
	07	WPO	0	1	WHITE POINT STRETCH OFF		00									
	08	DSK	0	1	SKIN TONE SWITCH	PICTURE MODE	00		00	00	00	00	00	00		
	09	ASK	0	1	SKIN TONE ANGLE SELECTION		00									
	0A	WSK	0	1	SKIN TONE WIDTH SELECTION		00									
	0B	SSK	0	1	SKIN TONE SIZE SELECTION		00									
	0C	DGR	1	1	GREEN ENHANCEMENT SWITCH	PICTURE MODE AND MULTIPLE MODE	00	00	01	01	00	00	01	01		
	0D	DGT	7	7	THRESHOLD OF GREEN ENHANCEMENT SWITCH		07									
	0E	GGR	0	1	GREEN ENHANCEMENT GAIN		00									
	0F	WGR	0	1	GREEN ENHANCEMENT WIDTH		00									
	10	SGR	0	1	GREEN ENHANCEMENT SIZE		00									
	11	DBL	0	1	BLUE STRETCH SWITCH		00									
	12	GBL	0	1	BLUE STRETCH GAIN SELECTION		00									
	13	SBL	0	1	BLUE STRETCH SIZE SELECTION		00									
	14	CDS	1	1	COLOR DEPENDENT SHARPNESS	PICTURE MODE	00		01	01	00	00	01	01		
	15	CST	7	7	THRESHOLD OF COLOR DEPENDENT SHARPNESS		07									
	16	CTI	0	1	COLOR TRANSIENT IMPROVEMENT	PICTURE MODE			00	00	00	00	00	00		
	17	BON	0	1	BLACK OFFSET COMPENSATION	PICTURE MODE			00	00	00	00	00	00		
	18	BTD	0	3F	ADAPTIVE BLACK STRETCH	PICTURE MODE			00	00	00	00	00	00		
	19	NLD	15	3F	NON-LINEARITY AMPLIFIER	PICTURE MODE AND MULTIPLE MODE		00		15	15	00	00	15		
1A	NLW	7	7	STEP WIDTH OF NON-LINEARITY AMPLIFIER		07										
1B	VGD	15	3F	VARIABLE GAMMA	PICTURE MODE AND MULTIPLE MODE		1F		1F	1F	1F	1F	1F			
1C	VGW	0	7	STEP WIDTH OF VARIABLE GAMMA		00										
1D	PKD	3F	3F	PEAKING AMPLITUDE	PICTURE MODE			3F	30	0E	0E	30	30			
1E	PKW	8	0F	STEP WIDTH OF PEAKING AMPLITUDE		08										
1F	SPD	0	3F	STEPNESS CORRECTION	PICTURE MODE			00	00	00	00	00	00			
20	CRD	11	3F	CORING LEVEL	PICTURE MODE			16	16	16	00	00	16			
21	CRW	9	0F	STEP WIDTH OF CORING LEVEL		09										
22	CRO	0	0F	CORING LEVEL OFFSET FOR VIDEO MODE		01										
23	LWD	1F	3F	LINE WIDTH CORRECTION		1F										
24	SNM	0	7	S/N MODE UNDER UNREALIBLE S/N CONDITION		00										
25	SNC	3	0F	S/N RATIO AVERAGE COUNTER	TV/Video			03	03							
26	FMC	2	0F	FEATURE MODE MATCHING COUNTER		02										

Adjustment Item Table

TVG Category	Functionality		Function	50						60						Device Name
	No.	Name		Single DRC 1250	Single DRC Progressive	PinP	TWIN	INDEX	Single DRC 100	Single DRC Progressive	PinP	TWIN	INDEX	Single DRC 100	Single DRC 100	
MID	00	HPH	HORIZONTAL ACTIVE DISPLAY AREA PHASE	52	52	52	92	8D	52	52	52	7E	78	52	MB94918	
	01	VPH	VERTICAL ACTIVE DISPLAY AREA PHASE	20	20	20	2A	26	12	25	25	2E	2D	14		
	02	HSZ	HORIZONTAL ACTIVE DISPLAY AREA SIZE	7F	7F	7F	7F	7F	7F	7F	7F	7F	7F	7F		
	03	VSZ	VERTICAL ACTIVE DISPLAY AREA SIZE	7F	7F	7F	7F	7F	7F	7F	7F	7F	7F	7F		
	04	HPW	DISPLAY H-SYNC PLUS WIDTH	3F	3F	3F	3F	3F	3F	3F	3F	3F	3F	3F		
	05	VPW	DISPLAY V-SYNC PLUS WIDTH	03	03	03	03	03	03	03	03	03	03	03		
	06	YDL	DISPLAY OUTPUT Y/C DELAY CORRECTION	00	00	00	00	00	00	00	00	00	00	00		
	07	MHP	MAIN PICTURE HORIZONTAL POSITION (SINGLE & PINP)	7F	7F	7F	7F	7F	7F	7F	7F	7F	7F	7F		
	08	MVP	MAIN PICTURE VERTICAL POSITION (SINGLE & PINP)	7F	7F	7F	7F	7F	7F	7F	7F	7F	7F	7F		
	09	MHS	MAIN PICTURE HORIZONTAL SIZE (SINGLE & PINP)	7F	7F	7F	7F	7F	7F	7F	7F	7F	7F	7F		
	0A	MVS	MAIN PICTURE VERTICAL SIZE (SINGLE & PINP)	7F	7F	7F	7F	7F	7F	7F	7F	7F	7F	7F		
	0B	PHP	PINP SUB PICTURE HORIZONTAL POSITION			6B										
	0C	PVP	PINP SUB PICTURE VERTICAL POSITION			5E										
	0D	PHS	PINP SUB PICTURE HORIZONTAL SIZE			7F										
	0E	PVS	PINP SUB PICTURE VERTICAL SIZE			7F										
	0F	PHO	PINP SUB PICTURE HORIZONTAL POSITION OFFSET			76										
	10	PVO	PINP SUB PICTURE VERTICAL POSITION OFFSET			6E										
	11	TMP	TWIN MAIN PICTURE HORIZONTAL POSITION				00					00				
	12	TSP	TWIN SUB PICTURE HORIZONTAL POSITION				01					01				
	13	TVP	TWIN MAIN & SUB PICTURE VERTICAL POSITION			00	00	00	00			00	00	00		
	14	THS	TWIN MAIN & SUB PICTURE HORIZONTAL SIZE			00	00	00	00			00	00	00		
	15	TVS	TWIN MAIN & SUB PICTURE VERTICAL SIZE			00	00	00	00			00	00	00		
	16	THO	TWIN MAIN & SUB PICTURE HORIZONTAL POSITION OFFSET													
	17	TVO	TWIN MAIN & SUB PICTURE VERTICAL POSITION OFFSET													
	18	XHS	INDEX SUB PICTURE HORIZONTAL SIZE													
	19	XVS	INDEX SUB PICTURE VERTICAL SIZE													
	1A	XHG	INDEX HORIZONTAL GAP WIDTH BETWEEN PICTURES													
	1B	XVG	INDEX VERTICAL GAP WIDTH BETWEEN PICTURES													
1C	XHP	INDEX 1ST SUB PICTURES HORIZONTAL POSITION														
1D	XVP	INDEX 1ST SUB PICTURES VERTICAL POSITION														
1E	DHP	DRC HORIZONTAL ACTIVE AREA POSITION														
1F	DHS	DRC HORIZONTAL ACTIVE PIXEL SIZE														
20	DVP	DRC VERTICAL ACTIVE AREA LINE POSITION														
21	DVS	DRC VERTICAL ACTIVE AREA LINE SIZE	1A	1A	1A	3F	8F	1A	1A	1A	39	39	1A			
22	VHP	VDO HORIZONTAL ACTIVE AREA POSITION	7F	7F	7F	7F	7F	7F	7F	7F	7F	7F	7F			
23	VHS	VDO HORIZONTAL ACTIVE PIXEL SIZE														
24	VEP	VDO VERTICAL ACTIVE AREA EVEN POSITION														
25	VVS	VDO VERTICAL ACTIVE AREA LINE SIZE														
26	VOP	VDO VERTICAL ACTIVE AREA ODD POSITION														
27	CLT	VDO CLAMP PULSE OUTPUT TIMING														
28	CLW	VDO CLAMP PULSE WIDTH														
29	VYD	VDO ANALOG INPUT Y/C DELAY CORRECTION														
2A	VCR	VDO CROMA SIGNAL ORDER														
2B	VDI	VDO DIGITAL ANALOG INPUT SELECTION														

Adjustment Item Table

TVG Category	Functionality No.	Name	Initial	Range	Function	Table and Note	Common			TV		NR MODE			PICTURE TUBE			Device Name
							TV	V/ideo	NRmode0	NRmode1	NRmode2	NRmode3	Dynamic	Standard/ Drama	Hi-Fine/ Soft	Personal		
3CM	00	FRZ	0	1	EXTERNAL MEMORY TEST BIT		00											UPD64082
	01	NRM	0	3	NOISE REDUCTION OPERATION MODE													
	02	YCO	0E	0F	Y/C SIGNAL OUTPUT SELECTION		0D											
	03	SYC	1	3	SYSTEM CLOCK SELECTION		01											
	04	STD	0	3	STANDARD/NON-STANDARD OPERATION SELECTION		00											
	05	MSS	0	3	INTER-FRAME/INTER-LINE OPERATION SELECTION		00											
	06	KIL	3	3	KILLER/NON-KILLER OPERATION SELECTION		03											
	07	EAD	0	1	EXTERNAL Y-ADC SWITCH		00											
	08	ECS	1	3	EXTERNAL C-SYNC INPUT SELECTION		01											
	09	OPP	2	3	ADC INPUT LEVEL & CLUMP PULSE WIDTH SELECTION		02											
	0A	PWR	0	1	ADC INPUT WIDTH SWITCH		00											
	0B	HDP	5	7	HORIZONTAL PHASE ADJUSTMENT		05											
	0C	CDL	4	7	C-SIGNAL ADJUSTMENT		04											
	0D	DYC	2	0F	DY DETECTION CORING LEVEL ADJUSTMENT	NR MODE (0-3)		02	02	02	04							
	0E	DYG	0A	0F	DY DETECTION GAIN ADJUSTMENT	NR MODE (0-3)		0A	0A	0A	0A							
	0F	DCC	5	0F	DC DETECTION CORING LEVEL ADJUSTMENT	NR MODE (0-3)		05	03	03	05							
	10	DCG	5	0F	DC DETECTION GAIN ADJUSTMENT	NR MODE (0-3)		05	0A	0A	05							
	11	YNR	1	0F	YNR NON-LINEAR FILTER SETUP		01											
	12	CNR	1	0F	CNR NON-LINEAR FILTER SETUP		01											
	13	WSC	1	3	NOISE DETECTION CORING ADJUSTMENT		01											
	14	VTH	1	3	HYSTERESIS SELECTION FOR H-SYNC NON-STANDARD	TV/V/ideo		01	01									
	15	VTR	1	3	SENSITIVITY SELECTION FOR H-SYNC NON-STANDARD	TV/V/ideo		01	01									
	16	LDR	2	3	SENSITIVITY SELECTION FOR FRAME-SYNC NON-STANDARD	TV/V/ideo		02	02									
	17	VAP	3	7	GAIN ADJUSTMENT FOR VERTICAL SHAPE CORRECTION	PICTURE MODE						03	00	00	00	00	00	
	18	VAI	0C	1F	VANISHING ADJUSTMENT FOR VERTICAL SHAPE CORRECTION	PICTURE MODE						0C	00	00	00	00	00	
	19	TST	0	1	TEST BIT		00											
	1A	YPF	3	3	CENTER FREQUENCY SELECTION FOR Y-PEAKING BPF	PICTURE MODE						03	03	03	03	03	03	
	1B	YPG	8	0F	GAIN ADJUSTMENT FOR Y-PEAKING BPF	PICTURE MOD						0A	08	08	08	08	08	
	1C	VSE	0A	0F	LINE COMB FILTER SETUP		0A											
	1D	CCN	0	1	C-SIGNAL SPLIT FILTER SETUP		00											
1E	COO	0	1	C-SIGNAL DELAY SWITCH AT NOISE REDUCTION		00												
1F	SDC	0	1	DC DETECTION SENSITIVITY SWITCH		00												
20	SDY	1	1	DY DETECTION LOWER-LEVEL SENSITIVITY SWITCH		01												
21	D2G	4	7	D2 GAIN SELECTION		04												
22	YHC	0	3	Y-SIGNAL HIGHER-LEVEL CORING SELECTION	PICTURE MOD	00					00	00	00	00	00	00		
23	YHG	0	1	Y-SIGNAL HIGHER-LEVEL GAIN SWITCH	PICTURE MOD	00					00	00	00	00	00	00		
24	SHT	0	0F	NON-STANDARD DETECTION & H/V COUNTER TEST		00												
25	CLK	8	0F	CLOCK TEST BIT		08												
26	PLL	0D	0F	PLL FILTER SETUP		0D												
27	KRF	3	0F	KILLER DETECTION REFERENCE ADJUSTMENT		03												
28	HSL	0C	0F	H-SYNC SLICE LEVEL ADJUSTMENT		0C												
29	VSL	8	0F	V-SYNC SLICE LEVEL ADJUSTMENT		08												
2A	BPS	4	0F	INTERNAL BURST GATE START POSITION ADJUSTMENT		04												
2B	BPW	0A	0F	INTERNAL BURST GATE WIDTH ADJUSTMENT		0A												
2C	ADC	3	3	ADC CLOCK DELAY SELECTION		03												
2D	APD	1	1	ADC POWER-DOWN SWITCH		01												
2E	NSD	1	3	NON-STANDARD DETECTION TEST BIT		01												
2F	SPD	2	3	MEMORY POWER-DOWN SWITCH		02												
30	CNT	0	1	CNR TEST BIT		00												

Adjustment Item Table

TVG Category	Functionality		Initial	Range	Function	Table and Note	Common	Initial Value (Detailed)							Device Name		
	No.	Name						Sur VDD	Sur VDP	Sur TRS	Sur SIM	Sur Off	Dynamic	Standard/ Drama		Hi-Fine/ Soft	Personal
DSP	00	DUL	0	3	DIP UNLOCK DETECTION MODE		00										TC9446F
	01	DIM	3	3	DIGITAL INPUT MODE		03										
	02	TFM	5A	7F	TRUSURROUND FRONT MINUS	VDD/VDP		5A	5A								
	03	TFP	12	7F	TRUSURROUND FRONT PLUS	VDD/VDP		12	12								
	04	TCE	40	7F	TRUSURROUND CENTER	VDD/VDP		40	40								
	05	TS1	20	FF	TRUSURROUND SURROUND #1	VDD/VDP		20	EO								
	06	TS2	20	7F	TRUSURROUND SURROUND #2	VDD/VDP		20	20								
	07	TSP	7B	7F	TRUSURROUND SURROUND PLUS	VDD/VDP		68	68								
	08	TSM	7B	7F	TRUSURROUND SURROUND MINUS	VDD/VDP		68	68								
	09	LFE	5A	7F	LOW FREQUENCY EFFECT		5A										
	0A	BHL	40	7F	BBE EFFECT 1 FOR BBE HIGH	VDD/VDP/TRS/SIM/OFF		33	33	33	28	40					
	0B	BHH	48	7F	BBE EFFECT 2 FOR BBE HIGH	VDD/VDP/TRS/SIM/OFF		33	33	33	28	40					
	0C	BLL	33	7F	BBE EFFECT 1 FOR BBE LOW	VDD/VDP/TRS/SIM/OFF		2B	2B	2B	24	33					
	0D	BLH	33	7F	BBE EFFECT 2 FOR BBE LOW	VDD/VDP/TRS/SIM/OFF		2B	2B	2B	24	33					
	0E	DLR	1	7	DELAY SELECTION AT DSP RESET		07										
	0F	BBE	1	3	BBE SELECTION	EXCEPT PERSONAL							01	01	01	03	

TVG Category	Functionality		Initial	Range	Function	Table and Note	VIDEO PICTURE MODE			TV PICTURE MODE			Device Name		
	No.	Name					Dynamic	Standard	Hi-Fine/ Soft	Personal	Dynamic	Standard/ Drama		Hi-Fine/ Soft	Personal
2CM	00	APA	1	1	2D COMB APACON ON/OFF		PICTURE MODE	01	00	00	00	00	00	00	CXA2069Q

TVG Category	Functionality		Initial	Range	Function	Common	Device Name
	No.	Name					
TXT	00	TXH	4B	3F	TELETEXT HORIZONTAL POSITION FOR PHILIPS	60	50
	01	TXV	0E	3F	TELETEXT VERTICAL POSITION FOR PHILIPS	60	50

Adjustment Item Table

TVG Category	Functionality		Initial	Range	Function	Table and Note	Common	Initial Value (Detailed)		Device Name
	No.	Name						50	60	
OPM	00	OSH	12	3F	OSD H POSITION		12			CXP750096
	01	FW1	0	3F	OSD ODD/EVEN FIELD WINDOW SETUP #1		00			
	02	FW2	3	3F	OSD ODD/EVEN FIELD WINDOW SETUP #2		03			
	03	OHO	9	0F	OSD H Position Offset for INDEX		05			
	04	IL1	1C	3F	INDEX SUB-SCREEN OSD 1st LINE VERTICAL POSITION	50/60Hz		25	22	
	05	IYO	2F	3F	INDEX SUB-SCREEN OSD VERTICAL POSITION	50/60Hz		2B	20	
	06	COM	0	03	COMB OPERATION SELECTION		00			
	07	APC	1	1	APC SWITCH		01			
	08	TSY	0	03	TV SYSTEM SELECTION UNDER SEARCHING WITH AUTO TV SYSTEM		03			
	09	MUT	0	1	NO SIGNAL MUTE		01			
	0A	AFM	1	1	AUTO FM SWITCH		01			
	0B	TVO	3	7	V-ANGLE CORRECTION TO PICTURE ROTATION		03			
	0C	DBL	0	1	DISABLE BLUEBACK FUNCTION		01			
	0D	SSO	1	3	SPEED CH SEARCH SELECTION		01			
	0E	TRP	0	3F	MPEG/JPEG NOISE REDUCTION FOR EACH INPUT		00			
0F	SCH	1	7F	CH SELECTION FOR SHIPPING CONDITION	NTSC	07				
10	SCA	1	1	CABLE/AIR SELECTION FOR SHIPPING CONDITION	NTSC	01				
11	DMG	0	1	DISABLE MENU-OPERATION GUIDE		00				
12	VSN	0	1	ENABLE NOISE REDUCTION IN VIDEO MODE		00				
13	RUC	0F	0F	RF SIGNAL CHANGE COUNTER AFTER UNLOCKED	Disabled if set to OFH	04				
14	RLC	0F	0F	RF SIGNAL CHANGE COUNTER AFTER LOCKED	Disabled if set to OFH	01				
15	LBB	0	1	LOWER BLUE BACK INTENSITY		00				

TVG Category	Functionality		Initial	Range	Function	Common	Device Name
	No.	Name					
OPB	00	OP1	E7	FF	OPTION BIT 1 (SEE THE SPECIFIED SHEET)	07	option-bit
	01	OP2	13	FF	OPTION BIT 2 (SEE THE SPECIFIED SHEET)	09	

Abbreviation:

FF = Flicker Free	ECO = Eco Mode
R4 = DRC1250	VC = V-Compressed Mode
PR = Progressive (PIP)	NC = Non-Compressed Mode
4P = R4 or PR	Sur = Surround
VC = V-Compressed Mode	VDD = Virtual Dolby Digital
NC = Non-compressed Mode	VDP = Virtual Dolby Prologic
	TRS = Tru Surround
	SIM = Simulated

NOTE

- shaded items are fixed data.
- no data
- Standard data listed on the Adjustment Item Table are reference values, therefore it may be different for each model and for each mode.
- Note for Different Data: Those are the standard data values written on the microprocessor. Therefore, the data values of the modes and stored respectively in the memory.
In case of a device replacement, adjustment by rewriting the data value is necessary for some items.

OPTION NOTE

COM	Comb Operation Selection	00 = automatic operation (depends on color system status), 01 = no comb operation, 02 = forced 2D-comb operation, 03 = forced 3D-comb operation
TSY	TV System Selection for Auto TV System	00 = B/G, 01 = I, 10 = D/K, 11 = M
SSO	Speed CH Search Selection	00 = normal, 01 = 4 times, 10 = 6 times, 11 = 8 times
TRP	MPEG/JPEG Noise Reduction	

Input	–	–	TV	Video 1	Video 2	Video 3	Video 4	DVD
-------	---	---	----	---------	---------	---------	---------	-----

OP1 Items

Item	TOP	NICAM	HDEV	Reserved	DRC 3 Mode	DVD Input	AV Input	
KV-ES38N90	1	1	1	0	0	1	1	1

DRC 3 Mode DRC - MF3 Mode 1 = 3 Mode (ES38)
AV Input 00 = no AV Input 01 = 1 AV Input 10 = 3 AV Input 11 = 4 AV Input

OP2 Items

Item	(reserved)	Korea Stereo	Video N3.58	A-TV SYS	USST	SSV - Model	OSD Language	
KV-ES38N90	0	0	0	0	0	0	0	1

K-stereo Korean Stereo 0 = Disabled, 1 = Enabled
Video N3.58 Video Color System 0 = Multi system, 1 = Single system (NTSC 3.58)
US ST USA Stereo (MTS) 0 = Disabled, 1 = Enabled
A-TV sys Auto TV System in Auto Program 0 = Disabled, 1 = Enabled
OSD Language 00 = English only, 01 = English & Chinese, 10 = English & Arabic 11 = English, Chinese & Arabic

NOTE

No.	Modes	Details	Entry Conditions
1.	50NC/60NC	Signal 50/60Hz Non-Compressed mode.	Input 50Hz(PAL)/60Hz(NTSC), wide mode OFF (TV/video mode)
2.	50VC/60VC	Signal 50/60Hz V-Compressed mode.	Input 50Hz(PAL)/60Hz(NTSC), wide mode ON (TV/Video mode)
3.	ECO ON/OFF NC	Eco mode ON/OFF Non-Compressed mode.	ECO mode ON/OFF, wide mode OFF
4.	ECO ON/OFF VC	ECO mode ON/OFF V-Compressed mode.	ECO mode ON/OFF, wide mode ON
5.	50/60 DVD	Signal 50/60Hz Digital Video Disk	Input 50Hz(PAL)/60Hz(NTSC), DVD
6.	Multi Comb	Multi Comb Filter	Input PAL, NTSC 3.58, Service mode category OPM 03 COM 01 (Multi Model only)
7.	3D Comb	3 Dimensional Comb Filter	Input NTSC 3.58 only, Service mode category OPM 03 COM 02 (NTSC model only)
8.	S-Input	S-Video Input	Connect S-Video Cable, video mode

6-3. PICTURE QUALITY ADJUSTMENTS

H-TRAPIZIUM ADJUSTMENT

1. Input a cross hatch/dot signal.
2. Adjust DAC 4 HTR to make H-Trapezoid distortion best.

SUB CONTRAST, SUB HUE, SUB COLOR

Adjustment condition

SAJ 00 PIC 3F
06 DYC 0
0E CLO 6
10 HUO 7
13 PIO 0
JGL 04 BBT 0
05 LML 3

PICTURE QUALITY : HI-FINE
ECO MODE : OFF
WIDE MODE : OFF
DRC-MF : DRC1050

INPUT SIGNAL

Video Color Bar (White and Color 75%)
RF Color Bar (White and Color 75%)

MEASUREMENT POINT

VR ; R100 (the pin 6 of CN1100 at A board)
VB ; B100 (the pin 7 of CN1100 at A board)

CAUTION

After the above Adjustment, these adjustment parameters must be recovered to the original condition.

Original condition

SAJ 00 PIC 28 HI-FINE
SAJ 06 DYC 0 HI-FINE

	50 TV	50 VIDEO	60 TV	60 VIDEO
OE CLO	9	8	6	6
10 HUO	8	8	9	9

13 PIO TWIN = 3
JGL 04 BBT 3
05 LML 0

1. NTSC VIDEO IN PUT

Input signal ; NTSC color bar, 75% to Video 1.
[TWIN] mode, [Service] mode.

(i) SUB CONTRAST

Condition : SAJ 00 PIC 3F
02 COL 0
JGL 01 RGB 4
SAJ 13 PIO 0

Adjusting parameter:

LEFT ; YCT 08 YOL
RIGHT ; SYC 08 YOL

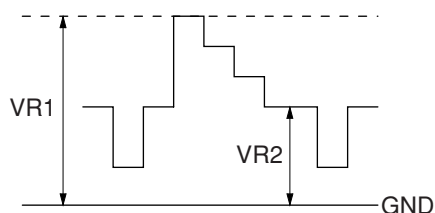

$$VR1 - VR2 = VR = 1.85 \pm 0.07 \text{ (Vp-p)}$$

(ii) SUB HUE/SUB COL

Condition : SAJ 02 COL 1F
JGL 01 RGB 7
SAJ 10 HUO 7

Adjusting parameter:

LEFT ; YCT 0A COL
YCT 00 TNT
RIGHT ; SYC 0A COL
SYC 00 TNT

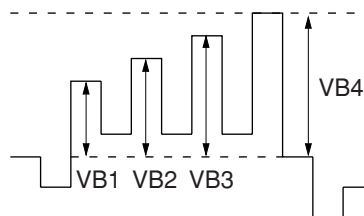

$$VB1 = VB4 \pm 70 \text{ mV}$$

$$VB2 = VB3 \pm 70 \text{ mV}$$

2. NTSC RF INPUT

Input signal ; NTSC RF color bar, 75%.
[TWIN] mode, [Service] mode.

(i) SUB CONTRAST

Condition : SAJ 00 PIC 3F
02 COL 0
JGL 01 RGB 4

Adjusting parameter:

LEFT ; YCT 04 SCT
RIGHT ; SYC 04 SCT

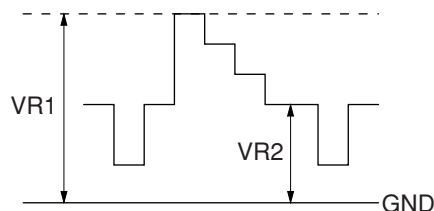

$$VR1 - VR2 = VR = 1.85 \pm 0.07 \text{ (Vp-p)}$$

(ii) SUB HUE/SUB COL

Condition : SAJ 02 COL 1F
JGL 01 RGB 7
SAJ 10 HUO 7

Adjusting parameter:

LEFT ; YCT 03 SCL
YCT 00 TNT
RIGHT ; SYC 03 SCL
SYC 00 TNT

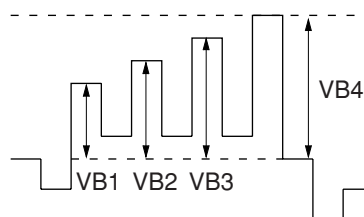

$$VB1 = VB4 \pm 70 \text{ mV}$$

$$VB2 = VB3 \pm 70 \text{ mV}$$

3. PAL RF INPUT

Input signal ; PAL RF color bar, 75%.
[TWIN] mode, [Service] mode.

(i) SUB CONTRAST

Condition : SAJ 00 PIC 3F
SAJ 02 COL 0
JGL 01 RGB 4

Adjusting parameter:

LEFT ; YCT 04 SCT
RIGHT ; SYC 04 SCT

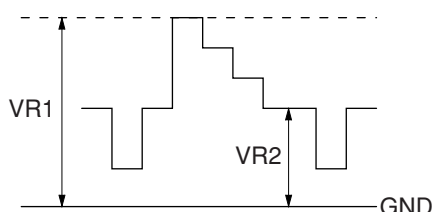

$$VR1 - VR2 = VR = 1.85 \pm 0.07 (V_{p-p})$$

(ii) SUB HUE/SUB COL

Condition : SAJ 02 COL 1F
JGL 01 RGB 7

Adjusting parameter:

LEFT ; YCT 03 SCL
RIGHT ; SYC 03 SCL

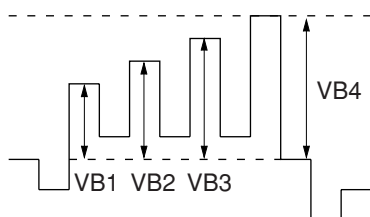

$$VB2 = VB3 = VB4 = \pm 70 \text{ mV}$$

6-4. DEFLECTION ADJUSTMENTS

FOR DRC 1050 MODE

1. Set to Service Mode.
2. Input a Pal cross hatch/dot signal.
3. Set the following condition.
Picture Mode to **[DYNAMIC]**, Picture Rotation to **[+/- 0]** and Eco Mode to OFF.
4. Set to DRC 1250 mode.
5. Using the **[1]** and **[4]** buttons select category GEO (Service Mode).
6. Raise/lower the data with the **[3]** and **[6]** buttons. Select and adjust the following items to obtain optimum image.

GEO: 00	VSZ	V SIZE
01	VPS	V POSITION
02	VLN	V LINEARITY
03	SCO	S CORRECTION
04	HSZ	H SIZE
05	HPS	H POSITION
06	PAP	PIN AMP
07	UPN	UPPER CORNER PIN
08	LPN	LOWER CORNER PIN
09	TRZ	TRAPEZIUM
0A	AGL	AFC ANGLE
0B	BOW	AFC BOW

7. Using the **[1]** and **[4]** buttons select category DAC (Service Mode).
8. Select and adjust the following items to obtain optimum image. Raise/lower the data with the **[3]** and **[6]** buttons. Select and adjust the following item to obtain optimum image.

GEO: 03	CCP	LOWER CORNER PIN
04	HTR	HORIZONTAL TRAPEZIUM

9. Select "GEO 04 HSZ" with the **[1]** and **[4]** buttons.
10. Confirm the H Size condition. If necessary, adjust the H SIZE to get a best condition.
11. Write into the memory by pressing **[MUTING]** then **[0]** on the remote commander.

FOR DRC100(50Hz) MODE

12. Change the DRC-MF to DRC100 and then adjust the following items.

Service Item

GEO:	00	VSZ	V SIZE
	01	VPS	V POSITION
	02	VLN	V LINEARITY
	03	SCO	S CORRECTION
	04	HSZ	H SIZE
	05	HPS	H POSITION
	06	PAP	PIN AMP
	07	UPN	UPPER CORNER PIN
	08	LPN	LOWER CORNER PIN
	09	TRZ	TRAPEZIUM
	0A	AGL	AFC ANGLE
	0B	BOW	AFC BOW

13. Repeat step 5 and 6.

FOR PIP(50Hz) MODE

14. Change to PIP mode. (PIP: ON) and then adjust the following items.

Service Item

GEO:	00	VSZ	V SIZE
	01	VPS	V POSITION
	02	VLN	V LINEARITY
	03	SCO	S CORRECTION
	04	HSZ	H SIZE
	05	HPS	H POSITION
	06	PAP	PIN AMP
	07	UPN	UPPER CORNER PIN
	08	LPN	LOWER CORNER PIN
	09	TRZ	TRAPEZIUM
	0A	AGL	AFC ANGLE
	0B	BOW	AFC BOW
DAC	01	HLN	H LINEARITY
	02	MDP	MIDDLE PIN
	03	CCP	LOWER CORNER PIN
	04	HTR	HORIZONTAL TRAPEZIUM

15. Repeat step 5, 6 and 8.

FOR TWIN(50Hz) MODE

16. Change to TWIN mode (TWIN: ON)

17. Copy "GEO 00 VSZ, 04 HSZ, 05 HPS (PIP 50Hz)"

"GEO 00 VSZ, 01 VPS, 04 HSZ, 05 HPS (TWIN 50Hz)"

18. Adjust "GEO 09 TRZ".

FOR PROGRAM INDEX(50Hz) MODE

19. Change to PROGRAM INDEX MODE.

20. Write "GEO 00 VSZ (INDEX 50Hz)" as "GEO 00 VSZ (PIP 50Hz)" - 4 step.

21. Copy "GEO 01 VPS, 04 HSZ, 05 HPS (PIP 50Hz)" to "GEO 01 VPS, 04 HSZ, 05 HPS (INDEX 50Hz)".

22. Adjust "GEO 09 TRZ".

FOR WIDE MODE DRC1050(60Hz)

23. Change to VIDEO MODE.

24. Change to DRC-MF: DRC1250, WIDE MODE: ON

25. Adjust the following item.

Service Item

GEO:	00	VSZ	V SIZE
	01	VPS	V POSITION
	02	VLN	V LINEARITY
	03	SCO	S CORRECTION
	04	HSZ	H SIZE
	05	HPS	H POSITION
	06	PAP	PIN AMP
	07	UPN	UPPER CORNER PIN
	08	LPN	LOWER CORNER PIN
	09	TRZ	TRAPEZIUM
	0A	AGL	AFC ANGLE
	0B	BOW	AFC BOW
DAC	01	HLN	H LINEARITY
	02	MDP	MIDDLE PIN
	03	CCP	LOWER CORNER PIN
	04	HTR	HORIZONTAL TRAPEZIUM

26. Repeat step 5, 6 and 8.

FOR WIDE MODE, DRC100(50Hz)

27. Change to VIDEO MODE.

28. Change to DRC-MF: DRC100, WIDE: ON

29. Adjust the following item.

Service Item

GEO:	00	VSZ	V SIZE
	01	VPS	V POSITION
	02	VLN	V LINEARITY
	03	SCO	S CORRECTION
	04	HSZ	H SIZE
	05	HPS	H POSITION
	06	PAP	PIN AMP
	07	UPN	UPPER CORNER PIN
	08	LPN	LOWER CORNER PIN
	09	TRZ	TRAPEZIUM
	0A	AGL	AFC ANGLE
	0B	BOW	AFC BOW
DAC	01	HLN	H LINEARITY
	02	MDP	MIDDLE PIN
	03	CCP	LOWER CORNER PIN
	04	HTR	HORIZONTAL TRAPEZIUM

FOR WIDE MODE, PIP(50Hz)

30. Change to VIDEO MODE.

31. Change to PIP: ON, WIDE MODE: ON

32. Adjust all items listed in number no.29.

33. Repeat step 5, 6 and 8.

FOR DRC1050(60Hz) MODE

34. Input 525/60Hz signal. Change to DRC-MF: DRC1250.
35. Copy "DAC 00 HCT (DRC1250, 50Hz)" to "DAC 00 HCT (DRC1250, 60Hz)".
36. Adjust the following items.

Service Item

GEO:	00	VSZ	V SIZE
	01	VPS	V POSITION
	02	VLN	V LINEARITY
	03	SCO	S CORRECTION
	04	HSZ	H SIZE
	05	HPS	H POSITION
	06	PAP	PIN AMP
	07	UPN	UPPER CORNER PIN
	08	LPN	LOWER CORNER PIN
	09	TRZ	TRAPEZIUM
	0A	AGL	AFC ANGLE
	0B	BOW	AFC BOW
DAC	01	HLN	H LINEARITY
	02	MDP	MIDDLE PIN
	03	CCP	LOWER CORNER PIN
	04	HTR	HORIZONTAL TRAPEZIUM

37. Repeat step 5, 6 and 8.

FOR DRC100(60Hz) MODE

38. Change to DRC-MF: DRC100 and then adjust the items listed in no.36.

FOR PIP(60Hz) MODE

39. Change to PIP mode (PIP: ON) and then adjust the items listed in no.36.
40. Repeat step 5, 6 and 8.

FOR TWIN(60Hz) MODE

41. Change to TWIN: ON
42. Copy "GEO 00 VSZ, 04 HSZ, 05 HPS (PIP 60Hz)" to "GEO 00 VSZ, 01 VPS, 04 HSZ, 05 HPS (TWIN 60Hz)"
43. Adjust "GEO 09 TRZ".

FOR PROGRAM INDEX(60Hz) MODE

43. Change to PROGRAM INDEX MODE.
44. Copy "GEO 00 VSZ, 04 HSZ, 05 HPS (PIP 60Hz)" to "GEO 00 VSZ, 01 VPS, 04 HSZ, 05 HPS (TWIN 60Hz)"
45. Adjust "GEO 09 TRZ".
46. Repeat step 5, 6 and 8.

FOR WIDE MODE, DRC1050(60Hz)

47. Change to VIDEO MODE: Input 525/60Hz signal.
48. Change to DRC-MF: DRC1050, WIDE MODE: ON
49. Adjust the items listed in no.36.

FOR WIDE MODE, DRC100(60Hz)

50. Change the VIDEO MODE: Input 525/60Hz signal.
51. Change to DRC-MF: DRC100, WIDE MODE: ON.
52. Adjust the items listed in no.36 and repeat step 5, 6 and 8.

FOR WIDE MODE, PIP(60Hz)

53. Change the VIDEO MODE: Input 525/60Hz signal.
54. Change to PIP: ON, WIDE MODE: ON.
55. Adjust the items listed in no.36 and repeat step 5, 6 and 8.

6-5. A BOARD ADJUSTMENT AFTER IC003 (MEMORY) REPLACEMENT

1. Enter to Service Mode.
2. Press commander buttons 5 and 0 (Data Initialize), and 2 and 0 (Data Copy) to initialize the data.
3. Call each item number and check if the respective screen shows the normal picture.
In cases where items are not well adjusted, rectify the items with fine adjustment.
4. Select item numbers "OPB00" (OP1), "OPB01" (OP2) and respectively set the bit per model with command buttons 3 and 6.
5. Press commander buttons 8 and 0 (Test Normal) to return to the data that was set on the shipment from the factory. (This will also cancel Service Mode).

6-6. PICTURE DISTORTION ADJUSTMENT (1)

Item Number 00 – 0B

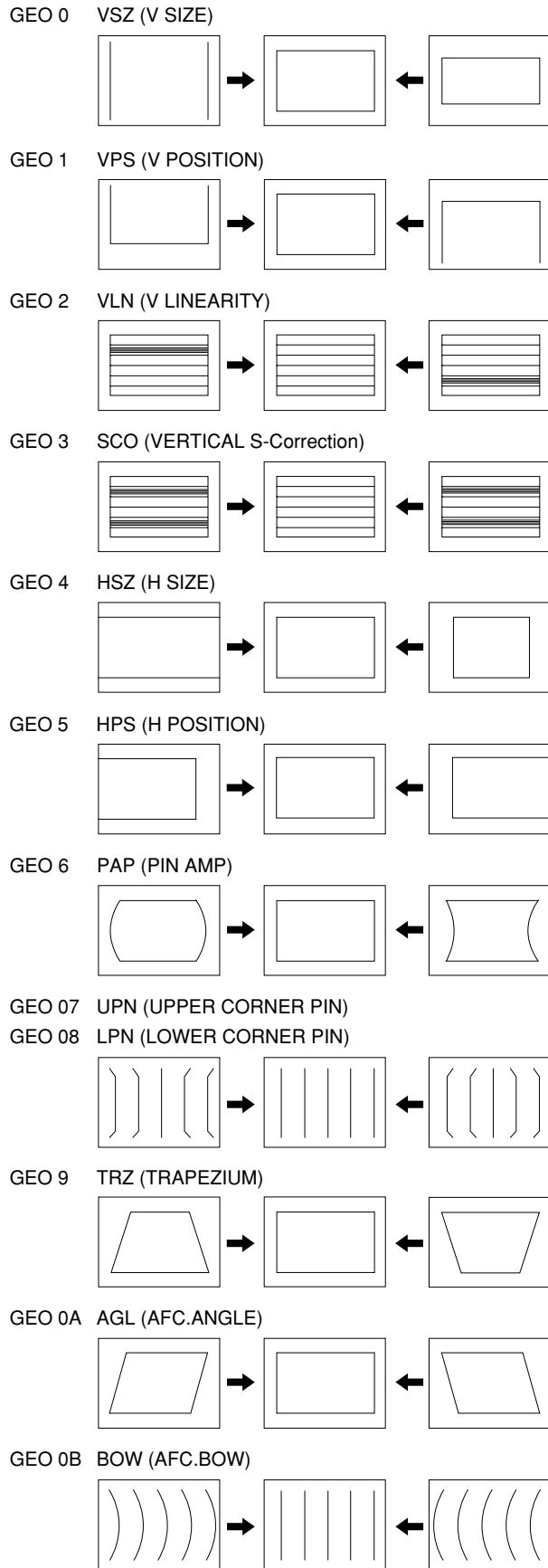

PICTURE DISTORTION ADJUSTMENT (2)

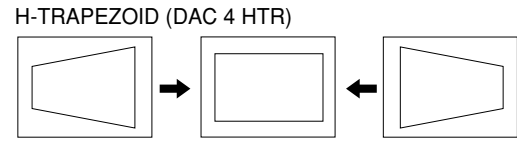

SECTION 7
DIAGRAMS

7-1. BLOCK DIAGRAM

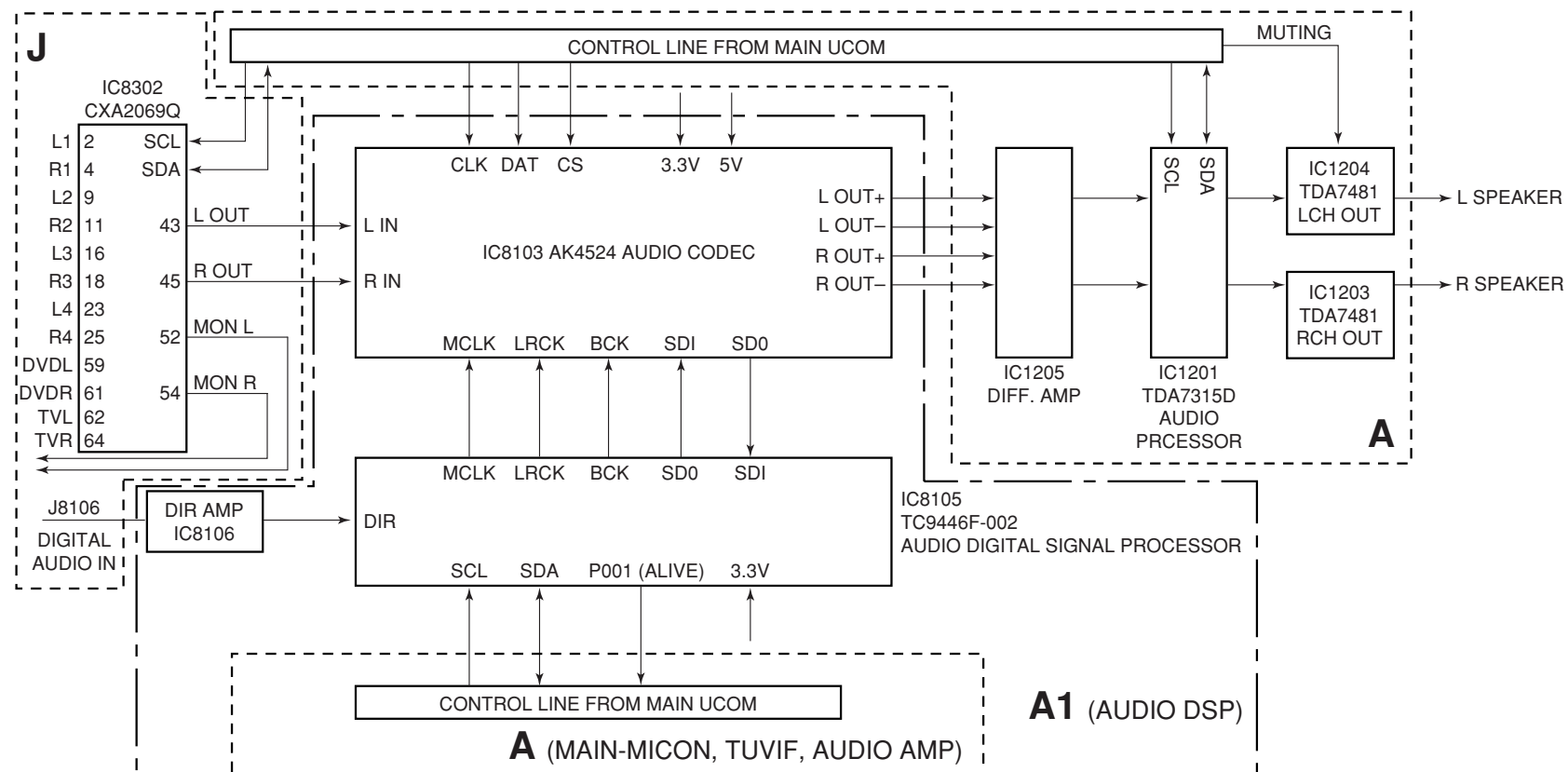
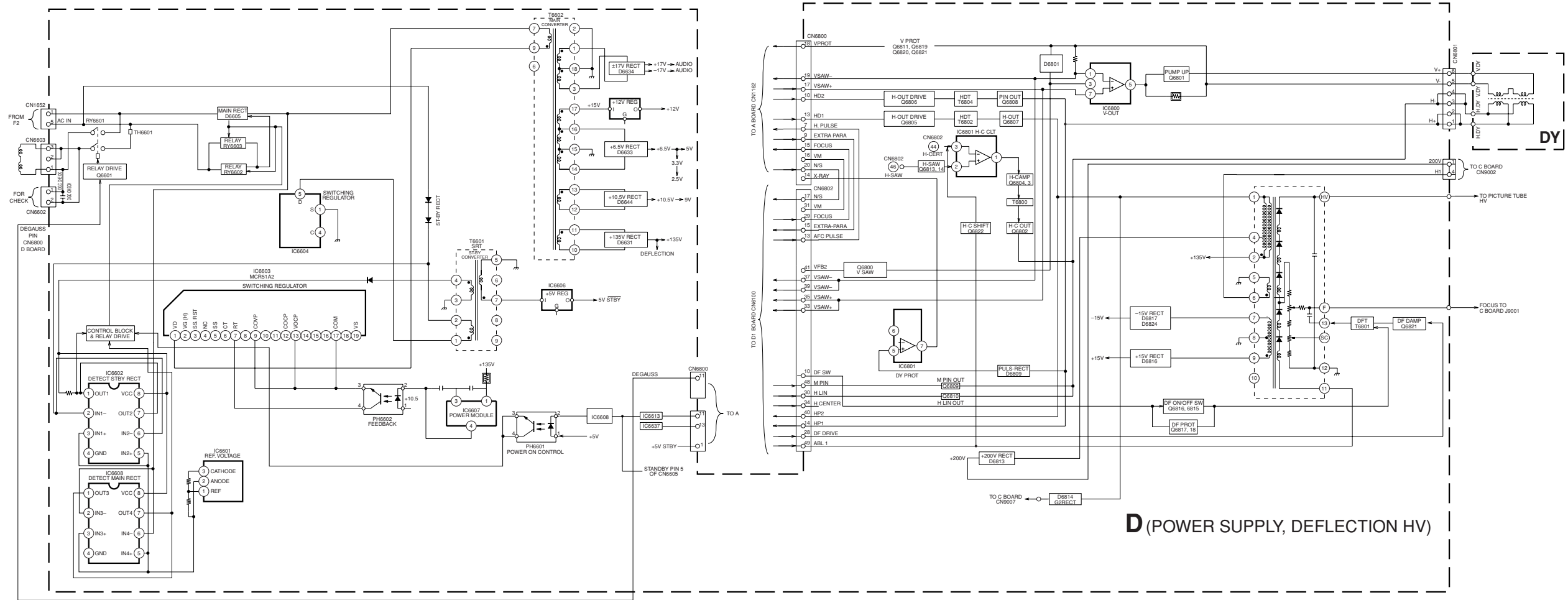

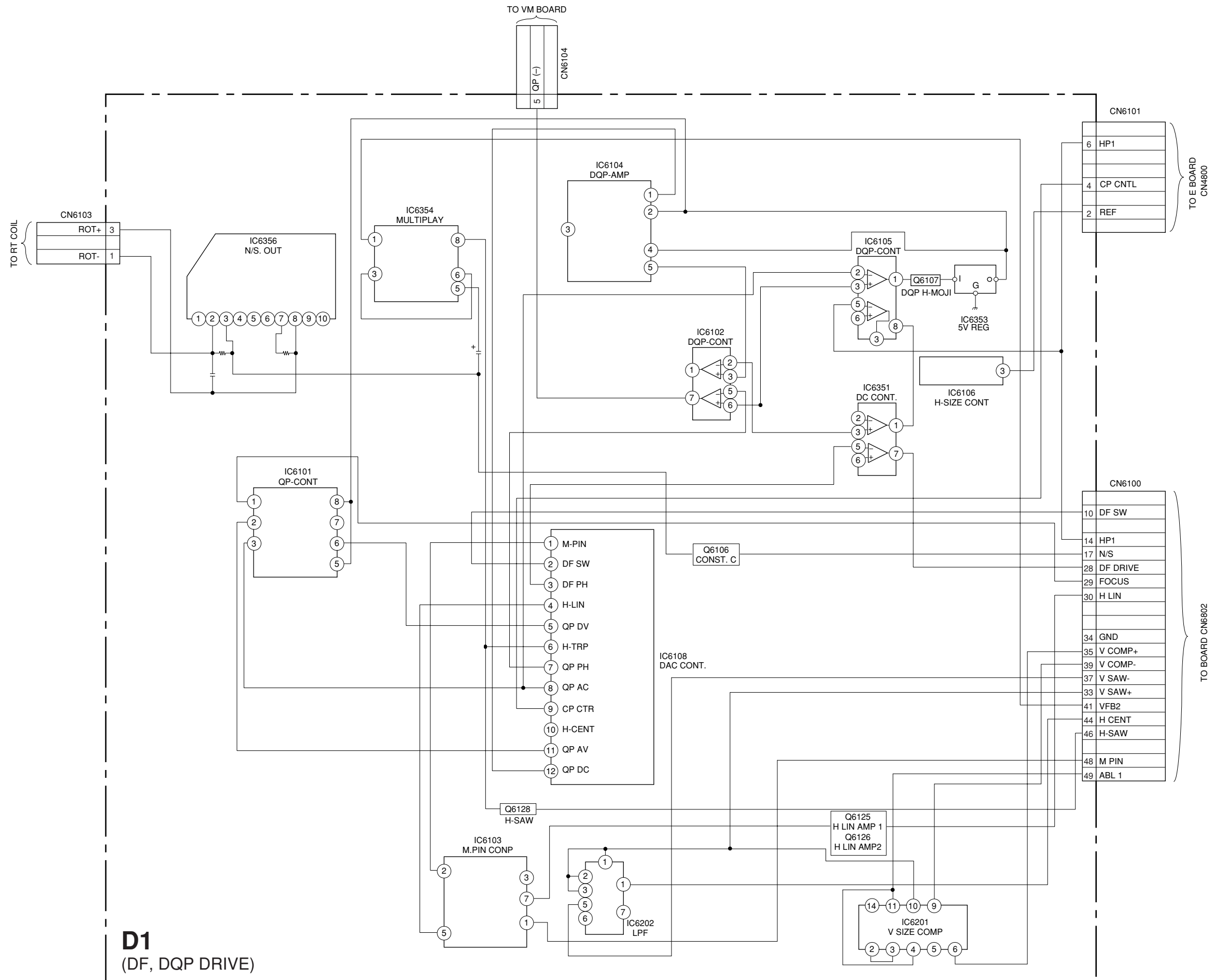

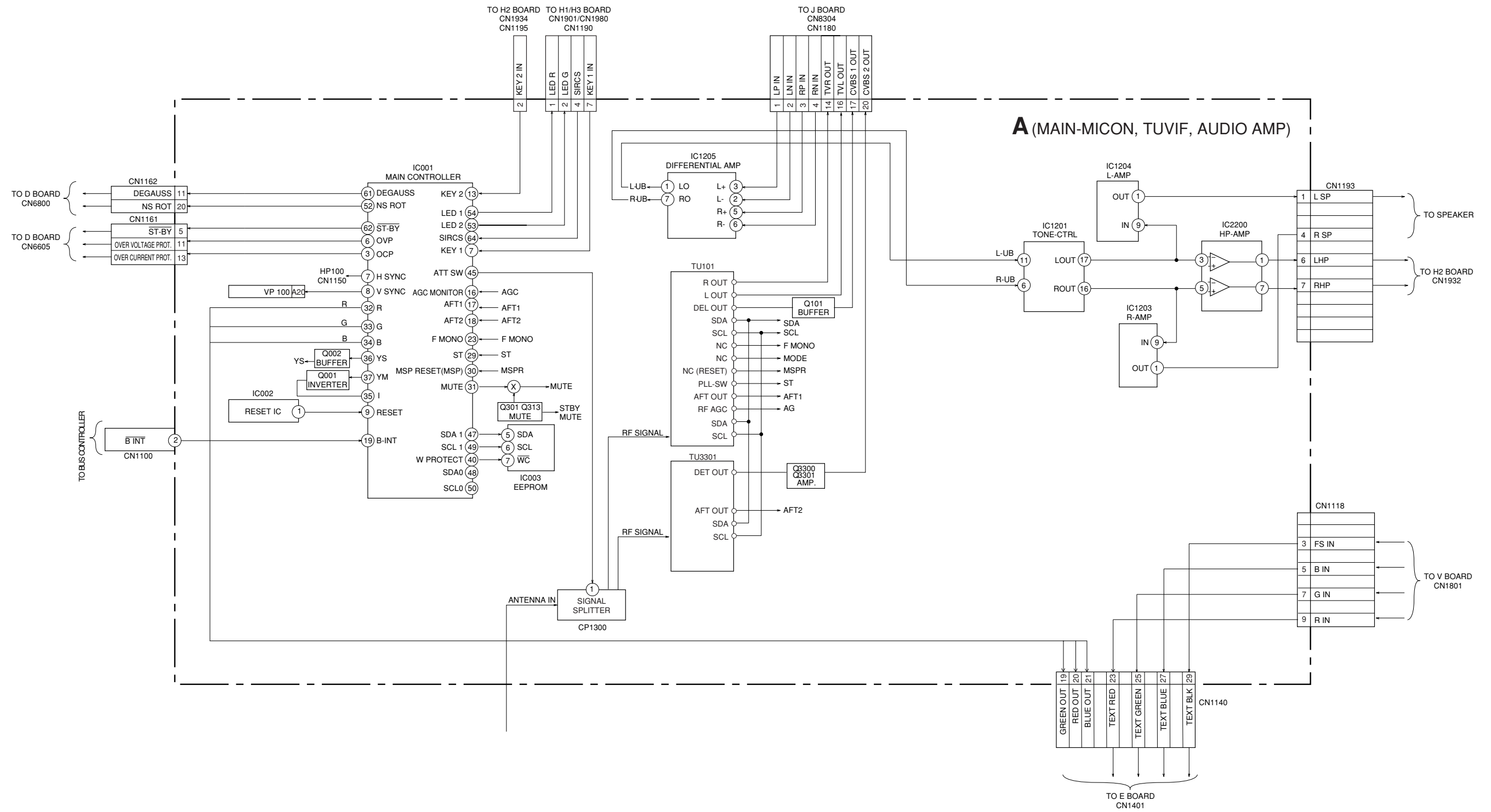

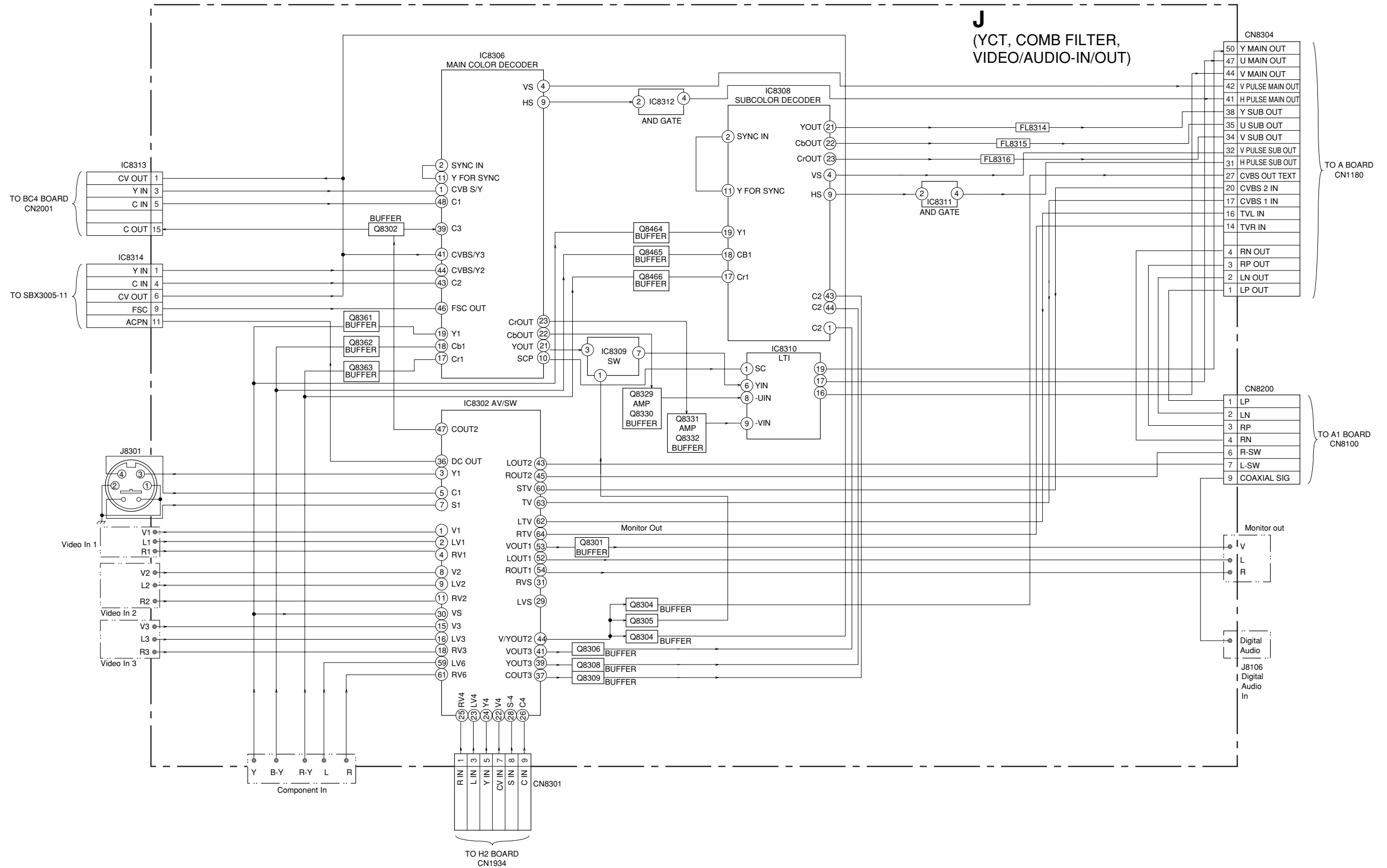

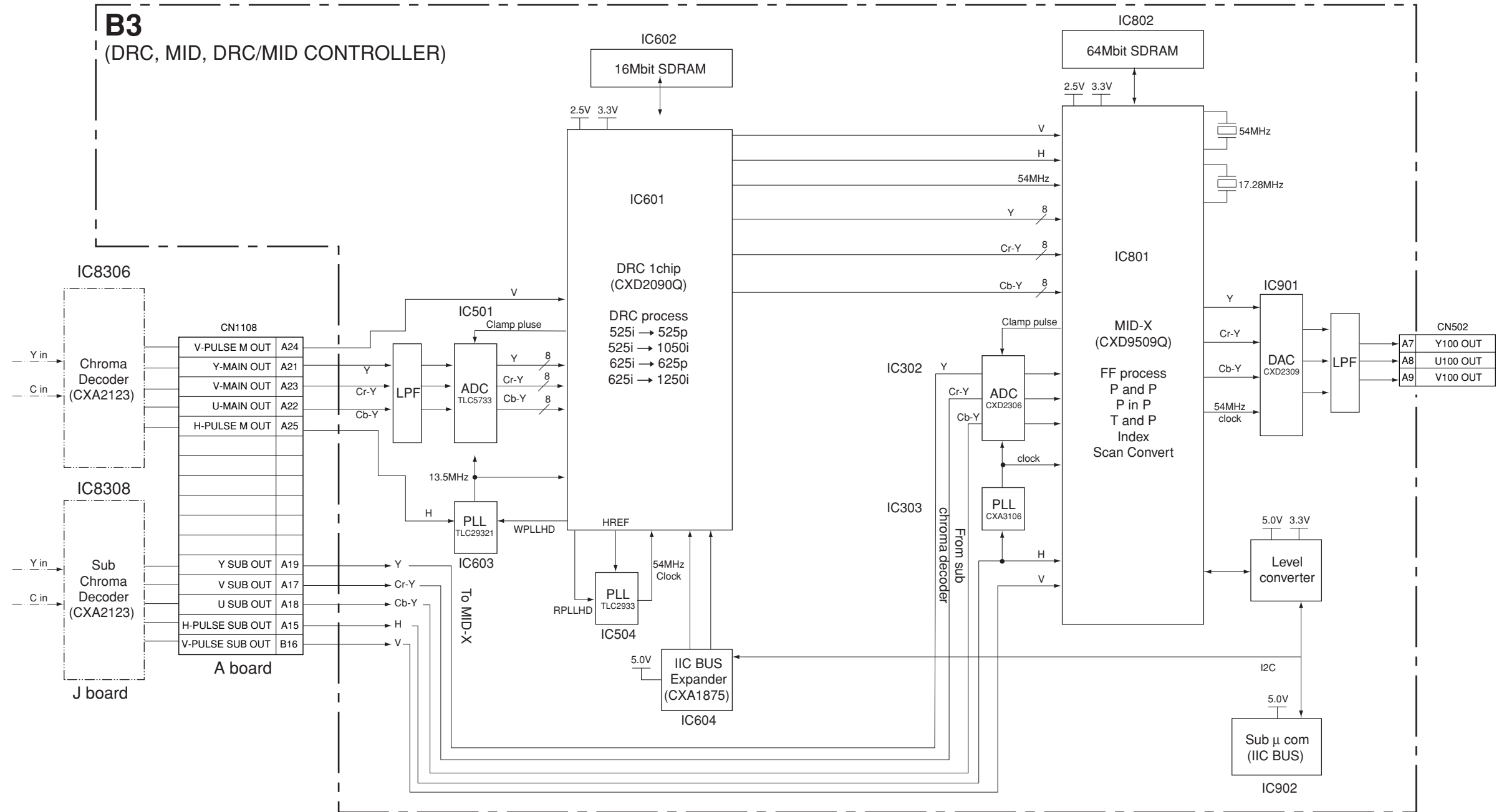

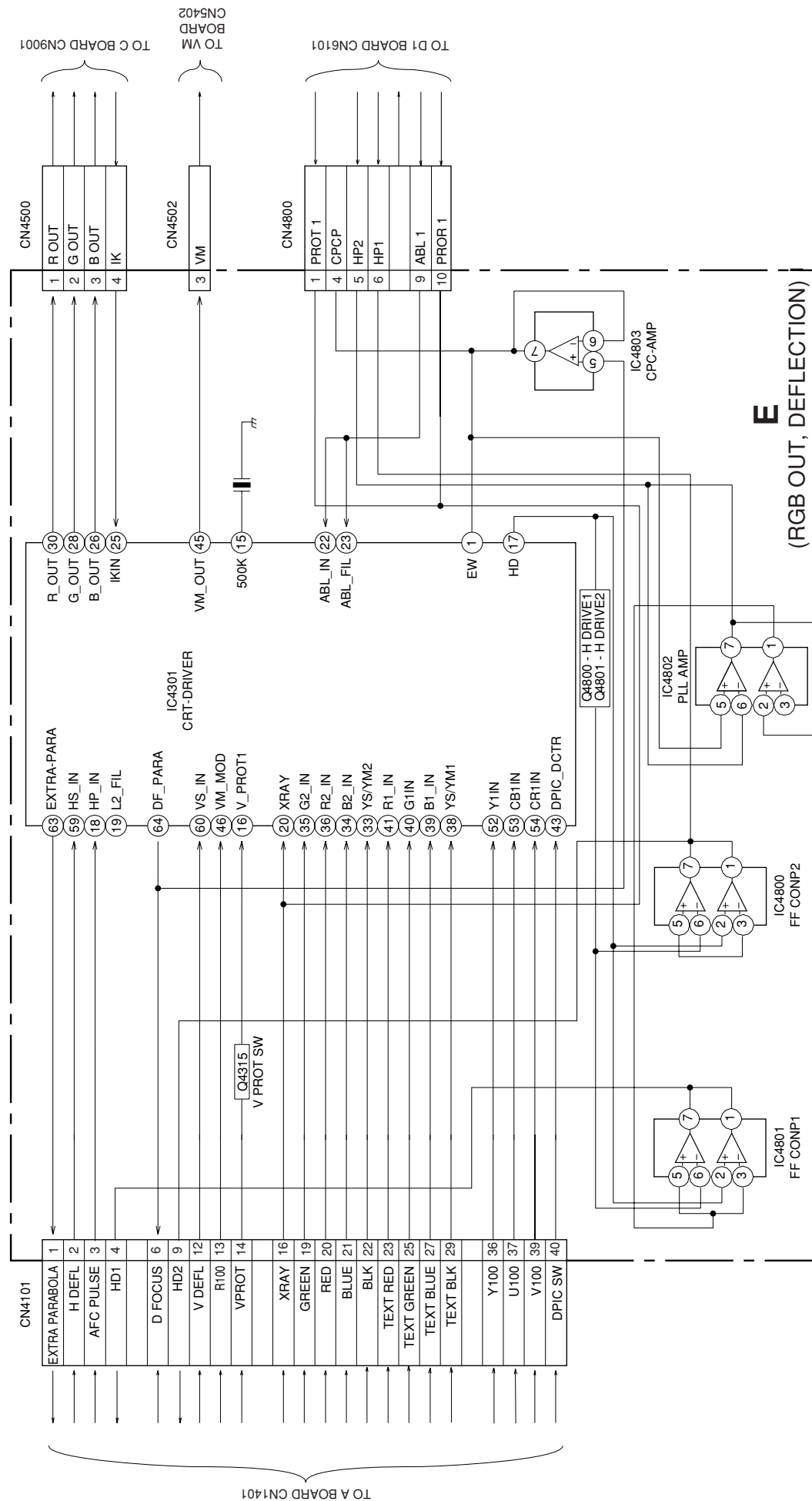

7-2. SCHEMATIC DIAGRAM

Note:

- All capacitors are in μF unless otherwise noted.
- All electrolytic capacitors are rated at 50V unless otherwise noted.
- All resistors are in ohms.
 $\text{k}\Omega = 1000\Omega$, $\text{M}\Omega = 1000\text{k}\Omega$
- Indication of resistance which does not have rating electrical power is as follows.

Pitch: 5 mm
Rating electrical power 1/4W (CHIP: 1/10W)

- : nonflammable resistor.
- : internal component.
- : panel designation or adjustment for rrepair.
- All variable and adjustable resistors have characteristic curve B unless otherwise noted.
- **Readings are taken with a color-bar signal input.**
no mark : Common
underline : PAL
() : SECAM
[] : NTSC 3.58
<< >> : NTSC 4.43
- **Readings are taken with a 10 M Ω digital multimeter.**
- **Voltage are dc with respect to ground unless otherwise noted.**
- **Voltage variations may be noted due to normal production tolerances.**
- **All voltage are in Volt.**
- * : Cannot be measured.
- **Circled numbers are waveform references.**
- : B +bus.
- : B -bus.
- : signal path.

Reference information

RESISTOR	: RN	METAL FILM
	: RC	SOLID
	: FPRD	NONFLAMMABLE CARBON
	: FUSE	NONFLAMMABLE FUSIBLE
	: RS	NONFLAMMABLE METAL OXIDE
	: RB	NONFLAMMABLE CEMENT
	: RW	NONFLAMMABLE WIREWOUND
	: *	ADJUSTMENT RESISTOR
COIL	: LF-8L	MICRO INDUCTOR
CAPACITOR	: TA	TANTALUM
	: PS	STYROL
	: PP	POLYPROPYLENE
	: PT	MYLAR
	: MPS	METALIZED POLYESTER
	: MPP	METALIZED POLYPROPYLENE
	: ALB	BIPOLAR
	: ALT	HIGH TEMPERATURE
	: ALR	HIGH RIPPLE

Note: The component identified by shading and mark Δ are critical for safety. Replace only with part number specified.

(1) Schematic Diagram of A Board

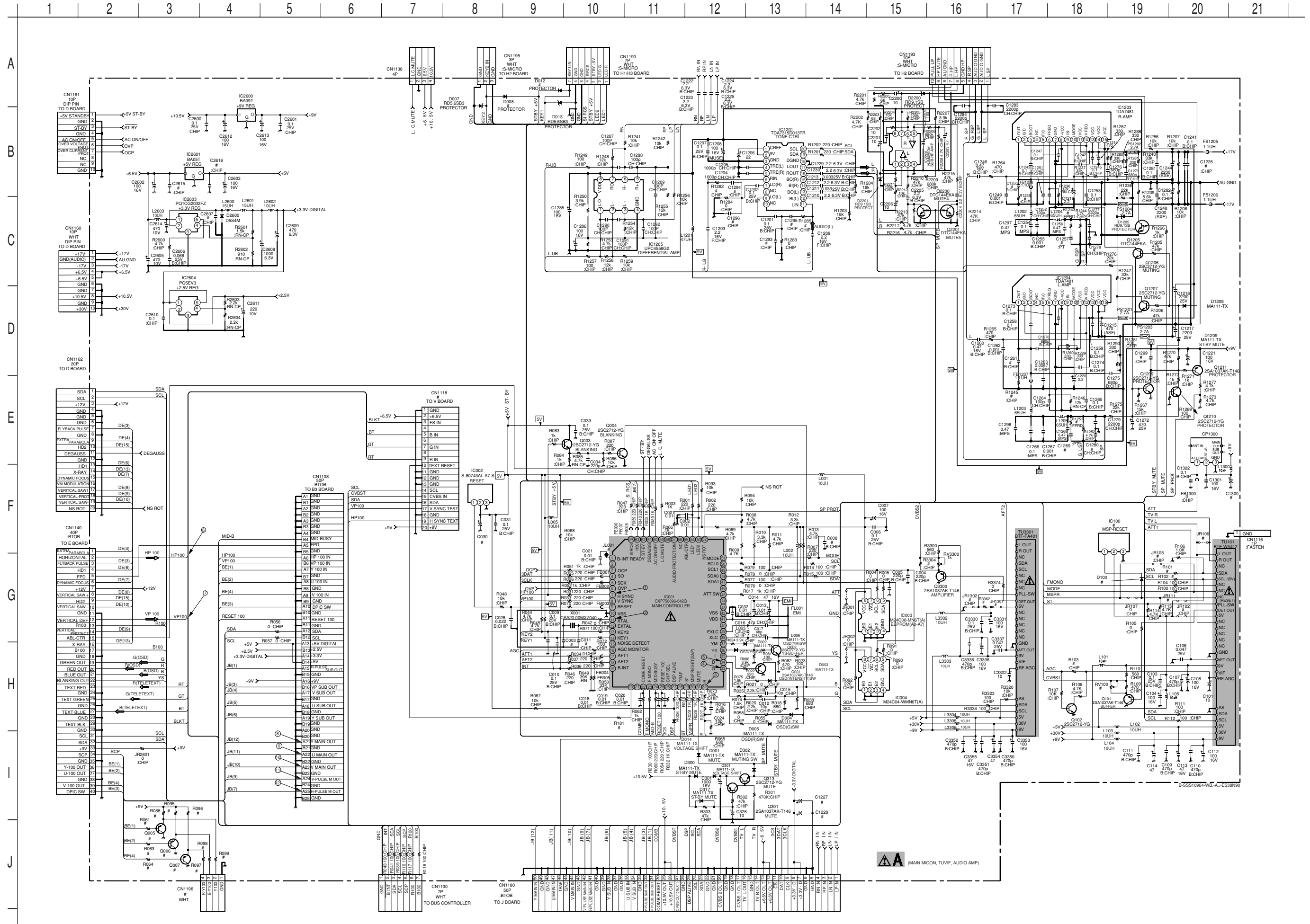

(3) Schematic Diagram of D1 Board

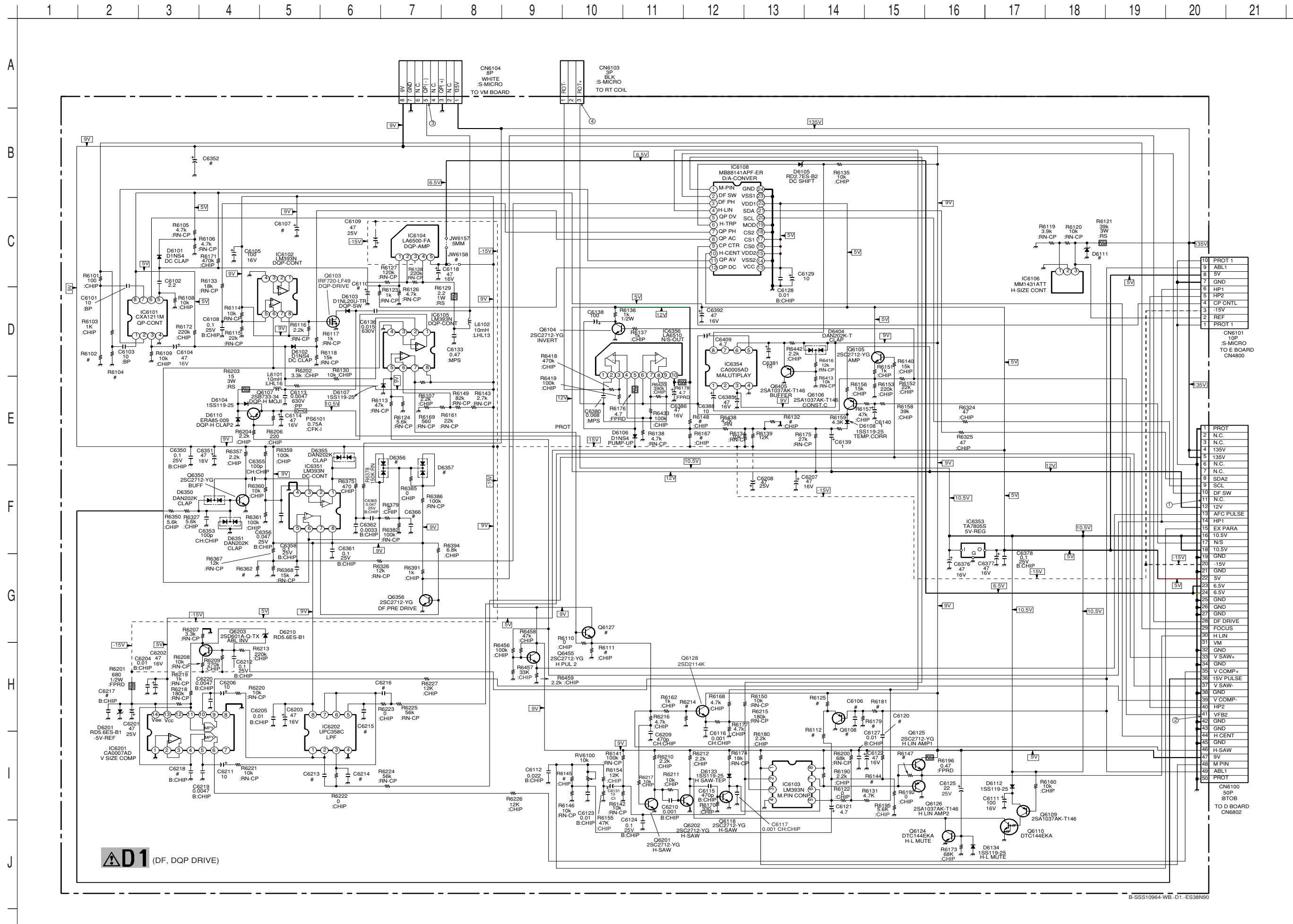

(4) Schematic Diagram of C Board

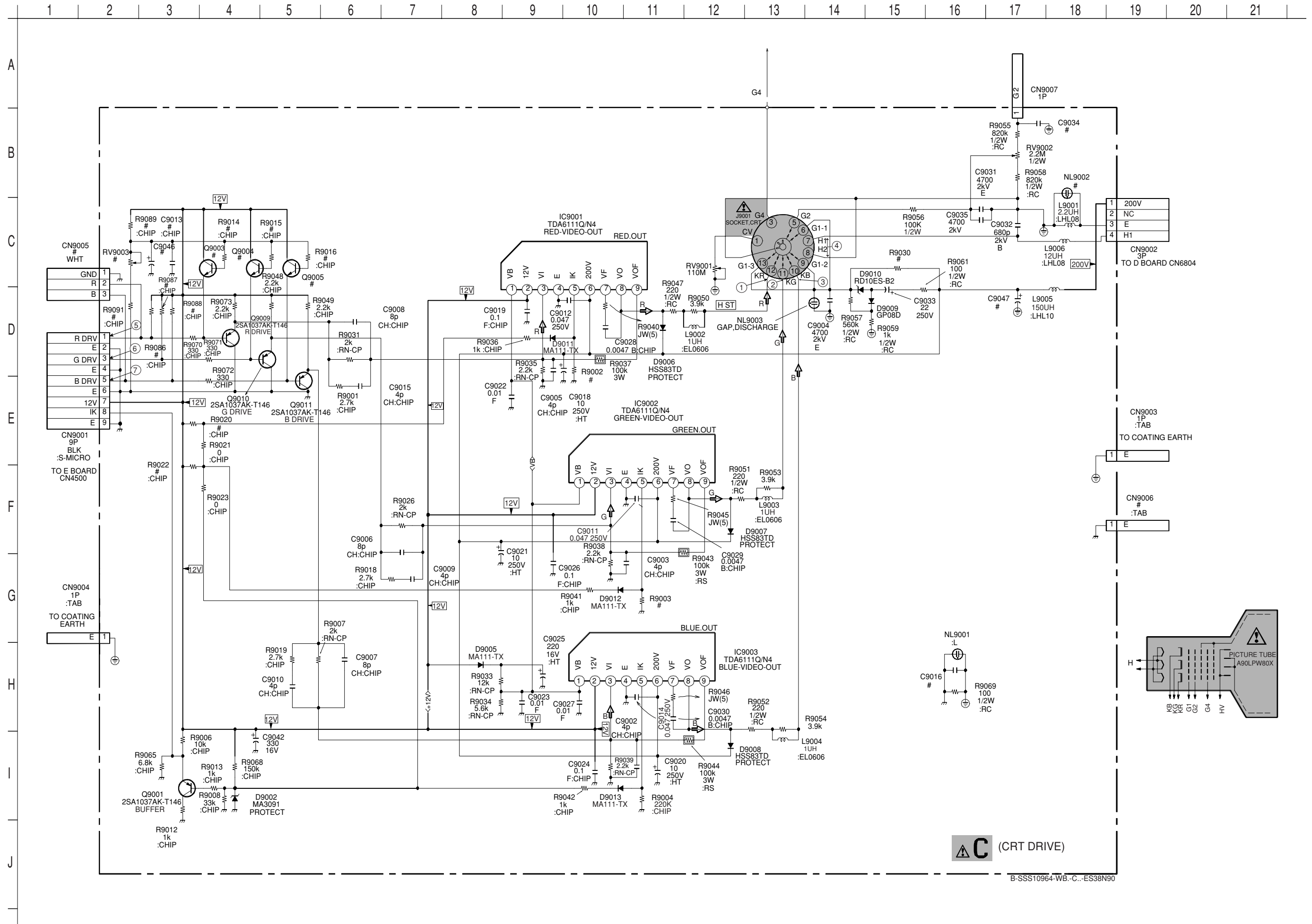

(7) Schematic Diagrams of VM and F1 Boards

1 2 3 4 5 6 7 8 9 10 11 12 13 14 15 16 17 18 19 20 21

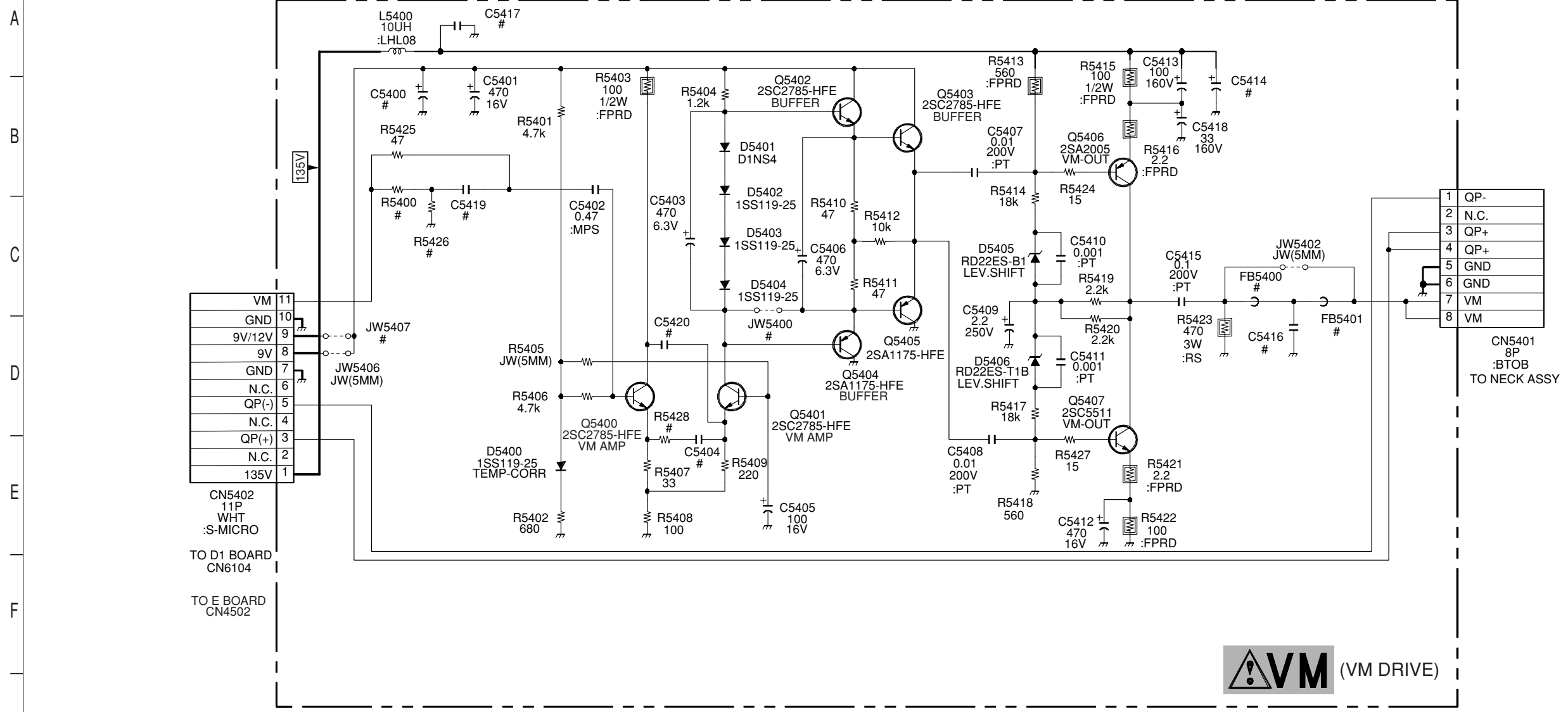

G

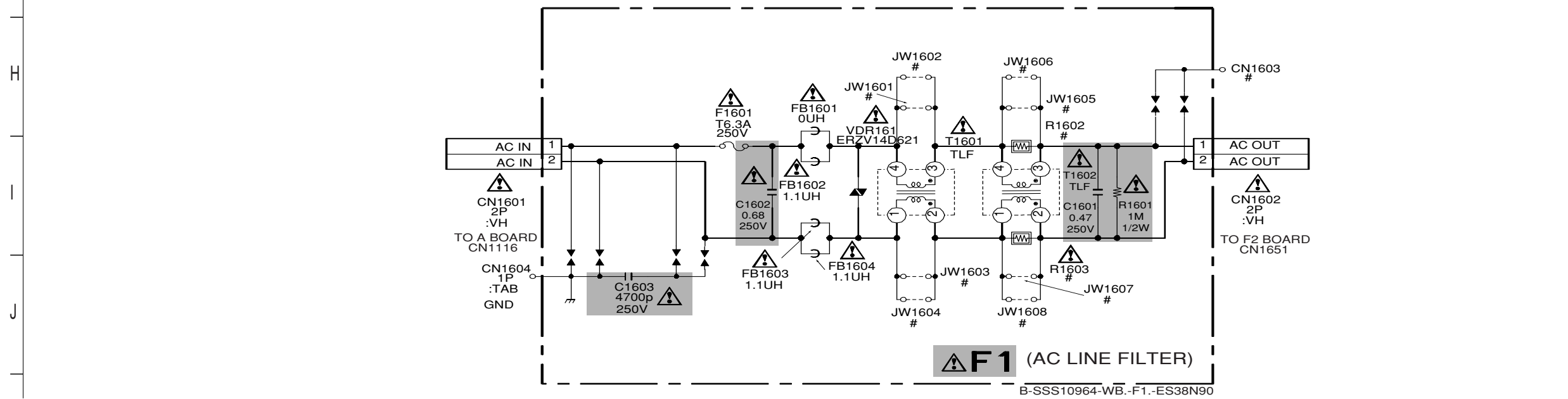

H I J

(8) Schematic Diagrams of H1, H3, F2 and SP Boards

1 2 3 4 5 6 7 8 9 10 11 12 13 14 15 16 17 18 19 20 21

A

B

C

D

E

F

G

H

I

J

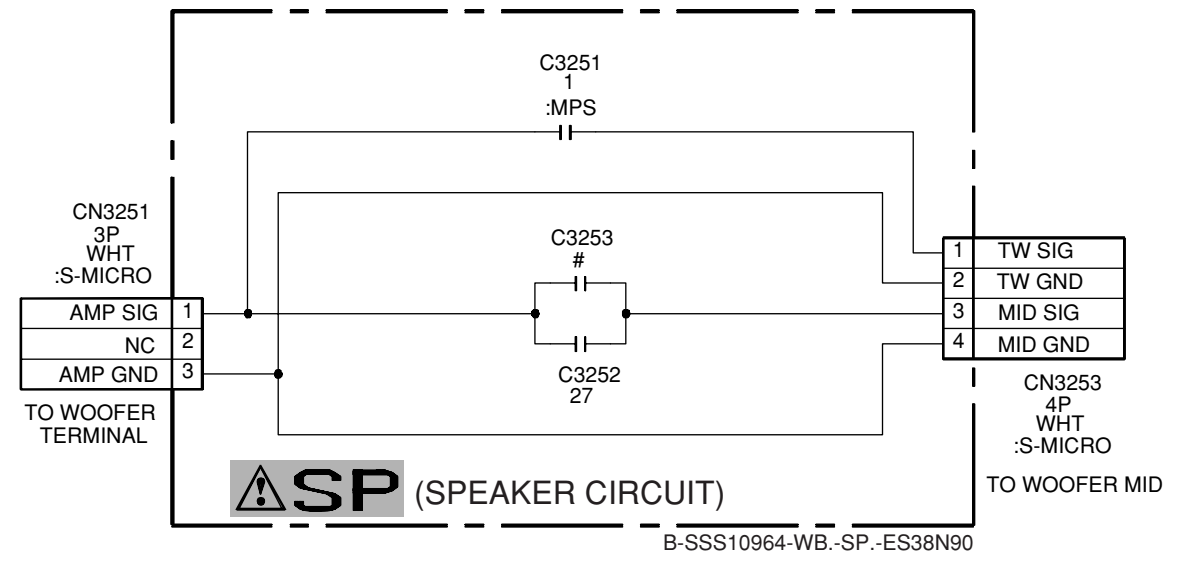
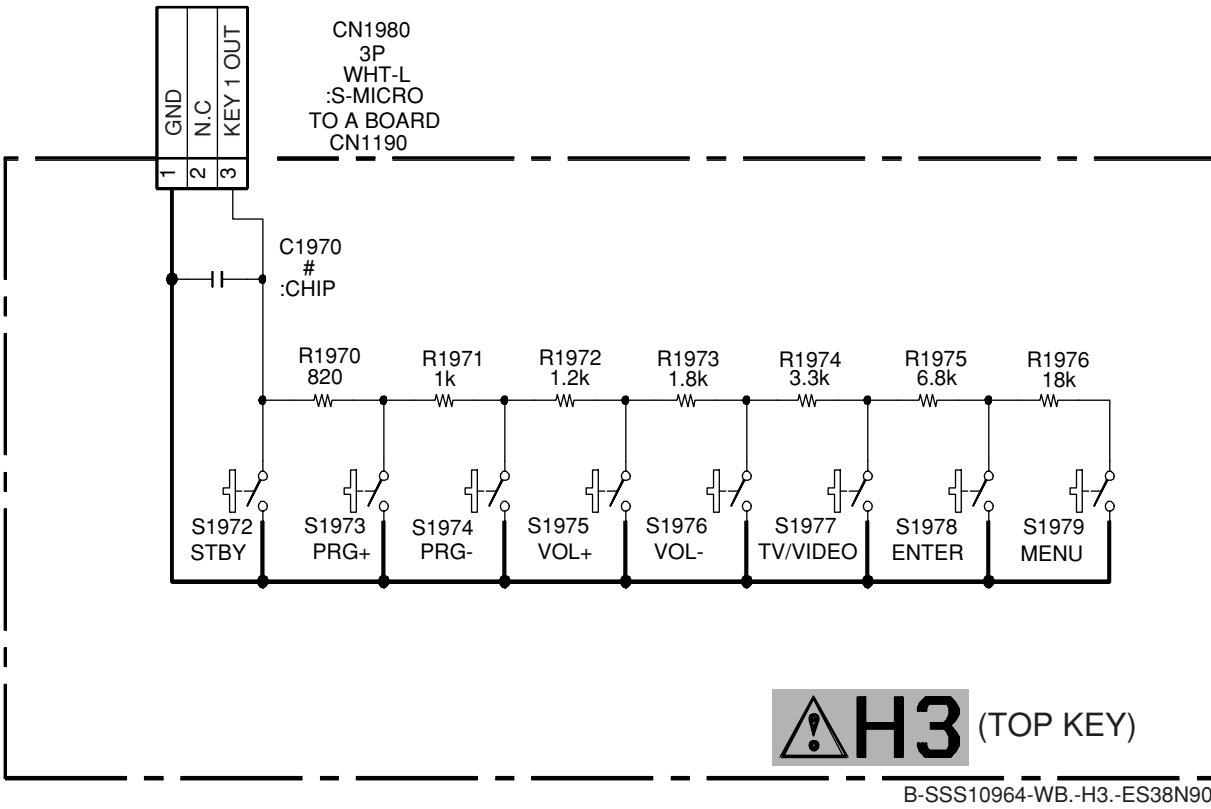
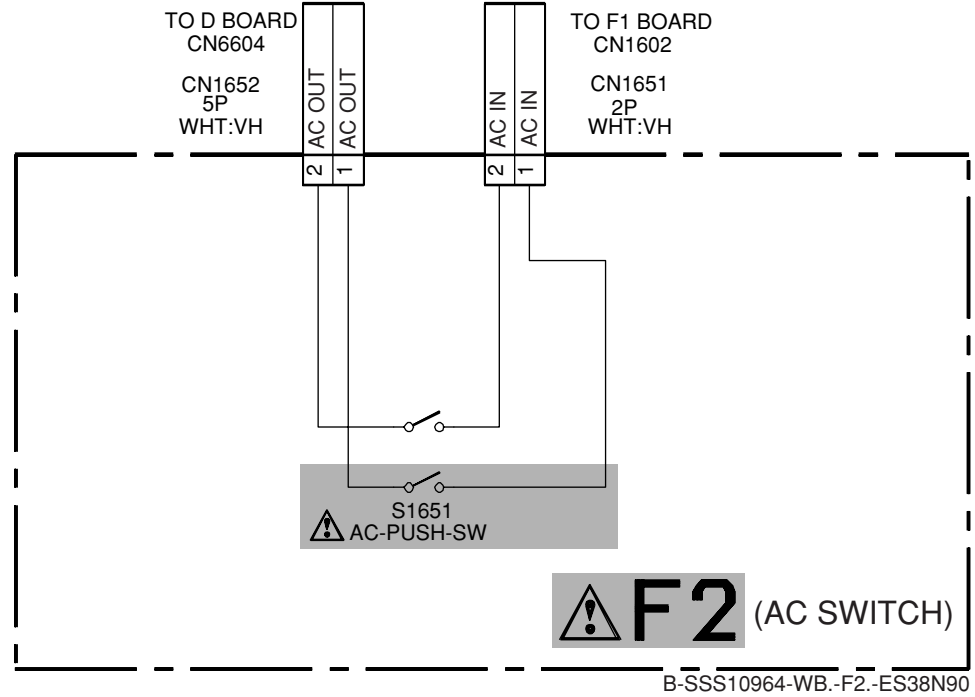
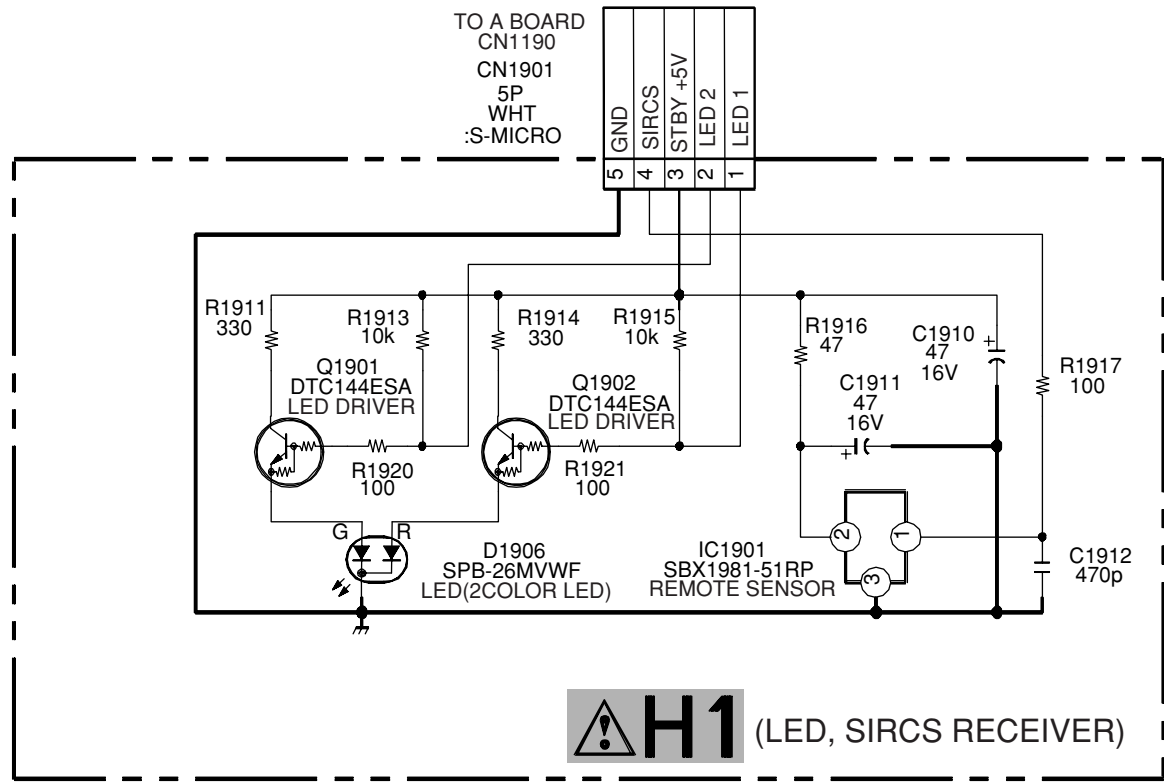

(10) Schematic Diagram of A1 Board

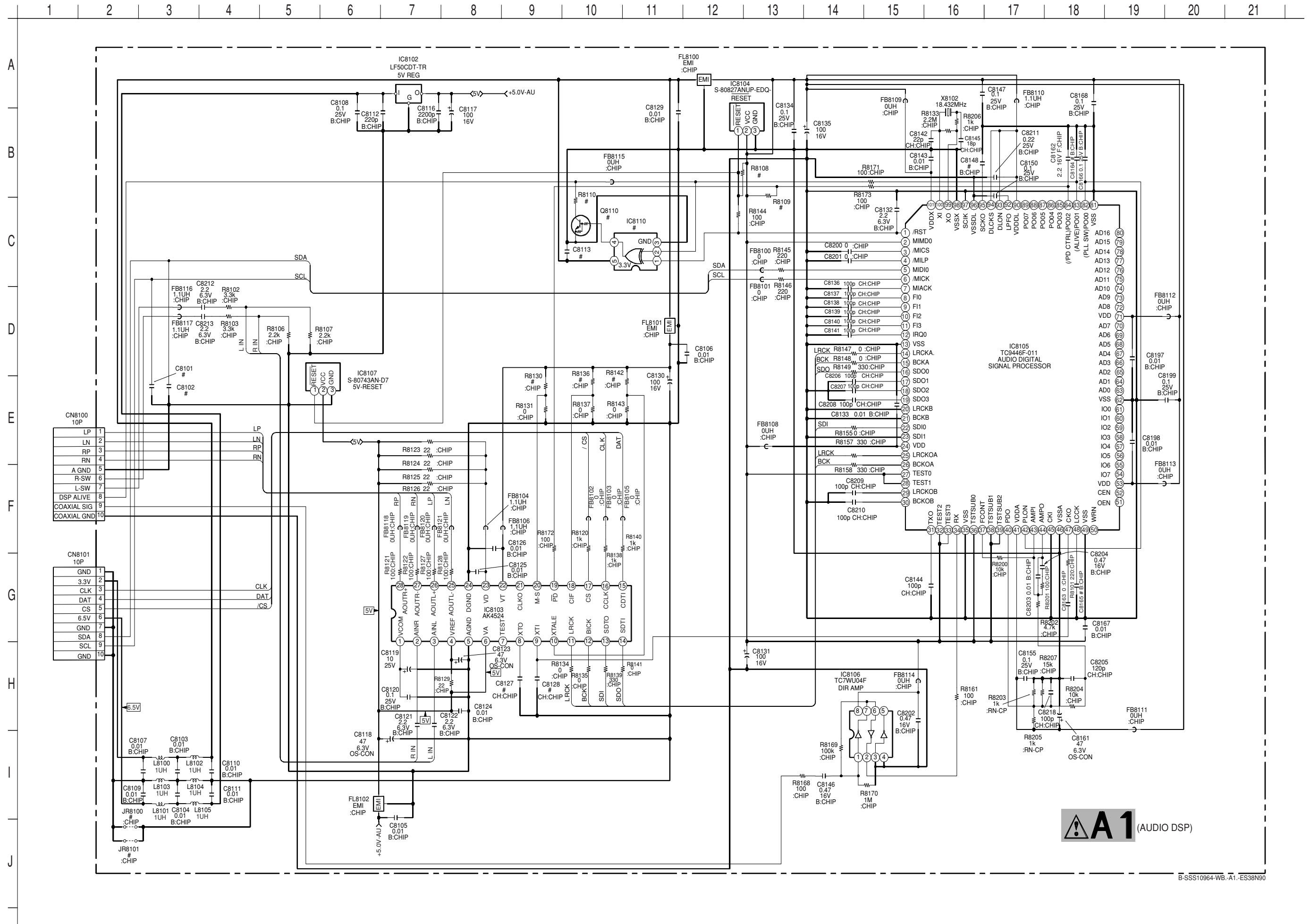

(11) Schematic Diagram of BC4 Board

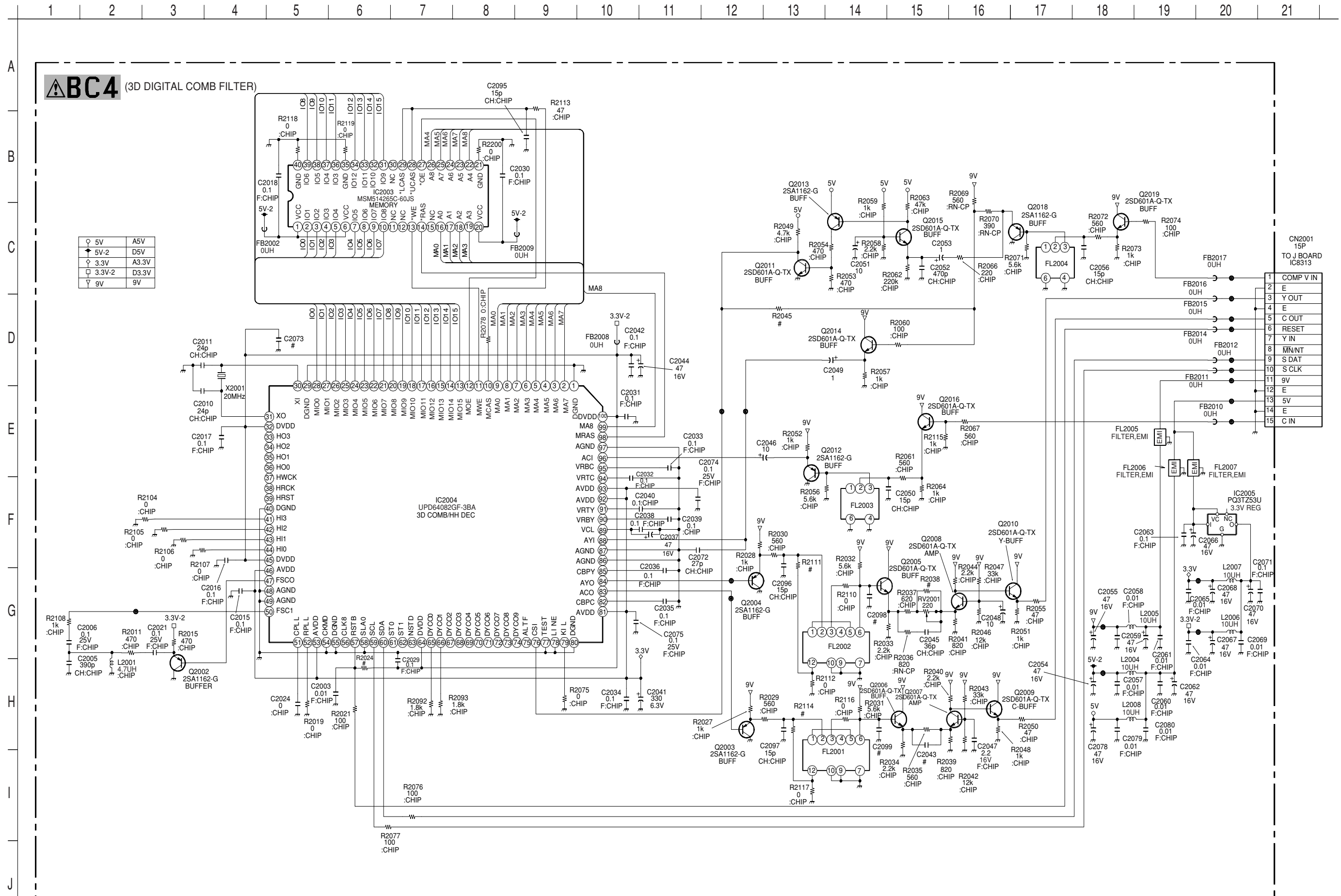

B-SSST0964-WB-BC4-ES38N90

1 2 3 4 5 6 7 8 9 10 11 12 13 14 15 16 17 18 19 20 21

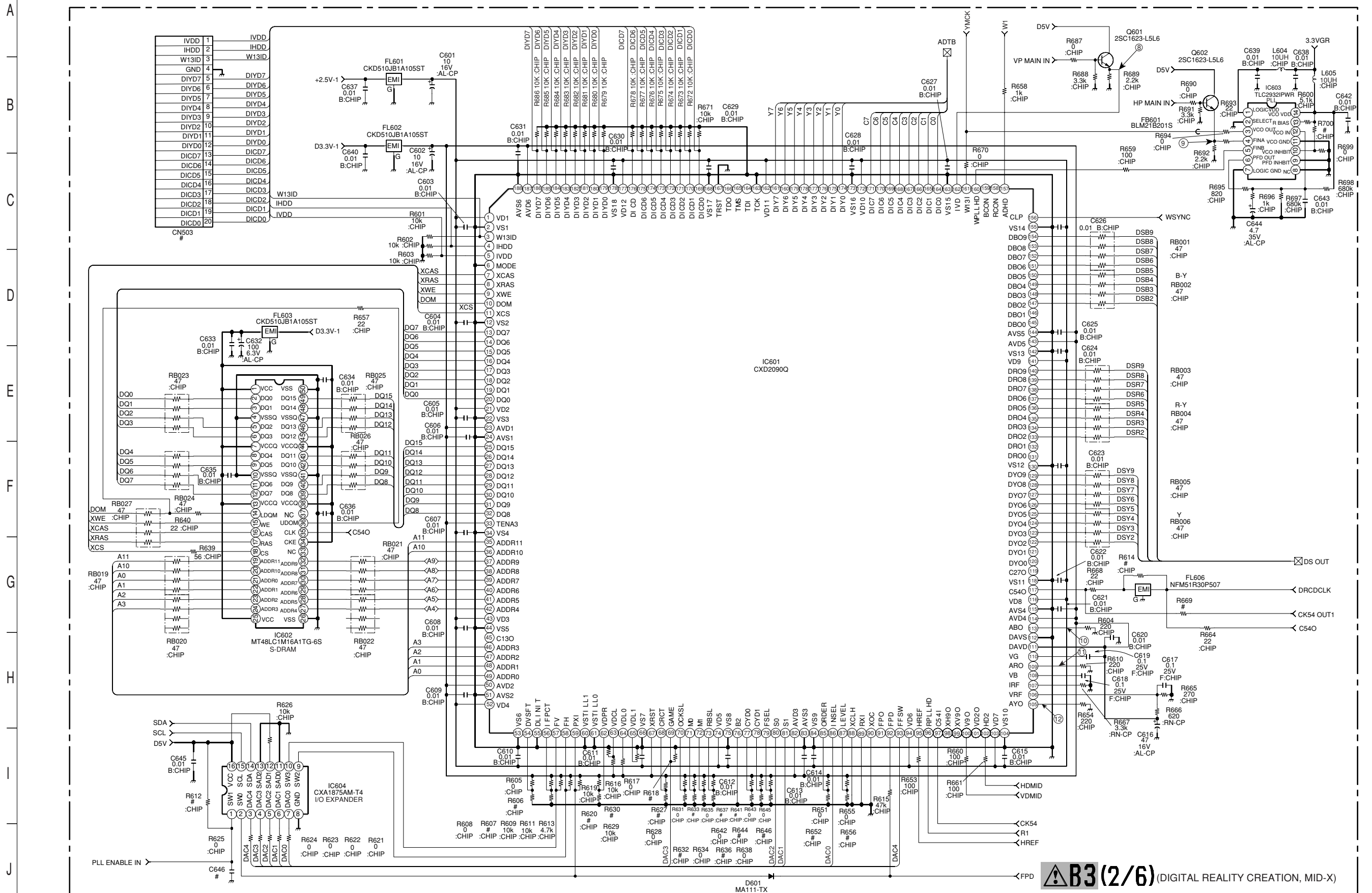

B3(2/6) (DIGITAL REALITY CREATION, MID-X)

1 2 3 4 5 6 7 8 9 10 11 12 13 14 15 16 17 18 19 20 21

A
B
C
D
E
F
G
H
I
J

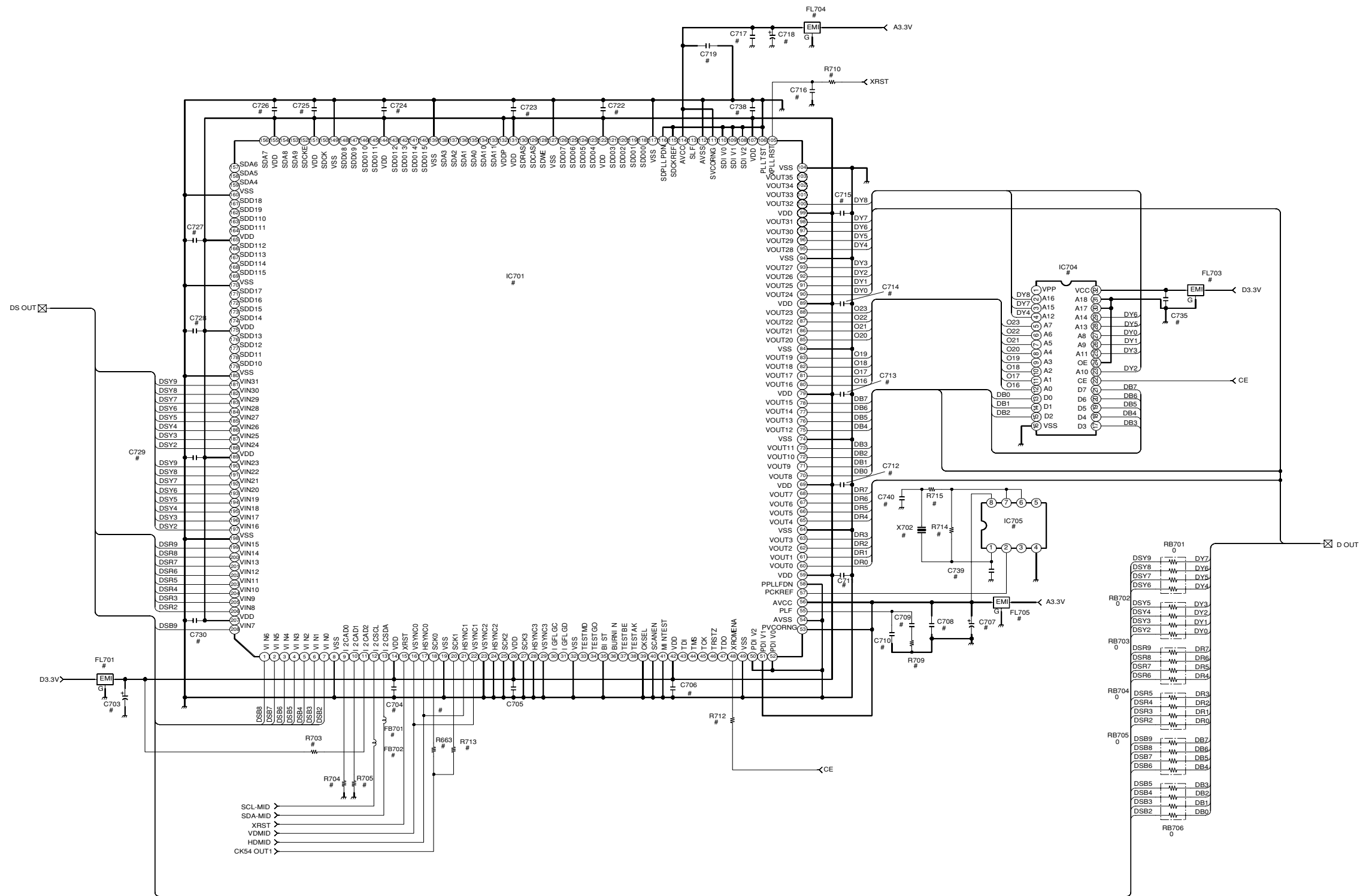

1 2 3 4 5 6 7 8 9 10 11 12 13 14 15 16 17 18 19 20 21

A
B
C
D
E
F
G
H
I
J

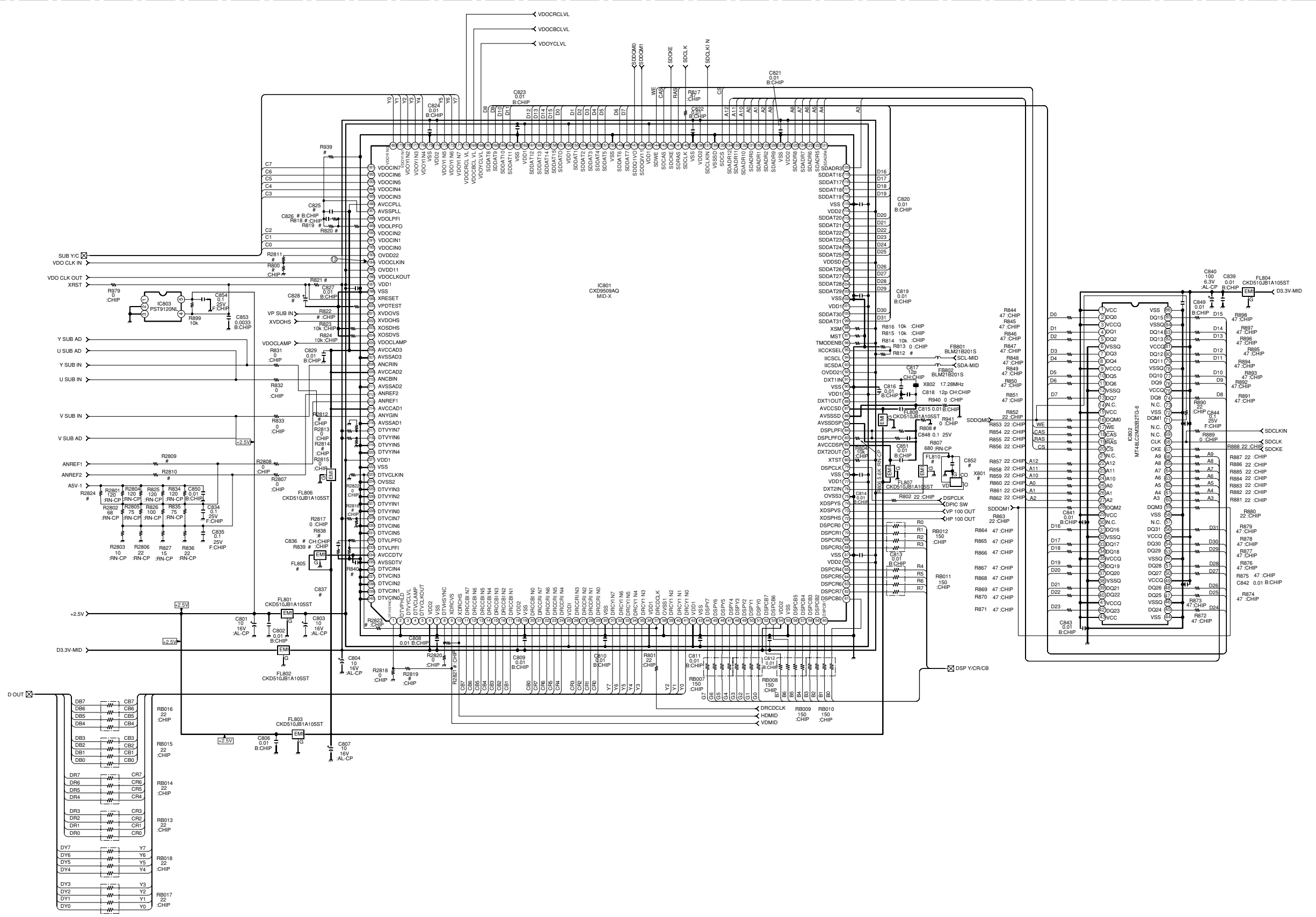

B3(4/6) (DIGITAL REALITY CREATION, MID-X)

B-SSS10964-WB-B3(P4)-ES38N90

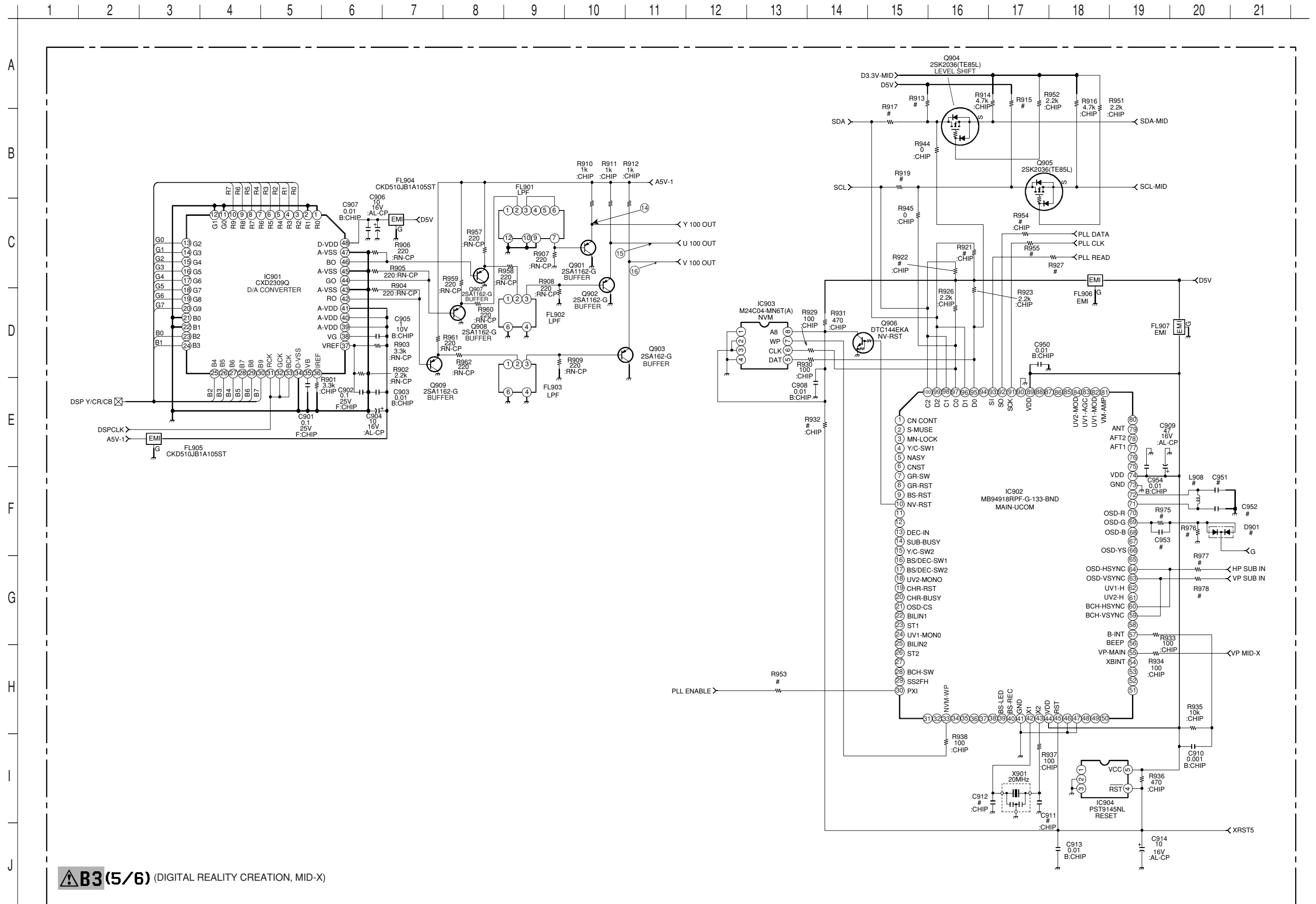

B3(5/6) (DIGITAL REALITY CREATION, MID-X)

1 2 3 4 5 6 7 8 9 10 11 12 13 14 15 16 17 18 19 20 21

A
B
C
D
E
F
G
H
I
J

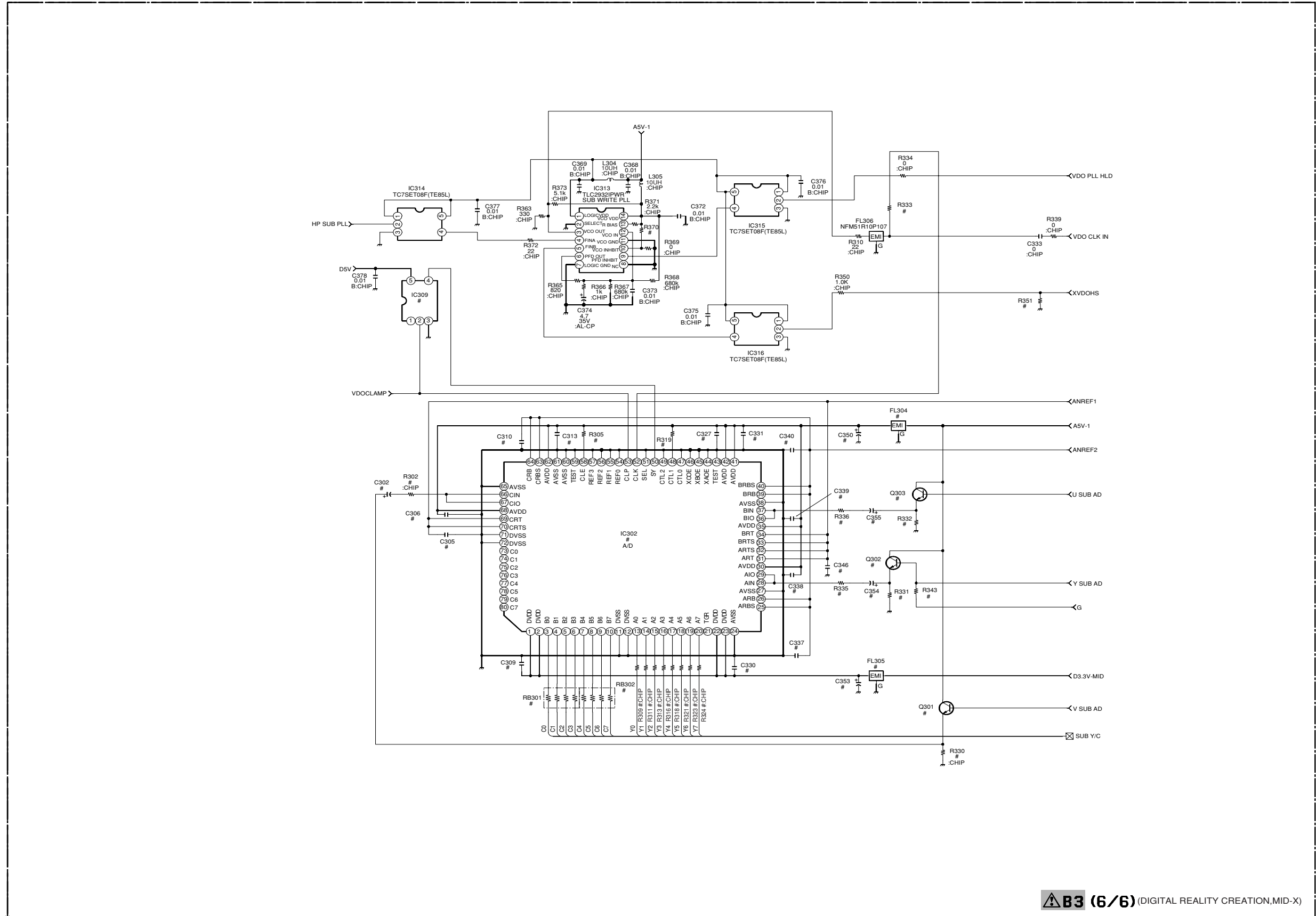

7-3. VOLTAGE MEASUREMENT

A BOARD VOLTAGE LIST

Ref	Pin No	Voltage[v]	Ref	Pin No	Voltage[v]	Ref	Pin No	Voltage[v]	
IC001	1	5.0	IC003	1	0		6	4.5	
	2	0		2	0		7	4.5	
	3	0.1		3	0		8	9.0	
	4	<[5.0]>(0)		4	0		IC2200	1	4.5
	5	5.0		5	5.0			2	0
	6	0		6	5.0			3	4.4
	7	0.3		7	0			4	0
	8	0.3		8	5.0			5	4.4
	9	<[0]>(5.0)	IC100	1	4.8	6		0	
	10	<[5.0]>(0)		2	4.8	7		4.5	
	11	<[0]>(2.4)		3	0	8		9.0	
	12	<[0]>(3.2)	IC1201	1	4.4	IC2600	I	12.1	
	13	<[0]>(5.0)		2	9.0		G	0	
	14	<[0]>(5.0)		3	0		O	9.0	
	15	0		4	4.4	IC2601	I	6.8	
	16	<[3.2]>(0.2)		5	4.4		G	0	
	17	<[2.5]>(2.0)		6	0		O	5.0	
	18	<[2.6]>(0)		7	4.4	IC2604	1	3.3	
	19	<[5.0]>(0)		8	0		2	2.5	
	20	0		9	4.4		3	0	
	21	0		10	0		4	1.2	
	22	<[0]>(5.0)		11	4.4		5	3.3	
	23	0		12	4.4	Q001	B	0	
	24	0		13	4.4		C	0	
	25	0		14	4.4		E	5.0	
	26	<[0]>(5.0)		15	4.4	Q002	B	5.0	
	27	<[0]>(0.6)		16	4.4		C	0	
	28	0		17	4.4		E	0	
	29	<[2.3]>(0)		18	4.4	Q101	B	8.9	
	30	<[0]>(5.0)		19	4.3		C	2.1	
	31	0		20	4.4		E	2.8	
	32	0	IC1203	1	-3.3	Q301	B	0	
	33	0		2	-15.8		C	12.0	
	34	0		3	*		E	11.6	
	35	<[5.0]>(0)		4	-0	Q313	B	11.6	
	36	0		5	-16.6		C	0	
	37	0		6	-5.3		E	0	
	38	<[2.6]>(0)		7	0	Q1205	B	0	
	39	<[2.6]>(0)		8	-18.3		C	0	
	40	<[4.8]>(0)		9	-16.1		E	0	
	41	5.0		10	7.4	Q1206	B	0.1	
	42	0		11	19.1		C	0	
	43	0.1		12	0		E	0	
	44	0.1		13	0	Q1207	B	5.5	
	45	0		14	0		C	0	
	46	0		15	0		E	0	
	47	<[5.0]>(0)	IC1204	1	0	Q1209	B	0	
	48	<[4.0]>(4.5)		2	-8.0		C	0	
	49	<[5.0]>(4.3)		3	9.9		E	0	
	50	<[4.5]>(3.9)		4	0	Q1210	B	0	
	51	0		5	0		C	0	
	52	<[2.4]>(0)		6	-15.9		E	0	
	53	0		7	0	Q1211	B	0	
	54	0		8	-19.0		C	0	
	55	0		9	0		E	0	
	56	0		10	5.9	Q2200	B	0	
	57	0.1		11	19.1		C	0	
	58	0		12	-8.0		E	0	
	59	0		13	19.1	Q2201	B	0	
	60	0		14	-19.0		C	0	
	61	0		15	-19.0		E	0	
	62	<[0]>(4.5)	IC1205	1	4.5	Q3300	B	3.1	
	63	0.3		2	0		C	8.9	
	64	<[4.9]>(0)		3	0		E	8.3	
64	0	4		0					
IC002	1	<[0]>(0.5)	5	4.5					
	2	5.0							
	3	0							

A1 BOARD VOLTAGE LIST

Ref	Pin No	Voltage[v]	Ref	Pin No	Voltage[v]	Ref	Pin No	Voltage[v]	
IC8102	I	3.1		16	0		65	3.2	
	G	0		17	0		66	0	
	O	5.0		18	0		67	3.2	
IC8103	1	2.5		19	0		68	0	
	2	2.5		20	0		69	0	
	3	2.5		21	0		70	3.2	
	4	0		22	0.7		71	3.2	
	5	0		23	0		72	3.2	
	6	4.9		24	3.2		73	3.2	
	7	0		25	0		74	3.2	
	8	1.4		26	0		75	0	
	9	1.4		27	3.2		76	0	
	10	3.2		28	3.2		77	3.2	
	11	0		29	0		78	3.2	
	12	1.6		30	0		79	0	
	13	1.2		31	0		80	0	
	14	1.2		32	3.2		81	0	
	15	4.9		33	3.2		82	0	
	16	2.4		34	0.3		83	0	
	17	4.9		35	0		84	0	
	18	0		36	3.2		85	0	
	19	0		37	1.6		86	0	
	20	3.2		38	3.2		87	0	
	21	0		39	3.2		88	0	
	22	0		40	1.6		89	3.2	
	23	4.9		41	3.2		90	3.2	
	24	0		42	0		91	0.9	
	25	2.5		43	2.9		92	3.2	
	26	2.5		44	0		93	3.2	
	27	2.4		45	0		94	0	
	28	2.4		46	0		95	0	
IC8104	1	2.2		47	0		96	0	
	2	3.2		48	0		97	0	
	3	0		49	0		98	1.3	
IC8105	1	3.2		50	3.2		99	1.4	
	2	3.2		51	0		100	3.3	
	3	0		52	3.2		IC8106	1	1.7
	4	0		53	3.2			2	0.3
	5	4.4		54	3.2			3	0.1
	6	4.5		55	3.2			4	0
	7	3.2		56	3.2			5	3.2
	8	3.2		57	3.2			6	1.9
	9	3.2		58	3.2			7	1.9
	10	3.2		59	3.2			8	3.2
	11	3.2		60	3.2		IC8107	1	-3.6
	12	0		61	3.2			2	1.3
	13	0		62	0			3	0
	14	0		63	0				
	15	0		64	3.2				

B3(1/5) BOARD VOLTAGE LIST

Ref	Pin No	Voltage[v]	Ref	Pin No	Voltage[v]	Ref	Pin No	Voltage[v]	
IC302	1	0		68	4.7	IC311	I	8.9	
	2	3.2		69	1.9		G	0	
	3	1.3		70	1.9		O	5	
	4	1.3		71	0	IC501	1	0	
	5	1.3		72	0		2	0	
	6	1.3		73	0.1		3	0	
	7	1.3		74	0		4	0	
	8	1.3		75	0		5	0	
	9	1.3		76	0		6	1.1	
	10	1.3		77	0		7	1.1	
	11	0		78	0.1		8	1.0	
	12	0		79	0.1		9	0.8	
	13	0.5		80	0.1		10	1.5	
	14	0.5		IC303	1		4.9	11	0
	15	0.5			2		0	12	1.6
	16	0.5			3		0	13	1.4
	17	0.5			4		0	14	3.2
	18	-0.5			5		0	15	0
	19	0.6			6		1.7	16	3.2
	20	0			7		4.4	17	1.4
	21	1.3			8	3.7	18	1.6	
	22	3.2			9	0.2	19	1.4	
	23	3.2			10	4.9	20	1.6	
	24	0			11	0	21	1.8	
	25	0.3			12	0	22	1.6	
	26	0.3			13	4.9	23	1.7	
27	0	14	4.9		24	1.6			
28	0.1	15	2.2		25	0			
29	0.1	16	2.7		26	4.7			
30	4.7	17	4.9		27	2.4			
31	1.9	18	4.9		28	0			
32	1.9	19	0		29	3.3			
33	1.9	20	0		30	0			
34	1.9	21	0		31	0			
35	4.7	22	0.1		32	0			
36	4.1	23	1.4		33	1.4			
37	4.1	24	0.3		34	0			
38	0	25	0		35	3.2			
39	0.3	26	4.9		36	1.4			
40	0.3	27	0	37	0				
41	4.7	28	4.9	38	0				
42	4.7	29	4.9	39	0				
43	0	30	0	40	0				
44	0	31	0	41	0				
45	0	32	0	42	0				
46	0	33	0	43	0				
47	4.6	34	0	44	0				
48	0	35	0	45	4.7				
49	4.9	36	4.9	46	0				
50	0	37	0	47	0				
51	1.5	38	0	48	0				
52	0	39	4.9	49	0.1				
53	0	40	0	50	0.1				
54	0	41	4.9	51	4.6				
55	0	42	0	52	4.6				
56	0	43	0	53	2.3				
57	4.6	44	1.1	54	2.3				
58	0	45	1.8	55	-0.0				
59	0	46	0	56	1.4				
60	0	47	0	57	-0.1				
61	0	48	0	58	3.1				
62	4.7	IC309	1	0	59	1.4			
63	0.3		2	0	60	1.4			
64	0		3	0	61	3.2			
65	0		4	4.9	62	4.6			
66	1		5	4.9	63	1.9			
67	1.1					64	-0.1		

B3(2/5) BOARD VOLTAGE LIST

Ref	Pin No	Voltage[v]	Ref	Pin No	Voltage[v]	Ref	Pin No	Voltage[v]
IC504	1	4.2		51	0		121	1.3
	2	0		52	2.3		122	0
	3	0		53	0		123	1.3
	4	0		54	3.2		124	1.4
	5	0		55	0		125	1.0
	6	0.3		56	0		126	1.1
	7	0		57	3.2		127	1.0
	8	0		58	3.2		128	1.0
	9	0		59	2.7		129	1.1
	10	0		60	0		130	0
	11	0		61	0		131	1.0
	12	1.4		62	0		132	1.1
	13	2.8		63	0		133	0
	14	4.2		64	3.0		134	1.5
IC505	1	0		65	0.4		135	0
	2	3.2		66	0		136	1.7
	3	0		67	3.2		137	1.6
	4	0		68	0		138	1.1
	5	0		69	0		139	0
IC601	1	2.3		70	0		140	1.8
	2	0		71	3.2		141	2.3
	3	0		72	0		142	0
	4	0		73	2.3		143	0
	5	0		74	0		144	0
	6	0		75	0		145	1.2
	7	3.1		76	0		146	1.2
	8	3.1		77	3.2		147	1.5
	9	3.1		78	3.2		148	0
	10	0.5		79	0		149	1.7
	11	3.1		80	0		150	2.0
	12	0		81	3.2		151	1.5
	13	1.3		82	0		152	0
	14	1.4		83	0		153	1.7
	15	1.3		84	3.2		154	1.4
	16	1.1		85	0.3		155	0
	17	1.4		86	3.2		156	0
	18	1.5		87	0		157	3.2
	19	1.6		88	0		158	3.0
	20	1.5		89	0		159	3.1
	21	0		90	0		160	1.3
	22	3.2		91	1.6		161	1.4
	23	0		92	3.0		162	0
	24	1.5		93	2.3		163	0
	25	1.2		94	1.6		164	1.6
	26	1.1		95	3.2		165	1.6
	27	1.1		96	1.8		166	1.6
	28	1.3		97	3.0		167	1.5
	29	1.4		98	3.2		168	1.6
	30	1.4		99	0		169	1.4
	31	1.4		100	0		170	1.5
	32	3.2		101	0		171	1.5
	33	0		102	0.2		172	2.3
	34	0		103	2.3		173	0
	35	0		104	0		174	1.4
	36	0		105	0.3		175	1.5
37	0		106	1.0		176	1.7	
38	0		107	0.9		177	1.5	
39	0		108	0		178	0.7	
40	0		109	0.5		179	1.0	
41	0		110	2.0		180	1.2	
42	0		111	3.3		181	1.2	
43	2.3		112	0		182	2.4	
44	0		113	0.5		183	0	
45	1.3		114	3.2		184	3.3	
46	0		115	0		185	3.3	
47	0		116	0		186	0	
48	0		117	1.5		187	3.3	
49	0		118	0		188	0	
50	3.2		119	1.7		189	0	
			120	1.3		190	0	

B3(3/5) BOARD VOLTAGE LIST

Ref	Pin No	Voltage[v]	Ref	Pin No	Voltage[v]	Ref	Pin No	Voltage[v]
	191	0		2	0		41	0
	192	0		3	1.4		42	-0.6
	193	0		4	0		43	-3.0
	194	0		5	1.3		44	-2.0
	195	0		6	1.4		45	-1.9
	196	0		7	0		47	-1.8
	197	2.3		8	0		48	-1.8
	198	0		9	0		49	-1.6
	199	0		10	0		50	-1.6
	200	0		11	0		51	1.2
	201	0		12	1.4		52	1.6
	202	0		13	0		53	1.5
	203	0		14	3.4		54	3.1
	204	0	IC604	1	4.9		55	-0.1
	205	0		2	0		56	1.3
	206	0		3	3.0		57	1.1
	207	3.2		4	3.0		58	1.1
	208	0		5	3.0		59	1.2
IC602	1	3.2		6	0.4		60	1.3
	2	1.5		7	0.3		121	0
	3	1.6		8	0		122	2.5
	4	0		9	0		123	0
	5	1.7		10	3.2		124	1.6
	6	1.5		11	0		125	0
	7	0		12	4.9		126	0
	8	1.2		13	0		127	0
	9	0		14	4.5		128	0
	10	0		15	4.4		129	2.4
	11	0		16	4.9		130	0
	12	0	IC801	1	0		131	0
	13	0		2	0		132	0
	14	0.5		3	0		133	1.6
	15	3.2		4	0		134	1.6
	16	3.1		5	0		135	2.7
	17	0		6	3.2		136	0
	18	0		7	0		137	1.6
	19	0		8	0		138	3.3
	20	0		9	0		139	0
	21	0		10	0.2		140	1.6
	22	0		11	1.4		141	3.2
	23	0		12	1.8		142	2.9
	24	0		13	1.7		143	2.8
	25	0		14	1.4		144	3.0
	26	0		15	2.0		145	2.4
	27	0		16	1.6		146	0
	28	0		17	1.7		147	0
	29	0		18	3.2		148	2.1
	30	0		19	0		149	2.1
	31	0		20	1.6		150	0
	32	0		21	1.7		151	0.2
	33	0		22	1.5		152	1.1
	34	3.2		23	1.3		153	0
	35	1.4		24	1.7		154	0
	36	0.5		25	2.4		155	1.0
	37	0		26	1.7		156	0
	38	3.2		27	1.5		157	1.3
	39	1.6		28	1.4		158	1.5
	40	1.6		29	1.5		159	2.1
	41	0		30	0		160	1.3
	42	1.5		31	1.0		161	0
	43	1.3		32	1.1		162	0
	44	3.2		33	-2.0		163	0
	45	1.1		34	-1.9		164	2.0
	46	1.2		35	-1.9		165	1.2
	47	0		36	-0.8		166	0.7
	48	1.4		37	-2.0		167	0.1
	49	1.4		38	-3.2		168	2.0
	50	0		39	-1.9		169	1.7
IC603	1	0		40	-1.7		170	1.7

B3(4/5) BOARD VOLTAGE LIST

Ref	Pin No	Voltage[v]	Ref	Pin No	Voltage[v]	Ref	Pin No	Voltage[v]
	171	0		238	0		66	0
	172	0.6		239	0		67	2.9
	173	0.6		240	0		68	1.6
	174	0	IC802	1	3.2		69	0
	175	0		2	1.4		70	0
	176	0		3	3.3		71	0
	177	0		4	0.8		72	0
	178	0.5		5	0.5		73	0
	179	0.5		6	0		74	0
	180	0.5		7	1.7		75	3.2
	181	1.3		8	0		76	0.9
	182	1.3		9	0.2		77	1.1
	183	0		10	2.0		78	0
	184	1.3		11	0		79	1.9
	185	1.3		12	0		80	1.6
	186	2.4		13	0		81	3.3
	187	0		14	0		82	1.7
	188	2.4		15	0		83	2.0
	189	2.4		16	0		84	0
	190	1.3		17	3.0		85	1.4
	191	0		18	2.8		86	0
	192	1.4	19	3.2	IC901	1	0	
	193	3.2	20	2.7		2	0	
	194	1.5	21	0		3	1.3	
	195	2.4	22	1.6		4	1.2	
	196	1.6	23	0		5	0	
	197	0	24	0		6	1.4	
	198	0	25	0		7	0	
	199	0	26	0		8	0	
	200	0	27	2.4		9	0	
	201	0	28	0		10	0	
	202	0	29	3.2		11	0	
	203	0	30	0		12	0	
	204	0	31	1.5		13	1.3	
	205	0	32	0		14	1.3	
	206	0.4	33	1.4		15	0	
	207	0	34	1.1		16	1.1	
	208	1.2	35	3.2		17	1.1	
	209	2.4	36	3.2		18	1	
	210	1.2	37	1.7		19	0	
	211	0	38	0		20	1.1	
	212	1.2	39	1.2		21	0	
	213	0	40	1.4		22	0	
	214	2.4	41	3.2		23	0	
	215	0	42	0.8		24	0	
	216	0	43	3.2		25	1.5	
	217	0	44	0		26	1.9	
	218	0	45	0		27	1.5	
	219	0	46	0		28	0	
	220	0	47	0		29	1.5	
	221	2.4	48	0		30	1.7	
	222	0	49	0		31	1.2	
	223	0	50	0		32	1.2	
	224	0	51	1.9		33	1.2	
	225	0	52	0		34	0	
	226	0	53	1.4		35	0.9	
	227	0	54	1.3		36	1.9	
	228	0	55	0		37	1.9	
	229	0	56	3.2	38	2.3		
	230	0	57	0	39	4.7		
	231	0	58	0	40	4.7		
	232	0.3	59	0	41	4.7		
	233	0	60	0	42	0.5		
	234	2.4	61	2.4	43	0		
	235	0	62	2.4	44	0.3		
	236	0	63	1.9	45	0		
	237	0	64	1.6	46	0.5		
			65	0	47	0		
					48	4.9		

B3(5/5) BOARD VOLTAGE LIST

Ref	Pin No	Voltage[v]	Ref	Pin No	Voltage[v]	Ref	Pin No	Voltage[v]
IC902	1	0		60	0.1	Q502	B	0
	2	0		61	4.9		C	0
	3	0		62	4.9		E	0
	4	0		63	0	Q503	B	0
	5	0		64	0.1		C	0
	6	0		65	0		E	1.1
	7	0		66	0	Q510	B	0
	8	0		67	0		C	2.6
	9	0		68	0		E	2
	10	0		69	0	Q511	B	0
	11	0		70	0		C	1.7
	12	0		71	4.9		E	1
	13	0		72	4.9	Q512	B	4.7
	14	0		73	0		C	1.6
	15	0		74	4.9		E	1
	16	0		75	0	Q513	B	4.7
	17	0		76	0		C	2
	18	0		77	0		E	2
	19	0		78	0	Q514	B	4.7
	20	0		79	0		C	1.7
	21	0		80	0		E	*
	22	0		81	0	Q515	B	4.7
	23	4.9		82	0		C	1.8
	24	0		83	4.9		E	0
	25	0		84	4.9	Q517	B	4.9
	26	0		85	1.1		C	4.9
	27	0		86	0		E	4.2
	28	0		87	0	Q521	B	0
	29	4.9		88	0		C	2.6
	30	4.9		89	4.9		E	1.9
	31	0		90	0	Q522	B	4.7
	32	0		91	4.9		C	3.1
	33	4.9		92	0		E	2.5
	34	0		93	2.2	Q523	B	4.7
	35	0		94	0		C	2.5
	36	0		95	4.9		E	1.9
	37	0		96	4.9	Q601	B	0
	38	0		97	4.9		C	0
	39	0		98	4.9		E	0
	40	0		99	4.5	Q602	B	4.9
	41	0		100	4.4		C	0
42	2.3				E	0		
43	2.3	IC903	1	0	Q903	B	0	
44	4.9		2	0		C	0.1	
45	4.9		3	4.9		E	0.5	
46	0		4	0	Q904	D	3.2	
47	0		5	4.9		G	4.9	
48	1.9		6	4.9		S	3.2	
49	2.4		7	4.9	Q905	D	3.2	
50	0		8	0		G	4.9	
51	0	IC904	1	0		S	0	
52	0		2	0	Q906	B	4.9	
53	0		3	0		C	0	
54	0		4	4.9		E	0	
55	0		5	4.9				
56	0	Q501	B	0				
57	4.9		C	0				
58	0		E	0				
59	0							

D1 BOARD VOLTAGE LIST

Ref	Pin No	Voltage[v]	Ref	Pin No	Voltage[v]	Ref	Pin No	Voltage[v]		
IC6101	1	3.4		7	1.8	Q6103	B	4.1		
	2	1.6		8	2.9		C	4.2		
	3	0		9	1.2		E	0		
	4	0		10	0.5	Q6104	B	5.2		
	5	2.1		11	1.6			C	0.5	
	6	0		12	2.3			E	0	
	7	2.6		13	5.0	Q6105	B	5.0		
	8	5.0		14	0			C	3.4	
		15		5.0			E	2.9		
IC6102	1	8.8		16	5.0	Q6106	B	-3.3		
	2	4.3		17	5.0			C	3.1	
	3	4.4		18	0			E	0	
	4	4.9		19	0	Q6107	B	12.4		
	5	0		20	4.1			C	12.0	
	6	1.6		21	4.5			E	5.8	
	7	1.7		22	5.0	Q6118	B	3.4		
	8	4.8		23	0			C	0	
		24		0			E	0		
IC6103	1	8.8		IC6351	1	8.8	Q6125	B	8.8	
	2	3.1			2	0.3			C	2.1
	3	3.4			3	4.4			E	2.2
	4	1.9			4	3.8	Q6126	B	0	
	5	0			5	0			C	2.2
	6	1.7			6	4.6			E	2.1
	7	1.7	7		4.2	Q6128	B	8.8		
	8	3.4	8		5.1			C	1.4	
					E		3.2			
IC6104	1	1.9	IC6353	I	12.4	Q6201	B	4.5		
	2	2.1		G	0			C	0.4	
	3	-15.8		O	5.0			E	0	
	4	1.4		IC6354	1	4.4	Q6202	B	2.8	
	5	6.9			2	0			C	0.7
		3	8.8		E	0				
IC6105	1	6.6	IC6354	4	0	Q6350	B	1.7		
	2	4.2		5	4.4			C	0.4	
	3	4.4		6	4.4			E	0	
	4	0		7	0	Q6356	B	1.8		
	5	1.3		8	3.9			C	0.3	
	6	1.3						E	0	
	7	0.2		IC6356	1	-3.4	Q6405	B	0	
	8	8.8			2	-3.4			C	4.4
		3	-3.2			E		3.8		
IC6106	1	0	4		-3.3	Q6455	B	8.8		
	2	0	5		-15.9			C	1.7	
	3	8.9	6		0			E	1.1	
IC6108	1	2.7	7		-3.3					
	2	4.9	8		-3.2					
	3	0.3	9	-3.3						
	4	4.7	10	11.9						
	5	3.6								
	6	1.9								

C BOARD VOLTAGE LIST

Ref	Pin No	Voltage[v]	Ref	Pin No	Voltage[v]	Ref	Pin No	Voltage[v]	
IC9001	1	<[0]>(3.4)	IC9003	6	<[0.1]>(200)		8	0	
	2	<[0]>(11.7)		7	<[1.2]>(128)			10	152.0
	3	<[0]>(3.3)		8	<[0]>(153.5)			11	153.6
	4	0		9	<[0]>(128)			12	157.0
	5	<[0]>(8.8)		1	<[0]>(3.4)	Q9001	B	0	
	6	<[0.1]>(200)		2	<[0]>(11.7)			C	<[0]>(4.5)
	7	<[0.8]>(14.7)		3	<[0]>(3.3)			E	<[0]>(8.2)
	8	<[0.5]>(15.6)		4	0		Q9009	B	0
	9	<[1.0]>(14.7)		5	<[0]>(8.9)				C
		6	<[0.1]>(200)		E	<[0]>(2.9)			
IC9002	1	<[0]>(3.4)	7	<[1.2]>(138.6)	Q9010	B	0		
	2	<[0]>(11.7)	8	<[0.6]>(152.4)			C	0	
	3	<[0]>(3.3)	9	<[1.6]>(138.6)			E	<[0]>(3.4)	
	4	0	J9001	5	317	Q9011	B	0	
	5	<[0]>(8.8)		7	0			C	<[0]>(3.8)
							E	<[0]>(3.2)	

D BOARD VOLTAGE LIST

Ref	Pin No	Voltage[v]	Ref	Pin No	Voltage[v]	Ref	Pin No	Voltage[v]	
IC6602	1	0	IC6801	2	14.0	Q6804	C	0	
	2	6.0		3	-13.1		E	6.5	
	3	4.2		4	-15.8		B	6.6	
	4	0.0		5	-0.5		C	8.8	
	5	18.6		6	14.6		E	6.5	
	6	0.0		7	1.3		Q6805	B	77.5
	7	6.2		1	6.6			C	-0.3
	8	4.0		2	1.4			E	0
IC6603	1	276	3	2.2	Q6806	B		-0.3	
	2	127	4	0		C	65.2		
	3	4.3	5	2.9		E	0		
	4	0.4	6	6.6	Q6807	B	-0		
	5	4.8	7	0.2		C	242		
	6	2.2	8	8.8		E	242		
	7	3.7	Q6602	B	0.3	Q6808	B	240	
	8	3.7		C	12.0		C	240	
	9	0		E	0.0		E	240	
	10	0	Q6603	B	11.2		Q6809	B	8.3
	11	0		C	11.9	C		3.4	
	12	0		E	12.0	E		0	
	13	0	Q6604	B	17.7	Q6810	B	135	
	14	18.5		C	18.4		C	0	
	15	10.9		E	18.6		E	0	
	16	4.9	Q6605	B	0.7	Q6811	B	8.8	
	17	0.1		C	0.0		C	-0	
	18	133		E	0.0		E	-0	
	IC6604	19	123	Q6606	B	17.9	Q6812	B	-0.8
1		0	C		18.5	C		8.6	
2		0	E		18.6	E		0	
3		0	Q6609	B	5.0	Q6813	B	5.8	
4		5.8		C	5.0		C	0.4	
5		269		E	0		E	0	
6		*	Q6610	B	0.5	Q6814	B	2.9	
7		0		C	5.0		C	8.8	
8	0	E		0.2	E		8.8		
IC6606	I	9.6	Q6611	B	0	Q6815	B	135	
	G	0		C	2.9		C	135	
	O	5.0		E	0		E	134	
IC6804	I	12.2	Q6612	B	2.9	Q6816	B	0.5	
	G	0		C	0		C	0	
	O	8.8		E	0		E	0	
IC6805	I	14.6	Q6613	B	0	Q6817	B	0.5	
	G	0		C	4.1		C	0	
	O	11.9		E	0		E	0	
IC6806	I	8.1	Q6614	B	0	Q6818	B	0	
	G	0		C	-75.6		C	3.2	
	VC	6.2		E	0		E	0	
	O	21.2		Q6615	B		0.4	Q6819	B
IC6607	1	134	C		18.6	C	-10.9		
	2	2.4	E		0.0	E	-0		
	3	10.7	Q6800		B	14.6	Q6820		B
	4	0		C	0.3	C		0.2	
IC6608	1	18.5		E	0.9	E		0	
	2	2.9	Q6801	B	0.2	Q6821	B	-10.9	
	3	4.9		C	11.1		C	0	
	4	0.0		E	-0.5		E	-0.1	
	5	18.6	Q6802	B	203				
	6	0.0		C	136				
	7	3.1		E	136				
	8	2.3	Q6803	B	6.6				
IC6800	1	1.3							

E BOARD VOLTAGE LIST

Ref	Pin No	Voltage[v]	Ref	Pin No	Voltage[v]	Ref	Pin No	Voltage[v]
IC4301	1	3.7		60	0	Q4319	B	1.9
	2	-0		61	4.5	Q4800	C	6.9
	3	-0		62	4.1		E	6.3
	4	4.7		63	4.2		B	-0
	5	3.4		64	3.5	C	-1.7	
	6	3.4	IC4800	1	0.2	E	-0	
	7	7.6		2	4.4	Q4801	B	3.2
	8	-0		3	4.6		C	2.2
	9	-0		4	0		E	0
	10	0.4		5	4.6	Q4802	B	4.4
	11	1.7		6	3.2		C	1.7
	12	8.9		7	0.3		E	0
	13	-0		8	8.9	Q4803	B	8.9
	14	5.0	IC4801	1	0.2		C	0
	15	2.5		2	4.5		E	4.7
	16	0		3	4.5	Q4804	B	-0
	17	-0		4	0		C	0.3
	18	2.6		5	4.5		E	-0
	19	4.1		6	3.2	Q4805	B	-0
	20	0		7	0.3		C	0
	21	6.0		8	8.9		E	-0
	22	1.5	IC4802	1	0	Q4806	B	3.2
	23	5.3		2	4.4		C	0
	24	-0		3	1.7		E	0
	25	5.1		4	1.7	Q4807	B	4.2
	26	2.6		5	0		C	0.2
	27	3.7		6	4.3		E	-0
	28	2.8		7	4.3	Q4808	B	-0
	29	4.1		8	4.9		C	2.0
	30	2.4	IC4803	1	7.7		E	3.2
	31	3.3		2	*	Q4809	B	-0
	32	8.9		3	0.4		C	2.0
	33	-0		4	0.0		E	3.1
	34	4.6		5	0.8	Q4810	B	8.9
	35	4.7		6	0.7		C	-0.1
	36	4.7		7	6.6		E	-0.1
	37	8.9		8	8.9	Q4304	B	8.9
	38	0	B	8.9	C		0	
	39	4.8	C	6.9	E		0.3	
	40	4.8	Q4307	B	-0	Q4812	B	1.4
	41	4.8		C	3.0		C	-0
	42	-0		E	2.3		E	-0
	43	-0	Q4308	B	-0	Q4813	B	0
	44	-0		C	3.4		C	0.5
	45	6.3		E	2.8		E	1.2
	46	8.9	Q4310	B	-0	Q4814	B	0
	47	8.9		C	3.2		C	1.5
	48	5.2		E	2.6		E	1.6
	49	2.4	Q4315	B	0	Q4815	B	0
	50	3.9		C	1.5		C	1.5
	51	-0		E	0		E	0
	52	6.1	Q4316	B	4.9	Q4816	B	-0
	53	5.8		C	0		C	0.6
	54	5.8		E	0		E	0
	55	-0	Q4317	B	0	Q4817	B	0
	56	5.8		C	2.7		C	2.5
	57	5.8		E	0		E	2.2
	58	5.8						
	59	0.3						

J(1/2) BOARD VOLTAGE LIST

Ref	Pin No	Voltage[v]	Ref	Pin No	Voltage[v]	Ref	Pin No	Voltage[v]		
IC8302	1	0.3	IC8306	1	-1.3		20	-1.2		
	2	0.8		2	-1.6		21	-1.6		
	3	0.3		3	-2.2		22	0		
	4	0.8		4	-3.4		23	-1.7		
	5	0.8		5	-1.2		24	0		
	6	-3.3		6	1.3		25	-0.7		
	7	1.3		7	-1.0		26	-0.8		
	8	0.3		8	-3.6		27	-0.7		
	9	0		9	-3.2		28	-3.6		
	10	0.9		10	-2.8		29	[
	11	0.8		11	-1.2		30	-0.7		
	12	0.8		12	1.3		31	-1.5		
	13	-3.3		13	0.9		32	1.3		
	14	1.3		14	0.8		33	0.6		
	15	0.3		15	0		34	-0.6		
	16	0		16	0		35	-0.6		
	17	0.9		17	0		36	0		
	18	0		18	0		37	-2.5		
	19	0.8		19	-2.2		38	0.3		
	20	-3.3		20	-1.1		39	1.9		
	21	1.3		21	-1.9		40	-0.2		
	22	0.3		22	-1.7		41	-0.2		
	24	0.3		23	1.8		42	1.0		
	25	0.8		24	-3.6		43	-1.9		
	26	0.8		25	-0.8		44	-1.7		
	27	-3.3		26	0.9		45	1.1		
	28	1.3		27	-0.8		46	-0.7		
	29	0.8		28	-3.6		47	-0.7		
	30	1.0		29	-0.8		48	1.8		
	31	0		30	-0.8		IC8309	1	0.5	
	32	-3.6		31	-1.6			2	0	
	33	0.8		32	1.3			3	-0.8	
	34	*		33	-0.8			4	0	
	35	-3.6		34	-0.7			5	0	
	36	0.2		35	-0.7			6	0	
	37	0.8		36	-3.6			7	0	
	38	0.8		37	-2.5			8	0	
	39	0.1		38	0.3		IC8310	1	-2.8	
	40	0.8		39	1.7			2	-3.6	
	41	1.7		40	3.2			3	-0	
	42	5.4		41	2.2			4	-0	
	43	0.8		42	0			5	-0	
	44	0.6		43	1.7			6	-1.5	
	47	0.8		44	2.2			7	-3.6	
	48	-3.6		45	4.9			8	1.4	
	49	1.1		46	2.3			9	2.1	
	50	0.8		47	3.7			10	-3.6	
	51	0.8		48	1.7			11	[
	52	0.8		IC8308	1	0.8		12	-3.6	
	53	0.7			2	-1.0		13	-3.6	
	54	0.1			3	-1.2		14	0.8	
	55	0.1			4	-3.4		15	1.4	
	56	-0.3			5	1.3		16	-0.9	
	57	-3.6			6	0	17	-0.8		
	58	0.7			7	-1.0	18	-3.6		
	59	0.8			8	-3.6	19	-0.5		
	60	1.1			9	3.2	20	4.6		
	61	0.8			10	0.7	21	-1.1		
	62	0.8			11	-0.5	22	0		
	63	0.6			12	0	23	-3.6		
	64	0.8			13	1.3	24	-3.6		
	IC8304	I			5.0	14	0	IC8312	1	-3.6
		G			0	15	-3.6		2	-3.2
		O			0	16	-3.6		3	1.3
IC8305	I	9.0	17	-1.1	4	1.3				
	G	0	18	-1.1	5	-3.2				
	O	12.3	19	-2.2						

J(2/2) BOARD VOLTAGE LIST

Ref	Pin No	Voltage[v]	Ref	Pin No	Voltage[v]	Ref	Pin No	Voltage[v]
Q8302	B	5.4	Q8328	E	-3.6	Q8343	C	0.9
	C	0.8		B	1.8		E	0
	E	0.2		C	-3.4		B	0.7
Q8303	B	5.4	Q8329	E	-3.6	Q8346	C	0
	C	0.6		B	2.0		E	4.8
	E	0		C	-1.1		B	0
Q8304	B	5.4	Q8330	E	-1.8	Q8347	C	5.4
	C	0.6		B	5.4		E	4.7
	E	0		C	2.0		B	4.7
Q8306	B	5.4	Q8331	E	1.4	Q8348	C	0
	C	1.7		B	2.7		E	-1.1
	E	1.1		C	-1.8		B	0
Q8308	B	5.4	Q8332	E	-0	Q8349	C	0
	C	0.1		B	5.4		E	0
	E	0.4		C	2.7		B	4.7
Q8309	B	5.4	Q8333	E	2.1	Q8350	C	-0.5
	C	0.8		B	2.0		E	-1.1
	E	0.2		C	1.5		B	0.7
Q8310	B	-0	Q8334	E	2.1	Q8351	C	0
	C	-3.5		B	5.4		E	0
	E	-3.5		C	2.9		B	4.7
Q8325	B	5.4	Q8335	E	2.2	Q8352	C	-0.9
	C	0		B	2.0		E	1.5
	E	0		C	1.5		B	0
Q8326	B	-0	Q8336	E	2.2	Q8355	C	5.4
	C	-3.3		B	5.4		E	4.7
	E	0		C	2.9		B	5.4
Q8327	B	-3.4	Q8342	E	2.3		C	0.1
	C	0		B	4.8		E	0.4

DH BOARD VOLTAGE LIST

Ref	Pin No	Voltage[v]	Ref	Pin No	Voltage[v]
IC3805	1	3.4	Q3807	B	0
	2	4.1		C	5.0
	3	2.8		E	0
	4	2.8	Q3808	B	5.0
	5	0		C	0
	6	0		E	0
	7	2.8	Q3809	B	0
	8	2.8		C	2.0
	9	2.4		E	2.8
	10	6.7	Q3810	B	2.5
IC3807	1	12.2		C	0
	2	0		E	3.2
	3	2.5	Q3811	B	3.2
	4	2.2		C	6.8
	6	0		E	2.5
	7	5.4	Q3812	B	0
	8	0		C	2.0
				E	2.8

VM BOARD VOLTAGE LIST

Ref	Pin No	Voltage[v]
Q5400	B	1.9
	C	8
	E	1.2
Q5401	B	5.0
	C	2.0
	E	1.4
Q5402	B	5.5
	C	8.8
	E	5.8
Q5403	B	5.9
	C	8.9
	E	5.7
Q5404	B	5.0
	C	0
	E	5.5
Q5405	B	5.5
	C	0
	E	5.7
Q5406	B	1.3
	C	0.7
	E	0.9
Q5407	B	134
	C	57
	E	134

7-4. WAVEFORMS

B3 BOARD WAVEFORMS

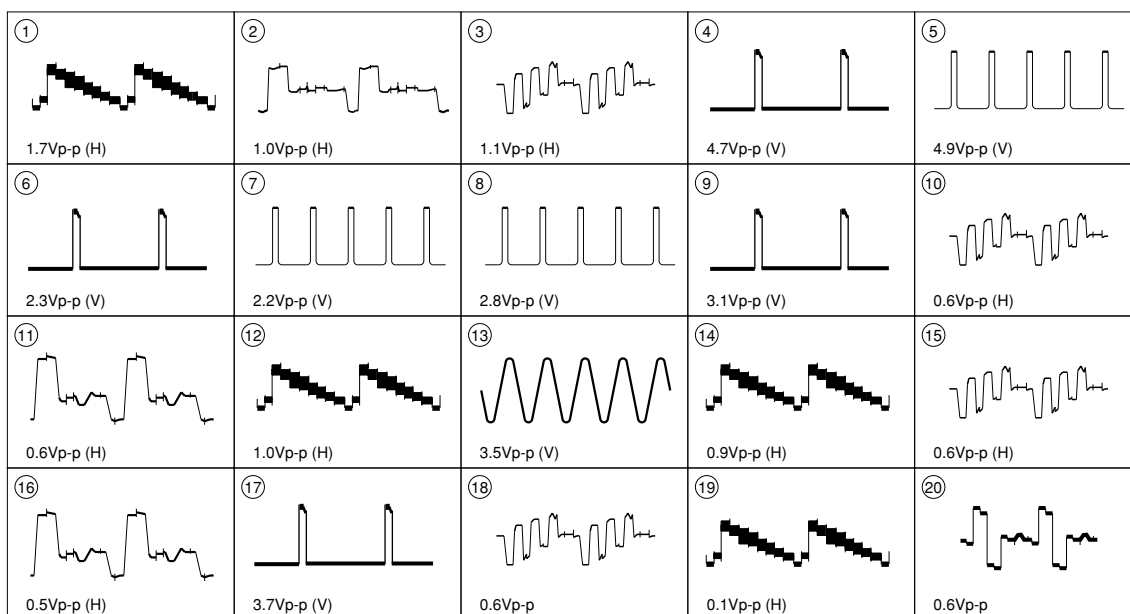

C BOARD WAVEFORMS

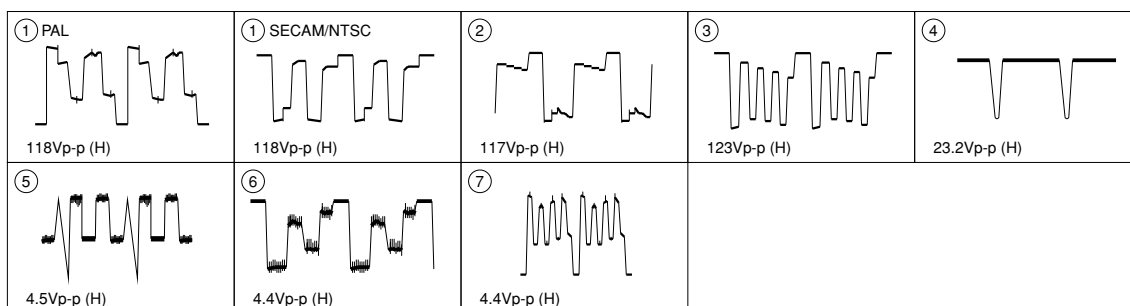

A BOARD WAVEFORMS

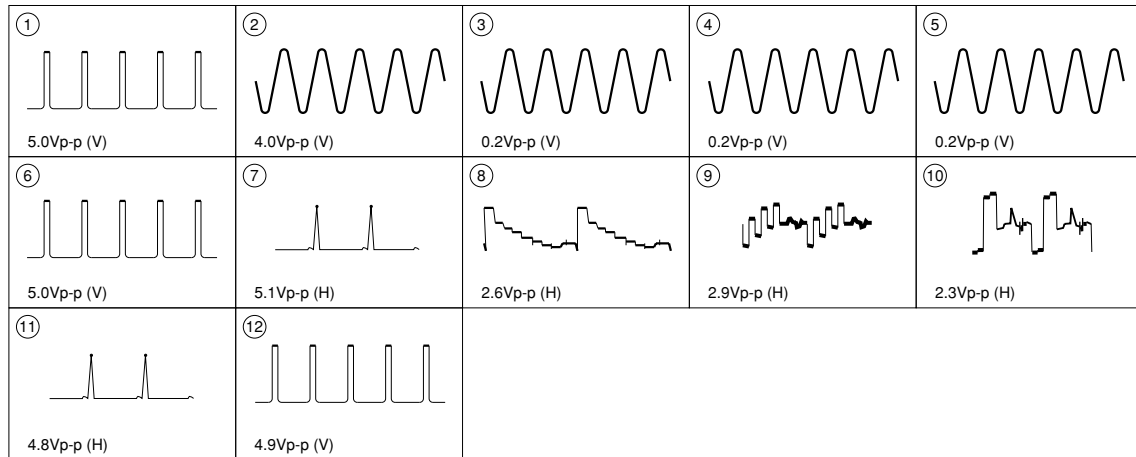

D BOARD WAVEFORMS

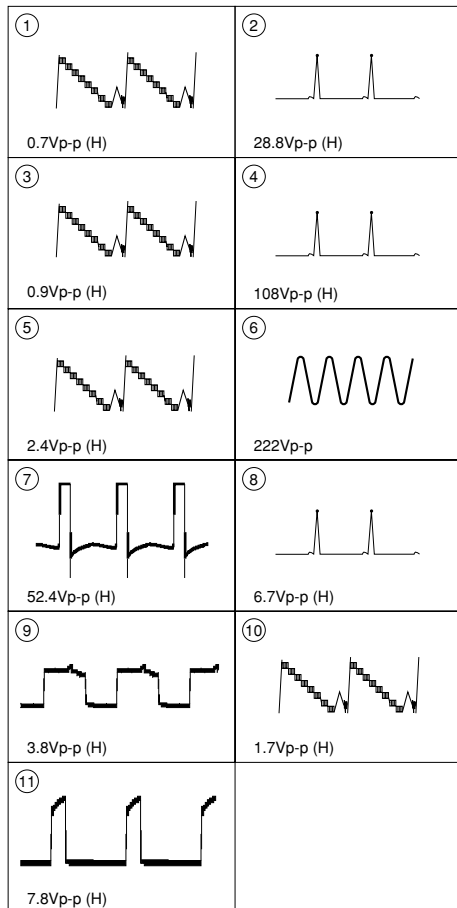

D1 BOARD WAVEFORMS

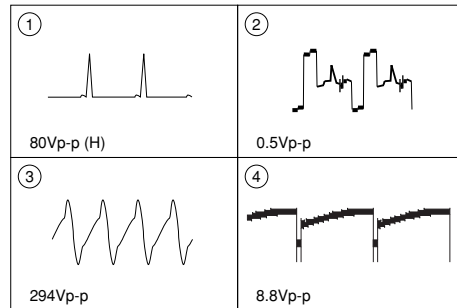

E BOARD WAVEFORMS

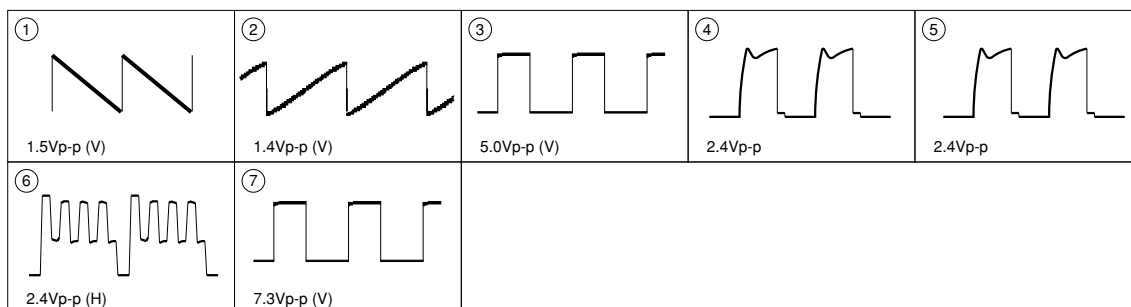

J BOARD WAVEFORMS

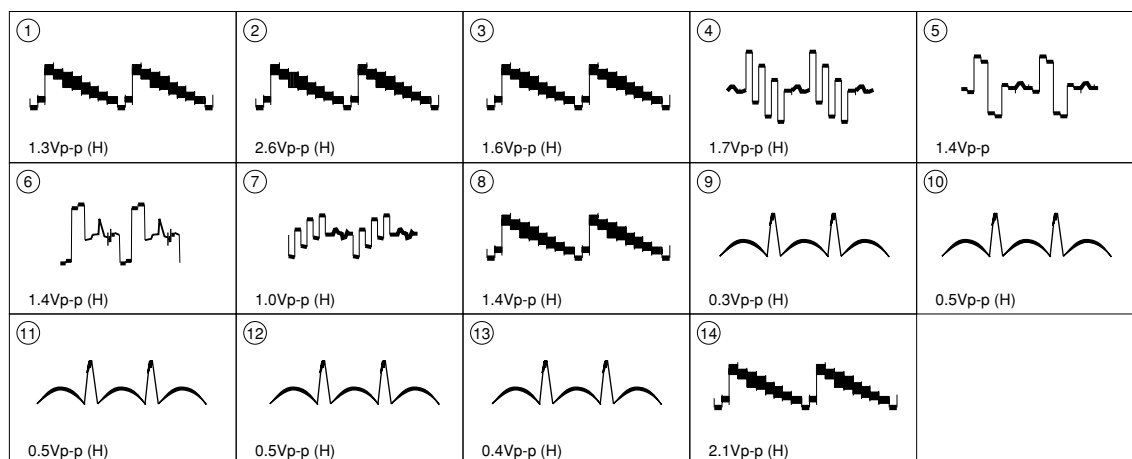

PRINTED WIRING BOARDS

A [MAIN-MICON, TUVIF, AUDIO AMP]

- A Board (Conductor Side) -

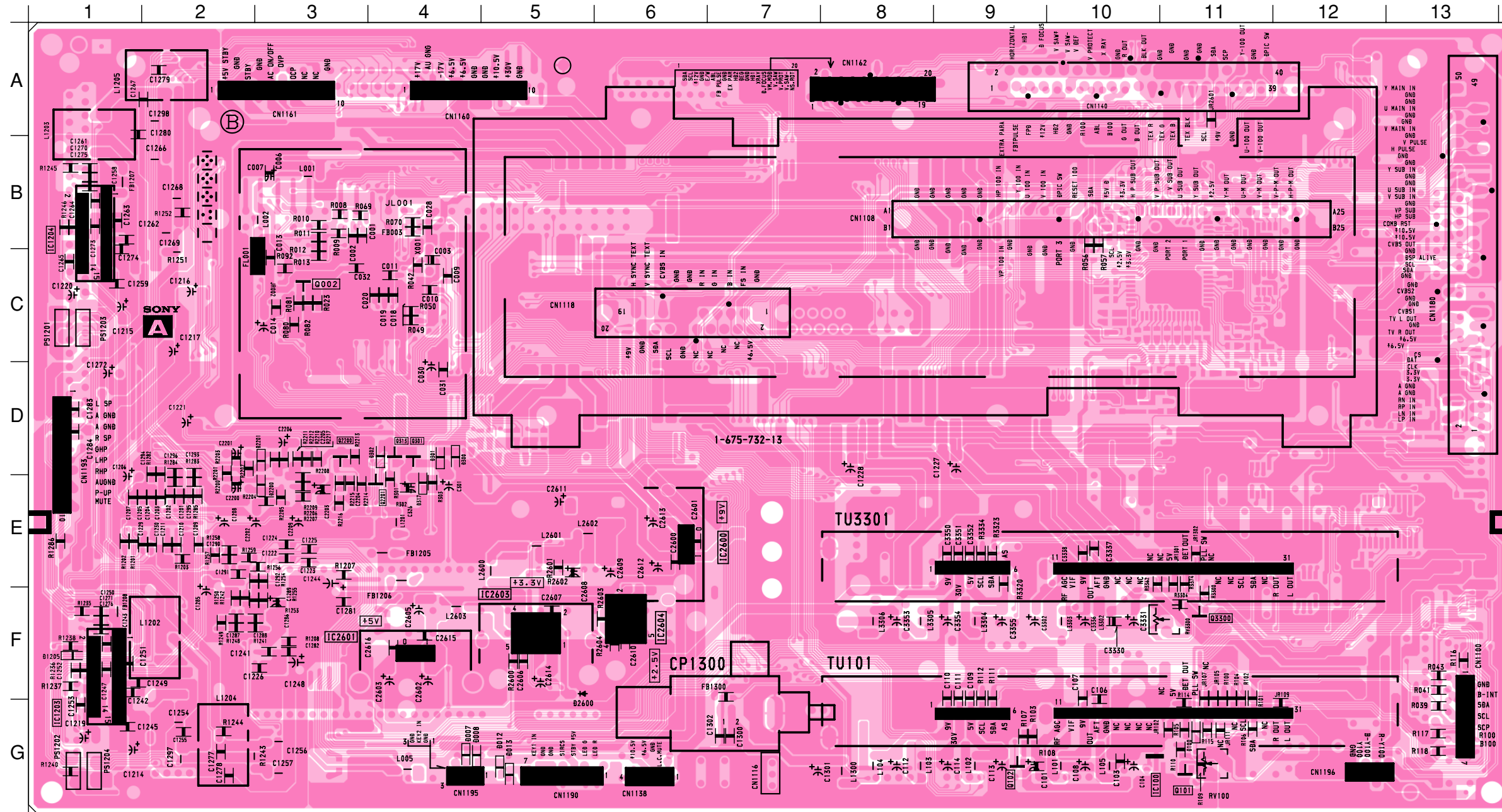

A BOARD

IC	
IC100	G-10
IC1203	G-1
IC1204	B-1
IC2601	F-3
IC2603	F-5
TRANSISTOR	
Q101	G-11
Q102	G-9
Q301	D-4
Q313	D-4
Q2200	D-3
Q2201	F-4
Q3300	F-11
DIODE	
D007	G-4
D008	G-4
D012	G-5
D013	G-5
D100	G-11
D302	D-3
D317	E-4
D1205	F-1
D2200	F-3
D2201	D-2

PRINTED WIRING BOARD

D [POWER SUPPLY DEFLECTION HV]

- D Board -

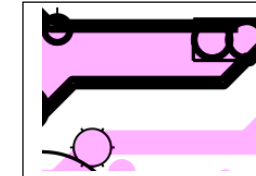

NOTE:
The circuit indicated at left contains high voltage of over 1220 Vp-p. Please pay attention when inspecting or re-pairing it to prevent an electric shock.

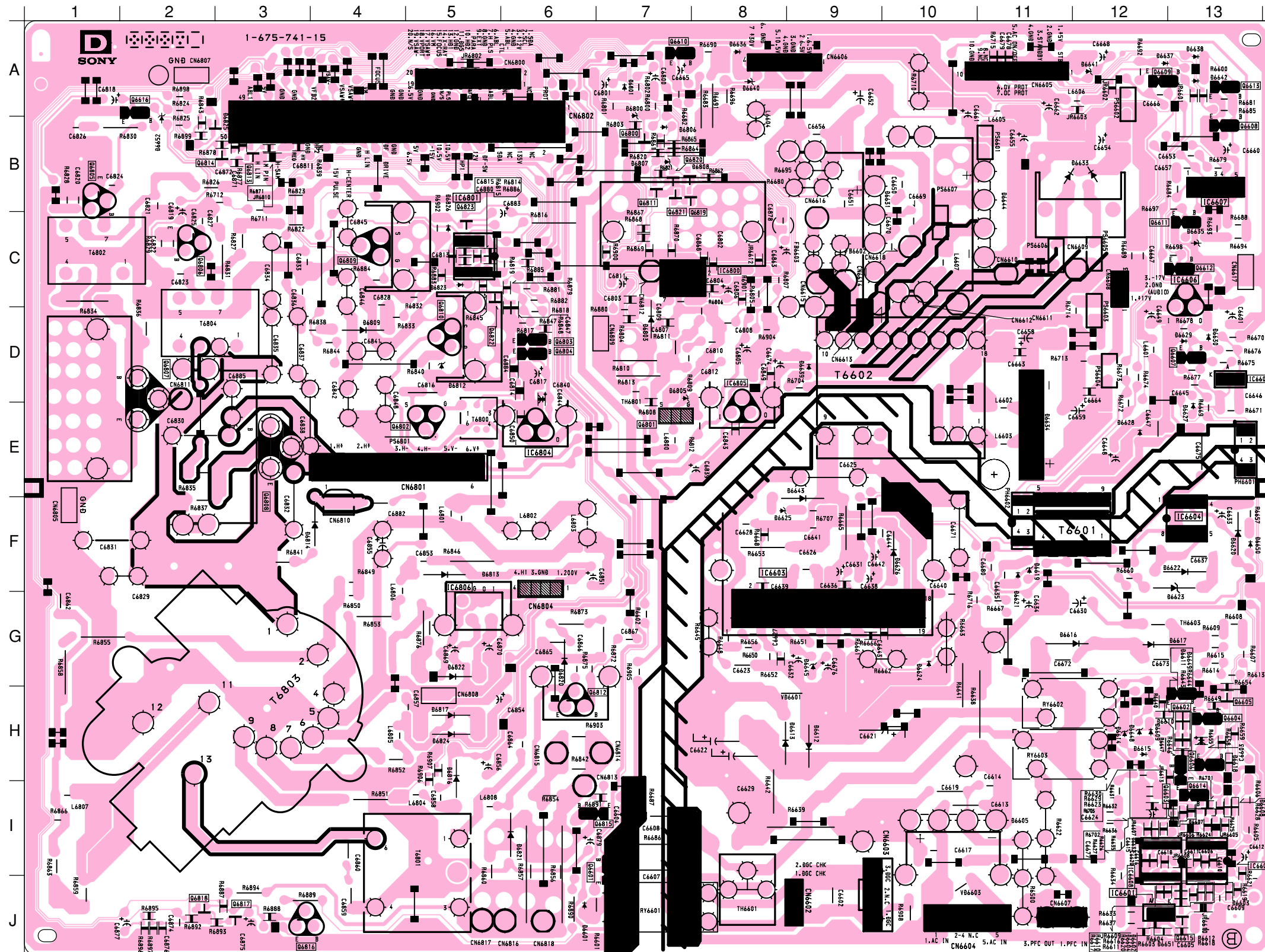

A BOARD

IC		D6607 I-13	D6630 D-13
IC6601 J-12	D6608 I-13	D6631 B-10	
IC6602 I-13	D6609 H-12	D6633 B-12	
IC6603 F-8	D6610 H-12	D6634 E-11	
IC6604 F-13	D6611 G-13	D6635 C-13	
IC6605 D-13	D6612 H-9	D6636 A-8	
IC6606 C-13	D6613 H-9	D6637 A-12	
IC6607 B-13	D6614 H-12	D6638 A-13	
IC6608 I-12	D6615 H-12	D6639 D-9	
IC6800 C-8	D6616 G-11	D6640 A-8	
IC8001 B-5	D6617 G-13	D6641 A-12	
IC8004 E-6	D6619 F-11	D6642 A-13	
IC8005 D-8	D6620 F-13	D6643 E-9	
IC8006 F-5	D6621 G-11	D6644 B-11	
	D6622 F-13	D6645 G-9	
	D6623 G-13	D6648 H-12	
	D6624 G-10	D6649 G-13	
	D6625 F-8	D6650 F-13	
	D6626 F-10	D6651 J-12	
	D6627 E-13	D6652 B-2	
	D6628 E-12	D6800 A-7	
	D6629 D-13	D8001 A-7	
	D6630 D-13	D8002 E-4	
	D6631 B-10	D8003 D-7	
	D6633 B-12	D8005 D-7	
	D6634 E-11	D8006 B-7	
	D6635 C-13	D8007 B-7	
	D6636 A-8	D8008 B-8	
	D6637 A-12	D8009 D-4	
	D6638 A-13	D8012 D-5	
	D6639 D-9	D8013 F-5	
	D6640 A-8	D8014 F-3	
	D6641 A-12	D8016 H-5	
	D6642 A-13	D8017 H-5	
	D6643 E-9	D8020 G-6	
	D6644 B-11	D8021 I-6	
	D6645 G-9	D8022 G-5	
	D6648 H-12	D8023 C-5	
	D6601 J-6	D8024 H-5	
	D6602 J-12	D8025 A-3	
	D6603 J-13		
	D6604 J-12		
	D6605 I-11		
	D6606 I-13		
	D6607 I-13		
	D6608 I-13		
	D6609 H-12		
	D6610 H-12		
	D6611 G-13		
	D6612 H-9		
	D6613 H-9		
	D6614 H-12		
	D6615 H-12		
	D6616 G-11		
	D6617 G-13		
	D6619 F-11		
	D6620 F-13		
	D6621 G-11		
	D6622 F-13		
	D6623 G-13		
	D6624 G-10		
	D6625 F-8		
	D6626 F-10		
	D6627 E-13		
	D6628 E-12		
	D6629 D-13		
DIODE			
D6601 J-6			
D6602 J-12			
D6603 J-13			
D6604 J-12			
D6605 I-11			
D6606 I-13			

PRINTED WIRING BOARD

B3 [DRC, MID, DRC/MID CONTROLLER]

D1 [DF, DQP DRIVE]

– B3 Board (Component Side) –

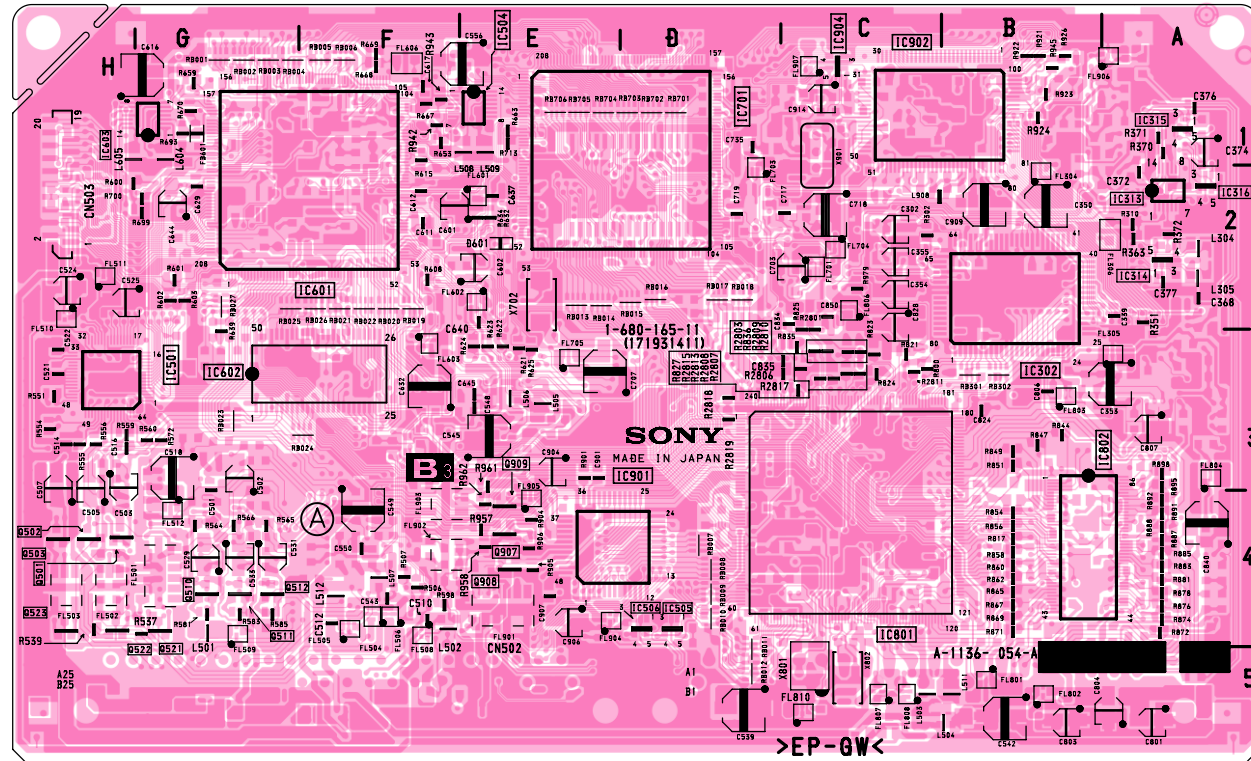

– B3 Board (Conductor Side) –

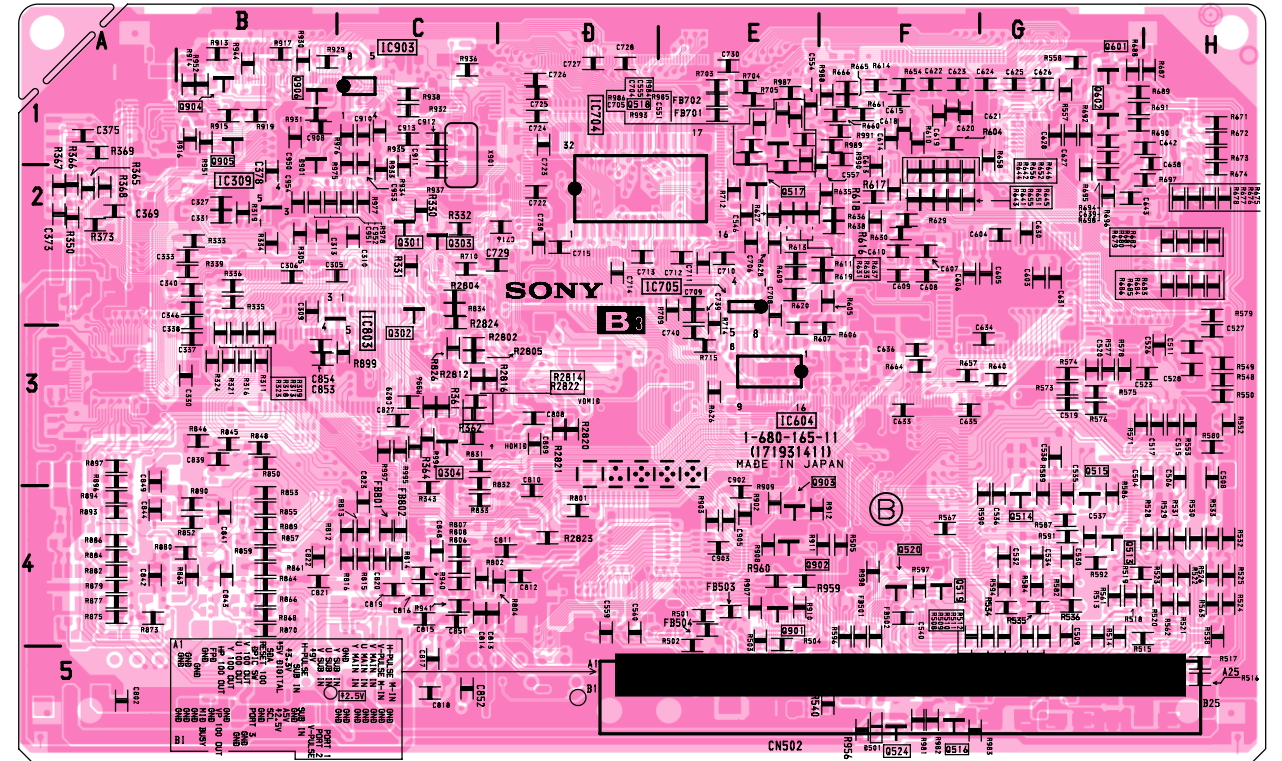

– D1 Board –

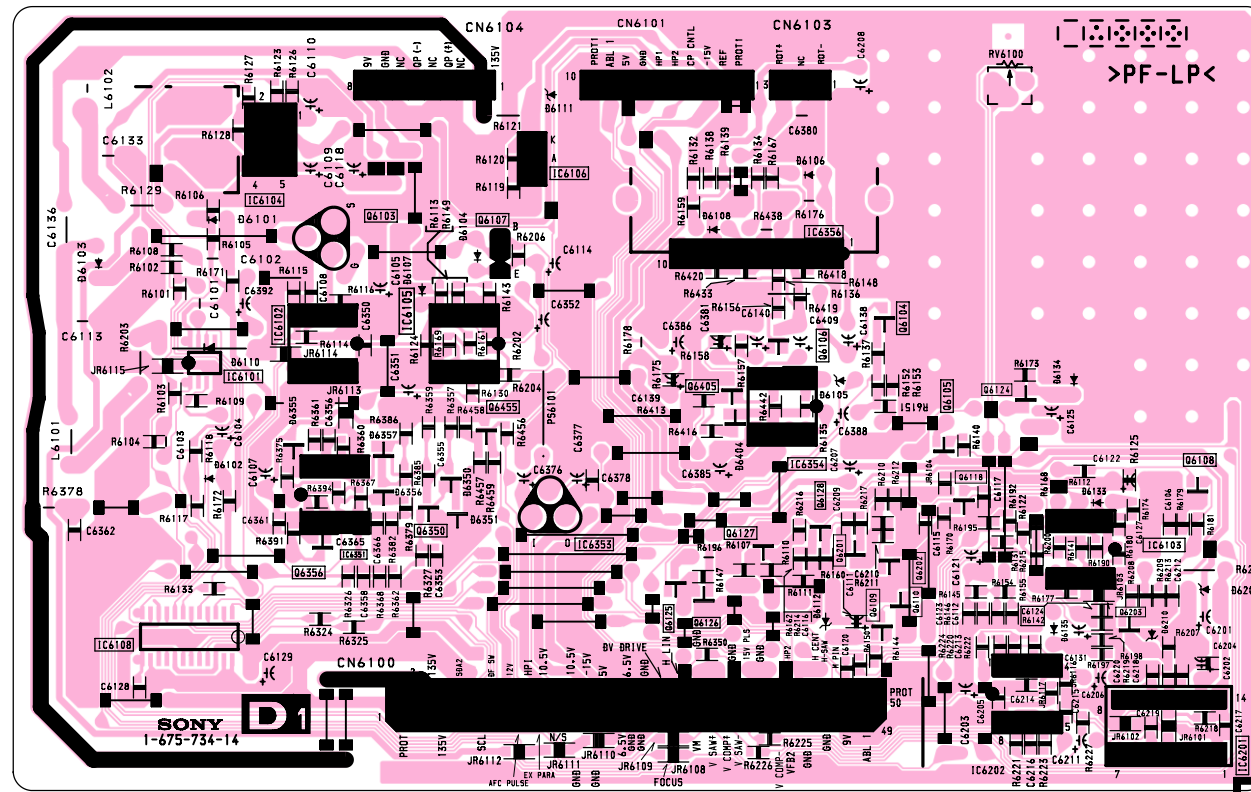

- :Pattern from the side which enables seeing.
- :Pattern from the rear side.

B3 BOARD (Conductor Side)

IC	Q519	D-6
IC304	A-1	Q520 D-6
IC309	B-2	Q524 E-6
IC311	C-1	Q601 A-7
IC604	C-5	Q901 D-5
IC704	A-4	Q902 D-5
IC705	B-4	Q903 C-6
IC803	C-3	Q904 A-2
IC903	A-3	Q905 A-2
		Q906 A-2
TRANSISTOR		
Q513	D-7	
Q514	D-7	
Q515	C-7	
Q516	E-6	
Q517	B-5	
Q518	A-4	
DIODE		
D301	A-7	
D302	B-5	
D901	B-11	

B3 BOARD (Component Side)

IC	TRANSISTOR
IC302	C-7
IC303	B-8
IC305	B-7
IC306	B-8
IC307	A-7
IC308	A-7
IC310	A-7
IC311	C-8
IC501	C-1
IC504	A-4
IC505	D-5
IC506	D-4
IC601	I-8
IC602	H-6
IC603	D-8
IC701	A-5
IC801	E-6
IC802	C-7
IC901	I-13
IC902	A-6
IC904	A-6
Q501	D-6
Q502	E-7
Q503	F-6
Q510	D-2
Q511	F-1
Q512	D-2
Q521	E-2
Q522	E-1
Q523	D-1
Q907	D-4
Q908	D-3
Q909	C-4
DIODE	
D601	I-8

PRINTED WIRING BOARD

J [YCT, COMB FILTER, VIDEO/AUDIO-IN/OUT]

- J Board (Component Side) -

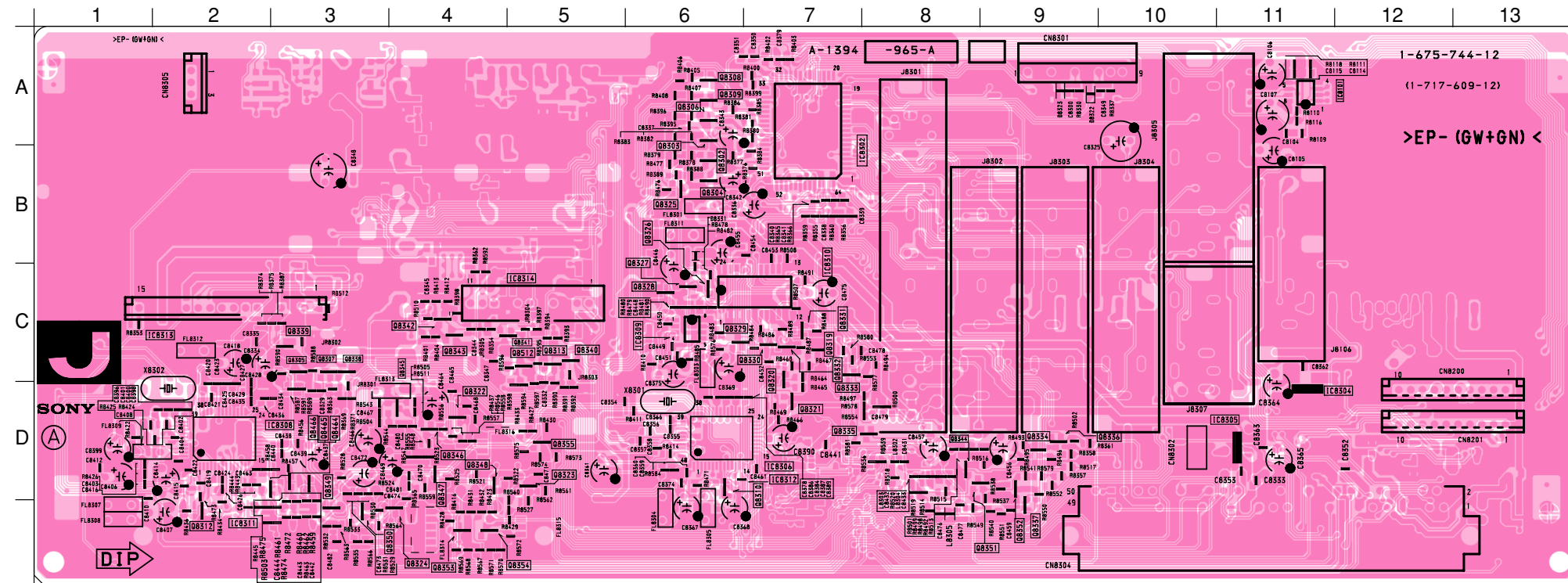

J BOARD (Component Side)

IC	Q8307 C-3	Q8339 C-3
IC0302 A-8	Q8308 A-6	Q8340 C-5
IC8101 A-12	Q8309 A-6	Q8341 C-5
IC8102 E-13	Q8310 D-7	Q8342 C-4
IC8103 B-13	Q8312 E-3	Q8343 C-4
IC8105 A-13	Q8313 C-5	Q8344 D-8
IC8106 C-12	Q8319 C-7	Q8345 C-3
IC8107 D-12	Q8320 C-7	Q8346 D-4
IC8304 D-12	Q8321 D-7	Q8347 D-4
IC8305 D-11	Q8322 D-4	Q8348 D-5
IC8306 D-7	Q8323 D-5	Q8349 E-3
IC8308 D-2	Q8324 D-4	Q8350 D-4
IC8309 C-6	Q8325 B-6	Q8351 D-9
IC8310 B-7	Q8326 B-6	Q8352 E-9
IC8311 E-3	Q8327 B-6	Q8353 E-5
IC8312 D-7	Q8328 C-6	Q8354 E-5
IC8313 C-2	Q8329 C-7	Q8355 D-5
IC8314 B-5	Q8330 C-7	
TRANSISTOR	Q8332 C-7	
Q8302 A-6	Q8333 C-7	
Q8303 A-6	Q8334 D-9	
Q8304 B-6	Q8335 D-7	
Q8305 C-3	Q8336 D10	
Q8306 A-6	Q8337 E-9	
	Q8338 C-3	

- J Board (Conductor Side) -

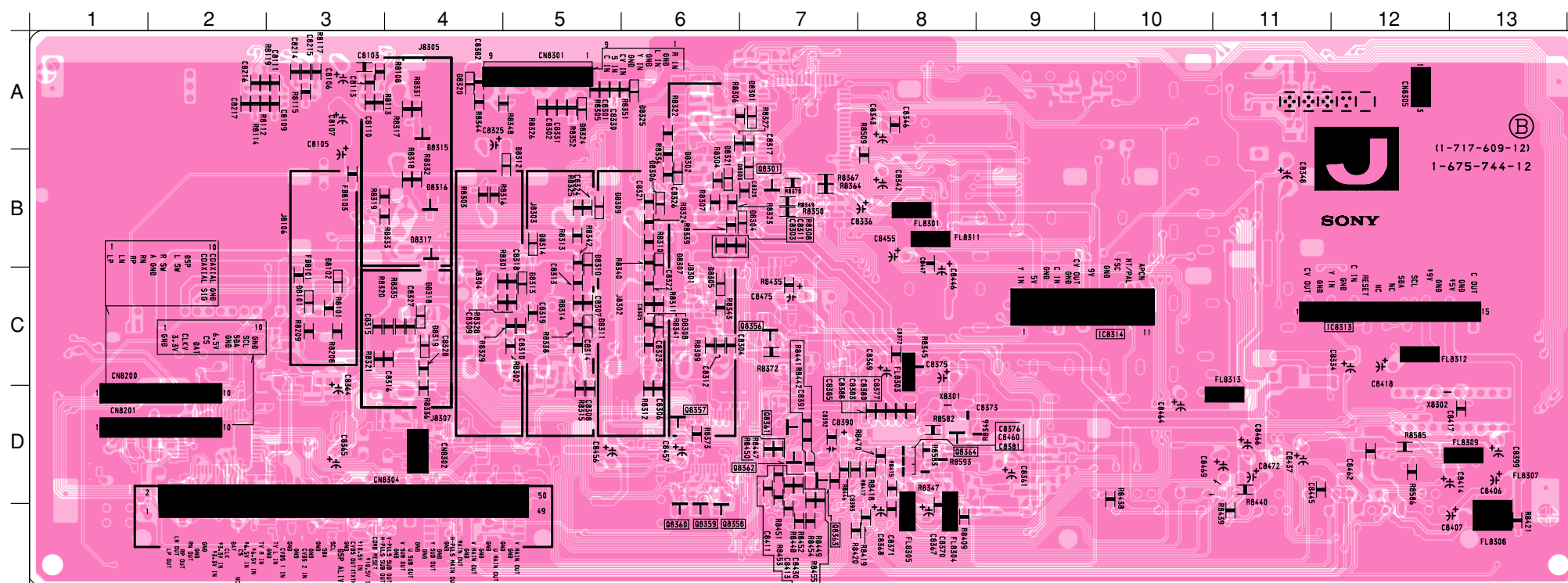

J BOARD (Conductor Side)

IC	D8302 B-6
IC8104 B-2	D8303 B-7
IC8313 C-12	D8304 B-7
IC8314 C-10	D8305 C-6
	D8306 B-6
TRANSISTOR	D8307 B-6
Q8301 B-7	D8308 C-6
Q8356 C-7	D8309 B-6
Q8357 D-6	D8310 B-5
Q8358 E-7	D8311 C-5
Q8359 E-6	D8313 C-5
Q8360 E-6	D8314 B-5
	D8315 A-4
DIODE	D8316 B-4
D8101 C-3	D8317 B-4
D8102 C-3	D8318 C-4
D8301 A-4	D8319 C-4
	D8320 A-4
	D8321 B-6
	D8325 A-4

- :Pattern from the side which enables seeing.
- :Pattern from the rear side.

PRINTED WIRING BOARD

E [RGB OUT, DEFLECTION]

A1 [AUDIO DSP]

- E Board (Component Side) -

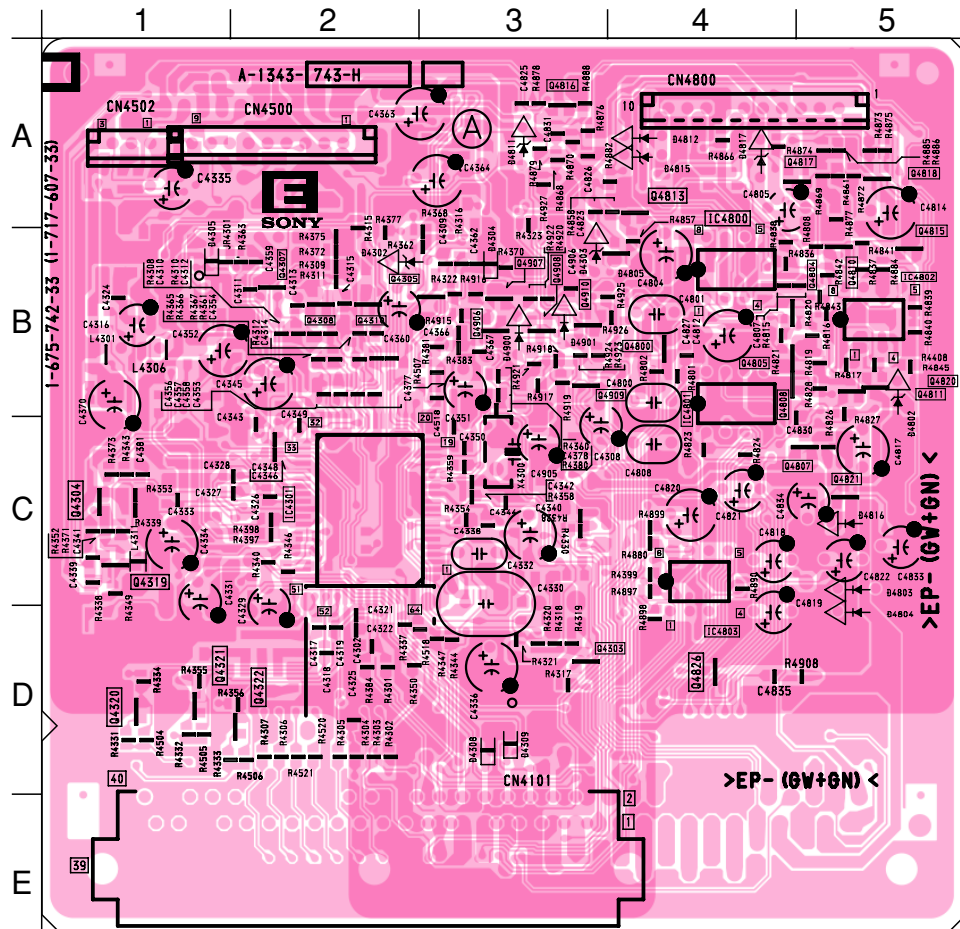

J BOARD (Component Side)

IC	Q4818 A-5	Q4820 B-5	Q4821 C-5	Q4826 D-4	Q4906 B-3	Q4907 B-3	Q4908 B-3	Q4909 B-3	Q4910 B-3	Q4808 B-4
IC4301 C-2										
IC4800 A-4										
IC4801 C-4										
IC4802 B-5										
IC4803 D-4										
TRANSISTOR	DIODE									
Q4303 D-3	D4302 B-2	D4303 B-3	D4304 B-3	D4305 B-1	D4308 D-3	D4802 C-5	D4803 C-5	D4804 D-5	D4805 B-4	D4811 A-3
Q4304 C-1										
Q4305 B-2										
Q4307 B-2										
Q4308 B-2										
Q4310 B-2										
Q4319 C-1										
Q4321 D-1										
Q4322 D-2										
Q4800 B-4	D4803 C-5	D4804 D-5	D4805 B-4	D4811 A-3	D4812 A-4	D4815 A-4	D4816 C-1	D4817 A-2	D4900 B-3	D4901 B-3
Q4804 B-5										
Q4805 B-4										
Q4807 C-5										
Q4810 B-5										
Q4811 B-5										
Q4813 A-4										
Q4815 B-5										
Q4816 A-3										
Q4817 A-4										

- E Board (Conductor Side) -

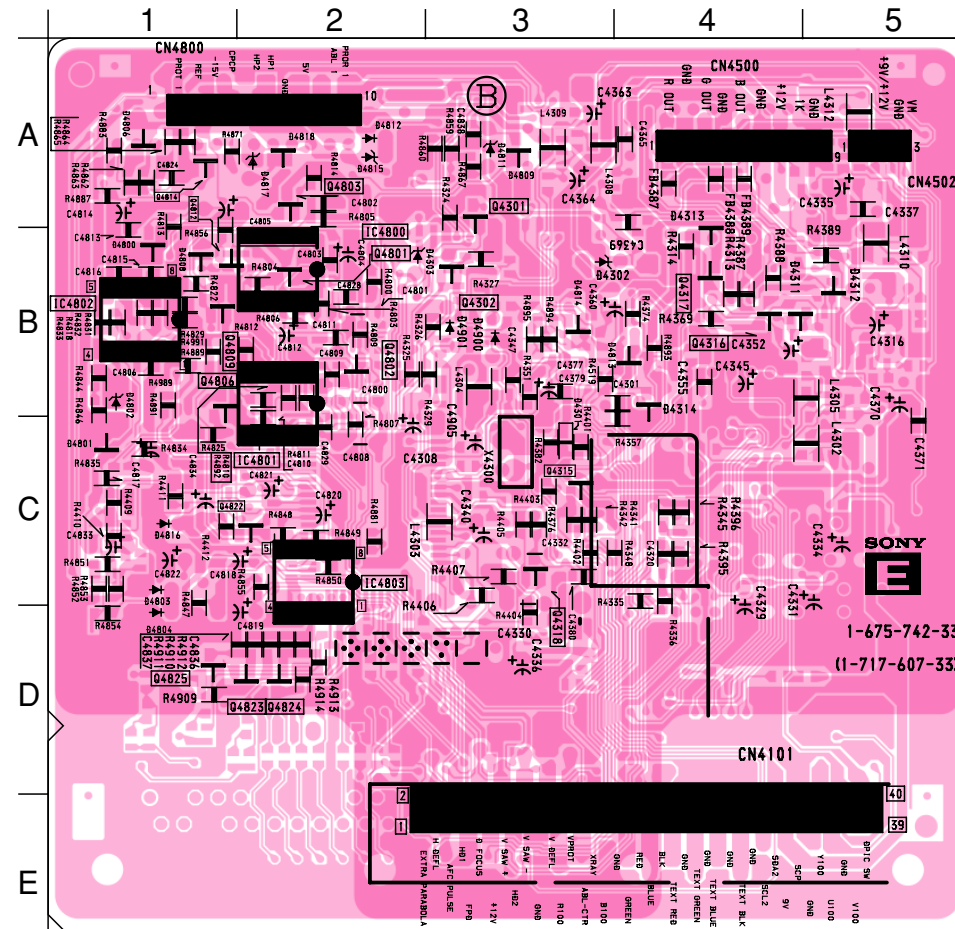

J BOARD (Conductor Side)

IC	DIODE
IC4800 B-2	D4301 C-3
IC4801 C-2	D4302 B-3
IC4802 B-1	D4303 B-2
IC4803 C-2	D4311 B-4
	D4312 B-5
	D4313 A-4
	D4314 C-4
TRANSISTOR	
Q4301 A-3	D4800 B-1
Q4302 B-3	D4801 C-1
Q4315 C-3	D4802 B-1
Q4316 B-4	D4803 C-1
Q4317 B-4	D4804 D-1
Q4318 D-3	D4806 A-1
Q4801 B-2	D4808 B-1
Q4802 B-2	D4809 A-3
Q4803 A-2	D4811 A-3
Q4806 B-1	D4812 A-2
Q4809 B-1	D4813 B-3
Q4812 A-1	D4814 B-3
Q4814 A-1	D4815 A-2
Q4822 C-1	D4816 C-1
Q4823 D-1	D4817 A-2
Q4824 D-2	D4818 A-2
Q4825 D-1	D4900 B-3
	D4901 B-3

- A1 Board (Component Side) -

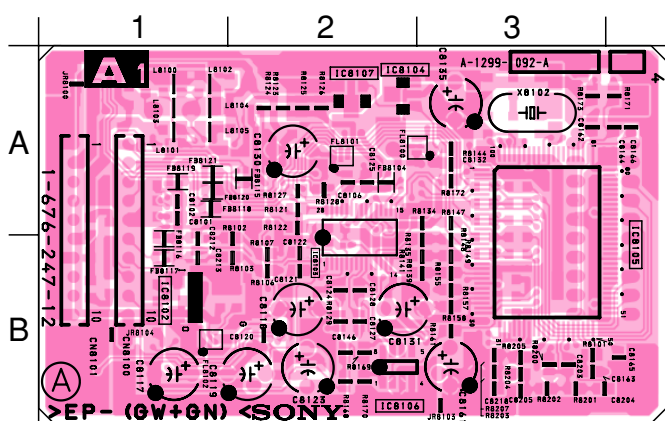

A1 BOARD (Component Side)

IC
IC8102 B-1
IC8104 A-2
IC8105 B-4
IC8106 B-3
IC8108 B-1

- A1 Board (Conductor Side) -

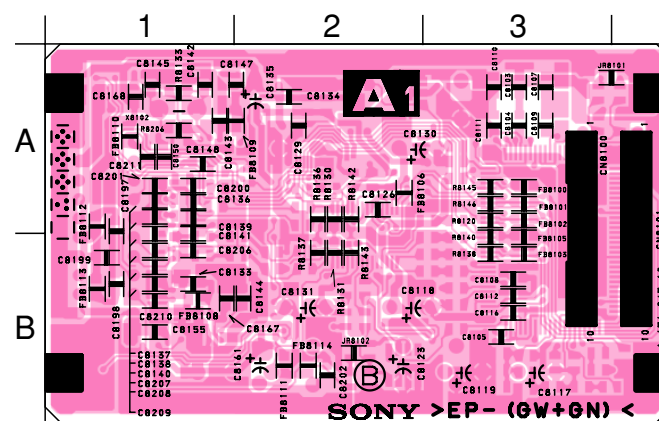

- :Pattern from the side which enables seeing.
- :Pattern from the rear side.

PRINTED WIRING BOARDS

C [CRT DRIVE]

F1 [AC LINE FILTER]

VM [VM DRIVE]

H1 [LED, SIRCS RECEIVER]

H3 [TOP KEY]

SP [SPEAKER CIRCUIT]

- C Board -

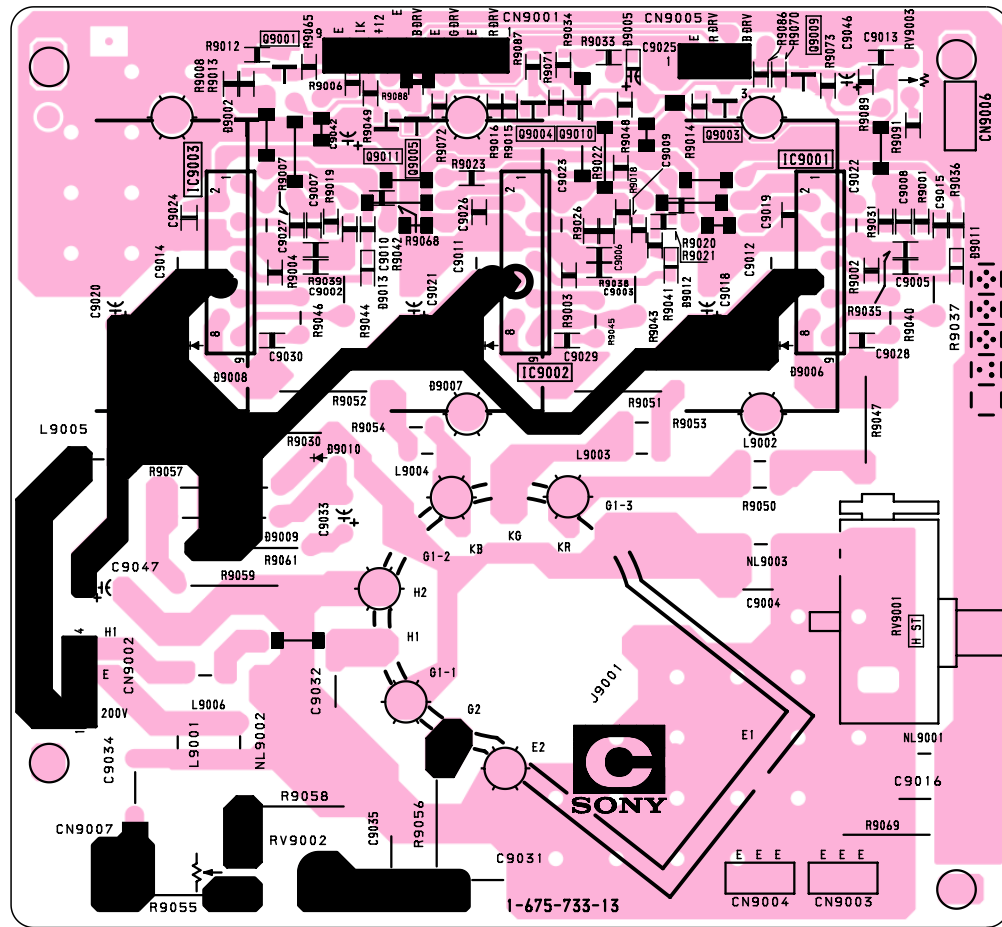

- F1 Board -

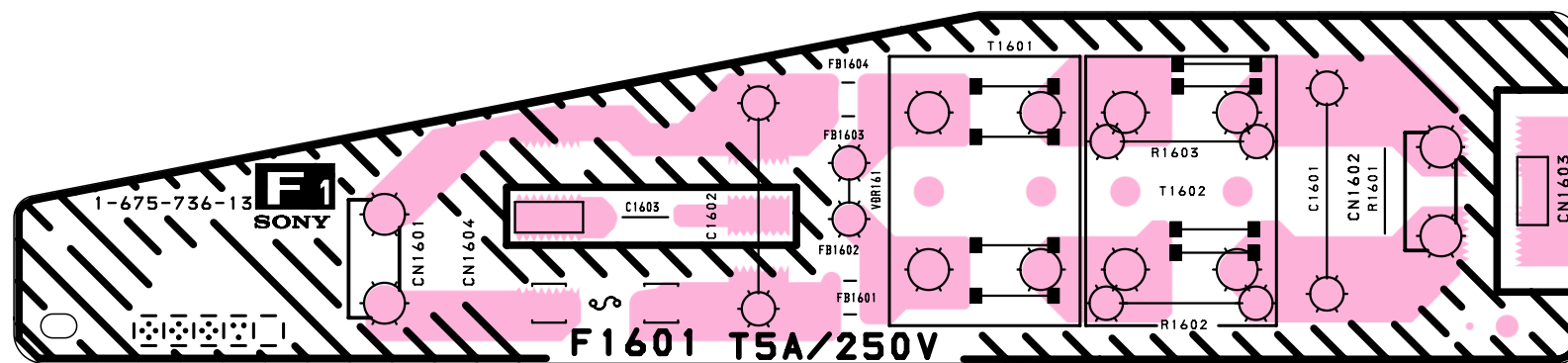

- VM Board -

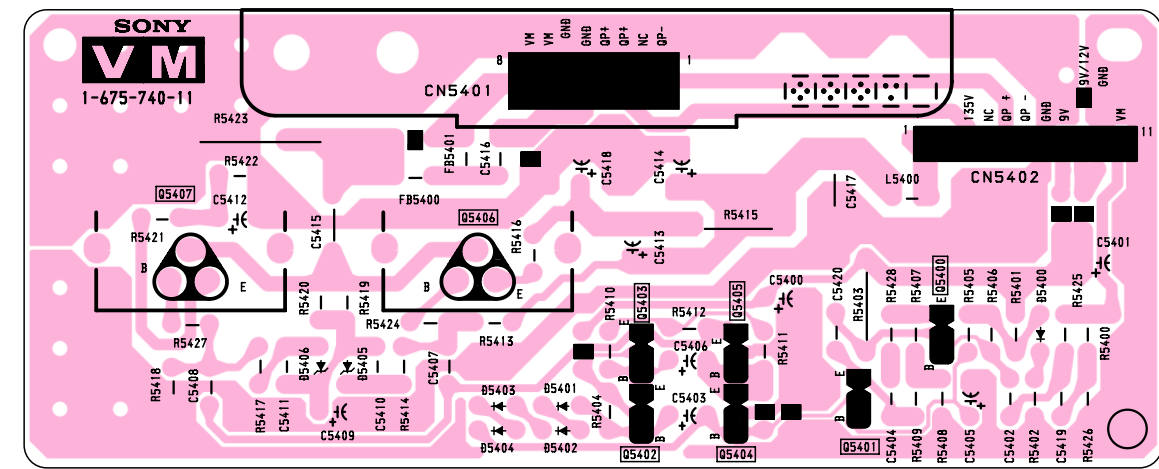

- H3 Board -



- H1 Board -

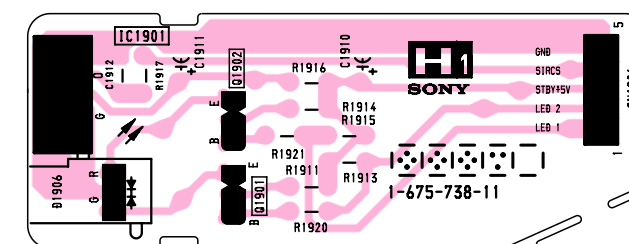

- SP Board -

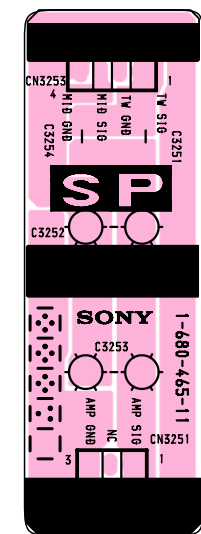

PRINTED WIRING BOARDS

BC4 [Y/C SEP]

DH [MAGNETIC FIELD CORRECTION]

H2 [AV INPUT, PRESET KEY, PHONE OUT]

F2 [AC SWITCH]

– BC4 Board –

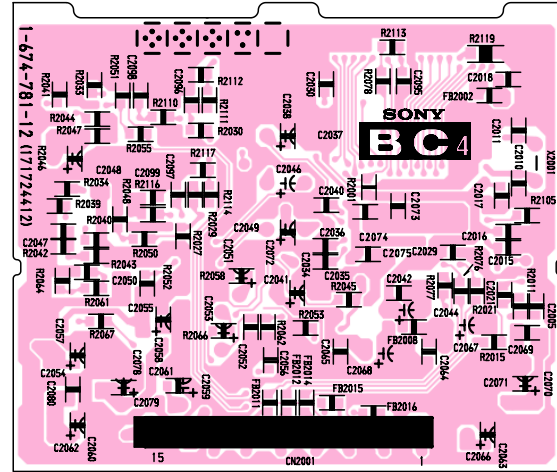

– H2 Board –

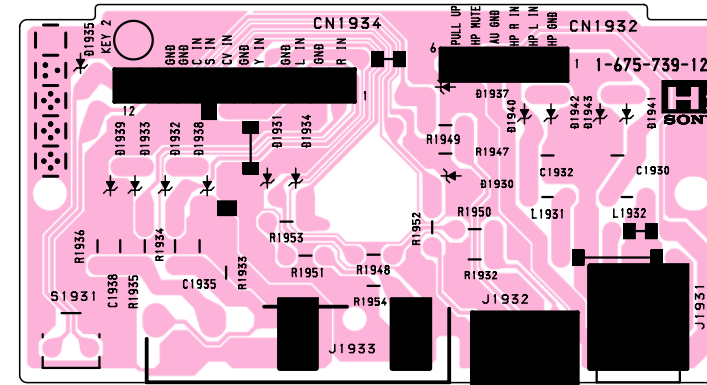

– DH Board –

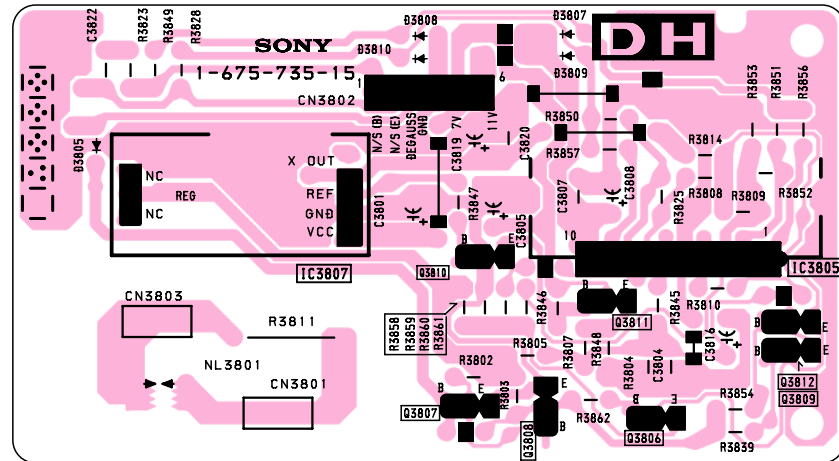

– F2 Board –

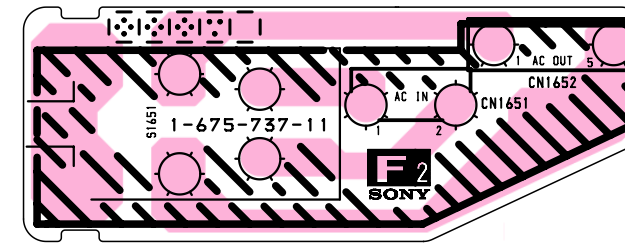

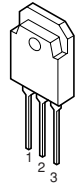
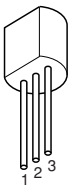
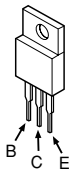
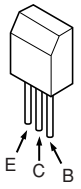
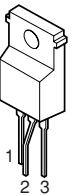
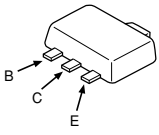

7-6. SEMICONDUCTORS

TRANSISTOR

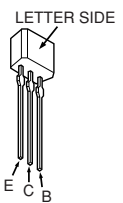
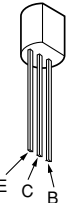
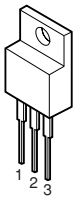
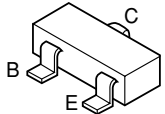
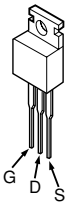
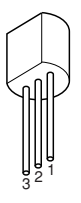
					
2SC5480-01	2SA1776TV2Q	IRF1740G	2SB733-34 2SD774-34	IRF720-LF49	2SK2036(TE85L) 2SK2251-01-F19

					
DTC144ESA 2SC2785-HFE 2SA1175-HFE DTA144ESA DTC114ESA	2SC2500-B	2SC3480(3) IRF1830G-LF49	DTC144EKA 2SC1623-L5L6 2SA1162-G 2SA1037AK-T146 2SC2712-YG 2SD2114K 2SD601A-Q-TX DTC114EK 2SB709A-QRS-TX	IRF620	2SA2005

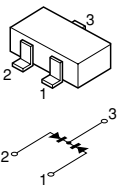
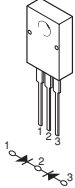
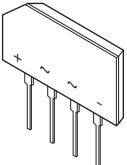
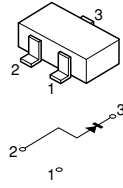
DIODE

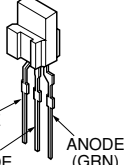
					
DAN202K	D10SC4M	D4SBS6	MA3091 MA3062M-TX STZ6.8N-T146	RN4Z	SPB-26MVWF

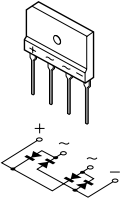
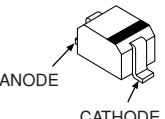
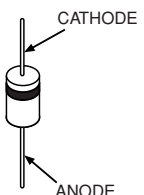
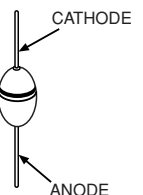
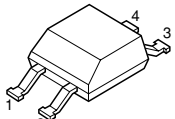
					
D4SBL20U D4SB60L	MA113-(TX) RD5.6SB3 RD9.1S-B UDZ-TE-17-3.9B MA111-TX UDZS-TE-179.1B	D1NL20U-TR HSS83TD HYS9.1NB2 1SS119-25 EL1Z S3L20U-F4 RGP02-20EL-6394	UF4005PKG23 GP08D P6KE200AG23	U05G	D10SBS4F

IC

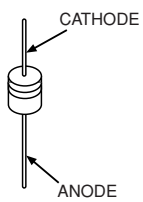
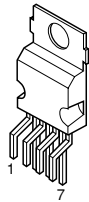
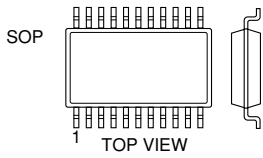
				 <p>SOP TOP VIEW Single In-line Package Pin 8~98</p>	
<p>D1NS4 RD10ESB2 RD2.7ESB2 RD5.6ES-B1 ERA85-009 RD2.2ES-B2 RD3.9ES-B2 RD4.7ESB2 RD5.6ESB2</p>	<p>RD15ES-B2 ERA38-06 RD22ES-B1 RD3.6ES-B1 RD6.8ES-B1 RD7.5ES-B2 RD12ES-B1 RD13ES-B2 RD15ES-B1</p>	<p>RD18ESB RD30ESB2</p>	<p>STV9379</p>	<p>CXA1875AM-T4 CXA1211M M24C08-MN6T(A) MB88141APF-ER MM115XFBE NJM4560M TLC2932IPWR TLC2933IPWR-12</p>	<p>TDA7315D013TR TDA9178T/N1.118 UPC4558G2 TCTSET08F4(TE85) TCTSET04F(TE85R)</p>

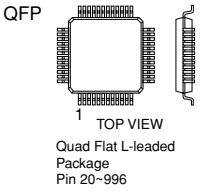
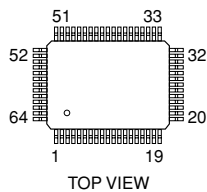
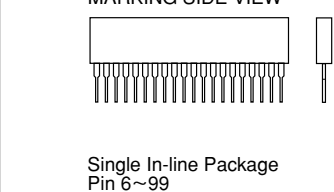
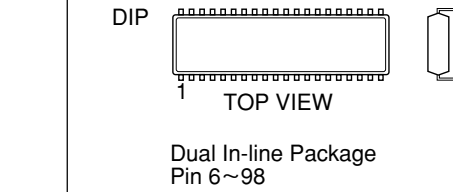
 <p>QFP TOP VIEW Quad Flat L-leaded Package Pin 20~996</p>	 <p>TOP VIEW</p>	 <p>MARKING SIDE VIEW Single In-line Package Pin 6~99</p>	 <p>DIP TOP VIEW Dual In-line Package Pin 6~98</p>
<p>CXD2090Q CXD9509AQ</p>	<p>CXP750096-042Q CXA2100AQ CXA2069Q PQ5EV3 TLC5733AIPM</p>	<p>DA7481</p>	<p>CA0007AD CA0005AD LM393N NJM3404AD-W TOP209P UPC358C</p>

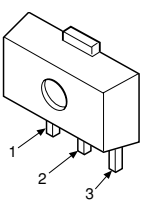
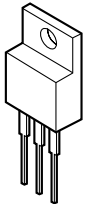
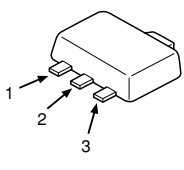
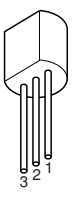
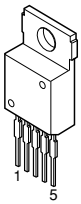
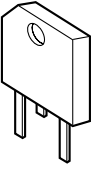
					
<p>S-80743AL-A7-S</p>	<p>BA09T BA12T PQ1CG2032F2 TA7805S 2SC5511</p>	<p>LF90CDT-TR LF50CDT-TR S-80743AN-D7 S-80827ANUP-EDQ</p>	<p>MM1431ATT MSM514265C-60JS</p>	<p>LA6500-FA LA6510</p>	<p>BA05T</p>

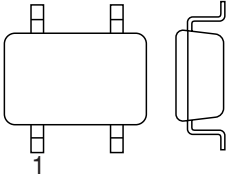
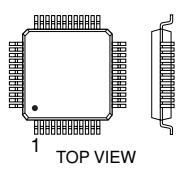
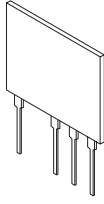
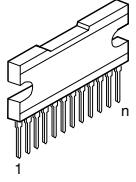
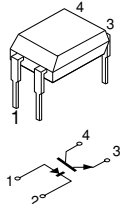
	 <p>TOP VIEW</p>			
<p>PST9145NL</p>	<p>CXD2309Q UPD640829F-3BA</p>	<p>DM-58</p>	<p>MCR5152</p>	<p>ON3171-R</p>

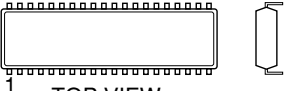
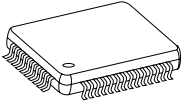
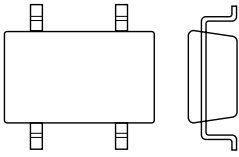
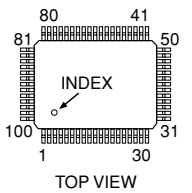
 <p>TOP VIEW</p> <p>Dual In-line Package Pin 6~98</p>				 <p>TOP VIEW</p>	
AK4524 TC7WU04F		CXA2123AQ-T6	PST9120NL		MB94918RPF-G-133 TC9446F-011

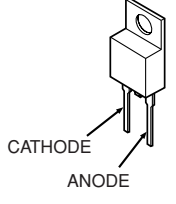
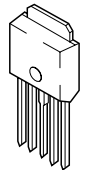
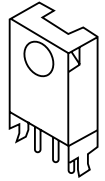
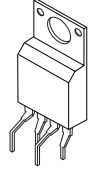
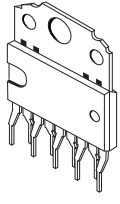
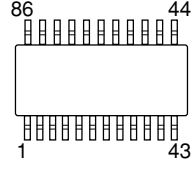
 <p>CATHODE</p> <p>ANODE</p>					
D5S4M	PQ3TZ534	SBX1981-51RP	PQ6RD83B	TDA6111Q/N4	MT48LC2M32B2TG

SECTION 8 EXPLODED VIEWS

NOTE:

- Items with no part number and no description are not stocked because they are seldom required for routine service.
- The construction parts of an assembled part are indicated with a collation number in the remark column.

• Items marked "*" are not stocked since they are seldom required for routine service. Some delay should be anticipated when ordering these items.

The components identified by shading and mark \triangle are critical for safety. Replace only with part number specified.

8-1. SPEAKER BRACKET

- : 7-685-663-71 SCREW +BVTP 4 x 16
- ▲ : 7-685-664-79 SCREW +BVTP 4 x 20
- : 7-685-648-79 SCREW +BVTP 3 x 12

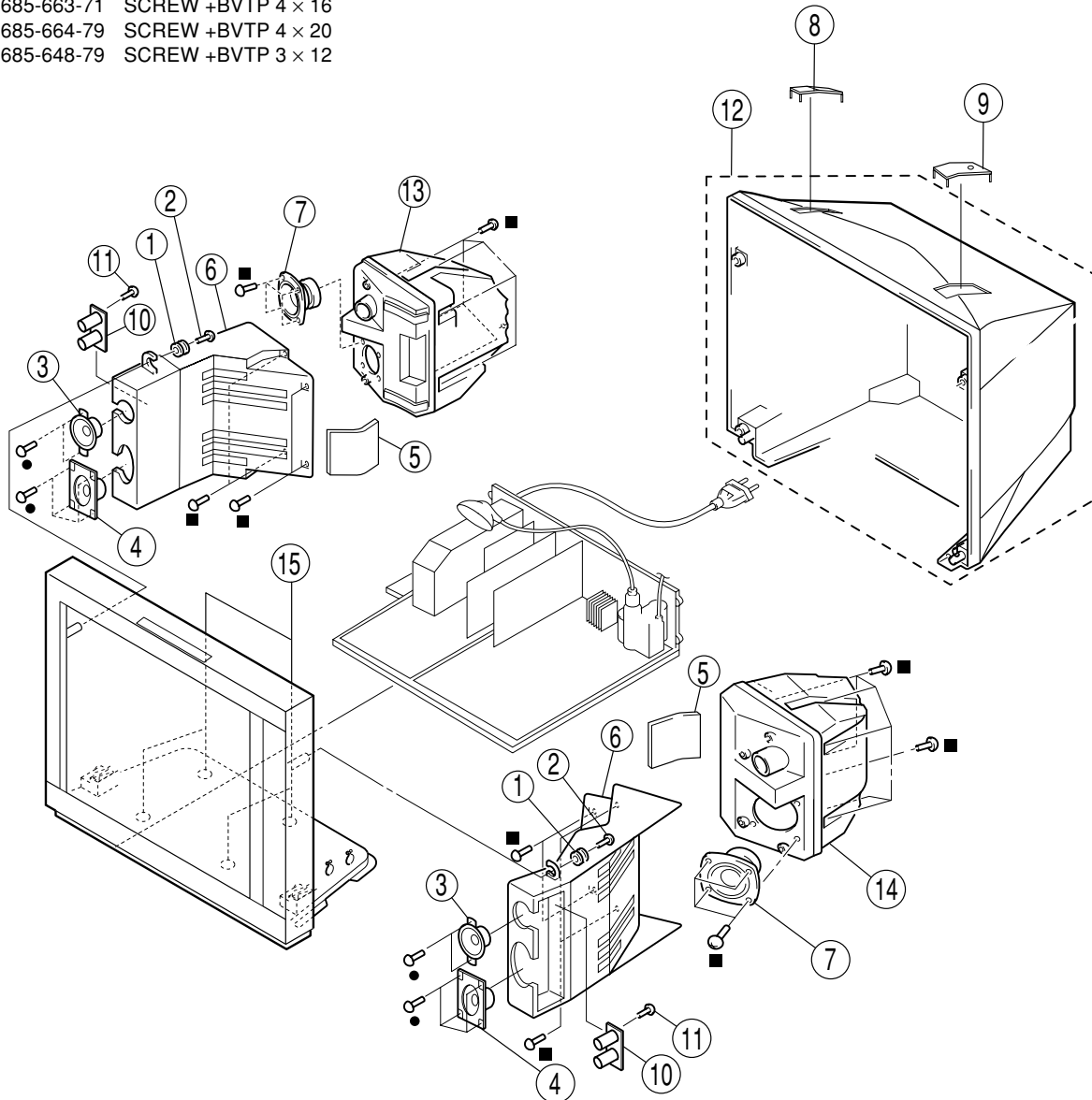

REF. NO.	PART NO.	DESCRIPTION	REMARK	REF. NO.	PART NO.	DESCRIPTION	REMARK
1	4-374-745-11	CUSHION A		11	4-046-797-01	SCREW (3 x 12), (+) BVTAP	
2	4-064-929-02	SCREW, TP + TWH 4 x 25		12	X-4038-430-2	COVER ASSY, REAR	(▲ 10 screws)
3	1-529-940-11	SPEAKER (5 cm)		13	A-1501-818-A	SP BOX (L) SUB ASSY	
4	1-529-939-11	SPEAKER (9 x 5 cm)		14	A-1501-820-A	SP BOX (R) SUB ASSY	
5	* 4-073-084-02	DUCT CUSHION		15	4-081-847-01	FOOT	
6	* 4-079-164-01	DUCT SPEAKER					
7	1-505-473-11	SPEAKER (12 cm)					
8	4-079-337-01	COVER, SCREW (L)					
9	4-079-336-01	COVER, SCREW (R)					
10	A-1391-163-A	SP BOARD MOUNT					

8-2. CHASSIS

● : 7-685-648-79 SCREW +BVTP 3 × 12

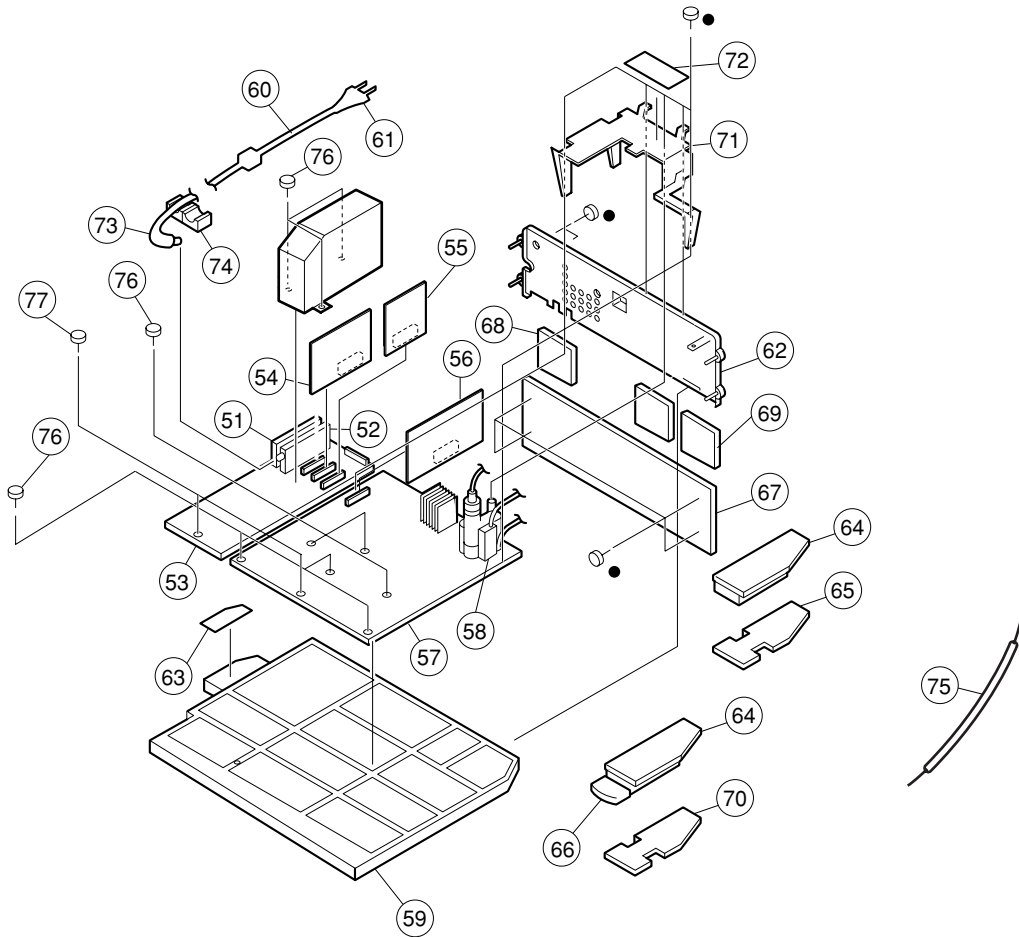

REF. NO.	PART NO.	DESCRIPTION	REMARK	REF. NO.	PART NO.	DESCRIPTION	REMARK
51	8-598-430-50	TUNER, FSS BTF-FA401		66	4-071-305-03	BUTTON, POWER	
52	8-598-542-30	TUNER, FSS BTF-WA412		67	* A-1395-042-A	J BOARD COMPLETE	
53	* A-1299-617-A	A BOARD COMPLETE		68	* A-1299-593-A	A1 BOARD COMPLETE	
54	* A-1136-251-A	B3 BOARD COMPLETE		69	* A-1136-252-A	BC4 BOARD COMPLETE	
55	* A-1333-173-A	E BOARD MOUNT		70	* A-1241-510-A	F2 BOARD MOUNT	
56	* A-1333-171-A	D1 BOARD MOUNT		71	* 4-071-316-02	SUPPORTER, PWB	
57	* A-1348-123-A	D BOARD COMPLETE		72	* A-1333-172-A	DH BOARD MOUNTED	
58	△ 1-453-360-11	TRANSFORMER ASSY, FLYBACK (NX-4601/J1J4)		73	1-792-458-11	CABLE RF (WITH FERRITE)	
59	* 4-071-314-03	BRACKET, MAIN		74	1-543-653-11	CORE ASSY, BEAD (DIVISION TYPE)	
60	△ 4-022-115-01	HOLDER, AC CORD		75	1-900-255-46	LEAD ASSY, G2	
61	△ 1-792-065-11	CORD, FILTER (WITH POWER)		76	4-302-428-03	SCREW(WASHER HEAD)(+P3 x 12)	
62	* 4-071-315-02	BRACKET, TERMINAL		77	4-046-797-01	SCREW(3 x 12),(+)BVTAP	
63	* A-1241-523-A	F1 BOARD MOUNTED					
64	* 4-071-307-03	HOLDER, F2/H1					
65	* A-1377-035-A	H1 BOARD MOUNT					

8-3. PICTURE TUBE

- ▲: 7-685-103-19 SCREW +P 2 × 5
- : 7-685-152-19 SCREW +P 3 × 25
- : 7-685-648-79 SCREW +BVTP 3 × 12
- : 7-685-663-71 SCREW +BVTP 4 × 16
- ◆: 7-685-661-14 SCREW +BVTP 4 × 12
- ▲: 7-685-664-79 SCREW +BVTP 4 × 20
- ▼: 7-682-262-04 SCREW +K 4 × 10

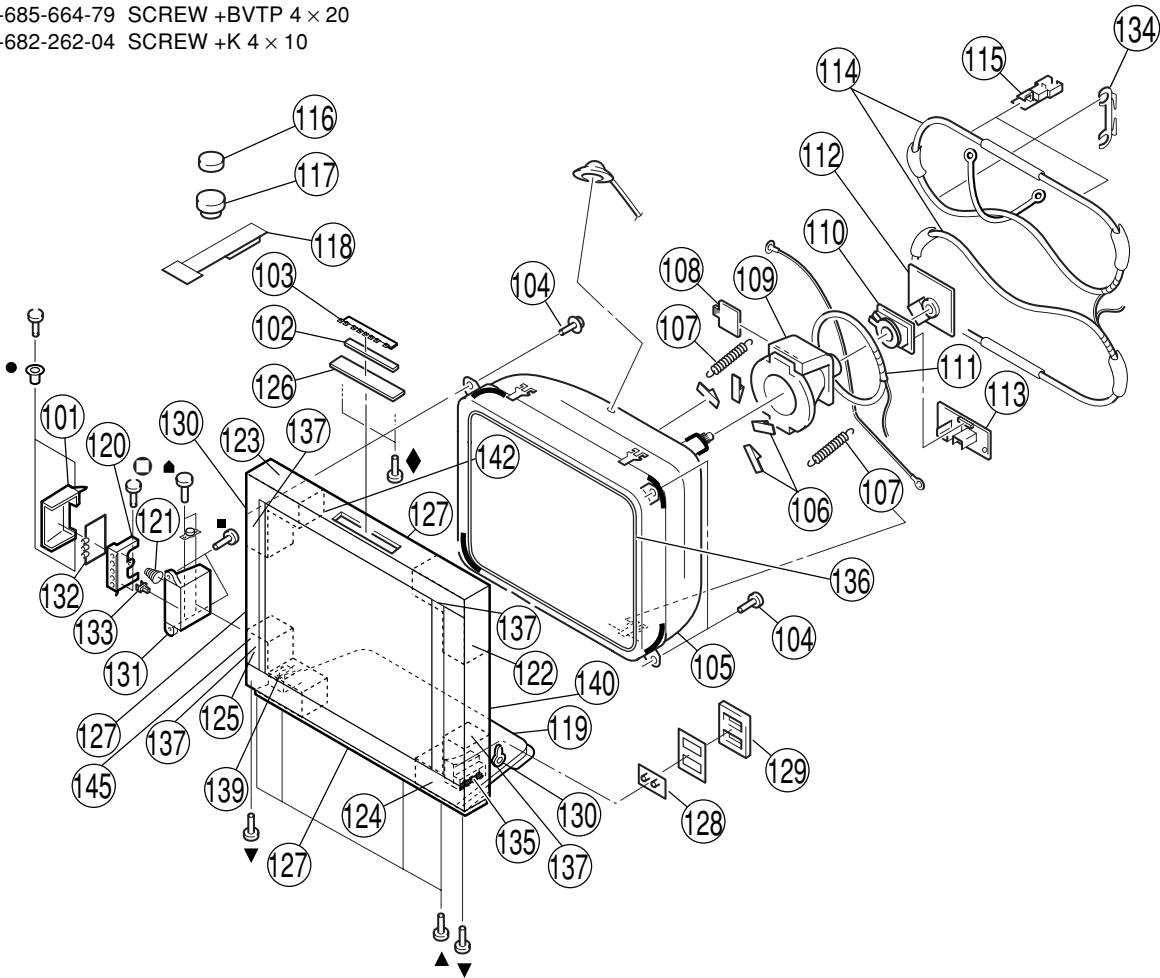

REF. NO.	PART NO.	DESCRIPTION	REMARK	REF. NO.	PART NO.	DESCRIPTION	REMARK
101	4-071-308-02	DOOR, CONTROL		121	4-071-323-01	SPRING, CONE	
102	* A-1372-730-A	H3 BOARD MOUNTED		122	* 4-079-161-02	BRACKET (TR), CRT	
103	4-071-312-03	BUTTON, TOP SW		123	* 4-079-160-02	BRACKET (TL), CRT	
104	4-046-765-12	SCREW, TAPPING 7+CROWN WASHER		124	* 4-079-163-01	BRACKET (BR), CRT	
105	▲ 8-735-090-05	PICTURE TUBE (A90LPW80X)		125	* 4-079-162-01	BRACKET (BL), CRT	
106	3-703-961-01	SPACER, DY		126	* 4-071-311-02	HOLDER, H3	
	4-082-357-11	SPACE (DY)		127	X-4039-368-1	FRAME ASSY	
107	* 4-369-318-61	SPRING, TENSION		128	* 4-071-306-01	LIGHT, GUIDE	
108	2-163-920-01	PLATE, TLH CORRECTION		129	* 4-072-950-01	BRACKET, LIGHT GUIDE	
109	▲ 1-451-528-12	DEFLECTION YOKE		130	4-073-080-01	FASTEN	
110	8-453-007-31	NA324-M3		131	* 4-071-310-04	BRACKET, SIDE	
111	1-452-896-61	COIL, NA ROTATION (RT200)		132	* A-1377-036-A	H2 BOARD MOUNTED	
112	* A-1332-227-A	C BOARD MOUNTED		133	4-047-464-01	CATCHER, PUSH	
113	* A-1342-625-A	VM BOARD MOUNTED		134	* 4-067-087-03	HOLDER(C), DGC	
114	▲ 1-424-907-11	COIL, DEGAUSSING		135	* 4-071-673-01	SHEET, COVER	
115	* 4-080-511-01	CLIP, DGC		136	1-419-844-11	COIL, LANDING CORRECTION	
116	1-452-032-00	MAGNET, DISC		137	4-072-956-01	SCREW SPECIAL (DIA.8) (+TP 4 X 9)	
117	1-452-094-00	CIRCULAR DISC MAGNET B		138	X-4039-357-1	FRAME SUB ASSY, TOP	
118	4-051-734-42	PIECE B(120), CONV. CORRECT		139	X-4038-427-1	FRAME SUB ASSY, BOTTOM	
119	* 4-079-159-01	COVER, FRONT		140	X-4039-358-1	FRAME SUB ASSY, RIGHT	
120	* X-4037-516-2	HOLDER ASSY, CONTROL		141	X-4038-429-2	FRAME SUB ASSY, LEFT	

SECTION 9
ELECTRICAL PARTS LIST

A

NOTE:

The components identified by shading and mark \triangle are critical for safety. Replace only with part number specified.

When indicating parts by reference number, please include the board name.

- Items marked " * " are not stocked since they are seldom required for routine service. Some delay should be anticipated when ordering these items.

- All variable and adjustable resistors have characteristic curve B, unless otherwise noted.

- All resistors are in ohms
- F : nonflammable

CAPACITORS

- MF : μ F, PF : μ μ F

COILS

- MMH : mH, UH : μ H

REF NO.	PART NO.	DESCRIPTION	REMARK	REF NO.	PART NO.	DESCRIPTION	REMARK
	* A-1299-617-A	A BOARD COMPLETE *****		C1206	1-126-965-91	ELECT 22UF	20.00% 50V
				C1207	1-164-004-11	CERAMIC CHIP 0.1UF	10.00% 25V
	* 1-555-110-00	CABLE, PIN		C1208	1-126-023-11	ELECT 100UF	20.00% 16V
	4-382-854-11	SCREW (M3X10), P, SW (+)		C1209	1-164-505-11	CERAMIC CHIP 2.2UF	16V
				C1210	1-125-838-11	CERAMIC CHIP 2.2UF	10% 6.3V
		<CAPACITOR>		C1211	1-163-989-11	CERAMIC CHIP 0.033UF	10.00% 25V
C001	1-163-021-91	CERAMIC CHIP 0.01UF	10.00% 50V	C1212	1-125-838-11	CERAMIC CHIP 2.2UF	10% 6.3V
C002	1-163-021-91	CERAMIC CHIP 0.01UF	10.00% 50V	C1213	1-163-989-11	CERAMIC CHIP 0.033UF	10.00% 25V
C004	1-163-001-11	CERAMIC CHIP 220PF	10.00% 50V	C1214	1-126-055-11	ELECT 470UF	20.00% 50V
C005	1-163-001-11	CERAMIC CHIP 220PF	10.00% 50V	C1215	1-126-055-11	ELECT 470UF	20.00% 50V
C006	1-164-004-11	CERAMIC CHIP 0.1UF	10.00% 25V	C1216	1-126-943-11	ELECT 2200UF	20.00% 25V
				C1217	1-126-943-11	ELECT 2200UF	20.00% 25V
C007	1-126-933-11	ELECT 100UF	20.00% 16V	C1219	1-126-961-11	ELECT 2.2UF	20.00% 50V
C009	1-164-004-11	CERAMIC CHIP 0.1UF	10.00% 25V	C1220	1-126-961-11	ELECT 2.2UF	20.00% 50V
C010	1-164-004-11	CERAMIC CHIP 0.1UF	10.00% 25V	C1221	1-126-933-11	ELECT 100UF	20.00% 16V
C012	1-163-227-11	CERAMIC CHIP 10PF	0.50PF 50V	C1222	1-125-838-11	CERAMIC CHIP 2.2UF	10% 6.3V
C013	1-163-021-91	CERAMIC CHIP 0.01UF	10.00% 50V	C1223	1-125-838-11	CERAMIC CHIP 2.2UF	10% 6.3V
C014	1-126-947-11	ELECT 47UF	20.00% 16V	C1224	1-125-838-11	CERAMIC CHIP 2.2UF	10% 6.3V
C015	1-163-227-11	CERAMIC CHIP 10PF	0.50PF 50V	C1225	1-125-838-11	CERAMIC CHIP 2.2UF	10% 6.3V
C016	1-163-243-11	CERAMIC CHIP 47PF	5.00% 50V	C1229	1-125-838-11	CERAMIC CHIP 2.2UF	10% 6.3V
C017	1-163-247-91	CERAMIC CHIP 68PF	5.00% 50V	C1230	1-125-838-11	CERAMIC CHIP 2.2UF	10% 6.3V
C018	1-163-021-91	CERAMIC CHIP 0.01UF	10.00% 50V	C1241	1-115-339-11	CERAMIC CHIP 0.1UF	10.00% 50V
C019	1-163-021-91	CERAMIC CHIP 0.01UF	10.00% 50V	C1242	1-115-339-11	CERAMIC CHIP 0.1UF	10.00% 50V
C020	1-163-021-91	CERAMIC CHIP 0.01UF	10.00% 50V	C1243	1-115-339-11	CERAMIC CHIP 0.1UF	10.00% 50V
C021	1-163-021-91	CERAMIC CHIP 0.01UF	10.00% 50V	C1244	1-110-617-51	ELECT 2200UF	20.00% 50V
C024	1-163-227-11	CERAMIC CHIP 10PF	0.50PF 50V	C1245	1-115-339-11	CERAMIC CHIP 0.1UF	10.00% 50V
C028	1-163-037-11	CERAMIC CHIP 0.022UF	10.00% 50V	C1246	1-107-823-11	CERAMIC CHIP 0.47UF	10.00% 16V
C031	1-164-004-11	CERAMIC CHIP 0.1UF	10.00% 25V	C1247	1-115-339-11	CERAMIC CHIP 0.1UF	10.00% 50V
C032	1-163-021-91	CERAMIC CHIP 0.01UF	10.00% 50V	C1248	1-110-617-51	ELECT 2200UF	20.00% 50V
C033	1-164-004-11	CERAMIC CHIP 0.1UF	10.00% 25V	C1249	1-163-009-91	CERAMIC CHIP 0.001UF	10.00% 50V
C034	1-163-259-91	CERAMIC CHIP 220PF	5.00% 50V	C1251	1-163-017-00	CERAMIC CHIP 0.0047UF	10.00% 50V
C101	1-126-964-11	ELECT 10UF	20.00% 50V	C1252	1-163-251-11	CERAMIC CHIP 100PF	5.00% 50V
C103	1-164-004-11	CERAMIC CHIP 0.1UF	10.00% 25V	C1253	1-115-339-11	CERAMIC CHIP 0.1UF	10.00% 50V
C104	1-126-933-11	ELECT 100UF	20.00% 16V	C1254	1-136-165-00	FILM 0.1UF	5.00% 50V
C106	1-163-809-11	CERAMIC CHIP 0.047UF	10.00% 25V	C1255	1-163-009-91	CERAMIC CHIP 0.001UF	10.00% 50V
C107	1-163-005-91	CERAMIC CHIP 470PF	10.00% 50V	C1256	1-137-194-81	FILM 0.47UF	5.00% 50V
C108	1-126-933-11	ELECT 100UF	20.00% 16V	C1258	1-115-339-11	CERAMIC CHIP 0.1UF	10.00% 50V
C109	1-163-005-91	CERAMIC CHIP 470PF	10.00% 50V	C1259	1-115-339-11	CERAMIC CHIP 0.1UF	10.00% 50V
C110	1-163-005-91	CERAMIC CHIP 470PF	10.00% 50V	C1260	1-107-823-11	CERAMIC CHIP 0.47UF	10.00% 16V
C111	1-163-005-91	CERAMIC CHIP 470PF	10.00% 50V	C1262	1-163-009-91	CERAMIC CHIP 0.001UF	10.00% 50V
C112	1-126-933-11	ELECT 100UF	20.00% 16V	C1263	1-163-017-00	CERAMIC CHIP 0.0047UF	10.00% 50V
C113	1-126-947-11	ELECT 47UF	20.00% 16V	C1264	1-163-251-11	CERAMIC CHIP 100PF	5.00% 50V
C114	1-126-967-11	ELECT 47UF	20.00% 50V	C1265	1-115-339-11	CERAMIC CHIP 0.1UF	10.00% 50V
C301	1-126-767-11	ELECT 1000UF	20.00% 16V	C1266	1-136-165-00	FILM 0.1UF	5.00% 50V
C326	1-126-964-11	ELECT 10UF	20.00% 50V	C1267	1-163-009-91	CERAMIC CHIP 0.001UF	10.00% 50V
C1201	1-164-004-11	CERAMIC CHIP 0.1UF	10.00% 25V	C1268	1-137-194-81	FILM 0.47UF	5.00% 50V
C1202	1-164-004-11	CERAMIC CHIP 0.1UF	10.00% 25V	C1270	1-163-007-11	CERAMIC CHIP 680PF	10.00% 50V
C1203	1-164-505-11	CERAMIC CHIP 2.2UF	16V	C1271	1-163-007-11	CERAMIC CHIP 680PF	10.00% 50V
C1204	1-163-275-11	CERAMIC CHIP 0.001UF	5.00% 50V	C1272	1-126-941-11	ELECT 470UF	20.00% 25V
C1205	1-163-275-11	CERAMIC CHIP 0.001UF	5.00% 50V	C1273	1-115-339-11	CERAMIC CHIP 0.1UF	10.00% 50V
				C1274	1-115-339-11	CERAMIC CHIP 0.1UF	10.00% 50V
				C1275	1-163-007-11	CERAMIC CHIP 680PF	10.00% 50V

A

REF NO.	PART NO.	DESCRIPTION	REMARK	REF NO.	PART NO.	DESCRIPTION	REMARK
C1276	1-163-007-11	CERAMIC CHIP	680PF 10.00% 50V	CN1180	1-793-495-11	CONNECTOR, BOARD TO BOARD 50P	
C1277	1-164-690-91	CERAMIC CHIP	0.0022UF 5.00% 50V	CN1190 *	1-564-510-11	PLUG, CONNECTOR 7P	
C1279	1-164-690-91	CERAMIC CHIP	0.0022UF 5.00% 50V	CN1193 *	1-764-333-11	PLUG, CONNECTOR 10P	
C1281	1-115-339-11	CERAMIC CHIP	0.1UF 10.00% 50V				
C1282	1-115-339-11	CERAMIC CHIP	0.1UF 10.00% 50V	CN1195 *	1-564-506-11	PLUG, CONNECTOR 3P	
C1283	1-164-690-91	CERAMIC CHIP	0.0022UF 5.00% 50V				
C1284	1-164-690-91	CERAMIC CHIP	0.0022UF 5.00% 50V				<COMPOSITION CIRCUIT BLOCK>
C1285	1-126-933-11	ELECT	100UF 20.00% 16V	CP1300	1-251-658-31	SPLITTER RF	
C1286	1-126-933-11	ELECT	100UF 20.00% 16V				
C1287	1-163-251-11	CERAMIC CHIP	100PF 5.00% 50V				<DIODE>
C1288	1-163-251-11	CERAMIC CHIP	100PF 5.00% 50V	D001	8-719-404-50	MA111-TX	
C1289	1-163-251-11	CERAMIC CHIP	100PF 5.00% 50V	D002	8-719-404-50	MA111-TX	
C1290	1-163-251-11	CERAMIC CHIP	100PF 5.00% 50V	D003	8-719-404-50	MA111-TX	
C1291	1-163-251-11	CERAMIC CHIP	100PF 5.00% 50V	D004	8-719-404-50	MA111-TX	
C1292	1-163-251-11	CERAMIC CHIP	100PF 5.00% 50V	D005	8-719-404-50	MA111-TX	
C1297	1-137-194-81	FILM	0.47UF 5.00% 50V	D006	8-719-404-50	MA111-TX	
C1298	1-137-194-81	FILM	0.47UF 5.00% 50V	D007	8-719-158-18	RD5.6SB3	
C1301	1-126-933-11	ELECT	100UF 20.00% 16V	D013	8-719-158-18	RD5.6SB3	
C1302	1-115-339-11	CERAMIC CHIP	0.1UF 10.00% 50V	D014	8-719-404-50	MA111-TX	
C2200	1-126-964-11	ELECT	10UF 20.00% 50V	D300	8-719-404-50	MA111-TX	
C2201	1-126-964-11	ELECT	10UF 20.00% 50V	D301	8-719-404-50	MA111-TX	
C2202	1-126-964-11	ELECT	10UF 20.00% 50V	D302	8-719-404-50	MA111-TX	
C2203	1-126-963-11	ELECT	4.7UF 20.00% 50V	D317	8-719-404-50	MA111-TX	
C2204	1-125-838-11	CERAMIC CHIP	2.2UF 10% 6.3V	D1205	8-719-158-35	RD9.1S-B	
C2205	1-125-838-11	CERAMIC CHIP	2.2UF 10% 6.3V	D1208	8-719-404-50	MA111-TX	
C2206	1-126-964-11	ELECT	10UF 20.00% 50V	D1209	8-719-404-50	MA111-TX	
C2209	1-126-968-11	ELECT	100UF 20.00% 50V	D2200	8-719-158-35	RD9.1S-B	
C2600	1-164-004-11	CERAMIC CHIP	0.1UF 10.00% 25V	D2201	8-719-158-35	RD9.1S-B	
C2601	1-164-004-11	CERAMIC CHIP	0.1UF 10.00% 25V	D2600	8-719-500-70	D5S4M	
C2602	1-126-933-11	ELECT	100UF 20.00% 16V				<FERRITE BEAD>
C2603	1-126-933-11	ELECT	100UF 20.00% 16V	FB001	1-414-233-22	FERRITE 0UH	
C2605	1-126-935-11	ELECT	470UF 20.00% 10V	FB002	1-414-233-22	FERRITE 0UH	
C2606	1-164-344-11	CERAMIC CHIP	0.068UF 10.00% 25V	FB003	1-414-233-22	FERRITE 0UH	
C2608	1-126-916-11	ELECT	1000UF 20.00% 6.3V	FB004	1-414-233-22	FERRITE 0UH	
C2609	1-126-935-11	ELECT	470UF 20.00% 6.3V	FB005	1-414-233-22	FERRITE 0UH	
C2610	1-164-004-11	CERAMIC CHIP	0.1UF 10.00% 25V	FB006	1-414-233-22	FERRITE 0UH	
C2611	1-126-934-11	ELECT	220UF 20.00% 10V	FB007	1-414-233-22	FERRITE 0UH	
C2612	1-126-933-11	ELECT	100UF 20.00% 16V	FB008	1-414-233-22	FERRITE 0UH	
C2613	1-126-933-11	ELECT	100UF 20.00% 16V	FB1205	1-410-397-21	FERRITE 1.1UH	
C2614	1-126-935-11	ELECT	470UF 20.00% 10V	FB1206	1-410-397-21	FERRITE 1.1UH	
C3302	1-126-964-11	ELECT	10UF 20.00% 50V	FB1207	1-410-397-21	FERRITE 1.1UH	
C3330	1-164-004-11	CERAMIC CHIP	0.1UF 10.00% 25V	FB1208	1-410-397-21	FERRITE 1.1UH	
C3331	1-126-933-11	ELECT	100UF 20.00% 16V	FB1300	1-216-295-91	SHORT 0	
C3336	1-126-933-11	ELECT	100UF 20.00% 16V				<FILTER>
C3337	1-163-809-11	CERAMIC CHIP	0.047UF 10.00% 25V	FL001	1-236-071-11	ENCAPSULATED COMPONENT	
C3338	1-163-005-91	CERAMIC CHIP	470PF 10.00% 50V				<IC>
C3350	1-163-005-91	CERAMIC CHIP	470PF 10.00% 50V	IC001	8-752-926-75	IC CXP750096-042Q	
C3351	1-163-005-91	CERAMIC CHIP	470PF 10.00% 50V	IC002	8-759-042-02	S-80743AL-A7-S	
C3352	1-163-005-91	CERAMIC CHIP	470PF 10.00% 50V	IC003	8-759-675-64	M24C08-MN6T(A)	
C3353	1-126-933-11	ELECT	100UF 20.00% 16V	IC004	6-700-149-01	IC M24C04-MN6T(A)	
C3354	1-126-967-11	ELECT	47UF 20.00% 50V	IC1201	8-759-273-12	TDA7315D013TR	
C3355	1-126-947-11	ELECT	47UF 20.00% 16V	IC1203	8-759-553-45	TDA7481	
		<CONNECTOR>		IC1204	8-759-553-45	TDA7481	
CN1100 *	1-560-218-00	PIN, CONNECTOR 7P		IC1205	8-759-100-96	UPC4558G2	
CN1108	1-695-299-11	CONNECTOR, BOARD TO BOARD 50P					
CN1116	1-695-915-11	TAB (CONTACT)					
CN1138 *	1-564-507-11	PLUG, CONNECTOR 4P					
CN1140	1-793-494-11	CONNECTOR, BOARD TO BOARD 40P					
CN1160 *	1-764-333-11	PLUG, CONNECTOR 10P					
CN1162	1-900-903-64	CONNECTOR ASSY 20P					

A

REF NO.	PART NO.	DESCRIPTION	REMARK	REF NO.	PART NO.	DESCRIPTION	REMARK
IC2200	8-759-745-64	NJM4560M		Q1211	8-729-026-49	2SA1037AK-T146-R	
IC2600	8-759-394-36	BA09T		Q2200	1-801-806-11	TR DTC144EKA	
IC2601	8-759-450-47	BA05T		Q2201	1-801-806-11	TR DTC144EKA	
IC2603	8-759-640-19	PQ1CG2032FZ		Q3300	8-729-026-49	2SA1037AK-T146-R	
IC2604	8-759-644-37	PQ5EV3				<RESISTOR>	
		<CHIP CONDUCTOR>		R001	1-216-033-00	RES-CHIP	220 5% 1/10W
JR001	1-216-295-91	SHORT	0	R002	1-216-033-00	RES-CHIP	220 5% 1/10W
JR002	1-216-295-91	SHORT	0	R003	1-216-049-11	RES-CHIP	1K 5% 1/10W
JR107	1-216-295-91	SHORT	0	R004	1-216-295-91	SHORT	0
JR2601	1-216-295-91	SHORT	0	R005	1-216-295-91	SHORT	0
		<COIL>		R006	1-216-033-00	RES-CHIP	220 5% 1/10W
L001	1-414-856-11	INDUCTOR	10UH	R007	1-216-033-00	RES-CHIP	220 5% 1/10W
L002	1-414-856-11	INDUCTOR	10UH	R008	1-216-065-91	RES-CHIP	4.7K 5% 1/10W
L003	1-414-751-11	INDUCTOR	1UH	R009	1-216-065-91	RES-CHIP	4.7K 5% 1/10W
L005	1-414-856-11	INDUCTOR	10UH	R010	1-216-061-91	RES-CHIP	3.3K 5% 1/10W
L101	1-414-856-11	INDUCTOR	10UH	R011	1-216-065-91	RES-CHIP	4.7K 5% 1/10W
L102	1-414-856-11	INDUCTOR	10UH	R012	1-216-061-91	RES-CHIP	3.3K 5% 1/10W
L103	1-414-856-11	INDUCTOR	10UH	R013	1-216-065-91	RES-CHIP	4.7K 5% 1/10W
L104	1-414-856-11	INDUCTOR	10UH	R014	1-216-025-11	RES-CHIP	100 5% 1/10W
L105	1-414-856-11	INDUCTOR	10UH	R015	1-216-025-11	RES-CHIP	100 5% 1/10W
L1201	1-414-187-11	INDUCTOR	47UH	R016	1-216-057-00	RES-CHIP	2.2K 5% 1/10W
L1202	1-416-857-11	INDUCTOR	65UH	R017	1-216-049-11	RES-CHIP	1K 5% 1/10W
L1203	1-416-857-11	INDUCTOR	65UH	R018	1-216-045-00	RES-CHIP	680 5% 1/10W
L1204	1-416-857-11	INDUCTOR	65UH	R020	1-216-057-00	RES-CHIP	2.2K 5% 1/10W
L1205	1-416-857-11	INDUCTOR	65UH	R021	1-216-295-91	SHORT	0
L1300	1-414-856-11	INDUCTOR	10UH	R022	1-216-033-00	RES-CHIP	220 5% 1/10W
L2600	1-419-249-11	INDUCTOR	15UH	R023	1-216-025-11	RES-CHIP	100 5% 1/10W
L2601	1-419-249-11	INDUCTOR	15UH	R024	1-216-063-91	RES-CHIP	3.9K 5% 1/10W
L2602	1-412-525-31	INDUCTOR	10UH	R025	1-216-033-00	RES-CHIP	220 5% 1/10W
L2603	1-412-525-31	INDUCTOR	10UH	R026	1-216-033-00	RES-CHIP	220 5% 1/10W
L3302	1-414-856-11	INDUCTOR	10UH	R027	1-216-049-11	RES-CHIP	1K 5% 1/10W
L3303	1-414-856-11	INDUCTOR	10UH	R028	1-216-049-11	RES-CHIP	1K 5% 1/10W
L3304	1-414-856-11	INDUCTOR	10UH	R029	1-216-049-11	RES-CHIP	1K 5% 1/10W
L3305	1-414-856-11	INDUCTOR	10UH	R030	1-216-025-11	RES-CHIP	100 5% 1/10W
L3306	1-414-856-11	INDUCTOR	10UH	R031	1-216-033-00	RES-CHIP	220 5% 1/10W
		<IC LINK>		R032	1-216-049-11	RES-CHIP	1K 5% 1/10W
PS1201	1-532-686-21	LINK, IC 2.7A/150V		R033	1-216-033-00	RES-CHIP	220 5% 1/10W
PS1202	1-532-686-21	LINK, IC 2.7A/150V		R034	1-216-295-91	SHORT	0
PS1203	1-532-686-21	LINK, IC 2.7A/150V		R035	1-216-057-00	RES-CHIP	2.2K 5% 1/10W
PS1204	1-532-686-21	LINK, IC 2.7A/150V		R036	1-216-083-00	RES-CHIP	27K 5% 1/10W
		<TRANSISTOR>		R037	1-216-083-00	RES-CHIP	27K 5% 1/10W
Q001	8-729-026-49	2SA1037AK-T146-R		R038	1-216-045-00	RES-CHIP	680 5% 1/10W
Q002	8-729-230-49	2SC2712-YG		R039	1-216-025-11	RES-CHIP	100 5% 1/10W
Q003	8-729-230-49	2SC2712-YG		R040	1-216-033-00	RES-CHIP	220 5% 1/10W
Q004	8-729-230-49	2SC2712-YG		R041	1-216-025-11	RES-CHIP	100 5% 1/10W
Q101	8-729-026-49	2SA1037AK-T146-R		R042	1-216-295-91	SHORT	0
Q102	8-729-230-49	2SC2712-YG		R043	1-216-025-11	RES-CHIP	100 5% 1/10W
Q301	8-729-026-49	2SA1037AK-T146-R		R044	1-216-065-91	RES-CHIP	4.7K 5% 1/10W
Q313	8-729-230-49	2SC2712-YG		R045	1-216-065-91	RES-CHIP	4.7K 5% 1/10W
Q1205	1-801-806-11	TR DTC144EKA		R046	1-216-033-00	RES-CHIP	220 5% 1/10W
Q1206	8-729-230-49	2SC2712-YG		R047	1-216-033-00	RES-CHIP	220 5% 1/10W
Q1207	8-729-230-49	2SC2712-YG		R048	1-216-073-91	RES-CHIP	10K 5% 1/10W
Q1209	8-729-230-49	2SC2712-YG		R049	1-216-689-11	METAL CHIP	39K 0.5% 1/10W
Q1210	8-729-230-49	2SC2712-YG		R050	1-216-085-91	RES-CHIP	33K 5% 1/10W
				R051	1-216-049-11	RES-CHIP	1K 5% 1/10W
				R052	1-216-049-11	RES-CHIP	1K 5% 1/10W
				R053	1-216-049-11	RES-CHIP	1K 5% 1/10W
				R054	1-216-033-00	RES-CHIP	220 5% 1/10W
				R055	1-216-295-91	SHORT	0
				R056	1-216-295-91	SHORT	0

A

REF NO.	PART NO.	DESCRIPTION	REMARK	REF NO.	PART NO.	DESCRIPTION	REMARK
R057	1-216-295-91	SHORT	0	R1238	1-216-081-00	RES-CHIP	22K 5% 1/10W
R058	1-216-295-91	SHORT	0	R1239	1-216-067-00	RES-CHIP	5.6K 5% 1/10W
R059	1-216-033-00	RES-CHIP	220 5% 1/10W	R1240	1-216-085-91	RES-CHIP	33K 5% 1/10W
R060	1-216-033-00	RES-CHIP	220 5% 1/10W	R1241	1-216-073-91	RES-CHIP	10K 5% 1/10W
R062	1-216-049-11	RES-CHIP	1K 5% 1/10W	R1242	1-216-073-91	RES-CHIP	10K 5% 1/10W
R065	1-216-045-00	RES-CHIP	680 5% 1/10W	R1244	1-216-065-91	RES-CHIP	4.7K 5% 1/10W
R066	1-216-049-11	RES-CHIP	1K 5% 1/10W	R1246	1-208-808-11	METAL CHIP	12K 0.5% 1/10W
R067	1-216-073-91	RES-CHIP	10K 5% 1/10W	R1247	1-216-085-91	RES-CHIP	33K 5% 1/10W
R068	1-216-073-91	RES-CHIP	10K 5% 1/10W	R1248	1-216-075-00	RES-CHIP	12K 5% 1/10W
R069	1-216-065-91	RES-CHIP	4.7K 5% 1/10W	R1249	1-216-025-11	RES-CHIP	100 5% 1/10W
R070	1-216-033-00	RES-CHIP	220 5% 1/10W	R1250	1-216-063-91	RES-CHIP	3.9K 5% 1/10W
R071	1-216-025-11	RES-CHIP	100 5% 1/10W	R1252	1-216-065-91	RES-CHIP	4.7K 5% 1/10W
R072	1-216-025-11	RES-CHIP	100 5% 1/10W	R1253	1-216-065-91	RES-CHIP	4.7K 5% 1/10W
R073	1-216-055-00	RES-CHIP	1.8K 5% 1/10W	R1254	1-216-075-00	RES-CHIP	12K 5% 1/10W
R074	1-216-055-00	RES-CHIP	1.8K 5% 1/10W	R1255	1-216-075-00	RES-CHIP	12K 5% 1/10W
R075	1-216-055-00	RES-CHIP	1.8K 5% 1/10W	R1256	1-216-073-91	RES-CHIP	10K 5% 1/10W
R076	1-216-295-91	SHORT	0	R1257	1-216-025-11	RES-CHIP	100 5% 1/10W
R077	1-216-025-11	RES-CHIP	100 5% 1/10W	R1258	1-216-075-00	RES-CHIP	12K 5% 1/10W
R078	1-216-295-91	SHORT	0	R1259	1-216-073-91	RES-CHIP	10K 5% 1/10W
R079	1-216-025-11	RES-CHIP	100 5% 1/10W	R1260	1-216-037-00	RES-CHIP	330 5% 1/10W
R080	1-216-063-91	RES-CHIP	3.9K 5% 1/10W	R1261	1-216-037-00	RES-CHIP	330 5% 1/10W
R081	1-216-025-11	RES-CHIP	100 5% 1/10W	R1264	1-216-041-00	RES-CHIP	470 5% 1/10W
R082	1-216-041-00	RES-CHIP	470 5% 1/10W	R1265	1-216-041-00	RES-CHIP	470 5% 1/10W
R083	1-216-049-11	RES-CHIP	1K 5% 1/10W	R1266	1-216-049-11	RES-CHIP	1K 5% 1/10W
R084	1-216-049-11	RES-CHIP	1K 5% 1/10W	R1267	1-216-077-91	RES-CHIP	15K 5% 1/10W
R085	1-208-798-11	METAL CHIP	4.7K 0.5% 1/10W	R1269	1-216-025-11	RES-CHIP	100 5% 1/10W
R086	1-216-073-91	RES-CHIP	10K 5% 1/10W	R1270	1-216-089-91	RES-CHIP	47K 5% 1/10W
R087	1-216-033-00	RES-CHIP	220 5% 1/10W	R1271	1-216-049-11	RES-CHIP	1K 5% 1/10W
R089	1-216-049-11	RES-CHIP	1K 5% 1/10W	R1272	1-216-049-11	RES-CHIP	1K 5% 1/10W
R090	1-216-295-91	SHORT	0	R1273	1-216-065-91	RES-CHIP	4.7K 5% 1/10W
R091	1-216-295-91	SHORT	0	R1275	1-216-081-00	RES-CHIP	22K 5% 1/10W
R092	1-216-033-00	RES-CHIP	220 5% 1/10W	R1276	1-216-081-00	RES-CHIP	22K 5% 1/10W
R093	1-216-073-91	RES-CHIP	10K 5% 1/10W	R1277	1-216-065-91	RES-CHIP	4.7K 5% 1/10W
R094	1-216-073-91	RES-CHIP	10K 5% 1/10W	R1280	1-216-037-00	RES-CHIP	330 5% 1/10W
R100	1-216-025-11	RES-CHIP	100 5% 1/10W	R1281	1-216-037-00	RES-CHIP	330 5% 1/10W
R104	1-216-025-11	RES-CHIP	100 5% 1/10W	R1283	1-216-295-91	SHORT	0
R105	1-216-295-91	SHORT	0	R1284	1-216-295-91	SHORT	0
R106	1-216-049-11	RES-CHIP	1K 5% 1/10W	R1286	1-216-073-91	RES-CHIP	10K 5% 1/10W
R107	1-216-073-91	RES-CHIP	10K 5% 1/10W	R1287	1-216-037-00	RES-CHIP	330 5% 1/10W
R108	1-216-065-91	RES-CHIP	4.7K 5% 1/10W	R1288	1-216-037-00	RES-CHIP	330 5% 1/10W
R109	1-216-041-00	RES-CHIP	470 5% 1/10W	R1289	1-216-037-00	RES-CHIP	330 5% 1/10W
R110	1-216-043-91	RES-CHIP	560 5% 1/10W	R1290	1-216-037-00	RES-CHIP	330 5% 1/10W
R111	1-216-025-11	RES-CHIP	100 5% 1/10W	R2200	1-216-021-00	RES-CHIP	68 5% 1/10W
R112	1-216-025-11	RES-CHIP	100 5% 1/10W	R2201	1-216-065-91	RES-CHIP	4.7K 5% 1/10W
R114	1-216-065-91	RES-CHIP	4.7K 5% 1/10W	R2202	1-216-065-91	RES-CHIP	4.7K 5% 1/10W
R115	1-216-065-91	RES-CHIP	4.7K 5% 1/10W	R2203	1-216-021-00	RES-CHIP	68 5% 1/10W
R116	1-216-025-11	RES-CHIP	100 5% 1/10W	R2204	1-216-073-91	RES-CHIP	10K 5% 1/10W
R117	1-216-025-11	RES-CHIP	100 5% 1/10W	R2205	1-216-097-11	RES-CHIP	100K 5% 1/10W
R118	1-216-025-11	RES-CHIP	100 5% 1/10W	R2206	1-216-117-00	RES-CHIP	680K 5% 1/10W
R301	1-216-113-00	RES-CHIP	470K 5% 1/10W	R2207	1-216-063-91	RES-CHIP	3.9K 5% 1/10W
R302	1-216-089-91	RES-CHIP	47K 5% 1/10W	R2208	1-216-065-91	RES-CHIP	4.7K 5% 1/10W
R303	1-216-089-91	RES-CHIP	47K 5% 1/10W	R2209	1-216-117-00	RES-CHIP	680K 5% 1/10W
R1201	1-216-033-00	RES-CHIP	220 5% 1/10W	R2210	1-216-089-91	RES-CHIP	47K 5% 1/10W
R1202	1-216-033-00	RES-CHIP	220 5% 1/10W	R2211	1-216-097-11	RES-CHIP	100K 5% 1/10W
R1203	1-216-079-00	RES-CHIP	18K 5% 1/10W	R2212	1-216-073-91	RES-CHIP	10K 5% 1/10W
R1204	1-216-079-00	RES-CHIP	18K 5% 1/10W	R2213	1-216-089-91	RES-CHIP	47K 5% 1/10W
R1205	1-216-089-91	RES-CHIP	47K 5% 1/10W	R2214	1-216-089-91	RES-CHIP	47K 5% 1/10W
R1206	1-216-089-91	RES-CHIP	47K 5% 1/10W	R2215	1-216-089-91	RES-CHIP	47K 5% 1/10W
R1207	1-216-073-91	RES-CHIP	10K 5% 1/10W	R2216	1-216-065-91	RES-CHIP	4.7K 5% 1/10W
R1208	1-216-073-91	RES-CHIP	10K 5% 1/10W	R2217	1-216-065-91	RES-CHIP	4.7K 5% 1/10W
R1236	1-208-808-11	METAL CHIP	12K 0.5% 1/10W	R2600	1-216-065-91	RES-CHIP	4.7K 5% 1/10W
R1237	1-216-085-91	RES-CHIP	33K 5% 1/10W				

A	A1
---	----

REF NO.	PART NO.	DESCRIPTION	REMARK	REF NO.	PART NO.	DESCRIPTION	REMARK
R2601	1-216-655-11	METAL CHIP	1.5K 0.5% 1/10W	C8135	1-126-382-11	ELECT	100UF 20.00% 16V
R2602	1-208-781-11	METAL CHIP	910 0.5% 1/10W	C8136	1-163-251-11	CERAMIC CHIP	100PF 5.00% 50V
R2603	1-208-790-11	METAL CHIP	2.2K 0.5% 1/10W	C8137	1-163-251-11	CERAMIC CHIP	100PF 5.00% 50V
R2604	1-208-790-11	METAL CHIP	2.2K 0.5% 1/10W	C8138	1-163-251-11	CERAMIC CHIP	100PF 5.00% 50V
R3300	1-216-043-91	RES-CHIP	560 5% 1/10W	C8139	1-163-251-11	CERAMIC CHIP	100PF 5.00% 50V
R3320	1-216-073-91	RES-CHIP	10K 5% 1/10W	C8140	1-163-251-11	CERAMIC CHIP	100PF 5.00% 50V
R3323	1-216-025-11	RES-CHIP	100 5% 1/10W	C8141	1-163-251-11	CERAMIC CHIP	100PF 5.00% 50V
R3334	1-216-025-11	RES-CHIP	100 5% 1/10W	C8142	1-163-235-11	CERAMIC CHIP	22PF 5.00% 50V
R3374	1-216-295-91	SHORT	0	C8143	1-163-021-91	CERAMIC CHIP	0.01UF 10.00% 50V
		<VARIABLE RESISTOR>		C8144	1-163-251-11	CERAMIC CHIP	100PF 5.00% 50V
RV3300	1-238-597-11	RES, ADJ, CARBON 1K		C8145	1-163-233-91	CERAMIC CHIP	18PF 5.00% 50V
		<TUNER>		C8146	1-107-823-11	CERAMIC CHIP	0.47UF 10.00% 16V
TU101	8-598-542-30	TUNER, FSS BTF-WA412		C8147	1-164-004-11	CERAMIC CHIP	0.1UF 10.00% 25V
TU3301	8-598-430-50	TUNER, FSS BTF-FA401		C8150	1-164-004-11	CERAMIC CHIP	0.1UF 10.00% 25V
		<CRYSTAL>		C8155	1-164-004-11	CERAMIC CHIP	0.1UF 10.00% 25V
X001	1-567-928-11	VIBLATOR, CERAMIC		C8161	1-127-532-11	ELECT	47UF 20.00% 6.3V
				C8162	1-164-505-11	CERAMIC CHIP	2.2UF 10.00% 16V
				C8163	1-216-295-91	SHORT	0
				C8166	1-164-004-11	CERAMIC CHIP	0.1UF 10.00% 25V
				C8167	1-163-021-91	CERAMIC CHIP	0.01UF 10.00% 50V
				C8168	1-164-004-11	CERAMIC CHIP	0.1UF 10.00% 25V
				C8197	1-163-021-91	CERAMIC CHIP	0.01UF 10.00% 50V
				C8198	1-163-021-91	CERAMIC CHIP	0.01UF 10.00% 50V
				C8199	1-164-004-11	CERAMIC CHIP	0.1UF 10.00% 25V
				C8200	1-216-295-91	SHORT	0
				C8201	1-216-295-91	SHORT	0
				C8202	1-107-823-11	CERAMIC CHIP	0.47UF 10.00% 16V
				C8203	1-163-021-91	CERAMIC CHIP	0.01UF 10.00% 50V
				C8204	1-107-823-11	CERAMIC CHIP	0.47UF 10.00% 16V
				C8205	1-163-253-11	CERAMIC CHIP	120PF 5.00% 50V
				C8206	1-163-251-11	CERAMIC CHIP	100PF 5.00% 50V
				C8207	1-163-251-11	CERAMIC CHIP	100PF 5.00% 50V
				C8208	1-163-251-11	CERAMIC CHIP	100PF 5.00% 50V
				C8209	1-163-251-11	CERAMIC CHIP	100PF 5.00% 50V
				C8210	1-163-251-11	CERAMIC CHIP	100PF 5.00% 50V
				C8211	1-115-340-11	CERAMIC CHIP	0.22UF 10.00% 25V
				C8212	1-125-838-11	CERAMIC CHIP	2.2UF 10% 6.3V
				C8213	1-125-838-11	CERAMIC CHIP	2.2UF 10% 6.3V
				C8218	1-163-251-11	CERAMIC CHIP	100PF 5.00% 50V
						<CONNECTOR>	
				CN8100	1-793-867-11	PIN, CONNECTOR (PC BORAD)	10P
				CN8101	1-793-867-11	PIN, CONNECTOR (PC BORAD)	10P
						<FERRITE BEAD>	
				FB8100	1-216-295-91	SHORT	0
				FB8101	1-216-295-91	SHORT	0
				FB8101	1-414-598-11	FERRITE	0UH
				FB8102	1-216-295-91	SHORT	0
				FB8103	1-216-295-91	SHORT	0
				FB8104	1-414-598-11	FERRITE	0UH
				FB8105	1-216-295-91	SHORT	0
				FB8106	1-414-598-11	FERRITE	0UH
				FB8108	1-414-598-11	FERRITE	0UH
				FB8109	1-414-598-11	FERRITE	0UH
				FB8110	1-414-598-11	FERRITE	0UH
				FB8111	1-414-598-11	FERRITE	0UH
				FB8112	1-414-598-11	FERRITE	0UH
				FB8113	1-414-598-11	FERRITE	0UH
				FB8114	1-414-598-11	FERRITE	0UH
C8103	1-163-021-91	CERAMIC CHIP	0.01UF 10.00% 50V				
C8104	1-163-021-91	CERAMIC CHIP	0.01UF 10.00% 50V				
C8105	1-163-021-91	CERAMIC CHIP	0.01UF 10.00% 50V				
C8106	1-163-021-91	CERAMIC CHIP	0.01UF 10.00% 50V				
C8107	1-163-021-91	CERAMIC CHIP	0.01UF 10.00% 50V				
C8108	1-164-004-11	CERAMIC CHIP	0.1UF 10.00% 25V				
C8109	1-163-021-91	CERAMIC CHIP	0.01UF 10.00% 50V				
C8110	1-163-021-91	CERAMIC CHIP	0.01UF 10.00% 50V				
C8111	1-163-021-91	CERAMIC CHIP	0.01UF 10.00% 50V				
C8112	1-163-001-11	CERAMIC CHIP	220PF 10.00% 50V				
C8116	1-164-161-11	CERAMIC CHIP	0.0022UF 10.00% 50V				
C8117	1-126-382-11	ELECT	100UF 20.00% 16V				
C8118	1-127-532-11	ELECT	47UF 20.00% 6.3V				
C8119	1-126-795-11	ELECT	10UF 20.00% 25V				
C8120	1-164-004-11	CERAMIC CHIP	0.1UF 10.00% 25V				
C8121	1-125-838-11	CERAMIC CHIP	2.2UF 10% 6.3V				
C8122	1-125-838-11	CERAMIC CHIP	2.2UF 10% 6.3V				
C8123	1-127-532-11	ELECT	47UF 20.00% 6.3V				
C8124	1-163-021-91	CERAMIC CHIP	0.01UF 10.00% 50V				
C8125	1-163-021-91	CERAMIC CHIP	0.01UF 10.00% 50V				
C8126	1-163-021-91	CERAMIC CHIP	0.01UF 10.00% 50V				
C8129	1-163-021-91	CERAMIC CHIP	0.01UF 10.00% 50V				
C8130	1-126-382-11	ELECT	100UF 20.00% 16V				
C8131	1-126-382-11	ELECT	100UF 20.00% 16V				
C8132	1-125-838-11	CERAMIC CHIP	2.2UF 10% 6.3V				
C8133	1-163-021-91	CERAMIC CHIP	0.01UF 10.00% 50V				
C8134	1-164-004-11	CERAMIC CHIP	0.1UF 10.00% 25V				

A1 **B3**

REF NO.	PART NO.	DESCRIPTION	REMARK
FB8115	1-414-598-11	FERRITE	0UH
FB8116	1-414-598-11	FERRITE	0UH
FB8117	1-414-598-11	FERRITE	0UH
FB8118	1-414-598-11	FERRITE	0UH
FB8119	1-414-598-11	FERRITE	0UH
FB8120	1-414-598-11	FERRITE	0UH
FB8121	1-414-598-11	FERRITE	0UH
<FILTER>			
FL8100	1-234-177-21	FILTER, CHIP EMI	
FL8101	1-234-177-21	FILTER, CHIP EMI	
FL8102	1-234-177-21	FILTER, CHIP EMI	
<IC>			
IC8102	8-759-576-72	LF50CDT-TR	
IC8103	8-759-579-68	AK4524	
IC8104	8-759-542-87	S-80827ANUP-EDQ	
IC8105	8-759-833-26	IC TC9446F-011	
IC8106	8-759-242-70	TC7WU04F	
IC8107	8-759-459-69	S-80743AN-D7	
<CHIP CONDUCTOR>			
JR8102	1-216-295-91	SHORT	0
JR8103	1-216-295-91	SHORT	0
<COIL>			
L8100	1-412-026-11	INDUCTOR	1UH
L8101	1-412-026-11	INDUCTOR	1UH
L8102	1-412-026-11	INDUCTOR	1UH
L8103	1-412-026-11	INDUCTOR	1UH
L8104	1-412-026-11	INDUCTOR	1UH
L8105	1-412-026-11	INDUCTOR	1UH
<RESISTOR>			
R8101	1-216-022-00	RES-CHIP	75 5% 1/10W
R8101	1-216-033-00	RES-CHIP	220 5% 1/10W
R8102	1-216-061-91	RES-CHIP	3.3K 5% 1/10W
R8103	1-216-061-91	RES-CHIP	3.3K 5% 1/10W
R8106	1-216-057-00	RES-CHIP	2.2K 5% 1/10W
R8107	1-216-057-00	RES-CHIP	2.2K 5% 1/10W
R8120	1-216-049-11	RES-CHIP	1K 5% 1/10W
R8121	1-216-025-11	RES-CHIP	100 5% 1/10W
R8122	1-216-025-11	RES-CHIP	100 5% 1/10W
R8123	1-216-009-91	RES-CHIP	22 5% 1/10W
R8124	1-216-009-91	RES-CHIP	22 5% 1/10W
R8125	1-216-009-91	RES-CHIP	22 5% 1/10W
R8126	1-216-009-91	RES-CHIP	22 5% 1/10W
R8127	1-216-025-11	RES-CHIP	100 5% 1/10W
R8128	1-216-025-11	RES-CHIP	100 5% 1/10W
R8129	1-216-009-91	RES-CHIP	22 5% 1/10W
R8131	1-216-295-91	SHORT	0
R8133	1-216-129-00	RES-CHIP	2.2M 5% 1/10W
R8134	1-216-295-91	SHORT	0
R8135	1-216-295-91	SHORT	0
R8137	1-216-295-91	SHORT	0
R8138	1-216-049-11	RES-CHIP	1K 5% 1/10W
R8139	1-216-037-00	RES-CHIP	330 5% 1/10W

REF NO.	PART NO.	DESCRIPTION	REMARK
R8140	1-216-049-11	RES-CHIP	1K 5% 1/10W
R8141	1-216-295-91	SHORT	0
R8143	1-216-295-91	SHORT	0
R8144	1-216-025-11	RES-CHIP	100 5% 1/10W
R8145	1-216-033-00	RES-CHIP	220 5% 1/10W
R8146	1-216-033-00	RES-CHIP	220 5% 1/10W
R8147	1-216-295-91	SHORT	0
R8148	1-216-295-91	SHORT	0
R8149	1-216-037-00	RES-CHIP	330 5% 1/10W
R8155	1-216-295-91	SHORT	0
R8157	1-216-037-00	RES-CHIP	330 5% 1/10W
R8158	1-216-037-00	RES-CHIP	330 5% 1/10W
R8161	1-216-025-11	RES-CHIP	100 5% 1/10W
R8168	1-216-025-11	RES-CHIP	100 5% 1/10W
R8169	1-216-097-11	RES-CHIP	100K 5% 1/10W
R8170	1-216-121-11	RES-CHIP	1M 5% 1/10W
R8171	1-216-025-11	RES-CHIP	100 5% 1/10W
R8172	1-216-025-11	RES-CHIP	100 5% 1/10W
R8173	1-216-025-11	RES-CHIP	100 5% 1/10W
R8200	1-216-073-91	RES-CHIP	10K 5% 1/10W
R8201	1-216-025-11	RES-CHIP	100 5% 1/10W
R8202	1-216-065-91	RES-CHIP	4.7K 5% 1/10W
R8203	1-208-782-11	METAL CHIP	1K 0.5% 1/10W
R8204	1-216-073-91	RES-CHIP	10K 5% 1/10W
R8205	1-208-782-11	METAL CHIP	1K 0.5% 1/10W
R8206	1-216-049-11	RES-CHIP	1K 5% 1/10W
R8207	1-216-077-91	RES-CHIP	15K 5% 1/10W
<CRYSTAL>			
X8102	1-781-041-11	VIBRATOR, CRYSTAL	

		* A-1136-251-A	B3 BOARD COMPLETE *****
<CAPACITOR>			
C333	1-216-295-91	SHORT	0
C368	1-163-021-91	CERAMIC CHIP	0.01UF 10.00% 50V
C369	1-163-021-91	CERAMIC CHIP	0.01UF 10.00% 50V
C372	1-163-021-91	CERAMIC CHIP	0.01UF 10.00% 50V
C373	1-163-021-91	CERAMIC CHIP	0.01UF 10.00% 50V
C374	1-126-603-11	ELECT CHIP	4.7UF 20.00% 35V
C375	1-163-021-91	CERAMIC CHIP	0.01UF 10.00% 50V
C376	1-163-021-91	CERAMIC CHIP	0.01UF 10.00% 50V
C377	1-163-021-91	CERAMIC CHIP	0.01UF 10.00% 50V
C378	1-163-021-91	CERAMIC CHIP	0.01UF 10.00% 50V
C501	1-163-021-91	CERAMIC CHIP	0.01UF 10.00% 50V
C502	1-124-779-00	ELECT CHIP	10UF 20.00% 16V
C503	1-124-779-00	ELECT CHIP	10UF 20.00% 16V
C505	1-124-779-00	ELECT CHIP	10UF 20.00% 16V
C507	1-124-779-00	ELECT CHIP	10UF 20.00% 16V
C509	1-163-021-91	CERAMIC CHIP	0.01UF 10.00% 50V
C510	1-163-021-91	CERAMIC CHIP	0.01UF 10.00% 50V
C511	1-163-038-91	CERAMIC CHIP	0.1UF 25V
C512	1-163-021-91	CERAMIC CHIP	0.01UF 10.00% 50V
C514	1-164-004-11	CERAMIC CHIP	0.1UF 10.00% 25V

The components identified by shading
and mark Δ are critical for safety.
Replace only with part number specified.

B3

REF NO.	PART NO.	DESCRIPTION	REMARK
C904	1-124-779-00	ELECT CHIP 10UF	20.00% 16V
C905	1-109-982-11	CERAMIC CHIP 1UF	10.00% 10V
C906	1-124-779-00	ELECT CHIP 10UF	20.00% 16V
C907	1-163-021-91	CERAMIC CHIP 0.01UF	10.00% 50V
C908	1-163-021-91	CERAMIC CHIP 0.01UF	10.00% 50V
C909	1-126-396-11	ELECT CHIP 47UF	20.00% 16V
C910	1-163-009-91	CERAMIC CHIP 0.001UF	10.00% 50V
C913	1-163-021-91	CERAMIC CHIP 0.01UF	10.00% 50V
C914	1-126-394-11	ELECT CHIP 10UF	20.00% 16V
C950	1-163-021-91	CERAMIC CHIP 0.01UF	10.00% 50V
C954	1-163-021-91	CERAMIC CHIP 0.01UF	10.00% 50V
<CONNECTOR>			
CN502	1-695-302-11	CONNECTOR, BOARD TO BOARD 50P	
<DIODE>			
D501	8-719-056-77	UDZ-TE-17-3.9B	
D601	8-719-404-50	MA111-TX	
<FERRITE BEAD>			
FB501	1-414-813-11	FERRITE 0UH	
FB502	1-414-813-11	FERRITE 0UH	
FB503	1-414-813-11	FERRITE 0UH	
FB504	1-414-813-11	FERRITE 0UH	
FB601	1-414-553-11	FERRITE 0UH	
FB801	1-414-553-11	FERRITE 0UH	
FB802	1-414-553-11	FERRITE 0UH	
<FILTER>			
FL306	1-239-558-11	FILTER, CHIP EMI	
FL501	1-233-877-11	FILTER, LOW PASS	
FL502	1-233-504-21	FILTER, LOW PASS	
FL503	1-233-504-21	FILTER, LOW PASS	
FL504	1-234-177-21	FILTER, CHIP EMI	
FL505	1-234-177-21	FILTER, CHIP EMI	
FL506	1-234-177-21	FILTER, CHIP EMI	
FL508	1-234-177-21	FILTER, CHIP EMI	
FL509	1-234-177-21	FILTER, CHIP EMI	
FL510	1-234-177-21	FILTER, CHIP EMI	
FL511	1-234-177-21	FILTER, CHIP EMI	
FL512	1-234-177-21	FILTER, CHIP EMI	
FL601	1-234-177-21	FILTER, CHIP EMI	
FL602	1-234-177-21	FILTER, CHIP EMI	
FL603	1-234-177-21	FILTER, CHIP EMI	
FL606	1-239-560-11	FILTER, CHIP EMI	
FL801	1-234-177-21	FILTER, CHIP EMI	
FL802	1-234-177-21	FILTER, CHIP EMI	
FL803	1-234-177-21	FILTER, CHIP EMI	
FL804	1-234-177-21	FILTER, CHIP EMI	
FL806	1-234-177-21	FILTER, CHIP EMI	
FL807	1-234-177-21	FILTER, CHIP EMI	
FL808	1-234-177-21	FILTER, CHIP EMI	
FL901	1-233-878-11	FILTER, LOW PASS	
FL902	1-233-876-11	FILTER, LOW PASS	
FL903	1-233-876-11	FILTER, LOW PASS	
FL904	1-234-177-21	FILTER, CHIP EMI	
FL905	1-234-177-21	FILTER, CHIP EMI	
FL906	1-234-177-21	FILTER, CHIP EMI	
FL907	1-234-177-21	FILTER, CHIP EMI	

REF NO.	PART NO.	DESCRIPTION	REMARK
		<IC>	
IC313	8-759-669-75	TLC2932IPWR	
IC314	8-759-525-10	TC7SET08F(TE85L)	
IC315	8-759-525-10	TC7SET08F(TE85L)	
IC316	8-759-525-10	TC7SET08F(TE85L)	
IC501	8-759-447-90	TLC5733AIPM	
IC504	8-759-669-78	TLC2933IPWR-12	
IC505	8-759-640-16	TC7SET04F(TE85R)	
IC506	8-759-640-16	TC7SET04F(TE85R)	
IC601	8-752-398-47	CXD2090Q	
IC602	8-759-836-37	IC MT48LC1M16A1TG-6S	
IC603	Δ 8-759-669-75	TLC2932IPWR	
IC604	8-752-072-94	CXA1875AM-T4	
IC801	8-759-672-57	CXD9509AQ	
IC802	8-759-677-37	MT48LC2M32B2TG	
IC803	8-759-460-29	PST9120NL	
IC901	8-752-367-59	CXD2309Q	
IC902	8-759-829-33	IC MB94918RPF-G-133-BND	
IC903	6-700-149-01	IC M24C04-MN6T(A)	
IC904	8-759-349-11	PST9145NL	
<COIL>			
L304	1-412-029-11	INDUCTOR 10UH	
L305	1-412-029-11	INDUCTOR 10UH	
L501	1-412-026-11	INDUCTOR 1UH	
L502	1-412-026-11	INDUCTOR 1UH	
L503	1-412-026-11	INDUCTOR 1UH	
L504	1-412-026-11	INDUCTOR 1UH	
L505	1-412-029-11	INDUCTOR 10UH	
L506	1-412-026-11	INDUCTOR 1UH	
L508	1-412-029-11	INDUCTOR 10UH	
L509	1-412-029-11	INDUCTOR 10UH	
L511	1-412-026-11	INDUCTOR 1UH	
L512	1-412-026-11	INDUCTOR 1UH	
L604	1-412-029-11	INDUCTOR 10UH	
L605	1-412-029-11	INDUCTOR 10UH	
<TRANSISTOR>			
Q304	8-729-120-28	2SC1623-L5L6	
Q501	8-729-216-22	2SA1162-G	
Q502	8-729-120-28	2SC1623-L5L6	
Q503	8-729-120-28	2SC1623-L5L6	
Q510	8-729-120-28	2SC1623-L5L6	
Q511	8-729-120-28	2SC1623-L5L6	
Q512	8-729-120-28	2SC1623-L5L6	
Q513	8-729-120-28	2SC1623-L5L6	
Q514	8-729-120-28	2SC1623-L5L6	
Q515	8-729-120-28	2SC1623-L5L6	
Q516	8-729-120-28	2SC1623-L5L6	
Q517	8-729-120-28	2SC1623-L5L6	
Q518	8-729-216-22	2SA1162-G	
Q519	1-801-806-11	TR DTC144EKA	
Q520	1-801-806-11	TR DTC144EKA	
Q521	8-729-120-28	2SC1623-L5L6	
Q522	8-729-120-28	2SC1623-L5L6	
Q523	8-729-120-28	2SC1623-L5L6	
Q524	8-729-120-28	2SC1623-L5L6	
Q601	8-729-120-28	2SC1623-L5L6	
Q602	8-729-120-28	2SC1623-L5L6	
Q901	8-729-216-22	2SA1162-G	

B3

REF NO.	PART NO.	DESCRIPTION	REMARK	REF NO.	PART NO.	DESCRIPTION	REMARK
Q902	8-729-216-22	2SA1162-G		R548	1-208-750-11	METAL CHIP	47 0.5% 1/10W
Q903	8-729-216-22	2SA1162-G		R549	1-208-750-11	METAL CHIP	47 0.5% 1/10W
Q904	8-729-028-28	2SK2036(TE85L)		R550	1-208-756-11	METAL CHIP	82 0.5% 1/10W
Q905	8-729-028-28	2SK2036(TE85L)		R551	1-208-756-11	METAL CHIP	82 0.5% 1/10W
Q906	1-801-806-11	TR DTC144EKA		R552	1-208-750-11	METAL CHIP	47 0.5% 1/10W
Q907	8-729-216-22	2SA1162-G		R553	1-216-295-91	SHORT	0
Q908	8-729-216-22	2SA1162-G		R554	1-208-750-11	METAL CHIP	47 0.5% 1/10W
Q909	8-729-216-22	2SA1162-G		R555	1-216-077-91	RES-CHIP	15K 5% 1/10W
		<RESISTOR>		R557	1-216-049-11	RES-CHIP	1K 5% 1/10W
R310	1-216-009-91	RES-CHIP	22 5% 1/10W	R558	1-216-025-11	RES-CHIP	100 5% 1/10W
R334	1-216-295-91	SHORT	0	R559	1-216-077-91	RES-CHIP	15K 5% 1/10W
R339	1-216-295-91	SHORT	0	R560	1-208-750-11	METAL CHIP	47 0.5% 1/10W
R350	1-216-049-11	RES-CHIP	1K 5% 1/10W	R561	1-216-043-91	RES-CHIP	560 5% 1/10W
R361	1-216-061-91	RES-CHIP	3.3K 5% 1/10W	R562	1-216-043-91	RES-CHIP	560 5% 1/10W
R362	1-216-057-00	RES-CHIP	2.2K 5% 1/10W	R563	1-216-043-91	RES-CHIP	560 5% 1/10W
R363	1-216-037-00	RES-CHIP	330 5% 1/10W	R564	1-216-065-91	RES-CHIP	4.7K 5% 1/10W
R364	1-216-295-91	SHORT	0	R565	1-216-065-91	RES-CHIP	4.7K 5% 1/10W
R365	1-216-047-91	RES-CHIP	820 5% 1/10W	R566	1-216-065-91	RES-CHIP	4.7K 5% 1/10W
R366	1-216-049-11	RES-CHIP	1K 5% 1/10W	R571	1-216-295-91	SHORT	0
R367	1-216-117-00	RES-CHIP	680K 5% 1/10W	R572	1-208-750-11	METAL CHIP	47 0.5% 1/10W
R368	1-216-117-00	RES-CHIP	680K 5% 1/10W	R575	1-208-756-11	METAL CHIP	82 0.5% 1/10W
R369	1-216-295-91	SHORT	0	R576	1-208-756-11	METAL CHIP	82 0.5% 1/10W
R371	1-216-057-00	RES-CHIP	2.2K 5% 1/10W	R577	1-208-750-11	METAL CHIP	47 0.5% 1/10W
R372	1-216-009-91	RES-CHIP	22 5% 1/10W	R578	1-208-750-11	METAL CHIP	47 0.5% 1/10W
R373	1-216-066-00	RES-CHIP	5.1K 5% 1/10W	R579	1-216-077-91	RES-CHIP	15K 5% 1/10W
R501	1-216-025-11	RES-CHIP	100 5% 1/10W	R580	1-216-295-91	SHORT	0
R502	1-216-025-11	RES-CHIP	100 5% 1/10W	R582	1-216-041-00	RES-CHIP	470 5% 1/10W
R503	1-216-295-91	SHORT	0	R584	1-216-041-00	RES-CHIP	470 5% 1/10W
R504	1-216-295-91	SHORT	0	R586	1-216-049-11	RES-CHIP	1K 5% 1/10W
R505	1-216-295-91	SHORT	0	R587	1-216-049-11	RES-CHIP	1K 5% 1/10W
R506	1-216-009-91	RES-CHIP	22 5% 1/10W	R589	1-216-049-11	RES-CHIP	1K 5% 1/10W
R507	1-216-009-91	RES-CHIP	22 5% 1/10W	R590	1-216-049-11	RES-CHIP	1K 5% 1/10W
R508	1-216-025-11	RES-CHIP	100 5% 1/10W	R591	1-216-049-11	RES-CHIP	1K 5% 1/10W
R509	1-216-025-11	RES-CHIP	100 5% 1/10W	R592	1-216-049-11	RES-CHIP	1K 5% 1/10W
R510	1-216-043-91	RES-CHIP	560 5% 1/10W	R594	1-216-041-00	RES-CHIP	470 5% 1/10W
R511	1-216-043-91	RES-CHIP	560 5% 1/10W	R596	1-216-049-11	RES-CHIP	1K 5% 1/10W
R512	1-216-043-91	RES-CHIP	560 5% 1/10W	R597	1-216-073-91	RES-CHIP	10K 5% 1/10W
R513	1-216-043-91	RES-CHIP	560 5% 1/10W	R598	1-216-025-11	RES-CHIP	100 5% 1/10W
R514	1-216-043-91	RES-CHIP	560 5% 1/10W	R600	1-216-066-00	RES-CHIP	5.1K 5% 1/10W
R515	1-216-043-91	RES-CHIP	560 5% 1/10W	R601	1-216-073-91	RES-CHIP	10K 5% 1/10W
R516	1-216-049-11	RES-CHIP	1K 5% 1/10W	R602	1-216-073-91	RES-CHIP	10K 5% 1/10W
R517	1-216-049-11	RES-CHIP	1K 5% 1/10W	R603	1-216-073-91	RES-CHIP	10K 5% 1/10W
R518	1-216-295-91	SHORT	0	R604	1-216-033-00	RES-CHIP	220 5% 1/10W
R520	1-208-776-11	METAL CHIP	560 0.5% 1/10W	R605	1-216-295-91	SHORT	0
R521	1-216-295-91	SHORT	0	R608	1-216-295-91	SHORT	0
R523	1-208-776-11	METAL CHIP	560 0.5% 1/10W	R609	1-216-073-91	RES-CHIP	10K 5% 1/10W
R524	1-216-295-91	SHORT	0	R610	1-216-033-00	RES-CHIP	220 5% 1/10W
R526	1-208-776-11	METAL CHIP	560 0.5% 1/10W	R611	1-216-073-91	RES-CHIP	10K 5% 1/10W
R528	1-216-037-00	RES-CHIP	330 5% 1/10W	R613	1-216-065-91	RES-CHIP	4.7K 5% 1/10W
R529	1-208-800-11	METAL CHIP	5.6K 0.5% 1/10W	R615	1-216-089-91	RES-CHIP	47K 5% 1/10W
R530	1-208-800-11	METAL CHIP	5.6K 0.5% 1/10W	R616	1-216-073-91	RES-CHIP	10K 5% 1/10W
R531	1-216-031-00	RES-CHIP	180 5% 1/10W	R617	1-216-295-91	SHORT	0
R532	1-208-800-11	METAL CHIP	5.6K 0.5% 1/10W	R619	1-216-073-91	RES-CHIP	10K 5% 1/10W
R533	1-216-031-00	RES-CHIP	180 5% 1/10W	R621	1-216-295-91	SHORT	0
R534	1-216-057-00	RES-CHIP	2.2K 5% 1/10W	R622	1-216-295-91	SHORT	0
R535	1-216-057-00	RES-CHIP	2.2K 5% 1/10W	R623	1-216-295-91	SHORT	0
R536	1-216-049-11	RES-CHIP	1K 5% 1/10W	R624	1-216-295-91	SHORT	0
R537	1-208-790-11	METAL CHIP	2.2K 0.5% 1/10W	R625	1-216-295-91	SHORT	0
R540	1-216-049-11	RES-CHIP	1K 5% 1/10W	R626	1-216-073-91	RES-CHIP	10K 5% 1/10W
				R628	1-216-295-91	SHORT	0
				R629	1-216-073-91	RES-CHIP	10K 5% 1/10W
				R631	1-216-295-91	SHORT	0

B3

REF NO.	PART NO.	DESCRIPTION	REMARK	REF NO.	PART NO.	DESCRIPTION	REMARK
R634	1-216-295-91	SHORT	0	R817	1-216-017-91	RES-CHIP	47 5% 1/10W
R635	1-216-295-91	SHORT	0	R823	1-216-073-91	RES-CHIP	10K 5% 1/10W
R638	1-216-295-91	SHORT	0				
R639	1-216-019-00	RES-CHIP	56 5% 1/10W	R824	1-216-073-91	RES-CHIP	10K 5% 1/10W
R640	1-216-009-91	RES-CHIP	22 5% 1/10W	R825	1-208-760-11	METAL CHIP	120 0.5% 1/10W
R642	1-216-295-91	SHORT	0	R826	1-208-758-11	METAL CHIP	100 0.5% 1/10W
R643	1-216-295-91	SHORT	0	R827	1-216-607-11	METAL CHIP	15 0.5% 1/10W
R645	1-216-295-91	SHORT	0	R831	1-216-295-91	SHORT	0
R651	1-216-295-91	SHORT	0	R832	1-216-295-91	SHORT	0
R653	1-216-025-11	RES-CHIP	100 5% 1/10W	R833	1-216-295-91	SHORT	0
R654	1-216-033-00	RES-CHIP	220 5% 1/10W	R834	1-208-760-11	METAL CHIP	120 0.5% 1/10W
R655	1-216-295-91	SHORT	0	R835	1-208-755-11	METAL CHIP	75 0.5% 1/10W
R657	1-216-009-91	RES-CHIP	22 5% 1/10W	R836	1-211-960-11	METAL CHIP	22 0.5% 1/10W
R658	1-216-049-11	RES-CHIP	1K 5% 1/10W	R844	1-216-017-91	RES-CHIP	47 5% 1/10W
R659	1-216-025-11	RES-CHIP	100 5% 1/10W	R845	1-216-017-91	RES-CHIP	47 5% 1/10W
R660	1-216-025-11	RES-CHIP	100 5% 1/10W	R846	1-216-017-91	RES-CHIP	47 5% 1/10W
R661	1-216-025-11	RES-CHIP	100 5% 1/10W	R847	1-216-017-91	RES-CHIP	47 5% 1/10W
R664	1-216-009-91	RES-CHIP	22 5% 1/10W	R848	1-216-017-91	RES-CHIP	47 5% 1/10W
R665	1-216-035-00	RES-CHIP	270 5% 1/10W	R849	1-216-017-91	RES-CHIP	47 5% 1/10W
R666	1-216-646-11	METAL CHIP	620 0.5% 1/10W	R850	1-216-017-91	RES-CHIP	47 5% 1/10W
R667	1-208-794-11	METAL CHIP	3.3K 0.5% 1/10W	R851	1-216-017-91	RES-CHIP	47 5% 1/10W
R668	1-216-009-91	RES-CHIP	22 5% 1/10W	R852	1-216-009-91	RES-CHIP	22 5% 1/10W
R670	1-216-295-91	SHORT	0	R853	1-216-009-91	RES-CHIP	22 5% 1/10W
R671	1-216-073-91	RES-CHIP	10K 5% 1/10W	R854	1-216-009-91	RES-CHIP	22 5% 1/10W
R672	1-216-073-91	RES-CHIP	10K 5% 1/10W	R855	1-216-009-91	RES-CHIP	22 5% 1/10W
R673	1-216-073-91	RES-CHIP	10K 5% 1/10W	R856	1-216-009-91	RES-CHIP	22 5% 1/10W
R674	1-216-073-91	RES-CHIP	10K 5% 1/10W	R857	1-216-009-91	RES-CHIP	22 5% 1/10W
R675	1-216-073-91	RES-CHIP	10K 5% 1/10W	R858	1-216-009-91	RES-CHIP	22 5% 1/10W
R676	1-216-073-91	RES-CHIP	10K 5% 1/10W	R859	1-216-009-91	RES-CHIP	22 5% 1/10W
R677	1-216-073-91	RES-CHIP	10K 5% 1/10W	R860	1-216-009-91	RES-CHIP	22 5% 1/10W
R678	1-216-073-91	RES-CHIP	10K 5% 1/10W	R861	1-216-009-91	RES-CHIP	22 5% 1/10W
R679	1-216-073-91	RES-CHIP	10K 5% 1/10W	R862	1-216-009-91	RES-CHIP	22 5% 1/10W
R680	1-216-073-91	RES-CHIP	10K 5% 1/10W	R863	1-216-009-91	RES-CHIP	22 5% 1/10W
R681	1-216-073-91	RES-CHIP	10K 5% 1/10W	R864	1-216-017-91	RES-CHIP	47 5% 1/10W
R682	1-216-073-91	RES-CHIP	10K 5% 1/10W	R865	1-216-017-91	RES-CHIP	47 5% 1/10W
R683	1-216-073-91	RES-CHIP	10K 5% 1/10W	R866	1-216-017-91	RES-CHIP	47 5% 1/10W
R684	1-216-073-91	RES-CHIP	10K 5% 1/10W	R867	1-216-017-91	RES-CHIP	47 5% 1/10W
R685	1-216-073-91	RES-CHIP	10K 5% 1/10W	R868	1-216-017-91	RES-CHIP	47 5% 1/10W
R686	1-216-073-91	RES-CHIP	10K 5% 1/10W	R869	1-216-017-91	RES-CHIP	47 5% 1/10W
R687	1-216-295-91	SHORT	0	R870	1-216-017-91	RES-CHIP	47 5% 1/10W
R688	1-216-061-91	RES-CHIP	3.3K 5% 1/10W	R871	1-216-017-91	RES-CHIP	47 5% 1/10W
R689	1-216-057-00	RES-CHIP	2.2K 5% 1/10W	R872	1-216-017-91	RES-CHIP	47 5% 1/10W
R690	1-216-295-91	SHORT	0	R873	1-216-017-91	RES-CHIP	47 5% 1/10W
R691	1-216-061-91	RES-CHIP	3.3K 5% 1/10W	R874	1-216-017-91	RES-CHIP	47 5% 1/10W
R692	1-216-057-00	RES-CHIP	2.2K 5% 1/10W	R875	1-216-017-91	RES-CHIP	47 5% 1/10W
R693	1-216-009-91	RES-CHIP	22 5% 1/10W	R876	1-216-017-91	RES-CHIP	47 5% 1/10W
R694	1-216-295-91	SHORT	0	R877	1-216-017-91	RES-CHIP	47 5% 1/10W
R695	1-216-047-91	RES-CHIP	820 5% 1/10W	R878	1-216-017-91	RES-CHIP	47 5% 1/10W
R696	1-216-049-11	RES-CHIP	1K 5% 1/10W	R879	1-216-017-91	RES-CHIP	47 5% 1/10W
R697	1-216-117-00	RES-CHIP	680K 5% 1/10W	R880	1-216-009-91	RES-CHIP	22 5% 1/10W
R698	1-216-117-00	RES-CHIP	680K 5% 1/10W	R881	1-216-009-91	RES-CHIP	22 5% 1/10W
R699	1-216-295-91	SHORT	0	R882	1-216-009-91	RES-CHIP	22 5% 1/10W
R801	1-216-009-91	RES-CHIP	22 5% 1/10W	R883	1-216-009-91	RES-CHIP	22 5% 1/10W
R802	1-216-009-91	RES-CHIP	22 5% 1/10W	R884	1-216-009-91	RES-CHIP	22 5% 1/10W
R804	1-216-073-91	RES-CHIP	10K 5% 1/10W	R885	1-216-009-91	RES-CHIP	22 5% 1/10W
R806	1-208-800-11	METAL CHIP	5.6K 0.5% 1/10W	R886	1-216-009-91	RES-CHIP	22 5% 1/10W
R807	1-208-778-11	METAL CHIP	680 0.5% 1/10W	R887	1-216-009-91	RES-CHIP	22 5% 1/10W
R813	1-216-295-91	SHORT	0	R888	1-216-009-91	RES-CHIP	22 5% 1/10W
R814	1-216-073-91	RES-CHIP	10K 5% 1/10W	R889	1-216-295-91	SHORT	0
R815	1-216-073-91	RES-CHIP	10K 5% 1/10W	R890	1-216-009-91	RES-CHIP	22 5% 1/10W
R816	1-216-073-91	RES-CHIP	10K 5% 1/10W	R891	1-216-017-91	RES-CHIP	47 5% 1/10W
				R892	1-216-017-91	RES-CHIP	47 5% 1/10W
				R893	1-216-017-91	RES-CHIP	47 5% 1/10W

B3

REF NO.	PART NO.	DESCRIPTION	REMARK	REF NO.	PART NO.	DESCRIPTION	REMARK
R894	1-216-017-91	RES-CHIP	47 5% 1/10W	R996	1-216-037-00	RES-CHIP	330 5% 1/10W
R895	1-216-017-91	RES-CHIP	47 5% 1/10W	R998	1-216-073-91	RES-CHIP	10K 5% 1/10W
R896	1-216-017-91	RES-CHIP	47 5% 1/10W	R2801	1-208-760-11	METAL CHIP	120 0.5% 1/10W
R897	1-216-017-91	RES-CHIP	47 5% 1/10W	R2802	1-208-754-11	METAL CHIP	68 0.5% 1/10W
R898	1-216-017-91	RES-CHIP	47 5% 1/10W	R2803	1-216-603-11	METAL CHIP	10 0.5% 1/10W
R899	1-216-073-91	RES-CHIP	10K 5% 1/10W	R2804	1-208-760-11	METAL CHIP	120 0.5% 1/10W
R901	1-216-061-91	RES-CHIP	3.3K 5% 1/10W	R2805	1-208-755-11	METAL CHIP	75 0.5% 1/10W
R902	1-208-790-11	METAL CHIP	2.2K 0.5% 1/10W	R2806	1-211-960-11	METAL CHIP	22 0.5% 1/10W
R903	1-208-794-11	METAL CHIP	3.3K 0.5% 1/10W	R2807	1-216-295-91	SHORT	0
R904	1-216-635-11	METAL CHIP	220 0.5% 1/10W	R2808	1-216-295-91	SHORT	0
R905	1-216-635-11	METAL CHIP	220 0.5% 1/10W	R2813	1-216-295-91	SHORT	0
R906	1-216-635-11	METAL CHIP	220 0.5% 1/10W	R2815	1-216-295-91	SHORT	0
R907	1-216-635-11	METAL CHIP	220 0.5% 1/10W	R2817	1-216-295-91	SHORT	0
R908	1-216-635-11	METAL CHIP	220 0.5% 1/10W	R2818	1-216-295-91	SHORT	0
R909	1-216-635-11	METAL CHIP	220 0.5% 1/10W	R2820	1-216-295-91	SHORT	0
R910	1-216-049-11	RES-CHIP	1K 5% 1/10W	R2822	1-216-295-91	SHORT	0
R911	1-216-049-11	RES-CHIP	1K 5% 1/10W	RB001	1-239-409-11	NETWORK RESISTOR (CHIP)	47
R912	1-216-049-11	RES-CHIP	1K 5% 1/10W	RB002	1-239-409-11	NETWORK RESISTOR (CHIP)	47
R914	1-216-065-91	RES-CHIP	4.7K 5% 1/10W	RB003	1-239-409-11	NETWORK RESISTOR (CHIP)	47
R916	1-216-065-91	RES-CHIP	4.7K 5% 1/10W	RB004	1-239-409-11	NETWORK RESISTOR (CHIP)	47
R923	1-216-057-00	RES-CHIP	2.2K 5% 1/10W	RB005	1-239-409-11	NETWORK RESISTOR (CHIP)	47
R924	1-216-073-91	RES-CHIP	10K 5% 1/10W	RB006	1-239-409-11	NETWORK RESISTOR (CHIP)	47
R926	1-216-057-00	RES-CHIP	2.2K 5% 1/10W	RB007	1-239-414-11	NETWORK RESISTOR (CHIP)	150
R929	1-216-025-11	RES-CHIP	100 5% 1/10W	RB008	1-239-414-11	NETWORK RESISTOR (CHIP)	150
R930	1-216-025-11	RES-CHIP	100 5% 1/10W	RB009	1-239-414-11	NETWORK RESISTOR (CHIP)	150
R931	1-216-041-00	RES-CHIP	470 5% 1/10W	RB010	1-239-414-11	NETWORK RESISTOR (CHIP)	150
R933	1-216-025-11	RES-CHIP	100 5% 1/10W	RB011	1-239-414-11	NETWORK RESISTOR (CHIP)	150
R934	1-216-025-11	RES-CHIP	100 5% 1/10W	RB012	1-239-414-11	NETWORK RESISTOR (CHIP)	150
R935	1-216-073-91	RES-CHIP	10K 5% 1/10W	RB013	1-239-621-11	NETWORK RESISTOR (CHIP)	22
R936	1-216-041-00	RES-CHIP	470 5% 1/10W	RB014	1-239-621-11	NETWORK RESISTOR (CHIP)	22
R937	1-216-025-11	RES-CHIP	100 5% 1/10W	RB015	1-239-621-11	NETWORK RESISTOR (CHIP)	22
R938	1-216-025-11	RES-CHIP	100 5% 1/10W	RB016	1-239-621-11	NETWORK RESISTOR (CHIP)	22
R940	1-216-295-91	SHORT	0	RB017	1-239-621-11	NETWORK RESISTOR (CHIP)	22
R941	1-216-295-91	SHORT	0	RB018	1-239-621-11	NETWORK RESISTOR (CHIP)	22
R942	1-216-037-00	RES-CHIP	330 5% 1/10W	RB019	1-239-409-11	NETWORK RESISTOR (CHIP)	47
R943	1-216-033-00	RES-CHIP	220 5% 1/10W	RB020	1-239-409-11	NETWORK RESISTOR (CHIP)	47
R944	1-216-295-91	SHORT	0	RB021	1-239-409-11	NETWORK RESISTOR (CHIP)	47
R945	1-216-295-91	SHORT	0	RB022	1-239-409-11	NETWORK RESISTOR (CHIP)	47
R951	1-216-057-00	RES-CHIP	2.2K 5% 1/10W	RB023	1-239-409-11	NETWORK RESISTOR (CHIP)	47
R952	1-216-057-00	RES-CHIP	2.2K 5% 1/10W	RB024	1-239-409-11	NETWORK RESISTOR (CHIP)	47
R956	1-216-089-91	RES-CHIP	47K 5% 1/10W	RB025	1-239-409-11	NETWORK RESISTOR (CHIP)	47
R957	1-216-635-11	METAL CHIP	220 0.5% 1/10W	RB026	1-239-409-11	NETWORK RESISTOR (CHIP)	47
R958	1-216-635-11	METAL CHIP	220 0.5% 1/10W	RB027	1-239-409-11	NETWORK RESISTOR (CHIP)	47
R959	1-216-635-11	METAL CHIP	220 0.5% 1/10W	RB701	1-239-711-91	NETWORK RESISTOR (CHIP)	0
R960	1-216-635-11	METAL CHIP	220 0.5% 1/10W	RB702	1-239-711-91	NETWORK RESISTOR (CHIP)	0
R961	1-216-635-11	METAL CHIP	220 0.5% 1/10W	RB703	1-239-711-91	NETWORK RESISTOR (CHIP)	0
R962	1-216-635-11	METAL CHIP	220 0.5% 1/10W	RB704	1-239-711-91	NETWORK RESISTOR (CHIP)	0
R979	1-216-295-91	SHORT	0	RB705	1-239-711-91	NETWORK RESISTOR (CHIP)	0
R981	1-216-037-00	RES-CHIP	330 5% 1/10W	RB706	1-239-711-91	NETWORK RESISTOR (CHIP)	0
R982	1-216-037-00	RES-CHIP	330 5% 1/10W			<CRYSTAL>	
R983	1-216-089-91	RES-CHIP	47K 5% 1/10W	X802	1-795-112-21	VIBRATOR, CRYSTAL	
R984	1-216-061-91	RES-CHIP	3.3K 5% 1/10W	X901	1-760-014-11	VIBRATOR, CERAMIC	
R985	1-216-113-00	RES-CHIP	470K 5% 1/10W				
R986	1-216-061-91	RES-CHIP	3.3K 5% 1/10W				
R987	1-216-049-11	RES-CHIP	1K 5% 1/10W				
R988	1-216-033-00	RES-CHIP	220 5% 1/10W				
R989	1-216-081-00	RES-CHIP	22K 5% 1/10W				
R990	1-216-113-00	RES-CHIP	470K 5% 1/10W				
R991	1-216-295-91	SHORT	0				
R993	1-216-089-91	RES-CHIP	47K 5% 1/10W				
R994	1-216-033-00	RES-CHIP	220 5% 1/10W				
R995	1-216-033-00	RES-CHIP	220 5% 1/10W				

BC4

REF NO.	PART NO.	DESCRIPTION	REMARK	REF NO.	PART NO.	DESCRIPTION	REMARK
* A-1136-252-A	BC4 BOARD COMPLETE	*****		C2075	1-163-038-91	CERAMIC CHIP 0.1UF	25V
3-350-679-01	WASHER, FIBER			C2078	1-126-947-11	ELECT 47UF	20.00% 16V
	<CAPACITOR>			C2079	1-163-031-91	CERAMIC CHIP 0.01UF	50V
C2003	1-163-031-91	CERAMIC CHIP 0.01UF	50V	C2080	1-163-031-91	CERAMIC CHIP 0.01UF	50V
C2005	1-163-131-00	CERAMIC CHIP 390PF	5.00% 50V	C2095	1-163-231-11	CERAMIC CHIP 15PF	5.00% 50V
C2006	1-163-038-91	CERAMIC CHIP 0.1UF	25V				
C2010	1-163-102-00	CERAMIC CHIP 24PF	5.00% 50V	C2096	1-163-231-11	CERAMIC CHIP 15PF	5.00% 50V
C2011	1-163-102-00	CERAMIC CHIP 24PF	5.00% 50V	C2097	1-163-231-11	CERAMIC CHIP 15PF	5.00% 50V
						<CONNECTOR>	
C2015	1-165-319-11	CERAMIC CHIP 0.1UF	50V	CN2001	* 1-793-685-11	PIN, CONNECTOR (PC BOARD) 15P	
C2016	1-165-319-11	CERAMIC CHIP 0.1UF	50V			<FERRITE BEAD>	
C2017	1-165-319-11	CERAMIC CHIP 0.1UF	50V	FB2002	1-414-234-22	FERRITE 0UH	
C2018	1-165-319-11	CERAMIC CHIP 0.1UF	50V	FB2008	1-414-234-22	FERRITE 0UH	
C2021	1-163-038-91	CERAMIC CHIP 0.1UF	25V	FB2009	1-414-234-22	FERRITE 0UH	
				FB2010	1-414-234-22	FERRITE 0UH	
C2024	1-216-295-91	SHORT 0		FB2011	1-414-234-22	FERRITE 0UH	
C2029	1-165-319-11	CERAMIC CHIP 0.1UF	50V	FB2012	1-414-234-22	FERRITE 0UH	
C2030	1-165-319-11	CERAMIC CHIP 0.1UF	50V	FB2014	1-414-234-22	FERRITE 0UH	
C2031	1-165-319-11	CERAMIC CHIP 0.1UF	50V	FB2015	1-414-234-22	FERRITE 0UH	
C2032	1-165-319-11	CERAMIC CHIP 0.1UF	50V	FB2016	1-414-234-22	FERRITE 0UH	
				FB2017	1-414-234-22	FERRITE 0UH	
C2033	1-165-319-11	CERAMIC CHIP 0.1UF	50V			<FILTER>	
C2034	1-165-319-11	CERAMIC CHIP 0.1UF	50V	FL2001	1-239-848-11	FILTER, LOW PASS	
C2035	1-165-319-11	CERAMIC CHIP 0.1UF	50V	FL2002	1-239-848-11	FILTER, LOW PASS	
C2036	1-165-319-11	CERAMIC CHIP 0.1UF	50V	FL2003	1-239-848-11	FILTER, LOW PASS	
C2037	1-126-947-11	ELECT 47UF	20.00% 16V	FL2004	1-239-848-11	FILTER, LOW PASS	
				FL2005	1-233-736-21	FILTER, EMI	
C2038	1-165-319-11	CERAMIC CHIP 0.1UF	50V	FL2006	1-233-736-21	FILTER, EMI	
C2039	1-165-319-11	CERAMIC CHIP 0.1UF	50V	FL2007	1-233-736-21	FILTER, EMI	
C2040	1-165-319-11	CERAMIC CHIP 0.1UF	50V			<IC>	
C2041	1-126-924-11	ELECT 330UF	20.00% 6.3V	IC2003	8-759-568-27	MSM514265C-60JS	
C2042	1-165-319-11	CERAMIC CHIP 0.1UF	50V	IC2004	8-759-594-44	UPD64082GF-3BA	
				IC2005	8-759-431-14	PQ3TZ53U	
C2044	1-126-947-11	ELECT 47UF	20.00% 16V			<COIL>	
C2045	1-163-106-00	CERAMIC CHIP 36PF	5.00% 50V	L2001	1-410-200-31	INDUCTOR 4.7UH	
C2046	1-126-964-11	ELECT 10UF	20.00% 50V	L2004	1-412-058-11	INDUCTOR 10UH	
C2047	1-164-505-11	CERAMIC CHIP 2.2UF	16V	L2005	1-412-058-11	INDUCTOR 10UH	
C2048	1-126-964-11	ELECT 10UF	20.00% 50V	L2006	1-412-058-11	INDUCTOR 10UH	
				L2007	1-412-058-11	INDUCTOR 10UH	
C2049	1-126-960-11	ELECT 1UF	20.00% 50V	L2008	1-412-058-11	INDUCTOR 10UH	
C2050	1-163-231-11	CERAMIC CHIP 15PF	5.00% 50V			<TRANSISTOR>	
C2051	1-126-964-11	ELECT 10UF	20.00% 50V	Q2002	8-729-216-22	2SA1162-G	
C2052	1-163-133-00	CERAMIC CHIP 470PF	5.00% 50V	Q2003	8-729-216-22	2SA1162-G	
C2053	1-126-960-11	ELECT 1UF	20.00% 50V	Q2004	8-729-216-22	2SA1162-G	
				Q2005	8-729-422-33	2SD601A-Q-TX	
C2054	1-126-947-11	ELECT 47UF	20.00% 16V	Q2006	8-729-422-33	2SD601A-Q-TX	
C2055	1-126-947-11	ELECT 47UF	20.00% 16V				
C2056	1-163-231-11	CERAMIC CHIP 15PF	5.00% 50V	Q2007	8-729-422-33	2SD601A-Q-TX	
C2057	1-163-031-91	CERAMIC CHIP 0.01UF	50V	Q2008	8-729-422-33	2SD601A-Q-TX	
C2058	1-163-031-91	CERAMIC CHIP 0.01UF	50V	Q2009	8-729-422-33	2SD601A-Q-TX	
				Q2010	8-729-422-33	2SD601A-Q-TX	
C2059	1-126-947-11	ELECT 47UF	20.00% 16V	Q2011	8-729-422-33	2SD601A-Q-TX	
C2060	1-163-031-91	CERAMIC CHIP 0.01UF	50V				
C2061	1-163-031-91	CERAMIC CHIP 0.01UF	50V				
C2062	1-126-947-11	ELECT 47UF	20.00% 16V				
C2063	1-165-319-11	CERAMIC CHIP 0.1UF	50V				
C2064	1-163-031-91	CERAMIC CHIP 0.01UF	50V				
C2065	1-163-031-91	CERAMIC CHIP 0.01UF	50V				
C2066	1-126-947-11	ELECT 47UF	20.00% 16V				
C2067	1-126-947-11	ELECT 47UF	20.00% 16V				
C2068	1-126-947-11	ELECT 47UF	20.00% 16V				
C2069	1-163-031-91	CERAMIC CHIP 0.01UF	50V				
C2070	1-126-947-11	ELECT 47UF	20.00% 16V				
C2071	1-165-319-11	CERAMIC CHIP 0.1UF	50V				
C2072	1-163-237-11	CERAMIC CHIP 27PF	5.00% 50V				
C2074	1-163-038-91	CERAMIC CHIP 0.1UF	25V				

The components identified by shading and mark Δ are critical for safety.
Replace only with part number specified.

C **D**

REF NO.	PART NO.	DESCRIPTION	REMARK
C9030	1-163-017-00	CERAMIC CHIP	0.0047UF 10.00% 50V
C9031	1-162-114-00	CERAMIC	0.0047UF 2KV
C9032	1-162-116-00	CERAMIC	680PF 10.00% 2KV
C9033	1-107-662-11	ELECT	22UF 20.00% 250V
C9035	1-162-114-00	CERAMIC	0.0047UF 2KV
C9042	1-104-661-91	ELECT	330UF 20.00% 16V
<CONNECTOR>			
CN9001	* 1-564-512-11	PLUG, CONNECTOR 9P	
CN9002	1-691-765-11	PLUG (MICRO CONNECTOR) 3P	
CN9003	1-695-915-11	TAB (CONTACT)	
CN9004	1-695-915-11	TAB (CONTACT)	
CN9007	1-785-879-11	CONNECTOR, ONE TOUCH	
<DIODE>			
D9002	8-719-400-75	MA3091	
D9005	8-719-404-50	MA111-TX	
D9006	8-719-051-85	HSS83TD	
D9007	8-719-051-85	HSS83TD	
D9008	8-719-051-85	HSS83TD	
D9009	8-719-908-03	GP08D	
D9010	8-719-110-17	RD10ESB2	
D9011	8-719-404-50	MA111-TX	
D9012	8-719-404-50	MA111-TX	
D9013	8-719-404-50	MA111-TX	
<IC>			
IC9001	8-759-360-83	TDA6111Q/N4	
IC9002	8-759-360-83	TDA6111Q/N4	
IC9003	8-759-360-83	TDA6111Q/N4	
<JACK>			
J9001	Δ 1-540-071-22	SOCKET, CRT	
<COIL>			
L9001	1-414-158-11	INDUCTOR	2.2UH
L9002	1-408-591-11	INDUCTOR	1UH
L9003	1-408-591-11	INDUCTOR	1UH
L9004	1-408-591-11	INDUCTOR	1UH
L9005	1-406-666-21	INDUCTOR	150UH
L9006	1-412-526-11	INDUCTOR	12UH
<NEON LAMP>			
NL9001	1-519-526-11	LAMP, NEON	
NL9003	1-519-421-11	GAP, DISCHARGE	
<TRANSISTOR>			
Q9001	8-729-026-49	2SA1037AK-T146-R	
Q9009	8-729-026-49	2SA1037AK-T146-R	
Q9010	8-729-026-49	2SA1037AK-T146-R	
Q9011	8-729-026-49	2SA1037AK-T146-R	

REF NO.	PART NO.	DESCRIPTION	REMARK
<RESISTOR>			
R9001	1-216-059-00	RES-CHIP	2.7K 5% 1/10W
R9004	1-216-105-91	RES-CHIP	220K 5% 1/10W
R9006	1-216-073-91	RES-CHIP	10K 5% 1/10W
R9007	1-208-789-11	METAL CHIP	2K 0.5% 1/10W
R9008	1-216-085-91	RES-CHIP	33K 5% 1/10W
R9012	1-216-049-11	RES-CHIP	1K 5% 1/10W
R9013	1-216-049-11	RES-CHIP	1K 5% 1/10W
R9018	1-216-059-00	RES-CHIP	2.7K 5% 1/10W
R9019	1-216-059-00	RES-CHIP	2.7K 5% 1/10W
R9021	1-216-295-91	SHORT	0
R9023	1-216-295-91	SHORT	0
R9026	1-208-789-11	METAL CHIP	2K 0.5% 1/10W
R9031	1-208-789-11	METAL CHIP	2K 0.5% 1/10W
R9033	1-208-808-11	METAL CHIP	12K 0.5% 1/10W
R9034	1-208-800-11	METAL CHIP	5.6K 0.5% 1/10W
R9035	1-208-790-11	METAL CHIP	2.2K 0.5% 1/10W
R9036	1-216-049-11	RES-CHIP	1K 5% 1/10W
R9037	1-240-233-21	METAL OXIDE	100K 5% 3W
R9038	1-208-790-11	METAL CHIP	2.2K 0.5% 1/10W
R9039	1-208-790-11	METAL CHIP	2.2K 0.5% 1/10W
R9041	1-216-049-11	RES-CHIP	1K 5% 1/10W
R9042	1-216-049-11	RES-CHIP	1K 5% 1/10W
R9043	1-240-233-21	METAL OXIDE	100K 5% 3W
R9044	1-240-233-21	METAL OXIDE	100K 5% 3W
R9047	1-202-557-00	SOLID	220 20% 1/2W
R9048	1-216-057-00	RES-CHIP	2.2K 5% 1/10W
R9049	1-216-057-00	RES-CHIP	2.2K 5% 1/10W
R9050	1-249-424-11	CARBON	3.9K 5% 1/4W
R9051	1-202-557-00	SOLID	220 20% 1/2W
R9052	1-202-557-00	SOLID	220 20% 1/2W
R9053	1-249-424-11	CARBON	3.9K 5% 1/4W
R9054	1-249-424-11	CARBON	3.9K 5% 1/4W
R9055	1-243-994-91	CEMENTED	820K 5% 0.5W
R9056	1-219-752-11	CARBON	100K 5% 1/2W
R9057	1-220-827-91	RESISTOR	560K 5% 1/2W
R9058	1-243-994-91	CEMENTED	820K 5% 0.5W
R9059	1-219-746-11	CARBON	1K 5% 1/2W
R9061	1-219-743-11	CARBON	100 5% 1/2W
R9065	1-216-069-00	RES-CHIP	6.8K 5% 1/10W
R9068	1-216-101-00	RES-CHIP	150K 5% 1/10W
R9069	1-219-743-11	CARBON	100 5% 1/2W
R9070	1-216-037-00	RES-CHIP	330 5% 1/10W
R9071	1-216-037-00	RES-CHIP	330 5% 1/10W
R9072	1-216-037-00	RES-CHIP	330 5% 1/10W
R9073	1-216-057-00	RES-CHIP	2.2K 5% 1/10W
<VARIABLE RESISTOR>			
RV9001	1-241-714-11	RES, ADJ, METAL FILM 110M	
RV9002	1-230-641-11	RES, ADJ, METAL GLAZE 2.2M	

* A-1348-123-A D BOARD COMPLETE

* 4-374-846-01 COVER, CAPACITOR, CAP TYPE
4-382-854-11 SCREW (M3X10), P, SW (+)
4-382-854-21 SCREW (M3X14), P, SW (+)

The components identified by shading
and mark \triangle are critical for safety.
Replace only with part number specified.

D

REF NO.	PART NO.	DESCRIPTION	REMARK	REF NO.	PART NO.	DESCRIPTION	REMARK
		<CAPACITOR>					
C6601	1-126-933-11	ELECT	100UF 20.00% 16V	C6804	1-102-129-00	CERAMIC	0.01UF 10.00% 50V
C6602	1-129-720-00	FILM	0.033UF 5.00% 630V	C6805	1-111-087-11	ELECT	330UF 20.00% 25V
C6604	1-126-947-11	ELECT	47UF 20.00% 16V	C6806	1-107-933-11	ELECT	100UF 20.00% 100V
C6607 \triangle	1-119-886-51	CERAMIC	470PF 10.00% 250V	C6808	1-137-401-11	MYLAR	0.22UF 10.00% 100V
C6608 \triangle	1-119-886-51	CERAMIC	470PF 10.00% 250V	C6809	1-102-074-00	CERAMIC	0.001UF 10.00% 50V
C6613	1-161-830-00	CERAMIC	0.0047UF 99% 500V	C6810	1-106-220-00	MYLAR	0.1UF 10.00% 100V
C6614	1-161-830-00	CERAMIC	0.0047UF 500V	C6811	1-111-087-11	ELECT	330UF 20.00% 25V
C6617	1-161-830-00	CERAMIC	0.0047UF 500V	C6812	1-130-785-11	MYLAR	0.47UF 10.00% 100V
C6619	1-161-830-00	CERAMIC	0.0047UF 99% 500V	C6813	1-163-009-91	CERAMIC CHIP	0.001UF 10.00% 50V
C6621	1-131-940-11	ELECT	1200UF 20% 250V	C6814	1-115-565-11	CERAMIC CHIP	2.2UF 10.00% 10V
C6622	1-131-940-11	ELECT	1200UF 20% 250V	C6815	1-163-009-91	CERAMIC CHIP	0.001UF 10.00% 50V
C6625	1-129-718-00	FILM	0.022UF 5.00% 630V	C6816	1-137-577-11	FILM	0.068UF 5.00% 400V
C6626	1-130-029-00	FILM	8200PF 2.00% 50V	C6817	1-126-947-11	ELECT	47UF 20.00% 16V
C6627	1-163-021-91	CERAMIC CHIP	0.01UF 10.00% 50V	C6818	1-126-960-11	ELECT	1UF 20.00% 50V
C6628	1-104-330-91	CERAMIC	470PF 10.00% 1KV	C6819	1-126-960-11	ELECT	1UF 20.00% 50V
C6630	1-107-680-91	ELECT	22UF 20.00% 450V	C6820	1-102-114-00	CERAMIC	470PF 10.00% 50V
C6631	1-126-964-11	ELECT	10UF 20.00% 50V	C6821	1-106-383-00	MYLAR	0.047UF 10.00% 200V
C6632	1-126-963-11	ELECT	4.7UF 20.00% 50V	C6822	1-102-114-00	CERAMIC	470PF 10.00% 50V
C6633	1-126-947-11	ELECT	47UF 20.00% 25V	C6823	1-106-383-00	MYLAR	0.047UF 10.00% 200V
C6634	1-126-968-11	ELECT	100UF 20.00% 50V	C6826	1-102-030-00	CERAMIC	330PF 10.00% 500V
C6635	1-102-973-00	CERAMIC	100PF 5.00% 50V	C6827	1-102-030-00	CERAMIC	330PF 10.00% 500V
C6637	1-109-879-11	CERAMIC	22PF 5.00% 2KV	C6828	1-107-364-11	MYLAR	0.01UF 10.00% 200V
C6638	1-107-906-11	ELECT	10UF 20.00% 50V	C6829	1-162-115-00	CERAMIC	330PF 10.00% 2KV
C6639	1-163-275-11	CERAMIC CHIP	0.001UF 5.00% 50V	C6830	1-117-619-11	FILM	1000PF 3.00% 1.2KV
C6640	1-104-330-91	CERAMIC	470PF 10.00% 1KV	C6831	1-117-838-21	FILM	8200PF 3.00% 1.5KV
C6641	1-136-189-00	MYLAR	0.1UF 10.00% 250V	C6832	1-117-842-21	FILM	12000PF 3.00% 1.5KV
C6642	1-126-964-11	ELECT	10UF 20.00% 50V	C6833	1-127-680-11	FILM MELF	4700PF 2% 100V
C6643	1-163-275-11	CERAMIC CHIP	0.001UF 5.00% 50V	C6834	1-125-893-11	FILM	680PF 3.00% 1.5KV
C6648	1-126-935-11	ELECT	470UF 20.00% 16V	C6835	1-125-893-11	FILM	680PF 3.00% 1.5KV
C6649	1-126-933-11	ELECT	100UF 20.00% 16V	C6836	1-127-681-11	FILM MELF	10000PF 2% 100V
C6650	1-162-115-00	CERAMIC	330PF 10.00% 1KV	C6837	1-125-893-11	FILM	680PF 3.00% 1.5KV
C6651	1-162-115-00	CERAMIC	330PF 10.00% 1KV	C6838	1-125-893-11	FILM	680PF 3.00% 1.5KV
C6652	1-110-626-11	ELECT	330UF 20.00% 160V	C6839	1-126-933-11	ELECT	100UF 20.00% 16V
C6653	1-137-368-11	MYLAR	0.0047UF 5.00% 50V	C6840	1-126-933-11	ELECT	100UF 20.00% 16V
C6654	1-126-936-11	ELECT	3300UF 20.00% 16V	C6841	1-115-511-11	FILM	0.12UF 5.00% 250V
C6655	1-126-942-61	ELECT	1000UF 20.00% 25V	C6842	1-117-673-11	FILM	1.5UF 5.00% 250V
C6656	1-136-165-00	FILM	0.1UF 5.00% 50V	C6843	1-115-339-11	CERAMIC CHIP	0.1UF 10.00% 50V
C6658	1-126-944-11	ELECT	3300UF 20.00% 25V	C6844	1-115-339-11	CERAMIC CHIP	0.1UF 10.00% 50V
C6659	1-126-944-11	ELECT	3300UF 20.00% 25V	C6845	1-117-664-11	FILM	0.27UF 5.00% 250V
C6660	1-126-960-11	ELECT	1UF 20.00% 50V	C6846	1-115-514-11	FILM	0.22UF 5.00% 250V
C6661	1-107-888-11	ELECT	47UF 20.00% 25V	C6847	1-164-004-11	CERAMIC CHIP	0.1UF 10.00% 25V
C6662	1-126-947-11	ELECT	47UF 20.00% 16V	C6848	1-113-979-51	FILM	0.047UF 5% 250V
C6663	1-163-021-91	CERAMIC CHIP	0.01UF 10.00% 50V	C6849	1-115-339-11	CERAMIC CHIP	0.1UF 10.00% 50V
C6664	1-163-021-91	CERAMIC CHIP	0.01UF 10.00% 50V	C6850	1-115-339-11	CERAMIC CHIP	0.1UF 10.00% 50V
C6665	1-126-964-11	ELECT	10UF 20.00% 50V	C6851	1-107-639-11	ELECT	47UF 20.00% 160V
C6666	1-137-150-11	MYLAR	0.01UF 5.00% 50V	C6853	1-102-228-00	CERAMIC	470PF 10.00% 500V
C6668	1-126-947-11	ELECT	47UF 20.00% 16V	C6854	1-126-941-11	ELECT	470UF 20.00% 25V
C6669	1-162-115-00	CERAMIC	330PF 10.00% 1KV	C6855	1-123-024-21	ELECT	33UF 160V
C6670	1-162-115-00	CERAMIC	330PF 10.00% 1KV	C6856	1-126-971-11	ELECT	470UF 20.00% 50V
C6671	1-129-718-00	FILM	0.022UF 5.00% 630V	C6857	1-102-228-00	CERAMIC	470PF 10.00% 500V
C6672	1-104-331-11	CERAMIC	0.0022UF 10.00% 1KV	C6858	1-102-228-00	CERAMIC	470PF 10.00% 500V
C6673	1-104-331-11	CERAMIC	0.0022UF 10.00% 1KV	C6859	1-162-129-00	CERAMIC	150PF 10.00% 2KV
C6674	1-128-527-11	ELECT	330UF 20.00% 25V	C6860	1-162-129-00	CERAMIC	150PF 10.00% 2KV
C6678	1-107-823-11	CERAMIC CHIP	0.47UF 10.00% 16V	C6862	1-130-202-00	FILM	0.022UF 5.00% 200V
C6679	1-115-339-11	CERAMIC CHIP	0.1UF 10.00% 50V	C6863	1-107-906-11	ELECT	10UF 20.00% 50V
C6680	1-136-157-00	FILM	0.022UF 5.00% 50V	C6864	1-129-898-00	FILM	0.0022UF 5.00% 630V
C6800	1-126-964-11	ELECT	10UF 20.00% 50V	C6865	1-130-202-00	FILM	0.022UF 5.00% 400V
C6801	1-126-960-11	ELECT	1UF 20.00% 50V	C6866	1-102-030-00	CERAMIC	330PF 10.00% 500V
C6802	1-163-021-91	CERAMIC CHIP	0.01UF 10.00% 50V	C6867	1-130-785-11	MYLAR	0.47UF 10.00% 100V
C6803	1-102-129-00	CERAMIC	0.01UF 10.00% 50V	C6868	1-163-021-91	CERAMIC CHIP	0.01UF 10.00% 50V
				C6869	1-107-882-91	ELECT	100UF 20.00% 16V
				C6870	1-128-528-11	ELECT	470UF 20.00% 25V

The components identified by shading
and mark Δ are critical for safety.
Replace only with part number specified.

D

REF NO.	PART NO.	DESCRIPTION	REMARK
C6871	1-163-133-00	CERAMIC CHIP	470PF 5.00% 50V
C6872	1-163-275-11	CERAMIC CHIP	0.001UF 5.00% 50V
C6874	1-136-165-00	FILM	0.1UF 5.00% 50V
C6875	1-126-947-11	ELECT	47UF 20.00% 16V
C6876	1-163-021-91	CERAMIC CHIP	0.01UF 10.00% 50V
C6877	1-126-964-11	ELECT	10UF 20.00% 50V
C6878	1-126-320-11	ELECT	10UF 20.00% 16V
C6879	1-107-960-11	ELECT	4.7UF 20.00% 160V
C6880	1-164-004-11	CERAMIC CHIP	0.1UF 10.00% 25V
C6882	1-104-574-11	CERAMIC	0.0047UF 10.00% 2KV
C6883	1-126-965-91	ELECT	22UF 20.00% 50V
C6884	1-115-565-11	CERAMIC CHIP	2.2UF 10.00% 10V
<CONNECTOR>			
CN6602 Δ	*1-508-786-13	PIN, CONNECTOR (5MM PITCH) 2P	
CN6603 Δ	*1-573-963-11	PIN, CONNECTOR (PC BOARD) 3P	
CN6604 Δ	*1-691-291-11	PIN, CONNECTOR (PC BOARD) 5P	
CN6605 Δ	*1-564-513-11	PLUG, CONNECTOR 10P	
CN6606	* 1-564-510-11	PLUG, CONNECTOR 7P	
CN6608	* 1-564-506-11	PLUG, CONNECTOR 3P	
CN6609	* 1-508-784-21	PIN, CONNECTOR (5MM PITCH) 1P	
CN6610	* 1-508-784-21	PIN, CONNECTOR (5MM PITCH) 1P	
CN6611	* 1-508-784-21	PIN, CONNECTOR (5MM PITCH) 1P	
CN6612	* 1-508-784-21	PIN, CONNECTOR (5MM PITCH) 1P	
CN6613	* 1-508-784-21	PIN, CONNECTOR (5MM PITCH) 1P	
CN6614	* 1-508-784-21	PIN, CONNECTOR (5MM PITCH) 1P	
CN6615	* 1-508-784-21	PIN, CONNECTOR (5MM PITCH) 1P	
CN6616	* 1-508-784-21	PIN, CONNECTOR (5MM PITCH) 1P	
CN6618	* 1-508-784-21	PIN, CONNECTOR (5MM PITCH) 1P	
CN6800	1-785-802-11	PIN, CONNECTOR (WITH PWB) 20P	
CN6801 Δ	*1-785-270-12	PIN, DY CONNECTOR (PC BOARD)	
CN6802	1-793-495-11	CONNECTOR, BOARD TO BOARD 50P	
CN6810	1-785-879-11	CONNECTOR, ONE TOUCH	
CN6811	* 1-508-784-21	PIN, CONNECTOR (5MM PITCH) 1P	
CN6812	* 1-508-784-21	PIN, CONNECTOR (5MM PITCH) 1P	
<DIODE>			
D6601	8-719-911-19	ISS119-25	
D6605	8-719-510-53	D4SB60L	
D6612	8-719-911-55	U05G	
D6613	8-719-911-55	U05G	
D6614	8-719-110-30	RD12ES-B1	
D6615	8-719-911-19	ISS119-25	
D6616	8-719-911-55	U05G	
D6617	8-719-911-55	U05G	
D6618	8-719-404-50	MA111-TX	
D6619	8-719-110-30	RD12ES-B1	
D6621	8-719-063-73	DIODE D1NL20U-TR	
D6622	8-719-979-64	UF4005PKG23	
D6623	8-719-059-23	P6KE200AG23	
D6624	8-719-510-02	D1NS4	
D6625	8-719-110-36	RD13ES-B2	
D6626	8-719-979-64	UF4005PKG23	
D6628	8-719-063-73	DIODE D1NL20U-TR	
D6631	8-719-050-18	D4SBL20U	
D6633	8-719-510-12	D10SC4M	
D6634	8-719-060-88	DIODE D4SBS6	
D6635	8-719-110-47	RD18ESB	
D6636	8-719-911-19	ISS119-25	

REF NO.	PART NO.	DESCRIPTION	REMARK
D6639	8-719-063-73	DIODE D1NL20U-TR	
D6640	8-719-110-72	RD30ESB2	
D6641	8-719-109-96	RD6.8ES-B1	
D6642	8-719-911-19	ISS119-25	
D6643	8-719-979-64	UF4005PKG23	
D6644	8-719-052-92	D10SBS4F	
D6650	8-719-911-19	ISS119-25	
D6800	8-719-110-03	RD7.5ESB2	
D6801	8-719-911-19	ISS119-25	
D6803	8-719-510-73	S3L20UF4	
D6805	8-719-110-39	RD15ES-B1	
D6806	8-719-911-19	ISS119-25	
D6807	8-719-109-68	RD3.6ES-B1	
D6808	8-719-914-43	DAN202K	
D6809	8-719-908-03	GP08D	
D6813	8-719-302-43	EL1Z	
D6814	8-719-018-82	RGP02-20EL-6394	
D6816	8-719-510-73	S3L20UF4	
D6817	8-719-510-73	S3L20UF4	
D6820	8-719-970-87	ERA38-06	
D6821	8-719-970-87	ERA38-06	
D6822	8-719-067-18	RN4Z	
D6823	8-719-911-19	ISS119-25	
D6824	8-719-510-73	S3L20UF4	
D6825	8-719-914-43	DAN202K	
D6826	8-719-911-19	ISS119-25	
<FERRITE BEAD>			
FB6602	1-239-358-21	FILTER, NOISE	
FB6603	1-239-358-21	FILTER, NOISE	
<IC>			
IC6603	8-749-016-66	MCR5152	
IC6604	8-759-468-89	TOP209P	
IC6606	8-759-450-47	BA05T	
IC6607	8-749-012-13	DM-58	
IC6800	8-759-192-71	STV9379	
IC6801	8-759-450-95	LM393N	
IC6804	8-759-394-36	BA09T	
IC6805	8-759-394-35	BA12T	
IC6806	8-749-013-76	PQ6RD83B	
<CHIP CONDUCTOR>			
JR6601	1-216-295-91	SHORT	0
JR6603	1-216-295-91	SHORT	0
JR6605	1-216-296-11	SHORT	0
JR6606	1-216-296-11	SHORT	0
JR6607	1-216-295-91	SHORT	0
JR6608	1-216-296-11	SHORT	0
JR6609	1-216-295-91	SHORT	0
JR6610	1-216-296-11	SHORT	0
JR6613	1-216-295-91	SHORT	0
JR6802	1-216-296-11	SHORT	0
JR6810	1-216-296-11	SHORT	0
<COIL>			
L6601	1-412-525-31	INDUCTOR	10UH
L6602	1-410-397-21	FERRITE	1.1UH

The components identified by shading
and mark Δ are critical for safety.
Replace only with part number specified.

D

REF NO.	PART NO.	DESCRIPTION	REMARK	REF NO.	PART NO.	DESCRIPTION	REMARK
L6603	1-410-397-21	FERRITE	1.1UH			<RESISTOR>	
L6604	1-412-525-31	INDUCTOR	10UH				
L6605	1-412-525-31	INDUCTOR	10UH	R6600	1-216-295-91	SHORT	0
L6606	1-412-525-31	INDUCTOR	10UH	R6602	1-249-417-11	CARBON	1K 5% 1/4W
L6607	1-412-519-11	INDUCTOR	3.3UH	R6638	1-240-876-11	CEMENTED	1 5% 15W
L6800	1-412-525-31	INDUCTOR	10UH	R6639	1-240-876-11	CEMENTED	1 5% 15W
L6801	1-406-986-21	INDUCTOR	3.3UH	R6641	1-260-131-11	CARBON	470K 5% 1/2W
L6802	1-416-775-21	INDUCTOR	1MH	R6642	1-260-131-11	CARBON	470K 5% 1/2W
L6803	1-406-982-11	INDUCTOR	680UH	R6645	1-202-933-61	FUSIBLE	0.1 10% 1/2W
L6804	1-412-519-11	INDUCTOR	3.3UH	R6647	1-215-864-00	METAL OXIDE	150 5% 1W
L6805	1-412-519-11	INDUCTOR	3.3UH	R6648	1-215-481-00	METAL	330K 1% 1/4W
L6806	1-412-519-11	INDUCTOR	3.3UH	R6649	1-216-065-91	RES-CHIP	4.7K 5% 1/10W
L6807	1-412-552-11	INDUCTOR	2.2MH	R6650	1-215-481-00	METAL	330K 1% 1/4W
L6808	1-406-674-11	INDUCTOR	3.3MH	R6651	1-215-430-00	METAL	2.4K 1% 1/4W
		<PHOTO COUPLER>		R6652	1-215-450-00	METAL	16K 1% 1/4W
PH6601	8-749-924-35	ON3171-R		R6653	1-219-776-11	CARBON	2.2M 10% 1/2W
PH6602	8-749-924-35	ON3171-R		R6654	1-216-089-91	RES-CHIP	47K 5% 1/10W
		<IC LINK>		R6656	1-215-481-00	METAL	330K 1% 1/4W
PS6605	1-533-597-41	LINK, IC		R6657	1-247-791-91	CARBON	22 5% 1/4W
PS6606	1-533-597-41	LINK, IC		R6658	1-216-073-91	RES-CHIP	10K 5% 1/10W
PS6607	1-533-597-41	LINK, IC		R6659	1-216-073-91	RES-CHIP	10K 5% 1/10W
PS6801	1-532-841-21	LINK, IC		R6660	1-249-389-11	CARBON	4.7 5% 1/4W
		<TRANSISTOR>		R6661	1-215-421-00	METAL	1K 1% 1/4W
Q6601	8-729-119-78	2SC2785-HFE		R6662	1-216-381-11	METAL OXIDE	0.22 5% 3W
Q6604	8-729-119-76	2SA1175-HFE		R6663	1-216-381-11	METAL OXIDE	0.22 5% 3W
Q6605	8-729-230-49	2SC2712-YG		R6665	1-219-776-11	CARBON	2.2M 10% 1/2W
Q6606	8-729-140-93	2SB733-34		R6666	1-208-782-11	METAL CHIP	1K 0.5% 1/10W
Q6608	8-729-200-21	2SC2500-B		R6667	1-249-413-11	CARBON	470 5% 1/4W
Q6609	8-729-029-56	DTA144ESA		R6668	1-216-017-91	RES-CHIP	47 5% 1/10W
Q6610	8-729-119-78	2SC2785-HFE		R6669	1-249-417-11	CARBON	1K 5% 1/4W
Q6611	8-729-029-66	DTC114ESA		R6672	1-249-421-11	CARBON	2.2K 5% 1/4W
Q6612	8-729-029-66	DTC114ESA		R6674	1-249-418-11	CARBON	1.2K 5% 1/4W
Q6613	8-729-030-02	DTC144ESA		R6679	1-249-437-11	CARBON	47K 5% 1/4W
Q6800	8-729-422-33	2SD601A-Q-TX		R6680	1-216-362-11	METAL OXIDE	0.27 5% 2W
Q6801	8-729-039-68	IRF620		R6681	1-249-429-11	CARBON	10K 5% 1/4W
Q6802	8-729-025-19	IRFI740G		R6682	1-249-416-11	CARBON	820 5% 1/4W
Q6803	8-729-119-76	2SA1175-HFE		R6683	1-260-127-11	CARBON	220K 5% 1/2W
Q6804	8-729-119-78	2SC2785-HFE		R6685	1-249-421-11	CARBON	2.2K 5% 1/4W
Q6805	8-729-140-96	2SD774-34		R6686 Δ	1-240-917-91	METAL	8.2M 5% 1W
Q6806	8-729-140-96	2SD774-34		R6688	1-249-417-11	CARBON	1K 5% 1/4W
Q6807	8-729-046-18	2SC5480-01		R6689	1-249-389-11	CARBON	4.7 5% 1/4W
Q6808	8-729-046-18	2SC5480-01		R6690	1-249-429-11	CARBON	10K 5% 1/4W
Q6809	8-729-038-83	TRANSISTOR 2SK2251-01-F19		R6691	1-260-131-11	CARBON	470K 5% 1/2W
Q6810	8-729-047-60	IRFI830G-LF49		R6692	1-249-410-11	CARBON	270 5% 1/4W
Q6811	1-801-806-11	TR DTC144EKA		R6693	1-215-451-00	METAL	18K 1% 1/4W
Q6812	8-729-043-95	2SC3840(3)		R6694	1-215-471-00	METAL	120K 1% 1/4W
Q6813	8-729-422-33	2SD601A-Q-TX		R6696	1-215-925-11	METAL OXIDE	22K 5% 3W
Q6814	8-729-026-49	2SA1037AK-T146-R		R6697	1-249-429-11	CARBON	10K 5% 1/4W
Q6815	8-729-045-65	2SA1776TV2Q		R6698	1-249-417-11	CARBON	1K 5% 1/4W
Q6816	8-729-140-96	2SD774-34		R6704	1-249-377-11	CARBON	0.47 5% 1/4W
Q6817	8-729-422-33	2SD601A-Q-TX		R6707	1-249-421-11	CARBON	2.2K 5% 1/4W
Q6818	1-801-806-11	TR DTC144EKA		R6710	1-217-158-00	METAL	0.47 10% 5W
Q6819	1-801-806-11	TR DTC144EKA		R6713	1-249-423-11	CARBON	3.3K 5% 1/4W
Q6820	8-729-422-33	2SD601A-Q-TX		R6714	1-249-423-11	CARBON	3.3K 5% 1/4W
Q6821	8-729-026-49	2SA1037AK-T146-R		R6715	1-216-073-91	RES-CHIP	10K 5% 1/10W
Q6822	8-729-026-49	2SA1037AK-T146-R		R6716	1-247-903-00	CARBON	1M 5% 1/4W
Q6823	8-729-422-33	2SD601A-Q-TX		R6800	1-249-429-11	CARBON	10K 5% 1/4W
				R6801	1-249-429-11	CARBON	10K 5% 1/4W
				R6802	1-249-429-11	CARBON	10K 5% 1/4W
				R6803	1-216-073-91	RES-CHIP	10K 5% 1/10W
				R6804	1-208-795-11	METAL CHIP	3.6K 0.5% 1/10W
				R6805	1-215-441-00	METAL	6.8K 1% 1/4W

The components identified by shading and mark \triangle are critical for safety.
Replace only with part number specified.

D

REF NO.	PART NO.	DESCRIPTION	REMARK
R6806	1-215-434-00	METAL	3.6K 1% 1/4W
R6807	1-249-383-11	CARBON	1.5 5% 1/4W
R6810	1-214-798-21	METAL	1.8 1% 1/2W
R6811	1-215-913-11	METAL OXIDE	220 5% 3W
R6812	1-247-843-11	CARBON	3.3K 5% 1/4W
R6813	1-214-798-21	METAL	1.8 1% 1/2W
R6814	1-216-057-00	RES-CHIP	2.2K 5% 1/10W
R6815	1-208-801-11	METAL CHIP	6.2K 0.5% 1/10W
R6816	1-214-915-00	METAL	120K 1% 1/2W
R6818	1-215-485-00	METAL	470K 1% 1/4W
R6819	1-249-421-11	CARBON	2.2K 5% 1/4W
R6820	1-216-065-91	RES-CHIP	4.7K 5% 1/10W
R6822	1-216-461-00	METAL OXIDE	5.6K 5% 2W
R6823	1-215-895-11	METAL OXIDE	3.3K 5% 2W
R6824	1-247-807-31	CARBON	100 5% 1/4W
R6825	1-247-807-31	CARBON	100 5% 1/4W
R6826	1-215-894-11	METAL OXIDE	2.2K 5% 2W
R6827	1-216-459-00	METAL OXIDE	2.7K 5% 2W
R6828	1-249-411-11	CARBON	330 5% 1/4W
R6829	1-249-411-11	CARBON	330 5% 1/4W
R6830	1-247-764-11	CARBON	10K 5% 1/2W
R6831	1-247-764-11	CARBON	10K 5% 1/2W
R6832	1-215-477-00	METAL	220K 1% 1/4W
R6833	1-215-493-00	METAL	1M 1% 1/4W
R6834	1-216-381-11	METAL OXIDE	0.22 5% 3W
R6835	1-216-381-11	METAL OXIDE	0.22 5% 3W
R6836	1-215-905-11	METAL OXIDE	10 5% 3W
R6837	1-215-905-11	METAL OXIDE	10 5% 3W
R6838	1-215-461-00	METAL	47K 1% 1/4W
R6839	1-249-405-11	CARBON	100 5% 1/4W
R6840	8-719-110-39	RD15ES-B1	
R6840	8-719-923-86	MTZJ-T-77-15	
R6841	1-216-434-11	METAL OXIDE	1.8K 5% 1W
R6842	1-215-923-00	METAL OXIDE	10K 5% 3W
R6843	1-216-073-91	RES-CHIP	10K 5% 1/10W
R6844	1-247-807-31	CARBON	100 5% 1/4W
R6845	1-208-826-11	METAL CHIP	68K 0.5% 1/10W
R6846	1-260-127-11	CARBON	220K 5% 1/2W
R6847	1-216-057-00	RES-CHIP	2.2K 5% 1/10W
R6848	1-216-101-00	RES-CHIP	150K 5% 1/10W
R6851	1-260-288-11	CARBON	0.47 5% 1/2W
R6852	1-216-345-11	METAL OXIDE	0.47 5% 1W
R6853	1-260-288-11	CARBON	0.47 5% 1/2W
R6854	1-215-923-00	METAL OXIDE	10K 5% 3W
R6855	1-214-898-81	METAL	24K 1% 1/2W
R6856	1-215-923-00	METAL OXIDE	10K 5% 3W
R6857	1-215-923-00	METAL OXIDE	10K 5% 3W
R6858	1-214-898-81	METAL	24K 1% 1/2W
R6859	1-215-871-11	METAL OXIDE	2.2K 5% 1W
R6860	1-215-923-00	METAL OXIDE	10K 5% 3W
R6861	1-216-295-91	SHORT	0
R6862	1-216-081-00	RES-CHIP	22K 5% 1/10W
R6863	1-215-894-11	METAL OXIDE	2.2K 5% 2W
R6864	1-216-081-00	RES-CHIP	22K 5% 1/10W
R6865	1-216-101-00	RES-CHIP	150K 5% 1/10W
R6866	1-215-431-00	METAL	2.7K 1% 1/4W
R6867	1-216-065-91	RES-CHIP	4.7K 5% 1/10W
R6868	1-216-065-91	RES-CHIP	4.7K 5% 1/10W
R6869	1-216-113-00	RES-CHIP	470K 5% 1/10W
R6870	1-216-057-00	RES-CHIP	2.2K 5% 1/10W
R6871	1-208-822-11	METAL CHIP	47K 0.5% 1/10W
R6872	1-260-125-11	CARBON	150K 5% 1/2W

REF NO.	PART NO.	DESCRIPTION	REMARK
R6873	1-260-125-11	CARBON	150K 5% 1/2W
R6875	1-249-417-11	CARBON	1K 5% 1/4W
R6876	1-260-288-11	CARBON	0.47 5% 1/2W
R6877	1-208-790-11	METAL CHIP	2.2K 0.5% 1/10W
R6878	1-208-770-11	METAL CHIP	330 0.5% 1/10W
R6879	1-216-105-91	RES-CHIP	220K 5% 1/10W
R6880	1-215-441-00	METAL	6.8K 1% 1/4W
R6881	1-215-447-00	METAL	12K 1% 1/4W
R6882	1-215-453-00	METAL	22K 1% 1/4W
R6883	1-208-806-11	METAL CHIP	10K 0.5% 1/10W
R6884	1-249-441-11	CARBON	100K 5% 1/4W
R6885	1-208-798-11	METAL CHIP	4.7K 0.5% 1/10W
R6886	1-208-798-11	METAL CHIP	4.7K 0.5% 1/10W
R6887	1-216-081-00	RES-CHIP	22K 5% 1/10W
R6888	1-216-089-91	RES-CHIP	47K 5% 1/10W
R6889	1-260-125-11	CARBON	150K 5% 1/2W
R6890	1-260-125-11	CARBON	150K 5% 1/2W
R6891	1-216-069-00	RES-CHIP	6.8K 5% 1/10W
R6892	1-216-097-11	RES-CHIP	100K 5% 1/10W
R6893	1-216-085-91	RES-CHIP	33K 5% 1/10W
R6894	1-260-133-11	CARBON	680K 5% 1/2W
R6895	1-216-097-11	RES-CHIP	100K 5% 1/10W
R6896	1-216-089-91	RES-CHIP	47K 5% 1/10W
R6897	1-216-097-11	RES-CHIP	100K 5% 1/10W
R6899	1-216-073-91	RES-CHIP	10K 5% 1/10W
R6900	1-208-810-11	METAL CHIP	15K 0.5% 1/10W
R6901	1-208-810-11	METAL CHIP	15K 0.5% 1/10W
R6902	1-249-441-11	CARBON	100K 5% 1/4W
R6903	1-215-923-00	METAL OXIDE	10K 5% 3W
R6905	1-249-389-11	CARBON	4.7 5% 1/4W
R6906	1-216-079-00	RES-CHIP	18K 5% 1/10W
R6907	1-216-079-00	RES-CHIP	18K 5% 1/10W
R6908	1-202-719-00	SOLID	1M 20% 1/2W
<RELAY>			
RY6601	1-515-840-11	RELAY	
RY6602	1-755-357-11	RELAY, AC POWER	
<TRANSFORMER>			
T6601	\triangle 1-431-732-12	TRANSFORMER, CONVERTER (SRT)	
T6602	\triangle 1-435-081-11	TRANSFORMER, CONVERTER (PIT)	
T6800	1-429-741-11	TRANSFORMER, DRIVE	
T6801	1-433-934-11	TRANSFORMER, FERRITE (DFT)	
T6802	1-433-489-11	TRANSFORMER, FERRITE (HDT)	
T6803	\triangle 1-453-360-11	TRANSFORMER ASSY FLYBACK (NX-4601//J1J4)	
T6804	1-433-489-11	TRANSFORMER, FERRITE (HDT)	
<THERMISTOR>			
TH6601	1-803-971-21	THERMISTOR, POSITIVE	
TH6603	1-803-586-11	THERMISTOR, NTC	
<VARISTOR>			
VD6603	1-803-830-11	VARISTOR (ERZV14D621)	

D1

REF NO.	PART NO.	DESCRIPTION	REMARK	REF NO.	PART NO.	DESCRIPTION	REMARK
* A-1333-171-A	D1 BOARD MOUNTED *****			C6380	1-136-495-11	FILM	0.068UF 5.00% 50V
				C6381	1-126-964-11	ELECT	10UF 20.00% 50V
				C6385	1-126-947-11	ELECT	47UF 20.00% 16V
4-382-854-11	SCREW (M3X10), P. SW (+)			C6386	1-126-947-11	ELECT	47UF 20.00% 16V
				C6388	1-126-964-11	ELECT	10UF 20.00% 50V
	<CAPACITOR>			C6392	1-126-947-11	ELECT	47UF 20.00% 16V
C6101	1-107-714-11	ELECT	10UF 20.00% 50V	C6409	1-126-963-11	ELECT	4.7UF 20.00% 50V
C6102	1-109-953-11	ELECT	2.2UF 20.00% 50V			<CONNECTOR>	
C6103	1-107-714-11	ELECT	10UF 20.00% 50V	CN6100	1-793-498-11	CONNECTOR, BOARD TO BOARD 50P	
C6104	1-126-947-11	ELECT	47UF 20.00% 16V	CN6101	* 1-564-525-11	PLUG, CONNECTOR 10P	
C6105	1-126-933-11	ELECT	100UF 20.00% 16V	CN6103	* 1-564-518-11	PLUG, CONNECTOR 3P	
C6108	1-164-004-11	CERAMIC CHIP	0.1UF 10.00% 25V	CN6104	* 1-564-523-11	PLUG, CONNECTOR 8P	
C6109	1-126-947-11	ELECT	47UF 20.00% 25V			<DIODE>	
C6111	1-126-933-11	ELECT	100UF 20.00% 16V	D6101	8-719-510-02	D1NS4	
C6112	1-163-037-11	CERAMIC CHIP	0.022UF 10.00% 50V	D6102	8-719-510-02	D1NS4	
C6113	1-137-493-11	FILM	0.0047UF 5.00% 630V	D6103	8-719-063-73	DIODE D1NL20U-TR	
C6114	1-107-909-11	ELECT	47UF 20.00% 16V	D6104	8-719-911-19	1SS119-25	
C6115	1-163-005-91	CERAMIC CHIP	470PF 10.00% 50V	D6105	8-719-109-60	RD2.7ESB2	
C6116	1-163-275-11	CERAMIC CHIP	0.001UF 5.00% 50V	D6106	8-719-510-02	D1NS4	
C6117	1-163-275-11	CERAMIC CHIP	0.001UF 5.00% 50V	D6107	8-719-911-19	1SS119-25	
C6118	1-107-909-11	ELECT	47UF 20.00% 16V	D6108	8-719-911-19	1SS119-25	
C6121	1-126-963-11	ELECT	4.7UF 20.00% 50V	D6110	8-719-987-87	ERA85-009	
C6122	1-126-947-11	ELECT	47UF 20.00% 16V	D6112	8-719-911-19	1SS119-25	
C6123	1-163-021-91	CERAMIC CHIP	0.01UF 10.00% 50V	D6133	8-719-911-19	1SS119-25	
C6124	1-164-004-11	CERAMIC CHIP	0.1UF 10.00% 25V	D6134	8-719-911-19	1SS119-25	
C6125	1-128-551-11	ELECT	22UF 20.00% 25V	D6135	8-719-911-19	1SS119-25	
C6127	1-163-021-91	CERAMIC CHIP	0.01UF 10.00% 50V	D6201	8-719-109-88	RD5.6ES-B1	
C6128	1-163-021-91	CERAMIC CHIP	0.01UF 10.00% 50V	D6210	8-719-109-88	RD5.6ES-B1	
C6129	1-126-964-11	ELECT	10UF 20.00% 50V	D6350	8-719-914-43	DAN202K	
C6131	1-126-964-11	ELECT	10UF 20.00% 50V	D6351	8-719-914-43	DAN202K	
C6133	1-137-194-81	FILM	0.47UF 5.00% 50V	D6355	8-719-914-43	DAN202K	
C6136	1-129-716-00	FILM	0.015UF 5.00% 630V	D6404	8-719-914-43	DAN202K	
C6138	1-126-968-11	ELECT	100UF 20.00% 50V			<IC>	
C6139	1-107-902-11	ELECT	1UF 20.00% 50V	IC6101	8-752-053-21	CXA1211M	
C6140	1-126-960-11	ELECT	1UF 20.00% 50V	IC6102	8-759-450-95	LM393N	
C6201	1-126-947-11	ELECT	47UF 20.00% 25V	IC6103	8-759-450-95	LM393N	
C6202	1-126-947-11	ELECT	47UF 20.00% 16V	IC6104	8-759-803-42	LA6500-FA	
C6203	1-126-947-11	ELECT	47UF 20.00% 16V	IC6105	8-759-450-95	LM393N	
C6204	1-163-021-91	CERAMIC CHIP	0.01UF 10.00% 50V	IC6106	8-759-682-42	MM1431ATT	
C6205	1-163-021-91	CERAMIC CHIP	0.01UF 10.00% 50V	IC6108	8-759-567-08	MB88141APF-ER	
C6206	1-126-964-11	ELECT	10UF 20.00% 50V	IC6201	8-759-183-37	CA0007AD	
C6207	1-126-947-11	ELECT	47UF 20.00% 16V	IC6202	8-759-135-80	UPC358C	
C6208	1-126-947-11	ELECT	47UF 20.00% 25V	IC6351	8-759-450-95	LM393N	
C6209	1-163-133-00	CERAMIC CHIP	470PF 5.00% 50V	IC6353	8-759-231-53	TA7805S	
C6210	1-163-009-91	CERAMIC CHIP	0.001UF 10.00% 50V	IC6354	8-759-325-48	CA0005AD	
C6211	1-126-964-11	ELECT	10UF 20.00% 50V	IC6356	8-759-822-38	LA6510	
C6212	1-164-004-11	CERAMIC CHIP	0.1UF 10.00% 25V			<CHIP CONDUCTOR>	
C6219	1-163-017-00	CERAMIC CHIP	0.0047UF 10.00% 50V	JR6101	1-216-296-11	SHORT	0
C6220	1-163-017-00	CERAMIC CHIP	0.0047UF 10.00% 50V	JR6102	1-216-296-11	SHORT	0
C6350	1-164-004-11	CERAMIC CHIP	0.1UF 10.00% 25V	JR6103	1-216-296-11	SHORT	0
C6351	1-126-947-11	ELECT	47UF 20.00% 16V	JR6104	1-216-295-91	SHORT	0
C6353	1-163-251-11	CERAMIC CHIP	100PF 5.00% 50V	JR6108	1-216-296-11	SHORT	0
C6355	1-163-251-11	CERAMIC CHIP	100PF 5.00% 50V	JR6109	1-216-296-11	SHORT	0
C6356	1-163-809-11	CERAMIC CHIP	0.047UF 10.00% 25V	JR6110	1-216-296-11	SHORT	0
C6358	1-164-004-11	CERAMIC CHIP	0.1UF 10.00% 25V				
C6361	1-164-004-11	CERAMIC CHIP	0.1UF 10.00% 25V				
C6362	1-164-182-11	CERAMIC CHIP	0.0033UF 10.00% 50V				
C6365	1-163-809-11	CERAMIC CHIP	0.047UF 10.00% 25V				
C6376	1-126-947-11	ELECT	47UF 20.00% 16V				
C6377	1-126-947-11	ELECT	47UF 20.00% 16V				
C6378	1-164-004-11	CERAMIC CHIP	0.1UF 10.00% 25V				

D1

REF NO.	PART NO.	DESCRIPTION	REMARK	REF NO.	PART NO.	DESCRIPTION	REMARK	
JR6111	1-216-296-11	SHORT	0	R6126	1-208-798-11	METAL CHIP	4.7K 0.5% 1/10W	
JR6112	1-216-296-11	SHORT	0	R6127	1-208-832-11	METAL CHIP	120K 0.5% 1/10W	
JR6113	1-216-296-11	SHORT	0	R6128	1-208-838-91	METAL CHIP	220K 0.5% 1/10W	
JR6114	1-216-296-11	SHORT	0	R6129	1-216-353-00	METAL OXIDE	2.2 5% 1W	
JR6115	1-216-296-11	SHORT	0	R6130	1-216-073-91	RES-CHIP	10K 5% 1/10W	
JR6116	1-216-295-91	SHORT	0	R6131	1-208-798-11	METAL CHIP	4.7K 0.5% 1/10W	
JR6117	1-216-295-91	SHORT	0	R6133	1-208-812-11	METAL CHIP	18K 0.5% 1/10W	
		<COIL>		R6134	1-208-806-11	METAL CHIP	10K 0.5% 1/10W	
L6101	1-416-920-11	INDUCTOR	10MH	R6135	1-216-073-91	RES-CHIP	10K 5% 1/10W	
L6102	1-406-989-21	INDUCTOR	10MH	R6136	1-260-328-11	CARBON	1K 5% 1/2W	
		<IC LINK>		R6137	1-216-049-11	RES-CHIP	1K 5% 1/10W	
PS6101	1-533-589-31	LINK, IC		R6138	1-208-798-11	METAL CHIP	4.7K 0.5% 1/10W	
		<TRANSISTOR>		R6139	1-208-808-11	METAL CHIP	12K 0.5% 1/10W	
Q6103	8-729-046-33	IRF720-LF49		R6140	1-216-077-91	RES-CHIP	15K 5% 1/10W	
Q6104	8-729-230-49	2SC2712-YG		R6141	1-208-830-11	METAL CHIP	100K 0.5% 1/10W	
Q6105	8-729-230-49	2SC2712-YG		R6142	1-208-806-11	METAL CHIP	10K 0.5% 1/10W	
Q6106	8-729-026-49	2SA1037AK-T146-R		R6143	1-208-792-11	METAL CHIP	2.7K 0.5% 1/10W	
Q6107	8-729-140-93	2SB733-34		R6146	1-208-806-11	METAL CHIP	10K 0.5% 1/10W	
Q6109	8-729-026-49	2SA1037AK-T146-R		R6149	1-208-828-11	METAL CHIP	82K 0.5% 1/10W	
Q6110	1-801-806-11	TR DTC144EKA		R6150	1-208-806-11	METAL CHIP	10K 0.5% 1/10W	
Q6118	8-729-230-49	2SC2712-YG		R6151	1-216-049-11	RES-CHIP	1K 5% 1/10W	
Q6124	1-801-806-11	TR DTC144EKA		R6152	1-216-081-00	RES-CHIP	22K 5% 1/10W	
Q6125	8-729-230-49	2SC2712-YG		R6153	1-216-105-91	RES-CHIP	220K 5% 1/10W	
Q6126	8-729-026-49	2SA1037AK-T146-R		R6154	1-208-808-11	METAL CHIP	12K 0.5% 1/10W	
Q6128	8-729-023-22	2SD2114K		R6155	1-208-822-11	METAL CHIP	47K 0.5% 1/10W	
Q6201	8-729-230-49	2SC2712-YG		R6156	1-216-077-91	RES-CHIP	15K 5% 1/10W	
Q6202	8-729-230-49	2SC2712-YG		R6157	1-216-089-91	RES-CHIP	47K 5% 1/10W	
Q6203	8-729-422-33	2SD601A-Q-TX		R6158	1-216-689-11	RES-CHIP	39K 5% 1/10W	
Q6350	8-729-230-49	2SC2712-YG		R6159	1-208-797-11	METAL CHIP	4.3K 0.5% 1/10W	
Q6356	8-729-230-49	2SC2712-YG		R6160	1-216-073-91	RES-CHIP	10K 5% 1/10W	
Q6405	8-729-026-49	2SA1037AK-T146-R		R6161	1-208-814-91	METAL CHIP	22K 0.5% 1/10W	
Q6455	8-729-230-49	2SC2712-YG		R6162	1-216-049-11	RES-CHIP	1K 5% 1/10W	
		<RESISTOR>		R6168	1-216-065-91	RES-CHIP	4.7K 5% 1/10W	
R6101	1-216-025-11	RES-CHIP	100 5%	1/10W	R6169	1-208-776-11	METAL CHIP	560 0.5% 1/10W
R6103	1-216-025-11	RES-CHIP	100 5%	1/10W	R6170	1-216-037-00	RES-CHIP	330 5% 1/10W
R6105	1-208-798-11	METAL CHIP	4.7K 0.5%	1/10W	R6171	1-216-113-00	RES-CHIP	470K 5% 1/10W
R6106	1-208-798-11	METAL CHIP	4.7K 0.5%	1/10W	R6172	1-216-105-91	RES-CHIP	220K 5% 1/10W
R6107	1-216-057-00	RES-CHIP	2.2K 5%	1/10W	R6173	1-216-093-91	RES-CHIP	68K 5% 1/10W
R6108	1-216-073-91	RES-CHIP	10K 5%	1/10W	R6174	1-208-812-11	METAL CHIP	18K 0.5% 1/10W
R6109	1-216-073-91	RES-CHIP	10K 5%	1/10W	R6175	1-208-816-11	METAL CHIP	27K 0.5% 1/10W
R6110	1-216-295-91	SHORT	0	R6176	1-249-389-11	CARBON	4.7 5% 1/4W	
R6113	1-208-822-11	METAL CHIP	47K 0.5%	1/10W	R6177	1-216-065-91	RES-CHIP	4.7K 5% 1/10W
R6114	1-208-806-11	METAL CHIP	10K 0.5%	1/10W	R6178	1-249-389-11	CARBON	4.7 5% 1/4W
R6115	1-208-814-91	METAL CHIP	22K 0.5%	1/10W	R6180	1-216-057-00	RES-CHIP	2.2K 5% 1/10W
R6116	1-216-057-00	RES-CHIP	2.2K 5%	1/10W	R6190	1-216-057-00	RES-CHIP	2.2K 5% 1/10W
R6117	1-208-782-11	METAL CHIP	1K 0.5%	1/10W	R6192	1-216-295-91	SHORT	0
R6118	1-208-810-11	METAL CHIP	15K 0.5%	1/10W	R6195	1-208-800-11	METAL CHIP	5.6K 0.5% 1/10W
R6119	1-208-796-11	METAL CHIP	3.9K 0.5%	1/10W	R6196	1-249-377-11	CARBON	0.47 5% 1/4W
R6120	1-208-806-11	METAL CHIP	10K 0.5%	1/10W	R6197	1-216-099-00	RES-CHIP	120K 5% 1/10W
R6121	1-216-490-11	METAL OXIDE	39K 5%	3W	R6198	1-216-093-91	RES-CHIP	68K 5% 1/10W
R6122	1-216-295-91	SHORT	0	R6200	1-208-826-11	METAL CHIP	68K 0.5% 1/10W	
R6123	1-208-782-11	METAL CHIP	1K 0.5%	1/10W	R6201	1-247-750-11	CARBON	680 5% 1/2W
R6124	1-208-800-11	METAL CHIP	5.6K 0.5%	1/10W	R6202	1-216-061-91	RES-CHIP	3.3K 5% 1/10W
				R6203	1-215-906-11	METAL OXIDE	15 5% 3W	
				R6204	1-216-057-00	RES-CHIP	2.2K 5% 1/10W	
				R6206	1-216-033-00	RES-CHIP	220 5% 1/10W	
				R6207	1-208-794-11	METAL CHIP	3.3K 0.5% 1/10W	
				R6208	1-208-806-11	METAL CHIP	10K 0.5% 1/10W	
				R6209	1-216-107-00	RES-CHIP	270K 5% 1/10W	
				R6210	1-216-057-00	RES-CHIP	2.2K 5% 1/10W	



REF NO.	PART NO.	DESCRIPTION	REMARK
R6211	1-216-073-91	RES-CHIP	10K 5% 1/10W
R6212	1-216-057-00	RES-CHIP	2.2K 5% 1/10W
R6213	1-216-105-91	RES-CHIP	220K 5% 1/10W
R6215	1-208-836-11	METAL CHIP	180K 0.5% 1/10W
R6216	1-216-065-91	RES-CHIP	4.7K 5% 1/10W
R6217	1-216-073-91	RES-CHIP	10K 5% 1/10W
R6218	1-208-836-11	METAL CHIP	180K 0.5% 1/10W
R6219	1-208-782-11	METAL CHIP	1K 0.5% 1/10W
R6220	1-208-806-11	METAL CHIP	10K 0.5% 1/10W
R6221	1-208-806-11	METAL CHIP	10K 0.5% 1/10W
R6222	1-216-295-91	SHORT	0
R6223	1-216-295-91	SHORT	0
R6224	1-208-824-11	METAL CHIP	56K 0.5% 1/10W
R6225	1-208-824-11	METAL CHIP	56K 0.5% 1/10W
R6226	1-208-808-11	METAL CHIP	12K 0.5% 1/10W
R6227	1-208-808-11	METAL CHIP	12K 0.5% 1/10W
R6324	1-216-017-91	RES-CHIP	47 5% 1/10W
R6325	1-216-017-91	RES-CHIP	47 5% 1/10W
R6326	1-208-808-11	METAL CHIP	12K 0.5% 1/10W
R6327	1-216-067-00	RES-CHIP	5.6K 5% 1/10W
R6350	1-216-067-00	RES-CHIP	5.6K 5% 1/10W
R6357	1-216-057-00	RES-CHIP	2.2K 5% 1/10W
R6359	1-216-097-11	RES-CHIP	100K 5% 1/10W
R6360	1-216-073-91	RES-CHIP	10K 5% 1/10W
R6361	1-216-097-11	RES-CHIP	100K 5% 1/10W
R6367	1-208-808-11	METAL CHIP	12K 0.5% 1/10W
R6368	1-208-810-11	METAL CHIP	15K 0.5% 1/10W
R6375	1-216-041-00	RES-CHIP	470 5% 1/10W
R6378	1-215-473-00	METAL	150K 1% 1/4W
R6379	1-216-295-91	SHORT	0
R6382	1-208-830-11	METAL CHIP	100K 0.5% 1/10W
R6385	1-216-295-91	SHORT	0
R6386	1-208-830-11	METAL CHIP	100K 0.5% 1/10W
R6391	1-216-049-11	RES-CHIP	1K 5% 1/10W
R6394	1-216-069-00	RES-CHIP	6.8K 5% 1/10W
R6413	1-208-806-11	METAL CHIP	10K 0.5% 1/10W
R6416	1-208-808-11	METAL CHIP	12K 0.5% 1/10W
R6418	1-216-113-00	RES-CHIP	470K 5% 1/10W
R6419	1-216-097-11	RES-CHIP	100K 5% 1/10W
R6420	1-216-111-00	RES-CHIP	390K 5% 1/10W
R6433	1-216-097-11	RES-CHIP	100K 5% 1/10W
R6438	1-215-437-00	METAL	4.7K 1% 1/4W
R6442	1-216-057-00	RES-CHIP	2.2K 5% 1/10W
R6456	1-216-097-11	RES-CHIP	100K 5% 1/10W
R6457	1-208-818-11	METAL CHIP	33K 0.5% 1/10W
R6458	1-216-089-91	RES-CHIP	47K 5% 1/10W
R6459	1-216-057-00	RES-CHIP	2.2K 5% 1/10W

<VARIABLE RESISTOR>

RV6100 1-241-785-11 RES, ADJ, CERMET 10K

* A-1333-172-A DH BOARD MOUNTED

4-382-854-11 SCREW (M3X10), P, SW (+)

REF NO.	PART NO.	DESCRIPTION	REMARK
<CAPACITOR>			
C3801	1-126-964-11	ELECT	10UF 20.00% 50V
C3804	1-102-129-00	CERAMIC	0.01UF 10.00% 50V
C3805	1-126-964-11	ELECT	10UF 20.00% 50V
C3807	1-102-129-00	CERAMIC	0.01UF 10.00% 50V
C3816	1-126-964-11	ELECT	10UF 20.00% 50V
C3819	1-126-960-11	ELECT	1UF 20.00% 50V
C3822	1-136-165-00	FILM	0.1UF 5.00% 50V
<CONNECTOR>			
CN3802	* 1-564-509-11	PLUG, CONNECTOR 6P	
<DIODE>			
D3805	8-719-911-19	1SS119-25	
<IC>			
IC3805	8-759-822-38	LA6510	
IC3807	1-418-597-11	SENSOR UNIT, MAGNETIC	
<TRANSISTOR>			
Q3806	8-729-119-78	2SC2785-HFE	
Q3807	8-729-030-02	DTC144ESA	
Q3808	8-729-030-02	DTC144ESA	
Q3809	8-729-119-78	2SC2785-HFE	
Q3812	8-729-119-78	2SC2785-HFE	
<RESISTOR>			
R3802	1-249-417-11	CARBON	1K 5% 1/4W
R3803	1-249-417-11	CARBON	1K 5% 1/4W
R3804	1-215-428-00	METAL	2K 1% 1/4W
R3805	1-215-423-00	METAL	1.2K 1% 1/4W
R3808	1-247-883-00	CARBON	150K 5% 1/4W
R3809	1-215-461-00	METAL	47K 1% 1/4W
R3810	1-249-425-11	CARBON	4.7K 5% 1/4W
R3814	1-249-411-11	CARBON	330 5% 1/4W
R3823	1-249-395-11	CARBON	15 5% 1/4W
R3825	1-249-417-11	CARBON	1K 5% 1/4W
R3828	1-249-377-11	CARBON	0.47 5% 1/4W
R3839	1-249-429-11	CARBON	10K 5% 1/4W
R3845	1-249-425-11	CARBON	4.7K 5% 1/4W
R3849	1-249-377-11	CARBON	0.47 5% 1/4W
R3852	1-249-441-11	CARBON	100K 5% 1/4W
R3854	1-249-429-11	CARBON	10K 5% 1/4W
R3858	1-215-451-00	METAL	18K 1% 1/4W
R3859	1-215-417-00	METAL	680 1% 1/4W
R3860	1-215-405-00	METAL	220 1% 1/4W
R3861	1-215-461-00	METAL	47K 1% 1/4W
R3862	1-249-429-11	CARBON	10K 5% 1/4W



REF NO.	PART NO.	DESCRIPTION	REMARK
	* A-1333-173-A	E BOARD MOUNTED *****	
		<CAPACITOR>	
C4301	1-164-004-11	CERAMIC CHIP	0.1UF 10.00% 25V
C4302	1-164-161-11	CERAMIC CHIP	0.0022UF 10.00% 50V
C4308	1-126-960-11	ELECT	1UF 20.00% 50V
C4309	1-164-489-11	CERAMIC CHIP	0.22UF 10.00% 16V
C4316	1-126-947-11	ELECT	47UF 20.00% 16V
C4317	1-164-004-11	CERAMIC CHIP	0.1UF 10.00% 25V
C4318	1-164-004-11	CERAMIC CHIP	0.1UF 10.00% 25V
C4319	1-164-004-11	CERAMIC CHIP	0.1UF 10.00% 25V
C4320	1-164-004-11	CERAMIC CHIP	0.1UF 10.00% 25V
C4321	1-164-004-11	CERAMIC CHIP	0.1UF 10.00% 25V
C4322	1-164-004-11	CERAMIC CHIP	0.1UF 10.00% 25V
C4324	1-164-004-11	CERAMIC CHIP	0.1UF 10.00% 25V
C4325	1-163-093-00	CERAMIC CHIP	10PF 5.00% 50V
C4326	1-164-004-11	CERAMIC CHIP	0.1UF 10.00% 25V
C4327	1-164-004-11	CERAMIC CHIP	0.1UF 10.00% 25V
C4328	1-164-004-11	CERAMIC CHIP	0.1UF 10.00% 25V
C4329	1-126-963-11	ELECT	4.7UF 20.00% 50V
C4330	1-136-244-11	FILM	0.1UF 5.00% 50V
C4331	1-126-959-11	ELECT	0.47UF 20.00% 50V
C4332	1-136-161-00	FILM	0.047UF 5.00% 50V
C4333	1-164-004-11	CERAMIC CHIP	0.1UF 10.00% 25V
C4334	1-126-947-11	ELECT	47UF 20.00% 16V
C4336	1-126-947-11	ELECT	47UF 20.00% 16V
C4338	1-164-004-11	CERAMIC CHIP	0.1UF 10.00% 25V
C4339	1-163-235-11	CERAMIC CHIP	22PF 5.00% 50V
C4340	1-126-947-11	ELECT	47UF 20.00% 16V
C4341	1-163-227-11	CERAMIC CHIP	10PF 0.50PF 50V
C4342	1-163-021-91	CERAMIC CHIP	0.01UF 10.00% 50V
C4343	1-164-004-11	CERAMIC CHIP	0.1UF 10.00% 25V
C4344	1-163-809-11	CERAMIC CHIP	0.047UF 10.00% 25V
C4345	1-126-947-11	ELECT	47UF 20.00% 16V
C4346	1-164-346-11	CERAMIC CHIP	1UF 16V
C4347	1-164-004-11	CERAMIC CHIP	0.1UF 10.00% 25V
C4348	1-164-346-11	CERAMIC CHIP	1UF 16V
C4349	1-164-346-11	CERAMIC CHIP	1UF 16V
C4350	1-164-004-11	CERAMIC CHIP	0.1UF 10.00% 25V
C4351	1-163-009-91	CERAMIC CHIP	0.001UF 10.00% 50V
C4352	1-126-947-11	ELECT	47UF 20.00% 16V
C4353	1-107-823-11	CERAMIC CHIP	0.47UF 10.00% 16V
C4354	1-107-823-11	CERAMIC CHIP	0.47UF 10.00% 16V
C4355	1-164-004-11	CERAMIC CHIP	0.1UF 10.00% 25V
C4356	1-164-004-11	CERAMIC CHIP	0.1UF 10.00% 25V
C4357	1-164-004-11	CERAMIC CHIP	0.1UF 10.00% 25V
C4358	1-164-004-11	CERAMIC CHIP	0.1UF 10.00% 25V
C4359	1-164-161-11	CERAMIC CHIP	0.0022UF 10.00% 50V
C4360	1-126-963-11	ELECT	4.7UF 20.00% 50V
C4362	1-164-004-11	CERAMIC CHIP	0.1UF 10.00% 25V
C4363	1-126-947-11	ELECT	47UF 20.00% 16V
C4364	1-126-947-11	ELECT	47UF 20.00% 16V
C4366	1-104-760-11	CERAMIC CHIP	0.047UF 10.00% 50V
C4367	1-164-004-11	CERAMIC CHIP	0.1UF 10.00% 25V
C4369	1-164-004-11	CERAMIC CHIP	0.1UF 10.00% 25V
C4370	1-126-947-11	ELECT	47UF 20.00% 16V
C4371	1-164-004-11	CERAMIC CHIP	0.1UF 10.00% 25V
C4378	1-163-251-11	CERAMIC CHIP	100PF 5.00% 50V

REF NO.	PART NO.	DESCRIPTION	REMARK
C4800	1-136-165-00	FILM	0.1UF 5.00% 50V
C4801	1-136-161-00	FILM	0.047UF 5.00% 50V
C4802	1-163-275-11	CERAMIC CHIP	0.001UF 5.00% 50V
C4803	1-163-021-91	CERAMIC CHIP	0.01UF 10.00% 50V
C4804	1-126-947-11	ELECT	47UF 20.00% 16V
C4805	1-126-964-11	ELECT	10UF 20.00% 50V
C4806	1-163-133-00	CERAMIC CHIP	470PF 5.00% 50V
C4807	1-163-133-00	CERAMIC CHIP	470PF 5.00% 50V
C4808	1-136-165-00	FILM	0.1UF 5.00% 50V
C4809	1-163-275-11	CERAMIC CHIP	0.001UF 5.00% 50V
C4810	1-163-133-00	CERAMIC CHIP	470PF 5.00% 50V
C4811	1-163-021-91	CERAMIC CHIP	0.01UF 10.00% 50V
C4812	1-126-947-11	ELECT	47UF 20.00% 16V
C4813	1-163-021-91	CERAMIC CHIP	0.01UF 10.00% 50V
C4814	1-126-947-11	ELECT	47UF 20.00% 16V
C4817	1-126-947-11	ELECT	47UF 20.00% 16V
C4820	1-107-909-11	ELECT	47UF 20.00% 16V
C4823	1-163-017-00	CERAMIC CHIP	0.0047UF 10.00% 50V
C4824	1-163-809-11	CERAMIC CHIP	0.047UF 10.00% 25V
C4825	1-164-004-11	CERAMIC CHIP	0.1UF 10.00% 25V
C4833	1-126-964-11	ELECT	10UF 20.00% 50V
C4834	1-126-933-11	ELECT	100UF 20.00% 16V
C4835	1-164-004-11	CERAMIC CHIP	0.1UF 10.00% 25V
C4836	1-164-004-11	CERAMIC CHIP	0.1UF 10.00% 25V
C4837	1-163-275-11	CERAMIC CHIP	0.001UF 5.00% 50V
C4838	1-164-004-11	CERAMIC CHIP	0.1UF 10.00% 25V
C4905	1-126-964-11	ELECT	10UF 20.00% 50V
C4906	1-164-004-11	CERAMIC CHIP	0.1UF 10.00% 25V
		<CONNECTOR>	
CN4101	1-793-497-11	CONNECTOR, BOARD TO BOARD 40P	
CN4500	* 1-564-512-11	PLUG, CONNECTOR 9P	
CN4502	* 1-564-506-11	PLUG, CONNECTOR 3P	
		<DIODE>	
D4302	8-719-110-41	RD15ES-B2	
D4303	8-719-109-72	RD3.9ES-B2	
D4304	8-719-069-60	UDZSTE-179.1B	
D4305	8-719-069-60	UDZSTE-179.1B	
D4311	8-719-914-43	DAN202K	
D4312	8-719-914-43	DAN202K	
D4313	8-719-401-63	MA3062M-TX	
D4314	8-719-914-43	DAN202K	
D4800	8-719-914-43	DAN202K	
D4801	8-719-914-43	DAN202K	
D4802	8-719-109-81	RD4.7ESB2	
D4805	8-719-914-43	DAN202K	
D4808	8-719-914-43	DAN202K	
D4809	8-719-914-43	DAN202K	
D4811	1-249-381-11	CARBON	1 5% 1/4W
D4812	8-719-911-19	1SS119-25	
D4812	8-719-991-33	1SS133T-77	
D4813	8-719-914-43	DAN202K	
D4814	8-719-914-43	DAN202K	
D4815	8-719-109-54	RD2.2ES-B2	
D4815	8-719-109-54	RD2.2ES-B2	
D4816	8-719-911-19	1SS119-25	
D4817	8-719-109-89	RD5.6ESB2	
D4818	8-719-914-43	DAN202K	
D4900	8-719-911-19	1SS119-25	

E

REF NO.	PART NO.	DESCRIPTION	REMARK	REF NO.	PART NO.	DESCRIPTION	REMARK
		<FERRITE BEAD>		Q4815	8-729-424-02	2SB709A-QRS-TX	
FB4387	1-216-295-91	SHORT	0	Q4816	8-729-424-02	2SB709A-QRS-TX	
FB4388	1-216-295-91	SHORT	0	Q4817	8-729-230-49	2SC2712-YG	
FB4389	1-216-295-91	SHORT	0	Q4818	8-729-424-02	2SB709A-QRS-TX	
		<IC>		Q4820	8-729-230-49	2SC2712-YG	
IC4301	8-752-090-87	CXA2100AQ		Q4821	1-801-806-11	TR DTC144EKA	
IC4800	8-759-450-95	LM393N		Q4822	8-729-230-49	2SC2712-YG	
IC4801	8-759-450-95	LM393N		Q4823	8-729-424-02	2SB709A-QRS-TX	
IC4802	8-759-638-79	NJM3404AD-W		Q4824	8-729-424-02	2SB709A-QRS-TX	
IC4803	8-759-135-80	UPC358C		Q4825	8-729-230-49	2SC2712-YG	
		<CHIP CONDUCTOR>		Q4826	8-729-230-49	2SC2712-YG	
JR4301	1-216-295-91	SHORT	0	Q4906	8-729-422-33	2SD601A-Q-TX	
		<COIL>		Q4907	8-729-424-02	2SB709A-QRS-TX	
L4301	1-412-029-11	INDUCTOR	10UH	Q4908	8-729-424-02	2SB709A-QRS-TX	
L4302	1-412-029-11	INDUCTOR	10UH	Q4909	8-729-422-33	2SD601A-Q-TX	
L4303	1-412-029-11	INDUCTOR	10UH	Q4910	8-729-424-02	2SB709A-QRS-TX	
L4304	1-412-029-11	INDUCTOR	10UH			<RESISTOR>	
L4305	1-412-029-11	INDUCTOR	10UH	R4301	1-216-025-11	RES-CHIP	100 5% 1/10W
L4306	1-412-029-11	INDUCTOR	10UH	R4302	1-216-025-11	RES-CHIP	100 5% 1/10W
L4308	1-412-031-11	INDUCTOR	47UH	R4303	1-216-025-11	RES-CHIP	100 5% 1/10W
L4309	1-412-031-11	INDUCTOR	47UH	R4304	1-216-025-11	RES-CHIP	100 5% 1/10W
L4311	1-412-002-31	INDUCTOR	4.7UH	R4305	1-216-025-11	RES-CHIP	100 5% 1/10W
		<TRANSISTOR>		R4306	1-216-025-11	RES-CHIP	100 5% 1/10W
Q4301	8-729-230-49	2SC2712-YG		R4307	1-216-025-11	RES-CHIP	100 5% 1/10W
Q4302	8-729-424-02	2SB709A-QRS-TX		R4308	1-216-295-91	SHORT	0
Q4303	8-729-120-28	2SC1623-L5L6		R4310	1-216-295-91	SHORT	0
Q4304	8-729-230-49	2SC2712-YG		R4312	1-216-295-91	SHORT	0
Q4305	8-729-230-49	2SC2712-YG		R4313	1-216-065-91	RES-CHIP	4.7K 5% 1/10W
Q4307	8-729-424-02	2SB709A-QRS-TX		R4314	1-216-057-00	RES-CHIP	2.2K 5% 1/10W
Q4308	8-729-424-02	2SB709A-QRS-TX		R4316	1-216-069-00	RES-CHIP	6.8K 5% 1/10W
Q4310	8-729-424-02	2SB709A-QRS-TX		R4317	1-216-081-00	RES-CHIP	22K 5% 1/10W
Q4315	1-801-806-11	TR DTC144EKA		R4318	1-208-804-11	METAL CHIP	8.2K 0.5% 1/10W
Q4316	8-729-230-49	2SC2712-YG		R4319	1-208-804-11	METAL CHIP	8.2K 0.5% 1/10W
Q4317	8-729-900-53	DTC114EK		R4320	1-208-790-11	METAL CHIP	2.2K 0.5% 1/10W
Q4319	8-729-424-02	2SB709A-QRS-TX		R4321	1-216-298-00	RES-CHIP	2.2 5% 1/10W
Q4320	8-729-424-02	2SB709A-QRS-TX		R4322	1-216-097-11	RES-CHIP	100K 5% 1/10W
Q4321	8-729-424-02	2SB709A-QRS-TX		R4323	1-208-814-91	METAL CHIP	22K 0.5% 1/10W
Q4322	8-729-424-02	2SB709A-QRS-TX		R4324	1-208-798-11	METAL CHIP	4.7K 0.5% 1/10W
Q4800	8-729-230-49	2SC2712-YG		R4325	1-208-818-11	METAL CHIP	33K 0.5% 1/10W
Q4801	8-729-230-49	2SC2712-YG		R4326	1-208-826-11	METAL CHIP	68K 0.5% 1/10W
Q4802	8-729-230-49	2SC2712-YG		R4327	1-208-822-11	METAL CHIP	47K 0.5% 1/10W
Q4803	8-729-230-49	2SC2712-YG		R4329	1-208-782-11	METAL CHIP	1K 0.5% 1/10W
Q4804	8-729-230-49	2SC2712-YG		R4330	1-216-089-91	RES-CHIP	47K 5% 1/10W
Q4805	8-729-230-49	2SC2712-YG		R4331	1-216-025-11	RES-CHIP	100 5% 1/10W
Q4806	8-729-230-49	2SC2712-YG		R4332	1-216-025-11	RES-CHIP	100 5% 1/10W
Q4807	8-729-230-49	2SC2712-YG		R4333	1-216-025-11	RES-CHIP	100 5% 1/10W
Q4808	8-729-424-02	2SB709A-QRS-TX		R4334	1-216-049-11	RES-CHIP	1K 5% 1/10W
Q4809	8-729-424-02	2SB709A-QRS-TX		R4335	1-216-025-11	RES-CHIP	100 5% 1/10W
Q4810	8-729-230-49	2SC2712-YG		R4336	1-216-025-11	RES-CHIP	100 5% 1/10W
Q4811	8-729-230-49	2SC2712-YG		R4337	1-216-025-11	RES-CHIP	100 5% 1/10W
Q4812	8-729-424-02	2SB709A-QRS-TX		R4338	1-216-041-00	RES-CHIP	470 5% 1/10W
Q4813	8-729-424-02	2SB709A-QRS-TX		R4339	1-216-051-00	RES-CHIP	1.2K 5% 1/10W
Q4814	8-729-424-02	2SB709A-QRS-TX		R4341	1-216-295-91	SHORT	0
				R4343	1-216-025-11	RES-CHIP	100 5% 1/10W
				R4344	1-216-025-11	RES-CHIP	100 5% 1/10W
				R4345	1-216-075-00	RES-CHIP	12K 5% 1/10W
				R4346	1-208-812-11	METAL CHIP	18K 0.5% 1/10W
				R4347	1-216-025-11	RES-CHIP	100 5% 1/10W
				R4348	1-216-025-11	RES-CHIP	100 5% 1/10W

E

REF NO.	PART NO.	DESCRIPTION	REMARK	REF NO.	PART NO.	DESCRIPTION	REMARK
R4349	1-216-041-00	RES-CHIP	470 5% 1/10W	R4813	1-216-089-91	RES-CHIP	47K 5% 1/10W
R4350	1-216-025-11	RES-CHIP	100 5% 1/10W	R4814	1-208-830-11	METAL CHIP	100K 0.5% 1/10W
R4351	1-216-081-00	RES-CHIP	22K 5% 1/10W				
R4352	1-216-041-00	RES-CHIP	470 5% 1/10W	R4815	1-208-830-11	METAL CHIP	100K 0.5% 1/10W
R4353	1-216-051-00	RES-CHIP	1.2K 5% 1/10W	R4816	1-216-073-91	RES-CHIP	10K 5% 1/10W
R4354	1-208-806-11	METAL CHIP	10K 0.5% 1/10W	R4817	* 1-208-852-11	METAL CHIP	820K 0.5% 1/10W
R4355	1-216-049-11	RES-CHIP	1K 5% 1/10W	R4818	1-216-057-00	RES-CHIP	2.2K 5% 1/10W
R4356	1-216-049-11	RES-CHIP	1K 5% 1/10W	R4819	1-216-049-11	RES-CHIP	1K 5% 1/10W
R4357	1-216-073-91	RES-CHIP	10K 5% 1/10W	R4820	1-216-073-91	RES-CHIP	10K 5% 1/10W
R4358	1-216-071-00	RES-CHIP	8.2K 5% 1/10W	R4821	1-216-073-91	RES-CHIP	10K 5% 1/10W
R4359	1-216-041-00	RES-CHIP	470 5% 1/10W	R4822	1-216-049-11	RES-CHIP	1K 5% 1/10W
R4360	1-216-057-00	RES-CHIP	2.2K 5% 1/10W	R4823	1-216-049-11	RES-CHIP	1K 5% 1/10W
R4361	1-216-133-91	RES-CHIP	3.3M 5% 1/10W	R4824	1-216-073-91	RES-CHIP	10K 5% 1/10W
R4362	1-216-049-11	RES-CHIP	1K 5% 1/10W	R4825	1-216-073-91	RES-CHIP	10K 5% 1/10W
R4363	1-216-025-11	RES-CHIP	100 5% 1/10W	R4826	1-216-049-11	RES-CHIP	1K 5% 1/10W
R4365	1-216-025-11	RES-CHIP	100 5% 1/10W	R4827	1-216-295-91	SHORT	0
R4366	1-216-025-11	RES-CHIP	100 5% 1/10W	R4828	1-216-053-00	RES-CHIP	1.5K 5% 1/10W
R4367	1-216-025-11	RES-CHIP	100 5% 1/10W	R4829	1-216-053-00	RES-CHIP	1.5K 5% 1/10W
R4368	1-216-049-11	RES-CHIP	1K 5% 1/10W	R4831	1-208-794-11	METAL CHIP	3.3K 0.5% 1/10W
R4369	1-216-025-11	RES-CHIP	100 5% 1/10W	R4832	1-216-691-11	METAL CHIP	47K 0.5% 1/10W
R4370	1-216-049-11	RES-CHIP	1K 5% 1/10W	R4833	1-216-691-11	METAL CHIP	47K 0.5% 1/10W
R4372	1-216-049-11	RES-CHIP	1K 5% 1/10W	R4834	1-208-790-11	METAL CHIP	2.2K 0.5% 1/10W
R4373	1-216-295-91	SHORT	0	R4835	1-208-790-11	METAL CHIP	2.2K 0.5% 1/10W
R4374	1-216-025-11	RES-CHIP	100 5% 1/10W	R4836	1-216-691-11	METAL CHIP	47K 0.5% 1/10W
R4375	1-216-049-11	RES-CHIP	1K 5% 1/10W	R4837	1-216-691-11	METAL CHIP	47K 0.5% 1/10W
R4376	1-216-025-11	RES-CHIP	100 5% 1/10W	R4838	1-208-830-11	METAL CHIP	100K 0.5% 1/10W
R4377	1-216-049-11	RES-CHIP	1K 5% 1/10W	R4839	1-208-802-11	METAL CHIP	6.8K 0.5% 1/10W
R4380	1-216-073-91	RES-CHIP	10K 5% 1/10W	R4840	1-216-295-91	SHORT	0
R4381	1-208-854-11	METAL CHIP	1M 0.5% 1/10W	R4841	1-216-057-00	RES-CHIP	2.2K 5% 1/10W
R4382	1-216-073-91	RES-CHIP	10K 5% 1/10W	R4842	1-216-691-11	METAL CHIP	47K 0.5% 1/10W
R4383	1-216-079-00	RES-CHIP	18K 5% 1/10W	R4843	1-216-057-00	RES-CHIP	2.2K 5% 1/10W
R4384	1-216-025-11	RES-CHIP	100 5% 1/10W	R4844	1-208-798-11	METAL CHIP	4.7K 0.5% 1/10W
R4387	1-216-295-91	SHORT	0	R4845	1-208-830-11	METAL CHIP	100K 0.5% 1/10W
R4388	1-216-295-91	SHORT	0	R4846	1-216-295-91	SHORT	0
R4389	1-216-295-91	SHORT	0	R4856	1-216-057-00	RES-CHIP	2.2K 5% 1/10W
R4395	1-216-295-91	SHORT	0	R4857	1-208-814-91	METAL CHIP	22K 0.5% 1/10W
R4396	1-216-295-91	SHORT	0	R4858	1-208-814-91	METAL CHIP	22K 0.5% 1/10W
R4397	1-216-295-91	SHORT	0	R4859	1-208-792-11	METAL CHIP	2.7K 0.5% 1/10W
R4399	1-216-025-11	RES-CHIP	100 5% 1/10W	R4860	1-216-655-11	METAL CHIP	1.5K 0.5% 1/10W
R4401	1-216-105-91	RES-CHIP	220K 5% 1/10W	R4861	1-216-057-00	RES-CHIP	2.2K 5% 1/10W
R4408	1-216-025-11	RES-CHIP	100 5% 1/10W	R4862	1-208-810-11	METAL CHIP	15K 0.5% 1/10W
R4409	1-216-073-91	RES-CHIP	10K 5% 1/10W	R4864	1-208-788-11	METAL CHIP	1.8K 0.5% 1/10W
R4410	1-216-057-00	RES-CHIP	2.2K 5% 1/10W	R4865	1-208-770-11	METAL CHIP	330 0.5% 1/10W
R4411	1-216-073-91	RES-CHIP	10K 5% 1/10W	R4866	1-216-081-00	RES-CHIP	22K 5% 1/10W
R4412	1-216-097-11	RES-CHIP	100K 5% 1/10W	R4869	1-208-814-91	METAL CHIP	22K 0.5% 1/10W
R4518	1-216-025-11	RES-CHIP	100 5% 1/10W	R4871	1-208-828-11	METAL CHIP	82K 0.5% 1/10W
R4519	1-216-073-91	RES-CHIP	10K 5% 1/10W	R4872	1-216-057-00	RES-CHIP	2.2K 5% 1/10W
R4520	1-216-025-11	RES-CHIP	100 5% 1/10W	R4874	1-216-295-91	SHORT	0
R4521	1-216-025-11	RES-CHIP	100 5% 1/10W	R4875	1-216-057-00	RES-CHIP	2.2K 5% 1/10W
R4800	1-216-057-00	RES-CHIP	2.2K 5% 1/10W	R4877	1-216-057-00	RES-CHIP	2.2K 5% 1/10W
R4801	1-216-049-11	RES-CHIP	1K 5% 1/10W	R4878	1-208-838-91	METAL CHIP	220K 0.5% 1/10W
R4802	1-216-073-91	RES-CHIP	10K 5% 1/10W	R4879	1-216-105-91	RES-CHIP	220K 5% 1/10W
R4803	1-216-049-11	RES-CHIP	1K 5% 1/10W	R4881	1-216-295-91	SHORT	0
R4804	1-216-065-91	RES-CHIP	4.7K 5% 1/10W	R4882	1-208-836-11	METAL CHIP	180K 0.5% 1/10W
R4805	1-208-792-11	METAL CHIP	2.7K 0.5% 1/10W	R4883	1-208-842-11	METAL CHIP	330K 0.5% 1/10W
R4806	1-208-792-11	METAL CHIP	2.7K 0.5% 1/10W	R4884	1-216-691-11	METAL CHIP	47K 0.5% 1/10W
R4807	1-216-049-11	RES-CHIP	1K 5% 1/10W	R4887	1-208-814-91	METAL CHIP	22K 0.5% 1/10W
R4809	1-216-073-91	RES-CHIP	10K 5% 1/10W	R4889	1-216-025-11	RES-CHIP	100 5% 1/10W
R4810	1-208-814-91	METAL CHIP	22K 0.5% 1/10W	R4891	1-216-025-11	RES-CHIP	100 5% 1/10W
R4811	1-208-814-91	METAL CHIP	22K 0.5% 1/10W	R4892	1-216-295-91	SHORT	0
R4812	1-216-295-91	SHORT	0	R4894	1-216-073-91	RES-CHIP	10K 5% 1/10W
				R4895	1-216-073-91	RES-CHIP	10K 5% 1/10W
				R4897	1-208-788-11	METAL CHIP	1.8K 0.5% 1/10W

The components identified by shading and mark Δ are critical for safety. Replace only with part number specified.

E **F1** **F2** **H1**

REF NO.	PART NO.	DESCRIPTION	REMARK
R4898	1-208-798-11	METAL CHIP	4.7K 0.5% 1/10W
R4899	1-216-025-11	RES-CHIP	100 5% 1/10W
R4908	1-216-049-11	RES-CHIP	1K 5% 1/10W
R4909	1-216-065-91	RES-CHIP	4.7K 5% 1/10W
R4910	1-216-065-91	RES-CHIP	4.7K 5% 1/10W
R4911	1-208-818-11	METAL CHIP	33K 0.5% 1/10W
R4912	1-208-806-11	METAL CHIP	10K 0.5% 1/10W
R4913	1-208-806-11	METAL CHIP	10K 0.5% 1/10W
R4914	1-216-057-00	RES-CHIP	2.2K 5% 1/10W
R4915	1-216-025-11	RES-CHIP	100 5% 1/10W
R4916	1-216-057-00	RES-CHIP	2.2K 5% 1/10W
R4917	1-216-057-00	RES-CHIP	2.2K 5% 1/10W
R4918	1-216-089-91	RES-CHIP	47K 5% 1/10W
R4921	1-208-790-11	METAL CHIP	2.2K 0.5% 1/10W
R4922	1-208-806-11	METAL CHIP	10K 0.5% 1/10W
R4924	1-208-820-11	METAL CHIP	39K 0.5% 1/10W
R4925	1-216-057-00	RES-CHIP	2.2K 5% 1/10W
R4926	1-216-057-00	RES-CHIP	2.2K 5% 1/10W
R4927	1-208-836-11	METAL CHIP	180K 0.5% 1/10W
R4989	1-216-051-00	RES-CHIP	1.2K 5% 1/10W
R4991	1-216-051-00	RES-CHIP	1.2K 5% 1/10W
<CRYSTAL>			
X4300	1-767-127-11	VIBRATOR, CERAMIC	

A-1241-523-A	F1 BOARD MOUNTED	*****	
1-533-223-11	HOLDER, FUSE		
4-085-498-01	LABEL, FUSE		
* 4-374-846-01	COVER, CAPACITOR, CAP TYPE		
<CAPACITOR>			
C1601	Δ 1-104-708-51	MYLAR	0.47UF 20.00% 250V
C1602	Δ 1-109-835-51	MYLAR	0.68UF 20.00% 250V
C1603	Δ 1-117-703-51	CERAMIC	0.0047UF 99% 250V
<CONNECTOR>			
CN1601	Δ 1-580-843-11	PIN, CONNECTOR (POWER)	
CN1602	Δ 1-580-843-11	PIN, CONNECTOR (POWER)	
CN1603	1-695-915-11	TAB (CONTACT)	
CN1604	1-695-915-11	TAB (CONTACT)	
<FUSE>			
F1601	1-532-325-00	FUSE, TIME-LAG 6.3A/250V	
<FERRITE BEAD>			
FB1601	1-410-397-21	FERRITE 1.1UH	
FB1602	1-410-397-21	FERRITE 1.1UH	
FB1603	1-410-397-21	FERRITE 1.1UH	
FB1604	1-410-397-21	FERRITE 1.1UH	

REF NO.	PART NO.	DESCRIPTION	REMARK
<RESISTOR>			
R1601	Δ 1-202-885-91	SOLID	1M 10% 1/2W
<TRANSFORMER>			
T1601	1-433-900-11	TRANSFORMER, LINE FILTER	
T1602	1-433-900-11	TRANSFORMER, LINE FILTER	
<VARISTOR>			
VDR161	1-803-830-11	VARISTOR (ERZV14D621)	

* A-1241-510-A	F2 BOARD MOUNTED	*****	
<CONNECTOR>			
CN1651	1-580-843-11	PIN, CONNECTOR (POWER)	
CN1652	* 1-691-291-11	PIN, CONNECTOR (PC BOARD) 5P	
<SWITCH>			
S1651	Δ 1-571-433-31	SWITCH, PUSH (AC POWER)	

* A-1377-035-A	H1 BOARD MOUNTED	*****	
* 4-055-304-01	HOLDER, LED		
<CAPACITOR>			
C1910	1-126-947-11	ELECT	47UF 20.00% 16V
C1911	1-126-947-11	ELECT	47UF 20.00% 16V
C1912	1-102-824-00	CERAMIC	470PF 5.00% 50V
<CONNECTOR>			
CN1901	* 1-564-520-11	PLUG, CONNECTOR 5P	
<DIODE>			
D1906	8-719-045-19	SPB-26MVWF	
<IC>			
IC1901	8-742-134-01	SBX1981-51RP	
<TRANSISTOR>			
Q1901	8-729-030-02	DTC144ESA	
Q1902	8-729-030-02	DTC144ESA	

H1 **H2** **H3** **J**

REF NO.	PART NO.	DESCRIPTION	REMARK
<RESISTOR>			
R1911	1-249-411-11	CARBON	330 5% 1/4W
R1913	1-249-429-11	CARBON	10K 5% 1/4W
R1914	1-249-411-11	CARBON	330 5% 1/4W
R1915	1-249-429-11	CARBON	10K 5% 1/4W
R1916	1-249-401-11	CARBON	47 5% 1/4W
R1917	1-247-807-31	CARBON	100 5% 1/4W
R1920	1-247-807-31	CARBON	100 5% 1/4W
R1921	1-247-807-31	CARBON	100 5% 1/4W

* A-1377-036-A H2 BOARD MOUNTED *****			
<CAPACITOR>			
C1930	1-136-153-00	FILM	0.01UF 5.00% 50V
C1932	1-136-153-00	FILM	0.01UF 5.00% 50V
C1935	1-102-824-00	CERAMIC	470PF 5.00% 50V
C1938	1-102-824-00	CERAMIC	470PF 5.00% 50V
<CONNECTOR>			
CN1932	* 1-564-509-11	PLUG, CONNECTOR 6P	
CN1934	* 1-564-515-11	PLUG, CONNECTOR 12P	
<DIODE>			
D1930	8-719-929-15	HZS9.1NB2	
D1935	8-719-929-15	HZS9.1NB2	
<JACK>			
J1931	1-770-786-11	JACK	
J1932	1-537-744-11	TERMINAL, S	
J1933	1-770-329-11	JACK, PIN 3P	
<COIL>			
L1931	1-408-603-31	INDUCTOR	10UH
L1932	1-408-603-31	INDUCTOR	10UH
<RESISTOR>			
R1933	1-247-895-91	CARBON	470K 5% 1/4W
R1934	1-247-807-31	CARBON	100 5% 1/4W
R1935	1-247-807-31	CARBON	100 5% 1/4W
R1936	1-247-895-91	CARBON	470K 5% 1/4W
R1952	1-249-421-11	CARBON	2.2K 5% 1/4W
<SWITCH>			
S1931	1-692-431-21	SWITCH, TACTILE	

REF NO.	PART NO.	DESCRIPTION	REMARK
* A-1372-730-A H3 BOARD MOUNTED *****			
<CONNECTOR>			
CN1980	* 1-564-518-11	PLUG, CONNECTOR 3P	
<RESISTOR>			
R1970	1-249-416-11	CARBON	820 5% 1/4W
R1971	1-249-417-11	CARBON	1K 5% 1/4W
R1972	1-249-418-11	CARBON	1.2K 5% 1/4W
R1973	1-249-420-11	CARBON	1.8K 5% 1/4W
R1974	1-247-843-11	CARBON	3.3K 5% 1/4W
R1975	1-249-427-11	CARBON	6.8K 5% 1/4W
R1976	1-249-432-11	CARBON	18K 5% 1/4W
<SWITCH>			
S1972	1-572-198-11	SWITCH, KEYBOARD	
S1973	1-572-198-11	SWITCH, KEYBOARD	
S1974	1-572-198-11	SWITCH, KEYBOARD	
S1975	1-572-198-11	SWITCH, KEYBOARD	
S1976	1-572-198-11	SWITCH, KEYBOARD	
S1977	1-572-198-11	SWITCH, KEYBOARD	
S1978	1-572-198-11	SWITCH, KEYBOARD	
S1979	1-572-198-11	SWITCH, KEYBOARD	

* A-1395-042-A J BOARD COMPLETE *****			
3-350-679-01 WASHER, FIBER			
<CAPACITOR>			
C8300	1-107-823-11	CERAMIC CHIP	0.47UF 10.00% 16V
C8301	1-163-133-00	CERAMIC CHIP	470PF 5.00% 50V
C8302	1-163-133-00	CERAMIC CHIP	470PF 5.00% 50V
C8303	1-163-133-00	CERAMIC CHIP	470PF 5.00% 50V
C8304	1-163-133-00	CERAMIC CHIP	470PF 5.00% 50V
C8305	1-163-133-00	CERAMIC CHIP	470PF 5.00% 50V
C8306	1-163-133-00	CERAMIC CHIP	470PF 5.00% 50V
C8307	1-163-133-00	CERAMIC CHIP	470PF 5.00% 50V
C8308	1-163-133-00	CERAMIC CHIP	470PF 5.00% 50V
C8309	1-163-133-00	CERAMIC CHIP	470PF 5.00% 50V
C8310	1-163-133-00	CERAMIC CHIP	470PF 5.00% 50V
C8311	1-164-346-11	CERAMIC CHIP	1UF 16V
C8312	1-164-346-11	CERAMIC CHIP	1UF 16V
C8313	1-164-346-11	CERAMIC CHIP	1UF 16V
C8314	1-164-346-11	CERAMIC CHIP	1UF 16V
C8315	1-163-133-00	CERAMIC CHIP	470PF 5.00% 50V
C8316	1-163-133-00	CERAMIC CHIP	470PF 5.00% 50V
C8317	1-164-004-11	CERAMIC CHIP	0.1UF 10.00% 25V
C8318	1-164-346-11	CERAMIC CHIP	1UF 16V
C8319	1-164-346-11	CERAMIC CHIP	1UF 16V
C8320	1-117-720-11	CERAMIC CHIP	4.7UF 10V
C8321	1-117-720-11	CERAMIC CHIP	4.7UF 10V

J

REF NO.	PART NO.	DESCRIPTION	REMARK	REF NO.	PART NO.	DESCRIPTION	REMARK
C8322	1-164-346-11	CERAMIC CHIP	1UF 16V	C8410	1-164-004-11	CERAMIC CHIP	0.1UF 10.00% 25V
C8323	1-164-346-11	CERAMIC CHIP	1UF 16V	C8411	1-117-720-11	CERAMIC CHIP	4.7UF 10V
C8324	1-117-720-11	CERAMIC CHIP	4.7UF 10V	C8412	1-164-004-11	CERAMIC CHIP	0.1UF 10.00% 25V
C8325	1-126-935-11	ELECT	470UF 20.00% 16V	C8413	1-117-720-11	CERAMIC CHIP	4.7UF 10V
C8326	1-107-823-11	CERAMIC CHIP	0.47UF 10.00% 16V	C8414	1-126-947-11	ELECT	47UF 20.00% 16V
C8327	1-164-346-11	CERAMIC CHIP	1UF 16V	C8415	1-164-346-11	CERAMIC CHIP	1UF 16V
C8328	1-164-346-11	CERAMIC CHIP	1UF 16V	C8416	1-164-004-11	CERAMIC CHIP	0.1UF 10.00% 25V
C8329	1-163-249-11	CERAMIC CHIP	82PF 5.00% 50V	C8417	1-163-227-11	CERAMIC CHIP	10PF 0.50PF 50V
C8330	1-164-346-11	CERAMIC CHIP	1UF 16V	C8418	1-126-964-11	ELECT	10UF 20.00% 50V
C8331	1-164-346-11	CERAMIC CHIP	1UF 16V	C8419	1-164-004-11	CERAMIC CHIP	0.1UF 10.00% 25V
C8333	1-115-340-11	CERAMIC CHIP	0.22UF 10.00% 25V	C8424	1-163-021-91	CERAMIC CHIP	0.01UF 10.00% 50V
C8334	1-126-947-11	ELECT	47UF 20.00% 16V	C8425	1-163-021-91	CERAMIC CHIP	0.01UF 10.00% 50V
C8335	1-164-004-11	CERAMIC CHIP	0.1UF 10.00% 25V	C8430	1-117-720-11	CERAMIC CHIP	4.7UF 10V
C8336	1-126-947-11	ELECT	47UF 20.00% 16V	C8437	1-126-963-11	ELECT	4.7UF 20.00% 50V
C8337	1-164-004-11	CERAMIC CHIP	0.1UF 10.00% 25V	C8438	1-164-004-11	CERAMIC CHIP	0.1UF 10.00% 25V
C8338	1-164-346-11	CERAMIC CHIP	1UF 16V	C8439	1-164-004-11	CERAMIC CHIP	0.1UF 10.00% 25V
C8339	1-164-346-11	CERAMIC CHIP	1UF 16V	C8440	1-164-004-11	CERAMIC CHIP	0.1UF 10.00% 25V
C8340	1-107-823-11	CERAMIC CHIP	0.47UF 10.00% 16V	C8441	1-164-346-11	CERAMIC CHIP	1UF 16V
C8341	1-107-823-11	CERAMIC CHIP	0.47UF 10.00% 16V	C8442	1-117-720-11	CERAMIC CHIP	4.7UF 10V
C8342	1-126-964-11	ELECT	10UF 20.00% 50V	C8443	1-117-720-11	CERAMIC CHIP	4.7UF 10V
C8343	1-126-947-11	ELECT	47UF 20.00% 16V	C8444	1-117-720-11	CERAMIC CHIP	4.7UF 10V
C8346	1-164-004-11	CERAMIC CHIP	0.1UF 10.00% 25V	C8445	1-164-346-11	CERAMIC CHIP	1UF 16V
C8349	1-117-720-11	CERAMIC CHIP	4.7UF 10V	C8446	1-126-947-11	ELECT	47UF 20.00% 16V
C8352	1-107-823-11	CERAMIC CHIP	0.47UF 10.00% 16V	C8447	1-164-004-11	CERAMIC CHIP	0.1UF 10.00% 25V
C8353	1-115-340-11	CERAMIC CHIP	0.22UF 10.00% 25V	C8448	1-164-690-91	CERAMIC CHIP	0.0022UF 5.00% 50V
C8354	1-107-823-11	CERAMIC CHIP	0.47UF 10.00% 16V	C8450	1-107-823-11	CERAMIC CHIP	0.47UF 10.00% 16V
C8355	1-163-021-91	CERAMIC CHIP	0.01UF 10.00% 50V	C8451	1-164-505-11	CERAMIC CHIP	2.2UF 16V
C8356	1-164-346-11	CERAMIC CHIP	1UF 16V	C8452	1-164-004-11	CERAMIC CHIP	0.1UF 10.00% 25V
C8359	1-163-037-11	CERAMIC CHIP	0.022UF 10.00% 50V	C8453	1-164-004-11	CERAMIC CHIP	0.1UF 10.00% 25V
C8360	1-163-021-91	CERAMIC CHIP	0.01UF 10.00% 50V	C8454	1-164-004-11	CERAMIC CHIP	0.1UF 10.00% 25V
C8361	1-126-961-11	ELECT	2.2UF 20.00% 50V	C8455	1-126-947-11	ELECT	47UF 20.00% 16V
C8362	1-164-004-11	CERAMIC CHIP	0.1UF 10.00% 25V	C8456	1-126-947-11	ELECT	47UF 20.00% 16V
C8363	1-164-004-11	CERAMIC CHIP	0.1UF 10.00% 25V	C8457	1-126-947-11	ELECT	47UF 20.00% 16V
C8364	1-126-947-11	ELECT	47UF 20.00% 16V	C8459	1-164-004-11	CERAMIC CHIP	0.1UF 10.00% 25V
C8365	1-126-947-11	ELECT	47UF 20.00% 16V	C8464	1-126-947-11	ELECT	47UF 20.00% 16V
C8366	1-163-021-91	CERAMIC CHIP	0.01UF 10.00% 50V	C8465	1-164-004-11	CERAMIC CHIP	0.1UF 10.00% 25V
C8367	1-126-947-11	ELECT	47UF 20.00% 16V	C8466	1-247-807-31	CARBON	100 5% 1/4W
C8368	1-126-947-11	ELECT	47UF 20.00% 16V	C8468	1-164-004-11	CERAMIC CHIP	0.1UF 10.00% 25V
C8369	1-126-947-11	ELECT	47UF 20.00% 16V	C8469	1-247-807-31	CARBON	100 5% 1/4W
C8370	1-164-004-11	CERAMIC CHIP	0.1UF 10.00% 25V	C8471	1-164-004-11	CERAMIC CHIP	0.1UF 10.00% 25V
C8371	1-164-004-11	CERAMIC CHIP	0.1UF 10.00% 25V	C8474	1-164-004-11	CERAMIC CHIP	0.1UF 10.00% 25V
C8372	1-164-004-11	CERAMIC CHIP	0.1UF 10.00% 25V				
C8373	1-163-227-11	CERAMIC CHIP	10PF 0.50PF 50V			<CONNECTOR>	
C8374	1-164-346-11	CERAMIC CHIP	1UF 16V	CN8301 *	1-564-524-11	PLUG, CONNECTOR 9P	
C8375	1-126-964-11	ELECT	10UF 20.00% 50V	CN8302	1-695-915-11	TAB (CONTACT)	
C8376	1-164-004-11	CERAMIC CHIP	0.1UF 10.00% 25V	CN8304	1-793-498-11	CONNECTOR, BOARD TO BOARD 50P	
C8381	1-163-021-91	CERAMIC CHIP	0.01UF 10.00% 50V			<DIODE>	
C8382	1-164-004-11	CERAMIC CHIP	0.1UF 10.00% 25V	D8101	8-719-404-50	MA111-TX	
C8386	1-163-021-91	CERAMIC CHIP	0.01UF 10.00% 50V	D8102	1-216-295-91	SHORT	0
C8390	1-126-963-11	ELECT	4.7UF 20.00% 50V	D8301	8-719-158-35	RD9.1S-B	
C8391	1-164-004-11	CERAMIC CHIP	0.1UF 10.00% 25V	D8302	8-719-158-35	RD9.1S-B	
C8392	1-164-004-11	CERAMIC CHIP	0.1UF 10.00% 25V	D8303	8-719-158-35	RD9.1S-B	
C8393	1-164-004-11	CERAMIC CHIP	0.1UF 10.00% 25V	D8304	8-719-158-35	RD9.1S-B	
C8396	1-107-823-11	CERAMIC CHIP	0.47UF 10.00% 16V	D8305	8-719-158-35	RD9.1S-B	
C8399	1-126-961-11	ELECT	2.2UF 20.00% 50V	D8306	8-719-158-35	RD9.1S-B	
C8401	1-163-021-91	CERAMIC CHIP	0.01UF 10.00% 50V	D8307	8-719-158-35	RD9.1S-B	
C8402	1-164-346-11	CERAMIC CHIP	1UF 16V	D8308	8-719-158-35	RD9.1S-B	
C8403	1-163-037-11	CERAMIC CHIP	0.022UF 10.00% 50V				
C8406	1-126-947-11	ELECT	47UF 20.00% 16V				
C8407	1-126-947-11	ELECT	47UF 20.00% 16V				
C8408	1-163-021-91	CERAMIC CHIP	0.01UF 10.00% 50V				

J

REF NO.	PART NO.	DESCRIPTION	REMARK	REF NO.	PART NO.	DESCRIPTION	REMARK
D8309	8-719-158-35	RD9.1S-B				<CHIP CONDUCTOR>	
D8310	8-719-158-35	RD9.1S-B					
D8311	8-719-158-35	RD9.1S-B		JR8301	1-216-295-91	SHORT	0
D8312	8-719-158-35	RD9.1S-B		JR8302	1-216-295-91	SHORT	0
D8313	8-719-158-35	RD9.1S-B				<TRANSISTOR>	
D8314	8-719-158-35	RD9.1S-B					
D8315	8-719-067-40	STZ6.8N-T146		Q8301	8-729-026-49	2SA1037AK-T146-R	
D8316	8-719-067-40	STZ6.8N-T146		Q8302	8-729-230-49	2SC2712-YG	
D8317	8-719-067-40	STZ6.8N-T146		Q8303	8-729-230-49	2SC2712-YG	
D8318	8-719-158-35	RD9.1S-B		Q8304	8-729-230-49	2SC2712-YG	
				Q8305	8-729-026-49	2SA1037AK-T146-R	
D8319	8-719-158-35	RD9.1S-B					
D8320	8-719-158-35	RD9.1S-B		Q8306	8-729-230-49	2SC2712-YG	
D8321	8-719-158-35	RD9.1S-B		Q8307	8-729-230-49	2SC2712-YG	
D8322	8-719-158-35	RD9.1S-B		Q8308	8-729-230-49	2SC2712-YG	
D8323	8-719-158-35	RD9.1S-B		Q8309	8-729-230-49	2SC2712-YG	
				Q8310	8-729-230-49	2SC2712-YG	
D8324	8-719-158-35	RD9.1S-B					
D8325	8-719-158-35	RD9.1S-B		Q8312	8-729-230-49	2SC2712-YG	
D8331	8-719-041-97	MA113-(TX)		Q8319	8-729-026-49	2SA1037AK-T146-R	
		<FERRITE BEAD>		Q8320	8-729-026-49	2SA1037AK-T146-R	
FB8101	1-216-295-91	SHORT	0	Q8321	8-729-026-49	2SA1037AK-T146-R	
FB8101	1-414-598-11	FERRITE	0UH	Q8322	8-729-026-49	2SA1037AK-T146-R	
		<FILTER>		Q8323	8-729-026-49	2SA1037AK-T146-R	
FL8301	1-236-071-11	ENCAPSULATED COMPONENT		Q8324	8-729-026-49	2SA1037AK-T146-R	
FL8303	1-236-071-11	ENCAPSULATED COMPONENT		Q8326	8-729-230-49	2SC2712-YG	
FL8304	1-236-071-11	ENCAPSULATED COMPONENT		Q8327	1-801-806-11	TR DTC144EKA	
FL8305	1-236-071-11	ENCAPSULATED COMPONENT		Q8328	1-801-806-11	TR DTC144EKA	
FL8307	1-236-071-11	ENCAPSULATED COMPONENT					
FL8308	1-236-071-11	ENCAPSULATED COMPONENT		Q8329	8-729-230-49	2SC2712-YG	
FL8309	1-236-071-11	ENCAPSULATED COMPONENT		Q8330	8-729-230-49	2SC2712-YG	
FL8311	1-236-071-11	ENCAPSULATED COMPONENT		Q8331	8-729-230-49	2SC2712-YG	
FL8312	1-236-071-11	ENCAPSULATED COMPONENT		Q8332	8-729-230-49	2SC2712-YG	
FL8313	1-236-071-11	ENCAPSULATED COMPONENT		Q8333	8-729-230-49	2SC2712-YG	
FL8314	1-233-877-11	FILTER, LOW PASS		Q8334	8-729-230-49	2SC2712-YG	
FL8315	1-233-504-21	FILTER, LOW PASS		Q8335	8-729-230-49	2SC2712-YG	
FL8316	1-233-504-21	FILTER, LOW PASS		Q8336	8-729-230-49	2SC2712-YG	
		<IC>		Q8345	8-729-230-49	2SC2712-YG	
IC8302	8-752-080-04	CXA2069Q		Q8346	8-729-026-49	2SA1037AK-T146-R	
IC8304	8-759-576-72	LF50CDT-TR					
IC8305	8-759-576-74	LF90CDT-TR		Q8347	8-729-230-49	2SC2712-YG	
IC8306	8-752-094-47	CXA2123AQ-T6		Q8348	8-729-026-49	2SA1037AK-T146-R	
IC8308	8-752-094-47	CXA2123AQ-T6		Q8349	8-729-230-49	2SC2712-YG	
IC8309	8-759-337-26	MM1115XFBE		Q8350	8-729-026-49	2SA1037AK-T146-R	
IC8310	8-759-572-04	TDA9178T/N1.118		Q8351	8-729-230-49	2SC2712-YG	
IC8311	8-759-485-79	TC7SET08FU(TE85L)					
IC8312	8-759-485-79	TC7SET08FU(TE85L)		Q8352	8-729-026-49	2SA1037AK-T146-R	
		<JACK>		Q8353	8-729-026-49	2SA1037AK-T146-R	
J8106	1-793-787-11	JACK BLOCK, PIN 1P		Q8354	8-729-026-49	2SA1037AK-T146-R	
J8301	1-774-748-11	TERMINAL BLOCK, S		Q8355	8-729-026-49	2SA1037AK-T146-R	
J8302	1-774-746-11	JACK BLOCK, PIN		Q8361	8-729-230-49	2SC2712-YG	
J8303	1-774-746-11	JACK BLOCK, PIN					
J8304	1-774-746-11	JACK BLOCK, PIN		Q8362	8-729-230-49	2SC2712-YG	
J8305	1-695-444-11	PIN JACK BLOCK 3P		Q8363	8-729-230-49	2SC2712-YG	
J8307	1-565-838-11	JACK BLOCK, PIN 2P		Q8364	8-729-026-49	2SA1037AK-T146-R	
				Q8464	8-729-230-49	2SC2712-YG	
				Q8465	8-729-230-49	2SC2712-YG	
				Q8466	8-729-230-49	2SC2712-YG	
						<RESISTOR>	
				R8101	1-216-022-00	RES-CHIP	75 5% 1/10W
				R8208	1-216-295-91	SHORT	0
				R8209	1-216-295-91	SHORT	0
				R8301	1-216-041-00	RES-CHIP	470 5% 1/10W
				R8302	1-216-041-00	RES-CHIP	470 5% 1/10W



REF NO.	PART NO.	DESCRIPTION	REMARK	REF NO.	PART NO.	DESCRIPTION	REMARK
R8303	1-216-021-00	RES-CHIP	68 5% 1/10W	R8369	1-216-041-00	RES-CHIP	470 5% 1/10W
R8304	1-216-057-00	RES-CHIP	2.2K 5% 1/10W	R8370	1-216-025-11	RES-CHIP	100 5% 1/10W
R8305	1-216-113-00	RES-CHIP	470K 5% 1/10W	R8372	1-216-295-91	SHORT	0
R8306	1-216-022-00	RES-CHIP	75 5% 1/10W	R8373	1-216-295-91	SHORT	0
R8307	1-216-022-00	RES-CHIP	75 5% 1/10W	R8374	1-216-039-00	RES-CHIP	390 5% 1/10W
R8308	1-216-105-91	RES-CHIP	220K 5% 1/10W	R8375	1-216-041-00	RES-CHIP	470 5% 1/10W
R8309	1-216-105-91	RES-CHIP	220K 5% 1/10W	R8376	1-216-049-11	RES-CHIP	1K 5% 1/10W
R8310	1-216-022-00	RES-CHIP	75 5% 1/10W	R8377	1-216-025-11	RES-CHIP	100 5% 1/10W
R8311	1-216-105-91	RES-CHIP	220K 5% 1/10W	R8378	1-216-033-00	RES-CHIP	220 5% 1/10W
R8312	1-216-105-91	RES-CHIP	220K 5% 1/10W	R8379	1-216-033-00	RES-CHIP	220 5% 1/10W
R8313	1-216-022-00	RES-CHIP	75 5% 1/10W	R8380	1-216-025-11	RES-CHIP	100 5% 1/10W
R8314	1-216-105-91	RES-CHIP	220K 5% 1/10W	R8381	1-216-025-11	RES-CHIP	100 5% 1/10W
R8315	1-216-105-91	RES-CHIP	220K 5% 1/10W	R8382	1-216-033-00	RES-CHIP	220 5% 1/10W
R8316	1-216-113-00	RES-CHIP	470K 5% 1/10W	R8383	1-216-033-00	RES-CHIP	220 5% 1/10W
R8317	1-216-022-00	RES-CHIP	75 5% 1/10W	R8384	1-216-025-11	RES-CHIP	100 5% 1/10W
R8318	1-216-022-00	RES-CHIP	75 5% 1/10W	R8385	1-216-025-11	RES-CHIP	100 5% 1/10W
R8319	1-216-022-00	RES-CHIP	75 5% 1/10W	R8386	1-216-025-11	RES-CHIP	100 5% 1/10W
R8320	1-216-105-91	RES-CHIP	220K 5% 1/10W	R8388	1-216-031-00	RES-CHIP	180 5% 1/10W
R8321	1-216-105-91	RES-CHIP	220K 5% 1/10W	R8389	1-216-033-00	RES-CHIP	220 5% 1/10W
R8322	1-216-022-00	RES-CHIP	75 5% 1/10W	R8395	1-216-033-00	RES-CHIP	220 5% 1/10W
R8323	1-216-295-91	SHORT	0	R8396	1-216-033-00	RES-CHIP	220 5% 1/10W
R8324	1-216-295-91	SHORT	0	R8399	1-216-025-11	RES-CHIP	100 5% 1/10W
R8325	1-216-295-91	SHORT	0	R8400	1-216-025-11	RES-CHIP	100 5% 1/10W
R8326	1-216-113-00	RES-CHIP	470K 5% 1/10W	R8405	1-216-033-00	RES-CHIP	220 5% 1/10W
R8327	1-216-295-91	SHORT	0	R8406	1-216-033-00	RES-CHIP	220 5% 1/10W
R8328	1-216-113-00	RES-CHIP	470K 5% 1/10W	R8407	1-216-033-00	RES-CHIP	220 5% 1/10W
R8329	1-216-113-00	RES-CHIP	470K 5% 1/10W	R8408	1-216-033-00	RES-CHIP	220 5% 1/10W
R8330	1-216-022-00	RES-CHIP	75 5% 1/10W	R8409	1-216-295-91	SHORT	0
R8331	1-216-295-91	SHORT	0	R8410	1-216-295-91	SHORT	0
R8332	1-216-295-91	SHORT	0	R8411	1-216-083-00	RES-CHIP	27K 5% 1/10W
R8333	1-216-295-91	SHORT	0	R8414	1-208-796-11	METAL CHIP	3.9K 0.5% 1/10W
R8334	1-216-295-91	SHORT	0	R8415	1-216-049-11	RES-CHIP	1K 5% 1/10W
R8335	1-216-065-91	RES-CHIP	4.7K 5% 1/10W	R8417	1-216-025-11	RES-CHIP	100 5% 1/10W
R8336	1-216-065-91	RES-CHIP	4.7K 5% 1/10W	R8418	1-216-025-11	RES-CHIP	100 5% 1/10W
R8337	1-216-022-00	RES-CHIP	75 5% 1/10W	R8419	1-216-017-91	RES-CHIP	47 5% 1/10W
R8338	1-216-065-91	RES-CHIP	4.7K 5% 1/10W	R8420	1-216-017-91	RES-CHIP	47 5% 1/10W
R8339	1-216-065-91	RES-CHIP	4.7K 5% 1/10W	R8421	1-216-295-91	SHORT	0
R8340	1-216-065-91	RES-CHIP	4.7K 5% 1/10W	R8422	1-216-295-91	SHORT	0
R8341	1-216-065-91	RES-CHIP	4.7K 5% 1/10W	R8424	1-216-083-00	RES-CHIP	27K 5% 1/10W
R8342	1-216-065-91	RES-CHIP	4.7K 5% 1/10W	R8425	1-216-089-91	RES-CHIP	47K 5% 1/10W
R8343	1-216-065-91	RES-CHIP	4.7K 5% 1/10W	R8426	1-208-796-11	METAL CHIP	3.9K 0.5% 1/10W
R8344	1-216-022-00	RES-CHIP	75 5% 1/10W	R8428	1-216-295-91	SHORT	0
R8345	1-216-033-00	RES-CHIP	220 5% 1/10W	R8429	1-216-295-91	SHORT	0
R8346	1-216-031-00	RES-CHIP	180 5% 1/10W	R8430	1-216-295-91	SHORT	0
R8347	1-216-025-11	RES-CHIP	100 5% 1/10W	R8431	1-216-049-11	RES-CHIP	1K 5% 1/10W
R8348	1-216-057-00	RES-CHIP	2.2K 5% 1/10W	R8432	1-216-049-11	RES-CHIP	1K 5% 1/10W
R8349	1-216-049-11	RES-CHIP	1K 5% 1/10W	R8433	1-216-049-11	RES-CHIP	1K 5% 1/10W
R8350	1-216-049-11	RES-CHIP	1K 5% 1/10W	R8434	1-216-049-11	RES-CHIP	1K 5% 1/10W
R8351	1-216-065-91	RES-CHIP	4.7K 5% 1/10W	R8435	1-216-295-91	SHORT	0
R8352	1-216-065-91	RES-CHIP	4.7K 5% 1/10W	R8436	1-216-017-91	RES-CHIP	47 5% 1/10W
R8353	1-216-017-91	RES-CHIP	47 5% 1/10W	R8440	1-216-295-91	SHORT	0
R8355	1-216-295-91	SHORT	0	R8441	1-216-049-11	RES-CHIP	1K 5% 1/10W
R8356	1-216-295-91	SHORT	0	R8442	1-216-049-11	RES-CHIP	1K 5% 1/10W
R8357	1-216-017-91	RES-CHIP	47 5% 1/10W	R8443	1-216-025-11	RES-CHIP	100 5% 1/10W
R8358	1-216-017-91	RES-CHIP	47 5% 1/10W	R8444	1-216-025-11	RES-CHIP	100 5% 1/10W
R8361	1-216-017-91	RES-CHIP	47 5% 1/10W	R8445	1-216-017-91	RES-CHIP	47 5% 1/10W
R8363	1-216-642-11	METAL CHIP	430 0.5% 1/10W	R8446	1-216-049-11	RES-CHIP	1K 5% 1/10W
R8364	1-216-041-00	RES-CHIP	470 5% 1/10W	R8447	1-216-025-11	RES-CHIP	100 5% 1/10W
R8365	1-216-049-11	RES-CHIP	1K 5% 1/10W	R8448	1-216-025-11	RES-CHIP	100 5% 1/10W
R8366	1-216-049-11	RES-CHIP	1K 5% 1/10W	R8449	1-216-025-11	RES-CHIP	100 5% 1/10W
R8367	1-216-041-00	RES-CHIP	470 5% 1/10W	R8450	1-216-089-91	RES-CHIP	47K 5% 1/10W



REF NO.	PART NO.	DESCRIPTION	REMARK
R8451	1-216-097-11	RES-CHIP	100K 5% 1/10W
R8452	1-216-089-91	RES-CHIP	47K 5% 1/10W
R8453	1-216-097-11	RES-CHIP	100K 5% 1/10W
R8454	1-216-089-91	RES-CHIP	47K 5% 1/10W
R8455	1-216-097-11	RES-CHIP	100K 5% 1/10W
R8456	1-216-049-11	RES-CHIP	1K 5% 1/10W
R8457	1-216-049-11	RES-CHIP	1K 5% 1/10W
R8458	1-216-049-11	RES-CHIP	1K 5% 1/10W
R8459	1-216-025-11	RES-CHIP	100 5% 1/10W
R8460	1-216-025-11	RES-CHIP	100 5% 1/10W
R8461	1-216-025-11	RES-CHIP	100 5% 1/10W
R8462	1-216-089-91	RES-CHIP	47K 5% 1/10W
R8463	1-216-097-11	RES-CHIP	100K 5% 1/10W
R8464	1-216-025-11	RES-CHIP	100 5% 1/10W
R8465	1-216-025-11	RES-CHIP	100 5% 1/10W
R8466	1-216-025-11	RES-CHIP	100 5% 1/10W
R8467	1-216-041-00	RES-CHIP	470 5% 1/10W
R8468	1-216-041-00	RES-CHIP	470 5% 1/10W
R8469	1-216-041-00	RES-CHIP	470 5% 1/10W
R8470	1-216-069-00	RES-CHIP	6.8K 5% 1/10W
R8471	1-216-025-11	RES-CHIP	100 5% 1/10W
R8472	1-216-089-91	RES-CHIP	47K 5% 1/10W
R8473	1-216-025-11	RES-CHIP	100 5% 1/10W
R8474	1-216-097-11	RES-CHIP	100K 5% 1/10W
R8475	1-216-089-91	RES-CHIP	47K 5% 1/10W
R8478	1-216-089-91	RES-CHIP	47K 5% 1/10W
R8479	1-216-097-11	RES-CHIP	100K 5% 1/10W
R8480	1-216-073-91	RES-CHIP	10K 5% 1/10W
R8481	1-216-095-00	RES-CHIP	82K 5% 1/10W
R8482	1-216-089-91	RES-CHIP	47K 5% 1/10W
R8484	1-216-045-00	RES-CHIP	680 5% 1/10W
R8485	1-216-037-00	RES-CHIP	330 5% 1/10W
R8486	1-216-049-11	RES-CHIP	1K 5% 1/10W
R8487	1-216-045-00	RES-CHIP	680 5% 1/10W
R8488	1-216-041-00	RES-CHIP	470 5% 1/10W
R8489	1-216-049-11	RES-CHIP	1K 5% 1/10W
R8490	1-216-049-11	RES-CHIP	1K 5% 1/10W
R8491	1-216-025-11	RES-CHIP	100 5% 1/10W
R8492	1-208-774-11	METAL CHIP	470 0.5% 1/10W
R8493	1-216-081-00	RES-CHIP	22K 5% 1/10W
R8494	1-208-774-11	METAL CHIP	470 0.5% 1/10W
R8495	1-216-081-00	RES-CHIP	22K 5% 1/10W
R8496	1-216-049-11	RES-CHIP	1K 5% 1/10W
R8497	1-216-025-11	RES-CHIP	100 5% 1/10W
R8498	1-208-776-11	METAL CHIP	560 0.5% 1/10W
R8499	1-216-081-00	RES-CHIP	22K 5% 1/10W
R8500	1-216-635-11	METAL CHIP	220 0.5% 1/10W
R8501	1-216-081-00	RES-CHIP	22K 5% 1/10W
R8502	1-216-049-11	RES-CHIP	1K 5% 1/10W
R8503	1-216-097-11	RES-CHIP	100K 5% 1/10W
R8504	1-216-295-91	SHORT	0
R8507	1-216-025-11	RES-CHIP	100 5% 1/10W
R8508	1-216-025-11	RES-CHIP	100 5% 1/10W
R8511	1-216-041-00	RES-CHIP	470 5% 1/10W
R8512	1-216-017-91	RES-CHIP	47 5% 1/10W
R8522	1-216-041-00	RES-CHIP	470 5% 1/10W
R8524	1-216-041-00	RES-CHIP	470 5% 1/10W
R8525	1-216-033-00	RES-CHIP	220 5% 1/10W
R8528	1-216-025-11	RES-CHIP	100 5% 1/10W
R8530	1-216-041-00	RES-CHIP	470 5% 1/10W
R8532	1-216-041-00	RES-CHIP	470 5% 1/10W
R8533	1-216-041-00	RES-CHIP	470 5% 1/10W

REF NO.	PART NO.	DESCRIPTION	REMARK
R8536	1-216-025-11	RES-CHIP	100 5% 1/10W
R8538	1-216-041-00	RES-CHIP	470 5% 1/10W
R8540	1-216-041-00	RES-CHIP	470 5% 1/10W
R8541	1-216-039-00	RES-CHIP	390 5% 1/10W
R8544	1-216-041-00	RES-CHIP	470 5% 1/10W
R8547	1-216-295-91	SHORT	0
R8548	1-216-033-00	RES-CHIP	220 5% 1/10W
R8556	1-216-025-11	RES-CHIP	100 5% 1/10W
R8557	1-216-049-11	RES-CHIP	1K 5% 1/10W
R8558	1-208-776-11	METAL CHIP	560 0.5% 1/10W
R8560	1-216-025-11	RES-CHIP	100 5% 1/10W
R8561	1-216-049-11	RES-CHIP	1K 5% 1/10W
R8562	1-208-776-11	METAL CHIP	560 0.5% 1/10W
R8564	1-216-025-11	RES-CHIP	100 5% 1/10W
R8565	1-216-049-11	RES-CHIP	1K 5% 1/10W
R8566	1-208-776-11	METAL CHIP	560 0.5% 1/10W
R8567	1-216-017-91	RES-CHIP	47 5% 1/10W
R8569	1-208-800-11	METAL CHIP	5.6K 0.5% 1/10W
R8570	1-216-017-91	RES-CHIP	47 5% 1/10W
R8572	1-208-800-11	METAL CHIP	5.6K 0.5% 1/10W
R8573	1-216-017-91	RES-CHIP	47 5% 1/10W
R8575	1-208-800-11	METAL CHIP	5.6K 0.5% 1/10W
R8576	1-216-013-00	RES-CHIP	33 5% 1/10W
R8577	1-216-295-91	SHORT	0
R8578	1-216-635-11	METAL CHIP	220 0.5% 1/10W
R8579	1-216-295-91	SHORT	0
R8582	1-208-291-11	RES-CHIP	4.7M 5% 1/10W
R8584	1-208-291-11	RES-CHIP	4.7M 5% 1/10W
R8585	1-208-291-11	RES-CHIP	4.7M 5% 1/10W
R8586	1-208-291-11	RES-CHIP	4.7M 5% 1/10W
R8587	1-216-295-91	SHORT	0
R8588	1-216-041-00	RES-CHIP	470 5% 1/10W
R8589	1-216-041-00	RES-CHIP	470 5% 1/10W
R8590	1-216-041-00	RES-CHIP	470 5% 1/10W
R8599	1-247-903-00	CARBON	1M 5% 1/4W
<CRYSTAL>			
X8301	1-781-612-11	VIBRATOR, CRYSTAL	
X8302	1-781-612-11	VIBRATOR, CRYSTAL	

		* A-1391-163-A	SP BOARD MOUNTED

<CAPACITOR>			
C3251	1-136-177-00	FILM	1UF 5.00% 50V
C3252	1-126-411-21	ELECT	27UF 20.00% 50V
<CONNECTOR>			
CN3251	1-564-506-11	PLUG, CONNECTOR 3P	
CN3253	1-564-507-11	PLUG, CONNECTOR 4P	



REF NO.	PART NO.	DESCRIPTION	REMARK
	* A-1342-625-A	VM BOARD MOUNTED *****	
	4-382-854-11	SCREW (M3X10), P, SW (+)	
		<CAPACITOR>	
C5401	1-126-935-11	ELECT	470UF 20.00% 16V
C5402	1-137-194-81	FILM	0.47UF 5.00% 50V
C5403	1-126-935-11	ELECT	470UF 20.00% 6.3V
C5405	1-126-933-11	ELECT	100UF 20.00% 16V
C5406	1-126-935-11	ELECT	470UF 20.00% 6.3V
C5407	1-107-364-11	MYLAR	0.01UF 10.00% 200V
C5408	1-107-364-11	MYLAR	0.01UF 10.00% 200V
C5409	1-107-649-11	ELECT	2.2UF 20.00% 250V
C5410	1-130-471-00	MYLAR	0.001UF 5.00% 50V
C5411	1-130-471-00	MYLAR	0.001UF 5.00% 50V
C5412	1-126-935-11	ELECT	470UF 20.00% 16V
C5413	1-107-648-91	ELECT	100UF 20.00% 160V
C5415	1-104-999-11	MYLAR	0.1UF 10.00% 200V
C5418	1-107-638-11	ELECT	33UF 20.00% 160V
		<CONNECTOR>	
CN5401	* 1-770-723-11	CONNECTOR, BOARD TO BOARD 8P	
CN5402	1-764-334-11	PLUG, CONNECTOR 11P	
		<DIODE>	
D5400	8-719-911-19	ISS119-25	
D5401	8-719-510-02	D1NS4	
D5402	8-719-911-19	ISS119-25	
D5403	8-719-911-19	ISS119-25	
D5404	8-719-911-19	ISS119-25	
D5405	8-719-110-56	RD22ES-B1	
D5406	8-719-110-56	RD22ES-B1	
		<COIL>	
L5400	1-412-525-31	INDUCTOR	10UH
		<TRANSISTOR>	
Q5400	8-729-119-78	2SC2785-HFE	
Q5401	8-729-119-78	2SC2785-HFE	
Q5402	8-729-119-78	2SC2785-HFE	
Q5403	8-729-119-78	2SC2785-HFE	
Q5404	8-729-119-76	2SA1175-HFE	
Q5405	8-729-119-76	2SA1175-HFE	
Q5406	8-729-045-05	2SA2005	
Q5407	8-729-045-04	2SC5511	
		<RESISTOR>	
R5401	1-249-425-11	CARBON	4.7K 5% 1/4W
R5402	1-249-415-11	CARBON	680 5% 1/4W
R5403	1-247-739-11	CARBON	100 5% 1/2W
R5404	1-249-418-11	CARBON	1.2K 5% 1/4W
R5406	1-249-425-11	CARBON	4.7K 5% 1/4W
R5407	1-249-399-11	CARBON	33 5% 1/4W
R5408	1-247-807-31	CARBON	100 5% 1/4W

REF NO.	PART NO.	DESCRIPTION	REMARK
R5409	1-249-409-11	CARBON	220 5% 1/4W
R5410	1-249-401-11	CARBON	47 5% 1/4W
R5411	1-249-401-11	CARBON	47 5% 1/4W
R5412	1-249-429-11	CARBON	10K 5% 1/4W
R5413	1-249-414-11	CARBON	560 5% 1/4W
R5414	1-249-432-11	CARBON	18K 5% 1/4W
R5415	1-247-739-11	CARBON	100 5% 1/2W
R5416	1-249-385-11	CARBON	2.2 5% 1/4W
R5417	1-249-432-11	CARBON	18K 5% 1/4W
R5418	1-249-414-11	CARBON	560 5% 1/4W
R5419	1-249-421-11	CARBON	2.2K 5% 1/4W
R5420	1-249-421-11	CARBON	2.2K 5% 1/4W
R5421	1-249-385-11	CARBON	2.2 5% 1/4W
R5422	1-249-405-11	CARBON	100 5% 1/4W
R5423	1-215-915-11	METAL OXIDE	470 5% 3W
R5424	1-249-395-11	CARBON	15 5% 1/4W
R5425	1-249-401-11	CARBON	47 5% 1/4W
R5427	1-249-395-11	CARBON	15 5% 1/4W

ACCESSORIES AND PACKING MATERIALS

1-765-167-41	CABLE, COAXIAL (WITH (F) PLUG)
3-701-910-00	SCREW, SPECIAL (DIA. 3.8X20)
* 4-055-673-01	SHEET, PROTECTION
* 4-081-299-01	BAG, PROTECTION
* 4-084-494-01	CUSHION (UPPER)
* 4-084-495-01	CUSHION (LOWER)
4-084-931-01	INDIVIDUAL CARTON
* 4-396-077-01	JOINT
4-079-895-61	MANUAL, INSTRUCTION
4-392-003-01	BAND, HOLD
4-392-004-11	CLIP
4-084-491-02	TRAY

BATTERY COVER REMOTE COMMANDER

1-418-824-11	REMOTE COMMANDER (RM-958)
4-074-721-01	BATTERY COVER REMOTE COMMANDER

