

# SERVICE MANUAL

# BG-3R CHASSIS

<u>MODEL</u>	<u>COMMANDER</u>	<u>DEST.</u>	<u>CHASSIS NO.</u>	<u>MODEL</u>	<u>COMMANDER</u>	<u>DEST.</u>	<u>CHASSIS NO.</u>
<i>KV-XA21M8J</i>	<i>RM-952</i>	<i>ME</i>	<i>SCC-U48K-A</i>				
<i>KV-XA21MSJ</i>	<i>RM-952</i>	<i>ME</i>	<i>SCC-U48L-A</i>				

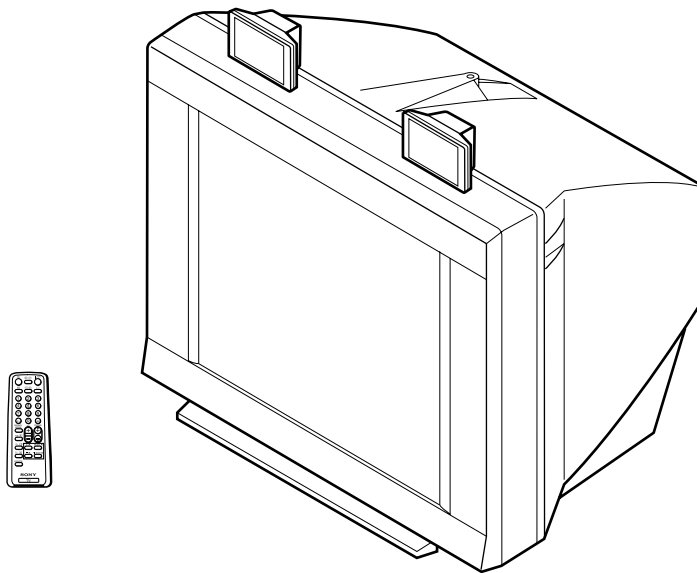

TRINITRON® COLOR TV  
**SONY®**

## SPECIFICATIONS

		Note
<b>Power requirements</b>	110-240 V AC, 50/60 Hz	
<b>Power consumption (W)</b>	Indicated on the rear of the TV	
<b>Television system</b>	B/G, I, D/K, M	
<b>Color system</b>	PAL, PAL 60, SECAM, NTSC4.43, NTSC3.58	
<b>Channel coverage</b>		
<b>B/G</b>	VHF: E2 to E12 / UHF: E21 to E69 / CATV: S01 to S03, S1 to S41	
<b>I</b>	UHF: B21 to B68 / CATV: S01 to S03, S1 to S41	
<b>D/K</b>	VHF: C1 to C12, R1 to R12 / UHF: C13 to C57, R21 to R60 CATV: S01 to S03, S1 to S41, Z1 to Z39	
<b>M</b>	VHF: A2 to A13 / UHF: A14 to A79 / CATV: A-8 to A-2, A to W+4, W+6 to W+84	
<b>⏏ (Antenna)</b>	75-ohm external terminal	
<b>Audio output</b>	5W + 5W	
<b>(Speaker)</b>	5W + 5W (TWEETER supplied)	KV-XA21MSJ only
<b>Number of terminal</b>		
📺 <b>(Video)</b>	Input: 2    Output: 1	Phono jacks; 1 V <sub>P-P</sub> , 75 ohms
🎵 <b>Audio</b>	Input: 2    Output: 1	Phono jacks; 500 mV <sub>rms</sub>
🎧 <b>(Headphone)</b>	Output: 1	Stereo minijack
<b>Picture tube</b>	21 inch	
<b>Tube size (cm)</b>	54	Measured diagonally
<b>Screen size (cm)</b>	51	Measured diagonally
<b>Dimension (w/h/d, mm)</b>	640 × 452 × 496	
<b>Mass (kg)</b>	26	

Design and specifications are subject to change without notice.

### CAUTION

SHORT CIRCUIT THE ANODE OF THE PICTURE TUBE AND THE ANODE CAP TO THE METAL CHASSIS, CRT SHIELD, OR CARBON PAINTED ON THE CRT, AFTER REMOVING THE ANODE.

### SAFETY-RELATED COMPONENT WARNING!!

COMPONENTS IDENTIFIED BY SHADING AND MARK  $\triangle$  ON THE SCHEMATIC DIAGRAMS, EXPLODED VIEWS AND IN THE PARTS LIST ARE CRITICAL TO SAFE OPERATION. REPLACE THESE COMPONENTS WITH SONY PARTS WHOSE PART NUMBERS APPEAR AS SHOWN IN THIS MANUAL OR IN SUPPLEMENTS PUBLISHED BY SONY.

## TABLE OF CONTENTS

<u>Section</u>	<u>Title</u>	<u>Page</u>	<u>Section</u>	<u>Title</u>	<u>Page</u>
	<b>SELF DIAGNOSIS FUNCTION</b> .....	4	<b>5. DIAGRAMS</b>		
<b>1. GENERAL</b> .....		7	5-1. Block Diagram .....		35
<b>2. DISASSEMBLY</b>			5-2. Circuit Boards Location .....		37
2-1. Rear Cover Removal .....		20	5-3. Schematic Diagrams .....		38
2-2. Speaker Removal .....		20	(1) Schematic Diagram of F, J2 and C1 Boards .....		39
2-3. Chassis Assy Removal .....		20	(2) Schematic Diagrams of A Board .....		41
2-4. F Bracket Removal .....		20	5-4. Voltage List Measurements .....		57
2-5. J2 Board and Terminal Bracket Removal .....		20	5-5. Waveforms .....		60
2-6. Service Position .....		21	5-6. Printed Wiring Boards and Parts Location .....		61
2-7. Replacement of Parts .....		21	5-7. Semiconductors .....		65
2-7-1. Replacement of Light Guide .....		21	<b>6. EXPLODED VIEWS</b>		
2-7-2. Replacement of Power Button .....		21	6-1. Picture Tube .....		67
2-8. Picture Tube Removal .....		21	6-2. Chassis .....		68
<b>3. SET-UP ADJUSTMENTS</b>			<b>7. ELECTRICAL PARTS LIST</b> .....		69
3-1. Beam Landing .....		23			
3-2. Convergence Adjustment .....		24			
3-3. Focus Adjustment .....		26			
3-4. G2 (Screen) and White Balance Adjustments .....		26			
<b>4. CIRCUIT ADJUSTMENT</b>					
4-1. Adjustments with Commander .....		27			
4-2. Adjustment Method .....		27			
4-3. Picture Quality Adjustments .....		32			
4-4. Deflection Adjustment .....		32			
4-5. A Board Adjustment After IC003 (memory) Replacement .....		32			
4-6. Picture Distortion Adjustment .....		33			

## SELF DIAGNOSTIC FUNCTION

The units in this manual contain a self-diagnostic function. If an error occurs, the STANDBY/TIMER lamp will automatically begin to flash.

The number of times the lamp flashes translates to a probable source of the problem. A definition of the STANDBY/TIMER lamp flash indicators is listed in the instruction manual for the user's knowledge and reference. If an error symptom cannot be reproduced, the remote commander can be used to review the failure occurrence data stored in memory to reveal past problems and how often these problems occur.

### 1. DIAGNOSTIC TEST INDICATORS

When an errors occurs, the STANDBY/TIMER lamp will flash a set number of times to indicate the possible cause of the problem. If there is more than one error, the lamp will identify the first of the problem areas.

Result for all of the following diagnostic items are displayed on screen. No error has occurred if the screen displays a "0".

Diagnostic Item Description	No. of times STANDBY/TIMER lamp flashes	Self-diagnostic display/Diagnostic result	Probable Cause Location	Detected Symptoms
• Power does not turn on	Does not light	—	<ul style="list-style-type: none"> <li>• Power cord is not plugged in.</li> <li>• Fuse is burned out F4601 (F)</li> </ul>	<ul style="list-style-type: none"> <li>• Power does not come on.</li> <li>• No power is supplied to the TV.</li> <li>• AC power supply is faulty.</li> </ul>
<ul style="list-style-type: none"> <li>• +B overcurrent (OCP) or overvoltage (OVP)</li> <li>• Vertical deflection stopped</li> <li>• Horizontal deflection overdrive</li> </ul>	2 times	002:000 or 002:001~255 003:001~255 004:001~255 at the same time	<ul style="list-style-type: none"> <li>• H.OUT Q511 is shorted. (A board)</li> <li>• IC700 is shorted (C1 board)</li> <li>• -13V is not supplied. (A board)</li> <li>• IC 503 faulty (A board)</li> </ul>	<ul style="list-style-type: none"> <li>• Power does not come on.</li> <li>• Load on power line is shorted.</li> <li>• Has entered standby state after horizontal raster.</li> <li>• Vertical deflection pulse is stopped.</li> <li>• Power line is shorted or power supply is stopped.</li> </ul>
• White balance failure (no PICTURE)	5 times	005:000 or 005:001~225	<ul style="list-style-type: none"> <li>• G2 is improperly adjusted. (Note 2)</li> <li>• CRT problem.</li> <li>• IC700 out is faulty (C1 board)</li> <li>• IC301 is faulty. (A board)</li> <li>• No connection A board to C1 board.</li> </ul>	<ul style="list-style-type: none"> <li>• No raster is generated.</li> <li>• CRT cathode current detection reference pulse output is small.</li> </ul>
• Micro reset	—	101:00 or 101:001~225	<ul style="list-style-type: none"> <li>• Discharge CRT (C1 Board)</li> <li>• Static discharge</li> <li>• External noise</li> </ul>	<ul style="list-style-type: none"> <li>• Power is shut down shortly, after this return back to normal.</li> <li>• Detect Micro latch up.</li> </ul>

Note 1: If a + B overcurrent is detected, stoppage of the vertical deflection is detected simultaneously.

The symptom that is diagnosed first by the microcontroller is displayed on the screen.

Note 2: Refer to screen (G2) Adjustment in section 3-4 of this manual.

\* IC700 out is faulty (C1 board).

## 2. DISPLAY OF STANDBY/TIMER LIGHT FLASH COUNT

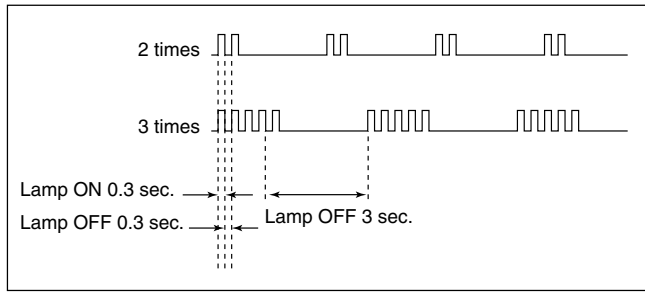

<u>Diagnostic Item</u>	<u>Flash Count*</u>
+B overcurrent/overvoltage	2 times
Vertical deflection stopped	2 times
White balance failure	5 times

\* One flash count is not used for self-diagnostic.

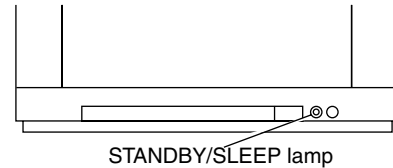

## 3. STOPPING THE STANDBY/TIMER FLASH

Turn off the power switch on the TV main unit or unplug the power cord from the outlet to stop the STANDBY/TIMER lamp from flashing.

## 4. SELF-DIAGNOSTIC SCREEN DISPLAY

For errors with symptoms such as "power sometimes shuts off" or "screen sometimes goes out" that cannot be confirmed, it is possible to bring up past occurrences of failure for confirmation on the screen:

### [To Bring Up Screen Test]

In standby mode, press buttons on the remote commander sequentially in rapid succession as shown below:

Screen display → channel [5] → Sound volume [ ] → Power ON  
↑

Note that this differs from entering the service mode (mode volume [ ]).

### Self-Diagnosis screen display

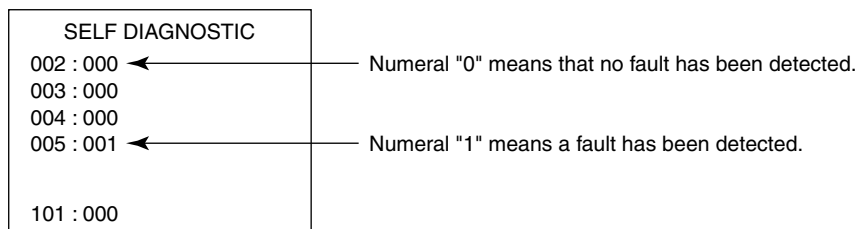

## 5. HANDLING OF SELF-DIAGNOSTIC SCREEN DISPLAY

Since the diagnostic results displayed on the screen are not automatically cleared, always check the self-diagnostic screen during repairs. When you have completed the repairs, clear the result display to "0".

Unless the result display is cleared to "0", the self-diagnostic function will not be able to detect subsequent faults after completion of the repairs.

### [Clearing the result display]

To clear the result display to "0", press buttons on the remote commander sequentially as shown below when the diagnostic screen is being displayed.

Channel **[8]** → 0

### [Quitting Self-diagnostic screen]

To quit the entire self-diagnostic screen, turn off the power switch on the remote commander or the main unit.

## 6. SELF-DIAGNOSTIC CIRCUIT

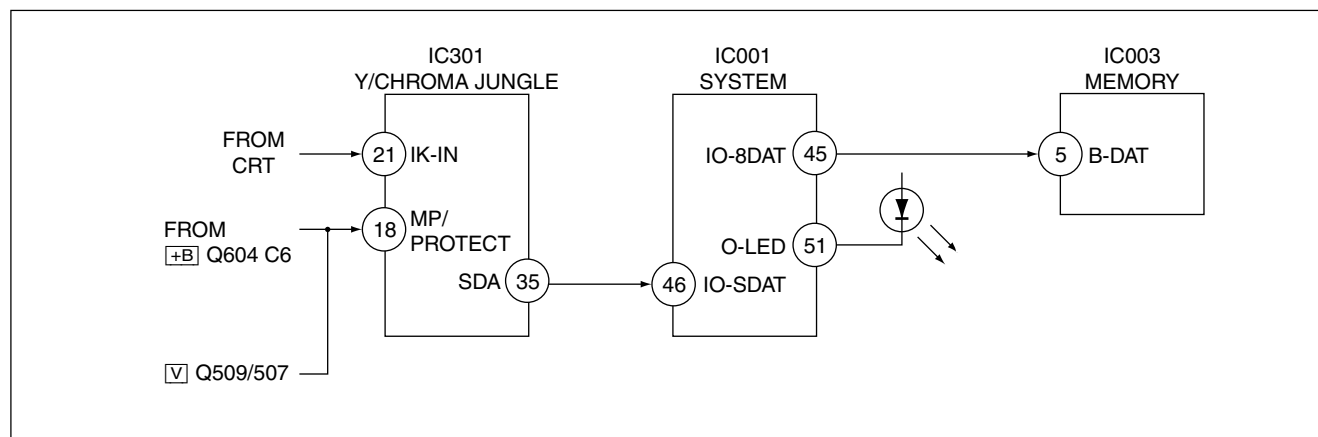

### **[+B overcurrent (OCP)]**

Occurs when an overcurrent on the +B(135) line is detected by Q604. If Q604 go to ON and the voltage to pin 18 of IC301 should go down when V.SYNC is more than seven verticals in a period, the unit will automatically turn off.

### **[Vertical deflection stopped]**

Occurs when an absence of the vertical deflection pulse is detected by Q509 and IC001 shut down the power supply.

### **[Vertical deflection overcurrent]**

Occurs when an overcurrent on V drive line is detected by Q507. Power supply will be shut down when detect this by IC001.

### **[White balance failure]**

If the RGB levels\* do not balance or become low level within 5 seconds, this error will be detected by IC301. TV will stay on, but there will be no picture.





\* (Refers to the RGB levels of the AKB detection Ref pulse that detects IK.)

The operating instruction mentioned here are partial abstracts from the Operating Instruction Manual. The page numbers of the Operating Instruction Manual remain as in the manual.

## SECTION 1 GENERAL

### WARNING

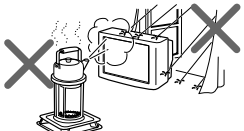
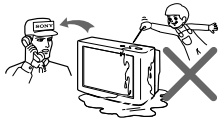
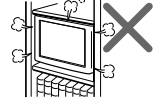
- Dangerously high voltages are present inside the TV.
- Operate the TV only between 110 – 240 V AC.

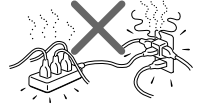
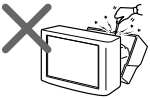
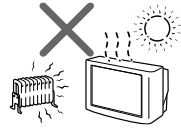
 <p>For your own safety, do not touch any part of the TV, the power cord and the antenna cable during lightning storms.</p>	 <p>For children's safety, do not leave children alone with the TV. Do not allow children to climb onto it.</p>
 <p>To prevent fire or shock hazard, do not expose the TV to rain or moisture.</p>	 <p>Do not operate the TV if any liquid or solid object falls into it. Have it checked immediately by qualified personnel only.</p>
 <p>Do not block the ventilation openings of the TV. Do not install the TV in a confined space, such as a bookcase or built-in cabinet.</p>	 <p>Clean the TV with a dry and soft cloth. Do not use benzine, thinner, or any other chemicals to clean the TV. Do not scratch the picture tube.</p>
 <p>Pull the power cord out by the plug. Do not pull the power cord itself. Disconnect the TV before moving it or if you are not going to use it for several days.</p>	 <p>Do not plug in too many appliances to the same power socket. Do not damage the power cord.</p>
 <p>Do not open the cabinet and the rear cover of the TV as high voltages and other hazards are present inside the TV. Refer servicing and disposal of the TV to qualified personnel.</p>	 <p>Your TV is recommended for home use only. Do not use the TV in any vehicle or where it may be subject to excessive dust, heat, moisture or vibrations.</p>

### WARNING (continued)

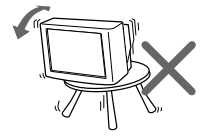
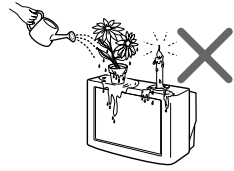
 <p>Do not install the TV in an unstable position. Use a proper TV stand.</p>	 <p>Do not place any objects on the TV.</p>
------------------------------------------------------------------------------------------------------------------------------------------------------------------	--------------------------------------------------------------------------------------------------------------------------------

# Using Your New TV

## Getting Started

### Step 1

#### Connect the antenna

If you wish to connect a VCR, see the Connecting a VCR diagram below.

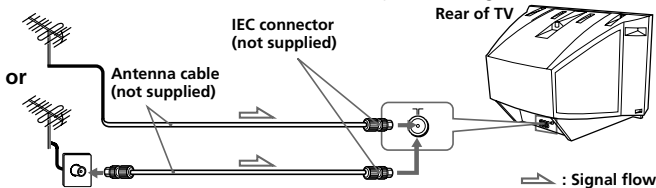

#### Connecting a VCR

To watch the video input, press  $\text{VCR}$  (see page 14).

Not used for this model

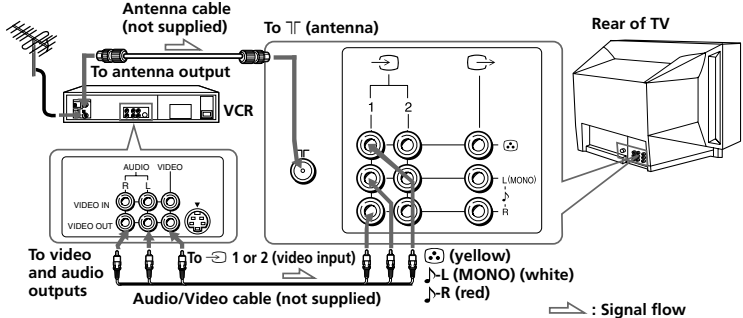

#### KV-XA21MSJ/XA21M8J

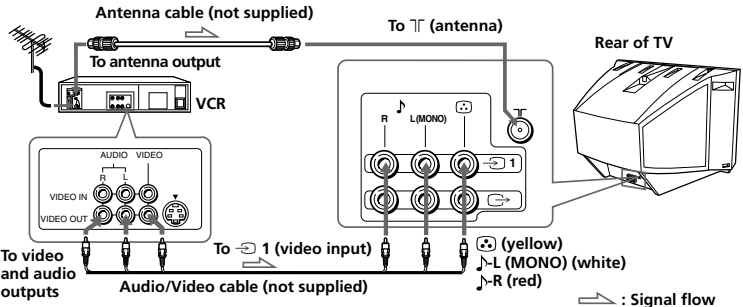

#### Notes

- If you connect a monaural VCR, connect the yellow plug to  $\text{L}$  (the yellow jack) and the black plug to  $\text{L (MONO)}$  (the white jack).
- If you connect a VCR to the  $\text{TV}$  (antenna) terminal, preset the signal output from the VCR to the program number 0 on the TV.
- When no signal is input from the connected video equipment, the TV screen becomes blue.

Not used for this model

- Do not connect video equipment to the  $\text{2}$  (video input) jacks at the front and the rear of your TV at the same time; otherwise the picture will not be displayed properly on the screen.

#### CAUTION

- Do not connect the power cord until you have completed making all other connections; otherwise a minimum leakage current might flow through the antenna and other terminals to ground.
- To avoid battery leakage and damage to the remote, remove the batteries from the remote if you are not going to use it for several days. If any liquid that leaks from the batteries touches you, immediately wash it away with water.

### Step 2

#### Insert the batteries into the remote

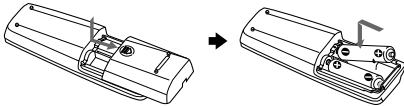

#### Note

- Do not use old batteries nor use different types of batteries together.

### Step 3

#### Preset the channels automatically

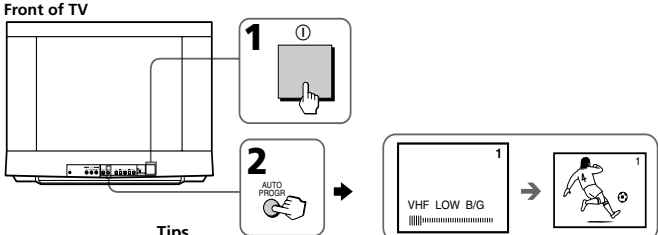

#### Tips

- If you want to stop automatic channel presetting, press SELECT twice.
- If your TV has preset an unwanted channel or cannot preset a particular channel, then preset your TV manually (see page 11).

#### Note

- During automatic channel presetting, your TV screen will indicate "B/G", "I", "D/K" or "M" for the TV system (TV SYS).



## Connecting the TWEETER

(KV-XA21MSJ only)

You can enjoy high quality sound by connecting the TWEETER.

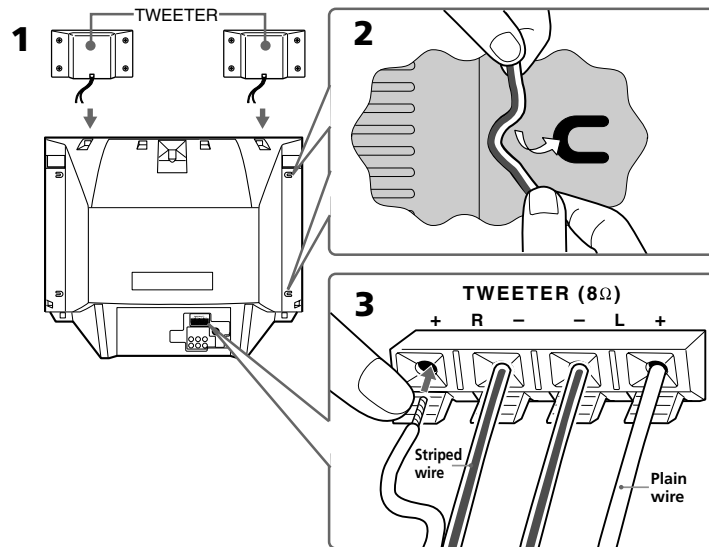

- 1** Place the TWEETER on top of your TV.
- 2** Bend the wire to hook it at the side of your TV.
- 3** Connect the wires to the TWEETER (8Ω) terminals at the rear of your TV. The plain wire should be connected to the ⊕ red terminal and the striped wire to the ⊖ black terminal.

### Notes

- Connect only the supplied TWEETER; otherwise your TV may malfunction.
- Unplug your TV from the wall outlet when connecting the TWEETER.
- To prevent a malfunction caused by a short circuit of the terminals, make sure that none of the TWEETER wire strands stick out, making contact with the neighbouring TWEETER terminal.

## Connecting optional components

You can connect optional audio/video components, such as a VCR, multi disc player, camcorder, video game or stereo system.

To watch the video input of the connected equipment, press (see page 14).

### Connecting a camcorder/video game equipment using the (video input) jacks

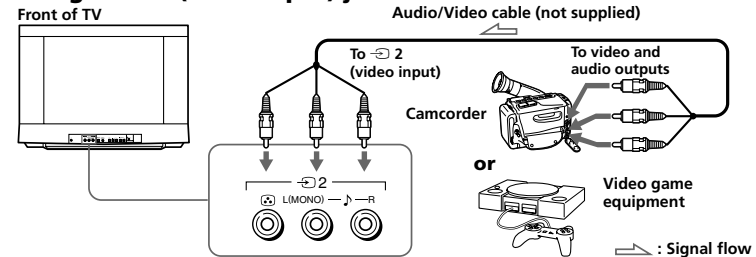

### Notes

*KV-XA21MSJ//XA21M8J only*

- You can also connect video equipment to the 1 (video input) jack at the rear of your TV.
- Not used for this model*
- You can also connect video equipment to the 1 or 2 (video input) jacks at the rear of your TV.
- Do not connect video equipment to the 2 (video input) jacks at the front and the rear of your TV at the same time; otherwise the picture will not be displayed properly on the screen.

### Connecting audio/video equipment using the (monitor output) jacks

*Not used for this model*

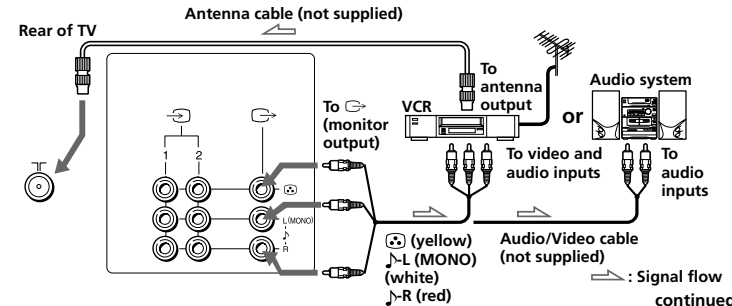

continued

## Connecting optional components (continued)

KV-XA21MSJ/XA21M8J

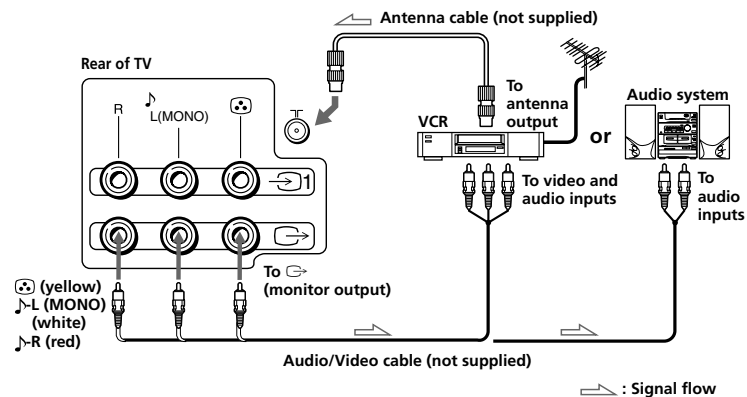

### Note

- If you connect a monaural VCR, connect the yellow plug to (yellow jack) and the black plug to L (MONO) (the white jack).

## Securing the TV

To prevent the TV from falling, secure the TV using one of the following methods:

- A** With the supplied screws, attach the band to the TV stand and to the rear of the TV using the provided hole.

or

- B** Put the cord or chain through the clamps to secure the TV against a wall or pillar.

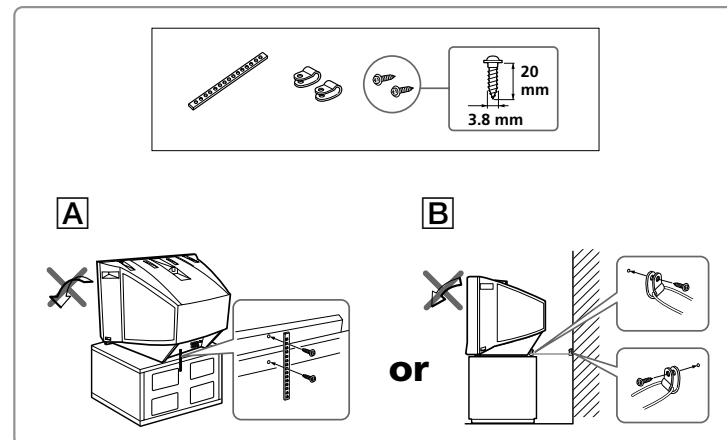

### Note

- Use only the supplied screws. Use of other screws may damage the TV.

## Presetting channels

You can preset up to 100 TV channels in numerical sequence from program number 1 using the remote and the buttons on your TV as well.

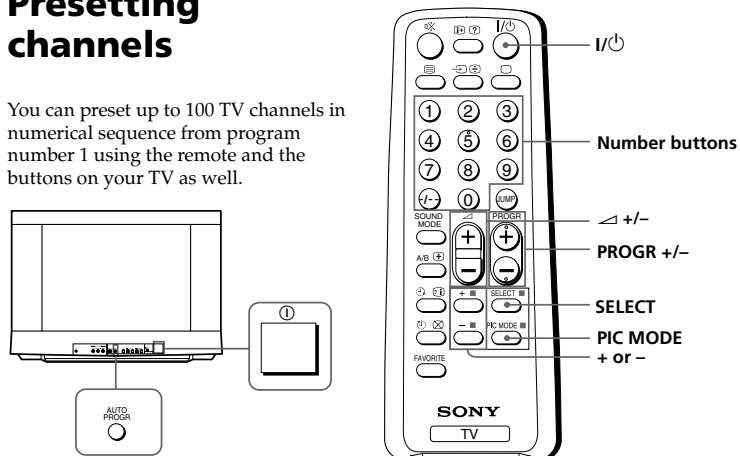

### Presetting channels automatically

- 1 Press ① to turn on the TV.



- 2 Press AUTO PROGR.

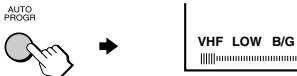

#### Note

- During automatic channel presetting, your TV screen will indicate "B/G", "I", "D/K" or "M" for the TV system (TV SYS).

### To preset channels automatically from a specified program number

- (1) Press SELECT until "AUTO PROGRAM" appears.
- (2) Press + or -.  
The on-screen display will start flashing.
- (3) Press PROGR +/- or the number buttons until the desired program number appears.
- (4) Press + or -.

### Presetting channels manually

- 1 Press SELECT until "MANUAL PROGRAM" appears.

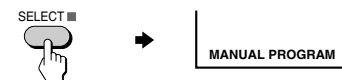

- 2 Press + or -.



- 3 Press PROGR +/- or the number buttons until the desired program number appears.

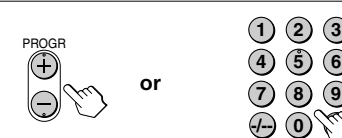

- 4 Press + or - until the desired channel picture appears.

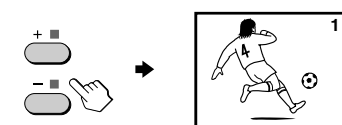

- 5 Press SELECT.



#### Note

- If you preset a locked program number, that particular program number will be unlocked automatically (page 20).

### To change the TV system setting

If the picture or sound is abnormal when receiving programs through the ㄗ (antenna) terminal

- (1) Press SELECT until "TV SYS" appears.



- (2) Press + or - to select the appropriate TV system until the picture or sound quality is optimal.

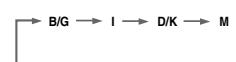

continued



## Watching the TV (continued)

### Additional tasks



To	Press
Turn off temporarily	I/⏻. The ⏻ indicator on the TV lights up red.
Turn off completely	⏻ on the TV.
Mute the sound	🔇.
Watch the video input (VCR, camcorder, etc.)	📺 to select "VIDEO 1" or "VIDEO 2". To return to the TV program, press □.
Jump back to the previous program number	JUMP.
Display the on-screen information*	ℹ.
Adjust the volume of all program numbers automatically	SELECT repeatedly until "INTELLIGENT VOL" appears, then press + or - to select "ON". To cancel, select "OFF".
Adjust the picture position when it is not aligned to the TV screen (KV-XG25M8J only)	SELECT repeatedly until "PIC ROTATION" appears, then press + or - to adjust the alignment of the picture position.

PIC ROTATION 🔄👆👇

The 🔄 or 👆/👇 icon on the screen flashes while adjusting.

\* The picture, sound, and either the program number or video input are displayed. The on-screen display for the picture and sound information disappears after about three seconds.

### Changing the on-screen display language

- Press SELECT until "LANGUAGE / اللغة : ENGLISH" appears on the screen.
 
- Press + or - to select "عربي".
 

#### Tip

- You can also use SELECT and ⏻ +/- on the TV to select the on-screen display language.

### Setting the Wake Up timer

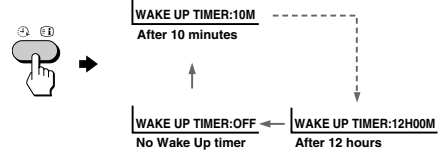
- Press ⏻ until the desired period of time appears. The Wake Up timer starts immediately after you have set it.
 
- Select the program number or video input you want to display when you wake up.
- Press I/⏻ or set the Sleep timer if you want the TV to turn off automatically. The ⏻ indicator on the TV lights up orange.

### To cancel the Wake Up timer

Press ⏻ until "WAKE UP TIMER: OFF" appears or turn off the TV's main power.

#### Note

- If no buttons or controls are pressed for more than two hours after the TV is turned on using the Wake Up timer, the TV automatically goes into the standby mode. To continue watching the TV, press any button or control on the TV or the remote.

### Setting the Sleep timer

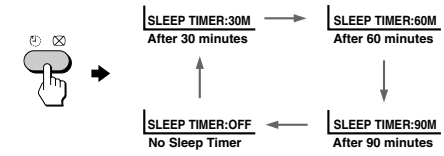
- Press ⏻ until the desired period of time appears. The Sleep timer starts immediately after you have set it.
- 

### To cancel the Sleep timer

Press ⏻ until "SLEEP TIMER: OFF" appears or turn the TV off.

## Advanced Operations

### Customizing the picture and sound

You can customize the picture and sound by selecting the picture and sound modes or by adjusting its settings.

You can change the sound effect by selecting the surround mode.

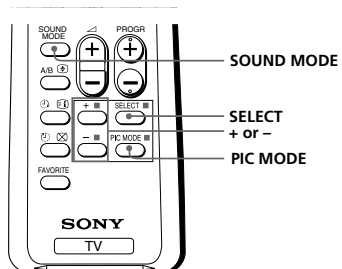

#### Selecting the picture and sound modes

##### To select the picture mode

Press PIC MODE repeatedly until you get the desired picture mode.

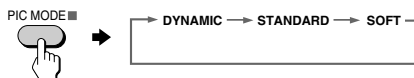

Select	To
"DYNAMIC"	receive high contrast pictures.
"STANDARD"	receive normal contrast pictures.
"SOFT"	receive mild pictures.

##### To select the sound mode

Press SOUND MODE repeatedly until you get the desired sound mode.

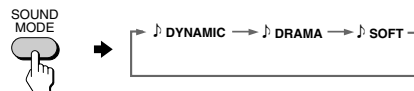

Select	To
"DYNAMIC"	listen to dynamic and clear sound that emphasizes the low and high sound.
"DRAMA"	listen to sound that emphasizes vocals and background music.
"SOFT"	receive soft sound.

#### Adjusting the picture and sound settings

- 1 Press SELECT until the desired setting appears.



Each time you press SELECT, the setting item will change as follows:

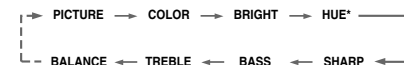

- 2 Press + or - to adjust the item.



- 3 To adjust other items, repeat steps 1 to 2.

\* "HUE" can be adjusted for the NTSC system only.

##### Notes

- When you select a picture or sound mode, the adjusted settings will be reset according to the selected mode.
- You can also use SELECT and  $\triangle$  +/- on the TV to adjust the picture and sound settings.

continued

## Customizing the picture and sound (continued)

### Selecting the surround mode

Not used for this model

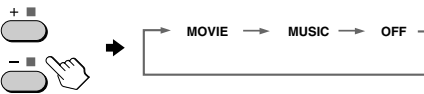
- Press SELECT repeatedly until "SURROUND" appears.
 
  - Press + or - to select the desired surround sound.
 
- | Select  | To                                                                                                  |
|---------|-----------------------------------------------------------------------------------------------------|
| "MOVIE" | listen to sound that spreads out over a large area, giving the feeling of being at a movie theatre. |
| "MUSIC" | listen to the sound that gives the feeling of being at a live concert.                              |
| "OFF"   | turn off the surround sound.                                                                        |

### KV-XA21MSJ/XA21M8J

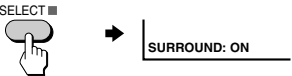
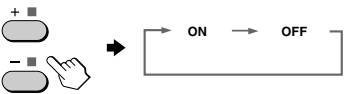
- Press SELECT repeatedly until "SURROUND" appears.
 
- Press + or - to select "ON". To turn off the surround mode, select "OFF".
 

## Viewing your favorite channels



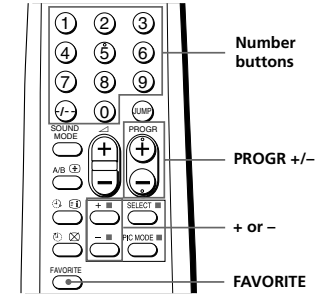

You can display six of your favorite channels for quick and easy selection. You can program the favorite channel as well.

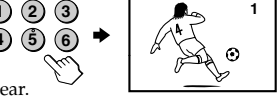

### Selecting a favorite channel

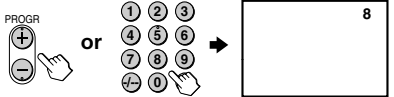
- Press FAVORITE.
 
  - Press the number button from 1 to 6 to select the desired favorite channel.
 
- When you use the "FAVORITE CH" feature for the first time, six preset favorite channels will appear.

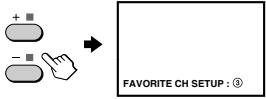
### Programming the favorite channel

- Press PROGR +/- or number buttons to select the program number you want to program (e.g., program number 8).
 
- Press SELECT until "FAVORITE CH SETUP" appears.
 
- Press + or - to select the favorite channel you want to program (e.g., ③).
 
- Press SELECT. The selected favorite channel (e.g., ③) turns red for about one second.
 
- To program other favorite channels, repeat steps 1 to 4.

## Blocking the channels (CHILD LOCK)

You can lock some program numbers to prevent children from watching certain channels, by using the buttons on the remote control.

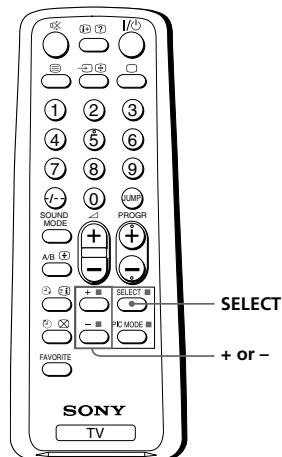



**1** Select the program number you want to lock.

**2** Press SELECT until "CHILD LOCK" appears on the screen.



**3** Press + or - to select "ON".

The  symbol appears on the screen.

To cancel, press + or - to select "OFF". The  symbol disappears from the screen.

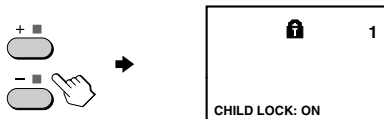



### Note

- If you preset a locked program number, that particular program number will be unlocked automatically (page 10).

## Additional Information

### Self-diagnosis function

Your TV is equipped with a self-diagnosis function. If there is a problem with your TV, the  indicator flashes red. The number of times the  indicator flashes indicates the possible causes.

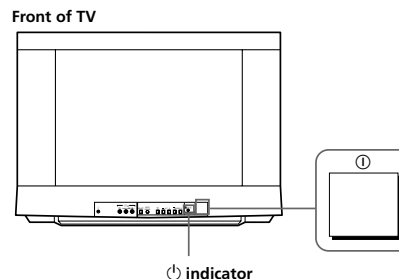

**1** Check that the  indicator flashes red a number of times between 3-second intervals.

**2** Count the number of times the  indicator flashes.









**3** Press  (main power) to turn off your TV.





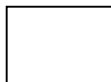

**4** Inform your nearest Sony service center about the number of times the  indicator flashes. Be sure to note the model name and serial number located on the rear of your TV.



# Troubleshooting

If you find any problem while viewing your TV, please check the following guide. If any problem persists, contact your Sony dealer .

Symptom	Possible cause	Solutions	Page
<b>Snowy picture</b> 	<ul style="list-style-type: none"> <li>Connection is loose or the cable is damaged.</li> <li>Channel presetting is inappropriate or incomplete.</li> </ul>	<ul style="list-style-type: none"> <li>Check the antenna cable and connection on the TV, VCR and on the wall.</li> <li>Press SELECT until "MANUAL PROGRAM" appears on the screen, then preset the channel again.</li> </ul>	<p>4</p> <p>11</p>
<b>Noisy sound</b> 	<ul style="list-style-type: none"> <li>The antenna type is inappropriate.</li> <li>The antenna direction is inappropriate.</li> <li>Signal transmission is low.</li> </ul>	<ul style="list-style-type: none"> <li>Check the antenna type (VHF/UHF). Contact a Sony dealer for advice.</li> <li>Adjust the antenna direction. Contact a Sony dealer for advice.</li> <li>Try using a booster.</li> </ul>	<p>-</p> <p>-</p> <p>-</p>
<b>Distorted picture</b> 	<ul style="list-style-type: none"> <li>Broadcast signals are too strong.</li> </ul>	<ul style="list-style-type: none"> <li>Turn off or disconnect the booster if it is in use.</li> </ul>	<p>-</p>
<b>Noisy sound</b> 			
<b>Good picture</b> 	<ul style="list-style-type: none"> <li>The TV system setting or channel presetting is inappropriate or incomplete.</li> </ul>	<ul style="list-style-type: none"> <li>If the sound of some channels are noisy, select the channel, then select the appropriate TV system (TV SYS).</li> </ul>	<p>11</p>
<b>Noisy sound</b> 			
<b>No picture</b> 	<ul style="list-style-type: none"> <li>The power cord, antenna or VCR is not connected.</li> <li>The TV is not turned on.</li> </ul>	<ul style="list-style-type: none"> <li>Check the power cord, antenna and the VCR connections.</li> <li>Press I/⏻ (power).</li> <li>Press ⏻ (main power) on the TV to turn off the TV for about five seconds, then turn it on again.</li> </ul>	<p>4</p> <p>14</p> <p>13</p>
<b>No sound</b> 			

Symptom	Possible cause	Solutions	Page
<b>Good picture</b> 	<ul style="list-style-type: none"> <li>The volume level is too low.</li> </ul>	<ul style="list-style-type: none"> <li>Press ⏪ + to increase the volume level.</li> </ul>	<p>13</p>
<b>No sound</b> 	<ul style="list-style-type: none"> <li>The sound is muted.</li> </ul>	<ul style="list-style-type: none"> <li>Press ⏸ to cancel the muting.</li> </ul>	<p>14</p>
<b>Dotted lines or stripes</b> 	<ul style="list-style-type: none"> <li>There is local interference from cars, neon signs, hair dryers, power generators, etc.</li> </ul>	<ul style="list-style-type: none"> <li>Do not use a hair dryer or other equipment near the TV.</li> <li>Adjust the antenna direction for minimum interference. Contact a Sony dealer for advice.</li> </ul>	<p>-</p> <p>-</p>
<b>Double images or "ghosts"</b> 	<ul style="list-style-type: none"> <li>Broadcast signals are reflected by nearby mountains or buildings.</li> <li>The antenna direction is inappropriate.</li> <li>Use of a booster is inappropriate.</li> </ul>	<ul style="list-style-type: none"> <li>Use a highly directional antenna.</li> <li>Use the fine tuning (FINE) function.</li> <li>Adjust the antenna direction. Contact a Sony dealer for advice.</li> <li>Turn off or disconnect the booster if it is in use.</li> </ul>	<p>-</p> <p>12</p> <p>-</p> <p>-</p>
<b>No color</b> 	<ul style="list-style-type: none"> <li>The color level setting is too low.</li> <li>The color system setting is inappropriate.</li> <li>The antenna direction is inappropriate.</li> </ul>	<ul style="list-style-type: none"> <li>Press SELECT until "COLOR" appears on the screen, then press + or - to adjust the color level.</li> <li>Press SELECT until "COLOR SYS " appears on the screen, then check the color system setting (usually set this to "AUTO").</li> <li>Adjust the antenna direction. Contact a Sony dealer for advice.</li> </ul>	<p>17</p> <p>12</p> <p>-</p>
<b>Abnormal color patches</b> 	<ul style="list-style-type: none"> <li>The magnetic disturbance from external speakers or other equipment, or the direction of the earth's magnetic field may affect the TV.</li> </ul>	<ul style="list-style-type: none"> <li>Keep external speakers or other electrical equipment away from the TV. Do not move the TV while the TV is turned on. Press ⏻ (main power) on the TV to turn off the TV for about five minutes, then turn it on again.</li> </ul>	<p>-</p>

continued

**Troubleshooting (continued)**

Symptom	Possible cause	Solutions	Page
Picture slant (KV-XG25M8J only) 	<ul style="list-style-type: none"> <li>The magnetic disturbance from external speakers or other equipment, or the direction of the earth's magnetic field may affect the TV.</li> </ul>	<ul style="list-style-type: none"> <li>Keep external speakers or other electrical equipment away from the TV.</li> <li>Press SELECT until "PIC ROTATION" appears on the screen, then press + or - to adjust the picture until it is optimal.</li> </ul>	14
Lines moving across the TV screen.	<ul style="list-style-type: none"> <li>There is interference from external sources, e.g., heavy machineries, nearby broadcast station.</li> </ul>	<ul style="list-style-type: none"> <li>Use the fine tuning (FINE) function.</li> </ul>	12
The indicator on your TV flashes red a number of times between 3-second intervals.	<ul style="list-style-type: none"> <li>Your TV may need service.</li> </ul>	<ul style="list-style-type: none"> <li>Contact your nearest Sony service center.</li> </ul>	21
TV cabinet creaks.	<ul style="list-style-type: none"> <li>Changes in room temperature sometimes make the TV cabinet expand or contract, making a noise. This does not indicate a malfunction.</li> </ul>	—	—
A "boom" sound is heard when the TV is turned on.	<ul style="list-style-type: none"> <li>The TV's demagnetizing function is working. This does not indicate a malfunction.</li> </ul>	—	—

**Overview of controls**

**TV front panel**

Not used for this model

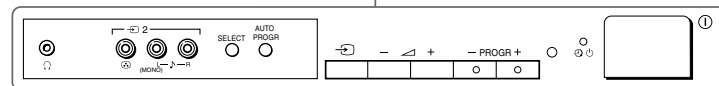
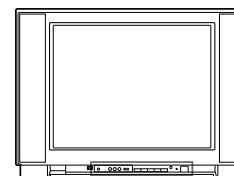

**KV-XA21MSJ/XA21M8J**

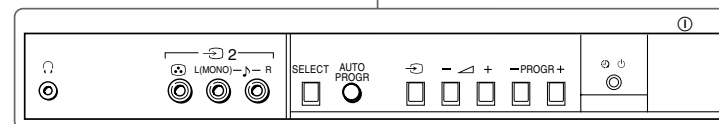
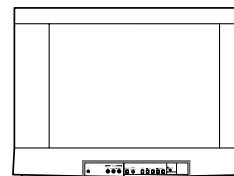

Button	Function	Page
AUTO PROGR	Preset channels automatically.	5
SELECT	Select the desired item.	12
PROGR +/-	Select program number.	13
Ⓛ	Turn off completely or turn on the TV.	13
⏮ +/-	Adjust volume.	13
⏻	Standby indicator.	13
⏪	Select TV or video input.	14
⌚	Wake Up indicator.	15
🎧	Headphone jack.	—

continued

**Overview of controls (continued)**

**Remote Control**

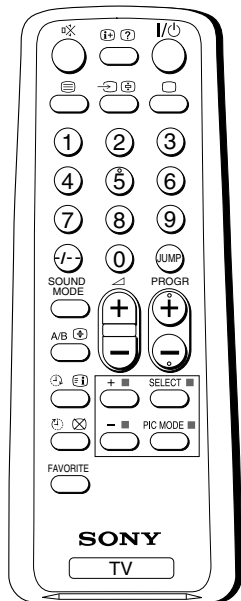

The names/symbols of buttons on the remote are indicated in different colors to represent the available functions.

Label color	Button function
White	For general TV operations
Green	For Teletext operations

Button	Function	Page
SELECT	Select the desired item.	11
+/-	Adjust value.	11
PROGR +/-	Select program number.	13
0 - 9, +/-	Input numbers.	13
▲ +/-	Adjust volume.	13
I/⏻	Turn off temporarily or turn on the TV.	13
⏪	Select TV or video input.	14
□	Display the TV program.	14
⊗	Mute the sound.	14
Ⓜ	Display on-screen information.	14
JUMP	Jump to previous program number.	14
<b>Timer operations</b>		
⌚	Set TV to turn on automatically.	15
⌚	Set TV to turn off automatically.	15
PIC MODE	Select picture mode.	16
SOUND MODE	Select sound mode.	16
FAVORITE	Display favorite channels.	19
<b>Stereo/bilingual operations (Not used for this model)</b>		
A/B	Select stereo/bilingual mode.	-
<b>Teletext operations (Not used for this model)</b>		
Ⓜ	Display Teletext broadcast.	-
Ⓜ	Display Teletext service contents.	-
⊕	Stop Teletext display from scrolling.	-
?	Reveal concealed information.	-
Ⓜ	Enlarge the Teletext display.	-
⊗	Show TV screen while waiting for Teletext page.	-
■ (red, green, yellow, blue)	Access a FASTEXT menu.	-

## SECTION 2 DISASSEMBLY

### 2-1. REAR COVER REMOVAL

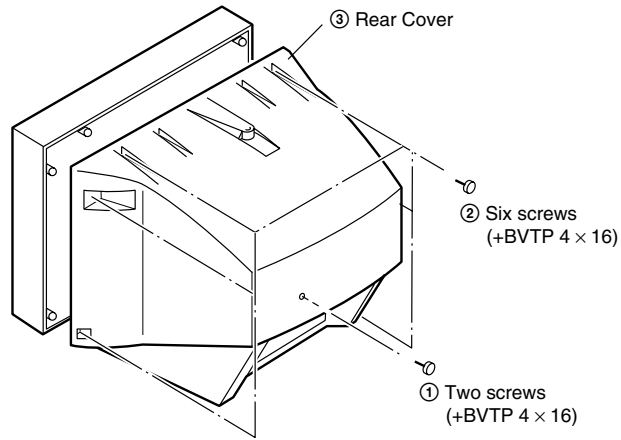

### 2-2. SPEAKER REMOVAL

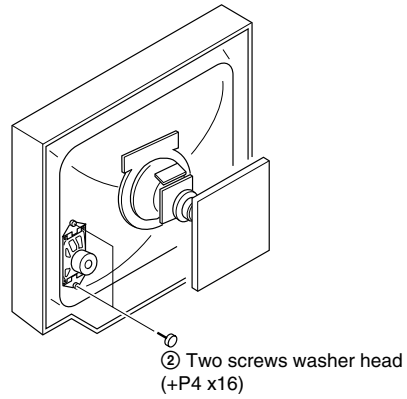

### 2-3. CHASSIS ASSY REMOVAL

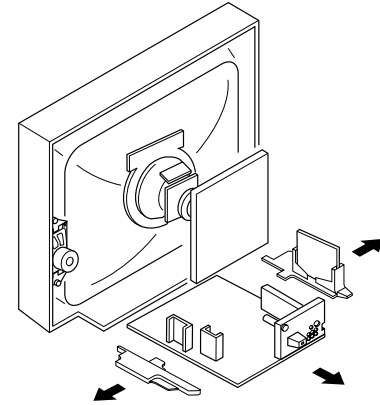

### 2-4. F BRACKET REMOVAL

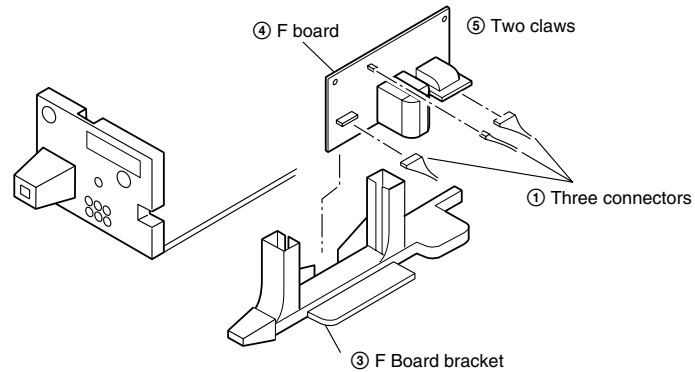

### 2-5. J2 BOARD AND TERMINAL BRACKET REMOVAL

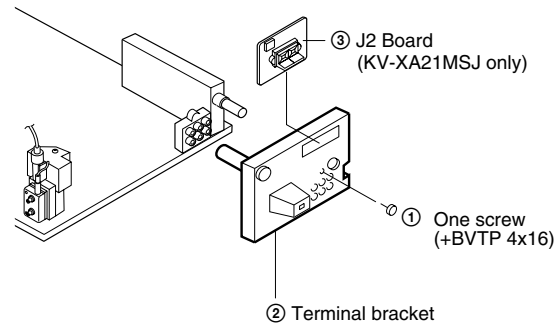

## 2-6. SERVICE POSITION

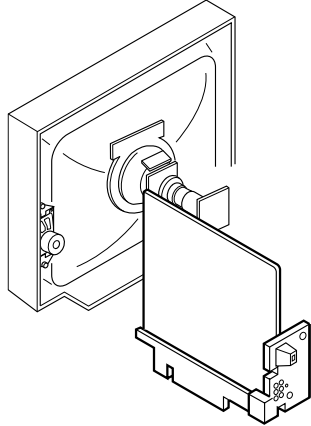

### Note:

1. Disconnect the speaker connection on the right side.
2. Undress necessary wires that creates tension while placing the chassis into Service Position.

## 2-7. REPLACEMENT OF PARTS

For replacement of light guide, unscrew them, exchange with new parts and fix them with screws respectively.

### 2-7-1. Replacement of Light Guide

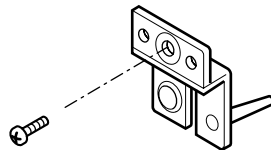

One screw  
(+BVTP 3 × 12)

### 2-7-2. Replacement of Power Button

- ① Push the claw to direction of arrow and remove
- ② Spring compression
- ③ Power Button

## 2-8. PICTURE TUBE REMOVAL

### Note:

- The picture tube for Australia model is upside down, and the position for the anode-cap and the tension spring are changed accordingly.
- Please remove necessary CRT support located on top left, top right, prior to removing the CRT.

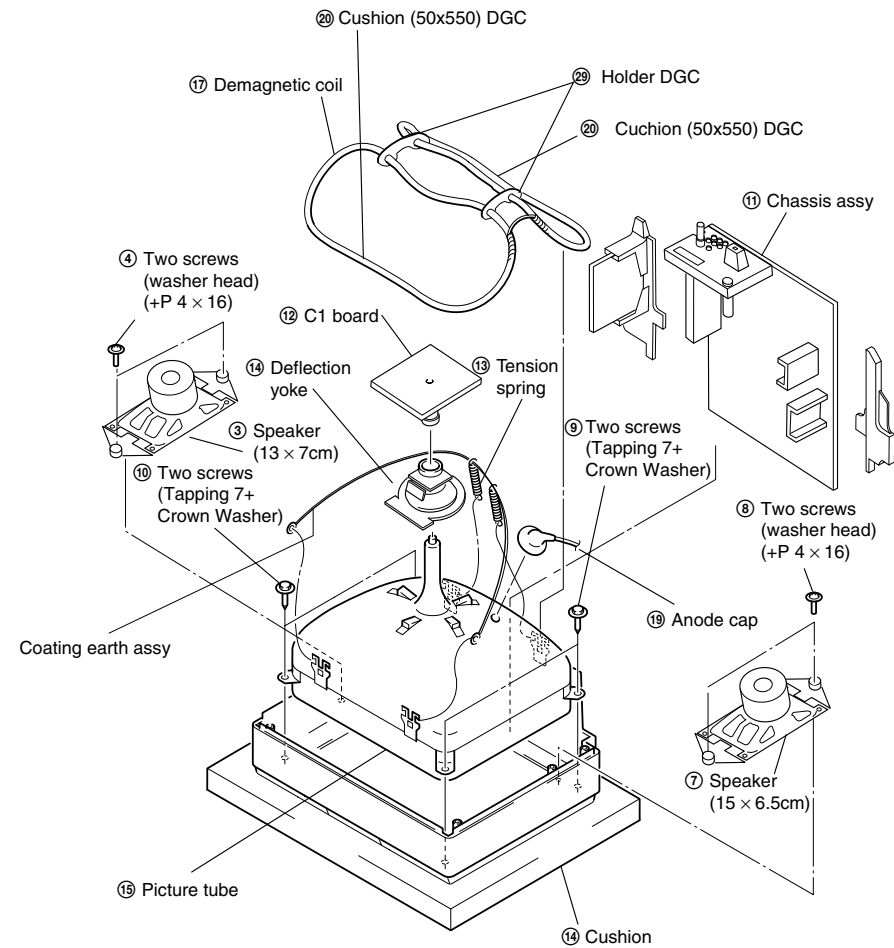

• **REMOVAL OF ANODE-CAP**

NOTE : After removing the anode, short circuit the anode of the picture tube and the anode cap to the metal chassis, CRT shield or carbon paint on the CRT.

• **REMOVING PROCEDURES**

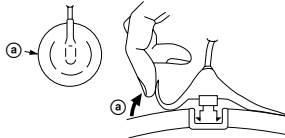

① Turn up one side of the rubber cap in the direction indicated by the arrow ①.

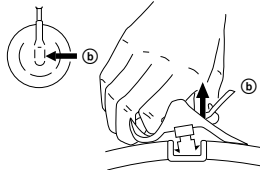

② Using a thumb pull up the rubber cap firmly in the direction indicated by the arrow ②.

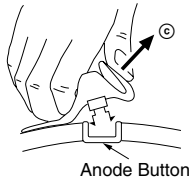

③ When one side of the rubber cap is separated from the anode button, the anode-cap can be removed by turning up the rubber cap and pulling it up in the direction of the arrow ③.

• **HOW TO HANDLE AN ANODE-CAP**

- ① Do not damage the surface of anode-caps with sharp shaped objects.
- ② Do not press the rubber too hard so as not to damage the inside of anode-cap. A metal fitting called the shatter-hook terminal is built into the rubber.
- ③ Do not turn the foot of rubber over too hard. The shatter-hook terminal will stick out or damage the rubber.

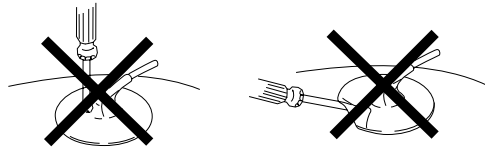

## SECTION 3 SET-UP ADJUSTMENTS

- The following adjustments should be made when a complete realignment is required or a new picture tube is installed.
- These adjustments should be performed with rated power supply voltage unless otherwise noted.

Controls and switches should be set as follows unless otherwise noted:

PICTURE control ..... normal  
BRIGHTNESS control ..... normal

### Preparation :

- In order to reduce the influence of geomagnetism on the set's picture tube, face it east or west.
- Switch on the set's power and degauss with the degausser.

### 3-1. BEAM LANDING

1. Input a white signal with the pattern generator.
 

Contrast	} normal
Brightness	
2. Set the pattern generator raster signal to a green raster.
3. Move the deflection yoke to the rear and adjust with the purity control so that the green is at the center and the blue and the red take up equally sized areas on each side. (See Figures 3-1 through 3-4.)
4. Move the deflection yoke forward and adjust so that the entire screen is green. (See Figure 3-1.)
5. Switch the raster signal to blue, then to red and verify the condition.
6. When the position of the deflection yoke has been decided, fasten the deflection yoke with the screws and DY spacers.
7. If the beam does not land correctly in all the corners, use a magnet to adjust it. (See Figure 3-4.)

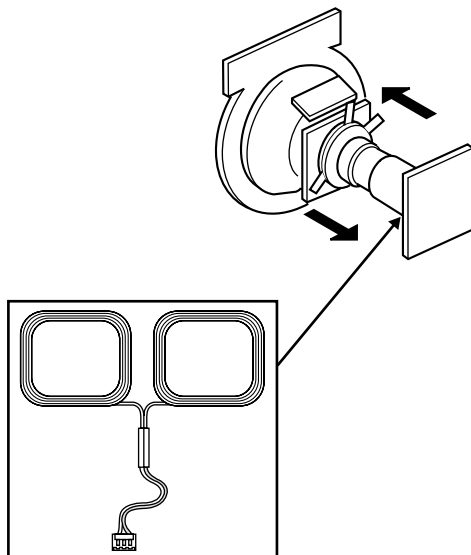

Fig. 3-1

Perform the adjustments in the following order :

1. Beam Landing
2. Convergence
3. Focus
4. White Balance

**Note :** Test Equipment Required.

1. Pattern Generator
2. Degausser
3. Oscilloscope

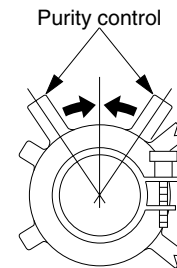

Fig. 3-2

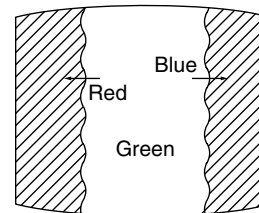

Fig. 3-3

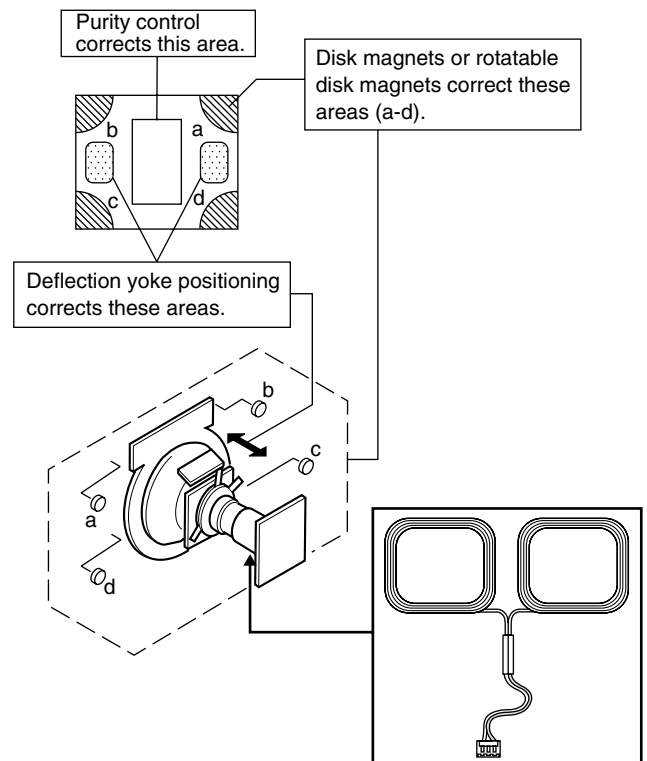

Fig. 3-4

### 3-2. CONVERGENCE

**Preparation :**

- Before starting this adjustment, adjust the focus, horizontal size and vertical size.
- Receive dot/hatch signal.
- Pic mode: Personal (Pic 90%, Brightness 50%, Col 50 %, Hue 50%, Shp 50%).

**(1) Horizontal and Vertical Static Convergence**

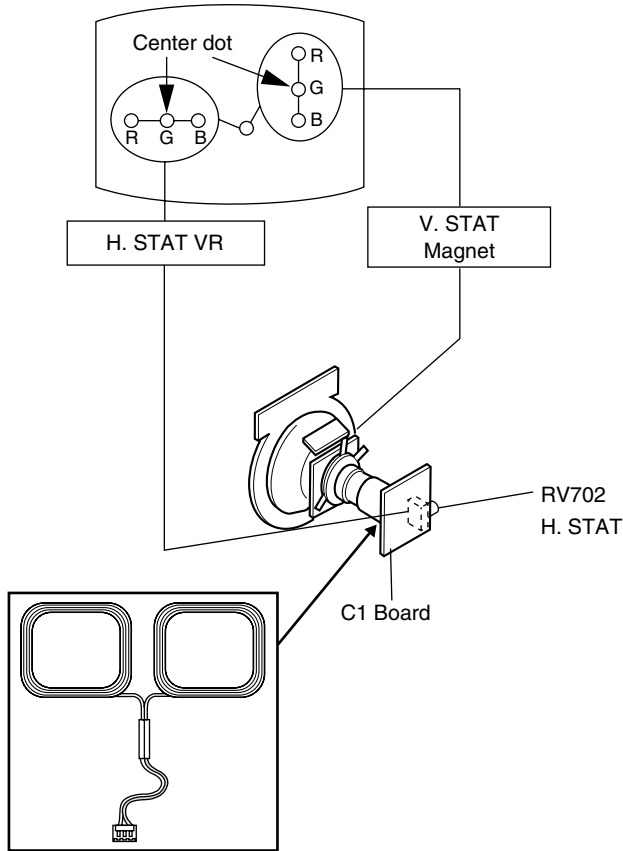

1. (Moving horizontally), adjust the H.STAT control so that the red, green and blue dots are on top of each other at the center of the screen.
2. (Moving vertically), adjust the V.STAT magnet so that the red, green and blue dots are on top of each other at the center of the screen.
3. If the H.STAT variable resistor cannot bring the red, green and blue dots together at the center of the screen, adjust the horizontal convergence with the H.STAT variable resistor and the V.STAT magnet in the manner given below.  
(In this case, the H.STAT variable resistor and the V.STAT magnet influence each other, so be sure to perform adjustments while tracking.)

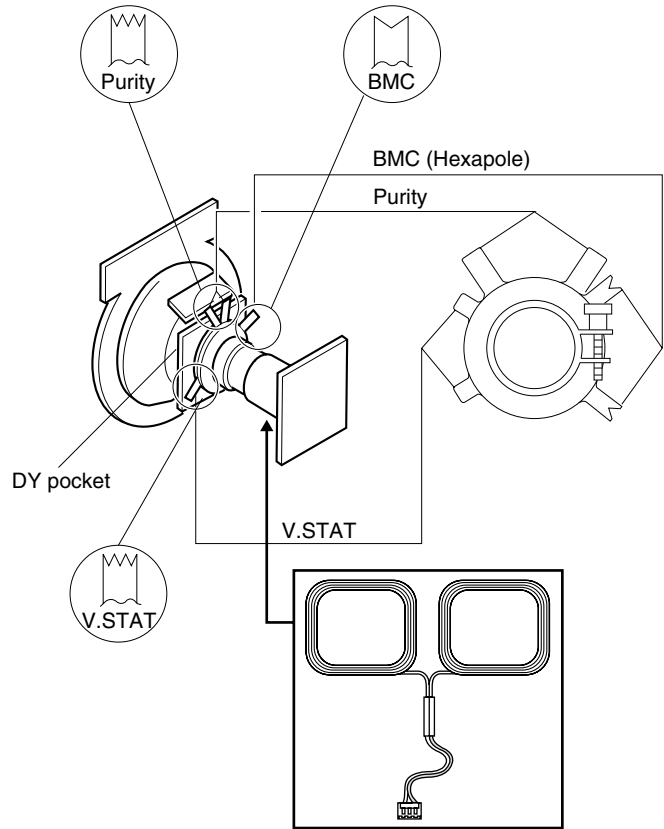

**① V. STAT**

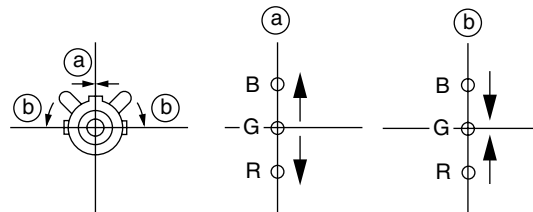

**② H. STAT VR**

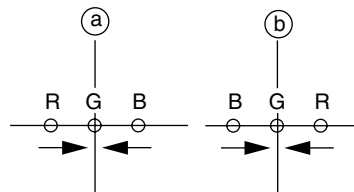

**③**

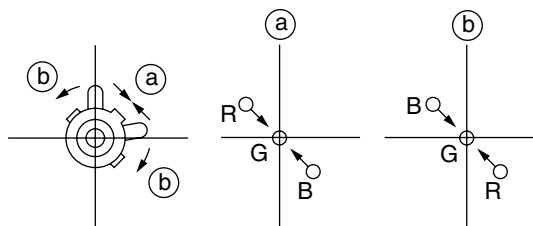



④ BMC (Hexapole) Magnet.

If the red, green and blue dots are not balanced or aligned, then use the BMC magnet to adjust in the manner described below.

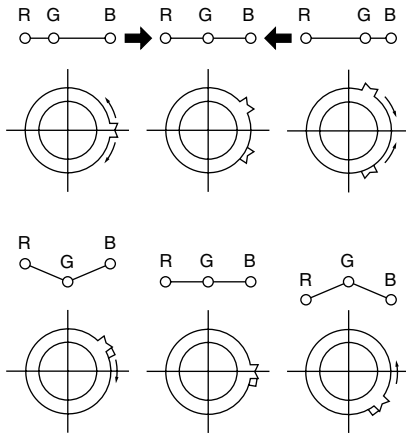

YCH Rotate YCH VOL on DY  
TLV Insert TLH Correction Plate to DY Pocket (Left or Right)

ON DY:

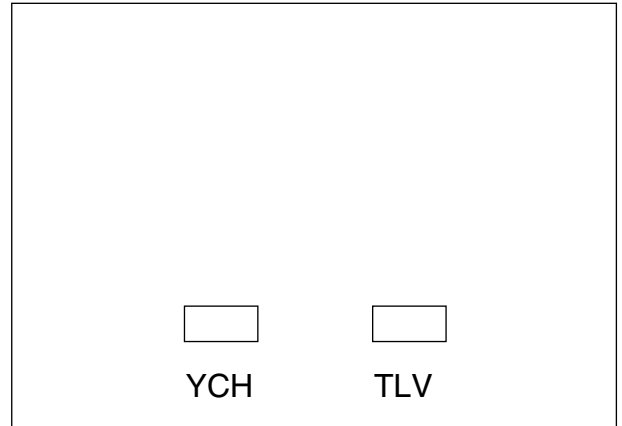

(3) Screen-corner Convergence

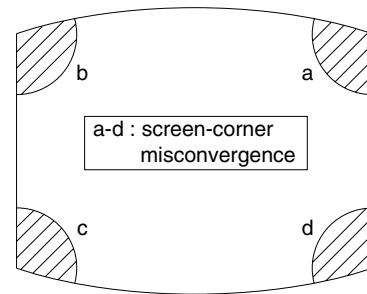

(2) Dynamic Convergence Adjustment

Preparation:

- Before starting this adjustment, adjust the horizontal static convergence and the vertical static convergence

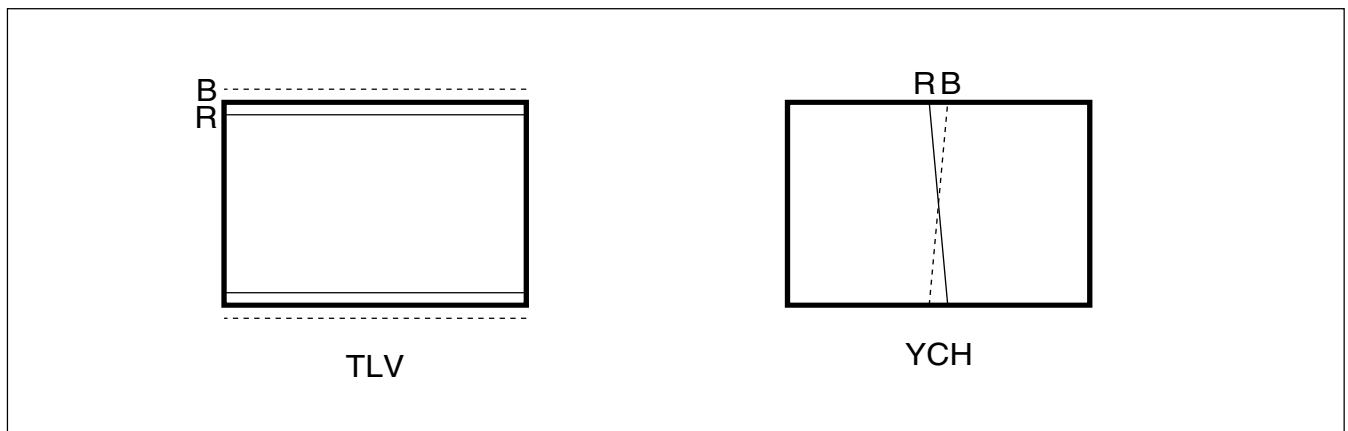

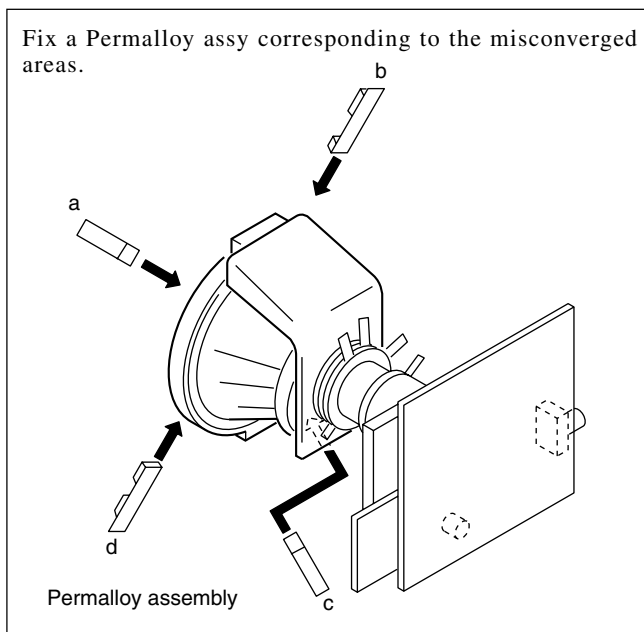

### 3-3. FOCUS ADJUSTMENT

FOCUS adjustment should be completed before W/B adjustment.

1. Receive digital monoscope pattern.
2. Set "Picture Mode" to "DYNAMIC".
3. Adjust focus VR so that the center of screen becomes just focus.
4. Change the receiving signal to white pattern and blue back.
5. Confirm magenta ring is not noticeable. In case magenta is very obvious, adjust focus VR to take balance of magenta ring and focus.

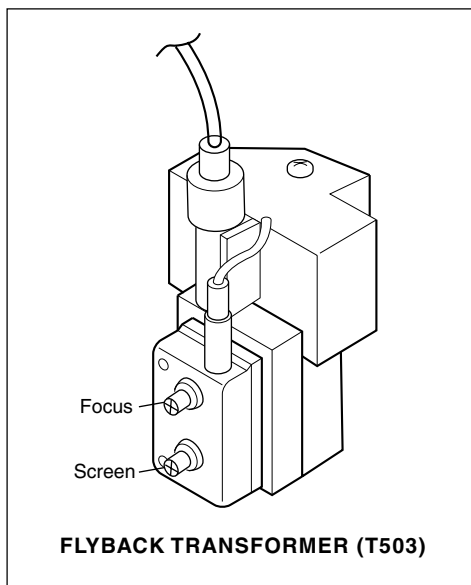

### 3-4. G2 (SCREEN) AND WHITE BALANCE ADJUSTMENTS

#### 1. G2 (SCREEN) ADJUSTMENT

- 1) Set the PICTURE to normal.
- 2) Put to VIDEO input mode without signals.
- 3) Connect R, G and B of the C1 board cathode to the oscilloscope.
- 4) Adjust BRIGHTNESS to obtain the cathode voltage to the value below.
- 5) Adjust G2 (screen) on the FBT until picture shows the point before cut off.

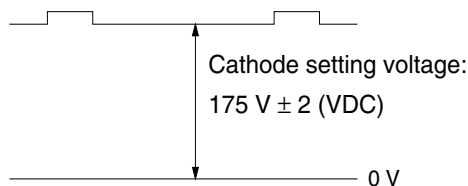

#### 2. WHITE BALANCE ADJUSTMENT

- 1) Set to Service Mode (Refer Section 5-1: ADJUSTMENTS WITH COMMANDER).
- 2) Input white raster signal.
- 3) Set the PICTURE to minimum.
- 4) Select GCT (WHB 4) and BCT (WHB 5) with [1] and [4], and adjust the level with [3] and [6] for the best white balance.
- 5) Set the PICTURE to maximum.
- 6) Select GDR (WHB 1) and BDR (WHB 2) with [1] and [4], and adjust the level with [3] and [6] for the best white balance.
- 7) Write into the memory by pressing [MUTING] then [0].

#### 3. SUB BRIGHT ADJUSTMENT

- 1) Set to service mode.
- 2) Input a staircase signal of black to white from the pattern generator.
- 3) BRIGHTNESS .... 50%.  
PICTURE ..... MINIMUM
- 4) Select SBR (WHB7) with [1] and [4], and adjust SBR (WHB7) level with [3] and [6] so that the second stripe from the right is dimly lit.

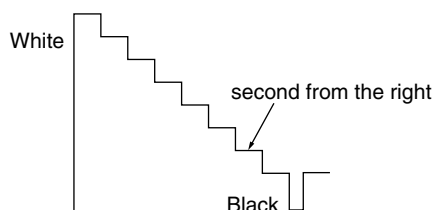

## SECTION 4 CIRCUIT ADJUSTMENTS

### 4-1. ADJUSTMENTS WITH COMMANDER

Service adjustments to this model can be performed using the supplied Remote Commander RM-952.

#### a. ENTERING SERVICE MODE

With the unit on standby

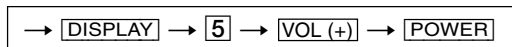

This operation sequence puts the unit into service mode.

The screen display is :

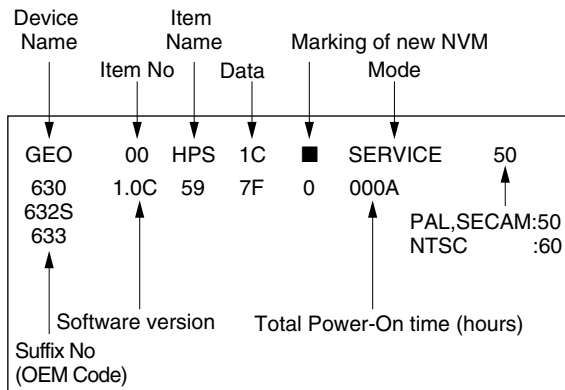

#### b. METHOD OF CANCELLATION FROM SERVICE MODE

Set the standby condition (Press [POWER] button on the commander), then press [POWER] button again, hereupon it becomes TV mode.

#### c. METHOD OF WRITE INTO MEMORY

- 1) Set to Service Mode.
- 2) Press [1] (UP) and [4] (DOWN), to select the adjustment.
- 4) Press [MUTING] button to indicate WRITE on the screen.
- 5) Press [0] button to write into memory.

#### d. MEMORY WRITE CONFIRMATION METHOD

- 1) After adjustment, pull out the plug from AC outlet, and then plug into AC outlet again.
- 2) Turn the power switch ON and set to Service Mode.
- 3) Call the adjusted items again to confirm adjustments were made.

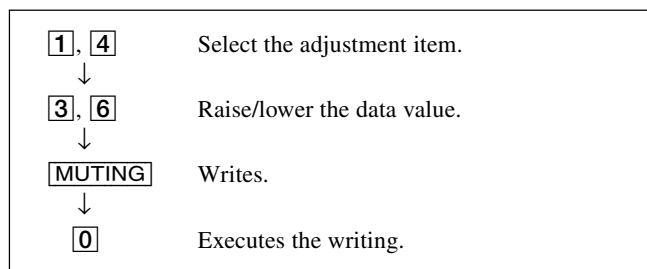

- [7], [0] All the data becomes the values in memory.
- [8], [0] All user control goes to the standard state.
- [5], [0] Service data initialization (Be sure not to use usually.)
- [2], [0] Write 50Hz adjustment data to 60Hz, or vice versa.

### 4-2. ADJUSTMENT METHOD

Item Number 00 of device GEO

This explanation uses H-Position as an example.

1. Select "GEO 00 HPS" with the [1] and [4] buttons.
2. Raise/lower the data with the [3] and [6] buttons.
3. Select the optimum state. (The standard is 1F for PAL reception.)
4. Write with the [MUTING] button. (The display changes to WRITE.)
5. Execute the writing with the [0] button. (The WRITE display will be changed to red color while executing, and back to SERVICE.)

Example on screen display :-

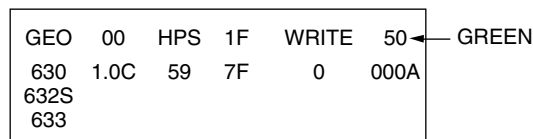
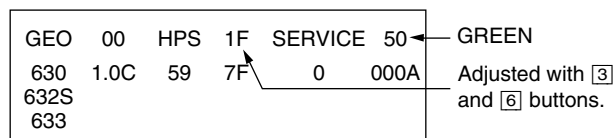

Write with [MUTING]

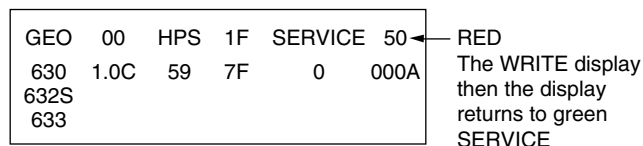

Write executed with [0]

Use the same method for all Items. Use [1] and [4] to select the adjustment item, use [3] and [6] to adjust, write with [MUTING], then execute the write with [0].

- Note :**
1. In [WRITE], the data for all items are written into memory together.
  2. For adjustment items that have different standard data between 50Hz or 60Hz, be sure to use the respective input signal after adjustment.

**Adjustment Item Table**

TVG Category	Functionality		Init.	Range	Function	Table & Note	Device Name
	No.	Name					Slave Address
GEO	00	HPS	7	3F	H POSITION	50/60Hz	CXA2159S (88H)
	01	HSZ	1F	3F	H SIZE	50/60Hz	
	02	PAP	1F	3F	PIN AMP	50/60Hz	
	03	TLT	7	0F	TRAPEZIUM	50/60Hz	
	04	VPS	1F	3F	V POSITION	50/60Hz	
	05	VSZ	1F	3F	V SIZE	50/60Hz	
	06	SCO	7	0F	S CORRECTION	50/60Hz	
	07	VLN	7	0F	V LINEARITY	50/60Hz	
	08	BOW	7	0F	AFC BOW	50/60Hz	
	09	AGL	7	0F	AFC ANGLE	50/60Hz	
	0A	UPN	1F	3F	UPPER PIN	50/60Hz	
	0B	LPN	1F	3F	LOWER PIN	50/60Hz	
	0C	HBL	0	1	H BLANKING ON/OFF		
	0D	LBL	2	0F	LEFT H BLANKING	50/60Hz	
0E	RBL	0B	0F	RIGHT H BLANKING	50/60Hz		
WHB	00	RDR	25	3F	R DRIVE	DYNAMIC/others	CXA2159S (88H)
	01	GDR	25	3F	G DRIVE	DYNAMIC/others	
	02	BDR	25	3F	B DRIVE	DYNAMIC/others	
	03	RCT	7	0F	R CUTOFF	SECAM/others	
	04	GCT	7	0F	G CUTOFF	SECAM/others	
	05	BCT	7	0F	B CUTOFF	SECAM/others	
	06	BMN	15	1F	BRIGHTNESS MINIMUM DATA		
	07	SBR	1F	3F	SUB BIGHTNESS CONTROL		
	08	APB	0	3	SUB BRIGHT CONTROL SWITCH FOT INTELLIGENCE PICTURE #3		
SAJ	00	PMX	33	3F	PICTURE MAXIMUM DATA		CXA2159S (88H)
	01	SHU	8	0F	SUB HUE CONTROL	TV/Video	
	02	SSH	3	0F	SUB SHARPNESS CONTROL	TV/Video	
	03	SCL	1F	3F	SUB COLOR CONTROL	(NTSC/others)	
OPB	00	OP1	FF	FF	OPTIONAL BITS 1 (SEE BELOW)	Option - Bits	CXP750097
	01	OP2	62	FF	OPTIONAL BITS 2 (SEE BELOW)		
	02	OP3	B1	FF	OPTIONAL BITS 3 (SEE BELOW)		
	03	OP4	02	FF	OPTIONAL BITS 4 (SEE BELOW)		

## Adjustment Item Table

TVG Category	Functionality		Init.	Range	Function	Table & Note	Device Name
	No.	Name					Slave Address
VP	00	EHT	4	0F	EHT COMP	50/60Hz	CXA2159S (88H)
	01	GMA	2	03	GAMMA CORRECTION	Refer NVM Map A4	
	02	APG	0	1	GAMMA CONTROL SWITCH FOR PNC #3		
	03	YDL	6	0F	Y DELAY	PAL/SECAM/NTSC	
	04	SST	1	03	SECAM ID START POSITION	SECAM/PAL	
	05	SSP	1	03	SECAM ID STOP POSITION	SECAM/PAL	
	06	RLM	0	3	RGB LIMIT		
	07	SLV	2	03	SECAM ID LEVEL	SECAM/PAL	
	08	SBF	22	3F	SECAM BELL FO	SECAM/PAL	
	09	DYC	1	1	DYNAMIC COLOR ON/OFF		
	0A	ABL	1	1	ABL MODE SWITCHING	STANDARD Always 0	
	0B	VTH	1	1	ABL DETECTION VTH SWITCHING		
	0C	SFO	1	1	FO SWITCHING FOR SHARPNESS	NTSC/others	
	0D	DCX	1	1	DC TRANS. RATIO SWITCHING		
	0E	SHT	1	1	PRE-/OVERSHOOT RATIO SWITCH	NTSC/others	
	0F	HDW	0	1	H DRIVE PULSE WIDTH SWITCH		
	10	AFC	1	03	AFC GAIN CONTROL	TV/Video/Text	
	11	HOS	7	0F	H OSCILLATION		
	12	HSS	0	1	SLICE LEVEL OF H SYNC SEP.		
	13	VSS	0	1	SLICE LEVEL OF V SYNC SEP.		
14	HMS	1	1	MACRO VISION C/M OFF/ON	50/60Hz		
15	YUV	0	1	YUV SWITCH CONTROL			
16	CDV	1	3	CD MODE FOR VIDEO AND RF UNDER NO SIGNAL	video only		
17	RON	1	1	R ON	not memorized		
18	GON	1	1	G ON	not memorized		
19	BON	1	1	B ON	not memorized		
1A	PON	1	1	P ON	not memorized		
1B	AXN	1	1	AXIS SW	NTSC/others (only for DYNAMIC)		
1C	RSL	0	1	RGB SEL			
1D	VBW	1	3	VBLKW			
1E	RFP	0	1	REFP			
1F	JMP	0	1	JUMP			
20	VMC	3	3	VM OFF			
AP	00	INF	5	3F	INPUT ATTENUATION WHEN SURROUND OFF		BH3868AFS (80H)
	01	INS	0A	3F	INPUT ATTENUATION WHEN SURROUND ON (XG-ONLY)		
	02	SEF	0	0F	SURROUND EFFECT CONTROL (XA-ONLY)		
	03	PH1	3	3	PHASE 1 REGISTER SELECTION		
	04	PH2	0	3	PHASE 2 REGISTER SELECTION (XG-ONLY)		
	05	PH3	0	3	PHASE 3 REGISTER SELECTION (XG-ONLY)		
	06	PH4	0	3	PHASE 4 REGISTER SELECTION (XG-ONLY)		
	07	BCS	2	3	BASS CENTER SHIFT		
	08	TCS	2	3	TREBLE CENTER SHIFT		
09	TRF	2	3	RF TREBLE OFFSET			

Adjustment Item Table

TVG Category	Functionality		Init.	Range	Function	Table & Note	Device Name
	No.	Name					Slave Address
MSP	00	WST	15	FF	W/G STEREO THRESHOLD		MSP3415D (84H)
	01	WBT	EA	FF	W/G BILINGUAL THRESHOLD		
	02	WLL	5	FF	W/G MONAURAL THRESHOLD		
	03	WAC	0	0F	W/G AGREEMENT COUNT		
	04	WDL	30	FF	W/G SEARCH DELAY		
	05	NDL	20	FF	NICAM SEARCH DELAY		
	06	SDL	10	FF	STEREO STATUS READ DELAY		
	07	AGC	1	1	AGC SWITCH AUTO/CONSTANT		
	08	REL	28	3F	AGC GAIN AT CONSTANT MODE		
	09	CRM	0	1	CARRIER MUTING ON/OFF		
	0A	ACO	1	1	AUDIO CLOCK OUT ON/OFF		
	0B	FP	1B	7F	FM PRESCALE FOR NON-M SYSTEM		
	0C	FPM	32	7F	FM PRESCALE FOR M SYSTEM		
	0D	FH	36	7F	FM PRESCALE FOR HDEV		
	0E	FHM	65	7F	FM PRESCALE FOR HDEV AND M		
	0F	WGP	2A	7F	W/G PRESCALE		
	10	NIP	6D	7F	NICAM PRESCALE		
11	ERR	50	FF	AUTO FM SWITCH THRESHOLD			
12	VOL	6D	FF	LOUD SPEAKER GAIN 7000H TO 7FF0H			
TXT	00	TXH	0	3	TELETEXT HORIZONTAL POSITION		SAA5261 (58H)
	01	TXV	0	3	TELETEXT VERTICAL POSITION		
OPM	00	OSH	0A	3F	OSD H POSITION	Option-Misc	CXP750097 (60H)
	01	COM	1	03	COMB SELECTION		
	02	APC	1	1	APC SWITCH		
	03	TSY	0	03	TV SYS AT AUTO TV SYS		
	04	MUT	0	1	NO SIGNAL MUTE		
	05	AFM	0	1	AUTO FM SWITCH		
	06	RFB	0	3	C-BPF CONTROL		
	07	TV0	0	7	TILT TO V-ANGLE OFFSET		
08	DBL	0	1	DISABLE BLUEBACK FUNCTION			

**NOTE**

- ■ shaded items are fixed data.
- Standard data listed on the Adjustment Item Table are reference values, therefore it may be different for each model and for each mode.
- Note for Different Data Those are the standard data values written on the microprocessor. Therefore, the data values of the modes and stored respectively in the memory.  
In case of a device replacement, adjustment by rewriting the data value is necessary for some items.



### 4-3. PICTURE QUALITY ADJUSTMENTS

#### SUB COLOR ADJUSTMENT

1. Select Video.
2. Input a PAL color-bar.
3. Set to the following condition:  
PICTURE 100%, BRIGHTNESS 50%, COLOR 50%
4. Connect an oscilloscope to pin ① (B OUT) of CN305, A board.
5. Set to Service Mode and select SAJ 'SCL' with [1] and [4] of the commander then adjust to VB2=VB3=VB4 with [3] and [6].
6. Press [MUTING] → [0] of the commander to write the data.
7. Adjust SAJ 'SCL' as step 3 to 5 when receiving NTSC color-bar.
8. Select the 'Wide' mode, write the 'same data-3 steps' for both PAL and NTSC input.

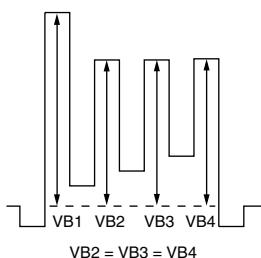

#### SUB HUE ADJUSTMENT

1. Select Video 1.
2. Input a NTSC 3.58 color-bar, video into Video 1.
3. Set the following condition:  
PICTURE 100%, BRIGHTNESS 50%, COLOR 50%
4. Connect an oscilloscope to pin ① (B OUT) of CN305, A board.
5. Select SAJ O1 "SHU" with [1] and [4] of the commander by setting to Service Mode and adjust to VB1=VB2=VB3=VB4 with [3] and [6].

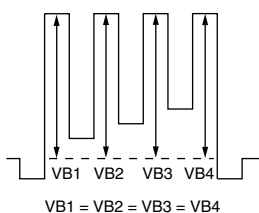

6. Press [MUTING] → [0] of the commander to write the data.
7. Adjust SAJ O1 "SHU" as step 3 to 6 when receiving TV mode.

### 4-4. DEFLECTION ADJUSTMENT

#### NORMAL MODE (50Hz)

1. Set to Service Mode.
2. Using the [1] and [4] button, select category GEO (Service Mode).
3. Raise/lower the data using the [3] and [6] buttons.  
Select and adjust the following items to obtain optimum image.

#### Service Item

GEO : 00	HPS	H POSITION
01	HSZ	H SIZE
02	PAP	PIN AMP
03	TLT	TILT
04	VPS	V POSITION
05	VSZ	V SIZE
06	SCO	S CORRECTION
07	VLN	V LINEARITY
08	BOW	AFC BOW
09	AGL	AFC ANGLE
0A	UPN	UPPER CORNER PIN
0B	LPN	LOWER CORNER PIN

#### NORMAL MODE (60Hz)

11. Input 525/60Hz signal.
12. Using the [1] and [4] buttons select category GEO (Service Mode).
13. Select and adjust the following items to obtain optimum image.  
Raise/lower the data with the [3] and [6] buttons.

#### Service Item

GEO : 00	HPS	H POSITION
01	HSZ	H SIZE
02	PAP	PIN AMP
03	TLT	TILT
04	VPS	V POSITION
05	VSZ	V SIZE
06	SCO	S CORRECTION
07	VLN	V LINEARITY
08	BOW	AFC BOW
09	AGL	AFC ANGLE
0A	UPN	UPPER CORNER PIN
0B	LPN	LOWER CORNER PIN

Note:

For Deflection Adjustment, set PICTURE MODE to "SOFT".

### 4-5. A BOARD ADJUSTMENT AFTER IC003 (MEMORY) REPLACEMENT

1. Enter to Service Mode.
2. Press commander buttons [5] and [0] (Data Initialize), and [2] and [0] (Data Copy) to initialize the data.
3. Call each item number and check if the respective screen shows the normal picture.  
In cases where items are not well adjusted, rectify the fine adjustment.  
Write the data per each item number ([MUTING] + [0]).
4. Select item numbers "OPB00" (OP1), "OPB01" (OP2), "OPB02" (OP3) and "OPB03" (OP4) respectively set the bit per model with command buttons [3] and [6].
5. Press commander buttons [8] and [0] (Test Normal) to return to the data that was set on the shipment from the factory.  
(This will also cancel Service Mode.)



### 4-6. PICTURE DISTORTION ADJUSTMENT (1)

Item Number 00 – 0B

GEO 0 HPS (H POSITION)

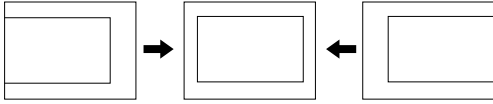

GEO 1 HSZ (H SIZE)

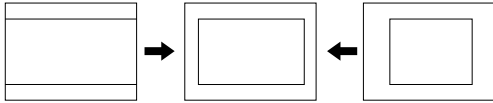

GEO 2 PAP (PIN AMP)

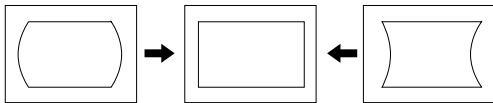

GEO 3 TLT (TRAPEZIUM)

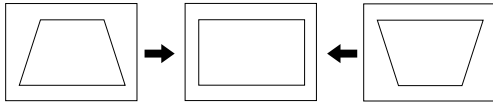

GEO 4 VPS (V POSITION)



GEO 5 VSZ (V SIZE)

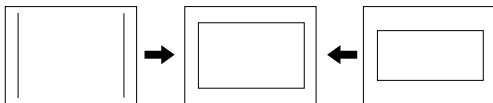

GEO 6 SCO (VERTICAL S-Correction)

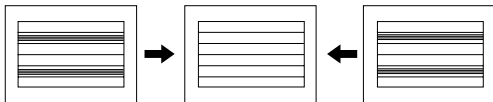

GEO 7 VLN (V LINEARITY)

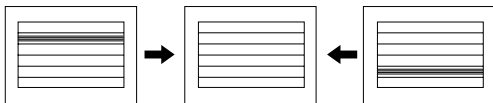

GEO 8 BOW (AFC.BOW)

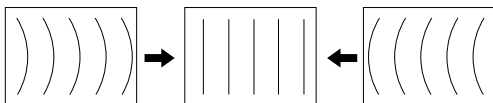

GEO 9 AGL (AFC.ANGLE)

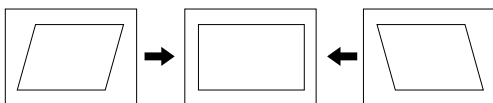

GEO 0A UPN (UPPER CORNER PIN)

GEO 0B LPN (LOWER CORNER PIN)

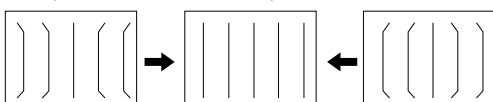





5-2. CIRCUIT BOARDS LOCATION

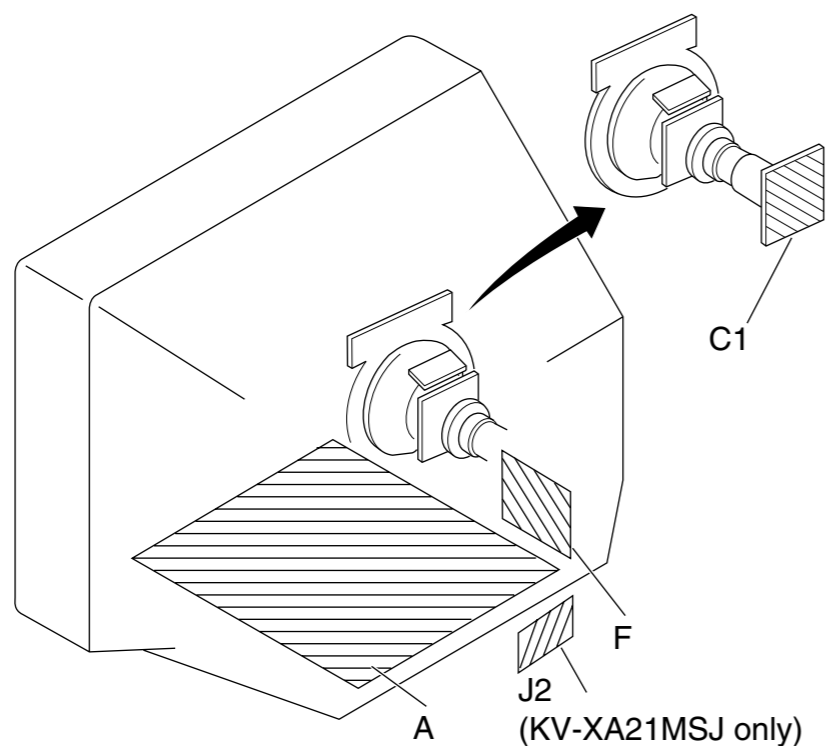

5-3. SCHEMATIC DIAGRAM

Note:

- All capacitors are in  $\mu\text{F}$  unless otherwise noted.
- All electrolytic capacitors are rated at 50V unless otherwise noted.
- All resistors are in ohms.  
 $\text{k}\Omega = 1000\Omega$ ,  $\text{M}\Omega = 1000\text{k}\Omega$
- Indication of resistance which does not have rating electrical power is as follows.

Pitch: 5 mm  
Rating electrical power 1/4W (CHIP: 1/10W)

- : nonflammable resistor.
- $\Delta$  : internal component.
- : panel designation or adjustment for rrepair.
- All variable and adjustable resistors have characteristic curve B unless otherwise noted.
- **Redings are taken with a color-bar signal input.**  
no mark : PAL  
( ) : SECAM  
[ ] : NTSC 3.58  
<< >> : NTSC 4.43
- **Readings are taken with a 10M $\Omega$  digital multimeter.**
- **Voltage are dc with respect to ground unless otherwise noted.**
- **Voltage variations may be noted due to normal production tolerances.**
- **All voltage are in V.**
- \* : Cannot be measured.
- **Circled numbers are waveform references.**
- : B +bus.
- : B -bus.
- : signal path.

Reference information

RESISTOR	: RN	METAL FILM
	: RC	SOLID
	: FPRD	NONFLAMMABLE CARBON
	: FUSE	NONFLAMMABLE FUSIBLE
	: RS	NONFLAMMABLE METAL OXIDE
	: RB	NONFLAMMABLE CEMENT
	: RW	NONFLAMMABLE WIREWOUND
	: *	ADJUSTMENT RESISTOR
COIL	: LF-8L	MICRO INDUCTOR
CAPACITOR	: TA	TANTALUM
	: PS	STYROL
	: PP	POLYPROPYLENE
	: PT	MYLAR
	: MPS	METALIZED POLYESTER
	: MPP	METALIZED POLYPROPYLENE
	: ALB	BIPOLAR
	: ALT	HIGH TEMPERATURE
	: ALR	HIGH RIPPLE

**Note:** The component identified by shading and mark  $\Delta$  are critical for safety. Replace only with part number specified.

(1) Schematic Diagrams of F, J2 and C1 Boards

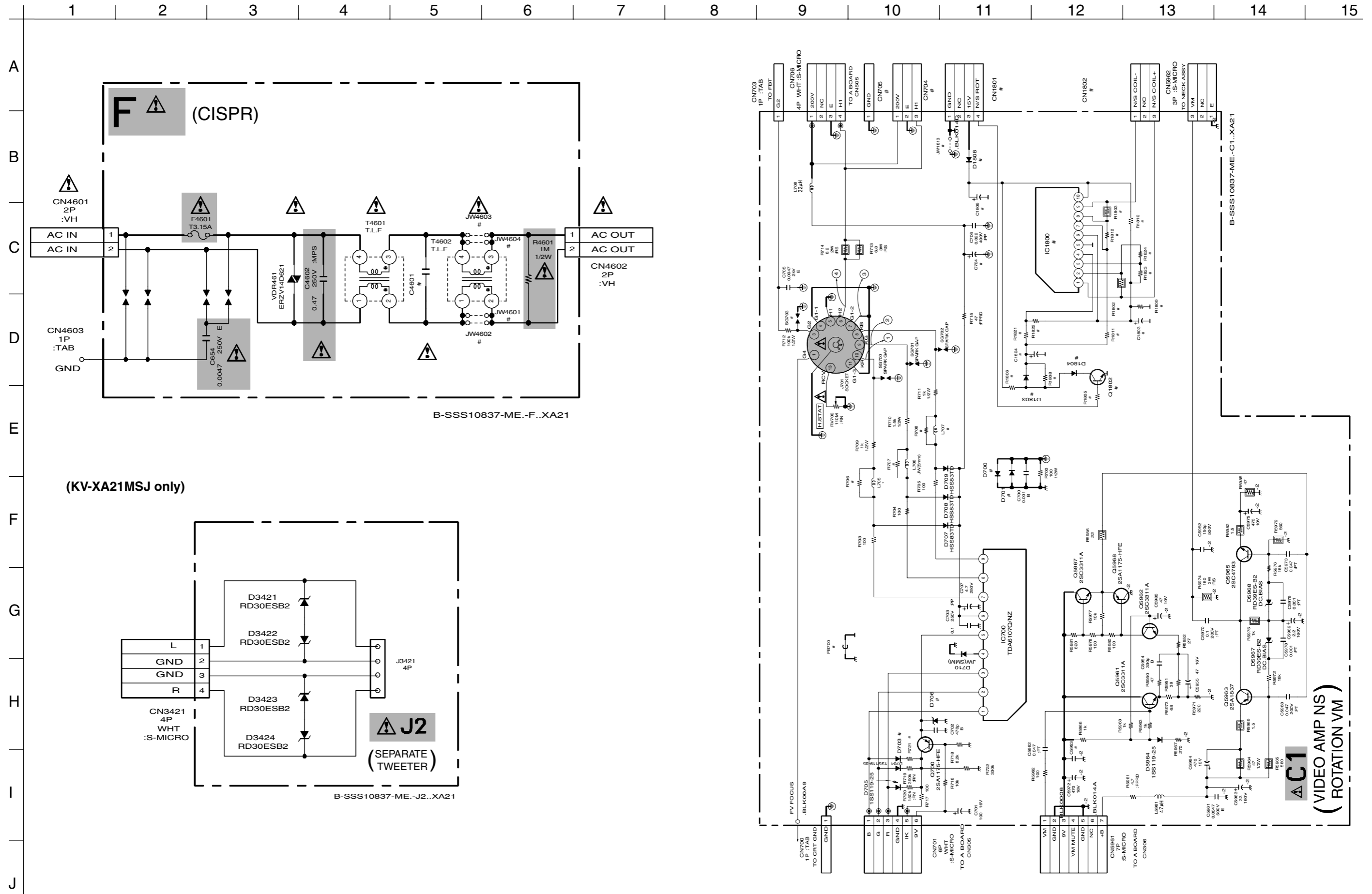

(2) Schematic Diagram of A Board

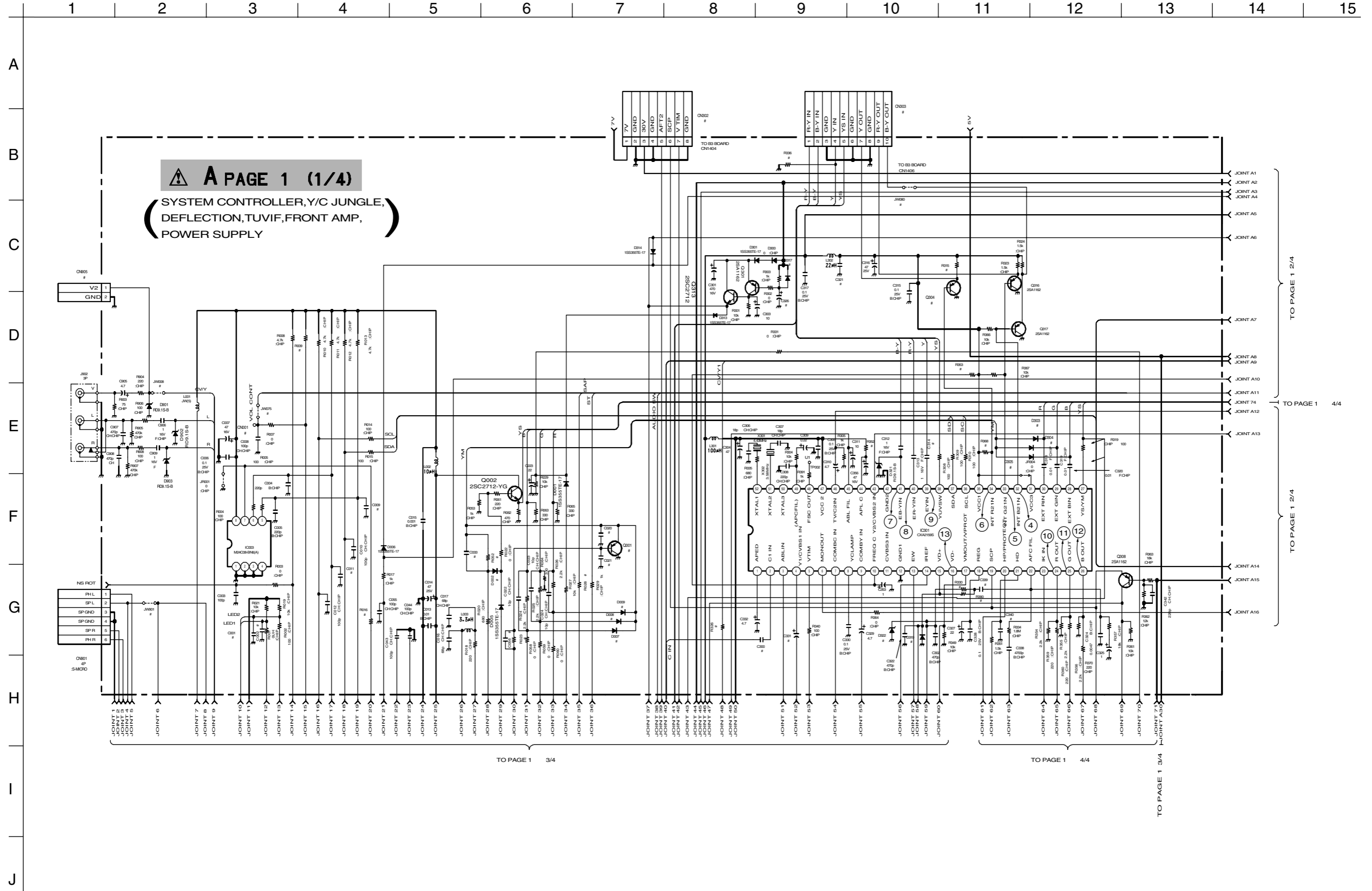

**A PAGE 1 (1/4)**  
(SYSTEM CONTROLLER, Y/C JUNGLE,  
DEFLECTION, TUVIF, FRONT AMP,  
POWER SUPPLY)

TO PAGE 1 2/4

TO PAGE 1 4/4

TO PAGE 1 2/4

TO PAGE 1 3/4

TO PAGE 1 4/4

TO PAGE 1 3/4

1 2 3 4 5 6 7 8 9 10 11 12 13 14 15

A  
B  
C  
D  
E  
F  
G  
H  
I  
J

**⚠ PAGE 1 (2/4)**  
**( SYSTEM CONTROLLER, Y/C JUNGLE, DEFLECTION, TUVIF, FRONT AMP, POWER SUPPLY )**

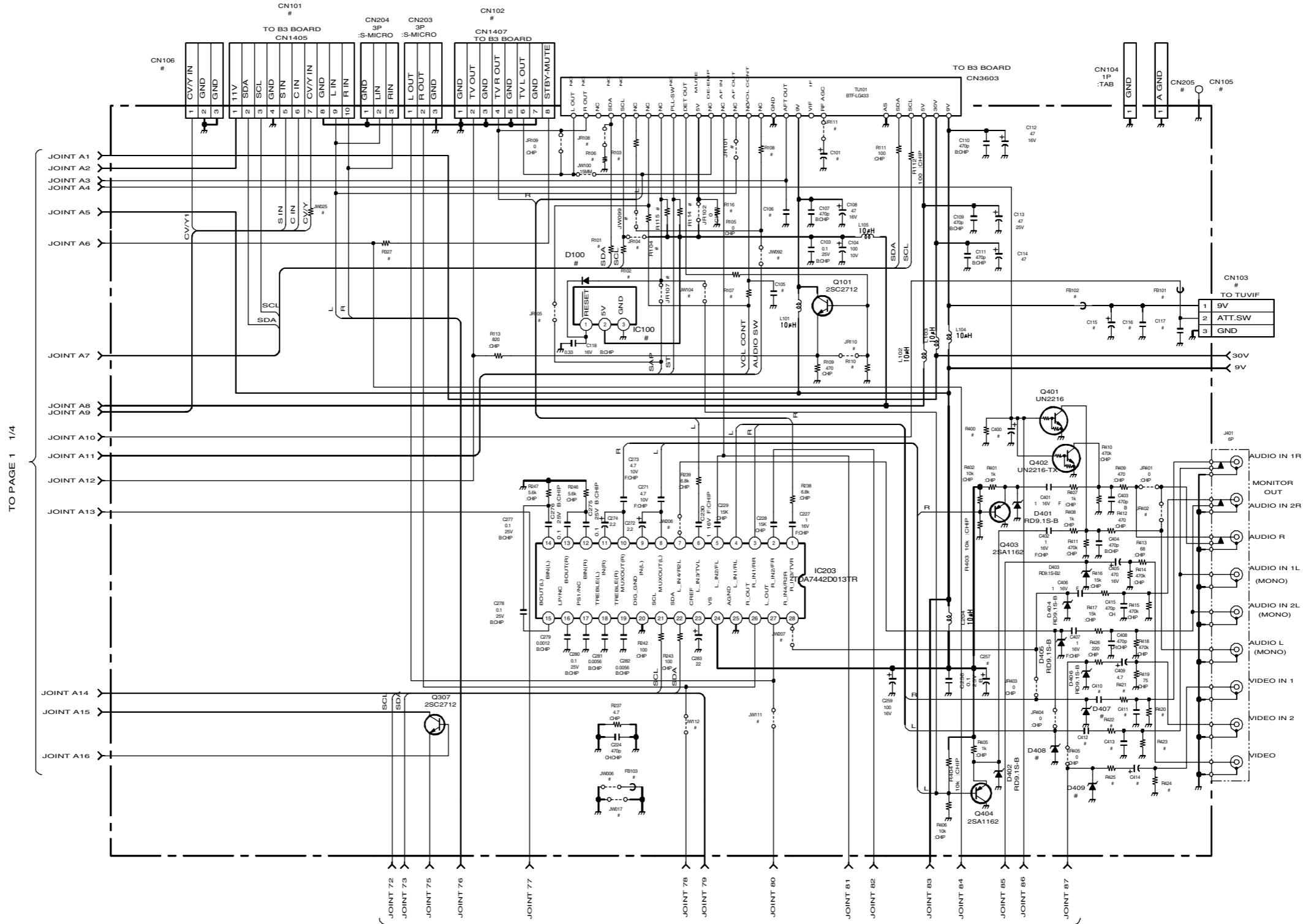

TO PAGE 1 1/4

TO PAGE 1 4/4





1 2 3 4 5 6 7 8 9 10 11 12 13 14 15

A  
B  
C  
D  
E  
F  
G  
H  
I  
J

**A PAGE 1 (4/4)**

**(SYSTEM CONTROLLER, Y/C JUNGLE,  
DEFLECTION, TUVIF, FRONT AMP,  
POWER SUPPLY)**

TO PAGE 1 1/4

TO PAGE 1 2/4

TO PAGE 1 3/4

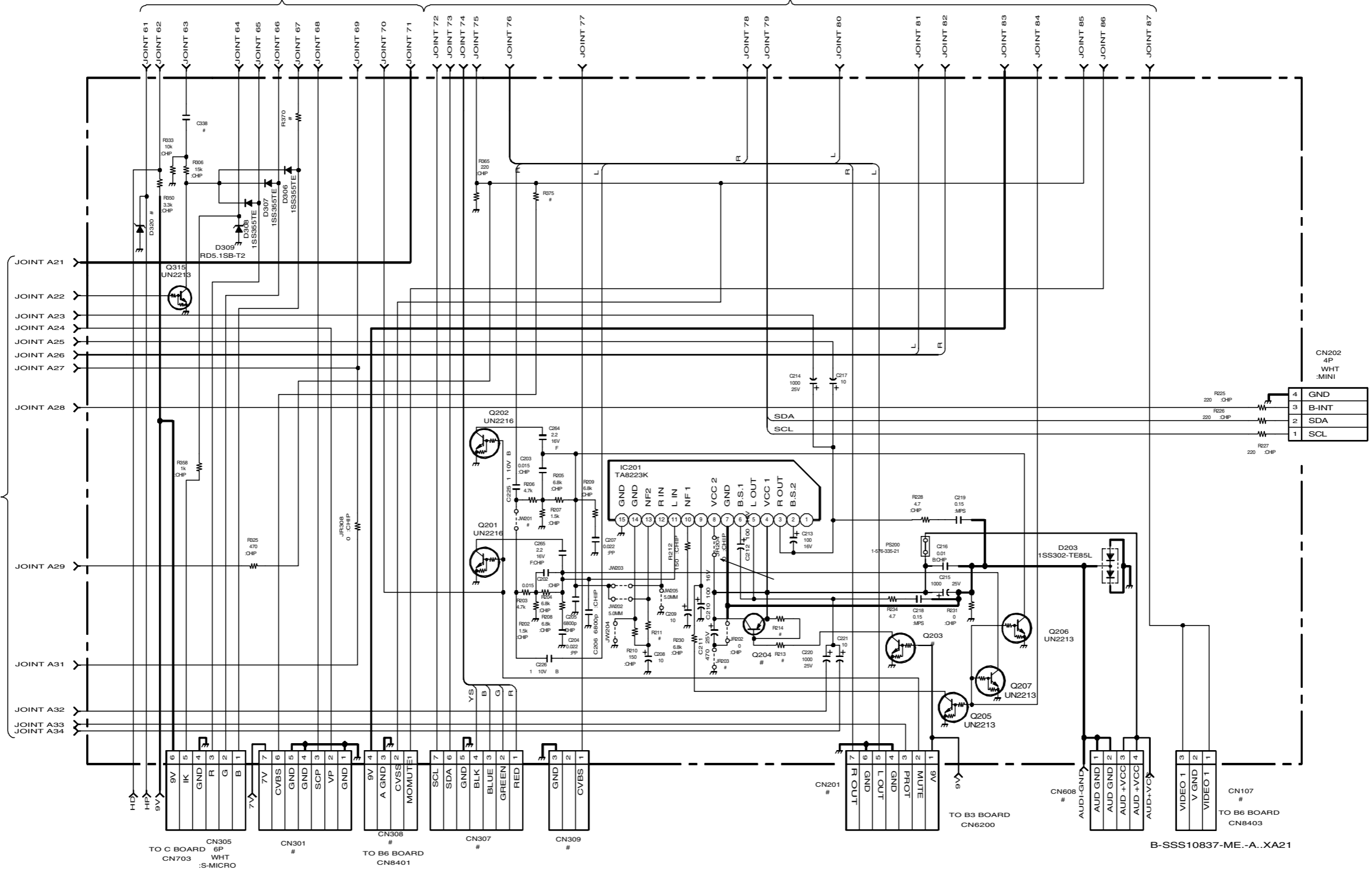

1 2 3 4 5 6 7 8 9 10 11 12 13 14 15

A  
B  
C  
D  
E  
F  
G  
H  
I  
J

**A PAGE 2 (1/4)**

(SYSTEM CONTROLLER, Y/C JUNGLE,  
DEFLECTION, TUVIF, FRONT AMP,  
POWER SUPPLY)

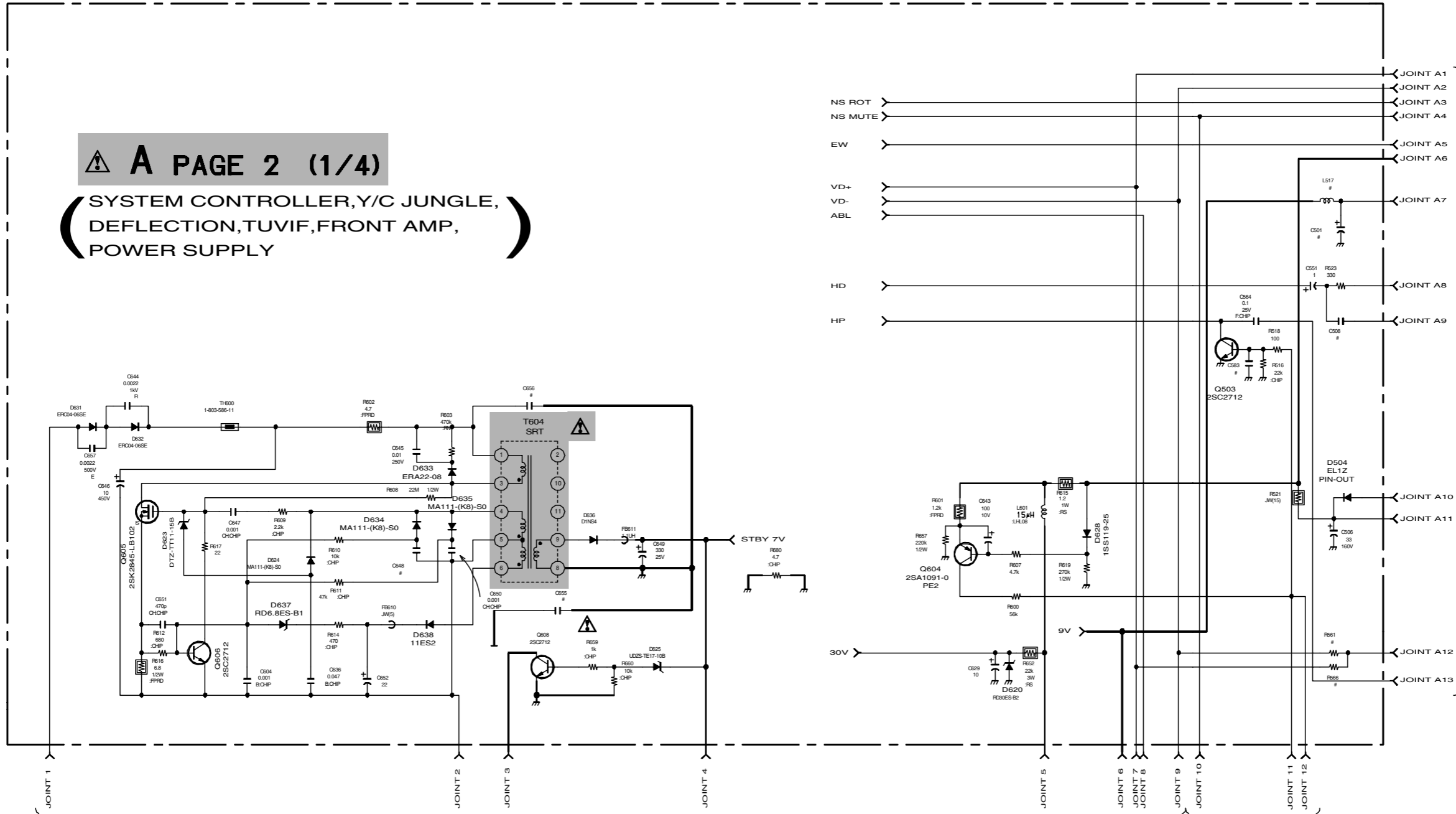

TO PAGE 2 3/4

TO PAGE 2 4/4

TO PAGE 2 2/4

1 2 3 4 5 6 7 8 9 10 11 12 13 14 15

A  
B  
C  
D  
E  
F  
G  
H  
I  
J

**⚠ A PAGE 2 (2/4)**  
(SYSTEM CONTROLLER, Y/C JUNGLE,  
DEFLECTION, TUVIF, FRONT AMP,  
POWER SUPPLY)

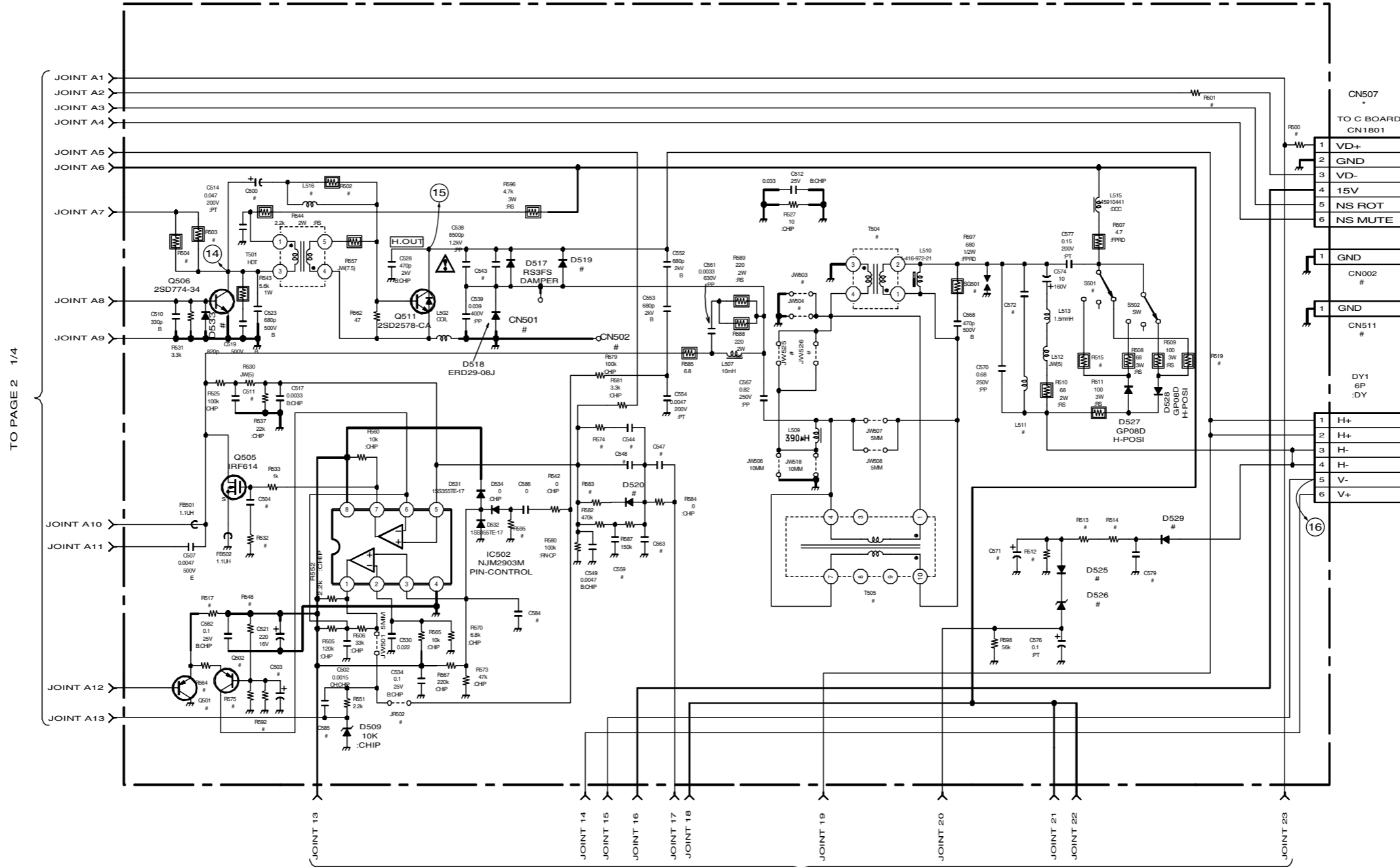

TO PAGE 2 1/4

TO PAGE 2 4/4

1 2 3 4 5 6 7 8 9 10 11 12 13 14 15

A

**⚠ A PAGE 2 (3/4)**

**( SYSTEM CONTROLLER, Y/C JUNGLE,  
DEFLECTION, TUVIF, FRONT AMP,  
POWER SUPPLY )**

TO PAGE 2 1/4

C

D

E

F

G

H

I

J

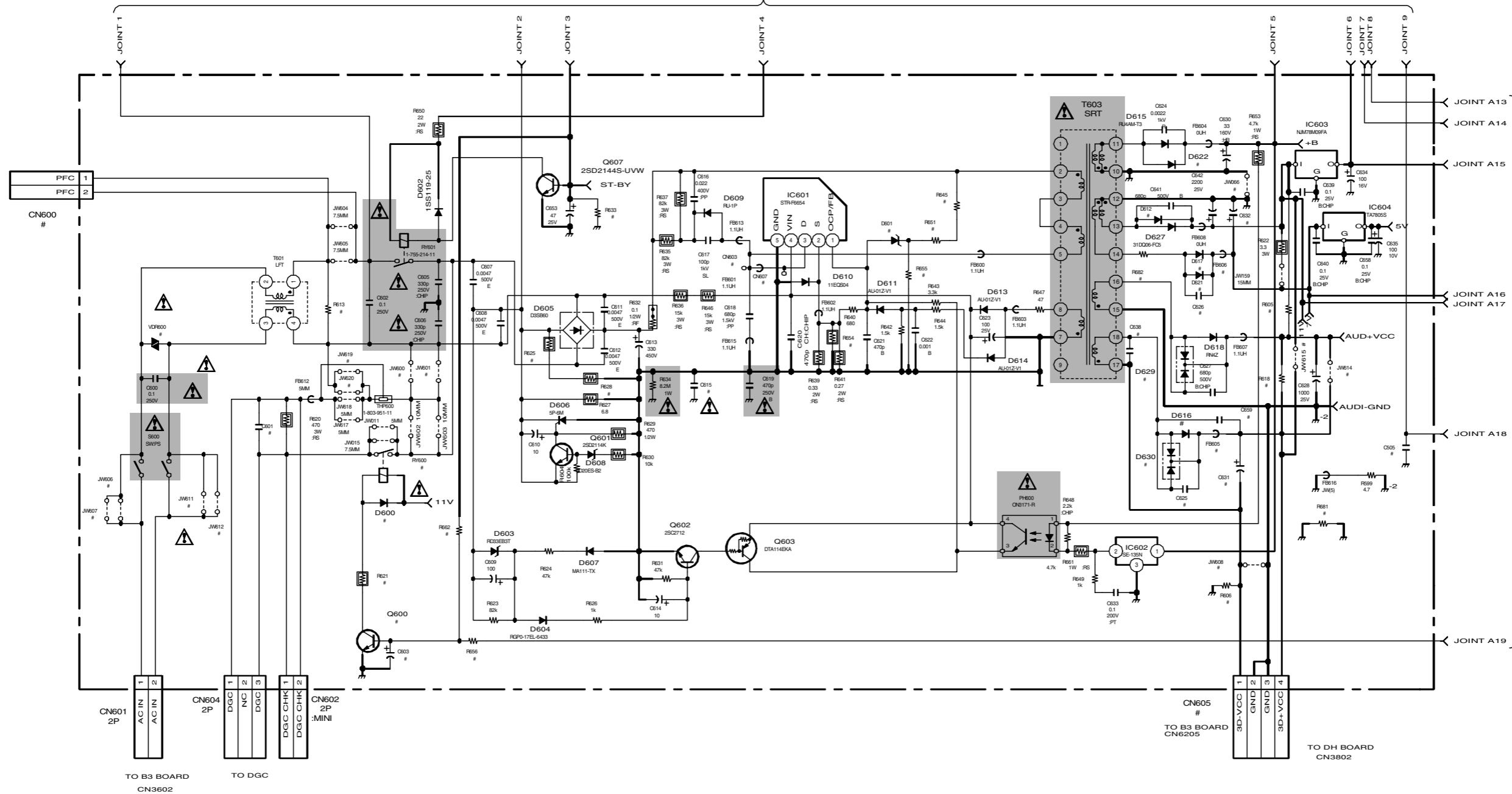

TO PAGE 2 4/4



5-4. VOLTAGE LIST MEASUREMENT

A BOARD VOLTAGE LIST

Ref	Pin No.	Voltage[v]	Ref	Pin No.	Voltage[v]	Ref	Pin No.	Voltage[v]
IC001	1	0	IC003	1	0		5	4.8
	2	4.5 <4.0>		2	0		6	4.3
	3	0.5 <0.3>		3	0		7	1.5
	4	5.0		4	0		8	3.8
	5	5.0		5	5.0		9	4.9
	6	0		6	5.0		10	3.8
	7	4.0		7	0		11	5.0
	8	4.8		8	5.0		12	0
	9	0.5	IC100	1	4.8		13	3.8
	10	4.8		2	4.8		14	2.3
	11	5.0		3	0		15	3.5
	12	0	IC201	1	0		16	3.4
	13	2.1		2	19.6		17	5.4
	14	2.0		3	10.4		18	7.6
	15	5.0		4	20.0		19	0.8
	16	5.0		5	10.5		20	3.6
	17	0		6	19.6		21	3.0
	18	0		7	0		22	3.8
	19	2.0 <2.7>	8	20.0	23		3.0 <3.5>	
	20	0.4	9	10.3	24		1.5	
	21	5.0	10	0.6	25		1.5	
	22	0	11	0	26		1.6	
	23	5.0	12	0	27		0	
	24	0.4	13	0	28		4.5	
	25	0	14	0.6	29		4.5	
	26	5.0	15	0	30		4.5	
	27	4.8	IC203	1	4.4		31	8.8
	28	5.0		2	4.4		32	4.1
	29	0		3	4.4		33	4.1
	30	0		4	4.4		34	3.6
	31	0		5	4.4		35	8.8
	32	0		6	4.4		36	4.5
	33	5.0		7	4.4		37	4.5
	34	0		8	4.4		38	0
	35	0		9	4.4		39	4.1
	36	2.3		10	4.4		40	4.7
	37	2.5		11	4.4		41	4.7
	38	4.9		12	4.4		42	0
	39	5.0		13	4.4		43	5.1
	40	0		14	4.4		44	4.9
	41	0.4		15	4.4		45	7.1 <6.5>
	42	0.4	16	4.4	46		5.0	
	43	0	17	4.4	47		8.7	
	44	5.0	18	4.4	48		0.2	
	45	5.0	19	4.4	49		5.1 (4.3) <0>	
	46	4.6	20	0	50		0	
	47	5.0	21	4.5	51		0	
	48	4.4	22	4.5	52		#	
	49	0	23	4.4	IC302		1	0.9
	50	2.0	24	8.8			2	0
	51	0	25	0			3	1.3
	52	5.0 <0>	26	3.7			4	0
IC002	1	0	27	3.7		5	4.9	
	2	5.0	28	4.4		6	4.9	
	3	4.9	IC301	1		3.4	7	1.0
	4	7.3		2		5.0	8	0
	5	5.0		3		2.4 <1.9>	9	0.5
	6	0		4		5.0	10	0
	7	0				11	0	

Ref	Pin No.	Voltage[v]	Ref	Pin No.	Voltage[v]	Ref	Pin No.	Voltage[v]
	12	1.6	Q206	B	0	Q403	B	4.5
	13	0		C	0		C	0
	14	1.5		E	0		E	5.2
	15	0	Q207	B	0		Q404	B
16	1.5	C		0	C	0		
IC502	1	1.3		E	0	E		5.2
	2	3.6	Q301	B	12.8	Q503	B	0
	3	1.2		C	0		C	3.6
	4	0		E	12.6		E	0
	5	3.4	Q302	B	1.5	Q505	D	8.6 <8.2>
6	3.0	C		8.1	G		6.9	
7	6.8	E		0.9	S		0	
8	8.9	Q303	B	8.1	Q506	B	-0.4	
IC503	1		1.0	C		1.5	C	48.6
	2		13.6	E		8.7	E	0
	3	-12.4 <12.1>	Q305	B	8.1	Q507	B	13.0
	4	-13.6		C	1.8		C	0
	5	0.2		E	8.7		E	13.5
6	13.8	Q306	B	1.5	Q509	B	0.6	
7	1.0		C	8.1		C	0.1	
IC601	1		3.3 (1.8)	E		0.9	E	0
	2	1.7 (0.2)	Q307	B	4.3	Q511	B	0
	3	113.3		C	8.7		C	122.6
	4	19.0 (17.5) <19.3>		E	3.7		E	0
	5	1.6 (0.1) <1.9>	Q308	B	3.6	Q600	B	0
IC602	1	121.1		C	0.5		C	0
	2	135.0		E	0.8		E	0
	3	0	Q310	B	0.2	Q604	B	133.9
IC603	I	12.8		C	4.9		C	0
	G	0		E	0		E	134.3
	O	8.9	Q312	B	5.3	Q605	D	121.6
IC604	I	10.5		C	0		G	-0.4 <-0.6>
	G	0		E	7.0 <6.5>		S	-2.1
	O	5.0	Q313	B	0	Q606	B	-1.5
IC901	1	4.9		C	12.7		C	-0.5
	2	0		E	0		E	-2.1
	3	4.7 <4.1>	Q314	B	0.5	Q607	B	0.7
Q002	B	0		C	0		C	0
	C	5.0		E	1.0		E	0
	E	0	Q315	B	0	Q608	B	0
Q101	B	2.8		C	1.6 <1.9>		C	0.7
	C	8.9		E	0		E	0
	E	2.2	Q316	B	4.1	Q901	B	0.1
Q201	B	0		C	0		C	5.0
	C	0		E	4.7		E	0.1
	E	0	Q317	B	4.1	Q902	B	0
Q202	B	0		C	0		C	5.0
	C	0		E	4.7		E	0
	E	0	Q401	B	0	PH600	1	128.7
Q205	B	0		C	0		2	127.7
	C	10.3		E	0		3	3.6
	E	0	Q402	B	0		4	17.5
	B	0		C	0			
	C	0		E	0			
	E	0						

C1 BOARD VOLTAGE LIST

Ref	Pin No	Voltage[v]	Ref	Pin No.	Voltage[v]	Ref	Pin No.	Voltage[v]
IC700	1	1.6	J701	G2	325.8 (328.2) <323.4>	Q5963	B	134.1
	2	1.6		H1	0		C	67.1
	3	1.5		KB	155.8 (153.2) <150.3>		E	134.7
	4	0		KG	158 (155.7) <153.7>	Q5965	B	0.9
	5	4.9<5.3>		KR	160.8 <154.57>		C	67.1
	6	194.5	Q700	B	4.5	E	0.3	
	7	160.5 <154>		C	3.6 (3.4) <4.3>	Q5967	B	5.9
	8	157.4 (155) <153>		E	4.9 <5.3>		C	8.9
	9	155.3 (152.2) <150>	Q1802	B	0.3	E	5.6	
IC1800	1	6.7		C	3.6	Q5968	B	5.3
	2	6.7		E	0		C	0
	3	6.7	Q5961	B	2.4		E	5.6
	4	6.6		C	8.9			
	5	0		E	1.8			
	6	6.6	Q5962	B	2.4			
	7	6.6		C	5.3			
	8	6.6		E	1.8			
	9	6.6						
	10	13.1						

5-5. WAVEFORMS

A BOARD WAVEFORMS

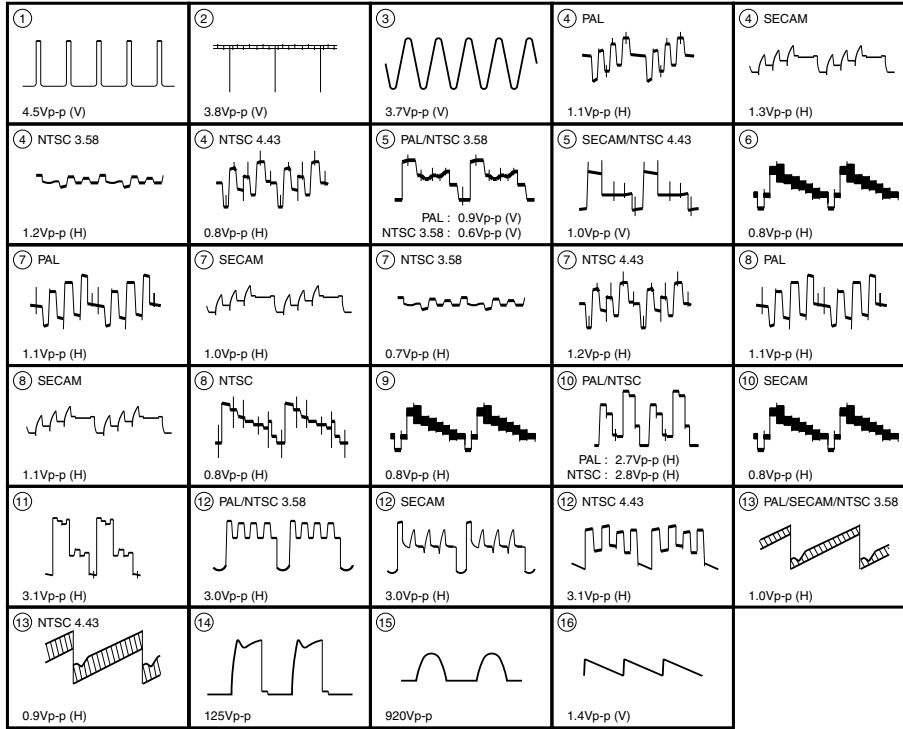

C1 BOARD WAVEFORMS

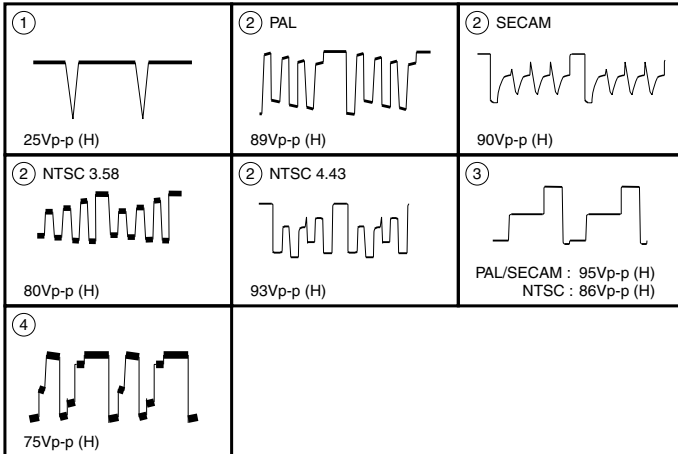



5-6. PRINTED WIRING BOARDS AND PARTS LOCATION  
PRINTING WIRING BOARD

**A** [SYSTEM CONTROLLER, Y/C JUNGLE, DEFLECTION, TUVIF, FRONT AMP, POWER SUPPLY]

- A Board -

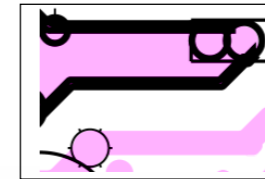
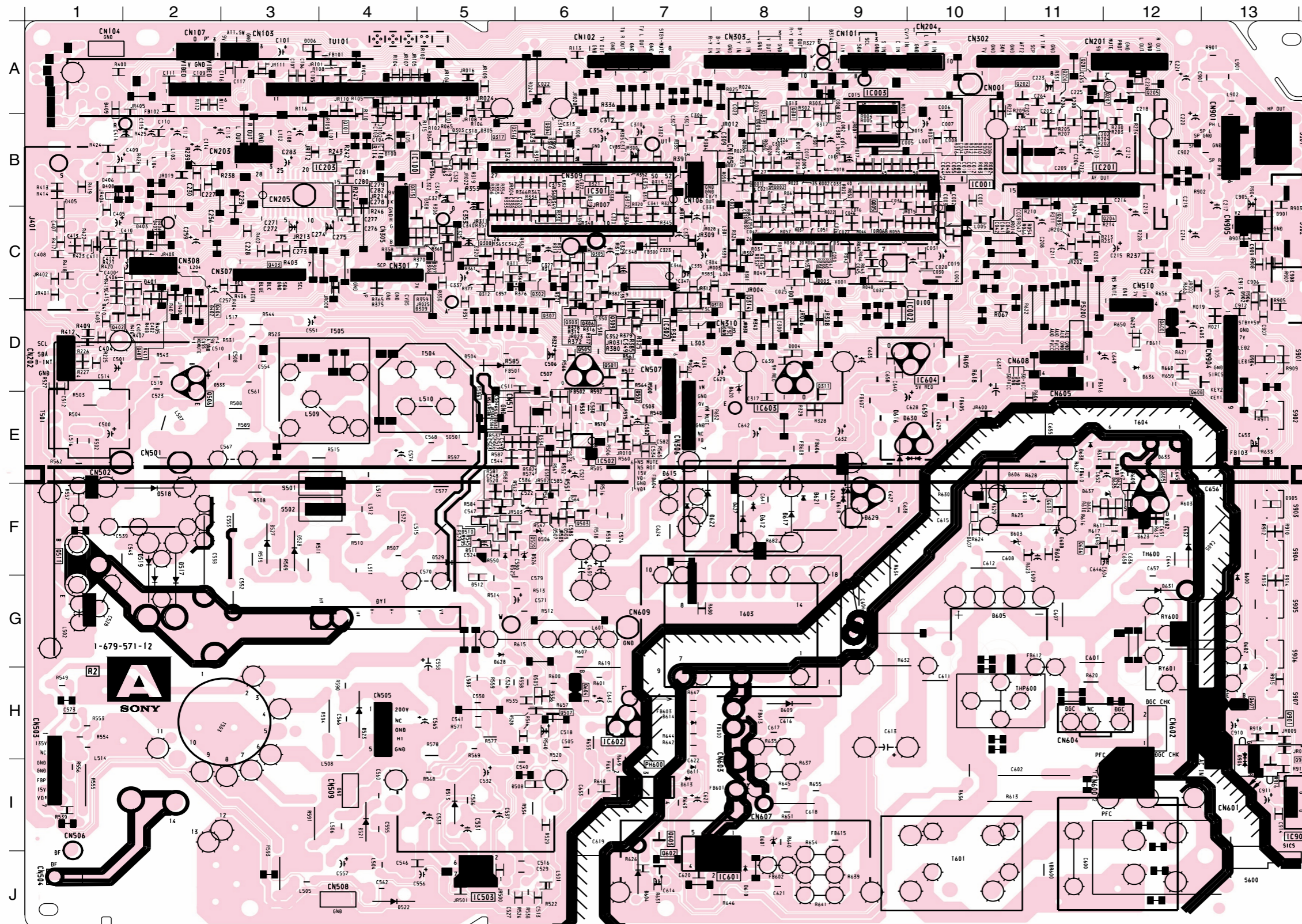

**NOTE:**  
The circuit indicated at left contains high voltage of over 1220 Vp-p. Please pay attention when inspecting or repairing it to prevent an electric shock.

**A BOARD**

IC	Q606	F-11	D531	E-6
IC001	Q607	H-13	D533	D-2
IC002	Q608	D-12	D534	E-6
IC003	Q901	H-13	D600	G-13
IC100	Q902	H-13	D601	I-8
IC201	<b>DIODE</b>		D602	G-13
IC203			D604	J-7
IC301	D001	B-8	D605	G-10
IC302	D003	C-9	D606	E-11
IC502	D004	D-8	D607	F-10
IC503	D005	B-8	D608	F-11
IC601	D006	A-3	D609	H-8
IC602	D007	B-8	D610	J-8
IC603	D008	B-8	D611	I-7
IC604	D009	B-8	D612	F-8
IC901	D100	B-4	D613	I-7
	D203	C-11	D616	E-9
	D300	A-9	D617	F-8
<b>TRANSISTOR</b>	D301	B-9	D618	F-9
Q001	D303	B-5	D620	D-8
Q002	D304	B-5	D621	F-9
Q005	D305	B-5	D622	F-8
Q101	D306	C-5	D623	F-12
Q201	D307	C-5	D624	F-12
Q202	D308	D-5	D625	D-12
Q203	D309	D-5	D627	F-8
Q204	D312	C-5	D628	G-5
Q205	D313	A-8	D629	F-9
Q206	D314	A-9	D630	E-10
Q207	D315	B-7	D631	G-10
Q301	D317	B-9	D632	F-12
Q302	D319	B-6	D633	E-12
Q303	D320	C-5	D634	F-11
Q304	D321	B-6	D635	F-12
Q305	D322	B-6	D636	D-12
Q306	D401	C-2	D637	F-11
Q307	D402	D-2	D638	E-11
Q308	D403	C-2	D651	E-7
Q309	D404	C-2	D901	C-13
Q310	D405	B-1	D902	C-13
Q311	D406	B-1	D903	C-13
Q312	D407	C-2	D904	C-13
Q313	D408	B-1	D905	F-13
Q314	D409	A-1	D906	H-13
Q315	D504	D-5		
Q316	D505	H-6		
Q317	D506	F-6		
Q401	D507	F-6		
Q402	D508	I-7		
Q403	D509	F-6		
Q404	D510	F-5		
Q501	D511	F-5		
Q502	D512	G-5		
Q503	D513	I-5		
Q505	D517	F-2		
Q506	D518	F-2		
Q507	D519	F-2		
Q509	D520	E-5		
Q511	D521	I-4		
Q600	D522	J-4		
Q601	D523	H-4		
Q602	D525	F-5		
Q603	D526	F-6		
Q604	D527	F-3		
Q605	D528	F-3		
	D529	F-5		

PRINTING WIRING BOARD

**C1** [AUDIO PROCESSOR, AUDIO AMP,  
SUB TUNER, AV IN/OUT, VM DRIVER]

**F** [FRONT AV IN, SENSOR, POWER SW]

– C1 Board –

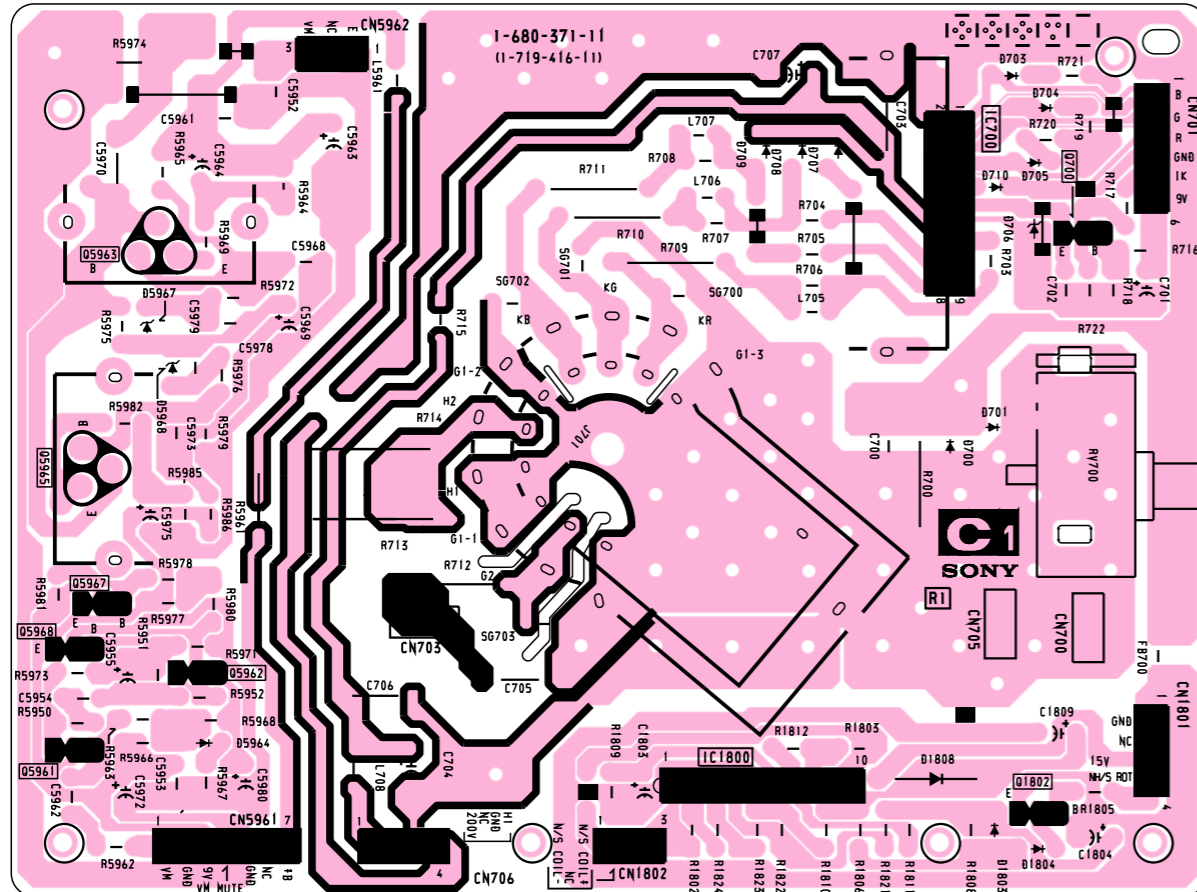

– F Board –

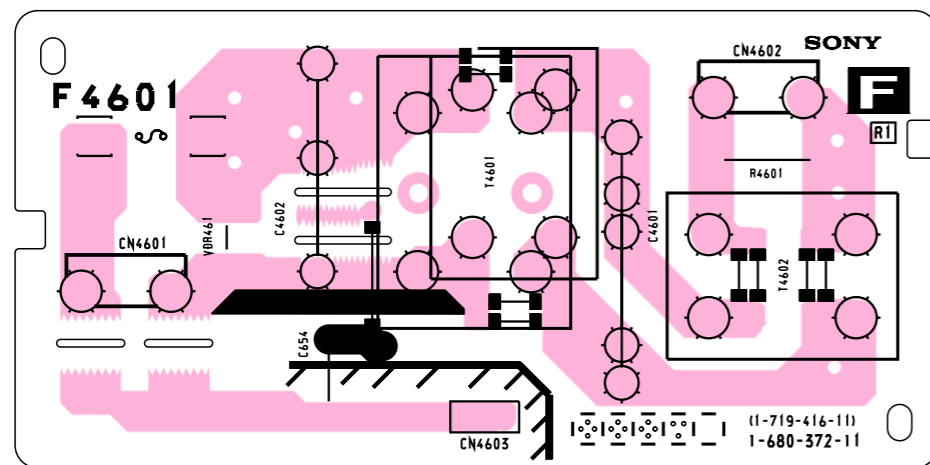

**J2** [FRONT AV IN, SENSOR, POWER SW]

– J2 Board – (KV-XA21MSJ only)

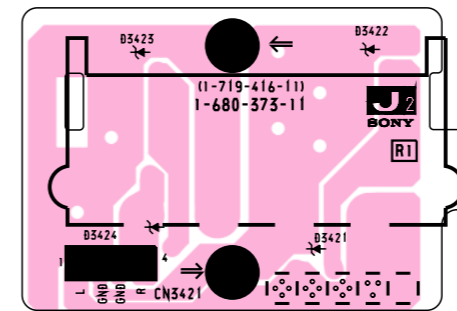

5-7 SEMICONDUCTORS

DIODE

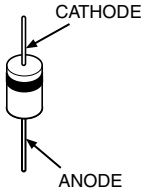
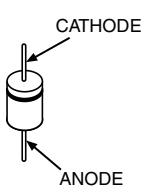
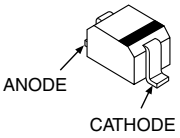
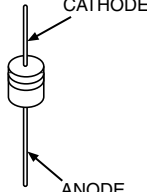
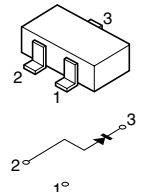
					
AU-01Z-V1 EL1Z ERA22-08 ERC04-06SE GP08D HSS83TD	31DQ06-FC5 RU4AM-T3 RS3FS RD33EB3T RGP02-17E-6433	ERD29-08J	DTZ-TT11-15B DTZ10B MA111-(K8).S0 RD5.1SB-T2 RD9.1S-B 1SS355TE17 ISS352	D1NS4 RD6.8ES-B1 RD6.8SB-T1 RD20ES-B2 RD30ES-B2 1SS119-25 11EQS04 11ES2	1SS302

TRANSISTOR

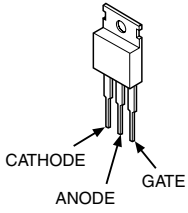
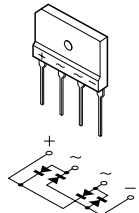
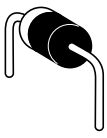
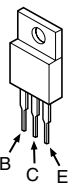
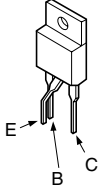
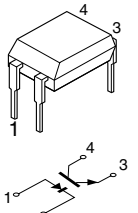
					
5P-6M	D3SB60	RN4Z	2SC4793 2SA1837	2SK2845-LB102	ON3171-R

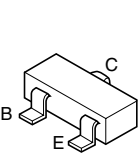
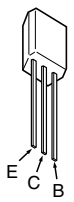
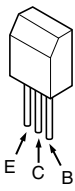
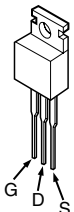
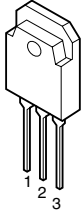
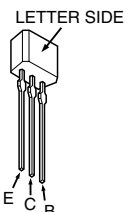
					
DTA114EKA-T146 UN2213 UN2216 UN2111 2SC2712-YG 2SA1162-G 2SD2114K 2SC1623-L5L6 2SA601A-Q	2SA1091-0 2SD2144S-UVW	2SD774-34	IRF614	2SD2578-CA	2SC3311A-QRSTA 2SA1175-HFE

IC

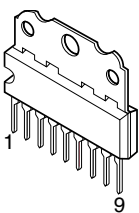
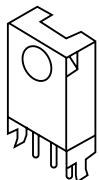
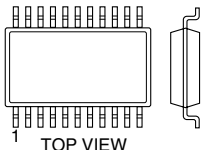
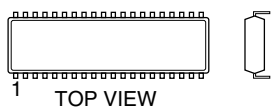
		<p>SOP</p>  <p>TOP VIEW</p> <p>Single In-line Package Pin 8~98</p>	<p>DIP</p>  <p>TOP VIEW</p> <p>Dual In-line Package Pin 6~98</p>
<p>TDA6107Q/N2</p>	<p>SBX1981-51(21)</p>	<p>MM1319AFBE NJM2903M</p>	<p>CXA2159S M24C08-BN6 TDA9183T</p>

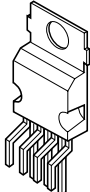
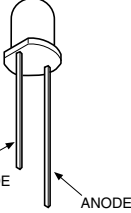
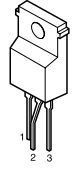
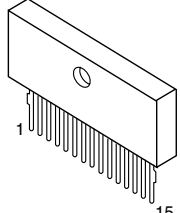
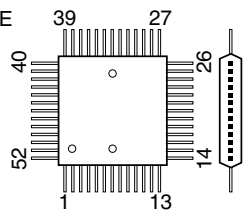
	 <p>CATHODE</p> <p>ANODE</p>	 <p>1 2 3</p>	 <p>1 15</p>	<p>MARKING SIDE VIEW</p>  <p>39 27</p> <p>40 26</p> <p>52 14</p> <p>1 13</p>
<p>TDA8172</p>	<p>NJM78M09FA</p>	<p>SE-135N</p>	<p>TA8223K</p>	<p>RU-1P</p>

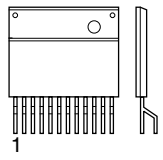
<p>MARKING SIDE VIEW</p>  <p>1</p> <p>Zig-zag In-line Package Pin 6~99</p>
<p>STR-F6654</p>

## SECTION 6 EXPLODED VIEWS

**NOTE:**

- Items with no part number and no description are not stocked because they are seldom required for routine service.
- The construction parts of an assembled part are indicated with a collation number in the remark column.
- Items marked " \* " are not stocked since they are seldom required for routine service. Some delay should be anticipated when ordering these items.

The components identified by shading and mark  $\Delta$  are critical for safety. Replace only with part number specified.

### 6-1. PICTURE TUBE

- : 7-685-648-79 SCREW +BVTP 3 × 12
- : 7-685-663-71 SCREW +BVTP 4 × 16

**NOTE:**

- The picture tube for OCE model is upside down, and the position for the anode cap and tension springs are changed accordingly.

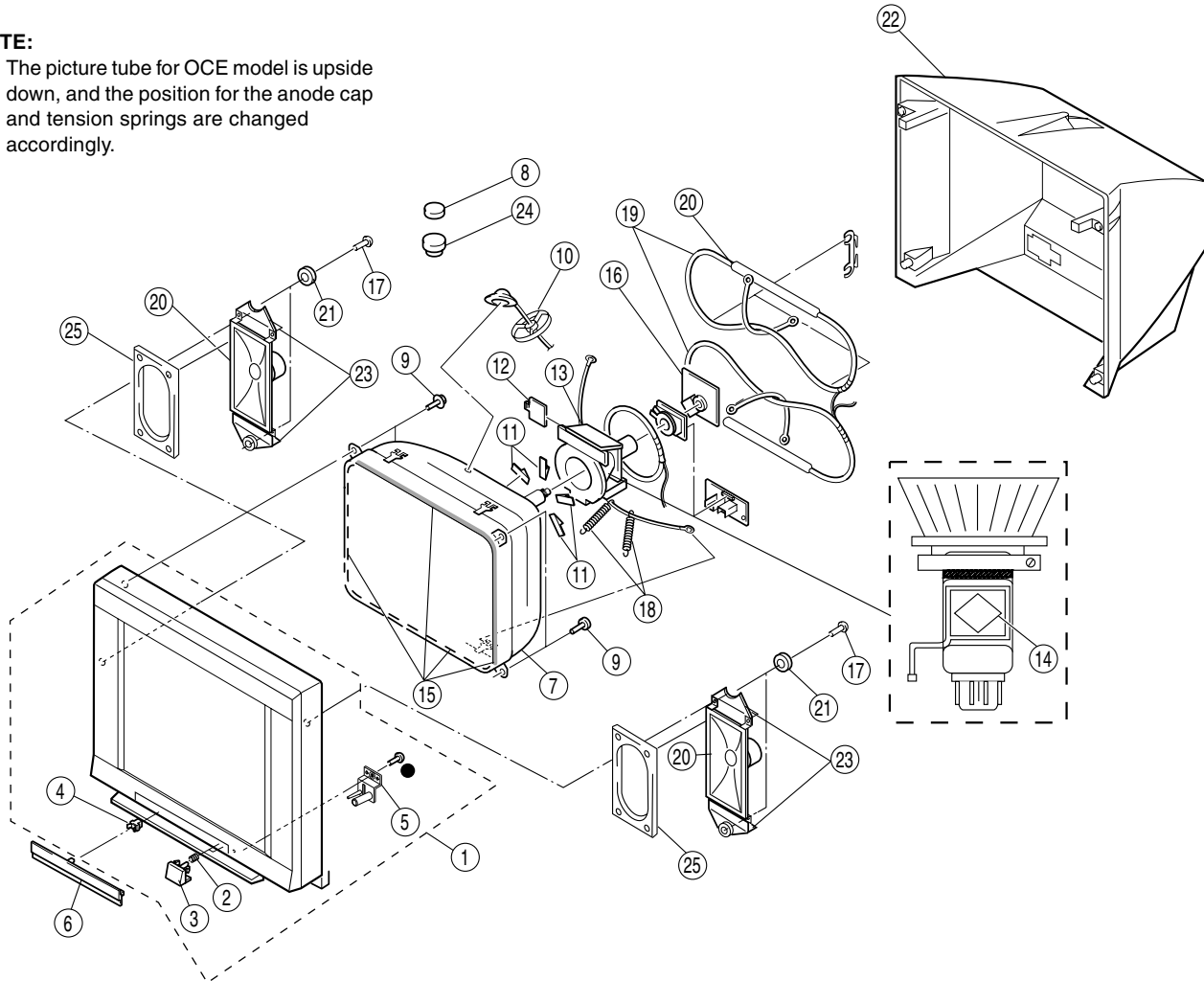

REF. NO.	PART NO.	DESCRIPTION	REMARK	REF. NO.	PART NO.	DESCRIPTION	REMARK
1	X-4038-769-1	BEZNET ASSY	2 - 5	13	$\Delta$ 8-451-505-11	DEFLECTION YOKE (Y21RSA-S)	
2	4-036-405-11	SPRING, COMPRESSION		14	1-416-864-12	COIL VM	
3	4-080-400-01	BUTTON, POWER		15	4-069-652-21	CUSHION (HS BAND)	
4	4-047-464-01	CATCHER, PUSH		16	* A-1332-175-A	C1 BOARD, MOUNTED	
5	* 4-080-401-01	GUIDE, LIGHT		17	4-302-404-03	SCREW (WASHED HEAD) (+P4 X 16)	
6	4-080-399-81	DOOR, CONTROL		18	4-369-318-00	SPRING, EXTENSION	
7	$\Delta$ 8-738-809-05	PICTURE TUBE (A51LPT70X)		19	$\Delta$ 1-416-946-11	COIL, DEMAGNETIC	
8	1-452-032-00	MAGNET, DISC		20	1-529-125-11	SPEAKER (13 X 7 cm)	
9	4-365-808-01	SCREW, (5)TAPPING		21	4-374-745-21	CUSHION A	
10	* 3-704-372-01	HOLDER, HV CABLE		22	4-080-398-01	COVER REAR	
11	4-046-600-01	SPACER, DY		23	* 4-046-981-01	BRACKET, SPEAKER	
12	4-074-013-01	PIECE, TLH CONVERGENCE		24	4-051-736-21	PIECE A(90) CONV, CORRECT	
				25	4-069-797-01	CUSHION SPEAKER (S)	

**6-2. CHASSIS**

- : 7-685-648-79 SCREW +BVTP 3 × 12
- : 7-685-663-71 SCREW +BVTP 4 × 16

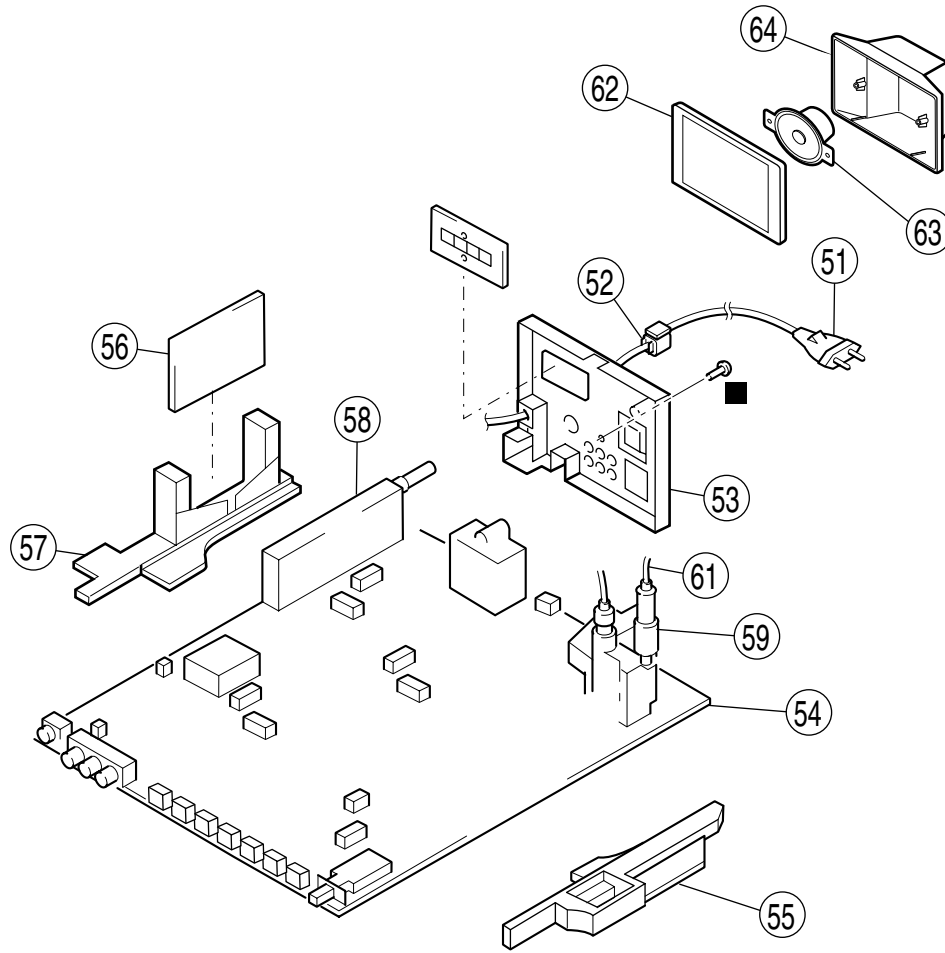

REF. NO.	PART NO.	DESCRIPTION	REMARK
51	△ 1-574-062-11	CORD, POWER (WITH CONNECTOR)	
52	△ 4-022-115-00	HOLDER, AC CORD	
53	* 4-067-877-11	BRACKET TERMINAL	
54	* A-1299-482-A	A BOARD, COMPLETE	
55	* 4-067-876-11	PWB(R) GUIDE	
56	* A-1241-481-A	F BOARD, MOUNTED	
57	* 4-067-875-11	PWB(L) GUIDE	
58	8-598-449-10	TUNER, FSS BTF-LG433	
59	△ 1-453-293-11	TRANSFORMER ASSY FLYBACK (NX-1748/M3A4)	

REF. NO.	PART NO.	DESCRIPTION	REMARK
60	A-1388-314-A	J2 BOARD MOUNTED (KV-XA21MSJ)	
61	1-900-212-58	LEAD ASSY, FOCUS	
62	4-080-403-01	BOX, FRONT (TWEETER)	
63	4-080-402-01	BOX, REAR (TWEETER)	
64	1-529-968-11	SPEAKER (5CM)	

SECTION 7  
ELECTRICAL PARTS LIST



NOTE:

The components identified by shading and mark  $\triangle$  are critical for safety. Replace only with part number specified.

When indicating parts by reference number, please include the board name.

- Items marked " \* " are not stocked since they are seldom required for routine service. Some delay should be anticipated when ordering these items.
- All resistors are in ohms
- F : nonflammable
- CAPACITORS
- MF :  $\mu$ F, PF :  $\mu$  $\mu$ F
- All variable and adjustable resistors have characteristic curve B, unless otherwise noted.
- COILS
- MMH : mH, UH :  $\mu$ H

REF. NO.	PART NO.	DESCRIPTION	REMARK	REF. NO.	PART NO.	DESCRIPTION	REMARK
* A-1299-479-A		A BOARD COMPLETE (KV-XA21MSJ)		C104	1-104-665-11	ELECT	100UF 20.00% 10V
* A-1299-482-A		A BOARD COMPLETE (KV-XA21M8J)		C107	1-163-005-11	CERAMIC CHIP	470PF 10.00% 50V
		*****		C108	1-104-664-11	ELECT	47UF 20.00% 16V
* 4-055-304-01		HOLDER, LED		C109	1-163-005-11	CERAMIC CHIP	470PF 10.00% 50V
4-067-182-01		HOLDER, FBT		C110	1-163-005-11	CERAMIC CHIP	470PF 10.00% 50V
4-352-844-01		PIN, LEAD, COATING		C111	1-163-005-11	CERAMIC CHIP	470PF 10.00% 50V
4-382-854-11		SCREW (M3X10), P, SW (+)		C112	1-104-664-11	ELECT	47UF 20.00% 16V
4-382-854-21		SCREW (M3X14), P, SW (+)		C113	1-104-664-11	ELECT	47UF 20.00% 25V
				C114	1-126-967-11	ELECT	47UF 20.00% 50V
7-685-648-79		SCREW +BVTP 3X12 TYPE2 IT-3		C118	1-110-501-11	CERAMIC CHIP	0.33UF 10.00% 16V
		<CAPACITOR>		C202	1-163-023-00	CERAMIC CHIP	0.015UF 10.00% 50V
C003	1-163-251-11	CERAMIC CHIP	100PF 5.00% 50V	C203	1-163-023-00	CERAMIC CHIP	0.015UF 10.00% 50V
C004	1-163-001-11	CERAMIC CHIP	220PF 10.00% 50V	C204	1-137-372-11	MYLAR	0.022UF 5.00% 50V
C005	1-163-001-11	CERAMIC CHIP	220PF 10.00% 50V	C205	1-163-019-00	CERAMIC CHIP	0.0068UF 10.00% 50V
C006	1-164-004-11	CERAMIC CHIP	0.1UF 10.00% 25V	C206	1-163-019-00	CERAMIC CHIP	0.0068UF 10.00% 50V
C007	1-104-664-11	ELECT	47UF 20.00% 16V	C207	1-137-372-11	MYLAR	0.022UF 5.00% 50V
C008	1-163-251-11	CERAMIC CHIP	100PF 5.00% 50V	C208	1-126-964-11	ELECT	10UF 20.00% 50V
C010	1-163-251-11	CERAMIC CHIP	100PF 5.00% 50V	C209	1-126-964-11	ELECT	10UF 20.00% 50V
C012	1-163-251-11	CERAMIC CHIP	100PF 5.00% 50V	C210	1-126-933-11	ELECT	100UF 20.00% 16V
C013	1-163-021-91	CERAMIC CHIP	0.01UF 10.00% 50V	C211	1-126-941-11	ELECT	470UF 20.00% 25V
C014	1-104-664-11	ELECT	47UF 20.00% 25V	C212	1-126-933-11	ELECT	100UF 20.00% 16V
C015	1-163-009-11	CERAMIC CHIP	0.001UF 10.00% 50V	C213	1-126-933-11	ELECT	100UF 20.00% 16V
C016	1-163-113-00	CERAMIC CHIP	68PF 5.00% 50V	C214	1-126-942-61	ELECT	1000UF 20.00% 25V
C017	1-163-113-00	CERAMIC CHIP	68PF 5.00% 50V	C215	1-126-942-61	ELECT	1000UF 20.00% 25V
C019	1-104-664-11	ELECT	47UF 20.00% 25V	C216	1-163-021-91	CERAMIC CHIP	0.01UF 10.00% 50V
C022	1-163-227-11	CERAMIC CHIP	10PF 0.50PF 50V	C217	1-126-964-11	ELECT	10UF 20.00% 50V
C023	1-163-227-11	CERAMIC CHIP	10PF 0.50PF 50V	C218	1-136-167-00	FILM	0.15UF 5.00% 50V
C024	1-163-227-11	CERAMIC CHIP	10PF 0.50PF 50V	C219	1-136-167-00	FILM	0.15UF 5.00% 50V
C026	1-164-004-11	CERAMIC CHIP	0.1UF 10.00% 25V	C220	1-126-942-61	ELECT	1000UF 20.00% 25V
C027	1-164-004-11	CERAMIC CHIP	0.1UF 10.00% 25V	C221	1-126-964-11	ELECT	10UF 20.00% 50V
C028	1-163-037-11	CERAMIC CHIP	0.022UF 10.00% 50V	C223	1-126-965-11	ELECT	22UF 20.00% 50V
C030	1-126-965-11	ELECT	22UF 20.00% 50V	C224	1-163-133-00	CERAMIC CHIP	470PF 5.00% 50V
C031	1-164-004-11	CERAMIC CHIP	0.1UF 10.00% 25V	C225	1-109-982-11	CERAMIC CHIP	1UF 10.00% 10V
C032	1-107-823-11	CERAMIC CHIP	0.47UF 10.00% 16V	C226	1-109-982-11	CERAMIC CHIP	1UF 10.00% 10V
C041	1-163-251-11	CERAMIC CHIP	100PF 5.00% 50V	C227	1-164-346-11	CERAMIC CHIP	1UF 16V
C042	1-163-251-11	CERAMIC CHIP	100PF 5.00% 50V	C228	1-216-077-91	RES-CHIP	15K 5% 1/10W
C043	1-163-251-11	CERAMIC CHIP	100PF 5.00% 50V	C229	1-216-077-91	RES-CHIP	15K 5% 1/10W
C044	1-163-251-11	CERAMIC CHIP	100PF 5.00% 50V	C230	1-164-346-11	CERAMIC CHIP	1UF 16V
C047	1-163-251-11	CERAMIC CHIP	100PF 5.00% 50V	C256	1-164-004-11	CERAMIC CHIP	0.1UF 10.00% 25V
C048	1-163-251-11	CERAMIC CHIP	100PF 5.00% 50V	C259	1-126-933-11	ELECT	100UF 20.00% 16V
C050	1-163-251-11	CERAMIC CHIP	100PF 5.00% 50V	C264	1-164-505-11	CERAMIC CHIP	2.2UF 16V
C051	1-163-251-11	CERAMIC CHIP	100PF 5.00% 50V	C265	1-164-505-11	CERAMIC CHIP	2.2UF 16V
C053	1-163-251-11	CERAMIC CHIP	100PF 5.00% 50V	C271	1-117-720-11	CERAMIC CHIP	4.7UF 10V
C054	1-163-251-11	CERAMIC CHIP	100PF 5.00% 50V	C272	1-126-961-11	ELECT	2.2UF 20.00% 50V
C055	1-163-251-11	CERAMIC CHIP	100PF 5.00% 50V	C273	1-117-720-11	CERAMIC CHIP	4.7UF 10V
C103	1-164-004-11	CERAMIC CHIP	0.1UF 10.00% 25V	C274	1-126-961-11	ELECT	2.2UF 20.00% 50V
				C275	1-164-004-11	CERAMIC CHIP	0.1UF 10.00% 25V
				C276	1-164-004-11	CERAMIC CHIP	0.1UF 10.00% 25V

The components identified by shading and mark  $\Delta$  are critical for safety. Replace only with part number specified.

**A**

REF. NO.	PART NO.	DESCRIPTION	REMARK	REF. NO.	PART NO.	DESCRIPTION	REMARK
C277	1-164-004-11	CERAMIC CHIP	0.1UF 10.00% 25V	C409	1-126-963-11	ELECT	4.7UF 20.00% 50V
C278	1-164-004-11	CERAMIC CHIP	0.1UF 10.00% 25V	C415	1-163-133-00	CERAMIC CHIP	470PF 5.00% 50V
C279	1-163-010-11	CERAMIC CHIP	0.0012UF 10.00% 50V	C502	1-163-145-00	CERAMIC CHIP	0.0015UF 5.00% 50V
C280	1-164-004-11	CERAMIC CHIP	0.1UF 10.00% 25V	C506	1-107-638-11	ELECT	33UF 20.00% 160V
C281	1-163-018-00	CERAMIC CHIP	0.0056UF 10.00% 50V	C507	1-161-830-00	CERAMIC	0.0047UF 500V
C282	1-163-018-00	CERAMIC CHIP	0.0056UF 10.00% 50V	C510	1-102-112-00	CERAMIC	330PF 10.00% 50V
C283	1-126-965-11	ELECT	22UF 20.00% 50V	C512	1-163-989-11	CERAMIC CHIP	0.033UF 10.00% 25V
C301	1-126-935-11	ELECT	470UF 20.00% 16V	C513	1-163-263-11	CERAMIC CHIP	330PF 5.00% 50V
C302	1-163-005-11	CERAMIC CHIP	470PF 10.00% 50V	C514	1-106-383-00	MYLAR	0.047UF 10.00% 200V
C303	1-126-964-11	ELECT	10UF 20.00% 50V	C517	1-164-182-11	CERAMIC CHIP	0.0033UF 10.00% 50V
C304	1-126-967-11	ELECT	47UF 20.00% 50V	C518	1-104-665-11	ELECT	100UF 20.00% 10V
C305	1-164-004-11	CERAMIC CHIP	0.1UF 10.00% 25V	C519	1-102-212-00	CERAMIC	820PF 10.00% 500V
C306	1-163-233-11	CERAMIC CHIP	18PF 5.00% 50V	C521	1-126-934-11	ELECT	220UF 20.00% 16V
C307	1-163-233-11	CERAMIC CHIP	18PF 5.00% 50V	C522	1-126-933-11	ELECT	100UF 20.00% 16V
C308	1-163-259-91	CERAMIC CHIP	220PF 5.00% 50V	C523	1-102-002-00	CERAMIC	680PF 10.00% 500V
C309	1-137-378-11	MYLAR	0.22UF 5.00% 50V	C524	1-126-967-11	ELECT	47UF 20.00% 50V
C310	1-126-963-11	ELECT	4.7UF 20.00% 50V	C526	1-130-495-00	MYLAR	0.1UF 5.00% 50V
C311	1-126-964-11	ELECT	10UF 20.00% 50V	C527	1-102-820-00	CERAMIC	330PF 5.00% 50V
C312	1-164-346-11	CERAMIC CHIP	1UF 16V	C528	1-162-134-11	CERAMIC	470PF 10.00% 2KV
C313	1-164-346-11	CERAMIC CHIP	1UF 16V	C530	1-137-372-11	MYLAR	0.022UF 5.00% 50V
C315	1-164-004-11	CERAMIC CHIP	0.1UF 10.00% 25V	C531	1-126-961-11	ELECT	2.2UF 20.00% 50V
C316	1-104-664-11	ELECT	47UF 20.00% 25V	C532	1-126-941-11	ELECT	470UF 20.00% 25V
C317	1-164-004-11	CERAMIC CHIP	0.1UF 10.00% 25V	C533	1-126-941-11	ELECT	470UF 20.00% 25V
C318	1-163-031-11	CERAMIC CHIP	0.01UF 50V	C534	1-164-004-11	CERAMIC CHIP	0.1UF 10.00% 25V
C319	1-163-031-11	CERAMIC CHIP	0.01UF 50V	C536	1-130-495-00	MYLAR	0.1UF 5.00% 50V
C320	1-163-031-11	CERAMIC CHIP	0.01UF 50V	C537	1-126-969-11	ELECT	220UF 20.00% 50V
C322	1-163-005-11	CERAMIC CHIP	470PF 10.00% 50V	C538	1-117-657-21	FILM	8500PF 3.00% 1.2KV
C324	1-163-017-00	CERAMIC CHIP	0.0047UF 10.00% 50V	C539	1-129-746-91	FILM	0.039UF 5.00% 400V
C325	1-126-960-11	ELECT	1UF 20.00% 50V	C540	1-136-171-00	FILM	0.33UF 5.00% 50V
C327	1-126-965-11	ELECT	22UF 20.00% 50V	C546	1-165-319-11	CERAMIC CHIP	0.1UF 50V
C328	1-164-004-11	CERAMIC CHIP	0.1UF 10.00% 25V	C549	1-163-017-00	CERAMIC CHIP	0.0047UF 10.00% 50V
C329	1-126-963-11	ELECT	4.7UF 20.00% 50V	C550	1-106-220-00	MYLAR	0.1UF 10.00% 100V
C330	1-164-004-11	CERAMIC CHIP	0.1UF 10.00% 25V	C551	1-126-960-11	ELECT	1UF 20.00% 50V
C332	1-126-963-11	ELECT	4.7UF 20.00% 50V	C552	1-162-116-00	CERAMIC	680PF 10.00% 2KV
C335	1-164-004-11	CERAMIC CHIP	0.1UF 10.00% 25V	C553	1-162-116-00	CERAMIC	680PF 10.00% 2KV
C336	1-164-004-11	CERAMIC CHIP	0.1UF 10.00% 25V	C554	1-137-417-11	MYLAR	0.0047UF 10.00% 200V
C337	1-126-961-11	ELECT	2.2UF 20.00% 50V	C556	1-126-941-11	ELECT	470UF 20.00% 25V
C338	1-163-017-00	CERAMIC CHIP	0.0047UF 10.00% 50V	C557	1-126-941-11	ELECT	470UF 20.00% 25V
C341	1-115-340-11	CERAMIC CHIP	0.22UF 10.00% 25V	C558	1-123-024-21	ELECT	33UF 160V
C342	1-163-259-91	CERAMIC CHIP	220PF 5.00% 50V	C560	1-102-228-00	CERAMIC	470PF 10.00% 500V
C347	1-126-933-11	ELECT	100UF 20.00% 16V	C561	1-129-708-91	FILM	0.0033UF 5.00% 630V
C348	1-164-004-11	CERAMIC CHIP	0.1UF 10.00% 25V	C562	1-102-228-00	CERAMIC	470PF 10.00% 500V
C349	1-164-004-11	CERAMIC CHIP	0.1UF 10.00% 25V	C564	1-163-038-11	CERAMIC CHIP	0.1UF 25V
C350	1-216-295-11	SHORT	0	C565	1-107-655-11	ELECT	47UF 20.00% 250V
C351	1-126-964-11	ELECT	10UF 20.00% 50V	C566	1-102-244-00	CERAMIC	220PF 10.00% 500V
C352	1-164-004-11	CERAMIC CHIP	0.1UF 10.00% 25V	C567	1-115-521-11	FILM	0.82UF 5.00% 250V
C353	1-126-960-11	ELECT	1UF 20.00% 50V	C568	1-102-228-00	CERAMIC	470PF 10.00% 500V
C356	1-126-962-11	ELECT	3.3UF 20.00% 50V	C570	1-115-520-11	FILM	0.68UF 5.00% 250V
C357	1-164-004-11	CERAMIC CHIP	0.1UF 10.00% 25V	C573	1-106-375-12	MYLAR	0.022UF 99% 200V
C401	1-164-346-11	CERAMIC CHIP	1UF 16V	C574	1-107-636-11	ELECT	10UF 20.00% 160V
C402	1-164-346-11	CERAMIC CHIP	1UF 16V	C576	1-130-495-00	MYLAR	0.1UF 5.00% 50V
C403	1-163-005-11	CERAMIC CHIP	470PF 10.00% 50V	C577	1-106-395-00	MYLAR	0.15UF 10.00% 200V
C404	1-163-005-11	CERAMIC CHIP	470PF 10.00% 50V	C582	1-164-004-11	CERAMIC CHIP	0.1UF 10.00% 25V
C405	1-126-935-11	ELECT	470UF 20.00% 16V	C586	1-216-295-11	SHORT	0
C406	1-164-346-11	CERAMIC CHIP	1UF 16V	C600 $\Delta$	1-104-705-11	MYLAR	0.1UF 20.00% 250V
C407	1-164-346-11	CERAMIC CHIP	1UF 16V	C602 $\Delta$	1-104-705-11	MYLAR	0.1UF 20.00% 250V
C408	1-163-133-00	CERAMIC CHIP	470PF 5.00% 50V	C604	1-163-009-11	CERAMIC CHIP	0.001UF 10.00% 50V



The components identified by shading and mark  $\triangle$  are critical for safety. Replace only with part number specified.

A

REF. NO.	PART NO.	DESCRIPTION	REMARK	REF. NO.	PART NO.	DESCRIPTION	REMARK
C605	$\triangle$ 1-127-942-51	CERAMIC	330PF 10% 250V			<CONNECTOR>	
C606	$\triangle$ 1-127-942-51	CERAMIC	330PF 10% 250V				
C607	1-161-830-00	CERAMIC	0.0047UF 99% 500V	CN104	1-695-915-11	TAB (CONTACT)	
C608	1-161-830-00	CERAMIC	0.0047UF 99% 500V	CN202	* 1-785-608-11	PIN, CONNECTOR 4P	
C609	1-126-968-11	ELECT	100UF 20.00% 50V	CN203	* 1-564-506-11	PLUG, CONNECTOR 3P	
C610	1-126-964-11	ELECT	10UF 20.00% 50V	CN204	* 1-564-506-11	PLUG, CONNECTOR 3P	
C611	1-161-830-00	CERAMIC	0.0047UF 99% 500V	CN305	* 1-564-509-11	PLUG, CONNECTOR 6P	
C612	1-161-830-00	CERAMIC	0.0047UF 99% 500V	CN306	* 1-564-510-11	PLUG, CONNECTOR 7P	
C613	1-117-752-11	ELECT(BLOCK)	330UF 20.00% 450V	CN505	1-564-507-11	PLUG, CONNECTOR 4P	
C614	1-126-964-11	ELECT	10UF 20.00% 50V	CN601	1-580-843-11	PIN, CONNECTOR (POWER)	
C616	1-130-202-00	FILM	0.022UF 5.00% 400V	CN602	* 1-508-786-00	PIN, CONNECTOR (5MM PITCH) 2P	
C617	1-107-792-11	CERAMIC	100PF 5.00% 1KV	CN604	* 1-573-963-11	PIN, CONNECTOR (PC BOARD) 3P	
C618	1-125-893-11	FILM	680PF 3.00% 1.5KV	CN609	* 1-508-784-21	PIN, CONNECTOR (5MM PITCH) 1P	
C619	$\triangle$ 1-119-886-51	CERAMIC	470PF 10.00% 250V	CN901	* 1-564-507-11	PLUG, CONNECTOR 4P	
C620	1-163-133-00	CERAMIC CHIP	470PF 5.00% 50V			<DIODE>	
C621	1-102-114-00	CERAMIC	470PF 10.00% 50V	D001	8-719-988-61	1SS355TE-17	
C622	1-102-074-00	CERAMIC	0.001UF 10.00% 50V	D005	8-719-988-61	1SS355TE-17	
C623	1-104-665-11	ELECT	100UF 20.00% 25V	D006	8-719-988-61	1SS355TE-17	
C624	1-104-331-11	CERAMIC	0.0022UF 10.00% 1KV	D010	8-719-158-35	RD9.1S-B	
C627	1-102-002-00	CERAMIC	680PF 10.00% 500V	D011	8-719-158-35	RD9.1S-B	
C628	1-126-942-61	ELECT	1000UF 20.00% 25V	D203	8-719-820-41	1SS302	
C629	1-126-964-11	ELECT	10UF 20.00% 50V	D300	1-216-295-11	SHORT	0
C630	1-123-024-21	ELECT	33UF 160V	D301	8-719-988-61	1SS355TE-17	
C633	1-104-999-11	MYLAR	0.1UF 10.00% 200V	D306	8-719-988-61	1SS355TE-17	
C634	1-126-933-11	ELECT	100UF 20.00% 16V	D307	8-719-988-61	1SS355TE-17	
C635	1-104-665-11	ELECT	100UF 20.00% 10V	D308	8-719-988-61	1SS355TE-17	
C636	1-104-760-11	CERAMIC CHIP	0.047UF 10.00% 50V	D309	8-719-159-10	RD5.1SB-T2	
C639	1-164-004-11	CERAMIC CHIP	0.1UF 10.00% 25V	D311	8-719-988-61	1SS355TE-17	
C640	1-164-004-11	CERAMIC CHIP	0.1UF 10.00% 25V	D312	8-719-988-61	1SS355TE-17	
C641	1-102-002-00	CERAMIC	680PF 10.00% 500V	D313	8-719-988-61	1SS355TE-17	
C642	1-107-890-11	ELECT	2200UF 20.00% 25V	D314	8-719-988-61	1SS355TE-17	
C643	1-104-665-11	ELECT	100UF 20.00% 10V	D315	8-719-988-61	1SS355TE-17	
C644	1-104-331-11	CERAMIC	0.0022UF 10.00% 1KV	D316	8-719-037-02	RD6.8SB-T1	
C645	1-137-605-11	MYLAR	0.01UF 10.00% 250V	D320	8-719-158-35	RD9.1S-B	
C646	1-107-679-91	ELECT	10UF 20.00% 450V	D321	8-719-158-35	RD9.1S-B	
C647	1-163-275-11	CERAMIC CHIP	0.001UF 5.00% 50V	D401	8-719-158-35	RD9.1S-B	
C649	1-126-940-11	ELECT	330UF 20.00% 25V	D402	8-719-158-35	RD9.1S-B	
C650	1-163-275-11	CERAMIC CHIP	0.001UF 5.00% 50V	D403	8-719-158-35	RD9.1S-B	
C651	1-163-133-00	CERAMIC CHIP	470PF 5.00% 50V	D404	8-719-158-35	RD9.1S-B	
C652	1-126-965-11	ELECT	22UF 20.00% 50V	D405	8-719-158-35	RD9.1S-B	
C653	1-104-664-11	ELECT	47UF 20.00% 25V	D406	8-719-158-35	RD9.1S-B	
C657	1-101-821-00	CERAMIC	0.0022UF 500V	D504	8-719-302-43	ELIZ	
C658	1-164-004-11	CERAMIC CHIP	0.1UF 10.00% 25V	D505	8-719-988-61	1SS355TE-17	
C901	1-136-153-00	FILM	0.01UF 5.00% 50V	D506	8-719-911-19	1SS119-25	
C902	1-136-153-00	FILM	0.01UF 5.00% 50V	D507	8-719-988-61	1SS355TE-17	
C905	1-126-963-11	ELECT	4.7UF 20.00% 50V	D508	8-719-988-61	1SS355TE-17	
C906	1-164-346-11	CERAMIC CHIP	1UF 16V	D509	1-216-073-00	RES-CHIP	10K 5% 1/10W
C907	1-163-133-00	CERAMIC CHIP	470PF 5.00% 50V	D510	8-719-988-61	1SS355TE-17	
C908	1-163-133-00	CERAMIC CHIP	470PF 5.00% 50V	D511	8-719-988-61	1SS355TE-17	
C909	1-164-346-11	CERAMIC CHIP	1UF 16V	D512	8-719-988-61	1SS355TE-17	
C910	1-126-967-11	ELECT	47UF 20.00% 50V	D513	8-719-908-03	GP08D	
C911	1-126-967-11	ELECT	47UF 20.00% 50V	D517	8-719-312-71	RS3FS	
C912	1-164-004-11	CERAMIC CHIP	0.1UF 10.00% 25V	D518	8-719-900-26	ERD29-08J	
C913	1-104-665-11	ELECT	100UF 20.00% 10V	D521	8-719-302-43	ELIZ	
C914	1-163-133-00	CERAMIC CHIP	470PF 5.00% 50V	D522	8-719-302-43	ELIZ	



REF. NO.	PART NO.	DESCRIPTION	REMARK	REF. NO.	PART NO.	DESCRIPTION	REMARK
D523	8-719-302-43	ELIZ		FB611	1-410-397-21	FERRITE	1.1UH
D527	8-719-908-03	GP08D		FB613	1-410-397-21	FERRITE	1.1UH
D528	8-719-908-03	GP08D		FB615	1-410-397-21	FERRITE	1.1UH
D531	8-719-988-61	1SS355TE-17				<IC>	
D532	8-719-988-61	1SS355TE-17					
D534	1-216-295-11	SHORT	0				
D602	8-719-911-19	1SS119-25		IC001	8-752-917-83	CXP86449-631S	
D603	8-719-150-92	RD33EB3T		IC002	8-759-371-21	MM1319AFBE	
D604	8-719-028-72	RGP02-17EL-6433		IC003	8-759-560-48	CAT24WC08P	
D605	8-719-510-22	D3SB60		IC201	8-759-336-30	TA8223K	
				IC203	8-759-827-61	TDA7442D013TR	
D606	8-719-108-18	5P-6M					
D607	8-719-073-01	MA111-(K8).S0		IC301	8-752-095-72	CXA2159S	
D608	8-719-110-53	RD20ES-B2		IC302	8-759-672-27	TDA9183T	
D609	8-719-311-31	RU-1P		IC502	8-759-700-07	NJM2903M	
D610	8-719-210-21	11EQS04		IC503	8-759-980-58	TDA8172	
				IC601	8-749-013-75	STR-F6654	
D611	8-719-046-74	AU-01Z-V1					
D613	8-719-046-74	AU-01Z-V1		IC602	8-749-920-61	SE-135N	
D614	8-719-046-74	AU-01Z-V1		IC603	8-759-701-59	NJM78M09FA	
D615	8-719-312-10	RU4AM-T3		IC604	8-759-231-53	TA7805S	
D618	8-719-067-18	RN4Z		IC901	8-742-014-21	SBX1981-51(21)	
						<JACK>	
D620	8-719-110-72	RD30ESB2		J401	1-779-850-11	JACK BLOCK, PIN 6P	
D623	8-719-978-65	DTZ-TT11-15B		J901	1-770-786-11	JACK	
D624	8-719-073-01	MA111-(K8).S0		J902	1-770-329-11	JACK, PIN 3P	
D625	8-719-977-28	DTZ10B					
D627	8-719-073-84	31DQ06-FC5				<CHIP CONDUCTOR>	
				JR001	1-216-295-11	SHORT	0
D628	8-719-911-19	1SS119-25		JR002	1-216-295-11	SHORT	0
D631	8-719-068-00	ERC04-06SE		JR003	1-216-295-11	SHORT	0
D632	8-719-068-00	ERC04-06SE		JR004	1-216-295-11	SHORT	0
D633	8-719-948-45	ERA22-08		JR006	1-216-295-11	SHORT	0
D634	8-719-073-01	MA111-(K8).S0					
D635	8-719-073-01	MA111-(K8).S0		JR007	1-216-295-11	SHORT	0
D636	8-719-510-02	D1NS4		JR009	1-216-295-11	SHORT	0
D637	8-719-109-96	RD6.8ES-B1		JR010	1-216-295-11	SHORT	0
D638	8-719-200-82	11ES2		JR011	1-216-295-11	SHORT	0
D901	8-719-158-35	RD9.1S-B		JR012	1-216-295-11	SHORT	0
D902	8-719-158-35	RD9.1S-B		JR014	1-216-295-11	SHORT	0
D903	8-719-158-35	RD9.1S-B		JR015	1-216-295-11	SHORT	0
D904	8-719-158-35	RD9.1S-B		JR016	1-216-295-11	SHORT	0
D905	8-719-158-35	RD9.1S-B		JR019	1-216-295-11	SHORT	0
D906	8-719-083-18	SPB-25MVWF		JR020	1-216-295-11	SHORT	0
		<CONNECTOR>		JR022	1-216-295-11	SHORT	0
DY1	* 1-580-798-11	CONNECTOR PIN (DY) 6P		JR023	1-216-295-11	SHORT	0
				JR024	1-216-295-11	SHORT	0
		<FERRITE BEAD>		JR025	1-216-295-11	SHORT	0
				JR028	1-216-295-11	SHORT	0
FB300	1-412-911-31	FERRITE	0UH				
FB501	1-410-397-21	FERRITE	1.1UH	JR102	1-216-295-11	SHORT	0
FB502	1-410-397-21	FERRITE	1.1UH	JR109	1-216-295-11	SHORT	0
FB600	1-410-397-21	FERRITE	1.1UH	JR112	1-216-295-11	SHORT	0
FB601	1-410-397-21	FERRITE	1.1UH	JR202	1-216-295-11	SHORT	0
				JR204	1-216-295-11	SHORT	0
FB602	1-410-397-21	FERRITE	1.1UH				
FB603	1-410-397-21	FERRITE	1.1UH	JR213	1-216-295-11	SHORT	0
FB604	1-412-911-31	FERRITE	0UH	JR214	1-216-295-11	SHORT	0
FB607	1-410-397-21	FERRITE	1.1UH	JR300	1-216-295-11	SHORT	0
FB608	1-412-911-31	FERRITE	0UH	JR304	1-216-295-11	SHORT	0
				JR308	1-216-295-11	SHORT	0





REF. NO.	PART NO.	DESCRIPTION	REMARK	REF. NO.	PART NO.	DESCRIPTION	REMARK
R017	1-216-049-11	RES-CHIP	1K 5%	R230	1-216-069-00	RES-CHIP	6.8K 5%
R018	1-216-033-00	RES-CHIP	220 5%	R231	1-216-295-11	SHORT	0
R019	1-216-073-00	RES-CHIP	10K 5%	R234	1-249-389-11	CARBON	4.7 5%
R020	1-216-045-00	RES-CHIP	680 5%	R237	1-216-308-00	RES-CHIP	4.7 5%
R021	1-216-073-00	RES-CHIP	10K 5%	R238	1-216-069-00	RES-CHIP	6.8K 5%
R022	1-216-295-11	SHORT	0	R239	1-216-069-00	RES-CHIP	6.8K 5%
R024	1-216-057-00	RES-CHIP	2.2K 5%	R242	1-216-025-11	RES-CHIP	100 5%
R025	1-216-057-00	RES-CHIP	2.2K 5%	R243	1-216-025-11	RES-CHIP	100 5%
R026	1-216-057-00	RES-CHIP	2.2K 5%	R246	1-216-067-00	RES-CHIP	5.6K 5%
R027	1-216-073-00	RES-CHIP	10K 5%	R247	1-216-067-00	RES-CHIP	5.6K 5%
R029	1-216-049-11	RES-CHIP	1K 5%	R301	1-216-073-00	RES-CHIP	10K 5%
R031	1-216-049-11	RES-CHIP	1K 5%	R302	1-216-295-11	SHORT	0
R035	1-216-025-11	RES-CHIP	100 5%	R303	1-216-049-11	RES-CHIP	1K 5%
R036	1-216-025-11	RES-CHIP	100 5%	R304	1-216-073-00	RES-CHIP	10K 5%
R037	1-216-025-11	RES-CHIP	100 5%	R305	1-216-049-11	RES-CHIP	1K 5%
R040	1-216-025-11	RES-CHIP	100 5%	R306	1-216-077-91	RES-CHIP	15K 5%
R041	1-216-025-11	RES-CHIP	100 5%	R308	1-216-025-11	RES-CHIP	100 5%
R042	1-216-295-11	SHORT	0	R309	1-216-025-11	RES-CHIP	100 5%
R043	1-216-049-11	RES-CHIP	1K 5%	R310	1-216-025-11	RES-CHIP	100 5%
R044	1-216-025-11	RES-CHIP	100 5%	R311	1-216-041-00	RES-CHIP	470 5%
R045	1-414-233-22	FERRITE	0UH	R312	1-216-039-00	RES-CHIP	390 5%
R046	1-216-049-11	RES-CHIP	1K 5%	R313	1-216-037-00	RES-CHIP	330 5%
R047	1-414-233-22	FERRITE	0UH	R314	1-216-083-00	RES-CHIP	27K 5%
R048	1-216-073-00	RES-CHIP	10K 5%	R316	1-216-037-00	RES-CHIP	330 5%
R050	1-216-073-00	RES-CHIP	10K 5%	R317	1-216-091-00	RES-CHIP	56K 5%
R053	1-216-049-11	RES-CHIP	1K 5%	R318	1-216-039-00	RES-CHIP	390 5%
R058	1-216-295-11	SHORT	0	R319	1-216-025-11	RES-CHIP	100 5%
R059	1-216-295-11	SHORT	0	R320	1-216-065-91	RES-CHIP	4.7K 5%
R060	1-216-295-11	SHORT	0	R321	1-216-073-00	RES-CHIP	10K 5%
R061	1-216-033-00	RES-CHIP	220 5%	R322	1-216-033-00	RES-CHIP	220 5%
R062	1-216-041-00	RES-CHIP	470 5%	R323	1-216-053-00	RES-CHIP	1.5K 5%
R063	1-216-037-00	RES-CHIP	330 5%	R324	1-216-053-00	RES-CHIP	1.5K 5%
R064	1-216-037-00	RES-CHIP	330 5%	R325	1-216-041-00	RES-CHIP	470 5%
R065	1-216-037-00	RES-CHIP	330 5%	R331	1-216-295-11	SHORT	0
R066	1-216-049-11	RES-CHIP	1K 5%	R332	1-216-033-00	RES-CHIP	220 5%
R067	1-216-049-11	RES-CHIP	1K 5%	R333	1-216-073-00	RES-CHIP	10K 5%
R068	1-216-041-00	RES-CHIP	470 5%	R334	1-216-127-11	RES-CHIP	1.8M 5%
R105	1-216-295-11	SHORT	0	R335	1-216-045-00	RES-CHIP	680 5%
R109	1-216-041-00	RES-CHIP	470 5%	R338	1-216-033-00	RES-CHIP	220 5%
R111	1-216-025-11	RES-CHIP	100 5%	R340	1-216-025-11	RES-CHIP	100 5%
R112	1-216-025-11	RES-CHIP	100 5%	R345	1-216-081-00	RES-CHIP	22K 5%
R113	1-216-047-91	RES-CHIP	820 5%	R348	1-208-806-11	METAL CHIP	10K 0.5%
R202	1-216-053-00	RES-CHIP	1.5K 5%	R349	1-216-073-00	RES-CHIP	10K 5%
R203	1-216-065-91	RES-CHIP	4.7K 5%	R350	1-216-061-00	RES-CHIP	3.3K 5%
R204	1-216-069-00	RES-CHIP	6.8K 5%	R351	1-216-053-00	RES-CHIP	1.5K 5%
R205	1-216-069-00	RES-CHIP	6.8K 5%	R354	1-216-057-00	RES-CHIP	2.2K 5%
R206	1-216-065-91	RES-CHIP	4.7K 5%	R355	1-216-057-00	RES-CHIP	2.2K 5%
R207	1-216-053-00	RES-CHIP	1.5K 5%	R356	1-216-057-00	RES-CHIP	2.2K 5%
R208	1-216-069-00	RES-CHIP	6.8K 5%	R357	1-216-079-00	RES-CHIP	18K 5%
R209	1-216-069-00	RES-CHIP	6.8K 5%	R358	1-216-049-11	RES-CHIP	1K 5%
R210	1-216-029-00	RES-CHIP	150 5%	R359	1-216-033-00	RES-CHIP	220 5%
R212	1-216-029-00	RES-CHIP	150 5%	R360	1-216-033-00	RES-CHIP	220 5%
R225	1-216-033-00	RES-CHIP	220 5%	R361	1-216-073-00	RES-CHIP	10K 5%
R226	1-216-033-00	RES-CHIP	220 5%	R362	1-216-075-00	RES-CHIP	12K 5%
R227	1-216-033-00	RES-CHIP	220 5%	R363	1-216-079-00	RES-CHIP	18K 5%
R228	1-249-389-11	CARBON	4.7 5%	R364	1-216-295-11	SHORT	0
R229	1-216-073-00	RES-CHIP	10K 5%	R365	1-216-033-00	RES-CHIP	220 5%
				R366	1-216-073-00	RES-CHIP	10K 5%

A

REF. NO.	PART NO.	DESCRIPTION		REMARK	REF. NO.	PART NO.	DESCRIPTION		REMARK
R367	1-216-073-00	RES-CHIP	10K	5%	1/10W	R541	1-216-065-91	RES-CHIP	4.7K 5% 1/10W
R370	1-216-033-00	RES-CHIP	220	5%	1/10W	R542	1-216-295-11	SHORT	0
R371	1-216-083-00	RES-CHIP	27K	5%	1/10W	R543	1-216-437-00	METAL OXIDE	5.6K 5% 1W
R372	1-216-091-00	RES-CHIP	56K	5%	1/10W	R544	1-215-894-11	METAL OXIDE	2.2K 5% 2W
R376	1-216-081-00	RES-CHIP	22K	5%	1/10W	R545	1-216-077-91	RES-CHIP	15K 5% 1/10W
R377	1-216-121-11	RES-CHIP	1M	5%	1/10W	R546	1-216-077-91	RES-CHIP	15K 5% 1/10W
R378	1-216-053-00	RES-CHIP	1.5K	5%	1/10W	R547	1-216-085-00	RES-CHIP	33K 5% 1/10W
R379	1-218-179-11	RES-CHIP	10M	5%	1/10W	R549	1-215-451-00	METAL	18K 1% 1/4W
R380	1-216-041-00	RES-CHIP	470	5%	1/10W	R550	1-216-097-11	RES-CHIP	100K 5% 1/10W
R383	1-216-049-11	RES-CHIP	1K	5%	1/10W	R551	1-249-421-11	CARBON	2.2K 5% 1/4W
R384	1-216-295-11	SHORT	0			R552	1-216-057-00	RES-CHIP	2.2K 5% 1/10W
R385	1-216-033-00	RES-CHIP	220	5%	1/10W	R553	1-215-457-00	METAL	33K 1% 1/4W
R391	1-216-049-11	RES-CHIP	1K	5%	1/10W	R554	1-215-457-00	METAL	33K 1% 1/4W
R401	1-216-049-11	RES-CHIP	1K	5%	1/10W	R556	1-215-437-00	METAL	4.7K 1% 1/4W
R402	1-216-073-00	RES-CHIP	10K	5%	1/10W	R558	1-249-421-11	CARBON	2.2K 5% 1/4W
R403	1-216-073-00	RES-CHIP	10K	5%	1/10W	R559	1-249-429-11	CARBON	10K 5% 1/4W
R404	1-216-073-00	RES-CHIP	10K	5%	1/10W	R560	1-216-073-00	RES-CHIP	10K 5% 1/10W
R405	1-216-049-11	RES-CHIP	1K	5%	1/10W	R562	1-249-401-11	CARBON	47 5% 1/4W
R406	1-216-073-00	RES-CHIP	10K	5%	1/10W	R565	1-216-073-00	RES-CHIP	10K 5% 1/10W
R407	1-216-049-11	RES-CHIP	1K	5%	1/10W	R567	1-216-105-91	RES-CHIP	220K 5% 1/10W
R408	1-216-049-11	RES-CHIP	1K	5%	1/10W	R568	1-249-383-11	CARBON	1.5 5% 1/4W
R409	1-216-041-00	RES-CHIP	470	5%	1/10W	R570	1-216-069-00	RES-CHIP	6.8K 5% 1/10W
R410	1-216-113-00	RES-CHIP	470K	5%	1/10W	R571	1-215-437-00	METAL	4.7K 1% 1/4W
R411	1-216-113-00	RES-CHIP	470K	5%	1/10W	R573	1-216-089-11	RES-CHIP	47K 5% 1/10W
R412	1-216-041-00	RES-CHIP	470	5%	1/10W	R577	1-215-913-11	METAL OXIDE	220 5% 3W
R413	1-216-021-00	RES-CHIP	68	5%	1/10W	R578	1-216-369-00	METAL OXIDE	1 5% 2W
R414	1-216-113-00	RES-CHIP	470K	5%	1/10W	R579	1-216-097-11	RES-CHIP	100K 5% 1/10W
R415	1-216-113-00	RES-CHIP	470K	5%	1/10W	R580	1-208-830-11	METAL CHIP	100K 0.5% 1/10W
R416	1-216-077-91	RES-CHIP	15K	5%	1/10W	R581	1-208-794-11	METAL CHIP	3.3K 0.5% 1/10W
R417	1-216-077-91	RES-CHIP	15K	5%	1/10W	R582	1-208-846-11	METAL CHIP	470K 0.5% 1/10W
R418	1-216-113-00	RES-CHIP	470K	5%	1/10W	R584	1-216-295-11	SHORT	0
R419	1-216-022-00	RES-CHIP	75	5%	1/10W	R585	1-249-391-11	CARBON	6.8 5% 1/4W
R426	1-216-033-00	RES-CHIP	220	5%	1/10W	R587	1-208-834-11	METAL CHIP	150K 0.5% 1/10W
R505	1-216-099-00	RES-CHIP	120K	5%	1/10W	R588	1-215-888-00	METAL OXIDE	220 5% 2W
R506	1-216-085-00	RES-CHIP	33K	5%	1/10W	R589	1-215-888-00	METAL OXIDE	220 5% 2W
R507	1-249-389-11	CARBON	4.7	5%	1/4W	R590	1-215-465-00	METAL	68K 1% 1/4W
R508	1-215-910-00	METAL OXIDE	68	5%	3W	R591	1-260-288-11	CARBON	0.47 5% 1/2W
R509	1-215-911-11	METAL OXIDE	100	5%	3W	R593	1-260-288-11	CARBON	0.47 5% 1/2W
R510	1-215-885-00	METAL OXIDE	68	5%	2W	R594	1-260-288-11	CARBON	0.47 5% 1/2W
R511	1-215-911-11	METAL OXIDE	100	5%	3W	R596	1-215-921-11	METAL OXIDE	4.7K 5% 3W
R516	1-216-081-00	RES-CHIP	22K	5%	1/10W	R597	1-247-750-11	CARBON	680 5% 1/2W
R518	1-247-807-31	CARBON	100	5%	1/4W	R598	1-249-438-11	CARBON	56K 5% 1/4W
R520	1-215-445-00	METAL	10K	1%	1/4W	R599	1-249-389-11	CARBON	4.7 5% 1/4W
R522	1-208-806-11	METAL CHIP	10K	0.5%	1/10W	R600	1-249-438-11	CARBON	56K 5% 1/4W
R523	1-249-411-11	CARBON	330	5%	1/4W	R601	1-249-418-11	CARBON	1.2K 5% 1/4W
R525	1-208-830-11	METAL CHIP	100K	0.5%	1/10W	R602	1-249-389-11	CARBON	4.7 5% 1/4W
R526	1-208-798-11	METAL CHIP	4.7K	0.5%	1/10W	R603	1-215-485-00	METAL	470K 1% 1/4W
R527	1-216-001-00	RES-CHIP	10	5%	1/10W	R604	1-216-097-11	RES-CHIP	100K 5% 1/10W
R528	1-208-814-91	METAL CHIP	22K	0.5%	1/10W	R607	1-249-425-11	CARBON	4.7K 5% 1/4W
R529	1-216-635-11	METAL CHIP	220	0.5%	1/10W	R608	1-240-205-91	CARBON	22M 5% 1/2W
R531	1-247-843-11	CARBON	3.3K	5%	1/4W	R609	1-216-057-00	RES-CHIP	2.2K 5% 1/10W
R533	1-249-417-11	CARBON	1K	5%	1/4W	R610	1-216-073-00	RES-CHIP	10K 5% 1/10W
R534	1-216-361-00	METAL OXIDE	0.22	5%	2W	R611	1-216-089-11	RES-CHIP	47K 5% 1/10W
R535	1-216-067-00	RES-CHIP	5.6K	5%	1/10W	R612	1-216-045-00	RES-CHIP	680 5% 1/10W
R536	1-216-067-00	RES-CHIP	5.6K	5%	1/10W	R614	1-216-041-00	RES-CHIP	470 5% 1/10W
R537	1-208-814-91	METAL CHIP	22K	0.5%	1/10W	R615	1-216-350-11	METAL OXIDE	1.2 5% 1W
R540	1-216-065-91	RES-CHIP	4.7K	5%	1/10W	R616	1-260-302-51	CARBON	6.8 5% 1/2W

The components identified by shading and mark  $\Delta$  are critical for safety. Replace only with part number specified.

**A** **C1**

REF. NO.	PART NO.	DESCRIPTION	REMARK
R617	1-247-791-91	CARBON 22	5% 1/4W
R619	1-260-128-91	CARBON 270K	5% 1/2W
R620	1-215-915-11	METAL OXIDE 470	5% 3W
R622	1-215-908-00	METAL OXIDE 33	5% 3W
R623	1-216-095-00	RES-CHIP 82K	5% 1/10W
R624	1-216-089-11	RES-CHIP 47K	5% 1/10W
R626	1-216-049-11	RES-CHIP 1K	5% 1/10W
R627	1-240-251-11	CMT-MELF 6.8	5% 10W
R629	1-247-747-11	CARBON 470	5% 1/2W
R630	1-249-429-11	CARBON 10K	5% 1/4W
R631	1-216-089-11	RES-CHIP 47K	5% 1/10W
R632	1-202-933-61	FUSIBLE 0.1	10% 1/2W
R634	$\Delta$ 1-218-265-11	METAL 8.2M	5% 1W
R635	1-216-492-11	METAL OXIDE 82K	5% 3W
R636	1-215-924-00	METAL OXIDE 15K	5% 3W
R637	1-216-492-11	METAL OXIDE 82K	5% 3W
R639	1-216-363-00	METAL OXIDE 0.33	5% 2W
R640	1-249-415-11	CARBON 680	5% 1/4W
R641	1-216-362-11	METAL OXIDE 0.27	5% 2W
R642	1-249-419-11	CARBON 1.5K	5% 1/4W
R643	1-247-843-11	CARBON 3.3K	5% 1/4W
R644	1-249-419-11	CARBON 1.5K	5% 1/4W
R646	1-215-924-00	METAL OXIDE 15K	5% 3W
R647	1-249-401-11	CARBON 47	5% 1/4W
R648	1-216-057-00	RES-CHIP 2.2K	5% 1/10W
R649	1-249-417-11	CARBON 1K	5% 1/4W
R650	1-215-882-00	METAL OXIDE 22	5% 2W
R652	1-215-925-11	METAL OXIDE 22K	5% 3W
R653	1-215-873-00	METAL OXIDE 4.7K	5% 1W
R657	1-260-127-11	CARBON 220K	5% 1/2W
R659	1-216-049-11	RES-CHIP 1K	5% 1/10W
R660	1-216-073-00	RES-CHIP 10K	5% 1/10W
R661	1-215-873-00	METAL OXIDE 4.7K	5% 1W
R680	1-216-308-00	RES-CHIP 4.7	5% 1/10W
R901	1-249-411-11	CARBON 330	5% 1/4W
R902	1-249-411-11	CARBON 330	5% 1/4W
R903	1-216-022-00	RES-CHIP 75	5% 1/10W
R904	1-216-033-00	RES-CHIP 220	5% 1/10W
R905	1-216-113-00	RES-CHIP 470K	5% 1/10W
R906	1-216-025-11	RES-CHIP 100	5% 1/10W
R907	1-216-113-00	RES-CHIP 470K	5% 1/10W
R908	1-216-025-11	RES-CHIP 100	5% 1/10W
R909	1-216-065-91	RES-CHIP 4.7K	5% 1/10W
R910	1-216-065-91	RES-CHIP 4.7K	5% 1/10W
R911	1-216-067-00	RES-CHIP 5.6K	5% 1/10W
R912	1-216-041-00	RES-CHIP 470	5% 1/10W
R913	1-216-049-11	RES-CHIP 1K	5% 1/10W
R914	1-216-055-00	RES-CHIP 1.8K	5% 1/10W
R915	1-216-061-00	RES-CHIP 3.3K	5% 1/10W
R916	1-216-017-91	RES-CHIP 47	5% 1/10W
R917	1-216-041-00	RES-CHIP 470	5% 1/10W
R918	1-216-041-00	RES-CHIP 470	5% 1/10W
		<RELAY>	
RY601	$\Delta$ 1-755-214-11	RELAY, AC POWER	

REF. NO.	PART NO.	DESCRIPTION	REMARK
		<SWITCH>	
S502	1-572-707-11	SWITCH, LEVER	
S600	$\Delta$ 1-571-433-21	SWITCH, PUSH (AC POWER)	
S901	1-692-431-21	SWITCH, TACTILE	
S902	1-692-431-21	SWITCH, TACTILE	
S903	1-692-431-21	SWITCH, TACTILE	
S904	1-692-431-21	SWITCH, TACTILE	
S905	1-692-431-21	SWITCH, TACTILE	
S906	1-692-431-21	SWITCH, TACTILE	
S907	1-692-431-21	SWITCH, TACTILE	
		<TRANSFORMER>	
T501	1-437-195-11	TRANSFORMER, HORIZONTAL DRIVE	
T503	$\Delta$ 1-453-293-11	TRANSFORMER ASSY FLY BACK NX-1748/M3A4	
T601	1-424-682-11	TRANSFORMER, LINE FILTER	
T603	$\Delta$ 1-433-513-31	TRANSFORMER, CONVERTER (SRT)	
T604	$\Delta$ 1-431-852-11	TRANSFORMER, CONVERTER (SRT)	
		<THERMISTOR>	
TH600	1-803-586-11	THERMISTOR, NTC	
		<THERMISTOR>	
THP600	1-803-951-11	THERMISTOR, PTC	
		<TUNER>	
TU101	8-598-449-10	TUNER, FSS BTF-LG433	
		<CRYSTAL>	
X001	1-579-125-11	VIBRATOR, CERAMIC	
X301	1-781-134-21	VIBRATOR, CRYSTAL	
X302	1-781-132-21	VIBRATOR, CRYSTAL	
*****			
	* A-1332-175-A	C1 BOARD MOUNTED	*****
	7-682-948-01	SCREW +PSW 3X8	
		<CAPACITOR>	
C700	1-102-074-00	CERAMIC 0.001UF	10.00% 50V
C701	1-126-933-11	ELECT 100UF	20.00% 16V
C702	1-102-114-00	CERAMIC 470PF	10.00% 50V
C703	1-110-389-11	FILM MELF 0.1UF	5% 250V
C705	1-162-114-00	CERAMIC 0.0047UF	2KV
C706	1-130-202-00	FILM 0.022UF	5.00% 400V
C707	1-107-651-11	ELECT 4.7UF	20.00% 250V
C5952	1-107-616-11	CERAMIC 150PF	10.00% 500V
C5954	1-102-112-00	CERAMIC 330PF	10.00% 50V
C5955	1-104-664-11	ELECT 47UF	20.00% 16V

The components identified by shading  
and mark  $\triangle$  are critical for safety.  
Replace only with part number specified.

C1

REF. NO.	PART NO.	DESCRIPTION	REMARK	REF. NO.	PART NO.	DESCRIPTION	REMARK
C5961	1-161-830-00	CERAMIC	0.0047UF 500V	Q5962	8-729-423-33	2SC3311A-QRSTA	
C5962	1-130-491-00	MYLAR	0.047UF 5.00% 50V	Q5963	8-729-017-05	2SA1837	
C5963	1-107-638-11	ELECT	33UF 20.00% 160V	Q5965	8-729-017-06	2SC4793	
C5964	1-126-935-11	ELECT	470UF 20.00% 10V	Q5967	8-729-423-33	2SC3311A-QRSTA	
C5968	1-106-383-00	MYLAR	0.047UF 10.00% 200V	Q5968	8-729-119-76	2SA1175-HFE	
C5969	1-107-949-11	ELECT	2.2UF 20.00% 160V			<RESISTOR>	
C5970	1-104-999-11	MYLAR	0.1UF 10.00% 200V	R700	1-219-743-11	CARBON 100	5% 1/2W
C5972	1-126-935-11	ELECT	470UF 20.00% 16V	R703	1-247-807-31	CARBON 100	5% 1/4W
C5973	1-130-491-00	MYLAR	0.047UF 5.00% 50V	R704	1-247-807-31	CARBON 100	5% 1/4W
C5975	1-126-935-11	ELECT	470UF 20.00% 10V	R705	1-247-807-31	CARBON 100	5% 1/4W
C5978	1-130-471-00	MYLAR	0.001UF 5.00% 50V	R709	1-219-746-11	CARBON 1K	5% 1/2W
C5979	1-130-471-00	MYLAR	0.001UF 5.00% 50V	R710	1-240-933-91	CARBON 1.5K	5% 0.5W
C5980	1-104-664-11	ELECT	47UF 20.00% 10V	R711	1-219-746-11	CARBON 1K	5% 1/2W
		<#####>		R712	1-219-752-11	CARBON 100K	5% 1/2W
CLP701	4-352-844-01	PIN, LEAD, COATING		R713	1-216-399-00	METAL OXIDE 6.8	5% 3W
CLP702	4-352-844-01	PIN, LEAD, COATING		R714	1-216-380-11	METAL OXIDE 8.2	5% 2W
		<CONNECTOR>		R715	1-249-401-11	CARBON 47	5% 1/4W
CN700	1-695-915-11	TAB (CONTACT)		R716	1-249-429-11	CARBON 10K	5% 1/4W
CN701	* 1-564-509-11	PLUG, CONNECTOR 6P		R717	1-247-807-31	CARBON 100	5% 1/4W
CN703	1-695-915-11	TAB (CONTACT)		R718	1-249-428-11	CARBON 8.2K	5% 1/4W
CN706	1-564-507-11	PLUG, CONNECTOR 4P		R719	1-215-473-00	METAL 150K	1% 1/4W
CN5961	* 1-564-510-11	PLUG, CONNECTOR 7P		R720	1-215-473-00	METAL 150K	1% 1/4W
CN5962	* 1-564-506-11	PLUG, CONNECTOR 3P		R722	1-247-891-00	CARBON 330K	5% 1/4W
		<DIODE>		R5950	1-249-401-11	CARBON 47	5% 1/4W
D704	8-719-911-19	ISS119-25		R5951	1-249-400-11	CARBON 39	5% 1/4W
D705	8-719-911-19	ISS119-25		R5952	1-249-398-11	CARBON 27	5% 1/4W
D707	8-719-051-85	HSS83TD		R5961	1-249-389-11	CARBON 4.7	5% 1/4W
D708	8-719-051-85	HSS83TD		R5962	1-247-807-31	CARBON 100	5% 1/4W
D709	8-719-051-85	HSS83TD		R5963	1-249-417-11	CARBON 1K	5% 1/4W
D5964	8-719-911-19	ISS119-25		R5964	1-260-312-11	CARBON 47	5% 1/2W
D5967	8-719-110-88	RD39ES-B2		R5965	1-249-414-11	CARBON 560	5% 1/4W
D5968	8-719-110-88	RD39ES-B2		R5966	1-249-417-11	CARBON 1K	5% 1/4W
		<IC>		R5967	1-249-410-11	CARBON 270	5% 1/4W
IC700	8-759-712-99			R5968	1-249-417-11	CARBON 1K	5% 1/4W
		<JACK>		R5969	1-249-383-11	CARBON 1.5	5% 1/4W
J701	$\triangle$ 1-540-071-22	SOCKET, CRT		R5971	1-249-409-11	CARBON 220	5% 1/4W
		<COIL>		R5972	1-249-432-11	CARBON 18K	5% 1/4W
L705	1-414-186-31	INDUCTOR 33UH		R5973	1-249-403-11	CARBON 68	5% 1/4W
L707	1-414-186-31	INDUCTOR 33UH		R5974	1-216-476-11	METAL OXIDE 180	5% 3W
L708	1-410-667-31	INDUCTOR 22UH		R5975	1-249-417-11	CARBON 1K	5% 1/4W
L5961	1-414-187-11	INDUCTOR 47UH		R5976	1-249-432-11	CARBON 18K	5% 1/4W
		<TRANSISTOR>		R5977	1-249-429-11	CARBON 10K	5% 1/4W
Q700	8-729-119-76	2SA1175-HFE		R5978	1-247-807-31	CARBON 100	5% 1/4W
Q5961	8-729-423-33	2SC3311A-QRSTA		R5979	1-249-414-11	CARBON 560	5% 1/4W
		<VARIABLE RESISTOR>		R5980	1-247-807-31	CARBON 100	5% 1/4W
				R5981	1-249-416-11	CARBON 820	5% 1/4W
				R5982	1-249-383-11	CARBON 1.5	5% 1/4W
				R5985	1-249-401-11	CARBON 47	5% 1/4W
				R5986	1-249-397-11	CARBON 22	5% 1/4W
						<VARIABLE RESISTOR>	
				RV700	1-241-656-11	RES, ADJ, METAL FILM 110M	

The components identified by shading and mark  $\Delta$  are critical for safety. Replace only with part number specified.



REF. NO.	PART NO.	DESCRIPTION	REMARK
		<SPARK GAP>	
SG700	1-519-422-11	GAP, SPARK	
SG701	1-519-422-11	GAP, SPARK	
SG702	1-519-422-11	GAP, SPARK	
*****			
	* A-1241-481-A	F BOARD MOUNTED	*****
	1-533-223-11	CLIP, FUSE	
	* 4-374-846-01	COVER, CAPACITOR, CAP TYPE	
		<CAPACITOR>	
C654	$\Delta$ 1-117-703-11	CERAMIC	0.0047UF 99% 250V
C4602	$\Delta$ 1-104-708-11	MYLAR	0.47UF 20.00% 250V
		<CONNECTOR>	
CN4601	1-580-843-11	PIN, CONNECTOR (POWER)	
CN4602	1-580-843-11	PIN, CONNECTOR (POWER)	
CN4603	1-695-915-11	TAB (CONTACT)	
		<FUSE>	
F4601	$\Delta$ 1-532-237-00	FUSE, TIME-LAG (BET) 3.15A/250V	
		<RESISTOR>	
R4601	$\Delta$ 1-202-719-00	SOLID	1M 10% 1/2W
		<TRANSFORMER>	
T4601	1-424-682-11	TRANSFORMER, LINE FILTER	
T4602	1-424-682-11	TRANSFORMER, LINE FILTER	
		<VARISTOR>	
VDR461	1-803-830-11	VARISTOR (ERZV14D621)	
*****			
	* A-1388-314-A	J2 BOARD MOUNTED (KV-XA21MSJ ONLY)	*****
		<CONNECTOR>	
CN3421	* 1-564-519-11	PLUG, CONNECTOR 4P	

REF. NO.	PART NO.	DESCRIPTION	REMARK
		<DIODE>	
D3421	8-719-110-72	RD30ESB2	
D3422	8-719-110-72	RD30ESB2	
D3423	8-719-110-72	RD30ESB2	
D3424	8-719-110-72	RD30ESB2	
		<JACK>	
J3421	1-694-719-11	TERMINAL, PUSH (4P)	
*****			
		MISCELLANEOUS	*****
	1-501-730-11	ANTENNA, TELESCOPIC	
	1-417-151-21	MATCHING TRANSFORMER, ANTENNA	
	1-569-008-21	ADAPTOR, CONVERSION 2P	
	1-529-968-11	SPEAKER (5CM) (KV-XA21MSJ ONLY)	
	1-416-864-12	COIL, VM	
	1-416-946-11	COIL, DEMAGNETIC	
	1-452-032-00	MAGNET, DISC	
	1-540-005-31	CAP ASSY, HIGH VOLTAGE	
	1-529-125-11	SPEAKER (13X7CM)	
	1-500-249-11	BEAD, FERRITE (CASE) (KV-XA21MSJ ONLY)	
	$\Delta$ 1-574-062-11	CORD, POWER (WITH CONNECTOR) 2.5A/250V	
	$\Delta$ 8-451-505-11	DEFLECTION YOKE (Y21RSA-S)	
	$\Delta$ 8-738-809-05	PICTURE TUBE (A51LPT70X)	
*****			
		ACCESSORIES AND PACKING MATERIALS	*****
	3-701-910-00	SCREW, SPECIAL (DIA. 3.8X20)	
	* 4-030-594-01	BAG, PROTECTION	
	* 4-082-176-01	INDIVIDUAL CARTON	
	* 4-082-177-01	CUSHION (UPPER)	
	* 4-082-178-01	CUSHION (LOWER)	
	4-081-670-11	MANUAL, INSTRUCTION	
	4-392-003-01	BAND, HOLD	
	4-392-004-01	CLIP	
*****			
		REMOTE COMMANDER	*****
	1-418-163-12	REMOTE COMMANDER	
	9-939-697-01	BATTERY COVER REMOTE COMMANDER	