

# PKG-EMG20-EDB20-CBLS

## System Diagram and Specifications

TO COMPUTER

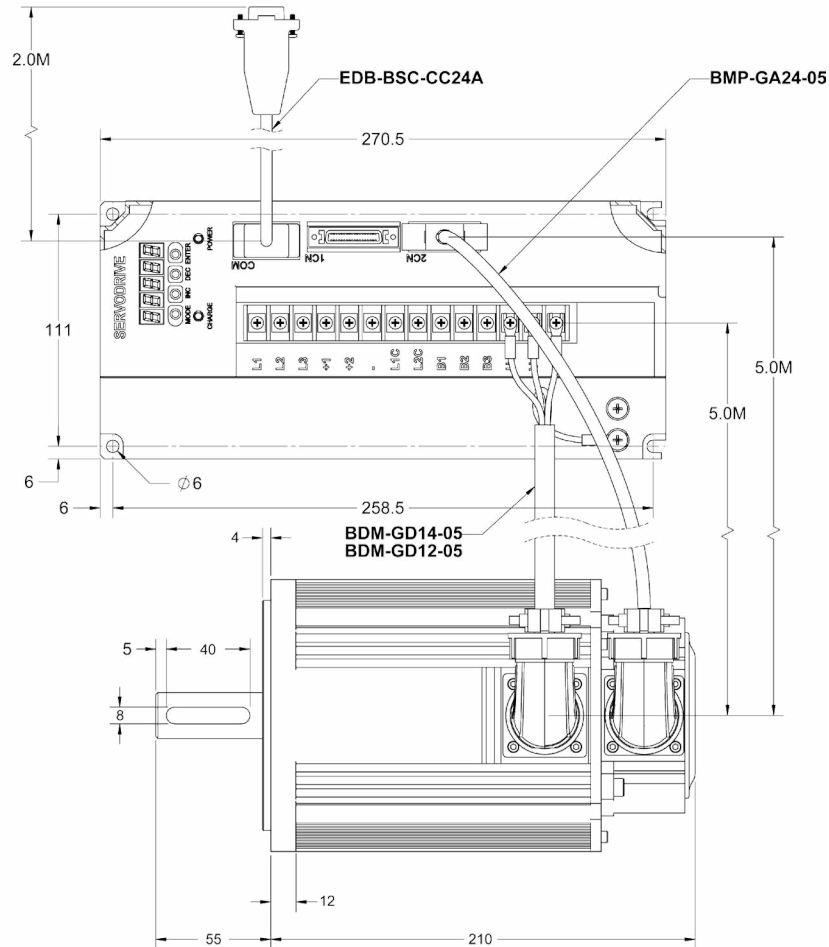
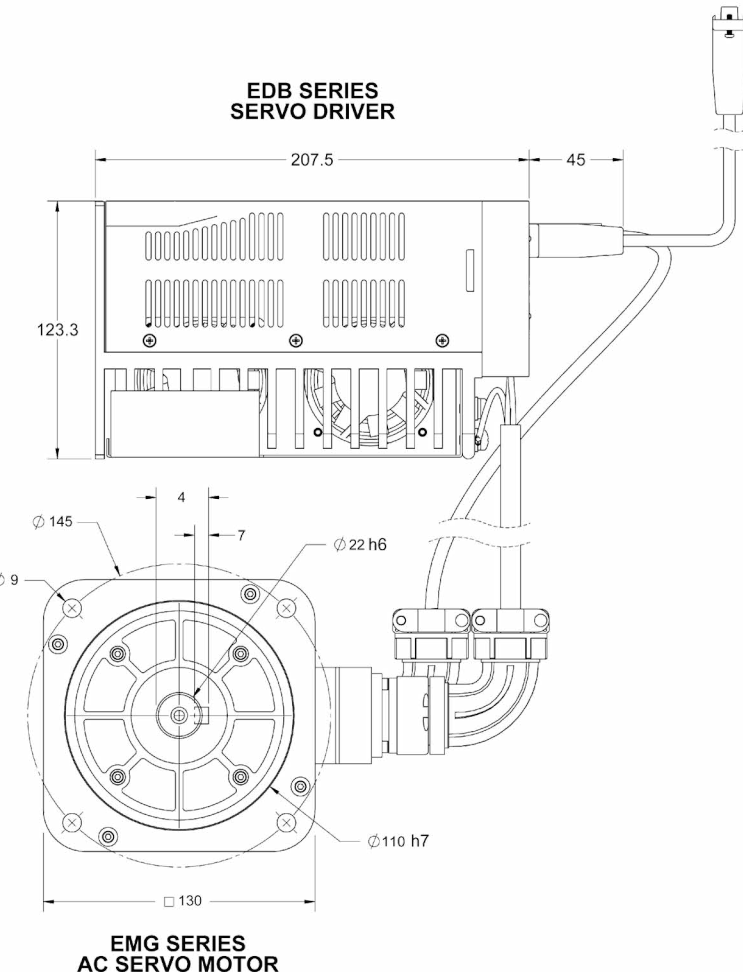

### Included Components:

EMG-20APA22	AC Servo Motor
EDB-20AMA	Servo Driver
BDM-GA16-05	Power Cable
BMP-GA24-05	Encoder Cable
EDB-BSC-CC24A	Comm Cable

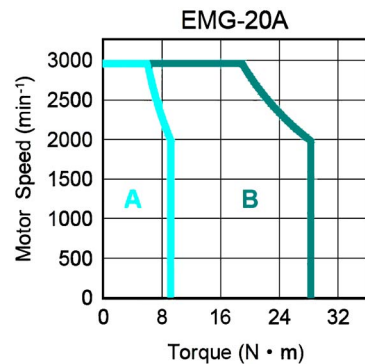

A: Continuous Working Area  
B: Repeatedly Working Area

L010907

# EMG-20APA22 130mm AC Servo Motor



DESCRIPTION

- **Rated Torque of 1,352 oz.-in.**
- **Medium Inertia to Maximize Torque**
- **Peak Torque up to 300% of Rated Torque**
- **Peak Current up to 300% of Rated Current**
- **Speed of up to 3,000 RPM**
- **2,500 PPR Incremental Encoder Attached**
- **Enclosed and Self-Cooled**
- **Power Rating of 2,000 Watts**
- **Oil Seal and Optional Brake**
- **Long Life and Highly Reliable**
- **Neodymium-Iron-Boron Magnets (NdFeB)**
- **CE Certified**



DESCRIPTION

Anaheim Automation's AC servo motor offers a simple solution to servo applications. The AC Servo motor is equipped with a 2,500 counts-per-revolution encoder. The AC Servo motor enables industrial motion control applications with medium inertia to attain a great combination of speed and positioning capability. The EMG AC Servo motor offers a cost-effective solution to many velocity and position controlled applications.

SPECIFICATIONS

Model #	Rated Torque (oz-in)	Rated Power (Watts)	Max Speed (rpm)	Rated Speed (rpm)	Rated Current (A rms)	Inertia (oz-in-sec <sup>2</sup> )	Electric Time Constant T <sub>E</sub> (ms)	Back EMF Voltage K <sub>E</sub> (V/krpm)	Torque Constant K <sub>T</sub> (oz-in/A)	Resistance (ohms)	Weight (lbs)
EMG-20APA22	1352	2000	3000	2000	12.0	0.2691	13.00	61.0	130.1	0.3	27.56

Power Requirement 220VAC	Vibration: 49m/s <sup>2</sup>	Running Air Pressure: 86-106 kPa
Insulation Class: F	Ambient Humidity: 20 to 80% RH	Insulation Voltage Endurance: AC 1800V, 50Hz, 1min
Ambient Temp: 0° to 40° C	IP Rating: IP65	Insulation Impedance: Not Less than 50M Under Normal Conditions
Running Temp: -25° to 40° C	Running Humidity: Not more than 90%, under 25°C	

---

# EDB series AC servo system

User's Manual V. 2.00



## Anaheim Automation Limited Warranty

This manual does not entitle you to any rights. Anaheim Automation reserves the right to change this manual without prior notice. All rights reserved. No part of this publication may be copied or reproduced without written permission from Anaheim Automation.

---

# General Precautions

---

- **Voltage of power supply is 200V**  
Please connect to 200V voltage electrical source
- **Don't connect Servomotor directly to the residential electric network.**  
Do not connect Servomotor directly to the residential electric network; otherwise, it will be damaged. Servomotor is not able to work without relevant Servo drive.
- **Don't plug or unplug the electric socket when power is ON.**  
Always turn the power OFF before plug or unplug to the electric socket.
- **Wait at least five minutes before inspection after turning OFF power**  
Note that even when the power is turned off, there will still be residual voltage remained in the capacitor. In order to avoid electrical shock, please make sure the Charge lamp is OFF before inspection.
- **The installation interval to other equipment is above 10mm.**  
The installation interval to other equipment should be at least 10mm breadthways and 50mm lengthways. The Servo drive generates heat, please layout the Installation the Servo drive which is good to radiate heat. Please install the Servo drive in an environment free from condensation, vibration and shock.
- **Please take treatment of anti-disturbance and grounding properly.**  
If there are disturbance in the signal line, vibration or malfunction will likely occur.  
Please stick to the following rules strictly:
  1. Separate high-voltage cable from low-voltage cable.
  2. Make cables as short as possible
  3. Apply one phase grounding (ground resistance less than 100Ω) for the installation of Servomotor and Servo drive.
  4. NO power input noise filter between servo drive and servomotor.
- **Please conduct voltage endurance under following conditions:**
  5. Voltage: AC 1500Vrms, 1 min
  6. Cut the current: 100mA
  7. Frequency: 50/60Hz
  8. Voltage applied point: L1, L2, L3 pins and FG  tie-in (Please fast the connection among terminals).
- **Creepage prevention instrument: please select quick-response type**  
For a ground-fault interrupter, always use a quick response type or one designed for PWM inverters. Do not use a time-delay type.
- **Don't perform continuous operation under overhanging load.**  
Continuous operation cannot be performed by rotating the motor from the load and applying regenerative braking. Regenerative braking by the Servo drive can be applied only for a short period, such as the motor deceleration time.

Turning the Power On and Power Off frequently will result in speeding up deterioration of internal elements. Please control the servo motor with reference signals.

---

# Content

Chapter 1 .....	6
Checking products and parts names .....	6
1. 1 Check products .....	6
1.1.1 Servo drive .....	7
1.2 Product Parts names .....	8
1.2.1 Servo drive .....	8
Chapter 2 .....	9
Installation .....	9
2.1 Servodrive .....	9
2.2.1 Storage .....	9
2.2.2 Installation sites .....	9
2.2.3 Installation orientation .....	10
2.2.4 Installation method .....	10
Chapter 3 .....	11
Wirings and connections .....	11
3.1 Wirings and connections for main circuit .....	11
3.1.1 Names and Functions of Main Circuit Terminals .....	11
3.1.2 Typical main circuit wiring example .....	12
3.2 Input and output signal .....	12
3.2 Input and output signal .....	13
3.2.1 Connection of input and output signals .....	13
3.2.2 Terminal layout of connector 1CN .....	14
3.2.3 I/O signal names and functions .....	15
3.2.4 Interface Circuit .....	17
3.3 wiring encoders .....	18
3.3.1 Connecting an Encoder (2CN) and Output Signals from the servodrive .....	18
3.3.2 Encoder Connector (CN2) Terminal Layout .....	18
3.4 Wiring servo motor .....	19
3.4.1 Encoder Connector Terminal Layout .....	19
3.4.2 Dynamic power Connector Terminal layout .....	19
3.5 Typical wiring example .....	20
3.5.1 Position control mode .....	20
3.5.1 Position control mode .....	21
3.5.2 Speed control mode .....	22
3.5.3 Torque control mode .....	23
Chapter 4 .....	24
Parameter Setting and function description .....	24
4.1 Setting Parameters according to mechanical features .....	24
4.1.1 Changing the Direction of Motor Rotation .....	24
Select the rotating direction by setting parameters below: .....	24
4.1.2 Setting overtravel limit .....	25
4.1.3 Limiting Torque .....	26

---

4.2 Setting Parameters According to Host Controller .....	29
4.2.1 Speed Reference .....	29
4.2.2 Position reference .....	34
4.2.3 Encoder signal output.....	38
4.2.4 Contact I/O Signals .....	41
4.2.5 Position control (parameter reference).....	42
4.2.7 Using Contact Input Speed Control .....	50
4.2.8 Using Torque Control .....	54
4.2.9 Using Torque Feed-forward Function.....	59
4.2.10 Using Torque Restriction by Analog Voltage Reference.....	60
4.2.11 Using the Reference Pulse Inhibit Function (INHIBIT).....	62
4.3 Setting up the parameter.....	64
4.3.1 Setting the Jog Speed.....	64
4.3.2 Selecting the control modes .....	64
4.4 Setting Stop Mode.....	72
4.4.1 Adjusting Offset.....	72
4.4.2 Using Dynamic Brake .....	72
4.4.3 Using Zero-Clamp.....	73
4.4.4 Using Holding Brake .....	75
4.5 Forming a Protective Sequence.....	79
4.5.1 Using Servo Alarm Output and Alarm Code Output.....	79
4.5.2 Using Servo ON Input Signal.....	80
4.5.3 Using Positioning Complete Signal .....	81
4.5.4 Using Speed Coincidence Output Signal .....	83
4.5.5 Using Running Output Signal .....	84
4.5.6 Using Servo Ready Output Signal.....	85
4.5.7 Handling of Power Loss.....	87
4.5.8 Using Regenerative Resistor Units.....	88
4.6 Running the Motor Smoothly.....	88
4.6.1 Using Smoothing function.....	88
4.6.2 Using the Soft Start Function.....	89
4.6.3 Setting the Torque Reference Filter Time Constant.....	90
4.7 Minimizing Positioning Time .....	90
4.7.1 Setting Servo Gain.....	90
4.7.2 Using Proportional Control.....	91
4.7.3 Setting Speed Bias .....	92
Chapter 5 .....	93
Using the digital operator.....	93
5.1 Basic operator .....	93
5.1.1 Digital Operator Functions.....	93
5.1.2 Resetting Servo Alarms .....	93
5.1.3 Basic Functions and Mode Selection .....	94
5.1.4 Operation in Status Display Mode .....	94
5.1.5 Operation in Parameter Setting Mode.....	97

---

5.1.6 Operation in Monitor Mode .....	97
Operation Using the Digital Operator .....	99
5.2.1 Alarm Trace-back Data .....	100
5.2.2 Operation of recovering to default value.....	100
5.2.3 Operation in JOG mode .....	101
5.2.4 Reference Offset Automatic Adjustment .....	101
5.2.5 Reference Offset Manual Adjustment Mode .....	103
5.2.6 Motor Current Detection Offset Adjustment .....	103
5.2.7 Checking Software Version .....	106
Chapter 6 .....	107
Communication functions .....	107
6.1    RS-485、RS-232、RS-422 Communication hardware interface.....	107
6.2    RS-485、RS-232、RS-422 communication parameter .....	108
6.3    MODBUS communication protocol .....	110
6.3.1    Code meaning.....	110
6.3.2    Communication fault disposal.....	115
6.3.3    Servo state data communication address .....	117
Chapter 7 .....	120
Technical Specifications and Features.....	120
7.1 Servomotor Technical specifications and Types .....	120
7.2 Servo Drive Mounting dimension .....	123
Appendix A .....	124
Parameter list.....	124
Appendix B.....	136

---

# Chapter 1

---

## Checking products and parts names

### 1. 1 Check products

Check the following items after receiving EDB Series AC servo drive products.

Check Items	Reference
Whether the models are the same as what were ordered.	Check the model numbers marked on the nameplates on the servo motor and Servo drive. (Refer to the descriptions of model numbers in the following section.)
Does the servomotor shaft rotate smoothly?	The servomotor shaft is normal if it can be turned smoothly by hand. Servomotors with brakes, however, cannot be turned manually.
Is there any damage?	Check the overall appearance, and check for damage or scratches that may have occurred during transportation.
Is there any screw loose?	Check with the screwdriver.

## 1.1.1 Servo drive

### ■ Appearance and nameplate

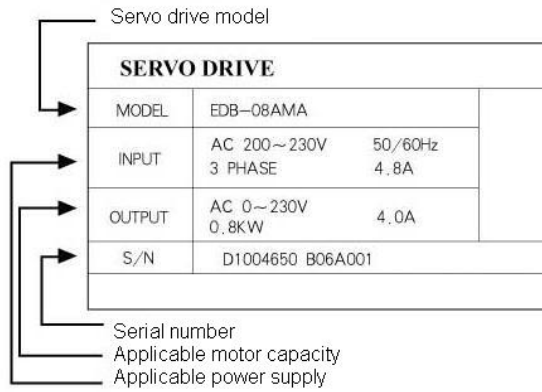

### ■ Check the model

**EDB** -  
Servo drive  
EDB type

**08**      **A**      **M**      **A**  
【 1 + 2 】   【 3 】   【 4 】   【 5 】

【 1 + 2 】 Rated power

Item	Specification
08	750W
10	1.0kW
15	1.5kW
20	2.0kW
30	3.0kW
50	5.0kW

【 3 】 Voltage

Item	Specification
A	200VAC
D	400VAC

【 5 】 Design sequence

Item	Specification
A	Design sequence

【 4 】 Control Type

Item	Specification
M	Position, speed and torque control
P	Position Control

---

## 1.2 Product Parts names

### 1.2.1 Servo drive

The part names of servo drive are shown as below:

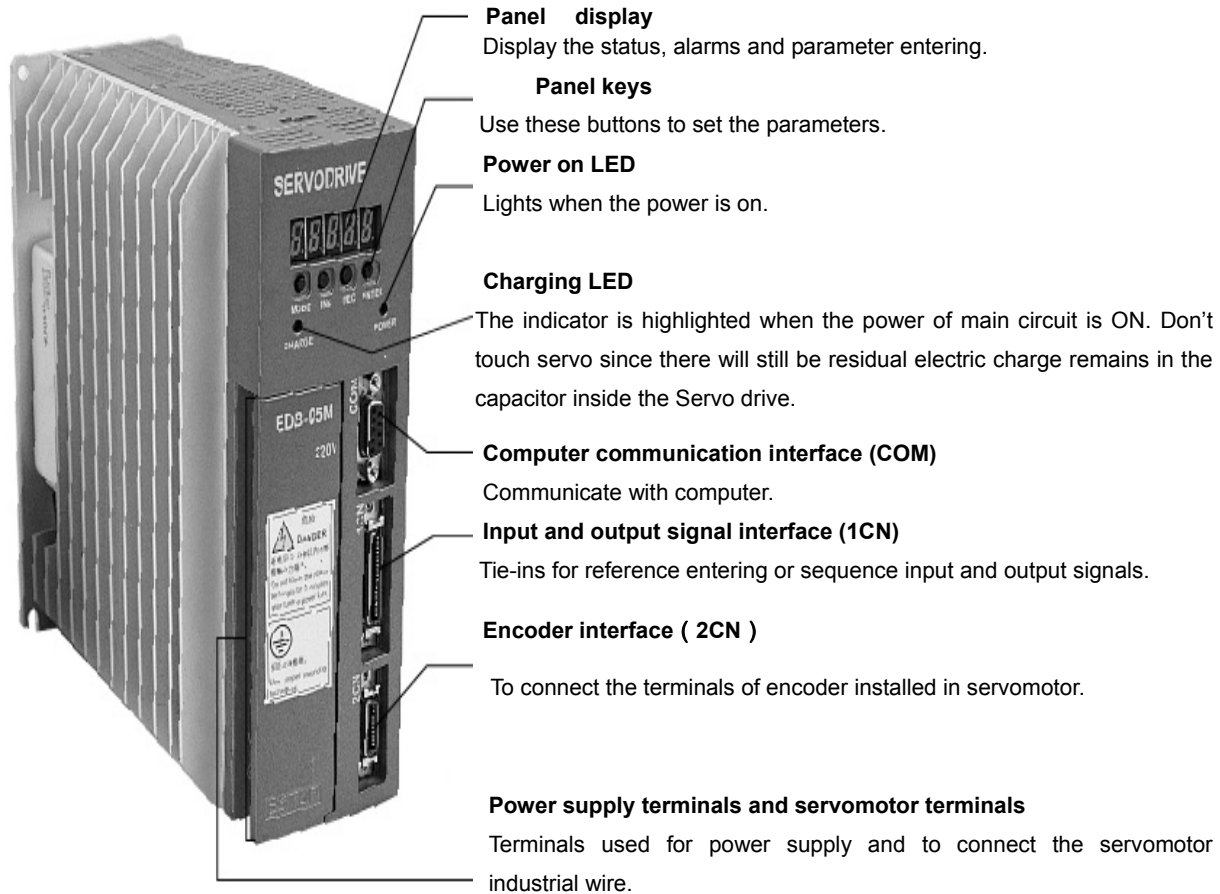

---

# Chapter 2

---

## Installation

### 2.1 Servodrive

EDB Series Servo drive is a base-mounted type servo controller. Incorrect installation will cause problems. Always observe the installation instructions described below.

#### 2.2.1 Storage

When the Servo drive is to be stored with the power cable disconnected, store it in the following temperature range:  
Between  $-20^{\circ}\text{C}$  and  $85^{\circ}\text{C}$

#### 2.2.2 Installation sites

Notes of operation installation are described as follows:

Condition	Safety notes
Installation in a Control Panel	Design the control panel size, unit layout, and cooling method so the temperature around the servo drive does not exceed $55^{\circ}\text{C}$ ( $131^{\circ}\text{F}$ )
Installation Near a Heating Unit	Minimize the heat radiating from the heating unit as well as any temperature rise caused by natural convection so the temperature around the servo drive does not exceed $55^{\circ}\text{C}$ ( $131^{\circ}\text{F}$ ).
Installation Near a Source of Vibration	Install a vibration isolator on the servo drive to avoid subjecting it to vibration.
Installation at a Site Exposed to Corrosive Gas	Corrosive gas does not have an immediate effect on the servo drive but will eventually cause the electronic components and contactor-related devices to malfunction. Take appropriate action to avoid corrosive gas.
Other Situations	Do not install the servo drive in hot, humid locations or locations subject to excessive dust or iron powder in the air.

## 2.2.3 Installation orientation

Install the SERVODRIVE perpendicular to the wall as shown in the figure. The Servo drive must be oriented this way because it is designed to be cooled by natural convection or a cooling fan.

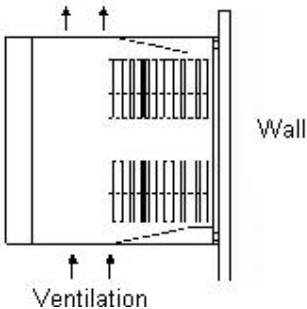

## 2.2.4 Installation method

When installing multiple Servos drives side by side in a control panel, observe the following installation method:

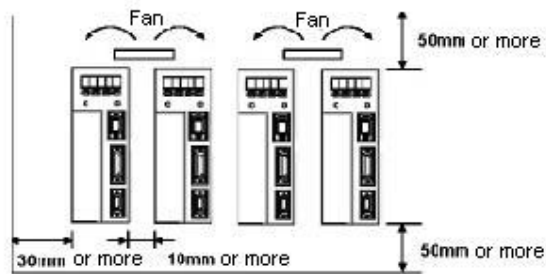

### ■ Servo drive orientation

Install the Servo drive perpendicular to the wall so the front panel containing connectors faces outward.

### ■ Cooling

As shown in the figure above, allow sufficient space around each Servo drive for cooling by cooling fans or natural convection.

### ■ Side-by-side Installation

When installing Servo drives side by side as shown in the figure above, allow at least 10 mm (0.39 in) between and at least 50 mm (1.97 in) above and below each Servo drive. Install cooling fans above the Servo drives to avoid excessive temperature rise and to maintain even temperature inside the control panel.

### ■ Environmental Conditions in the Control Panel

1. Ambient Temperature: 0 to 55°C (32 to 131 ° F)
2. Humidity: 90% RH or less
3. Vibration: 4.9 m/s<sup>2</sup>
4. Condensation and Freezing: None
5. Ambient Temperature for Long-term Reliability: 45 °C (113 °F) or less

# Chapter 3

## Wirings and connections

### 3.1 Wirings and connections for main circuit

Always observe the following notes when wire or connects the circuit.

	
<ul style="list-style-type: none"><li>● <b>Do not wire power lines and signal lines in the same duct or bundle them together. Wire such that signal lines are kept apart from power lines by at least 30 cm.</b></li><li>● <b>Twisted pair wire and multi-core twisted pair shielding wires should be used for signal lines, encoder (PG) feedback line.</b></li></ul>	<p>The length for wiring is 3m maximum for the reference input line, 20 m maximum for the PG feedback line.</p>
<ul style="list-style-type: none"><li>● <b>Do not touch the power terminal even if power is turned off.</b></li></ul>	<p>High voltage may still remain in Servo drive. Perform inspection only after the CHARGE LED extinct.</p>
<ul style="list-style-type: none"><li>● <b>Avoid frequently turning the power ON and OFF with the interval at least more than 1 min.</b></li></ul>	<p>Since the Servo drive has a capacitor in the power supply, a high charging current flows (for 0.2 second) when the power is turned ON. Therefore, frequently turning the power ON and OFF causes the main circuit devices (such as capacitors and fuses) to deteriorate, resulting in unexpected problems.</p>

#### 3.1.1 Names and Functions of Main Circuit Terminals

Terminal symbol	Name	Description
L1,L2,L3	Main circuit power supply input terminal	Three-phase 200-230VAC $+10\%$ $-15\%$ 50/60HZ
L1C, L2C	Control circuit power supply input terminal	Single-phase 200-230VAC $+10\%$ $-15\%$ 50/60HZ
U,V,W	Servo Motor connection terminals	Connects to servo motor
	Ground terminals	Connects to the power supply ground terminals and servo motor ground terminal.
B1, B2, B3 (EDB-08, EDB-10, and	Regenerative resistor connection terminal	Normally short B2 and B3 (for an internal regenerative resistor). Remove the wire

EDB-15 don't have B3 terminal.)		between B2 and B3 and connect an external regenerative resistor between B1 and B2 if the capacity of the internal regenerative resistor is insufficient.
⊕1 ⊕2 (EDB-08, EDB-10 And EDB-15 doesn't have those two terminals.)	DC reactor for harmonic suppression terminal	Normally short ⊕1 and ⊕2. If a countermeasure against power supply harmonic waves is needed, connect a DC reactor between ⊕1 and ⊕2.
⊖ (EDB-08, EDB-10 And EDB-15 doesn't have this terminal.)	Main circuit minus terminal	Normally not connected.

### 3.1.2 Typical main circuit wiring example

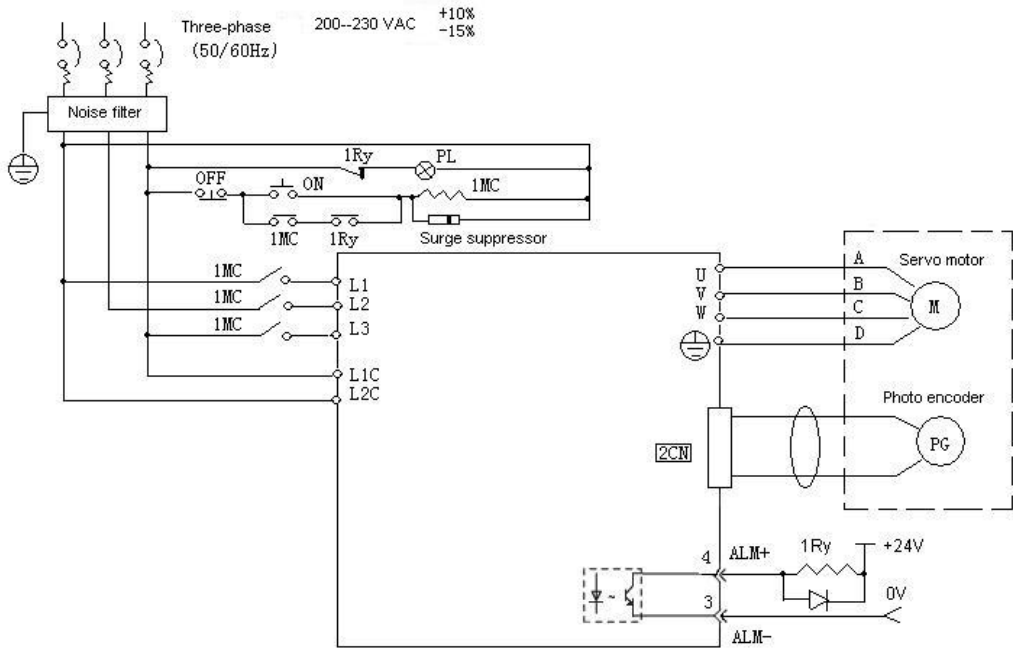

## 3.2 Input and output signal

### 3.2.1 Connection of input and output signals

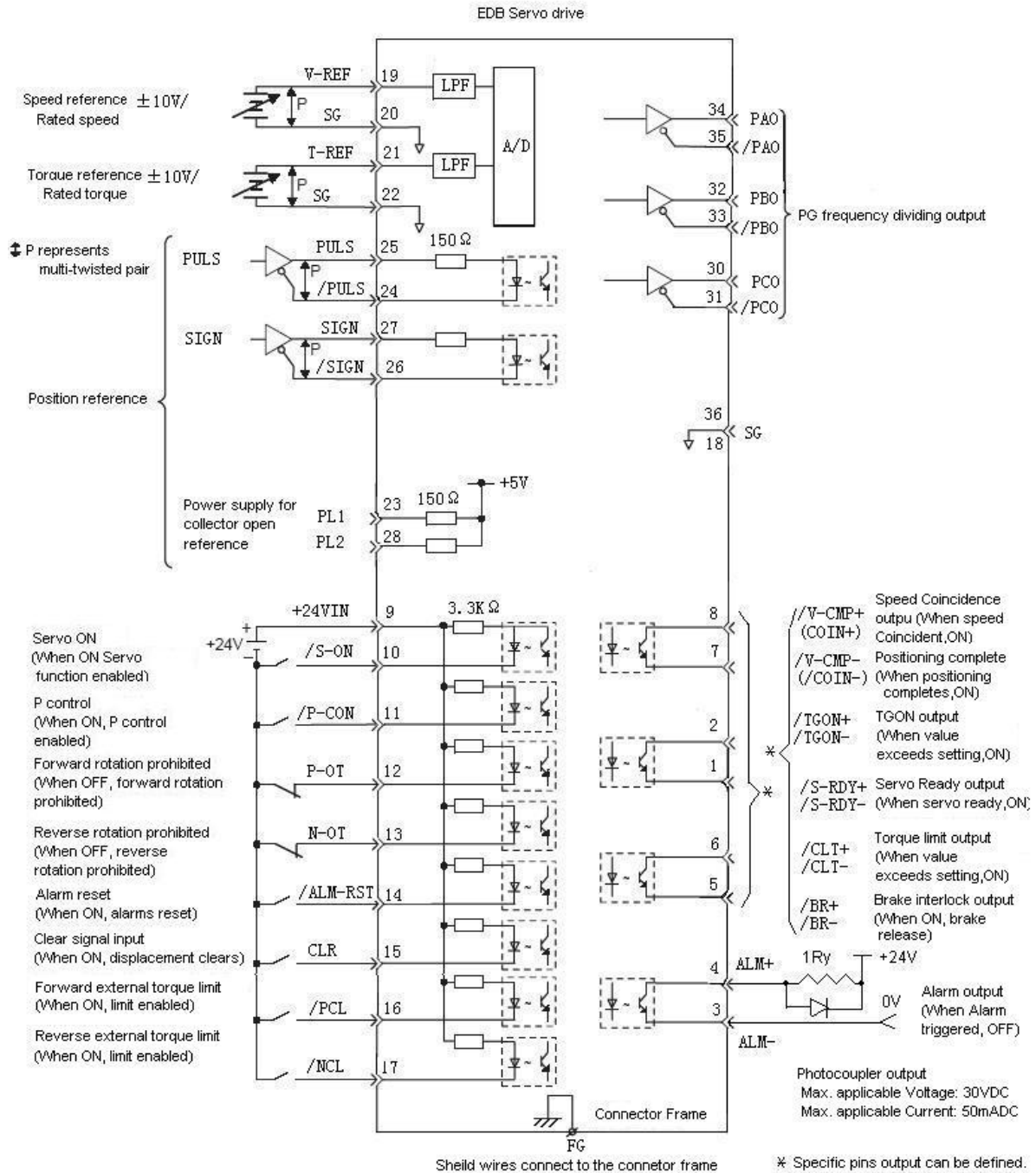

### 3.2.2 Terminal layout of connector 1CN

Pin number	Name	Description	Pin number	Name	Description
(*) 1 2	0:/COIN- /COIN+ (/V-CMP-) (/V-CMP+)	0 : Positioning completed signal output ( speed coincidence output)	19	V-REF	Speed reference output
			20	SG	0V
(*) 5 6	1:/TGON- /TGON+ 2:/S-RDY- /S-RDY+	1 : Run output 2 : Servo ready output	21	T-REF	Torque reference input
			22	SG	0V
(*) 7 8	3:/CLT- /CLT+ 4:/BR- /BR+	3 : Torque limit output 4 : Holding brake interlock output	23	PL1	Open-collector reference input power supply
			24	/PULS	Reference pulse input
3	ALM-	Alarm output	25	PULS	Reference pulse input
4	ALM+	Alarm output	26	/SIGN	Reference sign input
9	+24VIN	I/O power supply input	27	SIGN	Reference sign input
10	/S-ON	Servo ON input	28	PL2	Open-collector reference input power supply
11	/P-CON	P control input	29	—	—
12	P-OT	Forward overtravel input	30	PCO	PG Frequency dividing output
13	N-OT	Reverse overtravel input	31	/PCO	PG Frequency dividing output
14	/ALM-RST	Alarm reset output	32	PBO	PG Frequency dividing output
15	/CLR	Clear input	33	/PBO	PG Frequency dividing output
16	/PCL	Forward external torque limit	34	PAO	PG Frequency dividing output
17	/NCL	Reverse external torque limit	35	/PAO	PG Frequency dividing output
18	SG	0V	36	SG	0V

**Note:**

1. Do not use vacant pins for relay or other purposes.
2. Connect the shielded twisted pairs of I/O signals to connector frame.
3. Allocate and define function for pin 1CN-1, 2, 1CN-5, 6, 1CN-7, 8 according to parameter Pn053, Pn054, Pn055.

### 3.2.3 I/O signal names and functions

#### Input signal

Signal name	Pin number	Function	Reference	
+24VIN	9	Control power supply input for sequence signals: Users must provide the +24 V power supply.  Allowable Voltage range: +11V ~ +25V	4.2.4	
/S-ON	10	Servo ON : Servo power on	4.5.2	
/P-CON	11	Function differs with control modes.		
P-OT	12	Forward drive prohibited	4.1.2	
N-OT	13	Reverse drive prohibited		
/ALM-RST	14	Alarm reset: Releases the servo alarm state.	4.5.1	
/CLR	15	Clear signal input: Clears the positional error pulse during position control.	4.2.2	
/PCL	16	Forward external torque limit ON	4.1.3	
/NCL	17	Reverse external torque limit ON	4.1.3	
V-REF	19 (20)	Speed reference input: $\pm 10V$	4.2.1	
T-REF	21 (22)	Torque reference input: $\pm 10V$	4.2.8	
PL1 PL2	23 28	Open-collector reference power supply: Pull-up power is supplied when PULS, and SIGN reference signals are open-collector outputs (+5~24 VDC power supply is built into the Servo drive).	4.2.2	
/PULS PULS /SIGN SIGN	24 25 26 27	Reference pulse input: line driver or open collector	Input mode is set from the following pulses. *signals +pulse string *CCW/CW pulse * • Two-phase pulse (90° phase differential)	4.2.2

**Note:** 1. Pin numbers in parentheses ( ) indicate signal grounds.

## Output signal

Signal name	Pin number	Function	Reference
0 : /COIN-	1	0 : Positioning completed signal output	4.5.3
/COIN+	2	( Speed coincidence output )	4.5.4
( /V-CMP- )		1 : Detection during servomotor rotation:	4.5.5
( /V-CMP+ )	5	2 : Servo ready	4.5.6
	6	3 : Torque limit detection	4.1.3
1 : /TGON-		4 : Brake interlock output	4.4.4
/TGON+			
2 : /S-RDY-		Customer constant Pn053 sets output of CN1-7,8;	
/S-RDY+	7	Customer constant Pn054 sets output of CN1-1,2;	
3 : /CLT-	8	Customer constant Pn055 sets output of CN1-5, 6.	
/CLT+			
4 : /BR-			
/BR+			
ALM-	3	Servo alarm: Turns OFF when an error is detected.	4.5.1
ALM+	4		
PAO	34	Phase-A signal	4.2.3
/PAO	35	Phase-B signal	
PBO	32	Phase-C signal	
/PBO	33		
PCO	30		
/PCO	31 (18,36)		
FG	Shell	Connected to frame ground if the shield wire of the I/O signal cable is connected to the connector shell.	—

**Note:** 1. Pin numbers in parentheses ( ) indicate signal grounds.

### 3.2.4 Interface Circuit

This section shows examples of Servo drive connection to the host controller.

#### Interface for Analog reference Input Circuits

Analog signals are either speed or torque reference signals. The reference input resistor is about 40kΩ and Max. Allowable voltage of input signals is ±10V.

Speed reference input circuit:

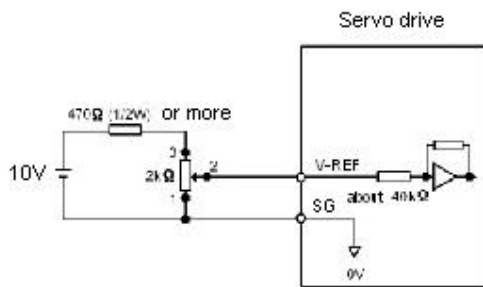

Torque reference input circuit :

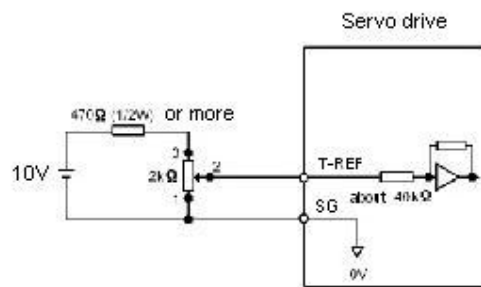

#### Sequence Input Circuit

The sequence input circuit interface connects through a relay or open-collector transistor circuit. Select a low current relay otherwise a faulty contact will result.

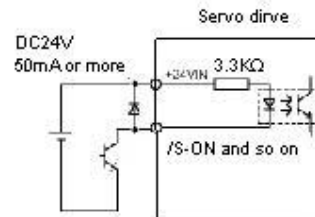
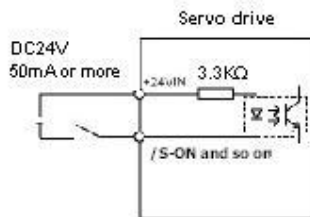

#### Line Driver Output Circuit

Encoder serial data converted to two-phase (phases A and B) pulse output signals (PAO, /PAO, PBO, /PBO), zero-point pulse signals (PCO, /PCO) are output via line-driver output circuits. Normally, the Servo drive uses this output circuit in speed control to comprise the position control system at the host controller. Connect the line-driver output circuit through a line receiver circuit at the host controller.

#### Sequence output circuit

Output signals of Servo alarm, Servo ready and other sequences are consist of photocoupler output circuit, please connect to relays.

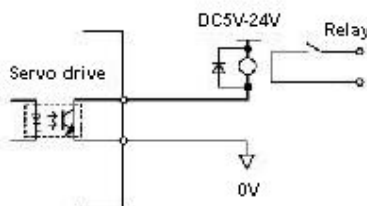

Note: MAX. allowable voltage and current are shown as follows:  
 \* Voltage: DC30V (MAX)  
 \* Current: DC50V (MAX)

### 3.3 wiring encoders

#### 3.3.1 Connecting an Encoder (2CN) and Output Signals from the servodrive

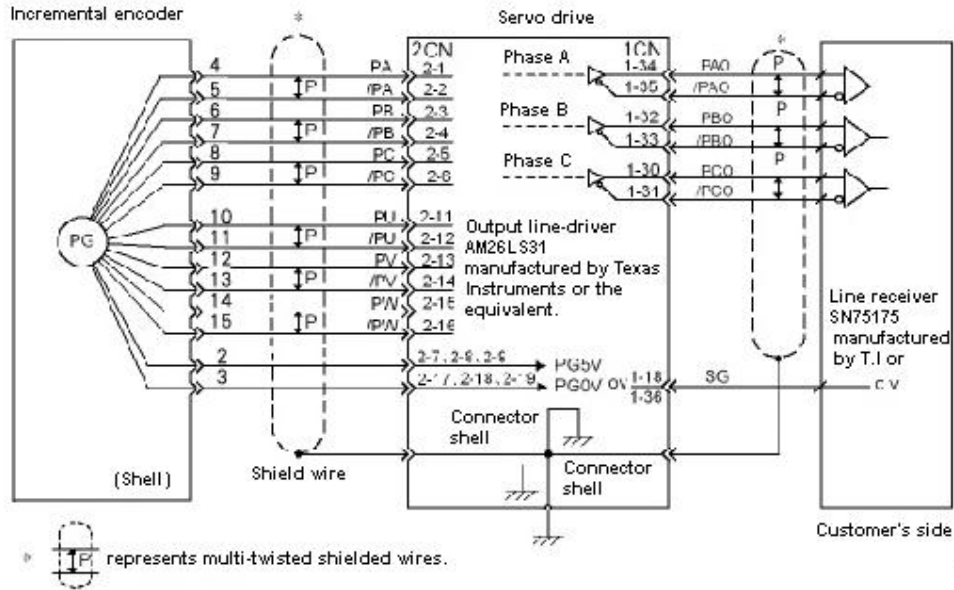

#### 3.3.2 Encoder Connector (CN2) Terminal Layout

2CN terminals layout is as follows:

Pin No.	Color	Name	Description	Pin No.	Color	Name	Description
1	Blue	PA	PG inputs phase A	11	Grass green	PU	PG input phase U
2	Pink	/PA	PG input /phase A	12	Brown	/PU	PG input phase U
3	Yellow	PB	PG input phase B	13	Green	PV	PG input phase V
4	Purple	/PB	PG input phase /B	14	Light purple	/PV	PG input phase /V
5	White	PC	PG input phase C	15	Grey	PW	PG input phase W
6	Light green	/PC	PG input phase /C	16	Light blue	/PW	PG input phase /W
7	Red	PG5V	PG power supply +5V	17	black	SG	PG power supply 0V
8				( orange )			
9							
10	—	—	—	20	—	—	—

---

### 3.4 Wiring servo motor

#### 3.4.1 Encoder Connector Terminal Layout

Pin No.	Color	Description
1	Red	+5V ( power supply )
2	Black ( orange )	0V ( power supply )
3	Blue	A channel output
4	Pink	/A channel output
5	Yellow	B channel output
6	Purple	/B channel output
7	White	C channel output
8	Light blue	/C channel output
9	Grass blue	U channel output
10	Brown	/U channel output
11	Green	V channel output
12	Light purple	/V channel output
13	Grey	W channel output
14	Light blue	/W channel output

#### 3.4.2 Dynamic power Connector Terminal layout

Pin No.	Color	Description
1	Blue	FG ( Frame grounding )
2	Pink	Phase U
3	Yellow	Phase V
4	Green	Phase W

### 3.5 Typical wiring example

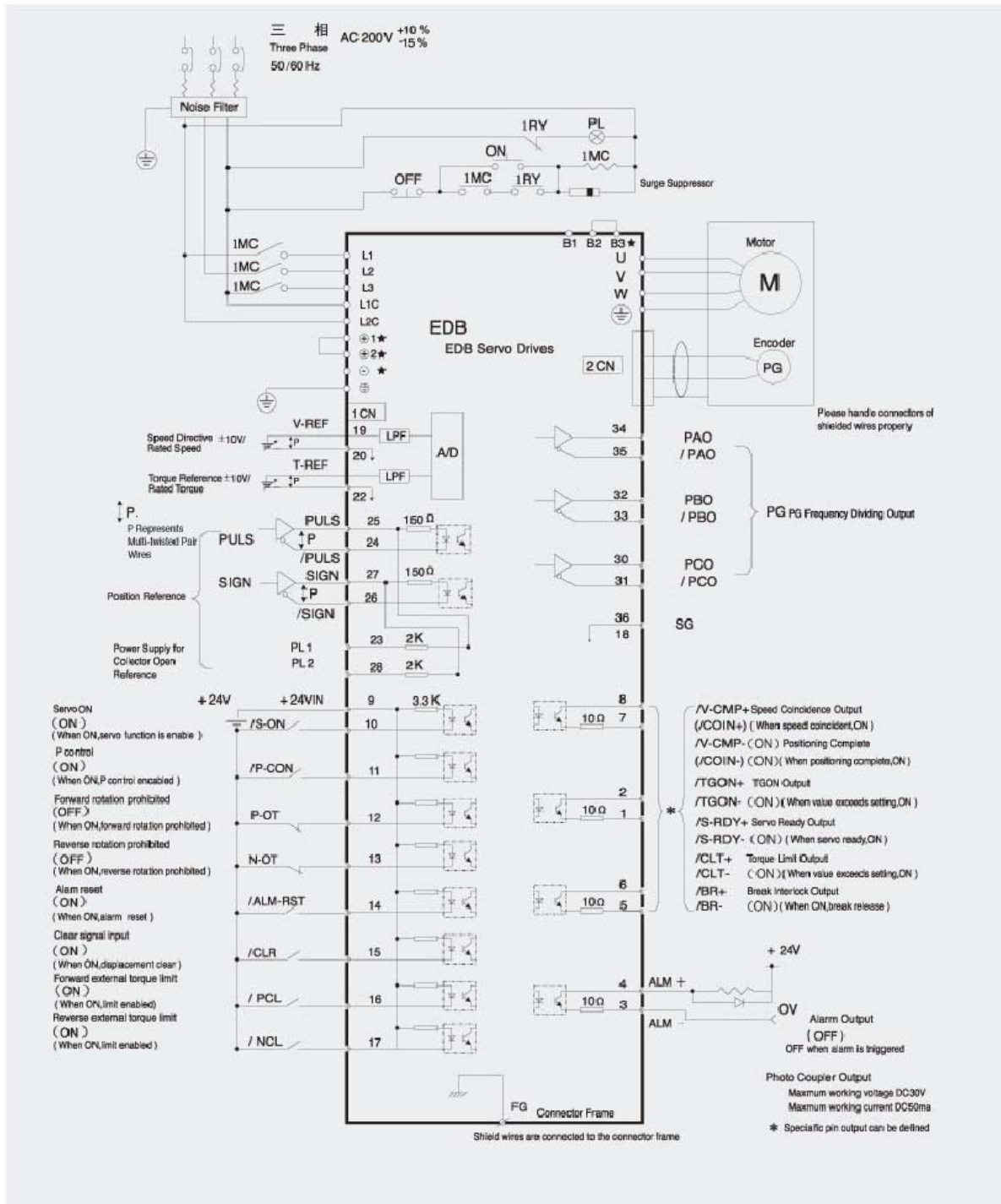

★ Notes: EDB-08/10/15, there are no terminals: B3, ⊕1, ⊕2, ⊖, no need of any connection.

### 3.5.1 Position control mode

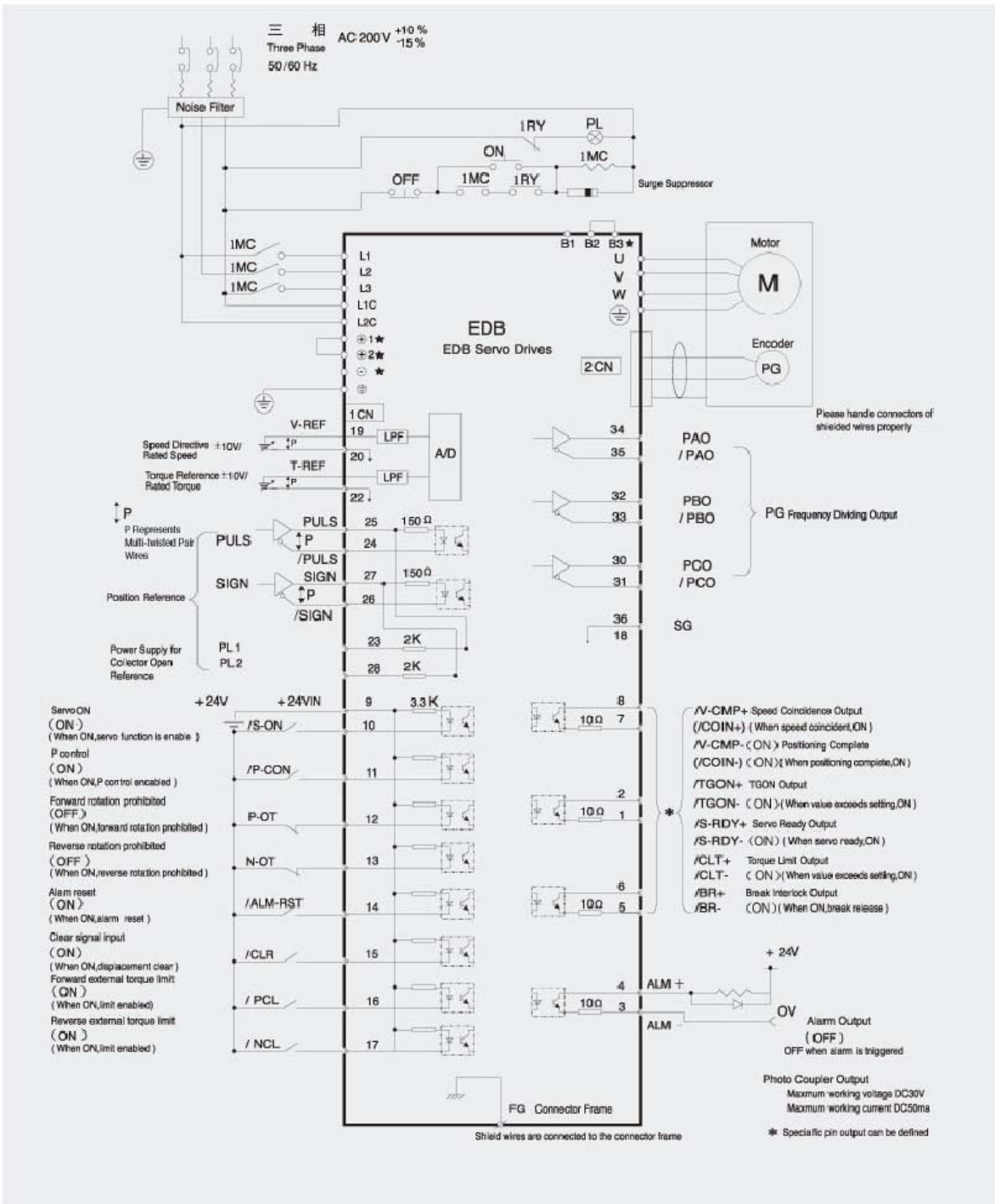

★ Notes: EDB-08/10/15, there are no terminals: B3, ⊕1, ⊕2, ⊖, no need of any connection.

### 3.5.2 Speed control mode

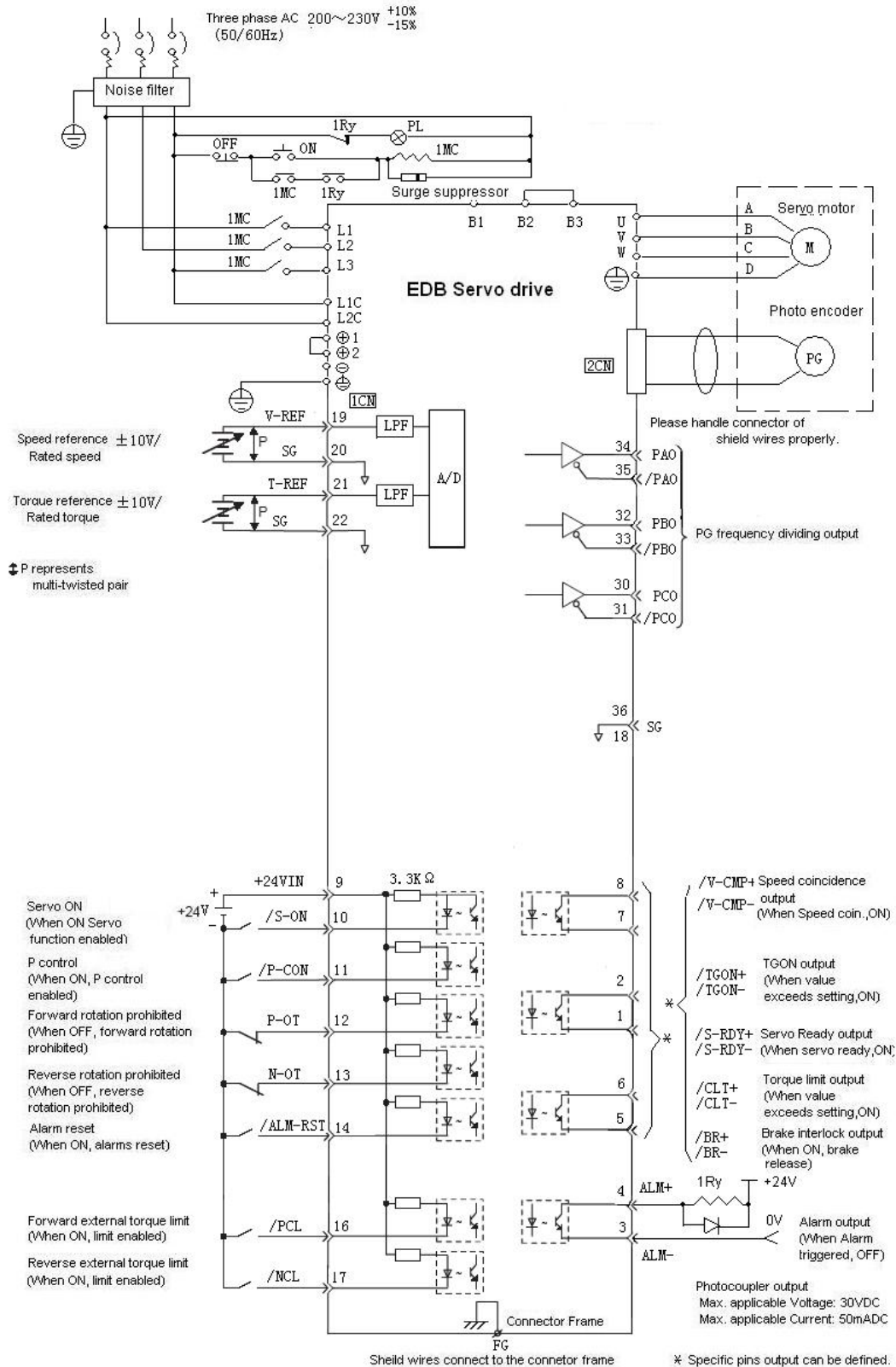

### 3.5.3 Torque control mode

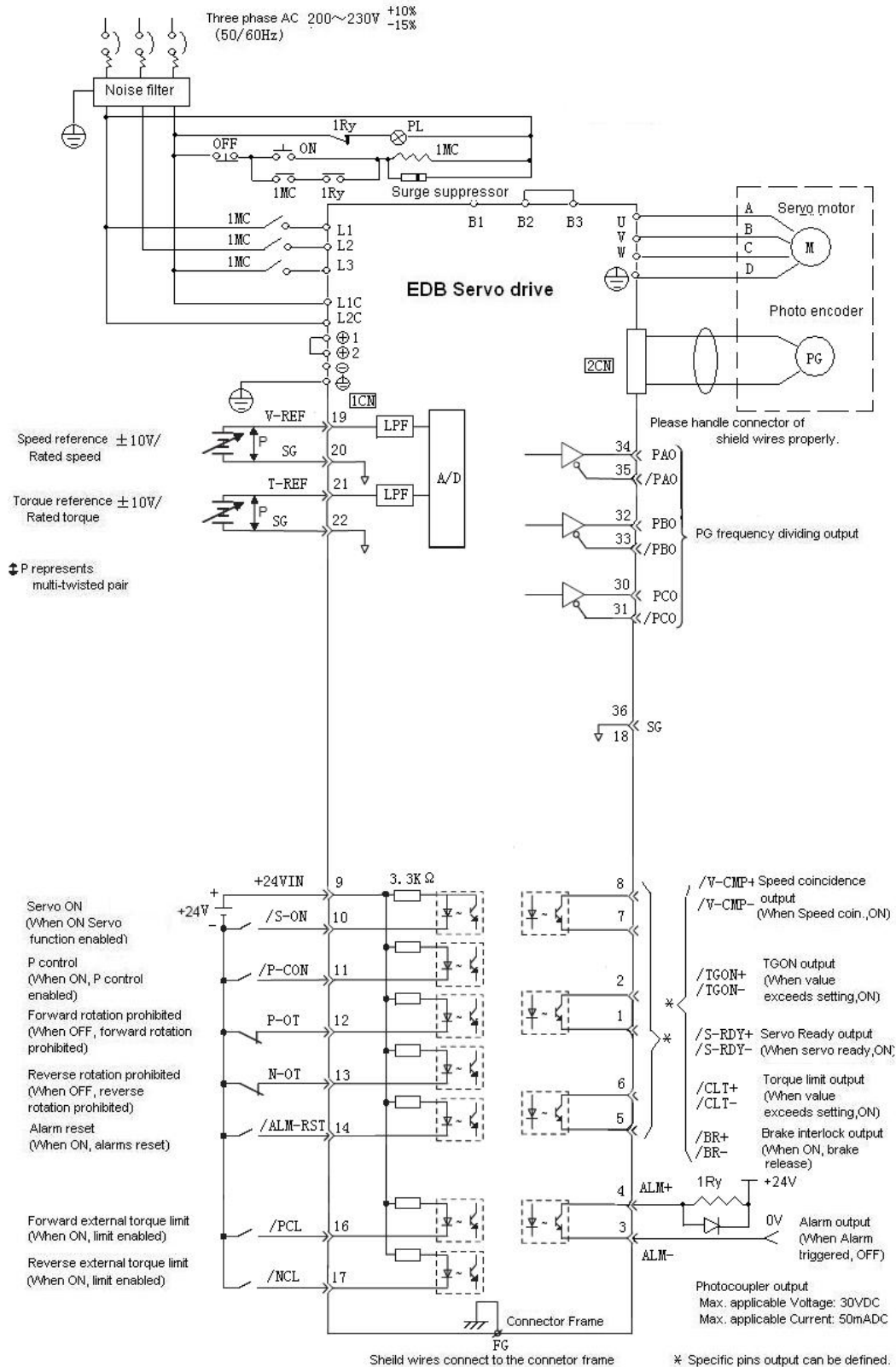

# Chapter 4

## Parameter Setting and function description

### 4.1 Setting Parameters according to mechanical features

#### 4.1.1 Changing the Direction of Motor Rotation

This Servo drive provides a reverse rotation mode in which the direction of rotation can be reversed without altering the servomotor wiring. With the standard setting, forward rotation is defined as counterclockwise (ccw) rotation viewed from the drive end. If reverse rotation mode is selected, the direction of motor rotation can be reversed without other conditions being changed. The direction (+/-) of axial motion is reversed and others remain unchanged.

	Standard setting	Reverse mode
FW run Ref	<p>Encoder output from Servo drive</p> <p>PAO (Phase A)</p> <p>PBO (Phase B)</p>	<p>Encoder output from Servo drive</p> <p>PAO (Phase A)</p> <p>PBO (Phase B)</p>
RV run Ref	<p>Encoder output from Servo drive</p> <p>PAO (Phase A)</p> <p>PBO (Phase B)</p>	<p>Encoder output from Servo drive</p> <p>PAO (Phase A)</p> <p>PBO (Phase B)</p>

#### ■ Setting Reverse Rotation Mode

Select the rotating direction by setting parameters below:

Parameter .No.	Name and description	Unit	Setting range	Default
Pn006	Rotation Direction Selection [0] Forward rotation is defined as counterclockwise rotation when viewed from the load side. (Standard setting) [1] Forward rotation is defined as clockwise rotation when viewed from the load side. (Reverse rotation mode)	—	0~1	0

Note: After changing these parameters, turn OFF the main circuit and control power supplies and then turn them ON

again to enable the new settings.

## 4.1.2 Setting overtravel limit

The overtravel limit function forces the moving part of the machine to stop when it exceeds the movable range.

### Using the Overtravel Limit Function

To use the overtravel limit function, connect the following overtravel limit switch input signal terminals to pins of 1CN connector correctly.

→Input P-OT 1CN-12	Forward Rotation Prohibited (Forward Overrun)
→Input N-OT 1CN-13	Reverse Rotation Prohibited (Reverse Overrun)

For linear motion, connect a limit switch to prevent damage to the machine.

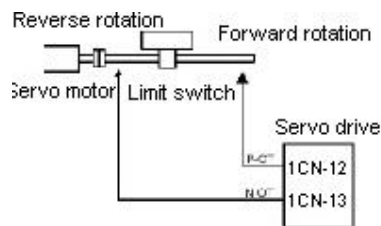

Input signal "ON/OFF" status are shown as follows:

Signals	Status	Input voltage	Description
P-OT	ON	1CN-12 : "L" level	Forward rotation allowed. Normal operation status.
	OFF	1CN-12 : "H" level	Forward rotation prohibited (reverse rotation allowed).
N-OT	ON	1CN-13 : "L" level	Reverse rotation allowed. Normal operation status.
	OFF	1CN-13 : "H" level	Reverse rotation prohibited (forward rotation allowed).

### Specifying whether Input Signals for Overtravel are to be used

Use the following parameters to specify whether input signals for overtravel is to be used. Default value is using.

Para. No	Name and description	Unit	Setting range	Default
Pn001	<b>Uses the P-OT input signal for prohibiting forward rotation or not</b> [0] Uses the P-OT input signal for prohibiting forward rotation. (Forward rotation is allowed when 1CN-12 is at 0 V.) [1] Does not use the P-OT input signal for prohibiting forward rotation. (Forward rotation is always allowed. This has the same effect as shorting 1CN-12 to 0 V.)	—	0~1	0
Pn002	<b>Uses the N-OT input signal for prohibiting reverse rotation or not</b> [0] Uses the N-OT input signal for prohibiting reverse rotation. (Reverse rotation is prohibited when 1CN-13 is open. Reverse rotation is allowed when 1CN-13 is at 0 V.)	—	0~1	0

	[1] Does not use the N-OT input signal for prohibiting reverse rotation. (Reverse rotation is always allowed. This has the same effect as shorting 1CN-13 to 0 V.)			
--	---	--	--	--

**Note:** When the servomotor stops due to overtravel during position control, the position error pulses are held. A clear signal input is required to clear the error pulses.

When P-OT and N-OT are not used, short wiring could be as easy as shown.

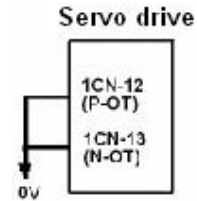

### ■ Stop motor when overtravel occurs

Please set user constant according to the method of stopping the motor when overtravel function is enabled.

Para.	Description	Para. range	Default
Pn004	Stop the mode when Servo OFF、 alarm or overtravel occurs	0 ~ 5	0

Para.	Descriptions
Pn004	<p>[0] DB stops the motor and then brake released</p> <p>[1] Coast to a stop:</p> <p>[2] Enable DB when Servo off; apply plug braking when OT occurs, Servo off after stop</p> <p>[3] Coast to stop when Servo off; apply plug braking when OT occurs, Servo off after stop</p> <p>[4] Enable DB when Servo off; apply plug braking when OT occurs and put at zero clamp after stop</p> <p>[5] Coast to stop when Servo off; apply plug braking when OT occurs and put at zero clamp after stop</p>

Note: Refer to 4.4.2 Dynamic brake about details of DB.

Para.	Description	Unit	Setting range	Default
Pn030	plug braking stop torque	1 %	0 ~ 300	300

### ■ Selecting the Motor Stop Method when Servo is OFF

The servo drive will disable all the servo functions at following condition:

1. /S-ON input signal (1CN-10) is OFF
2. Servo alarms triggered
3. Power OFF.

Setting Pn004 to select stop modes according to the demand

## 4.1.3 Limiting Torque

The servo drive could use the following method to limit torque:

Grade 1: Limit the Max output torque to protect press and parts. (Limit internal torque)

Grade 2: Limit torque to move to desired position (limit external torque)

Para.	Name and description	Unit	Setting range	Default
Pn026	Forward torque internal limit	%	0~300	300
Pn027	Reverse torque internal limit	%	0~300	300
Pn028	Forward torque external limit	%	0~300	100
Pn029	Reverse torque external limit	%	0~300	100

**Grade 1 set the internal torque limit**

Adjust forward and reverse torque limit by setting parameters (Pn026, Pn027) for limiting torque. After setting "/CLT" will output when reach the limit value. If the torque higher than the maximum torque of the servomotor, the torque of the servomotor is used.

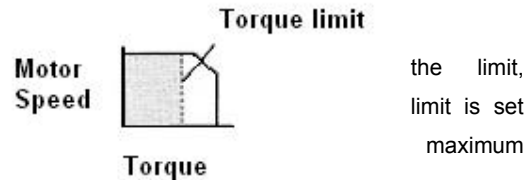

Example: for mechanical protection

**Grade 2 set the external torque limit**

First set the torque limit of user constant (Pn028, Pn029), then enable the limit with contact input signal. Both forward and reverse torque could be set separately.

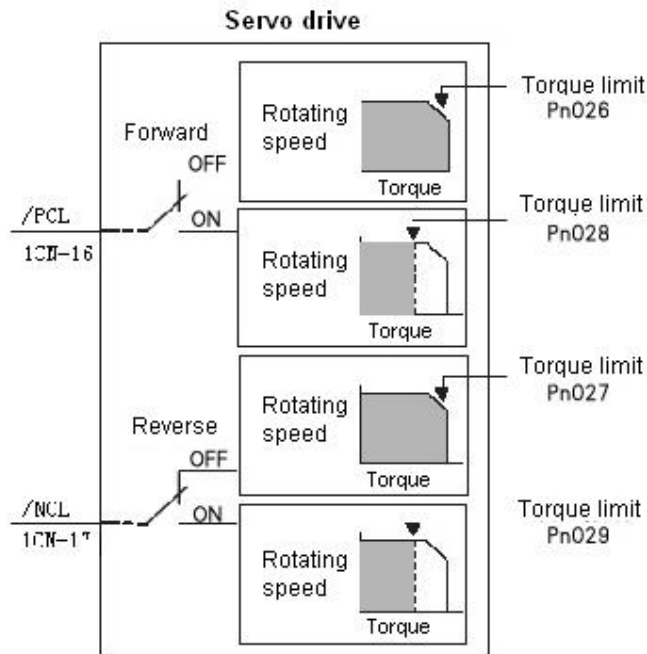

- >Input /PCL ( 1CN-16 )	input external forward torque limit	Speed ,torque control ,position control
- >Input /NCL ( 1CN-17 )	input external forward torque limit	Speed ,torque control ,position control

Signal	Status	Input voltage	Description	Setting
/PCL	ON	1CN-16:"L"level	External torque limits valid when forward rotation.	Limit: Pn028
	OFF	1CN-16:"H"level	Internal torque limits valid when forward rotation.	Limit: Pn026
/NCL	ON	1CN-17:"L"level	External torque limits valid when reverse rotation.	Limit: Pn029

	OFF	1CN-17:"H"level	Internal torque limits valid when forward rotation.	Limit: Pn027
--	-----	-----------------	---	--------------

Set or use torque limit according to external contact input, "/CLT" signal will output if exceeding torque limit. Please refer to 4.2.10 Torque Limiting Using an Analog Voltage Reference for limiting torque using analog voltage output.

Note:

- Do not set the torque limit higher than Max. torque of motor.
- Too small a torque limit setting will result in insufficient torque during acceleration and deceleration.

Note:

Please select proper mode for allocating "/PCL, /NCL" signals as torque limit input.

Parameter	Name	Range	Default	Application
Pn041	control mode selection	0~13	0	Speed, torque control, position control

"/PCL, /NCL" can't be allocated as torque limit input in internally set speed control mode.

Pn041 setting	Description	Possible input signal			
0, 1, 2, 7, 8, 9, 10, 11, 12, 13	Does not use internal speed selection	/P-CON(CN1-11)		<ul style="list-style-type: none"> <li>•PI control /P control switch</li> <li>• switch control mode</li> <li>• Switch to zero-clamp valid/ invalid</li> <li>•Switch INHIBIT valid /invalid</li> <li>•Step changing output</li> </ul>	
		/PCL(CN1-12)		<ul style="list-style-type: none"> <li>• Forward external torque limit output</li> <li>• looking for reference point</li> </ul>	
		/NCL(CN1-13)		<ul style="list-style-type: none"> <li>• reverse external torque limit output</li> <li>• looking for reference point</li> </ul>	
3, 4, 5, 6	Use internal speed selection	/P-CON	/PCL	/NCL	Speed setting
		Direction selection	0	0	Control mode switch
			0	1	SPEED1(Pn038)
		0 : forward	1	1	SPEED2(Pn039)
			1	0	SPEED3(Pn040)
1 : reverse					

Note: 0: OFF (H level), 1: ON (L level)

#### Application of CLT signal:

The application of output signal /CLT is as follows:

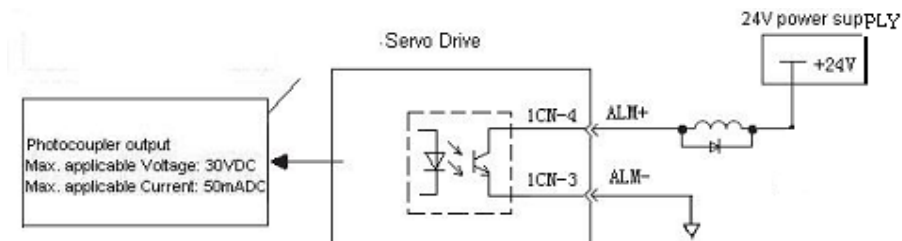

- >Output /CLT	Torque limit detection output	Speed, torque control, position control
----------------	-------------------------------	---

Indicates the output torque (current) of motor is limited.

/CLT+ when ON, "L" level	Motor output torque under limit (internal torque reference is higher than setting value )
/CLT+ when OFF "H" level	No torque limit (internal torque reference is lower than setting value )

Please use the following user constants to define output signals and pins when using /CLT signal.

Para. No.	Name and description	Setting range	Default
Pn053	Select output signals 1CN-7,8 functions	0~4	0
Pn054	Select output signals 1CN-1,2 functions	0~4	1
Pn055	Select output signals 1CN-5,6 functions	0~4	2

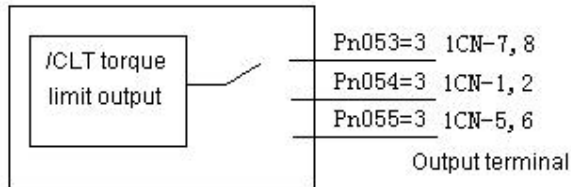

The pin definitions of Pn053, Pn054 and Pn055 parameter settings are as follows:

0	/COIN(/V-CMP) output
1	/TGON rotation detection output
2	/S-RDY servo ready output
3	/CLT torque limit output
4	BK brake interlock output

## 4.2 Setting Parameters According to Host Controller

### 4.2.1 Speed Reference

#### Analog reference

Input a speed reference by using the following input signal "speed reference input."

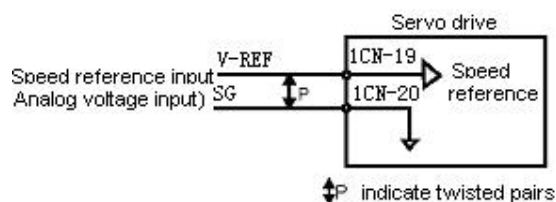

→ Input V-REF	1CN- 19	Speed reference input
→ Input SG	1CN- 20	Signal ground

Use when in speed control (analog reference) (Pn041=0, 4, 7, 9, 10)

For general speed control, always wire the VREF and SG terminals. Motor speed is controlled in proportion to the input voltage between V-REF and SG.

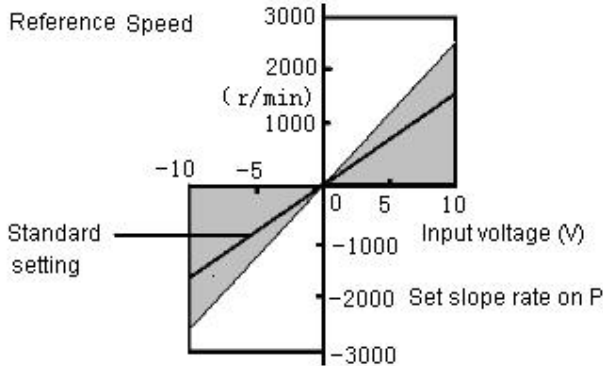

### Standard Example

Changing "Pn-012" may modify range of speed reference.

Pn-012 = 150: This setting means that 10 V is equal to rated speed (1500r/min).

Specific example is as follows:

Speed reference input	Rotation direction	Rotation speed
+10V	Forward	Rated speed 1500r/min
+1V	Forward	(1/10) Rated speed , 150r/min
-3V	Reverse	(3/10) Rated speed , 450r/min

### Example of input circuit

For noise control, always use multi-twisted cables.

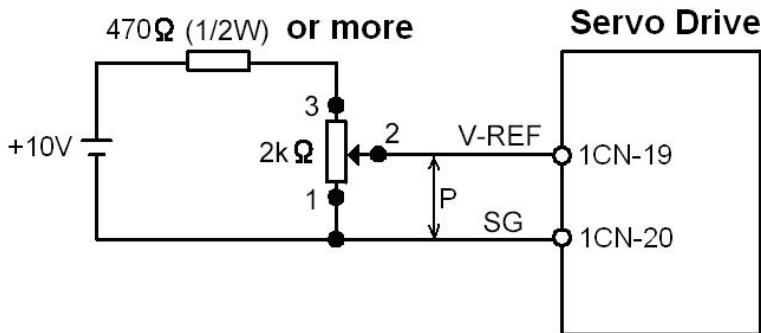

Connect V-REF and SG to speed reference output terminal when host controller is used for position control.

**Host controller    Servo dri**

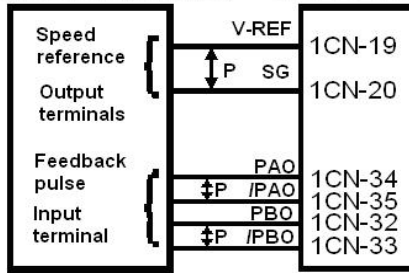

⚡P indicates twisted pair

Now please refer to the specification of output voltage to adjust “Pn012”.  
Adjust the input gain of speed reference by setting the following parameter:

Para .No.	Name and description	Unit	Setting range	Default
Pn012	Speed reference gain	(r/min)/V	0~2500	150

Speed reference is input from V-REF (1CN-19).Set the parameters according to the output of host controller or external circuit. The default setting is adjusted to be allowed by output voltage 10V rated speed.

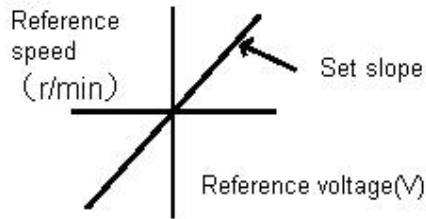

**Note:**

- Max allowable voltage is ±10VDC speed reference input end (between 1CN-19 and 20).

Select one of the following four control modes:

Para.	Name	Range	Default	Application
Pn041	Control mode selection	0~13	0	Speed, torque control, position control

Pn041	Control mode	
0	<p><b>Speed control (analog reference)</b></p> <p>Normal speed control</p> <ul style="list-style-type: none"> <li>• V-REF(1CN-19) input speed reference</li> <li>• Switching P/PI control mode using signal /P-CON(CN1-11)</li> </ul> <p>1CN-11 : OFF PI control ON P control</p>	

7	<p><b>Position control (pulse reference)&lt;-&gt;Speed control (analog reference)</b></p> <ul style="list-style-type: none"> <li>Inputs speed reference from V-REF(1CN-19)</li> <li>Switching control mode by using signal /P-CON(1CN-11)</li> </ul> <p>1CN-11 : OFF Position control (pulse reference) ON Speed control (analog reference)</p> <p>Note: /P-CON(1CN-11) is no longer used to switching modes of P/PI in speed control and position control mode.</p>	
---	--	--

9	<p><b>Torque control(Analog reference)&lt;-&gt; Speed control (Analog reference)</b></p> <p>Switch between Torque control (analog reference) and speed control (analog reference)</p> <ul style="list-style-type: none"> <li>Inputs speed reference or speed limit from V-REF(1CN-19)</li> </ul> <ul style="list-style-type: none"> <li>Inputs one of the following: torque reference, Torque feed forward reference or torque limit from T-REF(1CN-21)</li> <li>Switching torque control and speed control By /P-CON(1CN-11)</li> </ul> <p>1CN-11 OFF: torque control ;ON : speed control</p> <p><b>Torque control (when /P-CON is OFF)</b></p> <ul style="list-style-type: none"> <li>Torque controls according to T-REF.</li> <li>V-REF may provide speed control, (when Pn007=1), limit forward and reverse rotating speed according to V-REF (+).</li> <li>Limit Max. speed from user constant Pn042</li> </ul> <p><b>Speed control ( when /P-CON is ON )</b></p> <ul style="list-style-type: none"> <li>user constant Pn010、 Pn011is set as follows:</li> </ul>
---	---

User constant		Speed input reference	Torque input reference	Observation
Pn010	Pn011	V-REF(1CN-19)	T-REF(1CN-21)	

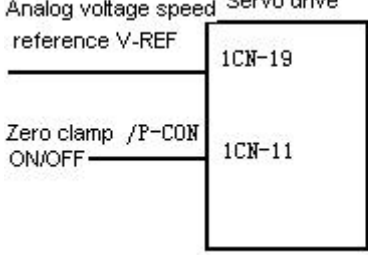
	0	0	Simple speed control		
			Speed reference	Not used	
	-	1	speed control with torque feed forward		Set Pn010 refer to 4.2.9
			Speed reference	Torque feed forward	
1	0	Torque limit speed control offered by analog voltage reference		Refer to 4.2.10	For details
		Speed reference	Torque limit		
10	<b>Speed control ( Analog reference &lt;-&gt; zero clamp</b> speed control with zero clamp function ·Inputs V-REF(1CN-19) from speed control ·Select zero clamp by /P-CON ( 1CN-11 )  1CN-11 : ON zero clamp valid OFF zero clamp invalid			Analog voltage speed reference V-REF  Zero clamp /P-CON ON/OFF	
				Servo drive Zero clamp acting when the following condition fulfilled 1 : /P-CON is ON 2 : motor speed is below Pn033 setting value	

### ■ / P-CON signal application

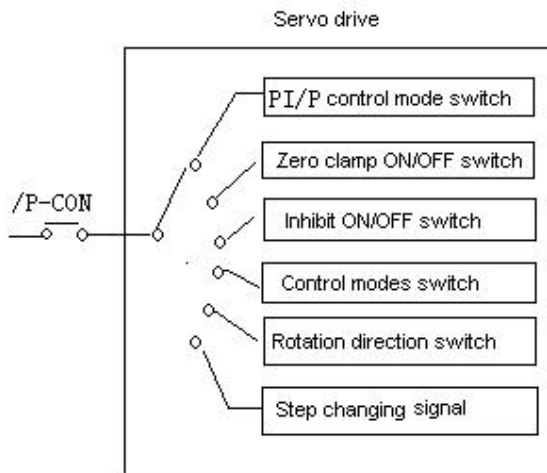

Pn041 setting	Meaning of /P-CON
0,1	Switch between P and PI
2	(not used)
3,4,5,6	change the rotation direction of internally setting speed chosen
7,8,9	Change control modes
10	Switch between zero clamp valid and invalid
11	Switch between INHIBIT valid and invalid

12	Step changing signal
13	(not used)

**Parameter speed reference**

Servo motor rotates constantly according to set speed and direction of Pn048 and Pn049 under parameter speed control mode (parameter reference Pn041= 13).

Para. No.	Name and description	Unit	Setting range	Default
Pn048	Speed level when parameter speed reference function	R/min	0 ~ 2500	500
Pn049	Rotation direction when parameter speed reference function 0:Forward ;1: Reverse		0 ~ 1	0

**4.2.2 Position reference**

Position reference includes: reference pulse input, reference sign input and error counter clear input. There are various applications, please set the best input reference in the system established.

**Move Reference by Pulse Input**

Inputs a move reference by pulse input

Position reference can correspond to the following three types of output form:

- Line driver output
- +24V Open collector output
- +12V, +5V Open collector output

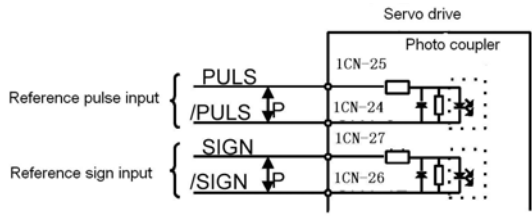

↕ P : Represents twisted-pair cables

**Connection Example 1: Line Driver Output**

Line Driver Used:

AM26LS31, SN75174 manufactured by Texas Instruments Inc., or MC3487 or equivalent.

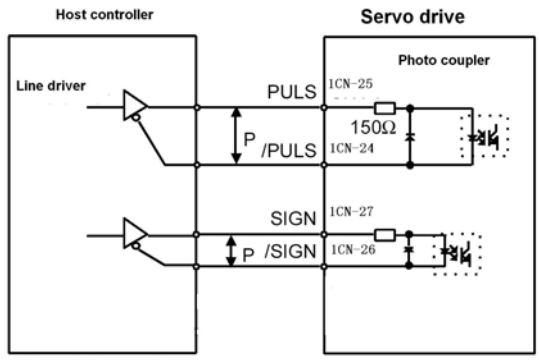

**Connection Example 2: Host controller is Open-Collector Output with 24VDC power supply**

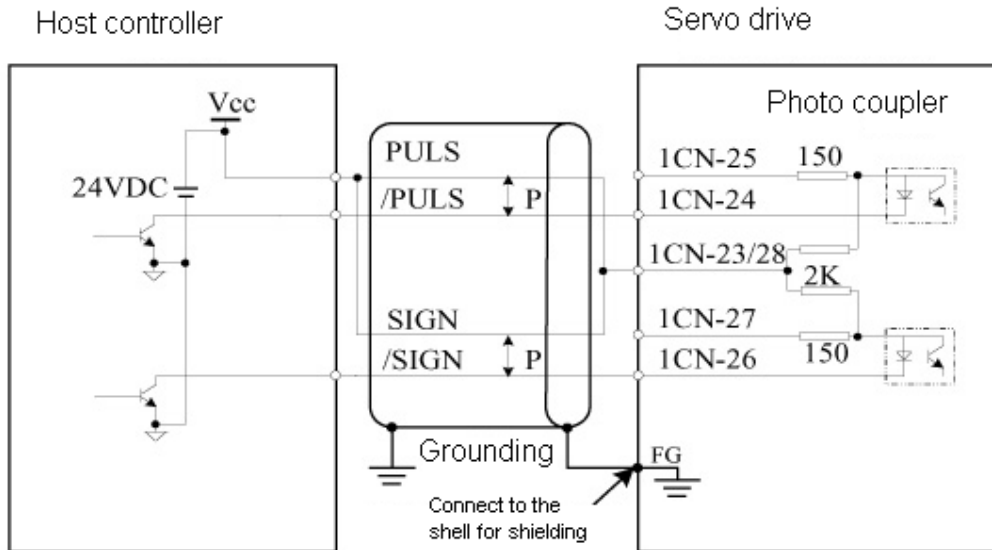

**Connection Example 3: Host controller is Open-Collector Output with 12VDC or 5VDC power supply**

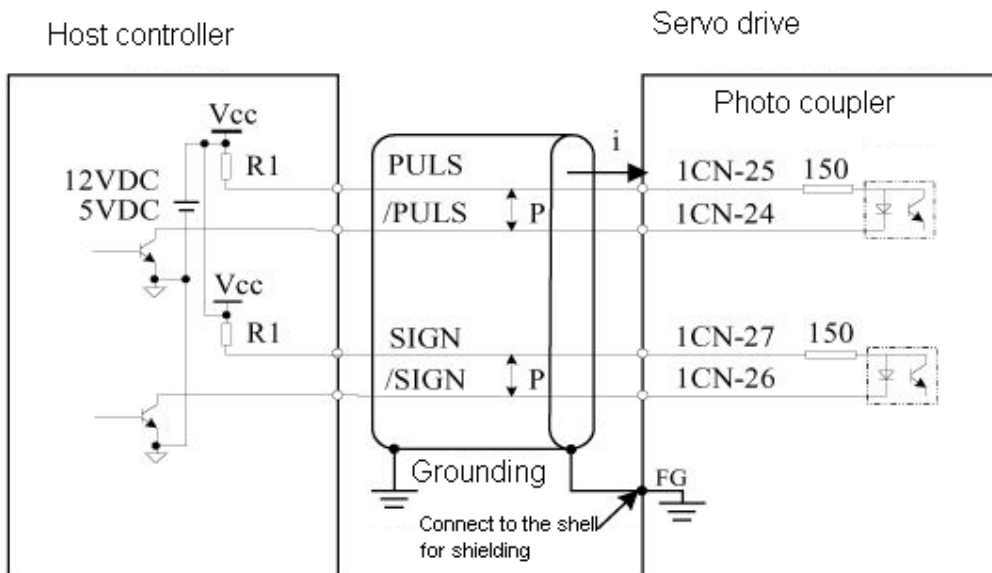

Sets the value of limiting resistor R1 according to following requirement.

Input current  $I = 10 \sim 15 \text{mA}$

- When Vcc is 12 V, R1 = 510 k $\Omega$
- When Vcc is 5 V, R1 = 180  $\Omega$

### ■ Selecting the Reference Pulse Form

→input	PULS	1CN- 25	Reference Pulse Input
→input	/PULS	1CN-24	Reference Pulse Input







→input <b>SIGN</b>	<b>1CN-27</b>	Reference Sign Input
→input <b>/SIGN</b>	<b>1CN-26</b>	Reference Sign Input

The motor only rotates at an angle proportional to the input pulse.

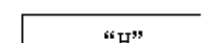
Select "reference pulse status" with the following parameters "Pn008 and Pn009".

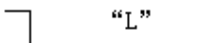
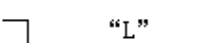
Parameter	Code	Name	Unit	Range	Default
Pn008	--	<b>Reference pulse form</b> [0] Sign + Pulse [1] CW+CCW [2] A-phase + B-phase ( x1 multiplication ) [3] A-phase + B-phase ( x2 multiplication ) [4] A+B ( x4 multiplication)	--	0~4	0
Pn009	--	<b>Input signals:</b> [0] does not invert PULS reference pulse logic, does not invert SIGN reference pulse logic [1] does not invert PULS reference pulse logic, inverts SIGN reference pulse logic [2] inverts PULS reference pulse logic, does not invert SIGN reference pulse logic [3] inverts PULS reference pulse logic, inverts SIGN reference pulse logic	--	0~3	0

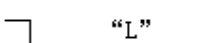
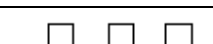
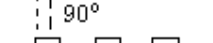
**Sets the pulse form according to the host controller specifications**

Pn008	Reference pulse form	Input Pulse Multiplier	Motor Forward Run Reference	Motor reverse Run Reference
0	Sign + pulse train	-	PULS (1CN-25)  SIGN (1CN-27)  "H"	PULS (1CN-25)  SIGN (1CN-27)  "L"
1	CW-CCW pulse	-	PULS (1CN-25)  "L" SIGN (1CN-27) 	PULS (1CN-25)  SIGN (1CN-27)  "L"
2	Two phase Pulse train with 90° difference	×1	PULS (1CN-25)  SIGN (1CN-27) 	PULS (1CN-25)  SIGN (1CN-27) 
3		×2		
4		×4		

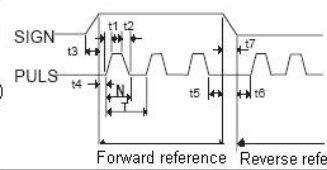
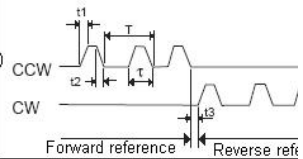
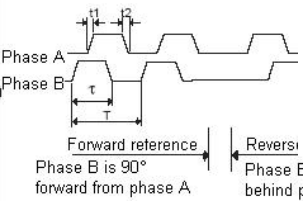
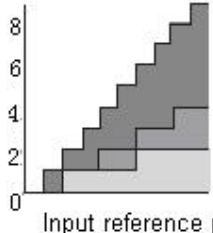
Reference Pulse signal Form	Electrical Specifications	Remarks	
Sign + pulse train input (SIGN + PULS signal) Max. reference frequency: 500 kpps (when 200kpps collector open output)	 <p>Forward reference    Reverse reference</p>	$t_1, t_2 \leq 0.1\mu s$ $t_3, t_7 \leq 0.1\mu s$ $t_4, t_5, t_6 > 3\mu s$ $\tau \geq 1.0\mu s$ $(\tau/T) \times 100 \leq 50\%$	Sign H = Forward reference L = Reverse reference
CCW pulse + CW pulse Maximum reference frequency: 500 kpps (when 200kpps collector open output)	 <p>Forward reference    Reverse ref</p>	$t_1, t_2 \leq 0.1\mu s$ $t_3 > 3\mu s$	
90° different two-phase pulse train (phase A + phase B) Maximum reference frequency x 1 multiplier: 500 kpps (when 200kpps collector open output) x 2 multiplier: 400 kpps x 4 multiplier: 200 kpps	 <p>Forward reference    Revers Phase B is 90° forward from phase A    Phase B is 90° behind phase A</p>	<p>Number of motor move pulses</p>  <p>× 4 × 2 × 1</p>	

Select if the input signal converted or not when setting parameter Pn009 according to your needs,

### Input

### Pulse Multiply Function

When the reference form is two-phase pulse train with 90° phase difference, the input pulse multiply function can be used.

The electronic gear function can also be used to convert input pulses.

### Allowable Voltage Level and Timing for Reference Pulse Input

### Cleaning the Error Counter

→ Input /CLR    1CN-15	Error Counter Clear Input
------------------------	---------------------------

Setting the /CLR signal to "L" level does the following:

- Sets the error counter inside the Servo drive to "0".
- Prohibits position loop control.

In the position control, when servo is OFF, pulse will still remains. Therefore when power is on again (S-ON) pulse signals have to be cleared or clear position move automatically when Servo is OFF by setting user constant Pn005.

Parameter	Name & descriptions	Setting range	Default
-----------	---------------------	---------------	---------

Pn005	0: S-OFF, clear pulse 1: S-OFF, not clear pulse	0-1	0
-------	--	-----	---

### Position reference one rank filter wave

Position reference one rank filter wave entitle the improvement of pulse reference form designated by the system, thus enhance the stability of position control. But if "position reference position one rack filter time constant (Pn024)" set too high, dynamic function of the system might be decreased.

Parameter	Name	Unit	Setting range	Default
Pn024	Position reference one rank filter wave time constant	0.1mS	0-32767	0

## 4.2.3 Encoder signal output

Encoder output signals divided inside the Servo drive can be output externally. These signals can be used to form a position control loop in the host controller.

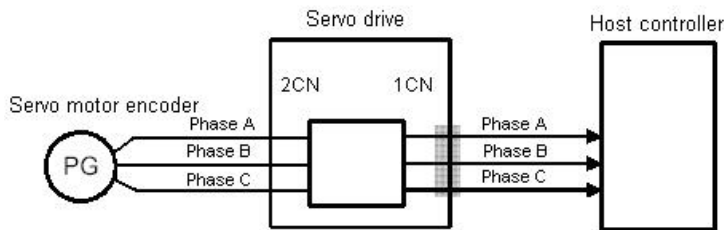

The output circuit is for line driver output. Connect each signal line according to the following circuit diagram.

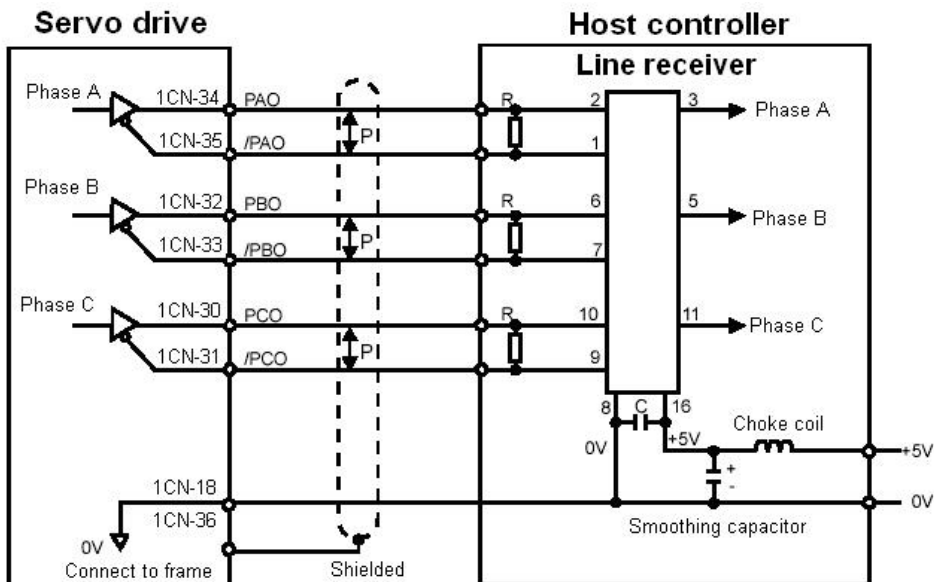

↕P Represents twisted-pair cables

R = 220 to 470Ω  
C = 0.1μF (decoupling capacitor)

**Note:** **dividing** means converting an input pulse train from the encoder mounted on the motor according to the preset pulse density and outputting the converted pulse. The unit is pulses per revolution.

### Output signal

Output → PAO 1CN- 34	Encoder Output Phase A	For Speed/Torque Control and Position Control
Output → /PAO 1CN- 35	Encoder Output/ Phase A	For Speed/Torque Control and Position Control
Output → PBO 1CN- 32	Encoder Output Phase B	For Speed/Torque Control and Position Control
Output → /PBO 1CN- 33	Encoder Output Phase /B	For Speed/Torque Control and Position Control
Output → PCO 1CN- 30	Encoder Output Phase C	For Speed/Torque Control and Position Control
Output → /PCO 1CN- 31	Encoder Output Phase /C	For Speed/Torque Control and Position Control
Output → SG 1CN- 18	Signal grounding	

Always connect these signal terminals when a position loop is formed in the host controller to perform position control. Connect SG to host controller 0V.

The output signals forms are shown in the following diagram:

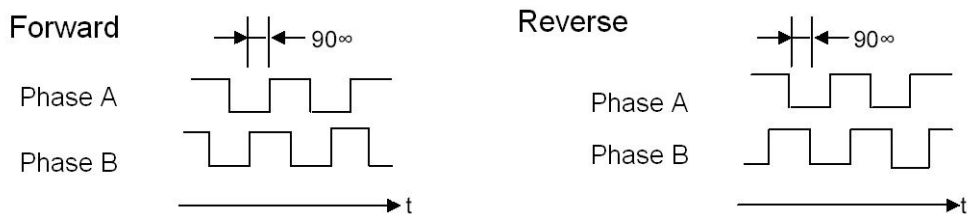

### Setting the Pulse Dividing Ratio

Set the pulse dividing ratio in the following parameter.

Parameter	Name	Unit	Range	Default
Pn021	PG Dividing Ratio Setting	P/R	1~2500	2500

Sets the number of output pulses for PG output signals (PAO, /PAO, PBO and /PBO).

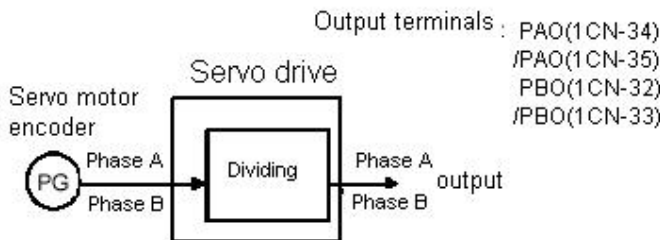

Pulses from motor encoder (PG) are divided by the preset number of pulses before being output. The number of output pulses per revolution is set in this parameter.

Set this value according to the reference unit of the machine or controller to be used. The setting range varies according to the encoder used.

---

---

**Note**

- After changing the parameter setting, always turn the power OFF, then ON.
-

## 4.2.4 Contact I/O Signals

Please wiring contact I/O signals that controls servo drive properly.

### ■ Contact Input Signal Terminal Connections

Connect these signal terminals as necessary.

#### Note:

Provide an external I/O power supply separately. There are no power terminals available from the servo drive outputs signals externally.

·External power supply : DC24V±1V,50mA or more

It is recommended that this external power supply be the same type as for the output circuit.

And the sequence input circuit operation voltage of +24V ranges from +11V ~ +25V. +12V power supply could also be applied, but bad contact will occur when the contacts are mechanical and in small current.

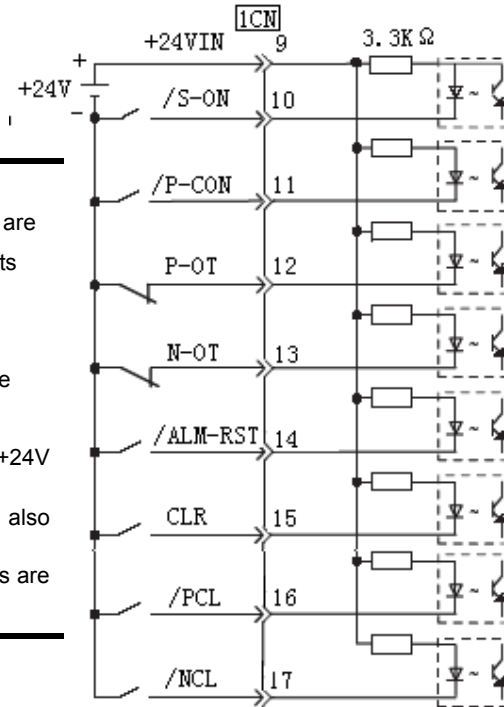

### Contact Output Signal Terminal Connections

→ Input +24VIN 1CN-9 External I/O power supply input

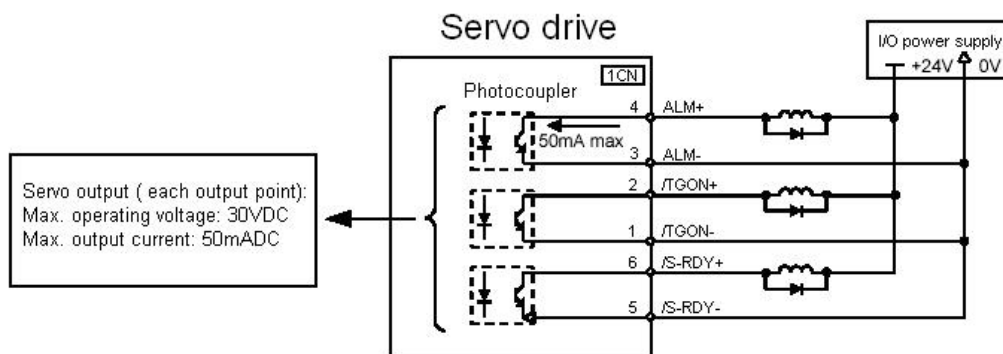

---

**Note :**

Provide an external I/O power supply separately. There are no power terminals available from the servo drive outputs signals externally. It is recommended that external power supply be the same type as for the output circuit.

---

## 4.2.5 Position control (parameter reference)

Position control under parameter reference (parameter Pn041= 12). In this mode, servo drive could position with a single axes without host controller.

There are 16 position control points with each could set move distance, running speed, constants for acceleration and deceleration and the stop time when positioning completed. Two speeds (1. speed moving towards distance switch “speed of looking for reference point”. 2. Speed moving away from distance switch “moving speed” of reference points could be set as:

Two position modes: 1. Absolute position mode 2. Relative position mode

Two running modes: 1. Circling mode 2. Non-circling mode

Two step switching method: 1. Delay step switching 2. /P-CON signal switching

Method of looking for reference points: 1. Forward direction 2. Reverse direction

### ■ Adjusting offset

Offset of each points has two correspondent parameters: one unit of the parameter is **【x 10000 reference pulse】** and the other is **【x 1 reference pulse】**. Setting range of both parameters is: (-9999-----+9999), while offset value equals sum of those two values.

For example:

No.0 offset correspond to parameter Pn059 **【x 10000 reference pulse】** and Pn060 **【x 1 reference pulse】** . Set Pn059 = 100, Pn060=-100.

$$\begin{aligned}\text{No.0 offset value} &= \text{Pn059} \times 10000 \text{ reference pulse} + \text{Pn060} \times 1 \text{ reference pulse} \\ &= 100 \times 10000 \text{ reference pulse} + (-100) \times 1 \text{ reference pulse} \\ &= 999900 \text{ reference pulse}\end{aligned}$$

With the same principle, we can conclude: in order to get the same results, we also can set Pn059 = 99 and Pn060 = 9900.

Thus, we can see when the two parameters are not zero; we can get same result by two ways: one is to set the two parameters both negative or both positive, or one negative the other positive.

It is no doubt that setting the parameter could be realized by communication. In computer, corresponding offset value could be set according to above mentioned method, and one also can set the value directly: choose “independent position running” in the “operation” menu, then set the value without considering sum of two parameter. (Refer to PC communication application software----- SP Windows help documents for detailed steps.)

### ■ Speed

Speed mention here refers to the steady speed during motor running, which is similar to the pulse frequency given from external in ordinary position control. However, this speed has nothing to do with electronic gear; it is just actual speed of the motor.

■ **One rank filter time constant**

Same as position reference one rank filter time constant Pn024 during ordinary position control (refer to 4.2.2 for details)

■ **Time for change steps after desired position reached**

Apply internally delay of changing steps to valid this parameter, that is to set Pn051= 0.

Para. No.	Name and description	Setting range	Default
Pn051	0: delay changing steps, no need of start signal. 1: change steps by /P-CON, no need of start signal 2. delay changing steps, need start signal. (/PCL or /NCL) 3. change steps by /P-CON, need start signal.(/PCL or /NCL)	0 ~ 1	0

Time for change steps outputs from positioning completed signal CON/, from Servo ON, or from the time when reference point is found till Servo perform the program to control position of the point. Such period of time depends on step changing time required by a point number among start point in program.

For example, the start point of the program Pn219=1, then the step changing time depends on the value of No.0 step changing time Pn187. It could be deduced by analogy when program start points are from 2-15. But when Pn219=0, then the delay time is No.15 point changing steps time Pn202. During this time and time before when Servo is OFF, the step display in monitor is the program start point minus one. If Pn219=0, then the “current point “displays in monitor is “-1”. If Servo OFF after point control program has been performed, then actual step will be displayed in the monitor. Looking for a new reference point, then the “current step” will display the step before program start point.

When running point control program, if error counter is set as “not clear error counter when Servo OFF”, then the error counter might flood. If it does not flood, then the servo drive will probably run at the max. running speed when Servo ON again. PLEASE PAY ATTENTION TO THE SAFETY OF INSTRUMENT.

Para. No.	Name and description	Setting range	Default
Pn005	0: clear the error counter when S-OFF 1: not clear the error counter when S-OFF	0 ~ 1	0

■ **Looking for the reference point**

Looking for the reference point is for establishing a zero physical point of the operating platform, which is used as zero point in the coordinates during point position control. And users may choose to find a reference point either in forward side or reverse side.

**How to find a reference point**

Mount a limit switch in the forward or reverse side, find a reference point in the forward direction after connect to

/PCL and in the reverse direction after connect to /NCL. When the operating platform bump into the limit switch, motor will first stop according to the way set by Pn004 and then rotates again against limit switch. When the operating platform completely departed from limit switch and put motor at the position of first photo encoder Phase C pulse. Then position of operating platform is set to be zero point of coordinates.

**How to find related parameters of reference point**

Speed that towards limit switch is called “speed of looking for reference point “, and the speed moving away from limit switch is called “ moving speed”. These two speeds could be set by following parameters:

Para. No.	Description	Unit	Setting range	Default
Pn221	speed of looking for reference point ( bump the limit switch )	r/min	0~2500	1500
Pn222	Moving speed ( move away from limit switch )	r/min	0~2000	30

Usually, set speed of looking for reference point (Pn221) high and Moving speed (Pn222) low. Note: if moving speed is too high, precision of finding a reference point would be affected.

Besides, /PCL and /NCL is no longer functioned to limiting external current when looking for a reference point.

**■ Related user constants**

Para. No.	Description	Observation
Pn050	Choose between cycle run and single run. 0: cycle run, /PCL as start signal, /NCL reverse to look for reference point. 1: single run, /PCL as start signal, /NCL reverse to look for reference point. 2. cycle run, /NCL as start signal, /PCL reverse to look for reference point. 3. single run, /NCL as start signal, /PCL reverse to look for reference point.	Changing steps will be performed till the end point completed and the next change will start from the start point during multi-points cycle run, Point control program will not change steps after the end point completed during multi- points single run.
Pn051	0: delay changing steps, no need of start signal. 1: change steps by /P-CON, no need of start signal 2. delay changing steps, need start signal. (/PCL or /NCL) 3. change steps by /P-CON, need start signal.(/PCL or /NCL)	Change steps by external /P-CON signals. The signal will be valid when drive output reach to desired position. And when signals of changing the signals valid, then steps will be changed by consequence from start point to end point.

---

Pn052	0: incremental 1: absolute	Incremental: relative moving distance (distance from current point to next point) programming Absolute: absolute moving distance(distance between operating platform and the reference point) programming.
-------	-------------------------------	---

## Wirings and connections in points control mode

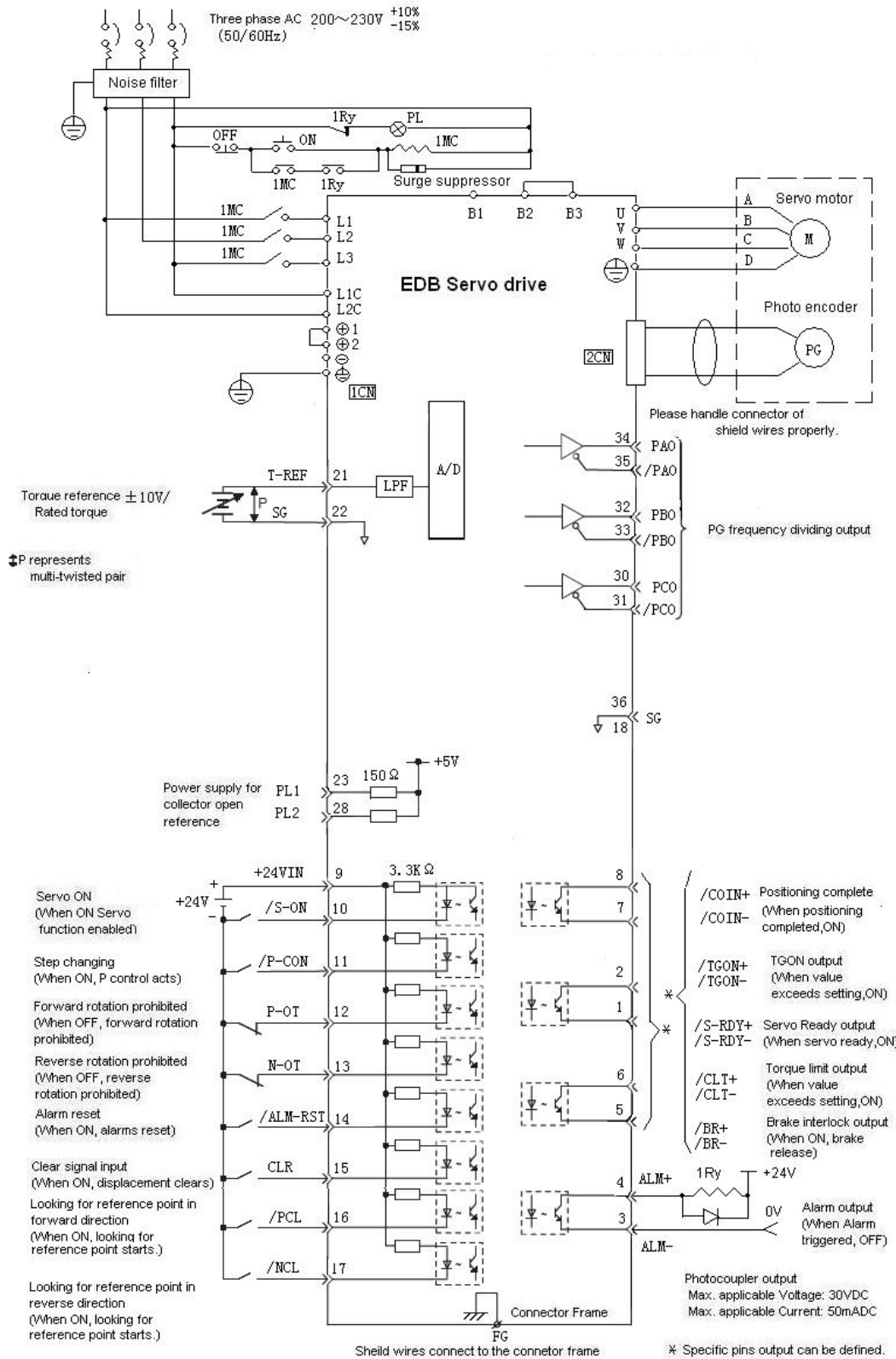

## 4.2.6 Electronic gear

The electronic gear function enables the motor travel distance per input reference pulse to be set to any value. It allows the host controller to perform control without having to consider the machine gear ratio and the number of encoder pulses.

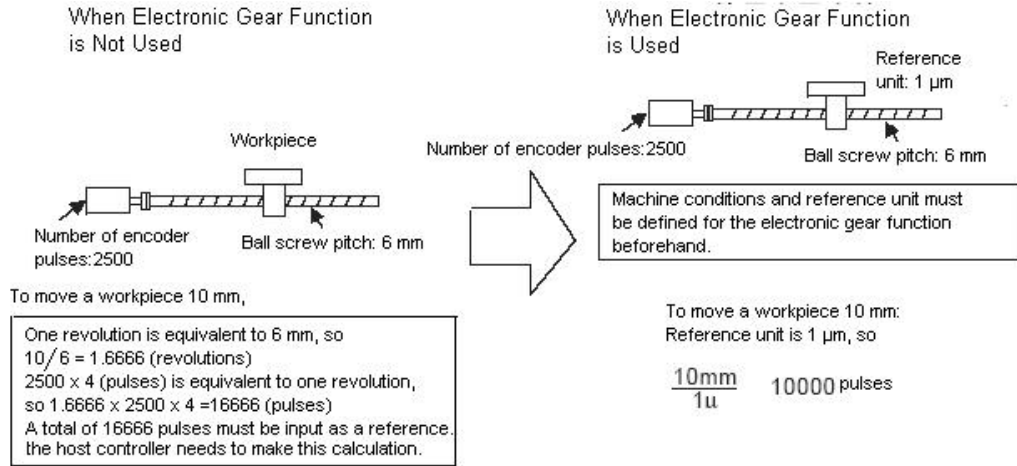

### Setting the Electronic Gear

Calculate the electronic gear ratio (B/A) according to the procedure below and set the value in Pn022 and Pn023.

1. Check the machine specifications.  
Items related to electronic gear:
  - Gear ratio
  - Ball screw pitch
  - Pulley diameter
2. Check the number of encoder pulses for the Servomotor.
3. Determine the reference unit to be used.

Reference unit is the minimum unit of position data used for moving the load. (Minimum unit of reference from host controller)

Examples:

0.01 mm, 0.001 mm, 0.1°, 0.01 inch

Reference input of one pulse moves the load by one reference unit.

Example: When reference unit is 1 µm

If a reference of 50,000 pulses is input, the load moves 50 mm  
( $50,000 \times 1 \mu\text{m}$ ).

To move a table in 0.001 mm units Reference unit: 0.001 mm

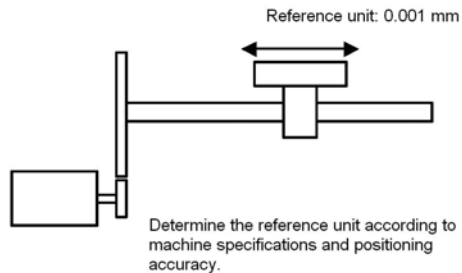



4. Determine the load travel distance per revolution of load shaft in reference units.

Load travel distance per revolution of load shaft (in reference units)

= Load travel distance per revolution of load shaft (in unit of distance)/ Reference unit

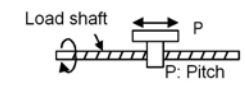
Example: When ball screw pitch is 5 mm and reference unit is 0.001 mm  $5/0.001 = 5,000$  (reference units)

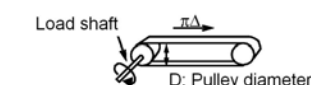
Ball Screw	Disc Table	Belt & Pulley
 <p>Load shaft</p> <p>P: Pitch</p> <p>1 revolution = <math>\frac{P}{\text{Reference unit}}</math></p>	 <p>Load shaft</p> <p>1 revolution = <math>\frac{360^\circ}{\text{Reference unit}}</math></p>	 <p>Load shaft</p> <p>D: Pulley diameter</p> <p>1 revolution = <math>\frac{\pi D}{\text{Reference unit}}</math></p>

5. Determine the electronic gear ratio (B/A) If the load shaft makes

“n” revolutions when the motor shaft makes “m” revolutions, the gear ratio of motor shaft and load shaft is  $m/n$

Electronic gear ratio  $\left(\frac{B}{A}\right) =$

$$\frac{\text{Number of encoder pulses} \times 4}{\text{Travel distance per revolution of load shaft (in reference units)}} \times \frac{m}{n}$$

Note: Make sure that the electronic gear ratio meets the following condition:

$$0.01 \leq \text{Electronic gear ratio (A/B)} \leq 100$$

If the electronic gear ratio is outside this range, the Servo drive does not work properly.

In this case, modify the load configuration or reference unit.

6. Set the electronic gear ratio in the parameters below.

Reduce the electronic gear ratio (B/A) to their lowest terms so that both A and B are an integer smaller than 65535, then set A and B in the following parameters.

Para.No.	Name	Unit	Setting range	Default
Pn022	Electronic gear ratio B (numerator)	--	1~65535	1
Pn023	Electronic gear ratio A (denominator)	--	1~65535	1

Set the electronic gear ratio according to machine specifications.

$$\text{Electronic gear ratio (B/A)} = \text{Pn022/Pn023}$$

### Examples of Setting an Electronic Gear Ratio

Examples for Different Load Mechanisms are as follows:

Belt & Pulley

Reference unit: 0.0010in (0.0254mm)

Load shaft

Gear ratio: 2.4:1

Pulley diameter: 44in (101.6mm)

Incremental encoder: 2500 pulses per revolution

Travel distance per revolution of load shaft =  $\frac{3.1416 \times 4in}{0.0010in} = 12566$

Electronic gear ratio =  $\left(\frac{B}{A}\right) = \frac{2500 \times 4 \times 2.4}{12566} = \frac{\text{Pn022}}{\text{Pn023}} = \frac{24000}{12566} = \frac{191}{100}$

Preset values	Pn022	191
	Pn023	100

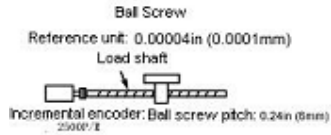

$$\text{Travel distance per revolution of load shaft} = \frac{6\text{mm}}{0.0001\text{mm}} = 60000$$

$$\text{Electronic gear ratio} = \left(\frac{B}{A}\right) = \frac{2500 \times 4 \times 1}{60000} = \frac{\text{Pn022}}{\text{Pn023}}$$

Preset values	Pn022	1
	Pn023	6

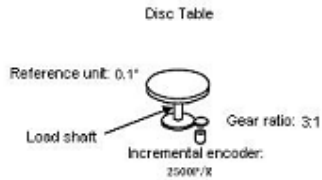

$$\text{Travel distance per revolution of load shaft} = \frac{360^\circ}{0.1^\circ} = 3600$$

$$\text{Electronic gear ratio} = \left(\frac{B}{A}\right) = \frac{2500 \times 4 \times 3}{3600} = \frac{\text{Pn022}}{\text{Pn023}}$$

Preset values	Pn022	75
	Pn023	9

### Control Block Diagram for Position Control

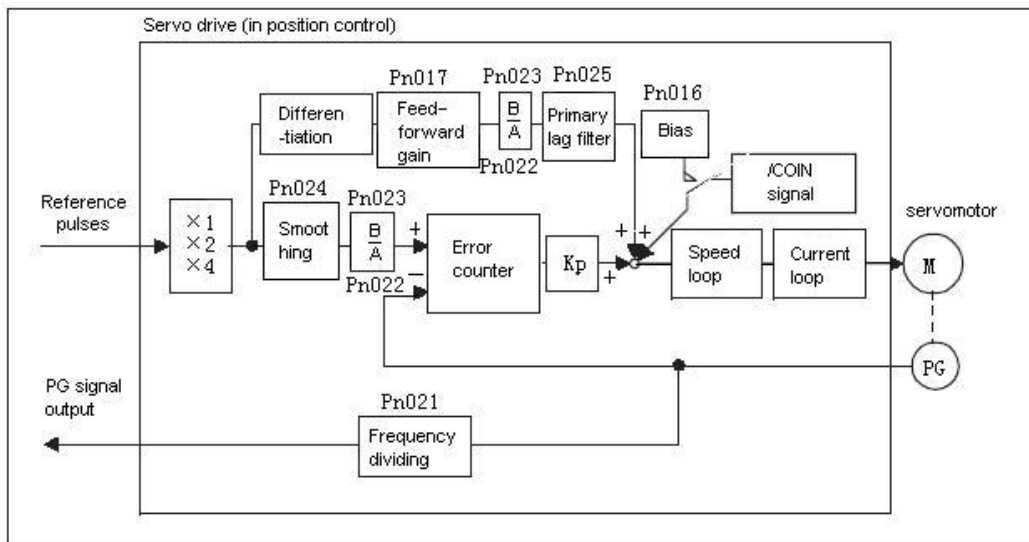

Note:

In the reference pulse mode, when set the number of actual position pulse, consider if pulse input multiplication function is selected besides electronic gear ratio.

## 4.2.7 Using Contact Input Speed Control

The contact input speed control function provides easy-to-use speed control. It allows the user to initially set three different motor speeds in user constants, select one of the speeds externally by contact input and run the motor.

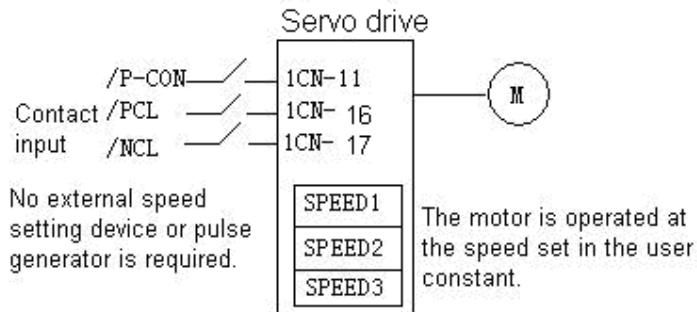

### ■ Use the contact input speed control function

To use the contact input speed control function, perform Steps 1 to 3

1. Set Pn41 parameter correctly, to enable contact input control function

Para. No.	Name and description	Setting range	Default	Application
Pn041	Control mode	0 ~ 13	0	Speed, Torque and Position Control

If the contact input speed control function is used, the contents of the input signals shown below will be changed.

Pn04 Setting	Meaning	Possible Input Signal meaning			
		/P-CON	/PCL	/NCL	Speed Setting
0, 1, 2, 7, 8, 9, 10, 11, 12, 13	Does not use the contact input speed control function.	/P-CON (CN1-11)		<ul style="list-style-type: none"> <li>• Switch between P control and PI control.</li> <li>• Switch between control modes</li> <li>• switch zero clamp status between valid/ invalid</li> <li>• Switch INHIBIT between valid and invalid</li> <li>• change step output</li> </ul>	
		/PCL (CN1-16)		<ul style="list-style-type: none"> <li>• forward external current limit input</li> <li>• looking for reference point forwardly</li> </ul>	
		/NCL (CN1-17)		<ul style="list-style-type: none"> <li>• reverse external current limit input</li> <li>• looking for reference point reversely</li> </ul>	
3, 4, 5, 6	Uses the contact input speed control function.	/P-CON	/PCL	/NCL	Speed Setting
		Direction of rotation 0: Forward 1: Reverse	0	0	Control modes switch
			0	1	SPEED1(Pn038)
			1	1	SPEED2(Pn039)
	1	0	SPEED3(Pn040)		

2. Set three motor speeds in the following user constants.

Pn038	SPEED1 1st Speed (Contact Input Speed Control)	Unit: r/min	Setting Range: 0 ~ 2500	Default: 100	Speed control
Pn039	SPEED2 2nd Speed (Contact Input Speed Control)	Unit: r/min	Setting Range: 0 ~ 2500	Default: 200	Speed control
Pn040	SPEED3 3rd Speed (Contact Input Speed Control)	Unit: r/min	Setting Range: 0 ~ 2500	Default: 300	Speed control

Use these parameters to set motor speeds when the contact input speed control function is used. If a value higher than the maximum speed is set, the maximum speed value is used.

Speed selection input signals /PCL (1CN-16) and /NCL (1CN-17), and rotation direction selection signal /P-CON (1CN-11) enable the motor to run at the preset speeds.

3. Set the soft start time.

Para. No.	Name	Unit	Setting range	default
Pn019	Soft Start Time (Acceleration)	ms	0~10000	0
Pn020	Soft Start Time ((Deceleration)	ms	0~10000	0

In the Servodrive, a speed reference is multiplied by the preset acceleration or deceleration value to provide speed control.

When a progressive speed reference is input or contact input speed control is used, smooth speed control can be performed. (For normal speed control, set "0" in each parameter.)

Set the following value in each parameter.

■ Pn019: Time interval from the time the motor starts until it reaches 1000r/min.

■ Pn020: Time interval from the time the motor is running at 1000r/min. until it stops

Operating by Contact Input Speed Control Function

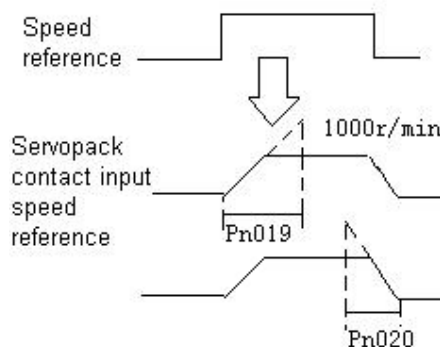

## Start / Stop

Select the speed by using following input signals:

- > Input /PCL 1CN-16	Speed Selection 1 (Forward External Torque Limit Input)	For Speed/Torque Control and Position Control
- >Input /NCL 1CN-17	Speed Selection 2 (Reverse External Torque Limit Input)	For Speed/Torque Control and Position Control

When Contact Input Speed Control is used and Pn041=3, 4, 5, 6, /PLC, /NLC are specified as internal speed selection. When Pn041=12 under parameter reference position control mode, /PCL and /NCL are specified as switches to look for the reference point. Besides mentioned above, Input signals are used as external torque limit input.

Contact Signal			Parameter	Selected Speed
/P-CON	/PCL	/NCL	3	Stopped by internal speed reference 0
-	0	0	4	Analog speed reference input (V-REF)
			5	Pulse reference input (position control)
			6	Analog torque reference input (T-REF)
Direction of rotation	0	1	Common to 3, 4, 5 and 6	SPEED1(Pn038)
0: Forward rotation	1	1		SPEED2(Pn039)
1: Reverse rotation	1	0		SPEED3(Pn040)

Note: 1) 0: OFF (High level). 1: ON (LOW level)

2) " - " means not used.

## Rotation direction selection

Input signal /P-CON is used to specify the direction of motor rotation.

- Input /P-CON CN1-11	Proportional Control, etc.	For Speed/Torque Control and Position Control
-----------------------	----------------------------	---

### •When Contact Input Speed Control is used:

Use input signal /P-CON to specify the direction of motor rotation.

/P-CON	Meaning
0 : OFF	Forward rotation
1 : ON	Reverse rotation

### •Modes Other Than Contact Input Speed Control:

/P-CON signal is used for proportional control, zero-clamp and torque/speed control changeover.

### ■ Example for contact input speed control operation

The figure below illustrates an example of operation in contact input speed control mode.

Using the soft start function reduces physical shock at speed changeover. Pn041=3.



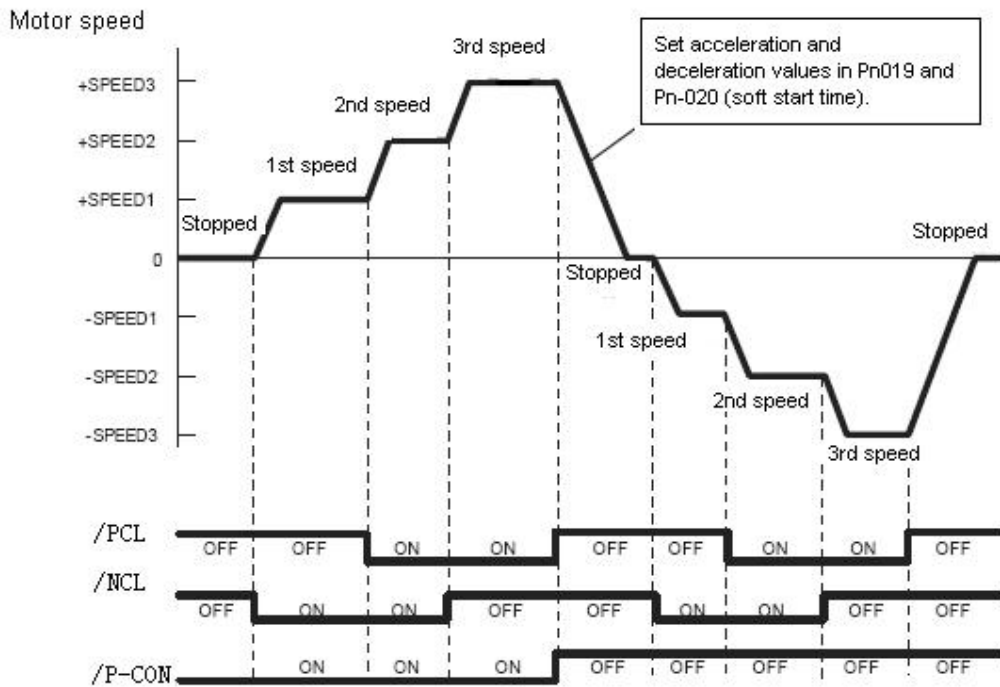

## 4.2.8 Using Torque Control

The Servodrive can provide the following torque control:

- Level 1: To restrict the maximum output torque to protect the machine or workpiece (internal Torque restriction) (refer to 4.1.3)
  - Level 2: To restrict torque after the motor moves the machine to a specified position (external Torque restriction) (refer to 4.1.3)
- Level 3: To always control output torque, not speed
  - Level 4: To switch between torque control and other control

This section describes how to use levels 3 and 4 of the torque control function.

### ■ Selecting Torque control

Use the following parameter to select level 3 or level 4 torque control.

Para. No.	Name	Setting range	Default	Description
<b>Pn041</b>	Control Mode Selection	0 ~ 13	0	For Speed/Torque Control and position Control

A motor torque reference value is externally input into the Servodrive to control torque.

Pn041	<b>Control Mode</b>
-------	---------------------

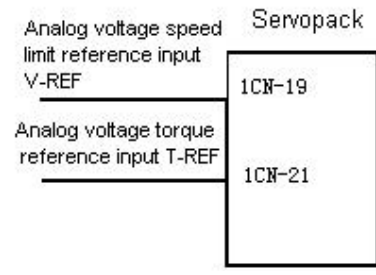
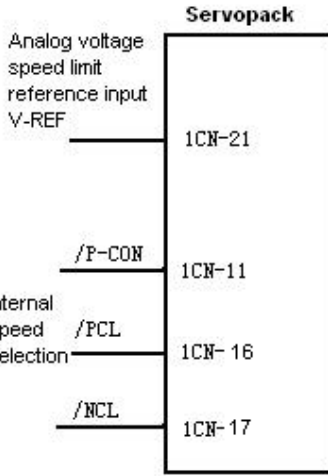
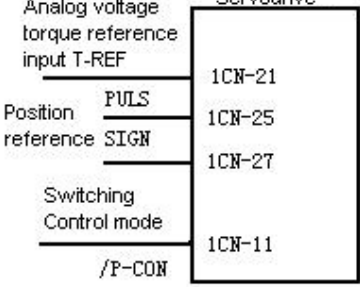
<p>2</p>	<p><b>Torque Control( analog reference)</b>  This is a dedicated torque control mode.</p> <ul style="list-style-type: none"> <li>• A torque reference is input from T-REF (1CN-21).</li> <li>• /P-CON is not used</li> <li>• Speed reference input V-REF (1CN-19) can be used as speed limit when Pn007 is set to be 1.</li> <li>• Parameter Pn042 can be used for maximum speed control.</li> </ul>	 <p>Diagram for Servopack Torque Control:  Analog voltage speed limit reference input V-REF is connected to terminal 1CN-19.  Analog voltage torque reference input T-REF is connected to terminal 1CN-21.</p>																			
<p>6</p>	<p><b>Speed control(Contact reference )&lt;-&gt;Torque control (analog reference)</b>  Torque control and speed control can be switched.</p> <ul style="list-style-type: none"> <li>• /PCL (1CN-16) and /NCL (1CN-17) are used to switch between torque control and speed control.</li> </ul> <p>Note: In this status, /PCL(1CN-16) and /NCL(1CN-17) could no longer be used as external torque limit output.</p> <table border="1" data-bbox="308 882 779 1228"> <thead> <tr> <th>/P-CON</th> <th>/PCL</th> <th>/NCL</th> <th></th> </tr> </thead> <tbody> <tr> <td>-</td> <td>0</td> <td>0</td> <td>Analog reference control</td> </tr> <tr> <td rowspan="2">0: forward rotation</td> <td>0</td> <td>1</td> <td>SPEED1</td> </tr> <tr> <td>1</td> <td>1</td> <td>SPEED2</td> </tr> <tr> <td rowspan="2">1 :reverse rotation</td> <td>1</td> <td>0</td> <td>SPEED3</td> </tr> </tbody> </table>	/P-CON	/PCL	/NCL		-	0	0	Analog reference control	0: forward rotation	0	1	SPEED1	1	1	SPEED2	1 :reverse rotation	1	0	SPEED3	 <p>Diagram for Servopack Speed/Torque Control:  Analog voltage speed limit reference input V-REF is connected to terminal 1CN-21.  Internal speed selection /P-CON is connected to terminal 1CN-11.  Internal speed selection /PCL is connected to terminal 1CN-16.  Internal speed selection /NCL is connected to terminal 1CN-17.</p>
/P-CON	/PCL	/NCL																			
-	0	0	Analog reference control																		
0: forward rotation	0	1	SPEED1																		
	1	1	SPEED2																		
1 :reverse rotation	1	0	SPEED3																		
	<p>8</p>	<p><b>Position control (pulse reference) &lt;-&gt; Torque control (Analog reference)</b></p> <ul style="list-style-type: none"> <li>• Use /P-CON(1CN-11) to switch between Position control (pulse reference) and Torque control (Analog reference)</li> </ul> <p>1CN-11 OFF: position control  ON: torque control</p>	 <p>Diagram for Servodrive Position/Torque Control:  Analog voltage torque reference input T-REF is connected to terminal 1CN-21.  Position reference PULS is connected to terminal 1CN-25.  Position reference SIGN is connected to terminal 1CN-27.  Switching Control mode /P-CON is connected to terminal 1CN-11.</p>																		
<p>9</p>	<p><b>Torque control(Analog reference)&lt;-&gt; Speed Reference (analog reference)</b></p>																				

Speed reference

Servodrive

V-REF

1CN-19

Torque reference

1CN-21

Speed ref./  
Torque ref.  
/P-CON

1CN-11

Switch between Torque control(Analog reference)and Speed Reference (analog reference)

- Inputs speed reference or speed limit from V-REF(1CN-19)
- T-REF (1CN-21) inputs a torque reference, torque feed-forward reference or torque limit value depending on the control mode used.
- /P-CON (1CN-11) is used to switch between torque control and speed control.

1CN-11 OFF: torque control ;ON: speed control

**In the Torque Control mode (/P-CON is OFF):**

- T-REF reference controls torque.
- V-REF can be used to limit motor speed. (when Pn007=1) V-REF voltage (+) limits motor speed during forward or reverse rotation.
- Parameter Pn042 can be used to limit the maximum motor speed.

**In the Speed Control mode (/P-CON is ON):**

- Values of parameter Pn010 and Pn011 are determined as following:

Parameter		Speed input reference	Torque input reference	Remarks
Pn010	Pn011	V-REF(1CN-19)	T-REF(1CN-21)	
0	0	Simple speed control		
		Speed reference	Not use	
-	1	Speed control with torque feed-forward		Any value can be set in Pn010; refer to 4.2.9 for details
		Speed reference	Torque feed-forward	
1	0	Speed control with torque limit by analog voltage reference		Refer to 4.2.10 for details
		Speed reference	Torque limit value	

**Input signal**

The following input signals perform torque control.

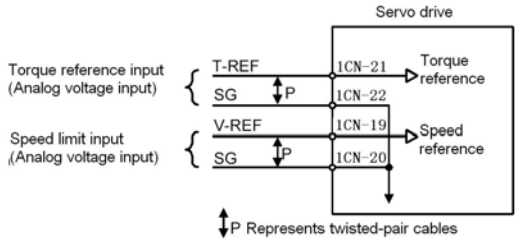

**Torque reference input:**

→ Input T-REF 1CN- 21	Torque Reference Input
-----------------------	------------------------

→ Input	<b>SG 1CN-22</b>	Signal Ground for Torque Reference Input
---------	------------------	--

These signals are used when torque control is selected.

Motor torque is controlled so that it is proportional to the input voltage between T-REF and SG.

**Standard setting**

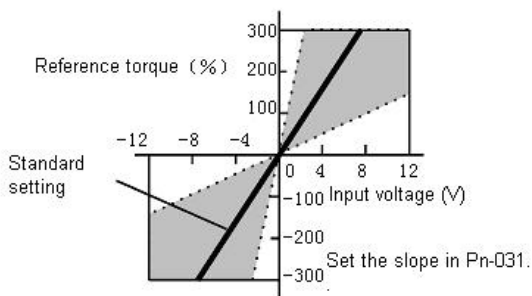

Para. No.	Name	Unit	Range	Default
Pn 031	Torque reference gain	0.1V/100%	10-100	30

Set the voltage range of torque reference input signal T-REF (1CN-21). Check and set the output status of host controller and external circuit.

For example: Set Pn031=30,

- +3 V input → Rated torque in forward direction
- +9 V input → 300% of rated torque in forward direction
- 0.3 V input → 10% of rated torque in reverse direction

**Example of Input Circuit: (See the figure below)**

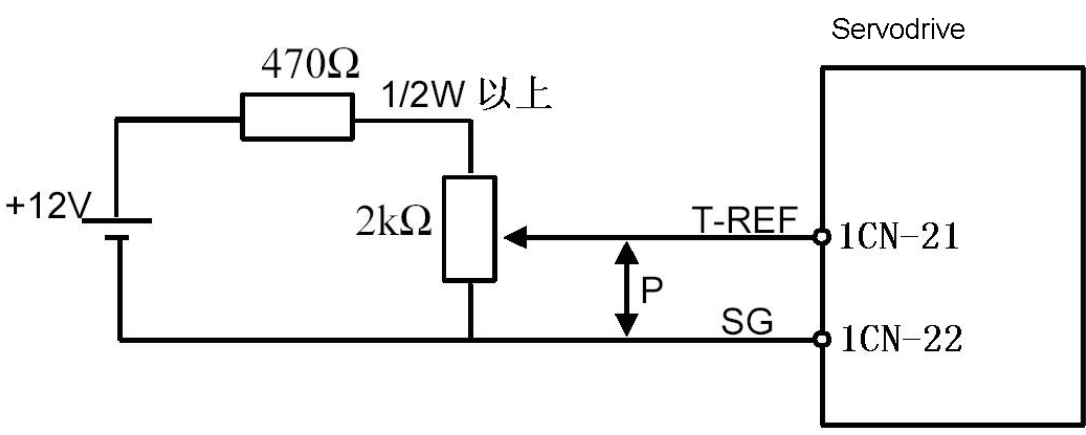

**Speed limit input:**

→ Input V-REF 1CN-19	Speed Reference Input (or Speed Limit Input)
→ Input SG 1CN-20	Signal Ground for Speed Reference Input

Motor speed is controlled so that it is proportional to the input voltage between V-REF and SG.

**Standard setting:**

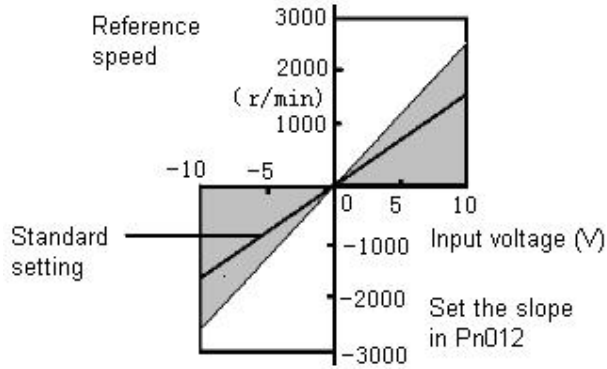

For example: Set Pn012=250, then

- +6 V input → 1500 r/min in forward direction
- +1 V input → 250 r/min in forward direction
- 3 V input → 750 r/min in reverse direction

Parameter Pn012 can be used to change the voltage input range. (This is also applicable to speed restriction.)

**Example of Input Circuit (see the following figure):**

- For noise control, always use twisted pair cables.

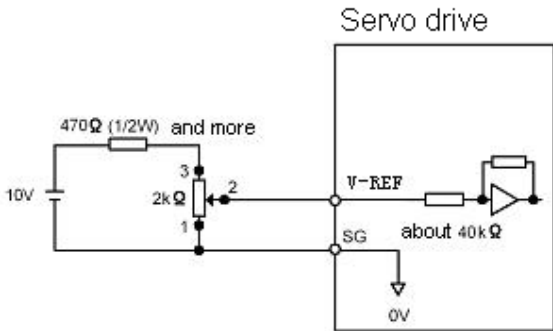

Speed limit function of torque control could be realized by set the following parameter with two modes available.

Para. No.	Description	Setting range	Default	Function
Pn007	0: no analog speed limit 1:with analog speed limit	0 ~ 1	0	For speed/torque limit

**Internal speed limit**

Set Pn007=0, there's no external analog speed limit with only internal speed limit available. Set Pn042 it sets internal

limit value of motor speed in torque control mode.

Para. No.	Description	Unit	Setting range	Default	Function
Pn042	Speed limit in torque control mode	r/min	1-2500	2500	For speed/torque control

### External speed limit

Set Pn007=1 to use external speed limit

Use Speed reference V-REF analog as external speed limit output. Usually, value of V-REF should be smaller than Pn042 max. speed limit to entitle the external speed limit meaningful.

Para. No.	Description	Unit	Setting range	Default	Function
Pn012	Speed reference input gain	(r/min)/V	0 ~ 2500	150	For Speed/torque control

According to status of host controller and external speed reference input gain and determine external

Motor speed

circuit, use Pn012 to set limit value. **Principle of**

#### Speed Restriction:

When the speed exceeds the speed limit, negative feedback of torque proportional to the difference between the current speed and the limit speed is performed to return the speed to within the normal speed range. Therefore, the actual motor speed limit value has a certain range depending on the load conditions.

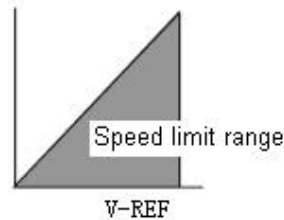

## 4.2.9 Using Torque Feed-forward Function

For speed control (analog reference) only.

The torque feed-forward function reduces positioning time. It differentiates a speed reference at the host controller to generate a torque feed-forward reference, and then sends this torque feed-forward reference and the speed reference to the SERVODRIVE.

Too high a torque feed-forward value will result in overshoot or undershoot. To prevent this, set the optimum value while observing system response.

Connect a speed reference signal line and torque feed-forward reference signal line from the host controller to

V-REF (1CN-19 , 20) and T-REF (1CN-21 , 22) respectively.

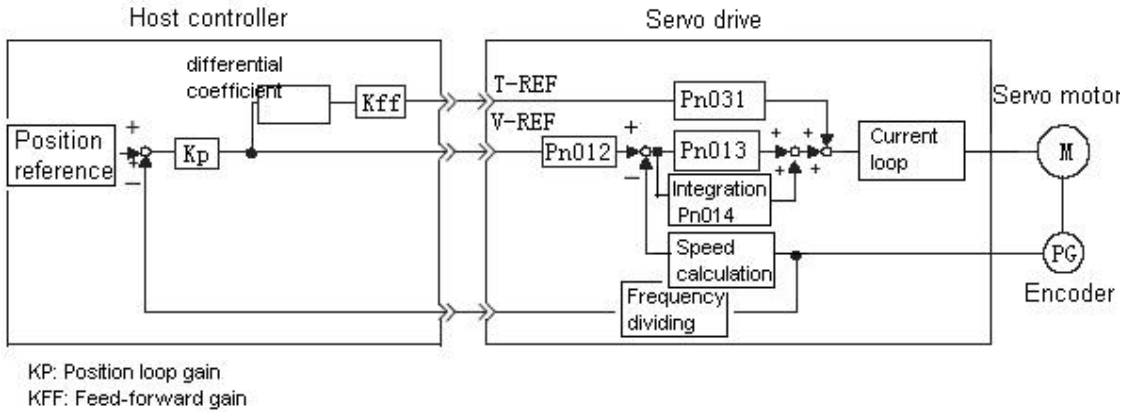

### How to Use Torque Feed-forward Function

To use the torque feed-forward function, set the following memory switch to 1.

Para. No.	Description	Setting range	Default
Pn011	0: Does not use Torque Feed-forward Function 1: Use Torque Feed-forward Function	0 ~ 1	0

This function cannot be used with the function for torque restriction by analog voltage reference.

To use the torque feed-forward function, input a speed reference to the V-REF terminal and a torque feed-forward reference to the T-REF terminal.

The host controller must generate a torque feed-forward reference.

### Setting:

The value of torque feed-forward value is determined by Pn031 (set according to Host controller)

The factory setting is Pn031 = 30. If, for example, the torque feed-forward value is  $\pm 3$  V, torque is restricted to  $\pm 100\%$  (rated torque).

Para. No.	Description	Unit	Setting range	Default
Pn031	Torque Reference gain	0.1V/100%	10 ~ 100	30

## 4.2.10 Using Torque Restriction by Analog Voltage Reference

For speed control (analog reference Pn041=9) only.

This function restricts torque by assigning the T-REF terminal (1CN-21, 1CN-22) a torque limit value in terms of analog voltage. Since torque reference input terminal T-REF is used as an input terminal, this function cannot be used for torque control. When /PCL signal (1CN-16) is ON, the forward torque is under restriction. When /NCL (1CN-17) is ON, the reverse torque is restricted.

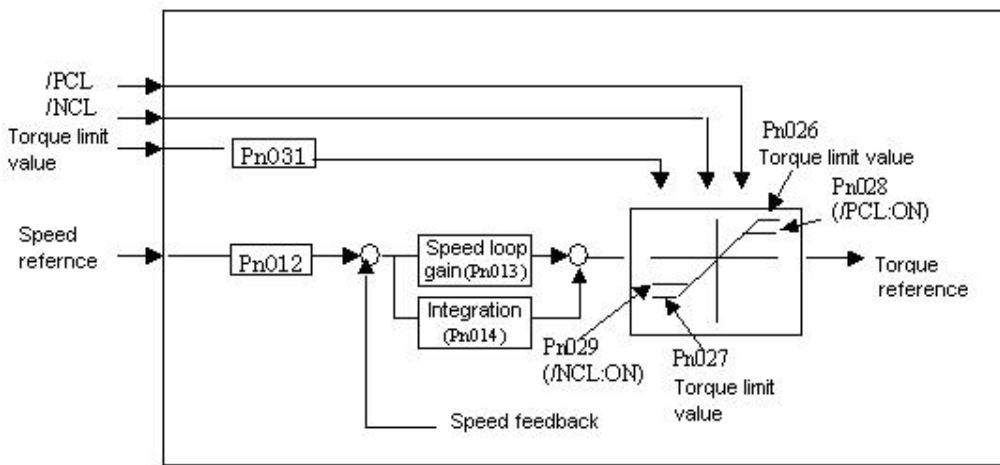

■ How to Use Torque Restriction by Analog Voltage Reference

To use this torque restriction function, set the following memory switch to 1 to enable analog voltage reference as external torque limit.

Para. No.	Function	Setting range	Default
Pn010	0: External torque limit restriction prohibited (analog voltage reference)	0 ~ 1	0
	1: External torque limit restriction enabled (analog voltage reference)		

Besides, set Pn011=0, torque feed-forward function is disenabled.

Para. No.	Description	Setting range	Default
Pn011	0: torque feed-forward function prohibited	0 ~ 1	0
	1: torque feed-forward function enabled		

To use this function, input a speed reference to the V-REF terminal and a torque limit value to the T-REF terminal. According to /PCL and /NCL status, set forward and reverse rotation torque limit respectively.

Refer to the following table for details,

Signal name	Status	Input voltage	Description	Setting
/PCL	ON	1CN-16:"L" level	Set torque limit on forward rotation	Limit value: T-REF value
	OFF	1CN-16:"H" level	Doesn't set torque limit on forward rotation Normal run	
/NCL	ON	1CN-17:"L" level	Set torque limit on reverse rotation	Limit value: T-REF value
	OFF	1CN-17:"H" level	Doesn't set torque limit on reverse rotation Normal run	

■ Setting

Set torque reference gain in parameter Pn031

Para. No.	Description	Unit	Setting range	Default
Pn031	Torque reference gain	0.1V/100%	10 ~ 100	30

## 4.2.11 Using the Reference Pulse Inhibit Function (INHIBIT)

This function causes the Servo drive to stop counting input reference pulses in position control mode. While this function is being used, the motor remains in servo locked (clamped) status.

The /P-CON signal is used to enable or prohibit this function.

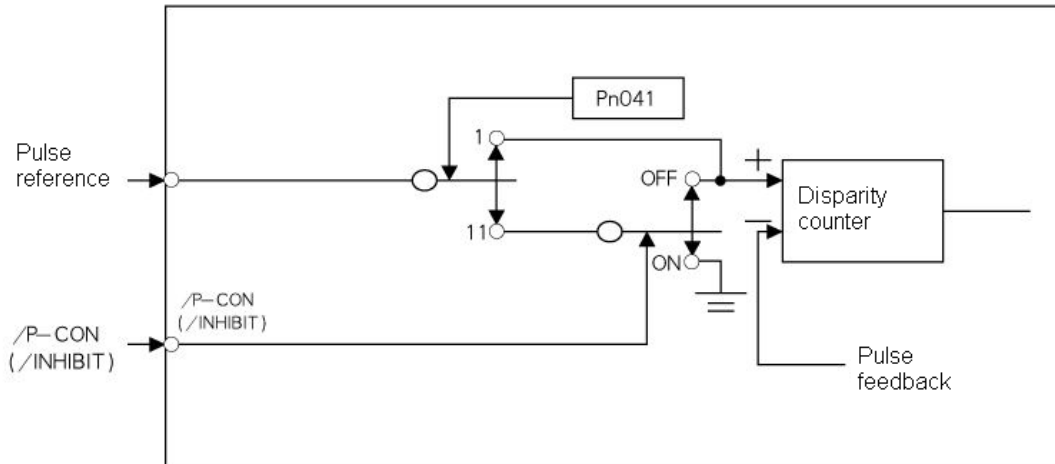

### How to Use Reference Pulse Inhibit Function: INHIBIT

To use the INHIBIT function, set parameters as follows.

Para. No.	Description	Setting range	Default	Function
<b>Pn041</b>	Control Mode Selection	0 ~ 13	0	For speed/torque and position control

<b>Pn041</b>	<b>Control mode</b>	
11	<p><b>Position control ( reference pulse &lt;-&gt;pulse prohibited )</b></p> <p>position control with pulse inhibit function</p> <p>· /P-CON ( 1CN-11 ) signal is used to enable or prohibit the INHIBIT function.</p> <p>1CN-11 : ON pulse inhibit enabled</p> <p>OFF pulse inhibit prohibited</p>	<p>Servo drive</p>

### Relationship between INHIBIT Signal and Reference Pulse

/INHIBIT signal  
(/P-CON)

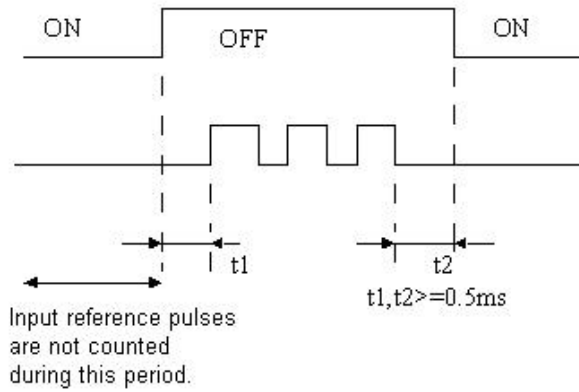

### How to use /P-CON signal

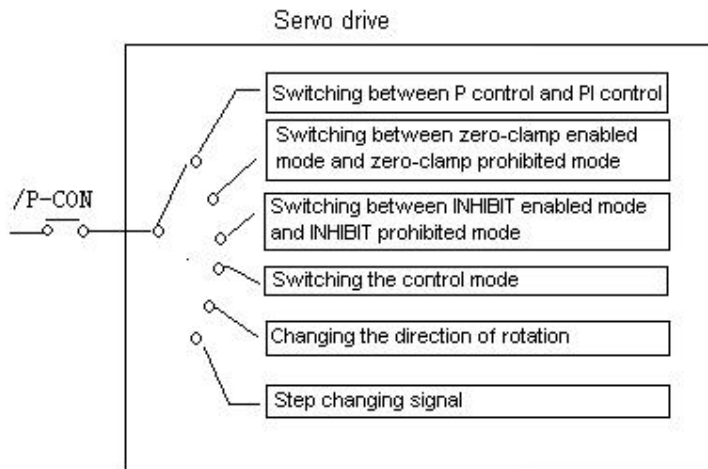

Setting of Pn041	Meaning of /P-CON
0, 1	Switching between P control and PI control
2	(not used)
3, 4, 5, 6	Switching the direction of rotation when contact input speed control mode is selected.
7, 8, 9	Switching the control mode
10	Switching between zero-clamp enabled mode and zero-clamp prohibited mode
11	Switching between INHIBIT enabled mode and INHIBIT prohibited mode
12	Step changing signal
13	(Not used)

---

## 4.3 Setting up the parameter

### 4.3.1 Setting the Jog Speed

Use the following parameter to set or modify a motor speed

Para. No.	Name and description	Unit	Setting range	Default
Pn037	JOG speed	r/min	0~2500	500

If a value higher than the maximum speed is set, the maximum speed value is used.

This parameter is used to set a motor speed when the motor is operated using a Digital Operator. Refer to 5.2.3 for details.

### 4.3.2 Selecting the control modes

Select different control modes by setting following parameters.

Para. No.	Name and description	Setting range	Default
-----------	----------------------	---------------	---------

Pn 041	<p>[0]speed control ( analog reference )</p> <p>[1]Position control ( pulse array reference )</p> <p>[2]torque control ( analog reference )</p> <p>[3]speed control ( I/O contact reference ) ↔ speed control ( Zero reference )</p> <p>[4]speed control ( I/O contact reference ) ↔ speed control ( analog reference )</p> <p>[5]speed control ( I/O contact reference ) ↔ Position control ( Pulse reference )</p> <p>[6]speed control ( I/O contact reference ) ↔ torque control ( analog reference )</p> <p>[7]Position control ( Pulse reference ) ↔ speed control ( analog reference )</p> <p>[8]Position control ( Pulse reference ) ↔ torque control ( analog reference )</p> <p>[9]torque control ( analog reference ) ↔ speed control ( analog reference )</p> <p>[10]speed control ( analog reference ) ↔ Zero-clamp control</p> <p>[11]Position control ( Pulse reference ) ↔ Position control ( pulse inhibited )</p> <p>[12]Position control ( parameter reference )</p> <p>[13]speed control ( parameter reference )</p>	0 ~ 13	0
-----------	---	--------	---

■ **Control mode introduction**

Control modes mentioned above are described as follows:

**[0]speed control ( analog reference )**

Speed control mode used for analog voltage reference input. Please refer to 4.2.1 Speed reference

**[1]position control ( pulse array reference )**

Position control mode for pulse array input reference. Please refer to 4.2.2 Position reference

**[2]Torque control ( analog reference )**

Torque control mode for analog voltage input reference. Please refer to 4.4.8 Torque control

**[3]speed control ( I/O contact reference ) ↔ speed control ( zero reference )**

Control mode for internally set speed selection and zero reference. Please refer to 4.2.7“Internally set speed selection”

**[4]speed control ( I/O contact reference ) ↔ speed control ( analog reference )**

Mode that could switch contact reference speed control and analog voltage reference speed control. When signal /PCL and /NCL are OFF ( H level ) , the analog reference speed control is enabled. Please refer to 4.2.7" internally set speed selection".

**[5]speed control ( I/O contact reference ) ↔ position control ( pulse instruction )**

Mode that could switch between contact reference speed control and pulse train reference position control. When signal /PCL and /NCL are OFF ( H level ) , pulse train reference position control is enabled. Please refer to 4.2.7" Internally set speed selection"

**[6]speed control ( I/O contact reference ) ↔ torque control ( analog reference )**

Mode that could switch between contact reference speed control and analog voltage input torque control. When /PCL and /NCL signals are OFF ( H level ) , Analog voltage reference torque control is enabled. Please refer to 4.2.7 " Internally set speed selection"

**[7]position control ( pulse reference ) ↔ speed control ( analog reference )**

Mode that could switch between position control and speed control by /P-CON signal

**[8]position control ( Pulse reference ) ↔ torque control ( analog reference )**

Mode that could switch between position control and torque control by /P-CON signal

**[9]torque control ( analog reference ) ↔ speed control ( analog reference )**

Mode that could switch between torque control and speed control by /P-CON signal  
Please refer to 4.2.8 Torque control

**[10]speed control ( analog reference ) ↔ zero-clamp control**

Speed control mode that allow zero clamp function setting when servo drive stops. Zero clamp acts after P-CON signal is "ON" ( L level ) . Please refer to 4.4.3" zero clamp".

**[11]position control ( pulse reference ) ↔ position control ( pulse prohibit )**

Position control mode that use /P-CON signal to stop reference pulse stop (prohibit). Please refer to 4.2.11" reference pulse inhibits function"

**[12]position control ( parameter reference )**

Servodrive could perform position control without host controller. Please refer to 4.2.5 contact control

**[13]speed control ( parameter reference )**

Servodrive performs according to the speed and rotation direction set by Pn048 and Pn049, please refer to 4.2.1.

Meanings of some parameters under various control modes are as follows

Pn041	Control mode
-------	--------------

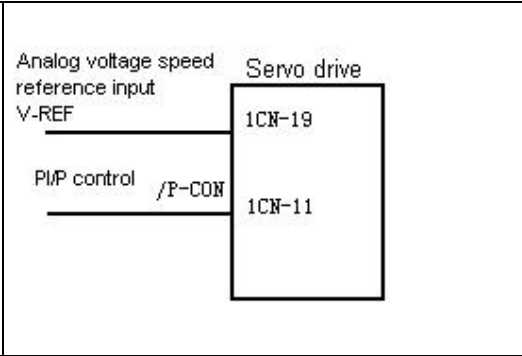
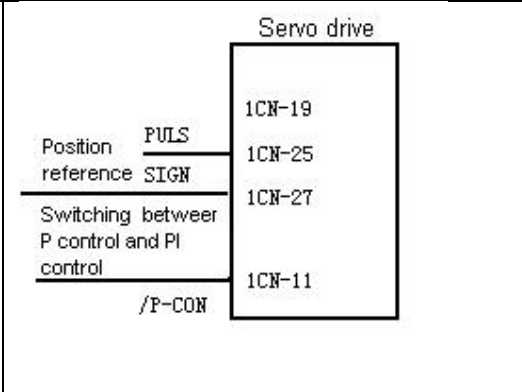
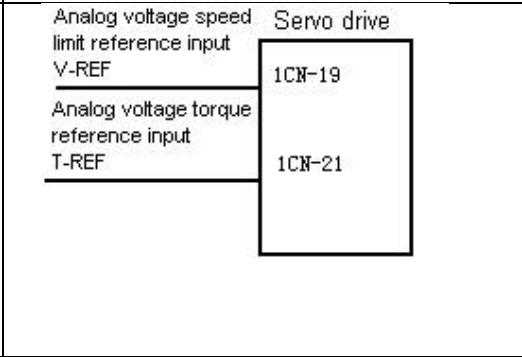
<p>0</p>	<p><b>Speed control mode ( analog reference )</b></p> <p>common speed control</p> <ul style="list-style-type: none"> <li>• V-REF(1CN-19) inputs speed reference</li> <li>• /P-CON(CN1-11) signal is used to switch between P control and PI control</li> </ul> <p>1CN-11 : OFF PI control ON P control</p>	 <p>Analog voltage speed reference input V-REF</p> <p>P/P control /P-CON</p> <p>Servo drive</p> <p>1CN-19</p> <p>1CN-11</p>
<p>1</p>	<p><b>Position control mode ( pulse train reference )</b></p> <p>Common position reference</p> <p>/P-CON ( 1CN-11 ) is used to switch between P control and PI control</p> <p>1CN-11 : ON "L" level P control OFF "H" level PI control</p>	 <p>Position reference PULS</p> <p>reference SIGN</p> <p>Switching between P control and PI control</p> <p>/P-CON</p> <p>Servo drive</p> <p>1CN-19</p> <p>1CN-25</p> <p>1CN-27</p> <p>1CN-11</p>
<p>2</p>	<p><b>Torque control (analog reference)</b></p> <p>Exclusive for torque control</p> <ul style="list-style-type: none"> <li>• Inputs torque reference from T-REF(1CN-21)</li> <li>• Does not use /P-CON</li> <li>• When Pn007 is set to be 1 and speed reference inputs V-REF (1CN-19). It could be used as maximum external speed limit.</li> <li>• Set user constant Pn042 value as internal maximum speed limit.</li> </ul>	 <p>Analog voltage speed limit reference input V-REF</p> <p>Analog voltage torque reference input T-REF</p> <p>Servo drive</p> <p>1CN-19</p> <p>1CN-21</p>

<p>3</p>	<p><b>Speed control ( Contact reference&lt;-&gt;zero reference )</b></p> <p>Switching speed control between contact reference and zero reference</p> <ul style="list-style-type: none"> <li>• Switching internally set speed by /P-CON(1CN-11),/PCL(1CN-16) and /NCL(1CN-17)</li> </ul> <table border="1"> <thead> <tr> <th>/P-CON</th> <th>/PCL</th> <th>/NCL</th> <th>Speed</th> </tr> </thead> <tbody> <tr> <td>-</td> <td>0</td> <td>0</td> <td>Zero speed</td> </tr> <tr> <td>0:Forward rotation</td> <td>0</td> <td>1</td> <td>SPEED 1</td> </tr> <tr> <td rowspan="2">1:Reverse rotation</td> <td>1</td> <td>1</td> <td>SPEED 2</td> </tr> <tr> <td>1</td> <td>0</td> <td>SPEED 3</td> </tr> </tbody> </table>	/P-CON	/PCL	/NCL	Speed	-	0	0	Zero speed	0:Forward rotation	0	1	SPEED 1	1:Reverse rotation	1	1	SPEED 2	1	0	SPEED 3	<p>Rotation direction selection</p> <ul style="list-style-type: none"> <li>/P-CON → 1CN-11</li> <li>/PCL → 1CN-16</li> <li>/NCL → 1CN-17</li> </ul> <p>Internally set speed selection</p> <ul style="list-style-type: none"> <li>/PCL → 1CN-16</li> <li>/NCL → 1CN-17</li> </ul>
/P-CON	/PCL	/NCL	Speed																		
-	0	0	Zero speed																		
0:Forward rotation	0	1	SPEED 1																		
1:Reverse rotation	1	1	SPEED 2																		
	1	0	SPEED 3																		
<p>4</p>	<p><b>Speed control mode ( contact reference&lt;-&gt;analog reference )</b></p> <p>Switching between contact control and analog reference control</p> <ul style="list-style-type: none"> <li>• Inputs analog from V-REF(1CN-19)</li> <li>• Select control mold and internal speed by /PCL(1CN-16) and /NCL(1CN-17)</li> </ul> <table border="1"> <thead> <tr> <th>/P-CON</th> <th>/PCL</th> <th>/NCL</th> <th></th> </tr> </thead> <tbody> <tr> <td>P/PI control switching</td> <td>0</td> <td>0</td> <td>Analog speed reference control</td> </tr> <tr> <td rowspan="2">0:Forward rotation</td> <td>0</td> <td>1</td> <td>SPEED1</td> </tr> <tr> <td>1</td> <td>1</td> <td>SPEED2</td> </tr> <tr> <td>1:Reverse rotation</td> <td>1</td> <td>0</td> <td>SPEED3</td> </tr> </tbody> </table>	/P-CON	/PCL	/NCL		P/PI control switching	0	0	Analog speed reference control	0:Forward rotation	0	1	SPEED1	1	1	SPEED2	1:Reverse rotation	1	0	SPEED3	<p>Speed reference V-REF</p> <ul style="list-style-type: none"> <li>/P-CON → 1CN-19</li> <li>/PCL → 1CN-11</li> <li>/NCL → 1CN-17</li> </ul> <p>Internally set speed reference selection</p> <ul style="list-style-type: none"> <li>/PCL → 1CN-16</li> <li>/NCL → 1CN-17</li> </ul>
/P-CON	/PCL	/NCL																			
P/PI control switching	0	0	Analog speed reference control																		
0:Forward rotation	0	1	SPEED1																		
	1	1	SPEED2																		
1:Reverse rotation	1	0	SPEED3																		

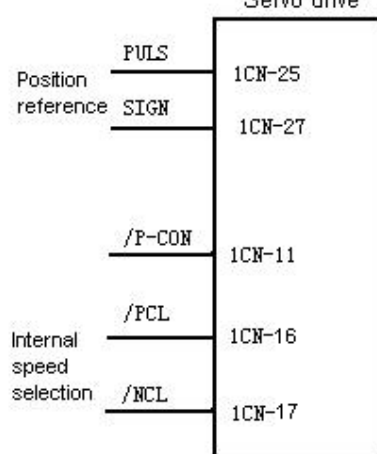
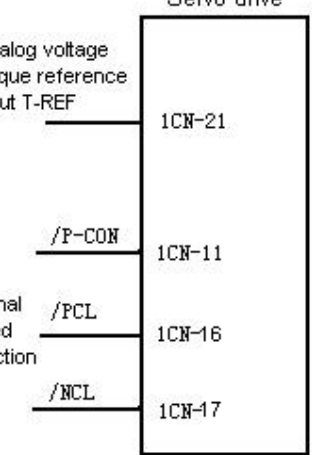
<p>5</p>	<p><b>Speed control ( contact reference ) &lt;-&gt;Position control ( Pulse reference )</b></p> <p>Switching position control between contact reference and pulse reference</p> <ul style="list-style-type: none"> <li>Select control mode or internal speed by /PCL(1CN-16) and /NCL(1CN-17)</li> </ul> <table border="1"> <thead> <tr> <th>/P-CON</th> <th>/PCL</th> <th>/NCL</th> <th></th> </tr> </thead> <tbody> <tr> <td>P/PI control switching</td> <td>0</td> <td>0</td> <td>Speed control (pulse reference)</td> </tr> <tr> <td rowspan="2">0:Forward rotation</td> <td>0</td> <td>1</td> <td>SPEED1</td> </tr> <tr> <td>1</td> <td>1</td> <td>SPEED2</td> </tr> <tr> <td>1:Reverse rotation</td> <td>1</td> <td>0</td> <td>SPEED3</td> </tr> </tbody> </table>	/P-CON	/PCL	/NCL		P/PI control switching	0	0	Speed control (pulse reference)	0:Forward rotation	0	1	SPEED1	1	1	SPEED2	1:Reverse rotation	1	0	SPEED3	<p>Servo drive</p> 
/P-CON	/PCL	/NCL																			
P/PI control switching	0	0	Speed control (pulse reference)																		
0:Forward rotation	0	1	SPEED1																		
	1	1	SPEED2																		
1:Reverse rotation	1	0	SPEED3																		
<p>6</p>	<p><b>Speed control ( contact reference ) &lt;-&gt; Torque control ( analog reference )</b></p> <p>Switching between Speed control ( contact reference ) and Torque control ( analog reference )</p> <ul style="list-style-type: none"> <li>Select control mode or internal speed by using /PCL(1CN-16) and /NCL(1CN-17) signals</li> </ul> <p>Note: /PCL(1CN-16) and /NCL(1CN-17) can not use as external torque output any more in torque control herein</p> <table border="1"> <thead> <tr> <th>/P-CON</th> <th>/PCL</th> <th>/NCL</th> <th></th> </tr> </thead> <tbody> <tr> <td>-</td> <td>0</td> <td>0</td> <td>Analog reference Torque control</td> </tr> <tr> <td rowspan="2">0:Forward rotation</td> <td>0</td> <td>1</td> <td>SPEED1</td> </tr> <tr> <td>1</td> <td>1</td> <td>SPEED2</td> </tr> <tr> <td>1:Reverse rotation</td> <td>1</td> <td>0</td> <td>SPEED3</td> </tr> </tbody> </table>	/P-CON	/PCL	/NCL		-	0	0	Analog reference Torque control	0:Forward rotation	0	1	SPEED1	1	1	SPEED2	1:Reverse rotation	1	0	SPEED3	<p>Servo drive</p> 
/P-CON	/PCL	/NCL																			
-	0	0	Analog reference Torque control																		
0:Forward rotation	0	1	SPEED1																		
	1	1	SPEED2																		
1:Reverse rotation	1	0	SPEED3																		

<p>7</p>	<p><b>Position control ( Pulse reference ) &lt;-&gt;Speed control ( analog reference )</b></p> <ul style="list-style-type: none"> <li>Inputs speed reference from V-REF(1CN-19)</li> <li>Switching control modes by using /P-CON(1CN-11)</li> </ul> <p>1CN-11 : OFF position control ( pulse reference ) ON speed control ( analog reference )</p> <p>Note: In this position control and speed control, /P-CON(1CN-11) is no longer used to switch between P control and PI control</p>	
<p>8</p>	<p><b>Position control ( Pulse reference ) &lt;-&gt;Torque control ( analog reference )</b></p> <ul style="list-style-type: none"> <li>Switching Position control ( Pulse reference ) and Torque control ( analog reference ) by using /P-CON ( 1CN-11 )</li> </ul> <p>1CN-11 OFF: Position control ON: torque control</p>	
<p>9</p>	<p><b>Torque control ( analog reference ) &lt;-&gt; Speed control ( analog reference )</b></p> <p><b>Switching between Torque control ( analog reference ) and Speed control ( analog reference )</b></p> <ul style="list-style-type: none"> <li>Inputs speed reference or speed limit value from V-REF(1CN-19)</li> <li>Inputs torque reference, torque feed-forward reference and torque limit from T-REF (1CN-21).</li> <li>Switches torque control and speed control by /P-CON(1CN-11)</li> </ul> <p>1CN-11 OFF: torque control; ON: speed control</p> <p><b>In torque control mode ( when /P-CON is OFF )</b></p> <ul style="list-style-type: none"> <li>Perform torque control according to T-REF reference.</li> <li>Offer speed limit according to V-REF. ( when Pn007=1 ) , determine rotation direction speed by referring voltage V-REF absolute value</li> <li>Limit max. speed by using Pn042.</li> </ul>	

<p><b>In speed control mode ( when /P-CON is ON )</b></p> <p>•Set Pn010 and Pn011 value as follows</p> <table border="1"> <thead> <tr> <th colspan="2">Parameter</th> <th>Speed input reference</th> <th>Torque input reference</th> <th rowspan="2">Remarks</th> </tr> <tr> <th>Pn010</th> <th>Pn011</th> <th>V-REF(1CN-19)</th> <th>T-REF(1CN-21)</th> </tr> </thead> <tbody> <tr> <td rowspan="2">0</td> <td rowspan="2">0</td> <td colspan="2">Simple speed control</td> <td rowspan="2"></td> </tr> <tr> <td>Speed reference</td> <td>Does not use</td> </tr> <tr> <td rowspan="2">-</td> <td rowspan="2">1</td> <td colspan="2">Speed control with torque feed- forward function</td> <td rowspan="2">Set Pn010 to any value, refer to 4.2.9</td> </tr> <tr> <td>Speed reference</td> <td>Torque feed - forward</td> </tr> <tr> <td rowspan="2">1</td> <td rowspan="2">0</td> <td colspan="2">Give torque limit speed control by analog voltage reference</td> <td rowspan="2">Refer to 4.2.10</td> </tr> <tr> <td>Speed reference</td> <td>Torque limit value</td> </tr> </tbody> </table>					Parameter		Speed input reference	Torque input reference	Remarks	Pn010	Pn011	V-REF(1CN-19)	T-REF(1CN-21)	0	0	Simple speed control			Speed reference	Does not use	-	1	Speed control with torque feed- forward function		Set Pn010 to any value, refer to 4.2.9	Speed reference	Torque feed - forward	1	0	Give torque limit speed control by analog voltage reference		Refer to 4.2.10	Speed reference	Torque limit value
Parameter		Speed input reference	Torque input reference	Remarks																														
Pn010	Pn011	V-REF(1CN-19)	T-REF(1CN-21)																															
0	0	Simple speed control																																
		Speed reference	Does not use																															
-	1	Speed control with torque feed- forward function		Set Pn010 to any value, refer to 4.2.9																														
		Speed reference	Torque feed - forward																															
1	0	Give torque limit speed control by analog voltage reference		Refer to 4.2.10																														
		Speed reference	Torque limit value																															
10	<p><b>Speed control ( Analog reference&lt;-&gt;zero clamp )</b></p> <p>Speed control mode with zero clamp function</p> <ul style="list-style-type: none"> <li>inputs speed reference from V-REF(1CN-19)</li> <li>Select zero clamp functions by using /P-CON ( 1CN-11 ) signal</li> </ul> <p>1CN-11 : ON zero clamp enabled OFF zero clamp prohibited</p>	<p>Zero clamp acts when meet following items :</p> <ol style="list-style-type: none"> <li>1: /P-CON is ON</li> <li>2: Motor speed is under Pn033 preset value</li> </ol>																																
11	<p><b>Position control ( pulse reference&lt;-&gt;pulse prohibited )</b></p> <p>Position control with pulse prohibit function</p> <ul style="list-style-type: none"> <li>Switching between pulse prohibit /P-CON ( 1CN-11 ) enabled or not</li> </ul> <p>1CN-11 : ON Pulse prohibit enabled OFF Pulse prohibit disenabled</p>																																	
12	<p><b>Position control( parameter reference)</b></p> <ul style="list-style-type: none"> <li>If Pn051=1, /P-CON(1CN-11) is used as step changing signal input</li> <li>Use /PCL(1CN-16) and /NCL(1CN-17) to look for reference point</li> </ul>																																	

13	<b>Speed control( parameter reference)</b> Motor rotates according to parameter preset speed and status -/P-CON input invalid	
----	---	--

## 4.4 Setting Stop Mode

### 4.4.1 Adjusting Offset

#### Why Does not the Motor Stop?"

When 0 V is specified as reference voltage for speed/torque control (analog reference), the motor may rotate at a very slow speed and fail to stop. This happens when reference voltage from the host controller or external circuit has a slight offset (equal to reference offset) (in mV units). If this offset is adjusted to 0 V, the motor will stop.

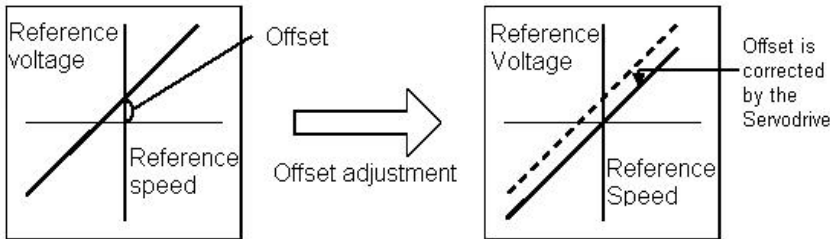

#### Adjusting the Reference Offset

The following two methods can be used to adjust the reference offset to 0 V.

Automatic adjustment of reference offset	Reference offset is automatically adjusted to 0 V.
Manual adjustment of reference offset	Reference offset can be intentionally set to a specified value.

Please refer to 5.2.4 “automatic adjustment of speed reference offset” and 5.2.5 “manual adjustment of speed reference offset” for detailed procedures.

**Note:** If a position control loop is formed in the host controller, do not use automatic adjustment and always use manual adjustment.

### 4.4.2 Using Dynamic Brake

To stop the servomotor by applying **dynamic brake (DB)**, set desired values in the following memory switch. If dynamic brake is not used, the servomotor will stop naturally due to machine friction.

Para.No.	Description	Setting range	Default
Pn004	Operation to Be Performed When Motor Stops After Servo is Turned OFF	0 ~ 5	0

Para.No.	Meaning

Pn004	<p>[0] Stops the motor by dynamic brake and release after motor stops</p> <p>[1] Coast to a stop</p> <p>[2] Performs DB when S-off; apply plug braking when overtravel, S-off after motor stops</p> <p>[3] Motor coasts to stop when S-off, apply plug braking when overtravel, S-off after motor stops</p> <p>[4] Performs DB when S-off, apply plug braking when overtravel, zero clamp after motor stops</p> <p>[5] Motor coasts to stop when S-off, apply plug braking when overtravel ,zero clamp after motor stops</p>
-------	--

The Servodrive enters servo OFF status when:

- Servo ON input signal (/S-ON, 1CN-10) is turned OFF
- Servo alarm arises
- Power is turned OFF

**Note:**

Dynamic brake is a performance that forces motor to stop. Don't use Power ON/OFF or Servo ON signal (/S-ON) to stop and restart servo motor frequently. Otherwise service life of internal elements of servo drive will be shortened.

**Dynamic brake (DB)**

One of the general methods to cause a motor sudden stop.

“Dynamic brake” suddenly stops a servomotor by shorting its electrical circuit.

This dynamic brake circuit is incorporated in the servodrive.

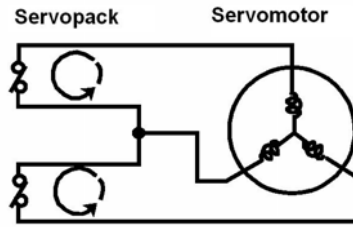

### 4.4.3 Using Zero-Clamp

The zero-clamp function is used for a system in which the host controller does not form a position loop by speed reference input. In other words, this function is used to cause the motor to stop and enter a servo locked status when the input voltage of speed reference V-REF is not 0 V. When the zero-clamp function is turned ON, an internal position loop is temporarily formed, causing the motor to be clamped within one pulse. Even if the motor is forcibly rotated by external force, it returns to the zero-clamp position.

Speed reference less than Pn031 setting is ingored.

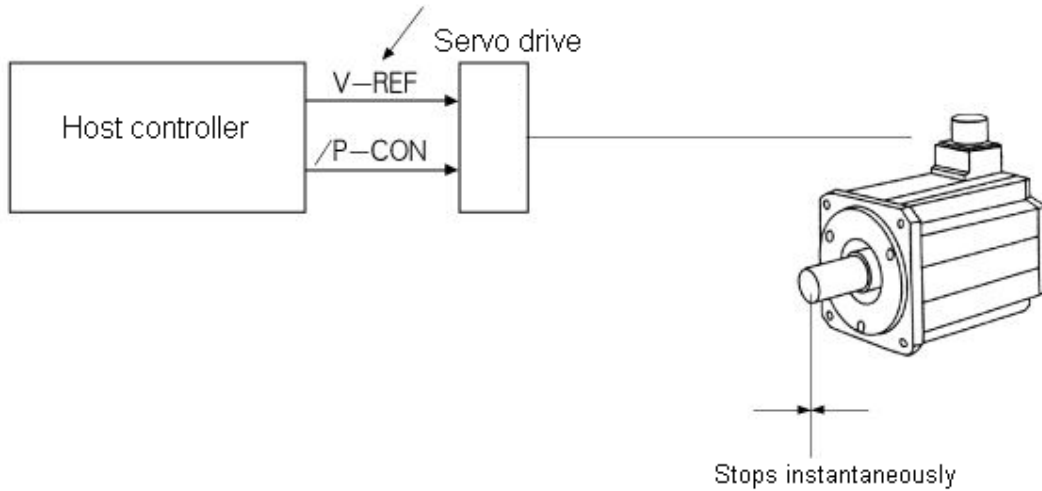

### Setting

Set the Pn041 to 10 and select speed control(analog reference)—zero clamp control so that input signal /P-CON can be used to enable or disable the zero-clamp function.

Pn041	Control mode selection	
10	<p><b>Speed control ( Analog reference&lt;-&gt;zero clamp )</b></p> <p>This speed control allows the zero-clamp function to be set when the motor stops.</p> <ul style="list-style-type: none"> <li>·D A speed reference is input from V-REF(1CN-19).</li> <li>·/P-CON ( 1CN-11 ) is used to turn the zero-clamp function ON or OFF.</li> </ul> <p>1CN-11: ON Turns zero-clamp function ON OFF Turns zero-clamp function OFF</p>	<p>Zero-clamp is performed when the following two conditions are met:</p> <ol style="list-style-type: none"> <li>1:/P-CON is ON</li> <li>2:Motor speed is below the value set Pn033</li> </ol>

→ input /P-CON 1CN- 11 Proportional Control, etc.

The following table shows zero clamp status when /P-CON is turned ON and OFF.

Signal	Status	Input le	Description
/P-CON	ON	1CN-11 : "L"level	Zero-clamp function is ON
	OFF	1CN-11 : "H"level	Zero-clamp function is OFF

Para. No.	Name and description	Unit	Setting range	Default
Pn033	Zero-clamp speed	r/min	0~2500	10

If zero-clamp speed control is selected, set the motor speed level at which zero-clamp is to be performed. If a value higher than the maximum motor speed is set, the maximum speed value is used.

**Conditions for Zero-clamp**

Zero-clamp is performed when all the following conditions are met:

- Zero-clamp speed control is selected (Parameter Pn041=10).
- /P-CON (1CN-11) is turned ON (0 V).
- Motor speed drops below the preset value.

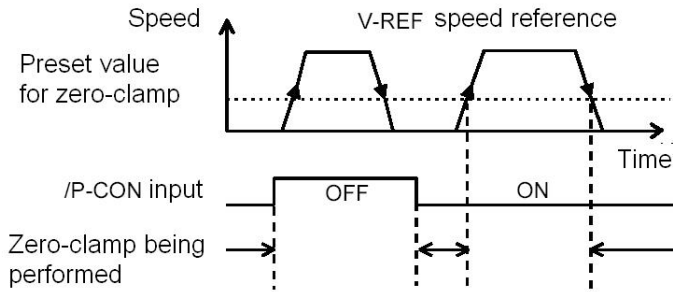

**4.4.4 Using Holding Brake**

Holding brake is useful when a servo drive is used to control a vertical axis. A servomotor with brake prevents the movable part from dropping due to gravitation when the system power is turned OFF.

Servodrive brake interlock outputs (/BK) signals to control if the holding brake function is turned on or not in a servomotor with brake.

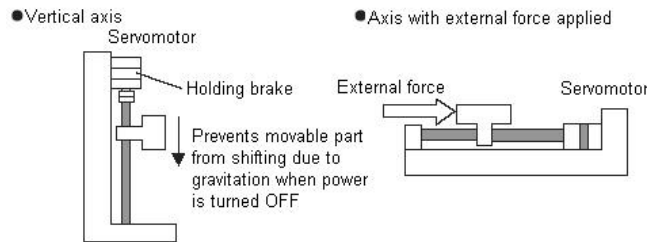

Before connection please make sure the servo motor is detached with the machine and confirm the performance of servomotor and holding brake action. If both works normal, then connect the servomotor and machine and test.

**■ Connecting example**

Use Servodrive contact output-signal /BK and brake power supply to form a brake ON/OFF circuit. An example of standard wiring is shown below.

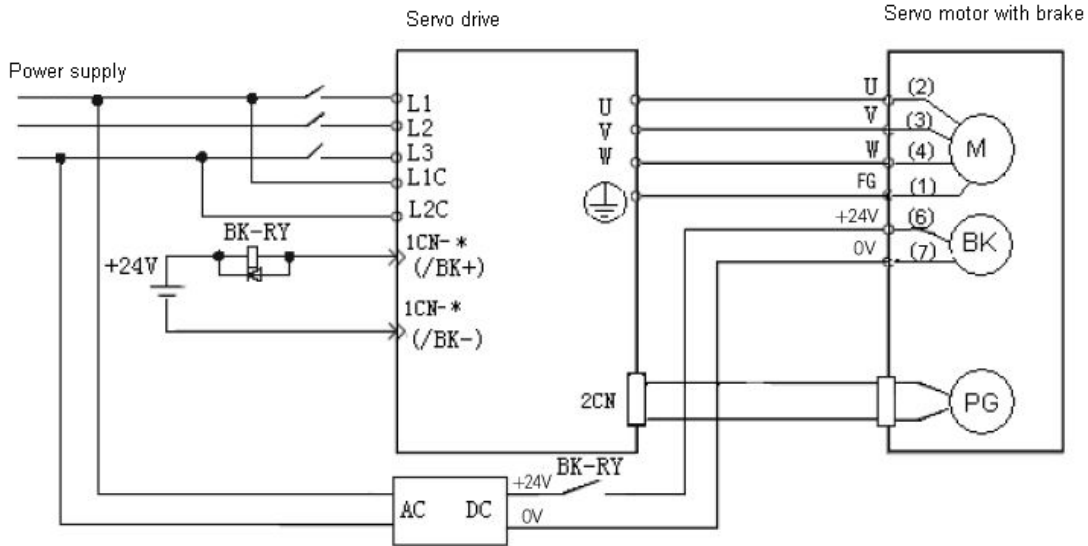

**BK-RY:** Brake control relay

**1CN-\* :** Number of terminals allocated by Pn053/Pn054/Pn055

→ <b>Output /BK</b>	Brake Interlock Output	For Speed, Torque and Position Control
---------------------	------------------------	--

This output signal controls the brake when a motor with brake is used. This signal terminal need not be connected when a motor without brake is used.

ON : "L" level	Releases the brake.
OFF : "H" level	Applies the brake.

Set the following parameter to specify the 1CN pin to which the BK signal is output.

Para. No.	Name and description	Setting range	Default
Pn053	Select output signals 1CN-7,8 functions	0~4	0
Pn054	Select output signals 1CN-1,2 functions	0~4	1
Pn055	Select output signals 1CN-5,6 functions	0~4	2

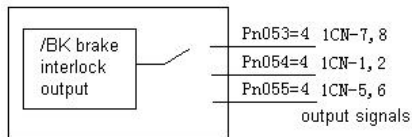

Pn053, Pn054 and Pn055 signal functions are shown as follows:

0	/COIN(V-CMP) output
1	/TGON complete position detection output
2	/S-RDY servo ready output

3	/CLT torque limit output
4	/BR brake interlock output

Related parameters:

Para. No.	Name and description	Unit	Setting range	Default
Pn043	Time delay from servo ON signal till Servo actually ON	ms	0-2000	0
Pn044	Time delay from the time a brake signal is output until servo OFF status occurs	10ms	0~500	0
Pn045	Speed level for brake signal output during operation	r/min	10 ~ 100	100
Pn046	Time delay from brake signal until servo OFF	10ms	10 ~ 100	50

### ■ Brake ON and OFF Timing

If the machine moves slightly due to gravity when the brake is applied, set the following parameter to adjust brake ON timing:

Para. No.	Name and description	Unit	Setting range	Default
Pn043	Time delay from servo ON signal till Servo actually ON	ms	0-2000	0
Pn044	Time delay from the time a brake signal is output until servo OFF status occurs	10ms	0~500	0

This parameter is used to set output timing of brake control signal /BK and servo OFF operation (motor output stop) when servomotor with brake is used.

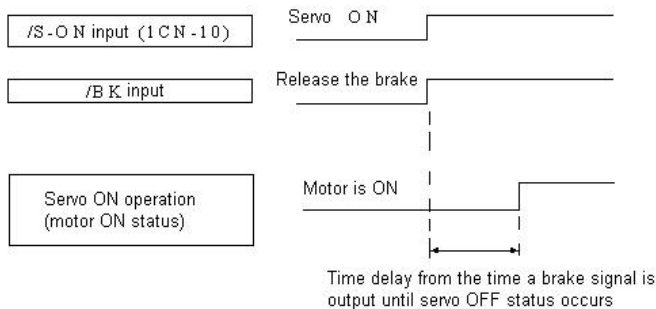

For brake ON timing during motor operation, use Pn045 and Pn046.

### Note:

When alarm triggers, motor will instantly turn OFF. Due to gravity and other reasons, machine might move until brake stops.

## Setting

Set the following parameters to adjust brake ON timing so that holding brake is applied when the motor stops.

Para. No.	Name and description	Unit	Setting range	Default
Pn045	Speed Level at which Brake Signal Is Output during Motor Operation	R/min	10 ~ 100	100
Pn046	Output Timing of Brake Signal during Motor Operation	10ms	10 ~ 100	50

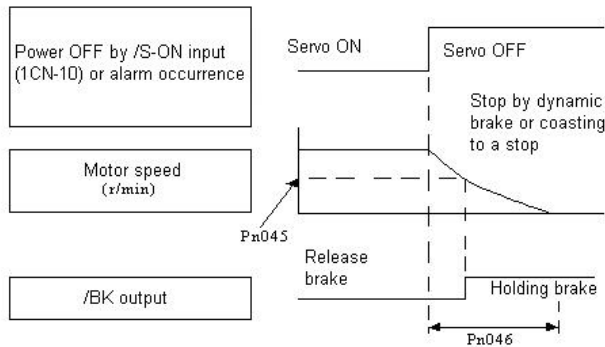

Pn045 and Pn046 are used for servomotors with brake. Use these parameters to set brake timing used when the servo is turned OFF by input signal /S-ON\ or alarm occurrence during motor rotation.

Brakes for servomotors are designed as holding brakes. Therefore, brake ON timing when the motor stops must be appropriate. And after this period of time, motor rotating speed will no longer affect the brake performance. Adjust the parameter settings while observing machine operation.

Conditions for /BK signal output during motor operation: (The circuit is opened in either of the following situations.)

1. Motor speed drops below the value set in Pn045 after servo OFF occurs.
2. The time set in Pn046 has elapsed since servo OFF occurred.

If a value higher than the maximum speed is set, the maximum speed value is used.

## 4.5 Forming a Protective Sequence

### 4.5.1 Using Servo Alarm Output and Alarm Code Output

#### Basic Wiring for Alarm Output Signals

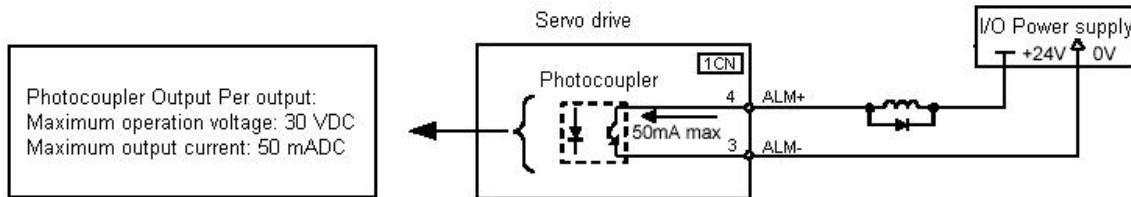

Provide an external +24V I/O power supply separately. There is no DC power available from servo drive for output signals

<b>Output</b>	→ ALM+ 1CN- 4	Servo alarm output
<b>Output</b>	→ ALM- 1CN- 3	Signal Ground for Servo Alarm Output

Signal ALM is output when the Servo drive detects an alarm.

Servo drive

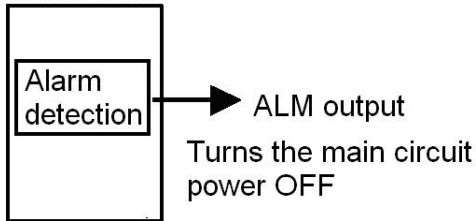

Design the external circuit so that the main circuit power to the servo drive is turned OFF by this alarm output signal.

Signal	Status	Output voltage	Description
<b>ALM</b>	ON	1CN-4 : "L" level	Normal state
	OFF	1CN-4 : "H" Level	Alarm state

When the servo alarm (ALM) is output, eliminate the cause of the alarm and the turn ON the following /ALM-RST input signal to reset the alarm state.

→ input /ALM-RST 1CN- 14	Alarm reset
--------------------------	-------------

Signal	Status	Output voltage	Description
/ALM-RST	ON	1CN-14 : "L" level	Clears alarm state
	OFF	1CN-14 : "H" level	Does not clear alarm state

Form an external circuit so that the main circuit power supply is turned OFF when servo alarm is output. Alarm state is automatically reset when control power supply is turned OFF. **Thus, no alarm reset signal necessary.**

Alarm state can be reset using the Digital Operator.

When an alarm occurs, always eliminate the cause before resetting the alarm state.

## 4.5.2 Using Servo ON Input Signal

This section describes how to wire and use contact input signal “servo ON (/S-ON).” Use this signal to forcibly turn the servomotor OFF from the host controller.

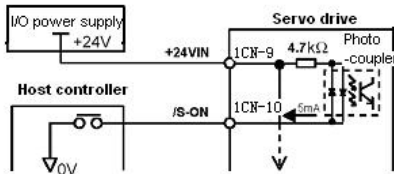

→ output /S-ON 1CN-10	Servo ON
-----------------------	----------

This signal is used to turn the motor ON or OFF

Signal	State	Input voltage	Description
/S-ON	ON	1CN-10 : “L”level	Servo ON: Motor is ON Motor is operated according to input signals.
	OFF	1CN-10 : “H”level	Servo OFF: Motor is OFF Motor cannot run.

Use Pn043 to set servo ON timing that is time from relay acts till motor excited.

Para. No.	Name and description	Unit	Setting range	Default
Pn043	Servo ON delay time	Ms	0~2000	0

### Note:

Do not use the /S-ON signal to start or stop the motor. Always use an input reference to start and stop the motor. Otherwise service life of the servo drive will be shortened.

This memory switch is used to enable or disable the servo ON input signal.

Para.No.	Name and description	Unit	Setting range	Default
Pn000	Enable/disenable servo ON input signal ( /S-ON )  [0] Uses servo ON signal /S-ON. (When 1CN-10 is open, servo is OFF. When 1CN-10 is at 0 V, servo is ON.)  [1] Does not use servo ON signal /S-ON. (Servo is always ON. Equivalent to short-circuiting 1CN-10 to 0 V.)	—	0~1	0

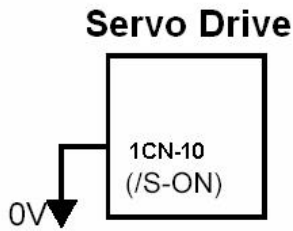

When /S-ON is not used, this short-circuit wiring can be omitted.

### 4.5.3 Using Positioning Complete Signal

This section describes how to wire and use contact output-signal “positioning complete output (/COIN).” This signal is output to indicate that servomotor operation is complete. The wiring and connections are shown as follows:

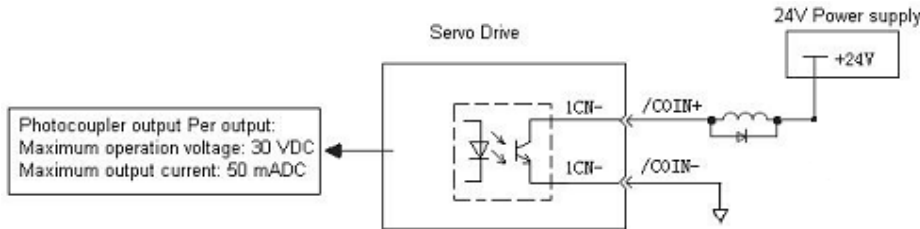

<b>Output → /COIN+</b>	Positioning Complete Output	Position control
<b>Output → /COIN-</b>	Positioning Complete Output Grounding signal	Position control

This output signal indicates that motor operation is complete during position control. The host controller uses this signal as an interlock to confirm that positioning is complete.

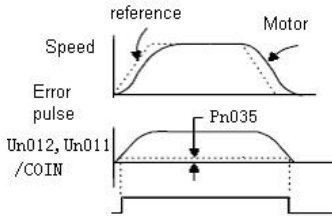

Un011 : error pulse counter monitor 16 bits lower

Un012 : error pulse counter monitor 16 bits higher

<b>ON status</b> /COIN+ : “L”level	Positioning Completed ( the position error range is below preset value )
<b>OFF status</b> /COIN+ : “H”level	Positioning does not complete ( the position error range is below preset value )

Define output signals and output pins by setting following parameters and according to actual needs in using /COIN:

Para. No.	Name and description	Setting range	Default
Pn053	Select signal 1CN-7,8 functions	0~4	0
Pn054	Select signal 1CN-1,2 functions	0~4	1
Pn055	Select signal 1CN-5,6 functions	0~4	2

---

Pn053, Pn054 and Pn055 functions are as follows:

0	/COIN(/V-CMP) output
1	/TGON running signal output
2	/S-RDY servo ready output
3	/CLT torque limit output
4	BK brake interlock output

Set the number of error pulses in the following parameter to adjust output timing of COIN (positioning complete output).

Para.	Function	Unit	Setting range	Default	Application
<b>Pn035</b>	<b>Positioning Complete Range</b>	<b>Reference Unit</b>	0 ~ 500	10	For Position Control Only

This parameter is used to set output timing of positioning complete signal to be output when motor operation is complete after a position reference pulse has been input. Set the number of error pulses in terms of reference unit (the number of input pulses that is defined using the electronic gear function).

**Note:**

/COIN is a signal for position control. For speed control, /V-CMP (speed coincidence output) is used instead. For torque control, /COIN is always ON.

### 4.5.4 Using Speed Coincidence Output Signal

This section describes how to wire and use contact output signal “speed coincidence output (/V-CMP).” This signal is output to indicate that actual motor speed matches a reference speed. The host controller uses this signal as an interlock. The connections and applications are shown as follows:

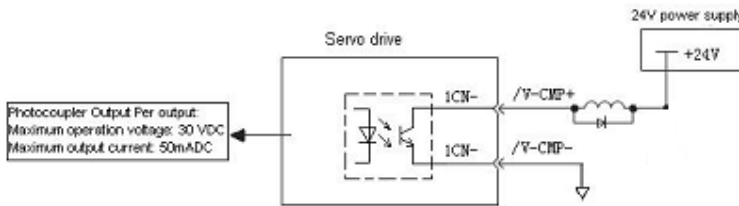

<b>Output → /V-CMP+</b>	Speed Coincidence Output	For speed control
<b>Output → /V-CMP-</b>	Speed coincidence grounding signal output	For speed control

<b>ON status / V-CMP+ “L” level</b>	Actual motor speed matches the speed reference (speed difference is below the preset value).
<b>OFF status /V-CMP+ “H” level</b>	Actual motor speed does not match the speed reference (speed difference is greater than the preset value).

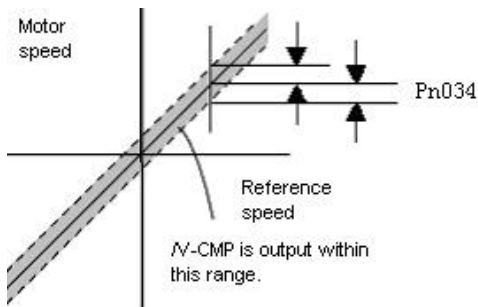

This parameter is used to specify a function signal as the 1CN output signal.

Para. No.	Name and description	Setting range	Default
Pn053	Output signals 1CN-7,8 functions	0~4	0
Pn054	Output signals 1CN-1,2 functions	0~4	1
Pn055	Output signals 1CN-5,6 functions	0~4	2

0	/COIN(/V-CMP) output
1	/TGON running signal output
2	/S-RDY servo ready output
3	/CLT torque limit output
4	BK brake interlock output

Set the following parameter to specify the output conditions for speed coincidence signal /V-CMP.

Para. No.	Function	Unit	Setting range	Default	Application
<b>Pn034</b>	Speed Coincidence Signal Output Width	<b>R/min</b>	0 ~ 100	10	For Speed Control Only

/V-CMP signal is output when the difference between the reference speed and actual motor speed is not greater than the preset value.

**Note:**

/V-CMP is a signal for speed control. For position control, /COIN (position complete output) is used instead. For torque control, /V-CMP is always ON.

## 4.5.5 Using Running Output Signal

This section describes how to wire and use photocoupler output: a running output signal /TGON. This signal indicates that a servomotor is currently running and could be used as interlock to external.

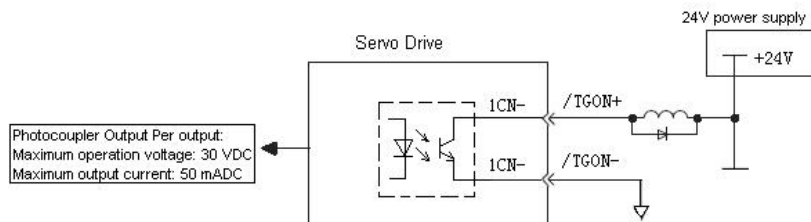

<b>Output</b> → /TGON+	Running Output
<b>Output</b> → /TGON-	Running output grounding signal

Signal	Status	Output voltage	Description
/TGON+	ON	/TGON+ "L" level	Motor is running. (Motor speed is greater than the preset value.)
	OFF	/TGON+ "H" level	Motor is stopped. (Motor speed is below the preset value.)

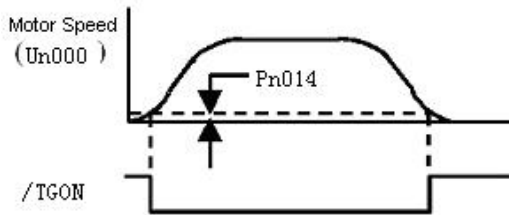

Para. No.	Name and description	Setting range	Default
Pn053	Select output signals 1CN-7,8 function	0~4	0
Pn054	Select output signals 1CN-1,2 function	0~4	1
Pn055	Select output signals 1CN-5,6 function	0~4	2

Pn053, Pn054 and Pn055 meanings and functions are shown as follows:

0	/COIN(/V-CMP) output
1	/TGON running position output
2	/S-RDY servo ready output
3	/CLT torque limit output
4	BK brake interlock output

Use the following parameter to specify the output conditions for /TGON (running output signal).

Para.No.	Name and description	Unit	Setting range	Default
Pn032	Zero-Speed Level	r/min	0-2500	20

When the motor is running its output speed is detected. If the speed level is above the rotating speed of preset value, /TGON will be output.

## 4.5.6 Using Servo Ready Output Signal

“Servo ready” means servodrive is not in servo alarm state when the main circuit is turned ON and could receive servo ON signals. The application and wirings are shown as follows:

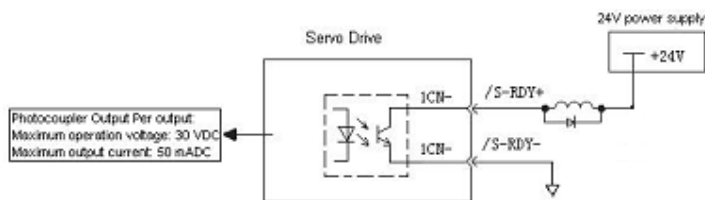

<b>Output</b> → /S-RDY+	Servo ready output
<b>Output</b> → /S-RDY-	Servo ready output grounding signals

Signals	Status	Output voltage	Description
/S-RDY +	ON	/S-RDY+ : “L” level	Servo ready state

---

	OFF	<b>/S-RDY+ : "H" level</b>	Not in servo ready state
--	-----	----------------------------	--------------------------

This parameter is used to specify a function signal as the 1PN output signal.

Para. No.	Name and description	Setting range	Default
Pn053	Select output signals 1CN-7,8 function	0~4	0
Pn054	Select output signals 1CN-1,2 function	0~4	1
Pn055	Select output signals 1CN-5,6 function	0~4	2

Pn053, Pn054 and Pn055 meanings and functions are shown as follows:

0	/COIN(/V-CMP) output
1	/TGON running position output
2	/S-RDY servo ready output
3	/CLT torque limit output
4	BK brake interlock output

## 4.5.7 Handling of Power Loss

Use the following memory switch to specify whether to output a servo alarm when power loss occurs.

Para.No.	Name and description	Unit	Setting range	Default
Pn003	Operation to Be Performed at Recovery from Power Loss [0] Does not output a servo alarm after recovery from power loss. ( ALM ) [1] Outputs a servo alarm after recovery from power loss. ( ALM )	—	0~1	0

If the Servodrive detects instantaneous voltage drop in power supply more than 20mS, it can shut the servo to prevent a hazardous situation. This memory switch is used to specify whether to output this alarm.

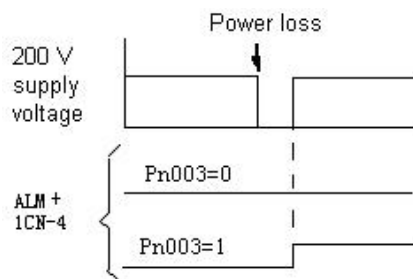

Normally, set this memory switch to 0. If the /S-RDY signal is not to be used, set the memory switch to 1. The /S-RDY signal remains OFF while the main power supply is OFF, regardless of the memory switch setting.

---

## 4.5.8 Using Regenerative Resistor Units

When servo motor is driven by dynamotor, the electric power goes back to servo amplifier, this is called regenerative power. Regenerative power is absorbed by smoothing capacitor. If the power exceeds capacity of the capacitor, then the regenerative resistor is applied to consume rest electric power.

Situations that will lead to dynamotor regenerative mode are shown as follows:

- During deceleration time
- Load on the vertical axis
- Continuous running of servomotor caused by load (minus load)

Note: The capacity of regenerative resistor in Servodrive is the short time rated specification used in deceleration and can't be used to load running. When the capacity of the built-in regenerative resistor is too small, external register could be applied.

■ The standard connection diagram for a regenerative resistor unit is shown below.

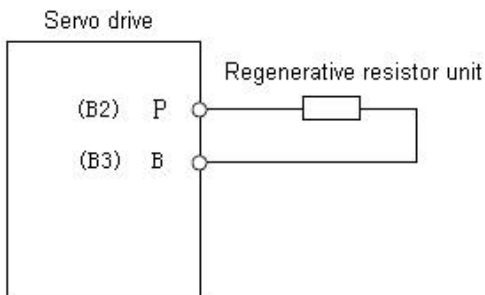

■ Regenerative circuit alarm

A regenerative resistor unit becomes very hot under some regenerative operation conditions of the servo system. Therefore, please choose appropriate regenerative resistor otherwise, the regenerative circuit might have problems and triggers A.16 alarm.

## 4.6 Running the Motor Smoothly

### 4.6.1 Using Smoothing function

In the Servodrive, some reference pulse of certain frequency could be filtered.

Para. No.	Name	Unit	Setting range	Default
Pn024	Position reference filter	0.1ms	0~32767	0
Pn025	Primary lag filter	0.1ms	0~640	0

Adjust these parameters to change the smoothing feature of position control.

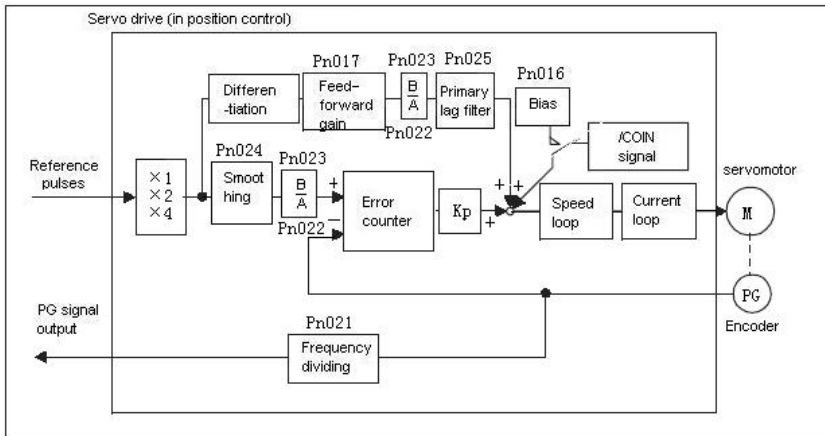

## 4.6.2 Using the Soft Start Function

The soft start function adjusts progressive speed reference input inside the Servodrive so that acceleration and deceleration can be as constant as possible. To use this function, set the following parameters.

Para. No.	Name	Unit	Setting range	default
Pn019	Soft Start Time (Acceleration)	ms	0~10000	0
Pn020	Soft Start Time (Deceleration)	ms	0~10000	0

■ Pn019: Time interval from stop time and the motor speed reaches to 1000r/min

■ Pn020: Time interval from the time the motor is running at the maximum speed until it stops

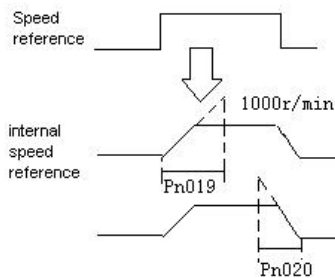

In the SERVODRIVE, a speed reference is multiplied by the acceleration or deceleration value to provide speed control.

Smooth speed control can be achieved when progressive speed references are input or when contact input speed control is used. Normally, set these to "0".

## 4.6.3 Setting the Torque Reference Filter Time Constant

If the machine causes vibration, possibly resulting from the servo drive, adjust the following filter time constant.

Vibration may stop.

Para.	Name	Unit	Setting range	Default
Pn018	Torque Reference Filter Time Constant	0.1ms	0~250	4

With the standard setting, the machine may cause vibration resulting from the servodrive. In this case, increase the constant setting. Vibration may stop. Vibration can be caused by incorrect gain adjustment, machine problems and so on

## 4.7 Minimizing Positioning Time

### 4.7.1 Setting Servo Gain

#### ■ Setting Speed Loop

Para.	Name	Unit	Setting range	Default
Pn013	Speed Loop Gain (Kv)	Hz	1~2500	180
Pn014	Speed Loop Integration Time Constant (Ti)	ms	1~5120	100

Pn-013 and Pn-014 are a speed loop gain and an integration time constant for the Servodrive, respectively.

The higher the speed loop gains value or the smaller the speed loop integration time constant value, the higher the speed control response. There is, however, a certain limit depending on machine characteristics.

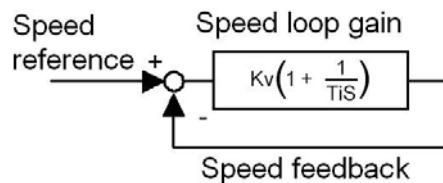

#### ■ Setting Position Loop

Set the following parameters related to position loop as necessary.

Para.	Name	Unit	Setting range	Default
Pn015	Position Loop Gain (Kp)	1/s	1~1000	40

Increasing the position loop gain value provides position control with higher response and less error. However, there is a certain limit depending on machine characteristics. This gain is also valid for zero clamp operation.

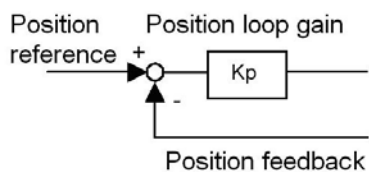

The gain is also valid in zero-clamp in EDB series servodrives.

Para.	Name	Unit	Setting range	Default
Pn036	Overflow	256 References	1 ~ 32767	1024

Set in this parameter the error pulse level at which a position error pulse overflow alarm (alarm A.06) is detected.

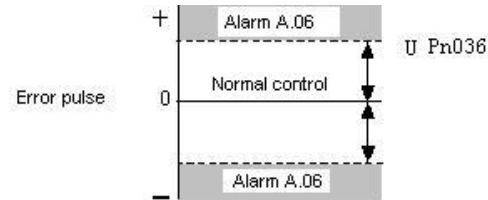

If the machine permits only a small position loop gain value to be set in Pn-036, an overflow alarm(A.06) may arise during high-speed operation.

### ■ Using Feed-forward Control

Feed-forward control shortens positioning time. To use feed-forward control, set the following parameter.

Para.	Name	Unit	Setting range	Default
<b>Pn036</b>	Feed-forward Gain	1%	0 ~ 100	80

Use this parameter to shorten positioning time. Too high a value may cause the machine to vibrate. For ordinary machines, set 80% or less in this constant.

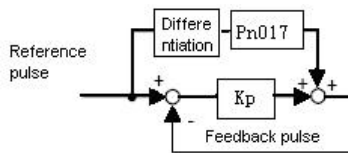

## 4.7.2 Using Proportional Control

If parameter Pn041 is set to 0 or 1 as shown below, input signal /P-CON serves as a PI/P control changeover switch.

■ PI Control: Proportional/Integral control

■ P Control: Proportional control

Pn041	Control mode
-------	--------------

0	<p><b>Speed control ( analog reference )</b></p> <p>normal speed control</p> <ul style="list-style-type: none"> <li>• V-REF(1CN-19) input speed reference</li> <li>• Signal /P-CON (CN1-11) is used to switch between P control and PI control.</li> </ul> <p>1CN-11 : OFF PI control ON P control</p>	
1	<p><b>Position control ( pulse train reference )</b></p> <p>Normal speed control</p> <p>/P-CON ( CN1-11 ) is used to switch between P control and PI control.</p> <p>CN1-11 : ON“L” level P control OFF“H” level PI control</p>	

### How To Use Proportional Control

Proportional control can be used in the following two ways.

- When operation is performed by sending speed references from the host controller to the Servodrive, the host controller can selectively use P control mode for particular conditions only. This method can prevent the occurrence of overshoot and also shorten settling time.
- If PI control mode is used when the speed reference has a reference offset, the motor may rotate at a very slow speed and fail to stop even if 0 is specified as a speed reference. In this case, use P control mode to stop the motor.

## 4.7.3 Setting Speed Bias

The settling time for positioning can be reduced by assigning bias to the speed reference output part in the Servodrive. To assign bias, use the following constant.

Para.	Name	Unit	Setting range	Default
Pn016	Speed bias	R/min	0~300	0

This parameter is set to assign an offset to a speed reference in the Servodrive. (In position control mode)

Use this constant to reduce the settling time.

Set this parameter according to machine conditions.

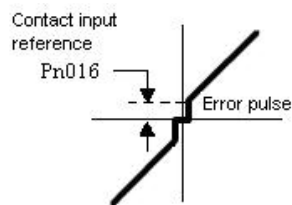

---

## Chapter 5

---

# Using the digital operator

## 5.1 Basic operator

### 5.1.1 Digital Operator Functions

The Digital Operator allows the user to set parameters, send commands, and display operating status. This section describes the key names and functions of the Digital Operator in the initial display status.

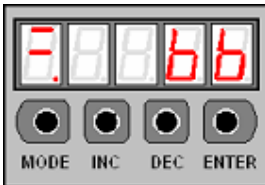

Name	Function
INC key	Press to display the parameter settings and set values. Press INC key to increment the set value
DEC key	Press DEC key to decrement the set value.
MODE key	Press to select the status display mode, setting mode, monitor mode, or error traceback mode. Press to cancel setting when set the parameters.
ENTER key	Press to display the parameter settings and set values.

### 5.1.2 Resetting Servo Alarms

Press ENTER key to reset servo alarm in state monitor mode

The alarm state could also be cleared by using 1CN-14(/ALM-RST) input signal.

The alarm state can be cleared by turning the main power supply OFF, then turning the control power supply OFF.

---

**Note:**

After an alarm occurs, remove the cause of the alarm before resetting it.

---

---

### 5.1.3 Basic Functions and Mode Selection

Digital Operator operation allows status display, parameter setting, operating reference, and auto-tuning operations.

#### Basic Mode Selection

The four basic modes are listed below. Each time the mode key is pressed, the next mode in the sequence is selected.

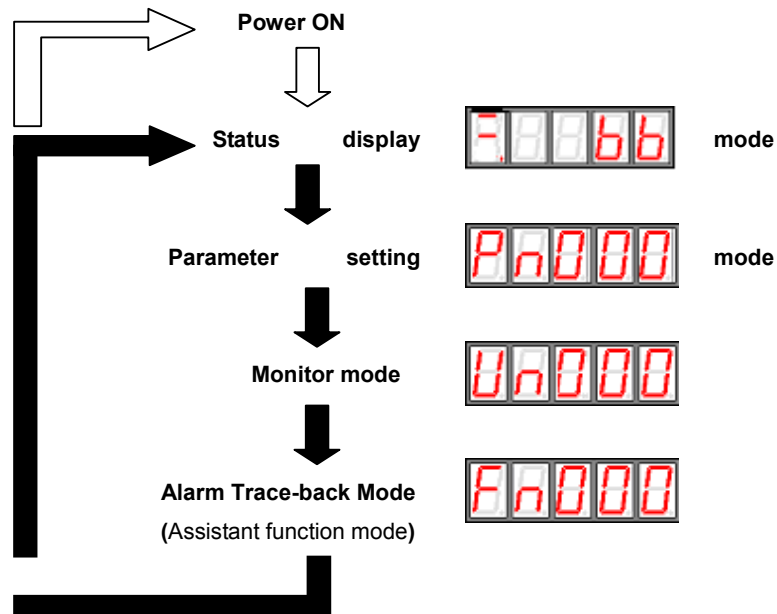

### 5.1.4 Operation in Status Display Mode

The status display mode displays the Servodrive status as bit data and codes.

#### ■ Selecting Status Display Mode

The status display mode is displayed when the power is turned ON. If the status display mode is not displayed, select the mode by using Mode Key to switch.

#### ■ Keys to the status display are shown below.

The display varies in different modes.

**For Speed and torque Control**

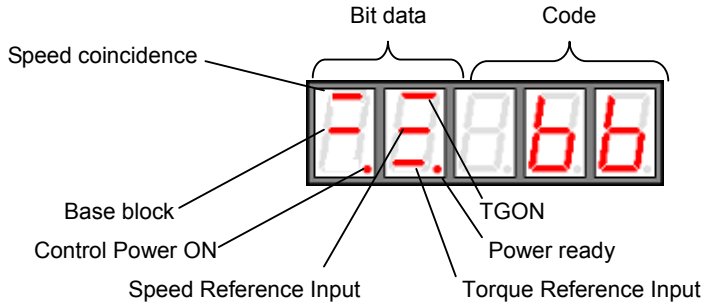

\* It is highlighted when in torque control mode.

**Bit displays**

Bit Data	Descriptions
Control Power ON	Lit when SERVODRIVE control power ON.
Base Block	Lit for base block. Not lit at servo ON.
Speed Coincidence	Lit if motor speed reaches speed reference. Otherwise, not lit. Preset value: Set in Pn034 (10 min <sup>-1</sup> is default setting)
/TGON	Lit if motor speed exceeds preset value. Not lit if motor speed is below preset value Preset value: Set in Pn032 (20 min <sup>-1</sup> is default setting)
Speed Reference Input	Lit if input speed reference exceeds preset value. Not lit if input speed reference is below preset value. Specified value: Set in Pn032 (20 min <sup>-1</sup> is default setting)
Torque Reference Input	Lit if input torque reference exceeds preset value. Not lit if input torque reference is below preset value. Preset value: 10% rated torque is standard setting
Power Ready	Lit when main power supply circuit is normal. Not lit when power is OFF or main power supply circuit is faulty.

**Code displays**

Code	Description
000	Base block Servo OFF (motor power OFF)
00n	Run Servo ON (motor power ON)
P0E	Forward Rotation Prohibited (P-OT) 1CN-12 (P-OT) OFF.
n0E	Reverse Rotation Prohibited (N-OT) 1CN-13 (N-OT) OFF.
R01	Alarm Status Displays the alarm number.

**For position control**

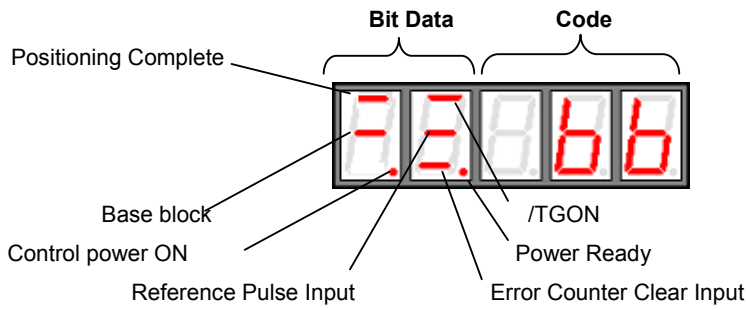

**Bit data displays**

Bit data	Description
Control Power ON	Lit when Servodrive control power ON.
Base Block	Lit for base block. Not lit at servo ON.
Positioning Complete	Lit if error between position reference and actual motor position is below preset value. Preset value: Set in Pn035(10 pulse is standard setting)
/TGON	Lit if motor speed exceeds preset value. Not lit if motor speed is below preset value. Preset value: Set in Pn032 (20 min <sup>-1</sup> is standard setting)
Reference Pulse Input	Lit if reference pulse is input Not lit if no reference pulse is input.
Error Counter Clear Input	Lit when error counter clear signal is input. Not lit when error counter clear signal is not input.
Power Ready	Lit when main power supply circuit is normal. Not lit when power is OFF or main power supply circuit is faulty.

**Code displays**

Code	Description
8bb	Base block Servo OFF (power OFF)
run	Run Servo ON (power ON)
Pot	Forward Rotation Prohibited 1CN-12 (P-OT) OFF.
not	Reverse Rotation Prohibited 1CN-13 (N-OT) OFF
AOI	Alarm Status Displays the alarm number.

---

## 5.1.5 Operation in Parameter Setting Mode

Select or adjust the functions by setting parameters. The parameter list is in the appendix.

■ Parameter changing procedures are described below:

The constant settings allow setting of a constant. Check the permitted range of the constant in Appendix List of Parameters, before changing the data. The example below shows how to change user setting Pn012 100 to 85.

1. Press MODE to select parameter setting mode.

A four-digit red LED display showing the text "Pn000".

2. Press INC key or DEC key to select parameter number.

A four-digit red LED display showing the text "Pn012".

3. Press ENTER key to display parameter data in step 2.

A four-digit red LED display showing the value "00100".

4. Press INC or DEC to change the data to the desired number 00085. Hold the button to accelerate the change of value. When the data reaches the max. or Min., the value will remain unchanged, if press INC/DEC.

A four-digit red LED display showing the value "00085".

5. Press ENTER to store the value.

A four-digit red LED display showing the value "00085". Each digit is enclosed in a square frame with diagonal lines extending from the corners, indicating that the value has been successfully stored.

6. Press ENTER again to go back to parameter display.

A four-digit red LED display showing the text "Pn012", indicating that the parameter selection screen has been returned to.

## 5.1.6 Operation in Monitor Mode

The monitor mode allows the reference values input into the SERVODRIVE, I/O signal status, and Servodrive internal status to be monitored.

The monitor mode can be set during motor operation.

### ■ Using the Monitor Mode

The example below shows how to display 1500, the contents of monitor number Un-001.

1. Press MODE to select monitor mode.

A four-digit red LED display showing the text "Un0000".

2. Press INC key or DEC key to select the monitor number to display.

A four-digit red LED display showing the text "Un0001".

3 . Press ENTER to display the data for the monitor number selected at step 2.



4 . Press ENTER once more to display the monitor number.



5 . Above is the procedure for display 1500 in monitor number Un001

### Monitor Mode Displays

Monitor number	Content
Un000	Actual motor speed Units: r/min
Un001	Input speed reference Units: r/min
Un002	Input torque reference Units:% (with respect to rated torque)
Un003	Internal torque reference Units:% (with respect to rated torque)
Un004	Number of pulses of Encoder angles
Un005	Input signal monitor
Un006	Encoder signal monitor
Un007	input signal monitor
Un008	Speed given by pulse (when gear ratio is 1:1)
Un009	Current position (*1 reference pulse)
Un010	Current position (*10000 reference pulse)
Un011	Error pulse counter lower 16 digit
Un012	Error pulse counter higher 16 digit
Un013	Received pulse counter lower digit
Un014	Received pulse counter high digit (x10 <sup>4</sup> )

internal status bit display



Note: 1. the current setting is (Un010\*10000+Un009) reference pulse

2. When Un011 between -9999 and 9999, Un011 displays as algorithm. Otherwise, it displays as hex.

3. Received pulse number displays as algorithm(Un014x10<sup>4</sup>+Un013). When it reaches 99999999, it shall not be able to increase anymore.

### Bit data

Monitor No.	Bit No.	Content	Related I/O Signal, Parameter
Un005	0	/S-ON input	1CN-10(/S-ON)
	1	/PCON input	1CN-11(/PCON)
	2	P-OT input	1CN-12(P-OT)
	3	N-OT input	1CN-13(N-OT)
	4	/ALM-RST input	1CN-14(/ALMRST)
	5	/CLR input	1CN-15(/CLR)
	6	/PCL input	1CN-16(/PCL)

	7	/NCL input	1CN-17(/NCL)
--	---	------------	--------------

Monitor No.	Bit No.	Content	Related I/O Signal, Parameter
Un006	0	W-phase	2CN-15(PW) , 2CN-16(/PW)
	1	V-phase	2CN-13(PV) , 2CN-14(/PV)
	2	U-phase	2CN-11(PU) , 2CN-12(/PU)
	3	C-phase	2CN-5(PC) , 2CN-6(/PC)
	4	B-phase	2CN-3(PB) , 2CN-4(/PB)
	5	A-phase	2CN-1(PA) , 2CN-2(/PA)
	6	( not used )	
	7	( not used )	

Monitor No	Bit No.	Content	Related I/O Signal, Parameter
Un007	0	ALM	1CN-3(ALM-) , 1CN-4(ALM+)
	1	Pn054 preset status	1CN-1 , 1CN-2
	2	Pn055 preset status	1CN-5 , 1CN-6
	3	Pn053 preset status	1CN-7 , 1CN-8

## Operation Using the Digital Operator

If it is in the assistant function mode, some operations could be select in digital operator. The detailed functions are shown as below:

Function No.	Content
Fn000	Display historical alarm data
Fn001	Turn to default value
Fn002	JOG mode
Fn003	Set speed reference offset automatically
Fn004	Set speed reference manually
Fn005	automatically adjustment of offset detected by motor current
Fn006	Manually adjustment of offset detected by motor current
Fn007	Servo software version display

---

## 5.2.1 Alarm Trace-back Data

In alarm trace-back data, latest ten times alarms could be displayed.

The following shows the procedure to display the historical record.

1. Press MODE to select assistant function mode
2. Press INC or DEC to select function number of alarm historical record.



3. Press ENTER to display the latest alarm code.

Alarm number    alarm code

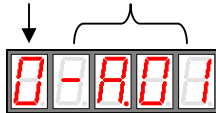

4. Press INC or DEC to display other recent occurred alarm code.

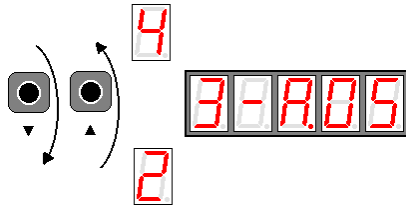

5. Press ENTER to return to function number display.



If the user wants to clear all the record, just hold ENTER for one second, then all the historical data will be deleted.



## 5.2.2 Operation of recovering to default value

The follows are procedures to recovery of default value.

1. Press MODE to select assistant mode.
2. Press INC or DEC to select function number of recovering to default value



3. Press ENTER to enter parameter default recovery mode.



4. Hold ENTER key for one second to recover the parameter to default setting.



5. Release ENTER key to return to function number display.



### 5.2.3 Operation in JOG mode

The following is steps in JOG mode

- 1 . Press MODE to select assistant mode.
- 2 . Press INC or DEC to select Function number of JOG mode.



- 3 . Press ENTER to enter JOG mode.



- 4 . Press MODE to enter Servo ON (motor ON) status.



- 5 . Press MODE to switch between servo ON and Servo OFF. If motor running is required, servo must be ON.
- 6 . Press INC or DEC (motor runs when press the keys.)

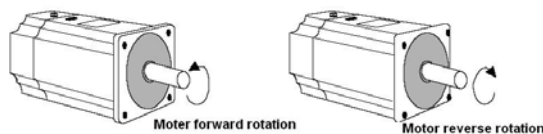

- 7 . Press ENTER to return to function number display.(Servo is OFF)



### 5.2.4 Reference Offset Automatic Adjustment

The motor may rotate slowly when the reference voltage is intended to be 0 V. This occurs when the host controller or external circuit has a small offset (measured in mV) in the reference voltage.

The reference offset automatic adjustment mode automatically measures the offset and adjusts the reference voltage. It adjusts both speed and torque references.

The following diagram illustrates automatic adjustment of an offset in the reference voltage from the host controller or external circuit.

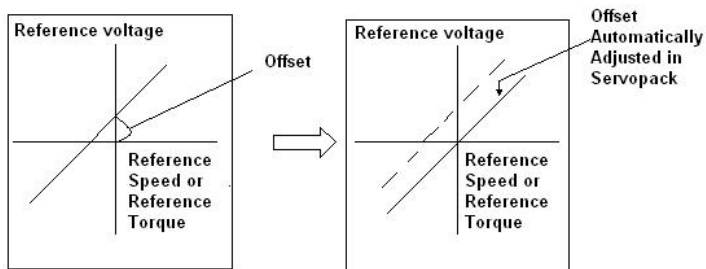

After completion of offset automatic adjustment, the amount of offset is stored in the Servodrive.

The amount of offset can be checked in the speed reference offset manual adjustment mode. Refer to Reference Offset Manual Adjustment Mode for details

The reference offset automatic adjustment mode cannot be used where a position loop is formed with the host controller and the error pulses are zeroed when servo lock is stopped.

In this case, use the speed reference offset manual adjustment mode. Refer to Reference Offset Manual Adjustment Mode for details.

Zero-clamp speed control is available to force the motor to stop during zero speed reference. Refer to Using Zero-Clamp for details.

Follow the procedure below to automatically adjust the reference offset:

1. Input the (intended) 0 V reference voltage from the host controller or external circuit.

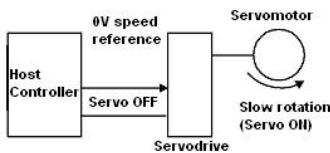

2. Press Mode to select assistant function mode.
3. Press INC or DEC key to select function number of speed reference offset.



4. Press ENTER to enter mode that automatically adjust the reference offset.



5. Press MODE. When the flashing lasts for one minute, the speed offset is adjusted automatically.



6. Press ENTER to return to function number display



7. This is the end of reference offset automatic adjustment.

## 5.2.5 Reference Offset Manual Adjustment Mode

Speed reference offset manual adjustment is very convenient in the following situations:

- If a loop is formed with the host controller and the error is zeroed when servo lock is stopped.
- To deliberately set the offset to some value.

Offset Adjustment Range and Setting Units are as follows:

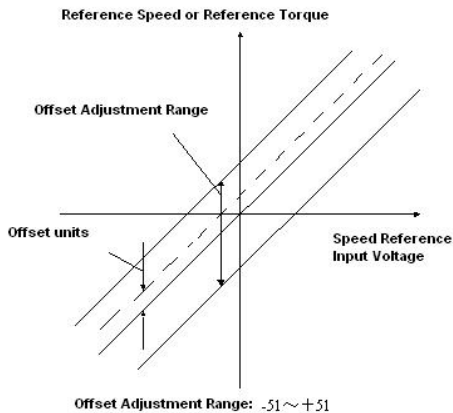

The following is procedures of adjusting reference offset manually.

- 1 . Press MODE to select assistant function mode.
- 2 . Press INC or DEC to select reference offset manual adjustment function number



- 3 . Select ON signal ( /S-ON ) ON, it displays as follows



- 4 . Press ENTER key for a second to display speed reference offset



- 5 . Press INC or DEC to adjust the offset.
- 6 . Press ENTER for a second to display the interface on step 4.
- 7 . Press ENTER again to go back to function display.



This ends the procedure.

## 5.2.6 Motor Current Detection Offset Adjustment

Current detection offset adjustment is performed at Anaheim Automation before shipping. Basically, the customer need not perform this adjustment. Perform this adjustment only if highly accurate adjustment is required when the Digital Operator is combined with a specific motor.

This section will describe the operation of automatic offset and manual offset.

### Note:

Current detection offset manual adjustment could only be performed when the Servo is OFF.

Any accidentally activation of this function especially the manual adjustment, deteriorated situations might occur.

If the torque pulse is obviously too high compared with other Servodrives. Please adjust the offset

---

automatically.

---

■ **motor current detection offset automatic adjustment**

Follow the procedure below to perform current detection offset automatic adjustment

1. Press MODE key to select assistant function mode.
2. Press INC key or DEC key to select function number of motor current detection offset automatic adjustment.



3. Press ENTER to enter motor current detection offset automatic adjustment.



4. Press MODE key and the adjustment will be finished after it flashes for a second.

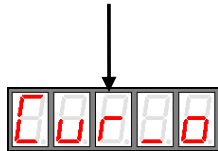
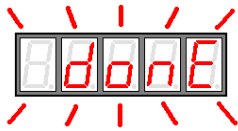

5. Press ENTER to return function number display.



This ends the operation of adjusting the motor current detection offset automatic adjustment

■ **motor current detection offset manual adjustment**

Follow the procedure below to perform current detection offset manual adjustment

1. Press MODE key and select assistant function mode.
2. Press INC key or DEC key to select function number of motor current detection offset manual adjustment.



3. Press ENTER key to enter into motor current detection offset manual adjustment.



4. Press MODE key to switch U phase ( Cu1\_o ) and V phase ( Cu2\_o ) current detection offset adjustment mode.



5. Hold ENTER key for a second, current phase current detection data will be displayed.



6. Press INC key or DEC key to adjust the offset.



---

7 . Hold ENTER key for a second to return the display of step 3 or step 4.

8 . Press ENTER again to go back to function number display.



This ends the operation of the motor current detection offset manual adjustment

---

**Note:**

motor current detection offset manual adjustment range:-102~+102。

---

---

## 5.2.7 Checking Software Version

Use the following procedure to check the software version.

1. Press MODE key and select assistant function mode.
2. Press INC key or DEC to select the function number for servo software version.



3. Press ENTER to display software version(D is displayed at the highest position)

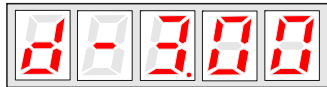

4. Press Mode key to display FPGA/CPLD software version(P is displayed at the highest position)



5. Reprress Mode key and switch back to display the DSP software version
6. Press ENTER key to return to display the function number

# Communication functions

## 6.1 RS-485、RS-232、RS-422 Communication hardware interface

EDB-A Servo drives have RS-485、RS-232、RS-422 communication functions. With the help of these functions, it can achieve reference modification and monitor servo drive status etc., However, RS-485, RS-232 and RS-422 can not be applied at the same time. It's selective for RS-485/RS-232/RS-422 through the options of parameter Pn213. The instruction as follows:

### RS-232

It's a must to use Anaheim Automation special RS232 cable of BST-CC24.

Instructions:

The cable length is less than 15 meters when in a less disturbed environment. However, if transmission speed is above 38.4Kbps, it's strongly recommended that the cable length is less than 3 meters to ensure the accuracy of transmission.

### RS-485、RS422

Communication cable wiring diagram:

## RS-485

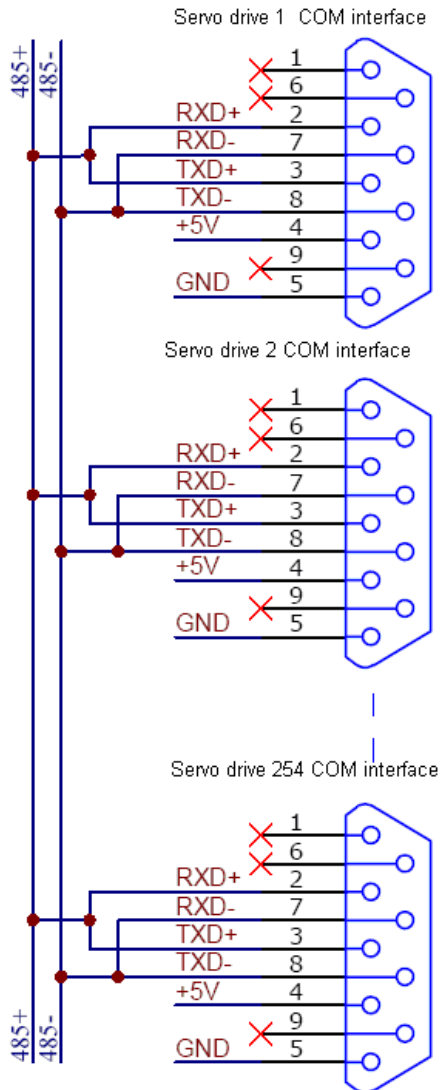

## RS-422

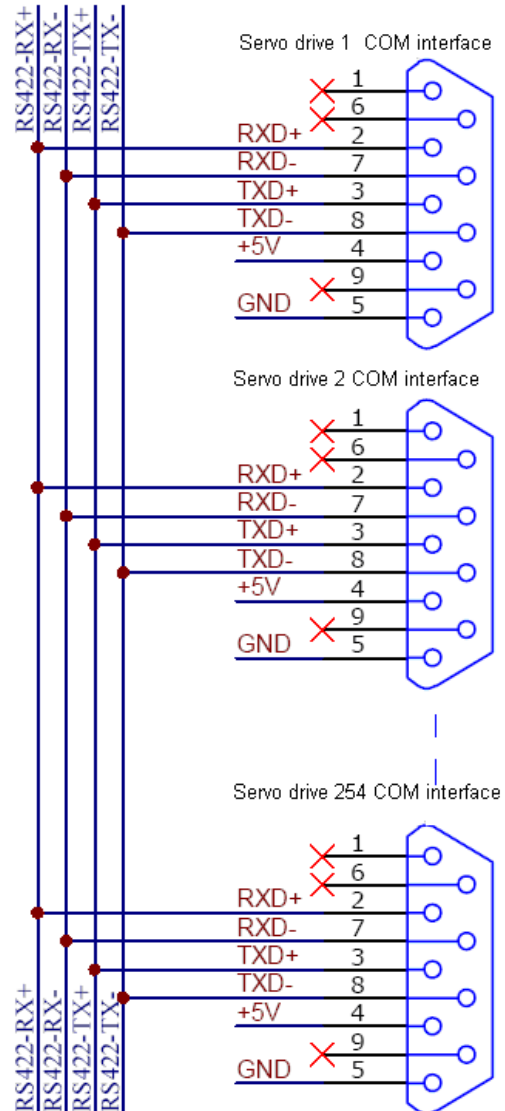

### Instructions:

1. The cable length is less than 100 meters when in a less disturbed environment. However, if transmission speed is above 38.4Kbps, it's strongly recommended that the cable length is less than 15 meters to ensure the accuracy of transmission.

2. It's available for up to 32 PCS servo drives to work together when RS422 or RS485 is applied. In case more servo drives control needed, relay stations are required.

## 6.2 RS-485、RS-232、RS-422 communication parameter

Para. No.	Name and description	Unit	Range	Default value
Pn210	Communication address setting	---	1~255	1

---

	Communication speed options:			
	0 : 4800bps			
Pn211	1 : 9600 bps	----	0~2	1
	2 : 19200bps			
	Communication protocol form:			
	0 : 7 , N , 2 ( Modbus,ASCII )			
	1 : 7 , E , 1 ( Modbus,ASCII )			
	2 : 7 , O , 1 ( Modbus,ASCII )			
	3 : 8 , N , 2 ( Modbus,ASCII )			
Pn212	4 : 8 , E , 1 ( Modbus,ASCII )	----	0~8	5
	5 : 8 , O , 1 ( Modbus,ASCII )			
	6 : 8 , N , 2 ( Modbus,RTU )			
	7 : 8 , E , 1 ( Modbus,RTU )			
	8 : 8 , O , 1 ( Modbus,RTU )			
	Communication protocol options:			
	0 : Self-definition protocol RS-232 Communication			
Pn213	1 : MODBUS Protocol RS-422/232 Communication	----	0~2	2
	2 : MODBUS Protocol RS-485 Communication			
Pn214	Not Used			
Pn215	Not Used			
	Communication bit control:			
	This parameter is designated through bit to decide input source of digital input port. Bit0~bit7 represent input port			
Pn216	0~7 respectively. Bit definition represents as follows:	----	0~255	0
	0 : input bit is controled by outside interface			
	1 : input bit is controled by communication.			

**Note:**

1. After change the communication address through communication (that is to say, after change the

---

---

value of Parameter Pn210), the servo drive will still response data with previous communication address. It takes 40ms for the servo drive to change into new communication adress.

2. After change the communication speed through communication (that is to say, after change the value of Parameter Pn211), the servo drive will still response data with previous communication speed. It takes 40ms for the servo drive to change into new communication adress.

3. After change the communication protocol through communication (that is to say, after change the value of Parameter Pn212), the servo drive will still response data with previous communication protocol. It takes 40ms for the servo drive to change into new communication adress.

4. If change the communication parameter (Pn210~Pn212) through key boards of the panel, turn off the power before turn on it again to enable the change effective.

---

## 6.3 MODBUS communication protocol

Only when Pn213 is set as 1 or 2 can communication be put into operation with MODBUS protocol. There are two modes for MODBUS communication. They are ASCII( American Standard Code for information interchange )mode or RTU ( Remote Terminal Unit ) mode.

The brief introduction as follows:

### 6.3.1 Code meaning

#### ASCII mode :

Every 8-bit datum is consisted by two ASCII characters. For instance: One 1-byte datum 64<sub>h</sub> ( Hex expression ) is expressed as ASCII code '64'. It contains '6'as ASCII code ( 36<sub>h</sub> ) and '4'as ASCII code ( 34<sub>h</sub> ) .

ASCII code for Number 0 to 9、 character A to F are as follows:

Number	'0'	'1'	'2'	'3'	'4'	'5'	'6'	'7'
Relevant ASCII code	30 <sub>h</sub>	31 <sub>h</sub>	32 <sub>h</sub>	33 <sub>h</sub>	34 <sub>h</sub>	35 <sub>h</sub>	36 <sub>h</sub>	37 <sub>h</sub>
Character	'8'	'9'	'A'	'B'	'C'	'D'	'E'	'F'
Relevant ASCIIcode	38 <sub>h</sub>	39 <sub>h</sub>	41 <sub>h</sub>	42 <sub>h</sub>	43 <sub>h</sub>	44 <sub>h</sub>	45 <sub>h</sub>	46 <sub>h</sub>

#### RTU mode :

Every 8-bit datum is consisted by two 4-bit hex datum. That is to say, a normal hex number. For instance: algorism 100

can be expressed into 1-byte RTU datum as 64<sub>h</sub>.

Datum structure:

**10bit character form ( apply in 7-bit datum )**

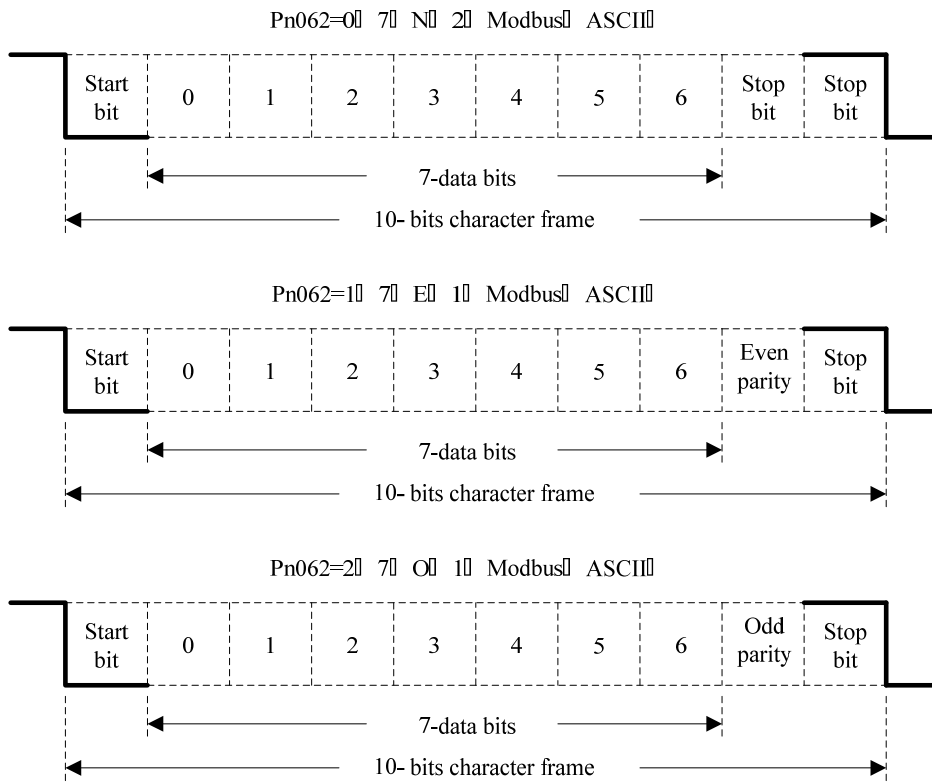

**11bit character form ( apply in 8-bit datum )**

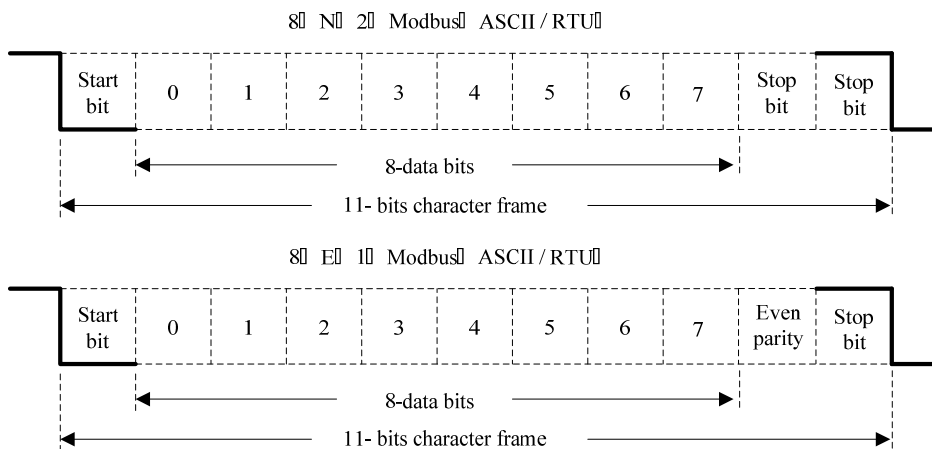

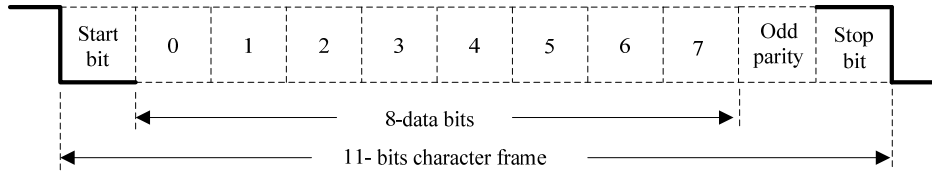

Communication protocol structure:

Communication protocol datum structure:

**ASCII mode :**

STX	Start character ' ' = > (3A <sub>h</sub> )
ADR	Communication address = > 1-byte contains 2 ASCII codes
CMD	Instruction code = > 1-byte contains 2 ASCII codes
DATA(n-1)	Datum content = > n-word=2n-byte contain n ASCII codes , n<12
.....	
DATA(0)	
LRC	Verifying code = > 1-byte contains 2 ASCII codes
End 1	End code 1 = > ( 0D <sub>h</sub> ) ( CR )
End 0	End code 0 = > ( 0A <sub>h</sub> ) ( LF )

---

**RTU Mode:**

STX	Sleep interval(no pulse) of transmission time which equals to four bytes at present transmission speed.
ADR	Communication address = > 1-byte
CMD	Instruction code = > 1-byte
DATA(n-1)	Datum content = > n-word=2n-byte , n < 12
.....	
DATA(0)	
CRC	CRC Verifying code = > 1-byte
End 1	Sleep interval(no pulse) of transmission time which equals to four bytes at present transmission speed.

Communication protocol datum structure instruction as follows:

**STX ( communication start )**

ASCII mode : ' ' character.

RTU mode: Sleep interval(no pulse) of transmission time which equals to four bytes at present transmission speed.

**ADR ( communication address )**

Acceptable communication addresses range from 1 to 254.

For instance, to communicate with servo address as 32 ( hex as 20 ) :

ASCII mode : ADR='2','0'=>'2'=32<sub>h</sub> , '0'=30<sub>h</sub>

RTU mode : ADR=20<sub>h</sub>

**CMD ( order instruction ) and DATA ( datum )**

Datum structure is formed by order code. Regular order code as follows:

Order code: 03<sub>h</sub> , read N words , N is not more than 20.

For instance: read 2 words from address 0200<sub>h</sub> from servo addressed at 01<sub>h</sub>.

**ASCII mode :**

Order information:

STX	‘;’
ADR	‘0’
	‘1’
CMD	‘0’
	‘3’
data start address	‘0’
	‘2’
	‘0’
	‘0’
data number (count as Word)	‘0’
	‘0’
	‘0’
	‘2’
LRC Verifying	‘F’
	‘8’
End 1	(0DH)(CR)
End 0	(0AH)(LF)

response information:

STX	‘;’
ADR	‘0’
	‘1’
CMD	‘0’
	‘3’
Data number (count as byte)	‘0’
	‘4’
Data start address Content of 0200H	‘0’
	‘0’
	‘B’
	‘1’
Second data start address Content of 0201H	‘1’
	‘F’
	‘4’
	‘0’
LRC Verifying	‘E’
	‘8’
End 1	(0DH)(CR)
End 0	(0AH)(LF)

**RTU mode:**

Order information:

ADR	01H
CMD	03H
Data start address	02H( high bits )
	00H(low bits )
Data number Count as Word	00H
	02H
CRC verifying	C5H(low bits )
CRC verifying	B3H(high bits )

Response information:

ADR	01H
CMD	03H
data number count as word	04H
data start address, content of 0200H	00H( high bits )
	B1H(low bits )
second data address, content of 0201H	1FH(high bits )
	40H(low bits )
CRC verifying	A3H(low bits )
CRC verifying	D3H(high bits )

Order code: 06<sub>h</sub> , write in one character ( word )

For instance: write 100 ( 0064<sub>h</sub> ) in address 0200<sub>h</sub> of servo addressed 01<sub>h</sub>.

**ASCII mode :**

Order information:

STX	‘;’
ADR	‘0’
	‘1’
CMD	‘0’
	‘6’
datum start address	‘0’
	‘2’
	‘0’
	‘0’
datum content	‘0’
	‘0’
	‘6’
	‘4’
LRC verifying	‘9’
	‘3’
End 1	(0DH)(CR)
End 0	(0AH)(LF)

Response information:

STX	‘;’
ADR	‘0’
	‘1’
CMD	‘0’
	‘6’
datum address	‘0’
	‘2’
	‘0’
	‘0’
datum address, content of 0200H	‘0’
	‘0’
	‘6’
	‘4’
LRC verifying	‘9’
	‘3’
End 1	(0DH)(CR)
End 0	(0AH)(LF)

RTU mode:

Order information:

ADR	01H
CMD	06H
datum start address	02H(high bits )
	00H(low bits )
datum content	00H(high bits )
	64H(low bits )
CRC verifying	89H( low bits )
CRC verifying	99H( high bits )

Response information:

ADR	01H
CMD	06H
datum start address	02H(high bits )
	00H(low bits )
datum content	00H(high bits )
	64H(low bits )
CRC verifying	89H( low bits )
CRC verifying	99H( high bits )

### 6.3.2 Communication fault disposal

While communication, faults may occur. Normal faults as follows:

- While read/write parameter, datum address is wrong;
- While write in parameter, the datum exceeds the maximum value of this parameter or is less than the minimum value of this parameter;
- Communication is disturbed, datum transmission fault or verifying code fault;

When above mentioned communication faults occur, servo drive running won't be affected. Meanwhile, servo drive will feed back a faulty frame.

The faulty frame form as follows:

**Host controller datum frame:**

start	Servo drive address	instruction	Datum address, data	verifying

**Servo drive feedback fault frame:**

start	Servo drive address	Response code	Fault code	verifying

Thereinto:

Fault frame response code=order+80<sub>h</sub>;

Fault code = 00<sub>h</sub> : communication in gear;

= 01<sub>h</sub> : servo drive cannot identify the required functions;

= 02<sub>h</sub> : the required address do not exist in the servo drive;

= 03<sub>h</sub> : the required datum in the servo is not workable. (beyond maximum or minimum value of the parameter);

= 04<sub>h</sub> : servo drive starts to execute the requirement, but cannot achieve it;

For instance: servo drive addressed at 03<sub>h</sub>, write in 06<sub>h</sub> into parameter Pn002, however, because both the maximum and minimum value of parameter Pn002 are zero, therefore the datum will not be adapted, servo drive will return a fault frame. The fault code is 03. Frame is as follows:

**Host controller datum frame:**

start	Servo drive address	instruction	Datum address, data	verifying
	03 <sub>h</sub>	06 <sub>h</sub>	0002 <sub>h</sub> 0006 <sub>h</sub>	

**Servo drive feedback fault frame:**

start	Servo drive address	Response code	Fault code	verifying
	03 <sub>h</sub>	86 <sub>h</sub>	03 <sub>h</sub>	

Besides, if the datum from host controller indicated servo drives address as 00<sub>h</sub>, it represents this datum is broadcasting datum, servo drives will not return any frames.

### 6.3.3 Servo state data communication address

Please refer to the following list for all of communication parameter address of this servo:

Communication datum address(hex)	meaning	instruction	operation
0 ~ 00DE <sub>h</sub>	Parameter area	Relevant to parameter in the parameter list	Read-write
07F1 <sub>h</sub> ~ 07FA <sub>h</sub>	Alarm information memory area	10 previous alarms	Read only
07FB <sub>h</sub>	Speed instruction zero offset		Read-write
07FC <sub>h</sub>	Torque instruction zero offset		Read-write
07FD <sub>h</sub>	Iu zero offset		Read only
07FE <sub>h</sub>	Iv zero offset		Read only
0806 <sub>h</sub> ~ 0814 <sub>h</sub>	Monitor data ( in accordance to displayed data )		Read only
0806 <sub>h</sub>	Speed feedback	unit : r/min	Read only
0807 <sub>h</sub>	Input speed instruction value	unit : r/min	Read only
0808 <sub>h</sub>	Input torque instruction percentage	Relevant to rated torque	Read only
0809 <sub>h</sub>	Inside torque instruction percentage	Relevant to rated torque	Read only
080A <sub>h</sub>	Encoder rotation pulse number		Read only
080B <sub>h</sub>	Input signal state		Read only
080C <sub>h</sub>	Encoder signal state		Read only
080D <sub>h</sub>	Output signal state		Read only
080E <sub>h</sub>	Pulse setting		Read only
080F <sub>h</sub>	Present position low bits	Unit: 1instruction pulse	Read only
0810 <sub>h</sub>	present position high bits	Unit: 10000 instruction pulse	Read only
0811 <sub>h</sub>	Deviation pulse counter low 16 bits		Read only
0812 <sub>h</sub>	Deviation pulse counter high bits		Read only
0813 <sub>h</sub>	Setting pulse counter low bits	Unit: 1 instruction pulse	Read only
0814 <sub>h</sub>	Setting pulse counter high bits	Unit: 10000 instruction pulse	Read only
0817 <sub>h</sub>	current alarm		Read only
0900 <sub>h</sub>	ModBus communication IO	No conservation when	Read-write

	signal	power off	
0901 h	Drive state		Read only
0902 h	Relevant phase value		Read only
0903 h	Inertia inspection value		Read only
0904 h	drive running time	Unit as minute	Read only
090E h	DSP software edition	represent by number	Read only
090F h	PLD software edition	represent by number	Read only
1021 h	Eliminate previous alarm record	01 : eliminate	Read-write
1022 h	Eliminate present alarm	01 : eliminate	Read-write
1023 h	JOG servo on	01 : servo on 00 : doesn't use servo on	Read-write
1024 h	JOG forward rotation	01 : forward rotation 00 : stop	Read-write
1025 h	JOG reverse rotation	01 : reverse rotation 00 : stop	Read-write

**Instruction:**

**1、 parameter area ( communication address 0000 h ~ 00DE h )**

is relevant to parameters in the parameter list. For instance: parameter Pn000 is relevant to communication address 0000 h; parameter Pn101 is relevant to communication address 0065 h; read-write operation to address 0000 h is the read-write operation to Pn000. if the input datum is out of the parameter range, the datum shall be abnegated and servo drive will return an operation unsuccessful signal. If the parameter is modified successfully, the parameter shall be memorized when power off.

**2、 alarm information storage area ( 07F1 h ~ 07FA h )**

Previous alarm number	instruction	Communication address
0	Previous alarm record 1 ( the last alarm )	07F1 h
1		07F2 h
2		07F3 h
3		07F4 h
4		07F5 h
5		07F6 h
6		07F7 h

7		07F8 h
8		07F9 h
9	Previous alarm record 10 ( the oldest in time )	07FA h

### 3、 monitor data area ( 0806 h ~ 0814 h )

These monitor data are relevant to servo drive display panel Un000~Un014.

For instance: read address 0807 h (speed setting) through communication as FB16 h. therefore, the speed setting is-1258RPM.

### 4、 ModBus communication IO signal

Use communication to control input number IO signal. This datum won't be reserved after power off.

### 5、 drive state ( 0901 h )

This 1-word represents the current state of the system. Meaning of each bit as follows:

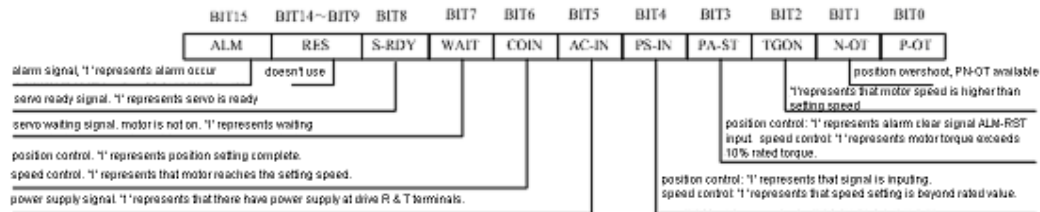

### 6、 software edition ( 090E h )

It represents drive's software edition by number. E.g. if the number is 0D300 h , it means the software edition is d-3.00.

## Chapter 7

# Technical Specifications and Features

## 7.1 Servomotor Technical specifications and Types

■ Technical specification and model

Servo drive model EDB-		08A	10A	15A	20A	30A	50A	
Basic data	Power supply	Three phase AC 200V $^{+10}_{-15}$ %,50/60Hz						
	Control mode	SVPWM						
	Feedback	incremental type encoder ( 2500P/R )						
	Working Conditio n	Operating/ storage temperature	0~55□/-20~85□					
		Operating/ storage humidity	Below 90%RH ( non-condensing )					
		Shock/vibration resistance	4.9m/s <sup>2</sup> /19.6 m/s <sup>2</sup>					
	Structure	Base mounted						
Speed control range	1:5000							
Speed								

control mode	Speed regulation	Load Regulation	0~100% : 0.01%以下(at rated speed)
		Voltage regulation	Rated speed $\pm 10\%$ : 0%(at rated speed)
		Temperature regulation	25 $\pm$ 25□ : below 0.1% (at rated speed)
	Frequency Characteristics		250Hz ( when $J_L \geq J_M$ )
Software startup time setting		0~10s (set acceleration and deceleration individually)	
Speed ref. input	Reference voltage	$\pm 10$ VDC	
	Input resistance	40K $\Omega$	
	Loop Time constant	47 $\mu$ s	
Node speed reference	Reverse rotation direction selection	Use P-CON signal	
	Speed selection	Use FWD/REV current limit signal(select speed 1~3), when both not OFF, select Stop or other control mode	
Position control mode	Reference Pulse	Type	SIGN + PULSE train, sin. Pulse phase A and phase B , CCW+CW pulse train
		Pulse Buffer	Line driving ( + 5V level ), open collector
		Pulse Frequency	Maxi. 500Kpps ( difference ) / 200 Kpps ( collector )
	Control signal		CLEAR
Offset setting		0~300r/min (set resolution as 1r/min)	
Feed forward compensation		0~100%(set resolution as 1%)	
In position error setting		0~500 reference unit(set resolution as 1 reference unit)	
I/O signals	Position output	Output signal	Phase A, phase B and phase C: line driving output
		Dividing ratio	(1~2500)/2500
	Sequence control input		Servo On, Proportional control or control mode switch, forward run prohibited, reverse run prohibited, alarm reset, FWD torque external limit, REV torque external limit, zero clamp signal
	Sequence control output		Servo Alarm, servo ready, positioning complete(speed coincidence), brake release, limiting torque, motor run detection
Built-in function	COM function		With RS232 interface for communication with host controller's special software, Parameter setting, Run operation and Status display can be done in Windows mode. Compatible with Modbus COM protocol and CANOpen protocol.

---

	LED display	Charge , Power, five 7-segment LEDs and 4 pushbuttons ( on handheld operator )
	Braking	Dynamic brake, overtravel protection
	Protection	Overcurrent, overload, overspeed, under voltage, overvoltage, encoder error, parameter error
	Regenerative treatment function	Built in regenerative resistance
	Other	Zero clamp ( with 16 internal position nodes)

# 7.2 Servo Drive Mounting dimension

■ EDB series servodrive mounting dimension

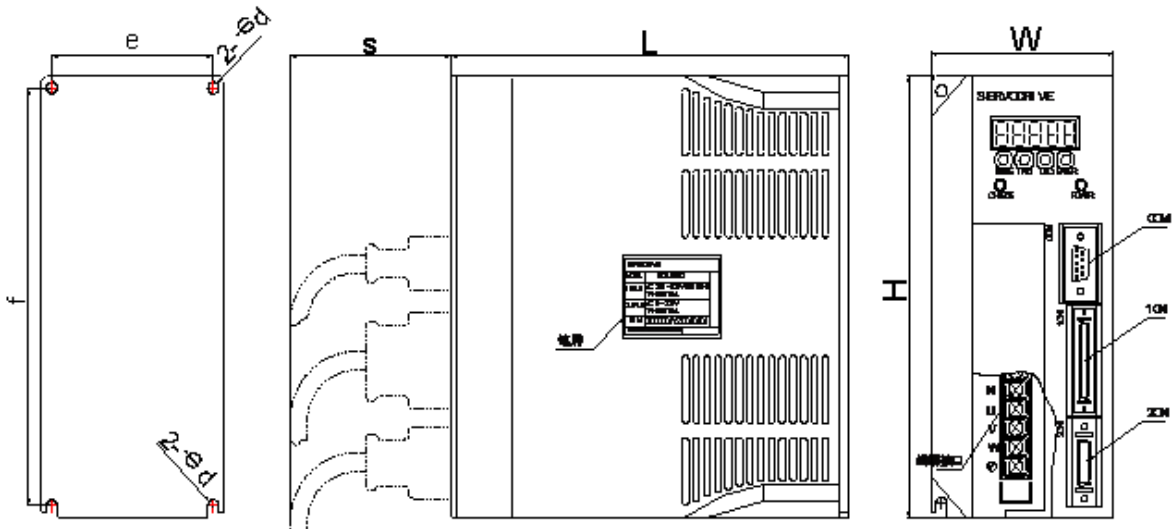

	L	W	H	s	e	f	d
EDB-08、EDB-10、EDB-15	185	85	187.5	75	75	177.5	5
EDB-20、EDB-30 EDB-50	207	123	270.5	75	111	258.5	6

# Appendix A

## Parameter list

Parameter	Name and description	Unit	Setting range	Default	remarks
Pn000	<p><b>Uses servo ON input signal ( /S-ON ) or not</b></p> <p>[0] Uses servo ON input (/S-ON). [1] Does not use servo ON input (/SON)</p>	—	0~1	0	□
Pn001	<p><b>Uses forward rotation prohibited input ( P-OT ) or not</b></p> <p>[0] Uses forward rotation prohibited input (P-OT). [1] Does not use forward rotation prohibited input (P-OT).</p>	—	0~1	0	□
Pn002	<p><b>Uses reverse rotation prohibited input signal ( N-OT ) or not</b></p> <p>[0] Uses reverse rotation input ( N-OT ) [1] Does not use reverse rotation prohibited input (N-OT).</p>	—	0~1	0	□
Pn003	<p><b>Operation performed at recovery from power loss</b></p> <p>[0] Resets servo alarm status at power recovery from its momentary power loss. ( ALM ) [1] Remains in servo alarm status at power recovery from momentary power loss. ( ALM )</p>	—	0~1	0	□
Pn004	<p><b>How to stop when Servo OFF or overtravel occurs</b></p> <p>[0] Stops the motor by applying dynamic brake (DB) and then release the brake [1] Coast to a stop [2] Performs DB when S-off; apply plug braking when overtravel,S-off after motor stops [3] Motor coasts to stop when S-off, apply plug braking when overtravel, S-off after motor stops</p>	—	0~5	0	□

Parameter	Name and description	Unit	Setting range	Default	remarks
	[4] Performs DB when S-off, apply plug braking when overtravel, zero clamp after motor stops [5] Motor coasts to stop when S-off, apply plug braking when overtravel ,zero clamp after motor stops				
Pn005	<b>if the error counter cleared when S-OFF</b> [0] clear the error counter when S-OFF [1]: does not clear the error counter when S-OFF	—	0~1	0	<input type="checkbox"/>
Pn006	<b>Rotation Direction Selection</b> [0] Forward rotation is defined as counterclockwise rotation when viewed from the drive end. (Standard setting) [1] Forward rotation is defined as clockwise rotation when viewed from the drive end. (Reverse rotation mode)	—	0~1	0	<input type="checkbox"/>
Pn007	<b>Doesn't or does use analog speed limit function</b> [0] Does not use analog speed limit function [1] Uses analog speed limit function	—	0~1	0	<input type="checkbox"/>
Pn008	<b>Reference pulse form</b> [0] Sign + Pulse [1] CW+CCW [2] A-phase + B-phase ( x1 multiplication ) [3] A-phase + B-phase ( x2 multiplication ) [4] A+B ( x4 multiplication)	—	0~4	0	<input type="checkbox"/>
Pn009	<b>Reference pulse form</b> [0] does not invert PULS reference pulse logic, does not invert SIGN reference pulse logic [1] does not invert PULS reference pulse logic, inverts SIGN reference pulse logic [2] inverts PULS reference pulse logic, does not invert SIGN reference pulse logic [3] inverts PULS reference pulse logic, inverts SIGN reference pulse logic	—	0~3	0	<input type="checkbox"/>
Pn010	uses analog current limit function or not [0] Does not use analog current limit function	—	0~1	0	<input type="checkbox"/>

Parameter	Name and description	Unit	Setting range	Default	remarks
	[1] Uses analog current limit function				
Pn011	use torque feed-forward function or not [0] Does not use torque feed-forward function [1] Uses torque feed-forward function	—	0~1	0	<input type="checkbox"/>
Pn012	Speed reference gain	(r/min)/V	0~2000	150	
Pn013	Speed loop gain	Hz	1~2000	16	
Pn014	Speed loop integration time constant	ms	1~5120	20	
Pn015	Position loop gain	1/s	1~1000	40	<input type="checkbox"/>
Pn016	Speed bias	r/min	0~300	0	
Pn017	Position feed forward	%	0~100	80	
Pn018	Torque reference filter time constant	0.1ms	0~250	4	
Pn019	Soft start accelerating time	ms	0~10000	0	<input type="checkbox"/>
Pn020	Soft start decelerating time	ms	0~10000	0	<input type="checkbox"/>
Pn021	PG dividing ratio	P/R	1~2500	2500	<input type="checkbox"/>
Pn022	Electronic gear A	—	1~65535	1	<input type="checkbox"/>
Pn023	Electronic gear B	—	1~65535	1	<input type="checkbox"/>
Pn024	Smoothing	0.1ms	0~32767	0	
Pn025	Feed-forward filter	0.1ms	0~640	0	
Pn026	Forward rotation torque limit	%	0~300	300	
Pn027	Reverse rotation torque limit	%	0~300	300	
Pn028	Forward external current limit	%	0~300	100	
Pn029	Reverse external current limit	%	0~300	100	
Pn030	plug braking stop torque	%	0~300	300	
Pn031	Torque reference gain	0.1V/100 %	33~100	33	
Pn032	Zero-Speed Level	r/min	1~2000	20	
Pn033	Zero clamp speed	r/min	0~2000	10	
Pn034	Speed Coincidence Signal Output Width	r/min	0~100	10	
Pn035	Positioning Complete Range	Reference unit	0~500	10	
Pn036	error counter overflow	256 reference unit	1~32767	1024	
Pn037	JOG speed	r/min	0~2000	500	
Pn038	SPEED1	r/min	0~2000	100	
Pn039	SPEED2	r/min	0~2000	200	
Pn040	SPEED3	r/min	0~2000	300	
Pn041	<b>Control mode selection</b> [0] Speed control (analog reference) [1] Position control (pulse train reference)	—	0~13	0	<input type="checkbox"/>

Parameter	Name and description	Unit	Setting range	Default	remarks
	[2] Torque control (analog reference) [3] Speed control (contact reference) Speed control (0 reference) [4] Speed control (contact reference) Speed control (analog reference) [5] Speed control (contact reference) Position control (pulse train reference) [6] Speed control (contact reference) Torque control (analog reference) [7] Position control (pulse train reference) Speed control (analog reference) [8] Position control (pulse train reference) Torque control (analog reference) [9] Torque control (analog reference) Speed control (analog reference) [10] Speed control (analog reference) Zero clamp control [11] Position control (pulse train reference) Position control (inhibit) [12] position control ( parameter reference) [13] speed control ( parameter reference) [14] electric knife frame function				
Pn042	Speed limit in torque control mode	r/min	0~6000	1500	
Pn043	Time delay from servo ON signal till Servo actually ON	ms	0~20	200	
Pn044	Time delay from the time a brake signal is output until servo OFF status occurs	10ms	0~500	0	
Pn045	Speed level for brake signal output during operation	r/min	0~2000	100	
Pn046	Time delay from brake signal until servo OFF	10ms	10~100	50	
Pn047	<b>Position error pulse overflow alarm</b> [0] no alarm output [1] alarm output	-	0~1	0	
Pn048	Speed when parameter speed reference functions	r/min	0~2000	500	
Pn049	Rotation direction when parameter speed reference function [0] Forward [1] Reverse	—	0~1	0	
Pn050	<b>Select cycle run</b> [0] multi- points cycle run [1] multi- points single run	—	0~1	0	
Pn051	<b>Use /P-CON signal as step changing signal or not</b> [0] delay step changing	—	0~1	0	

Parameter	Name and description	Unit	Setting range	Default	remarks
	[1] use P-CON as step changing signal				
Pn052	<b>Program method</b> [0] incremental [1] absolute	—	0~1	0	
Pn053	Select output signals 1CN-7,8 functions		0~4	0	
Pn054	Select output signals 1CN-1,2 functions		0~4	1	
Pn055	Select output signals 1CN-5,6 functions		0~4	2	
Pn056	The second electronic gear numerator B2		1-65535	1	
Pn057	Dynamic electronic gear on		0~1		
Pn058	Dynamic electronic gear switching		0~1		
Pn059	Moving distance 0	10 <sup>4</sup> reference pulse	-9999~9999	0	
Pn060	Moving distance 0	1reference pulse	-9999~9999	0	
Pn061	Moving distance 1	10 <sup>4</sup> reference pulse	-9999~9999	0	
Pn062	Moving distance 1	1reference pulse	-9999~9999	0	
Pn063	Moving distance 2	10 <sup>4</sup> reference pulse	-9999~9999	0	
Pn064	Moving distance 2	1reference pulse	-9999~9999	0	
Pn065	Moving distance 3	10 <sup>4</sup> reference pulse	-9999~9999	0	
Pn066	Moving distance 3	1reference pulse	-9999~9999	0	
Pn067	Moving distance 4	10 <sup>4</sup> reference pulse	-9999~9999	0	
Pn068	Moving distance 4	1reference pulse	-9999~9999	0	
Pn069	Moving distance 5	10 <sup>4</sup> reference pulse	-9999~9999	0	
Pn070	Moving distance 5	1reference pulse	-9999~9999	0	
Pn071	Moving distance 6	10 <sup>4</sup> reference pulse	-9999~9999	0	
Pn072	Moving distance 6	1reference pulse	-9999~9999	0	
Pn073	Moving distance 7	10 <sup>4</sup> reference pulse	-9999~9999	0	

Parameter	Name and description	Unit	Setting range	Default	remarks
Pn074	Moving distance 7	1reference pulse	-9999~9999	0	
Pn075	Moving distance 8	10 <sup>4</sup> reference pulse	-9999~9999	0	
Pn076	Moving distance 8	1reference pulse	-9999~9999	0	
Pn077	Moving distance 9	10 <sup>4</sup> reference pulse	-9999~9999	0	
Pn078	Moving distance 9	1reference pulse	-9999~9999	0	
Pn079	Moving distance 10	10 <sup>4</sup> reference pulse	-9999~9999	0	
Pn080	Moving distance 10	1reference pulse	-9999~9999	0	
Pn081	Moving distance 11	10 <sup>4</sup> reference pulse	-9999~9999	0	
Pn082	Moving distance 11	1reference pulse	-9999~9999	0	
Pn083	Moving distance 12	10 <sup>4</sup> reference pulse	-9999~9999	0	
Pn084	Moving distance 12	1reference pulse	-9999~9999	0	
Pn085	Moving distance 13	10 <sup>4</sup> reference pulse	-9999~9999	0	
Pn086	Moving distance 13	1reference pulse	-9999~9999	0	
Pn087	Moving distance 14	10 <sup>4</sup> reference pulse	-9999~9999	0	
Pn088	Moving distance 14	1reference pulse	-9999~9999	0	
Pn089	Moving distance 15	10 <sup>4</sup> reference pulse	-9999~9999	0	
Pn090	Moving distance 15	1reference pulse	-9999~9999	0	
Pn091	Encoder wrong alarm on	-	0~1	0	
Pn092	C pulse clear protection	-	0~1	0	
Pn093	Dynamic brake time	ms	50~2000	125	
Pn094	Position low speed complement on	-	0-1	0	
Pn095	Increase overload capacity	-	0-1	0	
Pn096	Input smoothing time constant	0.2ms	0-1000	1	
Pn097	Alarm inspection smoothing time constant	0.2ms	0~3	1	

Parameter	Name and description	Unit	Setting range	Default	remarks
Pn098	Reverse input port low bits	-	0~15	0	①
Pn099	Reverse input port high bits	-	0~15	0	①
Pn100	Speed loop setting curve form [0] slope [1] S curve [2] primary filter [3] secondary filter	-	0~3	0	①
Pn101	S curve raising time	ms	0-10000	0	
Pn102	Primary and secondary filter time	ms	0-10000	0	
Pn103	S form selection	-	1~3	0	
Pn104	Position reference primary and secondary filter selection	-	0-1	0	
Pn105	Not used				
Pn106	Not used				
Pn107	Not used				
Pn108	Not used				
Pn109	Not used				
Pn110	Not used				
Pn111	Not used				
Pn112	Speed forward-feedback percentage	-	0~100	0	
Pn113	Load inertia	Kg.cm <sup>2</sup>	0~10000	20	
Pn114	Torque switching percentage	-	0~300	200	
Pn115	P/PI switching condition [0] fixed PI [1] torque switch	-	0-1	0	
Pn116	Not used				
Pn117	Not used				
Pn118	Not used				
Pn119	Not used				
Pn120	Not used				
Pn121	Not used				
Pn122	Not used				
Pn123	Moving distance 0speed	r/min	0~2000	500	
Pn124	Moving distance 1speed	r/min	0~2000	500	
Pn125	Moving distance 2speed	r/min	0~2000	500	
Pn126	Moving distance 3speed	r/min	0~2000	500	
Pn127	Moving distance 4speed	r/min	0~2000	500	
Pn128	Moving distance 5speed	r/min	0~2000	500	
Pn129	Moving distance 6speed	r/min	0~2000	500	

Parameter	Name and description	Unit	Setting range	Default	remarks
Pn130	Moving distance 7speed	r/min	0~2000	500	
Pn131	Moving distance 8speed	r/min	0~2000	500	
Pn132	Moving distance 9speed	r/min	0~2000	500	
Pn133	Moving distance 10speed	r/min	0~2000	500	
Pn134	Moving distance 11speed	r/min	0~2000	500	
Pn135	Moving distance 12speed	r/min	0~2000	500	
Pn136	Moving distance 13speed	r/min	0~2000	500	
Pn137	Moving distance 14speed	r/min	0~2000	500	
Pn138	Moving distance 15speed	r/min	0~2000	500	
Pn139	Not used				
Pn140	Not used				
Pn141	Not used				
Pn142	Not used				
Pn143	Not used				
Pn144	Not used				
Pn145	Not used				
Pn146	Not used				
Pn147	Not used				
Pn148	Not used				
Pn149	Not used				
Pn150	Not used				
Pn151	Not used				
Pn152	Not used				
Pn153	Not used				
Pn154	Not used				
Pn155	Moving distance 0 time constant for acceleration and deceleration	0.1ms	0~32767	0	
Pn156	Moving distance 1 time constant for acceleration and deceleration	0.1ms	0~32767	0	
Pn157	Moving distance 2 time constant for acceleration and deceleration	0.1ms	0~32767	0	
Pn158	Moving distance 3 time constant for acceleration and deceleration	0.1ms	0~32767	0	
Pn159	Moving distance 4 time constant for acceleration and deceleration	0.1ms	0~32767	0	
Pn160	Moving distance 5 time constant for acceleration and deceleration	0.1ms	0~32767	0	
Pn161	Moving distance 6 time constant for acceleration and deceleration	0.1ms	0~32767	0	
Pn162	Moving distance 7 time constant for acceleration and deceleration	0.1ms	0~32767	0	

Parameter	Name and description	Unit	Setting range	Default	remarks
Pn163	Moving distance 8 time constant for acceleration and deceleration	0.1ms	0~32767	0	
Pn164	Moving distance 9 time constant for acceleration and deceleration	0.1ms	0~32767	0	
Pn165	Moving distance 10 time constant for acceleration and deceleration	0.1ms	0~32767	0	
Pn166	Moving distance 11 time constant for acceleration and deceleration	0.1ms	0~32767	0	
Pn167	Moving distance 12 time constant for acceleration and deceleration	0.1ms	0~32767	0	
Pn168	Moving distance 13 time constant for acceleration and deceleration	0.1ms	0~32767	0	
Pn169	Moving distance 14 time constant for acceleration and deceleration	0.1ms	0~32767	0	
Pn170	Moving distance 15 time constant for acceleration and deceleration	0.1ms	0~32767	0	
Pn171	Not used				
Pn172	Not used				
Pn173	Not used				
Pn174	Not used				
Pn175	Not used				
Pn176	Not used				
Pn177	Not used				
Pn178	Not used				
Pn179	Not used				
Pn180	Not used				
Pn181	Not used				
Pn182	Not used				
Pn183	Not used				
Pn184	Not used				
Pn185	Not used				
Pn186	Not used				
Pn187	Moving distance 0 Stop time after reaching desired position	50ms	0~300	10	
Pn188	Moving distance 1 Stop time after reaching desired position	50ms	0~300	10	
Pn189	Moving distance 2 Stop time after reaching desired position	50ms	0~300	10	
Pn190	Moving distance 3 Stop time after reaching desired position	50ms	0~300	10	
Pn191	Moving distance 4 Stop time after reaching desired	50ms	0~300	10	

Parameter	Name and description	Unit	Setting range	Default	remarks
	position				
Pn192	Moving distance 5 Stop time after reaching desired position	50ms	0~300	10	
Pn193	Moving distance 6 Stop time after reaching desired position	50ms	0~300	10	
Pn194	Moving distance 7 Stop time after reaching desired position	50ms	0~300	10	
Pn195	Moving distance 8 Stop time after reaching desired position	50ms	0~300	10	
Pn196	Moving distance9 Stop time after reaching desired position	50ms	0~300	10	
Pn197	Moving distance 10 Stop time after reaching desired position	50ms	0~300	10	
Pn198	Moving distance 11 Stop time after reaching desired position	50ms	0~300	10	
Pn199	Moving distance12 Stop time after reaching desired position	50ms	0~300	10	
Pn200	Moving distance 13 Stop time after reaching desired position	50ms	0~300	10	
Pn201	Moving distance 14 Stop time after reaching desired position	50ms	0~300	10	
Pn202	Moving distance 15 Stop time after reaching desired position	50ms	0~300	10	
Pn203	Motor reverse turnaround time [electric knife frame function]	ms	0~15000	2000	
Pn204	Motor reverse angle	degree	0~32767	1700	
Pn205	Not used				
Pn206	Not used				
Pn207	Not used				
Pn208	Not used				
Pn209	Not used				
Pn210	Communication address setting	----	1~255	1	
Pn211	Communication speed options: 0 : 4800bps 1 : 9600 bps 2 : 19200bps	----	0~2	1	
Pn212	Communication protocol form:	----	0~8	5	

Parameter	Name and description	Unit	Setting range	Default	remarks
	0 : 7 , N , 2 ( Modbus,ASCII ) 1 : 7 , E , 1 ( Modbus,ASCII ) 2 : 7 , O , 1 ( Modbus,ASCII ) 3 : 8 , N , 2 ( Modbus,ASCII ) 4 : 8 , E , 1 ( Modbus,ASCII ) 5 : 8 , O , 1 ( Modbus,ASCII ) 6 : 8 , N , 2 ( Modbus,RTU ) 7 : 8 , E , 1 ( Modbus,RTU ) 8 : 8 , O , 1 ( Modbus,RTU )				
Pn213	Communication protocol options: 0 : Self-definition protocol RS-232 Communication 1 : MODBUS Protocol RS-422/232 Communication 2 : MODBUS Protocol RS-485 Communication	---	0~2	2	
Pn214	Not Used				
Pn215	Not Used				
Pn216	Communication bit control: This parameter is designated through bit to decide input source of digital input port. Bit0~bit7 represent input port 0~7 respectively. Bit definition represents as follows: 0 : input bit is controlled by outside interface 1 : input bit is controlled by communication.	---	0~255	0	④
Pn217	Reverse the output port	-	0-15	0	
Pn218	Suitable motor type parameter	-	0~3	1	
Pn219	Start point for program	—	0~31	0	
Pn220	End point for program	—	0~31	1	

Parameter	Name and description	Unit	Setting range	Default	remarks
Pn221	speed of looking for reference point ( bump the limit switch )	r/min	0~2000	1500	
Pn222	Moving speed ( move away from limit switch )	r/min	0~2000	30	

Note:  After changing the setting, always turn the power OFF, then ON. This makes the new setting valid.

Valid even in the zero clamp mode

To use soft start function, always set both Pn-012 and Pn-013

this parameter's input source is decided by digital input port control through bit setting, bit0 ~ bit7 are

relevant to input port 0~7. bit setting as follows:

0: input pins are controlled by outside terminal.

1: input pins set as communication control.

## Appendix B

### List of Alarm Displays

Alarm display on digital operator	Alarm output	Alarm Name	Meaning
A . 01	<input type="checkbox"/>	Parameter breakdown	Checksum results of parameters are abnormal.
A . 02	<input type="checkbox"/>	A/D breakdown	ADS8322 chip breakdown
A . 03	<input type="checkbox"/>	Overspeed	Rotation speed of the motor has exceeded 2000r/min.
A . 04	<input type="checkbox"/>	Overloaded	The motor was running for several seconds to several tens of seconds under a torque largely exceeding ratings.
A . 05	<input type="checkbox"/>	Position error pulse overflow	Position error pulse has exceeded the value
A . 06	<input type="checkbox"/>	Position error pulse has exceeded the value	Position error pulse has exceeded the value set in parameter Pn-036 (overflow).
A . 10	<input type="checkbox"/>	Encoder PA , PB or PC disconnected	At least one of PA,PB or PC is disconnected
A . 11	<input type="checkbox"/>	Encoder PU , PV or PW disconnected	At least one of PU,PV or PW is disconnected
A . 12	<input type="checkbox"/>	Overcurrent	An overcurrent flowed through the IPM module.
A . 13	<input type="checkbox"/>	Overvoltage	Voltage supply for the main motor circuit exceeds rating.
A . 14	<input type="checkbox"/>	Undervoltage	Voltage supply for the main motor circuit is too low.
A . 15	<input type="checkbox"/>	Bleeder resistor damaged	Bleeder resistor is broken
A . 16	<input type="checkbox"/>	Regenerative error	Regenerative circuit error
A . 20	<input type="checkbox"/>	Power lines open phase	One phase is not connected in the main power supply
A . 21	<input type="checkbox"/>	power loss error	A power interruption exceeding one cycle occurred in AC power supply.
A . 41	×	Encoder type error	Encoder type error
A . 42	×	Motor type error	Motor type error
A . 70	×	Electric knife error	Electric knife error
A . 99	○	Not an error	Normal operation status

○ : Output transistor is OFF    □ : Output transistor is ON (alarm on)