

Item No.

High Performance, Fast Recovery, Energy-Saving...Half the Space, Half a Fryer

When you need one more basket for shrimp, fish or onion rings but don't have the space for a full size fryer, use the Anets Half-Fryer. Attached to a full-size fryer, it provides a very cost-efficient way to expand your offerings. Available with a fully automatic basket lift and Digital control (Model MX-7A).

STANDARD FEATURES

- **Warranty: 1 year Parts and Labor, 10 years Frypot Part only.**
- Stainless steel front panel, trim and door
- Copper-flashed heat exchangers transfer heat directly into frypot for maximum efficiency
- Open vat design with sloped sides forces food particles to fall into the easily accessible cold zone
- Fully insulated cabinet keeps the kitchen cool
- Stainless steel basket hanger lifts off for easy cleaning
- Front 1-1/4" NPT full port drain valve
- Unit must be banked to a 14" Anets fryer
- Stainless steel basket hanger lifts off for easy cleaning and access to the backsplash



MX-7E Shown banked with an MX-14E and optional casters

ANETS
GoldenFRY™



ANETS

ANETS INC PO BOX 501, CONCORD, NH 03302-0501
509 ROUTE 3A, BOW, NH 03304 TEL: 603-225-6684, FAX:603-225-8497
L10-501 R4 www.anets.com

We reserve the right to change specifications without notice and without incurring any Obligation for equipment previously or subsequently sold.



SPECIFICATIONS

- | | |
|--------------------------------------------------------------------------------------------------------------------------------------------------------------------------------------------------------------------------------------------------------------------------------------------------------------------------------------------------------------------------------------------------------|------------------------------------------------------------------------------------------------------------------------------------------------------------------------------------------------------------------------------------------------------------------------------------------------------------------------------------------------------------------------------------------------------------------------------------------------------------------------------------------------------------------------------------------------------------------------------------|
| <ul style="list-style-type: none"> ■ Model ■ Certification ■ BTUH ■ Gas Pressure ■ Gas Connection ■ Electrical Requirements ■ Thermostat ■ Temperature Range ■ Burners ■ Hi-limit ■ Safety Pilot ■ Spark Ignitor ■ Frypot ■ Cabinet ■ Shortening Capacity | <p>MX-7E, Basic
MX-7A, Fully automatic basket lift with Digital control</p> <p>CSA, NSF</p> <p>55,000 BTU/hr.</p> <p>NG 3.5" WC, LP 10" WC</p> <p>3/4" NPT</p> <p>MX-7E, 120V, 60Hz, 1Ph, 2 Amps
MX-7A, 120V, 60Hz, 1Ph, 4.5 Amps</p> <p>Electric snap action type</p> <p>200° to 375°F (93°-191°C)</p> <p>Atmospheric pre-mix</p> <p>Safety control turns off main gas supply at 440°F (227°C)</p> <p>100% gas shut off valve</p> <p>Piezo-electric</p> <p>Stainless steel</p> <p>All Stainless Steel construction, excluding rear and bottom braces</p> <p>17-25 lbs</p> |
|--------------------------------------------------------------------------------------------------------------------------------------------------------------------------------------------------------------------------------------------------------------------------------------------------------------------------------------------------------------------------------------------------------|------------------------------------------------------------------------------------------------------------------------------------------------------------------------------------------------------------------------------------------------------------------------------------------------------------------------------------------------------------------------------------------------------------------------------------------------------------------------------------------------------------------------------------------------------------------------------------|

STANDARD ACCESSORIES

- 1 Nickel plated basket
- Rack type basket support
- Clean out rod
- 6" adjustable legs
- Drain pipe extension

OPTIONS AND ACCESSORIES

- | | |
|-----------------------------------------------------------------------------------------------------------------------------------------------------------------------------------|----------------------------------------------------------------------------------------------------------------------------------------------------------------------------------------------------|
| <ul style="list-style-type: none"> ■ Automatic basket lift (Model MX-7A) ■ Casters ■ Fryer cover ■ Drain table ■ Sediment tray | <ul style="list-style-type: none"> ■ Solid state thermostat ■ Electronic ignition ■ Shortening melter ■ Front drain tray ■ Fryer cleaning brush |
|-----------------------------------------------------------------------------------------------------------------------------------------------------------------------------------|----------------------------------------------------------------------------------------------------------------------------------------------------------------------------------------------------|

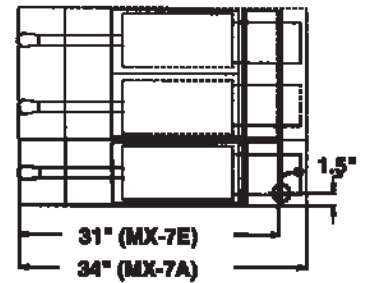

Top View

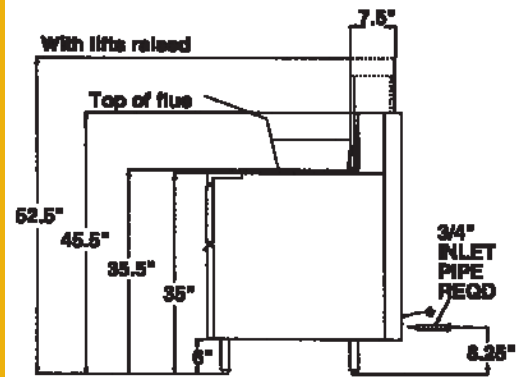

Side View

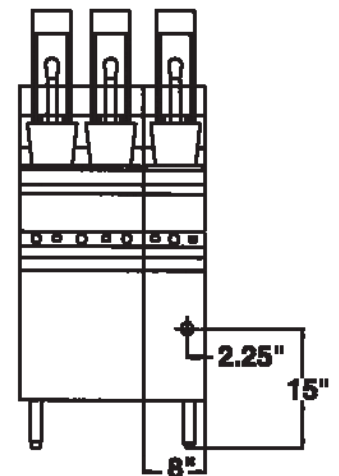

Front View