

## RoHS Compliant Short Wavelength SFP Transceiver for Fiber Channel and CPRI Application



### FEATURES

- Compliant with SFP transceiver SFF-8472 MSA specification and Fiber Channel FC-PI-2
- 850nm VCSEL laser
- Built-in digital diagnostic monitoring function
- Compliant with 4.25/2.125/1.0625 Gb/s Fiber Channel (400/200/100-M5/M5E/M6-SN-I)
- Compliant with Industry Standard RFT Electrical Connector and Cage
- Duplex LC connector
- Laser Class 1 Product which comply with the requirements of IEC 60825-1 and IEC 60825-2

### Description

The LCP-4250A4CDR series are hot pluggable 3.3V Small-Form-Factor transceiver modules designed expressly for high-speed communication applications that require rates of up to 4.25Gb/s. It is compliant with the Fiber Channel standards FC-PI-2, as well as MSA SFF-8472.

The LCP-4250A4CDR transceivers provide with the LC receptacle that is compatible with the industry standard LC™ connector. The transceiver is also compatible with industry standard RFT connector and cage.

The post-amplifier of the LCP-4250A4CDR also includes a LOS (Loss Of Signal) circuit that provides a TTL logic-high output when an unusable optical signal level is detected.

The LCP-4250A4CDR transceiver is a Class 1 eye safety product. The optical power levels, under normal operation, are at eye safe level.

### Applications

- Tri-Rate 1.063/2.125/4.25 Gb/s Fiber Channel
- Up to 400m link over OM3 MMF for 3.072Gbps CPRI application

### Transmission Distances

Data Rate	OM3 MMF	OM2 MMF	OM1 MMF
4.25Gb/s	380m	150m	70m
2.125Gb/s	500m	300m	150m
1.0625Gb/s	860m	550m	300m

## Absolute Maximum Ratings

Parameter	Symbol	Min.	Typ.	Max.	Unit	Note
Storage Temperature	$T_S$	-40		85	°C	
Supply Voltage	$V_{CC}$	0		5	V	

## Recommended Operating Conditions

Parameter	Symbol	Min.	Typ.	Max.	Unit	Note
Case Operating Temperature	$T_C$	-5		70	°C	1
Supply Voltage	$V_{CC}$	3.135		3.465	V	

## Electrical Characteristics

( $V_{CC}$ =3.135V to 3.465V)

Parameter	Symbol	Min.	Typ.	Max.	Unit	Note
Total Supply Current	$I_{CC}$		180	300	mA	
<b>Transmitter</b>						
Transmitter Differential Input Voltage	$V_{in,pp}$	0.5		2.4	V	2
Transmitter Disable Input-High	$V_{DISH}$	2		$V_{CC}+0.3$	V	
Transmitter Disable Input-Low	$V_{DISL}$	0		0.8	V	
Transmitter Fault Pull up Resistor	$R_{TX\_FAULT}$	4.7		10	k $\Omega$	3
Transmitter Fault Output-High	$V_{TXFH}$	2		$V_{CC}+0.3$	V	
Transmitter Fault Output-Low	$V_{TXFL}$	0		0.8	V	
<b>Receiver</b>						
Receiver Differential Output Voltage	$V_{out,pp}$	0.3		1	V	4
Receiver LOS Load	$R_{RXLOS}$	4.7		10	k $\Omega$	3
LOS Output Voltage-Low	$V_{LOSH}$	2		$V_{CC}+0.3$	V	
LOS Output Voltage-High	$V_{LOSL}$	0		0.8	V	
Output Data Rise/Fall Time	$t_r/ t_f$			120	psec	5

### Notes:

1. See Ordering information for detail
2. Internally AC coupled and terminated to 100 Ohm differential load.
3. Pull up to  $V_{CC}$  on host Board.
4. Internally AC coupled, but requires a 100 Ohm differential termination at or internal to Serializer/ Deserializer.
5. Unfiltered, 20 – 80%.

## Optical Characteristics

( $V_{CC}=3.135V$  to  $3.465V$ , Data Rate= $4.25Gb/sec$ , PRBS= $2^7-1$  NRZ,  $50/125\mu m$  MMF)

Parameter	Symbol	Min.	Typ.	Max.	Unit	Note
<b>Transmitter</b>						
Output Optical Power (Avg.)	$P_O$	-9			dBm	1
Optical Modulation Amplitude @ 4.25 Gb/s @ 2.125 Gb/s @ 1.0625 Gb/s	OMA	247 196 156			$\mu W$	2
Center Wavelength		830		860	nm	
Spectral Width (RMS)				0.85	nm	
Optical Rise/Fall Time (20% - 80%)	$t_r/ t_f$			90/90	psec	3
Relative Intensity Noise	RIN			-118	dB/Hz	
Output Eye	Complies with the ANSI FC-PI Rev. 13 specification, and is class 1 laser eye safety					
<b>Receiver</b>						
Average Receiver Power	$P_{x(MAX)}$			-3	dBm	
Sensitivity in OMA @ 4.25 Gbit/s @ 2.125 Gb/s @ 1.062 Gb/s	$P_{IN}$			61 49 31	$\mu W$	4
Input Optical Wavelength	$\lambda$	830		870	nm	
LOS-De-asserted (Avg.)	$P_D$			-19	dBm	
LOS-Asserted (Avg.)	$P_A$	-30			dBm	
LOS-Hysteresis	$P_D - P_A$	0.5			dB	
Optical Return Loss	ORL	12			dB	

### Notes:

1. Max output optical power is lesser than Class 1 safety limits (CDRH and EN 60825)
2. Equivalent extinction ratio specification for Fiber Channel. Allows smaller ER at higher average power.
3. Measured at nominal data rate. These are unfiltered 20%~80% values.
4. The sensitivity is tested at a BER of  $1 \times 10^{-12}$  or better with an input signal consisting of  $2^7-1$  NRZ PRBS.

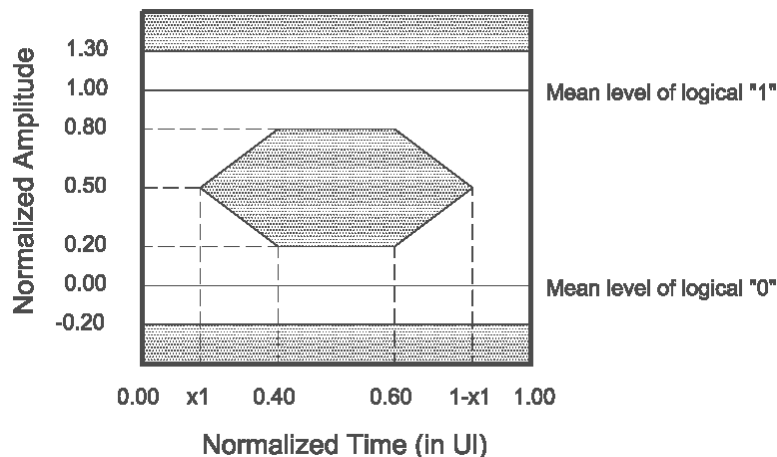

**Mask of the eye diagram for the optical transmit signal**

## SFP Transceiver Electrical Pad Layout

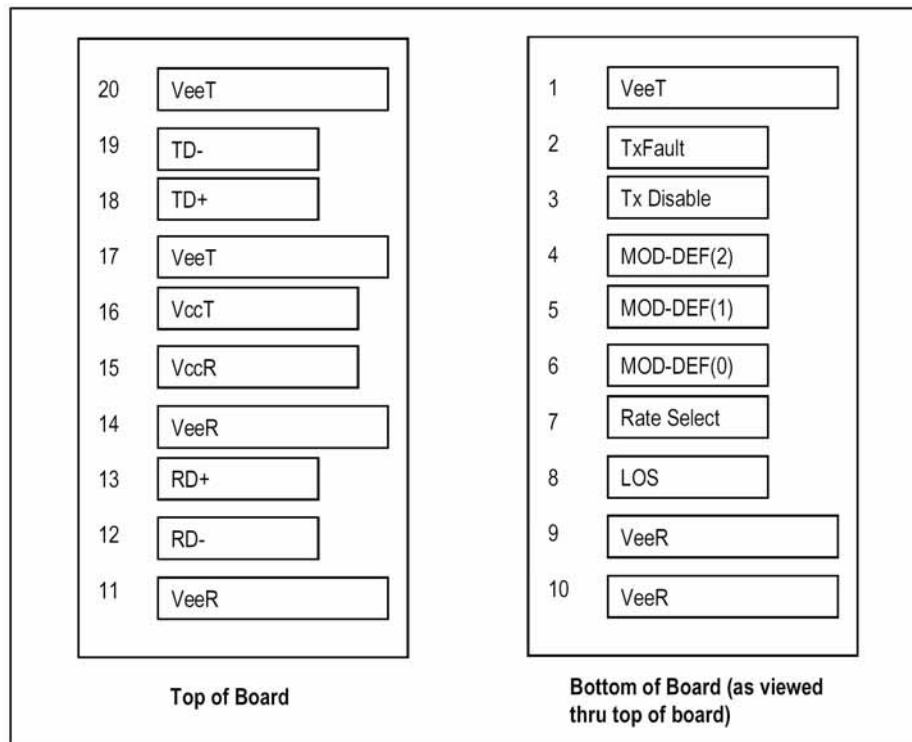

## Pin Function Definitions

Pin Num.	Name	Function	Plug Seq.	Notes
1	VeeT	Transmitter Ground	1	
2	TX Fault	Transmitter Fault Indication	3	Note 1
3	TX Disable	Transmitter Disable	3	Note 2 Module disables on high or open
4	MOD-DEF2	Module Definition 2	3	Note 3, 2 wire serial ID interface
5	MOD-DEF1	Module Definition 1	3	Note 3, 2 wire serial ID interface
6	MOD-DEF0	Module Definition 0	3	Note 3, Grounded in Module
7	Rate Select	1&2 or 2&4 Gbit/s	3	Note 4, Open or Low = 1.063Gb/s, High = 2.125Gb/s or 4.25Gb/s
8	LOS	Loss of Signal	3	Note 5
9	VeeR	Receiver Ground	1	Note 6
10	VeeR	Receiver Ground	1	Note 6
11	VeeR	Receiver Ground	1	Note 6
12	RD-	Inv. Received Data Out	3	Note 7
13	RD+	Received Data Out	3	Note 8
14	VeeR	Receiver Ground	1	Note 6
15	VccR	Receiver Power	2	3.3 ± 5%, Note 7
16	VccT	Transmitter Power	2	3.3 ± 5%, Note 7
17	VeeT	Transmitter Ground	1	Note 6
18	TD+	Transmit Data In	3	Note 9
19	TD-	Inv. Transmit Data In	3	Note 9
20	VeeT	Transmitter Ground	1	Note 6

Plug Seq.: Pin engagement sequence during hot plugging.

**Notes:**

- 1) TX Fault is an open collector/drain output, which should be pulled up with a 4.7K – 10K $\Omega$  resistor on the host board. Pull up voltage between 2.0V and VccT, R+0.3V. When high, output indicates a laser fault of some kind. Low indicates normal operation. In the low state, the output will be pulled to < 0.8V.
- 2) TX disable is an input that is used to shut down the transmitter optical output. It is pulled up within the module with a 4.7 – 10 K  $\Omega$  resistor. Its states are:

Low (0 – 0.8V):	Transmitter on
(>0.8, < 2.0V):	Undefined
High (2.0 – 3.465V):	Transmitter Disabled
Open:	Transmitter Disabled
- 3) Mod-Def 0,1,2. These are the module definition pins. They should be pulled up with a 4.7K – 10K $\Omega$ resistor on the host board. The pull-up voltage shall be VccT or VccR (see Section IV for further details). Mod-Def 0 is grounded by the module to indicate that the module is present Mod-Def 1 is the clock line of two wire serial interface for serial ID Mod-Def 2 is the data line of two wire serial interface for serial ID
- 4) In accordance to SFF Committee SFF-8079 Draft Rev. 1.6.
- 5) LOS (Loss of Signal) is an open collector/drain output, which should be pulled up with a 4.7K – 10K $\Omega$  resistor. Pull up voltage between 2.0V and VccT, R+0.3V. When high, this output indicates the received optical power is below the worst-case receiver sensitivity (as defined by the standard in use). Low indicates normal operation. In the low state, the output will be pulled to < 0.8V.
- 6) VeeR and VeeT may be internally connected within the SFP module.
- 7) RD-/+ : These are the differential receiver outputs. They are AC coupled 100 $\Omega$  differential lines which should be terminated with 100 $\Omega$  (differential) at the user SERDES. The AC coupling is done inside the module and is thus not required on the host board. The voltage swing on these lines will be between 370 and 2000 mV differential (185 – 1000 mV single ended) when properly terminated.
- 8) VccR and VccT are the receiver and transmitter power supplies. They are defined as 3.3V  $\pm$ 5% at the SFP connector pin. Maximum supply current is 300 mA. Recommended host board power supply filtering is shown below. Inductors with DC resistance of less than 1 ohm should be used in order to maintain the required voltage at the SFP input pin with 3.3V supply voltage. When the recommended supply-filtering network is used, hot plugging of the SFP transceiver module will result in an inrush current of no more than 30 mA greater than the steady state value. VccR and VccT may be internally connected within the SFP transceiver module.
- 9) TD-/+ : These are the differential transmitter inputs. They are AC-coupled, differential lines with 100  $\Omega$  differential termination inside the module. The AC coupling is done inside the module and is thus not required on the host board. The inputs will accept differential swings of 500 – 2400 mV (250 – 1200 mV single-ended), though it is recommended that values between 500 and 1200 mV differential (250 – 600 mV single-ended) be used for best EMI performance.

## Recommend Circuit Schematic

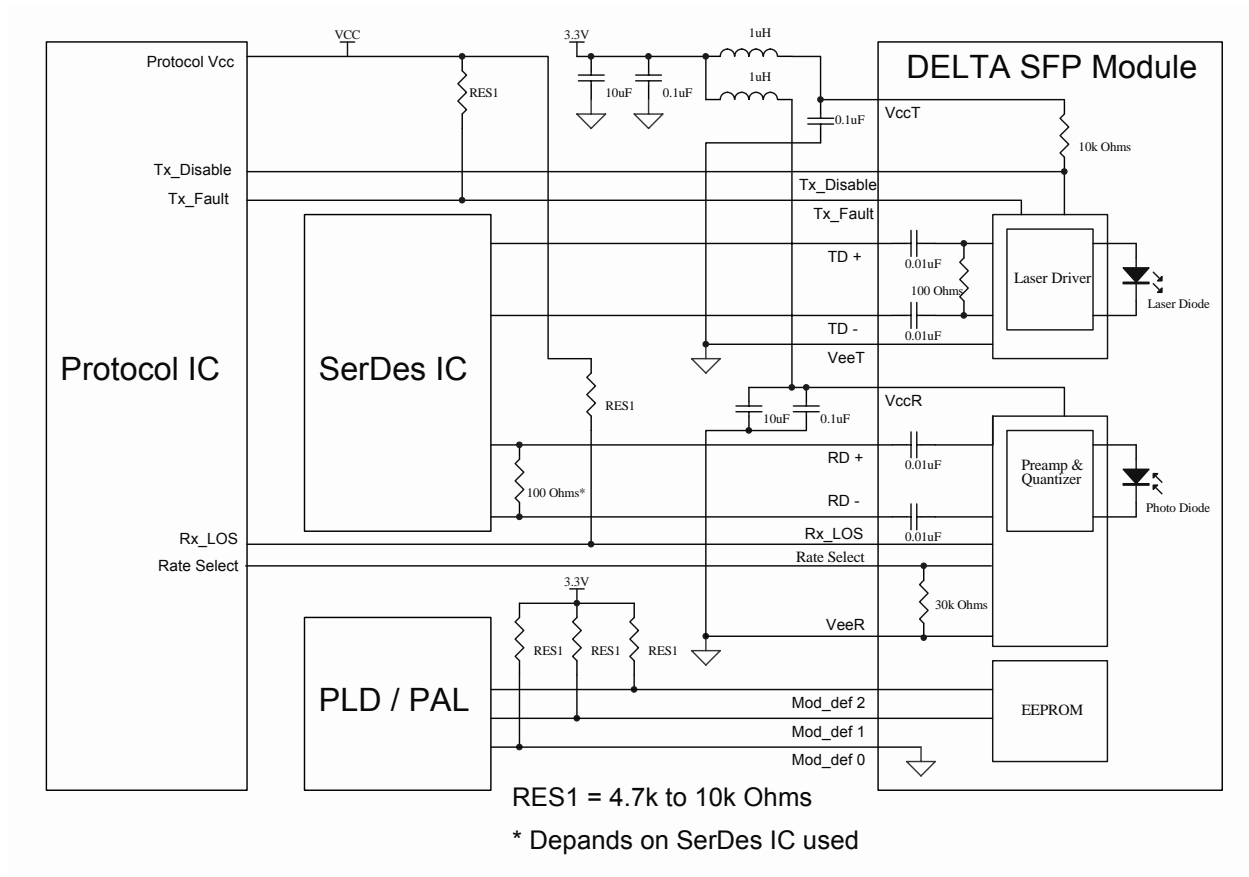

### Package Outline Drawing for Metal Housing with Bail de-latch

<b>Latch Color Identifier</b>
Black

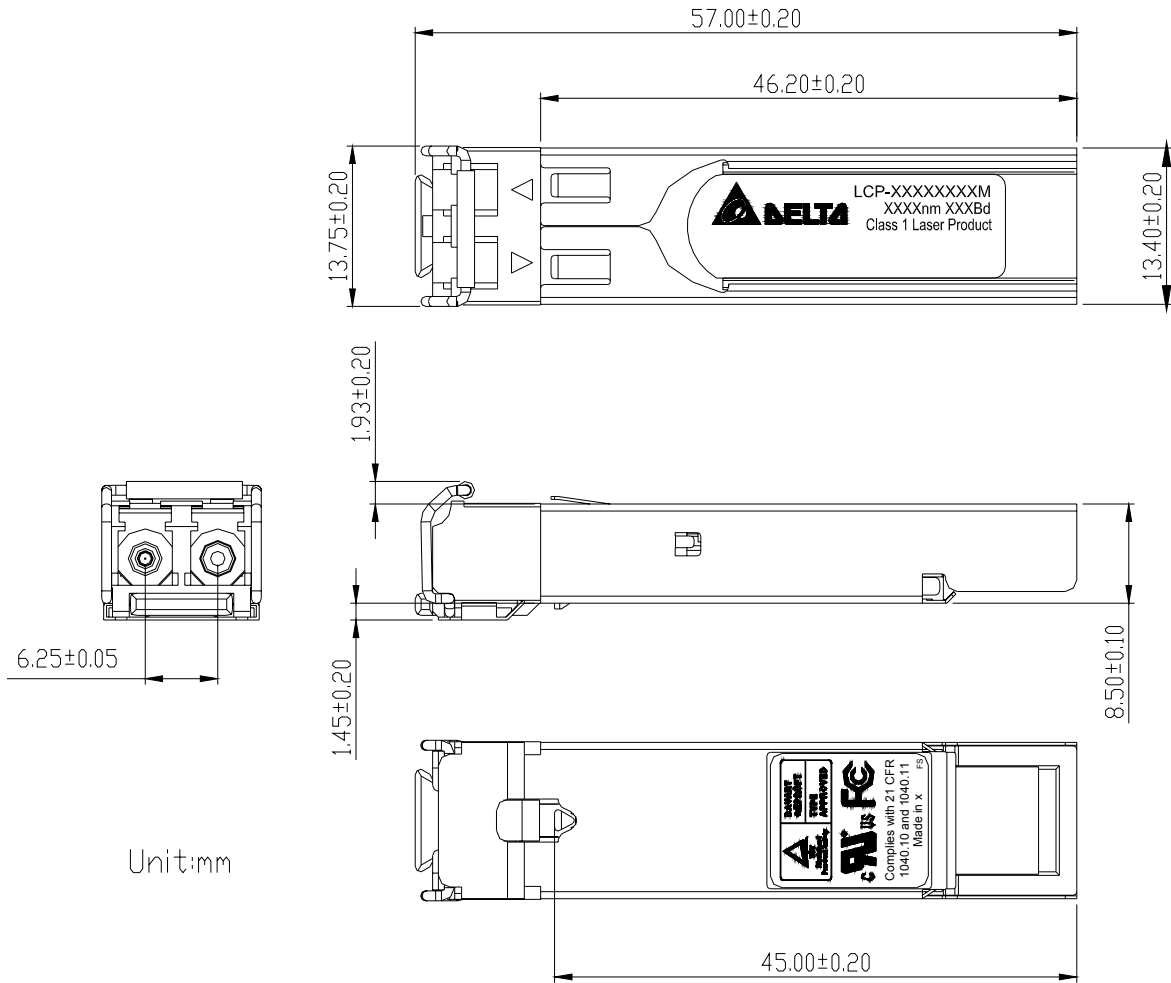

Unit:mm

## SFP timing parameters for SFP management

Parameter	Symbol	Min.	Max.	Unit	Note
TX_DISABLE Assert time	t_off		10	μsec	1
TX_DISABLE Negate time	t_on		1	msec	2
Time to initialize, including reset of TX_FAULT	t_init		300	msec	3
TX Fault Assert Time	t_fault		100	μsec	4
TX_DISABLE to reset	t_rest	10		μsec	5
LOS Assert Time	t_loss_on		100	μsec	6
LOS Deassert Time	t_loss_off		100	μsec	7
Serial ID Clock Rate	f_serial_clock		100	kHz	

### Notes:

- 1) Time from rising edge of TX\_DISABLE to when the optical output falls below 10% of nominal.
- 2) Time from falling edge of TX\_DISABLE to when the modulated optical output rises above 90% of nominal.
- 3) From power on or negation of TX\_Fault using TX Disable.
- 4) Time from fault to TX fault on.
- 5) Time TX Disable must be held high to reset TX\_Fault.
- 6) Time from LOS state to Rx LOS assert.
- 7) Time from non-LOS state to Rx LOS deassert.

## Enhanced Digital Diagnostic Interface

The memory map in the following describes an extension to the memory map defined in SFP MSA. The enhanced interface uses the two wire serial bus address 1010001X(A2h) to provide diagnostic information about the module's present operating conditions.

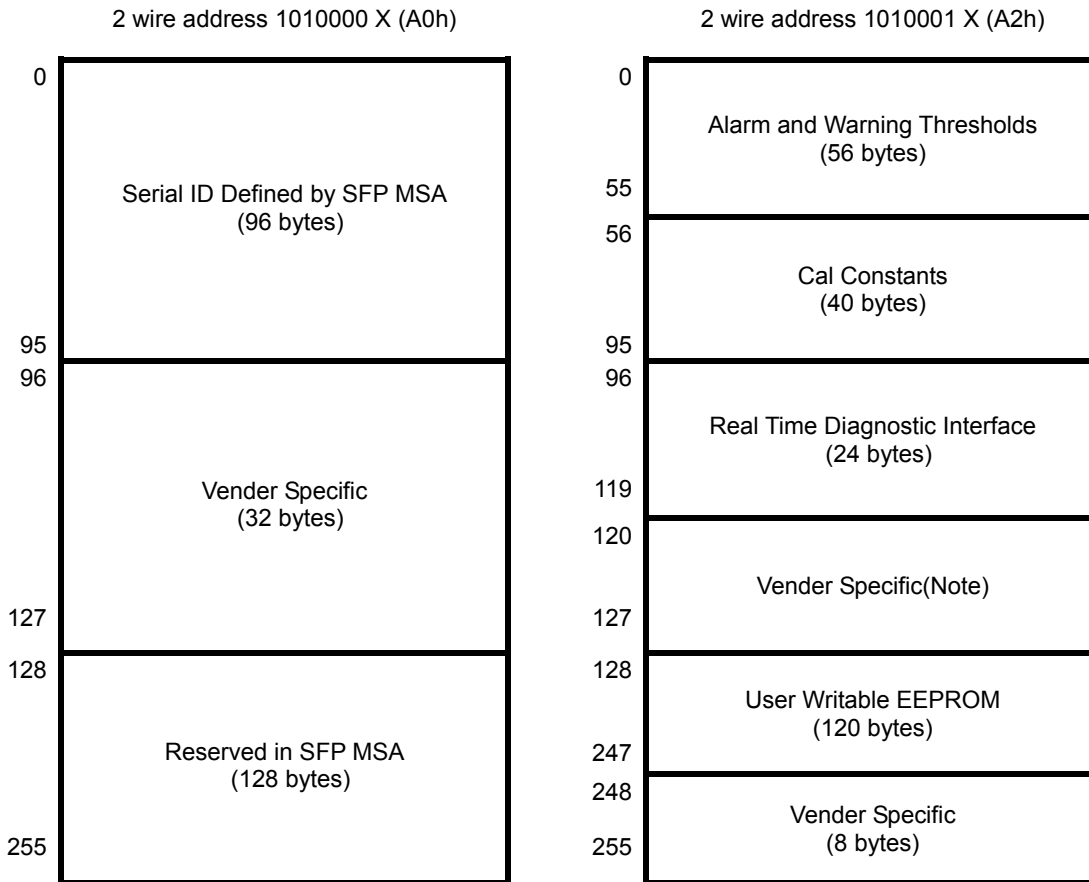

**Digital Diagnostic Memory Map Specific Data Field Descriptions**

**Note:**

- 1) Write the password (11h, 11h, 11h, 11h) on the bytes of 123-126 of address A2h then the address of bytes 128-255 (User Writable) can be read and written.



## EEPROM Serial ID Memory Contents (2-Wire Address A0h)

Address	Hex	ASCII	Address	Hex	ASCII	Address	Hex	ASCII
00	03		43	PN		86	DC	
01	04		44	PN		87	DC	
02	07		45	PN		88	DC	
03	00		46	PN		89	DC	
04	00		47	PN		90	DC	
05	00		48	PN		91	DC	
06	00		49	PN		92	68	
07	40		50	PN		93	F8	
08	40		51	PN		94	02	
09	0C		52	PN		95	CS2	Note 8
10	15		53	PN		96	00	
11	03		54	PN		97	00	
12	2B		55	PN		98	00	
13	00		56	30		99	00	
14	00		57	30		100	00	
15	00		58	30		101	00	
16	0F	Note 1	59	0A		102	00	
17	07	Note 2	60	CW	Note 4	103	00	
18	00		61	CW	Note 4	104	00	
19	26		62	00		105	00	
20	44	D	63	CS1	Note 5	106	00	
21	45	E	64	00		107	00	
22	4C	L	65	3A		108	00	
23	54	T	66	00		109	00	
24	41	A	67	75		110	00	
25	20		68	SN	Note 6	111	00	
26	20		69	SN		112	00	
27	20		70	SN		113	00	
28	20		71	SN		114	00	
29	20		72	SN		115	00	
30	20		73	SN		116	00	
31	20		74	SN		117	00	
32	20		75	SN		118	00	
33	20		76	SN		119	00	
34	20		77	SN		120	00	
35	20		78	SN		121	00	
36	00		79	SN		122	00	
37	00		80	SN		123	00	
38	00		81	SN		124	00	
39	00		82	SN		125	00	
40	PN	Note3	83	SN		126	00	
41	PN		84	DC	Note 7	127	00	
42	PN		85	DC		128	00	Note9

### Notes:

- 1) Byte 16: Link length supported for 50/125  $\mu$  m MM fiber, units of 10 m.
- 2) Byte 17: Link length supported for 62.5/125  $\mu$  m MM fiber, units of 10 m.
- 3) Byte 40-55: Delta part number
- 4) Byte 60-61: The center wavelength of transmitter
- 5) Byte 63: Check sum of bytes 0-62.
- 6) Byte 68-83: Serial number.
- 7) Byte 84-91: Date code.
- 8) Byte 95: Check sum of bytes 64-94.

9) Byte 128 to 255 had been set hex 00.

## Digital Diagnostic Monitoring Interface

### Alarm and Warning Thresholds (2-Wire Address A2h)

Address	# Bytes	Name	Value (Dec.)	Unit	Note
00-01	2	Temp High Alarm	$T_C$ (MAX.)+15		1
02-03	2	Temp Low Alarm	$T_C$ (MIN.)		
04-05	2	Temp High Warning	$T_C$ (MAX.)+10		
06-07	2	Temp Low Warning	$T_C$ (MIN.)+10		
08-09	2	Voltage High Alarm	$V_{CC}+5\%$	Volt	
10-11	2	Voltage Low Alarm	$V_{CC}-5\%$		
12-13	2	Voltage High Warning	$V_{CC}+3\%$		
14-15	2	Voltage Low Warning	$V_{CC}-3\%$		
16-17	2	Bias High Alarm	$I_{OP}+10$	mA	2
18-19	2	Bias Low Alarm	$I_{OP}-5$		
20-21	2	Bias High Warning	$I_{OP}+7$		
22-23	2	Bias Low Warning	$I_{OP}-3$		
24-25	2	TX Power High Alarm	P+3	dBm	3
26-27	2	TX Power Low Alarm	P-3		
28-29	2	TX Power High Warning	P+2		
30-31	2	TX Power Low Warning	P-2		
32-33	2	RX Power High Alarm	$P_0+3$	dBm	4
34-35	2	RX Power Low Alarm	$P_S-2$		
36-37	2	RX Power High Warning	$P_0+2$		
38-39	2	RX Power Low Warning	$P_S$		
40-45	16	Reversed			
56-91	36	External Calibration Constants			
92-94	3	Reversed			
95	1	Checksum			5
96-97	2	Real Time Temperature			
98-99	2	Real Time Supply Voltage			
100-101	2	Real Time Tx Bias Current			
102-103	2	Real Time Tx Optical Power			
104-105	2	Real Time Rx Received Power			
106-109	4	Reserved			
110	1	Optional Status/ Control Bits			6
111	1	Reserved			
112-119	8	Optional Set of Alarm and Warning			7

#### Notes:

- 1)  $T_C$ : Case Operating temperature
- 2)  $I_{OP}$ : Operating current at room temperature. The min. setting current is 0 mA.
- 3) P: Operating optical power of transmitter at room temperature.
- 4)  $P_0$ : Overload optical power of receiver  
 $P_S$ : Sensitivity optical power of receiver
- 5) Byte 95 contains the low order 8bits of sum of bytes 0-94

6)

### State/ Control Bits

Byte	Bit	Name	Description
110	7	Tx Disable State	Digital state of the Tx disable input pin
110	6	Soft Tx Disable	Read/ Write bit that allow software disable of laser
110	5	Reserved	
110	4	Rate Select tate	NA
110	3	Soft Rate Select	NA
110	2	Tx Fault	Digital state of the Tx fault output pin
110	1	LOS	Digital state of the LOS output pin.
110	0	Data_Ready_Bar	NA

7)

### Optional Set of Alarm and Warning

Byte	Bit	Name	Description
112	7	Temp High Alarm	Set when internal temperature exceeds high alarm level
112	6	Temp Low Alarm	Set when internal temperature is below low alarm level
112	5	Vcc High Alarm	Set when internal supply voltage exceeds high alarm level
112	4	Vcc Low Alarm	Set when internal supply voltage is below low alarm level
112	3	Tx Bias High Alarm	Set when Tx Bias current exceeds high alarm level
112	2	Tx Bias Low Alarm	Set when Tx Bias current is below low alarm level
112	1	Tx Power High Alarm	Set when Tx output power exceeds high alarm level
112	0	Tx Power Low Alarm	Set when Tx output power is below low alarm level
113	7	Rx Power High Alarm	Set when received power exceeds high alarm level
113	6	Rx Power Low Alarm	Set when received power is below low alarm level
113	5-0	Reserved	
116	7	Temp High Warning	Set when internal temperature exceeds high warning level
116	6	Temp Low Warning	Set when internal temperature is below low warning level
116	5	Vcc High Warning	Set when internal supply voltage exceeds high warning level
116	4	Vcc Low Warning	Set when internal supply voltage is below low warning level
116	3	Tx Bias High Warning	Set when Tx Bias current exceeds high warning level
116	2	Tx Bias Low Warning	Set when Tx Bias current is below low warning level
116	1	Tx Power High Warning	Set when Tx output power exceeds high warning level
116	0	Tx Power Low Warning	Set when Tx output power is below low warning level
117	7	Rx Power High Warning	Set when received power exceeds high warning level
117	6	Rx Power Low Warning	Set when received power is below low warning level
117	5-0	Reserved	

### Digital Diagnostic Monitor Accuracy

Parameter	Typical Value	Note
Transceiver Temperature	± 3	1
Power Supply Voltage	± 3%	2
TX Bias Current	± 10%	
TX Optical Power	± 1.5dB	
RX Optical Power	± 3dB	

#### Notes:

- 1) Temperature is measured internal to the transceiver
- 2) Voltage is measured internal to the transceiver

## Regulatory Compliance

Test Item	Reference	Qty'	Evaluation
(#1) Electromagnetic Interference EMC	FCC Class B EN 55022 Class B CISPR 22	5	(1) Satisfied with electrical characteristics of product spec.  (2) No physical damage
(#2) Immunity : Radio Frequency Electromagnetic Field	EN 61000-4-3 IEC 1000-4-3	5	
(#3) Immunity : Electrostatic Discharge to the Duplex SC Receptacle	EN 61000-4-2 IEC 1000-4-2 IEC 801.2	5	
(#4) Electrostatic Discharge to the Electrical Pins	MIL-STD-883C Method 3015.4 EIAJ#1988.3.2B Version 2, Machine model	5	

## Ordering information for SFP modules

LCP-4250A4CDRX <sub>1</sub>	
<b>X<sub>1</sub>:</b>	<b>Temperature</b> Blank: -5 to +70 degree C H: -10 to +85 degree C T: -40 to +85 degree C