



LG

Life's Good

North/Latin America
Europe/Africa
Asia/Oceania

Internal Use Only

<http://aic.lgservice.com>
<http://eic.lgservice.com>
<http://biz.lgservice.com>

LED LCD TV

SERVICE MANUAL

CHASSIS : LA22E

MODEL : 42LM6200 42LM6200-UE

CAUTION

BEFORE SERVICING THE CHASSIS,
READ THE SAFETY PRECAUTIONS IN THIS MANUAL.



CONTENTS

CONTENTS	2
PRODUCT SAFETY	3
SPECIFICATION	4
ADJUSTMENT INSTRUCTION	10
SCREW ASSEMBLY WORKING GUIDE	20
EXPLODED VIEW	21
SCHEMATIC CIRCUIT DIAGRAM	

SAFETY PRECAUTIONS

IMPORTANT SAFETY NOTICE

Many electrical and mechanical parts in this chassis have special safety-related characteristics. These parts are identified by \triangle in the Schematic Diagram and Exploded View.

It is essential that these special safety parts should be replaced with the same components as recommended in this manual to prevent Shock, Fire, or other Hazards.

Do not modify the original design without permission of manufacturer.

General Guidance

An **isolation Transformer should always be used** during the servicing of a receiver whose chassis is not isolated from the AC power line. Use a transformer of adequate power rating as this protects the technician from accidents resulting in personal injury from electrical shocks.

It will also protect the receiver and its components from being damaged by accidental shorts of the circuitry that may be inadvertently introduced during the service operation.

If any fuse (or Fusible Resistor) in this TV receiver is blown, replace it with the specified.

When replacing a high wattage resistor (Oxide Metal Film Resistor, over 1 W), keep the resistor 10 mm away from PCB.

Keep wires away from high voltage or high temperature parts.

Before returning the receiver to the customer,

always perform an **AC leakage current check** on the exposed metallic parts of the cabinet, such as antennas, terminals, etc., to be sure the set is safe to operate without damage of electrical shock.

Leakage Current Cold Check(Antenna Cold Check)

With the instrument AC plug removed from AC source, connect an electrical jumper across the two AC plug prongs. Place the AC switch in the on position, connect one lead of ohm-meter to the AC plug prongs tied together and touch other ohm-meter lead in turn to each exposed metallic parts such as antenna terminals, phone jacks, etc.

If the exposed metallic part has a return path to the chassis, the measured resistance should be between 1 M Ω and 5.2 M Ω .

When the exposed metal has no return path to the chassis the reading must be infinite.

An other abnormality exists that must be corrected before the receiver is returned to the customer.

Leakage Current Hot Check (See below Figure)

Plug the AC cord directly into the AC outlet.

Do not use a line Isolation Transformer during this check.

Connect 1.5 K / 10 watt resistor in parallel with a 0.15 uF capacitor between a known good earth ground (Water Pipe, Conduit, etc.) and the exposed metallic parts.

Measure the AC voltage across the resistor using AC voltmeter with 1000 ohms/volt or more sensitivity.

Reverse plug the AC cord into the AC outlet and repeat AC voltage measurements for each exposed metallic part. Any voltage measured must not exceed 0.75 volt RMS which corresponds to 0.5 mA.

In case any measurement is out of the limits specified, there is possibility of shock hazard and the set must be checked and repaired before it is returned to the customer.

Leakage Current Hot Check circuit

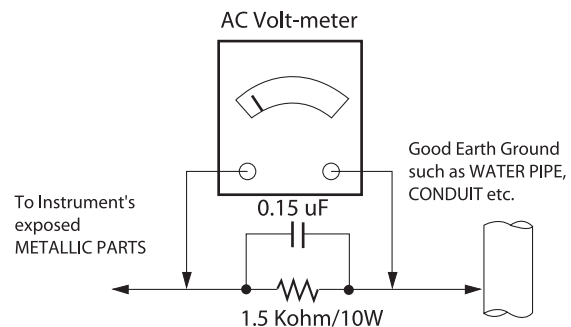

When 25A is impressed between Earth and 2nd Ground for 1 second, Resistance must be less than 0.1 Ω

*Base on Adjustment standard

SPECIFICATION

NOTE : Specifications and others are subject to change without notice for improvement.

1. Application range

This spec sheet is applied all of the 32", 42", 47", 55", 65"
LCD TV with LA22E chassis

2. Test condition

Each part is tested as below without special notice.

- 1) Temperature : 20 °C ± 5 °C
- 2) Relative Humidity: 65 % ± 10 %
- 3) Power Voltage
 - AC 110-240 V~, 50/60 Hz
 - * Standard Voltage of each products is marked by models.
- 4) Specification and performance of each parts are followed each drawing and specification by part number in accordance with BOM.
- 5) The receiver must be operated for about 5 minutes prior to the adjustment.

3. Test method

- 1) Performance: LGE TV test method followed
- 2) Demanded other specification
 - Safety: CE, IEC specification
 - EMC: CE, IEC specification
 - Wireless : WirelessHD Specification (Option)

4. General Specification

No	Item	Specification		Remark
1	Receiving System	1) ATSC / NTSC-M		
2	Available Channel	1) VHF : 02~13		
		2) UHF : 14~69		
		3) DTV : 02-69		
		4) CATV : 01~135		
		5) CADTV : 01~135		
3	Input Voltage	1) AC 100 ~ 240V 50/60Hz		120V, 50/60Hz on the label (USA)
4	Market	NORTH AMERICA		
5	Screen Size	42 inches		
6	Aspect Ratio	16:9		
7	Tuning System	FS		
8	Module	LC420EUE-SEF1	LGD	
9	Operating Environment	1) Temp : 0 ~ 40 deg 2) Humidity : ~ 80 %		
10	Storage Environment	1) Temp : -20 ~ 60 deg 2) Humidity : ~ 85 %		

5. Supported video resolutions

5.1. 2D mode

5.1.1. Component Video Input (Y, CB/PB, CR/PR)

No.	Resolution	H-freq(kHz)	V-freq.(kHz)	Pixel clock	Proposed
1.	720*480	15.73	60.00	13.5135	SDTV ,DVD 480I
2.	720*480	15.73	59.94	13.50	SDTV ,DVD 480I
3.	720*480	31.50	60.00	27.027	SDTV 480P
4.	720*480	31.47	59.94	27.00	SDTV 480P
5.	1280*720	45.00	60.00	74.25	HDTV 720P
6.	1280*720	44.96	59.94	74.176	HDTV 720P
7.	1920*1080	33.75	60.00	74.25	HDTV 1080I
8.	1920*1080	33.72	59.94	74.176	HDTV 1080I
9.	1920*1080	67.50	60.00	148.50	HDTV 1080P
10.	1920*1080	67.432	59.94	148.352	HDTV 1080P
11.	1920*1080	27.00	24.00	74.25	HDTV 1080P
12.	1920*1080	26.97	23.94	74.176	HDTV 1080P
13.	1920*1080	33.75	30.00	74.25	HDTV 1080P
14.	1920*1080	33.71	29.97	74.176	HDTV 1080P

5.1.2. RGB Input (PC)

No.	Resolution	H-freq(kHz)	V-freq.(kHz)	Pixel clock	Proposed	
1	640*350	31.468	70.09	25.17	EGA	X
2	720*400	31.469	70.08	28.32	DOS	O
3	640*480	31.469	59.94	25.17	VESA(VGA)	O
4	800*600	37.879	60.31	40.00	VESA(SVGA)	O
5	1024*768	48.363	60.00	65.00	VESA(XGA)	O
6	1152*864	54.348	60.053		VESA	
7	1360*768	47.712	60.015	85.50	VESA (WXGA)	X
8	1920*1080	67.5	60.00	148.5	WUXGA(CEA861D)	O

5.1.3. HDMI Input 1 (PC/DTV)

No	Resolution	H-freq(kHz)	V-freq.(Hz)	Pixel clock(MHz)		Proposed		Remark
PC (DVI)								
1	640*350	31.468	70.09	25.17		EGA	X	
2	720*400	31.469	70.08	28.32		DOS	O	
3	640*480	31.469	59.94	25.17		VESA(VGA)	O	
4	800*600	37.879	60.31	40.00		VESA(SVGA)	O	
5	1024*768	48.363	60.00	65.00		VESA(XGA)	O	
6	1152*864	54.348	60.053			VESA	O	
7	1280*1024	63.981	60.020			VESA(SXGA)		
8	1360*768	47.712	60.015	85.50		VESA(WXGA)		
9	1920*1080	67.5	60.00	148.5	HDTV 1080P	WUXGA(Reduced Blanking)	O	FHD only
DTV								
1	720*480	31.50	60.00	27.027		SDTV 480P		
2	720*480	31.47	59.94	27.00		SDTV 480P		
3	1280*720	45.00	60.00	74.25		HDTV 720P		
4	1280*720	44.96	59.94	74.176		HDTV 720P		
5	1920*1080	33.75	60.00	74.25		HDTV 1080I		
6	1920*1080	33.72	59.94	74.176		HDTV 1080I		
7	1920*1080	67.50	60.00	148.50		HDTV 1080P		
8	1920*1080	67.432	59.94	148.352		HDTV 1080P		
9	1920*1080	27.00	24.00	74.25		HDTV 1080P		
10	1920*1080	26.97	23.976	74.176		HDTV 1080P		
11	1920*1080	33.75	30.00	74.25		HDTV 1080P		
12	1920*1080	33.71	29.97	74.176		HDTV 1080P		

5.2. 3D mode

5.2.1. RF Input

No	Resolution	H-freq(kHz)	V-freq.(Hz)	Pixel clock(MHz)	Proposed	Remark
1	1920*1080	45	60	74.25	HDTV 1080I	Side by Side, Top & Bottom
2	1280*720	45	60	74.25	HDTV 720P	Side by Side, Top & Bottom

5.2.2. USB Input

No	Resolution	H-freq(kHz)	V-freq.(Hz)	Pixel clock(MHz)	Proposed	Remark
1	1920*1080	33.75	30.00	74.25	HDTV 1080p	Side by Side, Top & Bottom, Checkerboard, MPO (Photo)

5.2.3. RGB-PC Input

No	Resolution	H-freq(kHz)	V-freq.(Hz)	Pixel clock(MHz)	Proposed	Remark
1	1920*1080	66.587	59.934	138.5	HDTV 1080p	Side by Side, Top & Bottom

5.2.4. DLNA Input

No	Resolution	H-freq(kHz)	V-freq.(Hz)	Pixel clock(MHz)	Proposed	Remark
1	1920*1080	33.75	30	74.25	HDTV 1080p	Side by Side, Top & Bottom, Checker board

5.2.5. HDMI 1.3

No	Resolution	H-freq(kHz)	V-freq.(Hz)	Pixel clock(MHz)	Remark
1	1280*720p	45.00	60.00	74.25	Side by Side , Top & Bottom
2	1920*1080i	33.75	60.00	74.25	Side by Side , Top & Bottom
3	1920*1080p	67.50	60.00	148.50	Side by Side , Top & Bottom Checkerboard Single Frame Sequential
4	1920*1080p	27.00	24.000	74.25	Side by Side , Top & Bottom Checkerboard
5	1920*1080p	33.75	30.000	74.25	Side by Side, Top & Bottom Checkerboard



5.2.6. HDMI 1.4a

No	Resolution	H-freq(kHz)	V-freq.(Hz)	Pixel clock(MHz)	Proposed	Remark
1	1280*720p	90.00	60.00	148.50	Mandatory	Frame Packing,
2	1280*720p	45.00	60.00	74.25	Mandatory	Top & Bottom
3	1920*1080i	33.75	60.00	74.25	Mandatory	Side by Side (Half)
4	1920*1080p	54.00	24.000	148.50	Mandatory	Frame Packing,
5	1920*1080p	27.00	24.000	74.25	Mandatory	Top & Bottom
6	1280*720p	45.00	60.00	74.25	Primary	Side by Side (Half)
7	1920*1080i	67.50	60.00	148.50	Primary	Frame Packing
8	1920*1080p	67.50	60.00	148.50	Primary	Top & Bottom
9	1920*1080p	27.00	24.000	74.25	Primary	Side by Side (Half)
10	1920*1080p	67.50	30.000	148.50	Primary	Frame Packing,
11	1920*1080p	33.75	30.000	74.25	Primary	Top & Bottom
12	1920*1080i	33.75	60.00	74.25	Secondary	Top & Bottom
13	1920*1080p	67.50	60.00	148.50	Secondary	Side by Side (Half)
14	1920*1080p	33.75	30.000	74.25	Secondary	Side by Side (Half)
15	720*480p	63.00	60.00	54.054	Secondary (16:9)	Frame Packing,
16	720*480p	31.50	60.00	27.027	Secondary (16:9)	Top & Bottom
17	720*480p	31.50	60.00	27.027	Secondary (16:9)	Side by Side (Half)
18	720*480p	63.00	60.00	54.054	Secondary (4:3)	Frame Packing,
19	720*480p	31.50	60.00	27.027	Secondary (4:3)	Top & Bottom
20	720*480p	31.50	60.00	27.027	Secondary (4:3)	Side by Side (Half)
21	640*480p	63.00	60.00	50.40	Secondary	Frame Packing,
22	640*480p	31.50	60.00	25.20	Secondary	Top & Bottom
23	640*480p	31.50	60.00	25.20	Secondary	Side by Side (Half)
24	1280*720p	90.00	60.00	148.50		Line Alternative
25	1280*720p	45.00	60.00	148.50		Side by Side (Full)
26	1920*1080i	67.50	60.00	148.50		Field Alternative
27	1920*1080i	33.75	60.00	148.50		Side by Side (Full)
28	1920*1080p	54.00	24.000	148.50		Line Alternative
29	1920*1080p	27.00	24.000	148.50		Side by Side (Full)
30	1920*1080p	67.50	30.000	148.50		Line Alternative
31	1920*1080p	33.75	30.000	148.50		Side by Side (Full)
32	720*480p	63.00	60.00	54.054	16:9	Line Alternative
33	720*480p	31.50	60.00	54.054	16:9	Side by Side (Full)
34	720*480p	63.00	60.00	54.054	4:3	Line Alternative
35	720*480p	31.50	60.00	54.054	4:3	Side by Side (Full)
36	640*480p	63.00	60.00	50.40		Line Alternative
37	640*480p	31.50	60.00	50.40		Side by Side (Full)

5.3. 2D to 3D Mode

- Supports this function in all mode.

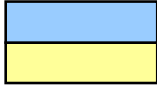
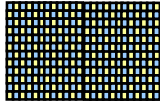
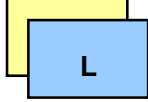
5.4. Remark: 3D Input mode

No.	Side by Side	Top & Bottom	Checkerboard	Single Frame Sequential	Frame Packing
1					

ADJUSTMENT INSTRUCTION

1. Application Range

This spec. sheet applies to LA22E Chassis applied LCD TV all models manufactured in TV factory.

2. Specification

- (1) Because this is not a hot chassis, it is not necessary to use an isolation transformer. However, the use of isolation transformer will help protect test instrument.
- (2) Adjustment must be done in the correct order.
- (3) The adjustment must be performed in the circumstance of 25 ± 5 °C of temperature and $65 \pm 10\%$ of relative humidity if there is no specific designation.
- (4) The input voltage of the receiver must keep 100~240V, 50/60Hz.
- (5) The receiver must be operated for about 5 minutes prior to the adjustment when module is in the circumstance of over 15 °C
In case of keeping module is in the circumstance of 0°C, it should be placed in the circumstance of above 15°C for 2 hours
In case of keeping module is in the circumstance of below -20°C, it should be placed in the circumstance of above 15°C for 3 hours.

[Caution]

When still image is displayed for a period of 20 minutes or longer (especially where W/B scale is strong. Digital pattern 13ch and/or Cross hatch pattern 09ch), there can some afterimage in the black level area

3. Adjustment items

3.1. Main PCBA Adjustments

- (1) ADC adjustment: Component 480i, 1080p / RGB-PC 1080p
- (2) EDID downloads for HDMI and RGB-PC

3.2. Final assembly adjustment

- (1) White Balance adjustment
- (2) RS-232C functionality check
- (3) Factory Option setting per destination
- (4) Shipment mode setting (IN-STOP)
- (5) GND and HI-POT test

3.3. Appendix

- (1) Tool option menu, USB Download (S/W Update, Option and Service only)
- (2) Manual adjustment for ADC calibration and White balance.
- (3) Shipment conditions, Channel pre-set

4. MAIN PCBA Adjustments

4.1. ADC Calibration

- An ADC calibration is not necessary because MAIN SoC (LGE35230) is already calibrated from IC Maker
- If it needs to adjust manually, refer to appendix.

4.2. MAC Address, ESN Key and Widevine Key download

4.2.1. Equipment & Condition

- 1) Play file: keydownload.exe

4.2.2. Communication Port connection

- 1) Key Write: Com 1,2,3,4 and 115200 (Baudrate)
- 2) Barcode: Com 1,2,3,4 and 9600 (Baudrate)

4.2.3. Download process

- 1) Select the download items.
- 2) Mode check: Online Only
- 3) Check the test process
 - US, Canada models: DETECT -> MAC_WRITE -> WIDEVINE_WRITE
 - Korea, Mexico models: DETECT -> MAC_WRITE -> WIDEVINE_WRITE
- 4) Play : START
- 5) Check of result: Ready, Test, OK or NG

4.2.4. Communication Port connection

- 1) Connect: PCBA Jig -> RS-232C Port == PC -> RS-232C Port

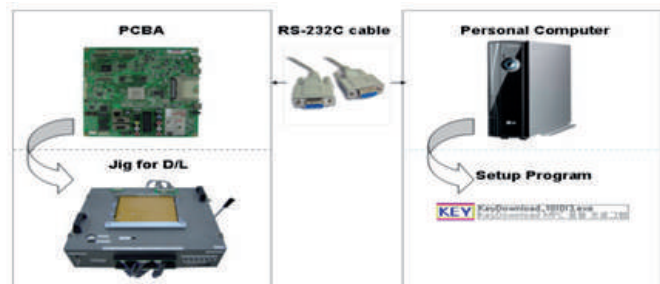

4.2.5. Download

- 1) US, Canada, Mexico models (11Y LCD TV + MAC + Widevine + ESN Key)

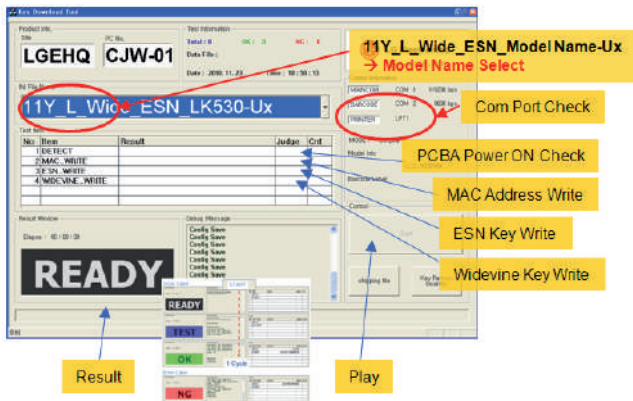

- 2) Korea and Philippine models (11Y LCD TV + MAC + Widevine Only)

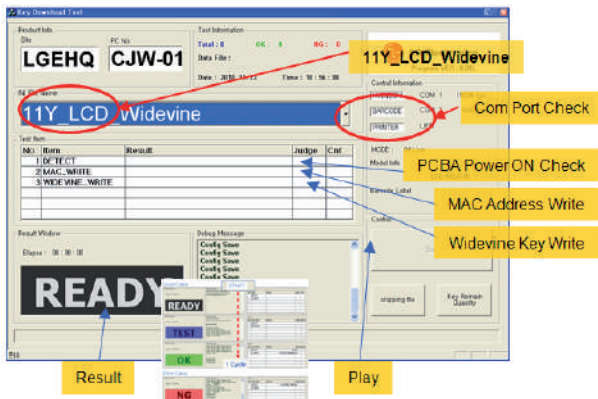

4.2.6. Inspection

- In INSTART menu, check these keys.

4.3. LAN PORT INSPECTION(PING TEST)

4.3.1. Equipment setting

- 1) Play the LAN Port Test PROGRAM.
- 2) Input IP set up for an inspection to Test Program.

*IP Number : 12.12.2.2.

Connect SET-> LAN Port == PC-> LAN Port



4.3.2. LAN PORT inspection (PING TEST)

- 1) Play the LAN Port Test Program.
- 2) connect each other LAN Port Jack.
- 3) Play Test (F9) button and confirm OK Message.
- 4) remove LAN CABLE

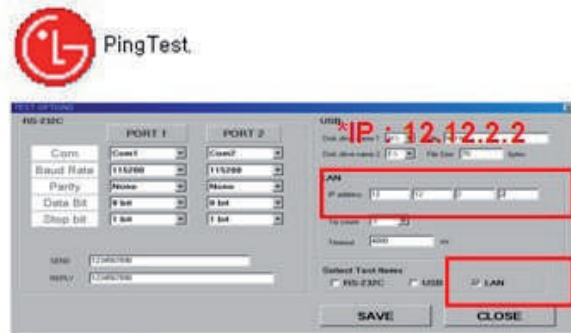

f) Vendor Specific(HDMI)

INPUT	MODEL NAME(HEX)
HDMI1	78 03 0C 00 10 00 80 2D 20 C0 0E 01 4F 00 FE 08 10 06 10 18 10 28 10 38 10
HDMI2	78 03 0C 00 20 00 80 2D 20 C0 0E 01 4F 00 FE 08 10 06 10 18 10 28 10 38 10
HDMI3	78 03 0C 00 30 00 80 2D 20 C0 0E 01 4F 00 FE 08 10 06 10 18 10 28 10 38 10
HDMI4	78 03 0C 00 40 00 80 2D 20 C0 0E 01 4F 00 FE 08 10 06 10 18 10 28 10 38 10

4.4.4.3. 3D PCM(US) _ XvYcc : off

HDMI EDID XvYcc_off_2D_PCM															
0x00	0x01	0x02	0x03	0x04	0x05	0x06	0x07	0x08	0x09	0x0A	0x0B	0x0C	0x0D	0x0E	0x0F
00	FF	FF	FF	FF	FF	FF	00	1E	6D						
01	01	03	80	A0	5A	78	0A	EE	91	A3	54	4C	99	26	
02	0F	50	54	A1	08	00	31	40	45	40	61	40	71	40	81
03	01	01	01	01	01	01	02	3A	80	18	71	38	2D	40	58
04	45	00	A0	5A	00	00	00	1E	66	21	50	B0	51	00	1B
05	40	70	36	00	A0	5A	00	00	00	1E	00	00	00	FD	00
06	3E	1E	53	10	00	0A	20	20	20	20	20	20	20	20	20
07	02	03	1D	F1	48	90	22	20	05	04	03	02	01	23	09
08	07									E3	05	00	00	02	3A
09	18	71	38	2D	40	58	2C	04	05	A0	5A	00	00	00	1E
0A	1D	80	18	71	1C	16	20	58	2C	25	00	A0	5A	00	00
0B	9E	01	1D	00	72	51	D0	1E	20	6E	28	55	00	A0	5A
0C	00	00	1E	8C	0A	D0	8A	20	E0	2D	10	10	3E	96	00
0D	5A	00	00	00	18	26	36	80	A0	70	38	1F	40	30	20
0E	00	A0	5A	00	00	00	1A	00	00	00	00	00	00	00	00
0F															02

RGB EDID

0x00	0x01	0x02	0x03	0x04	0x05	0x06	0x07	0x08	0x09	0x0A	0x0B	0x0C	0x0D	0x0E	0x0F
00	FF	FF	FF	FF	FF	FF	00	1E	6D						
01	01	03	80	A0	5A	78	0A	EE	91	A3	54	4C	99	26	
02	0F	50	54	A1	08	00	31	40	45	40	61	40	71	40	81
03	01	01	01	01	01	01	02	3A	80	18	71	38	2D	40	58
04	45	00	A0	5A	00	00	00	1E	66	21	50	B0	51	00	1B
05	40	70	36	00	A0	5A	00	00	00	1E	00	00	00	FD	00
06	3E	1E	53	10	00	0A	20	20	20	20	20	20	20	20	20
07	02	03	1D	F1	48	90	22	20	05	04	03	02	01	23	09
08	07									E3	05	00	00	02	3A
09	18	71	38	2D	40	58	2C	04	05	A0	5A	00	00	00	1E
0A	1D	80	18	71	1C	16	20	58	2C	25	00	A0	5A	00	00
0B	9E	01	1D	00	72	51	D0	1E	20	6E	28	55	00	A0	5A
0C	00	00	1E	8C	0A	D0	8A	20	E0	2D	10	10	3E	96	00
0D	5A	00	00	00	18	26	36	80	A0	70	38	1F	40	30	20
0E	00	A0	5A	00	00	00	1A	00	00	00	00	00	00	00	00
0F															02

- Reference 53
- HDMI1 ~ HDMI4 / RGB
- In the data of EDID, bellows may be different by S/W or Input mode.

a) Product ID

HEX	EDID Table	DDC Function
0001	0100	Analog
0001	0100	Digital

- b) Serial No: Controlled on production line.
- c) Month, Year: Controlled on production line:
ex) Monthly : '01' -> '01'
Year : '2012' -> '16'

d) Model Name(Hex): LGTV

Chassis	MODEL NAME(HEX)
LA22E	00 00 00 FC 00 4C 47 20 54 56 0A 20 20 20 20 20 20

e) Checksum(LG TV): Changeable by total EDID data.

	e1	e2	e3
HDMI1	43	B5	X
HDMI2	43	A5	X
HDMI3	43	95	X
HDMI4	43	85	X
RGB	X	X	5C

f) Vendor Specific(HDMI)

INPUT	MODEL NAME(HEX)
HDMI1	67 03 0C 00 10 00 80 2D
HDMI2	67 03 0C 00 20 00 80 2D
HDMI3	67 03 0C 00 30 00 80 2D
HDMI4	67 03 0C 00 40 00 80 2D

4.4.4.4. 3D PCM(US) _XvYcc : off

HDMI EDID XvYcc_off_3D_PCM															
0x00	0x01	0x02	0x03	0x04	0x05	0x06	0x07	0x08	0x09	0x0A	0x0B	0x0C	0x0D	0x0E	0x0F
00	FF	FF	FF	FF	FF	FF	FF	FF	FF	FF	00	1E	6D		
01	01	03	80	A0	5A	78	0A	EE	91	A3	54	4C	99	26	
02	0F	50	54	A1	08	00	31	40	45	40	61	40	71	40	81
03	01	01	01	01	01	01	02	3A	80	18	71	38	2D	40	58
04	45	00	A0	5A	00	00	00	1E	66	21	50	B0	51	00	1B
05	40	70	36	00	A0	5A	00	00	00	1E	00	00	00	FD	00
06	3E	1E	53	10	00	0A	20	20	20	20	20	20	20	20	20
07	02	03	1D	F1	48	90	22	20	05	04	03	02	01	23	09
08	07									E3	05	00	00	02	3A
09	18	71	38	2D	40	58	2C	04	05	A0	5A	00	00	00	1E
0A	1D	80	18	71	1C	16	20	58	2C	25	00	A0	5A	00	00
0B	9E	01	1D	00	72	51	D0	1E	20	6E	28	55	00	A0	5A
0C	00	00	1E	8C	0A	D0	8A	20	E0	2D	10	10	3E	96	00
0D	5A	00	00	00	18	26	36	80	A0	70	38	1F	40	30	20
0E	00	A0	5A	00	00	00	1A	00	00	00	00	00	00	00	00
0F															02

RGB EDID

0x00	0x01	0x02	0x03	0x04	0x05	0x06	0x07	0x08	0x09	0x0A	0x0B	0x0C	0x0D	0x0E	0x0F
00	FF	FF	FF	FF	FF	FF	FF	FF	FF	FF	00	1E	6D		
01	01	03	80	A0	5A	78	0A	EE	91	A3	54	4C	99	26	
02	0F	50	54	A1	08	00	31	40	45	40	61	40	71	40	81
03	01	01	01	01	01	01	02	3A	80	18	71	38	2D	40	58
04	45	00	A0	5A	00	00	00	1E	66	21	50	B0	51	00	1B
05	40	70	36	00	A0	5A	00	00	00	1E	00	00	00	FD	00
06	3E	1E	53	10	00	0A	20	20	20	20	20	20	20	20	20
07	02	03	1D	F1	48	90	22	20	05	04	03	02	01	23	09
08	07									E3	05	00	00	02	3A
09	18	71	38	2D	40	58	2C	04	05	A0	5A	00	00	00	1E
0A	1D	80	18	71	1C	16	20	58	2C	25	00	A0	5A	00	00
0B	9E	01	1D	00	72	51	D0	1E	20	6E	28	55	00	A0	5A
0C	00	00	1E	8C	0A	D0	8A	20	E0	2D	10	10	3E	96	00
0D	5A	00	00	00	18	26	36	80	A0	70	38	1F	40	30	20
0E	00	A0	5A	00	00	00	1A	00	00	00	00	00	00	00	00
0F															02

a) Product ID

HEX	EDID Table	DDC Function
0001	0100	Analog
0001	0100	Digital

- b) Serial No: Controlled on production line.
- c) Month, Year: Controlled on production line:
ex) Monthly : '01' -> '01'
Year : '2012' -> '16'

d) Model Name(Hex): LGTV

Chassis	MODEL NAME(HEX)
LA22E	00 00 00 FC 00 4C 47 20 54 56 0A 20 20 20 20 20 20

e) Checksum(LG TV): Changeable by total EDID data.

	e1	e2	e3
HDMI1	43	68	X
HDMI2	43	58	X
HDMI3	43	48	X
HDMI4	43	38	X
RGB	X	X	5C

f) Vendor Specific(HDMI)

INPUT	MODEL NAME(HEX)
HDMI1	78 03 0C 00 10 00 80 2D 20 C0 0E 01 4F 00 FE 08 10 06 10 18 10 28 10 38 10
HDMI2	78 03 0C 00 20 00 80 2D 20 C0 0E 01 4F 00 FE 08 10 06 10 18 10 28 10 38 10
HDMI3	78 03 0C 00 30 00 80 2D 20 C0 0E 01 4F 00 FE 08 10 06 10 18 10 28 10 38 10
HDMI4	78 03 0C 00 40 00 80 2D 20 C0 0E 01 4F 00 FE 08 10 06 10 18 10 28 10 38 10

5. Final Assembly Adjustment

5.1. White Balance Adjustment

5.1.1. Overview

5.1.1.1. W/B adj. Objective & How-it-works

- (1) Objective: To reduce each Panel's W/B deviation
- (2) How-it-works: When R/G/B gain in the OSD is at 192, it means the panel is at its Full Dynamic Range. In order to prevent saturation of Full Dynamic range and data, one of R/G/B is fixed at 192, and the other two is lowered to find the desired value.
- (3) Adj. condition: normal temperature
 - Surrounding Temperature: 25±5 °C
 - Warm-up time: About 5 Min
 - Surrounding Humidity: 20% ~ 80%
 - Before White balance adjustment, Keep power on status, don't power off

5.1.1.2. Adj. condition and cautionary items

- (1) Lighting condition in surrounding area surrounding lighting should be lower 10 lux. Try to isolate adj. area into dark surrounding.
- (2) Probe location: Color Analyzer (CA-210) probe should be within 10cm and perpendicular of the module surface (80°~ 100°)
- (3) Aging time
 - After Aging Start, Keep the Power ON status during 5 Minutes.
 - In case of LCD, Back-light on should be checked using no signal or Full-white pattern.

5.1.2. Equipment

- (1) Color Analyzer: CA-210 (NCG: CH 9 / WCG: CH12 / LED: CH14)
 - (2) Adj. Computer (During auto adj., RS-232C protocol is needed)
 - (3) Adjust Remocon
 - (4) Video Signal Generator MSPG-925F 720p/204-Gray (Model: 217, Pattern: 49)
- ※ Color Analyzer Matrix should be calibrated using CS-1000

5.1.3. Equipment connection

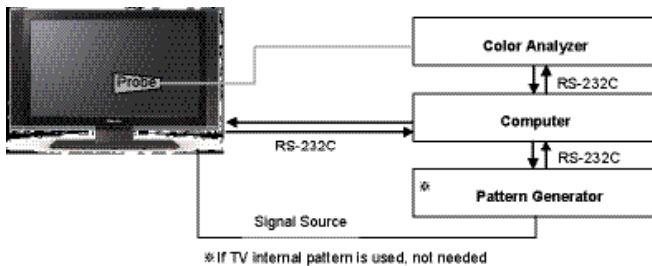

5.1.4. Adjustment Command (Protocol)

(1) RS-232C Command used during auto-adj.

RS-232C COMMAND			Explanation
CMD	DATA	ID	
Wb	00	00	Begin White Balance adj.
Wb	00	ff	End White Balance adj. (internal pattern disappears)

(2) Adjustment Map

	Adj. item	Command (lower caseASCII)		Data Range (Hex.)	
		CMD1	CMD2	MIN	MAX
Cool	R Gain	j	g	00	C0
	G Gain	j	h	00	C0
	B Gain	j	i	00	C0
Medium	R Gain	j	a	00	C0
	G Gain	j	b	00	C0
	B Gain	j	c	00	C0
Warm	R Gain	j	d	00	C0
	G Gain	j	e	00	C0
	B Gain	j	f	00	C0

5.1.5. Adjustment method

5.1.5.1 Auto WB calibration

- (1) Set TV in ADJ mode using P-ONLY key (or POWER ON key)
- (2) Place optical probe on the center of the display
 - It need to check probe condition of zero calibration before adjustment.
- (3) Connect RS-232C Cable
- (4) Select mode in ADJ Program and begin a adjustment.
- (5) When WB adjustment is completed with OK message, check adjustment status of pre-set mode (Cool, Medium, Warm)
- (6) Remove probe and RS-232C cable.
 - W/B Adj. must begin as start command "wb 00 00" , and finish as end command "wb 00 ff", and Adj. offset if need

5.1.6. Reference (White Balance Adj. coordinate and color temperature)

- (1) Luminance: 204 Gray, 80IRE
- (2) Standard color coordinate and temperature using CS-1000 (over 26 inch)

5.1.7. Reference (White Balance Adj. coordinate and color temperature)

- Luminance: 204 Gray
- Standard color coordinate and temperature using CS-1000 (over 26 inch)

Mode	Coordinate		Temp	△uv
	X	Y		
Cool	0.269	0.273	13,000K	0.0000
Medium	0.285	0.293	9,300K	0.0000
Warm	0.313	0.329	6,500K	0.0000

- Standard color coordinate and temperature using CA-210(CH 14)
- (1) LGD and 65"AUO

Mode	Coordinate		Temp	△uv
	X	Y		
Cool	0.269±0.002	0.273±0.002	13,000K	0.0000
Medium	0.285±0.002	0.293±0.002	9,300K	0.0000
Warm	0.313±0.002	0.329±0.002	6,500K	0.0000

- (2) O/S Module(AUO, CMI, Sharp,IPS...)

Mode	Coordinate		Temp	△uv
	X	Y		
Cool	0.271±0.002	0.276±0.002	13,000K	0.0000
Medium	0.287±0.002	0.296±0.002	9,300K	0.0000
Warm	0.315±0.002	0.332±0.002	6,500K	0.0000

- Standard color coordinate and temperature using CA-210(CH-14) – by aging time
- (1) Only Kumi factory in Korea

GP3 (3D모듈)	Aging time (Min)	Cool		Medium		Warm	
		x	y	x	y	x	y
		1	0-2	269	273	285	293
2	3-5	285	301	301	321	325	351
3	6-9	283	297	299	317	323	347
4	10-19	282	295	298	315	322	345
5	20-35	280	292	296	312	320	342
6	36-49	277	286	293	306	317	336
7	50-79	274	280	290	300	314	330
8	80-149	272	277	288	297	312	327
9	Over 150	271	275	287	295	311	325

- (2) Other factories(Only LS5700 series Module & 65LM6200-UA)

GP4	Aging time (Min)	Cool		Medium		Warm	
		X	Y	X	Y	X	Y
		269	273	285	293	313	329
1	0-2	280	287	296	307	320	337
2	3-5	279	285	295	305	319	335
3	6-9	277	284	293	304	317	334
4	10-19	276	283	292	303	316	333
5	20-35	274	280	290	300	314	330
6	36-49	272	277	288	297	312	327
7	50-79	271	275	287	295	311	325
8	80-119	270	274	286	294	310	324
9	Over 120	269	273	285	293	309	323

5.2. Tool Option setting & Inspection per countries

5.2.1. Overview

- (1) Tool option selection is only done for models in Non-USA North America due to rating
- (2) Applied model: LA02D and LA02E Chassis applied to CANADA and MEXICO

5.2.2. Country Group selection

- (1) Press ADJ key on the Adj. R/C, and then select Country Group Menu
- (2) Depending on destination, select KR or US, then on the lower Country option, select US, CA, MX.
Selection is done using +, - KEY

5.2.3. Tool Option Inspection

- (1) Press ADJ key on the Adj. R/C, and then select Country Group

Model	Tool 1	Tool 2	Tool 3	Tool 4	Tool 5	Tool 6	Tool 7
32LS5700-UA	356	8259	9997	13006	21015	1322	8971
42LS5700-UA(AUO)	4454	8259	9997	13006	21143	1322	13067
42LS5700-UA	358	8259	9997	13004	21015	1322	13067
47LS5700-UA(AUO)	4455	8259	9997	13006	21143	1322	12555
47LS5700-UA	359	8259	9997	13004	21015	1322	12555
55LS5700-UA(AUO)	4457	8259	9997	13006	21143	1321	12555
55LS5700-UA	361	8259	9997	13004	21015	1321	12555
60LS5700-UA(Sharp)	39274	8259	9997	13006	21015	1321	12555
42LS5750-UB	358	8259	9997	13004	21015	1322	13067
42LS5750-UB(AUO)	4454	8259	9997	13006	21143	1322	13067
47LS5750-UB	359	8259	9997	13004	21015	1322	12555
47LS5750-UB(AUO)	4455	8259	9997	13006	21143	1322	12555
55LS5750-UB	361	8259	9997	13004	21015	1321	12555
55LS5750-UB(AUO)	4457	8259	9997	13006	21143	1321	12555
60LS5750-UB(Sharp)	39274	8259	9997	13006	21015	1321	12555
32LM6200-UE	116	8259	26381	13006	23063	1322	8971
42LM6200-UE	118	8259	26381	13004	23063	1322	13067
47LM6200-UE	119	8259	26381	13004	23063	1322	12555
55LM6200-UE	121	8259	26381	13004	23063	1321	12555
65LM6200-UB	36987	8259	26381	13006	23063	1321	12427
42LM6210-UD	118	8259	26381	13004	23063	1322	13067
47LM6210-UD	119	8259	26381	13004	23063	1322	12555
47LM6250-UD	119	8259	26381	13004	23063	1322	12555
55LM6250-UD	121	8259	26381	13004	23063	1321	12555

- Tool option can be reconstructed by Software

5.3. Local Dimming Inspection

- Press 'TILT' key of the Adj. R/C and check moving patterns. The black bar patterns moves from top to bottom. If a local dimming function does not work, a whole screen shows full white.

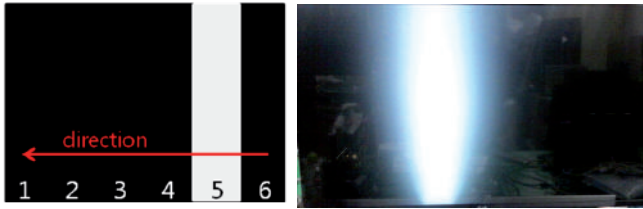

<T120 Model>

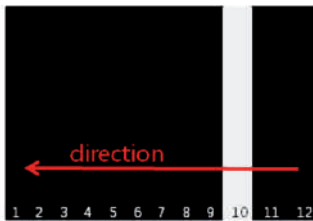

<T240 Model>

※ Except No local-dimming models

5.4. EYE-Q Check

- Turn on the TV..
- Press 'EYE' button' on the adjustment remote-controller.
- Cover 'Eye Q sensor' on the front of set with your hands, hold it for 6 seconds.
- Check "the Sensor Data" on the screen, make certain that Data is below 10. If Data isn't below 10 in 6 seconds, Eye Q sensor would be bad. You should change Eye Q sensor.
- Uncover your hands from Eye Q sensor, hold it for 6 seconds.
- Check "Back Light(XXX)" on the screen, check data increase . You should change Eye Q sensor.

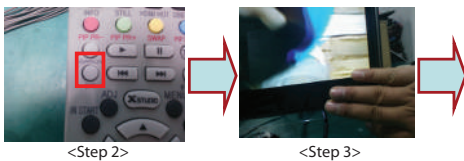

<Step 2>

<Step 3>



<Step 4>

<Step 5>

<Step 6>

5.5. Magic Motion remote controller Check

5.5.1. Test equipment

- RF-remote controller for check, IR-KEY-CODE remote controller.
- Check AA battery before test. A recommendation is that a tester change battery every lots.

5.5.2. Test

- Make pairing with TV set by pressing "Start key(Wheel key)" on RCU.
- Check a cursor on screen by pressing "Wheel key" of RCU
- Stop pairing with TV set by pressing "Back+ Home" key of RCU

5.5.3. Applied models

Chassis	Model Name	Magic RF receiver
LA22E	32/42/47/55LS5700-UA	Built-in
	42/47/55/65LM6200-UA	
	32/42/47/55LS5700-UA	
	42/47/55LM6700-UA	
	47/55LM7600-UA	

※LW5700-UE series: An USB dongle-type receiver will be supplied in form of accessory. So this pairing test is not necessary for these models.

5.6. Wi-Fi MAC Address Check

5.6.1. Using RS232 Command

	Command	Set ACK
Transmission	[A][][][Set ID][][20][Cr]	[O][K][x] or [N][G]

5.6.2. Check the menu on in-start

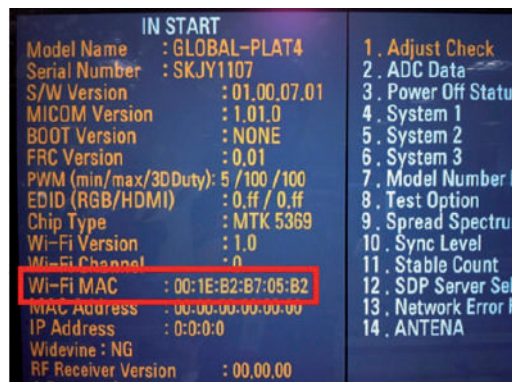

5.7. 3D pattern test (Only for 3D models)

5.7.1. Test equipment

- (1) Pattern Generator MSHG-600 or MSPG-6100 (HDMI 1.4 support)
- (2) Pattern: HDMI mode (model No. 872, pattern No. 83)

5.7.2. Test method

- (1) Input 3D test signal as Fig.1.



Fig.1
<HDMI Mode 872번, Pattern No. 83>

- (2) Press 'OK' key as a 3D input OSD is shown.
- (3) Check pattern as Fig2 without 3D glasses. (3D mode without 3D glasses)



Fig.2
<OK in 3D mode without 3D glasses>



Fig.3
<NG in 3D mode without 3D glasses>

5.8. HDMI ARC Function Inspection

5.8.1. Test equipment

- Optic Receiver Speaker
- MSHG-600 (SW: 1220 ↑)
- HDMI Cable (for 1.4 version)

5.8.2. Test method

- (1) Insert the HDMI Cable to the HDMI ARC port from the master equipment (HDMI1)



- (2) Check the sound from the TV Set



- (3) Check the Sound from the Speaker or using AV & Optic TEST program (It's connected to MSHG-600)

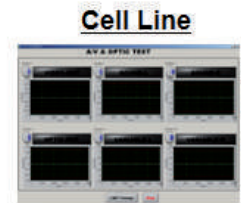

- * Remark: Inspect in Power Only Mode and check SW version in a master equipment



5.9. Ship-out mode check (In-stop)

- After final inspection, press In-Stop key of the Adj. R/C and check that the unit goes to Stand-by mode

6. AUDIO output check

6.1. Audio input condition

- (1) RF input: Mono, 1KHz sine wave signal, 100% Modulation
- (2) CVBS, Component: 1KHz sine wave signal (0.4Vrms)
- (3) RGB PC: 1KHz sine wave signal (0.7Vrms)

6.2. Specification

No	Item	Min	Typ	Max	Unit	Remark
1	Audio practical max Output, L/R	9.0 8.5	10.0 8.9	12.0 9.9	W Vrms	(1) Measurement condition - EQ/AVL/Clear Voice: Off (2) Speaker (8Ω Impedance)

7. GND and HI-POT Test

7.1. GND & HI-POT auto-check preparation

- (1) Check the POWER CABLE and SIGNAL CABLE insertion condition

7.2. GND & HI-POT auto-check

- (1) Pallet moves in the station. (POWER CORD / AV CORD is tightly inserted)
- (2) Connect the AV JACK Tester.
- (3) Controller (GWS103-4) on.
- (4) GND Test (Auto)
 - If Test is failed, Buzzer operates.
 - If Test is passed, execute next process (Hi-pot test). (Remove A/V CORD from A/V JACK BOX)
- (5) HI-POT test (Auto)
 - If Test is failed, Buzzer operates.
 - If Test is passed, GOOD Lamp on and move to next process automatically.

7.3. Checkpoint

- (1) Test voltage
 - GND: 1.5KV/min at 100mA
 - SIGNAL: 3KV/min at 100mA
- (2) TEST time: 1 second
- (3) TEST POINT
 - GND Test = POWER CORD GND and SIGNAL CABLE GND.
 - Hi-pot Test = POWER CORD GND and LIVE & NEUTRAL.
- (4) LEAKAGE CURRENT: At 0.5mA_{rms}

8. USB S/W Download

(optional, Service only)

- (1) Put the USB Stick to the USB socket
- (2) Automatically detecting update file in USB Stick
 - If your downloaded program version in USB Stick is lower than that of TV set, it didn't work. Otherwise USB data is automatically detected.
- (3) Show the message "Copying files from memory"

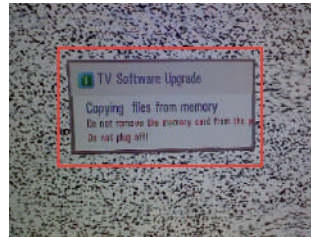

- (4) Updating is starting.

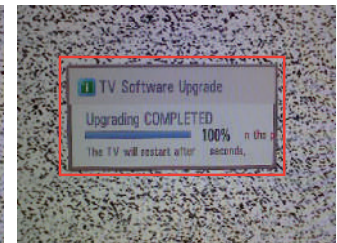
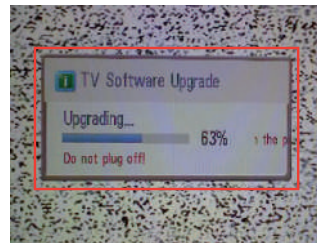

- (5) Updating Completed, The TV will restart automatically
- (6) If your TV is turned on, check your updated version and Tool option.

* If downloading version is more high than your TV have, TV can lost all channel data. In this case, you have to channel recover. If all channel data is cleared, you didn't have a DTV/ATV test on production line.

* After downloading, TOOL OPTION setting is needed again.

- (1) Push "IN-START" key in service remote controller.
- (2) Select "Tool Option 1" and Push "OK" button.
- (3) Punch in the number. (Each model has their number.)

9. Optional adjustments

9.1. Manual ADC Calibration

9.1.1. Equipment & Condition

- (1) Adjustment Remocon
- (2) 801GF (802B, 802F, 802R) or MSPG925FA Pattern Generator
- Resolution : 480i Comp1 (MSPG-925FA: model-209, pattern-65)
- Resolution : 1080p Comp1 (MSPG-925FA: model-225, pattern-65)
- Resolution : 1080p RGB (MSPG-925FA: model-225, pattern-65)
- Pattern : Horizontal 100% Color Bar Pattern
- Pattern level : 0.7±0.1 Vp-p

9.1.2. Adjust method

- 8.1.2.1 ADC 480i/1080p Comp1, RGB
- (1) Check connected condition of Comp1/RGB cable to the equipment
- (2) Give a 480i Mode, Horizontal 100% Color Bar Pattern to Comp1. (MSPG-925FA -> Model: 209, Pattern: 65)
- (3) Change input mode as Component1 and picture mode as "Standard"
- (4) Press the In-start Key on the ADJ remote after at least 1 min of signal reception. Then, select 7.External ADC. And Press OK or Right Button for going to sub menu.
- (5) Press OK in Comp 480i menu
- (6) Give a 1080p Mode, Horizontal 100% Color Bar Pattern to Comp1. (MSPG-925FA -> Model: 225, Pattern: 65)
- (7) Press OK in Comp 1080p menu
- (8) Perform (6) and (7) in RGB-PC
- (9) If ADC Comp is successful, "ADC Component Success" is displayed. If ADC calibration is failure, "ADC Component Fail" is displayed.
- (10) If ADC calibration is failure, after rechecking ADC pattern or condition, retry calibration
- (11) If ADC RGB calibration is successful, "ADC RGB Success" is displayed. If ADC calibration is failure, "ADC RGB Fail" is displayed.
- (12) If ADC calibration is failure, after recheck ADC pattern or condition, retry calibration

9.2. Manual White balance Adjustment

9.2.1. Adj. condition and cautionary items

- (1) Lighting condition in surrounding area surrounding lighting should be lower 10 lux. Try to isolate adj. area into dark surrounding.
- (2) Probe location: Color Analyzer (CA-210) probe should be within 10cm and perpendicular of the module surface (80°~ 100°)
- (3) Aging time
 - After Aging Start, Keep the Power ON status during 5 Minutes.
 - In case of LCD, Back-light on should be checked using no signal or Full-white pattern.

9.2.2. Equipment

- (1) Color Analyzer: CA-210 (NCG: CH 9 / WCG: CH12 / LED: CH14)
- (2) Adj. Computer (During auto adj., RS-232C protocol is needed)
- (3) Adjust Remocon
- (4) Video Signal Generator MSPG-925F 720p/216-Gray (Model: 217, Pattern: 78)

9.2.3. Adjustment

- (1) Set TV in Adj. mode using POWER ON
 - (2) Zero Calibrate the probe of Color Analyzer, then place it on the center of LCD module within 10cm of the surface.
 - (3) Press ADJ key -> EZ adjust using adj. R/C -> 6. White-Balance then press the cursor to the right (KEY▶). When KEY(▶) is pressed 216 Gray internal pattern will be displayed.
 - (4) One of R Gain / G Gain / B Gain should be fixed at 192, and the rest will be lowered to meet the desired value.
 - (5) Adj. is performed in COOL, MEDIUM, WARM 3 modes of color temperature.
- If internal pattern is not available, use RF input. In EZ Adj. menu 6.White Balance, you can select one of 2 Test-pattern: ON, OFF. Default is inner(ON). By selecting OFF, you can adjust using RF signal in 216 Gray pattern.

SCREW WORKING GUIDE

■ Screw specification and application situation

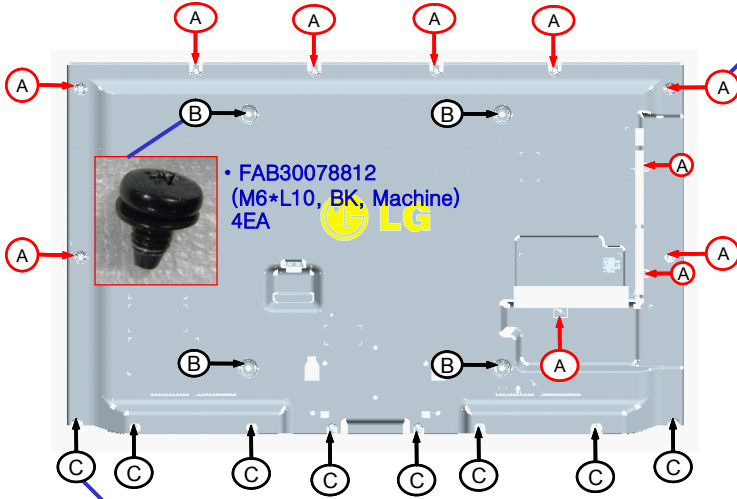

• FAB30078812
(M6*L10, BK, Machine)
4EA



• FAB31339402
(M3*L4.5, BK, Machine)
• 11EA

※ Warning

Check Screw Type When Screw is assembled at (A) Part. If (C) Screw is used at the (A) part Module will get damaged



• FAB31339201
(M3*L10, BK, Taptite)
• 8EA



• FAB30016122
(M4*L20, BK, Taptite)
• 4EA

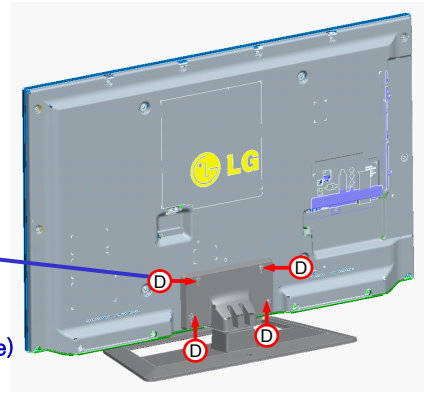

EXPLODED VIEW

IMPORTANT SAFETY NOTICE

Many electrical and mechanical parts in this chassis have special safety-related characteristics. These parts are identified by \triangle in the Schematic Diagram and EXPLODED VIEW. It is essential that these special safety parts should be replaced with the same components as recommended in this manual to prevent X-RADIATION, Shock, Fire, or other Hazards. Do not modify the original design without permission of manufacturer.

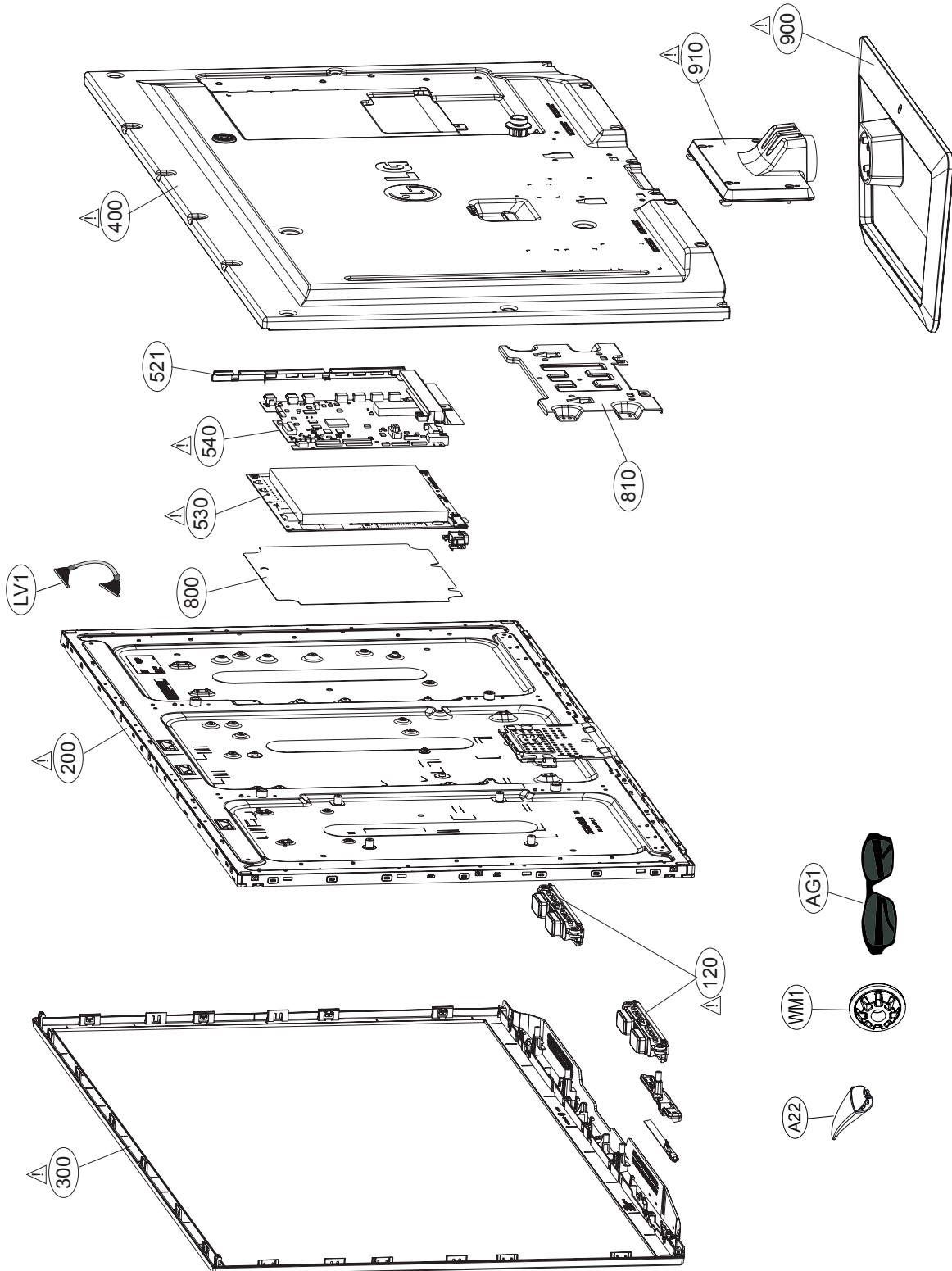

EAX6430790* : LD22* / LC22*
 EAX6443420* : LT22* / LJ22* / LA22* / LB22*

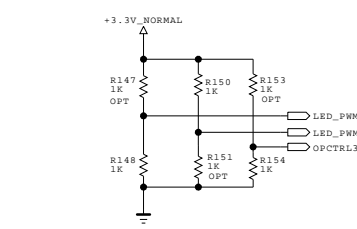
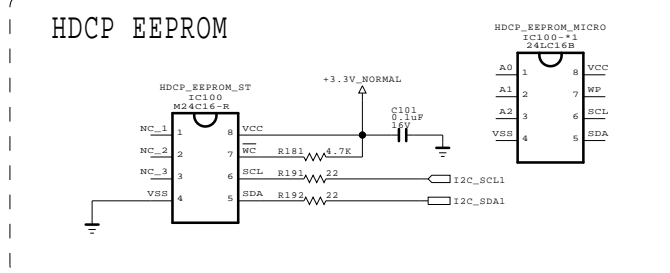
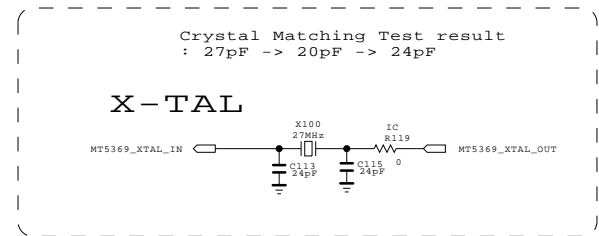
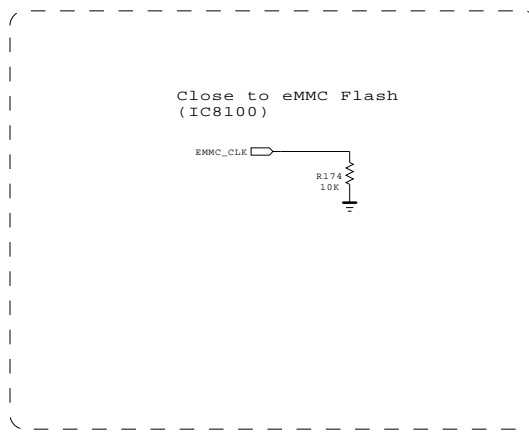
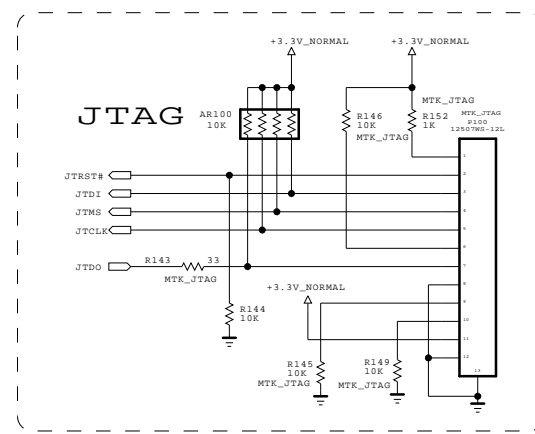
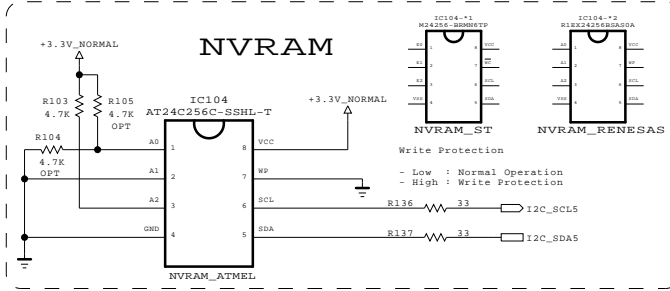

STRAPPING	LED_PWM0	LED_PWM1	OPCTRL3
ICE mode + 27M + Serial boot	0	0	0
ICE mode + 27M + ROM to NAND boot	0	0	1
ICE mode + 27M + Rom to eMMC boot from eMMC pins (share pins w/ NAND)	0	1	0
ICE mode + 27M + ROM to eMMC boot from SDIO pins	0	1	1

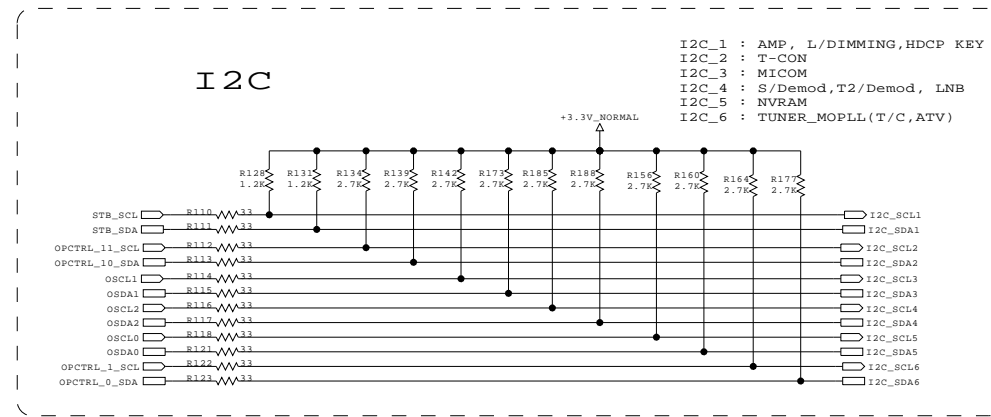
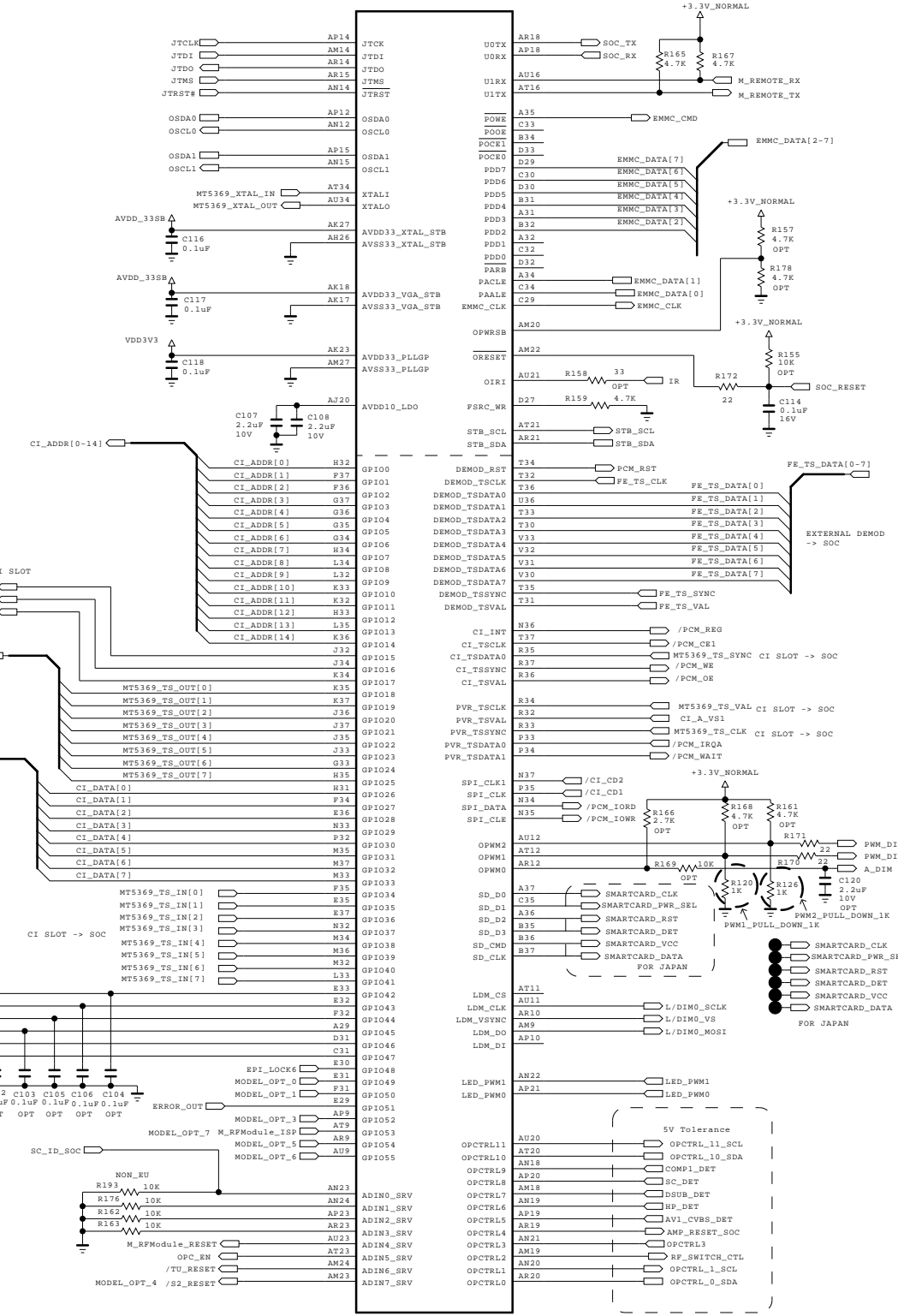

I2C_1 : AMP, L/DIMMING, HDCP KEY
 I2C_2 : T-COM
 I2C_3 : MI-COM
 I2C_4 : S/Demod, T2/Demod, LNB
 I2C_5 : NVRAM
 I2C_6 : TUNER_MOPLL (T/C, ATV)

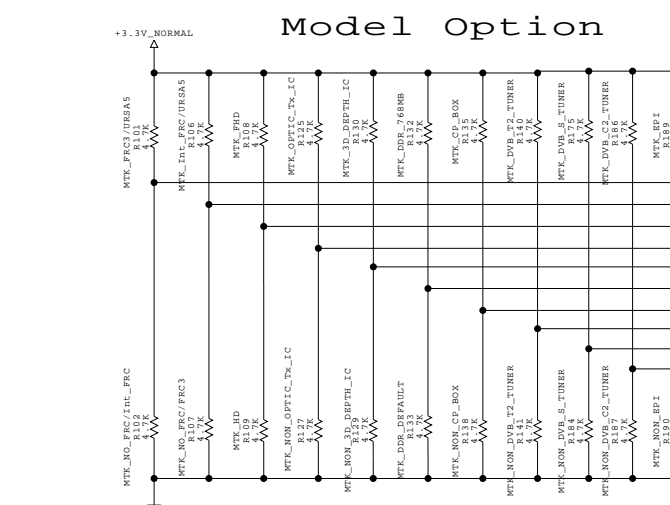

	NO_FRC	Soc internal FRC	LG FRC2	Reserved
MODEL_OPT_0	0	0	1	1
MODEL_OPT_1	0	1	0	1

	HIGH	LOW
MODEL_OPT_2	FHD	HD
MODEL_OPT_3	OPTIC	NON_OPTIC
MODEL_OPT_4	3D DEPTH	3D_Depth_IC NON_3D_Depth_IC
MODEL_OPT_5	DDR	DDR_768MB DDR_Default
MODEL_OPT_6	CP BOX	Enable Disable
MODEL_OPT_7	T2 Tuner	Support Not Support
MODEL_OPT_8	S Tuner	Support Not Support
MODEL_OPT_9	Reserved	Default
MODEL_OPT_10	EPI	Support Not Support

MODEL OPTION 8 is just for CP Box It should not be applied at MP

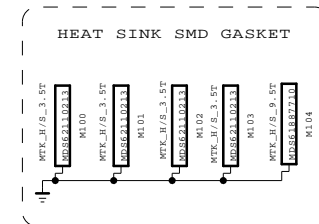

THE Δ SYMBOL MARK OF THIS SCHEMATIC DIAGRAM INCORPORATES SPECIAL FEATURES IMPORTANT FOR PROTECTION FROM X-RADIATION. FILRE AND ELECTRICAL SHOCK HAZARDS, WHEN SERVICING IF IS ESSENTIAL THAT ONLY MANUFACTURES SPECIFIED PARTS BE USED FOR THE CRITICAL COMPONENTS IN THE Δ SYMBOL MARK OF THE SCHEMATIC.

SECRET
 LG Electronics

LG ELECTRONICS

MODEL BLOCK MID_MAIN_1 **DATE SHEET** 2011.12.13
 8

PLACE AT JACK SIDE

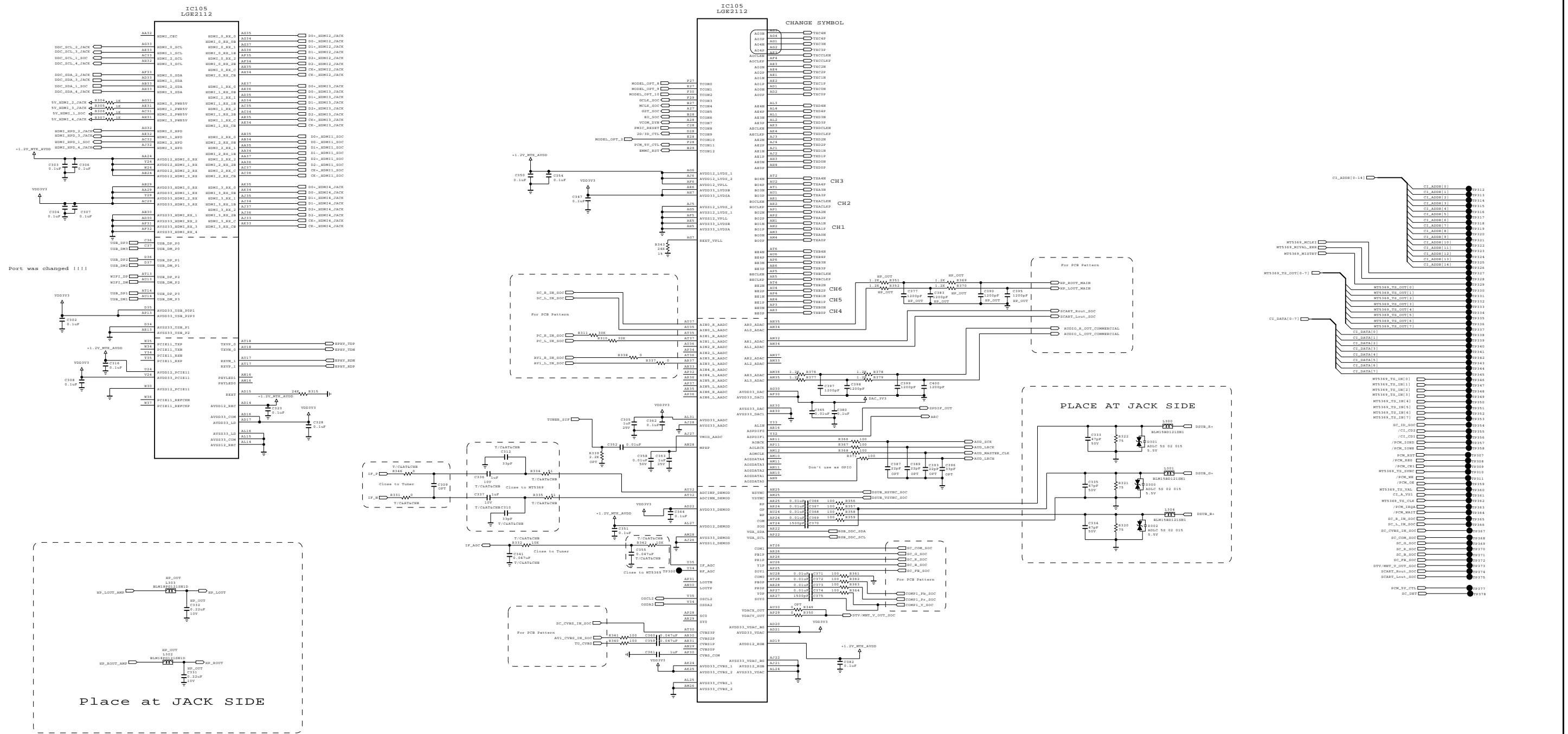
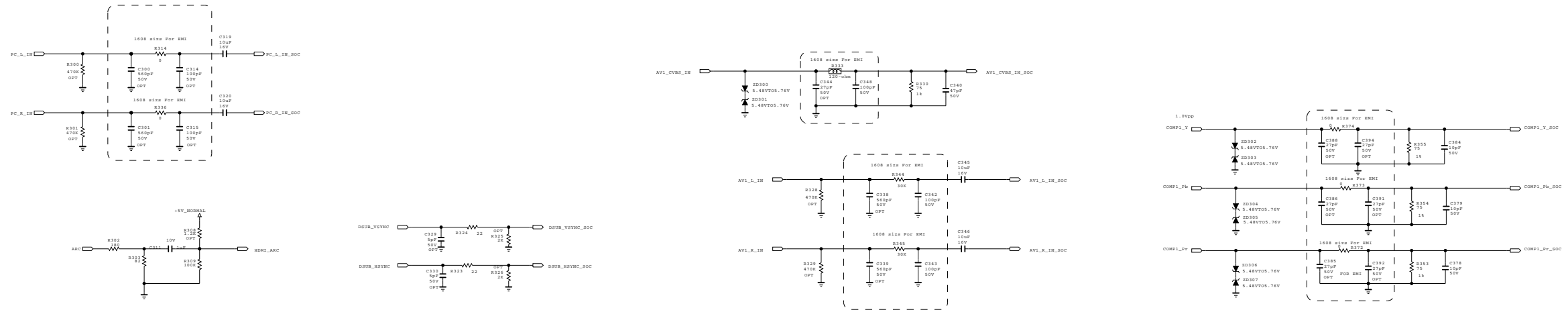

Place at JACK SIDE

THE SYMBOL MARK OF THIS SCHEMATIC DIAGRAM INCORPORATES SPECIAL FEATURES IMPORTANT FOR PROTECTION FROM X-RADIATION. FILTRER AND ELECTRICAL SHOCK HAZARDS, WHEN SERVICING IT IS ESSENTIAL THAT ONLY MANUFACTURERS SPECIFIED PARTS BE USED FOR THE CRITICAL COMPONENTS IN THE SYMBOL MARK OF THE SCHEMATIC.

SECRET
LGElectronics

LG ELECTRONICS

MODEL	MID_MAIN_2	DATE	2011.12.19
BLOCK		SHEET	9

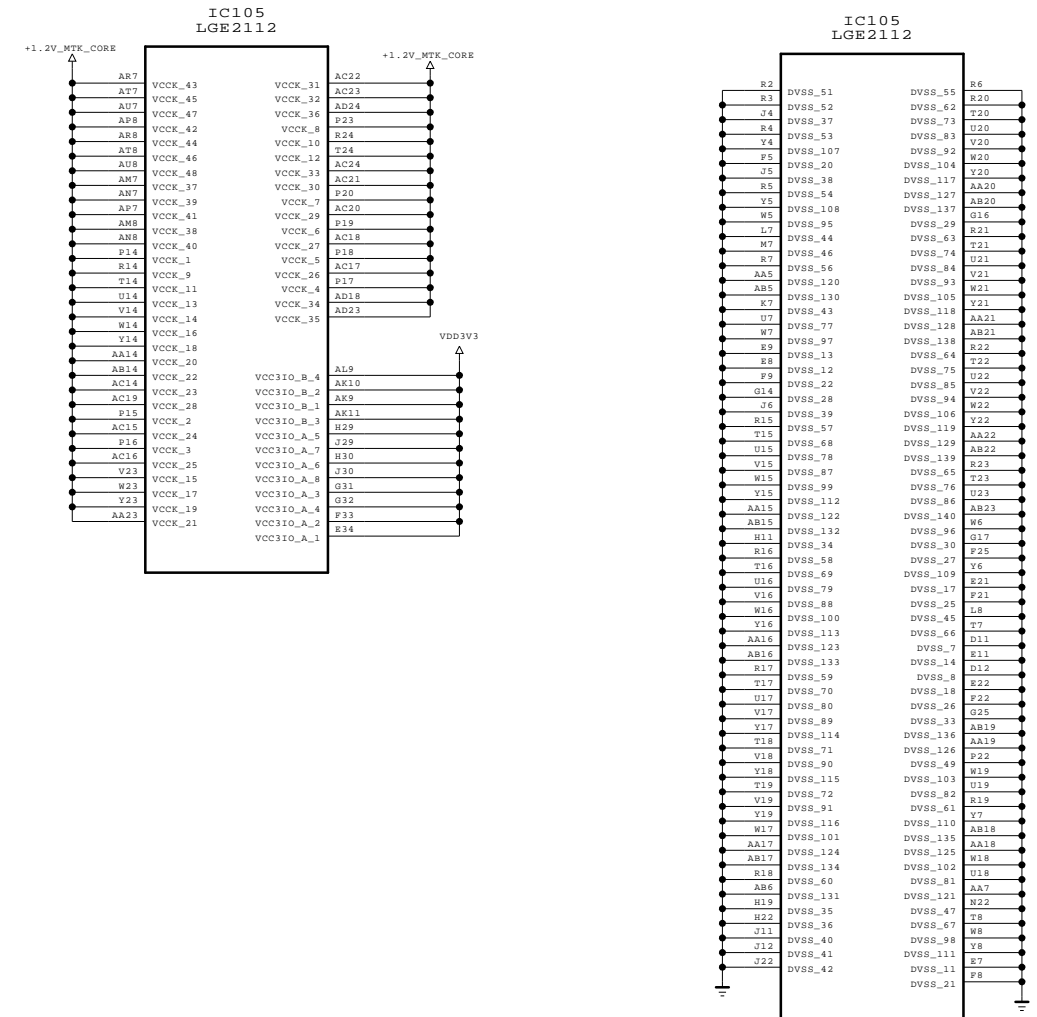
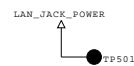
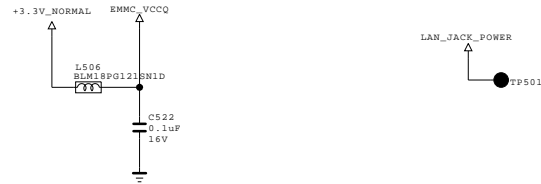
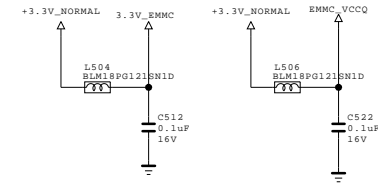
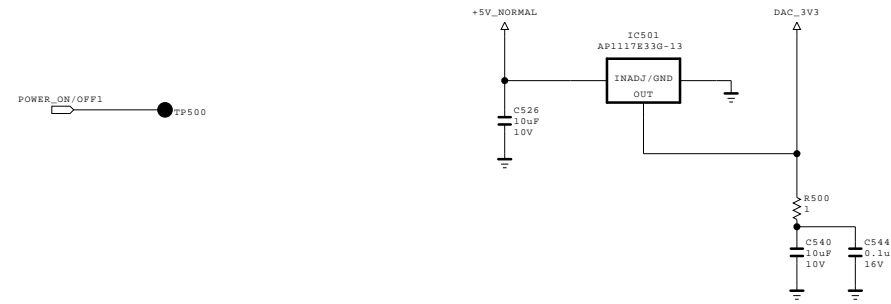
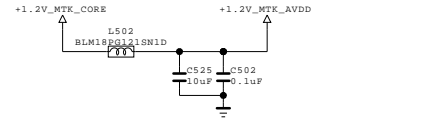
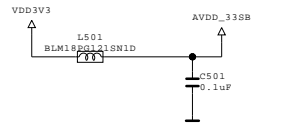
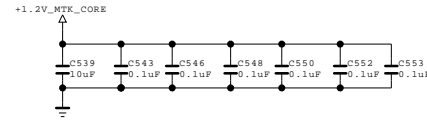
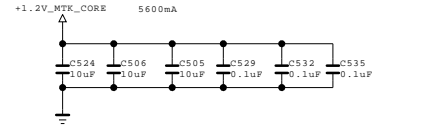
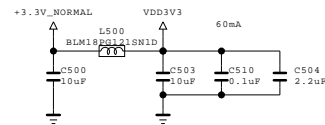

SMD Gasket

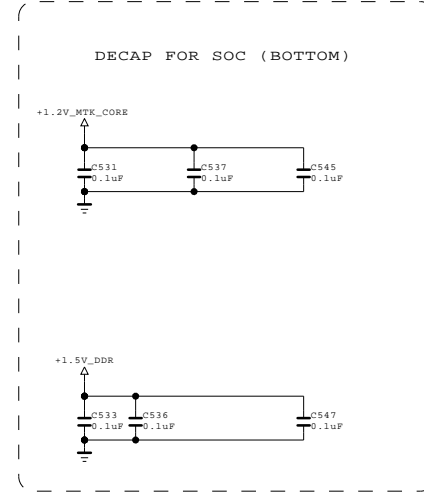
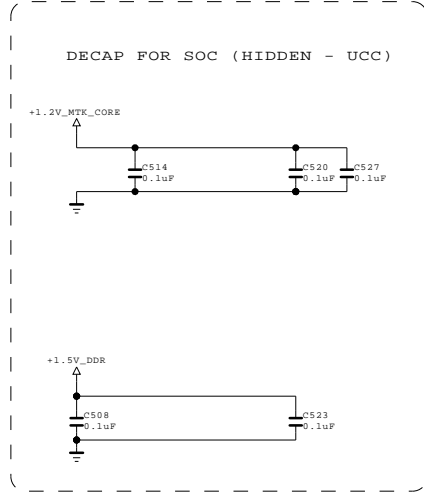
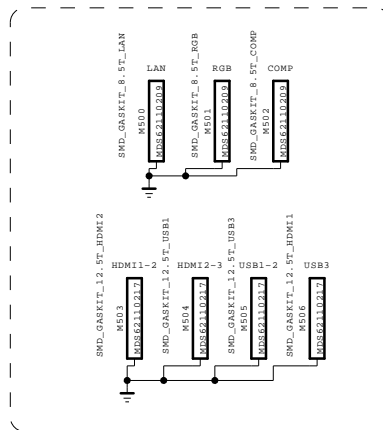

THE SYMBOL MARK OF THIS SCHEMATIC DIAGRAM INCORPORATES SPECIAL FEATURES IMPORTANT FOR PROTECTION FROM X-RADIATION. FILRE AND ELECTRICAL SHOCK HAZARDS, WHEN SERVICING IF IS ESSENTIAL THAT ONLY MANUFACTURES SPECIFIED PARTS BE USED FOR THE CRITICAL COMPONENTS IN THE SYMBOL MARK OF THE SCHEMATIC.

SECRET
LGElectronics



MODEL	MID_MAIN_3	DATE	2011.12.09
BLOCK		SHEET	10

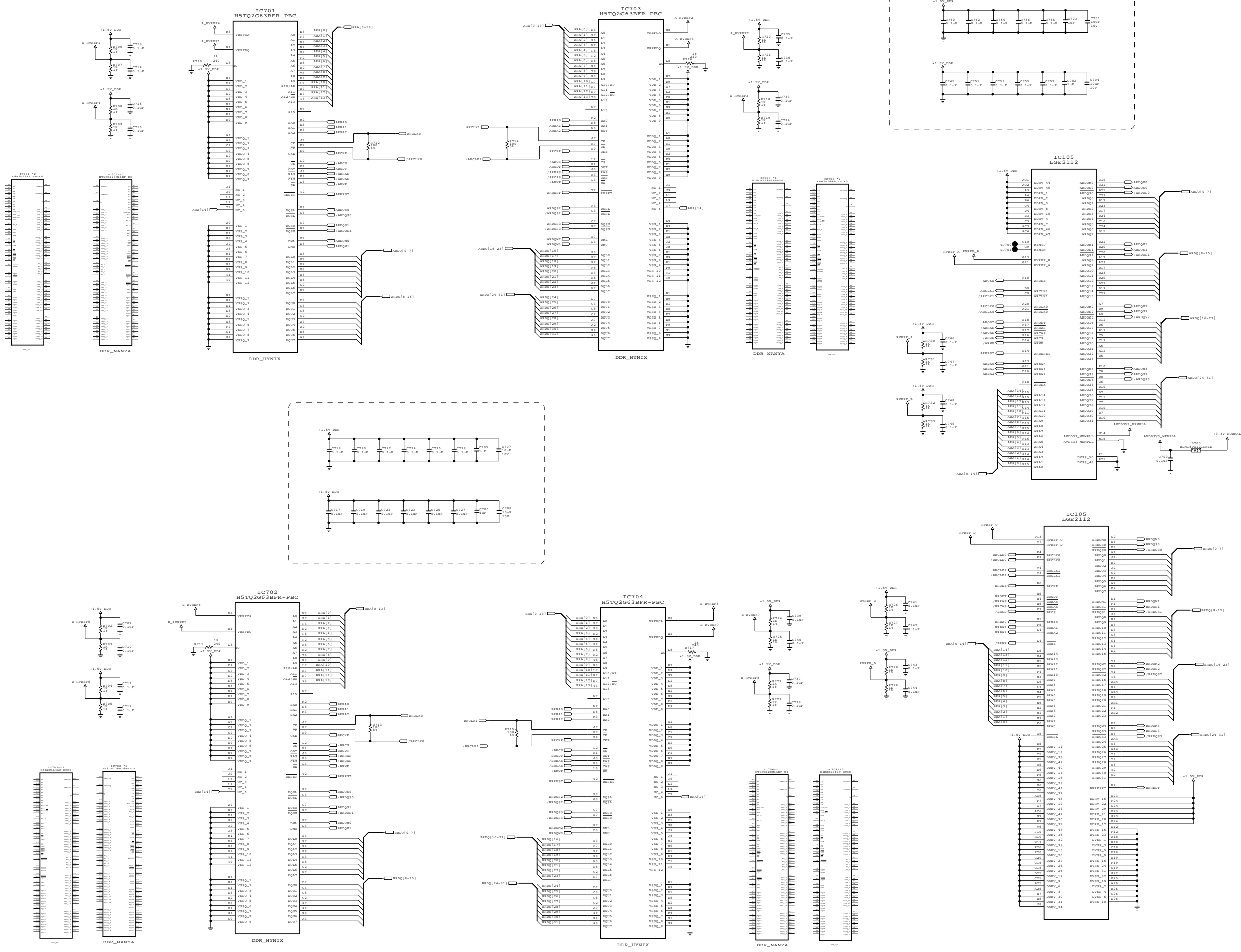

THE SYMBOL MARK OF THIS SCHEMATIC DIAGRAM INCORPORATES SPECIAL FEATURES IMPORTANT FOR PROTECTION FROM X-RADIATION. FILRE AND ELECTRICAL SHOCK HAZARDS, WHEN SERVICING IF IS ESSENTIAL THAT ONLY MANUFACTURERS SPECIFIED PARTS BE USED FOR THE CRITICAL COMPONENTS IN THE SYMBOL MARK OF THE SCHEMATIC.

SECRET
LGElectronics

LG ELECTRONICS

MODEL BLOCK	DDR ONE SIDE	DATE SHEET	2011.12.09 12 /
----------------	--------------	---------------	--------------------

FROM LIPS & POWER B/D

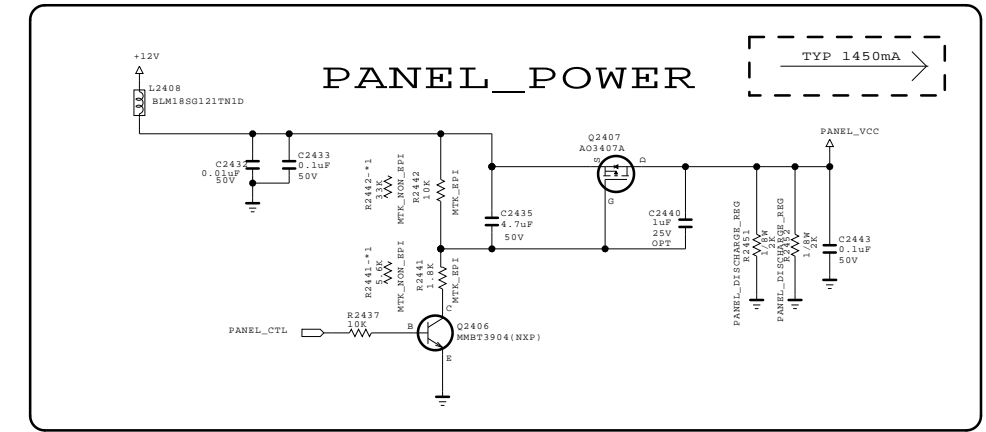
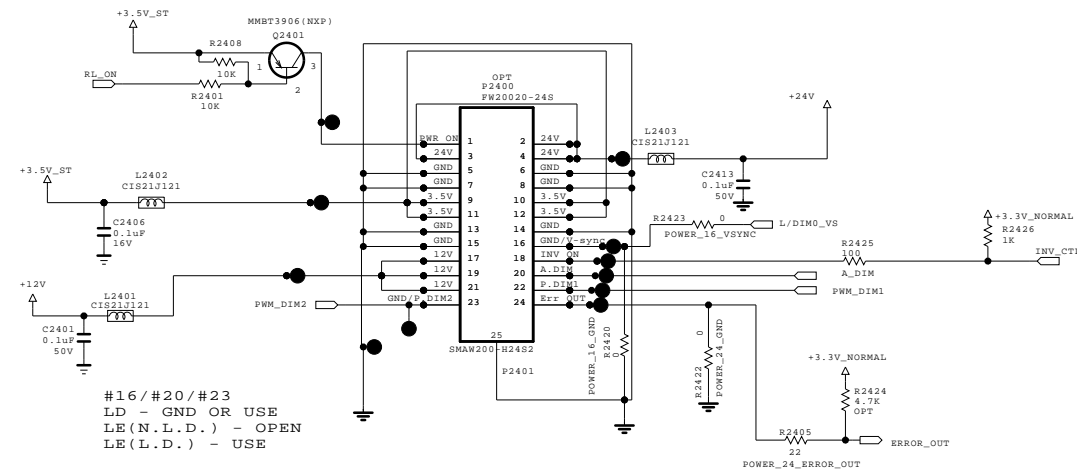

Power_DET

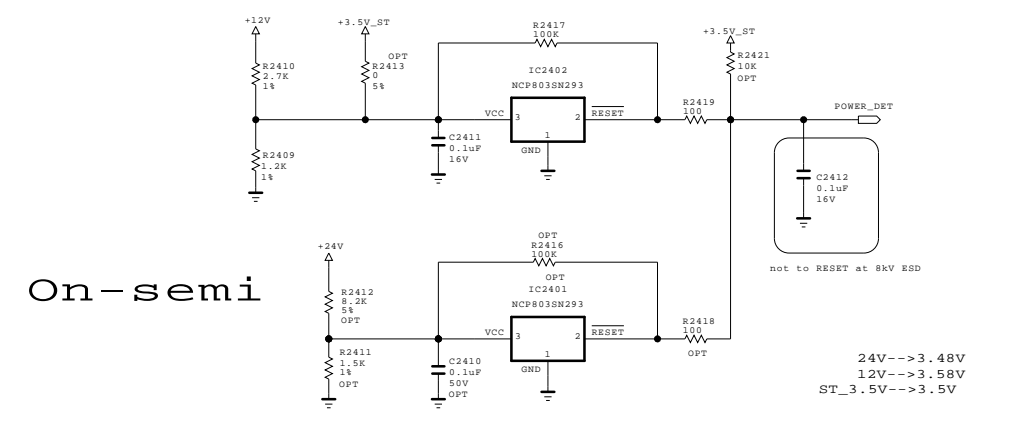

+5V_Normal

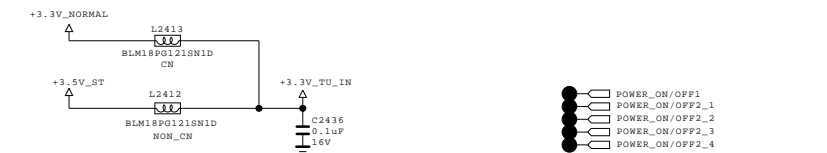
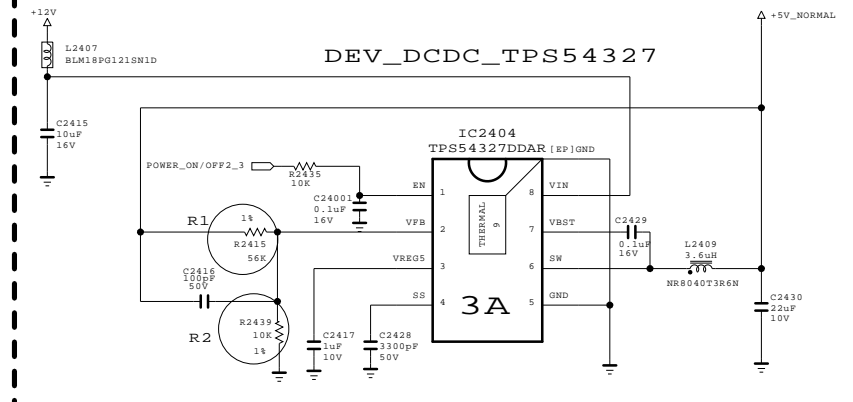

DDR MAIN 1.5V

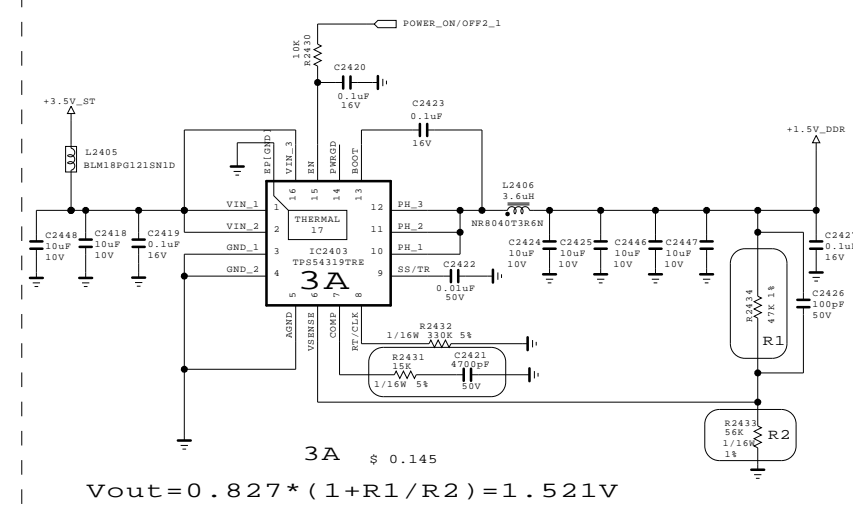

+3.3V_NORMAL

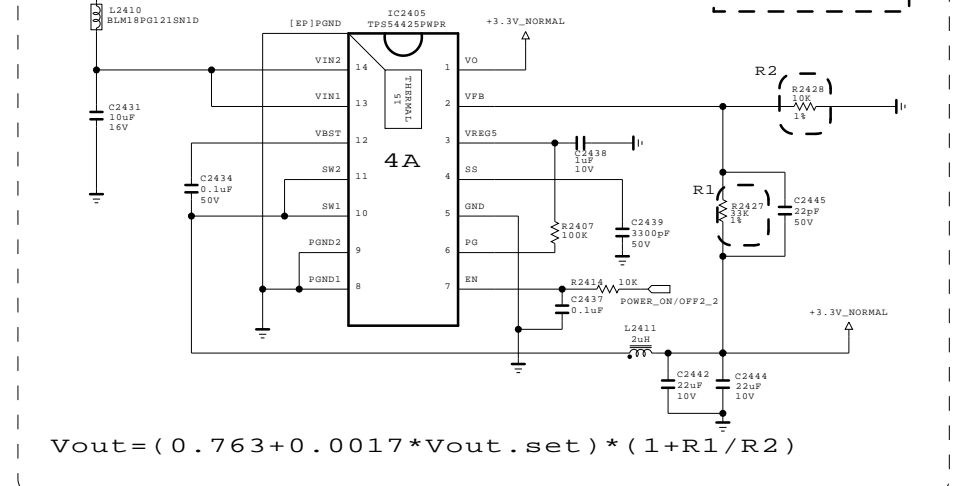

THE Δ SYMBOL MARK OF THIS SCHEMATIC DIAGRAM INCORPORATES SPECIAL FEATURES IMPORTANT FOR PROTECTION FROM X-RADIATION. FILRE AND ELECTRICAL SHOCK HAZARDS, WHEN SERVICING IF IS ESSENTIAL THAT ONLY MANUFACTURES SPECIFIED PARTS BE USED FOR THE CRITICAL COMPONENTS IN THE Δ SYMBOL MARK OF THE SCHEMATIC.

SECRET
LGElectronics



MODEL	MID_POWER	DATE	2011.11.25
BLOCK		SHEET	24

For Debug

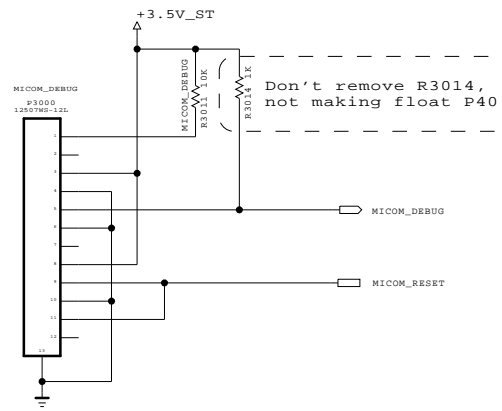

GP4 High/MID Power SEQUENCE

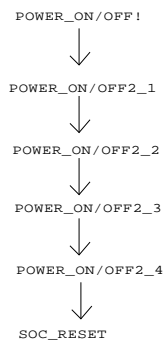

MICOM MODEL OPTION

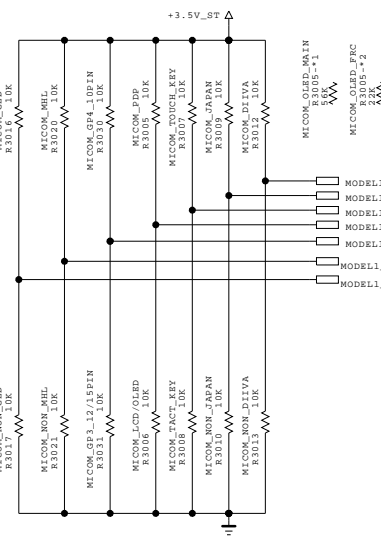

MICOM MODEL OPTION

	0	1	
MODEL_OPT_0	NON DIVA	DIVA	For China
MODEL_OPT_1	NON JAPAN	JAPAN	For JAPAN
MODEL_OPT_2	TACT_KEY	TOUCH_KEY	
MODEL_OPT_3	LCD / OLED	PDP	
MODEL_OPT_4	IR Wafer 12/15Pin (GP3 Soft touch)	IR Wafer 10Pin (GP4 TOOL)	For Sample Set
MODEL_OPT_5	NON_MHL	MHL	GP4_HIGH
MODEL_OPT_6	NON_GED	GED	

Eye Sensor Option

	0	1	
MODEL_OPT_4			
MODEL_OPT_2			
0	N/A	MC8101_ABOV (TACT_KEY)	
1	CM3231_CAPELLA (GP3 Soft touch)	CM3231_CAPELLA (GP4 Soft touch)	

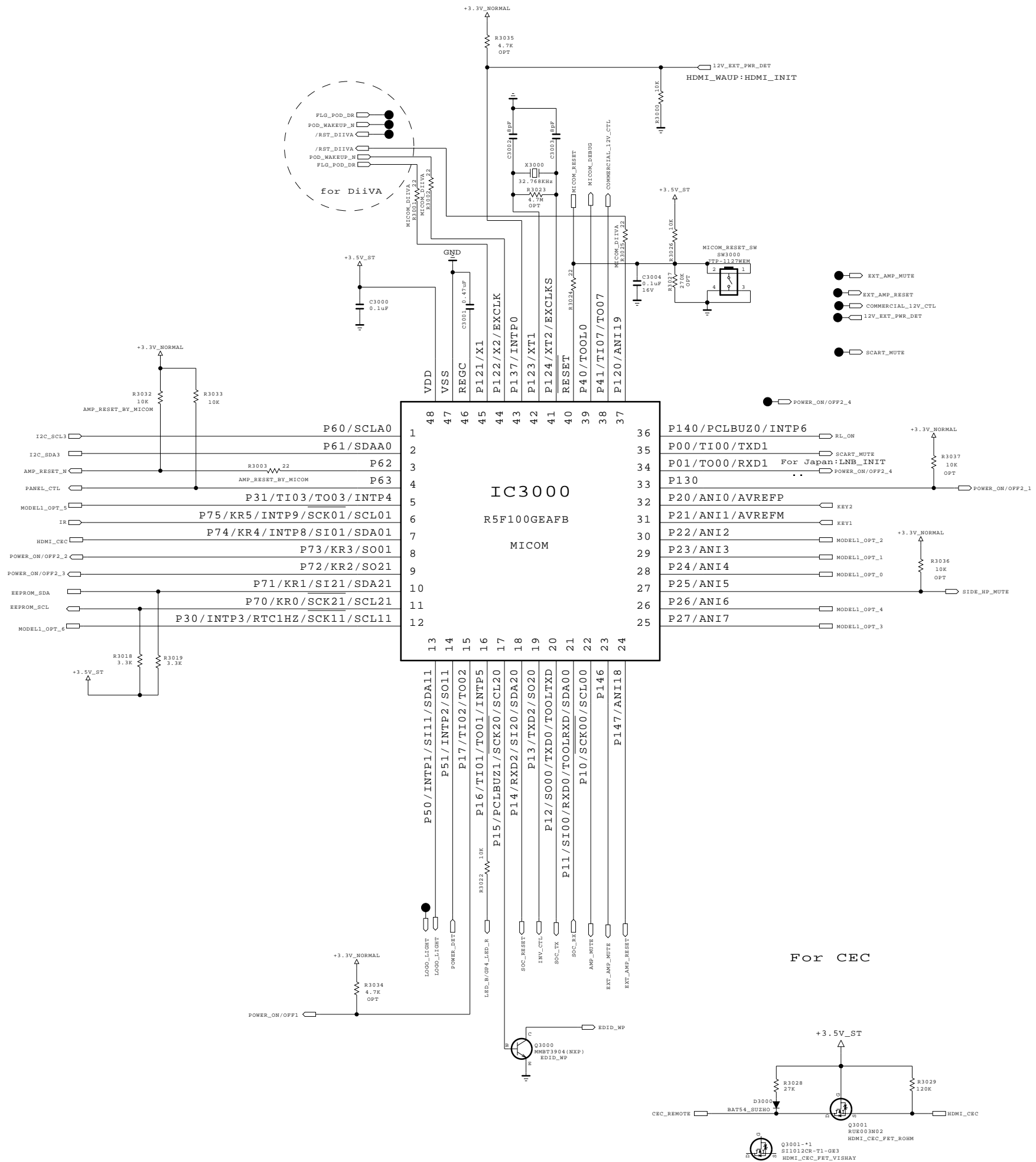

For CEC

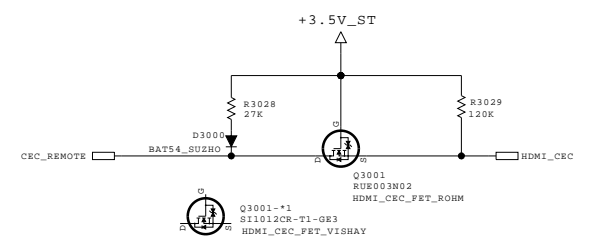

THE Δ SYMBOL MARK OF THIS SCHEMATIC DIAGRAM INCORPORATES SPECIAL FEATURES IMPORTANT FOR PROTECTION FROM X-RADIATION. FILRE AND ELECTRICAL SHOCK HAZARDS, WHEN SERVICING IF IS ESSENTIAL THAT ONLY MANUFACTURES SPECIFIED PARTS BE USED FOR THE CRITICAL COMPONENTS IN THE Δ SYMBOL MARK OF THE SCHEMATIC.

SECRET
LGElectronics



MODEL	DATE	2011.12.12
BLOCK	SHEET	30

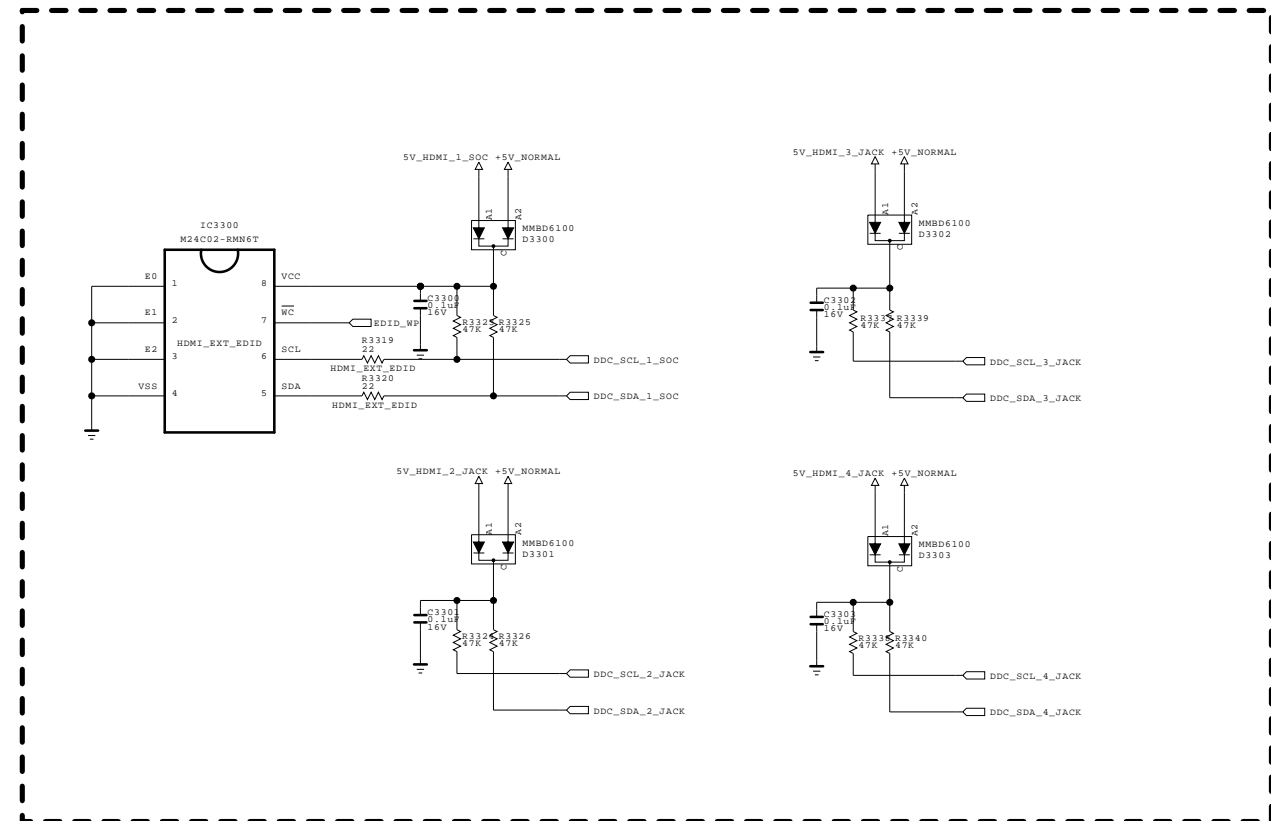
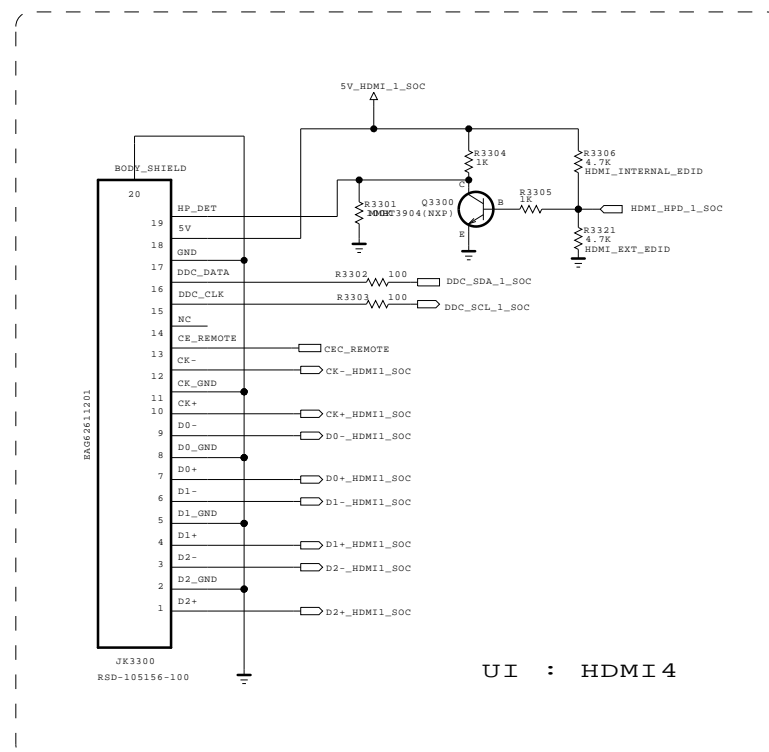
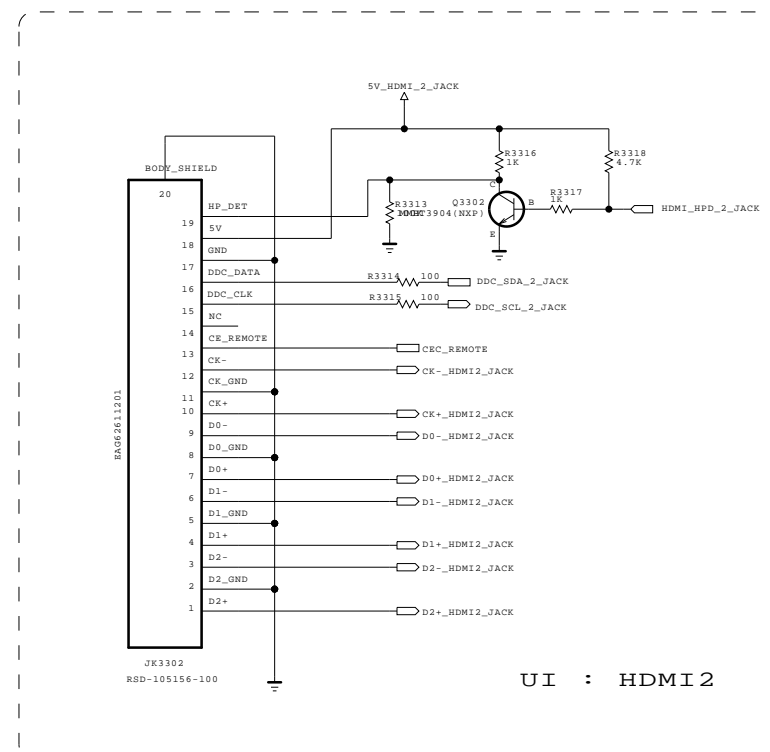
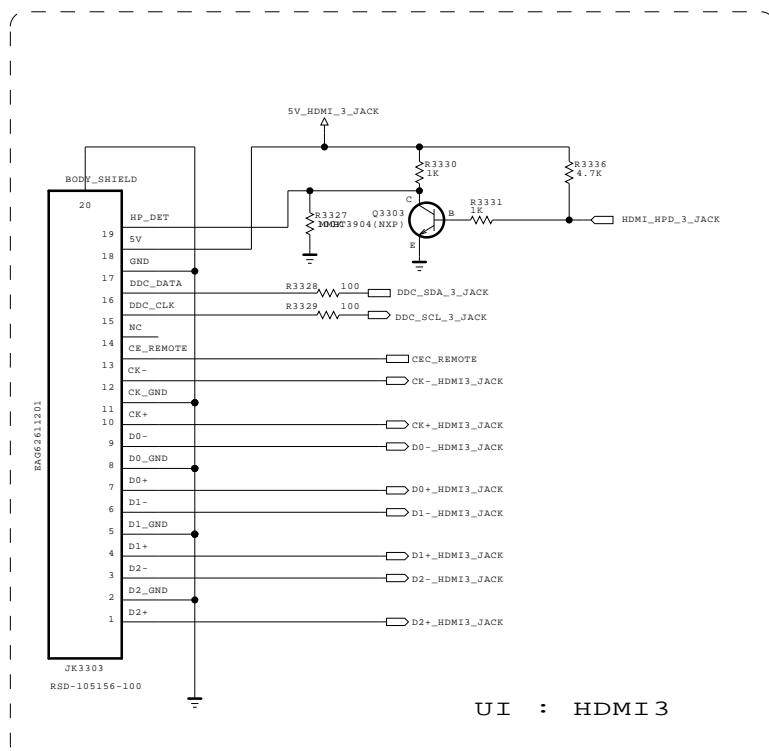
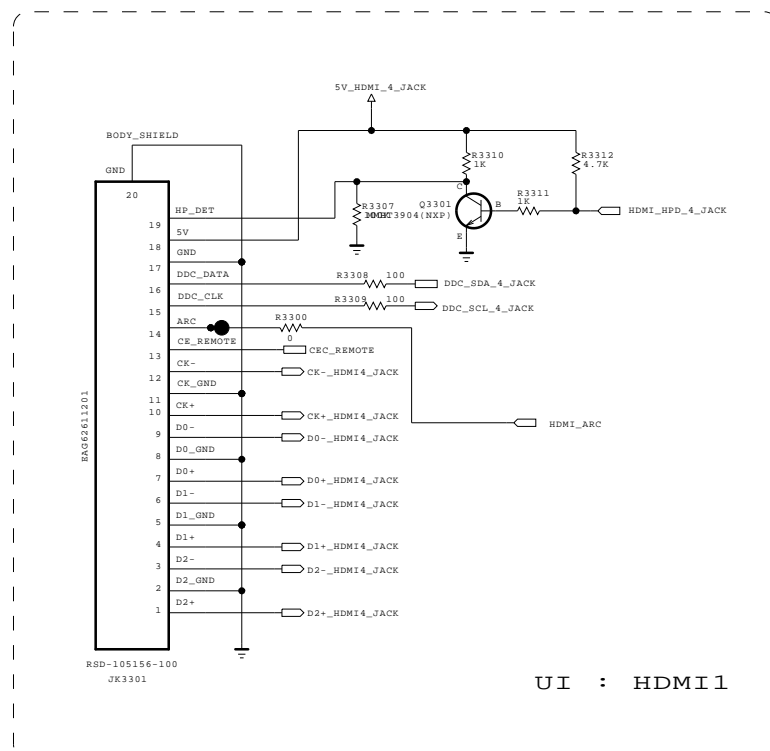

THE SYMBOL MARK OF THIS SCHEMATIC DIAGRAM INCORPORATES SPECIAL FEATURES IMPORTANT FOR PROTECTION FROM X-RADIATION. FILRE AND ELECTRICAL SHOCK HAZARDS, WHEN SERVICING IF IS ESSENTIAL THAT ONLY MANUFACTURES SPECIFIED PARTS BE USED FOR THE CRITICAL COMPONENTS IN THE SYMBOL MARK OF THE SCHEMATIC.

SECRET
LGElectronics



MODEL	HDMI 4	DATE	2011.10.29
BLOCK		SHEET	33

RGB / PC AUDIO / SPDIF

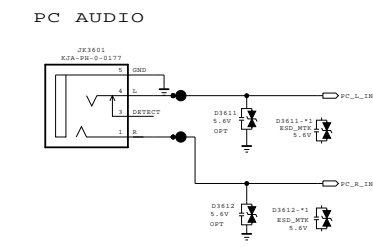
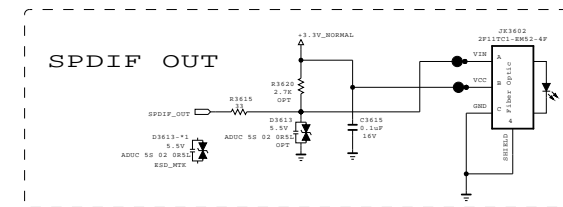
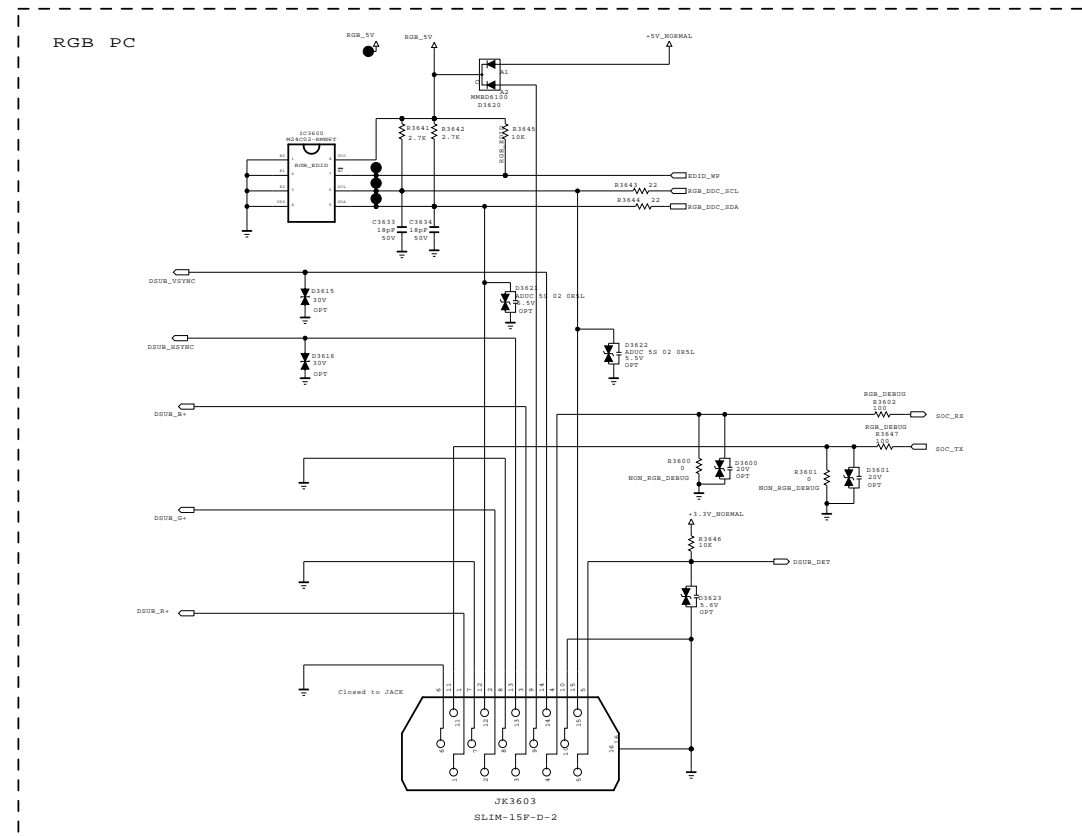

THE SYMBOL MARK OF THIS SCHEMATIC DIAGRAM INCORPORATES SPECIAL FEATURES IMPORTANT FOR PROTECTION FROM X-RADIATION. FILRE AND ELECTRICAL SHOCK HAZARDS, WHEN SERVICING IF IS ESSENTIAL THAT ONLY MANUFACTURES SPECIFIED PARTS BE USED FOR THE CRITICAL COMPONENTS IN THE SYMBOL MARK OF THE SCHEMATIC.

SECRET
LGElectronics



MODEL	JACK HIGH / MID	DATE	2011.11.21
BLOCK		SHEET	36 /

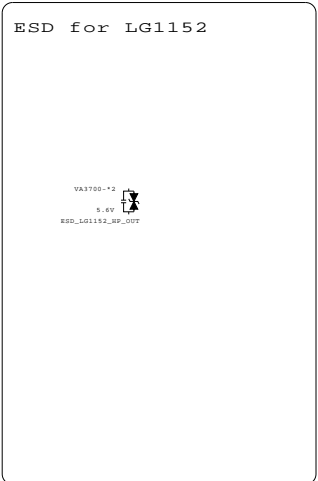
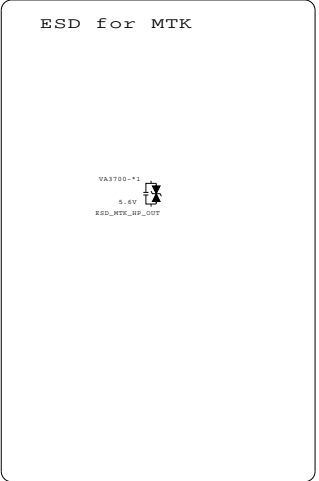
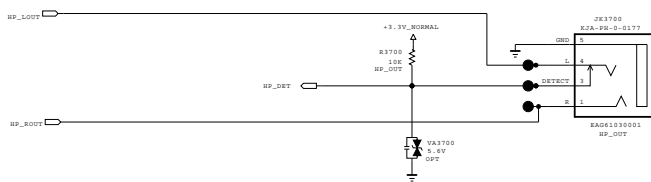

THE SYMBOL MARK OF THIS SCHEMATIC DIAGRAM INCORPORATES SPECIAL FEATURES IMPORTANT FOR PROTECTION FROM X-RADIATION. FILRE AND ELECTRICAL SHOCK HAZARDS, WHEN SERVICING IF IS ESSENTIAL THAT ONLY MANUFACTURES SPECIFIED PARTS BE USED FOR THE CRITICAL COMPONENTS IN THE SYMBOL MARK OF THE SCHEMATIC.

SECRET
LGElectronics

LG ELECTRONICS

MODEL	JACK_COMMON	DATE	2011.11.21
BLOCK		SHEET	37 /

RS232C

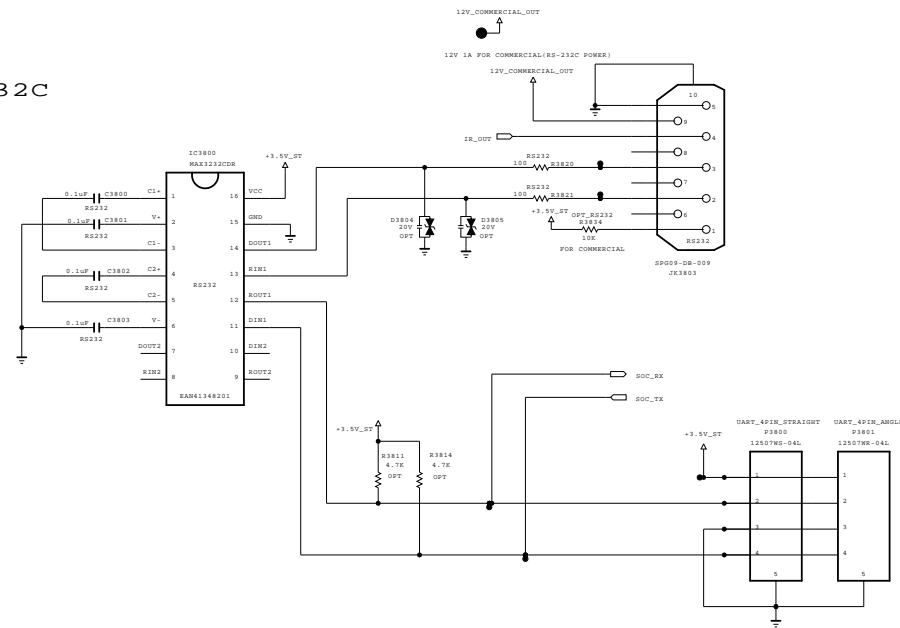

CVBS 1 PHONE JACK

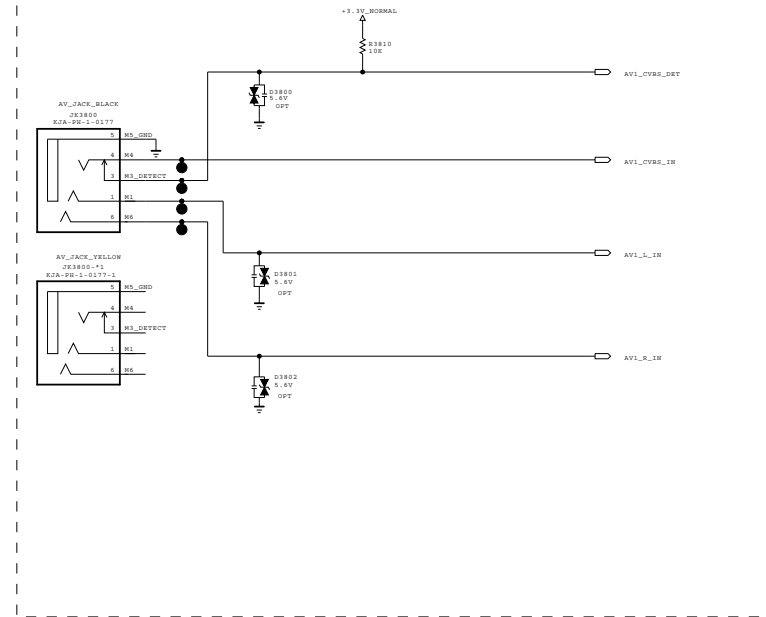

COMPONENT 1 PHONE JACK

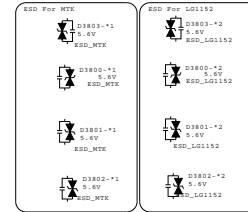
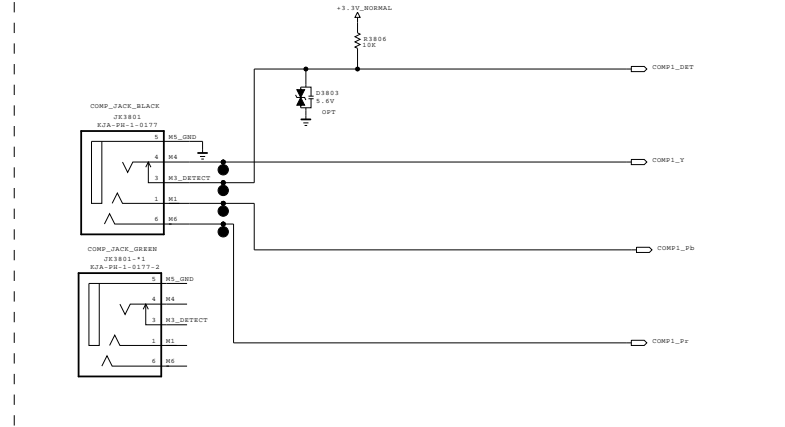

THE SYMBOL MARK OF THIS SCHEMATIC DIAGRAM INCORPORATES SPECIAL FEATURES IMPORTANT FOR PROTECTION FROM X-RADIATION, FILRE AND ELECTRICAL SHOCK HAZARDS, WHEN SERVICING IF IS ESSENTIAL THAT ONLY MANUFACTURES SPECIFIED PARTS BE USED FOR THE CRITICAL COMPONENTS IN THE SYMBOL MARK OF THE SCHEMATIC.

SECRET
LGElectronics



MODEL	JACK_COMMON	DATE	2011.11.21
BLOCK		SHEET	38 /

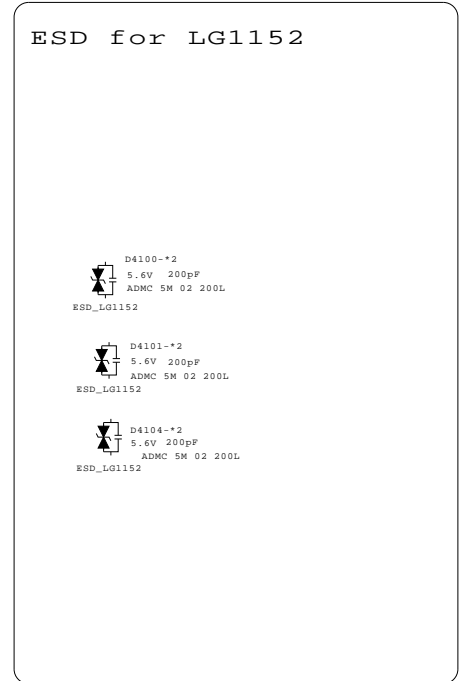
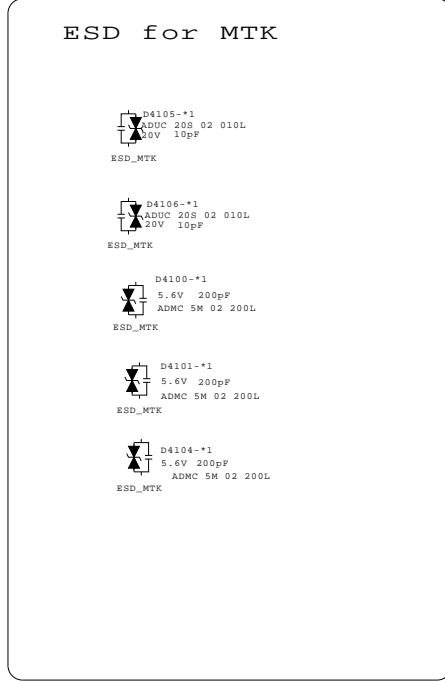
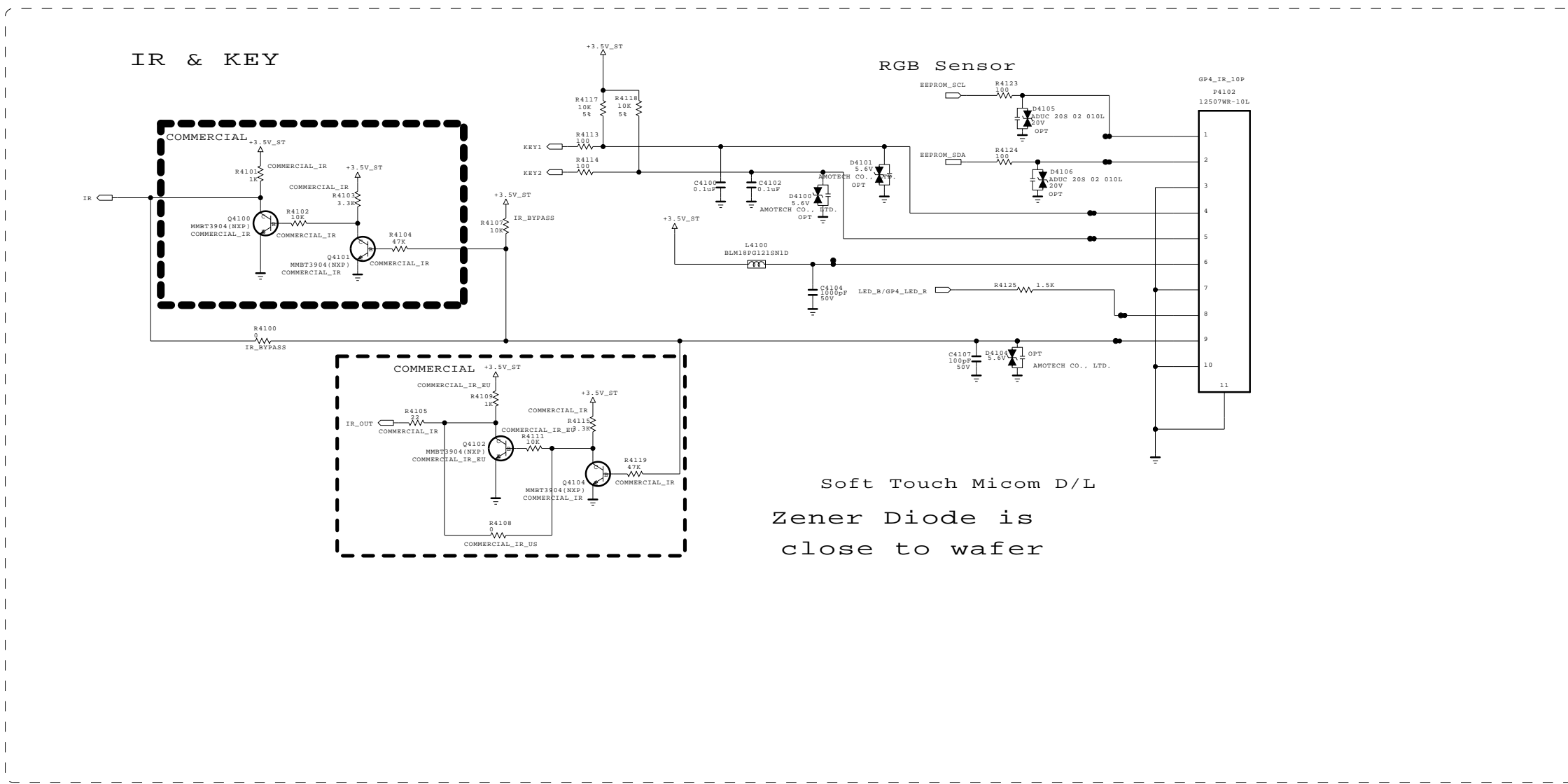

THE SYMBOL MARK OF THIS SCHEMATIC DIAGRAM INCORPORATES SPECIAL FEATURES IMPORTANT FOR PROTECTION FROM X-RADIATION. FILRE AND ELECTRICAL SHOCK HAZARDS, WHEN SERVICING IF IS ESSENTIAL THAT ONLY MANUFACTURES SPECIFIED PARTS BE USED FOR THE CRITICAL COMPONENTS IN THE SYMBOL MARK OF THE SCHEMATIC.

SECRET
LGElectronics



MODEL	IR / KEY	DATE	2011.11.21
BLOCK		SHEET	41

+5V_USB FOR USB1

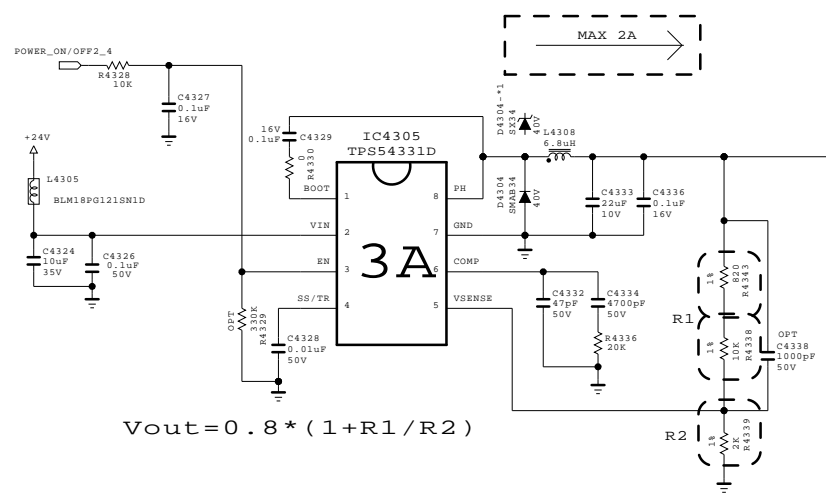

$$V_{out} = 0.8 * (1 + R1/R2)$$

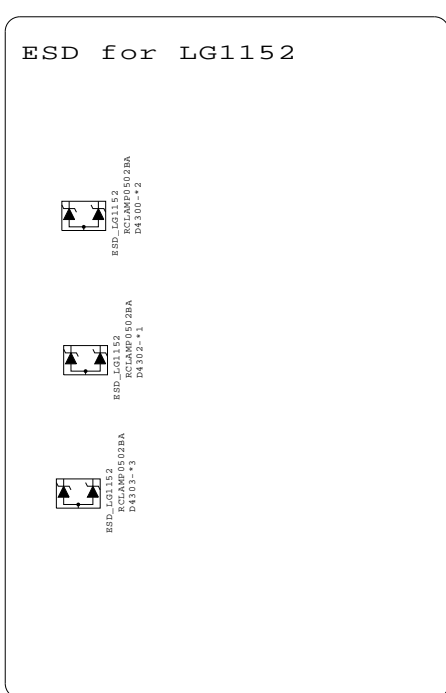
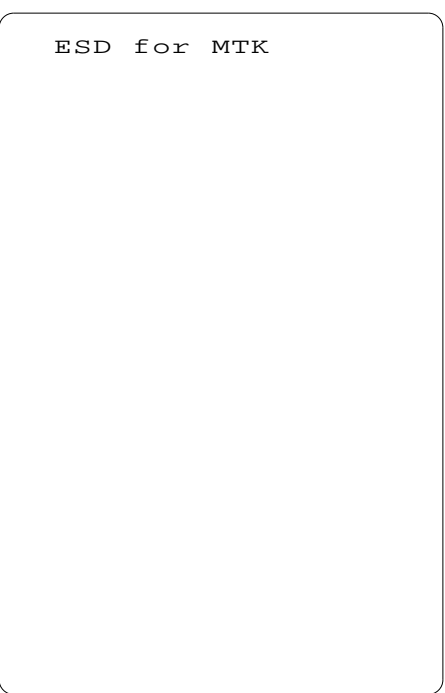
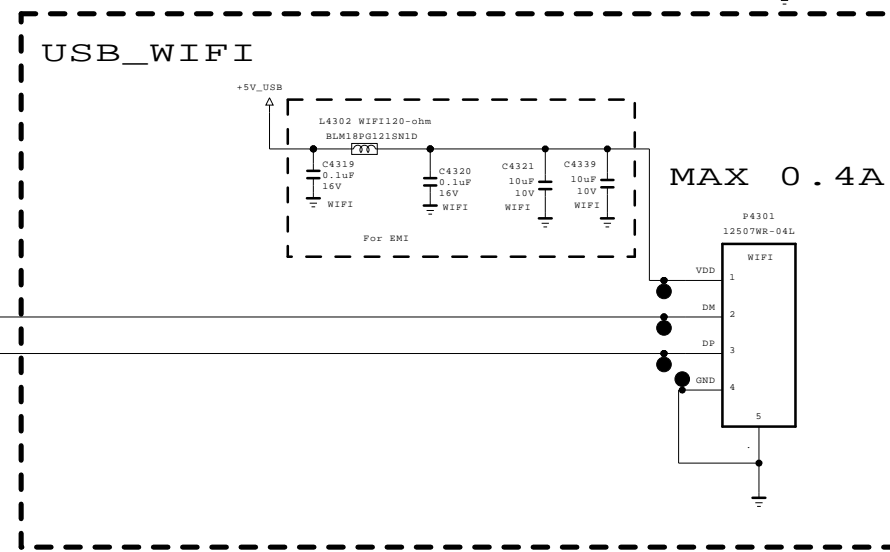
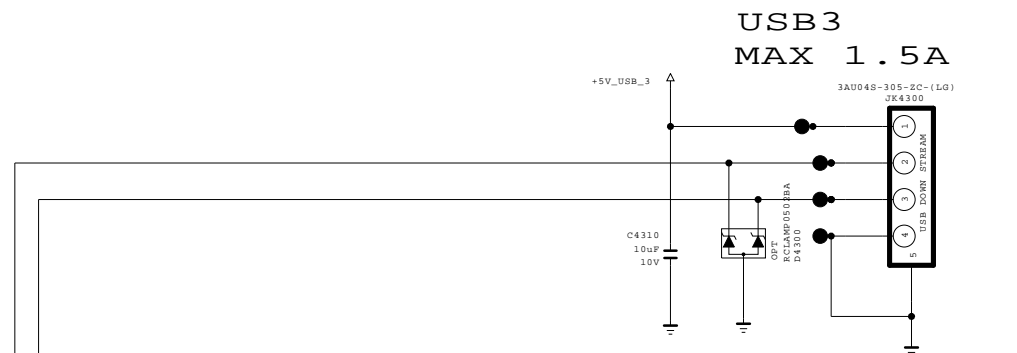
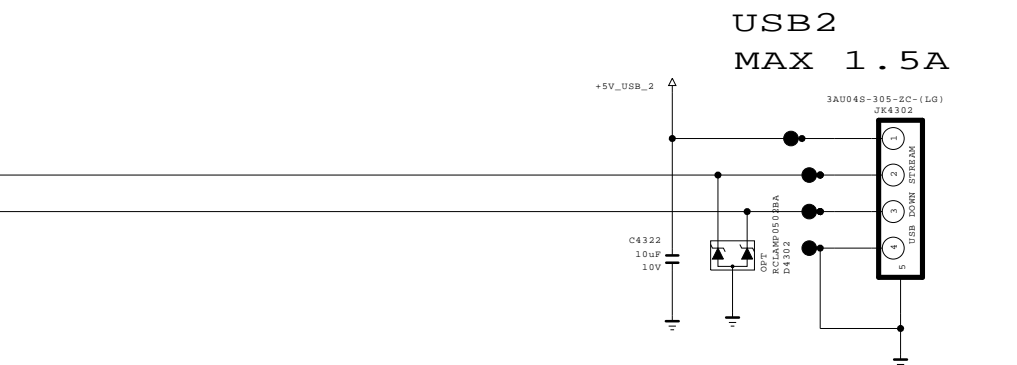
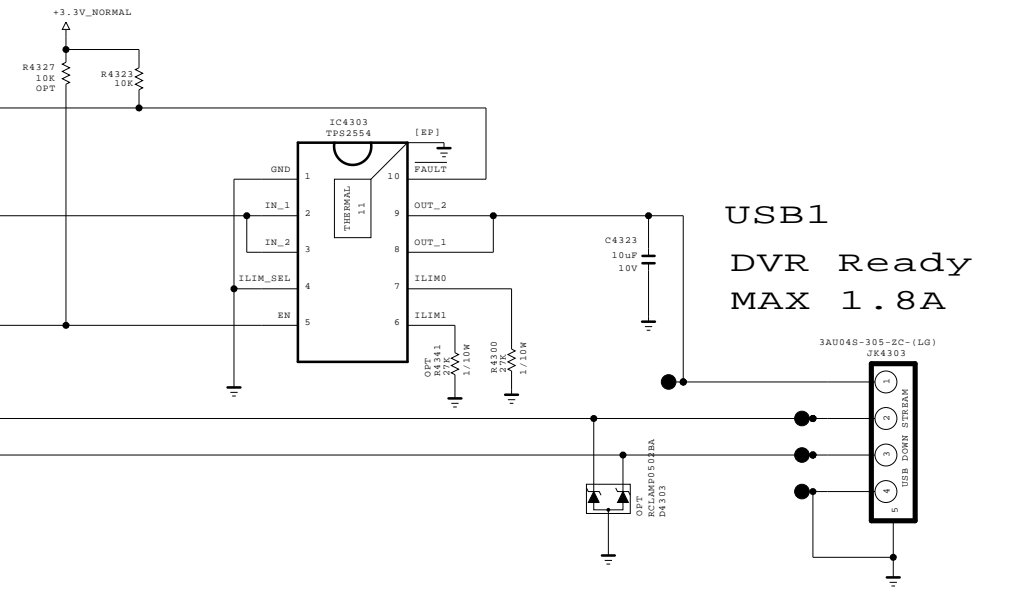
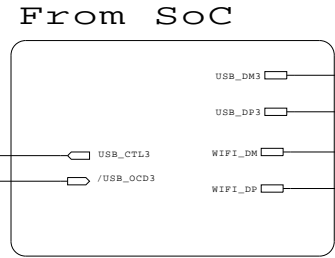
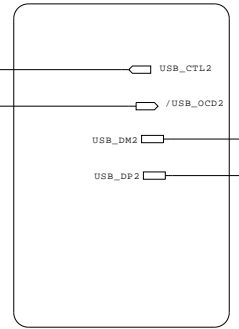
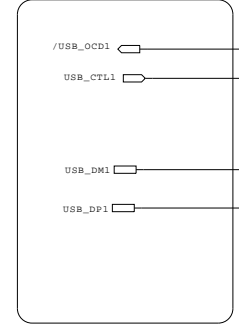
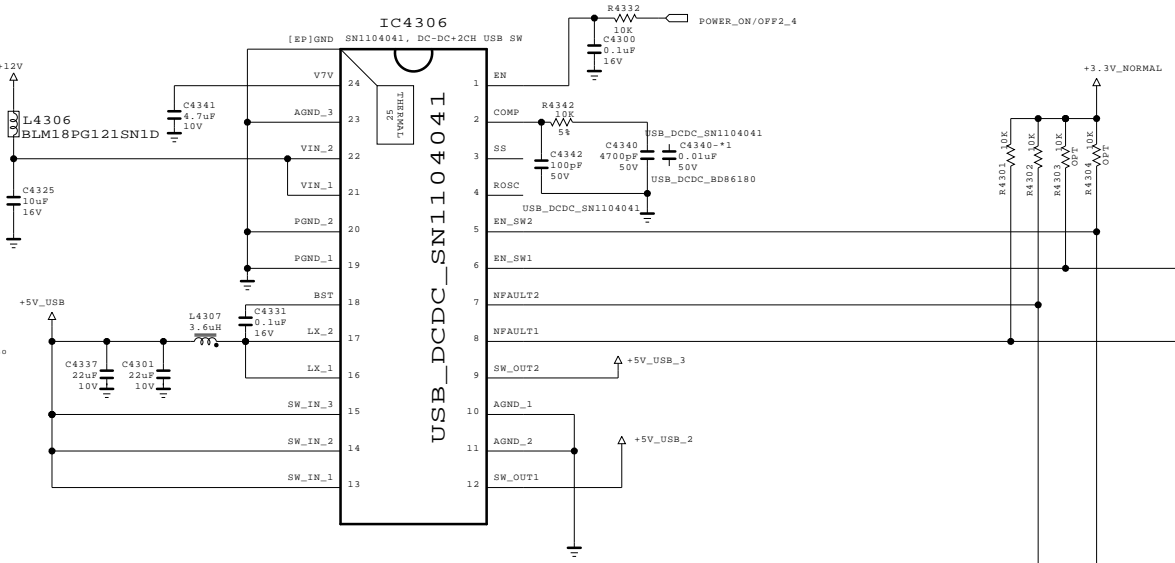

THE Δ SYMBOL MARK OF THIS SCHEMATIC DIAGRAM INCORPORATES SPECIAL FEATURES IMPORTANT FOR PROTECTION FROM X-RADIATION. FILRE AND ELECTRICAL SHOCK HAZARDS, WHEN SERVICING IF IS ESSENTIAL THAT ONLY MANUFACTURES SPECIFIED PARTS BE USED FOR THE CRITICAL COMPONENTS IN THE Δ SYMBOL MARK OF THE SCHEMATIC.

SECRET
LGElectronics



MODEL	USB3_HUB_WiFi	DATE	2011.10.26
BLOCK		SHEET	43

ZigBee_Radio Pulse M_REMOTE OPTION

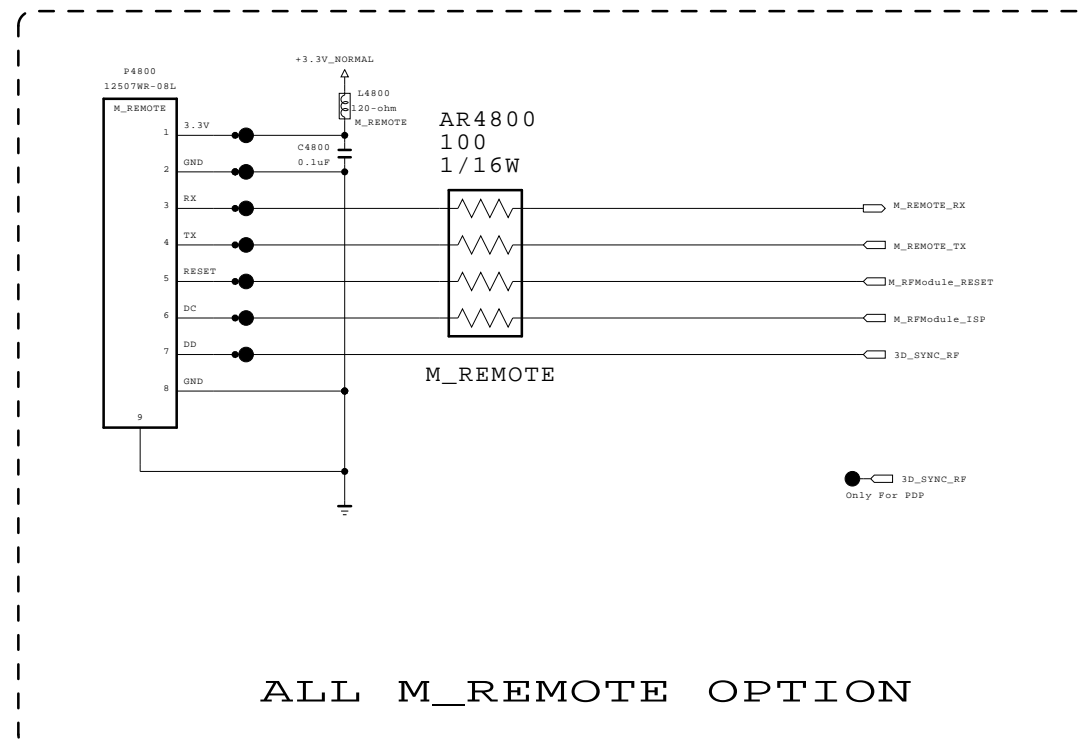

THE SYMBOL MARK OF THIS SCHEMATIC DIAGRAM INCORPORATES SPECIAL FEATURES IMPORTANT FOR PROTECTION FROM X-RADIATION. FILRE AND ELECTRICAL SHOCK HAZARDS, WHEN SERVICING IF IS ESSENTIAL THAT ONLY MANUFACTURES SPECIFIED PARTS BE USED FOR THE CRITICAL COMPONENTS IN THE SYMBOL MARK OF THE SCHEMATIC.

SECRET
LGElectronics



MODEL	MOTION REMOTE	DATE	2011.11.21
BLOCK		SHEET	48 /

Ethernet Block

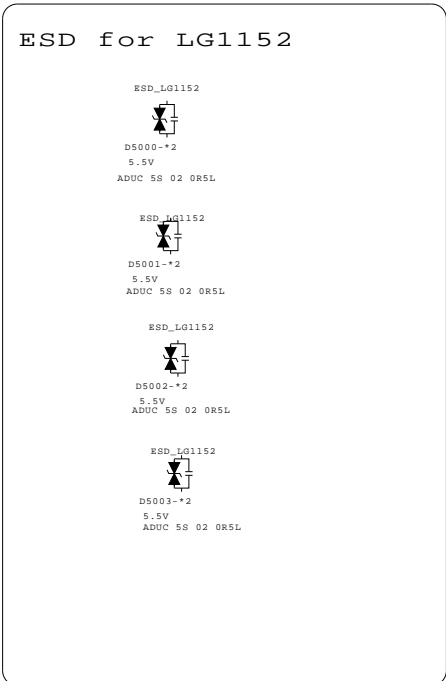
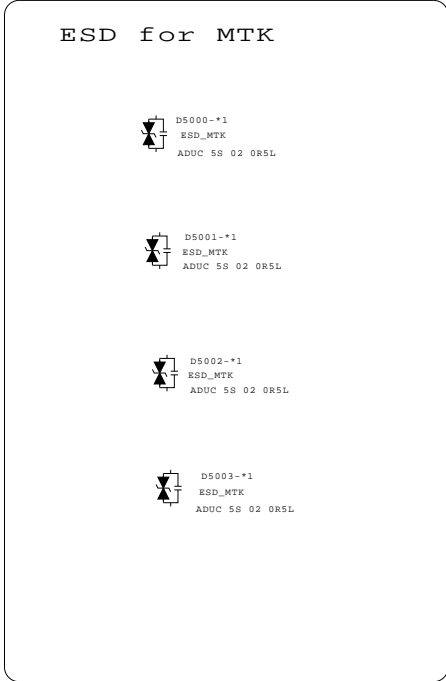
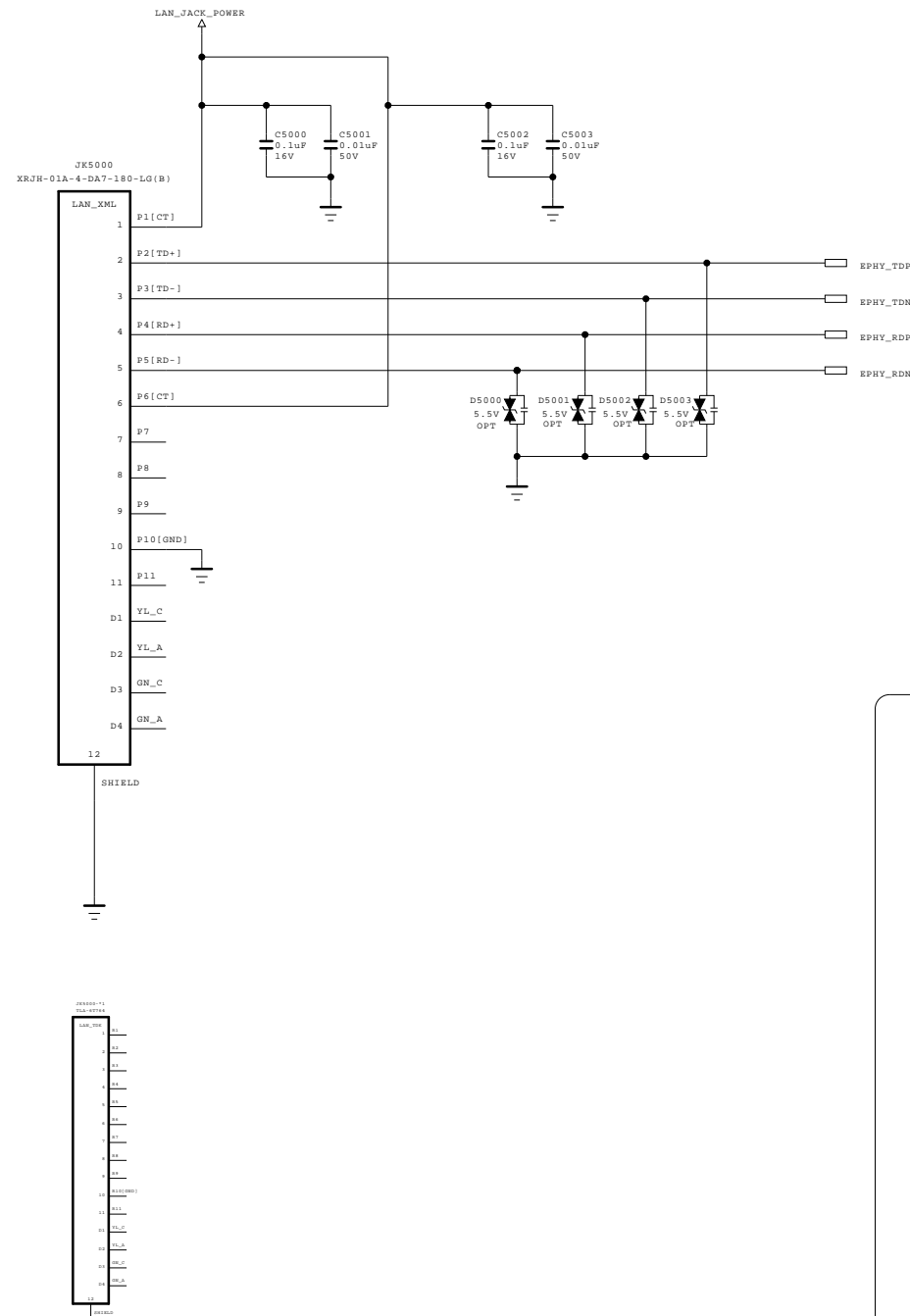



THE SYMBOL MARK OF THIS SCHEMATIC DIAGRAM INCORPORATES SPECIAL FEATURES IMPORTANT FOR PROTECTION FROM X-RADIATION. FILRE AND ELECTRICAL SHOCK HAZARDS, WHEN SERVICING IF IS ESSENTIAL THAT ONLY MANUFACTURES SPECIFIED PARTS BE USED FOR THE CRITICAL COMPONENTS IN THE SYMBOL MARK OF THE SCHEMATIC.

SECRET
LGElectronics

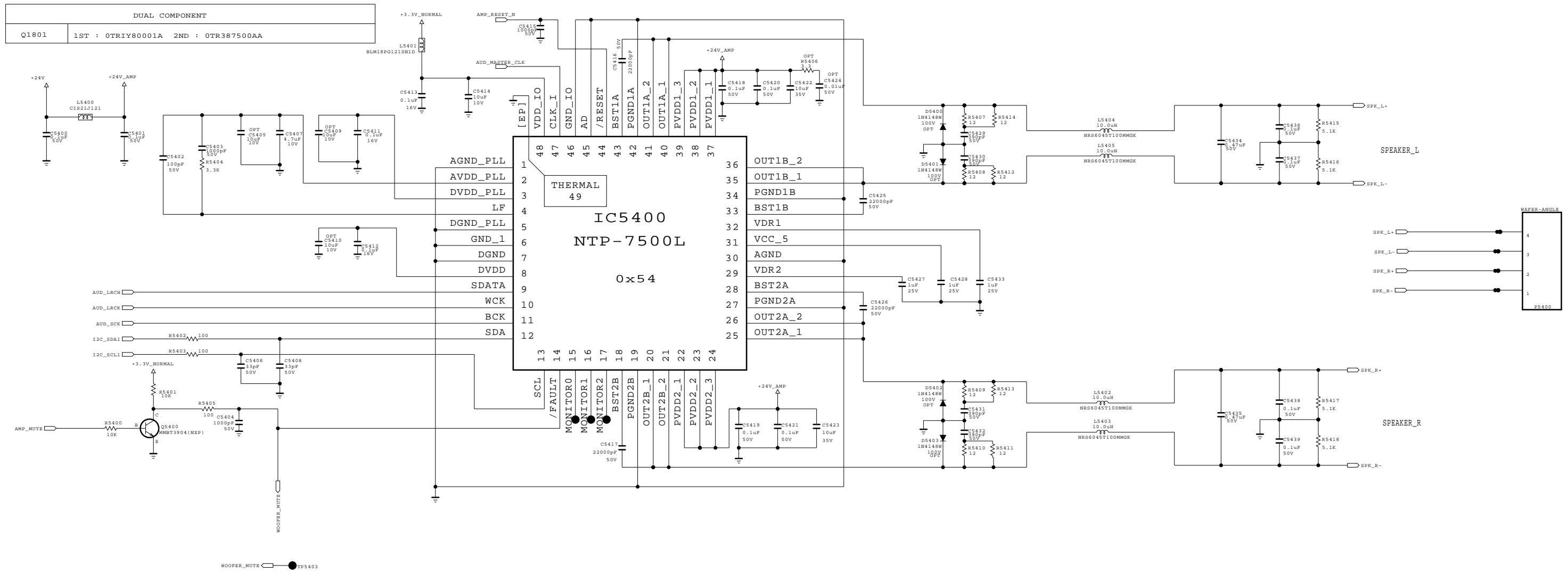

MODEL	LAN_VERTICAL	DATE	2011.12.09
BLOCK		SHEET	50



THE  SYMBOL MARK OF THIS SCHEMATIC DIAGRAM INCORPORATES SPECIAL FEATURES IMPORTANT FOR PROTECTION FROM X-RADIATION. FILRE AND ELECTRICAL SHOCK HAZARDS, WHEN SERVICING IF IS ESSENTIAL THAT ONLY MANUFACTURES SPECIFIED PARTS BE USED FOR THE CRITICAL COMPONENTS IN THE  SYMBOL MARK OF THE SCHEMATIC.



SECRET
LGElectronics

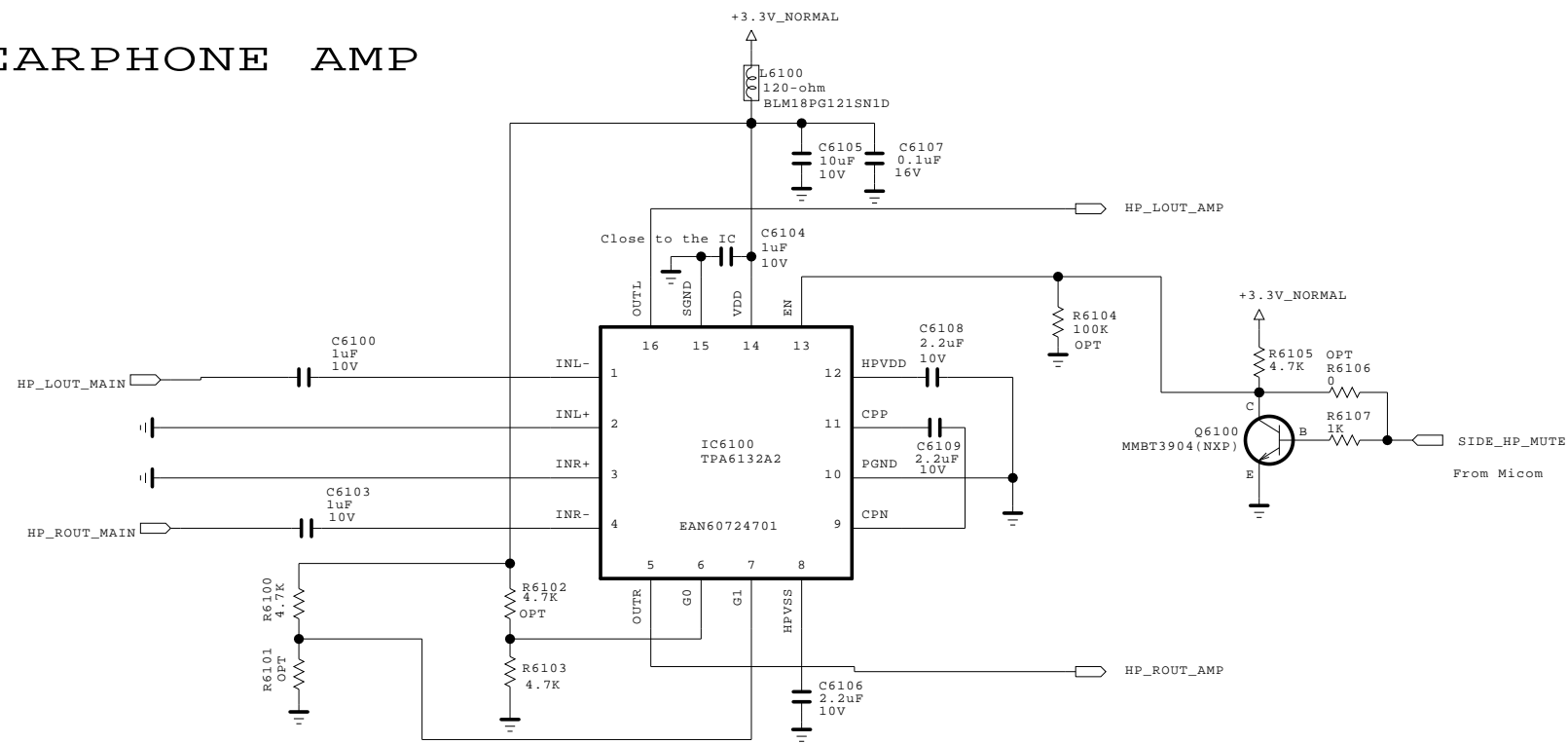

MODEL	AMP_NEO	DATE	2011.11.21
BLOCK		SHEET	54

EARPHONE AMP



THE  SYMBOL MARK OF THIS SCHEMATIC DIAGRAM INCORPORATES SPECIAL FEATURES IMPORTANT FOR PROTECTION FROM X-RADIATION. FILRE AND ELECTRICAL SHOCK HAZARDS, WHEN SERVICING IF IS ESSENTIAL THAT ONLY MANUFACTURES SPECIFIED PARTS BE USED FOR THE CRITICAL COMPONENTS IN THE  SYMBOL MARK OF THE SCHEMATIC.

SECRET	 LG ELECTRONICS
LGElectronics	

MODEL	HEADPHONE AMP	DATE	2011.09.29
BLOCK		SHEET	61 /

T/C/S & H/NIM & T2/C TUNER (EU & CHINA)

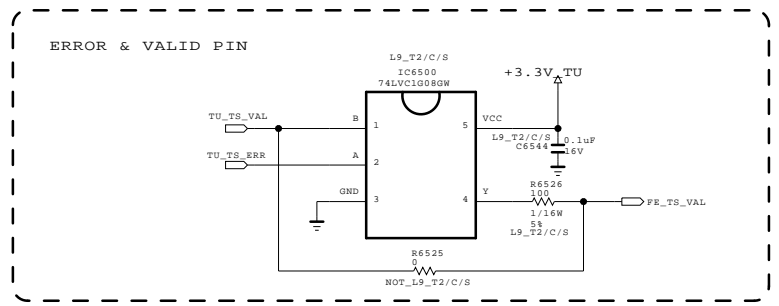
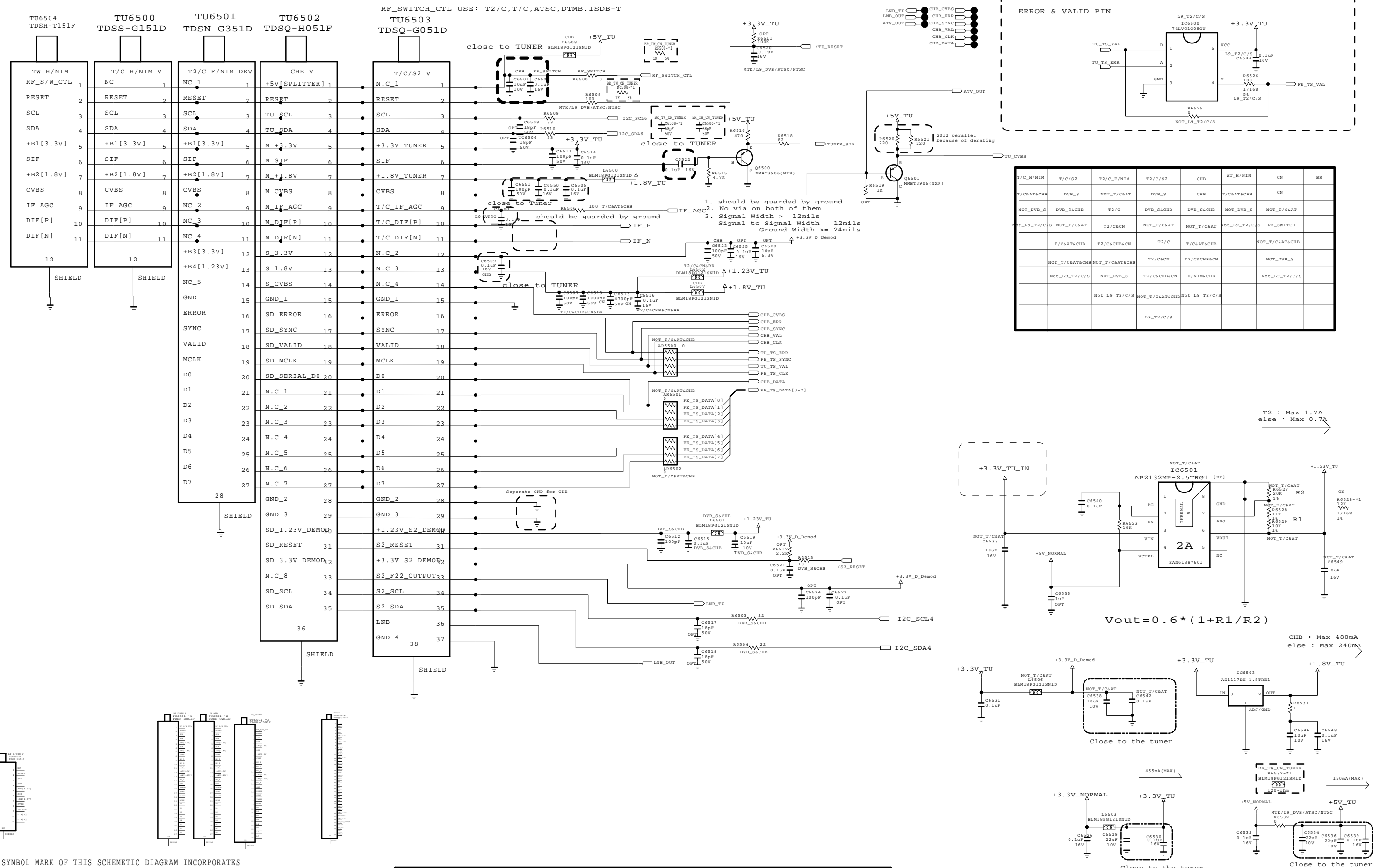

T/C/H/NIM	T/C/S2	T2/C/F/NIM	T2/C/S2	CHB	AT/H/NIM	CN	BR
T/C&AT&CHB	DVB_S	NOT_T/C&AT	DVB_S	CHB	F/C&AT&CHB	CN	
NOT_DVB_S	DVB_S&CHB	T2/C	DVB_S&CHB	DVB_S&CHB	NOT_DVB_S	NOT_T/C&AT	
NOT_L9_T2/C/S	NOT_T/C&AT	T2/C&CHB	NOT_T/C&AT	NOT_T/C&AT	NOT_L9_T2/C/S	RF_SWITCH	
	T/C&AT&CHB	T2/C&CHB&CN	T2/C	T/C&AT&CHB		NOT_T/C&AT&CHB	
	NOT_T/C&AT&CHB	NOT_T/C&AT&CHB	T2/C&CN	T2/C&CHB&CN		NOT_DVB_S	
	Not_L9_T2/C/S	NOT_DVB_S	T2/C&CHB&CN	H/NIM&CHB		Not_L9_T2/C/S	
		Not_L9_T2/C/S	NOT_T/C&AT&CHB	Not_L9_T2/C/S			
				L9_T2/C/S			

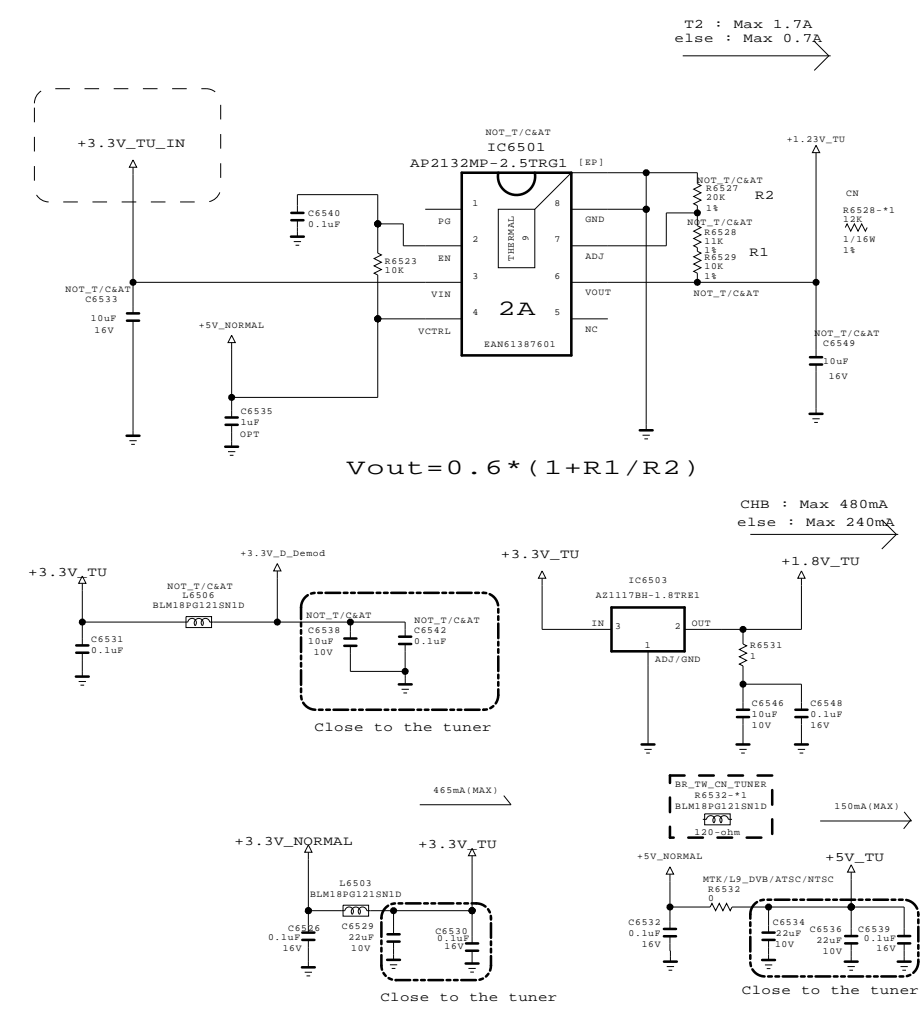

THE Δ SYMBOL MARK OF THIS SCHEMATIC DIAGRAM INCORPORATES SPECIAL FEATURES IMPORTANT FOR PROTECTION FROM X-RADIATION. FILRE AND ELECTRICAL SHOCK HAZARDS, WHEN SERVICING IF IS ESSENTIAL THAT ONLY MANUFACTURERS SPECIFIED PARTS BE USED FOR THE CRITICAL COMPONENTS IN THE Δ SYMBOL MARK OF THE SCHEMATIC.

SECRET
LGElectronics



MODEL	TUNER	DATE	2011.11.21
BLOCK		SHEET	65

FOR COMMERCIAL 12V OUT RS-232C 9 PIN
(OPT:COMMER_EXT_12V)

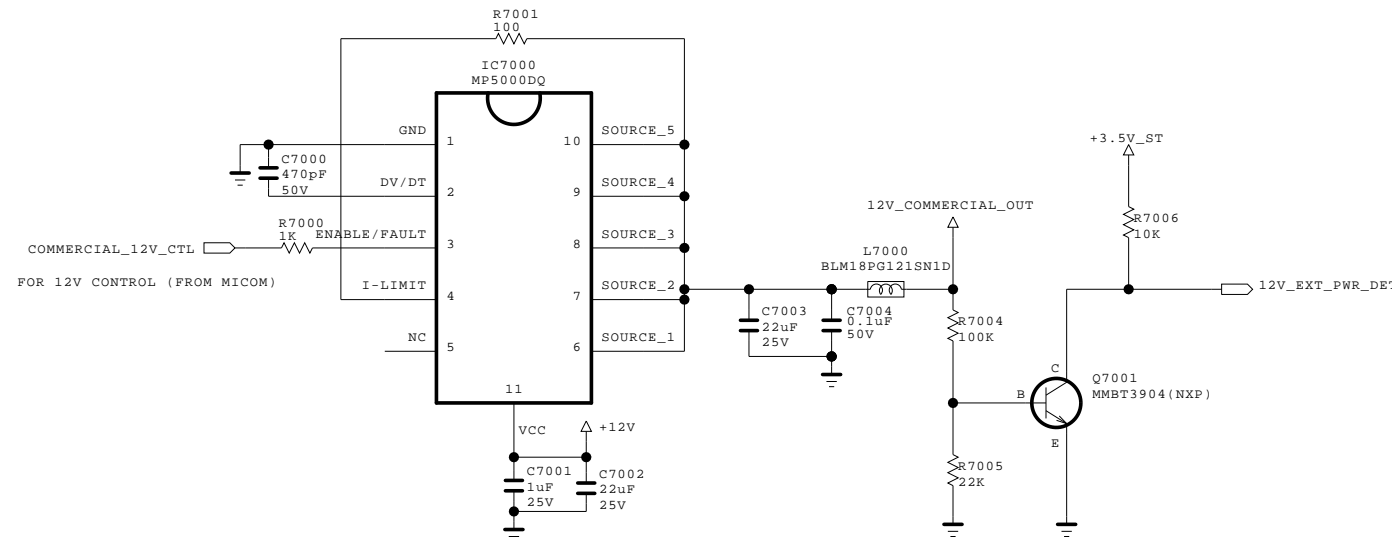

FOR COMMERCIAL AUDIO OUT
(OPT:COMMER_EXT_AMP)

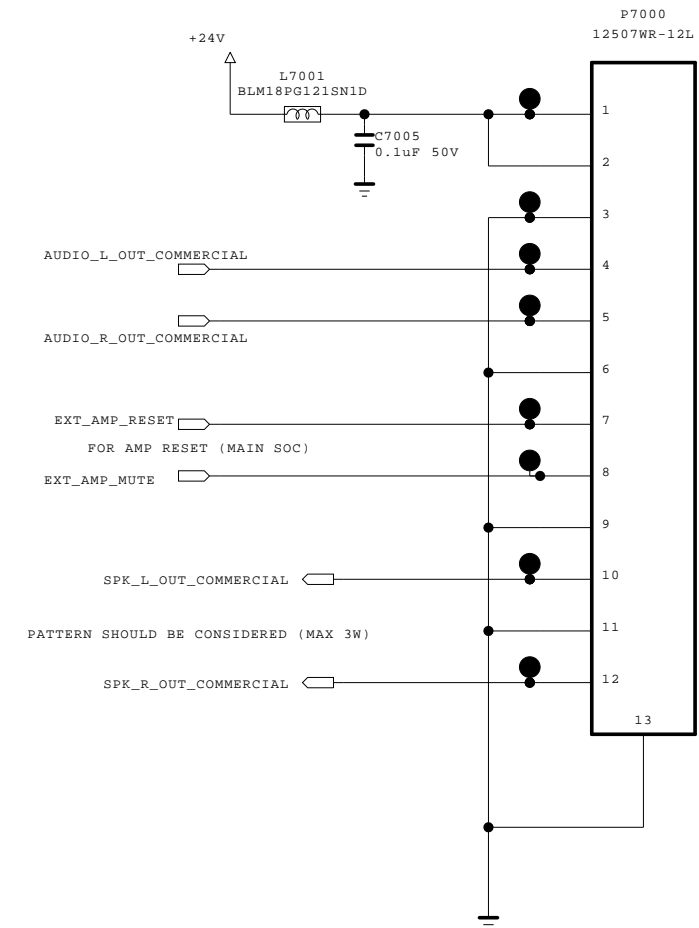

AUDIO OUT JACK
(OPT:COMMER_EXT_AMP)

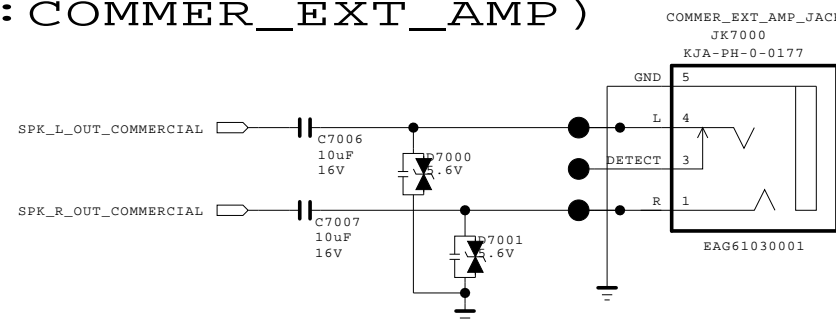

THE SYMBOL MARK OF THIS SCHEMATIC DIAGRAM INCORPORATES SPECIAL FEATURES IMPORTANT FOR PROTECTION FROM X-RADIATION. FILRE AND ELECTRICAL SHOCK HAZARDS, WHEN SERVICING IF IS ESSENTIAL THAT ONLY MANUFACTURES SPECIFIED PARTS BE USED FOR THE CRITICAL COMPONENTS IN THE SYMBOL MARK OF THE SCHEMATIC.

SECRET	LG ELECTRONICS
LGElectronics	

MODEL	COMMERCIAL_OPTION	DATE	2011.11.21
BLOCK		SHEET	70 /

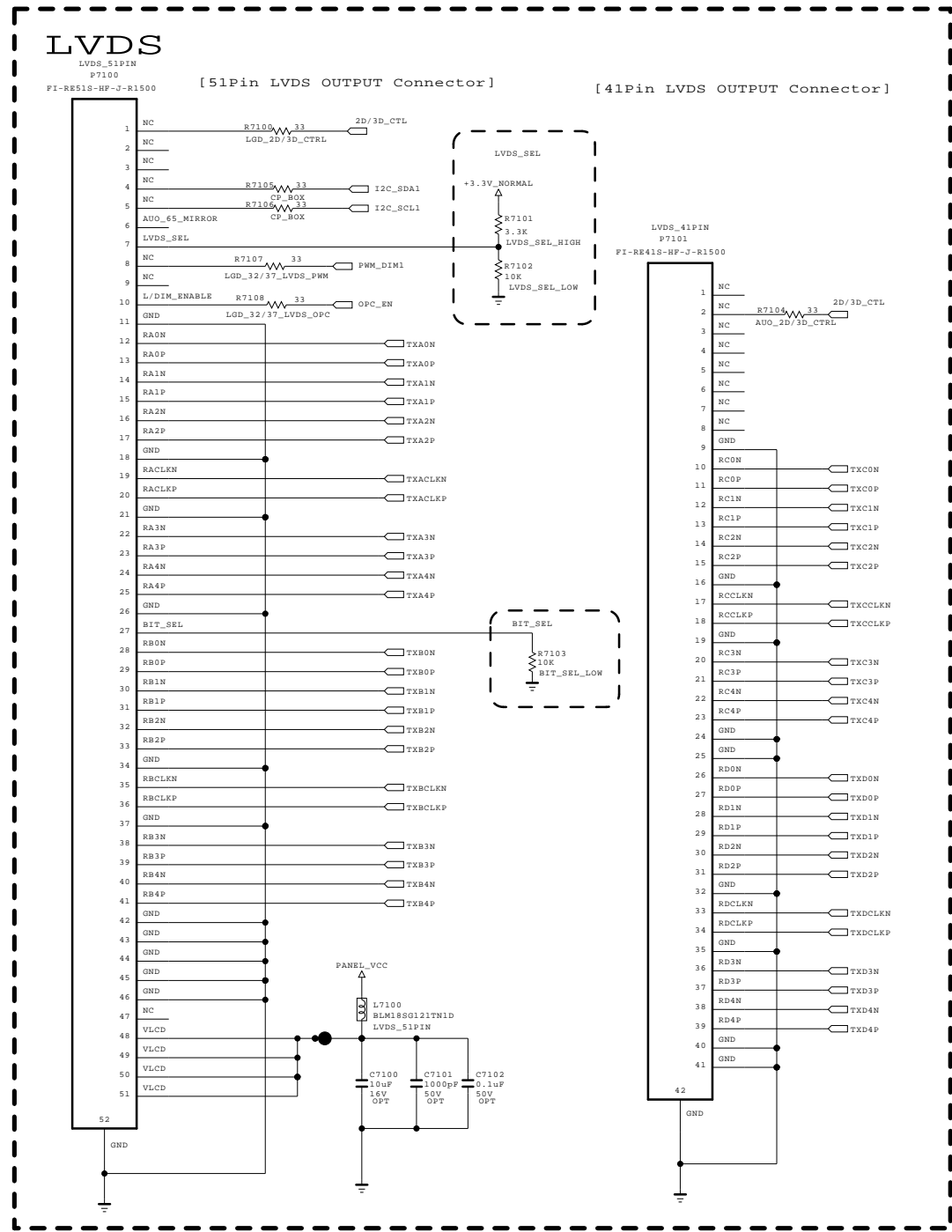

THE SYMBOL MARK OF THIS SCHEMATIC DIAGRAM INCORPORATES SPECIAL FEATURES IMPORTANT FOR PROTECTION FROM X-RADIATION. FILRE AND ELECTRICAL SHOCK HAZARDS, WHEN SERVICING IF IS ESSENTIAL THAT ONLY MANUFACTURES SPECIFIED PARTS BE USED FOR THE CRITICAL COMPONENTS IN THE SYMBOL MARK OF THE SCHEMATIC.

SECRET
LGElectronics



MODEL	LVDS_HIGH_MID	DATE	2011.08.11
BLOCK		SHEET	71 /

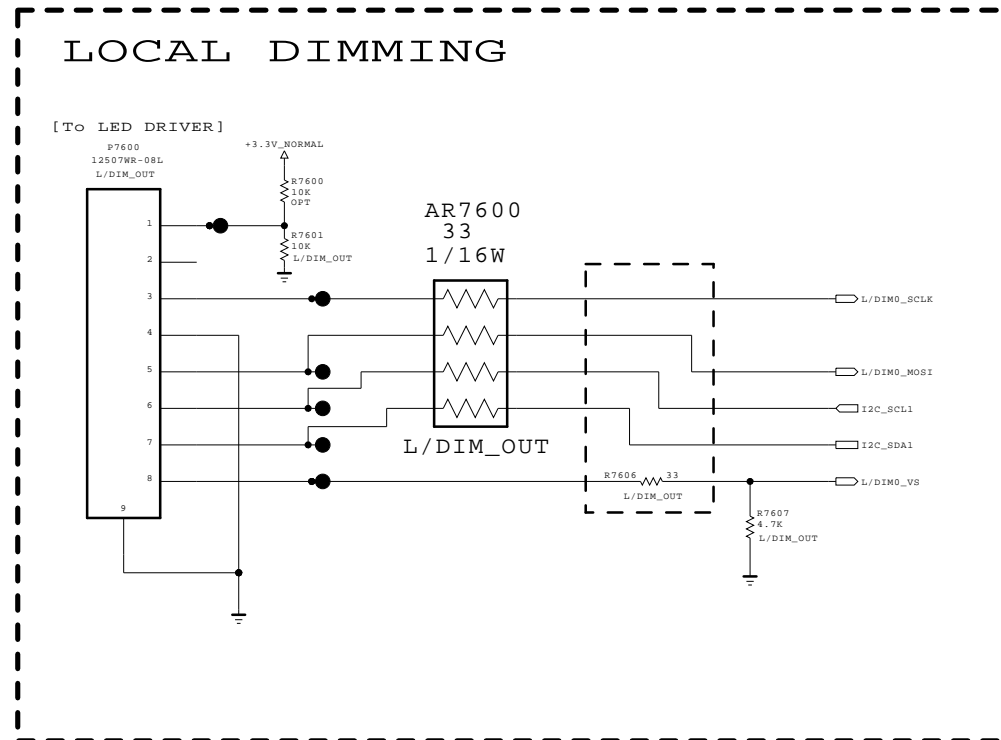

THE SYMBOL MARK OF THIS SCHEMATIC DIAGRAM INCORPORATES SPECIAL FEATURES IMPORTANT FOR PROTECTION FROM X-RADIATION. FILRE AND ELECTRICAL SHOCK HAZARDS, WHEN SERVICING IF IS ESSENTIAL THAT ONLY MANUFACTURES SPECIFIED PARTS BE USED FOR THE CRITICAL COMPONENTS IN THE SYMBOL MARK OF THE SCHEMATIC.

SECRET
LGElectronics



MODEL	LOCAL DIMMING	DATE	2011.12.13
BLOCK		SHEET	76 /

<POWER BLOCK>

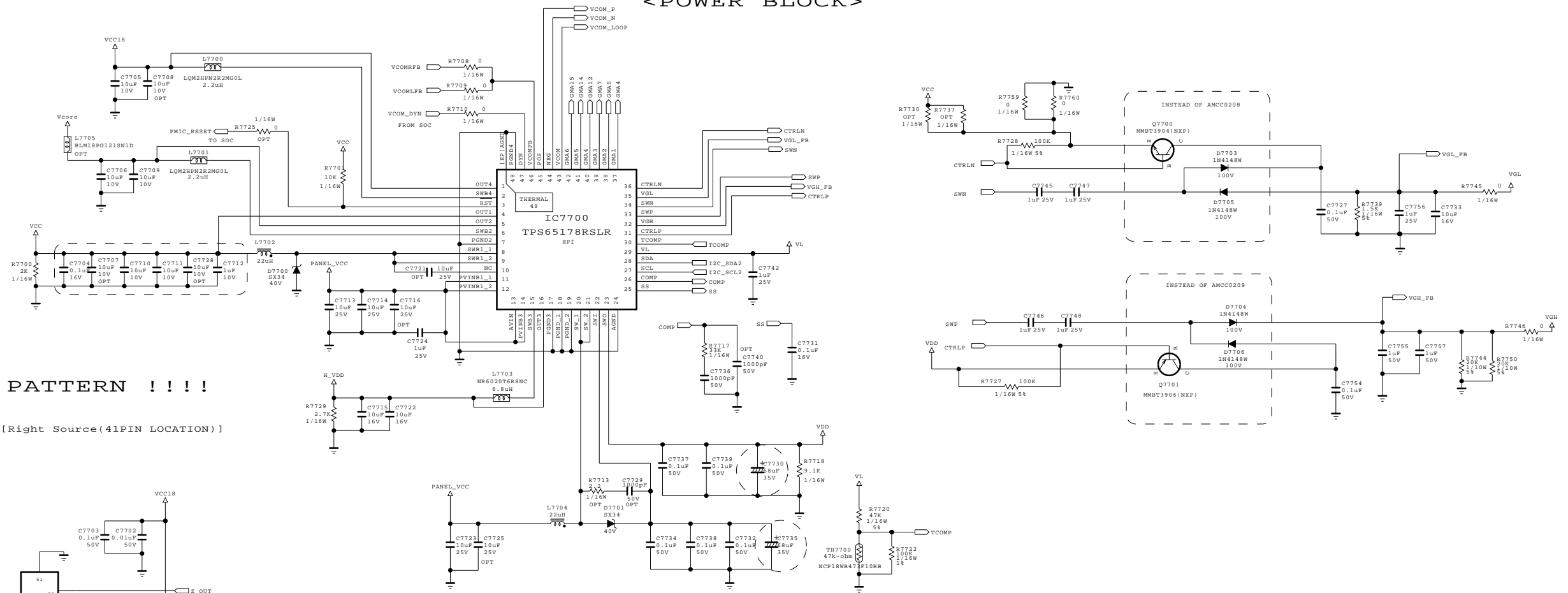

THIS IS REVERSE PATTERN !!!!

[Left Source(51PIN LOCATION)]

[Right Source(41PIN LOCATION)]

<LEVEL SHIFTER BLOCK>

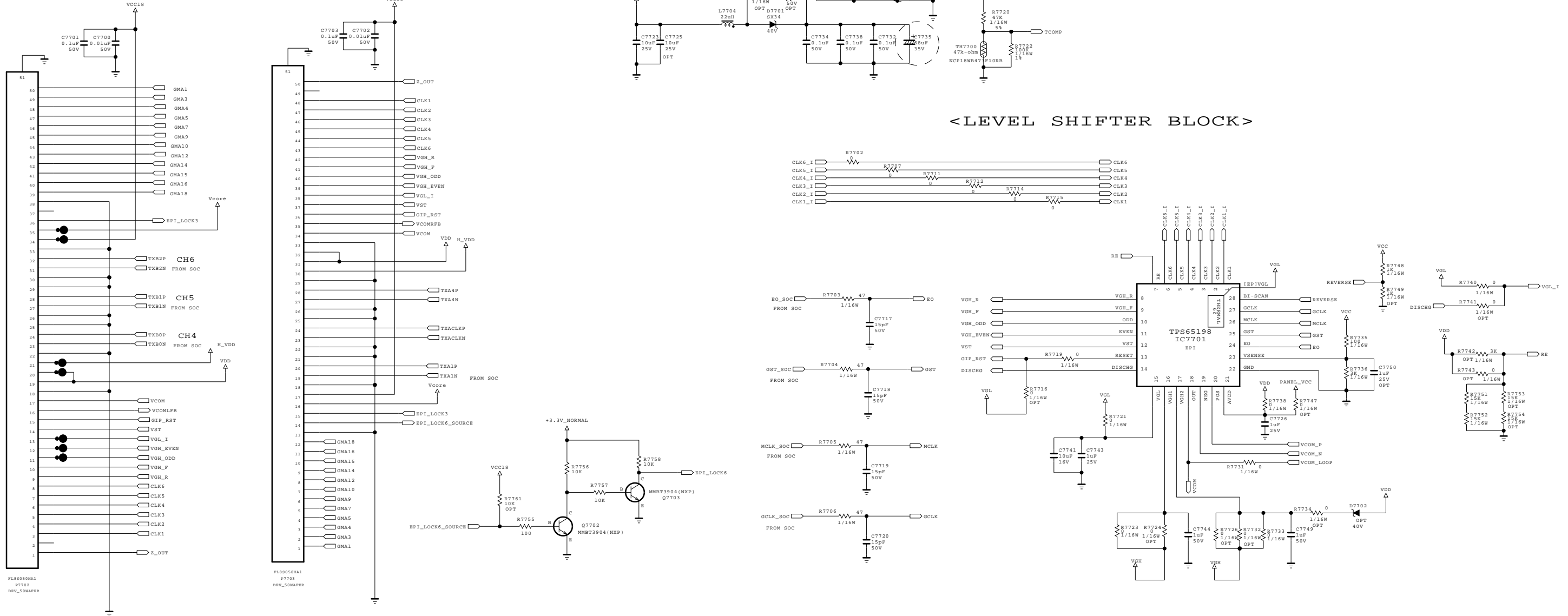

THE Δ SYMBOL MARK OF THIS SCHEMATIC DIAGRAM INCORPORATES SPECIAL FEATURES IMPORTANT FOR PROTECTION FROM X-RADIATION. FILRE AND ELECTRICAL SHOCK HAZARDS, WHEN SERVICING IF IS ESSENTIAL THAT ONLY MANUFACTURES SPECIFIED PARTS BE USED FOR THE CRITICAL COMPONENTS IN THE Δ SYMBOL MARK OF THE SCHEMATIC.

SECRET
LGElectronics



MODEL	DATE	2011.12.01
BLOCK	SHEET	77
T-Con		

eMMC I/F

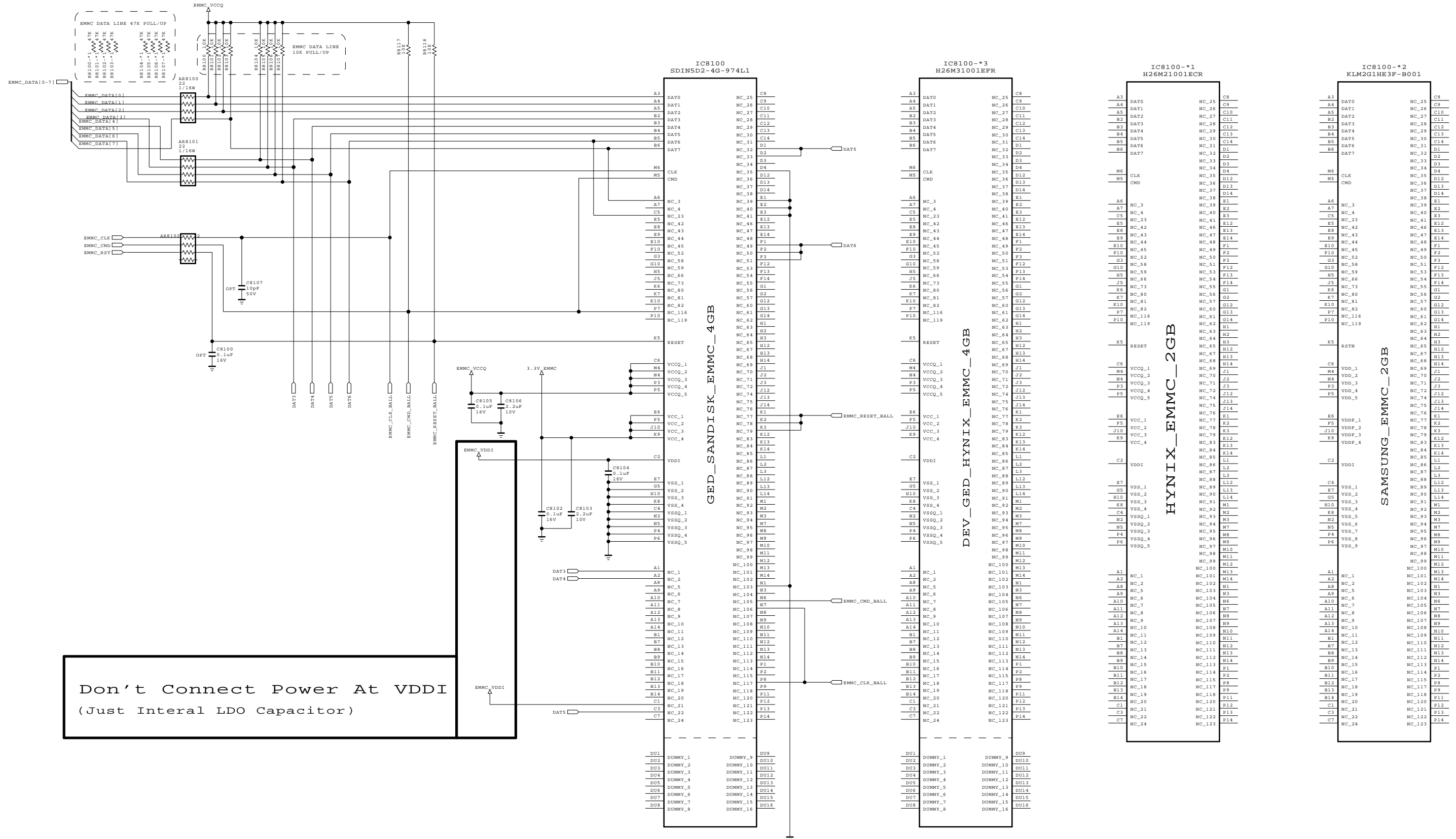

Don't Connect Power At VDDI
(Just Interual LDO Capacitor)

THE Δ SYMBOL MARK OF THIS SCHEMATIC DIAGRAM INCORPORATES SPECIAL FEATURES IMPORTANT FOR PROTECTION FROM X-RADIATION. FILRE AND ELECTRICAL SHOCK HAZARDS, WHEN SERVICING IF IS ESSENTIAL THAT ONLY MANUFACTURERS SPECIFIED PARTS BE USED FOR THE CRITICAL COMPONENTS IN THE Δ SYMBOL MARK OF THE SCHEMATIC.

SECRET
LGElectronics



MODEL BLOCK	eMMC	DATE SHEET	11.09.29
		81	

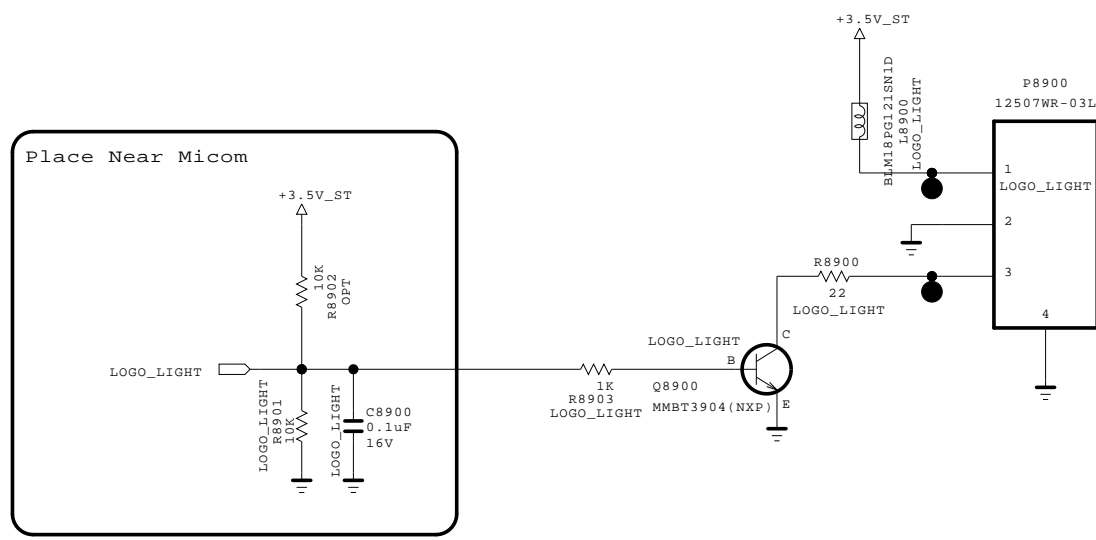

THE SYMBOL MARK OF THIS SCHEMATIC DIAGRAM INCORPORATES SPECIAL FEATURES IMPORTANT FOR PROTECTION FROM X-RADIATION. FILRE AND ELECTRICAL SHOCK HAZARDS, WHEN SERVICING IF IS ESSENTIAL THAT ONLY MANUFACTURES SPECIFIED PARTS BE USED FOR THE CRITICAL COMPONENTS IN THE SYMBOL MARK OF THE SCHEMATIC.

SECRET
LGElectronics



MODEL		DATE	
BLOCK		SHEET	/

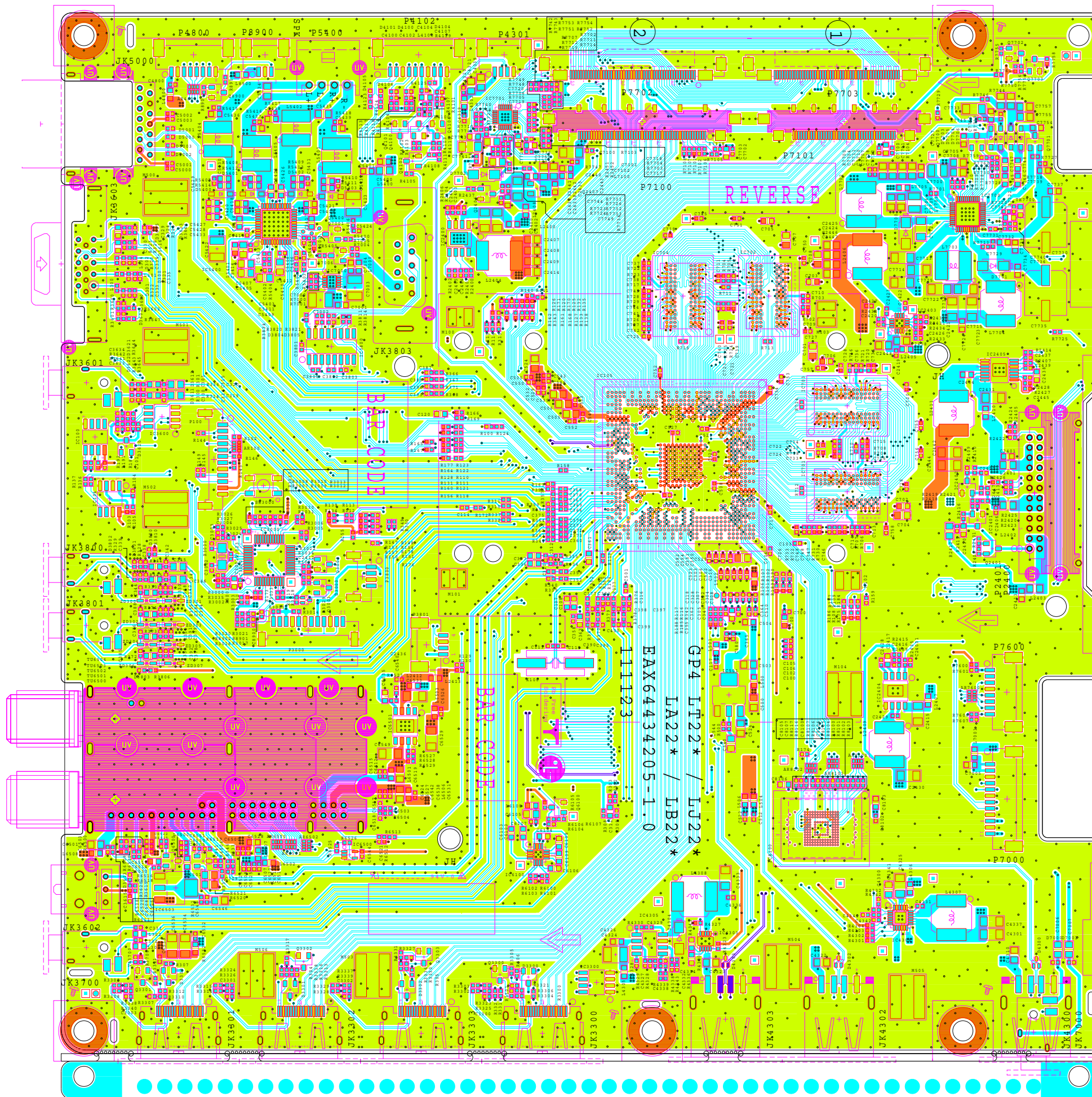



2012 LED/LCD TV Engineering guide

< Applicable Model >
XXLS5700-UA

◆ CONTENT ◆

1. '2012 Product line-up and features
2. Model naming and tool option
3. New features
4. Main PCBs
5. Block Diagrams, IIC Map
6. Structure of TV set and connection of sub ass'ys
7. New sub ass'ys
 - Instruction of new sub ass'ys
 - How to use tool
 - Download
8. Adjust way of new features (widevine...)
9. Repair guide
10. The latest issue and concerning issue

◆ CONTENT ◆

1. '2012 Product line-up and features

2. Model naming and tool option

3. New features

4. Main PCBs

5. Block Diagrams, IIC Map

6. Structure of TV set and connection of sub ass'ys

7. New sub ass'ys

- Instruction of new sub ass'ys

- How to use tool

- Download

8. Adjust way of new features

9. Repair guide

10. The latest issue and concerning issue

	'10	'11	'12
High end	<p>R LX9500 55F/47F(5.2W) Full LED Slim + 480Hz, 3D(SG), THX, Magic UI, Broadband</p> <p>BEST BUY R LE8500 55F/47F (2.4W : 47" CSKD Air, 55" SET Air) Full LED Slim + 240Hz, THX, Broadband</p>	<p>3D LW9800 55F (8.3W/TBD) NANO Full LED+480Hz, Cinema 3D, THX(TBD), Smart TV, M3, WiFi B/in</p> <p>3D LV9500 55F (8.4W) (*SG재고소진) NANO Full LED+480Hz, Smart TV</p>	<p>3D EM9600 55F (8/27W) OLED, 3D, Smart + 4 Mode</p> <p>3D LM9600 84(UD)*60F*/55F/47F (9/24*/3.21) ALEF + T480(*T240), 3D, Smart + 4 Mode</p> <p>3D LM9500 72F (5.28) IOL, T480Hz, 3D, Smart + 4Mode</p> <p>3D LM8600 55F/47F (3.21) LED, T240Hz, 3D, Smart + 4 Mode</p> <p>3D LMG860 55F/47F (5.16) LED, T240Hz, 3D, Smart (Google) + Qwerty 4 Mode</p> <p>3D LM7600 55F/47F (2.22) LED, T240Hz, 3D, Smart + 3 Mode</p> <p>3D LM6700 55F/47F/42F (2.22) LED, T120Hz, 3D, Smart + 3 Mode</p> <p>3D LM6400 55F/47F (5.14W) LED, T120Hz, 3D, Smart + 3 Mode</p> <p>3D LM6450 60F (8.27W) LED, T120Hz, 3D, +Smart + 3 Mode</p>
Mid end	<p>LE7300 47F/42F (4.2W) + 55F (6.1W) LED + 120Hz</p> <p>BEST BUY R LX6500 55F/47F/42F (5.1W) LED Plus + 240Hz, 3D(SG), Local Dimming, Broadband (LE5500 Tool)</p> <p>R LE5500 55F/47F/42F (2.3W) LED Plus + 120Hz, Local Dimming, Broadband</p> <p>BEST BUY R LE5400 55F/47F/42F (2.4W) + 32F (4.1W) LED + 120Hz, Broadband</p> <p>Club LE5350 42F(8.2W) LED + 120Hz, Broadband, Only</p> <p>BEST BUY R LE5300 37F/32F(4.1W) + 26/22/(2.2W) + 19(4.4W) LED + 120Hz(26/22/19: LED HD)</p>	<p>3D LW6500 65F*/55F/47F (4.29*/3.25) LED Plus+240Hz (65": LED+120Hz), Cinema 3D, Smart TV, M3, WiFi in-boxing</p> <p>Club 3D LW5700 55F/47F (3.29) LED +120Hz, Cinema 3D, Smart TV, M3(옵션), WiFi in-boxing</p> <p>BEST BUY 3D LW5600 55F/47F (2.15) LED Plus+120Hz, Cinema 3D, Smart TV, M3, WiFi in-boxing</p> <p>Club MM 3D LW5300 55F/47F/42F* (6.4W/8.4W*) LED Plus+120Hz, Cinema 3D, 3D Blu-ray in-boxing</p> <p>MM 3D LW5000 55F/47F/42F (7.1W) LED Plus+120Hz, Cinema 3D</p> <p>BEST BUY LV5500 55F/47F/42F (2.15) LED+120Hz, Smart TV, M3, WiFi in-boxing</p> <p>Club LV5400 55F/47F/42F (3.8) LED+120Hz, Smart TV, M3(옵션), WiFi in-boxing</p> <p>LV5300 55F (7.1W) LED+120Hz (*Rental재고소진)</p> <p>BEST BUY LV4400 55F/47F/42F (9.3W) LED+120Hz</p> <p>BEST BUY LV3700 55F*/47F/42F (2.7*/2.15) LED+FHD, Smart TV, M3(옵션), WiFi in-boxing</p> <p>BEST BUY LV3500 42F/37F (2.15) LED+FHD</p> <p>BEST BUY LV2500 32/26/22*(2.7/4.17*) LED+HD</p> <p>LV3400 32 (7.3W) LED+HD</p> <p>LV2400 32 (9.3W) LED+HD</p>	<p>3D LM6200 55F/47F (2.29) LED, T120Hz, 3D, Smart (Google) + Qwerty 4 Mode</p> <p>BEST BUY 3D LM6200 /50 65F*/55F/47F/42F/32F** (2.29/2.22/2.16) 55F/47F (4.2W) LED, T120Hz, 3D, Smart + 3 Mode / 3D BDP in-packing</p> <p>BEST BUY S5700/50 60F*/55F/47F/42F/32F** (4.2W TBD*/2.22/3.7**) / 60F*/55F/47F/42F** (4.4W TBD*/2.29/3.14**) LED, T120Hz, Smart + 3 Mode</p> <p>3D M5800/50 55F/47F/42F/32F (3.2W) / 55F/47F/42F (3.4W) LED, T120Hz, 3D, / 3D+Smart BDP in-packing</p> <p>LS5600/50 55F/47F/42F/37F/32F* (2.22/2.12*) / 55F/47F/42F* (2.29/3.7*) LED, T120Hz (37/32" : 60Hz)</p> <p>3D LM4600 55F/47F (5.4W) LED, T120Hz, 3D (시야각 10도)</p> <p>LS4600 55F/47F (3.2W) LED, T120Hz</p> <p>LS4000 50F(7.3W) LED, T120Hz</p>
Low end	<p>BEST BUY R LD550 60F(4.1W) + 52F(3.2W) + 46F/42F/32F(2.4W) 120Hz, Broadband</p> <p>BEST BUY MM LD520 55F/47F/42F (3.1W) + 32F (3.4W) 120Hz (LH50 Tool)</p> <p>BEST BUY LD500 47F(10.1W) 120Hz (ODM)</p> <p>BEST BUY LD450 47F/42F/37F/32F (2.2W) FHD</p> <p>BEST BUY LD400 42F/32F (10.3W/1W) FHD (ODM)</p> <p>BEST BUY LD350 32/26/22/19 (2.1W) HD</p>	<p>Club LK550 47F/42F (3.15) CCFL+120Hz, Smart TV, M3(옵션), WiFi in-boxing</p> <p>BEST BUY LK520 55F/47F/42F(2.15) CCFL+120Hz (LD650 Tool)</p> <p>BEST BUY LK450 42F/37F/32F (2.7) CCFL+FHD</p> <p>MM LK330 32(3.7) CCFL+HD (LD350 Tool)</p>	<p>LS3500 32*/26/22 (2.23*/2.27) LED, HD</p> <p>LS3400 42F/32 (3.3W) LED, 60Hz (32" : CCFL, 120Hz, LK450 Tool</p> <p>CS570 47F/42F (3.2W) CCFL, 60Hz, 3D, LK450 Tool</p> <p>3D CM565 47F/42F* (3.2W/4.1W*) CCFL, 60Hz, 3D, LK450 Tool</p> <p>CS560/530 42F/37F/32F / 42F (2.25) CCFL, 60Hz, LK450 Tool</p> <p>CS460 32*(2.25*) CCFL, HD</p>

DTV

Clear Screen

Borderless

Old Tool

	'10	'11	'12
High end	LX9500 55F/47F(5.3W) Full LED Slim + 480Hz, 3D, THX, Magic UI, Broadband	LW9800 55F/47F (9.2W) NANO Full LED+480Hz, Cinema 3D, THX(TBD), Smart TV, M3, WiFi B/in	EM9600 55F OLED, Cinema 3D, Smart + 4 Mode
	LE8500 55F/47F (3.1W : 47" CSKD Air, 55" SET) Full LED Slim + 240Hz, THX, Broadband		LM9600 84(UD)*60F*/55F/47F (10.8*/4.1W) ALEF + T480(*T240), Cinema 3D, Smart + 4 Mode
Mid end	LE7500 55F/47F/42F (5.3W) Edge LED + 120Hz, Local Dimming, Broadband	LW6500 55F/47F (4.3W) LED Plus+240Hz, Cinema 3D, Smart TV, M3, WiFi in-boxing	LM9500 72F (6/11) IOL, T480Hz, Cinema 3D, Smart + 4 Mode
	LE7300 47F/42F (4.4W) + 55F (6.3W) Edge LED + 120Hz	LW5700 55F/47F/42F (4.5) LED +120Hz, Cinema 3D, Smart TV, M3(옵션), WiFi in-boxing	LM8600 55F/47F (4.1W) LED, T240Hz, 3D, Smart + 4 Mode
	LX6500 55F/47F/42F (5.2W) LED Plus + 240Hz, 3D, Local Dimming, Broadband(LE5500 Tool)	LW5600 55F/47F/42F (3.3) LED Plus+120Hz, Cinema 3D, Smart TV, M3, WiFi in-boxing	LM7600 55F/47F (3.7) LED, T240Hz, 3D, Smart + 3 Mode
	LE5500 55F/47F/42F (3.3W) Edge LED + 120Hz, Local Dimming, BB	LW5300 55F/47F (7.3W) LED Plus+120Hz, Cinema 3D Blu-ray in-boxing	LM6700 55F/47F (3.7) LED, T120Hz, 3D, Smart + 3 Mode
	LE5400 55F/47F/42F (3.4W) Edge LED + 120Hz, Broadband	LW5000 55F/47F/42F (7.4W)	LM6400 55F/47F (5.4W) LED, T120Hz, 3D, Smart + 3 Mode
	LE5300 55F/47/42F(5.3W)/32(5.1W)/26/22/(3.2W) Edge LED + 120Hz /19(5.2W) (26/22/19: Edge LED HD)	LV5500 55F/47F/42F (3.3) LED Plus+120Hz, Cinema 3D LED+120Hz, Smart TV, M3, WiFi in-boxing	LM6200 65F*/55F/47F/42F (3.14*/3.7) LED, T120Hz, 3D, Smart + 3 Mode
	LD650 55F/47F (3.2W) 240Hz, Broadband	LV5400 55F/47F/42F (3.25) LED+120Hz, Smart TV, M3(옵션), WiFi in-	LM6250 55F/47F (4.3W) LED, T120Hz, 3D, Smart + 3 Mode, 3D BDP in-packing
	LD630 55F/47F/42F (4.3W) 240Hz (LD650 Tool)	LV4400 55F/47F/42F (10.2W) LED+120Hz	LS5700 55F/47F/42F/32F (3.7) LED, T120Hz, Smart + 3 Mode
		LV3500 47F*/42F/37F (3.3/ 3.14*) LED+FHD	LS5750 60F*/55F/47F/42F (4.4W TBD*/3.14) LED, T120Hz, Smart + 3 Mode
		LV2500 32/26/22*(3.3/4.25*) LED+HD	LM5800 55F/47F/42F (3.4W) LED, T120Hz, 3D
Low end	LD550 60F(5.1W) + 52F/46F/42F (3.3W) 120Hz, Broadband	LK550 47F/42F (3.29) CCFL+120Hz, Smart TV, M3(옵션), WiFi in-boxing	LM6450 60F (9.2W) LED, T120Hz, 3D+Smart
	LD520 55F/47F/42F (4.1W) 120Hz (LH50 Tool)	LK520 55F/47F/42F (3.15) CCFL+120Hz (LD650 Tool)	LS5850 55F/47F (3.21 일주차 RS 출하) LED, T120Hz, 3D, 3D+Smart BDP in-packing
	LD450 47F/42F/37F/32F (3.1W) FHD	LK450 47F*/42F/37F/32F (3.8*/3.3) CCFL+FHD	LS5600 55F/47F/42F/37F/32F* (3.7/2.26*) LED, T120Hz (37/32" : 60Hz)
	LD420 47F/42F/32F (4.4W) FHD (LH30 Tool)		LM4600 55F/47F (6.2W) LED, T120Hz, 3D
	LD350 32/26/22/19 (3.1W) HD	LD500 47F(11.1W) 120Hz (ODM)	LS4600 55F/47F (3.4W) LED, T120Hz
	LD320 32 (4.4W) HD (LH20 Tool)	LD400 42F/32F(11.1W) FHD (ODM)	LS4000 50F(8.1W) LED, T120Hz
		LK330 32/26/22(3.25) CCFL+HD (LD350 Tool)	LS3500 32*/26/22 (3.8*/3.12) LED, HD
			LS3400 42F/32 (4.1W) LED, 60Hz (32": HD)
			CS570 47F/42F (3.4W) CCFL, 120Hz, LK450 Tool
			CS560 42F/32F (3.10) CCFL, 60Hz, LK450 Tool
		CS460 32* (3.10*) CCFL, HD	

DTV

Clear Screen

Borderless

Old Tool

'10

'11

'12

High end

LX9500 55F/47F(5.2W)
Full LED Slim + 480Hz, 3D, THX, Magic UI, Broadband

LE8500 55F/47F (3.2W : 47" CSKD Air, 55" SET Air)
LED Slim + 240Hz, THX, Broadband

Mid end

LE7500 55F/47F/42F (5.1W)
Edge LED + 120Hz, Local Dimming, Broadband

LE7300 55F/47F/42F (8.4W)
LED + 120Hz

LX6500 55F/47F/42F (5.1W)
LED Plus + 240Hz, 3D, Local Dimming, Broadband(LE5500 Tool)

LE5400 55F/47F/42F (3.2W) + 32F (4.3W)
Edge LED + 120Hz, Broadband

LE5300 55F/47/42F(5.3W)/37F/32F(4.3W)
Edge LED + 120Hz(26/22/19: Edge LED HD) /26/22/(3.2W)/19(4.4W)

LD650 55F/47F (3.1W)
240Hz, Broadband

LD630 55F/47F/42F (4.3W)
240Hz (LD650 Tool)

Low end

LD550 60F(5.1W) + 52F/46F/42F/32F (3.2W)
120Hz, Broadband

LD520 47F/42F(3.3W), 32F(3.4w)
120Hz (LH50 Tool)

LD450 47F/42F/37F/32F (3.1W)
FHD

LD420 47F/42F/32F (4.4W)
FHD (LH30 Tool)

LD350 32/26/22/19 (3.1W)
HD

LD320 32 (4.4W)
HD (LH20 Tool)

LW9800 55F/47F (9.1W)
NANO Full LED+480Hz, Cinema 3D, THX(TBD), Smart TV, M3, WiFi B/in

LW6500 65F (5.1W)
LED +120Hz, Cinema 3D, Smart TV, M3, WiFi in-boxing

LW5700 55F/47F/42F/32F*(3.29/4.16*)
LED +120Hz, Cinema 3D, Smart TV, M3(옵션), WiFi in-boxing

(타 32" 는 WiFi in-boxing 없음)
LW5600 55F/47F/42F (3.20)
LED Plus+120Hz, Cinema 3D, Smart TV, M3, WiFi in-boxing

LW5000 55F/47F/42F (7.3W)
LED Plus+120Hz, Cinema 3D

LV4400 55F/47F/42F (10.1W)
LED+120Hz

LV3500 55F*/47F**/42F/37F/32F (2.28/3.7*/3.25**)
LED+FHD

LV3520 42F/32F (3.7)
LED+FHD

LV2500 32/26/22*/19**(2.28/4.17*/3.15**)
LED+HD

LV2520 32/26(4.25) LED+HD

LV2400 32 (10.1W) LED+HD

LK550 47F/42F (3.28)
CCFL+120Hz, Smart TV, M3(옵션), WiFi in-boxing

LK450 42F/37F/32F (2.28)
CCFL+FHD

LK430 42F/32F*(3.25/3.28*)
CCFL+FHD (LD450 Tool)

LK330 32/26/22(3.14)
CCFL+HD (LD350 Tool)

EM9600 55F
OLED, 3D, Smart + 4 Mode

LM9600 84(UD)*/60F*/55F/47F (10/15*/4.2W)
ALEF + T480(*T240), 3D, Smart + 4 Mode

LM9500 72F (6/18)
IOL, T480Hz, 3D, Smart + 4 Mode

LM8600 55F/47F (4.2W)
LED, T240Hz, 3D, Smart + 4 Mode

LM7600 55F/47F (3.14)
LED, T240Hz, 3D, Smart + 3 Mode

LM6700 55F/47F/42F* (3.14, 4.1W*)
LED, T120Hz, 3D, Smart + 3 Mode

LM6400 55F/47F (6.1W)
LED, T120Hz, 3D, Smart + 3 Mode

LM6450 60F (9.3W)
LED, T120Hz, 3D+Smart

LM6200 65F*/55F/47F/42F (3.21*/3.14)
LED, T120Hz, 3D, Smart + 3 Mode

LM6210 47F/42F (4.1W)
LED, T120Hz, 3D, Smart + 3 Mode

LS5700 60F*/55F/47F/42F/32F (5.1W TBD*/3.14)
LED, T120Hz, Smart + 3 Mode

LS5750 55F/47F/42F (3.21)
LED, T120Hz, Smart + 3 Mode

LS5600 55F/47F/42F/37F/32F* (3.14/3.4*)
LED, T120Hz (37/32* 60Hz)

LS5650 42F (3.7)
LED, T120Hz

LM5800 55F/47F/42F (4.1W)
LED, T120Hz, 3D

LM4600 55F/47F (6.3W)
LED, T120Hz, 3D

LS4600 55F/47F (4.1W)
LED, T120Hz

LS4000 50F(8.2W)
LED, T120Hz

LS3500 32*/26/22 (3.15*/3.19)
LED, HD

LS3400 42F/32 (4.2W)
LED, 60Hz (32": HD)

CS570 47F (4.1W)
CCFL, 120Hz, LK450 Tool

CM565 47F/42F (4.1W)
CCFL, 60Hz, 3D, LK450 Tool

CS560 42F/32F (3.17)
CCFL, 60Hz, LK450 Tool

CS530 42F (3.17)
CCFL, 60Hz, LK450 Tool

CS460 32* (3.17*) CCFL, HD

◆ CONTENT ◆

1. '2011 Product line-up and features
- 2. Model naming and tool option**
3. New features
4. Main PCBs
5. Block Diagrams, IIC Map
6. Structure of TV set and connection of sub ass'ys
7. New sub ass'ys
 - Instruction of new sub ass'ys
 - How to use tool
 - Download
8. Adjust way of new features
9. Repair guide
10. The latest issue and concerning issue

Model naming and Tool option



Standard of 2012y Model Name



12Y model name

Description of Tool Options



ToolOption

◆ CONTENT ◆

1. '2011 Product line-up and features
2. Model naming and tool option
- 3. New features**
4. Main PCBs
5. Block Diagrams, IIC Map
6. Structure of TV set and connection of sub ass'ys
7. New sub ass'ys
 - Instruction of new sub ass'ys
 - How to use tool
 - Download
8. Adjust way of new features
9. Repair guide
10. The latest issue and concerning issue

EPI Interface

● EPI(Embedded Point-Point Interface)

● Features

- Point-Point topology (support 2 Pair option)
- CDR (Clock Data Recovery)
- Bandwidth up to 1.85Gbps/pair at FHD 120Hz 10 bit application
- Lock signal cascading and feedback to T-Con
- Embedded Control Data

● Merits

- Better reliability on common noise
- No data skew and better EMI margin
- Fewer lines than mini-LVDS
- Slim PCB design

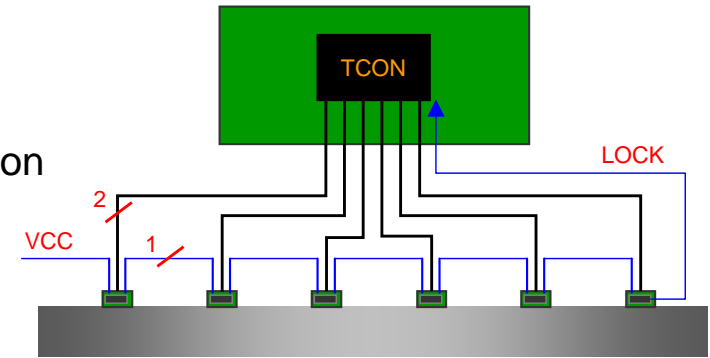

Figure1. Topology

Table 1. Example of FHD 120Hz TV

EPI	FHD (10bit) @ 960Ch		
	60Hz	120Hz	240Hz
Transmission Line	12	12	24
Bandwidth	0.84Gbps	1.68Gbps	1.68Gbps

EPI Interface (mini-LVDS vs. EPI)

Comparison

● HF mini-LVDS

HF mini-LVDS	FHD (10bit)		
	60Hz	120Hz	240Hz
No. of Signal	36	36	72
Connector	60pin (2ea)	60pin (2ea)	80pin (2ea)

- Difficult to upgrade bandwidth limit
- Multiple number of wires needed for higher bandwidth

● EPI (Embedded clock P-to-P Interface)

EPI	FHD (10bit)		
	60Hz	120Hz	240Hz
No. of Signal	12	12	32
Connector	-	50 pin (2ea)	70pin (2ea)

- Better reliability on common noise
- No data skew. Better EMI margin
- Lower cost (Cable, Connector)
- Slim S-PCB design (14mm → 10mm) helps slimmer TV

What to change

● LCM (T-con to S-Driver IC)

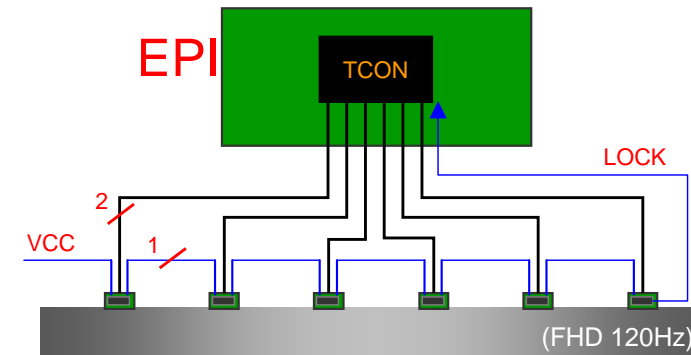
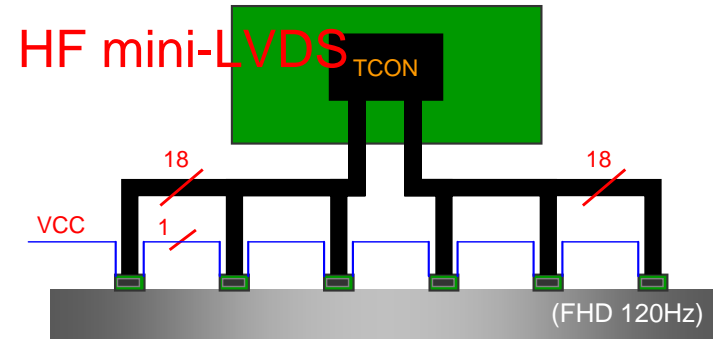

* Bandwidth Capability

- FHD 120Hz 10Bit : 594Mbps@36Lines → 1.65Gbps@12Lines
- FHD 240Hz 10Bit : 594Mbps@72Lines → 1.25Gbps@32Lines

EPI Interface (mini-LVDS vs. EPI)

	HF mini-LVDS	EPI												
Topology														
Protocol		<table border="1"> <thead> <tr> <th>Bit</th> <th>Name</th> <th>Description</th> </tr> </thead> <tbody> <tr> <td>0, 1</td> <td>CK</td> <td>Indicates a rising edge of bit clock. (Always "H")</td> </tr> <tr> <td>2 ~ 30</td> <td>-</td> <td>RGB data are transmitted. LSB is transmitted at first. 2 ~ 11 : R0 ~ R9 12 ~ 21 : G0 ~ G9 22 ~ 31 : B0 ~ B9</td> </tr> <tr> <td>32, 33</td> <td>DMY</td> <td>Dummy (Always "L")</td> </tr> </tbody> </table>	Bit	Name	Description	0, 1	CK	Indicates a rising edge of bit clock. (Always "H")	2 ~ 30	-	RGB data are transmitted. LSB is transmitted at first. 2 ~ 11 : R0 ~ R9 12 ~ 21 : G0 ~ G9 22 ~ 31 : B0 ~ B9	32, 33	DMY	Dummy (Always "L")
Bit	Name	Description												
0, 1	CK	Indicates a rising edge of bit clock. (Always "H")												
2 ~ 30	-	RGB data are transmitted. LSB is transmitted at first. 2 ~ 11 : R0 ~ R9 12 ~ 21 : G0 ~ G9 22 ~ 31 : B0 ~ B9												
32, 33	DMY	Dummy (Always "L")												
Features @10bit, FHD120	<ul style="list-style-type: none"> • Multi Drop • Data rate: 660Mbps • External clock 	<ul style="list-style-type: none"> • Point to Point • Data rate : 1.8Gbps • Embedded clock, Control 												
Merit	<ul style="list-style-type: none"> • Simple structure • Standardization 	<ul style="list-style-type: none"> • Fewer Lines : 12 • Embedded clock : low EMI, Clock skew free • Easy to PCB design 												
Demerit	<ul style="list-style-type: none"> • Too many lines : 36 • Clock skew • EMI due to clock lines • Bandwidth limit 	<ul style="list-style-type: none"> • Transmission Overhead : 4bit delimiter 												

◆ CONTENT ◆

1. '2011 Product line-up and features
2. Model naming and tool option
3. New features
- 4. Main PCBs**
5. Block Diagrams, IIC Map
6. Structure of TV set and connection of sub ass'ys
7. New sub ass'ys
 - Instruction of new sub ass'ys
 - How to use tool
 - Download
8. Adjust way of new features
9. Repair guide
10. The latest issue and concerning issue

Main PCB for Broadband

xxLS5700-UA

Chassis : LA22E
PCB P/No : EAX64434205

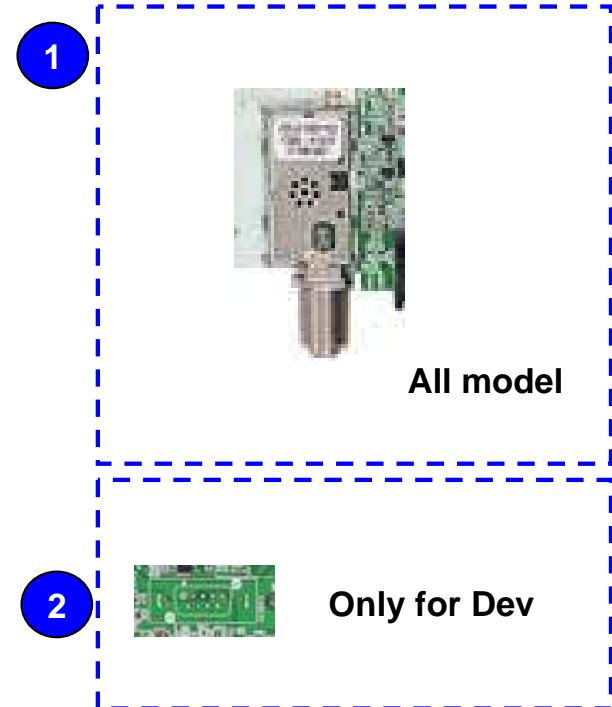
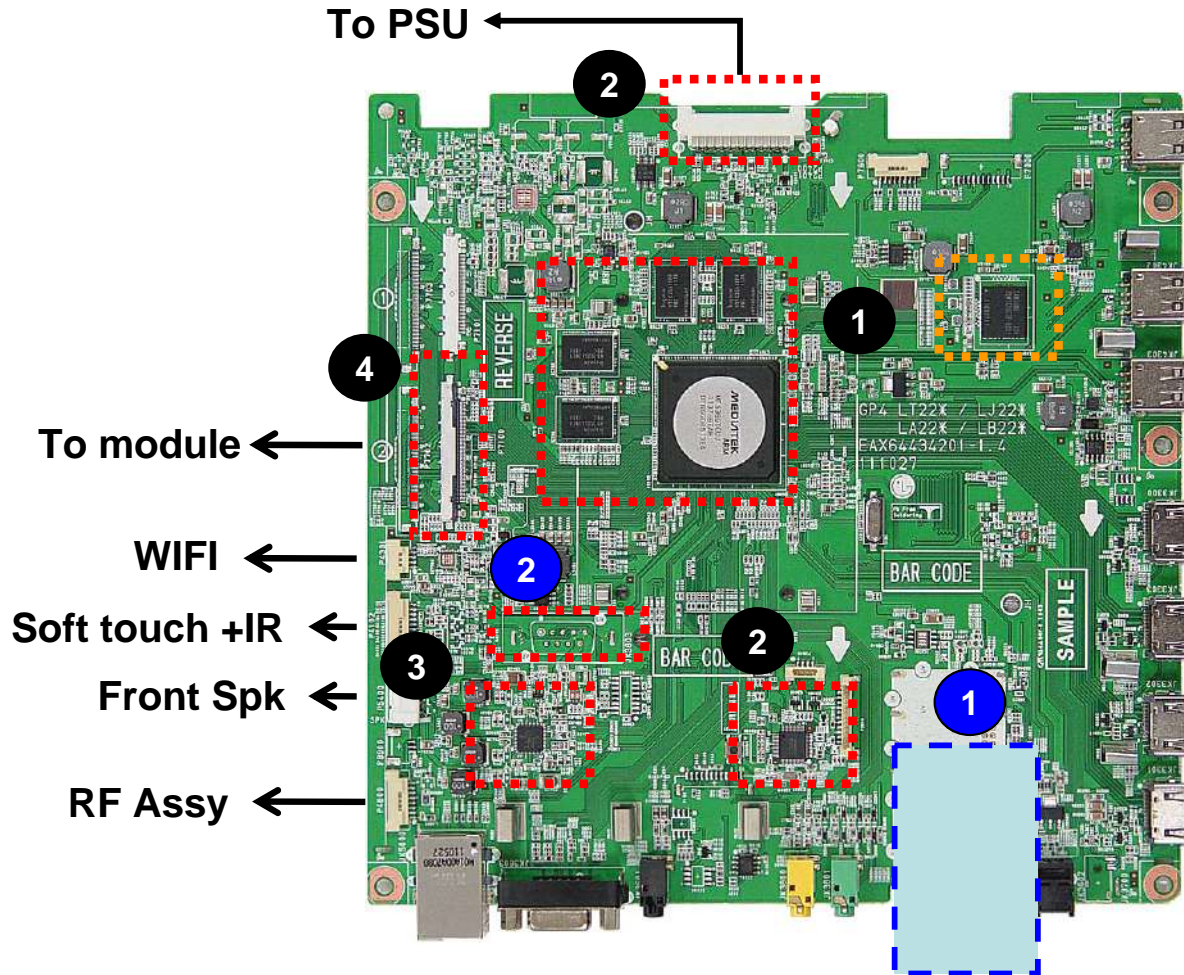

- 1** Main processor, DDR Memory
eMMC Memory
- 2** Micom for Key/IR sensing
- 3** Audio AMP (10W+10W)
- 4** LVDS & EPI Wafer

◆ CONTENT ◆

1. '2011 Product line-up and features
2. Model naming and tool option
3. New features
4. Main PCBs
- 5. Block Diagrams, IIC Map**
6. Structure of TV set and connection of sub ass'ys
7. New sub ass'ys
 - Instruction of new sub ass'ys
 - How to use tool
 - Download
8. Adjust way of new features
9. Repair guide
10. The latest issue and concerning issue

MTK5369 Block Diagram(LS57)

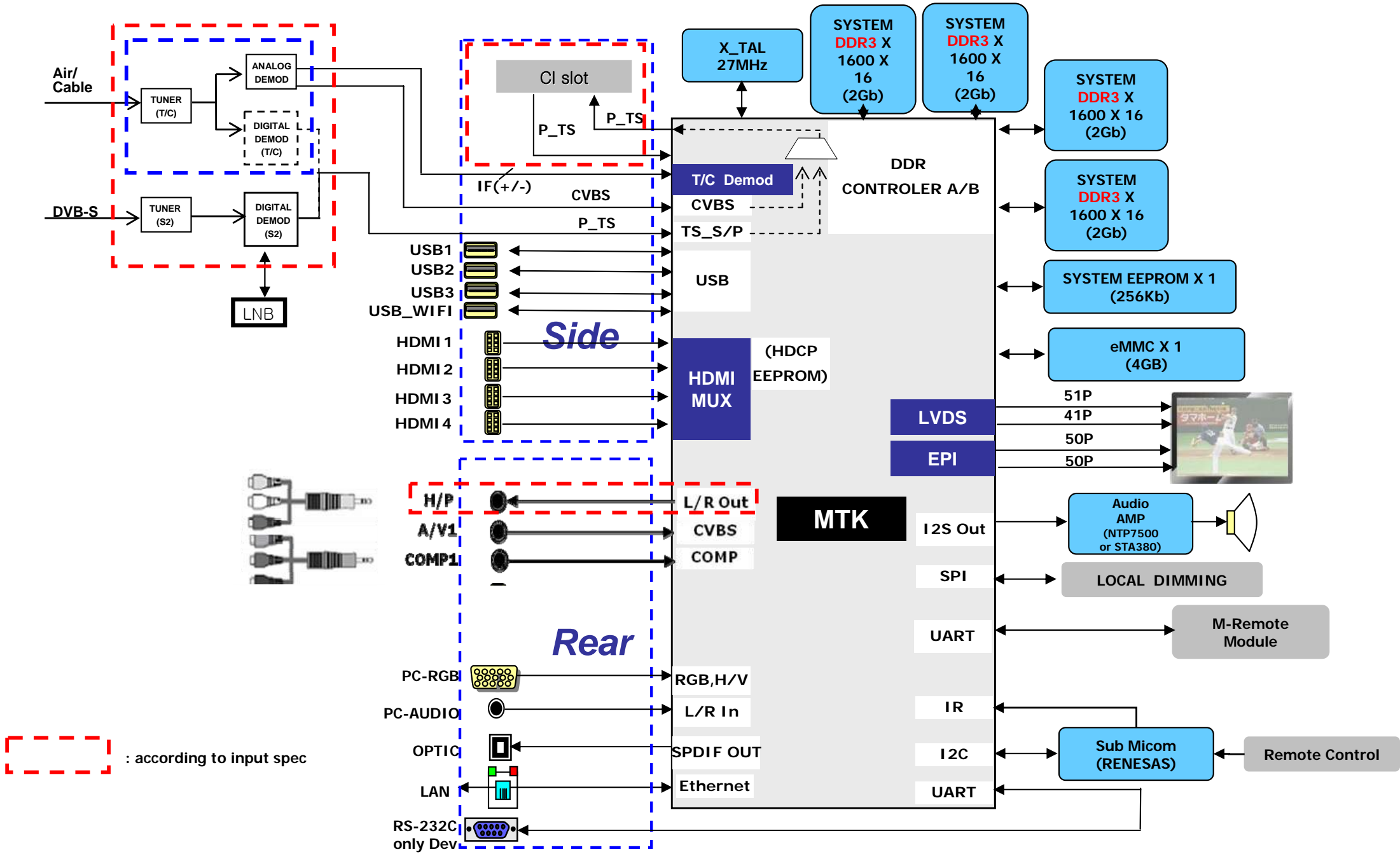

Jack Interface

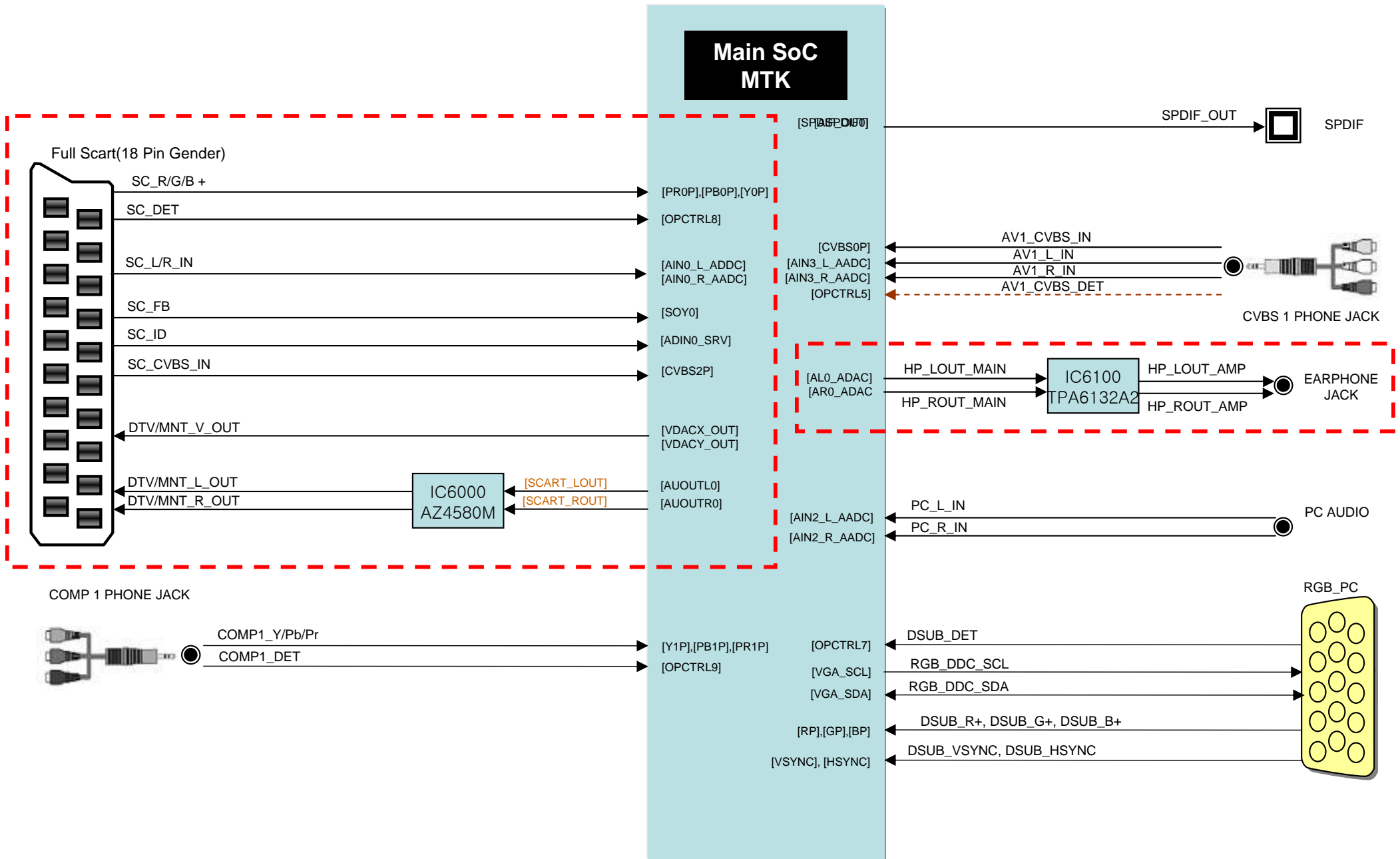

GP4 Backend block diagram (EPI & T-con)

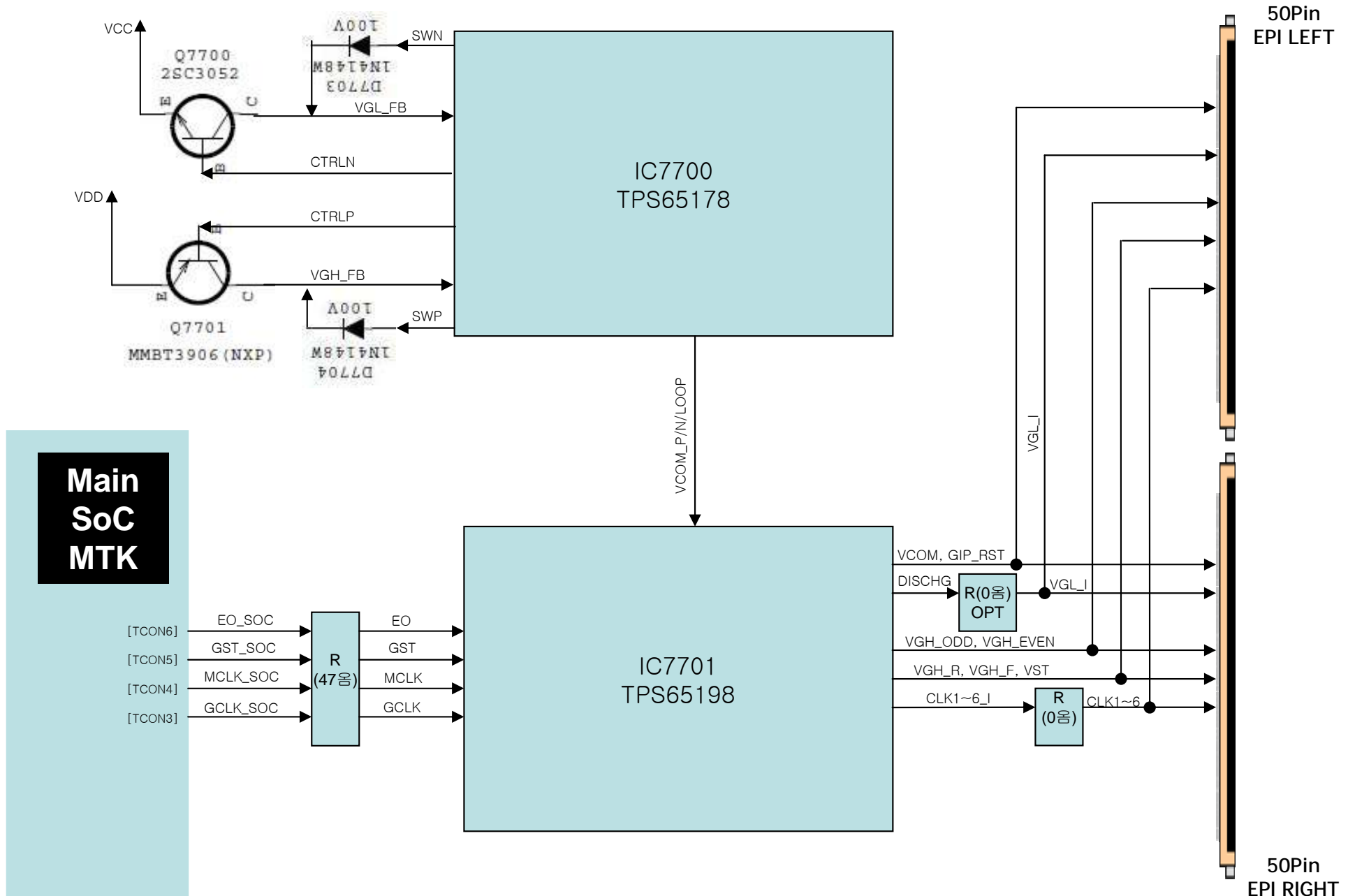

GP4 Backend block diagram (EPI & T-Con)

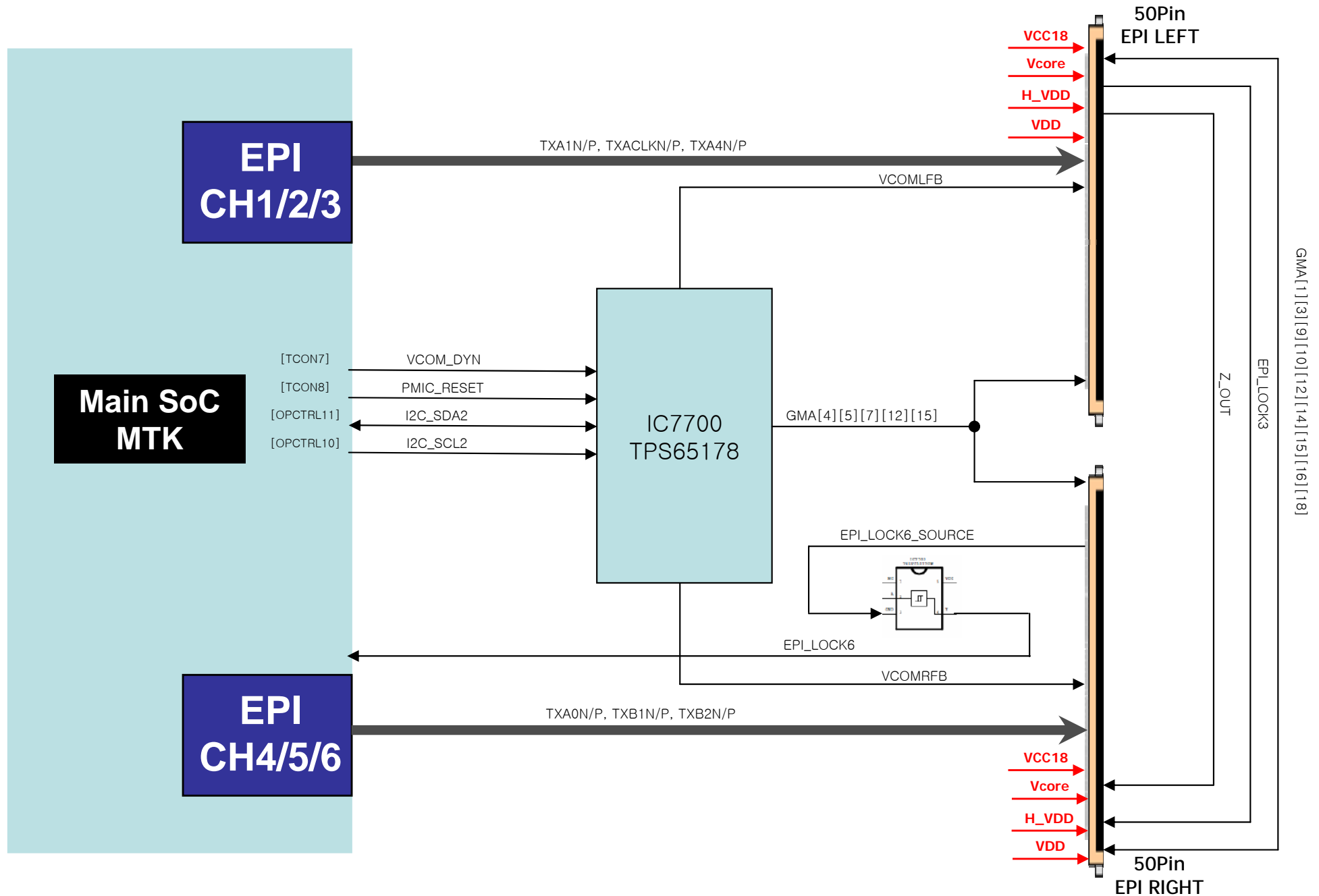

GP4 Backend block diagram (LVDS Tx & Local Dimming)

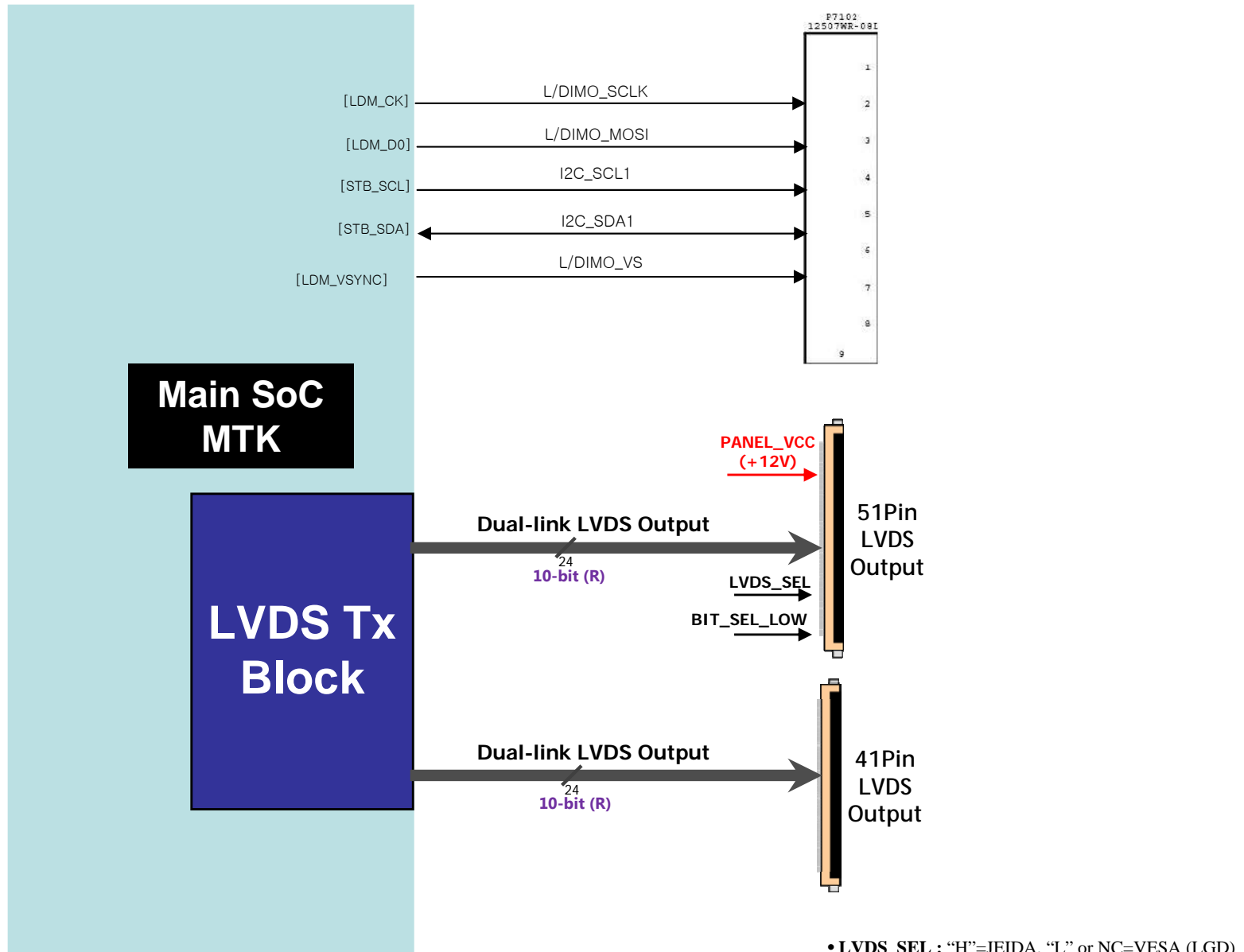

◆ CONTENT ◆

1. '2011 Product line-up and features
2. Model naming and tool option
3. New features
4. Main PCBs
5. Block Diagrams, IIC Map
- 6. Structure of TV set and connection of sub ass'ys**
7. New sub ass'ys
 - Instruction of new sub ass'ys
 - How to use tool
 - Download
8. Adjust way of new features
9. Repair guide
10. The latest issue and concerning issue

Interconnection - 1

47LS5700-UA

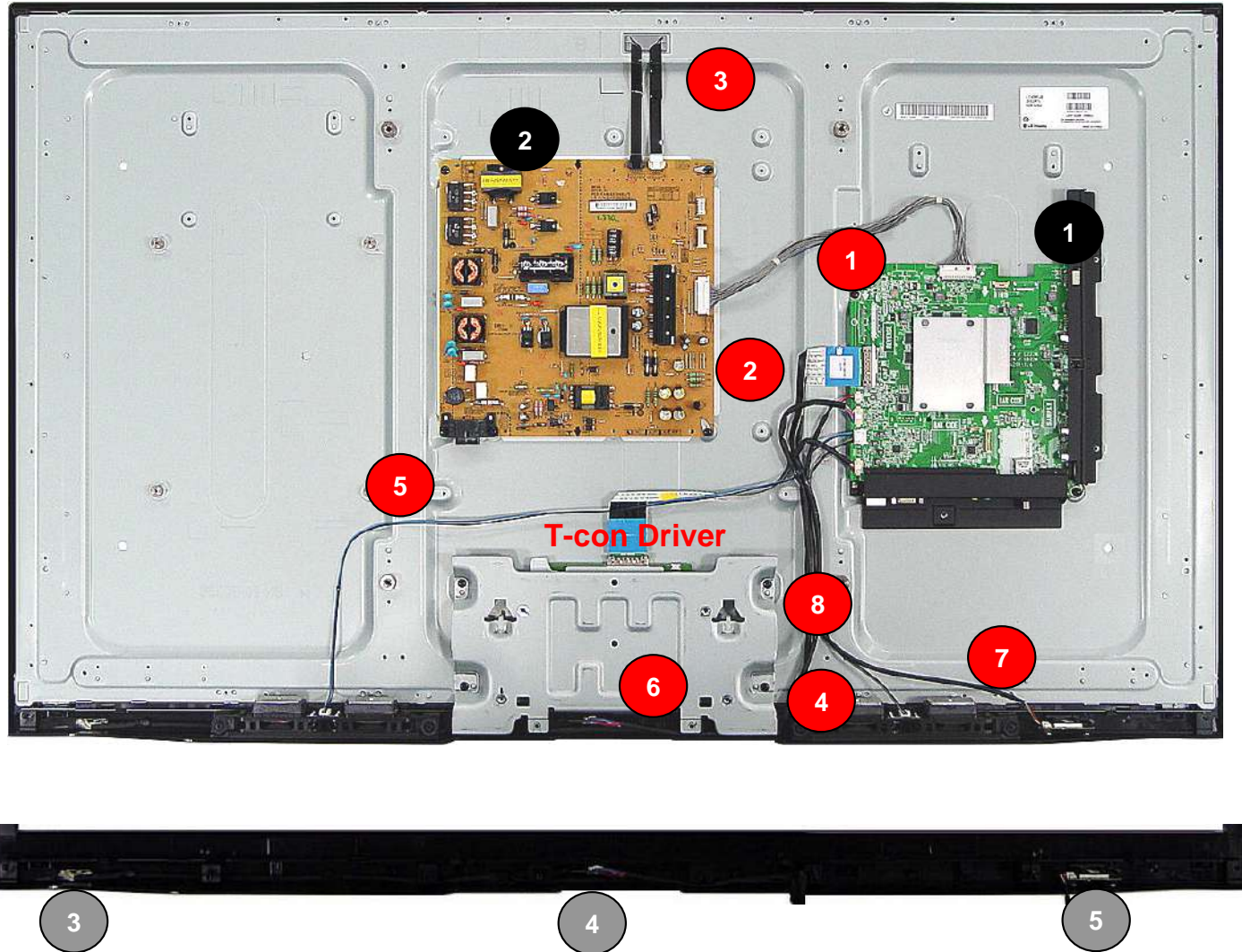

[PCBs]

- 1 Main PCB
- 2 Power Board
- 3 IR+Soft touch PCB
- 4 RF Assy
- 5 WIFI Assy

[Cables]

- 1 Main / LPB 24Pin cable
- 2 Main / Module LVDS Cable
- 3 LED driver / PSU
- 4 10Pin (IR+Touch) Cable
- 5 SPK Cable
- 6 RF Assy Cable
- 7 WIFI Assy Cable

◆ CONTENT ◆

1. '2011 Product line-up and features
2. Model naming and tool option
3. New features
4. Main PCBs
5. Block Diagrams, IIC Map
6. Structure of TV set and connection of sub ass'ys
- 7. New sub ass'ys**
 - Instruction of new sub ass'ys
 - How to use tool
 - Download
8. Adjust way of new features (widevine...)
9. Repair guide
10. The latest issue and concerning issue

Introductions of 12Y Model Soft-touch Ass'y

목차

- Introductions of soft-touch

2011년 12월 13일

LCD TV 사업부
LCD TV 연구소 / BP그룹

2012Y IR + Soft touch PCB Pinmap

Circuit Block Diagram

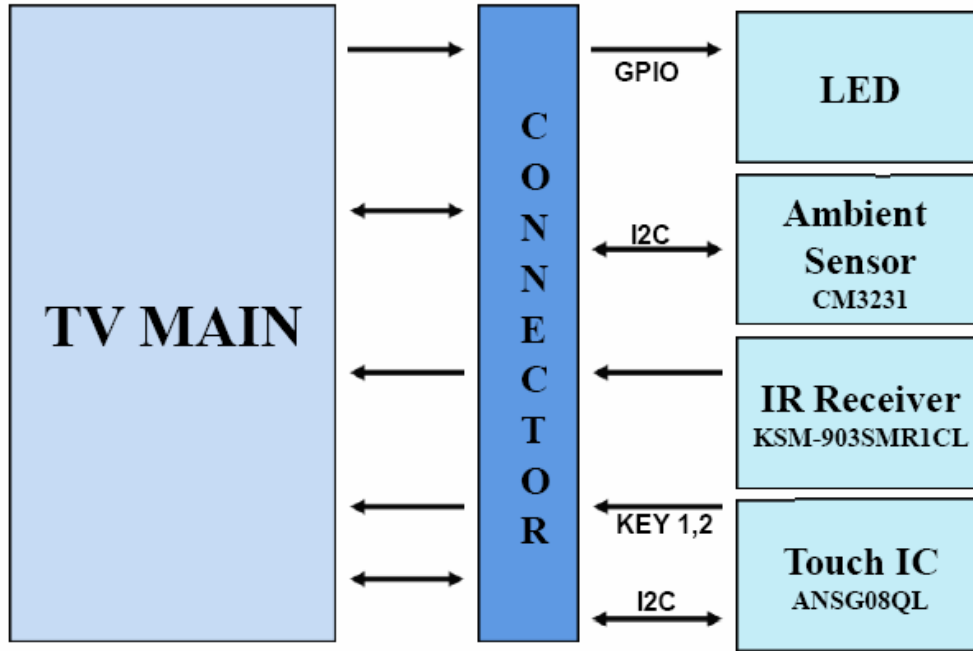

KEY1, KEY2 Voltage (Tolerance of voltage $\pm 0.2V$)

Parameter	POWER	INPUT	MENU	ENTER	VOL+	VOL-	CH+	CH-
KEY1			0.58V	0.09V	1.75V	1.18V		
KEY2	0.58V	0.09V					1.75V	1.18V

Ass'y Picture

TOP



BOTTOM



Pin Configuration

1	SCL	6	3.5V_ST
2	SDA	7	GND
3	GND	8	RED_LED
4	KEY1	9	IR
5	KEY2	10	GND

2012Y IR + Soft Touch LED Lighting Scenario

Power LED Scenario

구분		Spec 내용	비고	
Power Indicator UI		<ul style="list-style-type: none"> - 12Y GP4 High(L9), GP4 Mid(MTK), GP4 Low(S7LR2) → "Power Light" UI Delete compared with 11Y(GP3 model) - 11Y Carry Over Model : 12Y same Power LED scenario process → "Power Light" UI Delete, The way of 11Y Soft Touch Ass'y is used. White LED Disable 	-	
GP4 (High/Mid/Low) Power LED 시나리오	User Condition	Power On	<ul style="list-style-type: none"> - Stand-By condition to Red LED On : After DC ON, Red LED light Blinks twice and then Red LED is Off - Stand-By condition to Red LED Off : After DC ON, Red LED light Blinks three times and then Red LED is Off 	-
		Power Off	<ul style="list-style-type: none"> - Without Blink, Red LED On immediately But, If the mode of Power Indicator UI is Stand-By, keep staying Red LED Off status 	-
		Remote Key input	<ul style="list-style-type: none"> - When you put the remote Control button, Red LED Blinks once 	-
		Warm Stand-by	<ul style="list-style-type: none"> - Red LED On stays and In the case of Set On, Red LED turns Off → Including DVR Ready model, Japanese model 	Same as the 11Y
		3D mode	<ul style="list-style-type: none"> - Red LED Off (Power On condition is identical) 	Same as the 11Y
	Factory Condition	Factory Default Mode (In-Stop)	<ul style="list-style-type: none"> - 12Y LED Model : Stand-By On (Red LED On) - 12Y CCFL Model : Stand-By On (Red LED On) - 11Y Carry Over Model (CS5XX/CM5XX) : Stand-By On (Red LED On) - After In-Stop, Red LED On is processed and after In-Stop, Red LED turns on within 3 sec 	-
		Power Only Mode	<ul style="list-style-type: none"> - In the case of Power Only On, Red LED turns Off - In the case of DC Off, Red LED turns On 	-

Introductions of GP4 Sensor (Touch IC)

Manual of Touch Sensitivity

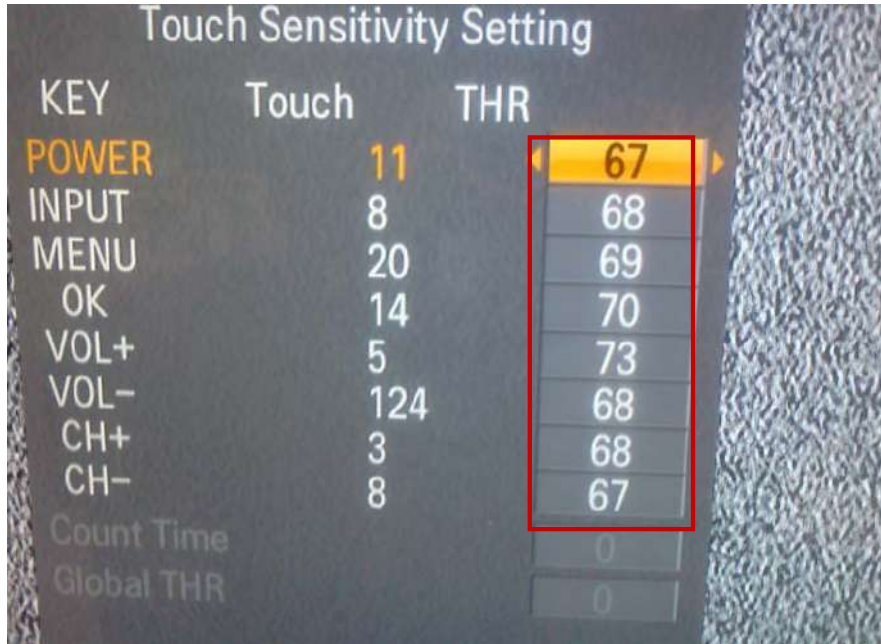

1. Verify the number of THR at first.
2. Once you correctly touch Touch button for more than 1 sec, you can see a Touch data while you keep touching the button.
3. Keep in mind that you can only read the Touch data during touch status.
4. It doesn't matter that Touch data gets low value after taking off your finger.

Touch Key Threshold Level (Ta = 25°C)

Parameter	POWER	INPUT	MENU	ENTER	VOL+	VOL-	CH+	CH-
Sensitivity	67	68	69	70	73	68	68	71

Introductions of GP4 Sensor (Touch IC)

Touch EEPROM Register change with USB port

ANSG08 2.03

File (F) Relay (R) Register (G) Monitoring (M)

Addr	Value	Addr	Value	Addr	Value	Addr	Value
01	FF	1E	FF	3F	44	7A	00
05	80	1F	FD	40	43	7B	00
06	48	20	7F	41	66	7C	00
08	11	21	00	42	66	7D	00
09	11	22	C0	43	00	7E	00
0A	11	23	00	44	00		
0B	11	24	C0	45	00		
0C	11	25	00	46	00		
0D	11	26	FF	47	0D		
0E	A1	27	FF	48	00		
0F	10	28	FF	4B	00		
10	F5	29	FF	4C	00		
11	20	2B	00	4F	00		
12	FF	2C	00	62	00		
13	92	34	06	6F	00		
14	83	35	C0	70	80		
15	73	36	4C	71	06		
16	64	37	FF	72	30		
17	FF	38	BC	73	00		
18	2B	39	43	74	00		
19	11	3A	44	75	00		
1A	00	3B	45	76	00		
1B	FF	3C	46	77	00		
1C	10	3D	49	78	00		
1D	FF	3E	44	79	00		

Chip ID: 48

EEPROM Load

CH0: 0
CH1: 0
CH2: 0
CH3: 0
CH4: 0
CH5: 0
CH6: 0
CH7: 0
DM1: 0

F F Set

 : Threshold address : Register Version
 : Company name : Model Information

1. Write all of the address, value (Hex) as a below. capable of only Touch.txt file based on the left picture



Touch.txt - 메모장

```

1 FF
5 80
6 48
8 11
9 11
0A 11
0B 11
0C 11
0D 11
0E A1
0F 10
10 F5
11 20
12 FF
13 92
14 83
15 73
16 64
17 FF
18 2B
19 11
1A 00
1B FF
1C 10
1D FF
1E FF
1F FD
20 7F
21 00
22 C0
23 00
24 C0
25 00
26 FF
27 FF
28 FF
29 FF
2A 00
2B 00
34 06
35 C0
36 4C
37 FF
38 BC
39 43
    
```

2. Make the file [Filename : 'Touch.txt'] and move it to USB (The outermost area, Don't move it to any folder)

3. Connect USB to TV and press button 'ADJ menu' and then choose the 'touch sensitivity setting'

4. Press button 'SIMPLINK (Simply Link key)' and then you can see the OK Pop up.

5. After that, you check it the IR LED version on In-start menu and verify it that the number of version is changed to what you want.

Addr Value

Introductions of 12Y RF ass'y + Magic Remote control

목차

**- Introductions of 12Y RF ass'y
+ Magic Remote control**

2011년 12월 19일

LCD TV 사업부
LCD TV 연구소 / BP그룹

1. System

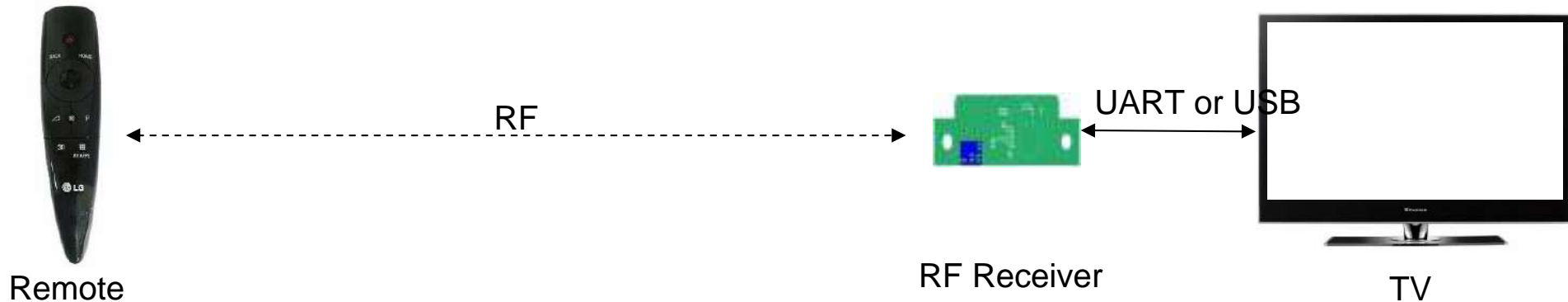

❖ *Pairing Information Transmission (Send to TV after Paired)*

- Static Calibration Data (Bypass only)
- Remote FW ver. (Save also in Receiver)
- BD_ADDR (Save also in Receiver)
- *Pairing Information Transmission Sequence*
 - When it is paired, the remote sends packets(pairing success, F/W version, BD_ADDR) to the receiver.
 - The receiver sends the pairing success packet to TV directly.
 - F/W version and BD_ADDR packets are just saved on the receiver.
 - The receiver sends F/W version or BD_ADDR packet to TV when it is required.

❖ *Motion Data Transmission*

- Period : 7.5msec
- Motion Data : gyro, accelerometer

❖ *Voice Data Transmission*

- Period : 10msec
- Voice sampling : 16khz 16bit

→ See “6-2. Packets” on page 8.

2. Remote Buttons (M3 vs. M4)

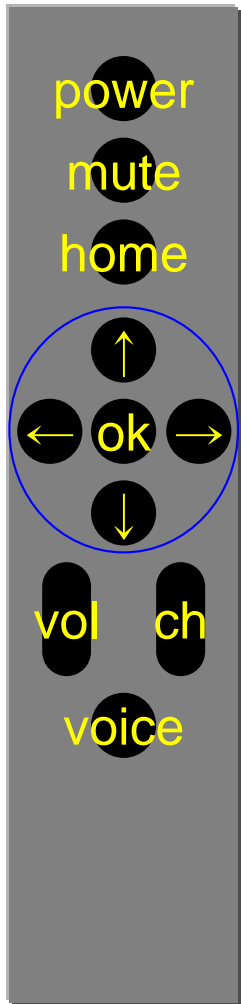

M3 Remote

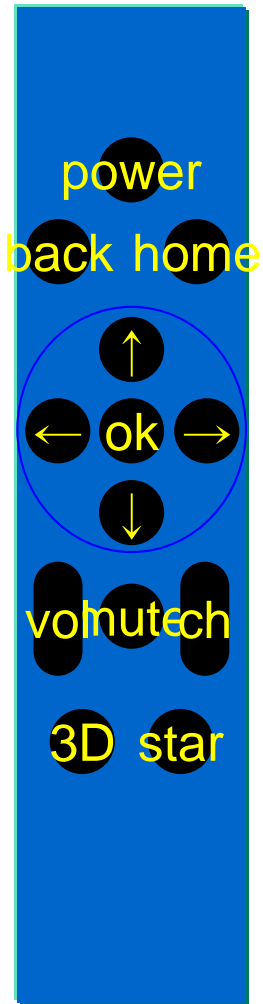

M4 Remote

BUTTON		RF Unpaired IR_CODE	RF Paired RF_CODE	IR continuous repeat	ETC.
Physical Buttons	POWER	0x08	0x08	Y	IR only
	BACK	0x28	0x8028	Y	
	HOME	0x7C	0x807C	Y	
	←	0x07	0x8007	Y	
	→	0x06	0x8006	Y	
	↑	0x40	0x8040	Y	
	↓	0x41	0x8041	Y	
	OK	0x75	0x8044	Y	
	CH +	0x00	0x8000	Y	
	CH -	0x01	0x8001	Y	
	VOL +	0x02	0x8002	Y	
	VOL -	0x03	0x8003	Y	
	MUTE	0x09	0x8009	Y	
	3D_Mode	0xDC	0x80DC	Y	
	MyAPPS	0x42	0x8042	Y	
	VOICE		0x800A	Y	= VOICE_START
Logical Buttons	AUTO_WAKEUP	X	0x800C		
	VOICE_START	X	0x800A		
	VOICE_STOP	X	0x800D		
	POINT_START	X	0x803E		
	POINT_STOP	X	0x803F		

3. M4 Block Diagram

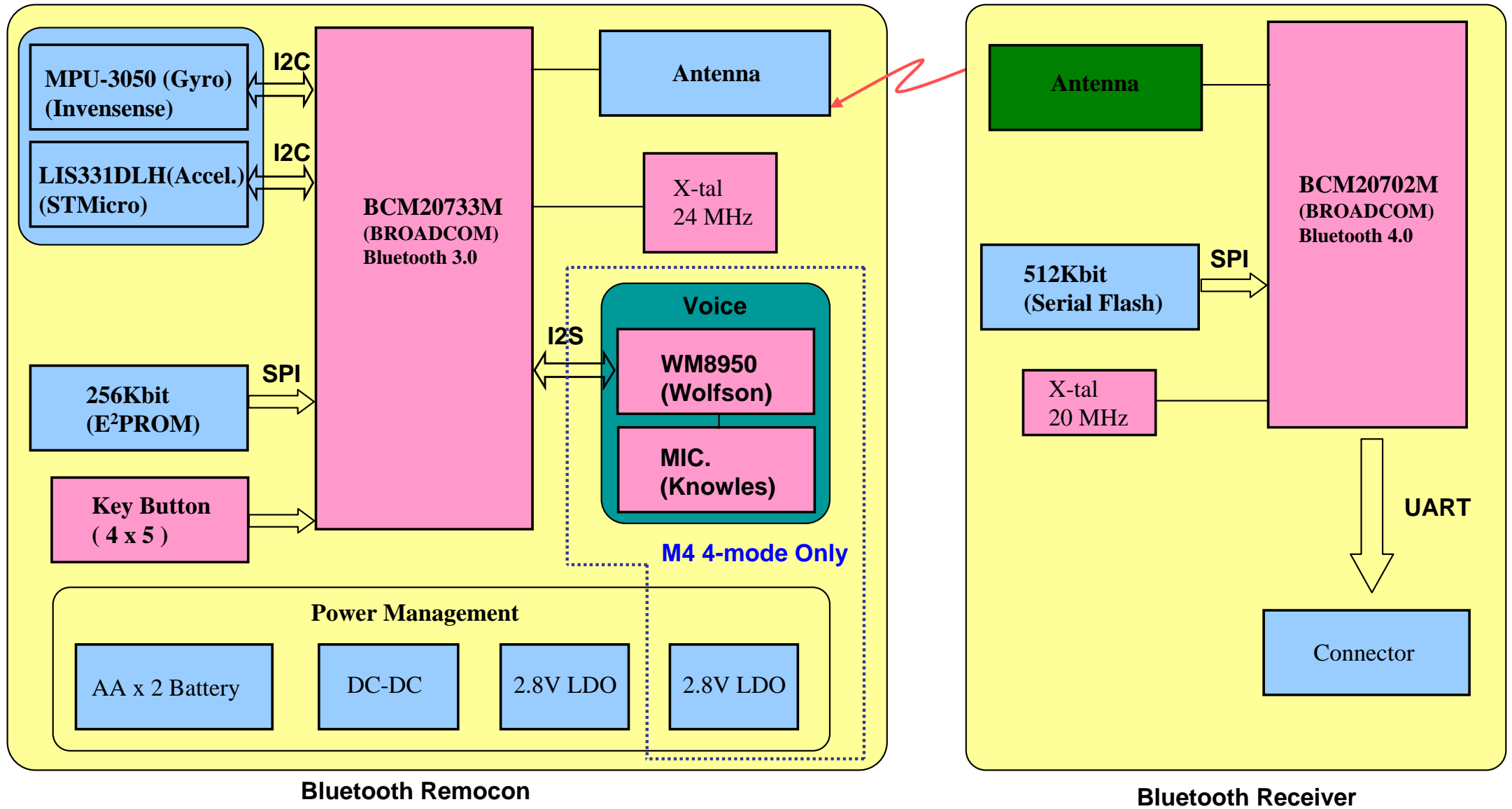

4. Function list

주요 Item		IC	Manufacturer	Function	
Remocon	Voice	Voice Codec	WM8950	Wolfson	16KHz Sampling of Audio data
		MEMS Mic.	SPU0414HR5H	Knowles	Sensing Voice
	Motion Sensor	Gyro Sensor	ITG3050	Invensense	Sensing angular velocity of X, Y, Z-axis
		Accelerometer	MMA8452	Stmicro	Sensing device tilt (Pitch & Roll angle)
	RF + Micom	RF Antenna	SDBTPTR3015	Partron	Wireless communication
		X-tal	24MHz	Partron	
		RF + Micom	BCM20733	Broadcom	
	DC-DC Converter		TPS61097	TI	Battery Boost up Regulator
	LDO1		uPI7716	uPI	RF, Gyro, Accelerometer Power Supply
	LDO2		uPI7716	uPI	Audio Codec, Mic. Power Supply

5. RF Pairing / Un-pairing Method

	Method	Description
RF Pairing	<ul style="list-style-type: none"> ❖ Method1 <ul style="list-style-type: none"> – If unpaired, just press "OK" button. – If paired, press "OK" button after unpairing. ❖ Method 2 (Repairing) <ul style="list-style-type: none"> – Press "BACK" button for 5 sec. 	<ul style="list-style-type: none"> • When do pairing, the remote should make pairing request IR signal(0x29) to TV. • When TV receive the IR signal, it should send "pairing request packet" to the RF receiver. • After pairing success, the remote should blink LED for some time and TV send "pairing success packet" back to TV. • When remote try to unpairing, it doesn't care about state of receiver(stand alone).
RF Unpairing	<p>Press "HOME" button and "BACK" button at the same time for 5 sec.</p>	<ul style="list-style-type: none"> • When remote try to unpairing, it doesn't care about state of receiver(stand alone). • After unpairing, all pairing information should be erased. • After unpairing, LED should be blinked for 3sec. • The remote just becomes to IR mode.

Introductions of 12Y WIFI built in ass'y

목차

**-Introductions of WIFI built in
ass'y**

2011년 12월 21일

LCD TV 사업부
LCD TV 연구소 / BP팀

WIFI Built in ass'y feature(LGIT)

WIFI built in feature



- Pin map

PIN	USB interface
1	5V
2	DM
3	DP
4	GND

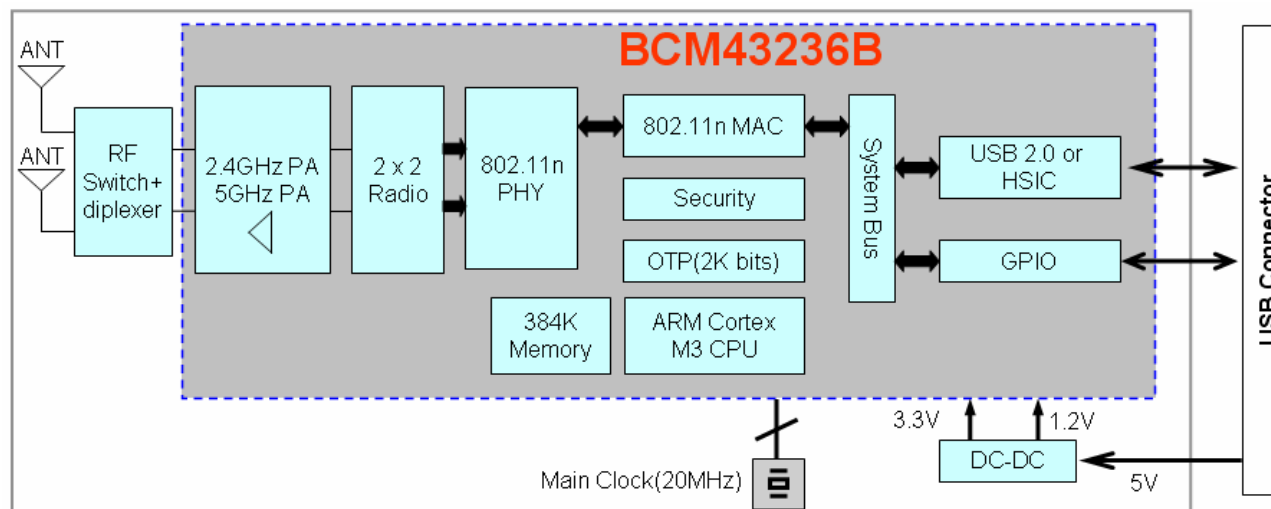

- Block diagram

WIFI Built in Block-diagram(Arcadyan)

WN8522D

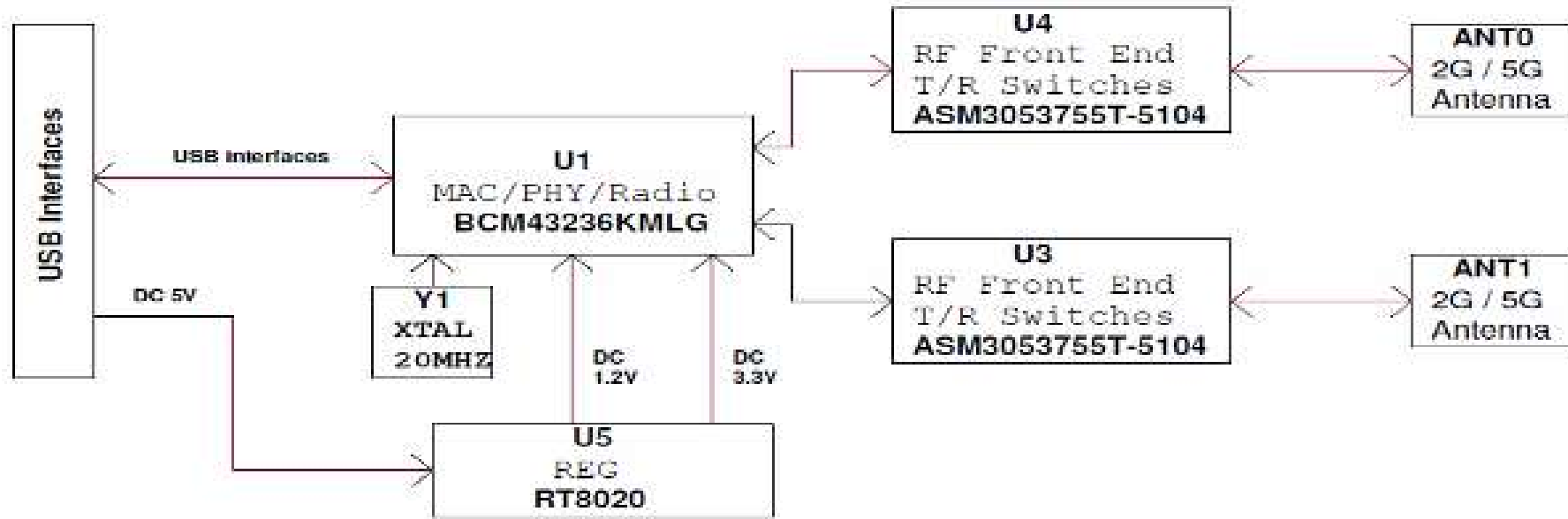

Power Table

Chip	5V	3.3V	1.2V
RT8020	315.7mA		
BCM43236KMLG ASM3053755T-5104 Serial FLASH		321.4mA	375.2mA
Total power	1.5785W		

arcadyan Arcadyan Technology Corporation
<http://www.arcadyan.com>

Title:	BLOCK DIAGRAM	Model:	WN8522D 1-19
Size:	Document Number	Drawn By:	Wing Chen
Custom:	165000057300J	Rev:	0A.1
Date:	Thursday, July 22, 2010	Sheet:	2 of 3

WiFi Built in ass'y Specification

◆ Frequency Band:

Draft 802.11n Radio: 2.4 GHz

802.11g Radio: 2.4 GHz

802.11b Radio: 2.4 GHz

USA – FCC

2412~2462MHz (Ch1~Ch11)

Canada – IC

2412~2462MHz (Ch1~Ch11)

Europe – ETSI

2412~2472MHz (Ch1~Ch13)

Japan – STD-T66/STD-33

2412~2484MHz (Ch1~Ch14)

802.11a Radio : 5 GHz

5.150~5.250GHz

5.725~5.850GHz

◆ Operating Channels:

IEEE 802.11b/g/n compliant:

11 channels (US, Canada)

13 channels (ETSI)

14 channels (Japan)

◆ Transmit Power and Sensitivity:

TX Output Power:(Typical) (Meet emission standard)

11b 17 +/- 2 dBm

11g 14 +/- 2 dBm@54Mbps (Each chain)

11n 13 +/- 2 dBm (Each chain)

Rx Sensitivity:(Typical)

-69dBm at HT20 m7 2.4GHz

-87dBm at HT20 m0 2.4GHz

-69dBm at HT20 m7 5.0GHz

-87dBm at HT20 m0 5.0GHz

◆ Modulation

DBPSK @1Mbps

DQPSK@2Mbps

CCK@5.5/11Mbps

BPSK@6/9 Mbps

QPSK@12/18Mbps

16-QAM@24Mbps

64-QAM@48/54Mbps and above

◆ Current consumption(5V DC):

Full load: 430mA

◆ Operating Temperature: 0 ~ 60 °C ambient

◆ Storage Temperature: -20 ~ 60 °C ambient

◆ Humidity: under 85% and must be non-condensing

◆ Regulation and certification compliance available:

◆ CE

◆ FCC

◆ WiFi



◆ WPS



◆ CONTENT ◆

1. '2011 Product line-up and features
2. Model naming and tool option
3. New features
4. Main PCBs
5. Block Diagrams, IIC Map
6. Structure of TV set and connection of sub ass'ys
7. New sub ass'ys
 - Instruction of new sub ass'ys
 - How to use tool
 - Download
- 8. Adjust way of new features**
9. Repair guide
10. The latest issue and concerning issue

12Y Widevine & HDCP 2.0 & NETFLX

Contents

1. Widevine?
2. HDCP 2.0 & NETFLIX?
3. DTCP?
4. Changed BOM

2011년 12월 22일

LCD TV 사업부
LCD TV 연구소 / BP그룹

1. Widevine?

[Widevine]

Widevine is the Solution(Library) offering Adaptive Streaming and DRM.

In BBTV, when special CP do service, this module is required key.

Currently CP which is requested to widevine, is typically Australian Bigpond Live and North American CinemaNow.

Furthermore, because the future will be the spread of CP, widevine key download for the global model should be applied to production.

(Because operation unique key should be downloaded for Widevine , Widevine key download by NSU is impossible.)

[Widevine Key]

Widevine Key is unique data stored TV for using Widevine.

2. HDCP 2.0 & NETFLIX?



HDCP

- ✓ High-bandwidth Digital Content Protection
- ✓ Protect high-value digital motion pictures, television programs and audio against unauthorized interception and copying between a digital set top box or digital video recorder and a digital TV or PC.
- ✓ Specification developed by Intel Corporation to protect digital entertainment across the DVI/HDMI interface.

Why HDCP2.0?

- ✓ HDCP revision 2.0 supports a broader range of wired and wireless interfaces.

Netflix

- ✓ the services maintain a huge selection of movies and latest releases and offer DVD rentals via mail & online streaming.

3. DTCP?

[DTCP]

The Digital Transmission Content Protection Specification defines a cryptographic protocol for protecting audio/video entertainment content from unauthorized copying, intercepting, and tampering as it traverses digital transmission mechanisms such as a high-performance serial bus that conforms to the IEEE 1394-1995 standard. Only legitimate entertainment content delivered to a source device via another approved copy protection system (such as the DVD Content Scrambling System) will be protected by this protection system.

[Three cryptographic Keys]

- Authentication Key which is formed as a result of authentication and used to protect the exchange keys.
- Exchange Key which is used to set up and protect content streams.
- Content Key which is used to encrypt the content being exchanged.

4. Changed BOM

As-Was

Current

주3) CNTV [Yes]: China Smart TV Only(CNTV ID 필요 모델)

○ Add Item

1. Marlin (Yes/No)
2. CNTV (Yes/No)
3. HDCP Tx (Yes/No)
4. DTCP Rx (Yes/No)
5. HDCP Rx (Yes/No)

주3) CNTV [Yes] : China Smart TV Only

4. Changed BOM

	Tool Option	bits	Range	Remark	Guide
Tool OPT7 (Automation Checkup)	Mac_AP Key	1	0/1 0:off 1:on	Automation checkup	Check whether or not key write
	ESN_AP Key	1	0/1 0:off 1:on	Automation checkup for Netflix Service	MAC-AP:Global
	CI_AP Key	1	0/1 0:off 1:on	Automation checkup	ESN_AP:Global(Except China)
	WIDEVINE_AP Key	1	0/1 0:off 1:on	Automation checkup for CP or 3D Zone Steaming Service	CI_AP:EU/CIS
	Marlin_AP key	1	0/1 0:off 1:on	Automation checkup	WIDEVINE_AP:Global
	EDID_TPE	2	0:PCM 1:AC3 2:Reserved		MARLIN_AP:Japan only
	LED Current	2	0/1/2/3/4 0: 85mA 1: 100mA 2: 105mA 3: 130mA	Setting PWM Duty each Module	Setting each model's Spec
	LED Bar Type(LCD Only) Pen Touch Tv(PDP Only)	2	LCD : V_12B,V_6B,H_12B,H_6B PDP : Off,Ready, BuiltIn,NULL	LED Bar (LCD Only) Pen touch (PDP Only)	In case of LPB(Tool OPT4/Power Type), This tool is valid.
	DiiVa	1	0/1		In case of LPB(Tool OPT4/Power Type), This tool is valid.
	XvYcc	1	0:not Support 1:Support	Check whether or not support of Module Color Gamut XvYCC	China : ON, Global(Except china) :OFF
	MRCU	1	0:not Support 1:Support	Check whether or not support of Voice recognition function	Setting each Module
	Gesture	1	0:not Support 1:Support	Check whether or not support of gesture recognition function	
	PWM_Freq	1	0:50_60Hz 1:PWM_DB	Setting each Module	L9 : ON, MTK : Off
	Sum of bits	16	Full Assign		

◆ CONTENT ◆

1. '2011 Product line-up and features
2. Model naming and tool option
3. New features
4. Main PCBs
5. Block Diagrams, IIC Map
6. Structure of TV set and connection of sub ass'ys
7. New sub ass'ys
 - Instruction of new sub ass'ys
 - How to use tool
 - Download
8. Adjust way of new features
- 9. Repair guide**
10. The latest issue and concerning issue

Contents of LCD TV Standard Repair Process

No.	Error symptom (High category)	Error symptom (Mid category)	Page	Remarks
1	A. Video error	No video/Normal audio	1	
2		No video/No audio	2	
3		Video error, video lag/stop, fail tuning	3, 4	
4		Color error	5	
5		Vertical/Horizontal bar, residual image, light spot, external device color error	6	
6	B. Power error	No power	7	
7		Off when on, off while viewing, power auto on/off	8	
8	C. Audio error	No audio/Normal video	9	
9		Wrecked audio/discontinuation/noise	10	
10	D. Function error	No response in remote controller, key error, recording error, memory error	11	
11		External device recognition error	12	
12	E. Noise	Circuit noise, mechanical noise	13	
13	F. Exterior error	Exterior defect	14	

First of all, Check whether there is SVC Bulletin in GCSC System for these model.

Contents of LCD TV Standard Repair Process Detail Technical Manual

No.	Error symptom	Content	Page	Remarks
1	A. Video error_ No video/Normal audio	Check LCD back light with naked eye	A1	
2		LED driver B+ 24V measuring method	A2	
3		Check White Balance value	A3	
4		Power Board voltage measuring method	A4	
6	A. Video error_ No video/Video lag/stop	TUNER input signal strength checking method	A6	
7		LCD-TV Version checking method	A7	
9	A. Video error_Color error	LCD TV connection diagram	A8	
10		Tuner Checking Part	A9	
11		Check Link Cable (LVDS) reconnection condition	A10 A11	A10 : 32/37/42/47/55 A11 : 32 AUO
12		Adjustment Test pattern – ADJ Key	A12	
13	A. Video error_Vertical/Horizontal bar, residual image, light spot	LCD TV connection diagram	A8	
14		Check Link Cable (LVDS) reconnection condition	A10 A11	A10 : 32/37/42/47/55 A11 : 32 AUO
15		Adjustment Test pattern – ADJ Key	A12	
16	<Appendix> Defected Type caused by T-Con/ Inverter/ Module	Exchange T-Con Board (1)	A-1/5	
17		Exchange T-Con Board (2)	A-2/5	
18		Exchange LED driver Board (PSU)	A-3/5	55" : driver board Other : PSU
19		Exchange Module itself (1)	A-4/5	
20		Exchange Module itself (2)	A-5/5	

Continue to the next page

LCD TV

Error symptom

A. Video error

Established date

2010. 12 .14

No video/ Normal audio

Revised date

1/13

**First of all, Check whether all of cables between board is inserted properly or not.
(Main B/D ↔ Power B/D, LVDS Cable, Speaker Cable, IR B/D Cable,,)**

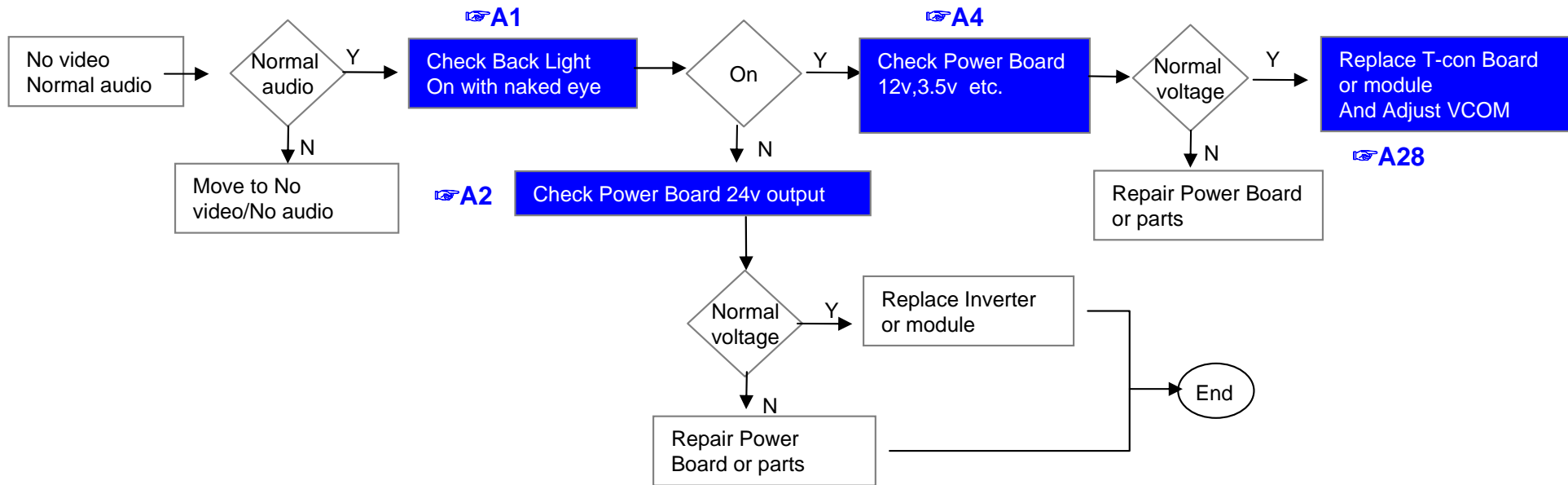

※ Precaution A7 & A3

Always check & record S/W Version and White Balance value before replacing the Main Board

Replace Main Board

Re-enter White Balance value

LCD TV	Error symptom	A. Video error	Established date	2010. 12 .14	
		No video/ No audio	Revised date		2/13

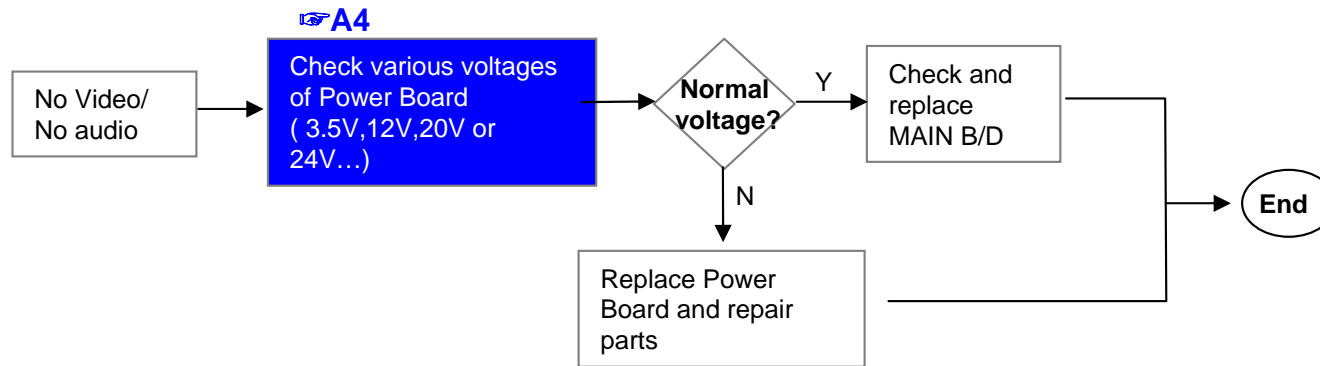

LCD TV	Error symptom	A. Picture Problem	Established date	2010. 12 .14	
		Picture broken/ Freezing	Revised date		3/13

A6

Check RF Signal level

- . By using Digital signal level meter
- . By using Diagnostics menu on OSD
(Menu → Set up → Support → Signal Test)
- Signal strength (Normal : over 50%)
- Signal Quality (Normal: over 50%)

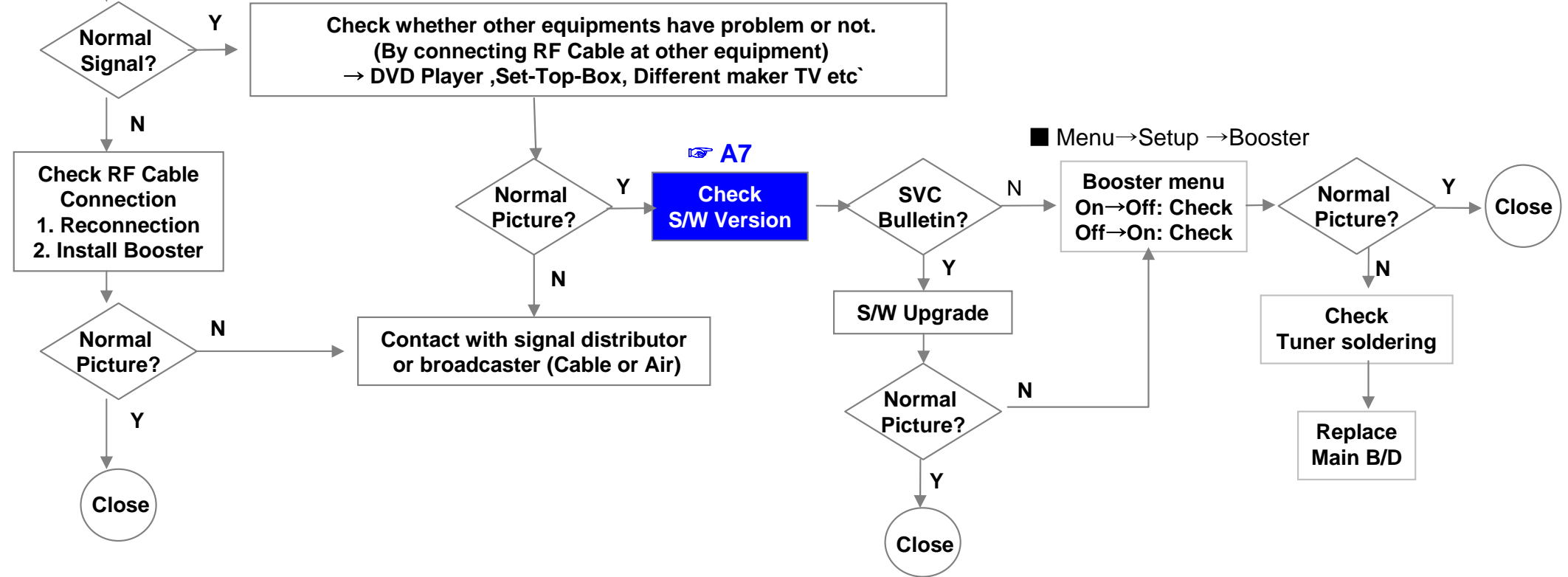

LCD TV	Error symptom	A. Picture Problem (DVB-S/S2)	Established date	2011. 01 .24	
		Tuning fail, Picture broken/ Freezing	Revised date		3/13

A6

Check RF Signal level

Check RF signal cable (DVB satellite signal or not)
 Check whether other equipments have problem or not.
 (By connecting RF Cable at other equipment)
 → Set-Top-Box, Different maker TV etc

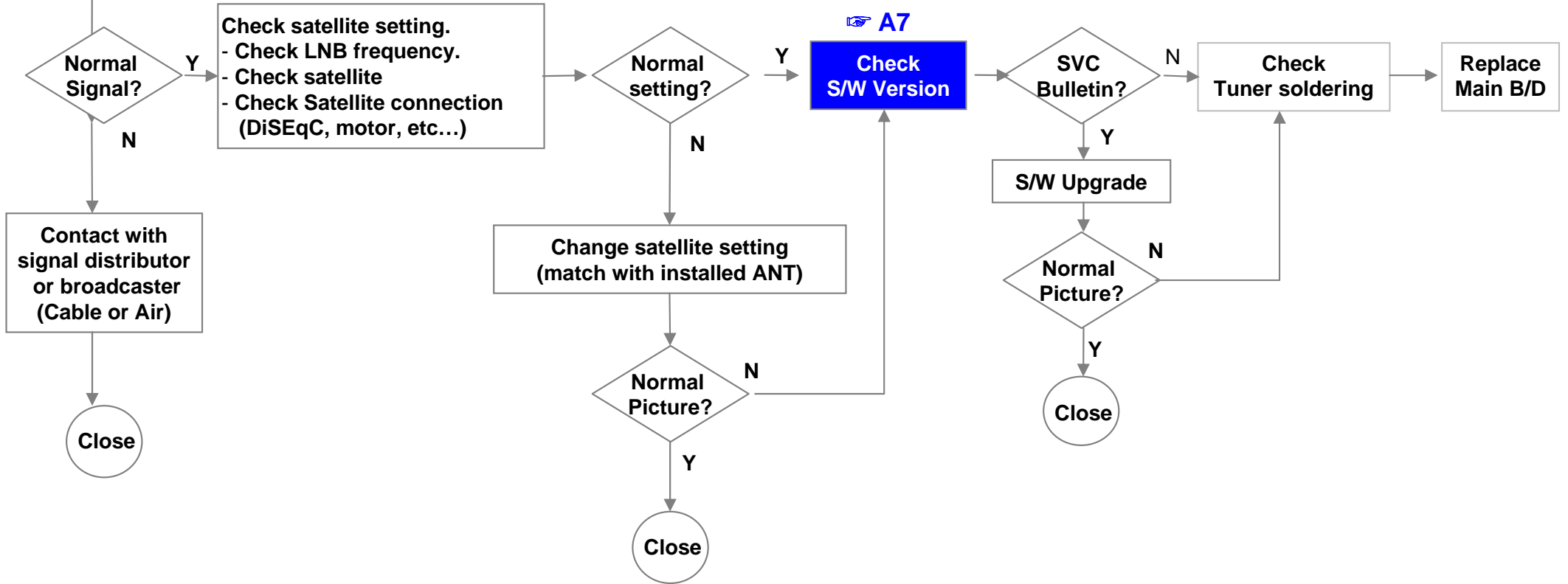

LCD TV	Error symptom	A. Video error	Established date	2010. 12 .14	
		Color error	Revised date		4/13

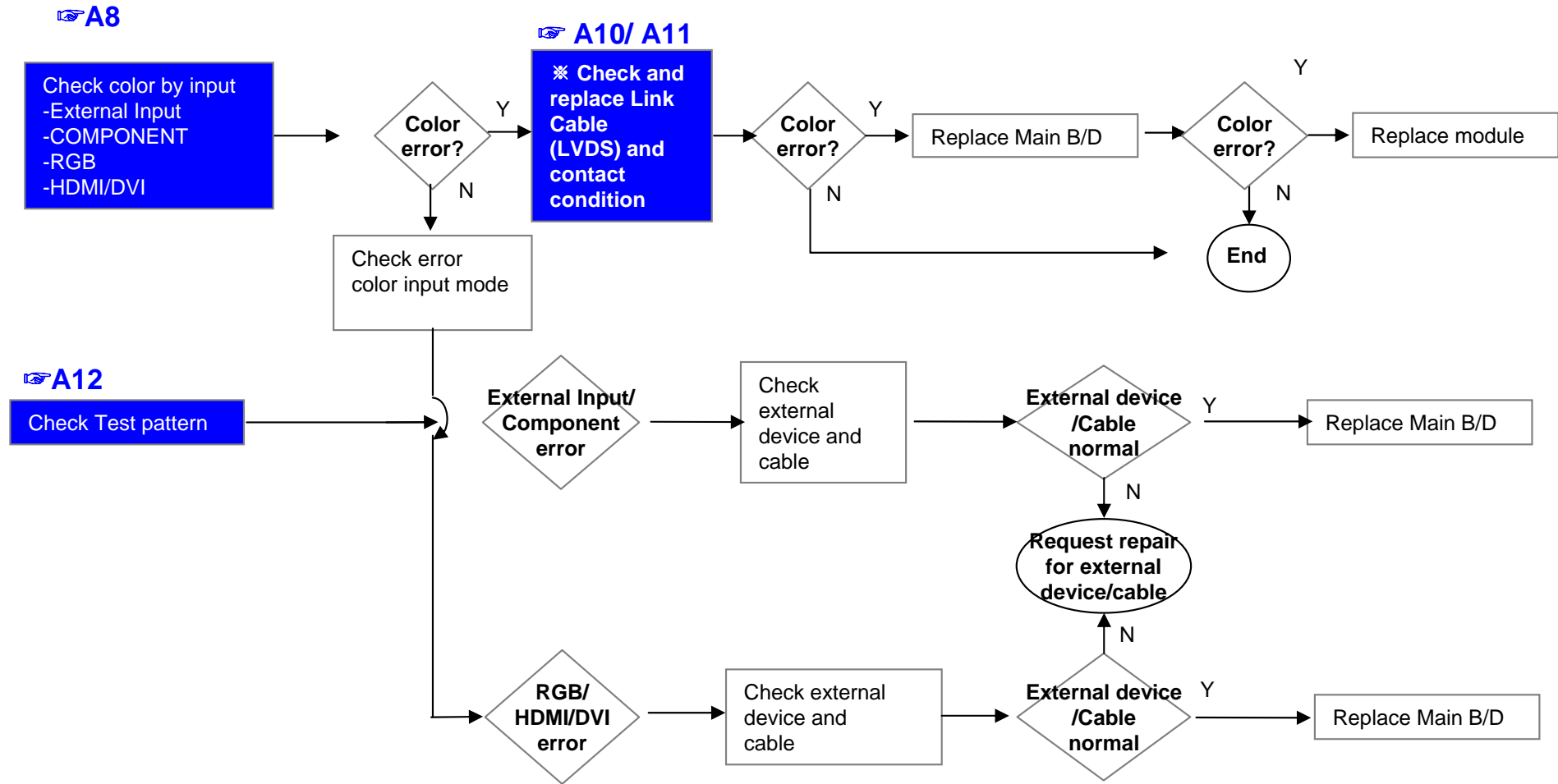

LCD TV	Error symptom	A. Video error	Established date	2010. 12 .14	
		Vertical / Horizontal bar, residual image, light spot, external device color error	Revised date		5/13

Vertical/Horizontal bar, residual image, light spot

A8

Check color condition by input
 -External Input
 -Component
 -RGB
 -HDMI/DVI

A12

Check Test pattern

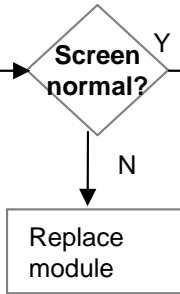

Check external device connection condition

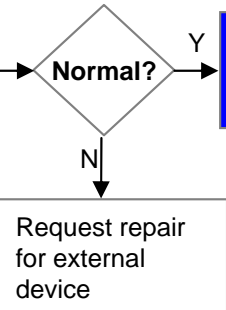

A10/ A11

Check and replace Link Cable

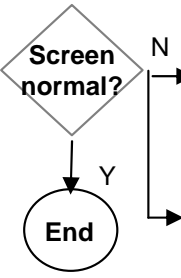

A28
 Replace Main B/D (adjust VCOM)
For LGD panel
 Replace Main B/D
For other panel

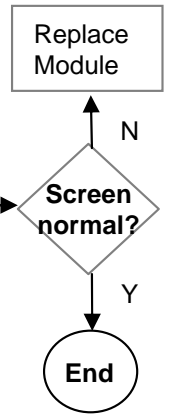

External device screen error-Color error

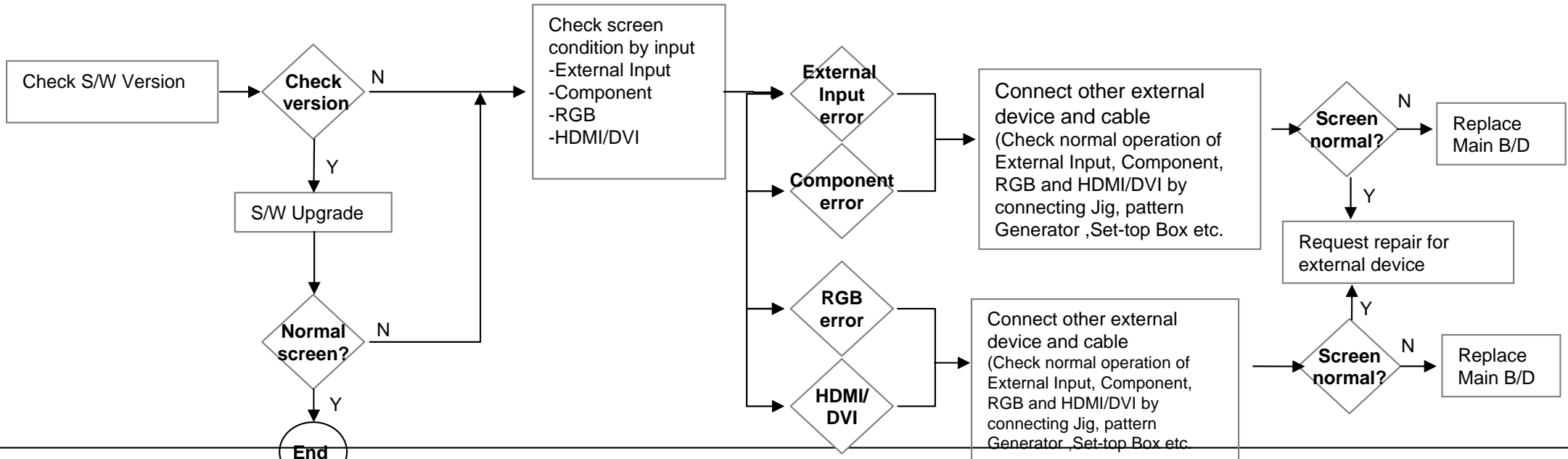

LCD TV	Error symptom	B. Power error	Established date	2010. 12 .14	
		No power	Revised date		6/13

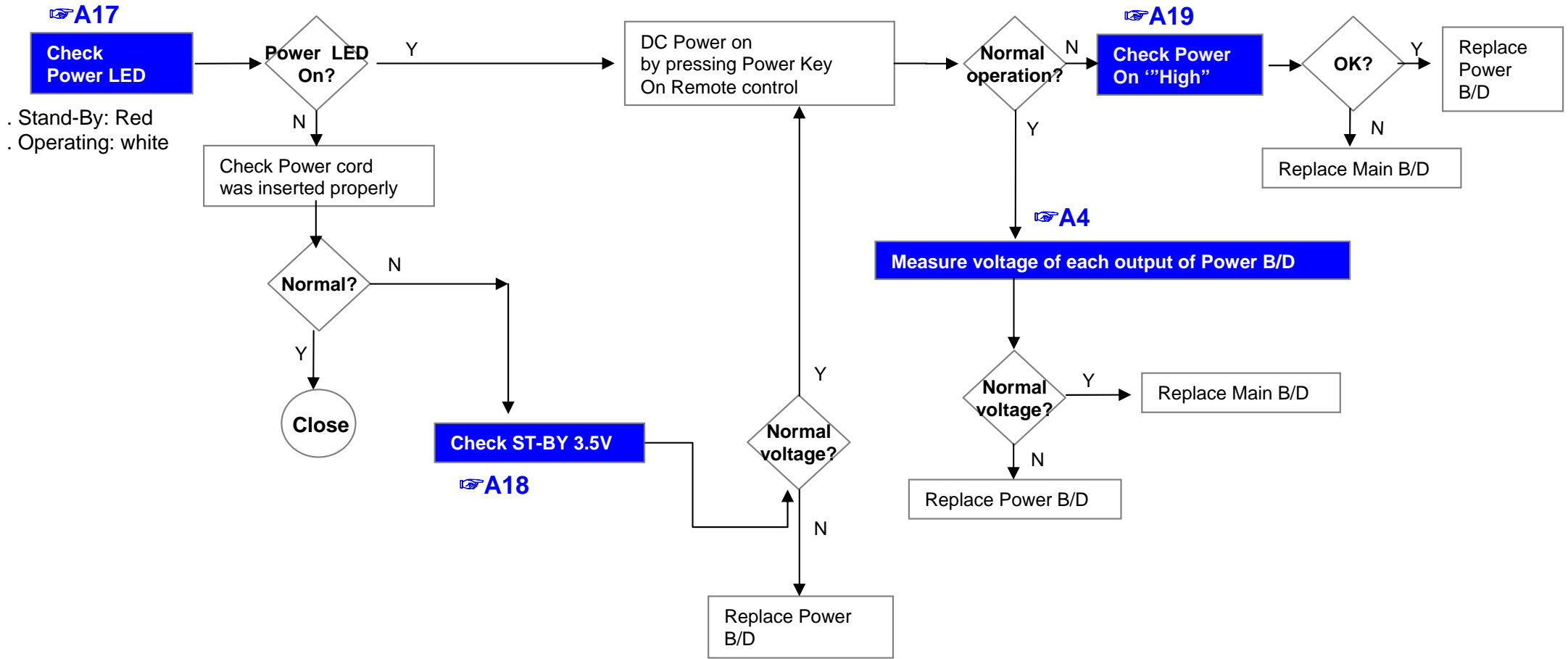

LCD TV	Error symptom	B. Power error	Established date	2010. 12 .14	
		Off when on, off while viewing, power auto on/off	Revised date		7/13

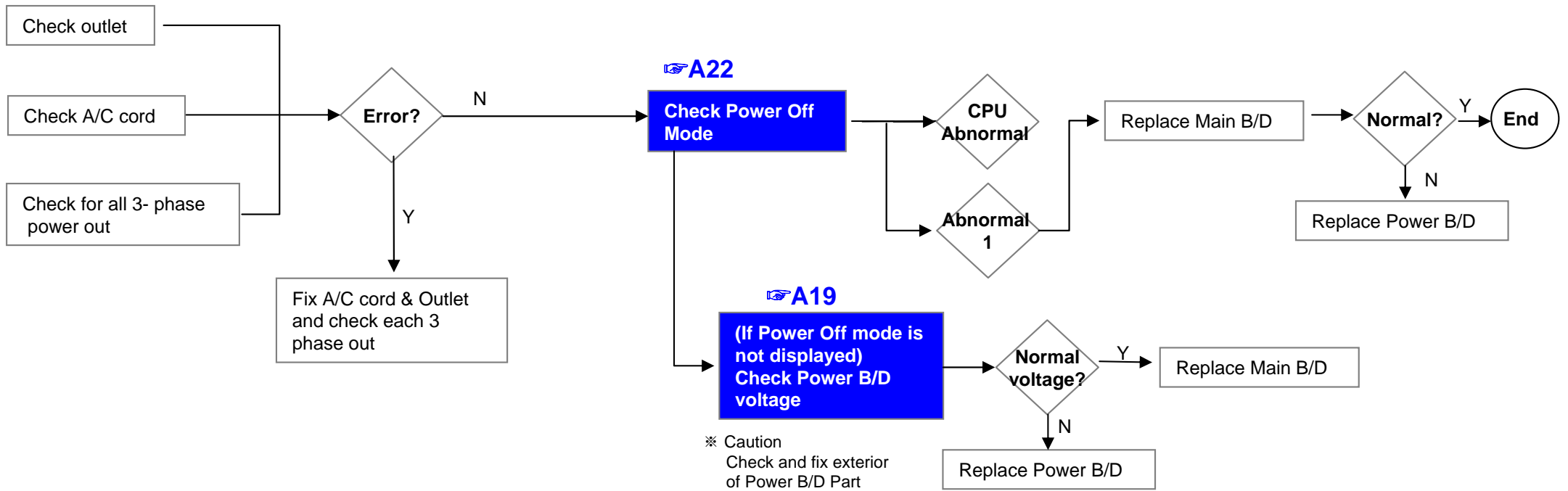

* Please refer to the all cases which can be displayed on power off mode.

Status	Power off List	Explanation
Normal	"POWEROFF_REMOTEKEY"	Power off by REMOTE CONTROL
	"POWEROFF_OFFTIMER"	Power off by OFF TIMER
	"POWEROFF_SLEEPTIMER"	Power off by SLEEP TIMER
	"POWEROFF_INSTOP"	Power off by INSTOP KEY
	"POWEROFF_AUTOOFF"	Power off by AUTO OFF
	"POWEROFF_ONTIMER"	Power off by ON TIMER
	"POWEROFF_RS232C"	Power off by RS232C
	"POWEROFF_RESREC"	Power off by Reserved Record
	"POWEROFF_RECEND"	Power off by End of Recording
	"POWEROFF_SWDOWN"	Power off by S/W Download
	"POWEROFF_UNKNOWN"	Power off by unknown status except listed case
Abnormal	"POWEROFF_ABNORMAL1"	Power off by abnormal status except CPU trouble
	"POWEROFF_CPUABNORMAL"	Power off by CPU Abnormal

LCD TV

Error symptom

C. Audio error

Established date

2010. 12 .14

No audio/ Normal video

Revised date

8/13

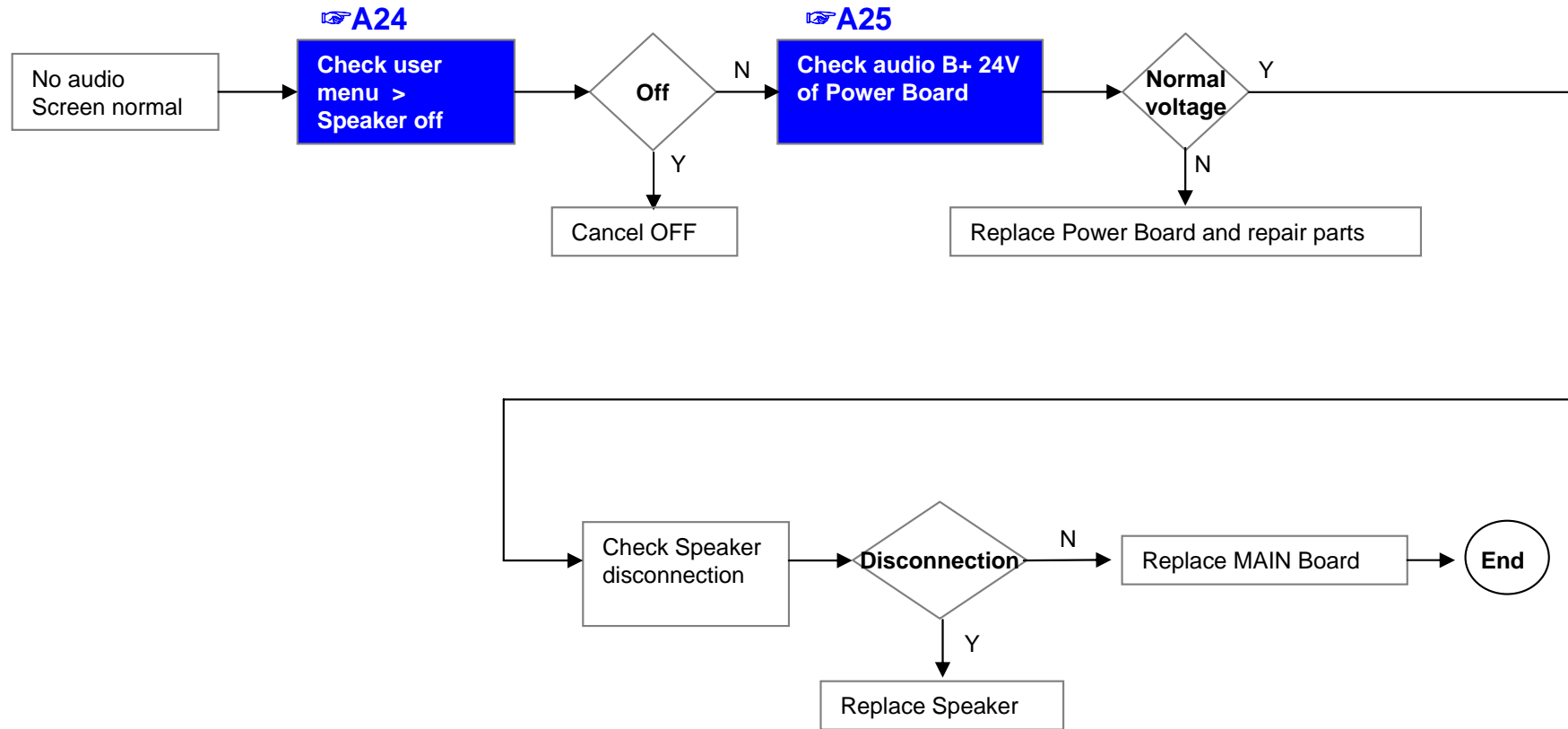

LCD TV	Error symptom	C. Audio error	Established date	2010. 12 .14	
		Wrecked audio/ discontinuation/noise	Revised date		9/13

→ abnormal audio/discontinuation/noise is same after “Check input signal” compared to No audio

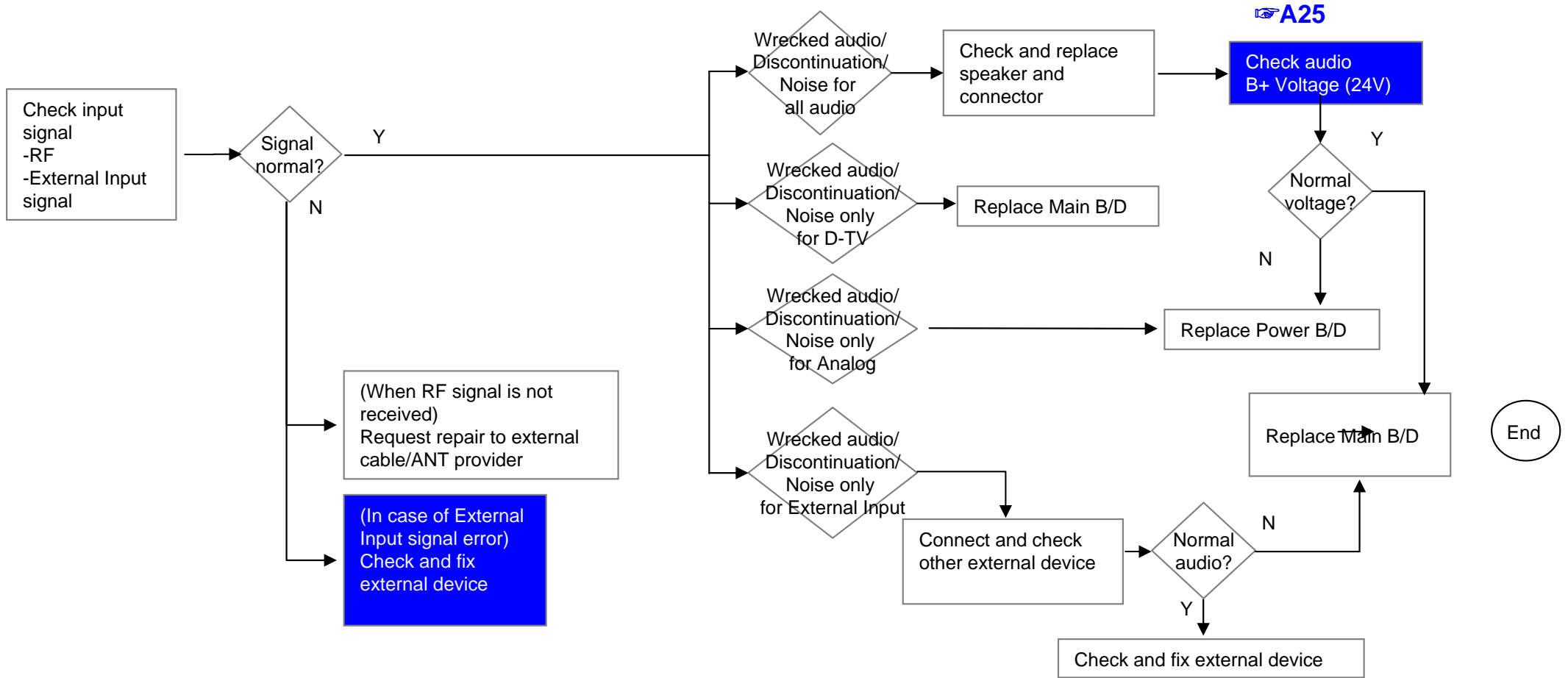

LCD TV	Error symptom	D. General Function Problem	Established date	2010. 12 .14	
		Remote control & Local switch checking	Revised date		10/13

1. Remote control(R/C) operating error

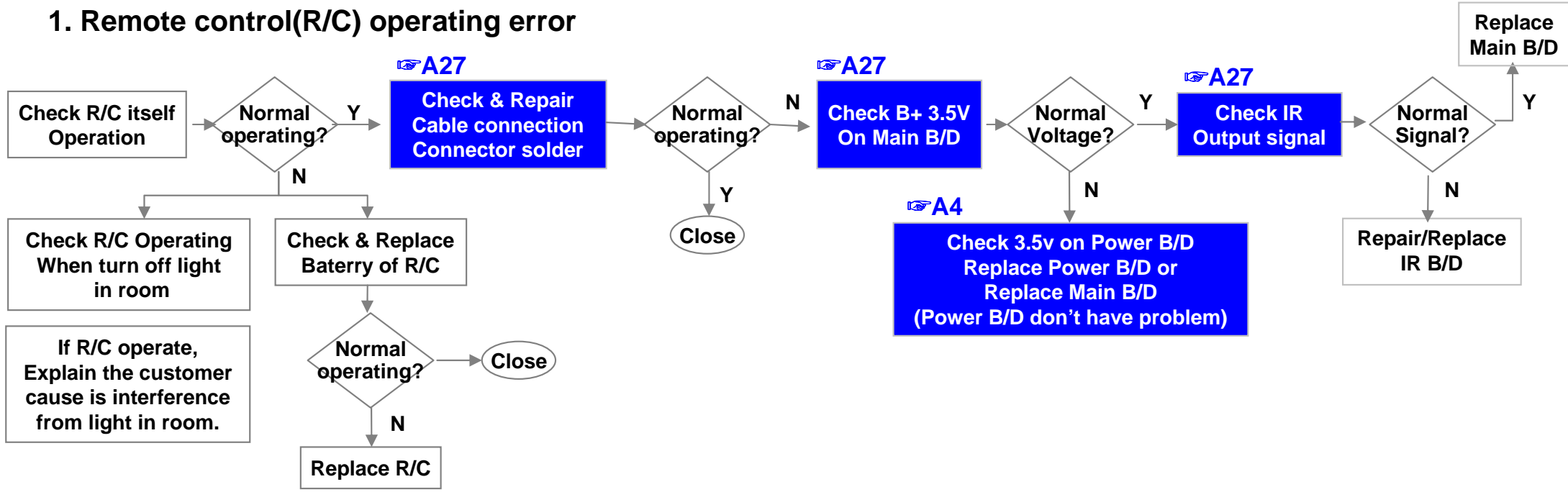

LCD TV	Error symptom	D. Function error	Established date	2010. 12 .14	
		External device recognition error	Revised date		11/13

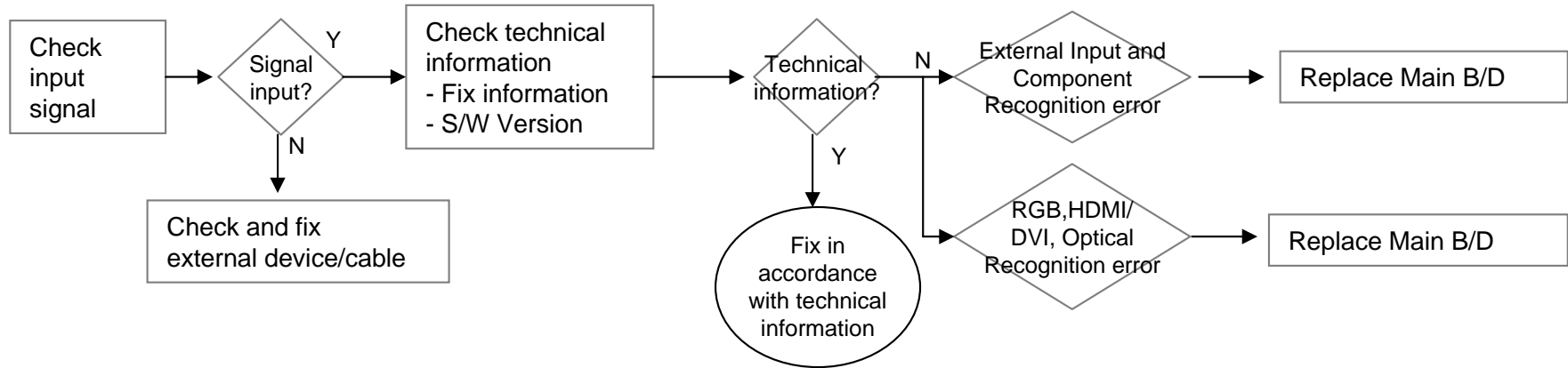

LCD TV	Error symptom	E. Noise	Established date	2010. 12 .14	
		Circuit noise, mechanical noise	Revised date		12/13

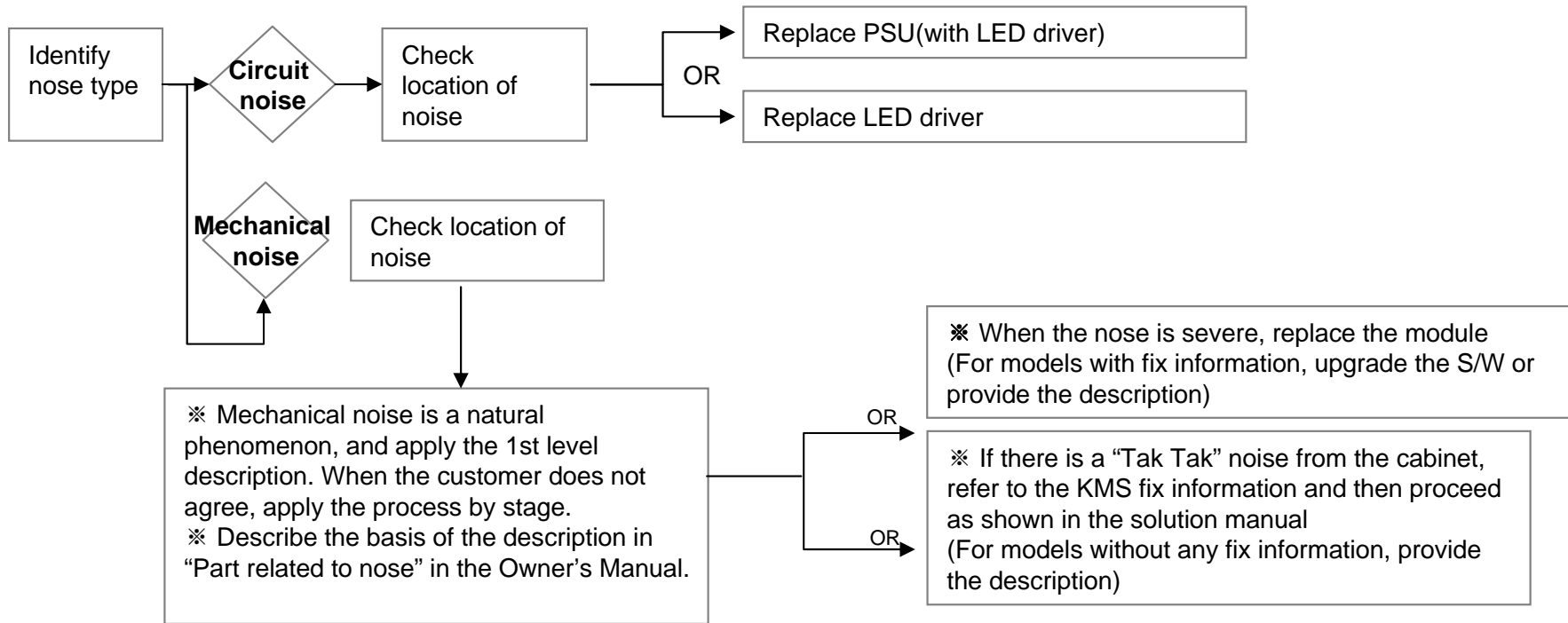

LCD TV	Error symptom	F. Exterior defect	Established date	2010. 12 .14	
		Exterior defect	Revised date		13/13

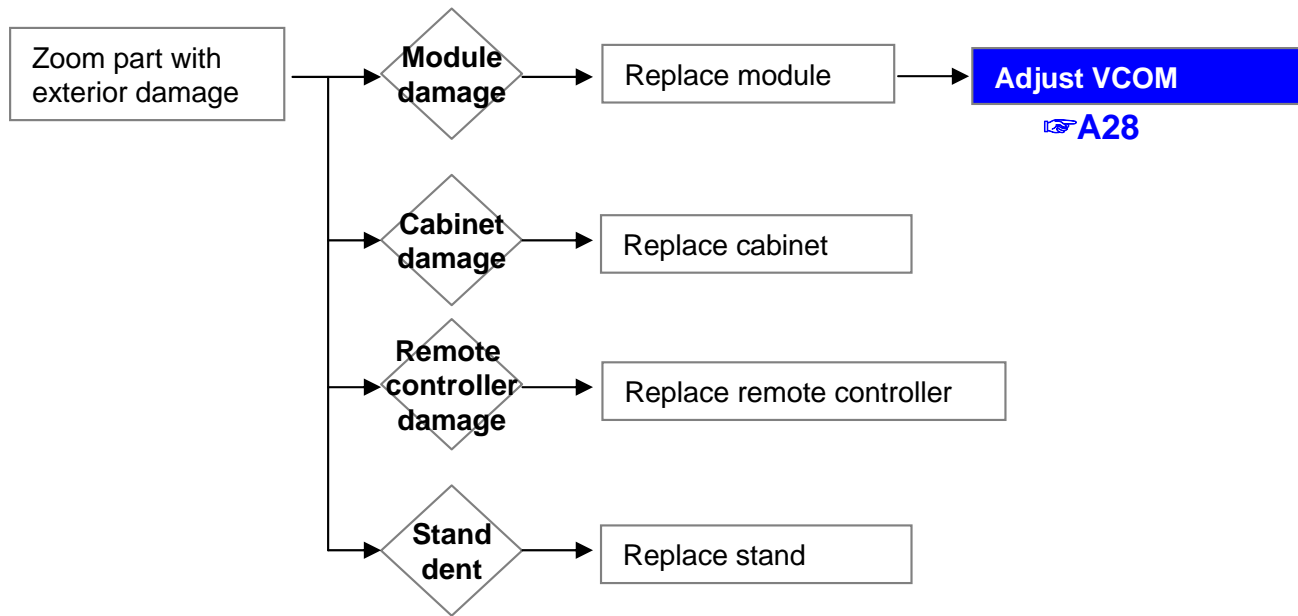

Contents of LCD TV Standard Repair Process Detail Technical Manual

Continued from previous page

No.	Error symptom	Content	Page	Remarks
21	B. Power error_No power	Check front display LED	A17	
22		Check power input Voltage & ST-BY 5V	A18	
23		Checking method when power is ON	A19	
24		POWER BOARD voltage measuring method	A4	
25				
26	B. Power error_Off when on, off while viewing	POWER OFF MODE checking method	A22	
27	B. Power error_Off when on, off while viewing	POWER BOARD PIN voltage checking method	A19	
28	C. Audio error_No audio/Normal video	Checking method in menu when there is no audio	A24	
29		Voltage and speaker checking method when there is no audio	A25	
30	C. Audio error_Wrecked audio/discontinuation	Voltage and speaker checking method in case of audio error	A25	
31	D. Function error_ No response in remote controller, key error	Remote controller operation checking method	A27	
32	D. VCOM Adjustment	Sequence of the Vcom adjustment	A28	

Standard Repair Process Detail Technical Manual

LCD TV	Error symptom	A. Video error_No video/Normal audio	Established date	2010. 12 .14	
	Content	Check White Balance value	Revised date		A4

<ALL MODELS>

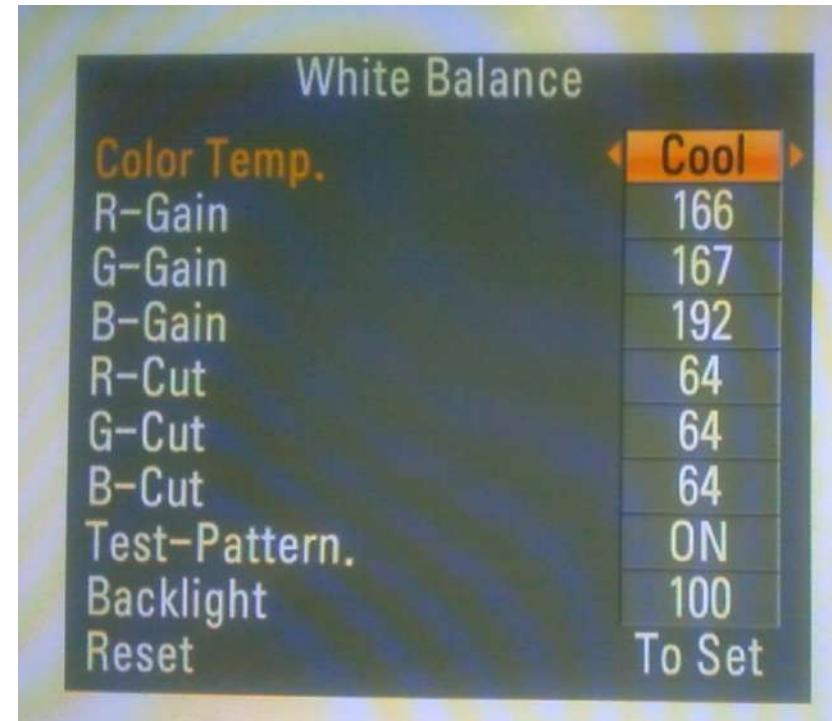
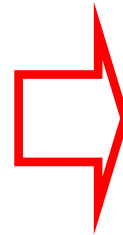
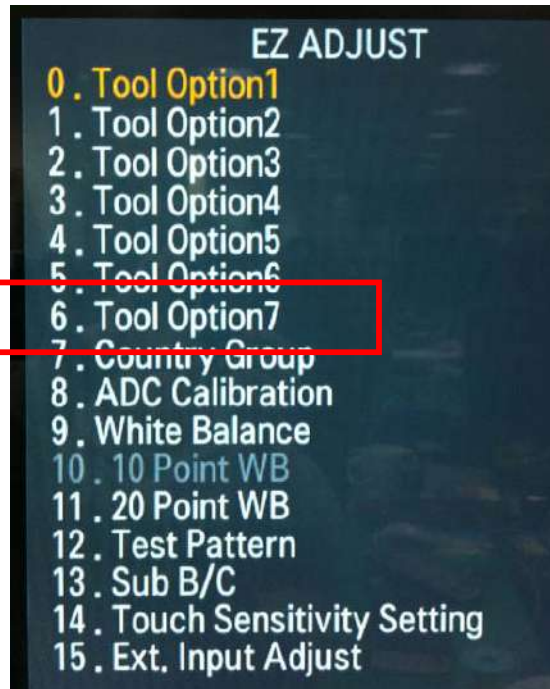

Entry method

1. Press the ADJ button on the remote controller for adjustment.
2. Enter into White Balance of item 7.
3. After recording the R, G, B (GAIN, Cut) value of Color Temp (Cool/Medium/Warm), re-enter the value after replacing the MAIN BOARD.

Standard Repair Process Detail Technical Manual

LCD TV	Error symptom	A. Video error_No video/ Audio	Established date	2010. 12 .14	
	Content	Power Board voltage measuring method	Revised date		A5

Check the DC 24V, 12V, 3.5V.

Edge LED

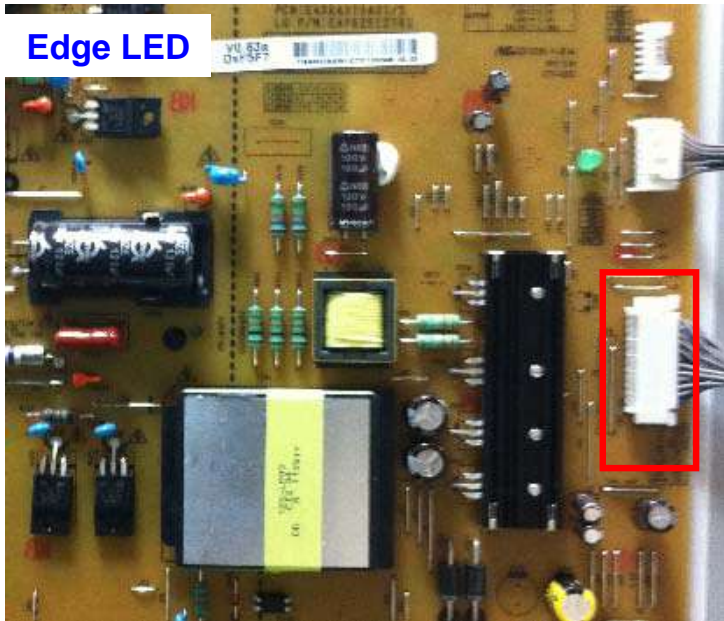

24 Pin (Power Board ↔ Main Board) – 공통

SMAW200-H24S (YEONHO)

1	Power on	2	24V
3	24V	4	24V
5	GND	6	GND
7	GND	8	GND
9	3.5V	10	3.5V
11	3.5V	12	3.5V
13	GND	14	GND
15	GND	16	GND
17	12V	18	Inverter On/off
19	12V	20	Lamp : A-Dim LED : N.C
21	12V	22	PWM Dim #1
23	GND/P_DIM2 • Lamp SCANNING Model : PWM Dim #2	24	Error-out



Standard Repair Process Detail Technical Manual

LCD TV	Error symptom	A. Video error_Video error, video lag/stop	Established date	2010. 12 .14	
	Content	TUNER input signal strength checking method	Revised date		A6

<ALL MODELS>

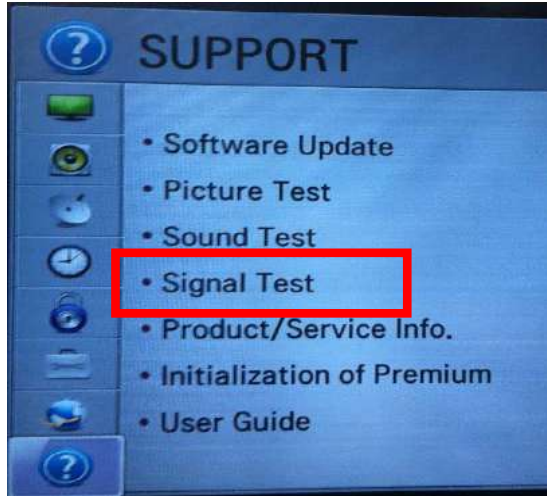

MENU -> Set up -> support -> signal test
-> select channel

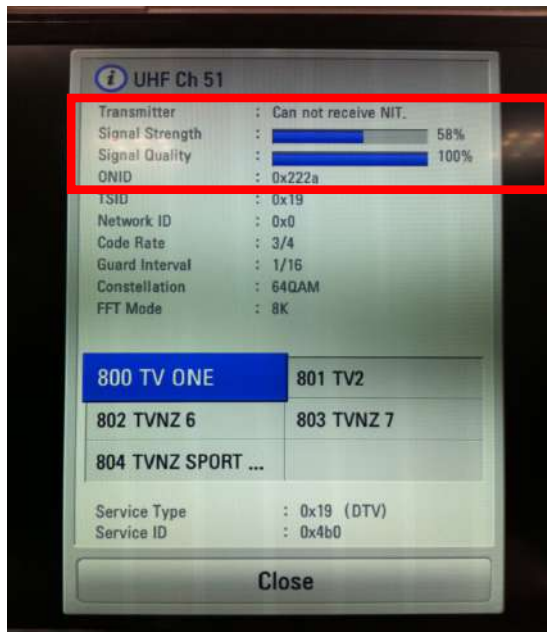

When the signal is strong, use the attenuator (-10dB, -15dB, -20dB etc.)



Standard Repair Process Detail Technical Manual

LCD TV	Error symptom	A. Video error_Video error, video lag/stop	Established date	2010. 12 .14	
	Content	LCD-TV Version checking method	Revised date		A7

<ALL MODELS>

1. Checking method for remote controller for adjustment

Version

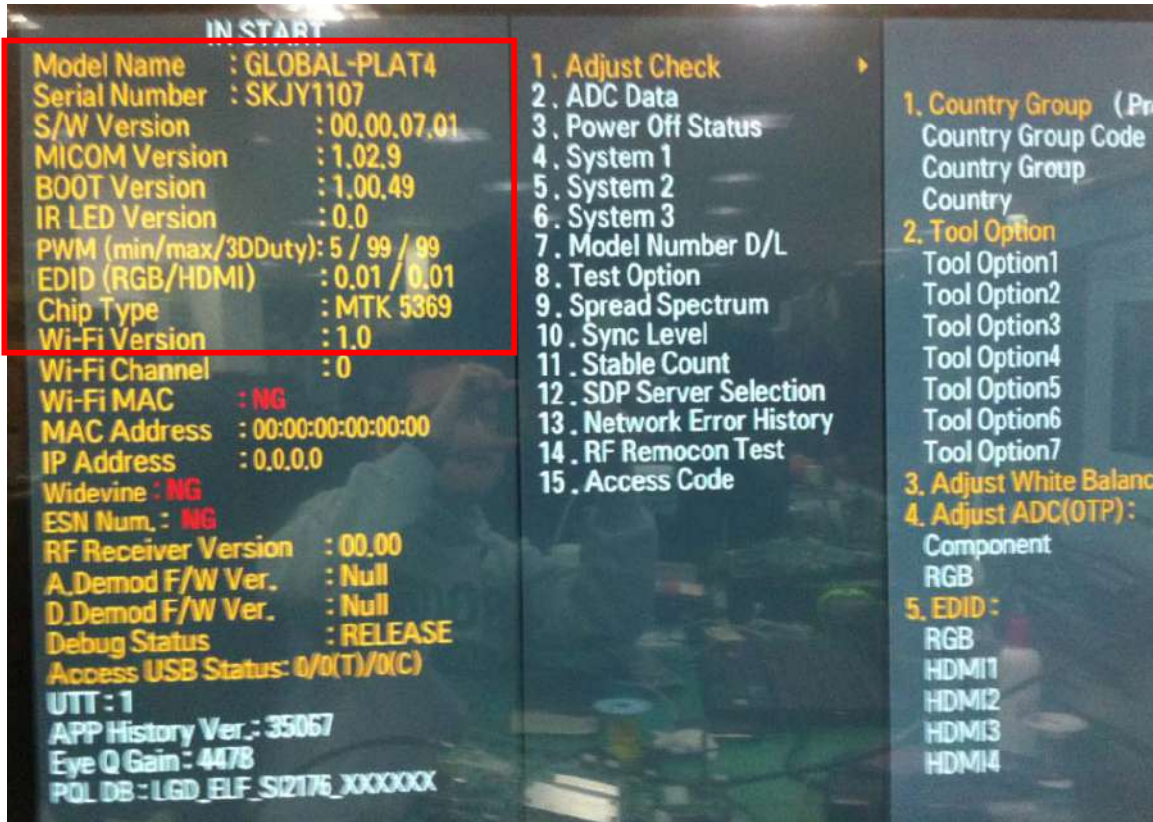

Press the IN-START with the remote controller for adjustment

Standard Repair Process Detail Technical Manual

LCD TV	Error symptom	A. Video error _Vertical/Horizontal bar, residual image, light spot	Established date	2010. 12 .14	
	Content	LCD TV connection diagram (1)	Revised date		A8

<ALL MODELS>

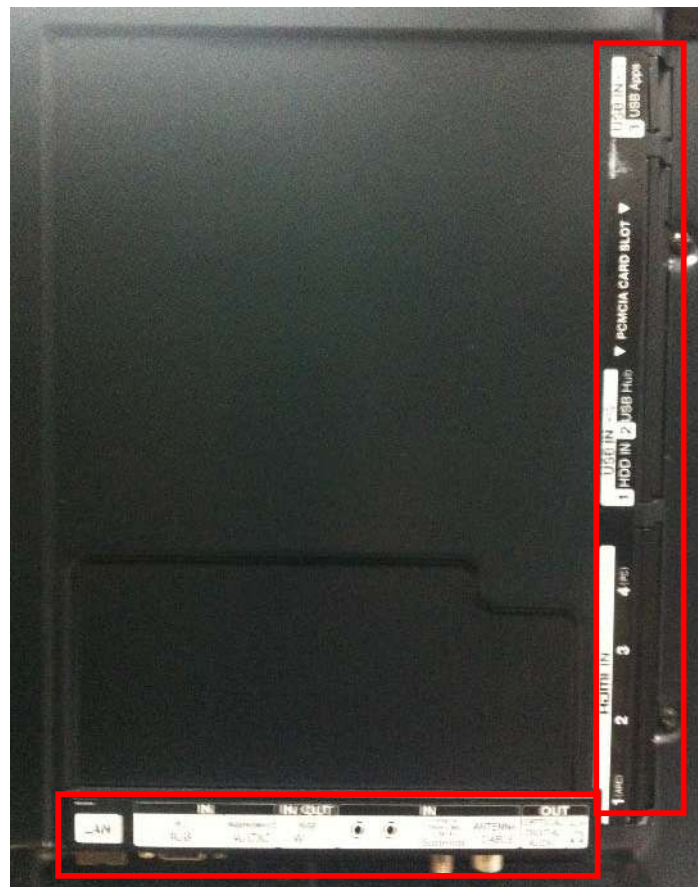

As the part connecting to the external input, check the screen condition by signal



Standard Repair Process Detail Technical Manual

LCD TV	Error symptom	A. Video error_Video error, video lag/stop	Established date	2010. 12 .14	
	Content	TUNER checking part	Revised date		A9

<ALL MODELS>

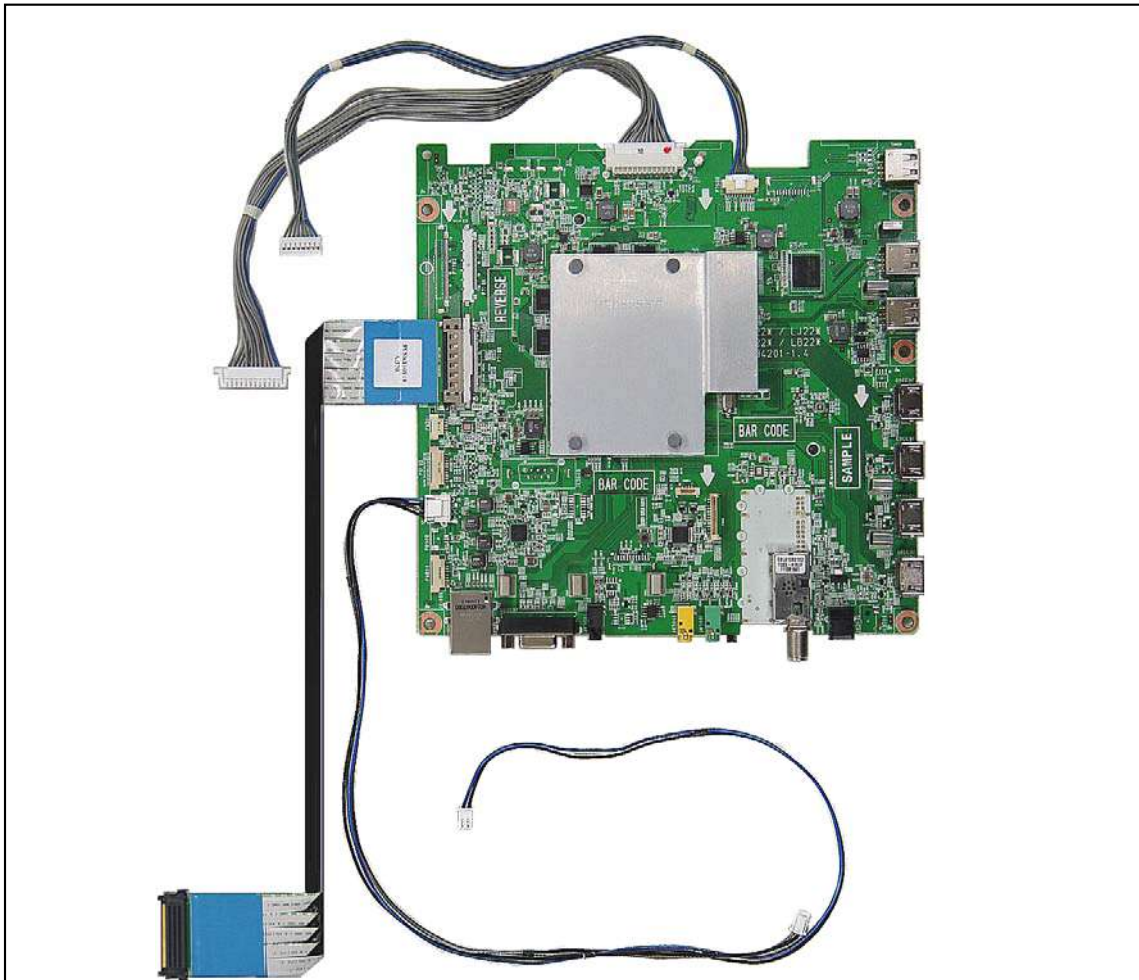

Checking method:

1. Check the signal strength or check whether the screen is normal when the external device is connected.
2. After measuring each voltage from power supply, finally replace the MAIN BOARD.

Standard Repair Process Detail Technical Manual

LCD TV	Error symptom	A. Video error_Color error	Established date	2010. 12 .14	
	Content	Adjustment Test pattern - ADJ Key	Revised date		A12

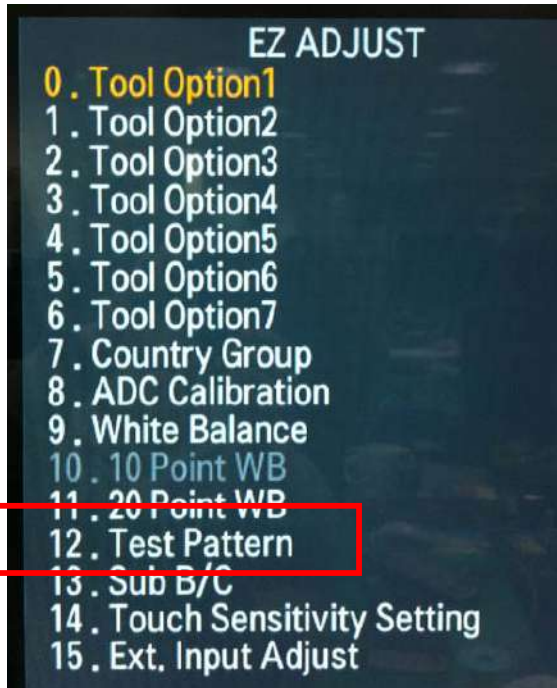

You can view 6 types of patterns using the ADJ Key

Checking item : 1. Defective pixel 2. Residual image 3. MODULE error (ADD-BAR,SCAN BAR..)
4.Video error (Classification of MODULE or Main-B/D!)



Appendix : Exchange T-Con Board (1)



Solder defect, CNT Broken

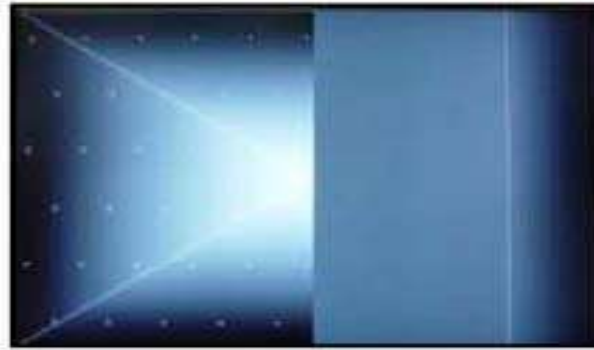

Solder defect, CNT Broken

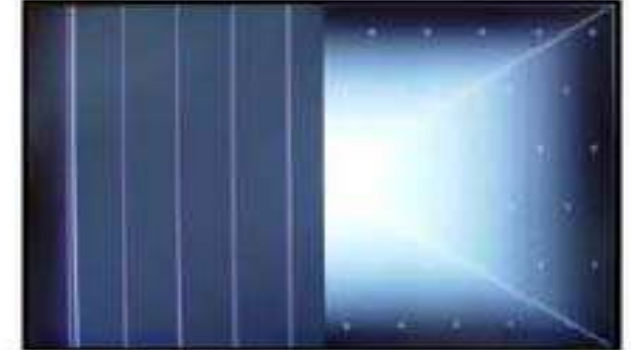

Solder defect, CNT Broken



Solder defect, CNT Broken

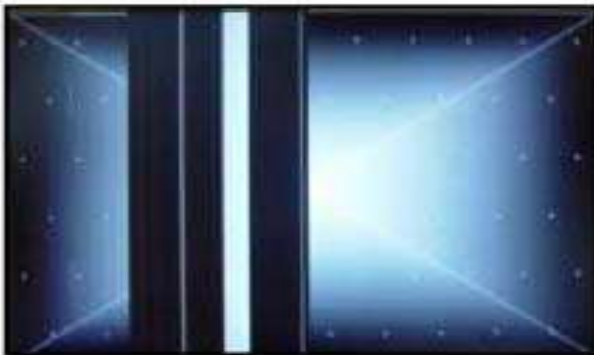

Solder defect, CNT Broken



Abnormal Power Section

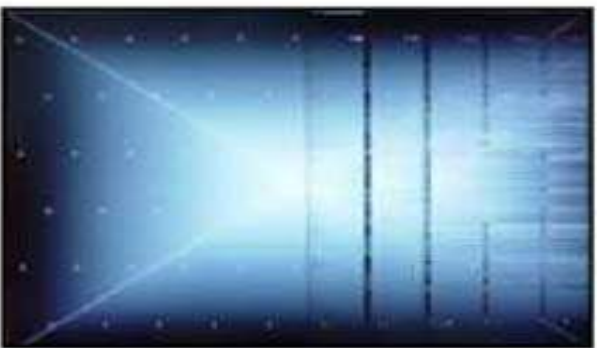

Solder defect, Short/Crack



Abnormal Power Section



Solder defect, Short/Crack

Appendix : Exchange T-Con Board (2)



Abnormal Power Section



Abnormal Power Section



Solder defect, Short/Crack



Solder defect, Short/Crack



Fuse Open, Abnormal power section



Abnormal Display



GRADATION



Noise

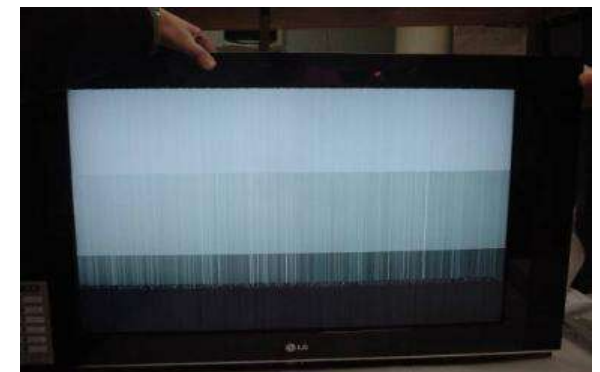

GRADATION

Appendix : Exchange PSU(LED driver)



No Light



Dim Light



Dim Light

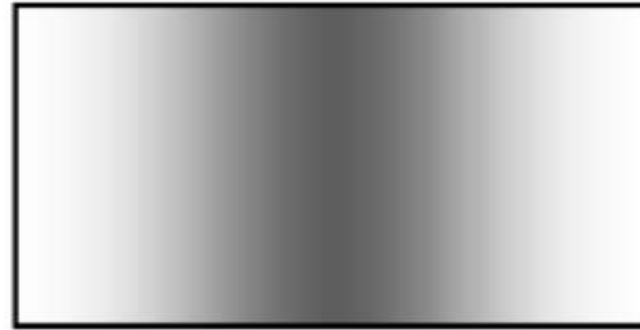

Dim Light



No picture/Sound Ok

Appendix : Exchange the Module (1)



Panel Mura, Light leakage



Panel Mura, Light leakage



Press damage

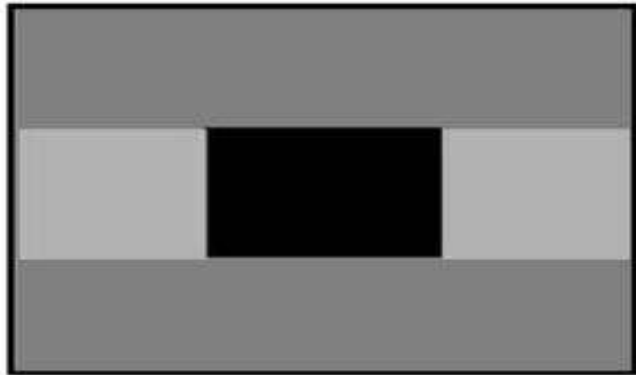

Crosstalk



Press damage



Crosstalk



Press damage

Un-repairable Cases

In this case please exchange the module.

Appendix : Exchange the Module (2)

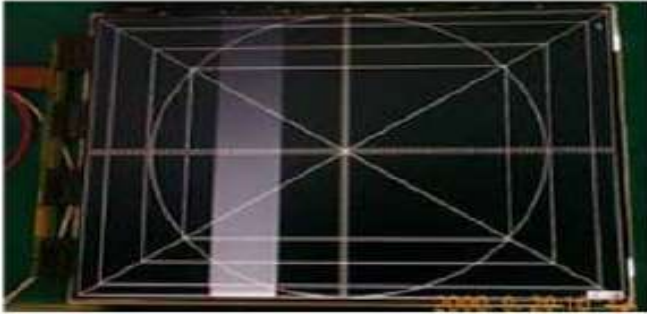

Vertical Block
Source TAB IC Defect



Vertical Line
Source TAB IC Defect



Vertical Block
Source TAB IC Defect



Horizontal Block
Gate TAB IC Defect



Horizontal Block
Gate TAB IC Defect

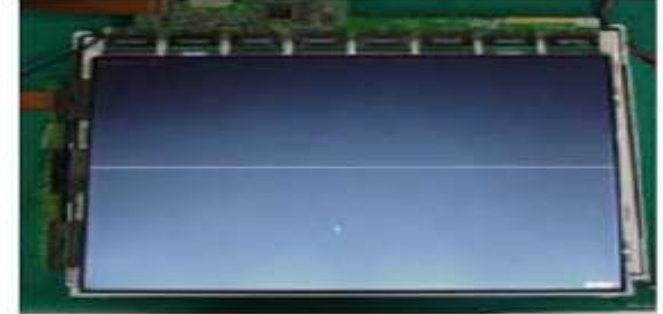

Horizontal line
Gate TAB IC Defect

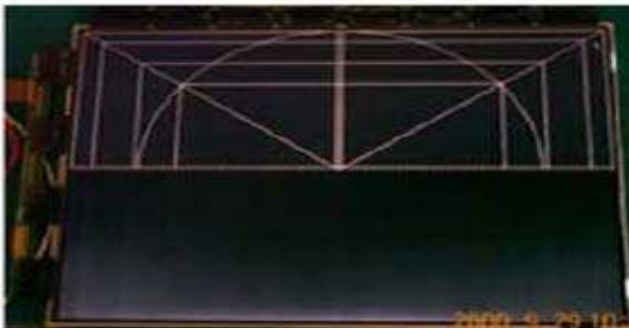

Horizontal Block
Gate TAB IC Defect

Un-repairable Cases
In this case please exchange the module.

Standard Repair Process Detail Technical Manual

LCD TV	Error symptom	B. Power error _No power	Established date	2010. 12 .14	
	Content	Check front display LED	Revised date		A17

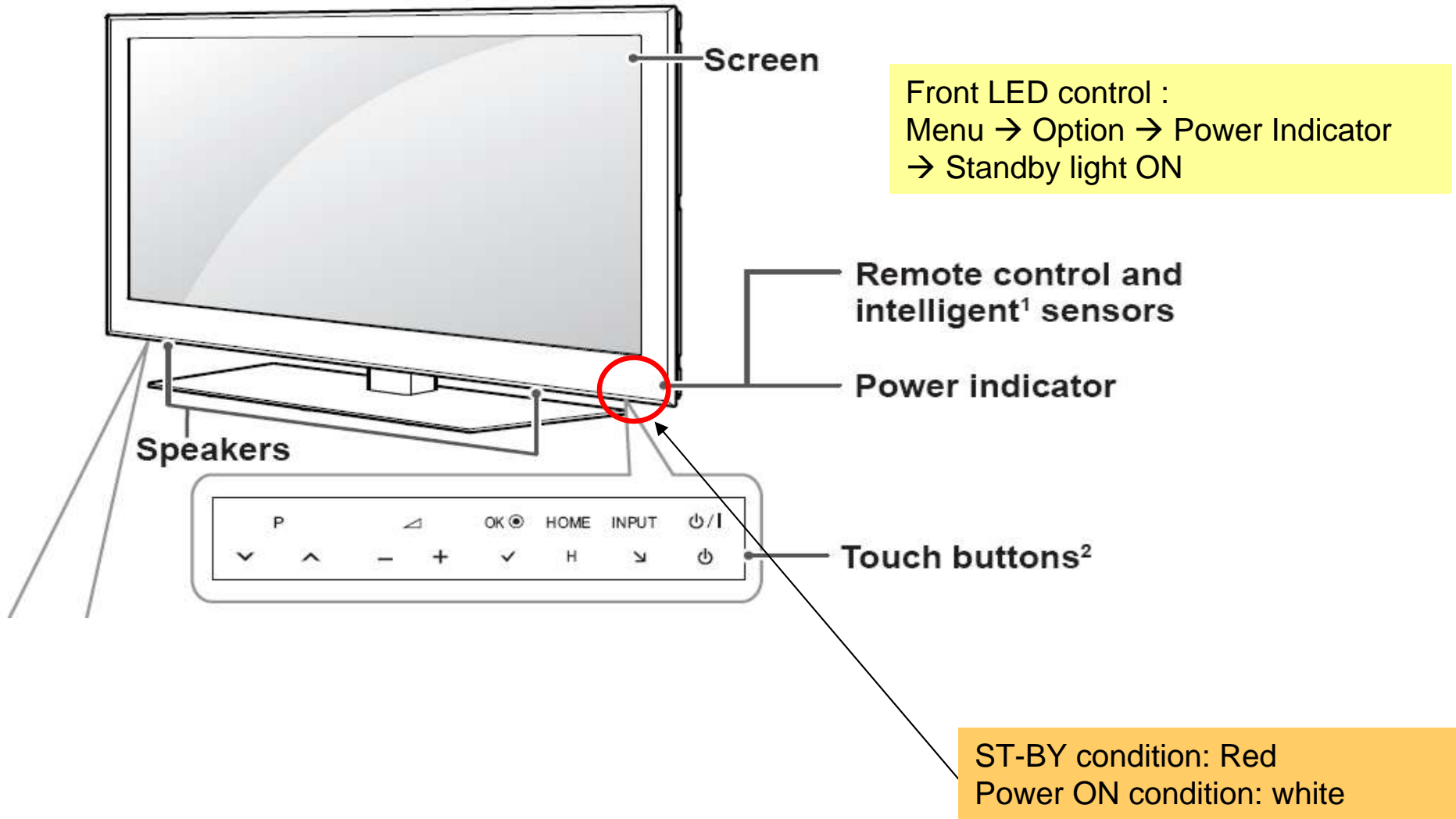

Standard Repair Process Detail Technical Manual

LCD TV	Error symptom	B. Power error _No power	Established date	2010. 12 .14	
	Content	Check power input voltage and ST-BY 5V	Revised date		A18

For '10 models, there is no voltage out for st-by purpose.
When st-by, only 3.5V is normally on.

Check the DC 20V/24V, 12V, 3.5V.

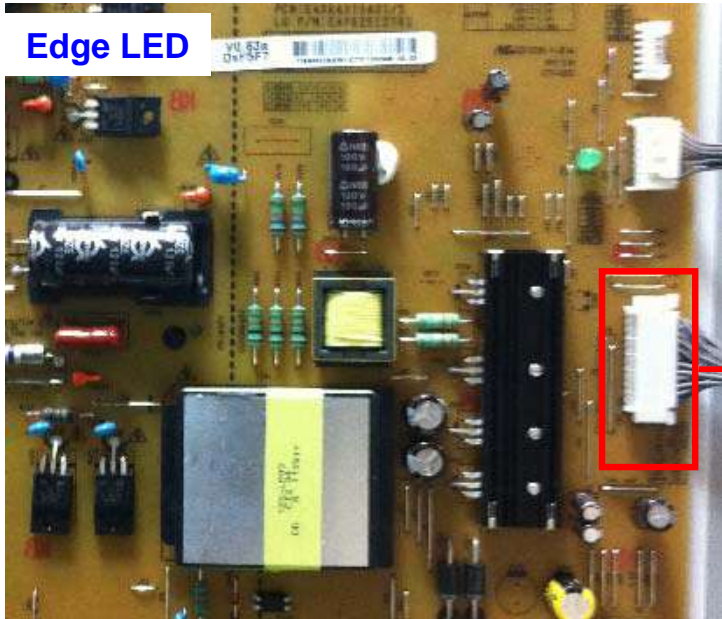

Edge LED

24 Pin (Power Board ↔ Main Board) – 공통			
SMAW200-H24S (YEONHO)			
1	Power on	2	24V
3	24V	4	24V
5	GND	6	GND
7	GND	8	GND
9	3.5V	10	3.5V
11	3.5V	12	3.5V
13	GND	14	GND
15	GND	16	GND
17	12V	18	Inverter On/off
19	12V	20	Lamp : A-Dim LED : N.C
21	12V	22	PWM Dim #1
23	GND/P_DIM2 • Lamp SCANNING Model : PWM Dim #2	24	Error-out

Standard Repair Process Detail Technical Manual

LCD TV	Error symptom	B. Power error _No power	Established date	2010. 12 .14	
	Content	Checking method when power is ON	Revised date		A19

Check "power on" pin is high

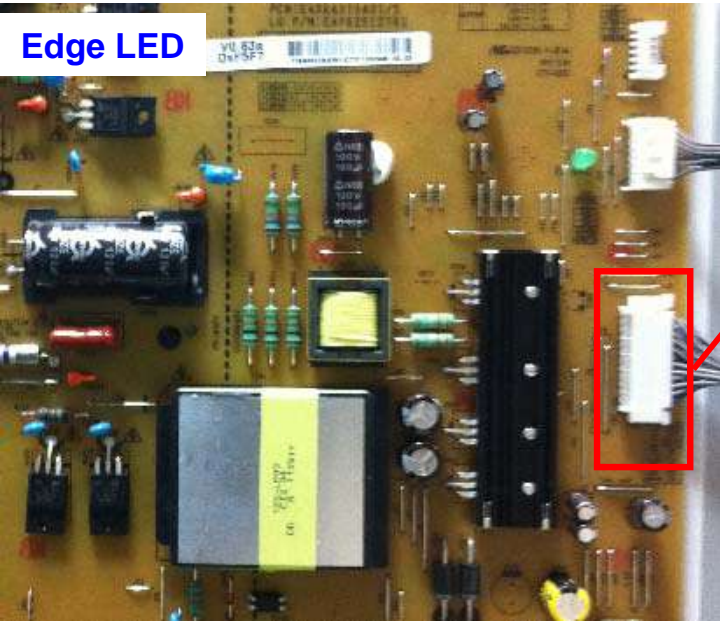

Edge LED

24 Pin (Power Board ↔ Main Board) – 공통			
SMAW200-H24S (YEONHO)			
1	Power on	2	24V
3	24V	4	24V
5	GND	6	GND
7	GND	8	GND
9	3.5V	10	3.5V
11	3.5V	12	3.5V
13	GND	14	GND
15	GND	16	GND
17	12V	18	Inverter On/off
19	12V	20	Lamp : A-Dim LED : N.C
21	12V	22	PWM Dim #1
23	GND/P_DIM2 • Lamp SCANNING Model : PWM Dim #2	24	Error-out



Standard Repair Process Detail Technical Manual

LCD TV	Error symptom	B. Power error _Off when on, off whiling viewing	Established date	2010. 12 .14	
	Content	POWER OFF MODE checking method	Revised date		A22

<ALL MODELS>

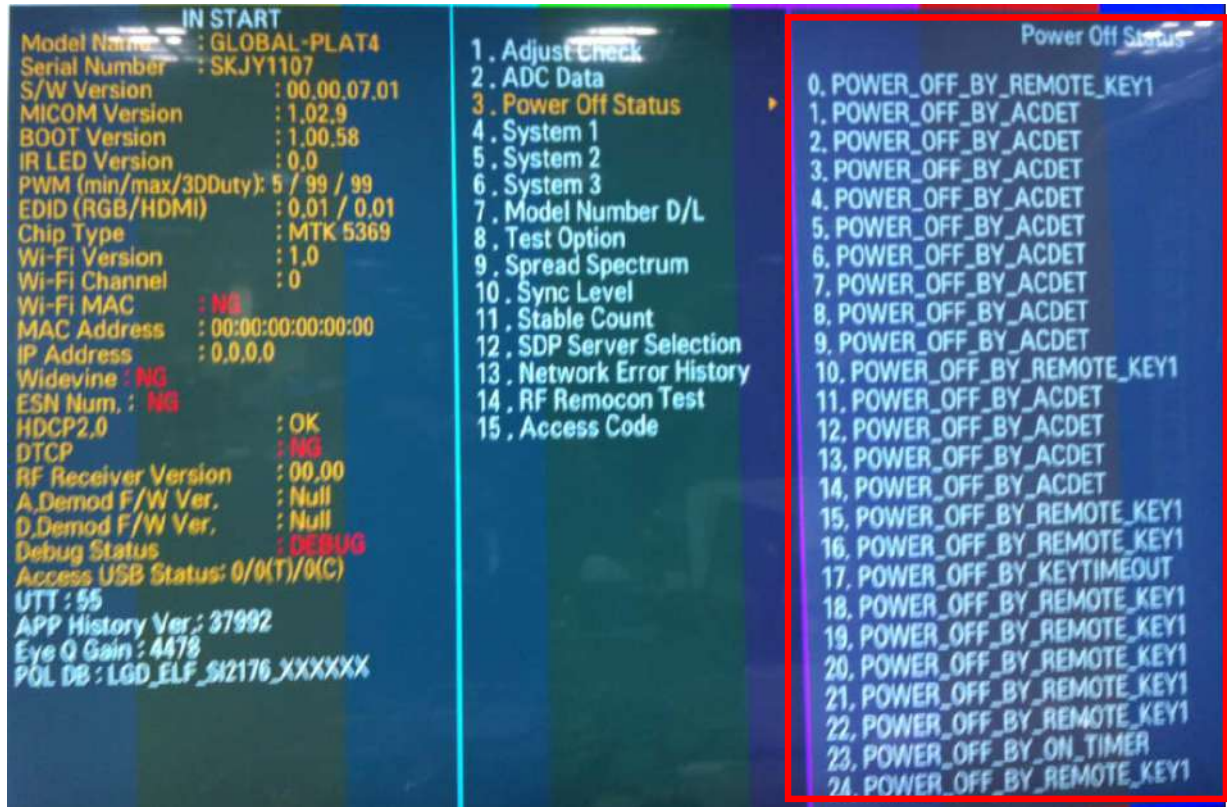

Entry method

1. Press the IN-START button of the remote controller for adjustment
2. Check the entry into adjustment item 3



Standard Repair Process Detail Technical Manual

LCD TV	Error symptom	C. Audio error_No audio/Normal video	Established date	2010. 12 .14	
	Content	Checking method in menu when there is no audio	Revised date		A24

<ALL MODELS>



Checking method

1. Press the MENU button on the remote controller
2. Select the AUDIO function of the Menu
3. Select TV Speaker from Off to On



Standard Repair Process Detail Technical Manual

LCD TV	Error symptom	C. Audio error_No audio/Normal video	Established date	2010. 12 .14	
	Content	Voltage and speaker checking method when there is no audio	Revised date		A25

<ALL MODELS>

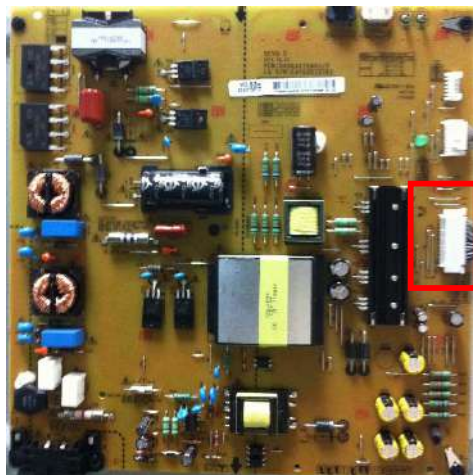

②

24 Pin (Power Board ↔ Main Board) - 공통			
SMAW200-H24S (YEONHO)			
1	Power on	2	20V (24V)
3	20V (24V)	4	20V (24V)
5	GND	6	GND
7	GND	8	GND
9	3.5V	10	3.5V
11	3.5V	12	3.5V
13	GND	14	GND
15	GND	16	GND
17	12V	18	Inverter On/off
19	12V	20	Lamp : A-Dim LED : N.C
21	12V	22	PWM Dim #1
23	GND/P_DIM2	24	Error-out

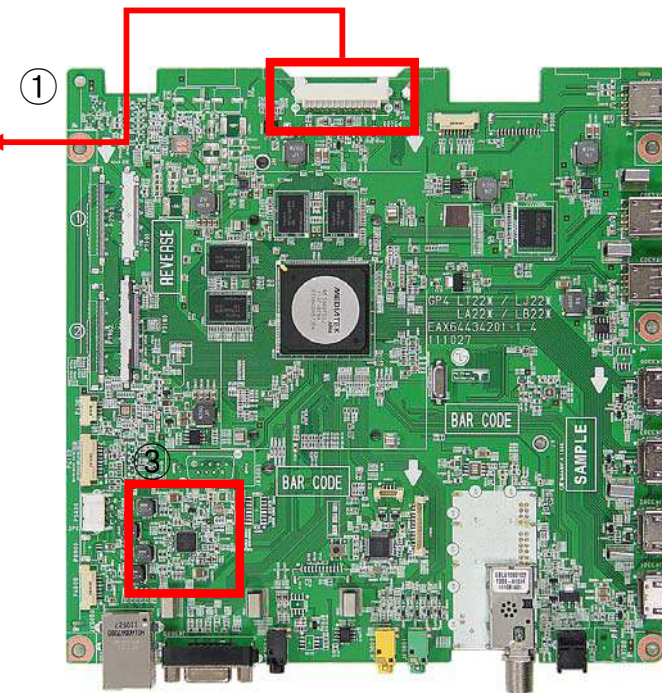

①

③

Checking order when there is no audio

- ① Check the contact condition of or 24V connector of Main Board
- ② Measure the 24V input voltage supplied from Power Board
(If there is no input voltage, remove and check the connector)
- ③ Connect the tester RX1 to the speaker terminal and if you hear the "Chik Chik" sound when you touch the GND and output terminal, the speaker is normal.



Standard Repair Process Detail Technical Manual

LCD TV	Error symptom	D. Function error_ No response in remote controller, key error	Established date	2010. 12 .14	
	Content	Remote controller operation checking method	Revised date		A27

<ALL MODELS>

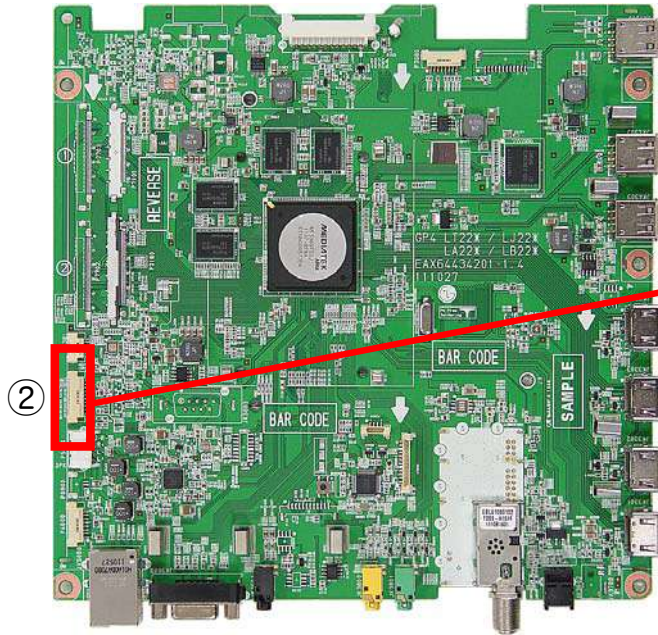
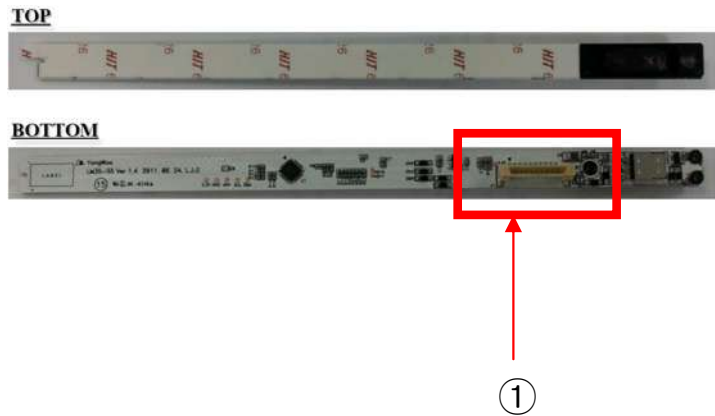

P4102	
1	SCL
2	SDA
3	GND
4	KEY1
5	KEY2
6	St 3.5V
7	GND
9	IR
10	GND

③

④

Checking order

- 1, 2. Check IR cable condition between IR & Main board.
3. Check the st-by 3.3V on the terminal 6.
4. When checking the Pre-Amp when the power is in ON condition, it is normal when the Analog Tester needle moves slowly, and defective when it does not move at all.



Standard Repair Process Detail Technical Manual

LCD TV	Error symptom	D. VCOM Adjustment	Established date	2010. 12 .14	
	Content	Sequence of the Vcom adjustment	Revised date		A28

1. Case

- LCD module change
- T-Con board change

2. Equipment

- Service Remote controller

3. Adjust sequence

- Press the 'adj' key
- select V-COM
- As pushing the right or the left button on the remote controller, And find the V-COM value Which is no or minimized the Flicker.

(If there is no flicker at default value, Press the exit key and finish the VCOM adjustment.)

- Push the OK key to store the value. Then the message "Saving OK" is pop.
- Press the exit key to finish V-COM adjustment.

