

PNEUMATIC X/Y POSITIONER (LP-300) AND ACCESSORIES USER MANUAL

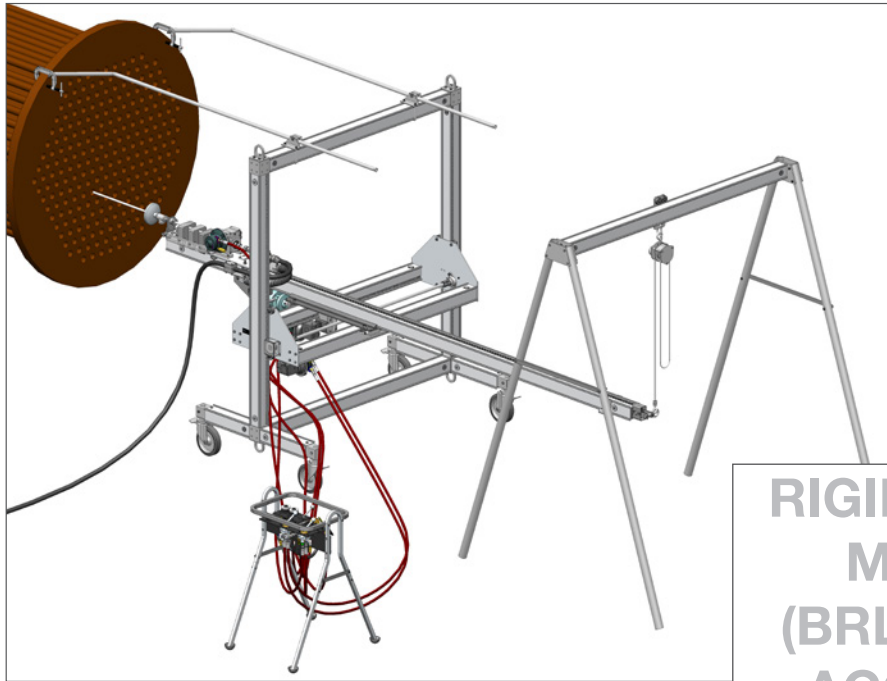

**RIGID LANCING
MACHINE
(BRLM 500-XX)
ACCESSORY**

**AUTOBOX[®] FLEX
LANCE ADAPTER
(ABX-LP-XX)
ACCESSORY**

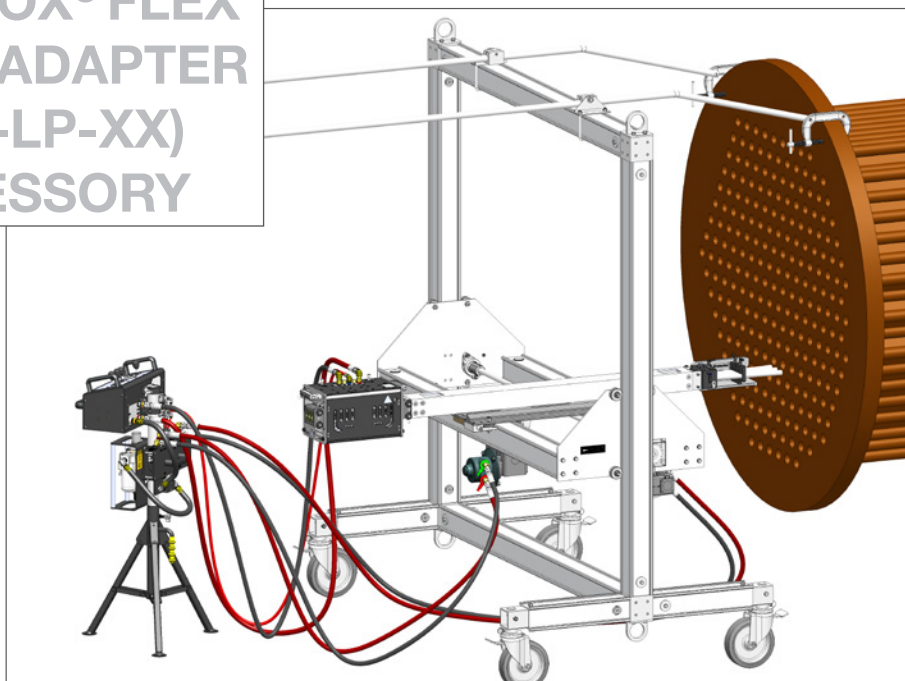

TABLE OF CONTENTS

MANUFACTURER'S INFORMATION	3
---	----------

CE DECLARATIONS OF INCORPORATION	4
---	----------

X/Y POSITIONER	4
----------------------	---

RIGID LANCING MACHINE WITH ROTARY DRIVE	5
---	---

AUTOBOX® FLEX LANCE ADAPTER	6
-----------------------------------	---

SPECIFICATIONS	7
-----------------------------	----------

X/Y POSITIONER (LP-300)

SPECIFICATIONS	7
----------------------	---

DESCRIPTION OF EQUIPMENT AND INTENDED USE	7
---	---

KEY FEATURES	7
--------------------	---

RIGID LANCING MACHINE (BRLM-500-XX)

SPECIFICATIONS	8
----------------------	---

DESCRIPTION OF EQUIPMENT AND INTENDED USE	8
---	---

KEY FEATURES	8
--------------------	---

AUTOBOX® FLEX LANCE ADAPTER (ABX-LP-XX)

SPECIFICATIONS	9
----------------------	---

DESCRIPTION OF EQUIPMENT AND INTENDED USE	9
---	---

KEY FEATURES	9
--------------------	---

WARNING AND SAFETY INSTRUCTIONS	10
--	-----------

OPERATOR TRAINING	10
-------------------------	----

PERSONAL PROTECTIVE EQUIPMENT REQUIREMENTS	10
--	----

PRE-RUN SAFETY CHECK	11
----------------------------	----

SYSTEM ASSEMBLY - OVERVIEWS	12
--	-----------

RIGID LANCING MACHINE ON X/Y POSITIONER	12
---	----

CONTROL BOX FOR RIGID LANCE MACHINE CB-LP	13
---	----

X/Y POSITIONER ASSEMBLY (LP-300-XX) SET-UP	14
---	-----------

REAR SUPPORT ASSEMBLY (LP 320) SET-UP	20
--	-----------

RIGID LANCING MACHINE ON X/Y POSITIONER SET-UP	22
---	-----------

CB-LP CONTROL BOX SET-UP	30
--------------------------------	----

RIGID LANCING MACHINE OPERATION	32
---------------------------------------	----

MAINTENANCE AND TROUBLESHOOTING	33
---------------------------------------	----

AUTOBOX® FLEX LANCE ADAPTER ON X/Y POSITIONER	34
--	-----------

CBX-TBX-LPA TUMBLE BOX TO CONTROL BOX SET-UP	35
--	----

AUTOBOX® FLEX LANCE ADAPTER SET-UP	36
--	----

PNEUMATIC CONTROL BOX TO AUTOBOX TRACTOR CONNECTIONS	38
--	----

PART DIAGRAMS	39
----------------------------	-----------

TERMS AND CONDITIONS	66
-----------------------------------	-----------

StoneAge Inc.
466 S. Skylane Drive
Durango, CO 81303, USA
Phone: 970-259-2869
Toll Free: 866-795-1586
www.stoneagetools.com

StoneAge Europe
Unit 2, Britannia Business Centre
Britannia Way
Malvern WR14 1GZ
United Kingdom
Phone: (+44) (0) 1684 892065

This manual must be used in accordance with all applicable national laws. The manual shall be regarded as a part of the machine and shall be kept for reference until the final dismantling of the machine, as defined by applicable national law(s).

Updated manuals can be downloaded at:
<https://www.stoneagetools.com/manuals>



EU DECLARATION OF CONFORMITY

Manufacturer: StoneAge Incorporated
466 South Skylane Drive
Durango, CO 81303
USA

Authorized Representative: StoneAge Europe
Unit 2, Britannia Business Centre
Britannia Way
Malvern WR14 1GZ
United Kingdom
Steve Ellis, Director StoneAge Europe

Declare that: **X/Y Positioner (LP-300)**
for high pressure water cleaning of system parts.

Is compliant with the following Directives and Standards:

Directive 2006/42/EC (Machinery Directive)

EN ISO 12100:2010 (E) Safety of machinery – General principles for design – Risk assessment and risk reduction

The Technical File for X/Y Positioner (LP-300)

is maintained at: StoneAge Incorporated, 466 South Skylane Drive, Durango, CO 81303, USA and was compiled by the Engineering Manager. The Technical File is available through the Authorized Representative.

This Declaration of Conformity is issued under the exclusive responsibility of StoneAge Incorporated.

StoneAge Incorporated, Durango, CO, USA
Adam Markham, Engineering Manager, Robotics

02/11/2019
Date





EU DECLARATION OF CONFORMITY

Manufacturer: StoneAge Incorporated
466 South Skylane Drive
Durango, CO 81303
USA

Authorized Representative: StoneAge Europe
Unit 2, Britannia Business Centre
Britannia Way
Malvern WR14 1GZ
United Kingdom
Steve Ellis, Director StoneAge Europe

Declare that: Rigid Lance Machine (BRLM 500-XX with BRLM 3XX-XX-XX)
for high pressure water cleaning of system parts.

Is compliant with the following Directives and Standards:

Directive 2006/42/EC (Machinery Directive)
EN ISO 12100:2010 (E) Safety of machinery – General principles for design – Risk assessment and risk reduction

The Technical File for Rigid Lance Machine (BRLM 500-XX with BRLM 3XX-XX-XX) is maintained at: StoneAge Incorporated, 466 South Skylane Drive, Durango, CO 81303, USA and was compiled by the Engineering Manager. The Technical File is available through the Authorized Representative.

This Declaration of Conformity is issued under the exclusive responsibility of StoneAge Incorporated.

StoneAge Incorporated, Durango, CO, USA
Adam Markham, Engineering Manager, Robotics

02/11/2019
Date





EU DECLARATION OF CONFORMITY

Manufacturer: StoneAge Incorporated
466 South Skylane Drive
Durango, CO 81303
USA

Authorized Representative: StoneAge Europe
Unit 2, Britannia Business Centre
Britannia Way
Malvern WR14 1GZ
United Kingdom
Steve Ellis, Director StoneAge Europe

Declare that: **Autobox® Flex Lance Adapter (ABX-LP-XX)
for high pressure water cleaning of system parts.**

Is compliant with the following Directives and Standards:

Directive 2006/42/EC (Machinery Directive)

EN ISO 12100:2010 (E) Safety of machinery – General principles for design – Risk assessment and risk reduction

The Technical File for Autobox® Flex Lance Adapter (ABX-LP-XX)

is maintained at: StoneAge Incorporated, 466 South Skylane Drive, Durango, CO 81303, USA and was compiled by the Engineering Manager. The Technical File is available through the Authorized Representative.



This Declaration of Conformity is issued under the exclusive responsibility of StoneAge Incorporated.

StoneAge Incorporated, Durango, CO, USA
Adam Markham, Engineering Manager, Robotics

02/11/2019
Date

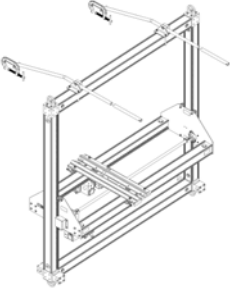

SPECIFICATIONS X/Y POSITIONER (LP-300)

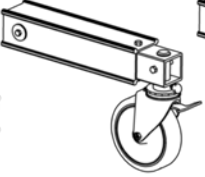
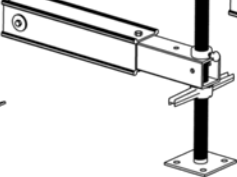
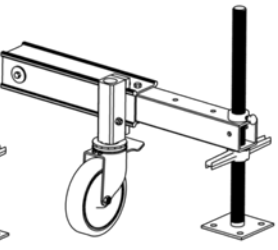
					
LP-300-XX	LP-320 REAR SUPPORT	LP 335-WE SWIVEL WHEEL KIT	LP 335-JE SWIVEL WHEEL KIT	LP 335-WJE SWIVEL WHEEL KIT	
WEIGHTS	310 lb 141 kg	96 lb 44 kg	20 lb 9 kg	24 lb 11 kg	35 lb 16 kg

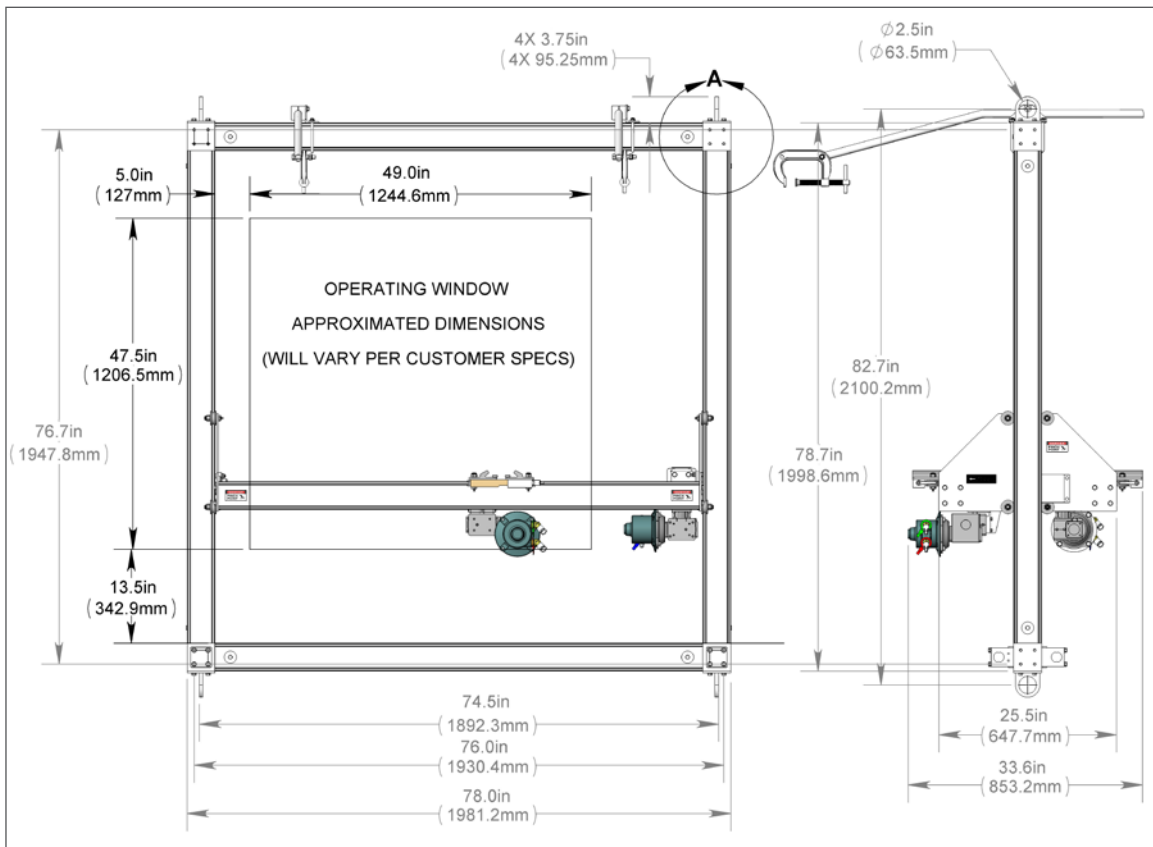

DESCRIPTION OF EQUIPMENT AND INTENDED USE

The X/Y Positioner (LP-300) provides a means for aligning and indexing the BRLM Rigid Lancing Machines. It moves in a straight line along the X and Y axes.

The Control Box (CB-LP) allows the operator to control the machinery from a safe distance away from the blast zone.

KEY FEATURES:

- Control Box - Control all movements of the complete package from up to 25 ft/8m away.
- Pneumatically driven
- Configurable operating window dimension- Allows for versatility for cleaning a variety of exchanger sizes.
- Steering control and tilt function - Positioner offers easy mobility and can be tilted to match the tube pitch angle of a bundle face.

SPECIFICATIONS RIGID LANCE MACHINE (BRLM 500-XX)

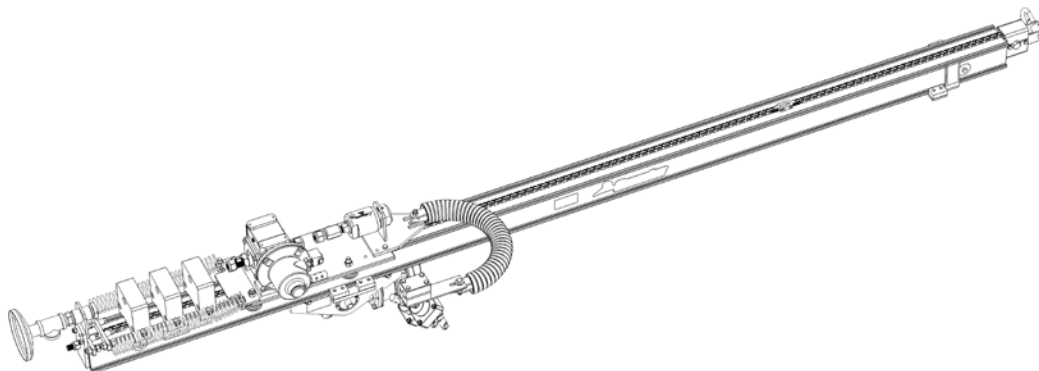

BRLM RIGID LANCE MACHINE SPECIFICATIONS

	BRLM 500 (15K)	BRLM 500 (22K)	BRLM 500 (40K)
Pressure Range	2–15k psi 140–1000 bar	15–22k psi 1000–1500 bar	22–40k psi 1500–2800 bar
Flow Range	Up to 50 gpm Up to 189 l/min	Up to 50 gpm Up to 189 l/min	Up to 20 gpm Up to 76 l/min
Flow Coefficient	2.3 Cv	2.0 Cv	0.3 Cv (UHS) 0.5 Cv (UH)
Inlet Connection	1/2 NPT (P8)	3/4 MP (MP12)	9/16 HP (H9)
Lance Connection	1/8, 1/4 NPT	3/8, 9/16 LH	3/8, 9/16 LH
Standard Rail Length	BRLM 500-15 15ft / 4.6m	BRLM 500-15 15ft / 4.6m	BRLM 500-15 15ft / 4.6m
Standard Extensions	BRLM 580-X 5, 10, or 15ft 1.5, 3, or 4.6m	BRLM 580-X 5, 10, or 15ft 1.5, 3, or 4.6m	BRLM 580-X 5, 10, or 15ft 1.5, 3, or 4.6m
Stroke Length	Up to 60 ft Up to 18m	Up to 60 ft Up to 18m	Up to 60 ft Up to 18m
Weight Complete	1200–1500 lb 544–680 kg	1200–1500 lb 544–680 kg	1200–1500 lb 544–680 kg
Water Swivels	SG-P8P8-0 / SL-P8P4-0	SL-MP9AV9-0 / SL-MP12AV12-0	UH-H9H6-0 / UHS-H9H9
Rotation Air Motor	Gast 4AM 20 to 40 cfm @ 80 psi	Gast 4AM 20 to 40 cfm @ 80 psi	Gast 4AM 20 to 40 cfm @ 80 psi
Feed Air Motor	Gast 6AM 30 to 50 cfm @ 80 psi	Gast 6AM 30 to 50 cfm @ 80 psi	Gast 6AM 30 to 50 cfm @ 80 psi
Maximum Water Temperature	160 °F 70 °C	160 °F 70 °C	160 °F 70 °C

DESCRIPTION OF EQUIPMENT AND INTENDED USE

The Rigid Lancing Machine was designed for the effective cleaning of the inside of tubes within a heat exchanger bundle.

It is used with a rigid lance and nozzle head. Rigid Lances provide more forward-hitting power than flex lancing to clean difficult deposits. It is possible to operate 3 rotary lances simultaneously and remotely from the control box.

Air or hydraulic motors supply rotation and feed power. Since the lance is continuously rotated, a fewer number of larger, more powerful jets are used to completely clean the insides of the tubes. Larger jets will also penetrate tougher deposits more effectively than many smaller, non-rotating jets. Rotation of the tip also makes this tool effective for polishing tube walls. The powered feed allows all the jet power to be used in attacking the material ahead of the tip.

KEY FEATURES:

RIGID LANCE MACHINE (BRLM 500)

- Adjustable feed rate for lance travel- Both directions of the lance can be regulated for speed to deliver appropriate cleaning.
- Adjustable lance stops- Forward stop to ensure complete tube coverage, optional retract stop to protect lances and operator
- Control Box - Control all movements of the complete package from up to 25 ft/8m away.
- Pneumatically driven

SPECIFICATIONS AUTOBOX® FLEX LANCE ADAPTER (ABX-LP-XX)

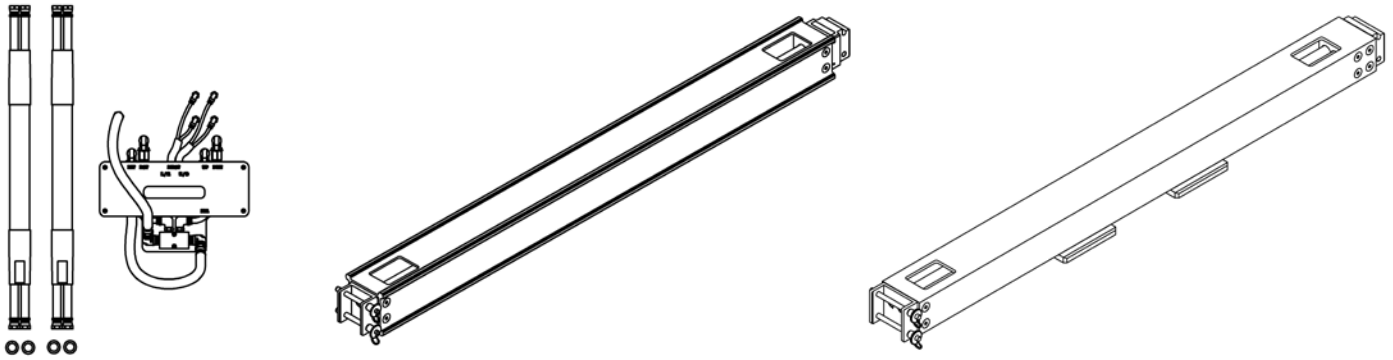

ABX-LP-XX SPECIFICATIONS

	CB-TBX-LPA	ABX-100-LP	ABX-300-LP
Weight Per Assembly	11 lbs 5 kg	25 lbs 11.4 kg	29.5 lbs 13.4 kg
Size Per Assembly	14in (W) x 7in (D) x 12in (H) 356mm (W) x 178mm (D) x 305mm (H)	4in (W) x 53in (D) x 4in (H) 102mm (W) x 1349mm (D) x 102mm (H)	4in (W) x 52in (D) x 4in (H) 102mm (W) x 1318mm (D) x 107mm (H)
Minimum System Supply Pressure	100 psi (7.9 bar)		
Minimum/Maximum Air Supply Volume	78 cfm Minimum /156 cfm Maximum		
Recommended Operational Temperature Range	20 to 140 °F (-29 to 60 °C)		
Recommended Operational Relative Humidity Range	Up to 100% RH		

DESCRIPTION OF EQUIPMENT AND INTENDED USE

The Tumble Box and Tractor Mount assemblies were designed to adapt ABX-2L and ABX-3L Flexible Lancing Machines the LP-300 X-Y Positioner. This positioner is also used with the standard Rigid Lancing Machine.

Flexible Lancing Machines used with the positioner are advantageous in tight physical locations for cleaning tube bundles on heat exchangers. For users that already own ABX Flexible Lancing machines, the Tumble Box and Tractor Mount assemblies provide additional capability for existing pad cleaning equipment.

Rigid Lancing Machines by contrast require more physical space to operate. However, rigid lance equipment can provide more unplugging power due to the ability to run all forward facing jets.

KEY FEATURES:

AUTOBOX® ADAPTER TO LP-300 (ABX-XXX-LP)

- Allows flex lance tractors, AUTOBOX® 2L and 3L to be operated on the X/Y Positioner LP-300
- Tumble Box mounts to CB-ABX and CBX-ABX universally.
- Tumble Box and adapts 1/4" air lines from the AUTOBOX® Control Boxes to the 1/2" air lines on the LP-300 Positioner.

WARNING AND SAFETY INSTRUCTIONS

OPERATOR TRAINING

Managers, Supervisors, and Operators MUST be trained in Health and Safety Awareness of High-pressure Water Jetting and hold a copy the Water Jetting Association (WJA) Code of Practice, or equivalent (see www.waterjetting.org.uk).

Operators MUST be trained to identify and understand all applicable standards for the equipment supplied. Operators should be trained in manual handling techniques to prevent bodily injury.

StoneAge has designed and manufactured this equipment considering all hazards associated with its operation. StoneAge assessed these risks and incorporated safety features in the design. StoneAge **WILL NOT** accept responsibility for the results of misuse.

IT IS THE RESPONSIBILITY OF THE INSTALLER/OPERATOR

to conduct a job specific risk assessment prior to use. Job specific risk assessment MUST be repeated for each different set up, material, and location.

The risk assessment MUST conform to the Health and Safety at Work Act 1974 and other relevant Health and Safety legislation.

Operators MUST read, understand, and follow the Operational and Training Requirements (Section 7.0) of WJTA-IMCA's Recommended Practices For The Use Of High-pressure Waterjetting Equipment, or equivalent.

Operators MUST read, understand and follow the Warnings, Safety Information, Assembly, Installation, Connection, Operation, Transport, Handling, Storage, and Maintenance Instructions detailed in this manual.

The risk assessment MUST consider potential material or substance hazards including:

- Aerosols
- Biological and microbiological (viral or bacterial) agents
- Combustible materials
- Dusts
- Explosion
- Fibers
- Flammable substances
- Fluids
- Fumes
- Gases
- Mists
- Oxidizing Agents

PERSONAL PROTECTIVE EQUIPMENT REQUIREMENTS

Use of Personal Protective Equipment (PPE) is dependent on the working pressure of water and the cleaning application. Managers, Supervisors, and Operators MUST carry out a job specific risk assessment to define the exact requirements for PPE. See Protective Equipment for Personnel (Section 6) of WJTA-IMCA's Recommended Practices For The Use Of High-pressure Waterjetting Equipment for additional information.

Hygiene - Operators are advised to wash thoroughly after all waterjetting operations to remove any waterblast residue which may contain traces of harmful substances.

First aid provision - users MUST be provided with suitable first aid facilities at the operation site.

PPE may include:

- **Eye protection:** Full face visor
- **Foot protection:** Kevlar® brand or steel toe capped, waterproof, non-slip safety boots
- **Hand protection:** Waterproof gloves
- **Ear protection:** Ear protection for a minimum of 85 dBA
- **Head protection:** Hard hat that accepts a full face visor and ear protection
- **Body protection:** Multi-layer waterproof clothing approved for waterjetting
- **Hose protection:** Hose shroud
- **Respiratory protection:** May be required; refer to job specific risk assessment

▲WARNING

Operations with this equipment can be potentially hazardous. Caution **MUST** be exercised prior to and during machine and water jet tool use. Please read and follow all of these instructions, in addition to the guidelines in the WJTA Recommended Practices handbook, available online at www.wjta.org. Deviating from safety instructions and recommended practices can lead to severe injury and/or death.

- Do not exceed the maximum operating pressure specified for any component in a system. The immediate work area **MUST** be marked off to keep out untrained persons.
- Inspect the equipment for visible signs of deterioration, damage, and improper assembly. Do not operate until repaired. Make sure all threaded connections are tight and free of leaks.
- Users of the BRLM Rigid Lancing System **MUST** be trained and/or experienced in the use and application of high-pressure technology and cleaning, as well as all associated safety measures, according to the WJTA Recommended Practices for the use of High-pressure Water jetting Equipment.
- The Control Box should be located in a safe location where the operator has good visibility of the pipe and hose. The BRLM Lancing System and Control Box **MUST** be supervised at all times and should never be left unattended.
- Test the Control Box before operating the BRLM Rigid Lancing System with high-pressure water to verify the control valves move the hose in the intended direction, and that the dump valve is working properly.
- Always de-energize the system before opening the door to service or replace any parts. Failure to do so can result in severe injury and/or death.

PRE-RUN SAFETY CHECK

Refer to WJTA-IMCA's, Recommended Practices For The Use Of High-pressure Water jetting Equipment and/or The Water Jetting Association's, WJA Code of Practice for additional safety information.

- Complete a job specific risk assessment and act on the resulting actions.
- Ensure the waterblasting zone is properly barricaded and that warning signs are posted.
- Adhere to all site safety procedures.
- Ensure no personnel are in the hydroblasting zone.
- Ensure the work place is free of unnecessary objects (e.g. loose parts, hoses, tools).
- Ensure all operators are using the correct Personal Protective Equipment (PPE).
- Check that the air hoses are properly connected and tight.
- Check all hoses and accessories for damage prior to use. Do not use damaged items. Only high quality hoses intended for waterblast applications should be used as high-pressure hoses.
- Ensure that operators never connect, disconnect, or tighten hoses, adapters, or accessories with the high-pressure water pump unit running.
- Check all high-pressure threaded connections for tightness.

OVERVIEW-X/Y POSITIONER (LP-300-XX) WITH BRLM ACCESSORY

X/Y POSITIONER LP-300-XX WITH BRLM RIGID LANCING MACHINE ACCESSORIES

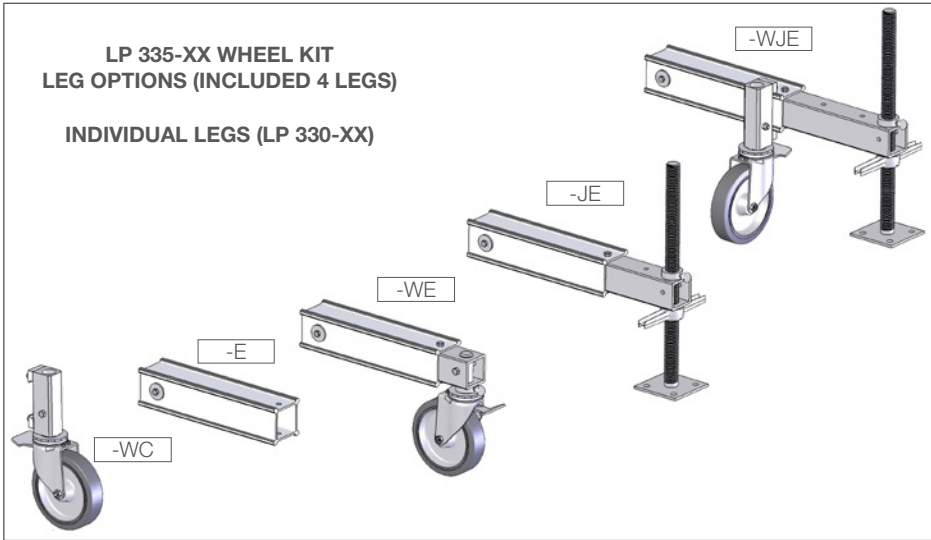
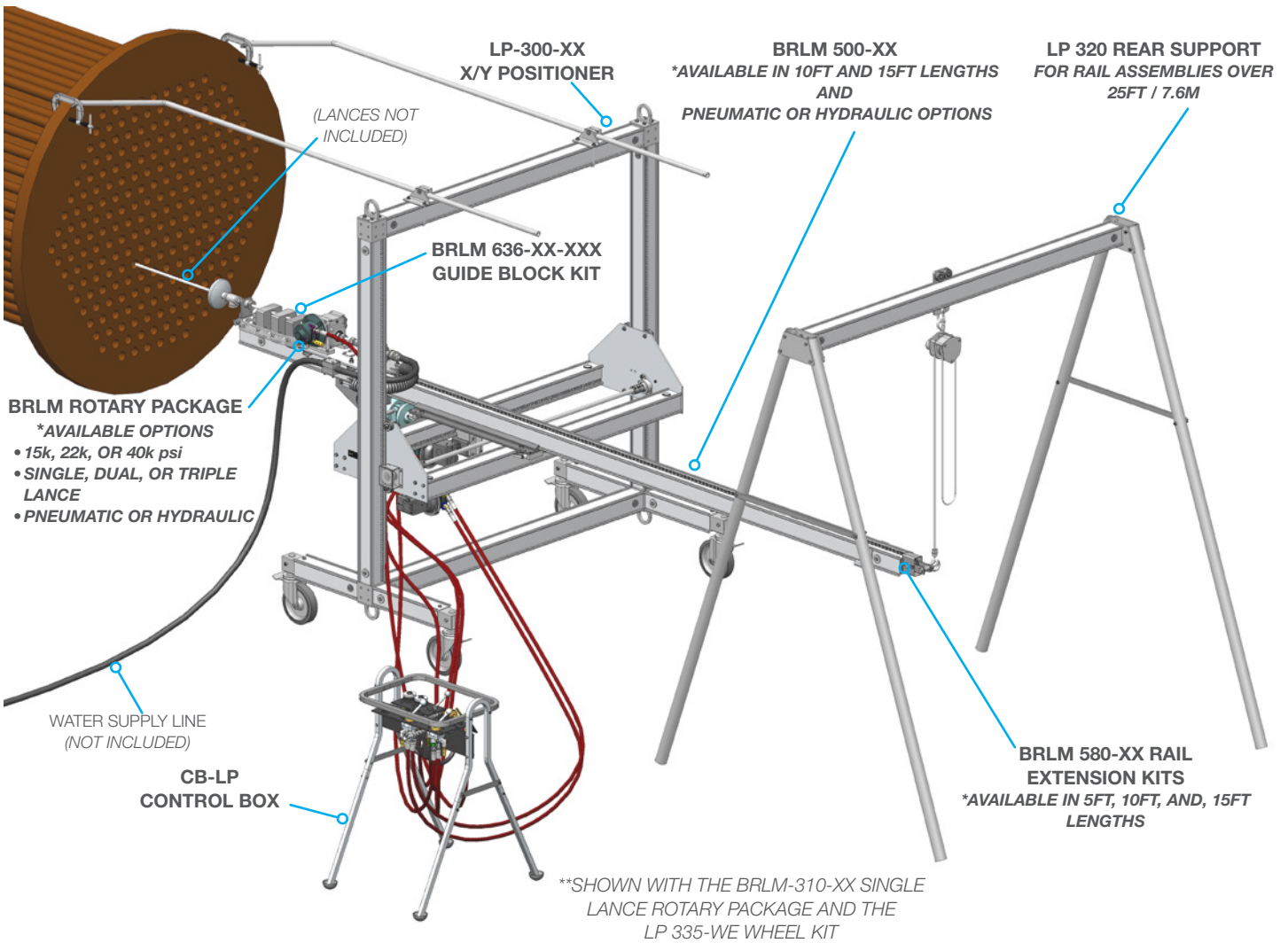

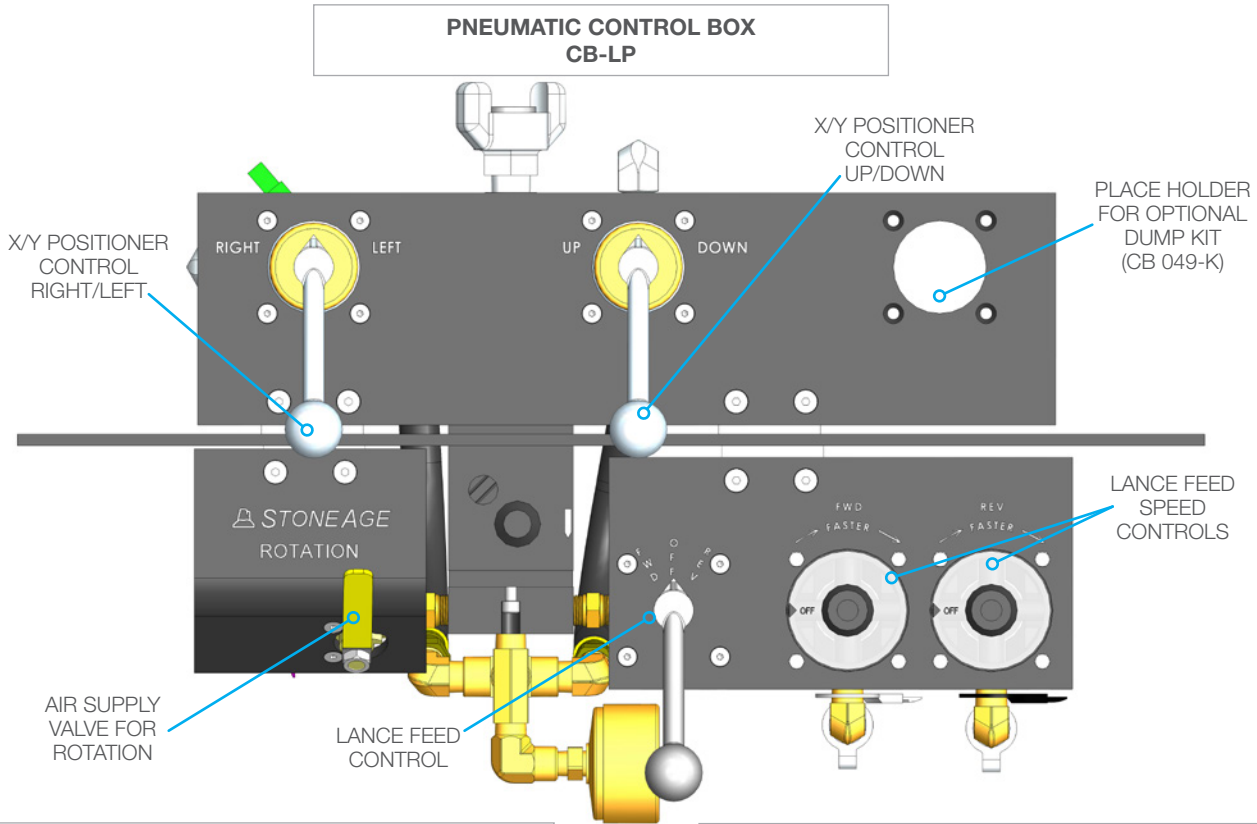

**CONTROL BOX
FRONT VIEW**

**CONTROL BOX
REAR VIEW**

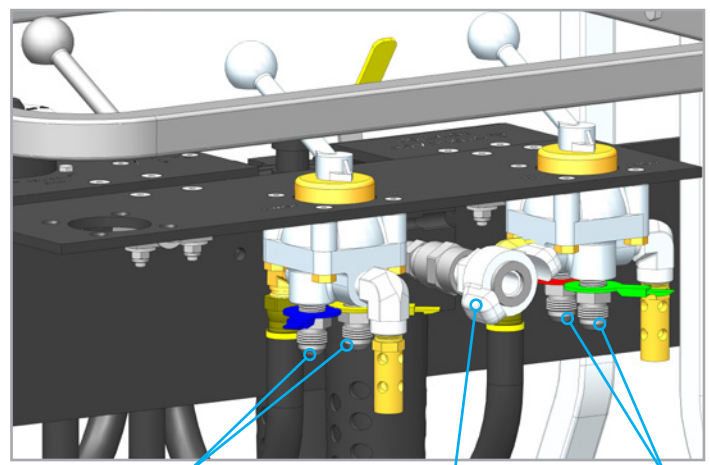
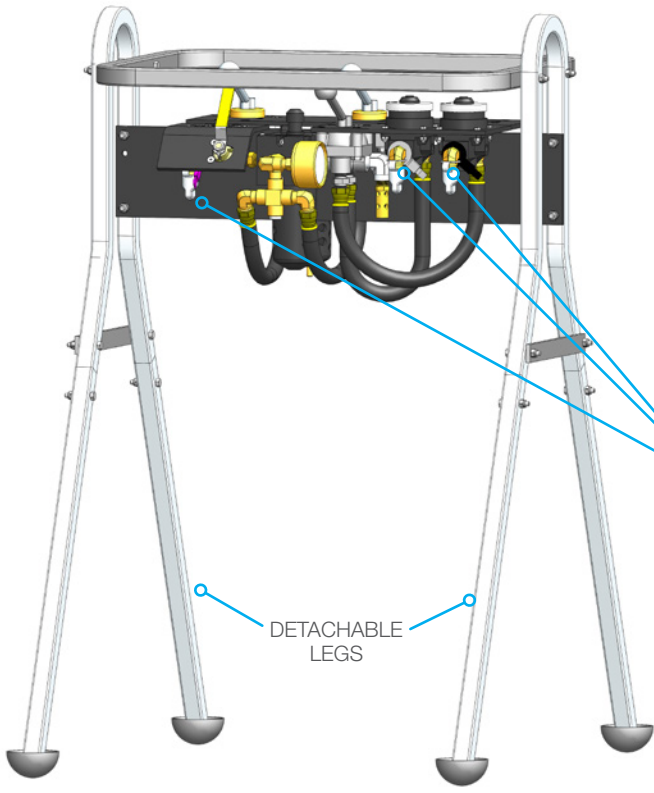

****SEE "PART DIAGRAM" SECTION AT THE BACK OF THIS MANUAL FOR MORE DETAILED PART BREAK DOWNS.**



X/Y POSITIONER (LP-300-XX) PACKAGE CONTENTS

X/Y POSITIONER (LP-300-XX) PACKAGE PARTS

The diagrams below illustrate a simple overview of the main components included in the LP-300-XX package. The LP Carriage Assembly comes assembled with either Pneumatic or Hydraulic motors.

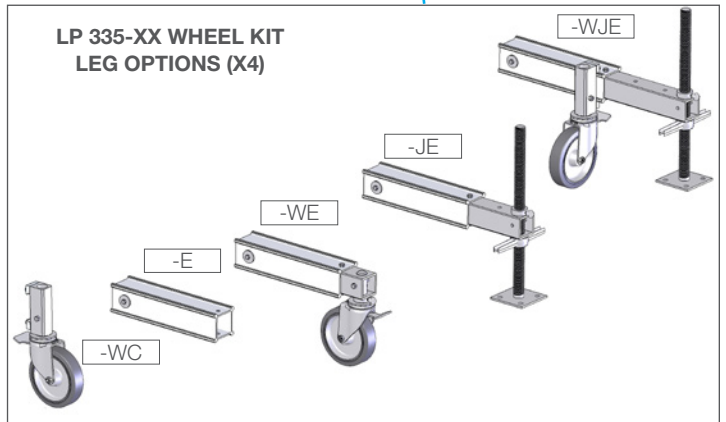
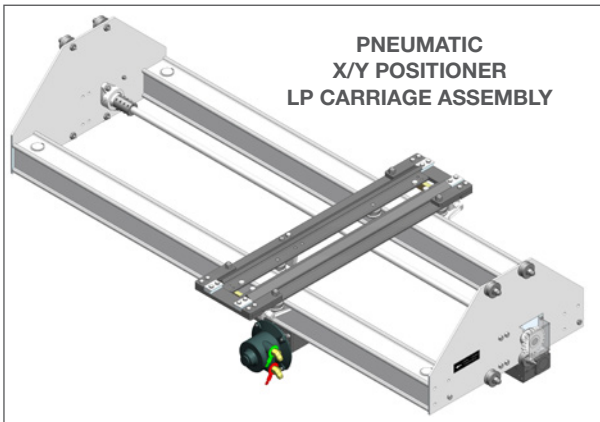
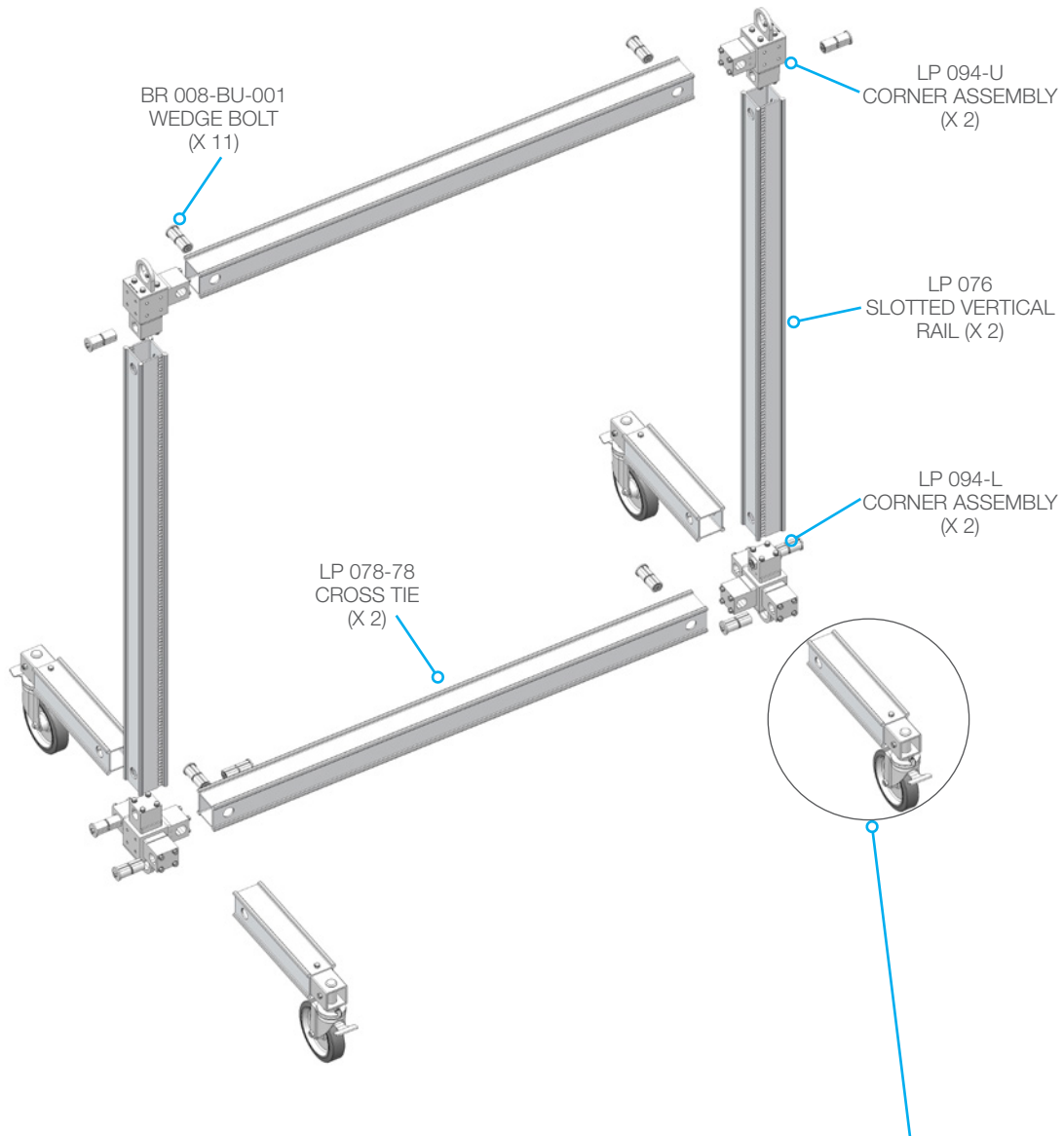

ASSEMBLY STEPS FOR THE X/Y POSITIONER (LP-300-XX)

1. **Assembling the base-** All Wheel Kit options fasten to the cross beam with Wedge Bolts. If changing out the leg option is necessary, it can be done by removing the wedge bolts, replacing the leg option and fastening the wedge bolts as shown. Install all Wedge Bolts with an adjustable or 9/16" open end wrench.

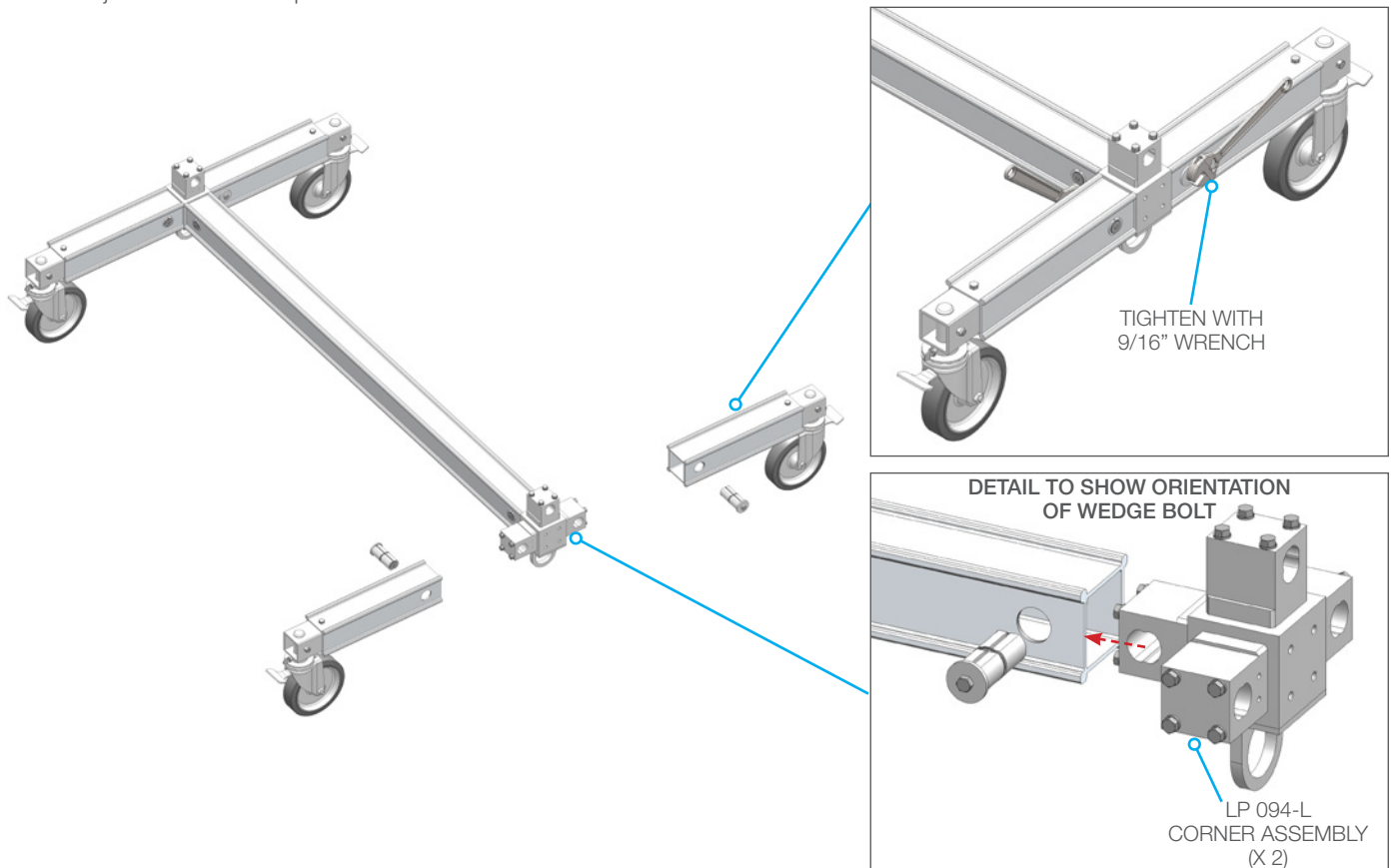

2. **Installing the LP Carriage Assembly-** Set the Carriage Assembly onto the Wheel Kit Base. Be sure to center the mounting blocks between the rollers on each side of the Carriage Assembly.



X/Y POSITIONER (LP-300-XX) ASSEMBLY

ASSEMBLY STEPS FOR THE X/Y POSITIONER (LP-300-XX) CONTINUED.....

3. Assemble the Upper Frame Assembly on the ground as shown below. Slide Brace Clamps on but do not tighten the U-Bolts until the positioner is oriented to the tube bundle face. Install all Wedge Bolts with an adjustable or 9/16" open end wrench.

NOTICE

Make sure the slotted sides of both vertical rails face the same direction.
Make sure Brace Clamps are oriented as shown.

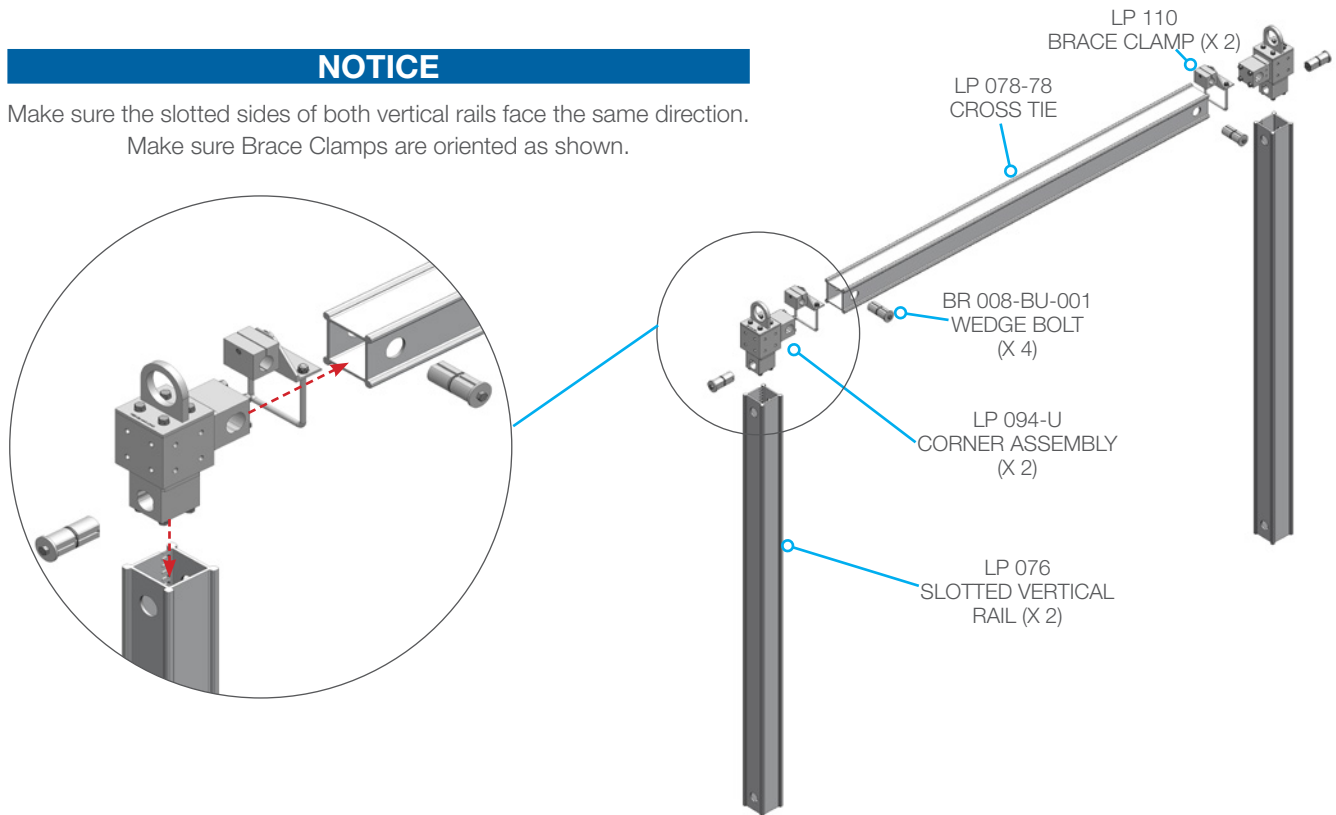

4. Slide the vertical rails on the Upper Frame Assembly over the mounting blocks. Align the slots in the vertical rails with the gears on the Carriage Assembly.

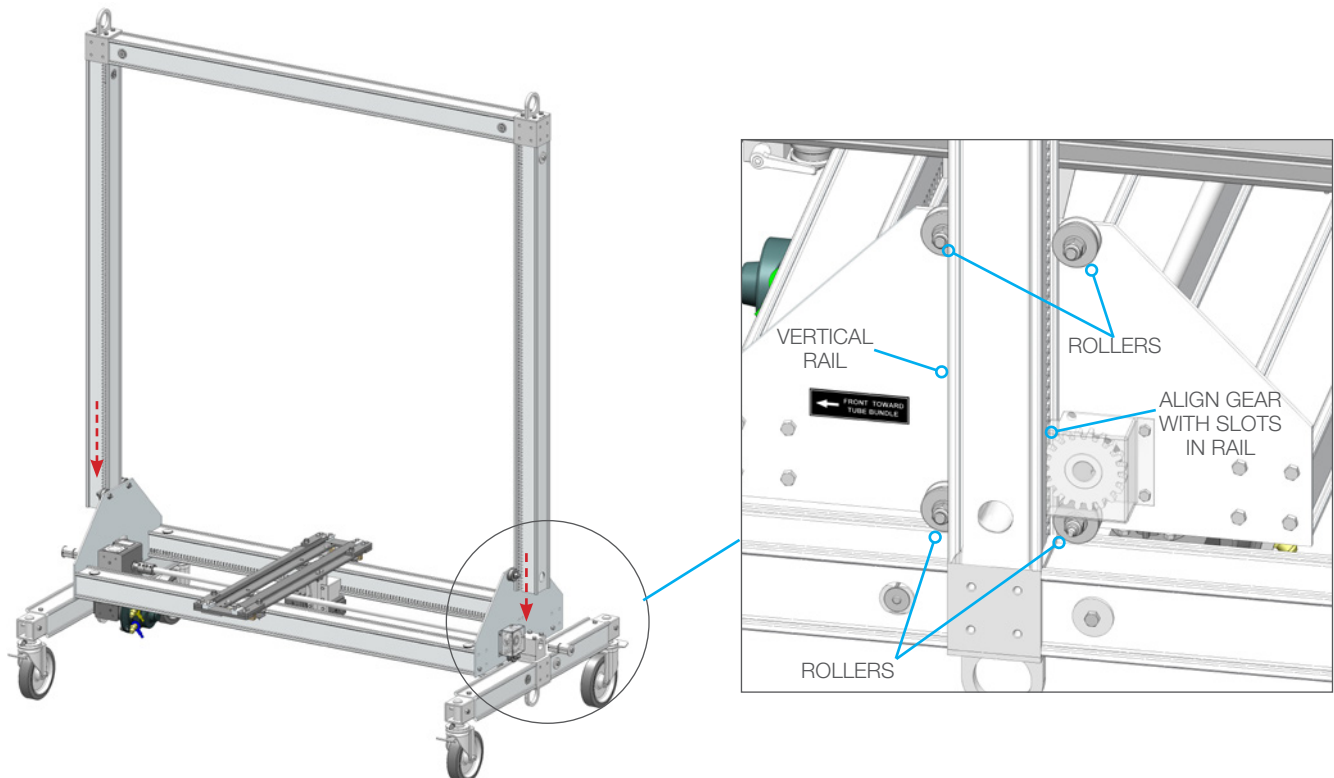

5. Connect the Upward Air fitting (BLUE) to the Control Box (See Control Box Assembly Instructions) to move the Carriage Assembly approximately half way up the Vertical Rails. This will help drive the vertical rails into place and make it easier to install the Wedge Bolts.

NOTICE

Make sure the Carriage Assembly is level on both vertical rails before moving the Carriage up

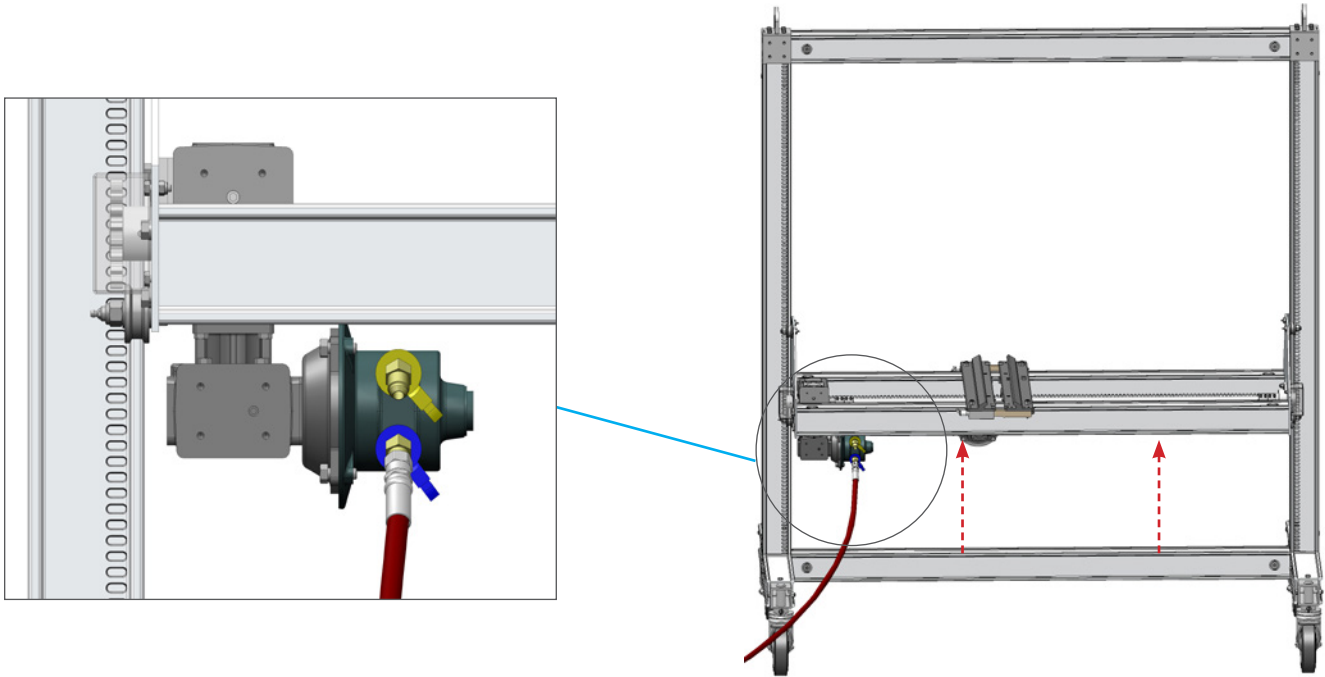

6. Insert Wedge Bolts through the vertical rails and mounting blocks on both sides of the frame assembly. Tighten using an adjustable or 9/16" open end wrench.

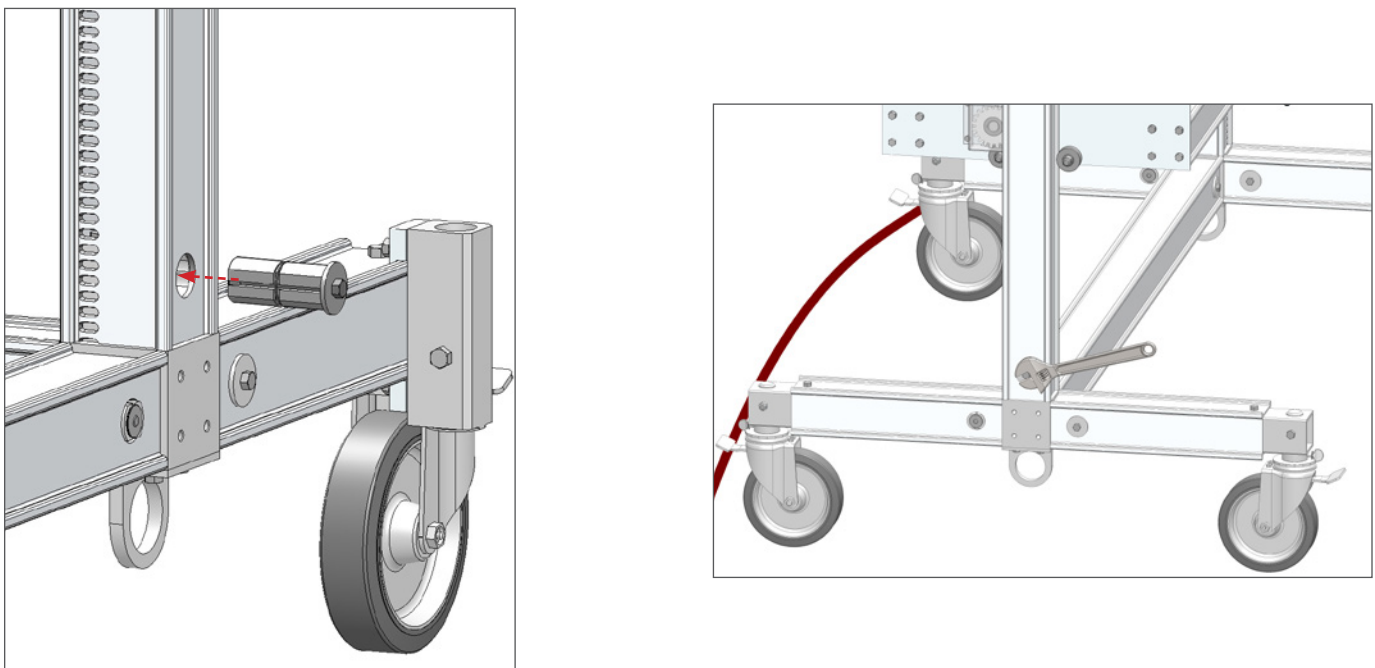

X/Y POSITIONER (LP-300-XX) ASSEMBLY

INSTALLATION OF BRACES AND PLACEMENT OF THE LANCE POSITIONER

- Loosen both Brace Clamps and insert the Braces with the C-Clamp ends facing the tube bundle face. Do not tighten the Brace Clamps until the X/Y Positioner has been set in front of the tube bundle.

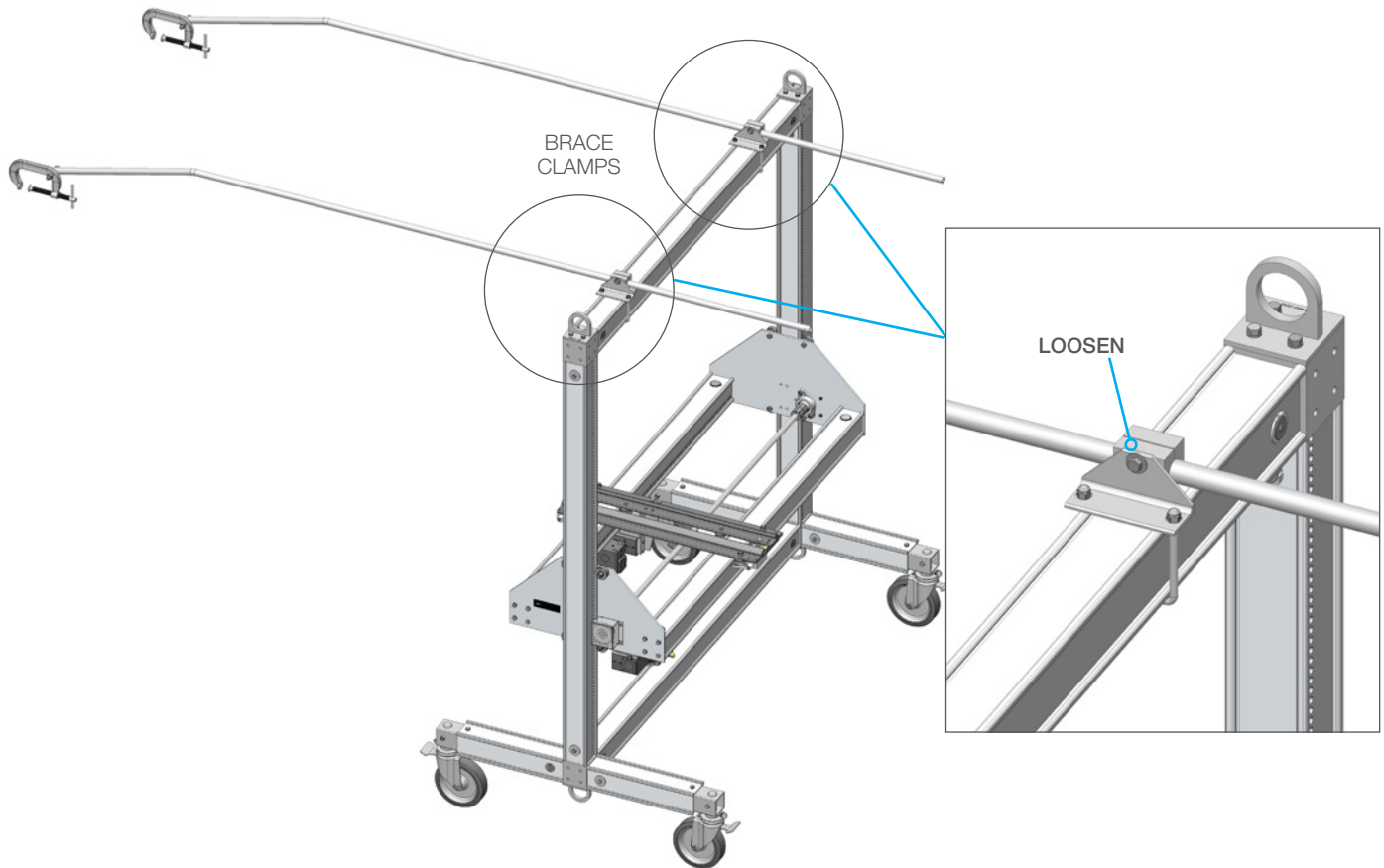

- For lancing rails 15 feet (457 cm) or shorter, the lance positioner may be used as the only support for the lancing machine. The lance positioner should be placed back from the tube bundle face at 5 to 7 feet (152cm-213cm). If the bundle is on rollers, it should be positioned so the tube rows are horizontal. It is recommended that the positioner be placed on jacks for stability instead of on the wheels. Use the leveling jacks to further align the horizontal axis of the positioner with the tube rows. Connect the Braces to the tube bundle face.

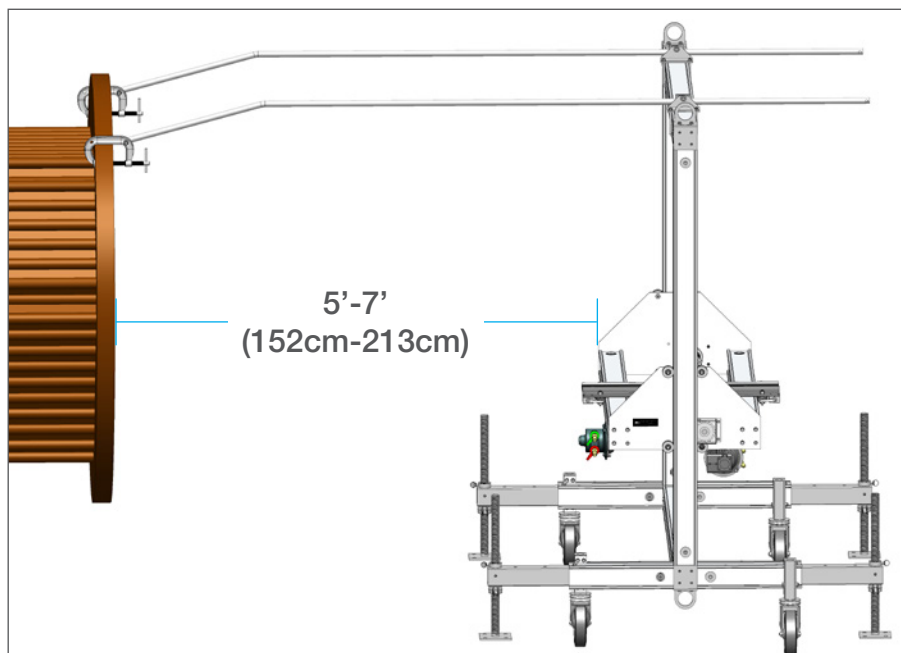

9. When the X/Y Positioner is in place, tighten the C-Clamps on the tube bundle face and the Brace Clamps on the X/Y Positioner.

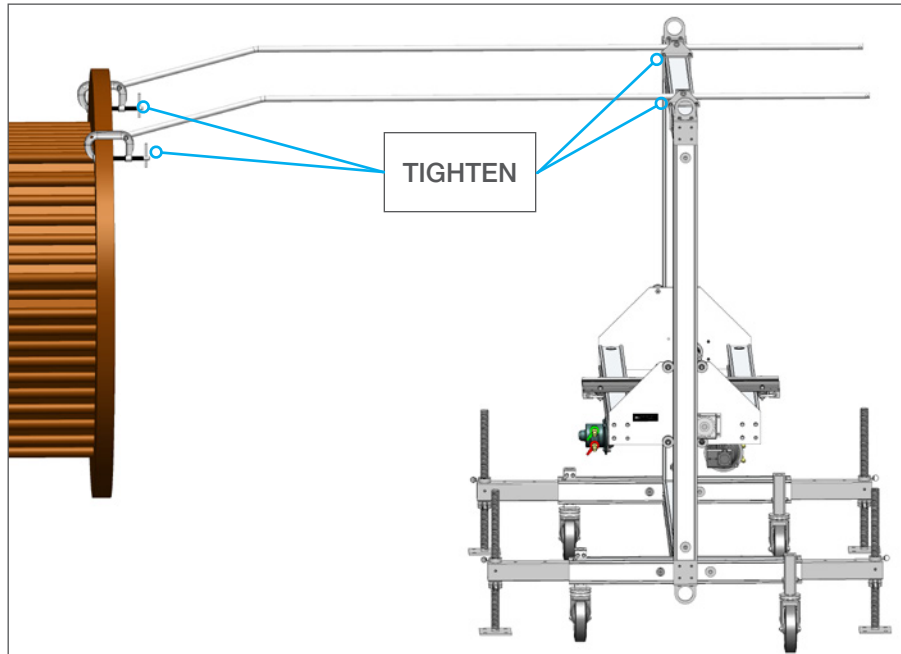

⚠ WARNING

The X/Y Lance Positioner **MUST** be rigidly mounted and tied back to tube bundle or other structure to support against thrust force of machine and reaction force of jetting nozzles. Machine **MUST BE** securely anchored to the tube bundle. Hydraulic forces can potentially reach several thousand pounds and if not avoided, **could** result in death or serious injury if the machinery were to become unanchored.

REAR SUPPORT (LP-320) ASSEMBLY

ASSEMBLY STEPS FOR THE REAR SUPPORT (LP-320)

THE REAR SUPPORT IS RECOMMENDED FOR LANCING RAILS GREATER THAN 15 FEET (457 Cm) LONG.

1. Slide the Trolley Assembly onto the Top Beam.

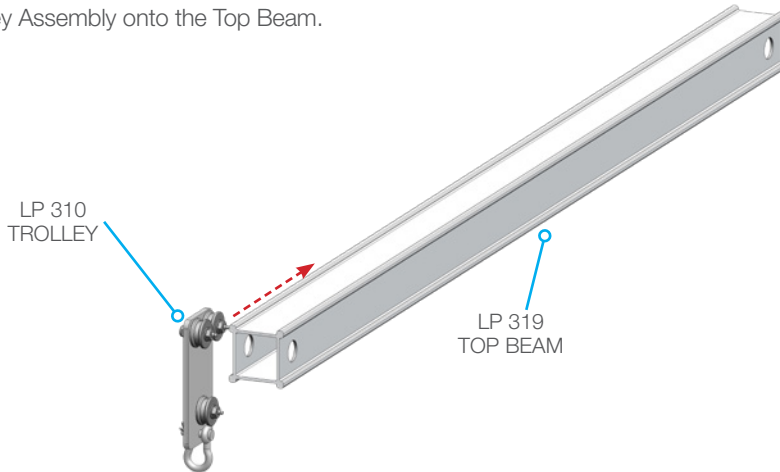

2. Attach the Top Beam to the Leg Assemblies with the Wedge Bolts and tighten with an adjustable or 9/16" open end wrench.
3. Using an adjustable or 9/16" open end wrench, fasten the two BJ 086.4 Links to the leg assemblies with the provided 3/8" Hex Head Bolts and Nylock Nuts.

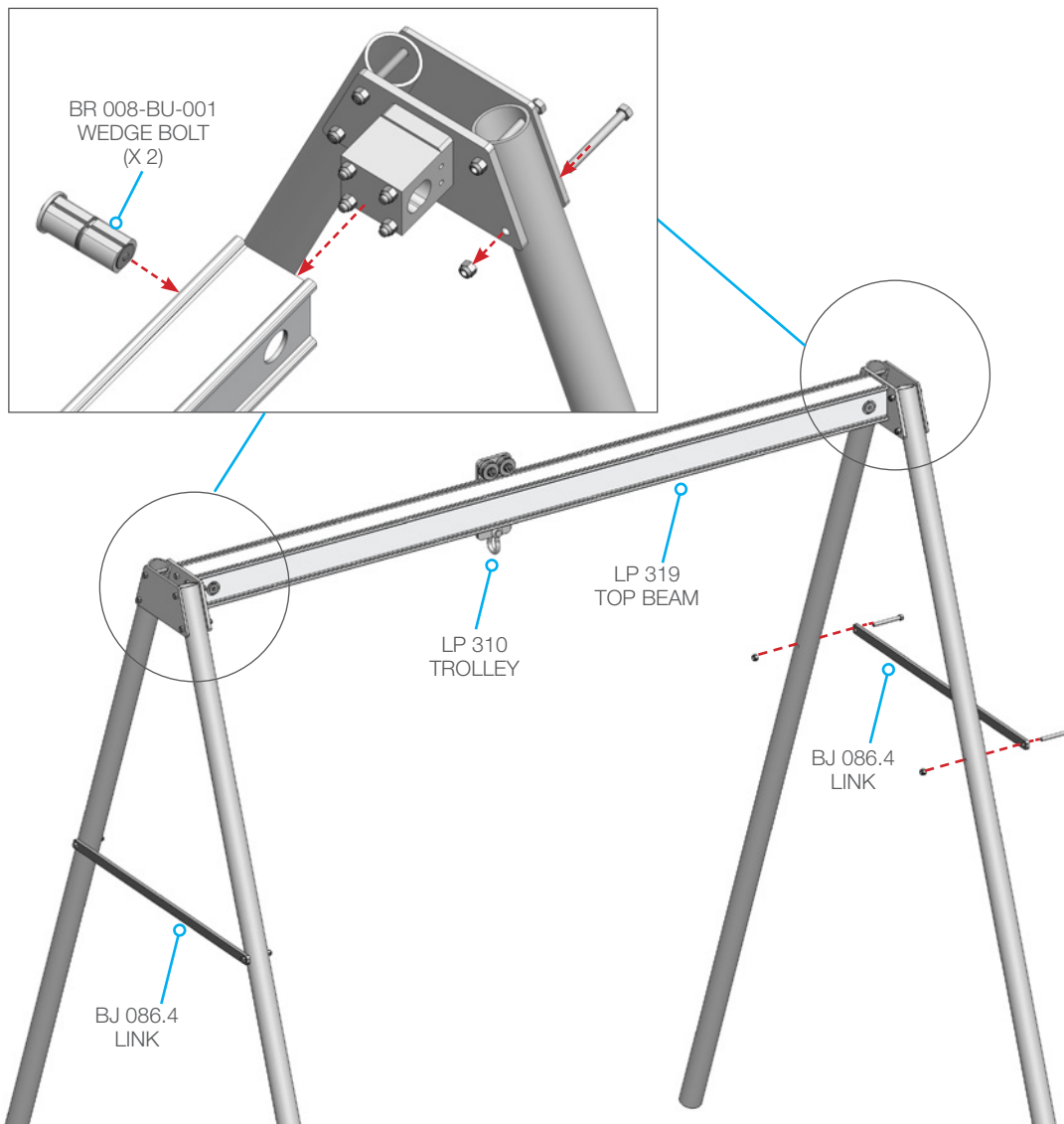

- Hook the UD 071-D Chain Hoist onto the Trolley, and the Rear Support is ready for use.



- Set up the Rear Support behind the X/Y Positioner to catch the extension rail when set in place.

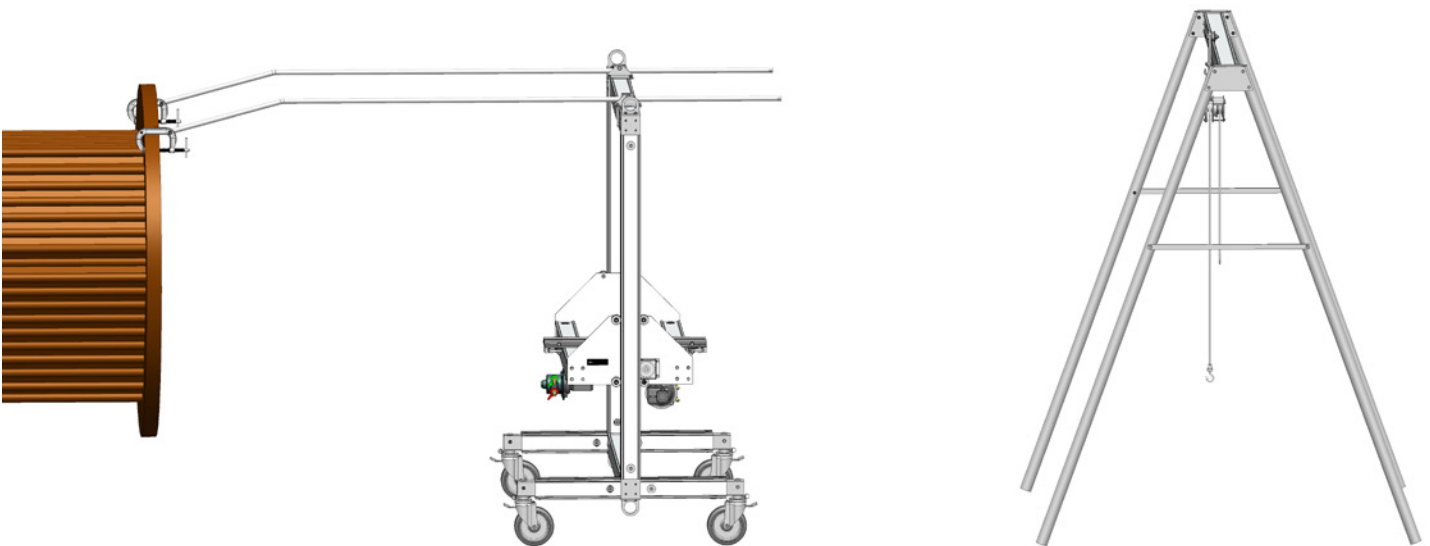

ASSEMBLING AND INSTALLING THE DRIVE RAIL

1. If an extension kit (BRLM 580) is used, insert the splice tube into the rear of the drive rail (the end without a slot) and slide the extension section over the splice tube. The extension rail has no slots and can be installed using either end. Use two wedge bolts oriented to pull and tighten these sections together. Splice the chain provided with the extension kit onto the chain from the drive section.

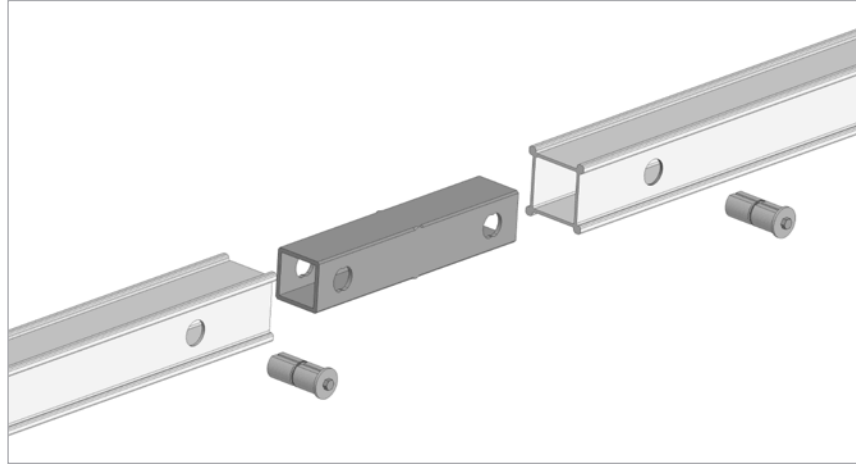

2. Loosen the Quick Release Handles on the Carriage Plate and place the completed Drive Rail between the sides of the Carriage Plate. The long slotted end should face up and be oriented toward the tube bundle face.
3. Secure the Drive Rail in position with the Quick Release Handles.

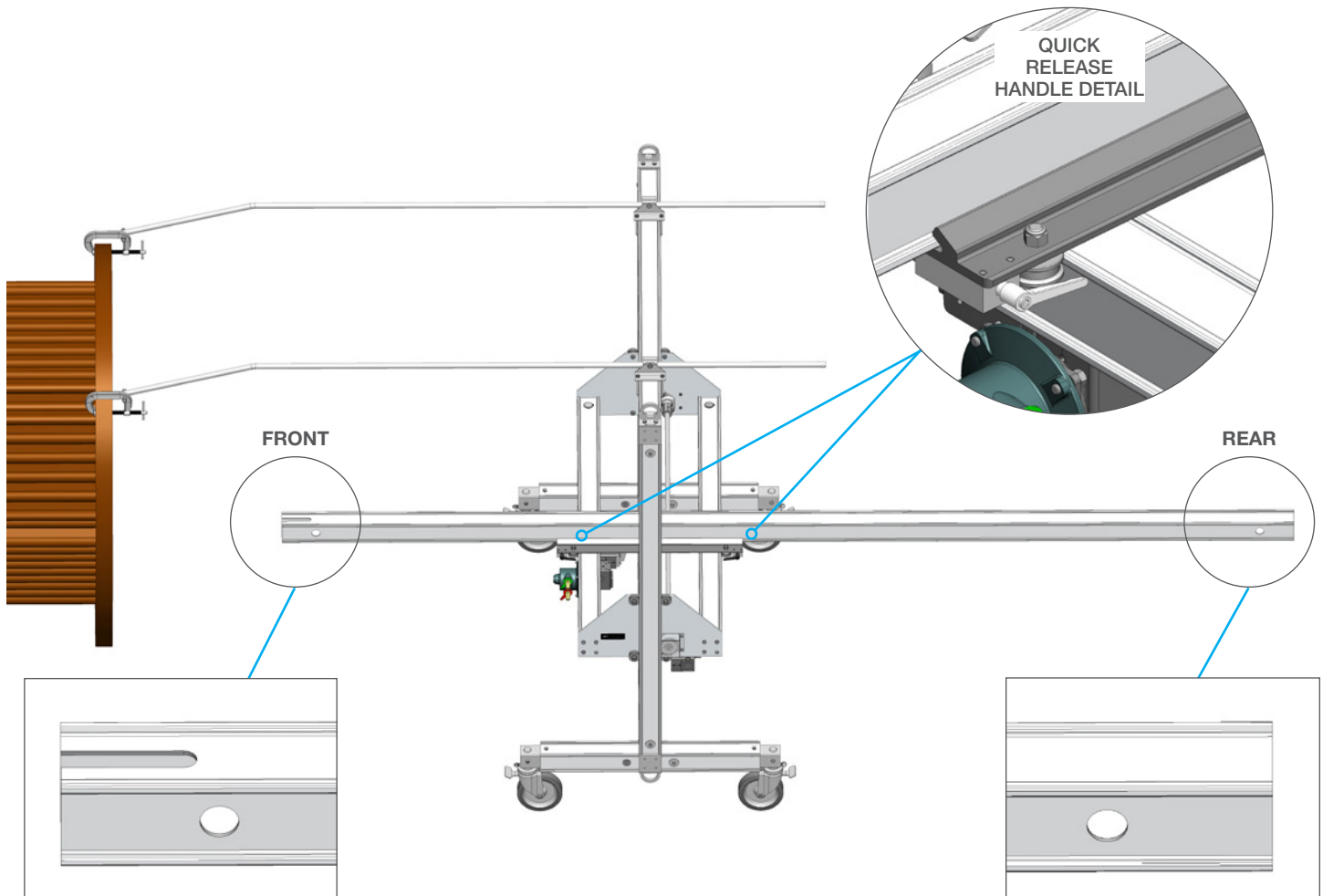

THREADING THE CHAIN THROUGH THE DRIVE RAIL

There are two possible mounting locations (one between each slot) on the underside of the Rail for the Drive Motor Assembly. These positions allow for clearance of channel heads or other obstructions.

- Choose the desired slot location (the Drive Motor Assembly will be centered between two slots) and feed a tape measure down through the rear slot selected out to the end of the rail.
- Use a piece of wire to attach one chain end to the tape measure, and pull the chain out through the slot.

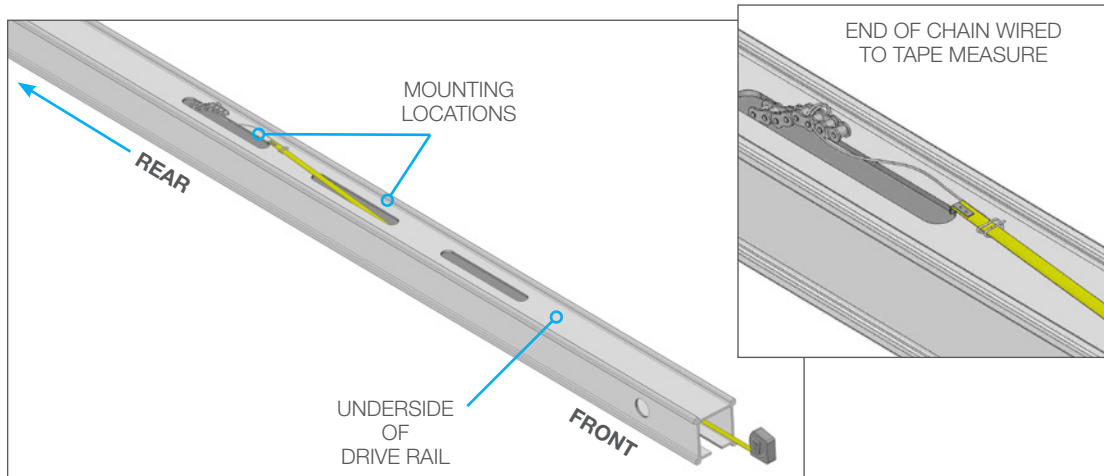

- Feed the Chain through and around the Front Idler gear. Then insert the Front Idler into the Drive Rail. Note the Front Idler gear is off center and should stick through the slot in the rail. Install the Wedge Bolt and tighten to secure the Idler Assembly to the rail.
- REPEAT the entire procedure for Rear Idler assembly. NOTE: There is no slot in the Drive Rail for the Rear Idler.

DO NOT CONNECT MASTER LINK CONNECTING THE ENDS OF THE CHAIN UNTIL THE DRIVE IS INSTALLED.

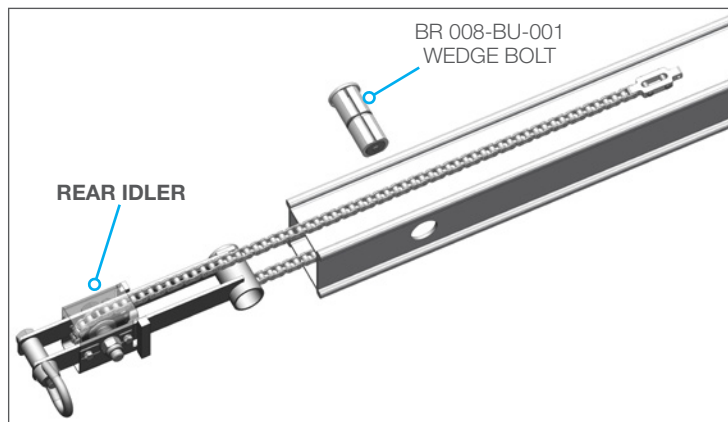
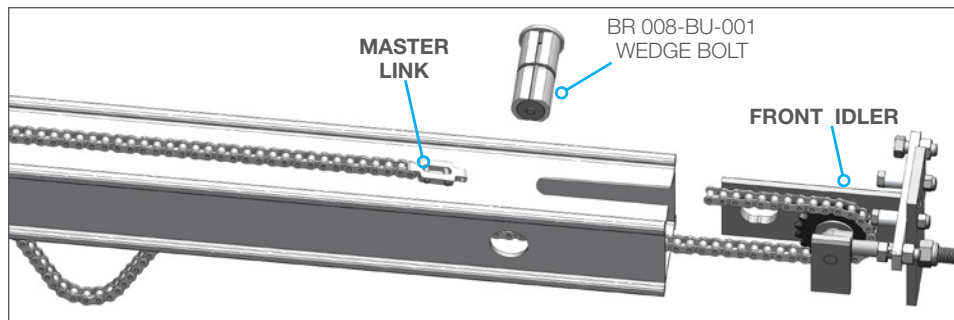

THREADING THE CHAIN THROUGH THE DRIVE MOTOR ASSEMBLY

8. Set the Drive Motor Assembly upside down on the ground and remove the chain guard, the two outside sprockets, and only two of the rail clamps. Slightly loosen the other two clamps.

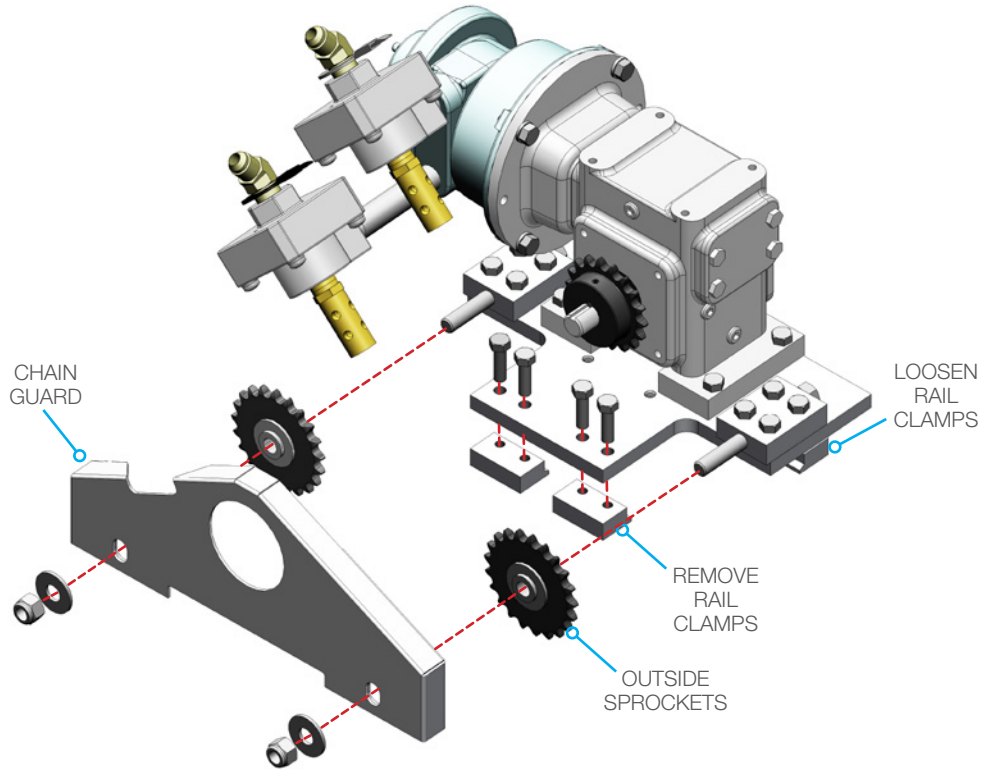

9. Center the Drive Motor Assembly between the two rail slots to receive the chain.
10. Thread the chain under the center sprocket. Attach but do not tighten all four rail clamps, two on each side of the rail. This will allow the Drive Assembly to rock back and forth for ease of installation of the two outside sprockets.

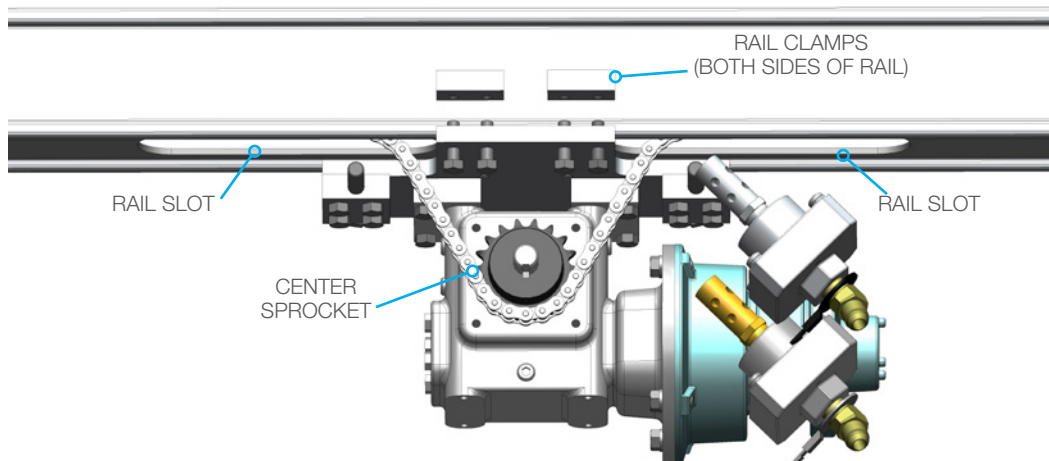

RIGID LANCING MACHINE AND ROTARY ASSEMBLY (BRLM 500-XX) & (BRLM 3XX-XX-XX)

11. Install the Outside Sprockets by pulling back on the two bolts, inserting the sprockets and inserting the bolts back through the sprockets. The Sprockets should be under the chain as shown in the Chain Path below.

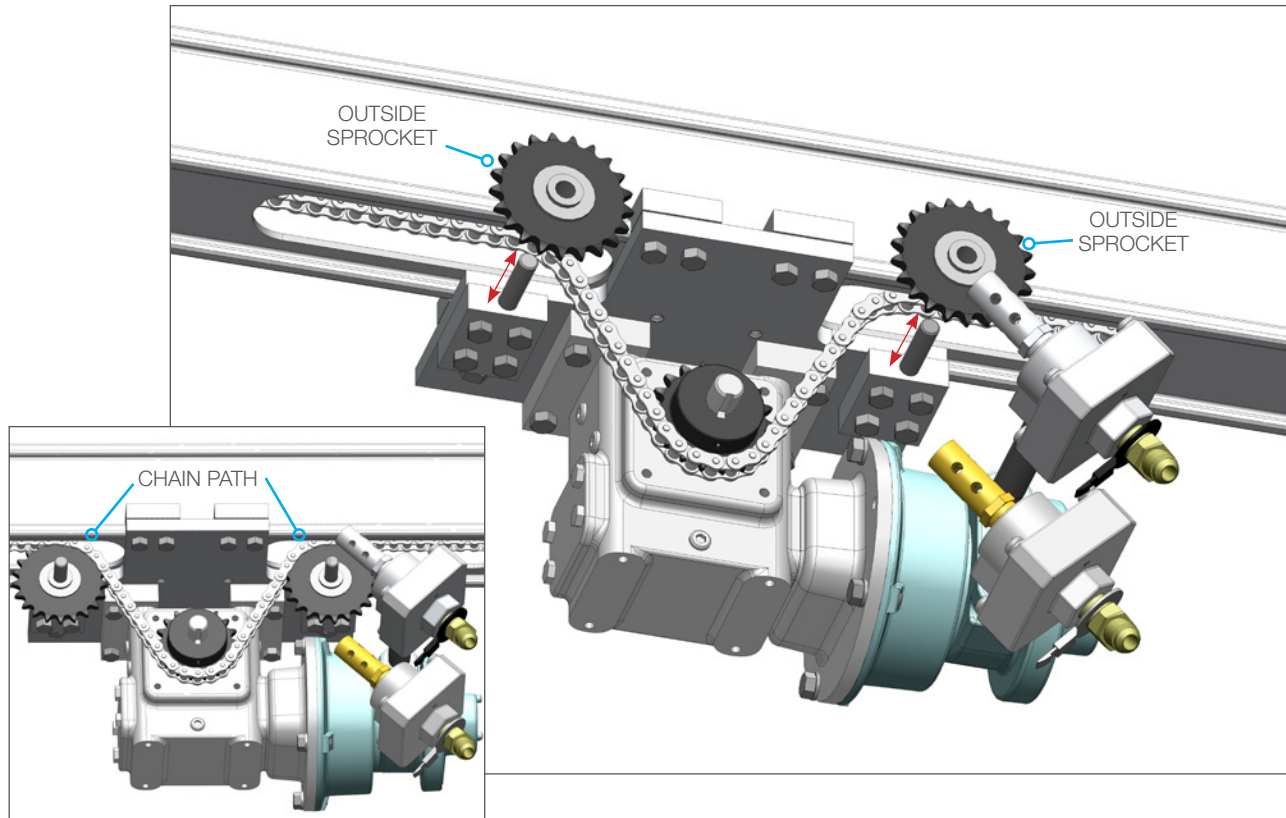

12. Replace the Chain Guard, Flat Washers, and Nylock Nuts. NOTE: Make sure to tighten all four rail clamps.

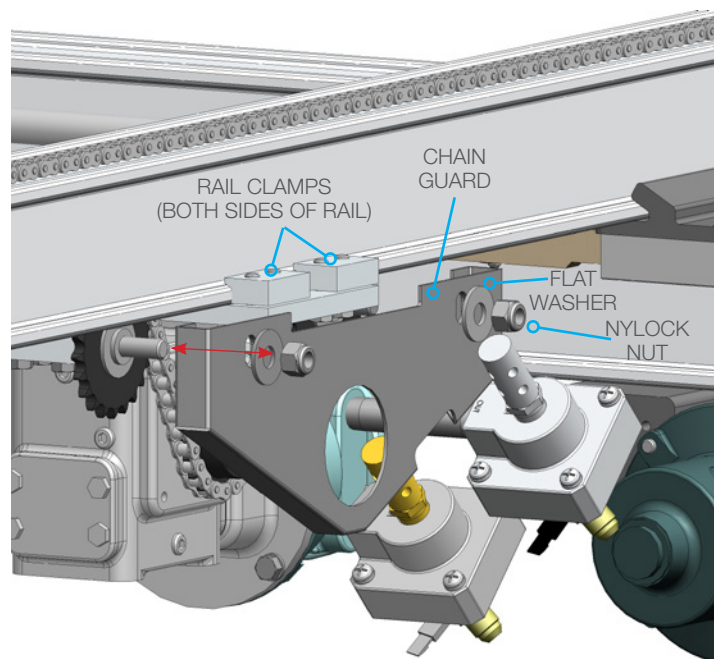

RIGID LANCING MACHINE AND ROTARY ASSEMBLY (BRLM 500-XX) & (BRLM 3XX-XX-XX)

13. Complete chain loop by attaching the chain to the chain hook link with (2) chain master links. Adjust the chain tension so there is about 1 inch of chain height for every 5 feet or rail length. This can be done by tightening the tension nut at the end of the rail.

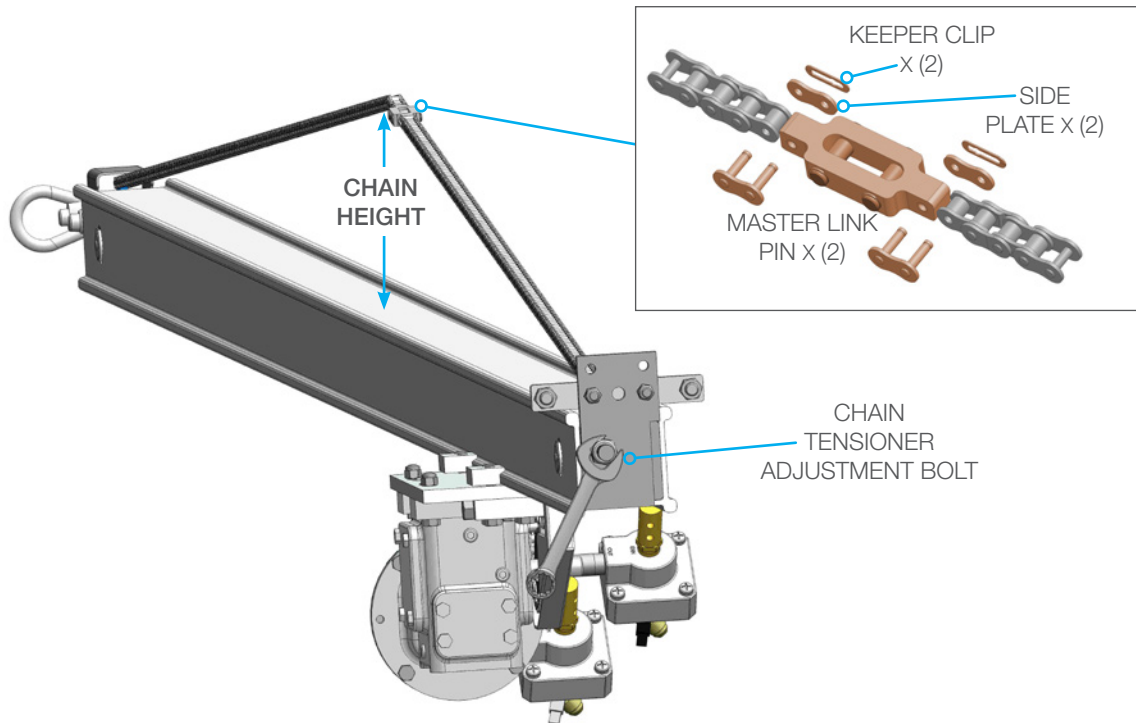

14. Remove Rear Chain Guard and slide the Guide Blocks onto the rail and move them all the way to the front. Next, remove the Chain Hook from the Rotary Drive Carriage and slide the Rotary Drive Carriage onto the rail. It may be necessary to loosen the rollers on one side to make it easier to install. Be sure to tighten all the rollers and replace the guard once finished.

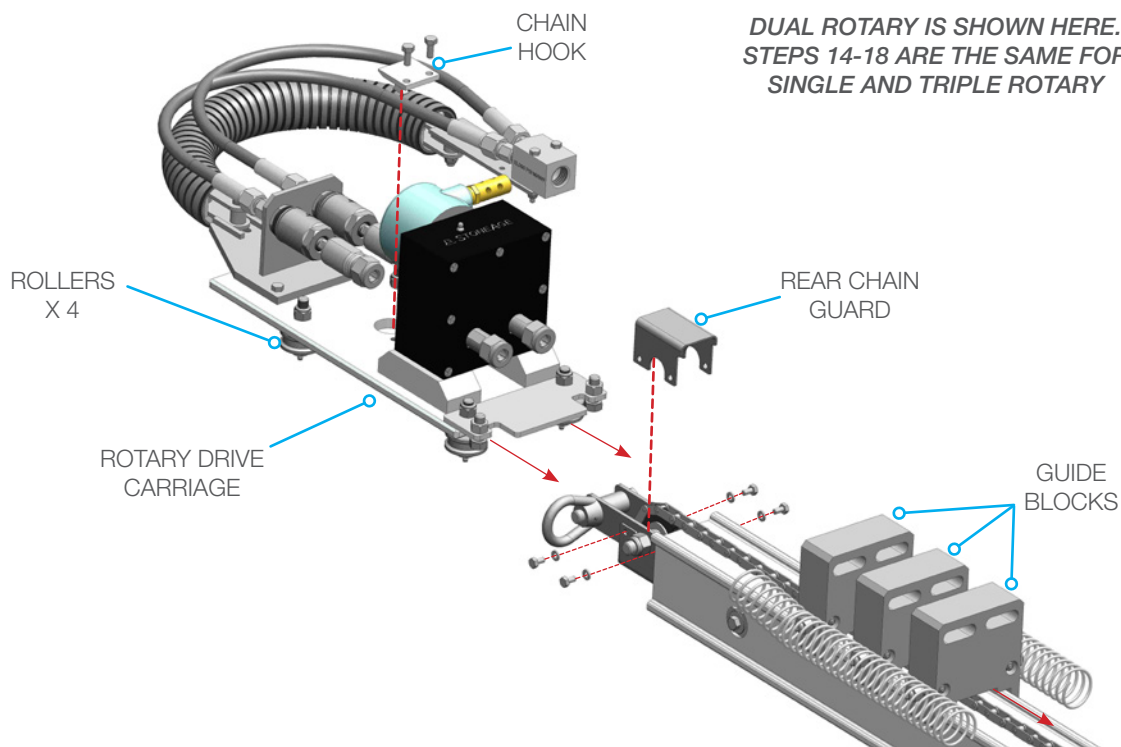

RIGID LANCING MACHINE AND ROTARY ASSEMBLY (BRLM 500-XX) & (BRLM 3XX-XX-XX)

15. Attach the Rear Stop to the Drive Rail. The exact position of the stop can be easily adjusted at a later time. Next, install the Chain Hook by slipping it through the carriage plate and in between the pins on the chain link. It often helps to move the carriage back and forth to lock it into place.

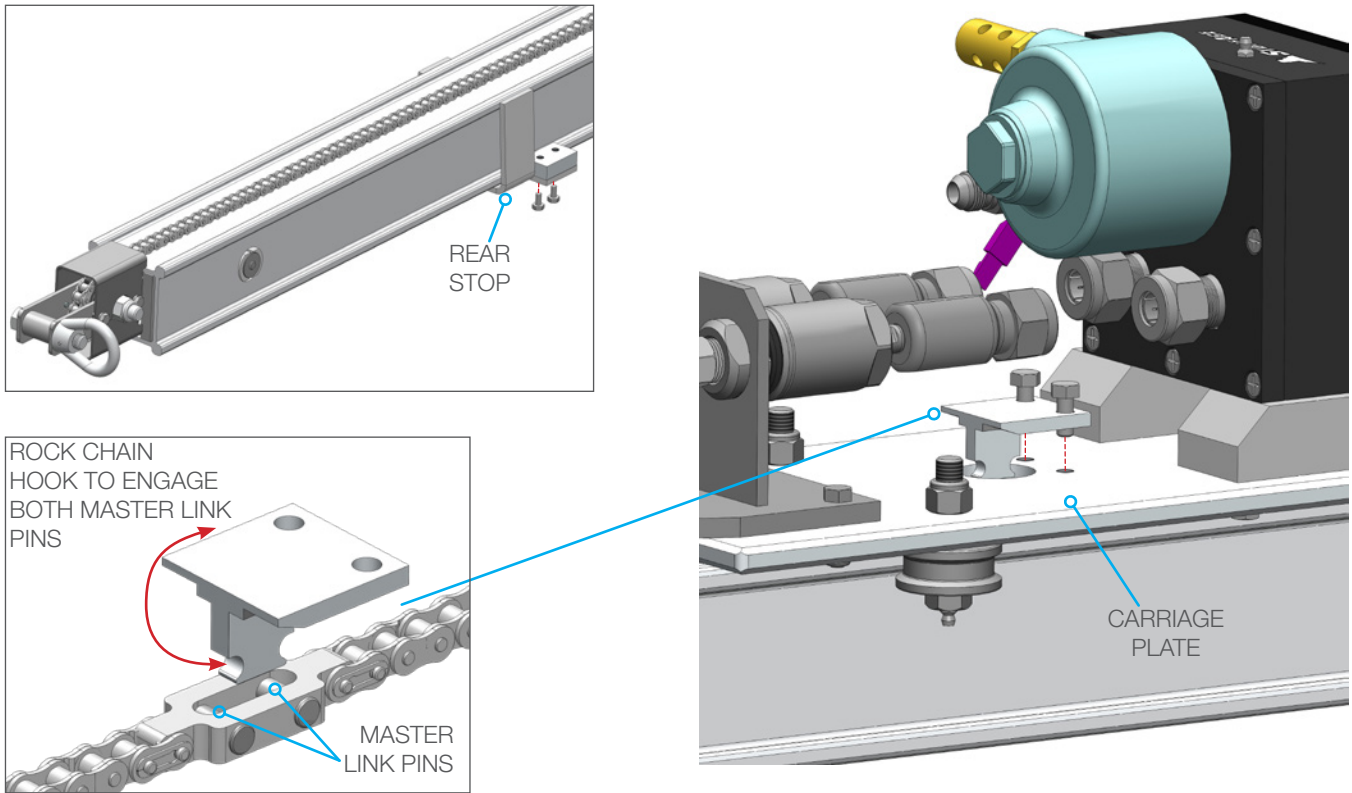

16. Attach the two Cable Coils to the carriage and to the front idler assembly using the slotted anchor bolts. Be sure not to tighten the bolt over 20 ft-lbs of torque or it may damage the cable.

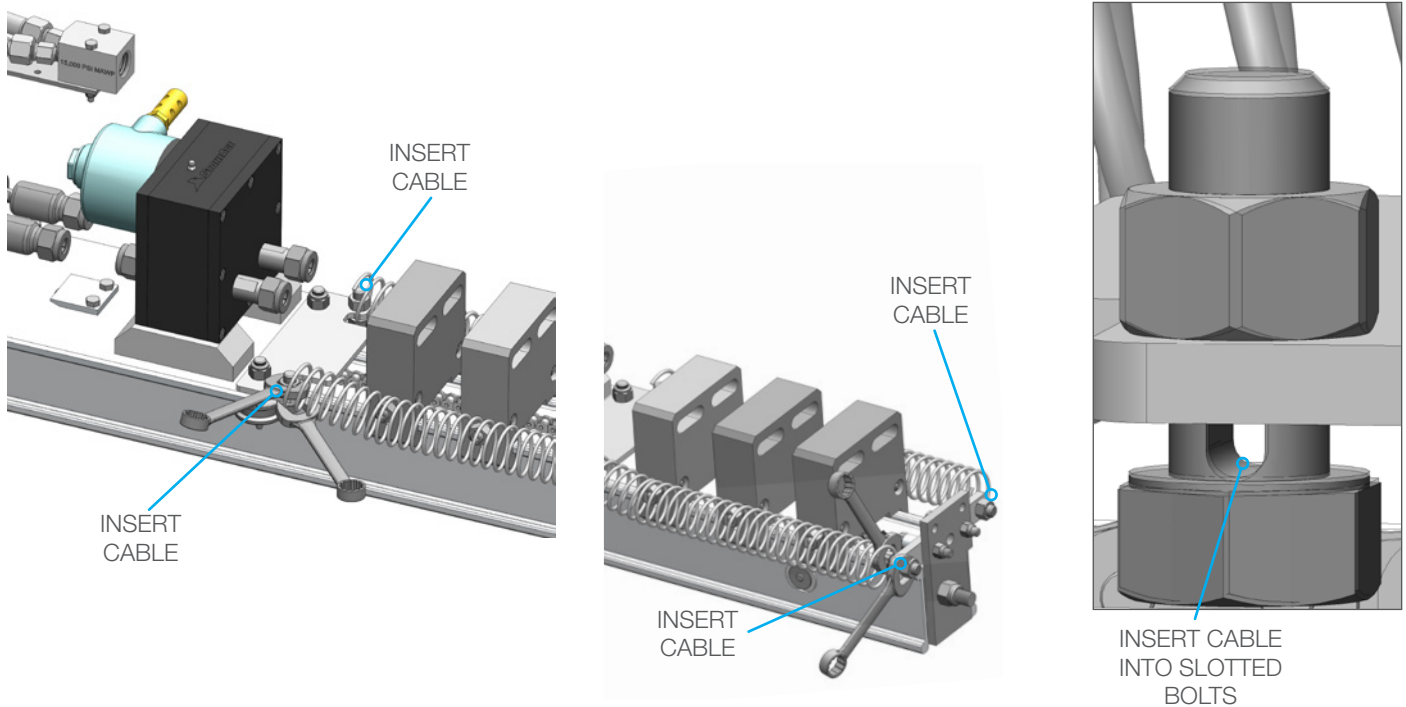

RIGID LANCING MACHINE AND ROTARY ASSEMBLY (BRLM 500-XX) & (BRLM 3XX-XX-XX)

17. Attach the appropriate sized guide tube assembly to the front of the rail. Advance or retract the carriage so the end of the lance where the tip will be located is about two inches inside the front splash guard (about the length of the nozzle tip). Install the rear stop up against the rear carriage rollers at this point to set the retract stop point. On a vertical setup, the rear stop will be way up in the air and not easily adjusted later.

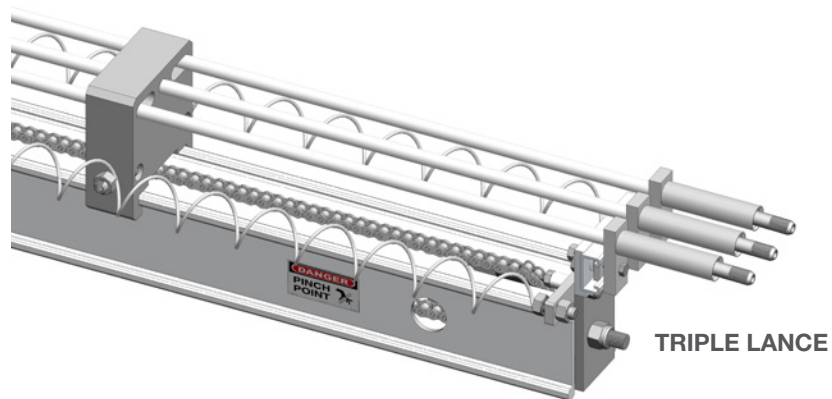
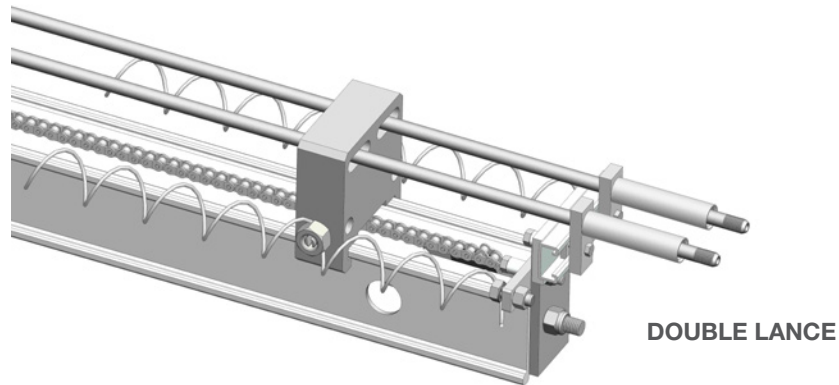
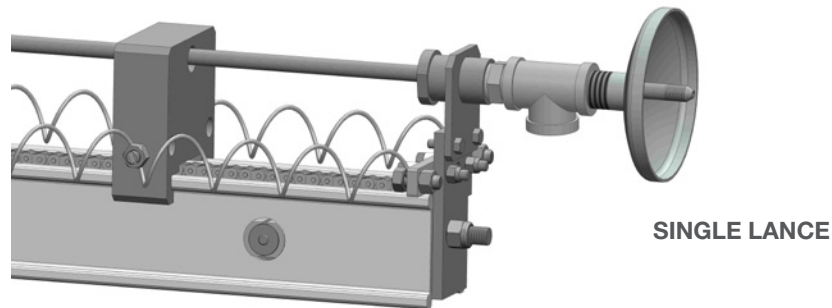
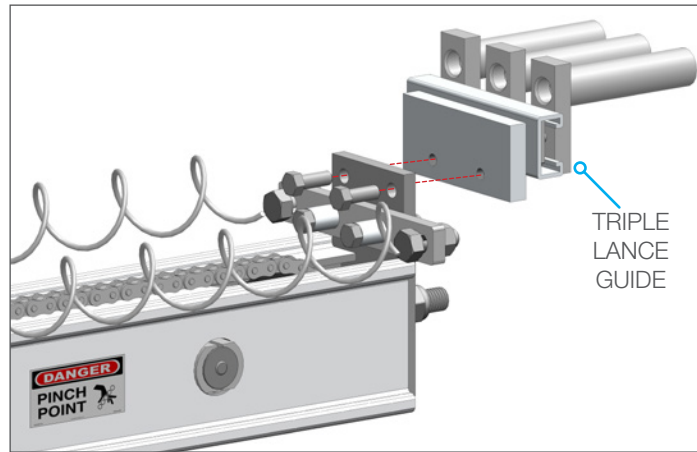

Lances and Tips:

Lances - It is recommended that high strength, high quality tubing be selected. The material selected should have adequate wall thickness for the pressure being used. Lances with larger inside diameters will minimize pressure drop at higher flows, but will be limited in their operating pressure.

Tips - There are several different lance tip types; the most basic and cheapest is the steel tip with drilled orifices. Jet patterns can be selected to optimize unplugging or polishing. Since the lancing machine provides rotation, fewer and larger jets can be used. When rigid lancing on a securely supported lancing machine, there is no need to put in backward facing jets. While the drilled steel tip can be used up to 40,000 psi, orifice life at this pressure is less than 10 hours. At 20,000 psi, about 20 hours useful life can be expected, while at 10,000 psi (depending on water filtration) a drilled tip can last up to 40 hours. For the higher pressures, replaceable sapphire orifices can be used. Jet angles can be somewhat limited with the replaceable orifices; depending on the tip diameter, it may not be possible to put in radial porting.

PNEUMATIC CONTROL BOX AND LEG ASSEMBLY

CB-LP CONTROL BOX ASSEMBLY

The Control Box may be operated with or without installing the detachable legs. Remove the legs for portability or to operate the Control Box in smaller spaces.

1. To attach the legs, remove the lower bolts and nuts from the Control Box frame.
2. Install the detachable legs onto the tube inserts.
3. Install the lower bolts and nuts through the legs and tube inserts. Use a 7/16 in wrench and socket to tighten the bolts.

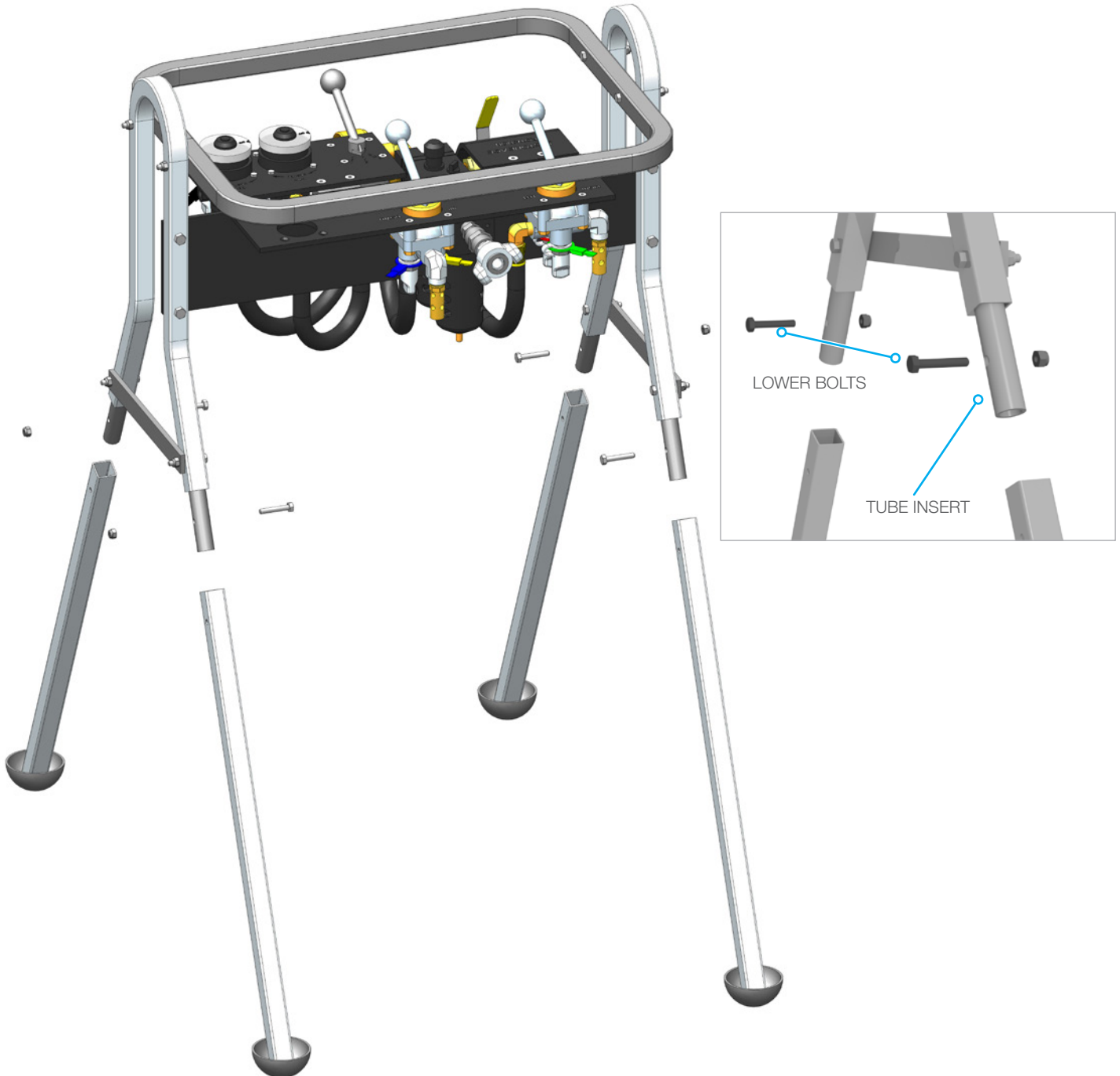

PNEUMATIC CONTROL BOX CONNECTIONS TO THE X/Y POSITIONER (LP-300) AND BRLM

PNEUMATIC SUPPLY LINES

1. Remove the dust caps from the Joint Industry Council (JIC) fittings on the Control Box and the motors on the LP-300 and BRLM.
2. Following the "Pneumatic Supply Line Color Chart", connect the hose ends to the fittings on the Control Box. Connect the air supply to the Control Box and blow out the hoses before connecting them to the motors on the LP-300 and BRLM to remove any debris.
3. Immediately following the blow out procedure, connect the other end to the motors on the LP-300 and BRLM using the color coding on the JIC fittings. Use a 7/8 in. wrench to tighten the JIC Swivel nuts.
4. Test the Control Box before operating with high-pressure water to verify the control valves move the hose in the intended direction, and that the dump valve is working properly.

PNEUMATIC SUPPLY LINE COLOR CHART

FROM CONTROL BOX TO X/Y POSITIONER (LP-300)

 DOWN	 RIGHT
 UP	 LEFT

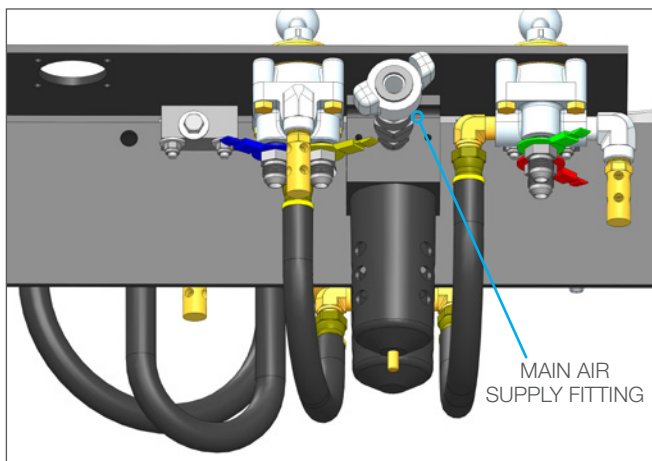

FROM CONTROL BOX TO BRLM

 ROTATION	 LANCE FEED SPEED REVERSE
	 LANCE FEED SPEED FORWARD

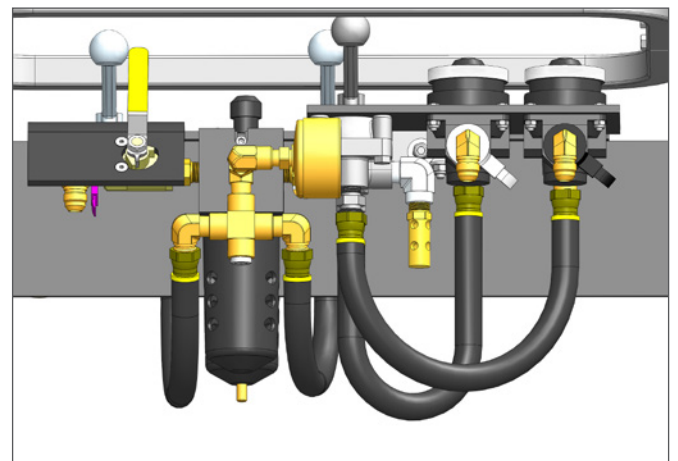

COLOR CODED CONNECTIONS ON X/Y POSITIONER (LP-300) AND BRLM FROM CONTROL BOX

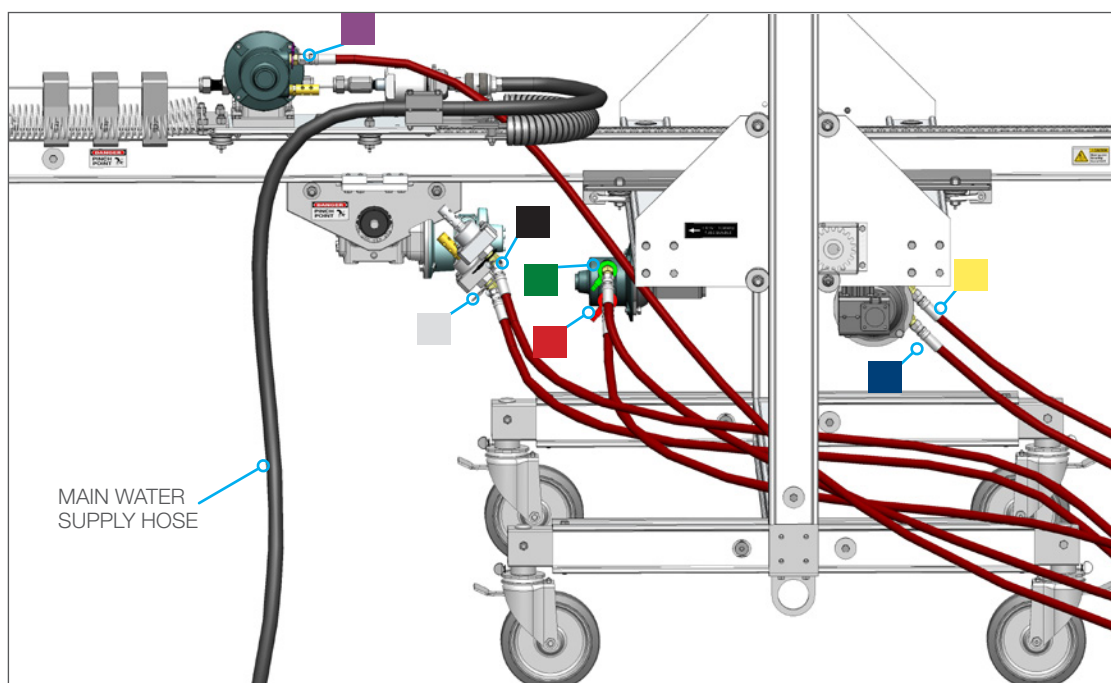

PNEUMATIC CONTROL BOX OPERATION

CB-LP CONTROL BOX

BRLM ROTARY CONTROLS-

- The **ROTATION BALL VALVE CONTROL** rotates the rigid lance. This control consists of a ball valve that is used to turn on/off the rotation of the lance. It can also be partially opened/closed to regulate the rotation speed. There is a single air line connected from the exit of the ball valve to the rotation port on the air motor; the port selected should rotate the lance in a direction to tighten the nozzle tip onto the lance. Always blow out the air hoses before connecting to the motor ports.
- The **LANCE FEED DIRECTION SELECTOR** will move the lance in the forward (feeding) and reverse (retracting) directions. The **OFF** position is at the 6 O'clock position.
- The **FORWARD AND REVERSE LANCE FEED SPEED CONTROLS** The two regulators are used to control the feed direction and speed as well as the push/pull force of the drive.

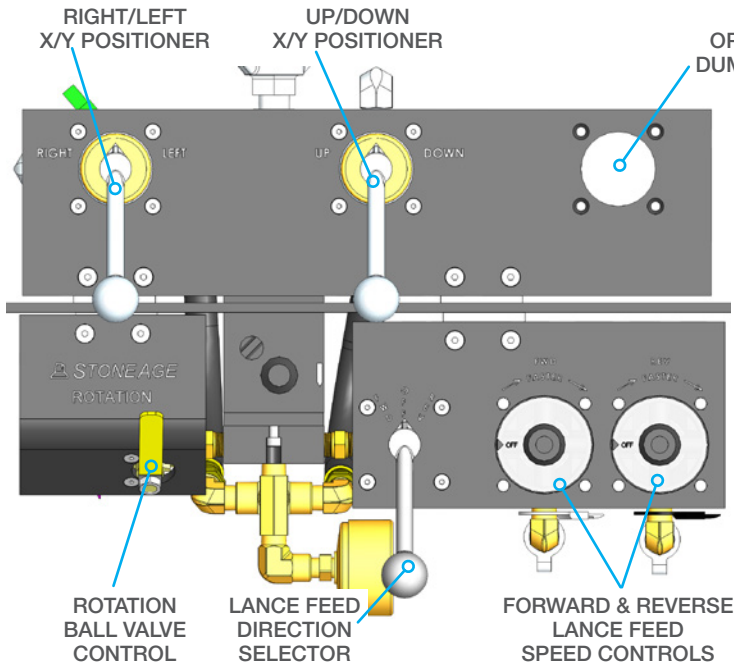

POSITIONER CONTROLS-

- **UP/DOWN** will move the X/Y Positioner (LP-300) up and down the tube face bundle. Turn selector to the left to move the assembly UP, Turn selector to the right to move the assembly down.
- **LEFT/RIGHT** will move the X/Y Positioner (LP-300) from side to side along the tube face bundle. Turn selector to the left to move the assembly Right, Turn selector to the right to move the assembly Left.

*OPTIONAL DUMP CONTROL TOGGLE-

- To use the **PNEUMATIC DUMP CONTROL TOGGLE**, hold it in the 12 O'clock, **HIGH PRESSURE ON** position to route the high-pressure water to the tool. Release the toggle to the **OFF** position to release the high-pressure water away from the tool.

* LOCATION FOR OPTIONAL PNEUMATIC DUMP CONTROL TOGGLE
DETAIL A

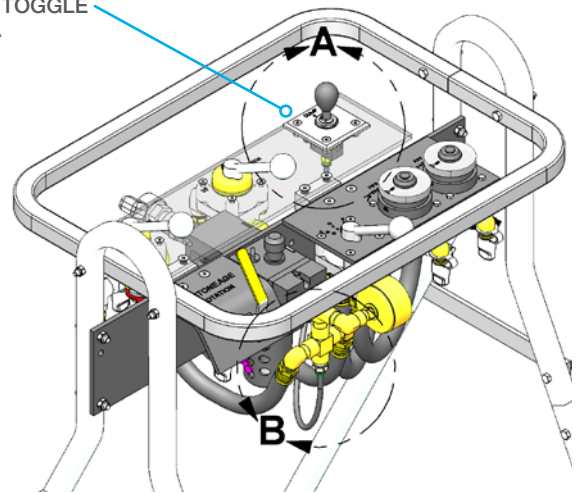

AIR SUPPLY FITTING

- A universal **AIR SUPPLY FITTING** (Chicago style) is located on the back of the Control Box. Connect a compatible compressed air line (not included) according to the manufacturer's instructions. If another pneumatic connection is preferred, this fitting can be removed and any male adapter may be used.

*OPTIONAL PNEUMATIC DUMP CONTROL FITTING AND LINE

- Install the **PNEUMATIC DUMP CONTROL TOGGLE** on the control panel as shown in **Detail A**. Remove and discard the 3/8 NPT pipe plug and replace with HRS 564 Fitting with Teflon tape. Cut and Install the included, 1/4 in OD tubing (HRS 565) by pushing the tubing into the fitting to connect the HRS 564 Fitting to the pneumatic dump valve. **Detail B**

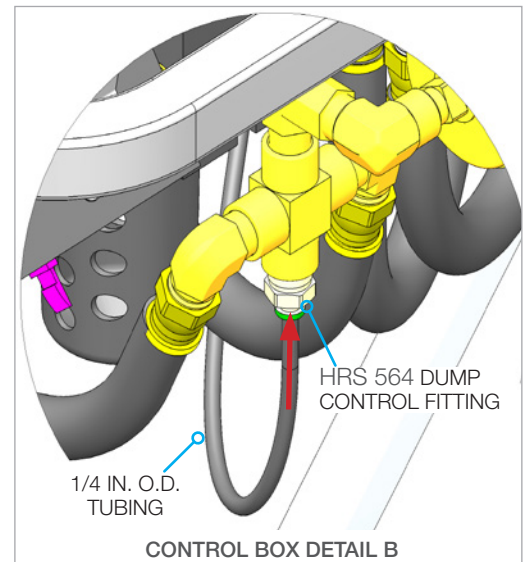

X/Y POSITIONER AND BRLM SYSTEM OPERATION

1. Make sure the far end of the tube bundle is flagged off and no one is within this area. A deflector plate is recommended for debris and water, particularly in horizontal bundles.
2. Turn the Forward Speed Control on the control box down to zero, switch the selector valve to “FORWARD” and slowly increase the speed until the carriage begins to move, switch the selector valve back to “OFF”, leaving the regulator at this low setting. Think of the regulators as controlling push force as well as speed.
3. Advance the carriage on the lancing machine until the tip is just inside the first tube if it is open or partially open; if it is a plugged tube, do not drive the tip into the material until the water pressure has started to come up; stop just short of the tip entering the tube.
4. Start the rotation of the lances and close the dump valve; bring the pressure up slowly with the pump throttle or bypass valve. If it is a plugged tube, advance the tip into the material.
5. Once operating pressure is reached, advance the lance into the tube. The forward regulator setting may need to be increased at this time to make the carriage move, as the jet thrust may be pushing back against the feed. Gradually increase the forward regulator, which is increasing the push force as well as the feed rate. Watch the lances to make sure they are not starting to flex; if they are, slightly decrease the regulator setting and leave it at this point. Also watch the machine and positioner for evidence of increasing load. If the machine hydraulicks more than once or twice while cleaning every tube, the feed rate should be decreased to prevent this. Hydraulicking forces can be high enough to bend and destroy the lances; they can pick up a vertical machine, positioner and scaffold with two people standing on platforms (at least 500 pounds). Once an optimum feed rate is determined, the regulator has an adjustable stop that can be set and repeatedly returned to if desired.
6. If the tubes are open and only being polished, there is an optimum feed rate to allow the jets to achieve complete coverage; multiply the number of jets by the orifice size of the jets and the rotation speed of the lance (600 rpm if the rotation speed is set on full). The result will be the feed rate in inches per minute to achieve complete jet coverage. Sometimes the material may require multiple jet strikes to be removed. The only way to determine this is to complete a cleaning pass at a certain speed, then check the tube for cleaning effectiveness and adjust the feed rate accordingly. If desired, set the adjustable stop in the regulator.
7. The direction of the carriage should be reversed when the operator hears or observes the jets exiting at the far end of the tube bundle. The retract regulator can be slowed to allow an additional cleaning pass on the return stroke, or retracted at full speed if the forward cleaning pass is sufficient. Dump the pressure when the jets begin to exit the tube. Once a tube is cleaned and the nozzle tip retracted to clear the tube, use the positioner to move the machine to the next tube or tubes in that row. A practiced operator will be able to align the machine very quickly and likely in one move, but an inexperienced operator should take time initially to make sure the tip is aligned, otherwise the tip will run into the tube face and possibly bend and destroy a lance, particularly if the forward regulator is set at a high push/feed rate. Leaving the forward speed slower helps with tube alignment for an inexperienced operator.

MAINTENANCE

Maintenance Item	Maintenance Required
Air Supply	A compressed air source of at least 70 cfm at 80 psi is required. Lower pressure will result in slower rotation and feed rates. Blow air through all hoses before connecting. Drain the filter bowl if it fills with water.
Rail	The lance rail should be kept clean. Do not apply any lubrication to the rail, as this tends to collect grit and increase wear.
Chain	Spray with a light oil occasionally to prevent corrosion
Air Motor	<p>Air motors should be lubricated after use to prevent internal corrosion and seizing. To do this, remove air hose from motor fitting and squirt in some light oil.</p> <p>Reconnect air line and run for a few seconds to distribute oil in motor. If the air motor seizes and does not run, remove air motor from gearbox, squirt some oil into ports, and try to rotate motor shaft with wrench until it breaks free. This does have the risk of damaging the vanes in the motor, but usually is successful.</p> <p>COLD WEATHER OPERATION: StoneAge recommends the following solutions to prevent decreased functionality in air motors during cold weather operations:</p> <p>Best method: Use regenerative desiccant air dryers in-line with the pneumatic hoses to lower the dew point.</p> <p>Next method: Use a Pneumatic Tool Anti- Freeze Lubricant in the oiler system of the StoneAge equipment. Common trade names are Tanner Gas, Killfrost, Dixon, and Polar-lube. These fluids act like gasoline antifreeze by drying out moisture that’s in the line</p>

OVERVIEW- X/Y POSITIONER WITH AUTOBOX® FLEX LANCING ADAPTER

**X/Y POSITIONER LP-300-XX
WITH
AUTOBOX® FLEX LANCING ADAPTER ACCESSORY**

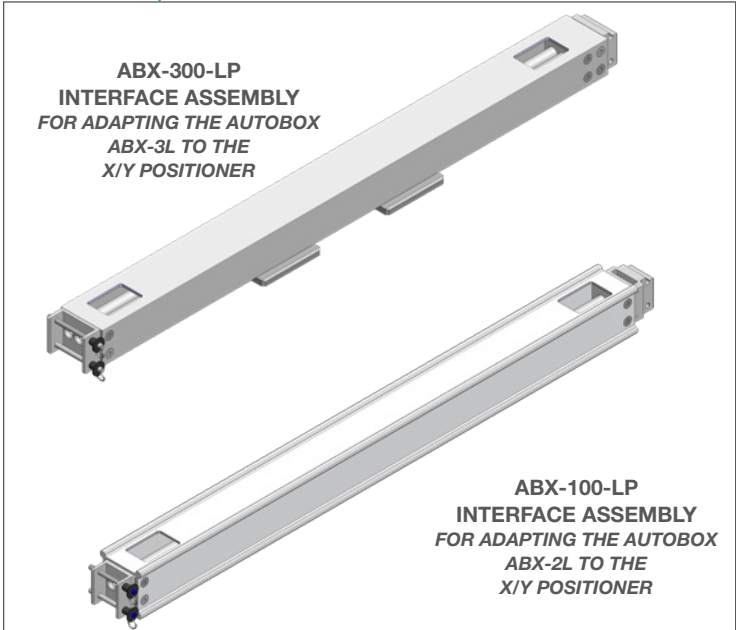
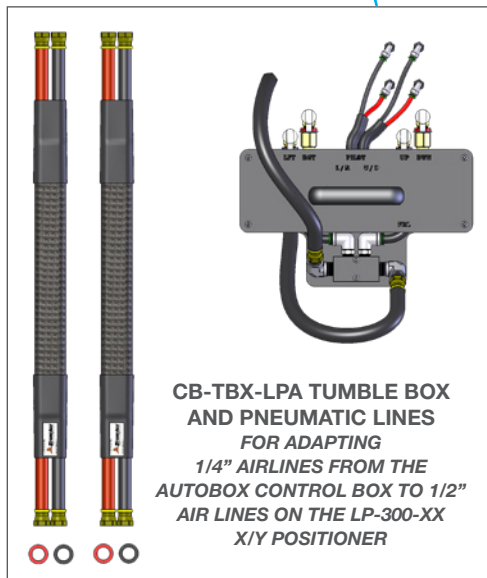
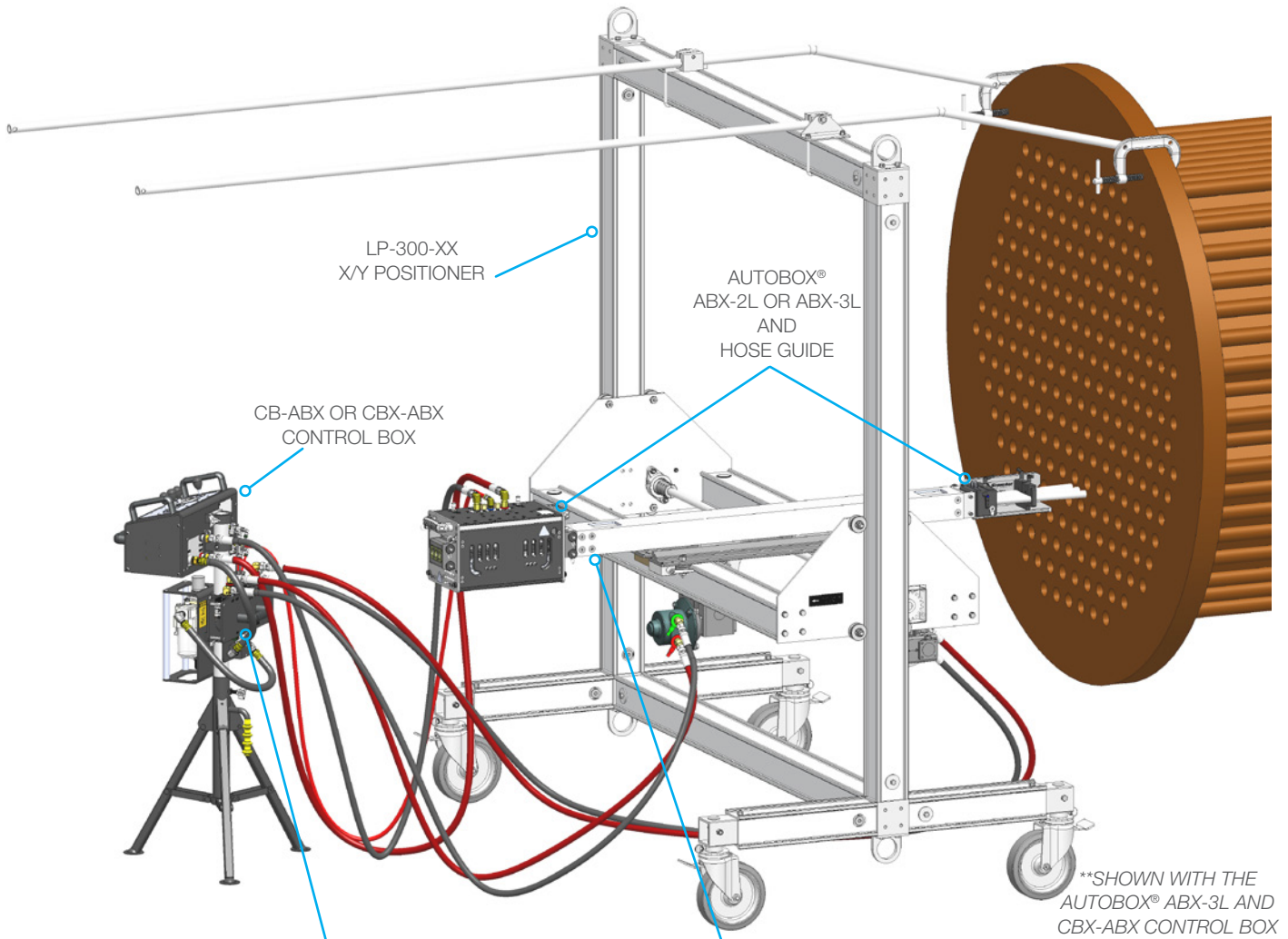

INSTALL CB-TBX-LPA TUMBLE BOX ONTO AUTOBOX® CONTROL BOX

ASSEMBLE CONTROL BOX, TUMBLE BOX, FRL, AND TRIPOD BASE

1. Setup the tripod base in a location with good visibility to the bundle face, but at a safe distance away from waterblast zone.
2. Slide the vertical tube into the tripod base. Secure with the supplied thumbscrew knob. Note: The vertical tube has a hole through one wall that the thumbscrew must engage.
3. Slide the Filter, Regulator, Lubricator (FRL) assembly over the vertical tube down to the tripod base. Secure with the supplied thumbscrew knob.
4. Slide the Tumble Box over the vertical tube and align the top of the clamp with the top of the FRL. Secure with the supplied thumbscrew knob
5. Slide the Control Box over the vertical tube. The Control Box has a stop that keeps it located at the top of the vertical tube. Secure with the supplied thumbscrew knob.
6. Install and tighten the two short 1/2 in. (13 mm) I.D. hoses. The Tumble Box is marked with "CB" and "FRL". Connect the hose marked "CB" to connection marked "AIR" on the back of the Control Box. Connect the hose marked "FRL" to the FRL.
7. Install and tighten the four short 1/4" hoses from the Tumble Box to the Control Box. The Tumble Box is marked "L/R" for Left and Right and "U/D" for Up and Down. Follow the diagram and color coding below.

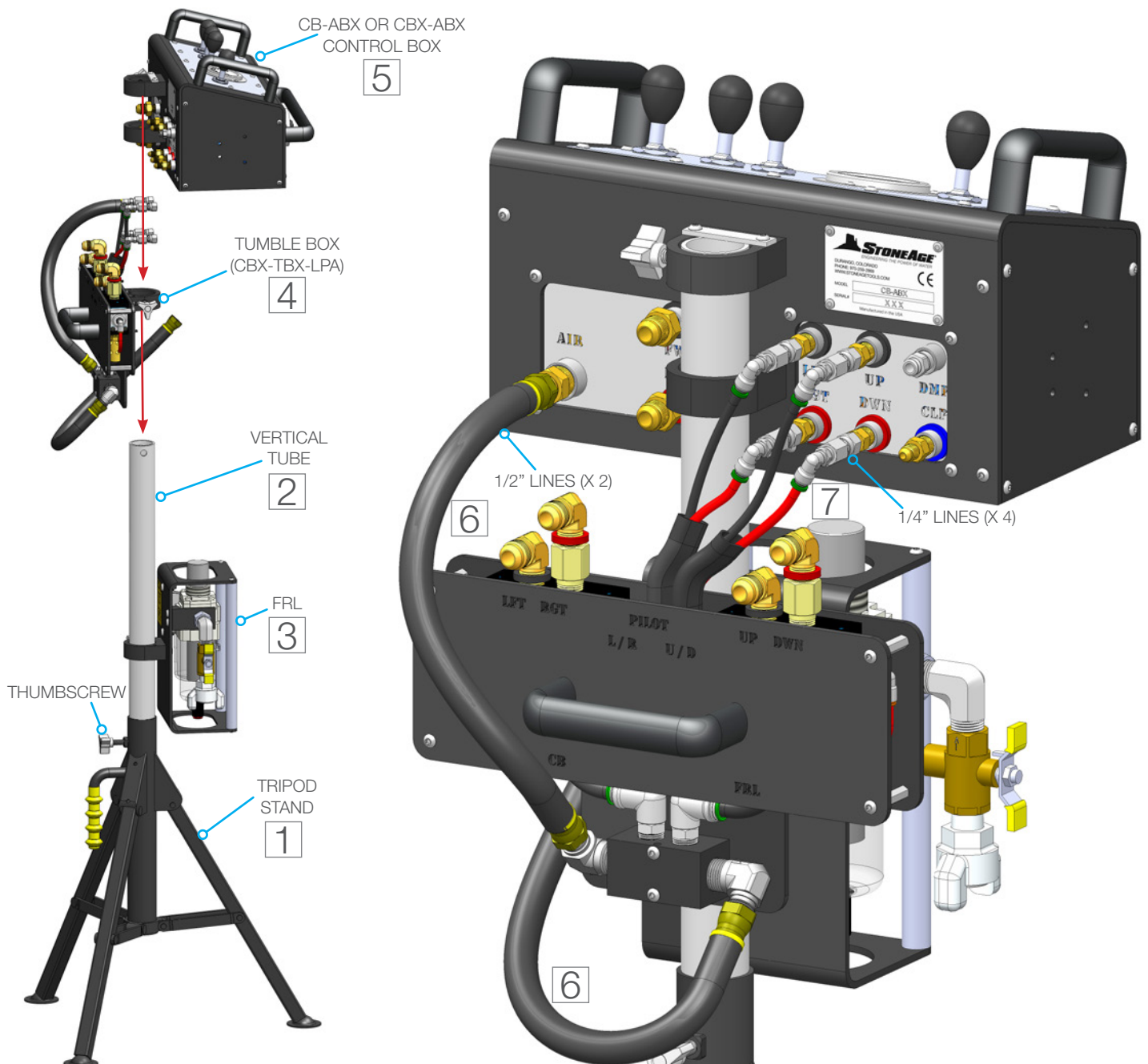

ABX-XXX-LP INSTALLATION ONTO X/Y POSITIONER CARRIAGE

CONNECT ABX-XXX-LP BEAM TO X/Y POSITIONER CARRIAGE

1. Loosen the Quick Release Handles on the Carriage Plate and place the Beam between the sides of the Carriage Plate. The ABX-300-LP (for the ABX-3L) has integral plates on the bottom that engage the Carriage. The ABX-100-LP (for the ABX-2L) has corner edges that will engage with the Carriage. Secure the Beam in position with the Quick Release Handles.

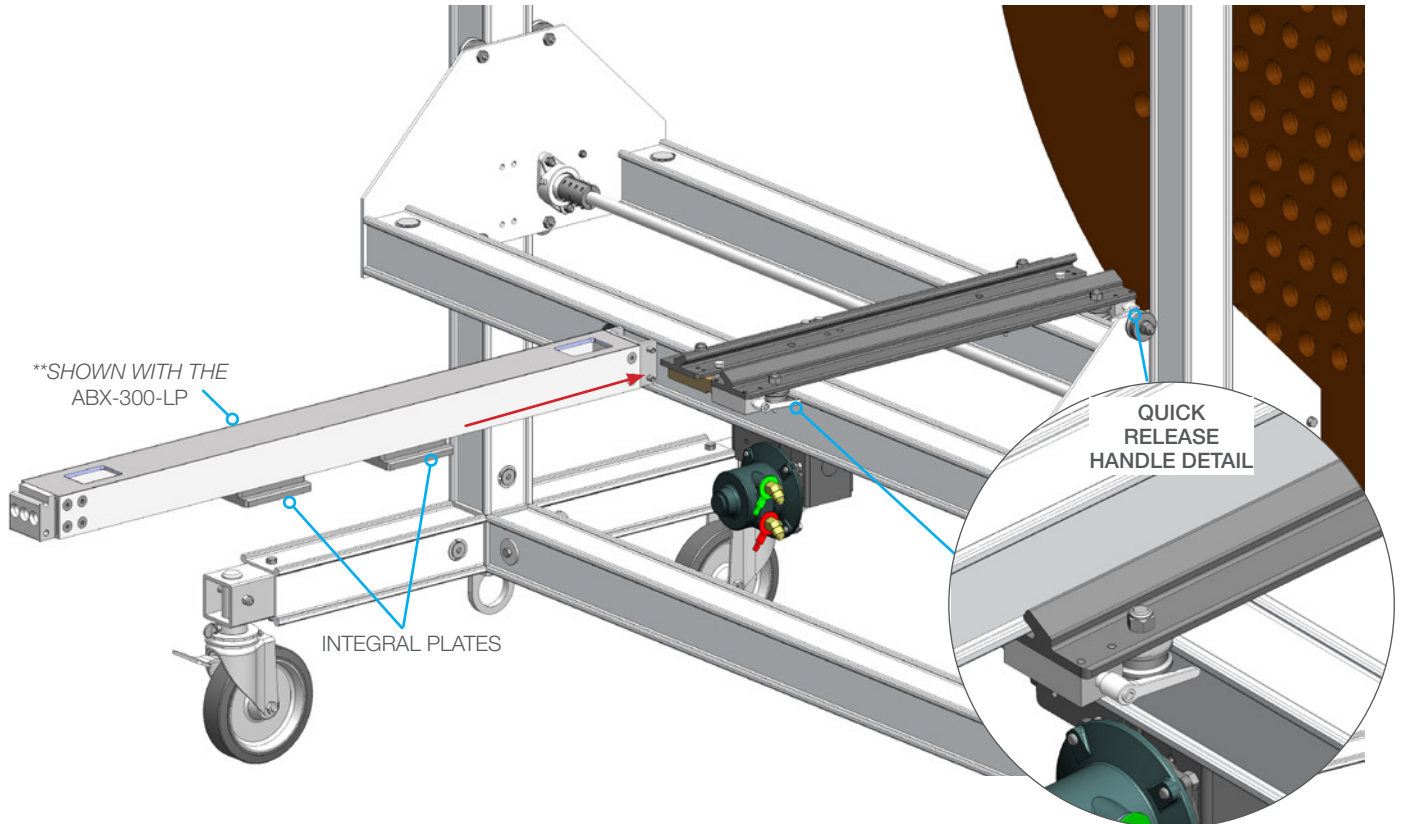

CONNECT AUTOBOX® TRACTOR TO ABX-XXX-LP BEAM

2. Remove the bottom Quick Release Pin from the AUTOBOX® Mounting Bracket. Set the top Quick Release Pin into the top groove on the Beam. Insert the Bottom Pin and make sure both pins are secure.

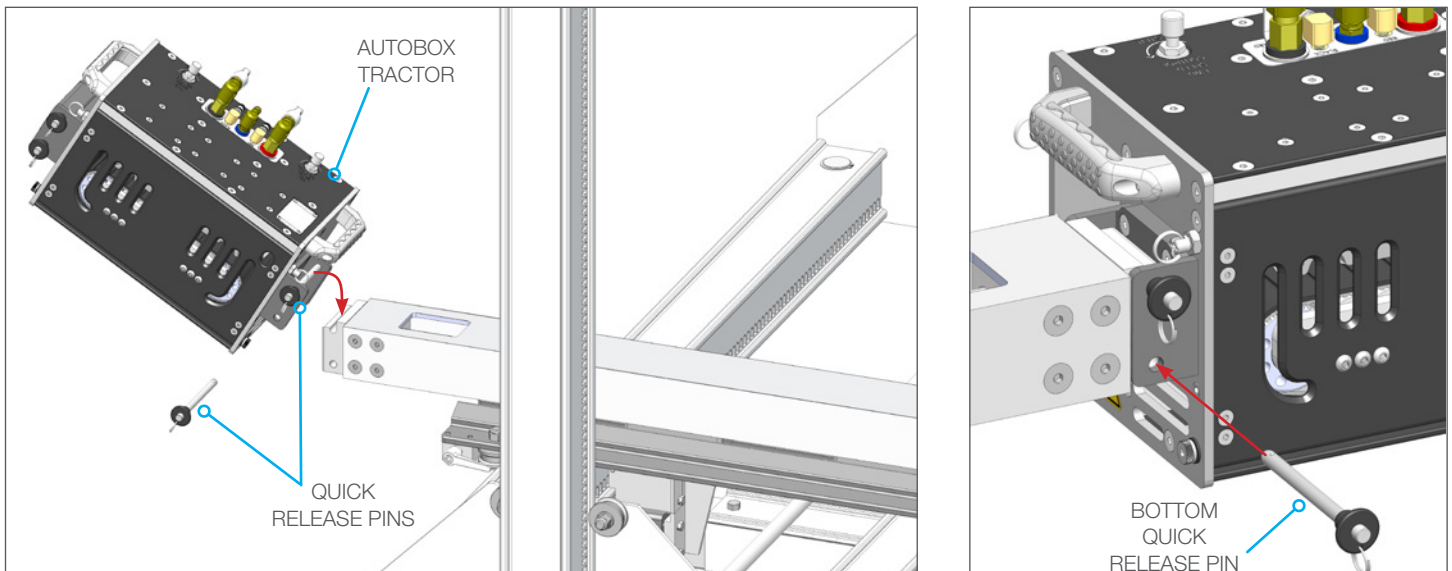

CONNECT HOSE GUIDE TO BEAM

3. Remove the bottom Quick Release Pin from the Hose Guide. Slip the top groove of the Hose Guide under the top Quick Release Pin on the Beam. Insert the Bottom Pin and make sure both pins are secure.

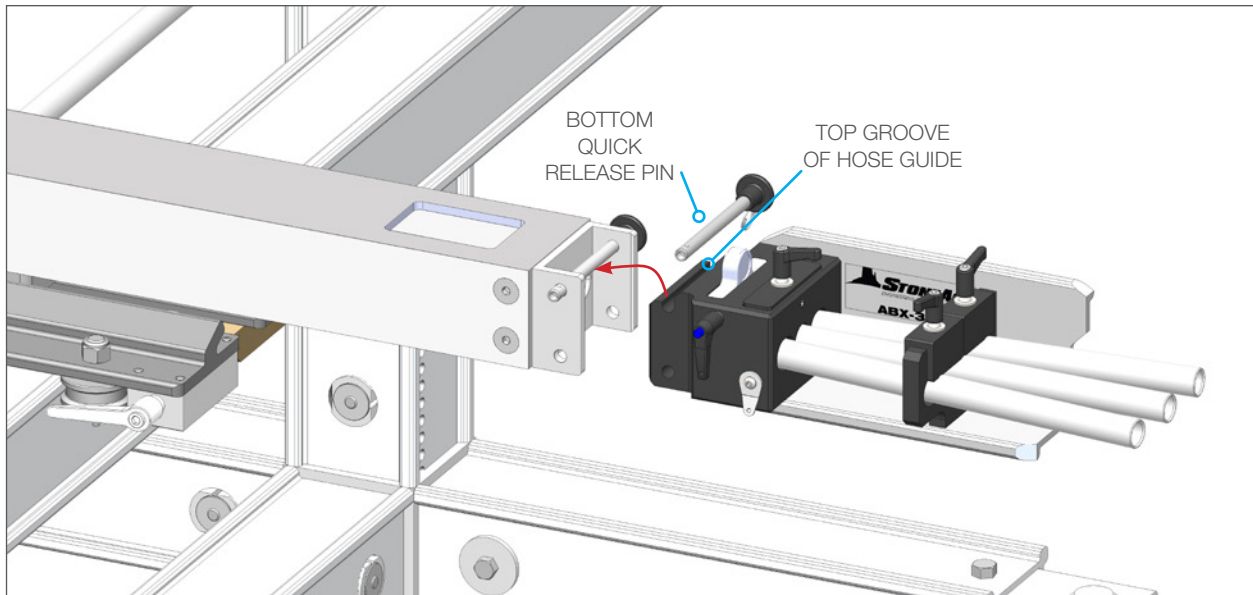

ASSEMBLY IS NOW READY FOR PNEUMATIC CONNECTIONS

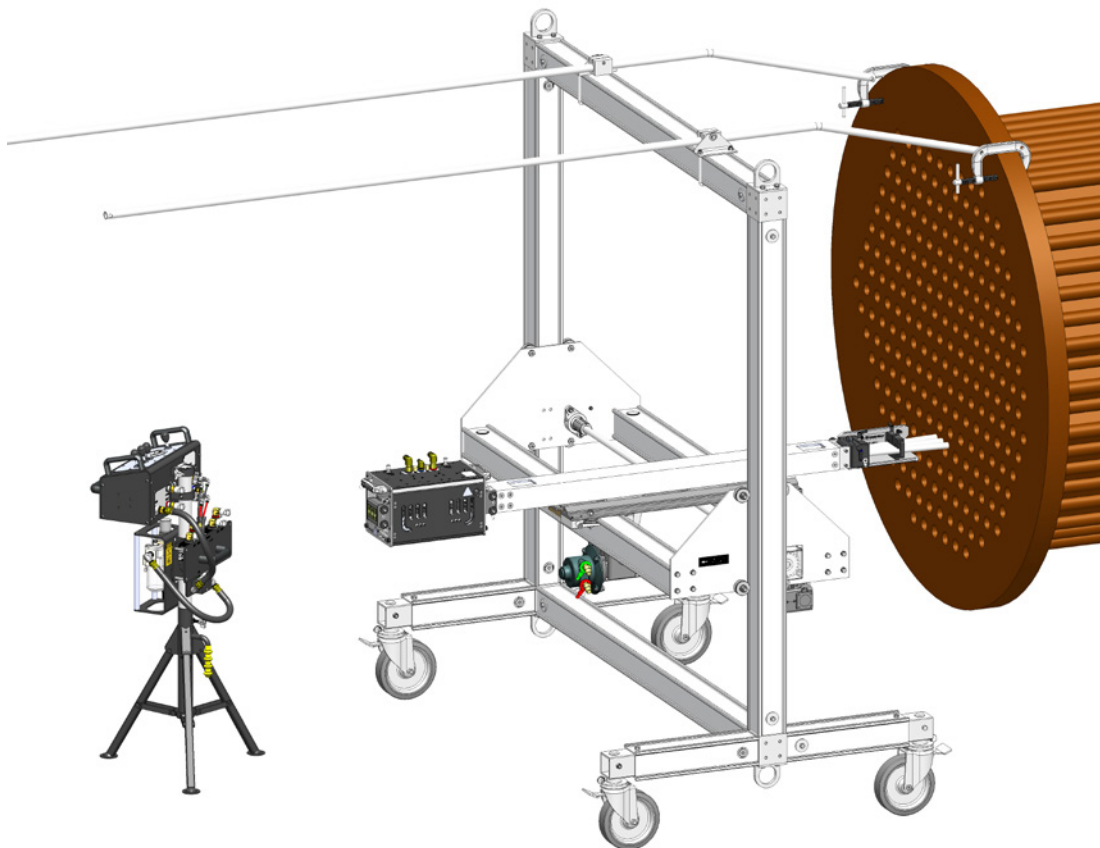

CONTROL BOX TO X/Y POSITIONER AND AUTOBOX TRACTOR CONNECTION

PNEUMATIC SUPPLY LINE CONNECTIONS

1. Remove the dust caps from the Joint Industry Council (JIC) fittings of the Control Box and the AUTOBOX® Hose Tractor.
2. Connect the AUTOBOX® Hose Tractor to the Control Box with two 1/2 in. (13 mm) JIC hoses and one 1/4 in. (6 mm) JIC hose. Verify the Control Box rotates the rollers in the appropriate direction and that the clamp functions correctly. **(See color coding below)**
3. Connect the Horizontal Positioner Drive air motor to the “RGT/LFT” connections on the Tumble Box with two 1/2 in. (13 mm) JIC hoses. Verify the Control Box moves the horizontal carriage in the appropriate direction. **(See color coding below)**
4. Connect the Vertical Positioner Drive air motor to the “UP/DWN” connections on the Tumble Box with two 1/2 in. (13 mm) JIC hoses. Verify the Control Box moves the vertical carriage in the appropriate direction. **(See color coding below)**
5. Test the Control Box before operating the AUTOBOX® Hose Tractor with high pressure water to verify the control valves move the hose in the intended direction, and that the dump valve is working properly. **(See the appropriate AUTOBOX® Hose Tractor manual for detailed operating instructions.)**

COLOR CODED CONNECTIONS FROM CONTROL BOX TO AUTOBOX® TRACTOR

FWD
 REV
 CLAMP

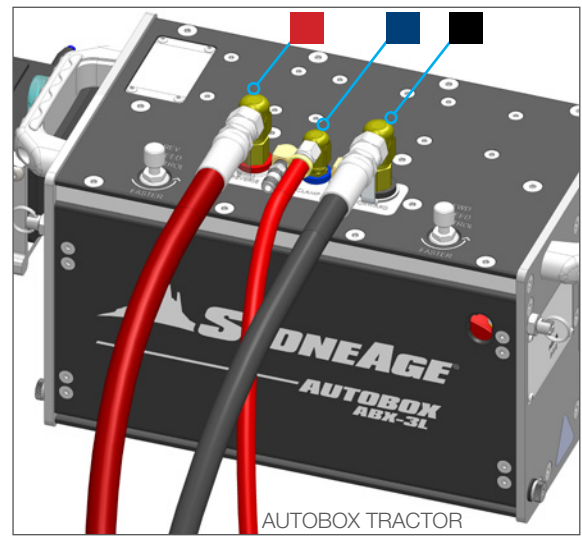
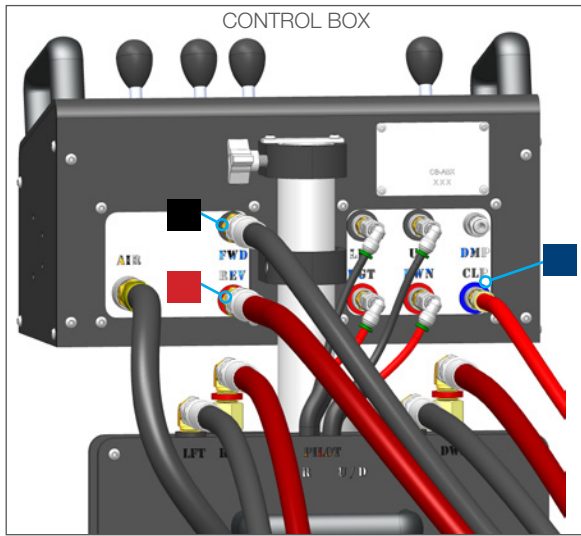

PNEUMATIC SUPPLY LINE COLOR CHART

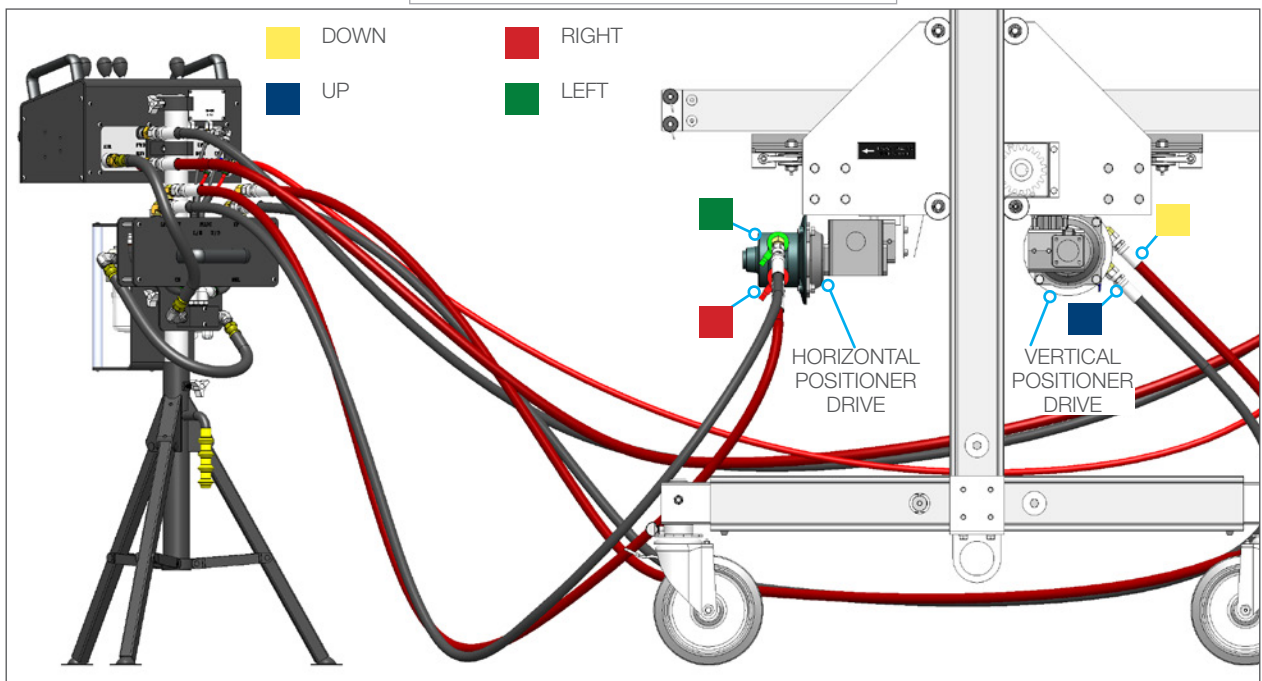
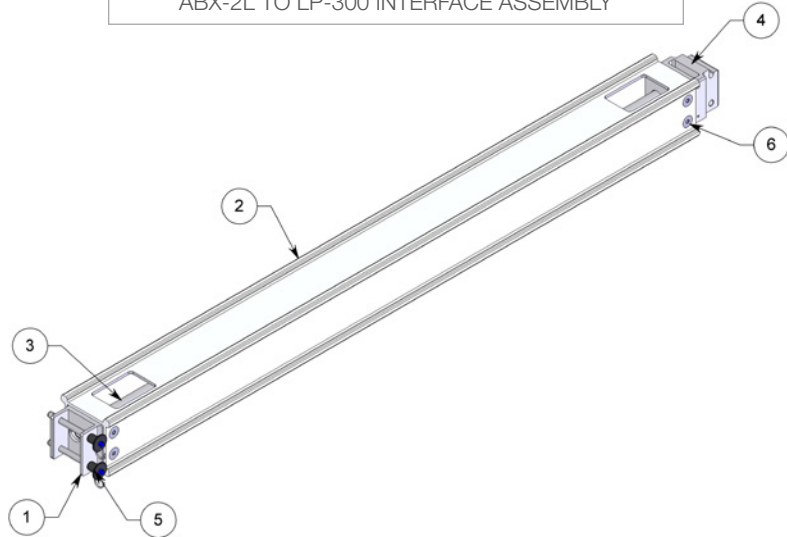

TABLE OF CONTENTS

ABX-100-LP ABX-2L TO LP-300 INTERFACE ASSEMBLY	40
ABX-300-LP ABX-3L TO LP-300 INTERFACE ASSEMBLY	40
BRLM 180 DUAL ROTARY GEARBOX	41
BRLM 210-CS TRIPLE ROTARY GEARBOX	42
BRLM 310-P8 SINGLE ROTARY ASSEMBLY 15 KPSI	43
BRLM 320 SINGLE ROTARY ASSEMBLY 22 KPSI	44
BRLM 330 SINGLE ROTARY ASSEMBLY 44 KPSI	45
BRLM 341 DUAL ROTARY ASSEMBLY 15 KPSI	46
BRLM 351 DUAL ROTARY ASSEMBLY 22 KPSI	47
BRLM 361 DUAL ROTARY ASSEMBLY 44 KPSI	48
BRLM 343-CS TRIPLE ROTARY ASSEMBLY 15 KPSI	49
BRLM 353-CS TRIPLE ROTARY ASSEMBLY 22 KPSI	50
BRLM 363-CS TRIPLE ROTARY ASSEMBLY 44 KPSI	51
BRLM 420 REAR IDLER ASSEMBLY	52
BRLM 430 FRONT IDLER ASSEMBLY	52
BRLM 500-XX RIGID LANCING MACHINE	53
BRLM 500.1 DRIVE PACKAGE	53
BRLM 510-EG FEED DRIVE ASSEMBLY (ELECTRA-GEAR)	54
BRLM 580-XX RAIL EXTENSION PACKAGE	55
BRLM 636-XXX-XXX GUIDE BLOCK KITS	56
CB-LP CONTROL BOX FOR LP-300 X/Y POSITIONER	57
CB-LP:1 CONTROL BOX INTERNALS FOR LP-300 X/Y POSITIONER	58
CB-TBX-LPA LPA TUMBLEBOX ASSEMBLY	59
LP-300-XX X/Y POSITIONER	60
LP-300-XX X/Y POSITIONER CONTINUED	61
LP 320 REAR SUPPORT	62
LP 335-XX WHEEL KITS	63
LP 700 CARRIAGE CLAMP ASSEMBLY	64
LP 071 2 SIDE PLATES AND ROLLER ASSEMBLY	65

PARTS DIAGRAM

AUTOBOX® (ABX-100-LP)
 ABX-2L TO LP-300 INTERFACE ASSEMBLY



#	PART NUMBER	QTY.
1	ABX 001-LP REAR BRACKET	1
2	ABX 002-LP BOX RAIL	1
3	ABX 003-LP GUIDE TUBE	2
4	ABX 120-001 MOUNTING BRACKET, INSIDE	1
5	ABX 298 QUICK PIN 17-4 SS .38 X 3.0	2
6	GSF 337-03 FHCS .37-16 X .75 SS	8

AUTOBOX® (ABX-300-LP)
 ABX-3L TO LP-300 INTERFACE ASSEMBLY

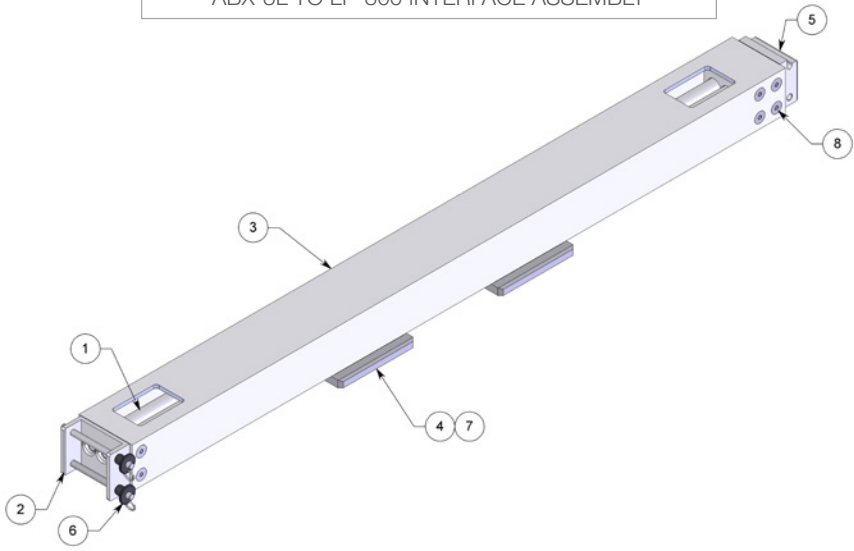

#	PART NUMBER	QTY.
1	ABX 003-LP GUIDE TUBE	3
2	ABX 301-LP REAR BRACKET	1
3	ABX 302-LP RAIL	1
4	ABX 303-LP RAIL BOTTOM PLATE	2

5	ABX 304-LP FRONT BRACKET	1
6	ABX 356 QUICK PIN 17-4 SS .38 X 3.75	2
7	GSF 325-06 FHCS .25-20 X 1.50 SS	8
8	GSF 337-03 FHCS .37-16 X .75 SS	12

BRLM 180
DUAL ROTARY GEARBOX

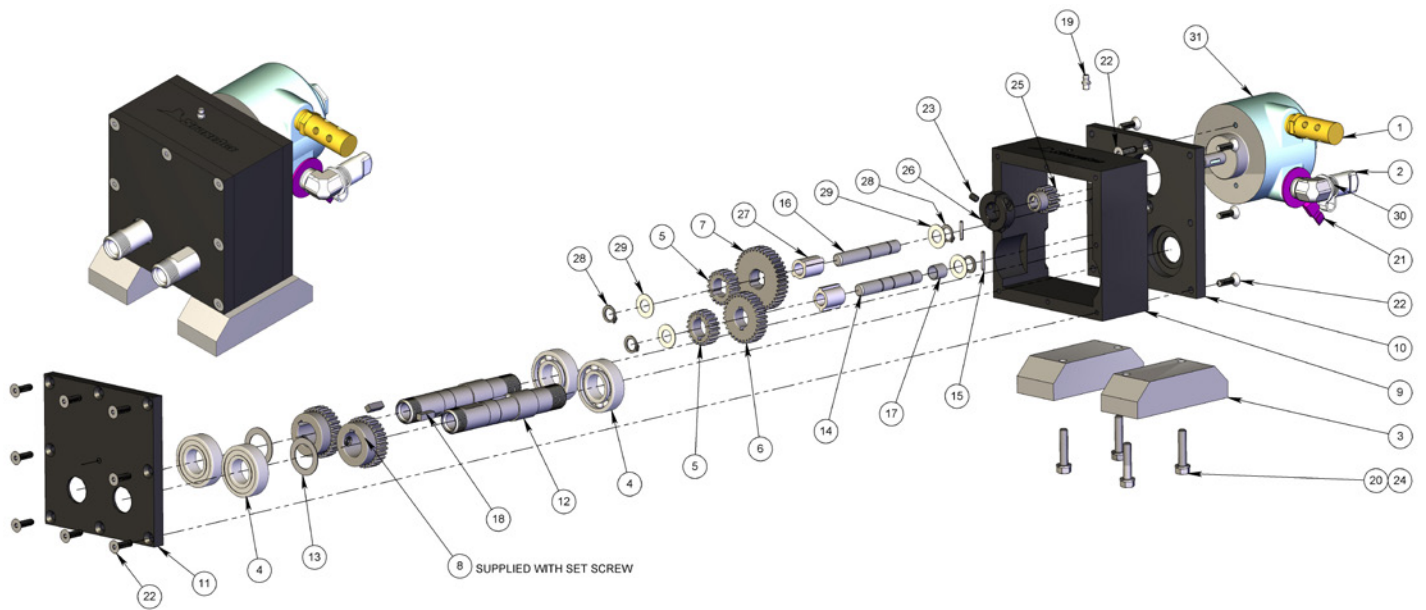

#	PART NUMBER	QTY.		QTY.	
1	BR 155 MUFFLER P8	1	16	BRLM 192 SHAFT, INTERMEDIATE	1
2	BR 167 DUST CAP J8	1	17	BRLM 193 SPACER, FINAL SHAFT	1
3	BRLM 024-SA BLOCK, MOUNT STD	2	18	BRLM 195 KEY, SQ .250 X .250 X .75	2
4	BRLM 109 BEARING	4	19	FS 004-0 ZERK, STRAIGHT	1
5	BRLM 172 BOSTONGEAR-GB20	2	20	GB 531-06 BOLT, HEX .31-18 X 1.50	4
6	BRLM 174 BOSTONGEAR-GB30	1	21	GP 010-P PLASTIC ID WASHER P8	1
7	BRLM 176 BOSTONGEAR-GB38	1	22	GSF 325-035 FHCS .25-20 X .88 SS	18
8	BRLM 178 BOSTONGEAR-NB30B-1	2	23	GSS 525-28-37CU SET SCREW, CUP PT	1
9	BRLM 182 HOUSING, SPUR	1	24	GW 531-L LOCK WASHER	4
10	BRLM 183 PLATE, COVER REAR	1	25	HRS 510 GEAR, 15T	1
11	BRLM 184 PLATE, COVER FRONT	1	26	HRS 510.2 COLLAR ASSY, PINION	1
12	BRLM 186 SHAFT, SPUR GEAR	2	27	HRS 515 GEAR BUSHING	2
13	BRLM 188 SHIM, SS	2	28	HRS 518 RETAINING RING, SL EXTERNAL	4
14	BRLM 190 SHAFT, FINAL	1	29	HRS 529 THRUST WASHER	4
15	BRLM 191 SPRING PIN, .125 X .75	2	30	HRS 573 FTG, ELBOW 90 P8M J8M	1
			31	SG 055 AIR MOTOR	1

PARTS DIAGRAM

BRLM 210-CS TRIPLE ROTARY GEARBOX

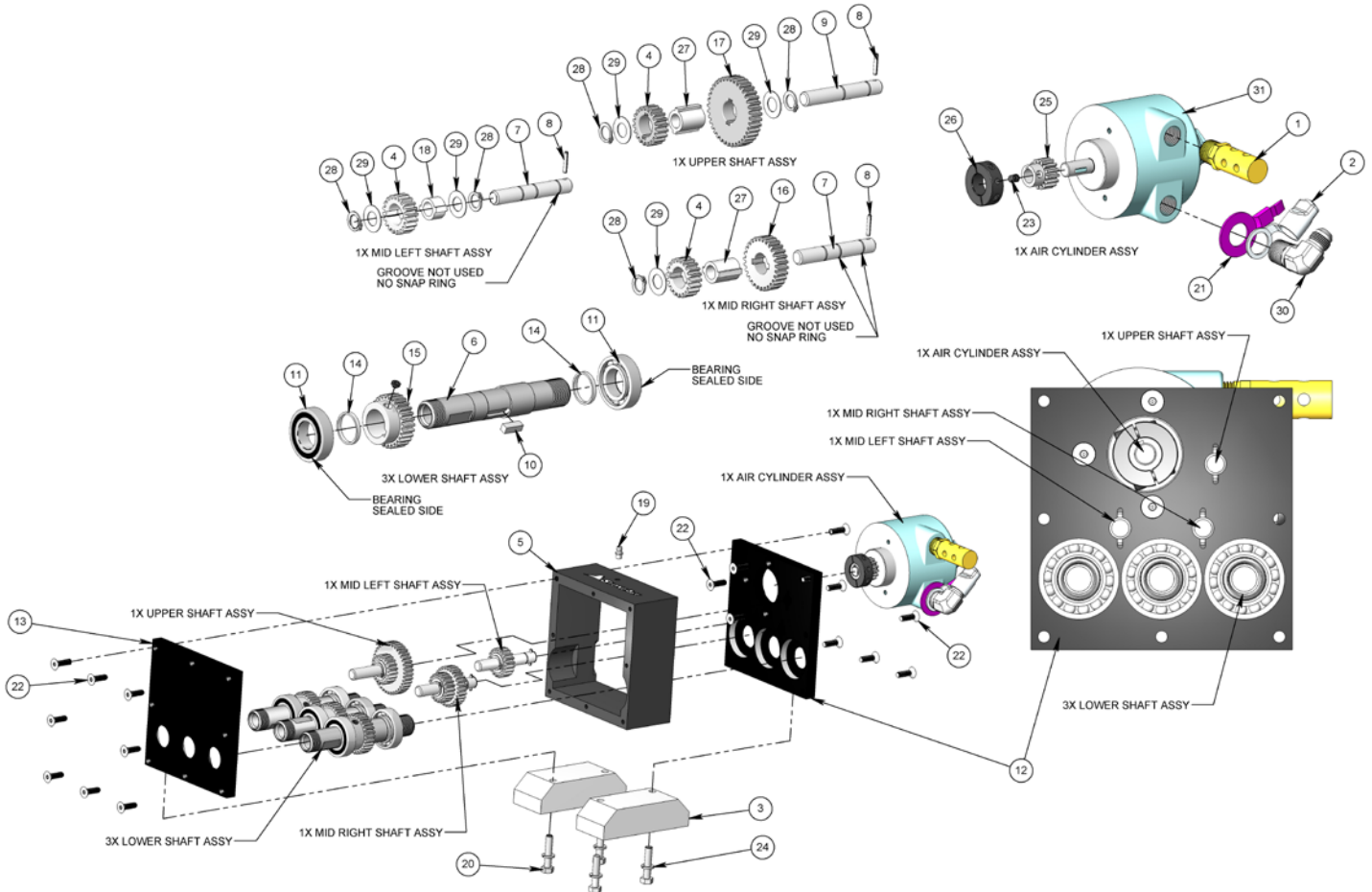

#	PART NUMBER	QTY.
1	BR 155 MUFFLER P8	1
2	BR 167 90° DUST CAP J8	1
3	BRLM 024-SA BLOCK, MOUNT STD	2
4	BRLM 172 BOSTONGEAR-GB20	3
5	BRLM 182 HOUSING, SPUR	1
6	BRLM 186 SHAFT, SPUR GEAR	3
7	BRLM 190 SHAFT, FINAL	2
8	BRLM 191 SPRING PIN, .125 X .75	3
9	BRLM 192 SHAFT, INTERMEDIATE	1
10	BRLM 195 KEY, SQ .250 X .250 X .75	3
11	BRLM 201 BEARING	6
12	BRLM 203 PLATE, COVER REAR	1
13	BRLM 204 PLATE, COVER FRONT	1
14	BRLM 207 SPACER, SPUR SHAFT	6
15	BRLM 211 GEAR, MODIFIED	3

16	BRLM 212 BOSTONGEAR-GB28	1
17	BRLM 213 BOSTONGEAR-GB37	1
18	BRLM 215 GEAR BUSHING MOD	1
19	FS 004-0 ZERK, STRAIGHT	1
20	GB 531-06 BOLT, HEX .31-18 X 1.50	4
21	GP 010-P PLASTIC ID WASHER P8	1
22	GSF 325-035 FHCS .25-20 X .88 SS	18
23	GSS 525-28-37CU SET SCREW, CUP PT	1
24	GW 531-L LOCK WASHER	4
25	HRS 510 GEAR, 15T	1
26	HRS 510.2 COLLAR ASSY, PINION	1
27	HRS 515 GEAR BUSHING	2
28	HRS 518 RETAINING RING, SL EXTERNAL	5
29	HRS 529 THRUST WASHER	5
30	HRS 573 FTG, ELBOW 90 P8M J8M	1
31	SG 055 AIR MOTOR	1

BRLM 310-P8
SINGLE ROTARY ASSEMBLY 15 KPSI

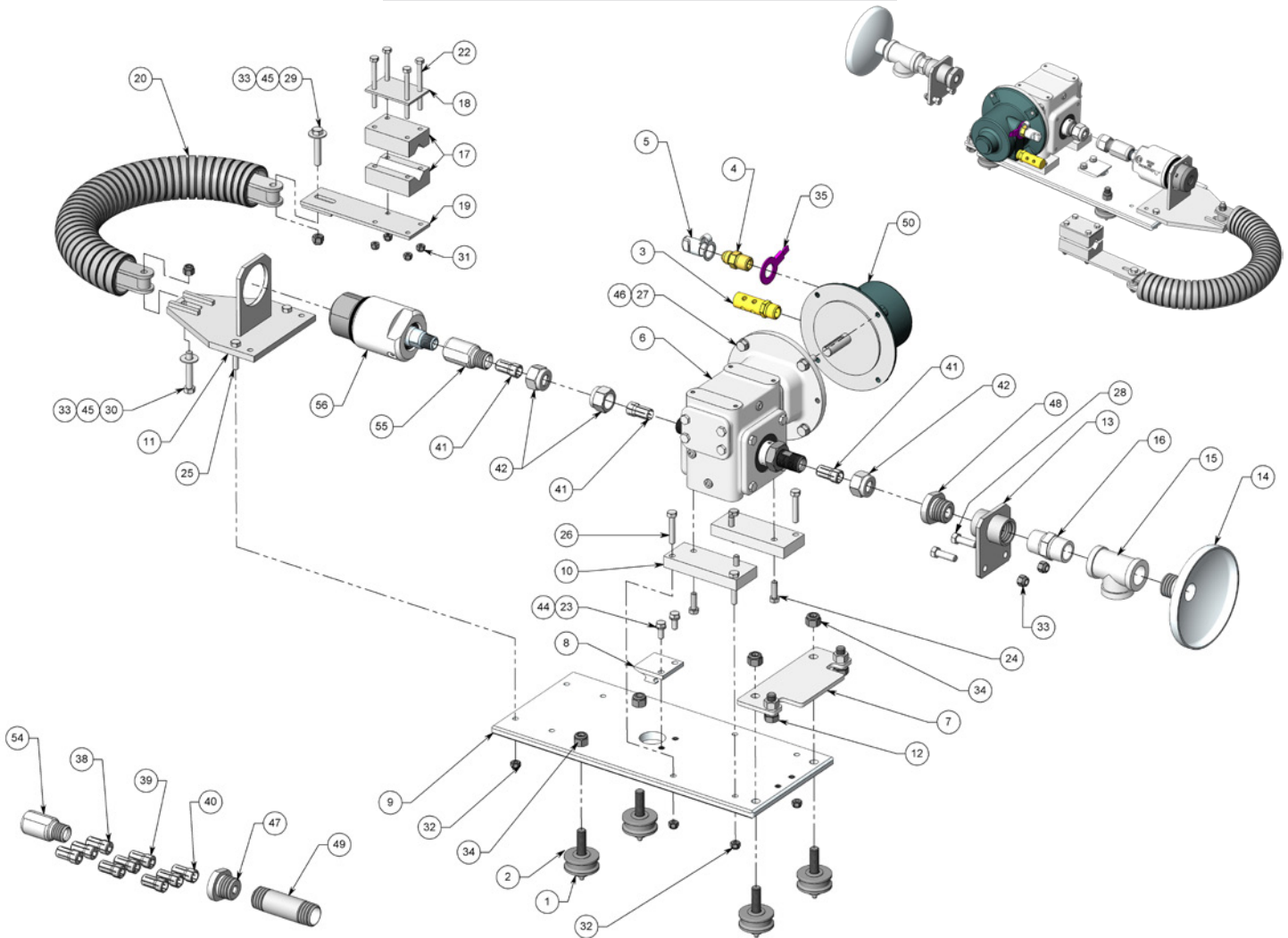

#	PART NUMBER	QTY.
1	BR 052-2.5 AXLE-ZERK	4
2	BR 055 ROLLER ASSY	4
3	BR 155 MUFFLER P8	1
4	BR 157 FTG, ADAPTER P8M J8M	1
5	BR 167 DUST CAP J8	1
6	BR 190-E5 GEARBOX WITH SHAFT, EG 5T01	1
7	BRLM 018-D PLATE, DUAL COIL	1
8	BRLM 019 CHAIN HOOK	1
9	BRLM 022 CARRIAGE PLATE	1
10	BRLM 024-EG PEDESTAL	2
11	BRLM 027-SGS BRACKET, TAIL, SG SINGLE	1
12	BRLM 036 BOLT, COIL ANCHOR	2
13	BRLM 040-1 FRONT PLATE	1
14	BRLM 150 SPLASH GUARD	1
15	BRLM 160 P16 TEE	1

16	BRLM 170 P16 NIPPLE	1
17	BRLM 270 CLAMP, HOSE	2
18	BRLM 271 PLATE, HOSE CLAMP	1
19	BRLM 272 PLATE, TAIL END	1
20	BRLM 273 TAIL CHAIN	1
22	GB 525-12 BOLT, HEX .25-20 X 3.00	4
23	GB 531-03 BOLT, HEX .31-18 X .75	2
24	GB 531-04 BOLT, HEX .31-18 X 1.00	4
25	GB 531-06 BOLT, HEX .31-18 X 1.50	2
26	GB 531-07 BOLT, HEX .31-18 X 1.75	4
27	GB 537-04 BOLT, HEX .37-16 X 1.00	4
28	GB 537-05 BOLT, HEX .37-16 X 1.25	2
29	GB 537-08 BOLT, HEX .37-16 X 2.00	1
30	GB 537-09 BOLT, HEX .37-16 X 2.25	1
31	GN 525-L NYLOK NUT	4
32	GN 531-L NYLOK NUT	6
33	GN 537-L NYLOK NUT	4

34	GN 550-L NYLOK NUT	4
35	GP 010-P PLASTIC ID WASHER P8	1
38	GP 075-375 COLLET	3
39	GP 075-406 COLLET	3
40	GP 075-547 COLLET	3
41	GP 075-562 COLLET	3
42	GP 076 COLLET NUT	3
44	GW 531-L LOCK WASHER	2
45	GW 537-F FLAT WASHER	2
46	GW 537-L LOCK WASHER	4
47	LM 012-06 BUSHING, FRONT	1
48	LM 012-09 BUSHING, FRONT	1
49	LM 014 NIPPLE	1
50	LM 016-4 AIR MOTOR	1
54	SA 056-P8P2 LANCE ADPT	1
55	SA 056-P8P4 LANCE ADPT	1
56	SG-P8P8-0 SWIVEL	1

PARTS DIAGRAM

BRLM 320-MP12 SINGLE ROTARY ASSEMBLY 22 KPSI

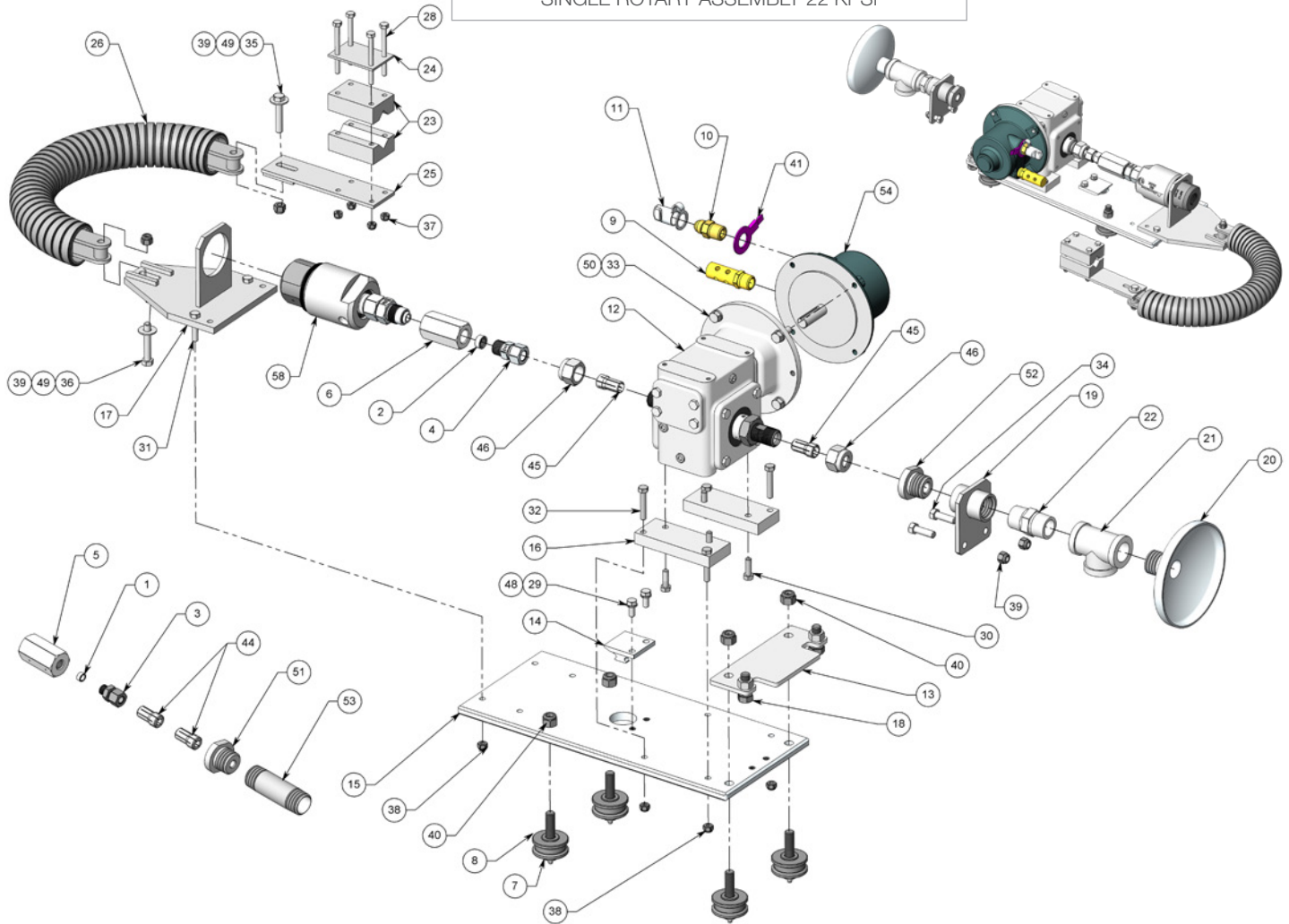

#	PART NUMBER	QTY.
1	AF 071-MP6 COLLAR	1
2	AF 071-MP9 COLLAR	1
3	AF 072-MP6 ANTIVIBE, GLAND ASSY	1
4	AF 072-MP9 ANTIVIBE, GLAND ASSY	1
5	AF 073-MP6MP12 COUPLING	1
6	AF 073-MP9MP12 COUPLING	1
7	BR 052-2.5 AXLE-ZERK	4
8	BR 055 ROLLER ASSY	4
9	BR 155 MUFFLER P8	1
10	BR 157 FTG, ADAPTER P8M J8M	1
11	BR 167 DUST CAP J8	1
12	BR 190-E5 GEARBOX WITH SHAFT, EG 5T01	1
13	BRLM 018-D PLATE, DUAL COIL	1
14	BRLM 019 CHAIN HOOK	1
15	BRLM 022 CARRIAGE PLATE	1
16	BRLM 024-EG PEDESTAL	2

17	BRLM 027-SGS BRACKET, TAIL, SG SINGLE	1
18	BRLM 036 BOLT, COIL ANCHOR	2
19	BRLM 040-1 FRONT PLATE	1
20	BRLM 150 SPLASH GUARD	1
21	BRLM 160 P16 TEE	1
22	BRLM 170 P16 NIPPLE	1
23	BRLM 270 CLAMP, HOSE	2
24	BRLM 271 PLATE, HOSE CLAMP	1
25	BRLM 272 PLATE, TAIL END	1
26	BRLM 273 TAIL CHAIN	1
28	GB 525-12 BOLT, HEX .25-20 X 3.00	4
29	GB 531-03 BOLT, HEX .31-18 X .75	2
30	GB 531-04 BOLT, HEX .31-18 X 1.00	4
31	GB 531-06 BOLT, HEX .31-18 X 1.50	2
32	GB 531-07 BOLT, HEX .31-18 X 1.75	4
33	GB 537-04 BOLT, HEX .37-16 X 1.00	4
34	GB 537-05 BOLT, HEX .37-16 X 1.25	2
35	GB 537-08 BOLT, HEX .37-16 X 2.00	1

36	GB 537-09 BOLT, HEX .37-16 X 2.25	1
37	GN 525-L NYLOK NUT	4
38	GN 531-L NYLOK NUT	6
39	GN 537-L NYLOK NUT	4
40	GN 550-L NYLOK NUT	4
41	GP 010-P PLASTIC ID WASHER P8	1
44	GP 075-375 COLLET	2
45	GP 075-562 COLLET	2
46	GP 076 COLLET NUT	2
48	GW 531-L LOCK WASHER	2
49	GW 537-F FLAT WASHER	2
50	GW 537-L LOCK WASHER	4
51	LM 012-06 BUSHING, FRONT	1
52	LM 012-09 BUSHING, FRONT	1
53	LM 014 NIPPLE	1
54	LM 016-4 AIR MOTOR	1
57	LM 123 FTG, ADAPTER ORB6M J8M	-
58	SG-MP12AV12-0 SWIVEL	1

BRLM 330
SINGLE ROTARY ASSEMBLY 44 KPSI

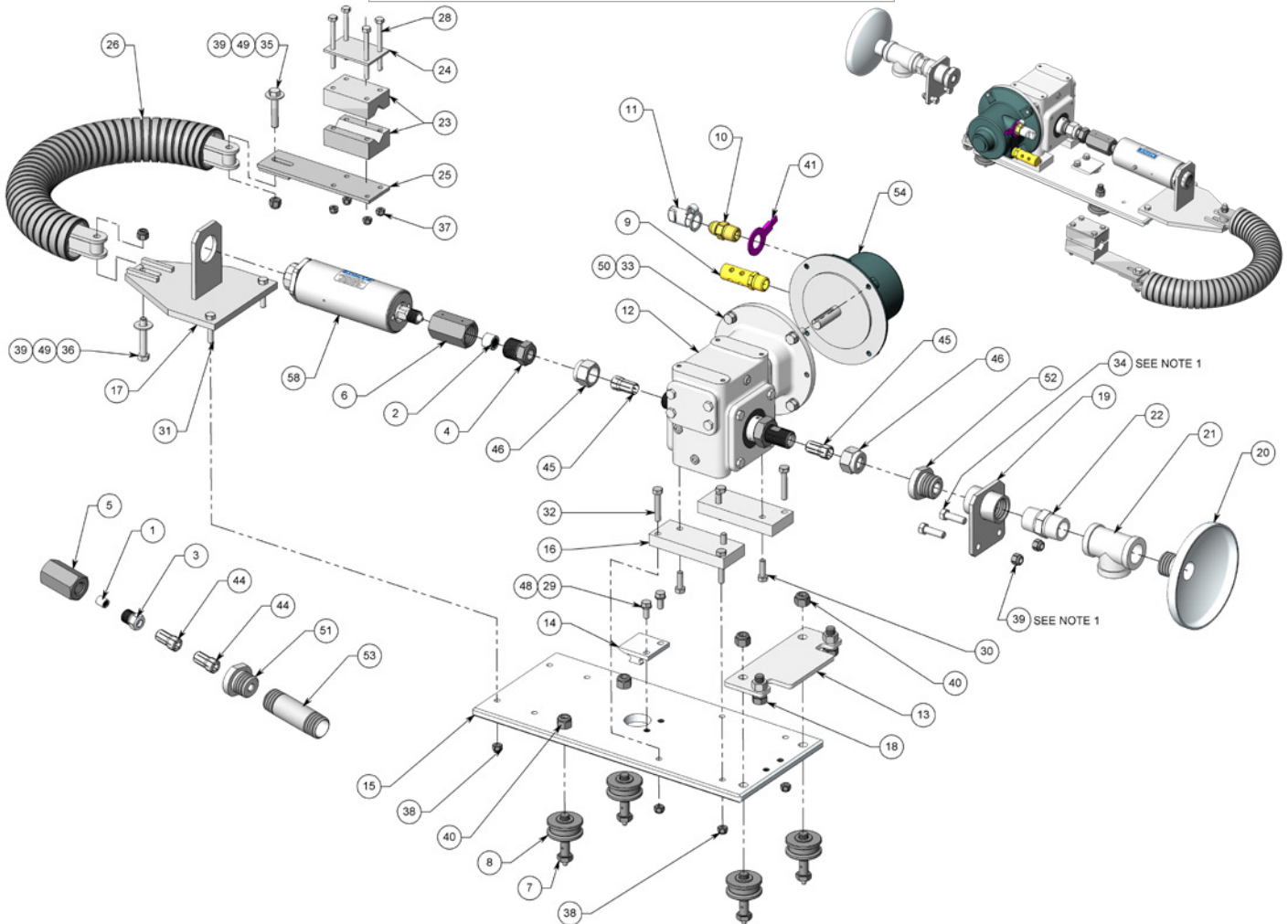

#	PART NUMBER	QTY.			
1	AF 071-H6 COLLAR	1	17	BRLM 027-JES BRACKET, TAIL JE SINGLE PLATE	1
2	AF 071-H9 COLLAR	1	18	BRLM 036 BOLT, COIL ANCHOR	2
3	AF 072-H6 ANTIVIBE, GLAND ASSY	1	19	BRLM 040-1 FRONT PLATE	1
4	AF 072-H9 ANTIVIBE, GLAND ASSY	1	20	BRLM 150 SPLASH GUARD	1
5	AF 073-H6 COUPLER	1	21	BRLM 160 P16 TEE	1
6	AF 073-H6H9 COUPLER	1	22	BRLM 170 P16 NIPPLE	1
7	BR 052-2.5 AXLE-ZERK	4	23	BRLM 270 CLAMP, HOSE	2
8	BR 055 ROLLER ASSY	4	24	BRLM 271 PLATE, HOSE CLAMP	1
9	BR 155 MUFFLER P8	1	25	BRLM 272 PLATE, TAIL END	1
10	BR 157 FTG, ADAPTER P8M J8M	1	26	BRLM 273 TAIL CHAIN	1
11	BR 167 DUST CAP J8	1	28	GB 525-12 BOLT, HEX .25-20 X 3.00	4
12	BR 190-E5 GEARBOX WITH SHAFT, EG 5T01	1	29	GB 531-03 BOLT, HEX .31-18 X .75	2
13	BRLM 018-D PLATE, DUAL COIL	1	30	GB 531-04 BOLT, HEX .31-18 X 1.00	4
14	BRLM 019 CHAIN HOOK	1	31	GB 531-06 BOLT, HEX .31-18 X 1.50	2
15	BRLM 022 CARRIAGE PLATE	1	32	GB 531-07 BOLT, HEX .31-18 X 1.75	4
16	BRLM 024-EG PEDESTAL	2	33	GB 537-04 BOLT, HEX .37-16 X 1.00	4
			34	GB 537-05 BOLT, HEX .37-16 X 1.25	2
			35	GB 537-08 BOLT, HEX .37-16 X 2.00	1
			36	GB 537-09 BOLT, HEX .37-16 X 2.25	1
			37	GN 525-L NYLOK NUT	4
			38	GN 531-L NYLOK NUT	6
			39	GN 537-L NYLOK NUT	4
			40	GN 550-L NYLOK NUT	4
			41	GP 010-P PLASTIC ID WASHER P8	1
			44	GP 075-375 COLLET	2
			45	GP 075-562 COLLET	2
			46	GP 076 COLLET NUT	2
			47	GS 525-025-28 SHCS .25-28 X .62 BLK	-
			48	GW 531-L LOCK WASHER	2
			49	GW 537-F FLAT WASHER	2
			50	GW 537-L LOCK WASHER	4
			51	LM 012-06 BUSHING, FRONT	1
			52	LM 012-09 BUSHING, FRONT	1
			53	LM 014 NIPPLE	1
			54	LM 016-4 AIR MOTOR	1
			57	LM 123 FTG, ADAPTER ORB6M J8M	-
			58	UH-H9H6 SWIVEL ASSEMBLY	1

PARTS DIAGRAM

BRLM 341 DUAL ROTARY ASSEMBLY 15 KPSI

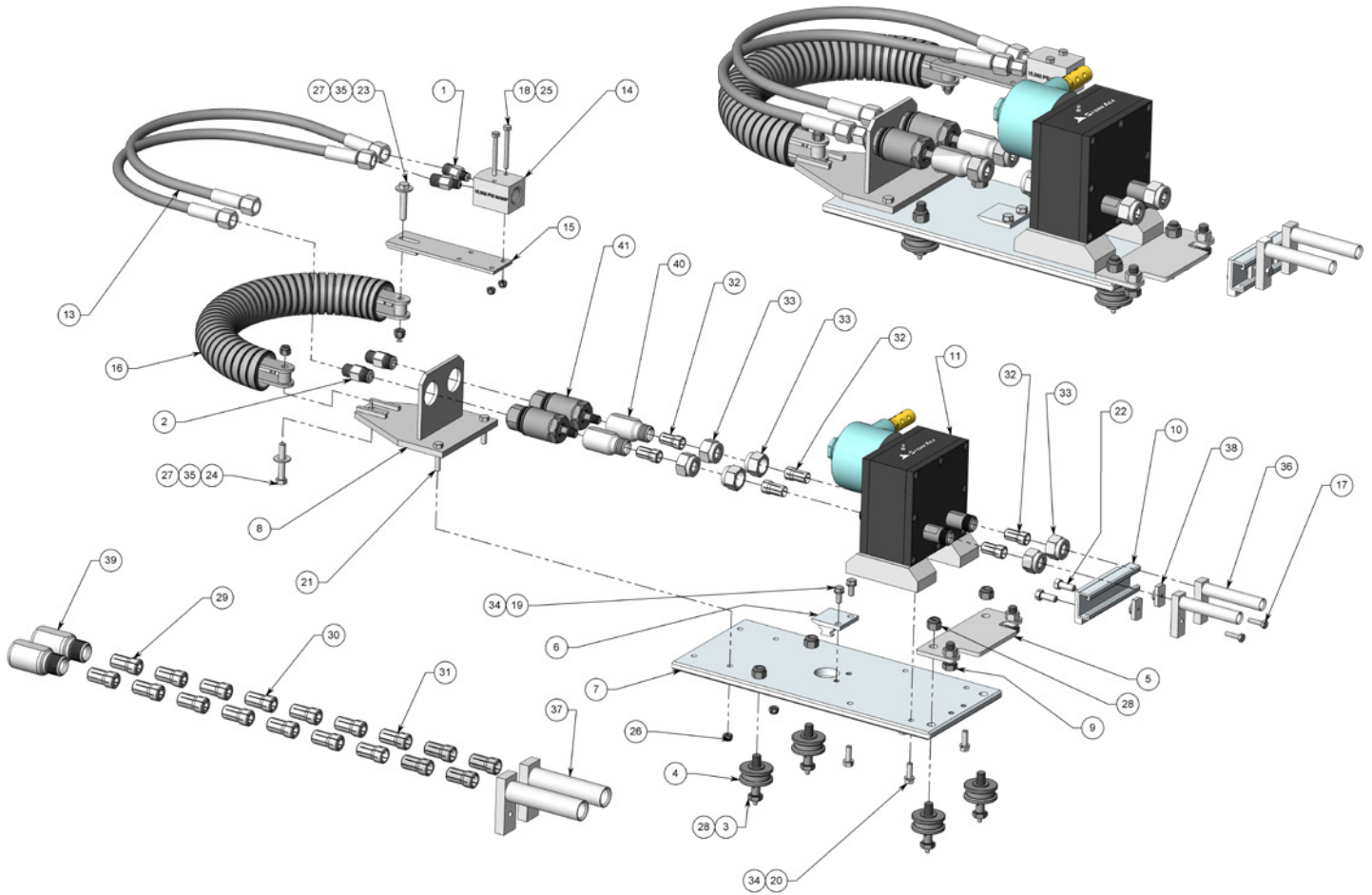

#	PART NUMBER	QTY.
1	AF 061-P4 ADAPTER .75 TYPE M TO P4	2
2	AF 061-P8 ADAPTER .75 TYPE M TO P8	2
3	BR 052-2.5 AXLE-ZERK	4
4	BR 055 ROLLER ASSY	4
5	BRLM 018-D PLATE, DUAL COIL	1
6	BRLM 019 CHAIN HOOK	1
7	BRLM 022 CARRIAGE PLATE	1
8	BRLM 027-SLD BRACKET, TAIL, SL DUAL	1
9	BRLM 036 BOLT, COIL ANCHOR	2
10	BRLM 041 MULTI CHANNEL	1
11	BRLM 180 DUAL ROTARY GBOX ASSY - SPUR	1
13	BRLM 268-003 HOSE	2

14	BRLM 269-P12 MANIFOLD	1
15	BRLM 272 PLATE, TAIL END	1
16	BRLM 273 TAIL CHAIN	1
17	GB 525-04 BOLT, HEX .25-20 X 1.00	2
18	GB 525-10 BOLT, HEX .25-20 X 2.50	2
19	GB 531-03 BOLT, HEX .31-18 X .75	2
20	GB 531-04 BOLT, HEX .31-18 X 1.00	4
21	GB 531-06 BOLT, HEX .31-18 X 1.50	2
22	GB 537-04 BOLT, HEX .37-16 X 1.00	2
23	GB 537-08 BOLT, HEX .37-16 X 2.00	1
24	GB 537-09 BOLT, HEX .37-16 X 2.25	1
25	GN 525-L NYLOK NUT	2
26	GN 531-L NYLOK NUT	2
27	GN 537-L NYLOK NUT	2

28	GN 550-L NYLOK NUT	4
29	GP 075-375 COLLET	3
30	GP 075-406 COLLET	3
31	GP 075-547 COLLET	3
32	GP 075-562 COLLET	6
33	GP 076 COLLET NUT	6
34	GW 531-L LOCK WASHER	6
35	GW 537-F FLAT WASHER	2
36	ML 072-P2 GUIDE, LONG ADJ	2
37	ML 072-P4-L GUIDE, LONG ADJ	1
38	ML 072.1 SPRING NUT	2
39	SA 056-P4P2 LANCE ADPT	1
40	SA 056-P4P4 LANCE ADPT	2
41	SL-P8P4-0 SWIVEL	2

BRLM 351
DUAL ROTARY ASSEMBLY 22 KPSI

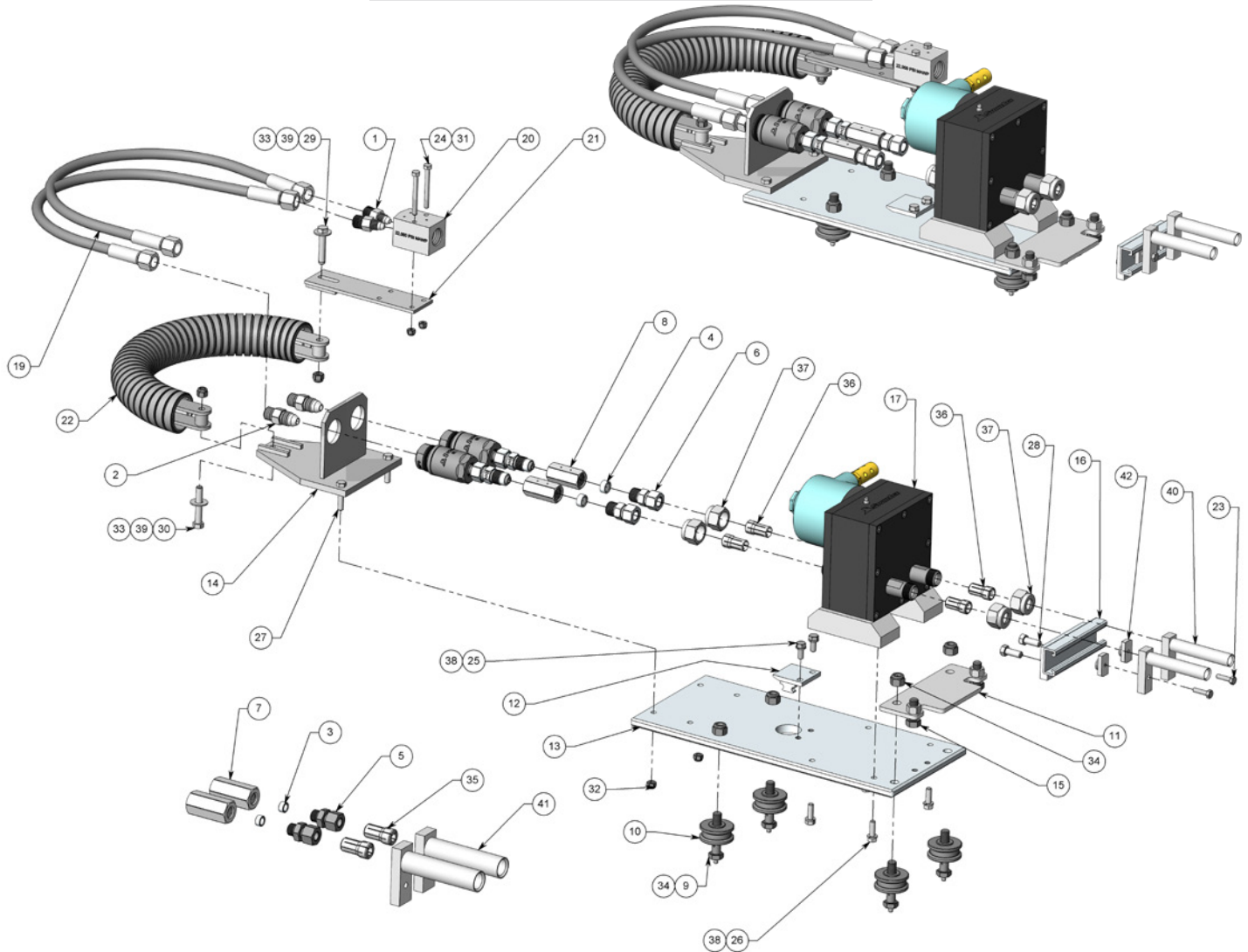

#	PART NUMBER	QTY.
1	AF 061-MP6 ADAPTER .75 TYPE M TO MP6	2
2	AF 061-MP9 ADAPTER .75 TYPE M TO MP9	2
3	AF 071-MP6 COLLAR	2
4	AF 071-MP9 COLLAR	2
5	AF 072-MP6 ANTIVIBE, GLAND ASSY	2
6	AF 072-MP9 ANTIVIBE, GLAND ASSY	2
7	AF 073-MP6MP9 COUPLING	2
8	AF 073-MP9 COUPLER	2
9	BR 052-2.5 AXLE-ZERK	4
10	BR 055 ROLLER ASSY	4
11	BRLM 018-D PLATE, DUAL COIL	1
12	BRLM 019 CHAIN HOOK	1
13	BRLM 022 CARRIAGE PLATE	1

14	BRLM 027-SLD BRACKET, TAIL, SL DUAL	1
15	BRLM 036 BOLT, COIL ANCHOR	2
16	BRLM 041 MULTI CHANNEL	1
17	BRLM 180 DUAL ROTARY GBOX ASSY - SPUR	1
19	BRLM 268-003 HOSE	2
20	BRLM 269-MP12 MANIFOLD	1
21	BRLM 272 PLATE, TAIL END	1
22	BRLM 273 TAIL CHAIN	1
23	GB 525-04 BOLT, HEX .25-20 X 1.00	2
24	GB 525-10 BOLT, HEX .25-20 X 2.50	2
25	GB 531-03 BOLT, HEX .31-18 X .75	2
26	GB 531-04 BOLT, HEX .31-18 X 1.00	4
27	GB 531-06 BOLT, HEX .31-18 X 1.50	2
28	GB 537-04 BOLT, HEX .37-16 X 1.00	2

29	GB 537-08 BOLT, HEX .37-16 X 2.00	1
30	GB 537-09 BOLT, HEX .37-16 X 2.25	1
31	GN 525-L NYLOK NUT	2
32	GN 531-L NYLOK NUT	2
33	GN 537-L NYLOK NUT	2
34	GN 550-L NYLOK NUT	4
35	GP 075-375 COLLET	2
36	GP 075-562 COLLET	4
37	GP 076 COLLET NUT	4
38	GW 531-L LOCK WASHER	6
39	GW 537-F FLAT WASHER	2
40	ML 072-P2 GUIDE, LONG ADJ	2
41	ML 072-P4-L GUIDE, LONG ADJ	2
42	ML 072.1 SPRING NUT	2
43	SL-MP9AV9-0 SWIVEL	2

PARTS DIAGRAM

BRLM 361 DUAL ROTARY ASSEMBLY 44 KPSI

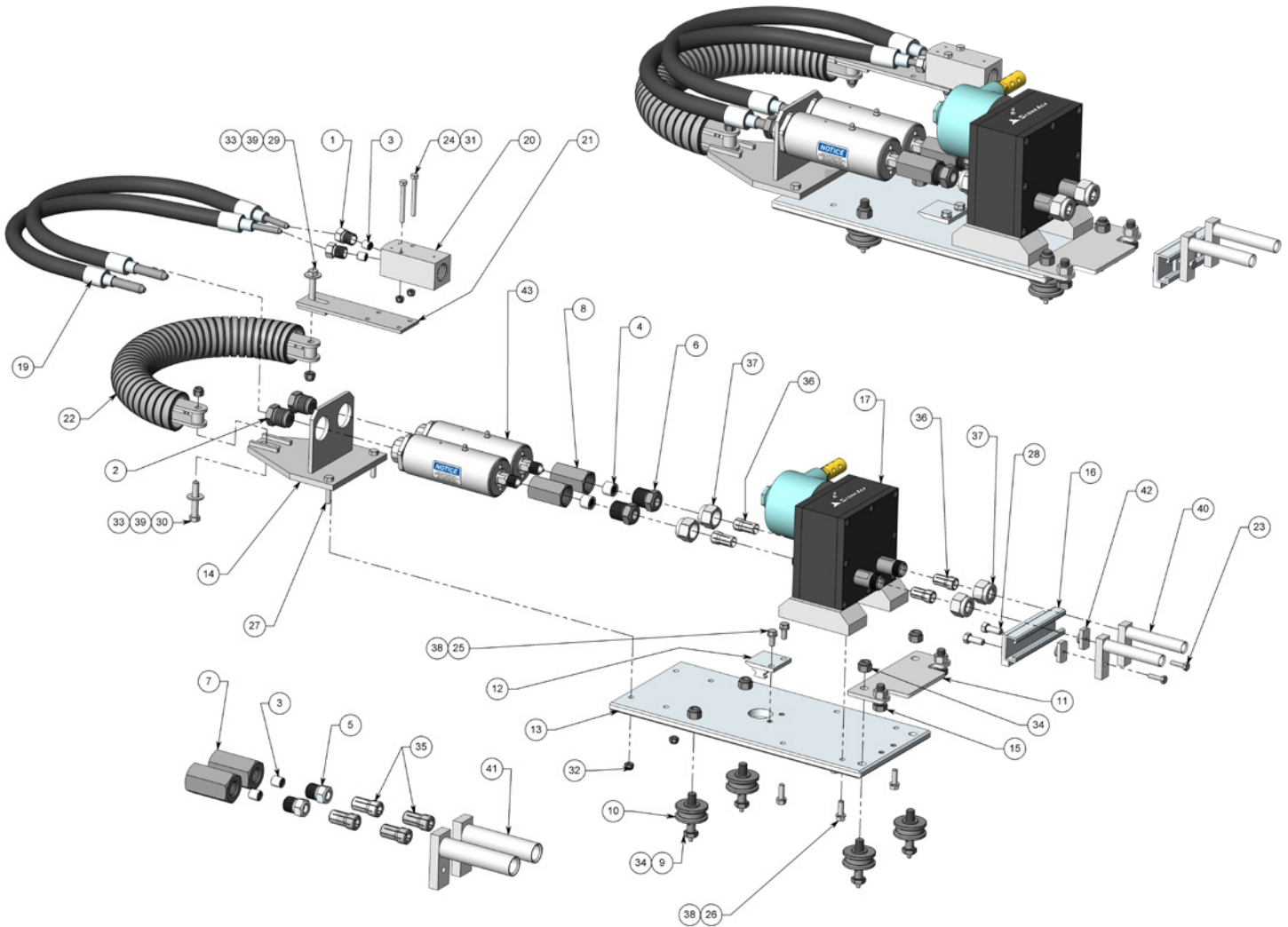

#	PART NUMBER	QTY.
1	AF 070-H6 GLAND HP	2
2	AF 070-H9 GLAND HP	2
3	AF 071-H6 COLLAR	4
4	AF 071-H9 COLLAR	4
5	AF 072-H6 ANTIVIBE, GLAND ASSY	2
6	AF 072-H9 ANTIVIBE, GLAND ASSY	2
7	AF 073-H6 COUPLER	2
8	AF 073-H6H9 COUPLER	2
9	BR 052-2.5 AXLE-ZERK	4
10	BR 055 ROLLER ASSY	4
11	BRLM 018-D PLATE, DUAL COIL	1
12	BRLM 019 CHAIN HOOK	1
13	BRLM 022 CARRIAGE PLATE	1
14	BRLM 027-JED PLATE TYPE	1

15	BRLM 036 BOLT, COIL ANCHOR	2
16	BRLM 041 MULTI CHANNEL	1
17	BRLM 180 DUAL ROTARY GBOX ASSY - SPUR	1
19	BRLM 266 HOSE ASSY	2
20	BRLM 269-H9 MANIFOLD	1
21	BRLM 272 PLATE, TAIL END	1
22	BRLM 273 TAIL CHAIN	1
23	GB 525-04 BOLT, HEX .25-20 X 1.00	2
24	GB 525-10 BOLT, HEX .25-20 X 2.50	2
25	GB 531-03 BOLT, HEX .31-18 X .75	2
26	GB 531-04 BOLT, HEX .31-18 X 1.00	4
27	GB 531-06 BOLT, HEX .31-18 X 1.50	2
28	GB 537-04 BOLT, HEX .37-16 X 1.00	2
29	GB 537-08 BOLT, HEX .37-16 X 2.00	1

30	GB 537-09 BOLT, HEX .37-16 X 2.25	1
31	GN 525-L NYLOK NUT	2
32	GN 531-L NYLOK NUT	2
33	GN 537-L NYLOK NUT	2
34	GN 550-L NYLOK NUT	4
35	GP 075-375 COLLET	4
36	GP 075-562 COLLET	4
37	GP 076 COLLET NUT	4
38	GW 531-L LOCK WASHER	6
39	GW 537-F FLAT WASHER	2
40	ML 072-P2 GUIDE, LONG ADJ	2
41	ML 072-P4-L GUIDE, LONG ADJ	2
42	ML 072.1 SPRING NUT	2
43	UH-H9H6 ASSEMBLY	2

BRLM 343-CS
TRIPLE ROTARY ASSEMBLY 15 KPSI

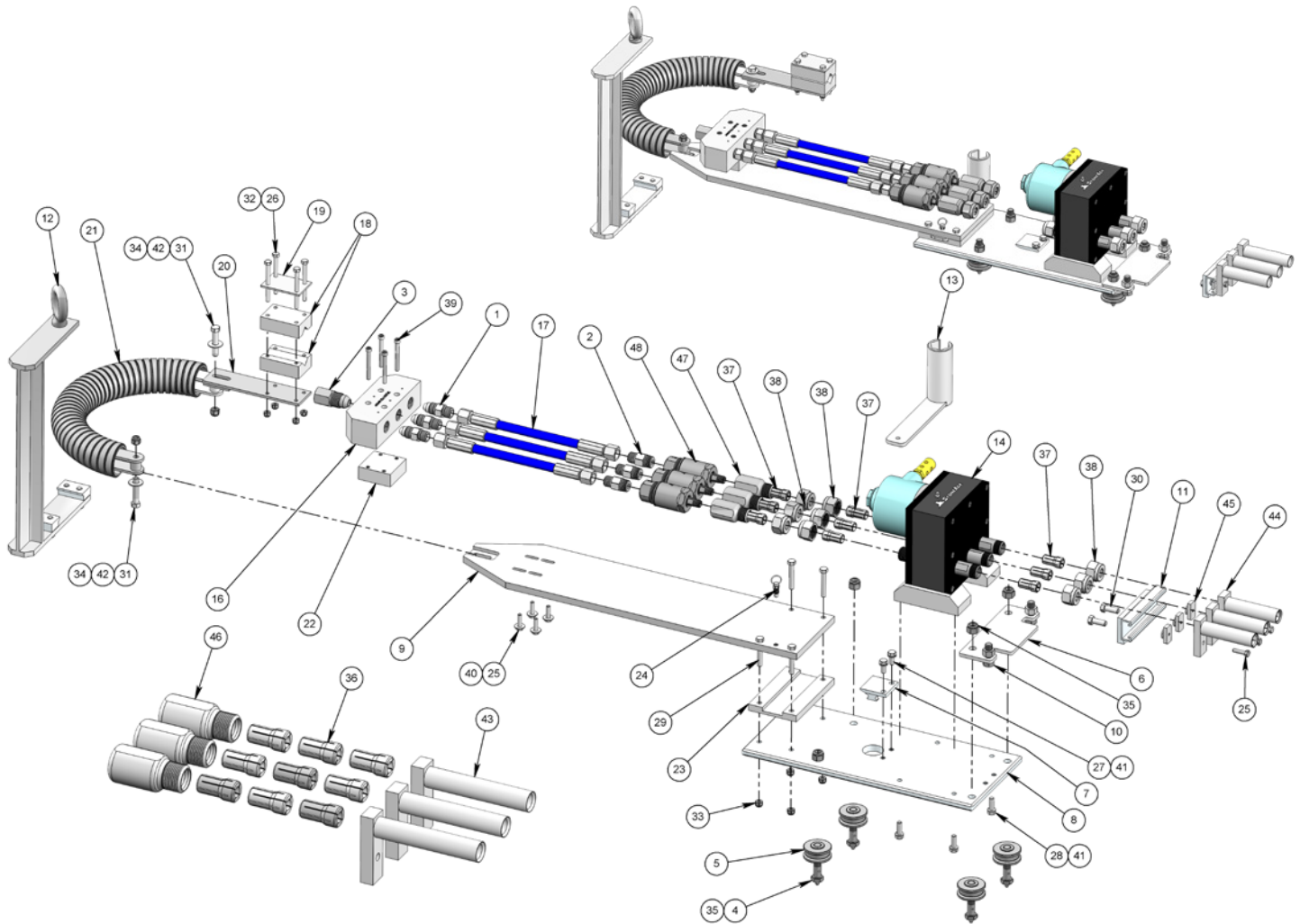

#	PART NUMBER	QTY.
1	AF 061-MP9 ADAPTER .75 TYPE M TO MP9	3
2	AF 061-P8 ADAPTER .75 TYPE M TO P8	3
3	AF 065-MP12P8 ADAPTER	1
4	BR 052-2.5 AXLE-ZERK	4
5	BR 055 ROLLER ASSY	4
6	BRLM 018-D PLATE, DUAL COIL	1
7	BRLM 019 CHAIN HOOK	1
8	BRLM 022 CARRIAGE PLATE	1
9	BRLM 027-SLT-L PLATE, TAIL BRACKET LONG	1
10	BRLM 036 BOLT, COIL ANCHOR	2
11	BRLM 041 MULTI CHANNEL	1
12	BRLM 060 MID SUPPORT BRACKET ASSY	1
13	BRLM 181 WRENCH WELDMENT	1

14	BRLM 210-CS TRI ROTARY GBOX ASSY - COLLET SHAFTS	1
16	BRLM 224 MANIFOLD MP9	1
17	BRLM 225 HOSE, TAIL 20K SHORT	3
18	BRLM 270 CLAMP, HOSE	2
19	BRLM 271 PLATE, HOSE CLAMP	1
20	BRLM 272 PLATE, TAIL END	1
21	BRLM 273 TAIL CHAIN	1
22	BRLM 316 PEDESTAL, MANIFOLD	1
23	BRLM 317 PEDESTAL, TAIL BRACKET	1
24	BRLM 318 SPRING PLUNGER	1
25	GB 525-04 BOLT, HEX .25-20 X 1.00	7
26	GB 525-12 BOLT, HEX .25-20 X 3.00	4
27	GB 531-03 BOLT, HEX .31-18 X .75	2
28	GB 531-04 BOLT, HEX .31-18 X 1.00	4
29	GB 531-08 BOLT, HEX .31-18 X 2.00	4
30	GB 537-04 BOLT, HEX .37-16 X 1.00	2
31	GB 537-08 BOLT, HEX .37-16 X 2.00	2

32	GN 525-L NYLOK NUT	4
33	GN 531-L NYLOK NUT	4
34	GN 537-L NYLOK NUT	2
35	GN 550-L NYLOK NUT	4
36	GP 075-406 COLLET	9
37	GP 075-547 COLLET	9
38	GP 076 COLLET NUT	9
39	GS 525-09 SHCS .25-20 X 2.25 ZINC	4
40	GW 525-F FLAT WASHER	4
41	GW 531-L LOCK WASHER	6
42	GW 537-F FLAT WASHER	2
43	ML 072-P2 GUIDE, LONG ADJ	3
44	ML 072-P4-L GUIDE, LONG ADJ	3
45	ML 072.1 SPRING NUT	3
46	SA 056-P4P2 LANCE ADPT	3
47	SA 056-P4P4 LANCE ADPT	3
48	SL-P8P4-0 SWIVEL	3

PARTS DIAGRAM

BRLM 353-CS TRIPLE ROTARY ASSEMBLY 22 KPSI

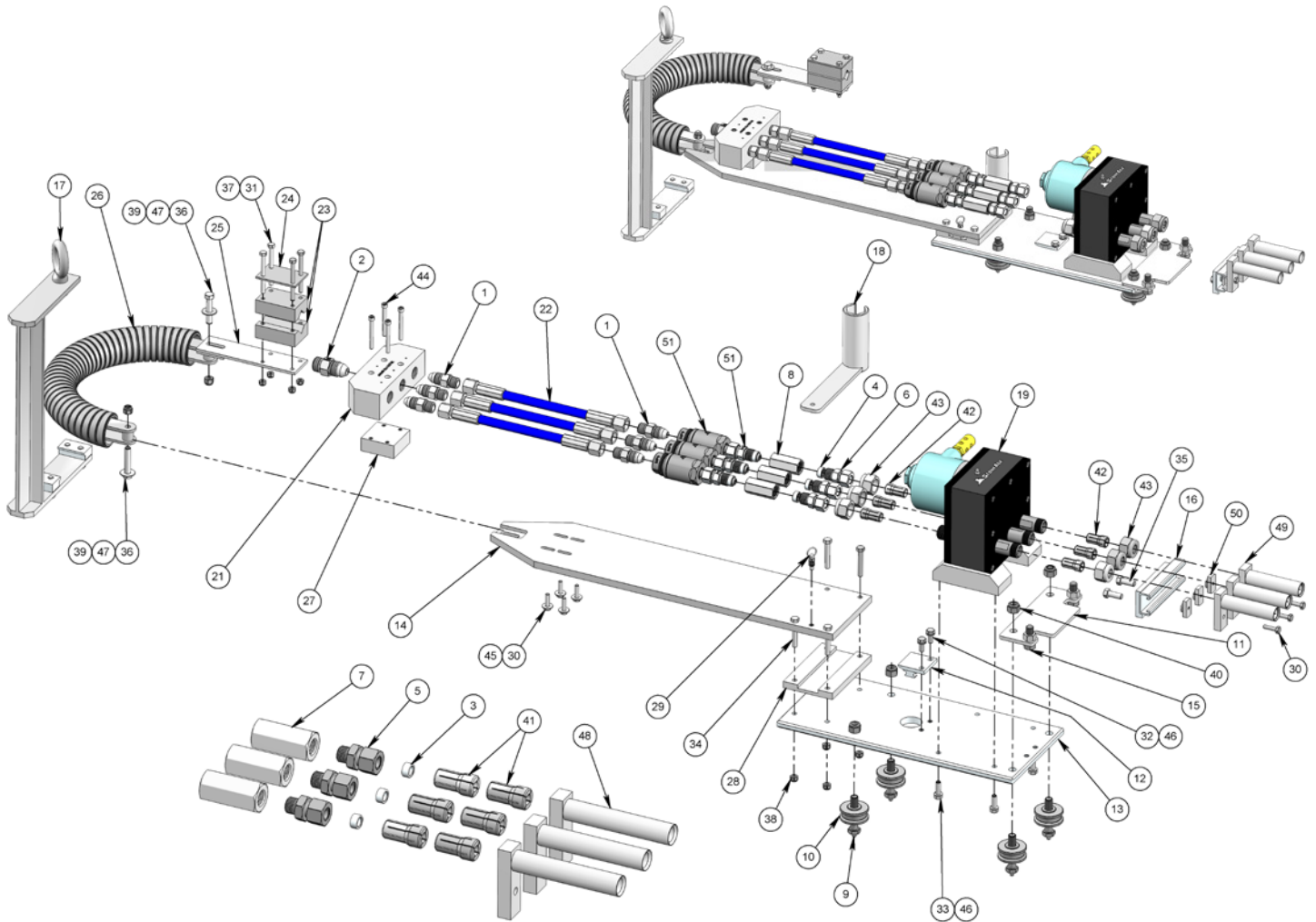

#	PART NUMBER	QTY.
1	AF 061-MP9 ADAPTER .75 TYPE M TO MP9	6
2	AF 063-MP12 ADAPTER 1.00 TYPE M TO MP12	1
3	AF 071-MP6 COLLAR	3
4	AF 071-MP9 COLLAR	3
5	AF 072-MP6 ANTIVIBE, GLAND ASSY	3
6	AF 072-MP9 ANTIVIBE, GLAND ASSY	3
7	AF 073-MP6MP9 COUPLING	3
8	AF 073-MP9 COUPLER	3
9	BR 052-2.5 AXLE-ZERK	4
10	BR 055 ROLLER ASSY	4
11	BRLM 018-D PLATE, DUAL COIL	1
12	BRLM 019 CHAIN HOOK	1
13	BRLM 022 CARRIAGE PLATE	1
14	BRLM 027-SLT-L PLATE, TAIL BRACKET LONG	1
15	BRLM 036 BOLT, COIL ANCHOR	2

16	BRLM 041 MULTI CHANNEL	1
17	BRLM 060 MID SUPPORT BRACKET ASSY	1
18	BRLM 181 WRENCH WELDMENT	1
19	BRLM 210-CS TRI ROTARY GBOX ASSY - COLLET SHAFTS	1
21	BRLM 224 MANIFOLD MP9	1
22	BRLM 225 HOSE, TAIL 20K SHORT	3
23	BRLM 270 CLAMP, HOSE	2
24	BRLM 271 PLATE, HOSE CLAMP	1
25	BRLM 272 PLATE, TAIL END	1
26	BRLM 273 TAIL CHAIN	1
27	BRLM 316 PEDESTAL, MANIFOLD	1
28	BRLM 317 PEDESTAL, TAIL BRACKET	1
29	BRLM 318 SPRING PLUNGER	1
30	GB 525-04 BOLT, HEX .25-20 X 1.00	7
31	GB 525-12 BOLT, HEX .25-20 X 3.00	4
32	GB 531-03 BOLT, HEX .31-18 X .75	2
33	GB 531-04 BOLT, HEX .31-18 X 1.00	4

34	GB 531-08 BOLT, HEX .31-18 X 2.00	4
35	GB 537-04 BOLT, HEX .37-16 X 1.00	2
36	GB 537-08 BOLT, HEX .37-16 X 2.00	2
37	GN 525-L NYLOK NUT	4
38	GN 531-L NYLOK NUT	4
39	GN 537-L NYLOK NUT	2
40	GN 550-L NYLOK NUT	4
41	GP 075-375 COLLET	6
42	GP 075-562 COLLET	6
43	GP 076 COLLET NUT	6
44	GS 525-09 SHCS .25-20 X 2.25 ZINC	4
45	GW 525-F FLAT WASHER	4
46	GW 531-L LOCK WASHER	6
47	GW 537-F FLAT WASHER	2
48	ML 072-P2 GUIDE, LONG ADJ	3
49	ML 072-P4-L GUIDE, LONG ADJ	3
50	ML 072.1 SPRING NUT	3
51	SL-MP9AV9-0 SWIVEL	3

BRLM 363-CS
TRIPLE ROTARY ASSEMBLY 44 KPSI

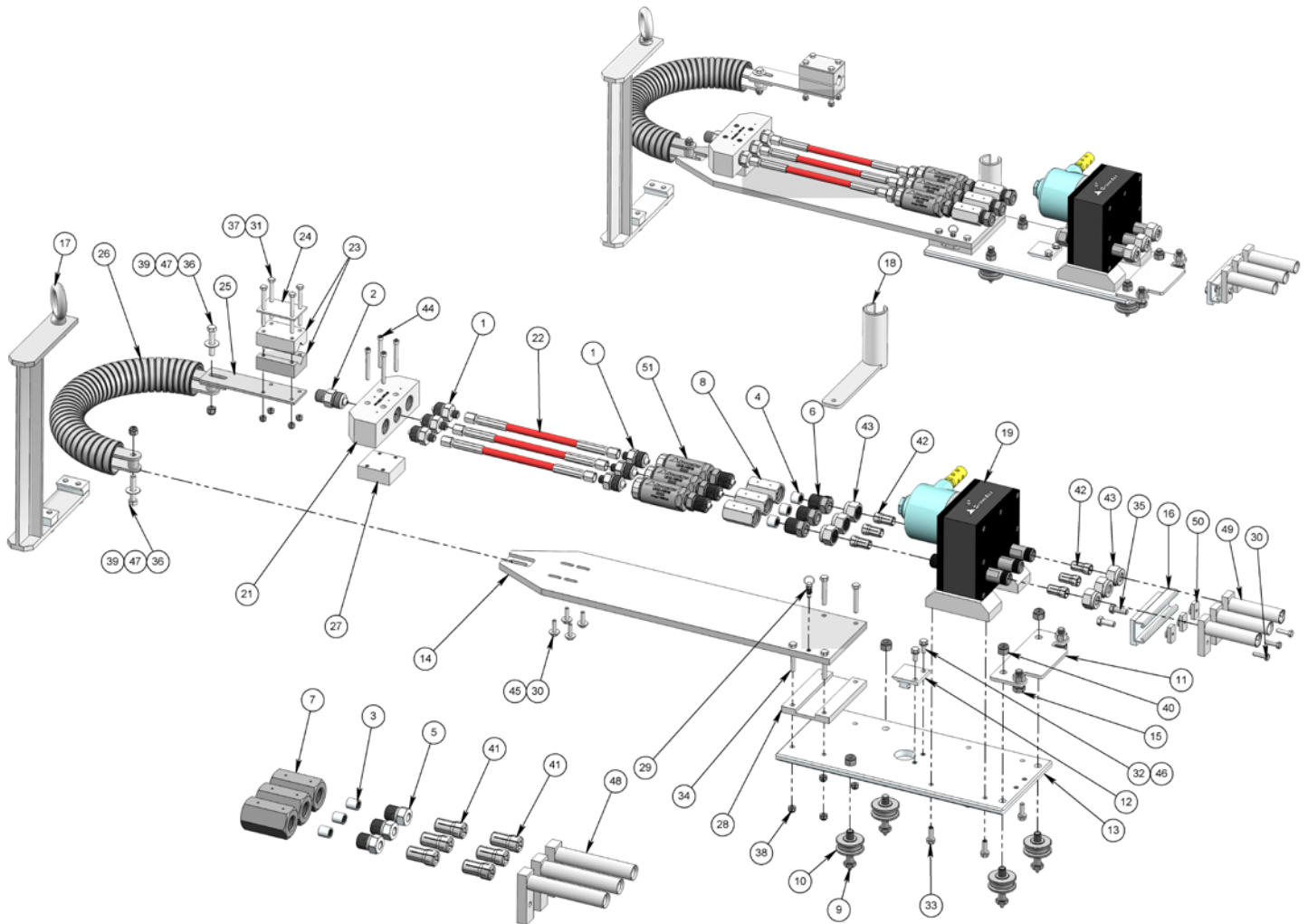

#	PART NUMBER	QTY.
1	AF 060-H9 ADAPTER .56 TYPE M TO H9	6
2	AF 062-H9 ADAPTER .88 TYPE M TO H9	1
3	AF 071-H6 COLLAR	3
4	AF 071-H9 COLLAR	3
5	AF 072-H6 ANTIVIBE, GLAND ASSY	3
6	AF 072-H9 ANTIVIBE, GLAND ASSY	3
7	AF 073-H6H9 COUPLER	3
8	AF 073-H9 COUPLING	3
9	BR 052-2.5 AXLE-ZERK	4
10	BR 055 ROLLER ASSY	4
11	BRLM 018-D PLATE, DUAL COIL	1
12	BRLM 019 CHAIN HOOK	1
13	BRLM 022 CARRIAGE PLATE	1
14	BRLM 027-SLT-L PLATE, TAIL BRACKET LONG	1
15	BRLM 036 BOLT, COIL ANCHOR	2

16	BRLM 041 MULTI CHANNEL	1
17	BRLM 060 MID SUPPORT BRACKET ASSY	1
18	BRLM 181 WRENCH WELDMENT	1
19	BRLM 210-CS TRI ROTARY GBOX ASSY - COLLET SHAFTS	1
21	BRLM 214 MANIFOLD H9	1
22	BRLM 265 HOSE, TAIL 40K SHORT	3
23	BRLM 270 CLAMP, HOSE	2
24	BRLM 271 PLATE, HOSE CLAMP	1
25	BRLM 272 PLATE, TAIL END	1
26	BRLM 273 TAIL CHAIN	1
27	BRLM 316 PEDESTAL, MANIFOLD	1
28	BRLM 317 PEDESTAL, TAIL BRACKET	1
29	BRLM 318 SPRING PLUNGER	1
30	GB 525-04 BOLT, HEX .25-20 X 1.00	7
31	GB 525-12 BOLT, HEX .25-20 X 3.00	4
32	GB 531-03 BOLT, HEX .31-18 X .75	2
33	GB 531-04 BOLT, HEX .31-18 X 1.00	4

34	GB 531-08 BOLT, HEX .31-18 X 2.00	4
35	GB 537-04 BOLT, HEX .37-16 X 1.00	2
36	GB 537-08 BOLT, HEX .37-16 X 2.00	2
37	GN 525-L NYLOK NUT	4
38	GN 531-L NYLOK NUT	4
39	GN 537-L NYLOK NUT	2
40	GN 550-L NYLOK NUT	4
41	GP 075-375 COLLET	6
42	GP 075-562 COLLET	6
43	GP 076 COLLET NUT	6
44	GS 525-09 SHCS .25-20 X 2.25 ZINC	4
45	GW 525-F FLAT WASHER	4
46	GW 531-L LOCK WASHER	6
47	GW 537-F FLAT WASHER	2
48	ML 072-P2 GUIDE, LONG ADJ	3
49	ML 072-P4-L GUIDE, LONG ADJ	3
50	ML 072.1 SPRING NUT	3
51	UHS-H9H9 ASSY	3

PARTS DIAGRAM

BRLM 430 FRONT IDLER ASSEMBLY

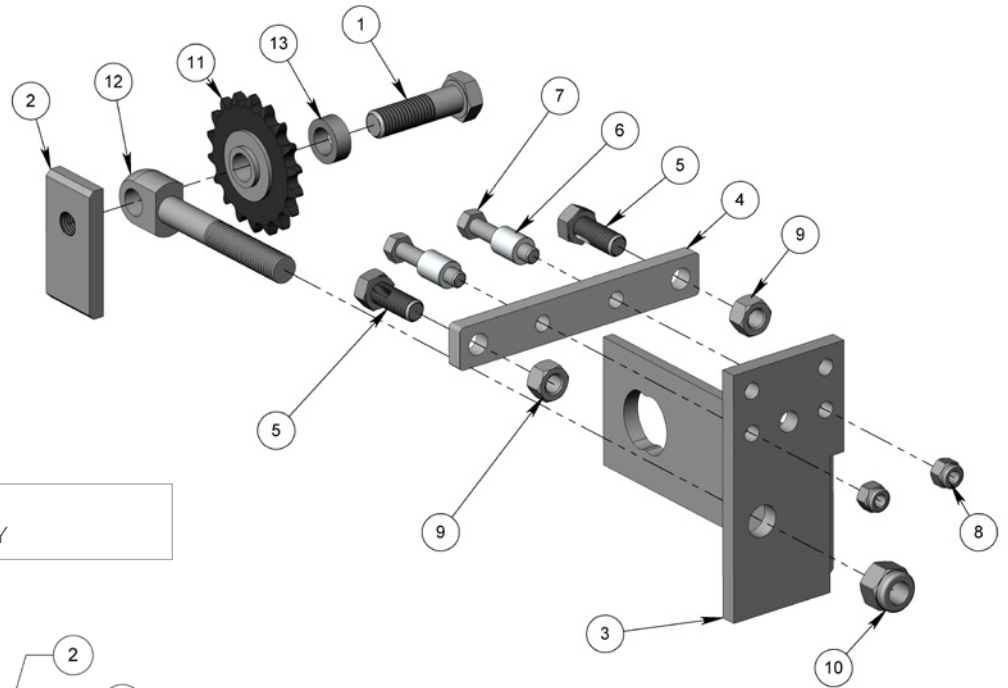

BRLM 420 REAR IDLER ASSEMBLY

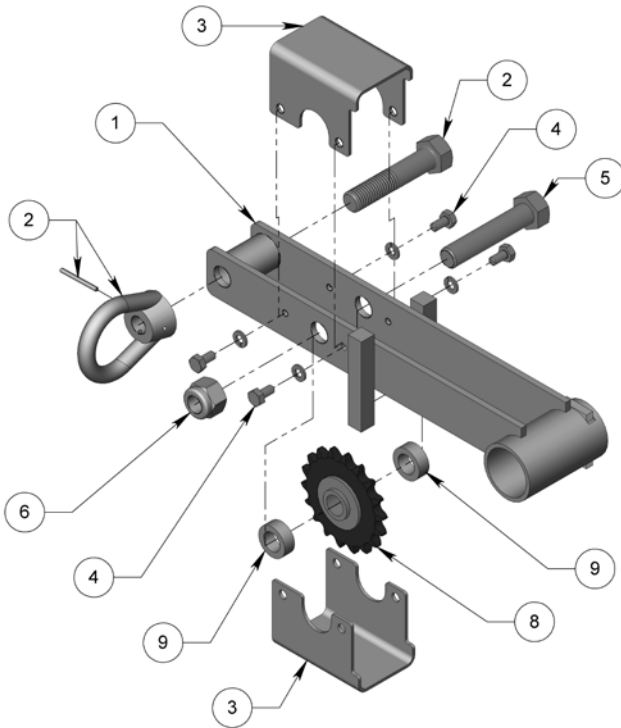

#	PART NUMBER	QTY.
1	BR 026 IDLER BOLT	1
2	BR 030 IDLER PLATE	1
3	BRLM 032 FRONT BRACKET	1
4	BRLM 032-D PLATE, DUAL COIL FRONT	1
5	BRLM 036 BOLT, COIL ANCHOR	2
6	BRUD 117 BUSHING	2
7	GB 537-08 BOLT, HEX .37-16 X 2.00	2
8	GN 537-L NYLOK NUT	2
9	GN 550-H HEX NUT	2
10	GN 562-L NYLOK NUT	1
11	LM 025.1 IDLER SPROCKET	1
12	LM 025.2 SWING BOLT	1
13	UD 045-D SPACER	1

#	PART NUMBER	QTY.
1	BR 010 REAR IDLER WELDMENT	1
2	BR 011 LIFTING EYE & BOLT	1
3	BR 137 GUARD, IDLER	2
4	GB 525-02 BOLT, HEX .25-20 X .50	4
5	GB 562-12 BOLT, HEX .62-11 X 3.00	1
6	GN 562-L NYLOK NUT	1
7	GW 525-L LOCK WASHER	4
8	LM 025.1 IDLER SPROCKET	1
9	UD 045-D SPACER	2

BRLM 500-XX
RIGID LANCING MACHINE

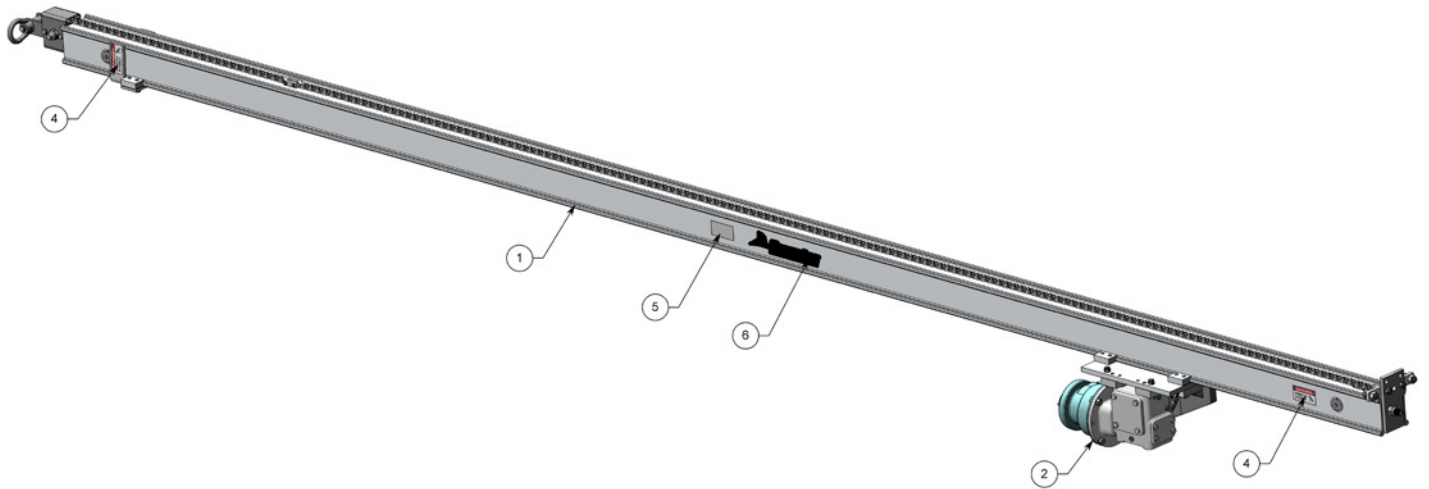

#	PART	QTY.
1	BRLM 005-15 DRIVE RAIL	1
2	BRLM 500.1-15 DRIVE PACKAGE	1
4	PL 160 PINCH POINT 1.5X3.0 DECAL	5
5	PL 167 CAUTION LABEL-MOVING-ROTATING	2
6	PL L STONEAGE STICKER, LARGE	2

BRLM 500.1-15
DRIVE PACKAGE

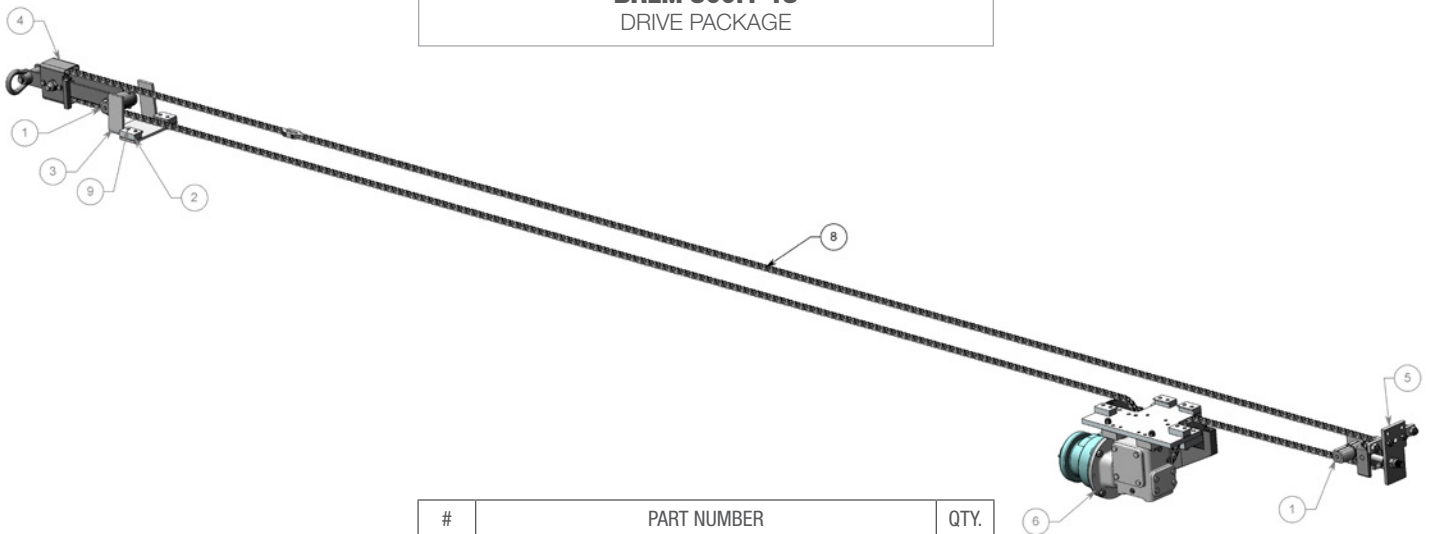

#	PART NUMBER	QTY.
1	BR 008-BU-001 WEDGE BOLT	2
2	BR 060 RAIL CLAMP	2
3	BRLM 070, STOP, CARRIAGE	1
4	BRLM 420 REAR IDLER ASSY EXP	1
5	BRLM 430 FRONT IDLER ASSY	1
6	BRLM 510-EG FEED DRIVE ASSY (ELECTRA-GEAR)	1
8	BRLM 520-15D CHAIN FOR BRLM 500-15	1
9	GB 537-04 BOLT, HEX .37-16 X 1.00	4

PARTS DIAGRAM

BRLM 510-EG FEED DRIVE ASSEMBLY (ELECTRA-GEAR)

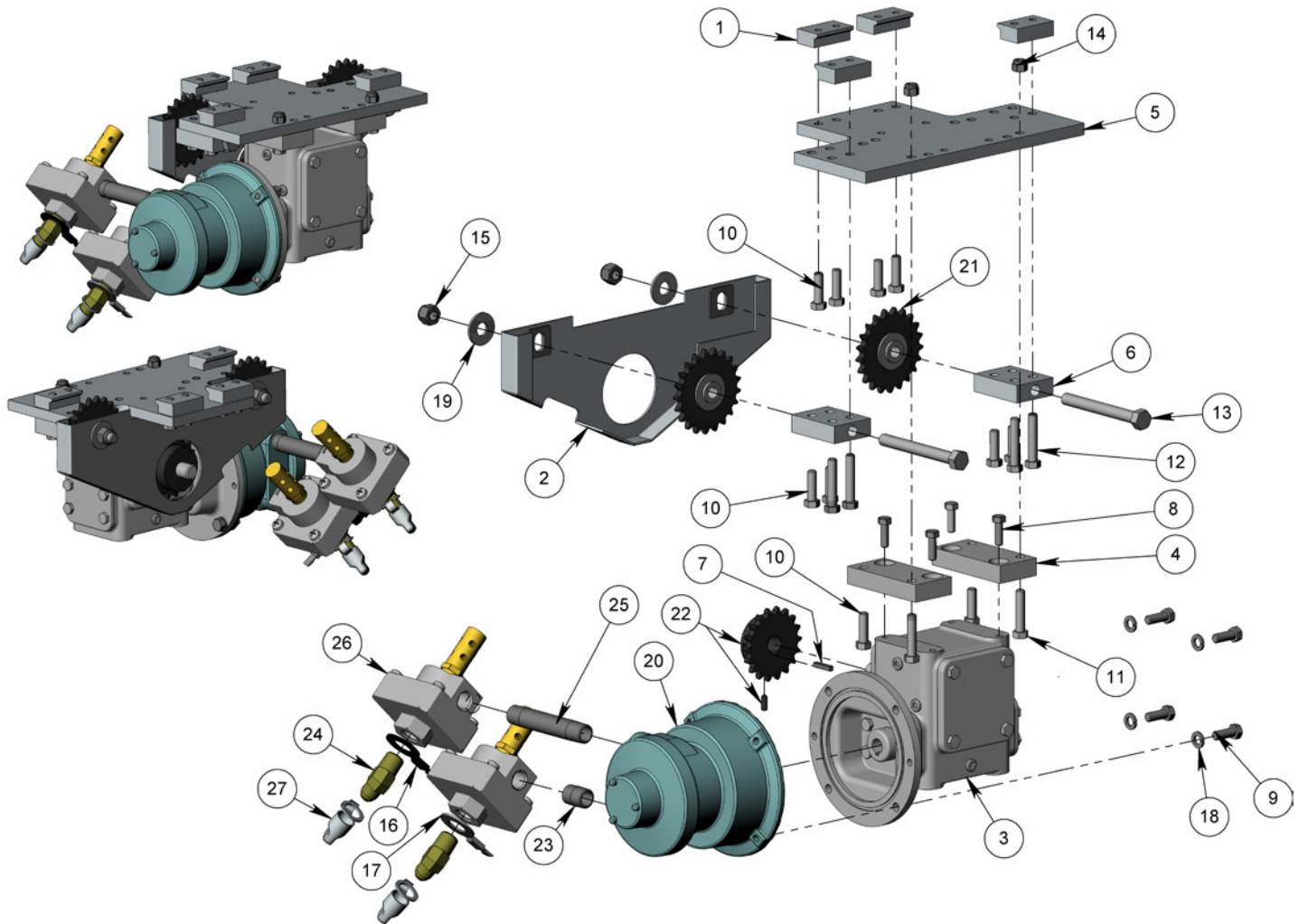

#	PART NUMBER	QTY.
1	BR 060 RAIL CLAMP	4
2	BR 133 CHAIN GUARD	1
3	BR 170-E30 GEARBOX, ELECTRA-GEAR 30-1	1
4	BRLM 023-EG DRIVE PED	2
5	BRLM 051 MID DRIVE PLATE (BONFIG)	1
6	BRLM 056 IDLER MOUNT	2
7	CST 022.1 KEY .187 SQ X 1.00	1
8	GB 531-04 BOLT, HEX .31-18 X 1.00	4
9	GB 537-04 BOLT, HEX .37-16 X 1.00	4
10	GB 537-05 BOLT, HEX .37-16 X 1.25	10
11	GB 537-07 BOLT, HEX .37-16 X 1.75	2
12	GB 537-08 BOLT, HEX .37-16 X 2.00	4
13	GB 550-18 BOLT, HEX .50-13 X 4.50	2
14	GN 537-L NYLOK NUT	2
15	GN 550-L NYLOK NUT	2
16	GP 010-BK BLACK PLASTIC ID WASHER P8	1
17	GP 010-S SILVER PLASTIC ID WASHER P8	1
18	GW 537-L LOCK WASHER	4
19	GW 550-F FLAT WASHER	2
20	LM 016-6 AIR MOTOR	1
21	LM 022.1 IDLER SPROCKET	2
22	LM 518-EG SPROCKET	1
23	ML 017-8.4 FTG, NIPPLE CLOSE P8M P8M	1
24	ML 017-8.8 FTG, ELBOW 45 P8M J8M	2
25	ML 017-8.7 FTG, NIPPLE P8M 4.50	1
26	ML 019 QUICK EXHAUST P8 WITH MUFFLER	2
27	BR 167 DUST CAP J8	2

BRLM 580-XX
RAIL EXTENSION KIT

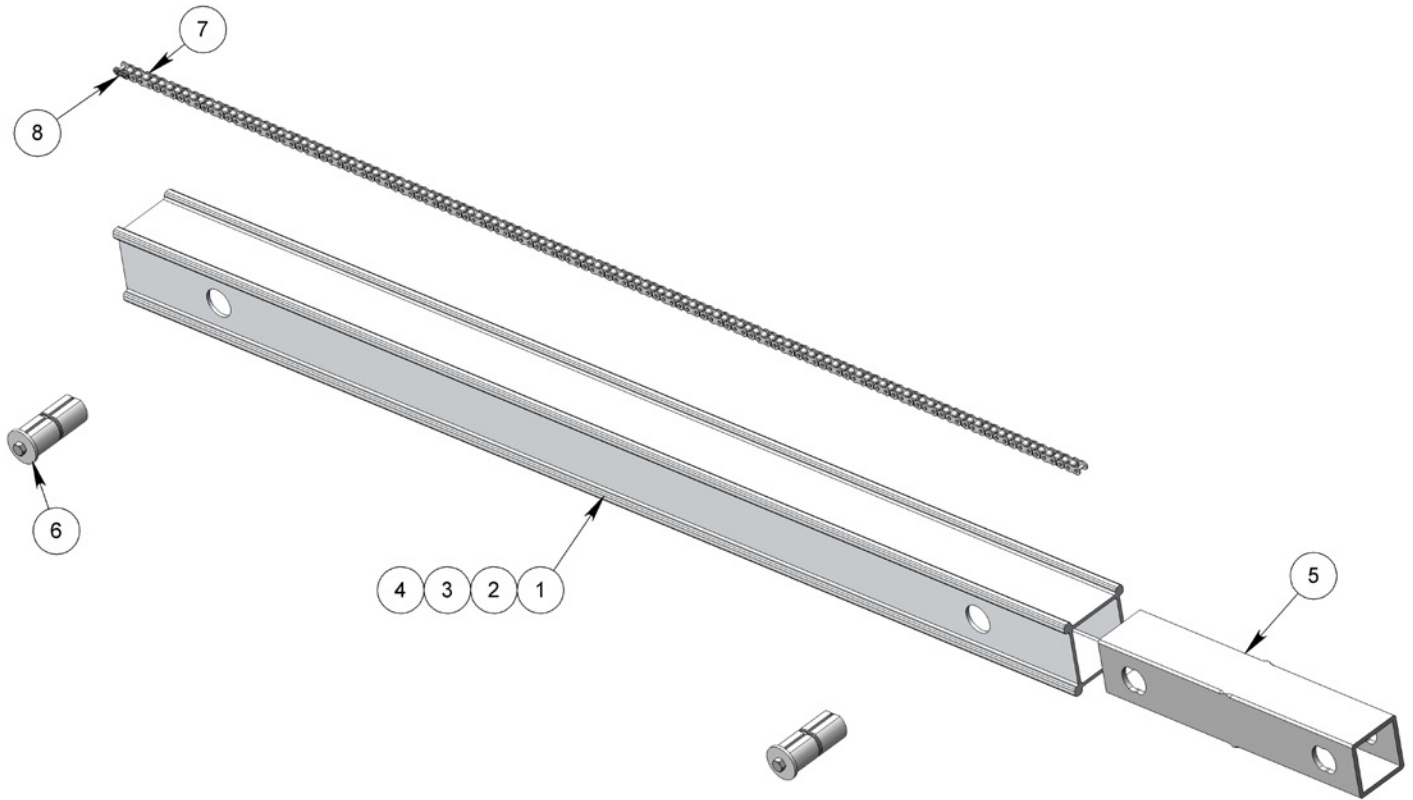

#	PART NUMBER	BRLM 580-05/QTY.	BRLM 580-08/QTY.	BRLM 580-10/QTY.	BRLM 580-15/QTY.
1	BR 004-05 BOX RAIL EXTENSION	1	-	-	-
2	BR 004-08 BOX RAIL EXTENSION	-	1	-	-
3	BR 004-10 BOX RAIL EXTENSION	-	-	1	-
4	BR 004-15 BOX RAIL EXTENSION	-	-	-	1
5	BR 006-N-001 SPLICE TUBE	1	1	1	1
6	BR 008-BU-001 WEDGE BOLT	2	2	2	2
7	BRLM 520 CHAIN	1	1	1	1
8	BRLM 521 MASTER LINK	1	1	1	1

BRLM 580-XX	BRLM 580-05	BRLM 580-08	BRLM 580-10	BRLM 580-15
BRLM 520-OAL	119.5"	191.5"	239.5"	359.5"

PARTS DIAGRAM

BRLM 636-XXX-XXX GUIDE BLOCK KITS

Attach blocks every 8th coil.

5 FT EXTENSION
(2 BLOCKS, 1 TAIL)



10 FT EXTENSION
(3 BLOCKS, 1 TAIL)

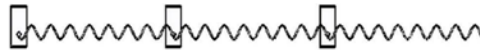

15 FT EXTENSION
(4 BLOCKS, 1 TAIL)



15 FT DRIVE
(4 BLOCKS, 2 TAILS)

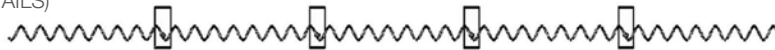

20 FT EXTENSION
(6 BLOCKS, 1 TAIL)



25 FT DRIVE
(7 BLOCKS, 2 TAILS)



BRLM 236-XXX GUIDE BLOCK

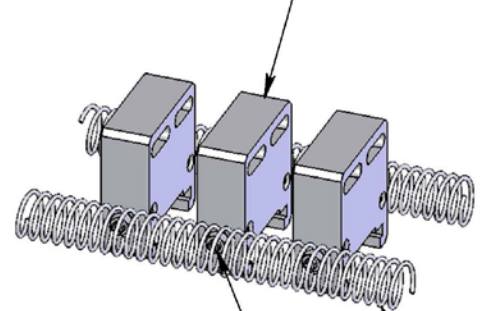

EACH BLOCK CONTAINS:
(2) BRLM 238 CLAMP, DUAL COIL
(2) GN 550-H HEX NUT

(2) BRLM 034-XX COIL

BRLM 636-XXX-XXX			
XX=LENGTH	X=DRIVE OR EXTENSION	X=NUMBER OF LANCES	XX=DIAMETER OF LANCE HOLE
5= 5FT	D=DRIVE	S=SINGLE	10 = 5/8"
10= 10FT	NO "D"= EXTENSION	D=DOUBLE	15 = 15/16"
15= 15FT		T=TRIPLE	18 = 1 1/8"
20= 20FT			
25= 25FT			

EXAMPLE: BRLM 636-25D-T10 = 25FT DRIVE FOR TRIPLE LANCE WITH 5/8" HOLES

BRLM 636-K DUAL COIL HARDWARE KIT

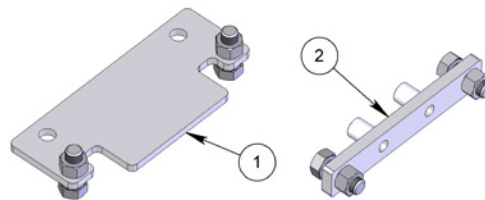

#	PART NUMBER	QTY.
1	BRLM 239 ASSEMBLY, CARRIAGE DUAL COIL PLATE	1
2	BRLM 240 ASSEMBLY, FRONT DUAL COIL ANCHOR	1

LANCE POSITIONER (CB-LP)
CONTROL BOX

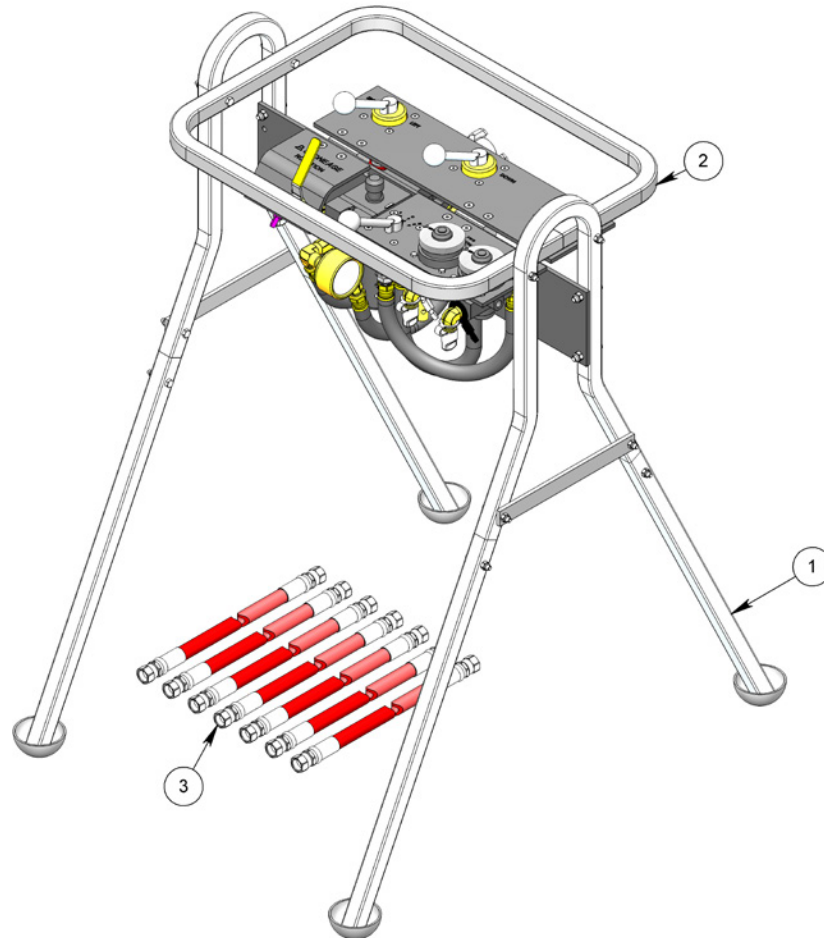

#	PART NUMBER	QTY.
1	CB 107 LEG WELDMENT	4
2	CB-LP.1 CONTROL BOX PANEL ASSY	1
3	CB 158 HOSE ASSY, 25 FT J8	7

PARTS DIAGRAM

LANCE POSITIONER (CB-LP.1)
CONTROL BOX SUB ASSEMBLY, DUAL REGULATOR, FOUR FUNCTION

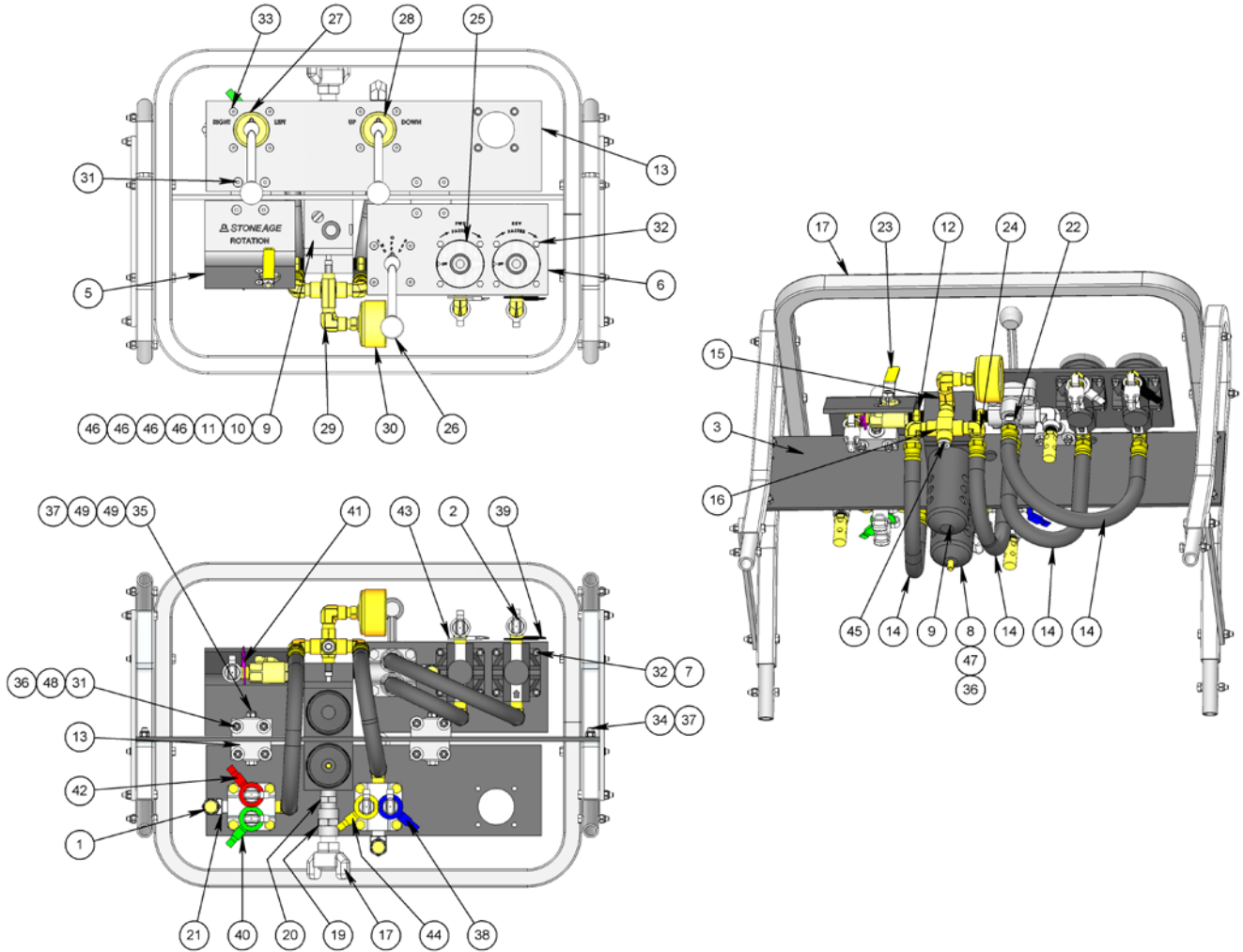

#	PART NUMBER	QTY.
1	BR 154 MUFFLER P6	3
2	BR 167 DUST CAP J8	7
3	CB 004-D MOUNTING PLATE	1
4	CB 006 MOUNT BLOCK	4
5	CB 010 ROTATION CONTROL PANEL	1
6	CB 012-D PLATE DUAL REGULATOR	1
7	CB 012.2 NUT, NYLOK 10-24 (GN 519-L)	8
8	CB 020 FILTER	1
9	CB 022 OILER	1
10	CB 023 PLATE, DIRECTION	1
11	CB 024 PLATE END	1
12	CB 026 FTG, NIPPLE HEX P6M P6M	2
13	CB 050 PLATE, XYZ	1
14	CB 052-14 HOSE ASSY	4
15	CB 054 FTG, TEE P6M P6F P6F	1
16	CB 058 FTG, CROSS P6F	1
17	CB 100 FRAME SUB ASSY	1

18	CB 114 INLET FITTING	1
19	CB 115 COUPLING	1
20	CB 116 NIPPLE	1
21	CB 120 FTG, ELBOW STREET 90 P6M P6F	3
22	CB 122 FTG, ADAPTER P6M J8M	6
23	CB 124 BALL VALVE ASSY	1
24	CB 126 FITTING, ELBOW OUTLET	9
25	CB 132 REGULATOR	2
26	CB 142 VALVE, SELECTOR	1
27	CB 142-C VALVE, SELECTOR	1
28	CB 142-C-001 VALVE, SELECTOR	1
29	CB 147 FTG, ELBOW 90 P6M P4F	1
30	CB 148 GAUGE	1
31	CB 508 FSHCS .25-20 X 1.75 SS	8
32	CB 512.1 HHMS .19-24 X .75 SS	8
33	CB 555 FSHCS .19-24 X .50 SS (GSF 319-02)	14
34	GB 531-07 BOLT, HEX .31-18 X 1.75	4

35	GB 531-11 BOLT, HEX .31-18 X 2.75	2
36	GN 525-L NYLOK NUT	10
37	GN 531-L NYLOK NUT	6
38	GP 009-B BLUE PLASTIC ID WASHER P6	1
39	GP 009-BK BLACK PLASTIC ID WASHER P6	1
40	GP 009-G GREEN PLASTIC ID WASHER P6	1
41	GP 009-P PURPLE PLASTIC ID WASHER P6	1
42	GP 009-R RED PLASTIC ID WASHER P6	1
43	GP 009-S SILVER PLASTIC ID WASHER P6	1
44	GP 009-Y YELLOW PLASTIC ID WASHER P6	1
45	GP 025-P6SS HEX SOCKET PLUG	1
46	GS 525-025 SHCS .25-20 X .62 ZINC	4
47	GS 525-05 SHCS .25-20 X 1.25 BLK (CB 021)	2
48	GW 525-F FLAT WASHER	8
49	GW 531-F FLAT WASHER	4

AUTOBOX® (CB-TBX-LPA)
LPA TUMBLEBOX ASSEMBLY

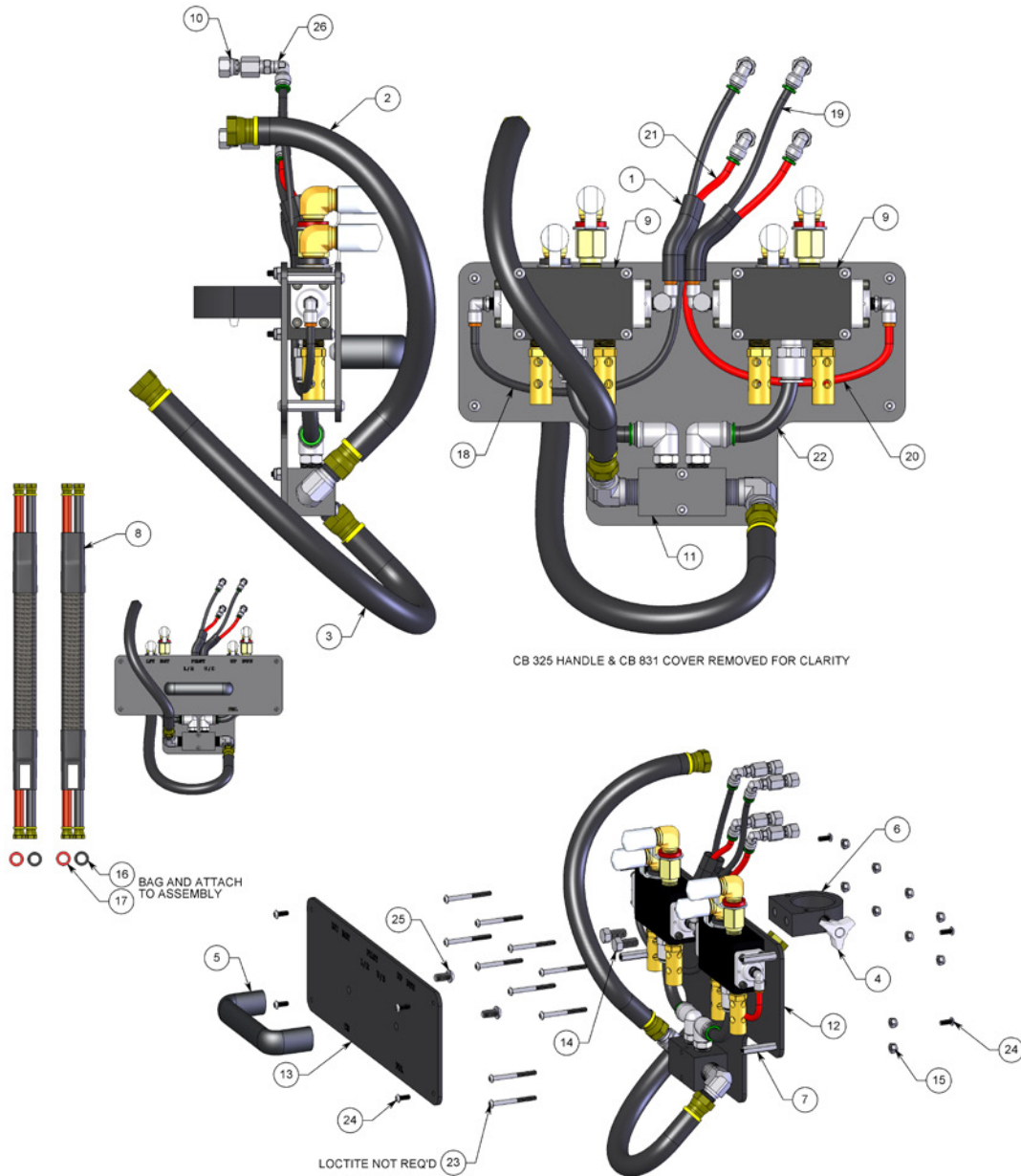

#	PART NUMBER	QTY.
1	CAM 153 HEAT SHRINK (CUT IN HALF)	1
2	CB 052-14 HOSE, INLET FOR LPA	1
3	CB 052-18 HOSE, OUTLET FOR LPA	1
4	CB 314 3-LOBE KNOB	1
5	CB 325 HANDLE TOP	1
6	CB 328-001 POLE MOUNT	1
7	CB 712 HEX STANDOFF	4
8	CB 745-25 SUPPLY HOSE BUNDLE	2
9	CB 825 SPOOL VALVE ASSY, LPA	2
10	CB 828 FTG, ADAPTER SWIVEL P2F J4F	4

11	CB 829 MANIFOLD ASSY, LPA	1
12	CB 830 FRAME, TUMBLEBOX LPA	1
13	CB 831 COVER, TUMBLEBOX LPA	1
14	GB 337-03 BOLT, HEX .37-16 X .75 SS	2
15	GN 319-L NYLOK NUT SS (HC 025.1)	10
16	GP 012-BK BLACK ID BAND LG	2
17	GP 012-RD RED ID BAND LG	2
18	GPTB 0250-PUR95A-BK (PILOT LEFT) FOR LPA	1
19	GPTB 0250-PUR95A-BK (PILOT UP) FOR LPA	1
20	GPTB 0250-PUR95A-RD (PILOT DOWN) FOR LPA	1

21	GPTB 0250-PUR95A-RD (PILOT RIGHT) FOR LPA	1
22	GPTB 0500-PUR95A-BK TUBE, .50 FOR LPA	2
23	GSB 319-08 BHCS 10-24 X 2.00 SS	10
24	GTB 319-02-32 BHTS .19-32 X .50 TORX SS	8
25	GTB 331-025 BHTS .31-18 X .62 TORX SS	2
26	HRS 563 FTG, ELBOW SWIVEL 90 P2M PL4	4

LANCE POSITIONER (LP-300-XX)
LANCE POSITIONER ASSEMBLY

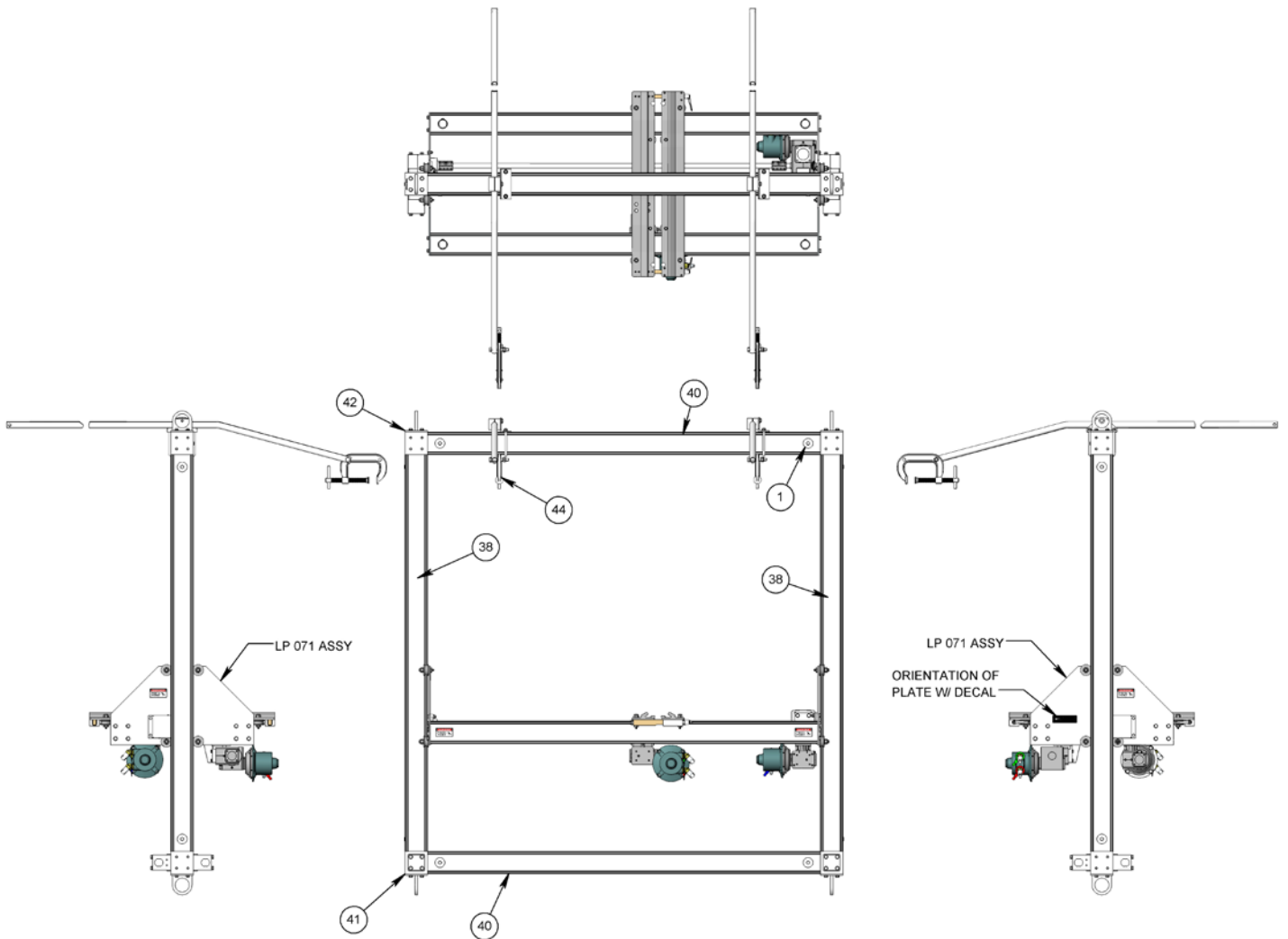

#	PART NUMBER	QTY.
1	BR 008-BU-001 WEDGE BOLT	8
38	LP 076 RAIL SLOTTED VERTICAL	2
40	LP 078-78 CROSS TIE	2
41	LP 094-L CORNER ASSY	2
42	LP 094-U CORNER ASSY	2
44	LP 210 FRONT BRACE ASSY	1

LANCE POSITIONER (LP-300-XX)
LANCE POSITIONER ASSEMBLY CONTINUED...

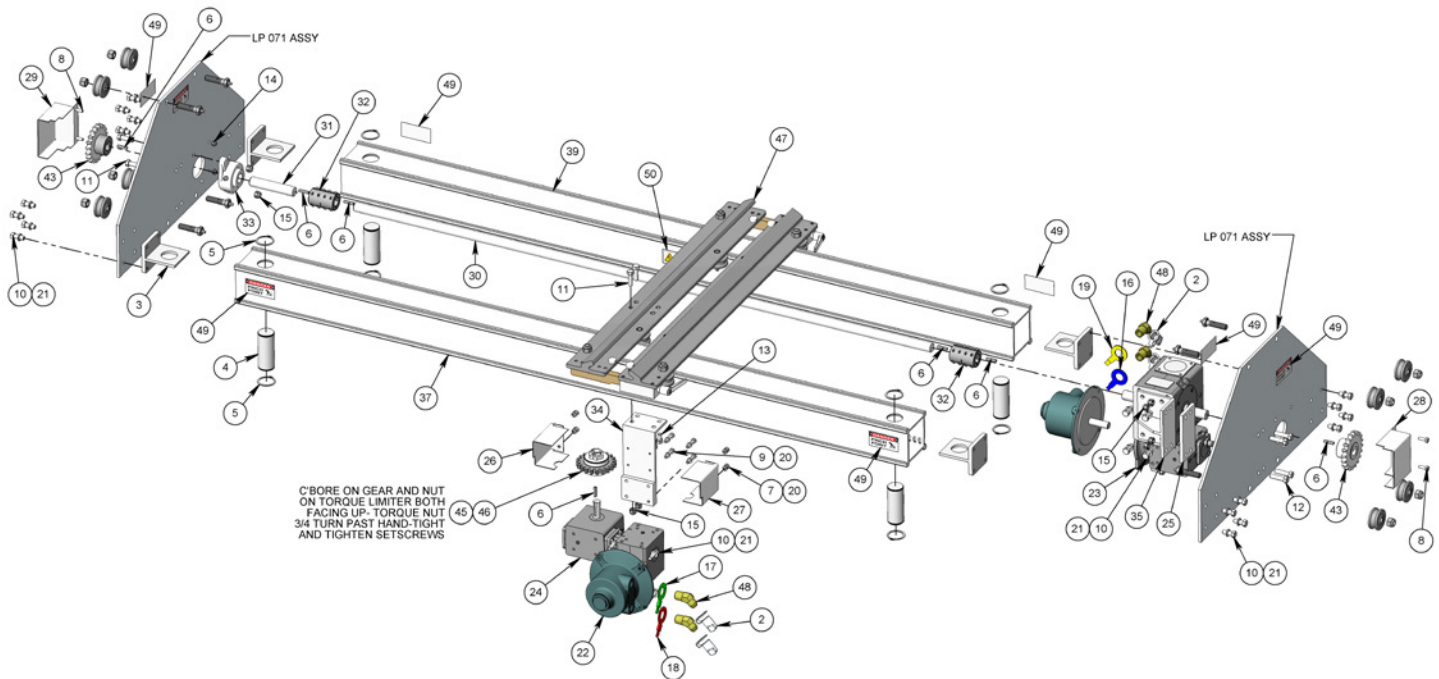

#	PART NUMBER	QTY.			
2	BR 167 DUST CAP J8	4	17	GP 010-G GREEN PLASTIC ID WASHER P8	1
3	BRUD 072 BEAM INSERT	4	18	GP 010-R RED PLASTIC ID WASHER P8	1
4	BRUD 073 BEAM PIN	4	19	GP 010-Y YELLOW PLASTIC ID WASHER P8	1
5	BRUD 172 RETAINING RING, EXTERNAL	8	20	GW 525-L LOCK WASHER	8
6	CST 022.1 KEY .187 SQ X 1.00	7	21	GW 537-L LOCK WASHER	28
7	GB 525-02 BOLT, HEX .25-20 X .50	4	22	LM 016-4 AIR MOTOR	2
8	GB 525-03 BOLT, HEX .25-20 X .75	4	23	LP 011-PC 2104 400-1 RALR	1
9	GB 525-05 BOLT, HEX .25-20 X 1.25	4	24	LP 012-PC 1304 400-1 ULR	1
10	GB 537-04 BOLT, HEX .37-16 X 1.00	28	25	LP 013 SPACER, VERTICAL GEARBOX	1
11	GB 537-05 BOLT, HEX .37-16 X 1.25	4	26	LP 028 GUARD, GEAR HZ RH	1
12	GB 537-06 BOLT, HEX .37-16 X 1.50	4	27	LP 029 GUARD, GEAR HZ LH	1
13	GB 537-025 BOLT, HEX .37-16 X .62	2	28	LP 030 GUARD, GEAR RH	1
14	GN 525-L NYLOK NUT	4	29	LP 031 GUARD, GEAR LH	1
15	GN 537-L NYLOK NUT	8	30	LP 032-78 SHAFT, DRIVE	1
16	GP 010-B BLUE PLASTIC ID WASHER P8	1	31	LP 033 SHAFT, STUB	1
			32	LP 034-001 COUPLING	2
			33	LP 036 BEARING, FLANGE MOUNT (MFR VARIATIONS)	1
			34	LP 050-SS GEARBOX MOUNT HORIZONTAL	1
			35	LP 055-SS GEARBOX MOUNT VERTICAL	1
			36	LP 071 ASSY, 2 SIDE PLATES & ROLLERS	1
			37	LP 074-78 RAIL SLOTTED HORIZONTAL	1
			39	LP 077-78 CROSS BEAM	1
			43	LP 170 GEAR WELDMENT	2
			45	LP 225 TORQUE LIMITER	1
			46	LP 270 GEAR, SPUR	1
			47	LP 700 CARRIAGE CLAMP ASSY	1
			48	ML 017-8.8 FTG, ELBOW 45 P8M J8M	4
			49	PL 160 PINCH POINT 1.5X3.0 DECAL	8
			50	PL 167 CAUTION LABEL-MOVING-ROTATING	1

LANCE POSITIONER (LP 320)
REAR SUPPORT ASSEMBLY

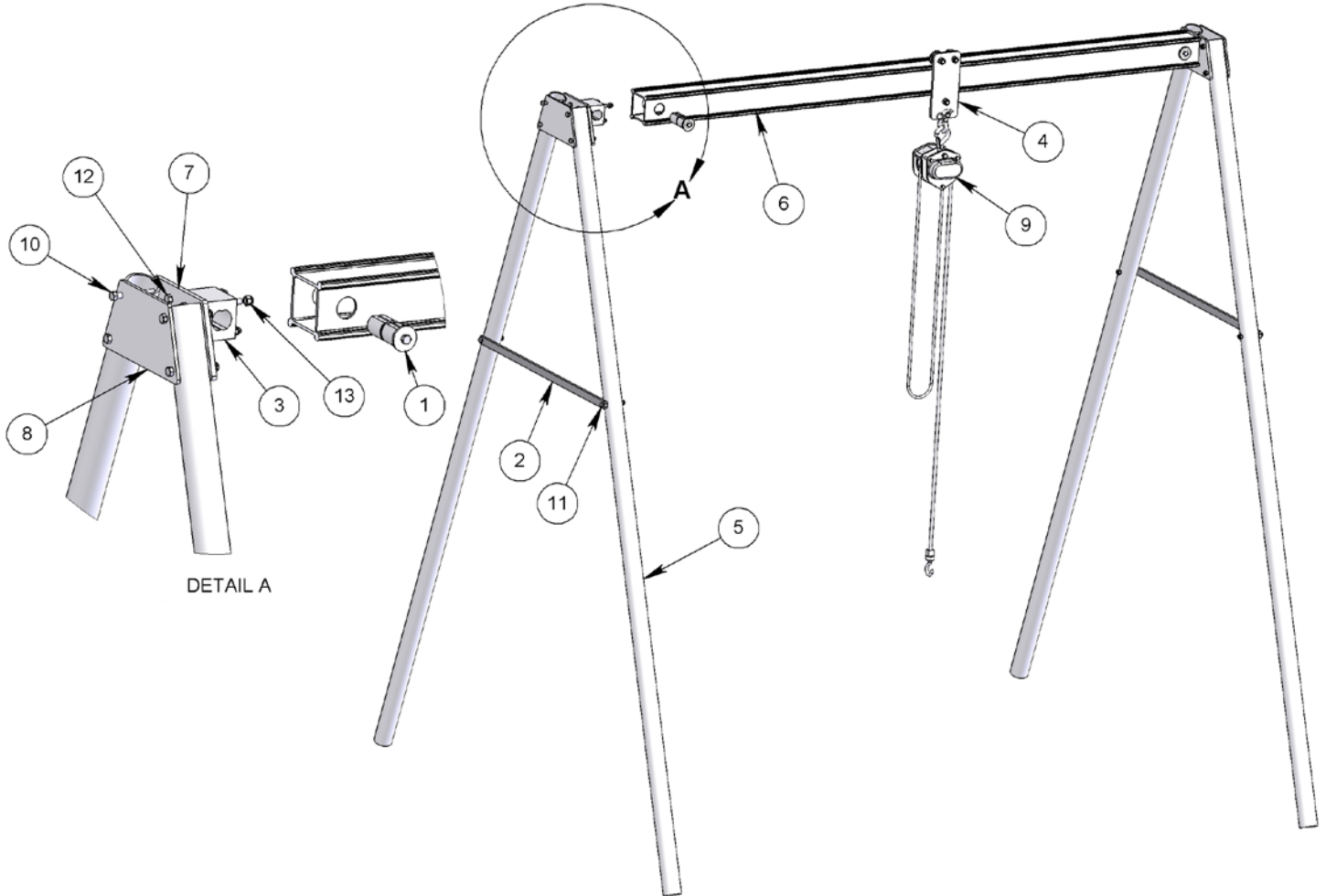

#	PART NUMBER	QTY.
1	BR 008-BU-001 WEDGE BOLT	2
2	BJ 086.4-L LINK	2
3	LP 095-001 CORNER POST	2
4	LP 310 TROLLEY ASSY	1
5	LP 313 LEG, PIPE	4
6	LP 319 TOP BEAM	1
7	LP 314 PLATE, END FITTING	2
8	LP 315 PLATE, END FITTING COVER	2
9	UD 071-D CHAIN HOIST (EXT)	1
10	GB 537-14 BOLT, HEX .37-16 X 3.50	8
11	GB 537-13 BOLT, HEX .37-16 X 3.25	4
12	GB 537-17 BOLT, HEX .37-16 X 4.25	8
13	GN 537-L NYLOK NUT	20

LANCE POSITIONER (LP 330-XX)
LANCE POSITIONER LEG OPTIONS

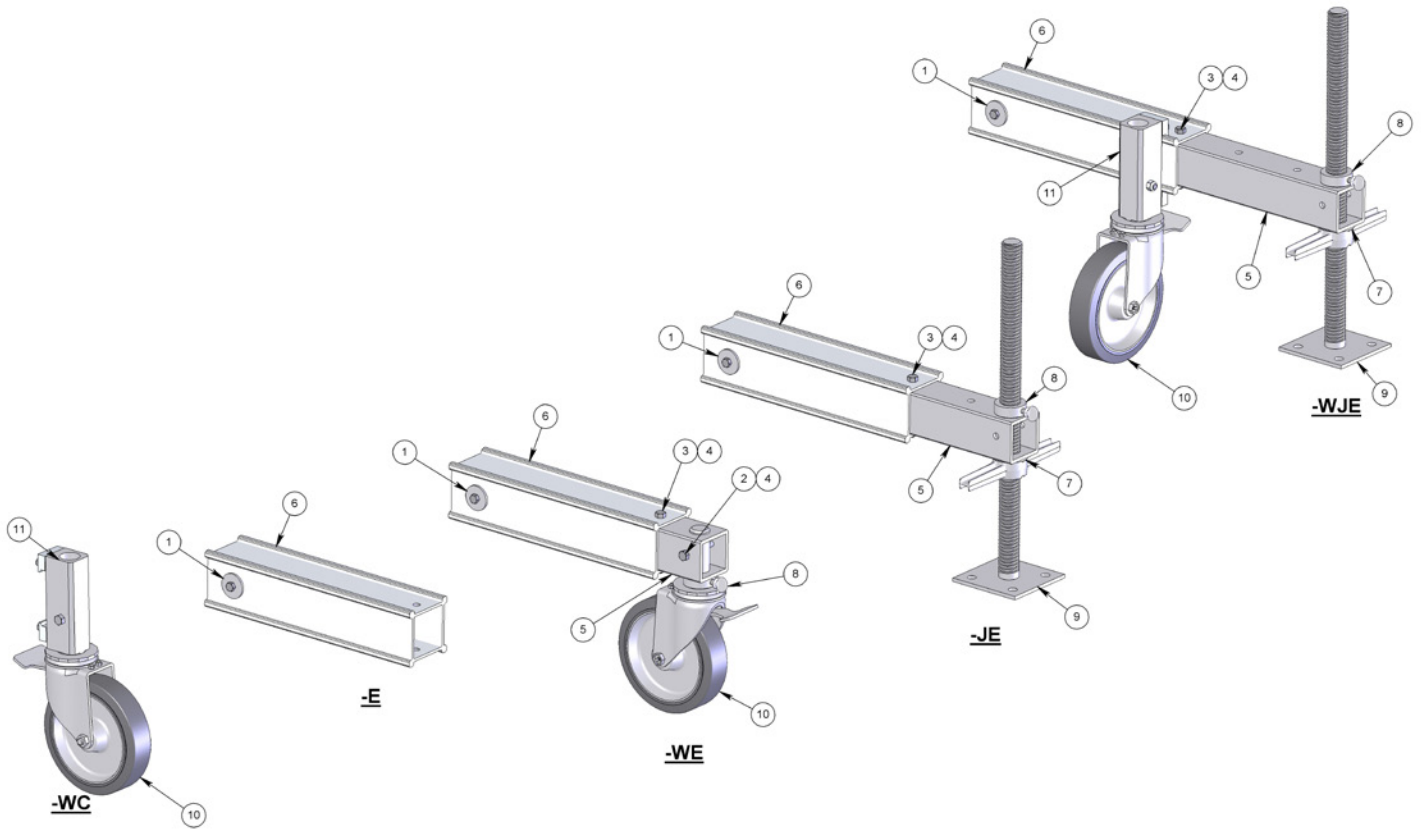

#	PART NUMBER	LP 335-WC QTY.	LP 335-E QTY.	LP 335-WE QTY.	LP 335-JE QTY.	LP 335-WJE QTY.
1	BR 008-BU-001 WEDGE BOLT	-	4	4	4	4
2	GB 543-14 BOLT, HEX .43-14 X 3.50	-	-	4	-	-
3	GB 543-16 BOLT, HEX .43-14 X 4.00	-	-	4	4	4
4	GN 543-L NYLOK NUT	-	-	8	4	4
5	LP 075 WHEEL INSERT	-	-	4	4	4
6	LP 079-17.5 WHEEL RAIL	-	4	4	4	4
7	LP 085 WASHER, CASTER	-	-	-	4	4
8	LP 086 COLLAR ASSY	-	-	4	4	4
9	LP 088 JACK ASSY	-	-	-	4	4
10	LP 089 WHEEL	4	-	4	-	4
11	LP 093 WHEEL MOUNT ASSY	4	-	-	-	4

LANCE POSITIONER (LP 700)
CARRIAGE CLAMP ASSEMBLY

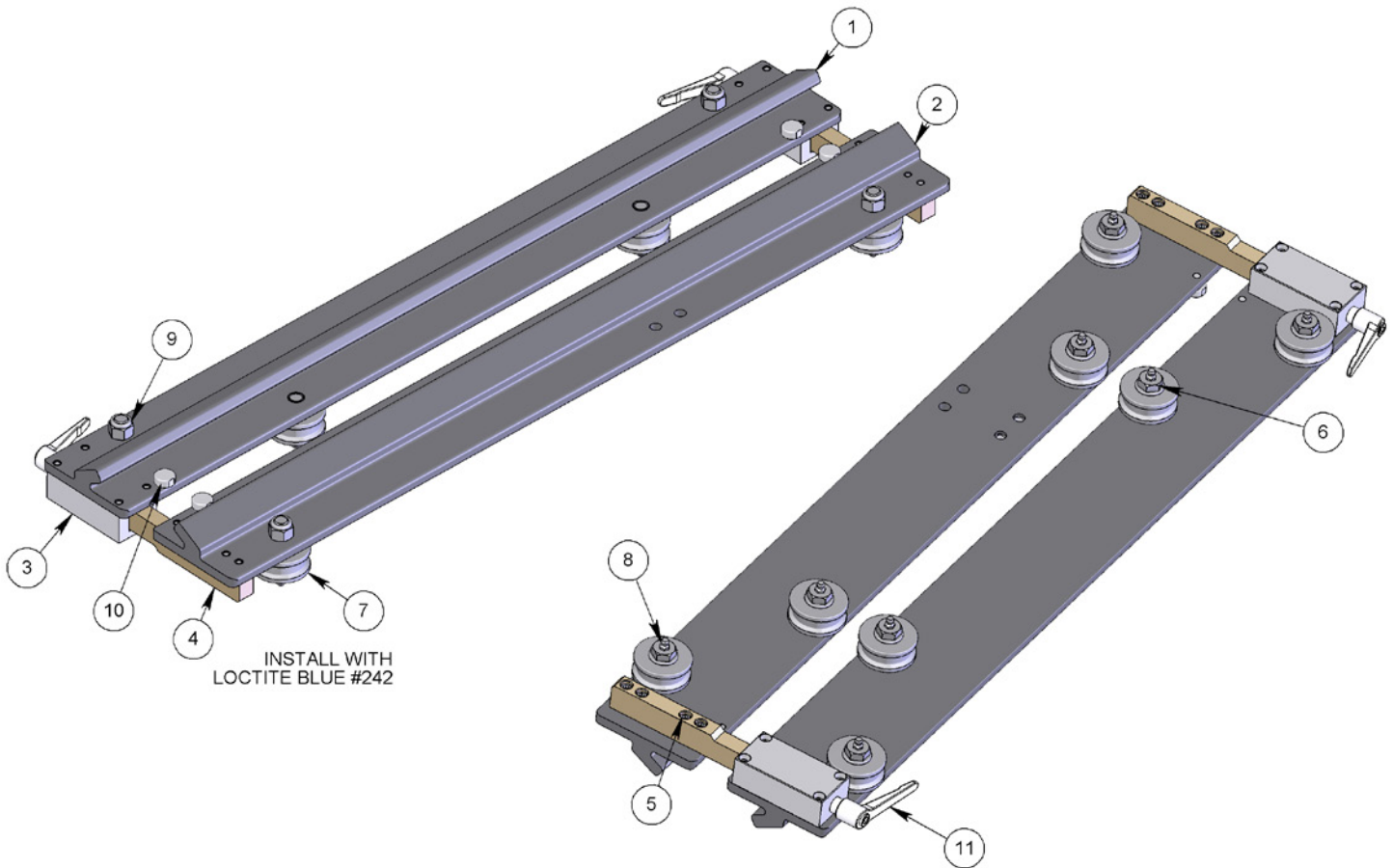

#	PART NUMBER	QTY.
1	LP 701 FIXED RAIL ASSY	1
2	LP 705 CLAMPING RAIL ASSY	1
3	LP 707 END CLAMP	2
4	LP 706 SLIDER	2
5	GS 325-04 SHCS .25-20 X 1.00 SS (BC 053)	16
6	LP 652-1.38 AXLE-ZERK	4
7	BR 055 ROLLER ASSY	8
8	BR 052-2.0 AXLE-ZERK	4
9	GN 550-L NYLOK NUT	4
10	LP 622 COMPRESSION SPACER	4
11	LP 708 .375-16 SS HANDLE	2

LANCE POSITIONER (LP 071)
2 SIDE PLATES AND ROLLER ASSEMBLY

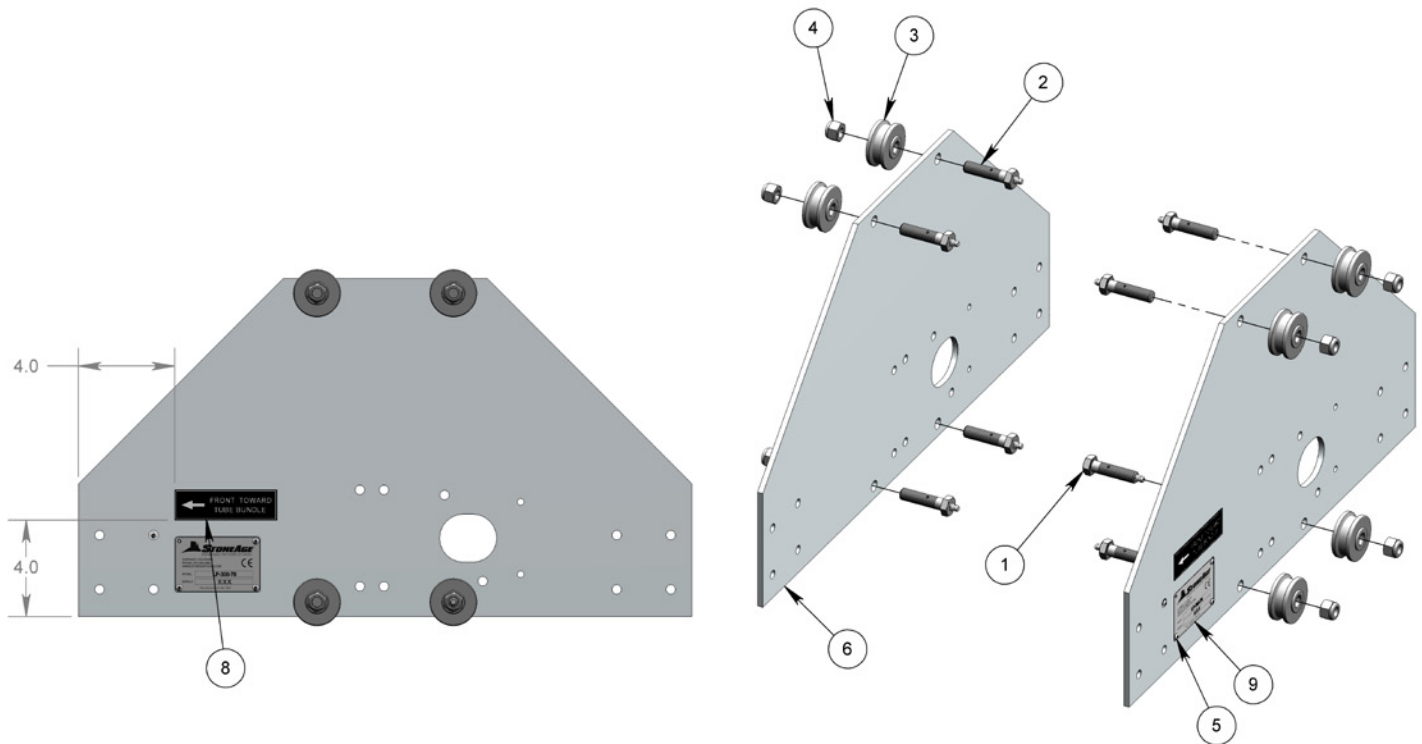

#	PART NUMBER	QTY.
1	BR 051-2.0-0 AXLE-ZERK	1
2	BR 052-2.0 AXLE-ZERK	7
3	BR 055 ROLLER ASSY	8
4	GN 550-L NYLOK NUT	8
5	GSB 313-0075 BHCS 6-32 X .19 SS	4
6	LP 070 SIDE PLATE	1
7	LP 070-001 SIDE PLATE	1
8	LP 072 LABEL, ORIENTATION	1
9	LP 073 CE SERIAL PLATE	1

TERMS AND CONDITIONS

1. Acceptance of Terms and Conditions. Receipt of these Terms and Conditions of Sale ("Terms and Conditions") shall operate as the acceptance by StoneAge, Inc. ("Seller") of the order submitted by the purchaser ("Buyer"). Such acceptance is made expressly conditional on assent by Buyer to these Terms and Conditions. Such assent shall be deemed to have been given unless written notice of objection to any of these Terms and Conditions (including inconsistencies between Buyer's purchase order and this acceptance) is given by Buyer to Seller promptly on receipt hereof.

Seller desires to provide Buyer with prompt and efficient service. However, to individually negotiate the terms of each sales contract would substantially impair Seller's ability to provide such service. Accordingly, the product(s) furnished by Seller are sold only according to the terms and conditions stated herein and with the terms and conditions stated in any effective StoneAge Dealer Agreement or StoneAge Reseller Agreement, if applicable. Notwithstanding any terms and conditions on Buyer's order, Seller's performance of any contract is expressly made conditional on Buyer's agreement to these Terms and Conditions unless otherwise specifically agreed to in writing by Seller. In the absence of such agreement, commencement of performance, shipment and/or delivery shall be for Buyer's convenience only and shall not be deemed or construed to be an acceptance of Buyer's terms and conditions.

2. Payment/Prices. Unless other arrangements have been made in writing between Seller and Buyer, payment for the product(s) shall be made upon receipt of invoice. The prices shown on the face hereof are those currently in effect. Prices invoiced shall be per pricelist in effect at the time of shipment. Prices are subject to increase for inclusion of any and all taxes which are applicable and which arise from the sale, delivery or use of the product(s), and the collection of which Seller is or may be responsible to provide to any governmental authority, unless acceptable exemption certificates are provided by Buyer in accordance with applicable law. Buyer shall pay all charges for transportation and delivery and all excise, order, occupation, use or similar taxes, duties, levies, charges or surcharges applicable to the product(s) being purchased, whether now in effect or hereafter imposed by any governmental authority, foreign or domestic.

3. Warranty. SELLER MAKES NO WARRANTIES OR REPRESENTATIONS AS TO THE PERFORMANCE OF ANY PRODUCT EXCEPT AS SET FORTH IN THE STONEAGE LIMITED WARRANTY PROVIDED WITH THE PRODUCT.

4. Delivery. Seller is not obligated to make delivery by a specified date, but will always use its best efforts to make delivery within the time requested. The proposed shipment date is an estimate. Seller will notify Buyer promptly of any material delay and will specify the revised delivery date as soon as practicable. UNDER NO CIRCUMSTANCES SHALL SELLER HAVE ANY LIABILITY WHATSOEVER FOR LOSS OF USE OR FOR ANY DIRECT OR CONSEQUENTIAL DAMAGES RESULTING FROM DELAY REGARDLESS OF THE REASON(S).

All product(s) will be shipped F.O.B. point of origin, unless specifically agreed otherwise, and Buyer shall pay all shipping costs and insurance costs from that point. Seller, in its sole discretion, will determine and arrange the means and manner of transportation of the product(s). Buyer shall bear all risk of loss commencing with the shipment or distribution of the product(s) from Seller's warehouse. Order shortages or errors must be reported within fifteen (15) business days from receipt of shipment to secure adjustment. No product(s) may be returned without securing written approval from Seller.

5. Modification. These Terms and Conditions are intended by Seller and Buyer to constitute a final, complete and exclusive expression of agreement relating to the subject matter hereof and cannot be supplemented or amended without Seller's prior written approval.

6. Omission. Seller's waiver of any breach or Seller's failure to enforce any of these Terms and Conditions at any time, shall not in any way affect, limit or waive Seller's right thereafter to enforce and compel strict compliance with every term and condition hereof.

7. Severability. If any provision of these Terms and Conditions is held to be invalid or unenforceable, such invalidity or unenforceability shall not affect the validity or enforceability of the other portions hereof.

8. Disputes. Seller and Buyer shall attempt in good faith to promptly resolve any dispute arising under these Terms and Conditions by negotiations between representatives who have authority to settle the controversy. If unsuccessful, Seller and Buyer shall further attempt in good faith to settle the dispute by nonbinding third-party mediation, with fees and expenses of such mediation apportioned equally to each side. Any dispute not so resolved by negotiation or mediation may then be submitted to a court of competent jurisdiction in accordance with the terms hereof. These procedures are the exclusive procedures for the resolution of all such disputes between the Seller and Buyer.

9. Governing Law. All sales, agreements for sale, offers to sell, proposals, acknowledgments and contracts of sale, including, but not limited to, purchase orders accepted by Seller, shall be considered a contract under the laws of the State of Colorado and the rights and duties of all persons, and the construction and effect of all provisions hereof shall be governed by and construed according to the laws of such state.

10. Jurisdiction and Venue. Seller and Buyer agree that the state or federal courts located within the City and County of Denver, Colorado shall have sole and exclusive jurisdiction over any litigation concerning any dispute arising under these Terms and Conditions not otherwise resolved pursuant to Section 9 as well as any alleged defects of any Products or damages sustained as a result of such alleged defects. Seller and Buyer further agree that should any litigation be commenced in connection with such a dispute, it shall only be commenced in such courts. Seller and Buyer agree to the exclusive jurisdiction of such courts and neither will raise any objection to the jurisdiction and venue of such courts, including as a result of inconvenience.

11. Attorney's Fees. If any litigation is commenced between Seller and Buyer, or their personal representatives, concerning any provision hereof, the party prevailing in the litigation shall be entitled, in addition to such other relief that is granted, to a reasonable sum as and for their attorneys' fees and costs in such litigation or mediation.

STONEAGE TRADEMARK LIST

View the list of StoneAge's trademarks and service marks and learn how the trademarks should be used. Use of StoneAge trademarks may be prohibited, unless expressly authorized.

<http://www.StoneAgetools.com/trademark-list/>

STONEAGE PATENT DATA

View the list of StoneAge's current U.S. patent numbers and descriptions.

<http://www.sapatents.com>

STONEAGE TERMS AND WARRANTY

View StoneAge's Terms and Warranty Conditions online.

<http://www.stoneagetools.com/terms>

<http://www.stoneagetools.com/warranty>

Warranties set forth herein extend only to End-Users, meaning customers acquiring, or that have previously acquired, a product manufactured by StoneAge ("Product") for their own use and not for resale, either directly from StoneAge Inc. ("StoneAge") or from a StoneAge Authorized Dealer or Reseller ("Dealer"). No warranty of any kind or nature is made by StoneAge beyond those expressly stated herein.

1. LIMITED WARRANTY PERIOD. Subject to the limitations and conditions hereinafter set forth, StoneAge warrants its Product to be free from defects in workmanship and material for a period of one (1) year from the date of purchase by the End-User, provided that the end of the limited warranty period shall not be later than eighteen (18) months from the date of shipment of the Product to the Dealer or the End-User by StoneAge ("Limited Warranty Period"). All replacement parts which are furnished under this Limited Warranty and properly installed shall be warranted to the same extent as the original Product under this Limited Warranty if, and only if, the original parts were found to be defective within the original Limited Warranty Period covering the original Product. Replacement parts are warranted for the remainder of the original Limited Warranty Period. This Limited Warranty does not cover any component part of any Product not manufactured by StoneAge. Any such component part is subject exclusively to the component manufacturer's warranty terms and conditions.

2. LIMITED WARRANTY COVERAGE. StoneAge's sole obligation under this Limited Warranty shall be, at StoneAge's option and upon StoneAge's inspection, to repair, replace or issue a credit for any Product which is determined by StoneAge to be defective in material or workmanship. StoneAge reserves the right to examine the alleged defective Product to determine whether this Limited Warranty is applicable, and final determination of limited warranty coverage lies solely with StoneAge. No statement or recommendation made by a StoneAge representative, Dealer or agent to End-User shall constitute a warranty by StoneAge or a waiver or modification to any of the provisions hereof or create any liability for StoneAge.

3. WARRANTY SERVICE PROVIDERS. Service and repair of the Product is to be performed only by StoneAge authorized service representatives, including Dealers who are authorized repair centers, with StoneAge approved parts. Information about StoneAge authorized service representatives can be obtained through the StoneAge website at www.stoneagetools.com/ service. Unauthorized service, repair or modification of the Product or use of parts not approved by StoneAge will void this Limited Warranty. StoneAge reserves the right to change or improve the material and design of the Product at any time without notice to End-User, and StoneAge is not obligated to make the same improvements during warranty service to any Product previously manufactured.

4. WARRANTY EXCLUSIONS. This Limited Warranty does not cover, and StoneAge shall not be responsible for the following, or damage caused by the following: (1) any Product that has been altered or modified in any way not approved by StoneAge in advance in writing; (2) any Product that has been operated under more severe conditions or beyond the rated capacity specified for that Product; (3) depreciation or damage caused by normal wear and tear, failure to follow operation or installation instructions, misuse, negligence or lack of proper protection during storage; (4) exposure to fire, moisture, water intrusion, electrical stress, insects, explosions, extraordinary weather and/or environmental conditions including, but not limited to lightning, natural disasters, storms, windstorms, hail, earthquakes, acts of God or any other force majeure event; (5) damage to any Product caused by any attempt to repair, replace, or service the Product by persons other than StoneAge authorized service representatives; (6) costs of normal maintenance parts and services; (7) damage sustained during unloading, shipment or transit of the Product; or (8) failure to perform the recommended periodic maintenance procedures listed in the Operator's Manual accompanying the Product.

5. REQUIRED WARRANTY PROCEDURES. To be eligible for warranty service, the End-User must: (1) report the Product defect to the entity where the Product was purchased (i.e. StoneAge or the Dealer) within the Limited Warranty Period specified in this Limited Warranty; (2) submit the original invoice to establish ownership and date of purchase; and (3) make the Product available to a StoneAge authorized service representative for inspection to

determine eligibility for coverage under this Limited Warranty. This Limited Warranty shall not extend to any person or entity who fails to provide proof of original purchase from StoneAge or a Dealer. No Product may be returned for credit or adjustment without prior written permission from StoneAge.

6. DISCLAIMER OF IMPLIED WARRANTIES AND OTHER REMEDIES. EXCEPT AS EXPRESSLY STATED HEREIN (AND TO THE FULLEST EXTENT ALLOWED UNDER APPLICABLE LAW), STONEAGE HEREBY DISCLAIMS ALL OTHER WARRANTIES, EXPRESS OR IMPLIED, INCLUDING WITHOUT LIMITATION ALL IMPLIED WARRANTIES OF MERCHANTABILITY OR FITNESS FOR A PARTICULAR PURPOSE, AND ANY AND ALL WARRANTIES, REPRESENTATIONS OR PROMISES AS TO THE QUALITY, PERFORMANCE OR FREEDOM FROM DEFECT OF THE PRODUCT COVERED BY THIS LIMITED WARRANTY. STONEAGE FURTHER DISCLAIMS ALL IMPLIED INDEMNITIES.

7. LIMITATION OF LIABILITY. End-User specifically acknowledges that the Product may be operated at high speeds and/or pressures, and that as such it may be inherently dangerous if not used correctly. End-User shall familiarize itself with all operation materials provided by StoneAge and shall at all times use and require its agents, employees and contractors to use all necessary and appropriate safety devices, guards and proper safe operating procedures. In no event shall StoneAge be responsible for any injuries to persons or property caused directly or indirectly by the operation of the Product if End-User or any agent, employee, or contractor of End-User: (1) fails to use all necessary and appropriate safety devices, guards and proper safe operating procedures; (2) fails to maintain in good working order such safety devices and guards; (3) alters or modifies the Product in any way not approved by StoneAge in advance in writing; (4) allows the Product to be operated under more severe conditions or beyond the rated capacity specified for the Product; or (5) otherwise negligently operates the Product. End-User shall indemnify and hold StoneAge harmless from any and all liability or obligation incurred by or against StoneAge, including costs and attorneys' fees, to or by any person so injured.

TO THE FULL EXTENT ALLOWED BY APPLICABLE LAW, STONEAGE SHALL NOT BE LIABLE FOR ANY INDIRECT, SPECIAL, INCIDENTAL, CONSEQUENTIAL, OR PUNITIVE DAMAGES (INCLUDING WITHOUT LIMITATION, LOSS OF PROFITS, LOSS OF GOODWILL, DIMINUTION OF VALUE, WORK STOPPAGE, INTERRUPTION OF BUSINESS, RENTAL OF SUBSTITUTE PRODUCT, OR OTHER COMMERCIAL LOSS EVEN TO THE EXTENT SUCH DAMAGES WOULD CONSTITUTE DIRECT DAMAGES), WITH RESPECT TO THE COVERED STONEAGE PRODUCT, OR OTHERWISE IN CONNECTION WITH THIS LIMITED WARRANTY, REGARDLESS OF WHETHER STONEAGE HAS BEEN ADVISED OF THE POSSIBILITY OF SUCH DAMAGES.

IT IS UNDERSTOOD THAT STONEAGE'S LIABILITY, WHETHER IN CONTRACT, IN TORT, UNDER ANY WARRANTY, IN NEGLIGENCE, OR OTHERWISE SHALL NOT EXCEED THE AMOUNT OF THE PURCHASE PRICE PAID BY THE END-USER FOR THE PRODUCT. STONEAGE'S MAXIMUM LIABILITY SHALL NOT EXCEED, AND END-USER'S REMEDY IS LIMITED TO EITHER (1) REPAIR OR REPLACEMENT OF THE DEFECTIVE WORKMANSHIP OR MATERIAL OR, AT STONEAGE'S OPTION, (2) REFUND OF THE PURCHASE PRICE, OR (3) ISSUANCE OF A CREDIT FOR THE PURCHASE PRICE, AND SUCH REMEDIES SHALL BE END-USER'S ENTIRE AND EXCLUSIVE REMEDY.

YOU, THE END-USER, UNDERSTAND AND EXPRESSLY AGREE THAT THE FOREGOING LIMITATIONS ON LIABILITY ARE PART OF THE CONSIDERATION IN THE PRICE OF THE STONEAGE PRODUCT YOU PURCHASED.

Some jurisdictions do not allow the limitation or exclusion of liability for certain damages, so the above limitations and exclusions may not apply to you. This Limited Warranty gives you specific legal rights, and you may also have other rights which vary from jurisdiction to jurisdiction. If any provisions of this Limited Warranty is held to be invalid or unenforceable, such invalidity or unenforceability shall not affect the validity or enforceability of the other portions hereof.



1-866-795-1586 • www.STONEAGETOOLS.com

© 2015 StoneAge, Inc. All Rights Reserved