

1 YEAR
WARRANTY

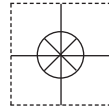

User's Guide

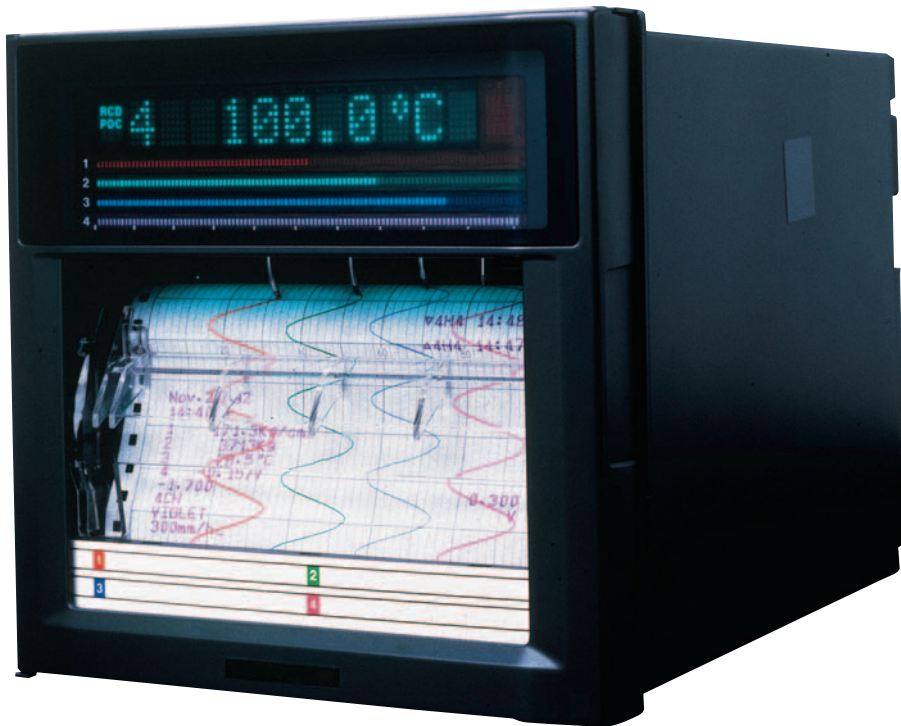

Shop online at

omega.com[®]

Ω OMEGA[®]

omega.com

e-mail: info@omega.com

**For latest product manuals:
omegamanual.info**

ISO 9001
CERTIFIED
CORPORATE QUALITY

STAMFORD, CT

ISO 9002
CERTIFIED
CORPORATE QUALITY

MANCHESTER, UK

RD100B/RD1800B Programmable Recorder Communication Interface



OMEGAnet® Online Service
omega.com

Internet e-mail
info@omega.com

Servicing North America:

U.S.A.:
ISO 9001 Certified

One Omega Drive, P.O. Box 4047
Stamford, CT 06907-0047
TEL: (203) 359-1660 FAX: (203) 359-7700
e-mail: info@omega.com

Canada:

976 Bergar
Laval (Quebec) H7L 5A1, Canada
TEL: (514) 856-6928 FAX: (514) 856-6886
e-mail: info@omega.ca

For immediate technical or application assistance:

U.S.A. and Canada: Sales Service: 1-800-826-6342 / 1-800-TC-OMEGA®
Customer Service: 1-800-622-2378 / 1-800-622-BEST®
Engineering Service: 1-800-872-9436 / 1-800-USA-WHEN®

Mexico:

En Español: (001) 203-359-7803 e-mail: espanol@omega.com
FAX: (001) 203-359-7807 info@omega.com.mx

Servicing Europe:

Benelux:

Postbus 8034, 1180 LA Amstelveen, The Netherlands
TEL: +31 (0)20 3472121 FAX: +31 (0)20 6434643
Toll Free in Benelux: 0800 0993344
e-mail: sales@omegaeng.nl

Czech Republic:

Frystatska 184, 733 01 Karviná, Czech Republic
TEL: +420 (0)59 6311899 FAX: +420 (0)59 6311114
Toll Free: 0800-1-66342 e-mail: info@omegashop.cz

France:

11, rue Jacques Cartier, 78280 Guyancourt, France
TEL: +33 (0)1 61 37 2900 FAX: +33 (0)1 30 57 5427
Toll Free in France: 0800 466 342
e-mail: sales@omega.fr

Germany/Austria:

Daimlerstrasse 26, D-75392 Deckenpfronn, Germany
TEL: +49 (0)7056 9398-0 FAX: +49 (0)7056 9398-29
Toll Free in Germany: 0800 639 7678
e-mail: info@omega.de

United Kingdom:

ISO 9002 Certified

One Omega Drive, River Bend Technology Centre
Northbank, Irlam, Manchester
M44 5BD United Kingdom
TEL: +44 (0)161 777 6611 FAX: +44 (0)161 777 6622
Toll Free in United Kingdom: 0800-488-488
e-mail: sales@omega.co.uk

It is the policy of OMEGA Engineering, Inc. to comply with all worldwide safety and EMC/EMI regulations that apply. OMEGA is constantly pursuing certification of its products to the European New Approach Directives. OMEGA will add the CE mark to every appropriate device upon certification.

The information contained in this document is believed to be correct, but OMEGA accepts no liability for any errors it contains, and reserves the right to alter specifications without notice.

WARNING: These products are not designed for use in, and should not be used for, human applications.

Foreword

Thank you for purchasing the OMEGA RD100B/RD1800B Recorder.

This user's manual describes the functions of the Ethernet interface and the RS-422A/485 communication interface. To ensure correct use, please read this manual thoroughly before beginning operation.

After reading the manual, keep it in a convenient location for quick reference whenever a question arises during operation.

The following five manuals, including this one, are provided as manuals for the RD100B/RD1800B Recorder. Please read all of them.

The figures used in this manual are mostly of the RD100B. If you are using the RD1800B, refer to the figures for reference.

- **Paper Manual**

Manual Title	Manual No.	Description
RD100B Recorder Operation Guide	M-4232	Explains the basic operations of the RD100B recorder.
RD1800B Recorder Operation Guide	M-4243	Explains the basic operations of the RD1800B recorder.

- **Electronic Manuals Provided on the Accompanying CD-ROM**

Manual Title	Manual No.	Description
RD100B Recorder User's Manual	M-4231	Explains all the functions and procedures of the RD100B recorder excluding the communication functions.
RD1800B Recorder User's Manual communication	M-4242	Explains all the functions and procedures of the RD1800B recorder excluding the functions.
RD100B/RD1800B Communication Interface User's Manual	M-4233	This manual. Explains the functions of the Ethernet interface and the RS-422A/485 communication interface.

Notes

- The contents of this manual are subject to change without prior notice as a result of continuing improvements to the instrument's performance and functions. The figures given in this manual may differ from those that actually appear on your screen.
- Every effort has been made in the preparation of this manual to ensure the accuracy of its contents. However, should you have any questions or find any errors, please contact OMEGA.
- Copying or reproducing all or any part of the contents of this manual without permission is strictly prohibited.
- The TCP/IP software of this product and the document concerning the TCP/IP software have been developed/created based on the BSD Networking Software, Release 1 that has been licensed from the University of California.

Revisions

- 1st Edition December 2004
- 2nd Edition March 2005
- 3rd Edition August 2005

Trademarks

- Microsoft, MS-DOS, Windows, Windows NT, and Windows XP are either registered trademarks or trademarks of Microsoft Corporation in the United States and/or other countries.
- Adobe, Acrobat, and PostScript are trademarks of Adobe Systems incorporated.
- For purposes of this manual, the TM and ® symbols do not accompany their respective trademark names or registered trademark names.
- Other company and product names are trademarks or registered trademarks of their respective holders.

Functional Enhancement of the RD100B Recorder

Functions have been added or modified on the RD100B Recorder since system version 1.11. You can check the system version on the system display. For details, see the RD100B User's Manual (M-4231).

Suffix Code	Added or Modified Functions	Reference
-	(Changed) Expanded the selectable range of alarm values during linear scaling (including 1-5V and SQRT) to -5% to 105% of the scale.	Section 4.4: SA command
-	(Changed) The procedure to set the start/end date and time of Daylight Saving Time (DST) has been changed. The TD command can be used on the μ R20000 and the RD100B with system version 1.11. The SS command can be used on the RD100B with system version 1.02 or earlier.	Section 4.4: TD command
-	(Added) The print/display format of the date can be changed.	Section 4.5: XN command
/C3	(Changed) Modbus slave protocol can be used. Two-wire sstem.	Section 4.5: YS command Section 3.2
/C7	(Changed) Users with the same user name cannot be registered.	Section 2.5

How to Use This Manual

Structure of the Manual

This user's manual consists of the following sections.

Chapter 1 Overview of the Communication Functions

Gives an overview of the communication functions.

Chapter 2 Using the Ethernet Interface (/C7 Option)

Explains the specifications of the Ethernet interface and how to use the interface.

Chapter 3 Using the RS-422A/485 Communication Interface (/C3 Option)

Explains the specifications of the RS-422A/485 communication interface and how to use the interface.

Chapter 4 Commands

Explains each command that is available.

Chapter 5 Responses

Explains the responses that the recorder returns and the output format of the setup data and measured/computed data.

Chapter 6 Status Information

Explains the registers that indicate the recorder statuses.

Appendix

Provides an ASCII character code table, flow charts for outputting data from the recorder, login procedure, and a list of error messages.

Index

Index of contents.

Conventions Used in This Manual

- **Unit**
 - k: Denotes 1000. Example: 5 kg, 100 kHz
 - K: Denotes 1024. Example: 640 KB

- **Note**

The following markings are used in this manual.



Improper handling or use can lead to injury to the user or damage to the instrument. This symbol appears on the instrument to indicate that the user must refer to the user's manual for special instructions. The same symbol appears in the corresponding place in the user's manual to identify those instructions. In the manual, the symbol is used in conjunction with the word "WARNING" or "CAUTION."

WARNING

Calls attention to actions or conditions that could cause serious or fatal injury to the user, and precautions that can be taken to prevent such occurrences.

CAUTION

Calls attentions to actions or conditions that could cause light injury to the user or damage to the instrument or user's data, and precautions that can be taken to prevent such occurrences.

Note

Calls attention to information that is important for proper operation of the instrument.

- **Bold Characters**

Bold characters are mainly characters and numbers that appear on the display.

- **Subheadings**

On pages that describe the operating procedures in Chapter 2 and 3, the following symbols are used to distinguish the procedures from their explanations.

Explanation

This subsection describes the setup parameters and the limitations on the procedures.

Procedure

Follow the numbered steps. All procedures are written with inexperienced users in mind; depending on the operation, not all steps need to be taken.

Names of Parts and Basic Key Operations

Display and Keys

You use the panel keys and the display to configure the communication functions. For a description of other parts of the recorder, see section 3.1 in the *Recorder User's Manual*. (The figure below is of the RD100B Recorder.)

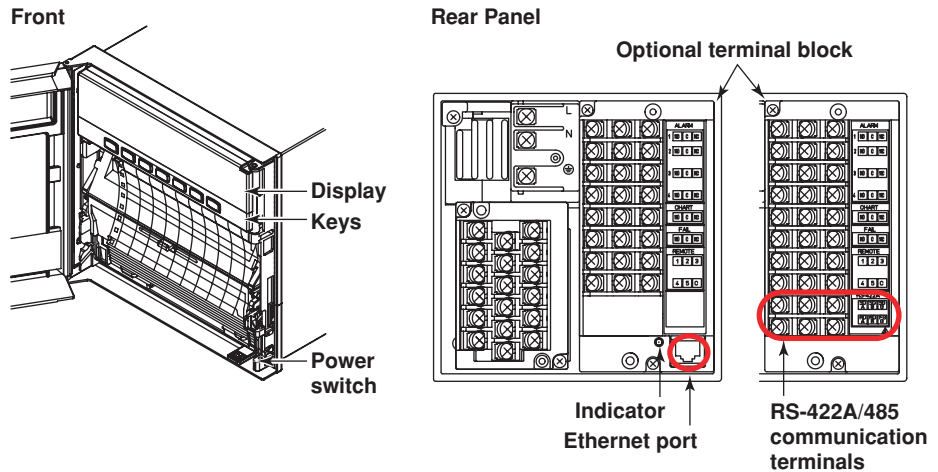

Keys

<While setting functions, when the FUNC key/DISP MENU key is pressed>

CHARACTER Key: Changes the character type when entering a character. Press this key while holding down the SHIFT key to switch the character type in reverse order.

UP/DOWN Key: Switches the setup item or the value. Press this key while holding down the SHIFT key to switch the setup item or the value in reverse order.

LEFT/RIGHT Key: Moves the cursor to the right when entering a value or character. Press this key while holding down the SHIFT key to move the cursor to the left..

ESC Key: Cancels the operation. When pressed with the SHIFT key, the display of the comment on the setting turns ON/OFF.

SHIFT Key: Used with the $\nabla\Delta$ key, $\langle\rangle$ key, or the CHARACTER key.

ENTER Key: Confirms the setup item or value.



<During normal operation>

CH UP key
Switches the displayed channel.
(when manual switching is specified)

FEED key
Feeds the chart paper.

DISP MENU key
Hold this key down for 3 seconds to switch to the data display setup screen. Hold this key down for 3 seconds also to exit from the data display setup screen.

FUNC key
Used when executing manual printout, message printout, etc.

DISP key
Switches the screen in the main display.

MENU key
Hold this key down for 3 seconds to enter Setting mode. Hold this key down for 3 seconds also to exit from Setting mode.

RCD key
Starts/stops recording.

Basic Key Operations

This section describes basic operations on the front panel keys to change various settings.

- **Execution Modes**

The recorder has the following execution modes.

- Operation mode: A mode used to perform recording and monitoring.
- Setting mode: A mode used to set the input range, alarms, chart speed, and other parameters.
- Basic Setting mode: A mode used to set the basic specifications of functions with the recording operation stopped.

* In the explanation of commands in (chapter 4), Run mode collectively refers to Operation mode and Setting mode.

Settings related to communications are configured in Basic Setting mode. You cannot enter Basic Setting mode while the recorder is recording or while computation is in progress on the computation function (/M1 option).

- **Entering Basic Setting Mode**

Hold down the **(MENU)** key for 3 seconds.

The Setting mode display appears.

```
Set=Range
Input range and s
```

The panel keys are set to the functions marked above the keys as shown below.

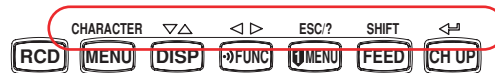

Hold down both the **∇Δ (DISP)** key and the **<|> (FUNC)** key for 3 seconds.

The Basic Setting mode display appears. The top and bottom lines are the setup item and comment, respectively. The section that is blinking in the setup item that you change. In this manual, the section that you change appears shaded.

The comment line shows useful information such as a description of the setup item and the range of selectable values. Read the comment and change the items as necessary.

```
Setup item → Basic=Alarm ← The item to be controlled blinks.
Comment → Auxiliary alarm
```

- **Selecting the Setup Item and Value**

The selected item change each time you press the **∇Δ (DISP)** key. The selected item change in reverse order if you press the **∇Δ (DISP)** while holding down the **SHIFT (FEED)** key.

```
Basic=Ethernet ← Selections
```

This manual denotes the operation of pressing a key while holding down the **SHIFT (FEED)** key as **SHIFT +** the other key (for example: **SHIFT + ∇Δ** key).

After you make a selection, press the **<|> (CH UP)** key. The next screen appears.

When the **Setting Complete** screen appears, the changed item is applied.

```
Ethernet host
Setting complete
```

- **Using the ESC Key**

If you press the **ESC (MENU)** key, the operation is cancelled, and the display returns to a higher level menu. If you do not show the Setting Complete screen, the changes you made up to that point are discarded.

You can show and hide the comment on the bottom line by pressing the **ESC (MENU)** key while holding down the **SHIFT (FEED)** key.

• **Entering Values**

Use the $\triangleleft \triangleright$ key or **SHIFT** + $\triangleleft \triangleright$ key to move the cursor. Use the $\nabla \Delta$ key or **SHIFT** + $\nabla \Delta$ key to change a digit value. You repeat these steps to enter the value.

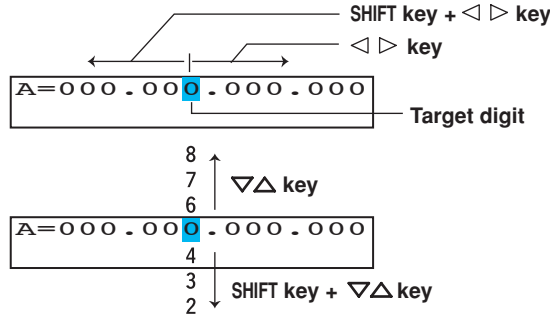

When you press the $\triangleleft \triangleright$ key, the change is applied and the next setup item is displayed.

• **Entering Characters**

Use the $\triangleleft \triangleright$ key or **SHIFT** + $\triangleleft \triangleright$ key to move the cursor.

Use the **CHARACTER** key or **SHIFT** + **CHARACTER** key to select the character type.

Use the $\nabla \Delta$ key or **SHIFT** + $\nabla \Delta$ key to select a character. You repeat these steps to set the character string.

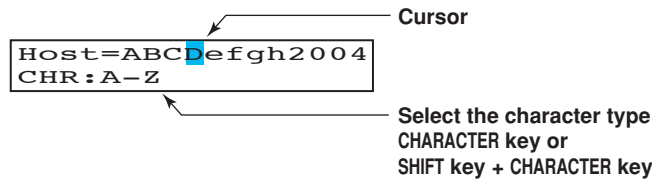

The character type changes in the following order: uppercase alphabet, lowercase alphabet, numbers, and symbols.

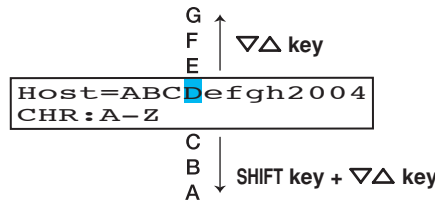

When you press the $\triangleleft \triangleright$ key, the change is applied and the next screen is displayed.

Inserting Characters

Press the **CHARACTER** key or **SHIFT** + **CHARACTER** key to show **Ins DISP** and then press the $\nabla \Delta$ key. A space for one character is inserted. Enter the character.

Deleting a Character

Press the **CHARACTER** key or **SHIFT** + **CHARACTER** key to show **Del DISP** and then press the $\nabla \Delta$ key. The character is deleted.

Deleting an Entire Character String

Press the **CHARACTER** key or **SHIFT** + **CHARACTER** key to show **Clear DISP** and then press the $\nabla \Delta$ key. The entire character string is deleted.

Copying & Pasting a Character String

Show the copy source character string.

Press the **CHARACTER** key or **SHIFT** + **CHARACTER** key to show **Copy DISP** and then press the $\nabla \Delta$ key. The character string is saved to the memory.

Show the copy destination.

Press the **CHARACTER** key or **SHIFT** + **CHARACTER** key to show **Paste DISP** and then press the $\nabla \Delta$ key. The character string is pasted.

- **Exiting from Basic Setting Mode**

Press the **ESC** key several times to return to the **Basic=** screen.

Press the $\nabla\Delta$ key or **SHIFT** + $\nabla\Delta$ key to select **End** and then press the \leftarrow key.

The setup save screen appears.

```
Basic=End
Save Setting
```

Press the $\nabla\Delta$ key to select **Store** and then press the \leftarrow key.

The setting is applied and the Operation mode screen appears.

If you select **Abort** and press the \leftarrow key, the setting is discarded and the Operation mode screen appears.

```
End=Store
Save settings and
```

Contents

Foreword	i
Functional Enhancement of the RD100B Recorder	ii
How to Use This Manual	iii
Names of Parts and Basic Key Operations	v
Chapter 1 Overview of the Communication Functions	
1.1 Communication Functions Using the Ethernet Interface (/C7 Option)	1-1
Functional Construction	1-1
Setting/Measurement Server	1-1
Maintenance/Test Server	1-2
Instrument Information Server	1-2
Other Functions	1-3
1.2 Communication Functions Using the RS-422A/485 Communication Interface (/C3 Option)	1-4
Functional Construction	1-4
Setting/Measurement Server	1-4
Modbus Slave	1-4
Chapter 2 Using the Ethernet Interface (/C7 Option)	
2.1 Ethernet Interface Specifications	2-1
Basic Specifications	2-1
The Maximum Number of Simultaneous Connections and the Number of Simultaneous Use	2-1
2.2 Connecting the Ethernet Interface	2-2
When Connecting Only the Recorder and a PC	2-2
When Connecting to a Preexisting Network	2-2
2.3 Configuring the Ethernet Interface	2-3
2.4 Checking the Connection Status	2-7
2.5 Registering Users	2-8
2.6 Setting the Communication Timeout and Keepalive	2-11
Chapter 3 Using the RS-422A/485 Communication Interface (/C3 Option)	
3.1 RS-422A/485 Communication Interface Specifications	3-1
△ 3.2 Terminal Arrangement and Signal Names and the Connection Procedure of the RS-422A/485 Communication Interface	3-2
Terminal Arrangement and Signal Names	3-2
Connection Procedure	3-2
Connection Example with a Host Computer	3-3
3.3 The Bit Structure of One Character and the Operation of the Receive Buffer	3-7
The Bit Structure of One Character	3-7
Receive Buffer and Received Data	3-7
3.4 Modbus Slave Protocol Specifications	3-8
Registers	3-9
Modbus Error Response	3-10
3.5 Setting the Serial Interface	3-11

1

2

3

4

5

6

App

Index

Chapter 4 Commands

4.1	Command Syntax	4-1
	Response	4-2
4.2	A List of Commands	4-3
	Execution Modes and User Levels	4-3
	Setting Commands	4-3
	Basic Setting Commands	4-4
	Control Commands	4-5
	Output Commands	4-5
	RS-422A/485 Dedicated Commands	4-5
	Maintenance/Test Commands	4-6
	Instrument Information Output Commands	4-6
4.3	Parameter Values	4-7
	Input Range	4-7
	Miscellaneous	4-8
4.4	Setting Commands	4-10
4.5	Basic Setting Commands	4-18
4.6	Control Commands	4-25
4.7	Output Commands	4-26
4.8	RS-422A/485 Dedicated Commands	4-28
4.9	Maintenance/Test Commands (Available when using the maintenance/test server function via Ethernet communications)	4-29
4.10	Instrument Information Output Commands (Available when using the instrument information server function via Ethernet communications)	4-30

Chapter 5 Responses

5.1	Response Syntax	5-1
	Affirmative Response	5-1
	Single Negative Response	5-1
	Multiple Negative Responses	5-1
	ASCII Output	5-2
	BINARY Output	5-2
	RS-422A/485 Dedicated Commands and Responses	5-5
5.2	Output Format of ASCII Data	5-6
	Setting/Basic Setting data	5-6
	Decimal Point Position/Unit Information	5-7
	Measured/computed Data	5-8
	Report Data Generated by the Periodic Printout	5-10
	Status Information	5-12
	User Information	5-12
5.3	Output Format of BINARY Data	5-13
	Measured/Computed Data and FIFO Data	5-13

Chapter 6 Status Information

6.1	Status Information and Filter	6-1
6.2	The Bit Structure of the Status Information	6-2
	Status Information 1	6-2
	Status Information 2	6-2
	Status Information 3	6-2
	Status Information 4	6-2

Appendix

Appendix 1 ASCII Character Codes App-1
Appendix 2 Output Flow of FIFO Data App-2
Appendix 3 Login Procedure App-4
Appendix 4 A List of Error Messages App-6
 Setting Errors App-6
 Operation Errors App-7
 Communication Errors App-7
 Warning Messages App-8
 System Errors App-8

Index

1

2

3

4

5

6

App

Index

1.1 Communication Functions Using the Ethernet Interface (/C7 Option)

The recorder can be equipped with an optional Ethernet interface. For details on how to use the Ethernet interface, see chapter 2.

Functional Construction

The following figure shows the relationship between the communication function of the recorder and the Ethernet interface. Perform communication according to the respective protocol.

* Protocol is a set of rules that two computers use to communicate via a communication line (or network).

Communication functions of the recorder			
Application	Setting/ Measurement Server	Maintenance/ Test Server	Instrument Information Server
	Login (user authentication/access privileges granting)		
Upper layer protocol	Dedicated protocol		UDP
Lower layer protocol	TCP		
IP			
Interface	Ethernet (10BASE-T)		

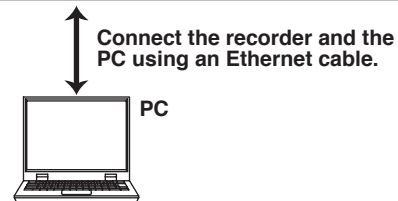

TCP (Transmission Control Protocol)

UDP (User Datagram Protocol)

IP (Internet Protocol)

Setting/Measurement Server

- You can specify settings that are approximately equivalent to those specified by front panel key operations. However, you cannot turn the power ON/OFF, set the user name and password for communications, nor set the key lock.
- The data below can be output.

Data Type	Output Format
Measured/computed data	BINARY/ASCII
Setup data	ASCII
Periodic printout and the most recent TLOG computation data	ASCII
Status information	ASCII
Information on connected users	ASCII

- The commands that can be used are Setting commands, Basic Setting commands, Control commands, and Output commands.

<Related Topics>

- Ethernet interface settings: Section 2.3
- Commands: Section 4.2
- Data output format: Chapter 5

Maintenance/Test Server

- Outputs Ethernet communication information such as connection information and network statistics from the recorder.
- The commands that can be used Maintenance/Test commands.

<Related Topics>

- Ethernet interface settings: Section 2.3
- Commands: Section 4.2

Instrument Information Server

- Outputs the serial number, model name, and other information about the recorder connected via the Ethernet network.
- The commands that can be used Instrument Information Output commands.

<Related Topics>

- Ethernet interface settings: Section 2.3
- Commands: Section 4.2

Other Functions

- **Login Function**

Only users that are registered in advance can access the Setting/Measurement and Maintenance/Test servers.

- Users are identified by their user name and password.
- You can register one administrator and six users.

Administrator privileges

The administrator can use all the functions on the Setting/Measurement and Maintenance/Test servers

User Privileges

- Setting/Measurement server
Users can output measured data, setup data, scheduled printing, and the most recent TLOG computation data. Users cannot control the recorder.
- Maintenance/Test server
Users cannot disconnect communications between the recorder and other PCs. All other operations are allowed.
- There is a maximum number of simultaneous connections that can be established with the recorder.

<Related Topics>

- Login function settings: Section 2.5
- Maximum number of simultaneous connections: Section 2.1
- Commands available to the administrator and users: Section 4.2

- **Communication Timeout**

This function drops the connection with the PC if there is no data transmission for a given time at the application level (see “Functional Construction”). For example, this function prevents a PC from being connected to the recorder indefinitely which would prohibit other users from making new connections for data transfer.

<Related Topics>

- Communication timeout setting: Section 2.6

- **Keepalive**

This function drops the connection if there is no response to the inspection packet that is periodically transmitted at the TCP level.

<Related Topics>

- Keepalive setting: Section 2.6

1.2 Communication Functions Using the RS-422A/485 Communication Interface (/C3 Option)

The recorder can be equipped with an optional RS-422A/485 communication interface. For details on how to use the RS-422A/485 communication interface, see chapter 3.

Functional Construction

The following figure shows the relationship between the communication function of the recorder and the RS-422A/485 communication interface. Perform communication according to the respective protocol.

* Protocol is a set of rules that two computers use to communicate via a communication line (or network).

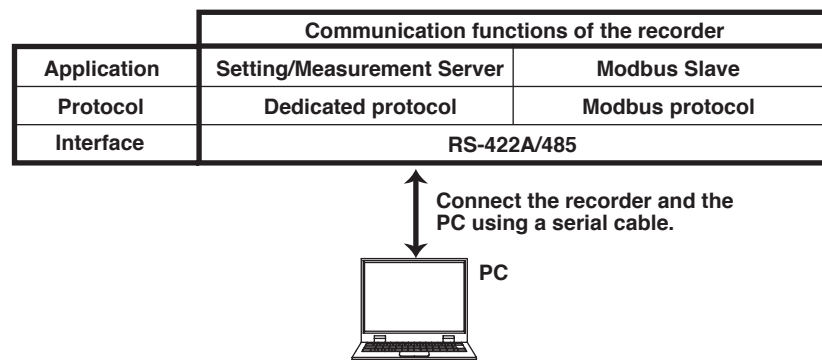

Setting/Measurement Server

The functions are the same as those of the Setting/Measurement server of the Ethernet interface. See page 1-1.

<Related Topics>

- RS-422A/485 communication interface settings: Section 3.5
- Commands: Section 4.2
- RS-422A/485 dedicated commands: Section 4.8
- Data output format: Chapter 5

Modbus Slave

- The Modbus protocol can be used to read the measured/computed data on your PC by reading the input registers of the recorder. The communication input data can be written or read by writing/reading the hold register of the recorder.
- For details on the Modbus function codes that the recorder supports, see section 3.4.
- This function can be used only when communicating via the serial interface (option).
- For a description on the settings required in using this function, see section 3.5.

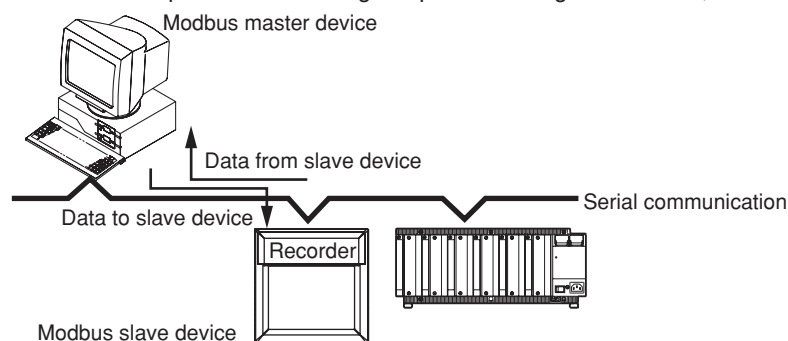

2.1 Ethernet Interface Specifications

Basic Specifications

Item	Specifications
Electrical and mechanical specifications	Conforms to IEEE 802.3 (Ethernet frames are of DIX specification)
Transmission medium type	10BASE-T
Protocol	TCP, IP, UDP, ICMP, and ARP

The Maximum Number of Simultaneous Connections and the Number of Simultaneous Use

The following table shows the maximum number of simultaneous connections, the number of simultaneous users, and the port numbers of the recorder.

Function	Maximum Number of Connections	Number of Simultaneous Users <Administrators>	Number of Simultaneous Users <Users>	Port Number [†]
Setting/Measurement server	3	1	2 ^{††}	34260/tcp
Maintenance/Test server	1	1	1 ^{††}	34261/tcp
Instrument Information server	-	-	-	34264/udp

[†] The port numbers are fixed.

^{††} For details on administrator and user privileges, see "Login Function" in section 1.1.

2.2 Connecting the Ethernet Interface

When Connecting Only the Recorder and a PC

Connect the recorder and the PC via a HUB as in the following figure.

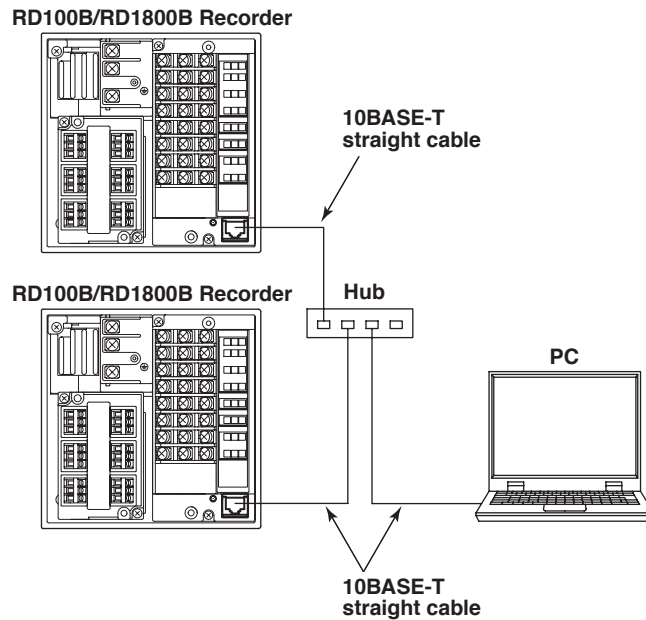

When Connecting to a Preexisting Network

The following figure illustrates an example in which a recorder and a PC are connected to the network. When connecting the recorder or the PC to a preexisting network, the transfer rate, connector type, etc. must be matched. For details, consult your system or network administrator.

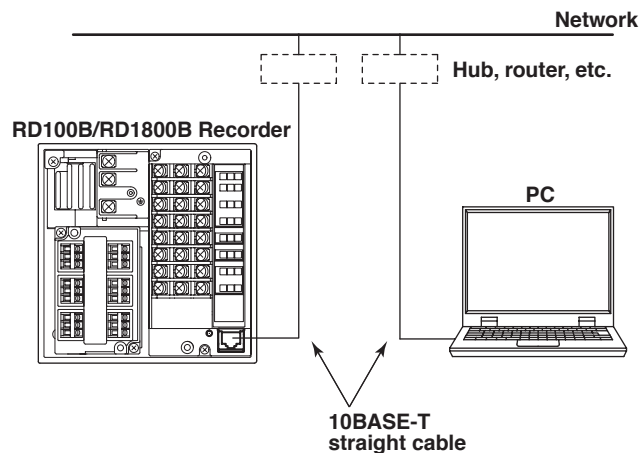

Note

- Depending on the reliability of the network or the volume of network traffic, all the transferred data may not be retrieved by the PC.
- Communication performance deteriorates if multiple PCs access the recorder simultaneously.

2.3 Configuring the Ethernet Interface

Set the host name and IP address of the recorder. You do not have to set the DNS (domain name system).

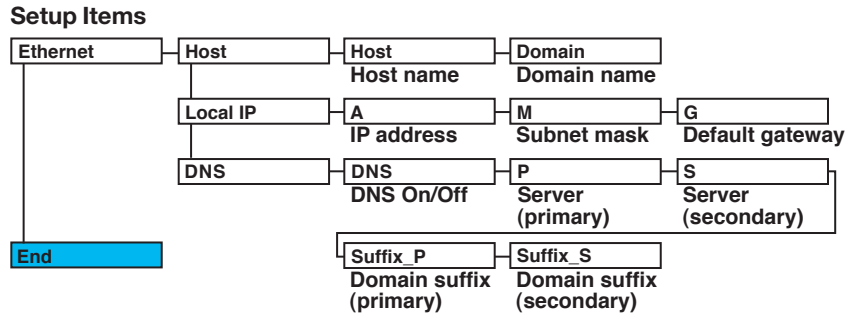

Procedure

For a description of the basic setup operations, see “Basic Key Operations” on page v.

Entering Basic Setting Mode

Hold down the **MENU** key for 3 seconds to display the Setting mode screen.

Next, hold down both the **▽△ (DISP)** key and the **◀▶ (FUNCTION)** key for 3 seconds to display the Basic Setting mode screen.

Note

To cancel an operation, press the **ESC** key.

Host Name and Domain Name

1. Press the **▽△** key to select **Ethernet** and then press the **↵** key.

```
Basic=Ethernet
```

2. Press the **▽△** key to select **Host** and then press the **↵** key.

```
Ethernet=Host
```

3. Set the host name of the recorder and then press the **↵** key.
Key operations

- Use the **◀▶** key to select the digit for entering a character.
- Use the **CHARACTER** key to select the character type.
- Use the **▽△** key to select the character you wish to enter.

```
Host=
```

4. Set the domain name and press the **↵** key in the same fashion as in step 3.
The setting complete screen appears.

```
Domain=
```



```
Ethernet host
Setting complete
```

5. Press the **ESC** key to return to the higher level menu. To save the settings and exit from Basic Setting mode, proceed to “Saving the Settings.”

* When the **◀▶** key, **▽△** key, or **CHARACTER** key is pressed while holding down the **SHIFT** key, the operation is reversed as when the respective key is pressed by itself.

IP Address, Subnet Mask, and Default Gateway

1. Press the $\nabla\Delta$ key to select **Ethernet** and then press the \leftarrow key.

```
Basic=Ethernet
```

2. Press the $\nabla\Delta$ key to select **Local IP** and then press the \leftarrow key.

```
Ethernet=Local IP
```

3. Set the IP address of the recorder and then press the \leftarrow key.

Key operations

- Use the \leftarrow \rightarrow key to select the digit for entering a value.
- Use the $\nabla\Delta$ key to select the value you wish to enter.

```
A=
```

4. Set the IP address of the subnet mask and then press the \leftarrow key in the same fashion as in step 3.

```
M=
```

5. Set the IP address of the default gateway and then press the \leftarrow key in the same fashion as in step 3.

The local IP setting complete screen appears.

```
G=
```



```
Ethernet address  
Setting complete
```

6. Press the **ESC** key to return to the higher level menu. To save the settings and exit from Basic Setting mode, proceed to “Saving the Settings.”

DNS (Domain Name System)

1. Press the $\nabla\Delta$ key to select **Ethernet** and then press the \leftarrow key.

```
Basic=Ethernet
```

2. Press the $\nabla\Delta$ key to select **DNS** and then press the \leftarrow key.

```
Ethernet=DNS
```

3. Press the $\nabla\Delta$ key to select **On** and then press the \leftarrow key.

```
DNS=On
```

4. Set the IP address of the primary DNS server and then press the \leftarrow key.

Key operations

- Use the \leftarrow \rightarrow key to select the digit for entering a value.
- Use the $\nabla\Delta$ key to select the value you wish to enter.

```
P=
```

5. Set the IP address of the secondary DNS server and then press the \leftarrow key in the same fashion as in step 4.

```
S=
```

* When the \leftarrow \rightarrow key, $\nabla\Delta$ key, or **CHARACTER** key is pressed while holding down the **SHIFT** key, the operation is reversed as when the respective key is pressed by itself.

6. Set the primary domain suffix and then press the \leftarrow key.

Key operations

 - Use the $\triangleleft \triangleright$ key to select the digit for entering a character.
 - Use the **CHARACTER** key to select the character type.
 - Use the $\nabla \triangle$ key to select the character you wish to enter.

```
Suffix_P=
```

7. Set the secondary domain suffix and then press the \leftarrow key in the same fashion as in step 6.

The DNS setting complete screen appears.

```
Suffix_S=
```



```
Ethernet DNS
Setting complete
```

8. Press the **ESC** key to return to the higher level menu. To save the settings and exit from Basic Setting mode, proceed to “Saving the Settings.”

Saving the Settings

1. Press the **ESC** key to return to the **Basic=** screen.
2. Press the $\nabla \triangle$ key to select **End** and then press the \leftarrow key.
3. Press the $\nabla \triangle$ key to select **Store** and then press the \leftarrow key.

The settings are activated, and the Operation mode screen appears.

Explanation

For details on the settings, consult your system or network administrator.

- **Host Name**

Set the recorder’s host name and the domain name of the network to which the recorder belongs. Be sure to set these items when using the DNS.

- **Host**

Set the recorder’s host name using up to 64 alphanumeric characters.

- **Domain**

Set the network domain name to which the recorder belongs using up to 64 alphanumeric characters.

- **IP Address, Subnet Mask, and Default Gateway**

- **IP address**

- Set the IP address to assign to the recorder. The default value is 0.0.0.0.
- The IP address is used to distinguish between the various devices connected to the Internet when communicating using the TCP/IP protocol. The address is a 32-bit value normally expressed with four values (0 to 255), each separated by a period as in 192.168.111.24.

- **M (Subnet Mask)**

- Specify the mask that is used to determine the network address from the IP address. The default value is 0.0.0.0.
- Set this value according to the system or the network to which the recorder belongs. In some cases, this setting may not be necessary.

* When the $\triangleleft \triangleright$ key, $\nabla \triangle$ key, or **CHARACTER** key is pressed while holding down the **SHIFT** key, the operation is reversed as when the respective key is pressed by itself.

- **G (Default Gateway)**

- Set the IP address of the gateway (router, etc.) used to communicate with other networks. The default value is 0.0.0.0.
- Set this value according to the system or the network to which the recorder belongs. In some cases, this setting may not be necessary.

- **Setting the DNS (Domain Name System)**

The DNS is a system that correlates the host name/domain name to the IP address. The host name/domain name can be used instead of the IP address when accessing the network. The DNS server manages the database that contains the host name/domain name and IP address correlation.

- **On/Off**

Select On when using the DNS.

- **P (Primary DNS Server)**

Set the IP address of the primary DNS server. The default value is 0.0.0.0.

- **S (Secondary DNS Server)**

Set the IP address of the secondary DNS server. The default value is 0.0.0.0. If the primary DNS server is down, the secondary server is used to search the host name and IP address correlation.

- **Suffix_P (Primary Domain Suffix), Suffix_S (Secondary Domain Suffix)**

When the recorder searches another server using the DNS server, the domain name of the recorder is appended to the host name as a possible domain name if it is omitted. If the IP address corresponding to the server name is not found on the DNS server, then it may be that the system is configured to use another domain name for searching. This alternate domain name is specified as the domain suffix.

- Set the domain suffix using up to 64 alphanumeric characters.
- Up to two domain suffixes can be specified (primary and secondary).

- **Saving the Settings**

To activate the settings made in the Basic Setting mode, the settings must be saved.

2.4 Checking the Connection Status

The connection status of the Ethernet interface can be confirmed with the indicator that is located to the left of the Ethernet port on the recorder.

Indicator	Connection Status of the Ethernet Interface
ON (Green)	The Ethernet interface is electrically connected.
Blinking (Green)	Transmitting data.
OFF	The Ethernet interface is not electrically connected.

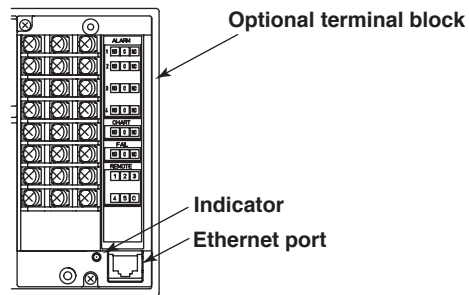

2.5 Registering Users

Users that can access the recorder via the Ethernet network must be registered. This function is called login function.

Setup Items

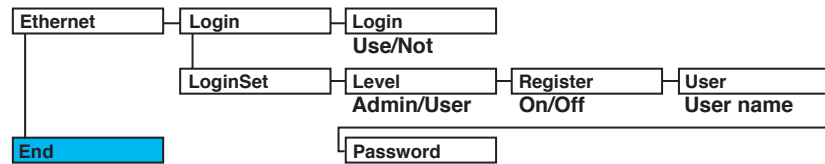

Procedure

For a description of the basic operations, see “Basic Key Operations” on page v.

Entering Basic Setting Mode

Hold down the **MENU** key for 3 seconds to display the Setting mode screen.

Next, hold down both the **▽△ (DISP)** key and the **◀▶ (FUNC)** key for 3 seconds to display the Basic Setting mode screen.

Note

To cancel an operation, press the **ESC** key.

Enabling/Disabling the Login Function

1. Press the **▽△** key to select **Ethernet** and then press the **↵** key.

```
Basic=Ethernet
```

2. Press the **▽△** key to select **Login** and then press the **↵** key.

```
Ethernet=Login
```

3. Press the **▽△** key to select **Use** and then press the **↵** key.
The setting complete screen appears.

```
Login=On
```

4. Press the **ESC** key to return to the **Ethernet** menu.

Registering Users

5. Press the **▽△** key to select **LoginSet** and then press the **↵** key.

```
Ethernet=LoginSet
```

6. Press the **▽△** key to select **Admin** (administrator) or **User1** to **User6**, and then press the **↵** key.

```
Level=Admin
```

7. Press the **▽△** key to select **On** and then press the **↵** key.

```
Register=On
```

* When the **◀▶** key, **▽△** key, or **CHARACTER** key is pressed while holding down the **SHIFT** key, the operation is reversed as when the respective key is pressed by itself.

8. Set the user name and then press the \leftarrow key.
Key operations
 - Use the \leftarrow \rightarrow key to select the digit for entering a character.
 - Use the **CHARACTER** key to select the character type.
 - Use the ∇ Δ key to select the character you wish to enter.

```
User= █
```

9. Set the password and then press the \leftarrow key in the same fashion as in step 8. The setting complete screen appears.

```
Password= █
```



```
Ethernet login  
Setting complete
```

To register other users, press the \leftarrow key to return to step 6 and repeat steps 8, 8, and 9.

Saving the Settings

1. Press the **ESC** key to return to the **Basic=** screen.
2. Press the ∇ Δ key to select **End** and then press the \leftarrow key.
3. Press the ∇ Δ key to select **Store** and then press the \leftarrow key.
The settings are activated, and the Operation mode screen appears.

Explanation

You can limit the users that can access the Setting/Measurement and Maintenance/Test servers on the recorder via the Ethernet interface.

- **Enabling/Disabling the Login Function**

Set whether to use the login function.

- **Registering Users**

- **User level**

Select either of the user levels, administrator or user.

- **Administrator**

One administrator can be registered. An administrator has the authority to use all Setting/Measurement server and Maintenance/Test server commands.

- **User**

Six users can be registered. A user has limited authority to use the commands. See section 4.2.

- **Selecting Whether to Register (On/Off) the User**

If On is selected, set the user name and password.

- **Setting the User Name**

- Set the user name using up to 16 alphanumeric characters.
- The same user name can not be registered.
- Since the word “quit” is reserved as a command on the recorder, the user name “quit” is not allowed.

- **Setting the Password**

Set the password using up to 4 alphanumeric characters and spaces.

* When the \leftarrow \rightarrow key, ∇ Δ key, or **CHARACTER** key is pressed while holding down the **SHIFT** key, the operation is reversed as when the respective key is pressed by itself.

Note

- The relationship between the login function and the user name that is used when accessing the recorder is as follows:
 - When the login function is set to “Use”
 - The registered user name and password can be used to login to the recorder.
 - The user level is the level that was specified when the user name was registered.
 - When the login function is set to “Not”
 - The user name “admin” can be used to login to the recorder as an administrator. Password is not necessary.
 - The user name “user” can be used to access the recorder as a user. Password is not necessary.
 - There are limitations on the number of simultaneous connections or simultaneous uses of the recorder from the PC (see section 2.1).
 - For a description of the login process of the Setting/Measurement server and Maintenance/Test server, see appendix 3.
-

- **Saving the Settings**

To activate the settings made in the Basic Setting mode, the settings must be saved.

2.6 Setting the Communication Timeout and Keepalive

The communication timeout function and the keepalive function can be configured.

Setup Items

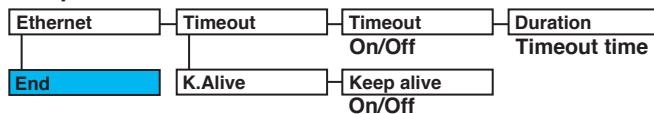

Procedure

For a description of the basic operations, see “Basic Key Operations” on page v.

Entering Basic Setting Mode

Hold down the **(MENU)** key for 3 seconds to display the Setting mode screen. Next, hold down both the **▽△ (DISP)** key and the **◀▶ (FUNC)** key for 3 seconds to display the Basic Setting mode screen.

Note

To cancel an operation, press the **ESC** key.

Communication Timeout

1. Press the **▽△** key to select **Ethernet** and then press the **↵** key.

```
Basic=Ethernet
```

2. Press the **▽△** key to select **Timeout** and then press the **↵** key.

```
Ethernet=Timeout
```

3. Press the **▽△** key to select **On** and then press the **↵** key.

```
Timeout=On
```

4. Set the timeout time and then press the **↵** key.

Key operations

- Use the **◀▶** key to select the digit for entering a value.
- Use the **▽△** key to select the value you wish to enter.

```
Duration=
```



```
Ethernet timeout
Setting complete
```

5. Press the **ESC** key to return to the higher level menu. To save the settings and exit from Basic Setting mode, proceed to “Saving the Settings.”

* When the **◀▶** key, **▽△** key, or **CHARACTER** key is pressed while holding down the **SHIFT** key, the operation is reversed as when the respective key is pressed by itself.

Keepalive

1. Press the $\nabla\Delta$ key to select **Ethernet** and then press the \leftarrow key.

```
Basic=Ethernet
```

2. Press the $\nabla\Delta$ key to select **K.Alive** and then press the \leftarrow key.

```
Ethernet=K. Alive
```

3. Press the $\nabla\Delta$ key to select **On** and then press the \leftarrow key.
The setting complete screen appears.

```
Keep alive=On
```



```
Keep alive  
Setting complete
```

5. Press the **ESC** key to return to the higher level menu. To save the settings and exit from Basic Setting mode, proceed to “Saving the Settings.”

Saving the Settings

1. Press the **ESC** key to return to the **Basic=** screen.
2. Press the $\nabla\Delta$ key to select **End** and then press the \leftarrow key.
3. Press the $\nabla\Delta$ key to select **Store** and then press the \leftarrow key.
The settings are activated, and the Operation mode screen appears.

Explanation

The communication timeout function and the keepalive function can be configured.

- **Communication Timeout**

- **Selecting On or Off**

- If On is selected, set the timeout time.

- **Timeout Time**

- If communication timeout is enabled, the connection is dropped if no data transfer is detected over a time period specified here.

- Selectable range: 1 to 120 minutes

- **Enabling (On)/Disabling (Off) Keepalive**

- Select On to enable the keepalive function.

- **Saving the Settings**

- To activate the settings made in the Basic Setting mode, the settings must be saved.

<Related Topics>

Keepalive: Section 1.1

* When the $\triangleleft\triangleright$ key, $\nabla\Delta$ key, or **CHARACTER** key is pressed while holding down the **SHIFT** key, the operation is reversed as when the respective key is pressed by itself.

3.1 RS-422A/485 Communication Interface Specifications

This section describes the RS-422A/485 communication interface specifications.

Item	Specifications
Terminal block type	Number of terminals: 6, terminal attachment screws: ISO M4/nominal length of 6 mm
Electrical and mechanical specifications	Complies with the EIA-422A(RS-422A) and EIA-485(RS-485) standards
Connection	Multidrop Four-wire system 1:32 Two-wire system 1:31 (Modbus slave protocol)
Transmission mode	Half-duplex
Synchronization	Start-stop synchronization
Baud rate	Select from 1200, 2400, 4800, 9600, 19200, and 38400 [bps].
Start bit	Fixed to 1 bit
Data length	Select 7 or 8 bits
Parity	Select Odd, Even, or None (no parity).
Stop bit	Fixed to 1 bit
Received buffer length	2047 bytes
Escape sequence	Open and close
Electrical characteristics	6 points consisting of FG, SG, SDB, SDA, RDB, and RDA The SG, SDB, SDA, RDB, and RDA terminals and the internal circuitry of the recorder are functionally isolated. The FG terminal is the frame ground.
Communication distance	Up to 1.2 km
Terminal resistance	120 Ω , 1/2 W

3.2 Terminal Arrangement and Signal Names and the Connection Procedure of the RS-422A/485 Communication Interface

Terminal Arrangement and Signal Names

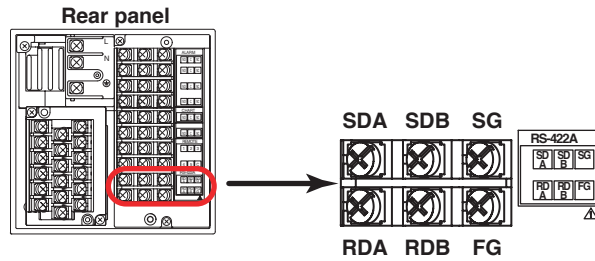

Terminal Name	Description
FG (Frame Ground)	Case ground of the recorder.
SG (Signal Ground)	Signal ground.
SDB (Send Data B)	Send data B (+).
SDA (Send Data A)	Send data A (-).
RDB (Received Data B)	Receive data B (+).
RDA (Received Data A)	Receive data A (-).

Connection Procedure

- Cable**

Use the cable that meets the conditions below.

Item	Conditions
Cable	Shielded twisted pair cable 3 pairs AWG24-14 (Four-wire system), 2 pairs 24 AWG or more (Two-wire system)
Characteristic impedance	100 Ω
Capacitance	50 pF/m
Cable length	Up to 1.2 km*

* The transmission distance of the RS-422A/485 interface is not the straight-line distance, but rather the total length of the (shielded twisted-pair) cable.

- Connecting the Cable**

As shown in the following figure, attach a crimp-on lug with isolation sleeves for 4 mm screws to the end of the cable. Keep the exposed section from the end of the shield within 5 cm.

Four-wire system

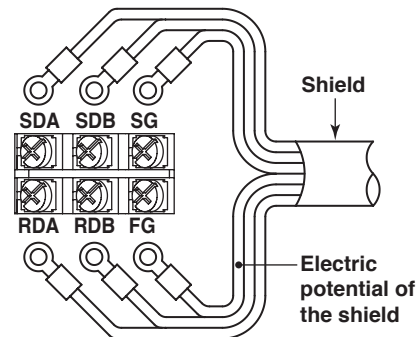

Two-wire system

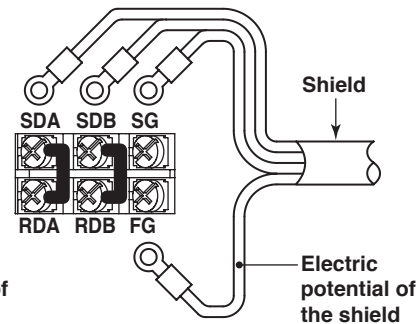



WARNING

To prevent the possibility of electric shock, connect the cables with the power turned OFF.

Note

- Connect the RD pin to the SD (TD) pin on the PC (converter) end and the SD pin to the RD pin on the PC end.
- The two-wire system can be used only when using the Modbus protocol.

Connection Example with a Host Computer

A connection can be made with a host computer having a RS-232, RS-422A, or RS-485 port.

- In the case of RS-232, a converter is used.
- For recommended converters, see “Serial Interface Converter” on the next page.
- The two-wire system can be used only when using the Modbus protocol. For the configuration procedure, see section 3.5

• **Four-Wire System**

Generally, a four-wire system is used to connect to a host computer. In the case of a four-wire system, the transmission and reception lines need to be crossed over.

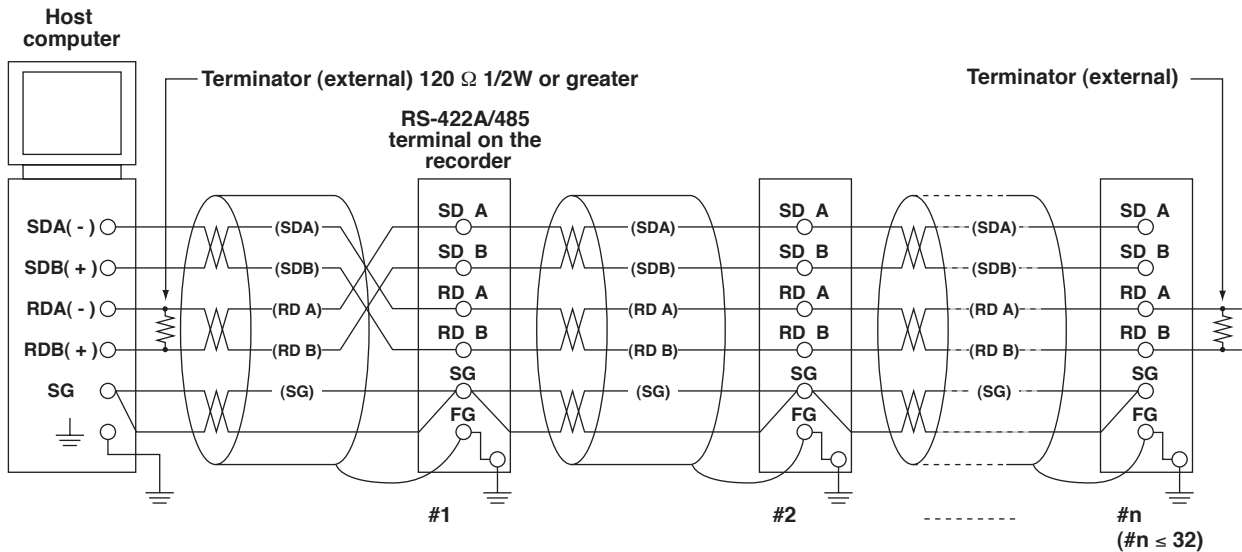

Do not connect terminators to #1 through #n-1.

3.2 Terminal Arrangement and Signal Names and the Connection Procedure of the RS-422A/485 Communication Interface

(The following figure illustrates the case when the host computer's interface is RS-232.)

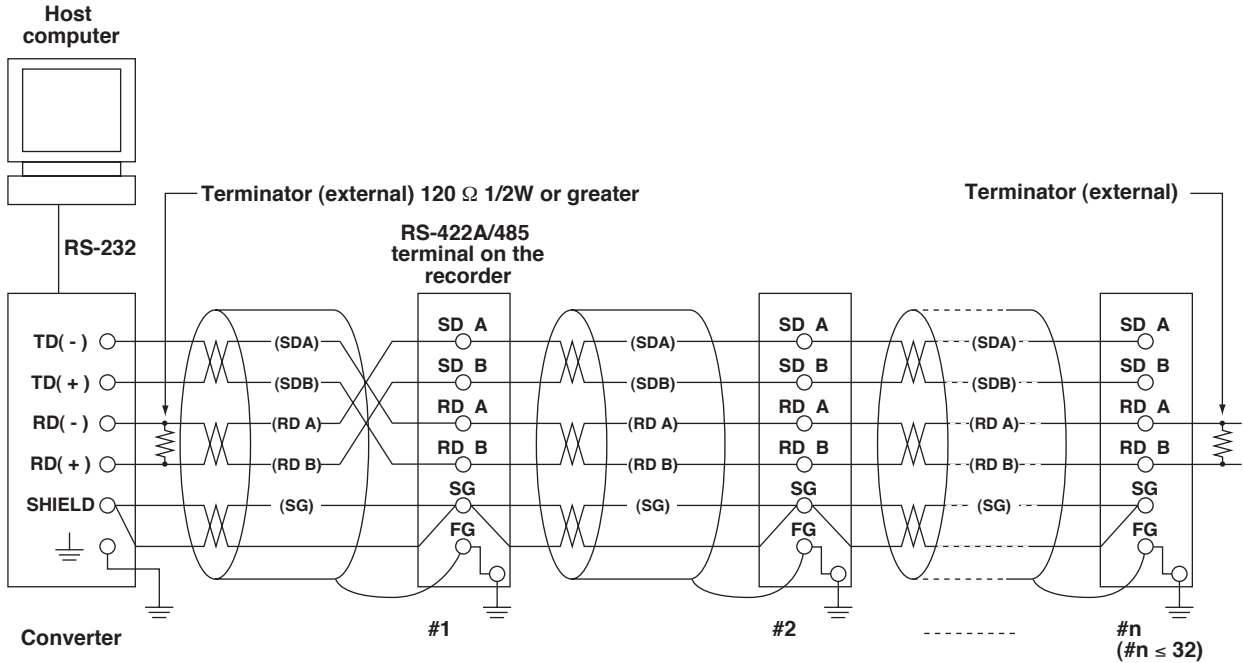

Do not connect terminators to #1 through #n-1.

- **Two-Wire System**

Connect the transmission and reception signals with the same polarity on the RS-422A/485 terminal block. The two-wire system can be used only when using the Modbus protocol.

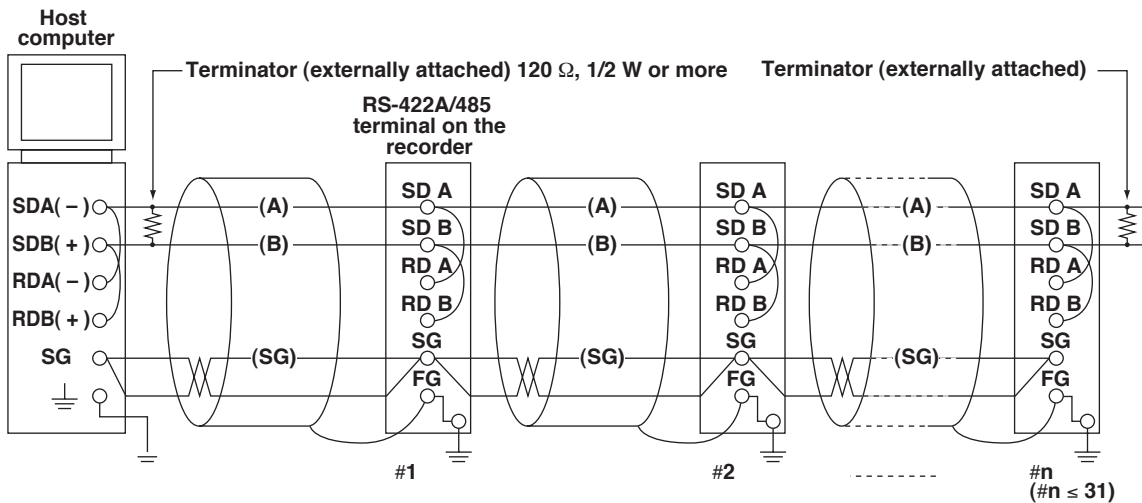

Do not connect terminator to #1 to #n-1

(The following figure illustrates the case when the host computer's interface is RS-232.)

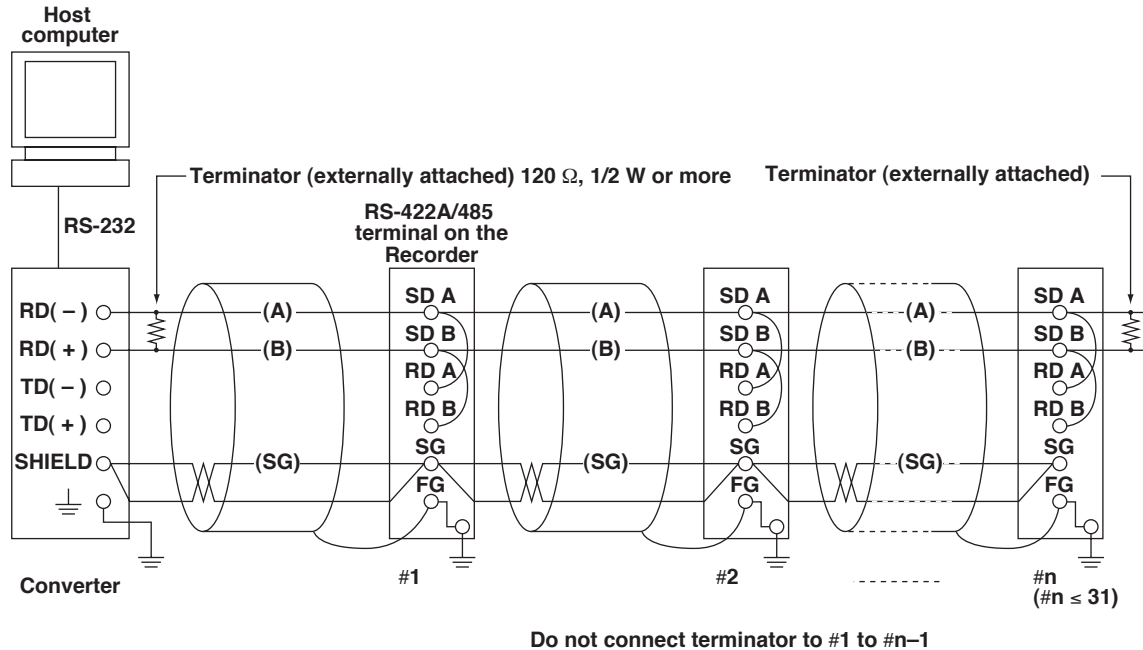

Note

- The method used to eliminate noise varies depending on the situation. In the connection example, the shield of the cable is connected only to the recorder's ground (one-sided grounding). This is effective when there is a difference in the electric potential between the computer's ground and the recorder's ground. This may be the case for long distance communications. If there is no difference in the electric potential between the computer's ground and the recorder's ground, the method of connecting the shield also to the computer's ground may be effective (two-sided grounding). In addition, in some cases, using two-sided grounding with a capacitor connected in series on one side is effective. Consider these possibilities to eliminate noise.
- When using the two-wire type interface (Modbus protocol), the 485 driver must be set to high impedance within 3.5 characters after the last data byte is sent by the host computer.

• **Serial Interface Converter**



CAUTION

Some converters have FG and SG pins that are not isolated. In this case, do not connect anything to the converter's FG and SG pins (unlike the figure on the previous page). Especially in the case of long distance communications, the potential difference that appears may damage the recorder or cause communication errors. For converters that do not have the SG pin, they can be used without using the signal ground. For details, see the manual that came with the converter.

On some non-recommended converters, the signal polarity may be reversed (A/B or +/- indication). In this case, reverse the connection.

3.2 Terminal Arrangement and Signal Names and the Connection Procedure of the RS-422A/485 Communication Interface

For a two-wire system, the host computer must control the transmission driver of the converter in order to prevent collisions of transmit and received data. When using the recommended converter, the driver is controlled using the RS (RTS) signal on the RS-232.

- **When Instruments That Support Only the RS-422A Interface Exist in the System**
When using the four-wire system, up to 32 recorders can be connected to a single host computer. However, this may not be true if instruments that support only the RS-422A interface exist in the system.

When the instrument that support only the RS-422A interface exist in the system

The maximum number of connection is 16. Some of OMEGA's conventional recorder only support the RS-422A driver. In this case, only up to 16 units can be connected.

Note

In the RS-422A standard, 10 is the maximum number of connections that are allowed on one port (for a four-wire system).

- **Terminator**

When using a multidrop connection (including a point-to-point connection), connect a terminator only to the recorder on the end of the chain. In addition, turn the terminator on the host computer ON (see the computer's manual). If a converter is being used, turn ON its terminator. The terminator must be attached externally to the recommended converters.

3.3 The Bit Structure of One Character and the Operation of the Receive Buffer

The Bit Structure of One Character

The serial interface on the recorder communicates using start-stop synchronization. In start-stop synchronization, a start bit is added every time a character is transmitted. The start bit is followed by the data bits, parity bit, and stop bit. (See the figure below.)

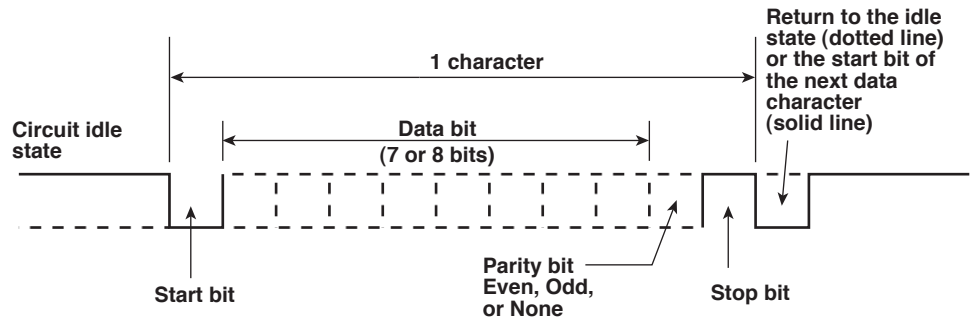

Receive Buffer and Received Data

The data received from the PC is first placed in the receive buffer of the recorder. When the received buffer becomes full, all of the data that overflow are discarded.

3.4 Modbus Slave Protocol Specifications

The Modbus slave protocol specifications of the recorder are as follows:

Item	Specifications
Transmission medium	RS-422A/485
Flow control	None only
Baud rate	Select from 1200, 2400, 4800, 9600, 19200, or 38400 [bps]
Start bit	Fixed to 1 bit
Stop bit	Fixed to 1 bit
Parity check	Select odd, even, or none (no parity).
Transmission mode	RTU (Remote Terminal Unit) mode only <ul style="list-style-type: none">• Data length: 8 bits• Data interval: 24 bits or less*• Error detection: Uses CRC-16 * Determines message termination with a time interval to 3.5 characters or more.
Maximum number of connected units	Four-wire system: 32 slave devices Two-wire system: 31 slave devices

The function codes of the Modbus slave protocol that the recorder supports are shown below. The recorder does not support broadcast commands.

Function Code	Specifications	Operation
3	Read the hold register (4xxxx).	The master device can read the communication input data written using function codes 6 and 16.
4	Read the input register (3xxxx).	The master device loads the computed, measured, alarm, and time data of the recorder.
6	Single write to hold register (4xxxx)	The master device writes to the communication input data of the recorder.
8	Loopback test	The master device performs a loopback test of the recorder. The recorder only supports message return (test code 0x00*)
16	Write to the hold register (4xxxx)	The master device writes to the communication input data of the recorder.

* Hexadecimal "00"

Registers

The registers for using the Modbus slave protocol are listed below.

The register data does not contain unit and decimal point position information. Set them on the Modbus master. Binary values are stored to the register in order from the highest byte.

Input register	Data
30001	Measured data of CH01
:	:
30024	Measured data of CH24
	<ul style="list-style-type: none"> The data is a 16-bit signed integer. The value is the same as the measured data in binary output format (see page 5-13). The decimal point and unit information varies depending on the range setting of each channel. Valid channels vary depending on the device. An error response (code 2) occurs when an invalid channel is read.
31001	Alarm status of the measured data of CH01
:	:
31024	Alarm status of the measured data of CH24
	<ul style="list-style-type: none"> The data is a 16-bit signed integer. The value is the same as the alarm status in binary output format (see page 5-13). The data is entered in the "A2A1A4A3" order in the register. Valid channels vary depending on the device. An error response (code 2) occurs when an invalid channel is read.
32001	Computed data of CH0A (lower word)
32002	Computed data of CH0A (upper word)
32003	Computed data of CH0B (lower word)
32004	Computed data of CH0B (upper word)
:	:
32048	Computed data of CH1P (upper word)
	<ul style="list-style-type: none"> Registers corresponding to models with the /M1 computation function option. The data is a 32-bit signed integer. Two registers are assigned for each data point. The value is the same as the computed data in binary output format (see page 5-13). The decimal point and unit information varies depending on the span setting of each channel. Valid channels vary depending on the device. An error response (code 2) occurs when an invalid channel is read.
33001	Alarm status of the computed data of CH0A
:	:
33024	Alarm status of the computed data of CH1P
	<ul style="list-style-type: none"> Registers corresponding to models with the /M1 computation function option. Data type and value are the same as those of the alarm status of the measured data. Valid channels vary depending on the device. An error response (code 2) occurs when an invalid channel is read.
36001	List of alarms of the measured data of CH01 to CH04
36002	List of alarms of the measured data of CH05 to CH08
36003	List of alarms of the measured data of CH09 to CH12
36004	List of alarms of the measured data of CH13 to CH16
36005	List of alarms of the measured data of CH17 to CH20
36006	List of alarms of the measured data of CH21 to CH24

Example of Register 36001

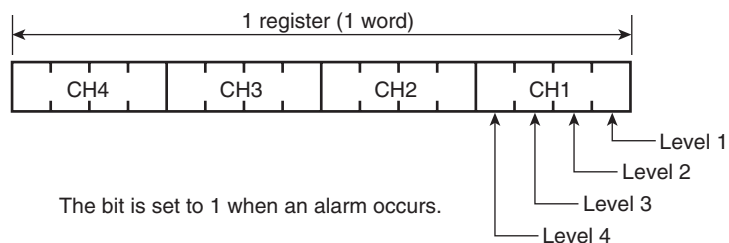

36007 to 36020 Always 0

3.4 Modbus Slave Protocol Specifications

Input register	Data
36021	List of alarms of the measured data of CH0A to CH0D
36022	List of alarms of the measured data of CH0E to CH0J
36023	List of alarms of the measured data of CH0K to CH0P
36024	List of alarms of the measured data of CH1A to CH1D
36025	List of alarms of the measured data of CH1E to CH1J
36026	List of alarms of the measured data of CH1K to CH1P
	<ul style="list-style-type: none"> The register details are same as the list of alarms of measured data. Registers 36001 to 35026 can be read with a single command.
39001	Year (4 digits)
39002	Month
39003	Day
39004	Hour
39005	Minute
39006	Second
39007	Millisecond
39008	Summer/Winter time

Hold register	Data
40001	Communication input data of C01
:	:
40024	Communication input data of C24
	<ul style="list-style-type: none"> Pen model: C01 to C08, dot model: C01 to C12 (RD100B), C01 to C24 (RD1800B) The data is a 16-bit signed integer.

Modbus Error Response

The recorder returns the following error codes to the master device. For the error messages related to communications that the recorder displays, see appendix 4.

Code	Meaning	Cause
1	Bad function code	Unsupported function request.
2	Bad register number	Attempted to read/write to a register that has no corresponding channel.
3	Bad number of registers	The specified number of registers is less than or equal to 0 or greater than or equal to 126 (when reading)/124 (when writing).

However, no response is returned for the following cases.

- CRC error
- Errors other than those in the table above.

3.5 Setting the Serial Interface

The serial interface must be configured.

Setup Items

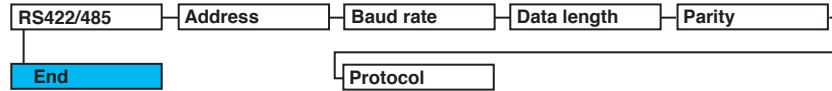

Procedure

For a description of the basic operations, see “Basic Key Operations” on page v.

Entering Basic Setting Mode

Hold down the **MENU** key for 3 seconds to display the Setting mode screen.

Next, hold down both the **▽△ (DISP)** key and the **◀▶ (FUNC)** key for 3 seconds to display the Basic Setting mode screen.

Note

To cancel an operation, press the **ESC** key.

1. Press the **▽△** key to select **RS422/485** and then press the **↵** key.
`Basic=RS422/485`
2. Press the **▽△** key to select the recorder's address and then press the **↵** key.
`Address=1`
3. Press the **▽△** key to select the **Baud rate** value and then press the **↵** key.
`Baud rate=38400`
4. Press the **▽△** key to select the **Data length** value and then press the **↵** key.
`Data length=8`
5. Press the **▽△** key to select the **Parity** value and then press the **↵** key.
`Parity=Even`
6. Press the **▽△** key to select the **NORMAL** value and then press the **↵** key.
The setting complete screen appears.

```
Protocol=NORMAL
↓
RS422/485
Setting complete
```

Saving the Settings

1. Press the **ESC** key to return to the **Basic=** screen.
2. Press the **▽△** key to select **End** and then press the **↵** key.
3. Press the **▽△** key to select **Store** and then press the **↵** key.
The settings are activated, and the Operation mode screen appears.

Explanation

- **Address**
Select the address from the following range.
01 to 32
- **Baud rate**
Select the baud rate from the following:
1200, 2400, 4800, 9600, 19200, or 38400
- **Data length**
Select the data length from below. To output data in BINARY format, be sure to set the data length to 8 bits.
7 or 8
- **Parity (Parity check method)**
Select the parity check from the following:
Odd, Even, or None
- **Protocol**
Select the protocol when using the Modbus slave protocol.
NORMAL: Standard protocol
MODBUS: Modbus slave protocol
- **Saving the Settings**
To activate the settings made in the Basic Setting mode, the settings must be saved.

4.1 Command Syntax

The syntax of the setting/basic setting/output commands (see sections 4.4 to 4.7) of the instrument is given below. ASCII codes (see appendix 1) are used for the character codes.

For the Maintenance/Test command syntax, see section 4.9.

For the Instrument Information server command syntax, see section 4.10.

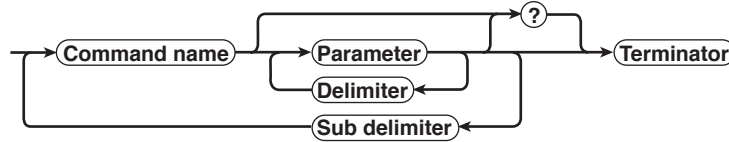

Command example

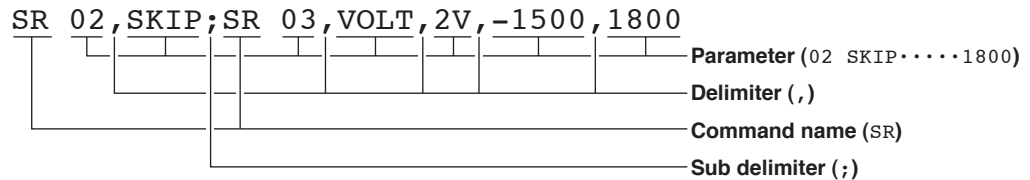

- **Command Name**

Defined using two alphabet characters.

- **Parameter**

- Command parameters.
- Set using alphabet characters or numerical values.
- Parameters are separated by delimiters (commas).
- When the parameter is a numerical value, the valid range varies depending on the command.
- Spaces before and after of the parameter are ignored (except for parameters that are specified using an ASCII character string (unit, tag, and message string), when spaces are valid.)
- You can omit the parameters that do not need to be changed from their current settings. However, delimiters cannot be omitted.

Example SR 01,,2V<terminator>

If multiple parameters are omitted and delimiters occur at the end of the command, those delimiters can be omitted.

Example SR 01,VOLT,,,<terminator> → SR 01,VOLT<terminator>

- The number of digits of the parameters below is fixed. If the number of digits is not correct when entering the command, a syntax error results.
 - Date YY/MM/DD (8 characters)
 - YY: Year (Enter the lower two digits of the year.)
 - MM: Month
 - DD: Day
 - Time HH:MM:SS (8 characters)
 - HH: Hour
 - MM: Minute
 - SS: Second
 - Channel number: 2 characters (Example: 01, 0A)
 - Relay number: 3 characters (Example: I01)
 - Communication input data: 3 characters (Example: C02)
 - Constants used in the computation function (/M1 option): 3 characters (Example: K03)
 - Remote control (/R1 option) input terminal status: 3 characters (Example: D04)

- **Query**

- A question mark is used to specify a query.
- By placing a query after a command or parameter, the setting information of the corresponding command can be queried. Some commands cannot execute queries. For the query syntax of each command, see sections 4.4 to 4.7.

Example 1 SR[p1]? SR? or SR p1? can be executed.

Example 2 SA[p1[,p2]]? SA?, SA p1?, or SA p1, p2? can be executed.

- **Delimiter**

- A comma is used as a delimiter.
- Parameters are separated by delimiters.

- **Sub Delimiter**

- A semicolon is used as a sub delimiter.
- By separating each command with a sub delimiter, up to 10 commands can be specified one after another. However, the following commands and queries cannot be specified one after another. Use them independently.
 - Output commands other than BO, CS, and IF commands.
 - YE command
 - Queries

* If there are consecutive sub delimiters, they are considered to be single. In addition, sub delimiters at the front and at the end are ignored.

Example ;SR01,VOLT;;SR02,VOLT;<terminator> is taken to be
SR01,VOLT;SR02,VOLT<terminator>.

- **Terminator (Terminating Character)**

Use either of the following two characters for the terminator.

- CR + LF (0DH 0AH in ASCII code.)
- LF (0AH in ASCII code.)

Note

- The total data length from the first character to the terminator must be less than 2047 bytes. In addition, the character string length of 1 command must be less than 512 bytes.
 - Commands are not case sensitive (with the exception of user-specified character strings).
 - All the commands that are listed using sub delimiters are executed even if one of the commands is erroneous.
 - Spaces that are inserted before and after a parameter are ignored. However, if spaces are inserted before a command, after a sub delimiter, or after a query, an error occurs.
-

Response

The recorder returns a response (affirmative/negative response) to a command that is separated by a single terminator.* The controller should follow the one command to one response format. When the command-response rule is not followed, the operation is not guaranteed.

For the response syntax, see section 5.1.

* The exceptions are the RS-422A/485 dedicated commands (see section 4.8).

Note

When using the RS-422A/485 interface, allow at least 1 ms before sending the next command after receiving a response. Otherwise, the command may not be processed correctly.

4.2 A List of Commands

Execution Modes and User Levels

Execution Modes

The recorder has two execution modes. Each command is specified to be used in a particular execution mode. If you attempt to execute a command in a mode that is different from the specification, a syntax error occurs. Use the DS command to switch to the appropriate mode, and then execute the command. Query commands can be executed in either mode.

- Basic Setting mode
Measurement/computation is stopped and settings are changed in this mode.
- Run mode
Run mode collectively refers to Operation mode and Setting mode of the recorder.

User Levels

The administrator and user specifications in the table indicate the user level that is specified using the login function for Ethernet communications. For details, see section 1.1.

Setting Commands

Command Name	Function	Execution Mode	Administrator	User	Page
SR	Sets the input range.	Run mode	Yes	No	4-10
SO	Sets the computing equation (/M1 option).	Run mode	Yes	No	4-11
VB	Sets the bias.	Run mode	Yes	No	4-11
SA	Sets the alarm.	Run mode	Yes	No	4-11
SN	Sets the unit.	Run mode	Yes	No	4-12
SC	Sets the chart speed.	Run mode	Yes	No	4-12
SD	Sets the date and time.	Run mode	Yes	No	4-13
VT	Sets the dot printing interval (dot model).	Run mode	Yes	No	4-13
SZ	Sets zone recording.	Run mode	Yes	No	4-13
SP	Sets the partial expanded recording.	Run mode	Yes	No	4-13
VR	Turns ON/OFF the recording on each channel.	Run mode	Yes	No	4-13
ST	Sets the tag.	Run mode	Yes	No	4-14
SG	Sets the message.	Run mode	Yes	No	4-14
SE	Sets the secondary chart speed (used by the remote control function (/R1 option)).	Run mode	Yes	No	4-14
SV	Sets the moving average (dot model).	Run mode	Yes	No	4-14
SF	Sets the input filter (pen model).	Run mode	Yes	No	4-14
BD	Sets the alarm delay time.	Run mode	Yes	No	4-14
VF	Sets the brightness of the display (VFD) and internal illumination.	Run mode	Yes	No	4-14
TD	Sets the DST.	Run mode	Yes	No	4-14
SS	Sets the DST. (Can be used on the RD100B with system version 1.02 or earlier)	Run mode	Yes	No	4-15
SK	Sets the computation constant (/M1 option).	Run mode	Yes	No	4-15
SJ	Sets the timer used in TLOG computation (/M1 option).	Run mode	Yes	No	4-15
CM	Sets the communication input data (/M1 option).	Run mode	Yes	No	4-15
FR	Sets the acquiring interval to the FIFO buffer.	Run mode	Yes	No	4-15
VD	Sets the data display screen.	Run mode	Yes	No	4-16

Yes: Command usable

No: Command not usable

Basic Setting Commands

Note

- In order to activate the settings that are changed using the basic setting commands, the settings must be saved using the YE or XE command.
- The settings that are returned in response to a query in the basic setting mode will contain the new settings even if they are not saved.
- When the settings are saved with the XE command, communication is not dropped. The settings that are changed using the YS/YB/YA/YN/YD/YQ/YK command are activated after power-cycling the recorder.
- When the YE command is executed, communication is dropped. The response to the YE command is not returned.

Command Name	Function	Execution Mode	Administrator	User	Page
XA	Sets alarm related settings.	Basic Setting mode	Yes	No	4-18
XI	Sets the A/D integral time.	Basic Setting mode	Yes	No	4-18
XB	Sets the burnout detection.	Basic Setting mode	Yes	No	4-19
XJ	Sets the RJC.	Basic Setting mode	Yes	No	4-19
UC	Changes the dot color (dot model).	Basic Setting mode	Yes	No	4-19
UO	Sets the pen offset compensation (pen model).	Basic Setting mode	Yes	No	4-19
UP	Sets the items to be printed.	Basic Setting mode	Yes	No	4-19
UR	Sets the periodic printout interval.	Basic Setting mode	Yes	No	4-19
UM	Sets the types of report data that are output to the periodic printout.	Basic Setting mode	Yes	No	4-20
UB	Sets the display mode of the bar graph.	Basic Setting mode	Yes	No	4-20
UI	Sets whether to use moving average (dot model).	Basic Setting mode	Yes	No	4-20
UJ	Sets whether to use the input filter (pen model).	Basic Setting mode	Yes	No	4-20
UK	Sets whether to use of partial expanded recording.	Basic Setting mode	Yes	No	4-20
UL	Selects the display/record language.	Basic Setting mode	Yes	No	4-20
XN	Selects the date format.	Basic Setting mode	Yes	No	4-20
XT	Selects the temperature unit.	Basic Setting mode	Yes	No	4-21
UF	Sets whether to use the extended functions.	Basic Setting mode	Yes	No	4-21
UT	Selects the time printout format.	Basic Setting mode	Yes	No	4-21
XR	Sets the remote control input (/R1 option).	Basic Setting mode	Yes	No	4-21
YS	Sets the RS-422A/485 interface (/C3 option).	Basic Setting mode	Yes	No	4-21
XQ	Sets the TLOG timer (/M1 option).	Basic Setting mode	Yes	No	4-22
UN	Changes the assignment of channels to the recording pen (pen model, /M1 option).	Basic Setting mode	Yes	No	4-22
US	Sets the computation error procedure (/M1 option).	Basic Setting mode	Yes	No	4-22
YB	Sets the host name and domain name (/C7 option).	Basic Setting mode	Yes	No	4-22
YA	Sets the IP address (/C7 option).	Basic Setting mode	Yes	No	4-22
YN	Sets the DNS (/C7 option).	Basic Setting mode	Yes	No	4-23
YD	Sets whether to use the login function via communication (/C7 option).	Basic Setting mode	Yes	No	4-23
YQ	Sets the communication timeout (/C7 option)	Basic Setting mode	Yes	No	4-23
YK	Sets keepalive (/C7 option).	Basic Setting mode	Yes	No	4-23
UA	Sets the record position.	Basic Setting mode	Yes	No	4-23
YE	Exits from Basic Setting mode.	Basic Setting mode	Yes	No	4-24
XE	Exits from Basic Setting mode.	Basic Setting mode	Yes	No	4-24

Yes: Command usable
 No: Command not usable

Control Commands

Key	Command Name	Function	Execution Mode	Administrator	User	Page
-	DS	Switches the execution mode.	All modes	Yes	No	4-25
RCD	PS	Starts/Stops recording.	Run mode	Yes	No	4-25
DISP	UD	Switches the screen/switches the channel.	Run mode	Yes	No	4-25
FUNC	AK	Executes alarm acknowledge (AlarmACK)	Run mode	Yes	No	4-25
FUNC	TL	Starts/stops/resets computation (/M1 option).	Run mode	Yes	No	4-25
FUNC	MP	Starts/Stops manual print.	Run mode	Yes	No	4-25
FUNC	LS	Starts/Stops the list (setting information) printout.	Run mode	Yes	No	4-25
FUNC	SU	Starts/Stops the setup list (basic setting information) printout.	Run mode	Yes	No	4-25
FUNC	MS	Executes the message printout.	Run mode	Yes	No	4-25
FUNC	AC	Clears the alarm printout buffer.	Run mode	Yes	No	4-25
FUNC	MC	Clears the message printout buffer.	Run mode	Yes	No	4-26
FUNC	VG	Resets the report data of the periodic printout.	Run mode	Yes	No	4-26
-	YC	Initializes the settings.	Basic Setting mode	Yes	No	4-26
-	UY	Stops the record position adjustment.	Basic Setting mode	Yes	No	4-26

Yes: Command usable

No: Command not usable

Output Commands

Command Type	Command Name	Function	Execution Mode	Administrator	User	Page
Control						
	BO	Sets the byte output order.	All modes	Yes	Yes	4-26
	CS	Sets the check sum (usable only during serial communications).	All modes	Yes	Yes	4-26
	IF	Sets the status filter	All modes	Yes	Yes	4-26
	CC	Disconnects an Ethernet connection (usable only during Ethernet communications)	All modes	Yes	Yes	4-26
Setup, measurement, and computation data output						
	FE	Outputs decimal point position, unit information, and setup data.	All modes	Yes	Yes	4-27
	FD	Outputs the most recent measured/computed data.	Run mode	Yes	Yes	4-27
	FY	Outputs the statistical computation results.	Run mode	Yes	Yes	4-27
	FF	Outputs FIFO data.	Run mode	Yes	Yes	4-27
	IS	Outputs status information.	All modes	Yes	Yes	4-28
	FU	Outputs user information.	All modes	Yes	Yes	4-28

Yes: Command usable

No: Command not usable

RS-422A/485 Dedicated Commands

Command Name	Function	Execution Mode	Administrator	User	Page
Esc O	Opens the instrument.	All modes	Yes	Yes	4-28
Esc C	Closes the instrument.	All modes	Yes	Yes	4-28

Yes: Command usable

No: Command not usable

4.2 A List of Commands

Maintenance/Test Commands

These commands can be used only when using Ethernet communications.

Command Name	Function	Execution Mode	Administrator	User	Page
close	Disconnects the connection between other instruments.	All modes	Yes	No	4-29
con	Outputs connection information.	All modes	Yes	Yes	4-29
eth	Output Ethernets statistical information.	All modes	Yes	Yes	4-29
help	Outputs help.	All modes	Yes	Yes	4-29
net	Outputs network statistical information.	All modes	Yes	Yes	4-29
quit	Disconnects the connection of the instrument being operated.	All modes	Yes	Yes	4-30

Yes: Command usable

No: Command not usable

Instrument Information Output Commands

These commands can be used only when using Ethernet communications.

Parameter	Function	Page
serial	Outputs the serial number.	4-30
host	Outputs the host name.	4-30
ip	Outputs the IP address.	4-30

4.3 Parameter Values

Input Range

This section explains frequently used parameters.

The following tables show the input types (VOLT, TC, RTD, DI, and 1-5V), range types, and the ranges for the leftmost and rightmost values of the span.

- **DC Voltage (VOLT), Square Root (SQRT), Difference between Channels (DELTA)**

Range Type	Parameter for the SR Command	Range of Leftmost and Rightmost Values of Span	Range of Leftmost and Rightmost Values of Span of the SR Command
20 mV	20 mV	-20.00 to 20.00 mV	-2000 to 2000
60 mV	60 mV	-60.00 to 60.00 mV	-6000 to 6000
200 mV	200 mV	-200.0 to 200.0 mV	-2000 to 2000
2 V	2 V	-2.000 to 2.000 V	-2000 to 2000
6 V	6 V	-6.000 to 6.000 V	-6000 to 6000
20 V	20 V	-20.00 to 20.00 V	-2000 to 2000
50 V	50 V	-50.00 to 50.00 V	-5000 to 5000

- **1-5V**

Range Type	Parameter for the SR Command	Range of Leftmost and Rightmost Values of Span	Range of Leftmost and Rightmost Values of Span of the SR Command
1-5V	1-5V	Leftmost value: 0.8000 to 1.200 V Rightmost value: 4.8000 to 5.200 V	800 to 1200 4800 to 5200

- **Thermocouple (TC)**

Range Type	Parameter for the SR Command	Range of Leftmost and Rightmost Values of Span	Range of Leftmost and Rightmost Values of Span of the SR Command
R	R	0.0 to 1760.0°C	0 to 17600
S	S	0.0 to 1760.0°C	0 to 17600
B	B	0.0 to 1820.0°C	0 to 18200
K	K	-200.0 to 1370.0°C	-2000 to 13700
E	E	-200.0 to 800.0°C	-2000 to 8000
J	J	-200.0 to 1100.0°C	-2000 to 11000
T	T	-200.0 to 400.0°C	-2000 to 4000
N	N	0.0 to 1300.0°C	0 to 13000
W	W	0.0 to 2315.0°C	0 to 23150
L	L	-200.0 to 900.0°C	-2000 to 9000
U	U	-200.0 to 400.0°C	-2000 to 4000
WRe	WRe	0.0 to 2400.0°C	0 to 24000
Difference between channels (DELTA)			
R	-	-1760.0 to 1760.0°C	-17600 to 17600
S	-	-1760.0 to 1760.0°C	-17600 to 17600
B	-	-1820.0 to 1820.0°C	-18200 to 18200
K	-	-1570.0 to 1570.0°C	-15700 to 15700
E	-	-1000.0 to 1000.0°C	-10000 to 10000
J	-	-1300.0 to 1300.0°C	-13000 to 13000
T	-	-600.0 to 600.0°C	-6000 to 6000
N	-	-1300.0 to 1300.0°C	-13000 to 13000
W	-	-1999.9 to 2315.0°C	-19999 to 23150
L	-	-1100.0 to 1100.0°C	-11000 to 11000
U	-	-600.0 to 600.0°C	-6000 to 6000
WRe	-	-1999.9 to 2400.0°C	-19999 to 24000

• **Resistance Temperature Detector (RTD)**

Range Type	Parameter for the SR Command	Range of Leftmost and Rightmost Values of Span	Range of Leftmost and Rightmost Values of Span of the SR Command
Pt100	PT	-200.0 to 600.0°C	-2000 to 6000
JPt100	JPT	-200.0 to 550.0°C	-2000 to 5500
Difference between channels (DELTA)			
Pt100	-	-800.0 to 800.0°C	-8000 to 8000
JPt100	-	-750.0 to 750.0°C	-7500 to 7500

• **ON/OFF input (DI)**

Range Type	Parameter for the SR Command	Range of Leftmost and Rightmost Values of Span	Range of Leftmost and Rightmost Values of Span of the SR Command
Level	LEVEL	0 to 1 [†]	0 to 1
Contact	CONT	0 to 1 ^{††}	0 to 1

[†] "0" when less than 2.4 V, "1" when greater than or equal to 2.4 V.

^{††} "0" when contact is OFF, "1" when contact is ON.

Miscellaneous

Channel Number

• **Pen model**

Measurement channel: 01 to 04

Computation channel: 0A, 0B, 0C, 0D, 0E, 0F, 0G, 0J

• **Dot model**

Measurement channel:

RD100B: 01 to 06

RD1800B: 01 to 24

Computation channel:

RD100B: 0A, 0B, 0C, 0D, 0E, 0F, 0G, 0J, 0K, 0M, 0N, 0P

RD1800B: 0A, 0B, 0C, 0D, 0E, 0F, 0G, 0J, 0K, 0M, 0N, 0P, 1A, 1B, 1C, 1D, 1E, 1F, 1G, 1J, 1K, 1M, 1N, 1P

Relay Number (/A1, /A2, /A3, /A4, and /A5 Options)

- Models with the /A1 option: I01, I02
- Models with the /A2 option: I01 to I04
- Models with the /A3 option: I01 to I06
- Models with the /A4 option: I01 to I06, I11 to I16 (RD1800B)
- Models with the /A5 option: I01 to I06, I11 to I16, I21 to I26, I31 to I36 (RD1800B)

Communication Input Data

RD100B Pen model: C01 to C08, dot model: C01 to C12

μR20000 Pen model: C01 to C08, dot model: C01 to C24

Computation Constant (/M1 option).

K01 to K30

Remote Control Input Terminal (/R1 Option)

D01 to D05

Chart Speed on the Pen Model

									mm/h
5	6	8	9	10	12	15	16	18	20
24	25	30	32	36	40	45	48	50	54
60	64	72	75	80	90	96	100	120	125
135	150	160	180	200	225	240	250	270	300
320	360	375	400	450	480	500	540	600	675
720	750	800	900	960	1000	1080	1200	1350	1440
1500	1600	1800	2000	2160	2250	2400	2700	2880	3000
3600	4000	4320	4500	4800	5400	6000	7200	8000	9000
10800	12000								

4.4 Setting Commands

SR Sets the input range.

When setting channels to skip

Syntax SR p1 , p2 <terminator>
 p1 Channel number
 p2 Measurement mode (SKIP)

Query SR[p1]?

Example Set channel 01 to skip.

SR 01 , SKIP

- Description • This command cannot be specified while computation is in progress.
- Measurements are not made on channels that are set to SKIP.

When setting channels to voltage, TC, RTD, or ON/OFF input

Syntax SR p1 , p2 , p3 , p4 , p5 <terminator>
 p1 Channel number
 p2 Measurement mode (Input type)
 VOLT DC voltage
 TC Thermocouple
 RTD Resistance temperature detector
 DI ON/OFF input
 p3 Range type
 p4 Leftmost value of span
 p5 Rightmost value of span

Query SR[p1]?

Example Measure 0°C to 1760.0°C on channel 01 using thermocouple type R.

SR 01 , TC , R , 0 , 17600

- Description • This command cannot be specified while computation is in progress.
- Set p3 according to the table in section 4.3.
 - For p4 and p5, enter an integer value of 5 digits or less according to the table in section 4.3. The decimal position is fixed to the position indicated in the table in section 4.3.

When setting channels to 1-5V range

Syntax SR p1 , p2 , p3 , p4 , p5 , p6 , p7 , p8 <terminator>
 p1 Channel number
 p2 Measurement mode (Input type) (1-5V)
 p3 Leftmost value of span
 p4 Rightmost value of span
 p5 Leftmost value of scaling (–20000 to 30000)
 p6 Rightmost value of scaling (–20000 to 30000)
 p7 Scale decimal point position (0 to 4)
 p8 Whether to use 1-5V low-cut function (ON, OFF)

Query SR[p1]?

Example Set channel 01 to 1-5V range and scale the input value in the range 0.0 to 1200.0. Do not use the low-cut function.

SR 01 , 1-5V , 1000 , 5000 , 0 , 12000 , 1 , OFF

- Description • This command cannot be specified while computation is in progress.
- For p3 and p4, enter an integer value of 5 digits or less according to the table in section 4.3. The decimal position is fixed to the position indicated in the table in section 4.3.
 - Be sure that p6 is greater than p5.
 - Parameter p8 is valid only when the low-cut function is enabled (see the UF command).

When computing the difference between channels

Syntax SR p1 , p2 , p3 , p4 , p5 <terminator>
 p1 Channel number
 p2 Measurement mode (DELTA)
 p3 Reference channel
 p4 Leftmost value of span
 p5 Rightmost value of span

Query SR[p1]?

Example Set channel 03 to channel difference computation with respect to channel 01 (reference channel). Set the leftmost and rightmost values of span to –200.0 and 200.0, respectively.

SR 03 , DELTA , 01 , –2000 , 2000

- Description • This command cannot be specified while computation is in progress.
- The reference channel must be a channel that is smaller in channel number than itself.
 - The range type is the same as that of the reference channel.
 - For p4 and p5, enter an integer value of 5 digits or less according to the table in section 4.3. The decimal position is fixed to the position indicated in the table in section 4.3.

When setting the linear scaling

Syntax SR p1 , p2 , p3 , p4 , p5 , p6 , p7 , p8 , p9 <terminator>

p1 Channel number
 p2 Measurement mode (SCALE)
 p3 Input type
 VOLT DC voltage
 TC Thermocouple
 RTD Resistance temperature detector
 DI ON/OFF input

p4 Range type
 p5 Leftmost value of span
 p6 Rightmost value of span
 p7 Leftmost value of scaling (–20000 to 30000)
 p8 Rightmost value of scaling (–20000 to 30000)
 p9 Scaling decimal point position (0 to 4)

Query SR[p1]?

Example Scale channel 02 whose input range is 0 to 10 V to –100.0 to 500.0.

SR 02 , SCALE , VOLT , 20V , 0 , 1000 , –1000 , 5000 , 1

- Description • This command cannot be specified while computation is in progress.
- Set p4 according to the table in section 4.3.
 - For p5 and p6, enter an integer value of 5 digits or less according to the table in section 4.3. The decimal position is fixed to the position indicated in the table in section 4.3.
 - Be sure that p8 is greater than p7.

When setting the square root

Syntax `SR p1 , p2 , p3 , p4 , p5 , p6 , p7 , p8 , p9 , p10 <terminator>`
 p1 Channel number
 p2 Measurement mode (SQRT)
 p3 Range type
 p4 Leftmost value of span
 p5 Rightmost value of span
 p6 Leftmost value of scaling (–20000 to 30000)
 p7 Rightmost value of scaling (–20000 to 30000)
 p8 Scaling decimal point position (0 to 4)
 p9 Low-cut function (ON, OFF)
 p10 Low-cut value

Query `SR[p1]?`

Example Given channel 01 whose input range is 0 to 10 V, take the square root of the input value and scale the result in the range 0.00 (m³/s) to 100.00 (m³/s). When the input value is less than or equal to 5.0% of the recording span, use the low-cut function.
`SR 01 , SQRT , 20V , 0 , 1000 , 0 , 10000 , 2 , ON , 50`

- Description • This command cannot be specified while computation is in progress.
- Set p3 according to the table in section 4.3.
 - For p4 and p5, enter an integer value of 5 digits or less according to the table in section 4.3. The decimal position is fixed to the position indicated in the table in section 4.3.
 - Be sure that p7 is greater than p6.
 - Parameters p9 and p10 is valid only when the low-cut function is enabled (see the UF command).

SO Sets the computing equation (/M1 option).

Syntax `SO p1 , p2 , p3 , p4 , p5 , p6 <terminator>`
 p1 Computation channel number
 p2 Turn ON/OFF the computing equation (ON, OFF)
 p3 Computing equation (up to 120 characters)
 p4 Leftmost value of span (–9999999 to 99999999)
 p5 Rightmost value of span (–9999999 to 99999999)
 p6 Span decimal point position (0 to 4)

Query `SO[p1]?`

Example Calculate the sum of channel 01 and 02 on computation channel 0A. Set the leftmost and rightmost values of span to –10.00 and 15.00, respectively.

`SO 0A , ON , 01+02 , -1000 , 1500 , 2`

- Description • This command cannot be specified while computation is in progress.
- For a description on the computing equations, see the *RD100B Recorder User's Manual*.
 - For p4 and p5, enter a value using 7 digits or less, excluding the decimal, for negative numbers and 8 digits or less for positive numbers.

VB Sets the bias.

Syntax `VB p1 , p2 , p3 <terminator>`
 p1 Channel number
 p2 Bias ON/OFF (ON, OFF)
 p3 Bias value

Query `VB[p1]?`

Example Given channel 03 whose range type is 2V (measurable range: –2.000 to 2.000 V), add a bias of 0.1 V.
`VB 03 , ON , 100`

- Description • Set p3 in the range of ±10% of the span of the measurable range at the range type or ±10% of the scaling span. Specify the value with an integer (see section 4.3).
- The bias setting is valid only when the bias function is enabled (see the UF command).

SA Sets the alarm.

When not using the alarm

Syntax `SA p1 , p2 , p3 <terminator>`
 p1 Channel number
 p2 Alarm number (1 to 4)
 p3 Alarm ON/OFF state (OFF)

Query `SA[p1 [, p2]]?`

Example Do not use alarm number 4 of channel 01.
`SA 01 , 4 , OFF`

When using the alarm

Syntax `SA p1 , p2 , p3 , p4 , p5 , p6 , p7 <terminator>`
 p1 Channel number
 p2 Alarm number (1 to 4)
 p3 Alarm ON/OFF state (ON)
 p4 Alarm type
 H High limit alarm
 L Low limit alarm
 h Difference high limit alarm
 l Difference low limit alarm
 R High limit on rate-of-change alarm
 r Low limit on rate-of-change alarm
 T Delay high limit alarm
 t Delay low limit alarm
 (Characters are case-sensitive.)
 p5 Alarm value

4.4 Setting Commands

	p6 Relay output ON Relay ON OFF Relay OFF
	p7 Relay number (RD100B: I01 to I06, RD1800B: I01 to I06, I11 to I16, I21 to I26, I31 to I36)
Query	SA[p1[, p2]]?
Example	Set a high limit alarm (alarm value = 1000) on alarm number 1 of channel 02 and output to relay I01. SA 02,1,ON,H,1000,ON,I01
Description	<ul style="list-style-type: none"> • When the input range is set to SKIP (SR command), p3 cannot be turned ON. • The alarm settings are all turned OFF for the following cases. <ul style="list-style-type: none"> • When the input type is changed (VOLT, TC, etc). • When the range type is changed. • When the span and scaling values are changed during linear scaling (includes changing the decimal position). • The h and l settings of p4 are valid only when the measurement range is set to computation between channels. • The hysteresis of alarm ON/OFF (valid when p4 is H or L) is set using the XA command. • If p4 is set to R or r, set the interval for the high/low limit on the rate-of-change using the XA command. • The T and t settings of p4 can be specified when the alarm delay function is enabled (UF command). • If p4 is set to T or t, set the alarm delay time for the delay high/low limit alarm using the BD command. • Parameter p5 for the high limit alarm/low limit alarm and delay high limit alarm/delay lowlimit alarm <ul style="list-style-type: none"> • For DC voltage, TC, and RTD input: Values within the measurable range in the specified range (example: -2.000 to 2.000 V for the 2 V range). • For ON/OFF input (DI): 0 or 1. • For scaling (1-5V, scaling, and square root): -5 to 105% of the scale span (except within -20000 to 30000). • Parameter p5 for the difference high limit alarm/difference low limit alarm: Values in the measurable range can be specified (example: -1760.0 to 1760.0°C for the TC type R). • Parameter p5 for the high limit on rate-of-change alarm/low limit on rate-of-change alarm: A value greater than or equal to 1 digit can be specified. For example, 1 digit corresponds 0.001 for the 2 V range (measurable range: -2.000 to 2.000 V). The maximum value that can be specified is the

width of the measurable range (4.000 V for 2 V range). For ON/OFF input, only "1" can be specified.

- On models with the computation function (/M1 option), alarms can be set on computation channels.
- When the computation equation setting (SO command) is turned OFF, p3 cannot be turned ON.
- For computation channels, the alarm types that can be specified are H (high limit alarm), L (low limit alarm), T (delay high limit alarm), and t (delay low limit alarm). T and t can be specified when the alarm delay function is enabled (UF command).
- If p4 is set to T or t, set the alarm delay time for the delay high/low limit alarm using the BD command.
- Set p5 within the range -9999999 to 99999999 excluding the decimal using an integer.
- The alarm ON/OFF hysteresis is set using the XA command.
- If the computation channel ON/OFF state, the computing equation, or the span value is changed, all alarm settings of that channel are turned OFF.

SN Sets the unit.

Syntax SN p1, p2<terminator>
p1 Channel number
p2 Unit string (up to 6 characters)

Query SN[p1]?

Example Set the unit of channel 02 to M/H.
SN 02, M/H

- Description
- The unit setting is valid on channels set to 1-5V, scaling, or square root.
 - For the characters that can be used for the units, see appendix 1, "ASCII Character Codes."
 - On models with the computation function (/M1 option), unit can be set on computation channels.

SC Sets the chart speed.

Syntax SC p1<terminator>
p1 Chart speed

Query SC?

Example Set the chart speed to 25 mm/h.
SC 25

- Description Select the chart speed from the list of choices below.
- Pen model
5 to 12000 mm/h (82 levels, see section 4.3)
 - Dot model
1 to 1500 mm/h (1 mm steps)

SD Sets the date and time.

Syntax	SD p1<terminator>
	p1 Date and time (fixed to the YY/MM/DD HH:MM:SS format)
	YY Year (00 to 99, the lower 2 digits)
	MM Month (01 to 12)
	DD Day (01 to 31)
	HH Hour (00 to 23)
	MM Minute (00 to 59)
	SS Second (00 to 59)
Query	SD?
Example	Set the recorder clock to 13:00:00, December 1, 2004. SD 04/12/01 13:00:00
Description	<ul style="list-style-type: none"> The format of p1 is fixed to 17 characters. An error results if a space is inserted in positions other than the specified positions. On the RD100B with system version 1.02 or earlier, the parameter p2 can be used. <ul style="list-style-type: none"> p2 Standard time or DST (winter, summer) <ul style="list-style-type: none"> winter Standard time summer DST

VT Sets the dot printing interval (dot model).

Syntax	VT p1<terminator>
	p1 Dot printing interval setting.
	AUTO Automatically adjust the dot printing interval according to the chart speed.
	FIX Record at the fastest printing interval.
Query	VT?
Example	Record at the fastest printing interval. VT FIX
Description	When trend recording is performed on 6 channels, the fastest printing interval is 10 seconds.

SZ Sets zone recording.

Syntax	SZ p1,p2,p3<terminator>
	p1 Channel number
	p2 Leftmost position of the zone (RD100B: 0 to 95, RD1800B: 0 to 175) [mm]
	p3 Rightmost position of the zone (RD100B: 5 to 100, RD1800B: 0 to 180) [mm]
Query	SZ[p1]?
Example	Display channel 02 in a zone between 30 and 50 mm. SZ 02,30,50
Description	<ul style="list-style-type: none"> Be sure that p3 is greater than p2 and that the zone width (p3 – p2) is greater than or equal to 5 mm. On models with the computation function (/M1 option), computation channels can be specified.

SP Sets the partial expanded recording.

Syntax	SP p1,p2,p3,p4<terminator>
	p1 Channel number
	p2 Partial expanded recording ON/OFF (ON, OFF)
	p3 Boundary position (1 to 99) [%]
	p4 Boundary value
Query	SP[p1]?
Example	Set the 25% position of channel 01 to 1.000 V. SP 01,ON,25,1000
Description	<ul style="list-style-type: none"> When the input range is set to SKIP (SR command), p2 cannot be turned ON. Set p3 as a percentage where 100 mm is assumed to be 100%. Parameter p4 can be set in the range (leftmost value of span + 1) to (rightmost value of span – 1). If scaling is enabled, the range is (leftmost value of scaling – 1) to (rightmost value of scaling + 1). Set the parameter using an integer. This setting is possible when partial expanded recording is enabled (UK command). This command cannot be used if the partial expanded recording range does not exist (when the span width is set to 1, for example). On models with the computation function (/M1 option), computation channels can be specified. When the computation equation setting (SO command) is turned OFF, p2 cannot be turned ON.

VR Turns ON/OFF the recording on each channel.

Dot model	
Syntax	VR p1,p2,p3<terminator>
	p1 Channel number
	p2 Trend recording ON/OFF (ON, OFF)
	p3 Periodic printout ON/OFF (ON, OFF)
Query	VR[p1]?
Example	Turn trend recording ON and turn periodic printout OFF on channel 06. VR 06,ON,OFF
Description	On models with the computation function (/M1 option), computation channels can be specified.
Pen model	
Syntax	VR p1,p2<terminator>
	p1 Channel number
	p2 Periodic printout ON/OFF (ON, OFF)
Query	VR[p1]?
Example	Turn periodic printing ON on channel 01. VR 01,ON
Description	On models with the computation function (/M1 option), computation channels can be specified.

4.4 Setting Commands

ST Sets the tag.

Syntax ST p1 , p2<terminator>
p1 Channel number
p2 Tag string (up to 7 characters)

Query ST[p1]?

Example Set the tag of channel 02 to TI-2.
ST 02 , TI-2

Description

- For the characters that can be used for the tags, see appendix 1, "ASCII Character Codes."
- On models with the computation function (/M1 option), computation channels can be specified.

SG Sets the message.

Syntax SG p1 , p2<terminator>
p1 Message number (1 to 5)
p2 Message string (up to 16 characters)

Query SG[p1]?

Example Set character string "START" in message number 1.
SG 1 , START

Description For the characters that can be used for the messages, see appendix 1, "ASCII Character Codes."

SE Sets the secondary chart speed (used by the remote control function (/R1 option)).

Syntax SE p1<terminator>
p1 Secondary chart speed
See the explanation.

Query SE?

Example Set the chart speed to 50 mm/h.
SE 50

Description Select the chart speed from the list of choices below.

Pen model
5 to 12000 mm/h (82 levels, see section 4.3)

Dot model
1 to 1500 mm/h (1 mm steps)

SV Sets the moving average (dot model).

Syntax SV p1 , p2<terminator>
p1 Channel number
p2 Number of samples for computing the moving average (OFF, 2 to 16) [times]

Query SV[p1]?

Example Set the number of samples for computing the moving average of channel 02 to 12.
SV 02 , 12

Description

- This setting is available on the dot model.
- This setting is possible when moving average is enabled (UI command).

SF Sets the input filter (pen model).

Syntax SF p1 , p2<terminator>
p1 Channel number
p2 Filter time constant (OFF, 2s, 5s, 10s)

Query SF[p1]?

Example Set the filter of channel 02 to 2 s.
SF 02 , 2s

Description This setting is possible when the input filter is enabled (UJ command).

BD Sets the alarm delay time.

Syntax BD p1 , p2<terminator>
p1 Channel number
p2 Alarm delay (1 to 3600) [s]

Query BD[p1]?

Example Set the alarm delay of channel 01 to 120 s.
BD 01 , 120

Description

- This setting is possible when the alarm delay function is enabled (UF command).
- On models with the computation function (/M1 option), computation channels can be specified.

VF Sets the brightness of the display (VFD) and internal illumination.

Syntax VF p1 , p2<terminator>
p1 VFD brightness (1 to 8)
p2 Internal illumination (OFF, 1 to 4)
OFF Turns OFF the internal illumination.

Query VF?

Example Set the display (VFD) brightness to 2 and the internal illumination to 1.
VF 2 , 1

Description The brightness increases as the value increases.

TD Sets the DST.

Syntax TD p1 , p2 , p3 , p4 , p5 , p6 , p7 , p8 , p9<terminator>
p1 Use/Not use DST (USE, NOT)
p2 DST start time: month (Jan, Feb, Mar, Apr, May, Jun, Jul, Aug, Sep, Oct, Nov, or Dec)
p3 DST start time: number of the week in the month (1st, 2nd, 3rd, 4th, or Last)
p4 DST start time: day of the week (Sun, Mon, Tue, Wed, Thu, Fri, or Sat)
p5 DST start time: hour (0 to 23)
p6 DST end time: month (Jan, Feb, Mar, Apr, May, Jun, Jul, Aug, Sep, Oct, Nov, or Dec)
p7 DST end time: number of the week in the month (1st, 2nd, 3rd, 4th, or Last)
p8 DST end time: day of the week (Sun, Mon, Tue, Wed, Thu, Fri, or Sat)
p9 DST end time: hour (0 to 23)

Query TD[p1]?

Example Enable DST and set the DST start time to hour 0 on the 2nd Sunday of June and the DST end time to hour 0 on the 2nd Sunday of December.

TD Use, Jun, 2nd, Sun, 0, Dec, 2nd, Sun, 0

- Description**
- The DST start time and end time cannot be set to the same time.
 - The TD command can be used on the RD100B and RD1800B with system version 1.11 or later. On the RD100B with system version 1.02 or earlier, use the SS command.

SS Sets the DST.

Syntax SS p1, p2, p3<terminator>

p1 Standard time/DST selection

Winter Standard time

Summer DST

p2 Switch time setting ON/OFF (ON, OFF)

p3 Date and time (fixed to the YY/MM/DD HH format)

YY Year (00 to 99, the lower 2 digits)

MM Month (01 to 12)

DD Day (01 to 31)

HH Hour (00 to 23)

Query SS[p1]?

Example Switch to DST on 0 hour of June 1st, 2005.

SS Summer, ON, 05/06/01 00

- Description**
- Parameter p3 is not available when p2 is OFF.
 - The SS command can be used on the RD100B with system version 1.02 or earlier.

SK Sets the computation constant (/M1 option).

Syntax SK p1, p2<terminator>

p1 Constant number (K01 to K30)

p2 Constant (up to 11 characters)

The range is $-9.9999\text{E}+29$ to $-1.0000\text{E}-30$, 0 , $1.0000\text{E}-30$ to $9.9999\text{E}+29$.

(The + sign of "E+" can be omitted.)

Query SK[p1]?

Example Set $1.0000\text{E}-10$ to constant K01.

SK K01, 1.0000E-10

- Description** This command cannot be specified while computation is in progress.

SJ Sets the timer used in TLOG computation (/M1 option).

Syntax SJ p1, p2, p3<terminator>

p1 Computation channel number

p2 Timer number (Periodic, 1, 2)

p3 Sum scale (for TLOG.SUM)

OFF Integrates the data per scan interval.

/s Integrates the physical amount that are in unit of /s.

/min Integrates the physical amount that are in unit of /min.

/h Integrates the physical amount that are in unit of /hour.

/day Integrates the physical amount that are in unit of /day.

Query SJ[p1]?

Example Enable timer 1 on computation channel 0B. No sum scale designation.

SJ 0B, 1, OFF

- Description**
- This command cannot be specified while computation is in progress.

About p3

The data for sum computation are sampled every scan interval. For data with units such as /s, /min, /h, and /day as in a flow rate, the data can be summed over the unit time as shown below. Parameter p3 is valid only for sum values.

OFF Σ (measured value)

/s Σ (measured value) \times scan interval

/min Σ (measured value) \times scan interval/60

/h Σ (measured value) \times scan interval/3600

/day Σ (measured value) \times scan interval/(3600 \times 24)

The unit of the scan interval is seconds.

CM Sets the communication input data (/M1 option).

Syntax CM p1, p2<terminator>

p1 Communication input data number (see section 4.3)

p2 Communication input data

The selectable range is $-9.9999\text{E}+29$ to $-1.0000\text{E}-30$, 0 , $1.0000\text{E}-30$ to $9.9999\text{E}+29$. (The + sign of "E+" can be omitted.)

Query CM?

Example Set $1.0000\text{E}-10$ to communication input data number C01.

CM C01, 1.0000E-10

FR Sets the interval for acquiring data to the FIFO buffer

Syntax FR p1<terminator>

p1 Pen model: 125ms, 250ms, 500ms, 1s, 2s, 2.5s, 5s, 10s

Dot model: 1s, 2s, 2.5s, 5s, 10s

Query FR?

Example Set the acquiring interval to the FIFO buffer to 1 s.

FR 1s

- Description**
- Set the acquiring interval to an integer multiple of the scan interval that is greater than the scan interval.

- The scan interval on the pen model is 125 ms.

- The scan interval on the dot model varies depends on the integration time of the A/D converter as follows:

When the integration time is 16.7 ms or 20 ms;

6 channels: 1 s

12, 18, or 24 channels: 2.5 s

4.4 Setting Commands

When the integration time is 100 ms;
6 channels: 2.5 s
12 channels: 5 s
18 and 24 channels: 10 s

VD Sets the data display screen.

On screens without detailed parameters

Syntax VD p1,p2<terminator>
p1 Screen number (01 to 15)
p2 Display type
4CH bargraph
4-channel bar graph display (pen model)
6CH bargraph
6-channel bar graph display (RD100B dot model)
Channel alarm status
Channel alarm status display
Time/Chart speed
Date/Time/Chart speed display
DI/DO
DI/DO status display
STATUS
Status display
System
System display
Light out
Screen OFF
SKIP
Skip

Query VD [p1]?

Example Assign the status display to screen 02.
VD 02,STATUS

On screens with the displayed channel switching interval

Syntax VD p1,p2,p3<terminator>
p1 Screen number (01 to 15)
p2 Display type
1CH digital
1-channel digital display
2CH digital
2-channel digital display
4CH digital
4-channel digital display
6CH digital
6-channel digital display (dot model)
12CH digital
12-channel digital display (RD1800B 12, 18 and 24 dot model)
1CH digital+1CH bargraph
1-channel digital display + 1 channel bar graph display
1CH digital+4CH bargraph
1-channel digital display + 4 channel bar graph display (pen model)

2CH digital+2CH bargraph
2-channel digital display + 2 channel bar graph display

Tag_1CH digital
1-channel digital display (tag)

Tag_2CH digital
2-channel digital display (tag)

Tag_1CH digital+1CH bargraph
1-channel digital display + 1 channel bar graph display (tag)

Tag_1CH digital+4CH bargraph
1-channel digital display + 4 channel bar graph display (tag, pen model)

p3 Displayed channel switching interval
MANUAL Fixed display channels, data update rate (pen model): 2 s, data update rate (dot model): scan interval
AUTO1S Switch the displayed channels and data every second.
AUTO2S Switch the displayed channels and data every 2 seconds.
AUTO3S Switch the displayed channels and data every 3 seconds.
AUTO4S Switch the displayed channels and data every 4 seconds.
AUTO5S Switch the displayed channels and data every 5 seconds.

Query VD [p1]?

Example Assign the 2-channel digital display to screen 04 and automatically switch the displayed channels every 5 seconds.
VD 04,2CH digital,AUTO5S

For flag display

Syntax VD p1,p2,p3<terminator>
p1 Screen number (01 to 15)
p2 Display type
FLAG Flag display (fixed)
p3 Display ON/OFF for each channel
Specify the ON/OFF state of each channel with 1 or 0 (see the explanation).

Query VD [p1]?

Example 1 On the 6-dot model, assign the flag display to screen 03 and display the flags of channel 01 and 02.
VD 03,FLAG,110000

Example 2 On the 2-pen model with the computation function (/M1 option), assign the flag display to screen 03 and display the flags of measurement channel 02 and computation channels 0A, 0B, 0E, and 0F.
VD 03,FLAG,01-11001100

Description Use the format below to specify the display ON/OFF state of each channel.

- List the values one after another for all channels and separate the measurement channels and computation channels with a hyphen.
- Channels cannot be omitted.
- The characters after the hyphen are valid only on models with the computation function (/M1 option).

For multiple display (display in which different screens can be assigned to the top and bottom sections)

```
Syntax  VD
        p1,p2,p3,p4,p5,p6,p7,p8,p9,p10,p11,p12<terminator>
p1  Screen number (01 to 15)
p2  Display type
    Multiple display
        Display in which different screens can
        be assigned to the top and bottom
        sections
p3  Top section display type
    1CH digital
        1-channel digital display
    2CH digital
        2-channel digital display
    3CH digital
        3-channel digital display (RD1800B)
    TIME
        Date/Time (RD100B)
    Chart speed
        Chart speed (RD100B)
    TIME/Chart speed
        Date/Time/Chart speed (RD1800B)
    Channel alarm status
        Channel alarm status display
    STATUS
        Status display
    Light out
        Screen OFF
    Tag_1CH digital
        1-channel digital display (tag)
```

Note

Parameters that become invalid due to p3, p4, p8, or p9 setting are skipped, and the next parameter is brought forward.

- p4 Displayed channel switching interval
Condition: Set this parameter when p3 is 1CH digital or 2CH digital.
MANUAL Fixed display channels, data update rate (pen model): 2 s, data update rate (dot model): scan interval

```
AUTO1S  Switch the displayed
         channels and data every 1
         second.
AUTO2S  Switch the displayed
         channels and data every 2
         seconds.
AUTO3S  Switch the displayed
         channels and data every 3
         seconds.
AUTO4S  Switch the displayed
         channels and data every 4
         seconds.
AUTO5S  Switch the displayed
         channels and data every 5
         seconds.
```

```
p5  Channel number
    Condition: This parameter can be specified
    when p3 is 1CH digital, 2CH digital,
    or Tag_1CH digital and p4 is MANUAL.
p6  2nd channel number
    Condition: This parameter is specified when
    p3 is 2CH digital and p4 is MANUAL.
p7  3rd channel number
    Condition: This parameter is specified when
    p3 is 3CH digital and p4 is MANUAL.
p8  Bottom section display type
    Same as p3
p9  Displayed channel switching interval
    Same as p4
p10 Channel number
    Same as p5
p11 2nd channel number
    Same as p6
p12 3rd channel number
    Same as p7
Query  VD[ p1]?
Example Assign the display in which different screens can
        be assigned to the top and bottom sections to
        screen 09. Set the top section to status display
        and the bottom section to 1-channel digital
        display. Switch the displayed channel every 3
        seconds (parameters p5 to p7, p10, and p12
        explained above are omitted).
        VD 09,Multiple display,STATUS,1CH
        digital,AUTO3S
```

4.5 Basic Setting Commands

- In order to activate the settings that are changed using the basic setting commands, the settings must be saved using the YE or XE command.
- The settings that are returned in response to a query in the basic setting mode will contain the new settings even if they are not saved.

Note

- The settings that are changed using the YS/YB/YA/YN/YD/YQ/YK command and saved using the XE command are activated after power-cycling the recorder.
- When the YE command is executed, communication is dropped.

XA Sets alarm related settings.

Syntax	XA p1 , p2 , p3 , p4 , p5 , p6 , p7 , p8 , p9 , p10 <terminator>
p1	Fault diagnosis output ON/OFF (ON, OFF)
p2	Reflash operation ON/OFF (ON, OFF)
p3	Relays that are to operate using AND logic
NONE	None (all relays operate using OR logic)
I01	I01
I01-I02	I01, I02
I01-I03	I01 to I03
I01-I04	I01 to I04
I01-I05	I01 to I05
I01-I06	I01 to I06
I01-I11	I01 to I11 (RD1800B)
I01-I12	I01 to I12 (RD1800B)
I01-I13	I01 to I13 (RD1800B)
I01-I14	I01 to I14 (RD1800B)
I01-I15	I01 to I15 (RD1800B)
I01-I16	I01 to I16 (RD1800B)
I01-I21	I01 to I21 (RD1800B)
I01-I22	I01 to I22 (RD1800B)
I01-I23	I01 to I23 (RD1800B)
I01-I24	I01 to I24 (RD1800B)
I01-I25	I01 to I25 (RD1800B)
I01-I26	I01 to I26 (RD1800B)
I01-I31	I01 to I31 (RD1800B)
I01-I32	I01 to I32 (RD1800B)
I01-I33	I01 to I33 (RD1800B)
I01-I34	I01 to I34 (RD1800B)
I01-I35	I01 to I35 (RD1800B)
I01-I36	I01 to I36 (RD1800B)
p4	Energize/De-energize the relay
ENERGIZE	Energize the relay when an alarm is detected
DE_ENERGIZE	De-energize the relay when an alarm is detected

p5	Hold/Not hold the relay
HOLD	Hold the relay output until an alarm acknowledge operation is executed
NONHOLD	Reset the relay output when the alarm is cleared.
p6	Hold/Not hold the alarm status display
HOLD	Hold the display until an alarm acknowledge operation is executed
NONHOLD	Clear the display output when the alarm is cleared.
p7	Interval for the high limit on rate-of-change alarm (01 to 15)
p8	Interval for the low limit on rate-of-change alarm (01 to 15)
p9	Alarm hysteresis on measurement channels (OFF, 0.1%, 0.2%, 0.3%, 0.4%, 0.5%, 0.6%, 0.7%, 0.8%, 0.9%, or 1.0%)
p10	Alarm hysteresis on computation channels (OFF, 0.1%, 0.2%, 0.3%, 0.4%, 0.5%, 0.6%, 0.7%, 0.8%, 0.9%, or 1.0%)

Query	XA?
Example	Enable fault diagnosis output. Disable reflash and AND operations. Set the relay operation to energize and hold. Set the alarm status display to hold. Set the interval for the high limit of rate-of-change alarm to 10, the interval for the low limit of rate-of-change alarm to 12, the measurement alarm hysteresis to 0.5%, and the computation alarm hysteresis to OFF. XA ON, OFF, NONE, ENERGIZE, HOLD, HOLD, 10, 12, 0.5%, OFF

- Description
- The interval for the high limit of rate-of-change alarm is equal to “scan interval × p7” and the interval for the low limit of rate-of-change alarm is equal to “scan interval × p8.”
 - Parameter p10 can be specified on models with the computation function (/M1 option).
 - For the details on the settings, see the *Recorder User's Manual*.

XI Sets the A/D integral time.

Syntax	XI p1<terminator>
p1	Integration time of the A/D converter
AUTO	Automatically set in synch with the power supply frequency.
50HZ	12.5 ms
60HZ	16.7 ms
100MS	100 ms (dot model)

Query	XI?
Example	Set the A/D integral time to 50 Hz. XI 50HZ
Description	100 ms is available only on the dot model.

XB Sets the burnout detection.

Syntax XB p1,p2<terminator>
 p1 Channel number
 p2 The procedure taken when a sensor burnout is detected
 OFF Disable the burnout detection.
 UP Set the recording off the scale to the right when a burnout is detected.
 DOWN Set the recording off the scale to the left when a burnout is detected.

Query XB[p1]?
 Example Set the recording off the scale to the right when a sensor burnout is detected on channel 01.
 XB 01,UP

XJ Sets the RJC.**When using the internal compensation circuit**

Syntax XJ p1,p2<terminator>
 p1 Channel number
 p2 Reference junction compensation selection (INTERNAL)

Query XJ[p1]?
 Example Use the internal compensation circuit on channel 01.
 XJ 01,INTERNAL

When using an external RJC

Syntax XJ p1,p2,p3<terminator>
 p1 Channel number
 p2 Reference junction compensation selection (EXTERNAL)
 p3 Compensation voltage (-20000 to 20000) [μ V]

Query XJ[p1]?
 Example Set the reference junction compensation of channel 02 to external and set the compensation voltage to 0 μ V.
 XJ 02,EXTERNAL,0

Description The unit of p3 is μ V (microvolts).

UC Changes the dot color (dot model).

Syntax UC p1,p2<terminator>
 p1 Channel number
 p2 Dot color
 PURPLE
 RED
 GREEN
 BLUE
 BROWN
 BLACK

Query UC[p1]?
 Example Set the dot color of channel 06 to purple.
 UC 06,PURPLE

Description On models with the computation function (/M1 option), the dot color of computation channels can be changed.

UO Sets the pen offset compensation (pen model).

Syntax UO p1<terminator>
 p1 Pen offset compensation ON/OFF (ON, OFF)

Query UO?
 Example Use the pen offset compensation.
 UO ON

UP Sets the items to be printed.**Pen model**

Syntax UP p1,p2,p3,p4,p5,p6<terminator>
 p1 Channel number/tag selection
 CHANNEL Print the channel number
 TAG Print the tag
 p2 Alarm printout
 ON1 Print at alarm occurrence and release
 ON2 Print at alarm occurrence
 OFF Do not print
 p3 Record start time printout ON/OFF (ON, OFF)
 p4 New chart speed printout ON/OFF (ON, OFF)
 p5 Scale printout ON/OFF (ON, OFF)
 p6 Recording color printout ON/OFF (ON, OFF)

Query UP?
 Example Print tags. Print all items.
 UP TAG,ON1,ON,ON,ON,ON

Dot model

Syntax UP p1,p2,p3,p4,p5,p6<terminator>
 p1 Channel number/tag selection
 CHANNEL Print the channel number
 TAG Print the tag
 p2 Channel number printout ON/OFF (ON, OFF) by the trend recording
 p3 Alarm printout
 ON1 Print at alarm occurrence and release
 ON2 Print at alarm occurrence
 OFF Do not print
 p4 Record start time printout ON/OFF (ON, OFF)
 p5 New chart speed printout ON/OFF (ON, OFF)
 p6 Scale printout ON/OFF (ON, OFF)

Query UP?
 Example Print the channel numbers. Print all items.
 UP CHANNEL,ON,ON1,ON,ON,ON

UR Sets the periodic printout interval.

Syntax UR p1,p2,p3,p4<terminator>
 p1 Print interval mode
 Auto Automatically set the interval according to the chart speed
 Manual Specify the interval
 p2 Reference time (00 to 23 [hour])
 p3 Interval (10min, 12min, 15min, 20min, 30min, 1h, 2h, 3h, 4h, 6h, 8h, 12h, 24h) (when p1 is Manual)

4.5 Basic Setting Commands

p4	Periodic printout mode
OFF	Disable periodic printout
INST	Print instantaneous values.
REPORT	Print the report data over the interval.
Query	UR?
Example	Carry out periodic printout every 2 hours with hour 0 as the reference. Print the measured values (instantaneous values) at each interval. UR Manual, 00, 2h, INST
Description	<ul style="list-style-type: none">When p1 is set to Auto, the periodic printout interval synchronizes to the chart speed.If p4 is set to REPORT, set the type of report data on each channel using the UM command.

UM Sets the types of report data that are output to the periodic printout.

Syntax	UM p1, p2, p3<terminator>
p1	Channel number
p2	Type of report data
INST	Instantaneous value
AVE	Average value
MIN	Minimum value
MAX	Maximum value
SUM	Sum value
MIX	Average + minimum + maximum values
p3	Sum scale
OFF	Integrates the data per scan interval.
/s	Integrates the physical amount that are in unit of /s.
/min	Integrates the physical amount that are in unit of /min.
/h	Integrates the physical amount that are in unit of /hour.
/day	Integrates the physical amount that are in unit of /day.
Query	UM[p1]?
Example	Print the average values of channel 03 using periodic printout. UM 03, AVE
Description	<ul style="list-style-type: none">This setting is possible when printing of report data (p4 is REPORT) is specified using the UR command.About p3 The data for sum computation are sampled every scan interval. For data with units such as /s, /min, /h, and /day as in a flow rate, the data can be summed over the unit time. Parameter p3 is valid only for sum values.On models with the computation function (/M1 option), computation channels can be specified.

UB Sets the display mode of the bar graph.

Syntax	UB p1, p2<terminator>
p1	Channel number
p2	Bar graph display mode
NORMAL	The reference position is set to the smaller of the two values, leftmost value and rightmost value.
CENTER	The reference position is set to the 50% position.
Query	UB[p1]?
Example	Display channel 01 using a bar graph with the reference position set to the 50% position. UB 01, CENTER
Description	On models with the computation function (/M1 option), computation channels can be specified.

UI Sets whether to use moving average (dot model).

Syntax	UI p1<terminator>
p1	Use/Not use moving average (USE, NOT)
Query	UI?
Example	Use moving average. UI USE

UJ Sets whether to use the input filter (pen model).

Syntax	UJ p1<terminator>
p1	Use/Not use the input filter (USE, NOT)
Query	UJ?
Example	Use the input filter. UJ USE

UK Sets whether to use of partial expanded recording.

Syntax	UK p1<terminator>
p1	Use/Not use partial expanded recording (USE, NOT)
Query	UK?
Example	Use partial expanded recording. UK USE

UL Selects the display/record language.

Syntax	UL p1<terminator>
p1	Language (ENGLISH, JAPANESE)
Query	UL?
Example	Use English. UL ENGLISH

XN Selects the date format.

Syntax	UL p1<terminator>
p1	Date format for displaying and printing Y/M/D: (example) 2005/08/31 M/D/Y: (example) 08/31/2005

D/M/Y: (example) 31/08/2005
 D.M.Y: (example) 31.08.2005
 M.D.Y: (example) Aug.31.2005

Query XN?

Example Set to the "2005/08/31" format.
 XN Y/M/D

Description This setting applies to the format of the date shown on the display and the date printed on the periodic printout, manual printout, alarm printout, message printout, recording start printout, and new chart speed printout.

Note

How this setting applies to the time printout format of the alarm printout, message printout, recording start printout, and new chart speed printout: The setting specifies the format of the "M/D" and "Y/M/D" section when the time printout format is set to "M/D H:M," "M/D H:M:S," or "Y/M/D H:M:S."

XT Selects the temperature unit.

Syntax XT p1<terminator>
 p1 Temperature unit
 C °C
 F °F

Query XT?

Example Use °F.
 XT F

UF Sets whether to use the extended functions.

Syntax UF p1,p2,p3,p4<terminator>
 p1 Bias function (USE, NOT)
 p2 Square root low-cut function (USE, NOT)
 p3 1-5V input low-cut function (USE, NOT)
 p4 Alarm delay function (USE, NOT)

Query UF?

Example Use all the extended functions.
 UF USE,USE,USE,USE

Description

- The input offset is set using the VB command.
- The low-cut function is set using the SR command.
- The delay alarm is set using the SA and BD commands.

UT Selects the time printout format.

Syntax UT p1,p2,p3,p4<terminator>
 p1 Time printout format of the alarm printout
 The available selections are the same as those of p2. None is not available.
 p2 Time printout format of the message printout
 HH:MM Hour:Minute
 HH:MM:SS Hour:Minute:Second
 M/D H:M Month Day Hour:Minute
 M/D H:M:S Month Day Hour:Minute:Second

YMD H:M:S Month Day Year Hour:Minute:Second

None No time printout

p3 Time printout format of the record start time printout

The available selections are the same as those of p2. None is not available.

p4 Time printout format of the new chart speed printout

The available selections are the same as those of p2. None is not available.

Query UT?

Example Set the all time printouts to Hour:Minute format.
 UT HH:MM,HH:MM,HH:MM,HH:MM

XR Sets the remote control input (/R1 option).

Syntax XR p1,p2<terminator>
 p1 Remote control input terminal number (1 to 5)
 p2 Action

NONE	No action
Record On/Off	Start/Stop recording.
Chart speed	Change the chart speed.
Time adjust	Reset the internal clock to the nearest hour.
Math start/stop	Start/Stop computation.
Math reset	Reset computation.
Manual print	Execute manual print.
Alarm Ack	Execute alarm acknowledge.
Message1	Print message 1
Message2	Print message 2
Message3	Print message 3
Message4	Print message 4
Message5	Print message 5

Query XR[p1]?

Example Assign the printout of message 2 to the remote control input of terminal number 1.
 XR 1,Message2

Description Math start/stop and Math reset can be specified on models with the computation function (/M1 option).

YS Sets the RS-422A/485 interface (/C3 option).

Syntax YS p1,p2,p3,p4,p5<terminator>
 p1 Address (1 to 32)
 p2 Baud rate (1200, 2400, 4800, 9600, 19200, 38400)
 p3 Data length (7, 8)
 p4 Parity check (ODD, EVEN, NONE)
 p5 Protocol (NORMAL, MODBUS)

4.5 Basic Setting Commands

- Query YS?
- Example Set the address to 2, the baud rate to 9600, the data length to 8, the parity check to ODD, and the NORMAL protocol.
YS 2,9600,8,ODD,NORMAL
- Description
- The settings specified by this command and saved using the XE command take effect after the recorder is power cycled.
 - If p5 is set to MODBUS, Modbus slave is selected.

XQ Sets the TLOG timer (/M1 option).

When not using the timer

- Syntax XQ p1,p2<terminator>
p1 Timer number (1 or 2)
p2 Timer type (OFF)

Query XQ[p1]?

- Example Disable the number 1 timer.
XQ 1,OFF

When using an absolute timer

- Syntax XQ p1,p2,p3,p4,p5,p6<terminator>
p1 Timer number (1 or 2)
p2 Timer type (ABSOLUTE)
p3 Interval (10min, 12min, 15min, 20min, 30min, 1h, 2h, 3h, 4h, 6h, 8h, 12h, 24h)
p4 Reference time (fixed to HH format)
HH Hour (00 to 23)
p5 Reset/not reset the data when the timer expires (ON/OFF)
p6 Printout ON/OFF (ON, OFF)

Query XQ[p1]?

- Example Set an absolute timer to timer number 1. Set the interval to 30 minutes, the reference time to hour 7, reset the data when the timer expires, and disable printout.
XQ 1,ABSOLUTE,30min,07,ON,OFF

Description Each time the interval specified by p3 elapses from the time specified by p4, the operations set with p5 and p6 are performed.

When using the relative timer

- Syntax XQ p1,p2,p3,p4,p5<terminator>
p1 Timer number (1 or 2)
p2 Timer type (RELATIVE)
p3 Interval (fixed to HH:MM format)
HH Hour (00 to 24)
MM Minute (00 to 59)
Set the interval in the range 00:01 to 24:00
p4 Reset/not reset the data when the timer expires (ON/OFF)
p5 Printout ON/OFF (ON, OFF)

Query XQ[p1]?

- Example Set a relative timer to timer number 1. Set the interval to 1 hour 15 minutes, reset the data when the timer expires, and disable printout.
XQ 1,RELATIVE,01:15,ON,OFF

Description Each time the interval specified by p3 elapses from the time the computation is started, the operations set with p4 and p5 are performed.

UN Changes the assignment of channels to the recording pen (pen model, /M1 option).

- Syntax UN p1,p2<terminator>
p1 Pen number (1 to 4)
p2 Channel number

Query UN[p1]?

- Example Assign computation channel 0A to pen number 4.
UN 4,0A

US Sets the computation error procedure (/M1 option).

- Syntax US p1,p2<terminator>
p1 Procedure taken when an error occurs.
+OVER Handle error data as +OVER
-OVER Handle error data as -OVER
p2 Procedure taken when the "input over" is detected (procedure taken when an "input over" value is applied to TLOG.SUM or TLOG.AVE computation)
SKIP Do not use the data for computation.
LIMIT Use the limit value given by the recorder for computation.

Query US?

- Example When the computed result is in error, handle the error data as +OVER. Use the limit value given by the recorder for computation instead of the "input over" value.
US +OVER,LIMIT

YB Sets the host name and domain name (/C7 option).

- Syntax YB p1,p2<terminator>
p1 Host name (up to 64 characters)
p2 Domain name (up to 64 characters)

Query YB?

- Example Set the host name to "ABC" and the domain name to "recorder.co.jp."
YB ABC,recorder.co.jp

Description The settings specified by this command and saved using the XE command take effect after the recorder is power cycled.

YA Sets the IP address (/C7 option).

- Syntax YA p1,p2,p3<terminator>
p1 IP address (0.0.0.0 to 255.255.255.255)
p2 Subnet mask (0.0.0.0 to 255.255.255.255)
p3 Default gateway (0.0.0.0 to 255.255.255.255)

Query YA?

Example Set the IP address to 192.168.111.24, the subnet mask to 255.255.255.0, and the default gateway to 0.0.0.0.

```
YA 192.168.111.24,255.255.255.0,
0.0.0.0
```

Description The settings specified by this command and saved using the XE command take effect after the recorder is power cycled.

YN Sets the DNS (/C7 option).

When not using the DNS

Syntax YN p1<terminator>
p1 Use/Not use the DNS (OFF)

Query YN?

Example Do not use the DNS.
YN OFF

When using the DNS

Syntax YN p1,p2,p3,p4,p5<terminator>
p1 Use/Not use the DNS (ON)
p2 Address of the primary DNS server (0.0.0.0 to 255.255.255.255)
p3 Address of the secondary DNS server (0.0.0.0 to 255.255.255.255)
p4 Domain suffix 1 (up to 64 characters)
p5 Domain suffix 2 (up to 64 characters)

Query YN?

Example Use the DNS server at 192.168.0.1.
YN ON,192.168.0.1

Description The settings specified by this command and saved using the XE command take effect after the recorder is power cycled.

YD Sets whether to use the login function via communication (/C7 option).

Syntax YD p1<terminator>
p1 Use/Not use the login function via communication (USE, NOT)

Query YD?

Example Use the login function via communication.
YD USE

Description The settings specified by this command and saved using the XE command take effect after the recorder is power cycled.

YQ Sets the communication timeout (/C7 option).

When not using the timeout

Syntax YQ p1<terminator>
p1 Enable/Disable communication timeout (OFF)

Query YQ?

Example Disable timeout.
YQ OFF

When using the timeout

Syntax YQ p1,p2<terminator>

p1 Enable/Disable communication timeout (ON)
p2 Timeout time (1 to 120) [minutes]

Query YQ?

Example Enable communication timeout and set the timeout period to 3 min.

```
YQ ON,3
```

Description The settings specified by this command and saved using the XE command take effect after the recorder is power cycled.

YK Sets keepalive (/C7 option).

Syntax YK p1<terminator>
p1 Enable/Disable keepalive (ON, OFF)

Query YK?

Example Disable keepalive.
YK OFF

Description The settings specified by this command and saved using the XE command take effect after the recorder is power cycled.

UA Sets the record position.

Pen model

Syntax UA p1,p2,p3<terminator>
p1 Record position selection
ZERO 0% position
FULL 100% position
p2 Pen number (1 to 4)
p3 Record position adjustment value
When p1 = ZERO RD100B: An integer between 0 and 70
RD1800B: An integer between 0 and 180
When p1 = FULL RD100B: An integer between -45 to 15 (reference value: 3026)
RD1800B: An integer between -165 to 165 (reference value: 5447)

Example Adjust the 0% position of pen 1. Set the record position adjustment value to 20.

```
UA ZERO,1,20
```

Description

- Check the recorded result and correct the record position adjustment value.
- To end the adjustment, execute the UY0 command. If you do not end the adjustment, you cannot change the execution mode.
- The unit for p3 is 1/30 mm.

4.5 Basic Setting Commands

Dot model

Syntax UA p1 , p2 <terminator>
p1 Record position selection
ZERO 0% position
FULL 100% position
Hysteresis
The difference in the record position according to the operating direction of the printer carriage
p2 Record position adjustment value
When p1 = Hysteresis
An integer between -7 to 7
When p1 = ZERO
RD100B: An integer between 0 and 15
RD1800B: An integer between 0 and 50
When p1 = FULL
RD100B: An integer between -30 to 30
(reference value: 1000)
RD1800B: An integer between -50 to 50
(reference value: 1800)

Example Adjust the 100% position. Set the record position adjustment value to 25.
UA FULL, 25

- Description
- Carry out the adjustment in the following order: P1 = Hysteresis, ZERO, and then FULL.
 - Check the recorded result and correct the record position adjustment value.
 - To end the adjustment, execute the UY0 command. If you do not end the adjustment, you cannot change the execution mode.
 - The unit for p2 is dot (0.1 mm).

YE Exits from Basic Setting mode.

When the YE command is executed, communication is dropped.

Syntax YE p1 <terminator>
p1 Apply/Discard the settings
STORE Apply the settings
ABORT Discard the settings

Example Apply the basic settings.
YE STORE

Description Applies the settings changed with the basic setting commands.

XE Exits from Basic Setting mode.

Communication is not dropped when the XE command is executed.

Syntax XE p1 <terminator>
p1 Apply/Discard the settings
STORE Apply the settings
ABORT Discard the settings

Example Apply the basic settings.
XE STORE

Description The settings specified by the following commands and saved using the XE command take effect after the recorder is power cycled. YS, YB, YA, YN, YD, YQ, and YK

4.6 Control Commands

DS Switches the execution mode.

Syntax DS p1<terminator>
 p1 Mode
 0 Run mode
 1 Basic Setting mode

Example Switch to Basic Setting mode.
 DS 1

Description The execution mode cannot be changed to Basic Setting Mode while recording or computation is in progress.

PS Starts/Stops recording.

Syntax PS p1<terminator>
 p1 Start/Stop recording.
 0 Start
 1 Stop

Example Start recording.
 PS 0

UD Switches the screen/switches the channel.

Returning to the data display screen

Returns from the Setting mode screen, the screen that appears when the FUNC key is pressed, or the screen that appears when the DISP MENU key is pressed back to the measurement data display screen.

Syntax UD p1<terminator>
 p1 Fixed to 0.

Example Return to the data display screen.
 UD 0

Displaying the specified data display screen

Syntax UD p1, p2<terminator>
 p1 Fixed to 1.
 p2 Screen number (1 to 15)

Example Display data display screen 2.
 UD 1, 2

Switching the display channel (manual switching)

Syntax UD p1<terminator>
 p1 Fixed to 2.

Example Switch the display channel.
 UD 2

Description • An error results if the specified screen is set to SKIP for UD1.
 • UD2 is valid on screens whose display channel is set to manual switching.

AK Executes alarm acknowledge (Alarm ACK).

Syntax AK p1<terminator>
 p1 Executes alarm acknowledge (0)

Example Execute alarm acknowledge.
 AK 0

TL Starts/stops/resets computation (/M1 option).

Syntax TL p1<terminator>
 p1 Operation type
 0 Computation start
 1 Computation stop
 2 Computation reset

Example Start the computation.
 TL 0

MP Starts/Stops manual print.

Syntax MP p1<terminator>
 p1 Operation type
 0 Manual print start
 1 Manual print stop

Example Start manual print.
 MP 0

LS Starts/Stops the list (setting information) printout.

Syntax LS p1<terminator>
 p1 Operation type
 0 List print start
 1 List print stop

Example Start list print.
 LS 0

Description List print refers to printing of settings of Setting mode.

SU Starts/Stops the setup list (basic setting information) printout.

Syntax SU p1<terminator>
 p1 Operation type
 0 Setup list print start
 1 Setup list print stop

Example Start setup list print.
 SU 0

Description Setup list print refers to printing of settings of Basic Setting mode.

MS Prints the message.

Syntax MS p1<terminator>
 p1 Message number (1 to 5)

Example Print the message of message number 3.
 MS 3

Description The message string is set with the SG command.

AC Clears the alarm printout buffer.

Syntax AC p1<terminator>
 p1 Clear the alarm printout buffer (0)

Example Clear the alarm printout buffer.
 AC 0

MC Clears the message printout buffer.

Syntax MC p1<terminator>
 p1 Clear the message printout buffer (0)

Example Clear the message printout buffer.
 MC 0

VG Resets the report data of the periodic printout.

Syntax VG p1<terminator>
 p1 Operation type
 2 Reset the report data of the periodic printout.

Example Reset the report data of the periodic printout.
 VG 2

Description This setting is valid when the recorder is set to print the report data using periodic printout.

YC Initializes settings.

Syntax YC p1<terminator>
 p1 Initialization type
 0 Initialize the Setting mode and Basic Setting mode settings.
 1 Initialize the Setting mode settings.

Example Initialize the Setting mode and Basic Setting mode settings.
 YC 0

UY Stops the record position adjustment.

Syntax UY p1<terminator>
 p1 Fixed to 0.

Query UY?

Example Stop the record position adjustment.
 UY 0

Description Returns the execution status of the record position adjustment in response to a query.
 0: Stopped, 1: In progress

4.7 Output Commands**BO** Sets the byte output order.

Syntax BO p1<terminator>
 p1 Byte order
 0 Outputs the data MSB first.
 1 Outputs the data LSB first.

Query BO?

Example Output the data MSB first.
 BO 0

Description This command applies to the byte order of numerical data during BINARY output.

CS Sets the checksum (/C3 option).

Syntax CS p1<terminator>
 p1 Use/Not use the checksum
 0 Not use
 1 Use

Query CS?

Example Use the checksum.
 CS 1

Description This command can be used only on the RS-422A/485 communication interface.

IF Sets the status filter.

Syntax IF p1<terminator>
 p1 Status filter value
 (0.0.0.0 to 255.255.255.255)

Query IF?

Example Set the status filter value to 1.0.4.0.
 IF 1.0.4.0

Description For details, see chapter 6.

Note**Initialization of BO/CS/IF Command Settings**

- **For serial communications**
 Settings entered using the BO/CS/IF commands revert to their initial values when the recorder is reset (when the recorder is power cycled, or the user exits the basic setting mode with the YE command).
 - Byte output order, checksum: 0
 - Status filter: 255.255.255.255
 If the recorder is reset, you must restore these settings.
- **For Ethernet communications**
 Settings entered using the BO/IF commands revert to their initial values when the connection to the recorder is cut. After reconnecting the recorder, you must reenter the settings.

CC Disconnects an Ethernet connection (/C7 option).

Syntax CC p1<terminator>
 p1 Disconnect the connection (0)

Example Disconnect the connection.
CC 0

FE Outputs decimal point position, unit information, and setup data.

Syntax FE p1 , p2 , p3 <terminator>
p1 Output data type
0 Setup data of Setting mode
1 Decimal point position and unit information
2 Setup data of Basic Setting mode
4 Setting data file
p2 First output channel number
p3 Last output channel number

Example Output the setup data of the Setting commands of channel 01 through 04.
FE 0 , 01 , 04

Description • Be sure to set p2 and p3 so that p3 is greater than or equal to p2.
• The settings of p2 and p3 are valid when p1 = 0, 1, or 2.
• The setting data file can be viewed using the configuration software.

FD Outputs the most recent measured/computed data.

Syntax FD p1 , p2 , p3 <terminator>
p1 Output data type
0 Output the most recent measured/computed data in ASCII format
1 Output the most recent measured/computed data in BINARY format
p2 First output channel number
p3 Last output channel number

Example Output the most recent measured/computed data from channel 01 to 04 in ASCII format.
FD 0 , 01 , 04

Description • The most recent measured/computed data indicates the most recent measured/computed data when the recorder receives the FD command.
• Be sure to set p2 and p3 so that p3 is greater than or equal to p2.

FY Outputs the statistical computation results.

Syntax FY p1 , p2 , p3 <terminator>
p1 Output data type
Inst Output the most recent periodic printout data (instantaneous value)
Report Output the statistical calculation data of periodic printout (report data)
Tlog1 Output the data at the most recent timeout of TLOG timer 1

Tlog2 Output the data at the most recent timeout of TLOG timer 2

p2 First output channel number
p3 Last output channel number

Example Outputs the most recent periodic printout data of channel 01 to 04.

FY Inst , 01 , 04

Description Tlog1 and Tlog2 are valid on models with the computation function (/M1 option).

FF Outputs the FIFO data.

Syntax FF p1 , p2 , p3 , p4 <terminator>
p1 Operation type
GET Output the data starting from the next to the previous read position
RESEND Retransmit the previous output
RESET Set the read position (block) to the most recent acquire position (block)
GETNEW Output the most recent data
p2 First output channel number
p3 Last output channel number
p4 The upper limit of number of blocks that are to be loaded
Pen model
1 to 240
Dot model
1 to 60
If the measured/computed data is less than the specified number of blocks, only the available data is transmitted.

Example Output two blocks of FIFO data from channels 01 to 06.
FF GET , 01 , 06 , 2

Description • The FIFO buffer is of a circular type which overwrites from the oldest data when it is full.
• The FR command is used to set the acquiring interval.

• There are two FIFO data output formats.

Logging output (GET)

Output the specified number of blocks (p4) of FIFO data starting from the next to the previous read position (block).
Make sure to read the data within the following buffer period to prevent data dropouts.

Pen model
FIFO buffer length 240 blocks
Maximum buffer period 240 intervals
Dot model
FIFO buffer length 60 blocks
Maximum buffer period 60 intervals

Newest value output (GETNEW)

Output the specified number of blocks (p4) of FIFO data back starting from the recent acquire position (block).

- Parameters p2, p3, and p4 are valid when p1 is set to GET or GETNEW.
- If p4 is omitted, all the data of all blocks acquired in the FIFO buffer are output.
- Be sure to set p2 and p3 so that p3 is greater than or equal to p2.
- For the output flow of FIFO data, see appendix 4.

IS Outputs status information.

Syntax `IS p1<terminator>`
`p1` Output status information (0)

Example Output status information.
`IS 0`

Description The output status can be masked using the status filter (IF command).

FU Outputs user information.

Syntax `FU p1<terminator>`
`p1` Output user information (0)

Example Output user information.
`FU 0`

Description Outputs the information of the user currently connected to the recorder.

4.8 RS-422A/485 Dedicated Commands

ESC O Opens the instrument.

The ASCII code of ESC is 1BH.

Syntax `ESC O p1<terminator:CR+LF>`
`p1` Instrument address (01 to 32)

Example Open the instrument at address 01.
`ESC O 01`

- Description
- Specifies the address of the instrument with which to communicate.
 - Only one instrument can be opened at any given time.
 - When an instrument is opened with the ESC O command, any other instrument that is currently open is automatically closed.
 - When this command is received correctly, the recorder transmits the data "ESC 0 xx" (xx: Instrument's address).
 - Use CR+LF for the terminator. LF cannot be used.

ESC C Closes the instrument.

The ASCII code of ESC is 1BH.

Syntax `ESC C p1<terminator:CR+LF>`
`p1` Instrument address (01 to 32)

Example Close the instrument at address 01.
`ESC C 01`

- Description
- Clears the current connection with the instrument.
 - When this command is received correctly, the recorder transmits the data "ESC C xx" (xx: Instrument's address).
 - Use CR+LF for the terminator. LF cannot be used.

4.9 Maintenance/Test Commands (Available when using the maintenance/test server function via Ethernet communications)

close Disconnects the connection between other instruments.

Syntax `close, p1, p2 : p3 <terminator>`
p1 Port on the recorder side (0 to 65535)
p2 IP address on the PC side (0.0.0.0 to 255.255.255.255)
p3 Port on the PC side (0 to 65535)

Example `close, 34159, 192.168.111.24 : 1054`
 E0

Description This command cannot be used to disconnect a server port. Also, it cannot disconnect the recorder being operated. Use the quit command for this purpose.

con Outputs connection information.

Syntax `con <terminator>`

Example

```
con
EA
04/10/01 12:34:56

Active connections

Proto Local Address      Foreign Address      State
TCP    192.168.111. 24:34159 192.168.111. 24:1053
                                             ESTABLISHED
TCP    0. 0. 0. 0:34155 0. 0. 0. 0: 0 LISTEN
TCP    0. 0. 0. 0:34159 0. 0. 0. 0: 0 LISTEN
TCP    0. 0. 0. 0:34150 0. 0. 0. 0: 0 LISTEN
EN

TCP
  Protocol used.
Local Address
  The recorder's socket address.
  Displays "IP address:port number."
Foreign Address
  The destination socket address.
  Displays "IP address:port number."
State
  Connection status.
ESTABLISHED
  Connection established.
```

eth Outputs Ethernet statistical information.

Syntax `eth <terminator>`

Example

```
eth
EA
04/10/01 12:34:56
```

Ethernet Statistics

Name	In Pkt	In Err	Out Pkt	Out Err	16 Coll
lo0	0	0	0	0	0
mb0	74	0	64	0	0
EN					

help Outputs help.

Syntax `help [, p1] <terminator>`
p1 Command name (close, con, eth, help, net, quit)

Example

```
help
EA
con      - echo connection information
eth     - echo ethernet information
help    - echo help
net     - echo network status
quit    - close this connection
EN
```

net Outputs network statistical information.

Syntax `net <terminator>`

Example

```
net
EA
04/10/01 12:34:56
```

Network Status

```
APP: power on time = 00/00/00 12:34:56
APP: applalive      = disable
APP: genedrops      = 0
APP: diagdrops      = 0
APP: ftpsdrops      = 0
TCP: keepalive      = 30 s
TCP: connects       = 14
TCP: closed         = 0
TCP: timeoutdrop    = 0
TCP: keepdrops      = 0
TCP: sndtotal       = 53
TCP: sndbyte        = 0
TCP: sndrexmitpack  = 0
TCP: sndrexmitbyte  = 1
TCP: rcvtotal       = 0
TCP: rcvbyte        = 0
DLC: 16 collisions  = 0
EN
```

TCP: keepalive
Keepalive check cycle.

TCP: connects
Total number of connections established.

TCP: closed
Total number of dropped connections.

TCP: timeoutdrop
Total number of dropped connections due to TCP retransmission timeout. When the transmitted packet (the unit of transmitted data) is not received, the packet is automatically retransmitted at a predetermined time interval. If the packet is not received after 14 retransmissions, timeout occurs and the connection is dropped.

TCP: keepdrops
Total number of dropped connections due to TCP keepalive timeout.

TCP: sndtotal
Total number of transmitted packets.

TCP: sndbyte
Total number of transmitted bytes.

TCP: sndrexitpack
Total number of retransmitted packets.

TCP: sndrexitbyte
Total number of retransmitted bytes.

TCP: rcvtotal
Total number of received packets.

TCP: rcvbyte
Total number of received bytes.

DLC: 16 collisions
Number of collision incidents. A collision occurs when two or more instruments on the network attempt to transmit simultaneously. The tendency for collisions to occur increases when the network is congested. 16 collisions would mean 16 consecutive collision incidents.

quit — Disconnects the connection of the instrument being operated

Syntax quit<terminator>

4.10 Instrument Information Output Commands (Available when using the instrument information server function via Ethernet communications)

The instrument information server function interprets one UDP packet to be one command and returns a single packet (containing the recorder's information) in response to the command.

Port number	34264/udp (see section 2.1)
Transfer data	ASCII
Received buffer length	128
Transmit buffer length	512
Maximum number of parameters	32

In the command packet, parameters corresponding to the desired information are placed one after another.

Parameter	Description
serial	Outputs the serial number.
host	Outputs the host name (the host name specified in section 2.3).
ip	Outputs the IP address (the IP address specified in section 2.3).

Example Query the IP address and host name. (Of the two frames below, the top frame represents the command packet, the bottom frame represents the response packet.)

```
ip host
```

```
EA
ip = 192.168.111.24
host = ABC
EN
```

- Description**
- Separate each parameter with one or more blanks (space, tab, carriage return, line feed).
 - Parameters are not case sensitive.
 - Undefined parameters are ignored.
 - Parameters beyond the 32nd parameter are ignored.

5.1 Response Syntax

The following table shows the types of responses for various commands described in the previous chapter.

The recorder returns a response (affirmative/negative response) to a command that is separated by a single terminator. The controller should follow the one command to one response format.

Function	Command		Response	
		Command Type	Affirmation	Negation
Setting/Measurement server	Setting command		Affirmative response	Single negative response or Multiple negative responses
	Basic setting command			
	Control command		ASCII output	Multiple negative responses
	Output command	Setup, measurement, and computation data output	BINARY output	
		RS-422A/485 dedicated	Dedicated response	No response
Maintenance/Test Server	See section 4.9.			
Instrument Information server	See section 4.10.			

Note

The "CRLF" used in this section denotes a terminator.

Affirmative Response

When the command is processed correctly, an affirmative response is returned.

- **Syntax**

E0CRLF

- **Example**

E0

Single Negative Response

When the command is not processed correctly, a single negative response is returned.

- **Syntax**

E1_nnn_mmm●●●mCRLF

nnn Error number (001 to 999)

mmm●●●m Message (variable length, one line)

_ Space

- **Example**

E1 001 "System error"

Multiple Negative Responses

- If there is an error in any one of the multiple commands that are separated by sub delimiters, multiple negative responses are returned.
- The response is generated for each erroneous command.
- If there are multiple commands that have errors, the negative responses are separated by commas.
- The error position number is assigned to the series of commands in order starting with "1" assigned to the first command.

- **Syntax**

E2_ee:nnnCRLF

(When there is only one error)

E2_ee:nnn,ee:nnn,●●●,ee:nnnCRLF

(When there are multiple errors)

ee Error position (01 to 10)

nnn Error number (001 to 999)

_ Space

- **Example**

E2 02:001

ASCII Output

The following types of ASCII data are available. For the data formats, see section 5.2.

Setting data, basic setting data, decimal position/unit information, measured/computed data, report data generated by the periodic printout, status information, and user information

- **Syntax**

```
EACRLF
.....CRLF
:
.....CRLF
.....CRLF
ENCRLF
```

BINARY Output

- **Conceptual Diagram**

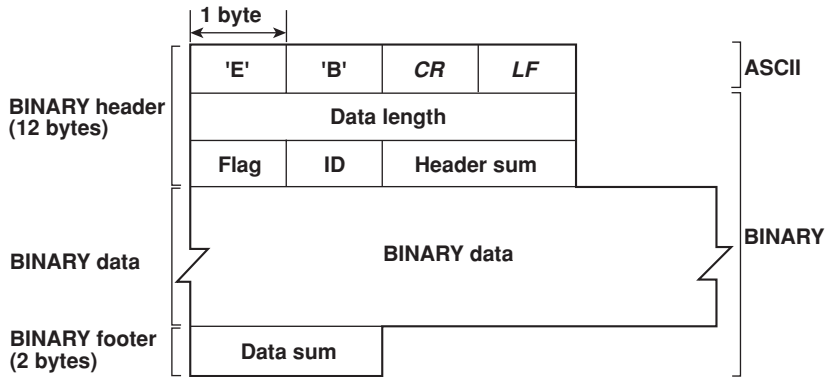

- **EBCRLF**

Indicates that the data is BINARY.

- **Data Length**

The byte value of “flag + identifier + header sum + BINARY data + data sum.”

- **Header Sum**

The sum value of “data length + flag + identifier.”

- **BINARY Data**

For the output format of various data types, see section 5.3.

- **Data Sum**

The sum value of “BINARY data.”

Note

The data length of the BINARY header section is output according to the byte order specified with the BO command.

- **Flag**

Bit	Name (Abbreviation)	Flag 0	Flag 1	Meaning of the Flag
7	BO	MSB	LSB	Output byte order
6	CS	No	Yes	Existence of a checksum
5	–	–	–	
4	–	–	–	
3	–	–	–	
2	–	–	–	
1	–	–	–	
0	Reserved	–	–	Fixed to 1.

- When the BO flag is “0,” the MSB is output first. When the BO flag is “1,” the LSB is output first.
- If the check sum is enabled (parameter = 1) using the CS command parameter, each sum value is inserted in the header sum and data sum sections in the “Conceptual Diagram” on the previous page. If the check sum is disabled (parameter = 0), a zero is inserted in the header sum and data sum sections. For a sample program that calculates the sum value, see “Calculating the Sum Value” on the next page.
- The bits that have “–” for the flag and flag are not used. The value is undefined.

- **Identifier**

ID Number	Binary Data Type	Format
0	Undefined file	–
1	Measured/computed data	Section 5.3
1	FIFO data	Section 5.3
10	Setup data file	Undisclosed

- The table above shows the different types of BINARY Data.
- Measured/computed data can be output using the FD command.
- FIFO data can be output using the FF command.
- The setup data file can be output using the FE command. The setup data file can be loaded in the configuration software.
- The identifier section in the “Conceptual diagram” on the previous page contains the ID number shown above.

Note

BINARY data that are not indicated in the above table are considered undefined files.

- **Calculating the Sum Value**

If you set the parameter of the CS command to “1 (enabled),” the checksum value is output only during serial communications. The check sum is the same as that used in the TCP/IP and is derived according to the following algorithm.

Buffer on Which the Sum Value Is Calculated

- For the header sum, it is calculated from “data length + flag + identifier” (fixed to 6 bytes).
- For the data sum, it is calculated from “BINARY data.”



If the data length of the buffer is odd, a “0” is padded so that it is even. (1) through (6) are summed as unsigned two-byte integers (unsigned short). If the digit overflows a “1” is added. Finally, the result is bit-wise inverted.

Sample Program

The sum value is determined using the following sample program, and the calculated result is returned. The sum determined by the sample program can be compared with the header sum of the output BINARY header section and the data sum of the output BINARY footer section.

```
/*
 * Sum Calculation Function (for a 32-bit CPU)
 *
 * Parameters buff: Pointer to the top of the data on which the sum is calculated
 *             len: Length of the data on which the sum is calculated
 * Return value: Calculated sum
 */

int cksum(unsigned char *buff, int len)
{
    unsigned short *p; /* Pointer to the next two-byte data word in the buffer
                       that is to be summed. */
    unsigned int csum; /* Checksum value */
    int i;
    int odd;
    csum = 0; /* Initialize. */
    odd = len%2; /* Check whether or not the number of data points is
                even. */
    len >>= 1; /* Determine the number of data points using a
                "short" data type. */
    p = (unsigned short *)buff;

    for(i=0;i<len;i++) /* Sum using an unsigned short data type. */
        csum += *p++;

    if(odd){ /* When the data length is odd */
        union tmp{ /* Pad with a 0, and add to the unsigned short data.
                  */
            unsigned short s;
            unsigned char c[2];
        }tmp;
        tmp.c[1] = 0;
        tmp.c[0] = *((unsigned char *)p);
        csum += tmp.s;
    }

    if((csum = (csum & 0xffff) + ((csum>>16) & 0xffff)) > 0xffff)
        /* Add the overflowed digits */
        csum = csum - 0xffff; /* If the digit overflows again, add a 1. */

    return((~csum) & 0xffff); /* bit inversion */
}
```

RS-422A/485 Dedicated Commands and Responses

The following table shows dedicated commands for the RS-422A/485 interface and their responses.

Command Syntax	Meaning	Response
<i>ESC O_xx CRLF</i> (_ space)	Open the instrument.	<ul style="list-style-type: none"> Response from the instrument with the specified address <i>ESC O xx CRLF</i> Response when the instrument with the specified address does not exist*
<i>ESC C_xx CRLF</i> (_ space)	Close the instrument.	<ul style="list-style-type: none"> Response from the instrument with the specified address <i>ESC C xx CRLF</i> Response when the instrument with the specified address does not exist*

* The causes that the condition become "The instrument with the specified address does not exist" is such as a command error, the address not matching that of the instrument, the instrument is not turned ON, and the instrument not being connected via the serial interface.

- The "xx" in the table indicates the instrument's address. Specify the address that is assigned to the instrument from 01 to 32.
- Only one instrument can be opened at any one time.
- When an instrument is opened with the ESC O command, all commands on the instrument become active.
- When an instrument is opened with the ESC O command, any other instrument that is open is automatically closed.
- Use CR+LF for the terminator. LF cannot be used.

Note

- The ASCII code of ESC is 1BH.

5.2 Output Format of ASCII Data

The following types of ASCII data are available.

- Setting data/Basic Setting data
- Decimal point position/unit information
- Measured/computed data
- Report data generated by the periodic printout
- Status information
- User information

Note

The “*CRLF*” used in this section denotes a terminator.

Setting/Basic Setting data

- The FE command (FE0 or FE2) is used to output the data.
- The setting/basic setting data are output in the order of the listed commands in the table in section 4.2, “A List of Commands.” However, the setting information for the following commands is not output.
 - Setting commands
SD, CM, and FR
 - Basic Setting commands
YE and XE
- The output format of the setting/basic setting data is the same as the syntax of each command.
- Some commands are output in multiple lines. (Example: Commands that are specified for each channel.)

- **Syntax**

The two-character command name and the succeeding parameters are output in the following syntax.

```
EACRLF  
ttsss•••sCRLF  
••••••••••••••••  
ENCRLF
```

tt Command name (SR, SA•••, XA, XI•••)
sss•••s Setting, basic setting data (variable length, one line)

- **Example**

```
EA  
SR01,VOLT,20mV,0,20  
SR02,VOLT,20mV,0,20  
••••••••••••••••  
EN
```

Decimal Point Position/Unit Information

- The FE command (FE1) is used to output the data.
- Syntax**
The data is output for each channel in the following syntax.

```
EACRLF
s_kccuuuuuu,ppCRLF
.....
ENCRLF
```

s	Data status (N, D, S) N: Normal D: Differential input S: Skip (When the input range is set to SKIP for a measurement channel or when the channel is turned OFF for a computation channel)
k	Channel type 0: Measurement channel A: Computation channel
cc	Channel number RD100B: 01 to 06, 0A to 0P RD1800B: 01 to 24, 0A to 1P
uuuuuu	Unit information (6 characters, left-justified) mV____: mV V____: V ^C____: °C xxxxxxx: (User-defined character string)
pp	Decimal point position (00 to 04) No decimal (00000) for 00. One digit to the right of the decimal (0000.0) for 01. Two digits to the right of the decimal (000.00) for 02. Three digits to the right of the decimal (00.000) for 03. Four digits to the right of the decimal (0.0000) for 04.
_	Space

- Example**
EA
N 001mV ,01
N 002mV ,01
EN

Measured/computed Data

- The FD (FD0) or FY (FYInst, FYTlog1, or FYTlog2) command is used to output the data.

- **Syntax**

The measured/computed data are output in the following syntax along with the date and time information for each channel

```

EACRLF
DATE_YY/mo/ddCRLF
TIME_hh:mi:ss.mmmt_S1S2S3S4S5S6CRLF
s_kcca1a2a3a4uuuuuuf1dddddeF2ppCRLF
.....
ENCRLF
    
```

YY	Year (00 to 99)
mo	Month (01 to 12)
dd	Day (01 to 31)
hh	Hour (00 to 23)
mi	Minute (00 to 59)
ss	Second (00 to 59)
mmm	Millisecond (000 to 999. A period is placed between seconds and milliseconds.)
t	'S'(=summer) or ' ' space(=winter)
S ₁ S ₂ S ₃ S ₄ S ₅ S ₆	Data status Takes on the values below for the FYTlog1 and FYTlog2 commands. For all other cases, they are all spaces.
S ₁	Time change during TLOG computation: T (occurred) or space (not occurred)
S ₂	Power OFF and ON during TLOG computation: P (occurred) or space (not occurred)
S ₃	Data reset during the TLOG computation: R (occurred) or space (not occurred)
S ₄ S ₅ S ₆	All spaces
s	Channel data status (N, D, S, O, B, E) N: Normal D: Differential input S: Skip O: Over B: Burnout E: Error
k	Channel type 0: Measurement channel A: Computation channel
cc	Channel number RD100B: 01 to 06, 0A to 0P RD1800B: 01 to 24, 0A to 1P
a ₁ a ₂ a ₃ a ₄	a ₁ Alarm status (level 1) a ₂ Alarm status (level 2) a ₃ Alarm status (level 3) a ₄ Alarm status (level 4)

Each status is set to H, L, h, l, R, r, T, t, or space.

H: high limit alarm, L: low limit alarm, h: difference high-limit alarm, l: difference low-limit alarm, R: high limit on rate-of-change alarm, r: low limit on rate-of-change alarm, T: delay high limit alarm, t: delay low limit alarm, space: no alarm

uuuuuu	Unit information (6 characters, left-justified) mV____: mV V____: V ^C____: °C xxxxxx: (User-defined character string)
f ₁	Sign (+, -) of mantissa <ul style="list-style-type: none"> • Positive over data, error data, and the burnout data when “up” is specified are positive. • Negative over data and the burnout data when “down” is specified are negative.
dddd	Mantissa (00000 to 99999, 5 digits) <ul style="list-style-type: none"> • 8 digits for computed data. • For error data (channel data status is E), over data (channel data status is O), or burnout data (channel status data is B), the mantissa is set to 99999 (99999999 for computed data).
f ₂	Sign (+, -) of exponent
pp	Exponent (00 to 04)
—	Space

- **Example**

```
EA
DATE 99/02/23
TIME 19:56:32.500
N 001h mV +12345E-03
N 002 mV -12345E-01
S 003
EN
```

Note

- Data for non-existing channels are not output (not even the channel number).
- For channels set to skip, output values from alarm status to exponent are spaces.

Report Data Generated by the Periodic Printout

- The FY command (FYREPORT) is used to output the data.
- Report data generated by the periodic printout is output.

Syntax

```

EACRLF
YY/MO/DD_HH:MI:SS.MMMTCRLF
yy/mo/dd_hh:mi:ss.mmmt_S1S2S3S4S5S6CRLF
s1s2s3s4s5s6kccuuuuuf1ddddEf2pp_f1ddddEf2pp_f1ddddEf2pp_f1dddd
Ef2pp_f1ddddddEf2ppCRLF
.....
ENCRLF

```

YY/MO/DD HH:MI:SS.MMMT	Report start time information
yy/mo/dd hh:mi:ss.mmmt	Report end time information
YY, yy	Year (00 to 99)
MO, mo	Month (01 to 12)
DD, dd	Day (01 to 31)
HH, hh	Hour (00 to 23)
MI, mi	Minute (00 to 59)
SS, ss	Second (00 to 59)
MMM, mmm	Millisecond (000 to 999)
T, t	'S'(=summer) or ' ' space(=winter)
S1S2S3S4S5S6	Data status
S1	Time change during reporting: T (occurred) or space (not occurred)
S2	Power OFF and ON during reporting: P (occurred) or space (not occurred)
S3	Data clear during reporting: R (occurred) or space (not occurred)
S4S5S6	All spaces
s1s2s3s4s5s6	Channel data status
s1	Channel mode at the end of reporting: S (Skipped) or space (Mode other than skipped)
s2	Range change during reporting: C (occurred) or space (not occurred)
s3	Error data occurrence during reporting: E (yes) or space (no)
s4	±over data occurrence during reporting: O (yes) or space (no)
s5s6	All spaces
cc	Channel number RD100B: 01 to 06, 0A to 0P RD1800B: 01 to 24, 0A to 1P
k	Channel type (0, A) 0: Measurement channel A: Computation channel
uuuuuu	Unit information (6 characters)

f₁ddddEf₂pp_f₁ddddEf₂pp_f₁ddddEf₂pp_f₁ddddEf₂pp_f₁dddddd
Ef₂pp

The data is output in the following order: most recent value, minimum value, maximum value, average value, and sum value.

f₁ddddEf₂pp Most recent value, minimum value, maximum value, and average value of the measurement channel

f₁ddddddEf₂pp Sum value of the measurement channel or the most recent value, minimum value, maximum value, average value, and sum value of the computation channel

f₁ Sign (+, -) of mantissa

dddd Mantissa (0000 to 9999)

ddddddd Mantissa (0000000 to 9999999)

f₂ Sign (+, -) of exponent

pp Exponent (00 to 04)

- **Example**

```
EA
04/08/04 10:22:20.500S
04/08/04 19:56:32.500S TP
    001mV +12345E-03 +12345E-03 +12345E-03 +12345E-03 +12345678E-03
C    002mV -12345E-01 -12345E-01 -12345E-01 -12345E-01 -12345678E-01
S    003
S    004
    A0A +12345678E-03 +12345678E-03 +12345678E-03 +12345678E-03
+12345678E-03
    A0B -12345678E-01 -12345678E-01 -12345678E-01 -12345678E-01 -
12345678E-01
S    A0C
S    A0D
EN
```

Status Information

- The IS command is used to output the data.
- The operation status of the recorder is output
- For details on the status information, see section 6.2, “The Bit Structure of the Status Information.”

- **Syntax**

```
EACRLF  
ddd.ccc.bbb.aaaCRLF  
ENCRLF
```

aaa	Status information 1 (000 to 255)
bbb	Status information 2 (000 to 255)
ccc	Status information 3 (000 to 255)
ddd	Status information 4 (000 to 255)

- **Example**

```
EA  
000.000.032.000  
EN
```

User Information

- The FU command is used to output the data.
- User name, user level, and other information are output.

- **Syntax**

```
EACRLF  
p_l_uuu●●●uCRLF  
ENCRLF
```

p	Physical layer
	E: Ethernet
	S: RS-422A/485
l	User level
	A: Administrator
	U: User
uuu●●●u	User name (up to 16 characters)
—	Space

- **Example**

```
EA  
E A admin  
EN
```

5.3 Output Format of BINARY Data

This section describes the output format of the BINARY data that is disclosed. For the BINARY output format, see “BINARY Output” on page 5-2. For other BINARY data types, see “Identifier” on page 5-3.

The measured data is output using signed 16-bit integer; the computed data is output using signed 32-bit integer. These integers can be understood as physical values by adding the decimal point and the unit.

Typical Examples to Obtain Physical Values

BINARY Value	Decimal Position Code	Physical Value (Measured Value)
10000	0	10000
10000	1	1000.0
10000	2	100.00
10000	3	10.000
10000	4	1.0000

Measured/Computed Data and FIFO Data

- The FD (FD1) command is used to output the most recent measured/computed data.
- The FF (FEGET, FERESEND, and FEGETNEW) command is used to output the FIFO data. The decimal point position and unit can be determined using the FE command.
- The ID number of the output format is 1. See “Identifier” on page 5-3.

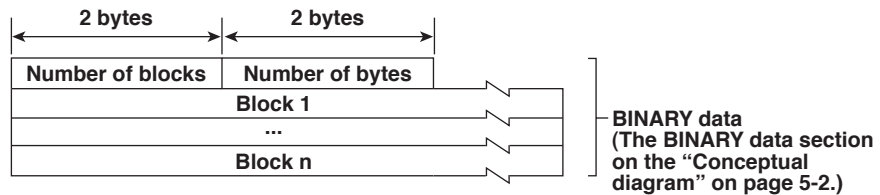

- **Number of Blocks**
This is the number of blocks.
- **Number of Bytes**
This is the size of one block in bytes.
- **Block**

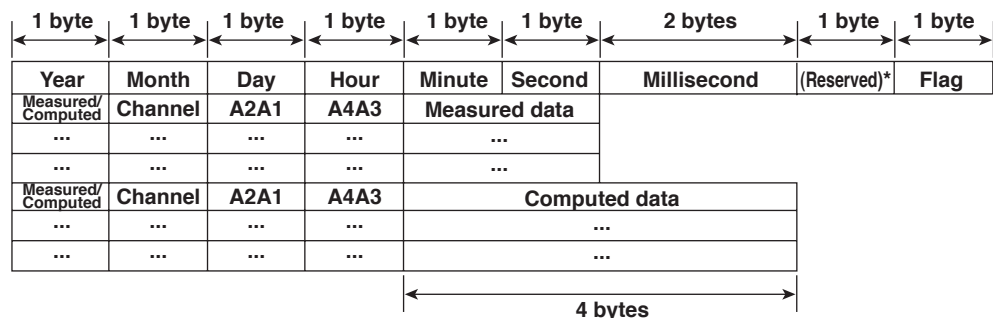

* The sections indicated as (Reserved) are not used. The value is undefined.

5.3 Output Format of BINARY Data

- **Flag**

The meanings of the flags are given on the table below. The flags are valid during FIFO data output. The flags are undefined for other cases.

Bit	Flag 0	Flag 1	Meaning of the Flag
6	–	–	
5	–	–	
4	–	–	
3	–	–	
2	No	Yes	Indicates that the decimal position or unit information was changed during measurement.
1	No	Yes	Indicates that the FIFO acquiring interval was changed during measurement.
0	No	Yes	Indicates that the internal process took too much time (computation, for example) and that FIFO dropout occurred.

The bits that have “–” for the flag column are not used. The value is undefined.

- **Block Member**

Name	BINARY Value
Year	0 to 99
Month	1 to 12
Day	1 to 31
Hour	0 to 23
Minute	0 to 59
Second	0 to 59
Millisecond	0 to 999
DST	1 (=summer) or 0 (=winter)
Measurement, computation Channel	00H: measurement, 80H: computation RD100B: 01 to 06 and 31 to 42 RD1800B: 01 to 24, 31 to 54
Alarm status*	
A1 (Bit 0 to 3)	
A2 (Bit 4 to 7)	0 to 8
A3 (Bit 0 to 3)	
A4 (Bit 4 to 7)	
Measured data	0 to FFFFH
Computed data	0 to FFFFFFFFH

* BINARY value 0 to 8 is entered in the upper and lower 4 bits of a byte (8 bits) for the alarm status. The binary values 0 to 8 correspond to H (high limit alarm), L (low limit alarm), h (difference high-limit alarm), l (difference low-limit alarm), R (high limit on rate-of-change alarm), r (low limit on rate-of-change alarm), T (delay high limit alarm), and t (delay low limit alarm) as follows:

0: no alarm, 1: H, 2: L, 3: h, 4: l, 5: R, 6: r, 7: T, and 8: t.

- **Special Data Value**

The measured/computed data take on the following values under special conditions.

Special Data Value	Measured Data	Computed Data
+ Over	7FFFH	7FFF7FFFH
– Over	8001H	80018001H
Skip	8002H	80028002H
Burnout (when “up” is set)	7FFAH	7FFF7FFFH
Burnout (when “down” is set)	8006H	80018001H
Error	8004H	80048004H
Undefined	8005H	80058005H

Note

The number of blocks, number of bytes, and measured/computed data are output according to the byte order specified with the BO command.

6.1 Status Information and Filter

The following figure illustrates the status information and filter on the recorder.

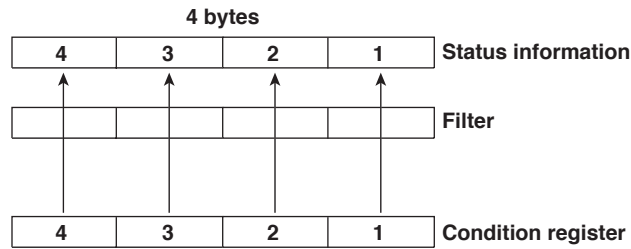

- When a status indicated on the following page is entered, the corresponding bit in the condition register is set to “1.” The logical AND of the condition register and the filter becomes the status information.
- The IF command can be used to set the filter.
- The IS command is used to output the status information. Status information 1 and 2 are cleared when they are output. Status information 3 and 4 are not cleared when it is output, and remains at “1” while the event is occurring.
- When multiple connections are up, filters can be specified for the individual connection. Therefore, the status information can be held for each connection.

6.2 The Bit Structure of the Status Information

The following four groups of status information are output in response to a status information output request using the IS command. For the output format, see “Status Information” in section 5.2, “Output Format of ASCII Data.”

Status Information 1

Bit	Name	Description
0	A/D conversion complete	Set to “1” when the A/D conversion of the measurement is complete.
1	–	–
2	Periodic printout timeout	Set to “1” when the periodic printout timer expires.
3	TLOG timeout	Set to “1” when the TLOG timer expires.
4	–	–
5	–	–
6	–	–
7	–	–

Status Information 2

Bit	Name	Description
0	Measurement drop	Set to “1” when the measurement process could not keep up.
1	Decimal point/unit information change	Set to “1” when the decimal point/unit information is changed.
2	Command error	Set to “1” when there is a command syntax error.
3	Execution error	Set to “1” when an error occurs during command execution.
4	–	–
5	–	–
6	–	–
7	–	–

Status Information 3

Bit	Name	Description
0	–	–
1	Chart end	Set to “1” while the recorder is out of chart paper.
2	–	–
3	–	–
4	–	–
5	Chart feeding	Set to “1” while the chart is being fed through the panel key.
6	–	–
7	–	–

Status Information 4

Bit	Name	Description
0	Basic setting	Set to “1” during Basic Setting mode.
1	Recording	Set to “1” while recording is in progress.
2	Computing	Set to “1” while computation is in progress.
3	Alarm generating	Set to “1” while the alarm is occurring.
4	–	–
5	–	–
6	–	–
7	–	–

Appendix 1 ASCII Character Codes

The table below contains the ASCII character codes of characters that can be used. The table below shows characters each command can use.

Command	Used for	Characters
SN	Unit	Alphanumeric characters, signs, and space
ST	Tag	Alphanumeric characters, signs, and space
SG	Message	Alphanumeric characters, signs, and space
YB	Host/Domain name	Alphanumeric characters and signs
YN	Domain suffix	Alphanumeric characters and signs
SO	Computing equation	Alphanumeric characters, signs, and space

Note

“μ”, “Ω”, “²”, “³”, and “°” are assigned to character codes as follows:

μ: 7BH (I), Ω: 7CH (I), ²: 7DH (I), ³: 7EH (~), °: 5EH (^)

Characters in the parentheses are characters assigned on a keyboard.

		Upper 4 bits															
		0	1	2	3	4	5	6	7	8	9	A	B	C	D	E	F
Lower 4 bits	0			SP (space)	0	@	P		p								
	1				1	A	Q	a	q								
	2				2	B	R	b	r								
	3			#	3	C	S	c	s								
	4				4	D	T	d	t								
	5			%	5	E	U	e	u								
	6				6	F	V	f	v								
	7				7	G	W	g	w								
	8			(8	H	X	h	x								
	9)	9	I	Y	i	y								
	A	LF		*		J	Z	j	z								
	B		ESC	+		K		k	μ								
	C					L		l	Ω								
	D	CR		-		M		m	²								
	E			.		N		n	³								
	F			/		O		o									

Appendix 2 Output Flow of FIFO Data

The recorder has a dedicated internal memory for outputting measured/computed data. This memory is structured as a FIFO (First-In-First-Out). Measured/computed data are constantly acquired to the internal memory at the specified acquiring interval (FIFO acquiring interval, set with the FR command). By using this function, it is possible to read measured/computed data that have been saved at the specified intervals regardless of the frequency at which the PC periodically reads the measured/computed data.

The following example shows the case when the acquiring interval is 1 s and the buffer capacity is for 8 intervals.

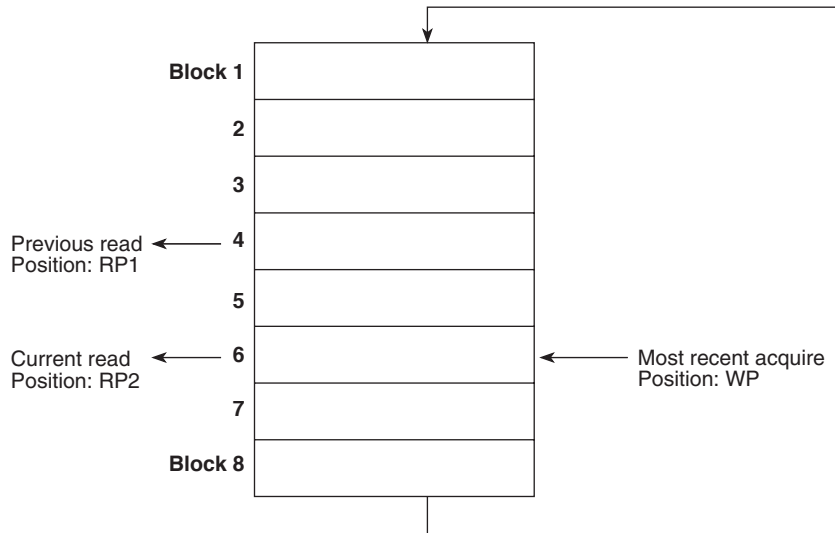

- **Acquiring of the measured/computed data**
 - The measured/computed data are acquired to the internal memory at 1 s intervals.
 - Measured/computed data are acquired to blocks 1 through 8 in order. After acquiring to block 8, the next acquiring operation returns to block 1.
- **Reading the measured/computed data (FF GET command is used, logging output)**

Outputs the data from the next to the previous read position (RP1) to the most recent acquire position (WP).

In this example, more than 2 s has elapsed from the previous read operation. Therefore, data in blocks 5 and 6 are output.
- **Reading the measured/computed data (FF GETNEW command is used, output of the most recent value)**

Output the specified number of blocks of FIFO data back starting from the recent acquire position (WP).

In this example, if you specify the number of blocks to "5," data in blocks 2 to 6 are output.

The buffer capacity varies depending on the model.

- Pen model: 240 intervals (30 s at an acquiring interval of 125 ms)
- Dot model: 60 intervals (60 s at an acquiring interval of 1 s)

Example in which the FIFO acquiring interval on the recorder is set to 1 s and the measured data from channel 01 to 06 are continuously output (logging function)

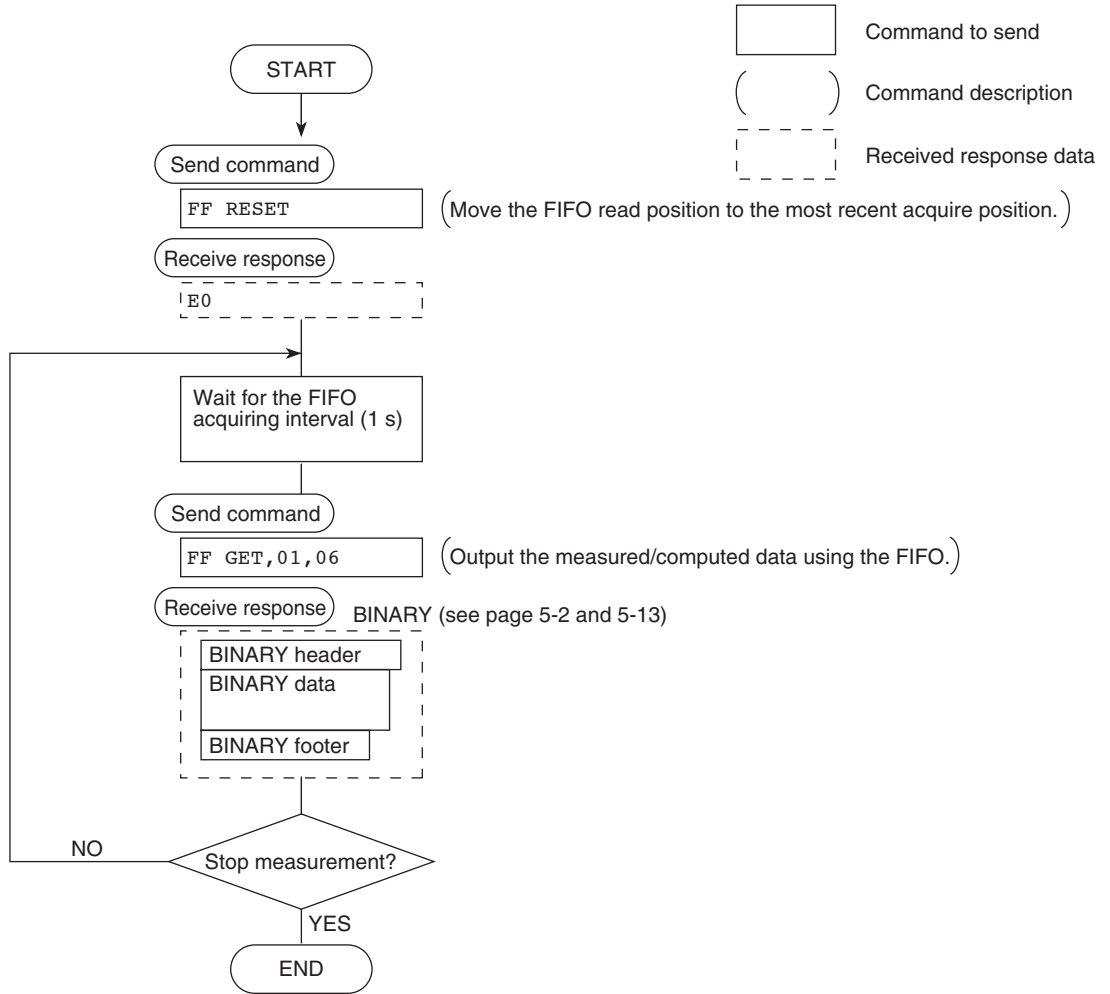

Note

- The FIFO acquiring interval must be set using the FR command beforehand.
- The FIFO acquiring interval applies to both serial and Ethernet communications.

Appendix 3 Login Procedure

When using the Setting/Measurement server or the Maintenance/Test server via the Ethernet interface (/C7 option), you must log into the recorder from the PC. If you complete the procedure successfully up to login complete in the following figure, the commands in chapter 4 become functional.

When using the login function

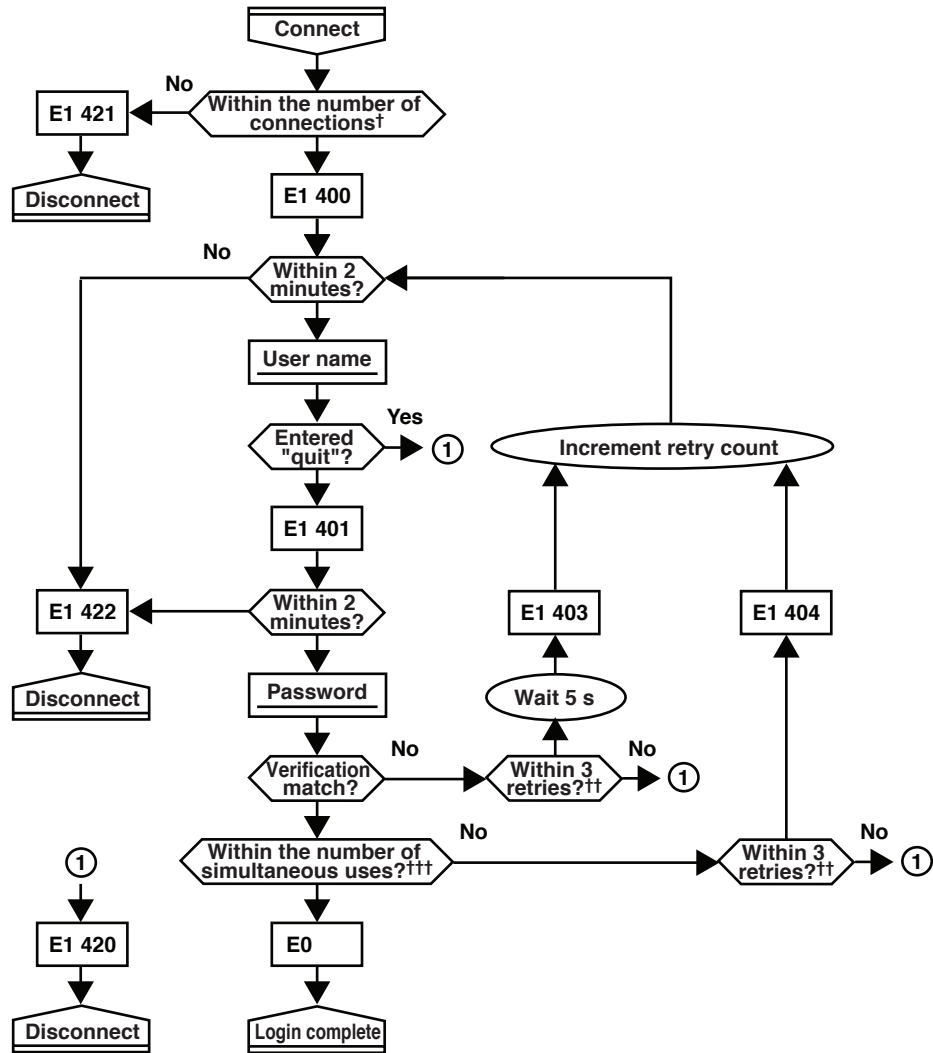

 Start  Judgment

 End  Transition

 User entry

E1 403 Response from the μ R (message omitted)
For a description of the response format, see section 5.1.

Code (for a description of codes and messages, see page App-6)

† Connections cannot exceed the maximum number of connections (see section 2.1).

†† If you attempt to log in using a wrong password four consecutive times, the communication is dropped (the number of retries for login is three).

††† If you attempt to log in causing the number of simultaneous uses at the administrator or user level to be exceeded (see section 2.1) four consecutive times, the communication is dropped (even if the password is correct).

When not using the login function

Login as "admin" or "user."

- The user name "admin" can be used to login to the recorder as an administrator.
- The user name "user" can be used to access the recorder as a user.

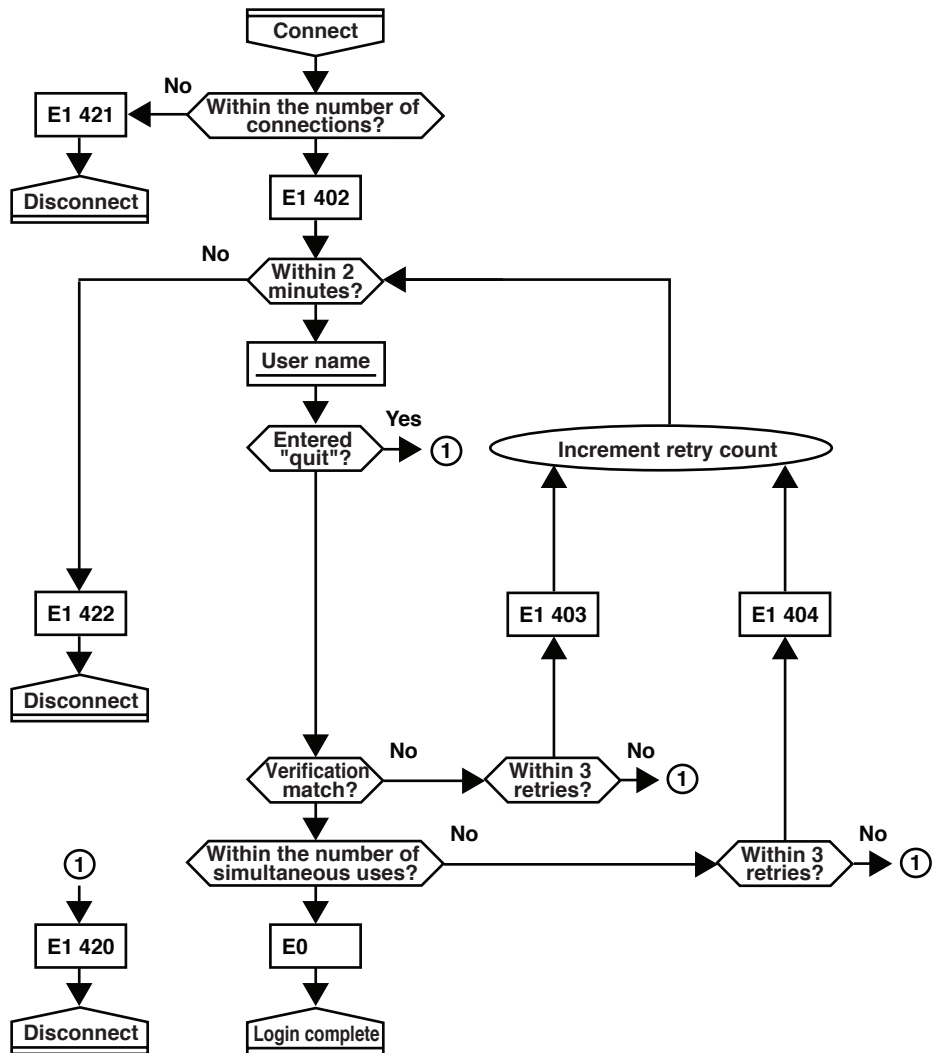

Appendix 4 A List of Error Messages

There are cases in which error codes and messages are displayed on the screen during operation. The error messages and their description are listed below.

Setting Errors

Code	Message	Explanation/Countermeasures
1	System error.	Contact OMEGA.
2	Incorrect date or time setting.	Check the setting.
3	A disabled channel is selected.	The channel does not exist.
4	Incorrect function parameter.	Incorrect communication parameter.
5	The input numerical value exceeds the set range.	–
6	Incorrect input character string.	The entered character cannot be used.
7	Too many characters.	–
8	Incorrect input mode.	Incorrect range mode (Volt, TC, Scale, etc.) setting.
9	Incorrect input range code.	Incorrect range type (2 V, R, PT100, etc.) setting.
10	Format error.	Incorrect character string format.
11	Range settings are not same within the selected channels.	Channels whose range differs cannot be set simultaneously.
12	An invalid characters.	Contains an invalid character.
13	Ref. CH error.	Specify a channel whose range is set to voltage, TC, or RTD for the reference channel.
21	Cannot set an alarm for a SKIPPED channel.	–
22	The upper and lower span limits are equal.	This is not allowed.
23	The upper and lower scale limits are equal.	This is not allowed.
24	The lower span limit is greater than the upper span limit.	–
25	The lower scale limit is greater than the upper scale limit.	–
26	Bias cannot be set to the SKIPPED channel.	–
27	Bias cannot be set to the DI channel.	–
30	The partial boundary value exceeds the range of the span.	–
31	Partial is invalid on the SKIPPED channel.	–
35	The upper and lower limits of the printing zone are equal.	Set the rightmost value of the zone – the leftmost value \geq 5 mm.
36	The lower limit of the printing zone is greater than the upper limit.	Set the rightmost value of the zone – the leftmost value \geq 5 mm.
37	The printing zone is narrower than the minimum width (5 mm).	Set the rightmost value of the zone – the leftmost value \geq 5 mm.
38	Partial is invalid on the DI channel.	–
47	All items in DISP menu parameters are set to SKIP.	–
48	Start = Finish.	The DST start time and end time cannot be set to the same time.
49	Invalid or missing DST time settings.	Since the time gains one hour when the DST starts, the set-up time does not exist.
61	There is no channel specified by the MATH expression.	Set a computation channel.
62	MATH expression grammar is incorrect.	Enter the equation correctly.
63	MATH expression sequence is incorrect.	Enter the equation correctly.
64	MATH upper and lower span values are equal.	This is not allowed.
70	MATH constant description is incorrect.	Incorrect computation constant syntax.
71	The range of the MATH constant is exceeded.	–
72	MATH channel is turned off	–

Code	Message	Explanation/Countermeasures
81	All space or 'quit' string cannot be specified.	–
86	The key-lock release password is incorrect.	Enter the correct password.
87	This key is locked.	–
91	Password is incorrect.	Enter the correct password.
100	IP address doesn't belong to class A, B, or C.	–
101	The result of the masked IP address is all 0s or 1s.	–
102	SUBNET mask is incorrect.	Set a correct subnet mask.
103	The net part of default gateway is not equal to that of IP address.	Set the correct default gateway.
151	This action is invalid during calculation.	–
160	This action is invalid during chart end.	–
161	This action is invalid during pen hold.	–
162	Cannot set an number for a skipped data.	–
163	This action is invalid during record.	–
164	This action is invalid during manual printing.	–
165	This action is invalid during list printing.	–
166	This action is invalid during setup list printing.	–
167	This action is invalid during chart feed.	–
169	This action is invalid during ribbon hold.	–

Operation Errors

Code	Message	Explanation/Countermeasures
232	There is no available data.	There is no data for periodic printout or data for calculating TLOG when the timer expired.

Communication Errors

The messages from 390 to 422 can only be returned via communication, and are not displayed on the recorder.

Code	Message	Explanation/Countermeasures
300	Command is too long.	–
301	Too many number of commands delimited with ';'. ;	Keep the number of commands separated by sub delimiters under 10.
302	This command has not been defined.	–
303	Data request command can not be enumerated with sub-delimiter.	–
350	Command is not permitted to the current user level.	–
351	This command cannot be specified in the current mode.	–
352	The option is not installed.	–
353	This command cannot be specified in the current setting.	–
354	This command is not available during calculation.	–
390	Command error.	–
391	Delimiter error.	–
392	Parameter error.	–
393	No permission.	–
394	No such connection.	–
395	Use "quit" to close this connection.	Attempted to disconnect its own connection.
396	Failed to disconnect.	–
397	No TCP control block.	The control block of the specified connection cannot be found.

Appendix 4 A List of Error Messages

Code	Message	Explanation/Countermeasures
400	Input username.	–
401	Input password.	–
402	Select username from 'admin' or 'user'.	If the recorder is configured not to use the user name and password, use user names 'admin' or 'user'.
403	Login incorrect, try again!	–
404	No more login at the specified level is acceptable.	–
420	Connection has been lost.	–
421	The number of simultaneous connection has been exceeded.	–
422	Communication has timed-out.	–

Warning Messages

Code	Message	Explanation/Countermeasures
600	Initialized.	Settings and measured data have been initialized.

System Errors

Code	Message	Explanation/Countermeasures
902	RAM failure.	Contact OMEGA.
910	A/D error.	Contact OMEGA.
921	A/D calibration value error.	Contact OMEGA.
922	A/D calibration is in the wrong order.	Contact OMEGA.
930	Memory acquisition failure.	Contact OMEGA.
940	The ethernet module is down.	Contact OMEGA.
950	A/D number error.	Contact OMEGA.
951	EEPROM write error.	Contact OMEGA.
960	Ribbon error	Contact OMEGA.
961	Printer error	Contact OMEGA.
962	Plotter error	Contact OMEGA.
963	Pen 1 error	Contact OMEGA.
964	Pen 2 error	Contact OMEGA.
965	Pen 3 error	Contact OMEGA.
966	Pen 4 error	Contact OMEGA.

Index

Symbols

1-5V input low-cut	4-21
--------------------------	------

A

	Page
A/D integral time	4-18
address	3-12
administrator	2-9
affirmative response	5-1
alarm	4-11, 4-18
alarm ACK	4-25
alarm acknowledge	4-25
alarm delay	4-21
alarm delay time	4-14
alarm printout buffer	4-25
ASCII character codes	App-1
ASCII data	5-6
ASCII output	5-2
assignment of channels	4-22

B

	Page
bar graph	4-20
basic setting commands	4-4
basic setting mode	vi, 4-3
baud rate	3-12
bias	4-11, 4-21
BINARY data	5-13
BINARY output	5-2
bit structure	3-7
brightness	4-14
burnout detection	4-19
byte output order	4-26

C

	Page
channel number	4-8
chart speed	4-9, 4-12
checksum	4-26
checksum value	5-3
closes the instrument	4-28
command	
AC	4-25
AK	4-25
BD	4-14
BO	4-26
CC	4-26
close	4-29
CM	4-15
con	4-29
CS	4-26
DS	4-25
ESC C	4-28
ESC O	4-28
eth	4-29
FD	4-27
FE	4-27
FF	4-27
FR	4-15
FU	4-28
FY	4-27
help	4-29

host	4-30
IF	4-26
ip	4-30
IS	4-28
LS	4-25
MC	4-26
MP	4-25
MS	4-25
net	4-29
PS	4-25
quit	4-30
SA	4-11
SC	4-12
SD	4-13
SE	4-14
serial	4-30
SF	4-14
SG	4-14
SJ	4-15
SK	4-15
SN	4-12
SO	4-11
SP	4-13
SR	4-10
SS	4-15
ST	4-14
SU	4-25
SV	4-14
SZ	4-13
TD	4-14
TL	4-25
UA	4-23
UB	4-20
UC	4-19
UD	4-25
UF	4-21
UI	4-20
UJ	4-20
UK	4-20
UL	4-20
UM	4-20
UN	4-22
UO	4-19
UP	4-19
UR	4-19
US	4-22
UT	4-21
UY	4-26
VB	4-11
VD	4-16
VF	4-14
VG	4-26
VR	4-13
VT	4-13
XA	4-18
XB	4-19
XE	4-24
XI	4-18
XJ	4-19
XN	4-20
XQ	4-22
XR	4-21
YA	4-22
YB	4-22

Index

YC	4-26
YD	4-23
YE	4-24
YK	4-23
YN	4-23
YQ	4-23
YS	4-21
command syntax	4-1
command-response rule	4-2
communication input data	4-8, 4-15
computation error	4-22
computing equation	4-11
connection (ethernet)	2-2
connection (RS-422A/485)	3-2
connection example (RS-422A/485)	3-3
connection information	4-29
connection status of the Ethernet interface	2-7
constant	4-8, 4-15
control commands	4-5
conventions	iv
converter	3-5
copying & pasting a character string	vii

D Page

data display screen	4-16
data length	3-12
date and time	4-13
decimal point position	4-27
decimal point position output	5-7
default gateway	2-6
deleting a character	vii
deleting an entire character string	vii
delimiter	4-2
disconnects an Ethernet connection	4-26
disconnects the connection	4-29, 4-30
display	v
DNS	2-6, 4-23
DNS server	2-6
domain name	2-5, 4-22
domain suffix	2-6
dot color	4-19
dot printing interval	4-13
DST	4-14, 4-15

E Page

entering basic setting mode	vi
entering characters	vii
entering values	vii
error messages	App-6
ESC key	vi
Ethernet interface	2-1
Ethernet statistical information	4-29
execution mode	4-25
execution modes	vi, 4-3
exiting from basic setting mode	viii
exits from basic setting mode	4-24
extended functions	4-21

F Page

FIFO	App-2
FIFO data	4-27, 5-13
filter (status information)	6-1
first-in-first-out	App-2
flag	5-3, 5-14

frequently used parameters	4-7
functional construction (ethernet)	1-1
functional construction (RS-422A/485)	1-4

H Page

help	4-29
Hold register	3-10
host name	2-5, 4-22, 4-30

I Page

identifier	5-3
indicator	2-7
initializes settings	4-26
input filter	4-14
input filter	4-20
input range	4-7, 4-10
Input register	3-9
inserting characters	vii
instrument information output commands	4-6
instrument information server	1-2
interval for acquiring data to the FIFO buffer	4-15
IP address	2-5, 4-22, 4-30
items to be printed	4-19

K Page

keepalive	1-3, 2-12, 4-23
key operations	vi
keys	v

L Page

language	4-20
list (setting information) printout	4-25
log into the recorder	App-4
login function	1-3, 2-9, 4-23

M Page

maintenance/test commands	4-6
maintenance/test server	1-2
manual print	4-25
maximum number of simultaneous connections	2-1
measured/computed data	4-27
measured/computed data output	5-8
message	4-14, 4-25
message printout buffer	4-26
Modbus	1-4, 3-8
moving average	4-14, 4-20
multiple negative responses	5-1

N Page

negative response	5-1
network statistical information	4-29

O Page

opens the instrument	4-28
operation mode	vi
output commands	4-5

P	Page
parameters	4-1
parity check	3-12
partial expanded recording	4-13, 4-20
password	2-9
pen offset compensation	4-19
periodic printout interval	4-19
port number	2-1
protocol	2-1

Q	Page
query	4-2

R	Page
rear panel	v
receive buffer	3-7
record position	4-23
recording on/off	4-13
relay number	4-8
remote control input	4-21
remote control input terminal	4-8
report data	4-20, 4-26
report data output	5-10
response	4-2
revisions	i
RJC	4-19
RS-422A/485 communication interface	3-1
RS-422A/485 dedicated commands	4-5
RS-422A/485 dedicated commands and responses	5-5
RS-422A/485 interface	4-21
run mode	vi, 4-3

S	Page
secondary chart speed	4-14
selecting the setup item and value	vi
serial number	4-30
setting commands	4-3
setting mode	vi
setting/basic setting data output	5-6
setting/measurement server (ethernet)	1-1
setting/measurement server (RS-422A/485)	1-4
setup data	4-27
setup list (basic setting information) printout	4-25
simultaneous users	2-1
special data value	5-14
square root low-cut	4-21
start bit	3-7
starts/stops recording	4-25
starts/stops/resets computation	4-25
statistical computation results	4-27
status filter	4-26
status information	4-28, 6-1
status information (bit structure)	6-2
status information output	5-12
stop bit	3-7
stops the record position adjustment	4-26
sub delimiter	4-2
subnet mask	2-5
sum value	5-4
switches the channel	4-25
switches the screen	4-25
syntax	4-1

T	Page
tag	4-14
temperature unit	4-21
terminator	3-6, 4-2
time printout format	4-21
timeout	1-3, 4-23
timeout time	2-12
timer	4-15
TLOG timer	4-22
types of responses	5-1

U	Page
unit	4-12
unit information	4-27
unit information output	5-7
user	2-9
user information	4-28
user information output	5-12
user level	2-9, 4-3
user name	2-9

Z	Page
zone recording	4-13

WARRANTY/DISCLAIMER

OMEGA ENGINEERING, INC. warrants this unit to be free of defects in materials and workmanship for a period of **13 months** from date of purchase. OMEGA's WARRANTY adds an additional one (1) month grace period to the normal **one (1) year product warranty** to cover handling and shipping time. This ensures that OMEGA's customers receive maximum coverage on each product.

If the unit malfunctions, it must be returned to the factory for evaluation. OMEGA's Customer Service Department will issue an Authorized Return (AR) number immediately upon phone or written request. Upon examination by OMEGA, if the unit is found to be defective, it will be repaired or replaced at no charge. OMEGA's WARRANTY does not apply to defects resulting from any action of the purchaser, including but not limited to mishandling, improper interfacing, operation outside of design limits, improper repair, or unauthorized modification. This WARRANTY is VOID if the unit shows evidence of having been tampered with or shows evidence of having been damaged as a result of excessive corrosion; or current, heat, moisture or vibration; improper specification; misapplication; misuse or other operating conditions outside of OMEGA's control. Components in which wear is not warranted, include but are not limited to contact points, fuses, and triacs.

OMEGA is pleased to offer suggestions on the use of its various products. However, OMEGA neither assumes responsibility for any omissions or errors nor assumes liability for any damages that result from the use of its products in accordance with information provided by OMEGA, either verbal or written. OMEGA warrants only that the parts manufactured by the company will be as specified and free of defects. OMEGA MAKES NO OTHER WARRANTIES OR REPRESENTATIONS OF ANY KIND WHATSOEVER, EXPRESSED OR IMPLIED, EXCEPT THAT OF TITLE, AND ALL IMPLIED WARRANTIES INCLUDING ANY WARRANTY OF MERCHANTABILITY AND FITNESS FOR A PARTICULAR PURPOSE ARE HEREBY DISCLAIMED. LIMITATION OF LIABILITY: The remedies of purchaser set forth herein are exclusive, and the total liability of OMEGA with respect to this order, whether based on contract, warranty, negligence, indemnification, strict liability or otherwise, shall not exceed the purchase price of the component upon which liability is based. In no event shall OMEGA be liable for consequential, incidental or special damages.

CONDITIONS: Equipment sold by OMEGA is not intended to be used, nor shall it be used: (1) as a "Basic Component" under 10 CFR 21 (NRC), used in or with any nuclear installation or activity; or (2) in medical applications or used on humans. Should any Product(s) be used in or with any nuclear installation or activity, medical application, used on humans, or misused in any way, OMEGA assumes no responsibility as set forth in our basic WARRANTY/DISCLAIMER language, and, additionally, purchaser will indemnify OMEGA and hold OMEGA harmless from any liability or damage whatsoever arising out of the use of the Product(s) in such a manner.

RETURN REQUESTS/INQUIRIES

Direct all warranty and repair requests/inquiries to the OMEGA Customer Service Department. BEFORE RETURNING ANY PRODUCT(S) TO OMEGA, PURCHASER MUST OBTAIN AN AUTHORIZED RETURN (AR) NUMBER FROM OMEGA'S CUSTOMER SERVICE DEPARTMENT (IN ORDER TO AVOID PROCESSING DELAYS). The assigned AR number should then be marked on the outside of the return package and on any correspondence.

The purchaser is responsible for shipping charges, freight, insurance and proper packaging to prevent breakage in transit.

FOR **WARRANTY** RETURNS, please have the following information available BEFORE contacting OMEGA:

1. Purchase Order number under which the product was PURCHASED,
2. Model and serial number of the product under warranty, and
3. Repair instructions and/or specific problems relative to the product.

FOR **NON-WARRANTY** REPAIRS, consult OMEGA for current repair charges. Have the following information available BEFORE contacting OMEGA:

1. Purchase Order number to cover the COST of the repair,
2. Model and serial number of the product, and
3. Repair instructions and/or specific problems relative to the product.

OMEGA's policy is to make running changes, not model changes, whenever an improvement is possible. This affords our customers the latest in technology and engineering.

OMEGA is a registered trademark of OMEGA ENGINEERING, INC.

© Copyright 2005 OMEGA ENGINEERING, INC. All rights reserved. This document may not be copied, photocopied, reproduced, translated, or reduced to any electronic medium or machine-readable form, in whole or in part, without the prior written consent of OMEGA ENGINEERING, INC.

Where Do I Find Everything I Need for Process Measurement and Control? **OMEGA...Of Course!** *Shop online at omega.com*

TEMPERATURE

- ☑ Thermocouple, RTD & Thermistor Probes, Connectors, Panels & Assemblies
- ☑ Wire: Thermocouple, RTD & Thermistor
- ☑ Calibrators & Ice Point References
- ☑ Recorders, Controllers & Process Monitors
- ☑ Infrared Pyrometers

PRESSURE, STRAIN AND FORCE

- ☑ Transducers & Strain Gages
- ☑ Load Cells & Pressure Gages
- ☑ Displacement Transducers
- ☑ Instrumentation & Accessories

FLOW/LEVEL

- ☑ Rotameters, Gas Mass Flowmeters & Flow Computers
- ☑ Air Velocity Indicators
- ☑ Turbine/Paddlewheel Systems
- ☑ Totalizers & Batch Controllers

pH/CONDUCTIVITY

- ☑ pH Electrodes, Testers & Accessories
- ☑ Benchtop/Laboratory Meters
- ☑ Controllers, Calibrators, Simulators & Pumps
- ☑ Industrial pH & Conductivity Equipment

DATA ACQUISITION

- ☑ Data Acquisition & Engineering Software
- ☑ Communications-Based Acquisition Systems
- ☑ Plug-in Cards for Apple, IBM & Compatibles
- ☑ Datalogging Systems
- ☑ Recorders, Printers & Plotters

HEATERS

- ☑ Heating Cable
- ☑ Cartridge & Strip Heaters
- ☑ Immersion & Band Heaters
- ☑ Flexible Heaters
- ☑ Laboratory Heaters

ENVIRONMENTAL MONITORING AND CONTROL

- ☑ Metering & Control Instrumentation
- ☑ Refractometers
- ☑ Pumps & Tubing
- ☑ Air, Soil & Water Monitors
- ☑ Industrial Water & Wastewater Treatment
- ☑ pH, Conductivity & Dissolved Oxygen Instruments