

Operating Manual

TranzSporter

LH-200 / LH-2000 / LH-400
Platform Hoist



LH-200

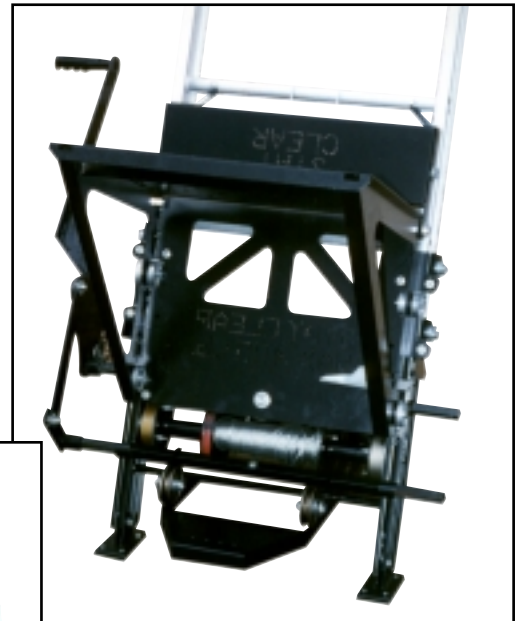

LH-400

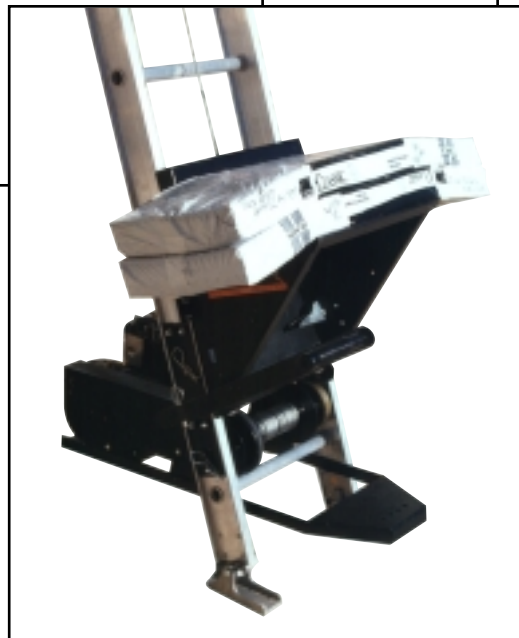

LH-2000

Instructions #15310

TIE DOWN ENGINEERING • 5901 Wheaton Drive • Atlanta GA, 30336
www.tiedown.com • (404) 344-0000 • FAX (404) 349-0401



050202.305

Congratulations on your Purchase of the TranzSporter Platform Hoist.

The TranzSporter LH - Series were designed to last. Features include...

- Unitized Design - Fewer parts, stronger, less maintenance
- Non-Slip Carriage Deck - Safer operation
- Heavy Duty Steel Frame - Absorbs more punishment
- Spring Loaded Safety Latch - Keeps deck in place when transporting or when operator is away from the hoist.
- Dual Brake System - Better control, longer brake life
- Hi-Impact Nylon Belt Guard - Safer operation
- Oven baked, Black Powder Coat Finish - Durable, long lasting
- Wide Foot Plate - Better control of lift operation
- Permanent Safety Information - Combination of stamped-in safety information and decals remind your operator to use hoist in a safe manner
- Large Steel Foot Pads - Adds more stability, lasts longer
- Extended Brake Handle - Keeps operator away from hoist when raising or lowering materials

User Responsibilities

PERFORM THE FOLLOWING AT THE START AND END OF THE WORK DAY AND AFTER 4 HOURS OF OPERATION DURING THE DAY:

- Check oil level in engine and fill according to manufacturer's specifications.
- Check cable for smooth operation and for signs of wear.
- Check for loose bolts and tighten according to specifications.
- Check track sections and all other moving parts for excessive wear or fatigue.
- Check general condition of equipment.
- Check operator's understanding of the proper operation for this equipment.
- Check extension cords and connections for wear or damage.
- Check brake parts regularly for wear or damage.

WARNING: DO NOT OPERATE THIS EQUIPMENT IF ANY UNSAFE CONDITIONS EXIST OR OCCUR DURING OPERATION.

REMEMBER: SAFETY FIRST!!

REMEMBER: SAFETY FIRST!!

Warning labels are attached to the LH-200, LH-400, & LH-2000 models, and are weather resistant. If you notice any of these decals missing from your hoist, please contact TIE DOWN ENGINEERING for a replacement label.

<p>⚠ WARNING</p> <p>IMPORTANT SAFETY INFORMATION</p> <ul style="list-style-type: none">• STAY CLEAR OF PLATFORM.• CHECK GENERAL CONDITION OF EQUIPMENT EACH DAY BEFORE USE.• TOP OF LADDER MUST BE SECURED TO ROOF USING 1" HOOKS (PROVIDED) AND TWO LENGTHS OF ROPE (NOT PROVIDED).• DO NOT OPERATE THIS EQUIPMENT IF ANY UNSAFE CONDITIONS EXIST OR OCCUR DURING OPERATION. <p>DO NOT REMOVE THIS TAG !</p>	<p>⚠ WARNING</p> <p>SHOCK HAZARD</p> <p>KEEP ENTIRE LADDER HOIST UNIT CLEAR OF ALL UTILITY AND ELECTRICAL WIRING.</p> <p>DO NOT REMOVE THIS TAG !</p>	<p>⚠ IMPORTANT</p> <ul style="list-style-type: none">• BRAKE TENSION SPRINGS MUST BE CHECKED FOR CORRECT TENSIONING DAILY (BEFORE USE) IN ORDER TO PREVENT LOAD SLIPPAGE.• DO NOT OPERATE THIS UNIT IF ANY COMPONENT PARTS EXHIBIT DAMAGE OR WEAR. THIS INCLUDES ALL LADDER SECTIONS. <p>DO NOT REMOVE THIS TAG !</p>	<p>⚠ WARNING</p> <ul style="list-style-type: none">• KEEP BRAKE DRUMS AND BRAKE SHOES FREE OF OIL, LUBRICANTS, AND EXCESSIVE MOISTURE.• CHECK FOR BRAKE SHOE AND BRAKE DRUM WEAR DAILY AND REPLACE WHEN NECESSARY. <p>DO NOT REMOVE THIS TAG !</p>
---	--	--	---

⚠ WARNING

- SAFETY LATCH MUST BE ENGAGED WHEN LADDER HOIST PLATFORM IS NOT IN USE.

DO NOT REMOVE THIS TAG !

WARNING:

SPLICE PLATES MUST BE INSTALLED ON INSIDE OF TRACK SECTIONS. CARRIAGE COULD DERAIL IF INSTALLED IMPROPERLY.



WRONG **RIGHT**

This Warning label applies only to the LH-400 model.

TranzSporter

Limited Warranty
for all models

Replaces all dated or undated limited warranties dated before May 1, 2001

Tie Down Engineering, Inc. will repair or replace, free of charge, any part, or parts of the TranzSporter material hoist that are defective in material or workmanship or both. The limited warranty is in effect for 90 days from date of purchase. Return the defective unit to the dealer or contact Tie Down direct at 800-241-1806, x344.

THERE IS NO OTHER EXPRESS WARRANTY IMPLIED WARRANTIES INCLUDING THOSE OF MERCHANTABILITY AND FITNESS FOR A PARTICULAR PURPOSE ARE LIMITED TO ONE YEAR FROM PURCHASE OR TO THE EXTENT PERMITTED BY LAW AND ALL IMPLIED WARRANTIES ARE EXCLUDED TO THE EXTENT EXCLUSION IS PERMITTED BY LAW. Some countries or states do not allow limitation on how long an implied warranty lasts and some countries or states do not allow the exclusion or limitation of incidental or consequential damages so the above limitation and exclusion may not apply to you. This warranty gives you specific legal rights and you may also have other rights which vary from country to country and state to state.

TIE DOWN ENGINEERING • 5901 Wheaton Drive • Atlanta GA, 30336
www.tiedown.com • (404) 344-0000 • FAX (404) 349-0401



050102.304

REPAIR INFORMATION

Your LH-Series platform hoist is designed to provide years of service, however, when your LH-Series hoist requires parts, service or repairs, please contact your nearest authorized dealer, or call 1-800-241-1806, ext. 329 for information on where to take your platform hoist.

WARNING:

- **KEEP TRACK SECTION CLEAR OF ALL ELECTRICAL WIRES AND EQUIPMENT**
- **BE AWARE OF OVERHEAD OBJECTS**
- **NEVER USE HOIST AS A LADDER**
- **NEVER OPERATE HOIST WITH A HUMAN ON PLATFORM**
- **NEVER STAND UNDER PLATFORM WHEN LOWERING**
- **NEVER USE INDOORS OR IN AN AREA WITH POOR VENTILATION**

LH - SERIES PLATFORM HOIST

PLEASE READ!

The equipment described herein has been engineered to perform specific lifting tasks, with a minimum of risk to the operator. The instructions for operation and safety contained herein were designed to help insure that this equipment, performs its function, as stated without adding to the endangerment of persons, equipment, and/or materials.

LH - Series Specifications:

200 lb. MAXIMUM hoisting capacity on LH-2000

200 lb. MAXIMUM hoisting capacity on LH-200*

400 lb. MAXIMUM hoisting capacity on LH-400*

LH - Series- gasoline power unit

(3 1/2 hp. Briggs & Stratton, 4 hp Honda or High Torque Electric Motor)

Self-energizing brake*

3 ft. steel base section*

4, 8, and 16 ft. track sections*

NOTE: Platform speeds and capacities are average and are based on 7/16 inch cable. Lifting speed and capacities decrease as cable builds up on drum assembly during lifting.

* Only available with LH-200 / LH-400

Safety instructions

CAUTION: Please read the safety warnings and Instructions contained in this manual before operating the LH-Series hoist. Failure to obey the warnings contained herein could result in personal injury or damage to the equipment; however, this information should not be a substitute for routine accident prevention, but rather an addition to routine accident prevention.

GENERAL SAFETY INSTRUCTIONS:

1. Transport and handle your LH-Series hoist with care.
2. Unpack the TranzSporter carefully and inspect for any damage that may occur during transportation. **DO NOT USE THE HOIST IF ANY PART IS DAMAGED**
3. Please observe all safety and warning labels attached to the hoist.
4. Use only replacement parts furnished by the manufacturer.
5. Always keep the area around the base section of the TranzSporter hoist clear to help prevent slipping, tripping or falling against the hoist.
6. **DO NOT ALLOW ANYONE TO OPERATE THE TRANZSPORTER HOIST WHO HAS NOT BEEN THOROUGHLY AND PROPERLY TRAINED IN THE CORRECT OPERATION AND USE OF THIS HOIST.**
7. This hoist is manufactured to lift materials only. Do not use the LH-Series hoist for the purpose of transporting personnel from one level to another.
8. Do not climb the LH-Series hoist or use as a personnel ladder.
9. Do not overload - maximum lifting capacity for the LH-200 & LH-2000 is 200 lbs. with a load capacity of 180 lbs. Maximum lifting capacity for the LH-400 is 400 lbs. with a load capacity of 380 lbs.
10. Keep hands, feet and other body parts as well as clothing away from the track sections and moving or rotating parts of the LH-Series hoist when starting the engine or when operating the hoist.
11. Do not allow any persons to walk or work under or near the LH-Series hoist while in operation.
12. Do not use this hoist to transport hot asphalt or any other hot molten substance from one elevation to another.
13. Store all parts of the LH-Series hoist in such a fashion as not to damage any of the components.
14. Do not operate indoors or in an area with poor ventilation.

GASOLINE POWER UNIT

1. Handle fuel with care. It is EXTREMELY flammable and explosive under certain conditions.
2. Do not smoke, allow open flames or sparks to be present during the refueling operation.
3. Use only an approved fuel container to transport fuel.
4. Do not fuel while engine is hot - allow to cool before attempting the refueling operation.
5. Replace all fuel tank caps securely and wipe the spilled fuel before restarting engine.
6. Do not operate the LH-Series gasoline hoist in an enclosed area. The exhaust can be especially hazardous in an enclosed area.
7. Stop the engine and lower the platform when leaving the vicinity of the LH-Series hoist.
8. Always stop the engine, lower the platform, wait for all moving parts to stop, and allow the engine to cool before disassembling or moving the hoist.
9. Disconnect the spark plug wire from the plug before disassembling or moving the hoist.
10. DO NOT store the engine in an enclosed area.
11. Allow engine to cool before storing.
12. DO NOT store engine where it might be subjected to flames, sparks, extreme heat or any other source of combustion.

Track Section Support

Track lengths in excess of 28 feet require the use of track support. The table below provides the suggested information for the distance of the bottom track from the building and the location of the track support for various conditions.

Building Height	Length of Track	Base of Track to Building	Track Support Location Cross Tie from Bottom
42	44(max)	10'6"	25th and 27th
40	44	10'0"	26th and 25th
36	40	9'0"	19th and 21st
32	36	8'0"	14th and 16th
28	32	7'6"	11th and 13th
24	28	6'6"	Not Required
20	24	6'6"	Not Required
16	20	5'0"	Not Required
12	16	4'6"	Not Required

Raising the track section assembly

WARNING: KEEP TRACK SECTIONS CLEAR OF ALL ELECTRICAL WIRES AND EQUIPMENT-BE AWARE OF OVERHEAD OBJECTS-NEVER CLIMB HOIST!

The hoist assembly is extremely top heavy and must be kept under control at all times.

Two alternate methods are suggested for raising the platform hoist to the operating position.

PROCEDURE "A"

This procedure requires two or preferably three men.

1. Lay the assembled track sections with the platform attached parallel to the building wall that is to support the hoist.
2. Tie a rope to the head bracket and have the man on roof pull up the hoist while the other man on the ground braces the shoes on the bottom section to prevent slippage of the hoist shoes. The third man on the ground may aid in erecting by "walking" the hoist up hand over hand by the rungs.
3. When the hoist reaches a vertical position, carefully turn the hoist 90 degrees with the platform pointing away from the building. Move the bottom of the hoist away from the building, 1/4 of the height of the building where the top of the hoist is to be supported. Make allowances for overhang. See track section support chart for approximate distances of the base from the bottom track.

ALTERNATE PROCEDURE "B"

1. Place track section assembly perpendicular to the building with the bottom shoes of the steel bottom section resting against the building to prevent slipping.
2. Tie a rope to the head bracket and have the man on the roof pull up the hoist while the other man on the ground braces the shoes on the steel bottom section to prevent slippage of the hoist shoes. The third man on the ground may aid in erecting by "walking" the hoist up hand over hand by the rungs.
3. When the hoist reaches a vertical position, carefully turn the hoist 180 degrees with the platform pointing away from the building. Move the bottom of the hoist away from the building, 1/4 of the height of the building where the top of the hoist is to be supported. Angle of track sections from building should be between 18 and 20 degrees. Make allowances for an overhang. See track section chart for approximate distances of the base from the building.

AFTER ERECTING THE HOIST USING PROCEDURE "A" OR "B", CONTINUE AS FOLLOWS:

4. Tie the track section to the roof with a rope fastened to a cross tie on the top bracket to prevent slippage of the track section. *DO NOT TIE ROPE TO THE RAILS - THIS WILL PREVENT THE PLATFORM FROM OPERATING PROPERLY.*
5. Mount the power unit to the top rung of the steel bottom section. Attach the V-belt to the pulley on the power unit. Slide the brake handle over the brake arm and install the pin provided.
6. Remove any ropes used to secure the platform during transportation.
7. Make certain the shoes on the steel bottom section are firmly resting on level ground. This will help to prevent track section slippage or uneven loading of the track section which could cause damage or injury to personnel and/or to equipment.

Lowering the track section assembly

WARNING: BEFORE LOWERING THE TRACK SECTIONS, CAREFULLY CHECK FOR OVERHEAD OBJECTS AND POWER LINES.

1. Lower and dismantle the platform hoist assembly in the reverse of the erection procedure, observing all safety procedures.

Raising the platform with or without load

WARNING: THE OPERATOR OF THIS HOIST UNIT SHOULD WEAR APPROPRIATE SAFETY EQUIPMENT WHICH SHOULD INCLUDE APPROVED HAND PROTECTION, HEAD PROTECTION AND EYE PROTECTION.

To raise the platform on LH-2000 & LH-200, face the platform and stand as far as possible from the hoist to operate. Place your foot on the foot control brace to engage the motor to drum belt, permitting the platform to roll up the track section. When the platform reaches the top, release foot IMMEDIATELY. This will apply the self energizing brake. Move away from the hoist while the load is being removed from the platform.

To raise the LH-400 you have 2 options. The first is the same as the LH-2000 & LH-200. The second is a handle that attaches to either side to be used to engage the motor.

Lowering the platform

To lower the platform, stand to the right or left side of the hoist and grasp the brake handle. Push or pull the handle to release the brake. Lower the platform to the ground at a slow speed (not to exceed 50/feet per minute). Continue to decelerate the platform as it nears the ground to prevent damage to the platform or bottom brace stops.

CAUTION: NEVER APPLY THE BRAKE ABRUPTLY - BROKEN HOIST CABLES AND/OR SEVERE INJURY TO PERSONNEL OR EQUIPMENT MAY OCCUR. MAKE CERTAIN PLATFORM DOES NOT STRIKE THE BOTTOM BRACE STOPS UPON REACHING THE BOTTOM OF THE TRACK SECTION.

Assembly Instructions LH-200 Hoist

Congratulations on purchasing the TranzSporter LH-200 Hoist. The two boxes contain the five assembled parts plus the owner's manual, making up the LH-200. Please read the following instructions completely before starting assembly. Refer to the owner's manual for further information on use and maintenance of the LH-200.

Parts found in the two boxes are:

- Ladder base
- Carriage assembly
- End cap
- Motor base
- Brake handle
- Owner's manual

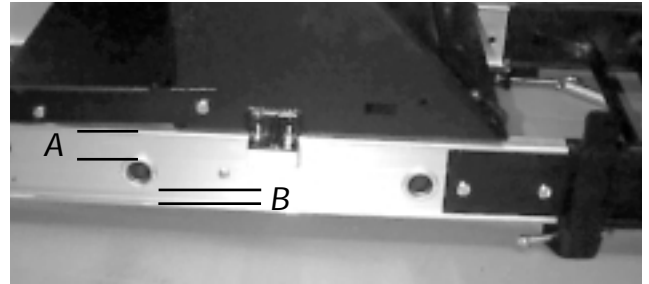

Picture 1

1. Remove all hoist parts from the two boxes and place on a clean floor or assembly area. Lay one Green Bull track section on a flat floor with the "front" side up. This is determined by the space between the track cross bar and the track section edge as shown in picture 1.

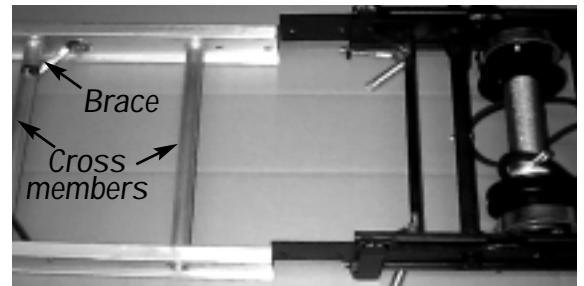

Picture 2

2. Remove slice plates from the Green Bull track section. Attach the ladder base to the bottom of the track section using four 3/8" x 3/4" hex head bolts provided or the bolts used in attaching the splice plates. Note: The ladder base mounts to the outside of the track section as shown in picture 3. The bottom of the track section is determined by making sure the braces are below the cross bars as shown in picture 2.

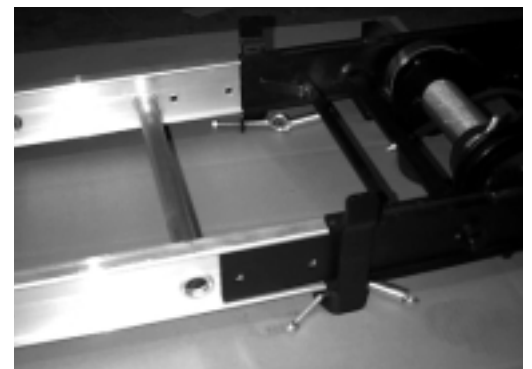

Picture 3

3. Starting at the top of the track section slide carriage assembly onto track section so that the four rollers connect to the top rail of the track section as shown in picture 4. "Roll" carriage assembly to the base. At this time lock the base in place using the safety latch as shown in picture 5.

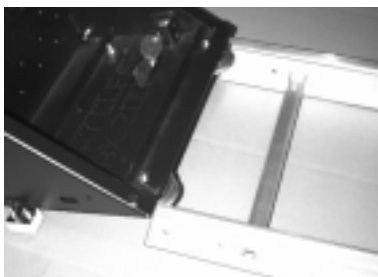

Picture 4



Picture 5

4. The end cap is bolted to the top end of the last section of track section you intend to use. Assemble as shown in picture 5 using two 3/8" x 3/4" hex head bolts with lock nuts provided.

5. Attach the track sections you will be using with the bolts and splice plates provided with the track sections.

6. From the back side of the hoist, remove the end of the cable from the drum. Staying on the outside of the base section and track section, take the cable to the top of the last ladder section where the cap and pulley are attached. Feed the cable end through the pulley as shown in picture 6, and down the front side of the track section to the back of the carriage assembly. Attach the end of the cable to the carriage assembly as shown in picture 7.

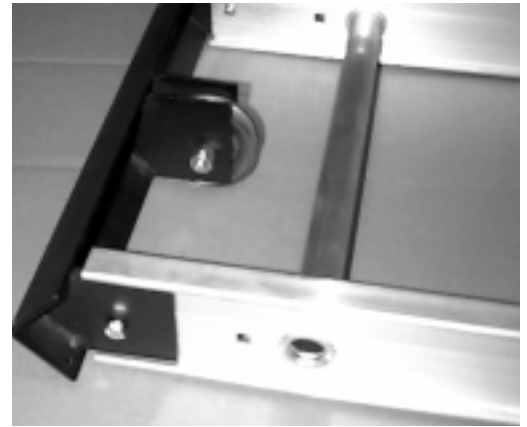

Picture 6

Picture 6



Assemble the track section as needed and make sure that the splice plates are mounted to the outside of the track. Make sure the hoist is secured to the building and proper bracing and space from the building is used according to the guidelines provided in the owner's manual.

7. After the track section with base is properly secured to the work site and properly braced, the motor assembly can be attached to the base unit. The foot pad slides under the base section, while "hanging" the motor base as shown in picture 8. Attach the "v" belt to the large pulley first, then to the small pulley on the motor.



Picture 7

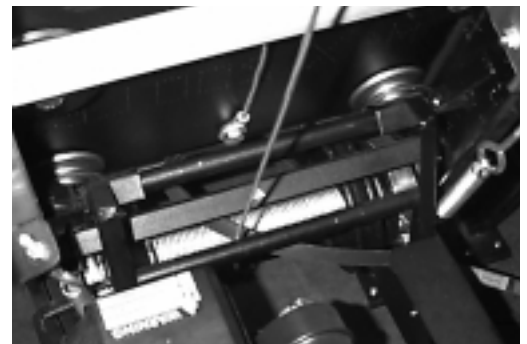

Picture 8



8. The handle is attached to the brake release bar, aligning the holes for the insertion of the pin provided.



Picture 9

Assembly Instructions LH400 Hoist

Congratulations on purchasing the TranzSporter LH-400 Platform hoist. The two boxes contain the five assembled parts plus the owner's manual, making up the LH-400. Please read the following instructions completely before starting assembly. Refer to the owner's manual for further information on use and maintenance of the LH-400.

Parts found in the two boxes are:	Ladder base Carriage assembly End cap Motor base Brake handles or optional Dual Operation Handle Owner's manual
--------------------------------------	---

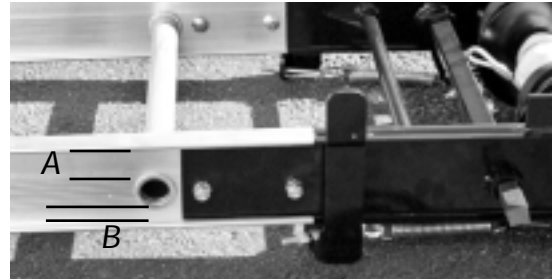

Picture 1

1. Remove all hoist parts from the two boxes and place on a clean floor or assembly area. Lay one Green Bull track section on a flat floor with the "front" side up. This is determined by the space between the track cross bar and the track section edge as shown in picture 1.

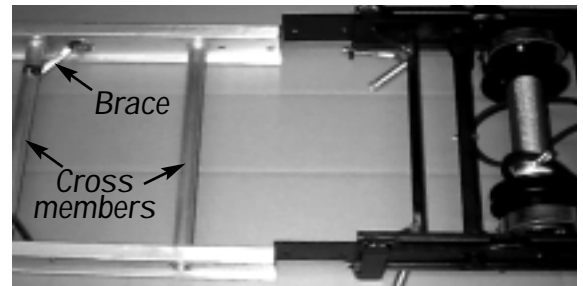

Picture 2

2. Remove splice plates from the Green Bull track section. Attach the ladder base to the bottom of the track section using four 3/8" x 3/4" hex head bolts provided or the bolts used in attaching the splice plates. Note, the ladder base mounts to the outside of the track section as shown in picture 3. The bottom of the track section is determined by making sure the braces are below the cross bars as shown in picture 2. Make sure that hex head bolts are installed from the outside so that lock nuts are to the inside of track sections.

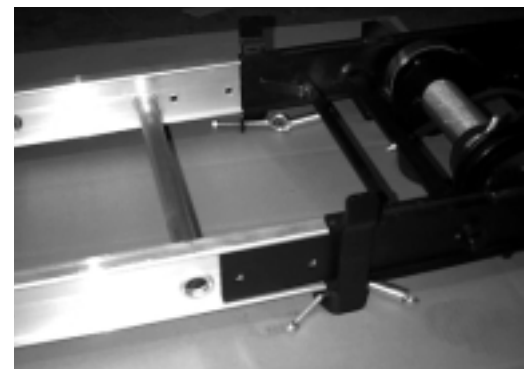

Picture 3

3. Starting at the top of the track section slide carriage assembly onto track section so that the four rollers connect to the top rail of the track section as shown in picture 5. "Roll" carriage assembly to the base.



Picture 5



4. Attach the track sections you will be using with the bolts and splice plates provided with the track sections. **Make sure that splice plates are to the inside of the track section.**

5. The end cap is bolted to the top end of the last section of track section you intend to use. Assemble as shown in picture 6 using four 3/8" x 3/4" hex head bolts with lock nuts provided. **Make sure that the top cap end slides into the inside of the track section.**

6. From the back side of the hoist, remove the end of the cable from the drum. Staying on the outside of the base section and track section, take the cable to the top of the last ladder section where the top cap pulley is attached. Feed the cable end through the pulley as shown in picture 7, and down the front side of the track section to the back of the carriage assembly. Feed cable through the cable retainer assembly (picture 8) attached to the carriage assembly, take the cable to the top cap assembly and bolt it as shown in picture.

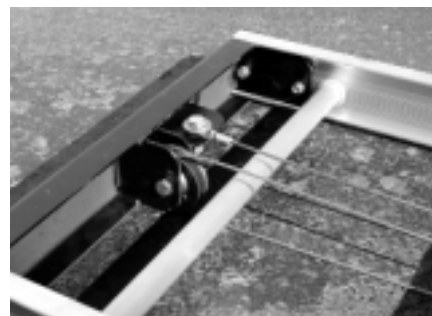

Picture 6



Picture 8



Picture 7



Picture 9

7. At this time make sure that you have read the owner's manual for information on proper set up. Make sure the hoist is secured to the building and proper bracing and space from the building is used according to the guidelines provided in the owner's manual.

8. After the track section with base is properly secured to the work site and properly braced, the motor assembly can be attached to the base unit. The foot pad slides under the base section, while "hanging" the motor base as shown in picture 10. Attach the "v" belt to the large pulley first, then to the small pulley on the motor (picture 11).



Picture 10



Picture 12

9. The handle is attached to the brake release bar aligning the holes for the insertion of the pin provided. Shown on the left.



Picture 11

LH-2000 Parts Description

TDE#	Motor Mount Assembly
10035	Engine, 3.5 HP Briggs & Stratton
10039	Engine, 4 HP Honda
48500	Motor Base
48514	Belt Guard
45005	Saddle Block
10037	Drive Pulley
48470	MOTOR MOUNT WITH BRIGGS & STRATTON
60001	MOTOR MOUNT WITH HONDA ENGINE
60003	MOTOR MOUNT WITH ELECTRIC DRIVE

	Carriage Assembly
48501	Carriage Frame (bucket only)
48504	Carriage Flap
48513	Guide Block
17020	Safety Latch Assembly
10032	Skate Wheel (2 required)
10036	Carriage Wheel w/bearing (4 required)
48480	CARRIAGE ASSEMBLY

	Top Cap Assembly
10036	Pulley w/bearing
10914	1/2" x 2" Bolt
10645	1/2" Nyloc Nut
48507	TOP LADDER CAP ASSEMBLY

	Ladder Base Frame Assembly
10094	8' Base Track section (21)
48560	Drive Support Plate (2 Required) (22)
10034	Drive Belt
48460	Cable Drum Assembly
48508	Cable Drum
48509	Shaft, Cable Drum (2 Required) (26)
10560	Cotter Pins (4 Required) (27)
48503-7R	Right Carriage Lock Down (28)
48561	Right Carriage Stop/brake Mount Bracket (29)
48562	Left Carriage Stop Bracket
	Guide Wheel Shims 1/2" x 7/8" (8 Required)
50383	Cable Assembly 100ft.
11080	Bearing, cable drum (2 required)
48490	LADDER BASE FRAME ASSEMBLY

	Brake Parts
48505	Brake Control Shaft
48515	Brake Control Arm
48506	Brake Handle
13000	Drum Brake
10033	Brake Strap (brake pad)
48510	Brake Linkage
10041	Brake Spring
13210	Eye Bolt 6.5" x 5/16"
10650	Nyloc Nut 5/16"

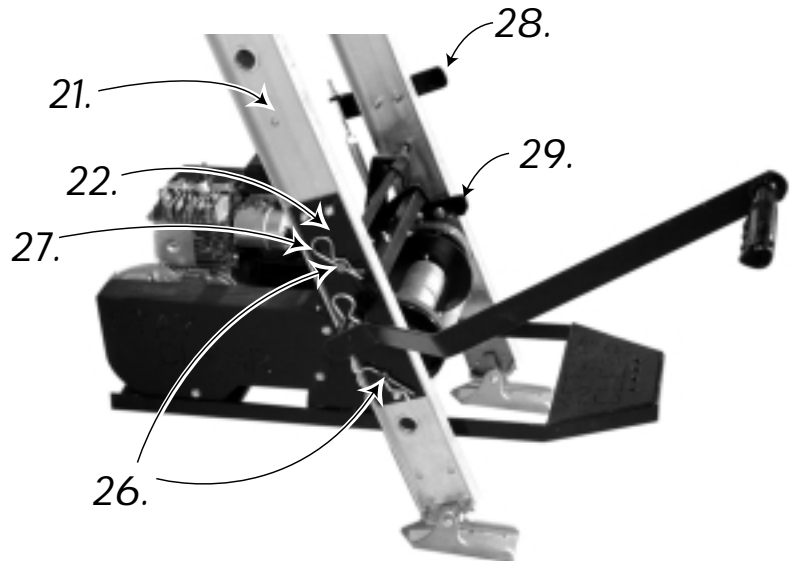

Track Sections

10091	Track Section, w/splice plates, 8ft.
10092	Track Section, w/splice plates, 4ft.
10093	Splice Plate w/Nuts & Bolts

LH-200 Parts Description

TDE# Motor Mount Assembly "1"

- 10035 Engine, 3.5 HP Briggs & Stratton
- 10039 Engine, 4 HP Honda
- 48500 Motor Base
- 48514 Belt Guard
- 45005 Saddle Block
- 10037 Drive Pulley
- 48470 MOTOR MOUNT WITH BRIGGS & STRATTON
- 60001 MOTOR MOUNT WITH HONDA ENGINE
- 60003 MOTOR MOUNT WITH ELECTRIC DRIVE

Carriage Assembly "2"

- 48501 Carriage Frame (bucket only)
- 48504 Carriage Flap
- 48513 Guide Block
- 17020 Safety Latch Assembly
- 10032 Skate Wheel (2 required)
- 10036 Carriage Wheel w/bearing (4 required)
- 48480 CARRIAGE ASSEMBLY

Top Cap Assembly "3"

- 10036 Pulley w/bearing
- 10914 1/2" x 2" Bolt
- 10645 1/2" Nyloc Nut
- 48507 TOP LADDER CAP ASSEMBLY

Ladder Base Frame Assembly "4"

- 48503 Ladder Base Frame
- 10034 Drive Belt
- 48460 Cable Drum Assembly
- 48508 Cable Drum
- 48509 Shaft, Cable Drum
- 50383 Cable Assembly 100ft.
- 11080 Bearing, cable drum (2 required)
- 48511 Ladder Base Shoe (Includes Skid Pad, # 48512)
- 48490 LADDER BASE FRAME ASSEMBLY

Brake Parts

- 48505 Brake Control Shaft
- 48515 Brake Control Arm
- 48506 Brake Handle
- 13000 Drum Brake
- 10033 Brake Strap (brake pad)
- 48510 Brake Linkage
- 10041 Brake Spring
- 13210 Eye Bolt 6.5" x 5/16"
- 10650 Nyloc Nut 5/16"

Track Sections "5"

- 10091 Track Section, w/splice plates, 8ft.
- 10092 Track Section, w/splice plates, 4ft.
- 10093 Splice Plate w/Nuts & Bolts

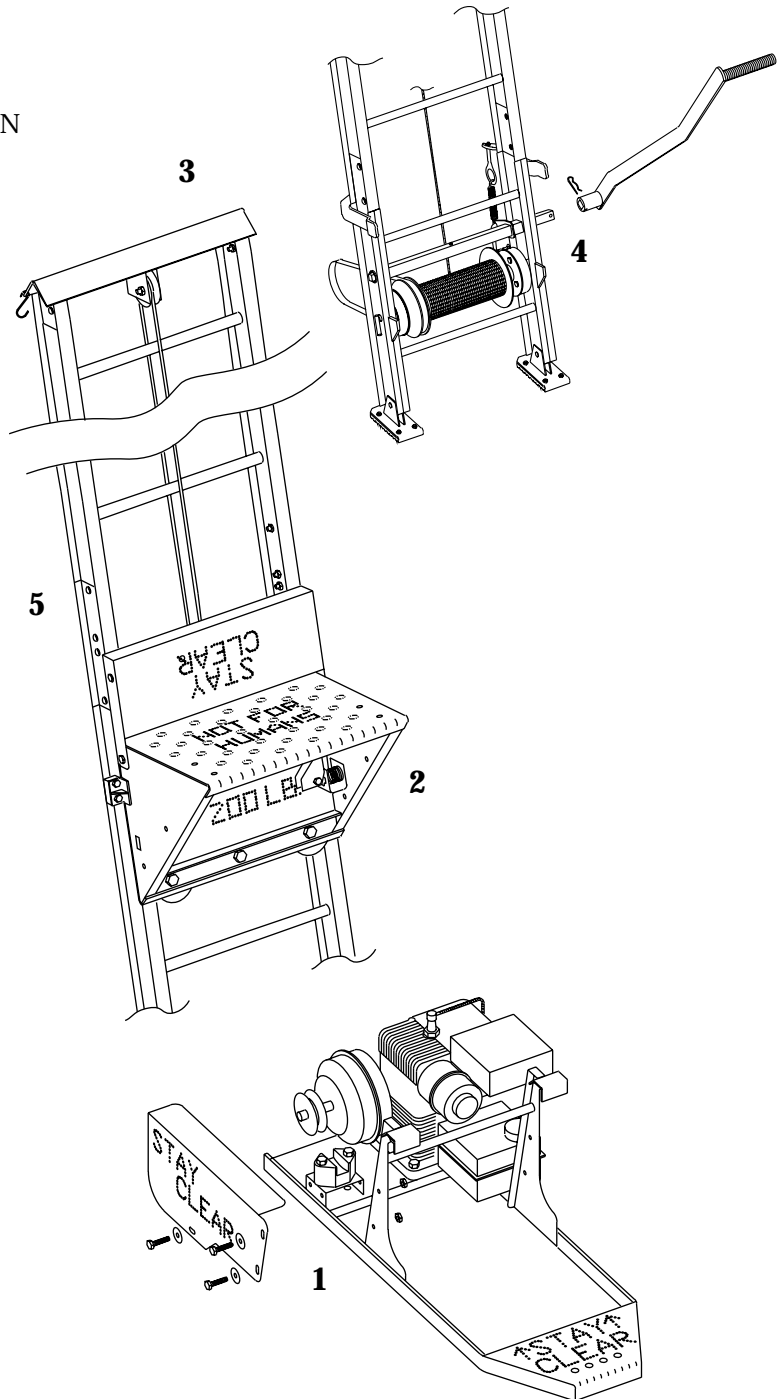

LH-400 Parts Description

TDE# MOTOR MOUNT ASSEMBLY "1"

- 10035 Engine, 3.5 HP Briggs & Stratton
- 10039 Engine, 4HP Honda
- 48514 Belt Guard
- 48500 Motor Base
- 45005 Saddle Block
- 10037 Drive pulley
- 48470 MOTOR BASE ASSEMBLY WITH BRIGGS
- 60001 MOTOR MOUNT WITH HONDA ENGINE
- 60003 MOTOR MOUNT WITH ELECTRIC DRIVE

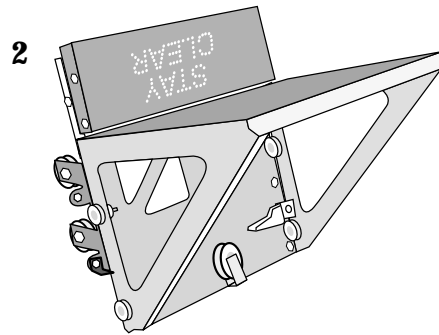

CARRIAGE ASSEMBLY "2"

- 48520 Carriage Frame
- 48527 Carriage Flap
- 17020 Safety Latch Assembly
- 11081 Outer Guide Bearing Wheels (4 required)
- 11083 Inner Guide Bearing Wheels (4 required)
- 48519 Guide Wheel Shims 1/2" x 7/8" (4 Required)
- 48536 Carriage Guide Wheels (10 required)
- 64005 Cable Retainer Assembly
- 64001 CARRIAGE ASSEMBLY COMPLETE

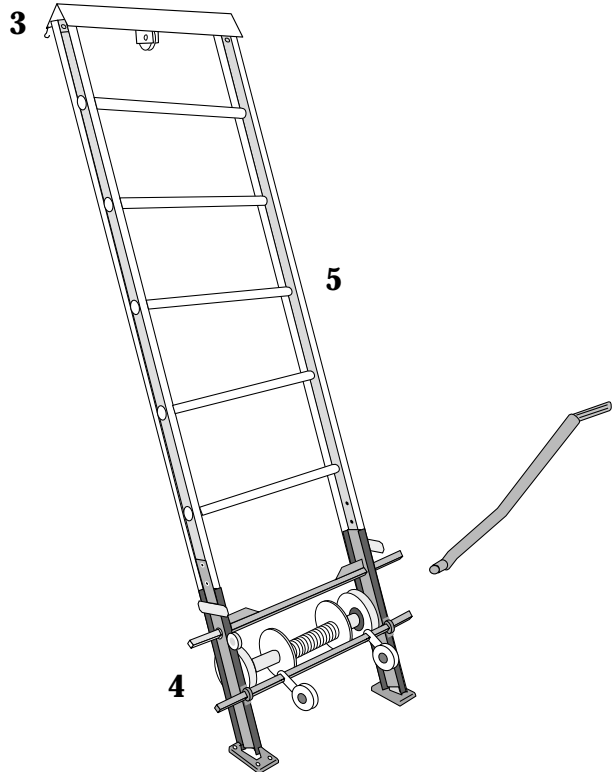

TOP CAP ASSEMBLY "3"

- 48507 Pulley w/bearing
- 10914 1/2" x 2" bolts
- 10645 1/2" Nyloc Nut
- 48526 Top Cap
- 64002 TOP CAP ASSEMBLY COMPLETE

LADDER BASE FRAME ASSEMBLY "4"

- 48521 Ladder Base Frame
- 10034 Drive Belt Briggs Stratton
- 48522 Cable Drum Assembly
- 48525 Shaft, Cable Drum
- 50384 Cable Assembly 5/32" X 130'
- 11080 Bearing, Cable Drum (2)
- 48511 Ladder Base Shoe (Includes Skid Pad, # 48512)
- 64003 LADDER BASE FRAME ASSEMBLY

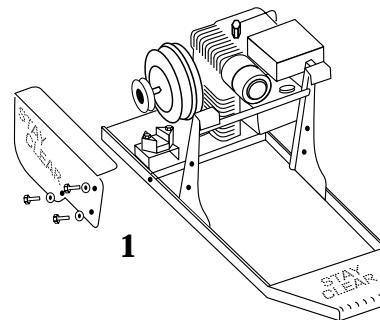

BRAKE PARTS

- 48524 Brake Control Arm
- 48523 Brake Control Shaft
- 13000 Brake drum
- 10033 Brake Strap (brake pads)
- 48510 Brake Linkage
- 10041 Brake Spring
- 13210 Eye Bolt 6.5" x 5/16"
- 10650 Nyloc Nut 5/16"
- 48506 Brake Handle

TRACK SECTIONS "5"

- 10080 4' 400 lb
- 10081 8' 400 lb
- 10082 16' 400 lb

OPTIONAL DUAL CONTROL HANDLE

- 48531 Drive Control Arm
- 48532 Brake Control Arm
- 48533 Lift Control Arm
- 48534 Lift Control Handle
- 64004 Handle Complete

TranzSporter Hoist Accessories



Gravel Hopper

- Available for 200 & 400 lb. Lift.
- Black powder coat finish.
- Automatic dump flap.
- Handles all your granular material needs*.
- * When using Hopper on lift, support brace is required (at all heights).

Track Sections Available

- in 4', 8', 16' for all models.
- Track sections come with splice plates, nuts and bolts.



Telescoping Brace

- Fits all brand track units.
- Telescoping from 12' to 24'.
- Quick - Set design.

Roofing Brackets

- Dimpled nail slits for quick removal.
- Heavy gauge steel.
- Welded construction.



45° 60°
2 x 6



90° 2 x 6



Narrow Wide
2 x 4

Adjustable Bracket

Holds a 10" plank and is adjustable to provide a level walkway on a 50°, 60°, 70°, or 80° roof. Bracket folds flat for storage or transporting.