

CPN – INSTROTEK, INC.

4057 Port Chicago Highway

Suite 100

Concord, CA 94520 USA

TEL: (925) 363-9770

FAX: (925) 363-9385

Website: www.instrotek.com

CAUTION

CPN nuclear gauges contain sealed sources of radioactive material for measuring the density and moisture of construction materials. It is important that you read this operating manual prior to using any nuclear gauge.

Prior to using any nuclear gauge, all gauge operators must receive radiation safety and gauge use training from a nuclear gauge manufacturer, or another qualified trainer.

All gauge operators must use nuclear gauges in compliance with the regulations of their state or federal radiation control agency, as well as the conditions of the radioactive material license issued to each company or agency possessing nuclear gauges.

CPN -InstroTek
4057 Port Chicago Highway, Suite 100
Concord, CA 94520 USA

Tel: 925-363-9770
Fax: 925-363-9385

Table of Contents

Section 1 - General Information

Product Description.....	1
CPN MC-3 PORTAPROBE® Features	2
Functional Description.....	3
Standard Equipment	4
Specifications.....	6
Dimensions/Shipping Weights.....	6
Performance.....	6
Electrical.....	7
Environmental	7
Radiological.....	7
Definitions	8
CPN MC-3 PORTAPROBE® Inspection.....	9

Section 2 - Operation

Learning to Use the CPN MC-3	11
Keyboard Functions	13
Configuring PORTAPROBE® for Measurements	16
Standard Counts	20
Taking a Test	22
Units of Measurement.....	23
Calibration	24
Edit Coefficients	24
Self Calibration	26
Data Logging.....	28
Storing Test Results.....	28
Reviewing Test Results	29
Operation Summary	30

Section 3 - Field Use

Asphalt Pavement.....	31
Backscatter Measurements.....	31
Percent Air Void Determination	32
Thin Lift Overlays	33
Soils/Aggregates	34
Transmission Measurements	34
Moisture Measurements.....	36
Over-sized Rock Correction	36
Trench Testing	37

Section 4 - Other Test Methods

Statistical Control	38
Core Correlation.....	38
Concrete Testing.....	38
Control Test Strip	39
Roller Compaction Evaluation.....	39

Section 5 - Maintenance

Clean and Lubricate Shutter Mechanism	40
Handle Assembly Inspection.....	41
Leak Test	42
Charging Battery Pack	43
Storage	43

APPENDIX A

Display Messages and Prompts.....	44
-----------------------------------	----

APPENDIX B

Troubleshooting Guide.....	45
----------------------------	----

APPENDIX C

Data Transfer	47
CPN MC-3 Dump Software	50

APPENDIX D

Accessories.....	51
------------------	----

APPENDIX E

Conversion Factors	52
--------------------------	----

GLOSSARY	53
-----------------------	----

INDEX	54
--------------------	----

Section 1 - General Information

Product Description

The **CPN MC-3 PORTAPROBE®** is a rugged, microprocessor-based instrument that measures the density and moisture of in-place soil and construction materials. The **PORTAPROBE®** provides fast and accurate measurements, rapidly calculates and converts the data to English or metric engineering units, and displays the results on a liquid crystal display (LCD).

The **PORTAPROBE®** complies with the following ASTM standard test methods:

- D 2922 - Density of Soil and Soil Aggregate in Place by the Nuclear Method
- D 3017 - Moisture Content of Soil and Soil Aggregate by the Nuclear Method
- D 2950 - Density of Bituminous Material in Place by the Nuclear Method
- D 6938 – Inplace Density and Water Content of Soil & Soil Aggregate by Nuclear Method

The **PORTAPROBE®**, depending upon the model, measures material density in 1 or 2 inch (25 or 50 mm) increments to depths of 8 or 12 inches (200 or 300 mm). Moisture measurement averages 6 inches (150 mm) depth.

The keypad of the **PORTAPROBE®** allows the operator to enter target maximum density values and density and moisture calibration biases. Other keys permit the operator to record and recall test results and transfer records to either a printer or a computer.

Proper use of the **CPN MC-3 PORTAPROBE®** will impose no radiation hazard on the operator. However, a potential danger does exist if the equipment is improperly used. Operators should read and understand the literature covering radiation safety, and attend a radiation safety and applications training course offered by the manufacturer or other licensed instructor.

CPN MC-3 PORTAPROBE[®] Features

- Simultaneous, direct readout of all test data and results on an easy-to-read, liquid crystal display:

Total (wet) density

Total moisture

Dry density

% Compaction - total (wet) or dry

Moisture content (%)

% Air voids

Record and test number

Time and date of test

Maximum values: wet density, dry density and bulk specific gravity

Density and moisture biases

- Memory storage and recall of up to 200 test results by record number
- Serial interface to personal computer or printer
- Operator-selectable time or precision of test
- Programmable maximum values from laboratory compaction tests
- Easy-to-use keyboard functions for all measurement parameters
- Rechargeable NICAD battery pack; up to 600 tests between charges
- Three testing modes: normal, thin layer calculation, and trench wall correction
- Self-calibration (self-coefficient determination)

Functional Description

The CPN MC-3 PORTAPROBE® operates by emitting radiation from two safety-sealed radioactive sources:

- Cesium-137, a gamma emitter for density measurement
- Americium-241:Beryllium, a neutron emitter for moisture measurement.

To determine density, the Cesium-137 source emits gamma radiation into the test material. Some of the gamma radiation will pass through the material and be detected by the Geiger-Mueller detectors located within the CPN MC-3. A material of low density will give a high count per time of test. A material of high density will give a low count for the same period of time, as the high-density material absorbs more gamma radiation.

To determine moisture content, the Americium-241:Beryllium source emits neutron radiation into the test material. The high-energy neutrons are moderated by collision with hydrogen atoms in the moisture of the material. Only low-energy, moderated neutrons are detected by the Helium-3 detector. A material that is wet will give a high count per time of test. A material that is dry will give a low count for the same period of time.

Standard Equipment

Each CPN MC-3 is provided with a durable plastic shipping case and the items listed below. There are no special instructions for unpacking the CPN MC-3 Portaprobe®. It comes fully assembled.

Item	Part Number
CPN MC-3 PORTAPROBE®	C-116122
Type A Shipping/Storage Case	C-704467
Standard Block	C-701423
Guideplate	C-200050
Drill Pin with extractor	C-100035X
Padlock and Keys	C-700472
Battery Charger, 115/230 VAC	C-400950.1
Allen Head (Hex Drive) Wrench	C-700760
Operating Manual	
Leak Test Certificate	



Figure 1-1. CPN MC-3 PORTAPROBE® Standard Equipment

Specifications

Dimensions/Shipping Weights

Model	Weight	Length	Width	Height
CPN MC-3 (gauge only)	31 lbs/14.3 kgs	14 in/356 mm	9 in/229 mm	22 in/559 mm
CPN MC-3 (with carrying case)	80 lbs/36 kgs	25.6 in/650 mm	15.4 in/391 mm	16.1 in/409 mm

Performance

Functions	In-place density and moisture measurements.		
Density Range	70 to 170 pcf (1.12 a 2.73 g/cm ³)		
Moisture Range	0 to 40 pcf (0 a 0.64 g/cm ³)		
Precision	[one minute test at 125 pcf (2.00 gm/cm ³) density; 10 pcf (0.24 g/cm ³) moisture]		
Backscatter (BS)	±0.80 pcf (0.013 g/cm ³)		
Asphalt-Concrete (AC)	±0.50 pcf (0.008 g/cm ³)		
Transmission(6 in)	±0.25 pcf (0.004 g/cm ³)		
Moisture	±0.25 pcf (0.004 g/cm ³)		
BS Chemical Error	±1.00 pcf (0.016 g/cm ³)		
Transmission Chemical Error	±0.75 pcf (0.012 g/cm ³)		
Surface Roughness Error	[0.05 in (1.3 mm); 100% void]		
Backscatter (BS)	-3.00 pcf (-0.048 g/cm ³)	0.05 pulg (1.3 mm);	
Asphalt-Concrete (AC)	-6.0 pcf (-0.0096 g/cm ³)	100% void	
Transmission(6 in)	-0.5 pcf (-0.008 g/cm ³)		
Moisture	-0.7 pcf (-0.011 g/cm ³)		
Depth of Measurement			
Backscatter (BS)	3.0 in (7.6 cm)		
Transmission	2 to 8 in (5.1 to 20.3 cm); optional 2 to 12 in (5.1 to 30.5 cm)		
Moisture	6 in (15.2 cm)		
Display	Sunlight readable high resolution LCD display, with 120° viewing angle		
Counting Time	Operator - selected precision (± pcf or g/cm ³) or time of test		

Specifications

Performance

Calibration	Factory calibration; operator entered or automatic determination of calibration coefficients
Units of Measurements	Operator selectable: pcf or g/cm ³
Memory Storage	Up to 200 readings of all displayed data
Data Interface	Rs-232-C for upload to computer or printer (300 to 9600 baud)

Electrical

Power Source	Internal battery pack (8 welded AA size NICAD batteries), 5 Wh.
Battery Life	500 to 1000 charge-discharge cycles
Power Consumption	12mA, average (based on 600+ 30-sec. counts)
Charging Time	14 hours at C/10 via charging unit

Environmental

Operating Temperature	Ambient: 32° to 150°F (0° to 66°C) Hot substrate Surface Temperature: Up to 350°F (177°C) for 15 min.
Storage Temperature	-4° to 140°F (-20° to 60°C)
Humidity (non-condensing)	95%

Radiological

Gamma Source	370 MBq (10 mCi) Cesium-137
Neutron Source	1.85 GBq (50 mCi) Americium-241:Beryllium
Encapsulation	Double-sealed capsule, CPN-131
Shipping Requirements	Radioactive Material, Special Form UN 3332, Transport Index 0.4, Yellow II Label, USA DOT 7A, Type A Package
Special Form Approval	USA/0356/S and CZ/1009/S or USA/0627/S and USA/0634/S

An NRC Agreement State license is required for domestic use. Contact CPN - InstroTek for assistance in obtaining training for a license.

Definitions

CHEMICAL COMPOSITION ERROR:

The error due to the variation in photon scattering and absorption coefficients for limestone and granite. Most natural soils and aggregates are between these limits.

SURFACE ROUGHNESS ERROR:

The error due to surface voids, determined by measuring the density or moisture content of a smooth surfaced standard and repeating the measurement with the instrument base elevated 0.05 inch above the standard.

DEPTH OF MEASUREMENT:

The depth through which 95% of the counted photons and thermal neutrons pass before reaching the detectors.

PRECISION (Pr):

The statistical precision of the gauge computed at the 68.3% confidence level (± 1 standard deviation). It states that the repeatability of the gauge is such that 68.3% of repeated measurements on the same site will fall within the average \pm precision value.

$$\text{Precision (Pr)} = \frac{\sqrt{\text{actual accumulated counts}}}{\text{slope of the calibration curve}}$$

The total density and total water precision values are calculated as follows:

$$\text{Pr, Dwet or Pr, H}_2\text{O} = \frac{\sqrt{\text{actual accumulated counts}}}{\text{slope of the calibration curve}}$$

The dry density precision value is calculated as follows:

$$\text{Pr, Dry} = \sqrt{\text{Pr, Dwet}^2 + \text{Pr, H}_2\text{O}^2}$$

CPN -InstroTek reserves the right to change equipment specifications and/or design to meet industry requirements or improve product performance.

CPN MC-3 PORTAPROBE® Inspection

To familiarize yourself with the CPN MC-3, perform the following review.

1. Remove **PORTAPROBE®** from shipping case and place on solid flat surface, such as a concrete floor.
2. Examine the keyboard, display screen, handle, and guidetube.

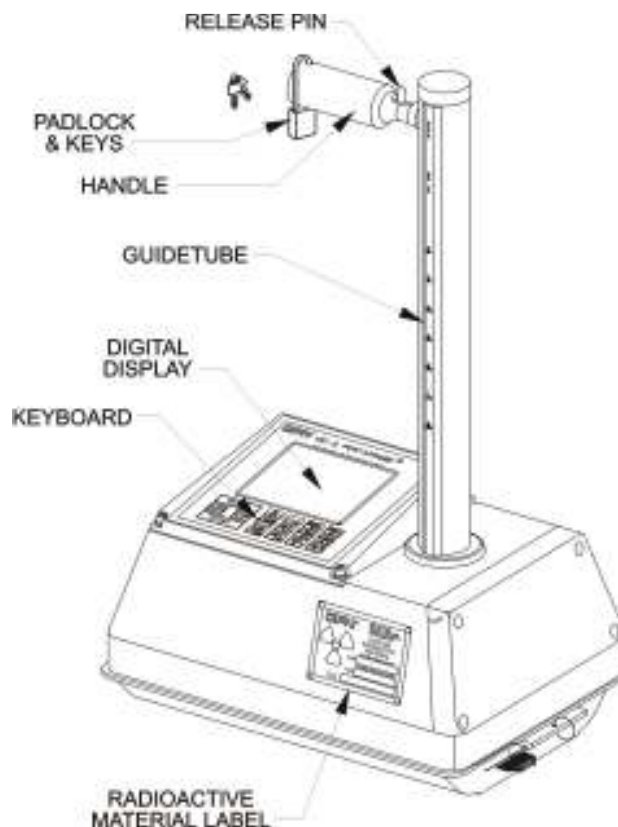

3. Examine the bottom of the unit. Behind the aperture in the cleanout plate is a carbide shutter block which is spring-mounted and automatically opens and closes when the source rod is lowered and retracted. A brass scraper ring around the opening cleans the source rod as it is retracted.

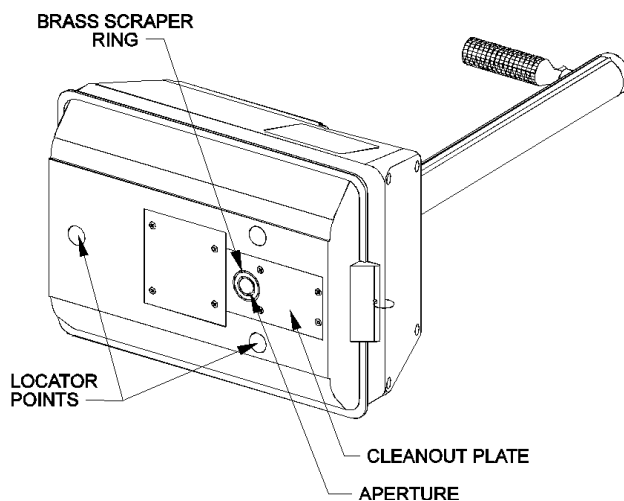

NOTE

A radioactive source is located in the source rod behind the shutter block. Do not touch the source rod or place yourself in front of unshielded source rod.

CPN MC-3 PORTAPROBE® Inspection

4. Examine the rear panel.

1. Reset Pushbutton. The power is normally ON. Holding the pushbutton depressed for 5 seconds or longer and then releasing it will act as a master reset. Master reset is only necessary if the gauge locks up.



2. Battery Charger Jack.

3. RS-232-C Connector. Port for uploading data to printer or computer.

5. Examine the guide tube assembly.

1. Guide Tube.
2. Release or Thumb Pin.
3. Probe Handle.
4. Locking Recesses.
5. Source Rod (gamma source at bottom).
6. Lock Hole

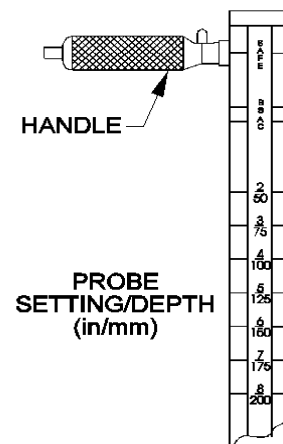
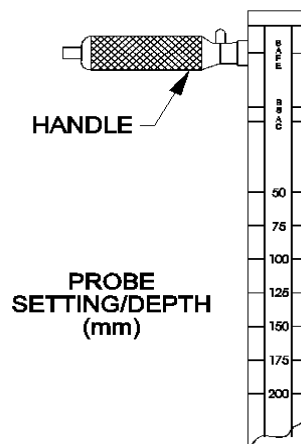
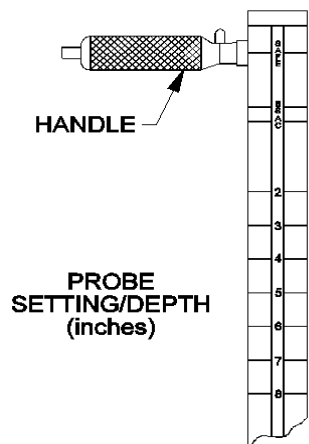
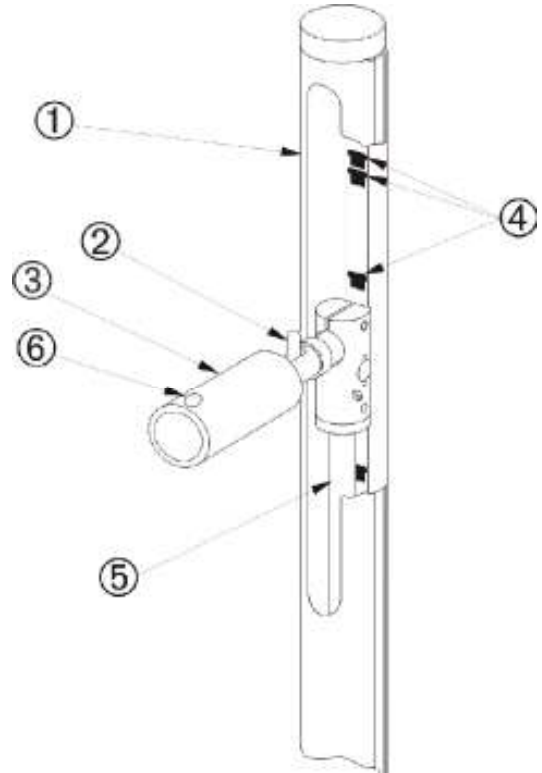

Section 2 - Operation

Learning to Use the CPN MC-3

1. Use key to unlock handle. Pull back release (thumb) pin, and set handle to BS position.

Instrument is now set up to perform an asphalt or concrete measurement.

NOTE

The display will temporarily switch to the counts per minute (cpm) screen if a test count is taken when the rod is in the **SAFE** position. It will automatically return to the density screen when a reading is taken with the rod in a valid depth.

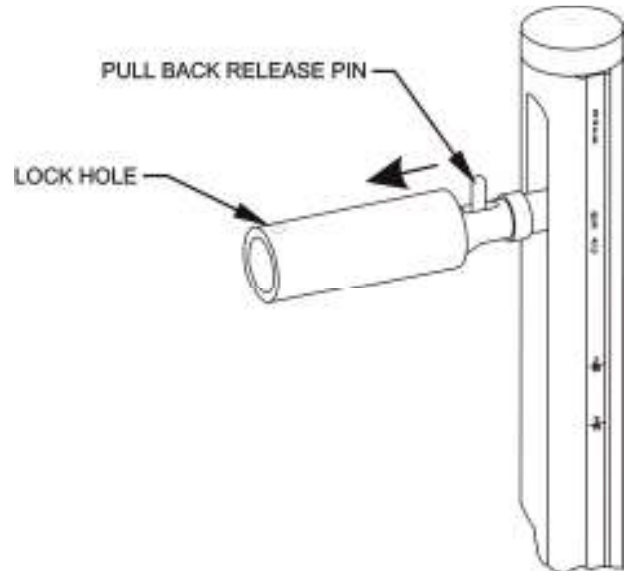

2. Press **CLEAR** key.

Screen displays results of factory test measurement made with CPN MC-3 prior to shipment.

DEPTH OF MEASUREMENT D normal mode T thin layer mode W trench wall mode S strata mode (optional)	RECORD NUMBER	NUMBER OF READINGS LOGGED INTO THIS RECORD	DATE OF LAST MEASUREMENT (MONTH/DAY)	TIME OF LAST MEASUREMENT (HOURS/ MIN)
DENSITY UNIT gcc - GRAMS PER CUBIC CENTIMETER (METRIC) pcf - POUNDS PER CUBIC FOOT (ENGLISH)	R1	- 2	0925	1325
DENSITY	DaBS	ET00:30	T00:30	
PRECISION	pcf	wet	h2o	dry
PERCENT OF MAXIMUM	Dn	147.5	10.75	136.7
TARGET MAXIMUM Mw = MAXIMUM WET Md = MAXIMUM DRY Av = AIR VOID WET and AIR VOID MAXIMUMS IN WET COLUMN. DRY MAXIMUM IN DRY COLUMN.	Pr	0.76	0.28	1.04
	%		7.68	91.13
	Md			150.0
BIAS	Bi	0.0	0.0	lob
DENSITY BIAS				
MOISTURE BIAS				

ET = ELAPSED TIME IN MIN:SEC AFTER END OF COUNT, OR
RT = REMAINING TIME DURING COUNTDOWN
T = PRESET COUNTING TIME (MIN:SEC)
P = PRESET WET PRECISION (DENSITY UNITS)

NOTE: ' * ' IN WET OR H2O COLUMNS INDICATE OUT-OF-SPEC Xi RATIO. See page 20

BATTERY STATUS
lob = BATTERIES 75% DISCHARGED
chg = BATTERIES CHARGING @ C/10
blank = BATTERIES O.K.

Learning to Use the CPN MC-3

3. Press **START** to begin a test. CPN MC-3 starts 30-second test count and, during countdown, displays:

R1	- 1	0925	1326
DaBS	RT00:30	T00:30	
pcf	wet	h2o	dry
Dn			
Pr	NORMAL		
%			
Md			150.0
Bi	0.0	0.0	

Annotations:

- DEPTH OF MEASUREMENT UPDATES AT START OF COUNTDOWN (points to R1)
- REMAINING TIME (points to RT00:30)
- DATE (MONTH/DAY) UPDATES AT START OF COUNTDOWN (points to 0925)
- TIME (HOURS/MIN) UPDATES AT START OF COUNTDOWN (points to T00:30)
- COUNTING MODE DISPLAYED DURING COUNTING PERIOD (points to NORMAL)

RT (remaining time) counts down each second until counting period is complete. At end of count, **CPN MC-3** beeps twice and screen displays results:

R1	- 1	0925	1326
DaBS	ET00:30	T00:30	
pcf	wet	h2o	dry
Dn	147.5	10.75	136.7
Pr	0.76	0.28	1.04
%		7.86	91.13
Md			150.0
Bi	0.0	0.0	

Annotations:

- ELAPSED TIME OF TEST (points to ET00:30)
- NEW DATA DERIVED FROM TEST COUNT (points to Dn, Pr, %)

The screen will shut off in 60 seconds if no key is pressed.

Keyboard Functions

Figure 2-1 shows the keyboard of the **PORTAPROBE®**

Key	Function
START	Starts a count.
STEP	Acts as shift key. Steps cursor to next parameter or display.
CLEAR	Clears operator-entered data if pressed before ENTER key. Stops in-progress measurements. Displays previous display or (from a blank screen) most recent measurement.
ENTER	Stores data in memory. Steps to next display.
ID	Sets record identification for logging data.
RECALL	Displays stored records from logging memory.
PRINT	Displays PRINT menu.

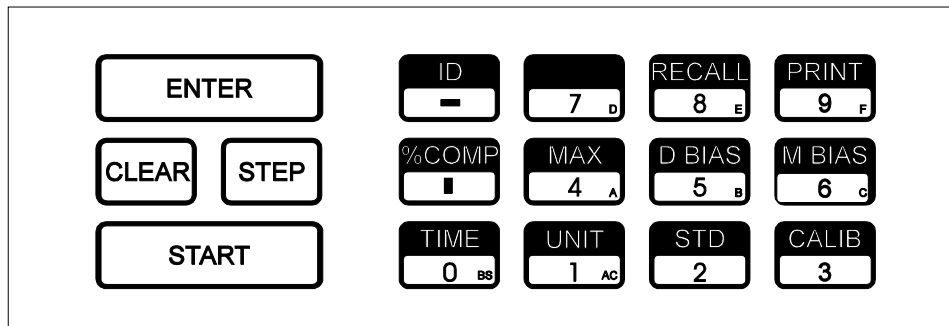

Figure 2-1. CPN MC-3 **PORTAPROBE®** Keyboard

Keyboard Functions

Key	Function
%COMP	Selects percent compaction to be calculated: Mw: Maximum wet density. Md: Maximum dry density. Av: Air void ratio.
MAX	Prompts for entering the maximum compaction values in pcf or g/cm ³ .
D BIAS	Prompts for entering moisture bias value (+ or - pcf or g/cm ³).
M BIAS	Prompts for entering moisture bias value (+ or - pcf or g/cm ³).
TIME	Prompts for setting counting to: Fixed time or constant precision mode. New time or precision value.
UNIT	No action.
STD	Displays density and moisture standard counts and prompts for new standard counts. Takes new standard counts.
CALIB	When Fixed Depth has been selected, prompts for setting the depth.

Keyboard Functions

The following functions are initiated by pressing the STEP key and holding it pressed while pressing a second key (i.e. the STEP key acts as a shift key).

Key	Function
STEP + TIME	Prompts for setting realtime clock (time/date).
STEP + UNIT	Displays menu to select between English (pcf and inches) or metric (gcc and mm) measurement units and select between density screen and counts per minute (cpm) screen.
STEP + CALIB	Displays menu to select displaying/entering coefficients, self-calibration, or setting fixed or automatic depth of measurement. (See Appendix B: Troubleshooting Guide.)
STEP + START	Displays measurement mode menu to select: Normal, Thin Layer, Trench Wall, Strata (optional).
STEP + CLEAR	Master clear. Restores main screen display directly from any other display.
ID, then STEP + ID	Clears entire record space of stored data.
STEP + ENTER	Displays monitor program, information used by a CPN service technician.

Configuring PORTAPROBE[®] for Measurements

The CPN MC-3 PORTAPROBE[®] displays the following direct measurements after all tests.

1. Dn wet: Wet or total density (pcf or gm/cm³).
2. Dn H₂O: Total moisture (pcf or gm/cm³).
3. Dn dry: Dn wet - Dn H₂O (pcf or gm/cm³).
4. % H₂O: (Dn H₂O / Dn dry) x 100

R1	- 1	0925	1326
DaBS	ET00:30	T00:30	
pcf	wet	h2o	dry
Dn	1	2	3
Pr			
%		4	
Md			
Bi			

The operator may enter target maximum values determined by standard laboratory tests (ASTM or comparable) before or after a test is taken.

5. **Mw**: The maximum wet density of a soil-aggregate or bulk specific gravity of a paving mixture in pcf or gm/cm³ (ASTM D 1188).
6. **Av**: The theoretical maximum specific gravity of a paving mixture in pcf or gm/cm³ (ASTM D 2041).
7. **Md**: The maximum dry density of a soil-aggregate in pcf or gm/cm³ (ASTM D 1557).

R1	- 1	0925	1326
DaBS	ET00:30	T00:30	
pcf	wet	h2o	dry
Dn			
Pr			
%			
Md	5 or 6		4
Bi			

Configuring PORTAPROBE® for Measurements

The **CPN MC-3 PORTAPROBE®** will now calculate and display relative (%) compactions.

For asphalt pavements and soils using total or wet maximum values:

$$8. \% M_w = (D_n \text{ wet} / M_w) \times 100$$

For asphalt pavements using maximum specific gravity values:

$$9. \% A_v = \frac{A_v - D_n \text{ wet}}{A_v} \times 100$$

For soil/aggregates using dry maximum values:

$$10. \% M_d = (D_n \text{ dry} / M_d) \times 100$$

R1	- 1	0925	1326
DaBS	ET00:30	T00:30	
pcf	wet	h2o	dry
Dn			
Pr			
%	8 or 9		1
Md			
Bi			

The operator may enter density and moisture bias values as needed.

11. ± density value (pcf or g/cm³).

12. ± moisture value (pcf or g/cm³).

R1	- 1	0925	1326
DaBS	ET00:30	T00:30	
pcf	wet	h2o	dry
Dn			
Pr			
%			
Md			
Bi	1	1	

Configuring PORTAPROBE[®] for Measurements

The following parameters can be configured for the **CPN MC-3 PORTAPROBE[®]** to meet your needs.

Parameter	Factory Configuration	Range
units	pcf	pcf, g/cm ³ or cpm.
time or precision	T01:00	user selectable mode: time or precision, and value: ±pcf or g/cm ³ .
% compaction	Md	Mw, Md, or Av
maximums		
Mw	150.0	
Md	150.0	0 to 999.9
Av	150.0	
biases		
density	0.0	+99.9 to -99.9
moisture	0.0	
counting mode	normal	normal, thin layer, or trench wall

Enter the **CPN MC-3 PORTAPROBE[®]** parameters according to the following instructions.

Action	Result
UNITS Parameters	
1. Press STEP + UNIT .	Displays menu to select units.
2. Press ENTER	Toggles units between pcf and g/cm ³ , displaying current selection on screen.
3. Press CLEAR .	Displayed units selected.
4. Press STEP .	
5. Press ENTER .	Toggles between density and counts-per-minute (cpm) screen, displaying current selection on screen.
6. Press CLEAR .	Display option selected.

Configuring PORTAPROBE[®] for Measurements

Action	Result
TIME and PRECISION Parameters	
1. Press TIME	Cursor moves to time field on screen.
2. Press STEP to toggle between time and precision.	Time or precision mode, as toggled, is displayed on screen.
3. Key in new time or precision value and press ENTER .	Value is displayed and stored (any previous value is replaced).
COMPACTION % and MAXIMUM Parameters	
1. Press % COMP	Compaction field rolls through Mw, Av, and Md. Continue pressing until desired maximum is displayed.
2. Press MAX .	Prompts for new maximum value.
3. Key in maximum value and press ENTER .	Value displayed and stored (any previous value is replaced).
DENSITY and MOISTURE BIAS Parameters	
1. Press D BIAS	Cursor moves to first digit in density bias field.
2. Key in density bias value and press ENTER .	Value is displayed and stored (any previous value is replaced).
3. Press M BIAS .	Cursor moves to first digit in H ₂ O bias field.
4. Key in moisture bias value and press ENTER .	Value is displayed and stored (any previous value is replaced).
Date and Time Reset	
1. Press STEP + TIME .	Screen displays date and time and prompts for entering the year.
2. Key in each prompted value and press ENTER .	Each value is stored; date and time updated.
3. Press START .	Clock begins again.
COUNTING MODE selection	
1. Press STEP + START .	Displays menu to select counting mode desired: normal, thin layer, or trench wall.
2. Press STEP .	Cursor moves through counting mode options. Continue pressing until desired option is prompted.
3. Press ENTER	Counting mode is selected.

Standard Counts

Because the radioactive sources in the **PORTAPROBE®** decay slowly over time, the user must periodically take a standard count on the reference standard provided. When this is done, the previous standard count is replaced and the CPN MC-3 program uses the new standard to calculate the field count/standard count ratio to compensate for source decay.

"Xi" is displayed and signifies the chi-squared distribution of the counts. This is the ratio of the actual distribution of the counts compared to the expected distribution. A ratio near 1.0, and small changes between previous and new counts, indicate that the **CPN MC-3** is working properly.

While standard counts need only be taken monthly to account for source decay, it is recommended that a new standard be taken daily to check "Xi" and changes in counts. The Xi ratio should be between 0.75 and 1.25, and the change between the present and previous standard counts should be smaller than the square root of the average count (1 standard deviation). This will verify the performance of the **PORTAPROBE®** every day of use. If the Xi value is outside of expected limits, repeat the standard count. If the statistics are again poor, consult the Troubleshooting Guide (Appendix B).

Standard Count Procedure

Action

1. Set the **PORTAPROBE®** on the standard count block. With the thick standard block (3 inches), take a standard count with the block on a dense material (compacted soil, asphalt or concrete). With a thin standard block (2 inches) take it on the shipping case.

NOTE
Locate the **PORTAPROBE®** at least 15 ft. (4.5 m) from any other nuclear gauge and at least 5 ft. (1.5 m) from other objects.

Result

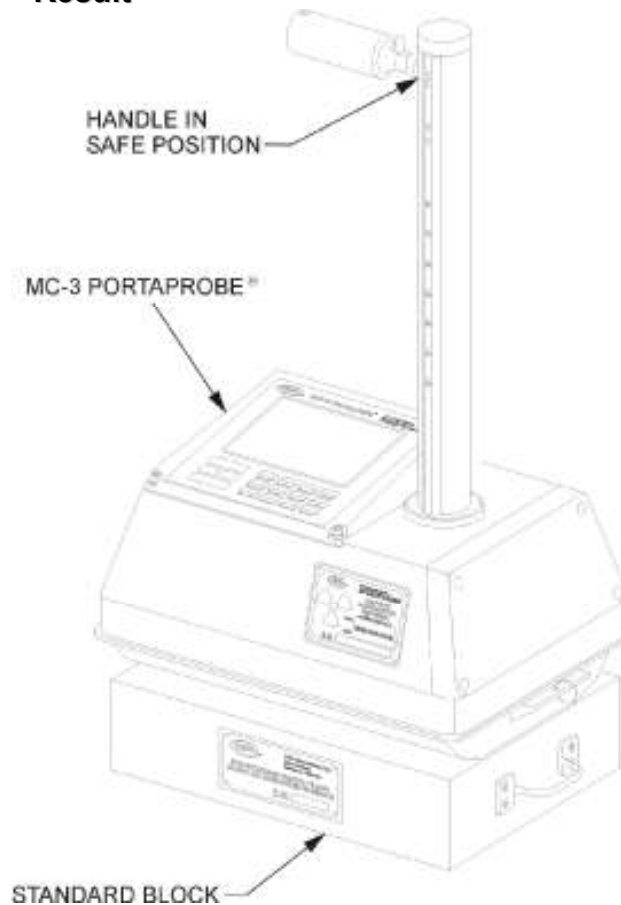

Figure 2-2. Standard Count Procedure

Standard Counts

Action

2. Set **PORTAPROBE**[®] handle to SAFE and press **STD**.

Result

Screen displays existing standard count data:

EXPRESSED IN COUNTS PER MINUTE (CPM)

	cpm	wet	h2o
PREVIOUS STANDARDS Prv	22027		16367
CURRENT STANDARDS Std	22080		16492
	Xi	.93	1.05
N = NUMBER OF SAMPLES N	256	256	
	Dat	940825	940825
DATES OF MOST RECENT STANDARD COUNT YEAR/MONTH/DAY START	new standard		
	CLEAR exit		

CONTINUOUSLY UPDATED DURING TAKING OF NEW STANDARDS

PROMPTS FOR NEXT COMMAND

3. Press **START** key.

PORTAPROBE[®] starts a standard count of 256 1-second samples. As each sample is taken, the sample number from 1 to 256 is displayed. A standard count takes approximately 4.4 minutes.

NOTE

To terminate the count and exit while the standard count is in progress, press **CLEAR**.

To stop the count early, press **STEP** (count is terminated and values stored).

At the end of the count, the CPN MC-3 displays and stores the new standard count data, replacing previous values.

Taking a Test

To take a field test, perform the following:

Action

1. Configure the CPN MC-3 (see **Configuring PORTAPROBE® for Measurements** instructions).
2. Prepare the site to be tested (see site preparation instructions in Field Use section).
3. Set the CPN MC-3 on the site to be tested and set the handle to the position (depth) in which the test will be performed.
4. Press START to commence field test.

NOTE

The depth of measurement will only be updated after a count is started.

Result

CPN MC-3 configured.

Site prepared for testing.

PORTAPROBE® prepared for testing.

PORTAPROBE® starts taking 1-second sample counts and display counts down. At end of count, CPN MC-3 beeps twice and displays test results on screen.

Typical transmission test display:

R1	-1	0925	1326
Da8	ET00:30	T00:30	
pcf	wet	h2o	dry
Dn	147.5	10.75	136.7
Pr	0.76	0.28	1.04
%		7.86	91.13
Md			150.0
Bi	0.0	0.0	

One of three testing modes can be selected:

Normal: for use on most soil/aggregates and pavements thicker than 2.5 inches (76 mm). (See above.)

Thin Layer: for use on asphalt pavement overlays of 1.0 to 2.5 inches (25 to 64 mm) thickness. (See Thin Lift Overlays in the Field Use section.)

Trench Wall: to eliminate counting errors caused by trench walls when testing backfill in trenches or excavations less than 30 inches (762 mm) in width. (See Trench Testing in the Field Use section.)

Units of Measurement

To Change Units

From pcf (pounds per cubic foot) to gcc (grams per cubic centimeter)
From gcc (grams per cubic centimeter) to pcf (pounds per cubic foot)

Action

1. Press **STEP + UNIT**

Result

Screen displays units menu.

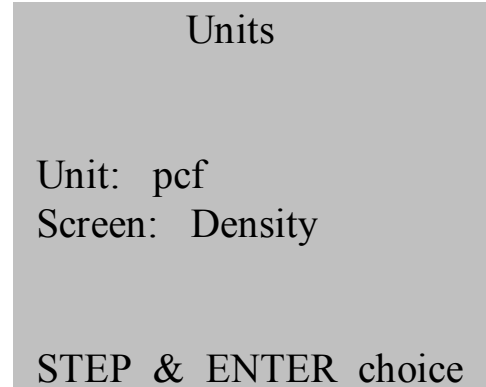

2. Press **ENTER** one or more times.
3. Press **CLEAR**.

Display alternates between pcf and gcc units.

Units displayed is now selected. Screen returns to **READY**.

To Change Results

Screen

From density (pcf or gcc) to cpm (count per minute)
From cpm (counts per minute) to density (pcf or gcc)

Action

1. Press **STEP + UNIT**
2. Press **STEP**.
3. Press **ENTER** one or more times.

Result

Screen displays units menu, as above.

Cursor moves to screen result options.

Display alternates between density and cpm screen results. If the cpm screen has been selected, the CPN MC-3 will count and display results as in the example:

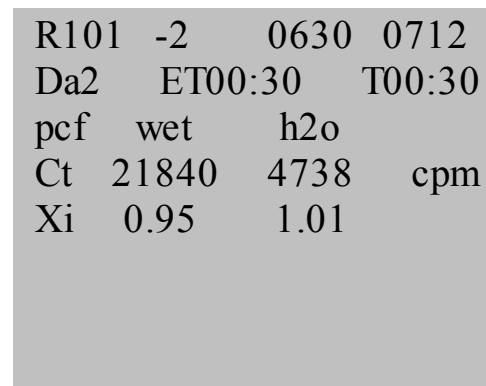

4. Press **CLEAR**.

Screen result displayed is now selected. Screen returns to **READY**.

Calibration

Each CPN MC-3 PORTAPROBE® is calibrated at the CPN factory. A typical computer printout of the calibration data is shown in Figure 2-3. If you require a different calibration, perform the following steps.

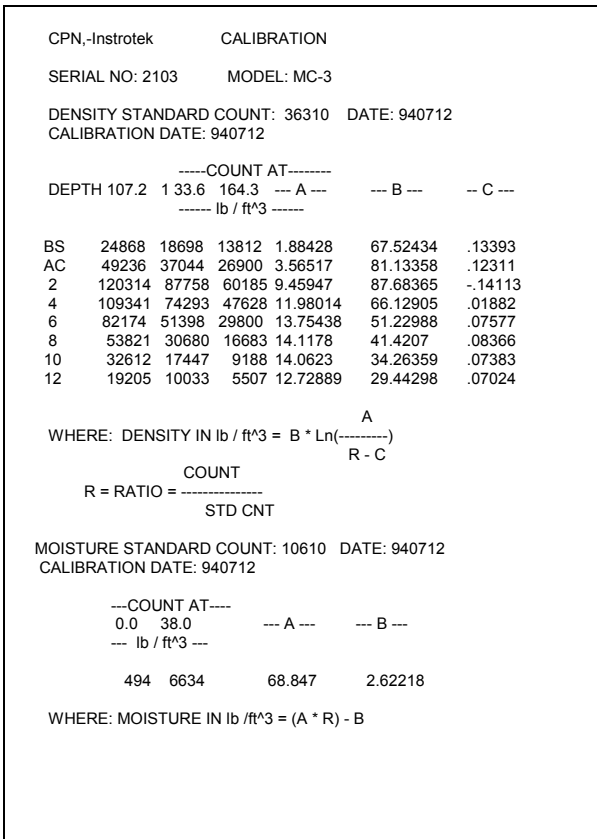

Figure 2-3. Computer Calibration Printout

Edit Coefficients

The wet density and H₂O coefficients allow the operator to edit (view/change/enter) density and moisture calibration coefficients. Write down factory calibration coefficients before overwriting with new ones in the CPN MC-3 so they can be reentered later.

Action

1. Press **STEP + CALIB**.

Result

Screen displays calibration menu with cursor prompting wet coefficients:

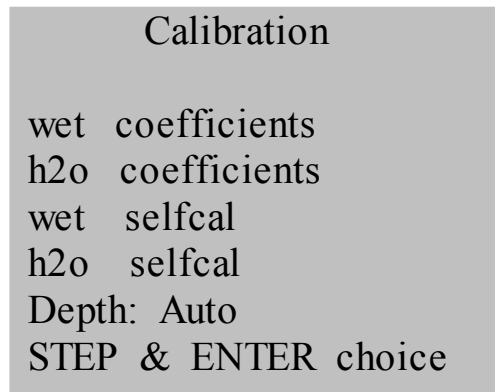

Action

2. Press **ENTER**.
3. Press **STEP** until desired depth and calibration
4. Press **ENTER**.
5. Enter the A coefficient value and press **ENTER**. Pressing **ENTER** will store the current value and a new value is not entered.
6. Repeat step 5 for B and C coefficients.
7. Repeat steps 3 through 6 for each depth.
8. Press **CLEAR** twice to exit Wet calibration coefficients screen.
9. Press **STEP** to move cursor H₂O field.
10. Press **ENTER**.

Result

CPN MC-3 displays Wet calibration screen with cursor prompting depth field (BS initially).

Depths field rolls through BS, AC, 2, etc. (Current coefficients are displayed for each depth), example:

```
Wet cal          2 in
```

```
A 10.65422
```

```
B 81.63265
```

```
C -.16853
```

```
STEP & ENTER depth  
CLEAR twice to exit
```

Cursor moves to A coefficient field and prompts for entry of new value.

Value displayed in A coefficient field and stored. Cursor moves to B coefficient field and prompts for entry of new value.

B and C coefficient values are displayed and stored. Cursor then moves to top of screen and prompts for next depth.

Wet calibration coefficients are entered in **PORTAPROBE®** memory.

Calibrations menu is displayed with cursor prompting.

Cursor prompts H₂O coefficients.

H₂O calibration coefficients screen is displayed. Cursor prompts for entry in the A coefficient field.

```
h2o cal
```

```
A 64.26693      pcf
```

```
B 4.78088      pcf
```

```
Enter coefficients  
CLEAR twice to exit
```

Calibration

Action

11. Enter A coefficient value and press **ENTER**.
12. Enter B coefficient value and press **ENTER**.
13. Press **CLEAR** twice to exit H₂O calibration coefficients screen.
14. Press **CLEAR** to return to main menu.

Result

Value displayed in A coefficient field. Cursor moves to B coefficient field and prompts for entry of new value.

Value displayed in B coefficient field. H₂O calibration coefficients are entered in CPN MC-3 memory and calibration menu is displayed.

Calibration menu is displayed with cursor prompting.

Main screen is displayed.

Self Calibration

The wet selfcal and H₂O selfcal options allow the operator to calibrate the CPN MC-3 on a set of three standards of known density (low, intermediate, and high) and two standards of known equivalent moisture (low and high). Calibration coefficients are automatically computed and stored in the CPN MC-3.

Action

1. Take a standard count.
- 2 Press **STEP + CALIB**.
3. **STEP** to wet selfcal, then **ENTER**.

Result

Screen displays calibration menu with cursor prompting wet coefficients.

Screen displays option: create a new calibration or edit old calibration data.

NOTE

Selecting the **Create new calib** option will erase the previous calibration counts.

Wet Selfcal
Last cal: 94-08-12

Create new calib
Edit old calib data

STEP & ENTER choice

4. Press **ENTER** to create a new calibration and move to step 6, or move to step 5 to edit calibration data.

Calibration

Action

5. Press **STEP**, then **ENTER** to edit old calibration data. Selecting "edit" retains previous calibration counts but allows one or more of them to be changed.

6. The wet density of H₂O density block values may be left unchanged by pressing **ENTER** on each value or keying in a new value followed by **ENTER**.

7. Press **STEP** to select or change the calibration block density. Move the source rod to the next desired depth. Press **START** to take a calibration count (automatically four minutes).

If prior calibration data is known, place the gauge in the **FIXED** Depth Mode via the **STEP+CALIB** menu and follow the above sequence except press "-" to advance to a new depth and key in the count data as appropriate.

8. When the coefficients are displayed, press **ENTER** to accept them or **CLEAR** to abort and start over.

Result

The existing density values of three wet density calibration blocks or two H₂O density calibration blocks will be displayed. For example:

Wet Selfcal
Block Weights

Low: 107.2

Med: 133.6

High: 164.3

Key weight & ENTER

The CPN MC-3 will then display the density value of one of the calibration blocks and the last count for the selected depth.

Wet Selfcal
107.2 pcf BLOCK
12 in 19448 cpm

Position Handle
STEP to roll block
START to count
or enter a value

When all three blocks have counts for a depth, the CPN MC-3 will compute the coefficients for that depth. While computing, a term will be displayed which will reduce to a small number before the gauge accepts the solution.

Data Logging

The **CPN MC-3 PORTAPROBE®** can log up to 200 tests in record numbers chosen by the operator. The information can be reviewed on the display screen at a later time or transferred to a computer or printer.

Storing Test Results

Action

1. Pick a record number between 0 and 65535.
2. Press **ID**, then enter record number chosen. Entering a previously used record number allows user to append test results to end of that record. If no number is picked, the previous record will be used.
3. After a test, press **ENTER** to store contents of main test screen. If a reading has already been stored **PORTAPROBE®** will abort storage and await another command.
4. To clear entire record space, first review and print out stored data (see Data Transfer section), press **ID** and then hold down **STEP** and press **ID**.

Result

CPN MC-3 sets up record number, or positions user at end of existing record.

Test results are stored in new record or appended to existing record. Number-of-tests counter on screen changes. CPN MC-3 beeps twice and displays **RECS FULL** when record space is full.

Record space and site numbers are all erased. Data that has been erased cannot be recovered from **PORTAPROBE®**. CPN MC-3 beeps twice and displays **RECS EMPTY**.

Reviewing Test Results

Action

1. Press **RECALL**. User can now move to next record with **STEP**, but not to next test within record.
2. Enter desired record number, then press **ENTER**. If first record displayed is desired, press **ENTER** to recall results within record.
3. Move from test to test within record with **STEP**.
4. To move from within a record to the next record, press **CLEAR** once.
5. To return to main screen (most recent results) from the first test in a record, press **CLEAR** once. To return from a test within a record, press **CLEAR** twice.

Result

Because a test may be stopped before completion by the operator, the **TIME/PRECISION** value is omitted.

User is now in desired record and first test result is displayed.

Test results are displayed in order they were taken. At the end of a record, **STEP** moves user to next record.

User can now move to next record with **STEP**, or to any record by entering record number and pressing **ENTER**.

User has left **RECALL** mode.

Operation Summary

To take a Count

Standard Count	STD, START STEP CLEAR	handle in SAFE position early finish abort
Field Count	START	handle in desired depth
Thin Layer Test	STEP + START , then STEP to desired counting mode, ENTER , and follow instructions	on display
Trench Test		
Display last reading	CLEAR	

To Program

Time/Precision	TIME (T) , xxxx (min/sec) or TIME, STEP (P) ,xx.xxx (pcf or gcc)	
% Compaction	% COMP	Press to display compaction calculation Mw: Wet/wetmax x 100 Md: Dry/drymax x 100 Av: (Avmax - wet)Avmax x 100
Maximum Density bias	MAX, xxx.x, ENTER	
Moisture bias	D BIAS, xxx.x, ENTER	
Units	M BIAS, xxx.x, ENTER STEP + UNIT STEP ENTER CLEAR	units menu displayed selects units or screen display toggles units between pcf and gcc, and screen between density and counts display units selected

Record Operation

Clear memory	ID, STEP + ID	
Identify site	ID, xxxxxx, ENTER	
Store last reading	ENTER	stores last reading into record once after each START, up to 200 readings per site number, 200 readings maximum
Display log	RECALL, xxxxxx, ENTER or STEP...STEP, ENTER , then STEP to view readings within a site number	
Printer dump	PRINT, ENTER	display screen format
Computer dump	PRINT, STEP, ENTER	data compressed and separated by commas

Miscellaneous

Real time clock	STEP + TIME	follow prompt to set date/time
Display counts/min	STEP + UNIT, STEP, ENTER, CLEAR	repeat to return to normal display
Calibrate	STEP + CALIB	select choice from calibration menu and follow instructions on display
Depth override		
depth mode	STEP + CALIB, STEP...ENTER	toggles display between fixed or auto mode
set fixed depth	CALIB, xxx, ENTER	fixed depth entered
Abort (one level)	CLEAR	clear entry, abort, stop
Abort (master)	STEP + CLEAR	clears to most recent reading on screen

Section 3 - Field Use

Asphalt Pavement

Backscatter Measurements

The **CPN MC-3 PORTAPROBE®** has two density modes of operation: (1) backscatter (BS and AC surface settings) and (2) transmission (depth settings). The backscatter settings provide non-destructive tests and are most often used for asphalt and concrete pavements where drilling a transmission hole is not feasible.

CPN MC-3 handle set to BS (backscatter) position. Raised or collimated source position blocks shallow photon path to provide effective deeper readings and minimize surface roughness effect. Measures density to a depth of 2.8 in (71 mm). Typically used on pavements thicker than 3.0 in (76 mm).

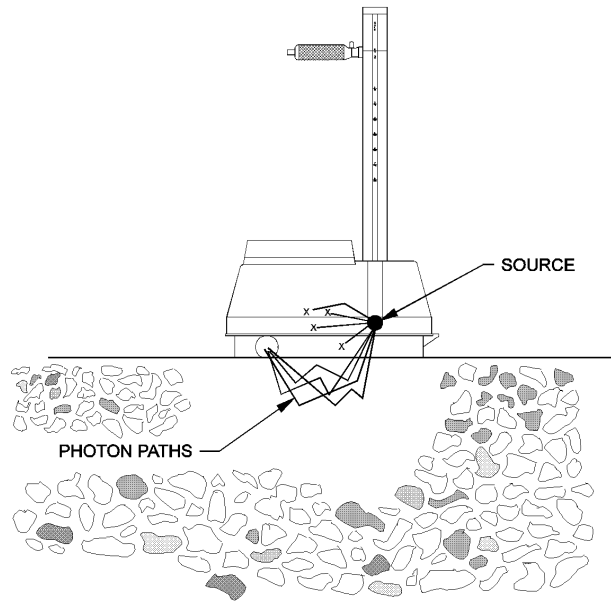

CPN MC-3 handle set to AC (asphaltic concrete) position. Source flush wth surface. Measures density to a depth of 2.0 in (51 mm). Typically used on thin pavement overlays.

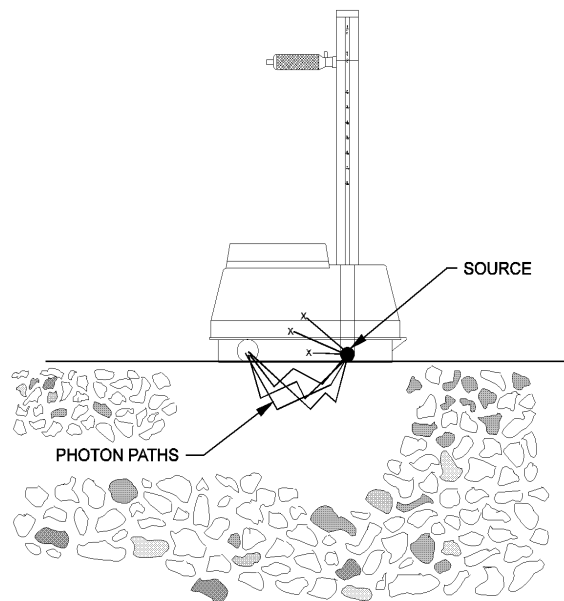

Asphalt Pavement

Backscatter Measurements

Density measurements are performed to determine the compaction of asphalt pavements. This type of measurement is made with the CPN MC-3 set in either the AC or BS position, depending on the thickness of the asphalt (see table below).

Probe Position	Type Asphalt Application	Maximum Measurement Depth (95% return)
AC	thin lift overlays; surface or wearing course	2.0 in (51 mm)
BS	asphalt base or final mat if 3.0 in (76 mm) or greater thickness.	2.8 in (71 mm)

To obtain accurate measurements, the asphalt surface must be flat and, if it contains voids, must first be prepared with a filler of #20 or #30 sieved sand. The sieved sand should be used to fill the depressions on the surface only. Use the edge of the guideplate to remove all excess sand and produce a level condition. Make sure the CPN MC-3 does not rock or wobble before taking a test. With these precautions, the effect of surface voids will be minimized.

Do not use a sand filler on smooth (voidless) surfaces as this may raise the gauge off the surface enough to cause lower density readings in error.

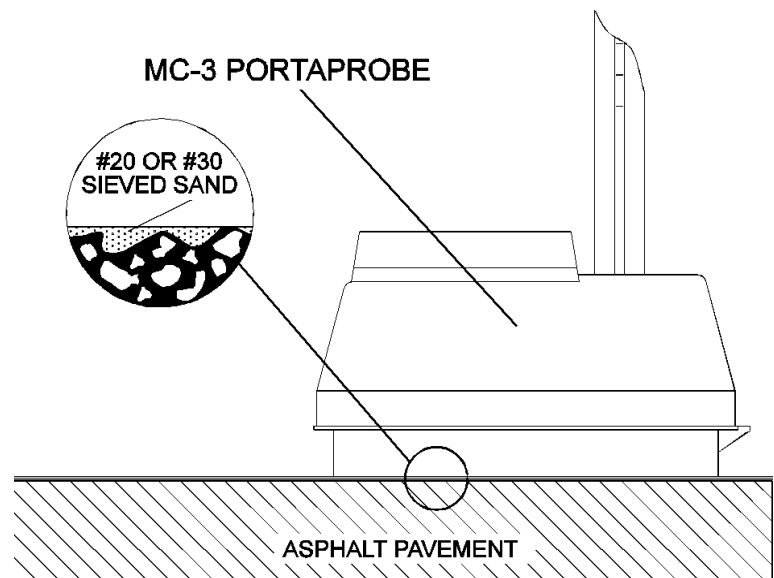

Percent Air Void Determination

To determine the percent air voids (% Av) of a compacted paving mixture, a lab-determined maximum specific gravity for the mix (SG) and a wet density determined by the CPN MC-3 (Dn wet) must be available. The **PORTAPROBE**[®] uses the formula:

$$\% Av = \frac{(SG - Dn \text{ wet})}{SG} \times 100$$

The theoretical maximum specific gravity of the mix (SG) can be converted to pcf total density units as follows:

$$SG \times 62.43 = Dn \text{ wet in pcf}$$

Thin Lift Overlays

The CPN MC-3 contains a Thin Layer mode of measurement which allows rapid density determination of thin lifts of asphalt pavement. It is necessary to know the density of the underlying material and the thickness of the upper lift. The underlying density is determined by CPN MC-3 density tests before the overlay is applied. The overlay is then placed and compacted at a known thickness. The Backscatter (or AC) density tests in the Thin Layer mode are used to compute and display the density of the upper layer. The procedure follows:

Action

1. Press **STEP + START**.

Result

The CPN MC-3 displays a menu which allows for selecting the measurement mode desired.

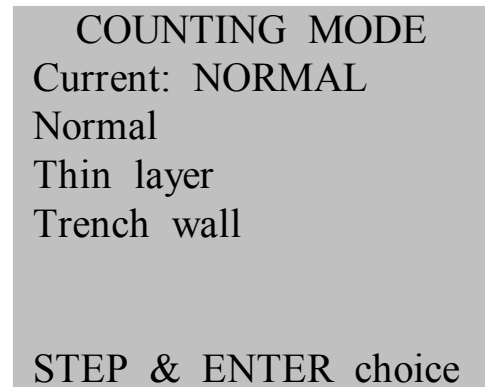

COUNTING MODE
Current: NORMAL
Normal
Thin layer
Trench wall

STEP & ENTER choice

2. **STEP** to the Thin Layer option and **ENTER**.

The Thin Layer mode prompts for the thickness (0.1 to 2.9 inches in 0.1 inch increments) or the overlay material and the density of the underlying or base material.

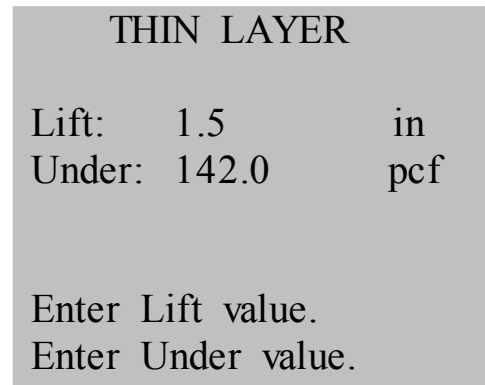

THIN LAYER

Lift: 1.5 in
Under: 142.0 pcf

Enter Lift value.
Enter Under value.

3. Enter the lift thickness and underlying density

The screen now returns to the most recent display from the keypad. The CPN MC-3 is in the Thin Layer mode

4. **START** a Thin Lift test.

While the gauge is counting, "THIN" is displayed. A "T" will be displayed with the depth of measurement (AC or BS) on the test result screen.

Soils/Aggregates

Transmission Measurements

The transmission mode of the **PORTAPROBE**[®] measures density of soils and aggregates to depths of 2 to 8 in (50 to 200 mm). Optional models measure to depths of 12 in (300 mm).

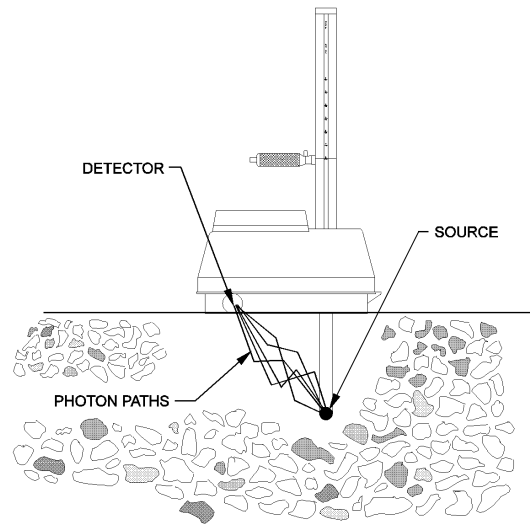

Density measurements are made with the CPN MC-3 **PORTAPROBE**[®] set to one of the transmission mode depths. Measurements performed on soils require no special preparation other than preparing a surface that is level and relatively smooth, and drilling a hole for inserting the source rod.

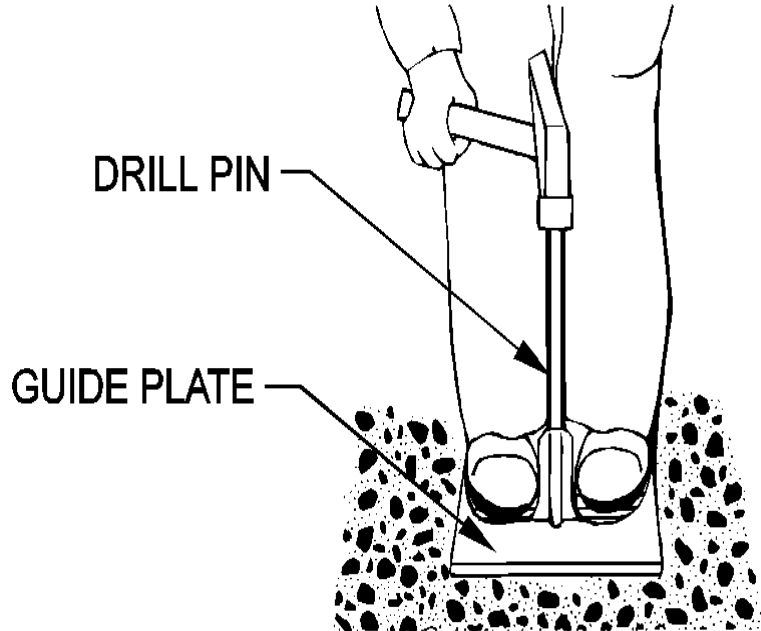

The guideplate can be used to smooth loose soil on an uneven surface. For soft soils, the hole can be drilled with the drill pin and a hammer or mallet, using the guideplate as a template. Extract the pin while standing on the guideplate to ensure an undisturbed hole. Do not use the guideplate as a tool to remove the drill pin.

Transmission Measurements

For hard soils, a Campbell hammer may be required, as shown in Figure 3-2. The weighted hammer is used to both drive and extract the pin while the operator stands on the guideplate. Drill the hole a minimum of 2 in (50 mm) deeper than the intended depth of measurement.

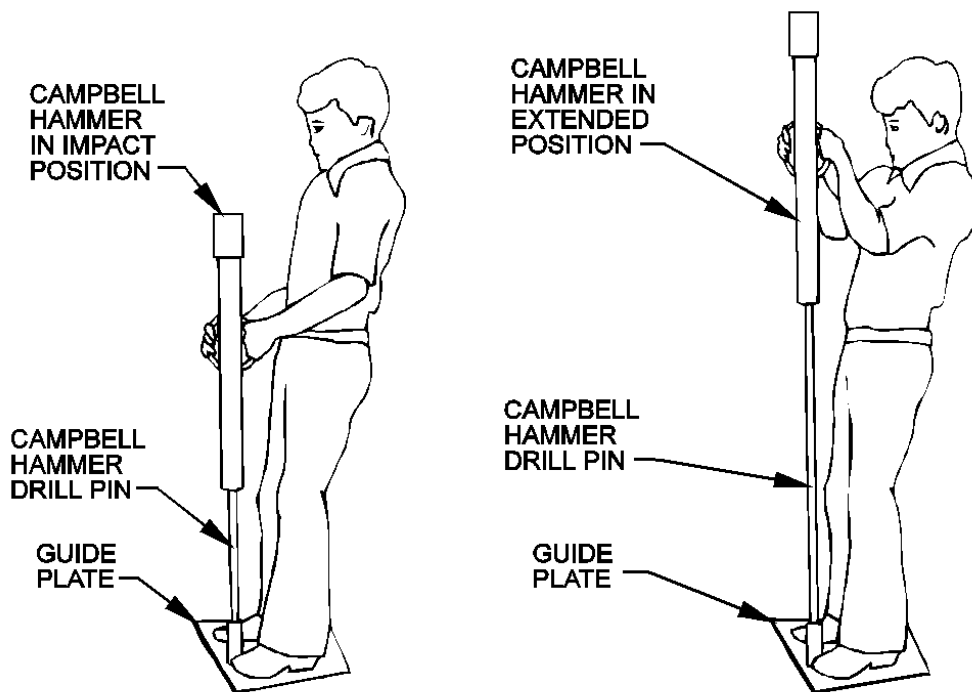
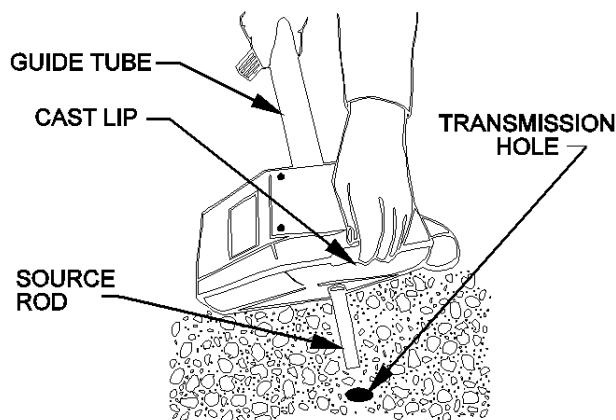

Figure 3-2. Using the Campbell Hammer

After drilling the transmission hole:

1. Tilt the **PORTAPROBE**[®] slightly using the cast lip on the front of the bottom casting.
2. Lower the source rod until the handle is between 2 and 4 in (50 and 100 mm).
3. Grasp the guide tube above the handle and raise the CPN MC-3 until the source rod is visibly going into the hole. (Look over the front end of the gauge.)
4. Lower the CPN MC-3 and source rod into the hole.
5. Set the handle to depth position desired and start test.



Trench Testing

Trench backfill measurements are made after ensuring that the surface in the bottom of the trench is smooth and level, as described in the Soils/Aggregates section.

For tests performed in trench excavations that are at least 30 in (762 mm) wide, the **PORTAPROBE®** should be centered in the bottom of the trench to avoid reflection errors from the trench walls.

When testing in confined excavations, such as trenches less than 30 in (762 mm) wide, use the Trench Wall mode of the CPN MC-3 and the 3-inch standard block to correct for the background influence of neutrons reflected from nearby trench walls. The procedure follows:

Action

1. Press **STEP + START**.

Result

The CPN MC-3 displays a menu which allow for selecting the counting mode desired.

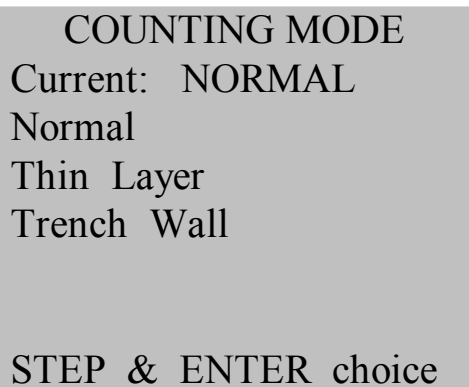

```
COUNTING MODE
Current: NORMAL
Normal
Thin Layer
Trench Wall

STEP & ENTER choice
```

2. **STEP** to the Trench Wall option and **ENTER**

The Trench Wall mode prompts for entry of a background count.

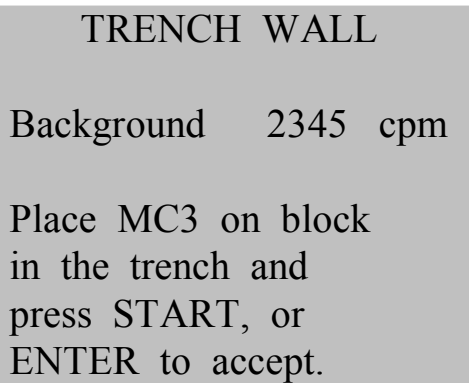

```
TRENCH WALL

Background 2345 cpm

Place MC3 on block
in the trench and
press START, or
ENTER to accept.
```

3. **START** a background count with the CPN MC-3 on standard block in the trench, or **ENTER** to accept the displayed value.
4. Remove the standard block and **START** a trench backfill test at the same location.

Upon completion, the screen returns to the most the recent display. The CPN MC-3 is in the Trench Wall mode.

While the gauge is counting, "WALL" is displayed. A "W" will be displayed with the depth of measurement on the test result screen.

Section 4 - Other Test Methods

Because of the increase in the rate of placement of earthworks and pavements in highway construction, state highway departments and other agencies have adopted procedures that simplify and speed density control testing with nuclear gauges. They are discussed in general terms below.

Statistical Control

A statistical approach to compaction control consists of taking several in-place density tests in an area designated by the engineer and based on the uniformity of materials to be tested. The acceptance or rejection is based on the average relative compaction and the percentage falling below the required relative compaction value. For example, a test specification might require that the average of 10 tests on an area must be above 95% relative compaction with no individual test below 90%.

Core Correlation

A common test method compares a series of CPN MC-3 density tests with laboratory determined core sample densities taken from directly beneath the site of the nuclear tests. A correction factor can now be established to program into D BIAS for all further testing on the same material. ASTM Standard Test Method D 2950 discusses these procedures in more detail. Historical data indicates D BIAS's of 1-2 pcf (0.016-0.032g/cm³) in BS and 3-4 pcf (0.048-0.064 g/cm³) in the AC position. For example, a series of 10 total density (Dw) readings on a 300-ft. test strip average 144 pcf and the 10 core determinations at the same locations average 145.5 pcf. The D BIAS is then 145.5 - 144.0 or +1.5 pcf.

Concrete Testing

The CPN MC-3 can be used to determine the density of concrete pavements or structures. Density measurements may be performed in either the transmission or the backscatter mode. It is best to prepare a transmission hole when the concrete is still setting. Before the concrete has initially begun to set, drill a transmission hole. After the concrete has set up, transmission tests can be taken. The **PORTAPROBE**[®] can be used on portland cement concrete, roller-compacted concrete, and soil-concrete mixtures.

Control Test Strip

The CPN MC-3 can be used to establish the maximum obtainable density of both embankments and asphalt pavements. An initial section of material under construction is used as a control strip. Nuclear density tests are taken after each successive pass of the roller until no further increase in density is achieved (see Figure 4-1). At this point, a number of CPN MC-3 tests are taken to accurately determine the maximum obtainable density.

The completed control strip becomes a part of the construction and specifications for the remainder of the project are established as a percent of the control strip density. A new control strip is required when a change in materials occurs. For example, a test method may require:

1. A 300-ft.-long by one lane control strip. After completion, the average of 10 CPN MC-3 total density tests (Dn wet) is the maximum obtainable density.
2. 2000-ft. by one lane or 100-ft. by two lane test sections. The average of 10 CPN MC-3 total density tests must be at least 98% of the maximum obtainable density (on the control strip), with no individual test below 95%.

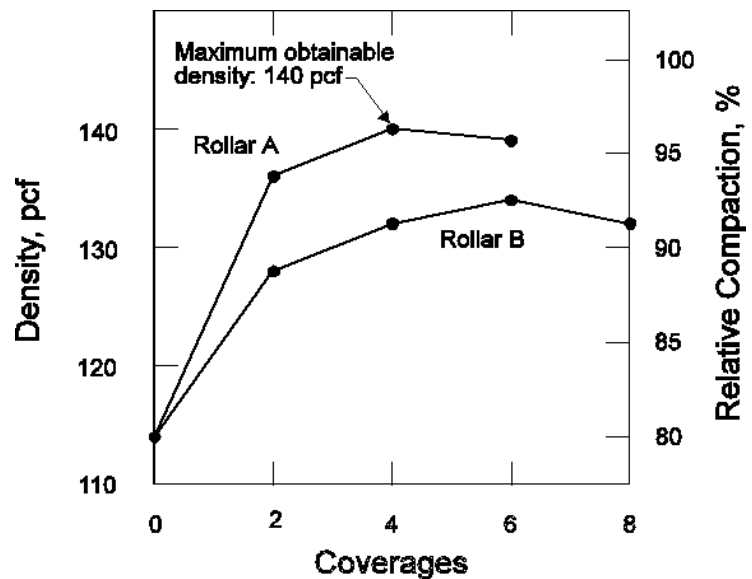

Figure 4-1. Test Strip Roller Pass Pattern

Roller Compaction Evaluation

The CPN MC-3 can be used to evaluate the capabilities of compactive rollers, allowing the most efficient use of time and equipment for a given project.

Section 5 - Maintenance

Clean and Lubricate Shutter Mechanism

The shutter should be cleaned and lubricated weekly during use, or whenever the source rod becomes dirty and begins to stick.

1. Remove the four screws securing shutter plate block assembly.
2. Remove shutter assembly.

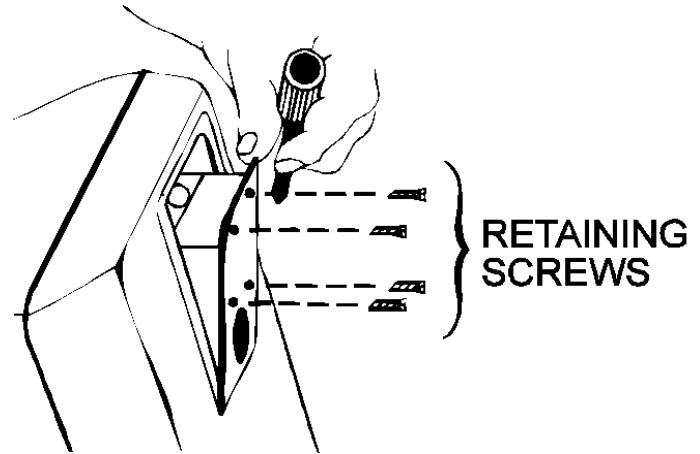

CAUTION

Radioactive source is located in base cavity. Do not touch the source rod tip and do not place yourself in front of the opening after the shutter block is removed.

3. Stand behind the gauge and use a long-handled brush or compressed air to clean exposed area inside CPN MC-3.
4. Clean entire shutter assembly and spray with the greaseless silicone lubricant provided.
5. Allow assembly to dry, then reinstall shutter block and plate.
6. Check CPN MC-3 handle to ensure it slides freely in guidetube.

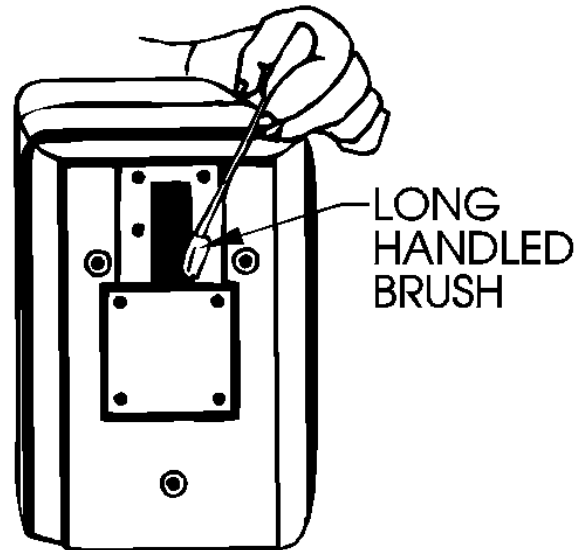

Cleaning and lubrication completed.

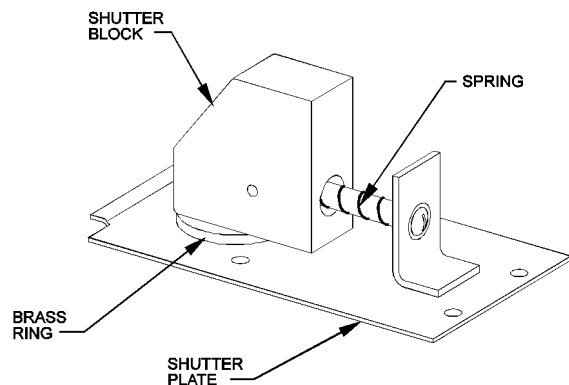

Handle Assembly Inspection

Inspect the handle assembly monthly for wear.

1. Set handle in BS position.
2. Loosen 5/32 in Allen head hex screw on side of guide tube ONLY until handle is free. Do not remove screw.
3. Pull handle away from guide tube.
4. Check beveled front edge of handle latch for excessive wear.

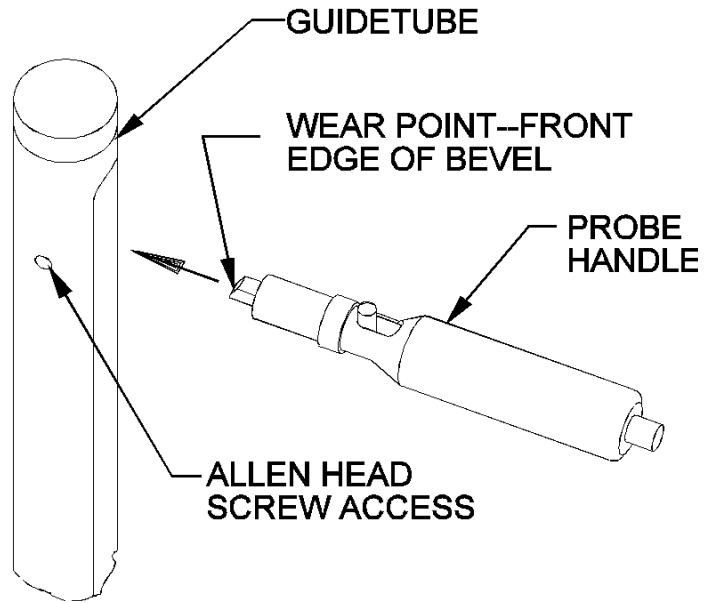

5. Check notches inside guide tube for excessive wear.

NOTE

If wear on the notches or latch appears to be excessive, contact your CPN - Instrotek service representative for assistance.

6. Reassemble handle to guide tube assembly and tighten Allen screw.

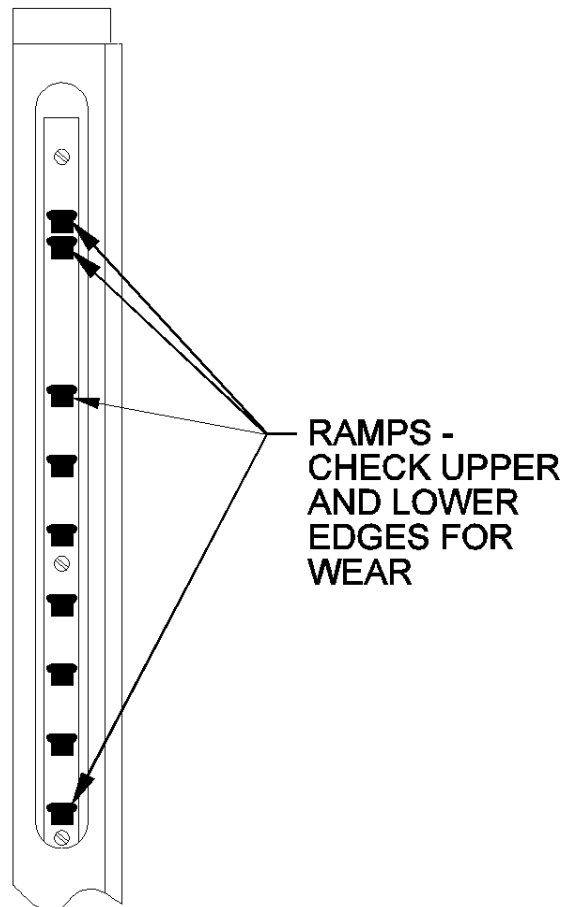

Leak Test

The leak test is required every six months or yearly.
(Check your Radioactive Materials license for the time interval.)

1. Use the CPN- InstroTek Leak Test Kit to perform this required test for leakage of the source material from its capsule. Set handle to SAFE position.
2. Remove four screws securing display/keyboard panel to CPN MC-3. Set keyboard/display panel aside, leaving cables connected.
3. Use the cotton swab in the kit and swab the source holder inside the CPN MC-3. This will pick up any removable traces of the Am-241:Be source material.
4. Reattach display/keyboard to CPN MC-3 with four screws that were removed in step 2.

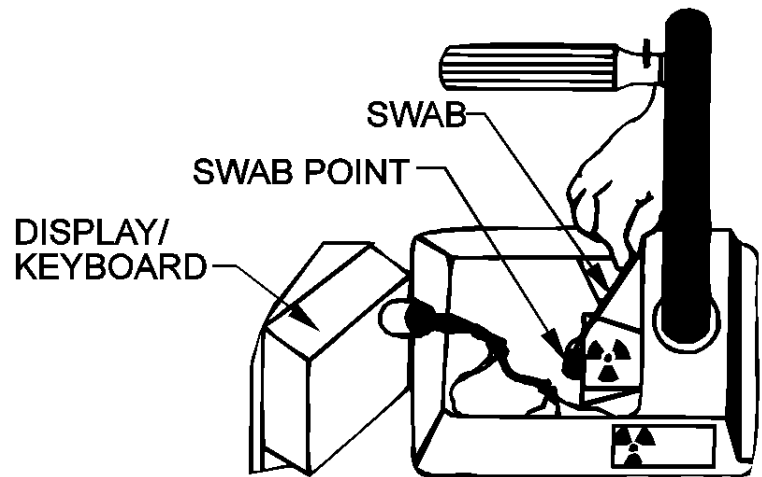

5. Use the cotton swab in the kit to swab around cleanout plate ring on the aperture. This will pick up any removable traces of the Cs-137 source material.
6. Break swab stick in half and place in plastic envelope. Complete form and staple envelope to it; mail to address on the kit. Within approximately two weeks you will receive notification of results.

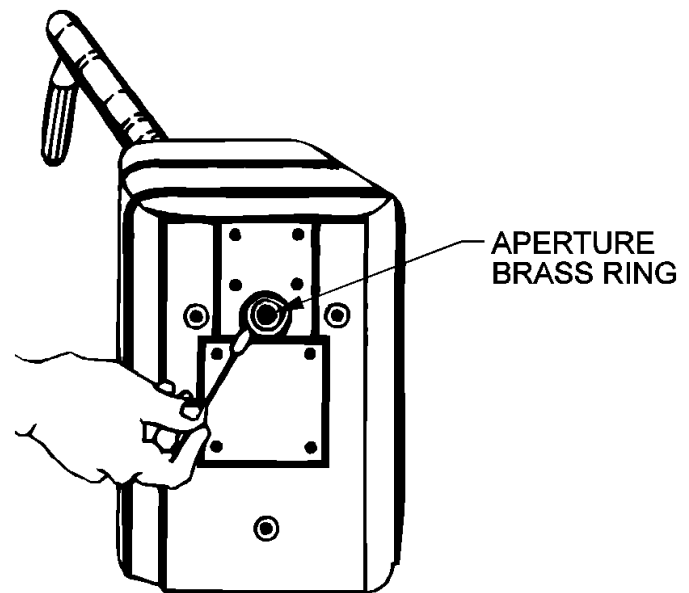

Charging Battery Pack

A battery pack of 8 welded AA rechargeable nickel cadmium batteries is located beneath the keyboard/display electronics package.

When "lob" appears in the lower right hand corner of the main screen, the instrument will take approximately 100 more 30-second tests before it will go into cutoff. Test for the presence of the "lob" by pressing the **CLEAR** key. This should be done before going into the field, preferably the evening before to allow time to recharge if necessary.

1. Set **PORTAPROBE**[®] handle to SAFE position.
2. Connect battery charger power cord to 120 VAC power outlet.
3. Connect battery charger to jack on rear panel. Press any key to update the screen.
4. Main display screen message "lob" is replaced with "chg", indicating batteries are being charged at C/10 charge rate. Full charge time is 12 to 14 hours.

NOTE

Prolonged overcharging or failure to allow the battery pack to discharge to "lob" condition may cause a loss of battery capacity which will be difficult to recover.

Storage

To protect the **PORTAPROBE**[®], store it in the packing case when not in use. The normal 8 year shelf life of the internal memory keep-alive lithium battery will be reduced to 4 years if the NICAD battery is not kept charged or is disconnected. For long term storage, charge the gauge before placing in storage and recharge every 3 months.

Close and latch the lid of the shipping container when not in use to prevent moisture intrusion.

APPENDIX A

Display Messages and Prompts

Message:	Meaning:	Action:
chg	Battery charging at C/10.	None.
lob	Low battery condition 25% charge remaining.	Charge battery.
START new standard CLEAR exit	Message displayed on standard count screen.	Press START to initiate a standard count. Press CLEAR to return to main display.
Put rod in SAFE and press START	Standard count attempted when probe is set to a depth other than SAFE position.	Set the handle to SAFE position and press START .
Press STEP to stop Press CLEAR to abort	Message displayed during a standard count.	No action required unless operator wishes to stop the standard count in progress. To stop the count and store the count taken to that point, press STEP . To abort the count, press CLEAR .
Bad depth: Put handle in proper position and press START	Test attempted when source rod is set to an unprogrammed depth position.	Set rod depth to correct depth position and press START .

APPENDIX B

Troubleshooting Guide

The **CPN MC-3 PORTAPROBE®** can generally be repaired by isolating the problem and replacing the defective component. Only the tools supplied in the shipping case are needed for component exchange.

Problem

Display remains blank. No beep, no response to keyboard commands.

Same condition as above, except batteries are fully charged.

CPN MC-3 operational but no change in density readings. Xi = 0.0 in count mode, wet* displayed.

CPN MC-3 operational but no change in moisture readings. Xi = 0.0 count mode, H₂O* displayed.

On all counts wet* displayed. On standard counts Xi value is out of limits.

On all counts H₂O* displayed. On standard counts Xi value is out of limits.

Action

1. Push the reset button on the rear panel.
2. Batteries are discharged below cutoff voltage and require charging.

OR

3. Batteries are dead and require replacement.

Replace main electronic assembly.

1. Replace density detector assembly.*
2. Replace wire harness.
3. Replace main electronic assembly.

1. Replace moisture detector.*
2. Replace wire harness.
3. Replace main electronic assembly.*

Replace density detector assembly.*

Replace moisture detector assembly.*

* Involves recalibration. Contact the CPN-Instrotek Service Center for further information.

Troubleshooting Guide

Problem

Upon taking a test, CPN MC-3 beeps twice and displays:

Bad depth :
Put handle in proper
position and press
START.

even though handle is in a proper depth position.

PRINT or DUMP reports fails to operate but screen displays "**PRINTING REPORTS**" or "**DUMPING REPORTS**".

PRINT or DUMP reports fails to operate. NO "Printing Reports" or "Dumping Reports" appear on CPN MC-3 screen.

Action

1. For continued field use, press **STEP + CAL**, **STEP** to Depth Mode, **ENTER** Fixed Mode (Depth: Fixed), and **CLEAR**.
2. Replace guidetube strip switch, when possible.

1. Check for proper baud rate setting in MENU field. Printers are usually 9600 BPS and computers can be 300, 600, 900, 1200, or 9600 BPS.
2. Check RS232 serial cable pin connectors. Check pins 2, 3, and 7 on 25-pin connector and handshake pins. If necessary check device manual or call CPN Service Center.

Record Log is empty. Data must be taken.

APPENDIX C

Data Transfer

To transfer (upload) stored data from the **CPN MC-3 PORTAPROBE®**, you will need a printer or computer with the following characteristics:

Asynchronous RS-232-C data interface (ASCII format)
300- to 9600-bps baud rate (to which the CPN MC-3 will be set)
11-bit character length (1 start bit, 7 data bits, 1 space parity bit, 2 stop bits)

Action

Result

1. Connect RS-232-C cable to printer and **CPN MC-3 PORTAPROBE®**.
2. Press **PRINT**.

Screen displays printer menu with cursor prompting:

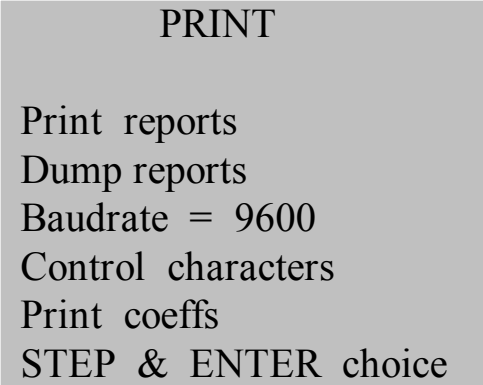

```
PRINT
Print reports
Dump reports
Baudrate = 9600
Control characters
Print coeffs
STEP & ENTER choice
```

3. Press **STEP** until prompt is at baud rate, then press **ENTER**.
4. Press **STEP** until desired baud rate is displayed, then press **ENTER**.
5. Press **STEP** until prompt is on control characters, then press **ENTER**. Follow prompted instructions on screen to select control characters.

Ready to select baud rate.

Baud rate selected.

Printer control characters set.

Data Transfer

Action

6. Press **STEP** to select the printout format.

Result

Either Print reports or Dump reports is selected. Print reports is a formatted output with headings identical to the test screen display. Dump reports is a condensed format with all numerical data separated by commas.

DUMP REPORT FORMAT		
101, 1, 10, 16, 13, 44		ID, TESTS, MONTH, DAY, HOUR, MIN
pcf, Da, 8, 00, 30		UNITS, DEPTHMODE, DEPTH, ELAPSED MIN, ELAPSED SEC
134.6,0.44,0.0		DWET, DWET PREC, DWET BIAS
14.2,0.25,0.0		H2O, H2O PREC, H2O BIAS
120.4,0.69		DRY, DRY PREC
11.8, Md, 125.5, 96.0		WATER%, COMPACTION TEST, MAXIMUM VALUE, %
COMPACTION		
8160,0.95,4738,1.01		DCOUNT, DXi, MCOUNT, MXi
PRINT REPORT FORMAT		
R101 -1 1016 1344		ID, TESTS, MONTH/DAY, HOUR/MIN
Da8 ET00:30		DEPTHMODE/DEPTH, ELAPSED TIME
pcf wet h2o dry		UNITS, WET HEADER H2O HEADER, DRY HEADER
Dn 134.6 14.2 120.4		DENSITY ROW, WET DENSITY, H2O DENSITY, DRY DENSITY
Pr 0.44 0.25 .7		PREC ROW, DWET PREC, H2O PREC, DRY PREC
% 11.8 96.0		% ROW, WATER %, % COMPACTION
Md 125.5		COMPACTION TEST, MAXIMUM VALUE
Bi 0.0 0.0		BIAS ROW, DWET BIAS, H2O BIAS
R101 -1 1016 1344		ID, TESTS, MONTH/DAY, HOUR/MIN
Da8 ET00:30		DEPTHMODE/DEPTH, ELAPSED TIME
pcf wet h2o		UNITS, WET HEADER, H2O HEADER
Ct 8160 4738		COUNTS ROW, DWET COUNT, H2O COUNT
Xi 0.95 1.01		Xi ROW, DWET Xi, H2O Xi

7. Press **ENTER**.

Printer starts printout and **PORTAPROBE®** screen displays:

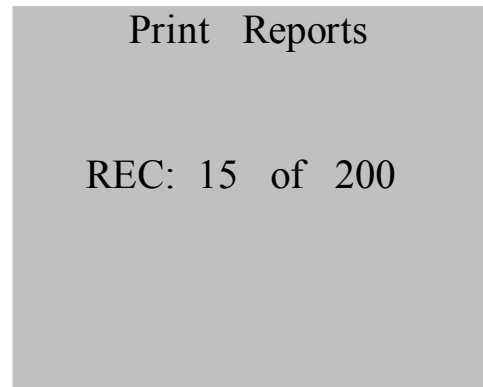

Line numbers on display will vary according to number of records stored in CPN MC-3 memory and currently being printed.

8. Press **STEP + CLEAR** to stop upload or to exit from print mode.

Printer stops printing and CPN MC-3 screen returns to print menu.

APPENDIX C

Data Transfer

To print calibration coefficients, proceed as follows:

Action	Result
1. Set correct baudrate and control characters as above.	
2. Press STEP until prompt is at print coefficients option, then press ENTER .	Printer starts printout and screen displays line number currently being printed. Upon completion, or by pressing STEP + CLEAR to stop transfer, screen returns to print menu.

Data Transfer

CPN MC-3 Dump Software

This is an optional software supplied by CPN-Instrotek on a CD along with the purchase of the RS-232 download cable. The program is intended to be used with all versions of CPN MC-3 nuclear gauges.

Both programs perform the same basic function; they establish a link to the CPN MC-3 through one of the PC's COM ports, send commands to the gauge to retrieve stored records, and output the data to a file on the PC. The only difference between them is in the format of the file produced.

The CPN MC-3 outputs its data in "Print Reports" format or "Dump Reports" format (see the description of these formats in Step 6 of Printing Records), the MC-3 DUMP program copies the data in either of these formats to the output file. The data as it appears in the output file is unaltered by the MC-3 DUMP program. The LOTUS MC3 program reads the data from the CPN MC-3 in the native "Dump Reports" format, and then modifies the data to a comma and quote delimited ASCII format before outputting it to the file.

If you will be using a spreadsheet or database program such as Lotus 1-2-3, Borland Quattro Pro, Microsoft Excel, dBase, Paradox, or similar application for your reports, it is recommended that you use the LOTUS MC-3 program. This program formats the data in the output file MC-3 LOTUS.PRN to accommodate the File Import feature of most spreadsheet and database applications. When importing the MC-3 LOTUS.PRN file into the application, it is sometimes necessary to specify to the application program that the data format is ASCII, with fields (columns) delimited by a comma, text delimited by quotes (""), and records (rows) terminated by a carriage return <CR>.

In Lotus 1-2-3, the keystrokes required to import a file are /FIN (mnemonic /File:Import:Numbers). If you use a program other than Lotus 1-2-3, refer to the program documentation to determine the exact procedure for importing a comma and quote delimited ASCII file.

The MC-3 connects to one of the COM ports on your computer via a serial cable fitted with a miniature LEMO connector on one end (for connection to the CPN MC-3) and a DB-25S (P/N 501516) or an AT-style DB-9S (P/N 500658) on the other end (for connection to your computer). Both MC-3DUMP and LOTUSMC-3 will work with either COM1 or COM2 on your computer.

NOTE

To use special upload options, contact **CPN - Instrotek** for assistance.

APPENDIX D

Accessories

Part Number	Description
C-101050	Campbell Hammer, impact type
C-400950.1	Battery charger, wall
C-702815	Battery charger, car, equipped with cigarette lighter connector
1520046	Survey Meter (Monitor 4) GM detector
500658	Download Cable, 6 ft (1.8m), equipped with RS-232-C/DP9S connectors (computer uploading) IBM, AT, PORTABLES & SOFTWARE

Conversion Factors

Multiply	By	To Obtain
inches (in)	25.4	millimeters*
millimeters (mm)	0.03937	inches
pounds per cubic foot (pcf)	16.01846	kilograms per cubic meter
kilograms per cubic meter (kg/m ³)	0.06243	pounds per cubic foot
pounds per cubic foot (pcf)	0.01601846	grams per cubic centimeter
grams per cubic centimeter (gr/cm ³)**	62.428	pounds per cubic foot

* On the source rod depth settings of the CPN MC-3 guidetube, 1 inch is equals to 25.0 millimeters.

** The **CPN MC-3 PORTAPROBE**[®] displays grams per cubic centimeter as gcc.

GLOSSARY

ASTM: American Society of Testing and Materials. Publish standard test methods for all materials, including moisture and density determination of soil- aggregates and pavements.

COMPACTION (DENSITY) CONTROL: The testing of soil and aggregate mixtures during field construction to assure that specified compaction levels are obtained relative to laboratory-determined values. The following ASTM standard test methods are used to obtain the maximum values to be entered into the **CPN MC-3 PORTAPROBE®** for relative (%) compaction determinations.

- D 1557: Moisture-Density Relations of Soils and Soil-Aggregate Mixtures Using 10-lb (4.54 kg) Rammer and 18-in (457 mm) Drop.
- D 1188: Bulk Specific Gravity of Compacted Bituminous Mixtures Using Paraffin-Coated Specimens.
- D 2041: Theoretical Maximum Specific Gravity of Bituminous Paving Mixtures.

DRY DENSITY (Dn Dry): Mass of soil, after drying for 24 hours at 110° C, contained in a unit volume of undried soil, expressed in pcf or g/cm³. Calculated by the CPN MC-3 as follows:
 $Dn\ wet - Dn\ H_2O = Dry\ Density.$

DRY DENSITY-MOISTURE CONTENT RELATIONSHIP: The relationship between dry density and moisture content of a soil under a given compactive effort. Commonly known as a Proctor Test after its originator, R.R. Proctor.

MAXIMUM BULK SPECIFIC GRAVITY (Av): the maximum bulk specific gravity of a paving mixture. Determined by laboratory test and programmable into the CPN MC-3 for percent air void calculations (%Av).

MAXIMUM DRY DENSITY (Md): The dry density obtained using a specified amount of compaction at the optimum moisture content. Commonly known as the Proctor value and programmable into the CPN MC-3.

MAXIMUM WET DENSITY (Mw): The maximum density of a paving mixture. Determined by laboratory test and commonly known as Marshall value. Programmable into the CPN MC-3 for relative compaction calculations (%MW).

MOISTURE CONTENT: (%H2O): The mass of water in a soil expressed as a percent of the dry soil mass. Calculated by the CPN MC-3 as:
 $Dn\ H_2O / Dn\ dry \times 100.$

OPTIMUM MOISTURE CONTENT (OMC): The moisture content of a soil at which a specified amount of compaction will produce the maximum dry density, expressed as % moisture.

PERCENT AIR VOIDS (%Av): The volume of air voids in a soil or paving mixture expressed as a percentage of the total volume of the material. Calculated by the CPN MC-3 as:
 $((Av - Dn\ wet) / Av) \times 100.$

RELATIVE or % COMPACTION, PAVEMENTS (%Mw): The percentage ratio between the total density of an in-place pavement (Dn wet) and its maximum total density (Mw) as determined by a specified laboratory compaction test.

RELATIVE or % COMPACTION, SOILS (%Md or Av): The percentage ratio between the dry density of an in-place soil (Dn dry) and its maximum dry density (Md), determined by a specified laboratory compaction test.

TOTAL MOISTURE (Dn H2O): The mass of water in a unit volume of soil, expressed in pcf or g/cm³. A direct measurement of the CPN MC-3.

WET DENSITY (Dn wet): Mass of bulk soil, including solids, water, and air, contained in a unit volume, expressed in pcf or g/cm³. A direct measurement of the CPN MC-3.

%

%COMP
key • 14

A

Accessories • 52
Americium-241:Beryllium • 3
Asphalt Pavement • 31, 33
ASTM • 54
Standards • 1

B

Backscatter Measurements • 31
Battery Charger Jack • 10
Battery Life • 7
battery pack • 2

C

CALIB
key • 14
Calibration • 7, 24, 26
Campbell Hammer
 usinf the • 35
Cesium-137 • 3
Changing Screen Results • 23
Changing Units • 23
Charging Battery Pack • 43
Charging Time • 7
CHEMICAL COMPOSITION • 8
Chemical Error • 6
Clean and Lubricate Shutter Mechanism • 40
CLEAR
 key • 13
COMPACTION % and MAXIMUM Parameters • 19
COMPACTION (DENSITY) CONTROL • 54
Concrete Testing • 38
Configuring PORTAPROBE® for Measurements • 16
Control Test Strip • 39
Conversion Factors • 53
Core Correlation • 38
COUNTING MODE selection • 19
CPN MC-3 Dump Software • 51
CPN MC-3 PORTAPROBE® Features • 2
CPN MC-3 PORTAPROBE® Inspection • 9

D

D BIAS
 key • 14
Data Interface • 7
Data Logging • 28
Date and Time Reset • 19
Definitions • 8
Density Range • 6

DENSITY and MOISTURE BIAS Parameters • 19
density measurement • 3
Depth of Measurement • 6, 8
Dimensions • 6
Display • 6
Display Messages and Prompts • 45
DRY DENSITY (Dn Dry): • 54
DRY DENSITY-MOISTURE CONTENT RELATIONSHIP •
 54

E

Edit Coefficients • 24
Electrical specifications • 7
Encapsulation • 7
ENTER
 key • 13
Environmental specifications • 7

F

Factory Configuration • 18
Field Use • 31
Functional Description • 3

G

gamma emitter • 3
Gamma Source • 7
Geiger-Mueller • 3
 detector • 3
General Information • 1
GLOSSARY • 54
guide tube assembly • 10

H

Handle Assembly Inspection • 41
Helium-3
 detector • 3
Humidity • 7

I

ID
 key • 13
Index • 55

K

Keyboard Functions • 13

L

Leak Test • 42
Learning to Use the CPN MC-3 • 11
LOTUSMC3 • 51

M

M BIAS
key • 14
Maintenance • 40
MAX
key • 14
MAXIMUM BULK SPECIFIC GRAVITY (Av) • 54
MAXIMUM DRY DENSITY (Md) • 54
MAXIMUM WET DENSITY (Mw) • 54
MC3DUMP • 51
Memory storage • 2, 7
MOISTURE CONTENT: (%H₂O) • 54
moisture measurement • 3
Moisture Measurements • 36
Moisture Range • 6

N

neutron emitter • 3
Neutron Source • 7
Normal
mode • 22

O

Operating Temperature • 7
Operation • 11
Operation Summary • 30
OPTIMUM MOISTURE CONTENT (OMC) • 54
Other Test Methods • 38
Over-sized Rock Correction • 36

P

Parameters
Range • 18
Percent Air Void Determination • 32
PERCENT AIR VOIDS (%Av) • 54
Performance • 6, 7
potential danger • 1
Power Consumption • 7
Power Source • 7
Precision • 6, 8
PRINT
key • 13
Product Description • 1

R

radiation
emitting • 3
hazard • 1
radioactive sources • 3
Radiological specifications • 7
Range
of Parameters • 18
RECALL
key • 13
RELATIVE or % COMPACTION, PAVEMENTS (%Mw) • 54
RELATIVE or % COMPACTION, SOILS (%Md or Av): • 54
Reviewing Test Results • 29

Roller Evaluation • 39
Roughness Error • 6
RS-232-C Connector • 10

S

Self Calibration • 26
Shipping Requirements • 7
Shipping Weights • 6
Soils/Aggregates • 34, 36, 37
Special Form Approval • 7
Specifications • 6, 7
Standard Count Procedure • 20
Standard Counts • 20, 21
Standard Equipment • 4, 5
START
key • 13
Statistical Control • 38
STD
key • 14
STEP
key • 13
STEP + CALIB • 15
STEP + CLEAR • 15
STEP + ENTER • 15
STEP + ID • 15
STEP + START • 15
STEP + TIME • 15
STEP + UNIT • 15
Storage • 43
Storage Temperature • 7
Storing Test Results • 28
SURFACE ROUGHNESS ERROR • 8

T

Taking a Test • 22
Thin Lift
mode • 22
Thin Lift Overlays • 33
TIME
key • 14
TIME and PRECISION Parameters • 19
TOTAL MOISTURE (Dn H₂O) • 54
training course • 1
Transmission Measurements • 35
Transmission Measurements • 34
Trench Testing • 37
Trench Wall
mode • 22
Troubleshooting Guide • 46, 47

U

UNIT
key • 14
Units of Measurements • 7
Units of Measurement • 23
UNITS Parameters • 18
Using the Campbell Hammer • 35

Nuclear Gauge Emergency Response Information for Transportation
Reference DOT p5800.5 ERG93, and 49CFR

Potential Hazard

1) Proper Shipping Name

- Radioactive Material Type A Package, special Form, Non-Fissile or Fissile-Excepted, 7, UN3332 RQ

2) Health Hazards

- Radiation presents minimal risk to lives of persons during transportation accidents.
- Undamaged packages are safe; damaged packages or materials released from packages can cause external radiation hazards. Contamination is not suspected.
- Packages (cartons, boxes, drums, articles, etc.) identified as "Type A" by marking on packages or by shipping papers contain non-Life endangering amounts. Radioactive sources may be released if packages are damaged in moderately severe accidents.
- Packages (large and small, usually metal) identified as "Type B" by marking on packages or by shipping papers contain potentially life endangering amounts. Because of design, evaluation, and testing of packages, life endangering releases are not expected in accidents except those of utmost severity.
- Commonly available instruments can detect most of these materials.
- Water from cargo fire control is not expected to cause pollution.

3) Fire or Explosion

- Packaging can be consumed without content loss from sealed source capsule.
- Radioactive source capsules and Type B packages are designed to withstand temperatures of 1475°F (800°C)

Emergency Action

4) Immediate Precautions

- Priority response actions can be performed before taking radiation measurements.
- Priorities are life saving, control of fire and other hazards, and first aid.
- Isolate hazard area and deny entry. Notify Radiation Authority of accident conditions.
- Delay final cleanup until instruction or advice of Radiation Authority.
- Positive pressure self-contained breathing apparatus (SCBA) and structural firefighter's protective clothing will provide adequate protection against internal radiation exposure, but not external radiation exposure.
- Call the following numbers depending on the gauge model:
 - Troxler Electronics Labs, Inc. (919)839-2676
 - CPN (800)852-7550
 - Humboldt Scientific (800)992-4589

5) Fire

- Do not move damaged packages; move undamaged packages out of fire zone.
- Small Fires: Dry chemical, CO₂ water spray or regular foam.
- Large Fires: Water spray, fog (flooding amounts)

6) Spill or Leak

- Do not touch damaged packages or spilled material.
- Slightly damaged or damp outer surfaces seldom indicate failure of inner container.
- If source is identified as being out of package, stay away and await advice from Radiation Authority.

7) First Aid

- Use First aid treatment according to the nature of the injury.
- Persons expose to special form sources are not likely to be contaminated with radiation material.

TIPS TO AVOID COSTLY WATER DAMAGE

- If you can avoid it, do not use the gauge in rain or let it be sprayed by a water truck
- If testing in rain, or light drizzle, cover the gauge with plastic.
- Keep the case dry by covering with plastic or storing in a covered area. In a heavy, water will seep through the case. If the gauge is stored in a wet case long enough, permanent water damage can occur.
- Do not store a wet gauge! Be sure the gauge and case are completely dry first. Remove the stack from the gauge, wipe off water, and store unit in a dry area. Leave the lid of the case open to allow it to dry. You may also use a hair dryer to dry it more quickly.

MC-1DR, MC-3 Radiation Profile Chart Readings in Mrem/hr

	FRONT		BACK		LEFT SIDE		RIGHT SIDE		TOP		BOTTOM		HANDLE	
	Gamma	Neutron	Gamma	Neutron	Gamma	Neutron	Gamma	Neutron	Gamma	Neutron	Gamma	Neutron	Gamma	Neutron
Gauge	0.05 M	7.25	3.09	2.17	6.33	1.86	9.50	1.00	8.44	1.84	30.99	6.37	0.61	0.30
	0.30 M	0.99	0.80	0.92	1.97	0.61	0.92	0.31	0.39	0.49	12.54	0.98		
	1.00 M	0.14	0.14	0.14	0.24	0.12	0.14	0.06	0.14	0.09	0.22	0.13		
Case	0.05 M	2.63	1.44	0.83	0.76	0.17	5.80	4.29	4.48	0.88	5.01	1.00		
	0.30 M	0.76	0.48	0.61	0.18	0.10	0.85	0.76	0.76	0.33	1.84	0.43		
	1.00 M	0.14	0.10	0.14	0.07	0.04	0.18	0.11	0.19	0.07	0.33	0.11		

Survey Meters Used:

Gamma:
Model: Eberline ESP-1 w/HP270, Serial# 1919, Calib. Date: Dec. 15 1998, Background Count: 0.03 mrem/Hr

Neutron:
Model Eberline ESP-1 w/NRD, Serial# 258, Calib. Date: Dec. 15, 1998, Background Count: 0.01 mrem/Hr