

1. General

MCR200 is an ideal multifunctional reader designed for Banking System. It can encode and read data of stripe in the bank passbook and card. Obtaining read/write parity functions together. According to user requirement the device can integrate with IC card and SAM card module. MCR200 is perfectly choice by bank, stock or etc.

2. Specification

- Voltage: +9V/DC \pm 10% or +5V/DC \pm 10%
- Current : \leq 300mA
- Sweep speed: 10 ~ 100cm/s
- Head life: 500,000 times
- IC card slot life (Main): 200,000 times
- IC card slot life (Sub): 100,000 times
- SAM card slot life: 5,000 times
- Encoding standard: According to IBM、ISO、ANSI
- Encoding density:
 - Track2:75BPI / 210BPI at optional
 - Track3:210BPI
- Encoding characters:
 - 210BPI Max length: 104
 - 75BPI Max length 37
- Environmental Requirement: Temp. 0 $^{\circ}$ C~45 $^{\circ}$ C, Humidity 10~90%RH
- Dimension (L*W*H, mm): 215*64*65
- Weight:
 - Equipped IC card module: 700g
 - Without IC card module : 650g
- IC card module according to IS07811/7816 Standard, Chinese financial IC card criterion (PBOC2.0) and EMV Standard

3. Appearance

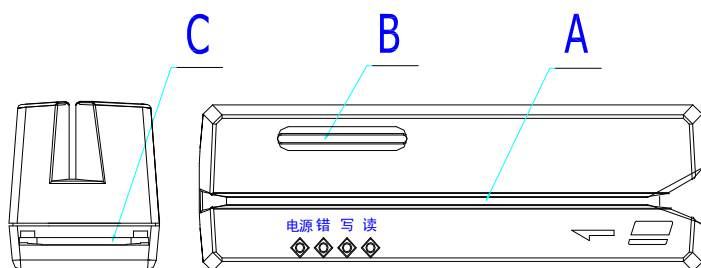

A、MSRE slot B、Main IC card slot C、Sub IC card slot

4. Framework of Working Principle

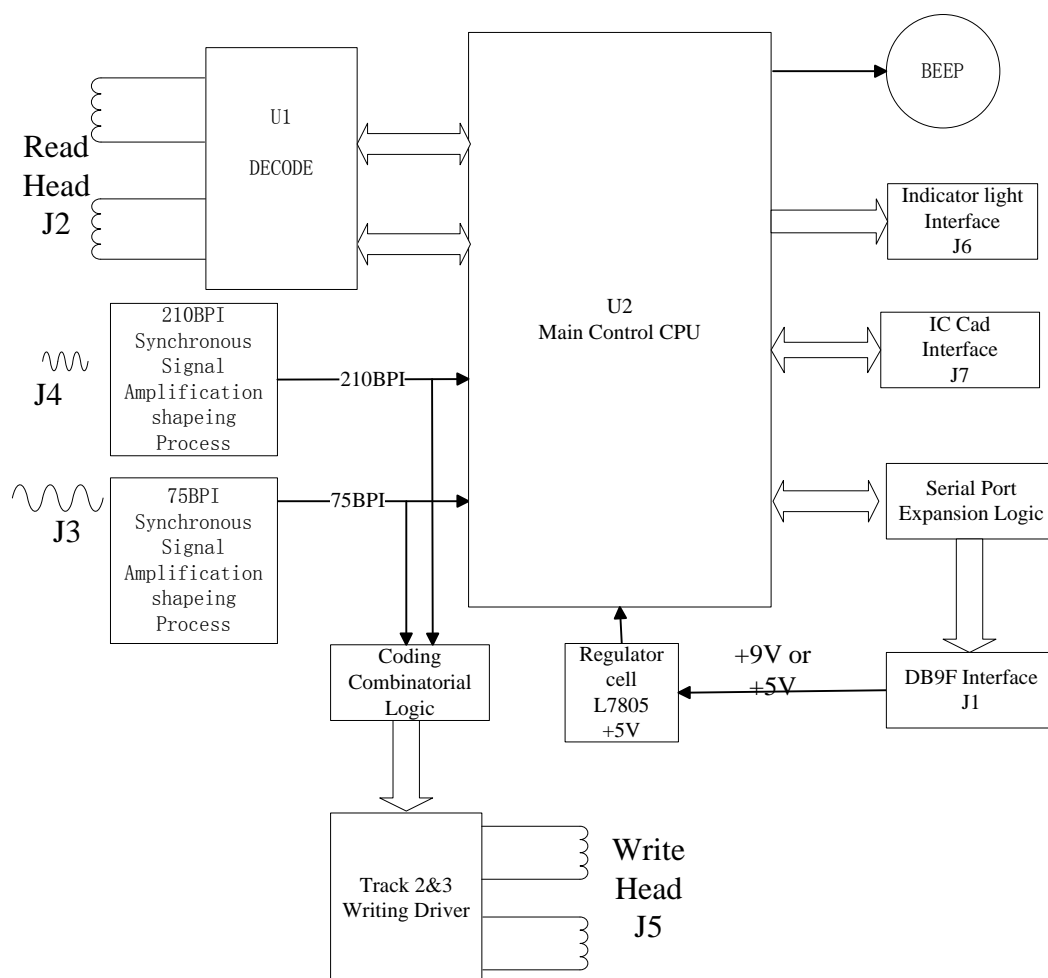

5. Installation

PC(or Terminal) power off, the included cable connect with PC' s(or Terminal) series port, and the DB9F connector link with MCR200. After that power on, the MCR200 will test-self, if all is ok, then can run the MCR200 normally. If the included cable has series port expansion ports(A, K), it can connect with pin pad or other series port device.

6. Interface definition

MCR200 can support 3 series ports. Through the 8 bits DIP switch, the communication parameter (baud rate, data bit) can be set (1 Stopping bit 1).

Signal definition:

Host connector (DB9F)	
1	+5V
2	TXD
3	RXD
4	TXD1
5	GNG

6	+9V
7	RXD2
8	TXD2
9	RXD1

7. Command Set

7.1 MSRE Module

7.1.1 Switch setting DIP8

There is a 8bit DIP switch and 1 reset button at the bottom of the MCR200. The DIP switch is used for default parameter, and the reset button is used for Hard Reset.

SW1	Baud Rate	SW2	Exit when write delay ovetime	SW3	Data Length
ON	1200	ON	Exit	ON	8Bits no verify
OFF	9600	OFF	No permission for exit	OFF	7Bit even verify

SW4	Character Set
ON	ABA1
OFF	ABA2

SW5	Track2 encoding density set
ON	75 BPI
OFF	210BPI

SW6	Emulation set
ON	BP8902V
OFF	STAR33III

SW7	Encoding Format
ON	Track2 is format3, track3 isformat4
OFF	Track2 and track3 is format4

SW8	A/B port Set when power on
ON	A port
OFF	B port

7.1.2 The Character set for reading and writing

MCR200 can select character set I or character set II, the default setting is set by SW2 switch.

Character set I

ASCII	0	1	2	3	4	5	6	7	8	9	:	#	@	'	=	?
Hex	30	31	32	33	34	35	36	37	38	39	3A	23	40	27	3D	3F
ABA	0	1	2	3	4	5	6	7	8	9	A	B	C	D	E	F

Note: For the characters listed in table, if >1FH, then will be as 30H; <20H, then will be neglected.

Character set II

ASCII	0	1	2	3	4	5	6	7	8	9	:	#	@	'	=	?
Hex	30	31	32	33	34	35	36	37	38	39	3A	23	40	27	3D	3F
ABA	0	1	2	3	4	5	6	7	8	9	A	B	C	D	D	F

Note: 1. For the characters listed in table, if >1FH, then will be as 30H; <20H, then will be neglected.

2. When = or ' (ASCII) is written in the magnetic card, it will be changed into D (ABA). When this data is read, D (ABA) will be changed into = (ASCII).

7.1.3 The data record format standard

Standard Sequence	Initiative Character	Stop Character	Remark
Standard 1	BA	F	IBMF
Standard 2	BA	F	IBMF
Standard 3	BA	C	IBMC
Standard 4	B	F	ISO
Standard 5	D	F	DIN
Standard 6	B	C	SPECIAL

7.1.4 Common Control Command**7.1.4.1 Reset and Handshake command**

Command	Function	Returning Code
ESC 0 (1b 30)	Soft Reset command, quit read/write status	No
ESC S (1b 53)	Reset command, reset the MCR200	No
ESC e (1b 65)	Handshake command	ESC y (1b 79)

7.1.4.2 Select port command

Command	Function
ESC % B (1b 25 42)	Select host port, close extend port
ESC % A (1b 25 41)	Select extend port A, close host port
ESC % D (1b 25 44)	Select extend port D, close host port
ESC % K (1b 25 4B)	Select extend port K, close host port
ESC % I (1b 25 49)	Select IC card interface, close host port, and the green LED will be lit
ESC % J (1b 25 4A)	Close IC card interface, select host port, and green LED will be closed

Note: If the extend port is selected, all control commands can not work except select

port command.

7.1.4.3 Initiative encoding position setting

Command	Initiative encoding position
ESC 6 (1B 36)	*12mm
ESC 7 (1B 37)	20mm
ESC 8 (1B 38)	22mm
ESC 9 (1B 39)	25mm

Noted: The default position is 12mm

7.1.4.4 Encoding density setting

Command	Function
ESC L(1b 4c)	Set second track as 75BPI
ESC H(1b 48)	Set second track as 210BPI

Note: The default setting of the second track is defined by DIP switch

7.1.4.5 Record Standard Command

Track	Command	Standard Sequence
Second	ESC 1 (1B 31)	Standard 1
	ESC 2 (1B 32)	Standard 2
	ESC 3 (1B 33)	Standard 3
	ESC 4 (1B 34)	Standard 4
	ESC 5 (1B 35)	Standard 5
	ESC Z (1B 5A)	Standard 6
Third	ESC T1 (1B 54 31)	Standard 1
	ESC T2 (1B 54 32)	Standard 2
	ESC T3 (1B 54 33)	Standard 3
	ESC T4 (1B 54 34)	Standard 4
	ESC T5 (1B 54 35)	Standard 5
	ESC TZ (1B 54 5A)	Standard 6
Double	ESC B1 (1B 42 31)	Standard 1
	ESC B2 (1B 42 32)	Standard 2
	ESC B3 (1B 42 33)	Standard 3
	ESC B4 (1B 42 34)	Standard 4
	ESC B5 (1B 42 35)	Standard 5
	ESC BZ (1B 42 5A)	Standard 6

7.1.5 The first control command set

Note: MCR200 can identify two control command sets. The user can select one of them.

(1) Read Command

Command	Function	Return Data
ESC] (1b 5d)	Read the second track	ESC s TK2data ? FS 1B 73 TK2data 3F 1C

ESC T] (1b 54 5d)	Read the third track	ESC s A TK3data ? FS 1B 73 41 TK3data 3F 1C
ESC B] (1b 42 5d)	Read double tracks	ESC s TK2data A TK3data ? FS 1B 73 TK2data 41 TK3data 3F 1C

Note:TK2data means the second track data has been read, and TK 3data means the third track data has been read. If the data reading failed, it will show the data as DEL (7f).

(2)Write Command

Command	Function
ESC t TK2data GS ESC \ 1b 74 TK2data 1d 1b 5c	Write the second track
ESC t A TK3data GS ESC \ 1b 74 41 TK2data 1d 1b 5c	Write the third track
ESC t TK2data A TK3data GS ESC \ 1b 74 TK2data 41 TK2data 1d 1b 5c	Write double tracks

Note: TK2data means the data is waiting for writing in the second track, and TK 3data means the data is waiting for writing in the third track.

(3)Command for returning the state

ESC j (1b 6a)

This command can return the state of the finish of reading/writing

Function	Return state code
The second track	ESC r p / q / r (1b 72 70/71/72)
The third track	ESC T r p / q / r (1b 54 72 70/71/72)
Double tracks	ESC B r p / q / r (1b 42 72 70/71/72)

Note: The last bit in the returning state code is ‘P’ that means success; ‘q’ means fail; ‘r’ means not reading/writing operation.

7.1.7 The Second control command set

(1)Read Command

Command	Function	Return Data
ESC r (1b 72)	Read the second track	ESC s TK2data ? FS ESC state character 1b 73 TK2data 3f 1c 1b state character
ESC p (1b 70)	Read the third track	ESC t TK3data ? FS ESC state character 1b 74 TK3data 3f 1c 1b state character
ESC q (1b 71)	Read double tracks	ESC s TK2data ? ESC t TK3data ? FS ESC state character 1b 73 TK2data 3f 1b 74 TK3data 3f 1c 1b state character

Note: TK2data means the second track data has been read, and TK 3data means the third

track data has been read. If the data reading failed, it will show the data as DEL (7f).

State character: 30H means reading success

31H means the second track reading failed

32H means the third track reading failed

33H means double tracks reading failed

(2) Write Command

Command	Function	Return Code
ESC w ESC s TK2data ? FS 1b 77 1b 73 TK2data 3f 1c	Write the second track	ESC state character
ESC u ESC t TK3data ? FS 1b 75 1b 74 TK2data 3f 1c	Write the third track	ESC state character
ESC v ESC s TK2data ? ESC t TK3data ? FS 1b 76 1b 73 TK2data 3f 1b 74 TK2data 3f 1c	Write double tracks	ESC state character

Note:TK2data means the data is waiting for writing in the second track, and TK 3data means the data is waiting for writing in the third track.

State character: 30H means writing success

31H means the second track writing failed

32H means the third track writing failed

33H means double tracks writing failed

34H means the write command or data format is illegal

7.2 IC card module

7.2.1 Communication protocol

There are two protocols to transfer::

(1) TLP224 (Intersected character) protocol

The format when transfer of information is right:

<ACK> <LN> <MESSAGE> <LRC>

ACK: 60H, State right command or status

LN: State the length of info (Command or status code)

MESSAGE: Command or status code

LRC: The longitudinal redundant character . The value of XOR with <ACK>, <LN>, <MESSAGE>.

The format when transfer of information is wrong:

< NACK > <LN> <LRC>

NACK: E0H, State error command or status

LN: 00H

LRC: E0H

Sound code file excute the following process:

The transferring byte will be divided up two ASCII codes, for example, transfer the “3AH” , the sound code file will send 33 and 41H, so that can avoid collision with

the system controlling characters. And append the stopping character (EOT) at the end.
EOT=03H

(2)BLOCK PROTOCOL

Format

NAD	PCB	LEN	DAT	EDC
-----	-----	-----	-----	-----

NAD: Initiative and objective identifier

Identifier

7	6	5	4	3	2	1	0
---	---	---	---	---	---	---	---

High half byte state objective identifier, low half byte state initiative identifier.

Host=2; IC card reader/writer=4;

PCB: State the type of block, the format will be decide by the type, describe as following:

Type1: I - Blocks(Information Blocks)Support the data exchange between initiative and objective.

Format:

Bit	7	6	5	4	3	2	1	0
	0	S	0	0	0	0	0	0

Sequence bit

Rest will not use

The six bit is sequence, it will be set “0” when power on, the sequence bit will be 0 when the initiative send the first I - Block, after that the sequence bit will be add 1 when transferring next I - Block.

The sequence bit will be the same as the initiative.

Type2: R - Blocks (Receive Ready Blocks)

Format:

Bit	7	6	5	4	3	2	1	0
	1	0	0	S	0	0	E	V

1 = XOR EDC Error

1 = Other error

1 = Sequence

Type3: S - Blocks (Supervisory Blocks)

S - Blocks Ask for the objective to set the sequence as 0, and return to state transfer over.

Bit	7	6	5	4	3	2	1	0	Synchronization require
	1	1	0	0	0	0	0	0	

Bit	7	6	5	4	3	2	1	0	Synchronization responses
	1	1	1	0	0	0	0	0	

LEN: the length of the info.

DAT: the transferring info(command block or returning status)

EDC: The longitudinal redundant character . The value of XOR with <ACK>, <LN>, <MESSAGE>.

For example: Pick up 4 stochastic data from main IC card:

TLP224 Format:

Power on, command: 12H

The head of command: 60H 01H 12H 73H

The format of intersect transferring data: 36H 30H 30H 31H 31H 32H 37H 33H 03H

To pick up 4 stochastic data: 00H 84H 00H 00H 04H

The head of command: 60H 06H 13H 00H 84H 00H 00H 04H F5H

The format of intersect transferring data: 36H 30H 30H 36H 31H 33H 30H 30H 38H 34H
30H 30H 30H 30H 30H 34H 46H 35H 03H

BLOCK PROTOCOL Format:

Transfer data:

Power on, command: 12H

Format: 42H 00H 01H 12H 51H

To pick up 4 stochastic data: 00H 84H 00H 00H 04H

Format: 42H 40H 06H 13H 00H 84H 00H 00H 04H 97H

7.2.2 Command

Note:

- 1、Default setting: Baud rate 9600, 8Bit no parity, 1 Starting bit, 1 stopping bit
- 2、Only Select IC card Interface (ESC%I) , the following command can be available.

7.2.2.1 Power Off

Command:	11H	have the main IC card module power off
	19H	have the selected sub card module or SAM module power off

7.2.2.2 Power On

Command:	12H	have the main IC card module power on
	1AH	have the selected sub card module or SAM module power on

7.2.2.3 ISO Output

Command:	13H	Pick up data from main IC card
	1BH	Pick up data from selected sub card module or SAM module

7.2.2.4 ISO Input

Command:	14H	Send the data to main IC card
	1CH	Send the data to selected sub card module or SAM module

7.2.2.5 APDU Data Envelopment Exchange

Command:	15H	Send APDU data to main IC card, and obtain the response
	1DH	Send APDU data to selected sub card module or SAM module, and obtain the response

7.2.2.6 Select and define the type of main IC card

Command: 17H T 00H

Description for the parameter “T” :

Hex	Type of main IC card
02H	CPU card
08H	SLE4418/4428 (GPM8K)
09H	SLE4432/4442 (GPM2K or PCB2032/2042)

7.2.2.7 Select and define the type of sub IC card(or SAM card)

Command: 1FH T N

Description for the parameter “T” :

Hex	Type of main IC card
02H	CPU card
08H	SLE4418/4428 (GPM8K)
09H	SLE4432/4442 (GPM2K or PCB2032/2042)

Description for the parameter “N” :

N(Hex)	Card for operation
01H	Sub card
02H	SAM card 1
03H	SAM card 2
04H	SAM card 3

7.2.2.8 SLE4432/4442 Command

Read data area:

(ISO OUT) 00H B0H 00H (Address) (Read Length)

Write data area:

(ISO IN) 00H D0H 00H (Address) (Write Length) (Data0..Data n)

Read protecting area:

(ISO OUT) 00H B0H 80H 00H 04H

Write protecting area:

(ISO IN) 00H D0H 80H (Address) (Write Length) (Data0..Data n)

Read cryptogram area

(ISO OUT) 00H B0H C0H 00H 04H

Write cryptogram area:

(ISO IN) 00H D0H C0H (Address) (Write Length) (Data0..Data n)

Compare cryptogram:

(ISO IN) 00H 20H 00H 00H 03H (Code3, Code2, Code1)

7.2.2.9 SLE4418/4428 Command

Read data area:

(ISO OUT) 00H B0H (AddressH) (AddressL) (Read Length)

Write data area:

(ISO IN) 00H D0H (AddressH) (AddressL) (Write Length) (Data0..Data n)

Read protecting area:

(ISO OUT) 00H B0H (80H+AddressH) 00H 20H

Write protecting area:

(ISO IN) 00H D0H (80H+AddressH) (AddressL) 01H (Data)

Read cryptogram area

(ISO OUT) 00H B0H C0H 00H 03H

Write cryptogram area:

(ISO IN) 00H D0H C0H (Address) (Write Length) (Data0..Data n)

Compare cryptogram:

(ISO IN) 00H 20H 00H 00H 02H (Code2, Code1)

7.2.2.10 Returning status value

Hex	Description
00H	Successfully execute for R/W operation
01H	Unknown driving or command
03H	The length of parameter is error
05H	Returning info overflow
09H	Communication protocol error
10H	Card resetting response erro
15H	Card power off
A2H	Halt connect for overtime
EEH	The module is busy
F8H	Card short circuit
FBH	Not insert card

7.2.2.11 Set Operating Mode

This command selects the operating mode of treatment of an asynchronous card.

The following two modes exist:

- Generic ISO mode
- EMV-compliant mode

Some commands are not allowed in EMV mode, while others undergo changes in their behavior.

Format

17h 00h Mode Main slot

1Fh 00h Mode Auxiliary slot

Where:

Mode: Represents the operating mode to be selected

47h selects the generic ISO mode

45h selects the EMV-compliant mode

00h returns the currently selected mode

Response

S Mode

Where:

Mode: Represents the currently selected mode

47h = generic ISO mode

45h = EMV-compliant mode

8. Maintenance

8. 1 Daily maintenance

Clean Magnetic Head	Use special cleaning card that is soaked by industrial alcohol to clean head for 5-10 times.
Clean encoder	Use special cleaning card that is soaked by industrial alcohol to clean the gear of encoder for 5-10 times.

8. 2 Common problem and solution

Common Problem	Solution
1. W/R error	Clean the head and encoder
2. No response when R/W MSRE or IC module	Check the cable connect and the setting for COMM.