

LVS

Low Voltage Switchgears

World Super
WS
Series

The complete solution for line and load side



**SUPER AE Air Circuit Breakers /// WSS Moulded-Case
Circuit Breakers /// MS-N Magnetic Contactors ///**

Breakthrough technology



75 years of experience

Mitsubishi Electric has been active in the low voltage switchgear (LVS) market since 1933. Ever since Mitsubishi developed and manufactured the first moulded-case circuit breakers, the company has been committed to research and development in this field, making it one of the world's leading manufacturers of circuit breakers.

Innovation

Groundbreaking research and design has resulted in innovative LV switchgear, providing users with greater quality, safety and reliability. Today's LV products feature meticulously designed technology: even the casing material is used in the PA (Polymer Ablation type Auto-Puffer) to provide greater safety and high voltage breaking performance.

Meeting global norms and standards

Mitsubishi Electric's low voltage switchgears meet all the standards and specifications laid down in the EU Low Voltage Directive 73/23/EEC and the Machinery Directive 98/37/EC. Needless to say, all the units carry the CE mark and are certified as conforming to UL, cUL and GOST.



Standards are at the center of our product development.

Contents

The six stoutly reasons

4 – 5



A complete solution for line and load side

6 – 7



SUPER AE – Air Circuit Breakers

8 – 9



WSS – Moulded-Case Circuit Breakers

10 – 11



MS-N – Magnetic Contactors

12 – 13



A wide field of applications

14



Six stoutly reasons for Mitsubishi



Air circuit breaker of the Super AE-SW series

High performance

The one class higher performance of the Mitsubishi low voltage switchgears realizes superb breaking performance. Hence the safety of valuable circuits can be securely maintained.



High reliability

Safe and fault-free operation is guaranteed by various protective mechanisms and safety functions. Reliability is provided due to high operating durability.



Global

In addition to complying with well-known international norms and standards, the low voltage switchgears are also certified by several marine approvals.



Mitsubishi LVS

Moulded-case circuit breaker of the NF-SW series

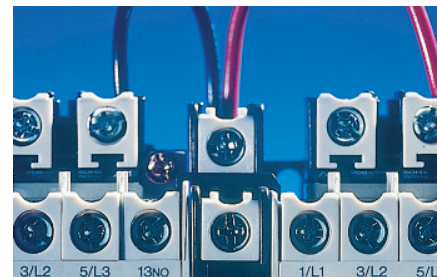
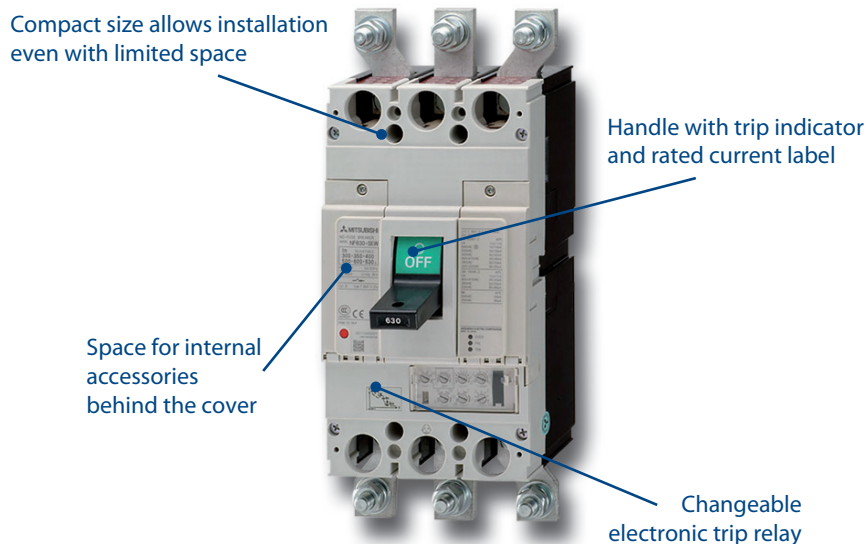

Best solution

The high flexibility of the various line-up, the plenty of accessories and the easy installation enable always the best solution for each application.

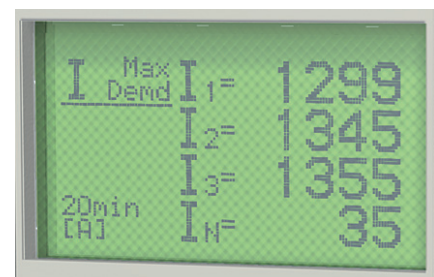

Magnetic contactor with mounted thermal overload relay of the MS-N series

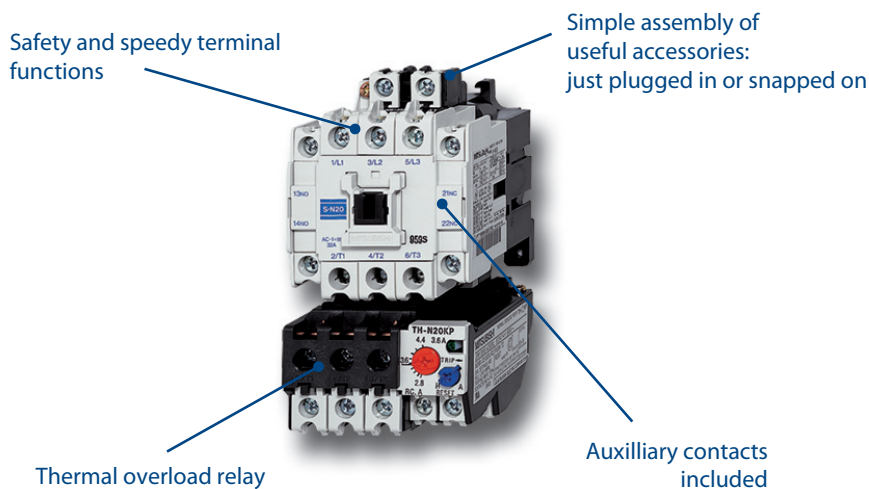

Intelligent

Mitsubishi's low voltage switchgears allows easy connection to various open networks, e.g. CCLink®, PROFIBUS/DP, and MODBUS® via optional interface units. This expands the future possibility in various communication and intelligent control.



Customer friendly

Functionality, compatibility and perfect mechanical design are the main features of the low voltage switchgears supplied by Mitsubishi Electric.

Not all features are available on all LVS. Please check applicability.

A complete solution for line and load side

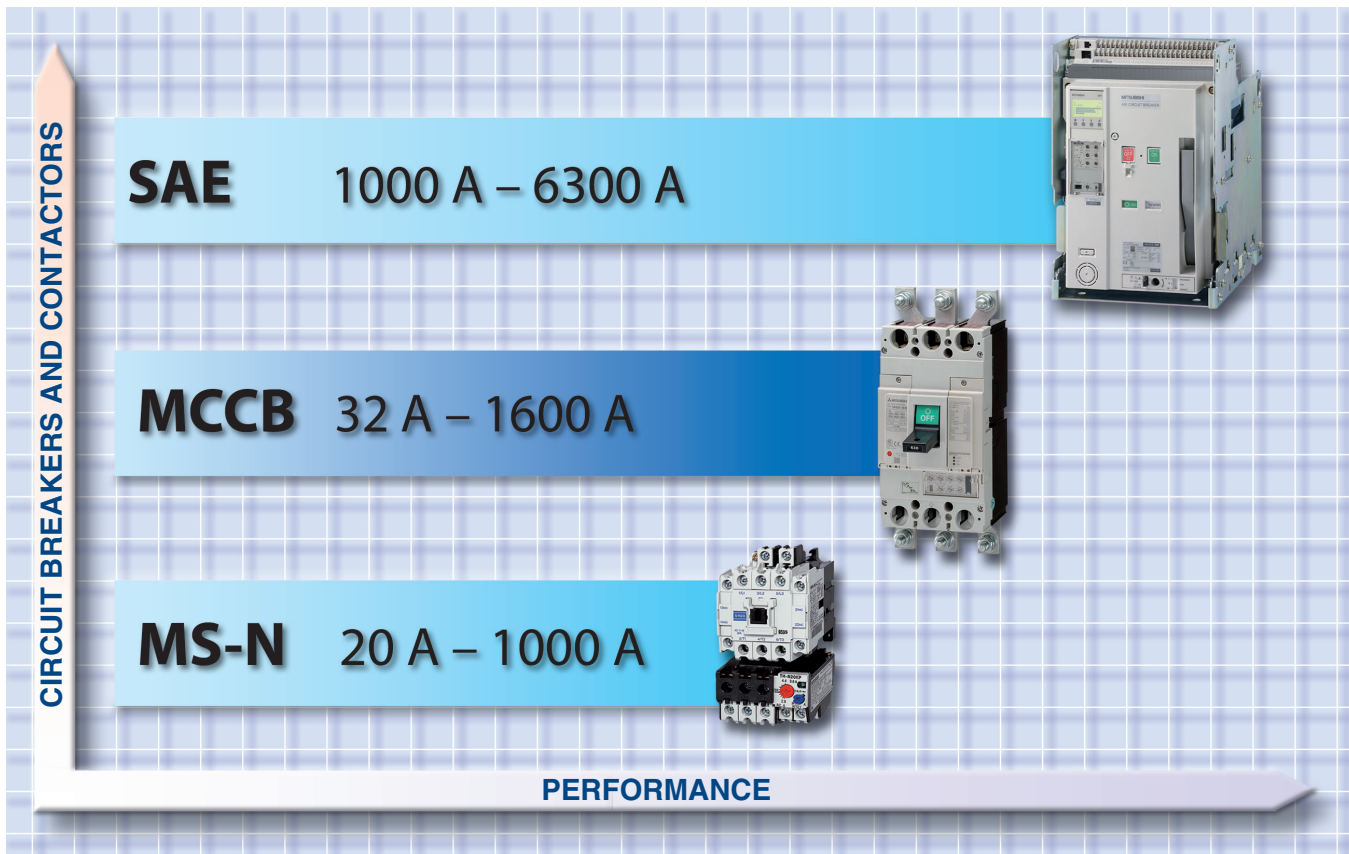

A diverse product range helps you make the right product choice.

Pioneering the future

In recent years, we have been promoting globalization and responding to rapidly expanding internationalization and efforts to protect the global environment through the development of next-generation circuit breakers and earth leakage circuit breakers, and through completion of our World Super (WS) Series product lineup.

We are pioneering a new future for circuit breakers, working to realize market globalization by responding to international needs with products that offer enhanced ease of operation and high performance, are developed with consideration for the environment in mind.

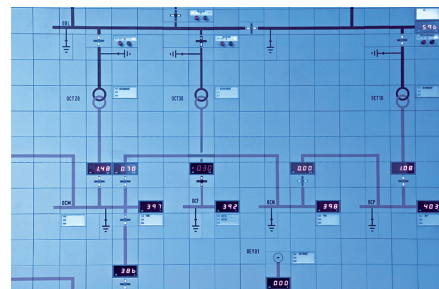

Mitsubishi breakers are used worldwide in modern power distribution systems.

nd load side

Mitsubishi offers a complete solution for line and load side distribution, ranging from air circuit breakers to moulded-case breakers and magnetic contactors.

■ Air Circuit Breakers (ACB's)

Low-voltage air circuit breakers can be used as the main circuit breakers of power distribution systems for buildings, factories, ships, and more to realize high-level circuit monitoring and friendly networking.



Mitsubishi SUPER AE are virtually maintenance free

Mitsubishi's compact Super AE units come in a broad spectrum of performance categories from 1.000 to 6.300 Amps. The basic unit is available as a fixed or "draw out" design, which can be augmented with options for enhanced overload control, network and energy consumption.

■ Molded-Case Circuit Breakers (MCCB's)

Molded-case circuit breakers are utilized to open/close low-voltage circuits and protect wiring by automatically closing circuits when overloading or short-circuiting occurs.

Mitsubishi's MCCBs of the World Super Series (WSS) provide protection across the current range from 3 to 1.600 Amps. Each unit is available in a fixed or slot-in design and has a range of additional options such as electronic trips.

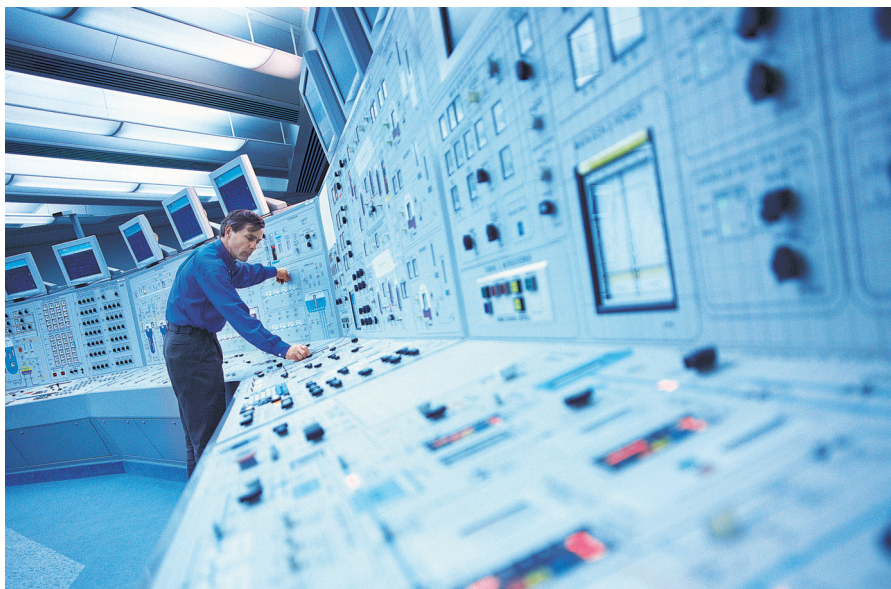

Reliable and secure switching performance even in complex high-power systems



Moulded-case circuit breakers in a compact housing

■ Contactors and Relays

Mitsubishi contactor range is made of magnetic contactors, thermal overload relays and contactor relays for reliable motor protection.

The MS-N range of LV switchgears is a reliable and customizable solution for load side connection. These space-efficient products are up to 25 % smaller than similar units. In addition the MS-N range has enhanced performance. For example, the magnetic contactors withstand voltage drops of up to 35 % while still, ensuring reliable operation.

The MS-N units can be customised with a wide range of options, including thermal overload relays, time delay modules, auxiliary contacts and trip indicators to suit the users specific needs.

Super AE – Air Circuit Breakers



Mitsubishi Air Circuit Breakers are built for the global demands of the 21st century

The range of air circuit breakers and load interrupter switches is complemented by a comprehensive range of accessories. In contrast to earlier models it is now possible to save space by installing some accessories (for example the UVT undervoltage trip) inside the breaker unit.

All live components in the vicinity of the control connections have IP20 protection rating.

Individually configured protection

The circuit breakers are delivered with an electronic trip relay. It is available in versions for all standard power supply voltages. Optional modules are also available for most common applications like protecting transformers, cables, motors and generators. This ensures optimum protection for long time, short time and instantaneous tripping.

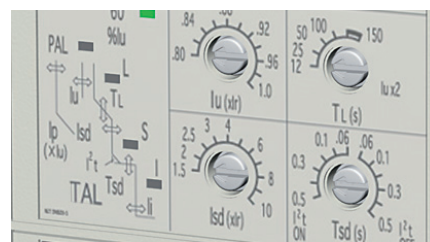

All parameters can be adjusted individually, ensuring that an optimum selectivity for every application is achieved.

In addition to options like pre-alarm, ground fault and earth leakage protection, the electronic trip relay provides complete protection against overloads and short circuits. The protection characteristic can be adjusted individually for the needs of your application.

The main functions, including trip status, alarm and load current are displayed on the LCD screen and can also be output as signals. For easy and quick recognition of alarms, the screen automatically turns red when a fault is detected.

Very user-friendly design

All breakers in the series are available in both 3 and 4 pole versions with fixed or drawout configurations to suit your individual requirements. There are only two standard sizes, making planning much easier.

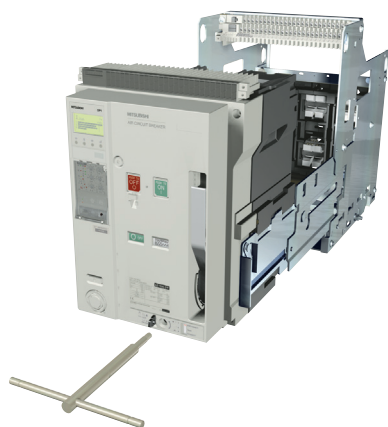

Draw-out type breaker SUPER AE-SW



AE1000-SW → AE2000-SWA

Frame size 1

AE2000-SW → AE4000-SWA

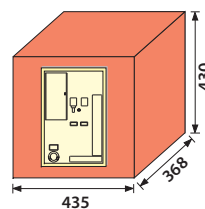
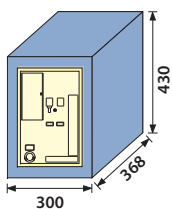

Frame size 2

AE4000-SW → AE6300-SW

Frame size 3

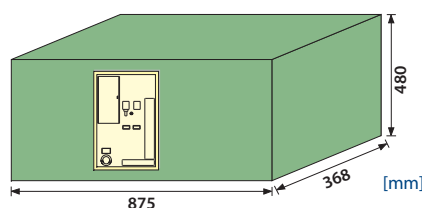

Broad performance range

The growing demand for power naturally increases the levels of short circuit currents in power distribution systems. The SUPER AE series breakers deliver excellent protection against thermal and mechanical damage. The rated surge withstand capability (Uimp) is 12 kV. With a short circuit breaking capacity of 65 – 85 kA they cover the great majority of applications, providing very high-quality protection for your systems.

Icu = Ics

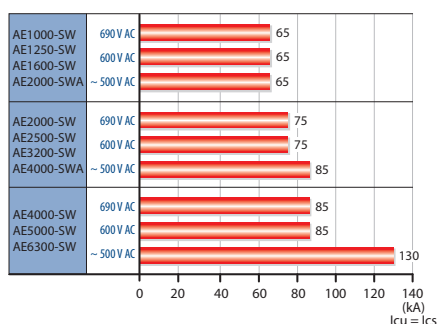

Rated short circuit breaking capacity Icu

Icw

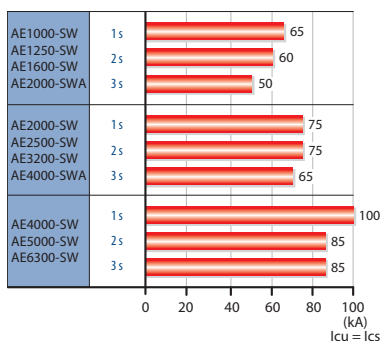

Rated short time withstand current Icw

The small number of components and high production standards ensure a long service life. The breakers of the SUPER AE series are virtually maintenance-free.

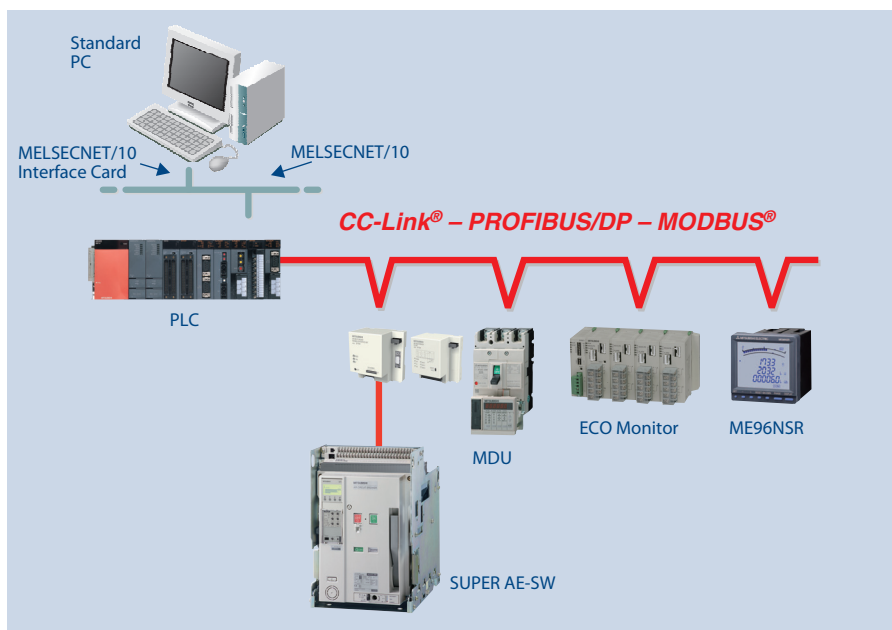

The SUPER AE in network configurations

Comprehensive communications capabilities

Together with optional network interface modules the SUPER AE can now become a fully integrated part of the total network and system concept. In addition to Profibus/DP and CC-Link®, an interface module for MODBUS® is also available.

In combination with an additional I/O module the breaker can be switched on and off remotely via the network. A drawout position switch can also be checked for the current drawout position via the network.



Profibus/DP module

The SUPER AE's network modules enable the monitoring and control of a number of different parameters including voltage and current performance values. In addition, the networking connection can also be used to report alarm and error messages from the breaker back to a centralized control point like a PLC or a SCADA system.

SUPER AE series at a glance

Power range

1000 – 6300 A

Rated insulation voltage

1000 V AC

Rated operation voltage

690 V AC

Number of poles

3, 4

Available types

Drawout type, fixed type

Network links*

Profibus/DP, CC-Link®, MODBUS®

*optional

WSS – Moulded-Case Circuit Breakers



Distinguished and secure breaking performance where reliability is needed



WSS – More performance to meet the needs of the next generation



The circuits of the Mitsubishi WSS breaker series are amongst the smallest compact circuit breakers in the world with electronic overload indication of this kind. The system is based, among other things, on the well-known and proven microprocessor technology.

The WSS breaker meets national and international protection ratings according to VDE, EN, and IEC standards for industrial applications as well as for extended shipping demands. The new tripping technology guarantees a high reliability and highest protection.

Intelligent breaking technology for your safety

With its innovative breaking technology all Mitsubishi breakers offer greater safety and even faster circuit-breaking speed through the use of the latest switch-off technology and innovative engineering, with a newly developed electronic trip relay.

ISTAC – The patented trip technology

This advanced technology is based on the proven Mitsubishi patent, and in consideration of the layout of the current leads provides excellent opening cycles of the main conductors.

Consequently, an instant and safe current breaking is guaranteed. By the high-speed opening and the arc driving, the rising rate of the arc voltage is increased and the peak current is decreased.

Shunt-less current flow technology

The constructive design of movable and fixed conductors considerably contributes to an increased lifetime.

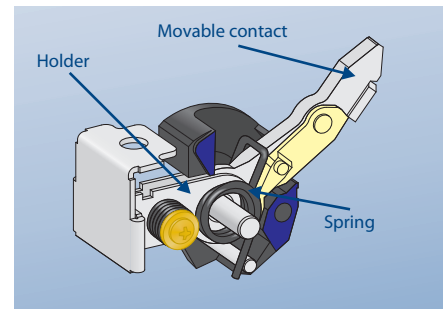

Constructive design for an increased lifetime

Polymer ablation type auto puffer

This technology increases the interrupting performance by blowing out the gas to the arc by right angle. The gas pressure which is generated from high-polymer materials is accumulated in the accumulating space, and the gas is blown to the arc to extinguish. Especially this technology improves the high voltage breaking performance.

400AF, 630AF & 800AF models easier to use

- 630AF models downsized to the size of 400AF model, contributing to compact panels and simplification of design.
- MCCB-AC/DC common use (excluded Electronic trip type) 3-pole: available up to 400 V DC, 4-pole: available up to 500 V DC (NF400-SW, NF630-SW)
- Improved breaking capacity at 690 V AC (NF400-HEW, NF630-HEW)
- Improved breaking capacity at 400/415 V AC (NF400-SEW, NF630-SW/SEW, NF800-SEW)

High-level flexibility

Mitsubishi moulded-case circuit breakers are available with two different kinds of trip relays to satisfy all needs.

The thermal adjustable relay features a wide thermomagnetic setting range and can be used for AC and DC.

The electronic relay provides options to set all relevant currents or time ranges. A pre-alarm function is standard equipment. The relay is particularly used where wide and precise setting ranges are required.

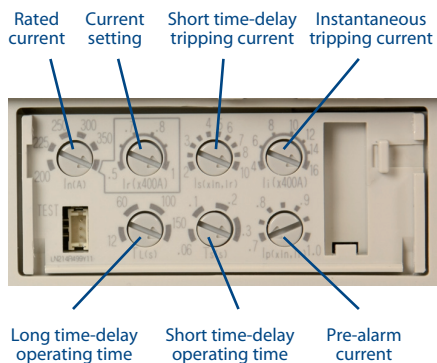

The electronic trip relay provides high-level flexibility according to your demands

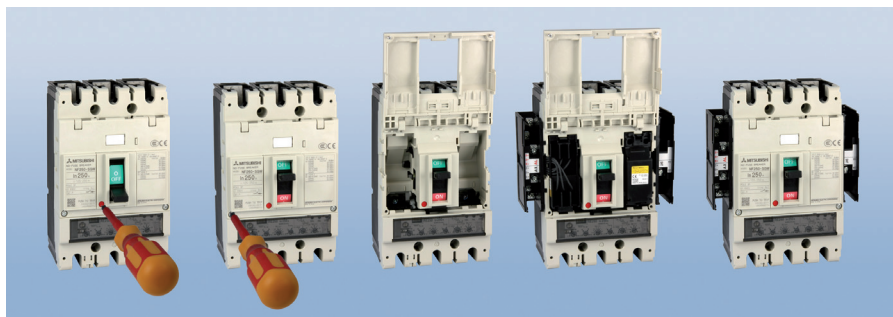

Easy installation of modular cassette type accessories.

Modular accessories

The arrangement and design of pluggable accessories such as indicator and auxiliary contacts allows you to modify the circuit in a way that saves time and space – at any time, even when built in and ready for operation. The presence of separate circuit chambers makes the system even safer.



Thus cassette type accessories ensure flexibility when upgrading circuits.

The cassette type accessories are available in 5 different versions and fit for breaker series from 30 AF up to 800 AF:

- alarm switch (AL)
- auxiliary switch (AX)
- alarm and auxiliary switch (AL+AX)
- shunt trip device (SHT)
- undervoltage trip device (UVT)

Intelligent breakers enable networking

Additional modules acquire status information of the breaker and enable networking and communications via the open networks CC-Link® and PROFIBUS/DP (possible only with ACB's).

The status information of the breaker directly reaches the central information control to be processed.

The breakers meet all regular requirements regarding energy management and network communications.

WSS series at a glance

Power range

3 – 1600 A

Rated insulation voltage

500 – 690 V AC

Rated operation voltage

up to 690 V AC, 300 V DC

Number of poles

3, 4

Tripping device

Thermal magnetic, electronic

Network links*

CC-Link®

*optional

MS-N – Magnetic Contactors

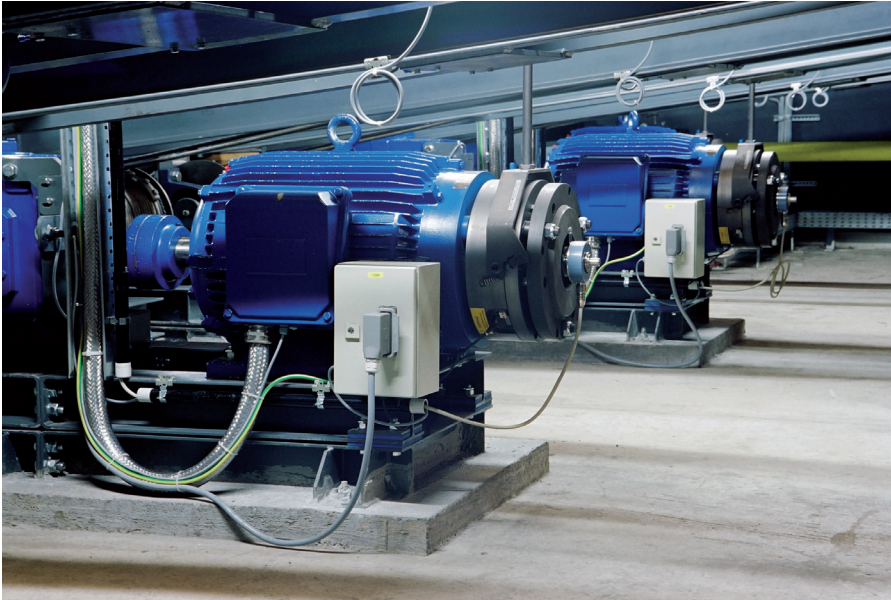

Mitsubishi magnetic contactors protect your investment

Incorporation of CAN terminal for simple wiring

By adopting a CAN terminal, there is no need to remove the screws. The integrated terminal screw and screw holder set in a plastic screw holder, prevent the loss of screw. When each pole is moved and the screw loosened, the screw naturally sets in the screw holder. This is Mitsubishi's original patented CAN terminal.

Unified design

The design of the MS-N Series is unified with a white front face brightening the inside of the panel and providing a cleaner image.

Reduced arc space

By developing a new extinguishing mechanism, the arc space has been reduced to approximately 1/3 against the previous generation. The new contactors are now significantly smaller, reducing the need for costly cubicle space and allowing the contactors to fit easily and neatly into small recesses of a machine or cabinet.

Reliable motor protection

Compact dimensions, modular expansion options and a power-saving design – those are the key characteristics of Mitsubishi's low-voltage switchgear products. The MS-N series includes magnetic contactors, thermal overload relays and contactor relays. DIN installation rail support and standardised terminal spacing make installation and wiring particularly simple.



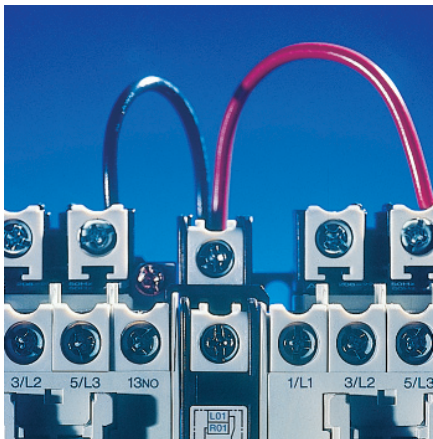

Easy wiring for all contactors

Easy mounting and wiring

MS-N new series contactors, starters and relays can all be mounted on DIN rail (35 mm width). For easy wiring coil terminals of those are arranged on upper side of contactors, moreover distance between center of the rail and the coil terminals are unified to 38.5 mm.

With this new wiring technology, we have designed wiring that is simple and safe for your fingers. Even a line with ring cable sockets can now be assembled fast and without any problems. The clamping screws cannot get lost.

Simple inspection

A visual check of the circuit contacts, all can be done by removing the front cover. You can check the installation after assembly.

The new contacts have led to a considerable improvement of the life and reliability of the auxiliary contacts.

Improved magnet

Use of a spiral kick-out spring improves the dynamic balance of the moving parts, extending the core life and generally stabilizing the core movement. Through the use of modern technology, the efficiency of the magnet has been improved. The contactor can withstand a voltage drop of 35 % with the contact closed.

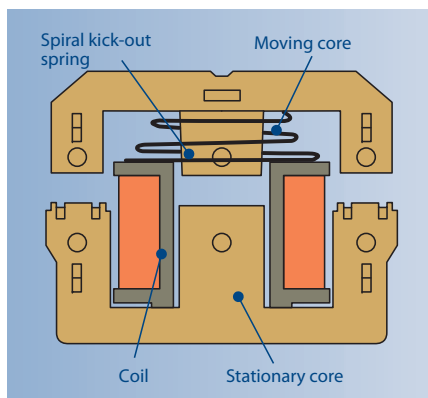

Efficient electromagnet thanks to advanced engineering

Improved safety

The arc blowoff has been improved for safety and space conservation. This was possible due to a new extinguishing structure, that eliminates arcing toward the front (in the direction of the control panel door) when current is cut off. This new element improved safety and potentially saves space.

MS-N series at a glance

Power range

20 – 1000 A

Operating voltage

280 – 440 V AC (50/60 Hz)

Integrated auxiliary contacts

1 – 4 (NO and/or NC)

Options

Auxiliary contact blocks, surge absorbers, interlocks, timers, and many more

Considerably accessories

A cleverly compiled programme of accessories ensures use for a very wide range of applications and requirements. Here too, very simple assembly was a key aspect: the accessory is not screwed but plugged in or snapped on.

Here are some examples of the accessory that is available for the MS-N series:

- Auxiliary contact blocks for front and side assembly
- Surge absorbers for coils
- Mechanical interlocks
- Pneumatic timers
- DC interface modules
- Single units for overload relays
- Connecting wire kit for reversing

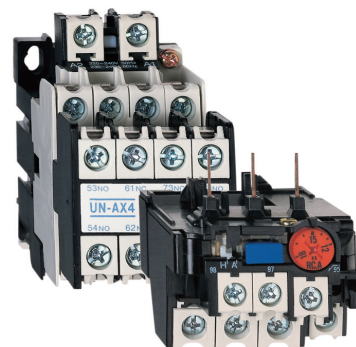

A selection of relays for optimum motor protection characteristics is available optionally.

A wide field of applications



Mitsubishi low voltage switchgears are used in a wide range of areas.

Mitsubishi Electric operates eight branches in Europe, where it has maintained a presence for more than 25 years and developed a constantly growing and far-extending network comprising links to other companies and reliable partnerships.

On the technical side, three manufacturing and automation centres form the basis of tailored automated solutions, further centres already being planned.

A Europe-wide network, the European Service Group (ESG), provides interfaces to experienced engineers and offers distributors support throughout every phase of the project.

Mitsubishi products are found in a variety of industrial, infrastructure and service sector contexts, ranging from critical applications in the pharmaceuticals industry to state-of-the-art leisure and entertainment facilities. Here are just a few examples of recent applications:

- Agriculture
 - Irrigation systems
 - Plant handling systems
 - Sawmills
- Building management
 - Smoke detection monitoring
 - Ventilation and temperature control
 - Lift (elevator) control
 - Automated revolving doors
 - Telephone management
 - Energy management
 - Swimming pool management
- Construction
 - Steel bridge manufacturing
 - Tunnel boring systems
- Food and drink
 - Bread manufacture (mixing/baking)
 - Food processing (washing/sorting/slicing/packaging)
- Leisure
 - Multiplex cinema projection
 - Animated mechatronics (museums/theme parks)
- Medical
 - Respiration machine testing
 - Sterilization
- Pharmaceutical/chemical
 - Dosing control
 - Pollution measurement systems
 - Cryogenic freezing
 - Gas chromatography
 - Packaging
- Plastics
 - Plastic welding systems
 - Energy management systems for injection moulding machines
 - Loading/unloading machines
 - Blow moulding test machines
 - Injection moulding machines
- Printing
- Textiles
- Transportation
 - Sanitation on passenger ships
 - Sanitation on rail rolling stock
 - Fire tender, pump management
 - Waste disposal truck management
- Utilities
 - Waste water treatment
 - Fresh water pumping

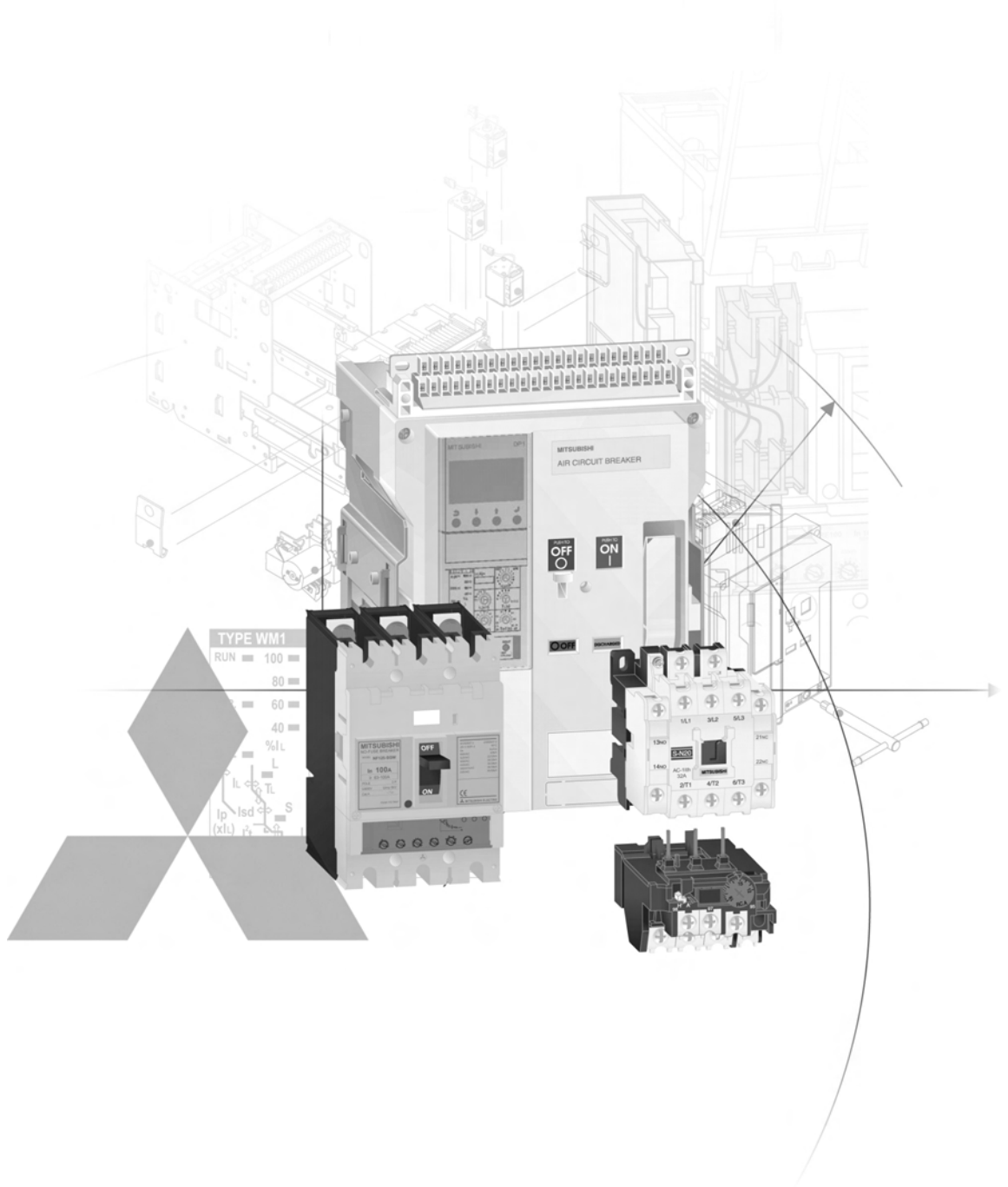

Technical Information Section

More information?

This technical catalogue is designed to give an overview of the extensive range of Low-voltage Switchgears, Air-Circuit Breakers, Moulded-case Circuit Breakers, Magnetic Contactors, Thermal Overload Relays and Contactor Relays and its related accessories. If you cannot find the information you require in this catalogue, there are a number of ways you can get further details on configuration and technical issues, pricing and availability.

For technical issues visit the www.mitsubishi-automation.com website.

Our website provides a simple and fast way of accessing further technical data and up to the minute details on our products and services. Manuals and catalogues are available in several different languages and can be downloaded for free.

For technical, configuration, pricing and availability issues contact our distributors and partners.

Mitsubishi partners and distributors are only too happy to help answer your technical questions or help with configuration building.

For a list of Mitsubishi partners please see the back of this catalogue or alternatively take a look at the "contact us" section of our website.

About this technical catalogue

This catalogue is a guide to the range of products available. For detailed configuration rules, system building, installation and configuration the associated product manuals must be read. You must satisfy yourself that any system you design with the products in this catalogue is fit for purpose, meets your requires and conforms to the product configuration rules as defined in the product manuals.

Specifications are subject to change without notice. All trademarks acknowledged.

© Mitsubishi Electric Europe B.V., Factory Automation - European Business Group

I AIR CIRCUIT BREAKERS

1	BASE UNITS	4
2	ACCESSORIES	10
3	ELECTRONIC TRIP RELAY	20

II MOULDED-CASE CIRCUIT BREAKERS, DISCONNECTORS

4	OVERVIEW	32
5	CIRCUIT BREAKERS	40
6	ACCESSORIES	52

III CONTACTORS, THERMAL OVERLOAD AND CONTACTOR RELAYS

7	OVERVIEW	72
8	MAGNETIC CONTACTORS, THERMAL OVERLOAD RELAYS	76
9	CONTACTOR RELAYS, OPTIONAL PARTS, ACCESSORIES	88

Product Skeleton of Accessories for SUPER AE Series Air Circuit Breakers

Mitsubishi Electric offers a wide range of accessories for the Air Circuit Breakers to serve almost all variations of applications.

1
SAE – BASIC COMPONENTS

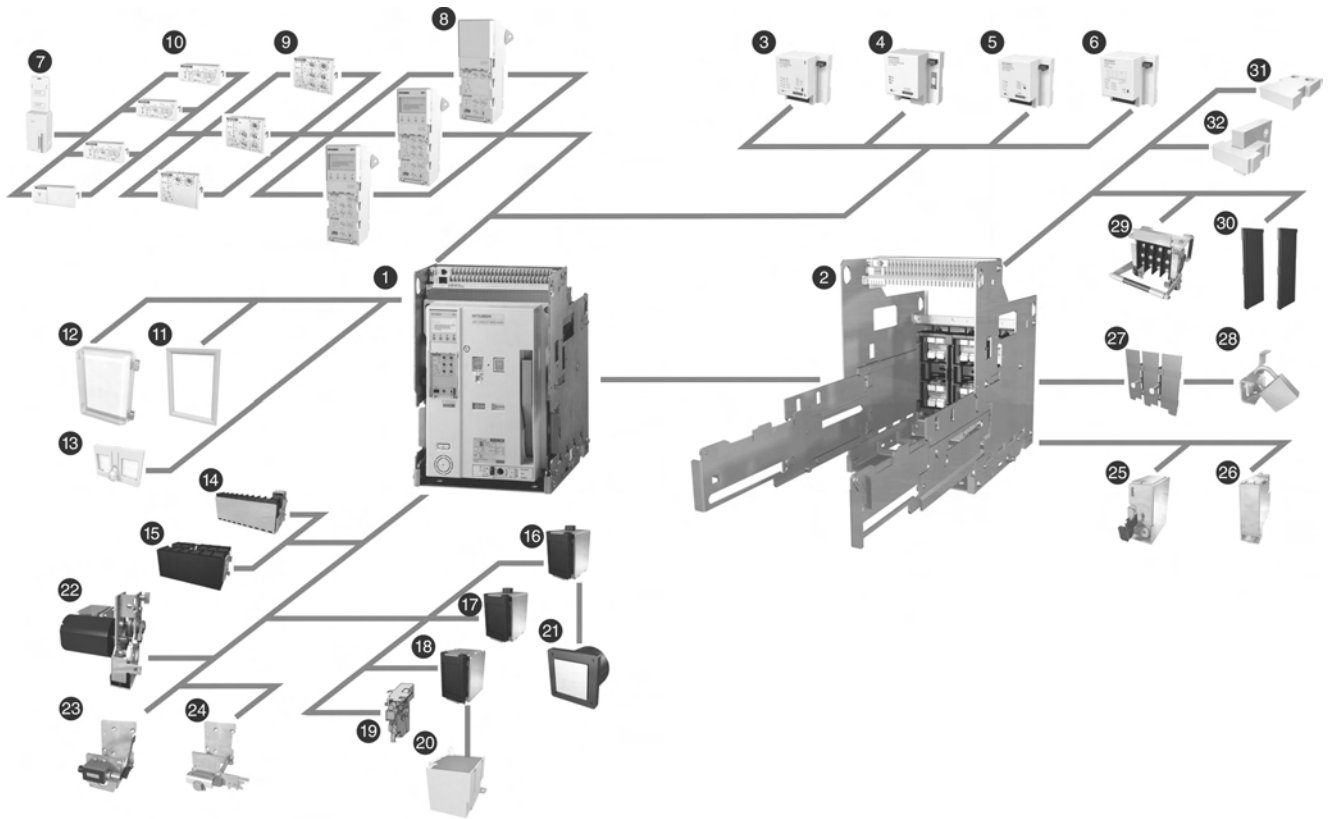

Position	Name
1	Air circuit breaker
2	Cradle
3	CC-Link® Interface unit
4	PROFIBUS-DP Interface unit
5	MODBUS® Interface unit
6	I/O unit
7	Extension module
8	ETR unit
9	Main setting module
10	Optional setting module
11	Door frame (DF)

Position	Name
12	Dust cover (DUC)
13	Push button cover (BC-L)
14	Auxiliary switch standard (AX)
15	Auxiliary switch high capacity type (HAX)
16	Shunt trip device (SHT)
17	Closing coil (CC)
18	Under voltage trip device (UVT)
19	Trip coil (TC (OCR-Alarm))
20	UVT-controller (U-CON)
21	Condenser trip device (COT)
22	Motor charging device (MD)

Position	Name
23	Counter (CNT)
24	Cylinder lock (CYL)
25	Door interlock (DI)
26	Mechanical interlock (MI)
27	Safety shutters (SST)
28	Safety shutter lock (SST-LOCK)
29	Cell switch (CL)
30	Interphase Barrier (BA)
31	Horizontal terminal
32	Vertical terminal

Product Introduction of Accessories for SUPER AE Series Air Circuit Breakers

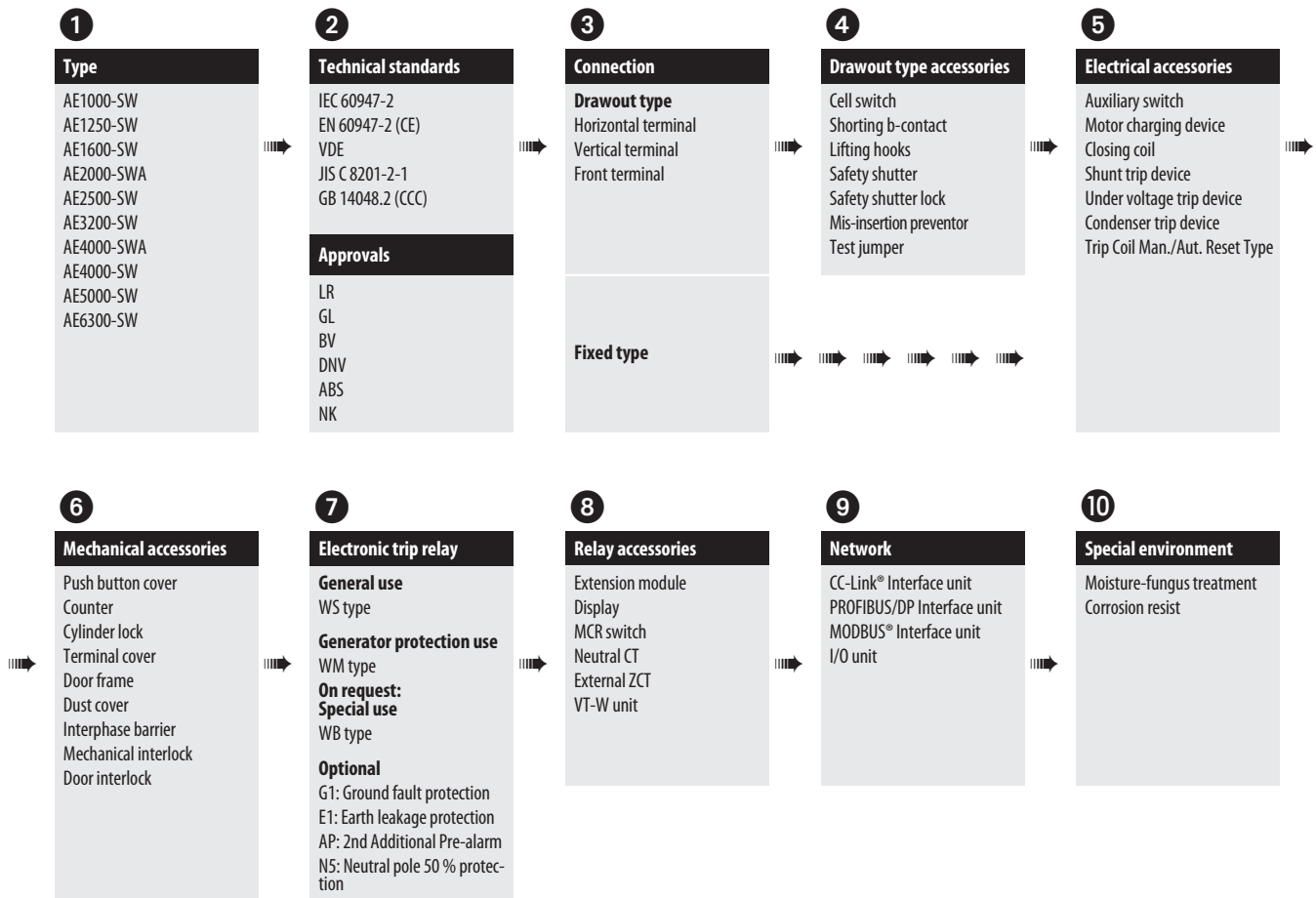

For details on our full range including accessories contact your local distributor

Specifications

SUPER AE – WORLD SUPER SERIES			Breaker type		AE 1000 -SW		AE 1250 -SW		AE 1600 -SW		AE 2000 -SWA		
Frame size	A		1000		1250		1600		2000				
Rated insulation voltage (AC V) 50/60 Hz	U _i						1000						
Rated operating voltage (AC V) 50/60 Hz	U _e						690						
Rated impulse withstand voltage (kV)	U _{imp}						12						
Pollution degree							3						
Number of poles	P		3	4	3	4	3	4	3	4	3	4	
Rated current in (CT rating)			1000		1250		1600		2000				
Adjustment range Rated current (A) I _r	General use (current rating adjustable 0.5 to 1.0 x I _n 0.05 step)		500-550-600-650- 700-750-800-850- 900-950-1000		625-687.5-750-812.5- 875-937.5-1000-1062.5-1125- 1187.5-1250		800-880-960-1040- 1120-1200-1280-1360- 1440-1520-1600		1000-1100-1200-1300- 1400-1500-1600-1700- 1800-1900-2000				
	Generator protection (current rating fixed)		400 ≤ I _r ≤ 1000		800 ≤ I _r ≤ 1250		1000 ≤ I _r ≤ 1600		1250 ≤ I _r ≤ 2000				
Rated current of neutral pole	(A)		1000		1250		1600		2000				
Ultimate breaking capacity I _{cu} (kA rms)	690 V AC		65		65		65		65		65		
	600 V AC		65		65		65		65		65		
	240 – 500 V AC		65		65		65		65		65		
	690 V AC		65		65		65		65		65		
	With MCR 600 V AC		65		65		65		65		65		
	240 – 500 V AC		65		65		65		65		65		
Without instantaneous	690 V AC		25 ^①		25 ^①		25 ^①		25 ^①		25 ^①		
	500 V AC		25 ^①		25 ^①		25 ^①		25 ^①		25 ^①		
Rated service breaking capacity I _{cs} (kA rms) % I _{cu}													
Rated making capacity I _{cm} (kA, peak)	690 V AC		143		143		143		143		143		
	600 V AC		143		143		143		143		143		
	240 – 500 V AC		143		143		143		143		143		
	690 V AC		143		143		143		143		143		
	With MCR 600 V AC		143		143		143		143		143		
	240 – 500 V AC		143		143		143		143		143		
Without instantaneous	690 V AC		52.5		52.5		52.5		52.5		52.5		
	500 V AC		52.5		52.5		52.5		52.5		52.5		
Disconnecter: switching capacity (6 x I _r at 690V AC)			○		○		○		○		○		
Rated short time withstand current (kA rms) I _t	1s		65		65		65		65		65		
	2s		60		60		60		60		60		
	3s		50		50		50		50		50		
Maximum total breaking time	(ms)		40 ^②		40 ^②		40 ^②		40 ^②		40 ^②		
Closing time	(ms)		80		80		80		80		80		
Number of operating cycles (ON/OFF)	With rated current		5000		5000		5000		5000		1500		
	500 V AC I _n		5000		5000		5000		5000		1500		
	690 V AC I _n		5000		5000		5000		5000		1500		
Without rated current		25000		25000		25000		25000		25000 ^④			
Connecting terminal	Horizontal terminal		○		○		○		○		—		
	Vertical terminal		○		○		○		○		○ ^③		
	Front terminal		○		○		○		○		—		
Dimensions (H x W x D mm)	Fixed type		3-pole		410 x 340 x 290		410 x 340 x 290		410 x 340 x 290		410 x 340 x 290		
	4-pole				410 x 425 x 290		410 x 425 x 290		410 x 425 x 290		410 x 425 x 290		
	Drawout type		3-pole		430 x 300 x 368		430 x 300 x 368		430 x 300 x 368		430 x 300 x 368		
	4-pole				430 x 385 x 368		430 x 385 x 368		430 x 385 x 368		430 x 385 x 368		
Weight (kg)	Fixed type		3-pole		41		41		42		47		
	4-pole				51		51		52		57		
	Drawout type (with cradle)		3-pole		64		64		65		70		
	4-pole				78		78		79		84		
	Cradle only		3-pole		26		26		26		31		
	4-pole				30		30		30		35		

① The columns for "without instantaneous" are the values when the bare main body and the external relay is combined.
 ② The number of operating cycles without rated current also include the number of operating cycles with rated current.
 ③ AE4000-SW, AE5000-SW, AE6300-SW, AE2000-SWA and AE4000-SWA apply for only vertical terminal of connecting terminal.
 ④ This value means number of operating cycles of ACB's body not including accessories.
 ⑤ Products with low rating types is available.

SAE – BASIC COMPONENTS 1

AE 2000-SW		AE 2500-SW		AE 3200-SW		AE 4000-SWA		AE 4000-SW		AE 5000-SW		AE 6300-SW	
2000		2500		3200		4000		4000		5000		6300	
		1000								1000			
		690								690			
		12								12			
		3								3			
3	4	3	4	3	4	3	4	3	4(HN, FN) ^②	3	4(HN, FN) ^②	3	4(HN, FN) ^②
2000		2500		3200		4000		4000		5000		6300	
1000-1100-1200-1300-1400-1500-1600-1700-1800-1900-2000 ^⑤		1250-1375-1500-1625-1750-1875-2000-2125-2250-2375-2500		1600-1760-1920-2080-2240-2400-2560-2720-2880-3040-3200		2000-2200-2400-2600-2800-3000-3200-3400-3600-3800-4000		2000-2200-2400-2600-2800-3000-3200-3400-3600-3800-4000		2500-2750-3000-3250-3500-3750-4000-4250-4500-4750-5000		3150-3465-3780-4095-4410-4725-5040-5355-5670-5985-6300	
800 ≤ Ir ≤ 2000		1600 ≤ Ir ≤ 2500		2000 ≤ Ir ≤ 3200		2500 ≤ Ir ≤ 4000		2500 ≤ Ir ≤ 4000		3150 ≤ Ir ≤ 5000		4000 ≤ Ir ≤ 6300	
2000		2500		3200		4000		2000 (4000) ^⑥		2500 (5000) ^⑥		3150 (6300) ^⑥	
75		75		75		75		85		85		85	
75		75		75		75		85		85		85	
85		85		85		85		130		130		130	
75		75		75		75		85		85		85	
75		75		75		75		85		85		85	
75		75		75		75		100		100		100	
45 ^①		45 ^①		45 ^①		45 ^①		65 ^①		65 ^①		65 ^①	
45 ^①		45 ^①		45 ^①		45 ^①		65 ^①		65 ^①		65 ^①	
		100%								100%			
165		165		165		165		187		187		187	
165		165		165		165		187		187		187	
187		187		187		187		286		286		286	
165		165		165		165		187		187		187	
165		165		165		165		187		187		187	
165		165		165		165		220		220		220	
94.5		94.5		94.5		94.5		143		143		143	
94.5		94.5		94.5		94.5		143		143		143	
○		○		○		○		○		○		○	
75		75		75		75		100		100		100	
75		75		75		75		85		85		85	
65		65		65		65		85		85		85	
40 ^⑥		40 ^⑥		40 ^⑥		40 ^⑥		50 ^⑥		50 ^⑥		50 ^⑥	
80		80		80		80		80		80		80	
1500		1500		1000		500		1000		1000		1000	
1500		1500		1000		500		1000		1000		1000	
20000		20000		20000		20000		10000 (3P) / 5000 (4P)		10000 (3P) / 5000 (4P)		10000 (3P) / 5000 (4P)	
○		○		○		—		—		—		—	
○		○		○		○ ^③		○ ^③		○ ^③		○ ^③	
○		○		○		—		—		—		—	
		410 x 475 x 290								414 x 873 x 290			
		410 x 605 x 290								414 x 1003 (1133) x 290 ^⑥			
		430 x 435 x 368				430 x 439 x 368				480 x 875 x 368			
		430 x 565 x 368				430 x 569 x 368				480 x 1005 (1135) x 368 ^⑥			
60		61		63		81		160		160		160	
72		73		75		99		180 (200) ^⑥		180 (200) ^⑥		180 (200) ^⑥	
92		93		95		108		233		233		240	
113		114		116		136		256 (279) ^⑥		256 (279) ^⑥		263 (286) ^⑥	
35		35		35		49		118		118		125	
43		43		43		61		133 (148) ^⑥		133 (148) ^⑥		140 (155) ^⑥	

④ This value means the instantaneous breaking time at short-circuit interruption. As for accessories (SHT, UVT) refer to page 12 and 13.

② 4 (HN) means the neutral poles current capacity is 50% of the rated current, for 4-poles.

4 (FN) means the neutral poles current capacity is 100% of the rated current, for 4-poles

③ () shows the value for 4P FN type.





Remarks:

- All models conform the isolating function according to IEC 60947-2.
- Reverse connection is possible

Connections

Connection arrangements

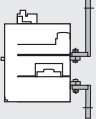
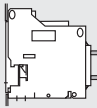
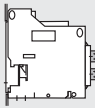

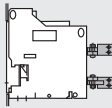
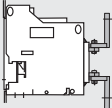
The following connecting methods are available for the **AE1000-SW – AE3200-SW**.

Connection	Horizontal connection	Vertical connection	Front connection	Vertical terminal adapter	Front terminal adapter
Mounting method	Standard	Optional	Optional	Accessory	Optional
Fixed type	 (Standard)	—	—	 (FIX-VTA)	 (FIX-FTA)
Drawout type	 (Standard)	 (DR-VT)	 (DR-FT)	 (DR-VTA)	 (DR-FTA)
Remark	Standard equipment (shipping version)	Special equipment (on request)	Special equipment (on request)	Available as accessory (refer to page 15)	Optional accessory (on request)

Connection image: AE 1000 – 1600-SW, 3-pole type

Standard Fixed type breakers AE1000/1250/1600/2000/2500/3200-SW are also available as Drawout type. Please order the corresponding cradle with the drawout mechanism (see table on next page)

The following connecting methods are available for the **AE2000-SWA, AE4000-SWA** and **AE4000-SW – AE6300-SW**.

Connection	Vertical connection
Mounting method	Standard
Fixed type	 (FIX-VT)
Drawout type	 (DR-VT)
Remark	Special equipment (on request)

Connection image: AE2000-SWA, 3-pole type

For AE2000-SWA, AE4000-SWA, AE4000-SW, AE5000-SW and AE6300-SW models, vertical terminal **only** is available.

Available Connections

Breakers		AE1000-SW	AE1250-SW	AE1600-SW	AE2000-SWA	AE2000-SW	AE2500-SW	AE3200-SW	AE4000-SWA	AE4000-SW	AE5000-SW	AE6300-SW
Connections												
Fixed type (FIX)	Horizontal	●	●	●	—	●	●	●	—	—	—	—
	FIX-VT	—	—	—	●	—	—	—	●	●	●	●
	FIX-VTA	○	○	○	—	○	○	○	—	—	—	—
	FIX-FTA	○	○	○	—	○	○	○	—	—	—	—
Drawout type (DR)	Horizontal	●	●	●	—	●	●	●	—	—	—	—
	DR-VT	○	○	○	●	○	○	○	●	●	●	●
	DR-FT	○	○	○	—	○	○	○	—	—	—	—
	DR-VTA	○	○	○	—	○	○	○	—	—	—	—
	DR-FTA	○	○	○	—	○	○	○	—	—	—	—

● Standard ○ Option

Order information – Air circuit breakers

Standard series AE-SW – Fixed type

Base unit equipment	Breaker	3-pole type	Art. no.	4-pole type	Art. no.
Shipping contents:	AE1000-SW	AE1000-SW 3P Fix, ETRBASE-P3, AX10	168373	AE1000-SW 4P Fix, ETRBASE-P3, AX10	168434
● Electronic trip Relay base unit	AE1250-SW	AE1250-SW 3P Fix, ETRBASE-P3, AX10	168435	AE1250-SW 4P Fix, ETRBASE-P3, AX10	168436
● Power supply PW3	AE1600-SW	AE1600-SW 3P Fix, ETRBASE-P3, AX10	168437	AE1600-SW 4P Fix, ETRBASE-P3, AX10	168438
● 10 auxiliary contacts (5 NO, 5 NC contacts)	AE2000-SW	AE2000-SW 3P Fix, ETRBASE-P3, AX10	168443	AE2000-SW 4P Fix, ETRBASE-P3, AX10	168444
● Automatic reset type trip coil (TCA-AL-W)	AE2500-SW	AE2500-SW 3P Fix, ETRBASE-P3, AX10	168445	AE2500-SW 4P Fix, ETRBASE-P3, AX10	168446
Further elements that must be ordered:	AE3200-SW	AE3200-SW 3P Fix, ETRBASE-P3, AX10	168447	AE3200-SW 4P Fix, ETRBASE-P3, AX10	168448
○ Main setting module for protection					
○ Accessories as required					

Cradle with the drawout mechanism

	Cradle	For type	Art. no.
	CRD163-W	Draw Out type AE1000-AE1600 3P	170078
	CRD164-W	Draw Out type AE1000-AE1600 4P	170079
	CRD323-W	Draw Out type AE2000-AE3200 3P	170080
	CRD324-W	Draw Out type AE2000-AE3200 4P	170081
	REC-FD-W	Drawout mechanism with drawout handle	169004

Air circuit breaker series AE-SWA

Base unit equipment	Breaker	Fixed type	Art. no.	Draw-out type	Art. no.
Shipping contents:	AE2000-SWA	AE2000-SWA 4P Fix, ETRBASE-P3, AX10	168440	AE2000-SWA 3P D/O, ETRBASE-P3, AX10	168441
● Electronic trip Relay base unit	AE2000-SWA	AE2000-SWA 3P Fix, ETRBASE-P3, AX10	168439	AE2000-SWA 4P D/O, ETRBASE-P3, AX10	168442
● Power supply PW3	AE4000-SWA	AE4000-SWA 3P Fix, ETRBASE-P3, AX10	168449	AE4000-SWA 3P D/O, ETRBASE-P3, AX10	168451
● 10 auxiliary contacts (5 NO, 5 NC contacts)	AE4000-SWA	AE4000-SWA 4P Fix, ETRBASE-P3, AX10	168450	AE4000-SWA 4P D/O, ETRBASE-P3, AX10	168452
● Automatic reset type trip coil (TCA-AL-W)					
Further elements that must be ordered:					
○ Main setting module for protection					
○ Accessories as required					

Air circuit breaker series AE4000 – 6300-SW – Fixed / Drawout type

Base unit equipment	Breaker	Fixed type 3/4-pole	Art. no.	Draw-out type 3/4-pole	Art. no.
Shipping contents:	AE4000-SW	AE4000-SW 3P Fix, ETRBASE-P3, AX10	205144	AE4000-SW 3P D/O, ETRBASE-P3, AX10	205153
● Electronic trip Relay base unit	AE5000-SW	AE5000-SW 3P Fix, ETRBASE-P3, AX10	205145	AE5000-SW 3P D/O, ETRBASE-P3, AX10	205154
● Power supply PW3	AE6300-SW	AE6300-SW 3P Fix, ETRBASE-P3, AX10	205146	AE6300-SW 3P D/O, ETRBASE-P3, AX10	205155
● 10 auxiliary contacts (5 NO, 5 NC contacts)	AE4000-SW HN	AE4000-SW HN 4P Fix, ETRBASE-P3, AX10	205147	AE4000-SW HN 4P D/O, ETRBASE-P3, AX10	205156
● Automatic reset type trip coil (TCA-AL-W)	AE4000-SW FN	AE4000-SW FN 4P Fix, ETRBASE-P3, AX10	205148	AE4000-SW FN 4P D/O, ETRBASE-P3, AX10	205157
Further elements that must be ordered:	AE5000-SW HN	AE5000-SW HN 4P Fix, ETRBASE-P3, AX10	205149	AE5000-SW HN 4P D/O, ETRBASE-P3, AX10	205158
○ Main setting module for protection	AE5000-SW FN	AE5000-SW FN 4P Fix, ETRBASE-P3, AX10	205150	AE5000-SW FN 4P D/O, ETRBASE-P3, AX10	205159
○ Accessories as required	AE6300-SW HN	AE6300-SW HN 4P Fix, ETRBASE-P3, AX10	205151	AE6300-SW HN 4P D/O, ETRBASE-P3, AX10	205160
	AE6300-SW FN	AE6300-SW FN 4P Fix, ETRBASE-P3, AX10	205152	AE6300-SW FN 4P D/O, ETRBASE-P3, AX10	205161

Switch-disconnector AE-SW – Fixed / Drawout type

Base unit equipment	Breaker	3-pole type	Art. no.	4-pole type	Art. no.
Shipping contents:	AE1000-SW	AE1000-SW 3P Fix, Bare, AX10	193919	AE1000-SW 4P Fix, Bare, AX10	193920
● 10 auxiliary contacts (5 NO, 5 NC contacts)	AE1250-SW	AE1250-SW 3P Fix, Bare, AX10	193921	AE1250-SW 4P Fix, Bare, AX10	193922
● Switching capacity I _n x 6	AE1600-SW	AE1600-SW 3P Fix, Bare, AX10	193923	AE1600-SW 4P Fix, Bare, AX10	193924
Further elements that must be ordered:	AE2000-SW	AE2000-SW 3P Fix, Bare, AX10	193929	AE2000-SW 4P Fix, Bare, AX10	193930
○ Accessories as required	AE2500-SW	AE2500-SW 3P Fix, Bare, AX10	193931	AE2500-SW 4P Fix, Bare, AX10	193932
	AE3200-SW	AE3200-SW 3P Fix, Bare, AX10	193933	AE3200-SW 4P Fix, Bare, AX10	193934
	AE2000-SWA	AE2000-SWA 3P Fix, Bare, AX10	193925	AE2000-SWA 4P Fix, Bare, AX10	193926
	AE4000-SWA	AE4000-SWA 3P Fix, Bare, AX10	193935	AE4000-SWA 4P Fix, Bare, AX10	193936
	AE2000-SWA	AE2000-SWA 3P D/O, Bare, AX10	193927	AE2000-SWA 4P D/O, Bare, AX10	193928
	AE4000-SWA	AE4000-SWA 3P D/O, Bare, AX10	193937	AE4000-SWA 4P D/O, Bare, AX10	193938

High performance series AE-SH – Drawout type – Fixed type (on request)

Overview and mounting positions of the main accessories

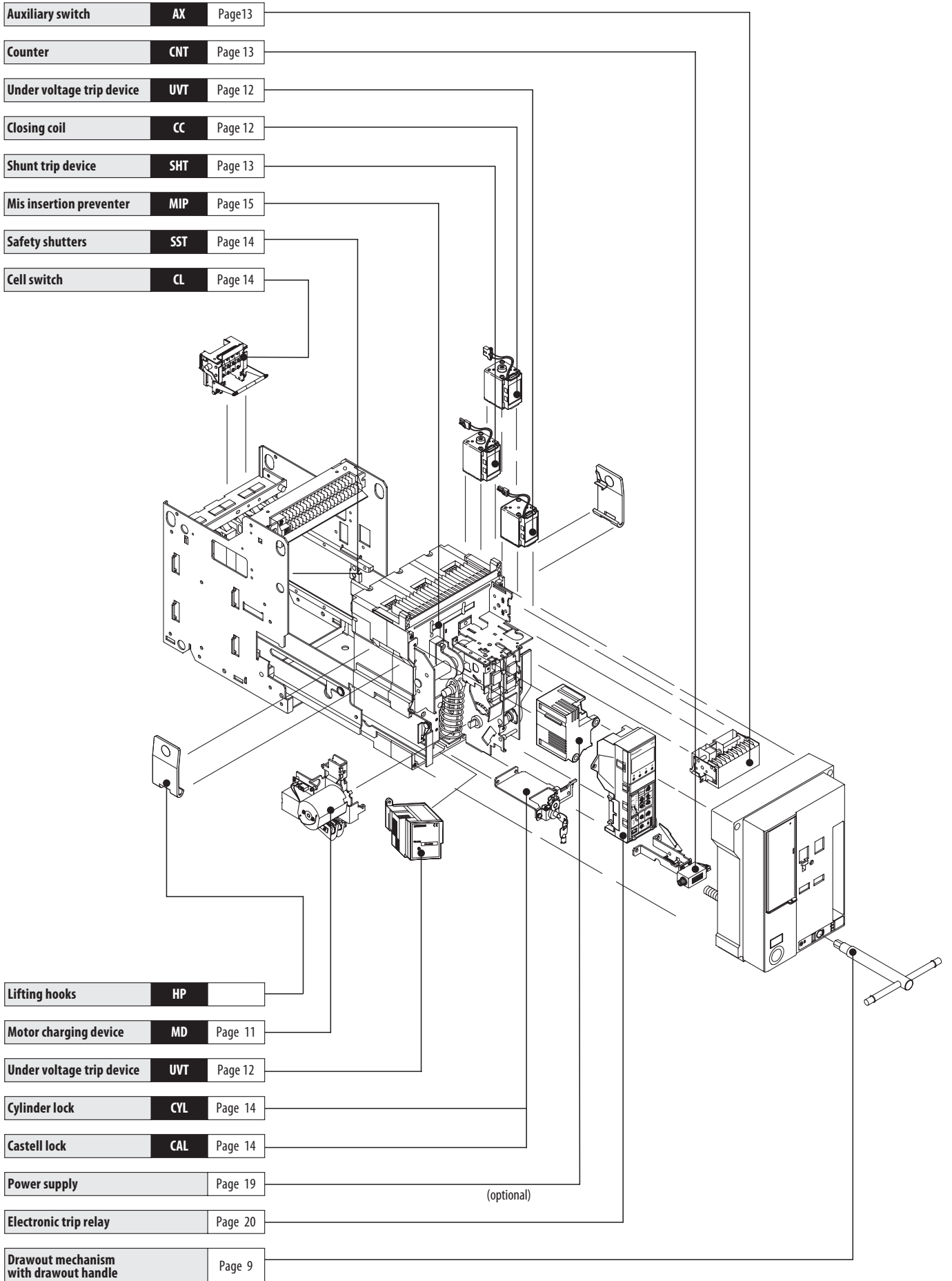

Overview and description on the optional accessories

Motor charging device (MD)

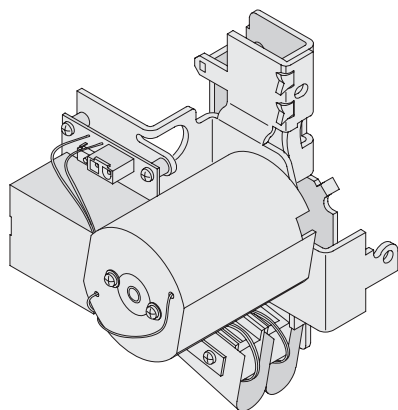

In addition to manual operation, the closing spring can be charged automatically by an electric motor every time the breaker is closed (ON charging method).

If the closing spring is to be charged automatically whenever the breaker is opened, then this can be done through an additional auxiliary contact (AXb) (OFF charging method). As soon as charging is completed, a visual display on the front says "CHARGED".

The "CHARGED" signal is also available via the 413 (TS+) and 414 (TS-) terminals (included in the standard MD configuration).

There is always the option of manual operation in an emergency. A closing coil (CC) is required for closing the breaker by remote control, and a shunt trip device (SHT) is required for opening it in this way. This warrants the prevention of pumping, both electronically and mechanically. The circuit of the motor is separate from the ON/OFF circuit (CC, SHT).

Specifications	MD-AD125-W	MD-AD250-W	MD-AD125-4A4W-W	MD-AD250-4A4W-W	MD-DO24-W	MD-DO48-W
Rated voltage	100 – 125 V AC/DC	200– 250 V AC/DC	100 – 125 V AC/DC	200– 250 V AC/DC	24V DC	48 V DC
Applicable voltage range (V)	85 – 137.5	170 – 275	85 – 137.5	170 – 275	18 – 26.4	36 – 52.8
Applied voltage (V)	100 / 125	200 / 250	100 / 125	200 / 250	24 V	48 V
Inrush current (peak value) (A)	10 / 12	5 / 6	10 / 12	7 / 8	22	14
Steady current (A)	3	1	4	2	6	3
Charging time (sec)	≤5	≤5	≤5	≤5	≤5	≤5
Criterion for power requirement (VA)	700 / 1000	700 / 1000	700 / 1000	700 / 1000	500	500
Order information	Art. no. 168514	168515	168516	168517	168518	168519

Trip Coil (AL)

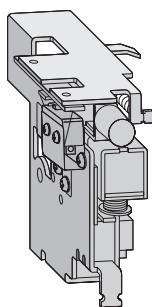

Automatic reset type (TCA-AL-W)

OCR alarm (AL) is provided as standard if ETR is equipped. OCR alarm (AL) is the contact (1a) of short-time operation (30 ms), being output when the breaker is tripped by the electronic trip relay.

Two types of automatic reset type (standard) and manual reset type (optional) are available. When ordering, specify either.

Manual reset type (TCM-AL-W)

On the manual reset type (optional), the gray manual reset button will stick out to continuously output OCR alarm (AL) if the breaker is tripped by the electronic trip relay. After tripping, the breaker can not be turned on unless the manual reset button on the front side of the breaker is pressed for resetting.

Specifications	TCA-AL-W	TCM-AL-W
Voltage	AC (V)	125 / 240
	DC (V)	30 / 125 / 240
Resistive load	AC (A)	5 / 3
	DC (A)	4 / 0.4 / 0.2
Inductive load	AC (A)	3 / 2
	DC (A)	3 / 0.4 / 0.2
Order information	Art. no. 168535 (standard)	168536

Notes:

- Though the control power supply is unnecessary to activate OCR alarm (AL), the self-holding circuit is necessary since the contact output is activated for the short time (30 ms).
- This works when tripping occurs in LTD, STD, INST, GFR or ER.
- If any continuous output of OCR alarm (AL) is necessary, use the trip indicator (TI) output contact of the electronic trip relay.

Undervoltage trip device (UVT)

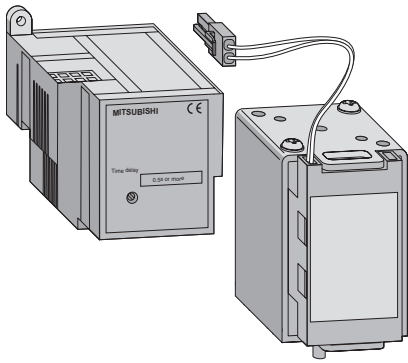

This is the device that automatically trips the breaker when the circuit voltage drops below the nominal voltage, and comprises a UVT coil and UVT controller.

Time range for tripping time:
INST (0.2 sec or less)/0.25 sec/0.5 sec/
0.8 sec/1.0 sec/1.5 sec/3 sec.

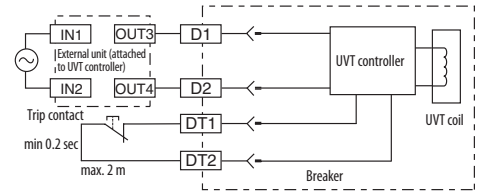
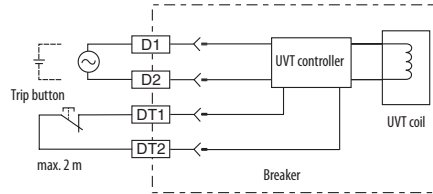

Specifications	UCON-D024B-W INST	UCON-D048B-W INST	UCON-D110B-W INST	UCON-D125B-W INST	UCON-D250B-W INST	UCON-A120B-W INST	UCON-A240B-W INST	UCON-A460B-W INST	
Rated voltage (V)	24 (DC)	48 (DC)	100–110 (DC)	120–125 (DC)	220–250 (DC)	100–120 (AC)	200–240 (AC)	380–460 (AC)	
Frequency	—					50/60 Hz			
Operating time (time delay)	□ INST (0.2 sec); □ 0.25 sec; □ 0.5 sec; □ 0.8 sec; □ 1.0 sec; □ 1.5 sec; □ 3.0 sec								
Pick-up voltage (V)	15.6–20.4	31.2–40.8	65–85	78–102	143–187	65–85	130–170	247–323	
Drop-out voltage (V)	10.8–16.8	21.6–33.6	45–70	54–84	99–154	45–70	90–140	171–260	
Trip function	With open circuit of DT1, DT2 terminals								
Power consumption (VA)	20								
Order information	Art. no.	203341	203342	203343	203344	203345	203346	203347	203348
Accessories	UVT coil: art. no. 168525; UCON label: art. no. 168526 (Packing unit: 10 pcs)								

Notes:

- Please order for each UCON one UVT coil, and for delay setting one UCON lable.
- In case of 380–460V AC, the external unit is attached.
- The operating time is a guarantee value when it drops from 85 % or more of rated voltage.
- Time delay should be allowed for 1.5 s between applying the voltage to the UVT and closing the breaker.
- If a remote trip function is required, remove the shorting bar (DT1 – DT2) and connect a normally closed switch, rated 0.5 A at 150 V DC across them.
- Usage ambient temperature is a range of max. 40 °C to -5 °C.

Closing coil (CC)

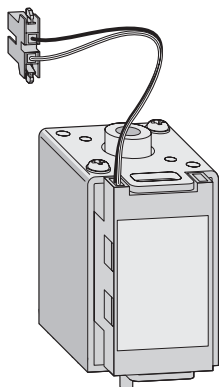

The closing coil is a device to close the breaker by remote control. Only one closing signal (about 100 msec.) is sent even when the closing coil supply is maintained ON.

- Closing time is from the initial energization of the closing coil to the completion of the closing of the main contacts.
- As CC is one-pulse driven, it is not necessary to insert AXb for burning prevention purposes. Inserting AXb will cause anti-pumping function to be ineffective.

- An interlock to prevent pumping is provided electrically.

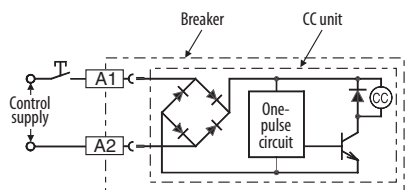

Diode rectifier is not used for control source 24 – 48 V DC.

Specifications	CC-D048-W	CC-AD250-W	
Rated voltage (V)	24–48 DC	100–250 AC/DC	
Applicable voltage range (V)	18–52.8	75–275	
Operating voltage (V)	24 / 48	100 / 250	
Inrush current	AC (A)	0.7 / 1.7 (AC 100 V 100 VA, AC 250 V 200 VA)	
	DC (A)	3 / 6 (DC 24 V 100 W, DC 48 V 200 W)	
Closing time ^① (sec)	max. 0.08 or less	max. 0.08 or less	
Order information	Art. no.	168521	168520

^① In case of double rating of rated voltage, it is the value to the lower rating. Example: In case of DC 24 to 48, it is operating time to DC 24 V.

Shunt trip device (SHT)

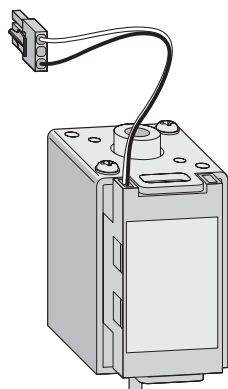

The shunt trip device is used to open the breaker by remote control.

A cut-off switch is included (AX /HAX).

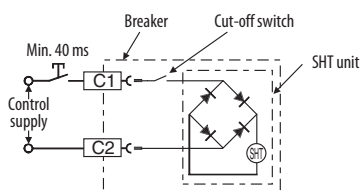

Diode rectifier is not used for control source 24 – 48 V DC.

Specifications		SHT-D048-W	SHT-A500-W	SHT-AD250-W
Rated voltage	(V)	24–48 DC	380–500 AC	100–250 (AC/DC)
Applicable voltage range	(V)	16.8–52.8	266–550	70–275
Operating voltage	(V)	24 / 48	380–500	100 / 250
Inrush current (peak value)	AC (A)	—	0.5 / 0.7 (AC 380 V 250 VA, AC 500 V 300 VA)	0.4 / 1.4 (AC 100 V 100 VA, AC 250 V 150 VA)
	DC (A)	2.5 / 6.0 (DC 24 V 100 W, DC 48 V 200 W)	—	0.6 / 1.6 (DC 100 V 100 W, DC 250 V 200 W)
Closing time ^①	(sec)	max. 0.04 or less	max. 0.04 or less	max. 0.04 or less
Order information	Art. no.	168524	168523	168522

^① In case of double rating of rated voltage, it is the value to the lower rating.
Example: In case of DC 24 to 48, it is operating time to DC 24 V.

Auxiliary switch (AX, HAX)

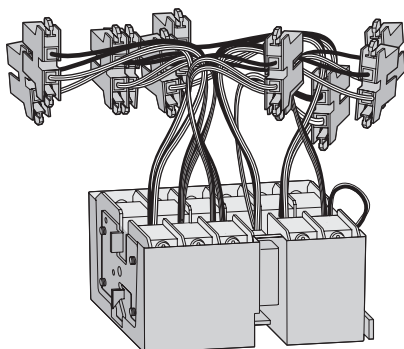

This is the contact that is used to remotely indicate the ON or OFF status of the breaker.

- The a and b contacts may turn simultaneously to ON instantaneously at the time of changing the contact; Pay attention to the contact state when designing circuits.

- The chattering time at the time of contact ON-OFF is below 0.025 sec.
- For special environment specification, the contact capacity gets deteriorated. Apply for further detail.

Specifications		AX-10-W		HAX-10-W		
Load	Contact capacity (A)	Resistance	Inductive	Resistance	Inductive	
		AC 460 V	5	2	5	2.5
		AC 250 V	10	10	10	10
		AC 125 V	10	10	10	10
		DC 250 V	0.3	0.3	3	1.5
		DC 125 V	0.6	0.6	10	6
	DC 30 V	10	6	10	10	
Maximum number of contacts		5a5b		5a5b		
Order information	Art. no.	168962 (standard)		168961		

Counter (CNT)

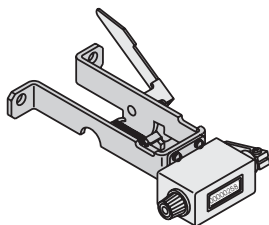

This is a mechanical counter which registers the total number of operating cycles (with 1 ON/OFF switching operation = 1 operating cycle).

The number of operating cycles is displayed on the front of the unit.

Specifications	CNT-W	
Counter type	Mechanical	
Display	5 digits	
Order information	Art. no.	168538

Cell switch (CL)

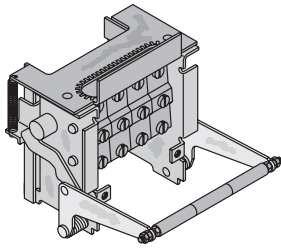

The cell switches can be set for all the relevant positions, i.e. connected, test and disconnected.
Each cell switch consists of 4 individual switches.

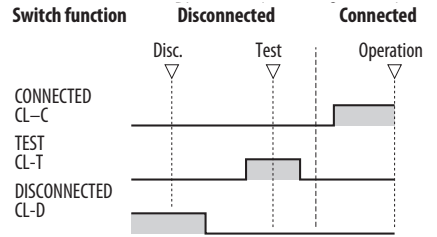

2 SAE - ACCESSORIES

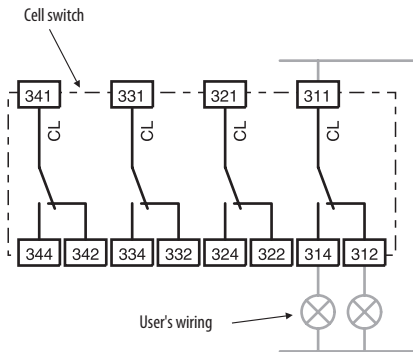

Specifications	CL-4-W		BIF-CL-W ^①		
Load	Resistive	Inductive	Resistive	Inductive	
Contact capacity (A)	AC 460 V	5	5	2.5	
	AC 250 V	10	10	10	
	AC 125 V	10	10	10	
	DC 250 V	3	1.5	3	1.5
	DC 125 V	10	6	10	6
	DC 30 V	10	10	10	10
Maximum contacts	Total 4c				
Order information	Art. no.	168512	168575		

^① BIF-CL only necessary for networks operation

Interlock device (CYL)

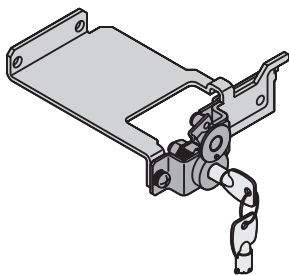

The interlock device locks the circuit breaker into the OFF position. The relevant key can only be taken out in the OFF position of the circuit breaker, so that it can also be used for unlocking other breakers.

There are two locking options available:
● Cylinder lock (CYL)
● Castell lock (CAL)^①

Specifications	CYL-WK-W	CYL-WK1-W	CYL-WK2-W	CYL-WK3-W	CYL-WK4-W	CYL-NK-W	
Interlock	Cylinder	Cylinder	Cylinder	Cylinder	Cylinder	Castell	
Closing	Basic	1	2	3	4	Basic	
Order information	Art. no.	168539	168540	168541	168542	168543	168544

^① The closing basis for the Castell lock can be designed individually. Further details on request.

Safety shutters (SST)

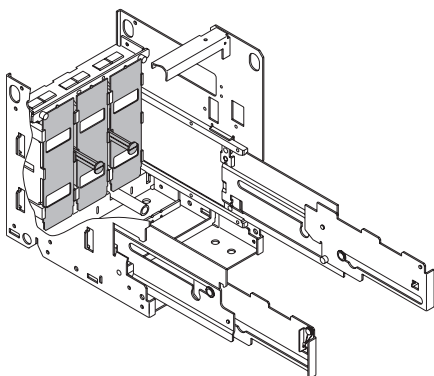

The safety shutters cover the main conductors of the cradle side (supply and load side) automatically when the circuit breaker is drawn out.

The safety shutters can also be locked with a mechanical locking device (SST LOCK). The padlocks have to be supplied by customer.

When checking the main circuit, the safety shutters on the supply and load sides can be opened independently of one another.

Specifications	SST-LOCK-W	SST-203-W	SST-204-W	SST-403-W	SST-404-W	
Breaker type	Drawout					
Number of poles	3/4	3	4	3	4	
Order information	Art. no.	168510	168973	168974	168975	168976

Mis-insertion preventor (MIP)

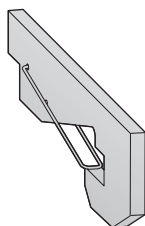

To obtain the right draw out configuration, it is extremely important that the breaker unit specifications (type, current rating, optional accessories, etc.) should match the cradle.

Mis-insertion is prevented by a combination of matching components (on the breaker and the cradle).

Specifications		MIP-W
Material		Metal
Order information	Art. no.	168547

Shorting b-contact (SBC)

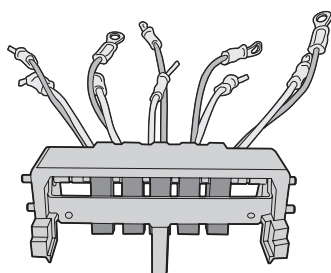

SBC-5-W

When moving the breaker from the connected to the test positions, this contact is used to short circuit auxiliary switch (Axb) thus maintaining the correct sequence of operation of the external control circuit.

Specifications	SBC-1-W	SBC-2-W	SBC-3-W	SBC-4-W	SBC-5-W	
Number of contacts	1	2	3	4	5	
Application (breaker)	All breakers					
Order information	Art. no.	168548	202337	202338	202339	202340

Vertical terminal adapter (VTA)

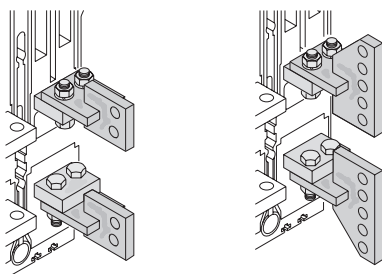

Vertical terminal adapters allow you to turn power connection by 90°.

For AE2000-SWA, AE4000-SWA, AE4000-SW, AE5000-SW and AE6300-SW models, vertical terminal only is available.

Specifications	VTA-02-W	VTA-03-W	VTA-32-W	
Application (breaker)	AE1000–AE1600-SW	AE2000–2500-SW	AE3200-SW	
Shipping contents	pieces	1	1	
Order information	Art. no.	168978	168979	168980

Front terminal adapter (FTA)

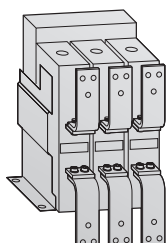

Front terminal adapters FTA allows a vertical connection for supply- and load-busbars.

Specifications	FTA-163F-W	FTA-164F-W	FTA-253F-W	FTA-254F-W	FTA-323F-W	FTA-324F-W	FTA-163D-W	FTA-164D-W	FTA-253D-W	FTA-254D-W	FTA-323D-W	FTA-324D-W	
Application (breaker)	AE1000–AE1600-SW	AE1000–AE1600-SW	AE2000–AE2500-SW	AE2000–AE2500-SW	AE3200-SW	AE3200-SW	AE1000–AE1600-SW	AE1000–AE1600-SW	AE2000–AE2500-SW	AE2000–AE2500-SW	AE3200-SW	AE3200-SW	
Pole	3	4	3	4	3	4	3	4	3	4	3	4	
Typ	Fixed						Drawout						
Shipping contents	pieces	6	8	6	8	6	8	6	8	6	8	81	
Order information	Art. no.	169331	169332	169333	169334	169335	169336	169337	169338	169339	169340	169341	169342

Mechanical interlock (MI)

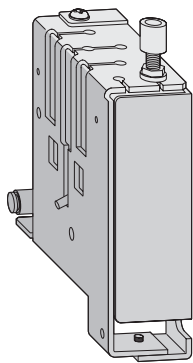

This is the device to prevent parallel charge of 2 or 3 units of breakers, and it can interlock the breakers mechanically without fail. All combinations are available among any models from AE1000-SW to AE4000-SWA.

Please apply for further details of AE4000-SW to AE6300-SW.

Further the interlock is possible among the different connection types or poles, such as fixed type or drawout type, 3 pole or 4 pole. In combination with electric interlock, the higher safety interlock system can be secured.

- In case of drawout type, the interlock works at "CONNECTED" position, and in another position the interlock is released, which is convenient for and easy maintenance and inspection of the breaker.
- When to turn OFF one breaker and then turn ON another breakers, please take an interval 0.5 seconds or more.
- MI for 3 breakers can not be installed to combine with Door Interlock (DI).

Vertical mounting

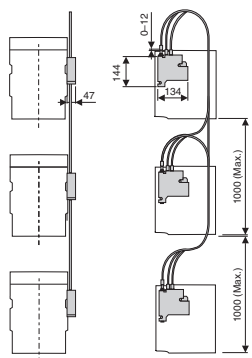

Horizontal mounting

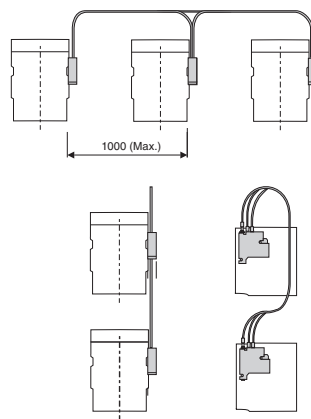

[mm]

Switching states (for 2 ACBs)

Type	①	②	③
ACB 1	○		○
ACB 2	○	○	

Type	①	②	③	④
ACB 1	○		○	○
ACB 2	○	○		○
ACB 3	○	○	○	

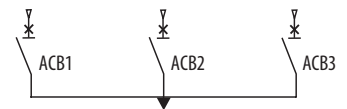

Verriegelung mit 3 Schaltern (ACBs)

Type	①	②	③	④	⑤	⑥	⑦
ACB 1	○		○	○			○
ACB 2	○	○		○		○	
ACB 3	○	○	○		○		

Type	①	②	③	④	⑤
ACB 1	○		○		○
ACB 2	○	○		○	○
ACB 3	○	○	○		

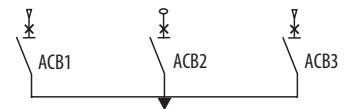
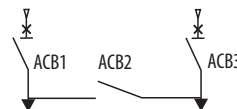

Specifications	MI-203F-W	MI-204F-W	MI-403F-W	MI-404F-W	MI-203D-W	MI-204D-W	MI-403D-W	MI-404D-W	MI-IW-W	
Application (breaker)	AE1000-1600-SW AE2000-SWA		AE2000-3200-SW AE4000-SWA		AE1000-1600-SW AE2000-SWA		AE2000-3200-SW AE4000-SWA		Wire set for all mechanical interlock devices required for combination of 3 ACBs	
Breaker type	Fixed				Drawout					
Number of poles	3	4	3	4	3	4	3	4		
Order information	Art. no.	168963	168964	168965	168966	168967	168968	168969	168970	168971

Door interlock (DI)

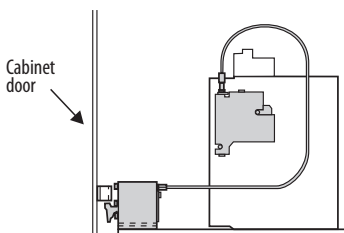

The device has been designed for panel doors with the groove on the left (standard). Locks for grooves on the right are available on request.

A wire-type mechanical interlock is used to allow flexibility in positioning breakers in the panel.

Note:

When using the door interlock (DI) the application of the mechanical interlock (MI) is not possible.

This mechanical interlock device makes it impossible to open the panel door unless the circuit breaker is not switched off.

Specifications	DI-F-W	DI-D-W	
Application (breaker)	For all breakers	For all breakers	
Breaker type	Fixed	Drawout	
Order information	Art. no.	168545	168546

■ Push button cover (BC-L)

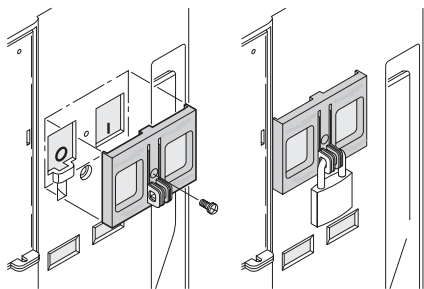

This mechanical device can be locked with a padlock or a seal (both is not included in the package) to protect the push buttons of the breaker unit against inadvertent ON/OFF operation.

The padlock has to be supplied by the customer.

Specifications		BCL-W
Material		Acrylic plate
Order information		Art. no. 168537

■ Dust cover (DUC)

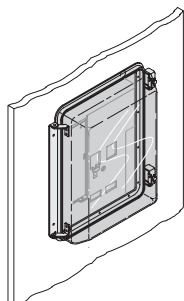

The transparent dust cover is hinged onto the panel door. It has a screw lock and prevents dust and water entering into the circuit breaker.

Specifications		DUC-W
Protection		IP 54
Order information		Art. no. 168960

■ Terminal cover (TTC)

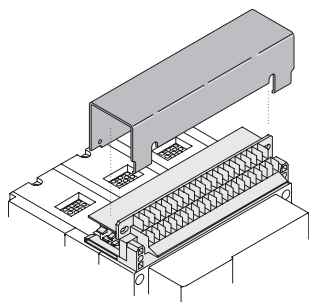

The terminal cover is a transparent cover for safety finger protection of control terminals.

The terminal cover prevents from careless touching to the live control terminals.

The TTC-F-W is included within the delivery of a fixed type AE-SW as standard.

Specifications		TTC-D-W	TTC-F-W
Application (breaker)		Drawout type	Fixed type
Protection		IP 20	IP 20
Order information		Art. no. 168549	168972 (standard)

■ Door frame (DF)

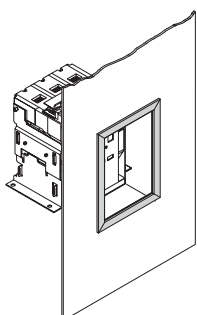

The door frame improves the appearance, after cutting out the panel door to install the breaker.

Details on request.

Specifications		DF-W
Application (breaker)		For all breakers
Material		Plastic
Protection		IP 20
Order information		Art. no. 168513

Current transformer (CT)

These current transformers (CT and sensor coil) are suitable for the main conductor and the N conductor.

Current transformers of type CT-06□□□ serve the reduction of I_{Nmax} on an AE1000.

Specifications	CT-06-W 025	CT-06-W 031	CT-06-W 050	CT-06-W 063	CT-10-W 100	CT-12-W 125	CT-16-W 160	CT-20-W 125	CT-20-W 160	CT-20-W 200	CT-25-W 250	CT-32-W 320
Application (breaker) ①	AE1000-SW	AE1000-SW	AE1000-SW	AE1000-SW	AE1000-SW	AE1250-SW	AE1600-SW	AE2000-SW	AE2000-SW	AE2000-SW	AE2500-SW	AE3200-SW
Rated current I_{Nmax} ② (A)	250	315	500	630	1000	1250	1600	1250	1600	2000	2500	3200
Order information	Art. no. 193939	193940	193941	193942	193943	193944	193945	193946	193947	193948	193949	193950

① Shipping contents includes CT and sensor coil for 1 pole. Other transformers on request.
 ② At 40 °C and 50/60 Hz

Neutral current transformer (NCT)

Block diagram with NCT function

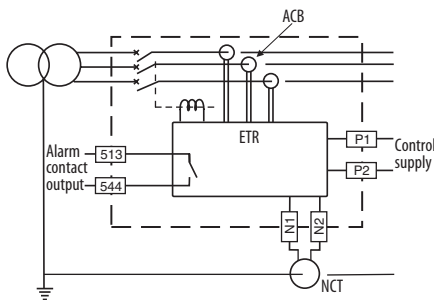

The neutral CT is used for ground fault protection when a 3 pole breaker is used on a 3 phase 4 wire system.

The Ground fault protection module type G1 should be used as optional setting module.

Specifications	NCT-06	NCT-10	NCT-12	NCT-16	NCT-20	NCT-25	NCT-32	NCT-40
Application (breaker)	AE630-SW	AE1000-SW	AE1250-SW AE2000-SW	AE1600-SW AE2000-SW	AE2000-SWA AE2000-SW	AE2500-SW	AE3200-SW	AE4000-SWA
Current range (A)	630	1000	1250	1600	2000	2500	3200	4000
Order information	Art. no. 168986	168987	168988	168989	168990	168991	168992	168993

External current transformer (ZCT/ZT)

Transformer ground wire method (ZCT)

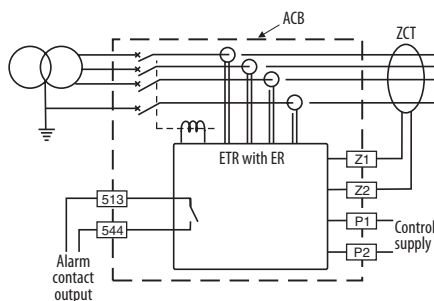

Transformer ground wire method (ZT)

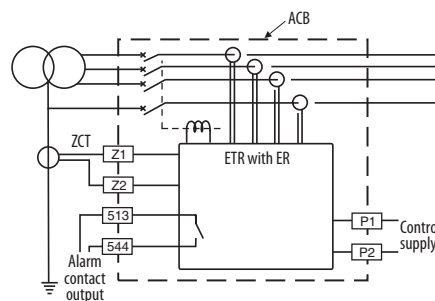

This option is used to detect several amperes of earth leakage when used in combination with an electronic trip relay that has the earth leakage tripping (ER) option.

Two methods are available:

- ZCT: three-load phase conductors (and the neutral conductor in a 4-wire system) are passed through the ZCT
- ZT: The other method uses a smaller ZCT (only supply transformer ground wire passes through to earth).

Specifications	ZCT-163-W	ZCT-323-W	ZCT-324-W	ZT-15B-W	ZT-30B-W	ZT-40B-W	ZT-60B-W	ZT-80B-W	ZT-100B-W
Application	Load circuits			Transformer ground wire					
Hole diameter for wire ① (mm)	230x60 (oval)	370x108 (oval)	500x108 (oval)	∅ 15	∅ 30	∅ 40	∅ 60	∅ 80	∅ 100
Order information	Art. no. 168994	168995	168996	168997	168998	168999	169000	169001	169002

① Further details on request.

Internal power supply units (PW)

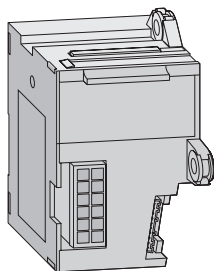

These power supplies are used for supplying the ETR base unit. They are equipped with 6 outputs (alarms and errors).

The PW3-W is included as standard power supply in the ACB's.

Specifications		PW3-W	PW4-W	PW5-W
Power supply	(V)	100–240 (AC) 100–125 (DC)	24 – 60 (DC)	100 – 240 (DC)
Output contacts		6	6	6 (SSR)
Order information	Art. no.	168985 (standard)	168562	168563

Field test device (Y-2000)

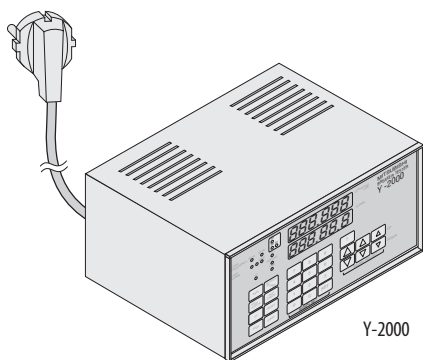

Y-2000

The electronic trip relay can be checked by this field test device when the breaker is at test or disconnect position. So it allows you to test the trip relay without the

breaker being connected to the main supply. The breaker will trip when tested.

Specifications	Y-2000
Power supply	100–240 V AC, 50/60 Hz
Test functions	LTD, INST, STD, Ground fault, pre-alarm
Test current signal setting	Continuously variable (10 – 2000 %)
Others	Ammeter, time counter
Order information	Art. no. 27496

Test jumper (TJ)

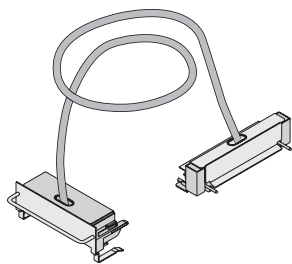

With the breaker taken out of its cradle, this device enables the breaker to be electrically opened and closed, and the operating sequence to be checked.

3 m length of cable is equipped as standard. Other lengths available on request.

Specifications	Test Jumper
Cable length	(m) 3 ^①
Order information	Art. no. 168977

^① Other lengths on request

Interphase barriers

Connections		AE1000-SW – AE1600-SW	AE2000-SWA	AE2000-SW – AE3200-SW	AE4000-SWA
Fixed type	Horizontal (FIX)	●	×	●	×
	Vertical terminal (FIX-VT)	×	▲	×	▲
	Vertical terminal adaptor (VTA)	▲	×	▲	×
	Front terminal adaptor (FIX-FTA)	▲	×	▲	×
Drawout type	Horizontal (DR)	●	×	●	×
	Vertical terminal (DR-VT)	●	▲	▲	▲
	Front terminal (DR-FT)	—	×	▲	×
	Vertical terminal adaptor (VTA)	▲	×	▲	×
	Front terminal adaptor (DR-FTA)	▲	×	▲	×

● = Available for the insulation ▲ = Available for separating terminals × = Not existing type — = Attachment is impossible
For AE4000-SW to AE6300-SW not available

Introduction and selection

Power supply module

This module provides control source for Display module, Trip indicator and several indicators (LEDs). (Even when the control power source is off, the function of over current protection and ground fault protection are effective.) The power supply modules provide 6 output contacts for external use (see page 22).

Extension module (option)

This module is required when installed VT-W unit, display module and each interface unit. (see page 28)

Display

Several measuring data (current, voltage, power etc) and alarms can be displayed with this module. (see page 28)

Load current LED (standard)

This indicator displays the maximum current of phase.

Main setting module

This module provides the function of over current protection. It is possible to select the two setting modules according to application (see page 25).

Neutral protection of rated current (100 %) function is standard at 4 pole breaker.

RUN LED, ERR. LED (standard)

This indicator displays the ETR situation (Run or Error)

Pre-alarm (PAL) (standard)

This indicator displays the Pre-alarm situation when the setting current exceeds. If a power supply module with alarm contacts is installed, the output contact of Pre-alarm is available.

*The output is reset when the electric current goes below the set level after an alarm is set off

Optional setting module (option)

(figure shows G1) Additional functions and characteristics can be selected by optional setting modules (see page 26).

Trip indicator LED (standard)

This indicator displays the trip cause.

TEST terminal (standard)

This terminal already installed as standard and is used for checking by the field test device Y-2000.

Pre-alarm current level setting dial (standard)

For setting the current level for Pre-Alarm. If current exceeds this level, pre-alarm is indicated.

RESET button (standard)

When push this reset button, trip indicator, and Pre-Alarm will be reset. And when the instantaneous test by field test device Y-2000 (optional) and push this reset button, as a result of LTD and STD function become ineffective.

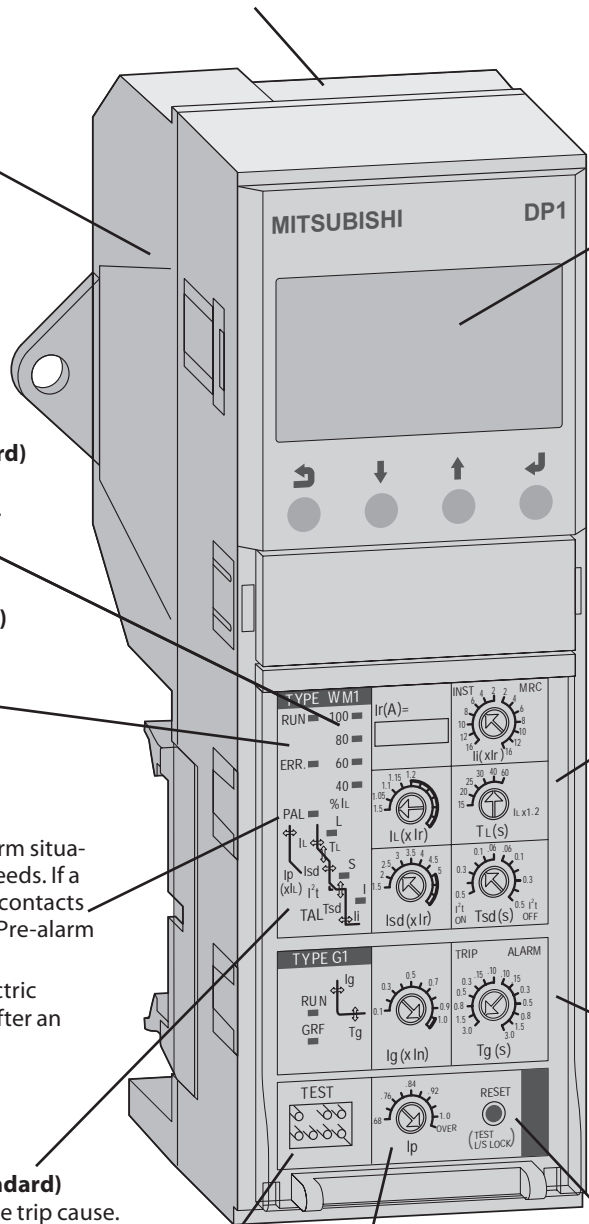

SAE - ELECTRONIC TRIP RELAY 3

Standard functions

■ OCR alarm (AL)

When it happens to trip by over current, ground fault (GFR) or Earth leakage (ER), this function issues a warning alarm.

■ Neutral pole overcurrent protection (NP)

When harmonics in load current are large, the current on neutral pole exceeding rated current may flow. Harmonics may cause some troubles. Neutral pole

overcurrent protection prevents them by operating at 100% of rated current on neutral pole. Please see page 27 for 50 % neutral protection.

Special Functions – Optional

■ MCR: Making current release

Just under the breaker closing operation (from open to close), Instantaneous characteristic become effective, but after closing the breaker, instantaneous characteristic become ineffective.

When you order the MCR switch, MCR switch is built in the main body. If MCR switch is built in the main body and the adjust dial of INST/MCR on main

setting module is set the MCR position, MCR function become effective (see page 27).

■ NCT

Neutral CT is required for Ground fault or Neutral pole protection, when 3 pole breaker is used for 3 phase 4 wires system. (see page 18)

■ ZCT

ZCT is required for a few amperes earth leakage protection, and is combining ER plug. (see page 18)

Characteristic table

Overview of tripping characteristics of main setting modules in combination with optional setting modules

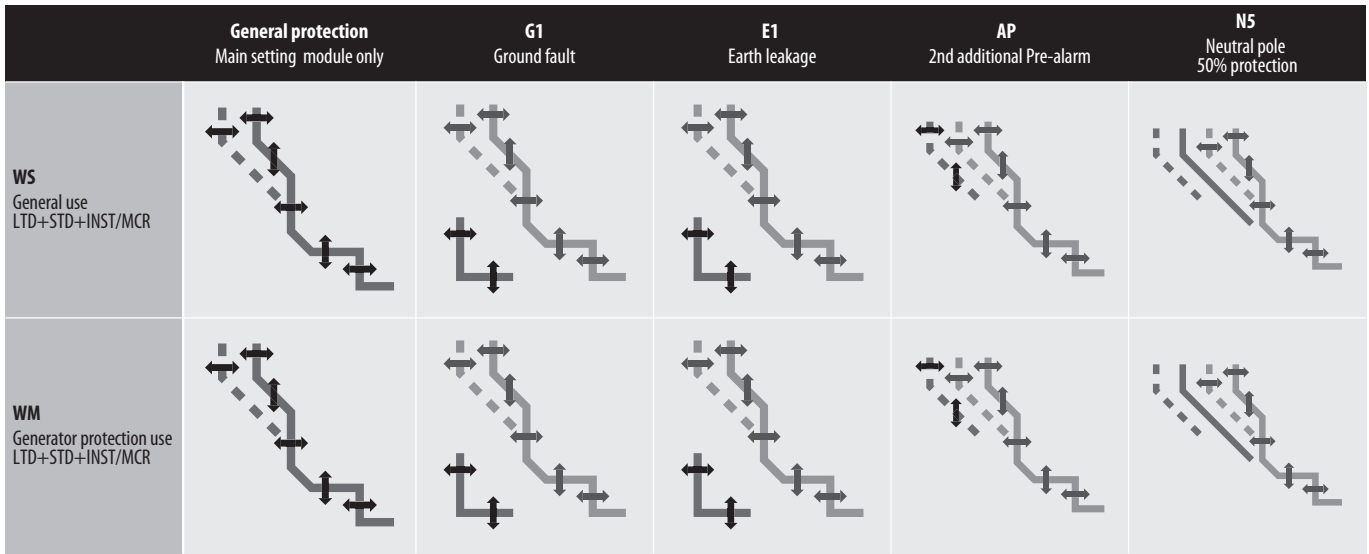

Note:
WB type for special use is available on request.

Power supply modules

Product overview

Type	Rating	Alarm output contacts
P3	100–240 V AC 100–125 V DC	6 output contacts
P4	24–60 V DC	6 output contacts
P5	100–240 V AC	6 output contacts (SSR)

Note:
Over current protection and ground fault protection operates without control power source.

Factory setting of 6 output contacts is as follows.

G1/E1/AP	LTD	STD/INST	PAL	TAL	ERR
Refer to lower table	Self-holding	Self-holding	Non Self-holding	Non Self-holding	Non Self-holding

ETR dial set	G1	E1	AP
TRIP side	Selfholding	Selfholding	—
ALARM side	Non Self-holding	Non Self-holding	Non Self-holding

Description:
Self-holding type: The output condition is held until it is reset.
Non self-holding type: The output is reset if it is returned to the normal condition.

Contact capacity (Type code P3, P4)

Voltage (V)	Resistive load		Inductive load $\cos\phi = 4.0$ L/R = 7ms
	$\cos\phi = 1.0$		
AC	240	1 A	0,5 A
	120	1 A	1 A
DC	125	0.1A	0.05 A
	30	1 A	1 A

Contact capacity (Type code P5)

Voltage (V)	Normal current	Peak inrush current	ON resistance (max.)
AC	240	0.1 A	0.3 A
	120	0.1 A	0.3 A
DC	125	0.1 A	0.3 A
	30	0.1 A	0.3 A

CT rating table

AE1000-SW	AE1250-SW	AE1600-SW	AE2000-SWA	AE2500-SW	AE3200-SW	AE4000-SWA	AE5000-SW	AE6300-SW
1000 A	1250 A	1600 A	2000 A	2500 A	3200 A	4000 A	5000 A	6300 A
250 A	315 A		AE2000-SW			AE4000-SW		
500 A	630 A		2000 A			4000 A		
			1250 A	1600 A				

Notes:

- AE1000-SW and AE2000-SW has low rating types, too.
- As for details of ratings, refer to pages 6 and 7.

Electronic trip relay (ETR configuration overview)

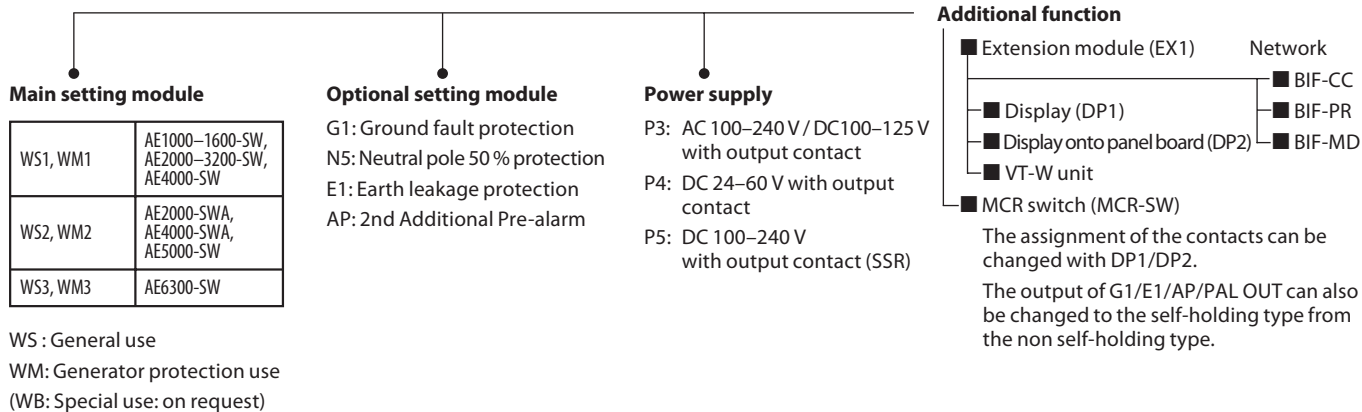

S Types – General Protection

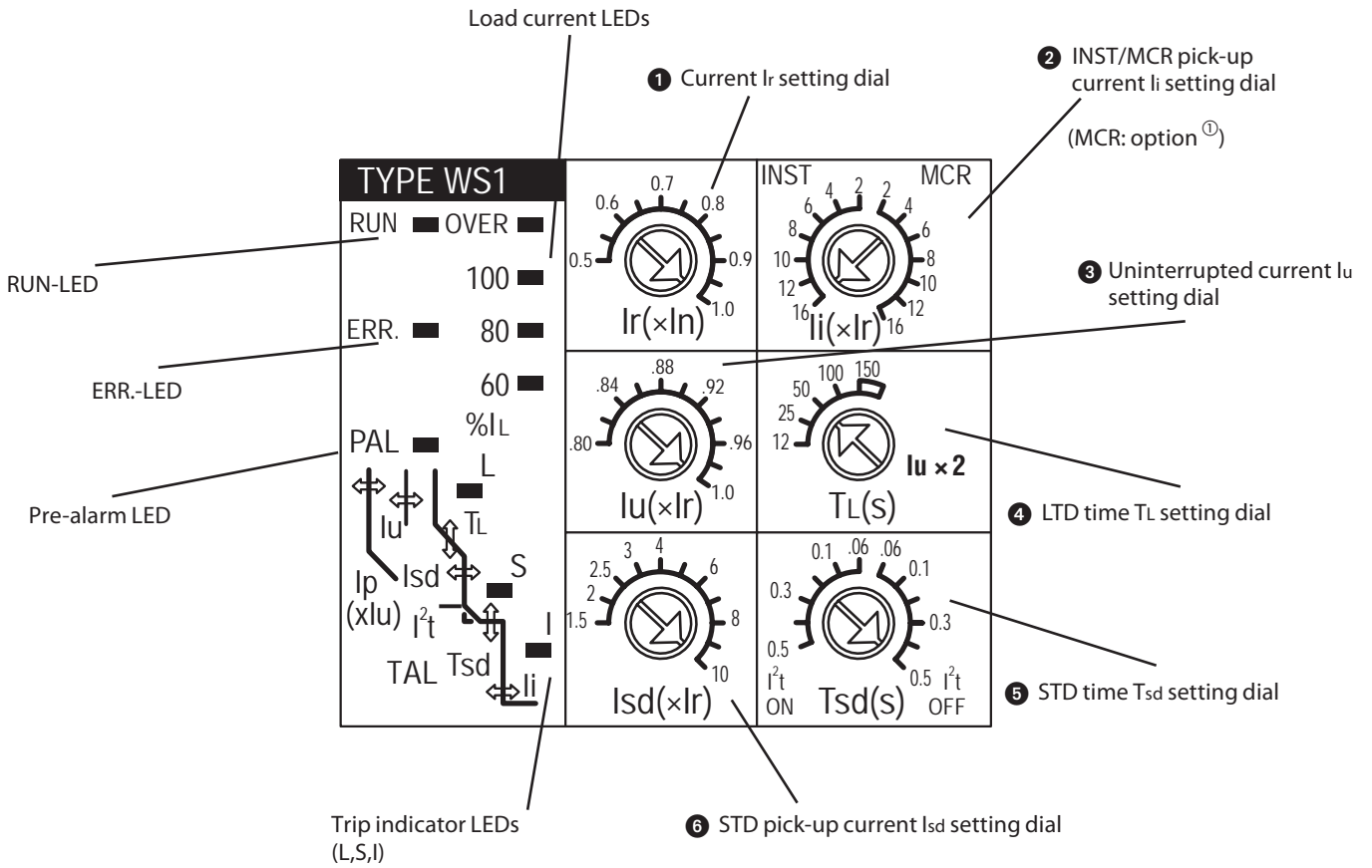

Adjustable setting range

No.	Setting item	Adjustable setting range	Accuracy	Setting for shipment	
1	Current setting	I_r 0.5 – 1.0 (0.05 step) x I_n (CT rating)	—	1.0	
3	Uninterrupted current	I_{lu} 0.8 – 1.0 x I_r (0.02 step), Pick-up current: 1.15 x I_{lu}	1.05 x I_{lu} ... Non Pick-up 1.25 x I_{lu} ... Pick-up	1.0	
4	LTD time	T_L 12–25–50–100–150 s at $I_{lu} \times 2$	± 20%	150	
6	STD pick-up current	I_{sd} 1.5–2–2.5–3–4–5–6–7–8–9–10 x I_r	± 15%	10	
5	STD time	T_{sd} 0.5–0.4–0.3–0.2–0.1–0.06 – 0.06–0.1–0.2–0.3–0.4–0.5 s (I ² t ON) (I ² t OFF) at $I_{sd} \times 1.5$	± 20% This means, it operates in the range between 0.04 and 0.08 s when the time set at 0.06 s.	0.5 (I ² t ON)	
2	INST/MCR pick-up current	AE1000-SW–AE1600-SW AE2000-SW–AE3200-SW AE4000-SW	WS1	16–12–10–8–6–4–2 – 2–4–6–8–10–12–16 x I_r (INST) (MCR) ^①	WS1: 16 (INST)
		AE2000-SWA, AE4000-SWA AE5000-SW	WS2	12–10–8–6–4–2 – 2–4–6–8–10–12 x I_r (INST) (MCR) ^①	WS2: 12 (INST)
		AE6300-SW	WS3	10–8–6–4–2 – 2–4–6–8–10 x I_r (INST) (MCR) ^①	WS3: 10 (INST)
	Pre-alarm current	I_p $I_{lu} \times 0.68$ – 1.0 (0.04 step) – OVER	± 10%	OVER ^②	
	Pre-alarm time	T_p 1/2 T_L (after 1/2 T_L , PAL contact output turns on.)	± 20%	—	

① Upper figure and table include optional MCR function.

② Pre-alarm current "OVER" setting is equal to 1.0.

Specifications	WS1-W	WS2-W	WS3-W
Main setting Module S type	WS1	WS2	WS3
Order information	Art. no. 168552	168553	205180

M Types – Generator Protection

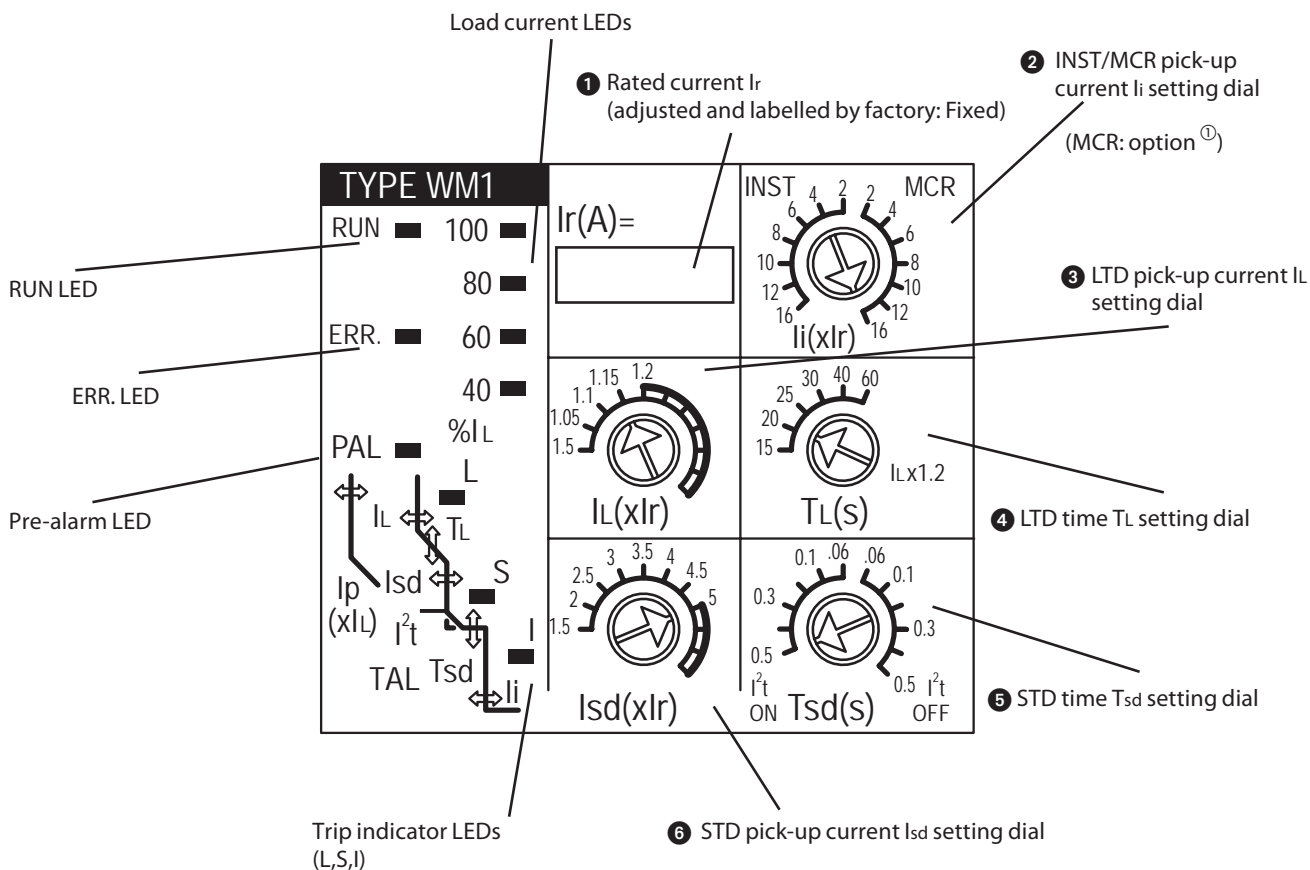

3 SAE – ELECTRONIC TRIP RELAY

Adjustable setting range

No.	Setting item	Adjustable setting range	Accuracy	Setting for shipment		
1	Current setting	I_r 0.63 – 1.0 x I_n (Adjust by factory: Fixed)	—	Specify when ordering		
3	LTD pick-up current	I_l 1.0–1.05–1.1–1.15–1.2 x I_r	± 5%	1.15		
4	LTD time	T_l 15–20–25–30–40–60 s at $I_l \times 1.2$	± 20%	20		
6	STD pick-up current	I_{sd} 1.5–2–2.5–3–3.5–4–4.5–5 x I_r	± 15%	5		
5	STD time	T_{sd} 0.5–0.4–0.3–0.2–0.1–0.06 – 0.06–0.1–0.2–0.3–0.4–0.5 s (I^2t ON) (I^2t OFF) at $I_{sd} \times 1.5$	± 20% This means, it operates in the range between 0.04 and 0.08 s when the time set at 0.06 s.	0.5 (I^2t ON)		
2	INST/MCR pick-up current	AE1000-SW–AE1600-SW AE2000-SW–AE3200-SW AE4000-SW	WM1	16–12–10–8–6–4–2 – 2–4–6–8–10–12–16 x I_r (INST) (MCR) ①	± 15%	WM1: 16 (INST)
		AE2000-SWA, AE4000-SWA AE5000-SW	WM2	12–10–8–6–4–2 – 2–4–6–8–10–12 x I_r (INST) (MCR) ①		WM2: 12 (INST)
		AE6300-SW	WM3	10–8–6–4–2 – 2–4–6–8–10 x I_r (INST) (MCR) ①		WM3: 10 (INST)
	Pre-alarm current	I_p $I_u \times 0.68 – 1.0$ (0.04 step) – OVER	± 5%	OVER ②		
	Pre-alarm time	T_p 1/2 T_l (after 1/2 T_l , PAL contact output turns on.)	± 20%	—		

① Upper figure and table include optional MCR function.

② Pre-alarm current "OVER" setting is equal to 1.0.

Specifications	WM1-W	WM2-W	WM3-W
Main setting Module M type	WM1	WM2	WM3
Order information	Art. no. 168554	168555	205181

Note:
WB type for special use is available on request.

Ground fault protection (GFR)

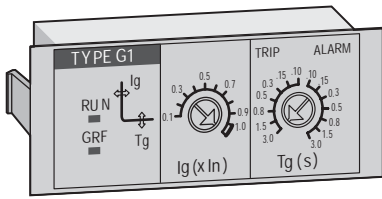

The ground fault protection (GFR) of several hundred amperes is possible. This function can be selected for trip and alarm (no trip). Power supply is necessary for this function, even if there is not power supply, it can function at 0.2 x I_n or higher.

Specifications	G1-W
Optional setting Module	G1 (Ground fault protection module)
Order information	Art. no. 168558

Setting item	Adjustable setting range	Accuracy	Setting for shipment
GFR pick-up current	I _g 0.1–0.2–0.3–0.4–0.5–0.6–0.7–0.8–0.9–1.0 x I _n	±20%	1.0
GFR time	T _g 3–1.5–0.8–0.5–0.3–0.15–<0.1 – <0.1–0.15–0.3–0.5–0.8–1.5–3 s (at 1.5 x I _g) TRIP ALARM	±20%	3 s (TRIP)

2nd Additional Pre-alarm (AP)

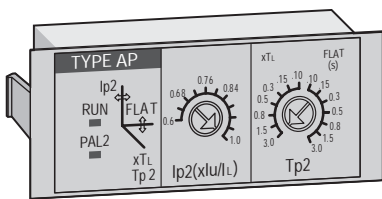

The Pre-Alarm (1st) function already installed in standard ETR, the 2nd additional Pre-Alarm function can be installed as option, thereby it is possible to monitor (observer) electric circuit in more detail by 2nd additional Pre-Alarm function.

Specifications	AP-W
Optional setting Module	AP (2nd Pre-alarm module)
Order information	Art. no. 168560

Pre-alarm timing chart

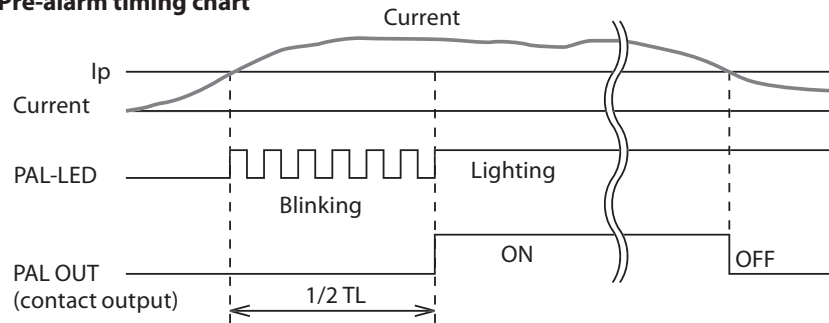

Setting item	Adjustable setting range	Accuracy	Setting for shipment
2nd additional Pre-alarm pick-up current	I _{p2} 0.5–0.6–0.7–0.8–0.84–0.88–0.92–0.96–1.0 x I _u (WS) 0.5–0.6–0.7–0.8–0.84–0.88–0.92–0.96–1.0 x I _i (WM)	±10% (WS) ±5% (WM)	1.0
2nd additional Pre-alarm time	T _{p2} 0.3–0.4–0.5–0.6–0.7–0.8–0.9 x T _L / 5–10–15–20–30–40–60s (FLAT)	±20%	0.9 x T _L

Neutral pole 50% protection (N5)

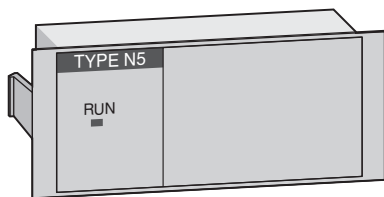

Neutral pole overcurrent protection (operating at 100% of rated current) already installed in standard ETR.

But if you would like to operate at 50% of rated current on neutral pole, neutral pole 50% protection realizes it.

Specifications		N5-W
Optional setting Module		N5 (Neutrale pole protection module)
Order information	Art. no.	168561

Earth leakage protection (ER)

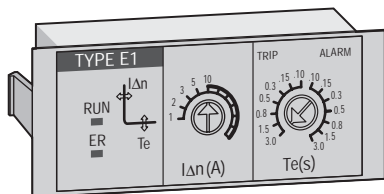

By combining the ETR with earth leakage protection (ER) and External ZCT, earth leakage protection is possible. Earth leakage protection, earth leakage tripping and earth leakage alarm can be selected. Control supply is necessary for this function.

Specifications		E1-W
Optional setting Module		E1 (Earth leakage protection module)
Order information	Art. no.	168559

Setting item	Adjustable setting range	Accuracy	Setting for shipment
ER pick-up current	$I_{\Delta n}$ 1–2–3–5–10 A	+0% –30%	10 A
ER time	T_e 3–1.5–0.8–0.5–0.3–0.15–<0.1 – <0.1–0.15–0.3–0.5–0.8–1.5–3 s (at 1.5 x $I_{\Delta n}$) TRIP ALARM	±20%	3 s (TRIP)

MCR switch (MCS-W)

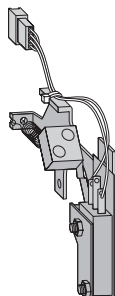

If MCR switch is built in the breaker and the dial for INST/MCR on Main setting module is set to any MCR position, MCR function is operative.

MCR function: During a closing operation of the breaker, Instantaneous characteristics is operative. And it becomes inoperative when the breaker is in the closed position.

Specifications		MCS-W
Switch		MCR
Order information	Art. no.	168570

Extension module (EX1)

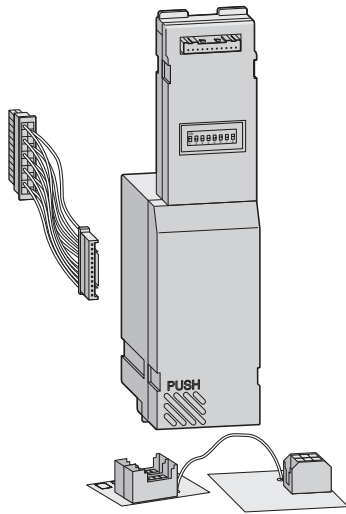

This is the module that realizes various additional functions combining Display module (DP1/DP2), Interface unit (BIF-CC/BIF-PR/BIF-MD) and VT-W unit.

- **Various measuring elements, high measuring accuracy**
By adopting high-performance ASIC, various measuring elements (load current, voltage, energy, harmonics, etc.) and high measuring accuracy are realized.

- **Communication function**
2 display modules and 1 interface unit can be connected simultaneously by internal communication.

Specifications		EX1-W
Type		Extension Module
Order information	Art. no.	168564

Display module (DP1/DP2)

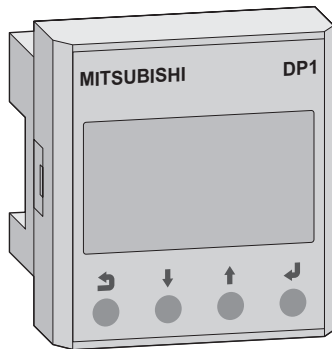

This is the module that displays and sets various information, for example, measurement, trip and alarm, setting of output contacts and so on.

- **Multi display of measuring element**
It enables to easily monitor the comparison of each measuring element by multi display (load current 4 phases multi display and voltage multi display) on one screen.
- **2-colours back light**
If trip or alarm occurred, back light colour changes from green to red automatically.

- **Graphical display**
By adopting dot matrix type LCD, graphical display such as bar graph display of load current, harmonic currents and characteristic curve are realized.
There are 2 types of this module. One is the ETR attachment type (DP1). Another is the panel attachment type (DP2) and is connected to extension terminals of control circuit by 2 m cable (5 m cable will be available on request).

Specifications		DP1-W	DP2-W
Type		Display module for ETR assembly	Display module for Panel assembly
Order information	Art. no.	168565	168566

Notes:
 – Extension module (EX1) is required.
 – The VT unit is required to display the measured data except the electric current.

VT-W unit

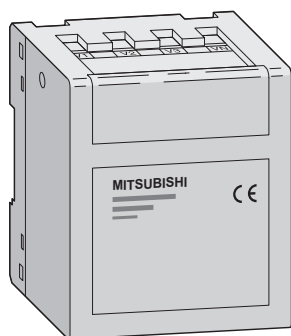

The VT-W unit enables to measure voltages, powers, energies, harmonic currents and etc. by connecting the ETR with Extension module (EX1).

Specifications		VT-W
Unit for		U/P/E/cos phi/earth leakage/average measuring/trip history/trip current measuring
Order information	Art. no.	168567

Interface unit (BIF-CC/BIF-PR/BIF-MD)

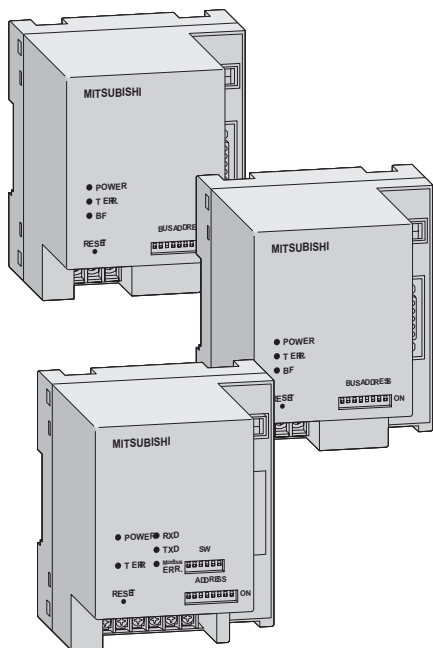

These Interface units can expand the future possibility in various communication and Intelligent control.^①

- **Applicable to various open networks.**
These units are applicable to various open network systems such as CC-Link®, PROFIBUS/DP and MODBUS® (RS-485), which can be built in easily.

- **Intelligent control by Multi-data communication**
It comes into being the Intelligent control by Multi-data communication through these interface units to PLC/SCADA, which transfer the measurement information, setting values, error information and trip and alarm information.

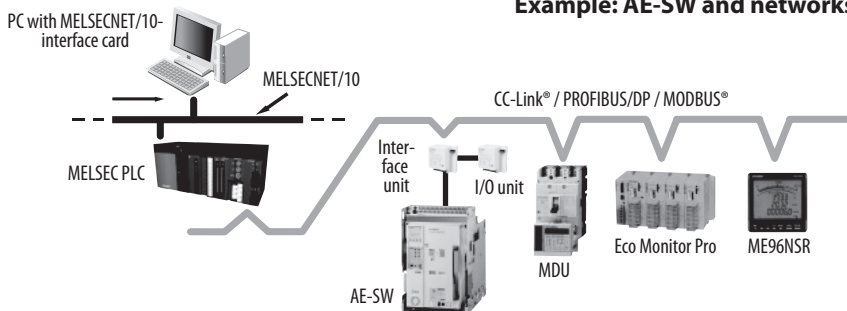

Example: AE-SW and networks

Specifications	BIF-CC-W	BIF-PR-W	BIF-MD-W
Application	CC-Link network	PROFIBUS/DP network	Modbus network
Order information	Art. no. 168571	168572	168573

- Notes:**
- Extension module (EX1) is required.
 - The VT-W unit is required to display the measured data except the electric current.

I/O unit (BIF-CON/BIF-CL)

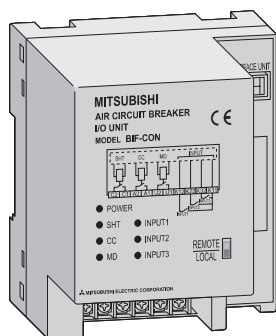

The input & output controlling unit BIF-CON is available for the remote controlling and remote monitoring of the breaker condition through the various network systems. With this BIF-CON in addition to the interface unit, it become possible to control the breaker remotely, like a ON or OFF opera-

tions or Spring-charging. Further, by combining the drawout position switch (BIF-CL), the monitoring of drawout position become available in case of the breaker drawout type.

Function	Description	Note
Control	Breaker ON operation	1 a contact for CC
	Breaker OFF operation	1 a contact for SHT (not applicable for AC380 – 500 V rating)
	Spring charge	1 a contact for MD
Monitor	Digital Input (DI) monitoring	In case of BIF-CC and BIF-MD, max.3 contacts monitoring are available. In case of BIF-PR, 1 contact monitoring is available.
	Breaker drawout position	Position: CONNECTED, TEST and DISCONNECTED BIF-CL is required.

Specifications	BIF-CON-W
Application	I/O unit network module
Order information	Art. no. 168574

Configuration table of ETR with EX1 and VT-W module

Combination sample Type	Display module + Extension module								Display module + Extension module + VT-W unit							
	① = EX1 ② = DP1 - ③ = DP2 ①								① = EX1 ② = DP1 - ③ = DP2,VT-W ①							
	WS				WM				WS				WM			
	NP	AP	G1	E1	NP	AP	G1	E1	NP	AP	G1	E1	NP	AP	G1	E1
① Main setting module																
② Optional setting module																
③ Power supply	P3 - P5								P3 - P5							
Measurement																
Load current (±2.5 %)																
Leakage current (±15 %) ③	-	-	-	○	-	-	-	○	-	-	-	○	-	-	-	○
Voltage (±2.5 %)																
Power (active, reactive, apparent) (±2.5 %)																
Power factor (±5 %)																
Energy (active, reactive) (±2.5 %)																
Harmonics current (±2.5 %)									○ (3.5 ... 19th)							
Frequency (±2.5 %)																
Trip history																
LTD																
STD																
INST																
GFR	-	-	○	-	-	-	○	-	-	-	○	-	-	-	○	-
ER	-	-	-	○	-	-	-	○	-	-	-	○	-	-	-	○
UVT																
Alarm history																
PAL1																
PAL2	-	○	-	-	-	○	-	-	-	○	-	-	-	○	-	-
OVER																
GFR	-	-	○	-	-	-	○	-	-	-	○	-	-	-	○	-
EPAL	-	-	-	○	-	-	-	○	-	-	-	○	-	-	-	○
ER	-	-	-	○	-	-	-	○	-	-	-	○	-	-	-	○
Characteristic setting (for panel attachment model DP2 only)																
LTD																
STD																
INST																
PAL1																
PAL2	-	○	-	-	-	○	-	-	-	○	-	-	-	○	-	-
GFR	-	-	○	-	-	-	○	-	-	-	○	-	-	-	○	-
EPAL	-	-	-	●	-	-	●	-	-	-	-	●	-	-	-	●
ER	-	-	-	○	-	-	-	○	-	-	-	○	-	-	-	○
Setting																
Output contacts setting change																
Date & Time																
Demand time																
Alarm holding method																
Reset																
Trip and alarm information																
Measurement information (min. and max. values)																
ETR information																
Main / Optional setting module information																
Error information																
CT rating																
Phase line method																
Normal connection or reverse connection																

○: can be displayed by DP1/DP2

●: can be displayed and set by DP1/DP2

① 2 units of display modules can be attached.

② Display is available only when UVT module is attached.

③ Included the accuracy of ZCT.

World Super Series WSS – The Extensive Breaker Series from MITSUBISHI ELECTRIC

The circuits of the Mitsubishi breaker series are amongst the smallest compact circuit breakers in the world with electronic overload indication of this kind.

The system is based, among other things, on the well-known and proven microprocessor technology.

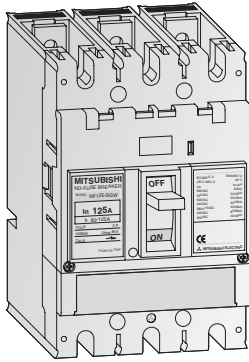

NF125-SGW RT, 3p

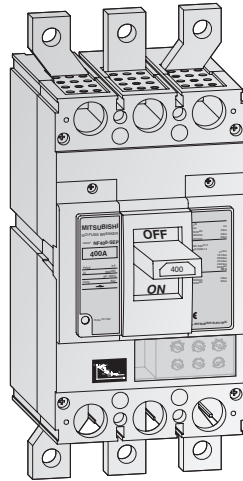

NF400-SEW, 3p

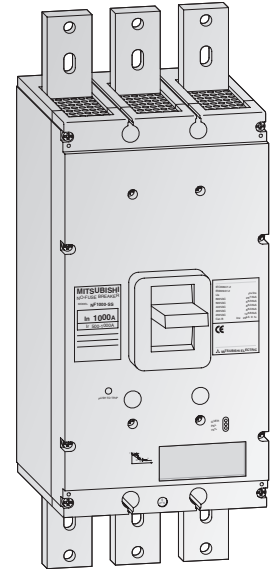

NF1000-SEW, 3p

WSS – World Super Series

The new WSS breaker series meets national and international protection ratings according to VDE, EN, and IEC standards for industrial applications as well as for extended shipping demands.

The new tripping technology guarantees a high reliability and highest protection.

- 16 to 250 A in one model size (3- and 4-pole)
- interchangeable relay unit (thermal type or electronic type)
- available in fixed and plug-in versions
- breaking capacity
 $I_{cs} = 100\% I_{cu}$, up to 690 V
- additional disconnectors available

The proven World Super Series features technical know-how and the microprocessor technology tried and tested in longstanding experience.

The fully enclosed circuit breakers provide an increased safety and at the same time decreased switching times.

- 400 to 800 A
- 2 model sizes (3- and 4-pole)
- electronic trip system
- available in fixed and plug-in versions
- additional disconnectors available

The proven standard series for a high breaking performance providing an optimum protection for transformer and generator feed in, and output breakers.

Circuit breakers can be used as section or disconnecting switch.

- 1000 to 1600 A
- 1 model size (3- and 4-pole)
- electronic trip system
- available in fixed versions
- additional disconnectors available

Intelligent Breaking Technology for Your Safety

With its innovative breaking technology all Mitsubishi breakers offer greater safety and even faster circuit-breaking speed through the use of the latest switch-off technology and innovative engineering, with a newly developed electronic trip relay.

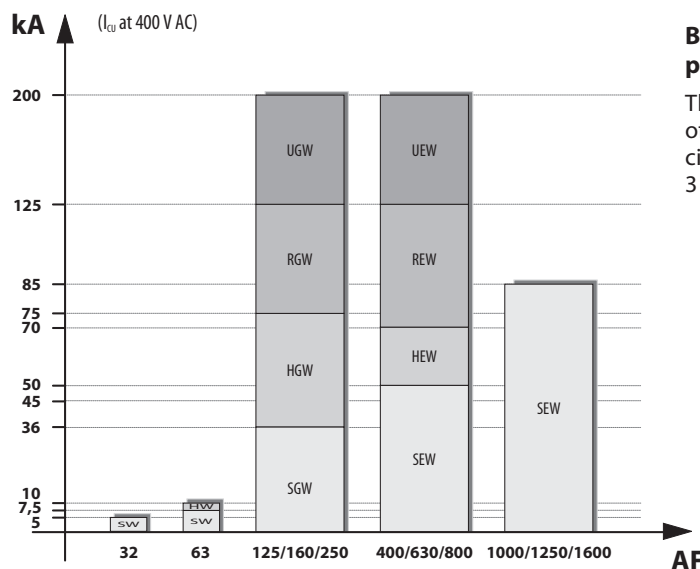

Breaking performance

The complete range of moulded case circuit breakers from 3 to 1600 A.

Outline

New breaking technology

With its new breaking technology the circuit breakers offer greater safety and even faster circuit-breaking speed through the use of the latest switch-off

technology and innovative engineering, with a newly developed electronic trip relay.

Arc-extinguishing device

Mitsubishi MCCBs feature excellent arc-extinguishing performance by virtue of the optimum combination of grid gap, shape, and material.

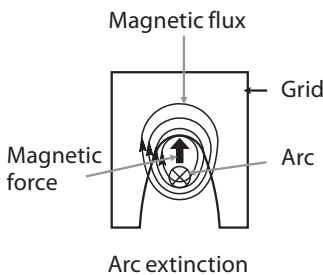

Arc runner

The arc is instantaneously transferred to the arc-extinguishing chamber (see the figure above) by the arc runner, which reduces damage to contacts and improves interrupting performance.

Trip button (push to trip)

Enables tripping mechanically from outside, for confirming the operation of the accessory switches and the manual resetting function.

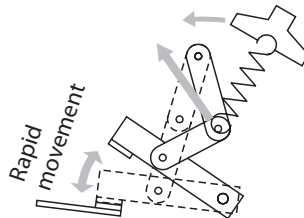

Switching mechanism

The contacts open and close rapidly, regardless of the moving speed of the handle, minimizing contact wear and ensuring safety.

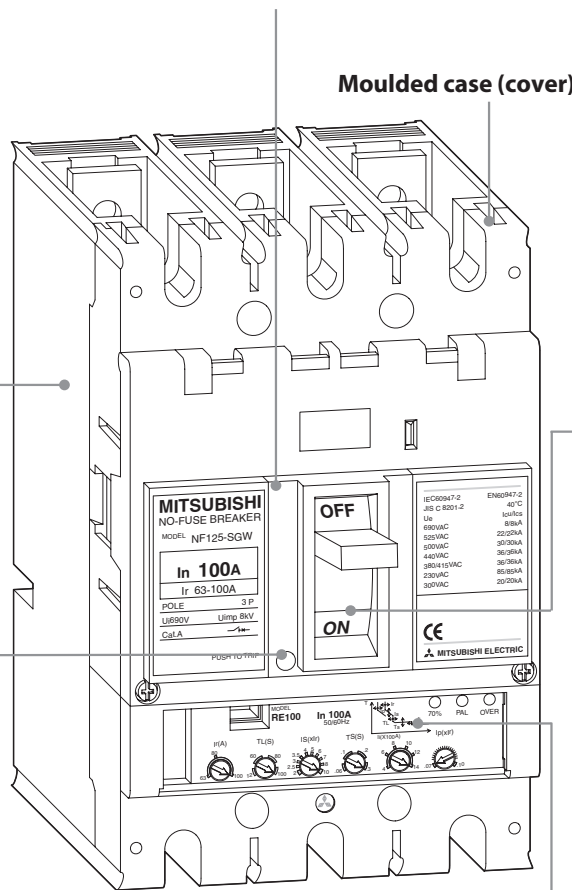

Type NF125-SGW construction

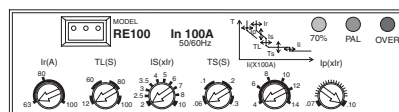

Trip relay with control dials

Handle

- Trip indication
The automatically tripped condition is indicated by the handle in the center position between ON and OFF; the yellow or white line cannot be seen in this position. The figure shows the handle in tripped position.

- Resetting
Resetting after tripping is performed by first moving the handle OFF position to engage the mechanism, then returning the handle to ON to reclose the circuit.

- Trip-Free
Even if the handle is held at ON, the breaker will trip if an overcurrent flows.
- Contact on Mechanism
Even in the worst case in which welding occurs owing to an overcurrent, the breaker will trip and the handle will maintain to ON, indicating the energizing state.

Adjustable thermal trip current value

The setting can be changed by simply turning the control dials, providing the optimum characteristics for particular road conditions.

A Microcomputer and Mitsubishi's Original IC fulfill a New High Level of Safety

Safer and more reliable power

Electronic device loads, such as inverters, distort the current waveform. Mitsubishi's electronic breakers use a digital detector to measure the current's effective value and minimize overload tripping errors. This enables precise protection of the circuit.

Alarm function monitors and anticipates interruptions

Our electronic moulded-case circuit breakers feature a pre-alarm system as standard. The pre-alarm outputs an alarm before the circuit breaker trip is activated. When the load current exceeds the set pre-alarm current, it outputs a pre-alarm signal (from a solid-state relay) and lights the LED.

The pre-alarm module (with contact output) is optional available with electronic moulded-case and earth-leakage circuit breakers (on request).

Improved protection against fluctuations in the load current

Our standard electronic trip relay offers a number of outstanding benefits.

The user has a choice of six different parameters as tripping characteristics with the multiple coordinated protection method.

Better protection can be obtained between the high-voltage fuse, OCR and the low voltage fuse.

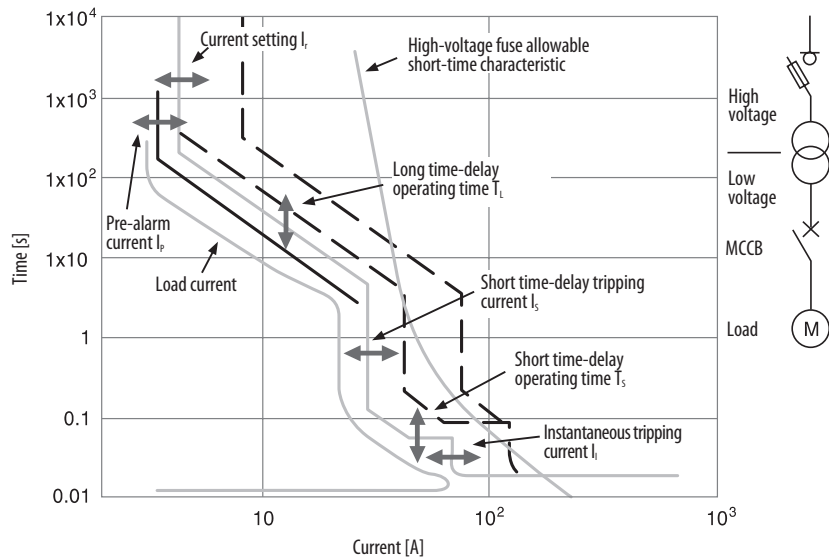

Coordinated protection from multiple tripping characteristics

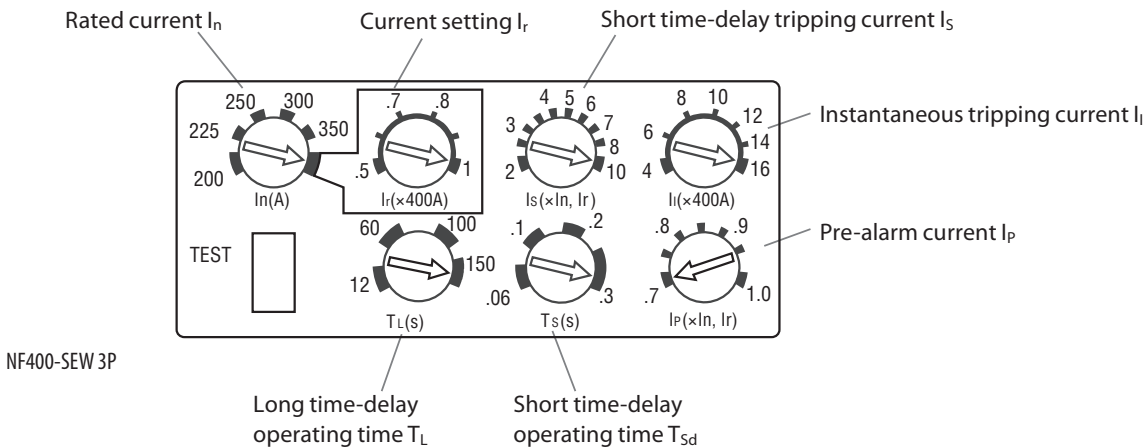

Portable tester facilitates checking and maintenance

The separately sold portable tester allows the user to check the four characteristics:

- 1. Long-delay tripping
- 2. Short-delay tripping
- 3. Instantaneous tripping
- 4. Pre-alarm characteristics

LEDs for load current, pre-alarm and over-current show the operating status.

Overload protection and safety

The neutral-pole overload protection circuit is standard with 4-wire electronic moulded-case devices.

It prevents burn-out when the neutral-pole's load current is greater than the voltage pole in a 3-phase 4 wire circuit which is prone to distorted third-harmonic current flows.

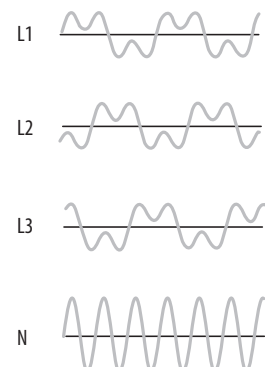

Calculation and Selection Software MELSHORT2

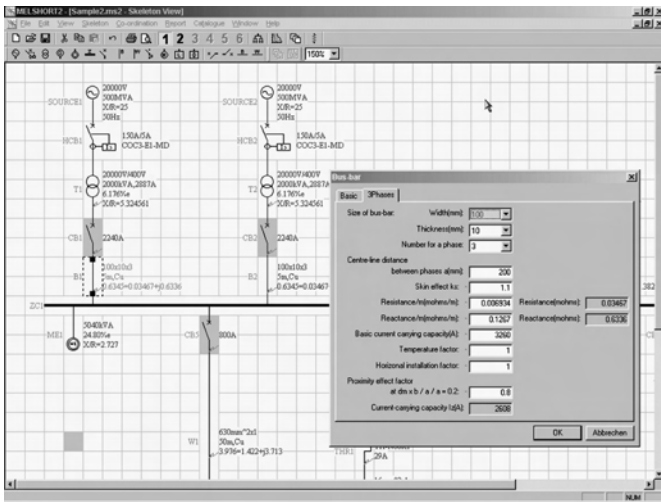

Circuit diagram of the network to be calculated, with input field

MELSHORT2 – The New Calculation Software for Low-Voltage Switchgears

MELSHORT2 is a software package that provides all the functions needed for planning and dimensioning switchgear systems. Increasingly demanding technical specifications and accountability regulations are making switchgear configuration much more critical than it used to be. In the past, software for calculating and dimensioning switchgear was helpful – nowadays it's absolutely essential. It supports all modern international electrical engineering standards and shines with simple and reliable operation.

The program calculates the short-circuit levels and currents at all necessary points for all switchgear components, including the power supply transformer and circuit breakers, the emergency generators, the individual motor and capacitor group branch circuits and all the other power distribution circuits, down to the last circuit breaker. This makes it possible to select the ideal breaker for every task, for optimum performance and cost-efficiency.

MELSHORT2 has a comprehensive range of powerful, easy-to-use functions, including:

- Selective shutdown
- Backup protection
- Coordination with the main power supply systems
- Allowance for the start-up currents of electric motors

These functions make it possible to optimise the configuration of your switchgear equipment for the specific requirements of your applications.

The calculated results, the hardware model suggestions and the wiring diagram with all the relevant values can be processed and used as documentation for the switchgear installation. Another welcome extra is the free Internet update service.

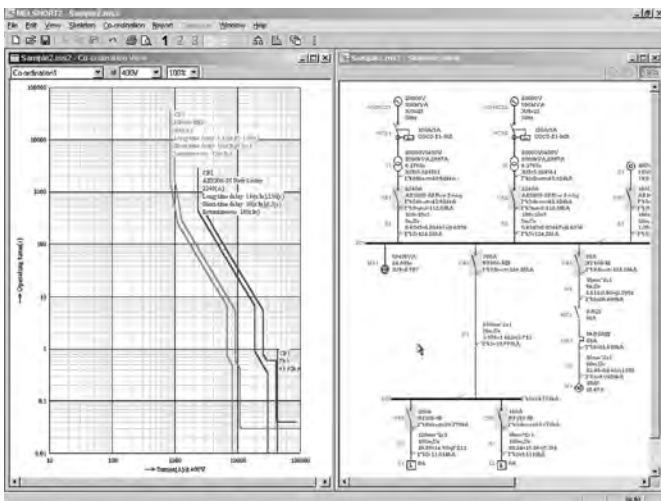

Display of the trip curves of a circuit breaker in the network

Specifications	MELSHORT2
Operating system	MS Windows 95/98/NT4.0/2000
Disk type	CD-ROM
Art. no.	129115

Product Skeleton of Accessories

MITSUBISHI ELECTRIC offers a wide range of accessories for the Moulded-case circuit breakers and Disconnectors to serve almost all variations of applications. Detailed information on request.

1	Circuit Breaker	see page 40
2	Solderless (Box) terminals	see page 63
3	Rear connection studs	see page 63
4	Insulating barriers (BA-F)	see page 69
5	Small terminal covers (TC-S)	see page 68
6	Large terminal covers (TC-L)	see page 68
7	Rear terminal covers (BTC)	see page 68
8	Plug-in base (PM)	see page 63
9	Connections for Plug-in	see page 63
10	Mechanical interlock (MI)	see page 69
11	OFF Lock with 3 padlocks (HL)	see page 65
12	Handle lock device (LC, HLF, HLN, HLS)	see page 65
13	Variable-depth operating handle, V type	see page 64
14	Rotary operating handle, R type	see page 64
15	Electrical operating device (MDS)	see page 67
16	Alarm and Auxiliary switches (AL, AX)	see page 54
17	Under voltage trip device (UVT)	see page 58
18	Shunt trip device (SHT)	see page 56

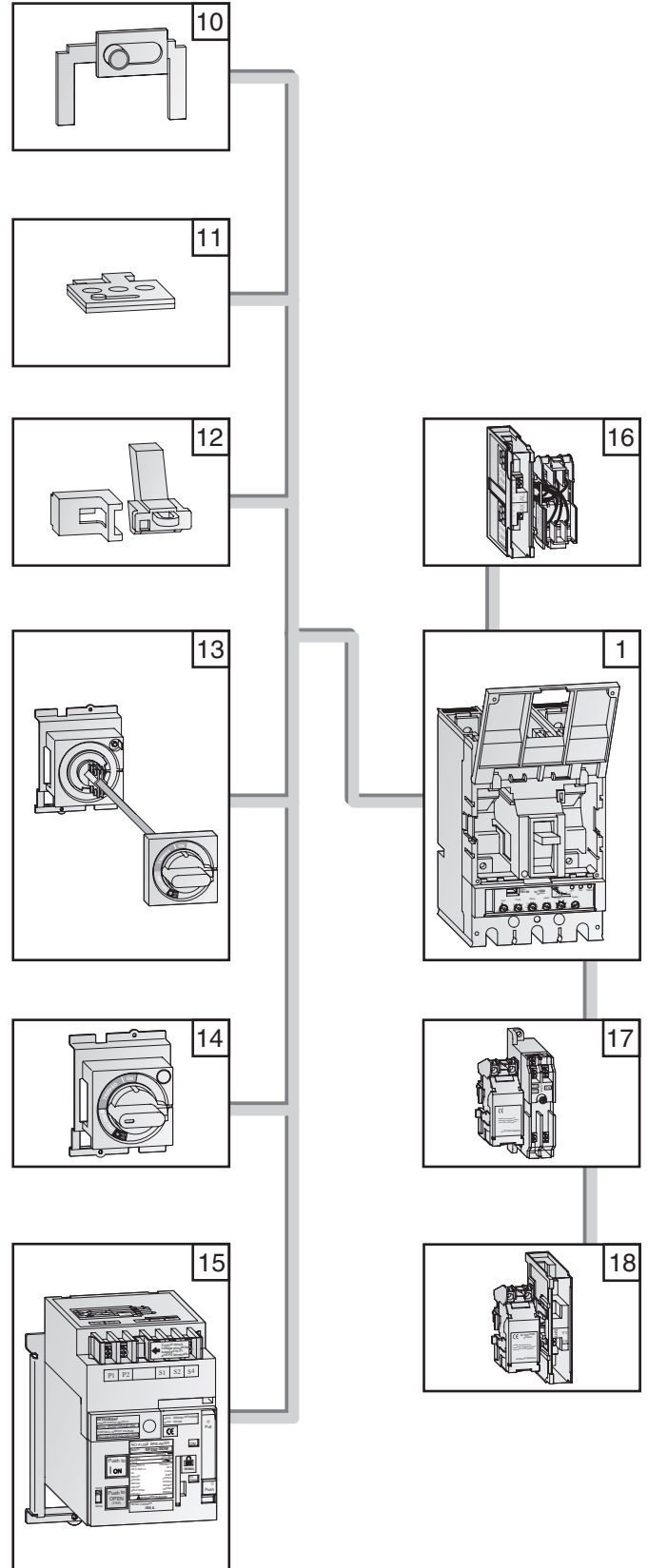

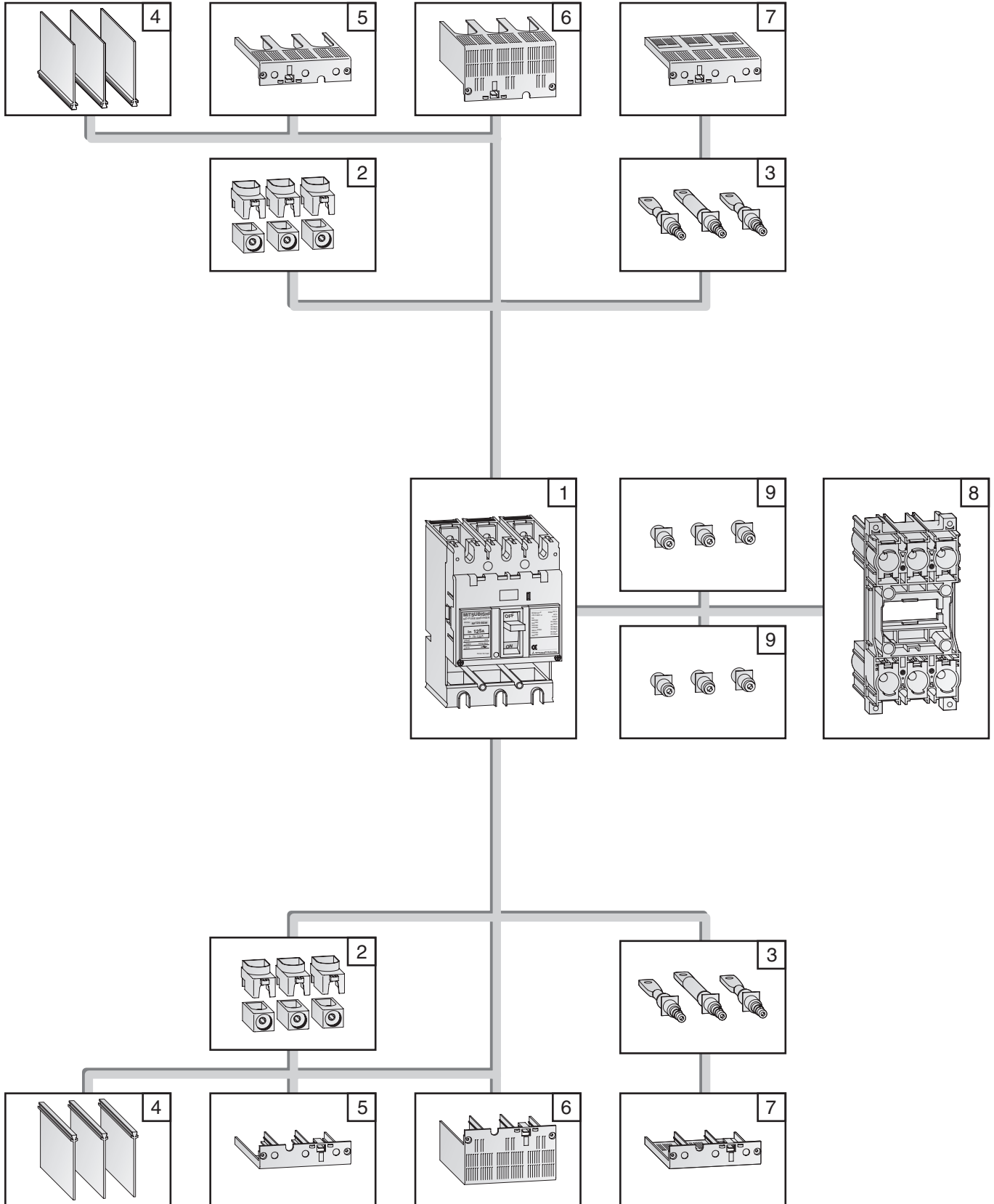

Model Overview and Specifications

Type / Series		WSS series						
		NF32-SW	NF63-SW	NF125-SGW RT	NF125-SGW RE	NF160-SGW RT	NF160-SGW RE	
S series	Rated current $I_{n \max}$ [A]	32	63	125*	125*	160*	160*	
	Rated insulation voltage U_i [V]	AC 600	600	690	690	690	690	
	Number of poles	3	3 / 4	3 / 4	3 / 4	3 / 4	3 / 4	
	Rated breaking capacity [kA] (I_{cu} / I_{cs})	690 V	—	—	8 / 8	8 / 8	8 / 8	8 / 8
		500 V	2.5 / 1	7.5 / 4	30 / 30	30 / 30	30 / 30	30 / 30
		440 V	2.5 / 1	7.5 / 4	36 / 36	36 / 36	36 / 36	36 / 36
		400 V	5 / 2	7.5 / 4	36 / 36	36 / 36	36 / 36	36 / 36
230 V	7.5 / 4	15 / 8	85 / 85	85 / 85	85 / 85	85 / 85		
Dimensions WxHxD	[mm]	75x130x68	75/100x130x68	105/140x165x86	105/140x165x86	105/140x165x86	105/140x165x86	
Type		NF63-HW						
H series	Rated current $I_{n \max}$ [A]	63						
	Rated insulation voltage U_i [V]	690						
	Number of poles	3 / 4						
	Rated breaking capacity [kA] (I_{cu} / I_{cs})	690 V	2.5 / 1					
		500 V	7.5 / 4					
		440 V	10 / 5					
		400 V	10 / 5					
230 V	25 / 13							
Dimensions WxHxD	[mm]	75/100x130x68						
Type		NF125-HGW RT						
R series	Rated current $I_{n \max}$ [A]	100						
	Rated insulation voltage U_i [V]	690						
	Number of poles	3						
	Rated breaking capacity [kA] (I_{cu} / I_{cs})	690 V	25 / 25					
		500 V	125 / 125					
		440 V	125 / 125					
		400 V	125 / 125					
230 V	125 / 125							
Dimensions WxHxD	[mm]	105x240x86						
Type		NF125-UGW RT						
U series	Rated current $I_{n \max}$ [A]	100						
	Rated insulation voltage U_i [V]	690						
	Number of poles	3 / 4						
	Rated breaking capacity [kA] (I_{cu} / I_{cs})	690 V	30 / 30					
		500 V	200 / 200					
		440 V	200 / 200					
		400 V	200 / 200					
230 V	200 / 200							
Dimensions WxHxD	[mm]	105/140x240x86						
Type		DSN32-SW	DSN63-SW	DSN125-SGW	DSN160-SGW			
Disconnectors	Rated current $I_{n \max}$ [A]	32	63	125	160			
	Rated insulation voltage U_i [V]	AC/DC 600	600	690	690			
	Rated voltage U_c [V]	AC (50/60 Hz) / DC	500 / 250	500 / 250	690 / 300	690 / 300		
	Number of poles	3	3 / 4	3 / 4	3 / 4			
	Max. switching current [A] (breaking)	AC/DC	256 / 128	504 / 252	1000 / 500	1280 / 640		
	Dimensions WxHxD		75x130x68	75/120x130x68	105/140x165x86	105/140x165x86		

① DC on request ② In case of solderless terminal, interrupting capacity reduces. * adjustable

WSS - CIRCUIT BREAKERS 5

WSS series							
NF250-SGW RT	NF250-SGW RE	NF400-SEW	NF630-SEW	NF800-SEW	NF1000-SEW	NF1250-SEW	NF1600-SEW
250*	250*	400*	630*	800*	1000*	1250*	1600*
690	690	690	690	690	690	690	690
3 / 4	3 / 4	3 / 4	3 / 4	3 / 4	3 / 4	3 / 4	3 / 4
8 / 8	8 / 8	10 / 10 ^②	10 / 10	10 / 10	25 / 13	25 / 13	25 / 13
30 / 30	30 / 30	30 / 30 ^②	30 / 30	30 / 30	65 / 33	65 / 33	65 / 33
36 / 36	36 / 36	42 / 42 ^②	42 / 42	42 / 42	85 / 43	85 / 43	85 / 43
36 / 36	36 / 36	50 / 50^②	50 / 50	50 / 50	85 / 43	85 / 43	85 / 43
85 / 85	85 / 85	85 / 85 ^②	85 / 85	85 / 85	125 / 63	125 / 63	125 / 63
105/140x165x86	105/140x165x86	140/185x257x103	140/185x257x103	210/280x275x103	210/280x406x140	210/280x406x140	210/280x406x140
NF250-HGW RT	NF250-HGW RE	NF400-HEW	NF630-HEW	NF800-HEW			
250*	250*	400*	630*	800*			
690	690	690	690	690			
3 / 4	3 / 4	3 / 4	3 / 4	3 / 4			
20 / 20	20 / 20	10 / 10	15 / 15	15 / 15			
50 / 50	50 / 50	50 / 50	50 / 50	50 / 50			
65 / 65	65 / 65	65 / 65	65 / 65	65 / 65			
75 / 75	75 / 75	70 / 70	70 / 70	70 / 70			
100 / 100	100 / 100	100 / 100	100 / 100	100 / 100			
105/140x165x86	105/140x165x86	140/185x257x103	140/185x257x103	210/280x275x103			
NF250-RGW RT			NF400-REW	NF630-REW	NF800-REW		
225			400*	630*	800*		
690			690	690	690		
3			3	3	3		
25 / 25			15 / 10	20 / 15	20 / 15		
125 / 125			70 / 35	70 / 35	70 / 35		
125 / 125			125 / 63	125 / 63	125 / 63		
125 / 125			125 / 63	125 / 63	125 / 63		
125 / 125			150 / 75	150 / 75	150 / 75		
105x240x86			140x257x103	140x257x103	210x275x103		
NF250-UGW RT			NF400-U EW	NF800-U EW			
225			400*	800*			
690			690	690			
3 / 4			3 / 4	3 / 4			
30 / 30			35 / 35	35 / 35			
200 / 200			170 / 170	170 / 170			
200 / 200			200 / 200	200 / 200			
200 / 200			200 / 200	200 / 200			
200 / 200			200 / 200	200 / 200			
105/140x240x86			140/280x297/322x200	210/280x322x200			
DSN250-SGW	DSN400-SW	DSN630-SW	DSN800-SW	DSN1000-SW	DSN1250-SW	DSN1600-SW	
250	400	630	800	1000	1250	1600	
690	690	690	690	660	660	660	
690 / 300	690 / 250	690 / 250	690 / 250	660 / 250	660 / 250	660 / 250	
3 / 4	3 / 4	3 / 4	3 / 4	3 / 4	3 / 4	3 / 4	
2000 / 1000	3200 / 1600	5040 / 2520	6400 / 3200	8000 / 14000	10000 / 5000	12800 / 6400	
105/140x165x86	140/185x257x103	140/185x257x103	210/280x275x103	210/280x406x140	210/280x406x140	210/280x406x140	

* adjustable

Specifications of Moulded-Case Circuit Breakers 3–125 A

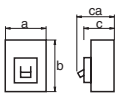
Type		(Reference for Order information on p. 50/51)	NF32-SW (1)	NF63-SW (2)	NF63-HW (3)	NF125-SGW RT (4)	NF125-SGW RE (5)		
Frame (A)			32	63	63	125	125		
Rated data	Rated current I_n [A] at ambient temperature	40 °C	3, 4, 6, 10, 16, 20, 25, 32 Fixed	3, 4, 6, 10, 16, 20, 25, 32, 40, 50, 63 Fixed	10, 16, 20, 25, 32, 40, 50, 63 Fixed	16–25, 25–40, 40–63, 63–100, 80–125 Adjustable	16–32, 32–63, 63–100, 75–125 Adjustable		
	Number of poles		3	3 / 4	3 / 4	3 / 4	3 / 4		
	Rated insulation voltage U_i [V]	AC	600	600	690	690	690		
	Rated breaking capacity [kA]	IEC/EN 60947-2	AC (50/60 Hz)	690 V	—	—	2.5 / 1	8 / 8	8 / 8
				500 V	2.5 / 1	7.5 / 4	7.5 / 4	30 / 30	30 / 30
				440 V	2.5 / 1	7.5 / 4	10 / 5	36 / 36	36 / 36
				400 V	5 / 2	7.5 / 4	10 / 5	36 / 36	36 / 36
				230 V	7.5 / 4	15 / 8	25 / 13	85 / 85	85 / 85
	(I_{cu} / I_{cs})		DC	300 V	—	—	20 / 20 ^④	—	
Utilization category			A	A	A	A	A		
Rated impulse withstand voltage U_{imp} [kV]			6	6	6	8	8		
Pollution degree			2	2	2	3	3		
Reverse connection			●	●	●	●	●		
Suitable for isolation 			●	●	●	●	●		
Dimensions [mm]		a	75	75 / 100	75 / 100	105 / 140	105 / 140		
		b	130	130	130	165	165		
		c	68	68	68	86	86		
		ca	90	90	90	110	110		
		Weight [kg]		0.55	0.60 / 0.70	0.60 / 0.70	2.0 / 2.6	2.0 / 2.6	
Mechanical data	Cassette-type accessories	Alarm switch (AL)	●	●	●	●	●		
		Auxiliary switch (AX)	●	●	●	●	●		
		Shunt trip (SHT)	●	●	●	●	●		
		Undervoltage trip	Non-synchronous closing (UVT-N)	●	●	●	●	●	
			Synchronous closing (UVT-S)	—	—	—	—	—	
	Accessories connection	with terminal block (SLT)	●	●	●	●	●		
		with internal terminal type	●	●	●	●	●		
	Installation and connection	Front	Screw terminal (standard)	●	●	●	●	●	
			Solderless terminal	—	—	—	●	●	
			Busbar terminal	—	—	—	—	—	
Rear		(B)	●	●	●	●	●		
Plug-in		Rear (PM)	●	●	●	—	—		
	Rear front IP 20 with auto trip (PM-IP)	—	—	—	●	●			
Built-in accessories	Pre-alarm-contact output ^① (PAL)	—	—	—	—	●			
	Overcurrent trip alarm ^① (OAL)	—	—	—	—	●			
Extern accessories	External operating handle	Door mounting (V)	●	●	●	●	●		
		Mounted on breaker (R)	—	—	—	●	●		
	Electrical operation device (MDS)	—	—	—	●	●			
	Handle lock device	Handle lock for use with padlock (HL)	●	●	●	●	●		
		(HL-S)	●	●	●	●	●		
		Lock cover (LC)	●	●	●	●	●		
	Terminal cover	Large (TC-L)	●	●	●	●	●		
		Small (TC-S)	●	●	●	●	●		
		For rear connection (BTC)	●	●	●	●	●		
		For plug-in (PTC)	●	●	●	●	●		
Mechanical interlock (MI)	●	●	●	●	●				
Insulating barrier Between phase (Standard) (BA-F)	●	●	●	●	●				
Adapter for IEC 35 mm rail	●	●	●	—	—				
Others	Marine approval ^② for 3 pole breakers		LR, GL, BV, DNV, AB	LR, GL, BV, DNV, AB	LR, GL, BV, DNV, AB	LR, GL, BV, DNV, AB	LR, GL, BV, DNV, AB		
	Automatic tripping device		Hydraulic-magnetic	Hydraulic-magnetic	Hydraulic-magnetic	Thermal-magnetic	Electronic		
	Trip button		Equipped	Equipped	Equipped	Equipped	Equipped		

① Both PAL and OAL is not available. Only one specified. ② Others on request. ③ On request. ④ Use of 3- or 4-pole breaker for DC, see wiring diagram on the next page. Missing specifications accord. to IEC/EN 60947-2 on request.

5 WSS - CIRCUIT BREAKERS

NF125-HGW RT (6)	NF125-HGW RE (7)	NF125-RGW RT (8)	NF125-UGW RT (9)
125	125	125	125
16-25, 25-40, 40-63, 63-100, 80-125 Adjustable	16-32, 32-63, 63-100, 75-125 Adjustable	16-25, 25-40, 40-63, 63-100 Adjustable	16-25, 25-40, 40-63, 63-100 Adjustable
3 / 4	3 / 4	3	3 / 4
690	690	690	690
20 / 20	20 / 20	25 / 25	30 / 30
50 / 50	50 / 50	125 / 125	200 / 200
65 / 65	65 / 65	125 / 125	200 / 200
75 / 75	75 / 75	125 / 125	200 / 200
100 / 100	100 / 100	125 / 125	200 / 200
40 / 40 ^②	—	—	—
A	A	A	A
8	8	8	8
3	3	3	3
●	●	●	●
●	●	●	●
105 / 140	105 / 140	105	105 / 140
165	165	240	240
86	86	86	86
110	110	110	110
2.0 / 2.6	2.0 / 2.6	3.1	3.1 / 3.9
●	●	●	●
●	●	●	●
●	●	●	●
●	●	●	●
—	—	—	—
●	●	●	●
●	●	●	●
●	●	●	●
●	●	●	●
—	—	—	—
●	●	●	●
—	—	—	— / ●
●	●	●	● / —
—	●	—	—
—	●	—	—
●	●	●	●
●	●	●	●
●	●	●	●
●	●	●	●
●	●	●	●
●	●	●	●
●	●	●	●
●	●	●	●
●	●	●	●
●	●	●	●
●	●	●	●
●	●	●	●
●	●	●	●
—	—	—	—
LR, GL, BV, DNV, AB	LR, GL, BV, DNV, AB	LR, GL, BV, DNV, AB	LR, GL, BV, DNV, AB
Thermal-magnetic	Electronic	Thermal-magnetic	Thermal-magnetic
Equipped	Equipped	Equipped	Equipped

Use of 3- and 4-pole breakers for DC

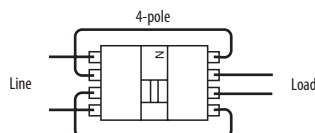
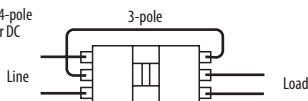

Specifications of Moulded-Case Circuit Breakers 160–250 A

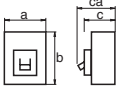
Type	(Reference for Order information on p. 50/51)	NF160-SGW RT (10)	NF160-SGW RE (11)	NF160-HGW RT (12)	NF160-HGW RE (13)		
Frame (A)		160	160	160	160		
Rated data	Rated current I_n [A] at ambient temperature	40 °C 125–160 Adjustable	80–160 Adjustable	125–160 Adjustable	80–160 Adjustable		
	Number of poles	3 / 4	3 / 4	3 / 4	3 / 4		
	Rated insulation voltage U_i [V]	AC 690 V	690	690	690		
	Rated breaking capacity [kA] (IEC/EN 60947-2)	AC (50/60 Hz)	690 V	8 / 8	8 / 8	20 / 20	
			500 V	30 / 30	30 / 30	50 / 50	
			440 V	36 / 36	36 / 36	65 / 65	
			400 V	36 / 36	36 / 36	75 / 75	
			230 V	85 / 85	85 / 85	100 / 100	
		DC	300 V	20 / 20 ^③	—	40 / 40 ^③	
		Utilization category	A	A	A	A	
Rated impulse withstand voltage U_{imp} [kV]		8	8	8	8		
Pollution degree		3	3	3	3		
Reverse connection		●	●	●	●		
Suitable for isolation 		●	●	●	●		
Mechanical data	Dimensions [mm] 	a	105 / 140	105 / 140	105 / 140	105 / 140	
		b	165	165	165	165	
		c	86	86	86	86	
		ca	110	110	110	110	
		Weight [kg]		2.0 / 2.6	2.0 / 2.6	2.0 / 2.6	2.0 / 2.6
	Cassette-type accessories	Alarm switch (AL)	●	●	●	●	
		Auxiliary switch (AX)	●	●	●	●	
		Shunt trip (SHT)	●	●	●	●	
		Undervoltage trip	Non-synchronous dosing (UVT-N)	—	—	—	—
			Synchronous closing (UVT-S)	●	●	●	●
Accessories connection	with terminal block (SLT)	●	●	●	●		
	with internal terminal type	●	●	●	●		
Installation and connection	Front	Screw terminal (standard)	●	●	●	●	
		Solderless terminal	●	●	●	●	
		Busbar terminal	—	—	—	—	
	Rear	(B)	●	●	●	●	
	Plug-in	Rear (PM)	—	—	—	—	
Rear front IP 20 with auto trip (PM-IP)		●	●	●	●		
Built-in accessories	Pre-alarm-contact output ^① (PAL)	—	●	—	●		
	Overcurrent trip alarm ^① (OAL)	—	●	—	●		
External accessories	External operating handle	Door mounting (V)	●	●	●	●	
		Mounted on breaker (R)	●	●	●	●	
	Electrical operation device (MDS)	●	●	●	●		
	Handle lock device	Handle lock for use with padlock (HL)	●	●	●	●	
		(HL-S)	●	●	●	●	
		Lock cover (LC)	●	●	●	●	
	Terminal cover	Large (TC-L)	●	●	●	●	
		Small (TC-S)	●	●	●	●	
		For rear connection (BTC)	●	●	●	●	
		For plug-in (PTC)	●	●	●	●	
	Mechanical interlock (MI)	●	●	●	●		
	Insulating barrier Between phase (Standard) (BA-F)	●	●	●	●		
	Adapter for IEC 35 mm rail	—	—	—	—		
	Others	Marine approval ^② for 3 pole breakers	—	—	—	—	
		Automatic tripping device	Thermal-magnetic	Electronic	Thermal-magnetic	Electronic	
Trip button		Equipped	Equipped	Equipped	Equipped		

^① Both PAL and OAL is not available. Only one specified. ^② Others on request. ^③ On request. ^④ Use of 3- or 4-pole breaker for DC, see wiring diagram on the next page. Missing specifications accord. to IEC/EN 60947-2 on request.

WSS – CIRCUIT BREAKERS 5

NF250-SGW RT (14)	NF250-SGW RE (15)	NF250-HGW RT (16)	NF250-HGW RE (17)	NF250-RGW RT (18)	NF250-UGW RT (19)
250	250	250	250	250	250
125-160, 160-250 Adjustable	125-250 Adjustable	125-160, 160-250 Adjustable	125-250 Adjustable	125-160, 160-225 Adjustable	125-160, 160-225 Adjustable
3/4	3/4	3/4	3/4	3	3/4
690	690	690	690	690	690
8/8	8/8	20/20	20/20	25/25	30/30
30/30	30/30	50/50	50/50	125/125	200/200
36/36	36/36	65/65	65/65	125/125	200/200
36/36	36/36	75/75	75/75	125/125	200/200
85/85	85/85	100/100	100/100	125/125	200/200
20/20 ⁽³⁾	—	40/40 ⁽³⁾	—	—	—
A	A	A	A	A	A
8	8	8	8	8	8
3	3	3	3	3	3
●	●	●	●	●	●
●	●	●	●	●	●
105/140	105/140	105/140	105/140	105	105/140
165	165	165	165	240	240
86	86	86	86	86	86
110	110	110	110	110	110
2.0/2.6	2.0/2.6	2.0/2.6	2.0/2.6	3.1	3.1/3.9
●	●	●	●	●	●
●	●	●	●	●	●
●	●	●	●	●	●
—	—	—	—	—	—
●	●	●	●	●	●
●	●	●	●	●	●
●	●	●	●	●	●
●	●	●	●	●	●
●	●	●	●	●	●
●	●	●	●	●	●
●	●	●	●	●	●
—	—	—	—	—	—
●	●	●	●	●	●
—	—	—	—	—	—/●
●	●	●	●	●	—
—	●	—	●	—	—
—	●	—	●	—	—
●	●	●	●	●	●
●	●	●	●	●	●
●	●	●	●	●	●
●	●	●	●	●	●
●	●	●	●	●	●
●	●	●	●	●	●
●	●	●	●	●	●
●	●	●	●	●	●
●	●	●	●	●	●/—
●	●	●	●	●	●
●	●	●	●	●	●
—	—	—	—	—	—
LR, GL, BV, DNV, AB	LR, GL, BV, DNV, AB	LR, GL, BV, DNV, AB	LR, GL, BV, DNV, AB	LR, GL, BV, DNV, AB	LR, GL, BV, DNV, AB
Thermal-magnetic	Electronic	Thermal-magnetic	Electronic	Thermal-magnetic	Thermal-magnetic
Equipped	Equipped	Equipped	Equipped	Equipped	Equipped

Use of 3- and 4-pole breakers for DC

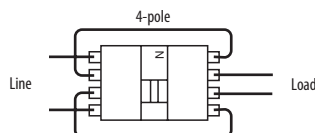
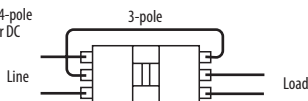

Specifications of Moulded-Case Circuit Breakers 400–630 A

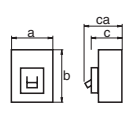
Type	(Reference for Order information on p. 50/51)	NF400-SEW (20)	NF400-HEW (21)	NF400-REW (22)		
Frame (A)		400	400	400		
Bemessungsdaten	Rated current I_n [A] at ambient temperature	40 °C 200–400 Adjustable	200–400 Adjustable	200–400 Adjustable		
	Number of poles	3 / 4	3 / 4	3		
	Rated insulation voltage U_i [V]	AC 690	690	690		
	Rated breaking capacity [kA] (IEC/EN 60947-2 AC ^① (50/60 Hz) (I_{cu} / I_{cs}))	690 V	10 / 10 (5 / 5) ^②	10 / 10	15 / 10	
		500 V	30 / 30 (25 / 25) ^②	50 / 50	70 / 35	
		440 V	42 / 42 (36 / 36) ^②	65 / 65	125 / 63	
		400 V	50 / 50 (36 / 36)^②	70 / 70	125 / 63	
		230 V	85 / 85 (65 / 65) ^②	100 / 100	150 / 75	
	Utilization category	B	B	B		
	Rated short-time withstand current I_{cw} [kA/s]	5 / 0.25	5 / 0.25	5 / 0.25		
	Rated impulse withstand voltage U_{imp} [kV]	8	8	8		
	Pollution degree	3	3	3		
	Reverse connection	●	●	●		
Suitable for isolation 	●	●	●			
Dimensions [mm] 	a	140 / 185	140 / 185	140		
	b	257	257	257		
	c	103	103	103		
	ca	155	155	155		
	Weight [kg]	6.0 / 7.8	6.0 / 7.8	6.0		
Mechanische Daten	Cassette-type accessories	Alarm switch (AL)	●	●	●	
		Auxiliary switch (AX)	●	●	●	
		Shunt trip (SHT)	●	●	●	
		Undervoltage trip	Non-synchronous closing (UVT-N)	●	●	●
			Synchronous closing (UVT-S)	●	●	●
	Accessories connection	with terminal block (SLT)	●	●	●	
		with internal terminal type ^③	●	●	●	
	Installation and connection	Front Busbar terminal (standard)	●	●	●	
		Rear (B)	●	●	●	
		Plug-in Rear (PM)	●	●	●	
Built-in accessories	Pre-alarm-contact output (PAL)	●	●	●		
	Trip indicator (TI)	●	●	●		
Externes Zubehör	External operating handle	Door mounting (V)	●	●	●	
		Mounted on breaker (R)	●	●	●	
	Electrical operation device	Spring-charge type (MDS)	●	●	●	
	Handle lock device	Handle lock for use with padlock (HL)	●	●	●	
		(HL-S)	●	●	●	
	Terminal cover	Large (TC-L)	●	●	●	
		For rear connection (BTC)	●	●	●	
	Mechanical interlock (MI)	●	●	●		
	Insulating barrier	Between phase (Standard) (BA-F)	●	●	●	
	Sonstiges	Marine approval ^④ for 3 pole breakers	LR, GL, BV, DNV, AB	LR, GL, BV, AB	LR, GL, BV, AB	
Automatic tripping device		Electronic	Electronic	Electronic		
Trip button		Equipped	Equipped	Equipped		

① DC type on request. ② In case of solderless terminal, interrupting capacity reduces. ③ On request. ④ Others on request. Missing specifications accord. to IEC/EN 60947-2 on request.

5 WSS – CIRCUIT BREAKERS

NF400-U EW (23) 400	NF630-SEW (24) 630	NF630-HEW (25) 630	NF630-REW (26) 630
200-400 Adjustable	300-630 Adjustable	300-630 Adjustable	300-630 Adjustable
3 / 4	3 / 4	3 / 4	3
690	690	690	690
35 / 35	10 / 10	35 / 18	20 / 15
170 / 170	30 / 30	50 / 50	70 / 35
200 / 200	42 / 42	65 / 65	125 / 63
200 / 200	50 / 50	70 / 70	125 / 63
200 / 200	85 / 85	100 / 100	150 / 75
B	B	B	B
5 / 0.25	7.6 / 0.25	7.6 / 0.25	7.6 / 0.25
8	8	8	8
3	3	3	3
●	●	●	●
●	●	●	●
140 / 280	140 / 185	140 / 185	140
297 / 322	257	257	257
200	103	103	103
252	155	155	155
16.7 / 26.1	6.5 / 8.3	6.5 / 8.3	6.5
●	●	●	●
●	●	●	●
●	●	●	●
●	●	●	●
●	●	●	●
●	●	●	●
●	●	●	●
●	●	●	●
●	●	●	●
● / —	●	●	●
●	●	●	●
●	●	●	●
—	●	●	●
—	●	●	●
—	●	●	●
●	●	●	●
●	●	●	●
●	●	●	●
●	●	●	●
●	●	●	●
●	●	●	●
LR, GL, BV, AB	LR, GL, BV, AB	LR, GL, BV, AB	LR, GL, BV, AB
Electronic	Electronic	Electronic	Electronic
Equipped	Equipped	Equipped	Equipped

Specifications of Moulded-Case Circuit Breakers 800–1600 A

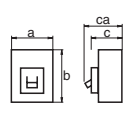
Type		(Reference for Order information on p. 50/51)		NF800-SEW (27)	NF800-HEW (28)	NF800-REW (29)	
Frame (A)				800	800	800	
Rated data	Rated current I_n [A] at ambient temperature	40 °C		400–800 Adjustable	400–800 Adjustable	400–800 Adjustable	
	Number of poles			3 / 4	3 / 4	3	
	Rated insulation voltage U_i [V]	AC		690	690	690	
	Rated breaking capacity [kA] (I_{cu} / I_{cs})	IEC/EN 60947-2 AC ① (50/60 Hz)	690 V		10 / 10	15 / 15	—
			500 V		30 / 30	50 / 50	70 / 35
			440 V		42 / 42	65 / 65	125 / 63
			400 V		50 / 50	70 / 70	125 / 63
			230 V		85 / 85	100 / 100	150 / 75
	Utilization category			B	B	B	
	Rated short-time withstand current I_{cw} [kA/s]			9.6 / 0.25	9.6 / 0.25	9.6 / 0.25	
	Rated impulse withstand voltage U_{imp} [kV]			8	8	8	
Pollution degree			3	3	3		
Reverse connection			●	●	●		
Suitable for isolation 			●	●	●		
Dimensions [mm]			a	210 / 280	210 / 280	210	
			b	275	275	275	
			c	103	103	103	
			ca	155	155	155	
			Weight [kg]			10.9 / 14.2	10.9 / 14.2
Mechanical data	Cassette-type accessories	Alarm switch (AL)	●	●	●		
		Auxiliary switch (AX)	●	●	●		
		Shunt trip (SHT)	●	●	●		
		Undervoltage trip	Non-synchronous closing (UVT-N)	●	●	●	
			Synchronous closing (UVT-S)	●	●	●	
	Accessories connection	with terminal block (SLT)	●	●	●		
		with internal terminal type ②	●	●	●		
	Installation and connection	Front	Busbar terminal (Standard)	●	●	●	
		Rear	(B)	●	●	●	
		Plug-in	Rear (PM)	●	●	●	
Built-in accessories	Pre-alarm-contact output (PAL)	●	●	●			
	Trip indicator (TI)	●	●	●			
External accessories	External operating handle	Door mounting (V)	●	●	●		
		Mounted on breaker (R)	●	●	●		
	Electrical operation device	Spring-charge type (MDS)	●	●	●		
	Handle lock device	Handle lock for use with padlock (HL)	●	●	●		
		(HL-S)	●	●	●		
	Terminal cover	Large (TC-L)	●	●	●		
		For rear connection (BTC)	●	●	●		
	Mechanical interlock (MI)	●	●	●			
	Insulating barrier	Between phase (Standard) (BA-F)	●	●	●		
	Others	Marine approval ③ for 3 pole breakers	LR, GL, BV, DV, AB	LR, GL, BV, AB	LR, GL, BV, AB		
Automatic tripping device		Electronic	Electronic	Electronic			
Trip button		Equipped	Equipped	Equipped			

① DC type on request. ② On request. ③ Others on request. ④ Assembly by factory.
Missing Specifications accord. to IEC/EN 60947-2 on request.

5 WSS - CIRCUIT BREAKERS



NF800-U EW (30)	NF1000-SEW (31)	NF1250-SEW (32)	NF1600-SEW (33)
800	1000	1250	1600
400–800 Adjustable	500–1000 Adjustable	600–1250 Adjustable	800–1600 Adjustable
3 / 4	3 / 4	3 / 4	3 / 4
690	690	690	690
35 / 35	25 / 13	25 / 13	25 / 13
170 / 170	65 / 33	65 / 33	65 / 33
200 / 200	85 / 43	85 / 43	85 / 43
200 / 200	85 / 43	85 / 43	85 / 43
200 / 200	125 / 63	125 / 63	125 / 63
B	B	B	B
9.6 / 0.25	20 / 0.3	20 / 0.3	20 / 0.3
8	8	8	8
3	3	3	3
●	●	●	●
●	●	●	●
210 / 280	210 / 280	210 / 280	210 / 280
322	406	406	406
200	140	140	140
252	190	190	190
27.6 / 33.7	23.5 / 30.7	23.5 / 30.7	34.5 / 41.2
●	●	●	●
●	●	●	●
●	●	●	●
●	●	●	●
●	●	●	●
●	●	●	●
●	●	●	●
●	●	●	●
●	●	●	●
●	●	●	●
—	—	—	—
—	—	—	—
●	●	●	●
●	●	●	●
—	●	●	●
—	●	●	●
●	●	●	●
●	●	●	●
●	—	—	—
●	●	●	—
●	—	—	—
●	●	●	●
●	●	●	●
—	LR, GL, AB	LR, GL, AB	—
Electronic	Electronic	Electronic	Electronic
Equipped	Equipped	Equipped	Equipped

5
WSS – CIRCUIT BREAKERS

Specifications of Disconnectors DSN, IEC 60947-3, EN 60947-3

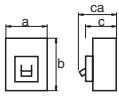
Type	(Reference for Order information on p. 50/51)	DSN32-SW (34)	DSN63-SW (35)	DSN125-SGW (36)	DSN160-SGW (37)	DSN250-SGW (38)			
Rated data	Rated current I_n [A]	40 °C	32	63	125	160	250		
	Number of poles		3	3 / 4	3 / 4	3 / 4	3 / 4		
	Rated insulation voltage U_i [V]		600	600	690	690	690		
	Rated voltage U_c [V]	AC	500	500	690	690	690		
		DC	250	250	300	300	300		
	Rated impulse withstand voltage U_{imp} [kV]	kV	6	6	8	8	8		
	Pollution degree		2	2	3	3	3		
	Utilization category		AC-23A, DC-23A	AC-23A, DC-23A	AC-23A, DC-23A	AC-23A, DC-23A	AC-23A, DC-23A		
	Making and braking current	Making current	AC / DC	A	320 / 128	630 / 252	1250 / 500	1600 / 640	2500 / 1000
			cycles		5	5	3 / 5	3 / 5	3 / 5
		Breaking current	AC / DC	A	256 / 128	504 / 252	1000 / 500	1280 / 640	2000 / 1000
			cycles		5	5	3 / 5	3 / 5	3 / 5
	Operational performance	Without current		10000	15000	50000	40000	25000	
		With current (440 V / 690 V)		6000 / —	8000 / —	30000 / 1000	20000 / 1000	10000 / 1000	
	Short-time withstand current I_{cw}	1 s	A	1000	1000	2000	3000	4000	
Short-circuit making capacity I_{cm}	1 s	A	1500	1500	3000	4000	6000		
Max. switching current ①	AC / DC	A	192 / 80	378 / 155	750 / 315	960 / 400	1500 / 625		
	cycles		12	12	12	12	12		
Suitable for isolation			●	●	●	●	●		
Dimensions [mm]		a	75	75 / 100	105 / 140	105 / 140	105 / 140		
		b	130	130	165	165	165		
		c	68	68	86	86	86		
		ca	90	90	110	110	110		
		Weight [kg]		0.55	0.6 / 0.7	2.0 / 2.6	2.0 / 2.6	2.0 / 2.6	
Mechanical data	Cassette-type accessories	Alarm switch (AL)	●	●	●	●	●		
		Auxiliary switch (AX)	●	●	●	●	●		
		Shunt trip (SHT)	●	●	●	●	●		
		Undervoltage trip (UVT)	●	●	●	●	●		
	Accessories connection	with terminal block (SLT)	●	●	●	●	●		
		with internal terminal type ②	—	—	●	●	●		
	Installation and connection	Front	Screw terminal	● ③	● ③	● ③	● ③	● ③	
			Solderless terminal	—	—	●	●	●	
			Busbar terminal	●	●	●	●	●	
		Rear	(B)	●	●	●	●	●	
Plug-in		Rear (PM)	●	●	—	—	—		
	Rear front IP 20 with auto trip (PM-IP)	—	—	●	●	●			
External accessories	External operating handle	Door mounting (V)	●	●	●	●	●		
		Mounted on breaker (R)	—	—	●	●	●		
	Electrical operation device (MDS)	—	—	●	●	●			
	Handle lock device	Handle lock for use with padlock (HL)	●	●	●	●	●		
		(HL-S)	●	●	●	●	●		
		Lock cover (LC)	●	●	●	●	●		
	Terminal cover	Large (TC-L)	●	●	●	●	●		
		Small (TC-S)	●	●	● / —	● / —	●		
		For rear connection (BTC)	●	●	● / —	● / —	●		
	Mechanical interlock (MI)	●	●	●	●	●			
	Insulating barrier	Between phase (Standard) (BA-F)	●	●	●	●	●		
	Adapter for IEC 35 mm rail		●	●	—	—	—		
	Corresponding type of circuit breaker		NF32-SW	NF63-SW	NF125-SGW	NF160-SGW	NF250-SGW		

① This performance is accordance with IEC60947-2 clause 7.2.4.1. ② On request. ③ Standard. ④ Assembly by factory. ⑤ TC-N. Missing specifications accord. to IEC/EN 60947-2 on request.

WSS - CIRCUIT BREAKERS 5

DSN400-SW (39)	DSN630-SW (40)	DSN800-SW (41)	DSN1000-SW (42)	DSN1250-SW (43)	DSN1600-SW (44)
400	630	800	1000	1250	1600
3 / 4	3 / 4	3 / 4	3 / 4	3 / 4	3 / 4
690	690	690	690	690	690
690	690	690	690	690	690
250	250	250	250	250	250
8	8	8	8	8	8
3	3	3	3	3	3
AC-23A, DC-23A	AC-23A, DC-23A	AC-23A, DC-23A	AC-23A, DC-23A	AC-23A, DC-23A	AC-23A, DC-23A
4000 / 1600	6300 / 2520	8000 / 3200	10000 / 4000	12500 / 5000	16000 / 6400
3 / 5	3 / 5	3 / 5	3 / 5	3 / 5	3 / 5
3200 / 1600	5040 / 2520	6400 / 3200	8000 / 4000	10000 / 5000	12800 / 6400
3 / 5	3 / 5	3 / 5	3 / 5	3 / 5	3 / 5
6000	6000	4000	3000	2500	2500
1000	1000	500	500	500	500
6000	8000	10000	12000	12000	16000
10200	13600	17000	24000	24000	32000
2400 / 1000	3780 / 1575	4800 / 2000	6000 / 2500	7500 / 3125	9600 / 4000
12	12	12	12	12	12
●	●	●	●	●	●
140 / 185	140 / 185	210 / 280	210 / 280	210 / 280	210 / 280
257	275	275	406	406	406
103	103	103	140	140	140
155	155	155	190	190	190
5.7 / 7.5	6.2 / 8.0	10.9 / 14.2	23.0 / 30.2	23.0 / 30.2	34.0 / 40.7
●	●	●	●	●	●
●	●	●	●	●	●
●	●	●	●	●	●
●	●	●	●	●	●
●	●	●	●	●	●
●	●	●	●	●	●
—	—	—	—	—	—
—	—	—	—	—	—
● ^①	● ^①	● ^①	● ^①	● ^①	● ^①
●	●	●	● ^④	● ^④	● ^④
●	●	●	● ^④	● ^④	● ^④
—	—	—	—	—	—
●	●	●	●	●	●
●	●	●	●	●	●
●	●	●	●	●	●
●	●	●	●	●	●
●	●	●	●	●	●
—	—	—	—	—	—
●	●	●	● ^⑤	● ^⑤	—
—	—	—	—	—	—
●	●	●	●	●	●
●	●	●	●	●	●
●	●	●	●	●	●
—	—	—	—	—	—
NF400-SW	NF630-SW	NF800-SW	NF1000-SEW	NF1250-SEW	NF1600-SEW

Order Information for Moulded-Case Circuit Breakers 3–125 A

Ref.①	Type	Rated current (In)	Art. no. 3 pole type	Art. no. 4 pole type
S series with hydraulic-magnetic tripping device, fixed, AC				
1	NF32-SW	3 A	204474	—
		4 A	204475	—
		6 A	204477	—
		10 A	204478	—
		16 A	204480	—
		20 A	204481	—
		25 A	204482	—
		32 A	204484	—
2	NF63-SW	3 A	204486	204501
		4 A	204487	204502
		6 A	204489	204504
		10 A	204490	204505
		16 A	204492	204507
		20 A	204493	204508
		25 A	204494	204509
		32 A	204496	204511
		40 A	204497	204512
		50 A	204498	204513
		63 A	204500	204515
H series with hydraulic-magnetic tripping device, fixed, AC				
3	NF63-HW	10 A	204516	204527
		16 A	204518	204529
		20 A	204519	204530
		25 A	204520	204531
		32 A	204522	204533
		40 A	204523	204534
		50 A	204524	204535
		63 A	204526	204537

Ref.①	Type	Rated current (In)	Art. no. 3 pole type	Art. no. 4 pole type
S series with thermal-magnetic tripping device, AC, DC				
4	NF125-SGW RT	16–25 A	204540	204545
		25–40 A	204541	204546
		40–63 A	204542	204547
		63–100 A	204543	204548
		80–125 A	204544	204549
S series with electronic tripping device, adjustable, AC				
5	NF125-SGW RE	16–32 A	204550	204554
		32–63 A	204551	204555
		63–100 A	204552	204556
		75–125 A	204553	204557
H series with thermal-magnetic tripping device, adjustable, AC, DC				
6	NF125-HGW RT	16–25 A	204558	204563
		25–40 A	204559	204564
		40–63 A	204560	204565
		63–100 A	204561	204566
		80–125 A	204562	204567
H series with electronic tripping device, AC				
7	NF125-HGW RE	16–32A	204568	204572
		32–63A	204569	204573
		63–100A	204570	204574
		75–125A	204571	204575
R series with thermal-magnetic tripping device, adjustable, AC				
8	NF125-RGW RT	16–25 A	204576	—
		25–40 A	204577	—
		40–63 A	204578	—
		63–100 A	204579	—
U series with thermal-magnetic tripping device, adjustable, AC				
9	NF125-UGW RT	16–25 A	204580	204584
		25–40 A	204581	204585
		40–63 A	204582	204586
		63–100 A	204583	204587

① Reference to breaker specifications on p. 40ff.

Order Information for Moulded-Case Circuit Breakers 160–250 A

Ref. ^①	Type	Rated current (In)	Art. no. 3 pole type	Art. no. 4 pole type
S series with thermal-magnetic tripping device, AC, DC				
10	NF160-SGW RT	125–160 A	204591	204592
S series with electronic tripping device, AC				
11	NF160-SGW RE	80–160 A	204593	204594
H series with thermal-magnetic tripping device, AC, DC				
12	NF160-HGW RT	125–160 A	204596	204597
H series with electronic tripping device, adjustable, AC				
13	NF160-HGW RE	80–160 A	204598	204599
S series with thermal-magnetic tripping device, adjustable, AC, DC				
14	NF250-SGW RT	125–160 A	212124	212125
		160–250 A	204602	204603
S series with electronic tripping device, adjustable, AC				
15	NF250-SGW RE	125–250 A	204604	204605

Ref. ^①	Type	Rated current (In)	Art. no. 3 pole type	Art. no. 4 pole type
H series with thermal-magnetic tripping device, adjustable, AC, DC				
16	NF250-HGW RT	125–160 A	212126	212127
		160–250 A	204606	204607
H series with electronic tripping device, adjustable, AC				
17	NF250-HGW RE	125–250 A	204608	204609
R series with thermal-magnetic tripping device, adjustable, AC				
18	NF250-RGW RT	160–225 A	204610	—
U series with thermal-magnetic tripping device, adjustable, AC				
19	NF250-UGW RT	125–160 A	204611	204613
		160–225 A	204612	204614

Order Information for Moulded-Case Circuit Breakers 400–800 A

Ref. ^①	Type	Rated current (In)	Art. no. 3 pole type	Art. no. 4 pole type
S series with electronic tripping device, adjustable, AC				
20	NF400-SEW	200–400 A	204780	204781
24	NF630-SEW	300–630 A	204789	204790
37	NF800-SEW	400–800 A	204797	204798
H series with electronic tripping device, adjustable, AC				
21	NF400-HEW	200–400 A	204782	204783
25	NF630-HEW	300–630 A	204791	204792
28	NF800-HEW	400–800 A	204799	204800

Ref. ^①	Type	Rated current (In)	Art. no. 3 pole type	Art. no. 4 pole type
R series with electronic tripping device, adjustable, AC				
22	NF400-REW	200–400 A	204784	—
26	NF630-REW	300–630 A	204793	—
29	NF800-REW	400–800 A	204801	—
U series with electronic tripping device, adjustable, AC				
23	NF400-UW	200–400 A	204785	204786
30	NF800-UW	400–800 A	204802	204803

Order Information for Moulded-Case Circuit Breakers 1000–1600 A

Ref. ^①	Type	Rated current (In)	Art. no. 3 pole type	Art. no. 4 pole type
SS/UR series with electronic tripping device, adjustable, AC				
31	NF1000-SEW	500–1000 A	204810	204811
32	NF1250-SEW	600–1250 A	204812	204813
33	NF1600-SEW	800–1600 A	204814	204815

Order Information for Disconnectors DSN series 32–1600 A

Ref. ^①	Type	Rated current (In)	Art. no. 3 pole type	Art. no. 4 pole type
Disconnectors (no tripping device)				
34	DSN32-SW	32 A	204473	—
35	DSN63-SW	63 A	204485	204817
36	DSN125-SGW	125 A	204538	204539
37	DSN160-SGW	160 A	204588	204589
38	DSN250-SGW	250 A	204600	204601
39	DSN400-SW	400 A	204778	204779
40	DSN630-SW	630 A	204787	204788
41	DSN800-SW	800 A	204794	204795
42	DSN1000-SW	1000 A	204804	204805
43	DSN1250-SW	1250 A	204806	204807
44	DSN1600-SW	1600 A	204808	204809

① Reference to breaker specifications on p. 40ff.

Internal Accessories

Modular cassette type accessories

The new arrangement and design of pluggable accessories such as indicator and auxiliary contacts allows you to modify the circuit in a way that saves time and space – at any time, even when built in and ready for operation.

The presence of separate circuit chambers makes the system even safer.

Thus cassette type accessories ensure flexibility when upgrading circuits.

The cassette type accessories are available in several versions and fit for breaker series from 32 A up to 800 A:

- alarm switch (AL)
- auxiliary switch (AX)
- alarm and auxiliary switch (AL+AX)
- shunt trip device (SHT)
- undervoltage trip device (UVT)

with lead-wire terminal block as standard. In addition you can choose the lead-wire version or the internal terminal type as an option.

Alarm switch (AL)

Provides for indication that the MCCB has tripped.

Auxiliary switch (AX)

Provides for indication of whether the breaker is ON or OFF.

Lead-wire terminal block (SLT)

The terminal block is used for bringing out the connections of the internal accessories.

The cassette type accessories are also available as internal terminal type without terminal block. The connection cables are lead out of the breaker housing in line-side direction. So it is possible to mount several breakers easy side-by-side in a row.

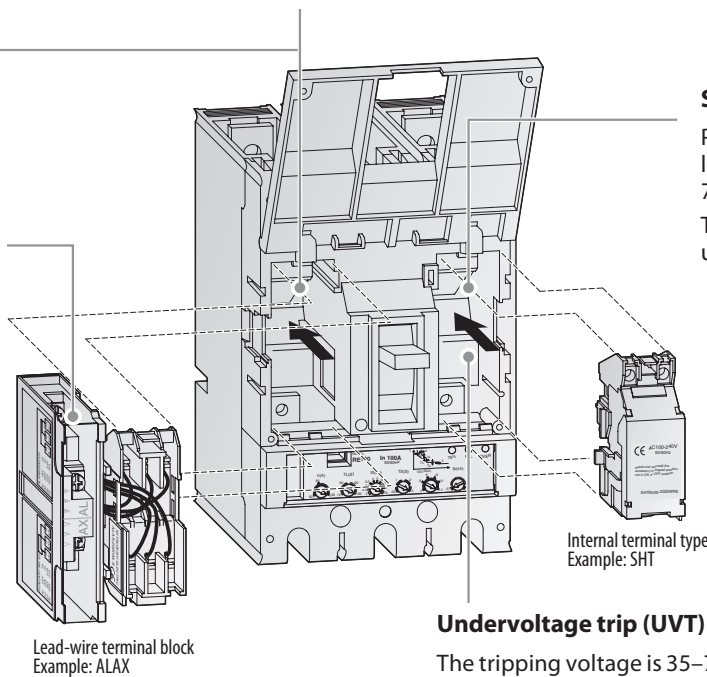

Shunt trip (SHT)

Provides for tripping from a remote location. The control voltage range is 70–100 % of rated voltage.

The shunt trip enables an MCCB to be used in combination with an ELR.

Undervoltage trip (UVT)

The tripping voltage is 35–70 % of the rated voltage. When the voltage recovers to at least 85 %, the breaker can be closed or reset.

Provides for electrical interlock, and is used where electrical machines need to be protected against voltage drop.

For the breakers of the Super Series, 1000 A up to 1600 A, please contact your Distributor.

Overview of Internal Accessories

Cassette-type internal accessory	Function	Catalogue reference
AL (Alarm switch)	The alarm switch AL indicates that the breaker has tripped.	page 54
AX (Auxiliary switch)	The auxiliary switch AX indicates whether the breaker is ON or OFF.	page 54
SHT (Shunt trip)	The shunt trip SHT trips the breaker automatically by remote. A cut-off switch is integrated. The allowable tripping voltage is 70% to 110% of the rated voltage for both AC and DC.	page 56
UVT (Undervoltage trip)	The undervoltage trip UVT trips the breaker automatically when the voltage drops. The tripping voltage is 35% to 70% of the rated voltage. When the voltage recovers to 85% of the rated voltage or above, the UVT can be reset and the breaker closed.	page 58

Connection of the Control Wires

For the connection of the control wires
MITSUBISHI ELECTRIC offers you two ways:

- Lead-wire terminal block (SLT)
- Internal terminal type for direct connection.

Lead-Wire Terminal Block (SLT)

Lead-wire terminal block SLT
with screw terminals

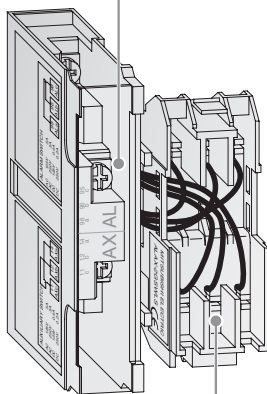

Cassette-type accessory
Example:
ALAX, also for SHT, UVT

Application

All cassette-type accessories are equipped with the Lead-wire terminal block SLT as standard.

The terminal cover for the lead-wire terminals is available for the safety of live parts.

It is available for front connection type, rear connection type and plug-in type.

- Correspondent terminals are not necessary.
- Uneven arrangement of terminal screws is adopted for easier wiring.
- Tightening check of a terminal screw is easy.
- Terminal cover of a terminal block is standard equipment (co-packed).

Internal Terminal Type for Direct Connection

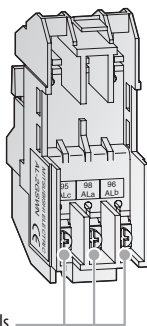

Screw terminals

Example:
AL, also for SHT, UVT

Application

Optional the cassette-type accessories are available as internal terminal type without terminal block.

The control wires can be connected to the integrated screw terminals and can be lead out of the breaker housing in line-side direction.

- Quick install and de-install of the internal accessories is possible without demounting the breaker.
- Mounting of several breakers side-by-side in a row is possible.
- Thus the screw terminals for control wires are inside of the breaker housing, no special terminal cover for the screw terminals is necessary.

Alarm Switch and Auxiliary Switch
(Mounted on left side)

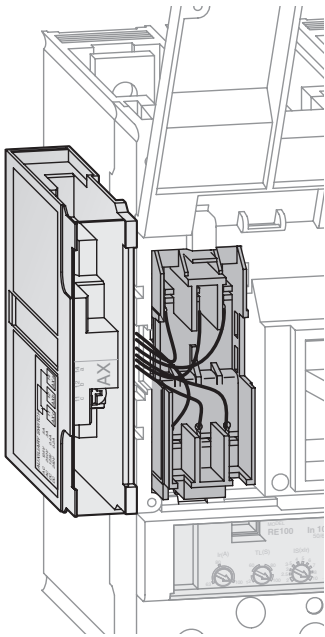

Figure shows Lead-wire terminal block type (SLT).

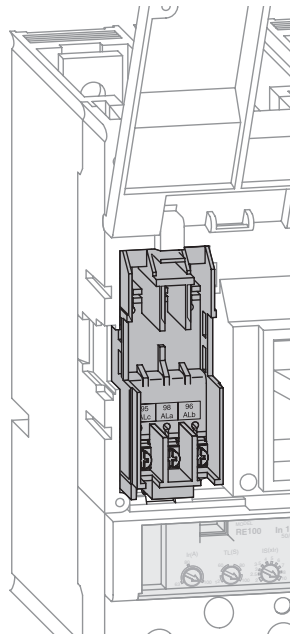

Figure shows Internal terminal type.

Application

The alarm switch AL indicates that the breaker has tripped.
The auxiliary switch AX indicates whether the breaker is ON or OFF.
The alarm and auxiliary switch ALAX is a combination of the alarm switch AL and the auxiliary switch AX in one housing.

- AL, AX and ALAX standard types are for left-side mounting and equipped with lead-wire terminal block SLT.
- Internal terminal type is also available.
- Please specify, if right-side mounted type or type with flying leads is needed.

Contact plans

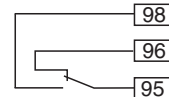

(1 W)
Alarm switch AL

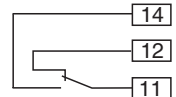

(1 W)
Auxiliary switch AX

Switching Operation

Alarm switch (AL) operation

Main MCCB conditions	Alarm contacts
OFF or ON 	 ALa 98 (open) ALc 95 (closed) (DC+) ^① ALb 96 (closed)
Trip 	 ALa 98 (closed) ALc 95 (open) (DC+) ^① ALb 96 (open)

^① When DC use, polarity must be considered.

Auxiliary switch (AX) operation

Main MCCB conditions	Auxiliary contacts
OFF or Trip 	 AXa 14 (open) AXc 11 (closed) (DC+) ^① AXb 12 (closed)
ON 	 AXa 14 (closed) AXc 11 (open) (DC+) ^① AXb 12 (open)

AL, AX switching capacities

Type of Micro-switch for	Voltage (V AC)	Resistive loads (A)	Inductive load (A)	Voltage (V DC) ^①	Resistive loads (A)	Inductive load (A)
AL/AX/ALAX-05-8	460	—	—	250	0.2	0.2
	250	3	2	125	0.4	0.4
	125	5	3	30	4	3
AL/AX/ALAX-10	460	5	2	250	0.3	0.3
	250	10	10	125	0.6	0.6
	125	10	10	30	10	6

^① When DC use, polarity must be considered.

Order Information for Alarm Switch and Auxiliary Switch

Type	Contacts	Breaker type	Mounted on	Art. no.
Alarm switch AL with lead-wire terminal block SLT				
AL-05SWLS	1 W	NF/DSN32-63	Left side	146379
AL-2GSWLS	1 W	NF/DSN125-250		139505
AL-4SWLS	1 W	NF/DSN400-800		205763
AL2-4SWLS	2 W			205764
AL3-8SWLS	3 W	NF/DSN800		205765
AL-10SWL	1 W	NF/DSN1000-1600		205766

Alarm switch AL for direct connection

AL-2GSWN	1 W + 1 W	NF/DSN125-250	Left side	139508
----------	-----------	---------------	-----------	--------

Auxiliary switch AX with lead-wire terminal block SLT

AX-05SWLS	1 W	NF/DSN32-63	Left side	146380
AX2-05SWLS	2 W			146382
AX-2GSWLS	1 W	NF/DSN125-250		139504
AX2-2GSWLS	2 W			139506
AX-4SWLS	1 W	NF/DSN400-800		205767
AX2-4SWLS	2 W			205768
AX3-8SWLS	3 W	NF/DSN800	205769	
AX4-8SWLS	4 W	NF400-UEW 4P	205770	
AX-10SWLS	1 W	NF/DSN1000-1600	205771	
AX2-10SWLS	2 W		205772	
AX3-10SWLS	3 W		205773	

Auxiliary switch AX for direct connection

AX-2GSWN	1 W	NF/DSN125-250	Left side	139507
AX2-2GSWLN	2 W			139510

Type	Contacts AL AX	Breaker type	Mounted on	Art. no.
Alarm switch and Auxiliary switch ALAX with lead-wire terminal block SLT				
ALAX-05SWLS	1 W + 1 W	NF/DSN32-63	Left side	146381
ALAX-2GSWLS	1 W + 1 W	NF/DSN125-250		137510
ALAX-4SWLS	1 W + 1 W	NF/DSN400-800 NF400-UEW 4P		205774
AL2AX2-4SWLS	2 W + 2 W			205775
ALAX-10SWL	1 W + 1 W	NF/DSN1000-1600		205776
AL1AX2-10SWL	1 W + 2 W			205777

Alarm switch and Auxiliary switch ALAX for direct connection

ALAX-2GSWN	1 W + 1 W	NF/DSN125-250	Left side	139509
------------	-----------	---------------	-----------	--------

Shunt Trip Device SHT

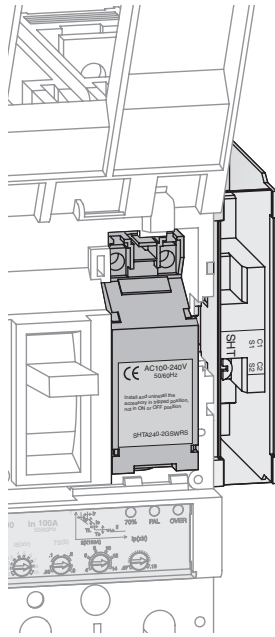

Figure shows Lead-wire terminal block type (SLT).

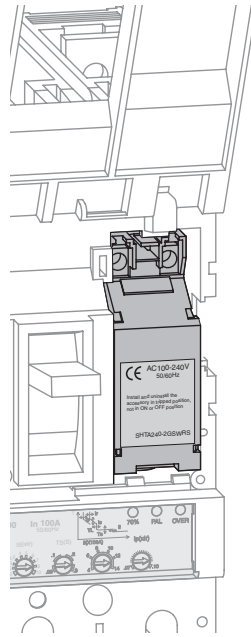

Figure shows Internal terminal type.

Application

The shunt trip device SHT trips the breaker automatically by remote. A cut-off switch is integrated.

The allowable tripping voltage range is 70 % to 110 % of the rated voltage for both AC and DC.

The SHT is mounted on the right side of the breaker and equipped with lead-wire terminal block SLT as standard.

Please specify, if left-side mounted type or type with flying leads is needed (optional available).

Please consider, the shunt trip device SHT for 3-pole and 4-pole breakers is different in the length of wires based on the outline dimension of the breaker.

Contact plan

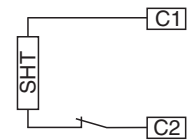

With cut-off switch

Coil ratings

MCCB type ^①	Cut-off switch	Voltage (V) ^②	Input ^③ AC (VA)	DC (W)	Operating time (msec) ^④
NF32-SW NF63-SW NF63-HW	Equipped			50	
NF125-SGW RT/RE NF125-HGW RT/RE NF125-RGW RT/UGW RT NF160-SGW RT/RE NF160-HGW RT/RE NF250-SGW RT/RE NF250-HGW RT/RE NF250-RGW RT/UGW RT	Equipped	AC 24-48 AC 100-240 AC 380-550 (50 / 60 Hz) DC 100-125	120	60	≤15
NF400-SEW / HEW / REW / UEW NF630-SEW / HEW / REW NF800-CEW / SEW / HEW / REW / UEW	Equipped	AC 24-48 / DC 24-48 AC 100-450 / DC 100-200 AC 380-550 (50 / 60 Hz)	100 V: 20 200 V: 50 330 V: 120 450 V: 170	100 V: 10 200 V: 35	5-15
NF1000-SEW NF1250-SEW NF1600-SEW	Equipped	AC 100-120 AC 200-240 AC 380-450 (50 / 60Hz) DC 100	200	70	7-15

① Also for DSN types.

② Other voltages on request

③ For the SHT operating power capacity, any voltage drop in the input electric power must not be below the allowable operating voltage range.

④ The operating time includes all the time up to the moment the main contact of the breaker disconnects after a voltage has been applied to the shunt trip devices.

Order Information for Shunt Trip Devices SHT

With lead-wire terminal block SLT, mounted on right-side

For 3-pole breaker			For 4-pole breaker			Rated voltage
Type	Breaker type	Art. no.	Type	Breaker type	Art. no.	
SHTA048-05SWRS	NF/DSN32-63	146383	SHTA048-05SWRFS	NF/DSN32-63	146384	AC 24-48 V
SHTA240-05SWRS		146385	SHTA240-05SWRFS		146386	AC 100-240 V
SHTA550-05SWRS		146387	SHTA550-05SWRFS		146388	AC 380-550 V
SHTD012-05SWRS		146389	SHTD012-05SWRFS		146390	DC 12 V
SHTD036-05SWRS		146391	SHTD036-05SWRFS		146392	DC 24-36 V
SHTD048-05SWRS		146393	SHTD048-05SWRFS		146394	DC 36-48 V
SHTD125-05SWRS		146395	SHTD125-05SWRFS		146396	DC 100-125 V
SHTD250-05SWRS		146397	SHTD250-05SWRFS		146398	DC 220-250 V
SHTA048-2GSWRS		NF/DSN125-250	139513		SHTA048-2GSWRFS	NF/DSN125-250
SHTA240-2GSWRS	139515		SHTA240-2GSWRFS	139516	AC 100-240 V	
SHTA550-2GSWRS	139517		SHTA550-2GSWRFS	139518	AC 380-550 V	
SHTD012-2GSWRS	139519		SHTD012-2GSWRFS	139520	DC 12 V	
SHTD036-2GSWRS	139521		SHTD036-2GSWRFS	139522	DC 24-36 V	
SHTD048-2GSWRS	139523		SHTD048-2GSWRFS	139524	DC 36-48 V	
SHTD125-2GSWRS	139525		SHTD125-2GSWRFS	139526	DC 100-125 V	
SHTD250-2GSWRS	139527		SHTD250-2GSWRFS	139528	DC 220-250 V	
SHT-4SWRS	NF/DSN400-800		205778	SHT-4SWRFS	NF/DSN400-630	
SHT48-4SWRS		205780	SHT48-4SWRFS	205781		AC 24-48 V / DC 24-48 V
SHTA550-4SWRS		205782	SHTA550-4SWRFS	205783		AC 380-550 V
—	—	—	SHT-8SWRFS	NF/DSN800 NF400-UEW 4P	205784	AC 100-450 V / DC 100-200 V
—	—	—	SHT48-8SWRFS		205785	AC 24-48 V / DC 24-48 V
—	—	—	SHTA550-8SWRFS		205786	AC 380-550 V
SHTA120-10SWRS	NF/DSN1000-1600	205787	SHTA120-10SWRFS	NF/DSN1000-1600	205788	AC 100-120 V
SHTA240-10SWRS		205789	SHTA240-10SWRFS		205790	AC 200-240 V
SHTA450-10SWRS		205791	SHTA450-10SWRFS		205792	AC 380-450 V
SHTD024-10SWRS		205793	SHTD024-10SWRFS		205794	DC 24 V
SHTD110-10SWRS		205795	SHTD110-10SWRFS		205796	DC 110 V

For direct connection, mounted on right-side

For 3-/4-pole breaker			
Type	Breaker type	Rated voltage	Art. no.
SHTA048-2GSWRN	NF/DSN125-250	AC 24-48 V	139529
SHTA240-2GSWRN		AC 100-240 V	139530
SHTA550-2GSWRN		AC 380-550 V	139531
SHTD012-2GSWRN		DC 12 V	139532
SHTD036-2GSWRN		DC 24-36 V	139533
SHTD048-2GSWRN		DC 36-48 V	139534
SHTD125-2GSWRN		DC 100-125 V	139535
SHTD250-2GSWRN		DC 220-250 V	139536

Undervoltage Tripping Device UVT

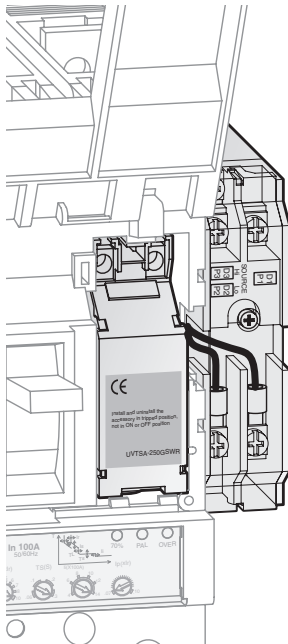

Figure shows Lead-wire terminal block type (SLT).

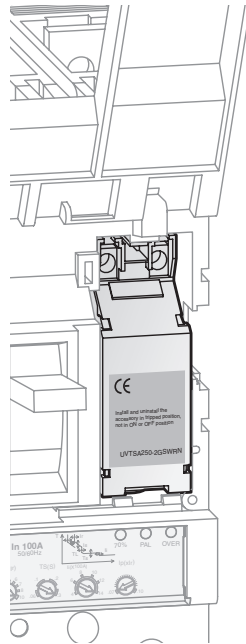

Figure shows Internal terminal type.

Application

The undervoltage tripping device UVT trips the breaker automatically when the voltage drops. The tripping voltage is 35 % to 70 % of the rated voltage. When the voltage recovers to 85 % of the rated voltage or above, the UVT can be reset and the breaker closed.

The UVT is mounted on the right side of the breaker and equipped with lead-wire terminal block SLT as standard.

Please specify, if left-side mounted type or type with flying leads is needed.

Please consider, the undervoltage trip UVT for 3-pole and 4-pole breaker is different in the length of wires based on the outline dimension of the breaker.

Contact plan

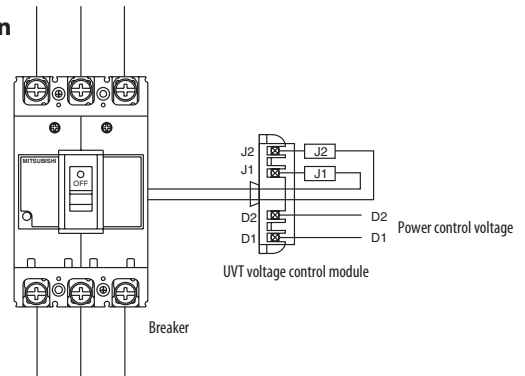

Coil ratings

Breaker type ①	For synchronous closing	Voltage (V) ② Standard	Input (VA)	Operating time ③ (msec)	Making/breaking data	
					Breaker OFF	Breaker ON
NF32-SW NF63-SW NF125-SGW RT/RE NF125-HGW RT/RE NF125-RGW RT/UGW RT NF160-SGW RT/RE NF160-HGW RT/RE NF250-SGW RT/RE NF250-HGW RT/RE NF250-RGW RT/UGW RT	●	AC 100–120 AC 200–240 AC 220–240 AC 380–450 AC 400–440 (50 / 60 Hz) DC 24, DC 110	5	≤ 30	35–70 % U _N	min. 85 % U _N
NF400-SEW / HEW / REW / UEW NF630-SEW / HEW / REW NF800-CEW / SEW / HEW / REW / UEW	●	AC 100–110/120–130 AC 200–220/230–250 AC 380–415/440–480 (50 / 60 Hz) DC100/110		5–30 (Instantaneous type)		
NF1000-SEW NF1250-SEW NF1600-SEW	● ④	AC 100–120/200–240/380–450 AC 200–250/380–450/460–550 (50 / 60 Hz)		5–35 (Time delay type with 3 voltage inputs)		

① Also for DSN types.
 ② Other voltages on request.
 ③ The operating time is the time from the start of operating the breaker since the undervoltage trip went from voltage to no-voltage condition.
 ④ DC version on request.
 UVTs with Time delay on request.

Types of UVTs

Breaker type	No. of Poles	Rated voltages						
		AC 24 / 48 V	AC 100–110 V / AC 120–130 V	AC 200–220 V / AC 230–250 V	AC 380–415 V / AC 440–480 V	AC 500–550 V / AC 600 V	DC 24 / 48 V	DC 100 / 110 V

Instantaneous trip type, with lead-wire terminal block SLT

NF/DSN32–63	3	UVTNA048-05SWRS	UVTNA130-05SWRS	UVTNA250-05SWRS	UVTNA480-05SWRS	UVTNA600-05SWRS	UVTND048-05SWRS	UVTND110-05SWRS	UVTND125-05SWRS
	4	UVTNA048-05SWRFS	UVTNA130-05SWRFS	UVTNA250-05SWRFS	UVTNA480-05SWRFS	UVTNA600-05SWRFS	UVTND048-05SWRFS	UVTND110-05SWRFS	UVTND125-05SWRFS
NF/DSN125–250	3	UVTSA048-2GSWRS	UVTSA130-2GSWRS	UVTSA250-2GSWRS	UVTSA480-2GSWRS	UVTSA600-2GSWRS	UVTSD048-2GSWRS	UVTSD110-2GSWRS	UVTSD125-2GSWRS
	4	UVTSA048-2GSWRF5	UVTSA130-2GSWRF5	UVTSA250-2GSWRF5	UVTSA480-2GSWRF5	UVTSA600-2GSWRF5	UVTSD048-2GSWRF5	UVTSD110-2GSWRF5	UVTSD125-2GSWRF5

Instantaneous trip type, for direct connection

NF/DSN125–250	3/4	UVTSA048-2GSWRN	UVTSA130-2GSWRN	UVTSA250-2GSWRN	UVTSA480-2GSWRN	UVTSA600-2GSWRN	UVTSD048-2GSWRN	UVTSD110-2GSWRN	UVTSD125-2GSWRN
---------------	-----	-----------------	-----------------	-----------------	-----------------	-----------------	-----------------	-----------------	-----------------

Breaker type	No. of Poles	Rated voltages				
		AC 100–110 V / AC 120–130 V	AC 200–220 V / AC 230–250 V	AC 380–415 V / AC 440–480 V	DC 24 / 48 V	DC 100 / 110 V

Instantaneous trip type, with lead-wire terminal block SLT

NF/DSN400–800	3	UVTSA130-4SWS	UVTSA250-4SWS	UVTSA480-4SWS	UVTSD048-4SWS	UVTSD110-4SWS
NF/DSN400–630	4	UVTSA130-4SWRFS	UVTSA250-4SWRFS	UVTSA480-4SWRFS	UVTSD048-4SWRFS	UVTSD110-4SWRFS
NF/DSN800	4	UVTSA130-8SWRFS	UVTSA250-8SWRFS	UVTSA480-8SWRFS	UVTSD048-8SWRFS	UVTSD110-8SWRFS
NF/DSN1000–1600	3	UVTSA130-10SWRS	UVTSA250-10SWRS	UVTSA480-10SWRS	UVTND048-10SWRS	UVTND110-10SWRS
	4	UVTSA130-10SWRFS	UVTSA250-10SWRFS	UVTSA480-10SWRFS	UVTND048-10SWRFS	UVTND110-10SWRFS

Breaker type	No. of Poles	Rated voltages				
		AC 24 / 48 V	AC 100–120 V / AC 200–240 V / AC 380–450 V	AC 200–250 V / AC 380–450 V / AC 460–550 V	AC 380–450 V / AC 460–550 V / AC 600–690 V	DC 24 / 48 V

Short-time delay type, with lead-wire terminal block SLT, short-time delay adjustable in steps 0.1–0.3–0.5 sec

NF/DSN32–63	3	UVTNA048-05SWRSU05	UVTNA450-05SWRSU05	UVTNA550-05SWRSU05	UVTNA690-05SWRSU05	UVTND048-05SWRSU05	UVTND110-05SWRSU05
	4	UVTNA048-05SWRFSU05	UVTNA450-05SWRFSU05	UVTNA550-05SWRFSU05	UVTNA690-05SWRFSU05	UVTND048-05SWRFSU05	UVTND110-05SWRFSU05
NF/DSN125–250	3	UVTSA048-2GSWRSU05	UVTSA450-2GSWRSU05	UVTSA550-2GSWRSU05	UVTSA690-2GSWRSU05	UVTSD048-2GSWRSU05	UVTSD110-2GSWRSU05
	4	UVTSA048-2GSWRF5U05	UVTSA450-2GSWRF5U05	UVTSA550-2GSWRF5U05	UVTSA690-2GSWRF5U05	UVTSD048-2GSWRF5U05	UVTSD110-2GSWRF5U05

Short-time delay type, for direct connection, short-time delay adjustable in steps 0.1–0.3–0.5 sec

NF/DSN125–250	3/4	UVTSA048-2GSWRNU05	UVTSA450-2GSWRNU05	UVTSA550-2GSWRNU05	UVTSA690-2GSWRNU05	UVTSD048-2GSWRNU05	UVTSD110-2GSWRNU05
---------------	-----	--------------------	--------------------	--------------------	--------------------	--------------------	--------------------

Breaker type	No. of Poles	Rated voltages	
		AC 100–120 / 200–240 / 380–450 V	AC 200–250 / 380–450 / 460–550 V

Long-time delay type, with lead-wire terminal block SLT, long-time delay adjustable in steps 0.5–1.0–3.0 sec

NF/DSN32–63	3	UVTNA450-05SWRSU30	UVTNA550-05SWRSU30
	4	UVTNA450-05SWRFSU30	UVTNA550-05SWRFSU30
NF/DSN125–250	3	UVTSA450-2GSWRSU30	UVTSA550-2GSWRSU30
	4	UVTSA450-2GSWRF5U30	UVTSA550-2GSWRF5U30

Long-time delay type, for direct connection, long-time delay adjustable in steps 0.5–1.0–3.0 sec

NF/DSN125–250	3/4	UVTSA450-2GSWRNU30	UVTSA550-2GSWRNU30
---------------	-----	--------------------	--------------------

UVTN...: non-synchronous closing type
UVTS...: synchronous closing type

Order Information for Undervoltage Tripping Devices UVT

Undervoltage tripping device UVT, instantaneous trip type, synchronous and closing non-synchronous closing, mounted on right-side

with lead-wire terminal block SLT, for 3-pole breakers

Type	Breaker type	Rated voltage	Art. no.
UVTNA048-05SWRS	NF/DSN32-63	AC 24 / 48 V	146399
UVTNA130-05SWRS		AC 100-110 / 120-130 V	146401
UVTNA250-05SWRS		AC 200-220 / 230-250 V	146403
UVTNA480-05SWRS		AC 380-415 / 440-480 V	146405
UVTNA600-05SWRS		AC 500-550 / 600 V	146407
UVTND048-05SWRS		DC 24 / 48 V	146409
UVTND125-05SWRS		DC 110 / 125 V	146411
UVTSA048-2GSWRS	NF/DSN125-250	AC 24 / 48 V	139537
UVTSA130-2GSWRS		AC 100-110 / 120-130 V	139539
UVTSA250-2GSWRS		AC 200-220 / 230-250 V	139541
UVTSA480-2GSWRS		AC 380-415 / 440-480 V	139543
UVTSA600-2GSWRS		AC 500-550 / 600 V	139545
UVTSD048-2GSWRS		DC 24 / 48 V	139547
UVTSD110-2GSWRS		DC 100 / 110 V	139548
UVTSD125-2GSWRS		DC 110 / 125 V	139550
UVTSA130-4SWS		NF/DSN400-800	AC 100-110 / 120-130 V
UVTSA250-4SWS	AC 200-220 / 230-250 V		205953
UVTSA480-4SWS	AC 380-415 / 440-480 V		205828
UVTSD048-4SWS	DC 24 / 48 V		205932
UVTSD110-4SWS	DC 100 / 110 V		205934
UVTSA130-10SWRS	NF/DSN1000-1600	AC 100-110 / 120-130 V	205941
UVTSA250-10SWRS		AC 200-220 / 230-250 V	205943
UVTSA480-10SWRS		AC 380-415 / 440-480 V	205945
UVTND048-10SWRS		DC 24 / 48 V	205947
UVTND110-10SWRS		DC 100 / 110 V	205949

with lead-wire terminal block SLT, for 4-pole breakers

Type	Breaker type	Rated voltage	Art. no.
UVTNA048-05SWRFS	NF/DSN 63	AC 24 / 48 V	146400
UVTNA130-05SWRFS		AC 100-110 / 120-130 V	146402
UVTNA250-05SWRFS		AC 200-220 / 230-250 V	146404
UVTNA480-05SWRFS		AC 380-415 / 440-480 V	146406
UVTNA600-05SWRFS		AC 500-550 / 600 V	146408
UVTND048-05SWRFS		DC 24 / 48 V	146410
UVTND125-05SWRFS		DC 110 / 125 V	146412
UVTSA048-2GSWRF	NF/DSN125-250	AC 24 / 48 V	139538
UVTSA130-2GSWRF		AC 100-110 / 120-130 V	139540
UVTSA250-2GSWRF		AC 200-220 / 230-250 V	139542
UVTSA480-2GSWRF		AC 380-415 / 440-480 V	139544
UVTSA600-2GSWRF		AC 500-550 / 600 V	139546
UVTSD048-2GSWRF		DC 24 / 48 V	137508
UVTSD110-2GSWRF		DC 100 / 110 V	139549
UVTSD125-2GSWRF		DC 110 / 125 V	139551
UVTSA130-4SWRFS		NF/DSN400-630	AC 100-110 / 120-130 V
UVTSA250-4SWRFS	AC 200-220 / 230-250 V		205954
UVTSA480-4SWRFS	AC 380-415 / 440-480 V		205955
UVTSD048-4SWRFS	DC 24 / 48 V		205933
UVTSD110-4SWRFS	DC 100 / 110 V		205935
UVTSA130-8SWRFS	NF/DSN800	AC 100-110 / 120-130 V	205936
UVTSA250-8SWRFS		AC 200-220 / 230-250 V	205937
UVTSA480-8SWRFS		AC 380-415 / 440-480 V	205938
UVTSD048-8SWRFS		DC 24 / 48 V	205939
UVTSD110-8SWRFS		DC 100 / 110 V	205940
UVTSA130-10SWRFS		NF/DSN1000-1600	AC 100-110 / 120-130 V
UVTSA240-10SWRFS	AC 200-220 / 230-250 V		205944
UVTSA480-10SWRFS	AC 380-415 / 440-480 V		205946
UVTND048-10SWRFS	DC 24 / 48 V		205948
UVTND110-10SWRFS	DC 100 / 110 V		205950

for direct connection, for 3- and 4-pole breakers

Type	Breaker type	Rated voltage	Art. no.
UVTSA048-2GSWRN	NF/DSN125-250	AC 24 / 48 V	139552
UVTSA130-2GSWRN		AC 100-110 / 120-130 V	139553
UVTSA250-2GSWRN		AC 200-220 / 230-250 V	139554
UVTSA480-2GSWRN		AC 380-415 / 440-480 V	139555
UVTSA600-2GSWRN		AC 500-550 / 600 V	139556
UVTSD048-2GSWRN		DC 24 / 48 V	139557
UVTSD110-2GSWRN		DC 100 / 110 V	139558
UVTSD125-2GSWRN	DC 110 / 125 V	139559	

UVTN...: non-synchronous closing type
 UVTS...: synchronous closing type

Order Information for Undervoltage Tripping Devices UVT

Undervoltage tripping device UVT, short-time delay type, adjustable in steps 0.1–0.3–0.5 sec, synchronous closing, mounted on right-side

with lead-wire terminal block SLT, for 3-pole breakers

Type	Breaker type	Rated voltage	Art. no.
UVTNA048-05SWRSU05	NF/DSN32–63	AC 24 / 48 V	146413
UVTNA450-05SWRSU05		AC 100–120 / 200–240 / 380–450 V	146425
UVTNA550-05SWRSU05		AC 200–250 / 380–450 / 460–550 V	146427
UVTNA690-05SWRSU05		AC 380–450 / 460–550 / 600–690 V	146429
UVTND048-05SWRSU05		DC 24 / 48 V	146431
UVTND110-05SWRSU05		DC 100–110 V	146433
UVTSA048-2GSWRSU05		NF/DSN125–250	AC 24 / 48 V
UVTSA450-2GSWRSU05	AC 100–120 / 200–240 / 380–450 V		139562
UVTSA550-2GSWRSU05	AC 200–250 / 380–450 / 460–550 V		139564
UVTSA690-2GSWRSU05	AC 380–450 / 460–550 / 600–690 V		139566
UVTSD048-2GSWRSU05	DC 24 / 48 V		139568
UVTSD110-2GSWRSU05	DC 100 / 110 V		139569
UVTSA450-4SWSU05	NF/DSN400–630		AC 100–120 / 200–240 / 380–450 V
UVTSD048-4SWSU05		DC 24 / 48 V	205838
UVTSD110-4SWSU05		DC 100 / 110 V	205842
UVTSA450-10SWRU05	NF/DSN1000–1600	AC 100–120 / 200–240 / 380–450 V	205856
UVTSA550-10SWRU05		AC 200–250 / 380–450 / 460–550 V	205868
UVTND048-10SWRU05		DC 24 / 48 V	205876
UVTND110-10SWRU05		DC 100 / 110 V	205880

with lead-wire terminal block SLT, for 4-pole breakers

Type	Breaker type	Rated voltage	Art. no.
UVTNA048-05SWRFSU05	NF/DSN32–63	AC 24 / 48 V	146424
UVTNA450-05SWRFSU05		AC 100–120 / 200–240 / 380–450 V	146426
UVTNA550-05SWRFSU05		AC 200–250 / 380–450 / 460–550 V	146428
UVTNA690-05SWRFSU05		AC 380–450 / 460–550 / 600–690 V	146430
UVTND048-05SWRFSU05		DC 24 / 48 V	146432
UVTND110-05SWRFSU05		DC 100–110 V	146434
UVTSA048-2GSWRFSU05		NF/DSN125–250	AC 24 / 48 V
UVTSA450-2GSWRFSU05	AC 100–120 / 200–240 / 380–450 V		139563
UVTSA550-2GSWRFSU05	AC 200–250 / 380–450 / 460–550 V		139565
UVTSA690-2GSWRFSU05	AC 380–450 / 460–550 / 600–690 V		139567
UVTSD048-2GSWRFSU05	DC 24 / 48 V		137509
UVTSD110-2GSWRFSU05	DC 100 / 110 V		139570
UVTSA450-4SWRFSU05	NF/DSN400–630		AC 100–120 / 200–240 / 380–450 V
UVTSD048-4SWRFSU05		DC 24 / 48 V	205839
UVTSD110-4SWRFSU05		DC 100 / 110 V	205843
UVTSA450-8SWRFSU05	NF/DSN800	AC 100–120 / 200–240 / 380–450 V	205845
UVTSD048-8SWRFSU05		DC 24 / 48 V	205852
UVTSD110-8SWRFSU05		DC 100 / 110 V	205854
UVTSA450-10SWRFSU05	NF/DSN1000–1600	AC 100–120 / 200–240 / 380–450 V	205858
UVTSA550-10SWRFSU05		AC 200–250 / 380–450 / 460–550 V	205872
UVTND048-10SWRFSU05		DC 24 / 48 V	205878
UVTND110-10SWRFSU05		DC 100 / 110 V	205882

for direct connection, for 3- and 4-pole breakers

Type	Breaker type	Rated voltage	Art. no.
UVTSA048-2GSWRNU05	NF/DSN125–250	AC 24 / 48 V	139571
UVTSA450-2GSWRNU05		AC 100–120 / 200–240 / 380–450 V	139572
UVTSA550-2GSWRNU05		AC 200–250 / 380–450 / 460–550 V	139573
UVTSA690-2GSWRNU05		AC 380–450 / 460–550 / 600–690 V	139574
UVTSD048-2GSWRNU05		DC 24 / 48 V	139575
UVTSD110-2GSWRNU05		DC 100–110 V	139576

UVTN...: non-synchronous closing type
UVTS...: synchronous closing type

Undervoltage tripping device UVT, long-time delay type, adjustable in steps 0.5–1.0–3.0 sec, mounted on right-side

with lead-wire terminal block SLT, for 3-pole breakers

Type	Breaker type	Rated voltage	Art. no.
UVTNA450-05SWRSU30	NF/DSN32–63	AC 100–120 / 200–240 / 380–450 V	146435
UVTNA550-05SWRSU30		AC 200–250 / 380–450 / 460–550 V	146437
UVTSA450-2GSWRSU30	NF/DSN125–250	AC 100–120 / 200–240 / 380–450 V	139577
UVTSA550-2GSWRSU30		AC 200–250 / 380–450 / 460–550 V	139579
UVTSA450-4SWSU30	NF/DSN400–800	AC 100–120 / 200–240 / 380–450 V	205826
UVTSA550-10SWRU30	NF/DSN1000–1600	AC 200–250 / 380–450 / 460–550 V	205870

with lead-wire terminal block SLT, for 4-pole breakers

Type	Breaker type	Rated voltage	Art. no.
UVTNA450-05SWRFSU30	NF/DSN32–63	AC 100–120 / 200–240 / 380–450 V	146436
UVTNA550-05SWRFSU30		AC 200–250 / 380–450 / 460–550 V	146438
UVTSA450-2GSWRFU30	NF/DSN125–250	AC 100–120 / 200–240 / 380–450 V	139578
UVTSA550-2GSWRFU30		AC 200–250 / 380–450 / 460–550 V	139580
UVTSA450-4SWRFSU30	NF/DSN400–630	AC 100–120 / 200–240 / 380–450 V	205827
UVTSA450-8SWRFSU30	NF/DSN800	AC 100–120 / 200–240 / 380–450 V	205849
UVTSA450-10SWRFU30	NF/DSN1000–1600	AC 100–120 / 200–240 / 380–450 V	205866
UVTSA550-10SWRFU30		AC 200–250 / 380–450 / 460–550 V	205874

for direct connection, for 3- and 4-pole breakers

Type	Breaker type	Rated voltage	Art. no.
UVTSA450-2GSWRNU30	NF/DSN125–250	AC 100–120 / 200–240 / 380–450 V	139581
UVTSA550-2GSWRNU30		AC 200–250 / 380–450 / 460–550 V	139582

UVTN...: non-synchronous closing type
 UVTS...: synchronous closing type

Accessories for Connection and Installation

If no connection method is specified with the order, we deliver the standard fixed-installation type with front connection.

The front-connection model can be modified to other types (excluding plug-in) with special purchase options.

More details on request.

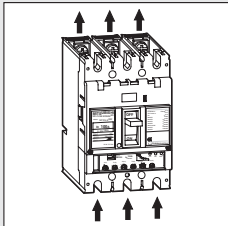
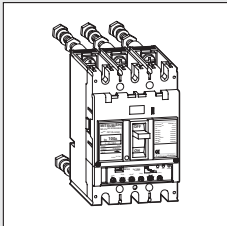
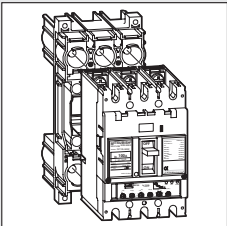
Connection Types			
Installation	Fixed		Plug-in
Connection	Front (F)	Rear (B)	Rear (PM)
Appearance			
	Standard	Option	Option

Available Terminal Connections

Frame size	Front (Standard)	Rear	Solderless terminals	Plug-in
32–250 A	●	●	● ^①	●
400–800 A	●	●	—	●
1000–1600 A	●	— ^②	—	— ^②

① Only for frame sizes 125/160/250 A

② On request, modified at factory.

Connection Accessories

Rear studs ST

Type	No. of Poles	Breaker type	Art. no.
ST-05SW3	3	NF/DSN32–63	146441
ST-05SW4	4		146442
ST-2GSW3	3	NF/DSN125–250	139591
ST-2GSW4	4		139592
ST-4SW3	3	NF/DSN400	205956
ST-4SW4	4		205957
ST-6SW3	3	NF/DSN630	205958
ST-6SW4	4		205959
ST-8SW3	3	NF/DSN800	205960
ST-8SW4	4		205961

Plug-in sets PM

Type	No. of Poles	Breaker type	Protection degree	Art. no.
PM-05SW3	3	NF/DSN32–63	—	146443
PM-05SW4	4			146444
PM-2GSWIP3	3	NF/DSN125–250	IP 20	137511
PM-2GSWIP4	4			137512
PM-4SW3	3	NF/DSN400	—	205962
PM-4SW4	4			205963
PM-6SW3	3	NF/DSN630	—	205964
PM-6SW4	4			205965
PM-8SW3	3	NF/DSN800	—	205966
PM-8SW4	4			205967

Solderless terminals SL

Type	No. of Poles	Breaker type	Art. no.	Packing unit	Connected wire size	Used for
SL-2GSW3	3	NF/DSN125–250	139593	1 Set = 3 pcs.	2.5–185 mm ²	Cu/Al
SL-2GSW4	4		139594	1 Set = 4 pcs.		

More types available on request.

V-Type Operating Handle

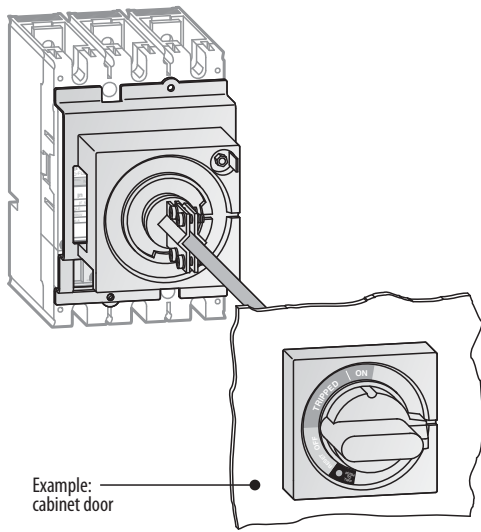

Application

The V-type operating handle is used to operate the breaker which is installed in a cabinet. With the installed V-type operating handle the breaker can be locked (with up to 3 padlocks, Ø 8 mm max., padlocks are not included) in OFF position only.

The door is locked when the breaker is ON and can only be opened when the breaker is in OFF position.

The V-type operating handle is available in the following colour combinations:

Handle and front in black/black and handle and front in red/yellow, or red/black, see also the following table.

- Protection degree (in accord. to IEC/EN 60 529): see table below.
- Variable axle length.

Specifications	V-type operating handle									
	V05SWN	V05SWEN	V2GSWN	V2GSWEN	V2GUWN	V2GUWEN	V4SW	V4SWE	V8SW	V8SWE
Breaker type	NF/DSN32-63		NF/DSN125/160/250-SGW/HGW		NF125/250-RGW/UGW		NF/DSN400-630		NF/DSN800	
Colour: handle/front	black	red/yellow	black	red/yellow	black	red/yellow	black	red/yellow	black	red/yellow
Protection degree	IP65	IP65	IP65	IP65	IP65	IP65	IP65	IP65	IP65	IP65
Art. no.	146457	146458	137513	139627	139626	139628	203761	203762	203763	203764

R-Type Operating Handle

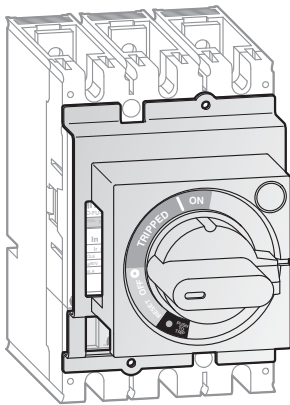

Application

The R-type operating handle is to be mounted directly on the breaker.

With the installed R-type operating handle the breaker can be locked (with up to 3 padlocks, Ø 8 mm max., padlocks are not included) in OFF position only.

The R-type operating handle is available in the following colour combinations:

Handle and front in black/black and handle and front in red/yellow, or red/black, see also the following table.

Specifications	R-type operating handle									
	R2GSWN	R2GSWEN	R2GUWN	R2GUWEN	R4SW	R4SWE	R8SW	R8SWE	R101	R101E
Breaker type	NF/DSN125/160/250-SGW/HGW		NF125/250-RGW/UGW		NF/DSN400-630		NF/DSN800		NF/DSN1000-1600	
Colour: handle/front	black	red/yellow	black	red/yellow	black	red/yellow	black	red/yellow	black	red/black
Art. no.	139622	139624	139623	139625	203765	203766	203767	203769	11620	11623

Handle Lock Devices

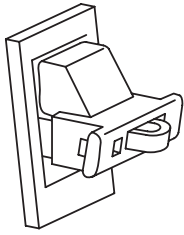

LC-2GSW

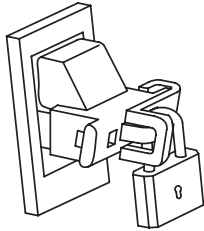

HLF-2GSW

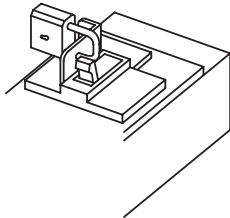

HLS-2GSW

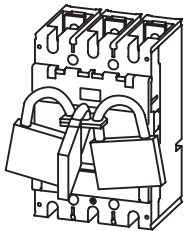

HLF3-2GSW

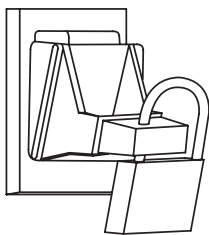

HL-4SW

Application

The handle lock device HL is used to lock the handle of the breaker against switching by not-allowed persons. The function of protection is given every time.

Different types are available.

- All handle lock devices can be mounted regardless of the number of poles.
- Padlocks are not included.
- More details on request.

Handle lock device LC type

- The handle lock can be used without padlock as a lock cover.

Handle lock device HL type

- The handle lock HL type can be used for 3- and 4-pole breaker types.
- The handle locks can be used without padlock as lock covers.
- The HLF types are used for OFF-lock and the HLN types are used for ON-lock.
- The handle lock HLF3 type enables the user to lock the handle with up to three padlocks against switching.
- The HLS types are used for OFF-lock only.

Type	Breaker type	Art. no.
LC-05SW	NF/DSN32-63	146453
LC-2GSW	NF/DSN125-250	139613
HLF-05SW	NF/DSN32-63	146454
HLF-2GSW	NF/DSN125-250	139614
HLF3-2GSW	NF/DSN125-250	139615
HLN-05SW	NF/DSN32-63	146455
HLN-2GSW	NF/DSN125-250	139616
HLS-05SW	NF/DSN32-63	146456
HLS-2GSW	NF/DSN125-250	139617
HL-4SW	NF/DSN400-800	205975
HL-10SW	NF/DSN100-1600	205976

Electrically Operated Breakers – Overview

Spring-charged types MDS

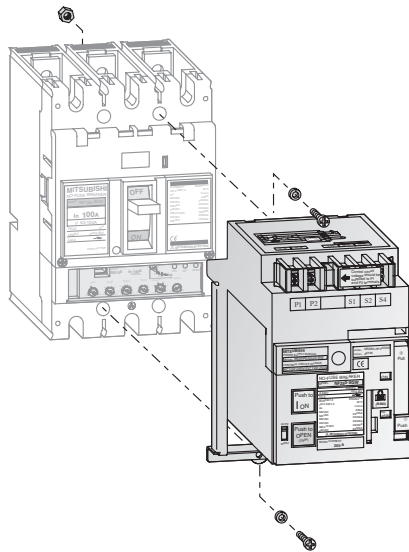

Spring-charged type MDSAD240-NF2GSWE and breaker type NF250-SGW

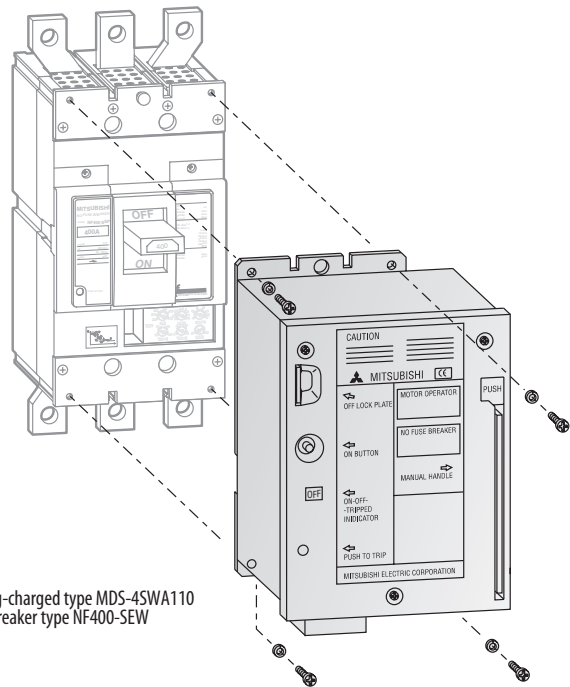

Spring-charged type MDS-4SWA110 and breaker type NF400-SEW

Specifications		MDS.../MDSA...	MDS-4.../8...	MDS-16...
Breaker type ①	NF-S/H series	NF125-SGW / HGW NF160-SGW / HGW NF250-SGW / HGW	NF400-SEW / HEW / REW NF630-SEW / HEW / REW NF800-SEW / HEW / REW	NF1000-SEW NF1250-SEW NF1600-SEW
	NF-R/U series	NF125-RGW / UGW NF250-RGW / UGW	NF400-UEW, NF800-UEW	—
Rated operating voltage (V) (allowable voltage range 85–110%) ②		DC 24 V DC48–60V AC100–240V / DC100–250V	AC 100/110 V, 200/220 V (AC 240 V) DC 100/110 V (DC 125 V)	AC 100/110 V, 200/220 V (AC 240 V) DC 100/110 V (DC125 V)
Operating current (A, eff.) ③	DC	100 / 110 V	0.20	OFF: 1.0 (3.0) ON: 8.0
	AC	100 / 110 V	0.50	OFF: 1.0 (3.0) ON: 10.0
		200 / 200 V	0.35	OFF: 0.5 (1.5) ON: 8.0
Operating time (sec.)	ON operating	0.05–0.1 (self holding)	0.05	0.07
	OFF operating	0.6 and less (self holding)	3 and less (self holding)	3 and less (self holding)
	Spring charging	1.2 and less	—	—
Transformer capacity required (VA)		150	700	700
Endurance voltage (V)		1500	1500	1500

① Also usable for Disconnectors DSN with 3 and 4 poles.

② The voltages in parentheses () are special options and might require an external resistor. For details, consult your distributor.

③ The values in parentheses () show starting current.

General precautions for motor-operated electrical MCCBs

- The motor operated types should not be operated 10 times consecutively (one on/off counts as an operation).
- The operating voltage should be between 85 – 110 % of the rated control voltage.
- The current breaker position ON, OFF or TRIPPED will be shown with a special display on the motor.
- The dielectric strength of the electrical operating circuits is 1500 V. When performing a dielectric strength test simultaneously with another device at a voltage over 1500 V, the operating circuit terminal should be disconnected.

Automatic Reset

If the breaker is an auto reset type, it contains a built-in alarm switch and the off-control circuit close when the breaker is tripped. Since the breaker automatically resets itself after tripping, the power is easily restored by switching on the breaker again. With a UVT mounted, however, auto reset may not be possible. In this case, please consult your distributor.

- More details on request.

Spring-Charged Type MDS

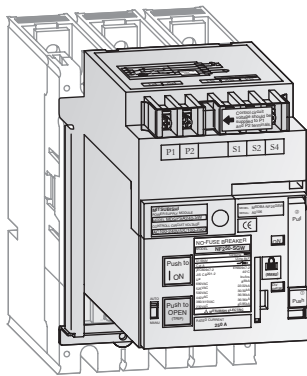

Spring-charged type MDS....-NF2GSWE and breaker type NF250-SGW

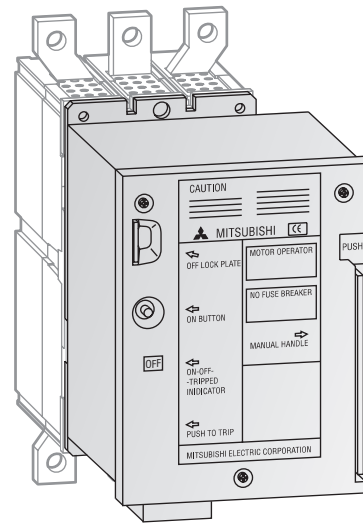

Spring-charged type MDS-4SW.... and breaker type NF400-SEW

Control circuit for MDS....-NF2GSWE

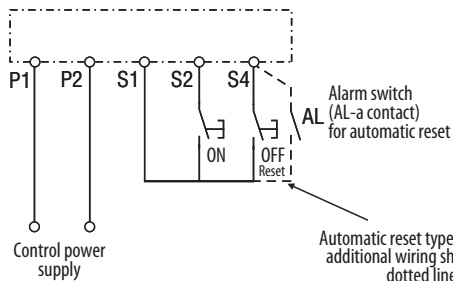

Control circuit for MDS-4/8/16 S....

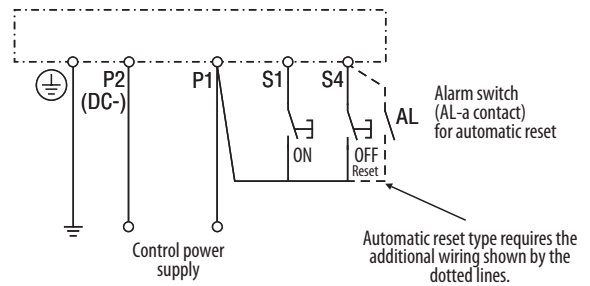

Spring-Charged Type

Electrical operation

When the ON switch is closed, the coil is releasing the latch mechanism, and the breaker is turned to ON.

When the OFF switch is closed, a relay operates to start a motor which turns the breaker OFF (RESET) and charges the spring at the same time.

Manual operation

When the ON button (on the front of the spring-charged type) is pressed, the latch mechanism is cancelled and the circuit breaker set momentarily to ON by the force of spring.

OFF operation (RESET operation)

The circuit breaker can be set to OFF (RESET) by pressing the leaf spring, pulling out the manual handle and moving it back and forth more than ten times. This charges the spring at the same time.

Cautions during electrical operation

When an electrical-operation device is mounted in a breaker or removed from an breaker, this device must be returned to the discharged state after tripping of the breaker.

A MCCB with an electrical-operation device will not trip in the OFF state "PUSH TO TRIP" is used. This does not indicate that the breaker is faulty.

Since it takes 3 sec to switch off a breaker provided with this device, if the breaker needs to be opened urgently by remote control, a breaker fitted with an SHT or UVT should be used.

The breaker is equipped with a relay for the prevention of pumping.

Control circuit

For breakers with automatic resetting capability, add the connection indicated by the dotted line in the diagrams.

- More details on request.

Type	Breaker type	Rated voltage	Art. no.
MDS024-NF2GSWE	NF/DSN125-250	DC 24 V	139583
MDS060-NF2GSWE		DC48-60V	139584
MDSAD240-NF2GSWE		AC100-240V / DC100-250V	137514
MDS-4SWA110	NF/DSN400-630	AC 100-110 V	205968
MDS-4SWA240		AC 230 V	205969
MDS-4SWD110		DC 100-110 V	205970
MDS-8SWA110	NF/DSN800	DC 100-110 V	205971
MDS-8SWA240		AC 230 V	205972
MDS-8SWD110		DC 100-110 V	205973
MDS-16SSA110	NF/DSN1000-1600	AC 100-110 V	11463
MDS-16SSA220		AC 230 V	9430
MDS-16SSD110		DC 100-110 V	11464

Terminal Covers

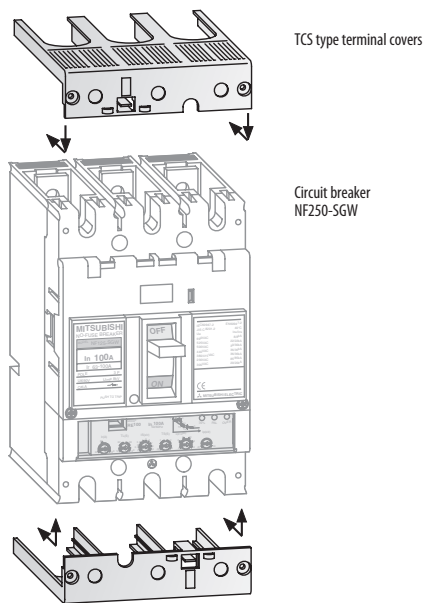

Application

The terminal covers are used to avoid exposure of charged parts.

Different types are available:

- for front connection as small terminal covers TCS or large terminal covers TCL, TTC (see figures below)
- for rear connection as closed type BTC
- for plug-in as PTC
- One set includes two pieces of terminal covers.
- Colour: black, white or transparent
- More types/details on request.

Small terminal covers TCS

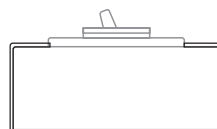

Large terminal covers TCL, TTC

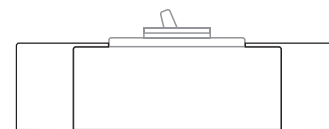

Small terminal covers TCS

(1 set = 2 pieces)

Type	No. of poles	Breaker type	Colour	Protection degree	Art. no.
TCS-05SW3W	3	NF/DSN32-63	white	IP20	146447
TCS-05SW4W	4				146448
TCS-2GSW3W	3	NF/DSN125-250	white	IP40	139605
TCS-2GSW4W	4				139606

Large terminal covers TCL

(1 set = 2 pieces)

Type	No. of poles	Breaker type	Colour	Protection degree	Art. no.
TCL-05SW3W	3	NF/DSN32-63	white	IP20	146445
TCL-05SW4W	4				146446
TCL-2GSW3W	3	NF/DSN125-250	white	IP40	139603
TCL-2GSW4W	4				139604
TCL-4SW3	3	NF/DSN400-630	black	IP20	205977
TCL-4SW4	4		transparent		205978
TCL-8SW3	3	NF/DSN800	transparent	IP20	205979
TCL-8SW4	4				205980
TCL-8UW3	3	NF/DSN800	transparent	IP20	205981
TCL-8UW4	4				205982
TCL-10SW3	3	NF/DSN1000-1250 (fixed with screws)	transparent	IP20	205983
TCL-10SW4	4				205984

Large terminal covers TTC

(1 set = 2 pieces)

Type	No. of poles	Breaker type	Colour	Protection degree	Art. no.
TTC-2GSW3	3	NF/DSN125-250	transparent	IP40	139611
TTC-2GSW4	4				139612

Terminal covers rear connection studs BTC

(1 set = 2 pieces)

Type	No. of poles	Breaker type	Colour	Protection degree	Art. no.
BTC-05SW3W	3	NF/DSN32-63	white	IP20	146449
BTC-05SW4W	4				146450
BTC-2GSW3W	3	NF/DSN125-250	white	IP40	139607
BTC-2GSW4W	4				139608
BTC-4SW3	3	NF/DSN400-630	transparent	IP20	205985
BTC-4SW4	4				205986
BTC-8SW3	3	NF/DSN800	transparent	IP20	205987
BTC-8SW4	4				205988

Terminal covers for 3-pole plug-in type PTC

(1 set = 2 pieces)

Type	No. of poles	Breaker type	Colour	Protection degree	Art. no.
PTC-05SW3W	3	NF/DSN32-63	white	IP20	146451
PTC-05SW4W	4				146452
PTC-2GSW3W	3	NF/DSN125-250	white	IP40	139609
PTC-2GSW4W	4				139610

■ Mechanical Interlock MI (Front side installation)

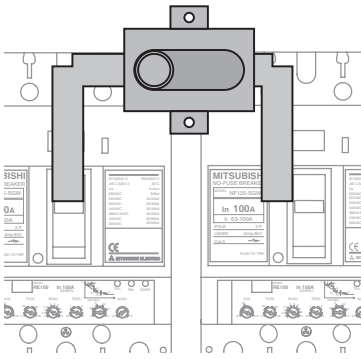

Application

With two breakers, use a panel-mounted mechanical interlock for one-way only input. It is usable for front, rear, and plug-in types.

A breaker-mounting mechanical to mount on the breaker main unit can be made to order.

- More details on request.

Mechanical interlocks for 3-pole breakers

Specifications	MI-05SW3	MI-4SW3	MI-8SW3	MI-10SW3	MI-16SW3
For use between two breakers of	125/160/250 AF	400 AF	630–800 AF	1000–1250 AF	1600 AF
Art. no.	139619	205989	205991	205993	205995

Mechanical interlocks for 4-pole breakers

Specifications	MI-2SW4	MI-4SW4	MI-8SW4	MI-10SW4	MI-16SW4
For use between two breakers of	125/160/250 AF	400 AF	630–800 AF	1000–1250 AF	1600 AF
Art. no.	139620	205990	205992	205994	205996

■ Isolation Barriers (Standard)

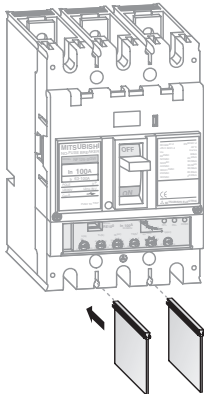

Application

The isolation barriers are used to avoid short-circuits between the terminals of the breaker due to dust or leakage current.

Every breaker is equipped with isolation barriers as standard.

■ IEC 35 mm Rail Mounting Adapter

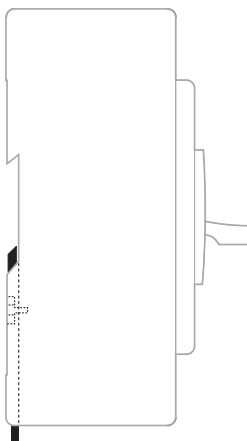

Application

The IEC 35 mm rail mounting adapter is used to mount the breaker on a IEC 35 mm mounting rail.

It is available for 3-pole breakers NF/DSN32–63.

Specifications	DIN-05SW
For 3-pole breakers	NF/DSN32–63
Art. no.	146459 (packing unit: 10 pcs)

■ **Tester for Electronic Breakers**

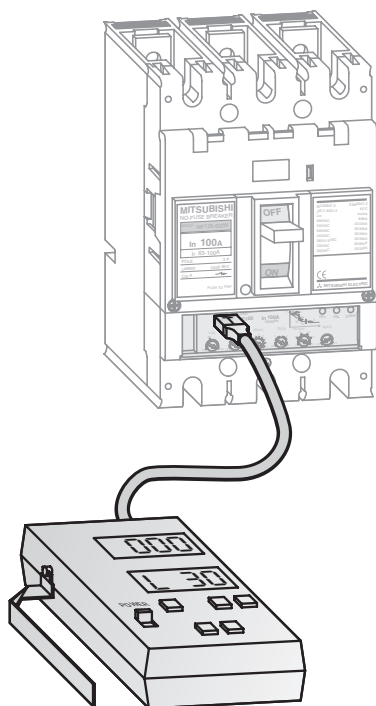

Application

The portable tester unit can be used to check the tripping characteristics of the electronic breakers from 100 A up to 1600 A.

Specifications	Y-250
for electronic breakers	100 A – 1600 A
Art. no.	68181

General purpose contactors

Description of the contactors

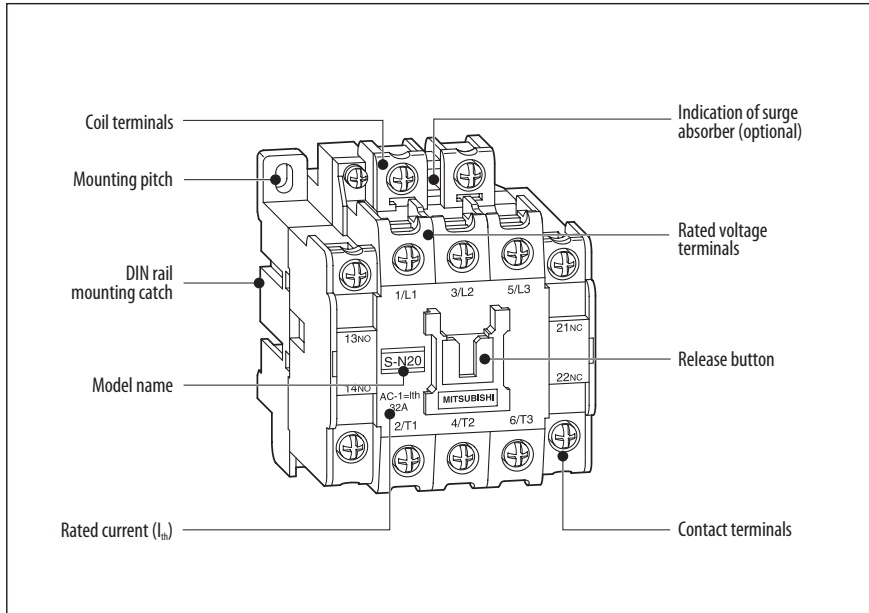

The main benefits:

- Easy mounting and wiring
- Easy inspection
- Built-in surge absorber
- Safety and speedy terminal functions
- Thermo plastic improves the barrier strength
- Coil boasts lower coil consumption
- Improvement of Electromagnet (DC electromagnet with AC operation)
- Less noise nor surge from coil
- Conform to IEC947-4-1, EN-Standards
- Mounting of the contactors is described on page 23.

Handling of the contactors

S-N10CX to S-N65CX units can all be mounted on DIN rail (35 mm wide).

A variety of blocks and optional features are available including:

- Standard front clip-on auxiliary contact blocks (4-pole-type and 2-pole-type)
- Low-level signal front-clip-on auxiliary contact blocks
- Side clip-on auxiliary contact blocks

- Surge absorbers (varistor and CR models)
- Surge absorbers with LED operating indicators
- Mechanical interlocks

Compact arc quenching and magnet layout greatly reduces installation space.

The coil rating is displayed in a location readily visible even after the unit is installed onto the panel.

Contacts are visible when the cover is removed, allowing them to be checked easily.

Contactors coils have ultra-wide range of ratings

The number of coil types has been cut by two-thirds and there is no need to re-wire for different frequencies. The coil also withstands large voltage drops.

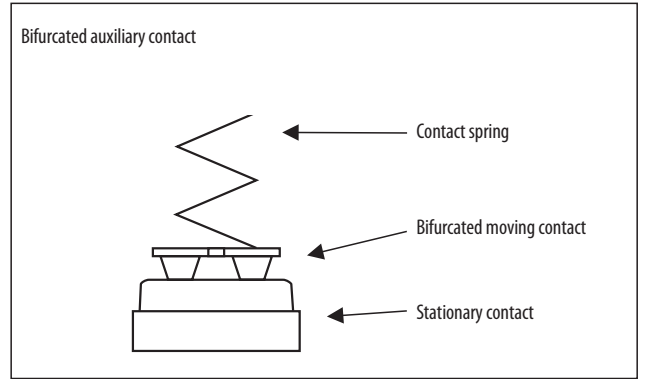
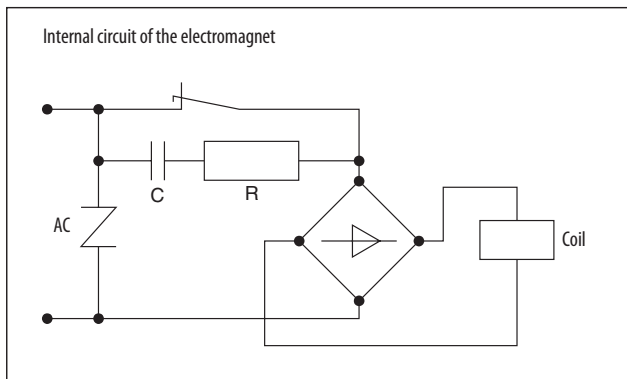

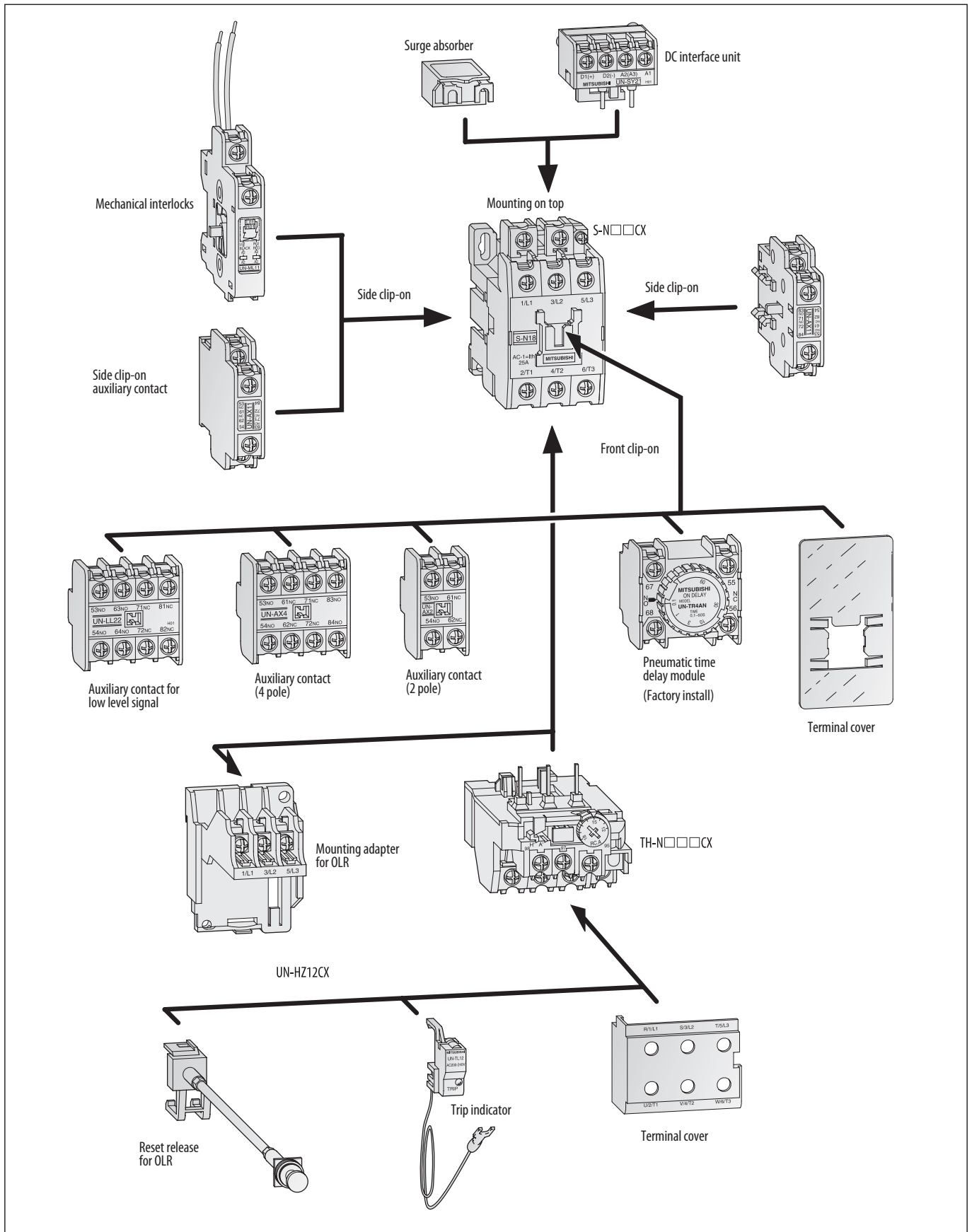

Three-phase motor ratings IEC category AC3 for Contactors

Contactor	AC-operated	S-N10CX	S-N11CX	S-N12CX	S-N18CX	S-N20CX	S-N21CX	S-N25CX	S-N35CX
	DC-operated	—	SD-N11CX	SD-N12CX	—	—	SD-N21CX	—	SD-N35CX
AC 380–440 V	kW	4	5.5	5.5	7.5	11	11	15	18.5
Rated continuous current I_{th}	A	20	20	20	25	32	32	50	60
Auxiliary contacts (standard)		1 NO or 1 NC	1 NO or 1 NC	1 NO + 1 NC	—	1 NO + 1 NC	2 NO + 2 NC	2 NO + 2 NC	2 NO + 2 NC

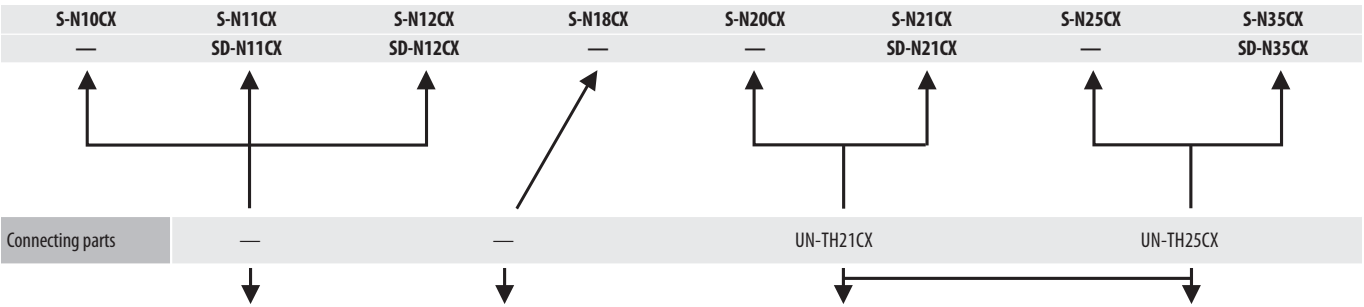
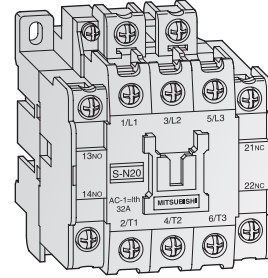
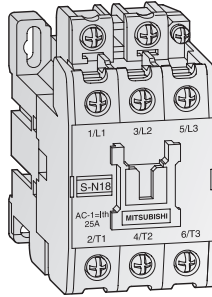
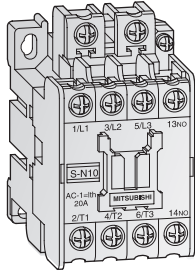

Thermal Overload Relays

Type	TH-N12KPCX	TH-N18KPCX	TH-N20KPCX	TH-N20TAKPCX
Setting range	0.1 – 13 A	1 – 18 A	0.2 – 22 A	18 – 40 A

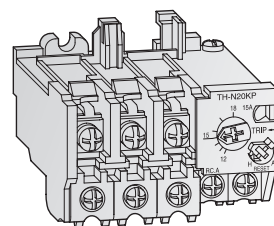
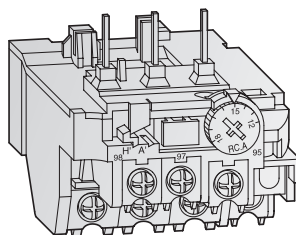
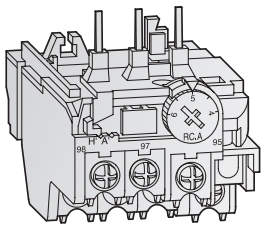

Contactor Relays

AC-operated type	SR-N4CX 4A	SR-N4CX 3A1B	SR-N4CX 2A2B
Auxiliary contacts	4 NO	3 NO, 1 NC	2 NO, 2 NC

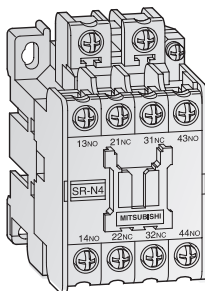

Three-phase motor ratings IEC category AC-3

S-N50CX	S-N65CX	S-N80	S-N95	S-N125	S-N150	S-N180	S-N220	S-N300	S-N400	S-N600	S-N800
SD-N50	SD-N65	SD-N80	SD-N95	SD-N125	SD-N150	—	SD-N220	SD-N300	SD-N400	SD-N600	SD-N800
22	30	45	55	60	75	90	132	160	220	330	440
80	100	135	150	150	200	260	260	350	450	800	1000
2 NO + 2 NC	2 NO + 2 NC	2 NO + 2 NC	2 NO + 2 NC	2 NO + 2 NC	2 NO + 2 NC	2 NO + 2 NC	2 NO + 2 NC	2 NO + 2 NC	2 NO + 2 NC	2 NO + 2 NC	2 NO + 2 NC

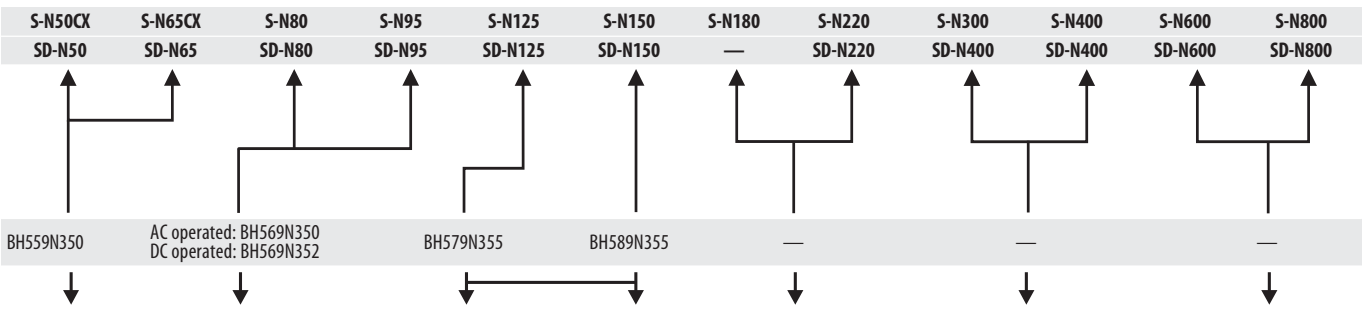
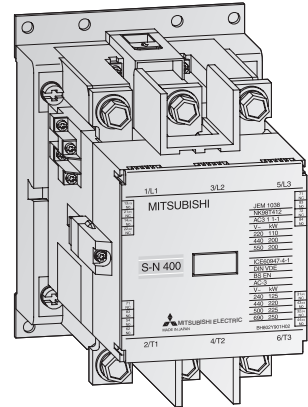
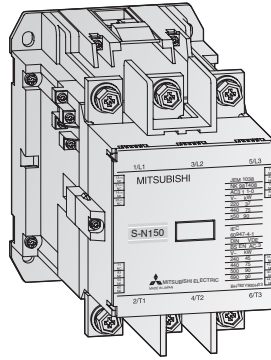
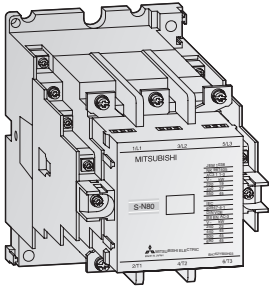

Thermal Overload Relays

TH-N60KPCX	TH-N60TAKP	TH-N120KP	TH-N120TAKP	TH-N220RHKP	TH-N400RHKP	TH-N600KP
12 – 65 A	54 – 105 A	34 – 100 A	85 – 150 A	65 – 250 A	85 – 400 A	200 – 800 A

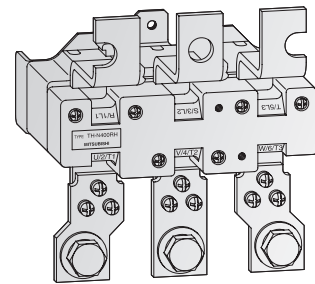
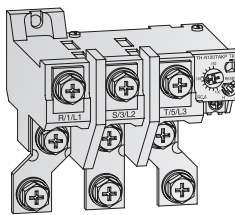
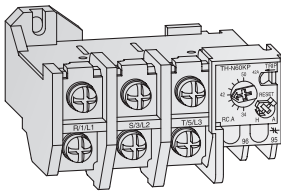

Contactors Relays

AC operated type	SRD-N4CX 4A	SRD-N4CX 3A1B	SRD-N4CX 2A2B
Auxiliary contacts	4 NO	3 NO, 1 NC	2 NO, 2 NC

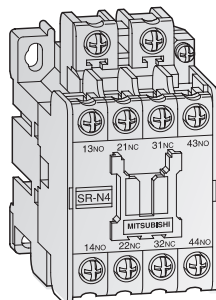

Specifications			S-N10CX AC□□□V1A	S-N10CX AC□□□V1B	S-N11CX AC□□□V1A	S-N11CX AC□□□V1B	S-N12CX AC□□□V	S-N18CX AC□□□V	S-N20CX AC□□□V	S-N21CX AC□□□V	S-N25CX AC□□□V	S-N35CX AC□□□V
Rated data												
Rated continuous current I _{th}	A		20	20	20	20	20	25	32	32	50	60
Rated motor capacity 3-phase Category AC-3	220–240 V	kW (A)	2.5 (11)	2.5 (11)	3.5 (13)	3.5 (13)	3.5 (13)	4.5 (18)	5.5 (22)	5.5 (22)	7.5 (30)	11 (40)
	380–440 V	kW (A)	4 (9)	4 (9)	5.5 (12)	5.5 (12)	5.5 (12)	7.5 (16)	11 (22)	11 (22)	15 (30)	18.5 (40)
	500	kW (A)	4 (7)	4 (7)	5.5 (9)	5.5 (9)	5.5 (9)	7.5 (13)	11 (17)	11 (17)	15 (24)	18.5 (32)
	690 V	kW (A)	4 (5)	4 (5)	5.5 (7)	5.5 (7)	5.5 (7)	7.5 (9)	7.5 (9)	7.5 (9)	11 (12)	15 (17)
Rated capacity for resistive loads 3ph, Category AC-1	220–240 V	kW (A)	7.5 (20)	7.5 (20)	7.5 (20)	7.5 (20)	7.5 (20)	9.5 (25)	12 (32)	12 (32)	18 (50)	20 (60)
	380–440 V	kW (A)	7 (11)	7 (11)	8.5 (13)	8.5 (13)	8.5 (13)	13 (20)	20 (32)	20 (32)	30 (50)	35 (60)
	500 V–550 V	kW (A)	7 (8)	7 (8)	9.5 (11)	9.5 (11)	9.5 (11)	13 (16)	25 (32)	25 (32)	40 (50)	50 (60)
	690 V	kW (A)	7 (6)	7 (6)	8 (8)	8 (8)	8 (8)	11 (10)	30 (32)	30 (32)	50 (50)	60 (60)
Rated capacity for jogging of AC motors 3-ph, Category AC-4 (electrical life is approx. 200,000 oper.)	220–240 V	kW	0.75	0.75	1.1	1.1	1.1	1.5	2.2	2.2	3	3.7
	380–440 V	kW	1.1	1.1	1.5	1.5	1.5	2.2	3.7	3.7	5.5	5.5
	500–550 V	kW	1.1	1.1	1.5	1.5	1.5	2.2	3.7	3.7	5.5	5.5
	690 V	kW	1.1	1.1	1.5	1.5	1.5	2.2	3.7	3.7	5.5	5.5
Max. current for AC-4 duty at 440 V	A	6	6	9	9	9	9	13	13	17	24	
Rated curr. for DC non-ind. loads, Category DC-1 100 oper./hour max. 500,000 oper.	48 V	A	10	10	12	12	12	12	20	20	25	35
	110 V	A	8	8	12	12	12	12	20	20	25	35
	220 V	A	8	8	12	12	12	12	20	20	22	30
Rated curr. for DC motors Category DC-2 & DC-4, 100 oper./hour max. 500,000 oper.	48 V	A	6	6	10	10	10	10	20	20	25	30
	110 V	A	4	4	8	8	8	8	15	15	20	20
	220 V	A	2	2	4	4	4	4	8	8	10	10
Rated capacity for 3-ph, capacitors, 15 oper./hour max. 100,000 oper. ① (ambient temp.: 40 °C)	220–240 V	kvar	2.2	2.2	3	3	3	4	5.5	5.5	8.5	12
	380–440 V	kvar	3.3	3.3	4	4	4	6	10	10	14	20
	550 V	kvar	4	4	5	5	5	6	10	10	14	20
	690 V	kvar	3.3	3.3	4.5	4.5	4.5	5.5	10	10	14	20
Current; 3-ph, cosφ = 0.35, 240/440 V	Making	A	110/110	110/110	130/120	130/120	130/120	180/180	220/220	220/220	300/300	400/400
	Breaking	A	100/72	100/72	120/100	120/100	120/100	180/130	220/220	220/220	300/240	400/320
Rated insulation voltage	V	690	690	690	690	690	690	690	690	690	690	690
Electrical data												
Coil consumption (at rated coil voltage)	Inrush	VA	60	60	60	60	60	60	90	90	110	110
	Sealed	VA	10	10	10	10	10	10	15	15	13	13
	Watts	W	3.5	3.5	3.5	3.5	3.5	3.5	5.3	5.3	5.3	5.3
Switching frequency	Category AC-1	oper./h	1,800	1,800	1,800	1,800	1,800	1,800	1,800	1,800	1,800	1,800
	Cat. AC2; AC-3	oper./h	1,800	1,800	1,800	1,800	1,800	1,800	1,800	1,800	1,800	1,800
	Category AC-4	oper./h	600	600	600	600	600	600	600	600	600	600
Operating time (at rated coil voltage)	Closing	ms	15	15	15	15	15	15	15	15	15	15
	Opening	ms	10	10	10	10	10	10	10	10	10	10
Mechanical data												
Electrical life (Category AC-3)	Oper. (million)		1	1	1	1	1	1	1	1	1	1
Mechanical life			10	10	10	10	10	10	10	10	10	10
Main terminal (contactor)	mm ²		1–2.5	1–2.5	1–2.5	1–2.5	1–2.5	1–6	1–6	1–6	2–16	2–16
Main terminal (overload relay)	mm ²		1–2.5	1–2.5	1–2.5	1–2.5	1–2.5	1–6	1–6	1–6	2–16	2–16
Control terminal	mm ²		1–2.5	1–2.5	1–2.5	1–2.5	1–2.5	1–2.5	1–2.5	1–2.5	1–2.5	1–2.5
Busbar width	mm		—	—	—	—	—	—	—	—	—	—
Standard auxiliary contacts	NO		1	—	1	—	1 ^②	—	1	2	2	2
	NC		—	1	—	1	1 ^②	—	1	2	2	2
Weight	kg		0.3	0.3	0.3	0.3	0.32	0.33	0.4	0.4	0.52	0.52
Dimensions (WxHxD)	mm		43 x 78 x 78	43 x 78 x 78	43 x 78 x 78	43 x 78 x 78	53 x 78 x 78	43 x 79 x 81	63 x 81 x 81	63 x 81 x 81	75 x 89 x 91	75 x 89 x 91
Order information ③	Art. no.	AC2 4 V	52566	52571	52576	52581	52586	57390	52591	52596	59365	59370
		AC4 8 V	52567	52572	52577	52582	52587	57391	52592	52597	59366	59371
		AC1 0 0 V	—	—	—	—	—	—	—	—	—	—
		AC1 2 0 V	52568	52573	52578	52583	52588	57392	52593	52598	59367	59372
		AC2 0 0 V	—	—	—	—	—	—	—	—	—	—
		AC2 3 0 V	52569	52574	52579	52584	52589	57393	52594	52599	59368	59373
	AC4 0 0 V	52570	52575	52580	52585	52590	57394	52595	52600	59369	59374	

① Peak value of inrush current < 2000 % of the effective value for rated current of capacitors. Selection is invalid for the circuit of parallel capacitors which are controlled individually.

② Special with 2 NO and without NC; on request.

③ Voltage range please see page 80.

④ 660 A at ambient temperature 40–55 °C.

⑤ 800 A ambient temperature 40–55 °C.

⑥ Conductor size in parentheses indicate compression terminal style not for bare clamping.

S-N50CX AC□□□V	S-N65CX AC□□□V	S-N80 AC□□□V	S-N95 AC□□□V	S-N125 AC□□□V	S-N150 AC□□□V	S-N180 AC□□□V	S-N220 AC□□□V	S-N300 AC□□□V	S-N400 AC□□□V	S-N600 AC□□□V	S-N800 AC□□□V
Rated data											
80	100	135	150	150	200	260	260	350	450	800 ^④	1000 ^⑤
15 (55)	18.5 (65)	22 (85)	30 (105)	37 (125)	45 (150)	55 (180)	75 (250)	90 (300)	125 (400)	190 (630)	220 (800)
22 (50)	30 (65)	45 (85)	55 (105)	60 (120)	75 (150)	90 (180)	132 (250)	160 (300)	220 (400)	330 (630)	440 (800)
25 (38)	37 (60)	45 (75)	55 (85)	60 (90)	90 (140)	110 (180)	132 (200)	160 (250)	225 (350)	330 (500)	500 (720)
22 (26)	30 (38)	45 (52)	55 (65)	60 (70)	90 (100)	110 (120)	132 (150)	200 (220)	250 (300)	330 (420)	500 (630)
30 (80)	35 (100)	50 (135)	55 (150)	55 (150)	75 (200)	95 (260)	95 (260)	130 (350)	170 (450)	250 (660)	300 (800)
50 (80)	65 (100)	85 (135)	90 (150)	90 (150)	130 (200)	170 (260)	170 (260)	230 (350)	290 (450)	430 (660)	530 (800)
65 (80)	85 (100)	110 (135)	120 (150)	120 (150)	170 (200)	220 (260)	220 (260)	300 (350)	380 (450)	570 (660)	700 (800)
80 (80)	100 (100)	135 (135)	150 (150)	150 (150)	200 (200)	260 (260)	260 (260)	350 (350)	450 (450)	660 (660)	900 (800)
5.5	7.5	7.5	11	15	18.5	22	22	37	45	65	75
7.5	11	15	18.5	22	30	37	45	60	75	110	130
7.5	11	15	18.5	22	37	45	55	60	90	130	130
7.5	11	15	18.5	22	30	50	55	75	90	130	150
32	47	62	75	90	110	150	180	220	300	400	630
50	65	80	93	120	150	180	220	300	400	630	800
50	65	80	93	100	150	180	220	300	400	630	800
40	50	60	70	80	150	180	220	300	300	630	800
35	40	60	90	90	130	180	220	280	280	630	630
30	35	50	80	80	120	150	150	200	200	630	630
12	15	20	50	50	80	100	100	150	150	630	630
20	20	35	35	38	50	60	60	95	115	190	190
40	40	60	60	65	80	120	120	150	200	350	350
30	35	48	60	65	80	150	150	200	250	350	350
30	40	50	60	65	80	150	150	200	200	400	400
550/460	650/620	850/850	1050/1050	1250/1250	1500/1500	1800/1800	2500/2500	3000/3000	4000/4000	6500/6500	8000/8000
550/460	650/620	800/750	930/930	1000/1000	1200/1200	1450/1450	2000/2000	2400/2400	3200/3200	5040/5040	6400/6400
690	690	690	690	690	690	1000	1000	1000	1000	1000	1000
Electrical data											
132	132	225	225	320	320	480	480	480	480	800	800
17	17	22	22	26	26	44	44	54	54	100	100
2.8	2.8	3.3	3.3	3.5	3.5	5	5	7.3	7.3	15	15
1200	1200	1200	1200	1200	1200	1200	1200	1200	1200	1200	1200
1200	1200	1200	1200	1200	1200	1200	1200	1200	1200	1200	1200
600	600	600	300	300	300	300	300	300	300	300	300
25	25	27	27	25	27	30	30	35	35	65	65
53	53	75	75	85	85	100	100	120	120	75	75
Mechanical data											
1	1	1	1	1	1	1	1	1	0.5	0.5	0.5
5	5	5	5	5	5	5	5	5	5	5	5
2-25	2-25	2-50	(2-60) ^⑥	(6-70) ^⑥	(6-95) ^⑥	(10-120) ^⑥	(10-150) ^⑥	(25-240) ^⑥	(25-240) ^⑥	(70-325) ^⑥	(70-325) ^⑥
2-25	2-25	2-50	2-50	(6-70) ^⑥	(6-95) ^⑥	(10-120) ^⑥	(10-150) ^⑥	(25-240) ^⑥	(25-240) ^⑥	—	—
1-2.5	1-2.5	1-2.5	1-2.5	1-2.5	1-2.5	1-2.5	1-2.5	1-2.5	1-2.5	1-4	1-4
—	—	15	15	15	20	25	25	30	30	35	35
2	2	2	2	2	2	2	2	2	2	2	2
2	2	2	2	2	2	2	2	2	2	2	2
1.1	1.1	1.8	1.8	2.5	3.2	5.5	5.5	9.5	9.5	27	27
88 x 106 x 106	88 x 106 x 106	100 x 124 x 127	100 x 124 x 127	100 x 150 x 136	120 x 160 x 145	138 x 204 x 174	138 x 204 x 174	163 x 243 x 195	163 x 243 x 195	290 x 310 x 234	290 x 310 x 234
113609	113633	113630	113645	113650	113654	—	—	—	—	—	—
113610	113636	113631	113646	—	—	—	—	—	—	—	—
113621	113611	113627	113642	113647	113651	113656	113659	113662	113665	113668	113672
—	—	—	—	—	—	—	—	—	—	—	—
113607	113632	113628	113643	113648	113652	113657	113660	113663	113666	113669	113673
—	—	—	—	—	—	—	—	—	—	—	—
113608	113635	113629	113644	113649	113653	113658	113661	113664	113667	113670	113674

For specifications of the standard auxiliary contacts refer to page 80.

Specifications			SD-N11CX 1A DC24V	SD-N11CX 1B DC24V	SD-N12CX DC24V	SD-N21CX DC24V	SD-N35CX DC24V	SD-N50 DC24V	SD-N65 DC24V
Rated data									
Rated continuous current I_{th}	A		20	20	20	32	60	80	100
		220–240 V kW (A)	3.5 (13)	3.5 (13)	3.5 (13)	5.5 (22)	11 (40)	15 (55)	18.5 (65)
Rated motor capacity 3-phase Category AC-3		380–440 V kW (A)	5.5 (12)	5.5 (12)	5.5 (12)	11 (22)	18.5 (40)	22 (50)	30 (65)
		500–550 V kW (A)	5.5 (9)	5.5 (9)	5.5 (9)	11 (17)	18.5 (32)	25 (38)	37 (60)
		690 V kW (A)	5.5 (7)	5.5 (7)	5.5 (7)	7.5 (9)	15 (17)	22 (26)	30 (38)
Rated capacity for resistive loads 3ph, category AC-1		220–240 V kW (A)	7.5 (20)	7.5 (20)	7.5 (20)	12 (32)	20 (60)	30 (80)	35 (100)
		380–440 V kW (A)	8.5 (13)	8.5 (13)	8.5 (13)	20 (32)	35 (60)	50 (80)	65 (100)
		500 V kW (A)	9.5 (11)	9.5 (11)	9.5 (11)	25 (32)	50 (60)	65 (80)	85 (100)
		690 V kW (A)	8 (8)	8 (8)	8 (8)	30 (32)	60 (60)	80 (80)	100 (100)
Rated capacity for jogging of AC motors 3-ph, category AC-4 (electrical life is approx. 200,000 oper.)		220–240 V kW	1.1	1.1	1.1	2.2	3.7	5.5	7.5
		380–440 V kW	1.5	1.5	1.5	3.7	5.5	7.5	11
		500–550 V kW	1.5	1.5	1.5	3.7	5.5	7.5	11
		690 V kW	1.5	1.5	1.5	3.7	5.5	7.5	11
Max. current for AC-4 duty at 440 V	A		9	9	9	13	24	32	47
Rated curr. for DC non-ind. loads, Category DC-1 100 oper./hour max. 500,000 oper.		48 V A	12	12	12	20	35	50	65
		110 V A	12	12	12	20	35	50	65
		220 V A	12	12	12	20	30	40	50
Rated curr. for DC motors Category DC-2 & DC-4, 100 oper./hour max. 500,000 oper.		48 V A	10	10	10	20	30	35	40
		110 V A	8	8	8	15	20	30	35
		220 V A	4	4	4	8	10	12	15
Rated capacity for 3-ph, capacitors, 15 oper./hour max. 100,000 oper. ①		220–240 V kvar	3	3	3	5.5	12	17	19
		380–440 V kvar	4	4	4	10	20	25	32
		550 V kvar	5	5	5	10	20	30	35
		690 V kvar	4.5	4.5	4.5	10	20	30	40
Current; 3-ph, $\cos\phi = 0.35, 240/440$ V	Making	A	130/120	130/120	130/120	220/220	400/400	550/460	650/620
	Breaking	A	120/100	120/100	120/100	220/220	400/320	550/460	650/620
Rated insulation voltage	V		690	690	690	690	690	690	690
Electrical data									
Coil consumption (at rated coil voltage)	Inrush	VA	7	7	7	16	18	24	24
	Sealed	VA	7	7	7	16	18	24	24
Switching frequency	Category AC-1	oper./h	1,800	1,800	1,800	1,800	1,800	1,200	1,200
	Cat. AC2; AC3	oper./h	1,800	1,800	1,800	1,800	1,800	1,200	1,200
	Category AC-4	oper./h	600	600	600	600	600	600	600
Operating time (at rated coil voltage)	Closing	ms	45	45	45	33	50	57	57
	Opening	ms	10	10	10	12	13	15	15
Mechanical data									
Electrical life (Category AC-3)	Oper. (million)		1	1	1	1	1	1	1
Mechanical life			10	10	10	10	10	5	5
Main terminal (contactor)	mm ²		1–2.5	1–2.5	1–2.5	1–6	2–16	2–25	2–25
Main terminal (overload relay)	mm ²		1–2.5	1–2.5	1–2.5	1–6	2–16	2–25	2–25
Control terminal	mm ²		1–2.5	1–2.5	1–2.5	1–2.5	1–2.5	1–2.5	1–2.5
Busbar width	mm		—	—	—	—	—	—	—
Standard auxiliary contacts	NO		1	—	1 ^②	2	2	2	2
	NC		—	1	1 ^②	2	2	2	2
Weight	kg		0.62	0.62	0.64	0.72	0.85	2.1	2.1
Dimensions (W x H x D)	mm		43 x 78 x 110	43 x 78 x 110	53 x 78 x 110	63 x 81 x 113	75 x 89 x 123	88 x 110 x 133	88 x 110 x 133
Order information ⑥	Art. no.		52601	52602	52603	52604	58533	113675	113678

① Peak value of inrush current < 2000 % of the effective value for rated current of capacitors. Selection is invalid for the circuit of parallel capacitors which are controlled individually.

② Special with 2 NO and without NC; on request

③ 660 A at ambient temperature 40–55 °C.

④ 800 A ambient temperature 40–55 °C.

⑤ Conductor size in parentheses indicate compression terminal style not for bare clamping.

⑥ Other coil voltages on request (please see page 80).

SD-N80 DC24V	SD-N95 DC24V	SD-N125 D 24V	SD-N150 DC24V	SD-N220 DC24V	SD-N300 DC24V	SD-N400 DC24V	SD-N600 DC24V	SD-N800 DC24V
Rated data								
135	150	150	200	260	350	450	800 ^③	1000 ^④
22 (85)	30 (105)	37 (125)	45 (150)	75 (250)	90 (300)	125 (400)	190 (630)	220 (800)
45 (85)	55 (105)	60 (120)	75 (150)	132 (250)	160 (300)	220 (400)	330 (630)	440 (800)
45 (75)	55 (85)	60 (90)	90 (140)	132 (200)	160 (250)	225 (350)	330 (500)	500 (720)
45 (52)	55 (65)	60 (70)	90 (100)	132 (150)	200 (220)	250 (300)	330 (420)	500 (630)
50 (135)	55 (150)	55 (150)	75 (200)	95 (260)	130 (350)	170 (450)	250 (660)	300 (800)
85 (135)	90 (150)	90 (150)	130 (200)	170 (260)	230 (350)	290 (450)	430 (660)	530 (800)
110 (135)	120 (150)	120 (150)	170 (200)	220 (260)	300 (350)	380 (450)	570 (660)	700 (800)
135 (135)	150 (150)	150 (150)	200 (200)	260 (260)	350 (350)	450 (450)	660 (660)	900 (800)
7,5	11	15	18,5	22	37	45	65	75
15	18,5	22	30	45	60	75	110	130
15	18,5	22	37	55	60	90	130	150
15	18,5	22	30	55	75	90	130	150
62	75	90	110	180	220	300	400	630
80	93	120	150	220	300	400	630	800
80	93	100	150	220	300	400	630	800
60	70	80	150	220	300	300	630	800
60	90	90	130	220	280	280	630	630
50	80	80	120	150	200	200	630	630
20	50	50	80	100	150	150	630	630
24	30	38	50	60	95	115	190	190
40	55	65	80	120	150	200	350	350
48	60	65	80	150	200	250	350	350
50	60	65	80	150	200	200	400	400
850/850	1050/1050	1250/1250	1500/1500	2500/2500	3000/3000	4000/4000	6500/6500	8000/8000
800/750	930/930	1000/1000	1200/1200	2000/2000	2400/2400	3200/3200	5040/5040	6400/6400
690	690	690	690	1000	1000	1000	1000	1000
Electrical data								
27	27	31	31	41	55	55	600	600
27	27	31	31	41	55	55	75	75
1200	1200	1200	1200	1200	1200	1200	1200	1200
1200	1200	1200	1200	1200	1200	1200	1200	1200
600	300	300	300	300	300	300	300	300
75	75	125	135	145	175	175	105	105
18	18	22	37	40	55	55	80	80
Mechanical data								
1	1	1	1	1	1	0,5	0,5	0,5
5	5	5	5	5	5	5	5	5
2-50	(2-60) ^⑤	(6-70) ^⑤	(6-95) ^⑤	(10-150) ^⑤	(25-240) ^⑤	(25-240) ^⑤	(70-325) ^⑤	(70-325) ^⑤
2-50	2-50	(6-70) ^⑤	(6-95) ^⑤	(10-150) ^⑤	(25-240) ^⑤	(25-240) ^⑤	—	—
1-2.5	1-2.5	1-2.5	1-2.5	1-2.5	1-2.5	1-2.5	1-4	1-4
—	—	15	20	25	30	30	35	35
2	2	2	2	2	2	2	2	2
2	2	2	2	2	2	2	2	2
3.3	3.3	4.3	4.3	7.5	13.5	13.5	28	28
100 x 134 x 158	100 x 134 x 158	100 x 150 x 161	120 x 160 x 170	138 x 204 x 200	163 x 243 x 220	163 x 243 x 220	375 x 310 x 234	375 x 310 x 234
113679	113681	113682	113683	113684	113686	113687	113688	on request

■ Specifications – standard auxiliary contacts

Rated data of auxiliary contacts			
Rated continuous current I_{th}	A	16	
Rated operating current			
Category AC-15	AC 110 V	A	6
	AC 230 V	A	5
	AC 500 V	A	3
	AC 660 V	A	1,5
Category DC-13	DC 24 V	A	5
	DC 48 V	A	3
	DC 110 V	A	1.2 (0.8 for UN-AX2CX, UN-AX4CX, UN-AX11CX)
	DC 220 V	A	0.2

For detailed description please see page 92.

■ Environmental conditions

Environmental conditions for all contactors			
Ambient temperature	°C	-25 to +55	
Ambient humidity	RH	45 to 85 %	
Coil voltage tolerance		0.85 to 1.1 times rated coil voltage	
Vibration resistance	10–55 Hz	G	2
Shock resistance		G	5

■ Coil ratings

In case of special order:

The following tables show the devices which are additionally available. Please contact MITSUBISHI ELECTRIC for further information.

AC rated voltage – S-N10CX to S-N35CX

Rating	Range 50 Hz	Range 60 Hz	Standard
AC 24 V	24	24	●
AC 48 V	48–50	48–50	●
AC 100 V	100	100–110	
AC 120 V	110–120	115–120	●
AC 127 V	125–127	127	
AC 200 V	200	200–220	
AC 220 V	208–220	220	
AC 230 V	220–240	230–240	●
AC 260 V	240–260	260–280	
AC 380 V	346–380	380	
AC 400 V	380–415	400–440	●
AC 440 V	415–440	460–480	
AC 500 V	500	500–550	

For detailed description of the types please see page 76 and 77.

DC rated voltage – SD-N types

Rating	Range	Standard
DC 12 V	12	
DC 24 V	24	●
DC 48 V	48	
DC 100 V	100	
DC 110 V	110	
DC 125 V	120–125	
DC 200 V	200	
DC 220 V	220	

For detailed description of the types please see page 78 and 79.

AC rated voltage – S-N50CX to S-N800

Ordering designation	50/60 Hz	Standard
AC 24 V ^①	24	
AC 48 V ^①	48–50	
AC 100 V	100–127	●
AC 200 V	200–240	●
AC 300 V	260–350	
AC 400 V	380–440	●
AC 500 V	460–550	

^① Available for S-N50CX to S-N150 only.

For detailed description of the types please see page 77.

■ Performance of S-N series contactors

Electrical life

The electrical life of the main contacts of a contactor is determined mainly by the circuit-opening duty it will perform. The relationship between electrical life and rated current of MITSUBISHI contactors under normal and jogging duties of squirrel-cage motors is shown in the figures. In the case of a mixture of normal and jogging duties, the expected contactor life can be determined as follows:

$$N = N_r/1 + \frac{\alpha}{100} (N_r/N_i - 1)$$

- N : Life in the case of α % jogging duty
- N_r: Life in the case of normal duty
- N_i: Life in the case of 100 % jogging duty
- α : Percentage of jogging duty

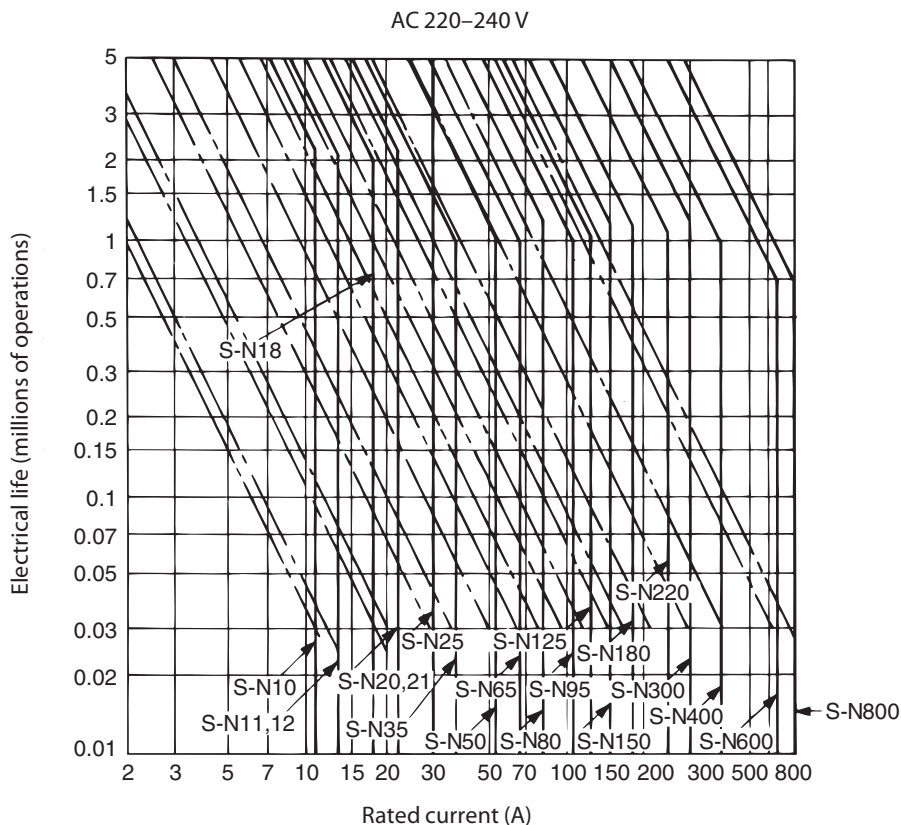

Electrical life versus rated operating current

- Normal duty, 6 le ON, 1e OFF, on-load factor 40 %, 1200 operations/hour (AC-3)
- Jogging duty, 6 le ON, 6 le OFF, on-load factor 7 %, 600 operations/hour (AC-4)-S-N10 to S-N300
300 operations/hour (AC-4)-S-N400 to S-N600
150 operations/hour (AC-4)-S-N800

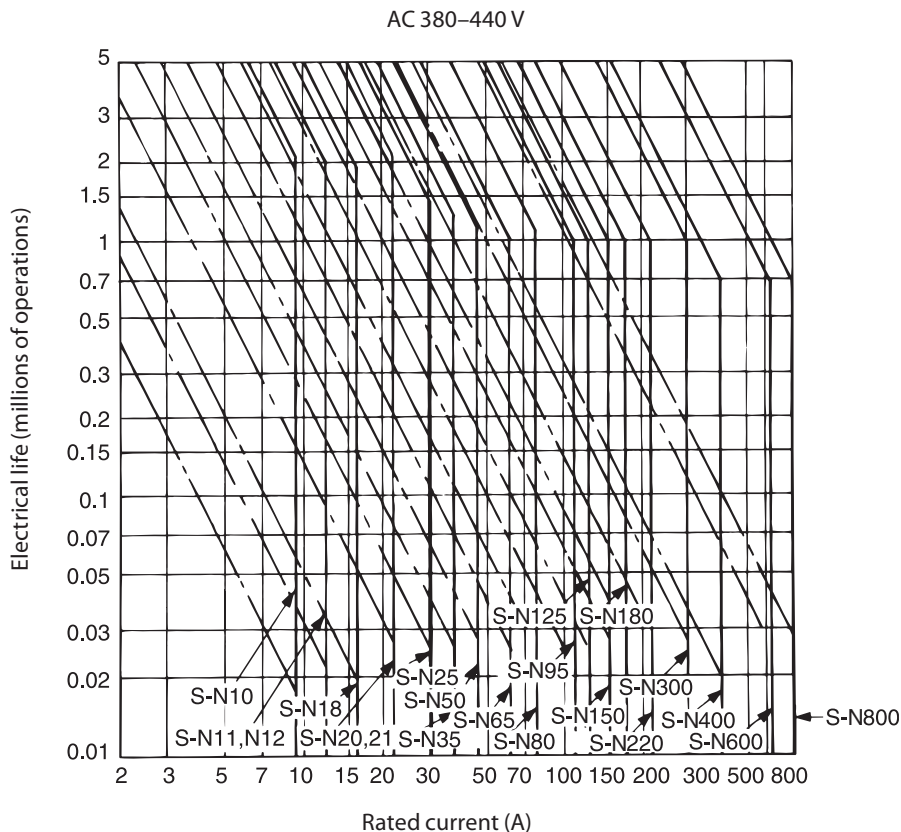

■ Thermal overload relays description

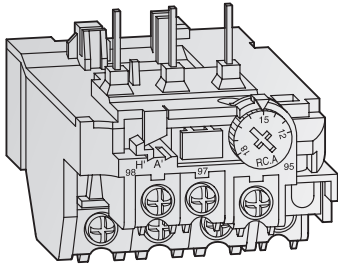

TH-N18KPCX

A selection of relays for optimum motor protection characteristics

The thermal relay line-up includes the phase failure protection type models (three-element relays).

This array of protection characteristics allows you to choose the units suited to your motor protection needs.

Benefits:

- An operation indicator makes maintenance and inspection easy.
- 1 NO and 1 NC contact
- Rated current can be set easily
- Finger protection up to TH-N60KPCX
- Trip-free reset bar
- Convenient reset release (optional)

■ Display

TH-N12KPCX, TH-N18KPCX

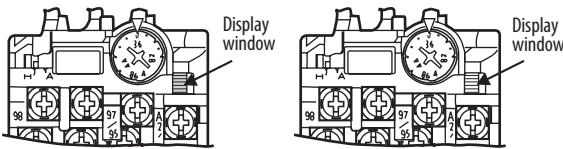

When the green of the display lever can be seen, the device has been reset.

■ External trip mechanism

TH-N12KPCX, TH-N18KPCX

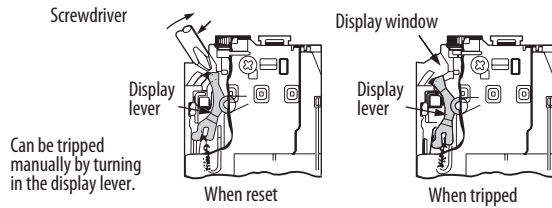

Can be tripped manually by turning in the display lever.

TH-N20KPCX – TH-N600KP

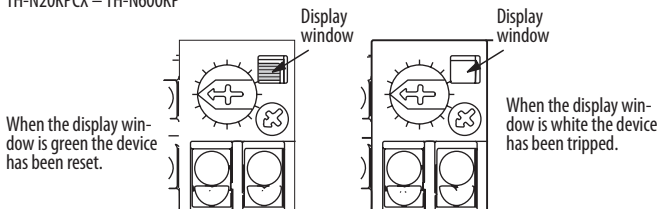

When the display window is green the device has been reset.

When the display window is white the device has been tripped.

TH-N20KPCX – TH-N600KP

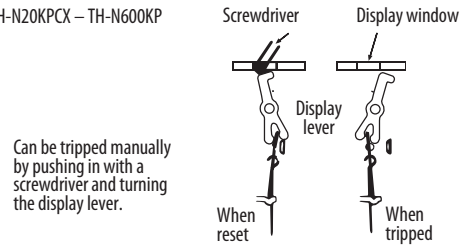

Can be tripped manually by pushing in with a screwdriver and turning the display lever.

■ Switching between automatic and manual reset

TH-N12KPCX – TH-N18KPCX

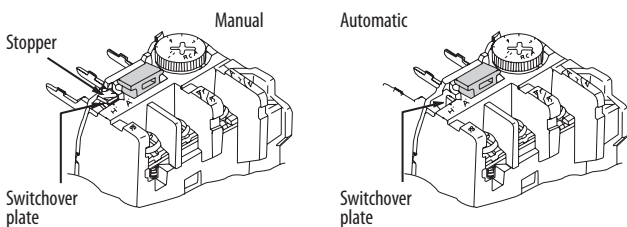

Switching from manual to automatic: Break the stopper off and then, slide the switchover plate to the right (to position "A") to immobilize the reset bar.

Switching from automatic to manual: Slide the switchover plate to the left (to position "H").

TH-N20KPCX – TH-N600KP

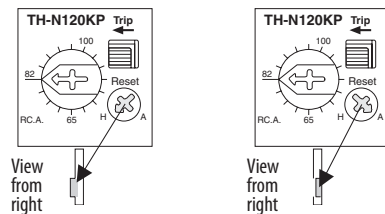

Switching from manual to automatic: Flip the stopper on the end of the reset bar down and then, after pushing it all the way in, rotate it counterclockwise 90° (to position "A").

Switching from automatic to manual: Rotate the reset bar 90° clockwise (to position "H") and the reset bar will pop out.

Specifications

Specifications		TH-N12KPCX □□□ A	TH-N18KPCX □□□ A	TH-N20KPCX □□□ A ^①	TH-N20TAKPCX □□□ A	TH-N60KPCX □□□ A	TH-N60TAKP □□□ A	TH-N120KP □□□ A	TH-N120TAKP □□□ A	TH-N220RHKP □□□ A	TH-N400RHKP □□□ A	TH-N600KP □□□ A ^②	
Rated data													
Max. setting current	A	13	18	22	40	65	105	100	150	220	400	800	
Range of setting current	A	0.1–13	1–18	0.2–22	18–40	12–65	54–105	34–100	85–150	65–250	85–400	200–800	
Rated insulation voltage	V	690	690	690	690	690	690	690	690	1000	1000	690	
Auxiliary contacts		For all types: 1 NO + 1 NC											
Max. heater dissipation per current path	Min. setting	W	0.8	0.9	0.8	1.4	1.7	2.4	2.5	3.2	2.5	2.5	
	Max. setting	W	1.8	2.2	2.2	3.5	4.9	5.2	7.1	8.6	6.0	6.0	
Rated operating current of auxiliary contacts													
Category AC-15	NO contact	120 V	A	2	2	2	2	2	2	2	2	2	
		240 V	A	1	1	1	1	1	1	1	1	1	
		500 V	A	0.5	0.5	0.5	0.5	0.5	0.5	0.5	0.5	0.5	
	NC contact	120 V	A	2	2	3	3	3	3	3	3	3	
		240 V	A	1	1	2	2	2	2	2	2	2	
		500 V	A	0.5	0.5	1	1	1	1	1	1	1	
Category DC-13	48 V	A	0.4	0.4	0.5	0.5	0.5	0.5	0.5	0.5	0.5		
	110 V	A	0.2	0.2	0.2	0.2	0.2	0.2	0.2	0.2	0.2		
	220 V	A	0.1	0.1	0.1	0.1	0.1	0.1	0.1	0.1	0.1		
Sizes													
Main terminal screw size	Line side	mm	—	—	M4	M4	M6	M6	M8	M8	—	—	M4
	Load side	mm	M3.5	M4	M4	M5	M6	M6	M8	M8	M10	M12	M4
Max. conductor size	Main	Line side	mm ²	2.5 ^③	—	6	—	25	—	38	60	—	6
		Load side	mm ²	2.5	6	6	16	25	38	38	60	70	240
	Busbar	Line side	mm	—	—	—	—	15	—	20	20	—	—
		Load side	mm	—	—	—	—	15	20	20	20	25	30
Auxiliary contacts	mm ²	2.5	2.5	4	4	4	4	4	4	4	4	4	
Bimetal heating		Direct	Direct	Direct	Direct	Direct	Direct	Direct	Direct	Via CTs	Via CTs	Via CTs ^④	
Weight	kg	0.11	0.14	0.14	0.2	0.26	0.32	0.48	0.75	2.5	2.7	0.14	
Dimensions (WxHxD) ^④	mm	46 x 55 x 76.5	54 x 59 x 80	63 x 51 x 79	74 x 72 x 83.5	92 x 57 x 87	89 x 73.5 x 8 3.5	103 x 67 x 105	112 x 87 x 105	144 x 114 x 180	144 x 160 x 194	63 x 42 x 83.5	
Order information	Art. no.	See page 84 for order information											

^① Specifications for the TH-N20HZKPCX (for stand-alone) are the same as for the TH-N20KPCX.

^② Used with current transformer (to be supplied by the customer), for further information, see table on bottom of the page.

^③ When used with UN-HZ12CX.

^④ Dimensions on request.

Selection guide of the current transformers for TH-N600KP

For the TH-N600KP the customer has to use a transformer with specifications as described in the following table.

Specifications		250	330	500	660
Heater designation	A	250	330	500	660
Setting range	A	200 – 300	260 – 400	400 – 600	520 – 800
Current transformer ratio		400 / 5A	500 / 5A	750 / 5A	1,000 / 5A
Current transformer capacity		at least 15 VA	at least 15 VA	at least 15 VA	at least 15 VA
Recommended MITSUBISHI current transformer model number	Cable	CW-15L 400/5A 15 VA	CW-15L 500/5A 15 VA	CW-15L 750/5A 15 VA	—
	Bus bar	CW-15LM 400/5A 15 VA	CW-15LM 500/5A 15 VA	CW-15LM 750/5A 15 VA	CW-40LM 1000/5A 40 VA

Range (A)	Heater designation	TH-N12KPCX □□□ A	TH-N18KPCX □□□ A	TH-N20KPCX □□□ A	TH-N20HZKPCX □□□ A ^①	TH-N20TAKPCX □□□ A	TH-N60KPCX □□□ A	TH-N60TAKPCX □□□ A	TH-N120KP □□□ A	TH-N120TAKPCX □□□ A	TH-N220RHKP □□□ A	TH-N400RHKP □□□ A	TH-N600KP □□□ A ^②
0.10–0.16	0.12A	52637											
0.14–0.22	0.17A	52638											
0.20–0.32	0.24A	52639		52656	63996								
0.28–0.42	0.35A	52640		52657	63997								
0.40–0.60	0.5A	52644		52658	63998								
0.55–0.85	0.7A	52645		52659	63999								
0.70–1.10	0.9A	52646		52660	64000								
1.00–1.60	1.3A	52647	57378	52661	64002								
1.40–2.00	1.7A	52648	57379	52662	64003								
1.70–2.50	2.1A	52649	57380	52663	64004								
2.00–3.00	2.5A	52650	57381	52664	64006								
2.80–4.40	3.6A	52651	57382	52665	64007								
4.00–6.00	5A	52652	57383	52666	64008								
5.20–8.00	6.6A	52653	57384	52667	64009								
7.00–11.0	9A	52654	57386	52668	64010								
9.00–13.0	11A	52655 ^①	57388	52669	64011								
12.0–18.0	15A		57389	52671	64012		113709						
16.0–22.0	19A			52672 ^②	64015								
18.0–26.0	22A					59393	113710						
24.0–34.0	29A					59394	113711						
30.0–40.0	35A					59395 ^③	113712						
34.0–50.0	42A						113713		124425				
43.0–65.0	54A						113714		124426				
54.0–80.0	67A							113715	124427				
65.0–100	82A							113716 ^④	124428		124432		
85.0–105	95A							113717 ^④					
85.0–125	105A									124430	124433	124438	
100–150	125A									124431 ^⑤	124434	124439	
120–180	150A										124435	124440	
140–220	180A										124436 ^⑥	124441	
170–250	210A										124437 ^⑥		
200–300	250A											124442	on request
260–400	330A											124443 ^⑦	on request
400–600	500A												on request
520–800	660A												on request ^⑧

⑧ Contactors modified with thermal overload relays correspond to motor starter combination^⑧ (see also the overview on p. 74/75)

Contactor	S-N10CX, S-N11CX, S-N12CX, SD-N11CX, SD-N12CX	S-N18CX	S-N20CX, S-N21CX, SD-N21CX	—	S-N25CX, S-N35CX, SD-N35CX	S-N50CX, S-N65CX, S-N80, S-N95, SD-N95, SD-N50, SD-N65, SD-N80, SD-N95	S-N80, S-N95, SD-N95	S-N125, S-N150, SD-N125, SD-N150	S-N125, S-N150, SD-N150	S-N180, S-N220, SD-N220	S-N300, S-N400, SD-N300, SD-N400	S-N600, S-N800, SD-N600, SD-N800
with connecting parts ^⑧			S-N25CX, S-N35CX, SD-N35CX	with UN-TH20 ^⑧								

Stand-alone

Stand-alone type ^⑧	●	—	—	◇	—	●	○	○	○	○	○	○
With connecting part	UN-HZ12CX	—	—	—	—	—	—	—	—	—	—	—

① Except for all S-N10.

② For all -N20 and all -N21 only.

③ For all -N35 only.

④ For all -N95 only.

⑤ For all -N150 only.

⑥ For all -N220 only.

⑦ For all -N400 only.

⑧ TH-N600KP must be used with the current transformers (to be supplied by the customer), see p. 15.

⑨ For all -N800 only.

⑩ For the standard operation it is important to use the thermal overload relay with one of the mentioned contactors and if necessary with a connecting part.

⑪ For further information, see accessories on page 30.

⑫ Stand-alone

⑬ ● Stand-alone with finger protection

○ Stand-alone without finger protection

◇ Stand-alone only

— Stand-alone not possible

⑭ with finger protection

Range (A)	Heater designation	Max. fuse rating (AC 660 V) IEC 269-1 (A)			Standard wire size, (mm ²) recommended	Motor capacity (three phase 50/60 Hz, based on four poles) (kW)			
		aM	gG	gM		AC 220–240 V	AC 380 V	AC 400–440 V	AC 500 V
0.10–0.16	0.12 A	0.5	0.5	—	2				
0.14–0.22	0.17 A	0.5	1	—	2				
0.20–0.32	0.24 A	1	2	—	2	0.03	0.06	0.06	0.09
0.28–0.42	0.35 A	1	2	—	2	0.05	0.09	0.09	0.12
0.40–0.60	0.5 A	1	2	—	2	0.06	0.12	0.12	0.18
0.55–0.85	0.7 A	2	4	—	2	0.09	0.18	0.18	0.25
0.70–1.10	0.9 A	2	4	—	2	0.12	0.25	0.25	0.37
1.00–1.60	1.3 A	2	4	—	2	0.18	0.37	0.37; 0.55	0.55
1.40–2.00	1.7 A	4	6	—	2	0.25	0.55	0.75	0.75
1.70–2.50	2.1 A	4	6	—	2	0.37	0.75	—	1.1
2.00–3.00	2.5 A	6	10	—	2	0.55	1.1	1.1	1.5
2.80–4.40	3.6 A	6	10	—	2	0.75	1.5	1.5	2.2
4.00–6.00	5 A	8	16	—	2	1.1	2.2	2.2	3
5.20–8.00	6.6 A	12	20	—	2	1.5	3	3; 3.7	3.7
7.00–11.0	9 A	12	20	—	2	2.2	3.7; 4	3; 3.7	5.5
9.00–13.0	11 A	16	25	32M35	2	3	5.5	5.5	7.5
12.0–18.0	15 A	20	32	32M50	3.5	3.7	7.5	7.5; 9	9
16.0–22.0	19 A	25	40	32M63	3.5	5.5	11	11	11
18.0–26.0	22 A	40	63	32M63	5.5	5.5	11	11	15
24.0–34.0	29 A	50	80	63M80	8	7.5	15	15	18.5
30.0–40.0	35 A	63	80	63M80	8	9	18.5	18.5	22
34.0–50.0	42 A	63	100	100M100	14	11	22	22	30
43.0–65.0	54 A	80	125	100M125	22	15	30	30	37
54.0–80.0	67 A	100	160	100M160	22	18.5	37	37	45
65.0–100	82 A	125	200	100M200	38	22	45	45	55
85.0–105	95 A	—	200	100M200	38	30	55	55	—
85.0–125	105 A	—	250	200M250	50	30	55	55	75
100–150	125 A	—	250	200M250	60	37	75	75	90
120–180	150 A	—	315	200M315	—	45	90	90	110
140–220	180 A	—	400	—	—	55	110	110	132
170–250	210 A	—	500	—	—	75	132	132	—
200–300	250 A	—	630	—	—	75	132; 160	132; 160	160
260–400	330 A	—	630	—	—	90; 110	200	200	220; 250
400–600	500 A	—	800	—	—	132; 160	220; 250; 300	220; 250; 300	400
520–800	660 A	—	1000	—	—	200; 220	400	400	500

■ TH-N12KP

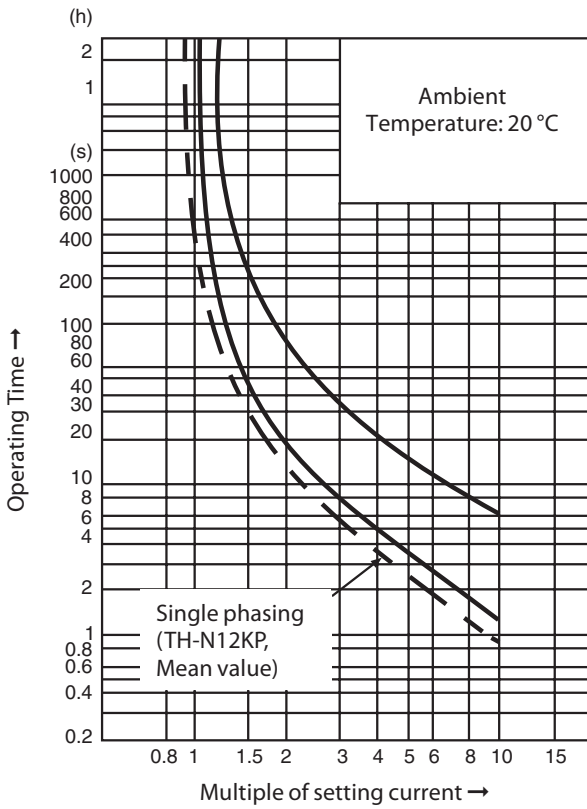

■ TH-N18KP

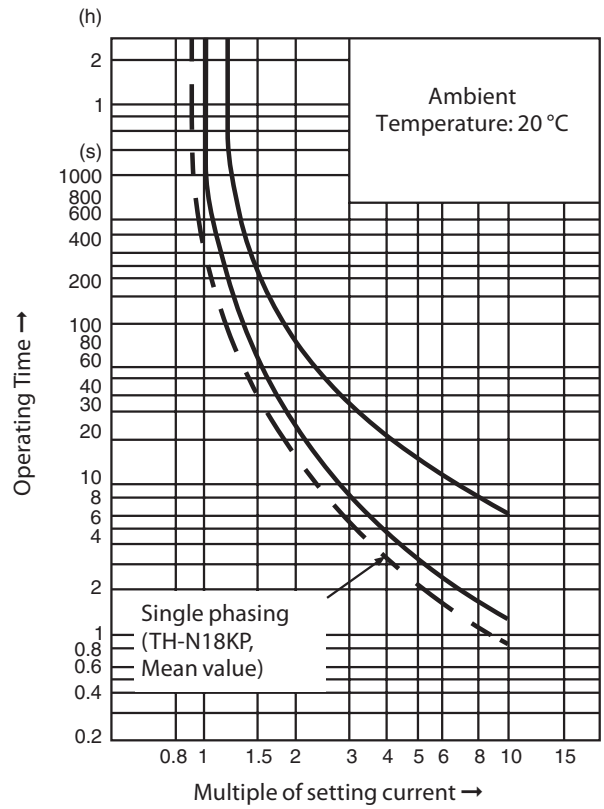

■ TH-N20KP, TH-N20HZKP

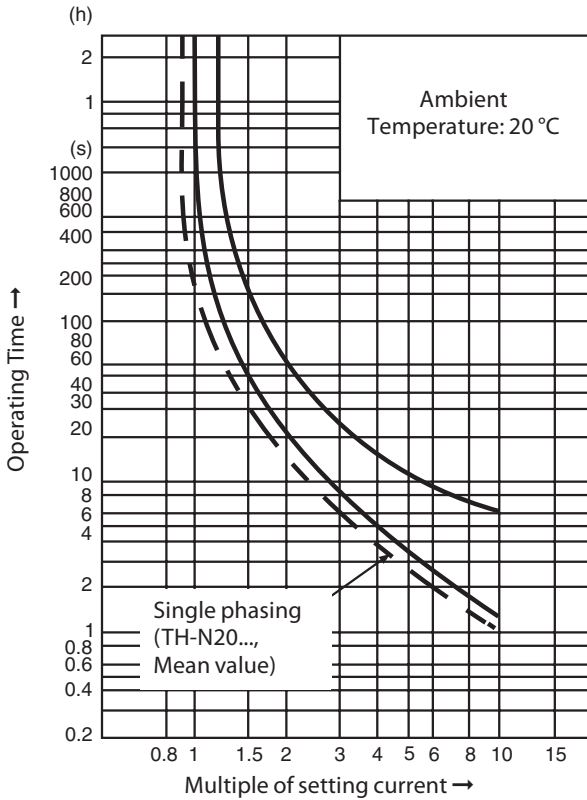

■ TH-N20TAKP

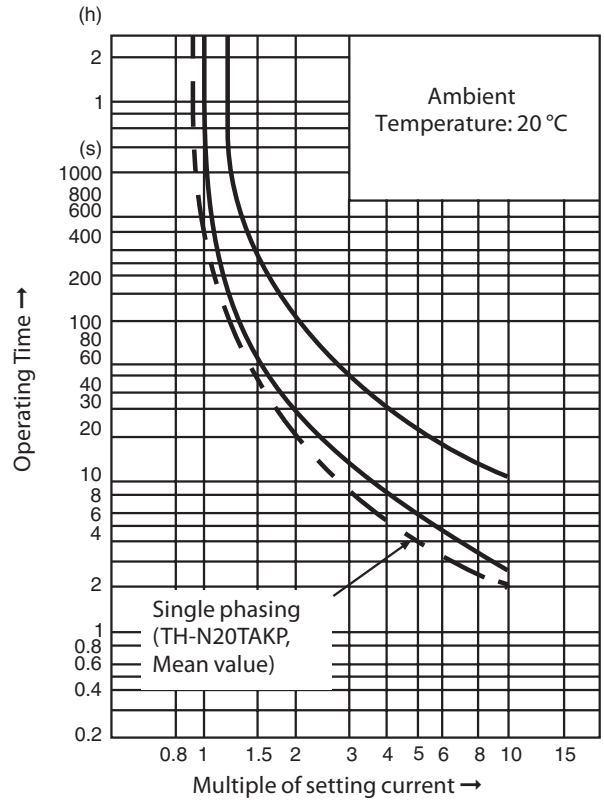

■ TH-N60KP, TH-N60TAKP

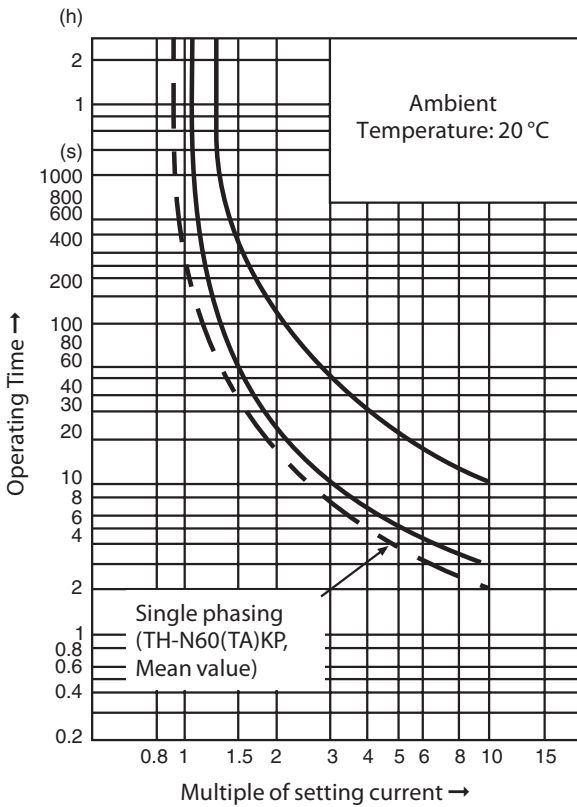

■ TH-N120KP, TH-N120TAKP

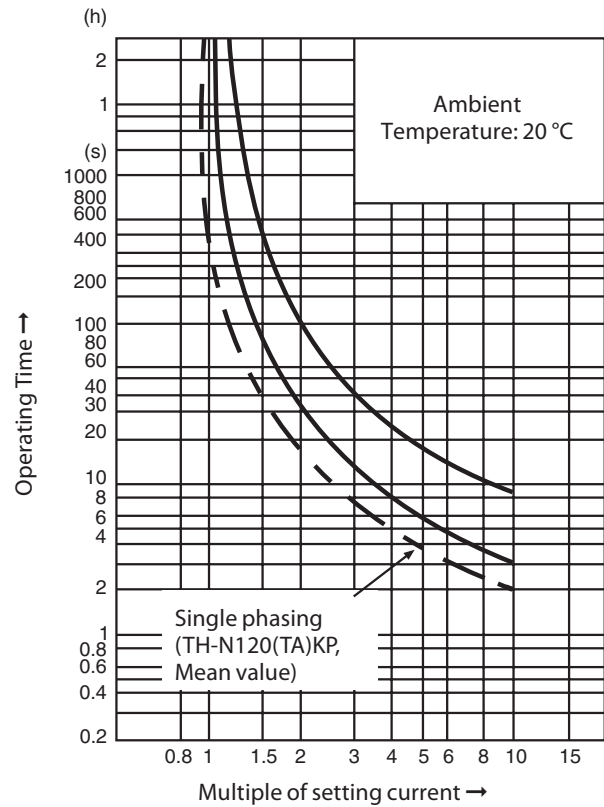

■ TH-N220RHKP, TH-N400RHKP

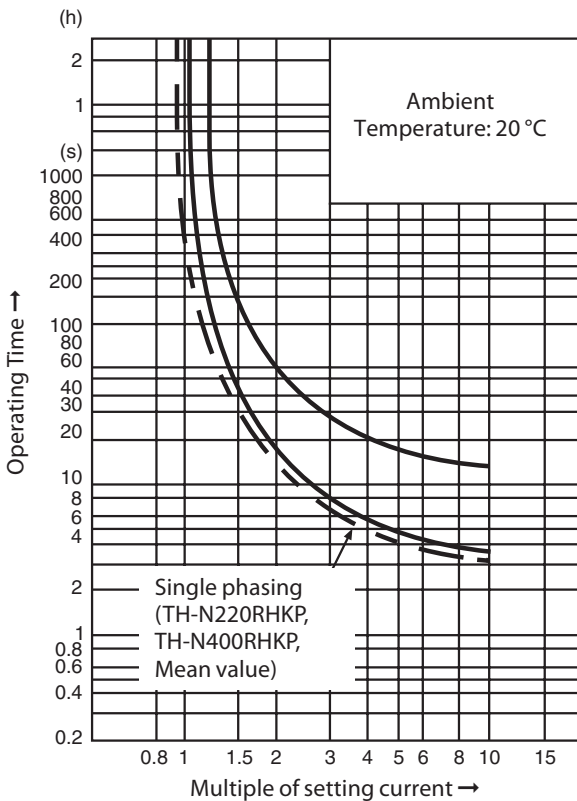

■ TH-N600KP

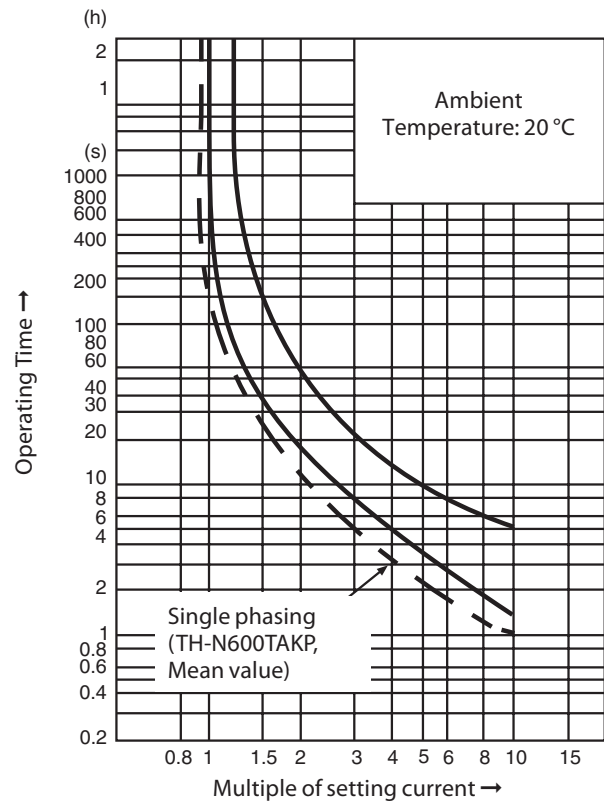

■ Contactor relay features

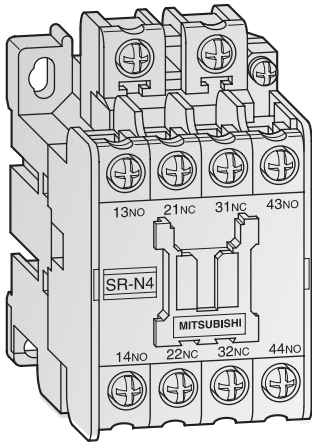

Contactor relays are designed for use in low voltage control circuit applications.

Benefits:

- High reliability: By adopting bifurcated moving contacts and by improving the shape of the contacts, contact performance has been made more reliable than ever.
- Different types as: Standard, big capacity or overlap contact
- Various contact arrangement
- Long life
- Mountable on 35 mm DIN rails
- Dust-proof construction
- Easily visible coil ratings
- Easy wiring (self-rising terminal screws)
- Various accessories common with the series S-N contactors (front and side clip-on type additional auxiliary contact blocks, surge absorbers)
- Finger protected types are available (DIN 57106/VDE 0106 Part 100) (Suffix "CX")

Our standard contactor relay version is with 4 auxiliary contacts.

With side clip-on or front clip-on a number of max. 8 auxiliary contacts is possible.

Type of auxiliary contact	Symbol		Code
Normally open	NO	=	A
Normally closed	NC	=	B

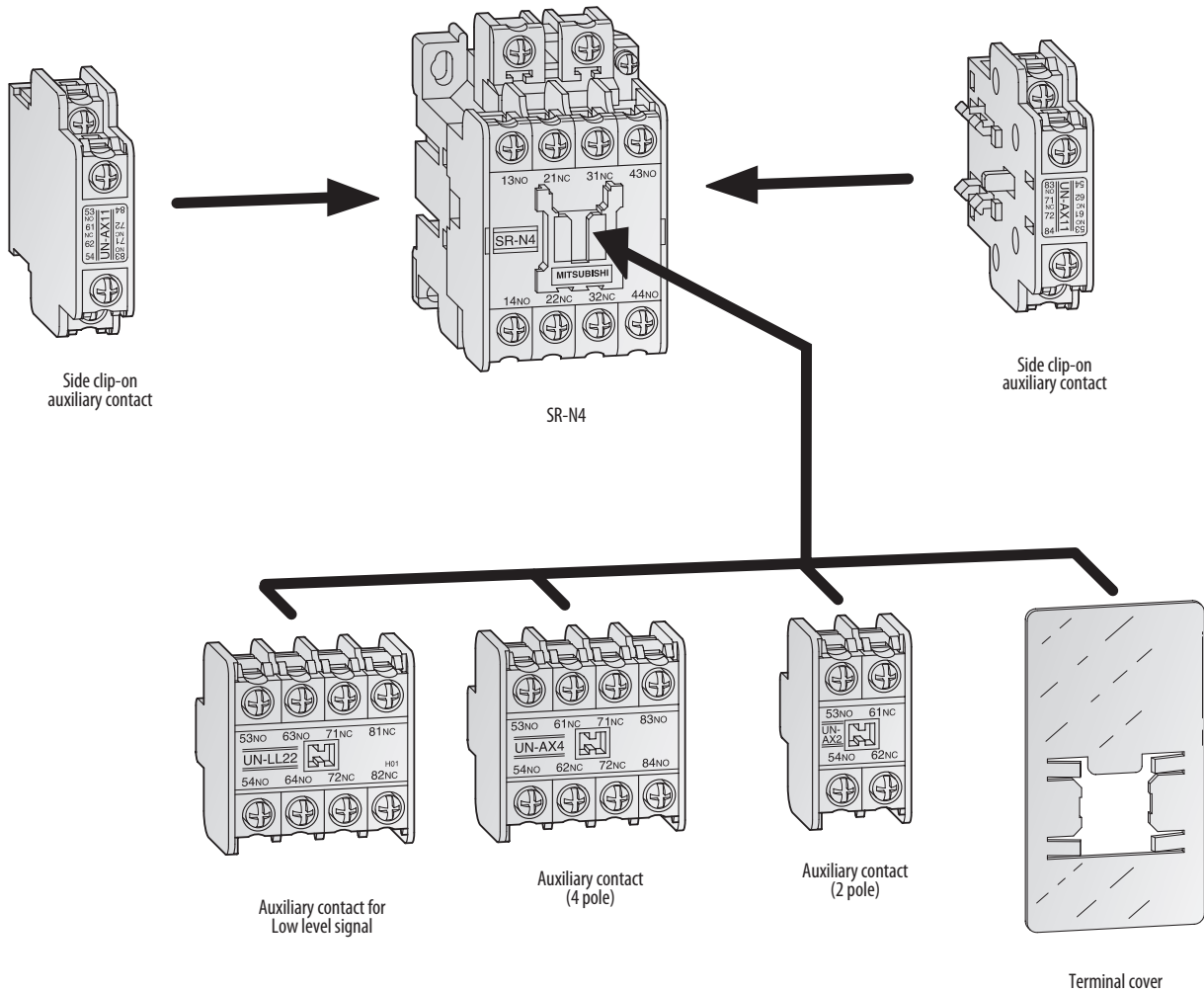

Specifications

Specifications		SR-N4CX AC□□V4A	SR-N4CX AC□□V3A1B	SR-N4CX AC□□V2A2B	SRD-N4CX DC24V4A	SRD-N4CX DC24V3A1B	SRD-N4CX DC24V2A2B
Contact arrangement							
Contact arrangement		4 NO	3 NO + 1 NC	2 NO + 2 NC	4 NO	3 NO + 1 NC	2 NO + 2 NC
Rated data							
Rated insulation voltage	V	690	690	690	690	690	690
Rated continuous current I _{th}	A	16	16	16	16	16	16
Rated operating current; Category AC-15 (coil load)	110 V	A 6	6	6	6	6	6
	230 V	A 5	5	5	5	5	5
	440 V	A 3	3	3	3	3	3
	550 V	A 3	3	3	3	3	3
Rated operating current; Category AC-12 (coil load)	110 V	A 16	16	16	16	16	16
	230 V	A 12	12	12	12	12	12
	440 V	A 5	5	5	5	5	5
	550 V	A 5	5	5	5	5	5
Rated operating current; Category DC-13 (large coil load)	24 V	A 5	5	5	5	5	5
	48 V	A 3	3	3	3	3	3
	110 V	A 0.8 (2) ^①	0.8 (2) ^①	0.8 (2) ^①	0.8 (2) ^①	0.8 (2) ^①	0.8 (2) ^①
	220 V	A 0.2 (0.8) ^①	0.2 (0.8) ^①	0.2 (0.8) ^①	0.2 (0.8) ^①	0.2 (0.8) ^①	0.2 (0.8) ^①
Rated operating current; Category DC-14	24 V	A 8	8	8	8	8	8
	48 V	A 3	3	3	3	3	3
	110 V	A 2 (4) ^①	2 (4) ^①	2 (4) ^①	2 (4) ^①	2 (4) ^①	2 (4) ^①
	220 V	A 0.4 (1) ^①	0.4 (1) ^①	0.4 (1) ^①	0.4 (1) ^①	0.4 (1) ^①	0.4 (1) ^①
Rated operating current; Category DC-12 (resistive load)	24 V	A 10	10	10	10	10	10
	48 V	A 8	8	8	8	8	8
	110 V	A 5 (8) ^①	5 (8) ^①	5 (8) ^①	5 (8) ^①	5 (8) ^①	5 (8) ^①
	220 V	A 1 (3) ^①	1 (3) ^①	1 (3) ^①	1 (3) ^①	1 (3) ^①	1 (3) ^①
Electrical data							
Coil consumption (at rated coil voltage)	Inrush	VA	60	60	60	—	—
	Sealed	VA	10	10	10	—	—
	Watts	W	3	3	3	7	7
Switching frequency	oper./h	1,800	1,800	1,800	1,800	1,800	1,800
Operating time (average)	Making	ms	15	15	15	50	50
	Breaking	ms	10	10	10	10	10
Mechanical data							
Electrical life	Oper. (million)	0.5	0.5	0.5	0.5	0.5	0.5
Mechanical life		10	10	10	10	10	10
Conductor size	mm ²	1–2.5	1–2.5	1–2.5	1–2.5	1–2.5	1–2.5
Weight	kg	0.3	0.3	0.3	0.62	0.62	0.62
Dimensions (WxHxD) ^②	mm	43 x 78 x 78	43 x 78 x 78	43 x 78 x 78	43 x 78 x 110	43 x 78 x 110	43 x 78 x 110
Order information	AC24V	Art. no.	52607	52612	52617	—	—
	AC48V		52608	52613	52618	—	—
	AC120V		52609	52614	52619	—	—
	AC230V		52610	52615	52620	—	—
	AC400V		52611	52616	52621	—	—
Order information	DC24V	Art. no.	—	—	—	52622	52623
							52624

^① Parenthesized rated operating current is for switching the load in 2-pole series connection.

^② Dimensions on request.

■ Environmental conditions

Environmental conditions for all contactor relays			
Ambient temperature	°C		-25 to +55
Ambient humidity	RH		45 to 85 %
Coil voltage tolerance			0.85 to 1.1 times rated coil voltage
Vibration resistance	10–55 Hz	G	2
Shock resistance		G	5

■ Coil ratings

In case of special order:

The following tables show the devices which are additionally available. Please contact MITSUBISHI ELECTRIC for further information.

AC rated voltage (for SR-N)

50 Hz	60 Hz	Ordering designation	Standard
24	24	AC 24 V	●
48–50	48–50	AC 48 V	●
100	100–110	AC 100 V	
110–120	115–120	AC 120 V	●
125–127	127	AC 127 V	
200	200–220	AC 200 V	
208–220	220	AC 220 V	
220–240	230–240	AC 230 V	●
240–260	260–280	AC 260 V	
346–380	380	AC 380 V	
380–415	400–440	AC 400 V	●
415–440	460–480	AC 440 V	
500	500–550	AC 500 V	

For detailed description of the types please see page 89.

DC rated voltage (for SRD-N)

	Ordering designation	Standard
24	AC 24 V	●
48	AC 48 V	
100	AC 100 V	
110	AC 120 V	
120–125	AC 127 V	
200	AC 200 V	
220	AC 220 V	

For detailed description of the types please see page 89.

■ Mounting

Mounting attitude of contactors and contactor relays

The construction and characteristics of contactors and contactor relays require that they be installed at the correct attitude. This attitude should not be changed, as the operating characteristics will be affected.

To assure proper performance, MITSUBISHI contactors and contactor relays should be mounted on a vertical supporting surface with the line terminals upwards and the load terminals downwards. The supporting surface may have a maximum inclination of 30° from the vertical in any direction.

Instruction in detail also for horizontal installation on request.

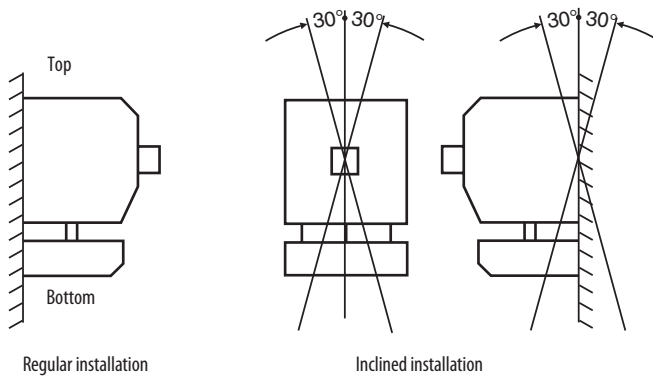

Minimal gaps for installation of contactor and contactor relays

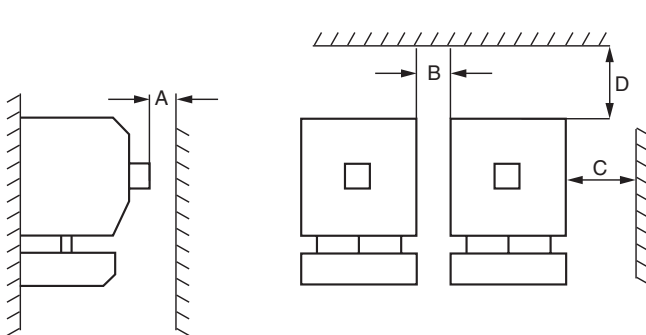

Frame size	A	B	C	D
S-N10CX	5	5	10	15
S-N11CX, S-N12CX	5	5	10	15
S-N18CX	5	5	10	15
S-N20CX, S-N21CX	5	5	10	15
S-N25CX, S-N35CX	5	5	10	15
S-N50CX, S-N65CX	5	10	10	25
S-N80, S-N95	10	10	16	25
S-N125	10	12	16	25
S-N150	10	12	16	30
S-N180, S-N220	10	12	16	50
S-N300, S-N400	10	12	16	90
S-N600, S-N800	10	15	20	90

All dimensions in mm

Auxiliary contact blocks

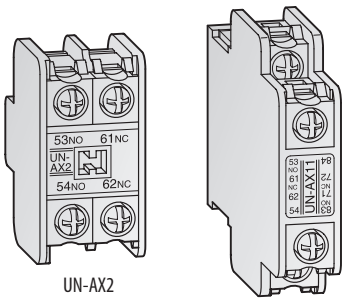

UN-AX2

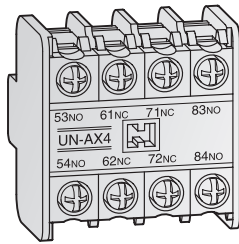

UN-AX4

UN-AX11

Application

All contactors can be extended by additional contacts which are available as a compact module.

The auxiliary contacts are simple and safe to extend by means of front or side clips.

When ordering please check that the auxiliary contact fits for your magnetic contactor.

Type of auxiliary contact	Symbol	Code
Normally open	NO =	A
Normally closed	NC =	B

Auxiliary contact blocks for S-N10CX to S-N65CX, SR-N4CX, SRD-N4CX

Specifications	UN-AX2CX 2A	UN-AX2CX 1A1B	UN-AX2CX 2B	UN-AX4CX 4A	UN-AX4CX 2A2B	UN-AX4CX 3A1B	UN-AX11CX	UN-LL22CX	
Contactors, Contactor relays	S-N10CX, S-N11CX, S-N12CX, S-N18CX, S-N20CX, S-N21CX, S-N25CX, S-N35CX, S-N50CX, S-N65CX, SD-N11CX, SD-N12CX, SD-N21CX, SD-N35CX, SD-N50CX, SD-N65CX, SR-N4CX, SRD-N4CX	S-N10CX, S-N11CX, S-N12CX, S-N18CX, S-N20CX, S-N21CX, S-N25CX, S-N35CX, S-N50CX, S-N65CX, SD-N11CX, SD-N12CX, SD-N21CX, SD-N35CX, SD-N50CX, SD-N65CX, SR-N4CX, SRD-N4CX	S-N10CX, S-N11CX, S-N12CX, S-N18CX, S-N20CX, S-N21CX, S-N25CX, S-N35CX, S-N50CX, S-N65CX, SD-N11CX, SD-N12CX, SD-N21CX, SD-N35CX, SD-N50CX, SD-N65CX, SR-N4CX, SRD-N4CX	S-N10CX, S-N11CX, S-N12CX, S-N18CX, S-N20CX, S-N21CX, S-N25CX, S-N35CX, S-N50CX, S-N65CX, SD-N11CX, SD-N12CX, SD-N21CX, SD-N35CX, SD-N50CX, SD-N65CX, SR-N4CX, SRD-N4CX	S-N10CX, S-N11CX, S-N12CX, S-N18CX, S-N20CX, S-N21CX, S-N25CX, S-N35CX, S-N50CX, S-N65CX, SD-N11CX, SD-N12CX, SD-N21CX, SD-N35CX, SD-N50CX, SD-N65CX, SR-N4CX, SRD-N4CX	S-N10CX, S-N11CX, S-N12CX, S-N18CX, S-N20CX, S-N21CX, S-N25CX, S-N35CX, S-N50CX, S-N65CX, SD-N11CX, SD-N12CX, SD-N21CX, SD-N35CX, SD-N50CX, SD-N65CX, SR-N4CX, SRD-N4CX	S-N10CX, S-N11CX, S-N12CX, S-N18CX, S-N20CX, S-N21CX, S-N25CX, S-N35CX, S-N50CX, S-N65CX, SD-N11CX, SD-N12CX, SD-N21CX, SD-N35CX, SD-N50CX, SD-N65CX, SR-N4CX, SRD-N4CX	S-N10CX, S-N11CX, S-N12CX, S-N18CX, S-N20CX, S-N21CX, S-N25CX, S-N35CX, S-N50CX, S-N65CX, SD-N11CX, SD-N12CX, SD-N21CX, SD-N35CX, SD-N50CX, SD-N65CX, SR-N4CX, SRD-N4CX	S-N10CX, S-N11CX, S-N12CX, S-N18CX, S-N20CX, S-N21CX, S-N25CX, S-N35CX, S-N50CX, S-N65CX, SD-N11CX, SD-N12CX, SD-N21CX, SD-N35CX, SD-N50CX, SD-N65CX, SR-N4CX, SRD-N4CX
Remarks	Low level signal (DC 5 V; 5 mA)								
Contact arrangement	2 NO	1 NO+ 1 NC	2 NC	4 NO	2 NO+ 2 NC	3 NO+1 NC	1 NO+ 1 NC	1 NO+ 1 NC	
Clip-on type	Front ^{②③}	Front ^{②③}	Front ^{②③}	Front ^{②③}	Front ^{②③}	Front ^{②③}	Seite ^{②④}	Front ^{②③}	
Rated cont. curr. I _{th}	A 16	16	16	16	16	16	16	1	
Rated insulation voltage	V 690	690	690	690	690	690	690	250	
Category AC-15 (coil load)	AC 110 V A 6	6	6	6	6	6	6	AC 240 V; 20 mA;	
	AC 230 V A 5	5	5	5	5	5	5	(cos φ ≥ 0.95);	
	AC 440 V A 3	3	3	3	3	3	3	DC 48 V;	
Category DC-13 (large coil load)	DC 48 V A 3	3	3	3	3	3	3	100 mA;	
	DC 110 V A 0.8	0.8	0.8	0.8	0.8	0.8	0.8	(L/R ≤ 1 ms);	
	DC 220 V A 0.2	0.2	0.2	0.2	0.2	0.2	0.2	Min. oper. curr. DC 5 V; 5 mA	
Mechanical life	oper. 10 mill.	10 mill.	10 mill.	10 mill.	10 mill.	10 mill.	10 mill.	2.5 mill.	
Electrical life	oper. 0.5 mill.	0.5 mill.	0.5 mill.	0.5 mill.	0.5 mill.	0.5 mill.	0.5 mill.	0.5 mill.	
Switching frequency	opr./hour For all types: 1.800								
Perm. amb. temperature	°C For all types: -25 to +55								
Perm. amb. humidity	RH For all types: 45 % to 85 %								
Conductor size	mm ² For all types: 1.0 to 2.5								
Order information	Art. no.	52625	52626	52627	52628	52629	52630	52631	52632

- ① Contact reliability may be decreased if it is operated more than 1 million operations.
- ② Front clip-on and side clip-on should not be mounted both.
- ③ Maximum 1 piece of auxiliary contact block can be mounted on a Contactor/Relay.
- ④ Maximum 2 pieces of auxiliary contact blocks can be mounted on a Contactor/Relay.

Auxiliary contact blocks

Auxiliary contact blocks for S-N80 to S-N800

Specifications	UN-AX80	UN-AX150	UN-AX600
Contactors	S-N80, S-N95, S-N125, SD-N80, SD-N95, SD-N125	S-N150, S-N180, S-N220, S-N300, S-N400, SD-N150, SD-N180, SD-N220, SD-N300, SD-N400	S-N600, S-N800, SD-N600, SD-N800
Contact arrangement	1 NO + 1 NC	1 NO + 1 NC	2 NO + 2 NC
Clip-on type	Side	Side	Side
Rated cont. curr. I_{th}	A 16	16	16
Rated insulation voltage	V 690	690	690
Category AC-15 (Coil load)	AC 110 V A 6	6	6
	AC 230 V A 5	5	5
	AC 440 V A 3	3	3
Category DC-13 (large coil load)	DC 48 V A 3	3	3
	DC 110 V A 0.8	0.8	0.8
	DC 220 V A 0.2	0.2	0.2
Mechanical life	oper. 10 mill.	10 mill.	10 mill.
Electrical life	oper. 0.5 mill.	0.5 mill.	0.5 mill.
Switching frequency	opr./hour For all types: 1,800		
Perm. amb. temperature	°C For all types: -25 to +55		
Perm. amb. humidity	RH For all types: 45 % to 85 %		
Conductor size	mm ² For all types: 1.0 to 2.5		
Order information	Art. no. 113691	113702	113703

Maximum 2 pieces of auxiliary contact blocks can be mounted on a Contactor/Relay.

Mechanical interlocks

UN-ML11CX

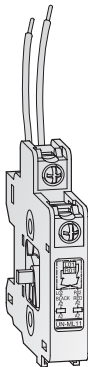

Application

Two contactors are safely and simply secured against one another through mechanical interlocking.

The mechanical interlocks are simple and safe to mount by means of side clips.

On UN-ML11CX the relevant interlock status can also be obtained through an electric query.

Specifications	UN-ML11CX	UN-ML21	UN-ML80	UN-ML150	UN-ML220
Contactors	S-N10CX, S-N11CX, SD-N11CX	S-N18CX, S-N20CX, S-N21CX, S-N25CX, S-N35CX, SD-N21CX, SD-N35CX, S-N50CX, S-N65CX, SD-N50, SD-N65	S-N80, S-N95, S-N125, SD-N80, SD-N95, SD-N125	S-N150, SD-N150	S-N180, S-N220, S-N300, S-N400, SD-N220, SD-N300, SD-N400
Order information	Art. no. 52633	52634	124294	125991	124293

DC interface modules

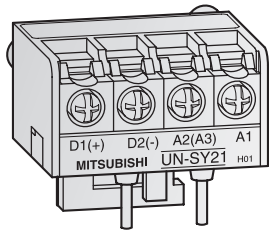

Application

Despite the low current requirements of our contactors and contactor relays, a number of PLC types with transistor outlets only allow direct control via the DC interface module.

In accordance to the used contactor it can be mounted directly on the contactor or on a separate location.

Specifications	UN-SY21CX	UN-SY22CX	UN-SY31	UN-SY32	UN-SY11	UN-SY12
Contactors	S-N10CX, S-N11CX, S-N12CX, S-N18CX, S-N20CX, S-N21CX, S-N25CX, S-N35CX, SR-N4CX	S-N10CX, S-N11CX, S-N12CX, S-N18CX, S-N20CX, S-N21CX, S-N25CX, S-N35CX, SR-N4CX	S-N50CX, S-N65CX	S-N50CX, S-N65CX	S-N80, S-N95, S-N125, S-N150, S-N180, S-N220, S-N300, S-N400	S-N80, S-N95, S-N125, S-N150, S-N180, S-N220, S-N300, S-N400
Output	Solid state	Relay	Solid state	Relay	Solid state	Relay
Mounting to contactor	Direct	Direct	Direct	Direct	Separate	Separate
Order information	Art. no. 52635	52636	on request	on request	on request	on request

Pneumatic time delay module

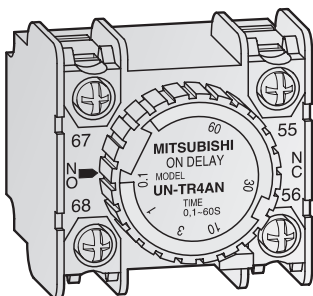

Application

The pneumatic time delay modules are designed for attachment for the front clip on to the series S-N-contactors and SR-N contactor relays.

Specifications	UN-TR4ANCX
Adjustable delay time range	s 0.1 to 60
Rated cont. curr. I _{th}	10
Rated oper. current	AC 110 V A 5
Category	AC 230 V A 3
AC-15	AC 440 V A 1
Rated oper. current	AC 110 V A 6
Category	AC 230 V A 4
AC-12	AC 440 V A 1.5
Rated operating current	DC 24 V A 1
Category	DC 48 V A 0.5
DC-13	DC 110 V A 0.3
	DC 220 V A 0.15
Rated operating current	DC 24 V A 2
Category	DC 48 V A 1
DC-12	DC 110 V A 0.6
	DC 220 V A 0.3
Rated insulation voltage	VAC 660
Mechanical life / electrical life	1 million operations / 1 million operations
Repeat accuracy	% ±10
Min. pause time	ms 500
Permissible ambient temperature	-5 °C to +55 °C
Conductor size	1.0 to 2.5
Contactors	AC-operated S-N10CX, S-N11CX, S-N18CX, SR-N4CX
	DC-operated SD-N11CX, SRD-N4CX
Type of delay	ON delay
Weight	kg 0.06
Dimensions (WxHxD)	mm 45 x 42 x 45
Order information	Art. no. 54160

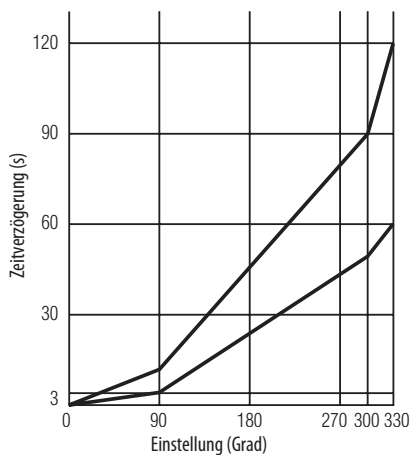

Surge absorbers

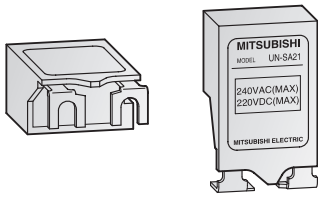

Application

Surge absorbers serve the purpose of avoiding current surges when coils are switched off.

They can be mounted safely and easily behind the terminal strips.

Contactors and relays with built-in surge absorbers, varistor-type are available on your request.

For S-N50 up to S-N800 the surge absorber are implemented as standard (refer to p 72).

Specifications	UN-SA21 AC□□□V	UN-SA22 AC□□□V	UN-SA23 AC□□□V	UN-SA25 AC□□□V	UN-SA13 DC□□□V	UN-SA721 AC□□□V	UN-SA722 AC□□□V	UN-SA725 AC□□□V	UN-SA713 DC□□□V	
Contactors	S-N10CX, S-N11CX, S-N12CX, S-N18CX, S-N20CX, S-N21CX, S-N25CX, S-N35CX, SD-N11CX, SD-N12CX, SD-N21CX, SD-N35CX, SR-N4CX, SRD-N4CX	S-N10CX, S-N11CX, S-N12CX, S-N18CX, S-N20CX, S-N21CX, S-N25CX, S-N35CX, SD-N11CX, SD-N12CX, SD-N21CX, SD-N35CX, SR-N4CX, SRD-N4CX	S-N10CX, S-N11CX, S-N12CX, S-N18CX, S-N20CX, S-N21CX, S-N25CX, S-N35CX, SR-N4CX	S-N10CX, S-N11CX, S-N18CX, S-N20CX, S-N21CX, S-N25CX, S-N35CX, SD-N11CX, SD-N12CX, SD-N21CX, SD-N35CX, SRD-N4CX	S-N10CX, S-N11CX, S-N18CX, S-N20CX, S-N21CX, S-N25CX, S-N35CX, SD-N11CX, SD-N12CX, SD-N21CX, SD-N35CX, SRD-N4CX	SD-N10CX, SD-N12CX, SD-N21CX, SD-N35CX, SRD-N4CX	SD-N50, SD-N65	SD-N50, SD-N65	SD-N50, SD-N65	SD-N50, SD-N65
Voltage range	for AC(2 0 0)V AC 24–240 V, DC 24–220 V	for AC(2 0 0)V AC 50–240 V, DC 60–220 V	for AC(2 0 0)V AC 24–240 V	for AC(0 4 8)V AC 24–50 V, DC 24–60 V	for DC(2 0 0)V DC 24–220 V	for AC(0 4 8)V DC 24–60 V	for AC(1 0 0)V DC 24–125 V	for AC(0 4 8)V DC 24–60 V	for AC(0 4 8)V DC 24–60 V	for DC(2 0 0)V DC 24–220 V
Varistor	●	—	—	—	—	●	—	—	—	
Varistor with operating indicator (LED)	—	●	—	—	—	—	●	—	—	
Varistor and CR	—	—	—	●	—	—	—	●	—	
CR	—	—	●	—	●	—	—	—	●	
Order information	Art. no.									
	AC(0 4 8)V	—	—	on request	—	on request	—	on request	—	
	AC(1 0 0)V	—	—	—	—	on request	on request	on request	—	
	AC(2 0 0)V	52605	on request	56152	70340	—	on request	on request	—	
	AC(4 0 0)V	52606	—	—	—	—	—	—	—	
DC(2 0 0)V	—	—	—	—	65340	—	—	—	on request	

Note:
For other voltage ranges please contact MITSUBISHI ELECTRIC.

Terminal covers

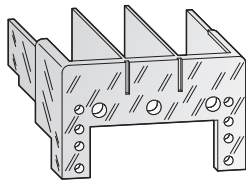

Application

The terminal covers warrant protection against contacts being accidentally touched.

These covers are to retrofit contactors which do not have a terminal cover (like types without “CX” designation).

Specifications	UN-CZ500 ^①	UN-CZ800 ^①	UN-CZ1250 ^①	UN-CZ1500 ^①	UN-CZ2200 ^①	UN-CZ3000 ^①
Contactors	SD-N50/N65	S-N80/N95, SD-N80/N95	S-N125, SD-N125	S-N150, SD-N150	S-N180/N220, SD-N220	S-N300/N400, SD-N300/N400
Order information	Art. no. 127116	113704	113705	113706	113707	113708

^① 2 pcs. are required for one contactor .

Specifications	UN-CZ501 ^②	UN-CZ801 ^②	UN-CZ1251 ^②	UN-CZ1501 ^②	UN-CZ2201 ^②	UN-CZ3001 ^②
Contactors and Thermal Overheat Relay	SD-N50/N65, TH-N	SD-N80/N95, TH-N	SD-N125, TH-N	SD-N150, TH-N	SD-N180/N220, TH-N	SD-N300/N400, TH-N
Order information	Art. no. 127117	125994	125995	125996	125997	125998

^② This part is only for the load side (1 piece). For the line side one UN-CZ□□0 is required.

Replacement coils

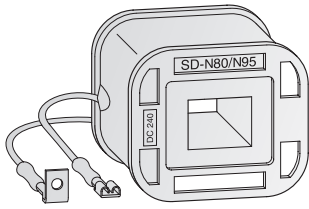

Application

If, for technical or logistic reasons, a coil needs to be replaced, then this can be done fast and safely, as it involves very simple operations.

When ordering please check for the right voltage classification.

Changing procedure is done for

- S-N10 to S-N95, SD-N11 to SD-N95, SR-N4 and SRD-N4 by loosening a number of screws
- S-N125 to S-N800, SD-N125 to SD-N800 by replacing the coil cartridge.

AC-operated coils

Specifications	S-N11-COIL AC□□□V	S-N21-COIL AC□□□V	S-N35-COIL AC□□□V	S-N50-COIL AC□□□V	S-N80-COIL AC□□□V	S-N125-COIL AC□□□V	S-N180-COIL AC□□□V	S-N300-COIL AC□□□V	S-N600-COIL AC□□□V	
Contactors	S-N10CX, S-N11CX, S-N12CX, S-N18CX, SR-N4CX	S-N20CX, S-N21CX	S-N25CX, S-N35CX	S-N50CX, S-N65CX	S-N80, S-N95	S-N125, S-N150	S-N180, S-N220	S-N300, S-N400	S-N600, S-N800	
Weight	kg	0.06	0.08	0.08	0.27	0.6	0.46	0.6	0.9	2.0
Order information	Art. no.									
	AC214V	56756	56719	59376	125881	125888	125895	—	—	—
	AC48V	56757	56720	59377	125885	125892	125899	—	—	—
	AC1100V	56758	56721	59378	125878	125886	125893	125900	125915	125920
	AC120V	56759	56722	59380	—	—	—	—	—	—
	AC127V	56760	56724	59381	—	—	—	—	—	—
	AC200V	56679	56725	59382	125880	125887	125894	125901	125916	125921
	AC220V	56680	56726	59383	—	—	—	—	—	—
	AC230V	56713	56727	59384	—	—	—	—	—	—
	AC260V	56714	56728	59385	—	—	—	—	—	—
	AC300V	on request	on request	on request	125882	125889	125896	125912	125917	125922
	AC380V	56715	56729	59386	—	—	—	—	—	—
	AC400V	56716	56730	59387	125883	125890	125897	125913	125918	125923
AC440V	56717	56731	59388	—	—	—	—	—	—	
AC500V	56718	56732	59389	125884	125891	125898	125914	125919	125924	

For information about the voltage range refer to page 80.

Note:

For other voltage ranges please contact MITSUBISHI ELECTRIC.

DC-operated coils

Specifications	SD-N11-COIL DC□□□V	SD-N21-COIL DC□□□V	SD-N35-COIL DC□□□V	SD-N50-COIL DC□□□V	SD-N80-COIL DC□□□V	SD-N125-COIL DC□□□V	SD-N220-COIL DC□□□V	SD-N300-COIL DC□□□V	SD-N600-COIL DC□□□V	
Contactors	SD-N11CX, SD-N12CX, SRD-N4CX	SD-N21CX	SD-N35CX	SD-N50, SD-N65	SD-N80, SD-N95	SD-N125, SD-N150	SD-N220	SD-N300, SD-N400	SD-N600, SD-N800	
Weight	kg	0.23	0.24	0.23	0.8	0.6	0.9	1.4	2.0	6.0
Order information	Art. no.									
	DC12V	56733	56741	61984	—	—	—	—	—	—
	DC24V	56734	56742	61985	125930	125937	125945	125952	125959	125966
	DC48V	56735	56743	61986	125931	125938	125946	125953	125960	125967
	DC1100V	56736	56744	61987	125925	125932	125939	125947	125954	125961
	DC1110V	56737	56746	61988	125926	125933	125940	125948	125955	125962
	DC125V	56738	56749	61989	125927	125934	125941	125949	125956	125963
	DC200V	56739	56751	61990	125928	125935	125943	125950	125957	125964
DC220V	56740	56753	61991	125929	125936	125944	125951	125958	125965	

Replacement contact kits

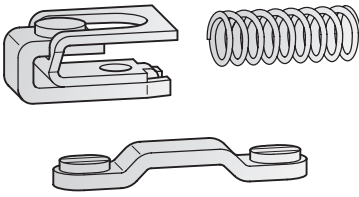

Application

If used correctly, the contact kit does not need replacing during the lifetime stated in the documentation. However, should this still be required, then it can be done fast and without any problems, as it involves no more than a few simple operations.

The kits consist of 3 moving contacts and 6 stationary contacts.

Main contact kit

Specifications	BH-719N300	BH-729N300	BH-739N300	BH-749N300	BH-749N301	BH-749N303	BH-759N300	BH-759N302	BH-759N301	BH-759N303	BH-769N300	
Contactors	S-N10CX, S-N11CX, S-N12CX, SD-N11CX, SD-N12CX	S-N18CX	S-N20CX, S-N21CX, SD-N21CX	S-N25CX	S-N35CX	SD-N35CX	S-N50CX	SD-N50	S-N65CX	SD-N65	S-N80	
Weight	kg	0.03	0.05	0.05	0.07	0.07	0.07	0.11	0.11	0.11	0.1	
Order information	Art. no.	56754	59390	56755	59391	59392	62053	125971	125973	125975	125976	125977

Specifications	BH-769N301	BH-769N303	BH-779N300	BH-779N301	BH-789N300	BH-799N300	BH-799N301	BH-609N300	BH-609N301	BH-619N300	BH-619N301	
Contactors	S-N95	SD-N95	S-N125	SD-N125	S-N150, SD-N150	S-N180	S-N220, SD-N220	S-N300, SD-N300	S-N400, SD-N400	S-N600, SD-N600	S-N800, SD-N800	
Weight	kg	0.1	0.1	0.1	0.1	0.2	0.4	0.4	0.8	0.8	2.5	2.5
Order information	Art. no.	125979	125980	125981	125982	125983	125984	125985	125986	125987	125988	125989

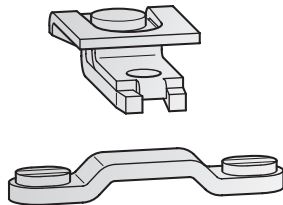

Application

If used correctly, the bifurcated moving contact warrants a maximum of contact safety and the longest possible lifetime.

Nevertheless, auxiliary contacts can be replaced safely and without any problems.

Auxiliary contact kit

Specifications	BH719N310	BH719N311	BH729N310	BH739N310	BH739N311	BH539N315	BH579N312	UN-AX150	UN-AX600
Contactors	S-N10CX, S-N11CX, SD-N11CX	S-N10CX, S-N11CX, SD-N11CX	S-N12CX, SD-N12CX	S-N20CX	S-N21CX, S-N25CX, S-N35CX, SD-N21CX, SD-N35CX	S-N50CX to S-N95, SD-N50 to SD-N95	S-N125, SD-N125	S-N150 to S-N400, SD-N150 to SD-N400	S-N600, S-N800, SD-N600, SD-N800
Kit contents									
Bifurcated moving contacts	1	1	2	2	4	4	4	—	—
Stationary contacts	2	2	4	4	8	8	8	—	—
Contact block	—	—	—	—	—	—	—	1	1
Contact arrangement	1 NO	1 NC	1 NO, 1 NC	1 NO, 1 NC	2 NO, 2 NC	2 NO, 2 NC	2 NO + 2 NC	1 NO + 1 NC	2 NO + 2 NC
Weight	kg	0.01	0.01	0.02	0.02	0.03	0.02	0.04	0.1
Order information	Art. no.	on request	on request	on request	on request	on request	on request	113702	113703

■ Connecting parts for contactors to thermal overload relays

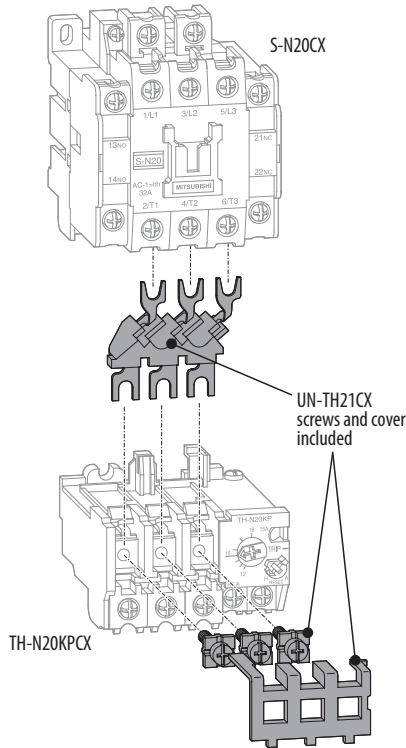

Application

For connection between the contactor and the thermal overload relay.

Connecting bars and mounting plate are included in the OLR of TH-N220RHKP and TH-N400RHKP for S-N180, S-N220, SD-N220, S-N300, SD-N300, S-N400, SD-N400.

Contactor and relay mounted with connecting bar kit

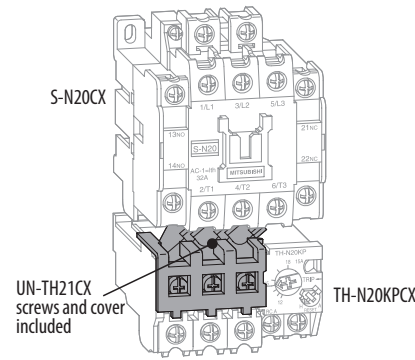

Connecting bar kit

Specifications	UN-TH21CX	UN-TH25CX	BH559N350	BH569N350	BH569N352	BH579N355	BH589N355
Contactors	S-N20CX, S-N21CX, SD-N21CX	S-N25CX, S-N35CX, SD-N25CX, SD-N35CX	S-N50CX, SD-N50, S-N65CX, SD-N65	S-N80, S-N95	SD-N80, SD-N95	S-N125, SD-N125	S-N150, SD-N150
Thermal overload relay	TH-N20KPCX	TH-N20KPCX, TH-N20TAKPCX	TH-N60KPCX	TH-N60KPCX, TH-N60TAKP	TH-N60KPCX, TH-N60TAKP	TH-N120KP, TH-N120TAKP	TH-N120KP, TH-N120TAKP
Weight	kg 0.02	0.02	0.02	0.04	0.04	0.36	0.36
Order information	Art. no. 141108	63695	126000	126001	126002	126003	126004

■ Separate mounting adapter

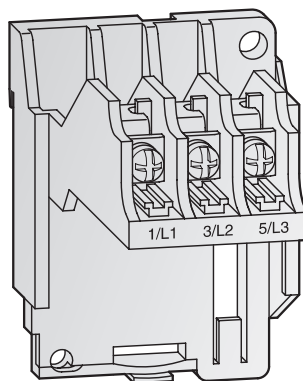

UN-HZ12CX

Application

For the stand-alone application the thermal overload relay TH-N12KPCX must be use with the separate mounting adapter UN-HZ12CX.

Specifications	UN-HZ12CX
Thermal overload relays	TH-N12KPCX
Order information	Art. Nr. 52673

■ Trip indicator

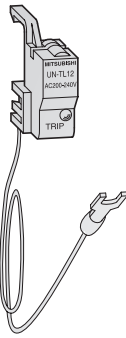

Application

An LED lights up to help you find and identify a thermal overload relay that has been actuated.

The trip indicator consist of a cable (length approx. 100 mm) and an indication module which can be mounted separate from the conductor.

Specifications	UN-TL15 DC 24 V	UN-TL15 AC 100 V	UN-TL15 AC 200 V	UN-TL20 DC 24 V	UN-TL20 AC 100 V	UN-TL20 AC 200 V	UN-TL60 DC 24 V	UN-TL60 AC 100 V	UN-TL60 AC 200 V
Thermal overload relay	TH-N12KPCX, TH-N18KPCX	TH-N12KPCX, TH-N18KPCX	TH-N12KPCX, TH-N18KPCX	TH-N20KPCX, TH-N20TAKPCX	TH-N20KPCX, TH-N20TAKPCX	TH-N20KPCX, TH-N20TAKPCX	TH-N60KP to TH-N600KP	TH-N60KP to TH-N600KP	TH-N60KP to TH-N600KP
Voltage	V AC 24 / DC 24	AC 100–127	AC 200–240	AC 24 / DC 24	AC 100–127	AC 200–240	AC 24 / DC 24	AC 100–127	AC 200–240
Order information	Art. no.	on request	on request	on request	on request	on request	on request	on request	on request

■ Reset release

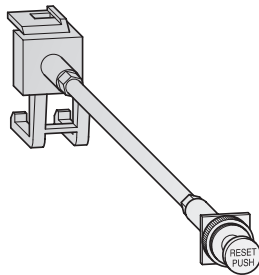

Application

The reset release allows you to reset the actuated thermal overload relay safely and without any problems while the cabinet door or drawout is shut.

It has to be mounted directly on the thermal overload relay.

Specifications	UN-RR205	UN-RR405	UN-RR555	UN-RR705	UN-RR200	UN-RR400
Thermal overload relay	TH-N12KPCX, TH-N18KPCX	TH-N12KPCX, TH-N18KPCX	TH-N12KPCX, TH-N18KPCX	TH-N12KPCX, TH-N18KPCX	TH-N20KPCX, TH-N20TAKPCX	TH-N20KPCX, TH-N20TAKPCX
Length	mm 200	400	550	700	200	400
Order information	Art. no.	52675	52676	52677	52678	52679

Specifications	UN-RR550	UN-RR700	UN-RR206	UA-RR400	UN-RR556	UN-RR706
Thermal overload relay	TH-N20KPCX, TH-N20TAKPCX	TH-N20KPCX, TH-N20TAKPCX	TH-N60KP to TH-N600KP	TH-N60KP to TH-N600KP	TH-N60KP to TH-N600KP	TH-N60KP to TH-N600KP
Length	mm 550	700	200	400	550	700
Order information	Art.no.	52681	52682	on request	on request	on request

Accessories for Air circuit breakers	10	Air circuit breakers	
Auxiliary switches AX, HAX	13	Refer to Section I	
Cell switch CL	14	Auxiliary contact blocks	92
Closing coil CC	12	Calculation and Selection Software	35
Counter CNT	13	Characteriscs	
Current transformer CT	18	Overcurrent relays	86
Door frame DF	17	Configuration table (ETR)	30
Door interlock DI	16	Connection arrangements	
Dust cover DUC	17	Air circuit breakers	8
Electronic Trip Relay	20	Contactors and Relays	
Field test device Y-2000	19	Refer to Section III	
Front terminal adapter FTA	15	Disconnectors	
Interlock device CYL	14	Refer to Circuit breakers	
Internal power supply units PW	19	Electronic trip relay	
Interphase barriers	19	Configuration overview	23
Mechanical interlock MI	16	Configuration table	30
Mis-insertion preventor MIP	15	CT rating table	23
Motor charging device MD	11	Extension module EX1	28
Neutral current transformer NCT	18	Interface units BIF	29
Push button cover BC-L	17	Introduction	20
Safety shutters SST	14	Optional setting modules	26
Shorting b-contact SBC	15	Power supply modules	22
Shunt trip device SHT	13	Setting examples	24
Terminal cover TTC	17	Standard and Special Functions	21
Test jumper TJ	19	Introduction and Description	
Trip Coil AL	11	Air Circuit Breakers	4
Undervoltage trip device UVT	12	Auxiliary contact blocks	92
Vertical terminal adapter VTA	15	Contactor relays	88
Accessories for Moulded-case circuit breakers		Moulded-case circuit breakers	32
Alarm switch AL	54	Thermal overload relays	82
Auxiliary switch AX	54	MELSHORT2	35
Connection of the Control Wires	53	Moulded-case circuit breakers	
Electrically Operated Breakers	66	Refer to Section II	
Handle lock devices	65	Order information	
IEC 35 mm rail mounting adapter	69	Air circuit breakers	9
Isolation Barriers	69	Contactors	84
Mechanical Interlock MI	69	Moulded-Case Circuit Breakers	50
Modular cassette type accessories	52	Product overviews	
Operating Handles V- and R-type	64	Accessories for Air circuit breakers	10
Overview	36	Accessories for contactor relays	73
Plug-in sets PM	63	Accessories for Moulded-case circuit breakers	36
Rear studs ST	63	Air circuit breakers	4
Shunt Trip Device SHT	56	Contactor relays	74
Solderless terminals SL	63	Moulded-case circuit breakers	32
Terminal Covers	68	Specifications	
Tester for Electronic Breakers Y-250	70	Air circuit breakers	6
Undervoltage Tripping Device UVT	58	Auxiliary contact blocks	92
Accessories für contactors		Contactors	76
Auxiliary contact blocks	92	Moulded-case circuit breakers	38
Connecting parts	98	Thermal overload relays	83
Contactor relay	88	Thermal overload relays	
DC interface modules	94	Refer to Section III	
Mechanical interlocks	93		
Pneumatic time delay module	94		
Replacement coils	96		
Replacement contact kits	97		
Reset release	99		
Separate mounting adapter	98		
Surge absorbers	95		
Terminal covers	95		
Trip indicator	99		

A world of automation solutions

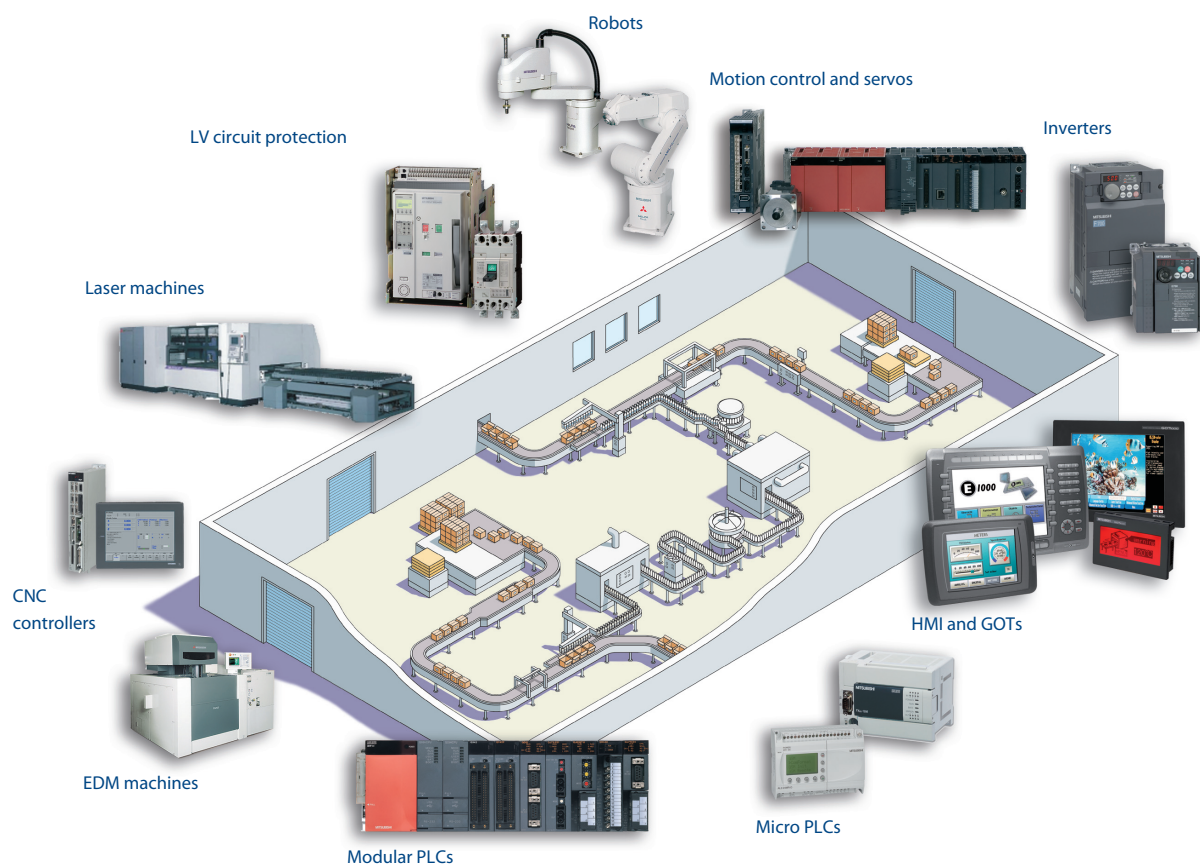

Mitsubishi offer a wide range of automation equipment from PLCs and HMIs to CNC and EDM machines

A name to trust

Since its beginnings in 1870, some 45 companies use the Mitsubishi name, covering a spectrum of finance, commerce and industry.

The Mitsubishi brand name is recognized around the world as a symbol of premium quality.

Mitsubishi Electric Corporation represents space development, transportation, semiconductors, energy systems, communications and information processing, audio visual equipment, home electronics, building and energy management and automation systems, and has 237 factories and laboratories worldwide in over 121 countries.

This is why you can rely on a Mitsubishi automation solution – because we know first hand about the need for reliable, efficient, easy-to-use automation and control.

As one of the world's leading companies with a global turnover of 3.4 trillion Yen (approximately \$30.8 billion), employing over 100 000 people, Mitsubishi Electric has the resource and the commitment to deliver the ultimate in service and support as well as the best products.

Global Partner. Local Friend.

EUROPEAN BRANCHES

MITSUBISHI ELECTRIC EUROPE B.V. Radlická 714/113a CZ-158 00 Praha 5 Phone: +420 (0)251 551 470	CZECH REPUBLIC
MITSUBISHI ELECTRIC EUROPE B.V. 25, Boulevard des Bouvets F-92741 Nanterre Cedex Phone: +33 (0)1 / 55 68 55 68	FRANCE
MITSUBISHI ELECTRIC EUROPE B.V. Gothaer Straße 8 D-40880 Ratingen Phone: +49 (0)2102 / 486-0	GERMANY
MITSUBISHI ELECTRIC EUROPE B.V. Westgate Business Park, Ballymount IRL-Dublin 24 Phone: +353 (0)1 4198800	IRELAND
MITSUBISHI ELECTRIC EUROPE B.V. Viale Colleoni 7 I-20041 Agrate Brianza (MI) Phone: +39 039 / 60 53 1	ITALY
MITSUBISHI ELECTRIC EUROPE B.V. Carretera de Rubí 76-80 E-08190 Sant Cugat del Vallés (Barcelona) Phone: 902 131121 // +34 935653131	SPAIN
MITSUBISHI ELECTRIC EUROPE B.V. Travellers Lane UK-Hatfield, Herts. AL10 8XB Phone: +44 (0)1707 / 27 61 00	UK

EUROPEAN REPRESENTATIVES

TEHNIKON Oktyabrskaya 16/5, Off. 703-711 BY-220030 Minsk Phone: +375 (0)17 / 210 46 26	BELARUS	ANTONIOS DREPANIAS S.A. 52, Arkadias Str. GR-12132 Peristeri, Athens Phone: +30 210 / 578 1599	GREECE	INTEHSIS SRL bld. Traian 23/1 MD-2060 Kishinev Phone: +373 (0)22 / 66 4242	MOLDOVA	CONSYS Promyshlennaya st. 42 RU-190099 St. Petersburg Phone: +7 812 / 325 36 53	RUSSIA	Euro Energy Components AB Järnvägsgränd 36 SE-434 24 Kungsbacka Phone: +46 (0)300 / 69 00 40	SWEDEN	GINO Industries Ltd. 26, Ophir street IL-32235 Haifa Phone: +972 (0)4 / 867 06 56	ISRAEL
Koning & Hartman b.v. Woluwelaan 31 BE-1800 Vilvoorde Phone: +32 (0)2 / 257 02 40	BELGIUM	UTEKO A.B.E.E. 5, Mavrogenous Str. GR-18542 Piraeus Phone: +30 211 / 1206 900	GREECE	Imtech M & O B.V. Sluisjesdijk 155 NL-3087 AG Rotterdam Phone: +31 (0)10 / 487 19 11	NETHERLANDS	CRAFT Cons. & Engineer. d.o.o. Bulevar Svetog Cara Konstantina 80-86 SER-18106 Nis Phone: +381 (0)18 / 292-24-4/5	SERBIA	TRIELEC AG Mühlentalstr. 136 CH-8201 Schaffhausen Phone: +41 (0)52 / 632 102 0	SWITZERLAND	CBI Ltd. Private Bag 2016 ZA-1600 Isando Phone: +27 (0)11 / 928 2000	SOUTH AFRICA
INEA BH d.o.o. Aleja Lipa 56 BA-71000 Sarajevo Phone: +387 (0)33 / 921 164	BOSNIA AND HERZEG.	MELTRADE Ltd. Fertő utca 14. HU-1107 Budapest Phone: +36 (0)1 / 431-9726	HUNGARY	SCANELEC AS Leirvikasen 43B NO-5179 Godvik Phone: +47 (0)55 / 50 60 00	NORWAY	AutoCont Control s.r.o. Radlinského 47 SK-02601 Dolny Kubin Phone: +421 (0)43 / 5868210	SLOVAKIA	GTS Darulaceze Cad. No. 43 KAT. 2 TR-34384 Okmeydani-Istanbul Phone: +90 (0)212 / 320 1640	SWITZERLAND	TURKEY	
AutoCont CS s.r.o. Technologická 374/6 CZ-708 00 Ostrava-Pustkovec Phone: +420 595 691 150	CZECH REPUBLIC	KAZPROMAUTOM. Ltd. Mustafina Str. 7/2 KAZ-470046 Karaganda Phone: +7 7212 / 50 11 50	KAZAKHSTAN	MPL Technology Sp. z o.o. Ul. Krakowska 50 PL-32-083 Balice Phone: +48 (0)12 / 630 47 00	POLAND	CS MTrade Slovensko, s.r.o. Vajanskeho 58 SK-92101 Piestany Phone: +421 (0)33 / 7742 760	SLOVAKIA	CSC Automation Ltd. 4-B, M. Raskovoyi St. UA-02660 Kiev Phone: +380 (0)44 / 494 33 55	UKRAINE		
B:TECH A.S. U Borové 69 CZ-58001 Havířkuv Brod Phone: +420 (0)569 / 777 777	CZECH REPUBLIC	RIFAS UAB Tinklu g. 29A LT-5300 Panevezys Phone: +370 (0)45 / 582 728	LITHUANIA	Sirius Trad. & Serv. srl Aleea Lacul Morii Nr. 3 RO-060841 Bucuresti, Sector 6 Phone: +40 (0)21 / 430 40 06	ROMANIA	INEA d.o.o. Stegne 11 SI-1000 Ljubljana Phone: +386 (0)1 / 513 8100	SLOVENIA				



Mitsubishi Electric Europe B.V. /// FA - European Business Group /// Gothaer Straße 8 /// D-40880 Ratingen /// Germany
Tel.: +49(0)2102-4860 /// Fax: +49(0)2102-4861120 /// info@mitsubishi-automation.com /// www.mitsubishi-automation.com

Specifications subject to change /// Art. no. 216798-A /// 12.2008

All trademarks and copyrights acknowledged.