



DIGITAL LASER PRINTER

ML-2850 Series

ML-2850D / ML-2851ND

ML-2851ND/SEE

Basic Model : ML-2851ND

SERVICE *Manual*

DIGITAL LASER PRINTER



The keynote of Product

Smallest Duplex Built-in Mono Laser Printer (Low Noise)

- 28ppm(A4) / 30ppm(Ltr)
- PCL6, PS3, 1,200x1,200dpi
- 400MHz processor
- USB 2.0, N/W (ML-2851ND only)
- 32MB (Max.160MB : factory option)
- 2K Standard, 5K High Yield
- Paper Input: 250 sh CST + 1 sh MP
- Standard Duplex Printing
- Options: 250 sh SCF



GSPN (Global Service Partner Network)

North America : service.samsungportal.com

Latin America : latin.samsungportal.com

CIS : cis.samsungportal.com

Europe : europe.samsungportal.com

China : china.samsungportal.com

Asia : asia.samsungportal.com

Mideast & Africa : mea.samsungportal.com

© Samsung Electronics Co.,Ltd. Aug. 2007
Printed in Korea.

VERSION NO. : 1.00

CODE : 2851-D0SEE

Contents

1. Precautions

1.1 Safety Warning	1-1
1.2 Caution for safety	1-2
1.3 ESD Precautions	1-5

2. Product spec and feature

2.1 Product Specifications	2-1
2.1.1 Product Overview	2-1
2.1.2 Specifications	2-1
2.1.3 Model Comparison Table	2-7
2.2 Summary of Product	2-9
2.2.1 Printer Components	2-9
2.2.2 System Layout	2-12
2.2.3 Engine H/W Specifications	2-17
2.2.4 S/W Descriptions	2-27

3. Disassembly and Reassembly

3.1 General Precautions on Disassembly	3-1
3.2 Used Screw List	3-2
3.3 Cover Unit	3-3
3.3.1 CASSETTE & Front Cover	3-3
3.3.2 DUPLEX UNIT & COVER-TOP/COVER-REAR	3-4
3.3.3 Cover-Side-LEFT/RIGHT	3-5
3.4 Fuser Ass'y	3-6
3.5 LSU(Laser Scanning Unit)	3-7
3.6 Drive Ass'y	3-8
3.7 Main PBA/SMPS/HVPS	3-9
3.8 HOLDER-PAD Disassembly	3-10

Continued

3.9 Transfer Roller	3-11
-------------------------------	------

4. Alignment & Troubleshooting

4.1 Alignment and Adjustments	4-1
4.1.1 Sample Pattern	4-1
4.1.2 Control Panel	4-4
4.1.3 Consumables and Replacement Parts	4-7
4.1.4 LED Status Error Message	4-7
4.1.5 Abnormal Image Printing and Defective Roller	4-8
4.1.6 How to use DCU	4-9
4.1.7 Paper Jam	4-15
4.1.8 Download & Reset FW	4-20
4.2 Troubleshooting	4-21
4.2.1 Procedure of Checking the Symptoms	4-21
4.2.2 The cause and solution of Bad image	4-22
4.2.3 The cause and solution of the bad discharge	4-38
4.2.4 The cause and solution of the malfunction	4-46
4.2.5 Toner Cartridge Service	4-56
4.2.6 The cause and solutions of bad environment of the software	4-58

5. Exploded Views & Parts List

5.1 Main	5-2
5.2 Top Cover	5-4
5.3 Cover Ass'y	5-6
5.4 Front Cover	5-8
5.5 Rear Cover	5-10
5.6 Frame	5-12
5.7 Main Drive	5-17
5.8 Rear Guide	5-19

Continued

5.9 Fuser	5-21
5.10 Duplex Unit	5-23
5.11 Cassette	5-25
5.12 SCF	5-27

6. System Diagram

6.1 Block Diagram	6-1
6.2 Connection Diagram	6-2

7. Reference Information

7.1 Tool for Troubleshooting	7-1
7.2 Acronyms and Abbreviations	7-2
7.3 Select a location for the printer	7-4
7.4 Sample Tests Patterns	7-5
7.5 LAN (Optional Function)	7-6
7.6 Information of model's code	7-6
7.7 Parts Life Cycle Maintenance Table	7-7
7.7.1 Parts Life Cycle Maintenance Table	7-7
7.7.2 Toner Cartridge Criterion	7-7
7.8 Model Information	7-8
7.8.1 Understanding for Model Code	7-8
7.8.2 Understanding Material Code & Name	7-9

1. Precautions

In order to prevent accidents and to prevent damage to the equipment please read the precautions listed below carefully before servicing the printer and follow them closely.

1.1 Safety Warning

(1) Only to be serviced by appropriately qualified service engineers.

High voltages and lasers inside this product are dangerous. This printer should only be serviced by a suitably trained and qualified service engineer.

(2) Use only Samsung replacement parts

There are no user serviceable parts inside the printer. Do not make any unauthorized changes or additions to the printer, these could cause the printer to malfunction and create electric shock or fire hazards.

(3) Laser Safety Statement

The Printer is certified in the U.S. to conform to the requirements of DHHS 21 CFR, chapter 1 Subchapter J for Class 1(1) laser products, and elsewhere, it is certified as a Class I laser product conforming to the requirements of IEC 825. Class I laser products are not considered to be hazardous. The laser system and printer are designed so there is never any human access to laser radiation above a Class I level during normal operation, user maintenance, or prescribed service condition.

Warning >> Never operate or service the printer with the protective cover removed from Laser/Scanner assembly. The reflected beam, although invisible, can damage your eyes. When using this product, these basic safety pre-cautions should always be followed to reduce risk of fire, electric shock, and injury to persons.



CAUTION - INVISIBLE LASER RADIATION □
WHEN THIS COVER OPEN. □
DO NOT OPEN THIS COVER.

VORSICHT - UNSICHTBARE LASERSTRAHLUNG, □
WENN ABDECKUNG GEÖFFNET. □
NICHT DEM STRAHL AUSSETZEN.

ATTENTION - RAYONNEMENT LASER INVISIBLE EN CAS □
D'OUVERTURE. EXPOSITION DANGEREUSE □
AU FAISCEAU. □

ATTENZIONE - RADIAZIONE LASER INVISIBLE IN CASO DI □
APERTURA. EVITARE L'ESPOSIZIONE AL □
FASCIO.

PRECAUCION - RADIACION LASER IVISIBLE CUANDO SE ABRE. □
EVITAR EXPONERSE AL RAYO.

ADVARSEL - USYNLIG LASERSTRÅLNING VED ÅBNING, NÅR □
SIKKERHEDSBRYDERE ER UDE AF FUNKTION. □
UNNGÅ UDSAETTELSE FOR STRÅLNING.

ADVARSEL - USYNLIG LASERSTRÅLNING NÅR DEKSEL □
ÅPNES. STIRR IKKE INN I STRÅLEN. □
UNNGÅ EKSPONERING FOR STRÅLEN.

VARNING - OSYNLIG LASERSTRÅLNING NÅR DENNA DEL □
ÅR ÖPPNAD OCH SPÅRREN ÅR URKOPPLAD. □
BETRAKTA EJ STRÅLEN. STRÅLEN ÅR FARLIG.

VARO! - AVATTAESSA JA SUOJALUKITUS OHITETTAESSA □
OLET ALTTIINA NÄKYMÄTTÖMÄLLE LASER-□
SÄTEILYLLE ÄLÄ KATSO SÄTEESEEN.

注 意 - 严禁揭开此盖, 以免激光泄露灼伤

주 의 - 이 덮개를 열면 레이저광에 노출될 수 있으므로
주의하십시오.

1.2 Caution for safety

1.2.1 Toxic material

This product contains toxic materials that could cause illness if ingested.

- (1) If the LCD control panel is damaged it is possible for the liquid inside to leak. This liquid is toxic. Contact with the skin should be avoided, wash any splashes from eyes or skin immediately and contact your doctor. If the liquid gets into the mouth or is swallowed see a doctor immediately.
- (2) Please keep toner cartridges away from children. The toner powder contained in the toner cartridge may be harmful and if swallowed you should contact a doctor.

1.2.2 Electric Shock and Fire Safety Precautions

Failure to follow the following instructions could cause electric shock or potentially cause a fire.

- (1) Use only the correct voltage, failure to do so could damage the printer and potentially cause a fire or electric shock.
- (2) Use only the power cable supplied with the printer. Use of an incorrectly specified cable could cause the cable to overheat and potentially cause a fire.
- (3) Do not overload the power socket, this could lead to overheating of the cables inside the wall and could lead to a fire.
- (4) Do not allow water or other liquids to spill into the printer, this can cause electric shock. Do not allow paper clips, pins or other foreign objects to fall into the printer these could cause a short circuit leading to an electric shock or fire hazard..
- (5) Never touch the plugs on either end of the power cable with wet hands, this can cause electric shock. When servicing the printer remove the power plug from the wall socket.
- (6) Use caution when inserting or removing the power connector. The power connector must be inserted completely otherwise a poor contact could cause overheating possibly leading to a fire. When removing the power connector grip it firmly and pull.
- (7) Take care of the power cable. Do not allow it to become twisted, bent sharply round corners or other wise damaged. Do not place objects on top of the power cable. If the power cable is damaged it could overheat and cause a fire or exposed cables could cause an electric shock. Replace a damaged power cable immediately, do not reuse or repair the damaged cable. Some chemicals can attack the coating on the power cable, weakening the cover or exposing cables causing fire and shock risks.
- (8) Ensure that the power sockets and plugs are not cracked or broken in any way. Any such defects should be repaired immediately. Take care not to cut or damage the power cable or plugs when moving the machine.
- (9) Use caution during thunder or lightening storms. Samsung recommends that this machine be disconnected from the power source when such weather conditions are expected. Do not touch the machine or the power cord if it is still connected to the wall socket in these weather conditions.
- (10) Avoid damp or dusty areas, install the printer in a clean well ventilated location. Do not position the machine near a humidifier. Damp and dust build up inside the machine can lead to overheating and cause a fire.
- (11) Do not position the printer in direct sunlight. This will cause the temperature inside the printer to rise possibly leading to the printer failing to work properly and in extreme conditions could lead to a fire.
- (12) Do not insert any metal objects into the machine through the ventilator fan or other part of the casing, it could make contact with a high voltage conductor inside the machine and cause an electric shock.

1.2.3 Handling Precautions

The following instructions are for your own personal safety, to avoid injury and so as not to damage the printer

- (1) Ensure the printer is installed on a level surface, capable of supporting its weight. Failure to do so could cause the printer to tip or fall.
- (2) The printer contains many rollers, gears and fans. Take great care to ensure that you do not catch your fingers, hair or clothing in any of these rotating devices.
- (3) Do not place any small metal objects, containers of water, chemicals or other liquids close to the printer which if spilled could get into the machine and cause damage or a shock or fire hazard.
- (4) Do not install the machine in areas with high dust or moisture levels, beside an open window or close to a humidifier or heater. Damage could be caused to the printer in such areas.
- (5) Do not place candles, burning cigarettes, etc on the printer, These could cause a fire.

1.2.4 Assembly / Disassembly Precautions

Replace parts carefully, always use Samsung parts. Take care to note the exact location of parts and also cable routing before dismantling any part of the machine. Ensure all parts and cables are replaced correctly. Please carry out the following procedures before dismantling the printer or replacing any parts.

- (1) Check the contents of the machine memory and make a note of any user settings. These will be erased if the mainboard or network card is replaced.
- (2) Ensure that power is disconnected before servicing or replacing any electrical parts.
- (3) Disconnect printer interface cables and power cables.
- (4) Only use approved spare parts. Ensure that part number, product name, any voltage, current or temperature rating are correct.
- (5) When removing or re-fitting any parts do not use excessive force, especially when fitting screws into plastic.
- (6) Take care not to drop any small parts into the machine.

1.2.5 Disregarding this warning may cause bodily injury

(1) Be careful with the high temperature part.

The fuser unit works at a high temperature. Use caution when working on the printer. Wait for the fuser to cool down before disassembly.

(2) Do not put finger or hair into the rotating parts.

When operating a printer, do not put hand or hair into the rotating parts (Paper feeding entrance, motor, fan, etc.). If do, you can get harm.

(3) When you move the printer.

This printer weighs 7.87kg. Use safe lifting and handling techniques. Use the lifting handles located on each side of the machine. Back injury could be caused if you do not lift carefully.

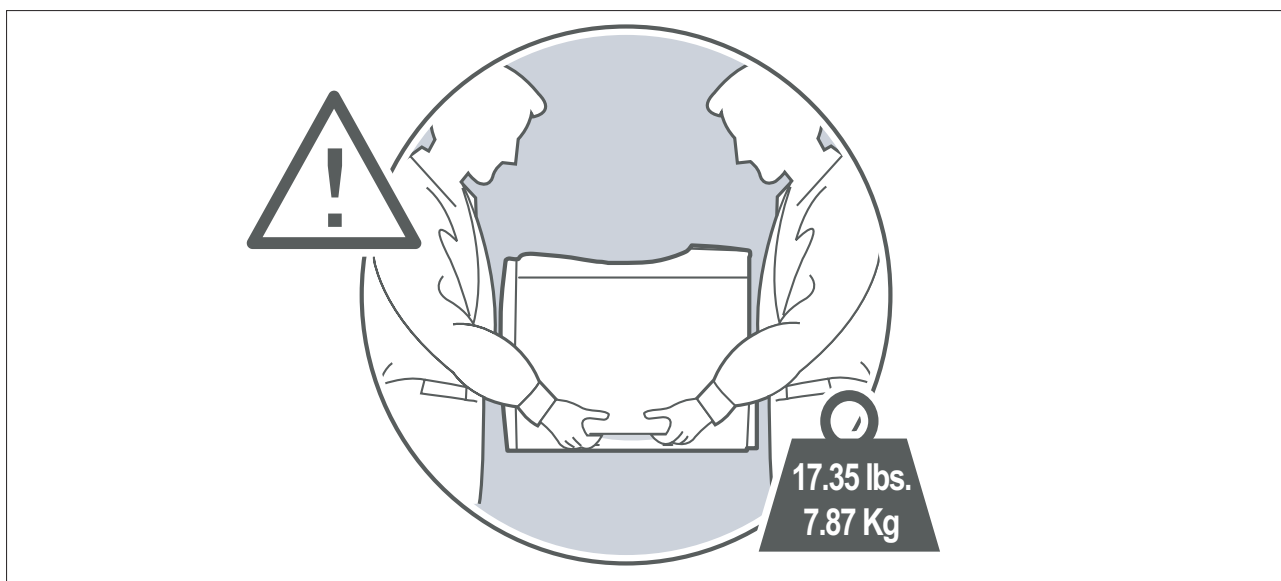

(4) Ensure the printer is installed safely.

The printer weighs 7.87Kg, ensure the printer is installed on a level surface, capable of supporting its weight. Failure to do so could cause the printer to tip or fall possibly causing personal injury or damaging the printer.

(5) Do not install the printer on a sloping or unstable surface. After installation, double check that the printer is stable.

1.3 ESD Precautions

Certain semiconductor devices can be easily damaged by static electricity. Such components are commonly called “Electrostatically Sensitive (ES) Devices”, or ESDs. Examples of typical ESDs are: integrated circuits, some field effect transistors, and semiconductor “chip” components.

The techniques outlined below should be followed to help reduce the incidence of component damage caused by static electricity.

Caution >>Be sure no power is applied to the chassis or circuit, and observe all other safety precautions.

1. Immediately before handling a semiconductor component or semiconductor-equipped assembly, drain off any electrostatic charge on your body by touching a known earth ground. Alternatively, employ a commercially available wrist strap device, which should be removed for your personal safety reasons prior to applying power to the unit under test.
2. After removing an electrical assembly equipped with ESDs, place the assembly on a conductive surface, such as aluminum or copper foil, or conductive foam, to prevent electrostatic charge buildup in the vicinity of the assembly.
3. Use only a grounded tip soldering iron to solder or desolder ESDs.
4. Use only an “anti-static” solder removal device. Some solder removal devices not classified as “anti-static” can generate electrical charges sufficient to damage ESDs.
5. Do not use Freon-propelled chemicals. When sprayed, these can generate electrical charges sufficient to damage ESDs.
6. Do not remove a replacement ESD from its protective packaging until immediately before installing it. Most replacement ESDs are packaged with all leads shorted together by conductive foam, aluminum foil, or a comparable conductive material.
7. Immediately before removing the protective shorting material from the leads of a replacement ESD, touch the protective material to the chassis or circuit assembly into which the device will be installed.
8. Maintain continuous electrical contact between the ESD and the assembly into which it will be installed, until completely plugged or soldered into the circuit.
9. Minimize bodily motions when handling unpackaged replacement ESDs. Normal motions, such as the brushing together of clothing fabric and lifting one’s foot from a carpeted floor, can generate static electricity sufficient to damage an ESD.

2. Product specification and feature

2.1 Product Specifications

2.1.1 Product Overview

28ppm(A4) / 30ppm(Ltr)	 <p>ML-2850D/2851ND</p>	2K Standard, 5K High Yield
PCL6, PS3, 1,200x1,200dpi		Paper Input: 250 CST + 1 MP
400MHz processor		Standard Duplex Printing (World Smallest)
USB 2.0, N/W (ML-2851ND only)		Options: - 250 sh SCF
32MB (Max.160MB : option)		

2.1.2 Specifications

- Product Specifications are subject to change without notice. See below for product specifications.

2.1.2.1 General Print Engine

ITEM		ML-2850D	ML-2851ND
Engine Speed	Simplex	Up to 28 ppm in A4 (30 ppm in Letter)	Up to 28 ppm in A4 (30 ppm in Letter)
	Duplex	Up to 14 ipm in A4 (14.5 ipm in Letter)	Up to 14 ipm in A4 (14.5 ipm in Letter)
Warmup time	From Sleep	15 sec	15 sec
FPOT	From Ready	8.5 sec	8.5 sec
	From Sleep	less than 23.5 sec	less than 23.5 sec
Resolution	-	Up to 1,200 x 1,200 dpi effective output	Up to 1,200 x 1,200 dpi effective output

2.1.2.2 Controller & S/W

ITEM		ML-2850D	ML-2851ND
Processor		Samsung 400 MHz	Samsung 400 MHz
Memory	Std.	32 MB	32 MB
	Max.	160MB(option)	160MB(option)
Printer Languages		PostScript3, PCL6, SPL, IBM ProPrinter, EPSON	PostScript3, PCL6, SPL, IBM ProPrinter, EPSON
Fonts		45 scalable, 1 bitmap, 136 PostScript3 fonts	45 scalable, 1 bitmap, 136 PostScript3 fonts
Driver	Default Driver	SPL	SPL
	Install	SPL, PCL6, PS3	SPL, PCL6, PS3
	Supporting OS	Windows 2000/XP(32/64bits)/Vista(32/64bits)/2003 Server(32/64bits)	Windows 2000/XP(32/64bits)/Vista(32/64bits)/2003 Server(32/64bits)
		Various Linux OS: - Red Hat 8~9, - Fedora Core 1~4 - Mandrake 9.2~10.1 - SuSE 8.2~9.2	Various Linux OS: - Red Hat 8~9, - Fedora Core 1~4 - Mandrake 9.2~10.1 - SuSE 8.2~9.2
		Mac OS 8.6~9.2 / 10.1~10.4	Mac OS 8.6~9.2 / 10.1~10.4
WHQL	Windows 2000, XP, 2003 Server, Vista(32/64bits)	Windows 2000, XP, 2003 Server, Vista(32/64bits)	
Compatibility	SPL & PCL6 : Win 2000/XP(32/64bits)/2003 server/Vista(32/64bits) PS3 : Win 2000/XP(32/64bits)/Vista(32/64bits)/2003 PPD, Mac PPD, Linux PPD	SPL & PCL6 : Win 2000/XP(32/64bits)/2003 server/Vista(32/64bits) PS3 : Win 2000/XP(32/64bits)/Vista(32/64bits)/2003 PPD, Mac PPD, Linux PPD	
Wired Network	Protocol	N/A	SPX/IPX, TCP/IP, EtherTalk, SNMP, HTTP 1.1
	Supporting OS	N/A	Windows NT4.0/2000/XP(32/64bits)/2003 Server/Vista(32/64bits)/NetWare 5.x, 6.x Mac OS 8.6~9.2, 10.1~10.4 Various Linux OS including Red Hat 8~9, Fedora Core 1~4, Mandrake 9.2~10.1, and SuSE 8.2~9.2/Unix HP-UX
Wireless Network	Protocol	N/A	N/A
	Supporting OS	N/A	N/A
Application	Smart Panel	SmartPanel for Windows/ Macintosh/LINUX	SmartPanel for Windows/ Macintosh/LINUX
	Printer Setting	PSU for Windows/ Macintosh/LINUX	PSU for Windows/ Macintosh/LINUX
	Network Management	N/A	SyncThru Web Admin Service 4.0
	IP Setting	N/A	SetIP
Interface			
Parallel	-	N/A	N/A
USB	-	Hi-Speed USB 2.0	Hi-Speed USB 2.0
Wired Network	-	N/A	Ethernet 10/100 Base TX (Internal)
Wireless Network	-	N/A	N/A
User Interface			
LCD	-	N/A	N/A
LED	-	2 LED, 1 Key	2 LED, 1 Key
Key	-	1 Key (Demo, Stop)	1 Key (Demo, Stop)

2.1.2.3 Paper Handling

ITEM		ML-2850D	ML-2851ND
Standard Capacity	-	250-sheet Cassette Tray, 1-sheet Multi Purpose Tray @80g/ m ²	250-sheet Cassette Tray, 1-sheet Multi Purpose Tray @80g/ m ²
Max. Capacity	-	501 sheets @ 80g/ m ²	501 sheets @ 80g/ m ²
Printing	Max. Size	216 x 356 mm (8.5" x 14")	216 x 356 mm (8.5" x 14")
	Min. Size	76 x 127 mm (3.0" x 5.0")	76 x 127 mm (3.0" x 5.0")
Multi-purpose tray			
Capacity	Plain Paper	1 sheets @ 80g/ m ²	1 sheets @ 80g/ m ²
	Envelope	1 sheets @75g/ m ²	1 sheets @75g/ m ²
Media sizes	-	A4, A5, A6, Letter, Legal, Folio, Oficio, Executive,ISO B5, JIS B5, 3"x5", Monarch, No.10, DL, C5, C6	A4, A5, A6, Letter, Legal, Folio, Oficio, Executive,ISO B5, JIS B5, 3"x5", Monarch, No.10, DL, C5, C6
Media type	-	Plain Paper, Transparency, Envelope, Labels, Post Card, Card stock	Plain Paper, Transparency, Envelope, Labels, Post Card, Card stock
Media weight	-	16~43lb (60 to 163g/ m ²)	16~43lb (60 to 163g/ m ²)
Sensing	-	N/A	N/A
Standard Cassette Tray			
Capacity	-	250 sheets @ 80g/ m ²	250 sheets @ 80g/ m ²
Media sizes	-	A4, A5, Letter, Legal, Executive, Folio, Oficio, ISO B5, JIS B5	A4, A5, Letter, Legal, Executive, Folio, Oficio, ISO B5, JIS B5
Media types	-	Plain paper	Plain paper
Media weight	-	16~28lb (60 to 105g/ m ²)	16~28lb (60 to 105g/ m ²)
Sensing	-	Paper empty sensor	Paper empty sensor
Optional Cassette Tray			
Capacity	-	250 sheets @ 80g/ m ²	250 sheets @ 80g/ m ²
Media sizes	-	A4, A5, Letter, Legal, Executive, Folio, Oficio, ISO B5, JIS B5	A4, A5, Letter, Legal, Executive, Folio, Oficio, ISO B5, JIS B5
Media types	-	Plain paper	Plain paper
Media weight	-	16~28lb (60 to 105g/ m ²)	16~28lb (60 to 105g/ m ²)
Sensing	-	Paper empty sensor	Paper empty sensor
Output Stacking			
Capacity	Face-Down	150 sheets @ 75g/ m ² (Baseline paper : samsung premium/ Xerox 4200) NN condition	150 sheets @ 75g/ m ² (Baseline paper : samsung premium/ Xerox 4200) NN condition
	Face-Up	N/A	N/A
Output Full sensing	-	N/A	N/A
Duplex			
Supporting	-	Built-in	Built-in
Media sizes	-	A4, Letter, Legal, Folio, Oficio	A4, Letter, Legal, Folio, Oficio
Media types	-	Plain Paper	Plain Paper
Media weight	-	20~24lb (75 to 90g/ m ²)	20~24lb (75 to 90g/ m ²)
Printable Area			
Non-Printable Area	Envelope	10mm(0.4") from edge(Top, Bottom, Left, Right)	10mm(0.4") from edge(Top, Bottom, Left, Right)
	Other Media	4mm(0.16") from edge(Top, Bottom, Left, Right)	4mm(0.16") from edge(Top, Bottom, Left, Right)

2.1.2.4 Consumables

ITEM		ML-2850D	ML-2851ND
Toner	Black	Standard: Average Cartridge Yield 2K standard pages. High Yield: Average cartridge Yield 5K standard pages. Declared cartridge yield in accordance with ISO/IEC 19752.	Standard: Average Cartridge Yield 2K standard pages. High Yield: Average cartridge Yield 5K standard pages. Declared cartridge yield in accordance with ISO/IEC 19752.
	Key	Electronic key(CRUM) Only	Electronic key(CRUM) Only
	Life detect	Toner gauge sensor by dot count	Toner gauge sensor by dot count
Drum	Yield	N/A	N/A

2.1.2.5 Reliability & Service

ITEM		ML-2850D	ML-2851ND
Max. Monthly Duty	-	50,000 sheets	50,000 sheets
MPBF	-	35,000 sheets	35,000 sheets
MTTR	-	30 min.	30 min.
SET Life Cycle	-	100,000 sheets or 5 years (whichever comes first)	100,000 sheets or 5 years (whichever comes first)
RDS	Comm. Mode	Yes	Yes
	Operation	Yes	Yes

2.1.2.6 Environment

ITEM		ML-2850D	ML-2851ND
Operating Environment	Temperature	10C to 32C	10C to 32C
	Humidity	20% to 80%	20% to 80%
Acoustic Noise Level(Sound Power/Pressure)	Printing	Less than 50dBA	Less than 50dBA
	Standby	Less than 26.0 dBA	Less than 26.0 dBA
	Sleep	Back Ground Level	Back Ground Level
Power Consumption	Ready	Less than 60W	Less than 60W
	AVG.	Less than 400W	Less than 400W
	Sleep / Power Off	Less than 8W / Less than 0.4W (Conformity to EPA)	Less than 8W / Less than 0.4W (Conformity to EPA)
Dimension (W x D x H)	SET	364 x 369 x 209.6 mm (14.33" x 14.523" x 8.25 ")	364 x 369 x 209.6 mm (14.33" x 14.523" x 8.25 ")
Weight	SET	7.87 Kg	7.87 Kg

2.1.2.7 Packing & Accessory

ITEM		ML-2850D	ML-2851ND
In-Box	-	Driver & Network Install CD-ROM Power Cable USB Cable (CIS/China/Korea/India) Quick Install Guide Warranty Registration Card User's Manual (PDF File)	Driver & Network Install CD-ROM Power Cable USB Cable (CIS/China/Korea/India) Quick Install Guide Warranty Registration Card User's Manual (PDF File)

2.1.2.8 Options



ITEM		ML-2850D	ML-2851ND
Memory		Option (128MB)	Option (128MB)
Second Cassette	-	250-sheet Cassette Tray	250-sheet Cassette Tray
Wired Network	-	N/A	N/A (Built-in)
Wireless Network	-	N/A	N/A
Hard Disk	-	N/A	N/A
Duplex Unit	-	Standard	Standard

2.1.2.9 Others

ITEM		ML-2850D	ML-2851ND
Memory	Upgradable Mem. Slot	N/A	N/A
	Upgradable Mem. Type	N/A	N/A
	Upgradable Mem. Unit	128MB(option)	128MB(option)
Sensor	Paper Empty	YES	YES
	Paper Size	NO	NO
	Media Type	NO	NO
	Paper Full	NO	NO
Service	Service Item & Period	1. Transfer Roller : 50K pages 2. Fuser Unit : 50K pages 3. Pick-up Roller : 50K pages	1. Transfer Roller : 50K pages 2. Fuser Unit : 50K pages 3. Pick-up Roller : 50K pages
Certification	Power	FCC Part 15 Class B ICES-003 EN55022 Class B	FCC Part 15 Class B ICES-003 EN55022 Class B
Performance	Jam Rate	Base Line Paper : 1/5K Standard Paper : 1/2.5K Stress Paper : 1/1500	Base Line Paper : 1/5K Standard Paper : 1/2.5K Stress Paper : 1/1500
	Speed	Be equal or better than E250DN	Be equal or better than E250DN
	Resolution	Be equal or better than E250DN	Be equal or better than E250DN



2.1.2.10 Reliability & Service

* Periodic Replacing Parts



No.	Parts	Code	Fig.	Yield (pages)
1	Transfer Roller	JC66-01218A		50,000
2	Pick-up Roller	JC97-03062A		50,000
3	Fuser Unit	JC96-04717A(220V) JC96-04718A(110V)		50,000

2.1.3 Model Comparison Table

2.1.3.1 SEC Model

	Samsung ML-2851ND	Samsung ML-2250
Image		
Print Speed	28 ppm/A4	20 ppm/A4
Resolution	1,200 dpi class	600 dpi class
Processor	400 MHz	166 MHz
Memory (Max.)	32 MB (160 MB)	16 MB (144 MB)
Emulation	PCL6, PS3	PCL6
Interface	USB 2.0, N/W	USB 2.0, N/W IEEE1284
Paper Input	150 CST	150 CST
FPOT (C/M)	30 sec/8.5 sec	50 sec/10 sec
Noise	50 dBA	51 dBA
Toner	2K/5K	3K/5K
Dim. (WDH)	364 x 369 x 209.6mm	358 x 452 x 278mm
Options	250 SCF, Memory (factory option)	250 SCF, Memory

2.1.3.2 Competitor Model

	Samsung ML-2851ND	Brother HL-5240	Lexmark E250D
Image			
Print Speed	28 ppm/A4	30 ppm/Ltr	30 ppm/Ltr
Resolution	1,200 dpi class	1,200 dpi class	600 x 600 dpi
Processor	400 MHz	264 MHz	300 MHz
Memory (Max.)	32 MB (160 MB)	16 MB (16 MB)	64 MB (576 MB)
Emulation	PCL6,PS3	PCL6,PS3	PCL6,PS3
Interface	USB 2.0, N/W	USB 2.0, N/W	USB 2.0, N/W
Paper Input	250 CST	250 OT	250 CST
FPOT (C/M)	30 sec/8.5 sec	20 sec	N/A
Noise	50 dBA	47 dBA	N/A
Toner	2K/5K	2K/2.5K	1K/2K
Dim. (WDH)	364 x 369 x 209.6mm	407 x 453 x 370mm	420 x 424 x 432mm
Options	250 SCF, Memory (factory option)	250 SCF	250/500 SCF, Memory

2.2 Summary of Product

This chapter describes the functions and operating principal of the main component.

2.2.1 Printer Components

2.2.1.1 Front View

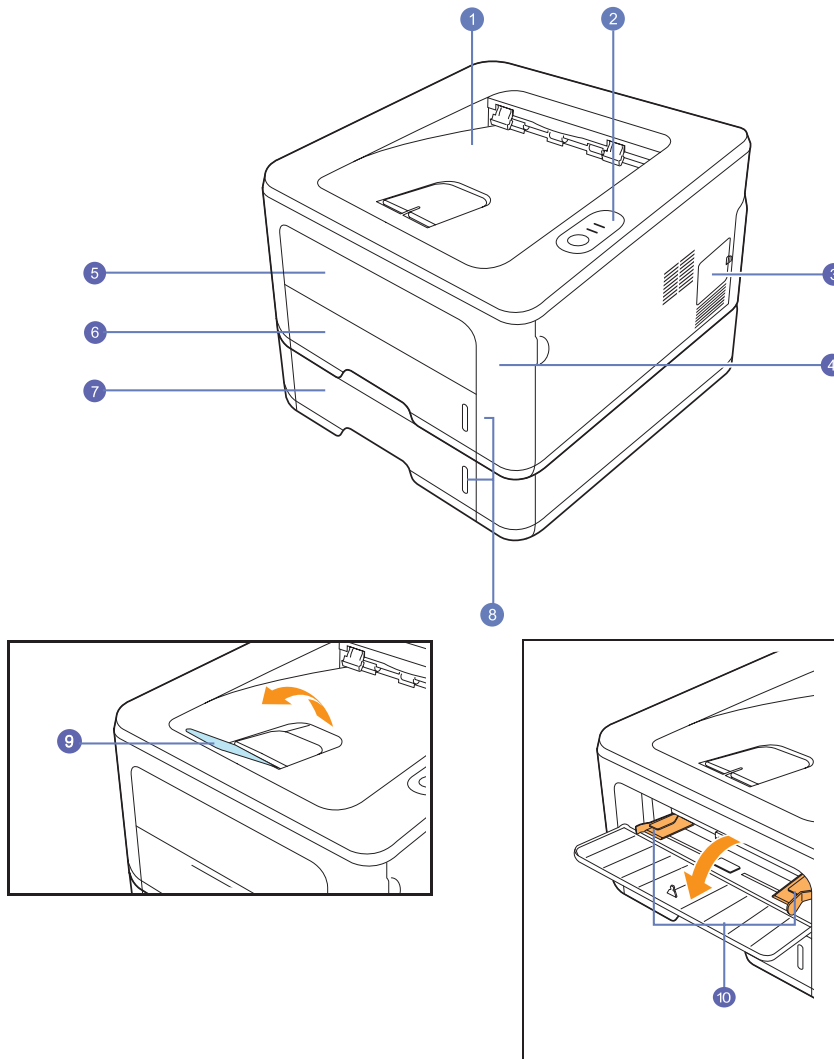

* The figure above shows an **ML-2851ND**.

1	output tray	6	tray 1
2	control panel	7	optional tray 2
3	control board cover	8	paper level indicator
4	front cover	9	output support
5	manual tray	10	manual tray paper width guides

2.2.1.2 Rear View

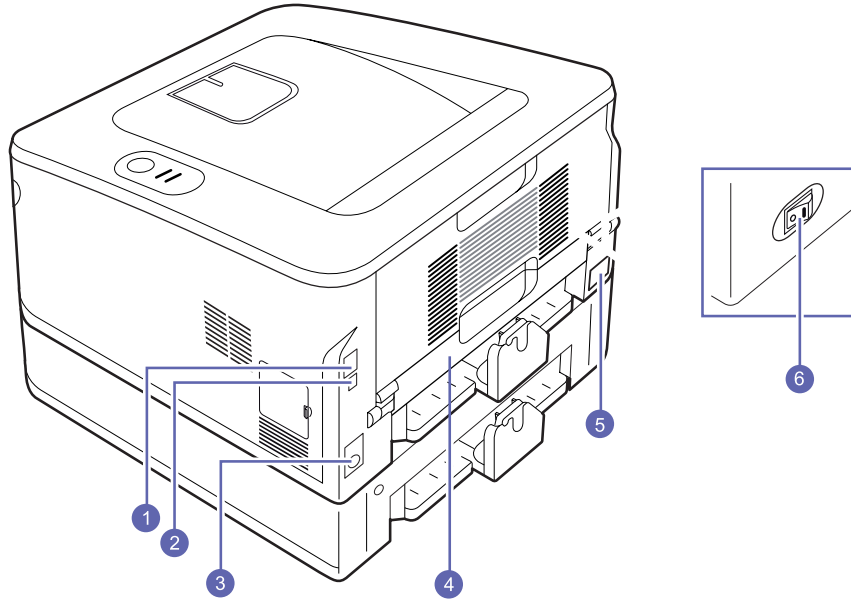

* The figure above shows an **ML-2851ND**.

1	network port ^a	4	duplex unit
2	USB port	5	power receptacle
3	optional tray 2 cable connector	6	power switch

a. ML-2851ND only.

2.2.1.3 Control Panel

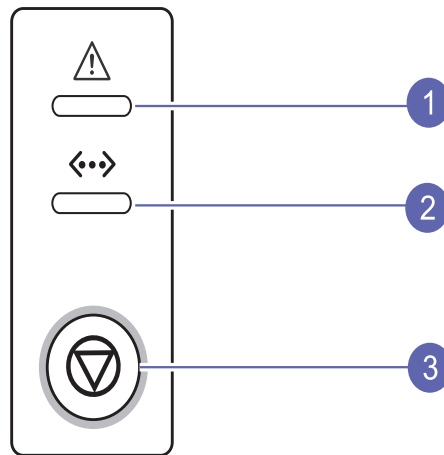

1	Error: Indicates the status of your printer.
2	Online: Indicates the status of your printer.
3	Cancel: Prints a demo page or configuration page. Cancels the print job. Makes the printer pick up the print media.

2.2.2 System Layout

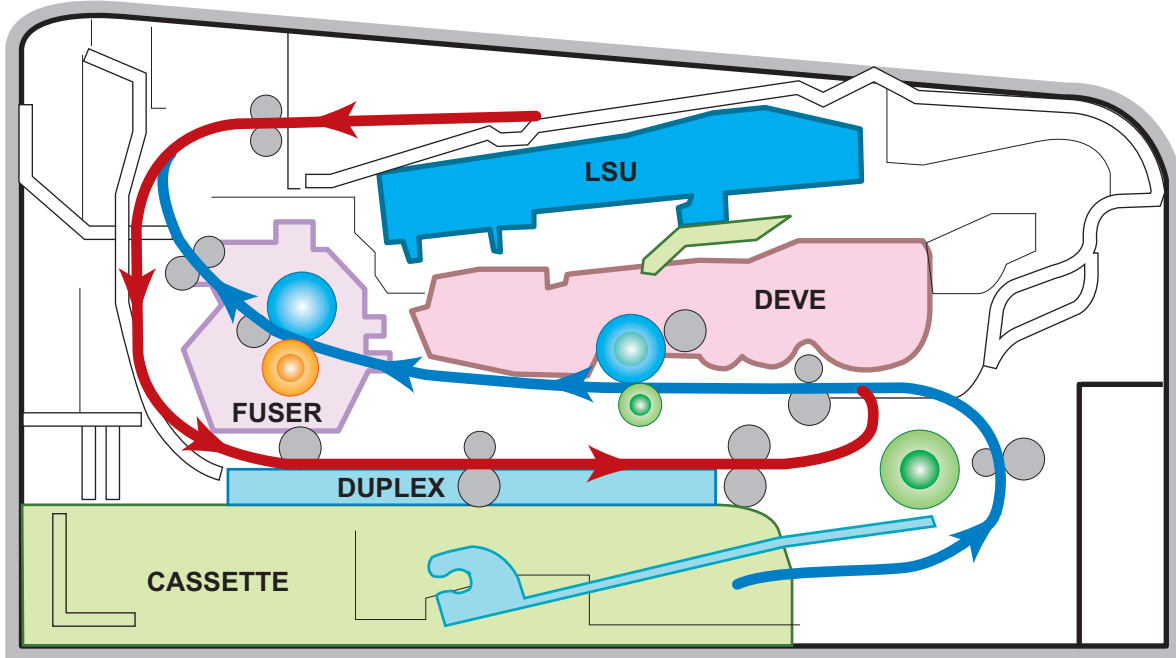

2.2.2.1 Feeding

It consists of a basic cassette, an MP tray for supplying different types of media (envelope, label, special paper) duplex unit, and parts related to paper transferring.

1) Separation method

Separate it from the friction pad mounted to the center of the cassette.

2) Basic cassette

It takes a center loading method and applies 'friction pad separating method.'

Both the side guide and the rear guide can be adjusted for various types of papers from A5 to legal size paper.

It has a paper existence sensing function (Capacity: 250 sheets of general paper), paper arranging function, various size papers accepting function, SCF paper path function, and displaying function of paper remaining amount.

In the front side, there is a paper level indicator.

3) Pick-up roller

It has functions such as a paper pickup function, driving control function, paper feeding function, and removing electronic static function.

4) Registration roller

It has a paper arranging function, paper transferring function, paper detecting function, jam removing function, and so on.

5) MP tray

It has a paper arranging function, paper transferring function, jam removing function, and so on. It uses rubbing pad method to feed 1 sheets of general papers and 1 envelopes.

6) Duplex unit

It has paper transferring function, paper guide function, jam removing function, paper sensing function, and main board supporting function.

It is designed for basic attachment, and the duplex feeding takes a side feeding method. Usable papers are A4, letter, and legal size paper.

For removing a jam occurred in a front part, it is designed to open a cassette and a guide.

It is designed to open a rear cover to remove a jam in a rear part.

7) SCF (Second Cassette Feeder)

It is the same method with the main cassette, and the capacity is 250 sheets.

It has a separate driving mechanism. It is designed for a common use with a main cassette.

2.2.2.2 Transfer

A transfer roller transfers toner on an OPC drum to the paper.

Life span: Print over 50,000 sheets (In 16~27 °C)

2.2.2.3 Driver Ass'y

By driving the motor, the system takes power. It consists of a main motor for feeding fuser and duplex reverse turn.

- Main Motor : DC 24V, Rated RPM : 2170rpm

2.2.2.4 Fuser

It is consisted of a heat lamp, heat roller, pressure roller, thermistor and thermostat. It sticks the toner on a paper by heat and pressure to complete the printing job.

- Halogen lamp : 750 Watt \pm 5%

1) Thermostat

When a heat lamp is overheated, a Thermostat cuts off the main power to prevent over-heating.

- Non-Contact type Thermostat

2) Heat roller

The heat roller transfers the heat from the lamp to apply a heat on the paper. The surface of a heat roller is coated with Teflon, so toner does not stick to the surface.

3) Pressure roller

A pressure roller mounted under a heat roller is made of a silicon resin, and the surface also is coated with Teflon. When a paper passes between a heat roller and a pressure roller, toner adheres to the surface of a paper permanently.

4) Items for safety

Protecting device for overheating

- 1st protection device: Hardware cuts off when overheated
- 2nd protection device: Software cuts off when overheated
- 3rd protection device: Thermostat cuts off main power.

Safety device

- A fuser power is cut off when a front cover is opened
- Maintain a temperature of fuser cover's surface under 80(C for user, and attach a caution label at where customer can see easily when customer open a rear cover.

2.2.2.5 LSU (Laser Scanner Unit)

It is the core part of the LBP which switches from the video data received to the controller to the electrostatic latent image on the OPC drum by controlling laser beam, exposing OPC drum, and turning principle of polygon mirror. The OPC drum is turned with the paper feeding speed. The /HSYNC signal is created when the laser beam from LSU reaches the end of the polygon mirror, and the signal is sent to the controller. The controller detects the /HSYNC signal to adjust the vertical line of the image on paper. In other words, after the /HSYNC signal is detected, the image data is sent to the LSU to adjust the left margin on paper. The one side of the polygon mirror is one line for scanning.

2.2.2.6 Print Cartridge

By using the electronic photo process, it creates a visual image. In the print cartridge, the OPC unit and the toner cartridge unit are in a body. The OPC unit has OPC drum and charging roller, and the toner cartridge unit has toner, supply roller, developing roller, and blade (Doctor blade)

- Developing Method: Non-contacting method
- Toner : Non magnetic 1 component pulverized type toner
- The life span of toner : 2,000 or 5,000 pages (LSA Pattern/A4 standard)
- Toner remaining amount detecting sensor : Yes
- OPC Cleaning : Cleaning blade type
- Management of disusable toner : Collect the toner by using Cleaning Blade
- OPC Drum protecting Shutter : No
- Classifying device for toner cartridge : ID is classified by CRUM. except for initial cartridge.

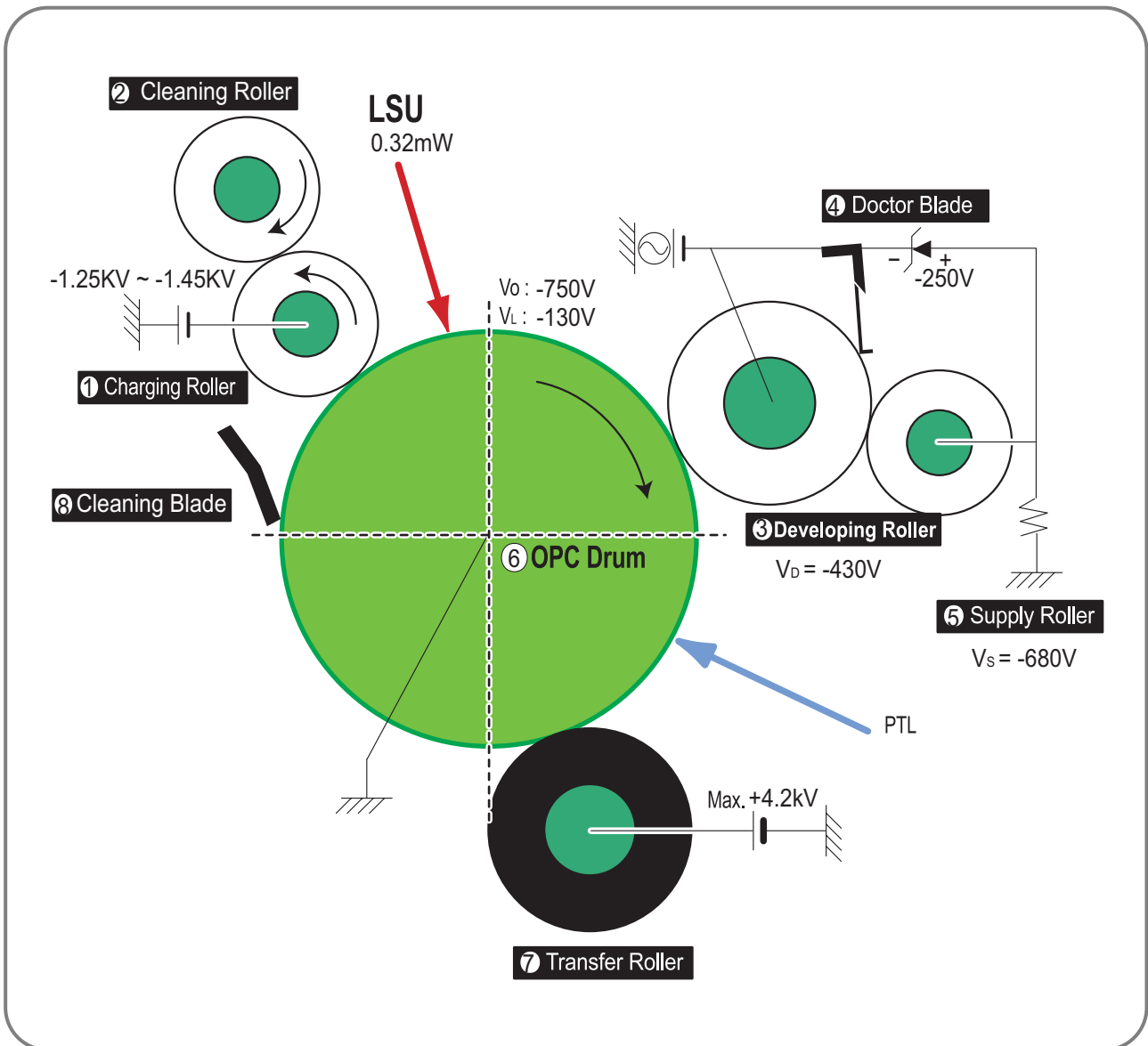

<Toner Cartridge Layout>

2.2.3 Engine H/W Specifications

2.2.3.1 Main Board

The Engine Board and the Controller Board are in one united board, and it is consisted of CPU part and print part in functional aspect. The CPU is functioned as the bus control, I/O handling, drivers, and PC interface. The main board sends the Current Image of Video data to the LSU and manages the conduct of Electrophotography for printing. It is consisted of the circuits of the motor (paper feed, pass) driving, clutch driving, pre-transfer lamp driving, current driving, and fan driving.

The signals from the paper feed jam sensor and paper empty sensor are directly inputted to the main board.

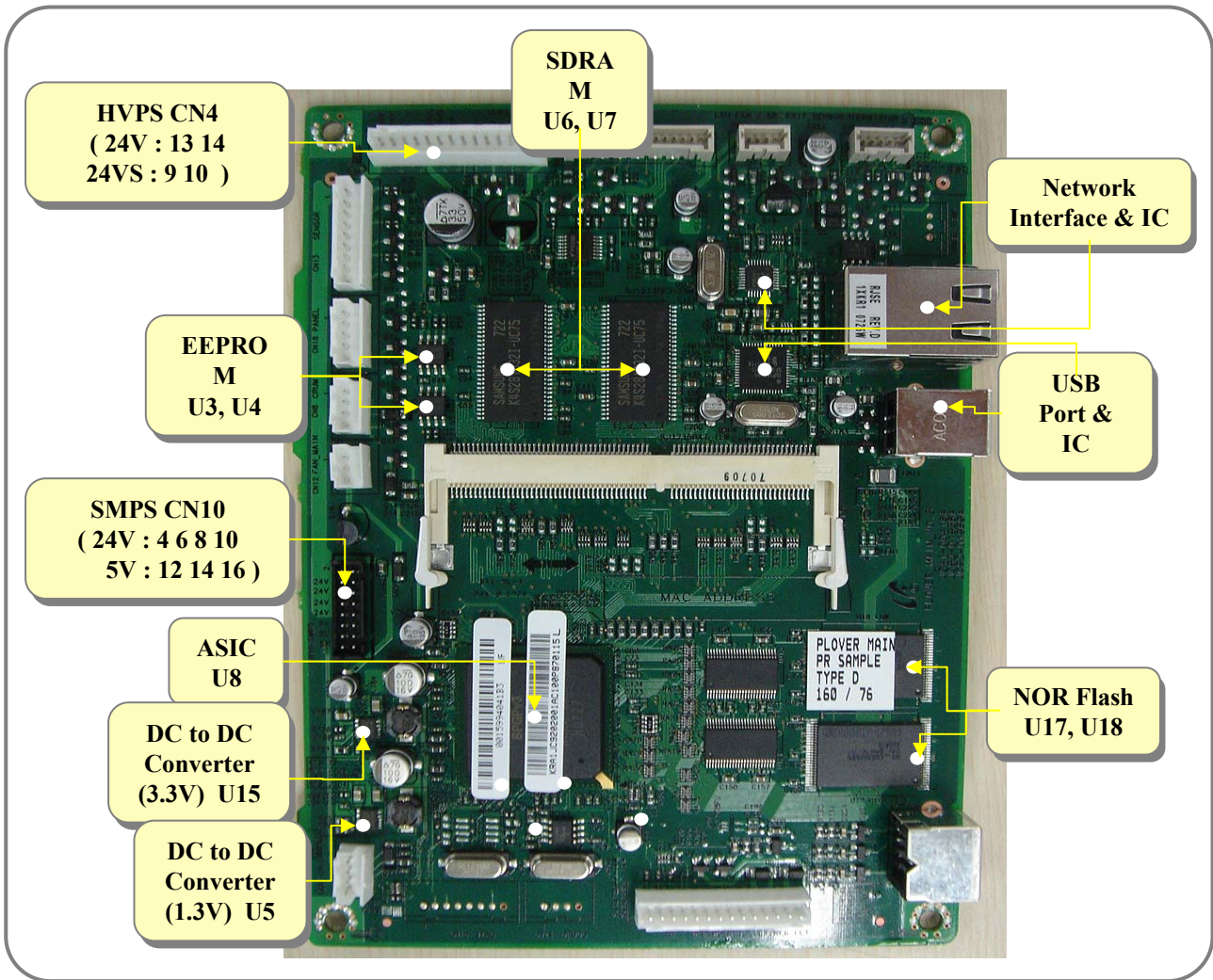

2.2.3.1(a) Asic(SPGPv3)

- CPU Core : ARM1020E
 - 32KB instruction cache and 32KB data cache
- Operating Frequency
 - CPU Core : over 300MHz
 - System Bus : 100MHz
- SDRAMC
 - 32Bits Only, 100MHz
 - 5 Banks (Up to 128MB per Bank)
- ROMC
 - 4 Banks (Up to 16MB per Bank)
- IOC
 - 6 Banks (Up to 16MB per Bank)
- DMAC
 - 4 Channels
- HPVC
 - Dual/Single Beam
 - LVDS Pad(VDO, HSYNC)
- UART
 - 5 Channels (1 Channels Supports DMA Operation)
- PCI Controller
 - 32Bits, 33/66MHz
 - PCI Local Bus Specification rev2.2 Complaint
 - Host / Agent Mode (Support 4 Devices in Host Mode)
- NAND Flash Controller
 - 8/16Bits, H/W EEC Generation
 - Auto Boot Mode (Using Internal SRAM, 4KB)
- MAC
 - 10M/100Mbps
 - Full IEEE 802.3 Compatibility
- Engine Controller
 - LSU Interface Unit
 - Step Motor : 2 Channels
 - PWM : 8 Channels
 - ADC : 6 Channels
- I2C Controller
 - I2C(S-BUS) Slave Device Support(I2C Version 2.1)
- RTC
 - RTC Core Voltage : 3V
- PLL
 - 3 PLL : MAIN, PCI, PVC

2.2.3.1(b) Memory

- Flash Memory : It stores System Program and downloads the System Program through PC Interface, and in case of model for export it compresses the PCL font, then stores it.
 - Capacity : 16M Byte (NOR Flash)
 - Random Access Time : 10 us (Max)
 - Serial Page Access Time : 50ns (Min)
- DRAM : It is used as Swath Buffer, System Working Memory Area, etc. when printing. It stores Font List, compressed into Flash memory, on DRAM and uses it as PCL font in case of model for export.
 - Capacity : 32M Byte(Basic), up to 160Mbyte (Factory Option)
 - Type : SDRAM 100MHz/133MHz , 32bit

2.2.3.1(c) Sensor Input Circuit

■ Paper Empty Sensing

The Paper empty sensor (Photo Interrupter) on the HVPS informs the state of paper to CPU whether it is empty or not with operation of the actuator.

When cassette is empty, it detects the fact by reading the E20 of CPU, and then informs the fact by displaying the RED.

■ Paper Feeding/With Toner Cartridge Sensing

When paper passes the actuator (feed sensor part), it detects the signal of Photo interrupter, informs the paper feeding state to CPU, and then sprays the image data after certain time.

If it doesn't detect the feed sensor within 1sec. after paper is fed, paper Jam0 is occurred (LED will be display Orange color). The fact whether the developer is inserted or not is detected by CRUM. After the developer is mounted, the sub-CRUM can read the information of toner cartridge from contact with CRUM involved in toner cartridge. If the information of toner cartridge is invalid, it will show invalid sign on LED.

■ Paper Exit Sensing

It detects paper state whether paper gets out from the set with operation of exit sensor on the HVPS and actuator on the frame. Paper detects the on/off time of exit sensor by reading D22 of CPU, and the normal operation or jam information is informed to the CPU.

The paper JAM2 is informed. (LED will be display Orange color)

■ Cover Open Sensing

The Cover open sensor is located on the HVPS. After the front cover is opened, +24VS (DC fan, Solenoid, Main Motor, Polygon motor part of LSU and HVPS), which is supplied to the each unit, is cut off. The cover-open sensing is operated by the D23 of CPU.

In case, the red will be ON for informing the facts to user.

■ DC FAN / SOLENOID Driving

It is driven by transistor and controlled by D14(FAN MAIN), E16(FAN DUPLEX), C23(PICK-UP CLUTCH), C18(REGI CLUTCH), D15(MPF CLUTCH) of CPU.

When it is high, the fan is driving by turning on the TR, and it is off when the sleep mode is selected. There are three solenoids, and they are driven by paper pick-up, regi and MPF signal. It is turned on or off by C23, C18, D15 of CPU.

The diode protects the driving TR from the noise pulse, which is flown when the solenoid id de-energizing.

FAN Driving Circuit is driven by Transistor, and controlled by D14, E16 of CPU.

■ Motor Driving

The main motor driving circuits is on the BLDC Motor Ass'y Unit. Main Controller has the interfacing circuits. There is motor driver IC on the motor control board of Motor Ass'y Unit.

The exit motor driving circuits is formed when the driver IC is selected. The AN44060A Motor Driver IC is used in this case. The resistance R_s value for sensing and voltage value for the V reference can be changed by motor driving voltage value. The motor driving voltage is calculated with the following formula.

IN 0, 2	IN 1, 3	Output Current
L	L	$V_{ref} / (10 \cdot R_s) = I_{out}$
H	L	$V_{ref} / (15 \cdot R_s) = I_{out} \cdot 2/3$
L	H	$V_{ref} / (30 \cdot R_s) = I_{out} \cdot 1/3$
H	H	0

The motor driving circuit is formed when the Driver IC is selected. The A3977 Motor Driver IC is used in this case. The resistance R_s value for sensing and voltage value for the V reference can be changed by motor driving voltage value. The motor driving voltage is calculated with the following formula.

$I = V_{ref} / R_s$, wherein V_{ref} is $(R_1 \times 5V) / (R_1 + R_2)$.

2.2.3.2 SMPS & HVPS board

The SMPS supplies DC Power to the System.

It takes 110V/220V and outputs the +5V, +24V to supply the power to the main board. The HVPS board creates the high voltage of THV/MHV/Supply/Dev and supplies it to the developer part for making best condition to display the image.

The HVPS part takes the 24V and outputs the high voltage for THV/MHV/BIAS, and the outputted high voltage is supplied to the toner, OPC cartridge, and transfer roller.

2.2.3.2(a) HVPS (High Voltage Power Supply)

- Transfer High Voltage (THV+)
 - Input Voltage : 24 V DC \pm 15%
 - Output Voltage : MAX +5.0KV \pm 5 %, (Duty Variable, no loading)
->1.2KV \pm 15% (when cleaning, 200 M Ω)
 - Output Voltage Trigger : 6.5 μ A
 - Input contrast of the Voltage stability degree : under \pm 5 % (fluctuating input 21.6V ~ 26.4V)
Loading contrast : \pm 5 % or less
 - Output Voltage Rising Time : 100 ms Max
 - Output Voltage Falling Time : 100 ms Max
 - Fluctuating transfer voltage with environmental various : +650 V (Duty 10%) ~ 5 KV (Duty 90%)
 - Environment Recognition Control Method : The THV-PWM ACTIVE is transfer active signal. It detects the resistance by recognizing the voltage value, F/B, while permits the environmental recognition voltage.
 - Output Voltage Control Method : Transfer Output Voltage is outputted and controlled by changing Duty of THVPWM Signal. 10% Duty : +650V, 90% Duty : +5KV \pm 5%
- Charge Voltage (MHV)
 - Input Voltage : 24 V DC \pm 15%
 - Output Voltage : -1.3KV ~ -1.8KV DC \pm 50V
 - Output Voltage Rising Time : 50 ms Max
 - Output Voltage Falling Time : 50 ms Max
 - Output Loading range : 30 M Ω ~ 1000 M Ω
 - Output Control Signal (MHV-PWM) : CPU is HV output when PWM is Low
- Cleaning Voltage (THV-)
 - The (+) Transfer Voltage is not outputted because the THV PWM is controlled with high.
 - The (-) Transfer Voltage is outputted because the THV-Enable Signal is controlled with low
 - The output fluctuation range is big because there is no Feedback control.
- Developing Voltage (DEV)
 - Input Voltage : 24 V DC \pm 15%
 - Output Voltage: -200V ~ -600V DC \pm 20 V
 - Output Voltage Fluctuation range: PWM Control
 - Input contrast of the output stability degree : \pm 5 % or less
Loading contrast : \pm 5 % or less
 - Output Voltage Rising Time : 50 ms Max
 - Output Voltage Falling Time : 50 ms Max
 - Output Loading range : 10M Ω ~ 1000 M Ω
 - Output Control Signal (BIAS-PWM) : the CPU output is HV output when PWM is low.

- Supply
 - Output Voltage : -400 V ~ -800V DC ± 50 V(ZENER using, DEV)
 - Input contrast of the output stability degree : under ± 5 %
 - Loading contrast : ± 5 % or less
 - Output Voltage Rising Time : 50 ms Max
 - Output Voltage Falling Time : 50 ms Max
 - Output Loading range : 10 M Ω ~ 1000 M Ω
 - Output Control Signal (BIAS-PWM) : the CPU is HV output when PWM is low.

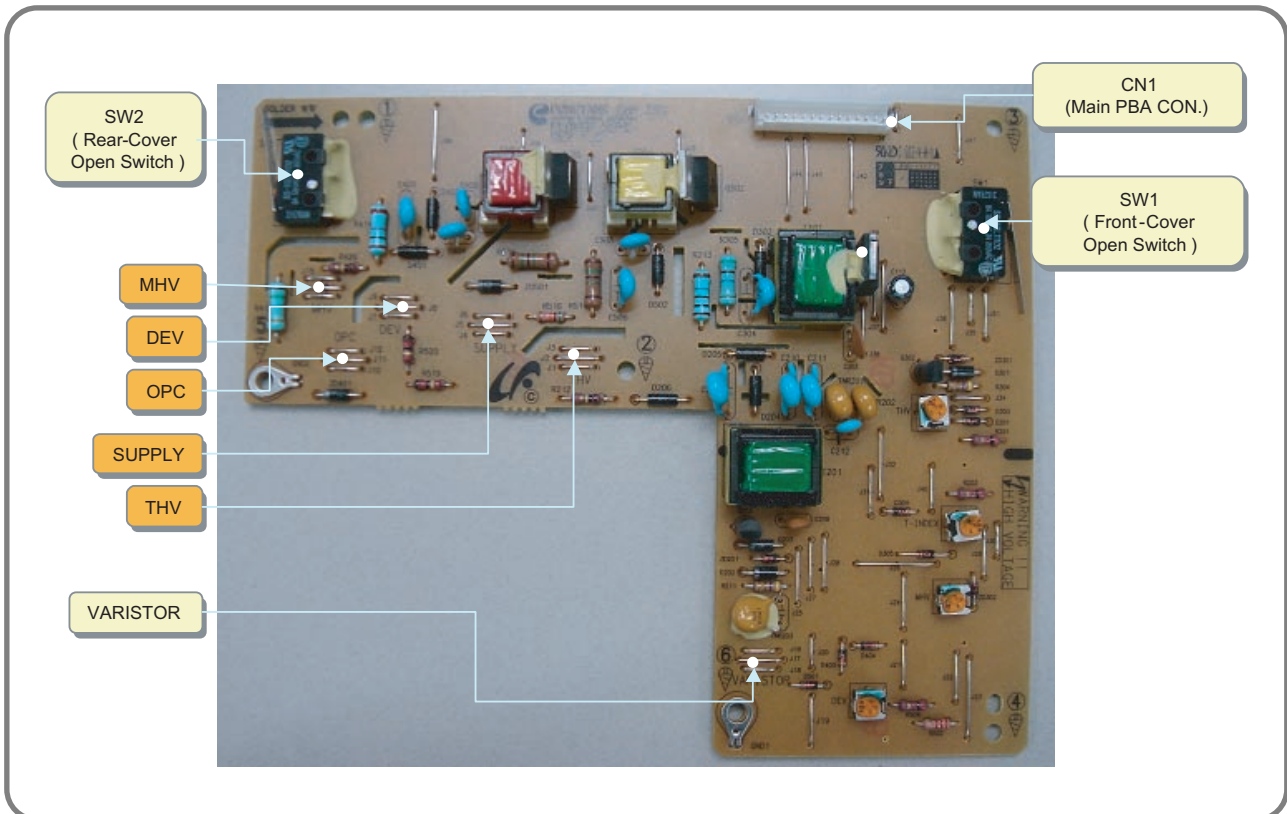

2.2.3.2(b) SMPS (Switching Mode Power Supply)

It is the power source of entire system. It is assembled by an independent module, so it is possible to use for common use. It is mounted at the side of the set.

It is consisted of the SMPS part, which supplies the DC power for driving the system, and the AC heater control part, which supplies the power to fuser. SMPS has two output channels. Which are +5V and +24V.

- AC Input
 - Input Rated Voltage : AC 220V ~ 240V AC 110V ~ 127V
 - Input Voltage fluctuating range : AC 198V ~ 264V AC 99V ~ 135V
 - Rated Frequency : 50/60 Hz
 - Frequency Fluctuating range : 47 ~ 63 Hz
 - Input Current : Under 4.0Arms / 2.0Arms (But, the status when e-coil is off or rated voltage is inputted/outputted)

· Rated Output Power

NO	ITEM	CH1	CH2	Remark
1	CHANNEL NAME	+5V	+24.0V	
2	CONNECTOR PIN	CON 35V PIN: 11,13,15 GND PIN: 12,14,16	CON 324V PIN:3,5,7,9 GND PIN:4,6,8,10	
3	Rated Output	+5V $\pm 5\%$ (4.75 ~5.25V)	+24V $\pm 10\%$ (21.6 ~26.4V)	
4	Max. Output Current	3 A	4.4 A	
5	Peak Loading Current	3.6 A	5.3 A	1ms
6	RIPPLE NOISE Voltage	100mVp-p	Under 500mVp-p	
7	Maximum output	15W	105.6W	
8	Peak output	18W	127.2W	1ms
9	Protection for loading shortage and overflowing current	Shut down or Fuse Protection	Shut down or Output Voltage Drop	

· Consumption Power

NO	ITEM	System
1	Stand-By	Less than 60W
2	PRINTING	Less than 400W
3	Sleep-Mode	Less than 8W

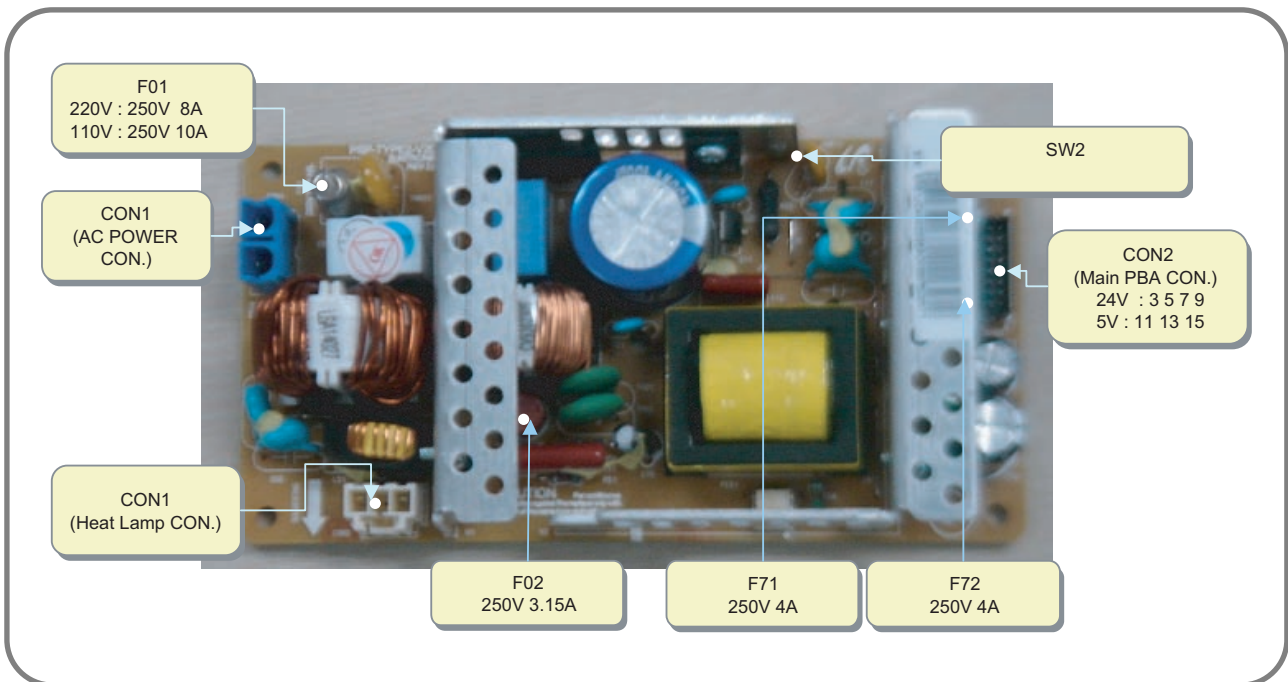

- Length of Power Cord : 1830 ±50mm
- Power Switch : Use
- Feature
 - Insulating Resistance : 100MΩ or more (at DC 500V)
 - Withstanding Voltage : Must be no problem within 1 min.
(at 1000V-LV model / 1500Vac-HV model,10mA)
 - Leaking Current : under 3.5mA
 - Running Current : under 40A PEAK (AT 25 °C, COLD START)
under 60A PEAK (In other conditions)
 - Rising Time : within 2Sec
 - Falling Time : over 20ms
 - Surge : Bi-Wave 3kV - Normal, 6KV - Common
- Environment Condition
 - Operating temperature range : 0 °C ~40 °C
 - Maintaining temperature range : -25 °C ~85 °C
 - Preserving Humidity Condition : 30% ~90% RH
 - Operating atmospheric pressure range : 1atm
- EMI Requirement : CISPR ,FCC, CE, MIC, C-Tick,
- Safty Requirement :IEC950 UL1950, CSA950, C-UL,NOM, TUV, Semko, Nemko, iK, CB, CCC(CCIB), GOST, EPA, Power Save

2.2.3.2(c) FUSER AC POWER CONTROL

Fuser(e-coil) gets heat from AC power. The AV power controls the switch with the Triac, a semiconductor switch. The ON/OFF control' is operated when the gate of the Triac is turned on/off by Phototriac (insulating part). In other words, the AC control part is passive circuit, so it turns the heater on/off with taking signal from engine control part.

When the 'HEATER ON' signal is turned on at engine, the LED of PC501 (Photo Triac) takes the voltage and flashes. From the flashing light, the Triac part (light receiving part) takes the voltage, and the voltage is supplied to the gate of Triac and flows into the Triac. As a result, the AC current flows in the e-coil, and heat is occurred.

On the other hand, when the signal is off, the PC501 is off, the voltage is cut off at the gate of Triac, the Triac becomes off, and then the e-coil is turned off.

- Triac (Q501) feature : 24A-LV model / 16A-HV model, 600V SWITCHING
- Phototriac Coupler (PC501)
 - Turn On If Current : 15mA ~50mA(Design: 16mA)
 - High Repetive Peak Off State Voltage : Min 600V

2.2.3.3 Engine F/W

2.2.3.3(a) Control Algorithm

• Feeding

If feeding from a cassette, the drive of the pickup roller is controlled by controlling the solenoid. The on/off of the solenoid is controlled by controlling the general output port or the external output port. If feeding from a manual feeder, decide to insert the paper according to the operation of the Regi sensor, and by driving the main motor, insert the paper in front of the feed sensor. While paper moves, occurrence of Jam is judged as below.

ITEM	Description
JAM 0	<ul style="list-style-type: none"> - After picking up, paper cannot be entered due to paper is not fed. - After picking up, paper entered but it cannot reach to the feed sensor in certain time due to slip, etc. - After picking up, if the feed sensor is not on, re-pick up. After re-picking up, if the feed sensor is not on after certain time, it is JAM 0. * It is a status that the leading edge of the paper doesn't pass the feed sensor. - Even though the paper reaches to the feed sensor, the feed sensor doesn't be ON. * It is a status that the leading edge of the paper already passes the feed sensor.
JAM 1	<ul style="list-style-type: none"> - After the leading edge of the paper passes the feed sensor, the trailing edge of the paper cannot pass the feed sensor after a certain time. (The feed sensor cannot be OFF) - After the leading edge of the paper passes the feed sensor, the paper cannot reach the exit sensor after certain time. (The exit sensor cannot be ON) * The paper exists between the feed sensor and the exit sensor.
JAM 2	<ul style="list-style-type: none"> - After the trailing edge of the paper passes the feed sensor, the paper cannot pass the exit sensor after certain time.
DUPLEX JAM 1	<ul style="list-style-type: none"> - After the trailing edge of the paper passes the exit sensor, the leading edge of the paper cannot reach the Regi sensor after certain time.
DUPLEX JAM 0	<ul style="list-style-type: none"> - After the leading edge of the paper passes the Regi sensor, the leading edge of the paper cannot reach the feed sensor after certain time.

2.2.3.3(b) Driver

By gearing, the main motor drives the rollers such as feeding roller, developing roller, fuser roller, and exiting roller. The BLDC motor is controlled for the such acceleration section and steady section.

The BLDC main motor is operated by the BLDC clock and the enable signal.

2.2.3.3(c) Transfer

The charging voltage, developing voltage and the transfer voltage are controlled by PWM (Pulse Width Modulation). The each output voltage is changeable due to the PWM duty. The transfer voltage admitted when the paper passes the transfer roller is decided by environment recognition. The resistance value of the transfer roller is changed due to the surrounding environment or the environment of the set, and the voltage value, which changes due to the environments, is changed through AD converter. The voltage value for impressing to the transfer roller is decided by the changed value. Each voltage value is controlled according to 3.3.4.2 Timing Chart.

2.2.3.3(d) Fusing

The temperature change of the heat roller's surface is changed to the resistance value through the thermistor. By converting the voltage value, which impressed to the resistance, to the digital value through the AD converter, the temperature is decided. The AC power is controller by comparing the target temperature to the value from the thermistor. If the value from the thermistor is out of controlling range while controlling the fusing, the error stated in the below table occurs.

• Lamp Method

Error	Description
OPEN HEAT ERROR	- When warming up, it has been lower than 90 °C over 20 seconds
LOW HEAT ERROR	- Standby has been lower than the Standby Reference Temperature -20 °C over 10 seconds. - Printing has been lower than the Printing Reference Temperature -20 °C over 10 seconds. - When WarmUp End Process, it have been lower than the WarmUp Reference Temperature -10 °C over 10 seconds.
OVER HEAT ERROR	- It has been higher than 220 °C over 20 seconds - It has been higher than 230 °C over 3 seconds - It has been higher than the Standby Reference Temperature +10 °C over 180 seconds.

=>This can be changed in the future.

2.2.3.3(e) LSU

The LSU is consisted of the LD (Laser Diode) and the polygon motor control. When the printing signal occurs, it turns on the LD and drives the polygon motor. When the detector detects the beam, Hsync occurs. When the polygon motor speed becomes strady, Lready occurs. If two conditions are satisfied, the status are not satisfied, the error shown in below occurs.

Error	Description
Polygon Motor Error	Whenthe polygon motor speed doesn ' t become steady
Hsync Error	The polygon motor speed is steady but the Hsync is not generated

2.2.4 S/W Descriptions

2.2.4.1 Overview

The software of Plover system is constructed with

- 1) Host Software part that the application software operated in Window and Web Environment, and
- 2) Firmware parts that is a Embedded software controls printing job.

2.2.4.2 Architecture

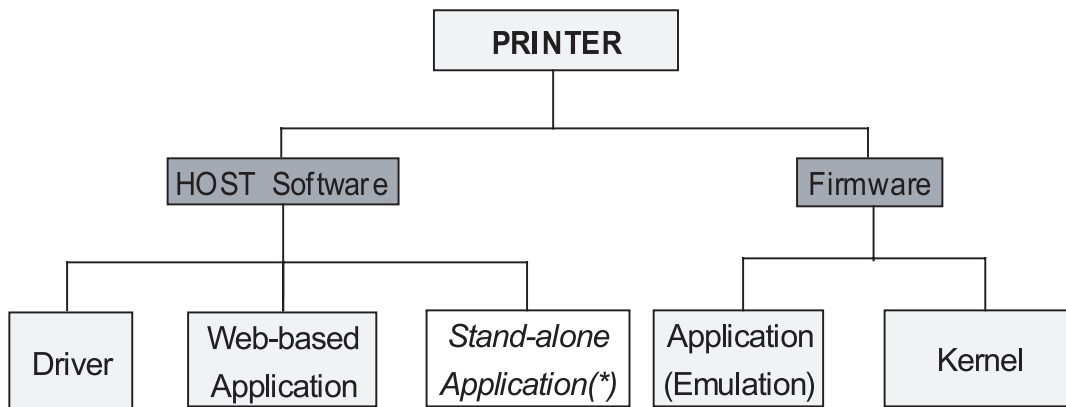

※ (*) is job for common S/W team

Host Software is made up of

1. Graphic User Interface that offers the various editing functions to user in Host,
2. Driver that translates the received document to a Printing Command language which printer can understand and transfers data to spooler,
3. Stand-alone Application that offers the various printing application, PSU(Printer Settings Utility), Printer Status Monitor, Network Management in Window system,
4. Web-based-Application that offers the same functions as Stand-alone Application and RDC(Remote Diagnosis Control) in Web environment.

Firmware is made up of

1. Application (Emulation) that is a interpreter translate data received from Host to a printing language (PCL, PS, GDI, etc.) to be able to make the user to take same output as originally one what composed in Host.
2. Kernel that control and management the whole procedure include of Control flow and Printing Job before transfer to Engine system.

2.2.4.3 Data and Control Flow

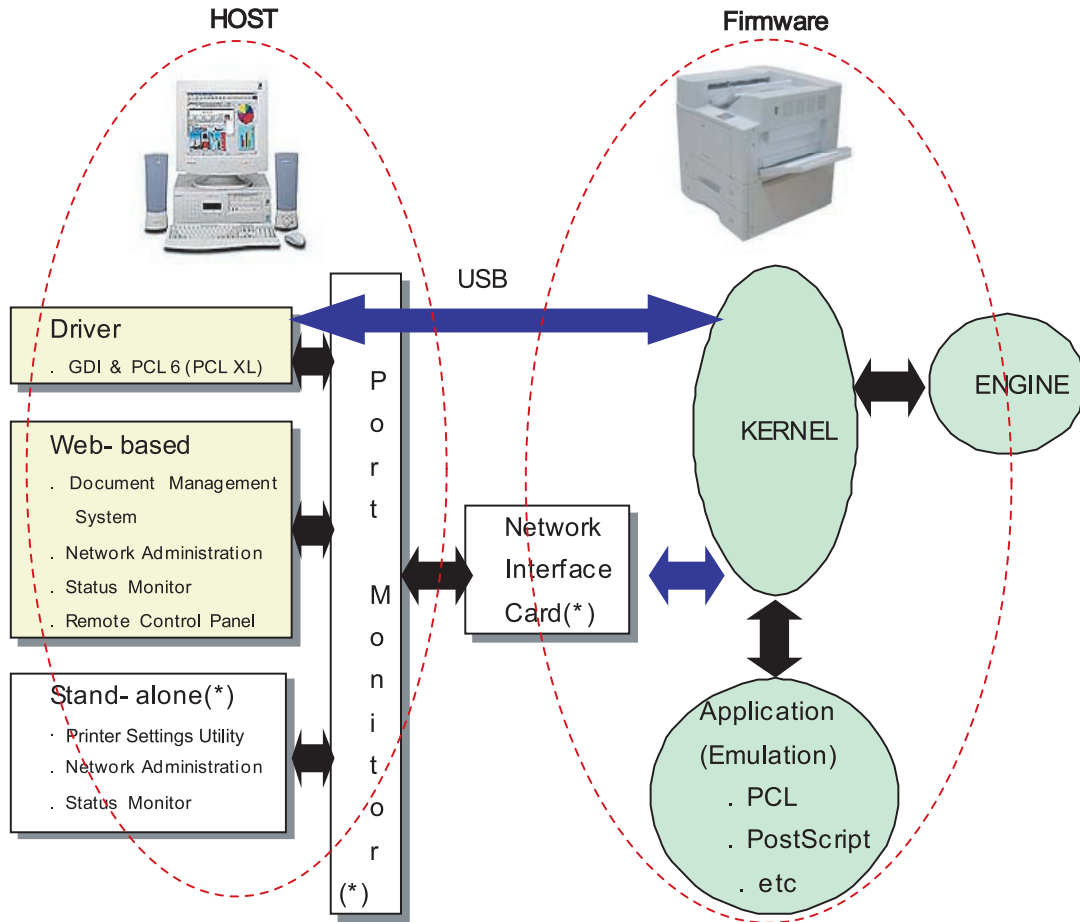

Note: (*) is role of N/W I/F

The above Block Diagram is explained that:

Host Side is made up of

1. Driver that is Windows application software translate printed data to one of printer language and create spooler file,
2. Web-based Application that offer a various printer additional functions, management of printing job, printer administration, Status monitor to monitoring the printer status by real time in Web, independent environment on OS.
3. Stand-alone Application that is a similar Window software as same as above 2,
4. Port Monitor that manages the network communication between spooler and Network Interface Card, or various additional application and Network Interface Card,(this is, at first, make communication logical port, manage the data, transfer them from spooler to network port, and offer the result of printing).

Firmware Side is made up of

1. Network Interface Card is that relay the communication between Host and kernel using various network protocol,
2. Kernel is that manages the flow control of emulation procedure, receiving data from Host or Network card and printing with engine & rendering job,
3. Emulation is that interprets the various output data from selected emulation,
4. Engine is that prints rendered bit-map data to paper with required size and type by Kernel.

And then, for Job Spooling function for Multi-User, Multi-Printing that is occurred in Network printing and various additional printing functions, this Kernel use max. 10 Queuing systems in a memory.

In Printing, the two procedures are**(1) Case of using USB Port**

- ① After user start to print the wanted document to PCL string or compressed GDI bit-map data, Driver translate the all graphic data of it and send data to host spooler. And then the spooler sends the data stream to the printer via USB port.
- ② Kernel receives this data from Host, and then select emulation fit to data and start selected one. After emulation job end, Kernel sends the output bit-map data to Engine using Printer Video Controller (by clock type for LSU).
- ③ Engine print the received data to required paper with the sequential developing process.

(2) Case of using Network Interface Card

- ① After user start to print the wanted document to PCL string or compressed GDI bit-map data, Driver translate the all graphic data of it and send data to host spooler.
- ② If so, Port monitor managing network port receives data from spooler and sends a data stream to the Network Interface Card.
- ③ Network interface card receives it and send to Kernel part,
- ④ Kernel receives this data from Host, and then select emulation fit to data and start selected one. After emulation job end, Kernel sends the output bit-map data to Engine using Printer Video Controller (by clock type for LSU).
- ⑤ Engine print the received data to required paper with the sequential developing process.

The additional printing function are realized in

- (1) Web environment
- (2) Window environment.

On addition, Kernel informs a status of printing status and printer status to user made printing job with the Status Monitor.

3. Disassembly and Reassembly

3.1 General Precautions on Disassembly

When you disassemble and reassemble components, you must use extreme caution. The close proximity of cables to moving parts makes proper routing a must.

If components are removed, any cables disturbed by the procedure must be restored as close as possible to their original positions. Before removing any component from the machine, note the cable routing that will be affected.

Whenever servicing the machine, you must perform as follows:



1. Check to verify that documents are not stored in memory.
2. Be sure to remove the toner cartridge before you disassemble parts.
3. Unplug the power cord.
4. Use a flat and clean surface.
5. Replace only with authorized components.
6. Do not force plastic-material components.
7. Make sure all components are in their proper position.

Releasing Plastic Latches

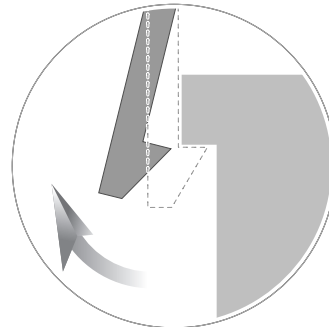
Many of the parts are held in place with plastic latches. The latches break easily; release them carefully. To remove such parts, press the hook end of the latch away from the part to which it is latched.

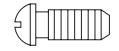

3.2 Used Screw List

No.	SEC-Code	Location	Description & Specification	QT'y
1	6003-000196 	DUPLEX UNIT	SCREW-TAPTITE;PWH,+ ,B,M3,L10,NI PLT,SWRCH18A	3
		FRAME	SCREW-TAPTITE;PWH,+ ,B,M3,L10,NI PLT,SWRCH18A	63
		FUSER	SCREW-TAPTITE;PWH,+ ,B,M3,L10,NI PLT,SWRCH18A	1
		ENGINE	SCREW-TAPTITE;PWH,+ ,B,M3,L10,NI PLT,SWRCH18A	9
		COVER TOP	SCREW-TAPTITE;PWH,+ ,B,M3,L10,NI PLT,SWRCH18A	1
		CASSETTE	SCREW-TAPTITE;PWH,+ ,B,M3,L10,NI PLT,SWRCH18A	2
2	6003-000261 	CASSETTE	SCREW-TAPTITE;BH,+ ,-,B,M3,L6,ZPC(WHT),SWRCH18A,-	1
3	6003-000264 	FRAME	SCREW-TAPTITE;PWH,+ ,-,B,M3,L6,ZPC(WHT),SWRCH18A,-	
		CASSETTE	SCREW-TAPTITE;PWH,+ ,-,B,M3,L6,ZPC(WHT),SWRCH18A,-	1
4	6003-000269 	DRIVE	SCREW-TAPTITE;BH,+ ,-,S,M3,L6,ZPC(WHT),SWRCH18A,-	11
5	6003-000282 	DUPLEX UNIT	SCREW-TAPTITE;BH,+ ,-,B,M3,L8,ZPC(BLK),SWRCH18A,-	
		FRAME	SCREW-TAPTITE;BH,+ ,-,B,M3,L8,ZPC(BLK),SWRCH18A,-	
		FUSER	SCREW-TAPTITE;BH,+ ,-,B,M3,L8,ZPC(BLK),SWRCH18A,-	4
		FRONT COVER	SCREW-TAPTITE;BH,+ ,-,B,M3,L8,ZPC(BLK),SWRCH18A,-	1
		LSU	SCREW-TAPTITE;BH,+ ,-,B,M3,L8,ZPC(BLK),SWRCH18A,-	10
			SCREW-TAPTITE;BH,+ ,-,B,M3,L8,ZPC(BLK),SWRCH18A,-	2
	SCREW-TAPTITE;BH,+ ,-,B,M3,L8,ZPC(BLK),SWRCH18A,-			
6	6003-000301 	FRAME	SCREW-TAPTITE;BH,+ ,-,S,M4,L6,ZPC(WHT),SWRCH18A,-	1
7	6003-001256 	ENGINE	SCREW-TAPTITE;BH,+ ,B,M4,L10,NI PLT,SWRCH18A	4
8	6006-001078 	FRAME	SCREW-TAPTITE;PH,+ ,WSP,B,M3,L10,ZPC(WHT),SWRCH18A,-	1
9	6002-000440 	Duplex 1, Frame 13	PWH,+ ,-,2,M3,L8,ZPC(BLK),SWRCH18A,-	1

3.3 Cover Unit

3.3.1 CASSETTE & Front Cover

1. Remove the CASSETTE
2. Remove the FRONT COVER carefully, especially hooks.
3. Remove the TONER CARTRIDGE.



3.3.2 DUPLEX UNIT & COVER-TOP/COVER-REAR

1. Remove two SCREW in front view
2. Turning back of SET, remove DUPLEX UNIT like below figure.
3. After open the COVER-REAR, remove two SCREWS, then disassemble the Cover-Top up.
4. Remove COVER-REAR.

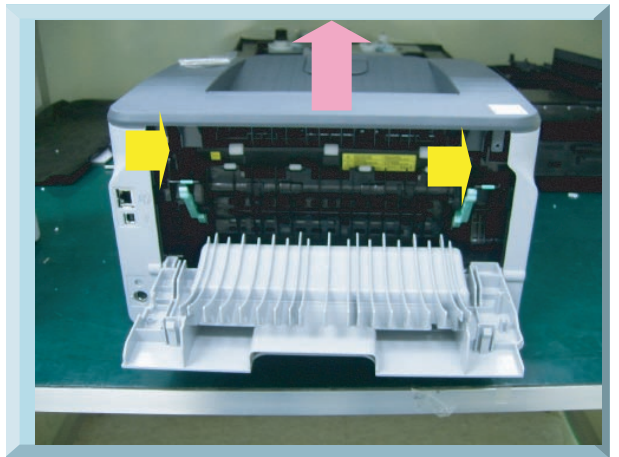
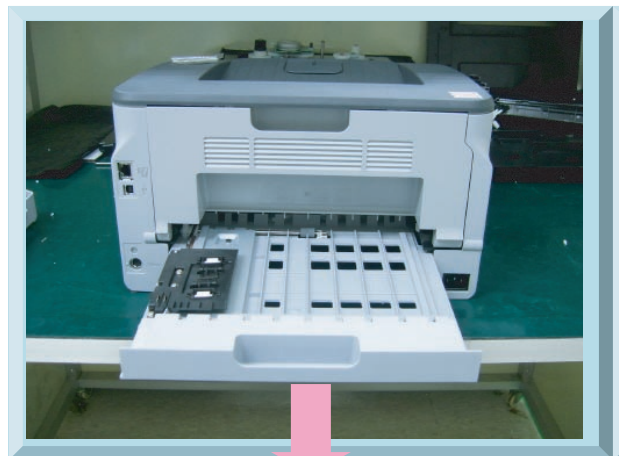

3.3.3 Cover-Side-LEFT/RIGHT

1. Remove their first hook from frame-base.
2. After removing the hook of backside, remove Cover-Side-LEFT/RIGHT.

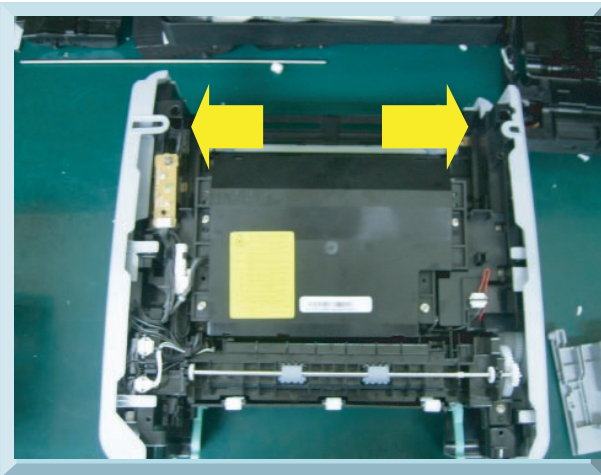

3.4 Fuser Ass'y

1. Before fuser ass'y removal, Remove COVER-TOP/DUPLEX/COVER-REAR.
2. After remove guide-rear assy like below figure, remove four screws of fuser assy.
3. In upper view, remove the three harness connected to fuser.
4. Remove fuser carefully not to damage HARNESSES.

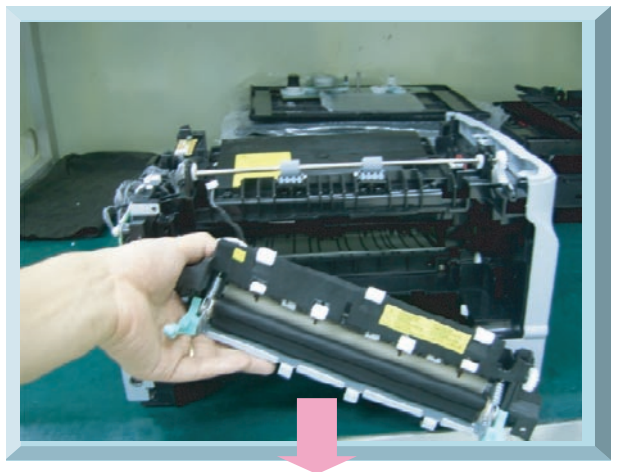
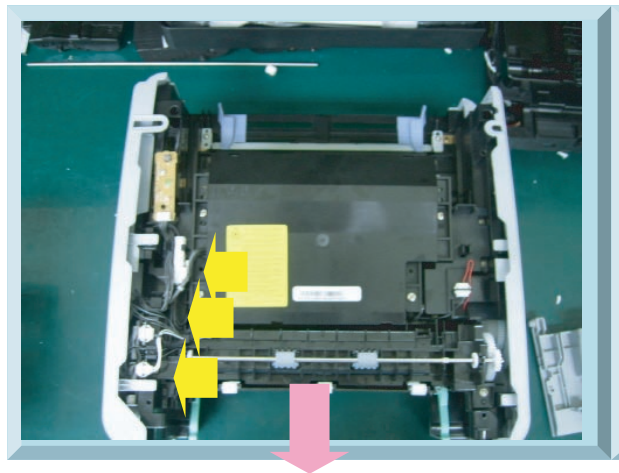
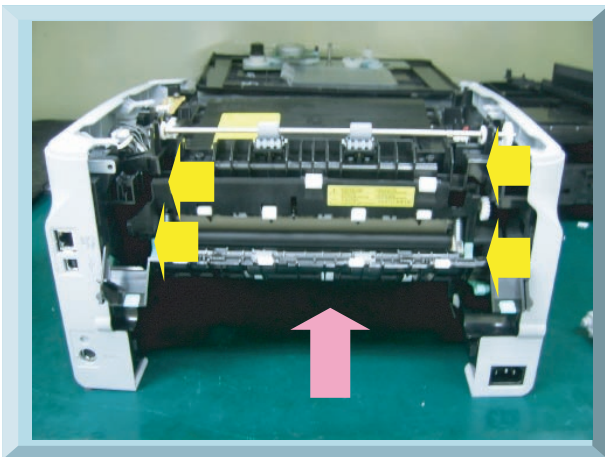

3.5 LSU(Laser Scanning Unit)

1. Before LSU ass'y removal :
 - Remove the COVER-TOP/COVER-RIGHT.
2. Remover four Screw (M4,L10) of LSU and one connector from Main B'D.

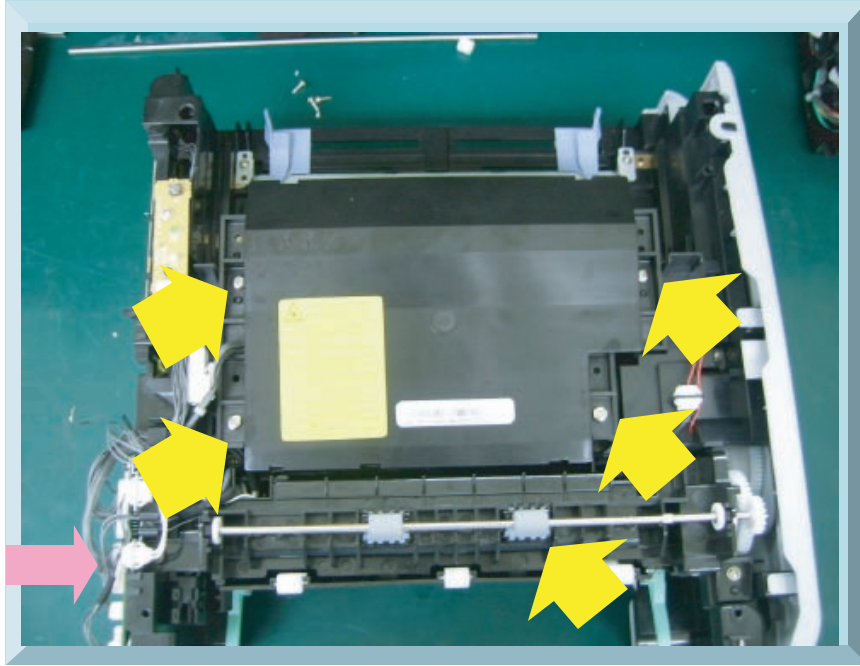

3.6 Drive Ass'y

1. Before Drive ass'y removal :
 - Remove the CASSETTE/Cover-FRONT/COVER-TOP/COVER-LEFT Assy.
2. Remove the seven Screws and remove Drive Ass'y carefully.
3. Remove the Connector of Drive Ass'y.

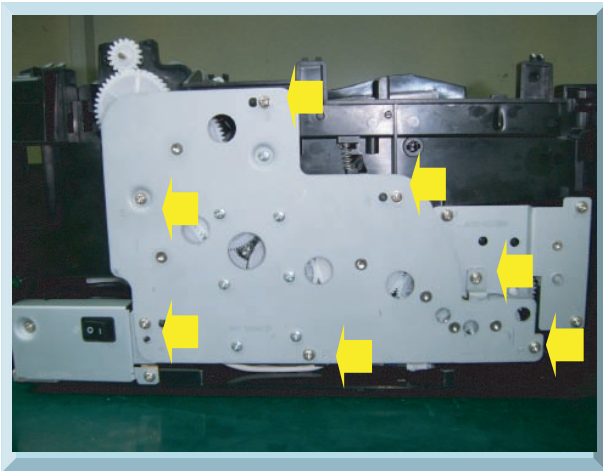

3.7 Main PBA/SMPS/HVPS

1. Before Main PBA/SMPS/HVPS removal ::
 - Remove CASSETTE/COVER-FRONT/COVER-TOP/COVER-RIGHT
2. HVPS : Remove 6 screws and 1 HARNESS
SMPS : Remove 4 screws and 3 HARNESSes
Main PBA : Remove 4 screws and all HARNESSes

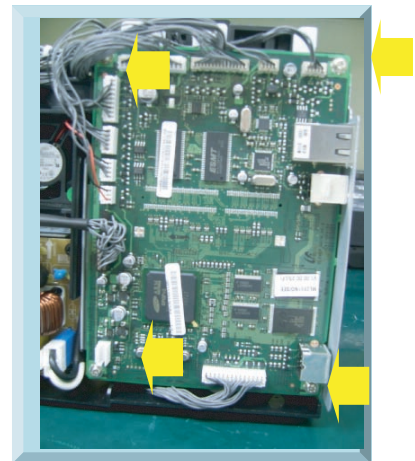
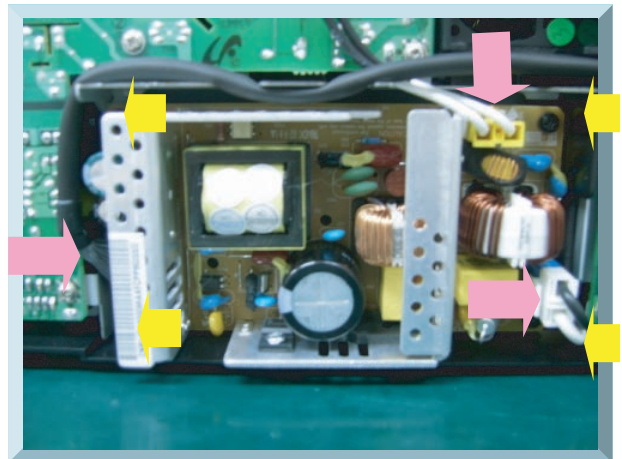
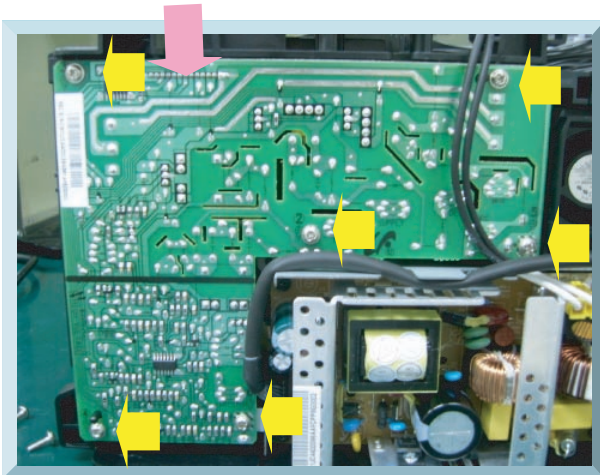

3.8 HOLDER-PAD Disassembly

1. Remove the CASSETTE from SET.
2. Disassemble HOLER-PAD after putting out three HOOKS

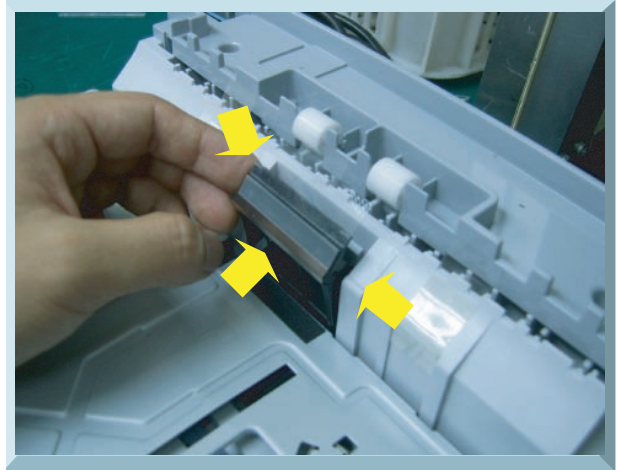
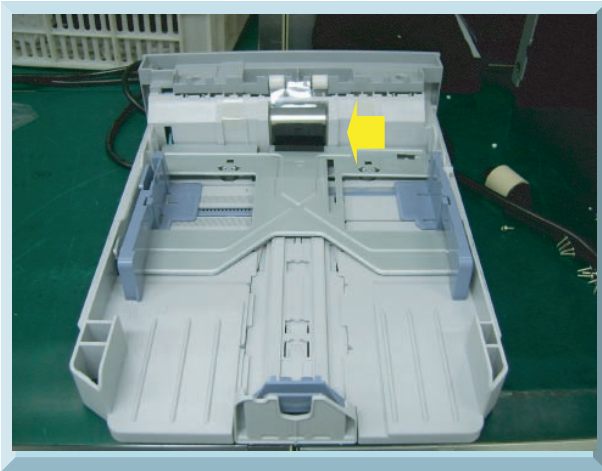

3.9 Transfer Roller

1. Open the COVER-FRONT.
2. Push HOLDER-TRANSFER, which holds the transfer roller and remove the roller from set.
3. Be carefull not to touch the sponge of Transfer Roller.

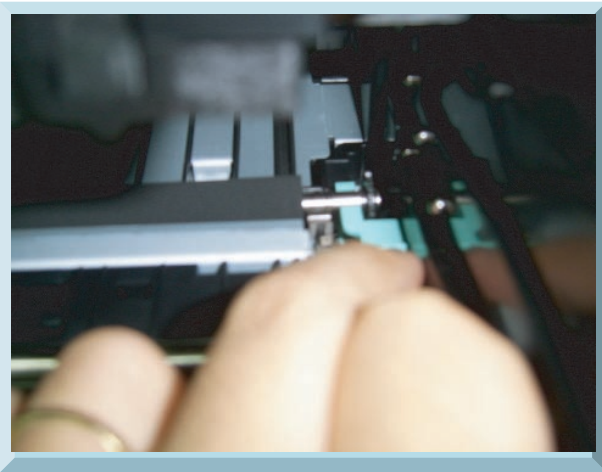

4. Adjustment and Troubleshooting

4.1 Alignment and Adjustments

4.1.1 Sample Pattern

This product has the several sample patterns for maintenance. With the sample patterns, check the existence of the abnormality. The patterns help to regularly maintain the product.

4.1.1.1 Printing a Demo Page

After setting up your printer, print a demo page to make sure that the printer is operating correctly. Press and hold the Cancel button for about 2 seconds. A demo page prints out.

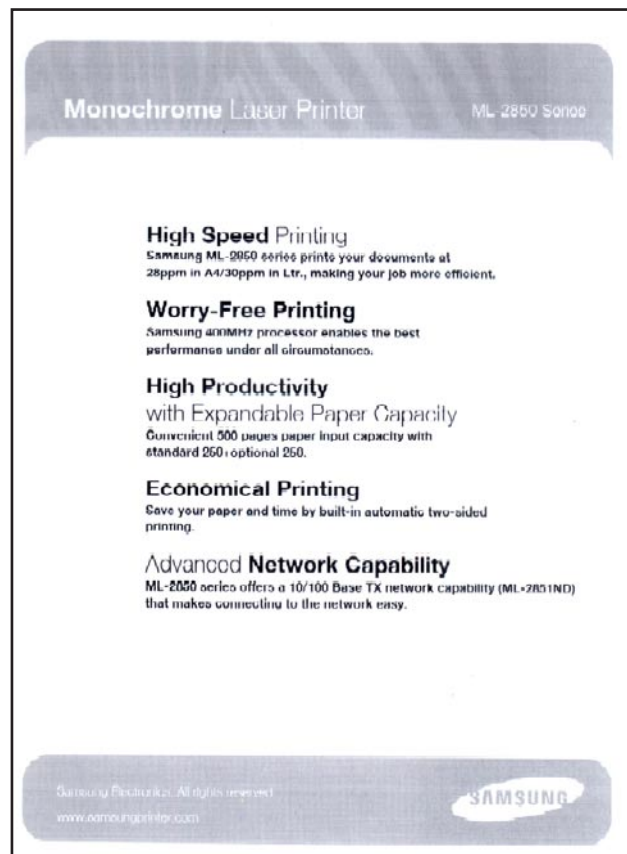
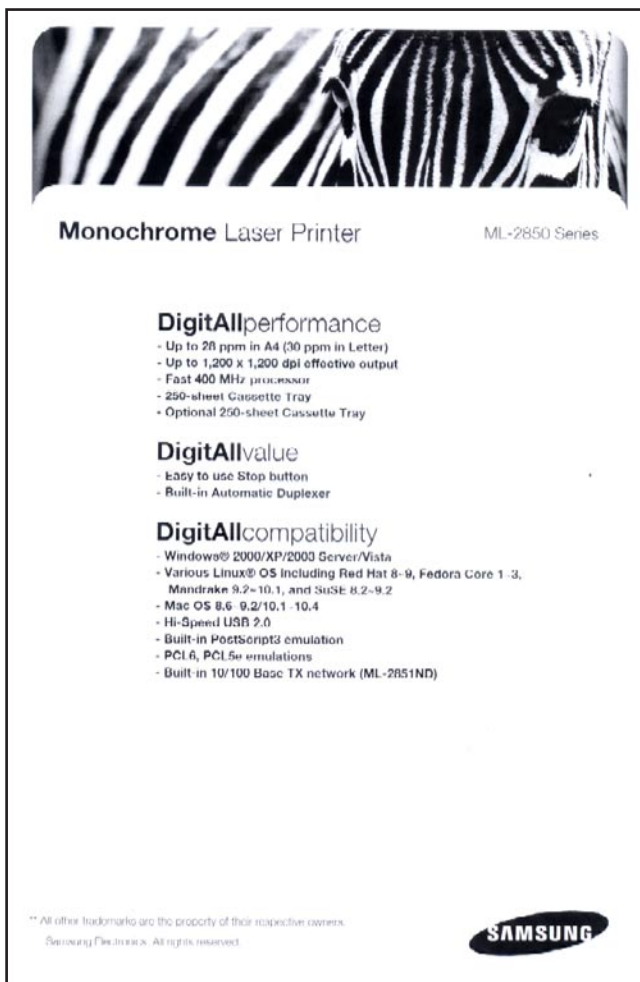

4.1.1.2 Printing a configuration Page

Press and hold the Cancel button for about 4 seconds.
A configuration page prints out.(print out with the menu map sheet)

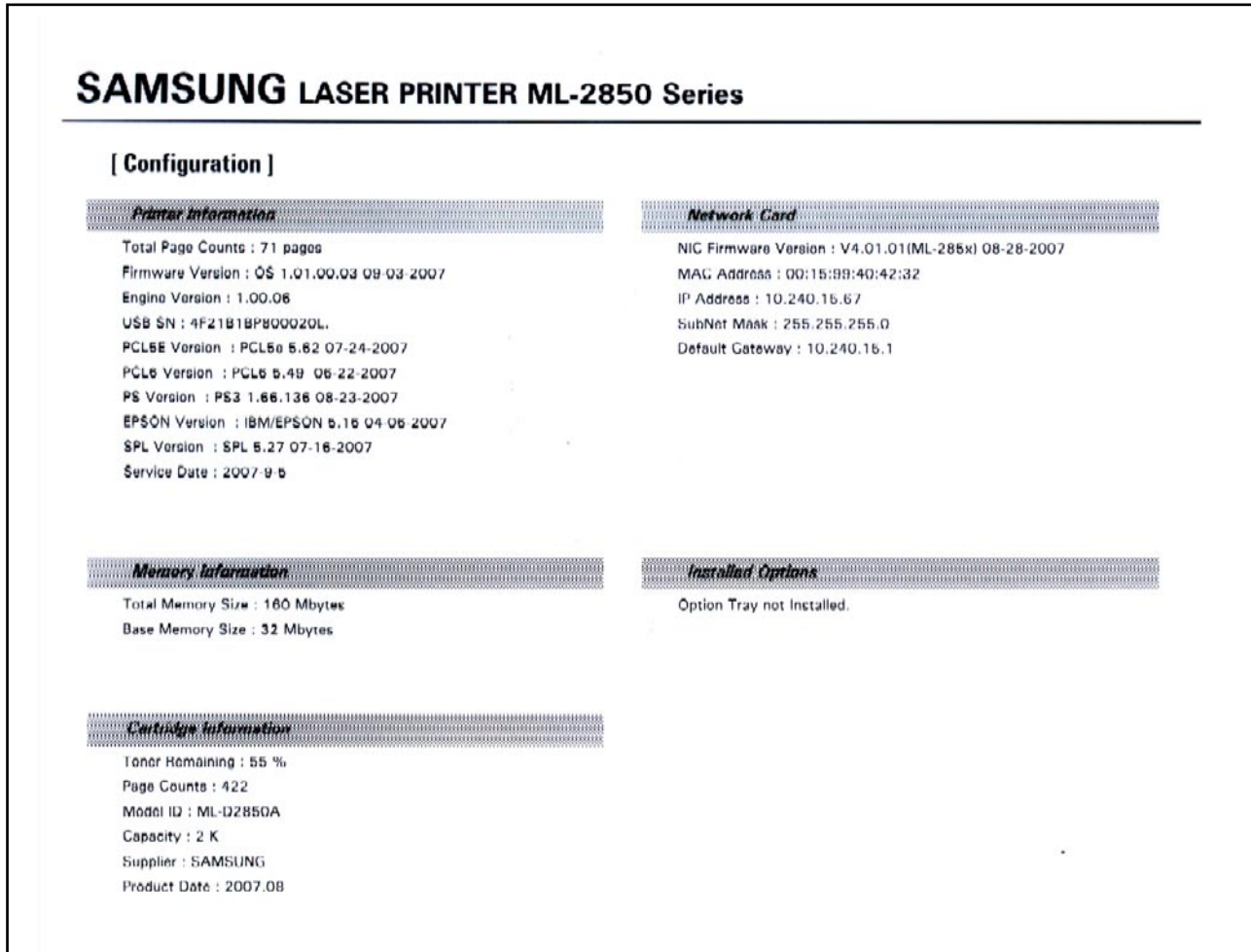

SAMSUNG LASER PRINTER ML-2850 Series

[Menu Map]

1. Information

Menu Map
 Configuration
 Demo Page
 PCL Font List
 PS3 Font List
 EPSON Font

2. Layout

Orientation : Portrait
 Simplex Margin
 *Top Margin : 0 mm
 *Left Margin : 0 mm
 Duplex : Off
 Duplex Margin
 *Top Margin : 5.0 mm
 *Left Margin : 5.0 mm
 *Short Binding : 0 mm
 *Long Binding : 0 mm

3. Paper

Copies : 1
 Paper Size : A4
 Paper Type : Plain Paper
 Paper Source : Auto

4. Graphic

Resolution : 600dpi-Normal
 Darkness : Normal
 Image Enhance : Normal

5. System Setup

Language : English
 Power Save : [15] Min
 Auto Continue : On
 Altitude Adj : Normal
 Auto CR : LF
 Job Timeout : 15
 Maintenance
 *Clean Drum
 *Clean Fuser
 *Supplies Life
 Clear Setting

6. Emulation

Emulation Type = Auto
 Setup
 *PCL (+)
 *PostScript (+)
 *EPSON (+)

7. Network

TCP/IP : Static
 EtherTalk : On
 Ethernet Speed : Auto
 Clear Setting
 Network Info.

PCL (+)

Typeface : PCL1
 Symbol : PG8
 Courier : Regular
 Pitch : 10.00
 Lines : 64

PostScript (+)

Print PS Error : Off

EPSON (+)

Font : SANSERIF
 Character Set : USA
 Character Tab. : PC437US
 Pitch : 10
 LPI : 6
 Auto Wrap : On

4.1.2 Control Panel

4.1.2.1 Control Panel

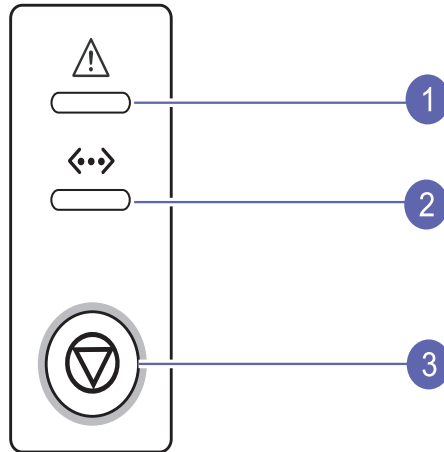

1	Error: Indicates the status of your printer.
2	Online: Indicates the status of your printer.
3	Cancel: Prints a demo page or configuration page. Cancels the print job. Makes the printer pick up the print media.

4.1.2.2 Network setup(ML-2851ND only)

This chapter gives you basic information for setting up your printer for network connections.

This chapter includes:

- Introduction
- Supported operating systems
- Using SetIP program

Introduction

Once you have connected your printer to a network with an RJ-45 Ethernet cable, you can share the printer with other network users.

You need to set up the network protocols on the printer to use it as your network printer. Protocols can be set up by the following programs:

- SyncThru™ Web Admin Service: A web-based printer management solution for network administrators. SyncThru™ Web Admin Service provides you with an efficient way of managing network devices and lets you remotely monitor and troubleshoot network printers from any site with corporate intranet access. You can download this program from <http://solution.samsungprinter.com>.
- SyncThru™ Web Service: A web server embedded to your network print server, which allows you to configure the network parameters necessary for the printer to connect to various network environments.
- SetIP: A utility program allowing you to select a network interface and manually configure the addresses for use with the TCP/IP protocol.
This program is on the software CD that comes with your printer.

Supported operating systems

The following table shows the network environments supported by the printer:

Item	Requirements
Network interface	• 10/100 Base-TX
Network operating system	• Windows 2000/XP(32/64 bit)/2003/Vista • Various Linux OS including Red Hat 8 ~ 9, Fedora Core 1 ~ 4, Mandrake 9.2 ~ 10.1, SuSE 8.2 ~ 9.2 • Mac OS 8.6 ~ 9.2, 10.1 ~ 10.4
Network protocols	• TCP/IP • EtherTalk • HTTP 1.1 • SNMP
Dynamic addressing server	• DHCP, BOOTP

- TCP/IP: Transmission Control Protocol/Internet Protocol
- DHCP: Dynamic Host Configuration Protocol
- BOOTP: Bootstrap Protocol

Using SetIP program

This program is for the network IP setting using the MAC address which is the hardware serial number of the network printer card or interface.

Especially, it is for the network administrator to set several network IPs at the same time.

Note

If you want to setup DHCP network protocol, go to the <http://developer.apple.com/networking/bonjour/download/>, select the program Bonjour for Windows due to your computer operating system, and install the program. This program will allow you to fix the network parameter automatically. Follow the instruction in the installation window. This program does not support Linux.

1. Insert the driver CD provided along with your machine.
2. Start Windows Explorer and open the X drive. (X represents your CD-ROM drive.)
3. Double click Application > SetIP
4. Open the language folder you want to use.
5. Double click Setup.exe to install this program.
6. From the Windows Start menu, select Programs > Samsung Network Printer Utilities > SetIP.
7. Select the name of your printer and click "  ".

Note

If you cannot find your printer name click "  " to refresh the list.

8. Enter the network card's MAC address, IP address, subnet mask, default gateway, and then click Apply.

Note

If you do not know the network card's MAC address, print the machine's network information report.

9. Click OK to confirm the settings.
10. Click Exit to close the SetIP program.

4.1.3 Consumables and Replacement Parts

To avoid print quality and paper feed problems resulting from worn parts and to maintain your printer in top working condition the following items will need to be replaced at the specified number of pages or when the life span of each item has expired.

COMPONENT	REPLACEMENT CYCLE
Pick-up Roller	50K Pages
Transfer Roller	50K Pages
Fuser	50K Pages
Toner Cartridge	2K Pages(Initial/Sales), 5K Pages(Sales)

4.1.4 LED Status Error Message

4.1.4.1 Status LED

Status			Description
Error	Red	On	<ul style="list-style-type: none"> The cover is open. Close the cover. There is no paper in the tray. Load paper in the tray. The printer has stopped printing due to a major error. The toner cartridge is not installed. Install the toner cartridge. Your system has some problems. If this problem occurs, contact your service representative. The toner is totally exhausted. Remove the old toner cartridge and install a new one.
		Blinking	<ul style="list-style-type: none"> A minor error is occurring and the printer is waiting for the error to be cleared. When the problem is cleared, the printer resumes printing. The toner cartridge is low. Order a new toner cartridge. You can temporarily improve print quality by redistributing the toner.
	Orange	On	<ul style="list-style-type: none"> A paper jam has occurred. To solve the problem..
Online	Green	On	<ul style="list-style-type: none"> The printer is in power save mode. The printer is on-line and can receive data from the computer.
		Blinking	<ul style="list-style-type: none"> Blinks slowly indicates that the printer is receiving data from the computer. Blinks quickly indicates that the printer is printing data.

4.1.5 Abnormal Image Printing and Defective Roller

If abnormal image prints periodically, check the parts shown below.

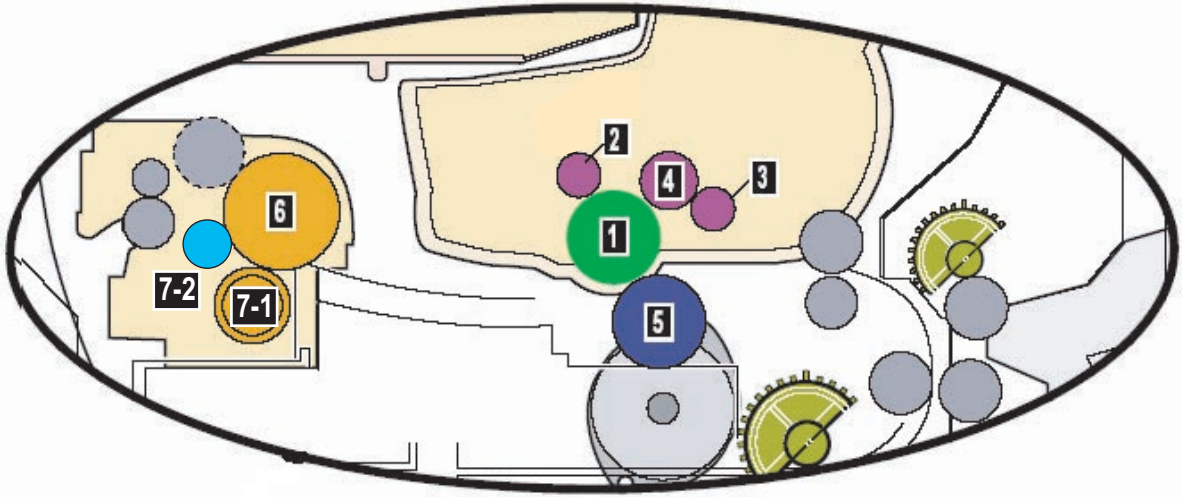

No	Roller	Abnormal image period	Kind of abnormal image
1	OPC Drum	75.5mm	White spot, Block Spots
2	Charge Roller	26.7mm	Block Spot and Periodic Band
3	Supply Roller	47.1mm	Periodic Band by little difference of density
4	Developing Roller	35.2mm	White Spot, Horizontal black band
5	Transfer Roller	47mm	Ghost, Damaged Image by abnormal transfer
6	Heat Roller	77.6mm	Black Spots or Vertical Black Band
7-1	Pressure Roller _1st	62.8mm	Background
7-2	Pressure Roller _2st	37.7mm	Background

4.1.6 How to use DCU

4.1.6.1 DCU Setup

You can examine the malfunction of the printer. To perform DCU, open the front discharge cover and leave the connect the harness wire(4 pin) to the CN17 of the Main control board.

ML SERIES DIAGNOSTIC CONTROL UNIT

STATUS

DIAGNOSTIC

04	DEV 300	DEV 350	DEV 350
05	LSU READY	LSU MT & LD	LSU MOTOR
07	PAPER EMPTY	PAPER WIDTH	NEW CRU
08		EXIT SENSOR	FEED SENSOR
09	COVER OPEN		
10	COER HEATING	PRINTING TEMP	READY HEAT
	ON	OFF	

SELF TEST

DIAGNOSTIC CODE	
00	MAIN MOTOR OPERATING SYSTEM
01	MAIN HIGH-VOLTAGE ON
02	TRANSFER HIGH-VOLTAGE (-)ON
03	THV(+) REFERENCE VOLTAGE
04	DEV/SUPPLY HIGH-VOLTAGE ON/PTL ON
05	LSU OPERATING SYSTEM
06	PICKUP CLUTCH ON
07	PEEMPTY/PWITH/NEW CRU TEST
08	FEED & EXIT SENSOR TEST
09	COVER OPEN SENSOR TEST
10	FUSER TEST
11	HOT BURN TEST
12	CLEAN MODE PRINT
13	THV(+)TRIGGER, ALL HV & FAN ON
14	THV(+) REFERENCE ON

STATUS CODE	
61	WARM UP
00	READY (REGAL)
01	READY (LETTER)
02	READY (A4)
03	READY (EXECUTIVE)
04	READY (B5)
20	PRINT START
30	FEED SENSOR ON
40	FEED SENSOR OFF
50	PAPER OUT
69	SLEEP MODE
❑ ERROR STATUS CODE	
60	OPEN FUSER ERROR
62	LOW TEMPERATURE ERROR
68	OVER HEATING ERROR
64	COVER OPEN ERROR
70	NO PAPERR
71	PAPER JAM 0
72	PAPER JAM 1
73	PAPER JAM 2
95	LSU NOT READY

DIAGNOSTIC MODE — DOWN — SHIFT — STOP

UP — ENTER

TO ENTER DIAGNOSTIC MODE, PUSH THREE BUTTONS SIMUL ANEOUSL AND TURN THE PRINTER POWER ON.

4.1.6.2 Code

Connect DCU to the printer and turn the power on. It show 7 Segment FND on the panel and each code tells the function of the printer.

1) Normal Code

While printing or warming up, it indicate the position of the paper

Code	State	Description
61	Warm up	The printer is on, the cover is open or close.
00~05	Ready(kind of paper)	The printer is ready, the paper is detected when the first paper is printed. 00: Legal ,01: Letter ,02: A4 ,03: EXEC ,04: B5 ,05: Folio, 06: A5/A6
20, 21, 22	Print Start	The engine controller received the print order from the video controller. 20: 1st, 21: MP, 22: SCF
30	Feed Sensor On	The paper is passing out of the Feed Sensor.
40	Feed Sensor off	The paper has passed out of the Feed Sensor.
50	Paper Out	The paper has passed out of Exit Sensor.
69	Sleep Mode	The fuser power turned off to minimize the power consumption.

2) Error Code

When detecting the malfunction, the printing is stopped to indicate error code.

Code	State	Description
60, 62, 68	Fuser Error	The error in the fuser occurred. There is a short circuit in the thermistor and the thermostat while printing, Low Temperature Error occurs. • 60: Open Fuser Error • 62: Low Heat Error • 68: Over Heat Error
64	Cover Open	The Printer Cover is open.
65	CRU Error	The Toner Cartridge not installed,
70	No Paper	No paper in the paper cassette.
71	Paper Jam 0	The front part of paper is jammed between pickup unit and Feed sensor.
72	Paper Jam 1	The front part of paper is jammed between the Discharge sensor and Feed sensor.
73	Paper Jam 2	The front part of paper is jammed just after passing through the discharge sensor.
95	LSU Not Ready	LSU Scanner Motor not ready.
96	LSU Not Ready	Hsync signal not output.

4.1.6.3 Self Diagnostic Mode

If Error code occurs due to malfunction of the printer, perform Self Diagnostic Mode to solve the problem.

The printer works only in the self-test mode to solve the malfunction problem.

To enter the self-test mode, turn the power on pressing the buttons of [Down], [Shift] and [Stop] at the same time. Release the button within 2 or 3 seconds if 78 shows in the DCU. If 00 shows in the DCU, press the button [Up] or [Shift] to select the self+test , and press the button of [Enter] to operate. To stop, press the button of [shift] and [Enter] together.

Code	Description
00	Main Motor Operating System Only the main motor is in operation.
01	Main High Voltage On(THV-) -1400 voltage output by MHV terminal. Caution : High voltage probe should be used.
02	Transfer High Voltage(-)On(THV-) -1000 voltage output by MHV terminal. Caution : High voltage probe should be used.
03	Transfer High Voltage (+)Reference on (THV +) +1300 voltage output by MHV terminal. Caution : High voltage probe should be used.
04	DEV/supply High Voltage : DEV/Supply High Voltage Test. The left one of the three LEDs in the self-test panel is on when DEV high voltage Supply high voltage output by each HV terminal. Press the [Up] button to switch the voltage. The middle and right one of the three LEDs are on and -350 voltage output by DEV HV terminal. Caution : High voltage probe should be used.
05	LSU Operating System The scanning motor of LSU is in operation, the right LED of the three buttons on. Press the [Up] button to Check LD. LD is functioning and the middle button is on. If the LD is normal, all LEDs are on.
06	Pickup clutch on The Solenoid in the printer is in operation. To stop the operation, Press the button [shift] and [Enter] together.

Code	Description
07	<p>Paper Empty Sensor Test :</p> <p>If activate the Actuator of the PEMPTY Sensor, the left and right of the three LEDs are on.</p> <p>Paper Empty Sensor ON/OFF 1st LED ON/OFF</p>
08	<p>Feed & Exit Sensor Test</p> <p>Test the Feed sensor and Discharge sensor in the same way as '07'.</p> <p>Feed Sensor ON/OFF 2nd LED ON/OFF</p> <p>Exit Sensor ON/OFF 3rd LED ON/OFF</p>
09	<p>Cover Open Sensor Test</p> <p>Test the Cover Open Sensor in th same way as code '07'</p> <p>Cover Open Sensor ON/OFF1st LED ON/OFF</p>
10	<p>Fuser Test</p> <p>If the [Enter] button pressed, the right LED is on and temperature of the fuser is up to READY Mode. If the [Up] button pressed, the middle LED is on and temperature of the fuser is up to Printing Mode.</p> <p>If you press the button once more, the left LED is on and temperature of the fuser is up to overheat Mode.</p>
11	<p>Hot Burn Test</p> <p>If the [enter] button pressed, the printer is continuously printing without detection.</p> <p>Turn the power off to stop operation.</p>
12	<p>Cleaning Mode Print Mode</p> <p>Print the paper to clean the OPC Drum in the Cartridge.</p>
13	<p>THV(+) TRIGGER. ALL HV :</p> <p>All high voltage output by each HV terminal and LSU and the fan is in operation. In this mode, electronic resistance of transfer roller and high voltage is detected.</p>
14	<p>Fan Test :</p> <p>Indicates the function of the Fan, same method of the code '07'.</p>
15	<p>Manual Pickup Test :</p> <p>Indicates the function of th Manual Pickup, same method of the code '07'.</p>
16	<p>Manual Sensor Test :</p> <p>Indicates the function of the Manual Sensor, same method of the code '07'.</p>

No.	Function	Enter	Up/Down		Stop	Remark
00	Motor	Motor Run			Motor Stop	
01	MHV	Mhv On			Mhv Off	-1300V
02	THV(-)	Thv Negative On			Thv Negative Off	-1000V
03	THV(+)	Thv On			Thv Off	+1300V
04	DEV	Dev On	Supply	DEV	Dev Off	-350V
			0 : -550V	0 : -350V		
05	LSU	LSU Run	● On	● Off	● Ready	LSU Stop 020mV
06	PickUp	Pickup On			Pickup Off	
07	PEmpty		● Paper Empty	●	●	
08	Sensor		●	● Exit	● Feed	
09	Cover		● Cover Open	●	●	
10	Fuser	Fuser On			Fuser Off	
11	Hot Burn	Hot Burn On				
12	Clean Print	Clean Printing				
13	Thv Reference		● low	● adequate	● high	
14	PTL	PTL On			PTL Off	PTL No
15	FAN	Fan On			Fan Off	
16	Manual PickUp	Manual Pickup On			Manual Pickup Off	
17	Manual Sensor		● Manual Sensor	●	●	

<DCU Function Table>

4.1.6.4 Self Test Button

If the Self-Test button pressed, vertical lines are printed.

Turn the power on while pressing this button, '89' shows in the DCU and the printer is warming up. After warming-up the printer is in READY Mode, and '88' shows in the DCU. In this mode, without any detection, the printer begins printing(trial printing and data from the PC). It is convenient to use this mode when the engine malfunction is detected in the control board.

4.1.6.5 Paper Path

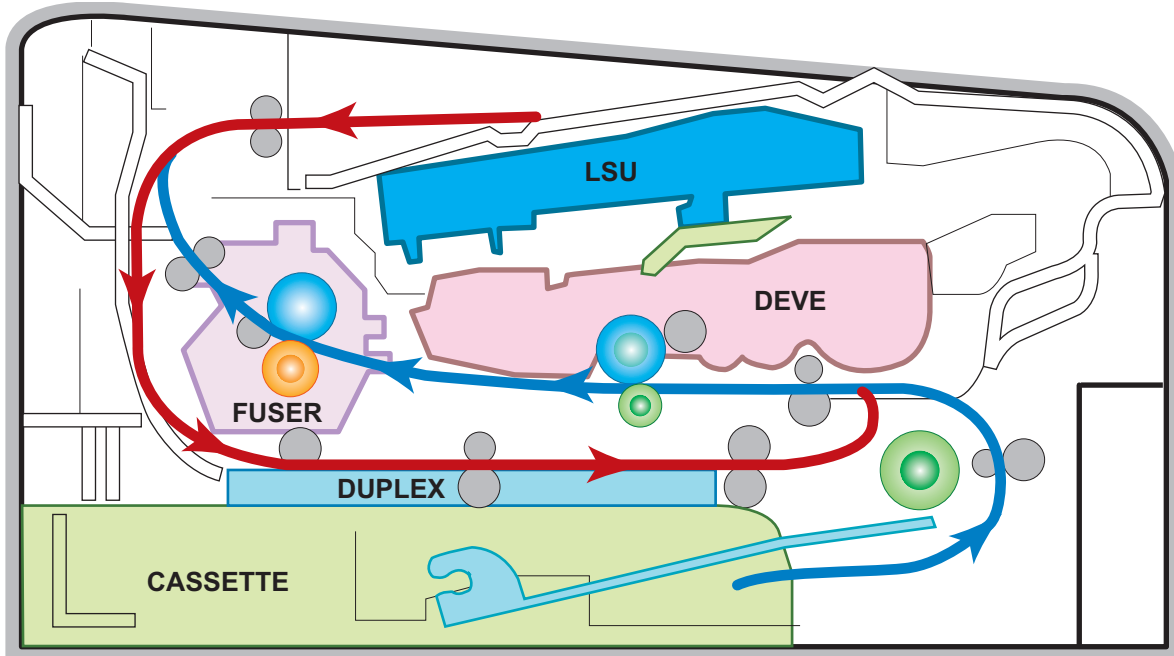

4.1.7 Paper Jam

4.1.7.1 In the paper feed area

In the tray 1

1. Pull the tray 1 open.

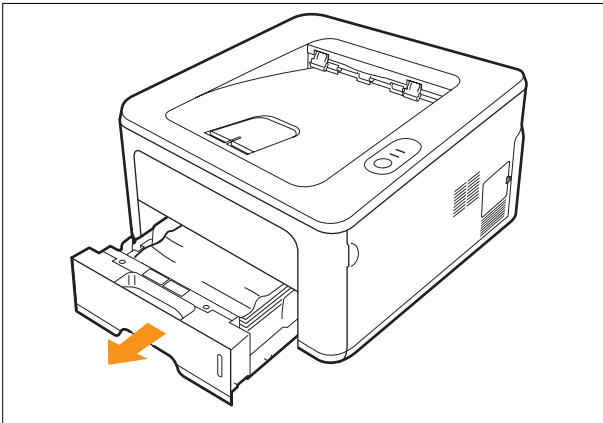

2. Remove the jammed paper by gently pulling it straight out. Make sure that all of the paper is properly aligned in the tray 1.

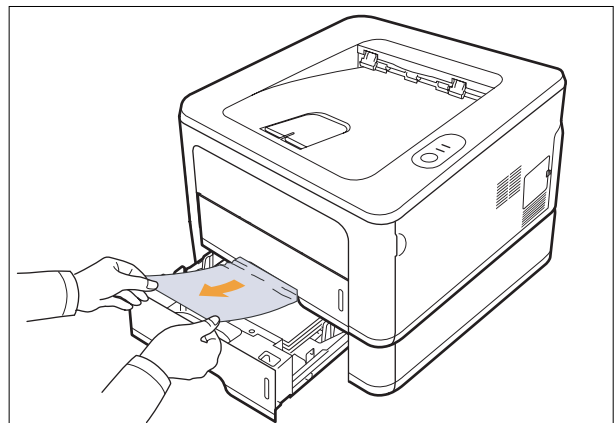

If the paper does not move when you pull, or if you do not see the paper in this area, check the fuser area around the toner cartridge.

3. Insert the tray 1 into the printer until it snaps into place. Printing automatically resumes.

In the optional tray 2

1. Pull the optional tray 2 open.
2. Remove the jammed paper from the printer.

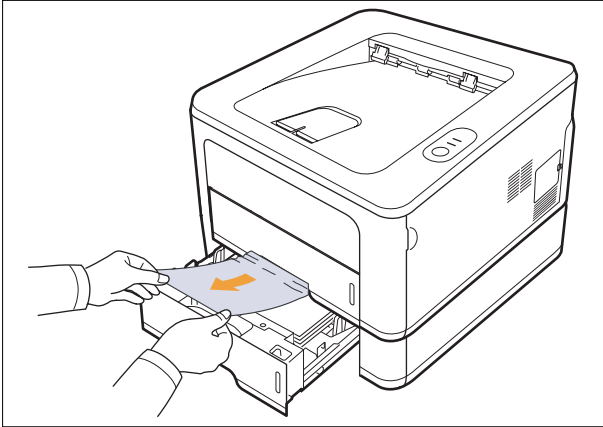

If the paper does not move when you pull, or if you do not see the paper in this area, stop and go to step 3.

3. Pull the tray 1 half.
4. Pull the paper straight up and out.

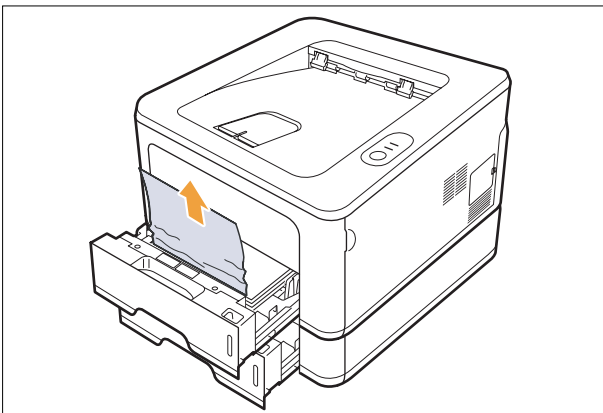

5. Insert the trays back into the printer. Printing automatically resumes.

In the manual tray

1. Remove the jammed paper from the printer.

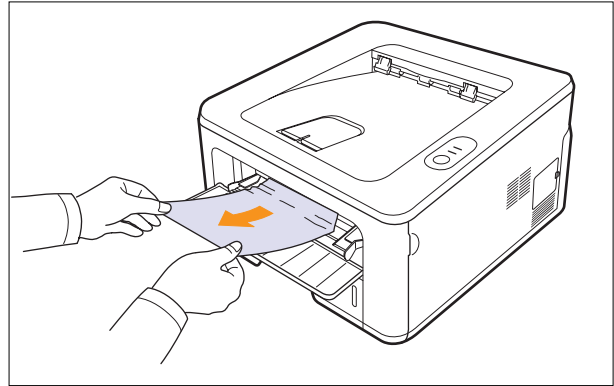

2. Open and close the front cover.
3. Load a paper into the manual feeder, then the printer resumes.

4.1.7.2 Around the toner cartridge

1. Open the front cover and pull the toner cartridge out.

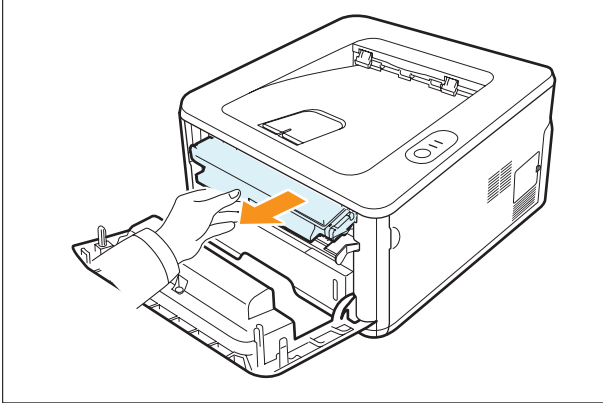

2. Remove the jammed paper by gently pulling it straight out.

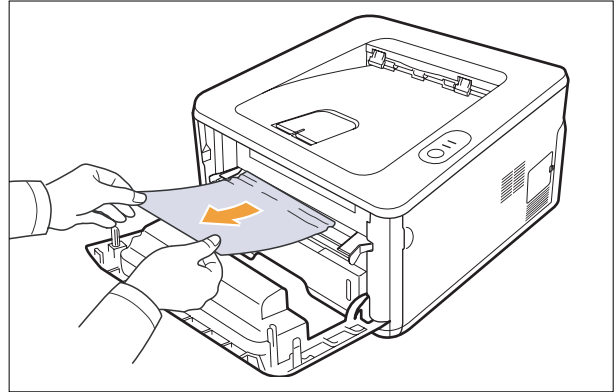

3. Replace the toner cartridge and close the front cover. Printing automatically resumes.

4.1.7.3 In the paper exit area

1. Open and close the front cover. The jammed paper is automatically ejected from the printer.

2. Gently pull the paper out of the output tray.

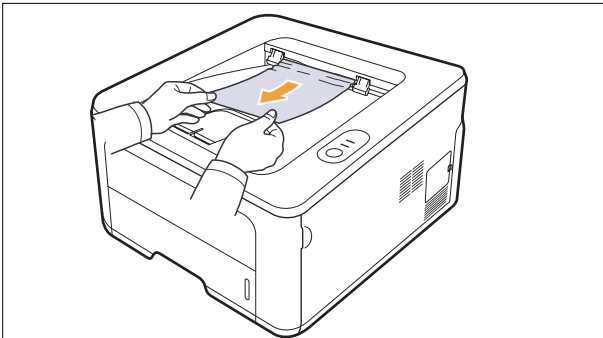

If you do not see the jammed paper or if there is any resistance when you pull, stop and go to the next step.

3. Open the rear cover.

4. Pull the guide rear on each side down and remove the paper. Return the guide rear to its original position.

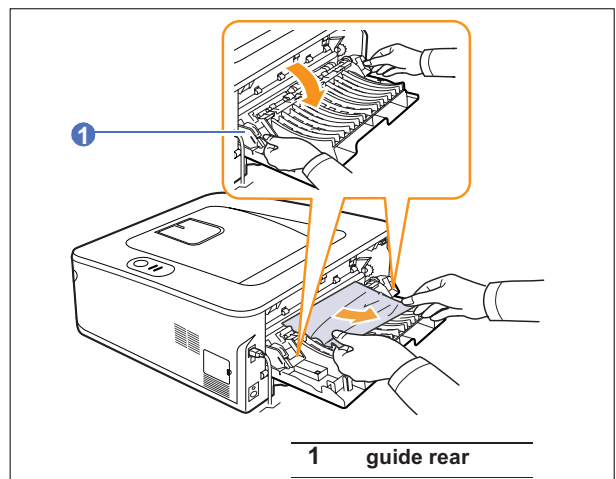

5. Close the rear cover. Printing automatically resumes.

4.1.7.4 In the duplex unit area

If the duplex unit is not inserted correctly, paper jam may occur. Make sure that the duplex unit is inserted correctly.

Duplex jam 0

1. Pull the duplex unit out of the printer.

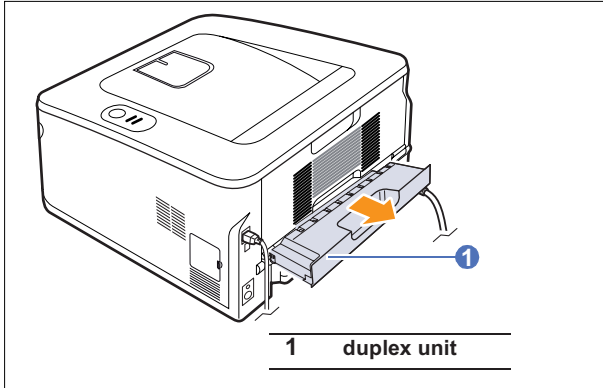

2. Remove the jammed paper from the duplex unit.

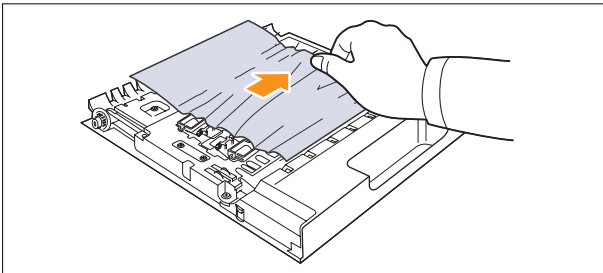

If the paper does not come out with the duplex unit, remove the paper from the bottom of the printer.

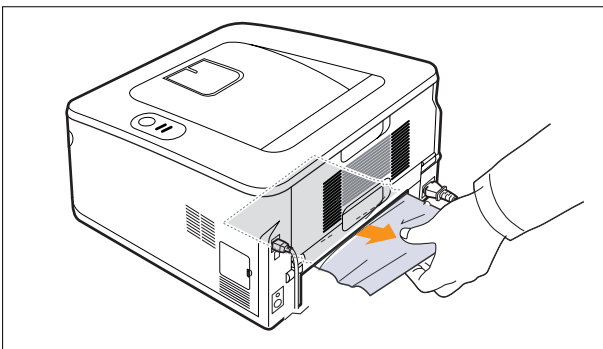

Duplex jam 1

1. Open the rear cover.
2. Pull the guide rear on each side down and remove the paper. Return the guide rear to its original position.

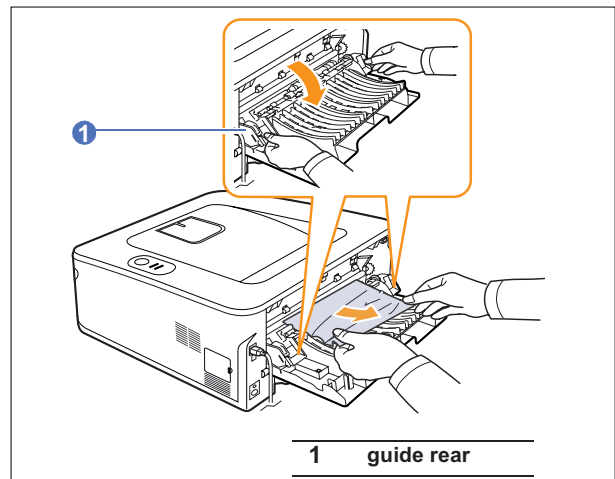

3. Close the rear cover. Printing automatically resumes.

4.1.7.5 TIPS for avoiding paper jams

By selecting the correct media types, most paper jams can be avoided.

- Follow the procedures. Ensure that the adjustable guides are positioned correctly.
- Do not overload the tray. Ensure that the paper level is below the paper capacity mark on the inside wall of the tray.
- Do not remove paper from the tray while your printer is printing.
- Flex, fan, and straighten paper before loading.
- Do not use creased, damp, or highly curled paper.
- Do not mix paper types in a tray.
- Use only recommended print media.
- Ensure that the recommended print side of print media is facing down in the tray, or facing up in the multi-purpose tray.
- If paper jams occur frequently when you print on A5-sized paper.
Load the paper into the tray with the long edge facing the front of the tray.

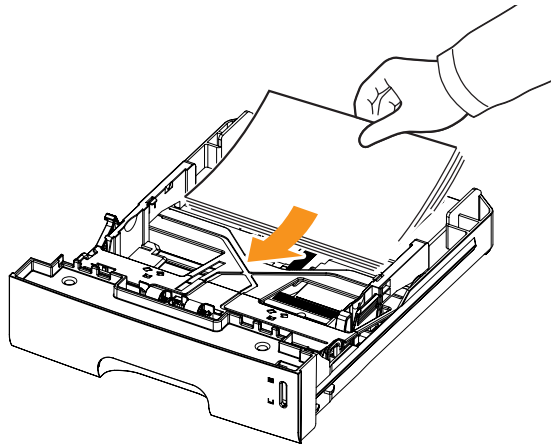

In the printer properties window, set the page orientation to be rotated 90 degrees.

4.1.8 Download & Reset F/W

Firmware download method		
Normal Download method	LED Panel	<ol style="list-style-type: none"> 1. In Dos Prompt, type "Usblist2 [Rom file name]" and Press Enter 2. Status LED Slow blink 3. Status LED & Toner Save LED are both blink 4. When download complete, set will be automatically power On/Off and it'll Warming Up
Boot Download method	LED Panel	<ol style="list-style-type: none"> 1. While Pressing Stop key, Power On the Printer 2. In Dos Prompt, type "Usblist2 [Rom file name]" and Press Enter 3. Status LED Slow blink 4. Status LED & Toner Save LED are both blink 5. When download complete, set will be automatically power On/Off and it'll Warming Up
Reset method		
	LED Panel	<ol style="list-style-type: none"> 1. In Dos Prompt, type "Usblist2 [Rom file name]" and Press Enter 2. Status LED Slow blink → Fast blink then print out configuration page 3. Check the OS version and total page value is "0" 4. Please set power On/Off

4.2 Troubleshooting

4.2.1 Procedure of Checking the Symptoms

Before attempting to repair the printer first obtain a detailed description of the problem from the customer.

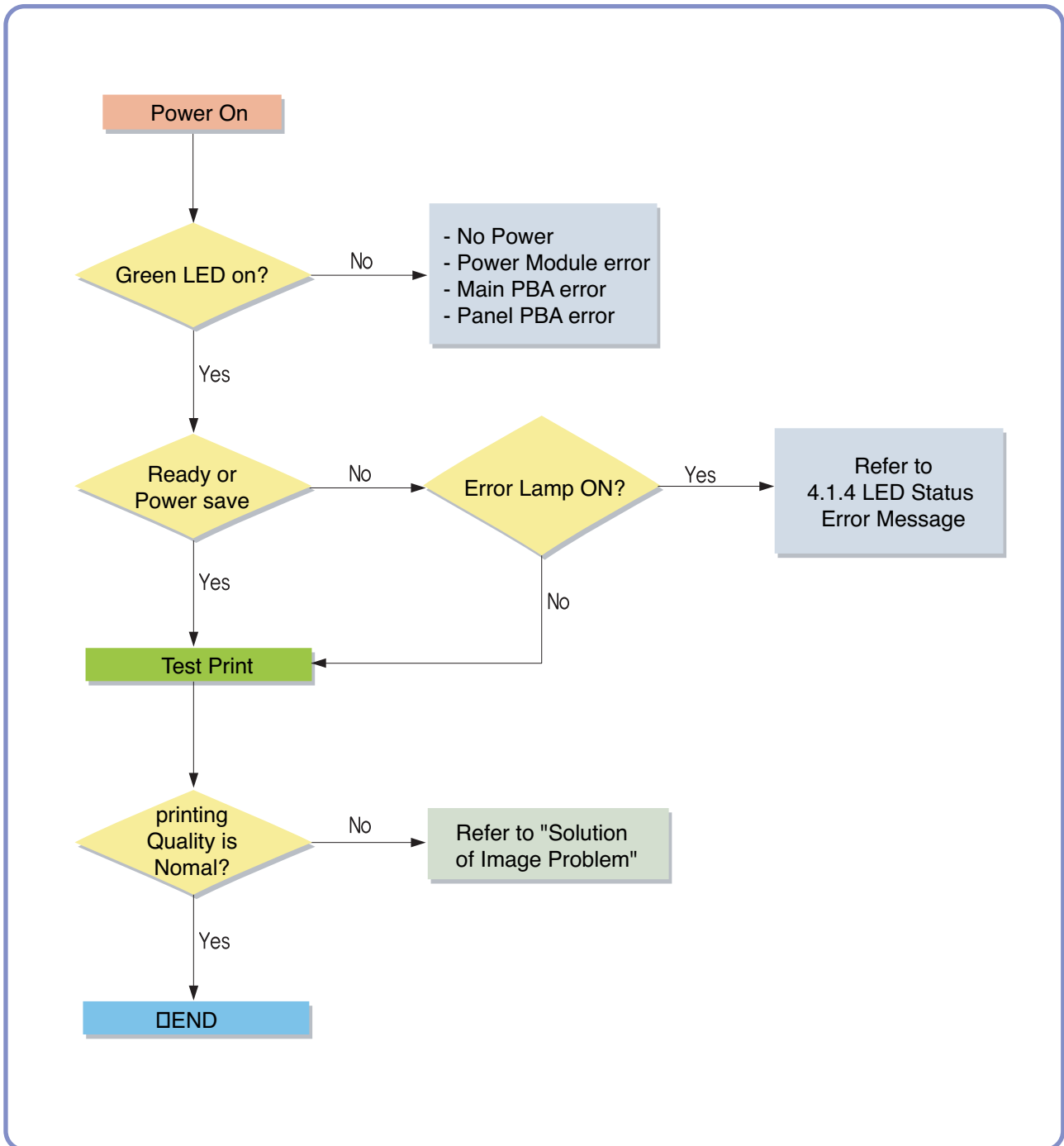

4.2.2 The cause and solution of Bad image

1) Vertical Black Line and Band

Description: 1. Straight thin black vertical line occurs in the printing.
2. Dark black vertical band occur in the printing.

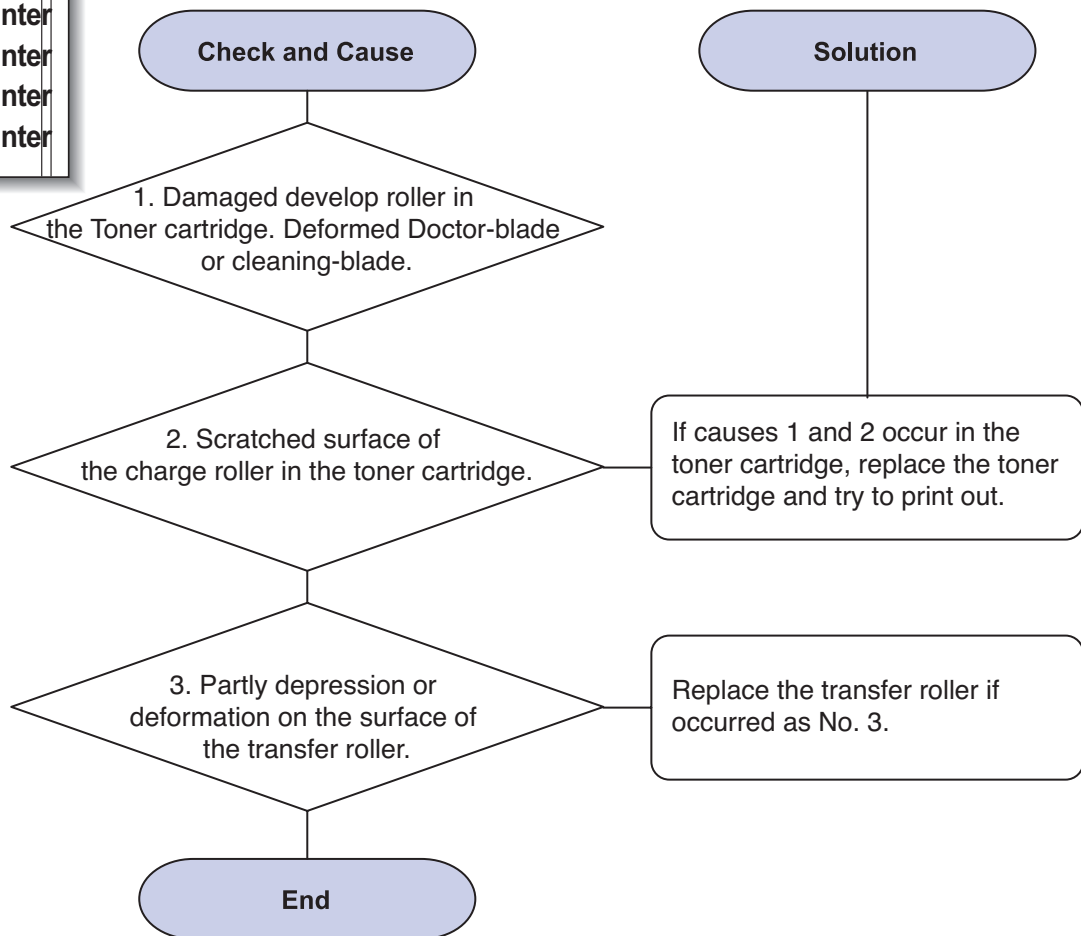
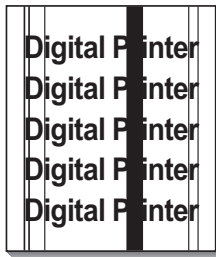

2) Vertical White Line

Description: White vertical voids in the image.

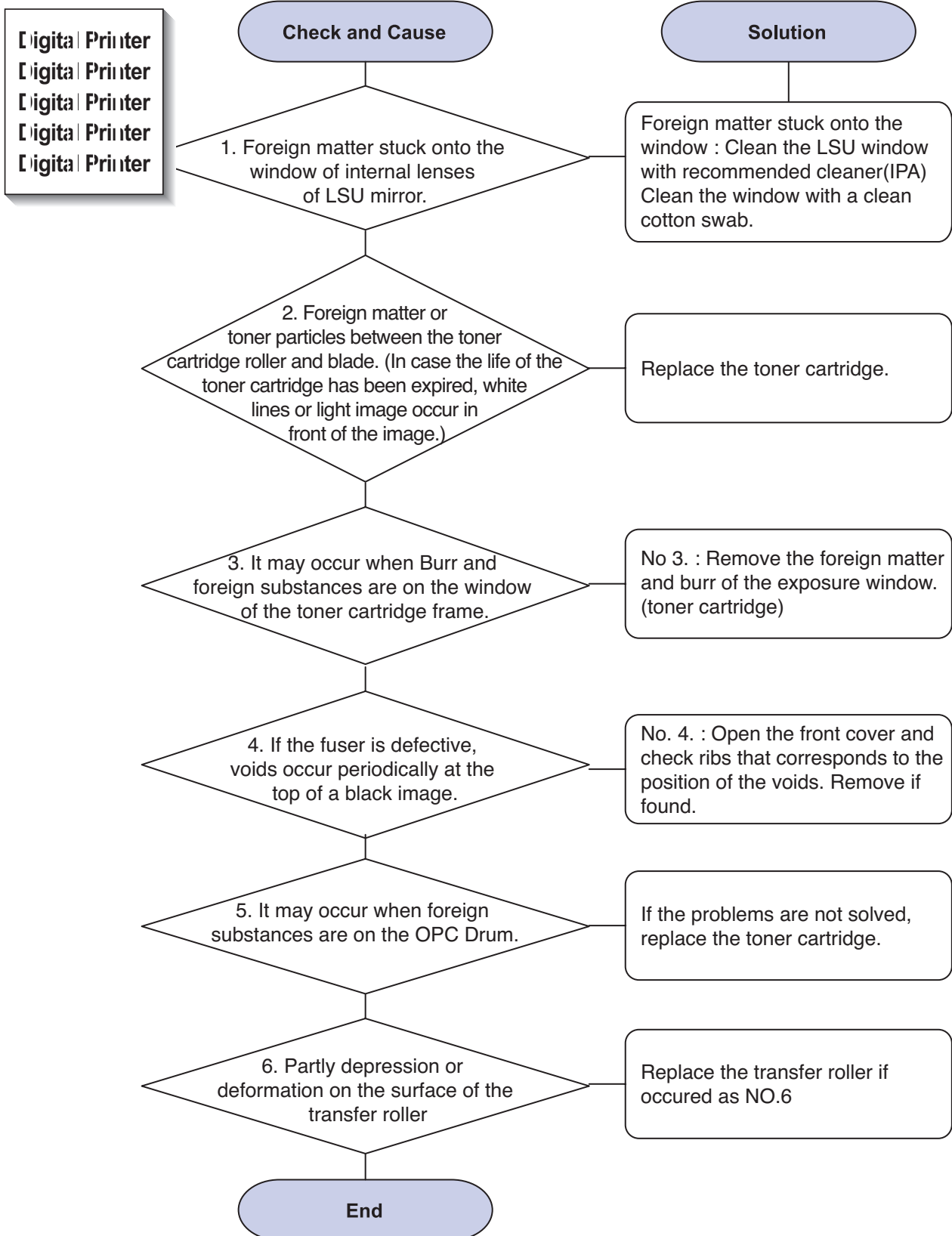

3) Horizontal Black Band

Description: Dark or blurry horizontal stripes occur in the printing periodically.
(They may not occur periodically.)

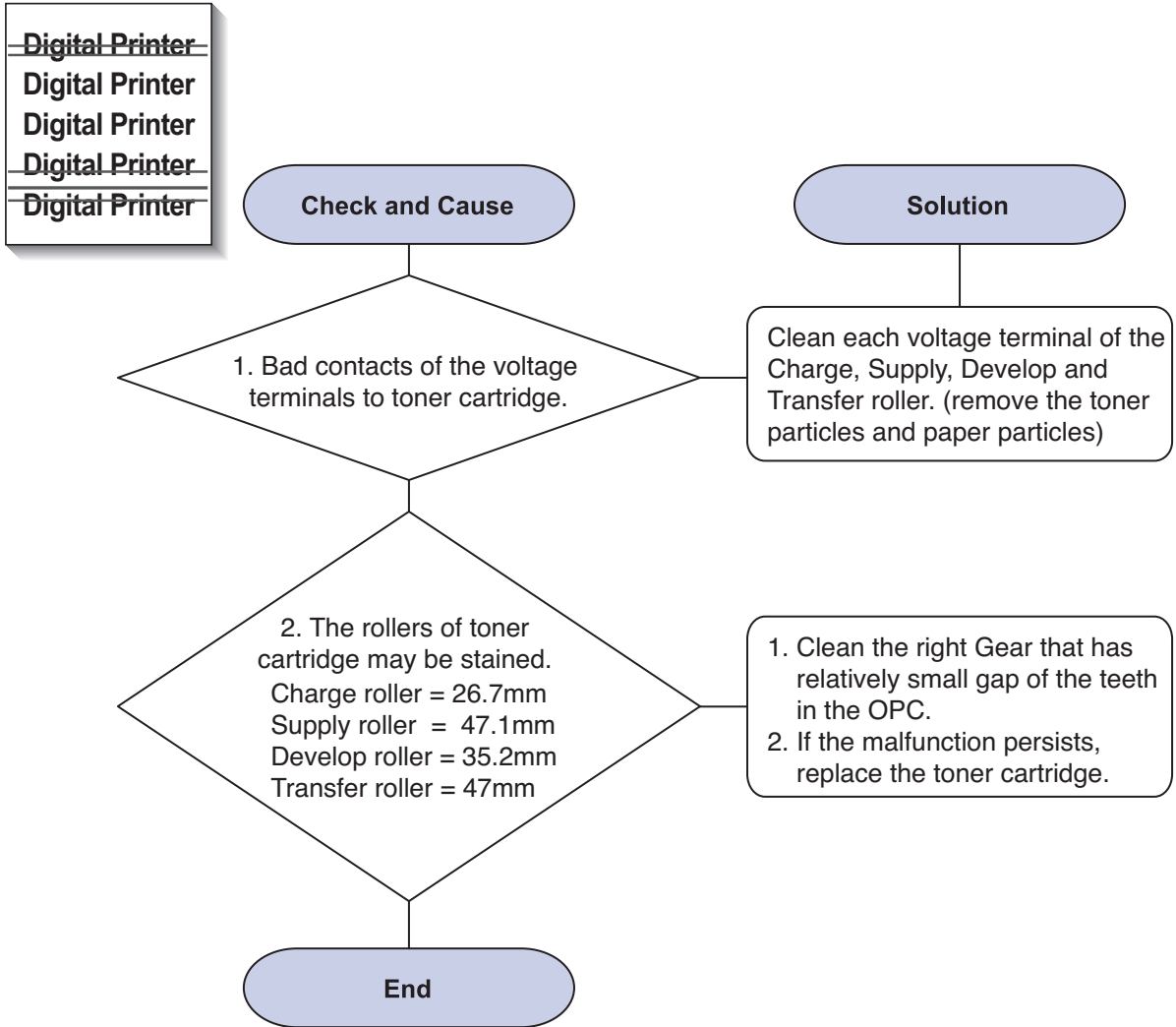

4) Black/White Spot

Description: 1. Dark or blurry spots occur periodically in the printing
 2. White spots occur periodically in the printing

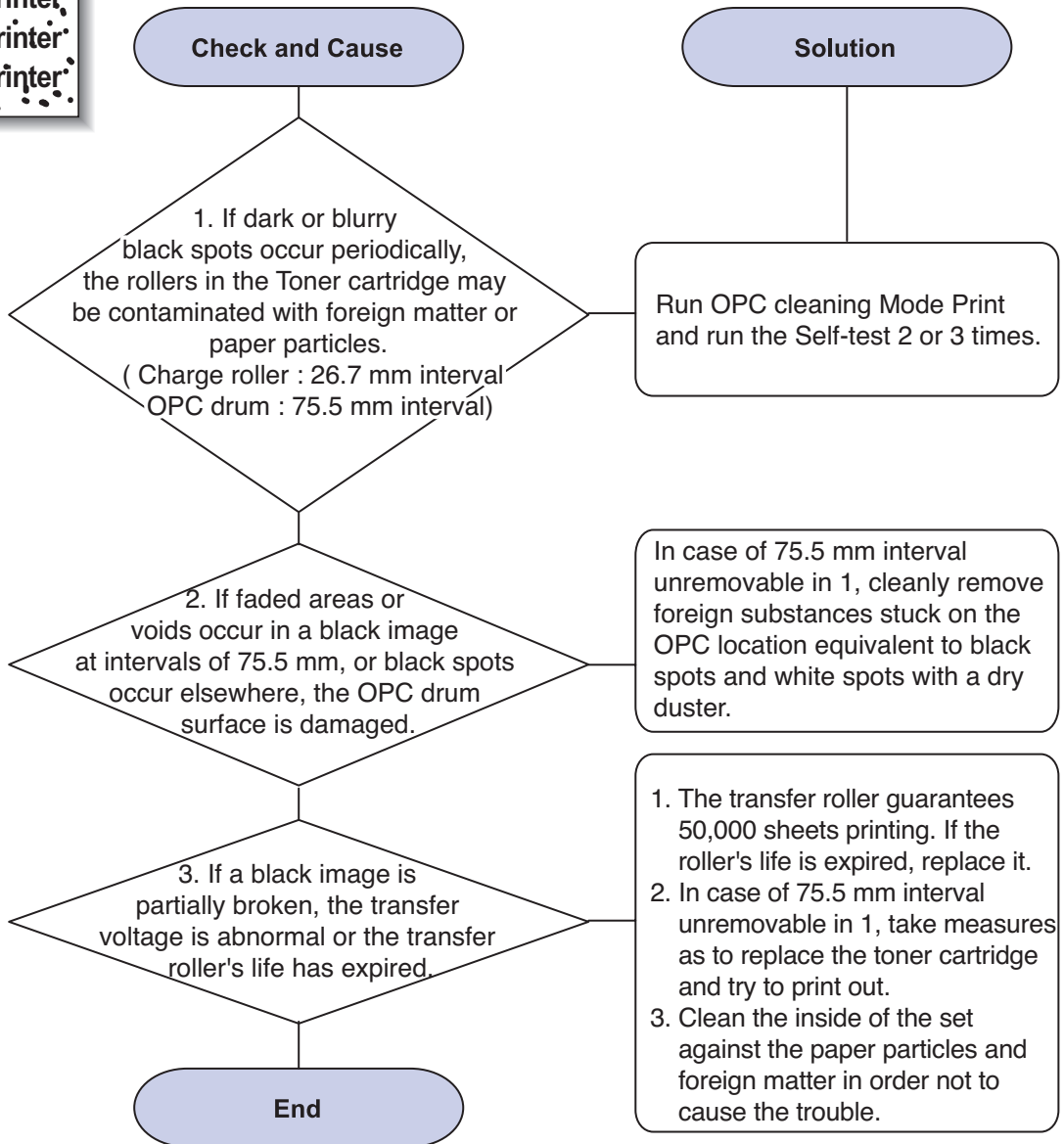

5) Light Image

Description: The printed image is light, with no ghost.

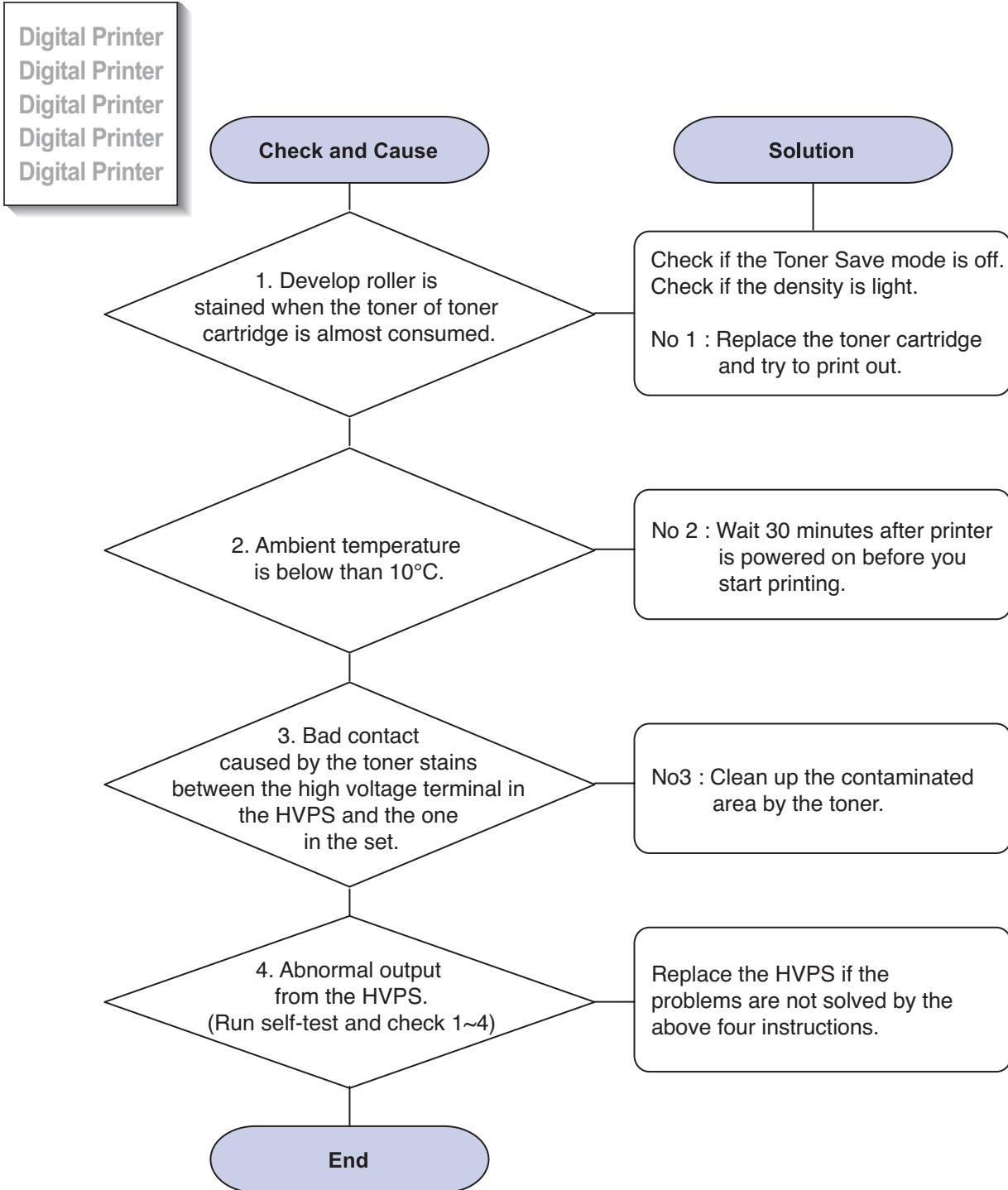

6) Dark Image or a Black Page

Description: The printed image is dark.

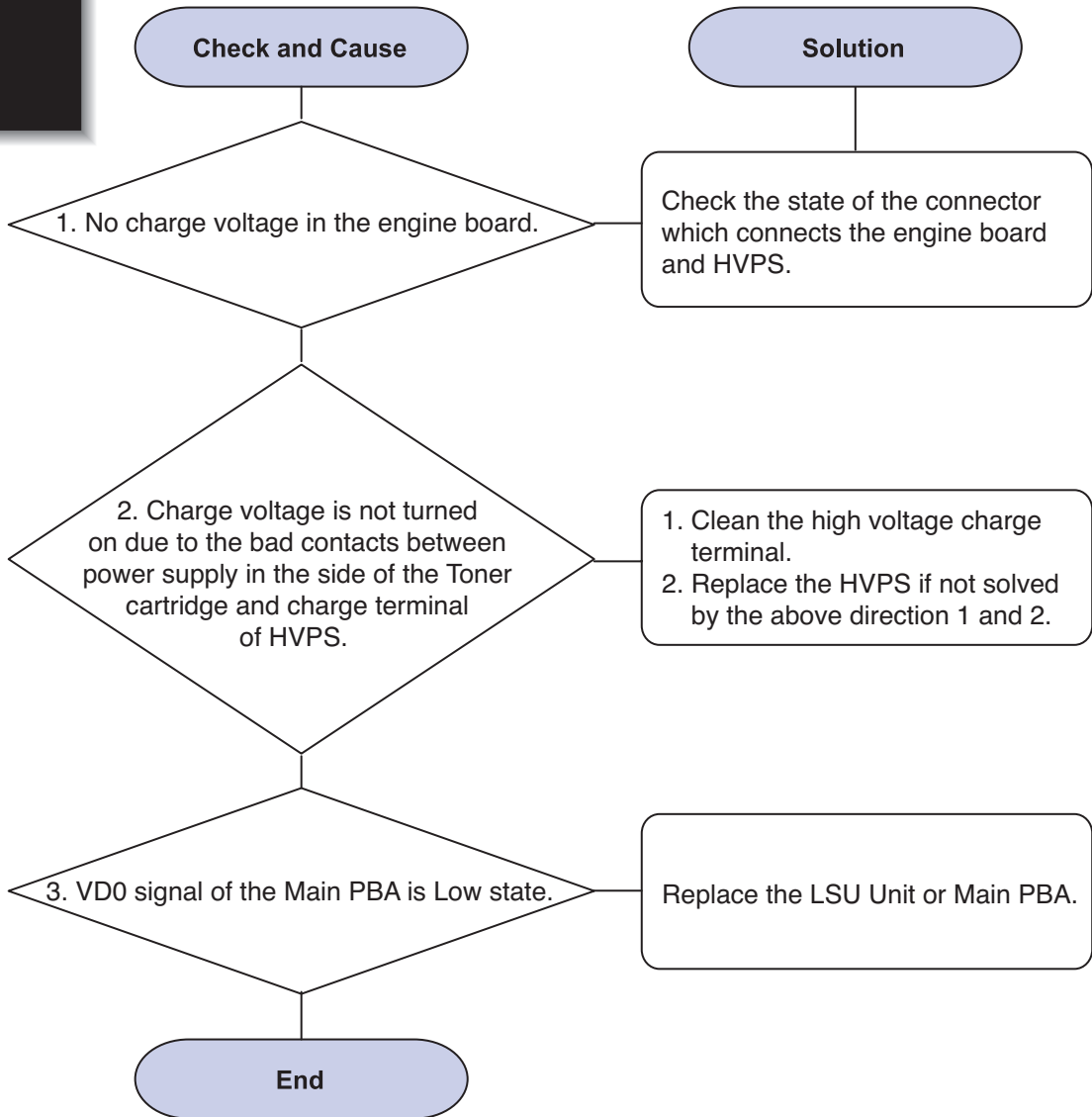
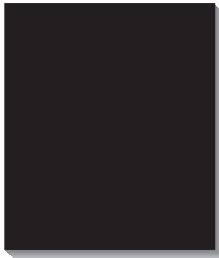

7) Uneven Density

Description: Print Density is uneven between left and right.

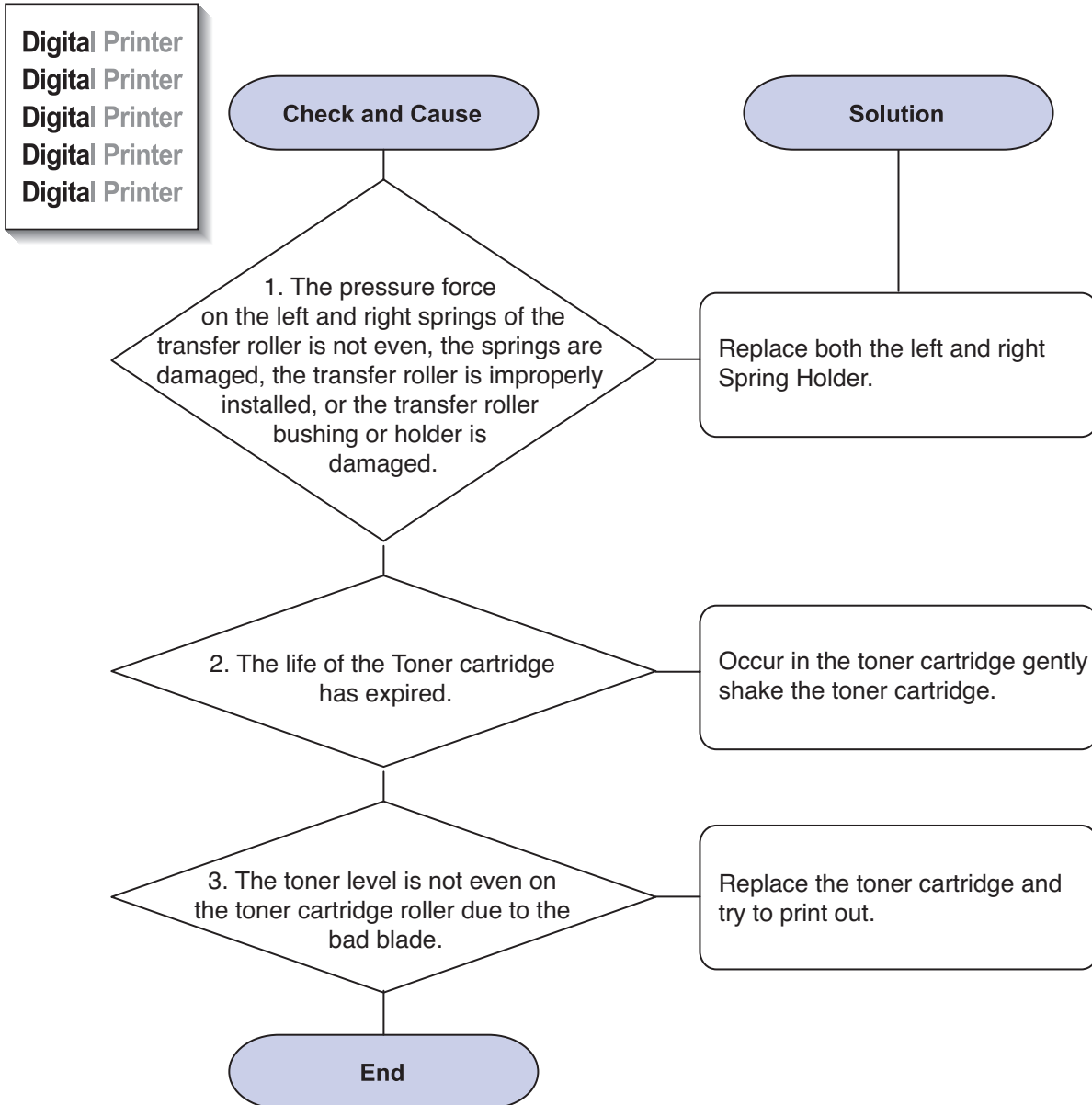

8) Background

Description: Light dark background appears in whole area of the printing.

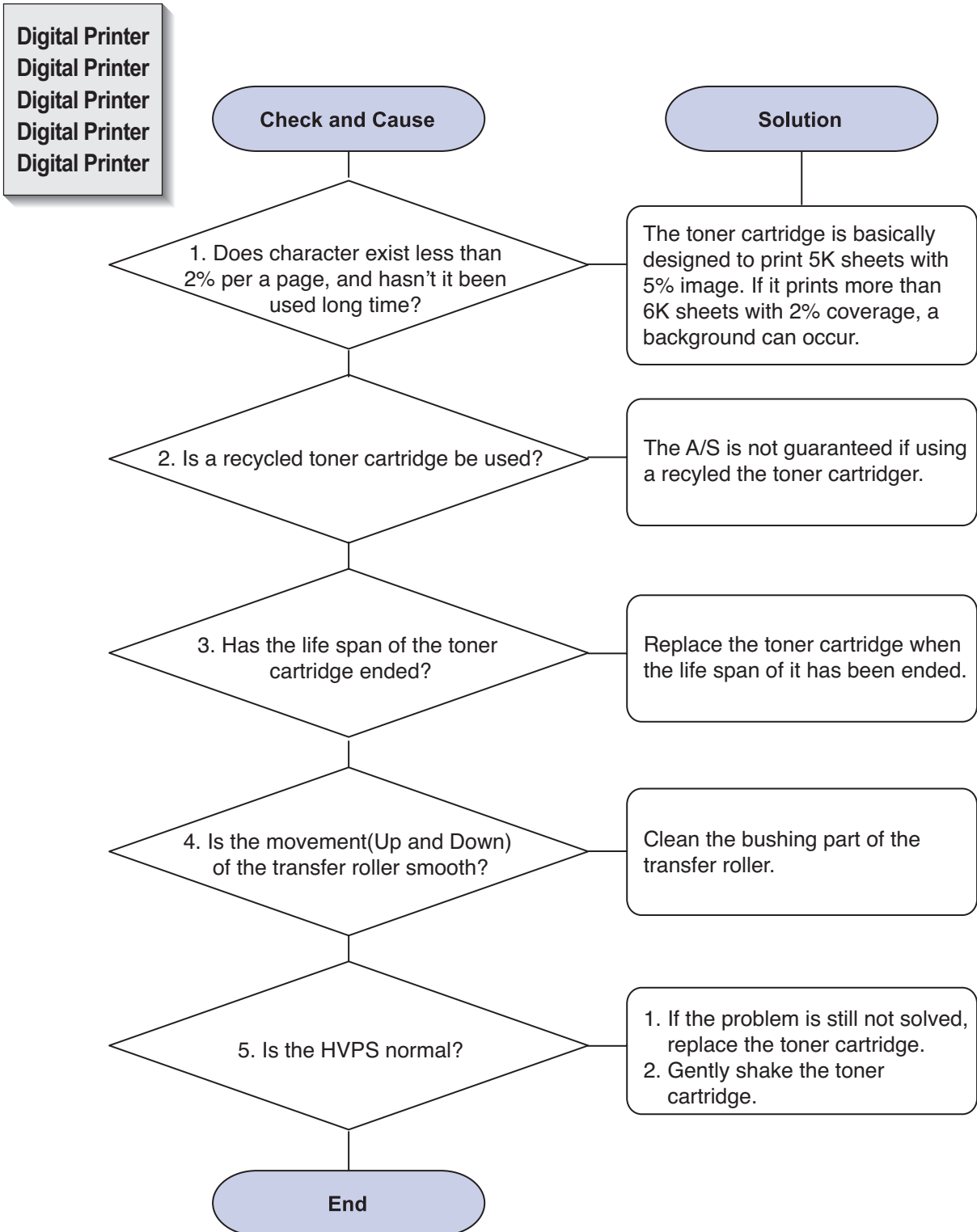

9) Ghost (1)

Description: Ghost occurs at 75.5 mm intervals of the OPC drum in the whole printing.

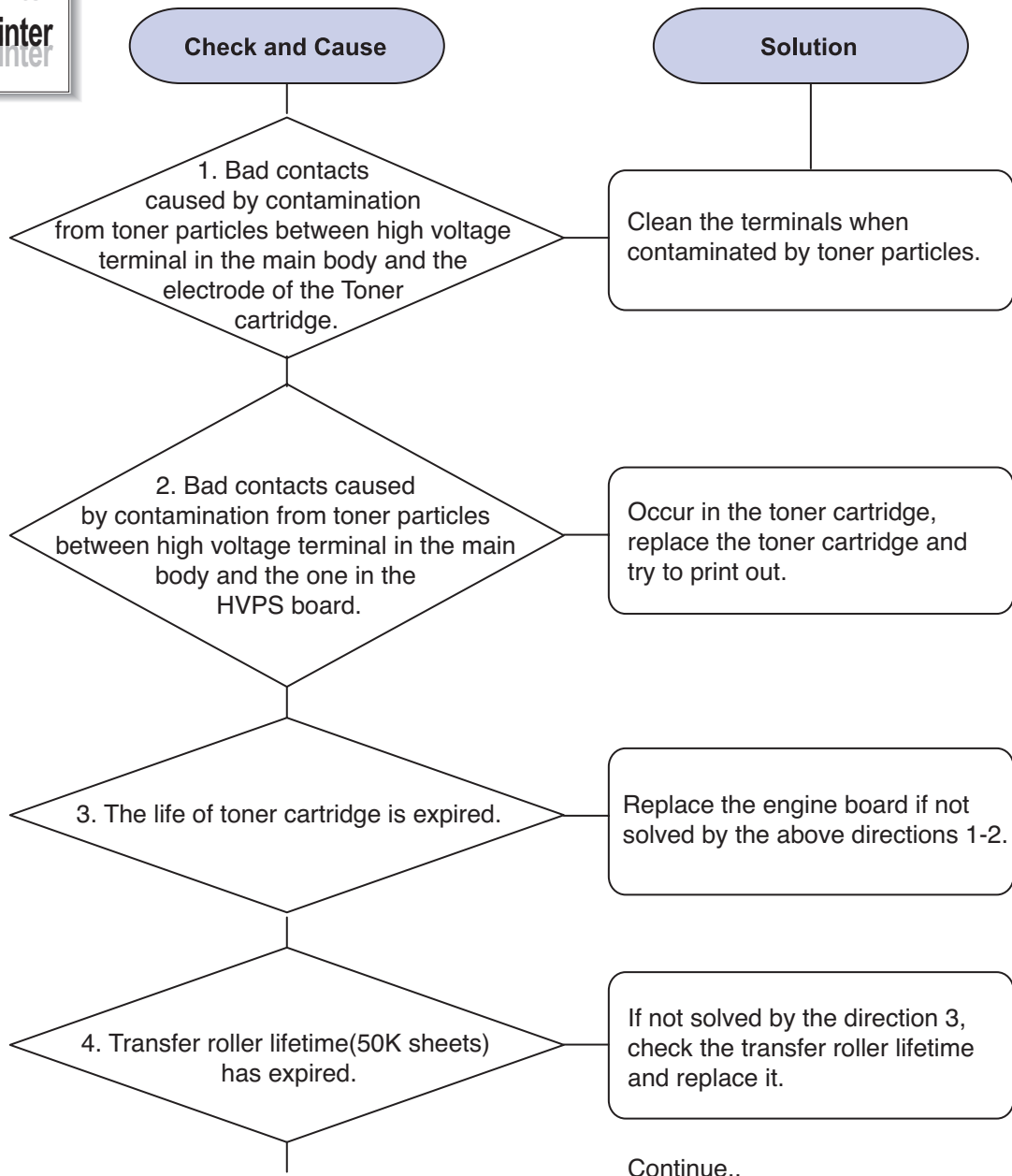
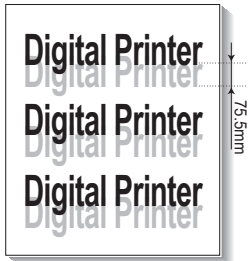

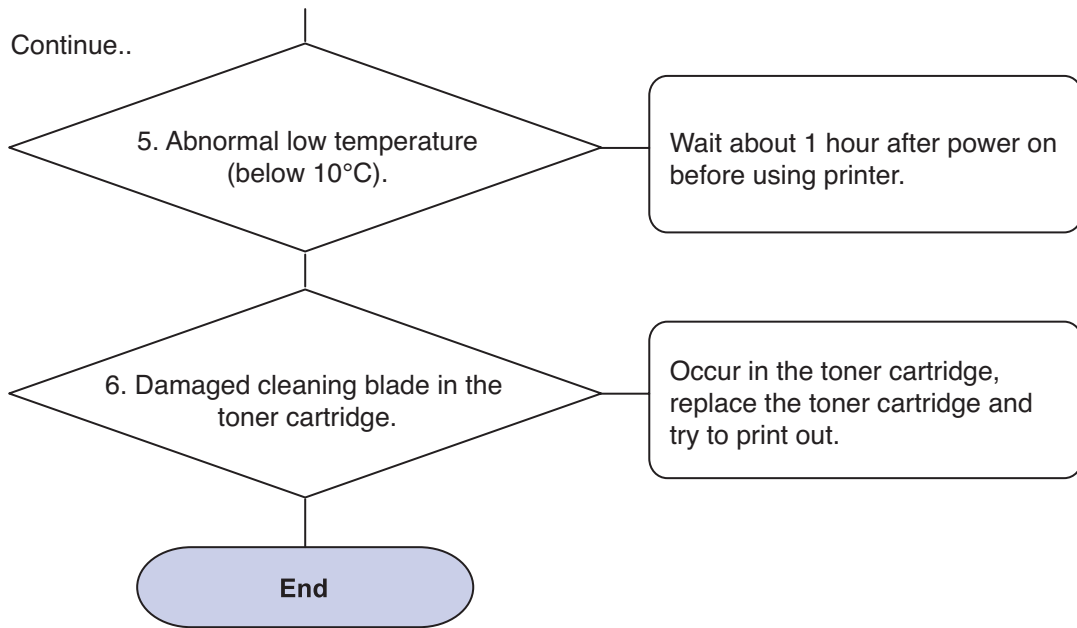

10) Ghost (2)

Description: Ghost occurs at 75.5 mm intervals of the OPC drum in the whole printing.
 (When printing on card stock or transparencies using manual feeder)

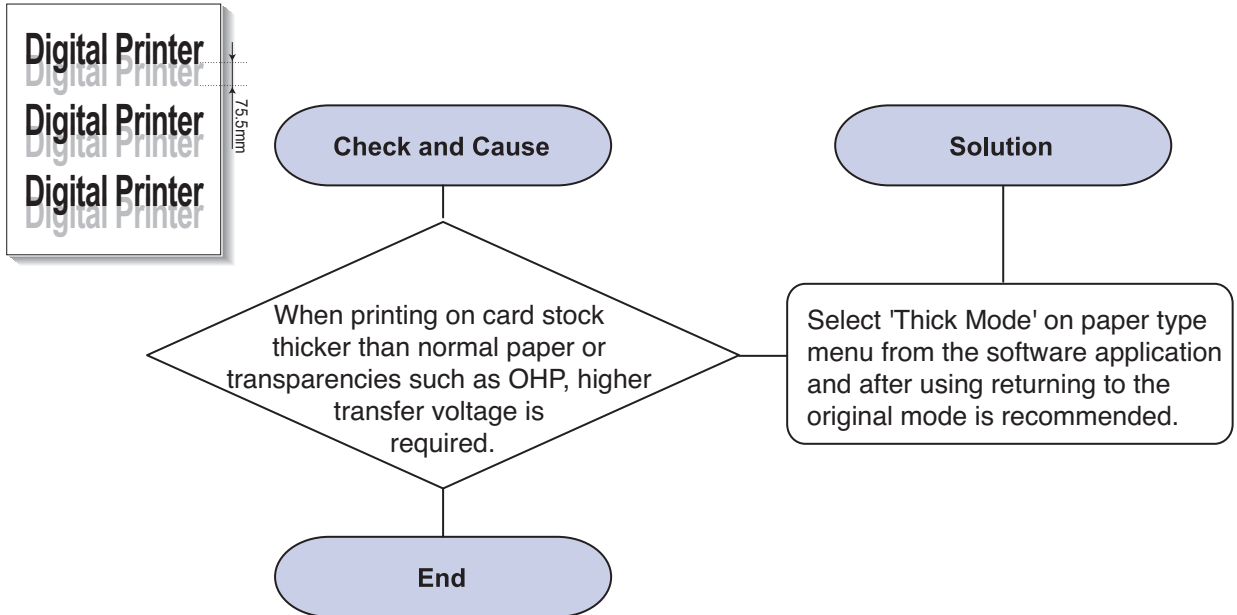

11) Ghost (3) : Fuser

Description: Ghost occurs at 62.8 mm or 77.6mm intervals.

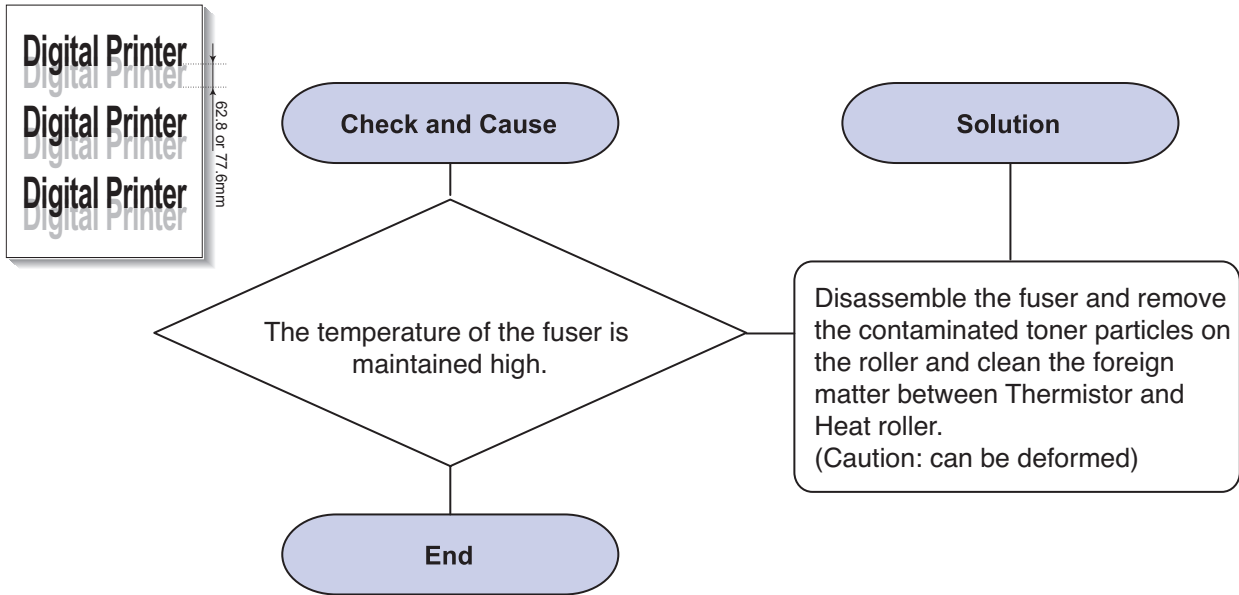

12) Stains on the Face of Page

Description: The background on the face of the printed page is stained.

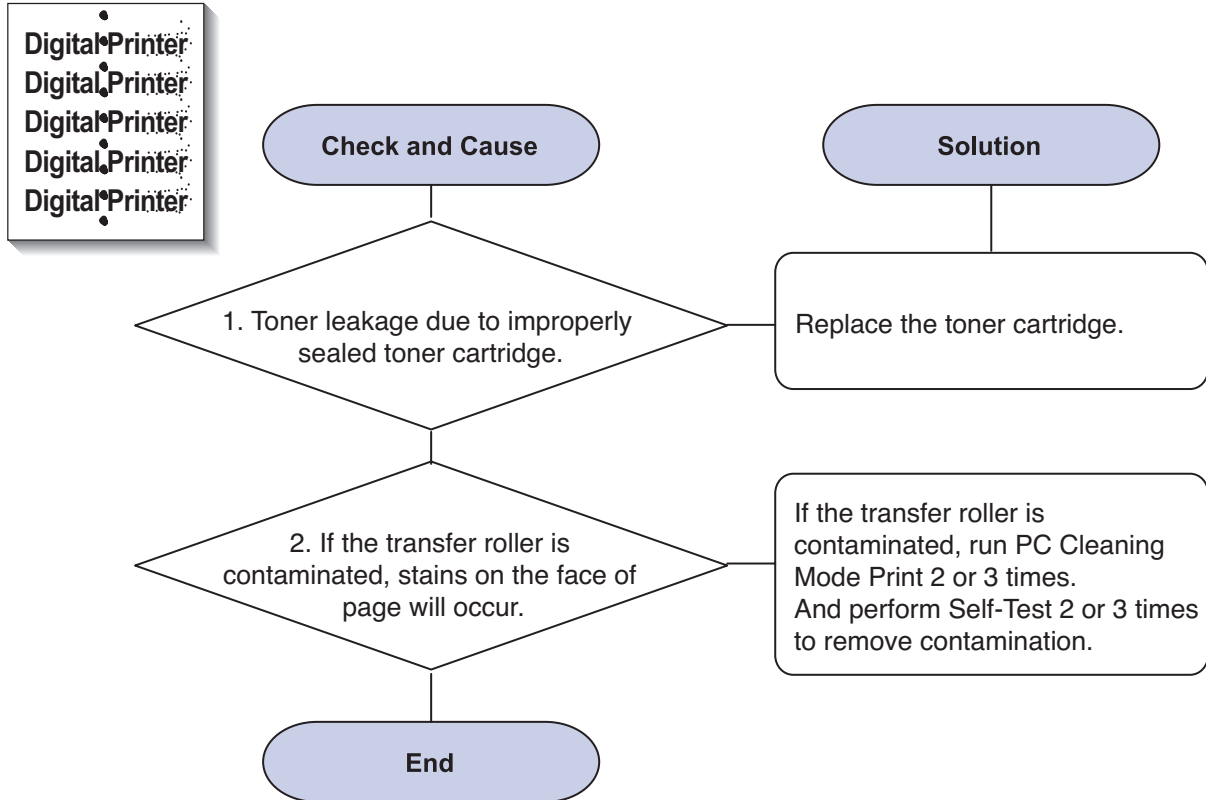

13) Stains on Back of Page

Description: The back of the page is stained at 47 mm or 62.8mm intervals.

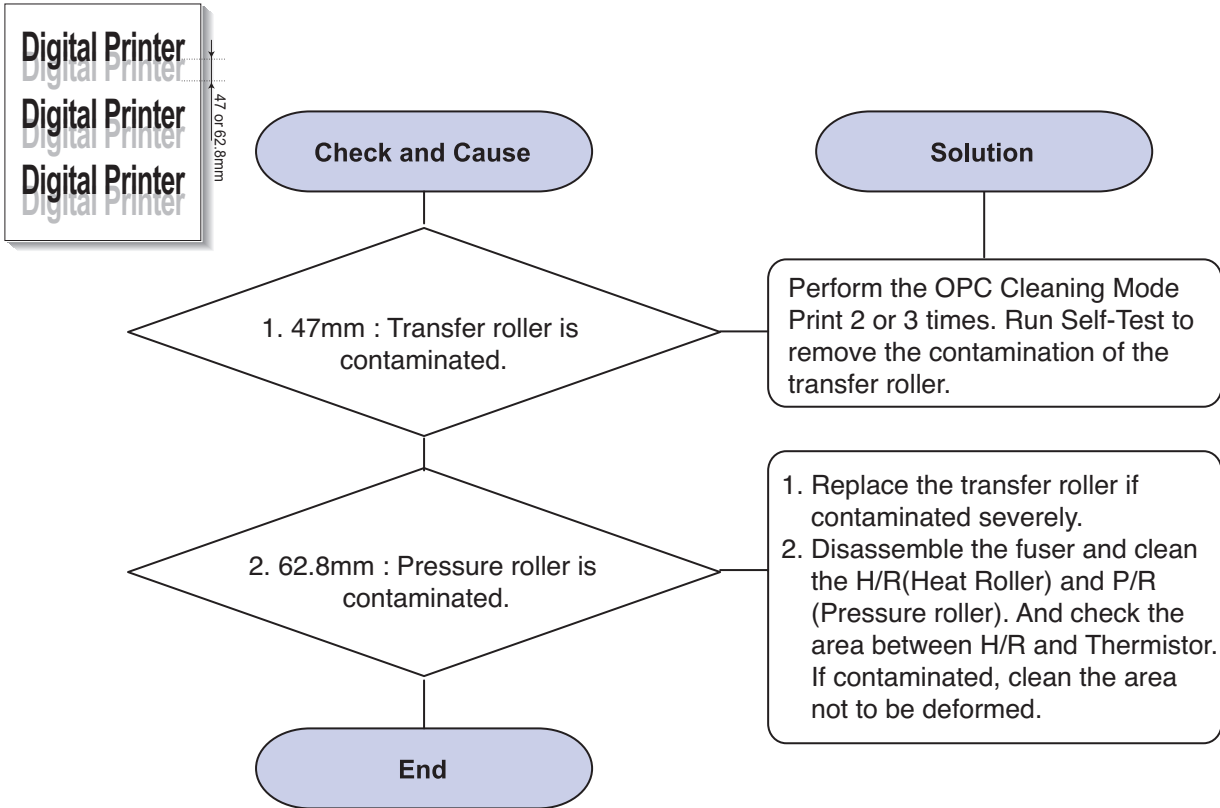

14) Blank Page Print out (1)

Description: Blank page is printed.

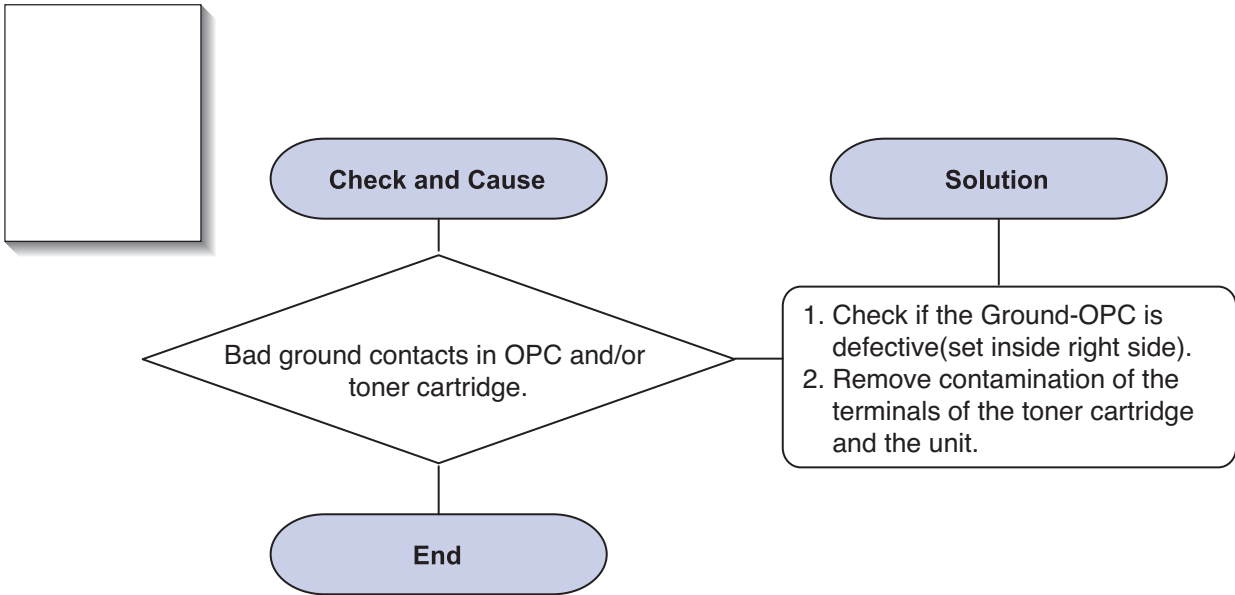

15) Blank Page Print out (2)

Description: 1. Blank page is printed.
 2. One or several blank pages are printed.
 3. When the printer turns on, several blank pages print.

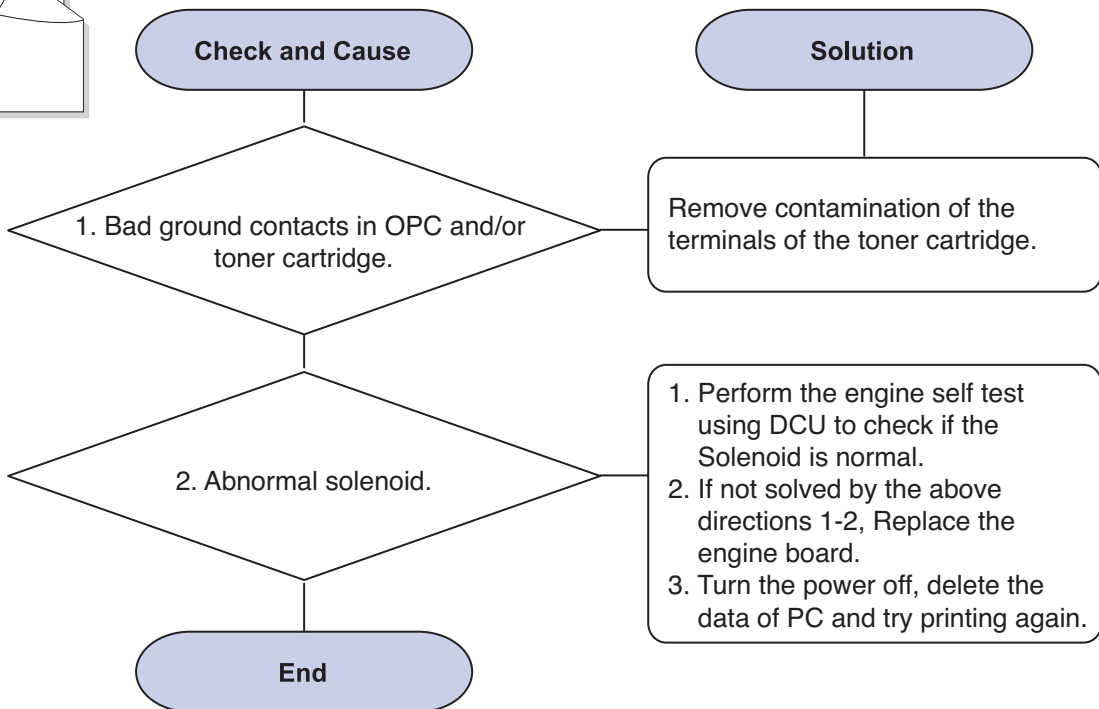
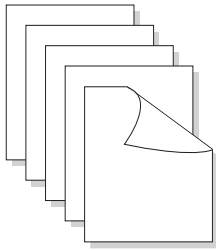

4.2.3 The cause and solution of the bad discharge

1) Wrong Print Position

Description: Printing begins at wrong position on the paper.

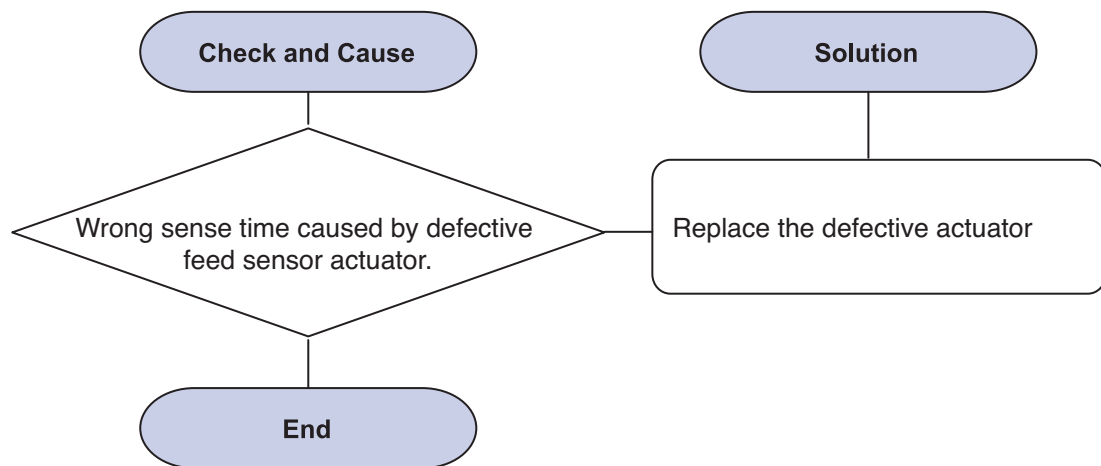

2) JAM 0

Description: 1. Paper is not exited from the cassette.
2. Jam-0 occurs when the paper feeds into the printer

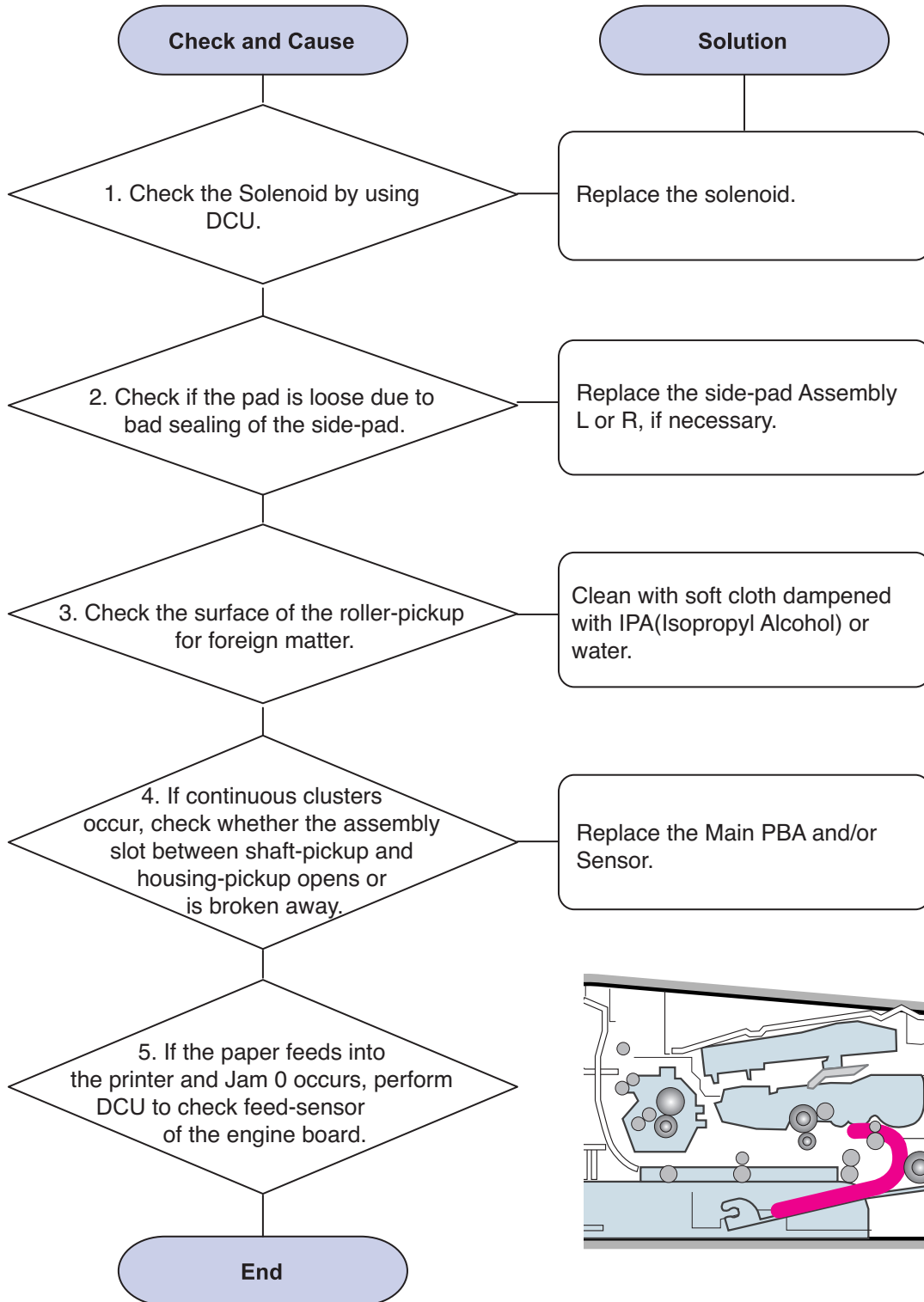

3) JAM 1

Description: 1. Recording paper is jammed in front of or inside the fuser.
 2. Recording paper is stuck in the discharge roller and in the fuser just after passing through the Actuator-Feed.

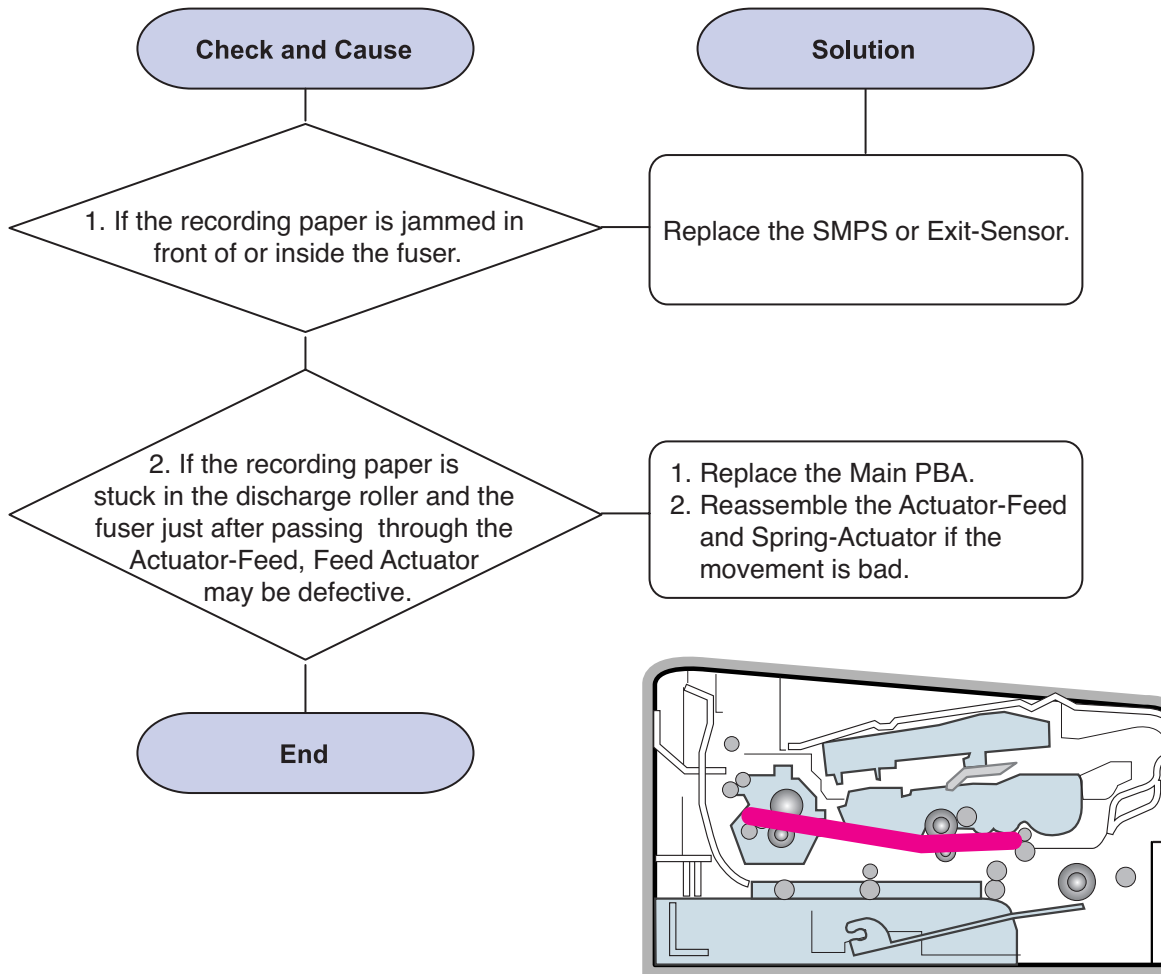

4) JAM 2

Description: 1. Recording paper is jammed in front of or inside the fuser.
 2. Recording paper is stuck in the discharge roller and in the fuser just after passing through the Actuator-Feed.

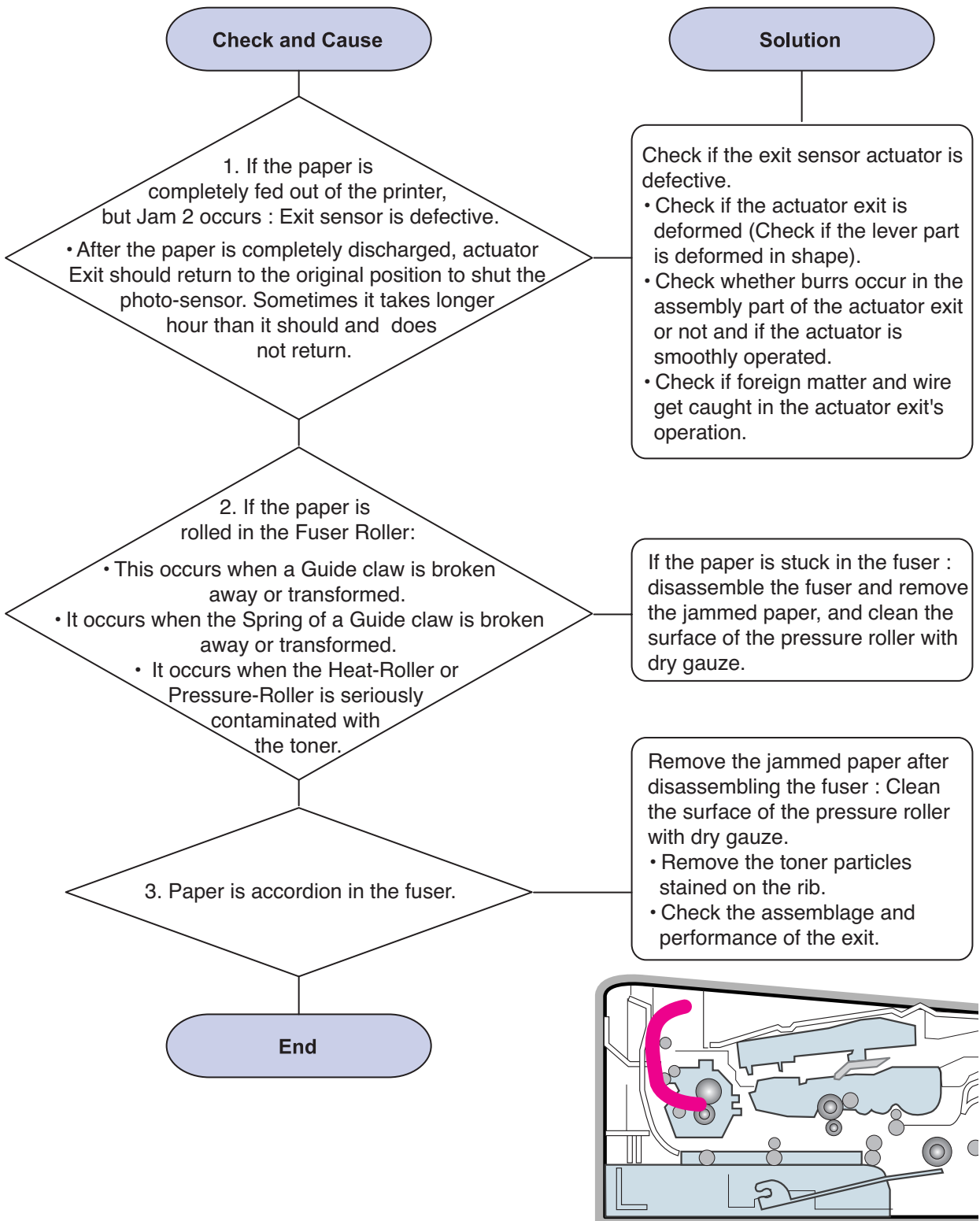

5) JAM Duplex

Description: Recording paper is Jammed in front or inside a duplex module.

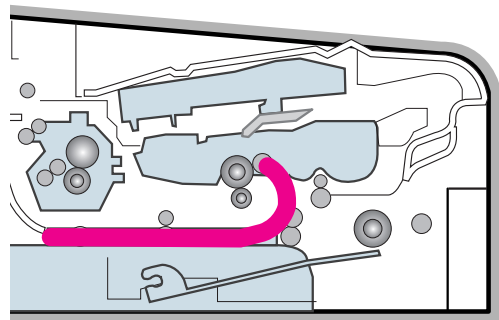
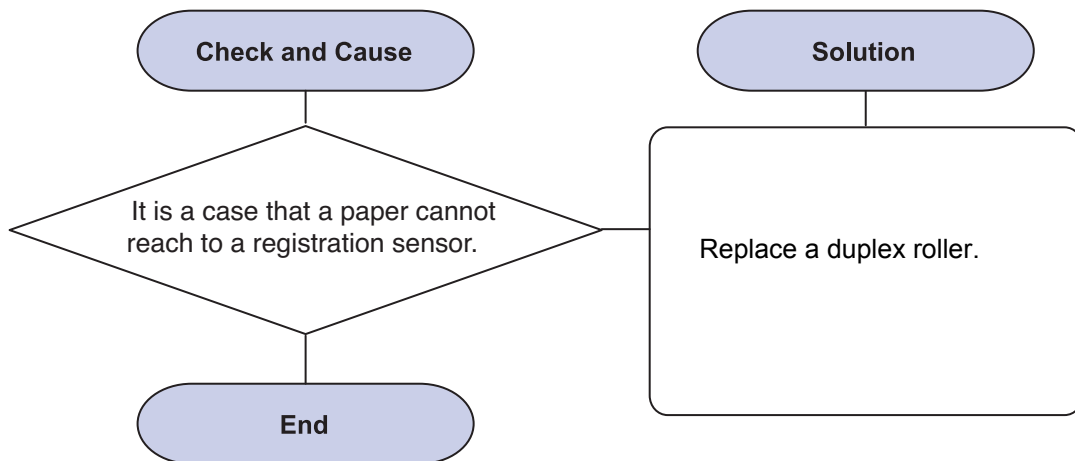

6) Multi-Feeding

Description: Multiple sheets of paper are fed at once.

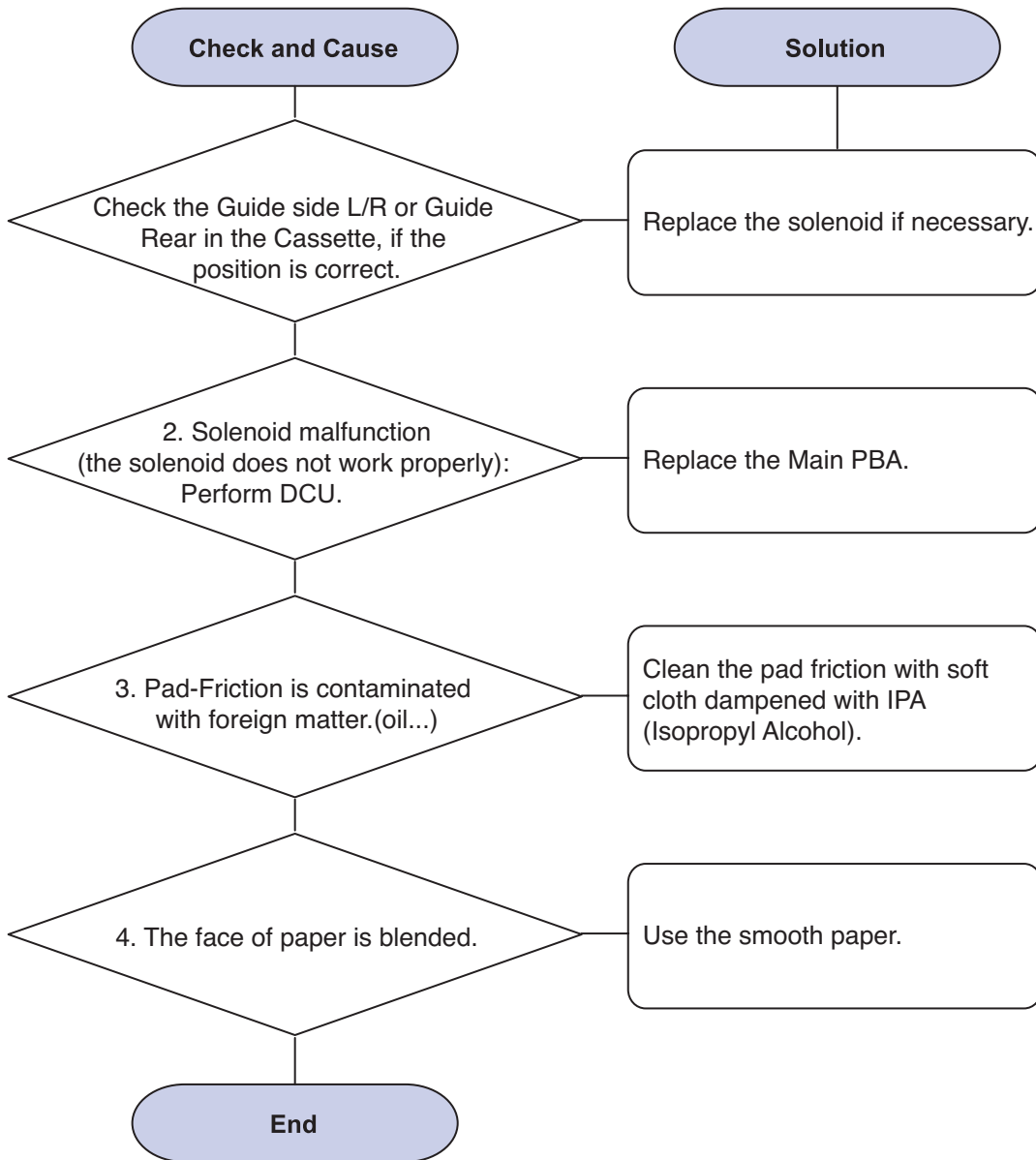

7) Paper rolled in the fuser

Description: If contaminated at intervals of 77.6mm on the back of a paper.

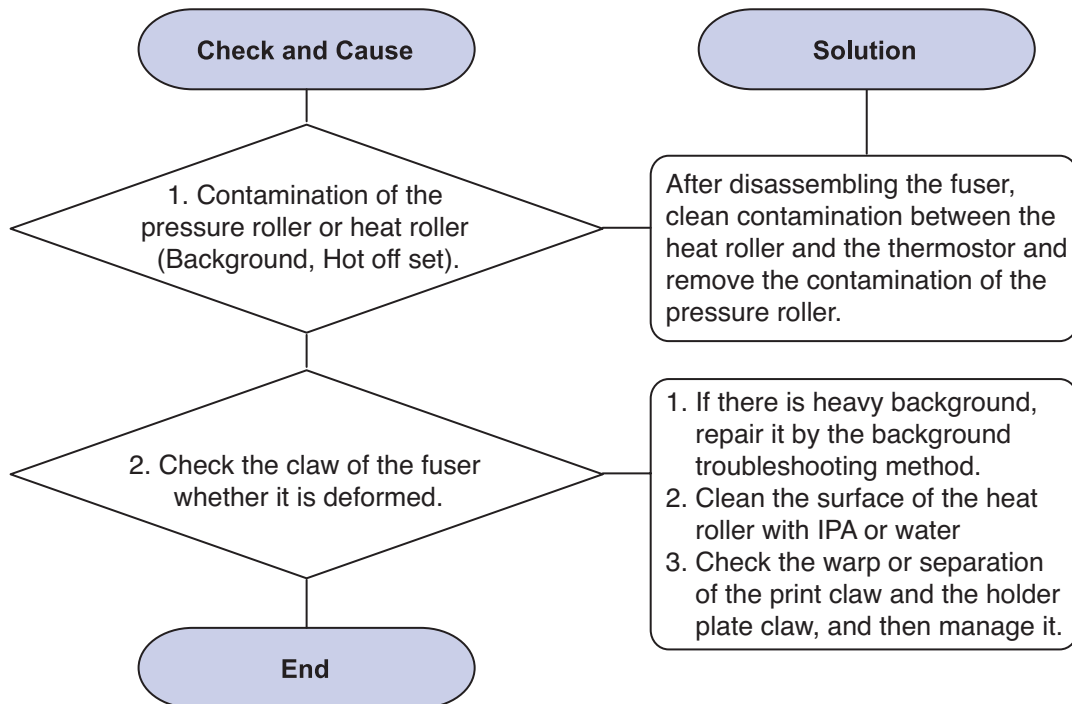

8) Paper rolled on the OPC Drum

Description: Paper is rolled up in the OPC.

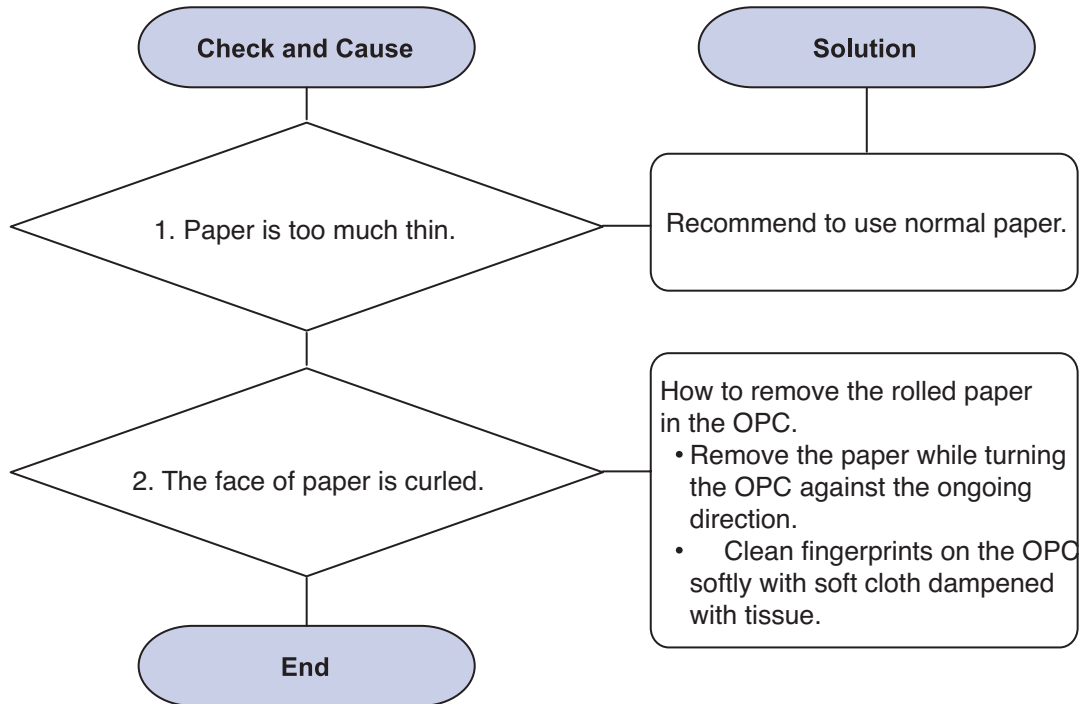

4.2.4 The cause and solution of the malfunction

1) Fuser Error

Description: All LEDs blinking.

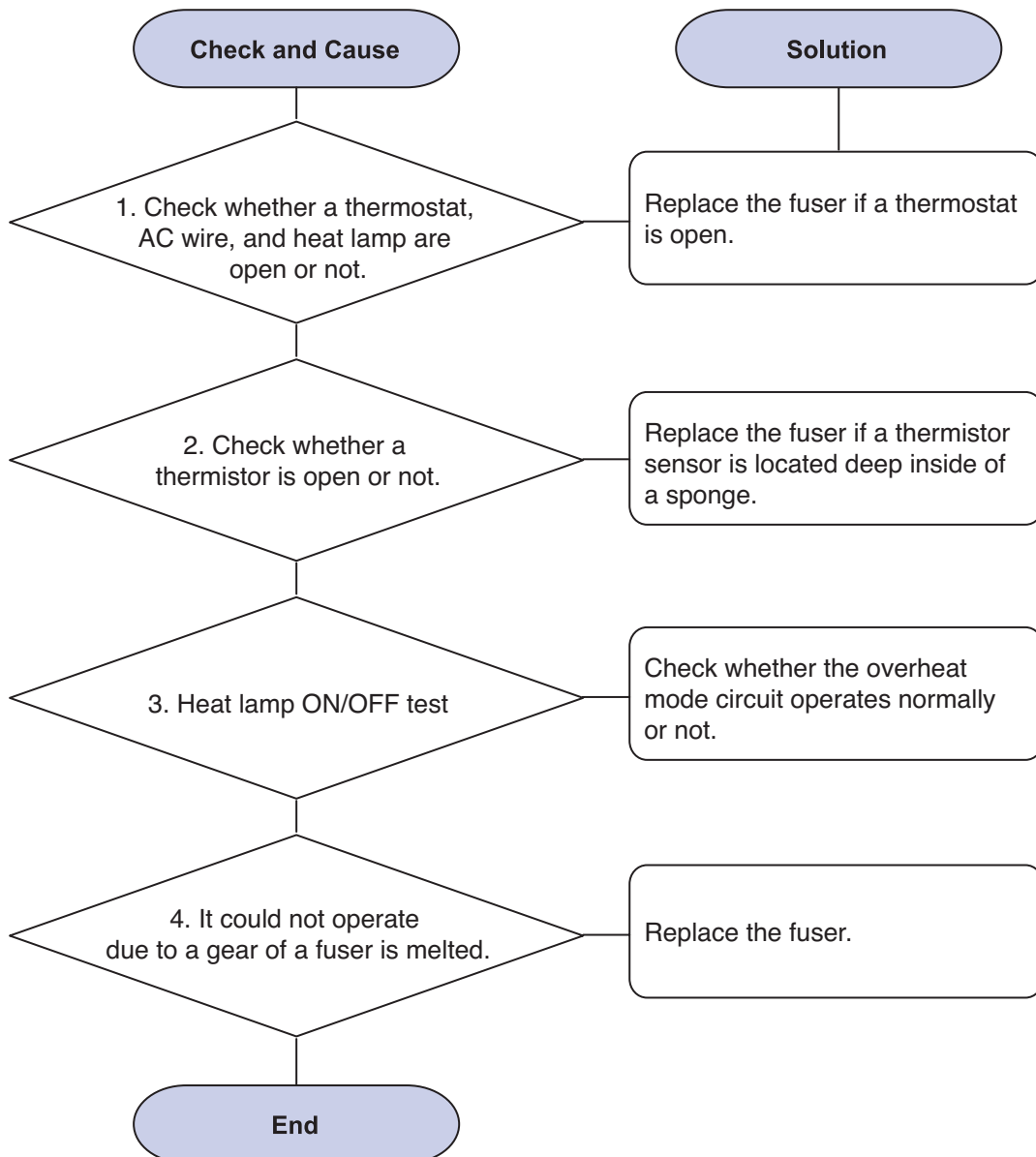

2) LSU Error

Description: "PMOTOR ERROR/HSYNC ERROR"

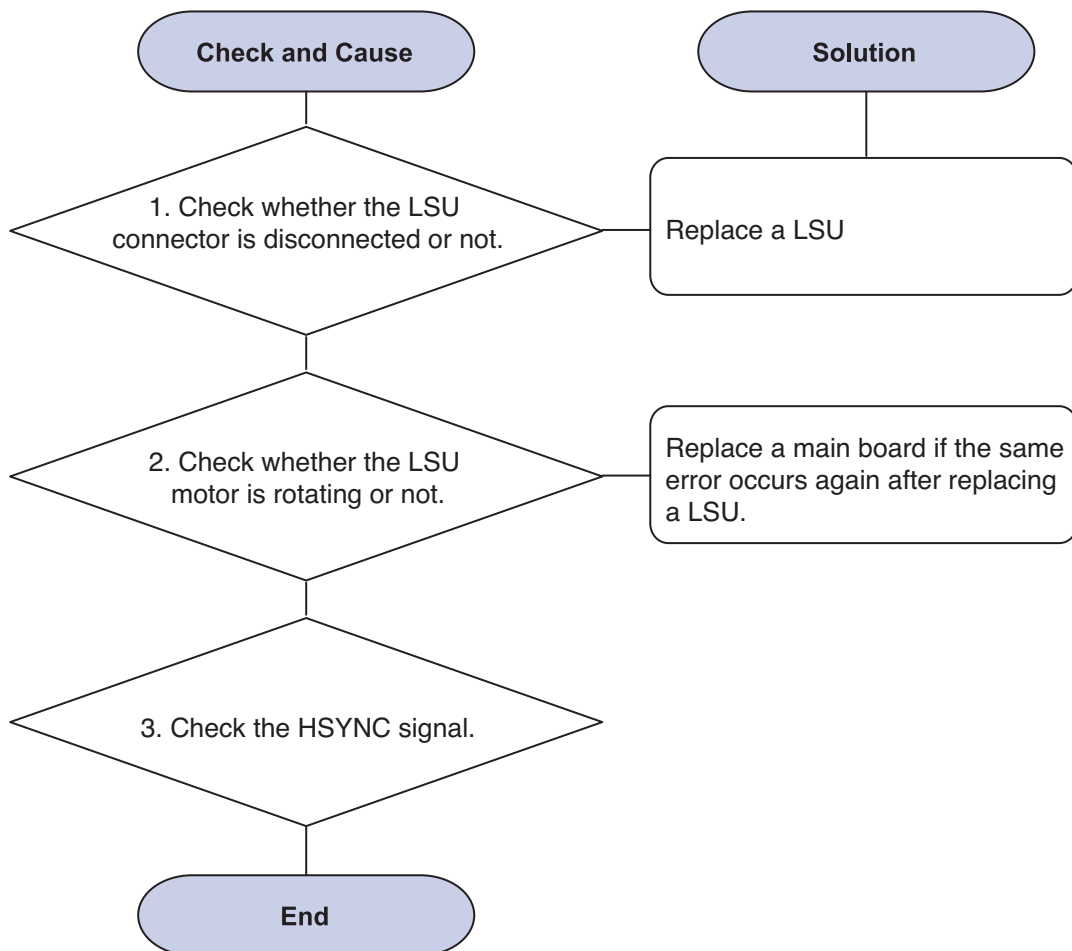

3) Not function of the gear of the fuser due to melting away

Description: The motor breaks away from its place due to gear melting away.

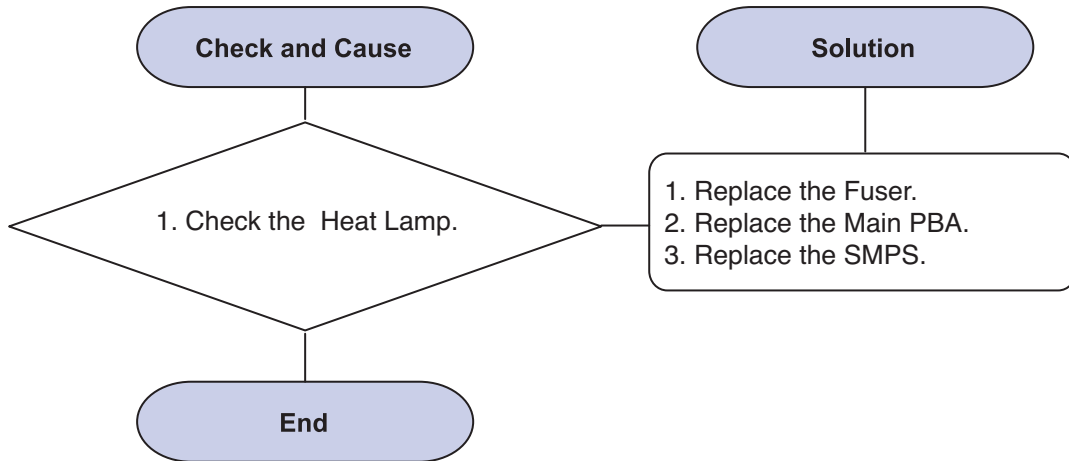

4) Paper Empty

Description: The paper lamp on the operator panel is on even when paper is loaded in the cassette.

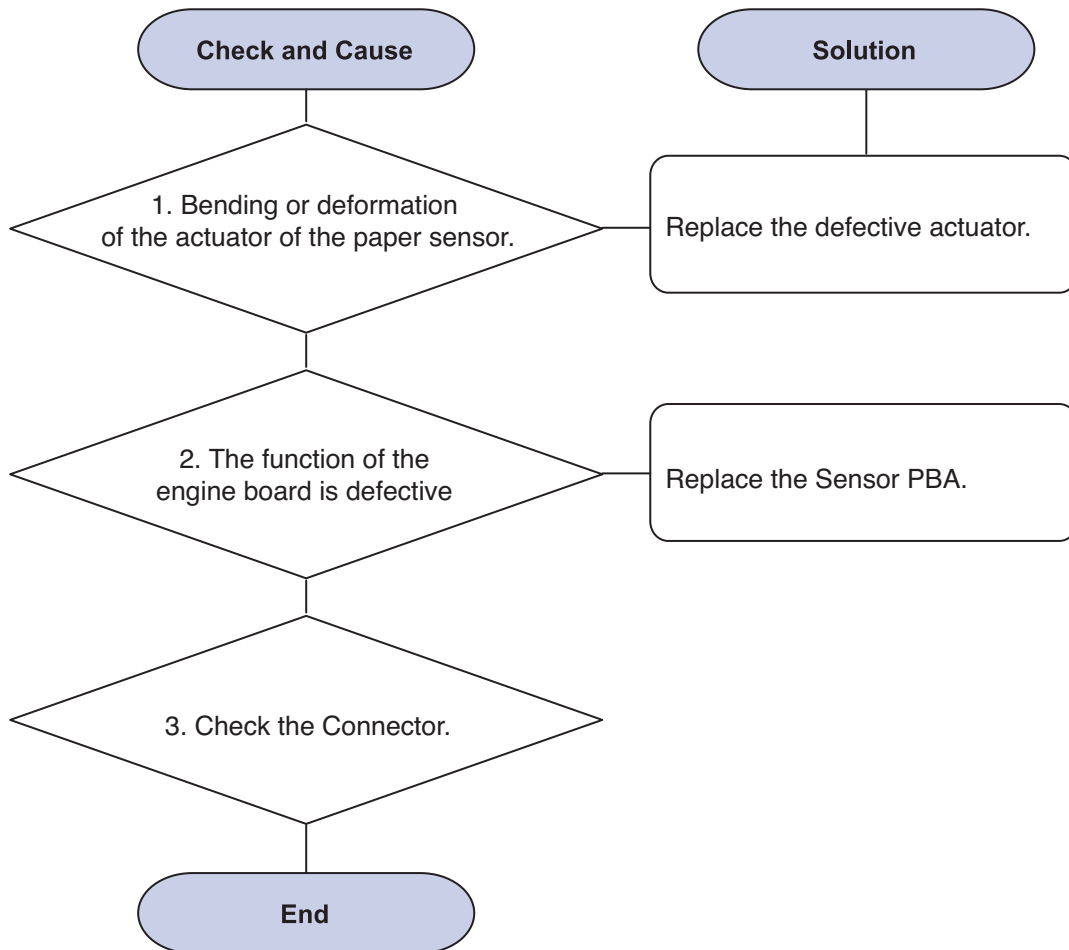

5) Paper Empty without indication

Description: The paper lamp on the operator panel does not come on when the paper cassette is empty.

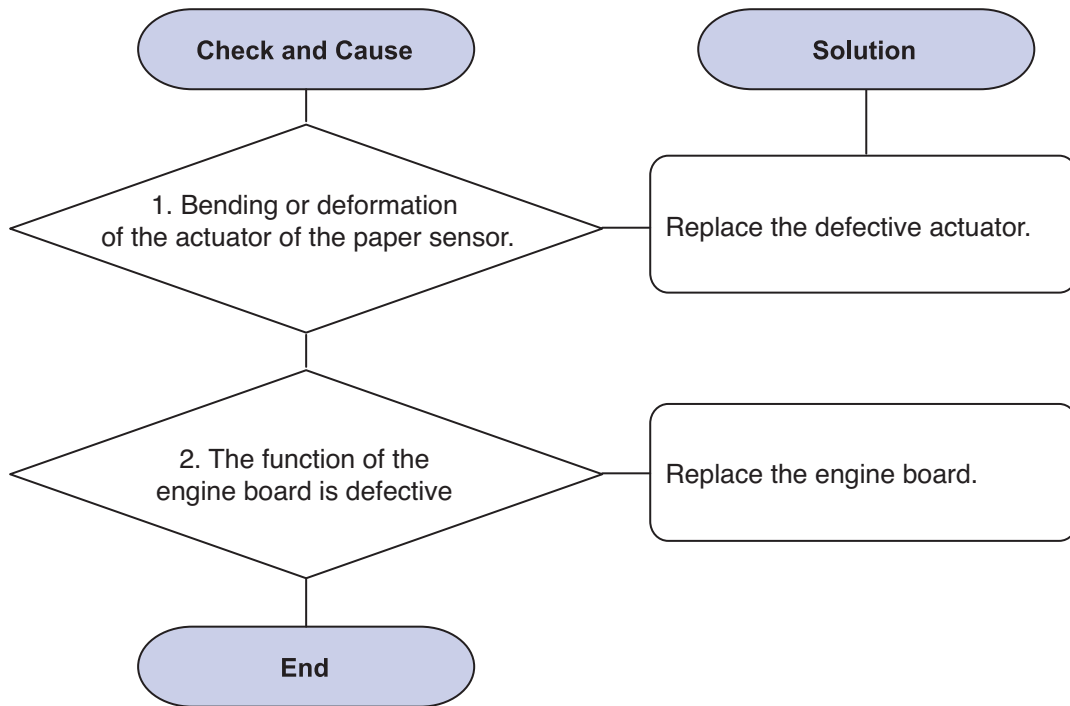

6) Cover Open

Description: The ERROR lamp is on even when the print cover is closed.

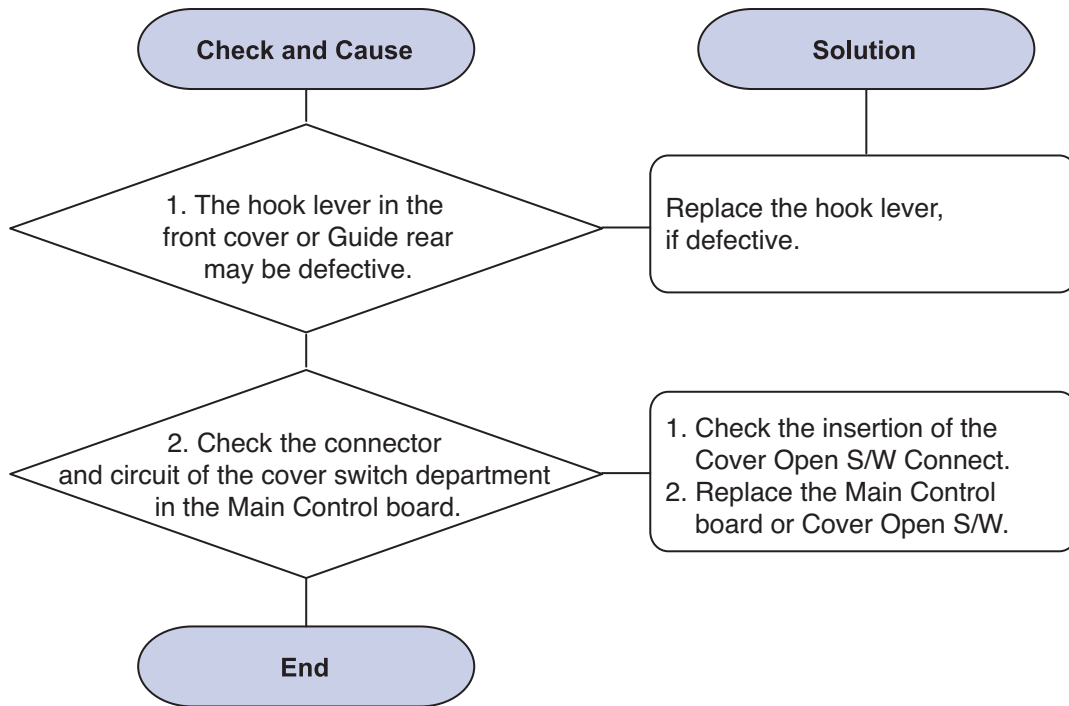

7) No error LED when the cover is open

Description: The Error LED does not come on even when the printer cover is open

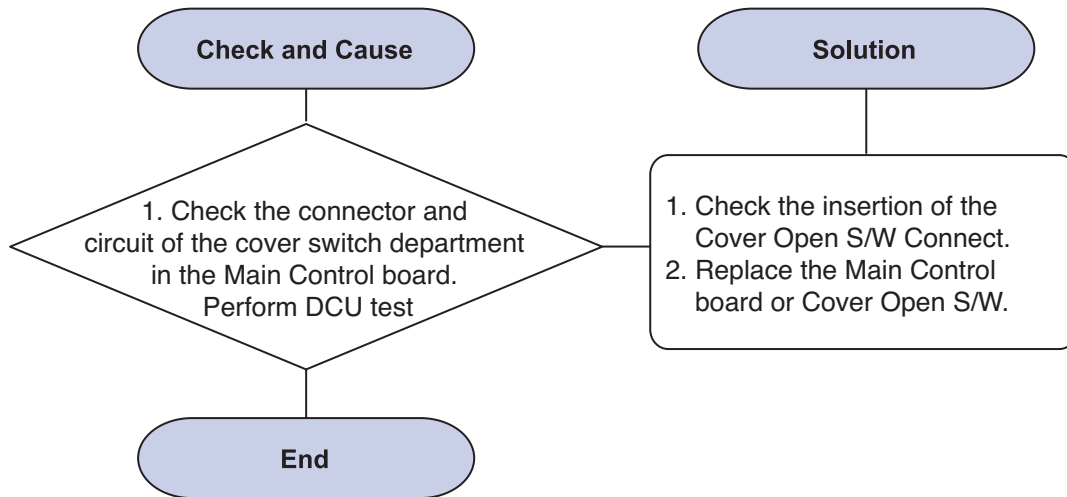

8) Defective motor operation

Description: Main motor is not driving when printing, and paper does not feed into the printer, resulting 'Jam 0'.

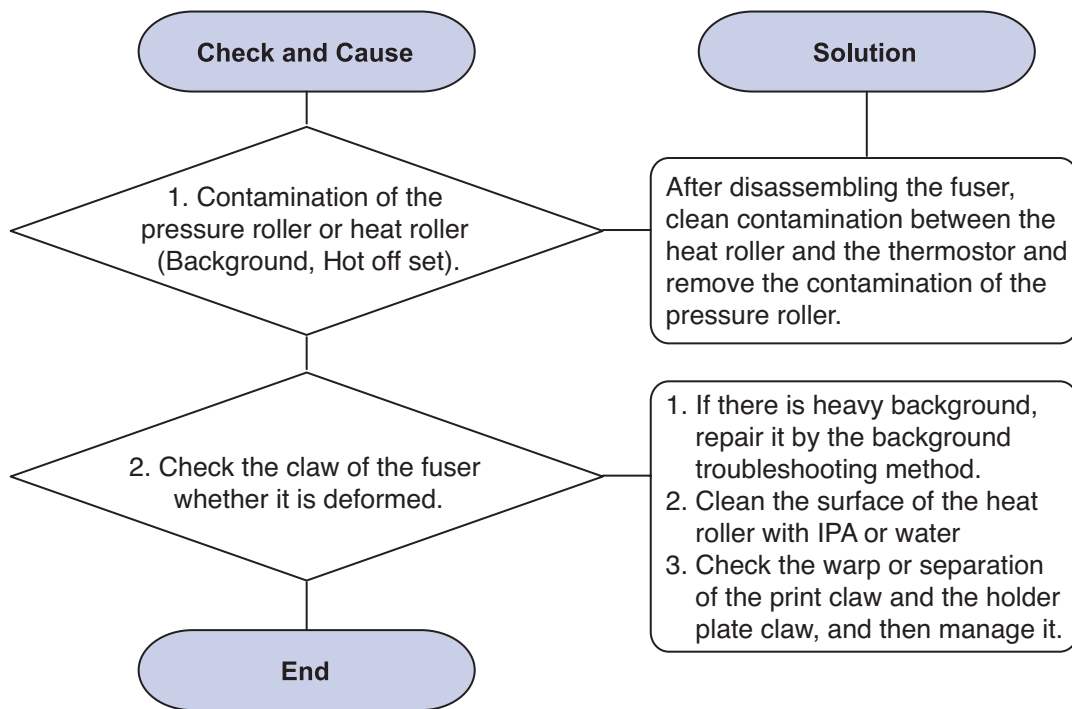

9) No Power

Description: When system power is turned on, all lamps on the operator panel do not come on.

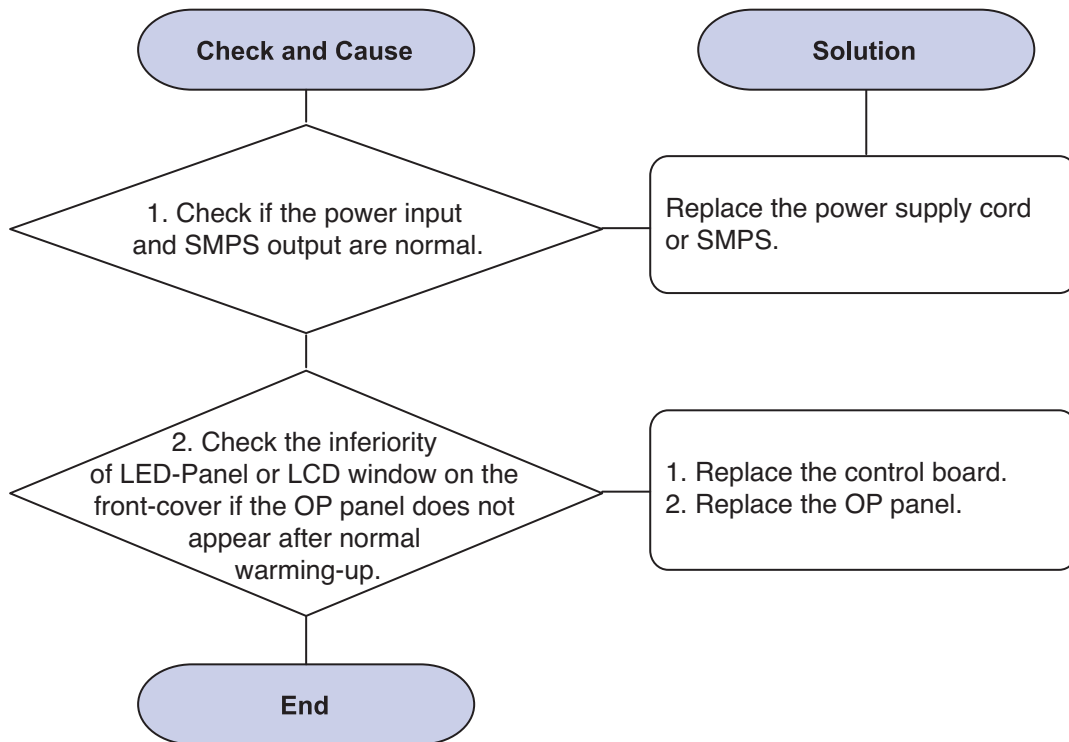

10) Vertical Line Getting Curved

Description: When printing, vertical line gets curved.

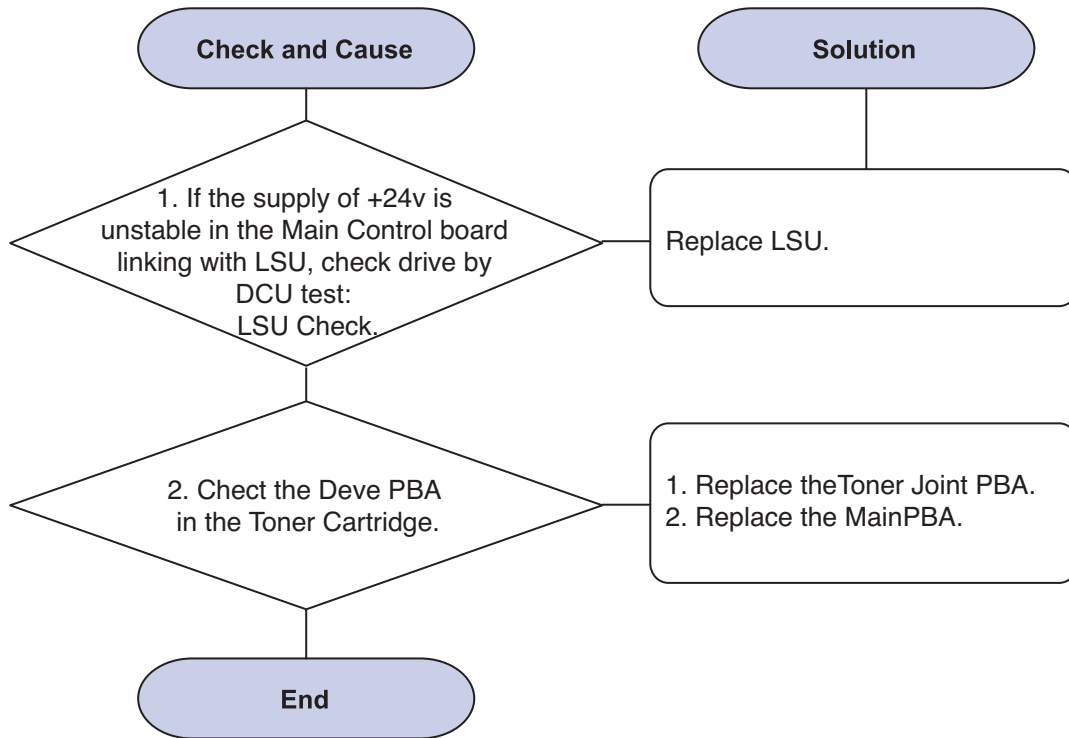

4.2.5 Toner Cartridge Service

It is not guaranteed for the default caused by using other toner cartridge other than the cartridge supplied by the Samsung Electronic or caused by non-licensed refill production.

4.2.5.1 Precautions on Safe-keeping of Toner Cartridge

Excessive exposure to direct light more than a few minutes may cause damage to the cartridge.

4.2.5.2 Service for the Life of Toner Cartridge

If the printed image is light due to the life of the toner, you can temporarily improve the print quality by redistributing the toner(Shake the toner cartridge), however, you should replace the toner cartridge to solve the problem thoroughly.

4.2.5.3 Distinguish function for choice cartridge

• Distinguish function for choice cartridge

An EEP ROM is mounted to a cartridge for distinguishing a choice toner cartridge. Items written in below are detected by checking up memory information.

If the data of the EEP ROM is broken, it cannot be detected.

- 1) Detecting existence of a toner cartridge: It detects whether a toner cartridge is mounted or not.
- 2) Detecting a serial number of a toner cartridge.
- 3) Detecting a toner cartridge supplying company: If it is not Samsung's, it is not operated.
- 4) Detecting an OPC rotating counter: It detects the life span of an OPC drum.

• Distinguish a refilled cartridge. (with eyes)

- 1) Check whether One-way screw is damaged or not
- 2) Check the cartridge on configuration sheet(Print out the self-test configuration)
: Manufacture date and serial number of toner cartridge are different(permissible range : +/- 1).

4.2.5.4 Error related in a toner sensor

It explains a message related in toner sensor in a LED.

4.2.5.4(a) Invalid Toner

- Contents: The red LED turns on when a supplier is different between a toner cartridge and a set.
- Solution: Attach a suitable toner cartridge (the same supplier's) to a set. (A unique key has been applied.)

4.2.5.4(b) Low Toner

- Contents: When a toner in the toner cartridge almost ended, the red LED is blinking.
- Solution: It means that a toner in the toner cartridge has been almost ended. Replace the new toner cartridge.

4.2.5.4(c) Replace Cartridge

- Contents: Turning the red LED on means the life span of a toner cartridge (except a toner part) has been ended.
- Solution: If an Toner Cartridge Life cycle Problem, in a worst case, a toner overflows and it may cause a system fail. Therefore, recommend a user to replace a toner cartridge.

4.2.6 The cause and solutions of bad environment of the software

1) The printer is not working (1)

Description: While Power turned on, the printer is not working in the printing mode.

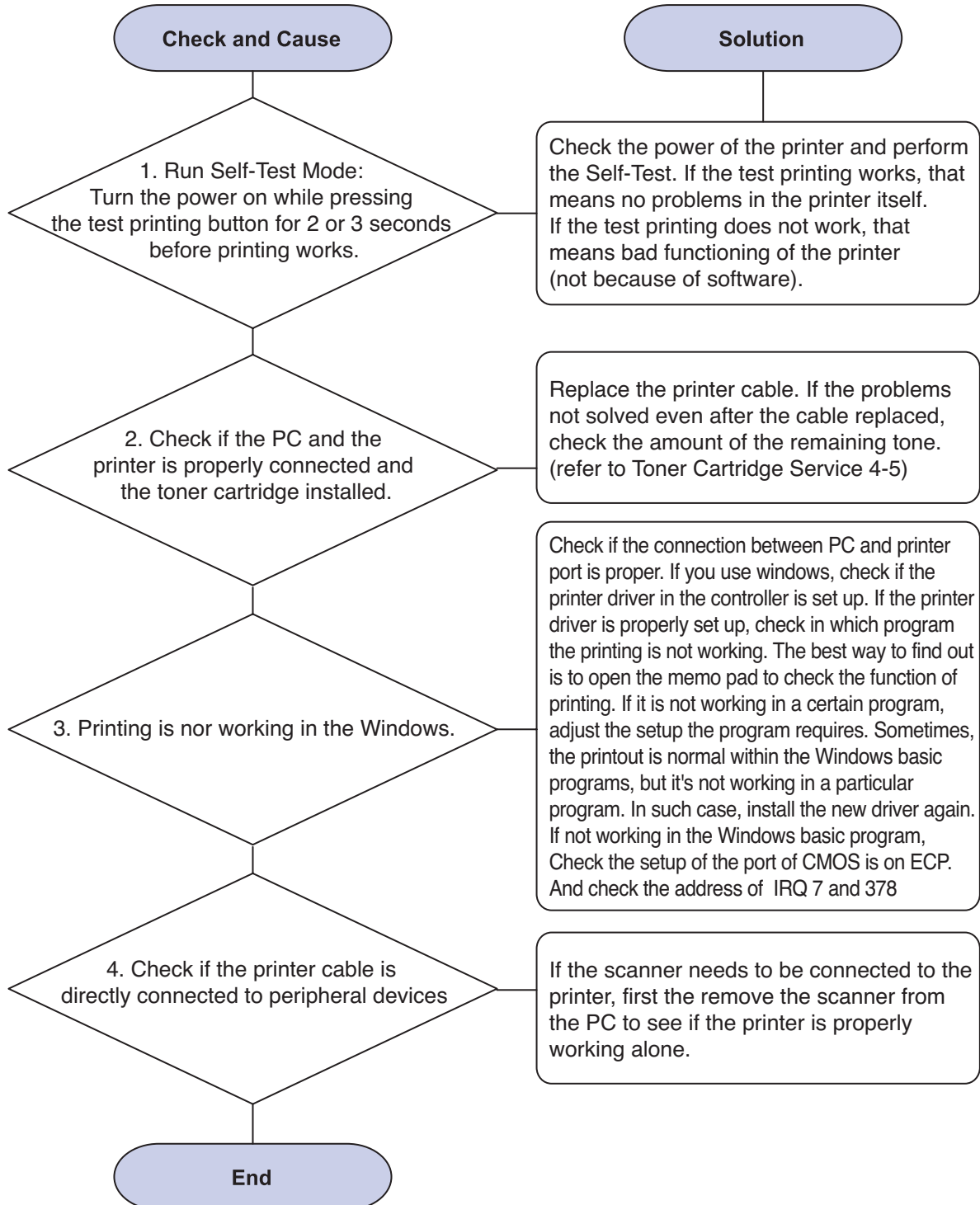

2) The printer is not working (2)

Description: After receiving the printing order, no response at all or the low speed of printing occurs due to wrong setup of the environment rather than malfunction of the printer itself.

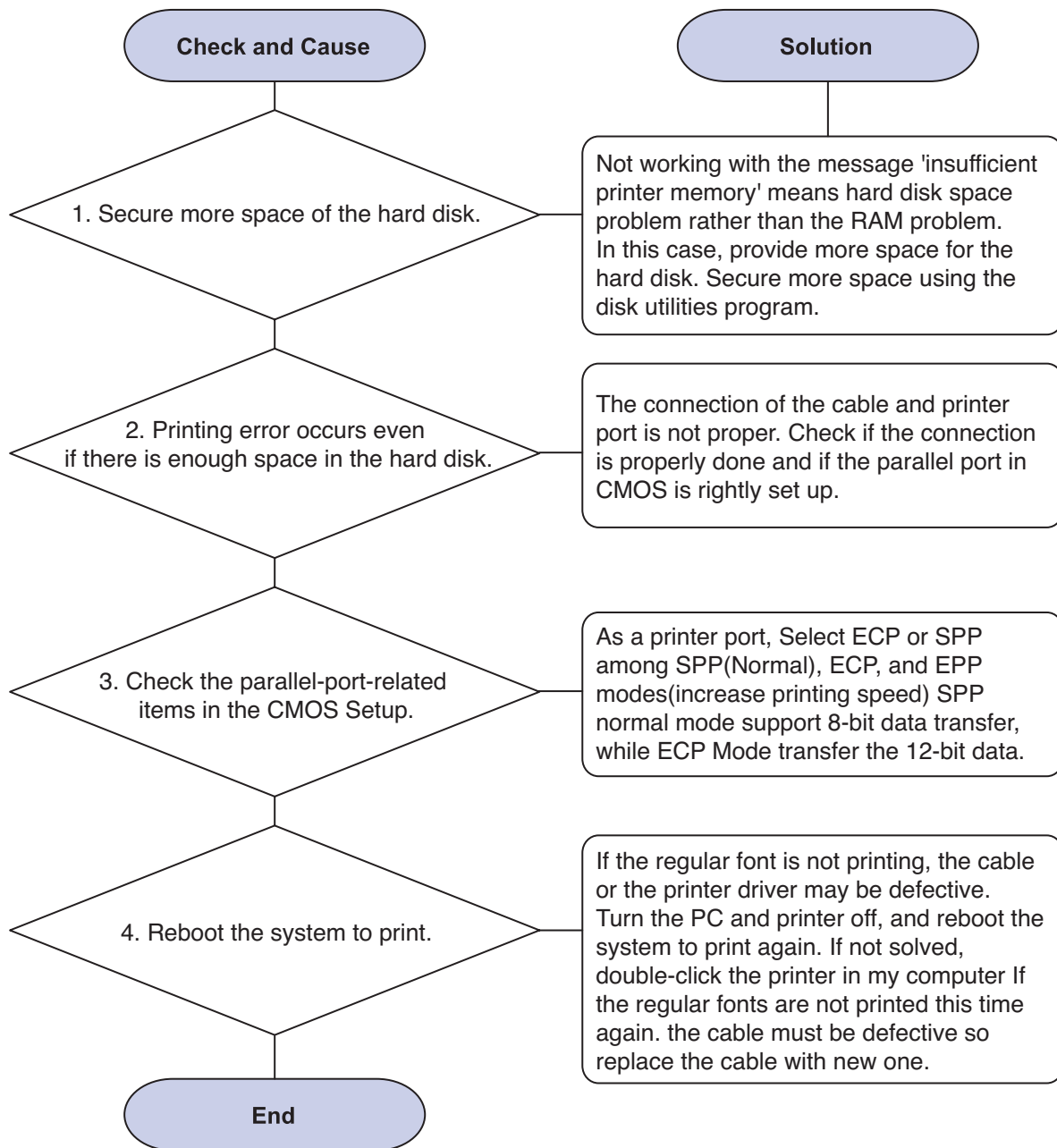

3) Abnormal Printing

Description: The printing is not working properly even when the cable has no problem.
(even after the cable is replaced)

If the printer won't work at all or the strange fonts are repeated, the printer driver may be defective or wrong setup in the CMOS Setup.

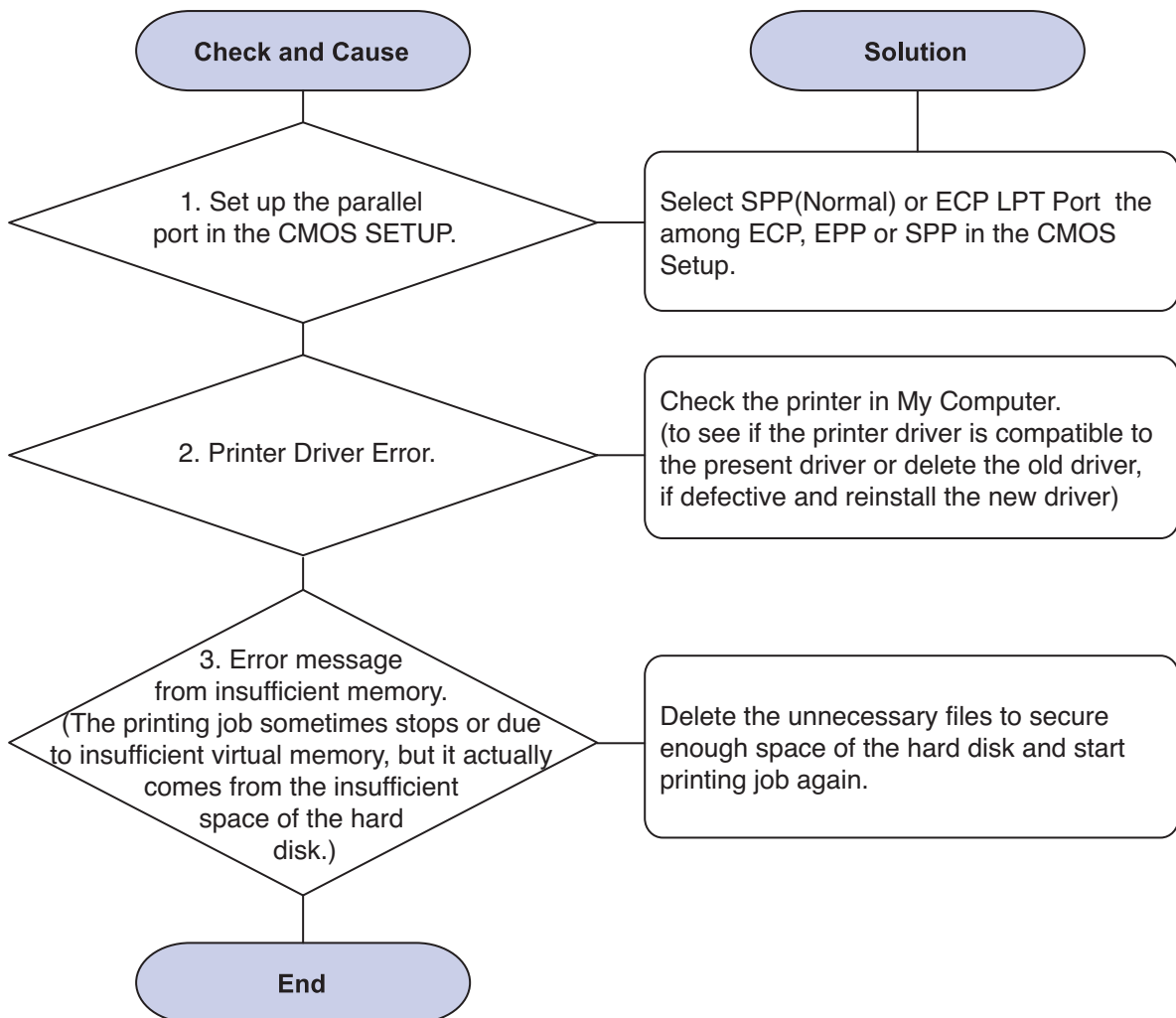

4) SPOOL Error

Description: To spool which stands for "simultaneous peripheral operations online" a computer document or task list (or "job") is to read it in and store it, usually on a hard disk or larger storage medium so that it can be printed or otherwise processed at a more convenient time (for example, when a printer is finished printing its current document).

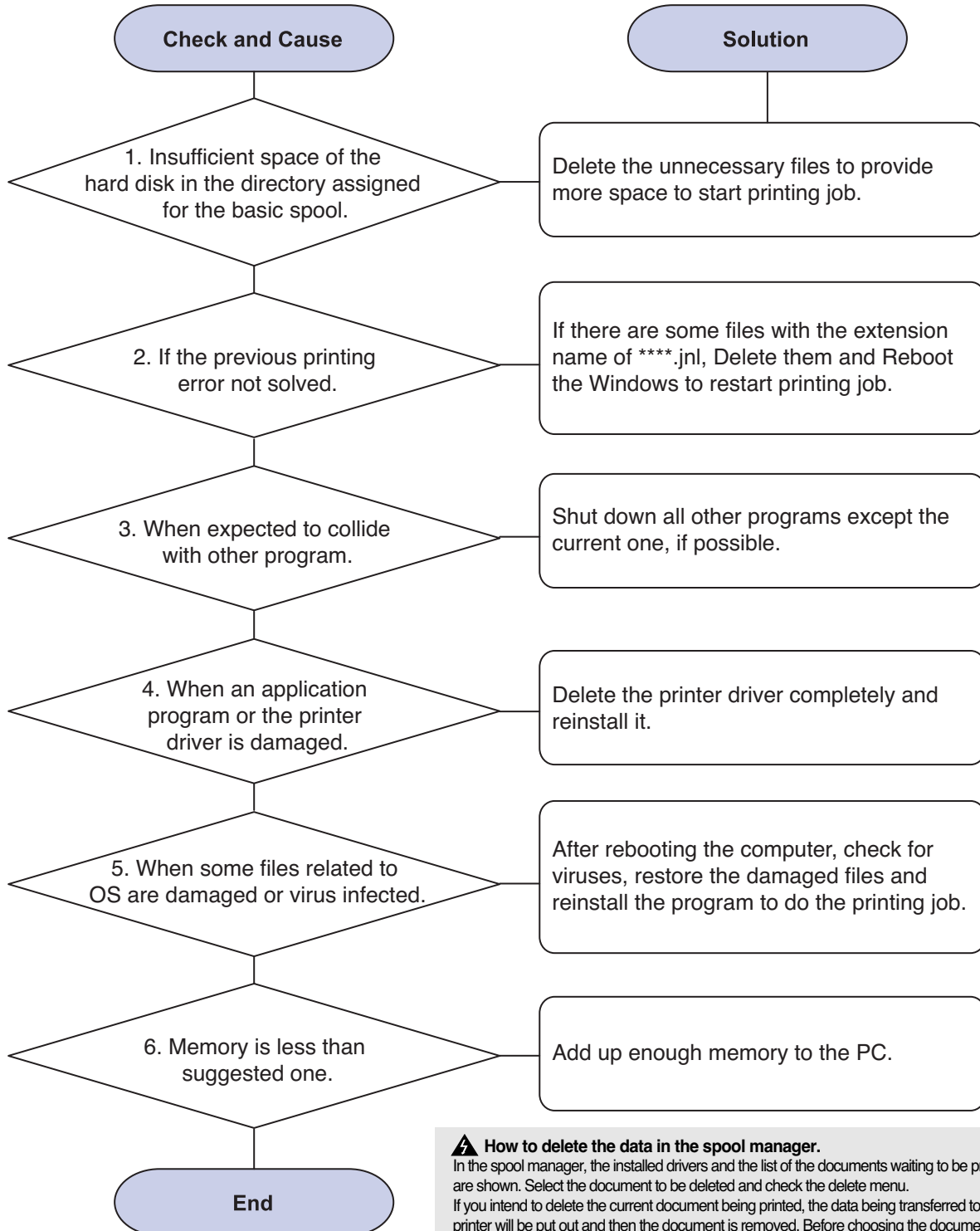

⚠ How to delete the data in the spool manager.

In the spool manager, the installed drivers and the list of the documents waiting to be printed are shown. Select the document to be deleted and check the delete menu. If you intend to delete the current document being printed, the data being transferred to the printer will be put out and then the document is removed. Before choosing the document, the menu is still inactive. Or put the document out of the list and repeat the routine as in the above or finish the spool manager.

5. Exploded Views and Parts List

Contents

5.1 Main	5-2	5.7 Main Drive	5-17
5.2 Top Cover	5-4	5.8 Rear Guide	5-19
5.3 Cover Ass'y	5-6	5.9 Fuser	5-21
5.4 Front Cover	5-8	5.10 Duplex Unit	5-23
5.5 Rear Cover	5-10	5.11 Cassette	5-25
5.6 Frame	5-12	5.12 SCF	5-27

DIGITAL LASER PRINTER



The keynote of Product

Smallest Duplex Built-in Mono Laser Printer (Low Noise)

- 28ppm(A4) / 30ppm(Ltr)
- PCL6, PS3, 1,200x1,200dpi
- 400MHz processor
- USB 2.0, N/W (ML-2851ND only)
- 32MB (Max.160MB : factory option)
- 2K Standard, 5K High Yield
- Paper Input: 250 sh CST + 1 sh MP
- Standard Duplex Printing
- Options: 250 sh SCF

5.1 Main

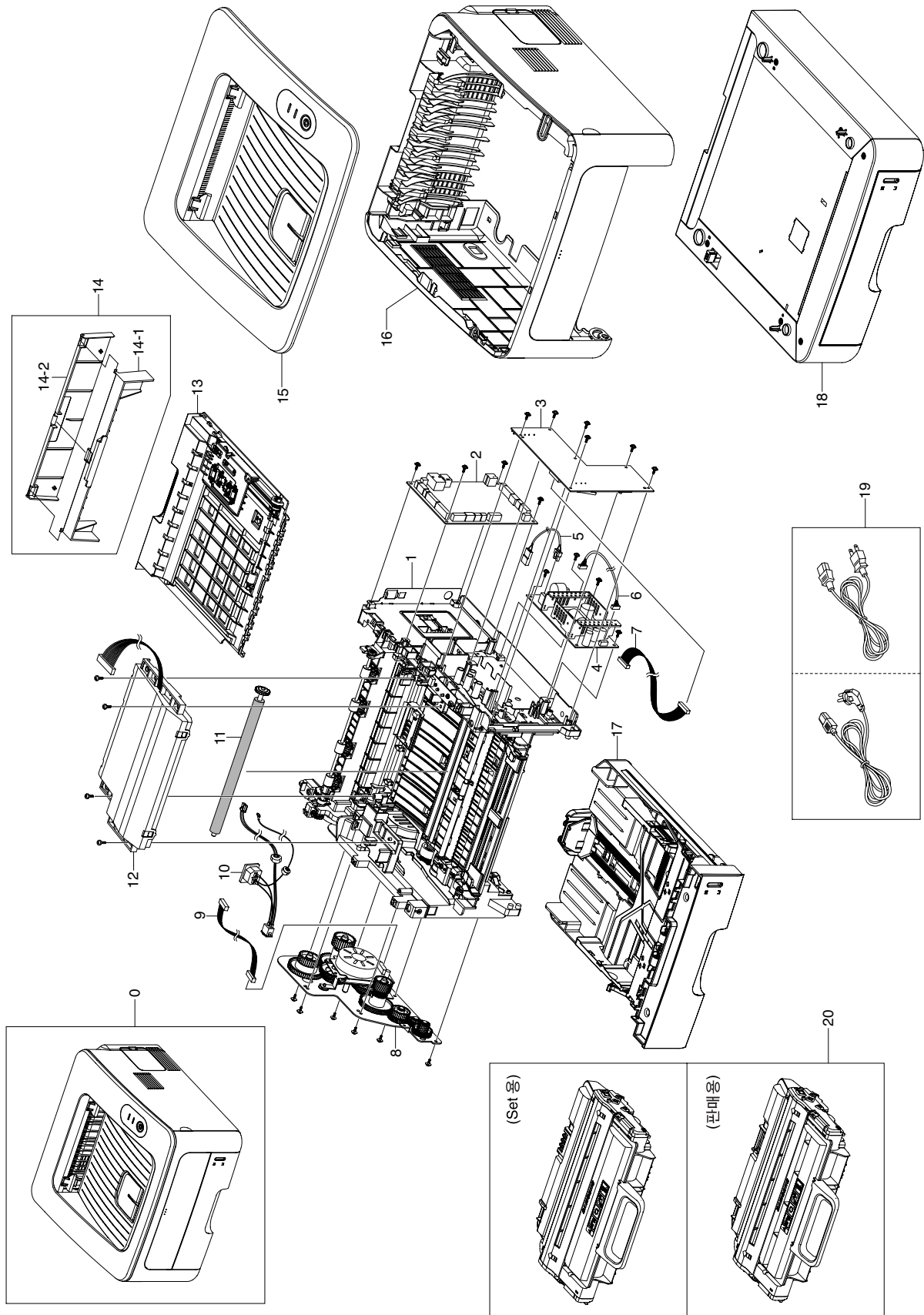

Main Parts List

SA : SERVICE AVAILABLE, SNA : SERVICE not AVAILABLE

Drawer#	SEC_Code	Description	QT'y	Service	Remark
5.1-0	ML-2851ND	SET			
5.1-1	JC63-01572A	SHIELD-CONTROLLER	1	SA	
5.1-2	JC92-01936B	PBA MAIN-CONTROLLER	1	SA	
5.1-3	JC44-00156A	HVPS	1	SA	
5.1-4	JC44-00096A	SMPS-PSP_TYPE2_V2C	1	SA	
5.1-5	JC39-00817A	CBF HARNESS-FUSER AC(SMPS)	1	SA	
5.1-6	JC39-00828A	CABLE FORM CONN COAX	1	SA	
5.1-7	JC39-00824A	CBF HARNESS-HVPS	1	SA	
5.1-8	JC96-04731A	ELA UNIT-RX DRIVE	1	SA	
5.1-9	JC39-00820A	CBF HARNESS-MOTOR & SOLENOID	1	SA	
5.1-10	JC39-00816A	CBF HARNESS-AC-INLET	1	SA	
5.1-11	JC66-01218A	ROLLER-TRANSFER	1	SA	
5.1-12	JC96-04733A	ELA UNIT-LSU	1	SA	
5.1-13	JC96-04736A	MEA UNIT-DUPLEX	1	SA	
5.1-14-1	JC63-01650A	COVER-DUPLEX	1	SA	
5.1-14-2	JC63-01651A	COVER-REAR DUPLEX	1	SA	
5.1-15	JC97-03012A	MEA-COVER TOP	1	SA	
5.1-16-1	JC97-03013A	MEA UNIT-COVER_LEFT	1	SA	
5.1-16-2	JC97-03014A	MEA UNIT-COVER_RIGHT	1	SA	
5.1-16-3	JC97-03015A	MEA UNIT-COVER_REAR	1	SA	
5.1-16-4	JC97-03016A	MEA UNIT-COVER FRONT	1	SA	
5.1-17	JC97-03017A	MEA UNIT-CASSETTE	1	SA	
5.1-18	JC96-04735A	ELA UNIT-SCF	1	SNA	
5.1-19	3903-000085	CBF-POWER CORD(110V)	1	SA	
5.1-19	3903-000042	CBF-POWER CORD(220V)		SA	
5.1-20	JC96-04823B	ELA HOU-DEVE	1	SNA	

5.2 Top Cover

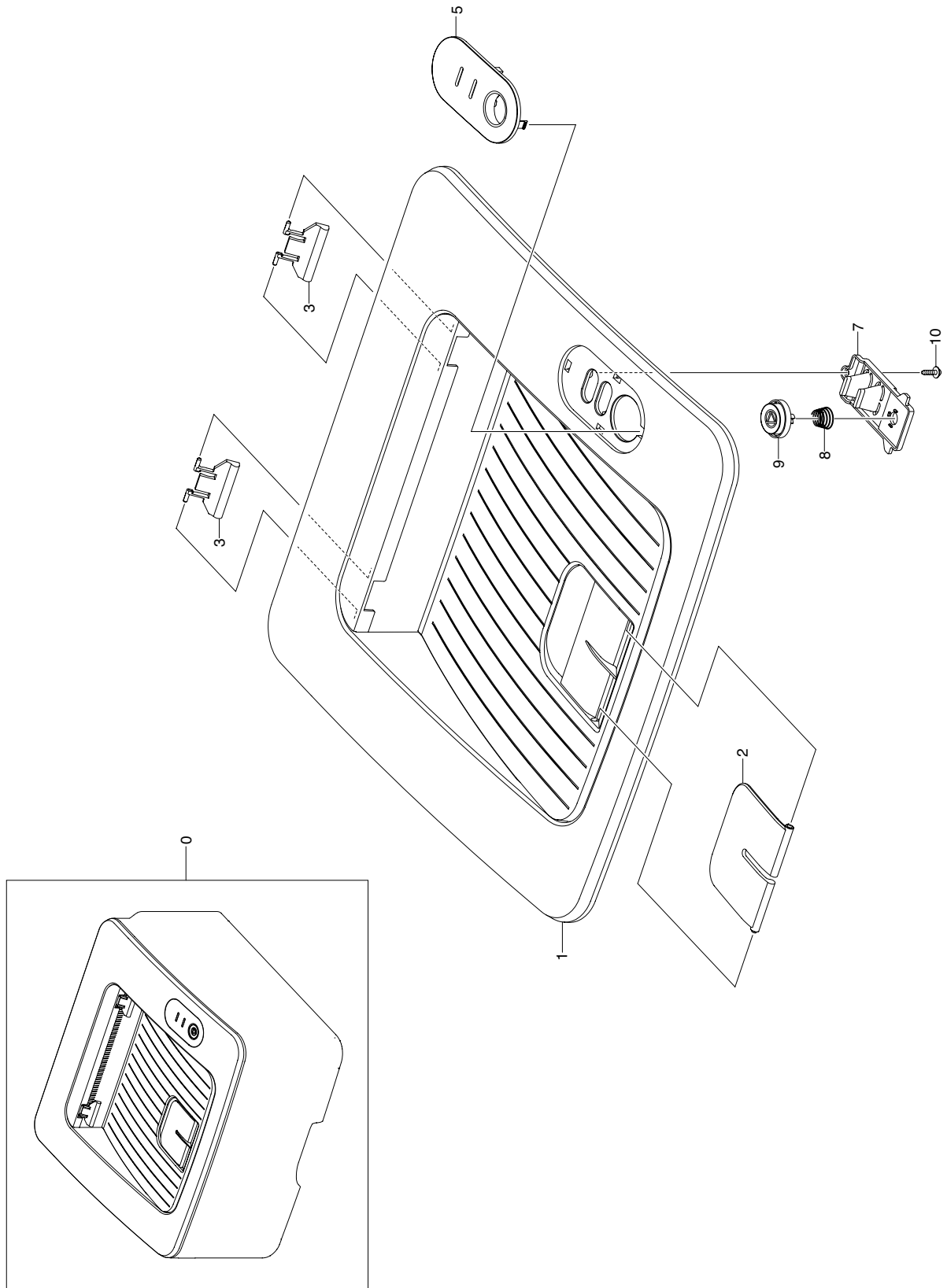

Top Cover Parts List

SA : SERVICE AVAILABLE, SNA : SERVICE not AVAILABLE

Drawer#	SEC_Code	Description	QT'y	Service	Remark
5.2-0	JC97-03012A	MEA UNIT-COVER_TOP	1	SA	
5.2-1	JC63-01523A	COVER-TOP	1	SNA	
5.2-2	JC61-02230A	STACKER-RX	1	SA	
5.2-3	JC72-01343A	PMO-SUB_M_STACKER	2	SA	
5.2-5	JC63-01528A	COVER-DUMMY KEY	1	SNA	
5.2-7	JC67-00274A	LENS-LED	1	SA	
5.2-8	6107-001169	SPRING-CS	1	SA	
5.2-9	JC64-00359A	KEY-ON_LINE	1	SA	
5.2-10	6003-000196	SCREW-TAPTITE	1	SNA	

5.3 Cover Ass'y

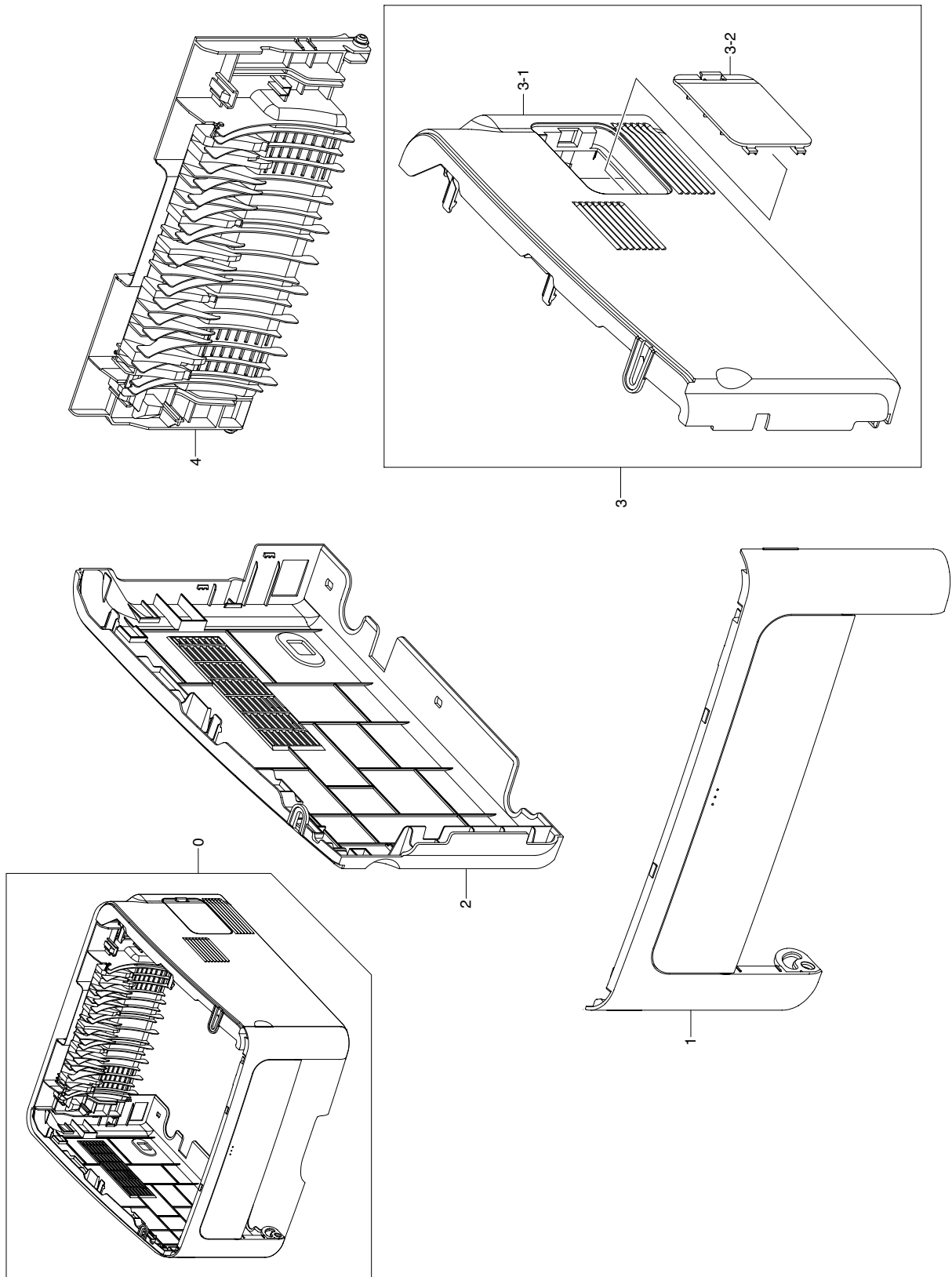

Cover Ass'y Parts List

SA : SERVICE AVAILABLE, SNA : SERVICE not AVAILABLE

Drawer#	SEC_Code	Description	QT'y	Service	Remark
5.3-0	JC96-04741A	ELA HOU-COVER	1	SA	
5.3-1	JC97-03016A	MEA UNIT-COVER_FRONT	1	SA	
5.3-2	JC97-03013A	MEA UNIT-COVER_LEFT	1	SA	
5.3-3	JC97-03014A	MEA UNIT-COVER_RIGHT	1	SA	
5.3-3-1	JC63-01525A	COVER-RIGHT	1	SNA	
5.3-3-2	JC63-01570A	COVER-RIGHT_DIMM	1	SNA	
5.3-4	JC97-03015A	MEA UNIT-COVER_REAR	1	SA	

5.4 Front Cover

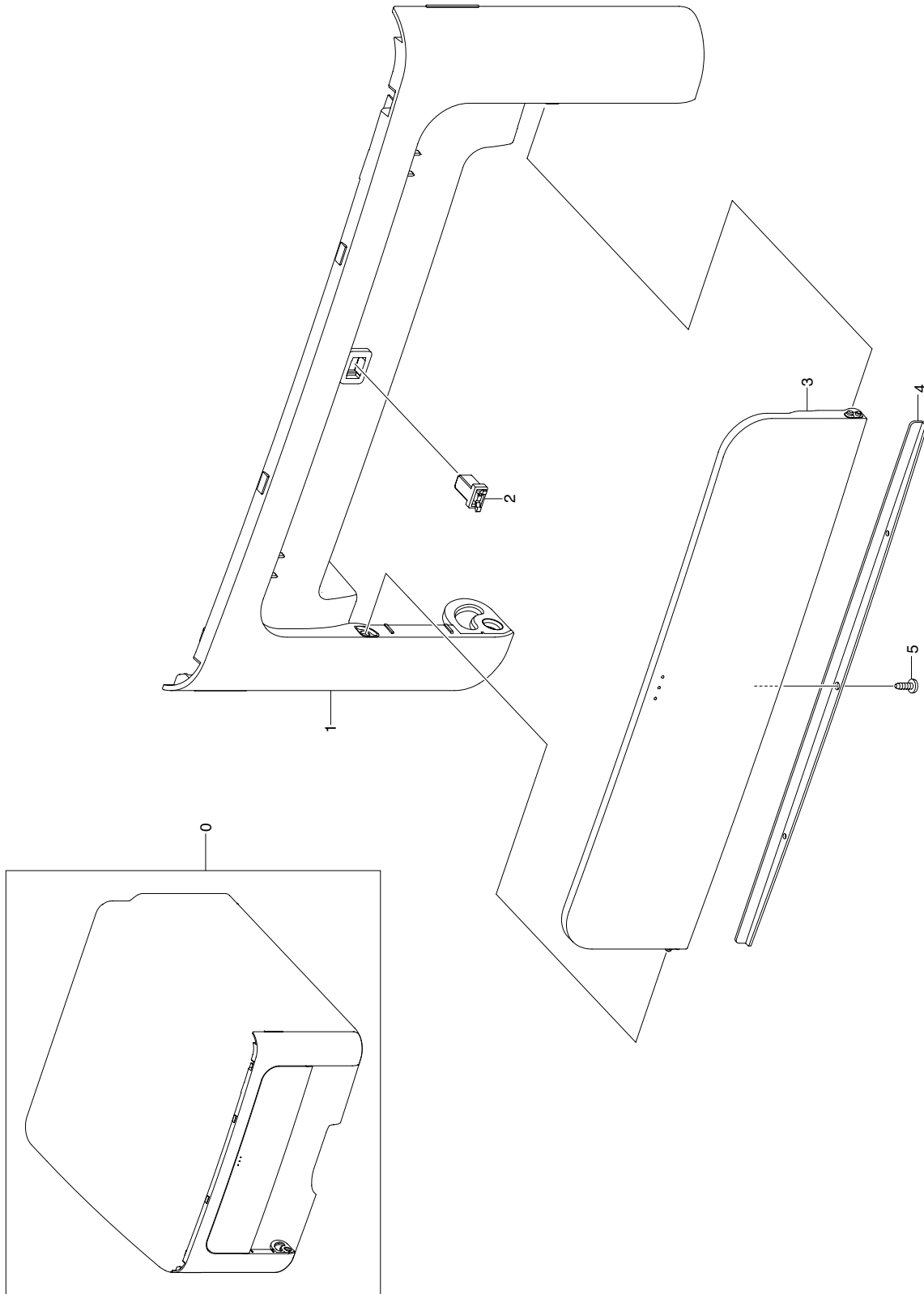

Front Cover Parts List

SA : SERVICE AVAILABLE, SNA : SERVICE not AVAILABLE

Drawer#	SEC_Code	Description	QT'y	Service	Remark
5.4-0	JC97-03016A	MEA UNIT-COVER_FRONT	1	SA	
5.4-1	JC63-01527A	COVER-FRONT	1	SA	
5.4-2	JB64-00007A	LOCKER-LATCH PUSH	1	SA	
5.4-3	JC63-01569A	COVER-MANUAL	1	SNA	
5.4-4	JC61-02267A	BRACKET-MANUAL	1	SNA	
5.4-5	6003-000282	SCREW-TAPTITE	1	SNA	

5.5 Rear Cover

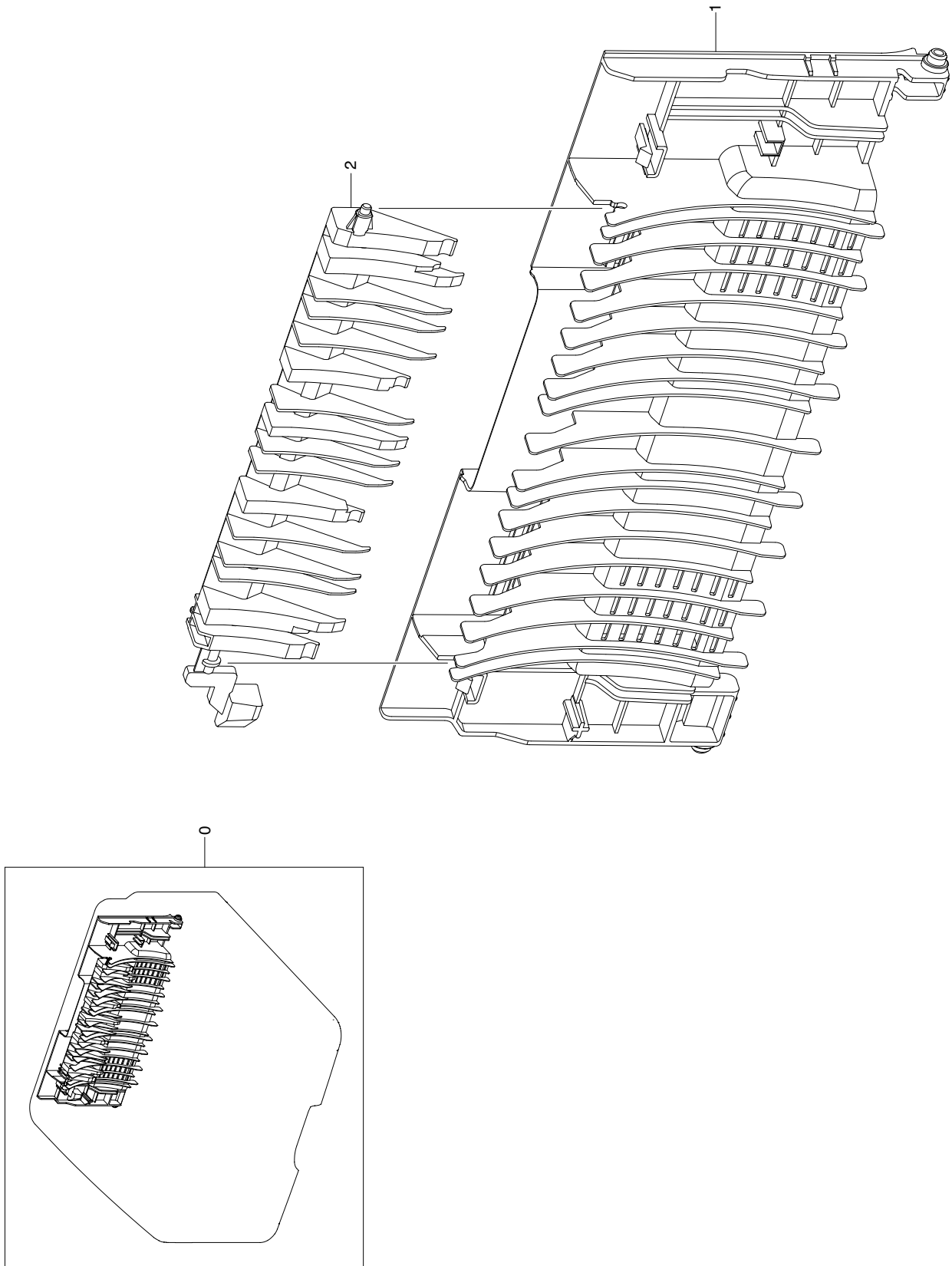

Rear Cover Parts List

SA : SERVICE AVAILABLE, SNA : SERVICE not AVAILABLE

Drawer#	SEC_Code	Description	QT'y	Service	Remark
5.5-0	JC97-03015A	MEA UNIT-COVER_REAR	1	SA	
5.5-1	JC63-01526A	COVER-REAR	1	SNA	
5.5-2	JC61-02399A	GUIDE-CHANGE_DUP	1	SNA	

5.6 Frame1

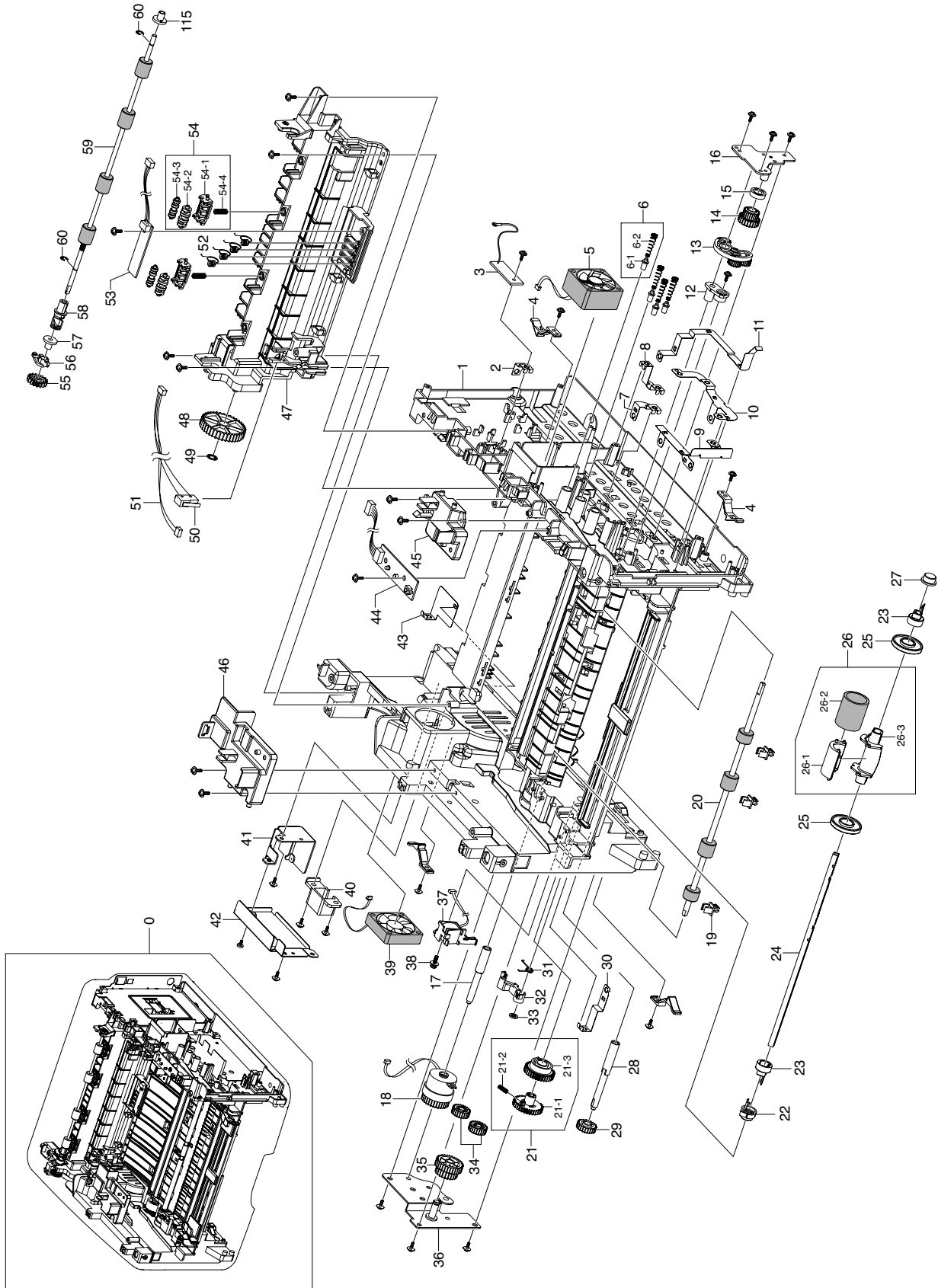

Frame2

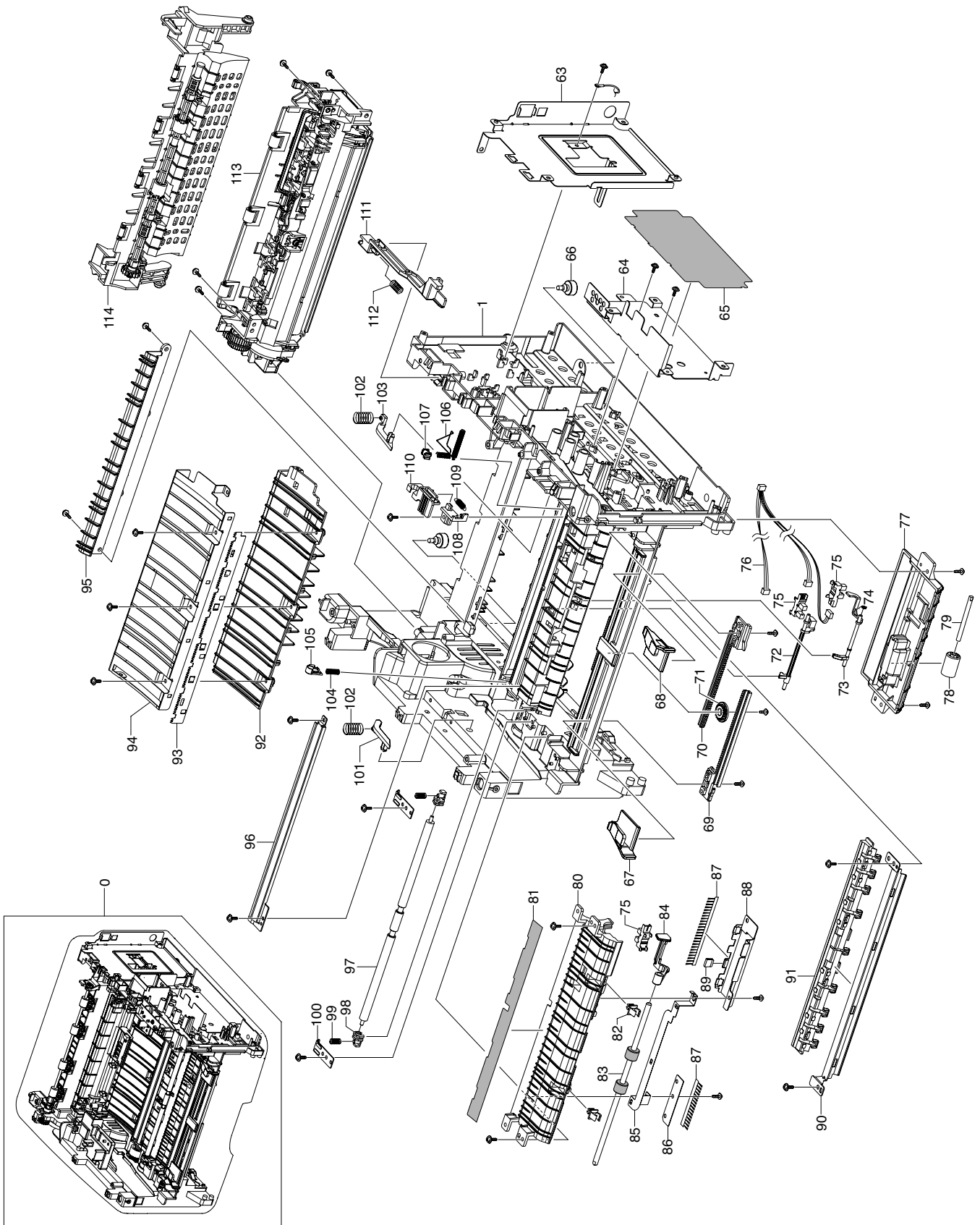

Frame Parts List

SA : SERVICE AVAILABLE, SNA : SERVICE not AVAILABLE

Drawer#	SEC_Code	Description	QT'y	Service	Remark
5.6-0	JC96-04738A	ELA HOU-FRAME_220V	1	SA	
5.6-1	JC61-02187A	FRAME-BASE	1	SA	
5.6-2	JC63-01616A	GROUND-ZENOR	1	SA	
5.6-3	JC92-01488A	PBA MAIN-ZENER	1	SA	
5.6-4	JC72-00983A	PMO-LOCKER CST	4	SA	
5.6-5	JC31-00085A	FAN-DC	1	SA	
5.6-6-1	JC70-40912A	ICT SHAFT HV LARGE	4	SA	
5.6-6-2	JC61-00031A	SPRING ETC-HV LARGE	4	SA	
5.6-7	JC63-01619A	GROUND-MOTOR_MAIN	1	SA	
5.6-8	JC63-01618A	GROUND-CONTROLLER	1	SA	
5.6-9	JC63-01620A	GROUND-PAPER	1	SA	
5.6-10	JC63-01613A	GROUND-BRKT FRONT	1	SA	
5.6-11	JC63-01621A	GROUND-TRANSFER	1	SA	
5.6-12	JC61-02233A	HOLDER-REGI	1	SA	
5.6-13	JC96-04732A	MEA UNIT SWING	1	SA	
5.6-14	JC66-01651A	GEAR RDCN 23/23	1	SA	
5.6-15	JC61-02220A	COLLAR SWING	1	SA	
5.6-16	JC61-02225A	BRKT SWING	1	SA	
5.6-17	JC66-01655A	SHAFT-FEED REGI	1	SA	
5.6-18	JC66-01865A	CLUTCH ELECTRIC	1	SA	
5.6-19	JC72-00382B	PMO-BUSHING FEED	5	SA	
5.6-20	JC66-01656A	ROLLER-FEED REGI	1	SA	
5.6-21	JC97-03141A	MEA UNIT-GEAR PICK UP	1	SA	
5.6-21-1	JC72-00979A	GEAR PICK UP A	1	SA	
5.6-21-2	6107-001167	SPRING-CS	1	SA	
5.6-21-3	JC72-00980A	GEAR PICKUP B	1	SA	
5.6-22	JC66-01889A	CAM-PICK UP	1	SA	
5.6-23	JC72-00982A	PMO-IDLE PICK_UP	2	SA	
5.6-24	JC66-01692A	SHAFT-P-PICK_UP	1	SA	
5.6-25	JC61-00915A	STOPPER-M-PICK UP_R2	2	SA	
5.6-26	JC97-03062A	MEA UNIT-PICK UP	1	SA	
5.6-26-1	JC73-00265A	RUBBER PICK_UP	1	SA	
5.6-26-2	JC61-00910A	HOUSING-M-PICK UP2_R2	1	SA	
5.6-26-3	JC61-00909A	HOUSING-M-PICK UP_R2	1	SA	
5.6-27	JC61-00587A	BUSH-M-PICK_UP R	1	SA	
5.6-28	JC66-01660A	SHAFT-FEED	1	SA	
5.6-29	JC66-01634A	GEAR-FEED DR 16	1	SA	
5.6-30	JC63-01614A	GROUND-GUIDE TR	1	SA	
5.6-31	6107-001352	SPRING-TS	1	SA	
5.6-32	JC66-00377A	CAM-M-PICK_UP	1	SA	
5.6-33	6044-000001	RING-CS;ID3,OD3,T0.25,BLACK,SU	1	SA	
5.6-34	JC66-40964A	GEAR-EXIT,IDLE(Z17)	2	SA	
5.6-35	JC66-01627A	GEAR-FEED RDCN 24/19	1	SA	

Frame Parts List

SA : SERVICE AVAILABLE, SNA : SERVICE not AVAILABLE

Drawer#	SEC_Code	Description	QT'y	Service	Remark
5.6-36	JC61-02226A	BRACKET-FEED	1	SA	
5.6-37	JC33-00026A	SOLENOID PCIKUP	1	SA	
5.6-38	6003-000301	SCREW-TAPTITE	1	SA	
5.6-39	JC31-00085A	FAN-DC	2	SA	
5.6-40	JC61-02232A	HOLDER-POWER	1	SA	
5.6-41	JC63-01571A	SHIELD-POWER_SWITCH	1	SA	
5.6-42	JC61-02238A	PLATE-POWER CAP	1	SA	
5.6-43	JC63-01615A	GROUND-SCF	1	SA	
5.6-44	JC92-01439A	PBA LED-PANEL	1	SA	
5.6-45	JC61-02312A	FRAME-LSU-HOLDER-R	1	SA	
5.6-46	JC61-02311A	FRAME-LSU-HOLDER_L	1	SA	
5.6-47	JC61-02310A	FRAME-EXIT_HIGH	1	SA	
5.6-48	JC66-00875A	GEAR-M-FUSER IDLE 1	1	SA	
5.6-49	6044-001005	RING-CS	1	SA	
5.6-50	JC39-00826A	CBF HARNESS-LSU SW&FAN	1	SA	
5.6-52	JC65-00019A	TERMINAL-CRUM	4	SA	
5.6-53	JC92-01829A	PBA SUB-TERMINAL	1	SA	
5.6-54-1	JC61-01172A	HOLDER-M-EXIT F/DOWN	2	SNA	
5.6-54-2	JC66-00824A	ROLLER-EXIT MAIN	2	SNA	
5.6-54-3	JC66-00830A	ROLLER-EXIT FR	2	SNA	
5.6-54-4	6107-001163	SPRING CS	2	SNA	
5.6-55	JC66-40209A	GEAR-M-EXIT	1	SA	
5.6-56	JC72-41191B	PMO-BEARING SHAFT	2	SA	
5.6-57	JC61-02308A	SUPPORT-ROLLER	1	SA	
5.6-59	JC66-01662A	ROLLER-EXIT F/DOWN	1	SA	
5.6-63	JC63-01572A	SHIELD-CONTROLLER	1	SA	
5.6-64	JC63-01573A	SHIELD-SMPS	1	SA	
5.6-65	JC62-00461A	INSULATION-SMPS	1	SA	
5.6-66	JC61-40001A	FOOT-ML80	2	SA	
5.6-67	JC70-00546A	ADJUST-MANUAL L	1	SA	
5.6-68	JC70-00547A	ADJUST-MANUAL R	1	SA	
5.6-69	JC70-00304A	ADJUST RACK-M-MANUAL	2	SA	
5.6-71	JC66-00387A	GEAR-RACK_PINION	1	SA	
5.6-72	JC66-01647A	ACTUATOR-FEED	1	SA	
5.6-73	JC66-01646A	ACTUATOR-DUPLEX	1	SA	
5.6-74	6107-001164	SPRING-TS	2	SA	
5.6-75	0604-001095	PHOTO INTERRUPTER	3	SA	
5.6-76	JC39-00824A	CBF HARNESS-HVPS	1	SA	
5.6-77	JC61-02309A	FRAME-DUPLEX_PATH	1	SA	
5.6-78	JC66-01022A	ROLLER-M-IDLE SCF	1	SA	
5.6-79	JC66-01846A	SHAFT-DUP_ROLLER	1	SA	
5.6-80	JC61-02303A	GUIDE-FRAME_DUPLEX	1	SA	
5.6-81	JC63-01743A	SHEET-GUIDE_DUP_PATH	1	SA	

Frame Parts List

SA : SERVICE AVAILABLE, SNA : SERVICE not AVAILABLE

Drawer#	SEC_Code	Description	QT'y	Service	Remark
5.6-82	JC72-00382B	PMO-BUSHING FEED	5	SA	
5.6-83	JC66-00598A	ROLLER-FEED	1	SA	
5.6-84	JC66-01648A	ACTUATOR-EMPTY	1	SA	
5.6-85	JC63-01617A	GROUND-PICK_UP	1	SA	
5.6-86	JC63-00527A	SHEET-BRUSH	1	SA	
5.6-87	JC75-00095A	MEC-BRUSH PICK UP	1	SNA	
5.6-88	JC61-02268A	BRACKET-COVER FRONT	1	SA	
5.6-89	JC63-01676A	GROUND-BRUSH PICK UP	1	SA	
5.6-90	JC61-02306A	GUIDE-PAPER	1	SA	
5.6-91	JC61-02400A	GUIDE FRONT PAPER	1	SA	
5.6-92	JC61-02305A	GUIDE-TR_RIB	1	SA	
5.6-93	JC61-00604B	PLATE-E_SAW	1	SA	
5.6-94	JC61-02307A	GUIDE-TR	1	SA	
5.6-95	JC61-02196A	GUIDE-INPUT	1	SA	
5.6-96	JC61-02236A	PLATE EARTH TRANSFER	1	SA	
5.6-97	JC66-01654A	SHAFT-FEED IDLE	1	SA	
5.6-98	JC61-00585A	BUSH-M-FEED IDLE	2	SA	
5.6-99	JC61-70958A	SPRING ETC-TR	2	SA	
5.6-100	JC61-00914A	PLATE-P-PUSH BUSHING	2	SA	
5.6-101	JC72-00984A	PMO-PLATE GUIDE DEVE_L	1	SA	
5.6-102	JC61-70932A	SPRING ETC-GUIDE DEVE	2	SA	
5.6-103	JC72-00985A	PMO-PLATE GUIDE DEVE_R	1	SA	
5.6-104	6107-001370	SPRING TR	1	SA	
5.6-105	JC61-02468A	BUSH-TR_L	1	SA	
5.6-106	JC65-00033A	TERMINAL SPRING TR	1	SA	
5.6-107	JC61-00588A	PMO-BUSHING_TR(L)	1	SA	
5.6-108	JC61-02304A	GUIDE-HOLDER_TR	1	SA	
5.6-109	JC61-00553A	SPRING ETC-ES (Guide holder TR)	1	SA	
5.6-110	JC61-02231A	HOLDER-TRANSFER	1	SA	
5.6-111	JC66-01649A	LINK-COVER_REAR	1	SA	
5.6-112	6107-001172	SPRING-CS	1	SA	
5.6-114	JC97-03067A	MEA UNIT-GUIDE REAR	1	SA	
5.6-115	JC61-00424A	BUSH-4	1	SNA	

5.7 Main Drive

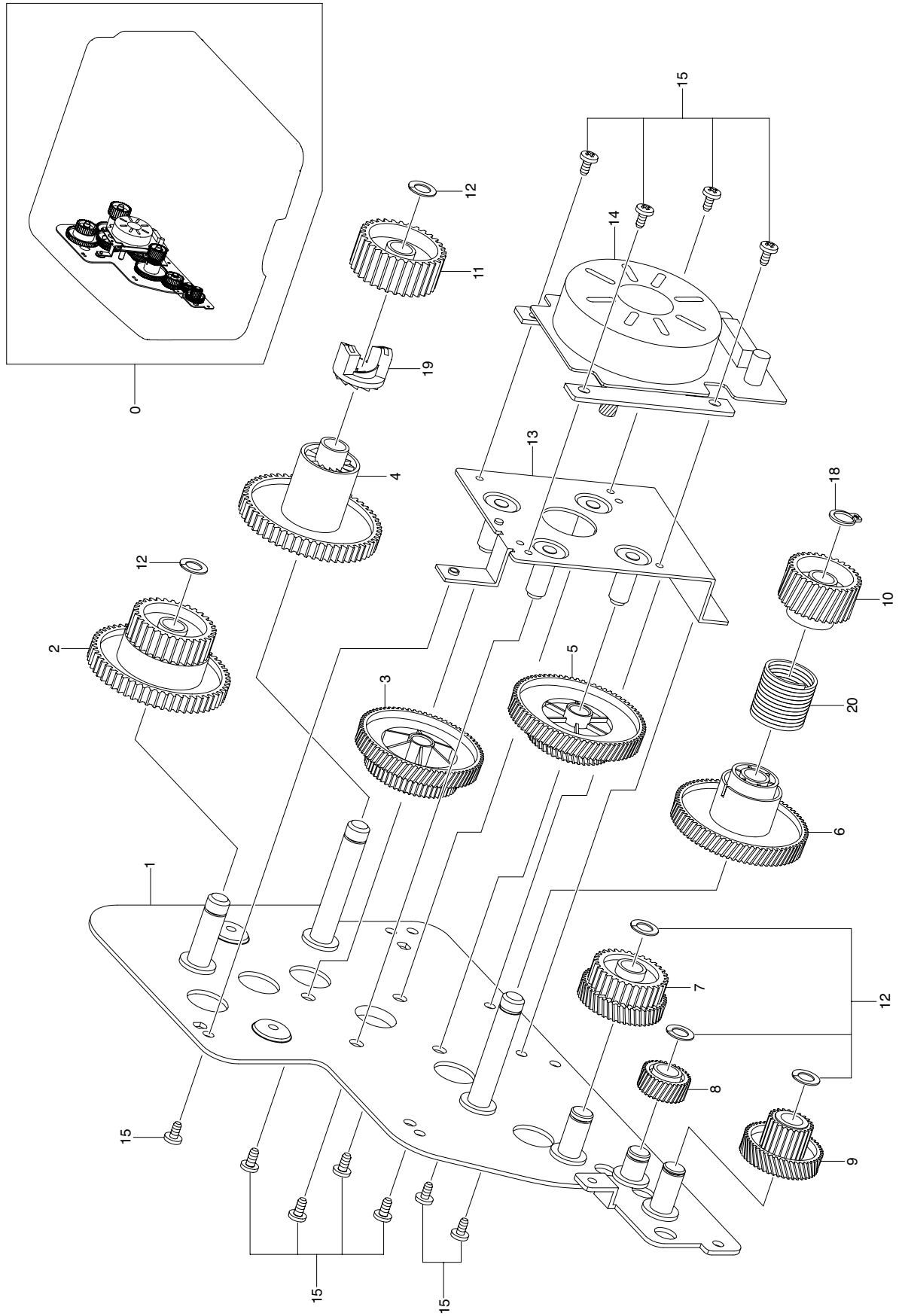

Main Drive Parts List

SA : SERVICE AVAILABLE, SNA : SERVICE not AVAILABLE

Drawer#	SEC_Code	Description	QT'y	Service	Remark
5.7-0	JC96-04731A	ELA UNIT-DRIVE	1	SA	
5.7-1	JC61-02195A	BRACKET-GEAR	1	SNA	
5.7-2	JC66-01641A	GEAR-EXIT RDCN 61/28	1	SA	
5.7-3	JC66-01628A	GEAR-RDCN 83/40	1	SA	
5.7-4	JC66-01632A	GEAR-FUSER DR IN 61	1	SA	
5.7-5	JC66-01626A	GEAR-RDCN 89/55	1	SA	
5.7-6	JC66-01633A	GEAR-OPC DR IN 89	1	SA	
5.7-7	JC66-01625A	GEAR-FEED RDCN 56/25	1	SA	
5.7-8	JC66-01640A	GEAR-PICKUP IDLE 31	1	SA	
5.7-9	JC66-01650A	GEAR-RDCN 52/18	1	SA	
5.7-10	JC66-01798A	GEAR-OPC CLUTCH 29	1	SA	
5.7-11	JC66-01637A	GEAR-FUSER DR OUT 37	1	SA	
5.7-12	6031-000023	WASHER-PLAIN	5	SNA	
5.7-13	JC61-02227A	BRACKET-MOTOR	1	SNA	
5.7-14	JC31-00090A	MOTOR BLDC	1	SNA	
5.7-15	6003-000269	SCREW-TAPTITE	11	SA	
5.7-18	6044-001130	RING-C	1	SNA	
5.7-19	JC70-00548A	HUB-CLUTCH	1	SNA	
5.7-20	6107-001372	SPRING CLUTCH	1	SNA	

5.8 Rear Guide

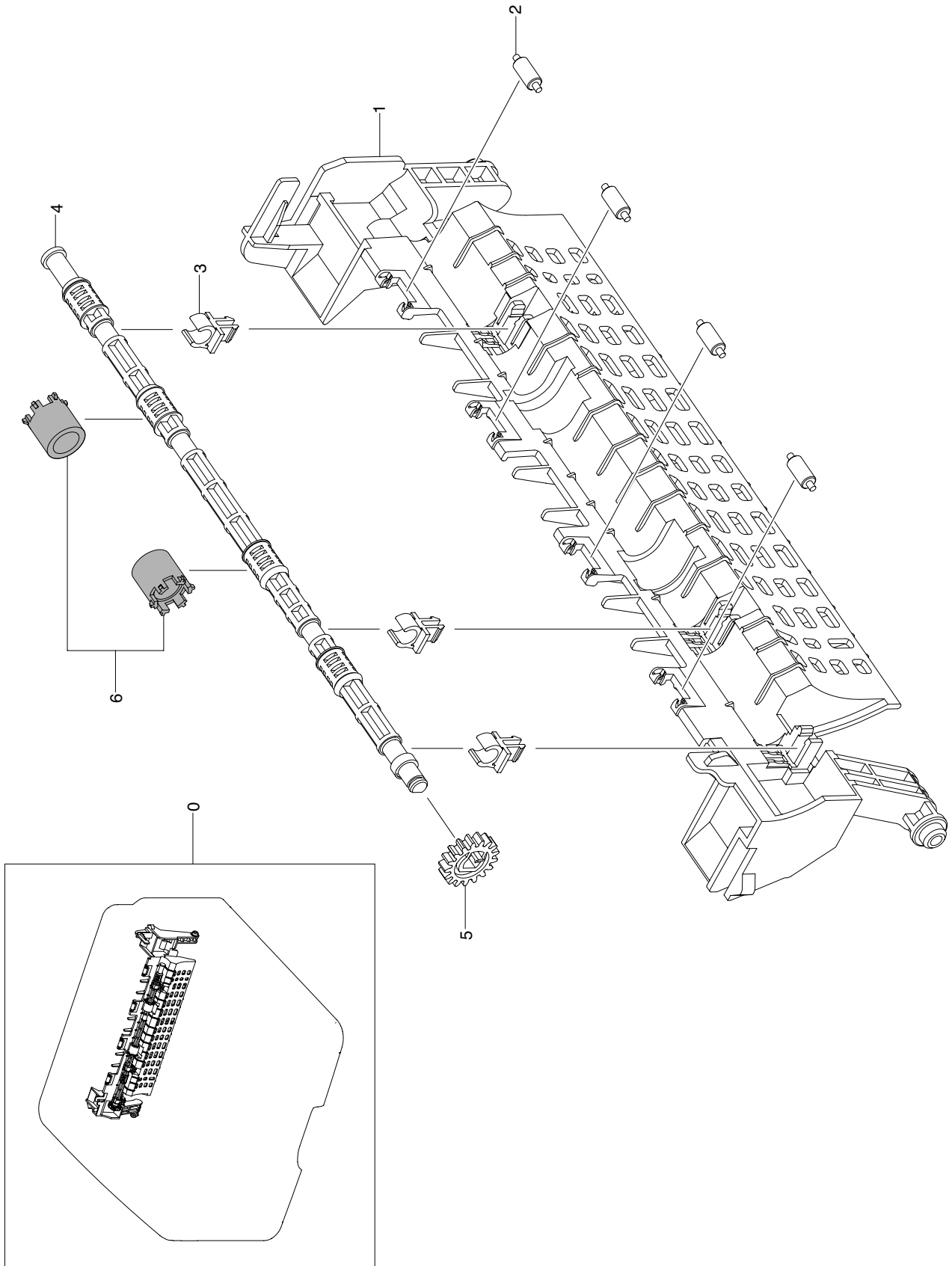

Rear Guide Parts List

SA : SERVICE AVAILABLE, SNA : SERVICE not AVAILABLE

Drawer#	SEC_Code	Description	QT'y	Service	Remark
5.8-0	JC97-03067A	MEA UNIT-GUIDE REAR	1	SA	
5.8-1	JC61-02198A	GUIDE-REAR	1	SNA	
5.8-2	JC66-01661A	ROLLER-IDLE_EXIT	4	SNA	
5.8-3	JC61-02158A	BUSH-TX	3	SNA	
5.8-4	JC66-01584A	SHAFT-EXIT_F/UP	1	SNA	
5.8-5	JC66-01583A	GEAR-EXIT	1	SA	
5.8-6	JC73-00259A	RUBBER-EXIT_F/UP	2	SNA	

Fuser Parts List

SA : SERVICE AVAILABLE, SNA : SERVICE not AVAILABLE

Drawer#	SEC_Code	Description	QT'y	Service	Remark
5.9-0	JC96-04717A	ELA UNIT-FUSER	1	SA	
5.9-1	JC63-01517A	COVER-FUSER	1	SNA	
5.9-2	JC72-40981A	PMO-ROLLER UPPER DP	3	SA	
5.9-3	JC66-01312A	ROLLER-IDLE	5	SA	
5.9-4	JC70-20901A	IEX-SHAFT IDLE,F/UP	3	SA	
5.9-5	1404-001438	THERMISTOR-NTC ASSY	1	SA	
5.9-6	6003-000196	SCREW-TAPTITE	1	SNA	
5.9-7	4712-001031	THERMOSTAT	1	SA	
5.9-8	6003-000282	SCREW-TAPTITE	4	SNA	
5.9-9	JC63-01536A	GROUND-FUSER	1	SNA	
5.9-10	JC66-01256B	ROLLER-HEAT	1	SNA	
5.9-11	JC66-01254A	GEAR-FUSER	1	SA	
5.9-12	JC61-02334A	BUSH-HR-L	1	SNA	
5.9-13	JC61-02335A	BUSH-HR-R	1	SNA	
5.9-14	JC72-20902A	PEX-ROLLER F/UP(2)	2	SA	
5.9-15	6107-001359	SPRING-ETC	4	SA	
5.9-16	JC61-02154A	GUIDE-CLAW	4	SNA	
5.9-17	JC61-01950A	SPRING ETC-CLAW	4	SA	
5.9-18	6107-001165	SPRING-TS	1	SA	
5.9-19	JC66-01595A	ACTUATOR-EXIT	1	SNA	
5.9-20	JC61-02197A	FRAME-FUSER	1	SNA	
5.9-21	JC66-01663A	ROLLER-PRESSURE	1	SNA	
5.9-22	JC61-02336A	BUSH-PR-1ST	2	SNA	
5.9-23	JC66-01664A	ROLLER-PRESSURE_2ND	1	SNA	
5.9-24	JC61-02337A	BUSH-PR-2ND	2	SNA	
5.9-25	JC66-01598A	LEVER-LINK JAM_R	1	SNA	
5.9-26	JC66-01597A	LEVER-LINK JAM_L	1	SNA	
5.9-27	6107-001246	SPRING-CS	2	SNA	
5.9-28	6044-000159	RING-C	2	SA	
5.9-29	6107-001361	SPRING-ES	2	SA	
5.9-30	4713-001212	LAMP-HALOGEN	1	SA	
5.9-31	JC67-00266A	CAP-LAMP_L	1	SNA	
5.9-32	JC67-00267A	CAP-LAMP_R	1	SNA	
5.9-33	JC66-01638A	GEAR-FUSER RDCN 28-20	1	SA	
5.9-34	JC66-00056A	GEAR-MPF 5	1	SNA	
5.9-35	6031-001051	WASHER-PLAIN	2	SNA	
5.9-36	6044-000001	RING-CS	2	SNA	
5.9-37	0604-001095	PHOTO-INTERRUPTER	1	SA	

5.10 Duplex Unit

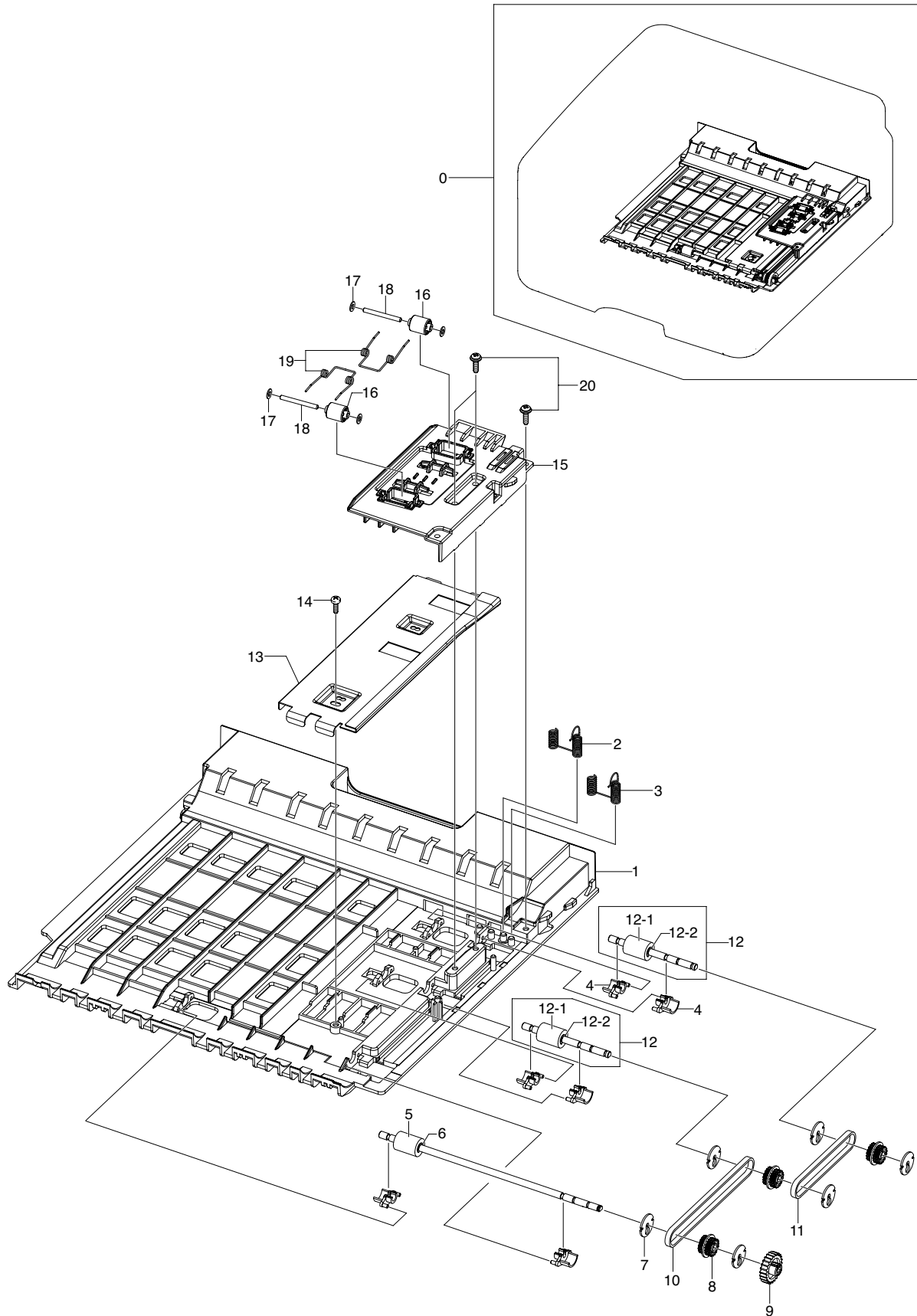

Duplex Unit Parts List

SA : SERVICE AVAILABLE, SNA : SERVICE not AVAILABLE

Drawer#	SEC_Code	Description	QT'y	Service	Remark
5.10-0	JC96-04736A	ELA UNIT-DUPLEX	1	SA	
5.10-1	JC61-02188A	FRAME-DUPLEX_BASE	1	SNA	
5.10-2	JC65-00036A	TERMINAL-GND_DUP L	1	SA	
5.10-3	JC65-00035A	TERMINAL-GND_DUP S	1	SA	
5.10-4	JC61-00665A	BUSH-M-FEED, DUP	6	SA	
5.10-5	JC66-01657A	ROLLER-FEED_DUP2	1	SNA	
5.10-6	6044-000107	RING-C	1	SNA	
5.10-7	JC66-00900A	PULLEY-M-18-DUMMY_DUP	6	SA	
5.10-8	JC66-00899A	PULLEY-18_DUP	3	SA	
5.10-9	JC66-00038A	GEAR-EXIT F/DOWN	1	SA	
5.10-10	6602-001589	BELT-TIMING GEAR	1	SA	
5.10-11	6602-001588	BELT-TIMING GEAR	1	SA	
5.10-12	JC96-03662A	ELA UNIT-ROLLER_DUP	2	SNA	
5.10-12-1	JC66-00901A	ROLLER-FEED_DUP	1	SA	
5.10-12-2	6044-000107	RING-C	1	SNA	
5.10-13	JC61-02235A	BRACKET-DUPLEX_ALIGN	1	SNA	
5.10-14	6003-000440	SCREW-TAPPING	1	SNA	
5.10-15	JC61-02314A	GUIDE-DUPLEX_UPPER	1	SNA	
5.10-16	JC66-00896A	ROLLER-M-IDLE_DUP	2	SA	
5.10-17	JK72-00058A	PCT-SILP WASHER	4	SNA	
5.10-18	JC66-00444A	SHAFT-IDLE ROLL, DUP	2	SA	
5.10-19	6107-001156	SPRING-TS	2	SA	
5.10-20	6003-000196	SCREW-TAPTITE	3	SNA	

5.11 Cassette

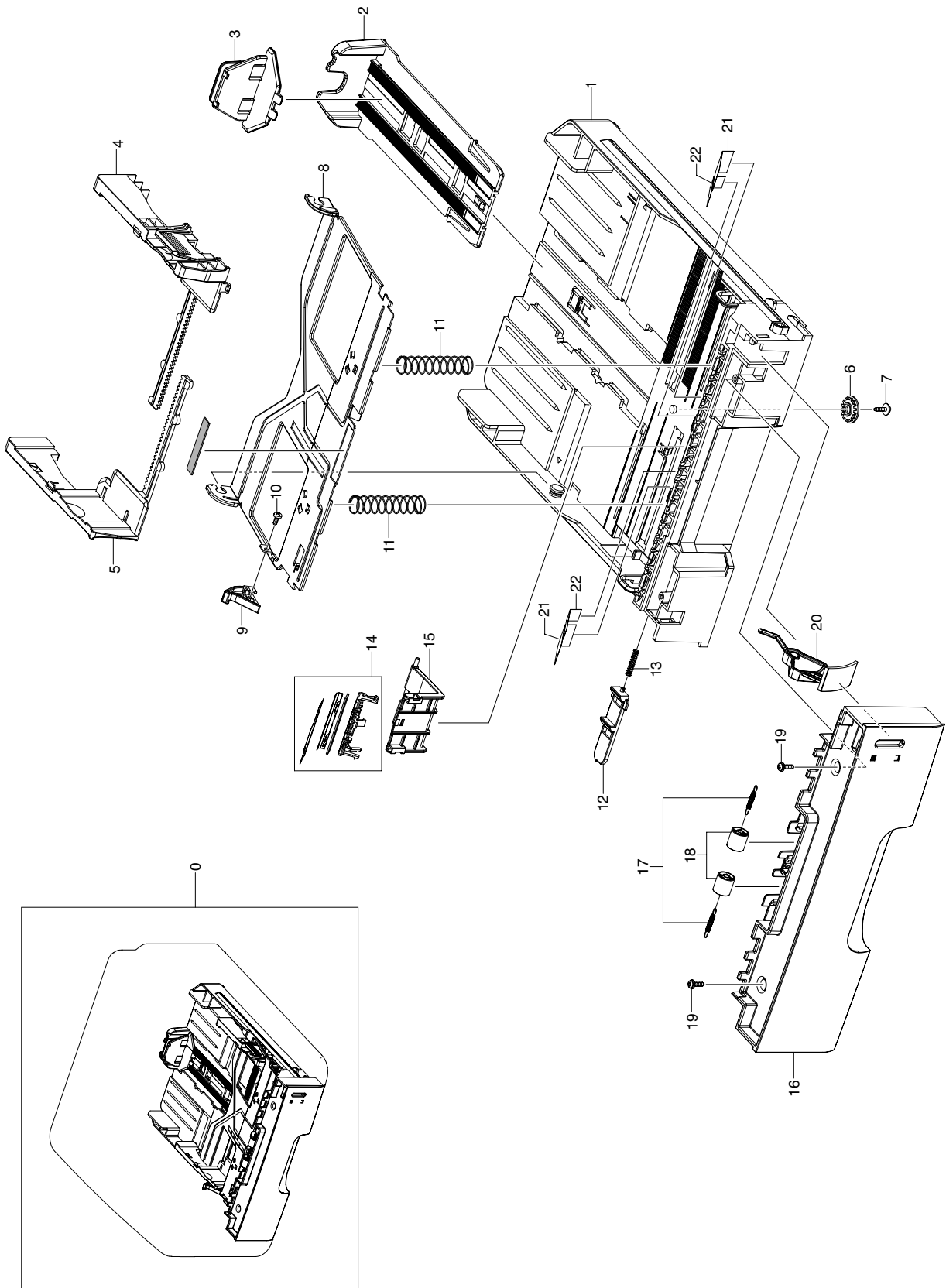

Cassette Parts List

SA : SERVICE AVAILABLE, SNA : SERVICE not AVAILABLE

Drawer#	SEC_Code	Description	QT'y	Service	Remark
5.11-0	JC97-03017A	MEA UNIT-CASSETTE	1	SA	
5.11-1	JC61-00876A	FRAME-M_CASSETTE	1	SA	
5.11-2	JC61-00918B	GUIDE-M-EXTENSION L2	1	SA	
5.11-3	JC72-00971A	PMO-EXTENSION SMALL	1	SA	
5.11-4	JC70-00301A	ADJUST-M-CASSETTE_R	1	SA	
5.11-5	JC70-00300A	ADJUST-M-CASSETTE_L	1	SA	
5.11-6	JG66-40003A	GEAR-PINION	1	SA	
5.11-7	6003-000264	SCREW-TAPTITE	1	SA	
5.11-8	JC61-00603A	PLATE-P-KNOCK_UP	1	SA	
5.11-9	JC66-00719A	CAM-M-KNOCK UP	1	SA	
5.11-10	6003-000261	SCREW-TAPTITE	1	SA	
5.11-11	6107-001166	SPRING-CS	2	SA	
5.11-12	JC72-00972A	PMO-PLATE_LOCKER	1	SA	
5.11-13	JG61-70531A	SPRING ETC-LOCKER,PLATE	1	SA	
5.11-14	JC96-04743A	ELA HOU-HOLDER_PAD	1	SA	
5.11-15	JC61-01978A	HOUSING-HOLDER PAD	1	SA	
5.11-16	JC63-01531A	COVER-HANDLE_CASSETTE	1	SA	
5.11-17	6107-001047	SPRING-ES	2	SA	
5.11-18	JC66-00529A	ROLLER-M-IDLE FEED	2	SA	
5.11-19	6003-000196	SCREW-TAPTITE	2	SA	
5.11-20	JC64-00353A	INDICATOR-PAPER	1	SA	
5.11-21	JC63-01670A	SHEET-GUIDE_SIDE_FAR	2	SA	
5.11-22	JC63-01671A	SHEET-GUIDE_SIDE_NEAR	1	SA	

5.12 SCF

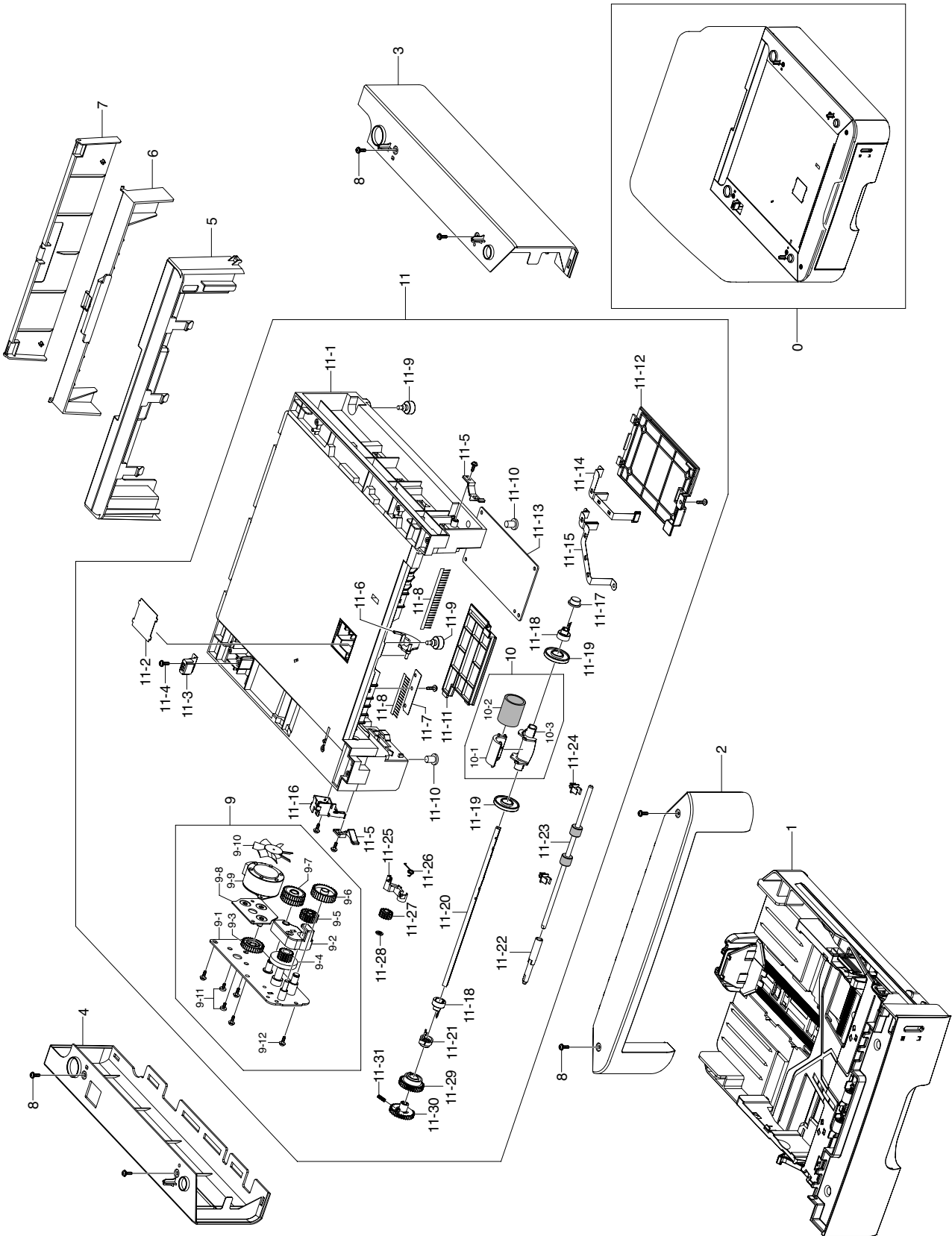

SCF Parts List

SA : SERVICE AVAILABLE, SNA : SERVICE not AVAILABLE

Drawer#	SEC_Code	Description	QT'y	Service	Remark
5.12-0	JC96-04735A	ELA UNIT-SCF	1	SNA	
5.12-1	JC97-03017A	MEA UNIT-CASSETTE	1	SNA	
5.12-2	JC63-01607A	COVER-FRONT_SCF	1	SNA	
5.12-3	JC63-01530A	COVER-RIGHT_SCF	1	SNA	
5.12-4	JC63-01529A	COVER-LEFT_SCF	1	SNA	
5.12-5	JC63-01608A	COVER-REAR_SCF	1	SNA	
5.12-6	JC63-01650A	COVER-DUPLEX	1	SNA	
5.12-7	JC63-01651A	COVER-REAR DUPLEX	1	SNA	
5.12-8	6003-000196	SCREW-TAPTITE	6	SNA	
5.12-9	JC96-04772A	ELA HOU-MOTOR_SCF	1	SA	
5.12-9-1	JC61-02228A	BRACKET-MOTOR_SCF	1	SNA	
5.12-9-2	JC61-02234A	SUPPORT-FEED_SCF	1	SNA	
5.12-9-3	JC66-01785A	GEAR-IDLE 59	1	SA	
5.12-9-4	JC66-00688A	GEAR-61/47 IDLE	1	SNA	
5.12-9-5	JC66-00396A	GEAR-IDLE 23	1	SA	
5.12-9-6	JC66-00690A	GEAR-35 IDLE	1	SNA	
5.12-9-7	JC66-01784A	GEAR-RDCN 57/18	1	SA	
5.12-9-8	JC61-02229A	BRACKET-GEAR_SCF	1	SNA	
5.12-9-9	JC31-00011E	MOTOR STEP	1	SA	
5.12-9-10	JC72-00825A	PMO-IMPELLER_DRV	1	SA	
5.12-9-11	6003-000269	SCREW-TAPTITE	5	SA	
5.12-9-12	6031-000023	WASHER-PLAIN	3	SNA	
5.12-10	JC97-03062A	MEA UNIT-PICK UP	1	SNA	
5.12-10-1	JC61-00909A	HOUSING-M-PICK UP_R2	1	SA	
5.12-10-2	JC73-00265A	RUBBER-PICK_UP	1	SA	
5.12-10-3	JC61-00910A	HOUSING-M-PICK UP2_R2	1	SA	
5.12-11	JC96-04771A	ELA HOU-FRAME_SCF	1	SNA	
5.12-11-1	JC61-02189A	FRAME-SCF	1	SNA	
5.12-11-2	JC63-00369A	SHEET-COVER SENSOR	1	SA	
5.12-11-3	JC70-11028A	IPR-GROUND TOP	1	SA	
5.12-11-4	6003-000196	SCREW-TAPTITE	11	SNA	
5.12-11-5	JC72-00983A	PMO-LOCKER CST	2	SA	
5.12-11-6	JC72-00975A	PMO-ACTUATOR EMPTY	1	SA	
5.12-11-7	JC63-00527A	SHEET-BRUSH	1	SA	
5.12-11-8	JC75-00095A	MEC-BRUSH ANTISTATIC	0.5	SA	
5.12-11-9	JC61-40001A	FOOT-ML80	2	SA	
5.12-11-10	JC61-00836A	FOOT-FRONT	2	SA	
5.12-11-11	JC63-01609A	COVER-HARNESSE_SCF	1	SNA	
5.12-11-12	JC63-00492A	COVER-M-SIMM R2	1	SA	
5.12-11-13	JC92-01911A	PBA-SCF	1	SA	
5.12-11-14	JC63-01636A	GROUND-PAPER_SCF	1	SNA	
5.12-11-15	JC63-01635A	GROUND-BRUSH_SCF	1	SNA	
5.12-11-16	JC33-00026A	SOLENOID-PICK UP	1	SA	

SCF Parts List

SA : SERVICE AVAILABLE, SNA : SERVICE not AVAILABLE

Drawer#	SEC_Code	Description	QT'y	Service	Remark
5.12-11-17	JC61-00587A	BUSH-M-PICK_UP R	1	SA	
5.12-11-18	JC61-00915A	STOPPER-M-PICK UP_R2	2	SA	
5.12-11-19	JC72-00982A	PMO-IDLE PICK_UP	2	SA	
5.12-11-27	JC66-00394A	GEAR-FEED 2	1	SA	
5.12-11-29	JC72-00980A	PMO-GEAR PICK_UP B	1	SA	
5.12-11-31	6107-001170	SPRING-TS	1	SA	
5.12-21	JC61-00586A	BUSH-M-PICK_UP L	1	SA	
5.12-22	JC66-01653A	SHAFT-FEED_SCF	1	SNA	
5.12-23	JC66-00598A	ROLLER-FEED	1	SA	
5.12-24	JC72-00382B	PMO-BUSHING FEED	2	SA	

6. System Diagram

6.1 Block Diagram

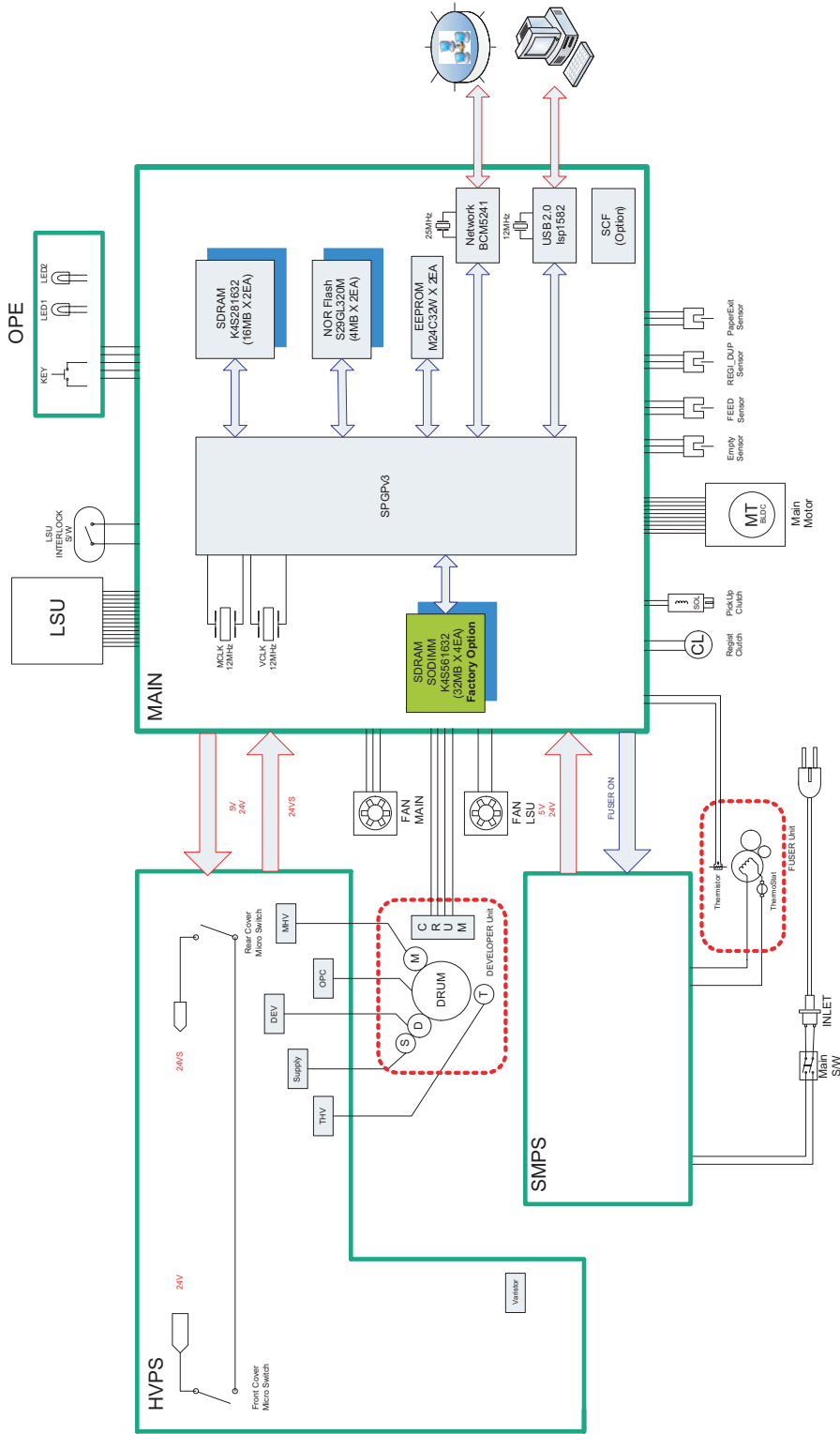

6.2 Connection Diagram

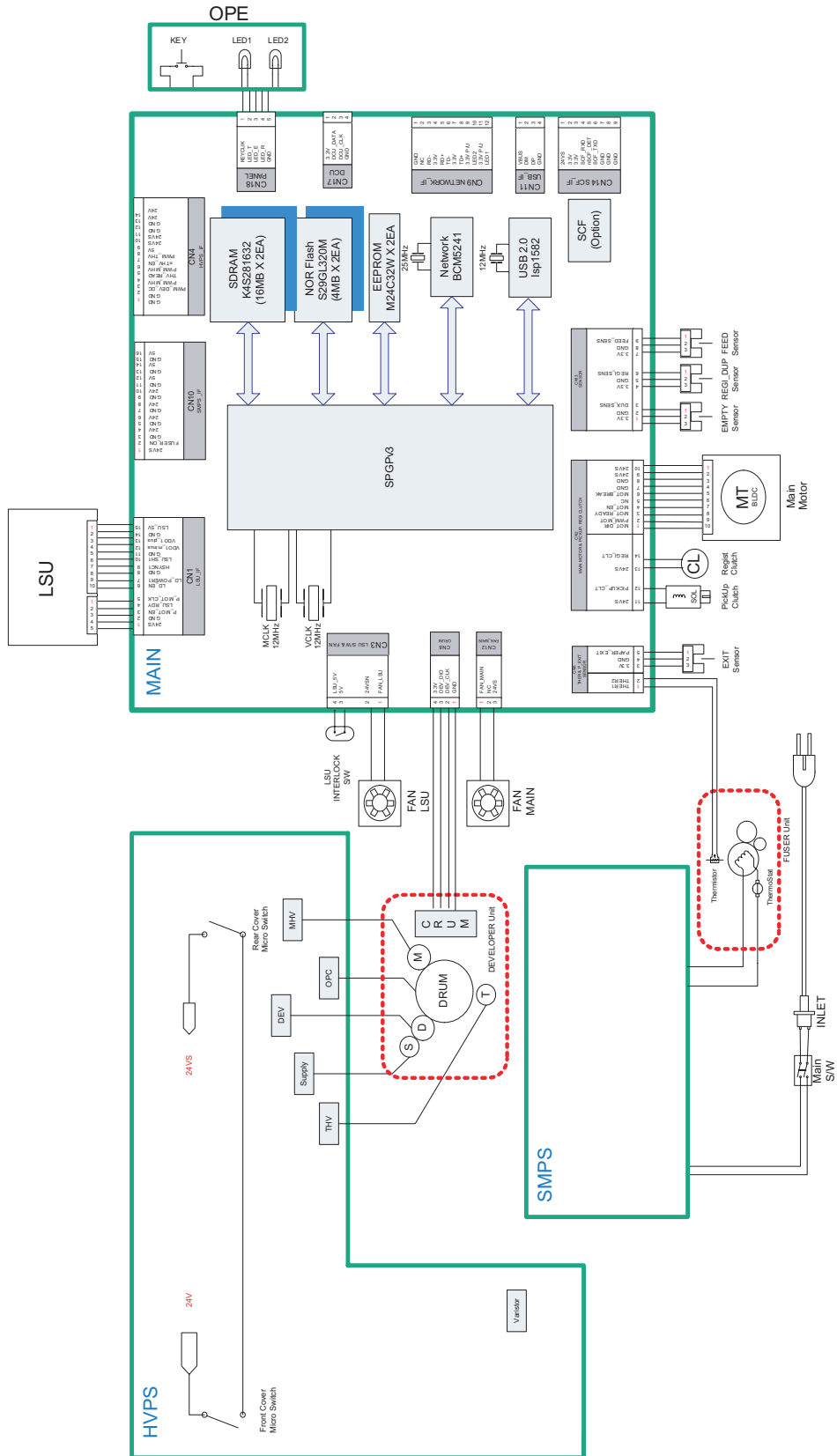

7. Reference Information

This chapter contains the tools list, list of abbreviations used in this manual, and a guide to the location space required when installing the printer. A definition of tests pages and Wireless Network information definition is also included.

7.1 Tool for Troubleshooting

The following tools are recommended safe and easy troubleshooting as described in this service manual.

- **DCU (Diagnostic Control Unit)**

Standard : Test equipment to diagnose the Laser printer supplied by Samsung Electronics.

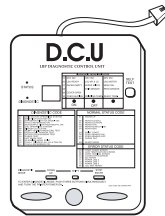

- **DVM (Digital Volt Meter)**

Standard : Indicates more than 3 digits.

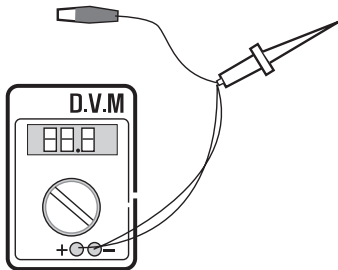

- **Driver**

Standard : "-" type, "+" type (M3 long, M3 short, M2 long, M2 short).

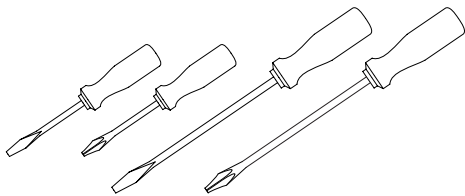

- **Tweezers**

Standard : For general home use, small type.



- **Cotton Swab**

Standard : For general home use, for medical service.



- **Cleaning Equipments**

Standard : An IPA(Isopropyl Alcohol)dry wipe tissue or a gentle neutral detergent and lint-free cloth.



- **Vacuum Cleaner**

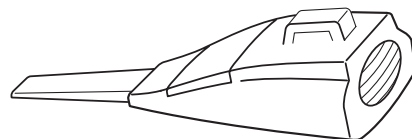

- **Software (Driver) installation CD ROM**

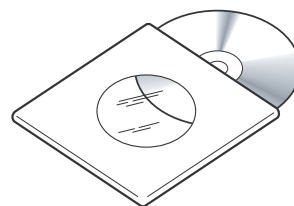

7.2 Acronyms and Abbreviations(1)

The table below explains the abbreviations and acronyms used in this service manual. Where abbreviations or acronyms are used in the text please refer to this table.

Abbreviations	Explanation
AP	Access Point
AC	Alternating Current
APC	Auto Power Control
ASIC	Application Specific Integrated Circuit
ASSY	assembly
BIOS	Basic Input Output System
BLDC	Brush-less Direct Current
CMOS	Complementary Metal Oxide Semiconductor
CN	connector
CON	connector
CPU	Central Processing Unit
dB	decibel
dBA	decibel A
dBm	decibel milliwatt
DC	direct current
DCU	Diagnostic Control Unit
DPI	Dot Per Inch
DRAM	Dynamic Random Access Memory
DVM	Digital Voltmeter
ECP	Enhanced Capability Port
EDC	Embedded Diagnostic control
EEPROM	Electrically Erasable Programmable Read Only Memory
EMI	Electro Magnetic Interference
EP	electrophotographic
EPP	Enhanced Parallel Port
FPOT	First Printout Time
FW	firmware
GDI	graphics device interface
GND	ground
HBP	Host Based Printing
HDD	Hard Disk Drive
H/H	High temperature and high marshy place
HV	high voltage
HVPS	High Voltage Power Supply
I/F	interface
I/O	Input and Output
IC	integrated circuit
IDE	Intelligent Drive electronics or Imbedded Drive Electronics

Acronyms and Abbreviations(2)

Abbreviations	Explanation
IEEE	Institute of Electrical and Electronics Engineers. Inc
IPA	Isopropy Alcohol
IPM	Images Per Minute
LAN	local area network
lb	pound(s)
LBP	Laser Beam Printer
LCD	Liquid Crystal Display
LED	Light Emitting Diode
L/L	Low temperature and low marshy place
LSU	Laser Scanning Unit
MB	megabyte
MHz	megahertz
MPF	Multi Purpose Feeder
NIC	Network Interface Card
N/N	Normal temperature and normal marshy place
NVRAM	nonvolatile random access memory
OPC	Organic Photo Conductor
OP	Operation Panel Equipment
PBA	Printed Board Assembly
PCL	Printer Command Language , Printer Control Language
PDL	Page Discription Language
PPM	Page Per Minute
PPS	Pulse Per Second
PS	Post Script
PTL	Pre-Transfer Lamp
PWM	Pulse Width Modulation
Q-PID	Quick Printer Initiating Device
Q'ty	quantity
RAM	Random Access Memory
ROM	Read Only Memory
SCF	Second Cassette Feeder
SMPS	Switching Mode Power Supply
SPGP	Samsung Printer Graphic Processor
SPL	Samsung Printer Language
Spool	Simultaneous Peripheral Operation Online
SW	switch
sync	synchronous or synchronization
USB	Universal Serial Bus
WECA	Wireless Ethernet Compatibility Alliance

7.3 Select a location for the printer

- Leave enough room to open the printer trays, covers, and allow for proper ventilation. (see diagram below)
- Provide the proper environment :
 - A firm, level surface
 - Away from the direct airflow of air conditioners, heaters, or ventilators
 - Free of extreme fluctuations of temperature, sunlight, or humidity
 - Clean, dry, and free of dust

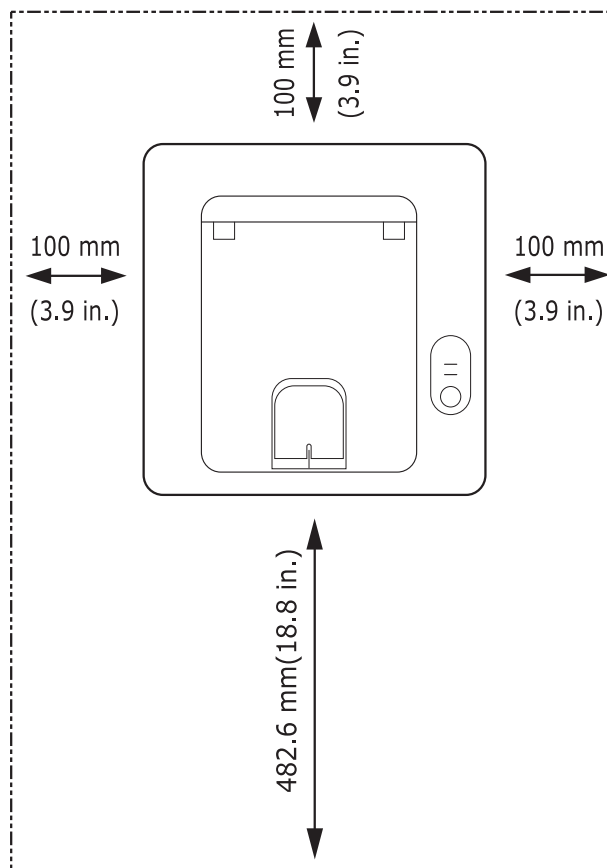

7.4 Sample Tests Patterns

The sample patterns shown below are the standard test patterns used in the factory. The life of the toner cartridge, developer cartridge and printing speed are measured with the pattern shown below (5%). The A4 ISO 19752 standard pattern samples are reproduced reduced to 70% of the actual A4 size.

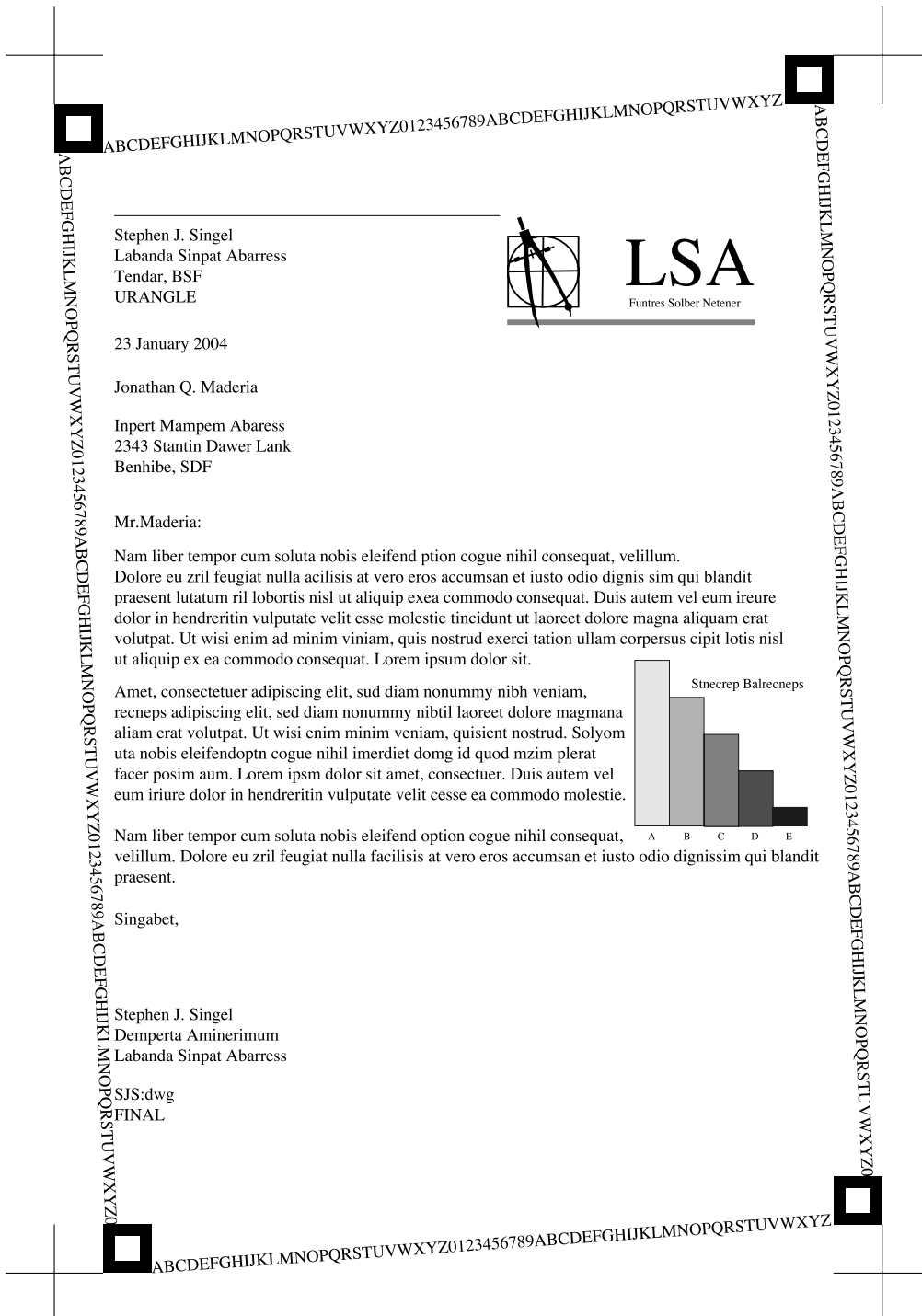

7.5 LAN (Network Model)

- This product can be used with a wired LAN (Option)
- LED Condition and Status

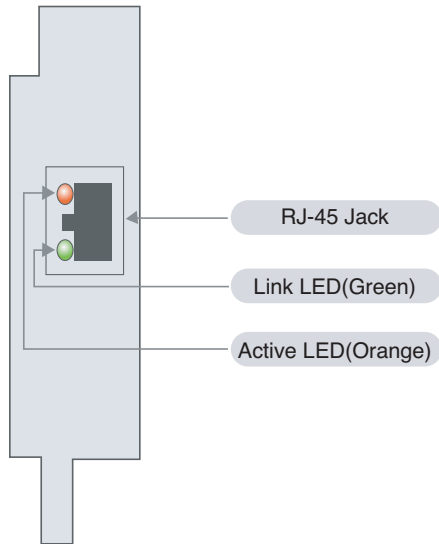

[LED STATUS]

LED Condition	Status
Active LED random blink	Normal NPC & Normal packet receive
Active LED regular blink	Normal NPC & No Packet
Active LED Off/On maintenance	NPC Initial inferiority
Link LED On	The link LED On, Normally linked
Link LED Off	Link LED off, Link Inferiority

7.6 Information of model's code

No.	Model code	Description	Remark
1	ML-2850D	Mono Laser printer, 28ppm/Duplex	Basic model
2	ML-S2850A	ELA UNIT-SCF	Option model
3	ML-2851ND	Mono Laser printer, 28ppm, Network, Duplex	Basic model
4	ML-D2850A/B	2/5K Toner Cartridge	High yield

7.7 Parts Life Cycle Maintenance Table

7.7.1 Parts Life Cycle Maintenance Table

Supplies	Life-Cycle	Condition	Engine-Codition	LCD- Indication	Custmoer - Panel Manage	Responding
Toner Cartridge	2K : For Product 5K :For Sale	Toner Low	Warning	None LCD	-	10% Remains
		Toner Empty	Warning	None LCD	-	Initialized at toner change
		Toner uninstalled				
Fuser	50K(page): Simplex	Exhausteted	No Indication	None LCD	Replaced at Exhausteted	
Transer Roller	50K(page): Simplex	Exhausteted	No Indication	None LCD	Replaced at Exhausteted	
PickUP Roller	50K(page): Simplex	Exhausteted	No Indication	None LCD	Replaced at Exhausteted	

7.7.2 Toner Cartridge Criterion

1) Supplies Criterion (Toner Cartridge)

1. Cartridge Main Defects

- White Point, Black Point : White or Black point on printing image
- Image contamination : Dirty printing image
- Image Fainted : Entire Image is faded and vertical white line emerge
- Black Line : Vertical black line emerge on printing image

2) Defect Symptoms

Symptoms	Criterion	Remarks
White, Black Point	Clean Up OPC (10 times), if disappeared, no failure. - If continuous, failure	
Image contamination (Toner leakage)	Drity printing image or conteminated reverse side - Clean up OPC (10 times) and inside of machine with cloth, if disappeared, no failure.	
Image Fainted	After shake cartridge right and left 5~6 times, if printing image is not faded, no failure. (Toner Exhausted)	
Vertical Black Line	Vertical thin line emerge, if cartridge is scratched. - (Customer fault)	

7.8 Model Information

7.8.1 Understanding for Model Code

Model code is inscribed and managed by product standard operation.
If understand the standard operation. It will help to comprehend basic and derived model.

Classification	Model abbreviation				Feature/Properties					
	1	2	3	4	5	6	7	8	9	10
DIGIT	1	2	3	4	5	6	7	8	9	10
Example	M	L		-	2	8	5	1	N	D
Definition	Product Classification		Color Product Classification	Division between code	1. Speed of Engine - If same speed models are released simultaneously higher model is added +1 at speed code. - If over 10 models with same speed are brought into, tenth model is added +1. 2. Domestic Entry Model Distribution - C&C : Engine speed - Information : The first number deleted	1. New model, series model division - Over 3rd grade project 2. Valuable model division in market despite of not over 3rd grade - VE model, etc. (Valuable model is decided by product planning group with sales prospect)	1. Basic : 0 2. Series model division - Below 4th grade project • PC Bundle • Domestic distribution (Entry model excepted)	Main feature description - N : NW - P : PS - S : NW+PS - B : Bluetooth - T : 2nd CST - M : Mac Compatible - X : Scanner • Beside above feature description, product conception to product planning group responded	Space (Basic: Omitted)	
Code Description	Printer Class of Product Description : C	Laser Beginning letter of printer Description: L	• Default= Omission • Only color printer "C" initial • Engine=E							
Description	Alphabet			-	Digit				Alphabet	

7.8.2 Understanding Material Code & Name

Material code and name is maintained by standard criteria.

If understand the criteria, it will help to order materials.

1. Two different description ways for material code. (● : Digit, ■ : Letter(Alphabet))

- Type 1	●●●●●-●●●●●●●●	ex) 2007-007961	R-CHIP
- Type 2	■●●●●-●●●●●●●■	ex)JB96-01268A	ELA UNIT-COVER TOP

Type1 : Parts managed by entire divisions : Materials used by all samsung products.
Most electrical parts are under the type 1.

Type 2 : Parts managed by a division : Material used by a certain product
Most mechanical parts are under type 2.

2. A/S Only material : Only for A/S, not related to product manufacturing.

3. Ass'y material : More than two materials are assembled. If the material order is out of service, the order can be processed by Ass'y material order.
Picture and numbers are also described on Service manual.

※ Ass'y Material and A/S Only material Code are recognizable by product name.
Those are under type 2 and known by material properties and beginning letters of product name.

Classification	Material Code	Material Name
A/S Only Material	**81-***** (JB81-00039A)	AS-***** (AS-FUSE)
A/S Only Material	**75-***** (JB75-00068A)	MEC-***** (MEC-CHUTE)
A/S Only Material	**92-***** (JB92-01131A)	PBA-***** (PBA MAIN-CONTROLLER)
A/S Only Material	**96-***** (JB96-01268A)	ELA-***** (ELA UNIT-COVER TOP)
A/S Only Material	**97-***** (JB97-01089A)	MEA-***** (MEA UNIT-PULLEY IDLE)