



G.A.L. Manufacturing Corporation
50 East 153rd Street, Bronx, N.Y. 10451
Phone (718) 292-9000 Fax (718) 292-2034

4/28/00

MOML/MOHL

DOOR OPERATOR INSTALLATION AND ADJUSTING MANUAL.

i
COMMENTS

All G.A.L. door operators are factory adjusted and tested for the actual job requirements. When installed correctly, they may require minor adjustments to suit actual job conditions.

IMPORTANT:

All equipment must be installed, adjusted, tested and maintained to comply with all Federal, State, and Local codes.

See section 10, page 22 in this manual for Kinetic Energy and closing force requirements.

Before mounting the operator, check that the car door is plumb, free and moves easily without bind. Check the attached standard measurements sheets .Install the operator according to the measurements supplied.

ii
FOREWORD

It is the intent of this manual to give the reader certain key points of information critical to the proper installation of the door operator. It is not intended to give comprehensive installation procedures nor does it cover the installation of door headers, tracks, hangers, etc.

It is hoped that the procedures presented in this manual will reduce the installation and adjustment time and result in a smooth, long lasting door operation.

When properly installed, G.A.L. operators will give many years of trouble free service.

iii
TABLE OF CONTENTS.

<u>SECTION</u>	<u>TITLE</u>	<u>PAGE</u>
i-	Comments.....	2
ii-	Foreword.....	3
iii-	Table of contents.....	4
1-	Illustrations of the MOML/MOHL operators.....	5
2-	Determining the hand of the door.....	6
3-	Mounting the operator.....	7
4-	Pre-adjustment tip.....	9
5-	Single speed and two speed slide doors.....	10
6-	Center-parting doors.....	13
7-	Electrical adjustments.....	16
	7.1- Preliminary checks.....	17
8-	Opening speed adjustments.....	18
	8.1- Opening speed observations.....	18
	8.2- Adjusting the slow start open.....	18
	8.3- Adjusting the high speed open.....	18
	8.4- Adjusting the overall opening speed.....	18
	8.5- Adjusting the slowdown zone.....	19
	8.6- Adjusting the door open limit.....	19
	8.7- Important checks.....	19
9-	Closing speed adjustments.....	20
	9.1- Closing speed observations.....	20
	9.2- Adjusting the high speed closing.....	20
	9.3- Adjusting the slowdown zone.....	20
	9.4- Adjusting the door close limit.....	21
	9.5- Important checks.....	21
	9.6- Reduced speed closing.....	21
10-	Kinetic Energy and closing force.....	22
11-	Troubleshooting table.....	25
12-	Maintenance.....	28
13-	Appendix.....	29
	Operator Specifications	
	Operator wiring diagrams dwg. S7587-1 & S7587-2	
	Operator cam adjustments dwg. 7825-3	
	Single speed 22-48 operator data table dwg. DATA21	
	Two speed 30-48 operator data table dwg. DATA22	
	Center opening 30-48 operator data table dwg. DATA23	
	Intermediate pulley dwg OP-20	
	Door operator motor data dwg. MTRPI.DOC	
	Door motor line amps dwg. dmtramps.wpd	

1

MOML/MOHL OPERATORS.

The MOML and the MOHL door operators are identical with the exception of the motor. The MOML has a ¼ HP motor, the MOHL has a ½ HP motor. Installation, wiring and adjustments are the same for both operators.

The illustrations on this page show the three different versions available; Left Hand, Right Hand and Center Parting.

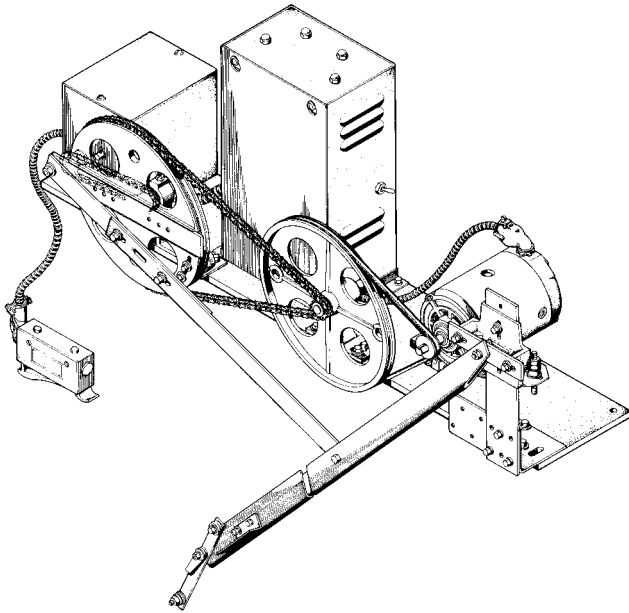

LEFT HAND SIDE OPENING

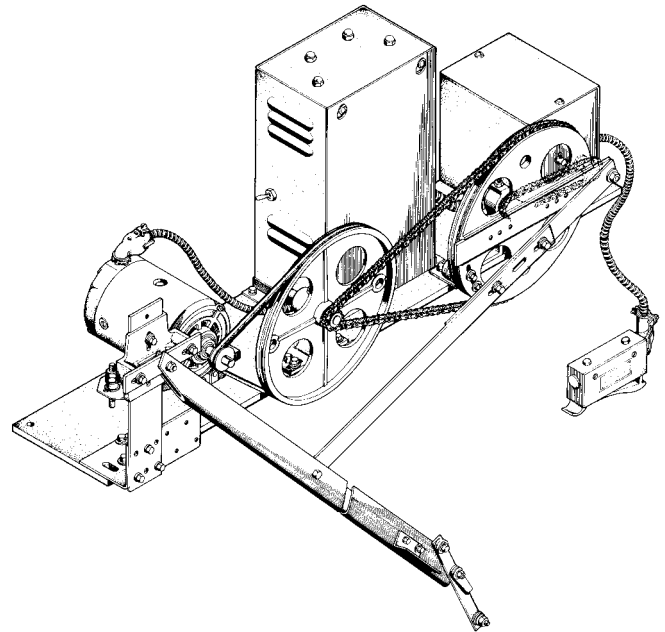

RIGHT HAND SIDE OPENING

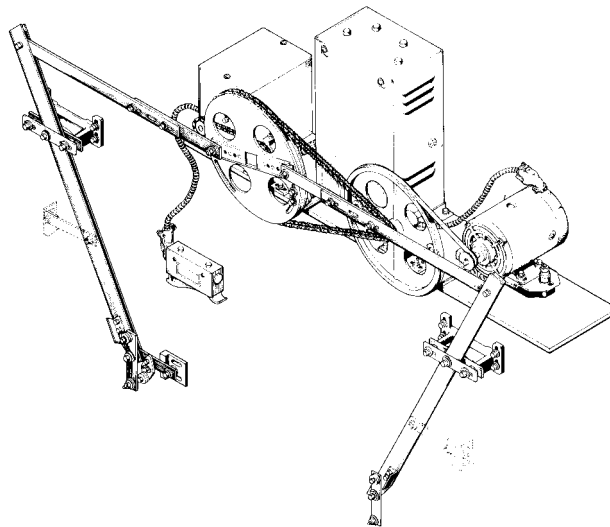

CENTER PARTING

2

DETERMINING THE HAND OF THE DOOR

G.A.L. door operators are available for right hand doors and for left hand doors. (Center parting doors use a variation of the left hand operator). To determine the hand of the door, stand in the lobby facing the elevator doors. If the doors close to the left, it is a left hand door. If the door closes to the right it is a right hand door. The left hand, center parting and right hand operators are not interchangeable. The figures below illustrate the door hand.

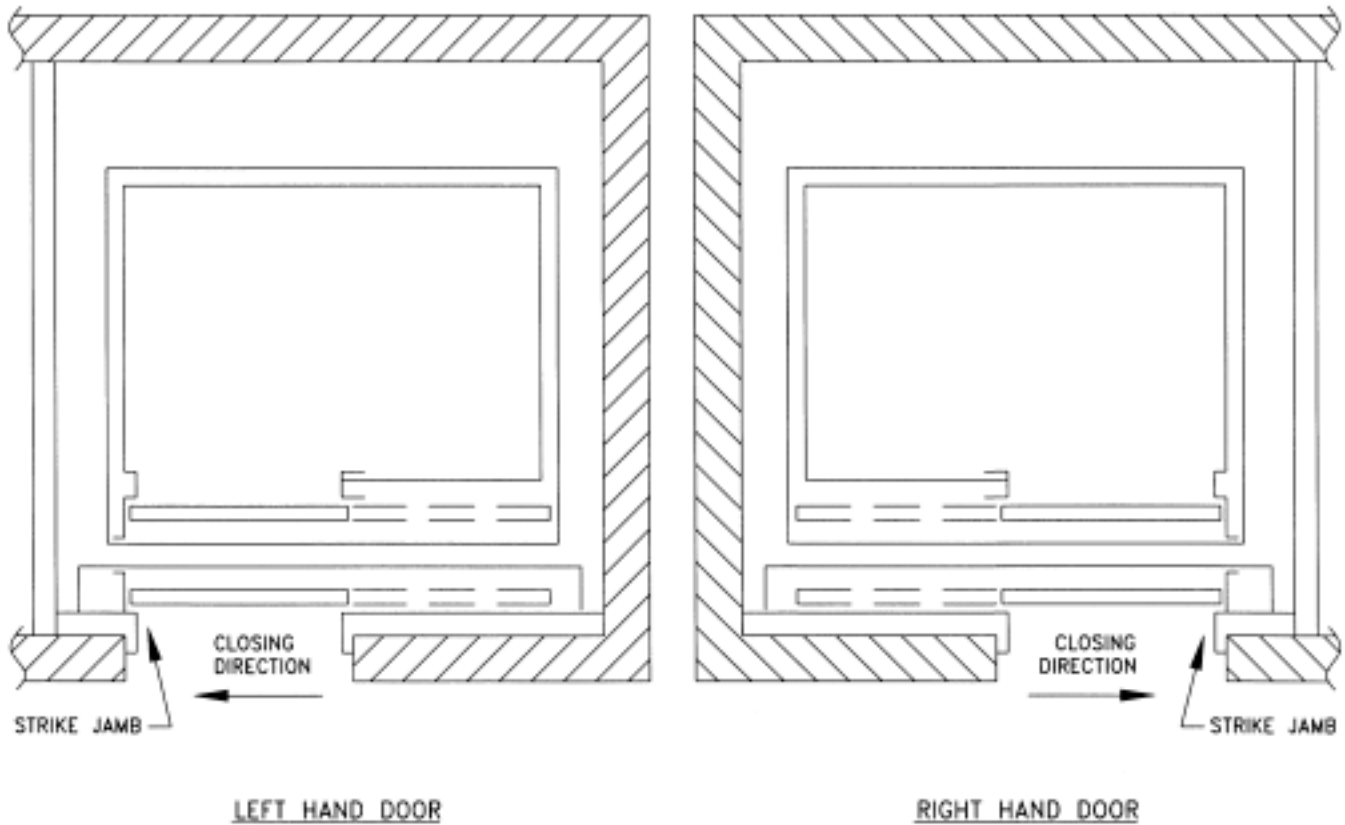

3 MOUNTING THE OPERATOR

As with all G.A.L. operators it is important to have the proper mechanical setup. Before continuing, check that doors are hung properly and glide freely with no binding. The spring closer should also be set so that the hoistway door will close fully. The door operator should be mounted in the proper position with the drive arm plumb and the operator arm and pivots set according to the DATA sheets (DATA21 for single speed, DATA22 for two speed). Slight differences are acceptable.

Install the isolation pads.

Isolation pads for the operator base are provided to minimize noise and vibration transmission into the cab. These pads must be glued to the operator base before mounting it to the car top.

Set the header plumb.

Place the operator over the pre-tapped holes in the header assembly. Set the base flush with the face of the header assembly and tighten the front bolts only. Move the operator base and header until the header is perfectly plumb. Temporarily clamp the rear of the base to the operator support to prevent any further movement of the header.

Side opening doors:

With the header assembly correctly installed, the vertical centerline of the operator drive pulley should be 9 $\frac{3}{4}$ " from daylight for a door opening of 22" to 44" and 14 $\frac{3}{4}$ " for a door opening of 45" to 48" (see Figure 3 and Appendix dwgs. # DATA21 & DATA22).

Center parting doors:

With the header assembly correctly installed, the center of the door opening lines up with the center of the header track. The center of the operator drive pulley should also line up with center of the opening (see Figure 6 and Appendix dwg. # DATA23).

Determining the position of the front edge of the door operator base:

Mount the drive arms to the drive arm support brackets on the header assembly for center parting doors and to the drive arm support bracket for slide doors. The mounting brackets are slotted for fine adjustments later, if needed. At this time, position the arms in the center of the bracket and tighten it.

Attach the connecting linkage(s) to the drive pulley, making sure that when the word "closed" is on top, the doors will be closed. Tighten the linkage(s) to the drive pulley.

Attach the clutch assembly to the drive door linkage, then attach the clutch to the drive door using the pre-tapped holes on the door panel. Tighten the clutch assembly to the drive door. Attach the other door(for center parting doors) to its linkage and tighten the door bracket to the center of the slots.

Raise or lower the rear operator support bracket mounted to the cab to vertically level the operator drive pulley. This helps to prevent binds in the opening and closing.

Check that the operator arms hang free and are not forced to or away from the operator drive pulley. Slide the operator forward or backward, if necessary. Turn the drive pulley by hand making sure that the drive arms and connecting links are perpendicular and clear of door and track. If necessary, slide the operator base forward or backward .

Proper positioning of the operator is critical to the life of the arm bearings. Bending of the drive arms will place stress on the bearings reducing their operating life.

Once the operator base is in correct position, drill the holes to permanently fasten the rear of the operator and tighten all mounting bolts.

4 PRE-ADJUSTMENT TIP.

BEFORE PROCEEDING TO THE ADJUSTMENT SECTIONS, READ THE FOLLOWING TIP. (REFER TO FIGURES 1A & 1B).

Think of the drive pulley crank arm(s) and the connecting link(s) as each having its own independent role.

The crank arm determines the total door travel.

The further the arm is away from the drive pulley, the longer the door travels.

The connecting link determines the door position.

The longer the arm, the further the door moves from the jamb.

Example:

If the door opening is 42" but the door travels only 40" as stopped by the open and close limit cams, do not alter the cams. The cams have been factory pre-set. Correct the under travel by extending the crank arm outward from the drive pulley until the door travels 42" from fully open to fully closed (as determined by the limit cams), then fasten the crank arm in place.

Now, loosen the connecting link bolts, close the door against the stop roller and tighten one of the link bolts. Open the door until the open limit is activated and check the door position. If the door is not in the proper open position, close the door and readjust the connecting link. Repeat the above steps until the operation is complete and then fasten the two link bolts. Make sure that the closing door is stopped against the stop roller and not the strike post.

Remembering the above two points will facilitate door adjustments.

Bear in mind, that the drive pulley crank arm position and the cams are pre-set by our factory as indicated on the installation drawings.

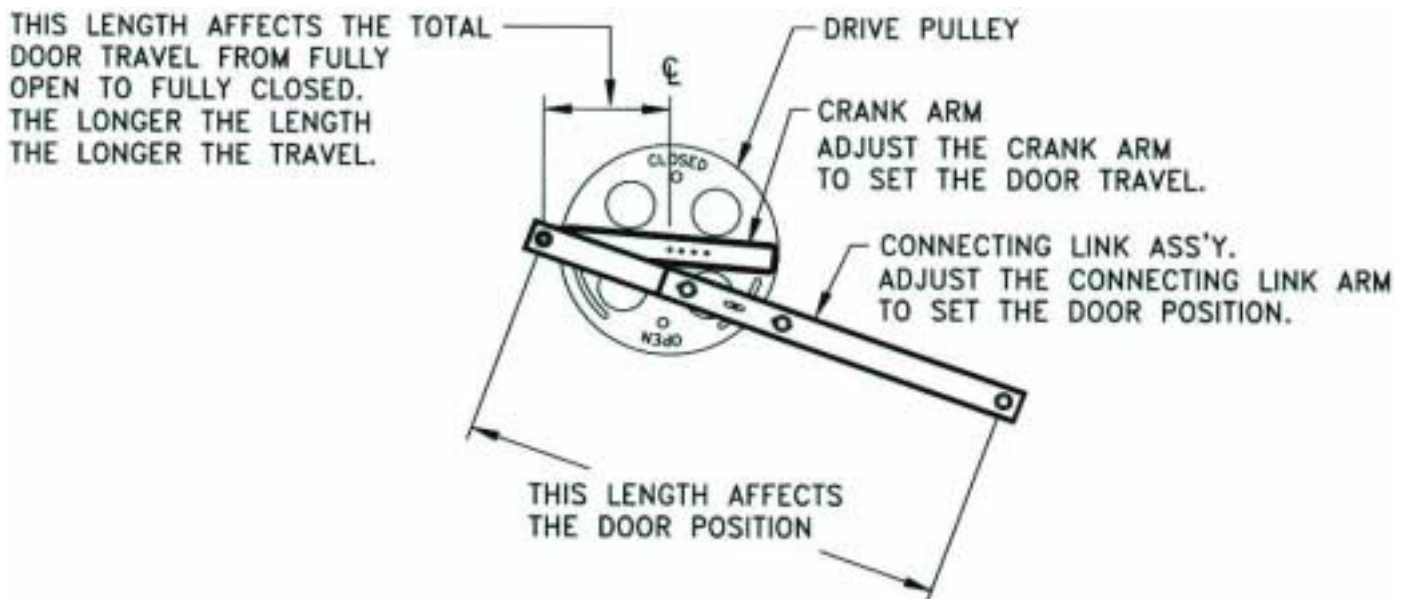

FIGURE 1

5

ADJUSTING THE SINGLE SPEED AND TWO SPEED SLIDE DOORS:**5.1 Removing the zone locking device and the bumpers:**

Before adjusting the operator, remove the car door bumpers and the locking cam from the zone locking device (see document LWZ-1). Removing the locking cam from the zone locking device, allows unimpeded movement of the doors.

Removing the bumpers – Because the car door moves to unlock the hoistway door, it must move approximately 7/16" further than the hoistway door. Removing the car door bumpers makes up some of this difference and allows better door alignment at full open.

5.2 Adjusting the release roller and clutch:

Referring to figure 2A, adjust the lock release rollers so that they will clear the clutch by about 3/16" when the car door is in its final closed position and the drive pulley stop roller is against the stop plate.

Adjust the clutch cam and roller depth as per figures 2C and 2D. The clutch should retract as late as possible in the closing cycle.

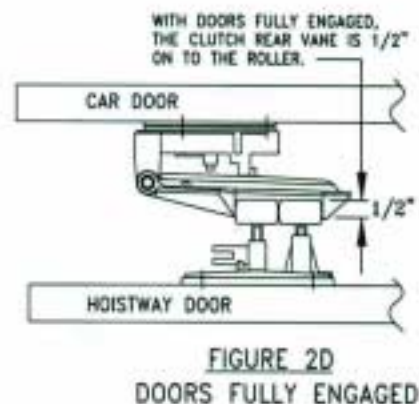
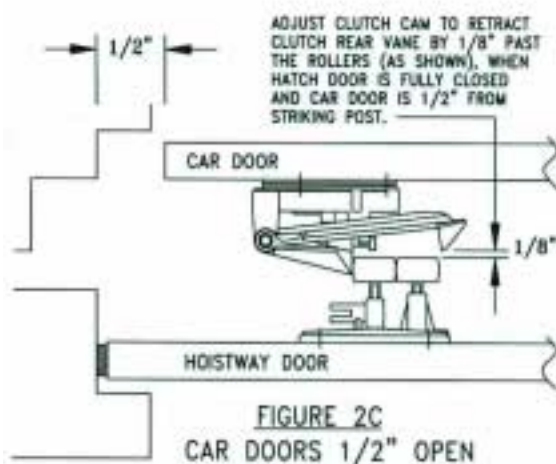
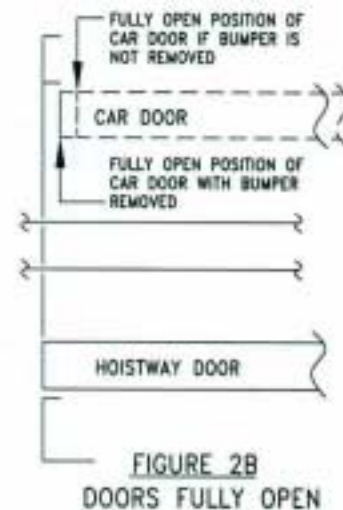
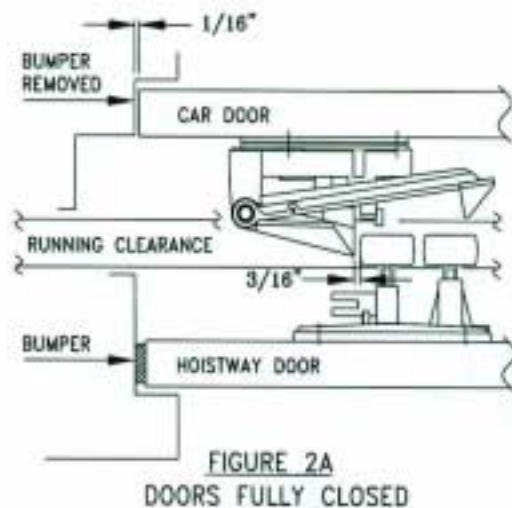

5.3 Crank arm and clutch link positions with door closed:

Referring to Figure 3, with the doors fully closed, the crank arm should be just a few degrees above the horizontal and the clutch link about 20 degrees above the horizontal. This setting will help prevent slamming and roll back, yet still allow manual opening of the doors when the car is stopped at a landing during a power failure.

If adjustments are necessary, close the car door. Loosen the two connecting link bolts and the two crank arm bolts. Keeping the door fully closed, adjust the link and arms to the proper positions. If necessary move the bolts to new holes. Re-tighten all four bolts when finished.

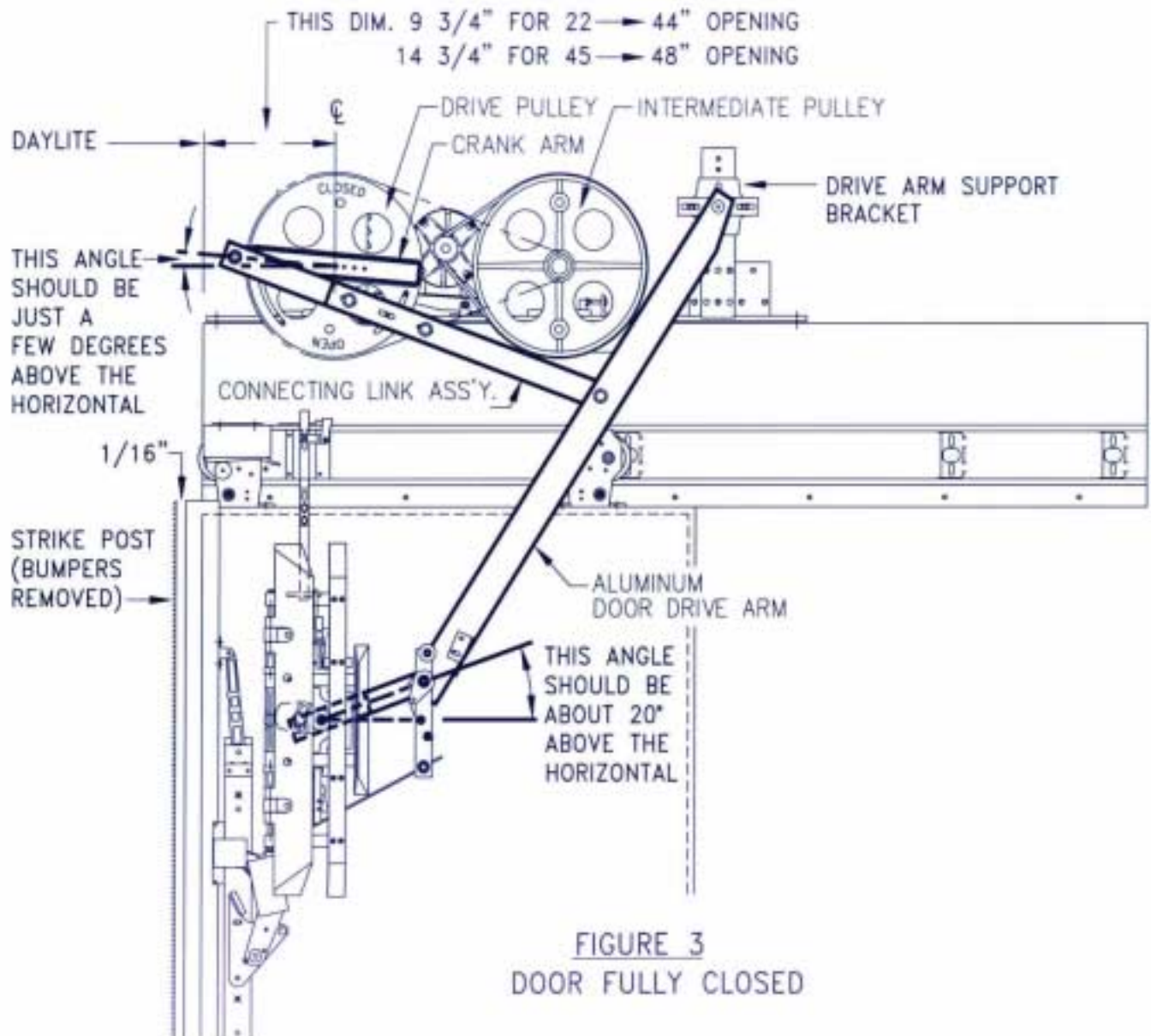

5.4 Crank arm and clutch link positions with door open:

Referring to figure 4, the best door opening operation occurs when the crank arm and the connecting link are in a straight line, the clutch link is about horizontal and the car door is approximately 1/2" past the return jamb. To make this adjustment, turn the drive pulley toward the open direction by hand until the crank arm and the connecting link are in line. Adjust the crank arm to bring the car door to 1/2" into the return jamb, then re-adjust the door open limit to stop the door electrically at this position.

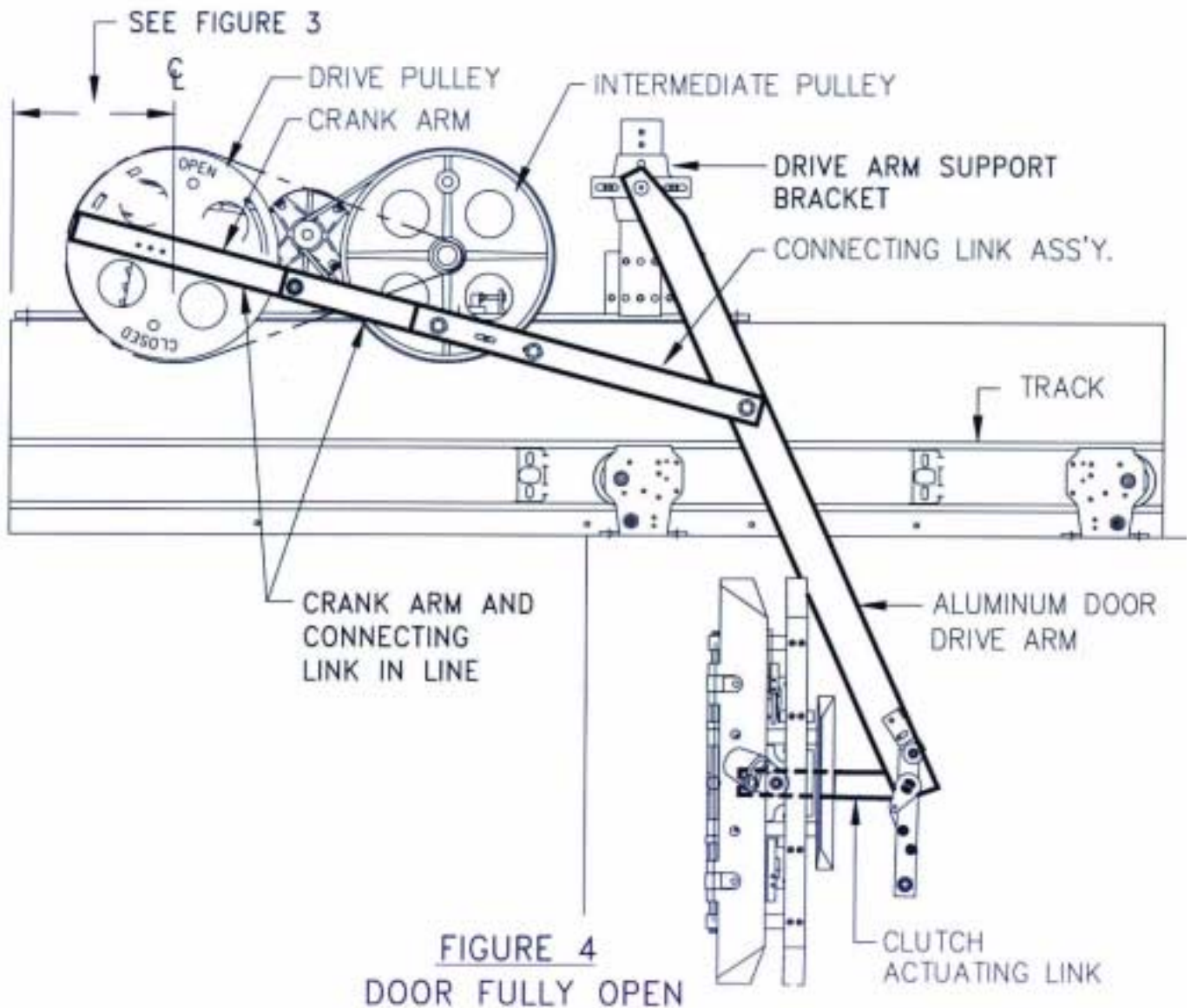

6

ADJUSTING CENTER-PARTING CAR DOORS.

6.1 Adjusting the stop roller:

Referring to figure 5A, we recommend adjusting the driven car door so that it leads the hoistway door by 1/4". This will make the car door more closely match the hoistway door when fully open.

Adjust the stop roller on the drive pulley so that the closing doors will be stopped by the roller as they meet. Do not have pressure on the meeting car doors, otherwise it will place unwanted stress on the arms.

6.2 Adjusting the release roller and clutch:

Referring to figure 5A, adjust the lock release rollers so that they will clear the clutch by about 3/16" when the car doors are in their final closed position and the operator stop roller is against the stop plate.

Adjust the clutch cam as per figures 5B and 5C. The clutch should retract as late as possible in the closing cycle.

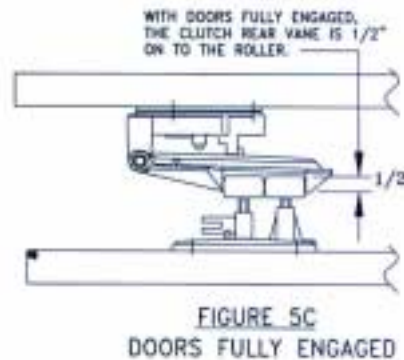
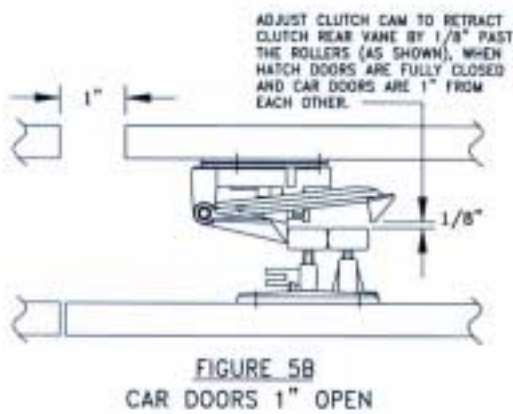
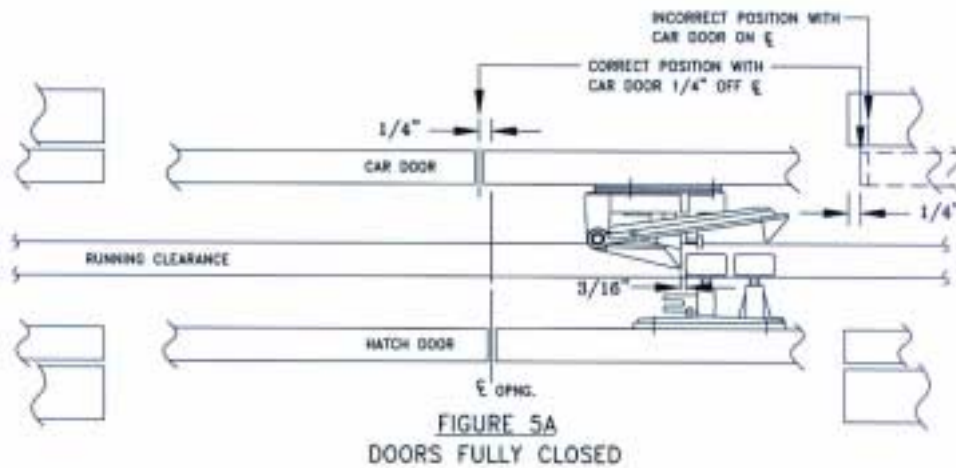

6.3 Crank arm and clutch link positions with doors closed:

Referring to figure 6, with the doors fully closed, the connecting links should be about 1 1/2" from the horizontal centerline of the pulley. The clutch link should be at about 20 degrees above the horizontal as shown.

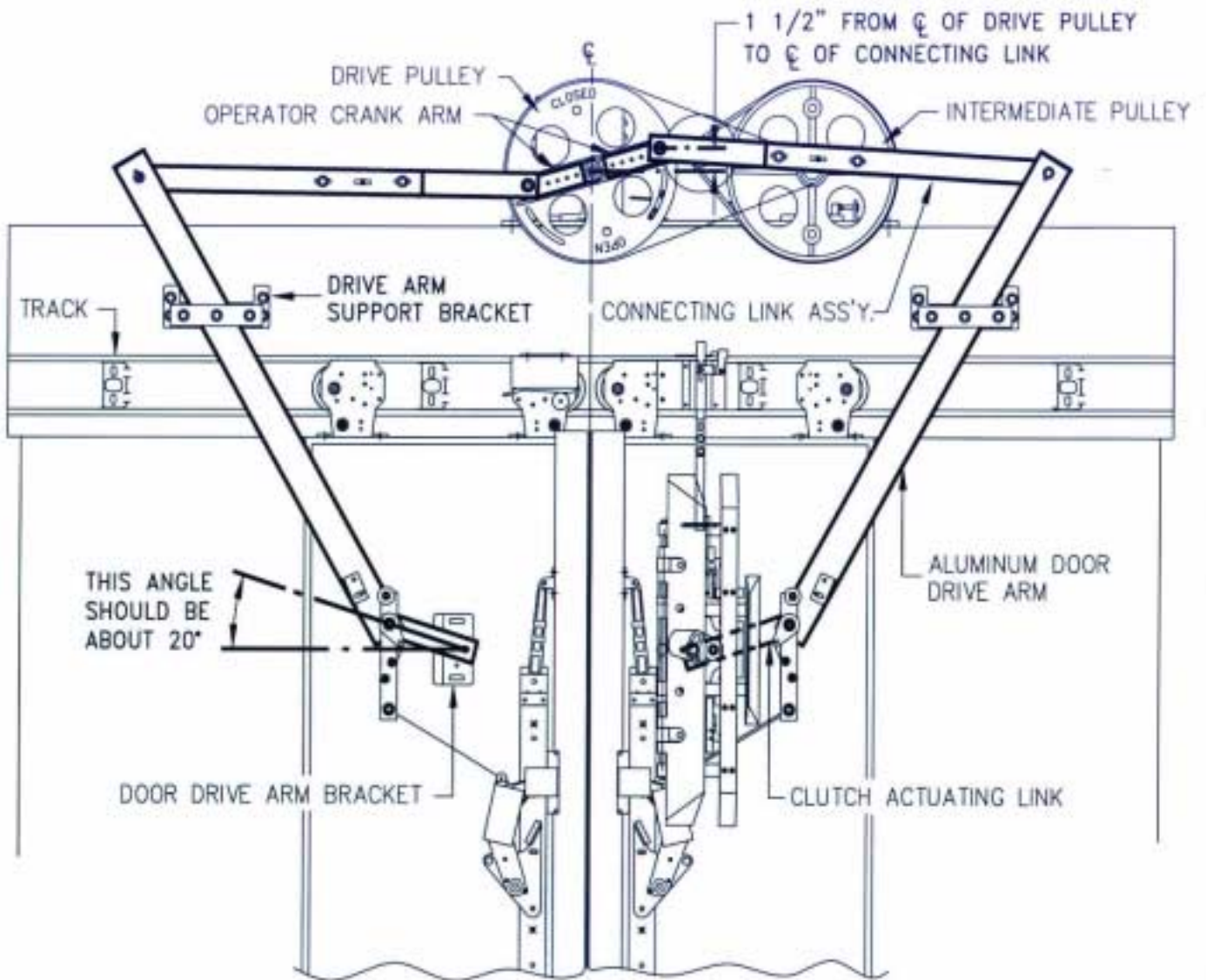

FIGURE 6
DOOR FULLY CLOSED

6.4 Crank arm and clutch link positions with doors open:

Referring to figure 7, with the door fully open, the connecting links should be about 1½" apart. The clutch link should be about horizontal.

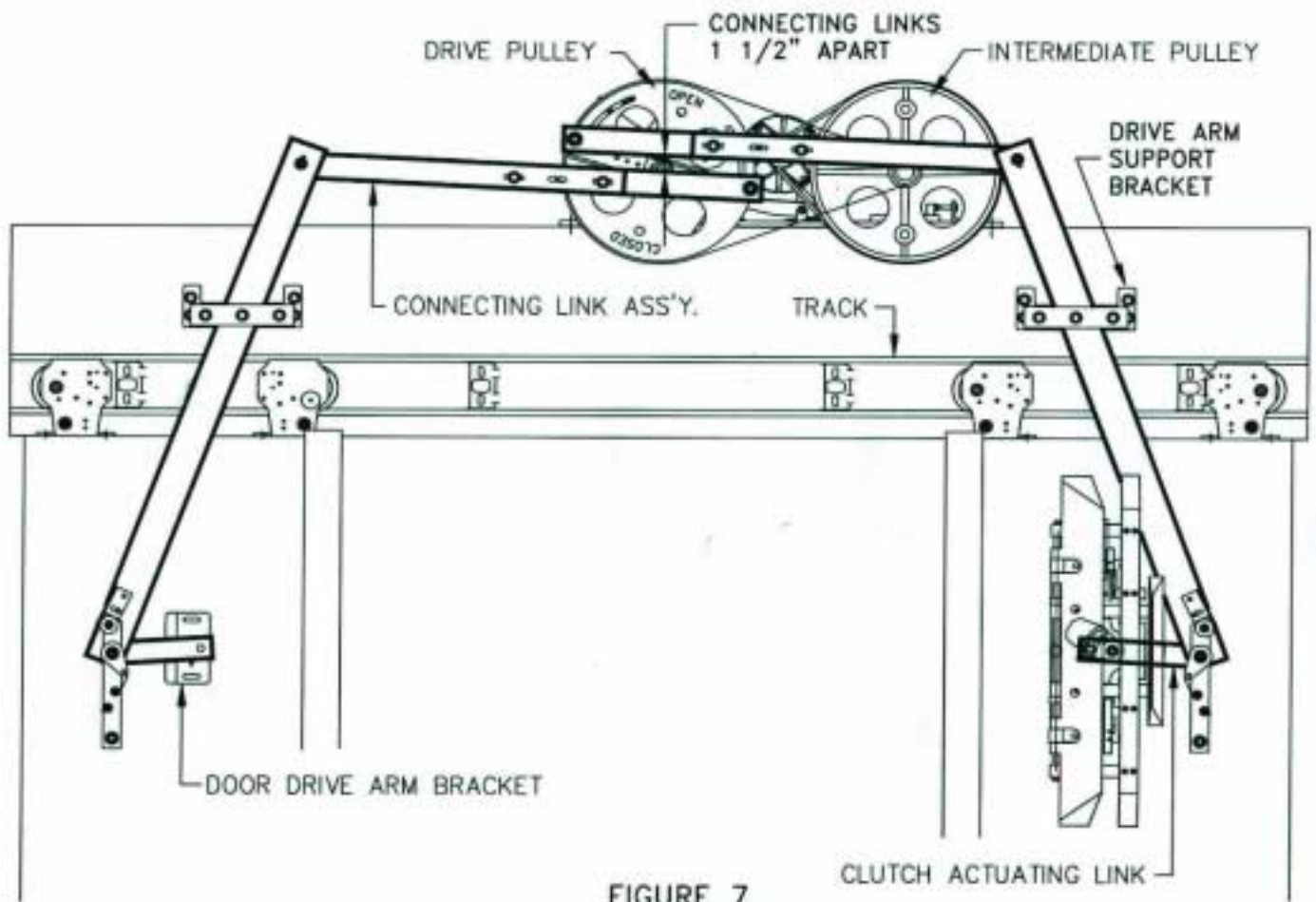

FIGURE 7
DOOR FULLY OPEN

7
ELECTRICAL ADJUSTMENTS

7.1 Preliminary checks:

Before proceeding with the electrical adjustments, we recommend making the following checks.

Remove the V-belt from the motor pulley. With the doors fully closed, energize the door open relay. Manually open the door by turning the drive pulley while observing the motor pulley. The motor should change speed as the various cams operate the speed controlling contacts. The motor should start turning at a slow speed gaining speed as the high speed contact makes and slowing down as the high speed contact breaks and the slowdown contacts make. Speed changes at the slowest speed may be more discernible by feeling the motor pulley by hand.

With the doors fully open repeat a similar test for the close direction.

If the motor speed does not change accordingly then refer to problems 3 and 4 in the trouble shooting table on page 26 before proceeding with the final adjustments.

PLEASE NOTE:

Although the following pages include instructions on cam adjustments, the reader is reminded that the operator cams have been factory preset. Speed adjustments should be made primarily with the resistor tubes. Cams should be adjusted only after resistor tube adjustments have been exhausted. Appendix drawing 7825-3 gives a detailed illustration of cam settings. The closing contact arms are colored RED, the opening contact arms are colored BLUE.

8

OPENING SPEED ADJUSTMENTS (REFER TO APPENDIX DWG. 7825-3)**8.1 Opening speed observations:**

Energize the open relay and observe the overall opening operation. The doors will start to open in the slow start zone, and then accelerate to high speed. After the high speed zone, there will be four steps of slowdown. The last slowdown decelerates the doors to the final opening speed. The door open limit then opens to de-energize the open relay.

8.2 Adjusting the slow start open zone:

The slow start opening zone (area A on 7825-3) allows the door clutch to make slow contact with the hoistway door roller, in order to minimize impact noise. The contact arm stays on the small cam until the hoistway door roller is engaged and the door starts to move, after that the contact arm comes off the small cam to initiate high speed. This occurs at about 1" into the opening.

The length of the slow start zone is determined by the setting of the slow start blue cam (the short cam). To adjust this cam, manually open the door to the point immediately after the clutch unlocks the hoistway door and adjust the cam to open contacts 3 & 4.

Next, adjust the slow start open speed with band 4 of resistor SD (the band immediately below the A1 band) so that the clutch engages the hoistway door smoothly.

Moving this band up gives a slower speed ; moving it down gives a faster speed.

8.3 Adjusting the high speed open:

High speed occurs during the dwell angle formed by the small cam and the long cam (area B on 7825-3) allowing the contact arm to drop and make contact number FSO. The high speed zone can be varied by rotating the long cam, changing the dwell angle.

The high speed is adjusted with the top band of resistor FS. Moving the band down gives a faster speed, moving the band up gives a slower speed.

8.4 Adjusting the overall opening speed:

The lowest band of resistor FS controls the opening speed. Moving the band up will increase the speed. Moving the band down will decrease the speed.

8.5 Adjusting the open slowdown zone:

There are two slowdown cams.

First slowdown is initiated when the first contact arm is lifted up by the low part of the cam making contact number 1 (area C on 7825-3). Second slowdown is initiated when the arm is further lifted by the higher part of the cam making contact number 2 (area D on 7825-3). When the cam is adjusted to change the slowdown position, both the first and second slowdown positions are affected.

Third slowdown is initiated when the second contact arm is lifted up by the low part of the cam making contact number 3 (area E on 7825-3).

Fourth and final slowdown is initiated when the arm is further lifted by the higher part of the cam making contact number 4 (area E on 7825-3). When the cam is adjusted to change the slowdown position, both the third and fourth slowdown positions are affected.

The cams can be rotated to advance or retard the slowdown point.

CAUTION ! If the fourth slowdown is too strong, door may stall if re-opened from the that slowdown position. Also, the operator controls will draw excessive current creating undesirable heat in the series resistors.

8.6 Adjusting the door open limit:

The door open limit is controlled by the blue DOL cam. Adjust this cam to open the DOL contact when the hoistway door is in line with the open jamb.

8.7 Adjusting the base speed resistor BS:

Resistor BS affects the overall speed equally in both the opening and closing direction. This resistor should be adjusted only when no further adjustments can be made to resistors L for closing or FS for opening.

8.8 Important checks.

After all opening adjustments have been made, make the following checks:

- a) Manually place the door at the various speed points, at each door position, allow the door open relay to energize and make sure that the door will open all the way under power.
- b) Allow the door to open from the fully closed position and observe the speed changes. If the changes are abrupt, re-adjust the slow downs.
- c) With the doors fully closed, lift the blue slowdown cams by hand and allow the door open relay to energize. The door should open all the way in slow speed. If the door stalls, it is being choked too much in the final slowdown speed. Move band 4 of resistor SD (the band immediately below the A1 band) down to increase the speed. If this causes the door to slam in the normal opening cycle, then reduce the high speed or advance the slowdown cam.
Make sure that with doors fully open, the contact arm is still on the slowdown cam.

9

CLOSING SPEED ADJUSTMENTS (REFER TO APPENDIX DWG. 7825-3)**9.1 Closing speed observations:**

Energize the close relay and observe the overall closing operation. The doors will start to close in the slow start zone, and then accelerate to high speed. After the high speed zone, there will be four steps of slowdown. The last slowdown decelerates the doors to the final closing speed. The door close limit then opens to de-energize the close relay.

The slow start closing zone (area F on 7825-3) allows the door clutch to make slow contact with the hoistway door roller, in order to minimize impact noise. The contact arm stays on the small cam until the hoistway door roller is engaged and the door has moved about 1" into the opening. After that the contact arm comes off the small cam to initiate high speed.

9.2 Adjusting the high speed close:

High speed occurs during the dwell angle formed by the short cam and the long cam (area G on 7825-3). The contact drops in between the two cams opening the slowdown contact. The high speed zone can be varied by rotating the long cam, changing the dwell angle.

If the high speed closing is too fast and the closing torque is too strong, move the band on resistor L, wired to terminal LC, up closer to the top of the tube.

If the high speed closing is too slow and the closing torque is too weak, move the band on resistor L, down closer to the bottom of the tube. This will increase the high speed and in turn increase the high speed stalled torque. When increasing the closing speed, make sure that it stays within the code limits for kinetic energy and stalled force (see section 10).

9.3 Adjusting the close slow down zone:

There are two slowdown cams.

First slowdown is initiated when the first contact arm is lifted up by the low part of the cam making contact number 1 (area H on 7825-3). Second slowdown is initiated when the arm is further lifted by the higher part of the cam making contact number 2 (area I on 7825-3). When the cam is adjusted to change the slowdown position, both the first and second slowdown positions are affected.

Third slowdown is initiated when the second contact arm is lifted up by the low part of the cam making contact number 3 (area J on 7825-3). Fourth and final slowdown is initiated when the arm is further lifted by the higher part of the cam making contact number 4 (area K on 7825-3). When the cam is adjusted to change the slowdown position, both the third and fourth slowdown positions are affected.

The cams can be rotated to advance or retard the slowdown point.

When adjusted properly, the doors will decelerate and reach near zero speed just when the hoistway door comes home. There are four slowdown bands on resistor SD (five bands

when nudging is provided (see section 9.6 below) each band is connected to its corresponding cam contact. Starting with the top uppermost band, these are 1,2,3 and 4. The rate of slow down is adjusted by these bands. The uppermost one being the first slowdown and the fourth (or fifth if nudging is provided) band the fourth slowdown. Raising the bands will weaken (stretch) the slowdown. Lowering the bands will strengthen the slowdown.

9.4 Adjusting the door close limit:

The door close limit should be adjusted to open just after the hoistway door interlock makes contact. When the elevator is running, the close limit contact is by-passed by the "run" contact on the controller to keep power on the motor. With power applied to the motor, the door is stopped by the stop roller on the drive pulley.

9.5 Important checks:

After all closing adjustments have been made, make the following checks:

- a) With the doors fully open, lift both red slowdown contact arms by hand and allow the door close relay to energize. The door should close all the way in slow speed. If the door stalls, it is being choked too much in the final slowdown speed. Move the close slowdown band 4 of resistor SD up to increase the speed. If this causes the door to slam in the normal closing cycle, then reduce the high speed or advance the slowdown cams.
- b) Make sure that with doors fully closed, the contact arm is still on the slowdown cam.
- c) Allow the door to close from the fully open position and observe the speed changes. If the changes are abrupt, re-adjust the slowdowns.

9.6 Reduced speed closing:

When nudging is provided, a fifth band is added to the top half of resistor SD, this band is third from the top and wired to terminal SDA. Moving this band down will reduce the closing speed when the nudging contact is made.

10 KINETIC ENERGY AND CLOSING FORCE

ASME A17.1-1996 Rule 112.4 requires that the force necessary to prevent closing of the door from rest shall not be more than 30 lbf (133 N). The kinetic energy for the average closing speed shall not exceed 7 ft-lbf (9.49 J) where a re-opening device is used and 2 1/2 ft-lbf where the re-opening device is disconnected or not used.

Code definitions: ft = foot; lbf = pound (force); N = Newton; J = Joule.

Measuring the closing force.

To measure the closing force at rest, allow the doors to close under power, place your foot against the door, stopping it at the high speed closing position (generally about 1/3 closed). Press the scale against the door, release the foot pressure and read the scale in pounds. Do not use the scale to stop the moving door, it will give you a false high reading.

What is kinetic energy and how is it measured ?

Kinetic Energy (abbreviated as K.E.) is defined as the energy of a moving mass.

The formula is $K.E. = \frac{1}{2} MV^2$ where M is the mass and V^2 is the velocity squared.

Calculating the average closing speed:

The average closing speed is calculated by dividing the code defined door opening distance in feet (CD) by the code defined measured closing time in seconds (t).

$$V = CD / t$$

For slide doors the code defined distance is the opening size minus 4"(2" from the open jamb and 2" from the opposite jamb).

For center parting doors the distance is the opening size minus 2"(1" from the open jamb and 1" from meeting point of the doors).

The time is measured within those points of door travel.

Calculating the mass of the elevator door equipment:

The mass is the sum of the weight of all the doors in pounds (Wd), the weight of the equipment on the doors (We) and the equivalent weight of the rotational equipment (Wr) (door operator, drive arms, spring closer) all divided by acceleration due to gravity (g).

$$\text{Mass} = (Wd+We+Wr) / g.$$

KINETIC ENERGY (Cont,d).

The equivalent weight of the G.A.L. door operator, drive arms and spring closer (W_r), can be closely approximated using the following formulas:

Single speed slide doors:

$$\text{MOD, MODCT, MOM: } W_r = (309 / CD^2) + 24$$

$$\text{MOH, MOHCT: } W_r = (352 / CD^2) + 28$$

Center parting doors:

$$\text{MOD, MODCT, MOM: } W_r = (168 / CD^2) + 43$$

$$\text{MOH, MOHCT: } W_r = (202 / CD^2) + 48$$

Two speed slide doors:

$$\text{MOD, MODCT, MOM (up to 59" opening): } W_r = (309 / CD^2) + 29$$

$$\text{MOD, MODCT, MOM (over 59" opening): } W_r = (1236 / CD^2) + 29$$

$$\text{MOH, MOHCT (up to 60" opening): } W_r = (352 / CD^2) + 29$$

$$\text{MOH, MOHCT (over 60" opening): } W_r = (1408 / CD^2) + 29$$

Sample calculation:

Calculate the Kinetic Energy of a single speed slide door, weighing 345 lbs, with 36" opening.

The weight of the equipment on the door is 54 lbs

The measured code closing time is 2.72 seconds.

Measured parameters:

$$W_d = 345 \text{ lbs}$$

$$W_e = 54 \text{ lbs}$$

$$CD = 36" - 4" = 32" (2.67 \text{ ft})$$

$$t = 2.72 \text{ sec}$$

Calculated parameters:

$$W_r (\text{MOD operator}) = (309 / CD^2) + 24$$

$$W_r = (309 / 2.67 \times 2.67) + 24 = 67 \text{ lbs}$$

$$\text{Mass } M = (W_d + W_e + W_r) / g = (345 + 54 + 67) / 32 = 14.6$$

$$\text{Average closing speed } V = CD / t = 2.67 / 2.72 = 0.98 \text{ ft/sec}$$

The Kinetic Energy $K.E. = \frac{1}{2} \times 14.6 \times 0.98 \times 0.98 = 7 \text{ ft-lbf}$ (foot pounds).

(Which is the maximum allowed by code).

If the K.E. were to exceed 7 ft-lbf then the overall closing speed would have to be reduced.

Tips on reducing the Kinetic Energy and the closing force:

Reducing the speed will reduce both the kinetic energy and the closing force.

Make the following adjustments one at a time in the order indicated, checking the kinetic energy and closing force after each adjustment.

- a)- Move the LC band on resistor L up.
- b)- Operators with shunt wound, 4-wire, motors are provided with the motor field resistor DMF. The band on this resistor can be moved up to weaken the motor field. A weaker field will reduce the torque but only to a small extent.
- c)- Reduce the AC voltage to the door rectifier on the controller.
- d)- To reduce the closing force only, replace the motor pulley with a larger diameter pulley. A larger pulley will reduce the torque (closing force), but may increase the kinetic energy somewhat.

Standard G.A.L. motor pulleys have 5/8" I.D. :

PULLEY PART NO.	TYPE	O.D.
HWPL-0001N	AS17	1.7"
HWPL-0005N	AS20	2.0"
HWPL-0006N	AS22	2.2"
HWPL-0011N	AS25 *	2.5"
HWPL-0012N	AK30 *	3.0"

* AS25 & AK30 pulleys require replacing the belt with # 2460, part # HWBL-0006N.

**11
TROUBLESHOOTING TABLE**

PROBLEM	PRIMARY FAULTS
Motor rotates in the wrong direction. How are the motor leads identified ?	1
Motor hums.	2
Door slams in the closed direction.	3, 5
Door slams in the open direction.	3, 6
Cannot get speed adjustments	4
Door stalls in the initial opening cycle	7
Door stalls or is sluggish on re-opening.	8
Closing torque is too strong.	9
Closing torque is too weak.	10
Door oscillates when fully open.	11
Door picks up speed at the final limit of travel	12
Drive belt gets twisted	13
Manual opening of c/p doors from within the car, when stopped at a floor, requires too much force.	14

PRIMARY FAULTS:

1- Motor leads identification:

PM motor:

MOTOR LEAD	OPERATOR TERM.	LEFT HAND & C/P	RIGHT HAND
red	A1	red	black
black	A2	black	red

Shunt motor:

MOTOR TERM.	OPERATOR TERM.	LEFT HAND & C/P	RIGHT HAND
A1 (red)	A1	A2 (blue)	A1(red)
F2 (yellow)	F2	F2 (yellow)	F2 (yellow)
F1 (green)	F1	F1 (green)	F1 (green)
A2 (red)	A2	A1 (red)	A2 (blue)

Check that the controller wires to terminals A1, A2 are correct. If the wires are correct then reverse the two color coded motor armature leads A1 & A2. Do not reverse the controller wires. If the controller wires are reversed, speed control will be erratic and uncontrollable.

- Motor hum is occurs when the control manufacturer provides an unfiltered single phase rectified power supply. Adding a 60 MFD, 350 VDC capacitor across the load side of the DC fuses should reduce the hum. Be sure to observe the capacitor polarity, making sure that the + side of the capacitor gets connected to the + fuse. Note that the capacitor will increase the DC voltage and the operator may run faster. In that event the operator resistor tubes will need to be adjusted.

3. The Slowdown resistor SD could be defective or of the wrong value. First visually inspect the resistor for open wiring, then measure the resistance value. Disconnect the wire from the top of the resistor and make sure the slowdown cam contacts are open before taking measurements. Compare the value measured with the required value. 250 ohm for the 115 volt motor and 750 ohm for the 230 volt motor.
4. The most common cause of unsatisfactory speed control is the improper controller wire connections to terminals OP and CL. An easy way to verify this is to simply swap the two wires. If the problem goes away then leave the wires in place.
Where diodes are used in lieu of the C and O n.c. contacts in the OP-CL terminals circuit, check that the diodes are in the right direction.
5. Refer to section 8.5, page 18.
6. Refer to section 9.3, page 20.
7. Stalled initial opening is probably caused by improper alignment of the crank arm and the connecting link. The more they are in-line when the door is fully open, the more favorably the mechanical advantage between motor and door. (Refer to figures 4 and 7). If, after adjusting the arm and link, the door still stalls, adjust the open slowdown bands 3 & 4 on resistor SD down. This will weaken the slowdown. If after adjusting the slowdown so that the door does not stall on initial opening you find that now the door slams open from the fully closed position, then advance the slowdown cam so that slowdowns occurs sooner. Caution: make sure that the contact arm does not fall off the cam. If the cam cannot be advanced any further then reduce the opening speed with the lower band of resistor FS.
8. Sluggish re-opening is probably caused by improper alignment of the crank arm and the connecting link. The more they are in-line when the door is fully open, the more favorably the mechanical advantage between motor and door. (Refer to figures 4 and 7). If, after adjusting the arm and link, re-opening is still sluggish, determine at which slowdown point the problem occurs and adjust the corresponding slowdown band on resistor SD down. This will weaken the slowdown. If after adjusting the slowdown so that the door does not stall on re-opening you find that now the door slams open from the fully closed position, then advance the slowdown cam so that slowdowns occurs sooner. Caution: make sure that the contact arm does not fall off the cam. If the cam cannot be advanced any further then reduce the opening speed with the bottom band on resistor SD.
9. The closing torque is directly related to the closing speed, the faster the speed the higher the torque and kinetic energy. See section 10, page 22 of this manual for code requirements of kinetic energy and closing force and for tips on how to reduce the closing speed.
10. The closing torque is directly related to the closing speed, the faster the speed the higher the torque. See section 10, page 22 of this manual for code requirements of kinetic energy and closing force limitations. If the closing speed cannot be made faster, try the following:
 - a) Check that the motor nameplate voltage matches the input power. If the input power voltage is lower than what it should be, check the controller rectifier fuses. If a 3-phase rectifier is used, one fuse may be blown causing only single phase voltage applied to the rectifier.
 - b) Check that the operator line resistors match the requirement of the input power.
 - c) Remove the motor drive belt, move the doors by hand. The doors should move free without bind.

- d) Replace the motor pulley with a smaller size. Consult with G.A.L.
- e) For large or heavy doors, power gearing may be required. Consult with G.A.L.

11-There are two primary causes for this problem.

- a) When the door is fully open, the open limit cam must snap open. If the stationary contact plate is too far from the movable contacts, the limit contact will open while still on the snap end of the cam. This will de-energize the open relay, but then the door will roll closed just enough to remake the limit contact, re-energizing the open relay and repeat the cycle, thus the door will continue to bounce back and forth. To correct this problem, loosen the four contact plate fastening screws and move the plate closer to the movable contact, making sure that there is proper clearance between all stationary and movable contacts. Retighten the fastening screws and check that the limit contact snaps off the cam when the contact opens.
- b) If the door oscillates even when the open limit snaps off the cam, then readjust the connecting link so that it is in line with crank arm when the door is fully open. (See figure 4, page 12).

12-If the door picks up speed at the final limits of travel, the slowdown contact arm must be falling off the cam. Rotate the cam so that the contact arm stays on the cam when the door is fully open or fully closed, whichever is the problem. After readjusting the cam, the related speeds may require re-adjusting.

13-Refer to Drive belt adjustment. Section 12.4, page 28

14-During a power failure, the car door may be manually opened from within the car when stopped at a floor. ASME A17.1-1996 Rule 204.5h requires not more than 75 pounds of force to open the door. To reduce the opening force of center parting doors, follow these steps:

- a) Measure the force needed to start the car and hatch door moving from within the car when the doors are fully closed.
- b) Now open the doors so that there is $\frac{1}{2}$ " between the leading edge of the doors and measure the force needed to start the doors moving. This force should be less than that measured in step "a" above and should be within code requirement.
- c) Once satisfied, relocate the drive pulley stop roller to this new position so that the doors are stopped when they are $\frac{1}{2}$ " apart. Try not to move the stop roller more than $\frac{1}{2}$ ". Now readjust the close limit cam accordingly. (Do not move the open limit cam).
- d) Operate the doors by power making sure that the closed doors stop $\frac{1}{2}$ " apart. Readjust the stop roller if necessary.
- e) Since the drive pulley will now rotate less, the doors will not travel as far. The drive arms will have to be readjusted. Before making any drive arms adjustments, mark the centerline of the doors. Move the drive pulley crank arms further out to compensate for the decreased door travel and adjust the connecting links to reposition the doors making sure that the fully closed door centerline is at the same point as before.

12 MAINTENANCE

12.1 Replacing oilers:

The G.A.L. type "A" oiler should be inspected annually and replaced if worn or dry. A properly installed oiler will keep the roller clean preventing buildup of gook, reduce noise and extend its life.

12.2 Adjusting the drive chain and belt:

Generally after a break-in period of 1 to 2 months, depending on usage, the drive chain and belt tension should be checked. If adjustments are necessary, the chain should be adjusted first. Adjusting the chain will require readjusting the drive belt tension.

12.3 Adjusting the drive chain:

Indications that the drive chain needs adjustment are inconsistent or "jerky" door movements.

Check the chain by applying moderate pressure on the chain. The deflection should be approximately 1/2".

Refer to drawing OP-20. If the chain needs to be tightened, first loosen the double nutted stud on the rear of the door motor base to decrease the belt tension, then loosen the four mounting bolts on the base of the intermediate pulley bearing block. Turn the bolt on the adjusting angle bracket so as to move the intermediate pulley away from the drive pulley. After the proper chain tension is obtained, check the two pulleys for alignment and tighten the four mounting bolts to secure the pulley. Now re-adjust the belt tension as indicated below.

12.4 Adjusting the drive belt:

Improper belt tension may result in belt slippage and erratic door operation.

Proper belt tension can be checked at the floor with the heaviest hoistway door by energizing the door open relay when the door is a few inches from fully open. If there is proper belt tension the door will open at this slow speed without belt slippage.

To adjust the belt tension, tighten down the double nutted stud on the rear of the door motor base to increase the belt tension or loosen the nuts to decrease the tension. If further adjustment is needed, the motor can be moved by loosening the four motor mounting bolts and sliding the motor away from or closer to the intermediate pulley, as needed.

Check that the belt seats properly on the intermediate pulley. Check that the motor pulley is in line with the intermediate pulley and tighten the four bolts. Allow the door to cycle a few times and check that the belt rides in the center of the pulley groove. If the belt rides to the edge of the pulley or becomes twisted, recheck the alignment of the motor and intermediate pulleys.

13
APPENDIX

MEDIUM SPEED DOOR OPERATOR SPECIFICATIONS TYPE MOML

The G.A.L. Model MOML, Master Operator Medium Speed, consists of a 1/4 HP, D.C. motor with heavy duty sprocket, chain, belt and sheaves. It is capable of opening the car and hoistway doors simultaneously at a speed up to 2 feet per second. The power supply requirement is 230VDC, 500 VA, fused at 3 amp and it is also available for 120 VDC.

Door speed is adjustable by means of resistor tubes located on the operator in a heavy duty steel box. The closing speed may be reduced to limit the stalled closing force and the closing kinetic energy to the values permitted by the ASME Code . The opening and closing limits of travel are cushioned by four steps of dynamic braking resistors. The operator is designed to produce a mechanical harmonic motion, creating a smooth opening and closing cycle. Adjustable initial opening and closing speeds cause the car door clutch to engage the hoistway door roller in a smooth and continuous manner accelerating to high speed and decelerating to a final stop.

HIGH SPEED DOOR OPERATOR SPECIFICATIONS TYPE MOHL

The G.A.L. Model MOHL, Master Operator High Speed, consists of a 1/2 HP, D.C. motor with heavy duty sprocket, chain, belt and sheaves. It is capable of opening the car and hoistway doors simultaneously at a speed up to 3 feet per second. The power supply requirement is 230VDC, 500 VA, fused at 3 amp and it is also available for 120 VDC. Door speed is adjustable by means of resistor tubes located on the operator in a heavy duty steel box. The closing speed may be reduced to limit the stalled closing force and the closing kinetic energy to the values permitted by the ASME Code . The opening and closing limits of travel are cushioned by four steps of dynamic braking resistors. The operator is designed to produce a mechanical harmonic motion, creating a smooth opening and closing cycle. Adjustable initial opening and closing speeds cause the car door clutch to engage the hoistway door roller in a smooth and continuous manner accelerating to high speed and decelerating to a final stop.

OPENING CYCLE

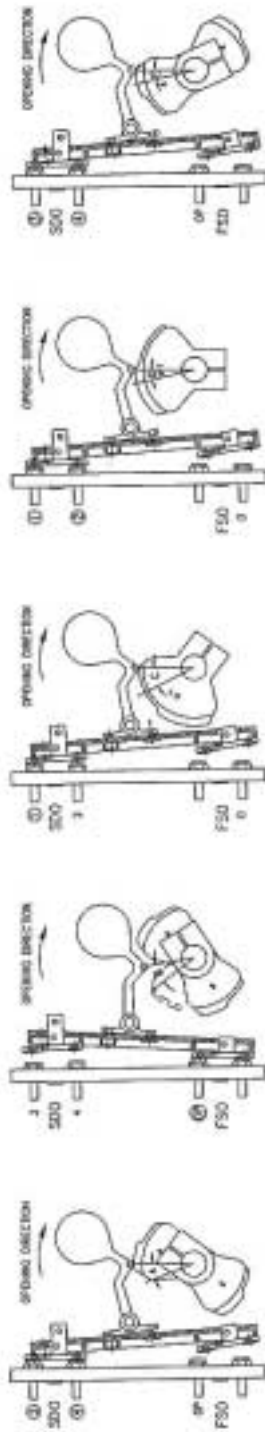

AREA E
3rd & 4th SLOW DOWN
DOOR FULLY OPEN

AREA D
2nd SLOW DOWN

AREA C
1st SLOW DOWN

AREA B
FAST SPEED

AREA A
SLOW START
DOOR FULLY CLOSED

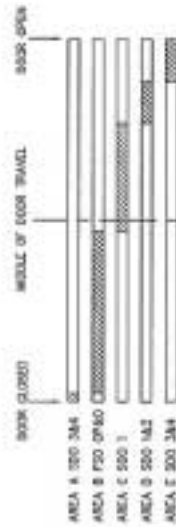

DOTTED CAM CONTACT IS CLOSED
SOLID CAM CONTACT IS OPEN

CLOSING CYCLE

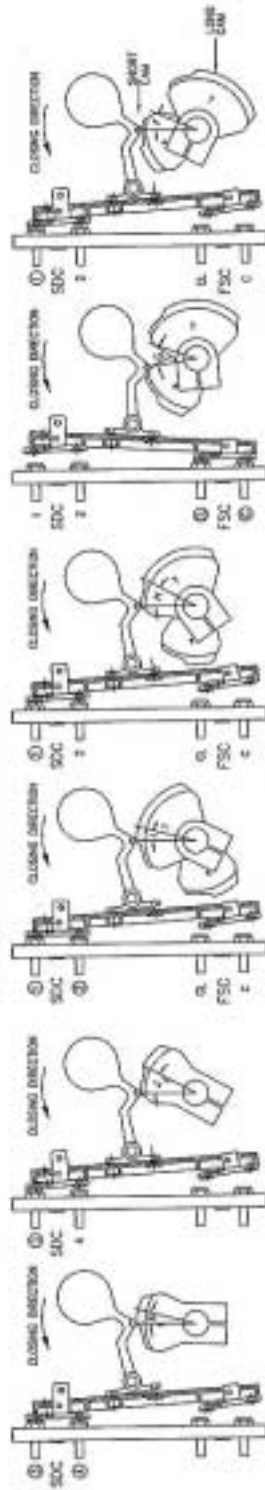

AREA E
4th SLOW DOWN
DOOR FULLY CLOSED

AREA D
3rd SLOW DOWN

AREA C
2nd SLOW DOWN

AREA B
1st SLOW DOWN

AREA A
FAST SPEED

AREA F
SLOW START
DOOR FULLY OPEN

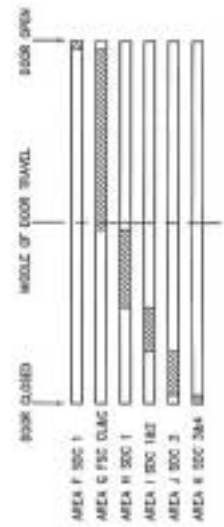

DOTTED CAM CONTACT IS CLOSED
SOLID CAM CONTACT IS OPEN

RIGHT HAND OPERATOR SHOWN
REFER TO WIRING DIAGRAM # S7587-2



MCM & MCH OPERATORS
HIGH SPEED & SLOW DOWN CAMS
ADJUSTMENTS

DATE 5/19/98
SCALE 3/16
DOCUMENT No. 7825-3

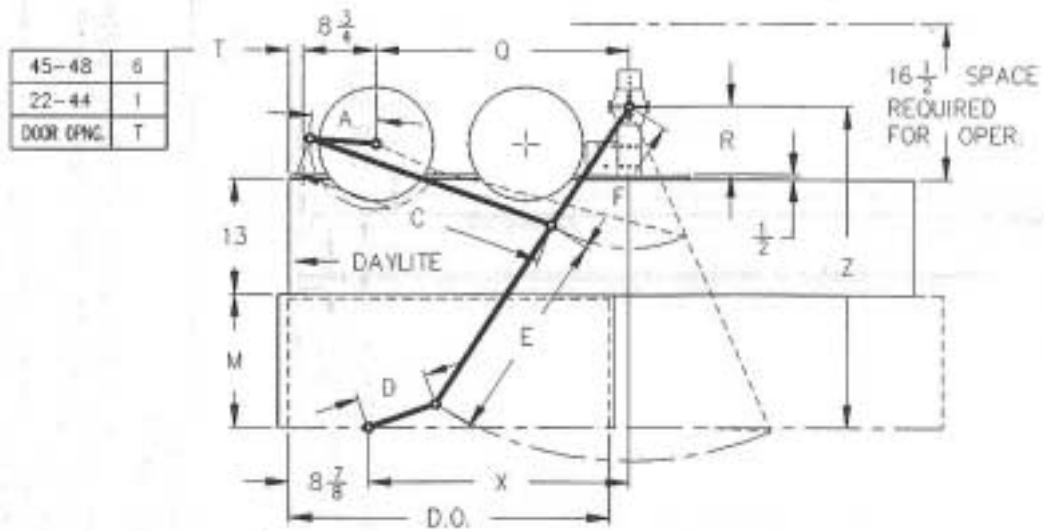

48	10 1/16	34 5/16	12	31	21	23	39 5/8	47 1/2	33 1/4	11
47	9 7/8	34 1/8	12	31	21	23	39 5/8	47 1/2	33 1/4	11
46	9 11/16	35 1/16	12	31	21	23	39 5/8	47 1/2	33 1/4	11
45	9 1/2	33 1/4	12	31	21	23	39 5/8	47 1/2	33 1/4	11
44	9 7/8	34 1/4	10	26	20	19	34 3/8	42	33 1/4	9 1/2
43	9 11/16	34 3/16	10	26	20	19	34 3/8	42	33 1/4	9 1/2
42	9 7/16	34 3/8	10	26	20	19	34 3/8	42	33 1/4	9 1/2
41	9 5/16	34 1/16	10	26	20	19	34 3/8	42	33 1/4	9 1/2
40	9	34	10	26	20	19	34 3/8	42	33 1/4	9 1/2
39	8	29 7/8	8	24	16	15	29 1/4	36 1/4	28 3/8	7 1/2
38	7 11/16	29 3/16	8	24	16	15	29 1/4	36 1/4	28 3/8	7 1/2
37	7 3/4	29	8	24	16	15	29 1/4	36 1/4	28 3/8	7 1/2
36	7 7/16	28 11/16	8	24	16	15	29 1/4	36 1/4	28 3/8	7 1/2
35	7 1/4	28 3/8	8	24	16	15	29 1/4	36 1/4	28 3/8	7 1/2
34	6 1/2	25 1/16	6	25	15	15	25 1/4	37	24 3/8	8 1/2
33	6 3/8	25	6	25	15	15	25 1/4	37	24 3/8	8 1/2
32	6 1/8	24 1/4	6	25	15	15	24 1/2	37 3/8	23 3/8	8 7/8
31	5 13/16	24 1/16	6	25	15	15	24 1/2	37 3/8	23 3/8	8 7/8
30	5 3/4	23 7/8	6	25	15	15	24 1/2	37 3/8	23 3/8	8 7/8
29	6 1/4	27 3/8	10	19	15	11	27 3/4	32	26 7/8	7 1/2
28	6 3/8	26 13/16	10	19	15	11	27 3/4	32	26 7/8	7 1/2
27	6 1/8	26 3/4	10	19	15	11	27 3/4	32	26 7/8	7 1/2
26	6 1/16	26 5/16	10	19	15	11	27 3/4	32	26 7/8	7 1/2
25	6	26 1/2	10	19	15	11	27 3/4	32	26 7/8	7 1/2
24	5 1/2	25 1/8	10	18	14	11	25 7/8	30 3/4	25	6 1/4
23	5 5/16	25 1/16	10	18	14	11	25 7/8	30 3/4	25	6 1/4
22	5 1/8	25	10	18	14	11	25 7/8	30 3/4	25	6 1/4

DOOR OPENING	A	C	D	E	F	M	X	Z	Q	R
	OPERATOR ARMS		DOOR ARMS			CLUTCH	PIVOT		OPERATOR	



SINGLE SPEED 22-48 D.O. OPERATOR DATA TABLE

NOV. 11, 1994

DATA21

45-48	6
30-44	1
DOOR OPNG.	T

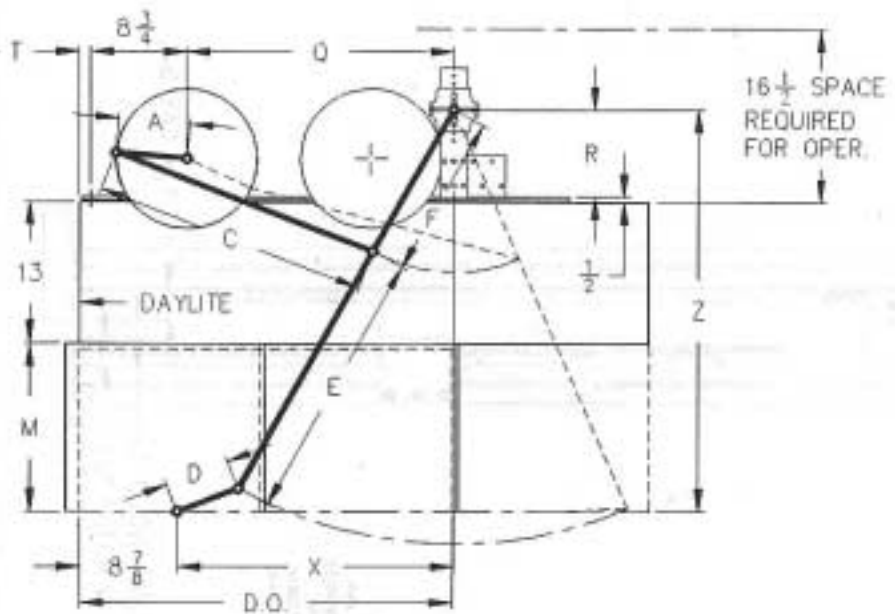

48	10 ¹ / ₁₆	34 ⁵ / ₁₆	12	31	21	23	39 ⁵ / ₈	47 ¹ / ₂	33 ³ / ₄	11
47	9 ⁷ / ₈	34 ¹ / ₈	12	31	21	23	39 ⁵ / ₈	47 ¹ / ₂	33 ³ / ₄	11
46	9 ¹¹ / ₁₆	33 ¹⁵ / ₁₆	12	31	21	23	39 ⁵ / ₈	47 ¹ / ₂	33 ³ / ₄	11
45	9 ¹ / ₂	33 ³ / ₄	12	31	21	23	39 ⁵ / ₈	47 ¹ / ₂	33 ³ / ₄	11
44	9 ⁷ / ₈	34 ¹ / ₄	10	26	20	19	34 ⁵ / ₈	42	33 ³ / ₄	9 ¹ / ₂
43	9 ¹¹ / ₁₆	34 ⁹ / ₁₆	10	26	20	19	34 ⁵ / ₈	42	33 ³ / ₄	9 ¹ / ₂
42	9 ⁷ / ₁₆	34 ³ / ₈	10	26	20	19	34 ⁵ / ₈	42	33 ³ / ₄	9 ¹ / ₂
41	9 ³ / ₁₆	34 ³ / ₁₆	10	26	20	19	34 ⁵ / ₈	42	33 ³ / ₄	9 ¹ / ₂
40	9	34	10	26	20	19	34 ⁵ / ₈	42	33 ³ / ₄	9 ¹ / ₂
39	8	29 ³ / ₈	8	24	16	15	29 ¹ / ₄	36 ¹ / ₄	28 ³ / ₈	7 ³ / ₄
38	7 ¹¹ / ₁₆	29 ³ / ₁₆	8	24	16	15	29 ¹ / ₄	36 ¹ / ₄	28 ³ / ₈	7 ³ / ₄
37	7 ⁵ / ₈	29	8	24	16	15	29 ¹ / ₄	36 ¹ / ₄	28 ³ / ₈	7 ³ / ₄
36	7 ⁷ / ₁₆	28 ¹³ / ₁₆	8	24	16	15	29 ¹ / ₄	36 ¹ / ₄	28 ³ / ₈	7 ³ / ₄
35	7 ¹ / ₄	28 ⁵ / ₈	8	24	16	15	29 ¹ / ₄	36 ¹ / ₄	28 ³ / ₈	7 ³ / ₄
34	6 ¹ / ₂	25 ³ / ₁₆	6	25	15	15	25 ¹ / ₄	37	23 ⁷ / ₈	8 ¹ / ₂
33	6 ³ / ₈	25	6	25	15	15	25 ¹ / ₄	37	23 ⁷ / ₈	8 ¹ / ₂
32	6 ¹ / ₈	24 ¹ / ₄	6	25	15	15	24 ¹ / ₂	37 ³ / ₈	23 ¹ / ₂	8 ⁷ / ₈
31	5 ¹⁵ / ₁₆	24 ¹ / ₁₆	6	25	15	15	24 ¹ / ₂	37 ³ / ₈	23 ¹ / ₂	8 ⁷ / ₈
30	5 ³ / ₄	23 ⁷ / ₈	6	25	15	15	24 ¹ / ₂	37 ³ / ₈	23 ¹ / ₂	8 ⁷ / ₈

DOOR OPENING	A	C	D	E	F	M	X	Z	Q	R
	OPERATOR ARMS		DOOR ARMS			CLUTCH	PIVOT		OPERATOR	



TWO SPEED 30-48 D.O. OPERATOR DATA TABLE

AUG. 23 1994

DATA22

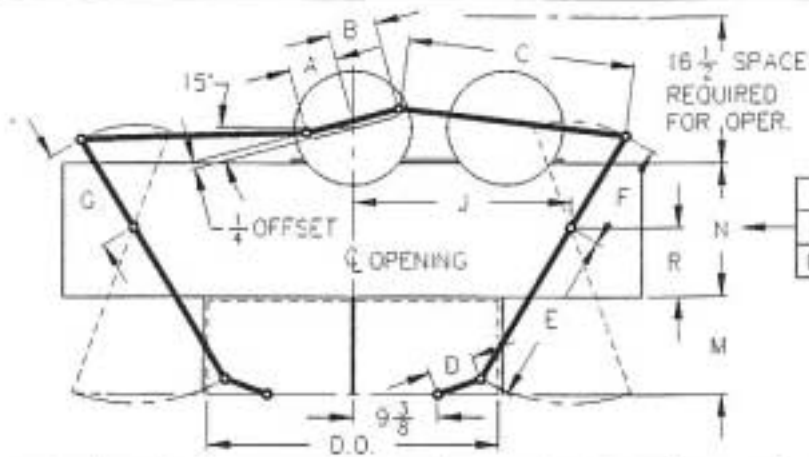

59	7 1/2	8 1/16	35	8	29 1/2	15	14 1/2	19	7 1/2	34
58	7 1/8	8 1/16	35 1/8	8	29 1/2	15	14 1/2	19	7 1/2	34
57	7 1/4	7 1/8	35 1/4	8	29 1/2	15	14 1/2	19	7 1/4	34
56	7 3/8	7 1/8	35 3/8	8	29 1/2	15	14 1/2	19	7 3/8	34
55	7 1/2	7 1/8	35 1/2	8	29 1/2	15	14 1/2	19	7 1/2	34
54	6 7/8	7 1/2	34	8	29 1/2	15	13	19	8 1/2	33
53	6 3/4	7 1/2	34 1/8	8	29 1/2	15	13	19	8 1/2	33
52	6 5/8	7 1/2	34 5/8	8	29 1/2	15	13	19	8 1/2	33
51	6 1/8	7 1/8	34 1/8	8	29 1/2	15	13	19	8 1/2	33
50	5 11/16	7	34 11/16	8	29 1/2	15	13	19	8 1/2	33
49	5 11/16	6 1/2	29 1/2	6	25 1/2	12	11 1/2	15	8 1/2	29
48	5 11/16	6 1/4	29 1/4	6	25 1/2	12	11 1/2	15	8 1/4	29
47	5 11/16	6	29 1/2	6	25 1/2	12	11 1/2	15	8 1/2	29
46	5 11/16	5 1/2	30	6	25 1/2	12	11 1/2	15	8 1/2	29
45	5 7/16	5 1/2	30 1/2	6	25 1/2	12	11 1/2	15	8 1/2	29
44	5 11/16	5 3/8	29 1/4	6	25 1/2	12	11 1/2	15	8 3/8	28 1/2
43	5 1/4	5 1/2	29 1/4	6	25 1/2	12	11 1/2	15	8 1/4	28 1/2
42	5 1/4	5 3/4	29 3/4	6	25 1/2	12	11 1/2	15	8 3/4	28 1/2
41	4 11/16	5 1/4	29 1/2	6	25 1/2	12	11 1/2	15	8 1/4	28 1/2
40	4 11/16	5 1/8	29 1/8	6	25 1/2	12	11 1/2	15	8 1/8	28 1/2
39	5 1/8	6 1/8	27 1/2	6	21	12	11 1/2	11	8 1/8	26 3/8
38	5 1/8	5 11/16	27 1/8	6	21	12	11 1/2	11	8 1/8	26 3/8
37	5 1/4	5 11/16	27 1/4	6	21	12	11 1/2	11	8 1/4	26 3/8
36	5 1/8	5 3/8	27 3/8	6	21	12	11 1/2	11	8 1/8	26 3/8
35	5 1/2	5 1/2	28	6	21	12	11 1/2	11	8 1/2	26 3/8
34	5	5 11/16	28 1/8	6	21	12	11 1/2	11	8 1/2	26 3/8
33	5 1/16	5 9/16	25 1/16	5	19 3/4	12	11 1/2	11	7 1/4	24 1/8
32	5 1/8	5 3/8	25 1/8	5	19 3/4	12	11 1/2	11	7 3/8	24 1/8
31	4 11/16	5 1/4	25 1/2	5	19 3/4	12	11 1/2	11	7 1/4	24 1/8
30	4 11/16	5 1/8	25 1/4	5	19 3/4	12	11 1/2	11	7 1/4	24 1/8

DOOR OPENING	A	B	C	D	E	F	G	M	R	J
	OPERATOR ARMS			DOOR ARMS				CLUTCH	PIVOT	
 CENTER OPENING 30-59 D.O. OPERATOR DATA TABLE										NOV. 11, 1994
										DATA23

DOOR OPERATOR MOTORS

SHUNT WOUND (4 WIRES)



MTR-0001N MOTOR, 1/6 HP 230 VDC
 MTR-0002N MOTOR, 1/6 HP 115 VDC
 MTR-0003N MOTOR, 1/4 HP 230 VDC
 MTR-0004N MOTOR, 1/4 HP 115 VDC
 MTR-0005N MOTOR, 1/2 HP 230 VDC

RPM: 1140
 WINDING: SHUNT-SEPARATELY EXCITED
 FRAME SIZE: 56
 SHAFT DIAMETER: 5/8
 INSULATION CLASS: B-R
 TIME RATING: CONTINUOUS
 AMB. TEMP: 40° C
 MANUFACTURER: GENERAL ELECTRIC

DESCRIPTION	PART NUMBER FOR SHUNT WOUND MOTOR				
	MTR-0001N	MTR-0002N	MTR-0003N	MTR-0004N	MTR-0005N
MODEL	5BCD56BD276	5BCD56BB77	5BCD56CD274	5BCD56CD261	5BCD56ED330
HORSE POWER	1/6	1/6	1/4	1/4	1/2
VOLTS (DC)	230	115	230	115	230
ARMATURE AMPS	0.75	1.5	1.1	2.2	2.4
FIELD AMPS	0.16	0.49	0.2	0.4	0.2
ARMATURE RESISTANCE	36	8.3	24	6	16
FIELD RESISTANCE	1050	175	775	210	880
RATED TORQUE (OZ-FT)	12.3	12.3	18.4		36.9

PERMANENT MAGNET (PM) (2 WIRES)



MTR-0008N MOTOR, 1/6 HP 230 VDC PM
 MTR-0011N MOTOR, 1/6 HP 115 VDC PM
 MTR-0009N MOTOR, 1/4 HP 230 VDC PM
 MTR-0012N MOTOR, 1/4 HP 115 VDC PM
 MTR-0010N MOTOR, 1/2 HP 230 VDC PM
 MTR-0013N MOTOR, 1/2 HP 115 VDC PM

RPM: 1140
 WINDING: PM
 FRAME SIZE: 56
 SHAFT DIAMETER: 5/8
 INSULATION CLASS: FR
 TIME RATING: CONTINUOUS
 AMB. TEMP: 40° C
 MANUFACTURER: GENERAL ELECTRIC

DESCRIPTION	PART NUMBER FOR PM MOTOR					
	MTR-0008N	MTR-0011N	MTR-0009N	MTR-0012N	MTR-0010N	MTR-0013N
MODEL	5BPA56HAC22	5BPA56HAC24	5BPA56KAG45	5BPA56KAG12	5BPA56KA52	5BPA56KAG7
HORSE POWER	1/6	1/6	1/4	1/4	1/2	1/2
VOLTS (DC)	230	115	230	115	230	115
ARMATURE AMPS	0.8	1.6	1.18	2.2	2.4	4.4
ARMATURE RESISTANCE	50	12.5	20	5.3	20	
RATED TORQUE (OZ-FT)	12.3	12.3	18.4	18.4	36.9	

**DOOR MOTOR LINE AMPS
(ALL VALUES ARE APPROXIMATE)**

230 VOLT MOTOR				
MOTOR HP	HS TORQUE OZ-FT	HS RPM	HS DC LINE AMPS	STALL FULLY CLOSED AMPS
1/6	40	780	2.04	0.8
1/4	42	1088	2.34	1.4
1/2	44	1158	2.59	1.4

115 VOLT MOTOR				
MOTOR HP	HS TORQUE OZ-FT	HS RPM	HS DC LINE AMPS	STALL FULLY CLOSED AMPS
1/6	40	780	4.08	0.9
1/4	42	1088	4.68	1.8
1/2	44	1158	5.18	1.8